

A
EC
C
D
E
F
G
H
I
J
K
L
M

SECTION EC

ENGINE CONTROL SYSTEM

CONTENTS

QR		
INDEX FOR DTC	15	
DTC No. Index	15	
Alphabetical Index	17	
PRECAUTIONS	21	
Precautions for Supplemental Restraint System (SRS) "AIR BAG" and "SEAT BELT PRE-TENSIONER"	21	
On Board Diagnostic (OBD) System of Engine and A/T	21	
Precaution	21	
Wiring Diagrams and Trouble Diagnosis	24	
PREPARATION	25	
Special Service Tools	25	
Commercial Service Tools	26	
ENGINE CONTROL SYSTEM	28	
System Diagram	28	
Multiport Fuel Injection (MFI) System	29	
Electronic Ignition (EI) System	31	
Fuel Cut Control (at No Load and High Engine Speed)	32	
AIR CONDITIONING CUT CONTROL	33	
Input/output Signal Chart	33	
System Description	33	
AUTOMATIC SPEED CONTROL DEVICE (ASCD) ..	34	
System Description	34	
Component Description	35	
CAN COMMUNICATION	36	
System Description	36	
EVAPORATIVE EMISSION SYSTEM	37	
Description	37	
Component Inspection	40	
Removal and Installation	41	
How to Detect Fuel Vapor Leakage	41	
ON BOARD REFUELING VAPOR RECOVERY (ORVR)	44	
System Description	44	
Diagnostic Procedure	45	
Component Inspection	48	
POSITIVE CRANKCASE VENTILATION	50	
Description	50	
Component Inspection	50	
NVIS (NISSAN VEHICLE IMMOBILIZER SYSTEM-NATS)	52	
Description	52	
ON BOARD DIAGNOSTIC (OBD) SYSTEM	53	
Introduction	53	
Two Trip Detection Logic	53	
Emission-related Diagnostic Information	54	
Malfunction Indicator Lamp (MIL)	67	
OBD System Operation Chart	70	
BASIC SERVICE PROCEDURE	75	
Basic Inspection	75	
Idle Speed and Ignition Timing Check	80	
Idle Mixture Ratio Adjustment	81	
VIN Registration	92	
Accelerator Pedal Released Position Learning	93	
Throttle Valve Closed Position Learning	93	
Idle Air Volume Learning	93	
Fuel Pressure Check	95	
TROUBLE DIAGNOSIS	99	
Trouble Diagnosis Introduction	99	
DTC Inspection Priority Chart	105	
Fail-safe Chart	107	
Symptom Matrix Chart	108	
Engine Control Component Parts Location	112	
Vacuum Hose Drawing	117	
Circuit Diagram	118	
ECM Harness Connector Terminal Layout	120	
ECM Terminals and Reference Value	120	
CONSULT-II Function (ENGINE)	128	
Generic Scan Tool (GST) Function	140	
CONSULT-II Reference Value in Data Monitor	142	
Major Sensor Reference Graph in Data Monitor Mode	146	
TROUBLE DIAGNOSIS - SPECIFICATION VALUE	148	
Description	148	
Testing Condition	148	

Inspection Procedure	148	DTC Confirmation Procedure	194
Diagnostic Procedure	149	Wiring Diagram	196
TROUBLE DIAGNOSIS FOR INTERMITTENT INCIDENT	158	Diagnostic Procedure	197
Description	158	Component Inspection	198
Diagnostic Procedure	158	Removal and Installation	198
POWER SUPPLY AND GROUND CIRCUIT	159	DTC P0117, P0118 ECT SENSOR	199
Wiring Diagram	159	Component Description	199
Diagnostic Procedure	160	On Board Diagnosis Logic	199
Ground Inspection	164	DTC Confirmation Procedure	200
DTC U1000, U1001 CAN COMMUNICATION LINE	166	Wiring Diagram	201
Description	166	Diagnostic Procedure	202
On Board Diagnosis Logic	166	Component Inspection	203
DTC Confirmation Procedure	166	Removal and Installation	203
Wiring Diagram	167	DTC P0122, P0123 TP SENSOR	204
Diagnostic Procedure	168	Component Description	204
DTC P0011 IVT CONTROL	169	CONSULT-II Reference Value in Data Monitor Mode	204
Description	169	On Board Diagnosis Logic	204
CONSULT-II Reference Value in Data Monitor Mode	169	DTC Confirmation Procedure	204
On Board Diagnosis Logic	170	Wiring Diagram	206
DTC Confirmation Procedure	170	Diagnostic Procedure	207
Diagnostic Procedure	171	Component Inspection	210
Component Inspection	172	Remove and Installation	210
Removal and Installation	172	DTC P0125 ECT SENSOR	211
DTC P0037, P0038 HO2S2 HEATER	173	Description	211
Description	173	On Board Diagnosis Logic	211
CONSULT-II Reference Value in Data Monitor Mode	173	DTC Confirmation Procedure	211
On Board Diagnosis Logic	173	Diagnostic Procedure	212
DTC Confirmation Procedure	173	Component Inspection	213
Wiring Diagram	175	Removal and Installation	213
Diagnostic Procedure	176	DTC P0127 IAT SENSOR	214
Component Inspection	177	Component Description	214
Removal and Installation	177	On Board Diagnosis Logic	214
DTC P0101 MAF SENSOR	178	DTC Confirmation Procedure	214
Component Description	178	Diagnostic Procedure	215
CONSULT-II Reference Value in Data Monitor Mode	178	Component Inspection	216
On Board Diagnosis Logic	178	Removal and Installation	216
DTC Confirmation Procedure	178	DTC P0128 THERMOSTAT FUNCTION	217
Overall Function Check	180	On Board Diagnosis Logic	217
Wiring Diagram	181	DTC Confirmation Procedure	217
Diagnostic Procedure	182	Diagnostic Procedure	217
Component Inspection	184	Component Inspection	218
Removal and Installation	186	Removal and Installation	218
DTC P0102, P0103 MAF SENSOR	187	DTC P0138 HO2S2	219
Component Description	187	Component Description	219
CONSULT-II Reference Value in Data Monitor Mode	187	CONSULT-II Reference Value in Data Monitor Mode	219
On Board Diagnosis Logic	187	On Board Diagnosis Logic	219
DTC Confirmation Procedure	187	DTC Confirmation Procedure	219
Wiring Diagram	189	Wiring Diagram	221
Diagnostic Procedure	190	Diagnostic Procedure	222
Component Inspection	192	Component Inspection	223
Removal and Installation	193	Removal and Installation	224
DTC P0112, P0113 IAT SENSOR	194	DTC P0139 HO2S2	225
Component Description	194	Component Description	225
On Board Diagnosis Logic	194	CONSULT-II Reference Value in Data Monitor Mode	225
DTC Confirmation Procedure	194	On Board Diagnosis Logic	225
DTC Confirmation Procedure	194	DTC Confirmation Procedure	226

Overall Function Check	226	DTC Confirmation Procedure	273	
Wiring Diagram	228	Wiring Diagram	275	A
Diagnostic Procedure	229	Diagnostic Procedure	276	
Component Inspection	231	Component Inspection	278	
Removal and Installation	232	Removal and Installation	279	EC
DTC P0171 FUEL INJECTION SYSTEM FUNCTION 233		DTC P0340 CMP SENSOR (PHASE) 280		
On Board Diagnosis Logic	233	Component Description	280	
DTC Confirmation Procedure	233	On Board Diagnosis Logic	280	C
Wiring Diagram	235	DTC Confirmation Procedure	280	
Diagnostic Procedure	236	Wiring Diagram	282	
DTC P0172 FUEL INJECTION SYSTEM FUNCTION 240		Diagnostic Procedure	283	
On Board Diagnosis Logic	240	Component Inspection	285	D
DTC Confirmation Procedure	240	Removal and Installation	286	
Wiring Diagram	242	DTC P0420 THREE WAY CATALYST FUNCTION 287		
Diagnostic Procedure	243	On Board Diagnosis Logic	287	E
DTC P0181 FTT SENSOR 246		DTC Confirmation Procedure	287	
Component Description	246	Overall Function Check	288	
On Board Diagnosis Logic	246	Diagnostic Procedure	288	F
DTC Confirmation Procedure	246	DTC P0441 EVAP CONTROL SYSTEM 292		
Wiring Diagram	248	System Description	292	
Diagnostic Procedure	249	On Board Diagnosis Logic	292	G
Component Inspection	250	DTC Confirmation Procedure	293	
Removal and Installation	250	Overall Function Check	293	
DTC P0182, P0183 FTT SENSOR 251		Diagnostic Procedure	294	
Component Description	251	DTC P0442 EVAP CONTROL SYSTEM 298		H
On Board Diagnosis Logic	251	On Board Diagnosis Logic	298	
DTC Confirmation Procedure	251	DTC Confirmation Procedure	299	
Wiring Diagram	252	Diagnostic Procedure	300	I
Diagnostic Procedure	253	DTC P0444, P0445 EVAP CANISTER PURGE VOL- UME CONTROL SOLENOID VALVE 306		
Component Inspection	254	Description	306	J
Removal and Installation	254	CONSULT-II Reference Value in Data Monitor Mode		
DTC P0222, P0223 TP SENSOR 255			306	
Component Description	255	On Board Diagnosis Logic	307	K
CONSULT-II Reference Value in Data Monitor Mode		DTC Confirmation Procedure	307	
	255	Wiring Diagram	308	
On Board Diagnosis Logic	255	Diagnostic Procedure	309	L
DTC Confirmation Procedure	255	Component Inspection	311	
Wiring Diagram	257	Removal and Installation	311	
Diagnostic Procedure	258	DTC P0447 EVAP CANISTER VENT CONTROL VALVE 312		M
Component Inspection	261	Component Description	312	
Remove and Installation	261	CONSULT-II Reference Value in Data Monitor Mode		
DTC P0300 - P0304 MULTIPLE CYLINDER MIS- FIRE, NO. 1 - 4 CYLINDER MISFIRE 262			312	
On Board Diagnosis Logic	262	On Board Diagnosis Logic	312	
DTC Confirmation Procedure	262	DTC Confirmation Procedure	312	
Diagnostic Procedure	263	Wiring Diagram	314	
DTC P0327, P0328 KS 269		Diagnostic Procedure	315	
Component Description	269	Component Inspection	317	
On Board Diagnosis Logic	269	DTC P0451 EVAP CONTROL SYSTEM PRESSURE SENSOR 319		
DTC Confirmation Procedure	269	Component Description	319	
Wiring Diagram	270	CONSULT-II Reference Value in Data Monitor Mode		
Diagnostic Procedure	271		319	
Component Inspection	272	On Board Diagnosis Logic	319	
Removal and Installation	272	DTC Confirmation Procedure	320	
DTC P0335 CKP SENSOR (POS) 273		Diagnostic Procedure	320	
Component Description	273	Component Inspection	321	
CONSULT-II Reference Value in Data Monitor Mode		DTC P0452 EVAP CONTROL SYSTEM PRESSURE		
	273			
On Board Diagnosis Logic	273			

SENSOR	322	On Board Diagnosis Logic	363
Component Description	322	DTC Confirmation Procedure	363
CONSULT-II Reference Value in Data Monitor Mode	322	Diagnostic Procedure	364
On Board Diagnosis Logic	322	DTC P0550 PSP SENSOR	365
DTC Confirmation Procedure	323	Component Description	365
Wiring Diagram	324	CONSULT-II Reference Value in Data Monitor Mode	365
Diagnostic Procedure	325	On Board Diagnosis Logic	365
Component Inspection	327	DTC Confirmation Procedure	365
DTC P0453 EVAP CONTROL SYSTEM PRESSURE SENSOR	328	Wiring Diagram	366
Component Description	328	Diagnostic Procedure	367
CONSULT-II Reference Value in Data Monitor Mode	328	Component Inspection	369
On Board Diagnosis Logic	328	DTC P0605 ECM	370
DTC Confirmation Procedure	329	Component Description	370
Wiring Diagram	330	On Board Diagnosis Logic	370
Diagnostic Procedure	331	DTC Confirmation Procedure	370
Component Inspection	334	Diagnostic Procedure	371
DTC P0455 EVAP CONTROL SYSTEM	335	DTC P1031, P1032 A/F SENSOR 1 HEATER	373
On Board Diagnosis Logic	335	Description	373
DTC Confirmation Procedure	336	CONSULT-II Reference Value in Data Monitor Mode	373
Diagnostic Procedure	337	On Board Diagnosis Logic	373
DTC P0456 EVAP CONTROL SYSTEM	343	DTC Confirmation Procedure	373
On Board Diagnosis Logic	343	Wiring Diagram	374
DTC Confirmation Procedure	344	Diagnostic Procedure	375
Overall Function Check	345	Component Inspection	377
Diagnostic Procedure	346	Removal and Installation	377
DTC P0460 FUEL LEVEL SENSOR	353	DTC P1065 ECM POWER SUPPLY	378
Component Description	353	Component Description	378
On Board Diagnostic Logic	353	On Board Diagnosis Logic	378
DTC Confirmation Procedure	353	DTC Confirmation Procedure	378
Diagnostic Procedure	354	Wiring Diagram	379
Removal and Installation	354	Diagnostic Procedure	380
DTC P0461 FUEL LEVEL SENSOR	355	DTC P1111 IVT CONTROL SOLENOID VALVE	382
Component Description	355	Component Description	382
On Board Diagnostic Logic	355	CONSULT-II Reference Value in Data Monitor Mode	382
Overall Function Check	355	On Board Diagnosis Logic	382
Diagnostic Procedure	356	DTC Confirmation Procedure	382
Removal and Installation	356	Wiring Diagram	383
DTC P0462, P0463 FUEL LEVEL SENSOR	357	Diagnostic Procedure	384
Component Description	357	Component Inspection	385
On Board Diagnostic Logic	357	Removal and Installation	385
DTC Confirmation Procedure	357	DTC P1121 ELECTRIC THROTTLE CONTROL ACTUATOR	386
Diagnostic Procedure	358	Component Description	386
Removal and Installation	358	On Board Diagnosis Logic	386
DTC P0500 VSS	359	DTC Confirmation Procedure	386
Description	359	Diagnostic Procedure	387
On Board Diagnosis Logic	359	DTC P1122 ELECTRIC THROTTLE CONTROL FUNCTION	388
DTC Confirmation Procedure	359	Description	388
Overall Function Check	359	On Board Diagnosis Logic	388
Diagnostic Procedure	360	DTC Confirmation Procedure	388
DTC P0506 ISC SYSTEM	361	Wiring Diagram	389
Description	361	Diagnostic Procedure	390
On Board Diagnosis Logic	361	Component Inspection	393
DTC Confirmation Procedure	361	Remove and Installation	393
Diagnostic Procedure	362	DTC P1124, P1126 THROTTLE CONTROL MOTOR	393
DTC P0507 ISC SYSTEM	363		
Description	363		

RELAY	394	DTC Confirmation Procedure	436	
Component Description	394	Diagnostic Procedure	437	A
CONSULT-II Reference Value in Data Monitor Mode	394	Remove and Installation	437	
On Board Diagnosis Logic	394	DTC P1229 SENSOR POWER SUPPLY	438	EC
DTC Confirmation Procedure	394	On Board Diagnosis Logic	438	
Wiring Diagram	396	DTC Confirmation Procedure	438	
Diagnostic Procedure	397	Wiring Diagram	439	
DTC P1128 THROTTLE CONTROL MOTOR	399	Diagnostic Procedure	440	C
Component Description	399	DTC P1271 A/F SENSOR 1	443	
On Board Diagnosis Logic	399	Component Description	443	
DTC Confirmation Procedure	399	CONSULT-II Reference Value in Data Monitor Mode	443	D
Wiring Diagram	400	On Board Diagnosis Logic	443	
Diagnostic Procedure	401	DTC Confirmation Procedure	443	
Component Inspection	402	Wiring Diagram	445	E
Removal and Installation	403	Diagnostic Procedure	446	
DTC P1146 HO2S2	404	Removal and Installation	447	
Component Description	404	DTC P1272 A/F SENSOR 1	448	F
CONSULT-II Reference Value in Data Monitor Mode	404	Component Description	448	
On Board Diagnosis Logic	404	CONSULT-II Reference Value in Data Monitor Mode	448	G
DTC Confirmation Procedure	405	On Board Diagnosis Logic	448	
Overall Function Check	405	DTC Confirmation Procedure	448	
Wiring Diagram	407	Wiring Diagram	450	
Diagnostic Procedure	408	Diagnostic Procedure	451	H
Component Inspection	410	Removal and Installation	452	
Removal and Installation	411	DTC P1273 A/F SENSOR 1	453	
DTC P1147 HO2S2	412	Component Description	453	I
Component Description	412	CONSULT-II Reference Value in Data Monitor Mode	453	
CONSULT-II Reference Value in Data Monitor Mode	412	On Board Diagnosis Logic	453	J
On Board Diagnosis Logic	412	DTC Confirmation Procedure	453	
DTC Confirmation Procedure	413	Wiring Diagram	455	
Overall Function Check	413	Diagnostic Procedure	456	
Wiring Diagram	415	Removal and Installation	459	K
Diagnostic Procedure	416	DTC P1274 A/F SENSOR 1	460	
Component Inspection	418	Component Description	460	L
Removal and Installation	419	CONSULT-II Reference Value in Data Monitor Mode	460	
DTC P1148 CLOSED LOOP CONTROL	420	On Board Diagnosis Logic	460	
On Board Diagnosis Logic	420	DTC Confirmation Procedure	460	M
DTC P1217 ENGINE OVER TEMPERATURE	421	Wiring Diagram	462	
Description	421	Diagnostic Procedure	463	
CONSULT-II Reference Value in Data Monitor Mode	422	Removal and Installation	466	
On Board Diagnosis Logic	422	DTC P1276 A/F SENSOR 1	467	
Overall Function Check	423	Component Description	467	
Wiring Diagram	425	CONSULT-II Reference Value in Data Monitor Mode	467	
Diagnostic Procedure	427	On Board Diagnosis Logic	467	
Main 12 Causes of Overheating	432	DTC Confirmation Procedure	467	
Component Inspection	432	Overall Function Check	468	
DTC P1225 TP SENSOR	434	Wiring Diagram	470	
Component Description	434	Diagnostic Procedure	471	
On Board Diagnosis Logic	434	Removal and Installation	472	
DTC Confirmation Procedure	434	DTC P1278 A/F SENSOR 1	473	
Diagnostic Procedure	435	Component Description	473	
Remove and Installation	435	CONSULT-II Reference Value in Data Monitor Mode	473	
DTC P1226 TP SENSOR	436	On Board Diagnosis Logic	473	
Component Description	436			
On Board Diagnosis Logic	436			

DTC Confirmation Procedure	474	CONSULT-II Reference Value in Data Monitor Mode	524
Wiring Diagram	476	On Board Diagnosis Logic	524
Diagnostic Procedure	477	DTC Confirmation Procedure	524
Removal and Installation	481	Overall Function Check	525
DTC P1279 A/F SENSOR 1	482	Wiring Diagram	526
Component Description	482	Diagnostic Procedure	528
CONSULT-II Reference Value in Data Monitor Mode	482	DTC P1800 VIAS CONTROL SOLENOID VALVE	532
On Board Diagnosis Logic	482	Component Description	532
DTC Confirmation Procedure	483	CONSULT-II Reference Value in Data Monitor Mode	532
Wiring Diagram	485	On Board Diagnosis Logic	532
Diagnostic Procedure	486	DTC Confirmation Procedure	532
Removal and Installation	490	Wiring Diagram	533
DTC P1444 EVAP CANISTER PURGE VOLUME CONTROL SOLENOID VALVE	491	Diagnostic Procedure	534
Description	491	Component Inspection	535
CONSULT-II Reference Value in Data Monitor Mode	491	Removal and Installation	536
On Board Diagnosis Logic	492	DTC P1805 BRAKE SWITCH	537
DTC Confirmation Procedure	492	Description	537
Wiring Diagram	493	CONSULT-II Reference Value in Data Monitor Mode	537
Diagnostic Procedure	494	On Board Diagnosis Logic	537
Component Inspection	497	DTC Confirmation Procedure	537
Removal and Installation	497	Wiring Diagram	538
DTC P1446 EVAP CANISTER VENT CONTROL VALVE	498	Diagnostic Procedure	539
Component Description	498	Component Inspection	540
CONSULT-II Reference Value in Data Monitor Mode	498	DTC P2122, P2123 APP SENSOR	542
On Board Diagnosis Logic	498	Component Description	542
DTC Confirmation Procedure	498	CONSULT-II Reference Value in Data Monitor Mode	542
Wiring Diagram	500	On Board Diagnosis Logic	542
Diagnostic Procedure	501	DTC Confirmation Procedure	542
Component Inspection	502	Wiring Diagram	544
DTC P1564 ASCD STEERING SWITCH	504	Diagnostic Procedure	545
Component Description	504	Component Inspection	547
CONSULT-II Reference Value in Data Monitor Mode	504	Removal and Installation	548
On Board Diagnosis Logic	504	DTC P2127, P2128 APP SENSOR	549
DTC Confirmation Procedure	504	Component Description	549
Wiring Diagram	506	CONSULT-II Reference Value in Data Monitor Mode	549
Diagnostic Procedure	508	On Board Diagnosis Logic	549
Component Inspection	509	DTC Confirmation Procedure	549
DTC P1572 ASCD BRAKE SWITCH	511	Wiring Diagram	551
Component Description	511	Diagnostic Procedure	552
CONSULT-II Reference Value in Data Monitor Mode	511	Component Inspection	556
On Board Diagnosis Logic	511	Remove and Installation	556
DTC Confirmation Procedure	512	DTC P2135 TP SENSOR	557
Wiring Diagram	513	Component Description	557
Diagnostic Procedure	515	CONSULT-II Reference Value in Data Monitor Mode	557
Component Inspection	520	On Board Diagnosis Logic	557
DTC P1574 ASCD VEHICLE SPEED SENSOR	522	DTC Confirmation Procedure	557
Component Description	522	Wiring Diagram	559
On Board Diagnosis Logic	522	Diagnostic Procedure	560
DTC Confirmation Procedure	522	Component Inspection	563
Diagnostic Procedure	523	Remove and Installation	563
DTC P1706 PNP SWITCH	524	DTC P2138 APP SENSOR	564
Component Description	524	Component Description	564
		CONSULT-II Reference Value in Data Monitor Mode	564

NATS)	667	Component Inspection	796
Description	667	Removal and Installation	796
ON BOARD DIAGNOSTIC (OBD) SYSTEM	668	DTC P0037, P0038, P0057, P0058 HO2S2 HEATER	797
Introduction	668	Description	797
Two Trip Detection Logic	668	CONSULT-II Reference Value in Data Monitor Mode	797
Emission-related Diagnostic Information	669	On Board Diagnosis Logic	797
Malfunction Indicator Lamp (MIL)	685	DTC Confirmation Procedure	798
OBD System Operation Chart	687	Wiring Diagram	799
BASIC SERVICE PROCEDURE	693	Diagnostic Procedure	802
Basic Inspection	693	Component Inspection	804
Idle Speed and Ignition Timing Check	698	Removal and Installation	805
Idle Mixture Ratio Adjustment	700	DTC P0101 MAF SENSOR	806
VIN Registration	711	Component Description	806
Accelerator Pedal Released Position Learning ...	711	CONSULT-II Reference Value in Data Monitor Mode	806
Throttle Valve Closed Position Learning	711	On Board Diagnosis Logic	806
Idle Air Volume Learning	712	DTC Confirmation Procedure	807
Fuel Pressure Check	714	Overall Function Check	808
TROUBLE DIAGNOSIS	716	Wiring Diagram	809
Trouble Diagnosis Introduction	716	Diagnostic Procedure	810
DTC Inspection Priority Chart	722	Component Inspection	812
Fail-safe Chart	724	Removal and Installation	814
Symptom Matrix Chart	725	DTC P0102, P0103 MAF SENSOR	815
Engine Control Component Parts Location	729	Component Description	815
Vacuum Hose Drawing	736	CONSULT-II Reference Value in Data Monitor Mode	815
Circuit Diagram	738	On Board Diagnosis Logic	815
ECM Harness Connector Terminal Layout	740	DTC Confirmation Procedure	816
ECM Terminals and Reference Value	740	Wiring Diagram	817
CONSULT-II Function (ENGINE)	750	Diagnostic Procedure	818
Generic Scan Tool (GST) Function	763	Component Inspection	820
CONSULT-II Reference Value in Data Monitor ...	766	Removal and Installation	821
Major Sensor Reference Graph in Data Monitor Mode	770	DTC P0112, P0113 IAT SENSOR	822
TROUBLE DIAGNOSIS - SPECIFICATION VALUE	772	Component Description	822
Description	772	On Board Diagnosis Logic	822
Testing Condition	772	DTC Confirmation Procedure	822
Inspection Procedure	772	Wiring Diagram	823
Diagnostic Procedure	773	Diagnostic Procedure	824
TROUBLE DIAGNOSIS FOR INTERMITTENT INCIDENT	782	Component Inspection	825
Description	782	Removal and Installation	825
Diagnostic Procedure	782	DTC P0117, P0118 ECT SENSOR	826
POWER SUPPLY AND GROUND CIRCUIT	783	Component Description	826
Wiring Diagram	783	On Board Diagnosis Logic	826
Diagnostic Procedure	784	DTC Confirmation Procedure	827
Ground Inspection	789	Wiring Diagram	828
DTC U1000, U1001 CAN COMMUNICATION LINE	790	Diagnostic Procedure	829
Description	790	Component Inspection	830
On Board Diagnosis Logic	790	Removal and Installation	830
DTC Confirmation Procedure	790	DTC P0122, P0123 TP SENSOR	831
Wiring Diagram	791	Component Description	831
Diagnostic Procedure	792	CONSULT-II Reference Value in Data Monitor Mode	831
DTC P0011, P0021 IVT CONTROL	793	On Board Diagnosis Logic	831
Description	793	DTC Confirmation Procedure	832
CONSULT-II Reference Value in Data Monitor Mode	793	Wiring Diagram	833
On Board Diagnosis Logic	794	Diagnostic Procedure	834
DTC Confirmation Procedure	794	Component Inspection	837
Diagnostic Procedure	795	Removal and Installation	837

DTC P0125 ECT SENSOR	838	Component Inspection	894	
Component Description	838	Removal and Installation	894	A
On Board Diagnosis Logic	838	DTC P0182, P0183 FTT SENSOR	895	
DTC Confirmation Procedure	839	Component Description	895	EC
Diagnostic Procedure	839	On Board Diagnosis Logic	895	
Component Inspection	840	DTC Confirmation Procedure	895	
Removal and Installation	840	Wiring Diagram	896	
DTC P0127 IAT SENSOR	841	Diagnostic Procedure	897	C
Component Description	841	Component Inspection	898	
On Board Diagnosis Logic	841	Removal and Installation	898	
DTC Confirmation Procedure	841	DTC P0222, P0223 TP SENSOR	899	
Diagnostic Procedure	842	Component Description	899	D
Component Inspection	843	CONSULT-II Reference Value in Data Monitor Mode		
Removal and Installation	843	899	
DTC P0128 THERMOSTAT FUNCTION	844	On Board Diagnosis Logic	899	E
On Board Diagnosis Logic	844	DTC Confirmation Procedure	900	
DTC Confirmation Procedure	844	Wiring Diagram	901	
Diagnostic Procedure	844	Diagnostic Procedure	902	F
Component Inspection	845	Component Inspection	905	
Removal and Installation	845	Removal and Installation	905	
DTC P0138, P0158 HO2S2	846	DTC P0300 - P0306 MULTIPLE CYLINDER MIS-		
Component Description	846	FIRE, NO. 1 - 6 CYLINDER MISFIRE	906	G
CONSULT-II Reference Value in Data Monitor Mode		On Board Diagnosis Logic	906	
.....	846	DTC Confirmation Procedure	906	
On Board Diagnosis Logic	846	Diagnostic Procedure	907	H
DTC Confirmation Procedure	847	DTC P0327, P0328 KS	916	
Wiring Diagram	848	Component Description	916	
Diagnostic Procedure	851	On Board Diagnosis Logic	916	I
Component Inspection	854	DTC Confirmation Procedure	916	
Removal and Installation	855	Wiring Diagram	917	
DTC P0139, P0159 HO2S2	856	Diagnostic Procedure	918	J
Component Description	856	Component Inspection	920	
CONSULT-II Reference Value in Data Monitor Mode		Removal and Installation	920	
.....	856	DTC P0335 CKP SENSOR (POS)	921	
On Board Diagnosis Logic	856	Component Description	921	K
DTC Confirmation Procedure	857	CONSULT-II Reference Value in Data Monitor Mode		
Overall Function Check	857	921	
Wiring Diagram	859	On Board Diagnosis Logic	921	L
Diagnostic Procedure	862	DTC Confirmation Procedure	921	
Component Inspection	865	Wiring Diagram	923	
Removal and Installation	867	Diagnostic Procedure	924	
DTC P0171, P0174 FUEL INJECTION SYSTEM		Component Inspection	927	M
FUNCTION	868	Removal and Installation	927	
On Board Diagnosis Logic	868	DTC P0340, P0345 CMP SENSOR (PHASE)	928	
DTC Confirmation Procedure	868	Component Description	928	
Wiring Diagram	870	On Board Diagnosis Logic	928	
Diagnostic Procedure	872	DTC Confirmation Procedure	928	
DTC P0172, P0175 FUEL INJECTION SYSTEM		Wiring Diagram	930	
FUNCTION	879	Diagnostic Procedure	933	
On Board Diagnosis Logic	879	Component Inspection	936	
DTC Confirmation Procedure	879	Removal and Installation	936	
Wiring Diagram	881	DTC P0400 EGR FUNCTION	937	
Diagnostic Procedure	883	Description	937	
DTC P0181 FTT SENSOR	890	CONSULT-II Reference Value in Data Monitor Mode		
Component Description	890	939	
On Board Diagnosis Logic	890	On Board Diagnosis Logic	939	
DTC Confirmation Procedure	890	DTC Confirmation Procedure	939	
Wiring Diagram	892	Wiring Diagram	941	
Diagnostic Procedure	893	Diagnostic Procedure	942	

DTC P0403 EGR VOLUME CONTROL VALVE	945		
Description	945	On Board Diagnosis Logic	991
CONSULT-II Reference Value in Data Monitor Mode		DTC Confirmation Procedure	992
	946	Diagnostic Procedure	992
On Board Diagnosis Logic	946	Component Inspection	993
DTC Confirmation Procedure	946		
Wiring Diagram	947	DTC P0452 EVAP CONTROL SYSTEM PRESSURE	
Diagnostic Procedure	948	SENSOR	994
Component Inspection	949	Component Description	994
Removal and Installation	951	CONSULT-II Reference Value in Data Monitor Mode	994
DTC P0405, P0406 EGRT SENSOR	952	On Board Diagnosis Logic	994
Component Description	952	DTC Confirmation Procedure	995
On Board Diagnosis Logic	952	Wiring Diagram	996
DTC Confirmation Procedure	953	Diagnostic Procedure	997
Wiring Diagram	955	Component Inspection	999
Diagnostic Procedure	956		
Component Inspection	957	DTC P0453 EVAP CONTROL SYSTEM PRESSURE	
Removal and Installation	958	SENSOR	1000
DTC P0420, P0430 THREE WAY CATALYST FUNCTION	959	Component Description	1000
On Board Diagnosis Logic	959	CONSULT-II Reference Value in Data Monitor Mode	1000
DTC Confirmation Procedure	959	On Board Diagnosis Logic	1000
Overall Function Check	960	DTC Confirmation Procedure	1001
Diagnostic Procedure	961	Wiring Diagram	1002
DTC P0441 EVAP CONTROL SYSTEM	964	Diagnostic Procedure	1003
System Description	964	Component Inspection	1007
On Board Diagnosis Logic	964	DTC P0455 EVAP CONTROL SYSTEM	1008
DTC Confirmation Procedure	964	On Board Diagnosis Logic	1008
Overall Function Check	965	DTC Confirmation Procedure	1009
Diagnostic Procedure	966	Diagnostic Procedure	1010
DTC P0442 EVAP CONTROL SYSTEM	969	DTC P0456 EVAP CONTROL SYSTEM	1016
On Board Diagnosis Logic	969	On Board Diagnosis Logic	1016
DTC Confirmation Procedure	970	DTC Confirmation Procedure	1017
Diagnostic Procedure	971	Overall Function Check	1018
DTC P0444, P0445 EVAP CANISTER PURGE VOLUME CONTROL SOLENOID VALVE	977	Diagnostic Procedure	1019
Description	977	DTC P0460 FUEL LEVEL SENSOR	1025
CONSULT-II Reference Value in Data Monitor Mode	977	Component Description	1025
	978	On Board Diagnosis Logic	1025
On Board Diagnosis Logic	978	DTC Confirmation Procedure	1025
DTC Confirmation Procedure	978	Diagnostic Procedure	1026
Wiring Diagram	979	Removal and Installation	1026
Diagnostic Procedure	981	DTC P0461 FUEL LEVEL SENSOR	1027
Component Inspection	983	Component Description	1027
Removal and Installation	983	On Board Diagnosis Logic	1027
DTC P0447 EVAP CANISTER VENT CONTROL VALVE	984	Overall Function Check	1027
Component Description	984	Diagnostic Procedure	1028
CONSULT-II Reference Value in Data Monitor Mode	984	Removal and Installation	1028
	984	DTC P0462, P0463 FUEL LEVEL SENSOR	1029
On Board Diagnosis Logic	984	Component Description	1029
DTC Confirmation Procedure	985	On Board Diagnosis Logic	1029
Wiring Diagram	986	DTC Confirmation Procedure	1029
Diagnostic Procedure	987	Diagnostic Procedure	1030
Component Inspection	989	Removal and Installation	1030
DTC P0451 EVAP CONTROL SYSTEM PRESSURE SENSOR	991	DTC P0500 VSS	1031
Component Description	991	Description	1031
CONSULT-II Reference Value in Data Monitor Mode	991	On Board Diagnosis Logic	1031
	991	DTC Confirmation Procedure	1031
On Board Diagnosis Logic	991	Overall Function Check	1031
DTC Confirmation Procedure	991	Diagnostic Procedure	1032
Wiring Diagram	992		
Diagnostic Procedure	992		
Component Inspection	993		

DTC P0506 ISC SYSTEM	1033	FUNCTION	1068	
Description	1033	Description	1068	A
On Board Diagnosis Logic	1033	On Board Diagnosis Logic	1068	
DTC Confirmation Procedure	1033	DTC Confirmation Procedure	1068	
Diagnostic Procedure	1034	Wiring Diagram	1069	EC
DTC P0507 ISC SYSTEM	1035	Diagnostic Procedure	1070	
Description	1035	Component Inspection	1073	
On Board Diagnosis Logic	1035	Remove and Installation	1073	C
DTC Confirmation Procedure	1035	DTC P1124, P1126 THROTTLE CONTROL MOTOR		
Diagnostic Procedure	1036	RELAY	1074	
DTC P0550 PSP SENSOR	1037	Component Description	1074	D
Component Description	1037	CONSULT-II Reference Value in Data Monitor Mode		
CONSULT-II Reference Value in Data Monitor Mode	1037	On Board Diagnosis Logic	1074	
On Board Diagnosis Logic	1037	DTC Confirmation Procedure	1074	E
DTC Confirmation Procedure	1037	Wiring Diagram	1076	
Wiring Diagram	1038	Diagnostic Procedure	1077	
Diagnostic Procedure	1039	DTC P1128 THROTTLE CONTROL MOTOR	1079	F
Component Inspection	1041	Component Description	1079	
DTC P0605 ECM	1042	On Board Diagnosis Logic	1079	
Component Description	1042	DTC Confirmation Procedure	1079	G
On Board Diagnosis Logic	1042	Wiring Diagram	1080	
DTC Confirmation Procedure	1042	Diagnostic Procedure	1081	
Diagnostic Procedure	1043	Component Inspection	1082	
DTC P1031, P1032, P1051, P1052 A/F SENSOR 1		Removal and Installation	1083	H
HEATER	1045	DTC P1146, P1166 HO2S2	1084	
Description	1045	Component Description	1084	I
CONSULT-II Reference Value in Data Monitor Mode	1045	CONSULT-II Reference Value in Data Monitor Mode	1084	
On Board Diagnosis Logic	1045	On Board Diagnosis Logic	1084	
DTC Confirmation Procedure	1045	DTC Confirmation Procedure	1085	J
Wiring Diagram	1047	Overall Function Check	1085	
Diagnostic Procedure	1050	Wiring Diagram	1087	
Component Inspection	1052	Diagnostic Procedure	1090	
Removal and Installation	1052	Component Inspection	1093	K
DTC P1065 ECM POWER SUPPLY	1053	Removal and Installation	1095	
Component Description	1053	DTC P1147, P1167 HO2S2	1096	
On Board Diagnosis Logic	1053	Component Description	1096	L
DTC Confirmation Procedure	1053	CONSULT-II Reference Value in Data Monitor Mode		
Wiring Diagram	1054	On Board Diagnosis Logic	1096	
Diagnostic Procedure	1055	DTC Confirmation Procedure	1097	M
DTC P1111, P1136 IVT CONTROL SOLENOID		Overall Function Check	1097	
VALVE	1057	Wiring Diagram	1099	
Component Description	1057	Diagnostic Procedure	1102	
CONSULT-II Reference Value in Data Monitor Mode	1057	Component Inspection	1105	
On Board Diagnosis Logic	1057	Removal and Installation	1107	
DTC Confirmation Procedure	1057	DTC P1148, P1168 CLOSED LOOP CONTROL	1108	
Wiring Diagram	1058	On Board Diagnosis Logic	1108	
Diagnostic Procedure	1061	DTC P1211 TCS CONTROL UNIT	1109	
Component Inspection	1064	Description	1109	
Removal and Installation	1065	On Board Diagnosis Logic	1109	
DTC P1121 ELECTRIC THROTTLE CONTROL		DTC Confirmation Procedure	1109	
ACTUATOR	1066	Diagnostic Procedure	1109	
Component Description	1066	DTC P1212 TCS COMMUNICATION LINE	1110	
On Board Diagnosis Logic	1066	Description	1110	
DTC Confirmation Procedure	1066	On Board Diagnosis Logic	1110	
Diagnostic Procedure	1067	DTC Confirmation Procedure	1110	
DTC P1122 ELECTRIC THROTTLE CONTROL		Diagnostic Procedure	1110	

DTC P1217 ENGINE OVER TEMPERATURE	1111	DTC Confirmation Procedure	1157
Description	1111	Wiring Diagram	1159
CONSULT-II Reference Value in Data Monitor Mode		Diagnostic Procedure	1162
	1112	Removal and Installation	1165
On Board Diagnosis Logic	1113	DTC P1276, P1286 A/F SENSOR 1	1166
Overall Function Check	1113	Component Description	1166
Wiring Diagram	1115	CONSULT-II Reference Value in Data Monitor Mode	1166
Diagnostic Procedure	1117	On Board Diagnosis Logic	1166
Main 12 Causes of Overheating	1122	DTC Confirmation Procedure	1166
Component Inspection	1122	Overall Function Check	1167
DTC P1225 TP SENSOR	1123	Wiring Diagram	1169
Component Description	1123	Diagnostic Procedure	1172
On Board Diagnosis Logic	1123	Removal and Installation	1174
DTC Confirmation Procedure	1123	DTC P1278, P1288 A/F SENSOR 1	1175
Diagnostic Procedure	1124	Component Description	1175
Removal and Installation	1124	CONSULT-II Reference Value in Data Monitor Mode	1175
DTC P1226 TP SENSOR	1125	On Board Diagnosis Logic	1175
Component Description	1125	DTC Confirmation Procedure	1176
On Board Diagnosis Logic	1125	Wiring Diagram	1178
DTC Confirmation Procedure	1125	Diagnostic Procedure	1181
Diagnostic Procedure	1126	Removal and Installation	1186
Removal and Installation	1126	DTC P1279, P1289 A/F SENSOR 1	1187
DTC P1229 SENSOR POWER SUPPLY	1127	Component Description	1187
On Board Diagnosis Logic	1127	CONSULT-II Reference Value in Data Monitor Mode	1187
DTC Confirmation Procedure	1127	On Board Diagnosis Logic	1187
Wiring Diagram	1128	DTC Confirmation Procedure	1188
Diagnostic Procedure	1129	Wiring Diagram	1190
DTC P1271, P1281 A/F SENSOR 1	1132	Diagnostic Procedure	1193
Component Description	1132	Removal and Installation	1198
CONSULT-II Reference Value in Data Monitor Mode	1132	DTC P1402 EGR FUNCTION	1199
On Board Diagnosis Logic	1132	Description	1199
DTC Confirmation Procedure	1132	CONSULT-II Reference Value in Data Monitor Mode	1201
Wiring Diagram	1134	On Board Diagnosis Logic	1201
Diagnostic Procedure	1137	DTC Confirmation Procedure	1201
Removal and Installation	1139	Wiring Diagram	1203
DTC P1272, P1282 A/F SENSOR 1	1140	Diagnostic Procedure	1204
Component Description	1140	DTC P1444 EVAP CANISTER PURGE VOLUME CONTROL SOLENOID VALVE	1206
CONSULT-II Reference Value in Data Monitor Mode	1140	Description	1206
On Board Diagnosis Logic	1140	CONSULT-II Reference Value in Data Monitor Mode	1206
DTC Confirmation Procedure	1140	On Board Diagnosis Logic	1207
Wiring Diagram	1142	DTC Confirmation Procedure	1207
Diagnostic Procedure	1145	Wiring Diagram	1208
Removal and Installation	1147	Diagnostic Procedure	1210
DTC P1273, P1283 A/F SENSOR 1	1148	Component Inspection	1213
Component Description	1148	Removal and Installation	1213
CONSULT-II Reference Value in Data Monitor Mode	1148	DTC P1446 EVAP CANISTER VENT CONTROL VALVE	1214
On Board Diagnosis Logic	1148	Component Description	1214
DTC Confirmation Procedure	1148	CONSULT-II Reference Value in Data Monitor Mode	1214
Wiring Diagram	1150	On Board Diagnosis Logic	1214
Diagnostic Procedure	1153	DTC Confirmation Procedure	1215
Removal and Installation	1156	Wiring Diagram	1216
DTC P1274, P1284 A/F SENSOR 1	1157		
Component Description	1157		
CONSULT-II Reference Value in Data Monitor Mode	1157		
On Board Diagnosis Logic	1157		

Diagnostic Procedure	1217	Wiring Diagram	1260	
Component Inspection	1218	Diagnostic Procedure	1261	A
DTC P1564 ASCD STEERING SWITCH	1220	Component Inspection	1263	
Component Description	1220	Removal and Installation	1264	
CONSULT-II Reference Value in Data Monitor Mode		DTC P2127, P2128 APP SENSOR	1265	EC
	1220	Component Description	1265	
On Board Diagnosis Logic	1220	CONSULT-II Reference Value in Data Monitor Mode		
DTC Confirmation Procedure	1221		1265	C
Wiring Diagram	1222	On Board Diagnosis Logic	1265	
Diagnostic Procedure	1223	DTC Confirmation Procedure	1266	
Component Inspection	1226	Wiring Diagram	1267	
DTC P1572 ASCD BRAKE SWITCH	1227	Diagnostic Procedure	1268	D
Component Description	1227	Component Inspection	1271	
CONSULT-II Reference Value in Data Monitor Mode		Removal and Installation	1271	
	1227	DTC P2135 TP SENSOR	1272	E
On Board Diagnosis Logic	1227	Component Description	1272	
DTC Confirmation Procedure	1228	CONSULT-II Reference Value in Data Monitor Mode		
Wiring Diagram	1229		1272	
Diagnostic Procedure	1231	On Board Diagnosis Logic	1272	F
Component Inspection	1236	DTC Confirmation Procedure	1273	
DTC P1574 ASCD VEHICLE SPEED SENSOR	1238	Wiring Diagram	1274	
Component Description	1238	Diagnostic Procedure	1275	G
On Board Diagnosis Logic	1238	Component Inspection	1278	
DTC Confirmation Procedure	1238	Removal and Installation	1278	
Diagnostic Procedure	1239	DTC P2138 APP SENSOR	1279	H
DTC P1706 PNP SWITCH	1240	Component Description	1279	
Component Description	1240	CONSULT-II Reference Value in Data Monitor Mode		
CONSULT-II Reference Value in Data Monitor Mode			1279	I
	1240	On Board Diagnosis Logic	1279	
On Board Diagnosis Logic	1240	DTC Confirmation Procedure	1280	
DTC Confirmation Procedure	1240	Wiring Diagram	1281	J
Overall Function Check	1241	Diagnostic Procedure	1282	
Wiring Diagram	1242	Component Inspection	1286	
Diagnostic Procedure	1245	Removal and Installation	1286	
DTC P1800 VIAS CONTROL SOLENOID VALVE	1248	IGNITION SIGNAL	1287	K
Component Description	1248	Component Description	1287	
CONSULT-II Reference Value in Data Monitor Mode		Wiring Diagram	1288	
	1248	Diagnostic Procedure	1293	L
On Board Diagnosis Logic	1248	Component Inspection	1298	
DTC Confirmation Procedure	1248	Removal and Installation	1299	
Wiring Diagram	1249	VIAS	1300	M
Diagnostic Procedure	1250	Description	1300	
Component Inspection	1251	CONSULT-II Reference Value in Data Monitor Mode		
Removal and Installation	1252		1301	
DTC P1805 BRAKE SWITCH	1253	Wiring Diagram	1302	
Description	1253	Diagnostic Procedure	1303	
CONSULT-II Reference Value in Data Monitor Mode		Component Inspection	1306	
	1253	Removal and Installation	1307	
On Board Diagnosis Logic	1253	INJECTOR CIRCUIT	1308	
DTC Confirmation Procedure	1253	Component Description	1308	
Wiring Diagram	1254	CONSULT-II Reference Value in Data Monitor Mode		
Diagnostic Procedure	1255		1308	
Component Inspection	1257	Wiring Diagram	1309	
DTC P2122, P2123 APP SENSOR	1258	Diagnostic Procedure	1310	
Component Description	1258	Component Inspection	1315	
CONSULT-II Reference Value in Data Monitor Mode		Removal and Installation	1315	
	1258	FUEL PUMP CIRCUIT	1316	
On Board Diagnosis Logic	1258	Description	1316	
DTC Confirmation Procedure	1259	CONSULT-II Reference Value in Data Monitor Mode		
			1316	

Wiring Diagram	1316	Diagnostic Procedure	1336
Diagnostic Procedure	1317	Component Inspection	1341
Component Inspection	1318	ASCD INDICATOR	1343
Removal and Installation	1321	Component Description	1343
ELECTRONIC CONTROLLED ENGINE MOUNT	1322	CONSULT-II Reference Value in Data Monitor Mode	1343
System Description	1322	Wiring Diagram	1344
CONSULT-II Reference Value in Data Monitor Mode	1322	Diagnostic Procedure	1345
Wiring Diagram	1323	MIL AND DATA LINK CONNECTOR	1346
Diagnostic Procedure	1324	Wiring Diagram	1346
REFRIGERANT PRESSURE SENSOR	1327	SERVICE DATA AND SPECIFICATIONS (SDS)	1348
Component Description	1327	Fuel Pressure	1348
Wiring Diagram	1328	Idle Speed and Ignition Timing	1348
Diagnostic Procedure	1329	Calculated Load Value	1348
Removal and Installation	1331	Mass Air Flow Sensor	1348
ELECTRICAL LOAD SIGNAL	1332	Intake Air Temperature Sensor	1348
Description	1332	Engine Coolant Temperature Sensor	1348
CONSULT-II Reference Value in Data Monitor Mode	1332	EGR Temperature Sensor	1348
Diagnostic Procedure	1332	Air Fuel Ratio (A/F) Sensor 1 Heater	1348
ASCD BRAKE SWITCH	1333	Heated Oxygen Sensor 2 Heater	1348
Component Description	1333	Crankshaft Position Sensor (POS)	1349
CONSULT-II Reference Value in Data Monitor Mode	1333	Camshaft Position Sensor (PHASE)	1349
Wiring Diagram	1334	Throttle Control Motor	1349
		Injector	1349
		Fuel Pump	1349

INDEX FOR DTC

[QR]

INDEX FOR DTC

PFP:00024

DTC No. Index

UBS002NS

NOTE:

If DTC U1000 or U1001 is displayed with other DTC, first perform the trouble diagnosis for DTC U1000, U1001. Refer to [EC-166. "DTC U1000, U1001 CAN COMMUNICATION LINE"](#).

×: Applicable —: Not applicable

DTC*1		Items (CONSULT-II screen terms)	Reference page
CONSULT-II GST*2	ECM*3		
U1000	1000*4	CAN COMM CIRCUIT	EC-166
U1001	1001*4	CAN COMM CIRCUIT	EC-166
P0000	0000	NO DTC IS DETECTED. FURTHER TESTING MAY BE REQUIRED.	—
P0011	0011	INT/V TIM CONT-B1	EC-169
P0037	0037	HO2S2 HTR (B1)	EC-173
P0038	0038	HO2S2 HTR (B1)	EC-173
P0101	0101	MAF SEN/CIRCUIT	EC-178
P0102	0102	MAF SEN/CIRCUIT	EC-187
P0103	0103	MAF SEN/CIRCUIT	EC-187
P0112	0112	IAT SEN/CIRCUIT	EC-194
P0113	0113	IAT SEN/CIRCUIT	EC-194
P0117	0117	ECT SEN/CIRCUIT	EC-199
P0118	0118	ECT SEN/CIRCUIT	EC-199
P0122	0122	TP SEN 2/CIRC	EC-204
P0123	0123	TP SEN 2/CIRC	EC-204
P0125	0125	ECT SENSOR	EC-211
P0127	0127	IAT SENSOR	EC-214
P0128	0128	THERMSTAT FNCTN	EC-217
P0138	0138	HO2S2 (B1)	EC-219
P0139	0139	HO2S2 (B1)	EC-225
P0171	0171	FUEL SYS-LEAN-B1	EC-233
P0172	0172	FUEL SYS-RICH-B1	EC-240
P0181	0181	FTT SENSOR	EC-246
P0182	0182	FTT SEN/CIRCUIT	EC-251
P0183	0183	FTT SEN/CIRCUIT	EC-251
P0222	0222	TP SEN 1/CIRC	EC-255
P0223	0223	TP SEN 1/CIRC	EC-255
P0300	0300	MULTI CYL MISFIRE	EC-262
P0301	0301	CYL 1 MISFIRE	EC-262
P0302	0302	CYL 2 MISFIRE	EC-262
P0303	0303	CYL 3 MISFIRE	EC-262
P0304	0304	CYL 4 MISFIRE	EC-262
P0327	0327	KNOCK SEN/CIRC-B1	EC-269
P0328	0328	KNOCK SEN/CIRC-B1	EC-269
P0335	0335	CKP SEN/CIRCUIT	EC-273

INDEX FOR DTC

[QR]

DTC*1		Items (CONSULT-II screen terms)	Reference page
CONSULT-II GST*2	ECM*3		
P0340	0340	CMP SEN/CIRC-B1	EC-280
P0420	0420	TW CATALYST SYS-B1	EC-287
P0441	0441	EVAP PURG FLOW/MON	EC-292
P0442	0442	EVAP SMALL LEAK	EC-298
P0444	0444	PURG VOLUME CONT/V	EC-306
P0445	0445	PURG VOLUME CONT/V	EC-306
P0447	0447	VENT CONTROL VALVE	EC-312
P0451	0451	EVAP SYS PRES SEN	EC-319
P0452	0452	EVAP SYS PRES SEN	EC-322
P0453	0453	EVAP SYS PRES SEN	EC-328
P0455	0455	EVAP GROSS LEAK	EC-335
P0456	0456	EVAP VERY SML LEAK	EC-343
P0460	0460	FUEL LEV SEN SLOSH	EC-353
P0461	0461	FUEL LEVEL SENSOR	EC-355
P0462	0462	FUEL LEVL SEN/CIRC	EC-357
P0463	0463	FUEL LEVL SEN/CIRC	EC-357
P0500	0500	VEH SPEED SEN/CIRC*5	EC-359
P0506	0506	ISC SYSTEM	EC-361
P0507	0507	ISC SYSTEM	EC-363
P0550	0550	PW ST P SEN/CIRC	EC-365
P0605	0605	ECM	EC-370
P0705	0705	PNP SW/CIRC	AT-105
P0710	0710	ATF TEMP SEN/CIRC	AT-111
P0720	0720	VEH SPD SEN/CIR AT*5	AT-117
P0725	0725	ENGINE SPEED SIG	AT-122
P0731	0731	A/T 1ST GR FNCTN	AT-126
P0732	0732	A/T 2ND GR FNCTN	AT-131
P0733	0733	A/T 3RD GR FNCTN	AT-136
P0734	0734	A/T 4TH GR FNCTN	AT-141
P0740	0740	TCC SOLENOID/CIRC	AT-148
P0744	0744	A/T TCC S/V FNCTN	AT-153
P0745	0745	L/PRESS SOL/CIRC	AT-161
P0750	0750	SFT SOL A/CIRC	AT-167
P0755	0755	SFT SOL B/CIRC	AT-172
P1031	1031	A/F SEN1 HTR (B1)	EC-373
P1032	1032	A/F SEN1 HTR (B1)	EC-373
P1065	1065	ECM BACK UP/CIRC	EC-378
P1111	1111	INT/V TIM V/CIR-B1	EC-382
P1121	1121	ETC ACTR	EC-386
P1122	1122	ETC FUNCTION/CIRC	EC-388
P1124	1124	ETC MOT PWR	EC-394
P1126	1126	ETC MOT PWR	EC-394

INDEX FOR DTC

[QR]

DTC*1		Items (CONSULT-II screen terms)	Reference page
CONSULT-II GST*2	ECM*3		
P1128	1128	ETC MOT	EC-399
P1146	1146	HO2S2 (B1)	EC-404
P1147	1147	HO2S2 (B1)	EC-412
P1148	1148	CLOSED LOOP-B1	EC-420
P1217	1217	ENG OVER TEMP	EC-421
P1225	1225	CTP LEARNING	EC-434
P1226	1226	CTP LEARNING	EC-436
P1229	1229	SENSOR POWER/CIRC	EC-438
P1271	1271	A/F SENSOR1 (B1)	EC-443
P1272	1272	A/F SENSOR1 (B1)	EC-448
P1273	1273	A/F SENSOR1 (B1)	EC-453
P1274	1274	A/F SENSOR1 (B1)	EC-460
P1276	1276	A/F SENSOR1 (B1)	EC-467
P1278	1278	A/F SENSOR1 (B1)	EC-473
P1279	1279	A/F SENSOR1 (B1)	EC-482
P1444	1444	PURG VOLUME CONT/V	EC-491
P1446	1446	VENT CONTROL VALVE	EC-498
P1564	1564	ASCD SW	EC-504
P1572	1572	ASCD BRAKE SW	EC-511
P1574	1574	ASCD VHL SPD SEN	EC-522
P1610 - P1615	1610 - 1615	NATS MALFUNCTION	EC-52
P1705	1705	TP SEN/CIRC A/T	AT-177
P1706	1706	P-N POS SW/CIRCUIT	EC-524
P1760	1760	O/R CLTCH SOL/CIRC	AT-183
P1800	1800	VIAS S/V CIRC	EC-532
P1805	1805	BRAKE SW/CIRCUIT	EC-537
P2122	2122	APP SEN 1/CIRC	EC-542
P2123	2123	APP SEN 1/CIRC	EC-542
P2127	2127	APP SEN 2/CIRC	EC-549
P2128	2128	APP SEN 2/CIRC	EC-549
P2135	2135	TP SENSOR	EC-557
P2138	2138	APP SENSOR	EC-564

*1: 1st trip DTC No. is the same as DTC No.

*2: This number is prescribed by SAE J2012.

*3: In Diagnostic Test Mode II (Self-diagnostic results), this number is controlled by NISSAN.

*4: The troubleshooting for this DTC needs CONSULT-II.

*5: When the fail-safe operations for both self-diagnoses occur, the MIL illuminates.

Alphabetical Index

UBS002NR

NOTE:

If DTC U1000 or U1001 is displayed with other DTC, first perform the trouble diagnosis for DTC U1000, U1001. Refer to [EC-166, "DTC U1000, U1001 CAN COMMUNICATION LINE"](#).

INDEX FOR DTC

[QR]

×: Applicable —: Not applicable

Items (CONSULT-II screen terms)	DTC*1		Reference page
	CONSULT-II GST*2	ECM*3	
A/F SENSOR1 (B1)	P1271	1271	EC-443
A/F SENSOR1 (B1)	P1272	1272	EC-448
A/F SENSOR1 (B1)	P1273	1273	EC-453
A/F SENSOR1 (B1)	P1274	1274	EC-460
A/F SENSOR1 (B1)	P1276	1276	EC-467
A/F SENSOR1 (B1)	P1278	1278	EC-473
A/F SENSOR1 (B1)	P1279	1279	EC-482
A/F SEN1 HTR (B1)	P1031	1031	EC-373
A/F SEN1 HTR (B1)	P1032	1032	EC-373
A/T 1ST GR FNCTN	P0731	0731	AT-126
A/T 2ND GR FNCTN	P0732	0732	AT-131
A/T 3RD GR FNCTN	P0733	0733	AT-136
A/T 4TH GR FNCTN	P0734	0734	AT-141
A/T TCC S/V FNCTN	P0744	0744	AT-153
APP SEN 1/CIRC	P2122	2122	EC-542
APP SEN 1/CIRC	P2123	2123	EC-542
APP SEN 2/CIRC	P2127	2127	EC-549
APP SEN 2/CIRC	P2128	2128	EC-549
APP SENSOR	P2138	2138	EC-564
ASCD BRAKE SW	P1572	1572	EC-511
ASCD SW	P1564	1564	EC-504
ASCD VHL SPD SEN	P1574	1574	EC-522
ATF TEMP SEN/CIRC	P0710	0710	AT-111
BRAKE SW/CIRCUIT	P1805	1805	EC-537
CAN COMM CIRCUIT	U1000	1000*4	EC-166
CAN COMM CIRCUIT	U1001	1001*4	EC-166
CKP SEN/CIRCUIT	P0335	0335	EC-273
CLOSED LOOP-B1	P1148	1148	EC-420
CMP SEN/CIRC-B1	P0340	0340	EC-280
CTP LEARNING	P1225	1225	EC-434
CTP LEARNING	P1226	1226	EC-436
CYL 1 MISFIRE	P0301	0301	EC-262
CYL 2 MISFIRE	P0302	0302	EC-262
CYL 3 MISFIRE	P0303	0303	EC-262
CYL 4 MISFIRE	P0304	0304	EC-262
ECM	P0605	0605	EC-370
ECM BACK UP/CIRC	P1065	1065	EC-378
ECT SEN/CIRCUIT	P0117	0117	EC-199
ECT SEN/CIRCUIT	P0118	0118	EC-199
ECT SENSOR	P0125	0125	EC-211
ENG OVER TEMP	P1217	1217	EC-421

INDEX FOR DTC

[QR]

Items (CONSULT-II screen terms)	DTC*1		Reference page
	CONSULT-II GST*2	ECM*3	
ENGINE SPEED SIG	P0725	0725	AT-122
ETC ACTR	P1121	1121	EC-386
ETC FUNCTION/CIRC	P1122	1122	EC-388
ETC MOT	P1128	1128	EC-399
ETC MOT PWR	P1124	1124	EC-394
ETC MOT PWR	P1126	1126	EC-394
EVAP GROSS LEAK	P0455	0455	EC-335
EVAP PURG FLOW/MON	P0441	0441	EC-292
EVAP SMALL LEAK	P0442	0442	EC-298
EVAP SYS PRES SEN	P0451	0451	EC-319
EVAP SYS PRES SEN	P0452	0452	EC-322
EVAP SYS PRES SEN	P0453	0453	EC-328
EVAP VERY SML LEAK	P0456	0456	EC-343
FTT SEN/CIRCUIT	P0182	0182	EC-251
FTT SEN/CIRCUIT	P0183	0183	EC-251
FTT SENSOR	P0181	0181	EC-246
FUEL LEV SEN SLOSH	P0460	0460	EC-353
FUEL LEVEL SENSOR	P0461	0461	EC-355
FUEL LEVL SEN/CIRC	P0462	0462	EC-357
FUEL LEVL SEN/CIRC	P0463	0463	EC-357
FUEL SYS-LEAN-B1	P0171	0171	EC-233
FUEL SYS-RICH-B1	P0172	0172	EC-240
HO2S2 (B1)	P0138	0138	EC-219
HO2S2 (B1)	P0139	0139	EC-225
HO2S2 (B1)	P1146	1146	EC-404
HO2S2 (B1)	P1147	1147	EC-412
HO2S2 HTR (B1)	P0037	0037	EC-173
HO2S2 HTR (B1)	P0038	0038	EC-173
IAT SEN/CIRCUIT	P0112	0112	EC-194
IAT SEN/CIRCUIT	P0113	0113	EC-194
IAT SENSOR	P0127	0127	EC-214
INT/V TIM CONT-B1	P0011	0011	EC-169
INT/V TIM V/CIR-B1	P1111	1111	EC-382
ISC SYSTEM	P0506	0506	EC-361
ISC SYSTEM	P0507	0507	EC-363
KNOCK SEN/CIRC-B1	P0327	0327	EC-269
KNOCK SEN/CIRC-B1	P0328	0328	EC-269
L/PRESS SOL/CIRC	P0745	0745	AT-161
MAF SEN/CIRCUIT	P0101	0101	EC-178
MAF SEN/CIRCUIT	P0102	0102	EC-187
MAF SEN/CIRCUIT	P0103	0103	EC-187
MULTI CYL MISFIRE	P0300	0300	EC-262

A
EC
C
D
E
F
G
H
I
J
K
L
M

INDEX FOR DTC

[QR]

Items (CONSULT-II screen terms)	DTC*1		Reference page
	CONSULT-II GST*2	ECM*3	
NATS MALFUNCTION	P1610 - P1615	1610 - 1615	BL-107
NO DTC IS DETECTED. FURTHER TESTING MAY BE REQUIRED.	P0000	0000	—
O/R CLTCH SOL/CIRC	P1760	1760	AT-183
P-N POS SW/CIRCUIT	P1706	1706	EC-524
PNP SW/CIRC	P0705	0705	AT-105
PURG VOLUME CONT/V	P0444	0444	EC-306
PURG VOLUME CONT/V	P0445	0445	EC-306
PURG VOLUME CONT/V	P1444	1444	EC-491
PW ST P SEN/CIRC	P0550	0550	EC-365
SENSOR POWER/CIRC	P1229	1229	EC-438
SFT SOL A/CIRC	P0750	0750	AT-167
SFT SOL B/CIRC	P0755	0755	AT-172
TCC SOLENOID/CIRC	P0740	0740	AT-148
THERMSTAT FNCTN	P0128	0128	EC-217
TP SEN 1/CIRC	P0222	0222	EC-255
TP SEN 1/CIRC	P0223	0223	EC-255
TP SEN 2/CIRC	P0122	0122	EC-204
TP SEN 2/CIRC	P0123	0123	EC-204
TP SENSOR	P2135	2135	EC-557
TP SEN/CIRC A/T	P1705	1705	AT-177
TW CATALYST SYS-B1	P0420	0420	EC-287
VEH SPD SEN/CIR AT*5	P0720	0720	AT-117
VEH SPEED SEN/CIRC*5	P0500	0500	EC-359
VENT CONTROL VALVE	P0447	0447	EC-312
VENT CONTROL VALVE	P1446	1446	EC-498
VIAS S/V CIRC	P1800	1800	EC-532

*1: 1st trip DTC No. is the same as DTC No.

*2: This number is prescribed by SAE J2012.

*3: In Diagnostic Test Mode II (Self-diagnostic results), this number is controlled by NISSAN.

*4: The troubleshooting for this DTC needs CONSULT-II.

*5: When the fail-safe operations for both self-diagnoses occur, the MIL illuminates.

PRECAUTIONS

Precautions for Supplemental Restraint System (SRS) “AIR BAG” and “SEAT BELT PRE-TENSIONER”

UBS001V

The Supplemental Restraint System such as “AIR BAG” and “SEAT BELT PRE-TENSIONER”, used along with a front seat belt, helps to reduce the risk or severity of injury to the driver and front passenger for certain types of collision. This system includes seat belt switch inputs and dual stage front air bag modules. The SRS system uses the seat belt switches to determine the front air bag deployment, and may only deploy one front air bag, depending on the severity of a collision and whether the front occupants are belted or unbelted. Information necessary to service the system safely is included in the SRS and SB section of this Service Manual.

WARNING:

- To avoid rendering the SRS inoperative, which could increase the risk of personal injury or death in the event of a collision which would result in air bag inflation, all maintenance must be performed by an authorized NISSAN/INFINITI dealer.
- Improper maintenance, including incorrect removal and installation of the SRS, can lead to personal injury caused by unintentional activation of the system. For removal of Spiral Cable and Air Bag Module, see the SRS section.
- Do not use electrical test equipment on any circuit related to the SRS unless instructed to in this Service Manual. SRS wiring harnesses can be identified by yellow and/or orange harnesses or harness connectors.

On Board Diagnostic (OBD) System of Engine and A/T

UBS002NU

The ECM has an on board diagnostic system. It will light up the malfunction indicator lamp (MIL) to warn the driver of a malfunction causing emission deterioration.

CAUTION:

- Be sure to turn the ignition switch OFF and disconnect the battery ground cable before any repair or inspection work. The open/short circuit of related switches, sensors, solenoid valves, etc. will cause the MIL to light up.
- Be sure to connect and lock the connectors securely after work. A loose (unlocked) connector will cause the MIL to light up due to the open circuit. (Be sure the connector is free from water, grease, dirt, bent terminals, etc.)
- Certain systems and components, especially those related to OBD, may use a new style slide-locking type harness connector. For description and how to disconnect, refer to [PG-66, "HARNESS CONNECTOR"](#).
- Be sure to route and secure the harnesses properly after work. The interference of the harness with a bracket, etc. may cause the MIL to light up due to the short circuit.
- Be sure to connect rubber tubes properly after work. A misconnected or disconnected rubber tube may cause the MIL to light up due to the malfunction of the fuel injection system, etc.
- Be sure to erase the unnecessary malfunction information (repairs completed) from the ECM and TCM (Transmission control module) before returning the vehicle to the customer.

Precaution

UBS002NV

- Always use a 12 volt battery as power source.
- Do not attempt to disconnect battery cables while engine is running.
- Before connecting or disconnecting the ECM harness connector, turn ignition switch OFF and disconnect battery ground cable. Failure to do so may damage the ECM because battery voltage is applied to ECM even if ignition switch is turned OFF.
- Before removing parts, turn ignition switch OFF and then disconnect battery ground cable.

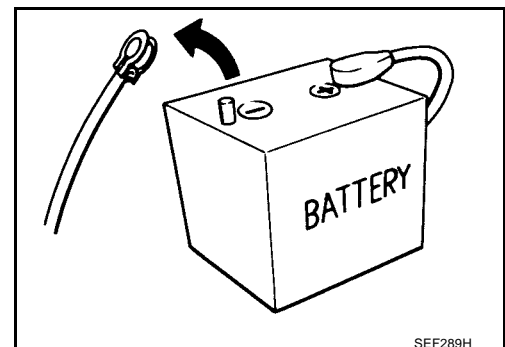

SEF289H

PRECAUTIONS

[QR]

- Do not disassemble ECM.
- If battery cable is disconnected, the memory will return to the initial ECM values.
The ECM will now start to self-control at its initial values. Engine operation can vary slightly when the cable is disconnected. However, this is not an indication of a malfunction. Do not replace parts because of a slight variation.
- If the battery is disconnected, the following emission-related diagnostic information will be lost within 24 hours.
 - Diagnostic trouble codes
 - 1st trip diagnostic trouble codes
 - Freeze frame data
 - 1st trip freeze frame data
 - System readiness test (SRT) codes
 - Test values

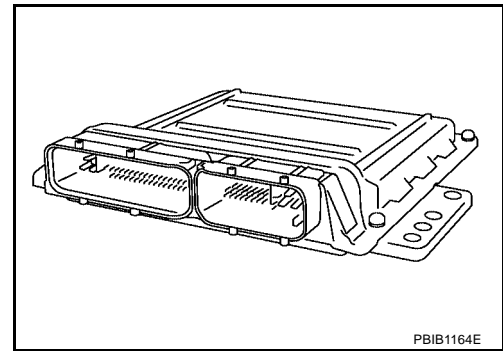

- When connecting ECM harness connector, fasten it securely with a lever as far as it will go as shown in the figure.

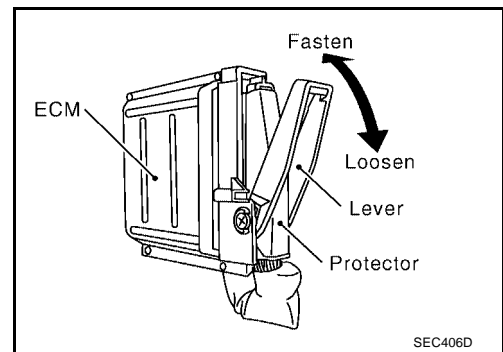

- When connecting or disconnecting pin connectors into or from ECM, take care not to damage pin terminals (bend or break).
Make sure that there are not any bends or breaks on ECM pin terminal, when connecting pin connectors.
- Securely connect ECM harness connectors.
A poor connection can cause an extremely high (surge) voltage to develop in coil and condenser, thus resulting in damage to ICs.
- Keep engine control system harness at least 10 cm (4 in) away from adjacent harness, to prevent engine control system malfunctions due to receiving external noise, degraded operation of ICs, etc.
- Keep engine control system parts and harness dry.
- Before replacing ECM, perform “ECM Terminals and Reference Value” inspection and make sure ECM functions properly. Refer to [EC-120](#).
- Handle mass air flow sensor carefully to avoid damage.
- Do not disassemble mass air flow sensor.
- Do not clean mass air flow sensor with any type of detergent.
- Do not disassemble electric throttle control actuator.
- Even a slight leak in the air intake system can cause serious incidents.
- Do not shock or jar the camshaft position sensor (PHASE), crankshaft position sensor (POS).

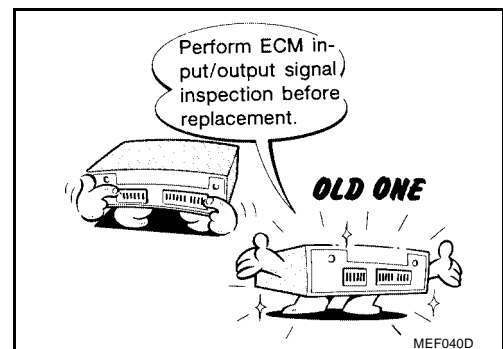
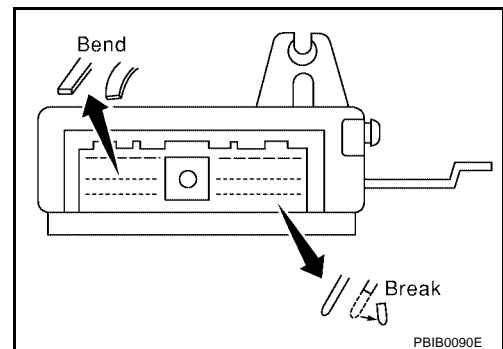

PRECAUTIONS

[QR]

- After performing each TROUBLE DIAGNOSIS, perform DTC Confirmation Procedure or Overall Function Check. The DTC should not be displayed in the DTC Confirmation Procedure if the repair is completed. The Overall Function Check should be a good result if the repair is completed.

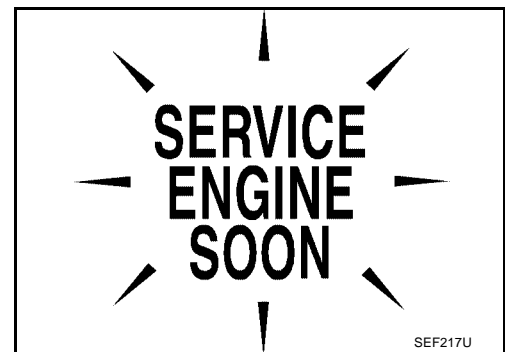

- When measuring ECM signals with a circuit tester, never allow the two tester probes to contact. Accidental contact of probes will cause a short circuit and damage the ECM power transistor.
- Do not use ECM ground terminals when measuring input/output voltage. Doing so may result in damage to the ECM's transistor. Use a ground other than ECM terminals, such as the ground.

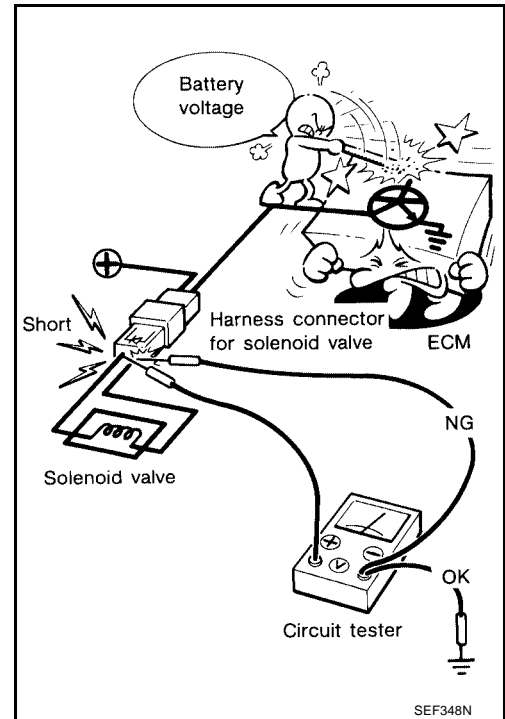

- Do not operate fuel pump when there is no fuel in lines.
- Tighten fuel hose clamps to the specified torque.

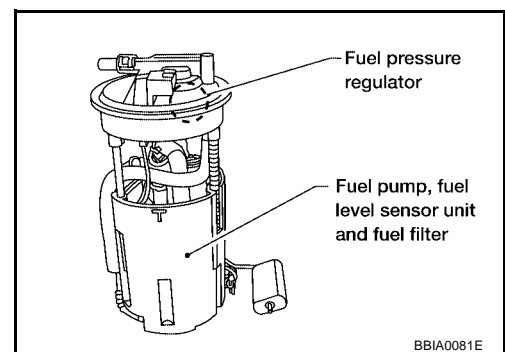

PRECAUTIONS

[QR]

- Do not depress accelerator pedal when starting.
- Immediately after starting, do not rev up engine unnecessarily.
- Do not rev up engine just prior to shutdown.

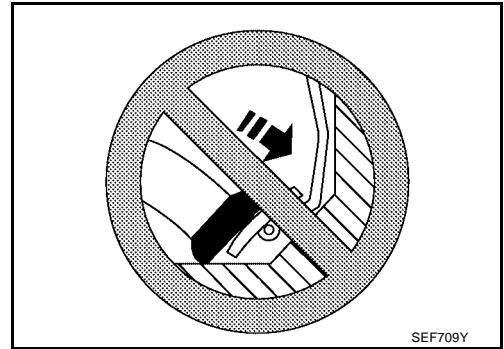

- When installing C.B. ham radio or a mobile phone, be sure to observe the following as it may adversely affect electronic control systems depending on installation location.
 - Keep the antenna as far as possible from the electronic control units.
 - Keep the antenna feeder line more than 20 cm (8 in) away from the harness of electronic controls. Do not let them run parallel for a long distance.
 - Adjust the antenna and feeder line so that the standing-wave ratio can be kept smaller.
 - Be sure to ground the radio to vehicle body.

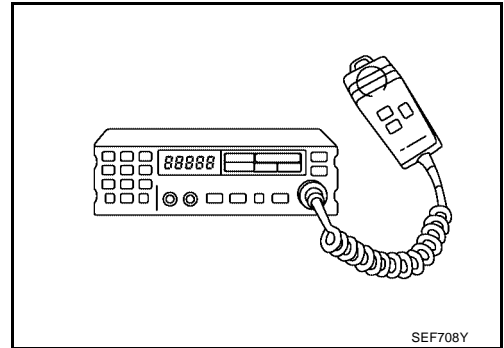

Wiring Diagrams and Trouble Diagnosis

UBS002NW

When you read wiring diagrams, refer to the following:

- [GI-14, "How to Read Wiring Diagrams"](#)
- [PG-4, "POWER SUPPLY ROUTING CIRCUIT"](#) for power distribution circuit

When you perform trouble diagnosis, refer to the following:

- [GI-10, "HOW TO FOLLOW TEST GROUPS IN TROUBLE DIAGNOSES"](#)
- [GI-26, "How to Perform Efficient Diagnosis for an Electrical Incident"](#)

PREPARATION

[QR]



PF0:00002

UBS002NX

PREPARATION

Special Service Tools

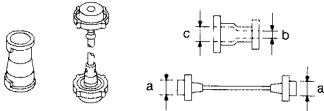
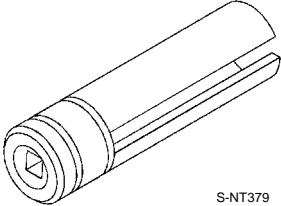
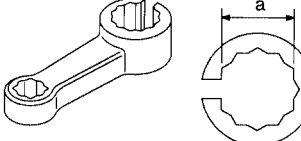
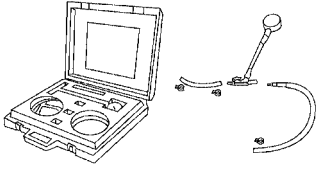
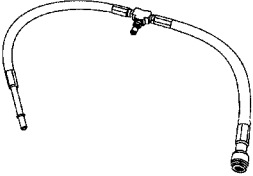
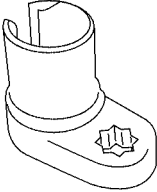
The actual shapes of Kent-Moore tools may differ from those of special service tools illustrated here.

Tool number (Kent-Moore No.) Tool name	Description	
EG17650301 (J-33984-A) Radiator cap tester adapter	 <p style="text-align: center;">S-NT564</p>	Adapting radiator cap tester to radiator cap and radiator filler neck a: 28 (1.10) dia. b: 31.4 (1.236) dia. c: 41.3 (1.626) dia. Unit: mm (in)
KV10117100 (J-36471-A) Heated oxygen sensor wrench	 <p style="text-align: center;">S-NT379</p>	Loosening or tightening heated oxygen sensors with 22 mm (0.87 in) hexagon nut
KV10114400 (J-38365) Heated oxygen sensor wrench	 <p style="text-align: center;">S-NT636</p>	Loosening or tightening heated oxygen sensors a: 22 mm (0.87 in)
(J-44321) Fuel pressure gauge kit	 <p style="text-align: center;">LEC642</p>	Checking fuel pressure
(J-44321-6) Fuel pressure adapter	 <p style="text-align: center;">LBIA0376E</p>	Connecting fuel pressure gauge to quick connector type fuel lines.
(J-44626) Air fuel ratio (A/F) sensor wrench	 <p style="text-align: center;">LEM054</p>	Loosening or tightening air fuel ratio (A/F) sensor 1
(J-45488) Quick connector re- lease	 <p style="text-align: center;">PBIC0198E</p>	Remove fuel tube quick connectors in engine room.

A

EC

C

D

E

F

G

H

I

J

K

L

M

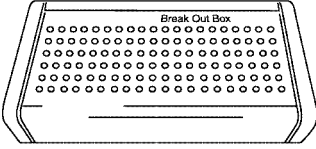
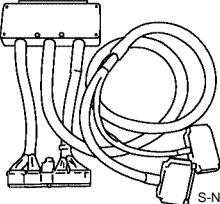

PREPARATION

[QR]

Tool number (Kent-Moore No.) Tool name	Description	
KV109E0010 (J-46209) Break-out box	 <p style="text-align: center;">S-NT825</p>	Measuring the ECM signals with a circuit tester
KV109E0080 (J-45819) Y-cable adapter	 <p style="text-align: center;">S-NT826</p>	Measuring the ECM signals with a circuit tester

Commercial Service Tools

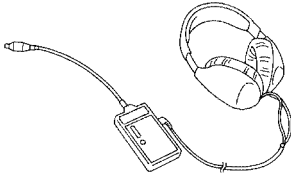
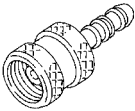
UBS002NY

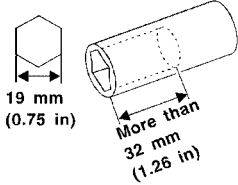
Tool name (Kent-Moore No.)	Description	
Leak detector i.e.:(J-41416)	 <p style="text-align: center;">S-NT703</p>	Locating the EVAP leak
EVAP service port adapter i.e.:(J-41413-OBDD)	 <p style="text-align: center;">S-NT704</p>	Applying positive pressure through EVAP service port
Fuel filler cap adapter i.e.:(J-41416)	 <p style="text-align: center;">S-NT815</p>	Checking fuel tank vacuum relief valve opening pressure
Socket wrench	 <p style="text-align: center;">S-NT705</p>	Removing and installing engine coolant temperature sensor

PREPARATION

[QR]

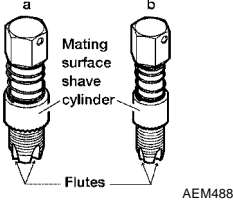
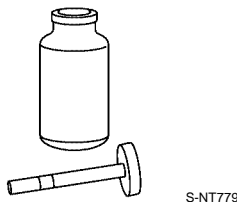
Tool name (Kent-Moore No.)	Description	
Oxygen sensor thread cleaner i.e.: (J-43897-18) (J-43897-12)		Reconditioning the exhaust system threads before installing a new oxygen sensor. Use with anti-seize lubricant shown below. a: 18 mm diameter with pitch 1.5 mm for Zirconia Oxygen Sensor b: 12 mm diameter with pitch 1.25 mm for Titania Oxygen Sensor
Anti-seize lubricant i.e.: (Permatex™ 133AR or equivalent meeting MIL specification MIL-A-907)		Lubricating oxygen sensor thread cleaning tool when reconditioning exhaust system threads.

A
EC
 C
 D
 E
 F
 G
 H
 I
 J
 K
 L
 M

ENGINE CONTROL SYSTEM

PFP:23710

System Diagram

UBS002NZ

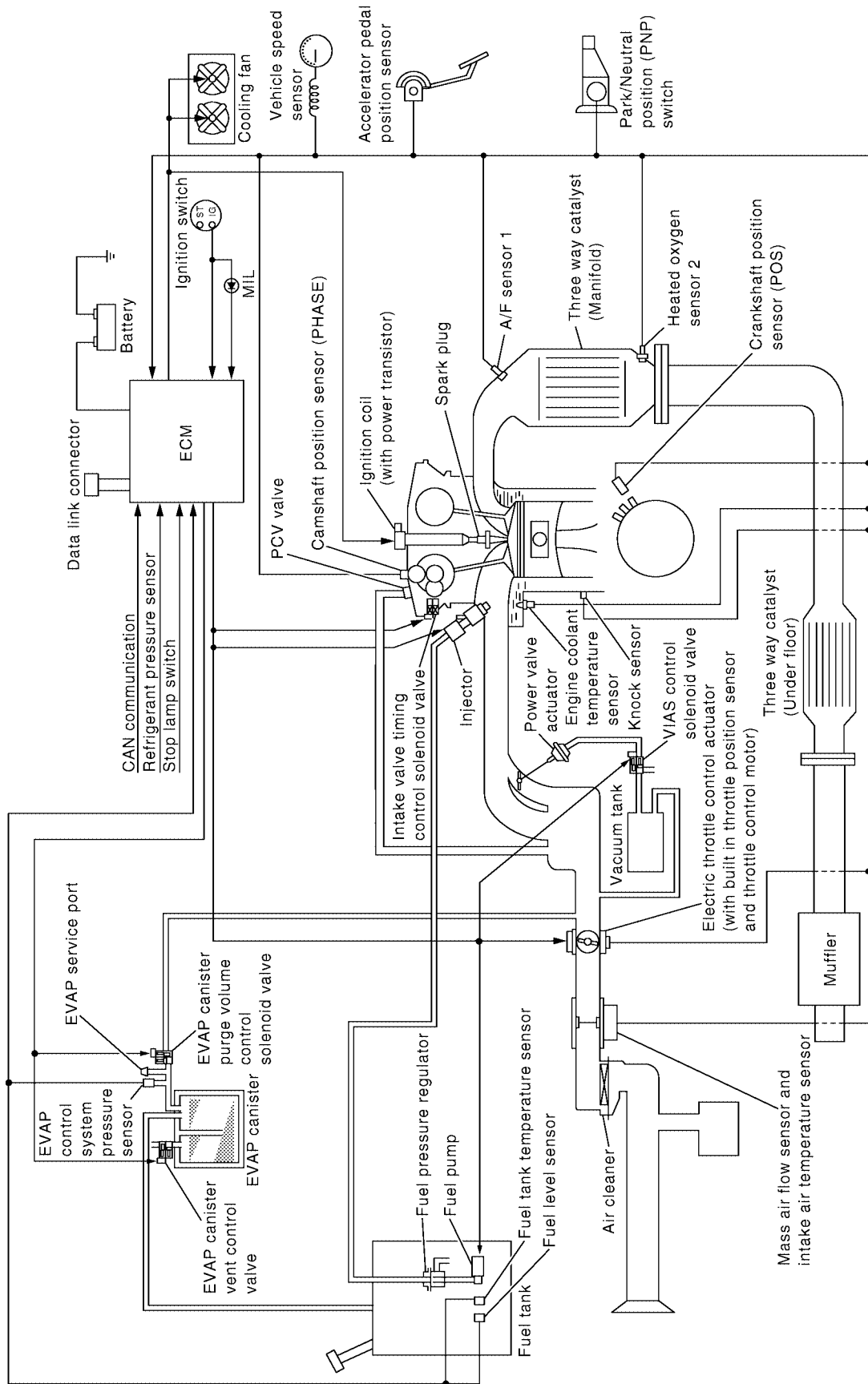

PBIB2585E

Multiport Fuel Injection (MFI) System INPUT/OUTPUT SIGNAL CHART

Sensor	Input Signal to ECM	ECM function	Actuator
Crankshaft position sensor (POS)	Engine speed*3	Fuel injection & mixture ratio control	Fuel injector
Camshaft position sensor (PHASE)	Piston position		
Mass air flow sensor	Amount of intake air		
Engine coolant temperature sensor	Engine coolant temperature		
Throttle position sensor	Throttle position		
Accelerator pedal position sensor	Accelerator pedal position		
Park/neutral position (PNP) switch	Gear position		
Knock sensor	Engine knocking condition		
Power steering pressure sensor	Power steering operation		
Air fuel ratio (A/F) sensor 1	Density of oxygen in exhaust gas		
Heated oxygen sensor 2*1	Density of oxygen in exhaust gas		
Vehicle speed sensor*2	Vehicle speed		
Air conditioner switch*2	Air conditioner operation		
Battery	Battery voltage*3		

*1: This sensor is not used to control the engine system under normal conditions.

*2: This signal is sent to the ECM through CAN communication line.

*3: ECM determines the start signal status by the signal of engine speed and battery voltage.

SYSTEM DESCRIPTION

The amount of fuel injected from the fuel injector is determined by the ECM. The ECM controls the length of time the valve remains open (injection pulse duration). The amount of fuel injected is a program value in the ECM memory. The program value is preset by engine operating conditions. These conditions are determined by input signals (for engine speed and intake air) from both the crankshaft position sensor and the mass air flow sensor.

VARIOUS FUEL INJECTION INCREASE/DECREASE COMPENSATION

In addition, the amount of fuel injected is compensated to improve engine performance under various operating conditions as listed below.

<Fuel increase>

- During warm-up
- When starting the engine
- During acceleration
- Hot-engine operation
- When selector lever is changed from N to D (A/T models)
- High-load, high-speed operation

<Fuel decrease>

- During deceleration
- During high engine speed operation

MIXTURE RATIO FEEDBACK CONTROL (CLOSED LOOP CONTROL)

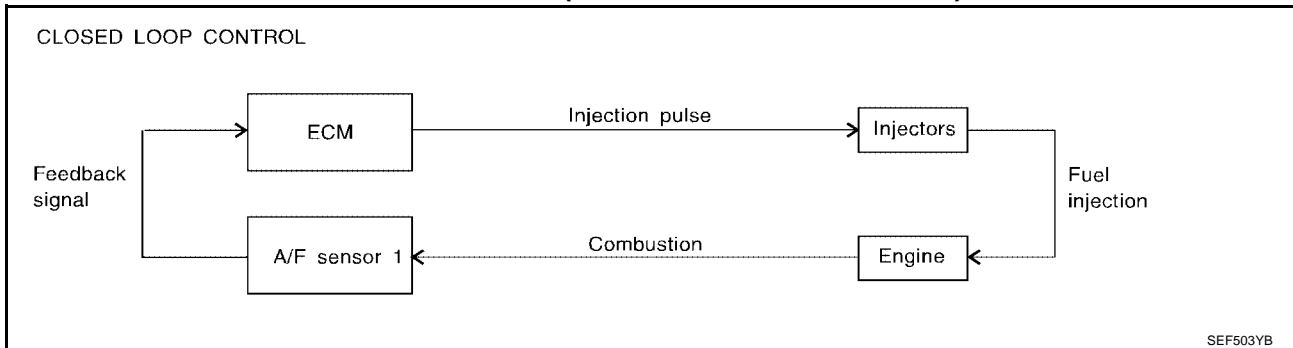

The mixture ratio feedback system provides the best air-fuel mixture ratio for driveability and emission control. The three way catalyst (manifold) can then better reduce CO, HC and NOx emissions. This system uses air fuel ratio (A/F) sensor 1 in the exhaust manifold to monitor whether the engine operation is rich or lean. The ECM adjusts the injection pulse width according to the sensor voltage signal. For more information about air fuel ratio (A/F) sensor 1, refer to [EC-443, "DTC P1271 A/F SENSOR 1"](#) . This maintains the mixture ratio within the range of stoichiometric (ideal air-fuel mixture).

This stage is referred to as the closed loop control condition.

Heated oxygen sensor 2 is located downstream of the three way catalyst (manifold). Even if the switching characteristics of air fuel ratio (A/F) sensor 1 shift, the air-fuel ratio is controlled to stoichiometric by the signal from heated oxygen sensor 2.

Open Loop Control

The open loop system condition refers to when the ECM detects any of the following conditions. Feedback control stops in order to maintain stabilized fuel combustion.

- Deceleration and acceleration
- High-load, high-speed operation
- Malfunction of air fuel ratio (A/F) sensor 1 or its circuit
- Insufficient activation of air fuel ratio (A/F) sensor 1 at low engine coolant temperature
- High engine coolant temperature
- During warm-up
- After shifting from N to D (A/T models)
- When starting the engine

MIXTURE RATIO SELF-LEARNING CONTROL

The mixture ratio feedback control system monitors the mixture ratio signal transmitted from air fuel ratio (A/F) sensor 1. This feedback signal is then sent to the ECM. The ECM controls the basic mixture ratio as close to the theoretical mixture ratio as possible. However, the basic mixture ratio is not necessarily controlled as originally designed. Both manufacturing differences (i.e., mass air flow sensor hot wire) and characteristic changes during operation (i.e., injector clogging) directly affect mixture ratio.

Accordingly, the difference between the basic and theoretical mixture ratios is monitored in this system. This is then computed in terms of "injection pulse duration" to automatically compensate for the difference between the two ratios.

"Fuel trim" refers to the feedback compensation value compared against the basic injection duration. Fuel trim includes short term fuel trim and long term fuel trim.

"Short term fuel trim" is the short-term fuel compensation used to maintain the mixture ratio at its theoretical value. The signal from air fuel ratio (A/F) sensor 1 indicates whether the mixture ratio is RICH or LEAN compared to the theoretical value. The signal then triggers a reduction in fuel volume if the mixture ratio is rich, and an increase in fuel volume if it is lean.

"Long term fuel trim" is overall fuel compensation carried out long-term to compensate for continual deviation of the short term fuel trim from the central value. Such deviation will occur due to individual engine differences, wear over time and changes in the usage environment.

FUEL INJECTION TIMING

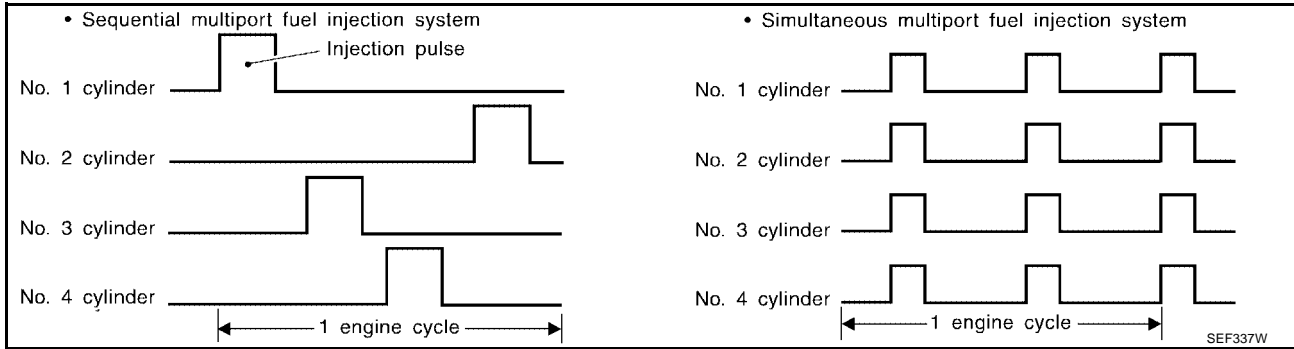

Two types of systems are used.

Sequential Multiport Fuel Injection System

Fuel is injected into each cylinder during each engine cycle according to the firing order. This system is used when the engine is running.

Simultaneous Multiport Fuel Injection System

Fuel is injected simultaneously into all four cylinders twice each engine cycle. In other words, pulse signals of the same width are simultaneously transmitted from the ECM.

The four injectors will then receive the signals two times for each engine cycle.

This system is used when the engine is being started and/or if the fail-safe system (CPU) is operating.

FUEL SHUT-OFF

Fuel to each cylinder is cut off during deceleration, operation of the engine at excessively high speeds or operation of the vehicle at excessively high speeds.

Electronic Ignition (EI) System

UBS00203

INPUT/OUTPUT SIGNAL CHART

Sensor	Input Signal to ECM	ECM function	Actuator
Crankshaft position sensor (POS)	Engine speed*2	Ignition timing control	Power transistor
Camshaft position sensor (PHASE)	Piston position		
Mass air flow sensor	Amount of intake air		
Engine coolant temperature sensor	Engine coolant temperature		
Throttle position sensor	Throttle position		
Accelerator pedal position sensor	Accelerator pedal position		
Knock sensor	Engine knocking		
Park/neutral position (PNP) switch	Gear position		
Vehicle speed sensor*1	Vehicle speed		
Battery	Battery voltage*2		

*1: This signal is sent to the ECM through CAN communication line.

*2: ECM determines the start signal status by the signal of engine speed and battery voltage.

SYSTEM DESCRIPTION

Firing order: 1 - 3 - 4 - 2

The ignition timing is controlled by the ECM to maintain the best air-fuel ratio for every running condition of the engine. The ignition timing data is stored in the ECM.

The ECM receives information such as the injection pulse width and camshaft position sensor signal. Computing this information, ignition signals are transmitted to the power transistor.

During the following conditions, the ignition timing is revised by the ECM according to the other data stored in the ECM.

- At starting
- During warm-up
- At idle

- At low battery voltage
- During acceleration

The knock sensor retard system is designed only for emergencies. The basic ignition timing is programmed within the anti-knocking zone, if recommended fuel is used under dry conditions. The retard system does not operate under normal driving conditions. If engine knocking occurs, the knock sensor monitors the condition. The signal is transmitted to the ECM. The ECM retards the ignition timing to eliminate the knocking condition.

Fuel Cut Control (at No Load and High Engine Speed) INPUT/OUTPUT SIGNAL CHART

UBS00205

Sensor	Input Signal to ECM	ECM function	Actuator
Park/neutral position (PNP) switch	Neutral position	Fuel cut control	Fuel injector
Accelerator pedal position sensor	Accelerator pedal position		
Engine coolant temperature sensor	Engine coolant temperature		
Crankshaft position sensor (POS) Camshaft position sensor (PHASE)	Engine speed		
Vehicle speed sensor*	Vehicle speed		

*: This signal is sent to the ECM through CAN communication line.

SYSTEM DESCRIPTION

If the engine speed is above 1,800 rpm under no load (for example, the shift position is neutral and engine speed is over 1,800 rpm) fuel will be cut off after some time. The exact time when the fuel is cut off varies based on engine speed.

Fuel cut will be operated until the engine speed reaches 1,500 rpm, then fuel cut will be cancelled.

NOTE:

This function is different from deceleration control listed under “Multiport Fuel Injection (MFI) System”, [EC-29](#) .

AIR CONDITIONING CUT CONTROL

Input/output Signal Chart

Sensor	Input Signal to ECM	ECM function	Actuator
Air conditioner switch*1	Air conditioner ON signal	Air conditioner cut control	Air conditioner relay
Throttle position sensor	Throttle position		
Accelerator pedal position sensor	Accelerator pedal position		
Crankshaft position sensor (POS) Camshaft position sensor (PHASE)	Engine speed*2		
Engine coolant temperature sensor	Engine coolant temperature		
Refrigerant pressure sensor	Refrigerant pressure		
Power steering pressure sensor	Power steering operation		
Vehicle speed sensor*1	Vehicle speed		
Battery	Battery voltage*2		

*1: This signal is sent to the ECM through CAN communication line.

*2: ECM determines the start signal status by the signal of engine speed and battery voltage.

System Description

This system improves engine operation when the air conditioner is used. Under the following conditions, the air conditioner is turned off.

- When the accelerator pedal is fully depressed.
- When cranking the engine.
- At high engine speeds.
- When the engine coolant temperature becomes excessively high.
- When operating power steering during low engine speed or low vehicle speed.
- When engine speed is excessively low.
- When refrigerant pressure is excessively low or high.

AUTOMATIC SPEED CONTROL DEVICE (ASCD)

[QR]

AUTOMATIC SPEED CONTROL DEVICE (ASCD)

PF1:18930

System Description INPUT/OUTPUT SIGNAL CHART

UBS0034F

Sensor	Input signal to ECM	ECM function	Actuator
ASCD brake switch	Brake pedal operation	ASCD vehicle speed control	Electric throttle control actuator
Stop lamp switch	Brake pedal operation		
ASCD clutch switch (M/T models)	Clutch pedal operation		
ASCD steering switch	ASCD steering switch operation		
Park/Neutral position (PNP) switch (A/T models)	Gear position		
Combination meter*	Vehicle speed		
TCM*	Powertrain revolution		

*: This signal is sent to the ECM through CAN communication line.

BASIC ASCD SYSTEM

Refer to Owner's Manual for ASCD operating instructions.

Automatic Speed Control Device (ASCD) allows a driver to keep vehicle at predetermined constant speed without depressing accelerator pedal. Driver can set vehicle speed in advance between approximately 40 km/h (25 MPH) and 144 km/h (89 MPH).

ECM controls throttle angle of electric throttle control actuator to regulate engine speed.

Operation status of ASCD is indicated by CRUISE indicator and SET indicator in combination meter. If any malfunction occurs in ASCD system, it automatically deactivates control.

NOTE:

Always drive vehicle in safe manner according to traffic conditions and obey all traffic laws.

SET OPERATION

Press ASCD CRUISE switch (Main switch). (The CRUISE indicator in combination meter illuminates.)

When vehicle speed reaches a desired speed between approximately 40 km/h (25 MPH) and 144 km/h (89 MPH), press SET/COAST switch. (Then SET indicator in combination meter illuminates.)

ACCEL OPERATION

If the RESUME/ACCEL switch is depressed during cruise control driving, increase the vehicle speed until the switch is released or vehicle speed reaches maximum speed controlled by the system.

And then ASCD will keep the new set speed.

CANCEL OPERATION

When any of following conditions exist, cruise operation will be canceled.

- CANCEL switch is depressed
- Brake pedal is depressed
- Clutch pedal is depressed or gear position is changed to the neutral position (M/T models)
- Selector lever is changed to N, P, R position (A/T models)

If CRUISE switch is turned to OFF during ASCD is activated, all of ASCD operations will be canceled and vehicle speed memory will be erased.

COAST OPERATION

When the SET/COAST switch is depressed during cruise control driving, decrease vehicle set speed until the switch is released. And then ASCD will keep the new set speed.

RESUME OPERATION

When the RESUME/ACCEL switch is depressed after cancel operation other than depressing CRUISE switch is performed, vehicle speed will return to last set speed. To resume vehicle set speed, vehicle condition must meet following conditions.

- Brake pedal is released.
- Clutch pedal is released (M/T models)
- A/T selector lever is in other than P and N positions (A/T models)

AUTOMATIC SPEED CONTROL DEVICE (ASCD)

[QR]

- Vehicle speed is greater than 40 km/h (25 MPH) and less than 144 km/h (89 MPH)

Component Description ASCD STEERING SWITCH

UBS0034G

A

Refer to [EC-504](#) .

ASCD BRAKE SWITCH

Refer to [EC-511](#) .

EC

ASCD CLUTCH SWITCH

Refer to [EC-511](#) .

C

STOP LAMP SWITCH

Refer to [EC-511](#) .

D

ELECTRIC THROTTLE CONTROL ACTUATOR

Refer to [EC-386](#) .

E

ASCD INDICATOR

Refer to [EC-620](#) .

F

G

H

I

J

K

L

M

CAN COMMUNICATION

PF2:23710

System Description

UBS00206

CAN (Controller Area Network) is a serial communication line for real time application. It is an on-vehicle multiplex communication line with high data communication speed and excellent error detection ability. Many electronic control units are equipped onto a vehicle, and each control unit shares information and links with other control units during operation (not independent). In CAN communication, control units are connected with 2 communication lines (CAN H line, CAN L line) allowing a high rate of information transmission with less wiring. Each control unit transmits/receives data but selectively reads required data only.

Refer to [LAN-21, "CAN COMMUNICATION"](#) , about CAN communication for detail.

EVAPORATIVE EMISSION SYSTEM

PFP:14950

Description SYSTEM DESCRIPTION

UBS00CF3

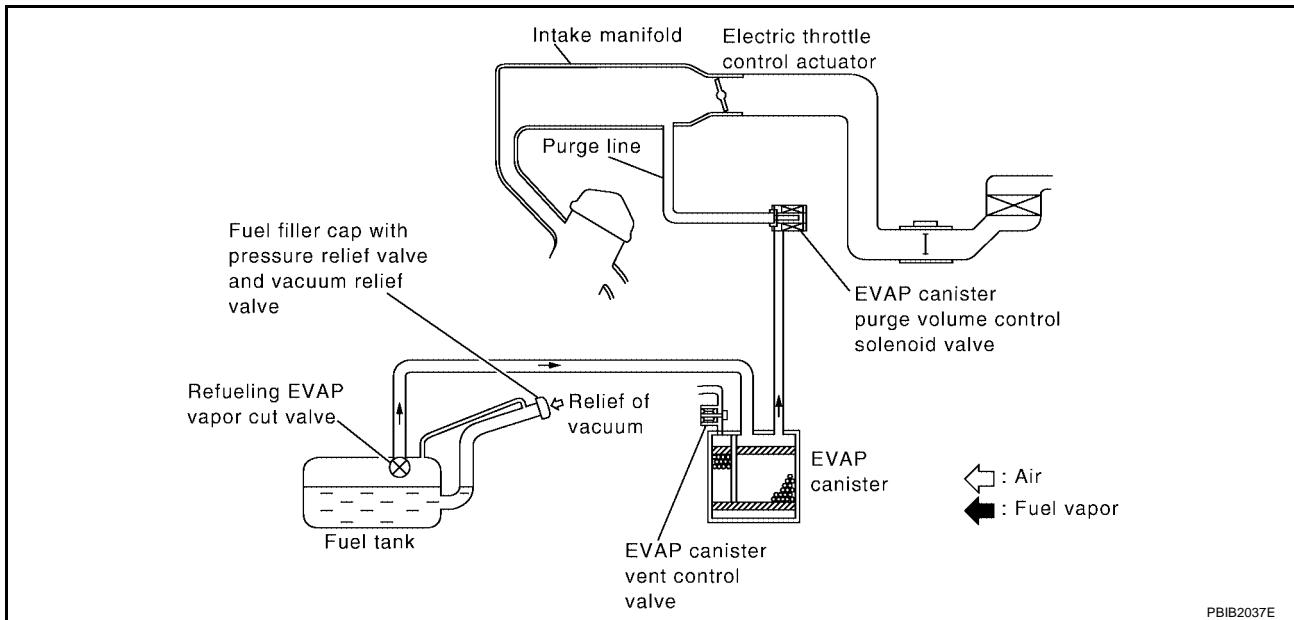

The evaporative emission system is used to reduce hydrocarbons emitted into the atmosphere from the fuel system. This reduction of hydrocarbons is accomplished by activated charcoals in the EVAP canister. The fuel vapor in the sealed fuel tank is led into the EVAP canister which contains activated carbon and the vapor is stored there when the engine is not operating or when refueling to the fuel tank. The vapor in the EVAP canister is purged by the air through the purge line to the intake manifold when the engine is operating. EVAP canister purge volume control solenoid valve is controlled by ECM. When the engine operates, the flow rate of vapor controlled by EVAP canister purge volume control solenoid valve is proportionally regulated as the air flow increases. EVAP canister purge volume control solenoid valve also shuts off the vapor purge line during decelerating and idling.

EVAPORATIVE EMISSION SYSTEM

[QR]

EVAPORATIVE EMISSION LINE DRAWING

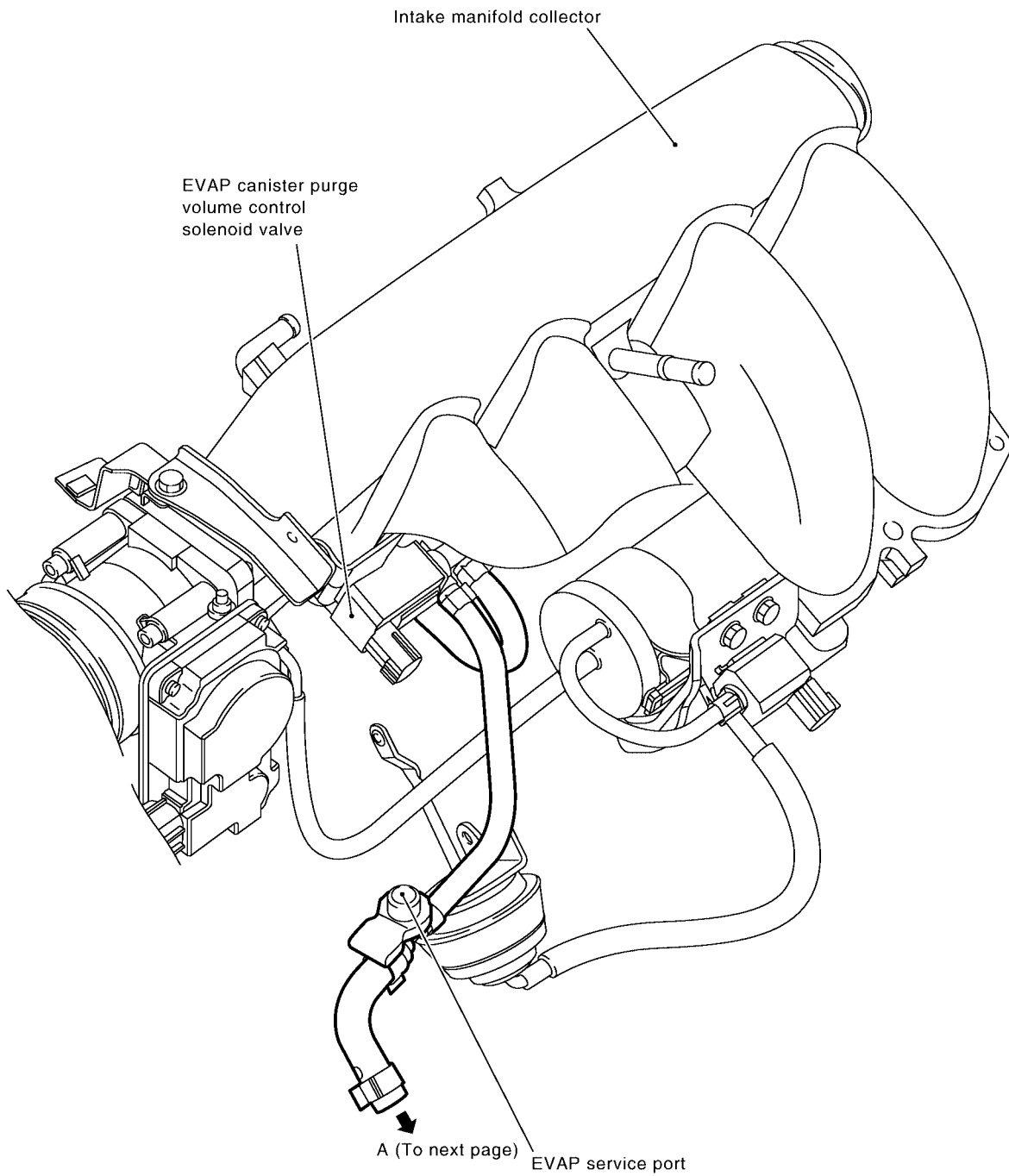

NOTE: Do not use soapy water or any type of solvent while installing vacuum hose or purge hoses.

BBIA0293E

EVAPORATIVE EMISSION SYSTEM

[QR]

Refer to
previous
page

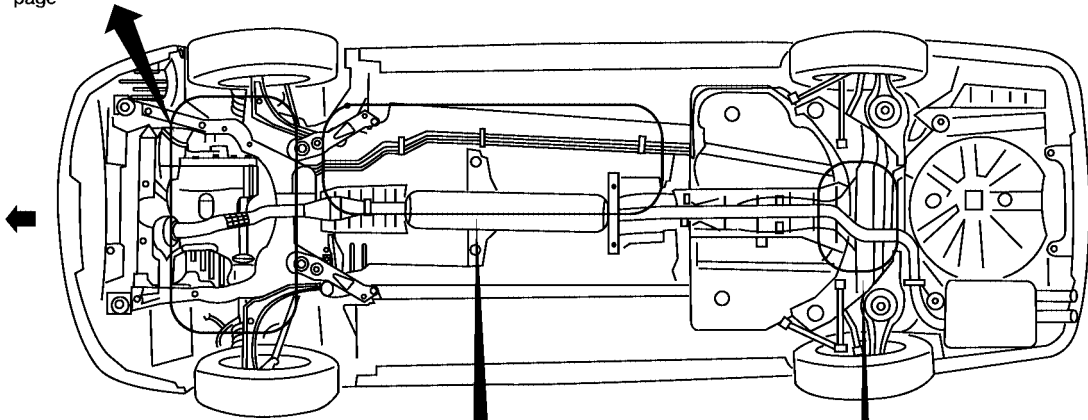

A →
Previous

EVAP vapor
purge line

→ B

View from under the vehicle
with rear crossmember removed

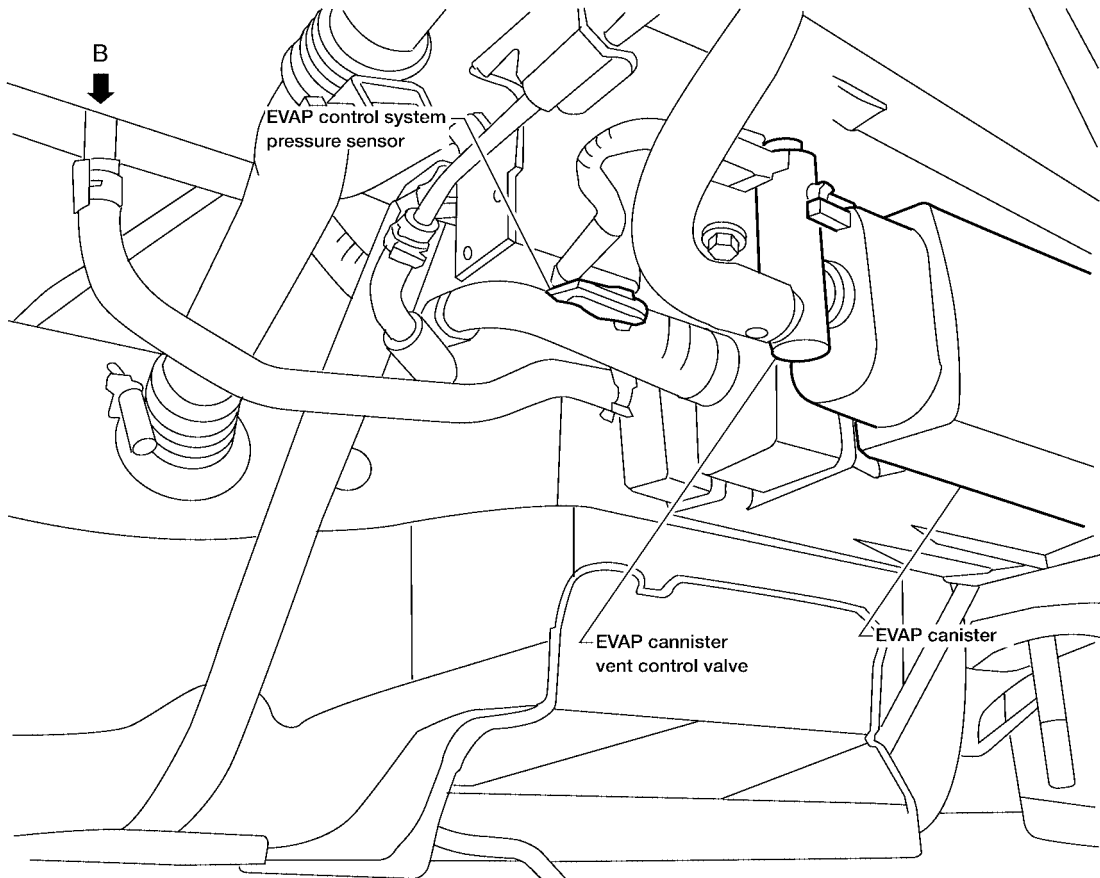

EVAP control system
pressure sensor

EVAP canister
vent control valve

EVAP canister

BBIA0413E

A
EC
C
D
E
F
G
H
I
J
K
L
M

Component Inspection EVAP CANISTER

Check EVAP canister as follows:

1. Block port **B** .
2. Blow air into port **A** and check that it flows freely out of port **C** .
3. Release blocked port **B** .
4. Apply vacuum pressure to port **B** and check that vacuum pressure exists at the ports **A** and **C** .
5. Block port **A** and **B** .
6. Apply pressure to port **C** and check that there is no leakage.

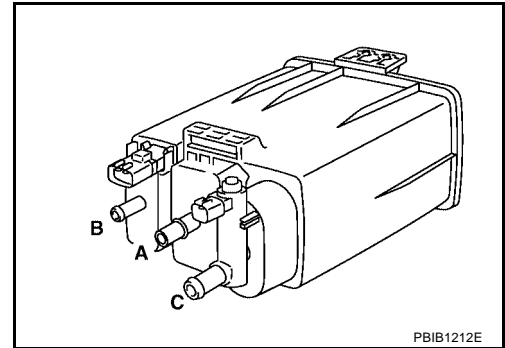

PBIB1212E

FUEL TANK VACUUM RELIEF VALVE (BUILT INTO FUEL FULLER CAP)

1. Wipe clean valve housing.

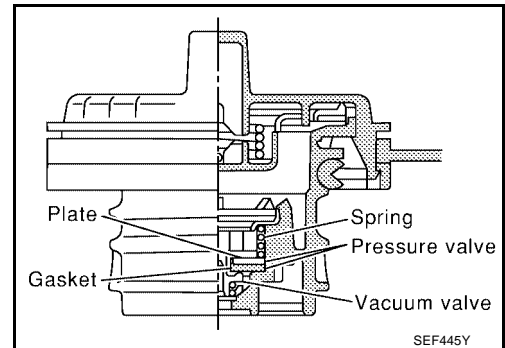

SEF445Y

2. Check valve opening pressure and vacuum.

Pressure: 15.3 - 20.0 kPa
(0.156 - 0.204 kg/cm² , 2.22 - 2.90 psi)

Vacuum: -6.0 to -3.4 kPa
(-0.061 to -0.035 kg/cm² , -0.87 to -0.48 psi)

3. If out of specification, replace fuel filler cap as an assembly.

CAUTION:

Use only a genuine fuel filler cap as a replacement. If an incorrect fuel filler cap is used, the MIL may come on.

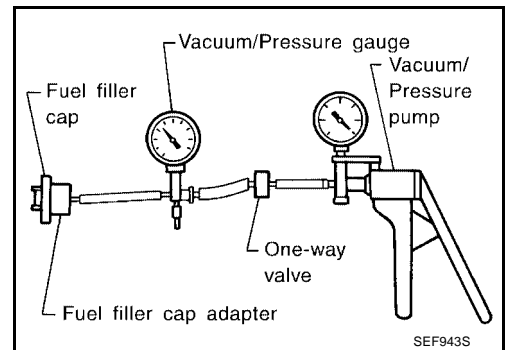

SEF943S

EVAP CANISTER PURGE VOLUME CONTROL SOLENOID VALVE

Refer to [EC-306](#)

FUEL TANK TEMPERATURE SENSOR

Refer to [EC-246](#) .

EVAP CANISTER VENT CONTROL VALVE

Refer to [EC-312](#) .

EVAP CONTROL SYSTEM PRESSURE SENSOR

Refer to [EC-322](#) .

EVAP SERVICE PORT

Positive pressure is delivered to the EVAP system through the EVAP service port. If fuel vapor leakage in the EVAP system occurs, use a leak detector to locate the leak.

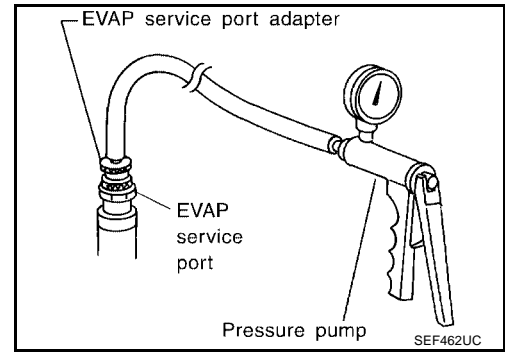

Removal and Installation EVAP CANISTER

Tighten EVAP canister as shown in the figure.

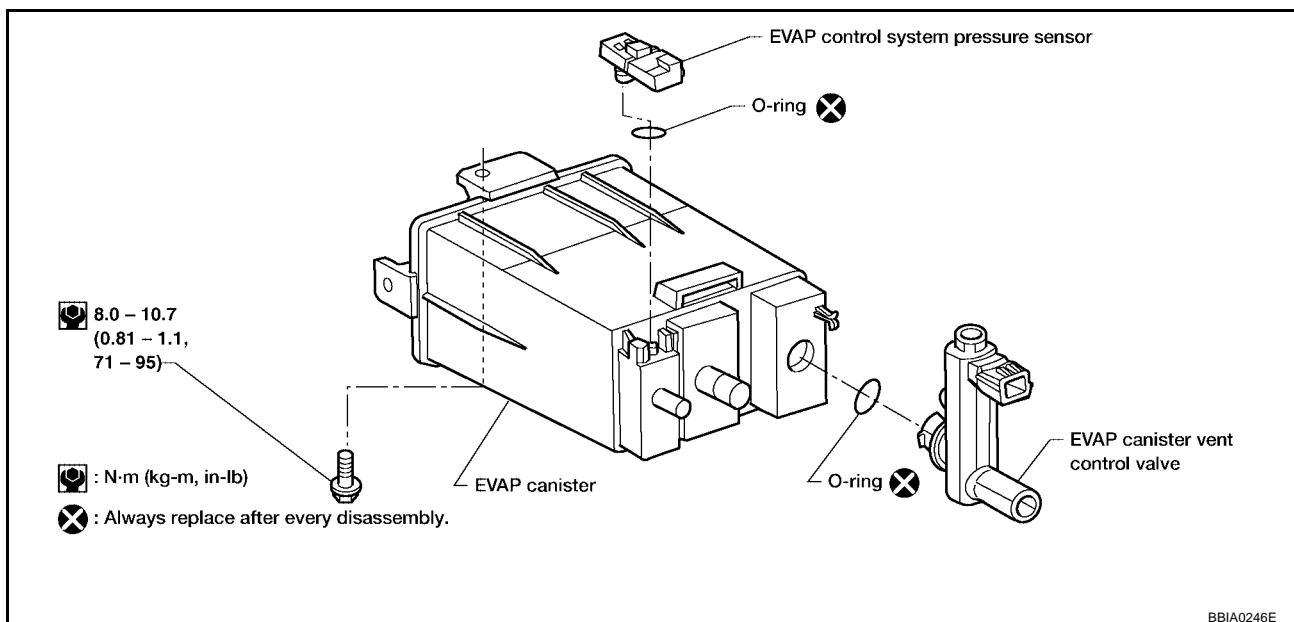

EVAP CANISTER VENT CONTROL VALVE

1. Turn EVAP canister vent control valve counterclockwise.
2. Remove the EVAP canister vent control valve.

Do not reuse the O-ring, replace it with a new one.

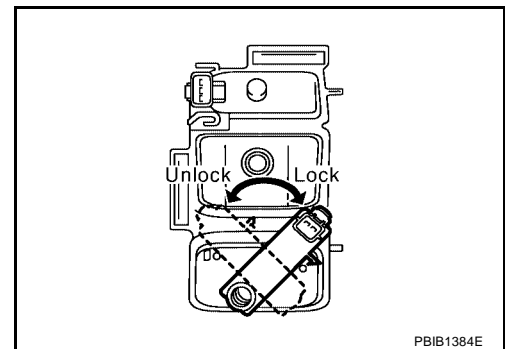

How to Detect Fuel Vapor Leakage

CAUTION:

- Never use compressed air or a high pressure pump.
- Do not exceed 4.12 kPa (0.042 kg/cm², 0.6 psi) of pressure in EVAP system.

NOTE:

- Do not start engine.
- Improper installation of EVAP service port adapter to the EVAP service port may cause a leak.

Ⓟ WITH CONSULT-II

1. Attach the EVAP service port adapter securely to the EVAP service port.
2. Also attach the pressure pump and hose to the EVAP service port adapter.
3. Turn ignition switch ON.
4. Select the "EVAP SYSTEM CLOSE" of "WORK SUPPORT MODE" with CONSULT-II.
5. Touch "START". A bar graph (Pressure indicating display) will appear on the screen.

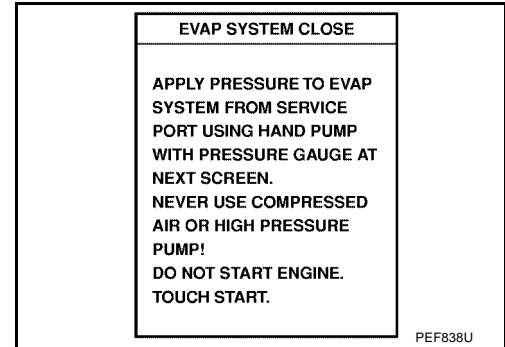

6. Apply positive pressure to the EVAP system until the pressure indicator reaches the middle of the bar graph.
7. Remove EVAP service port adapter and hose with pressure pump.

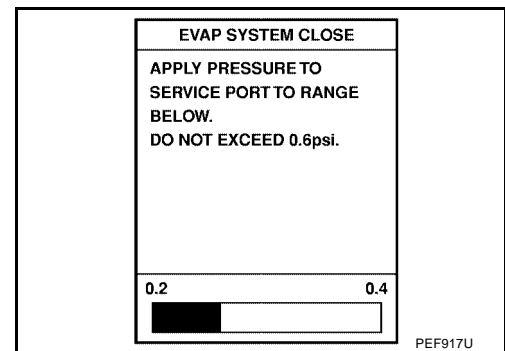

8. Locate the leak using a leak detector. Refer to [EC-38, "EVAPORATIVE EMISSION LINE DRAWING"](#).

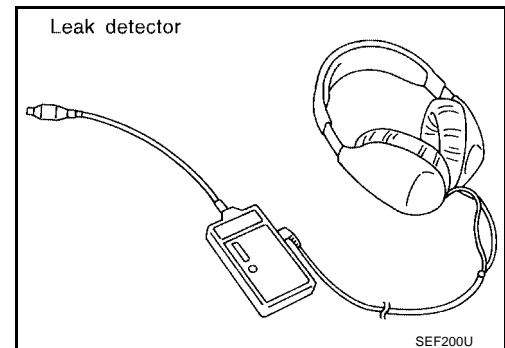

⊗ WITHOUT CONSULT-II

1. Attach the EVAP service port adapter securely to the EVAP service port.
2. Also attach the pressure pump with pressure gauge to the EVAP service port adapter.

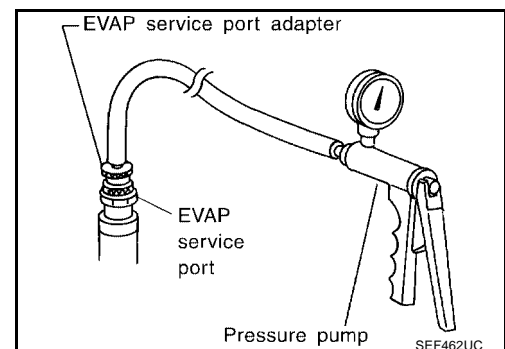

EVAPORATIVE EMISSION SYSTEM

[QR]

3. Apply battery voltage to the terminal of EVAP canister vent control valve to make a closed EVAP system.

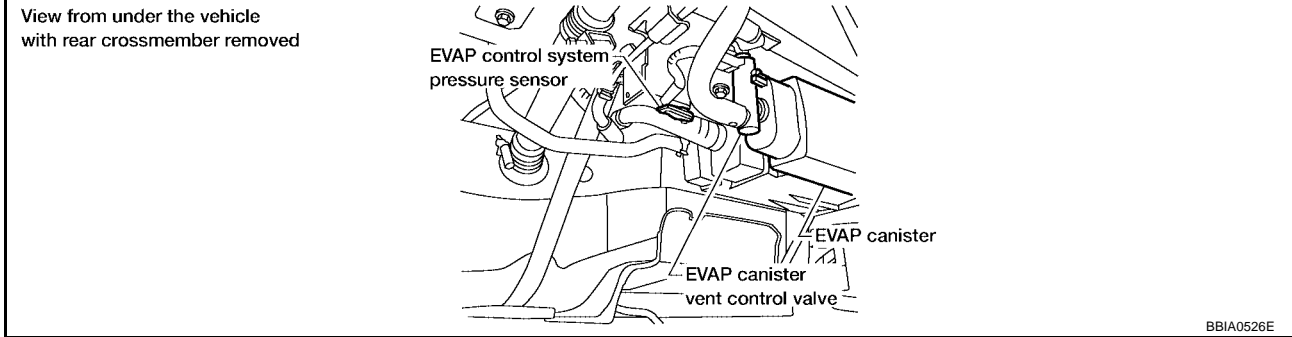

4. To locate the leak, deliver positive pressure to the EVAP system until pressure gauge points reach 1.38 to 2.76 kPa (0.014 to 0.028 kg/cm² , 0.2 to 0.4 psi).
5. Remove EVAP service port adapter and hose with pressure pump.
6. Locate the leak using a leak detector. Refer to [EC-38, "EVAPORATIVE EMISSION LINE DRAWING"](#) .

A

EC

C

D

E

F

G

H

I

J

K

L

M

ON BOARD REFUELING VAPOR RECOVERY (ORVR)

PFP:00032

System Description

UBS00CFA

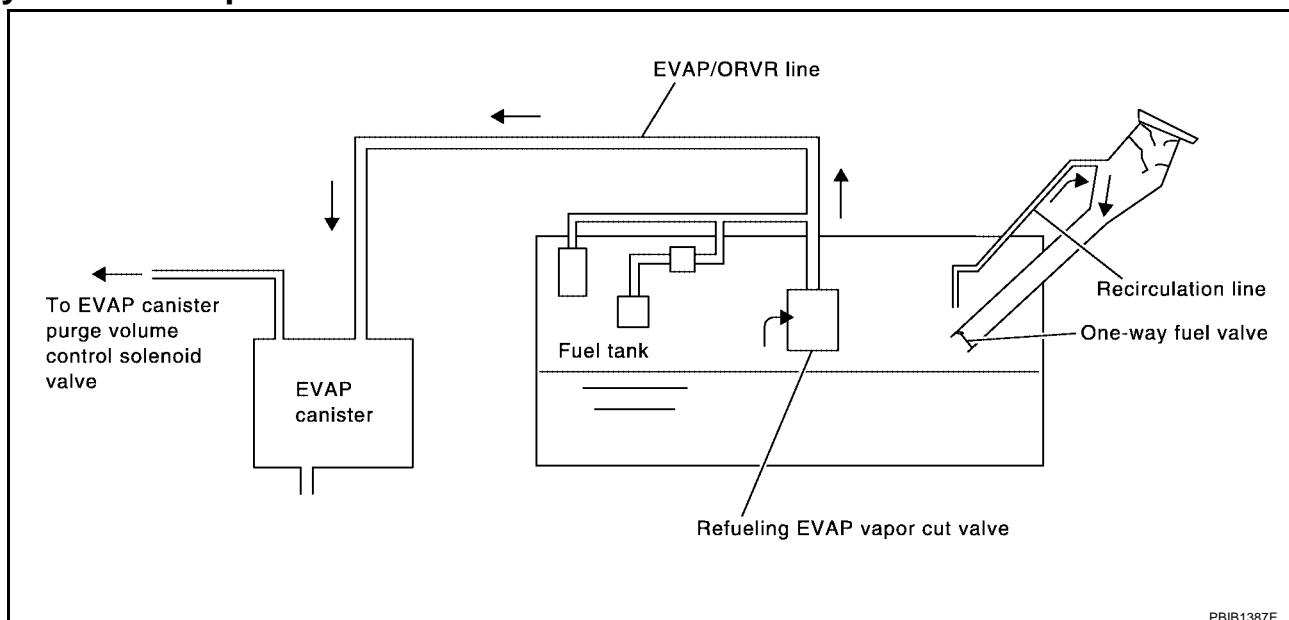

From the beginning of refueling, the air and vapor inside the fuel tank go through refueling EVAP vapor cut valve and EVAP/ORVR line to the EVAP canister. The vapor is absorbed by the EVAP canister and the air is released to the atmosphere.

When the refueling has reached the full level of the fuel tank, the refueling EVAP vapor cut valve is closed and refueling is stopped because of auto shut-off. The vapor which was absorbed by the EVAP canister is purged during driving.

WARNING:

When conducting inspections below, be sure to observe the following:

- Put a "CAUTION: INFLAMMABLE" sign in workshop.
- Do not smoke while servicing fuel system. Keep open flames and sparks away from work area.
- Be sure to furnish the workshop with a CO₂ fire extinguisher.

CAUTION:

- Before removing fuel line parts, carry out the following procedures:
 - Put drained fuel in an explosion-proof container and put lid on securely.
 - Release fuel pressure from fuel line. Refer to [EC-95. "FUEL PRESSURE RELEASE"](#) .
 - Disconnect battery ground cable.
- Always replace O-ring when the fuel gauge retainer is removed.
- Do not kink or twist hose and tube when they are installed.
- Do not tighten hose and clamps excessively to avoid damaging hoses.
- After installation, run engine and check for fuel leaks at connection.
- Do not attempt to top off the fuel tank after the fuel pump nozzle shuts off automatically. Continued refueling may cause fuel overflow, resulting in fuel spray and possibly a fire.

ON BOARD REFUELING VAPOR RECOVERY (ORVR)

[QR]

UBS00CFB

Diagnostic Procedure

SYMPTOM: FUEL ODOR FROM EVAP CANISTER IS STRONG.

1. CHECK EVAP CANISTER

1. Remove EVAP canister with EVAP canister vent control valve and EVAP control system pressure sensor attached.
2. Weigh the EVAP canister with EVAP canister vent control valve and EVAP control system pressure sensor attached.

The weight should be less than 2.1 kg (4.6 lb).

OK or NG

- OK >> GO TO 2.
NG >> GO TO 3.

2. CHECK IF EVAP CANISTER SATURATED WITH WATER

Does water drain from the EVAP canister?

Yes or No

- Yes >> GO TO 3.
No >> GO TO 5.

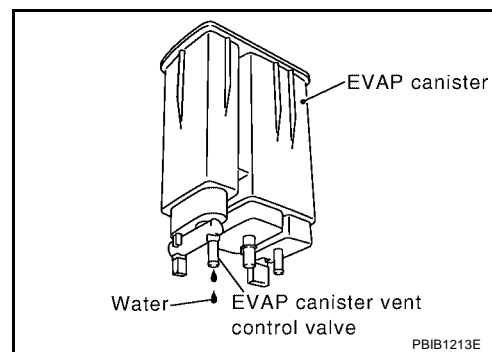

3. REPLACE EVAP CANISTER

Replace EVAP canister with a new one.

>> GO TO 4.

4. DETECT MALFUNCTIONING PART

Check the EVAP hose between EVAP canister and vehicle frame for clogging or poor connection.

>> Repair or replace EVAP hose.

5. CHECK REFUELING EVAP VAPOR CUT VALVE

Refer to [EC-48, "Component Inspection"](#).

OK or NG

- OK >> **INSPECTION END**
NG >> Replace refueling EVAP vapor cut valve with fuel tank.

ON BOARD REFUELING VAPOR RECOVERY (ORVR)

[QR]

SYMPTOM: CANNOT REFUEL/FUEL ODOR FROM THE FUEL FILLER OPENING IS STRONG WHILE REFUELING.

1. CHECK EVAP CANISTER

1. Remove EVAP canister with EVAP canister vent control valve and EVAP control system pressure sensor attached.
2. Weigh the EVAP canister with EVAP canister vent control valve and EVAP control system pressure sensor attached.

The weight should be less than 2.1 kg (4.6 lb).

OK or NG

- OK >> GO TO 2.
NG >> GO TO 3.

2. CHECK IF EVAP CANISTER SATURATED WITH WATER

Does water drain from the EVAP canister?

Yes or No

- Yes >> GO TO 3.
No >> GO TO 5.

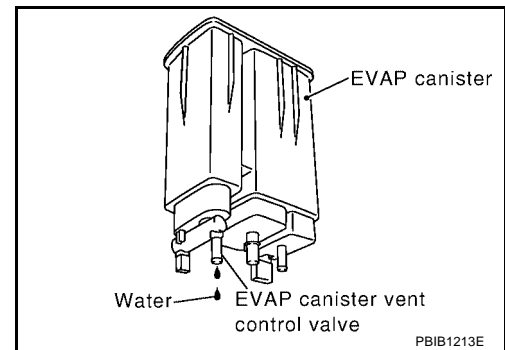

3. REPLACE EVAP CANISTER

Replace EVAP canister with a new one.

>> GO TO 4.

4. DETECT MALFUNCTIONING PART

Check the EVAP hose between EVAP canister and vehicle frame for clogging or poor connection.

>> Repair or replace EVAP hose.

5. CHECK VENT HOSES AND VENT TUBES

Check hoses and tubes between EVAP canister and refueling EVAP vapor cut valve for clogging, kink, looseness and improper connection.

OK or NG

- OK >> GO TO 6.
NG >> Repair or replace hoses and tubes.

6. CHECK FILLER NECK TUBE

Check recirculation line for clogging, dents and cracks.

OK or NG

- OK >> GO TO 7.
NG >> Replace filler neck tube.

7. CHECK REFUELING EVAP VAPOR CUT VALVE

Refer to [EC-48, "Component Inspection"](#) .

OK or NG

- OK >> GO TO 8.
- NG >> Replace refueling EVAP vapor cut valve with fuel tank.

8. CHECK FUEL FILLER TUBE

Check filler neck tube and hose connected to the fuel tank for clogging, dents and cracks.

OK or NG

- OK >> GO TO 9.
- NG >> Replace fuel filler tube.

9. CHECK ONE-WAY FUEL VALVE-I

Check one-way valve for clogging.

OK or NG

- OK >> GO TO 10.
- NG >> Repair or replace one-way fuel valve with fuel tank.

10. CHECK ONE-WAY FUEL VALVE-II

1. Make sure that fuel is drained from the tank.
2. Remove fuel filler tube and hose.
3. Check one-way fuel valve for operation as follows.
When a stick is inserted, the valve should open, when removing stick it should close.

Do not drop any material into the tank.

OK or NG

- OK >> **INSPECTION END**
- NG >> Replace fuel filler tube or replace one-way fuel valve with fuel tank.

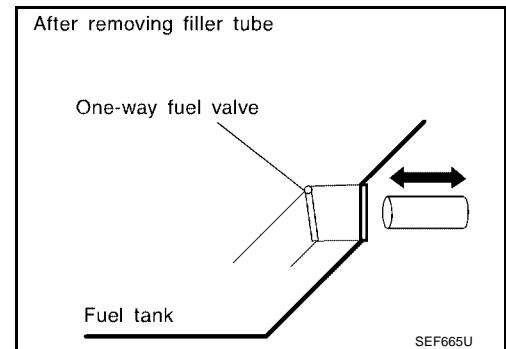

Component Inspection REFUELING EVAP VAPOR CUT VALVE

④ With CONSULT-II

1. Remove fuel tank. Refer to [FL-12, "FUEL TANK"](#) .
2. Drain fuel from the tank as follows:
 - a. Remove fuel feed hose located on the fuel gauge retainer.
 - b. Connect a spare fuel hose, one side to fuel gauge retainer where the hose was removed and the other side to a fuel container.
 - c. Drain fuel using "FUEL PUMP RELAY" in "ACTIVE TEST" mode with CONSULT-II.
3. Check refueling EVAP vapor cut valve for being stuck to close as follows.
Blow air into the refueling EVAP vapor cut valve (from the end of EVAP/ORVR line hose), and check that the air flows freely into the tank.
4. Check refueling EVAP vapor cut valve for being stuck to open as follows.
 - a. Connect vacuum pump to hose end.
 - b. Remove fuel gauge retainer with fuel gauge unit.
Always replace O-ring with new one.
 - c. Put fuel tank upside down.
 - d. Apply vacuum pressure to hose end [-13.3 kPa (-100 mmHg, -3.94 inHg)] with fuel gauge retainer remaining open and check that the pressure is applicable.

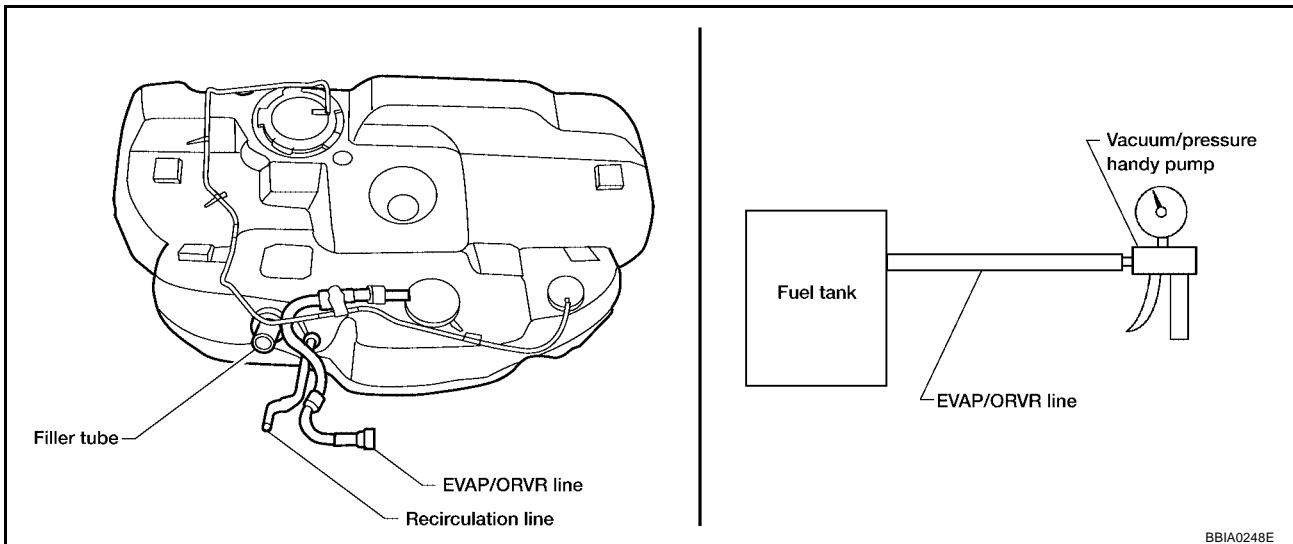

BBIA0248E

⊗ Without CONSULT-II

1. Remove fuel tank. Refer to [FL-12, "FUEL TANK"](#) .
2. Drain fuel from the tank as follows:
 - a. Remove fuel gauge retainer.
 - b. Drain fuel from the tank using a handy pump into a fuel container.
3. Check refueling EVAP vapor cut valve for being stuck to close as follows.
Blow air into the refueling EVAP vapor cut valve (from the end of EVAP/ORVR line hose), and check that the air flows freely into the tank.
4. Check refueling EVAP vapor cut valve for being stuck to open as follows.
 - a. Connect vacuum pump to hose end.
 - b. Remove fuel gauge retainer with fuel gauge unit.
Always replace O-ring with new one.
 - c. Put fuel tank upside down.

ON BOARD REFUELING VAPOR RECOVERY (ORVR)

[QR]

- d. Apply vacuum pressure to hose end [-13.3 kPa (-100 mmHg, -3.94 inHg)] with fuel gauge retainer remaining open and check that the pressure is applicable.

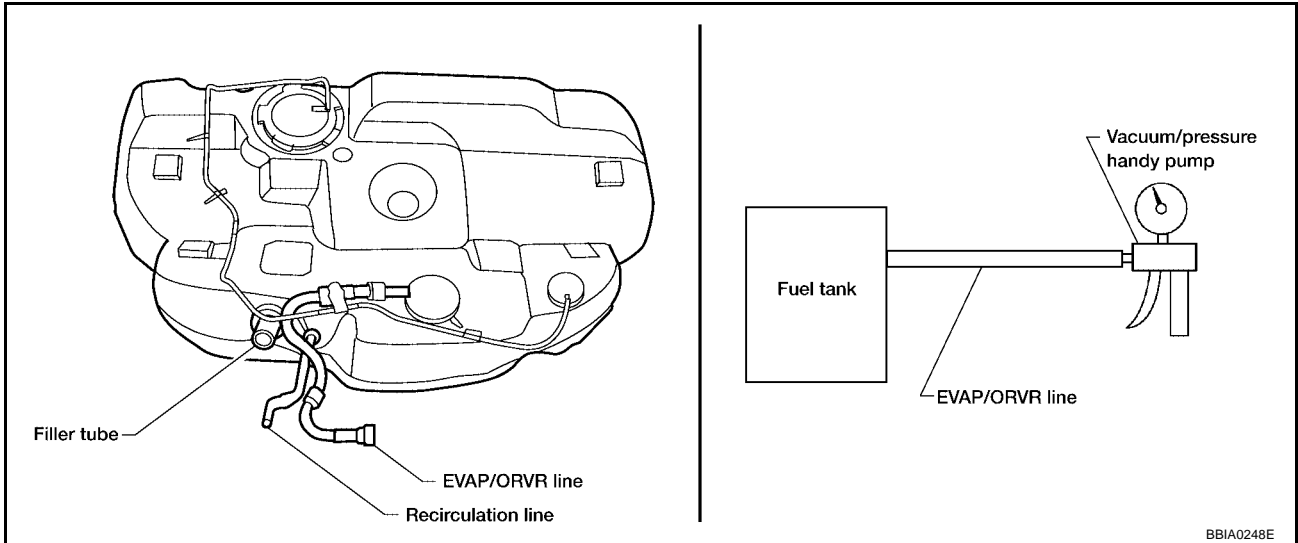

A
EC
C
D
E
F
G
H
I
J
K
L
M

POSITIVE CRANKCASE VENTILATION

PF1:11810

Description
SYSTEM DESCRIPTION

UBS0034D

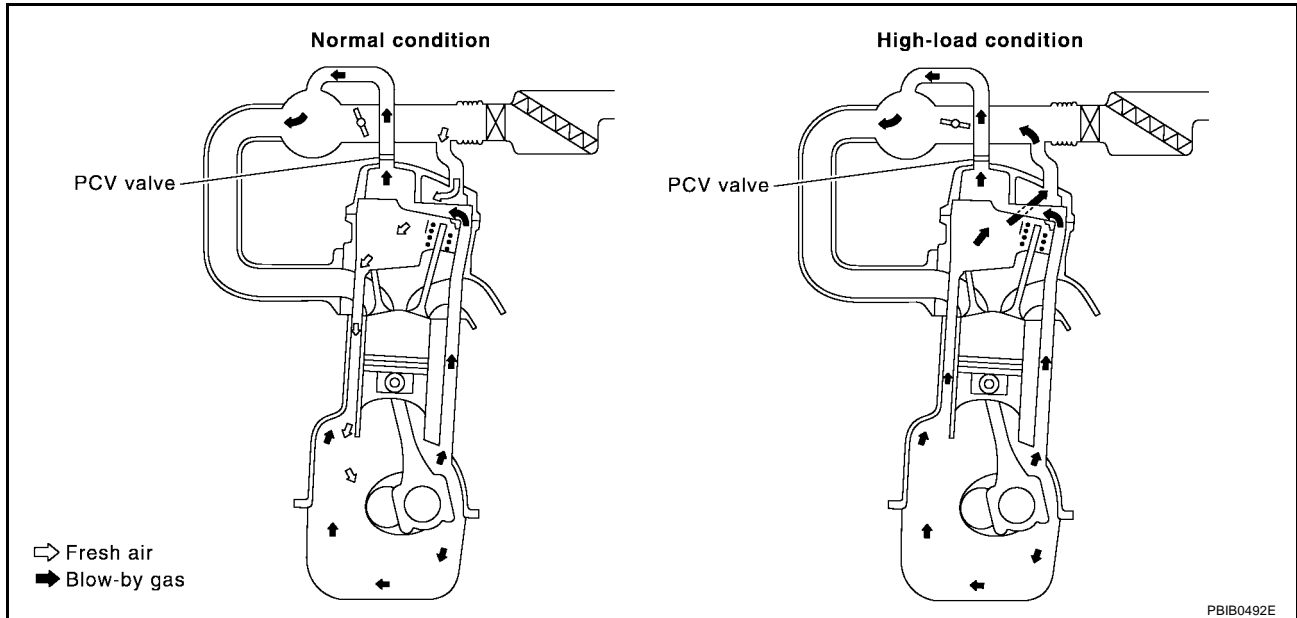

PBIB0492E

This system returns blow-by gas to the intake manifold.

The positive crankcase ventilation (PCV) valve is provided to conduct crankcase blow-by gas to the intake manifold. During partial throttle operation of the engine, the intake manifold sucks the blow-by gas through the PCV valve. Normally, the capacity of the valve is sufficient to handle any blow-by and a small amount of ventilating air. The ventilating air is then drawn from the air inlet tubes into the crankcase. In this process the air passes through the hose connecting air inlet tubes to rocker cover. Under full-throttle condition, the manifold vacuum is insufficient to draw the blow-by flow through the valve. The flow goes through the hose connection in the reverse direction.

On vehicles with an excessively high blow-by, the valve does not meet the requirement. This is because some of the flow will go through the hose connection to the air inlet tubes under all conditions.

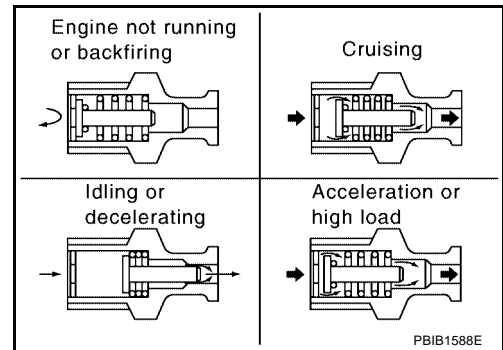

PBIB1588E

UBS0034E

Component Inspection
PCV (POSITIVE CRANKCASE VENTILATION) VALVE

With engine running at idle, remove PCV valve from rocker cover. A properly working valve makes a hissing noise as air passes through it. A strong vacuum should be felt immediately when a finger is placed over valve inlet.

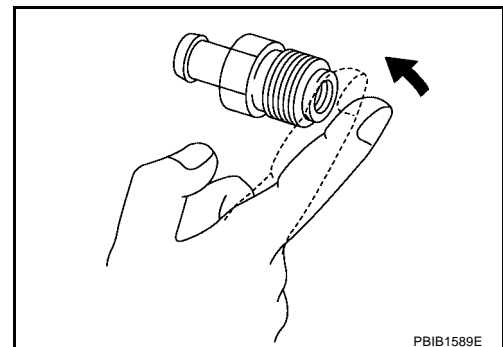

PBIB1589E

POSITIVE CRANKCASE VENTILATION

[QR]

PCV VALVE VENTILATION HOSE

1. Check hoses and hose connections for leaks.
2. Disconnect all hoses and clean with compressed air. If any hose cannot be freed of obstructions, replace.

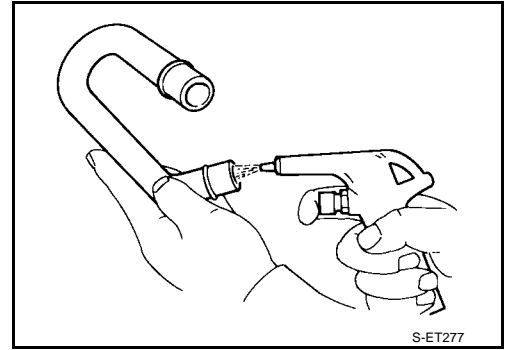

A

EC

C

D

E

F

G

H

I

J

K

L

M

NVIS (NISSAN VEHICLE IMMOBILIZER SYSTEM-NATS)

PFP:25386

Description

UBS00IT

- If the security indicator lights up with the ignition switch in the ON position or “NATS MALFUNCTION” is displayed on “SELF-DIAG RESULTS” screen, perform self-diagnostic results mode with CONSULT-II using NATS program card. Refer to [BL-107, "NVIS\(NISSAN Vehicle Immobilizer System-NATS\)"](#) .
- Confirm no self-diagnostic results of NVIS (NATS) is displayed before touching “ERASE” in “SELF-DIAG RESULTS” mode with CONSULT-II.
- When replacing ECM, initialization of NVIS (NATS) system and registration of all NVIS (NATS) ignition key IDs must be carried out with CONSULT-II using NATS program card. Therefore, be sure to receive all keys from vehicle owner. Regarding the procedures of NVIS (NATS) initialization and NVIS (NATS) ignition key ID registration, refer to CONSULT-II Operation Manual, IVIS/NVIS.

SELF DIAG RESULTS	
DTC RESULTS	TIME
NATS MALFUNCTION [P1610]	0

SEF543X

ON BOARD DIAGNOSTIC (OBD) SYSTEM

PFP:00028

Introduction

UBS0020D

The ECM has an on board diagnostic system, which detects malfunctions related to engine sensors or actuators. The ECM also records various emission-related diagnostic information including:

Emission-related diagnostic information	Diagnostic service
Diagnostic Trouble Code (DTC)	Service \$03 of SAE J1979
Freeze Frame data	Service \$02 of SAE J1979
System Readiness Test (SRT) code	Service \$01 of SAE J1979
1st Trip Diagnostic Trouble Code (1st Trip DTC)	Service \$07 of SAE J1979
1st Trip Freeze Frame data	
Test values and Test limits	Service \$06 of SAE J1979
Calibration ID	Service \$09 of SAE J1979

The above information can be checked using procedures listed in the table below.

×: Applicable —: Not applicable

	DTC	1st trip DTC	Freeze Frame data	1st trip Freeze Frame data	SRT code	SRT status	Test value
CONSULT-II	×	×	×	×	×	×	—
GST	×	×	×	—	×	×	×
ECM	×	×*	—	—	—	×	—

*: When DTC and 1st trip DTC simultaneously appear on the display, they cannot be clearly distinguished from each other.

The malfunction indicator lamp (MIL) on the instrument panel lights up when the same malfunction is detected in two consecutive trips (Two trip detection logic), or when the ECM enters fail-safe mode. (Refer to [EC-107](#).)

Two Trip Detection Logic

UBS0020E

When a malfunction is detected for the first time, 1st trip DTC and 1st trip Freeze Frame data are stored in the ECM memory. The MIL will not light up at this stage. <1st trip>

If the same malfunction is detected again during the next drive, the DTC and Freeze Frame data are stored in the ECM memory, and the MIL lights up. The MIL lights up at the same time when the DTC is stored. <2nd trip> The “trip” in the “Two Trip Detection Logic” means a driving mode in which self-diagnosis is performed during vehicle operation. Specific on board diagnostic items will cause the ECM to light up or blink the MIL, and store DTC and Freeze Frame data, even in the 1st trip, as shown below.

×: Applicable —: Not applicable

Items	MIL				DTC		1st trip DTC	
	1st trip		2nd trip		1st trip displaying	2nd trip displaying	1st trip displaying	2nd trip displaying
	Blinking	Lighting up	Blinking	Lighting up				
Misfire (Possible three way catalyst damage) — DTC: P0300 - P0304 is being detected	×	—	—	—	—	—	×	—
Misfire (Possible three way catalyst damage) — DTC: P0300 - P0304 is being detected	—	—	×	—	—	×	—	—
One trip detection diagnoses (Refer to EC-107 .)	—	×	—	—	×	—	—	—
Except above	—	—	—	×	—	×	×	—

When there is an open circuit on MIL circuit, the ECM cannot warn the driver by MIL lighting up when there is malfunction on engine control system.

Therefore, when electrical controlled throttle and part of ECM related diagnoses are continuously detected as NG for 5 trips, ECM warns the driver that engine control system malfunctions and MIL circuit is open by means of operating fail-safe function.

ON BOARD DIAGNOSTIC (OBD) SYSTEM

[QR]

The fail-safe function also operates when above diagnoses except MIL circuit are detected, and demands the driver to repair the malfunction.

Engine operating condition in fail-safe mode	Engine speed will not rise more than 2,500 rpm due to the fuel cut
--	--

Emission-related Diagnostic Information EMISSION-RELATED DIAGNOSTIC INFORMATION ITEMS

UBS001IS

×: Applicable —: Not applicable

Items (CONSULT-II screen terms)	DTC*1		SRT code	Test value/ Test limit (GST only)	Trip	MIL light- ing up	Reference page
	CONSULT-II GST*2	ECM*3					
CAN COMM CIRCUIT	U1000	1000*6	—	—	1	×	EC-166
CAN COMM CIRCUIT	U1001	1001*6	—	—	2	—	EC-166
NO DTC IS DETECTED. FURTHER TESTING MAY BE REQUIRED.	P0000	0000	—	—	—	Flashing*7	EC-61
INT/V TIM CONT-B1	P0011	0011	—	—	2	×	EC-169
HO2S2 HTR (B1)	P0037	0037	×	×	2	×	EC-173
HO2S2 HTR (B1)	P0038	0038	×	×	2	×	EC-173
MAF SEN/CIRCUIT	P0101	0101	—	—	2	×	EC-178
MAF SEN/CIRCUIT	P0102	0102	—	—	1	×	EC-187
MAF SEN/CIRCUIT	P0103	0103	—	—	1	×	EC-187
IAT SEN/CIRCUIT	P0112	0112	—	—	2	×	EC-194
IAT SEN/CIRCUIT	P0113	0113	—	—	2	×	EC-194
ECT SEN/CIRCUIT	P0117	0117	—	—	1	×	EC-199
ECT SEN/CIRCUIT	P0118	0118	—	—	1	×	EC-199
TP SEN 2/CIRC	P0122	0122	—	—	1	×	EC-204
TP SEN 2/CIRC	P0123	0123	—	—	1	×	EC-204
ECT SENSOR	P0125	0125	—	—	1	×	EC-211
IAT SENSOR	P0127	0127	—	—	2	×	EC-214
THERMSTAT FNCTN	P0128	0128	—	—	2	×	EC-217
HO2S2 (B1)	P0138	0138	—	×	2	×	EC-219
HO2S2 (B1)	P0139	0139	×	×	2	×	EC-225
FUEL SYS-LEAN-B1	P0171	0171	—	—	2	×	EC-233
FUEL SYS-RICH-B1	P0172	0172	—	—	2	×	EC-240
FTT SENSOR	P0181	0181	—	—	2	×	EC-246
FTT SEN/CIRCUIT	P0182	0182	—	—	2	×	EC-251
FTT SEN/CIRCUIT	P0183	0183	—	—	2	×	EC-251
TP SEN 1/CIRC	P0222	0222	—	—	1	×	EC-255
TP SEN 1/CIRC	P0223	0223	—	—	1	×	EC-255
MULTI CYL MISFIRE	P0300	0300	—	—	2	×	EC-262
CYL 1 MISFIRE	P0301	0301	—	—	2	×	EC-262
CYL 2 MISFIRE	P0302	0302	—	—	2	×	EC-262
CYL 3 MISFIRE	P0303	0303	—	—	2	×	EC-262
CYL 4 MISFIRE	P0304	0304	—	—	2	×	EC-262
KNOCK SEN/CIRC-B1	P0327	0327	—	—	2	—	EC-269
KNOCK SEN/CIRC-B1	P0328	0328	—	—	2	—	EC-269
CKP SEN/CIRCUIT	P0335	0335	—	—	2	×	EC-273

ON BOARD DIAGNOSTIC (OBD) SYSTEM

[QR]

Items (CONSULT-II screen terms)	DTC*1		SRT code	Test value/ Test limit (GST only)	Trip	MIL light- ing up	Reference page
	CONSULT-II GST*2	ECM*3					
CMP SEN/CIRC-B1	P0340	0340	—	—	2	×	EC-280
TW CATALYST SYS-B1	P0420	0420	×	×	2	×	EC-287
EVAP PURG FLOW/MON	P0441	0441	×	×	2	×	EC-292
EVAP SMALL LEAK	P0442	0442	×	×	2	×	EC-298
PURG VOLUME CONT/V	P0444	0444	—	—	2	×	EC-306
PURG VOLUME CONT/V	P0445	0445	—	—	2	×	EC-306
VENT CONTROL VALVE	P0447	0447	—	—	2	×	EC-312
EVAP SYS PRES SEN	P0451	0451	—	—	2	×	EC-319
EVAP SYS PRES SEN	P0452	0452	—	—	2	×	EC-322
EVAP SYS PRES SEN	P0453	0453	—	—	2	×	EC-328
EVAP GROSS LEAK	P0455	0455	—	—	2	×	EC-335
EVAP VERY SML LEAK	P0456	0456	×*4	×	2	×	EC-343
FUEL LEV SEN SLOSH	P0460	0460	—	—	2	×	EC-353
FUEL LEVEL SENSOR	P0461	0461	—	—	2	×	EC-355
FUEL LEVL SEN/CIRC	P0462	0462	—	—	2	×	EC-357
FUEL LEVL SEN/CIRC	P0463	0463	—	—	2	×	EC-357
VEH SPEED SEN/CIRC*5	P0500	0500	—	—	2	×	EC-359
ISC SYSTEM	P0506	0506	—	—	2	×	EC-361
ISC SYSTEM	P0507	0507	—	—	2	×	EC-363
PW STP SEN/CIRC	P0550	0550	—	—	2	—	EC-365
ECM	P0605	0605	—	—	1 or 2	× or —	EC-370
PNP SW/CIRC	P0705	0705	—	—	2	×	AT-105
ATF TEMP SEN/CIRC	P0710	0710	—	—	2	×	AT-111
VEH SPD SEN/CIR AT*5	P0720	0720	—	—	2	×	AT-117
ENGINE SPEED SIG	P0725	0725	—	—	2	×	AT-122
A/T 1ST GR FNCTN	P0731	0731	—	—	2	×	AT-126
A/T 2ND GR FNCTN	P0732	0732	—	—	2	×	AT-131
A/T 3RD GR FNCTN	P0733	0733	—	—	2	×	AT-136
A/T 4TH GR FNCTN	P0734	0734	—	—	2	×	AT-141
TCC SOLENOID/CIRC	P0740	0740	—	—	2	×	AT-148
A/T TCC S/V FNCTN	P0744	0744	—	—	2	×	AT-153
L/PRESS SOL/CIRC	P0745	0745	—	—	2	×	AT-161
SFT SOL A/CIRC	P0750	0750	—	—	1	×	AT-167
SFT SOL B/CIRC	P0755	0755	—	—	1	×	AT-172
A/F SEN1 HTR (B1)	P1031	1031	×	×	2	×	EC-373
A/F SEN1 HTR (B1)	P1032	1032	×	×	2	×	EC-373
ECM BACK UP/CIRC	P1065	1065	—	—	2	×	EC-378
INT/V TIM V/CIR-B1	P1111	1111	—	—	2	×	EC-382
ETC ACTR	P1121	1121	—	—	1	×	EC-386
ETC FUNCTION/CIRC	P1122	1122	—	—	1	×	EC-388
ETC MOT PWR	P1124	1124	—	—	1	×	EC-394
ETC MOT PWR	P1126	1126	—	—	1	×	EC-394

A
EC
C
D
E
F
G
H
I
J
K
L
M

ON BOARD DIAGNOSTIC (OBD) SYSTEM

[QR]

Items (CONSULT-II screen terms)	DTC*1		SRT code	Test value/ Test limit (GST only)	Trip	MIL light- ing up	Reference page
	CONSULT-II GST*2	ECM*3					
ETC MOT	P1128	1128	—	—	1	×	EC-399
HO2S2 (B1)	P1146	1146	×	×	2	×	EC-404
HO2S2 (B1)	P1147	1147	×	×	2	×	EC-412
CLOSED LOOP-B1	P1148	1148	—	—	1	×	EC-420
ENG OVER TEMP	P1217	1217	—	—	1	×	EC-421
CTP LEARNING	P1225	1225	—	—	2	—	EC-434
CTP LEARNING	P1226	1226	—	—	2	—	EC-436
SENSOR POWER/CIRC	P1229	1229	—	—	1	×	EC-438
A/F SENSOR1 (B1)	P1271	1271	—	×	2	×	EC-443
A/F SENSOR1 (B1)	P1272	1272	—	×	2	×	EC-448
A/F SENSOR1 (B1)	P1273	1273	—	×	2	×	EC-453
A/F SENSOR1 (B1)	P1274	1274	—	×	2	×	EC-460
A/F SENSOR1 (B1)	P1276	1276	—	×	2	×	EC-467
A/F SENSOR1 (B1)	P1278	1278	×	×	2	×	EC-473
A/F SENSOR1 (B1)	P1279	1279	×	×	2	×	EC-482
PURG VOLUME CONT/V	P1444	1444	—	—	2	×	EC-491
VENT CONTROL VALVE	P1446	1446	—	—	2	×	EC-498
ASCD SW	P1564	1564	—	—	1	—	EC-504
ASCD BRAKE SW	P1572	1572	—	—	1	—	EC-511
ASCD VHL SPD SEN	P1574	1574	—	—	1	—	EC-522
NATS MALFUNCTION	P1610 - P1615	1610 - 1615	—	—	2	—	BL-84
TPV SEN/CIRC A/T	P1705	1705	—	—	1	×	AT-177
P-N POS SW/CIRCUIT	P1706	1706	—	—	2	×	EC-524
O/R CLTCH SOL/CIRC	P1760	1760	—	—	2	×	AT-183
VIAS S/V CIRC	P1800	1800	—	—	2	—	EC-532
BRAKE SW/CIRCUIT	P1805	1805	—	—	2	—	EC-537
APP SEN 1/CIRC	P2122	2122	—	—	1	×	EC-542
APP SEN 1/CIRC	P2123	2123	—	—	1	×	EC-542
APP SEN 2/CIRC	P2127	2127	—	—	1	×	EC-549
APP SEN 2/CIRC	P2128	2128	—	—	1	×	EC-549
TP SENSOR	P2135	2135	—	—	1	×	EC-557
APP SENSOR	P2138	2138	—	—	1	×	EC-564

*1: 1st trip DTC No. is the same as DTC No.

*2: This number is prescribed by SAE J2012.

*3: In Diagnostic Test Made II (Self-diagnostic results), this number is controlled by NISSAN.

*4: SRT code will not be set if the self-diagnostic result is NG.

*5: When the fail-safe operations for both self-diagnoses occur at the same time, the MIL illuminates.

*6: The troubleshooting for this DTC needs CONSULT-II.

*7: When the ECM is in the mode of displaying SRT status, MIL may flash. For the details, refer to [EC-61, "How to Display SRT Status"](#) .

DTC AND 1ST TRIP DTC

The 1st trip DTC (whose number is the same as the DTC number) is displayed for the latest self-diagnostic result obtained. If the ECM memory was cleared previously, and the 1st trip DTC did not reoccur, the 1st trip DTC will not be displayed.

If a malfunction is detected during the 1st trip, the 1st trip DTC is stored in the ECM memory. The MIL will not light up (two trip detection logic). If the same malfunction is not detected in the 2nd trip (meeting the required driving pattern), the 1st trip DTC is cleared from the ECM memory. If the same malfunction is detected in the 2nd trip, both the 1st trip DTC and DTC are stored in the ECM memory and the MIL lights up. In other words, the DTC is stored in the ECM memory and the MIL lights up when the same malfunction occurs in two consecutive trips. If a 1st trip DTC is stored and a non-diagnostic operation is performed between the 1st and 2nd trips, only the 1st trip DTC will continue to be stored. For malfunctions that blink or light up the MIL during the 1st trip, the DTC and 1st trip DTC are stored in the ECM memory.

Procedures for clearing the DTC and the 1st trip DTC from the ECM memory are described in [EC-65, "HOW TO ERASE EMISSION-RELATED DIAGNOSTIC INFORMATION"](#).

For malfunctions in which 1st trip DTCs are displayed, refer to [EC-54, "EMISSION-RELATED DIAGNOSTIC INFORMATION ITEMS"](#). These items are required by legal regulations to continuously monitor the system/component. In addition, the items monitored non-continuously are also displayed on CONSULT-II.

1st trip DTC is specified in Service \$07 of SAE J1979. 1st trip DTC detection occurs without lighting up the MIL and therefore does not warn the driver of a malfunction. However, 1st trip DTC detection will not prevent the vehicle from being tested, for example during Inspection/Maintenance (I/M) tests.

When a 1st trip DTC is detected, check, print out or write down and erase (1st trip) DTC and Freeze Frame data as specified in Work Flow procedure Step II, refer to [EC-100, "WORK FLOW"](#). Then perform DTC Confirmation Procedure or Overall Function Check to try to duplicate the malfunction. If the malfunction is duplicated, the item requires repair.

How to Read DTC and 1st Trip DTC

DTC and 1st trip DTC can be read by the following methods.

 **WITH CONSULT-II**

 **WITH GST**

CONSULT-II or GST (Generic Scan Tool) Examples: P0340, P1148, P1706, etc.

These DTCs are prescribed by SAE J2012.

(CONSULT-II also displays the malfunctioning component or system.)

 **NO TOOLS**

The number of blinks of the MIL in the Diagnostic Test Mode II (Self-Diagnostic Results) indicates the DTC. Example: 0340, 1148, 1706, etc.

These DTCs are controlled by NISSAN.

- **1st trip DTC No. is the same as DTC No.**
- **Output of a DTC indicates a malfunction. However, GST or the Diagnostic Test Mode II do not indicate whether the malfunction is still occurring or has occurred in the past and has returned to normal. CONSULT-II can identify malfunction status as shown below. Therefore, using CONSULT-II (if available) is recommended.**

A sample of CONSULT-II display for DTC and 1st trip DTC is shown below. DTC or 1st trip DTC of a malfunction is displayed in SELF-DIAGNOSTIC RESULTS mode of CONSULT-II. Time data indicates how many times the vehicle was driven after the last detection of a DTC.

If the DTC is being detected currently, the time data will be 0.

If a 1st trip DTC is stored in the ECM, the time data will be [1t].

DTC display	SELF DIAG RESULTS		1st trip DTC display	SELF DIAG RESULTS	
	DTC RESULTS			DTC RESULTS	
	CKP SEN/CIRCUIT [P0335]	0		CKP SEN/CIRCUIT [P0335]	1t

PBIB0911E

FREEZE FRAME DATA AND 1ST TRIP FREEZE FRAME DATA

The ECM records the driving conditions such as fuel system status, calculated load value, engine coolant temperature, short term fuel trim, long term fuel trim, engine speed, vehicle speed, base fuel schedule and intake air temperature at the moment a malfunction is detected.

Data which are stored in the ECM memory, along with the 1st trip DTC, are called 1st trip freeze frame data. The data, stored together with the DTC data, are called freeze frame data and displayed on CONSULT-II or

ON BOARD DIAGNOSTIC (OBD) SYSTEM

[QR]

GST. The 1st trip freeze frame data can only be displayed on the CONSULT-II screen, not on the GST. For details, see [EC-57, "FREEZE FRAME DATA AND 1ST TRIP FREEZE FRAME DATA"](#). Only one set of freeze frame data (either 1st trip freeze frame data or freeze frame data) can be stored in the ECM. 1st trip freeze frame data is stored in the ECM memory along with the 1st trip DTC. There is no priority for 1st trip freeze frame data and it is updated each time a different 1st trip DTC is detected. However, once freeze frame data (2nd trip detection/MIL on) is stored in the ECM memory, 1st trip freeze frame data is no longer stored. Remember, only one set of freeze frame data can be stored in the ECM. The ECM has the following priorities to update the data.

Priority	Items	
1	Freeze frame data	Misfire — DTC: P0300 - P0304 Fuel Injection System Function — DTC: P0171, P0172
2		Except the above items (Includes A/T related items)
3	1st trip freeze frame data	

For example, the EGR malfunction (Priority: 2) was detected and the freeze frame data was stored in the 2nd trip. After that when the misfire (Priority: 1) is detected in another trip, the freeze frame data will be updated from the EGR malfunction to the misfire. The 1st trip freeze frame data is updated each time a different malfunction is detected. There is no priority for 1st trip freeze frame data. However, once freeze frame data is stored in the ECM memory, 1st trip freeze data is no longer stored (because only one freeze frame data or 1st trip freeze frame data can be stored in the ECM). If freeze frame data is stored in the ECM memory and freeze frame data with the same priority occurs later, the first (original) freeze frame data remains unchanged in the ECM memory.

Both 1st trip freeze frame data and freeze frame data (along with the DTCs) are cleared when the ECM memory is erased. Procedures for clearing the ECM memory are described in [EC-54, "EMISSION-RELATED DIAGNOSTIC INFORMATION ITEMS"](#).

SYSTEM READINESS TEST (SRT) CODE

System Readiness Test (SRT) code is specified in Service \$01 of SAE J1979.

As part of an enhanced emissions test for Inspection & Maintenance (I/M), certain states require the status of SRT be used to indicate whether the ECM has completed self-diagnosis of major emission systems and components. Completion must be verified in order for the emissions inspection to proceed.

If a vehicle is rejected for a State emissions inspection due to one or more SRT items indicating "INCMP", use the information in this Service Manual to set the SRT to "CMPLT".

In most cases the ECM will automatically complete its self-diagnosis cycle during normal usage, and the SRT status will indicate "CMPLT" for each application system. Once set as "CMPLT", the SRT status remains "CMPLT" until the self-diagnosis memory is erased.

Occasionally, certain portions of the self-diagnostic test may not be completed as a result of the customer's normal driving pattern; the SRT will indicate "INCMP" for these items.

NOTE:

The SRT will also indicate "INCMP" if the self-diagnosis memory is erased for any reason or if the ECM memory power supply is interrupted for several hours.

If, during the state emissions inspection, the SRT indicates "CMPLT" for all test items, the inspector will continue with the emissions test. However, if the SRT indicates "INCMP" for one or more of the SRT items the vehicle is returned to the customer untested.

NOTE:

If MIL is ON during the state emissions inspection, the vehicle is also returned to the customer untested even though the SRT indicates "CMPLT" for all test items. Therefore, it is important to check SRT ("CMPLT") and DTC (No DTCs) before the inspection.

ON BOARD DIAGNOSTIC (OBD) SYSTEM

[QR]

SRT Item

The table below shows required self-diagnostic items to set the SRT to "CMPLT".

SRT item (CONSULT-II indication)	Performance Priority*1	Required self-diagnostic items to set the SRT to "CMPLT"	Corresponding DTC No.
CATALYST	2	Three way catalyst function	P0420
EVAP SYSTEM	1	EVAP control system	P0442
	2	EVAP control system	P0456
	2	EVAP control system purge flow monitoring	P0441
HO2S	2	Air fuel ratio (A/F) sensor 1	P1278, P1279
		Heated oxygen sensor 2	P0139
		Heated oxygen sensor 2	P1146
		Heated oxygen sensor 2	P1147
HO2S HTR	2	Air fuel ratio (A/F) sensor heater	P1031, P1032
		Heated oxygen sensor 2 heater	P0037, P0038

*1: If completion of several SRTs is required, perform driving patterns (DTC confirmation procedure), one by one based on the priority for models with CONSULT-II.

SRT Set Timing

SRT is set as "CMPLT" after self-diagnosis has been performed one or more times. Completion of SRT is done regardless of whether the result is OK or NG. The set timing is different between OK and NG results and is shown in the table below.

Self-diagnosis result		Example					
		Diagnosis	Ignition cycle				
			← ON →	OFF	← ON →	OFF	
All OK	Case 1	P0400	OK (1)	— (1)	OK (2)	— (2)	
		P0402	OK (1)	— (1)	— (1)	OK (2)	
		P1402	OK (1)	OK (2)	— (2)	— (2)	
		SRT of EGR	"CMPLT"	"CMPLT"	"CMPLT"	"CMPLT"	
	Case 2	P0400	OK (1)	— (1)	— (1)	— (1)	
		P0402	— (0)	— (0)	OK (1)	— (1)	
		P1402	OK (1)	OK (2)	— (2)	— (2)	
		SRT of EGR	"INCMP"	"INCMP"	"CMPLT"	"CMPLT"	
NG exists	Case 3	P0400	OK	OK	—	—	
		P0402	—	—	—	—	
		P1402	NG	—	NG	NG	NG (Consecutive NG)
		(1st trip) DTC	1st trip DTC	—	1st trip DTC	DTC (= MIL "ON")	
		SRT of EGR	"INCMP"	"INCMP"	"INCMP"	"CMPLT"	

OK: Self-diagnosis is carried out and the result is OK.

NG: Self-diagnosis is carried out and the result is NG.

—: Self-diagnosis is not carried out.

When all SRT related self-diagnoses showed OK results in a single cycle (Ignition OFF-ON-OFF), the SRT will indicate "CMPLT". → Case 1 above

When all SRT related self-diagnoses showed OK results through several different cycles, the SRT will indicate "CMPLT" at the time the respective self-diagnoses have at least one OK result. → Case 2 above

If one or more SRT related self-diagnoses showed NG results in 2 consecutive cycles, the SRT will also indicate "CMPLT". → Case 3 above

ON BOARD DIAGNOSTIC (OBD) SYSTEM

[QR]

The table above shows that the minimum number of cycles for setting SRT as "INCMP" is one (1) for each self-diagnosis (Case 1 & 2) or two (2) for one of self-diagnoses (Case 3). However, in preparation for the state emissions inspection, it is unnecessary for each self-diagnosis to be executed twice (Case 3) for the following reasons:

- The SRT will indicate "CMPLT" at the time the respective self-diagnoses have one (1) OK result.
- The emissions inspection requires "CMPLT" of the SRT only with OK self-diagnosis results.
- When, during SRT driving pattern, 1st trip DTC (NG) is detected prior to "CMPLT" of SRT, the self-diagnosis memory must be erased from ECM after repair.
- If the 1st trip DTC is erased, all the SRT will indicate "INCMP".

NOTE:

SRT can be set as "CMPLT" together with the DTC(s). Therefore, DTC check must always be carried out prior to the state emission inspection even though the SRT indicates "CMPLT".

SRT Service Procedure

If a vehicle has failed the state emissions inspection due to one or more SRT items indicating "INCMP", review the flowchart diagnostic sequence on the next page.

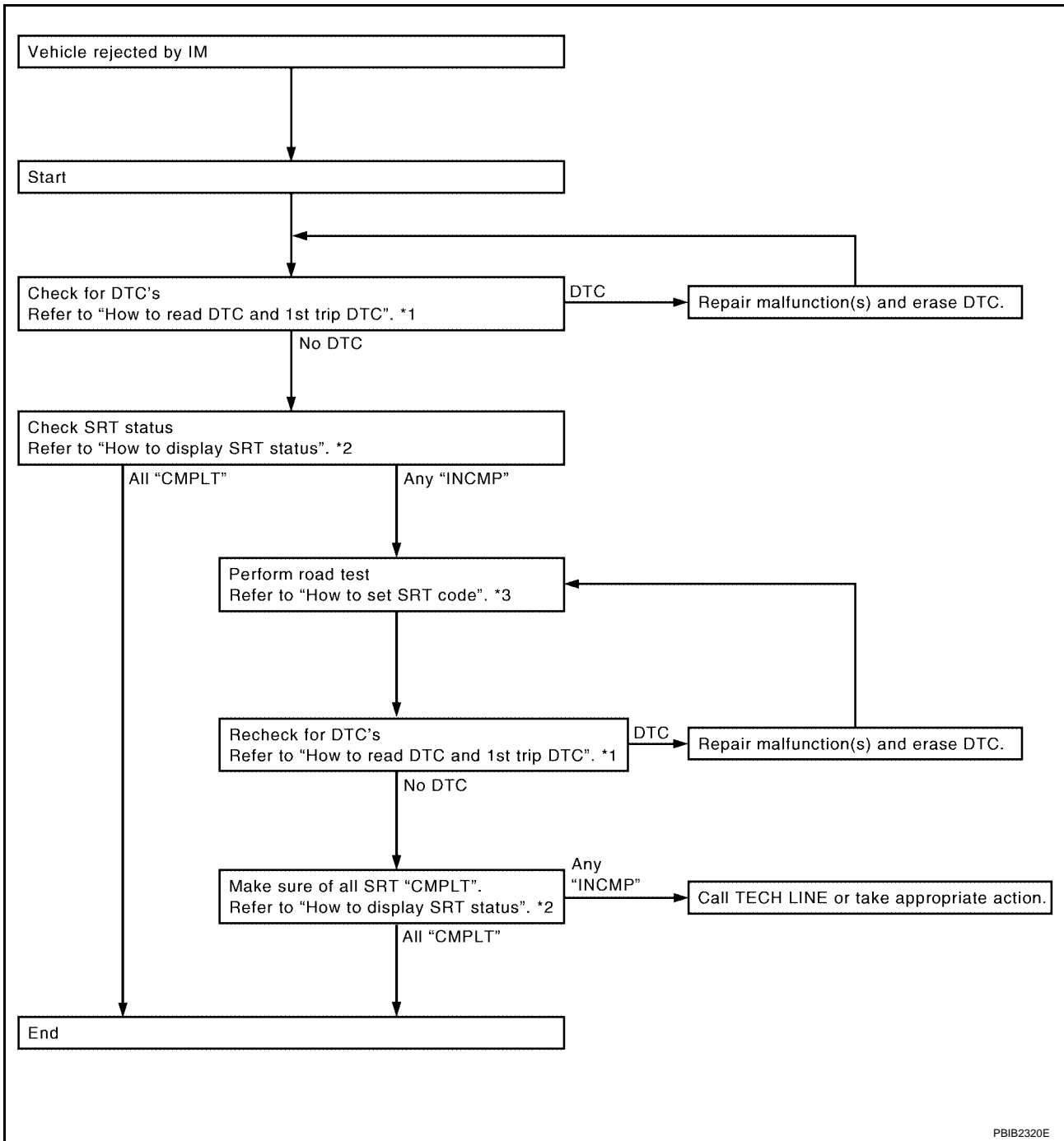

*1 [EC-57](#)

*2 [EC-61](#)

*3 [EC-62](#)

PBIB2320E

How to Display SRT Status

WITH CONSULT-II

Selecting "SRT STATUS" in "DTC CONFIRMATION" mode with CONSULT-II.

For items whose SRT codes are set, a "CMPLT" is displayed on the CONSULT-II screen; for items whose SRT codes are not set, "INCMP" is displayed.

A sample of CONSULT-II display for SRT code is shown at right.

"INCMP" means the self-diagnosis is incomplete and SRT is not set.

"CMPLT" means the self-diagnosis is complete and SRT is set.

WITH GST

Selecting Service \$01 with GST (Generic Scan Tool)

NO TOOLS

SRT STATUS	
CATALYST	CMPLT
EVAP SYSTEM	INCMP
HO2S HTR	CMPLT
HO2S	CMPLT

SEF949Z

A SRT code itself can not be displayed while only SRT status can be.

1. Turn ignition switch ON and wait 20 seconds.
2. SRT status is indicated as shown below.
 - When all SRT codes are set, MIL lights up continuously.
 - When any SRT codes are not set, MIL will flash periodically for 10 seconds.

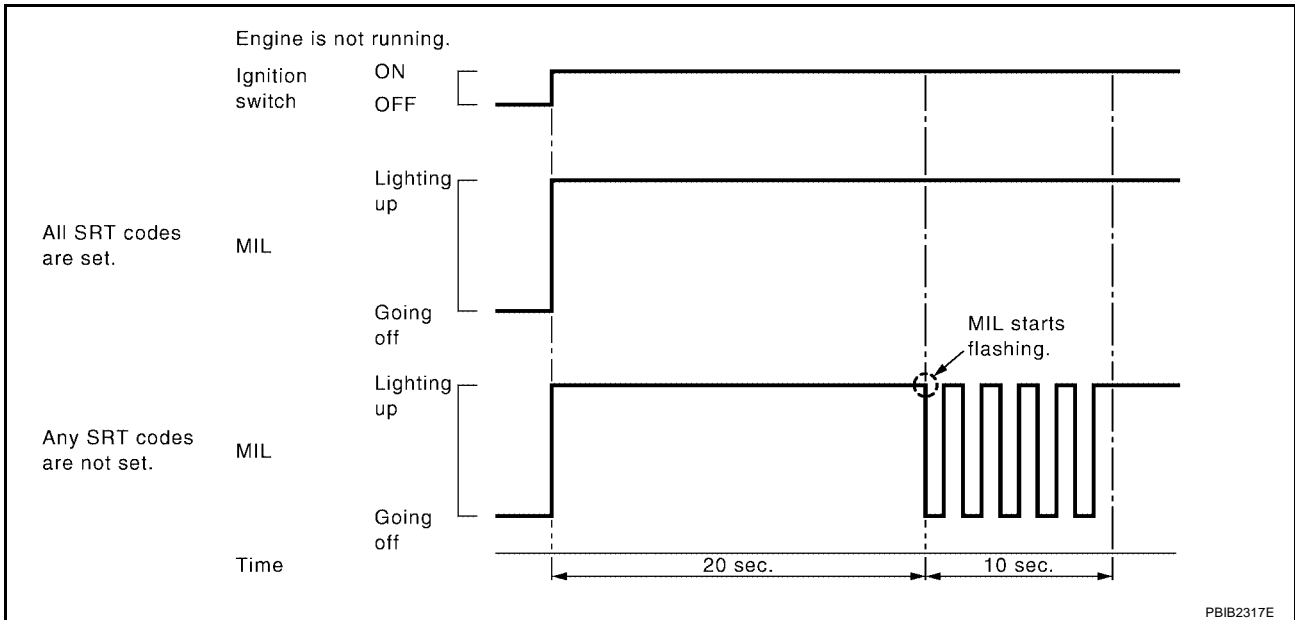

How to Set SRT Code

To set all SRT codes, self-diagnosis for the items indicated above must be performed one or more times. Each diagnosis may require a long period of actual driving under various conditions.

Ⓟ WITH CONSULT-II

Perform corresponding DTC Confirmation Procedure one by one based on "Performance Priority" in the table on [EC-59, "SRT Item"](#).

ⓧ WITHOUT CONSULT-II

The most efficient driving pattern in which SRT codes can be properly set is explained on the next page. The driving pattern should be performed one or more times to set all SRT codes.

Driving Pattern

**Note: Always drive vehicle in safe manner according to traffic conditions and obey all traffic laws.
Refer to next page for more information and explanation of chart.**

Driving pattern

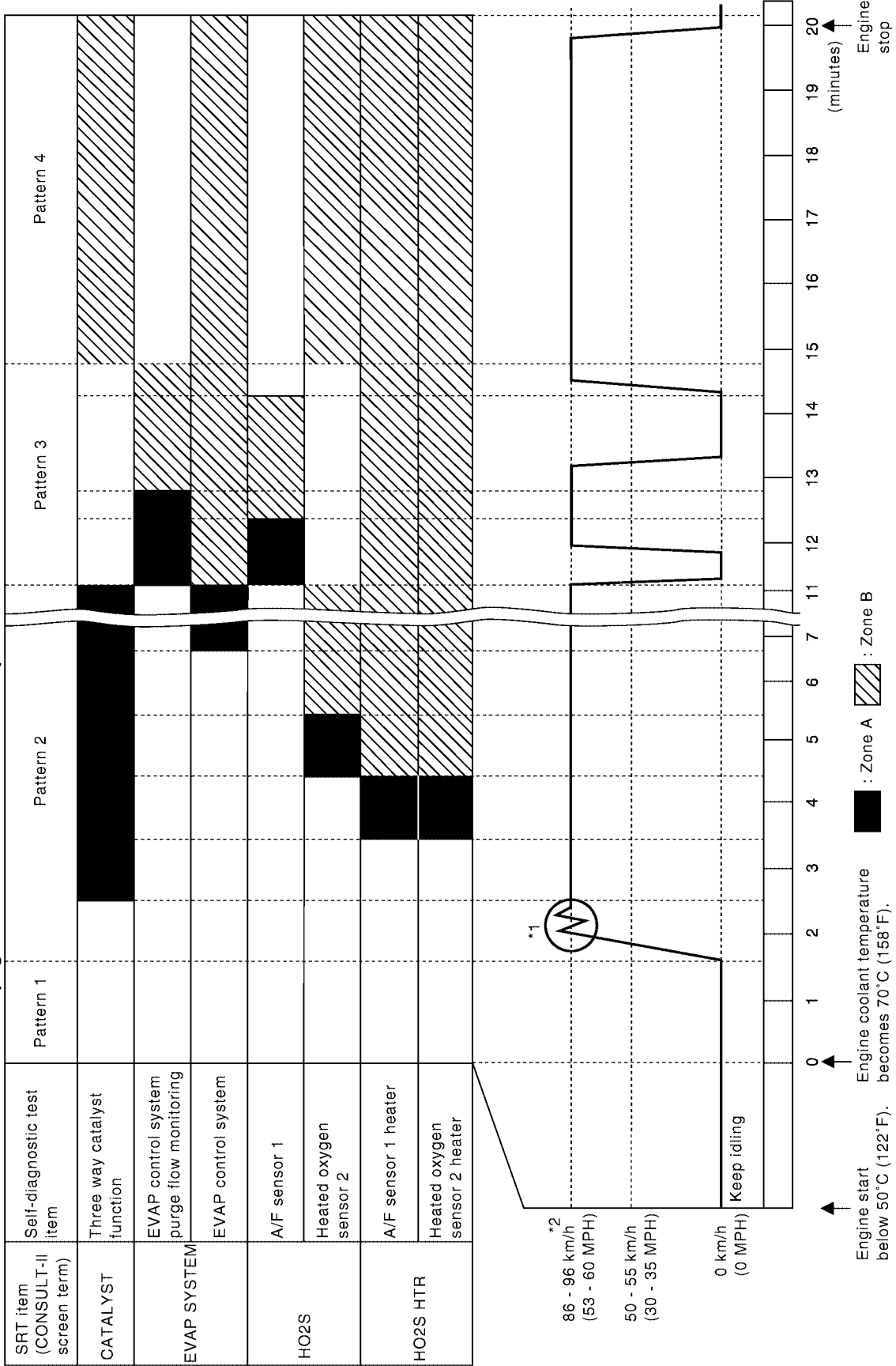

PBIB2314E

A
EC
C
D
E
F
G
H
I
J
K
L
M

ON BOARD DIAGNOSTIC (OBD) SYSTEM

[QR]

- The time required for each diagnosis varies with road surface conditions, weather, altitude, individual driving habits, etc.
Zone A refers to the range where the time, required for the diagnosis under normal conditions*, is the shortest.
Zone B refers to the range where the diagnosis can still be performed if the diagnosis is not completed within zone A.

*: Normal conditions refer to the following:

- Sea level
- Flat road
- Ambient air temperature: 20 - 30°C (68 - 86°F)
- Diagnosis is performed as quickly as possible under normal conditions.
Under different conditions [For example: ambient air temperature other than 20 - 30°C (68 - 86°F)], diagnosis may also be performed.

Pattern 1:

- The engine is started at the engine coolant temperature of -10 to 35°C (14 to 95°F) (where the voltage between the ECM terminal 73 and ground is 3.0 - 4.3V).**
- The engine must be operated at idle speed until the engine coolant temperature is greater than 70°C (158°F) (where the voltage between the ECM terminal 73 and ground is lower than 1.4V).**
- The engine is started at the fuel tank temperature of warmer than 0°C (32°F) (where the voltage between the ECM terminal 107 and ground is less than 4.1V).**

Pattern 2:

- When steady-state driving is performed again even after it is interrupted, each diagnosis can be conducted. In this case, the time required for diagnosis may be extended.

Pattern 3:

- Operate vehicle following the driving pattern shown in the figure.
- Release the accelerator pedal during decelerating vehicle speed from 90 km/h (56 MPH) to 0 km/h (0 MPH).

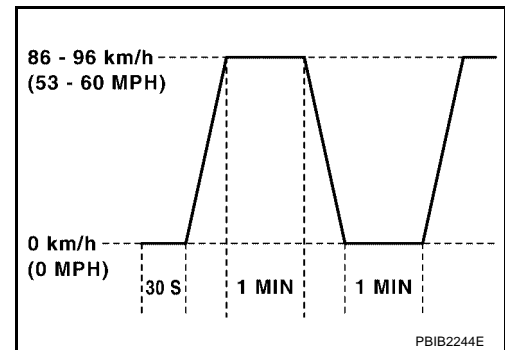

Pattern 4:

- The accelerator pedal must be held very steady during steady-state driving.
- If the accelerator pedal is moved, the test must be conducted all over again.

*1: Depress the accelerator pedal until vehicle speed is 90 km/h (56 MPH), then release the accelerator pedal and keep it released for more than 10 seconds. Depress the accelerator pedal until vehicle speed is 90 km/h (56 MPH) again.

*2: Checking the vehicle speed with GST is advised.

Suggested Transmission Gear Position for A/T Models

Set the selector lever in the D position with the overdrive switch turned ON.

Suggested upshift speeds for M/T models

Shown below are suggested vehicle speeds for shifting into a higher gear. These suggestions relate to fuel economy and vehicle performance. Actual upshift speeds will vary according to road conditions, the weather and individual driving habits.

	For normal acceleration in low altitude areas [less than 1,219 m (4,000 ft)]:	For quick acceleration in low altitude areas	For high altitude areas [over 1,219m (4,000 ft)]:
Gear change	ACCEL shift point km/h (MPH)	km/h (MPH)	km/h (MPH)
1st to 2nd	24 (15)	24 (15)	24 (15)
2nd to 3rd	28 (18)	40 (25)	40 (25)
3rd to 4th	48 (30)	57 (36)	64 (40)
4th to 5th	62 (39)	64 (40)	75 (45)

Suggested Maximum Speed in Each Gear

ON BOARD DIAGNOSTIC (OBD) SYSTEM

[QR]

Downshift to a lower gear if the engine is not running smoothly, or if you need to accelerate. Do not exceed the maximum suggested speed (shown below) in any gear. For level road driving, use the highest gear suggested for that speed. Always observe posted speed limits and drive according to the road conditions to ensure safe operation. Do not over-rev the engine when shifting to a lower gear as it may cause engine damage or loss of vehicle control.

Gear	km/h (MPH)
1st	50 (30)
2nd	90 (55)
3rd	—
4th	—
5th	—

TEST VALUE AND TEST LIMIT (GST ONLY — NOT APPLICABLE TO CONSULT-II)

The following is the information specified in Service \$06 of SAE J1979.

The test value is a parameter used to determine whether a system/circuit diagnostic test is “OK” or “NG” while being monitored by the ECM during self-diagnosis. The test limit is a reference value which is specified as the maximum or minimum value and is compared with the test value being monitored.

These data (test value and test limit) are specified by Test ID (TID) and Component ID (CID) and can be displayed on the GST screen.

Item	Self-diagnostic test item	DTC	Test value (GST display)		Test limit	Conversion
			TID	CID		
CATALYST	Three way catalyst function	P0420	01H	01H	Max.	1/128
		P0420	02H	81H	Min.	1
EVAP SYSTEM	EVAP control system (Small leak)	P0442	05H	03H	Max.	1/128 mm ²
	EVAP control system purge flow monitoring	P0441	06H	83H	Min.	20 mV
	EVAP control system (Very small leak)	P0456	07H	03H	Max.	1/128 mm ²
HO2S	A/F sensor 1	P1271	41H	8EH	Min.	5 mV
		P1272	42H	0EH	Max.	5 mV
		P1273	43H	0EH	Max.	0.002
		P1274	44H	8EH	Min.	0.002
		P1278	45H	8EH	Min.	0.004
		P1276	46H	0EH	Max.	5 mV
		P1276	47H	8EH	Min.	5 mV
		P1279	48H	8EH	Min.	0.004
	Heated oxygen sensor 2	P0139	19H	86H	Min.	10mV/500 ms
		P1147	1AH	86H	Min.	10 mV
P1146		1BH	06H	Max.	10 mV	
P0138		1CH	06H	Max.	10 mV	
HO2S HEATER	A/F sensor 1 heater	P1032	57H	10H	Max.	5 mV
		P1031	58H	90H	Min.	5 mV
	Heated oxygen sensor 2 heater	P0038	2DH	0AH	Max.	20 mV
		P0037	2EH	8AH	Min.	20 mV

HOW TO ERASE EMISSION-RELATED DIAGNOSTIC INFORMATION

How to Erase DTC

With CONSULT-II

The emission related diagnostic information in the ECM can be erased by selecting “ERASE” in the “SELF-DIAG RESULTS” mode with CONSULT-II.

If DTCs are displayed for both ECM and TCM (Transmission control module), they need to be erased individually from the ECM and TCM (Transmission control module).

NOTE:

If the DTC is not for A/T related items (see [EC-15, "INDEX FOR DTC"](#)), skip steps 2 through 4.

1. If the ignition switch stays ON after repair work, be sure to turn ignition switch OFF once. Wait at least 10 seconds and then turn it ON (engine stopped) again.
2. Turn CONSULT-II ON and touch "A/T".
3. Touch "SELF-DIAG RESULTS".
4. Touch "ERASE". [The DTC in the TCM (Transmission control module) will be erased.] Then touch "BACK" twice.
5. Touch "ENGINE".
6. Touch "SELF-DIAG RESULTS".
7. Touch "ERASE". (The DTC in the ECM will be erased.)

How to erase DTC (With CONSULT-II)

1. If the ignition switch stays "ON" after repair work, be sure to turn ignition switch "OFF" once. Wait at least 10 seconds and then turn it "ON" (engine stopped) again.

SELECT SYSTEM
A/T
ENGINE

2. Turn CONSULT-II "ON", and touch "A/T".

SELECT DIAG MODE
SELF-DIAG RESULTS
DATE MONITOR
CAN DIAG SUPPORT MNTR
DTC WORK SUPPORT
ECU PART NUMBER

3. Touch "SELF-DIAG RESULTS".

SELF-DIAG RESULTS
DTC RESULTS
TCC SOLENOID/CIRC [P0740]

4. Touch "ERASE". (The DTC in the TCM will be erased.)

Touch "BACK".

Touch "BACK".

SELECT SYSTEM
A/T
ENGINE

5. Touch "ENGINE".

SELECT DIAG MODE
WORK SUPPORT
SELF-DIAG RESULTS
DATA MONITOR
DATA MONITOR(SPEC)
CAN DIAG SUPPORT MNTR
ACTIVE TEST

6. Touch "SELF-DIAG RESULTS".

SELF-DIAG RESULTS	
DTC RESULTS	TIME
TCC SOLENOID/CIRC [P0740]	0

7. Touch "ERASE". (The DTC in the ECM will be erased.)

SCIA5334E

With GST

The emission related diagnostic information in the ECM can be erased by selecting Service \$04 with GST.

NOTE:

If the DTC is not for A/T related items (see [EC-15, "INDEX FOR DTC"](#)), skip step 2.

1. If the ignition switch stays ON after repair work, be sure to turn ignition switch OFF once. Wait at least 10 seconds and then turn it ON (engine stopped) again.
2. Perform [AT-42, "HOW TO ERASE DTC \(WITH GST\)"](#) . (The DTC in the TCM will be erased.)
3. Select Service \$04 with GST (Generic Scan Tool).

No Tools

NOTE:

If the DTC is not for A/T related items (see [EC-15, "INDEX FOR DTC"](#)), skip step 2.

1. If the ignition switch stays ON after repair work, be sure to turn ignition switch OFF once. Wait at least 10 seconds and then turn it ON (engine stopped) again.

ON BOARD DIAGNOSTIC (OBD) SYSTEM

[QR]

2. Perform [AT-42, "HOW TO ERASE DTC \(NO TOOLS\)"](#) . (The DTC in the TCM will be erased.)
3. Change the diagnostic test mode from Mode II to Mode I by depressing the accelerator pedal. Refer to [EC-68, "HOW TO SWITCH DIAGNOSTIC TEST MODE"](#) .
- **If the battery is disconnected, the emission-related diagnostic information will be lost within 24 hours.**
- **The following data are cleared when the ECM memory is erased.**
 - Diagnostic trouble codes
 - 1st trip diagnostic trouble codes
 - Freeze frame data
 - 1st trip freeze frame data
 - System readiness test (SRT) codes
 - Test values
 - Others

Actual work procedures are explained using a DTC as an example. Be careful so that not only the DTC, but all of the data listed above, are cleared from the ECM memory during work procedures.

Malfunction Indicator Lamp (MIL)

UBS0020H

DESCRIPTION

The MIL is located on the instrument panel.

1. The MIL will light up when the ignition switch is turned ON without the engine running. This is a bulb check.
If the MIL does not light up, refer to [DI-30, "WARNING LAMPS"](#) , or see [EC-623, "MIL AND DATA LINK CONNECTOR"](#) .
2. When the engine is started, the MIL should go off.
If the MIL remains on, the on board diagnostic system has detected an engine system malfunction.

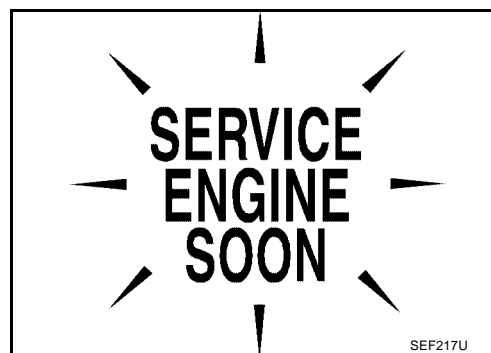





ON BOARD DIAGNOSTIC SYSTEM FUNCTION

The on board diagnostic system has the following 3 functions.

ON BOARD DIAGNOSTIC (OBD) SYSTEM

[QR]

Diagnostic Test Mode	KEY and ENG. Status	Function	Explanation of Function
Mode I	Ignition switch in ON position  Engine stopped 	BULB CHECK	This function checks the MIL bulb for damage (blown, open circuit, etc.). If the MIL does not come on, check MIL circuit.
	Engine running 	MALFUNCTION WARNING	This is a usual driving condition. When a malfunction is detected twice in two consecutive driving cycles (two trip detection logic), the MIL will light up to inform the driver that a malfunction has been detected. The following malfunctions will light up or blink the MIL in the 1st trip. <ul style="list-style-type: none"> ● Misfire (Possible three way catalyst damage) ● One trip detection diagnoses
Mode II	Ignition switch in ON position  Engine stopped 	SELF-DIAGNOSTIC RESULTS	This function allows DTCs and 1st trip DTCs to be read.

When there is an open circuit on MIL circuit, the ECM cannot warn the driver by MIL lighting up when there is malfunction on engine control system.

Therefore, when electrical controlled throttle and part of ECM related diagnoses are continuously detected as NG for 5 trips, ECM warns the driver that engine control system malfunctions and MIL circuit is open by means of operating fail-safe function.

The fail-safe function also operates when above diagnoses except MIL circuit are detected, and demands the driver to repair the malfunction.

Engine operating condition in fail-safe mode

Engine speed will not rise more than 2,500 rpm due to the fuel cut

MIL Flashing Without DTC

When any SRT codes are not set, MIL may flash without DTC. For the details, refer to [EC-61, "How to Display SRT Status"](#).

HOW TO SWITCH DIAGNOSTIC TEST MODE

NOTE:

- It is better to count the time accurately with a clock.
- It is impossible to switch the diagnostic mode when an accelerator pedal position sensor circuit has a malfunction.
- Always ECM returns to Diagnostic Test Mode I after ignition switch is turned OFF.

How to Set Diagnostic Test Mode II (Self-diagnostic Results)

1. Confirm that accelerator pedal is fully released, turn ignition switch ON and wait 3 seconds.
2. Repeat the following procedure quickly five times within 5 seconds.
 - a. Fully depress the accelerator pedal.
 - b. Fully release the accelerator pedal.
3. Wait 7 seconds, fully depress the accelerator pedal and keep it for approx. 10 seconds until the MIL starts blinking.
4. Fully release the accelerator pedal.

ECM has entered to Diagnostic Test Mode II (Self-diagnostic results).

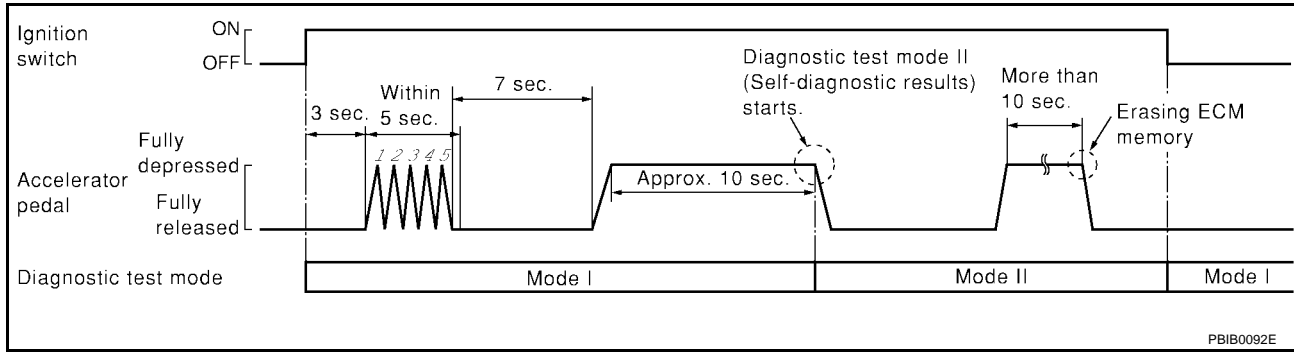

How to Erase Diagnostic Test Mode II (Self-diagnostic Results)

1. Set ECM in Diagnostic Test Mode II (Self-diagnostic results). Refer to [EC-68, "How to Set Diagnostic Test Mode II \(Self-diagnostic Results\)"](#).
2. Fully depress the accelerator pedal and keep it for more than 10 seconds. The emission-related diagnostic information has been erased from the backup memory in the ECM.
3. Fully release the accelerator pedal, and confirm the DTC 0000 is displayed.

DIAGNOSTIC TEST MODE I — BULB CHECK

In this mode, the MIL on the instrument panel should stay ON. If it remains OFF, check the bulb. Refer to [DI-30, "WARNING LAMPS"](#).

DIAGNOSTIC TEST MODE I — MALFUNCTION WARNING

MIL	Condition
ON	When the malfunction is detected.
OFF	No malfunction

These DTC numbers are clarified in Diagnostic Test Mode II (SELF-DIAGNOSTIC RESULTS)

DIAGNOSTIC TEST MODE II — SELF-DIAGNOSTIC RESULTS

In this mode, the DTC and 1st trip DTC are indicated by the number of blinks of the MIL as shown below. The DTC and 1st trip DTC are displayed at the same time. If the MIL does not illuminate in diagnostic test mode I (Malfunction warning), all displayed items are 1st trip DTCs. If only one code is displayed when the MIL illuminates in diagnostic test mode II (SELF-DIAGNOSTIC RESULTS), it is a DTC; if two or more codes are displayed, they may be either DTCs or 1st trip DTCs. DTC No. is same as that of 1st trip DTC. These unidentified codes can be identified by using the CONSULT-II or GST. A DTC will be used as an example for how to read a code.

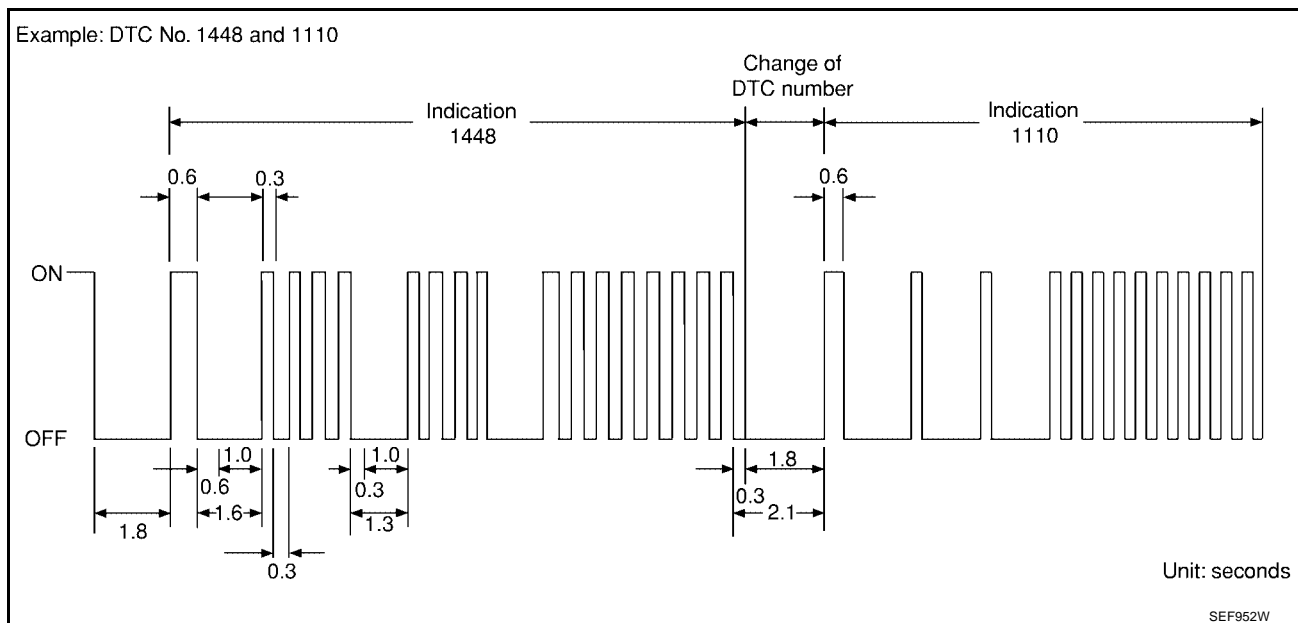

A particular trouble code can be identified by the number of four-digit numeral flashes. The “zero” is indicated by the number of ten flashes. The length of time the 1,000th-digit numeral flashes on and off is 1.2 seconds consisting of an ON (0.6-second) - OFF (0.6-second) cycle.

The 100th-digit numeral and lower digit numerals consist of a 0.3-second ON and 0.3-second OFF cycle.

A change from one digit numeral to another occurs at an interval of 1.0-second OFF. In other words, the later numeral appears on the display 1.3 seconds after the former numeral has disappeared.

A change from one trouble code to another occurs at an interval of 1.8-second OFF.

In this way, all the detected malfunctions are classified by their DTC numbers. The DTC 0000 refers to no malfunction. (See [EC-15, "INDEX FOR DTC"](#))

How to Erase Diagnostic Test Mode II (Self-diagnostic Results)

The DTC can be erased from the back-up memory in the ECM by depressing accelerator pedal. Refer to [EC-69, "How to Erase Diagnostic Test Mode II \(Self-diagnostic Results\)"](#) .

- If the battery is disconnected, the DTC will be lost from the backup memory within 24 hours.
- Be careful not to erase the stored memory before starting trouble diagnoses.

OBD System Operation Chart

UBS00201

RELATIONSHIP BETWEEN MIL, 1ST TRIP DTC, DTC, AND DETECTABLE ITEMS

- When a malfunction is detected for the first time, the 1st trip DTC and the 1st trip freeze frame data are stored in the ECM memory.
- When the same malfunction is detected in two consecutive trips, the DTC and the freeze frame data are stored in the ECM memory, and the MIL will come on. For details, refer to [EC-53, "Two Trip Detection Logic"](#) .
- The MIL will go off after the vehicle is driven 3 times with no malfunction. The drive is counted only when the recorded driving pattern is met (as stored in the ECM). If another malfunction occurs while counting, the counter will reset.
- The DTC and the freeze frame data will be stored until the vehicle is driven 40 times (driving pattern A) without the same malfunction recurring (except for Misfire and Fuel Injection System). For Misfire and Fuel Injection System, the DTC and freeze frame data will be stored until the vehicle is driven 80 times (driving pattern C) without the same malfunction recurring. The “TIME” in “SELF-DIAGNOSTIC RESULTS” mode of CONSULT-II will count the number of times the vehicle is driven.
- The 1st trip DTC is not displayed when the self-diagnosis results in OK for the 2nd trip.

SUMMARY CHART

Items	Fuel Injection System	Misfire	Other
MIL (goes off)	3 (pattern B)	3 (pattern B)	3 (pattern B)
DTC, Freeze Frame Data (no display)	80 (pattern C)	80 (pattern C)	40 (pattern A)
1st Trip DTC (clear)	1 (pattern C), *1	1 (pattern C), *1	1 (pattern B)
1st Trip Freeze Frame Data (clear)	*1, *2	*1, *2	1 (pattern B)

For details about patterns B and C under “Fuel Injection System” and “Misfire”, see [EC-72](#) .

For details about patterns A and B under “Other”, see [EC-74](#) .

*1: Clear timing is at the moment OK is detected.

*2: Clear timing is when the same malfunction is detected in the 2nd trip.

RELATIONSHIP BETWEEN MIL, DTC, 1ST TRIP DTC AND DRIVING PATTERNS FOR "MISFIRE <EXHAUST QUALITY DETERIORATION>", "FUEL INJECTION SYSTEM"

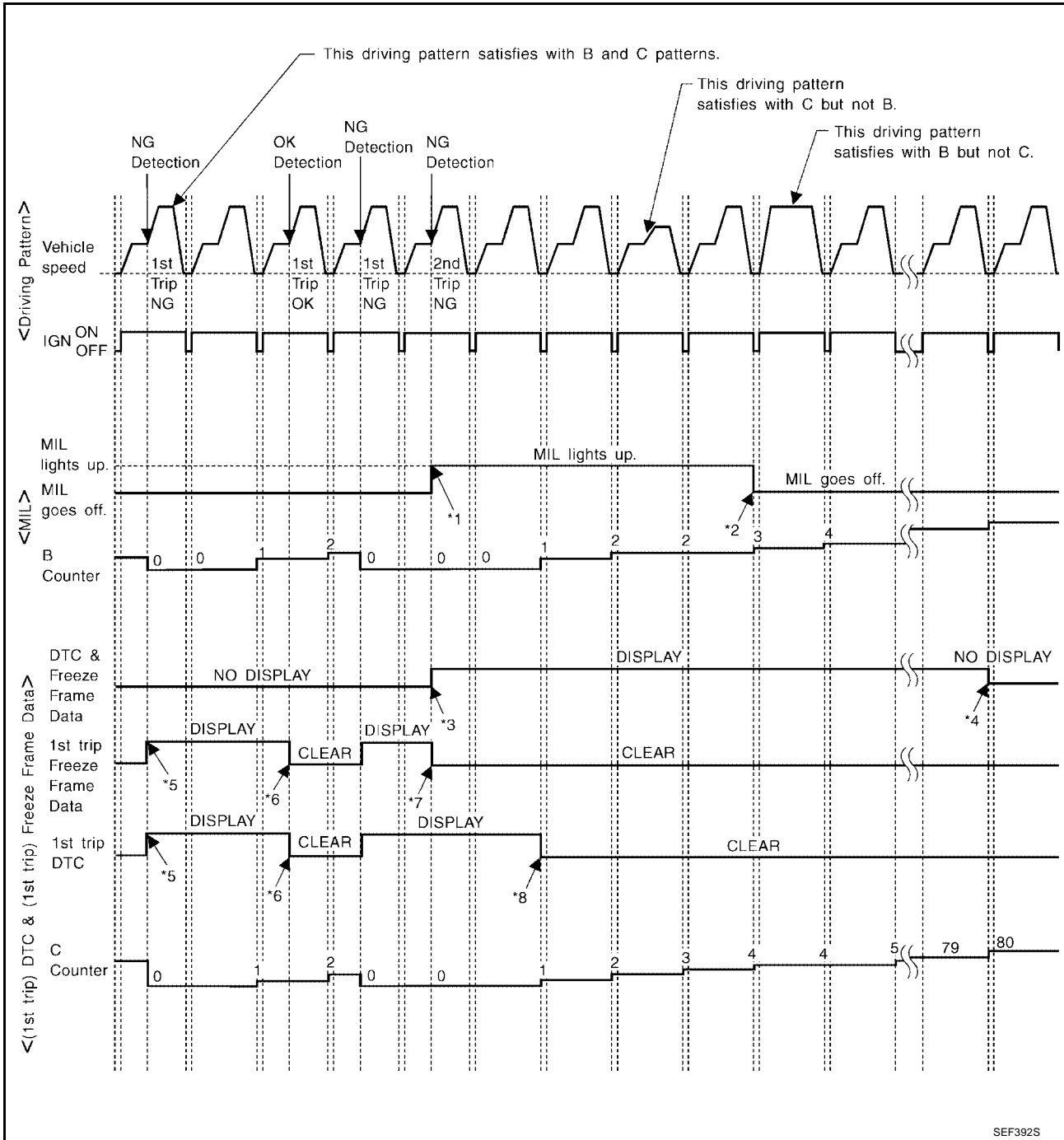

*1: When the same malfunction is detected in two consecutive trips, MIL will light up.

*2: MIL will go off after vehicle is driven 3 times (pattern B) without any malfunctions.

*3: When the same malfunction is detected in two consecutive trips, the DTC and the freeze frame data will be stored in ECM.

*4: The DTC and the freeze frame data will not be displayed any longer after vehicle is driven 80 times (pattern C) without the same malfunction. (The DTC and the freeze frame data still remain in ECM.)

*5: When a malfunction is detected for the first time, the 1st trip DTC and the 1st trip freeze frame data will be stored in ECM.

*6: The 1st trip DTC and the 1st trip freeze frame data will be cleared at the moment OK is detected.

*7: When the same malfunction is detected in the 2nd trip, the 1st trip freeze frame data will be cleared.

*8: 1st trip DTC will be cleared when vehicle is driven once (pattern C) without the same malfunction after DTC is stored in ECM.

EXPLANATION FOR DRIVING PATTERNS FOR “MISFIRE <EXHAUST QUALITY DETERIORATION>”, “FUEL INJECTION SYSTEM”

<Driving Pattern B>

Driving pattern B means the vehicle operation as follows:

All components and systems should be monitored at least once by the OBD system.

- The B counter will be cleared when the malfunction is detected once regardless of the driving pattern.
- The B counter will be counted up when driving pattern B is satisfied without any malfunction.
- The MIL will go off when the B counter reaches 3. (*2 in “OBD SYSTEM OPERATION CHART”)

<Driving Pattern C>

Driving pattern C means the vehicle operation as follows:

The following conditions should be satisfied at the same time:

Engine speed: (Engine speed in the freeze frame data) ± 375 rpm

Calculated load value: (Calculated load value in the freeze frame data) $\times (1 \pm 0.1)$ [%]

Engine coolant temperature (T) condition:

- When the freeze frame data shows lower than 70°C (158°F), “T” should be lower than 70°C (158°F).
- When the freeze frame data shows higher than or equal to 70°C (158°F), “T” should be higher than or equal to 70°C (158°F).

Example:

If the stored freeze frame data is as follows:

Engine speed: 850 rpm, Calculated load value: 30%, Engine coolant temperature: 80°C (176°F)

To be satisfied with driving pattern C, the vehicle should run under the following conditions:

Engine speed: 475 - 1,225 rpm, Calculated load value: 27 - 33%, Engine coolant temperature: more than 70°C (158°F)

- The C counter will be cleared when the malfunction is detected regardless of vehicle conditions above.
- The C counter will be counted up when vehicle conditions above is satisfied without the same malfunction.
- The DTC will not be displayed after C counter reaches 80.
- The 1st trip DTC will be cleared when C counter is counted once without the same malfunction after DTC is stored in ECM.

RELATIONSHIP BETWEEN MIL, DTC, 1ST TRIP DTC AND DRIVING PATTERNS EXCEPT FOR "MISFIRE <EXHAUST QUALITY DETERIORATION>", "FUEL INJECTION SYSTEM"

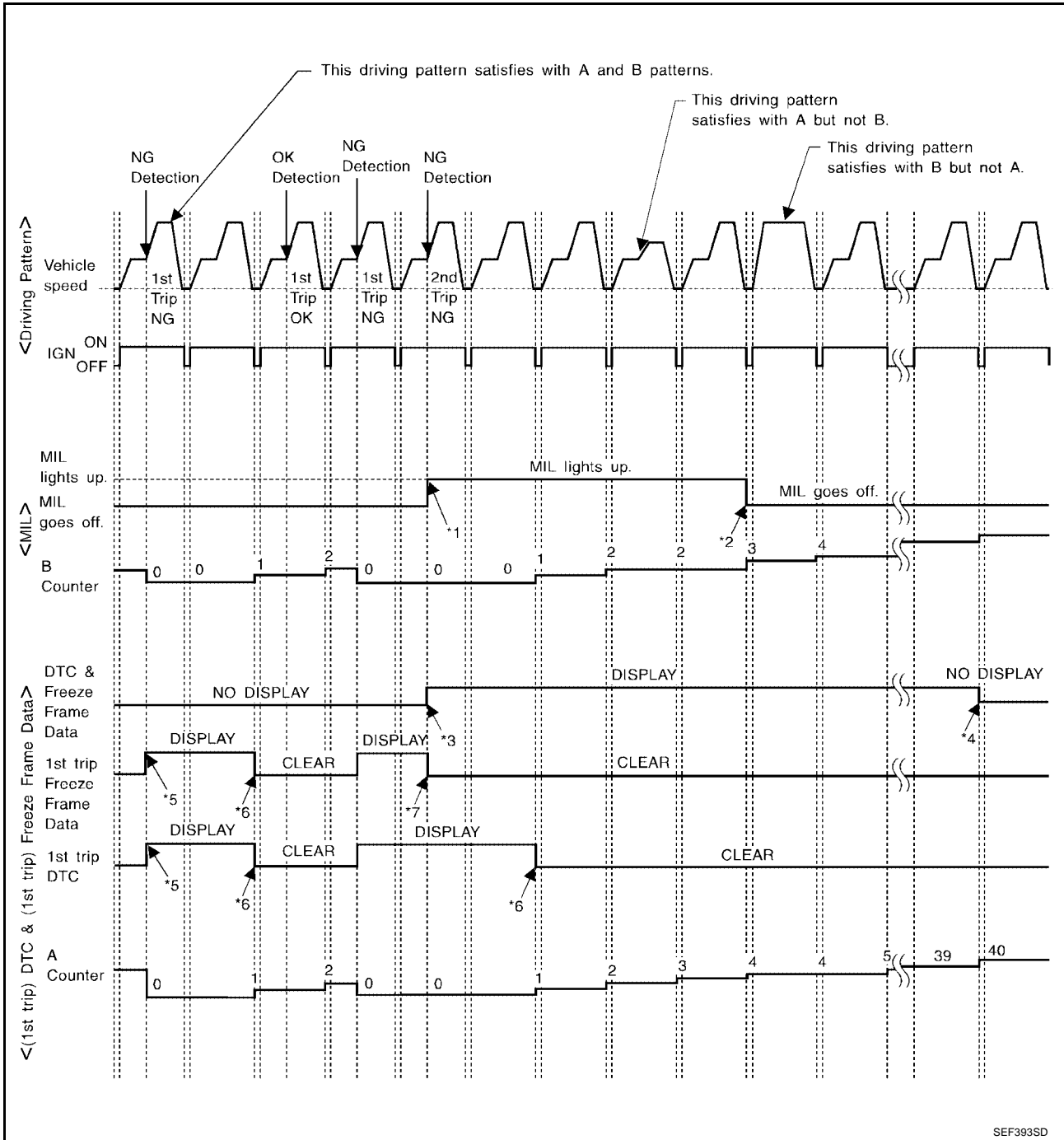

*1: When the same malfunction is detected in two consecutive trips, MIL will light up.

*2: MIL will go off after vehicle is driven 3 times (pattern B) without any malfunctions.

*3: When the same malfunction is detected in two consecutive trips, the DTC and the freeze frame data will be stored in ECM.

*4: The DTC and the freeze frame data will not be displayed any longer after vehicle is driven 40 times (pattern A) without the same malfunction. (The DTC and the freeze frame data still remain in ECM.)

*5: When a malfunction is detected for the first time, the 1st trip DTC and the 1st trip freeze frame data will be stored in ECM.

*6: 1st trip DTC will be cleared after vehicle is driven once (pattern B) without the same malfunction.

*7: When the same malfunction is detected in the 2nd trip, the 1st trip freeze frame data will be cleared.

EXPLANATION FOR DRIVING PATTERNS EXCEPT FOR "MISFIRE <EXHAUST QUALITY DETERIORATION>", "FUEL INJECTION SYSTEM"

<Driving Pattern A>

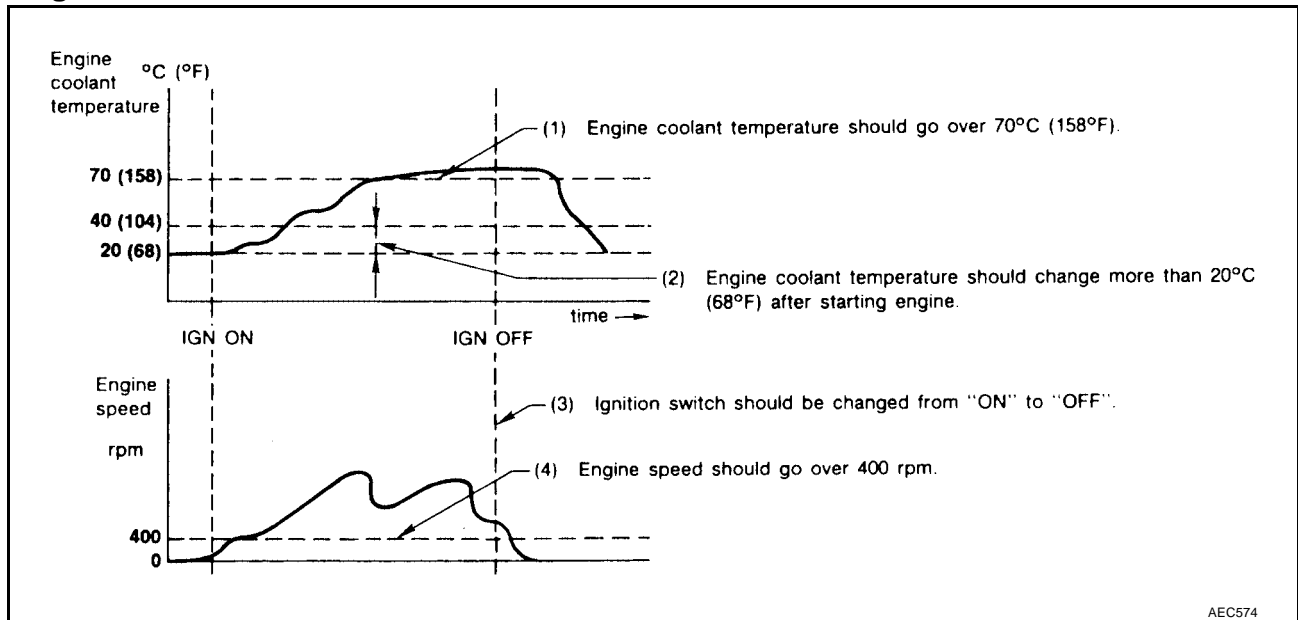

- The A counter will be cleared when the malfunction is detected regardless of (1) - (4).
- The A counter will be counted up when (1) - (4) are satisfied without the same malfunction.
- The DTC will not be displayed after the A counter reaches 40.

<Driving Pattern B>

Driving pattern B means the vehicle operation as follows:

All components and systems should be monitored at least once by the OBD system.

- The B counter will be cleared when the malfunction is detected once regardless of the driving pattern.
- The B counter will be counted up when driving pattern B is satisfied without any malfunctions.
- The MIL will go off when the B counter reaches 3 (*2 in "OBD SYSTEM OPERATION CHART").

BASIC SERVICE PROCEDURE

Basic Inspection

1. INSPECTION START

1. Check service records for any recent repairs that may indicate a related malfunction, or a current need for scheduled maintenance.
2. Open engine hood and check the following:
 - Harness connectors for improper connections
 - Wiring harness for improper connections, pinches and cut
 - Vacuum hoses for splits, kinks and improper connections
 - Hoses and ducts for leaks
 - Air cleaner clogging
 - Gasket
3. Confirm that electrical or mechanical loads are not applied.
 - Headlamp switch is OFF.
 - Air conditioner switch is OFF.
 - Rear window defogger switch is OFF.
 - Steering wheel is in the straight-ahead position, etc.
4. Start engine and warm it up until engine coolant temperature indicator points the middle of gauge. Ensure engine stays below 1,000 rpm.

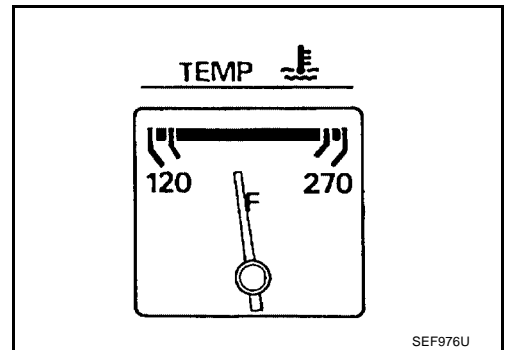
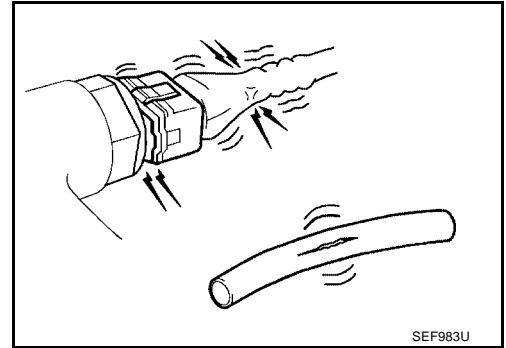

5. Run engine at about 2,000 rpm for about 2 minutes under no-load.
6. Make sure that no DTC is displayed with CONSULT-II or GST.

OK or NG

- OK >> GO TO 3.
 NG >> GO TO 2.

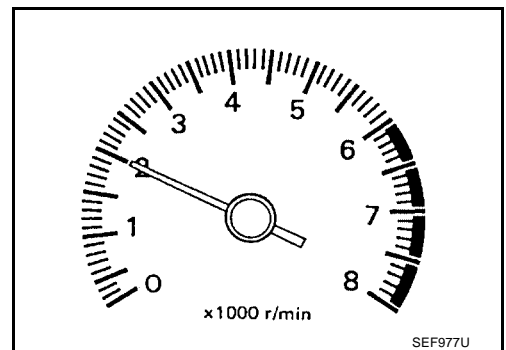

2. REPAIR OR REPLACE

Repair or replace components as necessary according to corresponding Diagnostic Procedure.

>> GO TO 3.

3. CHECK TARGET IDLE SPEED

Ⓟ With CONSULT-II

1. Run engine at about 2,000 rpm for about 2 minutes under no-load.
2. Rev engine (2,000 to 3,000 rpm) two or three times under no-load, then run engine at idle speed for about 1 minute.

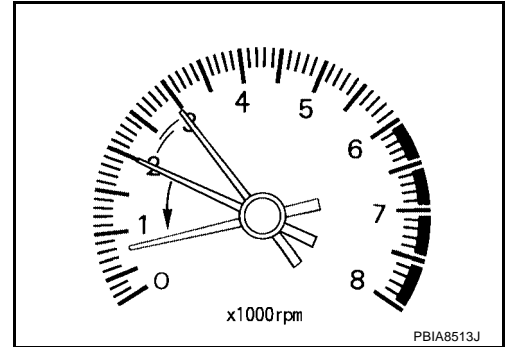

3. Read idle speed in "DATA MONITOR" mode with CONSULT-II. Refer to [EC-80](#).

M/T: 700 ± 50 rpm (in Neutral position)
A/T: 700 ± 50 rpm (in P or N position)

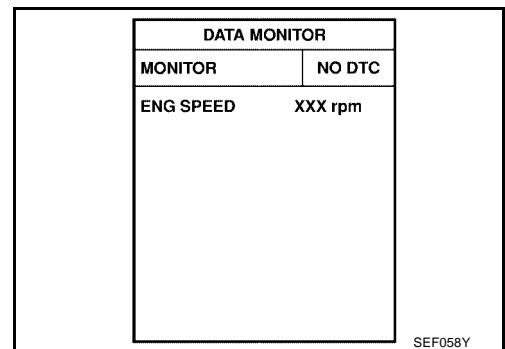

ⓧ Without CONSULT-II

1. Run engine at about 2,000 rpm for about 2 minutes under no-load.
2. Rev engine (2,000 to 3,000 rpm) two or three times under no-load, then run engine at idle speed for about 1 minute.
3. Check idle speed. Refer to [EC-80](#).

M/T: 700 ± 50 rpm (in Neutral position)
A/T: 700 ± 50 rpm (in P or N position)

OK or NG

- OK >> GO TO 10.
- NG >> GO TO 4.

4. PERFORM ACCELERATOR PEDAL RELEASED POSITION LEARNING

1. Stop engine.
2. Perform [EC-93, "Accelerator Pedal Released Position Learning"](#).

>> GO TO 5.

5. PERFORM THROTTLE VALVE CLOSED POSITION LEARNING

Perform [EC-93, "Throttle Valve Closed Position Learning"](#).

>> GO TO 6.

6. PERFORM IDLE AIR VOLUME LEARNING

Refer to [EC-93, "Idle Air Volume Learning"](#) .

Is Idle Air Volume Learning carried out successfully?

Yes or No

- Yes >> GO TO 7.
- No >> 1. Follow the instruction of Idle Air Volume Learning.
2. GO TO 4.

7. CHECK TARGET IDLE SPEED AGAIN

Ⓜ With CONSULT-II

1. Start engine and warm it up to normal operating temperature.
2. Read idle speed in "DATA MONITOR" mode with CONSULT-II. Refer to [EC-80](#) .

M/T: 700 ± 50 rpm (in Neutral position)

A/T: 700 ± 50 rpm (in P or N position)

ⓧ Without CONSULT-II

1. Start engine and warm it up to normal operating temperature.
2. Check idle speed. Refer to [EC-80](#) .

M/T: 700 ± 50 rpm (in Neutral position)

A/T: 700 ± 50 rpm (in P or N position)

DATA MONITOR	
MONITOR	NO DTC
ENG SPEED	XXX rpm
COOLAN TEMP/S	XXX °C

SEF174Y

OK or NG

- OK >> GO TO 10.
- NG >> GO TO 8.

8. DETECT MALFUNCTIONING PART

Check the following.

- Check camshaft position sensor (PHASE) and circuit. Refer to [EC-280](#) .
- Check crankshaft position sensor (POS) and circuit. Refer to [EC-273](#) .

OK or NG

- OK >> GO TO 9.
- NG >> 1. Repair or replace.
2. GO TO 4.

9. CHECK ECM FUNCTION

1. Substitute another known-good ECM to check ECM function. (ECM may be the cause of an incident, but this is a rare case.)
2. Perform initialization of NVIS (NATS) system and registration of all NVIS (NATS) ignition key IDs. Refer to [BL-107, "NVIS\(NISSAN Vehicle Immobilizer System-NATS\)"](#) .

>> GO TO 4.

10. CHECK IGNITION TIMING

1. Run engine at idle.
2. Check ignition timing with a timing light. Refer to [EC-80](#) .

M/T: 15 ± 5° BTDC (in Neutral position)
A/T: 15 ± 5° BTDC (in P or N position)

OK or NG

- OK >> GO TO 19.
 NG >> GO TO 11.

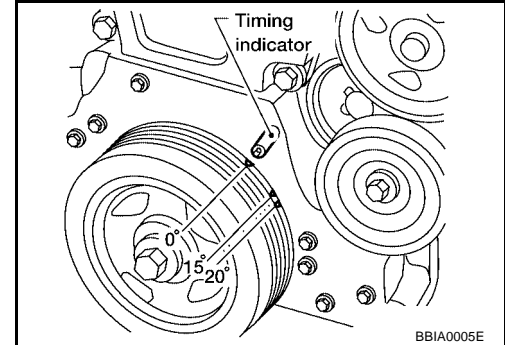

11. PERFORM ACCELERATOR PEDAL RELEASED POSITION LEARNING

1. Stop engine.
2. Perform [EC-93, "Accelerator Pedal Released Position Learning"](#) .

>> GO TO 12.

12. PERFORM THROTTLE VALVE CLOSED POSITION LEARNING

Perform [EC-93, "Throttle Valve Closed Position Learning"](#) .

>> GO TO 13.

13. PERFORM IDLE AIR VOLUME LEARNING

Refer to [EC-93, "Idle Air Volume Learning"](#) .

Is Idle Air Volume Learning carried out successfully?

Yes or No

- Yes >> GO TO 14.
 No >> 1. Follow the instruction of Idle Air Volume Learning.
 2. GO TO 4.

14. CHECK TARGET IDLE SPEED AGAIN

With CONSULT-II

1. Start engine and warm it up to normal operating temperature.
2. Read idle speed in "DATA MONITOR" mode with CONSULT-II. Refer to [EC-80](#) .

M/T: 700 ± 50 rpm (in Neutral position)
A/T: 700 ± 50 rpm (in P or N position)

Without CONSULT-II

1. Start engine and warm it up to normal operating temperature.
2. Check idle speed. Refer to [EC-80](#) .

M/T: 700 ± 50 rpm (in Neutral position)
A/T: 700 ± 50 rpm (in P or N position)

OK or NG

- OK >> GO TO 15.
 NG >> GO TO 17.

DATA MONITOR	
MONITOR	NO DTC
ENG SPEED	XXX rpm
COOLAN TEMP/S	XXX °C

SEF174Y

15. CHECK IGNITION TIMING AGAIN

1. Run engine at idle.
2. Check ignition timing with a timing light. Refer to [EC-80](#).

M/T: $15 \pm 5^\circ$ BTDC (in Neutral position)
A/T: $15 \pm 5^\circ$ BTDC (in P or N position)

OK or NG

- OK >> GO TO 19
 NG >> GO TO 16.

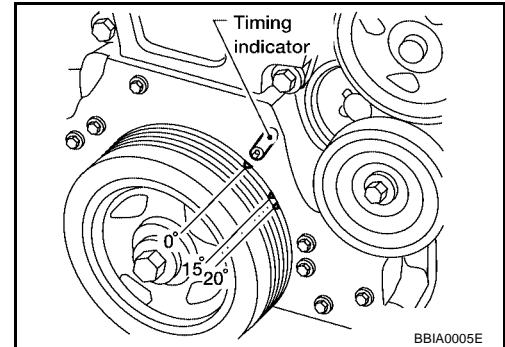

16. CHECK TIMING CHAIN INSTALLATION

Check timing chain installation. Refer to [EM-48, "TIMING CHAIN"](#).

OK or NG

- OK >> GO TO 17.
 NG >> 1. Repair the timing chain installation.
 2. GO TO 4.

17. DETECT MALFUNCTIONING PART

Check the following.

- Check camshaft position sensor (PHASE) and circuit. Refer to [EC-280](#).
- Check crankshaft position sensor (POS) and circuit. Refer to [EC-273](#).

OK or NG

- OK >> GO TO 18.
 NG >> 1. Repair or replace.
 2. GO TO 4.

18. CHECK ECM FUNCTION

1. Substitute another known-good ECM to check ECM function. (ECM may be the cause of an incident, but this is a rare case.)
2. Perform initialization of NVIS (NATS) system and registration of all NVIS (NATS) ignition key IDs. Refer to [BL-107, "NVIS\(NISSAN Vehicle Immobilizer System-NATS\)"](#).

>> GO TO 4.

19. INSPECTION END

Did you replace ECM, referring this Basic Inspection procedure?

Yes or No

- Yes >> 1. Perform [EC-92, "VIN Registration"](#).
 2. **INSPECTION END**
 No >> **INSPECTION END**

Idle Speed and Ignition Timing Check IDLE SPEED

With CONSULT-II

Check idle speed in "DATA MONITOR" mode with CONSULT-II.

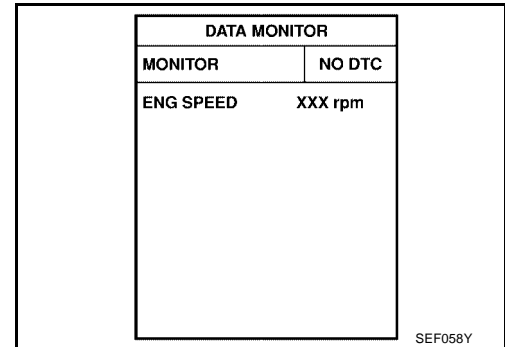

With GST

Check idle speed in "Service \$01" with GST.

IGNITION TIMING

Any of following two methods may be used.

Method A

1. Slide the harness protector off the ignition coil No.1 to clear the wires.
2. Attach timing light to the wires.
3. Check ignition timing.

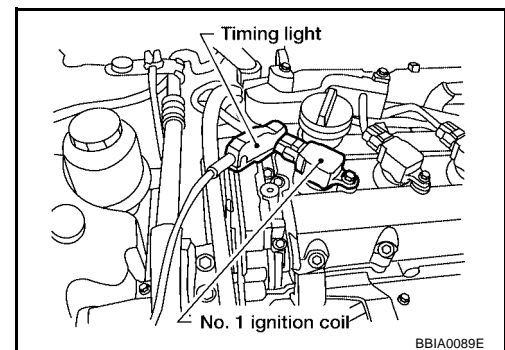

Method B

1. Remove No. 1 ignition coil.

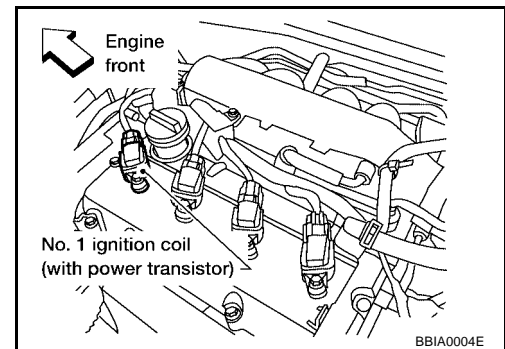

2. Connect No. 1 ignition coil and No. 1 spark plug with suitable high-tension wire as shown, and attach timing light clamp to this wire.

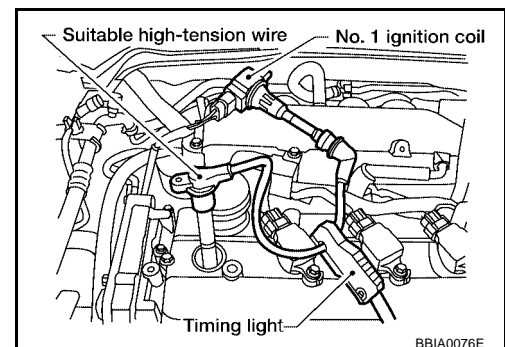

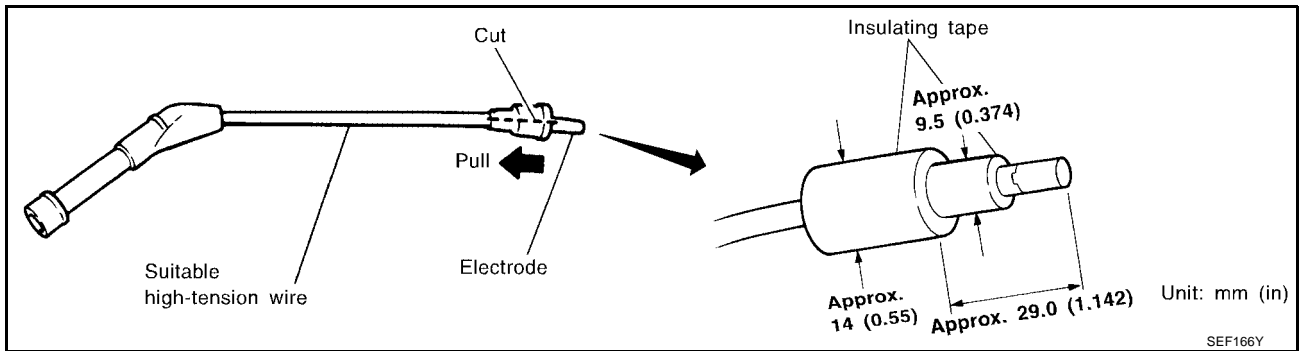

3. Check ignition timing.

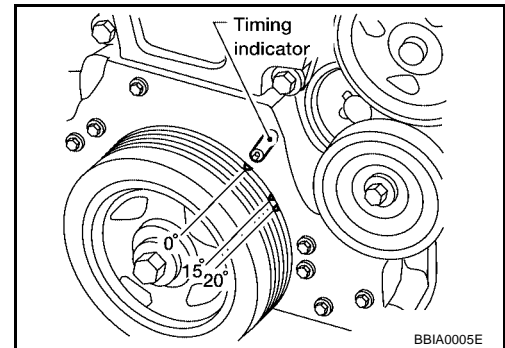

Idle Mixture Ratio Adjustment PREPARATION

UBS00208

1. Make sure that the following parts are in good order.
 - Battery
 - Ignition system
 - Engine oil and coolant levels
 - Fuses
 - ECM harness connector
 - Vacuum hoses
 - Air intake system
(Oil filler cap, oil level gauge, etc.)
 - Fuel pressure
 - Engine compression
 - Throttle valve
 - Evaporative emission system
2. On air conditioner equipped models, checks should be carried out while the air conditioner is OFF.
3. On automatic transmission equipped models, when checking idle rpm, ignition timing and mixture ratio, checks should be carried out while shift lever is in N position.
4. When measuring CO percentage, insert probe more than 40 cm (15.7 in) into tail pipe.
5. Turn off headlamps, heater blower, rear window defogger.
6. Keep front wheels pointed straight ahead.

OVERALL SEQUENCE

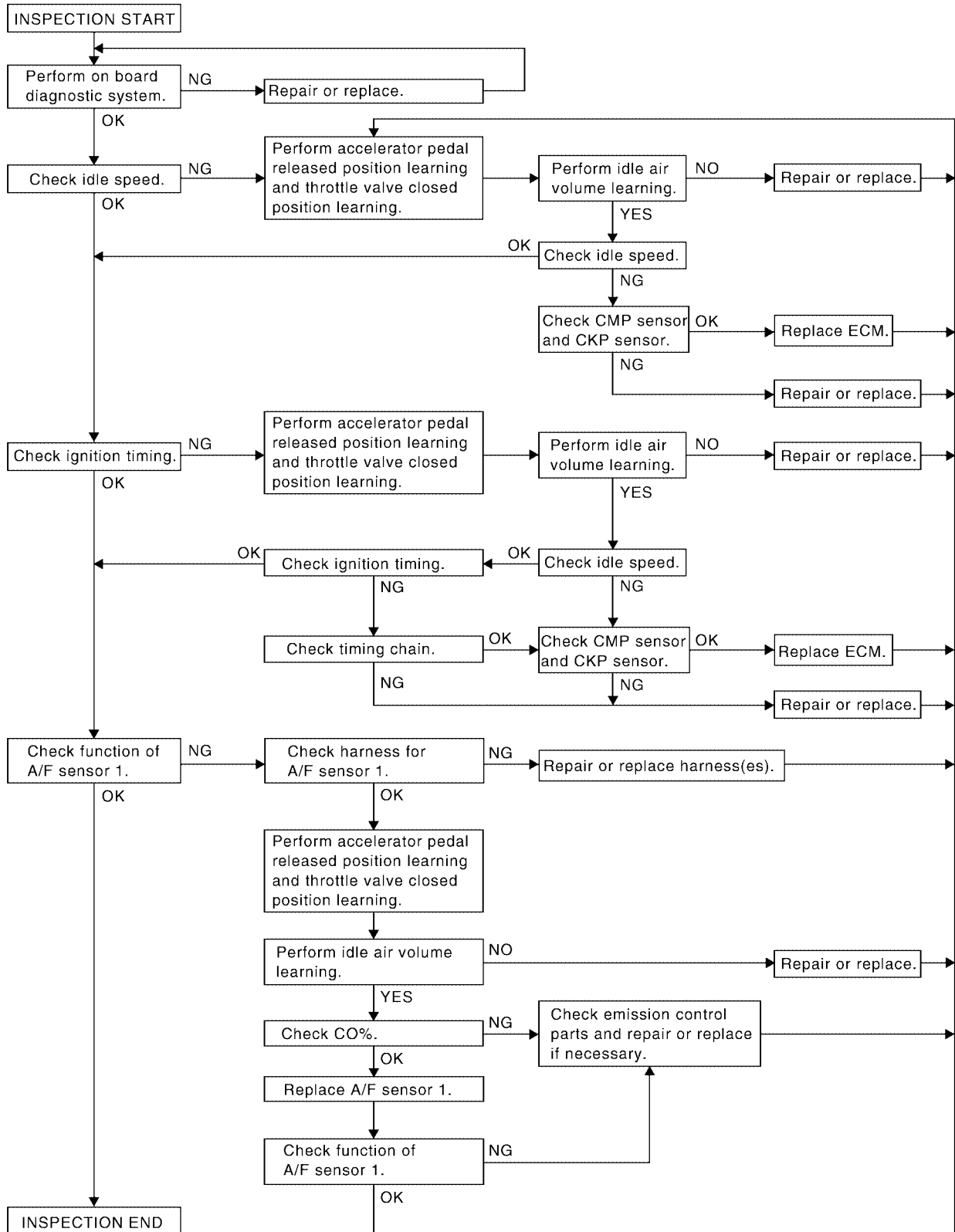

NOTE:

If a vehicle contains a part which is operating outside of design specifications with no MIL illumination, the part shall not be replaced prior to emission testing unless it is determined that the part has been tampered with or abused in such a way that the diagnostic system cannot reasonably be expected to detect the resulting malfunction.

DETAILED PROCEDURE

1. INSPECTION START

1. Check service records for any recent repairs that may indicate a related malfunction, or a current need for scheduled maintenance.
2. Open engine hood and check the following:
 - Harness connectors for improper connections
 - Wiring harness for improper connections, pinches and cut
 - Vacuum hoses for splits, kinks and improper connections
 - Hoses and ducts for leaks
 - Air cleaner clogging
 - Gasket
3. Confirm that electrical or mechanical loads are not applied.
 - Headlamp switch is OFF.
 - Air conditioner switch is OFF.
 - Rear window defogger switch is OFF.
 - Steering wheel is in the straight-ahead position, etc.
4. Start engine and warm it up until engine coolant temperature indicator points the middle of gauge. Ensure engine stays below 1,000 rpm.

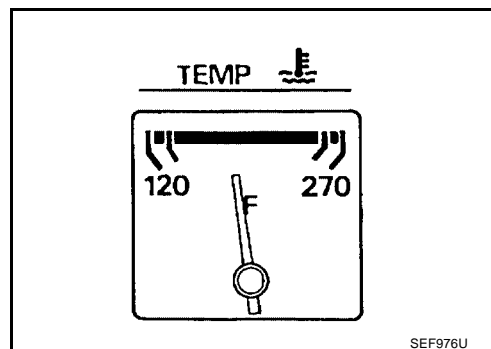
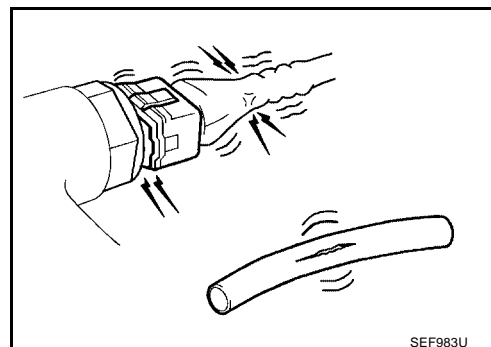

5. Run engine at about 2,000 rpm for about 2 minutes under no-load.
6. Make sure that no DTC is displayed with CONSULT-II or GST.

OK or NG

- OK >> GO TO 3.
- NG >> GO TO 2.

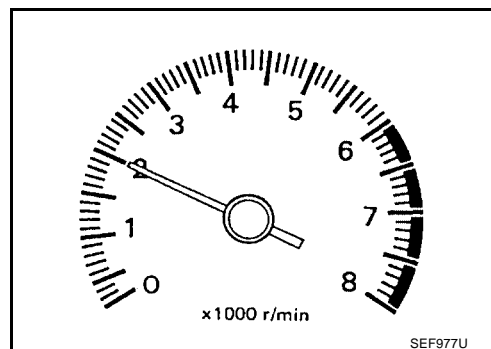

2. REPAIR OR REPLACE

Repair or replace components as necessary according to corresponding Diagnostic Procedure.

>> GO TO 3.

A
EC
C
D
E
F
G
H
I
J
K
L
M

3. CHECK TARGET IDLE SPEED

With CONSULT-II

1. Run engine at about 2,000 rpm for about 2 minutes under no-load.
2. Rev engine (2,000 to 3,000 rpm) two or three times under no-load, then run engine at idle speed for about 1 minute.

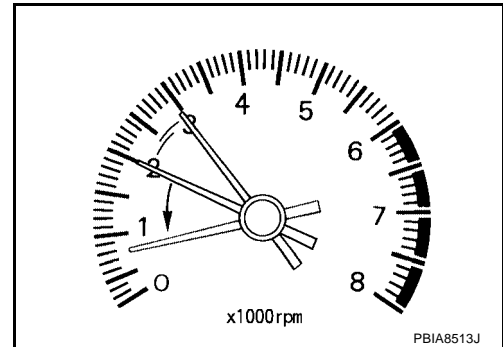

3. Read idle speed in "DATA MONITOR" mode with CONSULT-II. Refer to [EC-80](#).

M/T: 700 ± 50 rpm (in Neutral position)

A/T: 700 ± 50 rpm (in P or N position)

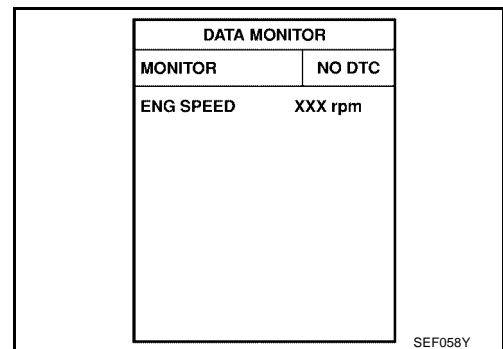

Without CONSULT-II

1. Run engine at about 2,000 rpm for about 2 minutes under no-load.
2. Rev engine (2,000 to 3,000 rpm) two or three times under no-load, then run engine at idle speed for about 1 minute.
3. Check idle speed. Refer to [EC-80](#).

M/T: 700 ± 50 rpm (in Neutral position)

A/T: 700 ± 50 rpm (in P or N position)

OK or NG

- OK >> GO TO 10.
- NG >> GO TO 4.

4. PERFORM ACCELERATOR PEDAL RELEASED POSITION LEARNING

1. Stop engine.
2. Perform [EC-93, "Accelerator Pedal Released Position Learning"](#).

>> GO TO 5.

5. PERFORM THROTTLE VALVE CLOSED POSITION LEARNING

Perform [EC-93, "Throttle Valve Closed Position Learning"](#).

>> GO TO 6.

6. PERFORM IDLE AIR VOLUME LEARNING

Perform [EC-93, "Idle Air Volume Learning"](#) .

Is Idle Air Volume Learning carried out successfully?

Yes or No

Yes >> GO TO 7.

No >> 1. Follow the instruction of Idle Air Volume Learning.

2. GO TO 4.

7. CHECK TARGET IDLE SPEED AGAIN**Ⓔ With CONSULT-II**

1. Start engine and warm it up to normal operating temperature.
2. Read idle speed in "DATA MONITOR" mode with CONSULT-II. Refer to [EC-80](#)

M/T: 700 ± 50 rpm (in Neutral position)

A/T: 700 ± 50 rpm (in P or N position)

ⓧ Without CONSULT-II

1. Start engine and warm it up to normal operating temperature.
2. Check idle speed. Refer to [EC-80](#) .

M/T: 700 ± 50 rpm (in Neutral position)

A/T: 700 ± 50 rpm (in P or N position)

OK or NG

OK >> GO TO 10.

NG >> GO TO 8.

8. DETECT MALFUNCTIONING PART

Check the following.

- Check camshaft position sensor (PHASE) and circuit. Refer to [EC-280](#) .
- Check crankshaft position sensor (POS) and circuit. Refer to [EC-273](#) .

OK or NG

OK >> GO TO 9.

NG >> 1. Repair or replace.

2. GO TO 4.

9. CHECK ECM FUNCTION

1. Substitute another known-good ECM to check ECM function. (ECM may be the cause of an incident, but this is a rare case.)
2. Perform initialization of NVIS (NATS) system and registration of all NVIS (NATS) ignition key IDs. Refer to [BL-107, "NVIS\(NISSAN Vehicle Immobilizer System-NATS\)"](#) .

>> GO TO 4.

10. CHECK IGNITION TIMING

1. Run engine at idle.
2. Check ignition timing with a timing light. Refer to [EC-80](#)

M/T: $15 \pm 5^\circ$ BTDC (in Neutral position)

A/T: $15 \pm 5^\circ$ BTDC (in P or N position)

OK or NG

- OK (With CONSULT-II)>>GO TO 19.
 OK (Without CONSULT-II)>>GO TO 20.
 NG >> GO TO 11.

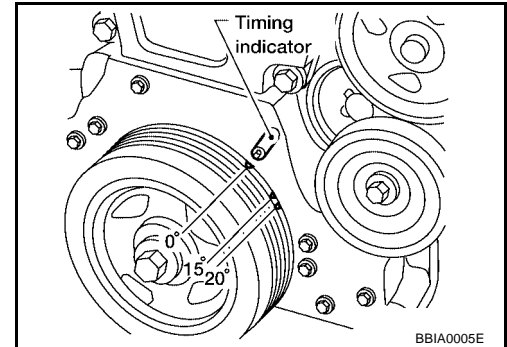

11. PERFORM ACCELERATOR PEDAL RELEASED POSITION LEARNING

1. Stop engine.
2. Perform [EC-93, "Accelerator Pedal Released Position Learning"](#) .

>> GO TO 12.

12. PERFORM THROTTLE VALVE CLOSED POSITION LEARNING

Perform [EC-93, "Throttle Valve Closed Position Learning"](#) .

>> GO TO 13.

13. PERFORM IDLE AIR VOLUME LEARNING

Perform [EC-93, "Idle Air Volume Learning"](#) .

Is Idle Air Volume Learning carried out successfully?

Yes or No

- Yes >> GO TO 14.
 No >> 1. Follow the instruction of Idle Air Volume Learning.
 2. GO TO 4.

14. CHECK TARGET IDLE SPEED AGAIN

With CONSULT-II

1. Start engine and warm it up to normal operating temperature.
2. Read idle speed in "DATA MONITOR" mode with CONSULT-II. Refer to [EC-80](#) .

M/T: 700 ± 50 rpm (in Neutral position)

A/T: 700 ± 50 rpm (in P or N position)

Without CONSULT-II

1. Start engine and warm it up to normal operating temperature.
2. Check idle speed. Refer to [EC-80](#) .

M/T: 700 ± 50 rpm (in Neutral position)

A/T: 700 ± 50 rpm (in P or N position)

OK or NG

- OK >> GO TO 15.
 NG >> GO TO 17.

15. CHECK IGNITION TIMING AGAIN

1. Run engine at idle.
2. Check ignition timing with a timing light. Refer to [EC-80](#).

M/T: $15 \pm 5^\circ$ BTDC (in Neutral position)

A/T: $15 \pm 5^\circ$ BTDC (in P or N position)

OK or NG

OK (With CONSULT-II)>>GO TO 19.

OK (With GST)>>GO TO 20.

NG >> GO TO 16.

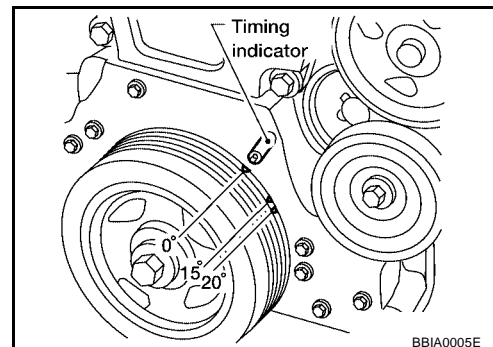

16. CHECK TIMING CHAIN INSTALLATION

Check timing chain installation. Refer to [EM-48, "TIMING CHAIN"](#).

OK or NG

OK >> GO TO 17.

NG >> 1. Repair the timing chain installation.

2. GO TO 4.

17. DETECT MALFUNCTIONING PART

Check the following.

- Check camshaft position sensor (PHASE) and circuit. Refer to [EC-280](#).
- Check crankshaft position sensor (POS) and circuit. Refer to [EC-273](#).

OK or NG

OK >> GO TO 18.

NG >> 1. Repair or replace.

2. GO TO 4.

18. CHECK ECM FUNCTION

1. Substitute another known-good ECM to check ECM function. (ECM may be the cause of an incident, but this is a rare case.)
2. Perform initialization of NVIS (NATS) system and registration of all NVIS (NATS) ignition key IDs. Refer to [BL-107, "NVIS\(NISSAN Vehicle Immobilizer System-NATS\)"](#).

>> GO TO 4.

19. CHECK AIR FUEL RATIO (A/F) SENSOR 1 FUNCTION

 **With CONSULT-II**

1. Turn ignition switch OFF and wait at a least 10 seconds.
2. Start engine and warm it up to normal operating temperature.
3. Drive the vehicle at a speed of 80 km/h (50 MPH) for a few minutes in D position with OD OFF (A/T models) or 4th position (M/T models).

NOTE:

Keep the accelerator pedal as steady as possible during the cruising.

4. Set OD ON, then release the accelerator pedal fully until the vehicle speed decreases to 50 km/h (30 MPH).

NOTE:

Never apply brake during releasing the accelerator pedal.

5. Repeat steps 3 to 4 for five times.
6. Stop the vehicle and connect CONSULT-II to the vehicle.
7. Make sure that no (1st trip) DTC is displayed in "SELF-DIAG RESULTS" mode.

OK or NG

OK >> **INSPECTION END**
 NG >> GO TO 21.

20. CHECK AIR FUEL RATIO (A/F) SENSOR 1 FUNCTION

 **With GST**

1. Turn ignition switch OFF and wait at a least 10 seconds.
2. Start engine and warm it up to normal operating temperature.
3. Drive the vehicle at a speed of 80 km/h (50 MPH) for a few minutes in D position with OD OFF (A/T models) or 4th position (M/T models).

NOTE:

Keep the accelerator pedal as steady as possible during the cruising.

4. Set OD ON, then release the accelerator pedal fully until the vehicle speed decreases to 50 km/h (30 MPH).

NOTE:

Never apply brake during releasing the accelerator pedal.

5. Repeat steps 3 to 4 for five times.
6. Stop the vehicle and connect GST to the vehicle.
7. Make sure that no (1st trip) DTC is displayed.

OK or NG

OK >> **INSPECTION END**
 NG >> GO TO 21.

21. CHECK AIR FUEL RATIO (A/F) SENSOR 1 HARNESS

1. Turn ignition switch OFF and disconnect battery ground cable.
2. Disconnect ECM harness connector.
3. Disconnect A/F sensor 1 harness connector.
4. Check harness continuity between the following terminals. Refer to [EC-445, "Wiring Diagram"](#) .

A/F sensor 1 terminal	ECM terminal
4	2
1	16
5	35
6	56
2	75

Continuity should exist.

5. Also check harness for short to ground and short to power.

OK or NG

OK >> GO TO 22.

- NG >> 1. Repair open circuit or short to ground or short to power in harness or connectors between ECM and A/F sensor 1.
 2. GO TO 4.

22. PERFORM ACCELERATOR PEDAL RELEASED POSITION LEARNING

1. Reconnect ECM harness connector.
2. Perform [EC-93, "Accelerator Pedal Released Position Learning"](#) .

>> GO TO 23.

23. PERFORM THROTTLE VALVE CLOSED POSITION LEARNING

Perform [EC-93, "Throttle Valve Closed Position Learning"](#) .

>> GO TO 24.

24. PERFORM IDLE AIR VOLUME LEARNING

Refer to [EC-93, "Idle Air Volume Learning"](#) .

Is Idle Air Volume Learning carried out successfully?

Yes or No

Yes (With CONSULT-II)>>GO TO 25.

Yes (Without CONSULT-II)>>GO TO 26.

- No >> 1. Follow the instruction of Idle Air Volume Learning.
 2. GO TO 4.

25. CHECK CO%

With CONSULT-II

1. Start engine and warm it up until engine coolant temperature indicator points the middle of gauge.
2. Turn ignition switch OFF, wait at least 10 seconds and then turn ON.
3. Select "ENG COOLANT TEMP" in "ACTIVE TEST" mode.
4. Set "ENG COOLANT TEMP" to 5°C (41°F) by touching "DWN" and "Qd".
5. Start engine and rev it (2,000 to 3,000 rpm) two or three times under no load, then run engine at idle speed.
6. Check CO%.

Idle CO: 0.3 – 9.5% and engine runs smoothly.

OK or NG

- OK >> GO TO 28.
 NG >> GO TO 27.

ACTIVE TEST	
ENG COOLANT TEMP	XXX °C
MONITOR	
ENG SPEED	XXX rpm
INJ PULSE-B1	XXX msec
IGN TIMING	XXX BTDC

SEF172Y

26. CHECK CO%

Without CONSULT-II

1. Start engine and warm it up until engine coolant temperature indicator points to the middle of gauge.
2. Turn ignition switch OFF.
3. Disconnect engine coolant temperature sensor harness connector.
4. Connect a resistor (4.4 kΩ) between terminals of engine coolant temperature sensor harness connector.
5. Start engine and rev it (2,000 to 3,000 rpm) two or three times under no load, then run engine at idle speed.
6. Check CO%.

Idle CO: 0.3 – 9.5% and engine runs smoothly.

7. After checking CO%, turn ignition switch OFF, disconnect the resistor from the terminals of engine coolant temperature sensor harness connector, and then connect engine coolant temperature sensor harness connector to engine coolant temperature sensor.

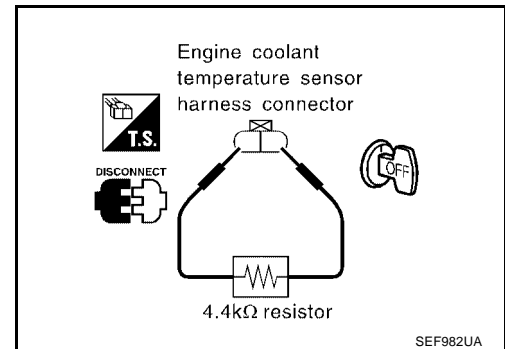

OK or NG

- OK >> GO TO 28.
 NG >> GO TO 27.

27. RECONNECT AIR FUEL RATIO (A/F) SENSOR 1 HARNESS CONNECTOR

1. Turn ignition switch OFF.
2. Reconnect A/F sensor 1 harness connector.

>> GO TO 31.

28. REPLACE AIR FUEL RATIO (A/F) SENSOR 1

1. Stop engine.
2. Replace A/F sensor 1.

With CONSULT-II>>GO TO 29.
 Without CONSULT-II>>GO TO 30.

29. CHECK AIR FUEL RATIO (A/F) SENSOR 1 FUNCTION

 **With CONSULT-II**

1. Turn ignition switch OFF and wait at a least 10 seconds.
2. Start engine and warm it up to normal operating temperature.
3. Drive the vehicle at a speed of 80 km/h (50 MPH) for a few minutes in D position with OD OFF (A/T models) or 4th position (M/T models).

NOTE:

Keep the accelerator pedal as steady as possible during the cruising.

4. Set OD ON, then release the accelerator pedal fully until the vehicle speed decreases to 50 km/h (30 MPH).

NOTE:

Never apply brake during releasing the accelerator pedal.

5. Repeat steps 3 to 4 for five times.
6. Stop the vehicle and connect CONSULT-II to the vehicle.
7. Make sure that no (1st trip) DTC is displayed in "SELF-DIAG RESULTS" mode.

OK or NG

- OK >> GO TO 4.
- NG >> GO TO 31.

30. CHECK AIR FUEL RATIO (A/F) SENSOR 1 FUNCTION

 **With GST**

1. Turn ignition switch OFF and wait at a least 10 seconds.
2. Start engine and warm it up to normal operating temperature.
3. Drive the vehicle at a speed of 80 km/h (50 MPH) for a few minutes in D position with OD OFF (A/T models) or 4th position (M/T models).

NOTE:

Keep the accelerator pedal as steady as possible during the cruising.

4. Set OD ON, then release the accelerator pedal fully until the vehicle speed decreases to 50 km/h (30 MPH).

NOTE:

Never apply brake during releasing the accelerator pedal.

5. Repeat steps 3 to 4 for five times.
6. Stop the vehicle and connect GST to the vehicle.
7. Make sure that no (1st trip) DTC is displayed.

OK or NG

- OK >> GO TO 4.
- NG >> GO TO 31.

A
EC
C
D
E
F
G
H
I
J
K
L
M

31. DETECT MALFUNCTIONING PART

Check the following.

- Check fuel pressure regulator, and repair or replace if necessary.
Refer to [EC-95, "Fuel Pressure Check"](#)
- Check mass air flow sensor and its circuit, and repair or replace if necessary.
Refer to [EC-178, "DTC P0101 MAF SENSOR"](#) and [EC-187, "DTC P0102, P0103 MAF SENSOR"](#) .
- Check injector and its circuit, and repair or replace if necessary.
Refer to [EC-592, "INJECTOR CIRCUIT"](#) .
- Check engine coolant temperature sensor and its circuit, and repair or replace if necessary.
Refer to [EC-199, "DTC P0117, P0118 ECT SENSOR"](#) and [EC-211, "DTC P0125 ECT SENSOR"](#) .

OK or NG

- OK >> GO TO 33.
- NG >> 1. Repair or replace.
2. GO TO 32.

32. ERASE UNNECESSARY DTC

After this inspection, unnecessary DTC might be displayed.

Erase the stored memory in ECM and TCM.

Refer to [AT-41, "HOW TO ERASE DTC"](#) and [EC-65, "HOW TO ERASE EMISSION-RELATED DIAGNOSTIC INFORMATION"](#) .

>> GO TO 4.

33. CHECK ECM FUNCTION

1. Substitute another known-good ECM to check ECM function. (ECM may be the cause of an incident, but this is a rare case.)
2. Perform initialization of NVIS (NATS) system and registration of all NVIS (NATS) ignition key IDs.
Refer to [BL-107, "NVIS\(NISSAN Vehicle Immobilizer System-NATS\)"](#) .

>> GO TO 4.

VIN Registration DESCRIPTION

UBS00IU

VIN Registration is an operation to registering VIN in ECM. It must be performed each time ECM is replaced.

NOTE:

Accurate VIN which is registered in ECM may be required for Inspection & Maintenance (I/M).

OPERATION PROCEDURE

With CONSULT-II

1. Check the VIN of the vehicle and note it. Refer to [GI-46, "IDENTIFICATION INFORMATION"](#) .
2. Turn ignition switch ON and engine stopped.
3. Select "VIN REGISTRATION" in "WORK SUPPORT" mode.
4. Follow the instruction of CONSULT-II display.

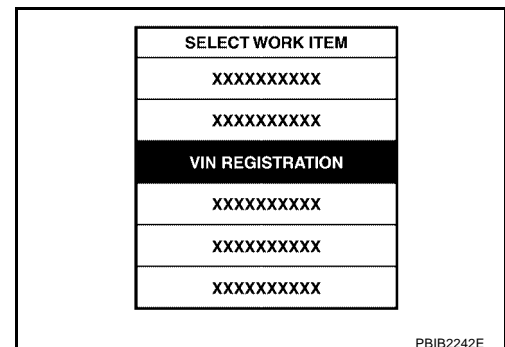

Accelerator Pedal Released Position Learning

DESCRIPTION

Accelerator Pedal Released Position Learning is an operation to learn the fully released position of the accelerator pedal by monitoring the accelerator pedal position sensor output signal. It must be performed each time harness connector of accelerator pedal position sensor or ECM is disconnected.

OPERATION PROCEDURE

1. Make sure that accelerator pedal is fully released.
2. Turn ignition switch ON and wait at least 2 seconds.
3. Turn ignition switch OFF and wait at least 10 seconds.
4. Turn ignition switch ON and wait at least 2 seconds.
5. Turn ignition switch OFF and wait at least 10 seconds.

Throttle Valve Closed Position Learning

DESCRIPTION

Throttle Valve Closed Position Learning is an operation to learn the fully closed position of the throttle valve by monitoring the throttle position sensor output signal. It must be performed each time harness connector of electric throttle control actuator or ECM is disconnected.

OPERATION PROCEDURE

1. Make sure that accelerator pedal is fully released.
2. Turn ignition switch ON.
3. Turn ignition switch OFF and wait at least 10 seconds.
Make sure that throttle valve moves during above 10 seconds by confirming the operating sound.

Idle Air Volume Learning

DESCRIPTION

Idle Air Volume Learning is an operation to learn the idle air volume that keeps each engine within the specific range. It must be performed under any of the following conditions:

- Each time electric throttle control actuator or ECM is replaced.
- Idle speed or ignition timing is out of specification.

PREPARATION

Before performing Idle Air Volume Learning, make sure that all of the following conditions are satisfied. Learning will be cancelled if any of the following conditions are missed for even a moment.

- Battery voltage: More than 12.9V (At idle)
- Engine coolant temperature: 70 - 95°C (158 - 203°F)
- PNP switch: ON
- Electric load switch: OFF
(Air conditioner, headlamp, rear window defogger)
On vehicles equipped with daytime light systems, if the parking brake is applied before the engine is started the headlamp will not be illuminated.
- Steering wheel: Neutral (Straight-ahead position)
- Vehicle speed: Stopped
- Transmission: Warmed-up
For A/T models with CONSULT-II, drive vehicle until "FLUID TEMP SE" in "DATA MONITOR" mode of "A/T" system indicates less than 0.9V.
For A/T models without CONSULT-II and M/T models, drive vehicle for 10 minutes.

OPERATION PROCEDURE

With CONSULT-II

1. Perform [EC-93, "Accelerator Pedal Released Position Learning"](#).
2. Perform [EC-93, "Throttle Valve Closed Position Learning"](#).
3. Start engine and warm it up to normal operating temperature.
4. Check that all items listed under the topic PREPARATION (previously mentioned) are in good order.

BASIC SERVICE PROCEDURE

[QR]

5. Select "IDLE AIR VOL LEARN" in "WORK SUPPORT" mode.

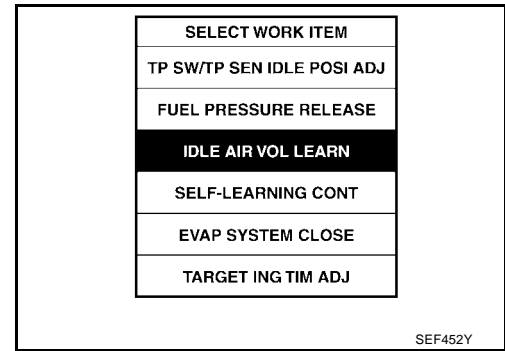

6. Touch "START" and wait 20 seconds.

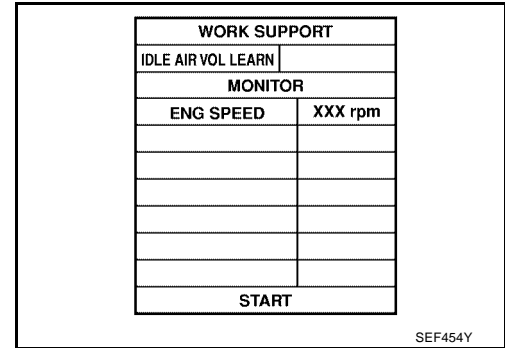

7. Make sure that "CMPLT" is displayed on CONSULT-II screen. If "CMPLT" is not displayed, Idle Air Volume Learning will not be carried out successfully. In this case, find the cause of the incident by referring to the DIAGNOSTIC PROCEDURE below.

8. Rev up the engine two or three times and make sure that idle speed and ignition timing are within the specifications. Refer to [EC-80](#).

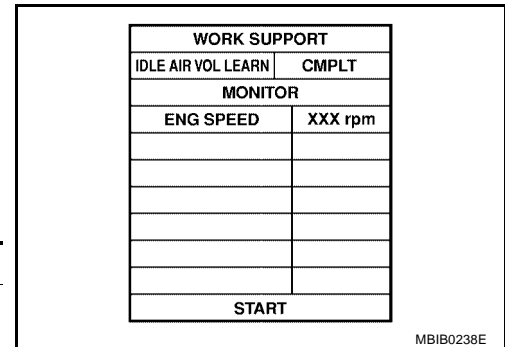

ITEM	SPECIFICATION
Idle speed	M/T: 700 ± 50 rpm (in Neutral position) A/T: 700 ± 50 rpm (in P or N position)
Ignition timing	M/T: 15 ± 5° BTDC (in Neutral position) A/T: 15 ± 5° BTDC (in P or N position)

⊗ Without CONSULT-II

NOTE:

- It is better to count the time accurately with a clock.
 - It is impossible to switch the diagnostic mode when an accelerator pedal position sensor circuit has a malfunction.
1. Perform [EC-93, "Accelerator Pedal Released Position Learning"](#).
 2. Perform [EC-93, "Throttle Valve Closed Position Learning"](#).
 3. Start engine and warm it up to normal operating temperature.
 4. Check that all items listed under the topic PREPARATION (previously mentioned) are in good order.
 5. Turn ignition switch OFF and wait at least 10 seconds.
 6. Confirm that accelerator pedal is fully released, turn ignition switch ON and wait 3 seconds.
 7. Repeat the following procedure quickly five times within 5 seconds.
 - a. Fully depress the accelerator pedal.
 - b. Fully release the accelerator pedal.
 8. Wait 7 seconds, fully depress the accelerator pedal and keep it for approx. 20 seconds until the MIL stops blinking and turned ON.
 9. Fully release the accelerator pedal within 3 seconds after the MIL turned ON.

10. Start engine and let it idle.
11. Wait 20 seconds.

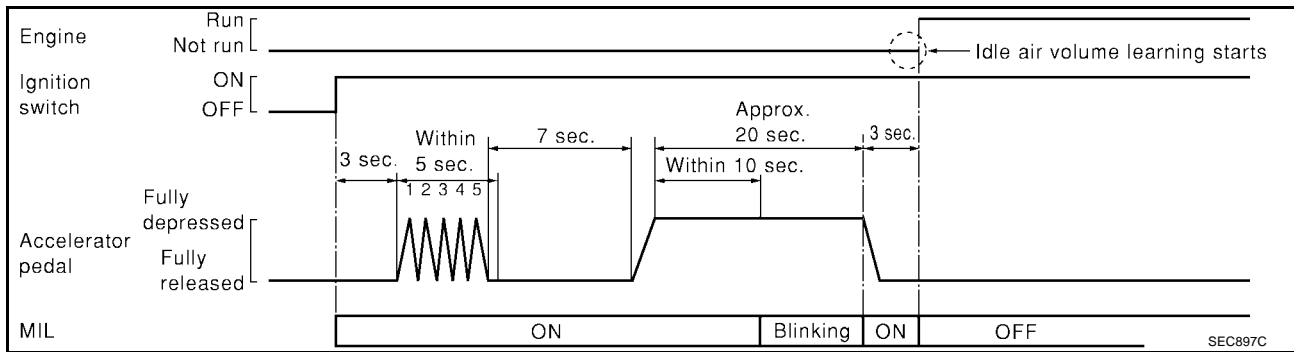

12. Rev up the engine two or three times and make sure that idle speed and ignition timing are within the specifications. Refer to [EC-80](#).

ITEM	SPECIFICATION
Idle speed	M/T: 700 ± 50 rpm (in Neutral position) A/T: 700 ± 50 rpm (in P or N position)
Ignition timing	M/T: 15 ± 5° BTDC (in Neutral position) A/T: 15 ± 5° BTDC (in P or N position)

13. If idle speed and ignition timing are not within the specification, Idle Air Volume Learning will not be carried out successfully. In this case, find the cause of the incident by referring to the Diagnostic Procedure below.

DIAGNOSTIC PROCEDURE

If idle air volume learning cannot be performed successfully, proceed as follows:

1. Check that throttle valve is fully closed.
2. Check PCV valve operation.
3. Check that downstream of throttle valve is free from air leakage.
4. When the above three items check out OK, engine component parts and their installation condition are questionable. Check and eliminate the cause of the incident.
It is useful to perform [EC-148, "TROUBLE DIAGNOSIS - SPECIFICATION VALUE"](#).
5. If any of the following conditions occur after the engine has started, eliminate the cause of the incident and perform Idle air volume learning all over again:
 - Engine stalls.
 - Erroneous idle.

Fuel Pressure Check FUEL PRESSURE RELEASE

UBS0020C

With CONSULT-II

1. Turn ignition switch ON.
2. Perform "FUEL PRESSURE RELEASE" in "WORK SUPPORT" mode with CONSULT-II.
3. Start engine.
4. After engine stalls, crank it two or three times to release all fuel pressure.
5. Turn ignition switch OFF.

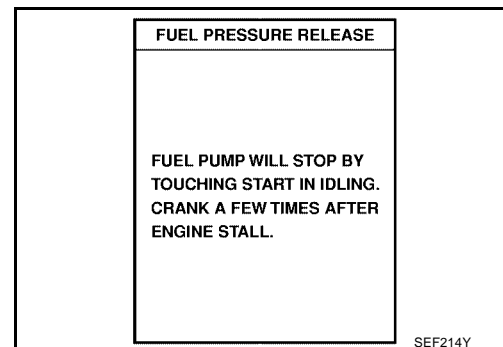

⊗ Without CONSULT-II

1. Remove fuel pump fuse located in IPDM E/R.
2. Start engine.
3. After engine stalls, crank it two or three times to release all fuel pressure.
4. Turn ignition switch OFF.
5. Reinstall fuel pump fuse after servicing fuel system.

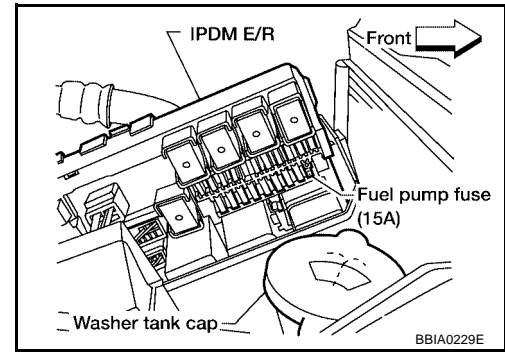

FUEL PRESSURE CHECK

Before disconnecting fuel line, release fuel pressure from fuel line to eliminate danger.

NOTE:

Prepare pans or saucers under the disconnected fuel line because the fuel may spill out. The fuel pressure cannot be completely released because L31 models do not have fuel return system.

Method A

CAUTION:

- The fuel hose connection method used when taking fuel pressure check must not be used for other purposes.
 - Be careful not to scratch or put debris around connection area when servicing, so that the quick connector maintains sealability with O-rings inside.
 - Do not perform fuel pressure check with electrical systems operating (i.e. lights, rear defogger, A/C, etc.) Fuel pressure gauge may indicate false readings due to varying engine load and changes in manifold vacuum.
1. Release fuel pressure to zero. Refer to [EC-95, "FUEL PRESSURE RELEASE"](#).
 2. Prepare fuel hose for fuel pressure check, and connect fuel pressure gauge.
 - Use suitable fuel hose for fuel pressure check (genuine NISSAN fuel hose without quick connector).
 - To avoid unnecessary force or tension to hose, use moderately long fuel hose for fuel pressure check.
 - Do not use the fuel hose for checking fuel pressure with damage or cracks on it.
 - Use Pressure Gauge to check fuel pressure.
 3. Remove fuel hose. Refer to [EM-19, "INTAKE MANIFOLD"](#).
 - Do not twist or kink fuel hose because it is plastic hose.
 - Do not remove fuel hose from quick connector.
 - Keep the original fuel hose to be free from intrusion of dust or foreign substances with a suitable cover.
 4. Install the fuel pressure gauge as shown in the figure.
 - Wipe off oil or dirt from hose insertion part using cloth moistened with gasoline.
 - Apply proper amount of gasoline between top of the fuel tube and No.1 spool.
 - Insert fuel hose for fuel pressure check until it touches the No.1 spool on fuel tube.
 - Use NISSAN genuine hose clamp (part number: 16439 N4710 or 16439 40U00).
 - When reconnecting fuel line, always use new clamps.
 - When reconnecting fuel hose, check the original fuel hose for damage and abnormality.
 - Use a torque driver to tighten clamps.

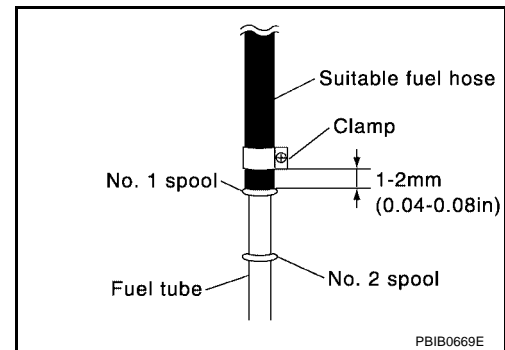

BASIC SERVICE PROCEDURE

[QR]

- Install hose clamp to the position within 1 - 2 mm (0.04 - 0.08 in).

Tightening torque: 1 - 1.5 N·m (0.1 - 0.15 kg-m, 9 - 13 in-lb)

- Make sure that clamp screw does not contact adjacent parts.
5. After connecting fuel hose for fuel pressure check, pull the hose with a force of approximately 98 N (10 kg, 22 lb) to confirm fuel tube does not come off.
 6. Turn ignition switch ON, and check for fuel leakage.
 7. Start engine and check for fuel leakage.
 8. Read the indication of fuel pressure gauge.
 - Do not perform fuel pressure check with system operating. Fuel pressure gauge may indicate false readings.
 - During fuel pressure check, confirm for fuel leakage from fuel connection every 3 minutes.

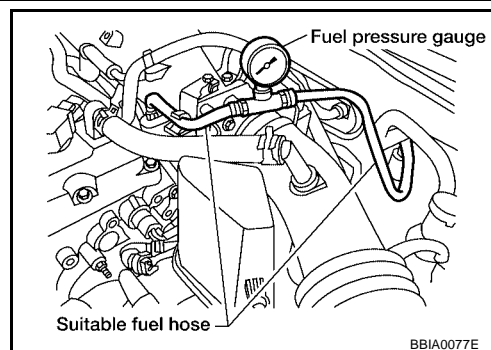

At idling: Approximately 350 kPa (3.57 kg/cm² , 51 psi)

9. If result is unsatisfactory, go to next step.
10. Check the following.
 - Fuel hoses and fuel tubes for clogging
 - Fuel filter for clogging
 - Fuel pump
 - Fuel pressure regulator for cloggingIf OK, replace fuel pressure regulator.
If NG, repair or replace.

Method B

CAUTION:

- Be careful not to scratch or get the fuel hose connection area dirty when servicing, so that the quick connector o-ring maintains sealability.
 - Use Fuel Pressure Gauge Kit J-44321 and Fuel Pressure Adapter J-44321-6 to check fuel pressure.
1. Release fuel pressure to zero. Refer to [EC-95, "FUEL PRESSURE RELEASE"](#).
 2. Remove fuel hose using Quick Connector Release J-45488. Refer to [EM-32, "FUEL INJECTOR AND FUEL TUBE"](#).
 - Do not twist or kink fuel hose because it is plastic hose.
 - Do not remove fuel hose from quick connector.
 - Keep fuel hose connections clean.
 3. Install Fuel Pressure Adapter J-44321-6 and Fuel Pressure Gauge (from kit J-44321) as shown in the figure.
 - Do not distort or bend fuel rail tube when installing fuel pressure gauge adapter.
 - When reconnecting fuel hose, check the original fuel hose for damage and abnormality.

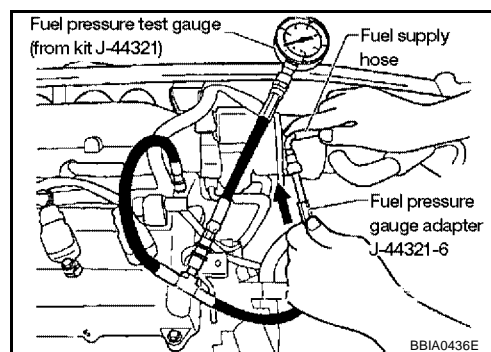

4. Turn ignition switch ON (reactivate fuel pump), and check for fuel leakage.
5. Start engine and check for fuel leakage.
6. Read the indication of fuel pressure gauge.
 - During fuel pressure check, check for fuel leakage from fuel connection every 3 minutes.

At idling: Approximately 350 kPa (3.57 kg/cm² , 51 psi)

7. If result is unsatisfactory, go to next step.
8. Check the following.
 - Fuel hoses and fuel tubes for clogging
 - Fuel filter for clogging
 - Fuel pump
 - Fuel pressure regulator for cloggingIf OK, replace fuel pressure regulator.
If NG, repair or replace.
9. Before disconnecting Fuel Pressure Gauge and Fuel Pressure Adapter J-44321-6, release fuel pressure to zero. Refer to [EC-95, "FUEL PRESSURE RELEASE"](#)

TROUBLE DIAGNOSIS

Trouble Diagnosis Introduction
INTRODUCTION

The engine has an ECM to control major systems such as fuel control, ignition control, idle air control system, etc. The ECM accepts input signals from sensors and instantly drives actuators. It is essential that both input and output signals are proper and stable. At the same time, it is important that there are no malfunctions such as vacuum leaks, fouled spark plugs, or other malfunctions with the engine.

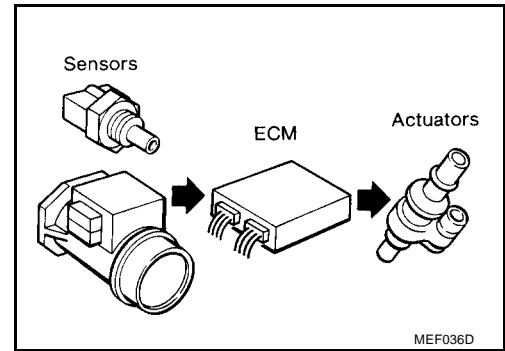

It is much more difficult to diagnose an incident that occurs intermittently rather than continuously. Most intermittent incidents are caused by poor electric connections or improper wiring. In this case, careful checking of suspected circuits may help prevent the replacement of good parts.

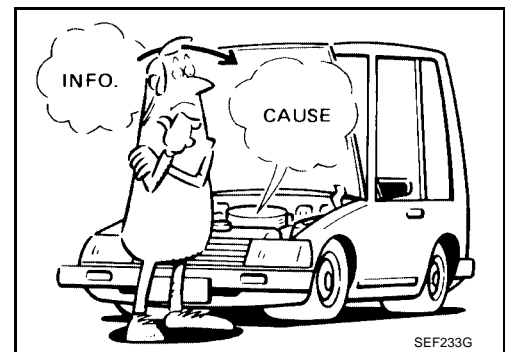

A visual check only may not find the cause of the incidents. A road test with CONSULT-II (or GST) or a circuit tester connected should be performed. Follow the WORK FLOW on [EC-100](#).

Before undertaking actual checks, take a few minutes to talk with a customer who approaches with a driveability complaint. The customer can supply good information about such incidents, especially intermittent ones. Find out what symptoms are present and under what conditions they occur. A DIAGNOSTIC WORKSHEET like the example on [EC-104](#) should be used.

Start your diagnosis by looking for conventional malfunctions first. This will help troubleshoot driveability malfunctions on an electronically controlled engine vehicle.

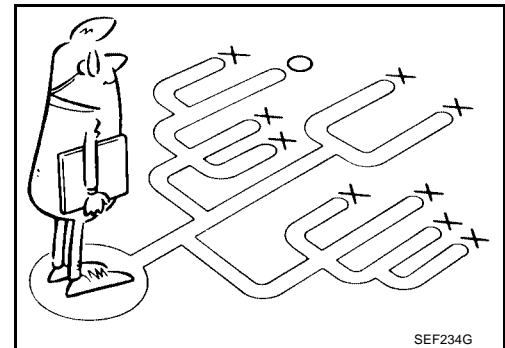

WORK FLOW
Overall Sequence

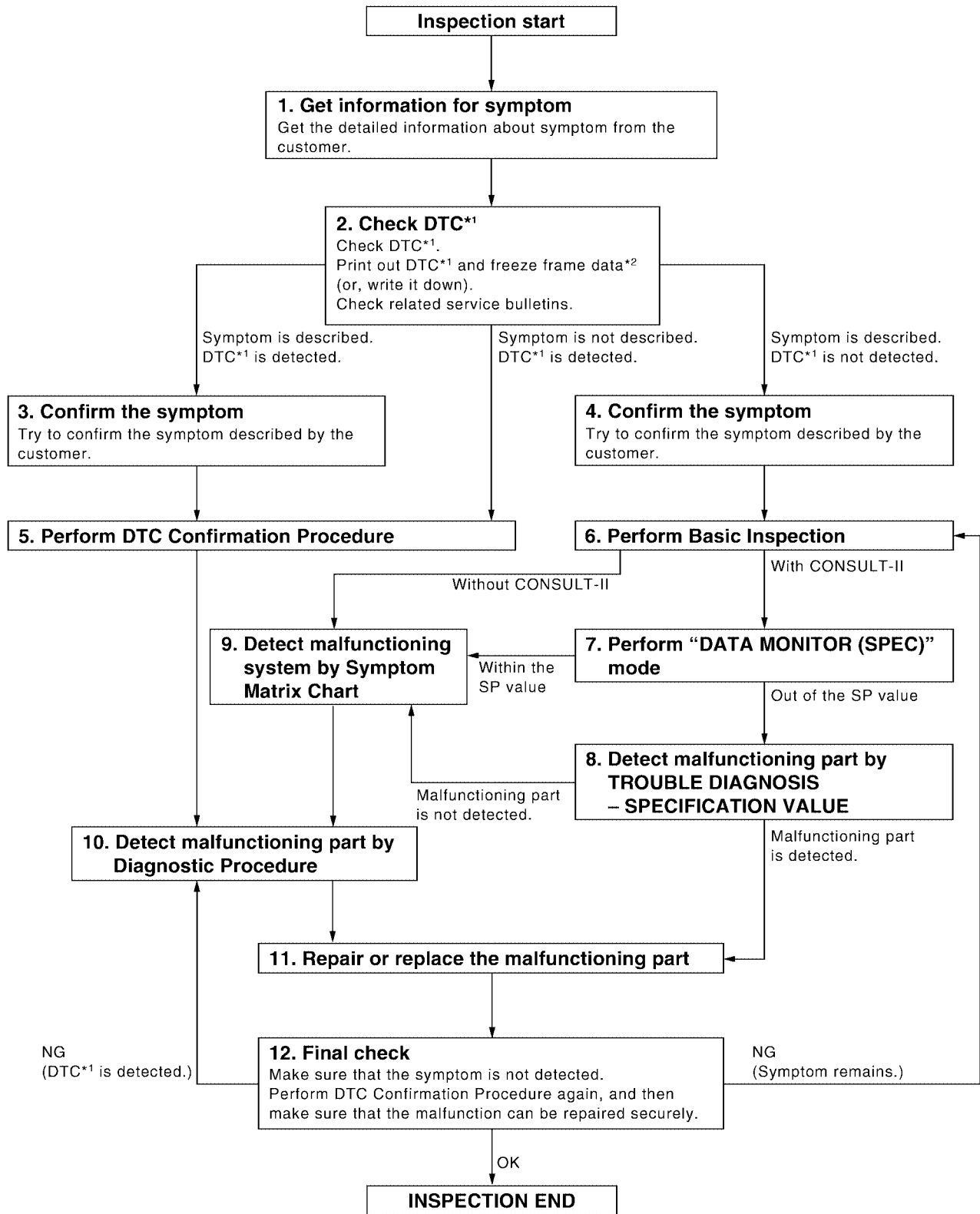

*1: Include 1st trip DTC.

*2: Include 1st trip freeze frame data.

Detailed Flow**1. GET INFORMATION FOR SYMPTOM**

Get the detailed information from the customer about the symptom (the condition and the environment when the incident/malfunction occurred) using the [EC-103, "DIAGNOSTIC WORKSHEET"](#) .

>> GO TO 2.

2. CHECK DTC*¹

1. Check DTC*¹ .
2. Perform the following procedure if DTC*¹ is displayed.
 - Record DTC*¹ and freeze frame data*² . (Print them out with CONSULT-II or GST.)
 - Erase DTC*¹ . (Refer to [EC-65, "HOW TO ERASE EMISSION-RELATED DIAGNOSTIC INFORMATION"](#) .)
 - Study the relationship between the cause detected by DTC*¹ and the symptom described by the customer. (Symptom Matrix Chart is useful. Refer to [EC-108](#) .)
3. Check related service bulletins for information.

Is any symptom described and any DTC detected?

Symptom is described, DTC*¹ is displayed>>GO TO 3.

Symptom is described, DTC*¹ is not displayed>>GO TO 4.

Symptom is not described, DTC*¹ is displayed>>GO TO 5.

3. CONFIRM THE SYMPTOM

Try to confirm the symptom described by the customer (except MIL ON).

DIAGNOSIS WORK SHEET is useful to verify the incident.

Connect CONSULT-II to the vehicle in DATA MONITOR (AUTO TRIG) mode and check real time diagnosis results.

Verify relation between the symptom and the condition when the symptom is detected.

>> GO TO 5.

4. CONFIRM THE SYMPTOM

Try to confirm the symptom described by the customer.

DIAGNOSIS WORK SHEET is useful to verify the incident.

Connect CONSULT-II to the vehicle in DATA MONITOR (AUTO TRIG) mode and check real time diagnosis results.

Verify relation between the symptom and the condition when the symptom is detected.

>> GO TO 6.

5. PERFORM DTC CONFIRMATION PROCEDURE

Perform DTC Confirmation Procedure for the displayed DTC*¹, and then make sure that DTC*¹ is detected again.

At this time, always connect CONSULT-II to the vehicle, and check diagnostic results in real time on "DATA MONITOR (AUTO TRIG)".

If two or more DTCs*¹ are detected, refer to [EC-105, "DTC Inspection Priority Chart"](#) and determine trouble diagnosis order.

NOTE:

- Freeze frame data*² is useful if the DTC*¹ is not detected.
- Perform Overall Function Check if DTC Confirmation Procedure is not included on Service Manual. This simplified check procedure is an effective alternative though DTC*¹ cannot be detected during this check. If the result of Overall Function Check is NG, it is the same as the detection of DTC*¹ by DTC Confirmation Procedure.

Is DTC*¹ detected?

Yes >> GO TO 10.

No >> Check according to [EC-158, "TROUBLE DIAGNOSIS FOR INTERMITTENT INCIDENT"](#).

6. PERFORM BASIC INSPECTION

Perform [EC-75, "Basic Inspection"](#).

With CONSULT-II>>GO TO 7.

Without CONSULT-II>>GO TO 9.

7. PERFORM DATA MONITOR (SPEC) MODE

☐ With CONSULT-II

Make sure that "MAS A/F SE-B1", "B/FUEL SCHDL", and "A/F ALPHA-B1" are within the SP value using CONSULT-II "DATA MONITOR (SPEC)" mode. Refer to [EC-149, "Diagnostic Procedure"](#).

Are they within the SP value?

Yes >> GO TO 9.

No >> GO TO 8.

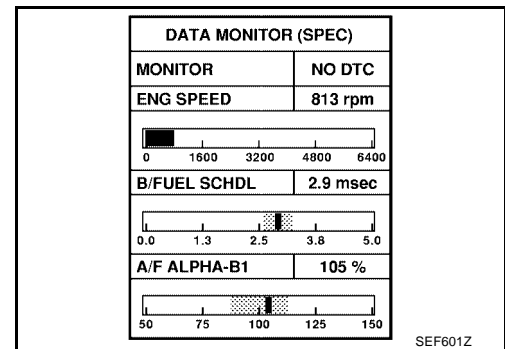

8. DETECT MALFUNCTIONING PART BY TROUBLE DIAGNOSIS - SPECIFICATION VALUE

Detect malfunctioning part according to [EC-148, "TROUBLE DIAGNOSIS - SPECIFICATION VALUE"](#).

Is malfunctioning part detected?

Yes >> GO TO 11.

No >> GO TO 9.

9. DETECT MALFUNCTIONING SYSTEM BY SYMPTOM MATRIX CHART

Detect malfunctioning system according to [EC-108, "Symptom Matrix Chart"](#) based on the confirmed symptom in step 4, and determine the trouble diagnosis order based on possible causes and symptom.

>> GO TO 10.

10. DETECT MALFUNCTIONING PART BY DIAGNOSTIC PROCEDURE

Inspect according to Diagnostic Procedure of the system.

NOTE:

The Diagnostic Procedure in EC section described based on open circuit inspection. A short circuit inspection is also required for the circuit check in the Diagnostic Procedure. For details, refer to Circuit Inspection in [GI-26, "How to Perform Efficient Diagnosis for an Electrical Incident"](#).

Is malfunctioning part detected?

Yes >> GO TO 11.

No >> Monitor input data from related sensors or check voltage of related ECM terminals using CONSULT-II. Refer to [EC-142, "CONSULT-II Reference Value in Data Monitor"](#), [EC-120, "ECM Terminals and Reference Value"](#).

11. REPAIR OR REPLACE THE MALFUNCTIONING PART

1. Repair or replace the malfunctioning part.
2. Reconnect parts or connectors disconnected during Diagnostic Procedure again after repair and replacement.
3. Check DTC. If DTC is displayed, erase it, refer to [EC-65, "HOW TO ERASE EMISSION-RELATED DIAGNOSTIC INFORMATION"](#).

>> GO TO 12.

12. FINAL CHECK

When DTC was detected in step 2, perform DTC Confirmation Procedure or Overall Function Check again, and then make sure that the malfunction have been repaired securely.

When symptom was described from the customer, refer to confirmed symptom in step 3 or 4, and make sure that the symptom is not detected.

OK or NG

NG (DTC*¹ is detected)>>GO TO 10.

NG (Symptom remains)>>GO TO 6.

OK >> 1. Before returning the vehicle to the customer, make sure to erase unnecessary DTC*¹ in ECM and TCM (Transmission Control Module). (Refer to [EC-65, "HOW TO ERASE EMISSION-RELATED DIAGNOSTIC INFORMATION"](#) and [EC-65, "How to Erase DTC"](#).)

2. If the completion of SRT is needed, drive vehicle under the specific driving pattern. Refer to [EC-63, "Driving Pattern"](#).

3. INSPECTION END

*1: Include 1st trip DTC.

*2: Include 1st trip freeze frame data.

DIAGNOSTIC WORKSHEET

Description

There are many operating conditions that lead to the malfunction of engine components. A good grasp of such conditions can make troubleshooting faster and more accurate.

In general, each customer feels differently about an incident. It is important to fully understand the symptoms or conditions for a customer complaint.

Utilize a diagnostic worksheet like the one on the next page in order to organize all the information for troubleshooting.

Some conditions may cause the MIL to come on steady or blink and DTC to be detected. Examples:

- Vehicle ran out of fuel, which caused the engine to misfire.
- Fuel filler cap was left off or incorrectly screwed on, allowing fuel to evaporate into the atmosphere.

KEY POINTS

WHAT Vehicle & engine model
WHEN Date, Frequencies
WHERE..... Road conditions
HOW Operating conditions,
 Weather conditions,
 Symptoms

SEF907L

TROUBLE DIAGNOSIS

[QR]

UBS0020K

DTC Inspection Priority Chart

If some DTCs are displayed at the same time, perform inspections one by one based on the following priority chart.

NOTE:

If DTC U1000 and/or U1001 is displayed with other DTC, first perform the trouble diagnosis for DTC U1000 and U1001. Refer to [EC-166](#).

Priority	Detected items (DTC)
1	<ul style="list-style-type: none"> ● U1000 U1001 CAN communication line ● P0101 P0102 P0103 Mass air flow sensor ● P0112 P0113 P0127 Intake air temperature sensor ● P0117 P0118 P0125 Engine coolant temperature sensor ● P0122 P0123 P0222 P0223 P1225 P1226 P2135 Throttle position sensor ● P0128 Thermostat function ● P0181 P0182 P0183 Fuel tank temperature sensor ● P0327 P0328 Knock sensor ● P0335 Crankshaft position sensor (POS) ● P0340 Camshaft position sensor (PHASE) ● P0460 P0461 P0462 P0463 Fuel level sensor ● P0500 Vehicle speed sensor ● P0605 ECM ● P1229 Sensor power supply ● P1610-P1615 NATS ● P1706 Park/Neutral position (PNP) switch ● P2122 P2123 P2127 P2128 P2138 Accelerator pedal position sensor

A
EC
C
D
E
F
G
H
I
J
K
L
M

TROUBLE DIAGNOSIS

[QR]

Priority	Detected items (DTC)
2	<ul style="list-style-type: none"> ● P0037 P0038 Heated oxygen sensor 2 heater ● P0138 P0139 P1146 P1147 Heated oxygen sensor 2 ● P0441 EVAP control system purge flow monitoring ● P0444 P0445 P1444 EVAP canister purge volume control solenoid valve ● P0447 P1446 EVAP canister vent control valve ● P0451 P0452 P0453 EVAP control system pressure sensor ● P0506 P0507 Idle speed control system ● P0550 power steering pressure sensor ● P0705-P0725, P0740-P0755, P1705 P1760 A/T related sensors and solenoid valves ● P1031 P1032 A/F sensor 1 heater ● P1065 ECM power supply ● P1111 Intake valve timing control solenoid valve ● P1122 Electric throttle control function ● P1124 P1126 P1128 Electric throttle control actuator ● P1271 P1272 P1273 P1274 P1276 P1278 P1279 A/F sensor 1 ● P1800 VIAS control solenoid valve ● P1805 Brake switch
3	<ul style="list-style-type: none"> ● P0011 Intake valve timing control ● P0171 P0172 Fuel injection system function ● P0300 - P0304 Misfire ● P0420 Three way catalyst function ● P0442 P0456 EVAP control system (SMALL LEAK, VERY SMALL LEAK) ● P0455 EVAP control system (GROSS LEAK) ● P0731-P0734 A/T function ● P1121 Electric throttle control actuator ● P1148 Closed loop control ● P1217 Engine over temperature (OVERHEAT) ● P1564 ASCD steering switch ● P1572 ASCD brake switch ● P1574 ASCD vehicle speed sensor

TROUBLE DIAGNOSIS

[QR]

UBS0020L

Fail-safe Chart

When the DTC listed below is detected, the ECM enters fail-safe mode and the MIL lights up.

DTC No.	Detected items	Engine operating condition in fail-safe mode								
P0102 P0103	Mass air flow sensor circuit	Engine speed will not rise more than 2,400 rpm due to the fuel cut.								
P0117 P0118	Engine coolant temperature sensor circuit	<p>Engine coolant temperature will be determined by ECM based on the time after turning ignition switch ON or START. CONSULT-II displays the engine coolant temperature decided by ECM.</p> <table border="1" style="width: 100%; border-collapse: collapse;"> <thead> <tr> <th style="width: 50%;">Condition</th> <th style="width: 50%;">Engine coolant temperature decided (CONSULT-II display)</th> </tr> </thead> <tbody> <tr> <td>Just as ignition switch is turned ON or START</td> <td style="text-align: center;">40°C (104°F)</td> </tr> <tr> <td>More than approx. 4 minutes after ignition ON or START</td> <td style="text-align: center;">80°C (176°F)</td> </tr> <tr> <td>Except as shown above</td> <td style="text-align: center;">40 - 80°C (104 - 176°F) (Depends on the time)</td> </tr> </tbody> </table> <p>When the fail-safe system for engine coolant temperature sensor is activated, the cooling fan operates while engine is running.</p>	Condition	Engine coolant temperature decided (CONSULT-II display)	Just as ignition switch is turned ON or START	40°C (104°F)	More than approx. 4 minutes after ignition ON or START	80°C (176°F)	Except as shown above	40 - 80°C (104 - 176°F) (Depends on the time)
Condition	Engine coolant temperature decided (CONSULT-II display)									
Just as ignition switch is turned ON or START	40°C (104°F)									
More than approx. 4 minutes after ignition ON or START	80°C (176°F)									
Except as shown above	40 - 80°C (104 - 176°F) (Depends on the time)									
P0122 P0123 P0222 P0223 P2135	Throttle position sensor	<p>The ECM controls the electric throttle control actuator in regulating the throttle opening in order for the idle position to be within +10 degrees. The ECM regulates the opening speed of the throttle valve to be slower than the normal condition. So, the acceleration will be poor.</p>								
P1121	Electric throttle control actuator	<p>(When electric throttle control actuator does not function properly due to the return spring malfunction:) ECM controls the electric throttle actuator by regulating the throttle opening around the idle position. The engine speed will not rise more than 2,000 rpm.</p> <p>(When throttle valve opening angle in fail-safe mode is not in specified range:) ECM controls the electric throttle control actuator by regulating the throttle opening to 20 degrees or less.</p> <p>(When ECM detects the throttle valve is stuck open:) While the vehicle is driving, it slows down gradually by fuel cut. After the vehicle stops, the engine stalls. The engine can restart in N or P position, and engine speed will not exceed 1,000 rpm or more.</p>								
P1122	Electric throttle control function	ECM stops the electric throttle control actuator control, throttle valve is maintained at a fixed opening (approx. 5 degrees) by the return spring.								
P1124 P1126	Throttle control relay	ECM stops the electric throttle control actuator control, throttle valve is maintained at a fixed opening (approx. 5 degrees) by the return spring.								
P1128	Throttle control motor	ECM stops the electric throttle control actuator control, throttle valve is maintained at a fixed opening (approx. 5 degrees) by the return spring.								
P1229	Sensor power supply	ECM stops the electric throttle control actuator control, throttle valve is maintained at a fixed opening (approx. 5 degrees) by the return spring.								
P2122 P2123 P2127 P2128 P2138	Accelerator pedal position sensor	<p>The ECM controls the electric throttle control actuator in regulating the throttle opening in order for the idle position to be within +10 degrees. The ECM regulates the opening speed of the throttle valve to be slower than the normal condition. So, the acceleration will be poor.</p>								

- When there is an open circuit on MIL circuit, the ECM cannot warn the driver by MIL lighting up when there is malfunction on engine control system.
Therefore, when electrical controlled throttle and part of ECM related diagnoses are continuously detected as NG for 5 trips, ECM warns the driver that engine control system malfunctions and MIL circuit is open by means of operating fail-safe function.
The fail-safe function also operates when above diagnoses except MIL circuit are detected, and demands the driver to repair the malfunction.

Engine operating condition in fail-safe mode

Engine speed will not rise more than 2,500 rpm due to the fuel cut

TROUBLE DIAGNOSIS

[QR]

UBS002ON

Symptom Matrix Chart SYSTEM — BASIC ENGINE CONTROL SYSTEM

		SYMPTOM												Reference page	
		HARD/NO START/RESTART (EXCP. HA)	ENGINE STALL	HESITATION/SURGING/FLAT SPOT	SPARK KNOCK/DETONATION	LACK OF POWER/POOR ACCELERATION	HIGH IDLE/LOW IDLE	ROUGH IDLE/HUNTING	IDLING VIBRATION	SLOW/NO RETURN TO IDLE	OVERHEATS/WATER TEMPERATURE HIGH	EXCESSIVE FUEL CONSUMPTION	EXCESSIVE OIL CONSUMPTION		BATTERY DEAD (UNDER CHARGE)
Warranty symptom code		AA	AB	AC	AD	AE	AF	AG	AH	AJ	AK	AL	AM	HA	
Fuel	Fuel pump circuit	1	1	2	3	2		2	2			3		2	EC-598
	Fuel pressure regulator system	3	3	4	4	4	4	4	4	4		4			EC-95
	Injector circuit	1	1	2	3	2		2	2			2			EC-592
	Evaporative emission system	3	3	4	4	4	4	4	4	4	4	4			EC-37
Air	Positive crankcase ventilation system	3	3	4	4	4	4	4	4	4		4	1		EC-50
	Incorrect idle speed adjustment	3	3				1	1	1	1		1			EC-75
	Electric throttle control actuator	1	1	2	3	3	2	2	2	2		2		2	EC-386 , EC-388 , EC-394 , EC-399
Ignition	Incorrect ignition timing adjustment	3	3	1	1	1		1	1			1			EC-75
	Ignition circuit	1	1	2	2	2		2	2			2			EC-572
Main power supply and ground circuit		2	2	3	3	3		3	3		2	3			EC-159
Mass air flow sensor circuit		1	1	2	2	2		2	2			2			EC-178 , EC-187 , EC-178
Engine coolant temperature sensor circuit		1	1	2	2	2	3	2	2	3	1	2			EC-199 , EC-211
Throttle position sensor circuit			1	2		2	2	2	2	2		2			EC-557 , EC-255 , EC-204 , EC-434 , EC-436
Accelerator pedal position sensor circuit				3	2	1	2			2					EC-564 , EC-542 , EC-549 , EC-438
A/F sensor 1 circuit			1	2	3	2		2	2			2			EC-443 , EC-448 , EC-453 , EC-460 , EC-467 , EC-473 , EC-482
Knock sensor circuit				2	2							3			EC-269

TROUBLE DIAGNOSIS

[QR]

	SYMPTOM												Reference page	
	HARD/NO START/RESTART (EXCP. HA)	ENGINE STALL	HESITATION/SURGING/FLAT SPOT	SPARK KNOCK/DETONATION	LACK OF POWER/POOR ACCELERATION	HIGH IDLE/LOW IDLE	ROUGH IDLE/HUNTING	IDLING VIBRATION	SLOW/NO RETURN TO IDLE	OVERHEATS/WATER TEMPERATURE HIGH	EXCESSIVE FUEL CONSUMPTION	EXCESSIVE OIL CONSUMPTION		BATTERY DEAD (UNDER CHARGE)
Warranty symptom code	AA	AB	AC	AD	AE	AF	AG	AH	AJ	AK	AL	AM	HA	
Crankshaft position sensor (POS) circuit	2	2												EC-273
Camshaft position sensor (PHASE) circuit	2	2												EC-280
Vehicle speed signal circuit		2	3		3						3			EC-359
Power steering pressure sensor circuit						3	3	3	3					EC-365
ECM	2	2	3	3	3	3	3	3	3	3	3			EC-370 , EC-378
Intake valve timing control solenoid valve circuit	3	3	2		1	3	2	2	3		3			EC-382
VIAS control solenoid valve circuit					1									EC-583
PNP switch circuit			3		3	3	3	3	3		3			EC-524
Refrigerant pressure sensor circuit		2				3	3	3	3		4			EC-605
Electrical load signal circuit						3	3	3	3					EC-610
Air conditioner circuit	2	2	3	3	3	3	3	3	3		3		2	ATC-28 , MTC-28

1 - 6: The numbers refer to the order of inspection.
(continued on next page)

A
EC
C
D
E
F
G
H
I
J
K
L
M

TROUBLE DIAGNOSIS

[QR]

SYSTEM — ENGINE MECHANICAL & OTHER

		SYMPTOM												Reference page	
		HARD/NO START/RESTART (EXCP. HA)	ENGINE STALL	HESITATION/SURGING/FLAT SPOT	SPARK KNOCK/DETONATION	LACK OF POWER/POOR ACCELERATION	HIGH IDLE/LOW IDLE	ROUGH IDLE/HUNTING	IDLING VIBRATION	SLOW/NO RETURN TO IDLE	OVERHEATS/WATER TEMPERATURE HIGH	EXCESSIVE FUEL CONSUMPTION	EXCESSIVE OIL CONSUMPTION		BATTERY DEAD (UNDER CHARGE)
Warranty symptom code		AA	AB	AC	AD	AE	AF	AG	AH	AJ	AK	AL	AM	HA	
Fuel	Fuel tank														FL-12
	Fuel piping	5		5	5	5		5	5			5			EC-593 , EM-32
	Vapor lock		5												—
	Valve deposit														—
	Poor fuel (Heavy weight gasoline, Low octane)	5		5	5	5		5	5			5			—
Air	Air duct														EM-17
	Air cleaner														EM-17
	Air leakage from air duct (Mass air flow sensor —electric throttle control actuator)		5	5		5		5	5			5			EM-17
	Electric throttle control actuator	5			5		5			5					EM-19
	Air leakage from intake manifold/Collector/Gasket														EM-19
Cranking	Battery														SC-4
	Generator circuit	1	1	1		1		1	1			1		1	SC-21
	Starter circuit	3													SC-9
	Signal plate/Flywheel/Drive plate	6													EM-75
	PNP switch	4													MT-13 or AT-105
Engine	Cylinder head	5	5	5	5	5		5	5			5	3		EM-59
	Cylinder head gasket										4				
	Cylinder block														
	Piston												4		
	Piston ring														
	Connecting rod	6	6	6	6	6		6	6			6			EM-75
	Bearing														
	Crankshaft														

TROUBLE DIAGNOSIS

[QR]

		SYMPTOM												Reference page	
		HARD/NO START/RESTART (EXCP. HA)	ENGINE STALL	HESITATION/SURGING/FLAT SPOT	SPARK KNOCK/DETONATION	LACK OF POWER/POOR ACCELERATION	HIGH IDLE/LOW IDLE	ROUGH IDLE/HUNTING	IDLING VIBRATION	SLOW/NO RETURN TO IDLE	OVERHEATS/WATER TEMPERATURE HIGH	EXCESSIVE FUEL CONSUMPTION	EXCESSIVE OIL CONSUMPTION		BATTERY DEAD (UNDER CHARGE)
Warranty symptom code		AA	AB	AC	AD	AE	AF	AG	AH	AJ	AK	AL	AM	HA	
Valve mechanism	Timing chain														EM-48
	Camshaft														EM-37
	Intake valve timing control	5	5	5	5	5		5	5			5			EM-48
	Intake valve												3		EM-59
	Exhaust valve														
Exhaust	Exhaust manifold/Tube/Muffler/Gasket	5	5	5	5	5			5	5		5			EM-24, EX-3
	Three way catalyst														
Lubrication	Oil pan/Oil strainer/Oil pump/Oil filter/Oil gallery	5	5	5	5	5			5	5		5	2		EM-26, LU-10, LU-11, LU-5
	Oil level (Low)/Filthy oil														LU-7
Cooling	Radiator/Hose/Radiator filler cap														CO-11
	Thermostat									5					CO-16
	Water pump														CO-14
	Water gallery	5	5	5	5	5		5	5		2	5			CO-7
	Cooling fan									5					CO-11
	Coolant level (low)/Contaminated coolant														CO-9
NVIS (NISSAN Vehicle Immobilizer System — NATS)		1	1												BL-107

1 - 6: The numbers refer to the order of inspection.

Engine Control Component Parts Location

UBS00200

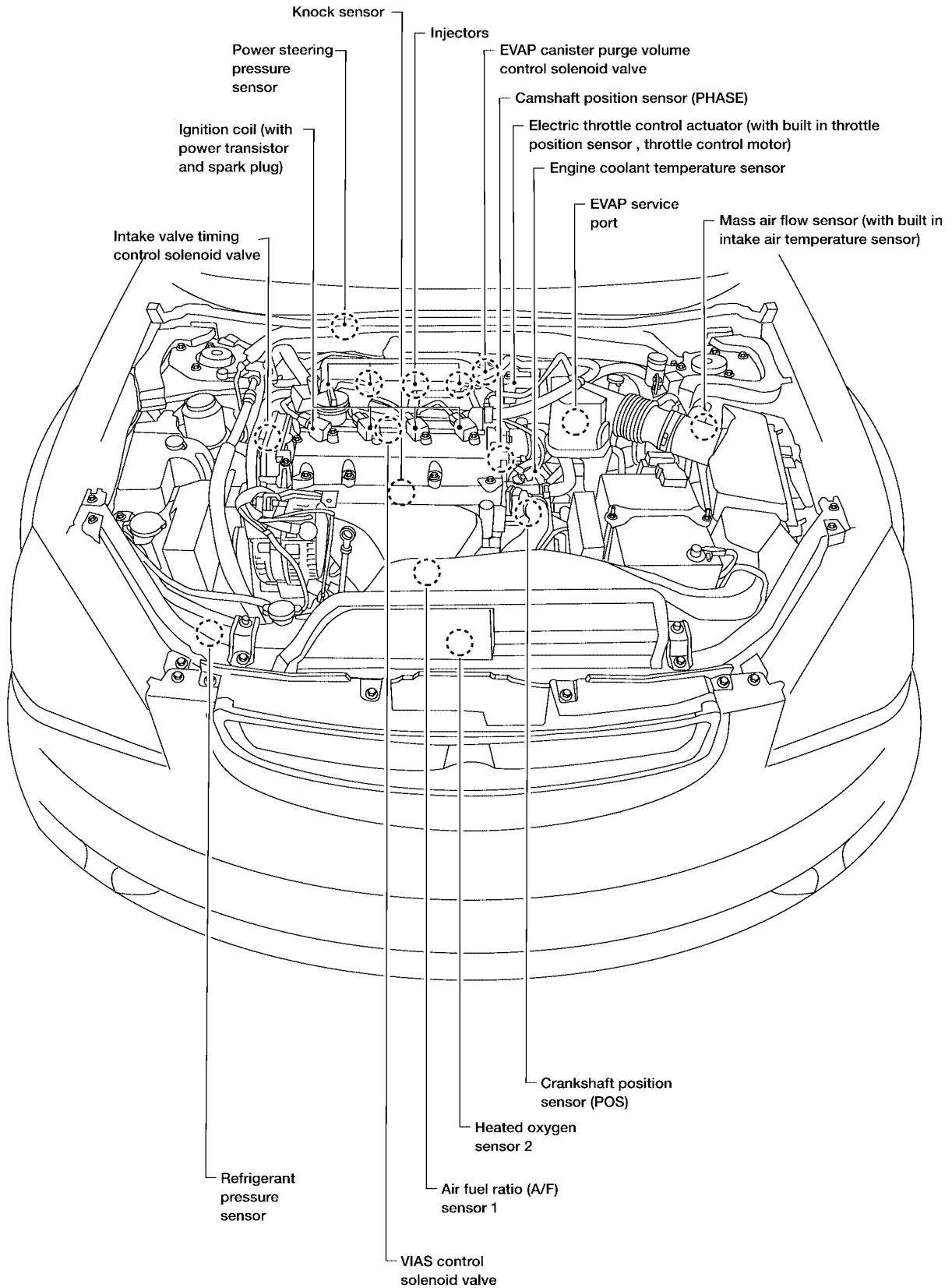

BBA0405E

A
EC
C
D
E
F
G
H
I
J
K
L
M

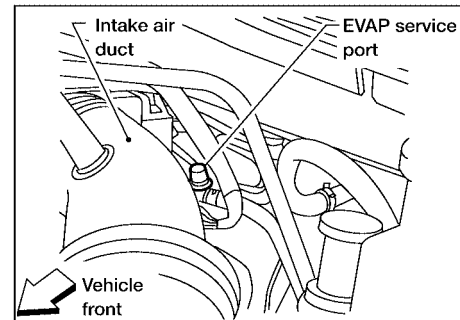
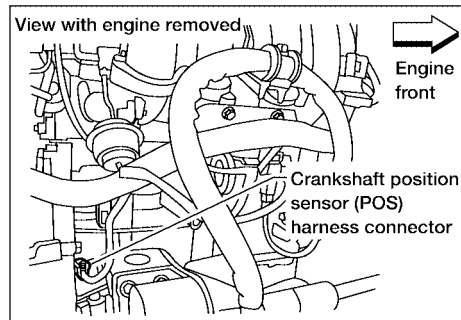
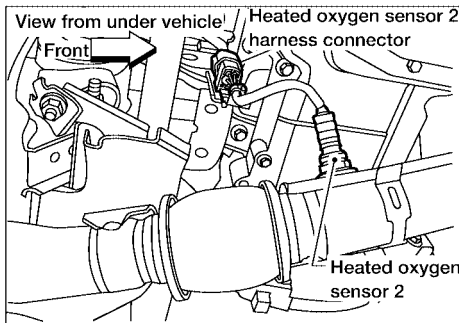
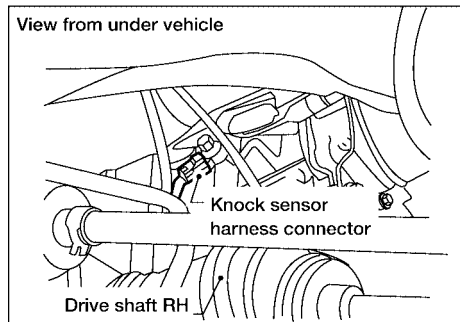
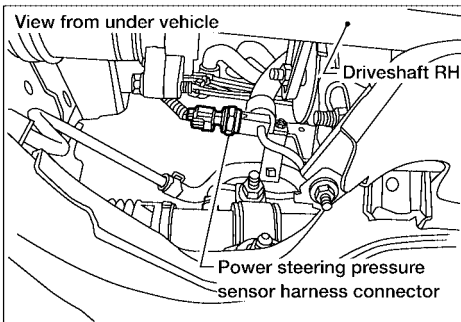
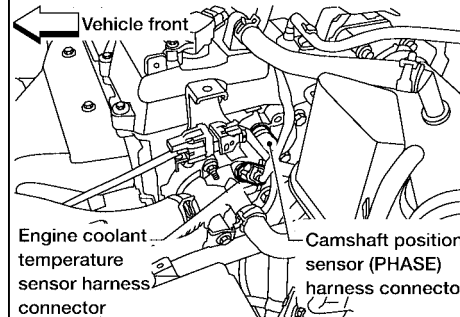
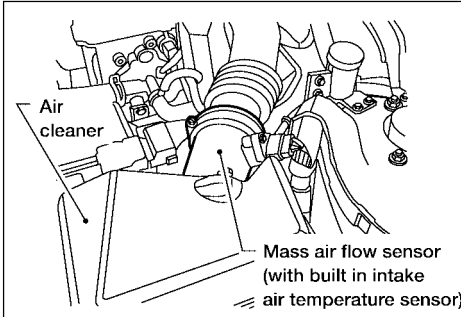
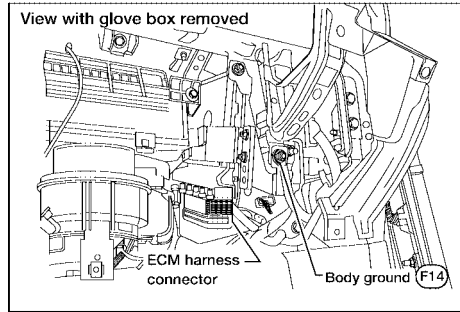
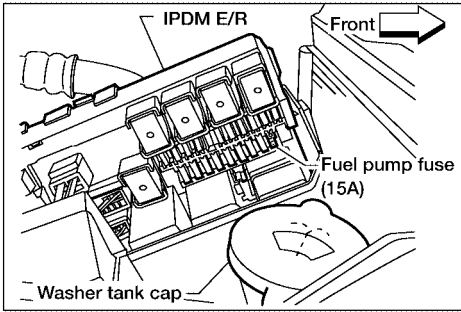

BBIA0406E

TROUBLE DIAGNOSIS

[QR]

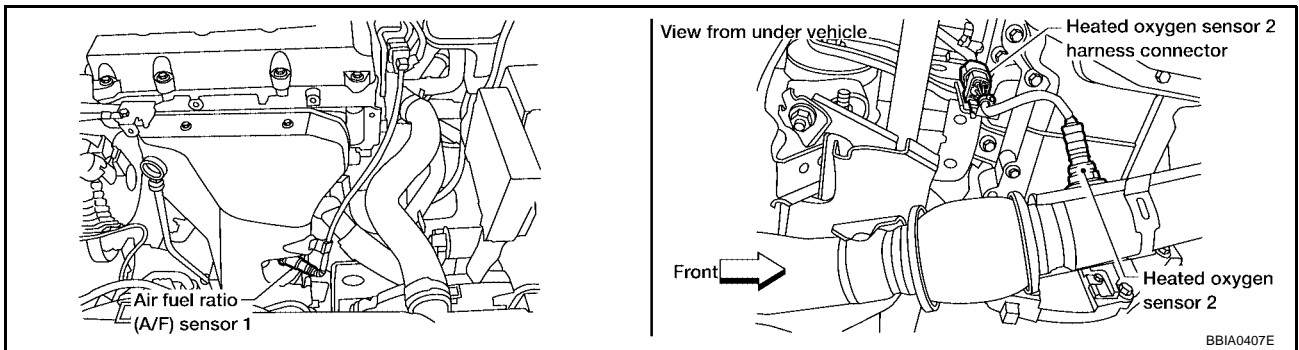
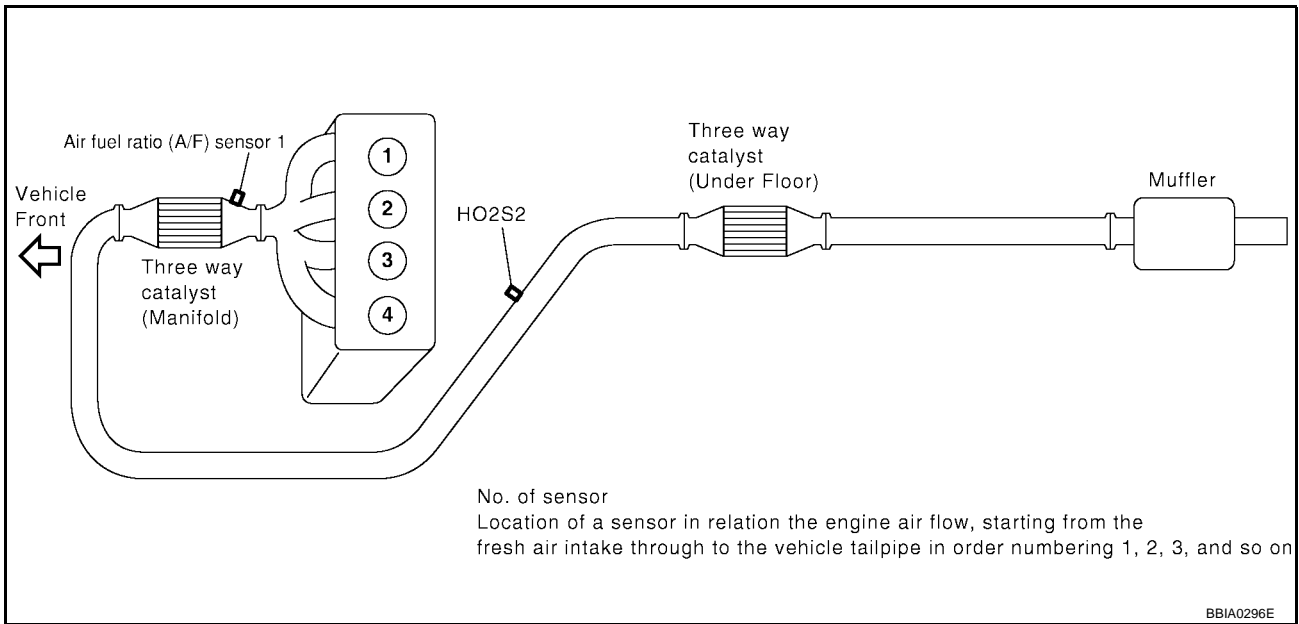

A
EC
C
D
E
F
G
H
I
J
K
L
M

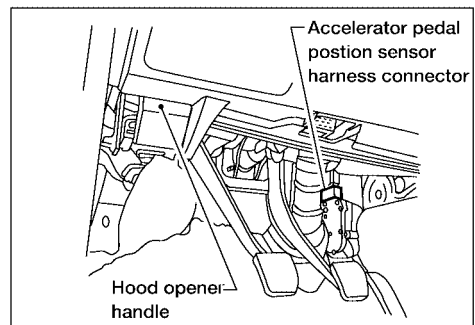
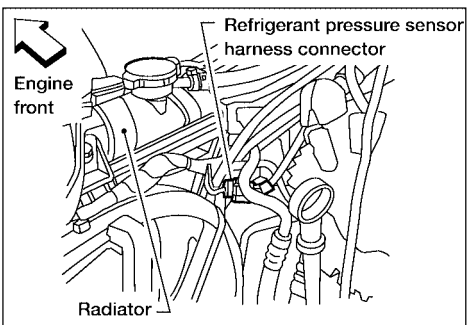
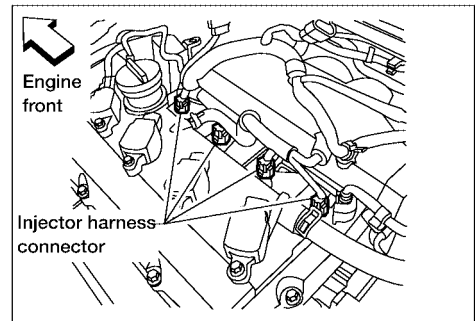
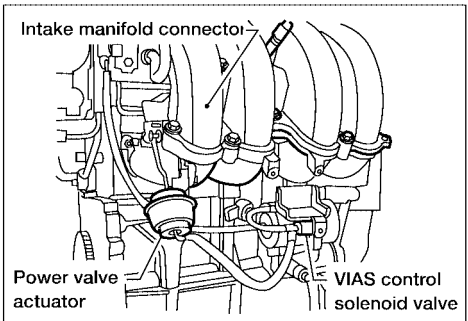
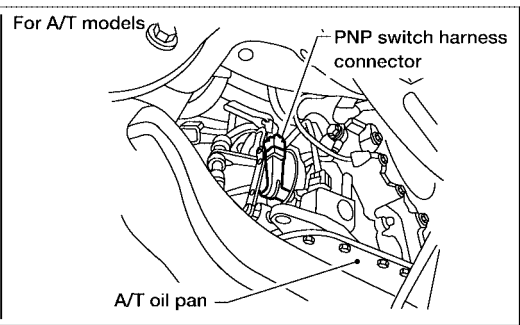
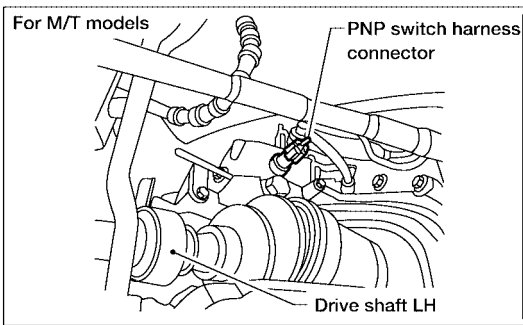
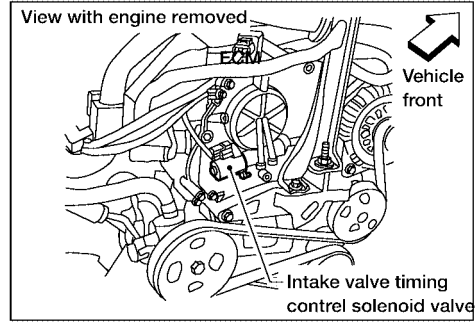
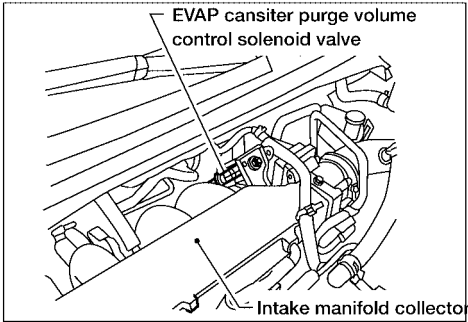

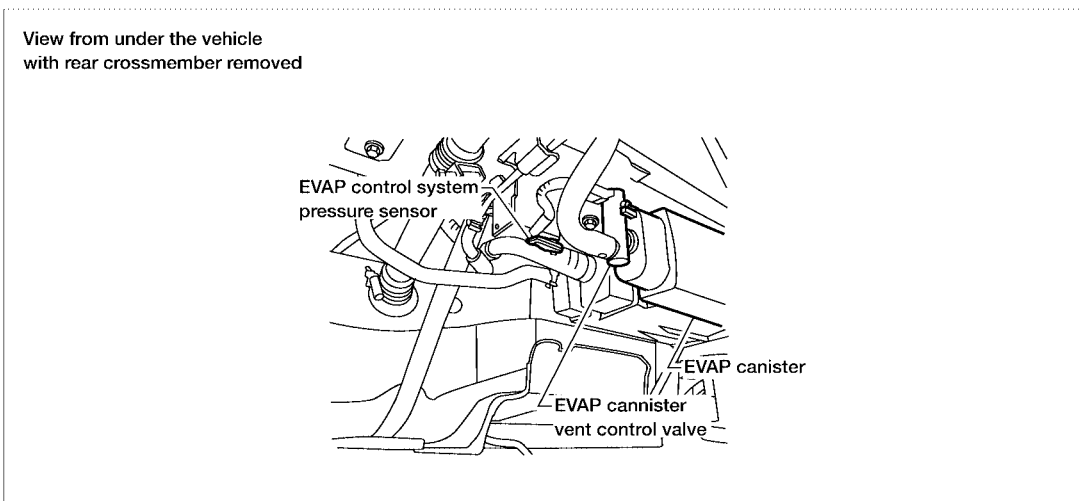
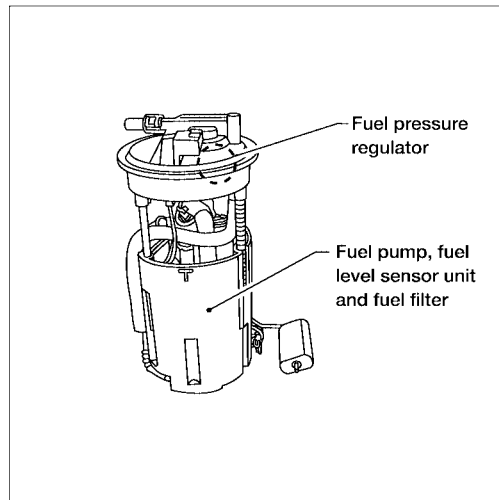
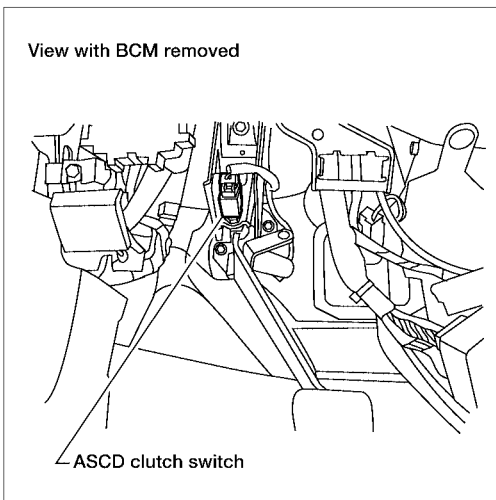
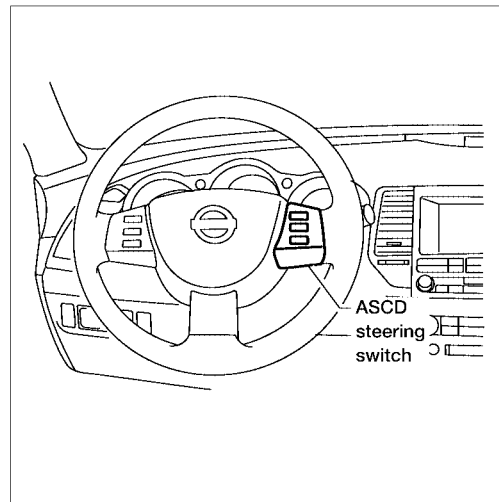
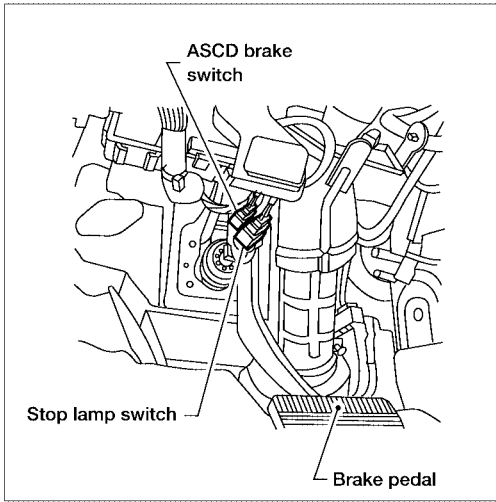

BBA0453E

Vacuum Hose Drawing

UBS00200

A

EC

C

D

E

F

G

H

I

J

K

L

M

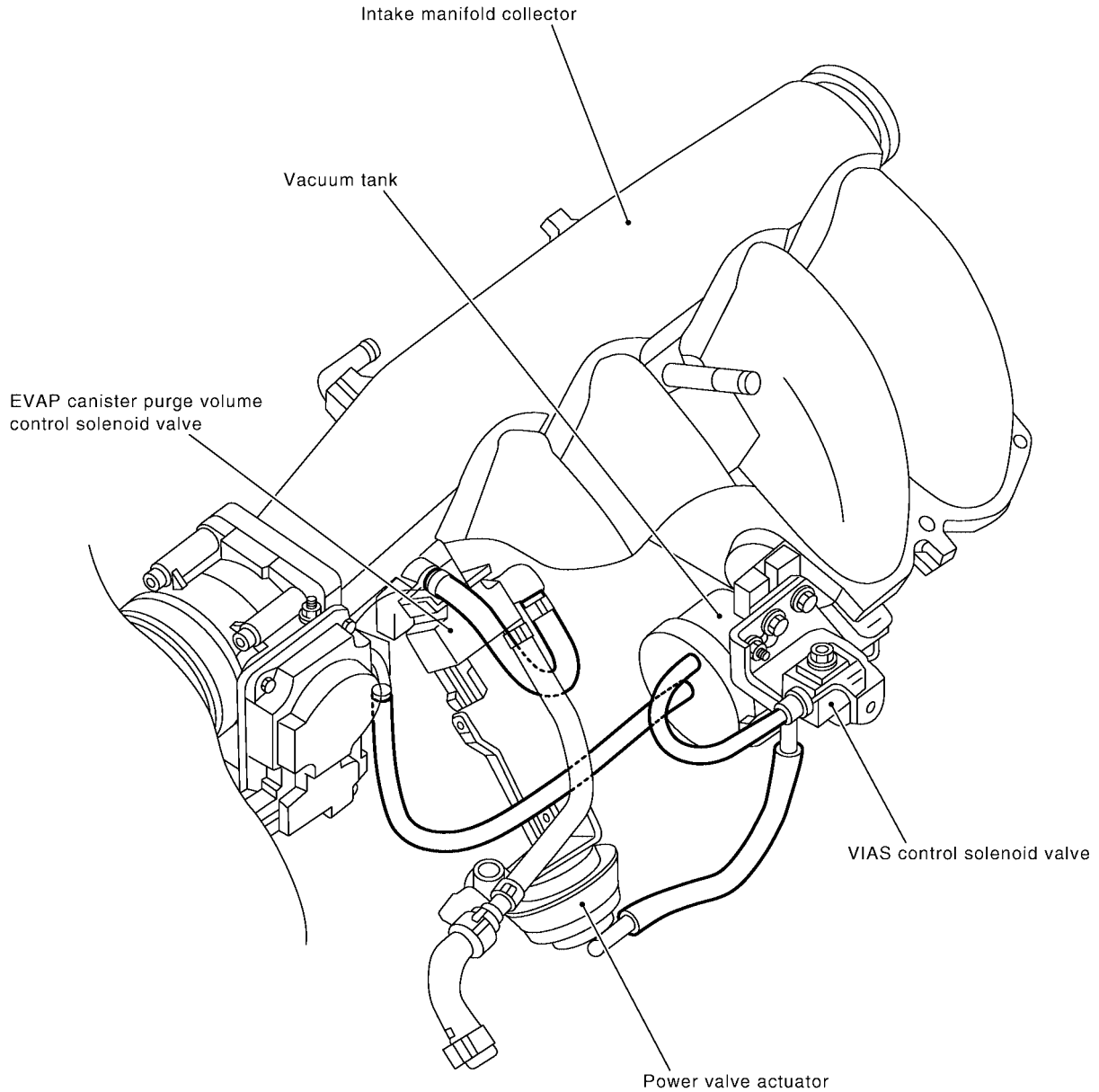

NOTE:
Do not use soapy water or any type of solvent while installing vacuum hose or purge hoses.

Refer to [EC-28, "System Diagram"](#) for Vacuum Control System.

PBIB2027E

TROUBLE DIAGNOSIS

[QR]

Circuit Diagram

UBS0020P

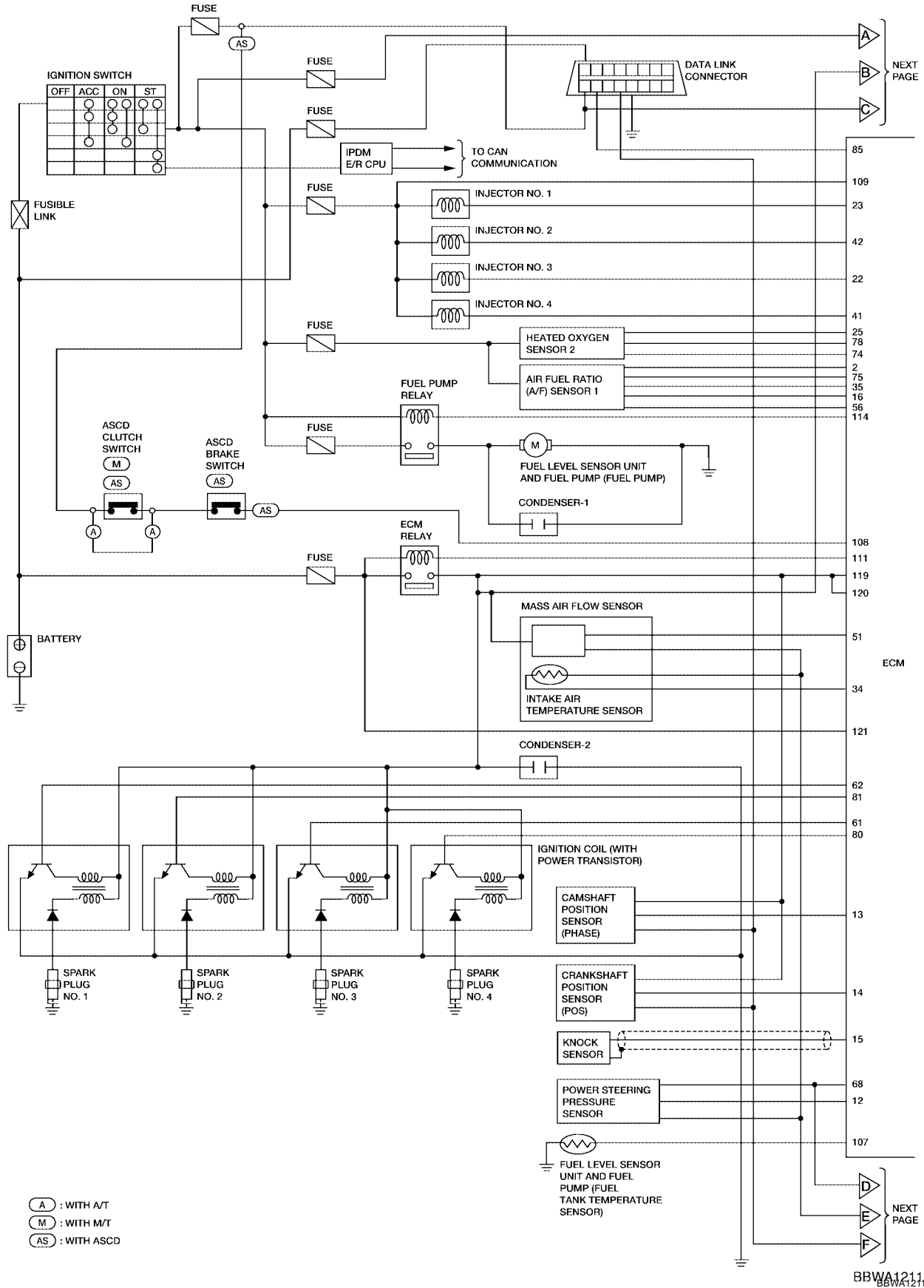

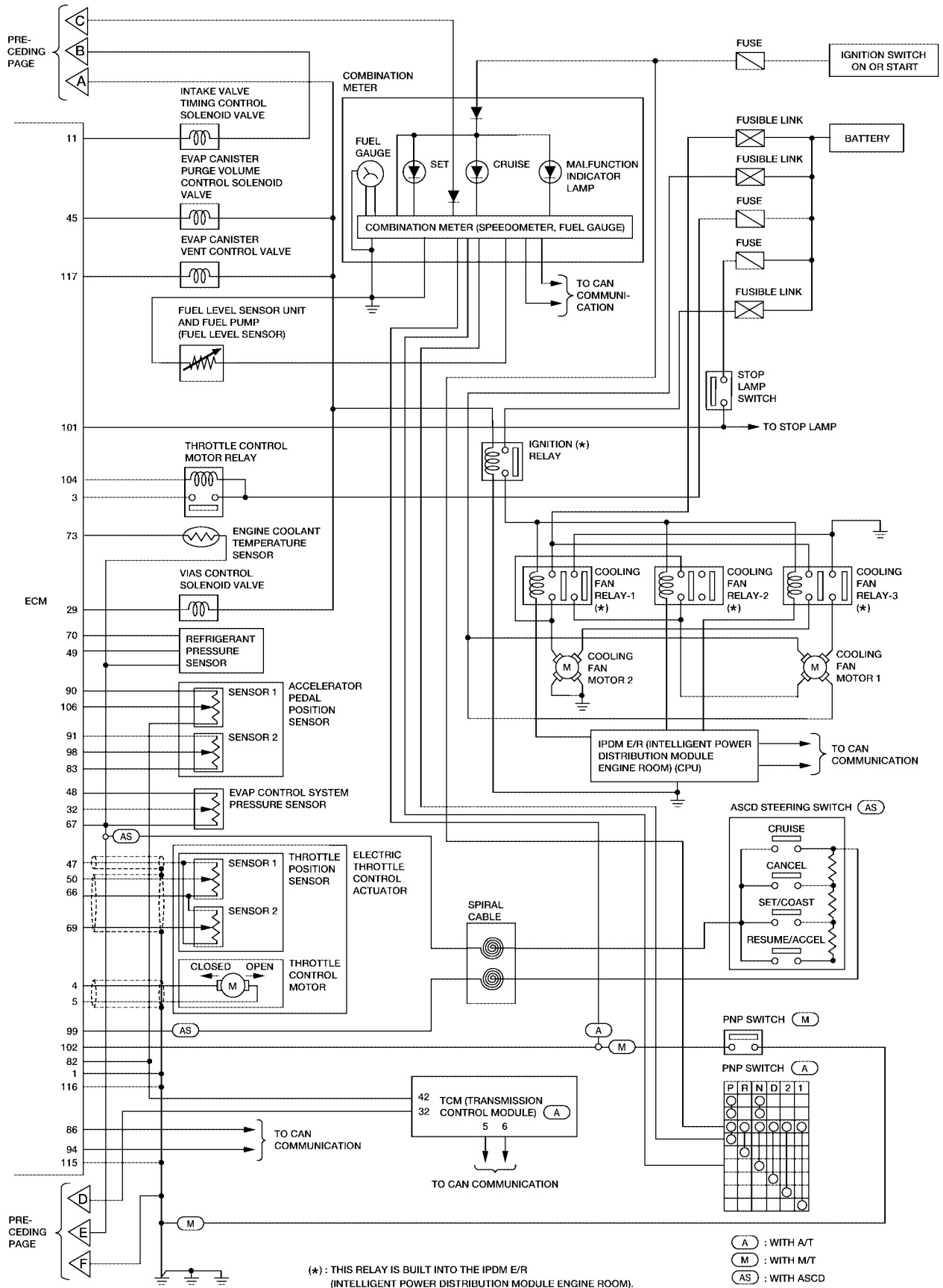

ECM Harness Connector Terminal Layout

UBS00200

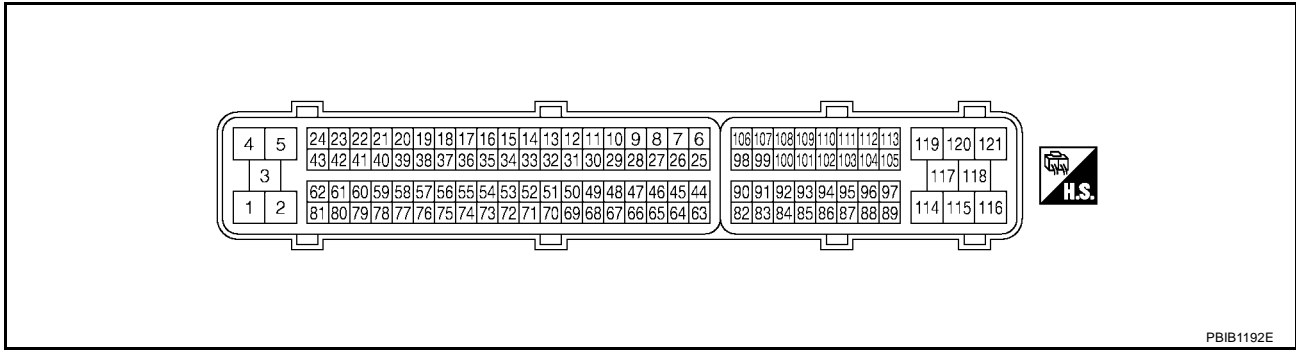

ECM Terminals and Reference Value PREPARATION

UBS00CC6

- ECM is located behind the glove box. For this inspection, remove glove box.

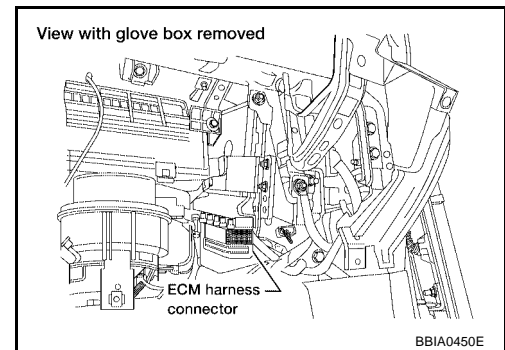

- Remove ECM harness protector.
- When disconnecting ECM harness connector, loosen it with lever as far as it will go as shown at right.
- Connect a break-out box (SST) and Y-cable adapter (SST) between the ECM and ECM harness connector.
 - Use extreme care not to touch 2 pins at one time.
 - Data is for comparison and may not be exact.

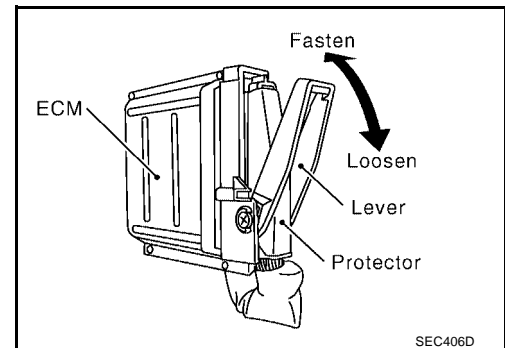

ECM INSPECTION TABLE

Specification data are reference values and are measured between each terminal and ground. Pulse signal is measured by CONSULT-II.

CAUTION:

Do not use ECM ground terminals when measuring input/output voltage. Doing so may result in damage to the ECM's transistor. Use a ground other than ECM terminals, such as the ground.

TROUBLE DIAGNOSIS

[QR]

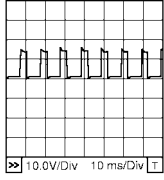
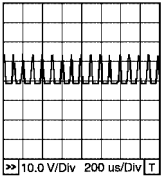
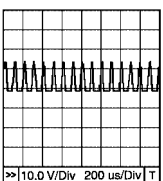
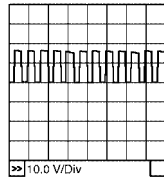
TERMI- NAL NO.	WIRE COLOR	ITEM	CONDITION	DATA (DC Voltage)	
1	B	ECM ground	[Engine is running] ● Idle speed	Body ground	A
2	R	A/F sensor 1 heater	[Engine is running] ● Warm-up condition ● Idle speed	Approximately 5V★  PBIB1584E	EC C
3	R	Throttle control motor power supply	[Ignition switch: ON]	BATTERY VOLTAGE (11 - 14V)	D E
4	BR	Throttle control motor (Close)	[Ignition switch: ON] ● Engine stopped ● Shift lever: D (A/T), 1ST (M/T) ● Accelerator pedal: Released	0 - 14V★  PBIB0534E	F G
5	Y	Throttle control motor (Open)	[Ignition switch: ON] ● Engine stopped ● Shift lever: D (A/T), 1ST (M/T) ● Accelerator pedal: Fully depressed	0 - 14V★  PBIB0533E	H I J
11	G	Intake valve timing control solenoid valve	[Engine is running] ● Warm-up condition ● Idle speed	BATTERY VOLTAGE (11 - 14V)	K
			[Engine is running] ● Warm-up condition ● Engine speed 2,500 rpm	7 - 10V★  PBIB1790E	L M
12	P	Power steering pressure sensor	[Engine is running] ● Steering wheel is being turned	0.5 - 4.0V	
			[Engine is running] ● Steering wheel is not being turned	0.4 - 0.8V	

TROUBLE DIAGNOSIS

[QR]

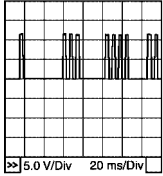
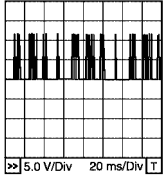
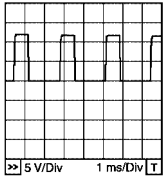
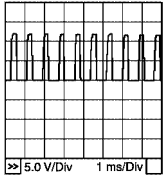
TERMI- NAL NO.	WIRE COLOR	ITEM	CONDITION	DATA (DC Voltage)
13	W	Camshaft position sensor (PHASE)	[Engine is running] <ul style="list-style-type: none"> ● Warm-up condition ● Idle speed NOTE: The pulse cycle changes depending on rpm at idle.	1.0 - 4.0V★  PBIB0525E
			[Engine is running] <ul style="list-style-type: none"> ● Engine speed is 2,000 rpm. 	1.0 - 4.0V★  PBIB0526E
14	W	Crankshaft position sensor (POS)	[Engine is running] <ul style="list-style-type: none"> ● Warm-up condition ● Idle speed NOTE: The pulse cycle changes depending on rpm at idle.	Approximately 3.0V★  PBIB0527E
			[Engine is running] <ul style="list-style-type: none"> ● Engine speed is 2,000 rpm 	Approximately 3.0V★  PBIB0528E
15	W	Knock sensor	[Engine is running] <ul style="list-style-type: none"> ● Idle speed 	Approximately 2.5V
16	OR/L	A/F sensor 1	[Engine is running] <ul style="list-style-type: none"> ● Warm-up condition ● Idle speed 	Approximately 3.1V
35	B/Y			Approximately 2.6V
56	OR			2 - 3V
75	W/L			2 - 3V

TROUBLE DIAGNOSIS

[QR]

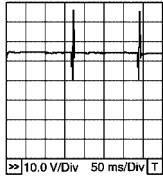
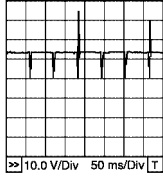
TERMI- NAL NO.	WIRE COLOR	ITEM	CONDITION	DATA (DC Voltage)	
22 23 41 42	R/Y R/B R/L R/W	Injector No. 3 Injector No. 1 Injector No. 4 Injector No. 2	<p>[Engine is running]</p> <ul style="list-style-type: none"> ● Warm-up condition ● Idle speed <p>NOTE: The pulse cycle changes depending on rpm at idle.</p>	<p>BATTERY VOLTAGE (11 - 14V)★</p>  <p style="text-align: right; font-size: small;">PBIB0529E</p>	EC
			<p>[Engine is running]</p> <ul style="list-style-type: none"> ● Warm-up condition ● Engine speed is 2,000 rpm 	<p>BATTERY VOLTAGE (11 - 14V)★</p>  <p style="text-align: right; font-size: small;">PBIB0530E</p>	C
25	P/B	Heated oxygen sensor 2 heater	<p>[Engine is running]</p> <ul style="list-style-type: none"> ● Warm-up condition ● Engine speed: Below 3,600 rpm after the following conditions are met. ● Keeping the engine speed between 3,500 and 4,000 rpm for 1 minute and at idle for 1 minute under on load 	0 - 1.0V	D
			<p>[Ignition switch: ON]</p> <ul style="list-style-type: none"> ● Engine stopped. <p>[Engine is running]</p> <ul style="list-style-type: none"> ● Engine speed is above 3,600 rpm. 	<p>BATTERY VOLTAGE (11 - 14V)</p>	E
29	Y/G	VIAS control solenoid valve	<p>[Engine is running]</p> <ul style="list-style-type: none"> ● Idle speed 	<p>BATTERY VOLTAGE (11 - 14V)</p>	F
			<p>[Engine is running]</p> <ul style="list-style-type: none"> ● Engine speed is above 5,000 rpm 	0 - 1.0V	G
32	W	EVAP control system pressure sensor	<p>[Ignition switch: ON]</p>	Approximately 1.8 - 4.8V	H
34	Y/G	Intake air temperature sensor	<p>[Engine is running]</p>	Approximately 0 - 4.8V Output voltage varies with intake air temperature.	I
					J
					K
					L
					M

TROUBLE DIAGNOSIS

[QR]

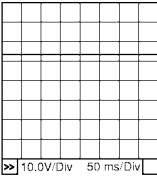
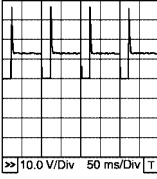
TERMI- NAL NO.	WIRE COLOR	ITEM	CONDITION	DATA (DC Voltage)
45	PU/R	EVAP canister purge vol- ume control solenoid valve	<p>[Engine is running]</p> <ul style="list-style-type: none"> ● Idle speed ● Accelerator pedal is not depressed even slightly, after engine starting 	<p>BATTERY VOLTAGE (11 - 14V)★</p>  <p style="text-align: right; font-size: small;">PBIB0050E</p>
			<p>[Engine is running]</p> <ul style="list-style-type: none"> ● Engine speed is about 2,000 rpm (More than 100 seconds after starting engine) 	<p>Approximately 10V★</p>  <p style="text-align: right; font-size: small;">PBIB0520E</p>
47	R	Sensor power supply (Throttle position sensor)	[Ignition switch: ON]	Approximately 5V
48	R	Sensor power supply (EVAP control system pres- sure sensor)	[Ignition switch: ON]	Approximately 5V
49	R	Sensor power supply (Refrigerant pressure sensor)	[Ignition switch: ON]	Approximately 5V
50	W	Throttle position sensor 1	<p>[Ignition switch: ON]</p> <ul style="list-style-type: none"> ● Engine stopped ● Shift lever: D (A/T), 1ST (M/T) ● Accelerator pedal: Fully released 	More than 0.36V
			<p>[Ignition switch: ON]</p> <ul style="list-style-type: none"> ● Engine stopped ● Shift lever: D (A/T), 1ST (M/T) ● Accelerator pedal: Fully depressed 	Less than 4.75V
51	W	Mass air flow sensor	<p>[Engine is running]</p> <ul style="list-style-type: none"> ● Warm-up condition ● Idle speed 	0.9 - 1.2V
			<p>[Engine is running]</p> <ul style="list-style-type: none"> ● Warm-up condition ● Engine speed is 2,500 rpm. 	1.4 - 1.7V

TROUBLE DIAGNOSIS

[QR]

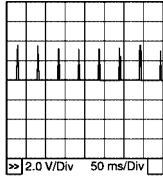
TERMI- NAL NO.	WIRE COLOR	ITEM	CONDITION	DATA (DC Voltage)	
61 62 80 81	L/R Y/R G/Y G/R	Ignition signal No. 3 Ignition signal No. 1 Ignition signal No. 4 Ignition signal No. 2	[Engine is running] <ul style="list-style-type: none"> ● Warm-up condition ● Idle speed NOTE: The pulse cycle changes depending on rpm at idle.	0 - 0.1V★  PBIB0521E	EC
			[Engine is running] <ul style="list-style-type: none"> ● Warm-up condition ● Engine speed is 2,000 rpm. 	0 - 0.2V★  PBIB0522E	
66	B	Sensor ground (Throttle position sensor)	[Engine is running] <ul style="list-style-type: none"> ● Warm-up condition ● Idle speed 	Approximately 0V	G
67	B	Sensor ground	[Engine is running] <ul style="list-style-type: none"> ● Warm-up condition ● Idle speed 	Approximately 0V	H
68	G/R	Sensor power supply (Power steering pressure sensor)	[Ignition switch: ON]	Approximately 5V	I
69	R	Throttle position sensor 2	[Ignition switch: ON] <ul style="list-style-type: none"> ● Engine stopped ● Shift lever: D (A/T), 1ST (M/T) ● Accelerator pedal: Fully released 	Less than 4.75V	J
			[Ignition switch: ON] <ul style="list-style-type: none"> ● Engine stopped ● Shift lever: D (A/T), 1ST (M/T) ● Accelerator pedal: Fully depressed 	More than 0.36V	K
70	W	Refrigerant pressure sensor	[Engine is running] <ul style="list-style-type: none"> ● Warm-up condition ● Both A/C switch and blower switch are ON (Compressor operates.) 	1.0 - 4.0V	M
73	Y	Engine coolant temperature sensor	[Engine is running]	Approximately 0 - 4.8V Output voltage varies with engine coolant temperature.	
74	W	Heated oxygen sensor 2	[Engine is running] <ul style="list-style-type: none"> ● Warm-up condition ● Revving engine from idle up to 3,000 rpm quickly after the following conditions are met. ● Keeping the engine speed between 3,500 and 4,000 rpm for 1 minute and at idle for 1 minute under no load. 	0 - Approximately 1.0V	
78	B	Sensor ground (Heated oxygen sensor)	[Engine is running] <ul style="list-style-type: none"> ● Warm-up condition ● Idle speed 	Approximately 0V	

TROUBLE DIAGNOSIS

[QR]

TERMI- NAL NO.	WIRE COLOR	ITEM	CONDITION	DATA (DC Voltage)
82	B	Sensor ground (Accelerator pedal position sensor 1)	[Engine is running] ● Warm-up condition ● Idle speed	Approximately 0V
83	G	Sensor ground (Accelerator pedal position sensor 2)	[Engine is running] ● Warm-up condition ● Idle speed	Approximately 0V
85	OR	DATA link connector	[Ignition switch: ON] ● CONSULT-II or GST is disconnected.	BATTERY VOLTAGE (11 - 14V)
86	P	CAN communication line	[Ignition switch: ON]	Approximately 2.3V
90	R	Sensor power supply (Accelerator pedal position sensor 1)	[Ignition switch: ON]	Approximately 5V
91	OR	Sensor power supply (Accelerator pedal position sensor 2)	[Ignition switch: ON]	Approximately 5V
94	L	CAN communication line	[Ignition switch: ON]	Approximately 2.8V
98	W/B	Accelerator pedal position sensor 2	[Ignition switch: ON] ● Engine stopped ● Accelerator pedal: Fully released	0.28 - 0.48V
			[Ignition switch: ON] ● Engine stopped ● Accelerator pedal: Fully depressed	More than 2.0V
99	G/Y	ASCD steering switch	[Ignition switch: ON] ● ASCD steering switch: OFF	Approximately 4V
			[Ignition switch: ON] ● CRUISE switch: Pressed	Approximately 0V
			[Ignition switch: ON] ● CANCEL switch: Pressed	Approximately 1V
			[Ignition switch: ON] ● SET/COAST switch: Pressed	Approximately 2V
			[Ignition switch: ON] ● RESUME/ACCEL switch: Pressed	Approximately 3V
101	R/G	Stop lamp switch	[Ignition switch: ON] ● Brake pedal: Fully released	Approximately 0V
			[Ignition switch: ON] ● Brake pedal: Depressed	BATTERY VOLTAGE (11 - 14V)
102	GW	PNP switch	[Ignition switch: ON] ● Gear position is P or N	Approximately 0V
			[Ignition switch: ON] ● Except the above gear position	A/T models BATTERY VOLTAGE (11 - 14V) M/T models Approximately 5V
104	OR	Throttle control motor relay	[Ignition switch: OFF]	BATTERY VOLTAGE (11 - 14V)
			[Ignition switch: ON]	0 - 1.0V

TROUBLE DIAGNOSIS

[QR]

TERMI- NAL NO.	WIRE COLOR	ITEM	CONDITION	DATA (DC Voltage)	A
106	W	Accelerator pedal position sensor 1	[Ignition switch: ON] <ul style="list-style-type: none"> ● Engine stopped ● Accelerator pedal: Fully released 	0.65 - 0.87V	EC
			[Ignition switch: ON] <ul style="list-style-type: none"> ● Engine stopped ● Accelerator pedal: Fully depressed 	More than 4.3V	C
107	P/L	Fuel tank temperature sensor	[Engine is running]	Approximately 0 - 4.8V Output voltage varies with fuel tank temperature.	D
108	G/B*1 G/R*2	ASCD brake switch	[Ignition switch: ON] <ul style="list-style-type: none"> ● Brake pedal: Depressed ● Clutch pedal: Depressed (M/T) 	Approximately 0V	E
			[Ignition switch: ON] <ul style="list-style-type: none"> ● Brake pedal: Fully released ● Clutch pedal: Released (M/T) 	BATTERY VOLTAGE (11 - 14V)	F
109	R	Ignition switch	[Ignition switch: OFF]	0V	G
			[Ignition switch: ON]	BATTERY VOLTAGE (11 - 14V)	H
111	W/B	ECM relay (Self shut-off)	[Engine is running] [Ignition switch: OFF] <ul style="list-style-type: none"> ● A few seconds after turning ignition switch OFF 	0 - 1.0V	I
			[Ignition switch: OFF] <ul style="list-style-type: none"> ● More than a few seconds after turning ignition switch OFF 	BATTERY VOLTAGE (11 - 14V)	J
114	B/OR	Fuel pump relay	[Ignition switch: ON] <ul style="list-style-type: none"> ● For 1 second after turning ignition switch ON 	0 - 1.0V	K
			[Engine is running] <ul style="list-style-type: none"> ● More than 1 second after turning ignition switch ON 	BATTERY VOLTAGE (11 - 14V)	L
115 116	B	ECM ground	[Engine is running] <ul style="list-style-type: none"> ● Idle speed 	Body ground	M
117	OR	EVAP canister vent control valve	[Ignition switch: ON]	BATTERY VOLTAGE (11 - 14V)	
119 120	R/G	Power supply for ECM	[Ignition switch: ON]	BATTERY VOLTAGE (11 - 14V)	
121	W/L	Power supply for ECM (Back-up)	[Ignition switch: OFF]	BATTERY VOLTAGE (11 - 14V)	

★: Average voltage for pulse signal (Actual pulse signal can be confirmed by oscilloscope.)

*1: A/T models

*2: M/T models

TROUBLE DIAGNOSIS

[QR]

CONSULT-II Function (ENGINE) FUNCTION

UBS0020S

Diagnostic test mode	Function
Work support	This mode enables a technician to adjust some devices faster and more accurately by following the indications on the CONSULT-II unit.
Self-diagnostic results	Self-diagnostic results such as 1st trip DTC, DTCs and 1st trip freeze frame data or freeze frame data can be read and erased quickly.*1
Data monitor	Input/Output data in the ECM can be read.
Data monitor (SPEC)	Input/Output of the specification for Basic fuel schedule, AFM, A/F feedback control value and the other data monitor items can be read.
CAN diagnostic support monitor	The results of transmit/receive diagnosis of CAN communication can be read.
Active test	Diagnostic Test Mode in which CONSULT-II drives some actuators apart from the ECMs and also shifts some parameters in a specified range.
Function test	This mode is used to inform customers when their vehicle condition requires periodic maintenance.
DTC & SRT confirmation	The status of system monitoring tests and the self-diagnosis status/result can be confirmed.
ECM part number	ECM part number can be read.

*1 The following emission-related diagnostic information is cleared when the ECM memory is erased.

1. Diagnostic trouble codes
2. 1st trip diagnostic trouble codes
3. Freeze frame data
4. 1st trip freeze frame data
5. System readiness test (SRT) codes
6. Test values

TROUBLE DIAGNOSIS

[QR]

ENGINE CONTROL COMPONENT PARTS/CONTROL SYSTEMS APPLICATION

Item		DIAGNOSTIC TEST MODE							A	
		WORK SUP-PORT	SELF-DIAGNOSTIC RESULTS		DATA MONI-TOR	DATA MONI-TOR (SPEC)	ACTIVE TEST	DTC & SRT CONFIRMATION		EC
			DTC*1	FREEZE FRAME DATA*2				SRT STATUS	DTC WORK SUP-PORT	
ENGINE CONTROL COMPONENT PARTS INPUT	Crankshaft position sensor (POS)		×	×	×	×				D
	Camshaft position sensor (PHASE)		×		×	×				E
	Mass air flow sensor		×		×	×				F
	Engine coolant temperature sensor		×	×	×	×	×			G
	A/F sensor 1		×		×			×	×	H
	Heated oxygen sensor 2		×		×	×		×	×	I
	Vehicle speed sensor		×	×	×	×				J
	Accelerator pedal position sensor		×		×	×				K
	Throttle position sensor		×		×	×				L
	Fuel tank temperature sensor		×		×	×	×			M
	EVAP control system pressure sensor		×		×	×				
	Intake air temperature sensor		×		×	×				
	Knock sensor		×							
	Refrigerant pressure sensor				×	×				
	Closed throttle position switch (accelerator pedal position sensor signal)				×	×				
	Air conditioner switch				×	×				
	Park/neutral position (PNP) switch		×		×	×				
	Stop lamp switch		×		×	×				
	Power steering pressure sensor		×		×	×				
	Battery voltage				×	×				
Load signal				×	×					
Fuel level sensor		×		×	×					
ASCD steering switch		×		×	×					
ASCD brake switch		×		×	×					

TROUBLE DIAGNOSIS

[QR]

Item		DIAGNOSTIC TEST MODE							
		WORK SUP-PORT	SELF-DIAGNOSTIC RESULTS		DATA MONI-TOR	DATA MONI-TOR (SPEC)	ACTIVE TEST	DTC & SRT CONFIRMATION	
			DTC*1	FREEZE FRAME DATA*2				SRT STATUS	DTC WORK SUP-PORT
ENGINE CONTROL COMPONENT PARTS OUTPUT	Injector				×	×	×		
	Power transistor (Ignition timing)				×	×	×		
	Throttle control motor relay		×		×	×			
	Throttle control motor		×						
	EVAP canister purge volume control solenoid valve		×		×	×	×		×
	Air conditioner relay				×	×			
	Fuel pump relay	×			×	×	×		
	Cooling fan relay		×		×	×	×		
	A/F sensor 1 heater		×		×	×		×	
	Heated oxygen sensor 2 heater		×		×	×		×	
	EVAP canister vent control valve	×	×		×	×	×		
	Intake valve timing control solenoid valve		×		×	×	×		
	VIAS control solenoid valve		×		×	×	×		
	Calculated load value			×	×	×			

X: Applicable

*1: This item includes 1st trip DTCs.

*2: This mode includes 1st trip freeze frame data or freeze frame data. The items appear on CONSULT-II screen in freeze frame data mode only if a 1st trip DTC or DTC is detected. For details, refer to [EC-57](#).

INSPECTION PROCEDURE

1. Turn ignition switch OFF.
2. Connect CONSULT-II and CONSULT-II CONVERTER to data link connector, which is located under LH dash panel.
3. Turn ignition switch ON.

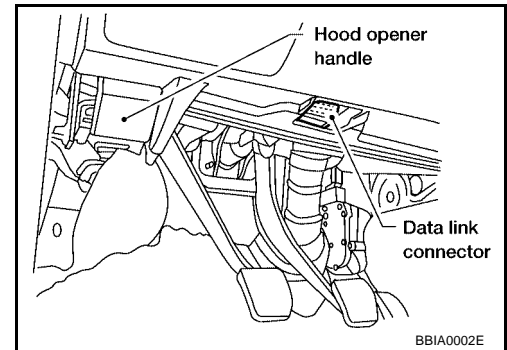

4. Touch "START" (NISSAN BASED VHCL).

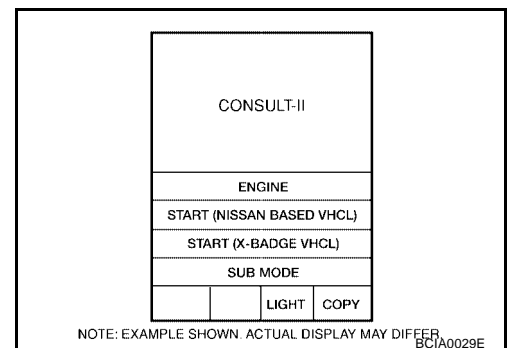

TROUBLE DIAGNOSIS

[QR]

5. Touch "ENGINE".
If "ENGINE" is not indicated, go to [GI-39, "Consult-II Data Link Connector \(DLC\) Circuit"](#).

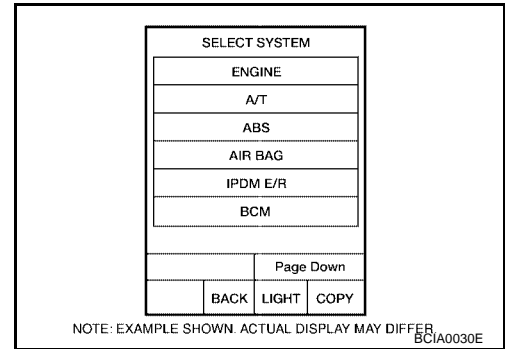

6. Perform each diagnostic test mode according to each service procedure.
For further information, see the CONSULT-II Operation Manual.

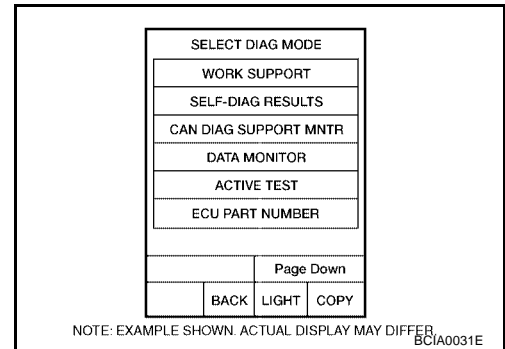

WORK SUPPORT MODE

Work Item

WORK ITEM	CONDITION	USAGE
FUEL PRESSURE RELEASE	<ul style="list-style-type: none"> FUEL PUMP WILL STOP BY TOUCHING "START" DURING IDLING. CRANK A FEW TIMES AFTER ENGINE STALLS. 	When releasing fuel pressure from fuel line
IDLE AIR VOL LEARN	<ul style="list-style-type: none"> THE IDLE AIR VOLUME THAT KEEPS THE ENGINE WITHIN THE SPECIFIED RANGE IS MEMORIZED IN ECM. 	When learning the idle air volume
SELF-LEARNING CONT	<ul style="list-style-type: none"> THE COEFFICIENT OF SELF-LEARNING CONTROL MIXTURE RATIO RETURNS TO THE ORIGINAL COEFFICIENT. 	When clearing the coefficient of self-learning control value
EVAP SYSTEM CLOSE	<p>CLOSE THE EVAP CANISTER VENT CONTROL VALVE IN ORDER TO MAKE EVAP SYSTEM CLOSE UNDER THE FOLLOWING CONDITIONS.</p> <ul style="list-style-type: none"> IGN SW ON ENGINE NOT RUNNING AMBIENT TEMPERATURE IS ABOVE 0°C (32°F). NO VACUUM AND NO HIGH PRESSURE IN EVAP SYSTEM FUEL TANK TEMP. IS MORE THAN 0°C (32°F). WITHIN 10 MINUTES AFTER STARTING "EVAP SYSTEM CLOSE" WHEN TRYING TO EXECUTE "EVAP SYSTEM CLOSE" UNDER THE CONDITION EXCEPT ABOVE, CONSULT-II WILL DISCONTINUE IT AND DISPLAY APPROPRIATE INSTRUCTION. <p>NOTE: WHEN STARTING ENGINE, CONSULT-II MAY DISPLAY "BATTERY VOLTAGE IS LOW. CHARGE BATTERY", EVEN IN USING CHARGED BATTERY.</p>	When detecting EVAP vapor leak point of EVAP system
VIN REGISTRATION	<ul style="list-style-type: none"> IN THIS MODE, VIN IS REGISTERED IN ECM 	When registering VIN in ECM

TROUBLE DIAGNOSIS

[QR]

WORK ITEM	CONDITION	USAGE
TARGET IDLE RPM ADJ*	● IDLE CONDITION	When setting target idle speed
TARGET IGN TIM ADJ*	● IDLE CONDITION	When adjusting target ignition timing

*: This function is not necessary in the usual service procedure.

SELF-DIAG RESULTS MODE

Self Diagnostic Item

Regarding items of "DTC and 1st trip DTC", refer to [EC-15, "INDEX FOR DTC"](#).

Freeze Frame Data and 1st Trip Freeze Frame Data

Freeze frame data item*	Description
DIAG TROUBLE CODE [PXXXX]	● The engine control component part/control system has a trouble code, it is displayed as "PXXXX". (Refer to EC-15, "INDEX FOR DTC" .)
FUEL SYS-B1	<ul style="list-style-type: none"> ● "Fuel injection system status" at the moment a malfunction is detected is displayed. ● One mode in the following is displayed. "Mode 2": Open loop due to detected system malfunction "Mode 3": Open loop due to driving conditions (power enrichment, deceleration enrichment) "Mode 4": Closed loop - using oxygen sensor(s) as feedback for fuel control "Mode 5": Open loop - has not yet satisfied condition to go to closed loop
CAL/LD VALUE [%]	● The calculated load value at the moment a malfunction is detected is displayed.
COOLANT TEMP [°C] or [°F]	● The engine coolant temperature at the moment a malfunction is detected is displayed.
L-FUEL TRM-B1 [%]	<ul style="list-style-type: none"> ● "Long-term fuel trim" at the moment a malfunction is detected is displayed. ● The long-term fuel trim indicates much more gradual feedback compensation to the base fuel schedule than short-term fuel trim.
S-FUEL TRM-B1 [%]	<ul style="list-style-type: none"> ● "Short-term fuel trim" at the moment a malfunction is detected is displayed. ● The short-term fuel trim indicates dynamic or instantaneous feedback compensation to the base fuel schedule.
ENGINE SPEED [rpm]	● The engine speed at the moment a malfunction is detected is displayed.
VEHICL SPEED [km/h] or [mph]	● The vehicle speed at the moment a malfunction is detected is displayed.
B/FUEL SCHDL [msec]	● The base fuel schedule at the moment a malfunction is detected is displayed.
INT/A TEMP SE [°C] or [°F]	● The intake air temperature at the moment a malfunction is detected is displayed.

*: The items are the same as those of 1st trip freeze frame data.

DATA MONITOR MODE

Monitored Item

×: Applicable

Monitored item [Unit]	ECM INPUT SIGNALS	MAIN SIGNALS	Description	Remarks
ENG SPEED [rpm]	×	×	<ul style="list-style-type: none"> ● Indicates the engine speed computed from the signals of the crankshaft position sensor (POS) and camshaft position sensor (PHASE). 	<ul style="list-style-type: none"> ● Accuracy becomes poor if engine speed drops below the idle rpm. ● If the signal is interrupted while the engine is running, an abnormal value may be indicated.
MAS A/F SE-B1 [V]	×	×	<ul style="list-style-type: none"> ● The signal voltage of the mass air flow sensor is displayed. 	<ul style="list-style-type: none"> ● When the engine is stopped, a certain value is indicated.

TROUBLE DIAGNOSIS

[QR]

Monitored item [Unit]	ECM INPUT SIGNALS	MAIN SIGNALS	Description	Remarks	
B/FUEL SCHDL [msec]		×	<ul style="list-style-type: none"> “Base fuel schedule” indicates the fuel injection pulse width programmed into ECM, prior to any learned on board correction. 		A EC
A/F ALPHA-B1 [%]		×	<ul style="list-style-type: none"> The mean value of the air-fuel ratio feedback correction factor per cycle is indicated. 	<ul style="list-style-type: none"> When the engine is stopped, a certain value is indicated. This data also includes the data for the air-fuel ratio learning control. 	C D
COOLAN TEMP/S [°C] or [°F]	×	×	<ul style="list-style-type: none"> The engine coolant temperature (determined by the signal voltage of the engine coolant temperature sensor) is displayed. 	<ul style="list-style-type: none"> When the engine coolant temperature sensor is open or short-circuited, ECM enters fail-safe mode. The engine coolant temperature determined by the ECM is displayed. 	E
A/F SEN1 (B1) [V]	×	×	<ul style="list-style-type: none"> The A/F signal computed from the input signal of the A/F sensor 1 is displayed. 		F
HO2S2 (B1) [V]	×		<ul style="list-style-type: none"> The signal voltage of the heated oxygen sensor 2 is displayed. 		G
HO2S2 MNTR (B1) [RICH/LEAN]	×		<ul style="list-style-type: none"> Display of heated oxygen sensor 2 signal: RICH... means the amount of oxygen after three way catalyst is relatively small. LEAN... means the amount of oxygen after three way catalyst is relatively large. 	<ul style="list-style-type: none"> When the engine is stopped, a certain value is indicated. 	H
VHCL SPEED SE [km/h] or [mph]	×	×	<ul style="list-style-type: none"> The vehicle speed computed from the vehicle speed signal sent from combination meter is displayed. 		I
BATTERY VOLT [V]	×	×	<ul style="list-style-type: none"> The power supply voltage of ECM is displayed. 		J
ACCEL SEN 1 [V]	×	×	<ul style="list-style-type: none"> The accelerator pedal position sensor signal voltage is displayed. 	<ul style="list-style-type: none"> ACCEL SEN 2 signal is converted by ECM internally. Thus, it differs from ECM terminal voltage signal. 	K
ACCEL SEN 2 [V]	×				
THRTL SEN 1 [V]	×	×	<ul style="list-style-type: none"> The throttle position sensor signal voltage is displayed. 	<ul style="list-style-type: none"> THRTL SEN 2 signal is converted by ECM internally. Thus, it differs from ECM terminal voltage signal. 	L
THRTL SEN 2 [V]	×				
FUEL T/TEMP SE [°C] or [°F]	×		<ul style="list-style-type: none"> The fuel temperature (determined by the signal voltage of the fuel tank temperature sensor) is displayed. 		M
VEHICLE SPEED [km/h] or [MPH]	×	×	<ul style="list-style-type: none"> Indicates the vehicle speed computed from the revolution sensor signal. 		
INT/A TEMP SE [°C] or [°F]	×	×	<ul style="list-style-type: none"> The intake air temperature (determined by the signal voltage of the intake air temperature sensor) is indicated. 		
EVAP SYS PRES [V]	×		<ul style="list-style-type: none"> The signal voltage of EVAP control system pressure sensor is displayed. 		
FUEL LEVEL SE [V]	×		<ul style="list-style-type: none"> The signal voltage of the fuel level sensor is displayed. 		
START SIGNAL [ON/OFF]	×	×	<ul style="list-style-type: none"> Indicates start signal status [ON/OFF] computed by the ECM according to the signals of engine speed and battery voltage. 	<ul style="list-style-type: none"> After starting the engine, [OFF] is displayed regardless of the starter signal. 	
CLSD THL POS [ON/OFF]	×	×	<ul style="list-style-type: none"> Indicates idle position [ON/OFF] computed by ECM according to the accelerator pedal position sensor signal. 		

TROUBLE DIAGNOSIS

[QR]

Monitored item [Unit]	ECM INPUT SIGNALS	MAIN SIGNALS	Description	Remarks
AIR COND SIG [ON/OFF]	×	×	<ul style="list-style-type: none"> Indicates [ON/OFF] condition of the air conditioner switch as determined by the air conditioner signal. 	
P/N POSI SW [ON/OFF]	×	×	<ul style="list-style-type: none"> Indicates [ON/OFF] condition from the park/neutral position (PNP) switch signal. 	
PW/ST SIGNAL [ON/OFF]	×	×	<ul style="list-style-type: none"> [ON/OFF] condition of the power steering pressure sensor as determined by the power steering pressure sensor signal is indicated. 	
LOAD SIGNAL [ON/OFF]	×	×	<ul style="list-style-type: none"> Indicates [ON/OFF] condition from the electrical load signal. ON... Rear window defogger switch is ON and/or lighting switch is in 2nd position. OFF... Both rear window defogger switch and lighting switch are OFF. 	
IGNITION SW [ON/OFF]	×	×	<ul style="list-style-type: none"> Indicates [ON/OFF] condition from ignition switch. 	
HEATER FAN SW [ON/OFF]	×		<ul style="list-style-type: none"> Indicates [ON/OFF] condition from the heater fan switch signal. 	
BRAKE SW [ON/OFF]	×		<ul style="list-style-type: none"> Indicates [ON/OFF] condition from the stop lamp switch signal. 	
INJ PULSE-B1 [msec]		×	<ul style="list-style-type: none"> Indicates the actual fuel injection pulse width compensated by ECM according to the input signals. 	<ul style="list-style-type: none"> When the engine is stopped, a certain computed value is indicated.
IGN TIMING [BTDC]		×	<ul style="list-style-type: none"> Indicates the ignition timing computed by ECM according to the input signals. 	<ul style="list-style-type: none"> When the engine is stopped, a certain value is indicated.
CAL/LD VALUE [%]			<ul style="list-style-type: none"> "Calculated load value" indicates the value of the current airflow divided by peak airflow. 	
MASS AIRFLOW [g·m/s]			<ul style="list-style-type: none"> Indicates the mass airflow computed by ECM according to the signal voltage of the mass air flow sensor. 	
PURG VOL C/V [%]			<ul style="list-style-type: none"> Indicates the EVAP canister purge volume control solenoid valve control value computed by the ECM according to the input signals. The opening becomes larger as the value increases. 	
INT/V TIM (B1) [°CA]			<ul style="list-style-type: none"> Indicates [°CA] of intake camshaft advanced angle. 	
INT/V SOL (B1) [%]			<ul style="list-style-type: none"> The control value of the intake valve timing control solenoid valve (determined by ECM according to the input signal) is indicated. The advance angle becomes larger as the value increases. 	
VIAS S/V [ON/OFF]			<ul style="list-style-type: none"> The control condition of the VIAS control solenoid valve (determined by ECM according to the input signals) is indicated. ON... VIAS control solenoid valve is operating. OFF... VIAS control solenoid valve is not operating. 	

TROUBLE DIAGNOSIS

[QR]

Monitored item [Unit]	ECM INPUT SIG- NALS	MAIN SIG- NALS	Description	Remarks	A
AIR COND RLY [ON/OFF]		×	<ul style="list-style-type: none"> The air conditioner relay control condition (determined by ECM according to the input signals) is indicated. 		EC
FUEL PUMP RLY [ON/OFF]		×	<ul style="list-style-type: none"> Indicates the fuel pump relay control condition determined by ECM according to the input signals. 		C
VENT CONT/V [ON/OFF]			<ul style="list-style-type: none"> The control condition of the EVAP canister vent control valve (determined by ECM according to the input signals) is indicated. ON... Closed OFF... Open 		D
THRTL RELAY [ON/OFF]		×	<ul style="list-style-type: none"> Indicates the throttle control motor relay control condition determined by the ECM according to the input signals. 		E
COOLING FAN [HI/LOW/OFF]			<ul style="list-style-type: none"> Indicates the condition of the cooling fan (determined by ECM according to the input signals). HI... High speed operation LOW... Low speed operation OFF... Stop 		F
HO2S2 HTR (B1) [ON/OFF]			<ul style="list-style-type: none"> Indicates [ON/OFF] condition of heated oxygen sensor 2 heater determined by ECM according to the input signals. 		G
IDL A/V LEARN [YET/CMPLT]			<ul style="list-style-type: none"> Display the condition of idle air volume learning YET... Idle air volume learning has not been performed yet. CMPLT... Idle air volume learning has already been performed successfully. 		H
TRVL AFTER MIL [km] or [mile]			<ul style="list-style-type: none"> Distance traveled while MIL is activated. 		I
A/F S1 HTR (B1) [%]			<ul style="list-style-type: none"> Indicates A/F sensor 1 heater control value computed by ECM according to the input signals. The current flow to the heater becomes larger as the value increases. 		J
AC PRESS SEN [V]	×		<ul style="list-style-type: none"> The signal voltage from the refrigerant pressure sensor is displayed. 		K
VHCL SPEED SE [km/h] or [mph]			<ul style="list-style-type: none"> The vehicle speed computed from the vehicle speed signal sent from TCM is displayed. 		L
SET VHCL SPD [km/h] or [mph]			<ul style="list-style-type: none"> The preset vehicle speed is displayed. 		M
MAIN SW [ON/OFF]			<ul style="list-style-type: none"> Indicates [ON/OFF] condition from CRUISE switch signal. 		
CANCEL SW [ON/OFF]			<ul style="list-style-type: none"> Indicates [ON/OFF] condition from CANCEL switch signal. 		
RESUME/ACC SW [ON/OFF]			<ul style="list-style-type: none"> Indicates [ON/OFF] condition from RESUME/ACCEL switch signal. 		
SET SW [ON/OFF]			<ul style="list-style-type: none"> Indicates [ON/OFF] condition from SET/COAST switch signal. 		

TROUBLE DIAGNOSIS

[QR]

Monitored item [Unit]	ECM INPUT SIGNALS	MAIN SIGNALS	Description	Remarks
BRAKE SW1 SW [ON/OFF]			<ul style="list-style-type: none"> Indicates [ON/OFF] condition from ASCD brake switch signal, and ASCD clutch switch signal (M/T models). 	
BRAKE SW2 SW [ON/OFF]			<ul style="list-style-type: none"> Indicates [ON/OFF] condition of stop lamp switch signal. 	
VHCL SPD CUT [NON/CUT]			<ul style="list-style-type: none"> Indicates the vehicle cruise condition. NON... Vehicle speed is maintained at the ASCD set speed. CUT...Vehicle speed increased to excessively high compared with the ASCD set speed, and ASCD operation is cut off. 	
LO SPEED CUT [NON/CUT]			<ul style="list-style-type: none"> Indicates the vehicle cruise condition. NON... Vehicle speed is maintained at the ASCD set speed. CUT...Vehicle speed decreased to excessively low compared with the ASCD set speed, and ASCD operation is cut off. 	
AT OD MONITOR [ON/OFF]			<ul style="list-style-type: none"> Indicates [ON/OFF] condition of A/T O/D according to the input signal from the TCM. 	<ul style="list-style-type: none"> For M/T models always "OFF" is displayed.
AT OD CANCEL [ON/OFF]			<ul style="list-style-type: none"> Indicates [ON/OFF] condition of A/T O/D cancel signal sent from the TCM. 	<ul style="list-style-type: none"> For M/T models always "OFF" is displayed.
CRUISE LAMP [ON/OFF]			<ul style="list-style-type: none"> Indicates [ON/OFF] condition of CRUISE lamp determined by the ECM according to the input signals. 	
SET LAMP [ON/OFF]			<ul style="list-style-type: none"> Indicates [ON/OFF] condition of SET lamp determined by the ECM according to the input signals. 	
Voltage [V]			<ul style="list-style-type: none"> Voltage, frequency, duty cycle or pulse width measured by the probe. 	<ul style="list-style-type: none"> Only "#" is displayed if item is unable to be measured. Figures with "#"s are temporary ones. They are the same figures as an actual piece of data which was just previously measured.
Frequency [msec], [Hz] or [%]				
DUTY-HI				
DUTY-LOW				
PLS WIDTH-HI				
PLS WIDTH-LOW				

DATA MONITOR (SPEC) MODE

Monitored Item

Monitored item [Unit]	ECM INPUT SIGNALS	MAIN SIGNALS	Description	Remarks
ENG SPEED [rpm]	×		<ul style="list-style-type: none"> Indicates the engine speed computed from the signal of the crankshaft position sensor (POS). 	
MAS A/F SE-B1 [V]	×	×	<ul style="list-style-type: none"> The signal voltage of the mass air flow sensor specification is displayed. 	<ul style="list-style-type: none"> When engine is running specification range is indicated.

TROUBLE DIAGNOSIS

[QR]

Monitored item [Unit]	ECM INPUT SIGNALS	MAIN SIGNALS	Description	Remarks
B/FUEL SCHDL [msec]			<ul style="list-style-type: none"> “Base fuel schedule” indicates the fuel injection pulse width programmed into ECM, prior to any learned on board correction. 	<ul style="list-style-type: none"> When engine is running specification range is indicated.
A/F ALPHA-B1 [%]		×	<ul style="list-style-type: none"> The mean value of the air-fuel ratio feedback correction factor per cycle is indicated. 	<ul style="list-style-type: none"> When engine is running specification range is indicated. This data also includes the data for the air-fuel ratio learning control.

NOTE:

- Any monitored item that does not match the vehicle being diagnosed is deleted from the display automatically.

ACTIVE TEST MODE

Test Item

TEST ITEM	CONDITION	JUDGEMENT	CHECK ITEM (REMEDY)
FUEL INJECTION	<ul style="list-style-type: none"> Engine: Return to the original trouble condition Change the amount of fuel injection using CONSULT-II. 	If trouble symptom disappears, see CHECK ITEM.	<ul style="list-style-type: none"> Harness and connectors Fuel injector A/F sensor 1
IGNITION TIMING	<ul style="list-style-type: none"> Engine: Return to the original trouble condition Timing light: Set Retard the ignition timing using CONSULT-II. 	If trouble symptom disappears, see CHECK ITEM.	<ul style="list-style-type: none"> Perform Idle Air Volume Learning.
POWER BALANCE	<ul style="list-style-type: none"> Engine: After warming up, idle the engine. A/C switch OFF Shift lever N Cut off each injector signal one at a time using CONSULT-II. 	Engine runs rough or dies.	<ul style="list-style-type: none"> Harness and connectors Compression Fuel injector Power transistor Spark plug Ignition coil
COOLING FAN	<ul style="list-style-type: none"> Ignition switch: ON Turn the cooling fan ON and OFF with CONSULT-II. 	Cooling fan moves and stops.	<ul style="list-style-type: none"> Harness and connectors Cooling fan relay Cooling fan motor
ENG COOLANT TEMP	<ul style="list-style-type: none"> Engine: Return to the original trouble condition Change the engine coolant temperature using CONSULT-II. 	If trouble symptom disappears, see CHECK ITEM.	<ul style="list-style-type: none"> Harness and connectors Engine coolant temperature sensor Fuel injector
FUEL PUMP RELAY	<ul style="list-style-type: none"> Ignition switch: ON (Engine stopped) Turn the fuel pump relay ON and OFF using CONSULT-II and listen to operating sound. 	Fuel pump relay makes the operating sound.	<ul style="list-style-type: none"> Harness and connectors Fuel pump relay
VIAS SOL VALVE	<ul style="list-style-type: none"> Ignition switch: ON Turn solenoid valve ON and OFF with CONSULT-II and listen for operating sound. 	Solenoid valve makes an operating sound.	<ul style="list-style-type: none"> Harness and connectors Solenoid valve
PURG VOL CONT/V	<ul style="list-style-type: none"> Engine: After warming up, run engine at 1,500 rpm. Change the EVAP canister purge volume control solenoid valve opening percent using CONSULT-II. 	Engine speed changes according to the opening percent.	<ul style="list-style-type: none"> Harness and connectors Solenoid valve

TROUBLE DIAGNOSIS

[QR]

TEST ITEM	CONDITION	JUDGEMENT	CHECK ITEM (REMEDY)
FUEL/T TEMP SEN	<ul style="list-style-type: none"> Change the fuel tank temperature using CONSULT-II. 		
VENT CONTROL/V	<ul style="list-style-type: none"> Ignition switch: ON (Engine stopped) Turn solenoid valve "ON" and "OFF" with the CONSULT-II and listen to operating sound. 	Solenoid valve makes an operating sound.	<ul style="list-style-type: none"> Harness and connectors Solenoid valve
V/T ASSIGN ANGLE	<ul style="list-style-type: none"> Engine: Return to the original trouble condition Change intake valve timing using CONSULT-II. 	If trouble symptom disappears, see CHECK ITEM.	<ul style="list-style-type: none"> Harness and connectors Intake valve timing control solenoid valve

DTC & SRT CONFIRMATION MODE

SRT STATUS Mode

For details, refer to [EC-58, "SYSTEM READINESS TEST \(SRT\) CODE"](#) .

SRT WORK SUPPORT Mode

This mode enables a technician to drive a vehicle to set the SRT while monitoring the SRT status.

DTC WORK SUPPORT Mode

Test mode	Test item	Condition	Reference page
EVAPORATIVE SYSTEM	PURGE FLOW P0441	Refer to corresponding trouble diagnosis for DTC.	EC-292
	EVAP SML LEAK P0442/P1442*		EC-298
	EVAP V/S SML LEAK P0456/P1456*		EC-343
	PURG VOL CN/V P1444		EC-491
A/F SEN1	A/F SEN1 (B1) P1276		EC-467
	A/F SEN1 (B1) P1278		EC-473
	A/F SEN1 (B1) P1279		EC-482
HO2S2	HO2S2 (B1) P0139		EC-225
	HO2S2 (B1) P1146		EC-404
	HO2S2 (B1) P1147		EC-412

*: DTC P1442 and P1456 does not apply to L31 models but appears in DTC Work Support Mode screens.

REAL TIME DIAGNOSIS IN DATA MONITOR MODE (RECORDING VEHICLE DATA)

Description

CONSULT-II has two kinds of triggers and they can be selected by touching "SETTING" in "DATA MONITOR" mode.

1. "AUTO TRIG" (Automatic trigger):

- The malfunction will be identified on the CONSULT-II screen in real time.

In other words, DTC/1st trip DTC and malfunction item will be displayed if the malfunction is detected by ECM.

At the moment a malfunction is detected by ECM, "MONITOR" in "DATA MONITOR" screen is changed to "Recording Data ... xx%" as shown at right, and the data after the malfunction detection is recorded. Then when the percentage reached 100%, "REAL-TIME DIAG" screen is displayed. If "STOP" is touched on the screen during "Recording Data ... xx%", "REAL-TIME DIAG" screen is also displayed.

The recording time after the malfunction detection and the recording speed can be changed by "TRIGGER POINT" and "Recording Speed". Refer to CONSULT-II OPERATION MANUAL.

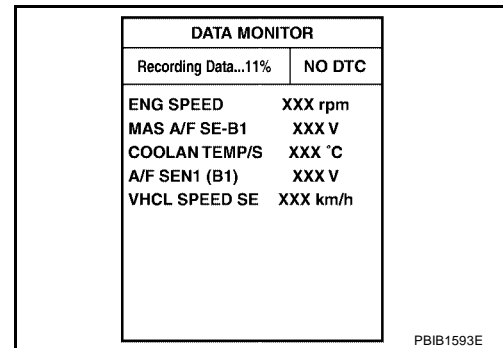

2. "MANU TRIG" (Manual trigger):

- DTC/1st trip DTC and malfunction item will not be displayed automatically on CONSULT-II screen even though a malfunction is detected by ECM.

DATA MONITOR can be performed continuously even though a malfunction is detected.

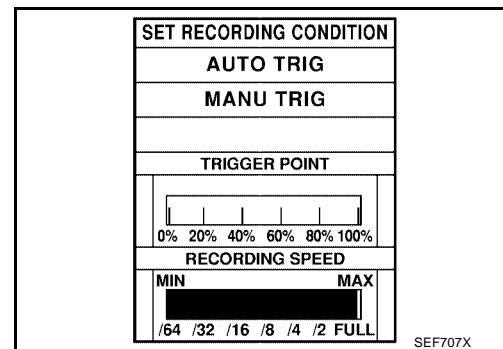

Operation

1. "AUTO TRIG"

- While trying to detect the DTC/1st trip DTC by performing the DTC Confirmation Procedure, be sure to select to "DATA MONITOR (AUTO TRIG)" mode. You can confirm the malfunction at the moment it is detected.
- While narrowing down the possible causes, CONSULT-II should be set in "DATA MONITOR (AUTO TRIG)" mode, especially in case the incident is intermittent. When you are inspecting the circuit by gently shaking (or twisting) the suspicious connectors, components and harness in the DTC Confirmation Procedure, the moment a malfunction is found the DTC/1st trip DTC will be displayed. (Refer to "Incident Simulation Tests" in [GI-26, "How to Perform Efficient Diagnosis for an Electrical Incident"](#) .)

2. "MANU TRIG"

- If the malfunction is displayed as soon as "DATA MONITOR" is selected, reset CONSULT-II to "MANU TRIG". By selecting "MANU TRIG" you can monitor and store the data. The data can be utilized for further diagnosis, such as a comparison with the value for the normal operating condition.

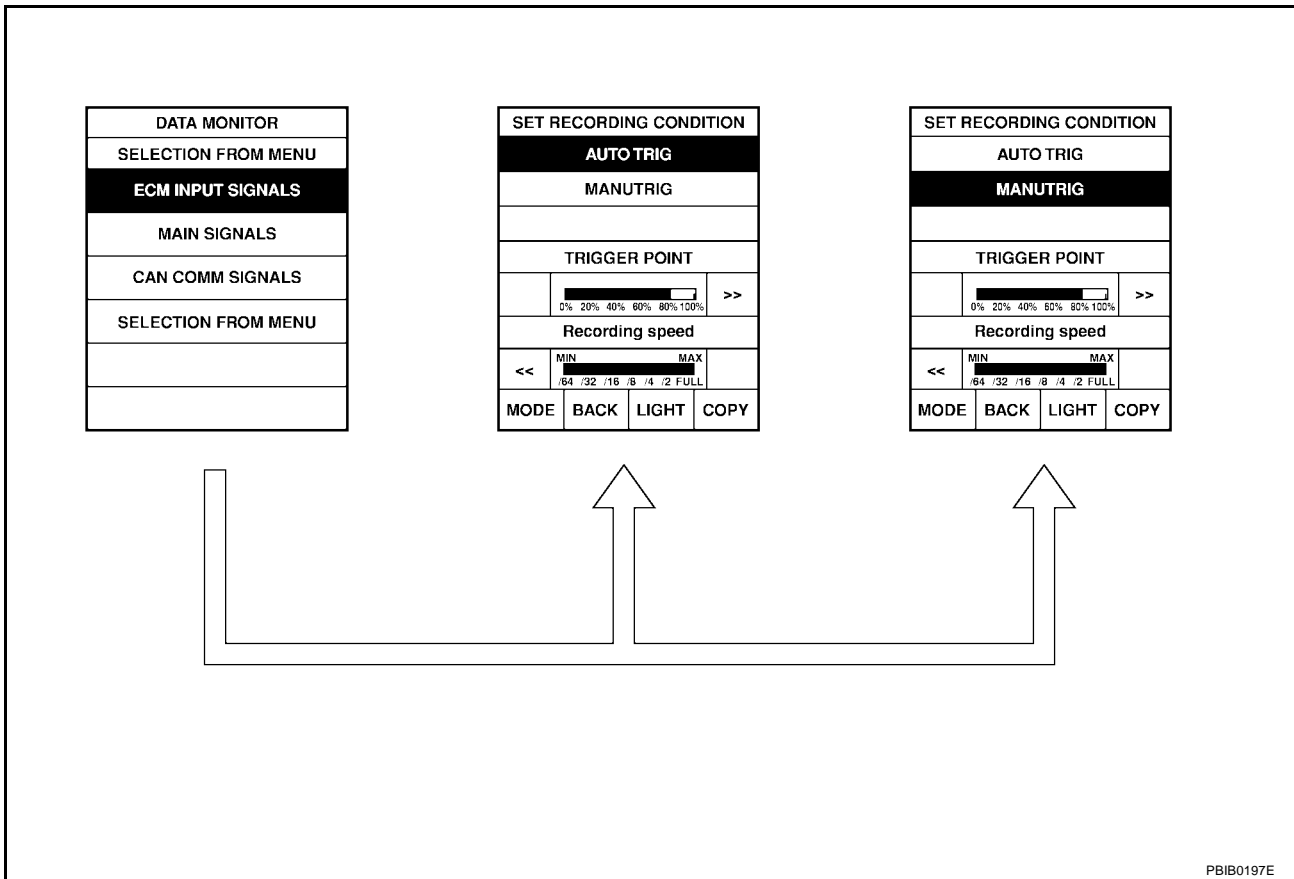

PBIB0197E

Generic Scan Tool (GST) Function DESCRIPTION

UBS0020T

Generic Scan Tool (OBDII scan tool) complying with SAE J1978 has 8 different functions explained below. ISO9141 is used as the protocol. The name "GST" or "Generic Scan Tool" is used in this service manual.

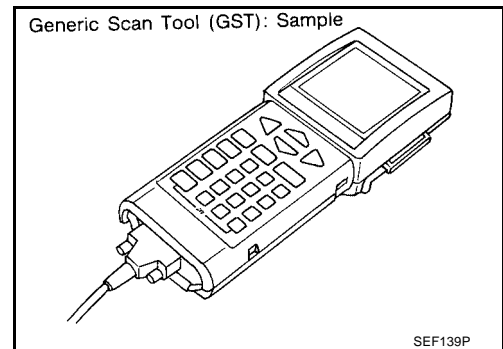

SEF139P

FUNCTION

Diagnostic service		Function
Service \$01	READINESS TESTS	This diagnostic service gains access to current emission-related data values, including analog inputs and outputs, digital inputs and outputs, and system status information.
Service \$02	(FREEZE DATA)	This diagnostic service gains access to emission-related data value which were stored by ECM during the freeze frame. For details, refer to EC-57, "FREEZE FRAME DATA AND 1ST TRIP FREEZE FRAME DATA" .
Service \$03	DTCs	This diagnostic service gains access to emission-related power train trouble codes which were stored by ECM.

TROUBLE DIAGNOSIS

[QR]

Diagnostic service		Function
Service \$04	CLEAR DIAG INFO	<p>This diagnostic service can clear all emission-related diagnostic information. This includes:</p> <ul style="list-style-type: none"> ● Clear number of diagnostic trouble codes (Service \$01) ● Clear diagnostic trouble codes (Service \$03) ● Clear trouble code for freeze frame data (Service \$01) ● Clear freeze frame data (Service \$02) ● Reset status of system monitoring test (Service \$01) ● Clear on board monitoring test results (Service \$06 and \$07)
Service \$06	(ON BOARD TESTS)	This diagnostic service accesses the results of on board diagnostic monitoring tests of specific components/systems that are not continuously monitored.
Service \$07	(ON BOARD TESTS)	This diagnostic service enables the off board test drive to obtain test results for emission-related powertrain components/systems that are continuously monitored during normal driving conditions.
Service \$08	—	<p>This diagnostic service can close EVAP system in ignition switch ON position (Engine stopped). When this diagnostic service is performed, EVAP canister vent control valve can be closed.</p> <p>In the following conditions, this diagnostic service cannot function.</p> <ul style="list-style-type: none"> ● Low ambient temperature ● Low battery voltage ● Engine running ● Ignition switch OFF ● Low fuel temperature ● Too much pressure is applied to EVAP system
Service \$09	(CALIBRATION ID)	This diagnostic service enables the off-board test device to request specific vehicle information such as Vehicle Identification Number (VIN) and Calibration IDs.

INSPECTION PROCEDURE

1. Turn ignition switch OFF.
2. Connect GST to data link connector, which is located under LH dash panel near the fuse box cover.
3. Turn ignition switch ON.

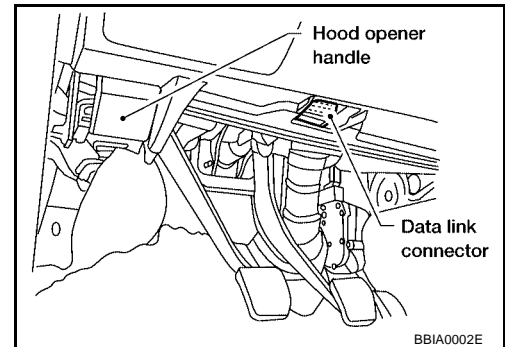

4. Enter the program according to instruction on the screen or in the operation manual.
(*: Regarding GST screens in this section, sample screens are shown.)

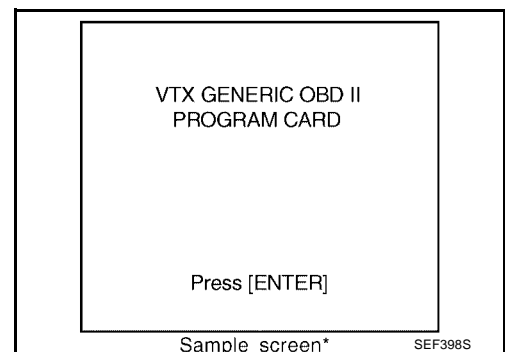

5. Perform each diagnostic service according to each service procedure.

For further information, see the GST Operation Manual of the tool maker.

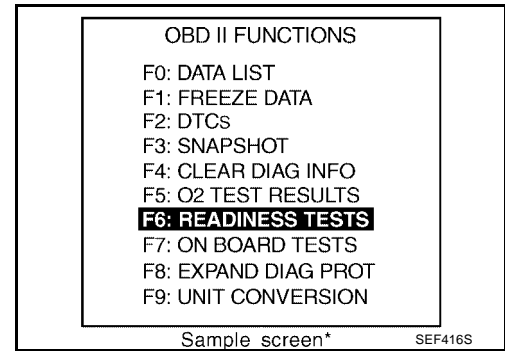

CONSULT-II Reference Value in Data Monitor

UBS0020U

Remarks:

- Specification data are reference values.
- Specification data are output/input values which are detected or supplied by the ECM at the connector.
- * Specification data may not be directly related to their components signals/values/operations.

i.e. Adjust ignition timing with a timing light before monitoring IGN TIMING, because the monitor may show the specification data in spite of the ignition timing not being adjusted to the specification data. This IGN TIMING monitors the data calculated by the ECM according to the signals input from the camshaft position sensor and other ignition timing related sensors.

MONITOR ITEM	CONDITION	SPECIFICATION
ENG SPEED	<ul style="list-style-type: none"> ● Tachometer: Connect ● Run engine and compare the CONSULT-II value with tachometer indication. 	Almost the same speed as the tachometer indication.
MAS A/F SE-B1	<ul style="list-style-type: none"> ● See EC-148, "TROUBLE DIAGNOSIS - SPECIFICATION VALUE". 	
B/FUEL SCHDL	<ul style="list-style-type: none"> ● See EC-148, "TROUBLE DIAGNOSIS - SPECIFICATION VALUE". 	
A/F ALPHA-B1	<ul style="list-style-type: none"> ● See EC-148, "TROUBLE DIAGNOSIS - SPECIFICATION VALUE". 	
COOLAN TEMP/S	<ul style="list-style-type: none"> ● Engine: After warming up 	More than 70°C (158°F)
A/F SEN1 (B1)	<ul style="list-style-type: none"> ● Engine: After warming up 	Maintaining engine speed at 2,000 rpm Fluctuates around 1.5V
HO2S2 (B1)	<ul style="list-style-type: none"> ● Warm-up condition ● After keeping engine speed between 3,500 and 4,000 rpm for 1 minute and at idle for 1 minute under no load. 	Revving engine from idle to 3,000 rpm quickly. 0 - 0.3V ←→ Approx. 0.6 - 1.0V
HO2S2 MNTR (B1)	<ul style="list-style-type: none"> ● Engine: After warming up ● After keeping engine speed between 3,500 and 4,000 rpm for 1 minute and at idle for 1 minute under no load. 	Revving engine from idle to 3,000 rpm quickly. LEAN ←→ RICH
VEH SPEED SE	<ul style="list-style-type: none"> ● Turn drive wheels and compare the CONSULT-II value with speedometer indication. 	Almost the same speed as the speedometer indication.
BATTERY VOLT	<ul style="list-style-type: none"> ● Ignition switch: ON (Engine stopped) 	11 - 14V
ACCEL SEN1	<ul style="list-style-type: none"> ● Ignition switch: ON (Engine stopped) 	Accelerator pedal: Fully released 0.65 - 0.87V
		Accelerator pedal: Fully depressed More than 4.3V
ACCEL SEN2*1	<ul style="list-style-type: none"> ● Ignition switch: ON (Engine stopped) 	Accelerator pedal: Fully released 0.56 - 0.96V
		Accelerator pedal: Fully depressed More than 4.0V
THRTL SEN1 THRTL SEN2*1	<ul style="list-style-type: none"> ● Ignition switch: ON (Engine stopped) ● Shift lever: D (A/T), 1ST (M/T) 	Accelerator pedal: Fully released More than 0.36V
		Accelerator pedal: Fully depressed Less than 4.75V
EVAP SYS PRES	<ul style="list-style-type: none"> ● Ignition switch: ON 	Approx. 1.8 - 4.8V
START SIGNAL	<ul style="list-style-type: none"> ● Ignition switch: ON → START → ON 	OFF → ON → OFF
VEHICLE SPEED	<ul style="list-style-type: none"> ● Turn drive wheels and compare CONSULT-II value with the speedometer indication. 	Almost the same speed as the speedometer indication
CLSD THL POS	<ul style="list-style-type: none"> ● Ignition switch: ON (Engine stopped) 	Accelerator pedal: Fully released ON
		Accelerator pedal: Slightly depressed OFF

TROUBLE DIAGNOSIS

[QR]

MONITOR ITEM	CONDITION	SPECIFICATION	
AIR COND SIG	<ul style="list-style-type: none"> ● Engine: After warming up, idle the engine 	Air conditioner switch: OFF	OFF
		Air conditioner switch: ON (Compressor operates.)	ON
P/N POSI SW	<ul style="list-style-type: none"> ● Ignition switch: ON 	Shift lever: P or N (A/T model) Neutral (M/T model)	ON
		Shift lever: Except above	OFF
PW/ST SIGNAL	<ul style="list-style-type: none"> ● Engine: After warming up, idle the engine 	Steering wheel is in neutral position. (Forward direction)	OFF
		Steering wheel is being turned.	ON
LOAD SIGNAL	<ul style="list-style-type: none"> ● Ignition switch: ON 	Rear window defogger switch is ON and/or lighting switch is in 2nd.	ON
		Rear window defogger switch is OFF and lighting switch is OFF.	OFF
IGNITION SW	<ul style="list-style-type: none"> ● Ignition switch: ON → OFF → ON 		ON → OFF → ON
HEATER FAN SW	<ul style="list-style-type: none"> ● Engine: After warming up, idle the engine 	Heater fan is operating.	ON
		Heater fan is not operating	OFF
BRAKE SW	<ul style="list-style-type: none"> ● Ignition switch: ON 	Brake pedal: Fully released	OFF
		Brake pedal: Slightly depressed	ON
INJ PULSE-B1	<ul style="list-style-type: none"> ● Engine: After warming up ● Shift lever: N (A/T), Neutral (M/T) ● Air conditioner switch: OFF ● No-load 	Idle	2.0 - 3.0 msec
		2,000 rpm	1.9 - 2.9 msec
IGN TIMING	<ul style="list-style-type: none"> ● Engine: After warming up ● Shift lever: N (A/T), Neutral (M/T) ● Air conditioner switch: OFF ● No-load 	Idle	10° - 20° BTDC
		2,000 rpm	25° - 45° BTDC
CAL/LD VALUE	<ul style="list-style-type: none"> ● Engine: After warming up ● Shift lever: N (A/T), Neutral (M/T) ● Air conditioner switch: OFF ● No-load 	Idle	10% - 35%
		2,500 rpm	10% - 35%
MASS AIRFLOW	<ul style="list-style-type: none"> ● Engine: After warming up ● Shift lever: N (A/T), Neutral (M/T) ● Air conditioner switch: OFF ● No-load 	Idle	1.0 - 4.0 g-m/s
		2,500 rpm	4.0 - 10.0 g-m/s
PURG VOL C/V	<ul style="list-style-type: none"> ● Engine: After warming up ● Shift lever: N (A/T), Neutral (M/T) ● Air conditioner switch: OFF ● No-load 	Idle (Accelerator pedal is not depressed even slightly, after engine starting)	0%
		2,000 rpm	20 - 30%
INT/V TIM (B1)	<ul style="list-style-type: none"> ● Engine: After warming up ● Shift lever: N (A/T), Neutral (M/T) ● Air conditioner switch: OFF ● No-load 	Idle	-5° - 5°C
		2,000 rpm	Approx. 0° - 20°C

A
EC
C
D
E
F
G
H
I
J
K
L
M

TROUBLE DIAGNOSIS

[QR]

MONITOR ITEM	CONDITION		SPECIFICATION
INT/V SOL (B1)	<ul style="list-style-type: none"> ● Engine: After warming up ● Shift lever: N (A/T), Neutral (M/T) ● Air conditioner switch: OFF ● No-load 	Idle	0% - 2%
		2,000 rpm	Approx. 25% - 60%
AIR COND RLY	<ul style="list-style-type: none"> ● Engine: After warming up, idle the engine 	Air conditioner switch: OFF	OFF
		Air conditioner switch: ON (Compressor operates)	ON
VIAS S/V	<ul style="list-style-type: none"> ● Engine: After warming up 	Idle	OFF
		More than 5,000 rpm	ON
FUEL PUMP RLY	<ul style="list-style-type: none"> ● For 1 second after turning ignition switch ON ● Engine running or cranking 		ON
		<ul style="list-style-type: none"> ● Except above conditions 	OFF
VENT CONT/V	<ul style="list-style-type: none"> ● Ignition switch: ON 		OFF
THRTL RELAY	<ul style="list-style-type: none"> ● Ignition switch: ON 		ON
COOLING FAN	<ul style="list-style-type: none"> ● Engine: After warming up, idle the engine ● Air conditioner switch: OFF 	Engine coolant temperature is 94°C (201°F) or less	OFF
		Engine coolant temperature is between 95°C (203°F) and 99°C (210°F)	LOW
		Engine coolant temperature is between 100°C (212°F) and 104°C (219°F)	MID
		Engine coolant temperature is 105°C (221°F) or more	HI
HO2S2 HTR (B1)	<ul style="list-style-type: none"> ● Engine speed: Below 3,600 rpm after the following conditions are met ● Engine: After warming up ● Keeping the engine speed between 3,500 and 4,000 rpm for 1 minute and at idle for 1 minute under no load. 		ON
		<ul style="list-style-type: none"> ● Engine speed: Above 3,600 rpm 	OFF
TRVL AFTER MIL	<ul style="list-style-type: none"> ● Ignition switch: ON 	Vehicle has traveled after MIL has turned ON.	0 - 65,535 km (0 - 40,723 mile)
A/F S1 HTR (B1)	<ul style="list-style-type: none"> ● Engine: After warming up, idle the engine 		0 - 100%
AC PRESS SEN	<ul style="list-style-type: none"> ● Ignition switch: ON (Engine stopped) ● Engine: Idle ● Air conditioner switch: OFF 		Approx. 0V
			1.0 - 4.0V
VEH SPEED SE	<ul style="list-style-type: none"> ● Turn drive wheels and compare the CONSULT-II value with speedometer indication. 		Almost the same speed as the speedometer indication
SET VHCL SPD	<ul style="list-style-type: none"> ● Engine: Running 	ASCD: Operating	The preset vehicle speed is displayed.
MAIN SW	<ul style="list-style-type: none"> ● Ignition switch: ON 	CRUISE switch: Pressed	ON
		CRUISE switch: Released	OFF
CANCEL SW	<ul style="list-style-type: none"> ● Ignition switch: ON 	CANCEL switch: Pressed	ON
		CANCEL switch: Released	OFF
RESUME/ACCEL SW	<ul style="list-style-type: none"> ● Ignition switch: ON 	RESUME/ACCEL switch: Pressed	ON
		RESUME/ACCEL switch: Released	OFF
SET SW	<ul style="list-style-type: none"> ● Ignition switch: ON 	SET/COAST switch: Pressed	ON
		SET/COAST switch: Released	OFF

TROUBLE DIAGNOSIS

[QR]

MONITOR ITEM	CONDITION	SPECIFICATION
BRAKE SW1 (ASCD brake switch)	● Ignition switch: ON	● Brake pedal: Fully released ● Clutch pedal: Fully released (M/T) ON
		● Brake pedal: Slightly depressed ● Clutch pedal: Fully depressed (M/T) OFF
BRAKE SW2 (STOP lamp switch)	● Ignition switch: ON	Brake pedal: Fully released OFF
		Brake pedal: Slightly depressed ON
CRUISE LAMP	● Ignition switch: ON	CRUISE switch is pressed at first time → second time ON → OFF
SET LAMP	● MAIN switch: ON ● When vehicle speed is between 40 km/h (25 MPH) and 144 km/h (89 MPH)	ASCD is operating ON
		ASCD is not operating OFF

*1: Accelerator pedal position sensor 2 signal and throttle position sensor 2 signal are converted by ECM internally. Thus, they differ from ECM terminals voltage signal.

A
EC
C
D
E
F
G
H
I
J
K
L
M

Major Sensor Reference Graph in Data Monitor Mode

The following are the major sensor reference graphs in "DATA MONITOR" mode.

CLSD THL POS, ACCEL SEN 1, THRTL SEN 1

Below is the data for "CLSD THL POS", "ACCEL SEN 1" and "THRTL SEN 1" when depressing the accelerator pedal with the ignition switch ON and with selector lever in D position (A/T models) or with shift lever in 1st position (M/T models).

The signal of "ACCEL SEN 1" and "THRTL SEN 1" should rise gradually without any intermittent drop or rise after "CLSD THL POS" is changed from ON to OFF.

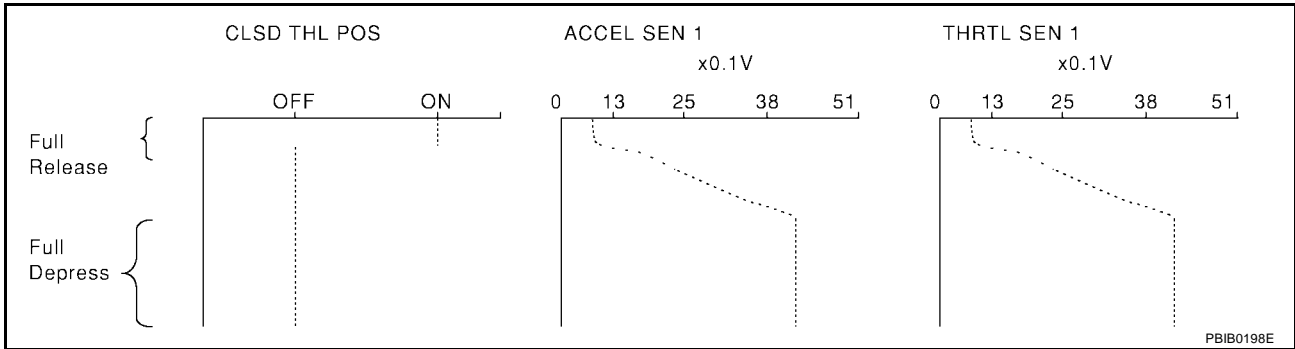

ENG SPEED, MAS A/F SE-B1, THRTL SEN 1, HO2S2 (B1), INJ PULSE-B1

Below is the data for "ENG SPEED", "MAS A/F SE-B1", "THRTL SEN 1", "HO2S2 (B1)" and "INJ PULSE-B1" when revving engine quickly up to 4,800 rpm under no load after warming up engine sufficiently.

Each value is for reference, the exact value may vary.

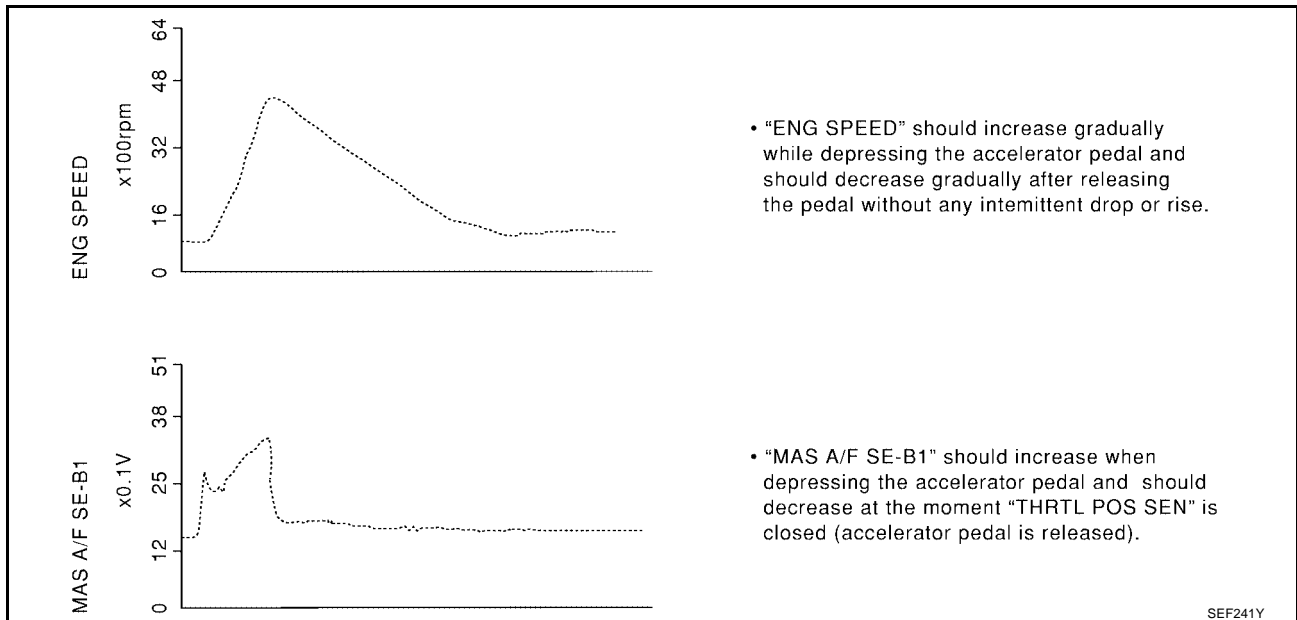

A

EC

C

D

E

F

G

H

I

J

K

L

M

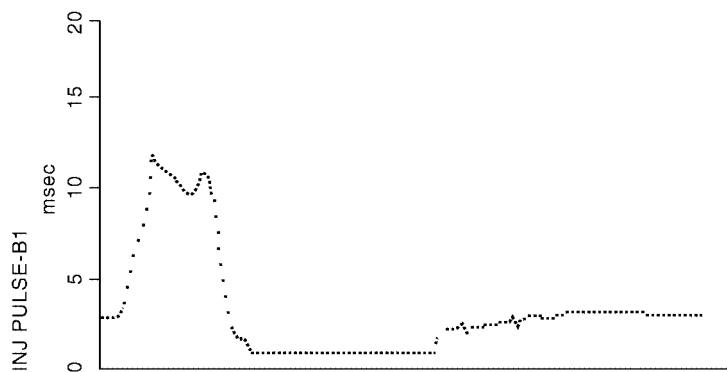
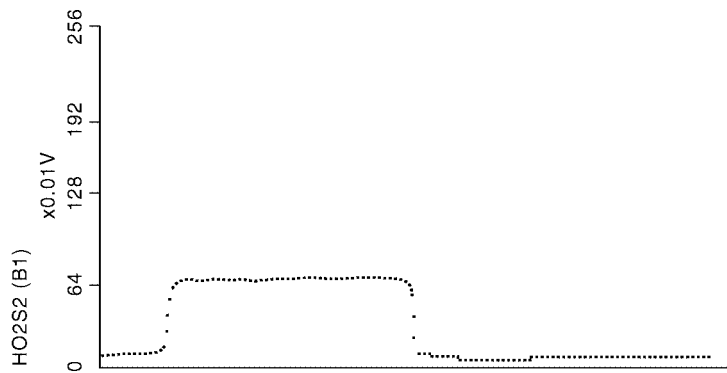
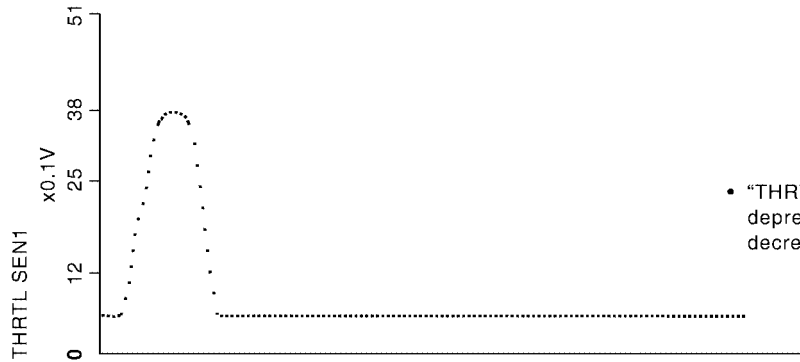

TROUBLE DIAGNOSIS - SPECIFICATION VALUE

PFP:00031

Description

UBS0020W

The specification (SP) value indicates the tolerance of the value that is displayed in “DATA MONITOR (SPEC)” mode of CONSULT-II during normal operation of the Engine Control System. When the value in “DATA MONITOR (SPEC)” mode is within the SP value, the Engine Control System is confirmed OK. When the value in “DATA MONITOR (SPEC)” mode is NOT within the SP value, the Engine Control System may have one or more malfunctions.

The SP value is used to detect malfunctions that may affect the Engine Control System, but will not light the MIL.

The SP value will be displayed for the following three items:

- B/FUEL SCHDL (The fuel injection pulse width programmed into ECM prior to any learned on board correction)
- A/F ALPHA-B1 (The mean value of air-fuel ratio feedback correction factor per cycle)
- MAS A/F SE-B1 (The signal voltage of the mass air flow sensor)

Testing Condition

UBS0020X

- Vehicle driven distance: More than 5,000 km (3,017 miles)
- Barometric pressure: 98.3 - 104.3 kPa (1.003 - 1.064 kg/cm² , 14.25 - 15.12 psi)
- Atmospheric temperature: 20 - 30°C (68 - 86°F)
- Engine coolant temperature: 75 - 95°C (167 - 203°F)
- Transmission: Warmed-up*1
- Electrical load: Not applied*2
- Engine speed: Idle

*1: For A/T models, after the engine is warmed up to normal operating temperature, drive vehicle until “FLUID TEMP SE” (A/T fluid temperature sensor signal) indicates more than 60°C (140°F).

For M/T models, after the engine is warmed up to normal operating temperature, drive vehicle for 5 minutes.

*2: Rear window defogger switch, air conditioner switch, lighting switch are OFF. Steering wheel is straight ahead.

Inspection Procedure

UBS0020Y

NOTE:

Perform “DATA MONITOR (SPEC)” mode in maximum scale display.

1. Perform [EC-75, "Basic Inspection"](#) .
2. Confirm that the testing conditions indicated above are met.
3. Select “B/FUEL SCHDL”, “A/F ALPHA-B1” and “MAS A/F SE-B1” in “DATA MONITOR (SPEC)” mode with CONSULT-II.
4. Make sure that monitor items are within the SP value.
5. If NG, go to [EC-149, "Diagnostic Procedure"](#) .

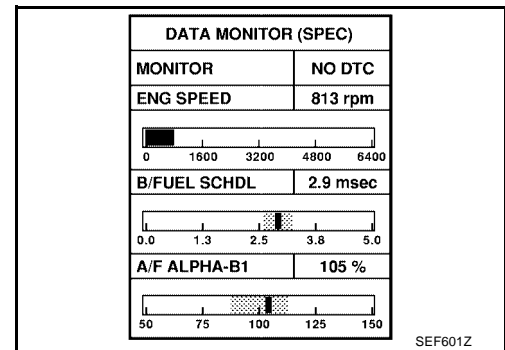

Diagnostic Procedure OVERALL SEQUENCE

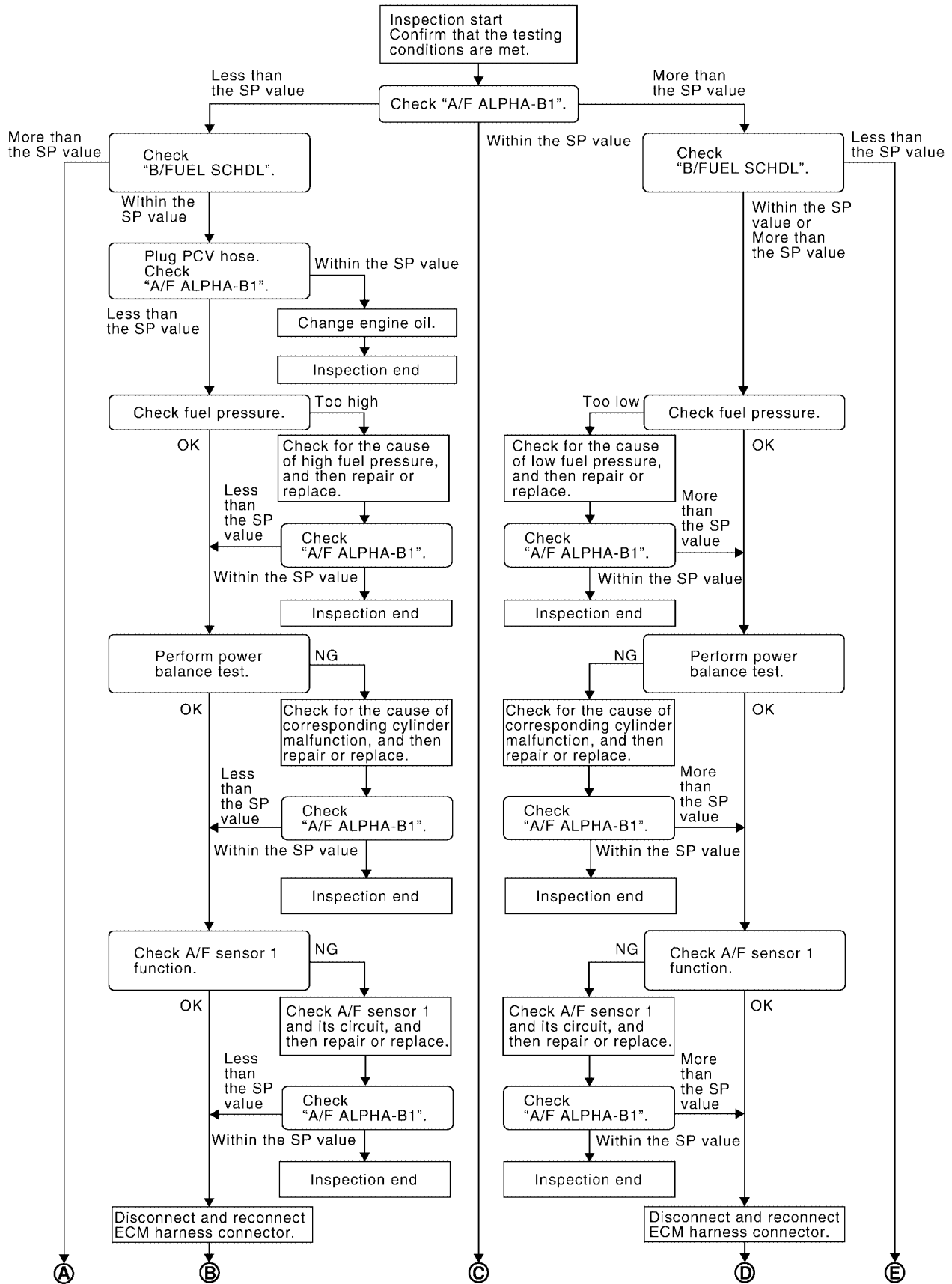

TROUBLE DIAGNOSIS - SPECIFICATION VALUE

[QR]

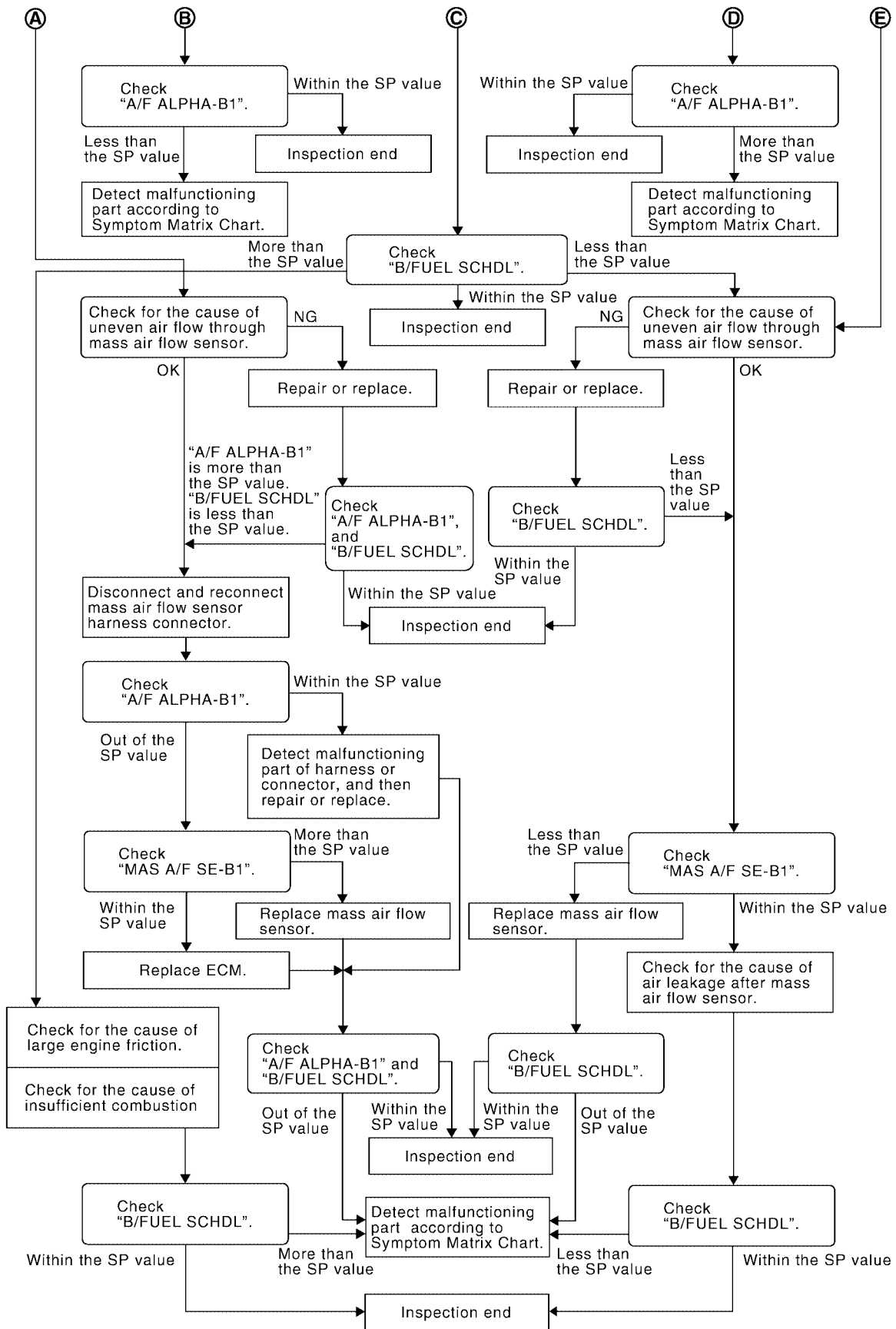

PBIB2509E

DETAILED PROCEDURE

1. CHECK "A/F ALPHA-B1"

1. Start engine.
2. Confirm that the testing conditions are met. Refer to [EC-148, "Testing Condition"](#) .
3. Select "A/F ALPHA-B1" in "DATA MONITOR (SPEC)" mode, and make sure that the indication is within the SP value.

NOTE:

Check "A/F ALPHA-B1" for approximately 1 minute because they may fluctuate. It is NG if the indication is out of the SP value even a little.

OK or NG

- OK >> GO TO 17.
- NG (Less than the SP value)>>GO TO 2.
- NG (More than the SP value)>>GO TO 3.

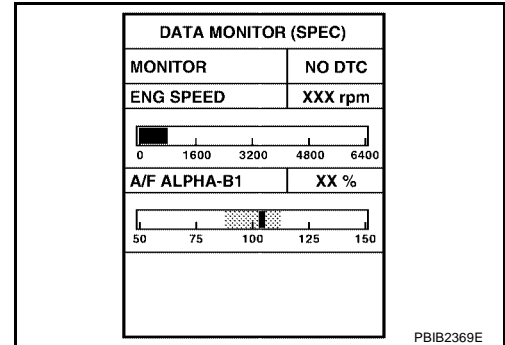

2. CHECK "B/FUEL SCHDL"

Select "B/FUEL SCHDL" in "DATA MONITOR (SPEC)" mode, and make sure that the indication is within the SP value.

OK or NG

- OK >> GO TO 4.
- NG (More than the SP value)>>GO TO 19.

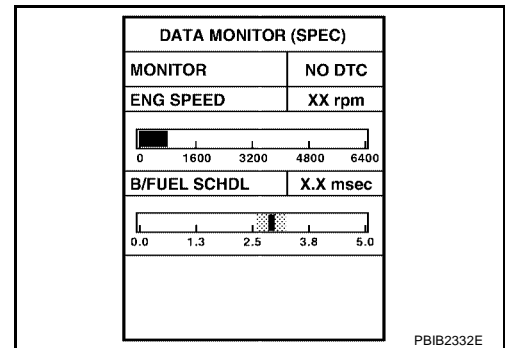

3. CHECK "B/FUEL SCHDL"

Select "B/FUEL SCHDL" in "DATA MONITOR (SPEC)" mode, and make sure that the indication is within the SP value.

OK or NG

- OK >> GO TO 6.
- NG (More than the SP value)>>GO TO 6.
- NG (Less than the SP value)>>GO TO 25.

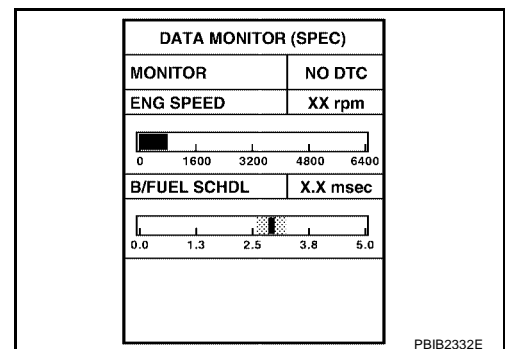

4. CHECK "A/F ALPHA-B1"

1. Stop the engine.
2. Disconnect PCV hose, and then plug it.
3. Start engine.
4. Select "A/F ALPHA-B1" in "DATA MONITOR (SPEC)" mode, and make sure that the indication is within the SP value.

OK or NG

- OK >> GO TO 5.
- NG >> GO TO 6.

5. CHANGE ENGINE OIL

1. Stop the engine.
2. Change engine oil.

NOTE:

This symptom may occur when a large amount of gasoline is mixed with engine oil because of driving conditions (such as when engine oil temperature does not rise enough since a journey distance is too short during winter). The symptom will not be detected after changing engine oil or changing driving condition.

>> **INSPECTION END**

6. CHECK FUEL PRESSURE

Check fuel pressure. (Refer to [EC-95. "Fuel Pressure Check"](#) .)

OK or NG

- OK >> GO TO 9.
 NG (Fuel pressure is too high)>>Replace fuel pressure regulator, refer to [EC-95](#) . GO TO 8.
 NG (Fuel pressure is too low)>>GO TO 7.

7. DETECT MALFUNCTIONING PART

1. Check the following.
 - Clogged and bent fuel hose and fuel tube
 - Clogged fuel filter
 - Fuel pump and its circuit (Refer to [EC-598](#) .)
2. If NG, repair or replace the malfunctioning part. (Refer to [EC-95](#) .)
 If OK, replace fuel pressure regulator.

>> GO TO 8.

8. CHECK "A/F ALPHA-B1"

1. Start engine.
2. Select "A/F ALPHA-B1" in "DATA MONITOR (SPEC)" mode, and make sure that the indication is within the SP value.

OK or NG

- OK >> **INSPECTION END**
 NG >> GO TO 9.

9. PERFORM POWER BALANCE TEST

1. Perform "POWER BALANCE" in "ACTIVE TEST" mode.
2. Make sure that the each cylinder produces a momentary engine speed drop.

OK or NG

- OK >> GO TO 12.
 NG >> GO TO 10.

ACTIVE TEST	
POWER BALANCE	
MONITOR	
ENG SPEED	XXX rpm
MAS A/F SE-B1	XXX V

PBIB0133E

10. DETECT MALFUNCTIONING PART

1. Check the following.
 - Ignition coil and its circuit (Refer to [EC-572](#) .)
 - Fuel injector and its circuit (Refer to [EC-592](#) .)
 - Intake air leakage
 - Low compression pressure (Refer to [EM-59](#) .)
2. If NG, repair or replace the malfunctioning part.
If OK, replace fuel injector. (It may be caused by leakage from fuel injector or clogging.)

>> GO TO 11.

11. CHECK "A/F ALPHA-B1"

1. Start engine.
2. Select "A/F ALPHA-B1" in "DATA MONITOR (SPEC)" mode, and make sure that the indication is within the SP value.

OK or NG

- OK >> **INSPECTION END**
 NG >> GO TO 12.

12. CHECK A/F SENSOR 1 FUNCTION

Perform all DTC Confirmation Procedure related with A/F sensor 1.

- For DTC P1271, refer to [EC-443, "DTC Confirmation Procedure"](#) .
- For DTC P1272, refer to [EC-448, "DTC Confirmation Procedure"](#) .
- For DTC P1273, refer to [EC-453, "DTC Confirmation Procedure"](#) .
- For DTC P1274, refer to [EC-460, "DTC Confirmation Procedure"](#) .
- For DTC P1276, refer to [EC-467, "DTC Confirmation Procedure"](#) .
- For DTC P1278, refer to [EC-474, "DTC Confirmation Procedure"](#) .
- For DTC P1279, refer to [EC-483, "DTC Confirmation Procedure"](#) .

OK or NG

- OK >> GO TO 15.
 NG >> GO TO 13.

13. CHECK A/F SENSOR 1 CIRCUIT

Perform Diagnostic Procedure according to corresponding DTC.

>> GO TO 14.

14. CHECK "A/F ALPHA-B1"

1. Start engine.
2. Select "A/F ALPHA-B1" in "DATA MONITOR (SPEC)" mode, and make sure that the indication is within the SP value.

OK or NG

- OK >> **INSPECTION END**
 NG >> GO TO 15.

15. DISCONNECT AND RECONNECT ECM HARNESS CONNECTOR

1. Stop the engine.
2. Disconnect ECM harness connector. Check pin terminal and connector for damage, and then reconnect it.

>> GO TO 16.

16. CHECK "A/F ALPHA-B1"

1. Start engine.
2. Select "A/F ALPHA-B1" in "DATA MONITOR (SPEC)" mode, and make sure that the indication is within the SP value.

OK or NG

OK >> **INSPECTION END**

NG >> Detect malfunctioning part according to [EC-108, "Symptom Matrix Chart"](#).

17. CHECK "B/FUEL SCHDL"

Select "B/FUEL SCHDL" in "DATA MONITOR (SPEC)" mode, and make sure that the indication is within the SP value.

OK or NG

OK >> **INSPECTION END**

NG (More than the SP value)>>GO TO 18.

NG (Less than the SP value)>>GO TO 25.

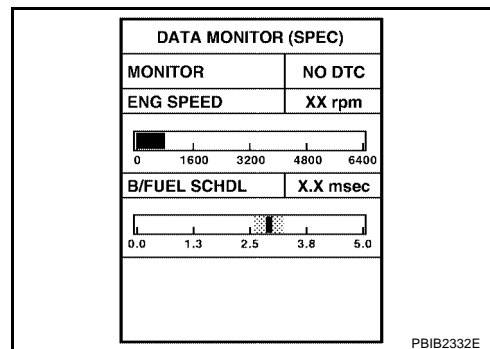

18. DETECT MALFUNCTIONING PART

1. Check for the cause of large engine friction. Refer to the following.
 - Engine oil level is too high
 - Engine oil viscosity
 - Belt tension of power steering, alternator, A/C compressor, etc. is excessive
 - Noise from engine
 - Noise from transmission, etc.
2. Check for the cause of insufficient combustion. Refer to the following.
 - Valve clearance malfunction
 - Intake valve timing control function malfunction
 - Camshaft sprocket installation malfunction, etc.

>> Repair or replace malfunctioning part, and then GO TO 30.

19. CHECK INTAKE SYSTEM

Check for the cause of uneven air flow through mass air flow sensor. Refer to the following.

- Crushed air ducts
- Malfunctioning seal of air cleaner element
- Uneven dirt of air cleaner element
- Improper specification of intake air system

OK or NG

OK >> GO TO 21.

NG >> Repair or replace malfunctioning part, and then GO TO 20.

20. CHECK "A/F ALPHA-B1" AND "B/FUEL SCHDL"

Select "A/F ALPHA-B1" and "B/FUEL SCHDL" in "DATA MONITOR (SPEC)" mode, and make sure that the each indication is within the SP value.

OK or NG

OK >> **INSPECTION END**

NG ("B/FUEL SCHDL" is more, "A/F ALPHA-B1" is less than the SP value)>>GO TO 21.

21. DISCONNECT AND RECONNECT MASS AIR FLOW SENSOR HARNESS CONNECTOR

1. Stop the engine.
2. Disconnect mass air flow sensor harness connector. Check pin terminal and connector for damage and then reconnect it again.

>> GO TO 22.

22. CHECK "A/F ALPHA-B1"

1. Start engine.
2. Select "A/F ALPHA-B1" in "DATA MONITOR (SPEC)" mode, and make sure that the indication is within the SP value.

OK or NG

OK >> 1. Detect malfunctioning part of mass air flow sensor circuit and repair it. Refer to [EC-187](#) .
2. GO TO 29.

NG >> GO TO 23.

23. CHECK "MAS A/F SE-B1"

Select "MAS A/F SE-B1" in "DATA MONITOR (SPEC)" mode, and make sure that the indication is within the SP value.

OK or NG

OK >> GO TO 24.

NG (More than the SP value)>>Replace mass air flow sensor, and then GO TO 29.

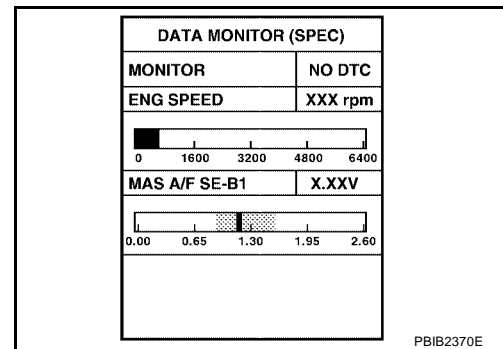
**24. REPLACE ECM**

1. Replace ECM.
2. Perform initialization of NVIS(NATS) system and registration of all NVIS(NATS) ignition key IDs. Refer to [BL-109, "ECM Re-communicating Function"](#) .
3. Perform [EC-92, "VIN Registration"](#) .
4. Perform [EC-93, "Accelerator Pedal Released Position Learning"](#) .
5. Perform [EC-93, "Throttle Valve Closed Position Learning"](#) .
6. Perform [EC-93, "Idle Air Volume Learning"](#) .

>> GO TO 29.

25. CHECK INTAKE SYSTEM

Check for the cause of uneven air flow through mass air flow sensor. Refer to the following.

- Crushed air ducts
- Malfunctioning seal of air cleaner element
- Uneven dirt of air cleaner element
- Improper specification of intake air system

OK or NG

OK >> GO TO 27.

NG >> Repair or replace malfunctioning part, and then GO TO 26.

26. CHECK "B/FUEL SCHDL"

Select "B/FUEL SCHDL" in "DATA MONITOR (SPEC)" mode, and make sure that the indication is within the SP value.

OK or NG

OK >> **INSPECTION END**

NG (Less than the SP value)>>GO TO 27.

27. CHECK "MAS A/F SE-B1"

Select "MAS A/F SE-B1" in "DATA MONITOR (SPEC)" mode, and make sure that the indication is within the SP value.

OK or NG

OK >> GO TO 28.

NG (Less than the SP value)>>Replace mass air flow sensor, and then GO TO 30.

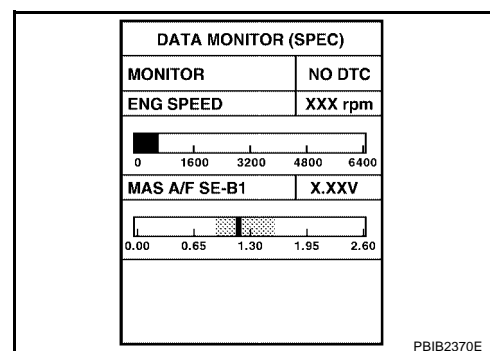

28. CHECK INTAKE SYSTEM

Check for the cause of air leak after the mass air flow sensor. Refer to the following.

- Disconnection, looseness, and cracks in air duct
- Looseness of oil filler cap
- Disconnection of oil level gauge
- Open stuck, breakage, hose disconnection, or cracks of PCV valve
- Disconnection or cracks of EVAP purge hose, open stuck of EVAP canister purge volume control solenoid valve
- Malfunctioning seal of rocker cover gasket
- Disconnection, looseness, or cracks of hoses, such as vacuum hose, connecting to intake air system parts
- Malfunctioning seal of intake air system, etc.

>> GO TO 30.

29. CHECK "A/F ALPHA-B1" AND "B/FUEL SCHDL"

Select "A/F ALPHA-B1" and "B/FUEL SCHDL" in "DATA MONITOR (SPEC)" mode, and make sure that the each indication is within the SP value.

OK or NG

OK >> **INSPECTION END**

NG >> Detect malfunctioning part according to [EC-108, "Symptom Matrix Chart"](#) .

30. CHECK "B/FUEL SCHDL"

Select "B/FUEL SCHDL" in "DATA MONITOR (SPEC)" mode, and then make sure that the indication is within the SP value.

OK or NG

OK >> **INSPECTION END**

NG >> Detect malfunctioning part according to [EC-108, "Symptom Matrix Chart"](#) .

A

EC

C

D

E

F

G

H

I

J

K

L

M

TROUBLE DIAGNOSIS FOR INTERMITTENT INCIDENT

PFP:00006

Description

UBS002P0

Intermittent incidents may occur. In many cases, the malfunction resolves itself (the part or circuit function returns to normal without intervention). It is important to realize that the symptoms described in the customer's complaint often do not recur on (1st trip) DTC visits. Realize also that the most frequent cause of Intermittent Incidents occurrences is poor electrical connections. Because of this, the conditions under which the incident occurred may not be clear. Therefore, circuit checks made as part of the standard diagnostic procedure may not indicate the specific malfunctioning area.

Common Intermittent Incidents Report Situations

STEP in Work Flow	Situation
2	The CONSULT-II is used. The SELF-DIAG RESULTS screen shows time data other than 0 or [1t].
3 or 4	The symptom described by the customer does not recur.
5	(1st trip) DTC does not appear during the DTC Confirmation Procedure.
10	The Diagnostic Procedure for PXXXX does not indicate the malfunctioning area.

Diagnostic Procedure

UBS002P1

1. INSPECTION START

Erase (1st trip) DTCs. Refer to [EC-65, "HOW TO ERASE EMISSION-RELATED DIAGNOSTIC INFORMATION"](#).

>> GO TO 2.

2. CHECK GROUND TERMINALS

Check ground terminals for corroding or loose connection.

Refer to [GI-26, "How to Perform Efficient Diagnosis for an Electrical Incident"](#), "CIRCUIT INSPECTION", "Ground Inspection".

OK or NG

OK >> GO TO 3.

NG >> Repair or replace.

3. SEARCH FOR ELECTRICAL INCIDENT

Perform [GI-26, "How to Perform Efficient Diagnosis for an Electrical Incident"](#), "INCIDENT SIMULATION TESTS".

OK or NG

OK >> GO TO 4.

NG >> Repair or replace.

4. CHECK CONNECTOR TERMINALS

Refer to [GI-23, "How to Check Terminal"](#), "HOW TO PROBE CONNECTORS", "How to Check Enlarged Contact Spring of Terminal".

OK or NG

OK >> **INSPECTION END**

NG >> Repair or replace connector.

POWER SUPPLY AND GROUND CIRCUIT

[QR]

POWER SUPPLY AND GROUND CIRCUIT

PF:24110

Wiring Diagram

UBS00ELQ

EC-MAIN-01

— : DETECTABLE LINE FOR DTC
 - - - : NON-DETECTABLE LINE FOR DTC

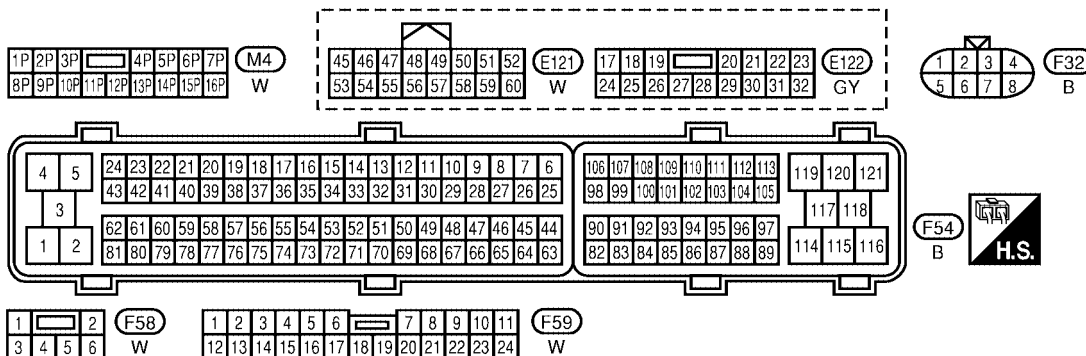
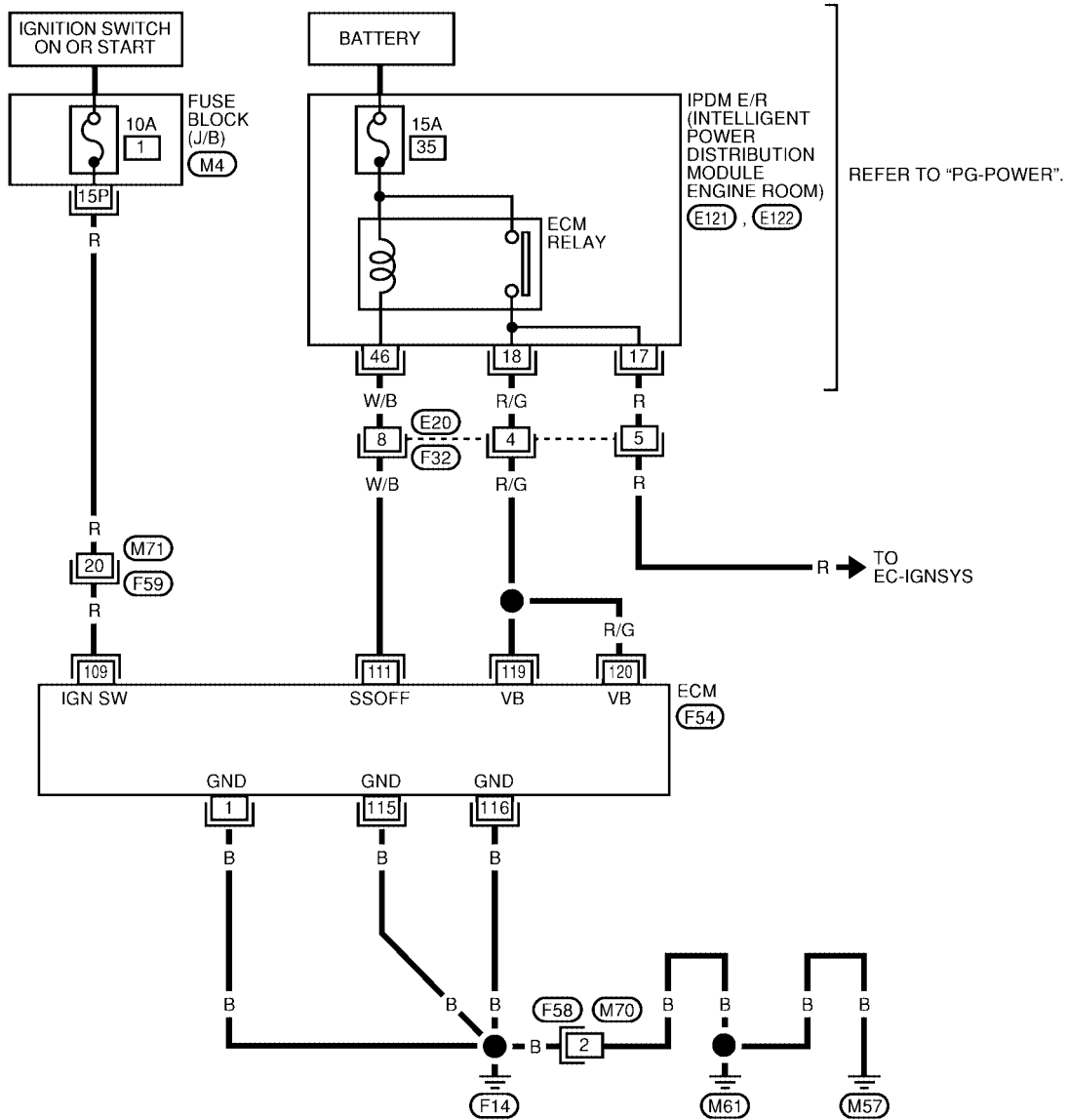

BBWA1213E

POWER SUPPLY AND GROUND CIRCUIT

[QR]

Specification data are reference values and are measured between each terminal and ground.

CAUTION:

Do not use ECM ground terminals when measuring input/output voltage. Doing so may result in damage to the ECM's transistor. Use a ground other than ECM terminals, such as the ground.

TER-MINAL NO.	WIRE COLOR	ITEM	CONDITION	DATA (DC Voltage)
1	B	ECM ground	[Engine is running] ● Idle speed	Body ground
109	R	Ignition switch	[Ignition switch: OFF]	0V
			[Ignition switch: ON]	BATTERY VOLTAGE (11 - 14V)
111	W/B	ECM relay (Self shut-off)	[Engine is running] [Ignition switch: OFF] ● A few seconds after turning ignition switch OFF	0 - 1.0V
			[Ignition switch: OFF] ● More than a few seconds after turning ignition switch OFF	BATTERY VOLTAGE (11 - 14V)
115 116	B B	ECM ground	[Engine is running] ● Idle speed	Body ground
119 120	R/G R/G	Power supply for ECM	[Ignition switch: ON]	BATTERY VOLTAGE (11 - 14V)

Diagnostic Procedure

UBS00ELR

1. INSPECTION START

Start engine.

Is engine running?

Yes or No

- Yes >> GO TO 8.
- No >> GO TO 2.

2. CHECK ECM POWER SUPPLY CIRCUIT-I

1. Turn ignition switch OFF and then ON.
2. Check voltage between ECM terminal 109 and ground with CONSULT-II or tester.

Voltage: Battery voltage

OK or NG

- OK >> GO TO 4.
- NG >> GO TO 3.

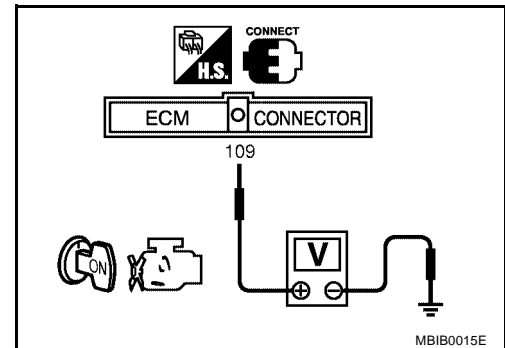

3. DETECT MALFUNCTIONING PART

Check the following.

- Fuse block (J/B) connector M4
- 10A fuse
- Harness connectors M71, F59
- Harness for open or short between ECM and fuse

>> Repair harness or connectors.

4. CHECK GROUND CONNECTIONS

1. Turn ignition switch OFF.
2. Loosen and retighten three ground screws on the body. Refer to [EC-164, "Ground Inspection"](#).

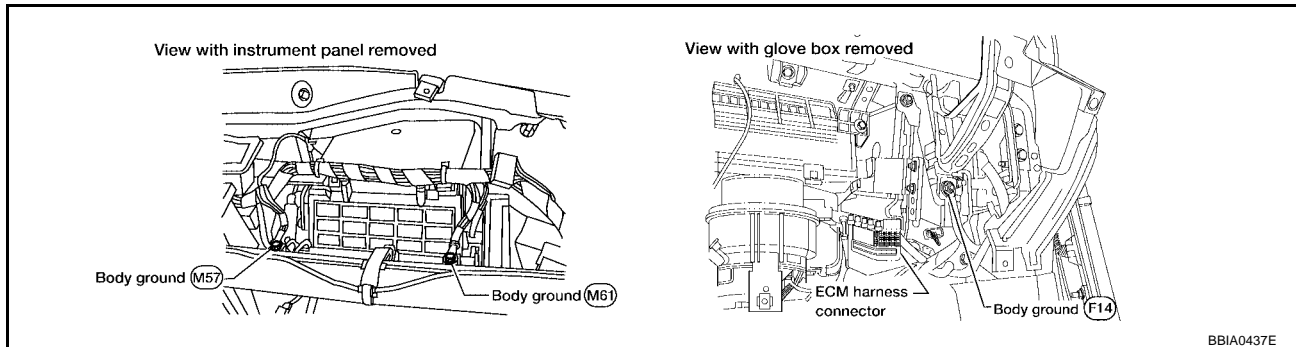

OK or NG

- OK >> GO TO 5.
- NG >> Repair or replace ground connections.

5. CHECK ECM GROUND CIRCUIT FOR OPEN AND SHORT-I

1. Turn ignition switch OFF.
2. Disconnect ECM harness connector.
3. Check harness continuity between ECM terminals 1, 115, 116 and ground. Refer to Wiring Diagram.

Continuity should exist.

4. Also check harness for short to power.

OK or NG

- OK >> GO TO 7.
- NG >> GO TO 6.

6. DETECT MALFUNCTIONING PART

Check the following.

- Harness connectors F58, M70
- Harness for open or short between ECM and ground

>> Repair open circuit or short to power in harness or connectors.

7. CHECK ECM POWER SUPPLY CIRCUIT-II

1. Reconnect ECM harness connector.
2. Turn ignition switch ON.
3. Check voltage between IPDM E/R terminal 17 and ground with CONSULT-II or tester.

Voltage: Battery voltage

OK or NG

- OK >> Go to [EC-572, "IGNITION SIGNAL"](#).
- NG >> GO TO 8.

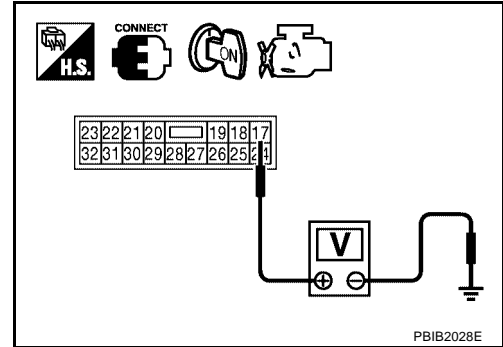

8. CHECK ECM POWER SUPPLY CIRCUIT-III

1. Turn ignition switch OFF and wait at least 10 seconds.
2. Turn ignition switch ON and then OFF.
3. Check voltage between ECM terminals 119, 120 and ground with CONSULT-II or tester.

Voltage: After turning ignition switch OFF, battery voltage will exist for a few seconds, then drop approximately 0V.

OK or NG

- OK >> GO TO 15.
- NG (Battery voltage does not exist.)>>GO TO 9.
- NG (Battery voltage exists for more than a few seconds.)>>GO TO 18.

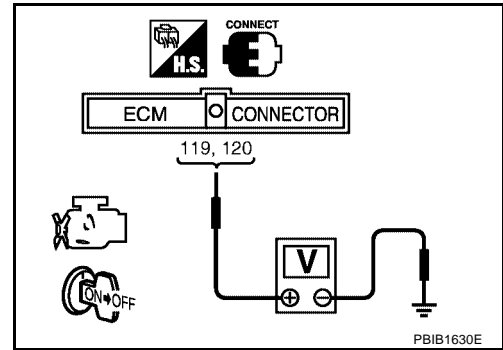

9. CHECK ECM POWER SUPPLY CIRCUIT-IV

1. Turn ignition switch OFF and wait at least 10 seconds.
2. Check voltage between ECM terminal 111 and ground with CONSULT-II or tester.

Voltage: Battery voltage

OK or NG

- OK >> GO TO 10.
- NG >> GO TO 12.

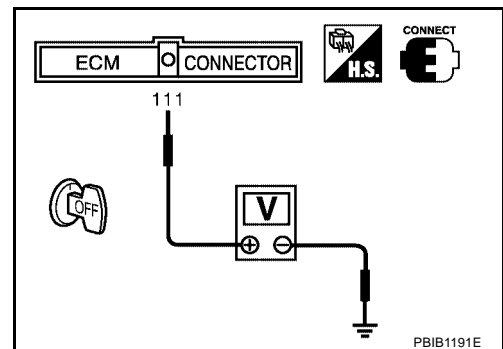

10. CHECK ECM POWER SUPPLY CIRCUIT-V

1. Disconnect ECM harness connector.
2. Disconnect IPDM E/R harness connector E122.
3. Check harness continuity between ECM terminals 119, 120 and IPDM E/R terminal 18.
Refer to Wiring Diagram.

Continuity should exist.

4. Also check harness for short to ground and short to power.

OK or NG

- OK >> GO TO 15.
NG >> GO TO 11.

11. DETECT MALFUNCTIONING PART

Check the following.

- Harness or connectors E20, F32
- Harness for open or short between ECM and IPDM E/R

>> Repair open circuit or short to ground or short to power in harness or connectors.

12. CHECK ECM POWER SUPPLY CIRCUIT-VI

1. Disconnect ECM harness connector.
2. Disconnect IPDM E/R harness connector E121.
3. Check harness continuity between ECM terminal 111 and IPDM E/R terminal 46.
Refer to Wiring Diagram.

Continuity should exist.

4. Also check harness for short to ground and short to power.

OK or NG

- OK >> GO TO 14.
NG >> GO TO 13.

13. DETECT MALFUNCTIONING PART

Check the following.

- Harness or connectors E20, F32
- Harness for open or short between ECM and IPDM E/R

>> Repair open circuit or short to ground or short to power in harness or connectors.

14. CHECK 15A FUSE

1. Disconnect 15A fuse from IPDM E/R.
2. Check 15A fuse.

OK or NG

- OK >> GO TO 18.
NG >> Replace 15A fuse.

15. CHECK GROUND CONNECTIONS

1. Turn ignition switch OFF.
2. Loosen and retighten three ground screws on the body. Refer to [EC-164, "Ground Inspection"](#).

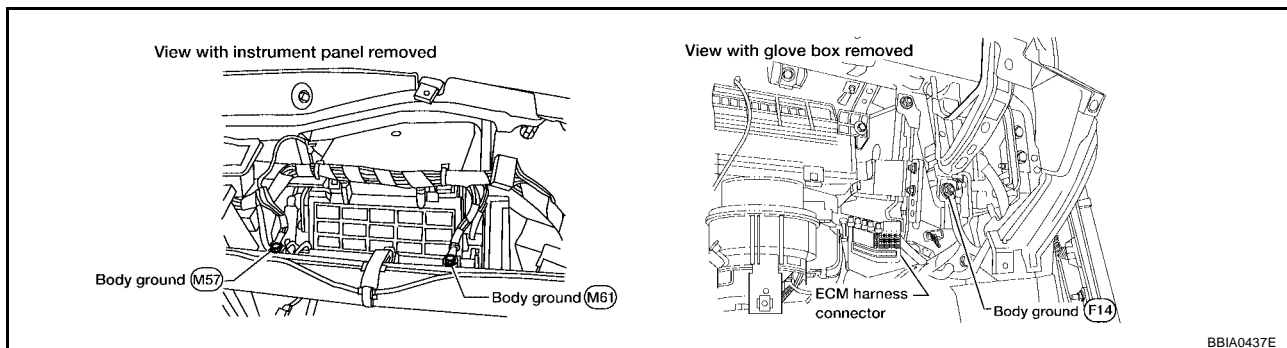

BBIA0437E

OK or NG

- OK >> GO TO 16.
 NG >> Repair or replace ground connections.

16. CHECK ECM GROUND CIRCUIT FOR OPEN AND SHORT-II

1. Turn ignition switch OFF.
2. Disconnect ECM harness connector.
3. Check harness continuity between ECM terminals 1, 115, 116 and ground. Refer to Wiring Diagram.

Continuity should exist.

4. Also check harness for short to power.

OK or NG

- OK >> GO TO 18.
 NG >> GO TO 17.

17. DETECT MALFUNCTIONING PART

Check the following.

- Harness connectors F58, M70
- Harness for open or short between ECM and ground

>> Repair open circuit or short to power in harness or connectors.

18. CHECK INTERMITTENT INCIDENT

Refer to [EC-158, "TROUBLE DIAGNOSIS FOR INTERMITTENT INCIDENT"](#).

OK or NG

- OK >> Replace IPDM E/R.
 NG >> Repair open circuit or short to ground or short to power in harness or connectors.

Ground Inspection

UBS00ELS

Ground connections are very important to the proper operation of electrical and electronic circuits. Ground connections are often exposed to moisture, dirt and other corrosive elements. The corrosion (rust) can become an unwanted resistance. This unwanted resistance can change the way a circuit works.

Electronically controlled circuits are very sensitive to proper grounding. A loose or corroded ground can drastically affect an electronically controlled circuit. A poor or corroded ground can easily affect the circuit. Even when the ground connection looks clean, there can be a thin film of rust on the surface.

When inspecting a ground connection follow these rules:

- Remove the ground bolt or screw.

POWER SUPPLY AND GROUND CIRCUIT

[QR]

- Inspect all mating surfaces for tarnish, dirt, rust, etc.
- Clean as required to assure good contact.
- Reinstall bolt or screw securely.
- Inspect for “add-on” accessories which may be interfering with the ground circuit.
- If several wires are crimped into one ground eyelet terminal, check for proper crimps. Make sure all of the wires are clean, securely fastened and providing a good ground path. If multiple wires are cased in one eyelet make sure no ground wires have excess wire insulation.

For detailed ground distribution information, refer to [PG-28, "Ground Distribution"](#) .

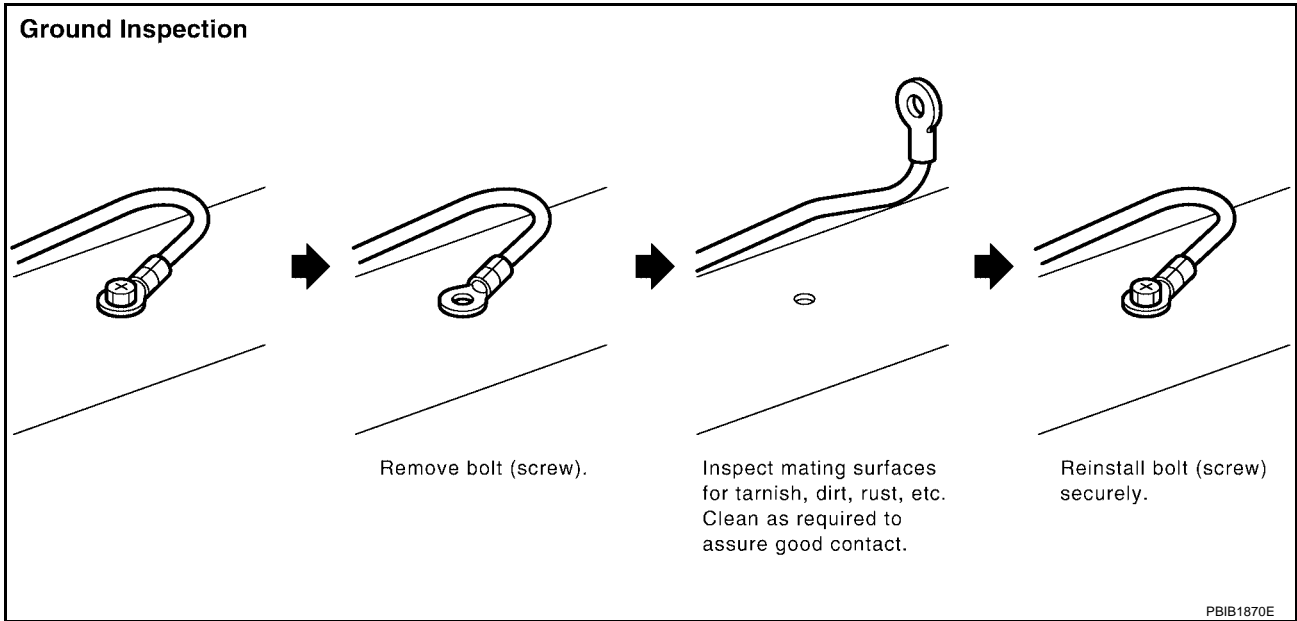

A
EC
C
D
E
F
G
H
I
J
K
L
M

DTC U1000, U1001 CAN COMMUNICATION LINE

[QR]

DTC U1000, U1001 CAN COMMUNICATION LINE

PF:23710

Description

UBS002P4

CAN (Controller Area Network) is a serial communication line for real time application. It is an on-vehicle multiplex communication line with high data communication speed and excellent error detection ability. Many electronic control units are equipped onto a vehicle, and each control unit shares information and links with other control units during operation (not independent). In CAN communication, control units are connected with 2 communication lines (CAN H line, CAN L line) allowing a high rate of information transmission with less wiring. Each control unit transmits/receives data but selectively reads required data only.

On Board Diagnosis Logic

UBS002P5

DTC No.	Trouble diagnosis name	DTC detecting condition	Possible cause
U1000*1 1000*1	CAN communication line	<ul style="list-style-type: none">● ECM cannot communicate to other control units.● ECM cannot communicate for more than the specified time.	<ul style="list-style-type: none">● Harness or connectors (CAN communication line is open or shorted)
U1001*2 1001*2			

*1: This self-diagnosis has the one trip detection logic.

*2: The MIL will not light up for this diagnosis.

DTC Confirmation Procedure

UBS002P6

1. Turn ignition switch ON and wait at least 3 seconds.
2. Select "DATA MONITOR" mode with CONSULT-II.
3. If 1st trip DTC is detected, go to [EC-168, "Diagnostic Procedure"](#).



DTC U1000, U1001 CAN COMMUNICATION LINE

[QR]

Wiring Diagram

UBS002P7

EC-CAN-01

-  : DETECTABLE LINE FOR DTC
-  : NON-DETECTABLE LINE FOR DTC
-  : DATA LINE

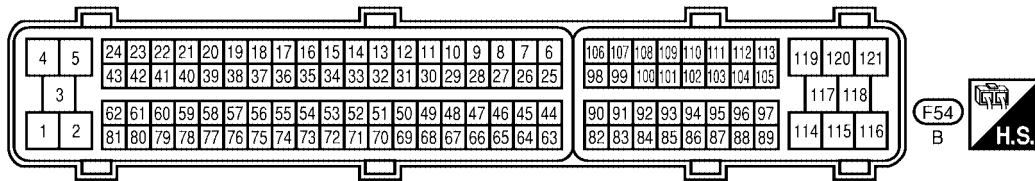
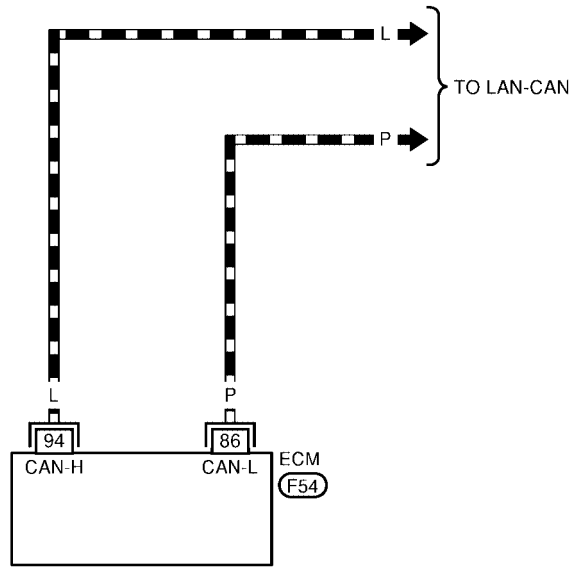

BBWA1214E

Diagnostic Procedure

UBS002P8

Go to [LAN-4, "PRECAUTIONS"](#) .

DTC P0011 IVT CONTROL

Description
SYSTEM DESCRIPTION

Sensor	Input signal to ECM	ECM function	Actuator
Crankshaft position sensor (POS)	Engine speed	Intake valve timing control	Intake valve timing control solenoid valve
Camshaft position sensor (PHASE)			
Engine coolant temperature sensor	Engine coolant temperature		
Vehicle speed sensor*	Vehicle speed		

*: This signal is sent to ECM through CAN communication line.

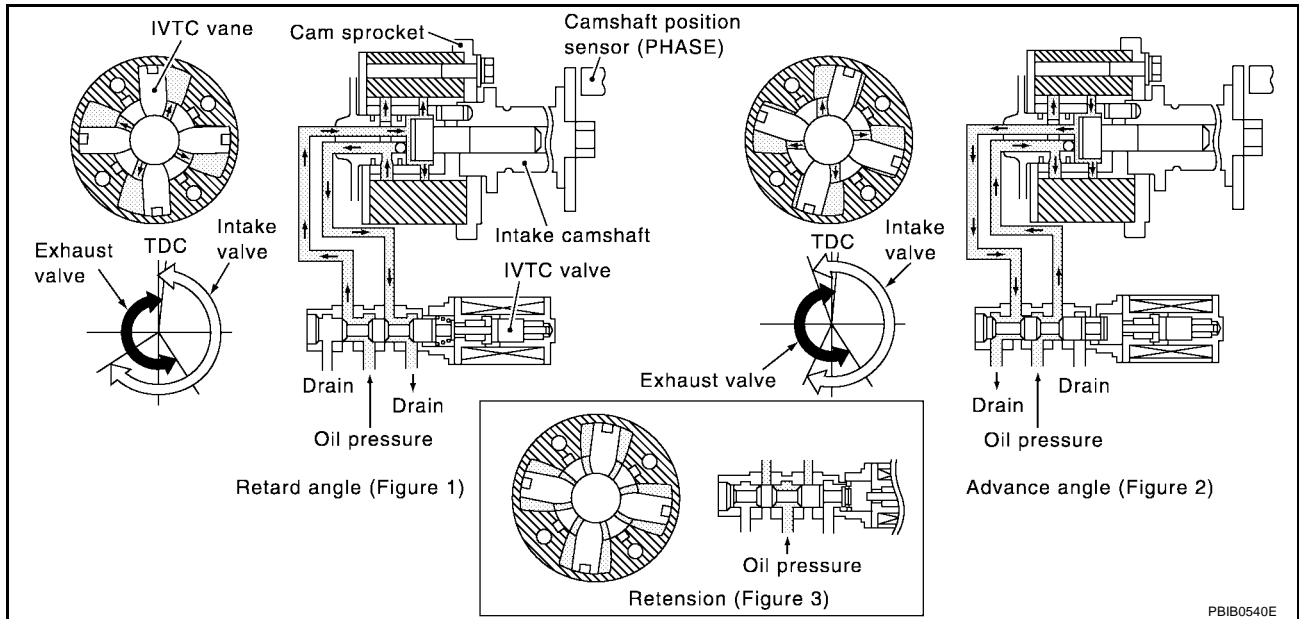

This mechanism hydraulically controls cam phases continuously with the fixed operating angle of the intake valve.

The ECM receives signals such as crankshaft position, camshaft position, engine speed, and engine coolant temperature. Then, the ECM sends ON/OFF pulse duty signals to the intake valve timing control solenoid valve depending on driving status. This makes it possible to control the shut/open timing of the intake valve to increase engine torque in low/mid speed range and output in high-speed range.

CONSULT-II Reference Value in Data Monitor Mode

Specification data are reference values.

MONITOR ITEM	CONDITION	SPECIFICATION
INT/V TIM (B1)	● Engine: After warming up ● Shift lever: N (A/T), Neutral (M/T) ● Air conditioner switch: OFF ● No-load Idle	-5° - 5°C
	2,000 rpm	Approx. 0° - 20°C
INT/V SOL (B1)	● Engine: After warming up ● Shift lever: N (A/T), Neutral (M/T) ● Air conditioner switch: OFF ● No-load Idle	0% - 2%
	2,000 rpm	Approx. 25% - 60%

On Board Diagnosis Logic

DTC No.	Trouble diagnosis name	Detecting condition	Possible cause
P0011 0011	Intake valve timing control performance	There is a gap between angle of target and phase-control angle degree.	<ul style="list-style-type: none"> ● Crankshaft position sensor (POS) ● Camshaft position sensor (PHASE) ● Intake valve control solenoid valve ● Accumulation of debris to the signal pick-up portion of the camshaft ● Timing chain installation ● Foreign matter caught in the oil groove for intake valve timing control

FAIL-SAFE MODE

ECM enters fail-safe mode when the malfunction is detected.

Detected items	Engine operating condition in fail-safe mode
Intake valve timing control	The signal is not energized to the solenoid valve and the valve control does not function

DTC Confirmation Procedure

CAUTION:

Always drive at a safe speed.

NOTE:

- If DTC P0011 is displayed with DTC P1111, first perform trouble diagnosis for DTC P1111. See [EC-382](#).
- If DTC Confirmation Procedure has been previously conducted, always turn ignition switch OFF and wait at least 10 seconds before conducting the next test.

TESTING CONDITION:

Before performing the following procedure, confirm that battery voltage is between 10V and 16V at idle.

WITH CONSULT-II

1. Turn ignition switch ON and select "DATA MONITOR" mode with CONSULT-II.
2. Start engine and warm it up to the normal operating temperature.
3. Maintain the following conditions for at least 10 consecutive seconds.
Hold the accelerator pedal as steady as possible.

ENG SPEED	500 - 2,000 rpm (A constant rotation is maintained.)
COOLANT TEMPS	70 - 120°C (158 - 248°F)
Selector lever	P or N position

DATA MONITOR	
MONITOR	NO DTC
ENG SPEED	XXX rpm
COOLANT TEMP/S	XXX °C

SEF174Y

4. Let engine idle for 10 seconds.
5. If the 1st trip DTC is detected, go to [EC-171, "Diagnostic Procedure"](#).
If the 1st trip DTC is not detected, go to next step.
6. Maintain the following conditions for at least 20 consecutive seconds.

ENG SPEED	1,800 - 3,175 rpm (A constant rotation is maintained.)
COOLANT TEMPS	70 - 105°C (158 - 221°F)
Selector lever	1st or 2nd position
Driving location uphill	Driving vehicle uphill (Increased engine load will help maintain the driving conditions required for this test.)

7. If the 1st trip DTC is detected, go to [EC-171, "Diagnostic Procedure"](#).

WITH GST

Follow the procedure "WITH CONSULT-II" above.

Diagnostic Procedure

UBS002PD

1. CHECK OIL PRESSURE WARNING LAMP

1. Start engine.
2. Check oil pressure warning lamp and confirm it is not illuminated.

OK or NG

- OK >> GO TO 2.
- NG >> Go to [LU-8](#).

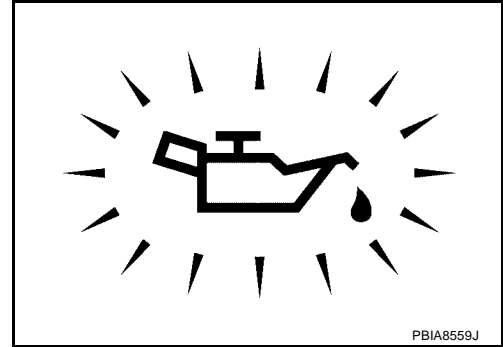

2. CHECK INTAKE VALVE TIMING CONTROL SOLENOID VALVE

Refer to [EC-172](#).

OK or NG

- OK >> GO TO 3.
- NG >> Replace intake valve timing control solenoid valve.

3. CHECK CRANKSHAFT POSITION SENSOR (POS)

Refer to [EC-278](#).

OK or NG

- OK >> GO TO 4.
- NG >> Replace crankshaft position sensor (POS).

4. CHECK CAMSHAFT POSITION SENSOR (PHASE)

Refer to [EC-285](#).

OK or NG

- OK >> GO TO 5.
- NG >> Replace camshaft position sensor (PHASE).

5. CHECK CAMSHAFT (INTAKE)

Check the following.

- Accumulation of debris to the signal plate of camshaft rear end
- Chipping signal plate of camshaft rear end

OK or NG

- OK >> GO TO 6.
- NG >> Remove debris and clean the signal plate of camshaft rear end or replace camshaft.

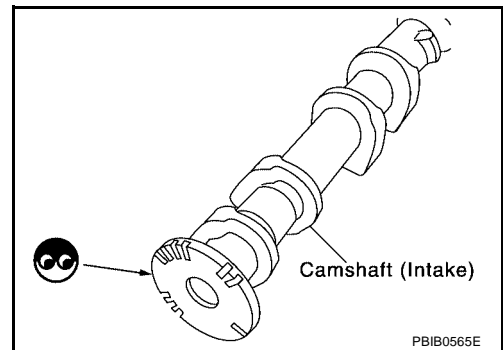

6. CHECK TIMING CHAIN INSTALLATION

Check service records for any recent repairs that may cause timing chain misaligned.

OK or NG

- OK >> Check timing chain installation. Refer to [EM-48](#) .
- NG >> GO TO 7.

7. CHECK LUBRICATION CIRCUIT

Refer to [EM-44, "Inspection of Camshaft Sprocket \(INT\) Oil Groove"](#) .

OK or NG

- OK >> GO TO 8.
- NG >> Clean lubrication line.

8. CHECK INTERMITTENT INCIDENT

Refer to [EC-158](#) .

For Wiring Diagram, refer to [EC-275](#) for CKP sensor (POS) and [EC-282](#) for CMP sensor (PHASE).

>> INSPECTION END

Component Inspection INTAKE VALVE TIMING CONTROL SOLENOID VALVE

UBS001J1

1. Disconnect intake valve timing control solenoid valve harness connector.
2. Check resistance between intake valve timing control solenoid valve as follows.

Terminal	Resistance
1 and 2	7.0 - 7.7Ω at 20°C (68°F)
1 or 2 and ground	(Continuity should not exist.)

If NG, replace intake valve timing control solenoid valve.
If OK, go to next step.

3. Remove intake valve timing control solenoid valve.
4. Provide 12V DC between intake valve timing control solenoid valve terminals and then interrupt it. Make sure that the plunger moves as shown in the figure.

CAUTION:

Do not apply 12V DC continuously for 5 seconds or more. Doing so may result in damage to the coil in intake valve timing control solenoid valve.

If NG, replace intake valve timing control solenoid valve.

NOTE:

Always replace O-ring when intake valve timing control solenoid valve is removed.

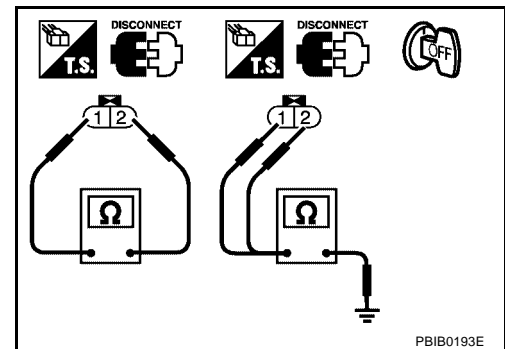

PBIB0193E

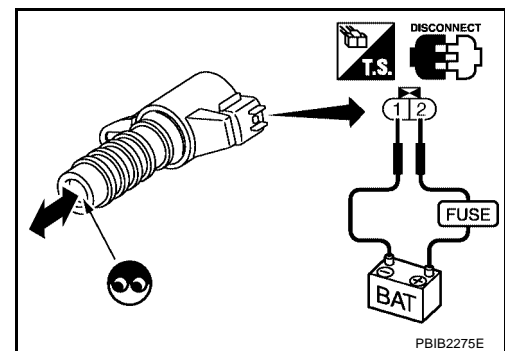

PBIB2275E

Removal and Installation INTAKE VALVE TIMING CONTROL SOLENOID VALVE

UBS001J2

Refer to [EM-48, "TIMING CHAIN"](#) .

DTC P0037, P0038 HO2S2 HEATER

[QR]

DTC P0037, P0038 HO2S2 HEATER

PF2:226A0

Description SYSTEM DESCRIPTION

UBS002PM

Sensor	Input Signal to ECM	ECM Function	Actuator
Camshaft position sensor (PHASE)	Engine speed	Heated oxygen sensor 2 heater control	Heated oxygen sensor 2 heater
Crankshaft position sensor (POS)			
Engine coolant temperature sensor	Engine coolant temperature		
Mass air flow sensor	Amount of intake air		

The ECM performs ON/OFF control of the heated oxygen sensor 2 heater corresponding to the engine speed, amount of intake air and engine coolant temperature.

OPERATION

Engine speed rpm	Heated oxygen sensor 2 heater
Above 3,600	OFF
<ul style="list-style-type: none"> Below 3,600 rpm after the following conditions are met. Engine: After warming up Keeping the engine speed between 3,500 and 4,000 rpm for 1 minute and at idle for 1 minute under no load 	ON

CONSULT-II Reference Value in Data Monitor Mode

UBS002PN

Specification data are reference values.

MONITOR ITEM	CONDITION	SPECIFICATION
HO2S2 HTR (B1)	<ul style="list-style-type: none"> Engine speed: Below 3,600 rpm after the following conditions are met Engine: After warming up Keeping the engine speed between 3,500 and 4,000 rpm for 1 minute and at idle for 1 minute under no load. 	ON
	<ul style="list-style-type: none"> Engine speed: Above 3,600 rpm 	OFF

On Board Diagnosis Logic

UBS002PO

DTC No.	Trouble diagnosis name	DTC detecting condition	Possible cause
P0037 0037	Heated oxygen sensor 2 heater control circuit low	The current amperage in the heated oxygen sensor 2 heater circuit is out of the normal range. (An excessively low voltage signal is sent to ECM through the heated oxygen sensor 2 heater.)	<ul style="list-style-type: none"> Harness or connectors (The heated oxygen sensor 2 heater circuit is open or shorted.) Heater oxygen sensor 2 heater
P0038 0038	Heated oxygen sensor 2 heater control circuit high	The current amperage in the heated oxygen sensor 2 heater circuit is out of the normal range. (An excessively high voltage signal is sent to ECM through the heated oxygen sensor 2 heater.)	<ul style="list-style-type: none"> Harness or connectors (The heated oxygen sensor 2 heater circuit is shorted.) Heater oxygen sensor 2 heater

DTC Confirmation Procedure

UBS002PP

NOTE:

If DTC Confirmation Procedure has been previously conducted, always turn ignition switch OFF and wait at least 10 seconds before conducting the next test.

TESTING CONDITION:

Before performing the following procedure, confirm that battery voltage is between 10.5V and 16V at idle.

WITH CONSULT-II

- Turn ignition switch ON and select "DATA MONITOR" mode with CONSULT-II.
- Start engine and warm it up to the normal operating temperature.
- Turn ignition switch OFF and wait at least 10 seconds.

DTC P0037, P0038 HO2S2 HEATER

[QR]

4. Start engine and keep the engine speed between 3,500 and 4,000 rpm for at least 1 minute under no load.
5. Let engine idle for 1 minute.
6. If 1st trip DTC is detected, go to [EC-176, "Diagnostic Procedure"](#)

DATA MONITOR	
MONITOR	NO DTC
ENG SPEED	XXX rpm
COOLAN TEMP/S	XXX °C

SEF174Y



WITH GST

Follow the procedure "WITH CONSULT-II" above.

DTC P0037, P0038 HO2S2 HEATER

[QR]

Wiring Diagram

UBS002PQ

EC-HO2S2H-01

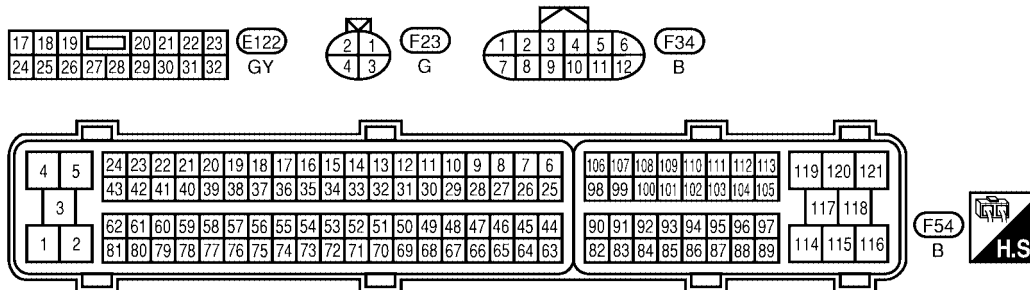
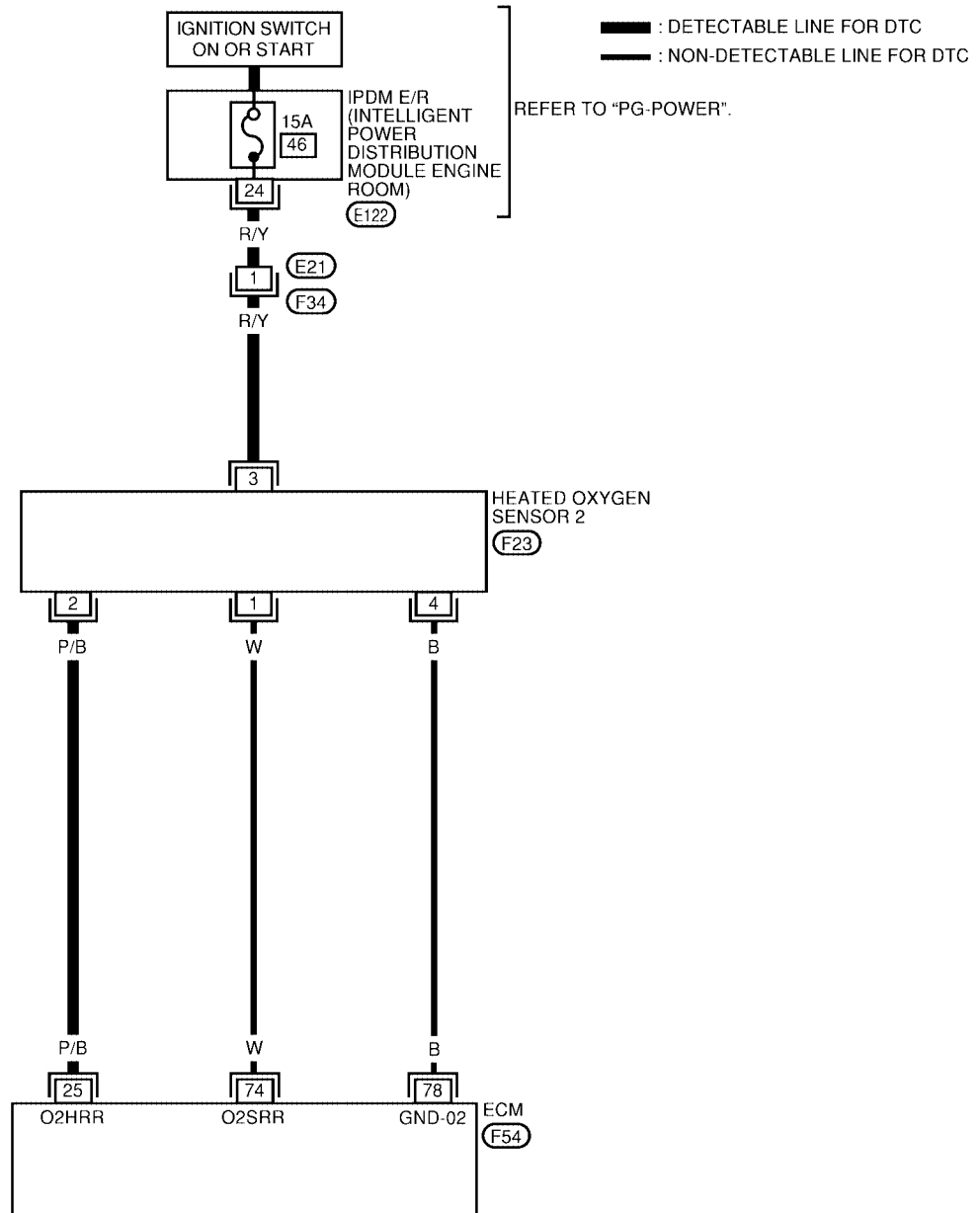

BBWA1215E

DTC P0037, P0038 HO2S2 HEATER

[QR]

Specification data are reference values and are measured between each terminal and ground.

CAUTION:

Do not use ECM ground terminals when measuring input/output voltage. Doing so may result in damage to the ECM's transistor. Use a ground other than ECM terminals, such as the ground.

TER-MINAL NO.	WIRE COLOR	ITEM	CONDITION	DATA (DC Voltage)
25	P/B	Heated oxygen sensor 2 heater	[Engine is running] <ul style="list-style-type: none"> ● Warm-up condition ● Engine speed: Below 3,600 rpm after the following conditions are met. ● Keeping the engine speed between 3,500 and 4,000 rpm for 1 minute and at idle for 1 minute under on load 	0 - 1.0V
			[Ignition switch: ON] <ul style="list-style-type: none"> ● Engine stopped. [Engine is running] <ul style="list-style-type: none"> ● Engine speed is above 3,600 rpm. 	BATTERY VOLTAGE (11 - 14V)

Diagnostic Procedure

UBS002PR

1. CHECK HO2S2 POWER SUPPLY CIRCUIT

1. Turn ignition switch OFF.
2. Disconnect heated oxygen sensor 2 harness connector.
3. Turn ignition switch ON.

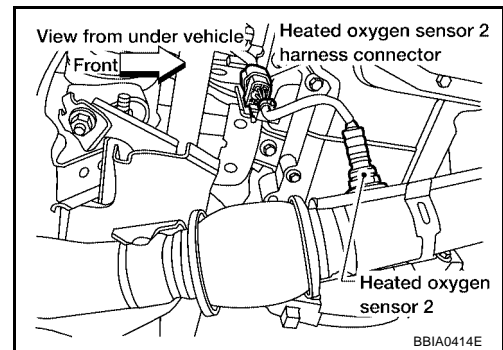

4. Check voltage between HO2S2 terminal 3 and ground with CONSULT-II or tester.

Voltage: Battery voltage

OK or NG

- OK >> GO TO 3.
- NG >> GO TO 2.

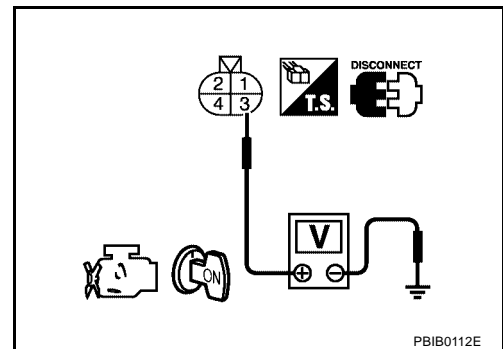

2. DETECT MALFUNCTIONING PART

Check the following.

- Harness connectors E21, F34
- IPDM E/R connector E122
- 15A fuse
- Harness for open or short between heated oxygen sensor 2 and fuse

>> Repair harness or connectors.

3. CHECK HO2S2 OUTPUT SIGNAL CIRCUIT FOR OPEN AND SHORT

1. Turn ignition switch OFF.
2. Disconnect ECM harness connector.
3. Check harness continuity between ECM terminal 25 and HO2S2 terminal 2. Refer to Wiring Diagram.

Continuity should exist.

4. Also check harness for short to ground and short to power.

OK or NG

OK >> GO TO 4.

NG >> Repair open circuit or short to ground short to power in harness or connectors.

4. CHECK HEATED OXYGEN SENSOR 2 HEATER

Refer to [EC-177, "Component Inspection"](#) .

OK or NG

OK >> GO TO 5.

NG >> Replace heated oxygen sensor 2.

5. CHECK INTERMITTENT INCIDENT

Refer to [EC-158, "TROUBLE DIAGNOSIS FOR INTERMITTENT INCIDENT"](#) .

>> INSPECTION END

Component Inspection HEATED OXYGEN SENSOR 2 HEATER

UBS002PS

1. Check resistance between HO2S2 terminals as follows.

Terminal No.	Resistance
2 and 3	5.0 - 7.0 Ω at 25°C (77°F)
1 and 2, 3, 4	∞ Ω (Continuity should not exist)
4 and 1, 2, 3	

2. If NG, replace heated oxygen sensor 2.

CAUTION:

- Discard any heated oxygen sensor which has been dropped from a height of more than 0.5 m (19.7 in) onto a hard surface such as a concrete floor; use a new one.
- Before installing new oxygen sensor, clean exhaust system threads using Oxygen Sensor Thread Cleaner tool J-43897-18 or J-43897-12 and approved anti-seize lubricant.

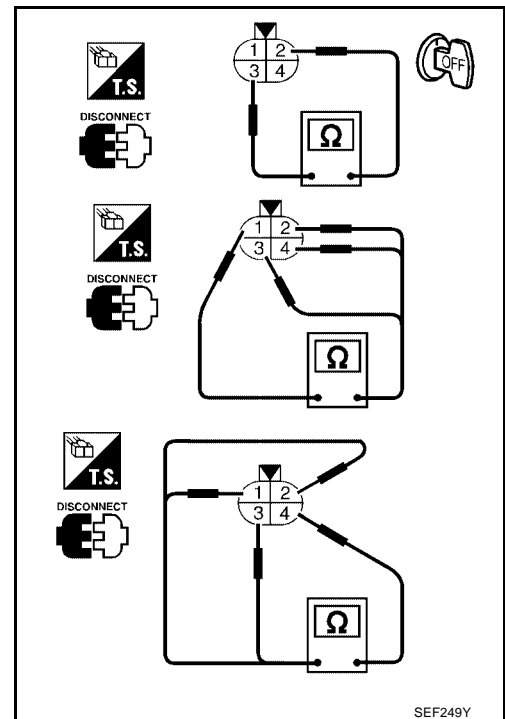

SEF249Y

Removal and Installation HEATED OXYGEN SENSOR 2

UBS002PT

Refer to [EX-3, "EXHAUST SYSTEM \(QR25DE\)"](#) .

DTC P0101 MAF SENSOR

Component Description

UBS002PU

The mass air flow sensor is placed in the stream of intake air. It measures the intake flow rate by measuring a part of the entire intake flow. The mass air flow sensor controls the temperature of the hot wire to a certain amount. The heat generated by the hot wire is reduced as the intake air flows around it. The more air, the greater the heat loss.

Therefore, the electric current supplied to hot wire is changed to maintain the temperature of the hot wire as air flow increases. The ECM detects the air flow by means of this current change.

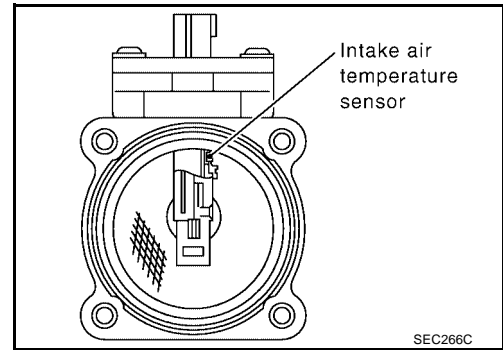

CONSULT-II Reference Value in Data Monitor Mode

UBS002PV

Specification data are reference values.

MONITOR ITEM	CONDITION	SPECIFICATION
MAS A/F SE-B1	<ul style="list-style-type: none"> See EC-148. "TROUBLE DIAGNOSIS - SPECIFICATION VALUE". 	
CAL/LD VALUE	<ul style="list-style-type: none"> Engine: After warming up Shift lever: N (A/T), Neutral (M/T) Air conditioner switch: OFF No-load 	Idle 10% - 35%
		2,500 rpm 10% - 35%
MASS AIRFLOW	<ul style="list-style-type: none"> Engine: After warming up Shift lever: N (A/T), Neutral (M/T) Air conditioner switch: OFF No-load 	Idle 1.0 - 4.0 g·m/s
		2,500 rpm 4.0 - 10.0 g·m/s

On Board Diagnosis Logic

UBS002PW

DTC No.	Trouble diagnosis name	DTC detecting condition		Possible cause
P0101 0101	Mass air flow sensor circuit range/performance problem	A)	A high voltage from the sensor is sent to ECM under light load driving condition.	<ul style="list-style-type: none"> Harness or connectors (The sensor circuit is open or shorted.) Mass air flow sensor EVAP control system pressure sensor Intake air temperature sensor
		B)	A low voltage from the sensor is sent to ECM under heavy load driving condition.	<ul style="list-style-type: none"> Harness or connectors (The sensor circuit is open or shorted.) Intake air leaks Mass air flow sensor EVAP control system pressure sensor Intake air temperature sensor

DTC Confirmation Procedure

UBS002PX

Perform PROCEDURE FOR MALFUNCTION A first.

If the DTC cannot be confirmed, perform PROCEDURE FOR MALFUNCTION B.

NOTE:

If DTC Confirmation Procedure has been previously conducted, always turn ignition switch OFF and wait at least 10 seconds before conducting the next test.

PROCEDURE FOR MALFUNCTION A

NOTE:

If engine will not start or stops soon, wait at least 10 seconds with engine stopped (Ignition switch ON) instead of running engine at idle speed.

With CONSULT-II

1. Turn ignition switch ON.
2. Select "DATA MONITOR" mode with CONSULT-II.
3. Start engine and warm it up to normal operating temperature.
4. Run engine for at least 10 seconds at idle speed.
5. If 1st trip DTC is detected, go to [EC-182, "Diagnostic Procedure"](#)

DATA MONITOR	
MONITOR	NO DTC
ENG SPEED	XXX rpm
COOLAN TEMP/S	XXX °C

SEF174Y

With GST

Follow the procedure "With CONSULT-II" above.

PROCEDURE FOR MALFUNCTION B

CAUTION:

Always drive vehicle at a safe speed.

With CONSULT-II

1. Turn ignition switch ON.
2. Start engine and warm it up to normal operating temperature.
If engine cannot be started, go to [EC-182, "Diagnostic Procedure"](#) .
3. Select "DATA MONITOR" mode with CONSULT-II.
4. Check the voltage of "MAS A/F SE-B1" with "DATA MONITOR".
5. Increases engine speed to about 4,000 rpm.
6. Monitor the linear voltage rise in response to engine speed increases.
If NG, go to [EC-182, "Diagnostic Procedure"](#) .
If OK, go to following step.

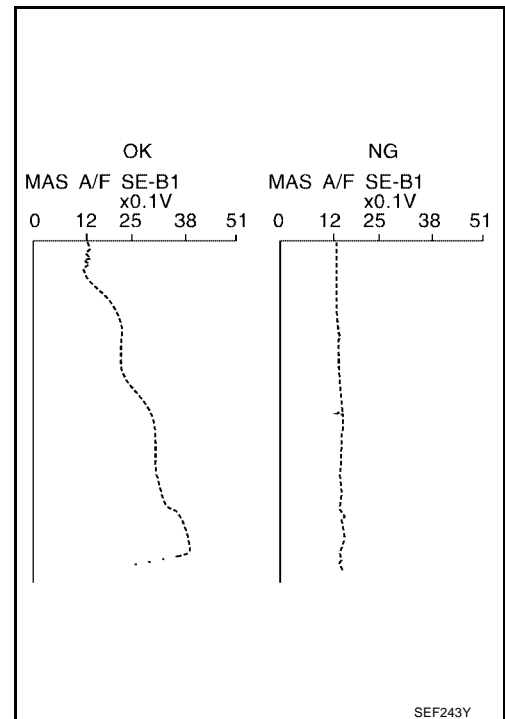

DTC P0101 MAF SENSOR

[QR]

7. Maintain the following conditions for at least 10 consecutive seconds.

ENG SPEED	More than 2,000 rpm
THRTL SEN 1	More than 3V
THRTL SEN 2	More than 3V
Selector lever	Suitable position
Driving location	Driving vehicle uphill (Increased engine load) will help maintain the driving conditions required for this test.

DATA MONITOR	
MONITOR	NO DTC
ENG SPEED	XXX rpm
VHCL SPEED SE	XXX km/h
THRTL SEN 1	XXX V
THRTL SEN 2	XXX V

PBIB0199E

8. If 1st trip DTC is detected, go to [EC-182, "Diagnostic Procedure"](#)

Overall Function Check PROCEDURE FOR MALFUNCTION B

UBS002PY

Use this procedure to check the overall function of the mass air flow sensor circuit. During this check, a 1st DTC might not be confirmed.

With GST

1. Start engine and warm it up to normal operating temperature.
2. Select "Service \$01" with GST.
3. Check the mass air flow sensor signal with "Service \$01".
4. Check for linear mass air flow sensor signal value rise in response to increases to about 4,000 rpm in engine speed.
5. If NG, go to [EC-182, "Diagnostic Procedure"](#) .

CALC LOAD	20%
COOLANT TEMP	95°C
SHORT FT #1	2%
LONG FT #1	0%
SHORT FT #2	4%
LONG FT #2	0%
ENGINE SPD	2637RPM
VEHICLE SPD	0MPH
IGN ADVANCE	41.0°
INTAKE AIR	41°C
MAF	14.1gm/sec
THROTTLE POS	3%

SEF534P

DTC P0101 MAF SENSOR

[QR]

UBS002PZ

Wiring Diagram

EC-MAFS-01

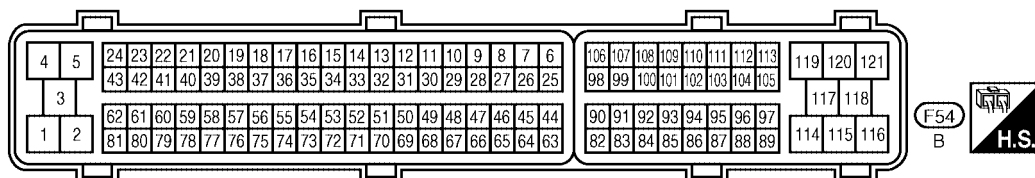
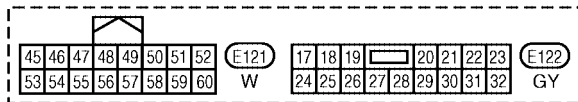
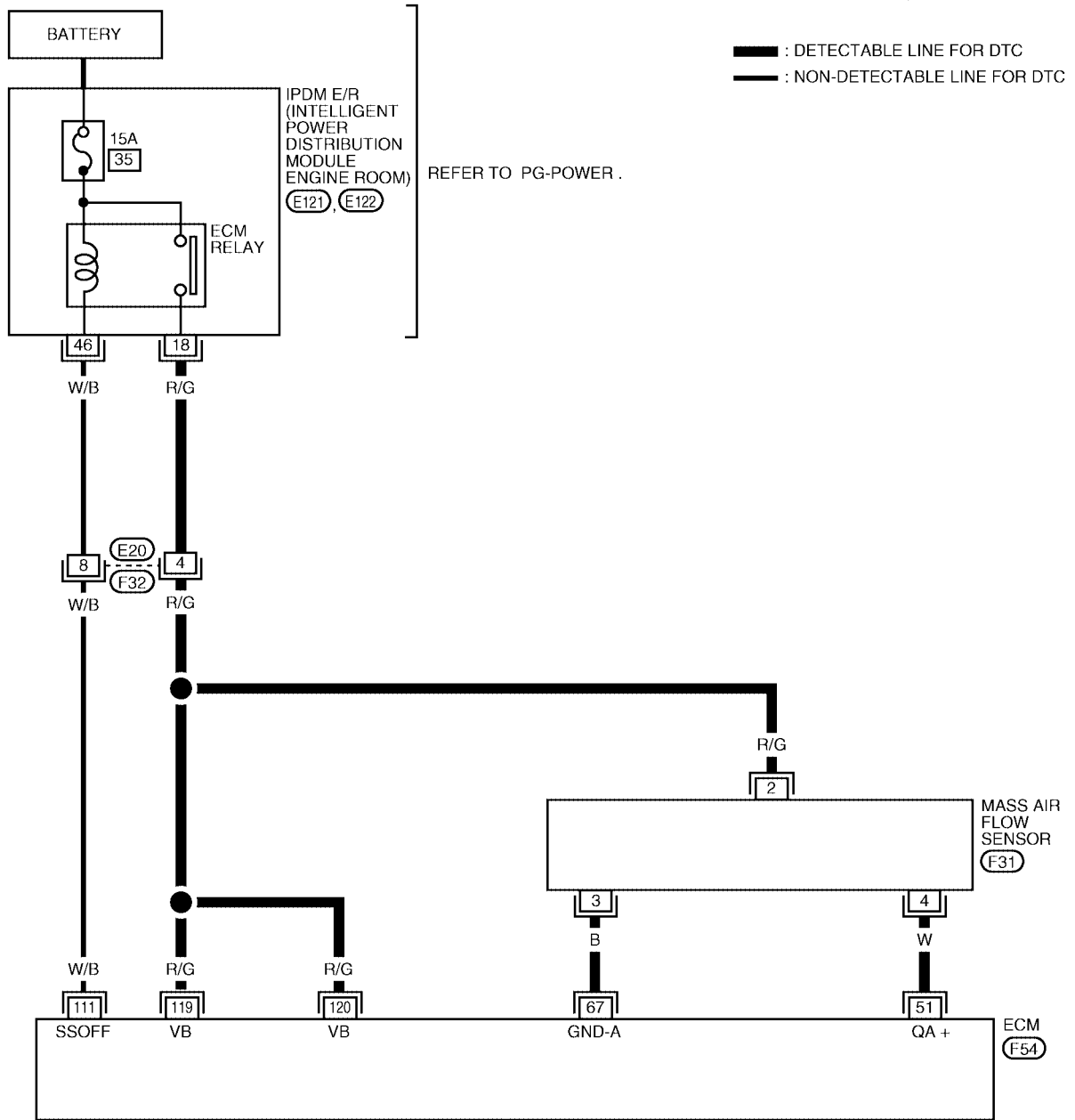

BBWA1216E

DTC P0101 MAF SENSOR

[QR]

Specification data are reference values and are measured between each terminal and ground.

CAUTION:

Do not use ECM ground terminals when measuring input/output voltage. Doing so may result in damage to the ECM's transistor. Use a ground other than ECM terminals, such as the ground.

TER-MINAL NO.	WIRE COLOR	ITEM	CONDITION	DATA (DC Voltage)
51	W	Mass air flow sensor	[Engine is running] <ul style="list-style-type: none">● Warm-up condition● Idle speed	0.9 - 1.2V
			[Engine is running] <ul style="list-style-type: none">● Warm-up condition● Engine speed is 2,500 rpm.	1.4 - 1.7V
67	B	Sensor ground	[Engine is running] <ul style="list-style-type: none">● Warm-up condition● Idle speed	Approximately 0V
111	W/B	ECM relay (Self shut-off)	[Engine is running] [Ignition switch: OFF] <ul style="list-style-type: none">● For a few seconds after turning ignition switch OFF	0 - 1.0V
			[Ignition switch: OFF] <ul style="list-style-type: none">● More than a few seconds after turning ignition switch OFF	BATTERY VOLTAGE (11 - 14V)
119 120	R/G	Power supply for ECM	[Ignition switch: ON]	BATTERY VOLTAGE (11 - 14V)

Diagnostic Procedure

UBS002Q0

1. INSPECTION START

Which malfunction (A or B) is duplicated?

A or B

- A >> GO TO 3.
- B >> GO TO 2.

2. CHECK INTAKE AIR LEAK

Check the following for connections.

- Air duct
- Vacuum hoses
- Intake air passage between air duct and intake manifold

OK or NG

- OK >> GO TO 3.
- NG >> Reconnect the parts.

3. CHECK GROUND CONNECTIONS

1. Turn ignition switch OFF.
2. Loosen and retighten three ground screws on the body. Refer to [EC-164, "Ground Inspection"](#).

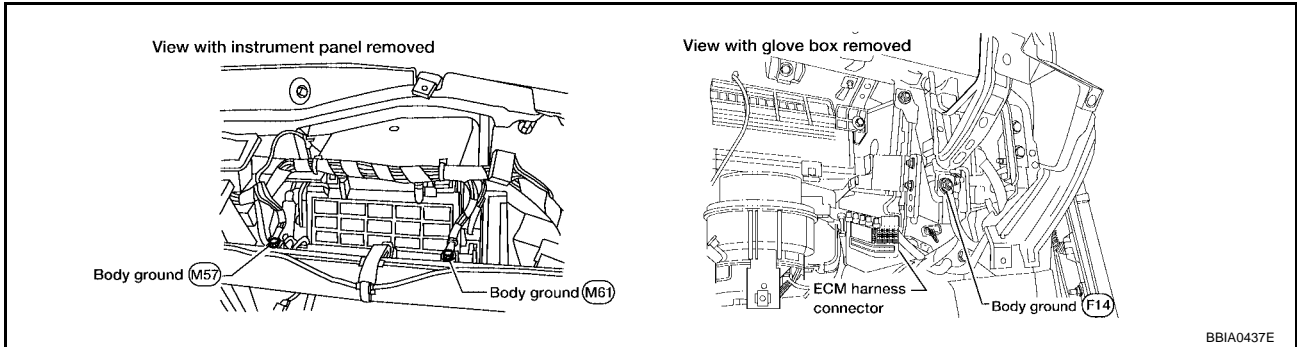

OK or NG

- OK >> GO TO 4.
- NG >> Repair or replace ground connections.

4. CHECK MAF SENSOR POWER SUPPLY CIRCUIT

1. Disconnect mass air flow (MAF) sensor harness connector.
2. Turn ignition switch ON.

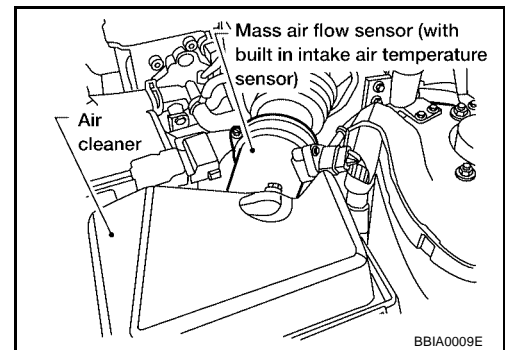

3. Check voltage between MAF sensor terminal 2 and ground with CONSULT-II or tester.

Voltage: Battery voltage

OK or NG

- OK >> GO TO 6.
- NG >> GO TO 5.

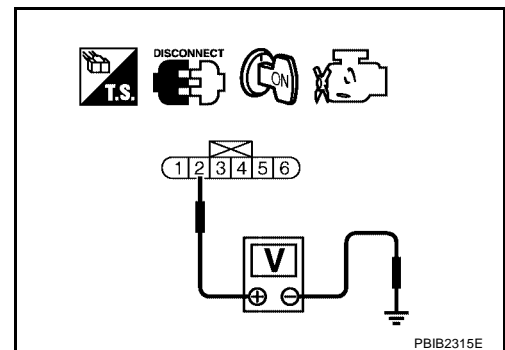

5. DETECT MALFUNCTIONING PART

Check the following.

- Harness connectors E20, F32
- Harness for open or short between IPDM E/R and mass air flow sensor
- Harness for open or short between mass air flow sensor and ECM

>> Repair harness or connectors.

6. CHECK MAF SENSOR GROUND CIRCUIT FOR OPEN AND SHORT

1. Turn ignition switch OFF.
2. Disconnect ECM harness connector.
3. Check harness continuity between MAF sensor terminal 3 and ECM terminal 67.
Refer to Wiring Diagram.

Continuity should exist.

4. Also check harness for short to ground and short to power.

OK or NG

- OK >> GO TO 7.
NG >> Repair open circuit or short to ground or short to power in harness or connectors.

7. CHECK MAF SENSOR INPUT SIGNAL CIRCUIT FOR OPEN AND SHORT

1. Check harness continuity between MAF sensor terminal 4 and ECM terminal 51.
Refer to Wiring Diagram.

Continuity should exist.

2. Also check harness for short to ground and short to power.

OK or NG

- OK >> GO TO 8.
NG >> Repair open circuit or short to ground or short or short to power in harness or connectors.

8. CHECK INTAKE AIR TEMPERATURE SENSOR

Refer to [EC-216, "Component Inspection"](#) .

OK or NG

- OK >> GO TO 9.
NG >> Replace intake air temperature sensor.

9. CHECK EVAP CONTROL SYSTEM PRESSURE SENSOR

Refer to [EC-321, "Component Inspection"](#) .

OK or NG

- OK >> GO TO 10.
NG >> Replace EVAP control system pressure sensor.

10. CHECK MASS AIR FLOW SENSOR

Refer to [EC-184, "Component Inspection"](#) .

OK or NG

- OK >> GO TO 11.
NG >> Replace mass air flow sensor.

11. CHECK INTERMITTENT INCIDENT

Perform [EC-158, "TROUBLE DIAGNOSIS FOR INTERMITTENT INCIDENT"](#) .

>> INSPECTION END

**Component Inspection
MASS AIR FLOW SENSOR**

UBS002Q1

④ With CONSULT-II

1. Reconnect all harness connectors disconnected.
2. Start engine and warm it up to normal operating temperature.
3. Connect CONSULT-II and select "DATA MONITOR" mode.

DTC P0101 MAF SENSOR

[QR]

4. Select "MAS A/F SE-B1" and check indication under the following conditions.

Condition	MAS A/F SE-B1 (V)
Ignition switch ON (Engine stopped.)	Approx 0.4
Idle (Engine is warmed-up to normal operating temperature.)	0.9 - 1.2
2,500 rpm (Engine is warmed-up to normal operating temperature.)	1.4 - 1.7
Idle to about 4,000 rpm*	0.9 - 1.2 to 2.4

*: Check for linear voltage rise in response to engine being increased to about 4,000 rpm.

DATA MONITOR	
MONITOR	NO DTC
ENG SPEED	XXX rpm
MAS A/F SE-B1	XXX V

PBIB2371E

5. If the voltage is out of specification, proceed the following.
- Check for the cause of uneven air flow through mass air flow sensor. Refer to following.
 - Crushed air ducts
 - Malfunctioning seal of air cleaner element
 - Uneven dirt of air cleaner element
 - Improper specification of intake air system parts
 - If NG, repair or replace malfunctioning part and perform step 2 to 4 again. If OK, go to next step.
- Turn ignition switch OFF.
 - Disconnect mass air flow sensor harness connector and reconnect it again.
 - Perform step 2 to 4 again.
 - If NG, clean or replace mass air flow sensor.

⊗ Without CONSULT-II

- Reconnect all harness connectors disconnected.
- Start engine and warm it up to normal operating temperature.
- Check voltage between ECM terminal 51 (Mass air flow sensor signal) and ground.

Condition	Voltage V
Ignition switch ON (Engine stopped.)	Approx 0.4
Idle (Engine is warmed-up to normal operating temperature.)	0.9 - 1.2
2,500 rpm (Engine is warmed-up to normal operating temperature.)	1.4 - 1.7
Idle to about 4,000 rpm*	0.9 - 1.2 to 2.4

*: Check for linear voltage rise in response to engine being increased to about 4,000 rpm.

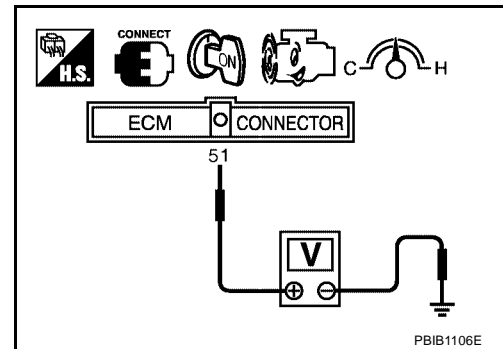

- If the voltage is out of specification, proceed the following.
 - Check for the cause of uneven air flow through mass air flow sensor. Refer to following.
 - Crushed air ducts
 - Malfunctioning seal of air cleaner element
 - Uneven dirt of air cleaner element
 - Improper specification of intake air system parts
 - If NG, repair or replace malfunctioning part and perform step 2 to 4 again. If OK, go to next step.
- Turn ignition switch OFF.
- Disconnect mass air flow sensor harness connector and reconnect it again.
- Perform step 2 and 3 again.
- If NG, clean or replace mass air flow sensor.

Removal and Installation
MASS AIR FLOW SENSOR

UBS002Q2

Refer to [EM-17, "AIR CLEANER AND AIR DUCT"](#) .

DTC P0102, P0103 MAF SENSOR

[QR]

PFP:22680

UBS002Q3

DTC P0102, P0103 MAF SENSOR

Component Description

The mass air flow sensor is placed in the stream of intake air. It measures the intake flow rate by measuring a part of the entire intake flow. The mass air flow sensor controls the temperature of the hot wire to a certain amount. The heat generated by the hot wire is reduced as the intake air flows around it. The more air, the greater the heat loss.

Therefore, the electric current supplied to hot wire is changed to maintain the temperature of the hot wire as air flow increases. The ECM detects the air flow by means of this current change.

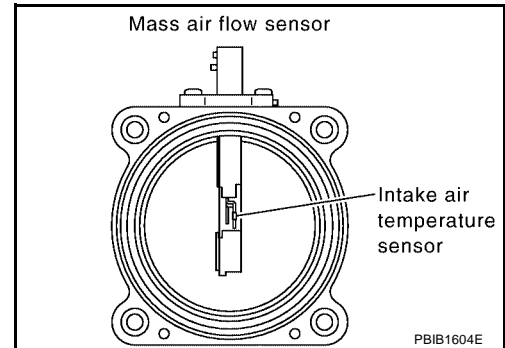

CONSULT-II Reference Value in Data Monitor Mode

UBS002Q4

Specification data are reference values.

MONITOR ITEM	CONDITION	SPECIFICATION
MAS A/F SE-B1	<ul style="list-style-type: none"> See EC-148, "TROUBLE DIAGNOSIS - SPECIFICATION VALUE". 	
CAL/LD VALUE	<ul style="list-style-type: none"> Engine: After warming up Shift lever: N (A/T), Neutral (M/T) Air conditioner switch: OFF No-load 	Idle 10% - 35%
	2,500 rpm	10% - 35%
MASS AIRFLOW	<ul style="list-style-type: none"> Engine: After warming up Shift lever: N (A/T), Neutral (M/T) Air conditioner switch: OFF No-load 	Idle 1.0 - 4.0 g-m/s
	2,500 rpm	4.0 - 10.0 g-m/s

On Board Diagnosis Logic

UBS002Q5

These self-diagnoses have the one trip detection logic.

DTC No.	Trouble diagnosis name	DTC detecting condition	Possible cause
P0102 0102	Mass air flow sensor circuit low input	An excessively low voltage from the sensor is sent to ECM.	<ul style="list-style-type: none"> Harness or connectors (The sensor circuit is open or shorted.) Intake air leaks Mass air flow sensor
P0103 0103	Mass air flow sensor circuit high input	An excessively high voltage from the sensor is sent to ECM.	<ul style="list-style-type: none"> Harness or connectors (The sensor circuit is open or shorted.) Mass air flow sensor

FAIL-SAFE MODE

When the malfunction is detected, the ECM enters fail-safe mode and the MIL lights up.

Detected items	Engine operating condition in fail-safe mode
Mass air flow sensor circuit	Engine speed will not rise more than 2,400 rpm due to the fuel cut.

DTC Confirmation Procedure

UBS002Q6

NOTE:

If DTC Confirmation Procedure has been previously conducted, always turn ignition switch OFF and wait at least 10 seconds before conducting the next test.

PROCEDURE FOR DTC P0102

With CONSULT-II

1. Turn ignition switch ON.

DTC P0102, P0103 MAF SENSOR

[QR]

2. Select "DATA MONITOR" mode with CONSULT-II.
3. Start engine and wait at least 5 seconds.
4. If DTC is detected, go to [EC-190, "Diagnostic Procedure"](#).

DATA MONITOR	
MONITOR	NO DTC
ENG SPEED	XXX rpm

SEF058Y

With GST

Follow the procedure "With CONSULT-II" above.

PROCEDURE FOR DTC P0103

With CONSULT-II

1. Turn ignition switch ON.
2. Select "DATA MONITOR" mode with CONSULT-II.
3. Wait at least 5 seconds.
4. If DTC is detected, go to [EC-190, "Diagnostic Procedure"](#).
If DTC is not detected, go to next step.
5. Start engine and wait at least 5 seconds.
6. If DTC is detected, go to [EC-190, "Diagnostic Procedure"](#).

DATA MONITOR	
MONITOR	NO DTC
ENG SPEED	XXX rpm

SEF058Y

With GST

Follow the procedure "With CONSULT-II" above.

DTC P0102, P0103 MAF SENSOR

[QR]

UBS002Q7

Wiring Diagram

EC-MAFS-01

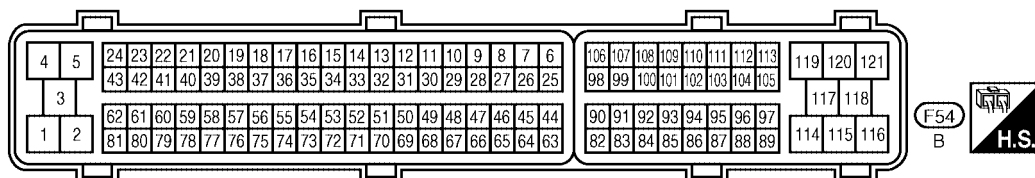
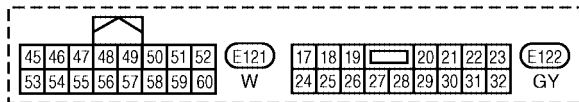
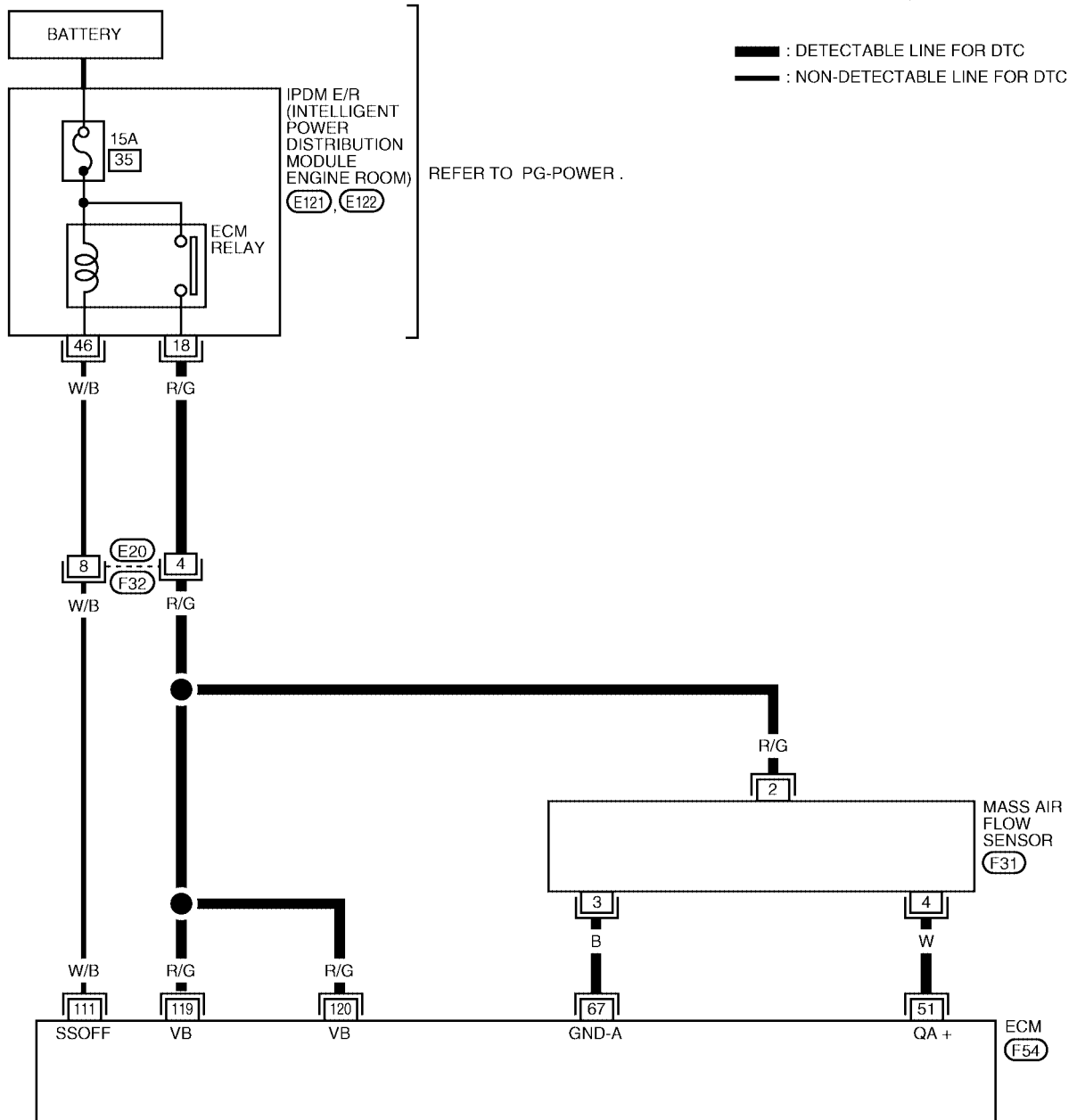

BBWA1216E

DTC P0102, P0103 MAF SENSOR

[QR]

Specification data are reference values and are measured between each terminal and ground.

CAUTION:

Do not use ECM ground terminals when measuring input/output voltage. Doing so may result in damage to the ECM's transistor. Use a ground other than ECM terminals, such as the ground.

TERMI- NAL NO.	WIRE COLOR	ITEM	CONDITION	DATA (DC Voltage)
51	W	Mass air flow sensor	[Engine is running] ● Warm-up condition ● Idle speed	0.9 - 1.2V
			[Engine is running] ● Warm-up condition ● Engine speed is 2,500 rpm.	1.4 - 1.7V
67	B	Sensor ground	[Engine is running] ● Warm-up condition ● Idle speed	Approximately 0V
111	W/B	ECM relay (Self shut-off)	[Engine is running] [Ignition switch: OFF] ● For a few seconds after turning ignition switch OFF	0 - 1.0V
			[Ignition switch: OFF] ● More than a few seconds after turning ignition switch OFF	BATTERY VOLTAGE (11 - 14V)
119 120	R/G R/G	Power supply for ECM	[Ignition switch: ON]	BATTERY VOLTAGE (11 - 14V)

Diagnostic Procedure

UBS002Q8

1. INSPECTION START

Which malfunction (P0102 or P0103) is duplicated?

P0102 or P0103

P0102 >> GO TO 2.

P0103 >> GO TO 3.

2. CHECK INTAKE SYSTEM

Check the following for connections.

- Air duct
- Vacuum hoses
- Intake air passage between air duct and intake manifold

OK or NG

OK >> GO TO 3.

NG >> Reconnect the parts.

3. CHECK GROUND CONNECTIONS

1. Turn ignition switch OFF.
2. Loosen and retighten three ground screws on the body. Refer to [EC-164, "Ground Inspection"](#).

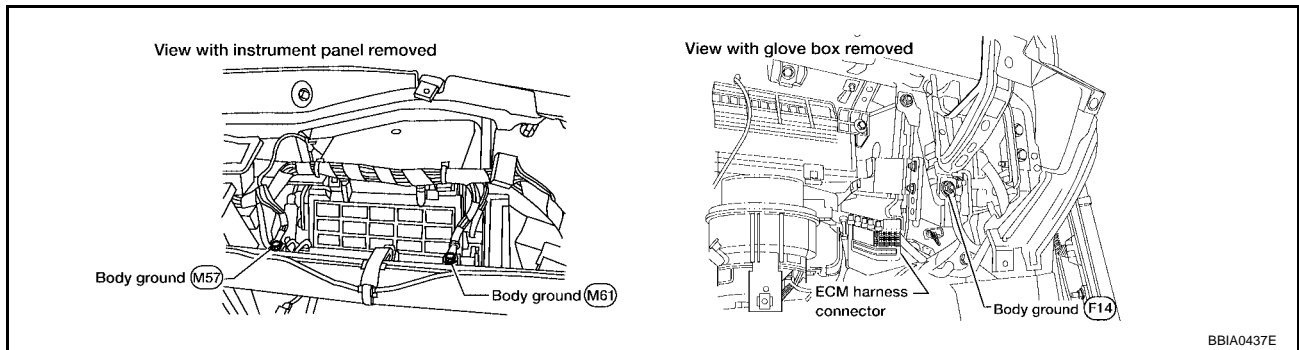

OK or NG

- OK >> GO TO 4.
- NG >> Repair or replace ground connections.

4. CHECK MAF SENSOR POWER SUPPLY CIRCUIT

1. Disconnect mass air flow (MAF) sensor harness connector.
2. Turn ignition switch ON.

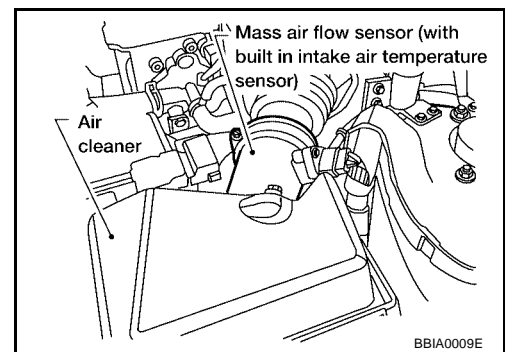

3. Check voltage between MAF sensor terminal 2 and ground with CONSULT-II or tester.

Voltage: Battery voltage

OK or NG

- OK >> GO TO 6.
- NG >> GO TO 5.

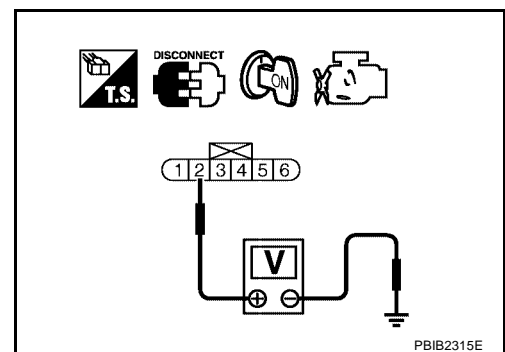

5. DETECT MALFUNCTIONING PART

Check the following.

- Harness connectors E20, F32
- Harness for open or short between IPDM E/R and mass air flow sensor
- Harness for open or short between mass air flow sensor and ECM

>> Repair harness or connectors.

6. CHECK MAF SENSOR GROUND CIRCUIT FOR OPEN AND SHORT

1. Turn ignition switch OFF.
2. Disconnect ECM harness connector.
3. Check harness continuity between MAF sensor terminal 3 and ECM terminal 67.
Refer to Wiring Diagram.

Continuity should exist.

4. Also check harness for short to ground and short to power.

OK or NG

- OK >> GO TO 7.
- NG >> Repair open circuit or short to ground or short to power in harness or connectors.

7. CHECK MAF SENSOR INPUT SIGNAL CIRCUIT FOR POEN AND SHORT

1. Check harness continuity between MAF sensor terminal 4 and ECM terminal 51.
Refer to Wiring Diagram.

Continuity should exist.

2. Also check harness for short to ground and short to power.

OK or NG

- OK >> GO TO 8.
- NG >> Repair open circuit or short to ground or short to power in harness or connectors.

8. CHECK MASS AIR FLOW SENSOR

Refer to [EC-192, "Component Inspection"](#) .

OK or NG

- OK >> GO TO 9.
- NG >> Replace mass air flow sensor.

9. CHECK INTERMITTENT INCIDENT

Perform [EC-158, "TROUBLE DIAGNOSIS FOR INTERMITTENT INCIDENT"](#) .

>> INSPECTION END

**Component Inspection
MASS AIR FLOW SENSOR**

UBS00UJ3

With CONSULT-II

1. Reconnect all harness connectors disconnected.
2. Start engine and warm it up to normal operating temperature.
3. Connect CONSULT-II and select "DATA MONITOR" mode.
4. Select "MAS A/F SE-B1" and check indication under the following conditions.

Condition	MAS A/F SE-B1 (V)
Ignition switch ON (Engine stopped.)	Approx 0.4
Idle (Engine is warmed-up to normal operating temperature.)	0.9 - 1.2
2,500 rpm (Engine is warmed-up to normal operating temperature.)	1.4 - 1.7
Idle to about 4,000 rpm*	0.9 - 1.2 to 2.4

*: Check for linear voltage rise in response to engine being increased to about 4,000 rpm.

DATA MONITOR	
MONITOR	NO DTC
ENG SPEED	XXX rpm
MAS A/F SE-B1	XXX V

PBIB2371E

5. If the voltage is out of specification, proceed the following.

DTC P0102, P0103 MAF SENSOR

[QR]

- a. Check for the cause of uneven air flow through mass air flow sensor. Refer to following.
 - Crushed air ducts
 - Malfunctioning seal of air cleaner element
 - Uneven dirt of air cleaner element
 - Improper specification of intake air system parts
- b. If NG, repair or replace malfunctioning part and perform step 2 to 4 again. If OK, go to next step.
6. Turn ignition switch OFF.
7. Disconnect mass air flow sensor harness connector and reconnect it again.
8. Perform step 2 to 4 again.
9. If NG, clean or replace mass air flow sensor.

⊗ Without CONSULT-II

1. Reconnect all harness connectors disconnected.
2. Start engine and warm it up to normal operating temperature.
3. Check voltage between ECM terminal 51 (Mass air flow sensor signal) and ground.

Condition	Voltage V
Ignition switch ON (Engine stopped.)	Approx 0.4
Idle (Engine is warmed-up to normal operating temperature.)	0.9 - 1.2
2,500 rpm (Engine is warmed-up to normal operating temperature.)	1.4 - 1.7
Idle to about 4,000 rpm*	0.9 - 1.2 to 2.4

*: Check for linear voltage rise in response to engine being increased to about 4,000 rpm.

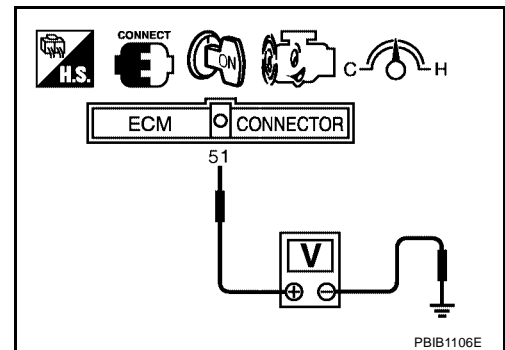

4. If the voltage is out of specification, proceed the following.
 - a. Check for the cause of uneven air flow through mass air flow sensor. Refer to following.
 - Crushed air ducts
 - Malfunctioning seal of air cleaner element
 - Uneven dirt of air cleaner element
 - Improper specification of intake air system parts
 - b. If NG, repair or replace malfunctioning part and perform step 2 to 4 again. If OK, go to next step.
 5. Turn ignition switch OFF.
 6. Disconnect mass air flow sensor harness connector and reconnect it again.
 7. Perform step 2 and 3 again.
 8. If NG, clean or replace mass air flow sensor.

Removal and Installation MASS AIR FLOW SENSOR

Refer to [EM-17. "AIR CLEANER AND AIR DUCT"](#) .

UBS002QA

DTC P0112, P0113 IAT SENSOR

Component Description

The intake air temperature sensor is built into mass air flow sensor. The sensor detects intake air temperature and transmits a signal to the ECM.

The temperature sensing unit uses a thermistor which is sensitive to the change in temperature. Electrical resistance of the thermistor decreases in response to the temperature rise.

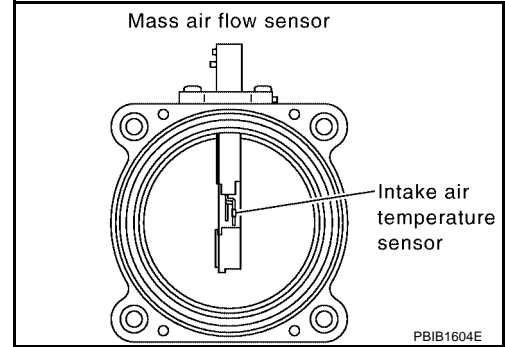

<Reference data>

Intake air temperature °C (°F)	Voltage* V	Resistance kΩ
-10 (14)	4.43	7.9 - 9.3
25 (77)	3.32	1.9 - 2.1
80 (176)	1.23	0.31 - 0.37

*: This data is reference values and is measured between ECM terminal 34 (Intake air temperature sensor) and ground.

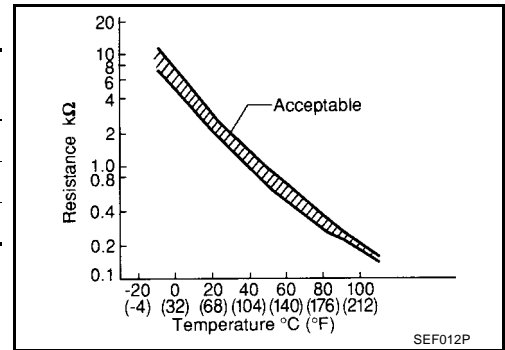

CAUTION:

Do not use ECM ground terminals when measuring input/output voltage. Doing so may result in damage to the ECM's transistor. Use a ground other than ECM terminals, such as the ground.

On Board Diagnosis Logic

DTC No.	Trouble diagnosis name	DTC detecting condition	Possible cause
P0112 0112	Intake air temperature sensor circuit low input	An excessively low voltage from the sensor is sent to ECM.	<ul style="list-style-type: none"> ● Harness or connectors (The sensor circuit is open or shorted.) ● Intake air temperature sensor
P0113 0113	Intake air temperature sensor circuit high input	An excessively low voltage from the sensor is sent to ECM.	

DTC Confirmation Procedure

NOTE:

If DTC Confirmation Procedure has been previously conducted, always turn ignition switch OFF and wait at least 10 seconds before conducting the next test.

WITH CONSULT-II

1. Turn ignition switch ON.
2. Select "DATA MONITOR" mode with CONSULT-II.
3. Wait at least 5 seconds.
4. If 1st trip DTC is detected, go to [EC-197, "Diagnostic Procedure"](#)

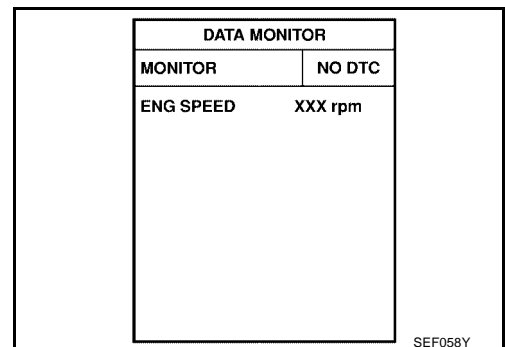

DTC P0112, P0113 IAT SENSOR

[QR]



WITH GST

Follow the procedure "With CONSULT-II" above.

A

EC

C

D

E

F

G

H

I

J

K

L

M



DTC P0112, P0113 IAT SENSOR

[QR]

Wiring Diagram

UBS002QE

EC-IATS-01

 : DETECTABLE LINE FOR DTC
 : NON-DETECTABLE LINE FOR DTC

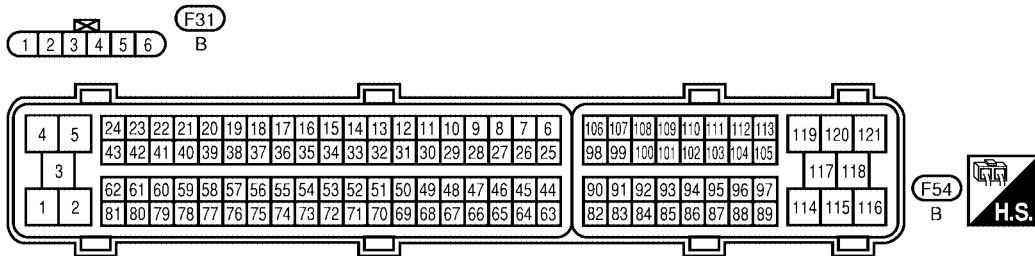
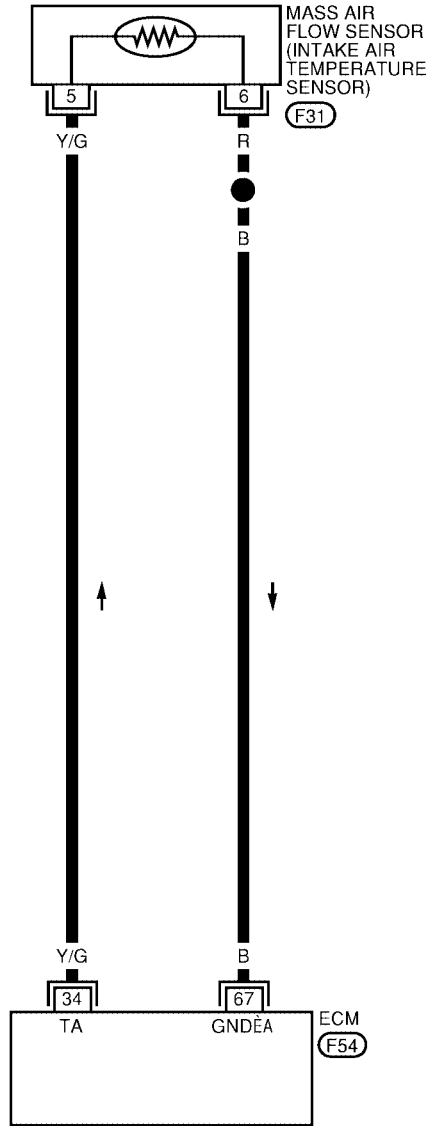

BBWA1217E

Diagnostic Procedure**1. CHECK GROUND CONNECTIONS**

1. Turn ignition switch OFF.
2. Loosen and retighten three ground screws on the body. Refer to [EC-164, "Ground Inspection"](#).

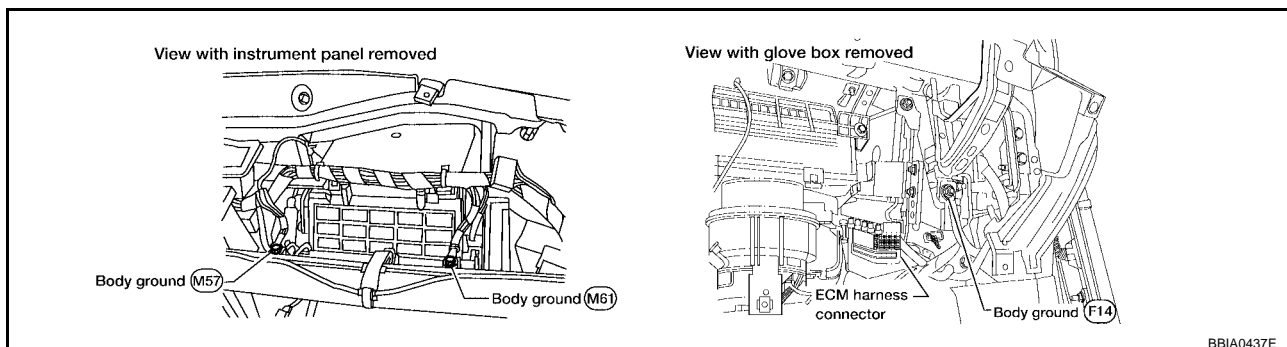
**OK or NG**

- OK >> GO TO 2.
 NG >> Repair or replace ground connections.

2. CHECK INTAKE AIR TEMPERATURE SENSOR POWER SUPPLY

1. Disconnect mass air flow sensor (intake air temperature sensor is built-into) sensor harness connector.
2. Turn ignition switch ON.

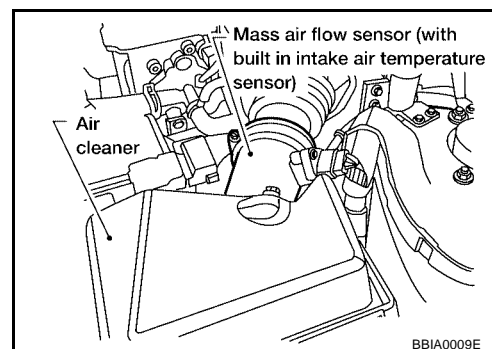

3. Check voltage between MAF sensor terminal 5 and ground with CONSULT-II or tester.

Voltage: Approximately 5V

OK or NG

- OK >> GO TO 3.
 NG >> Repair open circuit or short to ground or short to power in harness or connectors.

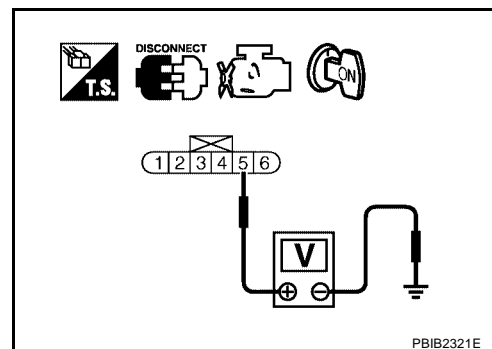
**3. CHECK INTAKE AIR TEMPERATURE SENSOR GROUND CIRCUIT FOR OPEN AND SHORT**

1. Turn ignition switch OFF.
2. Disconnect ECM harness connector.
3. Check harness continuity between mass air flow sensor terminal 6 and ECM terminal 67. Refer to wiring diagram.

Continuity should exist.

4. Also check harness for short to ground and short to power.

OK or NG

- OK >> GO TO 4.
 NG >> Repair open circuit or short to ground or short to power in harness or connectors.

4. CHECK INTAKE AIR TEMPERATURE SENSOR

Refer to [EC-198, "Component Inspection"](#) .

OK or NG

- OK >> GO TO 5.
- NG >> Replace intake air temperature sensor.

5. CHECK INTERMITTENT INCIDENT

Perform [EC-158, "TROUBLE DIAGNOSIS FOR INTERMITTENT INCIDENT"](#) .

>> INSPECTION END

**Component Inspection
INTAKE AIR TEMPERATURE SENSOR**

UBS002QG

1. Check resistance between intake air temperature sensor terminals 5 and 6 under the following conditions.

Intake air temperature °C (°F)	Resistance kΩ
25 (77)	1.9 - 2.1

2. If NG, replace mass air flow sensor (with intake air temperature sensor).

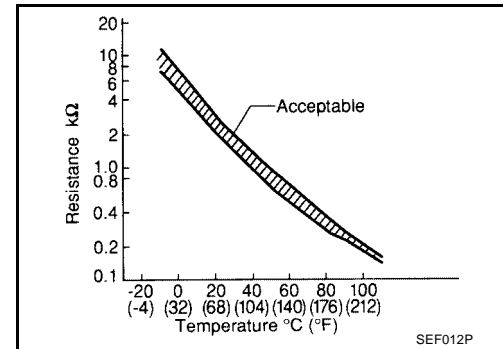
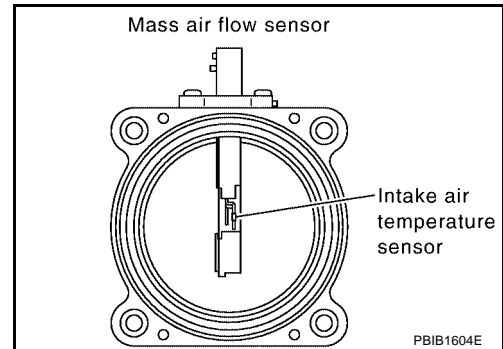

SEF012P

**Removal and Installation
MASS AIR FLOW SENSOR**

UBS002QH

Refer to [EM-17, "AIR CLEANER AND AIR DUCT"](#) .

DTC P0117, P0118 ECT SENSOR

Component Description

The engine coolant temperature sensor is used to detect the engine coolant temperature. The sensor modifies a voltage signal from the ECM. The modified signal returns to the ECM as the engine coolant temperature input. The sensor uses a thermistor which is sensitive to the change in temperature. The electrical resistance of the thermistor decreases as temperature increases.

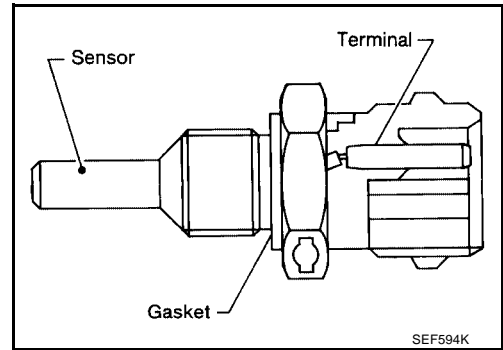

<Reference data>

Engine coolant temperature °C (°F)	Voltage* V	Resistance kΩ
-10 (14)	4.4	7.0 - 11.4
20 (68)	3.5	2.1 - 2.9
50 (122)	2.2	0.68 - 1.00
90 (194)	0.9	0.236 - 0.260

*: These data are reference values and are measured between ECM terminal 73 (Engine coolant temperature sensor) and ground.

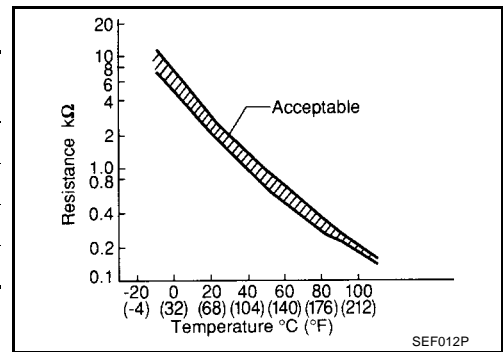

CAUTION:

Do not use ECM ground terminals when measuring input/output voltage. Doing so may result in damage to the ECM's transistor. Use a ground other than ECM terminals, such as the ground.

On Board Diagnosis Logic

These self-diagnoses have the one trip detection logic.

DTC No.	Trouble Diagnosis Name	DTC Detecting Condition	Possible Cause
P0117 0117	Engine coolant temperature sensor circuit low input	An excessively low voltage from the sensor is sent to ECM.	<ul style="list-style-type: none"> ● Harness or connectors (The sensor circuit is open or shorted.) ● Engine coolant temperature sensor
P0118 0118	Engine coolant temperature sensor circuit high input	An excessively high voltage from the sensor is sent to ECM.	

FAIL-SAFE MODE

When this malfunction is detected, the ECM enters fail-safe mode and the MIL lights up.

DTC P0117, P0118 ECT SENSOR

[QR]

Detected items	Engine operating condition in fail-safe mode	
Engine coolant temperature sensor circuit	Engine coolant temperature will be determined by ECM based on the time after turning ignition switch ON or START. CONSULT-II displays the engine coolant temperature decided by ECM.	
	Condition	Engine coolant temperature decided (CONSULT-II display)
	Just as ignition switch is turned ON or START	40°C (104°F)
	More than approx. 4 minutes after ignition ON or START	80°C (176°F)
	Except as shown above	40 - 80°C (104 - 176°F) (Depends on the time)
When the fail-safe system for engine coolant temperature sensor is activated, the cooling fan operates while engine is running.		

DTC Confirmation Procedure

UBS002QK

NOTE:

If DTC Confirmation Procedure has been previously conducted, always turn ignition switch OFF and wait at least 10 seconds before conducting the next test.

WITH CONSULT-II

1. Turn ignition switch ON.
2. Select "DATA MONITOR" mode with CONSULT-II.
3. Wait at least 5 seconds.
4. If DTC is detected, go to [EC-202, "Diagnostic Procedure"](#) .

DATA MONITOR	
MONITOR	NO DTC
ENG SPEED	XXX rpm

SEF058Y

WITH GST

Follow the procedure "WITH CONSULT-II" above.

DTC P0117, P0118 ECT SENSOR

[QR]

Wiring Diagram

UBS002QL

EC-ECTS-01

A
EC
C
D
E
F
G
H
I
J
K
L
M

— : DETECTABLE LINE FOR DTC
— : NON-DETECTABLE LINE FOR DTC

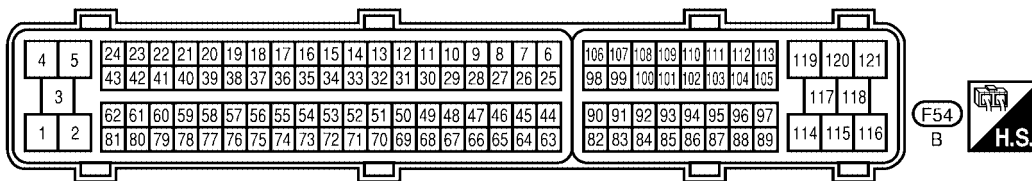
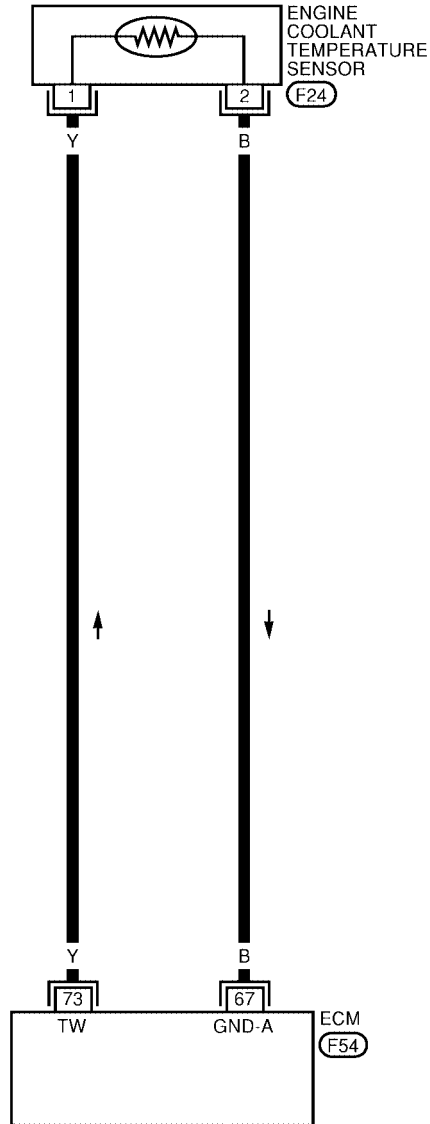

BBWA1218E

Diagnostic Procedure

1. CHECK GROUND CONNECTIONS

1. Turn ignition switch OFF.
2. Loosen and retighten three ground screws on the body. Refer to [EC-164, "Ground Inspection"](#).

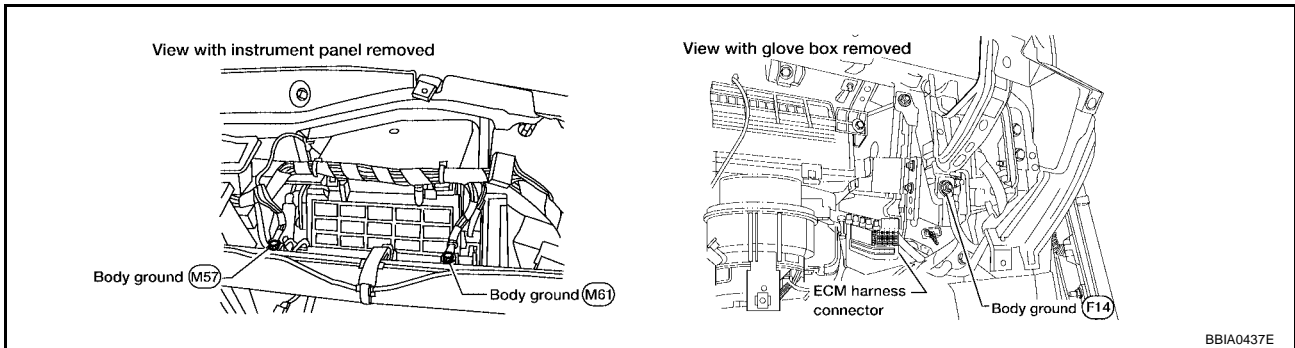

OK or NG

- OK >> GO TO 2.
- NG >> Repair or replace ground connections.

2. CHECK ECT SENSOR POWER SUPPLY CIRCUIT

1. Disconnect engine coolant temperature (ECT) sensor harness connector.
2. Turn ignition switch ON.

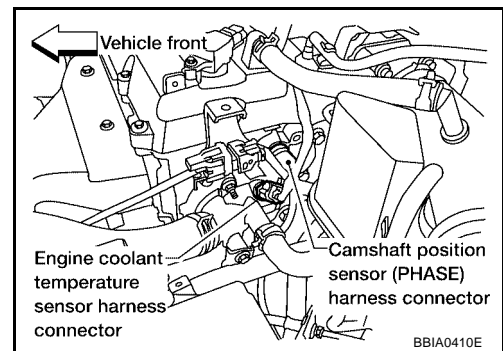

3. Check voltage between ECT sensor terminal 1 and ground with CONSULT-II or tester.

Voltage: Approximately 5V

OK or NG

- OK >> GO TO 3.
- NG >> Repair open circuit or short to ground or short to power in harness or connectors.

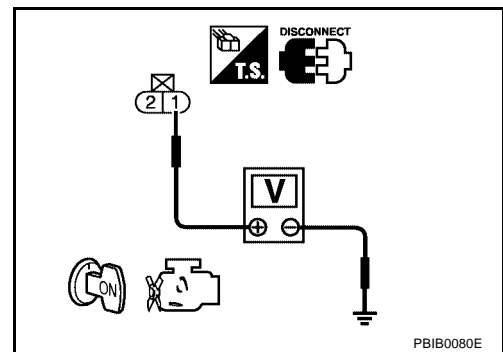

3. CHECK ECT SENSOR GROUND CIRCUIT FOR OPEN AND SHORT

1. Turn ignition switch OFF.
2. Check harness continuity between ECT sensor terminal 2 and ECM terminal 67. Refer to Wiring Diagram.

Continuity should exist.

3. Also check harness for short to ground and short to power.

OK or NG

- OK >> GO TO 4.
- NG >> Repair open circuit or short to ground or short to power in harness or connectors.

4. CHECK ENGINE COOLANT TEMPERATURE SENSOR

Refer to [CO-16, "THERMOSTAT AND THERMOSTAT HOUSING"](#) .

OK or NG

- OK >> GO TO 5.
- NG >> Replace engine coolant temperature sensor.

5. CHECK INTERMITTENT INCIDENT

Refer to [EC-158, "TROUBLE DIAGNOSIS FOR INTERMITTENT INCIDENT"](#) .

>> INSPECTION END

**Component Inspection
ENGINE COOLANT TEMPERATURE SENSOR**

UBS002QN

1. Check resistance between engine coolant temperature sensor terminals 1 and 2 as shown in the figure.

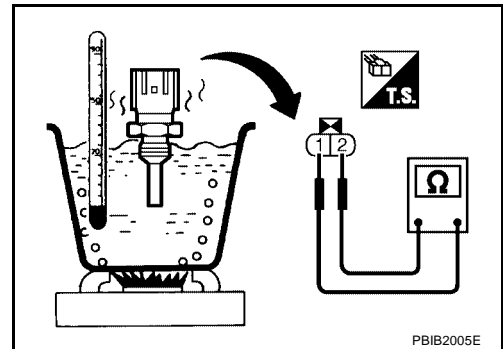

<Reference data>

Engine coolant temperature °C (°F)	Resistance kΩ
20 (68)	2.1 - 2.9
50 (122)	0.68 - 1.00
90 (194)	0.236 - 0.260

2. If NG, replace engine coolant temperature sensor.

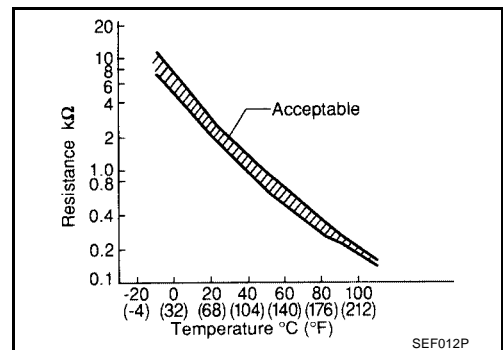

UBS002QO

**Removal and Installation
ENGINE COOLANT TEMPERATURE SENSOR**

Refer to [CO-16, "THERMOSTAT AND THERMOSTAT HOUSING"](#) .

A
EC
C
D
E
F
G
H
I
J
K
L
M

DTC P0122, P0123 TP SENSOR

Component Description

UBS002ZQ

Electric throttle control actuator consists of throttle control motor, throttle position sensor, etc. The throttle position sensor responds to the throttle valve movement.

The throttle position sensor has the two sensors. These sensors are a kind of potentiometers which transform the throttle valve position into output voltage, and emit the voltage signal to the ECM. In addition, these sensors detect the opening and closing speed of the throttle valve and feed the voltage signals to the ECM. The ECM judges the current opening angle of the throttle valve from these signals and the ECM controls the throttle control motor to make the throttle valve opening angle properly in response to driving condition.

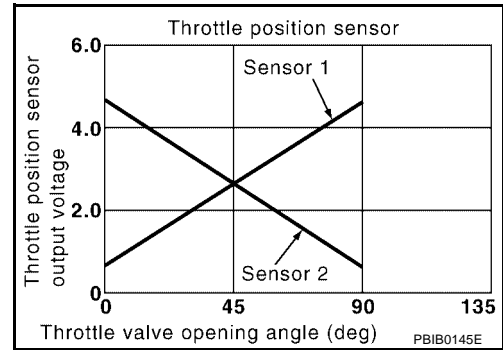

CONSULT-II Reference Value in Data Monitor Mode

UBS002ZR

Specification data are reference values.

MONITOR ITEM	CONDITION	SPECIFICATION
THRTL SEN1 THRTL SEN2*	<ul style="list-style-type: none"> Ignition switch: ON (Engine stopped) Accelerator pedal: Fully released	More than 0.36V
	<ul style="list-style-type: none"> Shift lever: D (A/T) 1ST (M/T) Accelerator pedal: Fully depressed	Less than 4.75V

*1: Throttle position sensor 2 signal is converted by ECM internally. thus it differs from ECM terminal voltage signal.

On Board Diagnosis Logic

UBS002ZS

These self-diagnoses have the one trip detection logic.

DTC No.	Trouble diagnosis name	DTC detecting condition	Possible cause
P0122 0122	Throttle position sensor 2 circuit low input	An excessively low voltage from the TP sensor 2 is sent to ECM.	<ul style="list-style-type: none"> Harness or connectors (The TP sensor 2 circuit is open or shorted.) (APP sensor 2 circuit is shorted.) Electric throttle control actuator (TP sensor 2) Accelerator pedal position sensor (APP sensor 2)
P0123 0123	Throttle position sensor 2 circuit high input	An excessively high voltage from the TP sensor 2 is sent to ECM.	

FAIL-SAFE MODE

When the malfunction is detected, the ECM enters fail-safe mode and the MIL lights up.

Engine operation condition in fail-safe mode

The ECM controls the electric throttle control actuator in regulating the throttle opening in order for the idle position to be within +10 degrees.

The ECM regulates the opening speed of the throttle valve to be slower than the normal condition. So, the acceleration will be poor.

DTC Confirmation Procedure

UBS002ZT

NOTE:

If DTC Confirmation Procedure has been previously conducted, always turn ignition switch OFF and wait at least 10 seconds before conducting the next test.

TESTING CONDITION:

Before performing the following procedure, confirm that battery voltage is more than 10V at idle.

WITH CONSULT-II

1. Turn ignition switch ON.

DTC P0122, P0123 TP SENSOR

[QR]

2. Select "DATA MONITOR" mode with CONSULT-II.
3. Start engine and let it idle for 1 second.
4. If DTC is detected, go to [EC-207, "Diagnostic Procedure"](#).

DATA MONITOR	
MONITOR	NO DTC
ENG SPEED	XXX rpm

SEF058Y

A

EC

C

D

E

F

G

H

I

J

K

L

M

WITH GST

Follow the procedure "WITH CONSULT-II" above.

DTC P0122, P0123 TP SENSOR

[QR]

Wiring Diagram

UBS002ZU

EC-TPS2-01

: DETECTABLE LINE FOR DTC
 : NON-DETECTABLE LINE FOR DTC

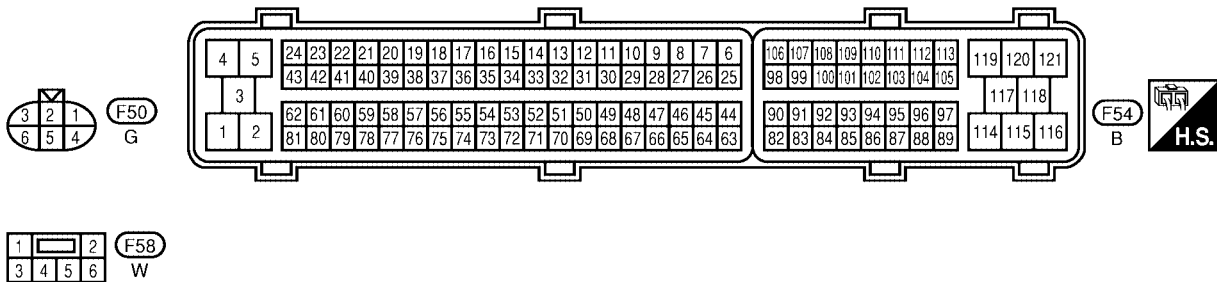
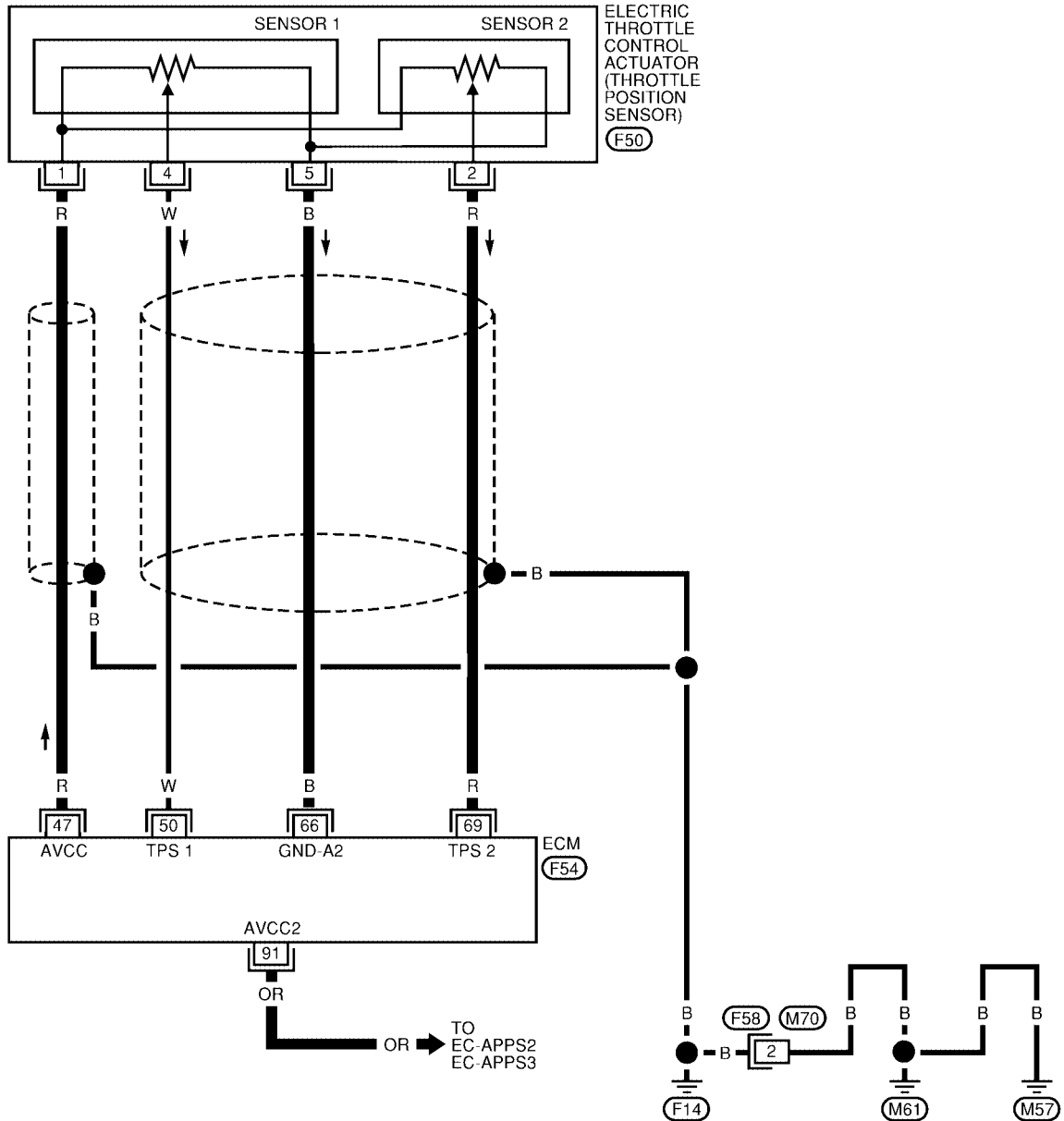

BBWA1219E

DTC P0122, P0123 TP SENSOR

[QR]

Specification data are reference values and are measured between each terminal and ground.

CAUTION:

Do not use ECM ground terminals when measuring input/output voltage. Doing so may result in damage to the ECM's transistor. Use a ground other than ECM terminals, such as the ground.

TER-MINAL NO.	WIRE COLOR	ITEM	CONDITION	DATA (DC Voltage)
47	R	Sensor power supply (Throttle position sensor)	[Ignition switch: ON]	Approximately 5V
50	W	Throttle position sensor 1	[Ignition switch: ON] <ul style="list-style-type: none"> ● Engine stopped ● Shift lever: D (A/T), 1ST (M/T) ● Accelerator pedal: Fully released 	More than 0.36V
			[Ignition switch: ON] <ul style="list-style-type: none"> ● Engine stopped ● Shift lever: D (A/T), 1ST (M/T) ● Accelerator pedal: Fully depressed 	Less than 4.75V
66	B	Sensor ground (Throttle position sensor)	[Engine is running] <ul style="list-style-type: none"> ● Warm-up condition ● Idle speed 	Approximately 0V
69	R	Throttle position sensor 2	[Ignition switch: ON] <ul style="list-style-type: none"> ● Engine stopped ● Shift lever: D (A/T), 1ST (M/T) ● Accelerator pedal: Fully released 	Less than 4.75V
			[Ignition switch: ON] <ul style="list-style-type: none"> ● Engine stopped ● Shift lever: D (A/T), 1ST (M/T) ● Accelerator pedal: Fully depressed 	More than 0.36V
91	OR	Sensor power supply (Accelerator pedal position sensor 2)	[Ignition switch: ON]	Approximately 5V

Diagnostic Procedure

UBS002ZV

1. CHECK GROUND CONNECTIONS

1. Turn ignition switch OFF.
2. Loosen and retighten three ground screws on the body. Refer to [EC-164, "Ground Inspection"](#).

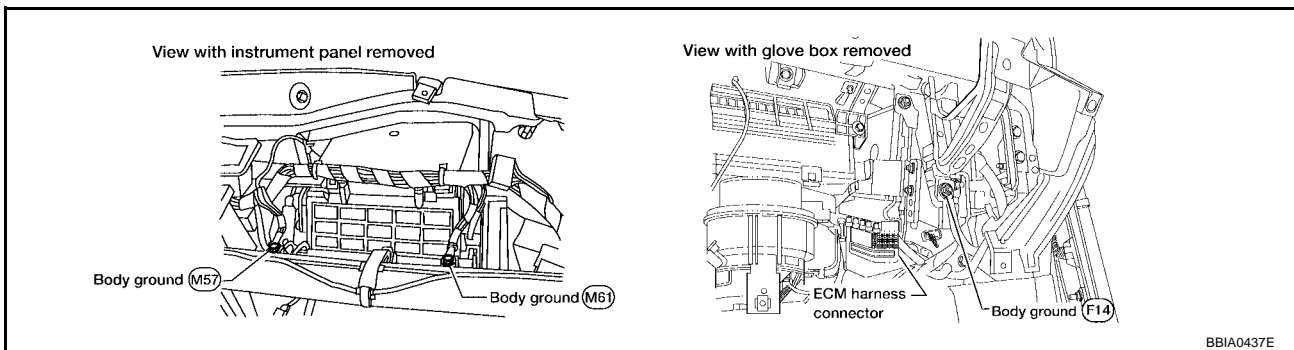

OK or NG

- OK >> GO TO 2.
- NG >> Repair or replace ground connections.

2. CHECK THROTTLE POSITION SENSOR 2 POWER SUPPLY CIRCUIT-I

1. Disconnect electric throttle control actuator harness connector.
2. Turn ignition switch ON.

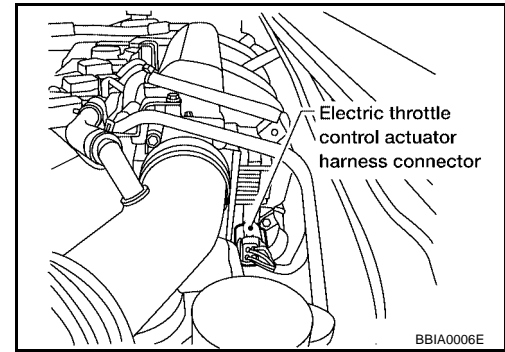

3. Check voltage between electric throttle control actuator terminal 1 and ground with CONSULT-II or tester.

Voltage: Approximately 5V

OK or NG

- OK >> GO TO 7.
 NG >> GO TO 3.

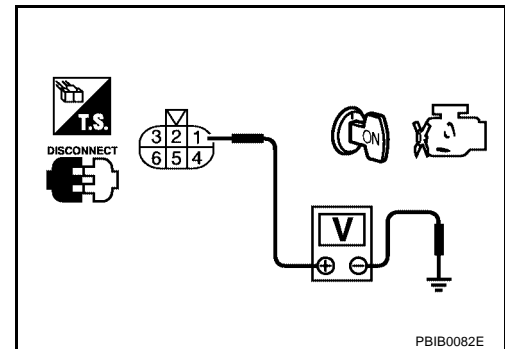

3. CHECK THROTTLE POSITION SENSOR 2 POWER SUPPLY CIRCUIT-II

1. Turn ignition switch OFF.
2. Disconnect ECM harness connector.
3. Check harness continuity between electric throttle control actuator terminal 1 and ECM terminal 47. Refer to Wiring Diagram.

Continuity should exist.

OK or NG

- OK >> GO TO 4.
 NG >> Repair or replace open circuit.

4. CHECK THROTTLE POSITION SENSOR 2 POWER SUPPLY CIRCUIT-III

Check the following.

- Harness for short to power and short to ground, between the following terminals.

ECM terminal	Sensor terminal	Reference Wiring Diagram
47	Electric throttle control actuator terminal 1	EC-206
91	APP sensor terminal 1	EC-542

OK or NG

- OK >> GO TO 5.
 NG >> Repair short to ground or short to power in harness or connectors.

5. CHECK APP SENSOR

Refer to [EC-547, "Component Inspection"](#)

OK or NG

- OK >> GO TO 11.
 NG >> GO TO 6.

6. REPLACE ACCELERATOR PEDAL ASSEMBLY

1. Replace accelerator pedal assembly.
2. Perform [EC-93, "Accelerator Pedal Released Position Learning"](#) .
3. Perform [EC-93, "Throttle Valve Closed Position Learning"](#) .
4. Perform [EC-93, "Idle Air Volume Learning"](#) .

>> INSPECTION END

7. CHECK THROTTLE POSITION SENSOR 2 GROUND CIRCUIT FOR OPEN AND SHORT

1. Turn ignition switch OFF.
2. Disconnect ECM harness connector.
3. Check harness continuity between ECM terminal 66 and electric throttle control actuator terminal 5.
Refer to Wiring Diagram.

Continuity should exist.

4. Also check harness for short to ground and short to power.

OK or NG

OK >> GO TO 8.

NG >> Repair open circuit or short to ground or short to power in harness or connectors.

8. CHECK THROTTLE POSITION SENSOR 2 INPUT SIGNAL CIRCUIT FOR OPEN AND SHORT

1. Check harness continuity between ECM terminal 69 and electric throttle control actuator terminal 2.
Refer to Wiring Diagram.

Continuity should exist.

2. Also check harness for short to ground and short to power.

OK or NG

OK >> GO TO 9.

NG >> Repair open circuit or short to ground or short to power in harness or connectors.

9. CHECK THROTTLE POSITION SENSOR

Refer to [EC-210, "Component Inspection"](#) .

OK or NG

OK >> GO TO 11.

NG >> GO TO 10.

10. REPLACE ELECTRIC THROTTLE CONTROL ACTUATOR

1. Replace the electric throttle control actuator.
2. Perform [EC-93, "Throttle Valve Closed Position Learning"](#) .
3. Perform [EC-93, "Idle Air Volume Learning"](#) .

>> INSPECTION END

11. CHECK INTERMITTENT INCIDENT

Refer to [EC-158, "TROUBLE DIAGNOSIS FOR INTERMITTENT INCIDENT"](#) .

>> INSPECTION END

Component Inspection THROTTLE POSITION SENSOR

1. Reconnect all harness connectors disconnected.
2. Perform [EC-93, "Throttle Valve Closed Position Learning"](#) .
3. Turn ignition switch ON.
4. Set shift lever to D position (A/T models) or 1st position (M/T models).
5. Check voltage between ECM terminals 50 (TP sensor 1), 69 (TP sensor 2) and ground under the following conditions.

Terminal	Accelerator pedal	Voltage
50 (Throttle position sensor 1)	Fully released	More than 0.36V
	Fully depressed	Less than 4.75V
69 (Throttle position sensor 2)	Fully released	Less than 4.75V
	Fully depressed	More than 0.36V

6. If NG, replace electric throttle control actuator and go to the next step.
7. Perform [EC-93, "Throttle Valve Closed Position Learning"](#) .
8. Perform [EC-93, "Idle Air Volume Learning"](#) .

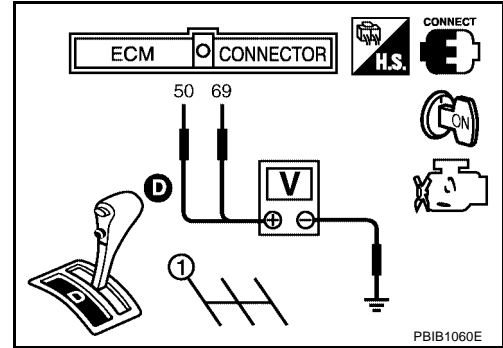

Remove and Installation ELECTRIC THROTTLE CONTROL ACTUATOR

Refer to [EM-19, "INTAKE MANIFOLD"](#) .

DTC P0125 ECT SENSOR

PFP:22630

Description

UBS002QP

NOTE:

If DTC P0125 is displayed with P0117 or P0118, first perform the trouble diagnosis for DTC P0117 or P0118. Refer to [EC-199](#).

COMPONENT DESCRIPTION

The engine coolant temperature sensor is used to detect the engine coolant temperature. The sensor modifies a voltage signal from the ECM. The modified signal returns to the ECM as the engine coolant temperature input. The sensor uses a thermistor which is sensitive to the change in temperature. The electrical resistance of the thermistor decreases as temperature increases.

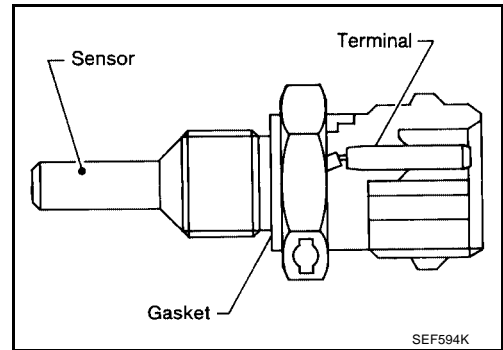

< Reference data >

Engine coolant temperature °C (°F)	Voltage* V	Resistance kΩ
-10 (14)	4.4	7.0 - 11.4
20 (68)	3.5	2.1 - 2.9
50 (122)	2.2	0.68 - 1.00
90 (194)	0.9	0.236 - 0.260

*: This data is reference values and is measured between ECM terminal 73 (Engine coolant temperature sensor) and ground.

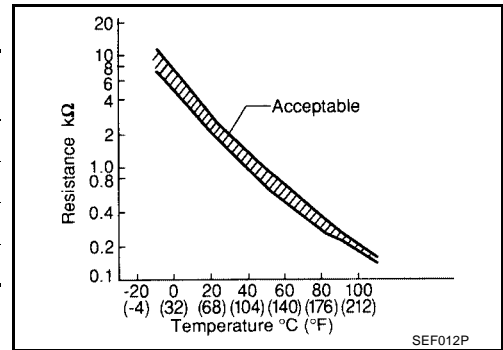

CAUTION:

Do not use ECM ground terminals when measuring input/output voltage. Doing so may result in damage to the ECM's transistor. Use a ground other than ECM terminals, such as the ground.

On Board Diagnosis Logic

UBS002QQ

This self-diagnosis has the one trip detection logic.

DTC No.	Trouble diagnosis name	DTC detecting condition	Possible cause
P0125 0125	Insufficient engine coolant temperature for closed loop fuel control	<ul style="list-style-type: none"> ● Voltage sent to ECM from the sensor is not practical, even when some time has passed after starting the engine. ● Engine coolant temperature is insufficient for closed loop fuel control. 	<ul style="list-style-type: none"> ● Harness or connectors (High resistance in the circuit) ● Engine coolant temperature sensor ● Thermostat

DTC Confirmation Procedure

UBS002QR

CAUTION:

Be careful not to overheat engine.

NOTE:

If DTC Confirmation Procedure has been previously conducted, always turn ignition switch OFF and wait at least 10 seconds before conducting the next test.

WITH CONSULT-II

1. Turn ignition switch ON.

DTC P0125 ECT SENSOR

[QR]

2. Select "DATA MONITOR" mode with CONSULT-II.
3. Check that "COOLAN TEMP/S" is above 10°C (50°F).
If it is above 10°C (50°F), the test result will be OK.
If it is below 10°C (50°F), go to following step.
4. Start engine and run it for 65 minutes at idle speed.
If "COOLAN TEMP/S" increases to more than 10°C (50°F) within 65 minutes, stop engine because the test result will be OK.
5. If DTC is detected, go to [EC-212, "Diagnostic Procedure"](#) .

DATA MONITOR	
MONITOR	NO DTC
ENG SPEED	XXX rpm

SEF058Y

WITH GST

Follow the procedure WITH CONSULT-II above.

Diagnostic Procedure

UBS002QS

1. CHECK GROUND CONNECTIONS

1. Turn ignition switch OFF.
2. Loosen and retighten three ground screws on the body. Refer to [EC-164, "Ground Inspection"](#) .

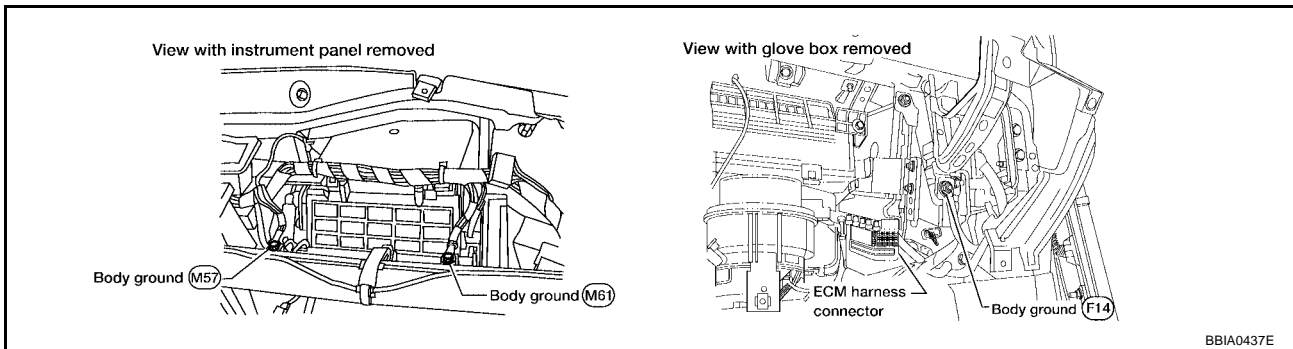

OK or NG

- OK >> GO TO 2.
- NG >> Repair or replace ground connections.

2. CHECK ENGINE COOLANT TEMPERATURE SENSOR

Refer to [EC-213, "Component Inspection"](#) .

OK or NG

- OK >> GO TO 3.
- NG >> Replace engine coolant temperature sensor.

3. CHECK THERMOSTAT OPERATION

When the engine is cold [lower than 70°C (158°F)] condition, grasp lower radiator hose and confirm the engine coolant does not flow.

OK or NG

- OK >> GO TO 4.
- NG >> Repair or replace thermostat. Refer to [CO-16, "THERMOSTAT AND THERMOSTAT HOUSING"](#) .

4. CHECK INTERMITTENT INCIDENT

Refer to [EC-158, "TROUBLE DIAGNOSIS FOR INTERMITTENT INCIDENT"](#) .

>> INSPECTION END

Component Inspection ENGINE COOLANT TEMPERATURE SENSOR

1. Check resistance between engine coolant temperature sensor terminals 1 and 2 as shown in the figure.

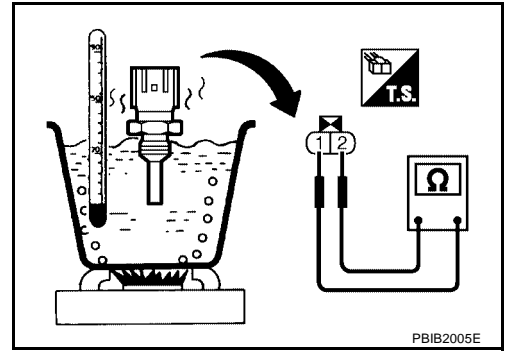

<Reference data>

Engine coolant temperature °C (°F)	Resistance kΩ
20 (68)	2.1 - 2.9
50 (122)	0.68 - 1.00
90 (194)	0.236 - 0.260

2. If NG, replace engine coolant temperature sensor.

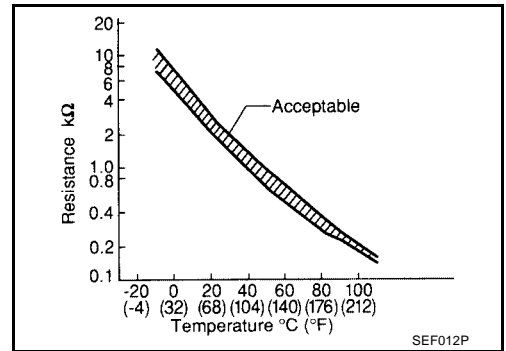

Removal and Installation ENGINE COOLANT TEMPERATURE SENSOR

Refer to [CO-16, "THERMOSTAT AND THERMOSTAT HOUSING"](#)

A
EC
C
D
E
F
G
H
I
J
K
L
M

DTC P0127 IAT SENSOR

Component Description

The intake air temperature sensor is built into mass air flow sensor. The sensor detects intake air temperature and transmits a signal to the ECM.

The temperature sensing unit uses a thermistor which is sensitive to the change in temperature. Electrical resistance of the thermistor decreases in response to the temperature rise.

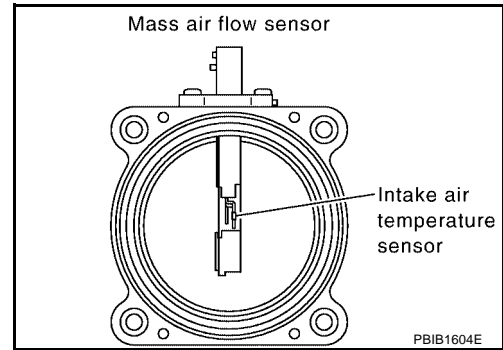

<Reference data>

Intake air temperature °C (°F)	Voltage* V	Resistance kΩ
-10 (14)	4.43	7.9 - 9.3
25 (77)	3.32	1.9 - 2.1
80 (176)	1.23	0.31 - 0.37

*: This data is reference values and is measured between ECM terminal 34 (Intake air temperature sensor) and ground.

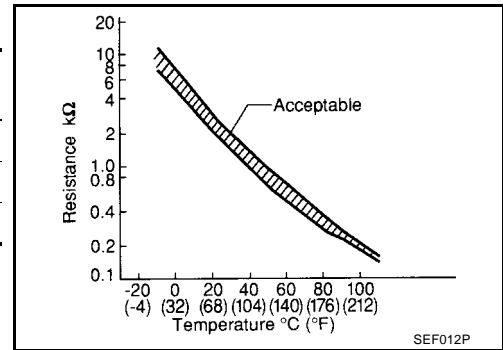

CAUTION:

Do not use ECM ground terminals when measuring input/output voltage. Doing so may result in damage to the ECM's transistor. Use a ground other than ECM terminals, such as the ground.

On Board Diagnosis Logic

DTC No.	Trouble diagnosis name	DTC detecting condition	Possible cause
P0127 0127	Intake air temperature too high	Rationally incorrect voltage from the sensor is sent to ECM, compared with the voltage signal from engine coolant temperature sensor.	<ul style="list-style-type: none"> ● Harness or connectors (The sensor circuit is open or shorted) ● Intake air temperature sensor

DTC Confirmation Procedure

CAUTION:

Always drive vehicle at a safe speed.

NOTE:

If DTC Confirmation Procedure has been previously conducted, always turn ignition switch OFF and wait at least 10 seconds before conducting the next test.

TESTING CONDITION:

This test may be conducted with the drive wheels lifted in the shop or by driving the vehicle. If a road test is expected to be easier, it is unnecessary to lift the vehicle.

Ⓟ WITH CONSULT-II

1. Wait until engine coolant temperature is less than 90°C (194°F)
 - a. Turn ignition switch ON.

DTC P0127 IAT SENSOR

[QR]

- b. Select "DATA MONITOR" mode with CONSULT-II.
- c. Check the engine coolant temperature.
- d. If the engine coolant temperature is not less than 90°C (194°F), turn ignition switch OFF and cool down engine.
 - Perform the following steps before engine coolant temperature is above 90°C (194°F).
2. Turn ignition switch ON.
3. Select "DATA MONITOR" mode with CONSULT-II.
4. Start engine.
5. Hold vehicle speed at more than 70 km/h (43 MPH) for 100 consecutive seconds.
6. If 1st trip DTC is detected, go to [EC-215, "Diagnostic Procedure"](#).

DATA MONITOR	
MONITOR	NO DTC
ENG SPEED	XXX rpm
COOLAN TEMP/S	XXX °C
VHCL SPEED SE	XXX km/h
B/FUEL SCHDL	XXX msec

SEF189Y

WITH GST

Follow the procedure With CONSULT-II above.

Diagnostic Procedure

UBS002QY

1. CHECK GROUND CONNECTIONS

1. Turn ignition switch OFF.
2. Loosen and retighten three ground screws on the body. Refer to [EC-164, "Ground Inspection"](#).

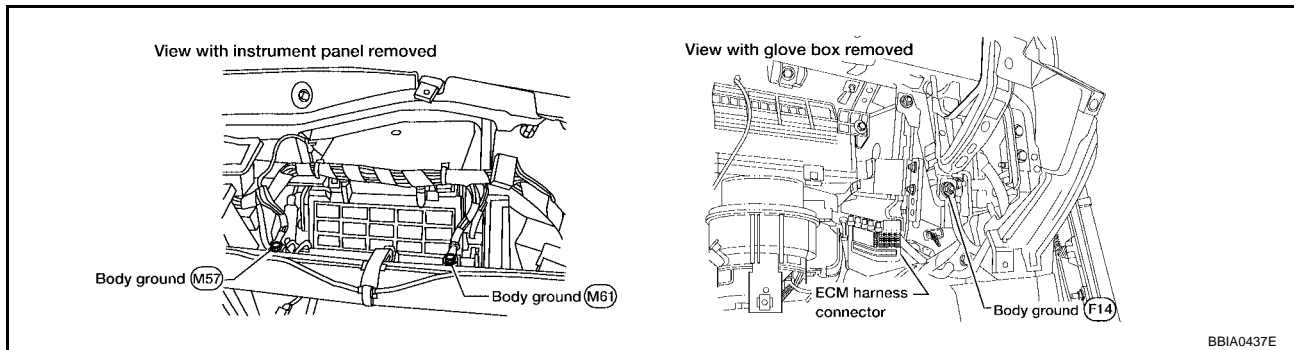

OK or NG

- OK >> GO TO 2.
- NG >> Repair or replace ground connections.

2. CHECK INTAKE AIR TEMPERATURE SENSOR

Refer to [EC-216, "Component Inspection"](#).

OK or NG

- OK >> GO TO 3.
- NG >> Replace mass air flow sensor (with intake air temperature sensor).

3. CHECK INTERMITTENT INCIDENT

Refer to [EC-158, "TROUBLE DIAGNOSIS FOR INTERMITTENT INCIDENT"](#).

Refer to [EC-196, "Wiring Diagram"](#).

>> INSPECTION END

Component Inspection INTAKE AIR TEMPERATURE SENSOR

1. Check resistance between intake air temperature sensor terminals 5 and 6 under the following conditions.

Intake air temperature °C (°F)	Resistance kΩ
25 (77)	1.9 - 2.1

2. If NG, replace mass air flow sensor (with intake air temperature sensor).

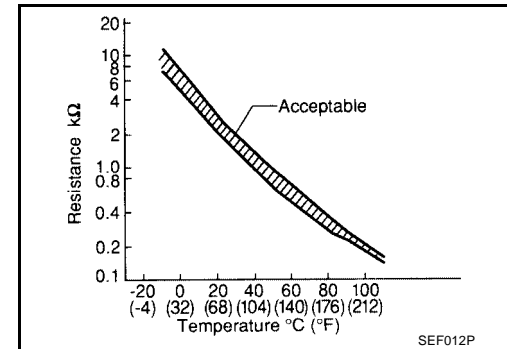
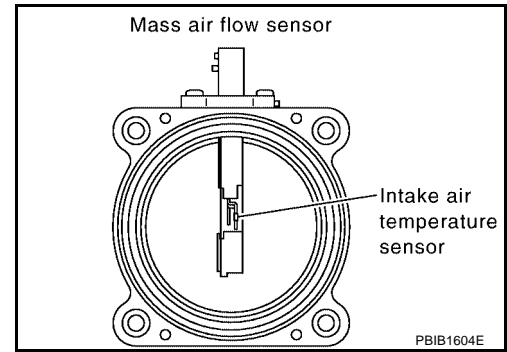

Removal and Installation MASS AIR FLOW SENSOR

Refer to [EM-17, "AIR CLEANER AND AIR DUCT"](#) .

DTC P0128 THERMOSTAT FUNCTION

[QR]

DTC P0128 THERMOSTAT FUNCTION

PF2:21200

On Board Diagnosis Logic

UBS002R1

Engine coolant temperature has not risen enough to open the thermostat even though the engine has run long enough.

This is due to a leak in the seal or the thermostat stuck open.

DTC No.	Trouble diagnosis name	DTC detecting condition	Possible cause
P0128 0128	Thermostat function	The engine coolant temperature does not reach to specified temperature even though the engine has run long enough.	<ul style="list-style-type: none">● Thermostat● Leakage from sealing portion of thermostat● Engine coolant temperature sensor

DTC Confirmation Procedure

UBS002R2

NOTE:

If DTC Confirmation Procedure has been previously conducted, always turn ignition switch OFF and wait at least 10 seconds before conducting the next test.

TESTING CONDITION:

- For best results, perform at ambient temperature of -10°C (14°F) or higher.
- For best results, perform at engine coolant temperature of -10°C (14°F) to 68°C (154°F).

WITH CONSULT-II

1. Replace thermostat with new one. Refer to [CO-16, "THERMOSTAT AND THERMOSTAT HOUSING"](#). Use only a genuine NISSAN thermostat as a replacement. If an incorrect thermostat is used, the MIL may come on.
2. Turn ignition switch ON.
3. Select "COOLAN TEMP/S" in "DATA MONITOR" mode with CONSULT-II.
4. Check that the "COOLAN TEMP/S" is above 68°C (154°F).
If it is below 68°C (154°F), go to following step.
If it is above 68°C (154°F), stop engine and cool down the engine to less than 68°C (154°F), then retry from step 1.
5. Drive vehicle for 10 consecutive minutes under the following conditions.

VHCL SPEED SE	80 - 120 km/h (50 - 75 MPH)
---------------	-----------------------------

If 1st trip DTC is detected, go to [EC-217, "Diagnostic Procedure"](#)

DATA MONITOR	
MONITOR	NO DTC
COOLAN TEMP/S	XXX °C
VHCL SPEED SE	XXX km/h

SEF176Y

WITH GST

Follow the procedure "WITH CONSULT-II" above.

Diagnostic Procedure

UBS002R3

1. CHECK ENGINE COOLANT TEMPERATURE SENSOR

Refer to [EC-218, "Component Inspection"](#).

OK or NG

- OK >> **INSPECTION END**
- NG >> Replace engine coolant temperature sensor.

Component Inspection ENGINE COOLANT TEMPERATURE SENSOR

1. Check resistance between engine coolant temperature sensor terminals 1 and 2 as shown in the figure.

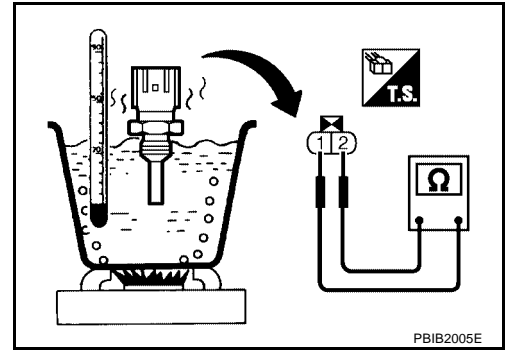

<Reference data>

Engine coolant temperature °C (°F)	Resistance kΩ
20 (68)	2.1 - 2.9
50 (122)	0.68 - 1.00
90 (194)	0.236 - 0.260

2. If NG, replace engine coolant temperature sensor.

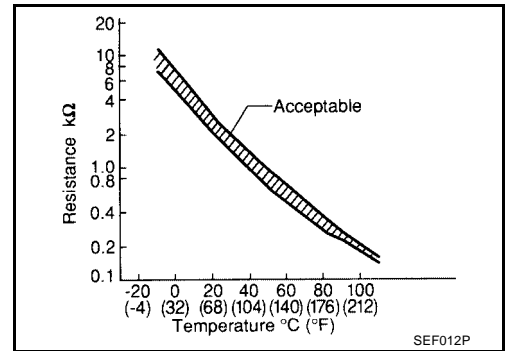

Removal and Installation ENGINE COOLANT TEMPERATURE SENSOR

Refer to [CO-16, "THERMOSTAT AND THERMOSTAT HOUSING"](#) .

DTC P0138 HO2S2

PF2:226A0

Component Description

UBS002RW

The heated oxygen sensor 2, after three way catalyst (manifold), monitors the oxygen level in the exhaust gas. Even if switching characteristics of the A/F sensor 1 are shifted, the air-fuel ratio is controlled to stoichiometric, by the signal from the heated oxygen sensor 2. This sensor is made of ceramic zirconia. The zirconia generates voltage from approximately 1V in richer conditions to 0V in leaner conditions. Under normal conditions the heated oxygen sensor 2 is not used for engine control operation.

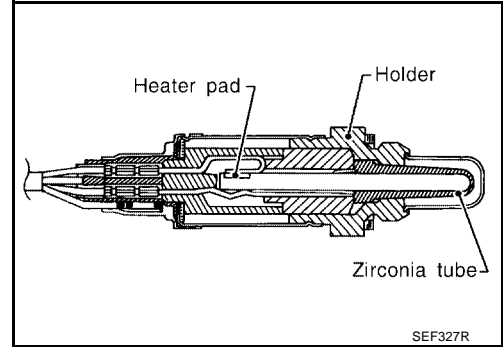

CONSULT-II Reference Value in Data Monitor Mode

UBS002RX

Specification data are reference values.

MONITOR ITEM	CONDITION		SPECIFICATION
HO2S2 (B1)	<ul style="list-style-type: none"> Warm-up condition After keeping engine speed between 3,500 and 4,000 rpm for 1 minute and at idle for 1 minute under no load. 	Revsing engine from idle to 3,000 rpm quickly.	0 - 0.3V ↔ Approx. 0.6 - 1.0V
HO2S2 MNTR (B1)	<ul style="list-style-type: none"> Engine: After warming up After keeping engine speed between 3,500 and 4,000 rpm for 1 minute and at idle for 1 minute under no load. 	Revsing engine from idle to 3,000 rpm quickly.	LEAN ↔ RICH

On Board Diagnosis Logic

UBS002RY

The heated oxygen sensor 2 has a much longer switching time between rich and lean than the A/F sensor 1. The oxygen storage capacity before the three way catalyst (manifold) causes the longer switching time. To judge the malfunctions of heated oxygen sensor 2, ECM monitors whether the voltage is unusually high during the various driving condition such as fuel-cut.

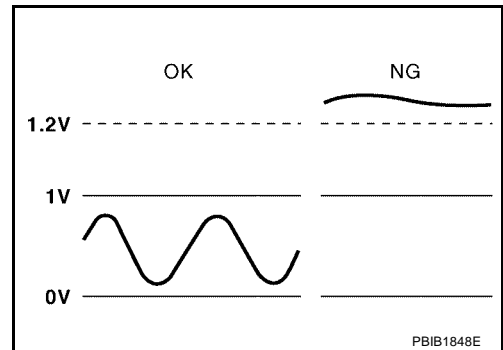

DTC No.	Trouble diagnosis name	DTC detecting condition	Possible cause
P0138 0138	Heated oxygen sensor 2 circuit high voltage	An excessively high voltage from the sensor is sent to ECM.	<ul style="list-style-type: none"> Harness or connectors (The sensor circuit is open or shorted) Heated oxygen sensor 2

DTC Confirmation Procedure

UBS002RZ

NOTE:

If DTC Confirmation Procedure has been previously conducted, always turn ignition switch OFF and wait at least 10 seconds before conducting the next test.

WITH CONSULT-II

- Turn ignition switch ON and select "DATA MONITOR" mode with CONSULT-II.
- Start engine and warm it up to the normal operating temperature.
- Turn ignition switch OFF and wait at least 10 seconds.

DTC P0138 HO2S2

[QR]

4. Start engine and keep the engine speed between 3,500 and 4,000 rpm for at least 1 minute under no load.
5. Let engine idle for 2 minutes.
6. If 1st trip DTC is detected, go to [EC-222, "Diagnostic Procedure"](#)

DATA MONITOR	
MONITOR	NO DTC
ENG SPEED	XXX rpm
COOLAN TEMP/S	XXX °C

SEF174Y



WITH GST

Follow the procedure "WITH CONSULT-II" above.

DTC P0138 HO2S2

[QR]

Wiring Diagram

UBS002S1

EC-HO2S2-01

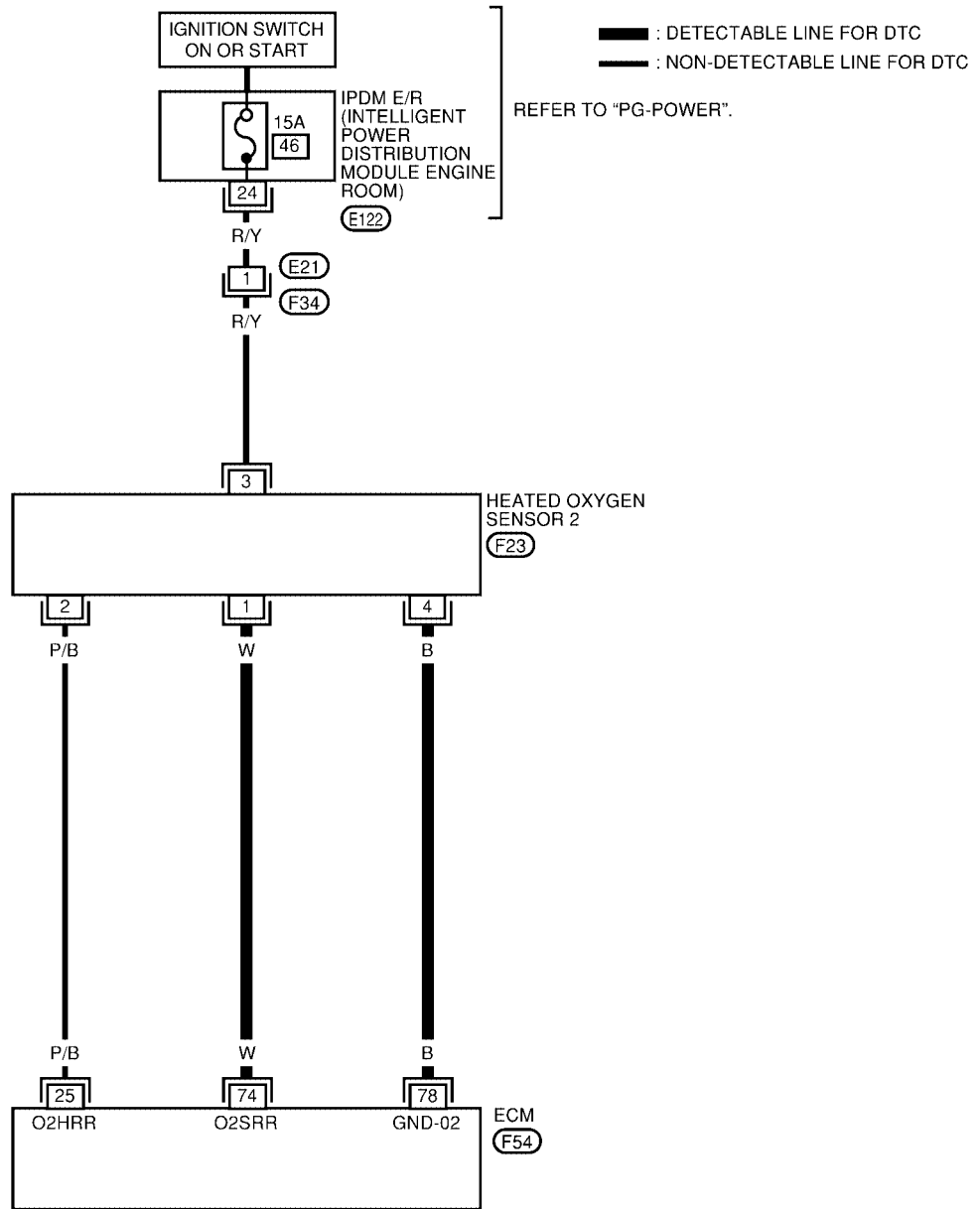

A
EC
C
D
E
F
G
H
I
J
K
L
M

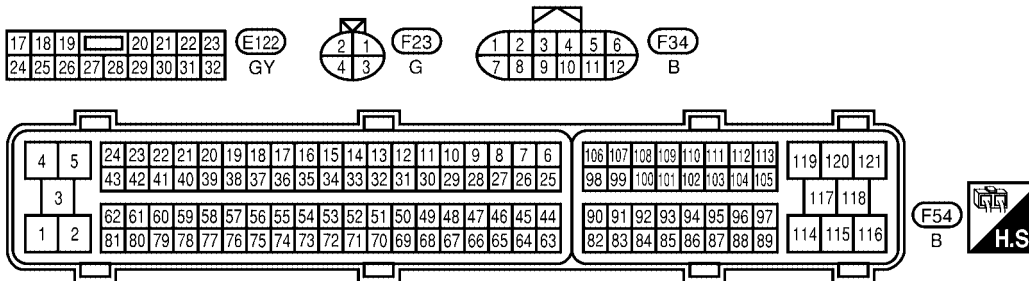

BBWA1220E

Specification data are reference values and are measured between each terminal and ground.

CAUTION:

Do not use ECM ground terminals when measuring input/output voltage. Doing so may result in damage to the ECM's transistor. Use a ground other than ECM terminals, such as the ground.

TER-MINAL NO.	WIRE COLOR	ITEM	CONDITION	DATA (DC Voltage)
74	W	Heated oxygen sensor 2	<p>[Engine is running]</p> <ul style="list-style-type: none"> ● Warm-up condition ● Revving engine from idle up to 3,000 rpm quickly after the following conditions are met. ● Keeping the engine speed between 3,500 and 4,000 rpm for 1 minute and at idle for 1 minute under no load. 	0 - Approximately 1.0V
78	B	Sensor ground (Heated oxygen sensor)	<p>[Engine is running]</p> <ul style="list-style-type: none"> ● Warm-up condition ● Idle speed 	Approximately 0V

Diagnostic Procedure

UBS002S2

1. CHECK GROUND CONNECTIONS

1. Turn ignition switch OFF.
2. Loosen and retighten three ground screws on the body. Refer to [EC-164, "Ground Inspection"](#).

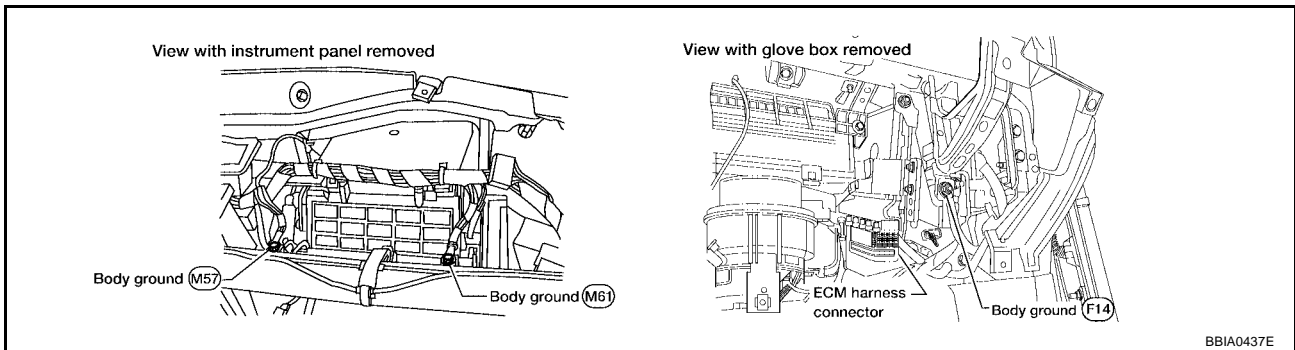

BBIA0437E

OK or NG

- OK >> GO TO 2.
- NG >> Repair or replace ground connections.

2. CHECK HO2S2 GROUND CIRCUIT FOR OPEN AND SHORT

1. Disconnect ECM harness connector.
2. Disconnect heated oxygen sensor 2 harness connector.
3. Check harness continuity between ECM terminal 78 and HO2S2 terminal 4.
Refer to Wiring Diagram.

Continuity should exist.

4. Also check harness for short to ground or short to power.

OK or NG

- OK >> GO TO 3.
- NG >> Repair open circuit or short to ground short to power in harness or connectors.

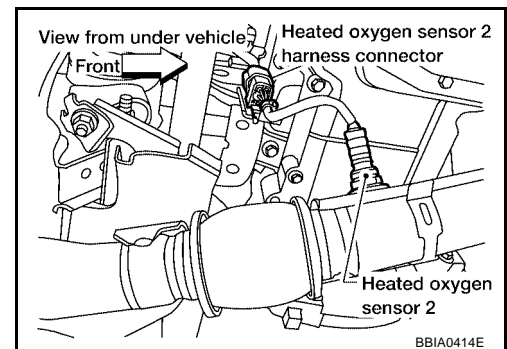

BBIA0414E

3. CHECK HO2S2 INPUT SIGNAL CIRCUIT FOR OPEN AND SHORT

1. Check harness continuity between ECM terminal 74 and HO2S2 terminal 1.
Refer to Wiring Diagram.

Continuity should exist.

2. Check harness continuity between ECM terminal 74 or HO2S2 terminal 1 and ground.
Refer to Wiring Diagram.

Continuity should not exist.

3. Also check harness for short to ground or short to power.

OK or NG

OK >> GO TO 4.

NG >> Repair open circuit or short to ground or short to power in harness or connectors.

4. CHECK HARNESS CONNECTOR

Check HO2S2 harness connector for water.

Water should not exist.

OK or NG

OK >> GO TO 5.

NG >> Repair or replace harness or connector.

5. CHECK HEATED OXYGEN SENSOR 2

Refer to [EC-223, "Component Inspection"](#) .

OK or NG

OK >> GO TO 6.

NG >> Replace heated oxygen sensor 2.

6. CHECK INTERMITTENT INCIDENT

Refer to [EC-158, "TROUBLE DIAGNOSIS FOR INTERMITTENT INCIDENT"](#) .

>> INSPECTION END

**Component Inspection
HEATED OXYGEN SENSOR 2**

UBS002S3

④ With CONSULT-II

1. Start engine and warm it up to the normal operating temperature.
2. Turn ignition switch OFF and wait at least 10 seconds.
3. Start engine and keep the engine speed between 3,500 and 4,000 rpm for at least 1 minute under no load.
4. Let engine idle for 1 minute.
5. Select "FUEL INJECTION" in "ACTIVE TEST" mode, and select "HO2S2 (B1)" as the monitor item with CONSULT-II.

ACTIVE TEST	
FUEL INJECTION	25 %
MONITOR	
ENG SPEED	XXX rpm
HO2S2 (B1)	XXX V

PBIB1783E

6. Check "HO2S2 (B1)" at idle speed when adjusting "FUEL INJECTION" to $\pm 25\%$.

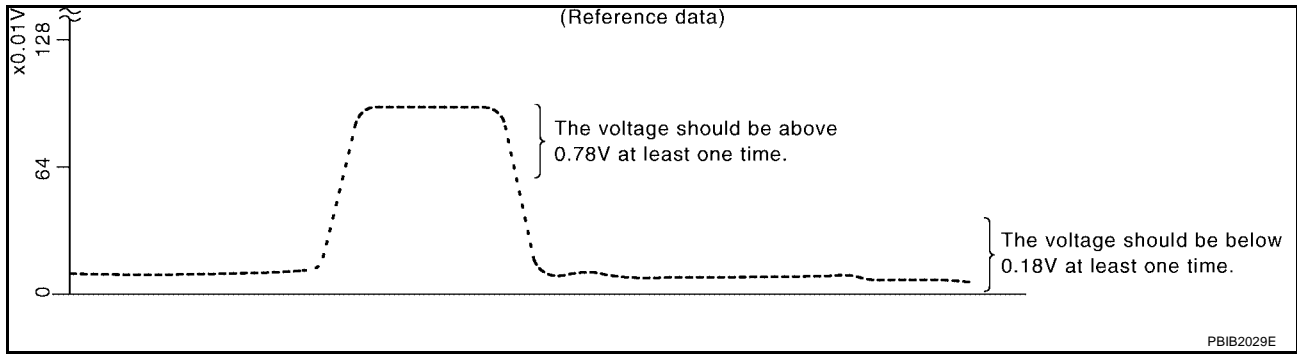

"HO2S2 (B1)" should be above 0.78V at least once when the "FUEL INJECTION" is +25%.
 "HO2S2 (B1)" should be below 0.18V at least once when the "FUEL INJECTION" is -25%.

CAUTION:

- Discard any heated oxygen sensor which has been dropped from a height of more than 0.5 m (19.7 in) onto a hard surface such as a concrete floor; use a new one.
- Before installing new oxygen sensor, clean exhaust system threads using Oxygen Sensor Thread Cleaner tool J-43897-18 or J-43897-12 and approved anti-seize lubricant.

⊗ **Without CONSULT-II**

1. Start engine and warm it up to the normal operating temperature.
2. Turn ignition switch OFF and wait at least 10 seconds.
3. Start engine and keep the engine speed between 3,500 and 4,000 rpm for at least 1 minute under no load.
4. Let engine idle for 1 minute.
5. Set voltmeter probes between ECM terminal 74 (HO2S2 signal) and ground.
6. Check the voltage when revving up to 4,000 rpm under no load at least 10 times.

(Depress and release accelerator pedal as soon as possible.)
The voltage should be above 0.78V at least once during this procedure.
If the voltage is above 0.78V at step 4, step 5 is not necessary.

7. Keep vehicle idling for 10 minutes, then check voltage. Or check the voltage when coasting from 80 km/h (50 MPH) in D position with OD OFF (A/T), 3rd gear position (M/T).
The voltage should be below 0.18V at least once during this procedure.

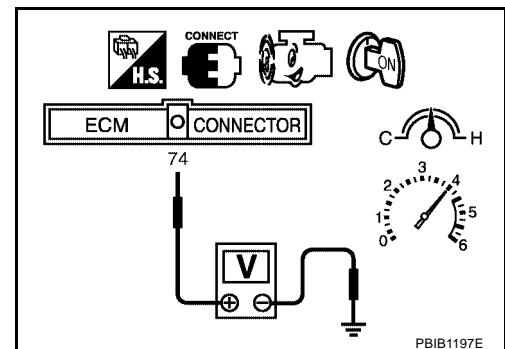

8. If NG, replace heated oxygen sensor 2.

CAUTION:

- Discard any heated oxygen sensor which has been dropped from a height of more than 0.5 m (19.7 in) onto a hard surface such as a concrete floor; use a new one.
- Before installing new oxygen sensor, clean exhaust system threads using Oxygen Sensor Thread Cleaner tool J-43897-18 or J-43897-12 and approved anti-seize lubricant.

**Removal and Installation
 HEATED OXYGEN SENSOR 2**

UBS002S4

Refer to [EX-3, "EXHAUST SYSTEM \(QR25DE\)"](#).

DTC P0139 HO2S2

Component Description

UBS002S5

The heated oxygen sensor 2, after three way catalyst (manifold), monitors the oxygen level in the exhaust gas.

Even if switching characteristics of the A/F sensor 1 are shifted, the air-fuel ratio is controlled to stoichiometric, by the signal from the heated oxygen sensor 2.

This sensor is made of ceramic zirconia. The zirconia generates voltage from approximately 1V in richer conditions to 0V in leaner conditions.

Under normal conditions the heated oxygen sensor 2 is not used for engine control operation.

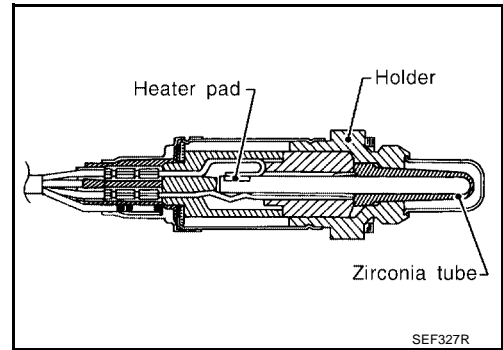

CONSULT-II Reference Value in Data Monitor Mode

UBS002S6

Specification data are reference values.

MONITOR ITEM	CONDITION		SPECIFICATION
HO2S2 (B1)	<ul style="list-style-type: none"> ● Engine: After warming up ● After keeping engine speed between 3,500 and 4,000 rpm for 1 minute and at idle for 1 minute under no load. 	Revving engine from idle to 3,000 rpm quickly	0 - 0.3V ↔ Approx. 0.6 - 1.0V
HO2S2 MNTR (B1)	<ul style="list-style-type: none"> ● Engine: After warming up ● After keeping engine speed between 3,500 and 4,000 rpm for 1 minute and at idle for 1 minute under no load. 	Revving engine from idle to 3,000 rpm quickly	LEAN ↔ RICH

On Board Diagnosis Logic

UBS002S7

The heated oxygen sensor 2 has a much longer switching time between rich and lean than the A/F sensor 1. The oxygen storage capacity before the three way catalyst (manifold) causes the longer switching time. To judge the malfunctions of heated oxygen sensor 2, ECM monitors whether the switching response of the sensor's voltage is faster than specified during the various driving condition such as fuel-cut.

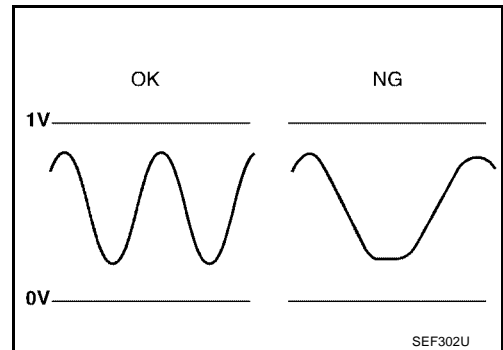

DTC No.	Trouble diagnosis name	DTC detecting condition	Possible cause
P0139 0139	Heated oxygen sensor 2 circuit slow response	It takes more time for the sensor to respond between rich and lean than the specified time.	<ul style="list-style-type: none"> ● Harness or connectors (The sensor circuit is open or shorted) ● Heated oxygen sensor 2 ● Fuel pressure ● Fuel injector ● Intake air leaks

DTC Confirmation Procedure

NOTE:

If DTC Confirmation Procedure has been previously conducted, always turn ignition switch OFF and wait at least 10 seconds before conducting the next test.

TESTING CONDITION:

For the best results, perform “DTC WORK SUPPORT” at a temperature of 0 to 30°C (32 to 86°F).
Open engine hood before conducting following procedure.

WITH CONSULT-II

1. Start engine and warm it up to normal operating temperature.
2. Turn ignition switch OFF and wait at least 10 seconds.
3. Start engine and keep the engine speed between 3,500 and 4,000 rpm for at least 1 minute under no load.
4. Let engine idle for 1 minute.
5. Select “HO2S2 (B1) P0139” of “HO2S2” in “DTC WORK SUPPORT” mode with CONSULT-II and follow the instruction of CONSULT-II.

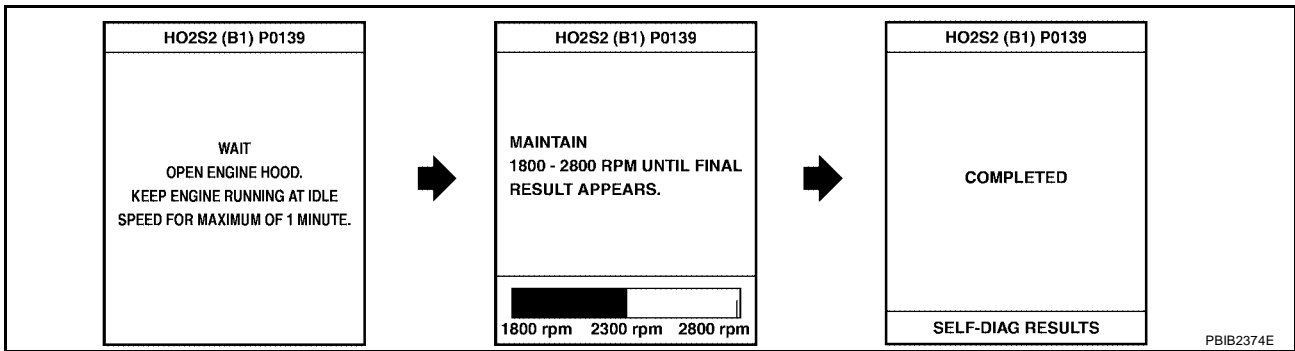

NOTE:

It will take at most 10 minutes until “COMPLETED” is displayed.

6. Make sure that “OK” is displayed after touching “SELF-DIAG RESULTS”.
If “NG” is displayed, refer to [EC-229. "Diagnostic Procedure"](#) .
If “CAN NOT BE DIAGNOSED” is displayed, perform the following.
 - a. Turn ignition switch OFF and leave the vehicle in a cool place (soak the vehicle).
 - b. Return to step 1.

Overall Function Check

Use this procedure to check the overall function of the heated oxygen sensor 2 circuit. During this check, a 1st trip DTC might not be confirmed.

CAUTION:

Always drive vehicle at a safe speed.

WITH GST

1. Start engine and warm it up to the normal operating temperature.
2. Turn ignition switch OFF and wait at least 10 seconds.
3. Start engine and keep the engine speed between 3,500 and 4,000 rpm for at least 1 minute under no load.
4. Let engine idle for 1 minute.
5. Set voltmeter probes between ECM terminal 74 (HO2S2 signal) and ground.

DTC P0139 HO2S2

[QR]

6. Check the voltage when revving up to 4,000 rpm under no load at least 10 times.
(Depress and release accelerator pedal as soon as possible.)
A change of voltage should be more than 0.06V for 1 second during this procedure.
If the voltage can be confirmed in step 6, step 7 is not necessary.
7. Keep vehicle at idling for 10 minutes, then check the voltage. Or check the voltage when coasting from 80 km/h (50 MPH) in D position with OD OFF (A/T), 3rd gear position (M/T).
A change of voltage should be more than 0.06V for 1 second during this procedure.
8. If NG, go to [EC-229, "Diagnostic Procedure"](#) .

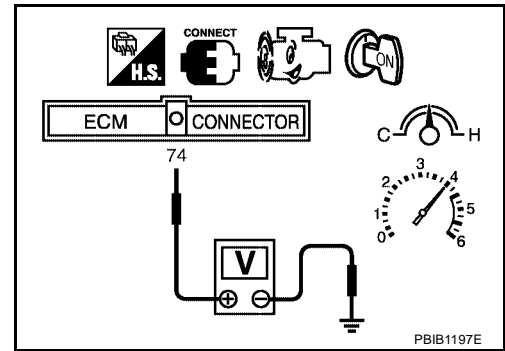

A

EC

C

D

E

F

G

H

I

J

K

L

M

Wiring Diagram

UBS002SA

EC-HO2S2-01

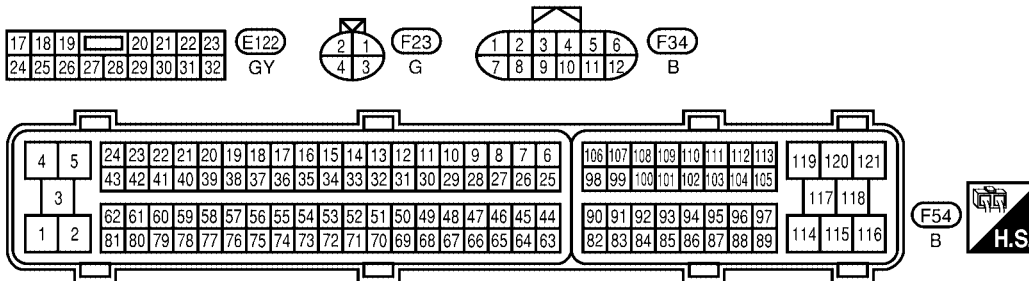
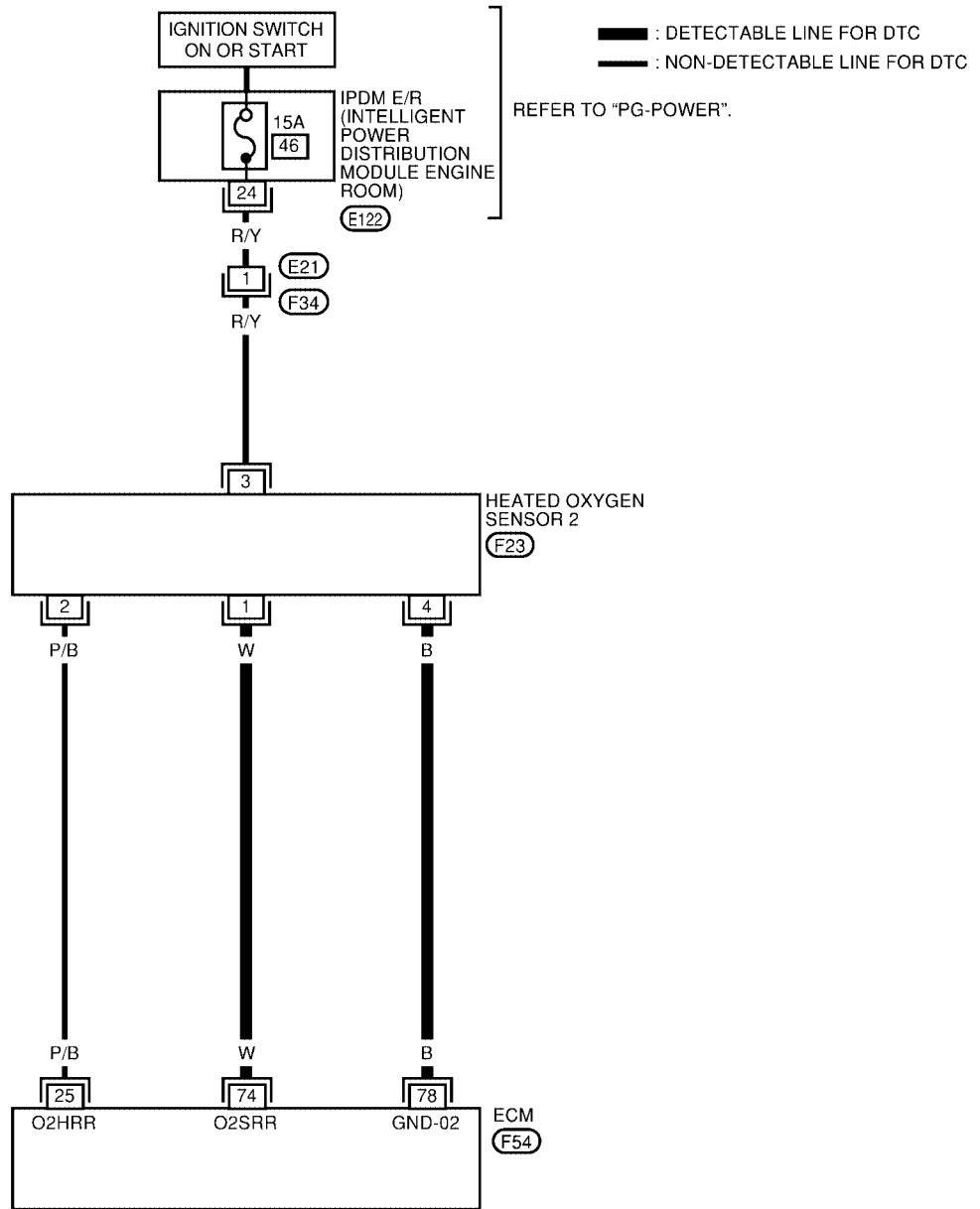

BBWA1220E

Specification data are reference values and are measured between each terminal and ground.

CAUTION:

Do not use ECM ground terminals when measuring input/output voltage. Doing so may result in damage to the ECM's transistor. Use a ground other than ECM terminals, such as the ground.

TER-MINAL NO.	WIRE COLOR	ITEM	CONDITION	DATA (DC Voltage)
74	W	Heated oxygen sensor 2	<p>[Engine is running]</p> <ul style="list-style-type: none"> ● Warm-up condition ● Revving engine from idle up to 3,000 rpm quickly after the following conditions are met. ● Keeping the engine speed between 3,500 and 4,000 rpm for 1 minute and at idle for 1 minute under no load. 	0 - Approximately 1.0V

Diagnostic Procedure

UBS002SB

1. CHECK GROUND CONNECTIONS

1. Turn ignition switch OFF.
2. Loosen and retighten three ground screws on the body. Refer to [EC-164, "Ground Inspection"](#).

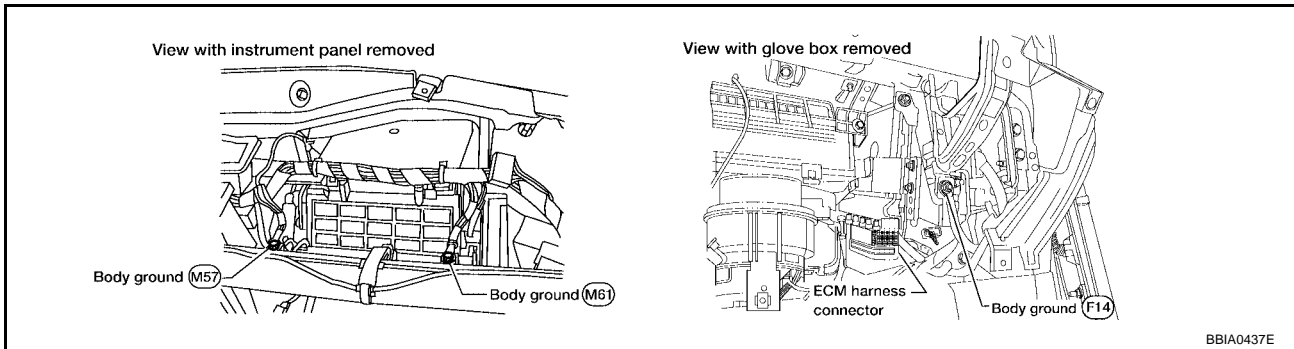

OK or NG

- OK >> GO TO 2.
- NG >> Repair or replace ground connections.

2. CLEAR THE SELF-LEARNING DATA

④ With CONSULT-II

1. Start engine and warm it up to normal operating temperature.
2. Select "SELF-LEARNING CONT" in "WORK SUPPORT" mode with CONSULT-II.
3. Clear the self-learning control coefficient by touching "CLEAR".
4. Run engine for at least 10 minutes at idle speed.
**Is the 1st trip DTC P0171 or P0172 detected?
Is it difficult to start engine?**

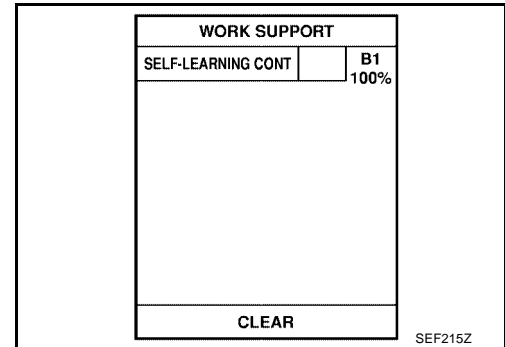

⊗ Without CONSULT-II

1. Start engine and warm it up to normal operating temperature.
2. Turn ignition switch OFF.
3. Disconnect mass air flow sensor harness connector, and restart and run engine for at least 5 seconds at idle speed.
4. Stop engine and reconnect mass air flow sensor harness connector.
5. Make sure DTC P0102 is displayed.
6. Erase the DTC memory. Refer to [EC-65, "HOW TO ERASE EMISSION-RELATED DIAGNOSTIC INFORMATION"](#).
7. Make sure DTC P0000 is displayed.
8. Run engine for at least 10 minutes at idle speed.
**Is the 1st trip DTC P0171 or P0172 detected?
Is it difficult to start engine?**

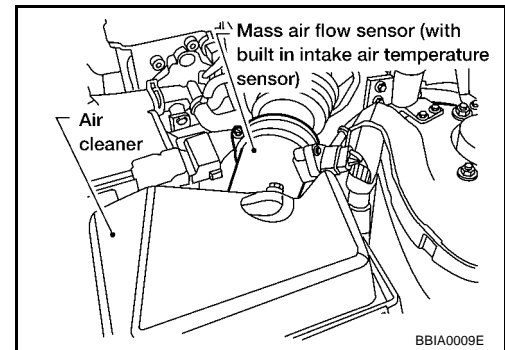

Yes or No

- Yes >> Perform trouble diagnosis for DTC P0171 or P0172. Refer to [EC-233](#) or [EC-240](#).
- No >> GO TO 3.

3. CHECK HO2S2 GROUND CIRCUIT FOR OPEN AND SHORT

1. Turn ignition switch OFF.
2. Disconnect ECM harness connector.
3. Disconnect heated oxygen sensor 2 harness connector.
4. Check harness continuity between ECM terminal 78 and HO2S2 terminal 4.
Refer to Wiring Diagram.

Continuity should exist.

5. Also check harness for short to ground or short to power.

OK or NG

- OK >> GO TO 4.
- NG >> Repair open circuit or short to ground or short to power in harness or connectors.

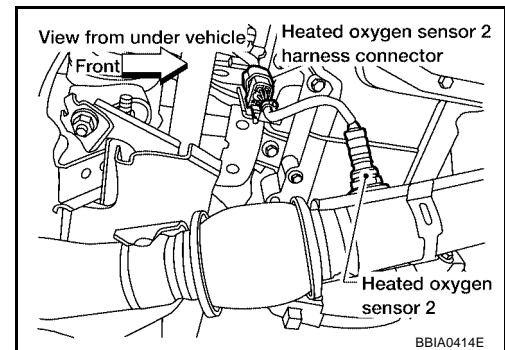

4. CHECK HO2S2 INPUT SIGNAL CIRCUIT FOR OPEN AND SHORT

1. Check harness continuity between ECM terminal 74 and HO2S2 terminal 1.
Refer to Wiring Diagram.

Continuity should exist.

2. Check harness continuity between ECM terminal 74 or HO2S2 terminal 1 and ground.
Refer to Wiring Diagram.

Continuity should not exist.

3. Also check harness for short to ground or short to power.

OK or NG

OK >> GO TO 5.

NG >> Repair open circuit or short to ground or short to power in harness or connectors.

5. CHECK HEATED OXYGEN SENSOR 2

Refer to [EC-231, "Component Inspection"](#) .

OK or NG

OK >> GO TO 6.

NG >> Replace heated oxygen sensor 2.

6. CHECK INTERMITTENT INCIDENT

Refer to [EC-158, "TROUBLE DIAGNOSIS FOR INTERMITTENT INCIDENT"](#) .

>> INSPECTION END

**Component Inspection
HEATED OXYGEN SENSOR 2**

UBS002SC

With CONSULT-II

1. Start engine and warm it up to the normal operating temperature.
2. Turn ignition switch OFF and wait at least 10 seconds.
3. Start engine and keep the engine speed between 3,500 and 4,000 rpm for at least 1 minute under no load.
4. Let engine idle for 1 minute.
5. Select "FUEL INJECTION" in "ACTIVE TEST" mode, and select "HO2S2 (B1)" as the monitor item with CONSULT-II.

ACTIVE TEST	
FUEL INJECTION	25 %
MONITOR	
ENG SPEED	XXX rpm
HO2S2 (B1)	XXX V

PBIB1783E

6. Check "HO2S2 (B1)" at idle speed when adjusting "FUEL INJECTION" to $\pm 25\%$.

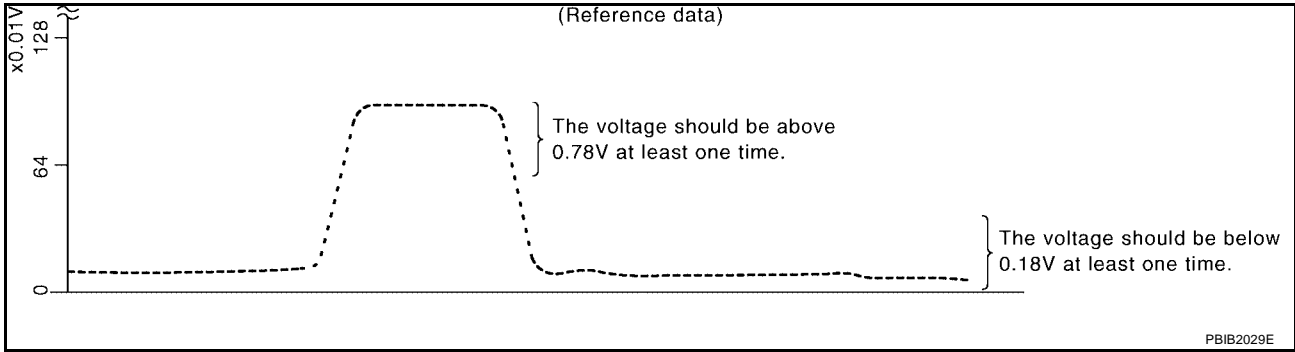

"HO2S2 (B1)" should be above 0.78V at least once when the "FUEL INJECTION" is +25%.
 "HO2S2 (B1)" should be below 0.18V at least once when the "FUEL INJECTION" is -25%.

CAUTION:

- Discard any heated oxygen sensor which has been dropped from a height of more than 0.5 m (19.7 in) onto a hard surface such as a concrete floor; use a new one.
- Before installing new oxygen sensor, clean exhaust system threads using Oxygen Sensor Thread Cleaner tool J-43897-18 or J-43897-12 and approved anti-seize lubricant.

⊗ **Without CONSULT-II**

1. Start engine and warm it up to the normal operating temperature.
2. Turn ignition switch OFF and wait at least 10 seconds.
3. Start engine and keep the engine speed between 3,500 and 4,000 rpm for at least 1 minute under no load.
4. Let engine idle for 1 minute.
5. Set voltmeter probes between ECM terminal 74 (HO2S2 signal) and ground.
6. Check the voltage when revving up to 4,000 rpm under no load at least 10 times.

(Depress and release accelerator pedal as soon as possible.)
The voltage should be above 0.78V at least once during this procedure.
If the voltage is above 0.78V at step 4, step 5 is not necessary.

7. Keep vehicle idling for 10 minutes, then check voltage. Or check the voltage when coasting from 80 km/h (50 MPH) in D position with OD OFF (A/T), 3rd gear position (M/T).
The voltage should be below 0.18V at least once during this procedure.

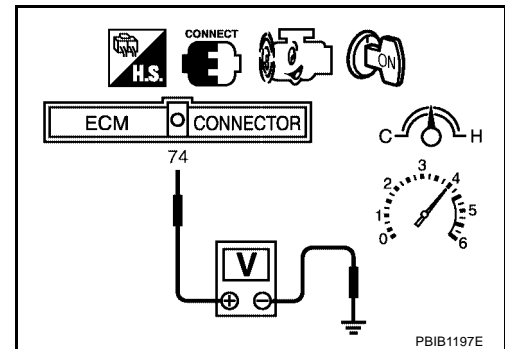

8. If NG, replace heated oxygen sensor 2.

CAUTION:

- Discard any heated oxygen sensor which has been dropped from a height of more than 0.5 m (19.7 in) onto a hard surface such as a concrete floor; use a new one.
- Before installing new oxygen sensor, clean exhaust system threads using Oxygen Sensor Thread Cleaner tool J-43897-18 or J-43897-12 and approved anti-seize lubricant.

Removal and Installation
HEATED OXYGEN SENSOR 2

UBS002SD

Refer to [EX-3, "EXHAUST SYSTEM \(QR25DE\)"](#).

DTC P0171 FUEL INJECTION SYSTEM FUNCTION

[QR]

DTC P0171 FUEL INJECTION SYSTEM FUNCTION

PF16600

On Board Diagnosis Logic

UBS002SE

With the Air-Fuel Mixture Ratio Self-Learning Control, the actual mixture ratio can be brought closely to the theoretical mixture ratio based on the mixture ratio feedback signal from the A/F sensor 1. The ECM calculates the necessary compensation to correct the offset between the actual and the theoretical ratios. In case the amount of the compensation value is extremely large (The actual mixture ratio is too lean.), the ECM judges the condition as the fuel injection system malfunction and lights up the MIL (2 trip detection logic).

Sensor	Input Signal to ECM	ECM function	Actuator
Air fuel ratio (A/F) sensor 1	Density of oxygen in exhaust gas (Mixture ratio feedback signal)	Fuel injection control	Fuel injector

DTC No.	Trouble diagnosis name	DTC detecting condition	Possible cause
P0171 0171	Fuel injection system too lean	<ul style="list-style-type: none"> Fuel injection system does not operate properly. The amount of mixture ratio compensation is too large. (The mixture ratio is too lean.) 	<ul style="list-style-type: none"> Intake air leaks Air fuel ratio (A/F) sensor 1 Fuel injector Exhaust gas leaks Incorrect fuel pressure Lack of fuel Mass air flow sensor Incorrect PCV hose connection

DTC Confirmation Procedure

UBS002SF

NOTE:

If DTC Confirmation Procedure has been previously conducted, always turn ignition switch OFF and wait at least 10 seconds before conducting the next test.

WITH CONSULT-II

- Start engine and warm it up to normal operating temperature.
- Turn ignition switch OFF and wait at least 10 seconds.
- Turn ignition switch ON and select "SELF-LEARNING CONT" in "WORK SUPPORT" mode with CONSULT-II.
- Clear the self-learning control coefficient by touching "CLEAR".
- Select "DATA MONITOR" mode with CONSULT-II.
- Start engine again and let it idle for at least 10 minutes. The 1st trip DTC P0171 should be detected at this stage, if a malfunction exists. If so, go to [EC-236, "Diagnostic Procedure"](#).

NOTE:

If 1st trip DTC is not detected during above procedure, performing the following procedure is advised.

- Turn ignition switch OFF and wait at least 10 seconds.
- Start engine and drive the vehicle under the similar conditions to (1st trip) Freeze Frame Data for 10 minutes. Refer to the table below.

Hold the accelerator pedal as steady as possible.

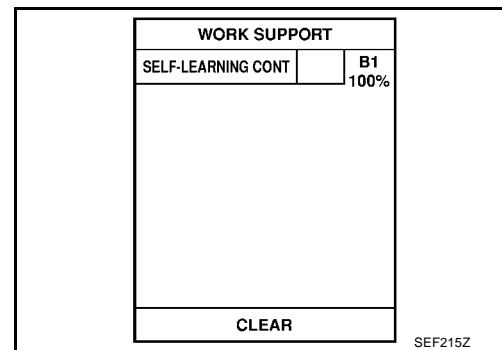

The similar conditions to (1st trip) Freeze Frame Data means the vehicle operation that the following conditions should be satisfied at the same time.

Engine speed	Engine speed in the freeze frame data ± 400 rpm
Vehicle speed	Vehicle speed in the freeze frame data ± 10 km/h (6 MPH)

DTC P0171 FUEL INJECTION SYSTEM FUNCTION

[QR]

Engine coolant temperature (T) condition	When the freeze frame data shows lower than 70 °C (158 °F), T should be lower than 70 °C (158 °F).
	When the freeze frame data shows higher than or equal to 70 °C (158 °F), T should be higher than or equal to 70 °C (158 °F).

7. If it is difficult to start engine at step 6, the fuel injection system has a malfunction, too.
8. Crank engine while depressing accelerator pedal. If engine starts, go to [EC-236, "Diagnostic Procedure"](#) . If engine does not start, check exhaust and intake air leak visually.

WITH GST

1. Start engine and warm it up to normal operating temperature.
2. Turn ignition switch OFF and wait at least 10 seconds.
3. Disconnect mass air flow sensor harness connector.
4. Restart engine and let it idle for at least 5 seconds.
5. Stop engine and reconnect mass air flow sensor harness connector.
6. Select Service \$03 with GST. Make sure DTC P0102 is detected.
7. Select Service \$04 with GST and erase the DTC P0102.
8. Start engine again and let it idle for at least 10 minutes.
9. Select Service \$07 with GST. The 1st trip DTC P0171 should be detected at this stage, if a malfunction exists. If so, go to [EC-236, "Diagnostic Procedure"](#) .

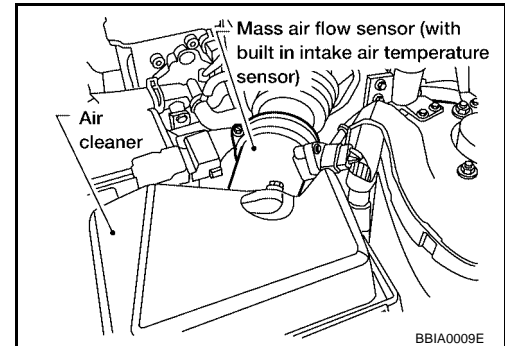

NOTE:

If 1st trip DTC is not detected during above procedure, performing the following procedure is advised.

- a. Turn ignition switch OFF and wait at least 10 seconds.
- b. Start engine and drive the vehicle under the similar conditions to (1st trip) Freeze Frame Data for 10 minutes. Refer to the table below.

Hold the accelerator pedal as steady as possible.

The similar conditions to (1st trip) Freeze Frame Data means the vehicle operation that the following conditions should be satisfied at the same time.

Engine speed	Engine speed in the freeze frame data \pm 400 rpm
Vehicle speed	Vehicle speed in the freeze frame data \pm 10 km/h (6 MPH)
Engine coolant temperature (T) condition	When the freeze frame data shows lower than 70 °C (158 °F), T should be lower than 70 °C (158 °F).
	When the freeze frame data shows higher than or equal to 70 °C (158 °F), T should be higher than or equal to 70 °C (158 °F).

10. If it is difficult to start engine at step 8, the fuel injection system has a malfunction.
11. Crank engine while depressing accelerator pedal. If engine starts, go to [EC-236, "Diagnostic Procedure"](#) . If engine does not start, check exhaust and intake air leak visually.

DTC P0171 FUEL INJECTION SYSTEM FUNCTION

[QR]

UBS002SG

Wiring Diagram

EC-FUEL-01

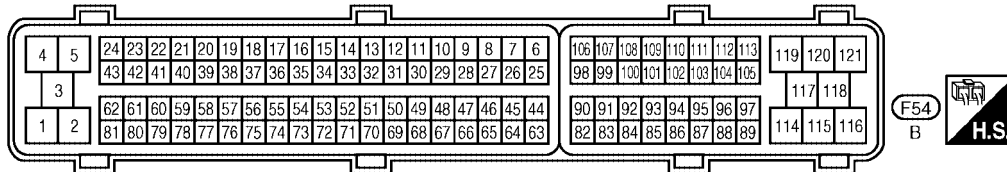
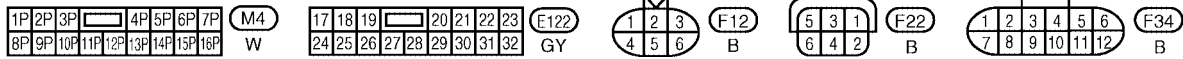
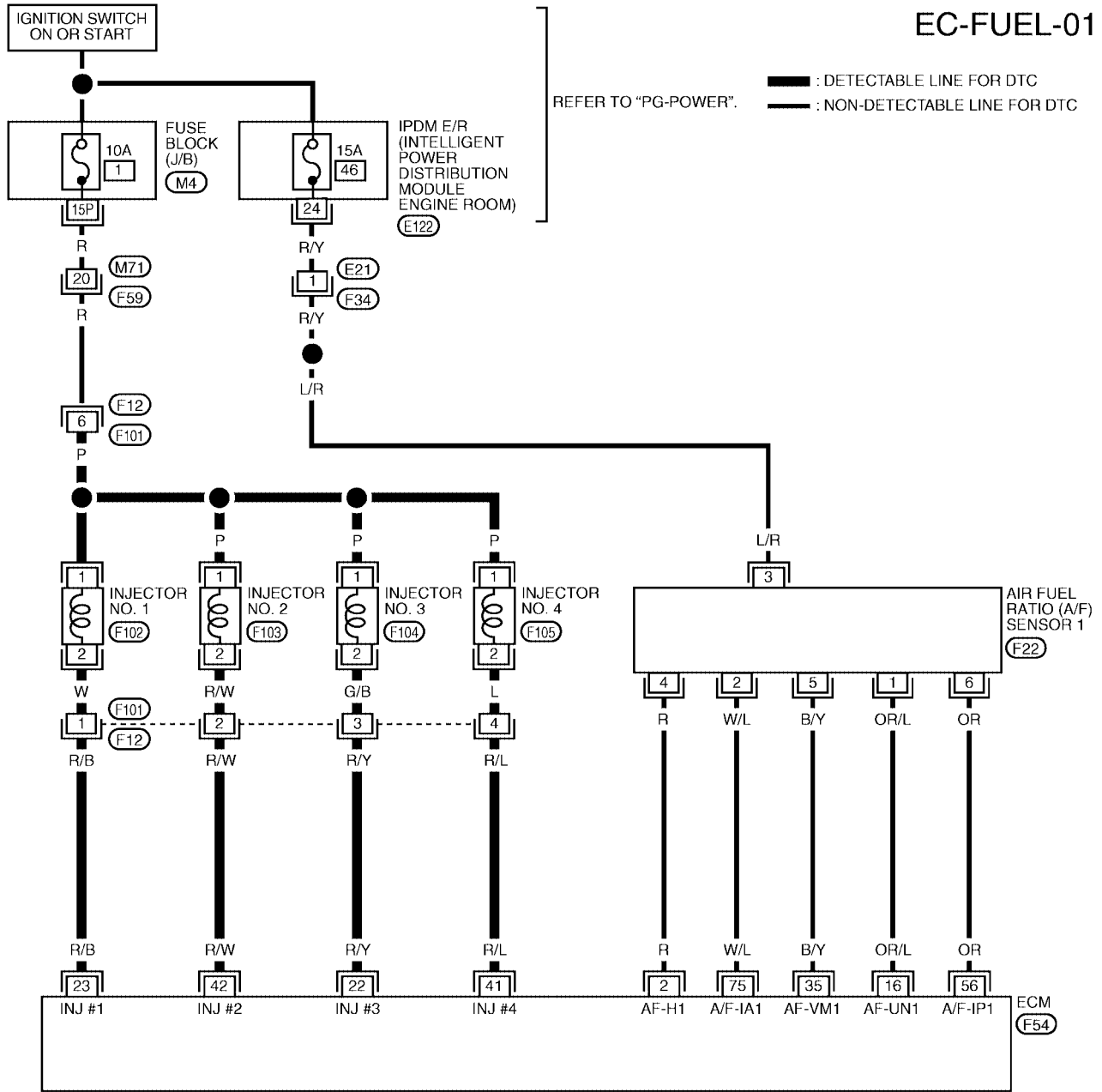

BBWA1221E

Diagnostic Procedure

1. CHECK EXHAUST GAS LEAK

1. Start engine and run it at idle.
2. Listen for an exhaust gas leak before three way catalyst (manifold).

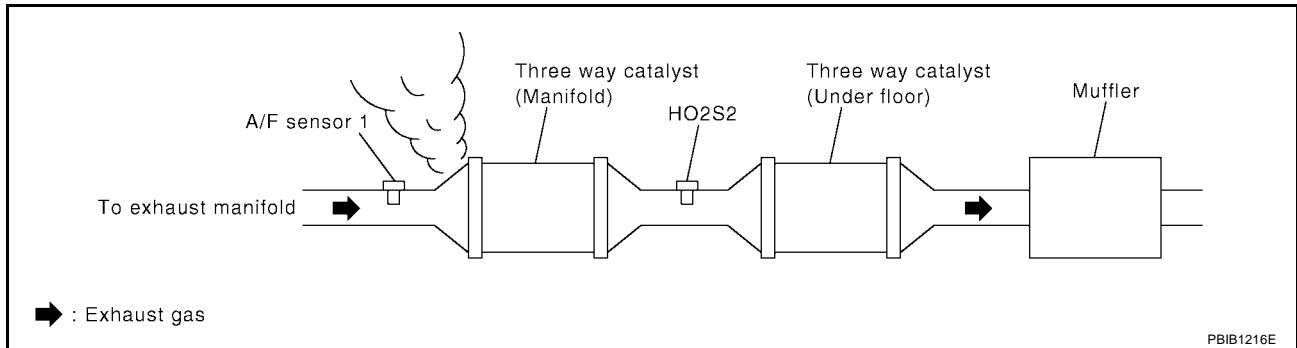

OK or NG

- OK >> GO TO 2.
- NG >> Repair or replace.

2. CHECK FOR INTAKE AIR LEAK AND PCV HOSE

1. Listen for an intake air leak after the mass air flow sensor.
2. Check PCV hose connection.

OK or NG

- OK >> GO TO 3.
- NG >> Repair or replace.

3. CHECK AIR FUEL RATIO (A/F) SENSOR 1 CIRCUIT FOR OPEN AND SHORT

1. Turn ignition switch OFF.
2. Disconnect A/F sensor 1 harness connector and ECM harness connector.
3. Check harness continuity between ECM terminals and A/F sensor 1 terminals as follows. Refer to Wiring Diagram.

A/F sensor 1	ECM terminal
1	16
5	35
6	56
2	75

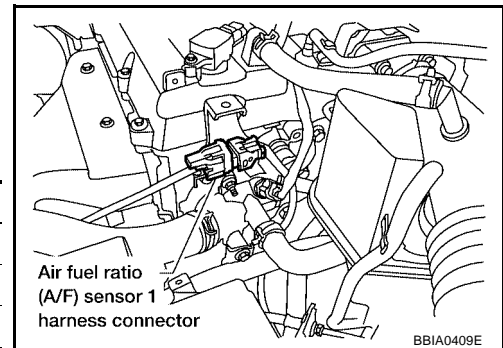

Continuity should exist.

4. Check harness continuity between ECM terminals 16, 35, 56, 75 and ground, or A/F sensor 1 terminals 1, 2, 5, 6 and ground. Refer to Wiring Diagram.

Continuity should not exist.

5. Also check harness for short to ground and short to power.

OK or NG

- OK >> GO TO 4.
- NG >> Repair open circuit or short to ground or short to power in harness or connectors.

4. CHECK FUEL PRESSURE

1. Release fuel pressure to zero.
Refer to [EC-95, "FUEL PRESSURE RELEASE"](#) .
2. Install fuel pressure gauge and check fuel pressure. Refer to [EC-96, "FUEL PRESSURE CHECK"](#) .

At idling: 350 kPa (3.57 kg/cm² , 51 psi)

OK or NG

- OK >> GO TO 5.
NG >> Follow the instruction of FUEL PRESSURE CHECK.

5. CHECK MASS AIR FLOW SENSOR** With CONSULT-II**

1. Install all removed parts.
2. Check "MASS AIR FLOW" in "DATA MONITOR" mode with CONSULT-II.

at idling: 1.0 - 4.0 g-m/sec

at 2,500 rpm: 4.0 - 10.0 g-m/sec

 With GST

1. Install all removed parts.
2. Check mass air flow sensor signal in SERVICE \$01 with GST.

at idling: 1.0 - 4.0 g-m/sec

at 2,500 rpm: 4.0 - 10.0 g-m/sec

OK or NG

- OK >> GO TO 6.
NG >> Check connectors for rusted terminals or loose connections in the mass air flow sensor circuit or grounds. Refer to [EC-178](#) .

6. CHECK FUNCTION OF INJECTORS

With CONSULT-II

1. Start engine.
2. Perform "POWER BALANCE" in "ACTIVE TEST" mode with CONSULT-II.
3. Make sure that each circuit produces a momentary engine speed drop.

ACTIVE TEST	
POWER BALANCE	
MONITOR	
ENG SPEED	XXX rpm
MAS A/F SE-B1	XXX V

PBIB0133E

Without CONSULT-II

1. Start engine.
2. Listen to each injector operating sound.
Clicking noise should be heard.

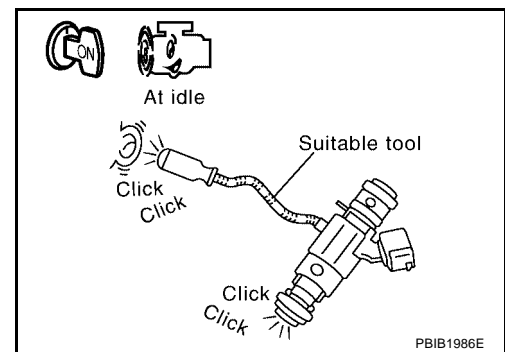

OK or NG

- OK >> GO TO 7.
 NG >> Perform trouble diagnosis for [EC-592, "INJECTOR CIRCUIT"](#) .

7. CHECK INJECTOR

1. Confirm that the engine is cooled down and there are no fire hazards near the vehicle.
2. Turn ignition switch OFF.
3. Remove injector gallery assembly. Refer to [EM-32, "FUEL INJECTOR AND FUEL TUBE"](#) .
Keep fuel hose and all injectors connected to injector gallery.
The injector harness connectors should remain connected.
4. Disconnect all ignition coil harness connectors.
5. Prepare pans or saucers under each injector.
6. Crank engine for about 3 seconds. Make sure that fuel sprays out from injectors.

Fuel should be sprayed evenly for each injector.

OK or NG

- OK >> GO TO 8.
 NG >> Replace injectors from which fuel does not spray out.
 Always replace O-ring with new ones.

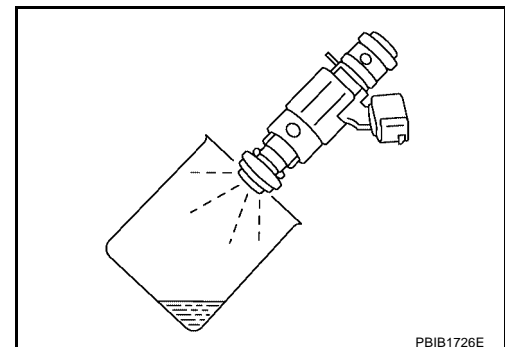

8. CHECK INTERMITTENT INCIDENT

Perform [EC-158, "TROUBLE DIAGNOSIS FOR INTERMITTENT INCIDENT"](#) .

>> INSPECTION END

A

EC

C

D

E

F

G

H

I

J

K

L

M

DTC P0172 FUEL INJECTION SYSTEM FUNCTION

[QR]

DTC P0172 FUEL INJECTION SYSTEM FUNCTION

PF16600

On Board Diagnosis Logic

UBS002SI

With the Air-Fuel Mixture Ratio Self-Learning Control, the actual mixture ratio can be brought closely to the theoretical mixture ratio based on the mixture ratio feedback signal from the A/F sensor 1. The ECM calculates the necessary compensation to correct the offset between the actual and the theoretical ratios. In case the amount of the compensation value is extremely large (The actual mixture ratio is too rich.), the ECM judges the condition as the fuel injection system malfunction and lights up the MIL (2 trip detection logic).

Sensor	Input Signal to ECM	ECM function	Actuator
Air fuel ratio (A/F) sensor 1	Density of oxygen in exhaust gas (Mixture ratio feedback signal)	Fuel injection control	Fuel injector

DTC No.	Trouble diagnosis name	DTC detecting condition	Possible cause
P0172 0172	Fuel injection system too rich	<ul style="list-style-type: none"> Fuel injection system does not operate properly. The amount of mixture ratio compensation is too large. (The mixture ratio is too rich.) 	<ul style="list-style-type: none"> Air fuel ratio (A/F) sensor 1 Fuel injector Exhaust gas leaks Incorrect fuel pressure Mass air flow sensor

DTC Confirmation Procedure

UBS002SJ

NOTE:

If DTC Confirmation Procedure has been previously conducted, always turn ignition switch OFF and wait at least 10 seconds before conducting the next test.

WITH CONSULT-II

- Start engine and warm it up to normal operating temperature.
- Turn ignition switch OFF and wait at least 10 seconds.
- Turn ignition switch ON and select "SELF-LEARNING CONT" in "WORK SUPPORT" mode with CONSULT-II.
- Clear the self-learning control coefficient by touching "CLEAR".
- Select "DATA MONITOR" mode with CONSULT-II.
- Start engine again and let it idle for at least 10 minutes. The 1st trip DTC P0172 should be detected at this stage, if a malfunction exists. If so, go to [EC-243, "Diagnostic Procedure"](#).

NOTE:

If 1st trip DTC is not detected during above procedure, performing the following procedure is advised.

- Turn ignition switch OFF and wait at least 10 seconds.
- Start engine and drive the vehicle under the similar conditions to (1st trip) Freeze Frame Data for a certain time. Refer to the table below.

Hold the accelerator pedal as steady as possible.

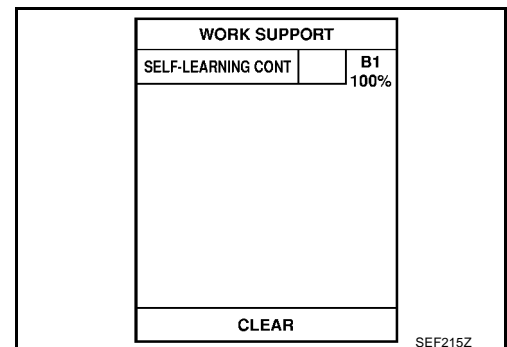

The similar conditions to (1st trip) Freeze Frame Data means the vehicle operation that the following conditions should be satisfied at the same time.

Engine speed	Engine speed in the freeze frame data \pm 400 rpm
Vehicle speed	Vehicle speed in the freeze frame data \pm 10 km/h (6 MPH)
Engine coolant temperature (T) condition	When the freeze frame data shows lower than 70 °C (158 °F), T should be lower than 70 °C (158 °F).
	When the freeze frame data shows higher than or equal to 70 °C (158 °F), T should be higher than or equal to 70 °C (158 °F).

- If it is difficult to start engine at step 6, the fuel injection system has a malfunction, too.

DTC P0172 FUEL INJECTION SYSTEM FUNCTION

[QR]

8. Crank engine while depressing accelerator pedal.
If engine starts, go to [EC-243, "Diagnostic Procedure"](#) . If engine does not start, remove spark plugs and check for fouling, etc.

 **WITH GST**

1. Start engine and warm it up to normal operating temperature.
2. Turn ignition switch OFF and wait at least 10 seconds.
3. Disconnect mass air flow sensor harness connector. Then restart and run engine for at least 5 seconds at idle speed.
4. Stop engine and reconnect mass air flow sensor harness connector.
5. Select Service \$03 with GST. Make sure DTC P0102 is detected.
6. Select Service \$04 with GST and erase the DTC P0102.
7. Start engine again and let it idle for at least 10 minutes.
8. Select Service \$07 with GST. The 1st trip DTC P0172 should be detected at this stage, if a malfunction exists. If so, go to [EC-243, "Diagnostic Procedure"](#) .

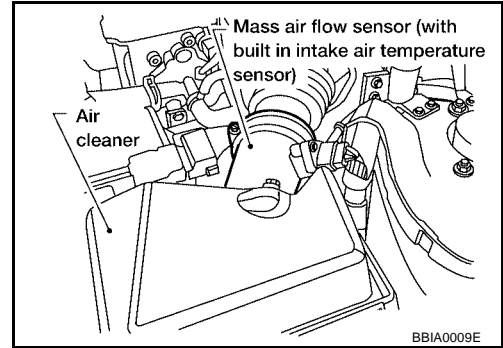

NOTE:

If 1st trip DTC is not detected during above procedure, performing the following procedure is advised.

- a. Turn ignition switch OFF and wait at least 10 seconds.
- b. Start engine and drive the vehicle under the similar conditions to (1st trip) Freeze Frame Data for a certain time. Refer to the table below.

Hold the accelerator pedal as steady as possible.

The similar conditions to (1st trip) Freeze Frame Data means the vehicle operation that the following conditions should be satisfied at the same time.

Engine speed	Engine speed in the freeze frame data \pm 400 rpm
Vehicle speed	Vehicle speed in the freeze frame data \pm 10 km/h (6 MPH)
Engine coolant temperature (T) condition	When the freeze frame data shows lower than 70 °C (158 °F), T should be lower than 70 °C (158 °F).
	When the freeze frame data shows higher than or equal to 70 °C (158 °F), T should be higher than or equal to 70 °C (158 °F).

9. If it is difficult to start engine at step 7, the fuel injection system has a malfunction.
10. Crank engine while depressing accelerator pedal.
If engine starts, go to [EC-243, "Diagnostic Procedure"](#) . If engine does not start, remove ignition plugs and check for fouling, etc.

DTC P0172 FUEL INJECTION SYSTEM FUNCTION

[QR]

UBS002SK

Wiring Diagram

EC-FUEL-01

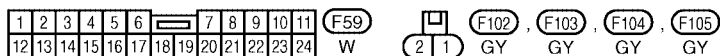
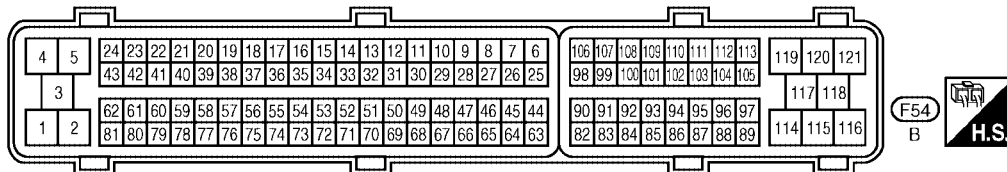
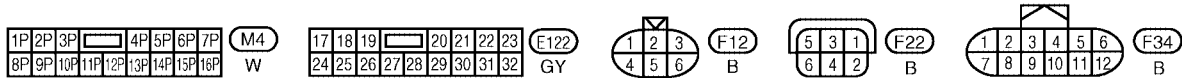
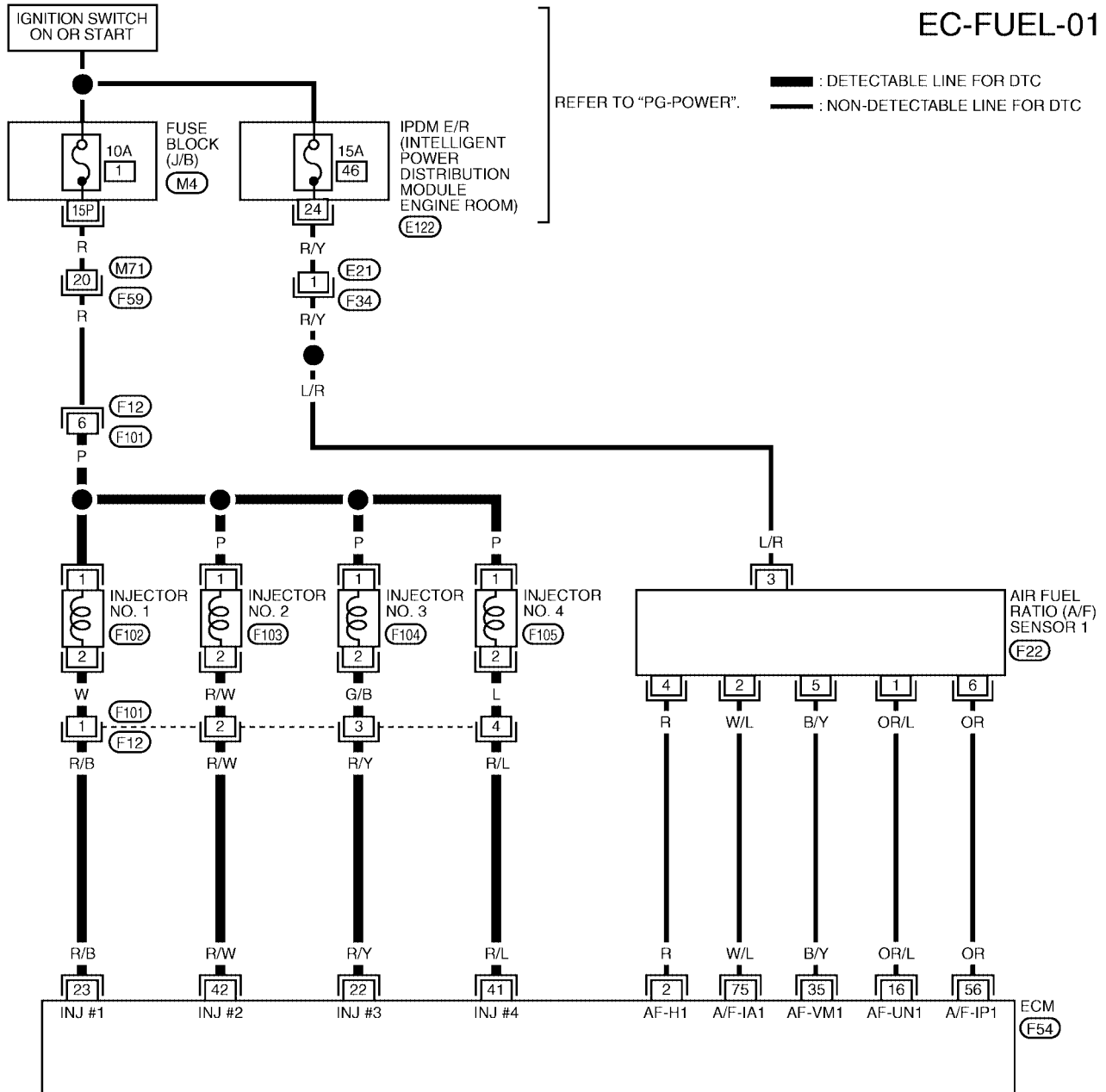

BBWA1221E

Diagnostic Procedure

1. CHECK FOR EXHAUST GAS LEAK

1. Start engine and run it at idle.
2. Listen for an exhaust gas leak before three way catalyst (manifold).

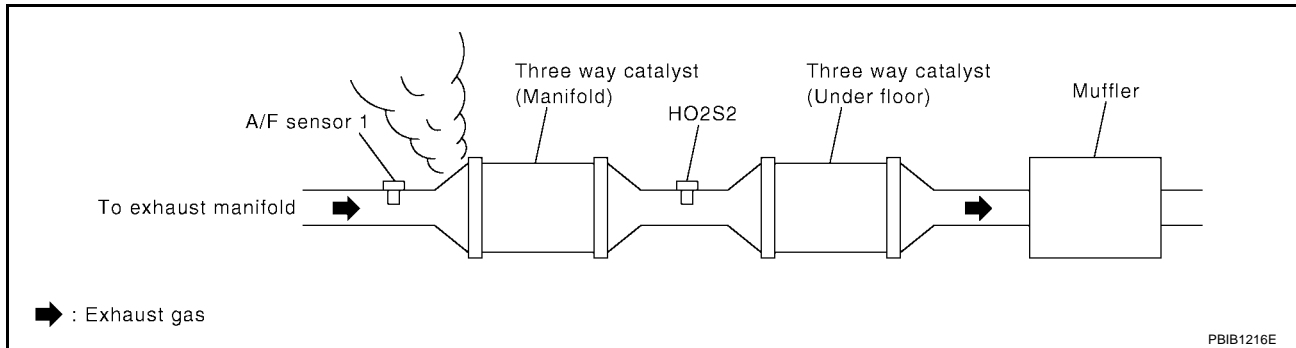

OK or NG

- OK >> GO TO 2.
- NG >> Repair or replace.

2. CHECK AIR FUEL RATIO (A/F) SENSOR 1 CIRCUIT FOR OPEN AND SHORT

1. Turn ignition switch OFF.
2. Disconnect A/F sensor 1 harness connector and ECM harness connector.
3. Check harness continuity between ECM terminals and A/F sensor 1 terminals as follows. Refer to Wiring Diagram.

A/F sensor 1	ECM terminal
1	16
5	35
6	56
2	75

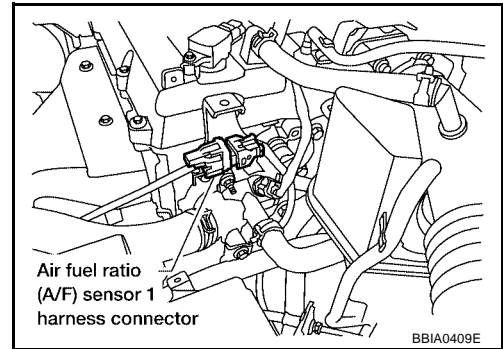

Continuity should exist.

4. Check harness continuity between ECM terminals 16, 35, 56, 75 and ground, or A/F sensor 1 terminal 1, 2, 5, 6 and ground. Refer to Wiring Diagram.

Continuity should not exist.

5. Also check harness for short to ground and short to power.

OK or NG

- OK >> GO TO 3.
- NG >> Repair open circuit or short to ground or short to power in harness or connectors.

3. CHECK FUEL PRESSURE

1. Release fuel pressure to zero. Refer to [EC-95, "FUEL PRESSURE RELEASE"](#).
2. Install fuel pressure gauge and check fuel pressure.

At idling: Approximately 350 kPa (3.57 kg/cm² , 51 psi)

OK or NG

- OK >> GO TO 5.
- NG >> GO TO 4.

4. DETECT MALFUNCTIONING PART

Check the following.

- Fuel pump and circuit (Refer to [EC-598](#).)

OK or NG

- OK >> Replace fuel pressure regulator.
NG >> Repair or replace.

5. CHECK MASS AIR FLOW SENSOR

 **With CONSULT-II**

1. Install all removed parts.
2. Check "MASS AIR FLOW" in "DATA MONITOR" mode with CONSULT-II.

at idling : 1.0- 4.0 g-m/sec
at 2,500 rpm : 4.0 - 10.0 g-m/sec

 **With GST**

1. Install all removed parts.
2. Check mass air flow sensor signal in SERVICE \$01 with GST.

at idling : 1.0 - 4.0 g-m/sec
at 2,500 rpm : 4.0 - 10.0 g-m/sec

OK or NG

- OK >> GO TO 6.
NG >> Check connectors for rusted terminals or loose connections in the mass air flow sensor circuit or grounds. Refer to [EC-178](#) .

6. CHECK FUNCTION OF INJECTORS

④ With CONSULT-II

1. Start engine.
2. Perform "POWER BALANCE" in "ACTIVE TEST" mode with CONSULT-II.
3. Make sure that each circuit produces a momentary engine speed drop.

ACTIVE TEST	
POWER BALANCE	
MONITOR	
ENG SPEED	XXX rpm
MAS A/F SE-B1	XXX V

PBIB0133E

⊗ Without CONSULT-II

1. Start engine.
2. Listen to each injector operating sound.
Clicking noise should be heard.

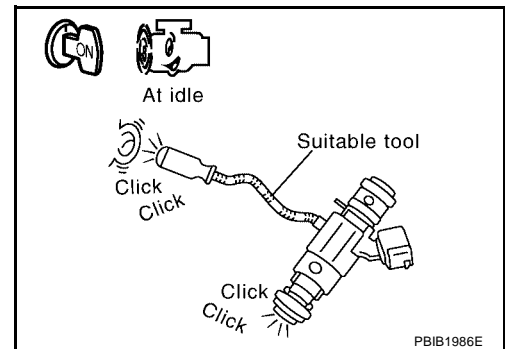

OK or NG

- OK >> GO TO 7.
- NG >> Perform trouble diagnosis for [EC-592, "INJECTOR CIRCUIT"](#) .

7. CHECK INJECTOR

1. Remove injector assembly. Refer to [EM-32, "FUEL INJECTOR AND FUEL TUBE"](#) .
Keep fuel hose and all injectors connected to injector gallery.
2. Confirm that the engine is cooled down and there are no fire hazards near the vehicle.
3. Disconnect all injector harness connectors.
The injector harness connectors should remain connected.
4. Disconnect all ignition coil harness connectors.
5. Prepare pans or saucers under each injectors.
6. Crank engine for about 3 seconds.
Make sure fuel does not drip from injector.

OK or NG

- OK (Does not drip.)>>GO TO 8.
- NG (Drips.)>>Replace the injectors from which fuel is dripping. Always replace O-ring with new one.

8. CHECK INTERMITTENT INCIDENT

Perform [EC-158, "TROUBLE DIAGNOSIS FOR INTERMITTENT INCIDENT"](#) .

>> INSPECTION END

DTC P0181 FTT SENSOR

Component Description

The fuel tank temperature sensor is used to detect the fuel temperature inside the fuel tank. The sensor modifies a voltage signal from the ECM. The modified signal returns to the ECM as the fuel temperature input. The sensor uses a thermistor which is sensitive to the change in temperature. The electrical resistance of the thermistor decreases as temperature increases.

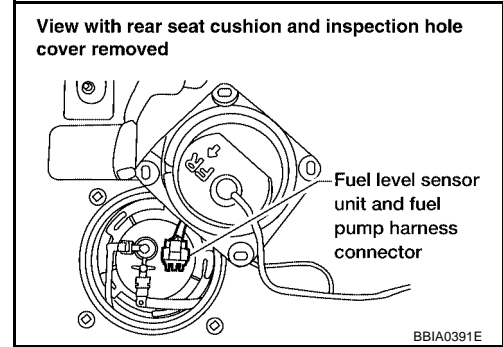

<Reference data>

Fluid temperature °C (°F)	Voltage* V	Resistance kΩ
20 (68)	3.5	2.3 - 2.7
50 (122)	2.2	0.79 - 0.90

*: This data is reference values and is measured between ECM terminal 107 (Fuel tank temperature sensor) and ground.

CAUTION:

Do not use ECM ground terminals when measuring input/output voltage. Doing so may damage the ECM's transistor. Use ground other than ECM, such as ground.

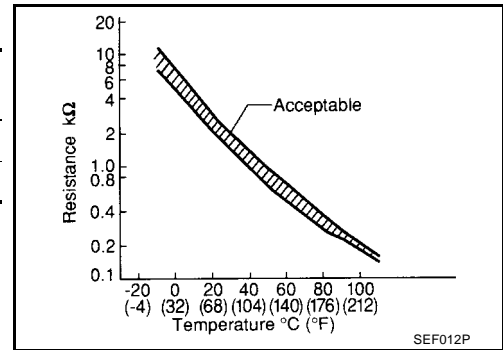

On Board Diagnosis Logic

DTC No.	Trouble diagnosis name	DTC detecting condition	Possible cause
P0181 0181	Fuel tank temperature sensor circuit range/performance	Rationally incorrect voltage from the sensor is sent to ECM, compared with the voltage signals from engine coolant temperature sensor and intake air temperature sensor.	<ul style="list-style-type: none"> ● Harness or connectors (The sensor circuit is open or shorted) ● Fuel tank temperature sensor

DTC Confirmation Procedure

NOTE:

If DTC Confirmation Procedure has been previously conducted, always turn ignition switch OFF and wait at least 10 seconds before conducting the next test.

WITH CONSULT-II

1. Turn ignition switch ON.
2. Select "DATA MONITOR" mode with CONSULT-II.
3. Wait at least 10 seconds.
If the result is NG, go to [EC-249, "Diagnostic Procedure"](#).
If the result is OK, go to following step.
4. Check "COOLAN TEMP/S" value.
If the "COOLANT TEMP/S" is less than 60°C (140°F), the result will be OK.
If the "COOLANT TEMP/S" is above 60°C (140°F), go to the following step.
5. Cool engine down until "COOLAN TEMP/S" signal is less than 60°C (140°F).
6. Wait at least 10 seconds.
7. If 1st trip DTC is detected, go to [EC-249, "Diagnostic Procedure"](#).

DATA MONITOR	
MONITOR	DTC
ENG SPEED	XXX rpm
COOLAN TEMP/S	XXX °C
INT/A TEMP/S	XXX °C

SEF475Y

DTC P0181 FTT SENSOR

[QR]



WITH GST

Follow the procedure "WITH CONSULT-II" above.

A

EC

C

D

E

F

G

H

I

J

K

L

M

DTC P0181 FTT SENSOR

[QR]

Wiring Diagram

UBS00CC0

EC-FTTS-01

— : DETECTABLE LINE FOR DTC
 — : NON-DETECTABLE LINE FOR DTC

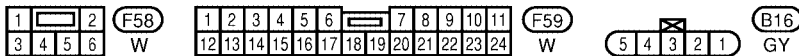
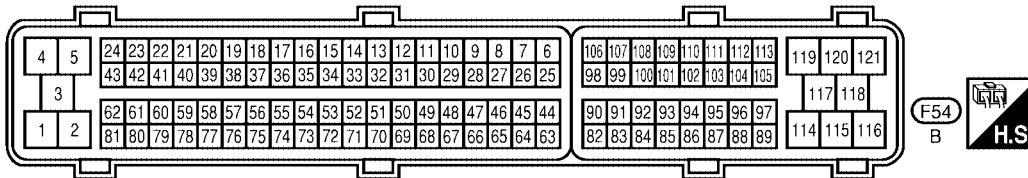
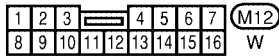
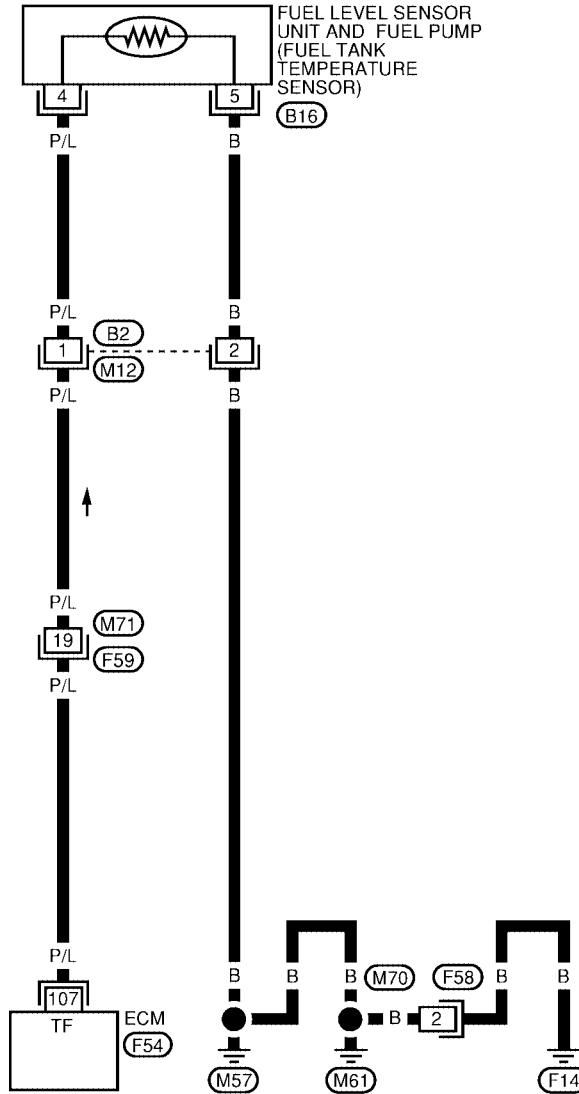

BBWA1222E

Diagnostic Procedure

1. CHECK GROUND CONNECTIONS

1. Turn ignition switch OFF.
2. Loosen and retighten three ground screws on the body. Refer to [EC-164, "Ground Inspection"](#).

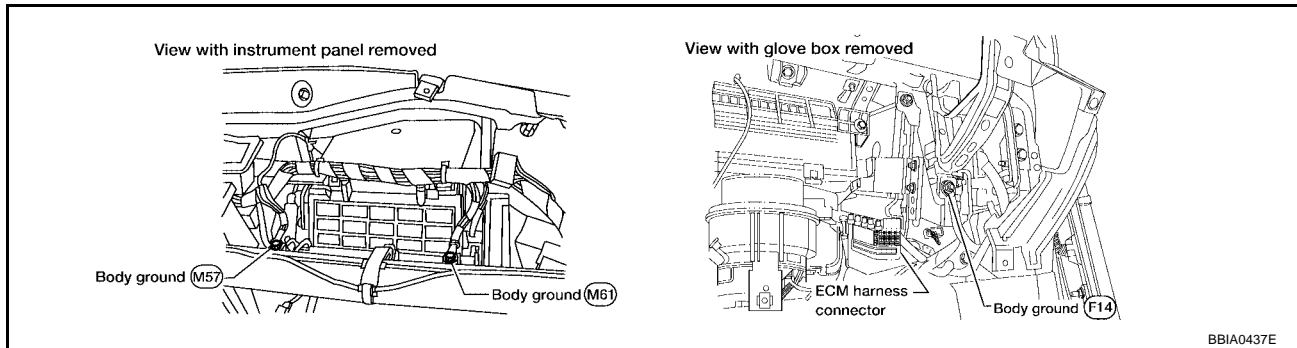

OK or NG

- OK >> GO TO 2.
- NG >> Repair or replace ground connections.

2. CHECK FUEL TANK TEMPERATURE SENSOR POWER SUPPLY CIRCUIT

1. Turn ignition switch OFF.
2. Disconnect "fuel level sensor unit and fuel pump" harness connector.
3. Turn ignition switch ON.

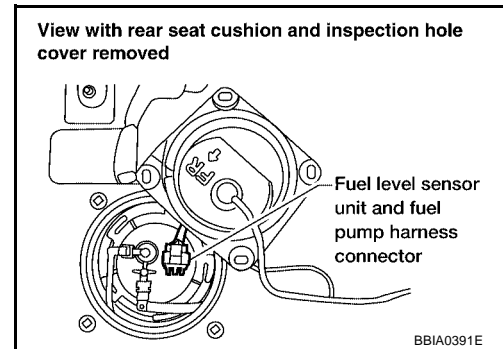

4. Check voltage between "fuel level sensor unit and fuel pump" terminal 4 and ground with CONSULT-II or tester.

Voltage: Approximately 5V

OK or NG

- OK >> GO TO 4.
- NG >> GO TO 3.

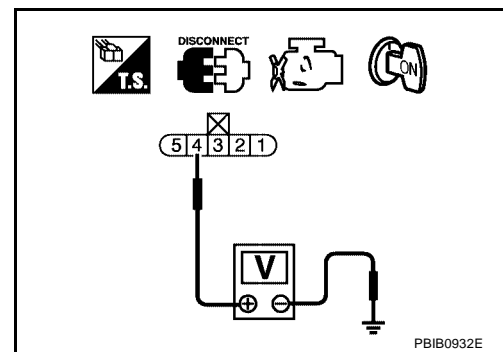

3. DETECT MALFUNCTIONING PART

Check the following.

- Harness connectors F59, M71
- Harness connectors B2, M12
- Harness for open or short between ECM and "fuel level sensor unit and fuel pump"

>> Repair harness or connector.

4. CHECK FUEL TANK TEMPERATURE SENSOR GROUND CIRCUIT FOR OPEN AND SHORT

1. Turn ignition switch OFF.
2. Check harness continuity between “fuel level sensor unit and fuel pump” terminal 5 and ground. Refer to Wiring Diagram.

Continuity should exist.

3. Also check harness for short to power.

OK or NG

- OK >> GO TO 6.
- NG >> GO TO 5.

5. DETECT MALFUNCTIONING PART

Check the following.

- Harness connectors B2,M12
- Harness connectors M70, F58
- Harness for open or short between “fuel level sensor unit and fuel pump” and ground.

>> Repair open circuit or short to power in harness or connectors.

6. CHECK FUEL TANK TEMPERATURE SENSOR

Refer to, [EC-250, "Component Inspection"](#) .

OK or NG

- OK >> GO TO 7.
- NG >> Replace fuel level sensor unit.

7. CHECK INTERMITTENT INCIDENT

Perform [EC-158, "TROUBLE DIAGNOSIS FOR INTERMITTENT INCIDENT"](#) .

>> INSPECTION END

**Component Inspection
FUEL TANK TEMPERATURE SENSOR**

UBS00CCS

Check resistance by heating with hot water or heat gun as shown in the figure.

Temperature °C (°F)	Resistance kΩ
20 (68)	2.3 - 2.7
50 (122)	0.79 - 0.90

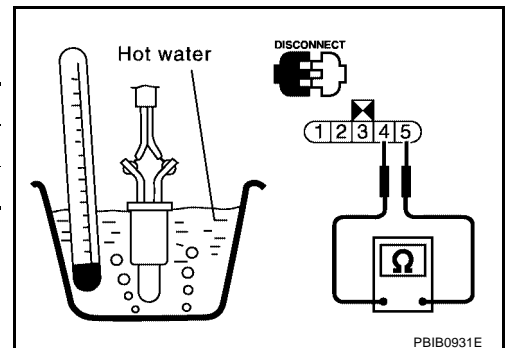

UBS00CCT

**Removal and Installation
FUEL TANK TEMPERATURE SENSOR**

Refer to [FL-5, "FUEL LEVEL SENSOR UNIT, FUEL FILTER AND FUEL PUMP ASSEMBLY"](#) .

DTC P0182, P0183 FTT SENSOR

PFP:22630

UBS00CCU

Component Description

The fuel tank temperature sensor is used to detect the fuel temperature inside the fuel tank. The sensor modifies a voltage signal from the ECM. The modified signal returns to the ECM as the fuel temperature input. The sensor uses a thermistor which is sensitive to the change in temperature. The electrical resistance of the thermistor decreases as temperature increases.

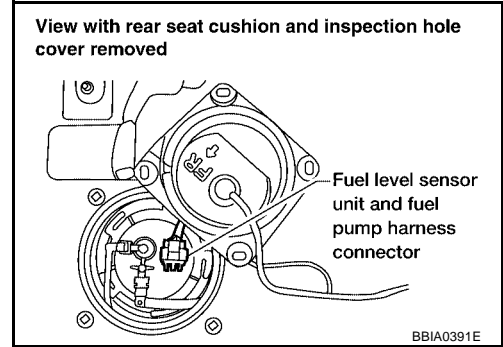

<Reference data>

Fluid temperature °C (°F)	Voltage* V	Resistance kΩ
20 (68)	3.5	2.3 - 2.7
50 (122)	2.2	0.79 - 0.90

*: This data is reference values and is measured between ECM terminal 107 (Fuel tank temperature sensor) and ground.

CAUTION:

Do not use ECM ground terminals when measuring input/output voltage. Doing so may damage the ECM's transistor. Use ground other than ECM, such as ground.

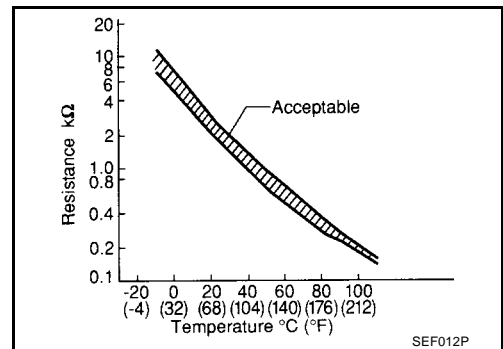

On Board Diagnosis Logic

UBS00CCV

DTC No.	Trouble diagnosis name	DTC detecting condition	Possible cause
P0182 0182	Fuel tank temperature sensor circuit low input	An excessively low voltage from the sensor is sent to ECM.	<ul style="list-style-type: none"> ● Harness or connectors (The sensor circuit is open or shorted.) ● Fuel tank temperature sensor
P0183 0183	Fuel tank temperature sensor circuit high input	An excessively high voltage from the sensor is sent to ECM.	

DTC Confirmation Procedure

UBS00CCW

NOTE:

If DTC Confirmation Procedure has been previously conducted, always turn ignition switch OFF and wait at least 10 seconds before conducting the next test.

WITH CONSULT-II

1. Turn ignition switch ON.
2. Select "DATA MONITOR" mode with CONSULT-II.
3. Wait at least 5 seconds.
4. If 1st trip DTC is detected, go to [EC-253, "Diagnostic Procedure"](#)

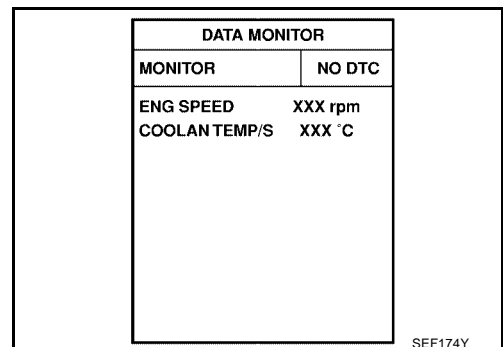

WITH GST

Follow the procedure "WITH CONSULT-II" above.

DTC P0182, P0183 FTT SENSOR

[QR]

Wiring Diagram

UBS00CCX

EC-FTTS-01

— : DETECTABLE LINE FOR DTC
 — : NON-DETECTABLE LINE FOR DTC

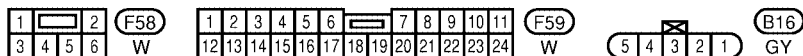
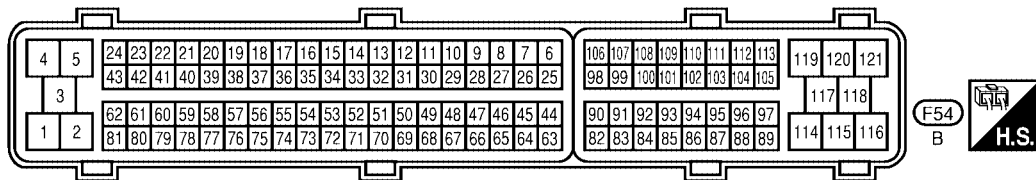
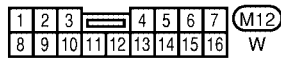
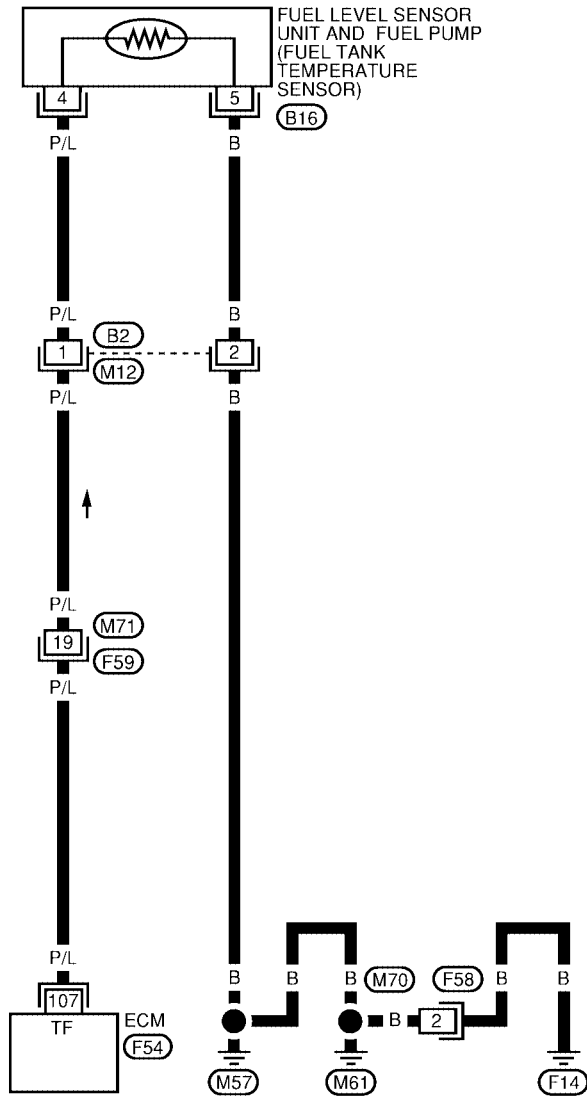

BBWA1222E

Diagnostic Procedure

1. CHECK GROUND CONNECTIONS

1. Turn ignition switch OFF.
2. Loosen and retighten three ground screws on the body. Refer to [EC-164, "Ground Inspection"](#).

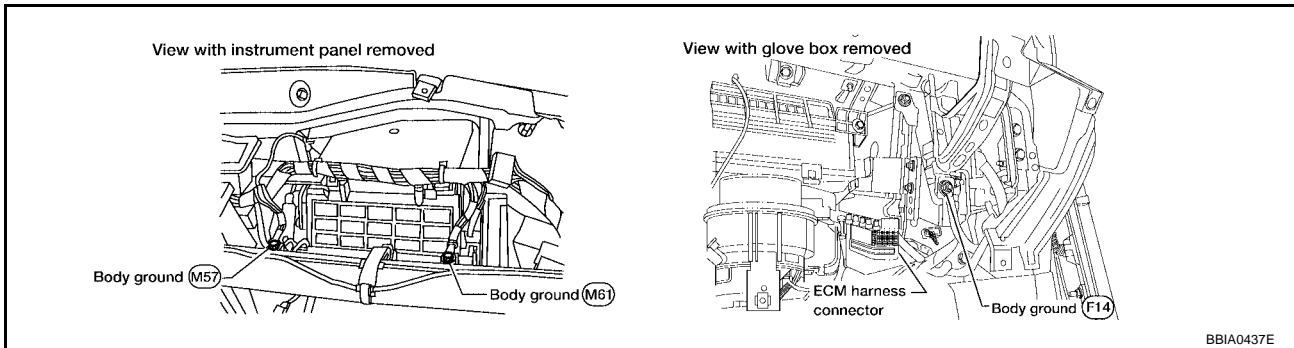

OK or NG

- OK >> GO TO 2.
- NG >> Repair or replace ground connections.

2. CHECK FUEL TANK TEMPERATURE SENSOR POWER SUPPLY CIRCUIT

1. Disconnect "fuel level sensor unit and fuel pump" harness connector.
2. Turn ignition switch ON.

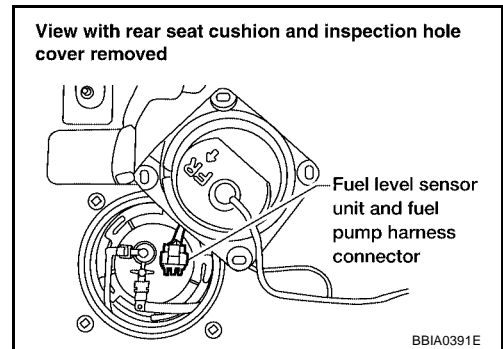

3. Check voltage between "fuel level sensor unit and fuel pump" terminal 4 and ground with CONSULT-II or tester.

Voltage: Approximately 5V

OK or NG

- OK >> GO TO 4.
- NG >> GO TO 3.

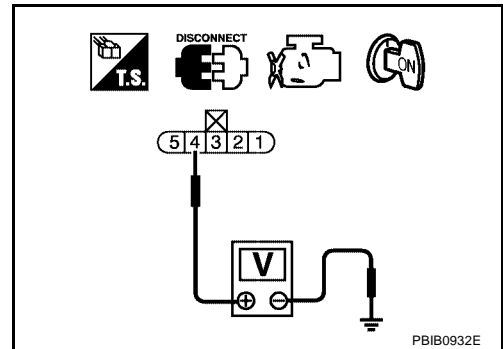

3. DETECT MALFUNCTIONING PART

Check the following.

- Harness connectors M59, M71
- Harness connectors B2, M12
- Harness for open or short between ECM and "fuel level sensor unit and fuel pump"

>> Repair open circuit or short to power in harness or connector.

4. CHECK FUEL TANK TEMPERATURE SENSOR GROUND CIRCUIT FOR OPEN AND SHORT

1. Turn ignition switch OFF.
2. Check harness continuity between “fuel level sensor unit and fuel pump” terminal 5 and ground. Refer to Wiring Diagram.

Continuity should exist.

3. Also check harness for short to power.

OK or NG

- OK >> GO TO 6.
- NG >> GO TO 5.

5. DETECT MALFUNCTIONING PART

Check the following.

- Harness connectors M70, F58
- Harness connectors B2, M12
- Harness for open or short between “fuel level sensor unit and fuel pump” and ground

>> Repair open circuit or short to power in harness or connector.

6. CHECK FUEL TANK TEMPERATURE SENSOR

Refer to, [EC-254, "Component Inspection"](#) .

OK or NG

- OK >> GO TO 7.
- NG >> Replace “fuel level sensor unit and fuel pump”.

7. CHECK INTERMITTENT INCIDENT

Perform [EC-158, "TROUBLE DIAGNOSIS FOR INTERMITTENT INCIDENT"](#) .

>> **INSPECTION END**

**Component Inspection
FUEL TANK TEMPERATURE SENSOR**

UBS00CCZ

Check resistance by heating with hot water or heat gun as shown in the figure.

Temperature °C (°F)	Resistance kΩ
20 (68)	2.3 - 2.7
50 (122)	0.79 - 0.90

If NG, replace “fuel level sensor unit and fuel pump”.

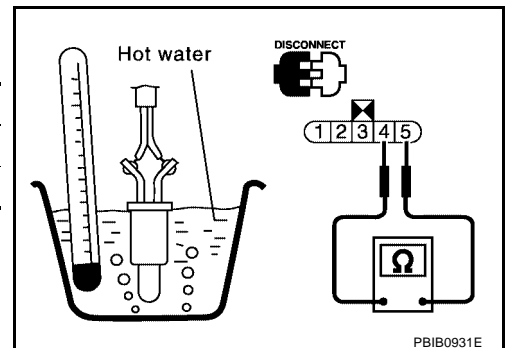

UBS00CD0

**Removal and Installation
FUEL TANK TEMPERATURE SENSOR**

Refer to [FL-5, "FUEL LEVEL SENSOR UNIT, FUEL FILTER AND FUEL PUMP ASSEMBLY"](#) .

DTC P0222, P0223 TP SENSOR

PF16119

Component Description

UBS002TF

Electric throttle control actuator consists of throttle control motor, throttle position sensor, etc. The throttle position sensor responds to the throttle valve movement.

The throttle position sensor has the two sensors. These sensors are a kind of potentiometers which transform the throttle valve position into output voltage, and emit the voltage signal to the ECM. In addition, these sensors detect the opening and closing speed of the throttle valve and feed the voltage signals to the ECM. The ECM judges the current opening angle of the throttle valve from these signals and the ECM controls the throttle control motor to make the throttle valve opening angle properly in response to driving condition.

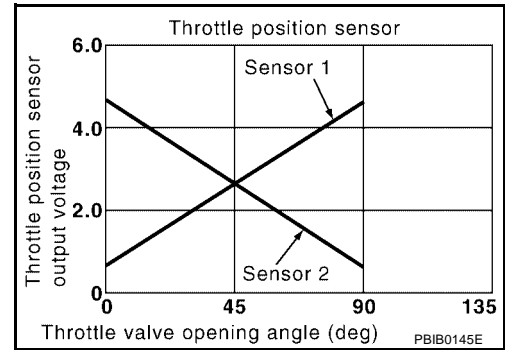

CONSULT-II Reference Value in Data Monitor Mode

UBS002TG

Specification data are reference values.

MONITOR ITEM	CONDITION		SPECIFICATION
THRTL SEN1 THRTL SEN2*	● Ignition switch: ON (Engine stopped)	Accelerator pedal: Fully released	More than 0.36V
	● Shift lever: D (A/T), 1ST (M/T)	Accelerator pedal: Fully depressed	Less than 4.75V

*: Throttle position sensor 2 signal is converted by ECM internally. Thus, it differs from ECM terminal voltage signal.

On Board Diagnosis Logic

UBS002TH

These self-diagnoses have the one trip detection logic.

DTC No.	Trouble diagnosis name	DTC detecting condition	Possible cause
P0222 0222	Throttle position sensor 1 circuit low input	An excessively low voltage from the TP sensor 1 is sent to ECM.	<ul style="list-style-type: none"> ● Harness or connectors (The TP sensor 1 circuit is open or shorted.) (APP sensor 2 circuit is shorted.) ● Electric throttle control actuator (TP sensor 1) ● Accelerator pedal position sensor (APP sensor 2)
P0223 0223	Throttle position sensor 1 circuit high input	An excessively high voltage from the TP sensor 1 is sent to ECM.	

FAIL-SAFE MODE

When the malfunction is detected, the ECM enters fail-safe mode and the MIL lights up.

Engine operation condition in fail-safe mode

The ECM controls the electric throttle control actuator in regulating the throttle opening in order for the idle position to be within +10 degrees.

The ECM regulates the opening speed of the throttle valve to be slower than the normal condition.

So, the acceleration will be poor.

DTC Confirmation Procedure

UBS002TI

NOTE:

If DTC Confirmation Procedure has been previously conducted, always turn ignition switch OFF and wait at least 10 seconds before conducting the next test.

TESTING CONDITION:

Before performing the following procedure, confirm that battery voltage is more than 10V at idle.

WITH CONSULT-II

1. Turn ignition switch ON.

DTC P0222, P0223 TP SENSOR

[QR]

2. Select "DATA MONITOR" mode with CONSULT-II.
3. Start engine and let it idle for 1 second.
4. If DTC is detected, go to [EC-258, "Diagnostic Procedure"](#) .

DATA MONITOR	
MONITOR	NO DTC
ENG SPEED	XXX rpm

SEF058Y



WITH GST

Follow the procedure "WITH CONSULT-II" above.

DTC P0222, P0223 TP SENSOR

[QR]

Wiring Diagram

UBS002TJ

EC-TPS1-01

A
EC
C
D
E
F
G
H
I
J
K
L
M

— : DETECTABLE LINE FOR DTC
- - - : NON-DETECTABLE LINE FOR DTC

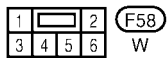
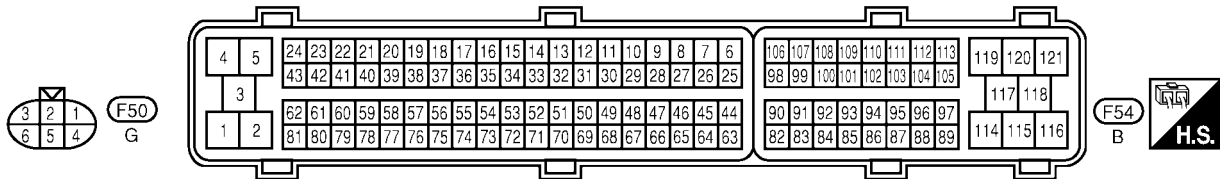
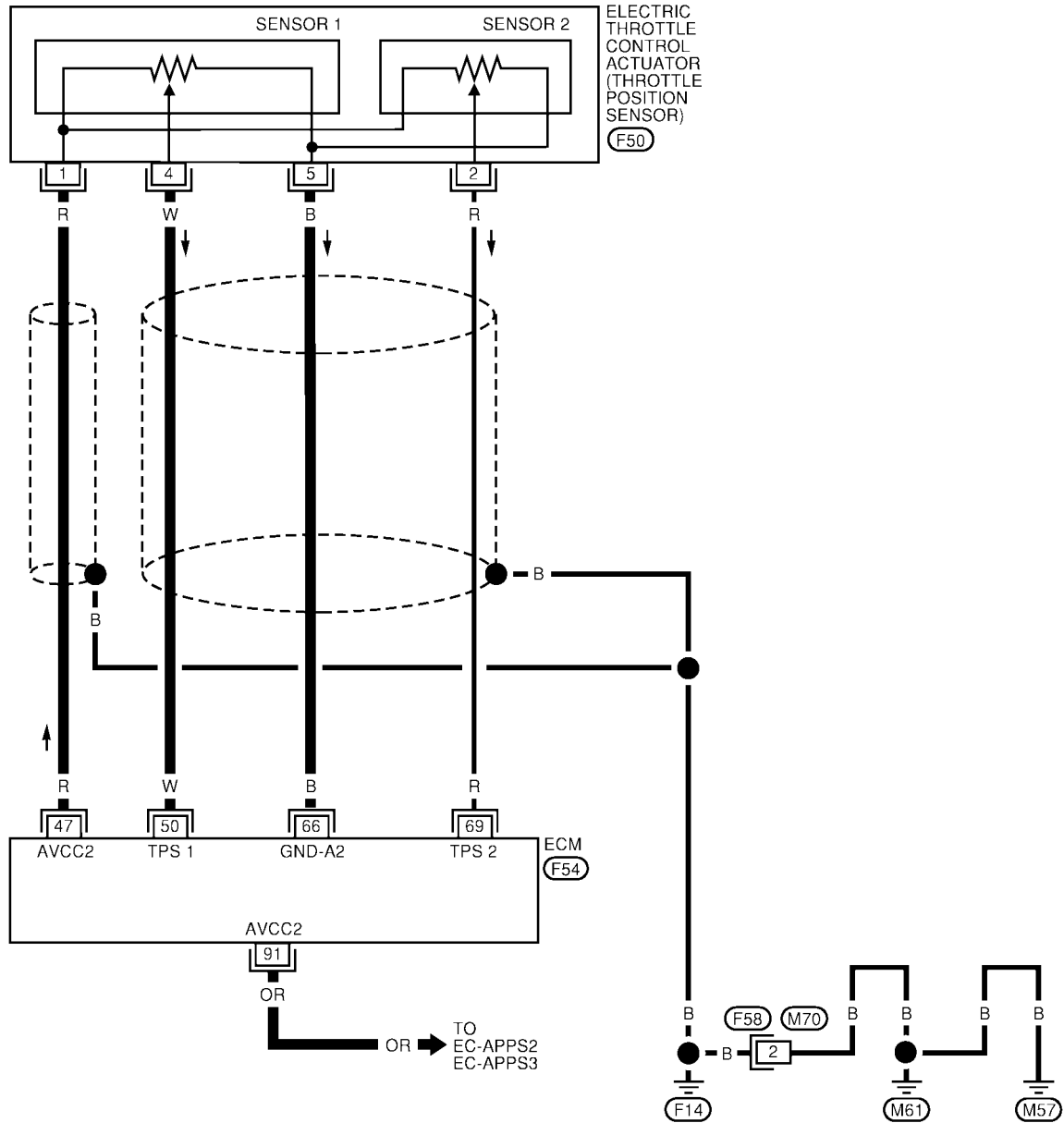

BBWA1223E

DTC P0222, P0223 TP SENSOR

[QR]

Specification data are reference values and are measured between each terminal and ground.

CAUTION:

Do not use ECM ground terminals when measuring input/output voltage. Doing so may result in damage to the ECM's transistor. Use a ground other than ECM terminals, such as the ground.

TERMI- NAL NO.	WIRE COLOR	ITEM	CONDITION	DATA (DC Voltage)
47	R	Sensor power supply (Throttle position sensor)	[Ignition switch: ON]	Approximately 5V
50	W	Throttle position sensor 1	[Ignition switch: ON] ● Engine stopped ● Shift lever: D (A/T), 1ST (M/T) ● Accelerator pedal: Fully released	More than 0.36V
			[Ignition switch: ON] ● Engine stopped ● Shift lever: D (A/T), 1ST (M/T) ● Accelerator pedal: Fully depressed	Less than 4.75V
66	B	Sensor ground (Throttle position sensor)	[Engine is running] ● Warm-up condition ● Idle speed	Approximately 0V
69	R	Throttle position sensor 2	[Ignition switch: ON] ● Engine stopped ● Shift lever: D (A/T), 1ST (M/T) ● Accelerator pedal: Fully released	Less than 4.75V
			[Ignition switch: ON] ● Engine stopped ● Shift lever: D (A/T), 1ST (M/T) ● Accelerator pedal: Fully depressed	More than 0.36V
91	OR	Sensor power supply (Accelerator pedal position sensor 2)	[Ignition switch: ON]	Approximately 5V

Diagnostic Procedure

UBS00CVD

1. CHECK GROUND CONNECTIONS

1. Turn ignition switch OFF.
2. Loosen and retighten three ground screws on the body. Refer to [EC-164, "Ground Inspection"](#) .

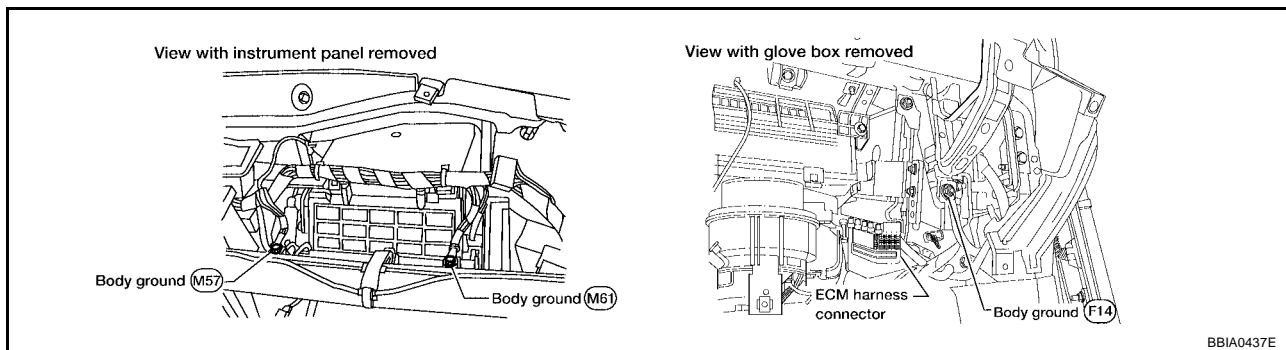

OK or NG

- OK >> GO TO 2.
- NG >> Repair or replace ground connections.

2. CHECK THROTTLE POSITION SENSOR 1 POWER SUPPLY CIRCUIT-I

1. Disconnect electric throttle control actuator harness connector.
2. Turn ignition switch ON.

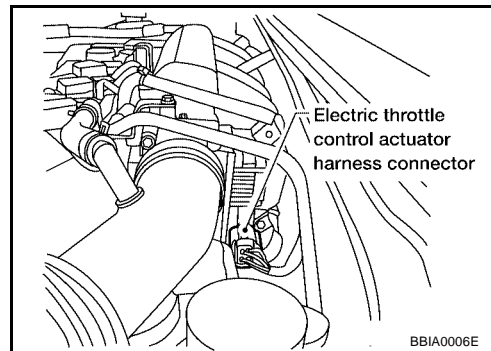

3. Check voltage between electric throttle control actuator terminal 1 and ground with CONSULT-II or tester.

Voltage: Approximately 5V

OK or NG

- OK >> GO TO 7.
 NG >> GO TO 3.

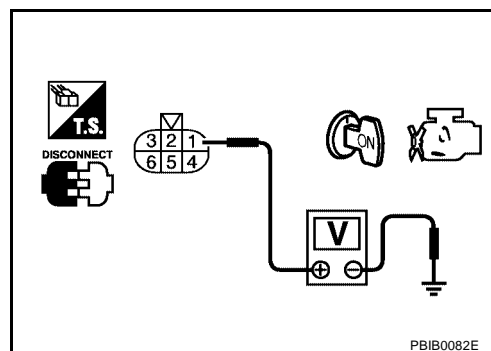

3. CHECK THROTTLE POSITION SENSOR 1 POWER SUPPLY CIRCUIT-II

1. Turn ignition switch OFF.
2. Disconnect ECM harness connector.
3. Check harness continuity between electric throttle control actuator terminal 1 and ECM terminal 47. Refer to Wiring Diagram.

Continuity should exist.

OK or NG

- OK >> GO TO 4.
 NG >> Repair or replace open circuit.

4. CHECK THROTTLE POSITION SENSOR 1 POWER SUPPLY CIRCUIT-III

Check the following.

- Harness for short to power and short to ground, between the following terminals.

ECM terminal	Sensor terminal	Reference Wiring Diagram
47	Electric throttle control actuator terminal 1	EC-389
91	APP sensor terminal 1	EC-544

OK or NG

- OK >> GO TO 5.
 NG >> Repair short to ground or short to power in harness or connectors.

5. CHECK APP SENSOR

Refer to [EC-547, "Component Inspection"](#) .

OK or NG

- OK >> GO TO 11.
 NG >> GO TO 6.

6. REPLACE ACCELERATOR PEDAL ASSEMBLY

1. Replace accelerator pedal assembly.
2. Perform [EC-93, "Accelerator Pedal Released Position Learning"](#) .
3. Perform [EC-93, "Throttle Valve Closed Position Learning"](#) .
4. Perform [EC-93, "Idle Air Volume Learning"](#) .

>> **INSPECTION END**

7. CHECK THROTTLE POSITION SENSOR 1 GROUND CIRCUIT FOR OPEN AND SHORT

1. Turn ignition switch OFF.
2. Disconnect ECM harness connector.
3. Check harness continuity between ECM terminal 66 and electric throttle control actuator terminal 5.
Refer to Wiring Diagram.

Continuity should exist.

4. Also check harness for short to ground or short to power.

OK or NG

OK >> GO TO 8.

NG >> Repair open circuit or short to ground or short to power in harness or connectors.

8. CHECK THROTTLE POSITION SENSOR 1 INPUT SIGNAL CIRCUIT FOR OPEN AND SHORT

1. Check harness continuity between ECM terminal 50 and electric throttle control actuator terminal 4.
Refer to Wiring Diagram.

Continuity should exist.

2. Also check harness for short to ground and short to power.

OK or NG

OK >> GO TO 9.

NG >> Repair open circuit or short to ground or short to power in harness or connectors.

9. CHECK THROTTLE POSITION SENSOR

Refer to [EC-261, "Component Inspection"](#) .

OK or NG

OK >> GO TO 11.

NG >> GO TO 10.

10. REPLACE ELECTRIC THROTTLE CONTROL ACTUATOR

1. Replace the electric throttle control actuator.
2. Perform [EC-93, "Throttle Valve Closed Position Learning"](#) .
3. Perform [EC-93, "Idle Air Volume Learning"](#) .

>> **INSPECTION END**

11. CHECK INTERMITTENT INCIDENT

Refer to [EC-158, "TROUBLE DIAGNOSIS FOR INTERMITTENT INCIDENT"](#) .

>> **INSPECTION END**

Component Inspection THROTTLE POSITION SENSOR

1. Reconnect all harness connectors disconnected.
2. Perform [EC-93, "Throttle Valve Closed Position Learning"](#) .
3. Turn ignition switch ON.
4. Set shift lever to D position (A/T) or 1st position (M/T).
5. Check voltage between ECM terminals 50 (TP sensor 1 signal), 69 (TP sensor 2 signal) and ground under the following conditions.

Terminal	Accelerator pedal	Voltage
50 (Throttle position sensor 1)	Fully released	More than 0.36V
	Fully depressed	Less than 4.75V
69 (Throttle position sensor 2)	Fully released	Less than 4.75V
	Fully depressed	More than 0.36V

6. If NG, replace electric throttle control actuator and go to the next step.
7. Perform [EC-93, "Throttle Valve Closed Position Learning"](#) .
8. Perform [EC-93, "Idle Air Volume Learning"](#) .

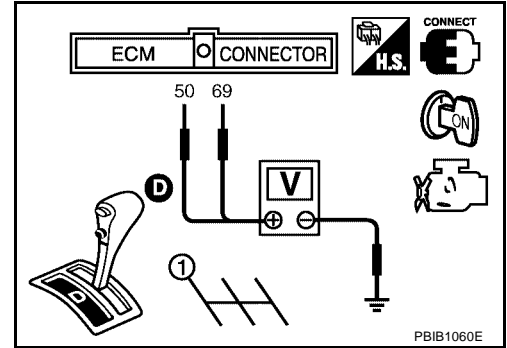

Remove and Installation ELECTRIC THROTTLE CONTROL ACTUATOR

Refer to [EM-19, "INTAKE MANIFOLD"](#) .

DTC P0300 - P0304 MULTIPLE CYLINDER MISFIRE, NO. 1 - 4 CYLINDER MISFIRE

[QR]

DTC P0300 - P0304 MULTIPLE CYLINDER MISFIRE, NO. 1 - 4 CYLINDER MISFIRE

PF0:0000

On Board Diagnosis Logic

UBS002U3

When a misfire occurs, engine speed will fluctuate. If the engine speed fluctuates enough to cause the crankshaft position (CKP) sensor (POS) signal to vary, ECM can determine that a misfire is occurring.

Sensor	Input Signal to ECM	ECM function
Crankshaft position sensor (POS)	Engine speed	On board diagnosis of misfire

The misfire detection logic consists of the following two conditions.

- One Trip Detection Logic (Three Way Catalyst Damage)**
 On the first trip that a misfire condition occurs that can damage the three way catalyst (TWC) due to overheating, the MIL will blink.
 When a misfire condition occurs, the ECM monitors the CKP sensor (POS) signal every 200 engine revolutions for a change.
 When the misfire condition decreases to a level that will not damage the TWC, the MIL will turn off.
 If another misfire condition occurs that can damage the TWC on a second trip, the MIL will blink.
 When the misfire condition decreases to a level that will not damage the TWC, the MIL will remain on.
 If another misfire condition occurs that can damage the TWC, the MIL will begin to blink again.
- Two Trip Detection Logic (Exhaust quality deterioration)**
 For misfire conditions that will not damage the TWC (but will affect vehicle emissions), the MIL will only light when the misfire is detected on a second trip. During this condition, the ECM monitors the CKP sensor signal every 1,000 engine revolutions.
 A misfire malfunction can be detected on any one cylinder or on multiple cylinders.

DTC No.	Trouble diagnosis name	DTC detecting condition	Possible cause
P0300 0300	Multiple cylinder misfire detected	Multiple cylinder misfire.	<ul style="list-style-type: none"> ● Improper spark plug ● Insufficient compression
P0301 0301	No. 1 cylinder misfire detected	No. 1 cylinder misfires.	<ul style="list-style-type: none"> ● Incorrect fuel pressure ● The injector circuit is open or shorted
P0302 0302	No. 2 cylinder misfire detected	No. 2 cylinder misfires.	<ul style="list-style-type: none"> ● Fuel injector ● Intake air leak
P0303 0303	No. 3 cylinder misfire detected	No. 3 cylinder misfires.	<ul style="list-style-type: none"> ● The ignition signal circuit is open or shorted
P0304 0304	No. 4 cylinder misfire detected	No. 4 cylinder misfires.	<ul style="list-style-type: none"> ● Lack of fuel ● Drive plate or flywheel ● Air fuel ratio (A/F) sensor 1 ● Incorrect PCV hose connection

DTC Confirmation Procedure

UBS00CVF

CAUTION:

Always drive vehicle in safe manner according to traffic conditions and obey all traffic laws when driving.

NOTE:

If DTC Confirmation Procedure has been previously conducted, always turn ignition switch OFF and wait at least 10 seconds before conducting the next test.

WITH CONSULT-II

1. Turn ignition switch ON, and select "DATA MONITOR" mode with CONSULT-II.
2. Start engine and warm it up to normal operating temperature.
3. Turn ignition switch OFF and wait at least 10 seconds.
4. Restart engine and let it idle for about 15 minutes.
5. If 1st trip DTC is detected, go to [EC-263, "Diagnostic Procedure"](#).

DATA MONITOR	
MONITOR	NO DTC
ENG SPEED	XXX rpm
COOLAN TEMP/S	XXX °C
VHCL SPEED SE	XXX km/h
B/FUEL SCHDL	XXX msec
PBIB0164E	

NOTE:

If 1st trip DTC is not detected during above procedure, performing the following procedure is advised.

- a. Turn ignition switch OFF and wait at least 10 seconds.
- b. Start engine and drive the vehicle under the similar conditions to (1st trip) Freeze Frame Data for a certain time. Refer to the table below.
Hold the accelerator pedal as steady as possible.

The similar conditions to (1st trip) Freeze Frame Data means the vehicle operation that the following conditions should be satisfied at the same time.

Engine speed	Engine speed in the freeze frame data ± 400 rpm
Vehicle speed	Vehicle speed in the feaze frame data ± 10 km/h (6 MPH)
Engine coolant temperature (T) condition	When the freeze frame data shows lower than 70 °C (158 °F), T should be lower than 70 °C (158 °F).
	When the freeze frame data shows higher than or equal to 70 °C (158 °F), T should be higher than or equal to 70 °C (158 °F).

The time to driving varies according to the engine speed in the freeze frame data.

Engine speed	Time
Around 1,000 rpm	Approximately 10 minutes
Around 2,000 rpm	Approximately 5 minutes
More than 3,000 rpm	Approximately 3.5 minutes

WITH GST

Follow the procedure "WITH CONSULT-II" above.

Diagnostic Procedure

UBS00CVG

1. CHECK FOR INTAKE AIR LEAK AND PCV HOSE

1. Start engine and run it at idle speed.
2. Listen for the sound of the intake air leak.
3. Check PCV hose connection.

OK or NG

- OK >> GO TO 2.
 NG >> Discover air leak location and repair.

2. CHECK FOR EXHAUST SYSTEM CLOGGING

Stop engine and visually check exhaust tube, three way catalyst (manifold) and muffler for dents.

OK or NG

- OK (With CONSULT-II)>>GO TO 3.
 OK (Without CONSULT-II)>>GO TO 4.
 NG >> Repair or replace it.

3. PERFORM POWER BALANCE TEST

 With CONSULT-II

1. Perform "POWER BALANCE" in "ACTIVE TEST" mode.
2. Is there any cylinder which does not produce a momentary engine speed drop?

ACTIVE TEST	
POWER BALANCE	
MONITOR	
ENG SPEED	XXX rpm
MAS A/F SE-B1	XXX V

PBIB0133E

Yes or No

- Yes >> GO TO 4.
 No >> GO TO 9.

4. CHECK INJECTOR

Does each injector make an operating sound at idle?

Yes or No

- Yes >> GO TO 5.
 No >> Check injector(s) and circuit(s). Refer to [EC-592](#) .

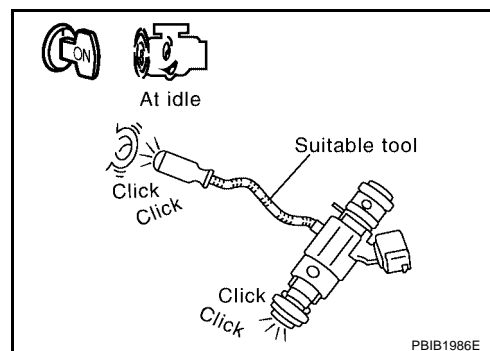

5. CHECK FUNCTION OF IGNITION COIL-I

CAUTION:

Do the following procedure in the place where ventilation is good without the combustibles.

1. Turn ignition switch OFF.
2. Remove fuel pump fuse in IPDM E/R to release fuel pressure.
NOTE:
 Do not use CONSULT-II to release fuel pressure, or fuel pressure applies again during the following procedure.
3. Start engine.
4. After engine stalls, crank it two or three times to release all fuel pressure.
5. Turn ignition switch OFF.
6. Remove all ignition coil harness connectors to avoid the electrical discharge from the ignition coils.
7. Remove ignition coil and spark plug of the cylinder to be checked.
8. Crank engine for five seconds or more to remove combustion gas in the cylinder.
9. Connect spark plug and harness connector to ignition coil.
10. Fix ignition coil using a rope etc. with gap of 13 - 17 mm between the edge of the spark plug and grounded metal portion as shown in the figure.
11. Crank engine for about three seconds, and check whether spark is generated between the spark plug and the grounded metal portion.

Spark should be generated.

CAUTION:

- Do not approach to the spark plug and the ignition coil within 50cm. Be careful not to get an electrical shock while checking, because the electrical discharge voltage becomes 20kV or more.

- It might cause to damage the ignition coil if the gap of 17 mm or more is taken.

NOTE:

When the gap is 13 mm or less, the spark might be generated even if the coil is malfunctioning.

OK or NG

- OK >> GO TO 9.
- NG >> GO TO 6.

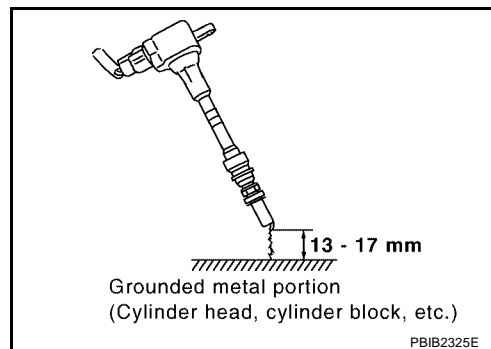
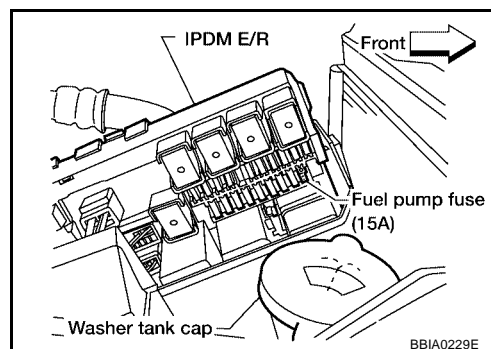

6. CHECK FUNCTION OF IGNITION COIL-II

1. Turn ignition switch OFF.
2. Disconnect spark plug and connect a known-good spark plug.
3. Crank engine for about three seconds, and recheck whether spark is generated between the spark plug and the grounded metal portion.

Spark should be generated.

OK or NG

- OK >> GO TO 7.
- NG >> Check ignition coil, power transistor and their circuits. Refer to [EC-572](#).

7. CHECK SPARK PLUG

Check the initial spark plug for fouling, etc.

OK or NG

- OK >> Replace spark plug(s) with standard type one(s). For spark plug type, refer to [MA-19](#).
- NG >> 1. Repair or clean spark plug.
2. GO TO 8.

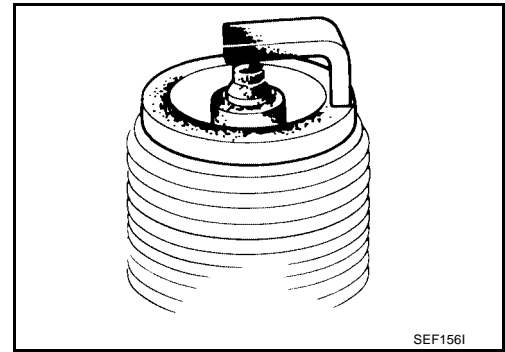

8. CHECK FUNCTION OF IGNITION COIL-III

1. Reconnect the initial spark plugs.
2. Crank engine for about three seconds, and recheck whether spark is generated between the spark plug and the grounded portion.

Spark should be generated.

OK or NG

- OK >> **INSPECTION END**
- NG >> Replace spark plug(s) with standard type one(s). For spark plug type, refer to [MA-19](#).

9. CHECK COMPRESSION PRESSURE

Check compression pressure.

Refer to [EM-59, "CHECKING COMPRESSION PRESSURE"](#).

Standard:	1,190 kPa (12,1 kg/cm² , 172 psi)/300 rpm
Minimum:	990 kPa (10,1 kg/cm² , 144 psi)/300 rpm
Difference between each cylinder:	98 kPa (1.0 kg/cm² , 14 psi)/300 rpm

OK or NG

- OK >> GO TO 10.
- NG >> Check pistons, piston rings, valves, valve seats and cylinder head gaskets.

10. CHECK FUEL PRESSURE

1. Install all removed parts.
2. Release fuel pressure to zero. Refer to [EC-95, "FUEL PRESSURE RELEASE"](#).
3. Install fuel pressure gauge and check fuel pressure.

At idle: Approximately 350 kPa (3.57 kg/cm² , 51 psi)

OK or NG

- OK >> GO TO 12.
- NG >> GO TO 11.

11. DETECT MALFUNCTIONING PART

Check the following.

- Fuel pump and circuit (Refer to [EC-598, "FUEL PUMP CIRCUIT"](#) .)
- Fuel pressure regulator (Refer to [FL-5, "FUEL LEVEL SENSOR UNIT, FUEL FILTER AND FUEL PUMP ASSEMBLY"](#) .)
- Fuel lines (Refer to [FL-3, "Checking Fuel Lines"](#) .)
- Fuel filter for clogging

>> Repair or replace.

12. CHECK IGNITION TIMING

Perform [EC-75, "Basic Inspection"](#) .

Items	Specifications	
Target idle speed	A/T	700 ± 50 rpm (in P or N position)
	M/T	700 ± 50 rpm (in Neutral position)
Ignition timing	A/T	15 ± 5° BTDC (in P or N position)
	M/T	15 ± 5° BTDC (in Neutral position)

OK or NG

OK >> GO TO 13.

NG >> Follow the [EC-75, "Basic Inspection"](#) .

13. CHECK A/F SENSOR 1 INPUT SIGNAL CIRCUIT

1. Turn ignition switch OFF.
2. Disconnect ECM harness connector and A/F sensor 1 harness connector.
3. Check harness continuity between the following terminals. Refer to Wiring Diagram.

A/F sensor 1 terminal	ECM terminal
1	16
5	35
6	56
2	75

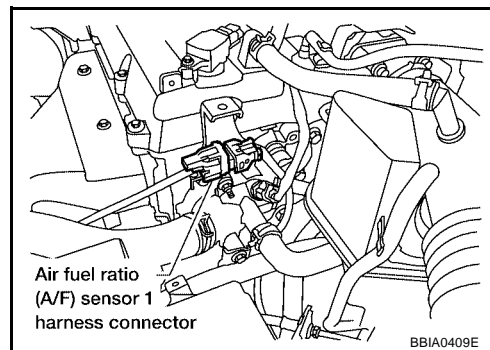

Continuity should exist.

4. Check harness continuity between ECM terminals 16, 35, 56, 75 or A/F sensor 1 terminals 1, 2, 5, 6 and ground. Refer to Wiring Diagram.

Continuity should not exist.

5. Also check harness for short to power.

OK or NG

OK >> GO TO 14.

NG >> Repair open circuit or short to ground or short to power in harness or connectors.

14. CHECK A/F SENSOR 1 HEATER

Refer to [EC-377, "Component Inspection"](#) .

OK or NG

OK >> GO TO 15.

NG >> Replace A/F sensor 1.

15. CHECK MASS AIR FLOW SENSOR

 **With CONSULT-II**

Check "MASS AIR FLOW" in "DATA MONITOR" mode with CONSULT-II.

1.0 - 4.0 g-m/sec: at idling
4.0 - 10.0 g-m/sec: at 2,500 rpm

 **With GST**

Check mass air flow sensor signal in SERVICE \$01 with GST.

1.0 - 4.0 g-m/sec: at idling
4.0 - 10.0 g-m/sec: at 2,500 rpm

OK or NG

OK >> GO TO 17.
NG >> GO TO 16.

16. CHECK CONNECTORS

Check connectors for rusted terminals or loose connections in the mass air flow sensor circuit or grounds. Refer to [EC-178, "DTC P0101 MAF SENSOR"](#) and [EC-187, "DTC P0102, P0103 MAF SENSOR"](#).

OK or NG

OK >> GO TO 19.
NG >> Repair or replace it.

17. CHECK SYMPTOM MATRIX CHART

Check items on the rough idle symptom in [EC-108, "Symptom Matrix Chart"](#).

OK or NG

OK >> GO TO 18.
NG >> Repair or replace.

18. ERASE THE 1ST TRIP DTC

Some tests may cause a 1st trip DTC to be set.

Erase the 1st trip DTC from the ECM memory after performing the tests. Refer to [EC-65, "HOW TO ERASE EMISSION-RELATED DIAGNOSTIC INFORMATION"](#).

>> GO TO 19.

19. CHECK INTERMITTENT INCIDENT

Perform [EC-158, "TROUBLE DIAGNOSIS FOR INTERMITTENT INCIDENT"](#).

>> INSPECTION END

DTC P0327, P0328 KS

PF2:22060

Component Description

UBS002U6

The knock sensor is attached to the cylinder block. It senses engine knocking using a piezoelectric element. A knocking vibration from the cylinder block is sensed as vibrational pressure. This pressure is converted into a voltage signal and sent to the ECM.

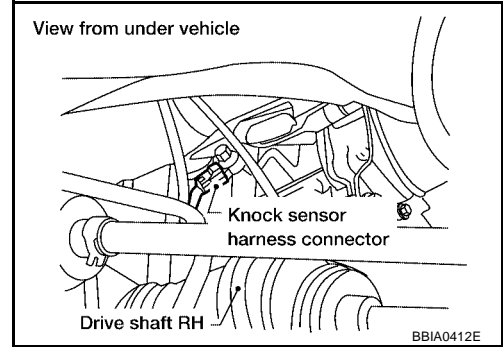

On Board Diagnosis Logic

UBS002U7

The MIL will not light up for these diagnoses.

DTC No.	Trouble Diagnosis Name	DTC Detected Condition	Possible Cause
P0327 0327	Knock sensor circuit low input	An excessively low voltage from the sensor is sent to ECM.	<ul style="list-style-type: none"> ● Harness or connectors (The sensor circuit is open or shorted.) ● Knock sensor
P0328 0328	Knock sensor circuit high input	An excessively high voltage from the sensor is sent to ECM.	

DTC Confirmation Procedure

UBS002U8

NOTE:

If DTC Confirmation Procedure has been previously conducted, always turn ignition switch OFF and wait at least 10 seconds before conducting the next test.

TESTING CONDITION:

Before performing the following procedure, confirm that battery voltage is more than 10V at idle.

WITH CONSULT-II

1. Turn ignition switch ON and select "DATA MONITOR" mode with CONSULT-II.
2. Start engine and run it for at least 5 seconds at idle speed.
3. If 1st trip DTC is detected, go to [EC-271, "Diagnostic Procedure"](#)

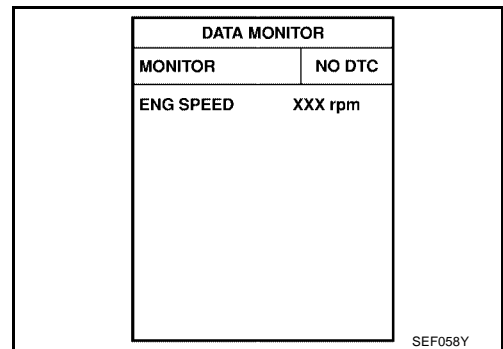

WITH GST

Follow the procedure "WITH CONSULT-II" above.

Wiring Diagram

UBS002U9

EC-KS-01

— : DETECTABLE LINE FOR DTC
 - - - : NON-DETECTABLE LINE FOR DTC

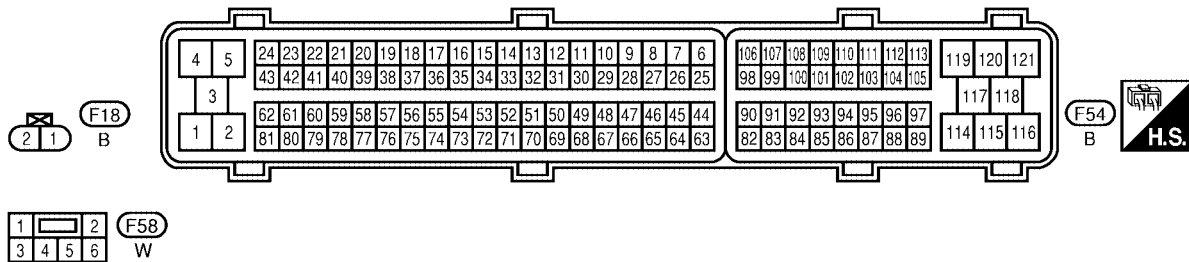
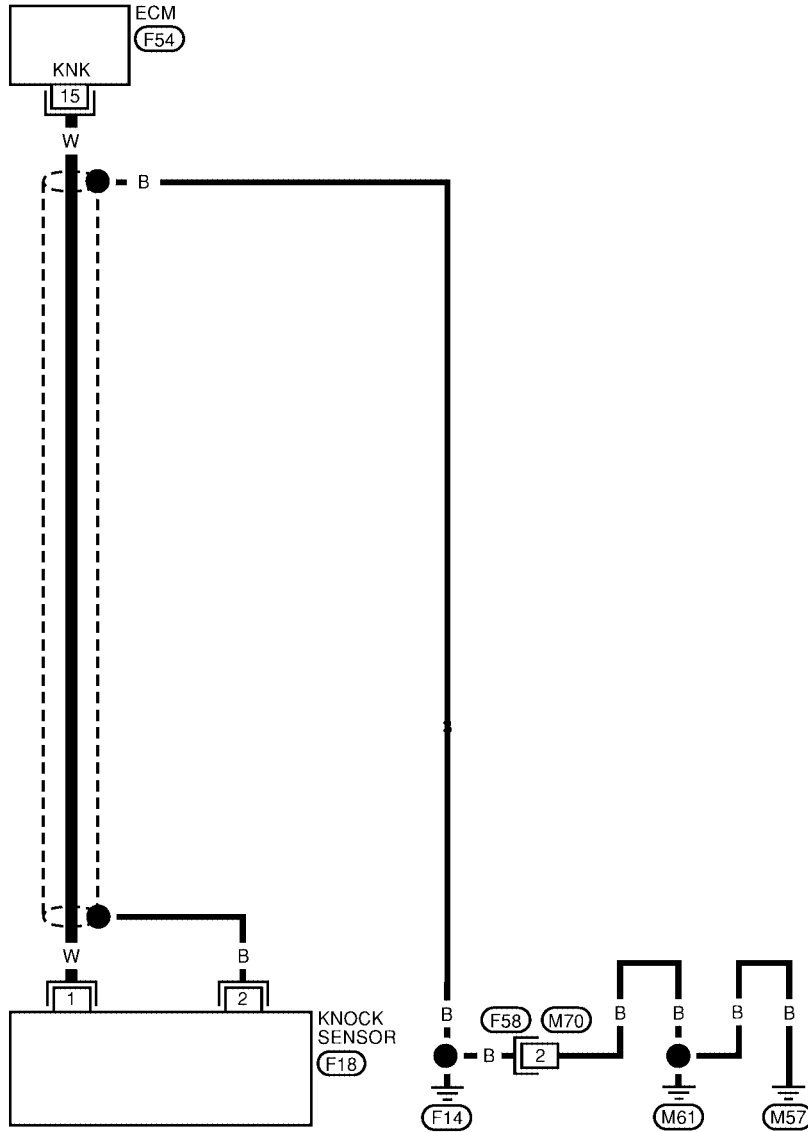

BBWA1224E

Specification data are reference values and are measured between each terminal and ground.

CAUTION:

Do not use ECM ground terminals when measuring input/output voltage. Doing so may result in damage to the ECM's transistor. Use a ground other than ECM terminals, such as the ground.

TERMI- NAL NO.	WIRE COLOR	ITEM	CONDITION	DATA (DC Voltage)
15	W	Knock sensor	[Engine is running] ● Idle speed	Approximately 2.5V

Diagnostic Procedure

UBS002UA

1. CHECK GROUND CONNECTIONS

1. Turn ignition switch OFF.
2. Loosen and retighten three ground screws on the body. Refer to [EC-164, "Ground Inspection"](#) .

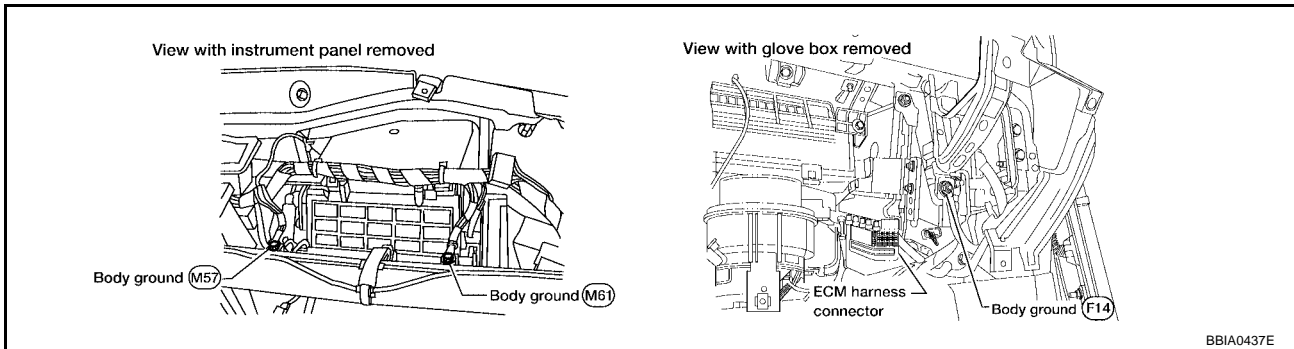

OK or NG

- OK >> GO TO 2.
- NG >> Repair or replace ground connections.

2. CHECK KNOCK SENSOR INPUT SIGNAL CIRCUIT-I

1. Disconnect ECM harness connector.
2. Check resistance between ECM terminal 15 and ground. Refer to Wiring Diagram.

NOTE:

It is necessary to use an ohmmeter which can measure more than 10 MΩ.

Resistance: Approximately 532 - 588kΩ [at 20°C (68°F)]

3. Also check harness for short to ground and short to power.

OK or NG

- OK >> GO TO 5.
- NG >> GO TO 3.

3. CHECK KNOCK SENSOR INPUT SIGNAL CIRCUIT-II

1. Disconnect knock sensor harness connector.
2. Check harness continuity between ECM terminal 15 and knock sensor terminal 1. Refer to Wiring Diagram.

Continuity should exist.

3. Also check harness for short to ground and short to power.

OK or NG

- OK >> GO TO 4.
- NG >> Repair open circuit or short to ground or short to power in harness or connectors.

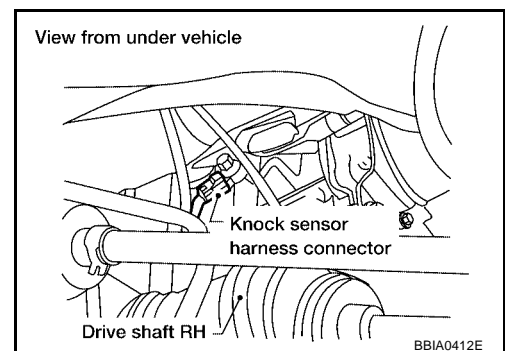

4. CHECK KNOCK SENSOR

Refer to [EC-272, "Component Inspection"](#) .

OK or NG

OK >> GO TO 5.

NG >> Replace knock sensor.

5. CHECK INTERMITTENT INCIDENT

Refer to [EC-158, "TROUBLE DIAGNOSIS FOR INTERMITTENT INCIDENT"](#) .

>> INSPECTION END

Component Inspection KNOCK SENSOR

UBS002UB

Check resistance between knock sensor terminal 1 and ground.

NOTE:

It is necessary to use an ohmmeter which can measure more than 10 M Ω .

Resistance: Approximately 532 - 588k Ω [at 20°C (68°F)]

CAUTION:

Do not use any knock sensors that have been dropped or physically damaged. Use only new ones.

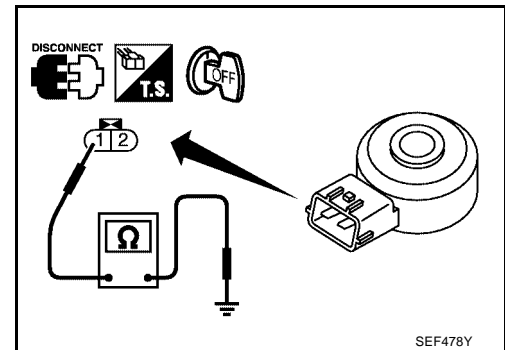

UBS002UC

Removal and Installation KNOCK SENSOR

Refer to [EM-75, "CYLINDER BLOCK"](#) .

DTC P0335 CKP SENSOR (POS)

[QR]

DTC P0335 CKP SENSOR (POS)

PF:23731

UBS002UD

Component Description

The crankshaft position sensor (POS) is located on the cylinder block rear housing facing the gear teeth (cogs) of the signal plate at the end of the crankshaft. It detects the fluctuation of the engine revolution.

The sensor consists of a permanent magnet and Hall IC.

When the engine is running, the high and low parts of the teeth cause the gap with the sensor to change.

The changing gap causes the magnetic field near the sensor to change.

Due to the changing magnetic field, the voltage from the sensor changes.

The ECM receives the voltage signal and detects the fluctuation of the engine revolution.

ECM receives the signals as shown in the figure.

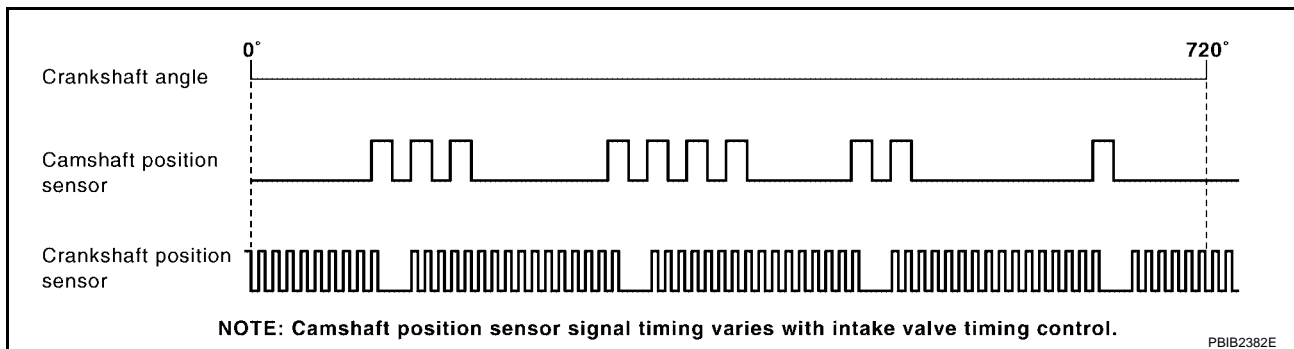
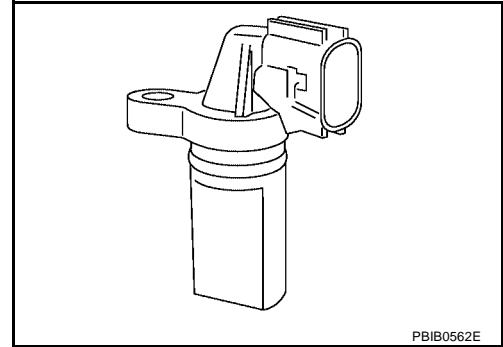

CONSULT-II Reference Value in Data Monitor Mode

UBS002UE

Specification data are reference values.

MONITOR ITEM	CONDITION	SPECIFICATION
ENG SPEED	<ul style="list-style-type: none"> Tachometer: Connect Run engine and compare the CONSULT-II value with tachometer indication. 	Almost the same speed as the tachometer indication.

On Board Diagnosis Logic

UBS002UF

DTC No.	Trouble diagnosis name	DTC detecting condition	Possible cause
P0335 0335	Crankshaft position sensor (POS) circuit	<ul style="list-style-type: none"> The crankshaft position sensor (POS) signal is not detected by the ECM during the first few seconds of engine cranking. The proper pulse signal from the crankshaft position sensor (POS) is not sent to ECM while the engine is running. The crankshaft position sensor (POS) signal is not in the normal pattern during engine running. 	<ul style="list-style-type: none"> Harness or connectors (The sensor circuit is open or shorted) Crankshaft position sensor (POS) Signal plate

DTC Confirmation Procedure

UBS002UG

NOTE:

If DTC Confirmation Procedure has been previously conducted, always turn ignition switch OFF and wait at least 10 seconds before conducting the next test.

TESTING CONDITION:

Before performing the following procedure, confirm that battery voltage is more than 10.5V with ignition switch ON.

DTC P0335 CKP SENSOR (POS)

[QR]

WITH CONSULT-II

1. Turn ignition switch ON and select "DATA MONITOR" mode with CONSULT-II.
2. Crank engine for at least 2 seconds and run it for at least 5 seconds at idle speed.
3. If 1st trip DTC is detected, go to [EC-276. "Diagnostic Procedure"](#)

DATA MONITOR	
MONITOR	NO DTC
ENG SPEED	XXX rpm

SEF058Y

WITH GST

Follow the procedure "WITH CONSULT-II" above.

DTC P0335 CKP SENSOR (POS)

[QR]

Wiring Diagram

UBS002UH

EC-POS-01

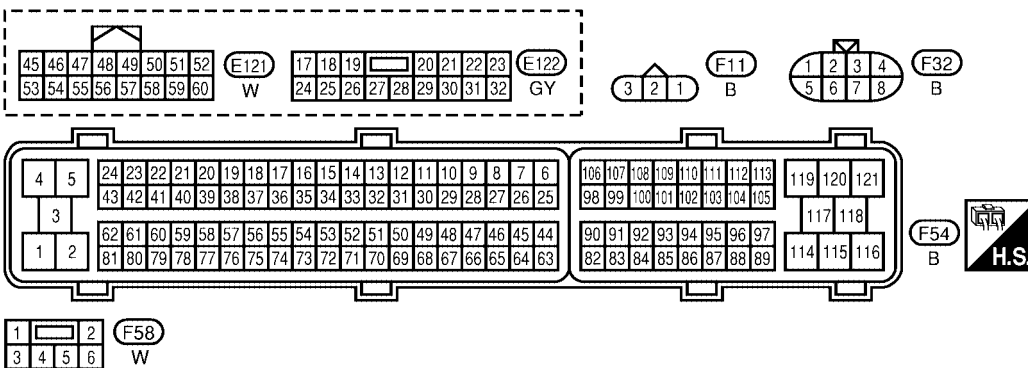
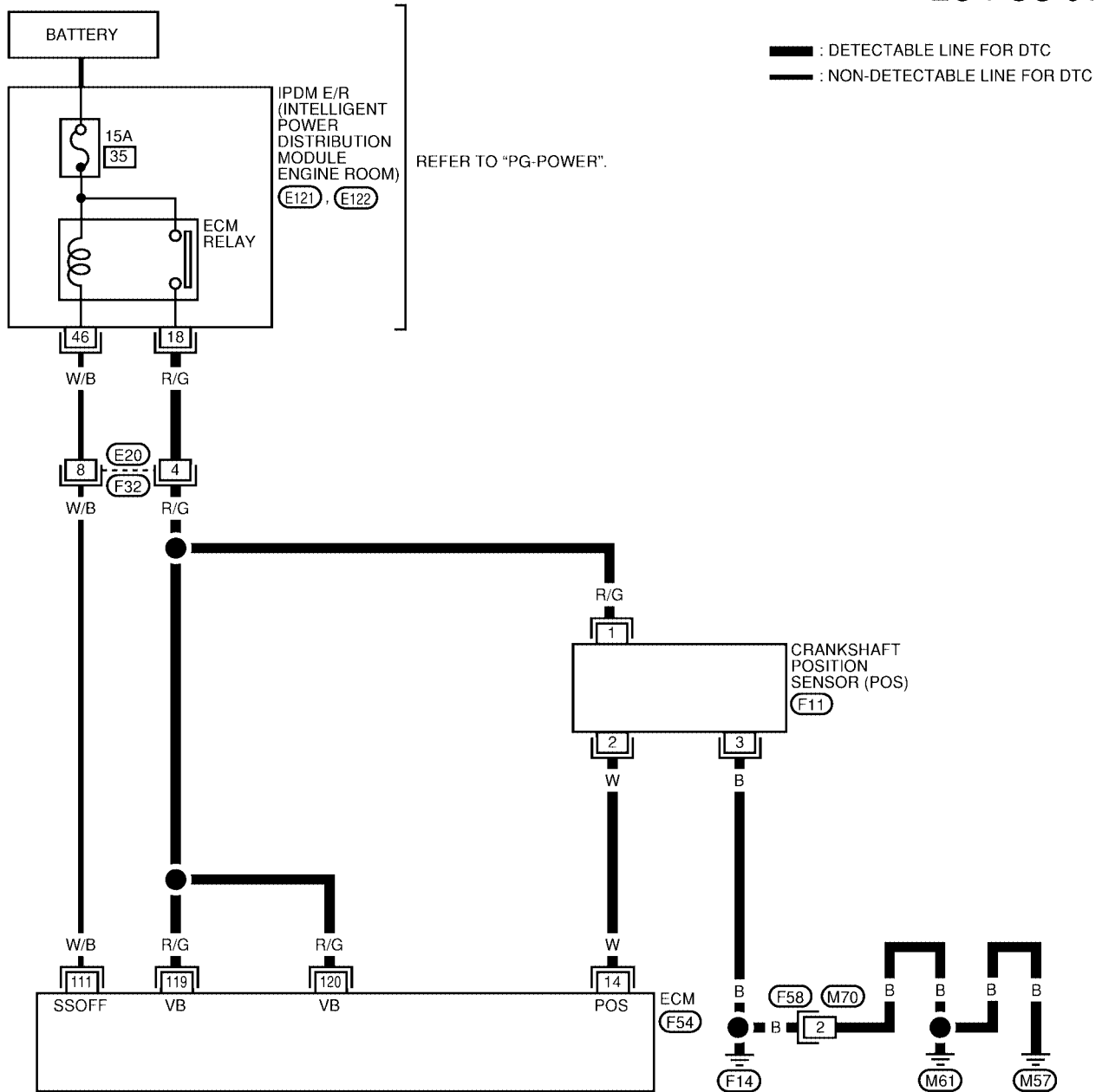

BBWA1225E

DTC P0335 CKP SENSOR (POS)

[QR]

Specification data are reference values and are measured between each terminal and ground.
Pulse signal is measured by CONSULT-II.

CAUTION:

Do not use ECM ground terminals when measuring input/output voltage. Doing so may result in damage to the ECM's transistor. Use a ground other than ECM terminals, such as the ground.

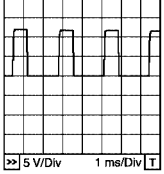
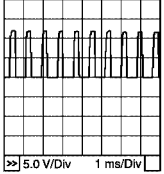
TER-MINAL NO.	WIRE COLOR	ITEM	CONDITION	DATA (DC Voltage)
14	W	Crankshaft position sensor (POS)	<p>[Engine is running]</p> <ul style="list-style-type: none"> ● Warm-up condition ● Idle speed <p>NOTE: The pulse cycle changes depending on rpm at idle.</p>	<p>Approximately 3.0V★</p>  <p>PBIB0527E</p>
			<p>[Engine is running]</p> <ul style="list-style-type: none"> ● Engine speed is 2,000 rpm 	<p>Approximately 3.0V★</p>  <p>PBIB0528E</p>

★: Average voltage for pulse signal (Actual pulse signal can be confirmed by oscilloscope.)

Diagnostic Procedure

UBS002UI

1. CHECK GROUND CONNECTIONS

1. Turn ignition switch OFF.
2. Loosen and retighten three ground screws on the body. Refer to [EC-164, "Ground Inspection"](#).

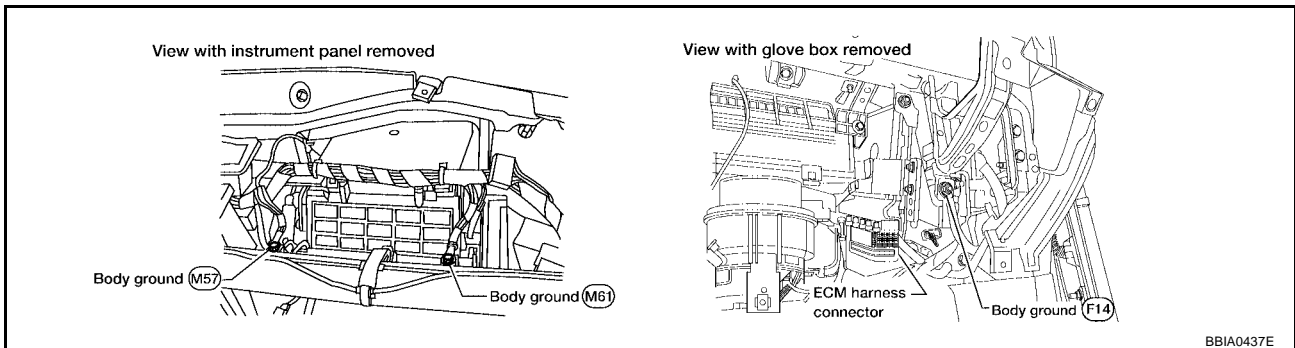

BBA0437E

OK or NG

- OK >> GO TO 2.
- NG >> Repair or replace ground connections.

2. CHECK CRANKSHAFT POSITION (CKP) SENSOR (POS) POWER SUPPLY CIRCUIT

1. Disconnect crankshaft position (CKP) sensor (POS) harness connector.
2. Turn ignition switch ON.

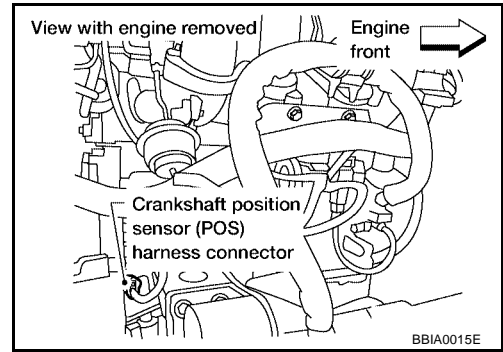

3. Check voltage between CKP sensor (POS) terminal 1 and ground with CONSULT-II or tester.

Voltage: Battery voltage

4. Also check harness for short to ground and short to power.

OK or NG

- OK >> GO TO 4.
- NG >> GO TO 3.

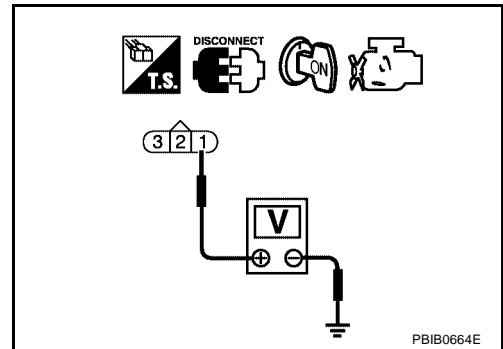

3. DETECT MALFUNCTIONING PART

Check the following.

- Harness connectors E20, F32
- Harness for open or short between crankshaft position sensor (POS) and ECM
- Harness for open or short between crankshaft position sensor (POS) and IPDM E/R

>> Repair open circuit or short to ground or short to power in harness or connectors.

4. CHECK CKP (POS) GROUND CIRCUIT FOR OPEN AND SHORT

1. Turn ignition switch OFF.
2. Check harness continuity between CKP sensor (POS) terminal 3 and ground. Refer to Wiring Diagram.

Continuity should exist.

3. Also check harness for and short to power.

OK or NG

- OK >> GO TO 6.
- NG >> GO TO 5.

5. DETECT MALFUNCTIONING PART

Check the following.

- Harness connectors F58, M70
- Harness for open or short between crankshaft position sensor (POS) and ground.

>> Repair open circuit or short to power in harness or connectors.

6. CHECK CKP SENSOR (POS) INPUT SIGNAL CIRCUIT FOR OPEN AND SHORT

1. Disconnect ECM harness connector.
2. Check harness continuity between ECM terminal 14 and CKP sensor (POS) terminal 2.
Refer to Wiring Diagram.

Continuity should exist.

3. Also check harness for short to ground and short to power.

OK or NG

OK >> GO TO 7.

NG >> Repair open circuit or short to ground or short to power in harness or connectors.

7. CHECK CRANKSHAFT POSITION SENSOR (POS)

Refer to [EC-278, "Component Inspection"](#) .

OK or NG

OK >> GO TO 8.

NG >> Replace crankshaft position sensor (POS).

8. CHECK GEAR TOOTH

Visually check for chipping signal plate gear tooth.

OK or NG

OK >> GO TO 9.

NG >> Replace the signal plate.

9. CHECK INTERMITTENT INCIDENT

Refer to [EC-158, "TROUBLE DIAGNOSIS FOR INTERMITTENT INCIDENT"](#) .

>> **INSPECTION END**

**Component Inspection
CRANKSHAFT POSITION SENSOR (POS)**

UBS002UJ

1. Loosen the fixing bolt of the sensor.
2. Disconnect crankshaft position sensor (POS) harness connector.
3. Remove the sensor.
4. Visually check the sensor for chipping.

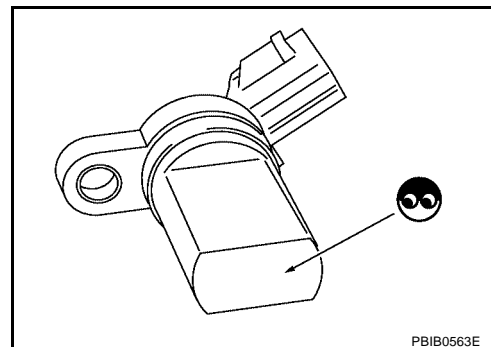

PBIB0563E

DTC P0335 CKP SENSOR (POS)

[QR]

5. Check resistance as shown in the figure.

Terminal No. (Polarity)	Resistance Ω [at 25°C (77°F)]
1 (+) - 2 (-)	Except 0 or ∞
1 (+) - 3 (-)	
2 (+) - 3 (-)	

6. If NG, replace crankshaft position sensor (POS).

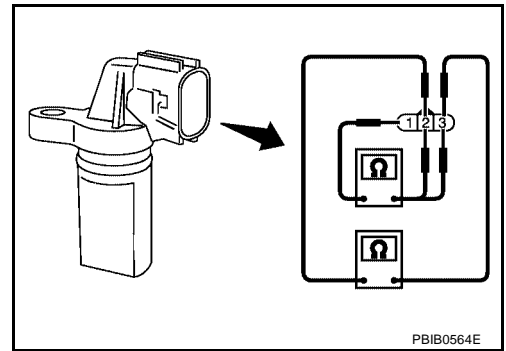

Removal and Installation CRANKSHAFT POSITION SENSOR (POS)

Refer to [EM-75, "CYLINDER BLOCK"](#) .

A
EC
C
D
E
F
G
H
I
J
K
L
M

DTC P0340 CMP SENSOR (PHASE)

Component Description

UBS002UL

The camshaft position sensor (PHASE) senses the retraction with camshaft (intake) to identify a particular cylinder. The camshaft position sensor (PHASE) senses the piston position.

When the crankshaft position sensor (POS) system becomes inoperative, the camshaft position sensor (PHASE) provides various controls of engine parts instead, utilizing timing of cylinder identification signals.

The sensor consists of a permanent magnet and Hall IC.

When engine is running, the high and low parts of the teeth cause the gap with the sensor to change.

The changing gap causes the magnetic field near the sensor to change.

Due to the changing magnetic field, the voltage from the sensor changes. ECM receives the signals as shown in the figure.

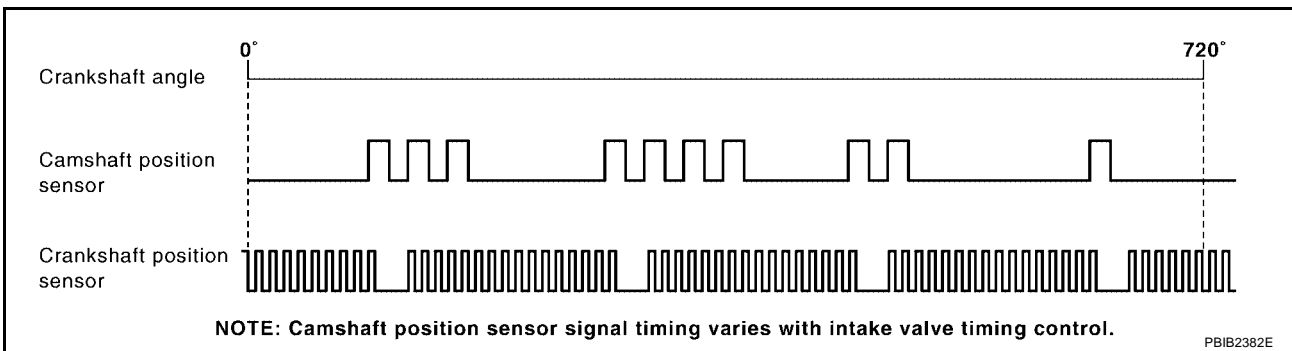
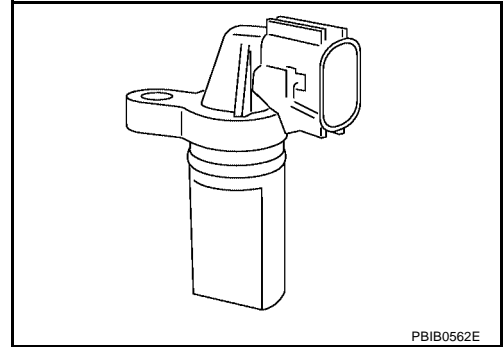

On Board Diagnosis Logic

UBS002UM

DTC No.	Trouble diagnosis name	DTC detecting condition	Possible cause
P0340 0340	Camshaft position sensor (PHASE) circuit	<ul style="list-style-type: none"> ● The cylinder No. signal is not sent to ECM for the first few seconds during engine cranking. ● The cylinder No. signal is not set to ECM during engine running. ● The cylinder No. signal is not in the normal pattern during engine running. 	<ul style="list-style-type: none"> ● Harness or connectors (The sensor circuit is open or shorted) ● Camshaft position sensor (PHASE) ● Camshaft (Intake) ● Starter motor (Refer to SC-9 .) ● Starting system circuit (Refer to SC-9 .) ● Dead (Weak) battery

DTC Confirmation Procedure

UBS002UN

NOTE:

If DTC Confirmation Procedure has been previously conducted, always turn ignition switch OFF and wait at least 10 seconds before conducting the next test.

TESTING CONDITION:

Before performing the following procedure, confirm that battery voltage is more than 10.5V with ignition switch ON.

④ WITH CONSULT-II

1. Turn ignition switch ON.

DTC P0340 CMP SENSOR (PHASE)

[QR]

2. Select "DATA MONITOR" mode with CONSULT-II.
3. Crank engine for at least 2 seconds and run it for at least 5 seconds at idle speed.
4. If 1st trip DTC is detected, go to [EC-283, "Diagnostic Procedure"](#).
If 1st trip DTC is not detected, go to next step.
5. Maintaining engine speed at more than 800 rpm for at least 5 seconds.
6. If 1st trip DTC is detected, go to [EC-283, "Diagnostic Procedure"](#).

DATA MONITOR	
MONITOR	NO DTC
COOLAN TEMP/S	XXX °C

SEF013Y

WITH GST

Follow the procedure "WITH CONSULT-II" above.

A

EC

C

D

E

F

G

H

I

J

K

L

M

DTC P0340 CMP SENSOR (PHASE)

[QR]

UBS002U0

Wiring Diagram

EC-PHASE-01

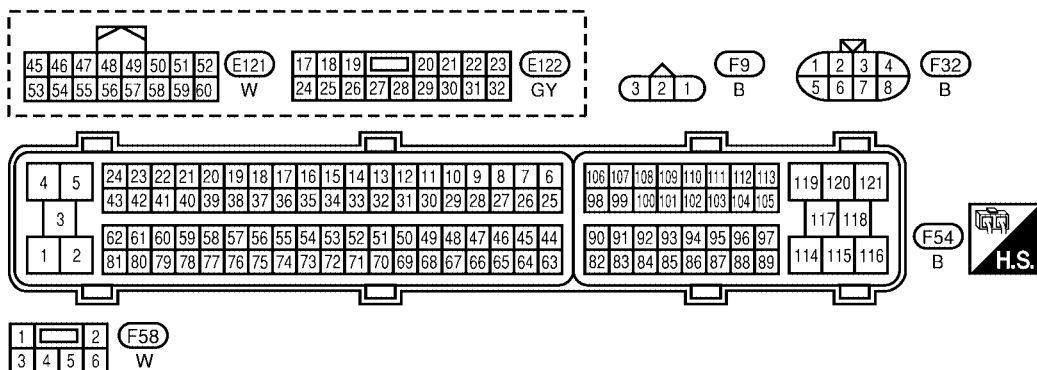
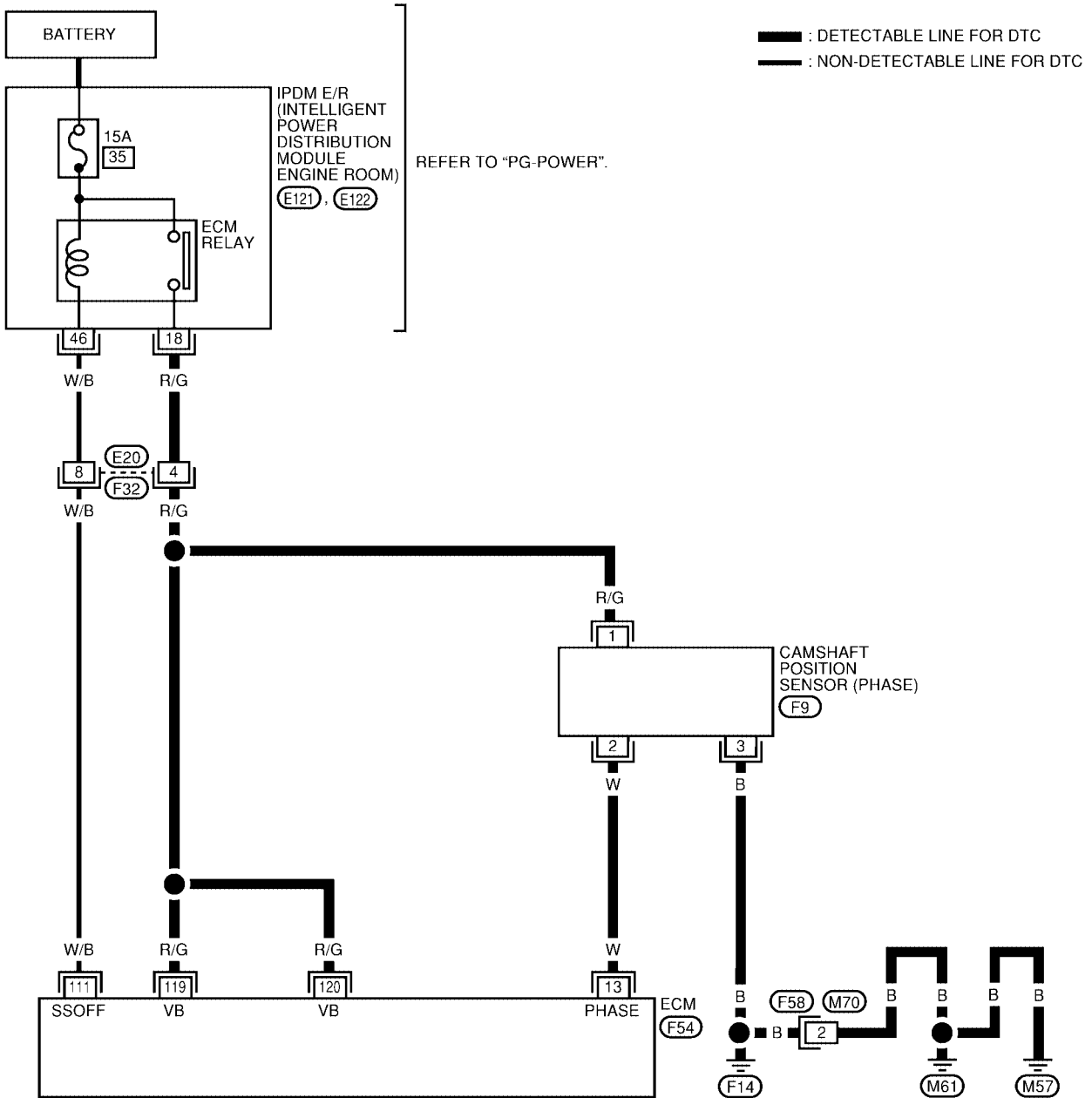

BBWA1226E

DTC P0340 CMP SENSOR (PHASE)

[QR]

Specification data are reference values and are measured between each terminal and ground.
Pulse signal is measured by CONSULT-II.

CAUTION:

Do not use ECM ground terminals when measuring input/output voltage. Doing so may result in damage to the ECM's transistor. Use a ground other than ECM terminals, such as the ground.

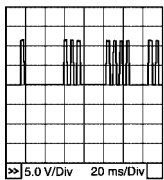
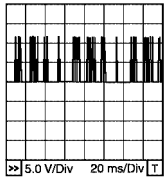
TERMI- NAL NO.	WIRE COLOR	ITEM	CONDITION	DATA (DC Voltage)
13	W	Camshaft position sensor (PHASE)	<p>[Engine is running]</p> <ul style="list-style-type: none"> ● Warm-up condition ● Idle speed <p>NOTE: The pulse cycle changes depending on rpm at idle.</p>	<p>1.0 - 4.0V★</p> 
			<p>[Engine is running]</p> <ul style="list-style-type: none"> ● Engine speed is 2,000 rpm. 	<p>1.0 - 4.0V★</p> 

★: Average voltage for pulse signal (Actual pulse signal can be confirmed by oscilloscope.)

Diagnostic Procedure

UBS002UP

1. CHECK STARTING SYSTEM

Turn ignition switch to START position.

Does the engine turn over?

Does the starter motor operate?

Yes or No

Yes >> GO TO 2.

No >> Check starting system. (Refer to [SC-9, "STARTING SYSTEM"](#) .)

2. CHECK GROUND CONNECTIONS

1. Turn ignition switch OFF.

2. Loosen and retighten three ground screws on the body. Refer to [EC-164, "Ground Inspection"](#) .

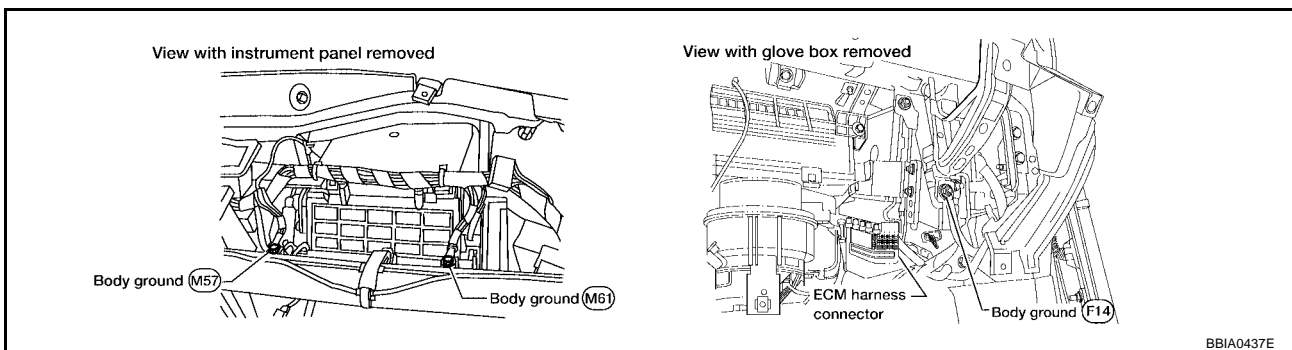

OK or NG

OK >> GO TO 3.

NG >> Repair or replace ground connections.

3. CHECK CAMSHAFT POSITION (CMP) SENSOR (PHASE) POWER SUPPLY CIRCUIT

1. Disconnect camshaft position (CMP) sensor (PHASE) harness connector.
2. Turn ignition switch ON.

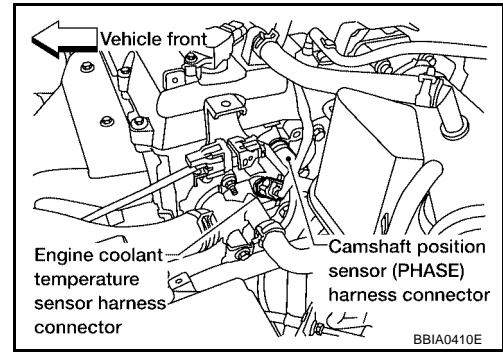

3. Check voltage between CMP sensor (PHASE) terminal 1 and ground with CONSULT-II or tester.

Voltage: Battery voltage

4. Also check harness for short to ground and short to power.

OK or NG

- OK >> GO TO 5.
 NG >> GO TO 4.

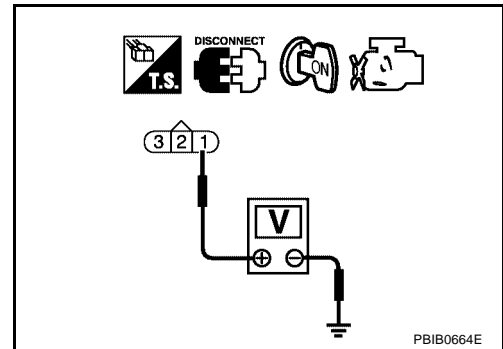

4. DETECT MALFUNCTIONING PART

Check the following.

- Harness connectors E20, F32
- Harness for open or short between camshaft position sensor (PHASE) and ECM
- Harness for open or short between camshaft position sensor (PHASE) and IPDM E/R

>> Repair open circuit or short to ground or short to power in harness or connectors.

5. CHECK CMP SENSOR (PHASE) GROUND CIRCUIT FOR OPEN AND SHORT

1. Turn ignition switch OFF.
2. Check harness continuity between CMP sensor (PHASE) terminal 3 and ground.

Continuity should exist.

3. Also check harness for short to power.

OK or NG

- OK >> GO TO 7.
 NG >> GO TO 6.

6. DETECT MALFUNCTIONING PART

Check the following.

- Harness connector F58, M70
- Harness for open or short between CMP sensor (PHASE) and ground.

>> Repair open circuit or short to power in harness or connectors.

7. CHECK CMP SENSOR (PHASE) INPUT SIGNAL CIRCUIT FOR OPEN AND SHORT

1. Disconnect ECM harness connector.
2. Check harness continuity between ECM terminal 13 and CMP sensor (PHASE) terminal 2.
Refer to Wiring Diagram.

Continuity should exist.

3. Also check harness for short to ground or short to power.

OK or NG

OK >> GO TO 8.

NG >> Repair open circuit or short to ground or short to power in harness or connectors.

8. CHECK CAMSHAFT POSITION SENSOR (PHASE)

Refer to [EC-285, "Component Inspection"](#) .

OK or NG

OK >> GO TO 9.

NG >> Replace camshaft position sensor (PHASE).

9. CHECK CAMSHAFT (INTAKE)

Check the following.

- Accumulation of debris to the signal plate of camshaft rear end
- Chipping signal plate of camshaft rear end

OK or NG

OK >> GO TO 10.

NG >> Remove debris and clean the signal plate of camshaft rear end or replace camshaft.

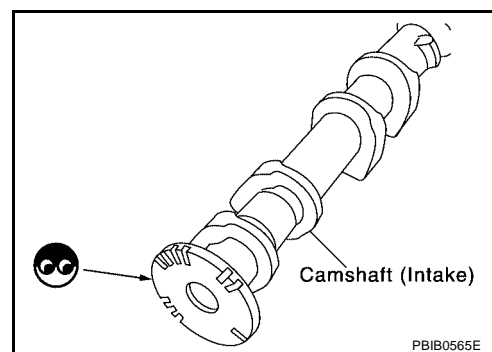
**10. CHECK INTERMITTENT INCIDENT**

Refer to [EC-158, "TROUBLE DIAGNOSIS FOR INTERMITTENT INCIDENT"](#) .

>> INSPECTION END

**Component Inspection
CAMSHAFT POSITION SENSOR (PHASE)**

UBS002UQ

1. Loosen the fixing bolt of the sensor.
2. Disconnect camshaft position sensor (PHASE) harness connector.
3. Remove the sensor.
4. Visually check the sensor for chipping.

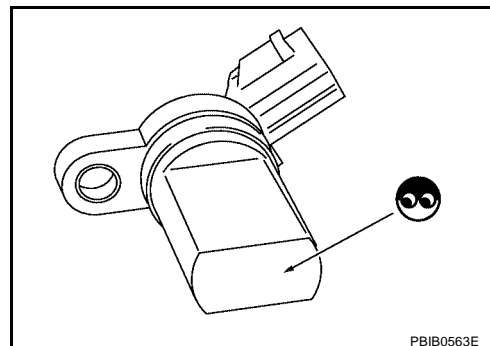

DTC P0340 CMP SENSOR (PHASE)

[QR]

5. Check resistance as shown in the figure.

Terminal No. (Polarity)	Resistance Ω [at 25°C (77°F)]
1 (+) - 2 (-)	Except 0 or ∞
1 (+) - 3 (-)	
2 (+) - 3 (-)	

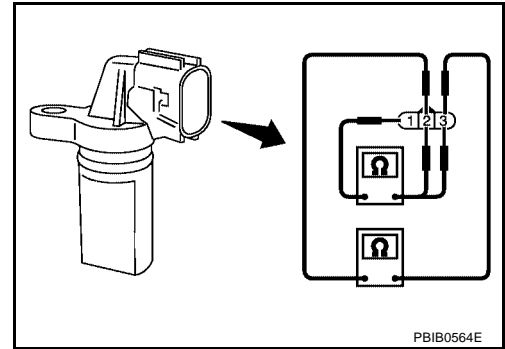

Removal and Installation CAMSHAFT POSITION SENSOR (PHASE)

Refer to [EM-37, "CAMSHAFT"](#) .

UBS002UR

DTC P0420 THREE WAY CATALYST FUNCTION

[QR]

DTC P0420 THREE WAY CATALYST FUNCTION

PF2:20905

On Board Diagnosis Logic

UBS00CVH

The ECM monitors the switching frequency ratio of air fuel ratio (A/F) sensor 1 and heated oxygen sensor 2.

A three way catalyst (manifold) with high oxygen storage capacity will indicate a low switching frequency of heated oxygen sensor 2. As oxygen storage capacity decreases, the heated oxygen sensor 2 switching frequency will increase.

When the frequency ratio of air fuel ratio (A/F) sensor 1 and heated oxygen sensor 2 approaches a specified limit value, the three way catalyst (manifold) malfunction is diagnosed.

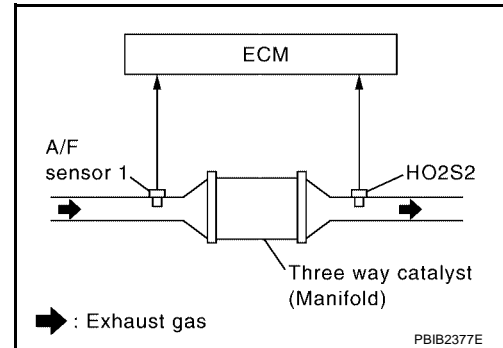

DTC No.	Trouble diagnosis name	DTC detecting condition	Possible cause
P0420 0420	Catalyst system efficiency below threshold	<ul style="list-style-type: none"> Three way catalyst (manifold) does not operate properly. Three way catalyst (manifold) does not have enough oxygen storage capacity. 	<ul style="list-style-type: none"> Three way catalyst (manifold) Exhaust tube Intake air leaks Fuel injector Fuel injector leaks Spark plug Improper ignition timing

DTC Confirmation Procedure

UBS00CVI

NOTE:

If DTC Confirmation Procedure has been previously conducted, always turn ignition switch OFF and wait at least 10 seconds before conducting the next test.

WITH CONSULT-II

TESTING CONDITION:

Do not hold engine speed for more than the specified minutes below.

- Turn ignition switch ON and select "DATA MONITOR" mode with CONSULT-II.
- Start engine and warm it up to normal operating temperature.
- Turn ignition switch OFF and wait at least 10 seconds.
- Start engine and keep the engine speed between 3,500 and 4,000 rpm for at least 1 minute under no load.
- Let engine idle for 1 minute.
- Make sure that "COOLAN TEMP/S" indicates more than 70°C (158°F).
- Open engine hood.
- Select "DTC & SRT CONFIRMATION" then "SRT WORK SUPPORT" mode with CONSULT-II.
- Rev engine up to 2,500 to 3,500 rpm and hold it for 3 consecutive minutes, then release the accelerator pedal completely. If "INCMP" of "CATALYST" changed to "COMPLT", go to step 12.
- Wait 5 seconds at idle.

DATA MONITOR	
MONITOR	NO DTC
ENG SPEED	XXX rpm
COOLAN TEMP/S	XXX °C
VHCL SPEED SE	XXX km/h
B/FUEL SCHDL	XXX msec

SEF189Y

SRT WORK SUPPORT	
CATALYST	INCMP
EVAP SYSTEM	INCMP
HO2S HTR	CMPLT
HO2S	INCMP
MONITOR	
ENG SPEED	XXX rpm
MAS A/F SE-B1	XXX V
B/FUEL SCHDL	XXX msec
A/F ALPHA-B1	XXX V
COOLAN TEMP/S	XX °C
A/F SEN1 (B1)	XXX V

PBIB1784E

DTC P0420 THREE WAY CATALYST FUNCTION

[QR]

- Rev engine up to 2,000 to 3,000 rpm and maintain it until "IMCMP" of "CATALYST" changes to "CMPLT" (it will take approximately 5 minutes).
If not "CMPLT", stop engine and cool it down to less than 70°C (158°F) and then retest step 1.

SRT WORK SUPPORT	
CATALYST	CMPLT
EVAP SYSTEM	INCMP
HO2S HTR	CMPLT
HO2S	INCMP
MONITOR	
ENG SPEED	XXX rpm
MAS A/F SE-B1	XXX V
B/FUEL SCHDL	XXX msec
A/F ALPHA-B1	XXX V
COOLAN TEMP/S	XX °C
A/F SEN1 (B1)	XXX V

PBIB1785E

- Select "SELF-DIAG RESULTS" mode with CONSULT-II.
- Confirm that the 1st trip DTC is not detected.
If the 1st trip DTC is detected, go to [EC-288, "Diagnostic Procedure"](#).

SELF DIAG RESULTS	
DTC RESULTS	TIME
NO DTC IS DETECTED. FURTHER TESTING MAY BE REQUIRED.	

SEF535Z

Overall Function Check

UBS00CVJ

Use this procedure to check the overall function of the three way catalyst (Manifold). During this check, a 1st trip DTC might not be confirmed.

CAUTION:

Always drive vehicle at a safe speed.

WITH GST

- Start engine and warm it up to the normal operating temperature.
- Turn ignition switch OFF and wait at least 10 seconds.
- Start engine and keep the engine speed between 3,500 and 4,000 rpm for at least 1 minute under no load.
- Let engine idle for 1 minute.
- Open engine hood.
- Set voltmeter probe between ECM terminal 74 and ground.
- Keep engine speed at 2,500 rpm constant under no load.
- Make sure that the voltage does not vary for more than 5 seconds.

If the voltage fluctuation cycle takes less than 5 seconds, go to [EC-288, "Diagnostic Procedure"](#).

- 1 cycle: 0.6 - 1.0 V → 0 - 0.3 V → 0.6 - 1.0 V

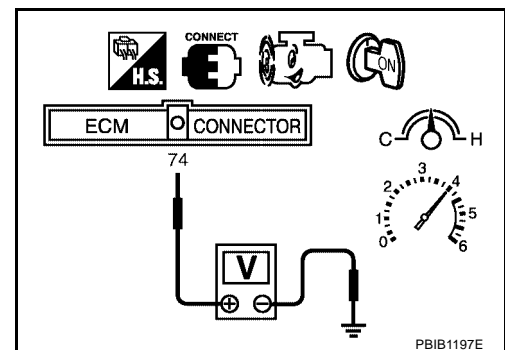

UBS00CVK

Diagnostic Procedure

1. CHECK EXHAUST SYSTEM

Visually check exhaust tubes and muffler for dent.

OK or NG

- OK >> GO TO 2.
- NG >> Repair or replace.

2. CHECK EXHAUST GAS LEAK

1. Start engine and run it at idle.
2. Listen for an exhaust gas leak before the three way catalyst (manifold).

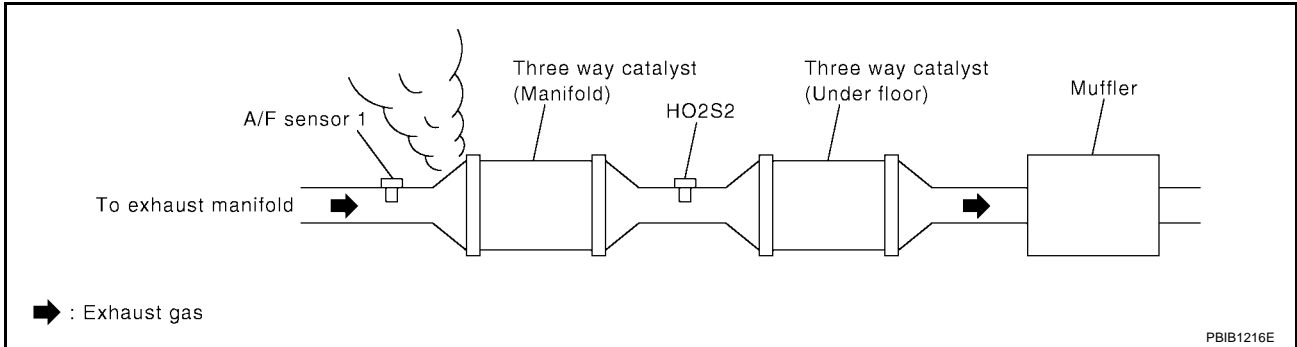

OK or NG

- OK >> GO TO 3.
- NG >> Repair or replace.

3. CHECK INTAKE AIR LEAK

Listen for an intake air leak after the mass air flow sensor.

OK or NG

- OK >> GO TO 4.
- NG >> Repair or replace.

4. CHECK IGNITION TIMING

Check for ignition timing. Refer to [EC-75, "Basic Inspection"](#) .

Items	Specifications	
Target idle speed	A/T	700 ± 50 rpm (in P or N position)
	M/T	700 ± 50 rpm (in Neutral position)
Ignition timing	A/T	15 ± 5° BTDC (in P or N position)
	M/T	15 ± 5° BTDC (in Neutral position)

OK or NG

- OK >> GO TO 5.
- NG >> Follow the Basic Inspection.

5. CHECK INJECTORS

1. Refer to Wiring Diagram for Injectors, [EC-593](#) .
2. Stop engine and then turn ignition switch ON.
3. Check voltage between ECM terminals 22, 23, 41, 42 and ground with CONSULT-II or tester.

Battery voltage should exist.

OK or NG

- OK >> GO TO 6.
- NG >> Perform [EC-594](#) .

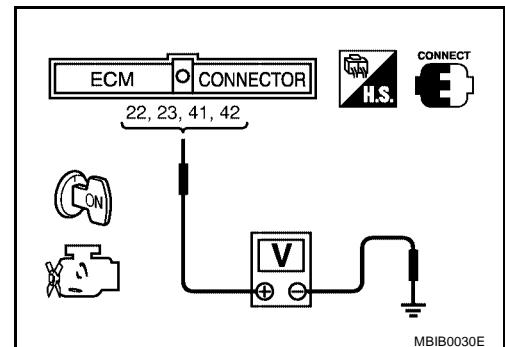

6. CHECK FUNCTION OF IGNITION COIL-I

CAUTION:

Do the following procedure in the place where ventilation is good without the combustible.

1. Turn ignition switch OFF.
 2. Remove fuel pump fuse in IPDM E/R to release fuel pressure.
- NOTE:**
Do not use CONSULT-II to release fuel pressure, or fuel pressure applies again during the following procedure.
3. Start engine.
 4. After engine stalls, crank it two or three times to release all fuel pressure.
 5. Turn ignition switch OFF.
 6. Remove all ignition coil harness connectors to avoid the electrical discharge from the ignition coils.
 7. Remove ignition coil and spark plug of the cylinder to be checked.
 8. Crank engine for five seconds or more to remove combustion gas in the cylinder.
 9. Connect spark plug and harness connector to ignition coil.
 10. Fix ignition coil using a rope etc. with gap of 13 - 17 mm between the edge of the spark plug and grounded metal portion as shown in the figure.
 11. Crank engine for about three seconds, and check whether spark is generated between the spark plug and the grounded metal portion.

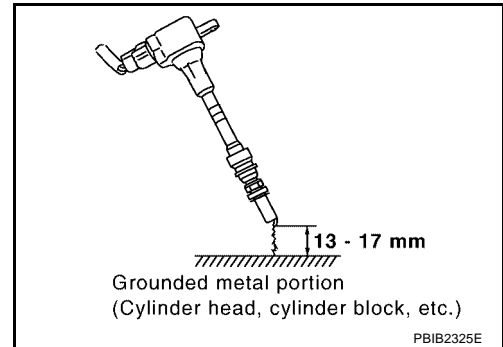
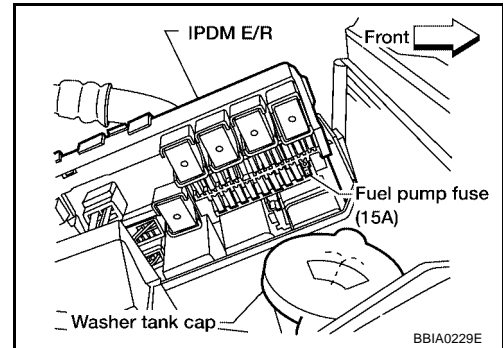

Spark should be generated.

CAUTION:

- Do not approach to the spark plug and the ignition coil within 50cm. Be careful not to get an electrical shock while checking, because the electrical discharge voltage becomes 20kV or more.
- It might cause to damage the ignition coil if the gap of 17 mm or more is taken.

NOTE:

When the gap is 13 mm or less, the spark might be generated even if the coil is malfunctioning.

OK or NG

- OK >> GO TO 10.
- NG >> GO TO 7.

7. CHECK FUNCTION OF IGNITION COIL-II

1. Turn ignition switch OFF.
2. Disconnect spark plug and connect a known-good spark plug.
3. Crank engine for about three seconds, and recheck whether spark is generated between the spark plug and the grounded metal portion.

Spark should be generated.

OK or NG

- OK >> GO TO 8.
- NG >> Check ignition coil, power transistor and their circuits. Refer to [EC-572](#).

8. CHECK SPARK PLUG

Check the initial spark plug for fouling, etc.

OK or NG

- OK >> Replace spark plug(s) with standard type one(s). For spark plug type, refer to [MA-19](#) .
- NG >> 1. Repair or clean spark plug.
2. GO TO 9.

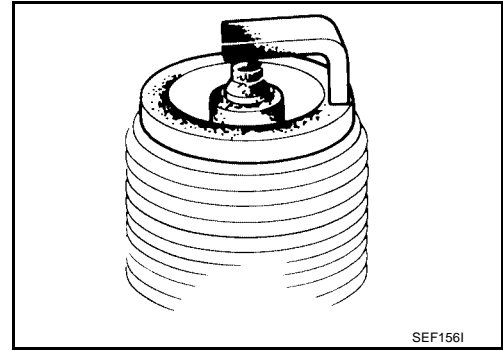

9. CHECK FUNCTION OF IGNITION COIL-III

1. Reconnect the initial spark plugs.
2. Crank engine for about three seconds, and recheck whether spark is generated between the spark plug and the grounded portion.

Spark should be generated.

OK or NG

- OK >> **INSPECTION END**
- NG >> Replace spark plug(s) with standard type one(s). For spark plug type, refer to [MA-26](#) .

10. CHECK INJECTOR

1. Turn ignition switch OFF.
2. Remove injector assembly. Refer to [EM-32, "FUEL INJECTOR AND FUEL TUBE"](#) .
Keep fuel hose and all injectors connected to injector gallery.
3. Disconnect ignition coil assembly harness connector.
4. Turn ignition switch ON.
Make sure fuel does not drip from injector.

OK or NG

- OK (Does not drip)>>GO TO 11.
- NG (Drips)>>Replace the injector(s) from which fuel is dripping.

11. CHECK INTERMITTENT INCIDENT

Perform [EC-158, "TROUBLE DIAGNOSIS FOR INTERMITTENT INCIDENT"](#) .

- Trouble is fixed>>**INSPECTION END**
- Trouble is not fixed>>Replace three way catalyst (manifold).

A
EC
C
D
E
F
G
H
I
J
K
L
M

DTC P0441 EVAP CONTROL SYSTEM

PFP:14950

System Description

UBS00CD1

NOTE:

If DTC P0441 is displayed with other DTC such as P2122, P2123 P2127, P2128, P2138, first perform trouble diagnosis for other DTC.

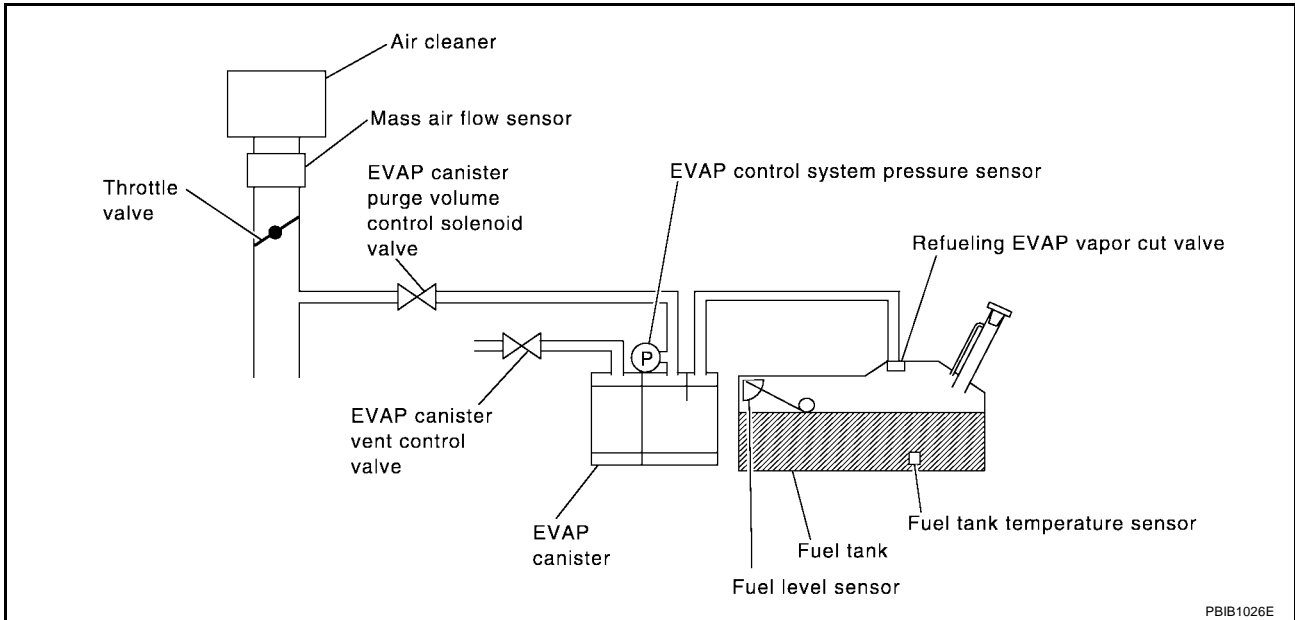

In this evaporative emission (EVAP) control system, purge flow occurs during non-closed throttle conditions. Purge volume is related to air intake volume. Under normal purge conditions (non-closed throttle), the EVAP canister purge volume control solenoid valve is open to admit purge flow. Purge flow exposes the EVAP control system pressure sensor to intake manifold vacuum.

On Board Diagnosis Logic

UBS00CD2

Under normal conditions (non-closed throttle), sensor output voltage indicates if pressure drop and purge flow are adequate. If not, a malfunction is determined.

DTC No.	Trouble diagnosis name	DTC detecting condition	Possible cause
P0441 0441	EVAP control system incorrect purge flow	EVAP control system does not operate properly, EVAP control system has a leak between intake manifold and EVAP control system pressure sensor.	<ul style="list-style-type: none"> ● EVAP canister purge volume control solenoid valve stuck closed ● EVAP control system pressure sensor and the circuit ● Loose, disconnected or improper connection of rubber tube ● Blocked rubber tube ● Cracked EVAP canister ● EVAP canister purge volume control solenoid valve circuit ● Accelerator pedal position sensor ● Blocked purge port ● EVAP canister vent control valve

DTC Confirmation Procedure

CAUTION:

Always drive vehicle at a safe speed.

NOTE:

If DTC Confirmation Procedure has been previously conducted, always turn ignition switch OFF and wait at least 10 seconds before conducting the next test.

TESTING CONDITION:

Always perform test at a temperature of 5°C (41°F) or more.

WITH CONSULT-II

1. Start engine and warm it up to normal operating temperature.
2. Turn ignition switch OFF and wait at least 10 seconds.
3. Start engine and let it idle for at least 70 seconds.
4. Select "PURG FLOW P0441" of "EVAPORATIVE SYSTEM" in "DTC CONFIRMATION" mode with CONSULT-II.
5. Touch "START".
If "COMPLETED" is displayed, go to step 7.
6. When the following conditions are met, "TESTING" will be displayed on the CONSULT-II screen. Maintain the conditions continuously until "TESTING" changes to "COMPLETED". (It will take at least 35 seconds.)

Selector lever	Suitable position
Vehicle speed	32 - 120 km/h (20 - 75 MPH)
ENG SPEED	500 - 3,800 rpm
B/FUEL SCHDL	1.0 - 10.0 msec
Engine coolant temperature	More than 0°C

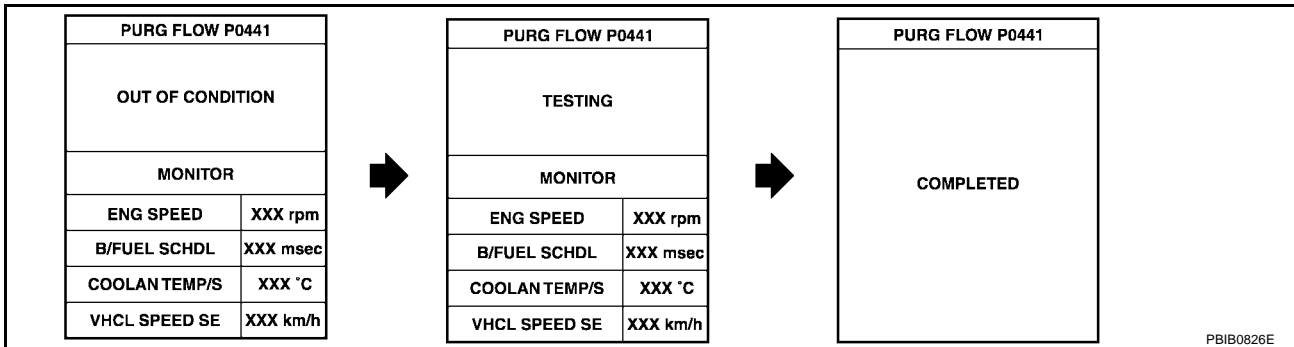

If TESTING is not changed for a long time, retry from step 2.

7. Make sure that "OK" is displayed after touching "SELF-DIAG RESULTS". If "NG" is displayed, refer to [EC-294, "Diagnostic Procedure"](#).

Overall Function Check

Use this procedure to check the overall monitoring function of the EVAP control system purge flow monitoring. During this check, a 1st trip DTC might not be confirmed.

WITH GST

1. Lift up drive wheels.
2. Start engine and warm it up to normal operating temperature.
3. Turn ignition switch OFF, wait at least 10 seconds.
4. Start engine and wait at least 70 seconds.

DTC P0441 EVAP CONTROL SYSTEM

[QR]

5. Set voltmeter probes to ECM terminals 32 (EVAP control system pressure sensor signal) and ground.
6. Check EVAP control system pressure sensor value at idle speed and note it.
7. Establish and maintain the following conditions for at least 1 minute.

Air conditioner switch	ON
Headlamp switch	ON
Rear window defogger switch	ON
Engine speed	Approx. 3,000 rpm
Shift lever	Any position other than P, N or R

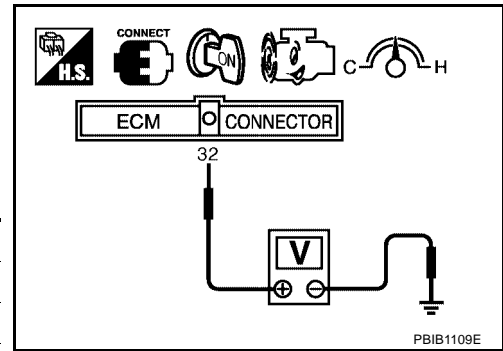

8. Verify that EVAP control system pressure sensor value stays 0.1V less than the value at idle speed (measured at step 6) for at least 1 second.
9. If NG, go to [EC-294, "Diagnostic Procedure"](#).

Diagnostic Procedure

UBS00CD5

1. CHECK EVAP CANISTER

1. Turn ignition switch OFF.
2. Check EVAP canister for cracks.

OK or NG

- OK (With CONSULT-II)>>GO TO 2.
- OK (Without CONSULT-II)>>GO TO 3.
- NG >> Replace EVAP canister.

2. CHECK PURGE FLOW

With CONSULT-II

1. Disconnect vacuum hose connected to EVAP canister purge volume control solenoid valve at EVAP service port and install vacuum gauge.
2. Start engine and let it idle.
3. Select "PURG VOL CONT/V" in "ACTIVE TEST" mode with CONSULT-II.
4. Rev engine up to 2,000 rpm.

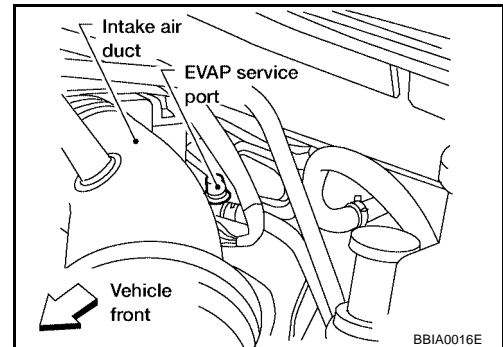

5. Touch "Qd" and "Qu" on CONSULT-II screen to adjust "PURG VOL CONT/V" opening and check vacuum existence.

PURG VOL CONT/V	VACUUM
100%	Should exist.
0%	should not exist.

OK or NG

- OK >> GO TO 7.
- NG >> GO TO 4.

ACTIVE TEST	
PURG VOL CONT/V	XXX %
MONITOR	
ENG SPEED	XXX rpm
A/F ALPHA-B1	XXX %

PBIB1786E

3. CHECK PURGE FLOW

⊗ Without CONSULT-II

1. Start engine and warm it up to normal operating temperature.
2. Stop engine.
3. Disconnect vacuum hose connected to EVAP canister purge volume control solenoid valve at EVAP service port and install vacuum gauge. For the location of EVAP service port, refer to [EC-38, "EVAPORATIVE EMISSION LINE DRAWING"](#).
4. Start engine and let it idle.
Do not depress accelerator pedal even slightly.
5. Check vacuum gauge indication before 60 seconds passed after starting engine.

Vacuum should not exist.

6. Revving engine up to 2,000 rpm after 100 seconds passed after starting engine.

Vacuum should exist.

OK or NG

- OK >> GO TO 7.
- NG >> GO TO 4.

4. CHECK EVAP PURGE LINE

1. Turn ignition switch OFF.
2. Check EVAP purge line for improper connection or disconnection.
Refer to [EC-38, "EVAPORATIVE EMISSION LINE DRAWING"](#).

OK or NG

- OK >> GO TO 5.
- NG >> Repair it.

5. CHECK EVAP PURGE HOSE AND PURGE PORT

1. Disconnect purge hoses connected to EVAP service port **A** and EVAP canister purge volume control solenoid valve **B**.
2. Blow air into each hose and EVAP purge port **C**.

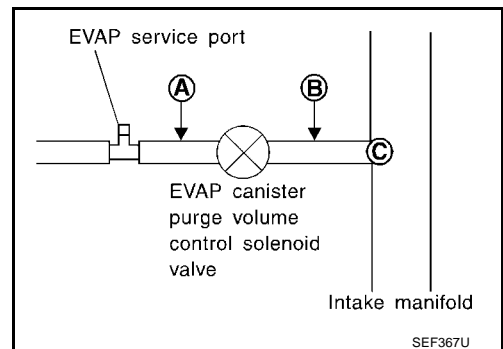

3. Check that air flows freely.

OK or NG

- OK (With CONSULT-II) >> GO TO 6.
- OK (Without CONSULT-II) >> GO TO 7.
- NG >> Repair or clean hoses and/or purge port.

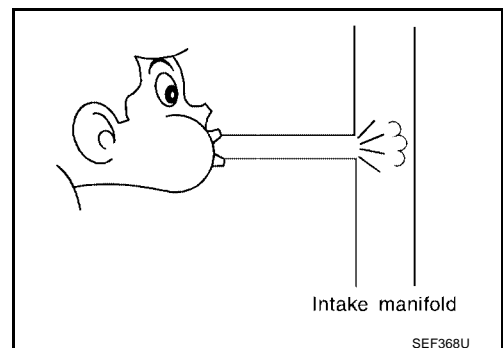

6. CHECK EVAP CANISTER PURGE VOLUME CONTROL SOLENOID VALVE

 **With CONSULT-II**

1. Start engine.
2. Perform "PURG VOL CONT/V" in "ACTIVE TEST" mode with CONSULT-II. Check that engine speed varies according to the valve opening.

OK or NG

- OK >> GO TO 8.
- NG >> GO TO 7.

ACTIVE TEST	
PURG VOL CONT/V	XXX %
MONITOR	
ENG SPEED	XXX rpm
A/F ALPHA-B1	XXX %

PBIB1786E

7. CHECK EVAP CANISTER PURGE VOLUME CONTROL SOLENOID VALVE

Refer to [EC-311, "Component Inspection"](#) .

OK or NG

- OK >> GO TO 8.
- NG >> Replace EVAP canister purge volume control solenoid valve.

8. CHECK EVAP CONTROL SYSTEM PRESSURE SENSOR CONNECTOR

1. Disconnect EVAP control system pressure sensor harness connector.
2. Check connectors for water.

Water should not exist

OK or NG

- OK >> GO TO 9.
- NG >> Replace EVAP control system pressure sensor.

9. CHECK EVAP CONTROL SYSTEM PRESSURE SENSOR FUNCTION

Refer to DTC Confirmation Procedure for DTC P0452, [EC-322](#) P0453, [EC-328](#) .

OK or NG

- OK >> GO TO 10.
- NG >> Replace EVAP control system pressure sensor.

10. CHECK RUBBER TUBE FOR CLOGGING

1. Disconnect rubber tube connected to EVAP canister vent control valve.
2. Check the rubber tube for clogging.

OK or NG

- OK >> GO TO 11.
- NG >> Clean the rubber tube using an air blower.

11. CHECK EVAP CANISTER VENT CONTROL VALVE

Refer to [EC-317](#) .

OK or NG

- OK >> GO TO 12.
- NG >> Replace EVAP canister vent control valve.

12. CHECK EVAP PURGE LINE

Inspect EVAP purge line (pipe and rubber tube). Check for evidence of leaks.
Refer to [EC-38, "EVAPORATIVE EMISSION LINE DRAWING"](#) .

OK or NG

- OK >> GO TO 13.
- NG >> Replace it.

13. CLEAN EVAP PURGE LINE

Clean EVAP purge line (pipe and rubber tube) using air blower.

>> GO TO 14.

14. CHECK INTERMITTENT INCIDENT

Refer to [EC-158, "TROUBLE DIAGNOSIS FOR INTERMITTENT INCIDENT"](#) .

>> **INSPECTION END**

A

EC

C

D

E

F

G

H

I

J

K

L

M

DTC P0442 EVAP CONTROL SYSTEM

On Board Diagnosis Logic

This diagnosis detects leaks in the EVAP purge line using engine intake manifold vacuum. If pressure does not increase, the ECM will check for leaks in the line between the fuel tank and EVAP canister purge volume control solenoid valve, under the following Vacuum test conditions. The EVAP canister vent control valve is closed to shut the EVAP purge line off. The EVAP canister purge volume control solenoid valve will then be opened to depressurize the EVAP purge line using intake manifold vacuum. After this occurs, the EVAP canister purge volume control solenoid valve will be closed.

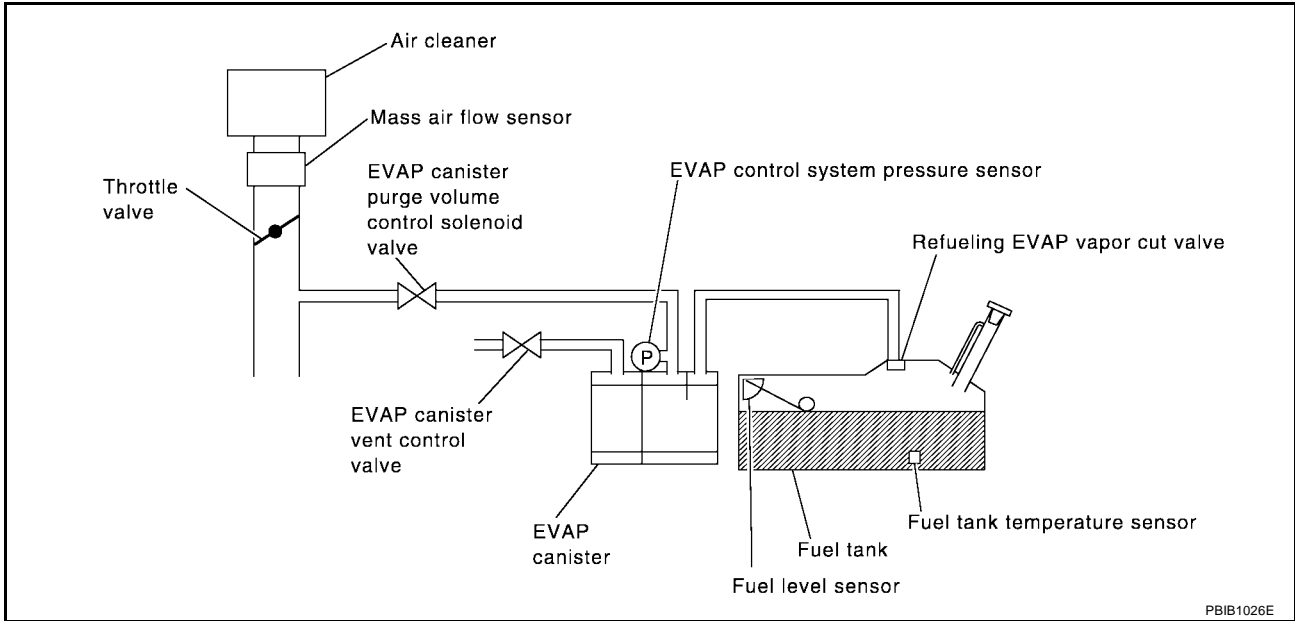

DTC No.	Trouble diagnosis name	DTC detecting condition	Possible cause
P0442 0442	EVAP control system small leak detected (negative pressure)	EVAP control system has a leak, EVAP control system does not operate properly.	<ul style="list-style-type: none"> ● Incorrect fuel tank vacuum relief valve ● Incorrect fuel filler cap used ● Fuel filler cap remains open or fails to close. ● Foreign matter caught in fuel filler cap. ● Leak is in line between intake manifold and EVAP canister purge volume control solenoid valve. ● Foreign matter caught in EVAP canister vent control valve. ● EVAP canister or fuel tank leaks ● EVAP purge line (pipe and rubber tube) leaks ● EVAP purge line rubber tube bent ● Loose or disconnected rubber tube ● EVAP canister vent control valve and the circuit ● EVAP canister purge volume control solenoid valve and the circuit ● Fuel tank temperature sensor ● O-ring of EVAP canister vent control valve is missing or damaged ● EVAP canister is saturated with water ● EVAP control system pressure sensor ● Fuel level sensor and the circuit ● Refueling EVAP vapor cut valve ● ORVR system leaks

CAUTION:

- Use only a genuine NISSAN fuel filler cap as a replacement. If an incorrect fuel filler cap is used, the MIL may come on.
- If the fuel filler cap is not tightened properly, the MIL may come on.
- Use only a genuine NISSAN rubber tube as a replacement.

DTC Confirmation Procedure

UBS00CD7

NOTE:

If DTC Confirmation Procedure has been previously conducted, always turn ignition switch OFF and wait at least 10 seconds before conducting the next test.

TESTING CONDITION:

- Perform “DTC WORK SUPPORT” when the fuel level is between 1/4 and 3/4 full, and vehicle is placed on flat level surface.
- Always perform test at a temperature of 0 to 30°C (32 to 86°F).
- Open engine hood before conducting following procedure.

WITH CONSULT-II

1. Turn ignition switch ON.
2. Turn ignition switch OFF and wait at least 10 seconds.
3. Turn ignition switch ON and select “DATA MONITOR” mode with CONSULT-II.
4. Check the following conditions are met.
COOLAN TEMP/S: 0 - 70°C (32 - 158°F)
INT/A TEMP SE: 0 - 30°C (32 - 86°F)
5. Select “EVAP SML LEAK P0442/P1442” of “EVAPORATIVE SYSTEM” in “DTC WORK SUPPORT” mode with CONSULT-II. Follow the instruction displayed.

DATA MONITOR	
MONITOR	DTC
ENG SPEED	XXX rpm
COOLAN TEMP/S	XXX °C
INT/A TEMP/S	XXX °C

SEF475Y

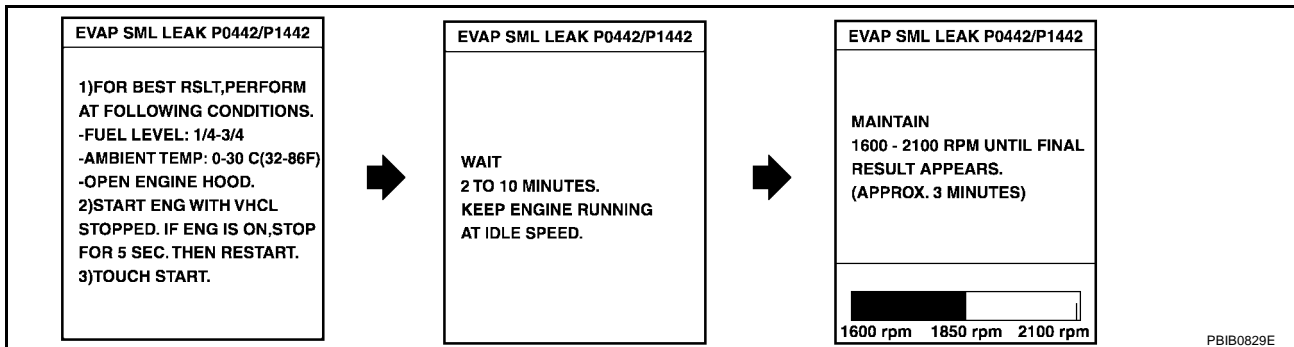

NOTE:

If the engine speed cannot be maintained within the range displayed on the CONSULT-II screen, go to [EC-75, "Basic Inspection"](#).

6. Make sure that “OK” is displayed. If “NG” is displayed, refer to [EC-300, "Diagnostic Procedure"](#).

NOTE:

Make sure that EVAP hoses are connected to the EVAP canister purge volume control solenoid valve properly.

EVAP SML LEAK P0442/P1442
OK
SELF-DIAG RESULTS
NO DTC DETECTED. FURTHER TESTING MAY BE REQUIRED.

SEC763C

WITH GST**NOTE:**

Be sure to read the explanation of Driving Pattern on [EC-63](#) before driving vehicle.

1. Start engine.
2. Drive vehicle according to Driving Pattern, [EC-63](#)
3. Stop vehicle.
4. Turn ignition switch OFF and wait at least 10 seconds and then turn ignition switch ON.
5. Select Service \$07 with GST.
 - If P0442 is displayed on the screen, go to [EC-300, "Diagnostic Procedure"](#) .
 - If P0441 is displayed on the screen, go to Diagnostic Procedure for DTC P0441, [EC-294](#) .

Diagnostic Procedure

UBS00CD8

1. CHECK FUEL FILLER CAP DESIGN

1. Turn ignition switch OFF.
2. Check for genuine NISSAN fuel filler cap design.

OK or NG

- OK >> GO TO 2.
 NG >> Replace with genuine NISSAN fuel filler cap.

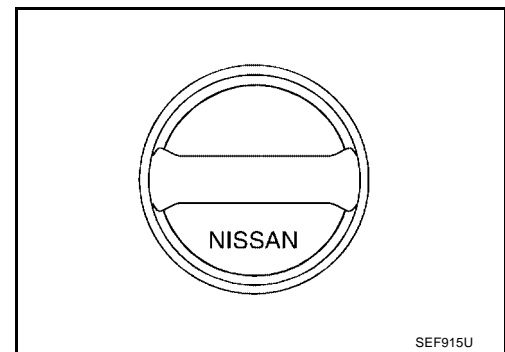

SEP915U

2. CHECK FUEL FILLER CAP INSTALLATION

Check that the cap is tightened properly by rotating the cap clockwise.

OK or NG

- OK >> GO TO 3.
 NG >> 1. Open fuel filler cap, then clean cap and fuel filler neck threads using air blower.
 2. Retighten until ratcheting sound is heard.

3. CHECK FUEL FILLER CAP FUNCTION

Check for air releasing sound while opening the fuel filler cap.

OK or NG

- OK >> GO TO 5.
 NG >> GO TO 4.

4. CHECK FUEL TANK VACUUM RELIEF VALVE

Refer to [EC-40, "FUEL TANK VACUUM RELIEF VALVE \(BUILT INTO FUEL FULLER CAP\)"](#) .

OK or NG

- OK >> GO TO 5.
 NG >> Replace fuel filler cap with a genuine one.

5. INSTALL THE PRESSURE PUMP

To locate the EVAP leak, install EVAP service port adapter and pressure pump to EVAP service port securely. For the location of EVAP service port, refer to [EC-38, "EVAPORATIVE EMISSION LINE DRAWING"](#).

NOTE:

Improper installation of the EVAP service port adapter to the EVAP service port may cause leaking.

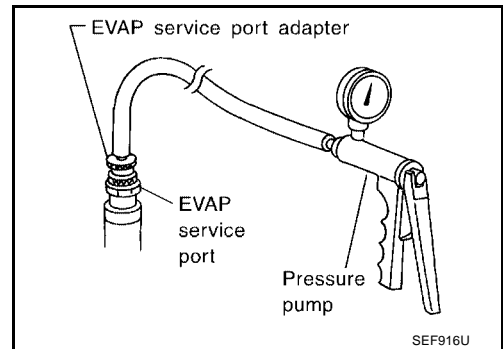
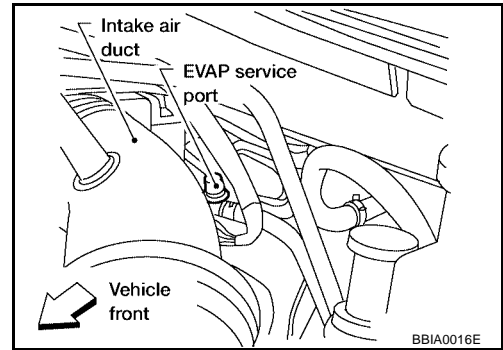

With CONSULT-II>>GO TO 6.
Without CONSULT-II>>GO TO 7.

6. CHECK FOR EVAP LEAK

With CONSULT-II

1. Turn ignition switch ON.
2. Select "EVAP SYSTEM CLOSE" of "WORK SUPPORT" mode with CONSULT-II.
3. Touch "START" and apply pressure into the EVAP line until the pressure indicator reaches the middle of the bar graph.

CAUTION:

- Never use compressed air or a high pressure pump.
- Do not exceed 4.12 kPa (0.042 kg/cm² , 0.6 psi) of pressure in the system.

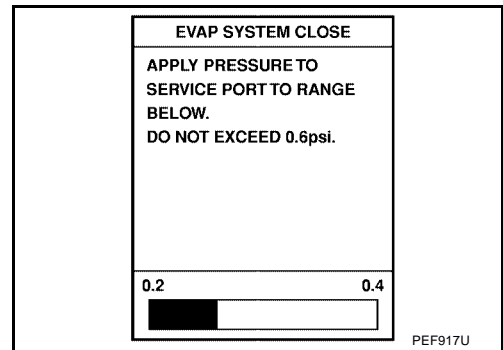

4. Using EVAP leak detector, locate the EVAP leak. For the leak detector, refer to the instruction manual for more details. Refer to [EC-38, "EVAPORATIVE EMISSION LINE DRAWING"](#).

OK or NG

- OK >> GO TO 8.
- NG >> Repair or replace.

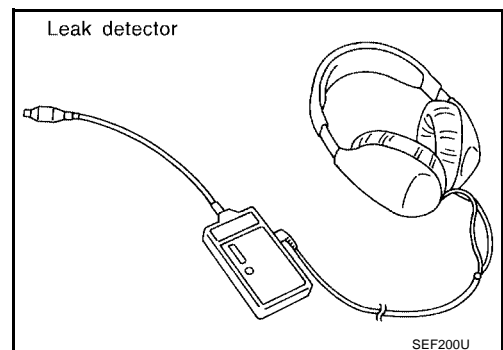

7. CHECK FOR EVAP LEAK

⊗ **Without CONSULT-II**

1. Turn ignition switch OFF.
2. Apply 12 volts DC to EVAP canister vent control valve. The valve will close. (Continue to apply 12 volts until the end of test.)

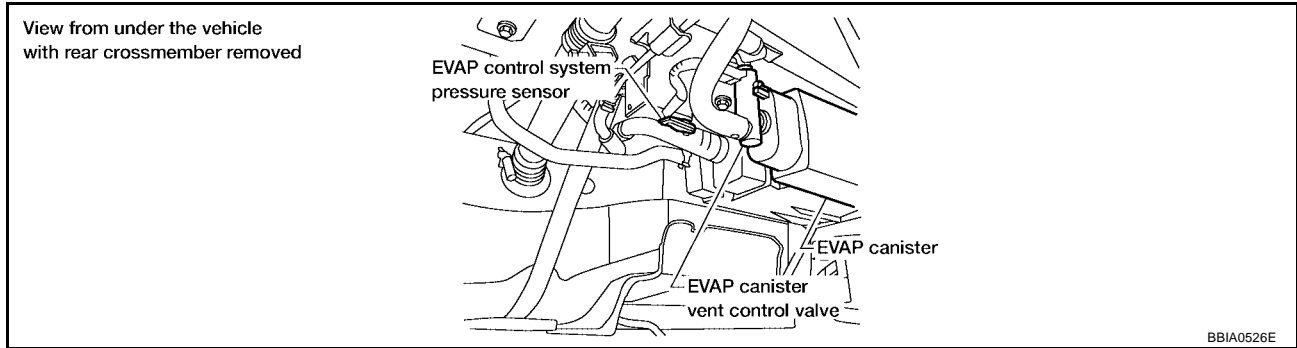

3. Pressurize the EVAP line using pressure pump with 1.3 to 2.7 kPa (10 to 20 mmHg, 0.39 to 0.79 inHg), then remove pump and EVAP service port adapter.

CAUTION:

- Never use compressed air or a high pressure pump.
- Do not exceed 4.12 kPa (0.042 kg/cm², 0.6 psi) of pressure in the system.

4. Using EVAP leak detector, locate the EVAP leak. For the leak detector, refer to the instruction manual for more details. Refer to [EC-38, "EVAPORATIVE EMISSION LINE DRAWING"](#).

OK or NG

- OK >> GO TO 8.
 NG >> Repair or replace.

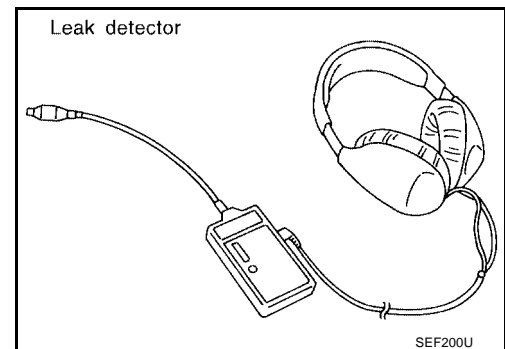

8. CHECK EVAP CANISTER VENT CONTROL VALVE

Check the following,

- EVAP canister vent control valve is installed properly.
Refer to [EC-41, "Removal and Installation"](#).
- EVAP canister vent control valve.
Refer to [EC-317, "Component Inspection"](#).

OK or NG

- OK >> GO TO 9.
 NG >> Repair or replace EVAP canister vent control valve and O-ring.

9. CHECK IF EVAP CANISTER SATURATED WITH WATER

1. Remove EVAP canister with EVAP canister vent control valve and EVAP control system pressure sensor attached.
2. Does water drain from the EVAP canister?

Yes or No

- Yes >> GO TO 10.
- No (With CONSULT-II)>>GO TO 12.
- No (Without CONSULT-II)>>GO TO 13.

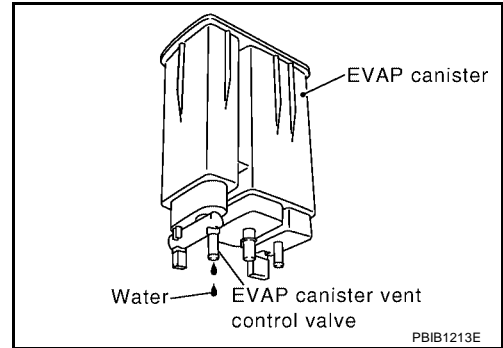

10. CHECK EVAP CANISTER

Weigh the EVAP canister with the EVAP canister vent control valve and EVAP control system pressure sensor attached.

The weight should be less than 2.1 kg (4.6 lb).

OK or NG

- OK (With CONSULT-II)>>GO TO 12.
- OK (Without CONSULT-II)>>GO TO 13.
- NG >> GO TO 11.

11. DETECT MALFUNCTIONING PART

Check the following.

- EVAP canister for damage
- EVAP hose connected to EVAP canister for clogging or poor connection

>> Repair hose or replace EVAP canister.

12. CHECK EVAP CANISTER PURGE VOLUME CONTROL SOLENOID VALVE OPERATION

With CONSULT-II

1. Disconnect vacuum hose to EVAP canister purge volume control solenoid valve at EVAP service port.
2. Start engine.
3. Perform "PURG VOL CONT/V" in "ACTIVE TEST" mode.
4. Touch "Qu" on CONSULT-II screen to increase "PURG VOL CONT/V" opening to 100%.
5. Check vacuum hose for vacuum when revving engine up to 2,000 rpm.

Vacuum should exist.

OK or NG

- OK >> GO TO 15.
- NG >> GO TO 14.

ACTIVE TEST	
PURG VOL CONT/V	XXX %
MONITOR	
ENG SPEED	XXX rpm
A/F ALPHA-B1	XXX %

PBIB1786E

13. CHECK EVAP CANISTER PURGE VOLUME CONTROL SOLENOID VALVE OPERATION

⊗ **Without CONSULT-II**

1. Start engine and warm it up to normal operating temperature.
2. Stop engine.
3. Disconnect vacuum hose to EVAP canister purge volume control solenoid valve at EVAP service port.
4. Start engine and let it idle for at least 80 seconds.
5. Check vacuum hose for vacuum when revving engine up to 2,000 rpm.

Vacuum should exist.

OK or NG

- OK >> GO TO 16.
NG >> GO TO 14.

14. CHECK VACUUM HOSE

Check vacuum hoses for clogging or disconnection. Refer to [EC-38, "EVAPORATIVE EMISSION LINE DRAWING"](#).

OK or NG

- OK >> GO TO 15.
NG >> Repair or reconnect the hose.

15. CHECK EVAP CANISTER PURGE VOLUME CONTROL SOLENOID VALVE

Refer to [EC-311, "Component Inspection"](#).

OK or NG

- OK >> GO TO 16.
NG >> Replace EVAP canister purge volume control solenoid valve.

16. CHECK FUEL TANK TEMPERATURE SENSOR

Refer to [EC-250, "Component Inspection"](#).

OK or NG

- OK >> GO TO 17.
NG >> Replace fuel level sensor unit.

17. CHECK EVAP CONTROL SYSTEM PRESSURE SENSOR

Refer to [EC-327, "Component Inspection"](#).

OK or NG

- OK >> GO TO 18.
NG >> Replace EVAP control system pressure sensor.

18. CHECK EVAP PURGE LINE

Check EVAP purge line (pipe, rubber tube, fuel tank and EVAP canister) for cracks or improper connection. Refer to [EC-37, "EVAPORATIVE EMISSION SYSTEM"](#).

OK or NG

- OK >> GO TO 19.
NG >> Repair or reconnect the hose.

19. CLEAN EVAP PURGE LINE

Clean EVAP purge line (pipe and rubber tube) using air blower.

>> GO TO 20.

20. CHECK EVAP/ORVR LINE

Check EVAP/ORVR line between EVAP canister and fuel tank for clogging, kink, looseness and improper connection. For location, refer to [EC-44, "ON BOARD REFUELING VAPOR RECOVERY \(ORVR\)"](#) .

OK or NG

- OK >> GO TO 21.
- NG >> Repair or replace hoses and tubes.

21. CHECK RECIRCULATION LINE

Check recirculation line between filler neck tube and fuel tank for clogging, kink, cracks, looseness and improper connection.

OK or NG

- OK >> GO TO 22.
- NG >> Repair or replace hoses, tubes or filler neck tube.

22. CHECK REFUELING EVAP VAPOR CUT VALVE

Refer to [EC-48, "Component Inspection"](#) .

OK or NG

- OK >> GO TO 23.
- NG >> Replace refueling EVAP vapor cut valve with fuel tank.

23. CHECK FUEL LEVEL SENSOR

Refer to [FL-5, "FUEL LEVEL SENSOR UNIT, FUEL FILTER AND FUEL PUMP ASSEMBLY"](#) .

OK or NG

- OK >> GO TO 24.
- NG >> Replace fuel level sensor unit.

24. CHECK INTERMITTENT INCIDENT

Refer to [EC-158, "TROUBLE DIAGNOSIS FOR INTERMITTENT INCIDENT"](#) .

>> **INSPECTION END**

A
EC
C
D
E
F
G
H
I
J
K
L
M

DTC P0444, P0445 EVAP CANISTER PURGE VOLUME CONTROL SOLENOID VALVE

[QR]

DTC P0444, P0445 EVAP CANISTER PURGE VOLUME CONTROL SOLENOID VALVE

PFP:14920

Description SYSTEM DESCRIPTION

UBS00CD9

Sensor	Input Signal to ECM	ECM function	Actuator
Crankshaft position sensor (POS) Camshaft position sensor (PHASE)	Engine speed* ¹	EVAP canister purge flow control	EVAP canister purge volume control solenoid valve
Mass air flow sensor	Amount of intake air		
Engine coolant temperature sensor	Engine coolant temperature		
Battery	Battery voltage* ¹		
Throttle position sensor	Throttle position		
Accelerator pedal position sensor	Accelerator pedal position		
Air fuel ratio (A/F) sensor 1	Density of oxygen in exhaust gas (Mixture ratio feedback signal)		
Fuel tank temperature sensor	Fuel temperature in fuel tank		
Vehicle speed signal* ²	Vehicle speed		

*1: The ECM determines the start signal status by the signal of engine speed and battery voltage.

*2: This signal is sent to the ECM through CAN communication line.

This system controls flow rate of fuel vapor from the EVAP canister. The opening of the vapor by-pass passage in the EVAP canister purge volume control solenoid valve changes to control the flow rate. The EVAP canister purge volume control solenoid valve repeats ON/OFF operation according to the signal sent from the ECM. The opening of the valve varies for optimum engine control. The optimum value stored in the ECM is determined by considering various engine conditions. When the engine is operating, the flow rate of fuel vapor from the EVAP canister is regulated as the air flow changes.

COMPONENT DESCRIPTION

The EVAP canister purge volume control solenoid valve uses a ON/OFF duty to control the flow rate of fuel vapor from the EVAP canister. The EVAP canister purge volume control solenoid valve is moved by ON/OFF pulses from the ECM. The longer the ON pulse, the greater the amount of fuel vapor that will flow through the valve.

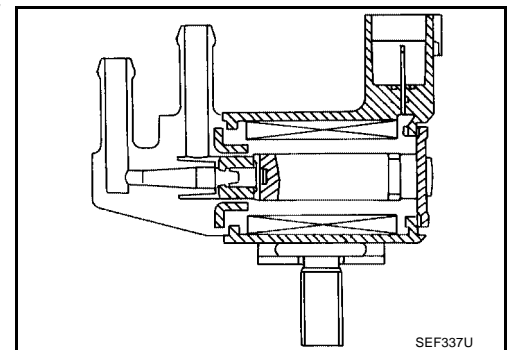

CONSULT-II Reference Value in Data Monitor Mode

UBS00CDA

Specification data are reference values.

MONITOR ITEM	CONDITION	SPECIFICATION
PURG VOL C/V	<ul style="list-style-type: none"> ● Engine: After warming up ● Shift lever: N (A/T), Neutral (M/T) ● Air conditioner switch: OFF ● No-load 	Idle (Accelerator pedal is not depressed even slightly, after engine starting) 0%
	2,000 rpm	20 - 30%

DTC P0444, P0445 EVAP CANISTER PURGE VOLUME CONTROL SOLENOID VALVE

[QR]

On Board Diagnosis Logic

UBS00CDB

DTC No.	Trouble diagnosis name	DTC detecting condition	Possible cause
P0444 0444	EVAP canister purge volume control solenoid valve circuit open	An excessively low voltage signal is sent to ECM through the valve	<ul style="list-style-type: none"> ● Harness or connectors (The solenoid valve circuit is open or shorted.) ● EVAP canister purge volume control solenoid valve
P0445 0445	EVAP canister purge volume control solenoid valve circuit shorted	An excessively high voltage signal is sent to ECM through the valve	<ul style="list-style-type: none"> ● Harness or connectors (The solenoid valve circuit is shorted.) ● EVAP canister purge volume control solenoid valve

DTC Confirmation Procedure

UBS00CDC

NOTE:

If DTC Confirmation Procedure has been previously conducted, always turn ignition switch OFF and wait at least 10 seconds before conducting the next test.

TESTING CONDITION:

Before performing the following procedure, confirm battery voltage is more than 11V at idle.

WITH CONSULT-II

1. Turn ignition switch ON.
2. Select "DATA MONITOR" mode with CONSULT-II.
3. Start engine and let it idle for at least 13 seconds.
4. If 1st trip DTC is detected, go to [EC-309, "Diagnostic Procedure"](#)

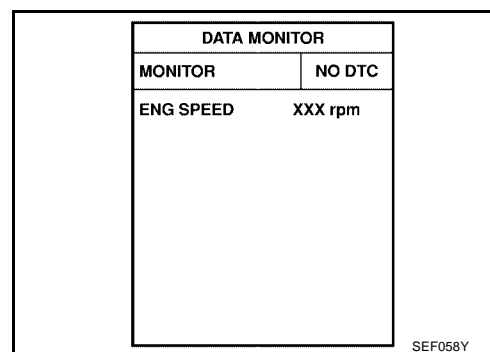

WITH GST

Follow the procedure "WITH CONSULT-II" above.

DTC P0444, P0445 EVAP CANISTER PURGE VOLUME CONTROL SOLENOID VALVE

[QR]

Wiring Diagram

UBS00CDD

EC-PGC/V-01

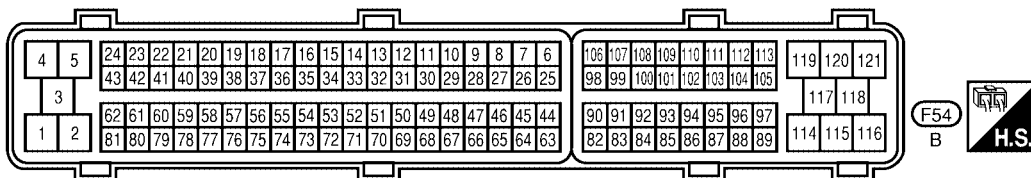
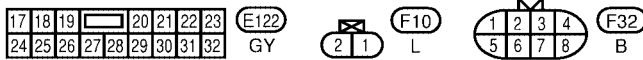
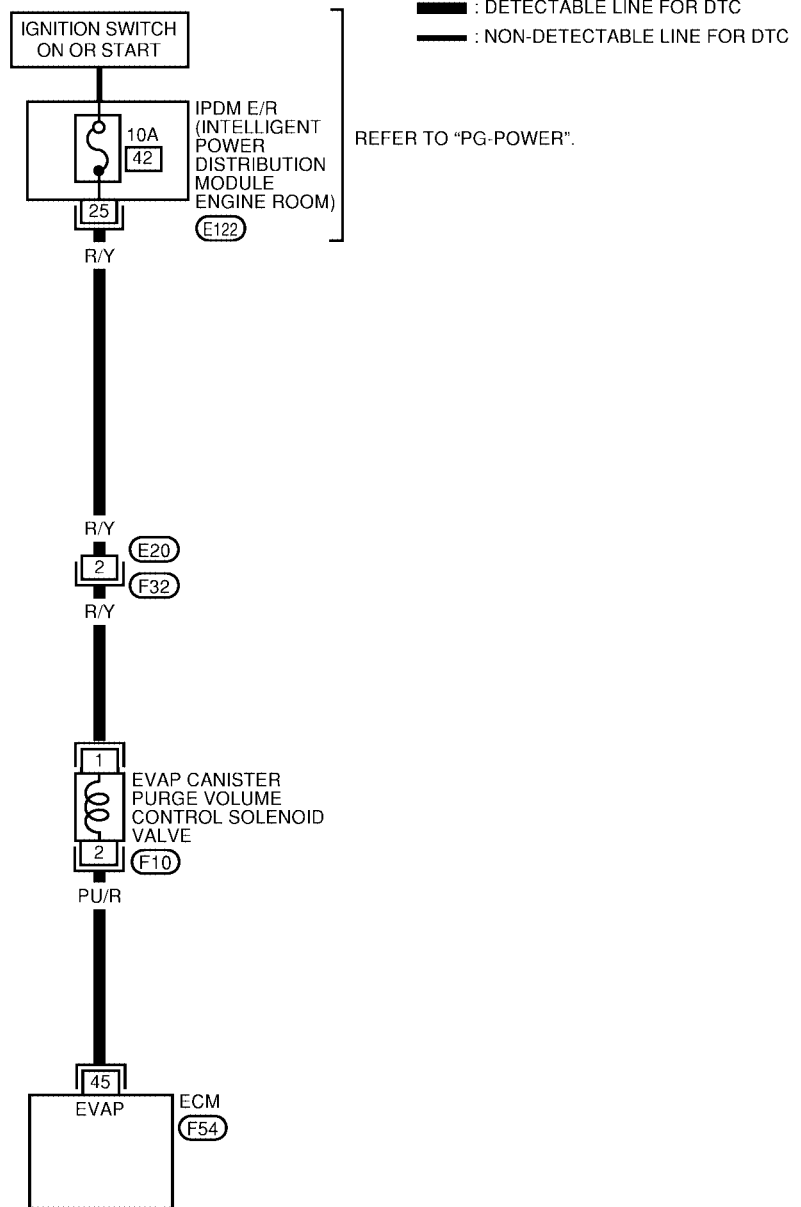

BBWA1227E

DTC P0444, P0445 EVAP CANISTER PURGE VOLUME CONTROL SOLENOID VALVE

[QR]

Specification data are reference values and are measured between each terminal and ground. Pulse signal is measured by CONSULT-II.

CAUTION:

Do not use ECM ground terminals when measuring input/output voltage. Doing so may result in damage to the ECM's transistor. Use a ground other than ECM terminals, such as the ground.

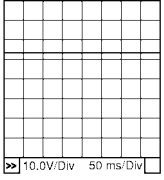
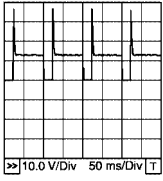
TER-MINAL NO.	WIRE COLOR	ITEM	CONDITION	DATA (DC Voltage)
45	PU/R	EVAP canister purge volume control solenoid valve	<p>[Engine is running]</p> <ul style="list-style-type: none"> ● Idle speed ● Accelerator pedal is not depressed even slightly, after engine starting 	<p>BATTERY VOLTAGE (11 - 14V)★</p>  <p>PBIB0050E</p>
			<p>[Engine is running]</p> <ul style="list-style-type: none"> ● Engine speed is about 2,000 rpm (More than 100 seconds after starting engine) 	<p>Approximately 10V★</p>  <p>PBIB0520E</p>

★: Average voltage for pulse signal (Actual pulse signal can be confirmed by oscilloscope.)

Diagnostic Procedure

UBS00CDE

1. CHECK EVAP CANISTER PURGE VOLUME CONTROL SOLENOID VALVE POWER SUPPLY CIRCUIT

1. Turn ignition switch OFF.
2. Disconnect EVAP canister purge volume control solenoid valve harness connector.
3. Turn ignition switch ON.

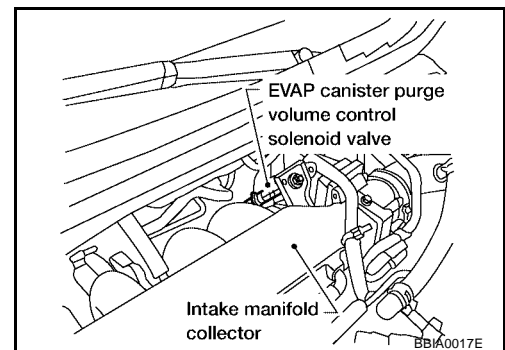

4. Check voltage between EVAP canister purge volume control solenoid valve terminal 1 and ground with CONSULT-II or tester.

Voltage: Battery voltage

OK or NG

- OK >> GO TO 3.
NG >> GO TO 2.

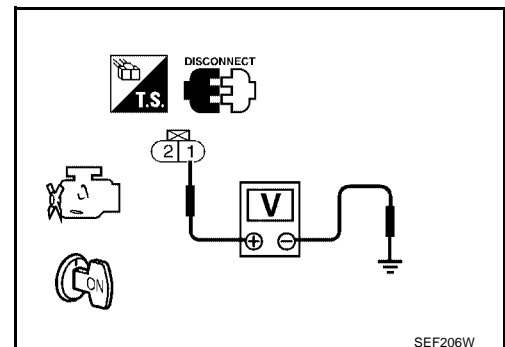

2. DETECT MALFUNCTIONING PART

Check the following.

- 10A fuse
- IPDM E/R harness connector E122
- Harness connectors E20, F32
- Harness for open or short between EVAP canister purge volume control solenoid valve and IPDM E/R

>> Repair open circuit or short to ground or short to power in harness or connectors.

3. CHECK EVAP CANISTER PURGE VOLUME CONTROL SOLENOID VALVE OUTPUT SIGNAL CIRCUIT FOR OPEN AND SHORT

1. Turn ignition switch OFF.
2. Disconnect ECM harness connector.
3. Check harness continuity between ECM terminal 45 and EVAP canister purge volume control solenoid valve terminal 2.
Refer to Wiring Diagram.

Continuity should exist.

4. Also check harness for short to ground and short to power.

OK or NG

OK (With CONSULT-II)>>GO TO 4.

OK (Without CONSULT-II)>>GO TO 5.

NG >> Repair open circuit or short to ground or short to power in harness or connectors.

4. CHECK EVAP CANISTER PURGE VOLUME CONTROL SOLENOID VALVE OPERATION

Ⓜ **With CONSULT-II**

1. Reconnect all harness connectors disconnected.
2. Start engine.
3. Perform "PURG VOL CONT/V" in "ACTIVE TEST" mode with CONSULT-II. Check that engine speed varies according to the valve opening.

OK or NG

OK >> GO TO 6.

NG >> GO TO 5.

ACTIVE TEST	
PURG VOL CONT/V	XXX %
MONITOR	
ENG SPEED	XXX rpm
A/F ALPHA-B1	XXX %

PBIB1786E

5. CHECK EVAP CANISTER PURGE VOLUME CONTROL SOLENOID VALVE

Refer to [EC-311, "Component Inspection"](#) .

OK or NG

OK >> GO TO 6.

NG >> Replace EVAP canister purge volume control solenoid valve.

6. CHECK INTERMITTENT INCIDENT

Refer to [EC-158, "TROUBLE DIAGNOSIS FOR INTERMITTENT INCIDENT"](#) .

>> **INSPECTION END**

DTC P0444, P0445 EVAP CANISTER PURGE VOLUME CONTROL SOLENOID VALVE

[QR]

UBS00CDF

Component Inspection

EVAP CANISTER PURGE VOLUME CONTROL SOLENOID VALVE

With CONSULT-II

Check air passage continuity of EVAP canister purge volume control solenoid valve under the following conditions.

Condition (PURG VOL CONT/V value)	Air passage continuity between A and B
100%	Yes
0%	No

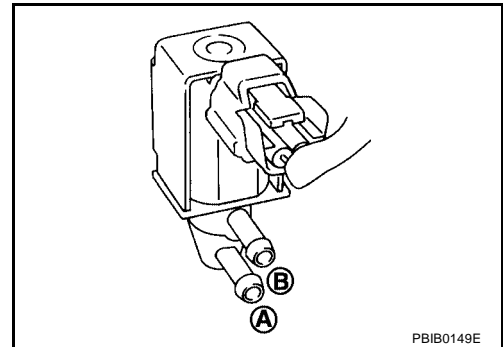

Without CONSULT-II

Check air passage continuity of EVAP canister purge volume control solenoid valve under the following conditions.

Condition	Air passage continuity between A and B
12V direct current supply between terminals 1 and 2	Yes
No supply	No

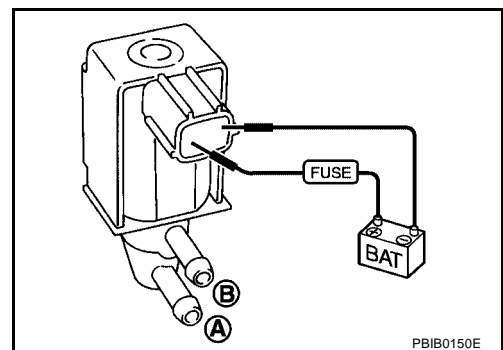

Removal and Installation

EVAP CANISTER PURGE VOLUME CONTROL SOLENOID VALVE

Refer to [EM-19, "INTAKE MANIFOLD"](#).

UBS00CDG

DTC P0447 EVAP CANISTER VENT CONTROL VALVE

PF1:14935

Component Description

UBS00CDH

The EVAP canister vent control valve is located on the EVAP canister and is used to seal the canister vent.

This solenoid valve responds to signals from the ECM. When the ECM sends an ON signal, the coil in the solenoid valve is energized. A plunger will then move to seal the canister vent. The ability to seal the vent is necessary for the on board diagnosis of other evaporative emission control system components.

This solenoid valve is used only for diagnosis, and usually remains opened.

When the vent is closed, under normal purge conditions, the evaporative emission control system is depressurized and allows EVAP Control System diagnoses.

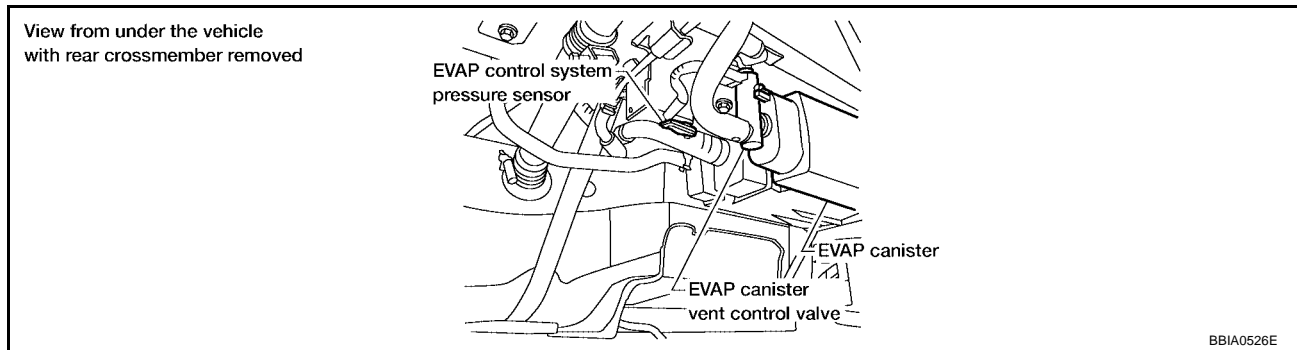
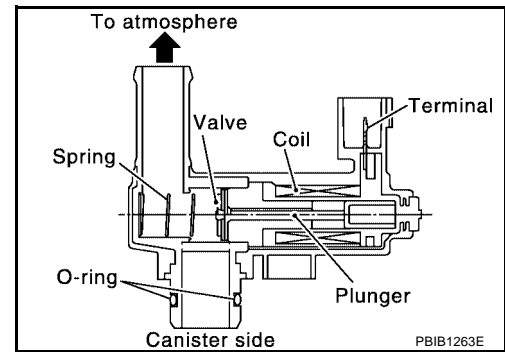

CONSULT-II Reference Value in Data Monitor Mode

UBS00CDI

Specification data are reference values.

MONITOR ITEM	CONDITION	SPECIFICATION
VENT CONT/V	● Ignition switch: ON	OFF

On Board Diagnosis Logic

UBS00CDJ

DTC No.	Trouble diagnosis name	DTC detecting condition	Possible cause
P0447 0447	EVAP canister vent control valve circuit open	An improper voltage signal is sent to ECM through EVAP canister vent control valve.	<ul style="list-style-type: none"> ● Harness or connectors (The valve circuit is open or shorted.) ● EVAP canister vent control valve

DTC Confirmation Procedure

UBS00CDK

NOTE:

If DTC Confirmation Procedure has been previously conducted, always turn ignition switch OFF and wait at least 10 seconds before conducting the next test.

TESTING CONDITION:

Before performing the following procedure, confirm battery voltage is more than 11V at idle.

WITH CONSULT-II

1. Turn ignition switch ON.

DTC P0447 EVAP CANISTER VENT CONTROL VALVE

[QR]

2. Select "DATA MONITOR" mode with CONSULT-II.
3. Start engine and wait at least 8 seconds.
4. If 1st trip DTC is detected, go to [EC-315, "Diagnostic Procedure"](#)

DATA MONITOR	
MONITOR	NO DTC
ENG SPEED	XXX rpm

SEF058Y

A

EC

C

D

E

F

G

H

I

J

K

L

M

WITH GST

Follow the procedure "WITH CONSULT-II" above.

DTC P0447 EVAP CANISTER VENT CONTROL VALVE

[QR]

Wiring Diagram

UBS00CDL

EC-VENT/V-01

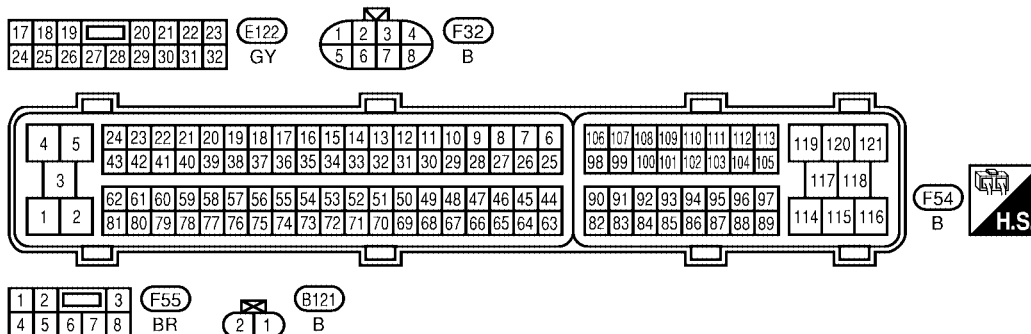
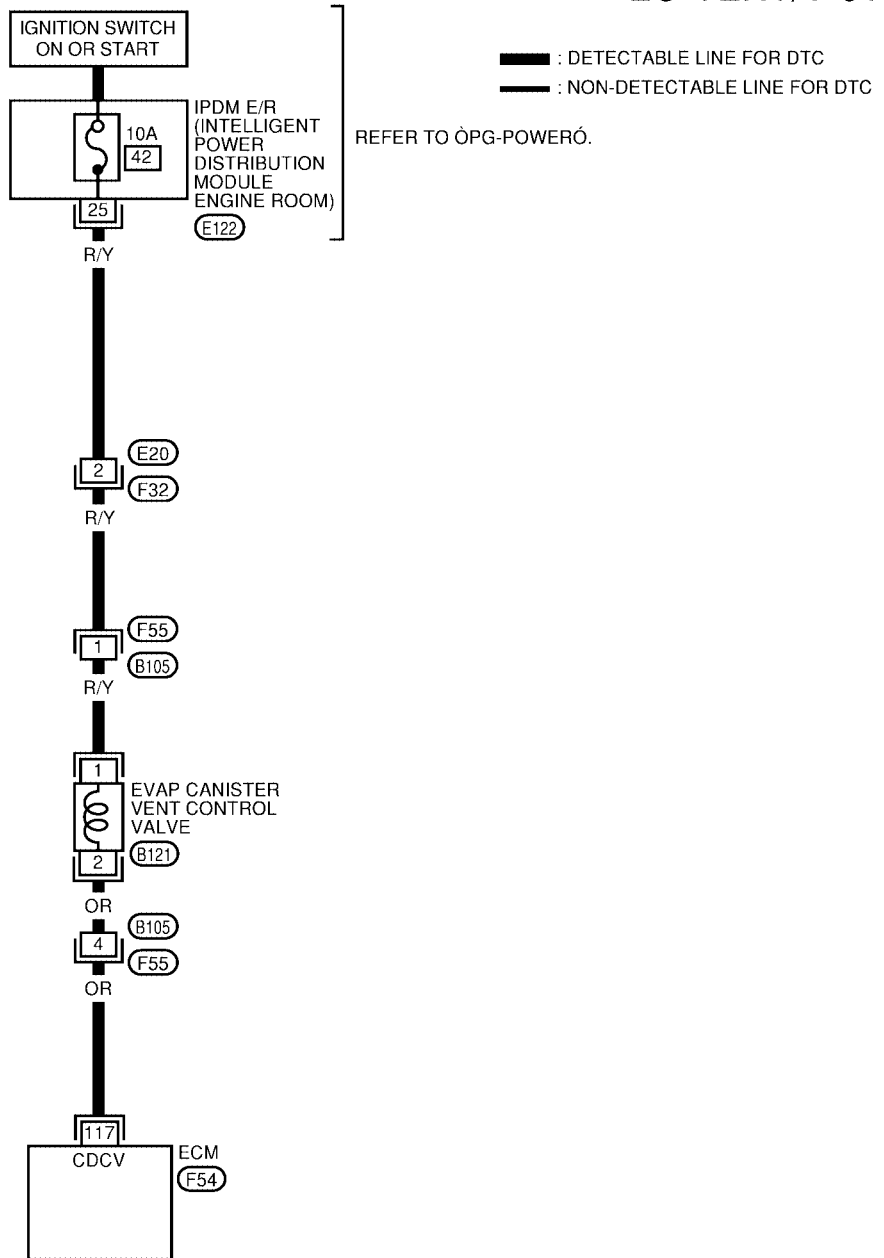

BBWA1228E

DTC P0447 EVAP CANISTER VENT CONTROL VALVE

[QR]

Specification data are reference values and are measured between each terminal and ground.

CAUTION:

Do not use ECM ground terminals when measuring input/output voltage. Doing so may result in damage to the ECM's transistor. Use a ground other than ECM terminals, such as the ground.

TER-MINAL NO.	WIRE COLOR	ITEM	CONDITION	DATA (DC Voltage)
117	OR	EVAP canister vent control valve	[Ignition switch: ON]	BATTERY VOLTAGE (11 - 14V)

Diagnostic Procedure

UBS00CDM

1. INSPECTION START

1. Do you have CONSULT-II?

Yes or No

- Yes >> GO TO 2.
- No >> GO TO 3.

2. CHECK EVAP CANISTER VENT CONTROL VALVE CIRCUIT

 **With CONSULT-II**

1. Turn ignition switch OFF and then turn ON.
2. Select "VENT CONTROL/V" in "ACTIVE TEST" mode with CONSULT-II.
3. Touch "ON/OFF" on CONSULT-II screen.
4. Check for operating sound of the valve.
Clicking noise should be heard.

OK or NG

- OK >> GO TO 7.
- NG >> GO TO 3.

ACTIVE TEST	
VENT CONTROL/V	OFF
MONITOR	
ENG SPEED	XXX rpm
A/F ALPHA-B1	XXX %

PBIB1787E

3. CHECK EVAP CANISTER VENT CONTROL VALVE POWER SUPPLY CIRCUIT

1. Turn ignition switch OFF.
2. Disconnect EVAP canister vent control valve harness connector.

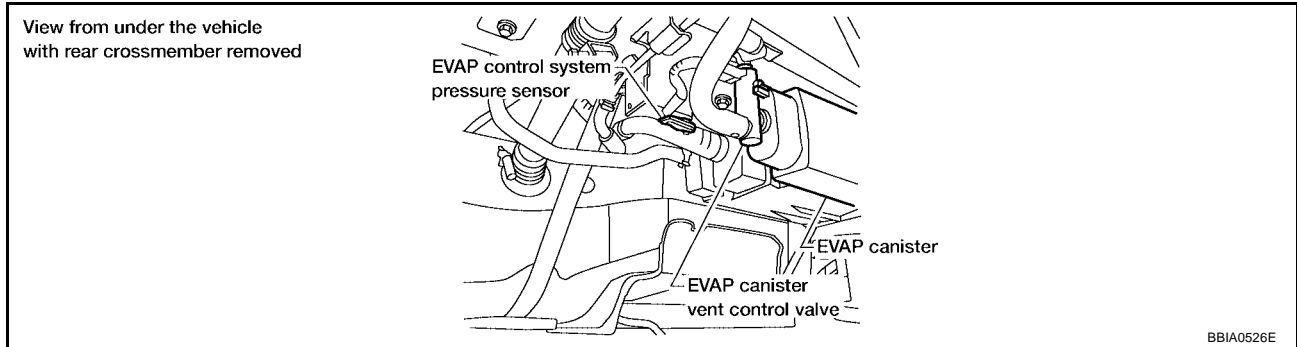

3. Turn ignition switch ON.
4. Check voltage between EVAP canister vent control valve terminal 1 and ground with CONSULT-II or tester.

Voltage: Battery voltage

OK or NG

- OK >> GO TO 5.
 NG >> GO TO 4.

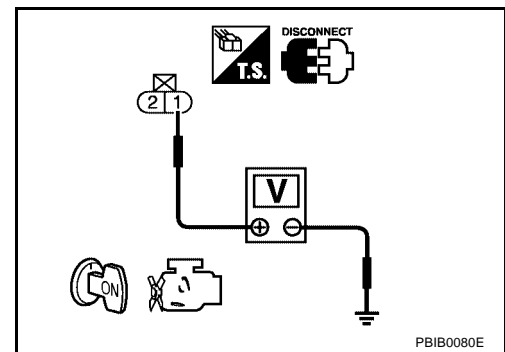

4. DETECT MALFUNCTIONING PART

Check the following.

- Harness connectors E20, F32
- Harness connectors F55, B105
- IPDM E/R harness connectors E122
- 10A fuse
- Harness for open or short between EVAP canister vent control valve and IPDM E/R

>> Repair open circuit or short to ground or short to power in harness or connectors.

5. CHECK EVAP CANISTER VENT CONTROL VALVE OUTPUT SIGNAL CIRCUIT FOR OPEN AND SHORT

1. Turn ignition switch OFF.
2. Disconnect ECM harness connector.
3. Check harness continuity between ECM terminal 117 and EVAP canister vent control valve terminal 2. Refer to Wiring Diagram.

Continuity should exist.

4. Also check harness for short to ground and short to power.

OK or NG

- OK >> GO TO 7.
 NG >> GO TO 6.

6. DETECT MALFUNCTIONING PART

Check the following.

- Harness connectors B105, F55
- Harness for open or short between EVAP canister vent control valve and ECM

>> Repair open circuit or short to ground or short to power in harness or connectors.

7. CHECK RUBBER TUBE FOR CLOGGING

1. Disconnect rubber tube connected to EVAP canister vent control valve.
2. Check the rubber tube for clogging.

OK or NG

- OK >> GO TO 8.
- NG >> Clean the rubber tube using an air blower.

8. CHECK EVAP CANISTER VENT CONTROL VALVE

Refer to [EC-317, "Component Inspection"](#) .

OK or NG

- OK >> GO TO 9.
- NG >> Replace EVAP canister vent control valve.

9. CHECK INTERMITTENT INCIDENT

Refer to [EC-158, "TROUBLE DIAGNOSIS FOR INTERMITTENT INCIDENT"](#) .

>> INSPECTION END

Component Inspection EVAP CANISTER VENT CONTROL VALVE

UBS00CDN

With CONSULT-II

1. Remove EVAP canister vent control valve from EVAP canister.
2. Check portion **B** of EVAP canister vent control valve for being rusted.
If NG, replace EVAP canister vent control valve.
If OK, go to next step.
3. Reconnect harness connectors disconnected.
4. Turn ignition switch ON.

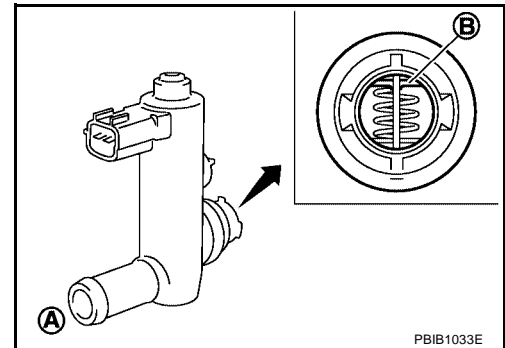

5. Perform "VENT CONTROL/V" in "ACTIVE TEST" mode.
6. Check air passage continuity and operation delay time.
Make sure new O-ring is installed properly.

Condition VENT CONTROL/V	Air passage continuity between A and B
ON	No
OFF	Yes

Operation takes less than 1 second.

- If NG, replace EVAP canister vent control valve.
- If OK, go to next step.

ACTIVE TEST	
VENT CONTROL/V	OFF
MONITOR	
ENG SPEED	XXX rpm
A/F ALPHA-B1	XXX %

PBIB1787E

DTC P0447 EVAP CANISTER VENT CONTROL VALVE

[QR]

7. Clean the air passage (Portion **A** to **B**) of EVAP canister vent control valve using an air blower.
8. Perform step 6 again.

⊗ **Without CONSULT-II**

1. Remove EVAP canister vent control valve from EVAP canister.
2. Check portion **B** of EVAP canister vent control valve for being rusted.

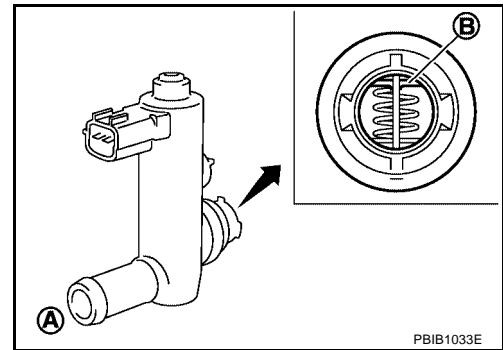

3. Check air passage continuity and operation delay time under the following conditions.

Make sure new O-ring is installed properly.

Condition	Air passage continuity between A and B
12V direct current supply between terminals 1 and 2	No
OFF	Yes

Operation takes less than 1 second.

If NG, replace EVAP canister vent control valve.
If OK, go to next step.

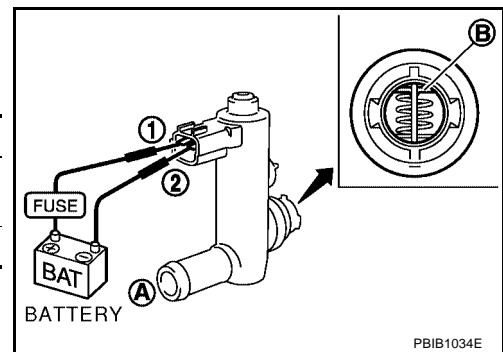

4. Clean the air passage (Portion **A** to **B**) of EVAP canister vent control valve using an air blower.
5. Perform step 3 again.

DTC P0451 EVAP CONTROL SYSTEM PRESSURE SENSOR

[QR]

DTC P0451 EVAP CONTROL SYSTEM PRESSURE SENSOR

PFP:22365

Component Description

UBS00CUU

The EVAP control system pressure sensor detects pressure in the purge line. The sensor output voltage to the ECM increases as pressure increases.

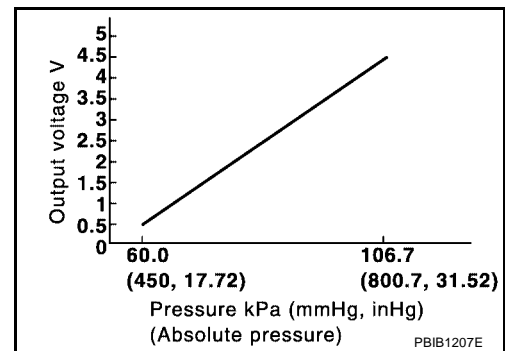
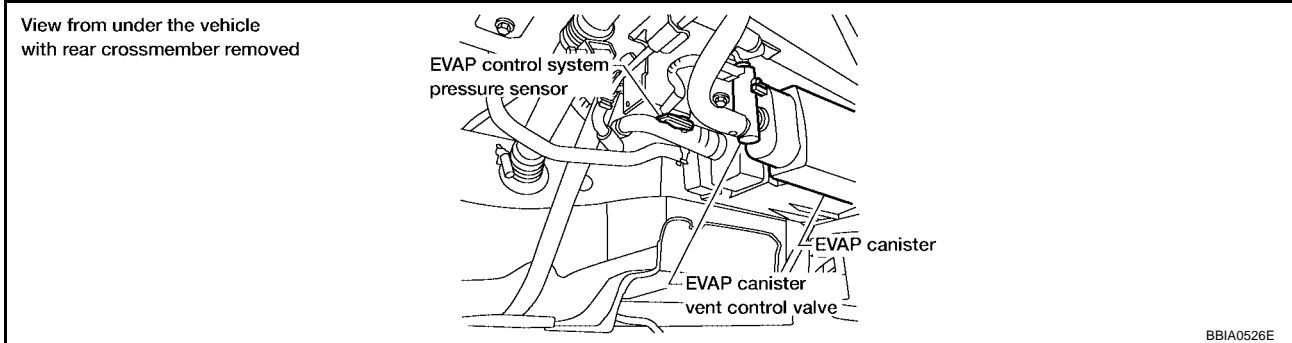

CONSULT-II Reference Value in Data Monitor Mode

UBS00CUV

Specification data are reference values.

MONITOR ITEM	CONDITION	SPECIFICATION
EVAP SYS PRES	● Ignition switch: ON	Approx. 1.8 - 4.8V

On Board Diagnosis Logic

UBS00CUW

NOTE:

If DTC P0451 is displayed with DTC P1229, first perform the trouble diagnosis for DTC P1229. Refer to [EC-438](#).

DTC No.	Trouble diagnosis name	DTC detecting condition	Possible cause
P0451 0451	EVAP control system pressure sensor performance	ECM detects a sloshing signal from the EVAP control system pressure sensor	<ul style="list-style-type: none"> ● Harness or connectors ● EVAP control system pressure sensor

DTC P0451 EVAP CONTROL SYSTEM PRESSURE SENSOR

[QR]

UBS00CUX

DTC Confirmation Procedure

NOTE:

If DTC Confirmation Procedure has been previously conducted, always turn ignition switch OFF and wait at least 10 seconds before conducting the next test.

④ WITH CONSULT-II

1. Turn ignition switch OFF and wait at least 10 seconds.
2. Turn ignition switch ON and select "DATA MONITOR" mode with CONSULT-II.
3. Start engine and wait at least 40 seconds.

NOTE:

Do not depress accelerator pedal even slightly.

If 1st trip DTC is detected, go to [EC-320, "Diagnostic Procedure"](#)

DATA MONITOR	
MONITOR	NO DTC
ENG SPEED	XXX rpm
COOLAN TEMP/S	XXX °C
FUEL T/TMP SE	XXX °C

SEF194Y

④ WITH GST

Follow the procedure "WITH CONSULT-II" above.

Diagnostic Procedure

UBS00CUY

1. CHECK GROUND CONNECTIONS

1. Turn ignition switch OFF.
2. Loosen and retighten three ground screws on the body. Refer to [EC-164, "Ground Inspection"](#).

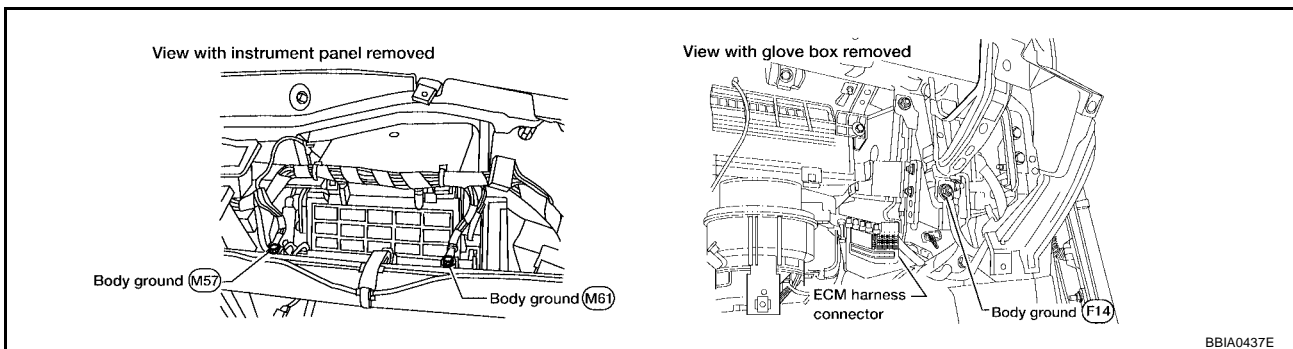

OK or NG

- OK >> GO TO 2.
NG >> Repair or replace ground connections.

2. CHECK EVPA CONTROL SYSTEM PRESSURE SENSOR CONNECTOR FOR WATER

1. Disconnect EVAP control system pressure sensor harness connector.

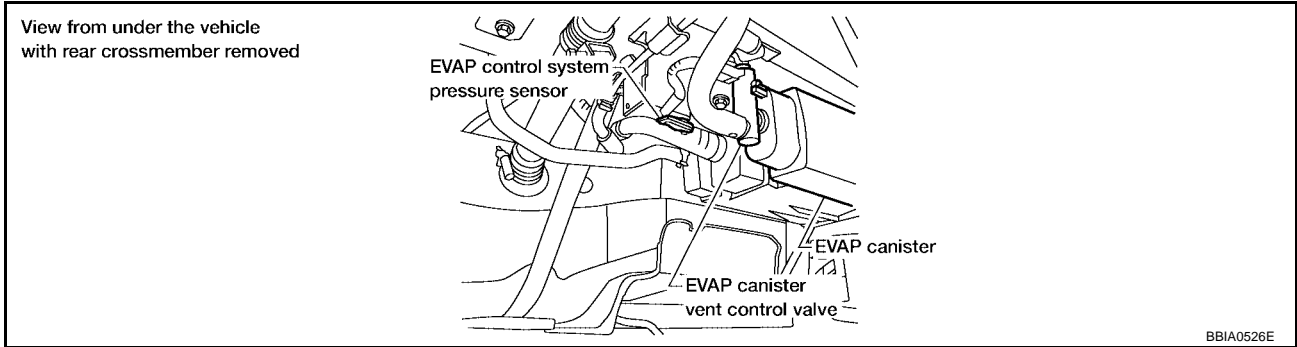

2. Check sensor harness connector for water.

Water should not exist.

OK or NG

- OK >> GO TO 3.
- NG >> Repair or replace harness connector.

3. CHECK EVAP CONTROL SYSTEM PRESSURE SENSOR

Refer to [EC-321, "Component Inspection"](#) .

OK or NG

- OK >> GO TO 4.
- NG >> Replace EVAP control system pressure sensor.

4. CHECK INTERMITTENT INCIDENT

Refer to [EC-158, "TROUBLE DIAGNOSIS FOR INTERMITTENT INCIDENT"](#) .
For wiring diagram, refer to [EC-324](#) .

>> INSPECTION END

Component Inspection EVAP CONTROL SYSTEM PRESSURE SENSOR

UBS00CUZ

1. Remove EVAP control system pressure sensor with its harness connector connected from EVAP canister.
Do not reuse the O-ring, replace it with a new one.
2. Install a vacuum pump to EVAP control system pressure sensor.
3. Turn ignition switch ON and check output voltage between ECM terminal 32 and ground under the following conditions.

Applied vacuum kPa (mmHg, inHg)	Voltage V
Not applied	1.8 - 4.8
-26.7 (-200, -7.87)	2.1 to 2.5V lower than above value

CAUTION:

- Always calibrate the vacuum pump gauge when using it.
- Do not apply below -93.3 kPa (-700 mmHg, -27.56 inHg) or pressure over 101.3 kPa (760 mmHg, 29.92 inHg).

4. If NG, replace EVAP control system pressure sensor.

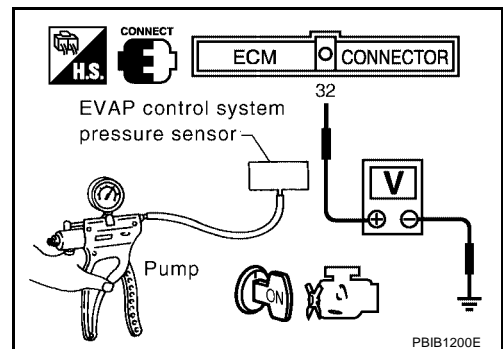

DTC P0452 EVAP CONTROL SYSTEM PRESSURE SENSOR

[QR]

DTC P0452 EVAP CONTROL SYSTEM PRESSURE SENSOR

PFP:25085

Component Description

UBS00CDO

The EVAP control system pressure sensor detects pressure in the purge line. The sensor output voltage to the ECM increases as pressure increases.

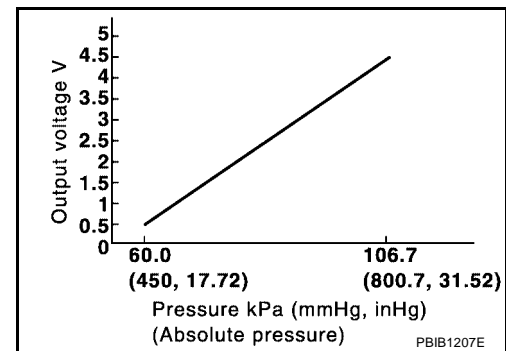
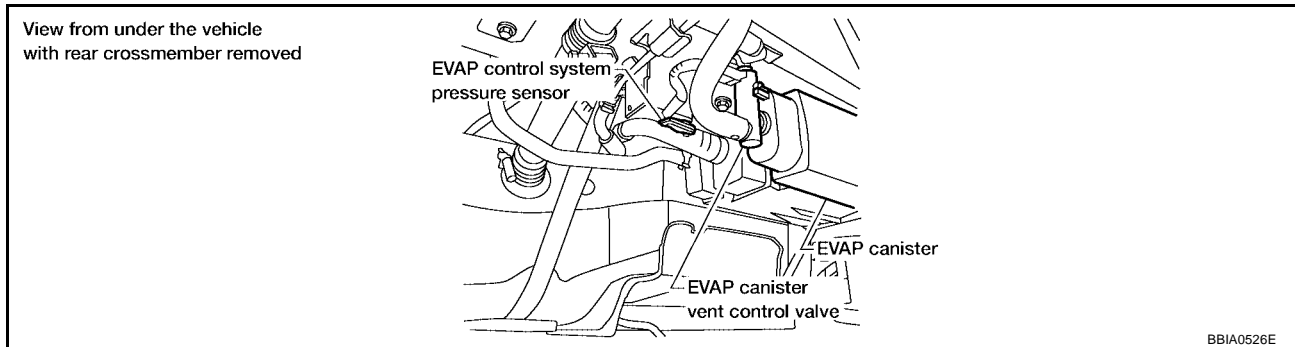

CONSULT-II Reference Value in Data Monitor Mode

UBS00CDP

Specification data are reference values.

MONITOR ITEM	CONDITION	SPECIFICATION
EVAP SYS PRES	● Ignition switch: ON	Approx. 1.8 - 4.8V

On Board Diagnosis Logic

UBS00CDQ

NOTE:

If DTC P0452 is displayed with DTC P1229, first perform the trouble diagnosis for DTC P1229. Refer to [EC-438](#).

DTC No.	Trouble diagnosis name	DTC detecting condition	Possible cause
P0452 0452	EVAP control system pressure sensor low input	An excessively low voltage from the sensor is sent to ECM.	<ul style="list-style-type: none"> ● Harness or connectors (The sensor circuit is open or shorted.) ● EVAP control system pressure sensor

DTC Confirmation Procedure

NOTE:

If DTC Confirmation Procedure has been previously conducted, always turn ignition switch OFF and wait at least 10 seconds before conducting the next test.

TESTING CONDITION:

Always perform test at a temperature of 5°C (41°F) or more.

WITH CONSULT-II

1. Start engine and warm it up to normal operating temperature.
2. Turn ignition switch OFF and wait at least 10 seconds.
3. Turn ignition switch ON.
4. Select "DATA MONITOR" mode with CONSULT-II.
5. Make sure that "FUEL T/TMP SE" is more than 0°C (32°F).
6. Start engine and wait at least 20 seconds.
If 1st trip DTC is detected, go to [EC-325, "Diagnostic Procedure"](#)

DATA MONITOR	
MONITOR	NO DTC
ENG SPEED	XXX rpm
COOLAN TEMP/S	XXX °C
FUEL T/TMP SE	XXX °C

SEF194Y

WITH GST

1. Start engine and warm it up to normal operating temperature.
2. Check that voltage between ECM terminal 107 (Fuel tank temperature sensor signal) and ground is less than 4.2V.
3. Turn ignition switch OFF and wait at least 10 seconds.
4. Start engine and wait at least 20 seconds.
5. Select Service \$07 with GST.
If 1st trip DTC is detected, go to [EC-325, "Diagnostic Procedure"](#)

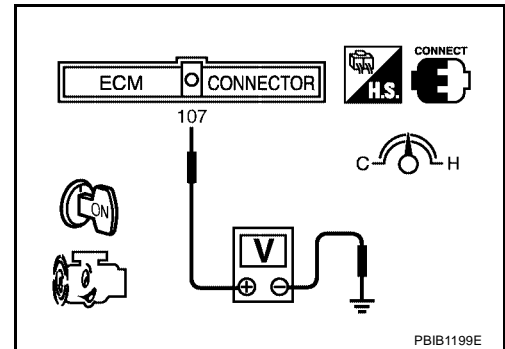

DTC P0452 EVAP CONTROL SYSTEM PRESSURE SENSOR

[QR]

Wiring Diagram

UBS00CDS

EC-PRE/SE-01

: DETECTABLE LINE FOR DTC
 : NON-DETECTABLE LINE FOR DTC

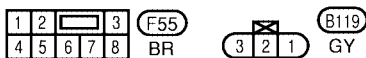
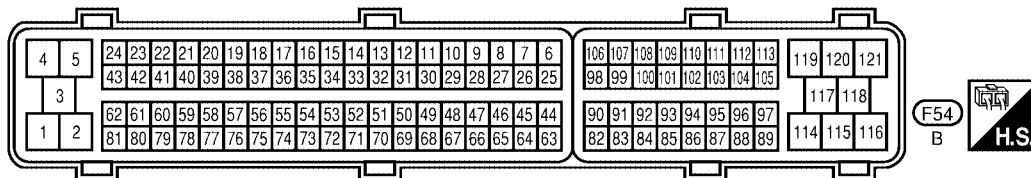
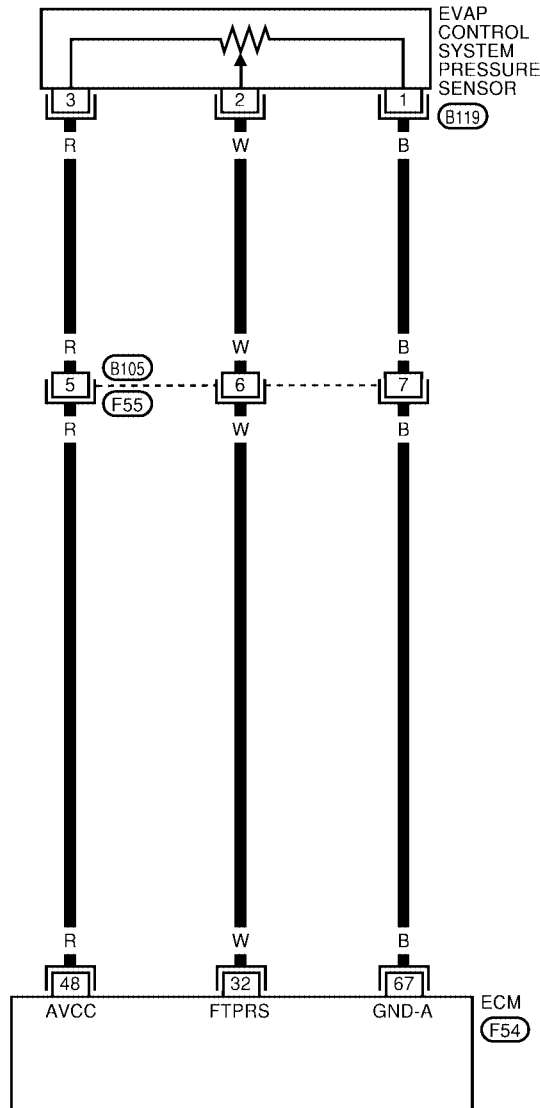

BBWA1229E

DTC P0452 EVAP CONTROL SYSTEM PRESSURE SENSOR

[QR]

Specification data are reference values and are measured between each terminal and ground.

CAUTION:

Do not use ECM ground terminals when measuring input/output voltage. Doing so may result in damage to the ECM's transistor. Use a ground other than ECM terminals, such as the ground.

TER-MINAL NO.	WIRE COLOR	ITEM	CONDITION	DATA (DC Voltage)
32	W	EVAP control system pressure sensor	[Ignition switch: ON]	Approximately 1.8 - 4.8V
48	R	Sensor power supply (EVAP control system pressure sensor)	[Ignition switch: ON]	Approximately 5V
67	B	Sensor ground	[Engine is running] ● Warm-up condition ● Idle speed	Approximately 0V

Diagnostic Procedure

UBS00CDT

1. CHECK GROUND CONNECTIONS

1. Turn ignition switch OFF.
2. Loosen and retighten three ground screws on the body. Refer to [EC-164, "Ground Inspection"](#).

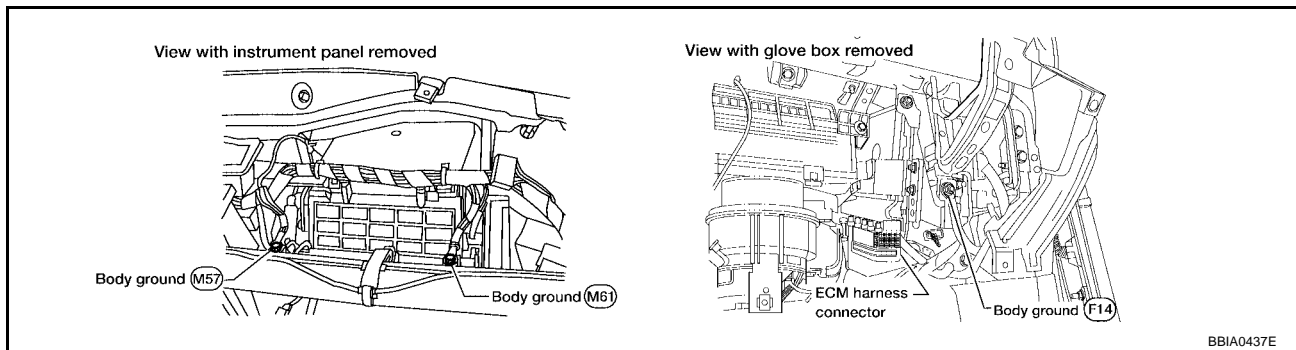

OK or NG

- OK >> GO TO 2.
- NG >> Repair or replace ground connections.

2. CHECK CONNECTOR

1. Disconnect EVAP control system pressure sensor harness connector.

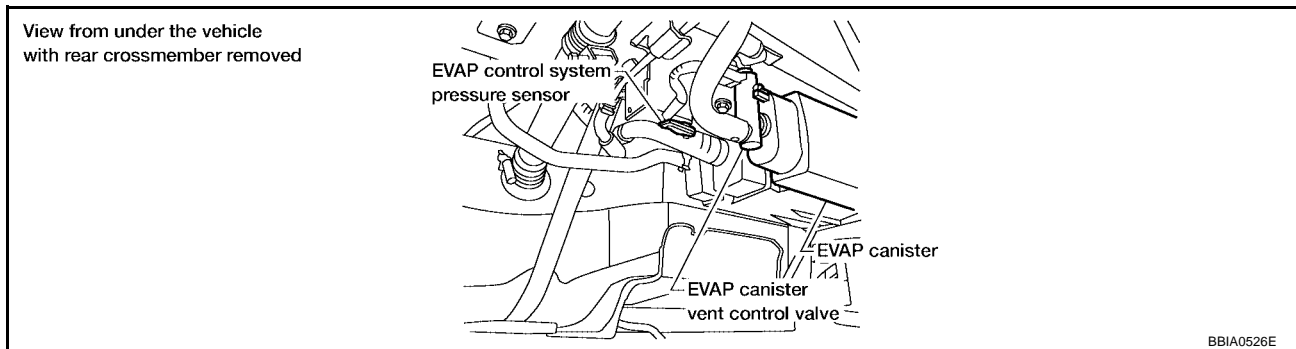

2. Check sensor harness connector for water.

Water should not exist.

OK or NG

- OK >> GO TO 3.
- NG >> Repair or replace harness connector.

3. CHECK EVAP CONTROL SYSTEM PRESSURE SENSOR POWER SUPPLY CIRCUIT

1. Turn ignition switch ON.
2. Check voltage between EVAP control system pressure sensor terminal 3 and ground with CONSULT-II or tester.

Voltage: Approximately 5V

OK or NG

- OK >> GO TO 5.
 NG >> GO TO 4.

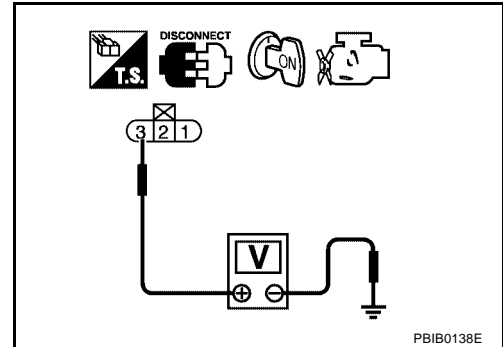

4. DETECT MALFUNCTIONING PART

Check the following.

- Harness connectors B105, F55
- Harness for open or short between EVAP control system pressure sensor and ECM

>> Repair open circuit or short to ground or short to power in harness or connectors.

5. CHECK EVAP CONTROL SYSTEM PRESSURE SENSOR GROUND CIRCUIT FOR OPEN AND SHORT

1. Turn ignition switch OFF.
2. Disconnect ECM harness connector.
3. Check harness continuity between EVAP control system pressure sensor terminal 1 and ECM terminal 67.
Refer to Wiring Diagram.

Continuity should exist.

4. Also check harness for short to ground and short to power.

OK or NG

- OK >> GO TO 7.
 NG >> GO TO 6.

6. DETECT MALFUNCTIONING PART

Check the following.

- Harness connectors B105, F55
- Harness for open or short between EVAP control system pressure sensor and ECM

>> Repair open circuit or short to ground or short to power in harness or connectors.

7. CHECK EVAP CONTROL SYSTEM PRESSURE SENSOR INPUT SIGNAL CIRCUIT FOR OPEN AND SHORT

1. Check harness continuity between ECM terminal 32 and EVAP control system pressure sensor terminal 2.
Refer to Wiring Diagram.

Continuity should exist.

2. Also check harness for short to ground and short to power.

OK or NG

- OK >> GO TO 9.
- NG >> GO TO 8.

8. DETECT MALFUNCTIONING PART

Check the following.

- Harness connectors B105, F55
- Harness for open or short between ECM and EVAP control system pressure sensor

>> Repair open circuit or short to ground or short to power in harness or connectors.

9. CHECK EVAP CONTROL SYSTEM PRESSURE SENSOR

Refer to [EC-327, "Component Inspection"](#) .

OK or NG

- OK >> GO TO 10.
- NG >> Replace EVAP control system pressure sensor.

10. CHECK INTERMITTENT INCIDENT

Refer to [EC-158, "TROUBLE DIAGNOSIS FOR INTERMITTENT INCIDENT"](#) .

>> INSPECTION END

Component Inspection EVAP CONTROL SYSTEM PRESSURE SENSOR

UBS00CDU

1. Remove EVAP control system pressure sensor with its harness connector connected from EVAP canister.
Do not reuse the O-ring, replace it with a new one.
2. Install a vacuum pump to EVAP control system pressure sensor.
3. Turn ignition switch ON and check output voltage between ECM terminal 32 and ground under the following conditions.

Applied vacuum kPa (mmHg, inHg)	Voltage V
Not applied	1.8 - 4.8
-26.7 (-200, -7.87)	2.1 to 2.5V lower than above value

CAUTION:

- Always calibrate the vacuum pump gauge when using it.
 - Do not apply below -93.3 kPa (-700 mmHg, -27.56 inHg) or pressure over 101.3 kPa (760 mmHg, 29.92 inHg).
4. If NG, replace EVAP control system pressure sensor.

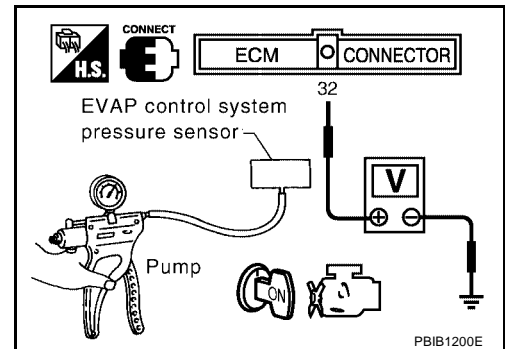

DTC P0453 EVAP CONTROL SYSTEM PRESSURE SENSOR

[QR]

DTC P0453 EVAP CONTROL SYSTEM PRESSURE SENSOR

PFP:25085

Component Description

UBS00CDV

The EVAP control system pressure sensor detects pressure in the purge line. The sensor output voltage to the ECM increases as pressure increases.

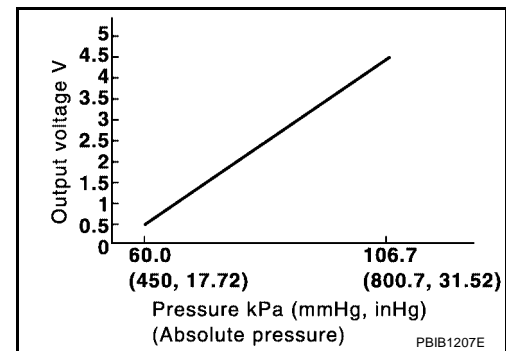
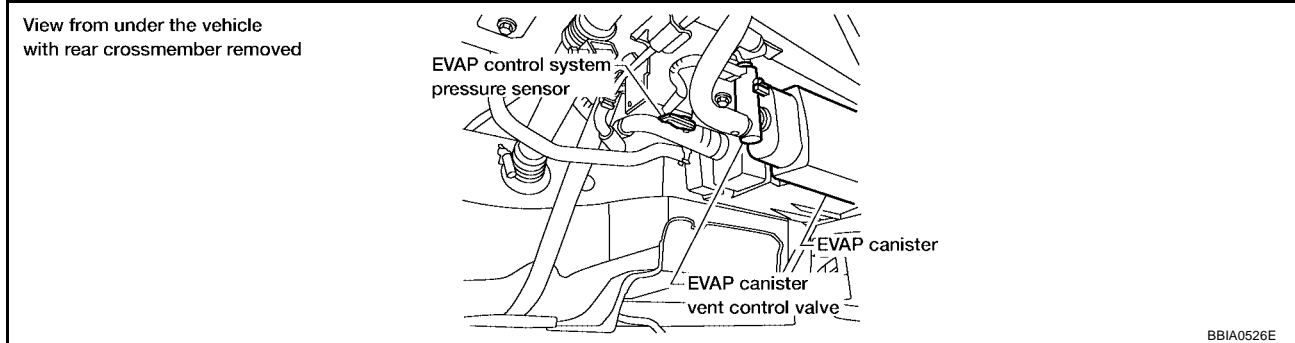

CONSULT-II Reference Value in Data Monitor Mode

UBS00CDW

Specification data are reference values.

MONITOR ITEM	CONDITION	SPECIFICATION
EVAP SYS PRES	● Ignition switch: ON	Approx. 1.8 - 4.8V

On Board Diagnosis Logic

UBS00CDX

NOTE:

If DTC P0453 is displayed with DTC P1229, first perform the trouble diagnosis for DTC P1229. Refer to [EC-438](#).

DTC No.	Trouble diagnosis name	DTC detecting condition	Possible cause
P0453 0453	EVAP control system pressure sensor high input	An excessively high voltage from the sensor is sent to ECM.	<ul style="list-style-type: none"> ● Harness or connectors (The sensor circuit is open or shorted.) ● EVAP control system pressure sensor ● EVAP canister vent control valve ● EVAP canister ● Rubber hose to EVAP canister vent control valve

DTC Confirmation Procedure

NOTE:

If DTC Confirmation Procedure has been previously conducted, always turn ignition switch OFF and wait at least 10 seconds before conducting the next test.

TESTING CONDITION:

Always perform test at a temperature of 5°C (41°F) or more.

WITH CONSULT-II

1. Start engine and warm it up to normal operating temperature.
2. Turn ignition switch OFF and wait at least 10 seconds.
3. Turn ignition switch ON.
4. Select "DATA MONITOR" mode with CONSULT-II.
5. Make sure that "FUEL T/TMP SE" is more than 0°C (32°F).
6. Wait at least 10 seconds.
If 1st trip DTC is detected, go to [EC-331, "Diagnostic Procedure"](#)

DATA MONITOR	
MONITOR	NO DTC
ENG SPEED	XXX rpm
COOLAN TEMP/S	XXX °C
FUEL T/TMP SE	XXX °C

SEF194Y

WITH GST

1. Start engine and warm it up to normal operating temperature.
2. Check that voltage between ECM terminal 107 (Fuel tank temperature sensor signal) and ground is less than 4.2V.
3. Turn ignition switch OFF and wait at least 10 seconds.
4. Wait at least 10 seconds.
5. Select Service \$07 with GST.
If 1st trip DTC is detected, go to [EC-331, "Diagnostic Procedure"](#)

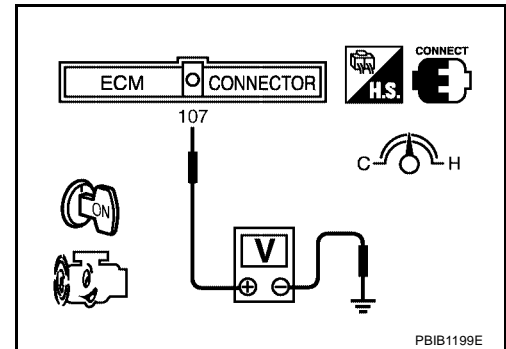

DTC P0453 EVAP CONTROL SYSTEM PRESSURE SENSOR

[QR]

Wiring Diagram

UBS00CDZ

EC-PRE/SE-01

: DETECTABLE LINE FOR DTC
 : NON-DETECTABLE LINE FOR DTC

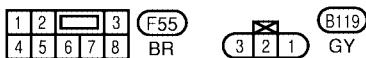
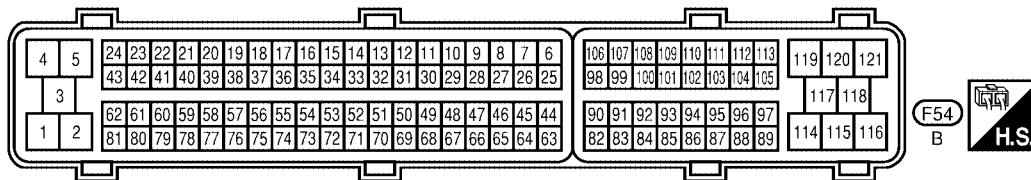
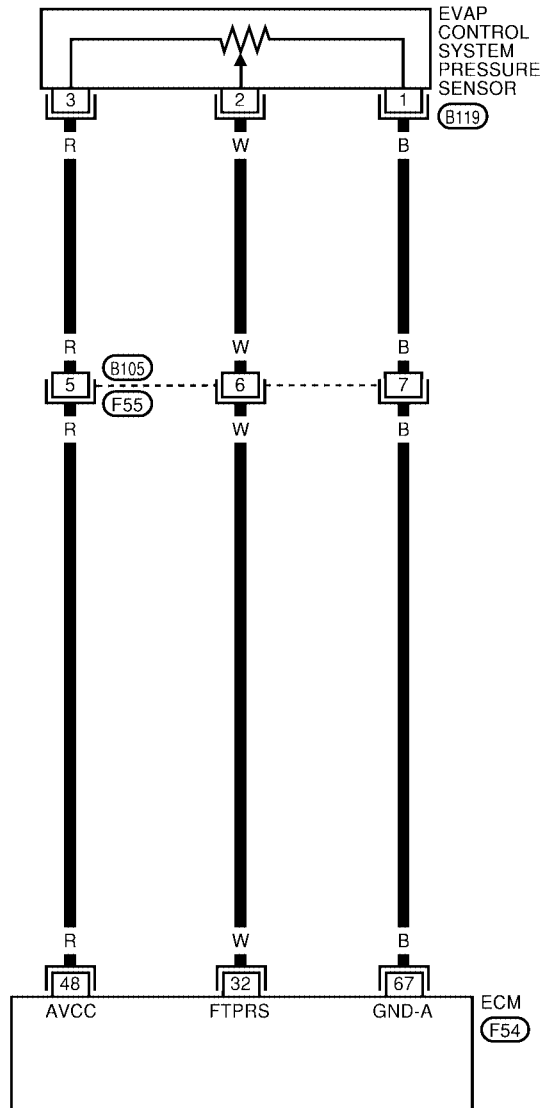

BBWA1229E

DTC P0453 EVAP CONTROL SYSTEM PRESSURE SENSOR

[QR]

Specification data are reference values and are measured between each terminal and ground.

CAUTION:

Do not use ECM ground terminals when measuring input/output voltage. Doing so may result in damage to the ECM's transistor. Use a ground other than ECM terminals, such as the ground.

TERMINAL NO.	WIRE COLOR	ITEM	CONDITION	DATA (DC Voltage)
32	W	EVAP control system pressure sensor	[Ignition switch: ON]	Approximately 1.8 - 4.8V
48	R	Sensor power supply (EVAP control system pressure sensor)	[Ignition switch: ON]	Approximately 5V
67	B	Sensor ground	[Engine is running] ● Warm-up condition ● Idle speed	Approximately 0V

Diagnostic Procedure

UBS00CE0

1. CHECK GROUND CONNECTIONS

1. Turn ignition switch OFF.
2. Loosen and retighten three ground screws on the body. Refer to [EC-164, "Ground Inspection"](#).

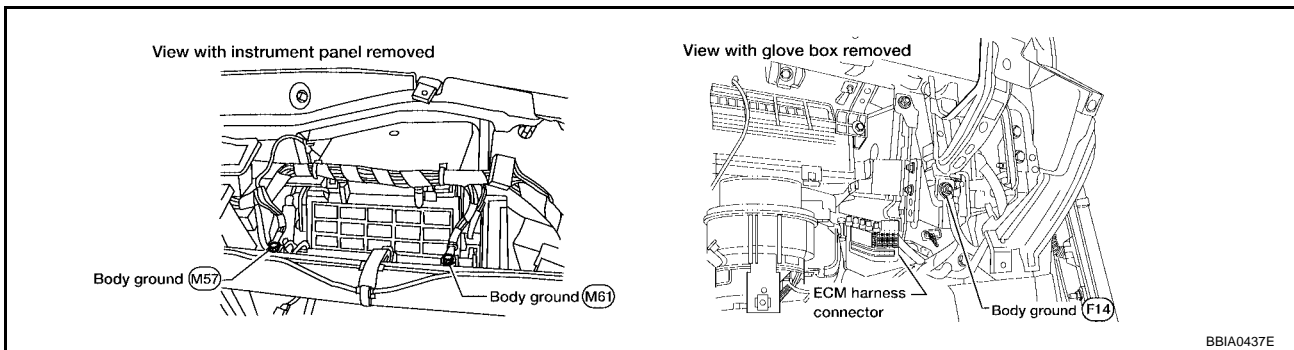

OK or NG

- OK >> GO TO 2.
- NG >> Repair or replace ground connections.

2. CHECK CONNECTOR

1. Disconnect EVAP control system pressure sensor harness connector.

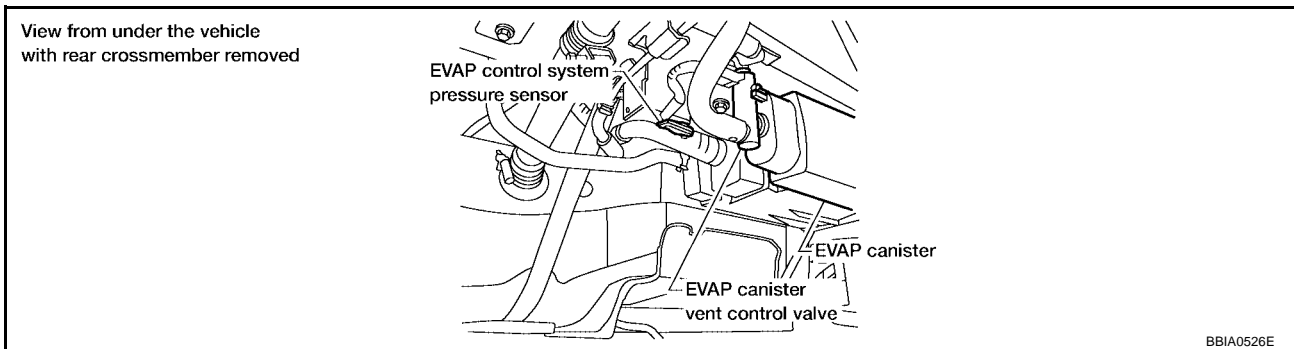

2. Check sensor harness connector for water.

Water should not exist.

OK or NG

- OK >> GO TO 3.
- NG >> Repair or replace harness connector.

3. CHECK EVAP CONTROL SYSTEM PRESSURE SENSOR POWER SUPPLY CIRCUIT

1. Turn ignition switch ON.
2. Check voltage between EVAP control system pressure sensor terminal 3 and ground with CONSULT-II or tester.

Voltage: Approximately 5V

OK or NG

- OK >> GO TO 5.
NG >> GO TO 4.

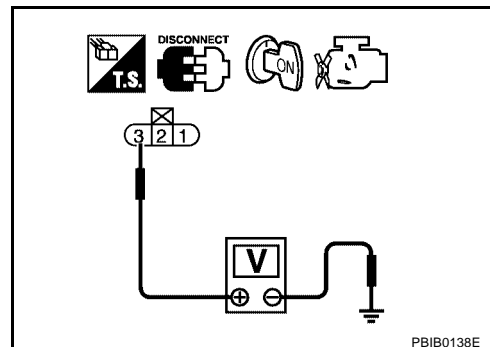

4. DETECT MALFUNCTIONING PART

Check the following.

- Harness connectors B105, F55
- Harness for open or short between EVAP control system pressure sensor and ECM

>> Repair open circuit or short to ground or short to power in harness or connectors.

5. CHECK EVAP CONTROL SYSTEM PRESSURE SENSOR GROUND CIRCUIT FOR OPEN AND SHORT

1. Turn ignition switch OFF.
2. Disconnect ECM harness connector.
3. Check harness continuity between EVAP control system pressure sensor terminal 1 and ECM terminal 67.
Refer to Wiring Diagram.

Continuity should exist.

4. Also check harness for short to ground and short to power.

OK or NG

- OK >> GO TO 7.
NG >> GO TO 6.

6. DETECT MALFUNCTIONING PART

Check the following.

- Harness connectors B105, F55
- Harness for open or short between EVAP control system pressure sensor and ECM

>> Repair open circuit or short to ground or short to power in harness or connectors.

7. CHECK EVAP CONTROL SYSTEM PRESSURE SENSOR INPUT SIGNAL CIRCUIT FOR OPEN AND SHORT

1. Check harness continuity between ECM terminal 32 and EVAP control system pressure sensor terminal 2.
Refer to Wiring Diagram.

Continuity should exist.

2. Also check harness for short to ground and short to power.

OK or NG

- OK >> GO TO 9.
NG >> GO TO 8.

8. DETECT MALFUNCTIONING PART

Check the following.

- Harness connectors B105, F55
- Harness for open or short between ECM and EVAP control system pressure sensor

>> Repair open circuit or short to ground or short to power in harness or connectors.

9. CHECK RUBBER TUBE

1. Disconnect rubber tube connected to EVAP canister vent control valve.
2. Check the rubber tube for clogging, vent and kinked.

OK or NG

- OK >> GO TO 10.
NG >> Clean the rubber tube using an air blower, repair or replace rubber tube.

10. CHECK EVAP CANISTER VENT CONTROL VALVE

Refer to [EC-317, "Component Inspection"](#) .

OK or NG

- OK >> GO TO 11.
NG >> Replace EVAP canister vent control valve.

11. CHECK EVAP CONTROL SYSTEM PRESSURE SENSOR

Refer to [EC-334, "Component Inspection"](#) .

OK or NG

- OK >> GO TO 12.
NG >> Replace EVAP control system pressure sensor.

12. CHECK IF EVAP CANISTER SATURATED WITH WATER

1. Remove EVAP canister with EVAP canister vent control valve and EVAP control system pressure sensor attached.
2. Check if water will drain from the EVAP canister.

Yes or No

- Yes >> GO TO 13.
- No >> GO TO 15.

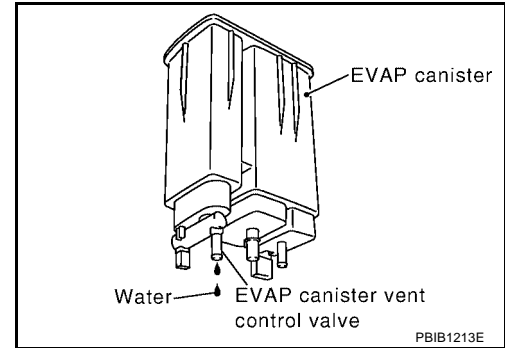

13. CHECK EVAP CANISTER

Weigh the EVAP canister with the EVAP canister vent control valve and EVAP control system pressure sensor attached.

The weight should be less than 2.1 kg (4.6 lb).

OK or NG

- OK >> GO TO 15.
- NG >> GO TO 14.

14. DETECT MALFUNCTIONING PART

Check the following.

- EVAP canister for damage
- EVAP hose connected to EVAP canister for clogging or poor connection

>> Repair hose or replace EVAP canister.

15. CHECK INTERMITTENT INCIDENT

Refer to [EC-158. "TROUBLE DIAGNOSIS FOR INTERMITTENT INCIDENT"](#) .

>> INSPECTION END

Component Inspection EVAP CONTROL PRESSURE SENSOR

UBS00CE1

1. Remove EVAP control system pressure sensor with its harness connector connected from EVAP canister.
Do not reuse the O-ring, replace it with a new one.
2. Install a vacuum pump to EVAP control system pressure sensor.
3. Turn ignition switch ON and check output voltage between ECM terminal 32 and ground under the following conditions.

Applied vacuum kPa (mmHg, inHg)	Voltage V
Not applied	1.8 - 4.8
-26.7 (-200, -7.87)	2.1 to 2.5V lower than above value

CAUTION:

- Always calibrate the vacuum pump gauge when using it.
 - Do not apply below -93.3 kPa (-700 mmHg, -27.56 inHg) or pressure over 101.3 kPa (760 mmHg, 29.92 inHg).
4. If NG, replace EVAP control system pressure sensor.

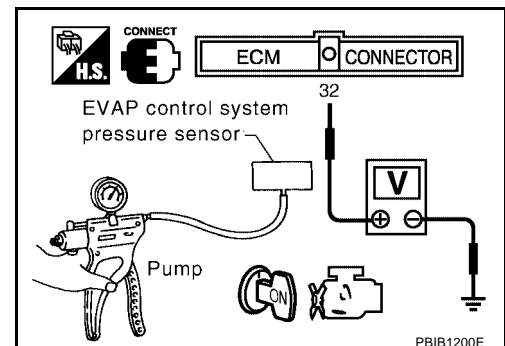

DTC P0455 EVAP CONTROL SYSTEM

PFP:14950

On Board Diagnosis Logic

UBS00CE2

This diagnosis detects a very large leak (fuel filler cap fell off etc.) in EVAP system between the fuel tank and EVAP canister purge volume control solenoid valve.

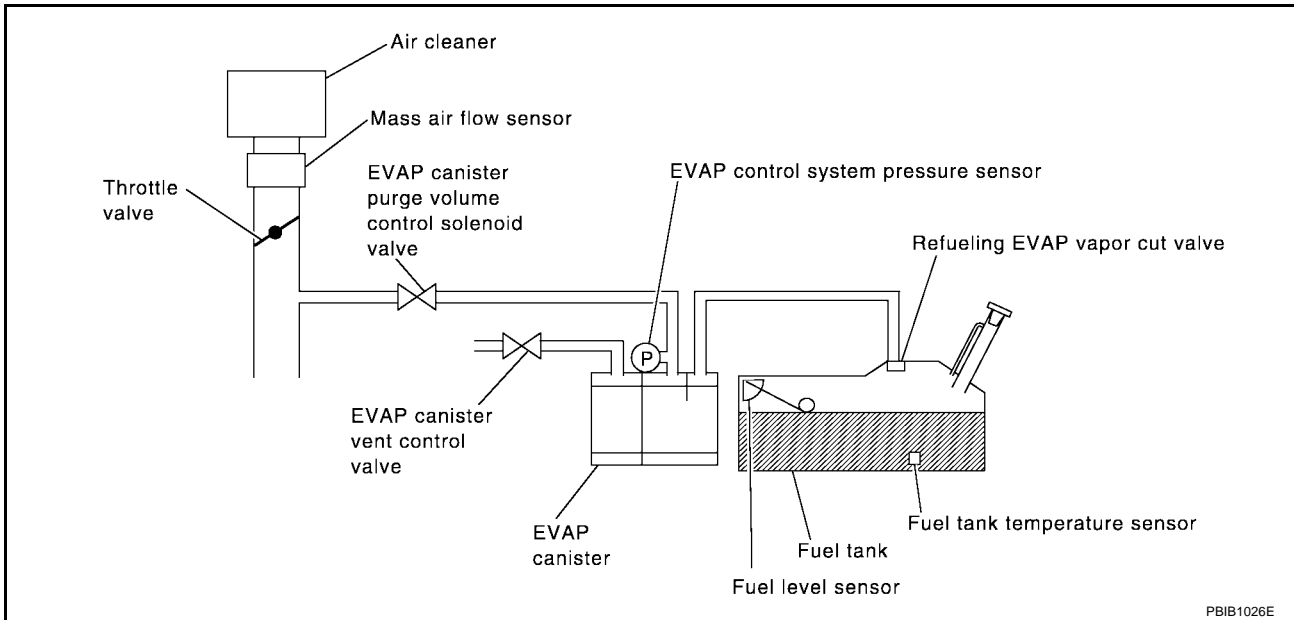

DTC No.	Trouble diagnosis name	DTC detecting condition	Possible cause
P0455 0455	EVAP control system gross leak detected	EVAP control system has a very large leak such as fuel filler cap fell off, EVAP control system does not operate properly.	<ul style="list-style-type: none"> ● Fuel filler cap remains open or fails to close. ● Incorrect fuel tank vacuum relief valve ● Incorrect fuel filler cap used ● Foreign matter caught in fuel filler cap. ● Leak is in line between intake manifold and EVAP canister purge volume control solenoid valve. ● Foreign matter caught in EVAP canister vent control valve. ● EVAP canister or fuel tank leaks ● EVAP purge line (pipe and rubber tube) leaks ● EVAP purge line rubber tube bent. ● Loose or disconnected rubber tube ● EVAP canister vent control valve and the circuit ● EVAP canister purge volume control solenoid valve and the circuit ● Fuel tank temperature sensor ● O-ring of EVAP canister vent control valve is missing or damaged. ● EVAP control system pressure sensor ● Refueling EVAP vapor cut valve ● ORVR system leaks

CAUTION:

- Use only a genuine NISSAN fuel filler cap as a replacement. If an incorrect fuel filler cap is used, the MIL may come on.
- If the fuel filler cap is not tightened properly, the MIL may come on.
- Use only a genuine NISSAN rubber tube as a replacement.

DTC Confirmation Procedure

CAUTION:

Never remove fuel filler cap during the DTC Confirmation Procedure.

NOTE:

- Make sure that EVAP hose are connected to EVAP canister purge volume control solenoid valve properly.
- If DTC Confirmation Procedure has been previously conducted, always turn ignition switch OFF and wait at least 10 seconds before conducting the next test.

TESTING CONDITION:

- Perform “DTC WORK SUPPORT” when the fuel level is between 1/4 and 3/4 full, and vehicle is placed on flat level surface.
- Open engine hood before conducting the following procedure.

WITH CONSULT-II

1. Tighten fuel filler cap securely until rereaching sound is heard.
2. Turn ignition switch ON.
3. Turn ignition switch OFF and wait at least 10 seconds.
4. Turn ignition switch ON and select “DATA MONITOR” mode with CONSULT-II.
5. Make sure that the following conditions are met.
COOLAN TEMP/S: 0 - 70°C (32 - 158°F)
INT/A TEMP SE: 0 - 60°C (32 - 140°F)
6. Select “EVAP SML LEAK P0442/P1442” of “EVAPORATIVE SYSTEM” in “DTC WORK SUPPORT” mode with CONSULT-II. Follow the instruction displayed.

DATA MONITOR	
MONITOR	DTC
ENG SPEED	XXX rpm
COOLAN TEMP/S	XXX °C
INT/A TEMP/S	XXX °C

SEF475Y

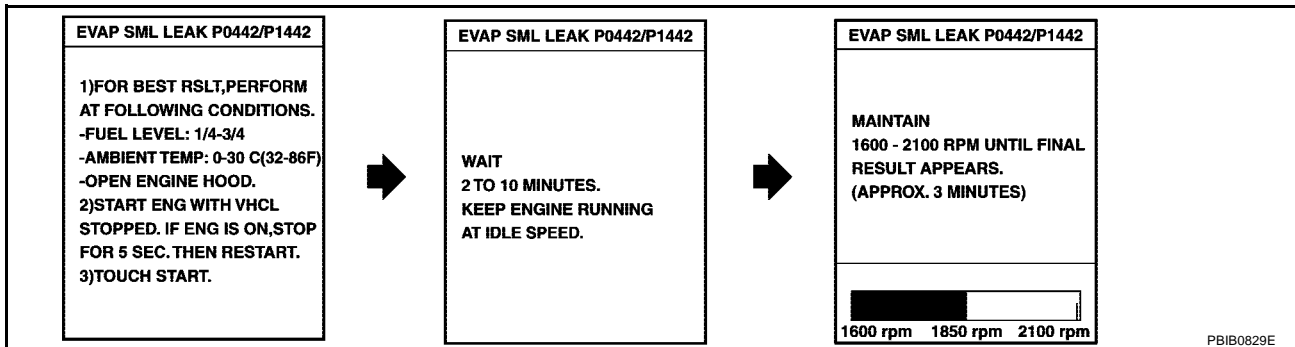

NOTE:

If the engine speed cannot be maintained within the range displayed on the CONSULT-II screen, go to [EC-75, "Basic Inspection"](#).

7. Make sure that “OK” is displayed. If “NG” is displayed, select “SELF-DIAG RESULTS” mode with CONSULT-II and make sure that “EVAP GROSS LEAK [P0455]” is displayed. If it is displayed, refer to [EC-337, "Diagnostic Procedure"](#). If P0442 is displayed, perform Diagnostic Procedure for DTC P0442, [EC-300](#).

EVAP SML LEAK P0442/P1442
OK
SELF-DIAG RESULTS
NO DTC DETECTED. FURTHER TESTING MAY BE REQUIRED.

SEC763C

WITH GST**NOTE:**

Be sure to read the explanation of Driving Pattern on [EC-63](#) before driving vehicle.

1. Start engine.
2. Drive vehicle according to Driving Pattern, [EC-63](#).
3. Stop vehicle.
4. Turn ignition switch OFF, wait at least 10 seconds and then turn ignition switch ON.
5. Select SERVICE \$07 with GST.
 - If P0455 is displayed on the screen, go to [EC-337, "Diagnostic Procedure"](#).
 - If P0442 is displayed on the screen, go to Diagnostic Procedure, for DTC P0442, [EC-300](#).
 - If P0441 is displayed on the screen, go to Diagnostic Procedure for DTC P0441, [EC-294](#).

Diagnostic Procedure**1. CHECK FUEL FILLER CAP DESIGN**

UBS00CE4

1. Turn ignition switch OFF.
2. Check for genuine NISSAN fuel filler cap design.

OK or NG

- OK >> GO TO 2.
 NG >> Replace with genuine NISSAN fuel filler cap.

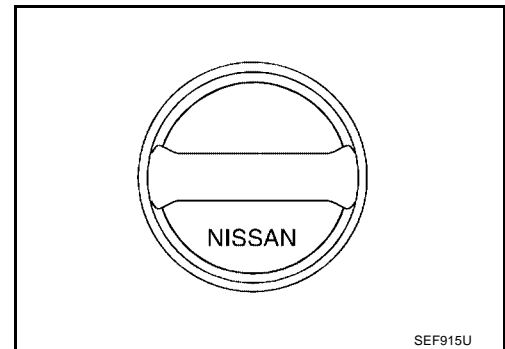
**2. CHECK FUEL FILLER CAP INSTALLATION**

Check that the cap is tightened properly by rotating the cap clockwise.

OK or NG

- OK >> GO TO 3.
 NG >> 1. Open fuel filler cap, then clean cap and fuel filler neck threads using air blower.
 2. Retighten until reteaching sound is heard.

3. CHECK FUEL FILLER CAP FUNCTION

Check for air releasing sound while opening the fuel filler cap.

OK or NG

- OK >> GO TO 5.
 NG >> GO TO 4.

4. CHECK FUEL TANK VACUUM RELIEF VALVE

Refer to [EC-40, "FUEL TANK VACUUM RELIEF VALVE \(BUILT INTO FUEL FULLER CAP\)"](#)

OK or NG

- OK >> GO TO 5.
 NG >> Replace fuel filler cap with a genuine one.

5. CHECK EVAP PURGE LINE

Check EVAP purge line (pipe, rubber tube, fuel tank and EVAP canister) for cracks, improper connection or disconnection.

Refer to [EC-37, "EVAPORATIVE EMISSION SYSTEM"](#) .

OK or NG

- OK >> GO TO 6.
- NG >> Repair or reconnect the hose.

6. CLEAN EVAP PURGE LINE

Clean EVAP purge line (pipe and rubber tube) using air blower.

>> GO TO 7.

7. CHECK EVAP CANISTER VENT CONTROL VALVE

Check the following.

- EVAP canister vent control is installed properly.
Refer to [EC-41, "Removal and Installation"](#)
- EVAP canister vent control valve.
Refer to [EC-317, "Component Inspection"](#)

OK or NG

- OK >> GO TO 8.
- NG >> Repair or replace EVAP canister vent control valve and O-ring.

8. INSTALL THE PRESSURE PUMP

To locate the EVAP leak, install EVAP service port adapter and pressure pump to EVAP service port securely.

NOTE:

Improper installation of the EVAP service port adapter to the EVAP service port may cause leaking.

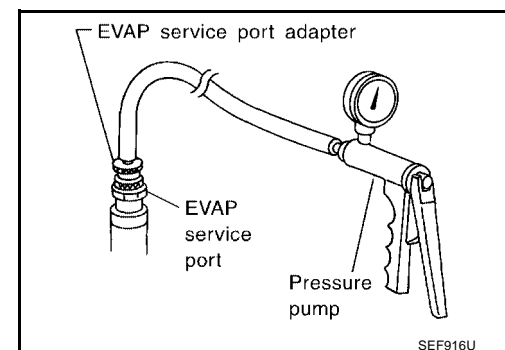
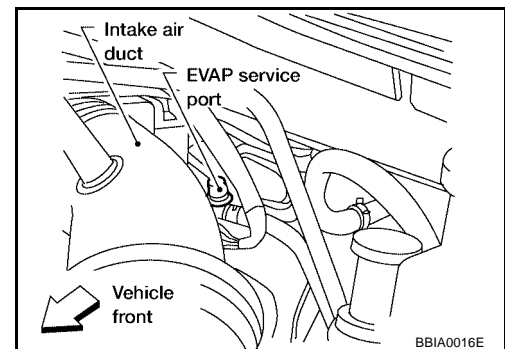

With CONSULT-II>>GO TO 9.
Without CONSULT-II>>GO TO 10.

9. CHECK FOR EVAP LEAK

With CONSULT-II

1. Turn ignition switch ON.
2. Select "EVAP SYSTEM CLOSE" of "WORK SUPPORT" mode with CONSULT-II.
3. Touch "START" and apply pressure into the EVAP line until the pressure indicator reaches the middle of the bar graph.

CAUTION:

- Never use compressed air or a high pressure pump.
- Do not exceed 4.12 kPa (0.042 kg/cm² , 0.6 psi) of pressure in the system.

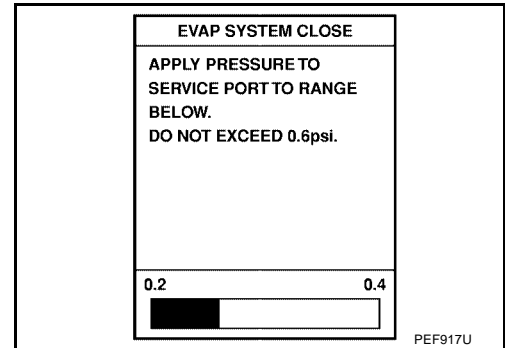

4. Using EVAP leak detector, locate the EVAP leak. For the leak detector, refer to the instruction manual for more details. Refer to [EC-38, "EVAPORATIVE EMISSION LINE DRAWING"](#).

OK or NG

- OK >> GO TO 11.
NG >> Repair or replace.

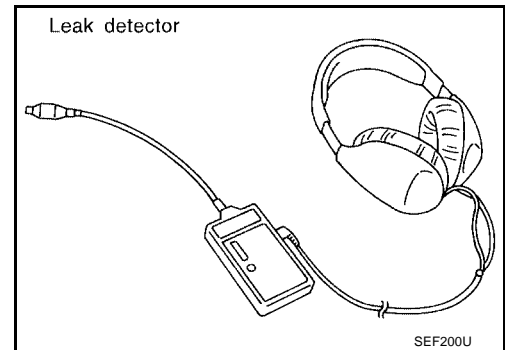

A

EC

C

D

E

F

G

H

I

J

K

L

M

10. CHECK FOR EVAP LEAK

⊗ Without CONSULT-II

1. Turn ignition switch OFF.
2. Apply 12 volts DC to EVAP canister vent control valve. The valve will close. (Continue to apply 12 volts until the end of test.)

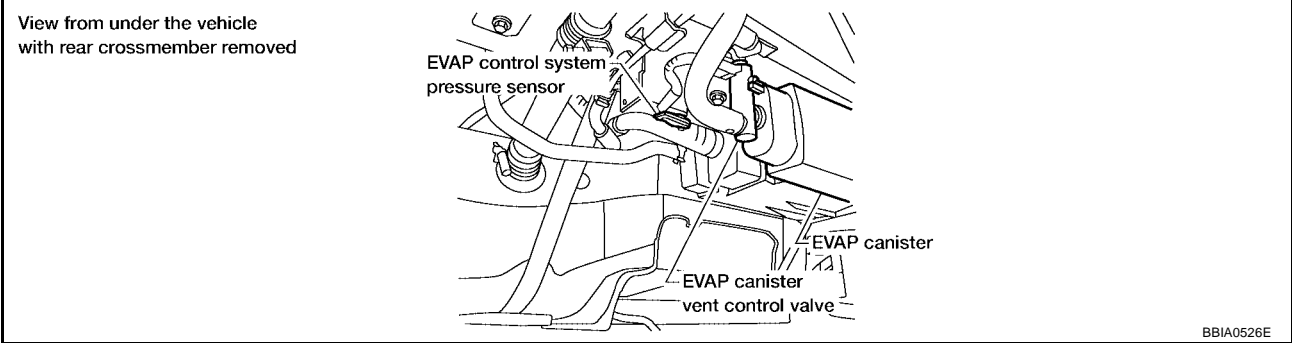

3. Pressurize the EVAP line using pressure pump with 1.3 to 2.7 kPa (10 to 20 mmHg, 0.39 to 0.79 inHg), then remove pump and EVAP service port adapter.

CAUTION:

- Never use compressed air or a high pressure pump.
- Do not exceed 4.12 kPa (0.042 kg/cm², 0.6 psi) of pressure in the system.

4. Using EVAP leak detector, locate the EVAP leak. For the leak detector, refer to the instruction manual for more details. Refer to [EC-38, "EVAPORATIVE EMISSION LINE DRAWING"](#).

OK or NG

- OK >> GO TO 12.
- NG >> Repair or replace.

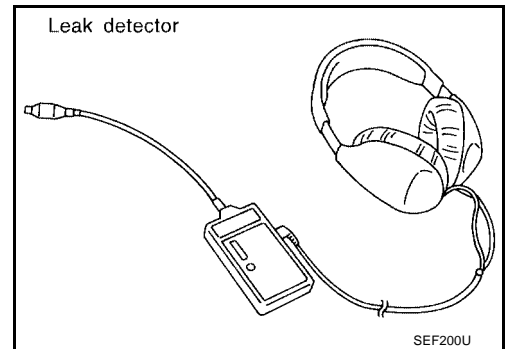

11. CHECK EVAP CANISTER PURGE VOLUME CONTROL SOLENOID VALVE OPERATION

Ⓜ With CONSULT-II

1. Disconnect vacuum hose to EVAP canister purge volume control solenoid valve at EVAP service port.
2. Start engine.
3. Perform "PURG VOL CONT/V" in "ACTIVE TEST" mode.
4. Touch "Qu" on CONSULT-II screen to increase "PURG VOL CONT/V" opening to 100%.
5. Check vacuum hose for vacuum when revving engine up to 2,000 rpm.

Vacuum should exist.

OK or NG

- OK >> GO TO 14.
- NG >> GO TO 13.

ACTIVE TEST	
PURG VOL CONT/V	XXX %
MONITOR	
ENG SPEED	XXX rpm
A/F ALPHA-B1	XXX %

PBIB1786E

12. CHECK EVAP CANISTER PURGE VOLUME CONTROL SOLENOID VALVE OPERATION

⊗ **Without CONSULT-II**

1. Start engine and warm it up to normal operating temperature.
2. Stop engine.
3. Disconnect vacuum hose to EVAP canister purge volume control solenoid valve at EVAP service port.
4. Start engine and let it idle for at least 80 seconds.
5. Check vacuum hose for vacuum when revving engine up to 2,000 rpm.

Vacuum should exist.

OK or NG

- OK >> GO TO 15.
- NG >> GO TO 13.

13. CHECK VACUUM HOSE

Check vacuum hoses for clogging or disconnection. Refer to [EC-38, "EVAPORATIVE EMISSION LINE DRAWING"](#).

OK or NG

- OK (With CONSULT-II)>>GO TO 14.
- OK (Without CONSULT-II)>>GO TO 15.
- NG >> Repair or reconnect the hose.

14. CHECK EVAP CANISTER PURGE VOLUME CONTROL SOLENOID VALVE

Ⓜ **With CONSULT-II**

1. Start engine.
2. Perform "PURG VOL CONT/V" in "ACTIVE TEST" mode with CONSULT-II. Check that engine speed varies according to the valve opening.

OK or NG

- OK >> GO TO 16.
- NG >> GO TO 15.

ACTIVE TEST	
PURG VOL CONT/V	XXX %
MONITOR	
ENG SPEED	XXX rpm
A/F ALPHA-B1	XXX %

PBIB1786E

15. CHECK EVAP CANISTER PURGE VOLUME CONTROL SOLENOID VALVE

Refer to [EC-311, "Component Inspection"](#).

OK or NG

- OK >> GO TO 16.
- NG >> Replace EVAP canister purge volume control solenoid valve.

16. CHECK FUEL TANK TEMPERATURE SENSOR

Refer to [EC-250, "Component Inspection"](#).

OK or NG

- OK >> GO TO 17.
- NG >> Replace fuel level sensor unit.

17. CHECK EVAP CONTROL SYSTEM PRESSURE SENSOR

Refer to [EC-327, "Component Inspection"](#) .

OK or NG

- OK >> GO TO 18.
- NG >> Replace EVAP control system pressure sensor.

18. CHECK EVAP/ORVR LINE

Check refueling EVAP/ORVR line between EVAP canister and fuel tank for clogging, kink, looseness and improper connection. For location, refer to [EC-44, "ON BOARD REFUELING VAPOR RECOVERY \(ORVR\)"](#) .

OK or NG

- OK >> GO TO 19.
- >> Repair or replace hoses and tubes.

19. CHECK RECIRCULATION LINE

Check recirculation line between filler neck tube and fuel tank for clogging, kink, cracks, looseness and improper connection.

OK or NG

- OK >> GO TO 20.
- >> Repair or replace hoses, tubes or filler neck tube.

20. CHECK REFUELING EVAP VAPOR CUT VALVE

Refer to [EC-48, "Component Inspection"](#) .

OK or NG

- OK >> GO TO 21.
- >> Replace refueling EVAP vapor cut valve with fuel tank.

21. CHECK INTERMITTENT INCIDENT

Refer to [EC-158, "TROUBLE DIAGNOSIS FOR INTERMITTENT INCIDENT"](#) .

>> INSPECTION END

DTC P0456 EVAP CONTROL SYSTEM

PFP:14950

On Board Diagnosis Logic

UBS00CE5

This diagnosis detects very small leaks in the EVAP line between fuel tank and EVAP canister purge volume control solenoid valve, using the intake manifold vacuum in the same way as conventional EVAP small leak diagnosis.

If ECM judges a leak which corresponds to a very small leak, the very small leak P0456 will be detected.

If ECM judges a leak equivalent to a small leak, EVAP small leak P0442 will be detected.

If ECM judges there are no leaks, the diagnosis will be OK.

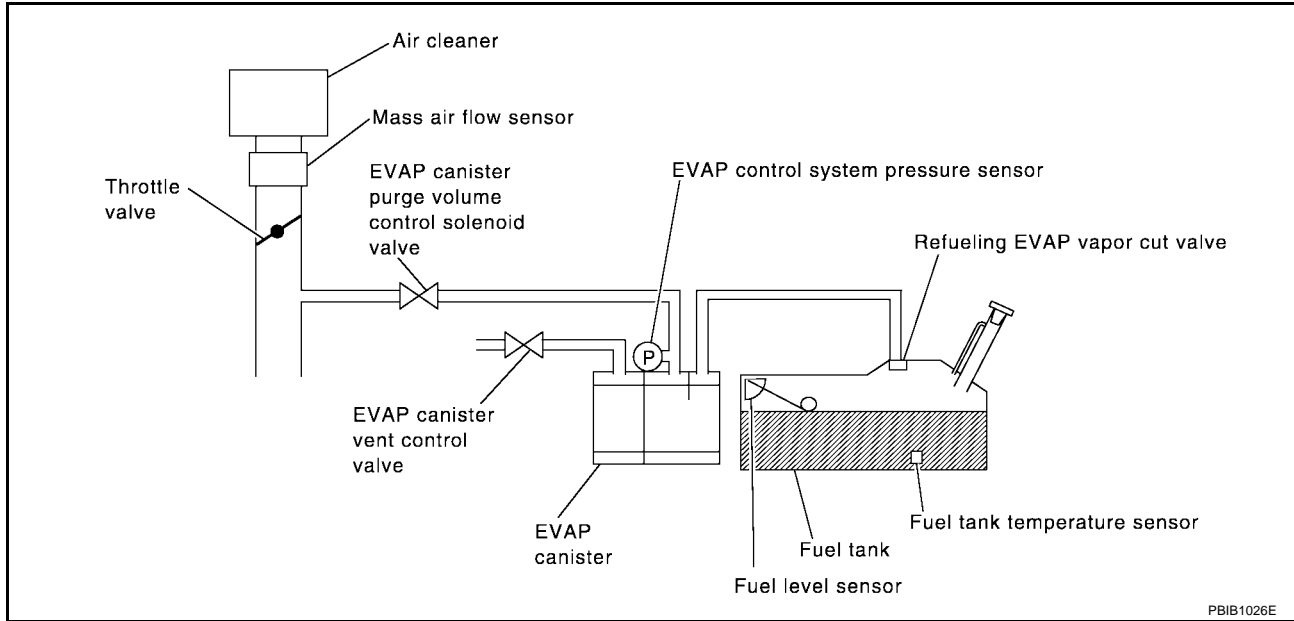

PBIB1026E

DTC No.	Trouble diagnosis name	DTC detecting condition	Possible cause
P0456 0456	Evaporative emission control system very small leak (negative pressure check)	<ul style="list-style-type: none"> ● EVAP system has a very small leak. ● EVAP system does not operate properly. 	<ul style="list-style-type: none"> ● Incorrect fuel tank vacuum relief valve ● Incorrect fuel filler cap used ● Fuel filler cap remains open or fails to close. ● Foreign matter caught in fuel filler cap. ● Leak is in line between intake manifold and EVAP canister purge volume control solenoid valve. ● Foreign matter caught in EVAP canister vent control valve. ● EVAP canister or fuel tank leaks ● EVAP purge line (pipe and rubber tube) leaks ● EVAP purge line rubber tube bent ● Loose or disconnected rubber tube ● EVAP canister vent control valve and the circuit ● EVAP canister purge volume control solenoid valve and the circuit ● Fuel tank temperature sensor ● O-ring of EVAP canister vent control valve is missing or damaged ● EVAP canister is saturated with water ● EVAP control system pressure sensor ● Refueling EVAP vapor cut valve ● ORVR system leaks ● Fuel level sensor and the circuit ● Foreign matter caught in EVAP canister purge volume control solenoid valve

CAUTION:

- Use only a genuine NISSAN fuel filler cap as a replacement. If an incorrect fuel filler cap is used, the MIL may come on.
- If the fuel filler cap is not tightened properly, the MIL may come on.
- Use only a genuine NISSAN rubber tube as a replacement.

DTC Confirmation Procedure

UBS00CE6

NOTE:

- If DTC P0456 is displayed with P0442, first perform trouble diagnosis for DTC P0456.
- After repair, make sure that the hoses and clips are installed properly.
- If DTC Confirmation Procedure has been previously conducted, always turn ignition switch OFF and wait at least 10 seconds before conducting the next test.

TESTING CONDITION:

- Open engine hood before conducting following procedure.
- If any of following conditions are met just before the DTC confirmation procedure, leave the vehicle for more than 1 hour.
 - Fuel filler cap is removed.
 - Refilled or drained the fuel.
 - EVAP component parts is/are removed.
- Before performing the following procedure, confirm that battery voltage is more than 11V at idle.

WITH CONSULT-II

1. Turn ignition switch ON and select "DATA MONITOR" mode with CONSULT-II.
2. Make sure the following conditions are met.
FUEL LEVEL SE: 0.25 - 1.4V
COOLAN TEMP/S: 0 - 32°C (32 - 90°F)
FUEL T/TMP SE: 0 - 35°C (32 - 95°F)
INT A/TEMP SE: More than 0°C (32°F)
 If NG, turn ignition switch OFF and leave the vehicle in a cool place (soak the vehicle) or refilling/draining fuel until the output voltage condition of the "FUEL LEVEL SE" meets within the range above and leave the vehicle for more than 1 hour. Then start from step 1).
3. Turn ignition switch OFF and wait at least 10 seconds.
4. Turn ignition switch ON.
5. Select "EVAP V/S LEAK P0456" of "EVAPORATIVE SYSTEM" in "DTC WORK SUPPORT" mode with CONSULT-II.
Follow the instruction displayed.

DATA MONITOR	
MONITOR	DTC
ENG SPEED	XXX rpm
COOLAN TEMP/S	XXX °C
INT/A TEMP/S	XXX °C
FUEL LEVEL SE	XXX V
FUEL T/TEMP/S	XXX °C

PBIB1953E

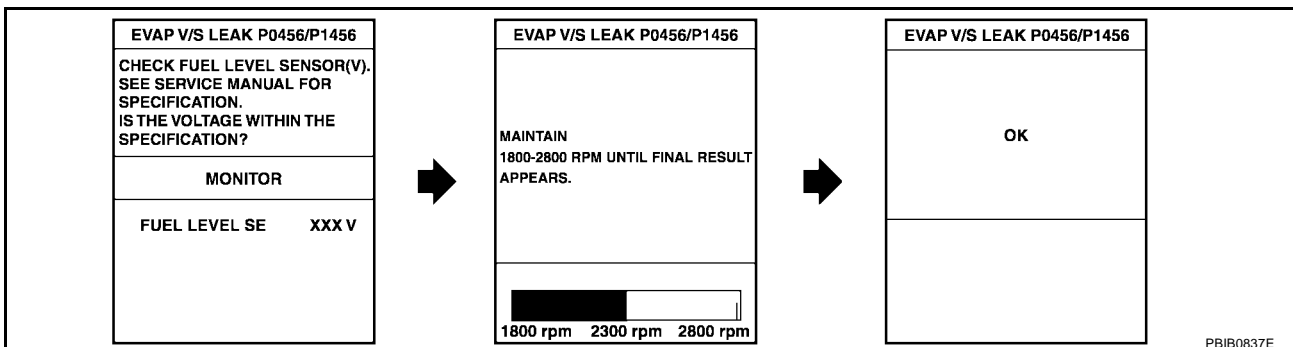

6. Make sure that "OK" is displayed.
If "NG" is displayed, refer to [EC-346, "Diagnostic Procedure"](#).

NOTE:

- If the engine speed cannot be maintained within the range displayed on CONSULT-II screen, go to [EC-75, "Basic Inspection"](#).

DTC P0456 EVAP CONTROL SYSTEM

[QR]

- Make sure that EVAP hoses are connected to EVAP canister purge volume control solenoid valve properly.

Overall Function Check

UBS00CE7

WITH GST

Use this procedure to check the overall function of the EVAP very small leak function. During this check, a 1st trip DTC might not be confirmed.

CAUTION:

- Never use compressed air, doing so may damage the EVAP system.
- Do not start engine.
- Do not exceeded 4.12 kPa (0.042 kg/cm² , 0.6 psi).

1. Attach the EVAP service port adapter securely to the EVAP service port.

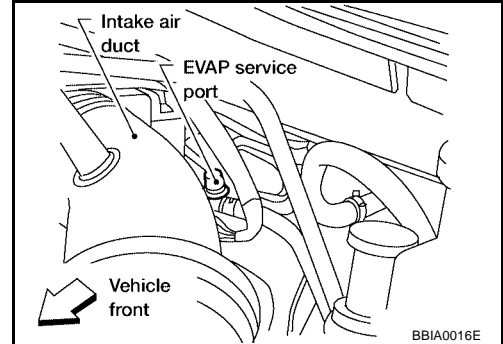

2. Set the pressure pump and a hose.
3. Also set the pressure pump with pressure gauge to the EVAP service port adapter.
4. Turn ignition switch ON.
5. Connect GST and select Service \$08.
6. Using Service \$08 control the EVAP canister vent control valve (close).
7. Apply pressure and make sure the following conditions are satisfied.

Pressure to be applied: 2.7 kPa (20 mmHg, 0.79 inHg)

Time to be waited after the pressure drawn in to the EVAP system and the pressure to be dropped: 60 seconds and the pressure should not be dropped more than 0.4 kPa (3 mmHg, 0.12 inHg).

If NG, go to [EC-346, "Diagnostic Procedure"](#) .

If OK, go to next step.

8. Disconnect GST.
9. Start engine and warm it up to normal operating temperature.
10. Turn ignition switch OFF and wait at least 10 seconds.
11. Restart engine and let it idle for 90 seconds.
12. Keep engine speed at 2,000 rpm for 30 seconds.
13. Turn ignition switch OFF.

NOTE:

For more information, refer to GST Instruction Manual.

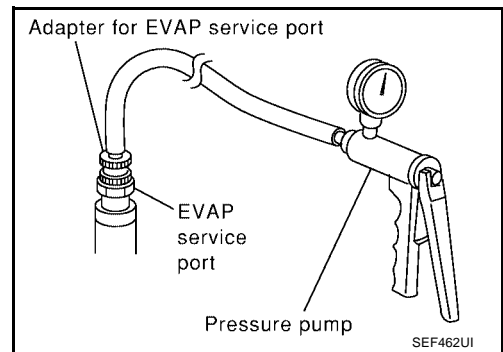

Diagnostic Procedure**1. CHECK FUEL FILLER CAP DESIGN**

1. Turn ignition switch OFF.
2. Check for genuine NISSAN fuel filler cap design.

OK or NG

- OK >> GO TO 2.
NG >> Replace with genuine NISSAN fuel filler cap.

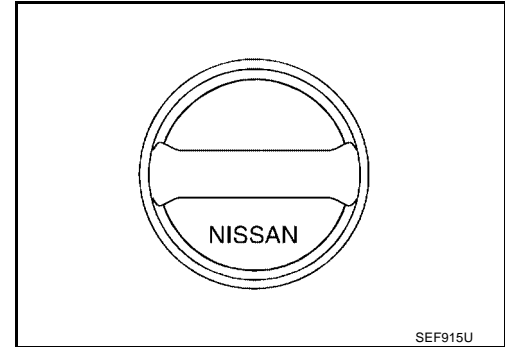
**2. CHECK FUEL FILLER CAP INSTALLATION**

Check that the cap is tightened properly by rotating the cap clockwise.

OK or NG

- OK >> GO TO 3.
NG >> 1. Open fuel filler cap, then clean cap and fuel filler neck threads using air blower.
2. Retighten until reteaching sound is heard.

3. CHECK FUEL FILLER CAP FUNCTION

Check for air releasing sound while opening the fuel filler cap.

OK or NG

- OK >> GO TO 5.
NG >> GO TO 4.

4. CHECK FUEL TANK VACUUM RELIEF VALVE

Refer to [EC-40, "FUEL TANK VACUUM RELIEF VALVE \(BUILT INTO FUEL FULLER CAP\)"](#).

OK or NG

- OK >> GO TO 5.
NG >> Replace fuel filler cap with a genuine one.

5. INSTALL THE PRESSURE PUMP

To locate the EVAP leak, install EVAP service port adapter and pressure pump to EVAP service port securely.

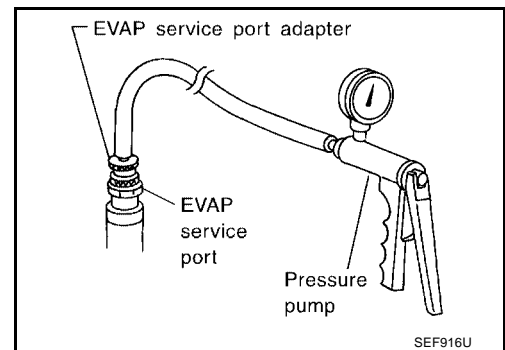
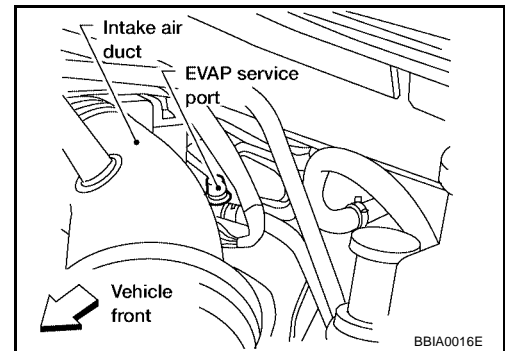

NOTE:

Improper installation of the EVAP service port adapter to the EVAP service port may cause leaking.

With CONSULT-II>>GO TO 6.
Without CONSULT-II>>GO TO 7.

6. CHECK FOR EVAP LEAK

With CONSULT-II

1. Turn ignition switch ON.
2. Select "EVAP SYSTEM CLOSE" of "WORK SUPPORT" mode with CONSULT-II.
3. Touch "START" and apply pressure into the EVAP line until the pressure indicator reaches the middle of the bar graph.

CAUTION:

- Never use compressed air or a high pressure pump.
- Do not exceed 4.12 kPa (0.042 kg/cm² , 0.6 psi) of pressure in the system.

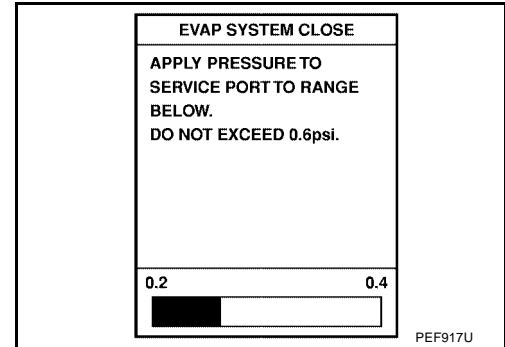

4. Using EVAP leak detector, locate the EVAP leak. For the leak detector, refer to the instruction manual for more details. Refer to [EC-38. "EVAPORATIVE EMISSION LINE DRAWING"](#) .

OK or NG

- OK >> GO TO 8.
 NG >> Repair or replace.

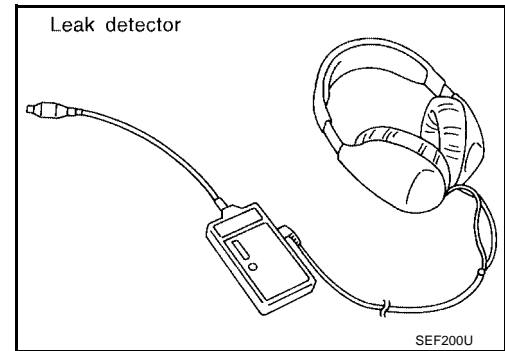

7. CHECK FOR EVAP LEAK

⊗ Without CONSULT-II

1. Turn ignition switch OFF.
2. Apply 12 volts DC to EVAP canister vent control valve. The valve will close. (Continue to apply 12 volts until the end of test.)

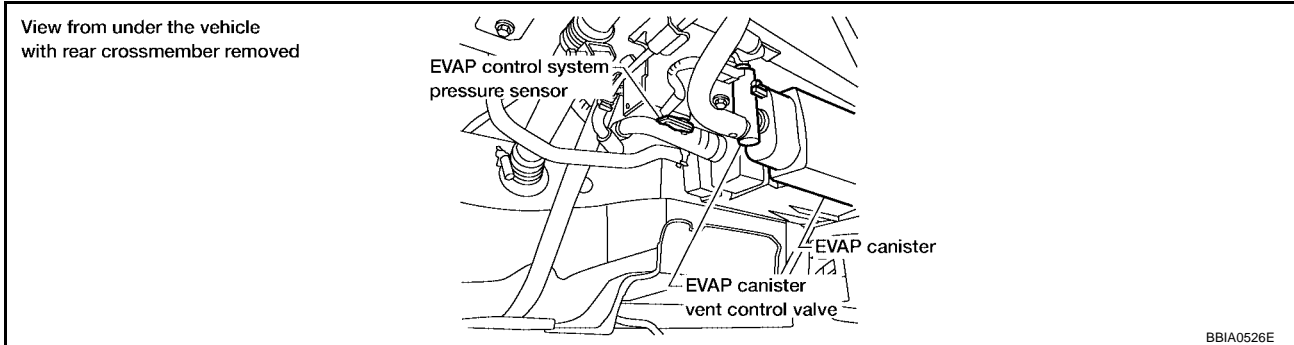

3. Pressurize the EVAP line using pressure pump with 1.3 to 2.7 kPa (10 to 20 mmHg, 0.39 to 0.79 inHg), then remove pump and EVAP service port adapter.

CAUTION:

- Never use compressed air or a high pressure pump.
- Do not exceed 4.12 kPa (0.042 kg/cm² , 0.6 psi) of pressure in the system.

4. Using EVAP leak detector, locate the EVAP leak. For the leak detector, refer to the instruction manual for more details. Refer to [EC-38, "EVAPORATIVE EMISSION LINE DRAWING"](#) .

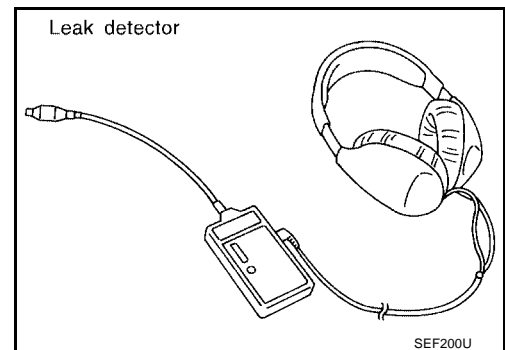

OK or NG

- OK >> GO TO 8.
- NG >> Repair or replace.

8. CHECK EVAP CANISTER VENT CONTROL VALVE

Check the following.

- EVAP canister vent control valve is installed properly.
Refer to [EC-41, "Removal and Installation"](#)
- EVAP canister vent control valve.
Refer to [EC-317, "Component Inspection"](#)

OK or NG

- OK >> GO TO 9.
- NG >> Repair or replace EVAP canister vent control valve and O-ring.

9. CHECK IF EVAP CANISTER SATURATED WITH WATER

1. Remove EVAP canister with EVAP canister vent control valve and EVAP control system pressure sensor attached.
2. Does water drain from the EVAP canister?

Yes or No

- Yes >> GO TO 10.
- No (With CONSULT-II)>>GO TO 12.
- No (Without CONSULT-II)>>GO TO 13.

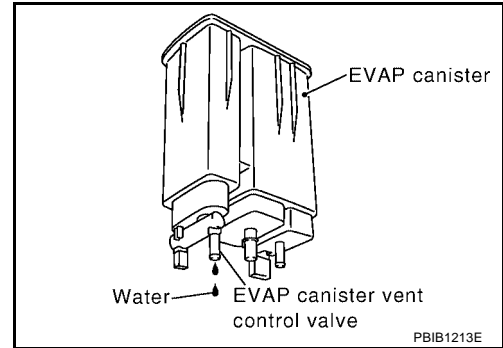

10. CHECK EVAP CANISTER

Weigh the EVAP canister with the EVAP canister vent control valve and EVAP control system pressure sensor attached.

The weight should be less than 2.1 kg (4.6 lb).

OK or NG

- OK (With CONSULT-II)>>GO TO 12.
- OK (Without CONSULT-II)>>GO TO 13.
- NG >> GO TO 11.

11. DETECT MALFUNCTIONING PART

Check the following.

- EVAP canister for damage
- EVAP hose between EVAP canister and vehicle frame for clogging or poor connection

>> Repair hose or replace EVAP canister.

12. CHECK EVAP CANISTER PURGE VOLUME CONTROL SOLENOID VALVE OPERATION

Ⓟ With CONSULT-II

1. Disconnect vacuum hose to EVAP canister purge volume control solenoid valve at EVAP service port.
2. Start engine.
3. Perform "PURG VOL CONT/V" in "ACTIVE TEST" mode.
4. Touch "Qu" on CONSULT-II screen to increase "PURG VOL CONT/V" opening to 100%.
5. Check vacuum hose for vacuum when revving engine up to 2,000 rpm.

OK or NG

- OK >> GO TO 15.
- NG >> GO TO 14.

ACTIVE TEST	
PURG VOL CONT/V	XXX %
MONITOR	
ENG SPEED	XXX rpm
A/F ALPHA-B1	XXX %

PBIB1786E

13. CHECK EVAP CANISTER PURGE VOLUME CONTROL SOLENOID VALVE OPERATION**⊗ Without CONSULT-II**

1. Start engine and warm it up to normal operating temperature.
2. Stop engine.
3. Disconnect vacuum hose to EVAP canister purge volume control solenoid valve at EVAP service port.
4. Start engine and let it idle for at least 80 seconds.
5. Check vacuum hose for vacuum when revving engine up to 2,000 rpm.

Vacuum should exist.

OK or NG

- OK >> GO TO 16.
 NG >> GO TO 14.

14. CHECK VACUUM HOSE

Check vacuum hoses for clogging or disconnection. Refer to [EC-117, "Vacuum Hose Drawing"](#) .

OK or NG

- OK >> GO TO 15.
 NG >> Repair or reconnect the hose.

15. CHECK EVAP CANISTER PURGE VOLUME CONTROL SOLENOID VALVE

Refer to [EC-311, "Component Inspection"](#) .

OK or NG

- OK >> GO TO 16.
 NG >> Replace EVAP canister purge volume control solenoid valve.

16. CHECK FUEL TANK TEMPERATURE SENSOR

Refer to [EC-250, "Component Inspection"](#) .

OK or NG

- OK >> GO TO 17.
 NG >> Replace fuel level sensor unit.

17. CHECK EVAP CONTROL SYSTEM PRESSURE SENSOR

Refer to [EC-327, "Component Inspection"](#) .

OK or NG

- OK >> GO TO 18.
 NG >> Replace EVAP control system pressure sensor.

18. CHECK EVAP PURGE LINE

Check EVAP purge line (pipe, rubber tube, fuel tank and EVAP canister) for cracks or improper connection. Refer to [EC-38, "EVAPORATIVE EMISSION LINE DRAWING"](#) .

OK or NG

- OK >> GO TO 19.
 NG >> Repair or reconnect the hose.

19. CLEAN EVAP PURGE LINE

Clean EVAP purge line (pipe and rubber tube) using air blower.

>> GO TO 20.

20. CHECK EVAP/ORVR LINE

Check EVAP/ORVR line between EVAP canister and fuel tank for clogging, kink, looseness and improper connection. For location, refer to [EC-44, "ON BOARD REFUELING VAPOR RECOVERY \(ORVR\)"](#) .

OK or NG

- OK >> GO TO 21.
- NG >> Repair or replace hoses and tubes.

21. CHECK RECIRCULATION LINE

Check recirculation line between filler neck tube and fuel tank for clogging, kink, cracks, looseness and improper connection.

OK or NG

- OK >> GO TO 22.
- NG >> Repair or replace hose, tube or filler neck tube.

22. CHECK REFUELING EVAP VAPOR CUT VALVE

Refer to [EC-48, "Component Inspection"](#) .

OK or NG

- OK >> GO TO 23.
- NG >> Replace refueling EVAP vapor cut valve with fuel tank.

23. CHECK FUEL LEVEL SENSOR

Refer to [FL-5, "FUEL LEVEL SENSOR UNIT, FUEL FILTER AND FUEL PUMP ASSEMBLY"](#) .

OK or NG

- OK >> GO TO 24.
- NG >> Replace fuel level sensor unit.

24. CHECK INTERMITTENT INCIDENT

Refer to [EC-158, "TROUBLE DIAGNOSIS FOR INTERMITTENT INCIDENT"](#) .

>> **INSPECTION END**

DTC P0460 FUEL LEVEL SENSOR

PFP:25060

Component Description

UBS00CE9

The fuel level sensor is mounted in the fuel level sensor unit. The sensor detects a fuel level in the fuel tank and transmits a signal to the combination meter. The combination meter sends the fuel level sensor signal to the ECM through CAN communication line. It consists of two parts, one is mechanical float and the other is variable resistor. Fuel level sensor output voltage changes depending on the movement of the fuel mechanical float.

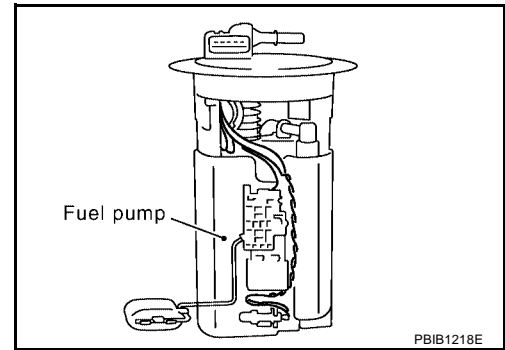

On Board Diagnostic Logic

UBS00CEA

NOTE:

If DTC P0460 is displayed with DTC U1000, U1001, first perform the trouble diagnosis for DTC U1000, U1001. Refer to [EC-166, "DTC U1000, U1001 CAN COMMUNICATION LINE"](#).

When the vehicle is parked, naturally the fuel level in the fuel tank is stable. It means that output signal of the fuel level sensor does not change. If ECM senses sloshing signal from the sensor, fuel level sensor malfunction is detected.

DTC No.	Trouble diagnosis name	DTC detecting condition	Possible cause
P0460 0460	Fuel level sensor circuit noise	Even though the vehicle is parked, a signal being varied is sent from the fuel level sensor to ECM.	<ul style="list-style-type: none"> ● Harness or connectors (The CAN communication line is open or shorted) ● Harness or connectors (The sensor circuit is open or shorted) ● Combination meter ● Fuel level sensor

DTC Confirmation Procedure

UBS00CEB

NOTE:

If DTC Confirmation Procedure has been previously conducted, always turn ignition switch OFF and wait at least 10 seconds before conducting the next test.

WITH CONSULT-II

1. Turn ignition switch ON.
2. Select "DATA MONITOR" mode with CONSULT-II.
3. Start engine and wait maximum of 2 consecutive minutes.
4. If 1st trip DTC is detected, go to [EC-354, "Diagnostic Procedure"](#)

DATA MONITOR	
MONITOR	NO DTC
FUEL T/TMP SE	XXX °C
FUEL LEVEL SE	XXX V

SEF195Y

WITH GST

Follow the procedure "WITH CONSULT-II" above.

Diagnostic Procedure

UBS00CEC

1. CHECK COMBINATION METER FUNCTION

Refer to [DI-4, "COMBINATION METERS"](#) .

OK or NG

OK >> GO TO 2.

NG >> GO TO [DI-7, "CHECK"](#) .

2. CHECK INTERMITTENT INCIDENT

Refer to [EC-158, "TROUBLE DIAGNOSIS FOR INTERMITTENT INCIDENT"](#) .

>> INSPECTION END

Removal and Installation FUEL LEVEL SENSOR

UBS00CED

Refer to [FL-5, "FUEL LEVEL SENSOR UNIT, FUEL FILTER AND FUEL PUMP ASSEMBLY"](#)

DTC P0461 FUEL LEVEL SENSOR

Component Description

The fuel level sensor is mounted in the fuel level sensor unit. The sensor detects a fuel level in the fuel tank and transmits a signal to the combination meter. The combination meter sends the fuel level sensor signal to the ECM through CAN communication line. It consists of two parts, one is mechanical float and the other is variable resistor. Fuel level sensor output voltage changes depending on the movement of the fuel mechanical float.

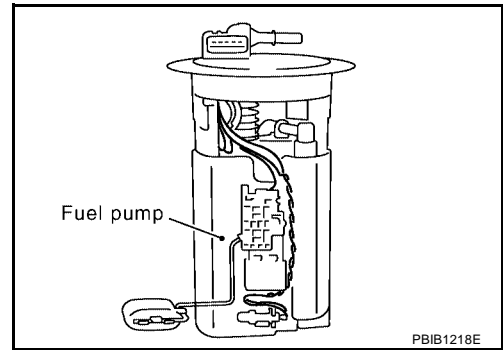

On Board Diagnostic Logic

NOTE:

If DTC P0461 is displayed with DTC U1000, U1001, first perform the trouble diagnosis for DTC U1000, U1001. Refer to [EC-166, "DTC U1000, U1001 CAN COMMUNICATION LINE"](#).

Driving long distances naturally affect fuel gauge level.

This diagnosis detects the fuel gauge malfunction of the gauge not moving even after a long distance has been driven.

DTC No.	Trouble diagnosis name	DTC detecting condition	Possible cause
P0461 0461	Fuel level sensor circuit range/performance	The output signal of the fuel level sensor does not change within the specified range even though the vehicle has been driven a long distance.	<ul style="list-style-type: none"> ● Harness or connectors (the CAN communication line is open or shorted) ● Harness or connectors (The sensor circuit is open or shorted) ● Combination meter ● Fuel level sensor

Overall Function Check

Use this procedure to check the overall function of the fuel level sensor function. During this check, a 1st trip DTC might not be confirmed.

WARNING:

When performing following procedure, be sure to observe the handling of the fuel. Refer to [FL-12, "FUEL TANK"](#).

TESTING CONDITION:

Before starting overall function check, preparation of draining fuel and refilling fuel is required.

WITH CONSULT-II

NOTE:

Start from step 10, if it is possible to confirm that the fuel cannot be drained by 30 ℓ (7-7/8 US gal, 6-5/8 Imp gal) in advance.

1. Prepare a fuel container and a spare hose.
2. Release fuel pressure from fuel line, refer to [EC-95, "FUEL PRESSURE RELEASE"](#).
3. Remove the fuel feed hose on the fuel level sensor unit.
4. Connect a spare fuel hose where the fuel feed hose was removed.

DTC P0461 FUEL LEVEL SENSOR

[QR]

5. Turn ignition switch OFF and wait at least 10 seconds then turn ON.
6. Select "FUEL LEVEL SE" in "DATA MONITOR" mode with CONSULT-II.
7. Check "FUEL LEVEL SE" output voltage and note it.
8. Select "FUEL PUMP" in "ACTIVE TEST" mode with CONSULT-II.
9. Touch "ON" and drain fuel approximately 30 ℓ (7-7/8 US gal, 6-5/8 Imp gal) and stop it.
10. Check "FUEL LEVEL SE" output voltage and note it.
11. Fill fuel into the fuel tank for 30 ℓ (7-7/8 US gal, 6-5/8 Imp gal).
12. Check "FUEL LEVEL SE" output voltage and note it.
13. Confirm whether the voltage changes more than 0.03V during step 7 to 10 and 10 to 12.
If NG, go to Diagnostic Procedure [EC-356](#) .

DATA MONITOR	
MONITOR	NO DTC
FUEL T/TMP SE	XXX °C
FUEL LEVEL SE	XXX V

SEF195Y

WITH GST

NOTE:

Start from step 8, if it is possible to confirm that the fuel cannot be drained by 30 ℓ (7-7/8 US gal, 6-5/8 Imp gal) in advance.

1. Prepare a fuel container and a spare hose.
2. Release fuel pressure from fuel line, refer to [EC-95, "FUEL PRESSURE RELEASE"](#) .
3. Remove the fuel feed hose on the fuel level sensor unit.
4. Connect a spare fuel hose where the fuel feed hose was removed.
5. Turn ignition switch ON.
6. Drain fuel by 30 ℓ (7-7/8 US gal, 6-5/8 Imp gal) from the fuel tank using proper equipment.
7. Confirm that the fuel gauge indication varies.
8. Fill fuel into the fuel tank for 30 ℓ (7-7/8 US gal, 6-5/8 Imp gal).
9. Confirm that the fuel gauge indication varies.
10. If NG, go to Diagnostic Procedure, [EC-356](#) .

Diagnostic Procedure

UBS00CEH

1. CHECK COMBINATION METER FUNCTION

Refer to [DI-4, "COMBINATION METERS"](#)

OK or NG

OK >> GO TO 2.

NG >> GO TO [DI-7, "CHECK"](#) .

2. CHECK INTERMITTENT INCIDENT

Refer to [EC-158, "TROUBLE DIAGNOSIS FOR INTERMITTENT INCIDENT"](#) .

>> INSPECTION END

Removal and Installation FUEL LEVEL SENSOR

UBS00CEI

Refer to [FL-5, "FUEL LEVEL SENSOR UNIT, FUEL FILTER AND FUEL PUMP ASSEMBLY"](#) .

DTC P0462, P0463 FUEL LEVEL SENSOR

Component Description

The fuel level sensor is mounted in the fuel level sensor unit. The sensor detects a fuel level in the fuel tank and transmits a signal to the combination meter. The combination meter sends the fuel level sensor signal to the ECM through CAN communication. It consists of two parts, one is mechanical float and the other is variable resistor. Fuel level sensor output voltage changes depending on the movement of the fuel mechanical float.

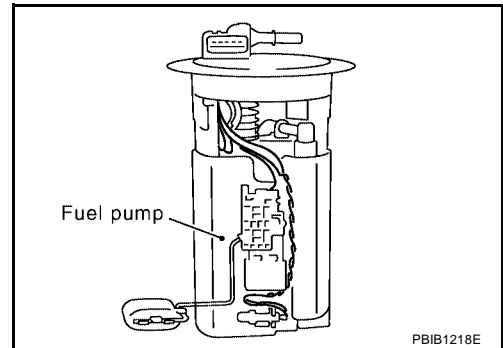

On Board Diagnostic Logic

NOTE:

If DTC P0462 or P0463 is displayed with DTC U1000, U1001, first perform the trouble diagnosis for DTC U1000, U1001. Refer to [EC-166, "DTC U1000, U1001 CAN COMMUNICATION LINE"](#).

ECM receives two signals from the fuel level sensor circuit.

One is fuel level sensor power supply circuit, and the other is fuel level sensor ground circuit.

This diagnosis indicates the former, to detect open or short circuit malfunction.

DTC No.	Trouble diagnosis name	DTC detecting condition	Possible cause
P0462 0462	Fuel level sensor circuit low input	An excessively low voltage from the sensor is sent to ECM.	<ul style="list-style-type: none"> ● Harness or connectors (The CAN communication line is open or shorted)
P0463 0463	Fuel level sensor circuit high input	An excessively high voltage from the sensor is sent to ECM.	<ul style="list-style-type: none"> ● Harness or connectors (The sensor circuit is open or shorted) ● Combination meter ● Fuel level sensor

DTC Confirmation Procedure

NOTE:

If DTC Confirmation Procedure has been previously conducted, always turn ignition switch OFF and wait at least 10 seconds before conducting the next test.

TESTING CONDITION:

Before performing the following procedure, confirm that battery voltage is more than 11V at ignition switch ON.

ⓑ WITH CONSULT-II

1. Turn ignition switch ON.
2. Select "DATA MONITOR" mode with CONSULT-II.
3. Wait at least 5 seconds.
4. If 1st trip DTC is detected, go to [EC-358, "Diagnostic Procedure"](#)

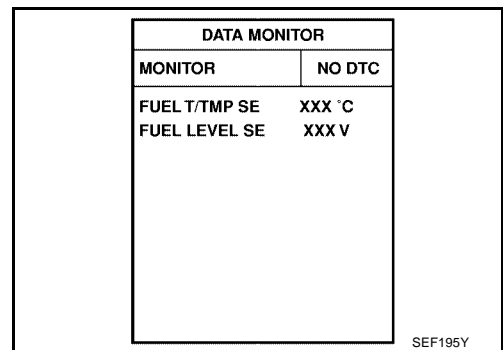

Ⓒ WITH GST

Follow the procedure "WITH CONSULT-II" above.

Diagnostic Procedure

1. CHECK COMBINATION METER FUNCTION

Refer to [DI-4, "COMBINATION METERS"](#) .

OK or NG

OK >> GO TO 2.

NG >> GO TO [DI-7, "CHECK"](#) .

2. CHECK INTERMITTENT INCIDENT

Refer to [EC-158, "TROUBLE DIAGNOSIS FOR INTERMITTENT INCIDENT"](#) .

>> INSPECTION END

Removal and Installation FUEL LEVEL SENSOR

Refer to [FL-5, "FUEL LEVEL SENSOR UNIT, FUEL FILTER AND FUEL PUMP ASSEMBLY"](#) .

DTC P0500 VSS

Description

NOTE:

If DTC P0500 is displayed with DTC U1000 or U1001, first perform the trouble diagnosis for DTC U1000, U1001. Refer to [EC-166, "DTC U1000, U1001 CAN COMMUNICATION LINE"](#).

The vehicle speed sensor is installed in the transaxle. It contains a pulse generator which provides a vehicle speed signal to the combination meter. The combination meter then sends a signal to the ECM through CAN communication line.

On Board Diagnosis Logic

DTC No.	Trouble diagnosis name	DTC detecting condition	Possible cause
P0500 0500	Vehicle speed sensor	The almost 0 km/h (0 MPH) signal from vehicle speed sensor is sent to ECM even when vehicle is being driven.	<ul style="list-style-type: none"> ● Harness or connectors (The CAN communication line is open or shorted) ● Harness or connectors (The vehicle speed sensor circuit is open or shorted) ● Vehicle speed sensor ● Combination meter

DTC Confirmation Procedure

CAUTION:

Always drive vehicle at a safe speed.

NOTE:

If DTC Confirmation Procedure has been previously conducted, always turn ignition switch OFF and wait at least 10 seconds before conducting the next test.

TESTING CONDITION:

Steps 1 and 2 may be conducted with the drive wheels lifted in the shop or by driving the vehicle. If a road test is expected to be easier, it is unnecessary to lift the vehicle.

WITH CONSULT-II

1. Start engine.
2. Read "VHCL SPEED SE" in "DATA MONITOR" mode with CONSULT-II. The vehicle speed on CONSULT-II should exceed 10 km/h (6 MPH) when rotating wheels with suitable gear position.
If NG, go to [EC-360, "Diagnostic Procedure"](#).
If OK, go to following step.
3. Select "DATA MONITOR" mode with CONSULT-II.
4. Warm engine up to normal operating temperature.
5. Maintain the following conditions for at least 60 consecutive seconds.

ENG SPEED	1,200 - 6,000 rpm (A/T models) 1,800 - 6,000 rpm (M/T models)
COOLAN TEMP/S	More than 70°C (158°F)
B/FUEL SCHDL	6.0 - 31.8 msec (A/T models) 5.0 - 31.8 msec (M/T models)
Selector lever	Suitable position
PW/ST SIGNAL	OFF

DATA MONITOR	
MONITOR	NO DTC
ENG SPEED	XXX rpm
COOLAN TEMP/S	XXX °C
B/FUEL SCHDL	XXX msec
PW/ST SIGNAL	OFF
VHCL SPEED SE	XXX km/h

SEF196Y

6. If 1st trip DTC is detected, go to [EC-360, "Diagnostic Procedure"](#).

Overall Function Check

Use this procedure to check the overall function of the vehicle speed sensor circuit. During this check, a 1st trip DTC might not be confirmed.



WITH GST

1. Lift up drive wheels.
2. Start engine.
3. Read vehicle speed sensor signal in "Service \$01" with GST.
The vehicle speed sensor on GST should be able to exceed 10 km/h (6 MPH) when rotating wheels with suitable gear position.
4. If NG, go to [EC-360, "Diagnostic Procedure"](#) .

Diagnostic Procedure

UBS002WP

1. CHECK VEHICLE SPEED SENSOR CIRCUIT

Refer to [DI-17, "Vehicle Speed System"](#) .

OK or NG

- OK >> GO TO 2.
- NG >> Repair or replace.

2. CHECK COMBINATION METER

Check combination meter function.

Refer to [DI-4, "COMBINATION METERS"](#) .

>> **INSPECTION END**

DTC P0506 ISC SYSTEM

Description

NOTE:

If DTC P0506 is displayed with other DTC, first perform the trouble diagnosis for the other DTC displayed.

The ECM controls the engine idle speed to a specified level through the fine adjustment of the air, which is let into the intake manifold, by operating the electric throttle control actuator. The operating of the throttle valve is varied to allow for optimum control of the engine idling speed. The crankshaft position sensor (POS) detects the actual engine speed and sends a signal to the ECM.

The ECM controls the electric throttle control actuator so that the engine speed coincides with the target value memorized in the ECM. The target engine speed is the lowest speed at which the engine can operate steadily. The optimum value stored in the ECM is determined by taking into consideration various engine conditions, such as during warming up, deceleration, and engine load (air conditioner, power steering and cooling fan operation, etc.).

On Board Diagnosis Logic

DTC No.	Trouble diagnosis name	DTC detecting condition	Possible cause
P0506 0506	Idle speed control system RPM lower than expected	The idle speed is less than the target idle speed by 100 rpm or more.	<ul style="list-style-type: none"> ● Electric throttle control actuator ● Intake air leak

DTC Confirmation Procedure

NOTE:

- If DTC Confirmation Procedure has been previously conducted, always turn ignition switch OFF and wait at least 10 seconds before conducting the next test.
- If the target idle speed is out of the specified value, perform [EC-93, "Idle Air Volume Learning"](#), before conducting DTC Confirmation Procedure. For the target idle speed, refer to the [EC-625, "SERVICE DATA AND SPECIFICATIONS \(SDS\)"](#).

TESTING CONDITION:

- Before performing the following procedure, confirm that battery voltage is more than 11V at idle.
- Always perform the test at a temperature above -10°C (14°F).

WITH CONSULT-II

1. Open engine hood.
2. Start engine and warm it up to normal operating temperature.
3. Turn ignition switch OFF and wait at least 10 seconds.
4. Turn ignition switch ON again and select "DATA MONITOR" mode with CONSULT-II.
5. Start engine and run it for at least 1 minute at idle speed.
6. If 1st trip DTC is detected, go to [EC-362, "Diagnostic Procedure"](#)

DATA MONITOR	
MONITOR	NO DTC
ENG SPEED	XXX rpm
COOLAN TEMP/S	XXX °C

WITH GST

Follow the procedure "WITH CONSULT-II" above.

Diagnostic Procedure**1. CHECK INTAKE AIR LEAK**

1. Start engine and let it idle.
2. Listen for an intake air leak after the mass air flow sensor.

OK or NG

- OK >> GO TO 2.
NG >> Discover air leak location and repair.

2. REPLACE ECM

1. Stop engine.
2. Replace ECM.
3. Perform initialization of NVIS (NATS) system and registration of all NVIS (NATS) ignition key IDs. Refer to [BL-107, "NVIS\(NISSAN Vehicle Immobilizer System-NATS\)"](#) .
4. Perform [EC-92, "VIN Registration"](#) .
5. Perform [EC-93, "Accelerator Pedal Released Position Learning"](#) .
6. Perform [EC-93, "Throttle Valve Closed Position Learning"](#) .
7. Perform [EC-93, "Idle Air Volume Learning"](#) .

>> **INSPECTION END**

DTC P0507 ISC SYSTEM

Description

NOTE:

If DTC P0507 is displayed with other DTC, first perform the trouble diagnosis for the other DTC displayed.

The ECM controls the engine idle speed to a specified level through the fine adjustment of the air, which is let into the intake manifold, by operating the electric throttle control actuator. The operating of the throttle valve is varied to allow for optimum control of the engine idling speed. The crankshaft position sensor (POS) detects the actual engine speed and sends a signal to the ECM.

The ECM controls the electric throttle control actuator so that the engine speed coincides with the target value memorized in the ECM. The target engine speed is the lowest speed at which the engine can operate steadily. The optimum value stored in the ECM is determined by taking into consideration various engine conditions, such as during warming up, deceleration, and engine load (air conditioner, power steering and cooling fan operation, etc.).

On Board Diagnosis Logic

DTC No.	Trouble diagnosis name	DTC detecting condition	Possible cause
P0507 0507	Idle speed control system RPM higher than expected	The idle speed is more than the target idle speed by 200 rpm or more.	<ul style="list-style-type: none"> ● Electric throttle control actuator ● Intake air leak ● PCV system

DTC Confirmation Procedure

NOTE:

- If DTC Confirmation Procedure has been previously conducted, always turn ignition switch OFF and wait at least 10 seconds before conducting the next test.
- If the target idle speed is out of the specified value, perform [EC-93, "Idle Air Volume Learning"](#), before conducting "DTC Confirmation Procedure". For the target idle speed, refer to the [EC-625, "SERVICE DATA AND SPECIFICATIONS \(SDS\)"](#).

TESTING CONDITION:

- Before performing the following procedure, confirm that battery voltage is more than 11V at idle.
- Always perform the test at a temperature above -10°C (14°F).

WITH CONSULT-II

1. Open engine hood.
2. Start engine and warm it up to normal operating temperature.
3. Turn ignition switch OFF and wait at least 10 seconds.
4. Turn ignition switch ON again and select "DATA MONITOR" mode with CONSULT-II.
5. Start engine and run it for at least 1 minute at idle speed.
6. If 1st trip DTC is detected, go to [EC-364, "Diagnostic Procedure"](#)

DATA MONITOR	
MONITOR	NO DTC
ENG SPEED	XXX rpm
COOLAN TEMP/S	XXX °C

SEF174Y

WITH GST

Follow the procedure "WITH CONSULT-II" above.

Diagnostic Procedure**1. CHECK PCV HOSE CONNECTION**

Confirm that PCV hose is connected correctly.

OK or NG

OK >> GO TO 2.

NG >> Repair or replace.

2. CHECK INTAKE AIR LEAK

1. Start engine and let it idle.
2. Listen for an intake air leak after the mass air flow sensor.

OK or NG

OK >> GO TO 3.

NG >> Discover air leak location and repair.

3. REPLACE ECM

1. Stop engine.
2. Replace ECM.
3. Perform initialization of NVIS (NATS) system and registration of all NVIS (NATS) ignition key IDs. Refer to [BL-107, "NVIS\(NISSAN Vehicle Immobilizer System-NATS\)"](#) .
4. Perform [EC-92, "VIN Registration"](#) .
5. Perform [EC-93, "Accelerator Pedal Released Position Learning"](#) .
6. Perform [EC-93, "Throttle Valve Closed Position Learning"](#) .
7. Perform [EC-93, "Idle Air Volume Learning"](#) .

>> **INSPECTION END**

DTC P0550 PSP SENSOR

Component Description

Power steering pressure (PSP) sensor is installed to the power steering high-pressure tube and detects a power steering load. This sensor is a potentiometer which transforms the power steering load into output voltage, and emits the voltage signal to the ECM. The ECM controls the electric throttle control actuator and adjusts the throttle valve opening angle to increase the engine speed and adjusts the idle speed for the increased load.

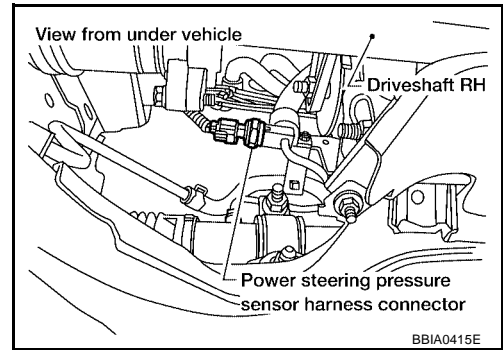

CONSULT-II Reference Value in Data Monitor Mode

Specification data are reference values.

MONITOR ITEM	CONDITION		SPECIFICATION
PW/ST SIGNAL	<ul style="list-style-type: none"> Engine: After warming up, idle the engine 	Steering wheel is in neutral position. (Forward direction)	OFF
		Steering wheel is being turned.	ON

On Board Diagnosis Logic

The MIL will not light up for this diagnosis.

NOTE:

If DTC P0550 is displayed with DTC P1229, first perform the trouble diagnosis for DTC P1229. Refer to [EC-438](#).

DTC No.	Trouble diagnosis name	DTC detecting condition	Possible cause
P0550 0550	Power steering pressure sensor circuit	An excessively low or high voltage from the sensor is sent to ECM.	<ul style="list-style-type: none"> Harness or connectors (The sensor circuit is open or shorted.) Power steering pressure sensor

DTC Confirmation Procedure

NOTE:

If DTC Confirmation Procedure has been previously conducted, always turn ignition switch OFF and wait at least 10 seconds before conducting the next test.

WITH CONSULT-II

- Turn ignition switch ON.
- Select "DATA MONITOR" mode with CONSULT-II.
- Start engine and let it idle for at least 5 seconds.
- If 1st trip DTC is detected, go to [EC-367, "Diagnostic Procedure"](#).

WITH GST

Follow the procedure "WITH CONSULT-II" above.

DTC P0550 PSP SENSOR

[QR]

Wiring Diagram

UBS00C81

EC-PS/SEN-01

- : DETECTABLE LINE FOR DTC
- : NON-DETECTABLE LINE FOR DTC
- ⬡ : WITH A/T

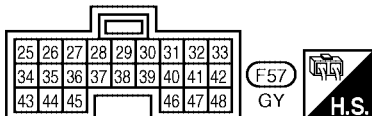
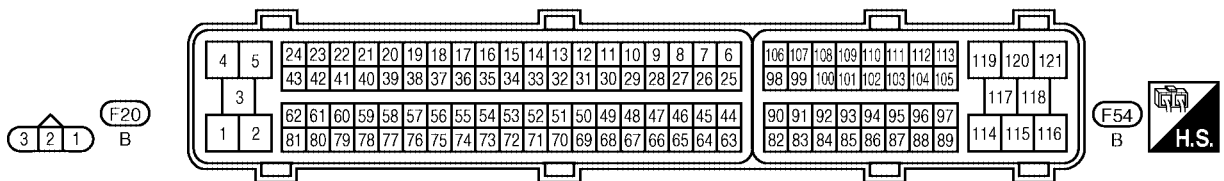
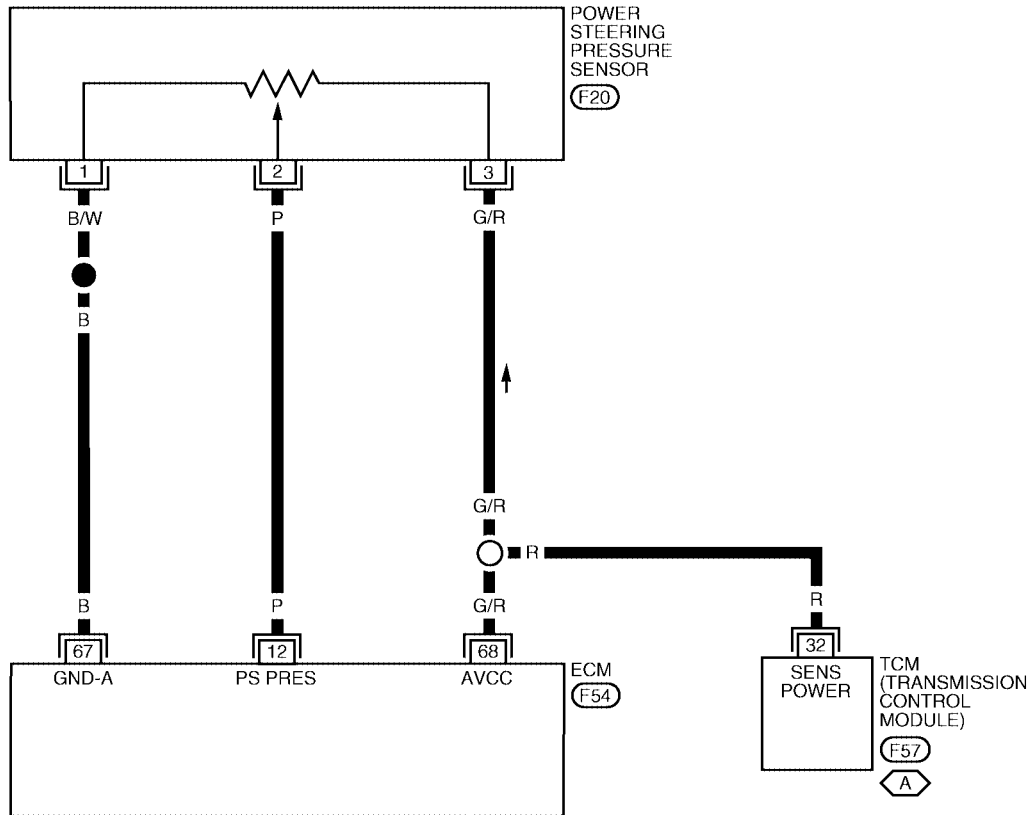

BBWA1945E

DTC P0550 PSP SENSOR

[QR]

Specification data are reference values and are measured between each terminal and ground.

CAUTION:

Do not use ECM ground terminals when measuring input/output voltage. Doing so may result in damage to the ECM's transistor. Use a ground other than ECM terminals, such as the ground.

TER-MINAL NO.	WIRE COLOR	ITEM	CONDITION	DATA (DC Voltage)
12	P	Power steering pressure sensor	[Engine is running] ● Steering wheel is being turned	0.5 - 4.0V
			[Engine is running] ● Steering wheel is not being turned	0.4 - 0.8V
67	B	Sensor ground	[Engine is running] ● Warm-up condition ● Idle speed	Approximately 0V
68	G/R	Sensor power supply (Power steering pressure sensor)	[Ignition switch: ON]	Approximately 5V

Diagnostic Procedure

UBS00C82

1. CHECK GROUND CONNECTIONS

1. Turn ignition switch OFF.
2. Loosen and retighten three ground screws on the body. Refer to [EC-164, "Ground Inspection"](#).

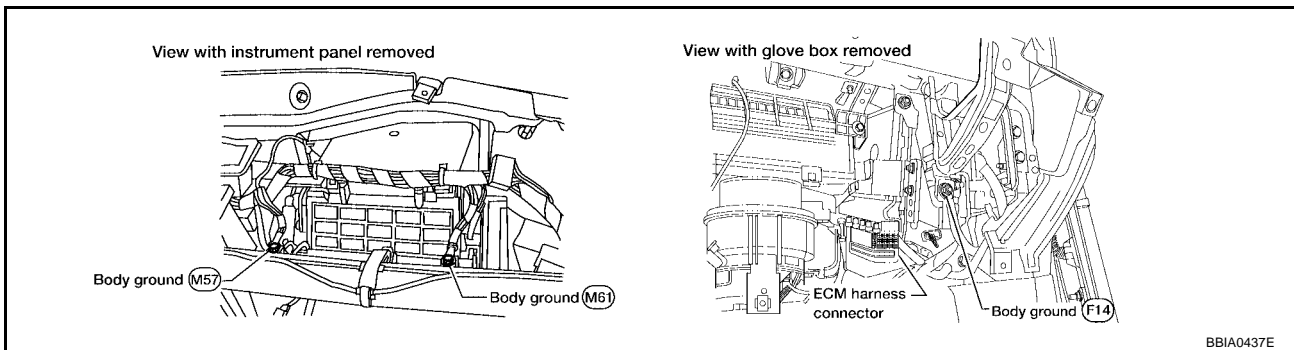

OK or NG

- OK >> GO TO 2.
- NG >> Repair or replace ground connections.

2. CHECK PSP SENSOR POWER SUPPLY CIRCUIT

1. Disconnect PSP sensor harness connector.
2. Turn ignition switch ON.

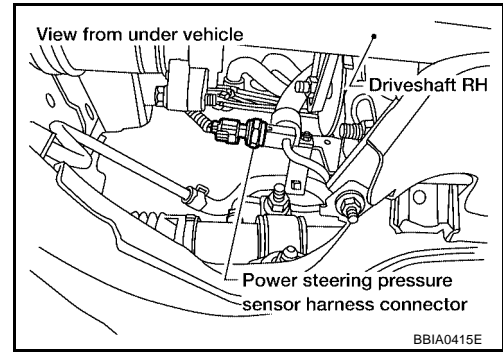

3. Check voltage between PSP sensor terminal 3 and ground with CONSULT-II or tester.

Voltage: Approximately 5V

OK or NG

OK >> GO TO 3.

NG >> Repair open circuit or short to ground or short to power in harness or connectors.

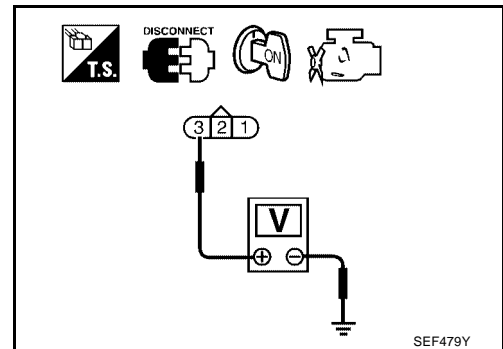

3. CHECK PSP SENSOR GROUND CIRCUIT FOR OPEN AND SHORT

1. Turn ignition switch OFF.
2. Disconnect ECM harness connector.
3. Disconnect TCM harness connector (A/T models).
4. Check harness continuity between PSP sensor terminal 1 and ECM terminal 67, TCM terminal 32 (A/T models).

Continuity should exist.

5. Also check harness for short to ground or short to power.

OK or NG

OK >> GO TO 5.

NG >> GO TO 4.

4. DETECT MALFUNCTIONING PART

Check the following.

- Harness for open or short between power steering pressure sensor and ECM
- Harness for open or short between power steering pressure sensor and TCM (A/T models)

>> Repair open circuit or short to ground or short to power in harness or connectors.

5. CHECK PSP SENSOR INPUT SIGNAL CIRCUIT FOR OPEN AND SHORT

1. Disconnect ECM harness connector.
2. Check harness continuity between ECM terminal 12 and PSP sensor terminal 2.

Continuity should exist.

3. Also check harness for short to ground and short to power.

OK or NG

OK >> GO TO 6.

NG >> Repair open circuit or short to ground or short to power in harness or connectors.

6. CHECK PSP SENSOR

Refer to [EC-369, "Component Inspection"](#) .

OK or NG

OK >> GO TO 7.

NG >> Replace PSP sensor.

7. CHECK INTERMITTENT INCIDENT

Refer to [EC-158, "TROUBLE DIAGNOSIS FOR INTERMITTENT INCIDENT"](#) .

>> **INSPECTION END**

**Component Inspection
POWER STEERING PRESSURE SENSOR**

UBS00C83

1. Reconnect all harness connectors disconnected.
2. Start engine and let it idle.
3. Check voltage between ECM terminal 12 and ground under the following conditions.

Condition	Voltage
Steering wheel is being turned fully.	0.5 - 4.5V
Steering wheel is not being turned.	0.4 - 0.8V

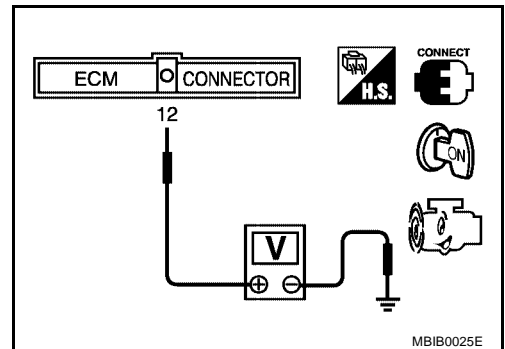

DTC P0605 ECM

Component Description

UBS002WY

The ECM consists of a microcomputer and connectors for signal input and output and for power supply. The ECM controls the engine.

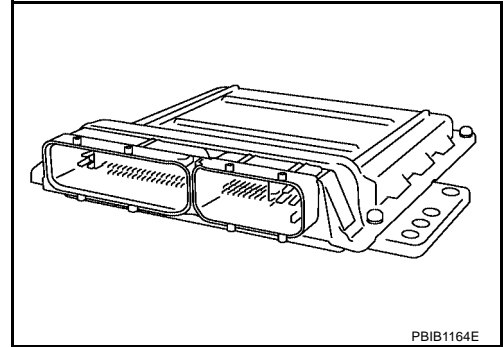

UBS002WZ

On Board Diagnosis Logic

This self-diagnosis has one or two trip detection logic.

DTC No.	Trouble diagnosis name	DTC detecting condition		Possible cause
P0605 0605	Engine control module	A)	ECM calculation function is malfunctioning.	● ECM
		B)	ECM EEP-ROM system is malfunctioning.	
		C)	ECM self shut-off function is malfunctioning.	

FAIL-SAFE MODE

ECM enters fail-safe mode when malfunction A is detected.

Detected items	Engine operation condition in fail-safe mode
Malfunction A	<ul style="list-style-type: none"> ● ECM stops the electric throttle control actuator control, throttle valve is maintained at a fixed opening (approx. 5 degrees) by the return spring. ● ECM deactivates ASCD operation.

DTC Confirmation Procedure

UBS002X0

Perform **PROCEDURE FOR MALFUNCTION A** first. If the 1st trip DTC cannot be confirmed, perform **PROCEDURE FOR MALFUNCTION B**. If there is no malfunction on **PROCEDURE FOR MALFUNCTION B**, perform **PROCEDURE FOR MALFUNCTION C**.

NOTE:

If DTC Confirmation Procedure has been previously conducted, always turn ignition switch OFF and wait at least 10 seconds before conducting the next test.

PROCEDURE FOR MALFUNCTION A

Ⓟ **With CONSULT-II**

1. Turn ignition switch ON.
2. Select "DATA MONITOR" mode with CONSULT-II.
3. If 1st trip DTC is detected, go to [EC-371, "Diagnostic Procedure"](#)

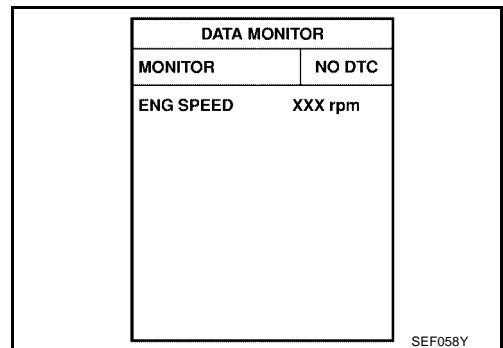

Ⓟ **With GST**

Follow the procedure "With CONSULT-II" above.

PROCEDURE FOR MALFUNCTION B

With CONSULT-II

1. Turn ignition switch ON and wait at least 1 second.
2. Select "DATA MONITOR" mode with CONSULT-II.
3. Turn ignition switch OFF, wait at least 10 seconds, and then turn ON.
4. If 1st trip DTC is detected, go to [EC-371, "Diagnostic Procedure"](#)

DATA MONITOR	
MONITOR	NO DTC
ENG SPEED	XXX rpm

SEF058Y

With GST

Follow the procedure "With CONSULT-II" above.

PROCEDURE FOR MALFUNCTION C

With CONSULT-II

1. Turn ignition switch ON and wait at least 1 second.
2. Select "DATA MONITOR" mode with CONSULT-II.
3. Turn ignition switch OFF, wait at least 10 seconds, and then turn ON.
4. Repeat step 3 for 32 times.
5. If 1st trip DTC is detected, go to [EC-371, "Diagnostic Procedure"](#)

DATA MONITOR	
MONITOR	NO DTC
ENG SPEED	XXX rpm

SEF058Y

With GST

Follow the procedure "With CONSULT-II" above.

Diagnostic Procedure

UBS002X1

1. INSPECTION START

With CONSULT-II

1. Turn ignition switch ON.
2. Select "SELF DIAG RESULTS" mode with CONSULT-II.
3. Touch "ERASE".
4. **Perform DTC Confirmation Procedure.**
See [EC-370](#) .
5. Is the 1st trip DTC P0605 displayed again?

With GST

1. Turn ignition switch ON.
2. Select Service \$04 with GST.
3. Touch "ERASE".
4. **Perform DTC Confirmation Procedure.**
See [EC-370](#) .
5. Is the 1st trip DTC P0605 displayed again?

Yes or No

Yes >> GO TO 2.

No >> **INSPECTION END**

2. REPLACE ECM

1. Replace ECM.
2. Perform initialization of NVIS (NATS) system and registration of all NVIS (NATS) ignition key IDs. Refer to [BL-107, "NVIS\(NISSAN Vehicle Immobilizer System-NATS\)"](#) .
3. Perform [EC-92, "VIN Registration"](#) .
4. Perform [EC-93, "Accelerator Pedal Released Position Learning"](#) .
5. Perform [EC-93, "Throttle Valve Closed Position Learning"](#) .
6. Perform [EC-93, "Idle Air Volume Learning"](#) .

>> INSPECTION END

DTC P1031, P1032 A/F SENSOR 1 HEATER

[QR]

DTC P1031, P1032 A/F SENSOR 1 HEATER

PF2:22693

Description SYSTEM DESCRIPTION

UBS00C84

Sensor	Input Signal to ECM	ECM function	Actuator
Camshaft position sensor (PHASE) Crankshaft position sensor (POS)	Engine speed	Air fuel ratio (A/F) sensor 1 heater control	Air fuel ratio (A/F) sensor 1 heater
Mass air flow sensor	Amount of intake air		

The ECM performs ON/OFF duty control of the A/F sensor 1 heater corresponding to the engine operating condition to keep the temperature of A/F sensor 1 element at the specified range.

CONSULT-II Reference Value in Data Monitor Mode

UBS00C85

Specification data are reference values.

MONITOR ITEM	CONDITION	SPECIFICATION
A/F S1 HTR (B1)	● Engine: After warming up, idle the engine	0 - 100%

On Board Diagnosis Logic

UBS00C86

DTC No.	Trouble diagnosis name	DTC detecting condition	Possible cause
P1031 1031	Air fuel ratio (A/F) sensor 1 heater control circuit low	The current amperage in the air fuel ratio (A/F) sensor 1 heater circuit is out of the normal range. (An excessively low voltage signal is sent to ECM through the air fuel ratio (A/F) sensor 1 heater.)	<ul style="list-style-type: none"> ● Harness or connectors (The A/F sensor 1 heater circuit is open or shorted.) ● Air fuel ratio (A/F) sensor 1 heater
P1032 1032	Air fuel ratio (A/F) sensor 1 heater control circuit high	The current amperage in the air fuel ratio (A/F) sensor 1 heater circuit is out of the normal range. (An excessively high voltage signal is sent to ECM through the air fuel ratio (A/F) sensor 1 heater.)	<ul style="list-style-type: none"> ● Harness or connectors (The A/F sensor 1 heater circuit is shorted.) ● Air fuel ratio (A/F) sensor 1 heater

DTC Confirmation Procedure

UBS00C87

NOTE:

If DTC Confirmation Procedure has been previously conducted, always turn ignition switch OFF and wait at least 10 seconds before conducting the next test.

TESTING CONDITION:

Before performing the following procedure, confirm that battery voltage is between 10.5V and 16V at idle.

With CONSULT-II

WITH CONSULT-II

1. Turn ignition switch ON and select "DATA MONITOR" mode with CONSULT-II.
2. Start engine and run it for at least 10 seconds at idle speed.
3. If 1st trip DTC is detected, go to [EC-375, "Diagnostic Procedure"](#)

DATA MONITOR	
MONITOR	NO DTC
ENG SPEED	XXX rpm

SEF058Y

WITH GST

Follow the procedure "WITH CONSULT-II" above.

DTC P1031, P1032 A/F SENSOR 1 HEATER

[QR]

UBS00C88

Wiring Diagram

EC-A/FH-0

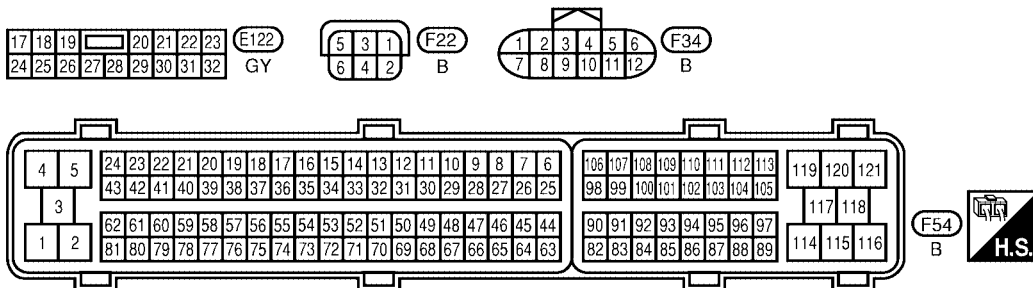
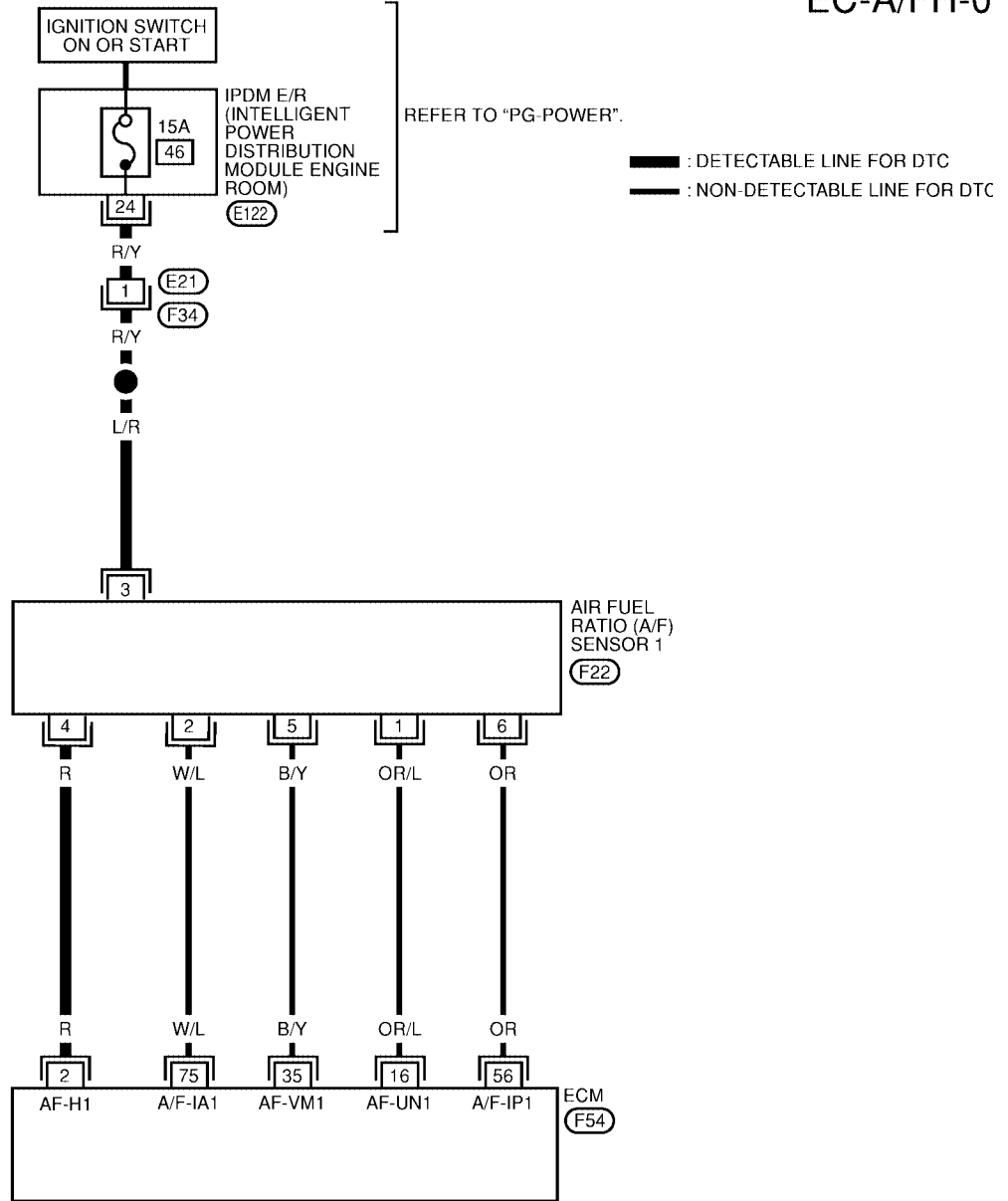

BBWA1233E

DTC P1031, P1032 A/F SENSOR 1 HEATER

[QR]

Specification data are reference values and are measured between each terminal and ground.

CAUTION:

Do not use ECM ground terminals when measuring input/output voltage. Doing so may result in damage to the ECM's transistor. Use a ground other than ECM terminals, such as the ground.

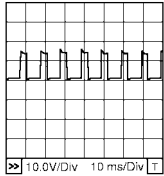
TERMI- NAL NO.	WIRE COLOR	ITEM	CONDITION	DATA (DC Voltage)
2	R	A/F sensor 1 heater	<p>[Engine is running]</p> <ul style="list-style-type: none"> ● Warm-up condition ● Idle speed 	<p>Approximately 5V★</p>  <p>PBIB1584E</p>

★: Average voltage for pulse signal (Actual pulse signal can be confirmed by oscilloscope.)

Diagnostic Procedure

UBS00C89

1. CHECK GROUND CONNECTIONS

1. Turn ignition switch OFF.
2. Loosen and retighten three ground screws on the body. Refer to [EC-164, "Ground Inspection"](#).

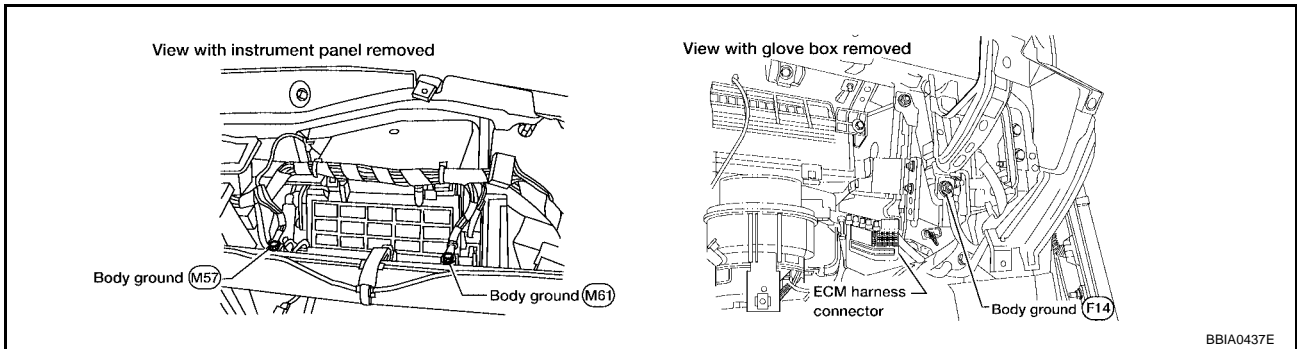

OK or NG

- OK >> GO TO 2.
- NG >> Repair or replace ground connections.

2. CHECK AIR FUEL RATIO (A/F) SENSOR 1 POWER SUPPLY CIRCUIT

1. Disconnect air fuel ratio (A/F) sensor 1 harness connector.
2. Turn ignition switch ON.

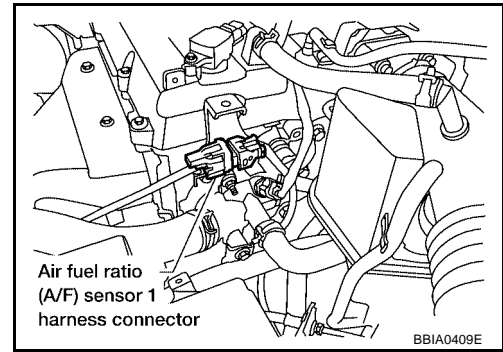

3. Check voltage between A/F sensor 1 terminal 3 and ground with CONSULT-II or tester.

Voltage: Battery voltage

OK or NG

- OK >> GO TO 4.
 NG >> GO TO 3.

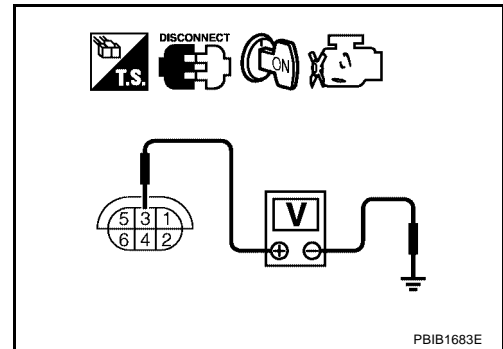

3. DETECT MALFUNCTIONING PART

Check the following.

- Harness connectors E21, F34
- IPDM E/R connector E122
- 15A fuse
- Harness for open or short between A/F sensor 1 and fuse

>> Repair or replace harness or connectors.

4. CHECK A/F SENSOR 1 HEATER OUTPUT SIGNAL CIRCUIT

1. Turn ignition switch OFF.
2. Disconnect ECM harness connector.
3. Check harness continuity between ECM terminal 2 and A/F sensor 1 terminal 4. Refer to Wiring Diagram.

Continuity should exist.

4. Also check harness for short to ground short to power.

OK or NG

- OK >> GO TO 5.
 NG >> Repair open circuit or short to ground or short to power in harness or connectors.

5. CHECK A/F SENSOR 1 HEATER

Refer to [EC-377, "Component Inspection"](#) .

OK or NG

- OK >> GO TO 6.
 NG >> Replace A/F sensor 1.

6. CHECK INTERMITTENT INCIDENT

Perform [EC-158, "TROUBLE DIAGNOSIS FOR INTERMITTENT INCIDENT"](#) .

OK or NG

OK >> Replace A/F sensor 1.

NG >> Repair or replace.

Component Inspection**AIR FUEL RATIO (A/F) SENSOR 1 HEATER**

Check resistance between terminals 3 and 4.

Resistance: 2.3 - 4.3Ω at 25°C (77°F)

Check continuity between terminals 3 and 1, 2, 5, 6, terminals 4 and 1, 2, 5, 6.

Continuity should not exist.

If NG, replace the A/F sensor 1.

CAUTION:

- Discard any A/F sensor which has been dropped from a height of more than 0.5 m (19.7 in) onto a hard surface such as a concrete floor; use a new one.
- Before installing new A/F sensor, clean exhaust system threads using Heated Oxygen Sensor Thread Cleaner tool J-43897-18 or J-43897-12 and approved anti-seize lubricant.

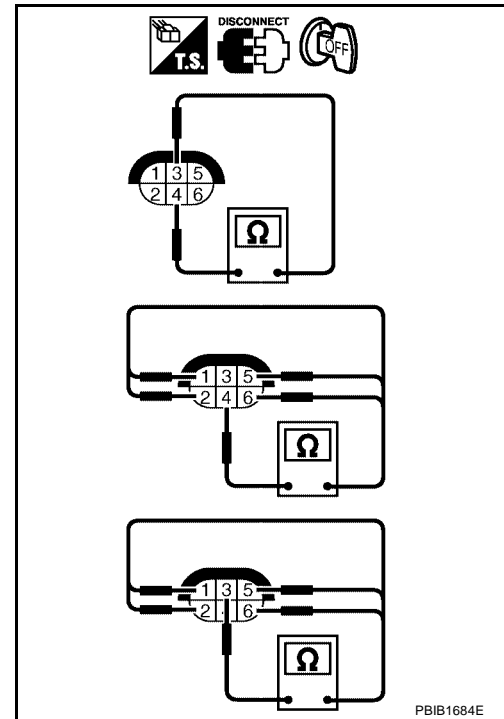
**Removal and Installation****AIR FUEL RATIO SENSOR HEATER**

Refer to [EM-24, "EXHAUST MANIFOLD AND THREE WAY CATALYST"](#) .

DTC P1065 ECM POWER SUPPLY

Component Description

UBS002X7

Battery voltage is supplied to the ECM even when the ignition switch is turned OFF for the ECM memory function of the DTC memory, the air-fuel ratio feedback compensation value memory, the Idle Air Volume Learning value memory, etc.

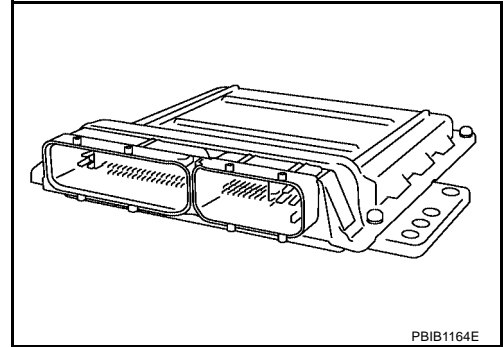

On Board Diagnosis Logic

UBS002X8

DTC No.	Trouble diagnosis name	DTC detecting condition	Possible cause
P1065 1065	ECM power supply circuit	ECM back-up RAM system does not function properly.	<ul style="list-style-type: none"> ● Harness or connectors [ECM power supply (back-up) circuit is open or shorted.] ● ECM

DTC Confirmation Procedure

UBS002X9

NOTE:

If DTC Confirmation Procedure has been previously conducted, always turn ignition switch OFF and wait at least 10 seconds before conducting the next test.

WITH CONSULT-II

1. Turn ignition switch ON and wait at least 1 second.
2. Select "DATA MONITOR" mode with CONSULT-II.
3. Start engine and let it idle for 1 second.
4. Turn ignition switch OFF, wait at least 10 seconds, and then turn ON.
5. Repeat steps 3 and 4 for 4 times.
6. If 1st trip DTC is detected, go to [EC-380, "Diagnostic Procedure"](#)

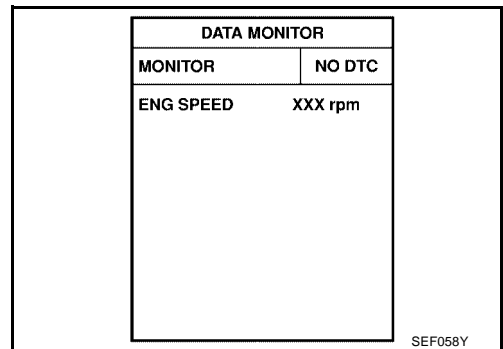

WITH GST

Follow the procedure "WITH CONSULT-II" above.

DTC P1065 ECM POWER SUPPLY

[QR]

Wiring Diagram

UBS002XA

EC-ECM/PW-01

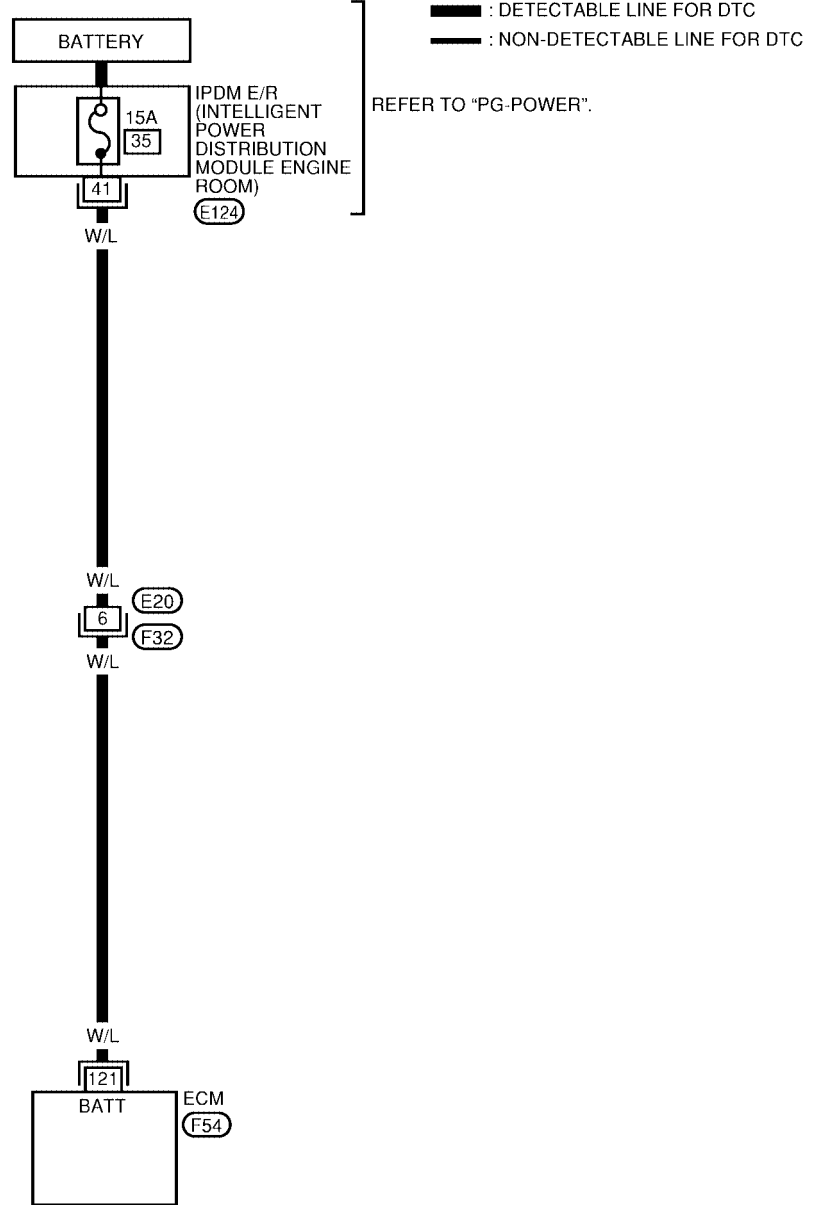

A
 EC
 C
 D
 E
 F
 G
 H
 I
 J
 K
 L
 M

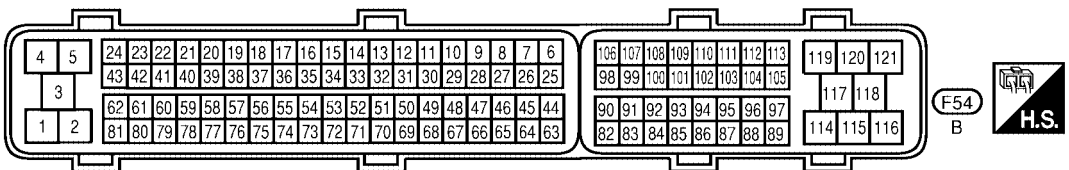
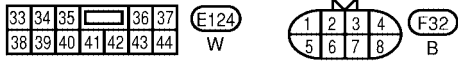

BBWA1234E

DTC P1065 ECM POWER SUPPLY

[QR]

Specification data are reference values and are measured between each terminal and ground.

CAUTION:

Do not use ECM ground terminals when measuring input/output voltage. Doing so may result in damage to the ECM's transistor. Use a ground other than ECM terminals, such as the ground.

TER-MINAL NO.	WIRE COLOR	ITEM	CONDITION	DATA (DC Voltage)
121	W/L	Power supply for ECM (Back-up)	[Ignition switch: OFF]	BATTERY VOLTAGE (11 - 14V)

Diagnostic Procedure

UBS002XB

1. CHECK ECM POWER SUPPLY

1. Turn ignition switch OFF.
2. Disconnect ECM harness connector.
3. Check voltage between ECM terminal 121 and ground with CONSULT-II or tester.

Voltage: Battery voltage

OK or NG

- OK >> GO TO 3.
- NG >> GO TO 2.

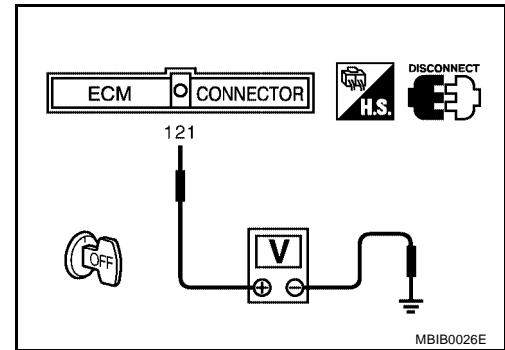

2. DETECT MALFUNCTIONING PART

Check the following.

- Harness connectors E20, F32
- 15A fuse
- Harness for open or short between ECM and IPDM E/R
- IPDM E/R harness connector E124

>> Repair or replace harness or connectors.

3. CHECK INTERMITTENT INCIDENT

Refer to [EC-158, "TROUBLE DIAGNOSIS FOR INTERMITTENT INCIDENT"](#) .

OK or NG

- OK >> GO TO 4.
- NG >> Repair open circuit or short to ground or short to power in harness or connectors.

4. PERFORM DTC CONFIRMATION PROCEDURE

Ⓟ With CONSULT-II

1. Turn ignition switch ON.
2. Select "SELF DIAG RESULTS" mode with CONSULT-II.
3. Touch "ERASE".
4. **Perform DTC Confirmation Procedure.**
See [EC-378](#) .
5. Is the 1st trip DTC P1065 displayed again?

Ⓢ With GST

1. Turn ignition switch ON.
2. Select Service \$04 with GST.
3. Touch "ERASE".
4. **Perform "DTC Confirmation Procedure".**
See [EC-378](#) .
5. Is the 1st trip DTC P1065 displayed again?

Yes or No

- Yes >> GO TO 5.
No >> **INSPECTION END**

5. REPLACE ECM

1. Replace ECM.
2. Perform initialization of NVIS (NATS) system and registration of all NVIS (NATS) ignition key IDs. Refer to [BL-107, "NVIS\(NISSAN Vehicle Immobilizer System-NATS\)"](#) .
3. Perform [EC-92, "VIN Registration"](#) .
4. Perform [EC-93, "Accelerator Pedal Released Position Learning"](#) .
5. Perform [EC-93, "Throttle Valve Closed Position Learning"](#) .
6. Perform [EC-93, "Idle Air Volume Learning"](#) .

>> **INSPECTION END**

A
EC
C
D
E
F
G
H
I
J
K
L
M

DTC P1111 IVT CONTROL SOLENOID VALVE

PFP:23796

Component Description

UBS002XK

Intake valve timing control solenoid valve is activated by ON/OFF pulse duty (ratio) signals from the ECM.

The intake valve timing control solenoid valve changes the oil amount and direction of flow through intake valve timing control unit or stops oil flow.

The longer pulse width advances valve angle.

The shorter pulse width retards valve angle.

When ON and OFF pulse widths become equal, the solenoid valve stops oil pressure flow to fix the intake valve angle at the control position.

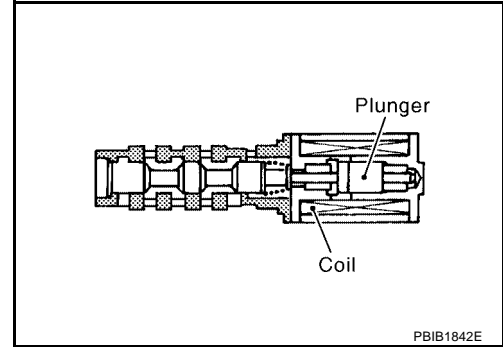

CONSULT-II Reference Value in Data Monitor Mode

UBS002XL

Specification data are reference values.

MONITOR ITEM	CONDITION	SPECIFICATION
INT/V SOL (B1)	● Engine: After warming up ● Shift lever: N (A/T), Neutral (M/T) ● Air conditioner switch: OFF ● No-load	Idle
		2,000 rpm
		0% - 2%
		Approx. 25% - 60%

On Board Diagnosis Logic

UBS002XM

DTC No.	Trouble diagnosis name	DTC detecting condition	Possible cause
P1111 1111	Intake valve timing control solenoid valve circuit	An improper voltage is sent to the ECM through intake valve timing control solenoid valve.	<ul style="list-style-type: none"> ● Harness or connectors (Intake valve timing control solenoid valve circuit is open or shorted.) ● Intake valve timing control solenoid valve

DTC Confirmation Procedure

UBS002XN

NOTE:

If DTC Confirmation Procedure has been previously conducted, always turn ignition switch OFF and wait at least 10 seconds before conducting the next test.

④ WITH CONSULT-II

1. Turn ignition switch ON.
2. Select "DATA MONITOR" mode with CONSULT-II.
3. Start engine and let it idle for 5 seconds.
4. If 1st trip DTC is detected, go to [EC-384, "Diagnostic Procedure"](#)

DATA MONITOR	
MONITOR	NO DTC
ENG SPEED	XXX rpm

SEF058Y

④ WITH GST

Following the procedure "WITH CONSULT-II" above.

DTC P1111 IVT CONTROL SOLENOID VALVE

[QR]

Wiring Diagram

UBS002X0

EC-IVC-01

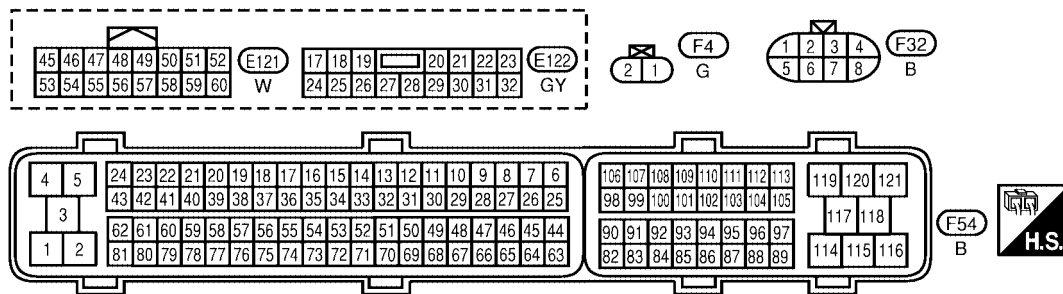
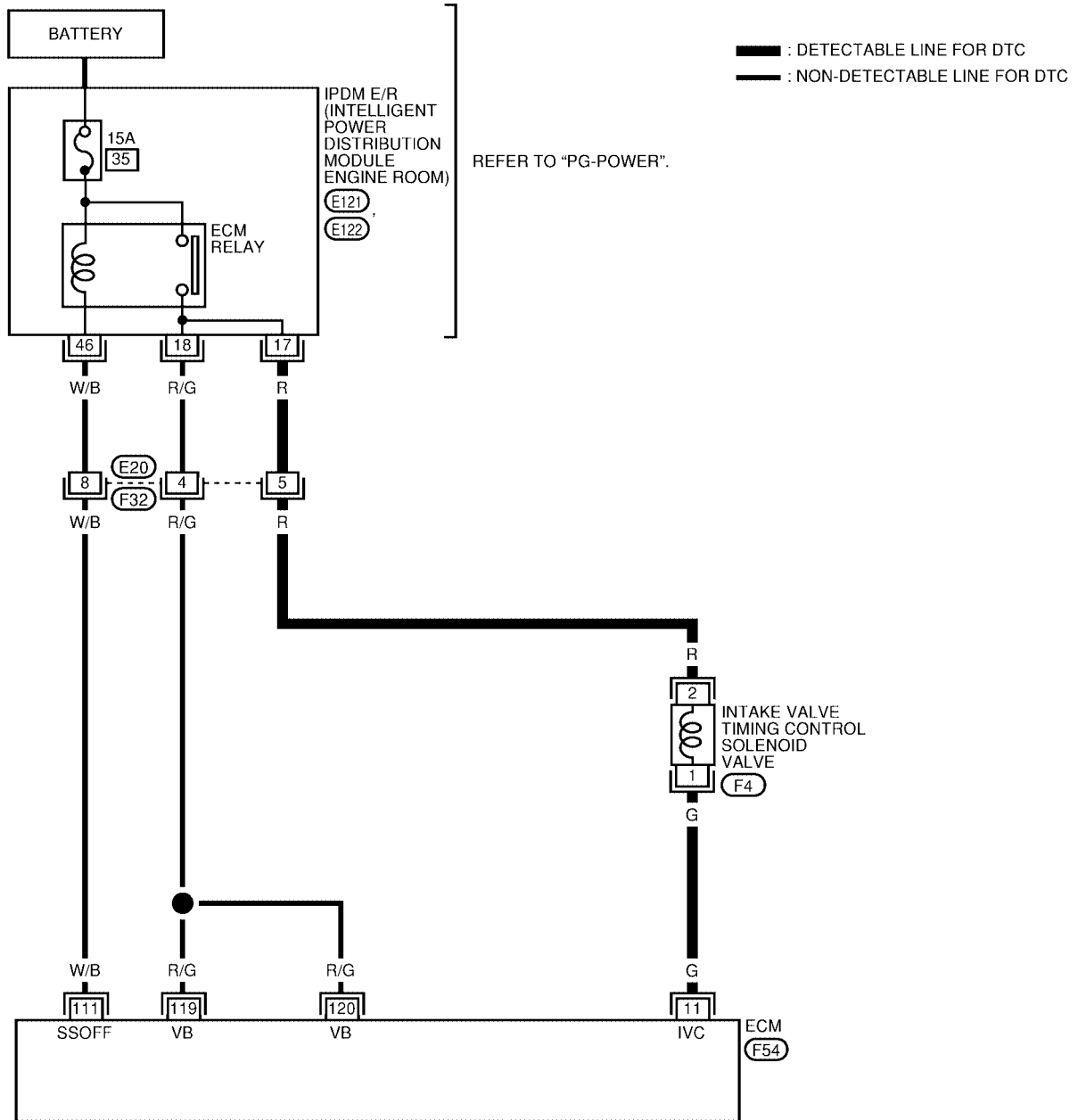

BBWA1235E

DTC P1111 IVT CONTROL SOLENOID VALVE

[QR]

Specification data are reference values and are measured between each terminal and ground.
Pulse signal is measured by CONSULT-II.

CAUTION:

Do not use ECM ground terminals when measuring input/output voltage. Doing so may result in damage to the ECM's transistor. Use a ground other than ECM terminals, such as the ground.

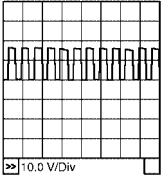
TER-MINAL NO.	WIRE COLOR	ITEM	CONDITION	DATA (DC Voltage)
11	G	Intake valve timing control solenoid valve	[Engine is running] <ul style="list-style-type: none"> ● Warm-up condition ● Idle speed 	BATTERY VOLTAGE (11 - 14V)
			[Engine is running] <ul style="list-style-type: none"> ● Warm-up condition ● Engine speed 2,500 rpm 	7 - 10V★ 

PBIB1790E

★: Average voltage for pulse signal (Actual pulse signal can be confirmed by oscilloscope.)

Diagnostic Procedure

UBS002XP

1. CHECK INTAKE VALVE TIMING CONTROL SOLENOID VALVE POWER SUPPLY CIRCUIT

1. Turn ignition switch OFF.
2. Disconnect intake valve timing control solenoid valve harness connector.
3. Turn ignition switch ON.

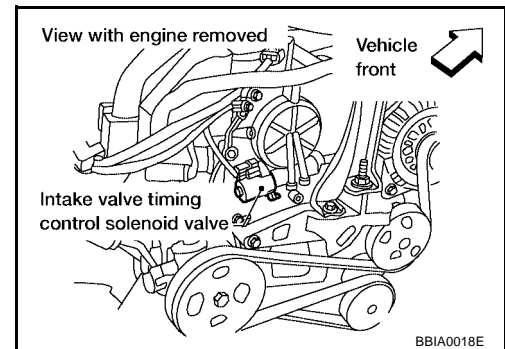

BBA0018E

4. Check voltage between intake valve timing control solenoid valve terminal 2 and ground with CONSULT-II or tester.

Voltage: Battery voltage

OK or NG

- OK >> GO TO 3.
- NG >> GO TO 2.

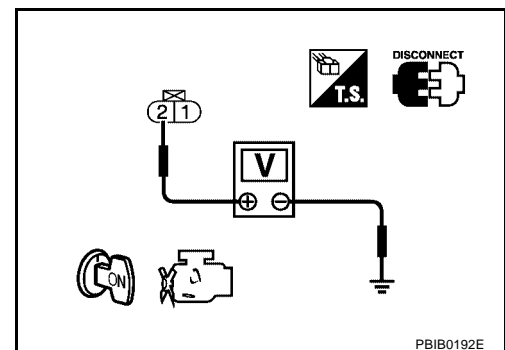

PBIB0192E

2. DETECT MALFUNCTION PART

Check the following.

- Harness connectors E20, F32
- Harness for open or short between intake valve timing control solenoid valve and IPDM E/R

>> Repair or replace harness or connectors.

3. CHECK INTAKE VALVE TIMING CONTROL SOLENOID VALVE OUTPUT SIGNAL CIRCUIT FOR OPEN AND SHORT

1. Turn ignition switch OFF.
2. Disconnect ECM harness connector.
3. Check harness continuity between ECM terminal 11 and intake valve timing control solenoid valve terminal 1. Refer to Wiring Diagram.

Continuity should exist.

4. Also check harness for short to ground and short to power.

OK or NG

OK >> GO TO 4.

NG >> Repair open circuit or short to ground or short to power in harness or connectors.

4. CHECK INTAKE VALVE TIMING CONTROL SOLENOID VALVE

Refer to [EC-385, "Component Inspection"](#) .

OK or NG

OK >> GO TO 5.

NG >> Replace intake valve timing control solenoid valve.

5. CHECK INTERMITTENT INCIDENT

Refer to [EC-158, "TROUBLE DIAGNOSIS FOR INTERMITTENT INCIDENT"](#) .

>> INSPECTION END

Component Inspection INTAKE VALVE TIMING CONTROL SOLENOID VALVE

UBS002XQ

1. Disconnect intake valve timing control solenoid valve harness connector.
2. Check resistance between intake valve timing control solenoid valve as follows.

Terminal	Resistance
1 and 2	7.0 - 7.7Ω at 20°C (68°F)
1 or 2 and ground	(Continuity should not exist.)

If NG, replace intake valve timing control solenoid valve.
If OK, go to next step.

3. Remove intake valve timing control solenoid valve.

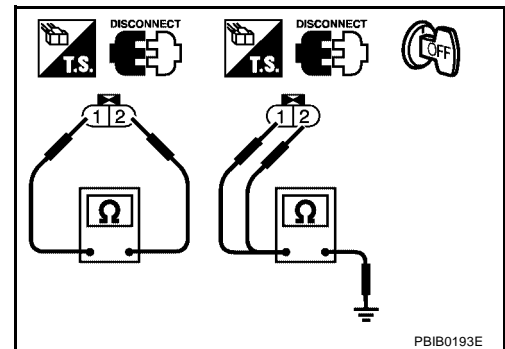

PBIB0193E

4. Provide 12V DC between intake valve timing control solenoid valve terminals and then interrupt it. Make sure that the plunger moves as shown in the figure.

CAUTION:

Do not apply 12V DC continuously for 5 seconds or more. Doing so may result in damage to the coil in intake valve timing control solenoid valve.

If NG, replace intake valve timing control solenoid valve.

NOTE:

Always replace O-ring when intake valve timing control solenoid valve is removed.

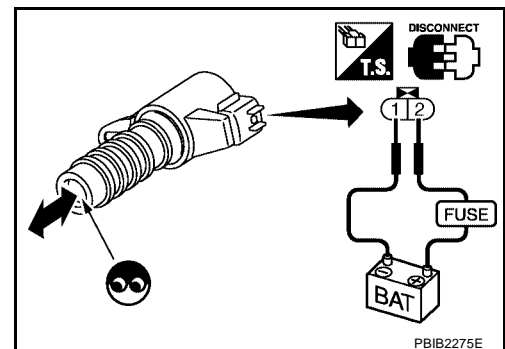

PBIB2275E

Removal and Installation INTAKE VALVE TIMING CONTROL SOLENOID VALVE

UBS002XR

Refer to [EM-48, "TIMING CHAIN"](#) .

DTC P1121 ELECTRIC THROTTLE CONTROL ACTUATOR

[QR]

DTC P1121 ELECTRIC THROTTLE CONTROL ACTUATOR

PFP:16119

Component Description

UBS002XS

Electric throttle control actuator consists of throttle control motor, throttle position sensor, etc. The throttle control motor is operated by the ECM and it opens and closes the throttle valve. The throttle position sensor detects the throttle valve position, and the opening and closing speed of the throttle valve and feeds the voltage signals to the ECM. The ECM judges the current opening angle of the throttle valve from these signals and the ECM controls the throttle control motor to make the throttle valve opening angle properly in response to driving condition.

On Board Diagnosis Logic

UBS002XT

This self-diagnosis has the one trip detection logic.

DTC No.	Trouble diagnosis name	DTC detecting condition		Possible cause
P1121 1121	Electric throttle control actuator	A)	Electric throttle control actuator does not function properly due to the return spring malfunction.	● Electric throttle control actuator
		B)	Throttle valve opening angle in fail-safe mode is not in specified range.	
		C)	ECM detects the throttle valve is stuck open.	

FAIL-SAFE MODE

When the malfunction is detected, ECM enters fail-safe mode and the MIL lights up.

Detected items	Engine operating condition in fail-safe mode
Malfunction A	ECM controls the electric throttle actuator by regulating the throttle opening around the idle position. The engine speed will not rise more than 2,000 rpm.
Malfunction B	ECM controls the electric throttle control actuator by regulating the throttle opening to 20 degrees or less.
Malfunction C	While the vehicle is driving, it slows down gradually by fuel cut. After the vehicle stops, the engine stalls. The engine can restart in N or P position, and engine speed will not exceed 1,000 rpm or more.

DTC Confirmation Procedure

UBS00CVM

NOTE:

- Perform PROCEDURE FOR MALFUNCTION A AND B first. If the DTC cannot be confirmed, perform PROCEDURE FOR MALFUNCTION C.
- If DTC Confirmation Procedure has been previously conducted, always turn ignition switch OFF and wait at least 10 seconds before conducting the next test.

PROCEDURE FOR MALFUNCTION A AND B

With CONSULT-II

1. Turn ignition switch ON and wait at least 1 second.
2. Select "DATA MONITOR" mode with CONSULT-II.
3. Shift shift lever to D position (A/T) or 1st position (M/T), and wait at least 3 seconds.
4. Shift shift lever to P position (A/T) or Neutral position (M/T).
5. Turn ignition switch OFF and wait at least 10 seconds.
6. Turn ignition switch ON and wait at least 1 second.
7. Shift shift lever to D position (A/T) or 1st position (M/T), and wait at least 3 seconds.
8. Shift shift lever to P position (A/T) or Neutral position (M/T).
9. Turn ignition switch OFF, wait at least 10 seconds, and then turn ON.
10. If DTC is detected, go to [EC-387, "Diagnostic Procedure"](#).

DATA MONITOR	
MONITOR	NO DTC
ENG SPEED	XXX rpm

SEF058Y

With GST

Follow the procedure "With CONSULT-II" above.

PROCEDURE FOR MALFUNCTION C

With CONSULT-II

1. Turn ignition switch ON and wait at least 1 second.
2. Select "DATA MONITOR" mode with CONSULT-II.
3. Shift shift lever to D position (A/T) or 1st position (M/T) and wait at least 3 seconds.
4. Shift shift lever to N, P position (A/T) or Neutral (M/T) position.
5. Start engine and let it idle for 3 seconds.
6. If DTC is detected, go to [EC-387, "Diagnostic Procedure"](#) .

DATA MONITOR	
MONITOR	NO DTC
ENG SPEED	XXX rpm

SEF058Y

With GST

Follow the procedure "With CONSULT-II" above.

Diagnostic Procedure

UBS002XV

1. CHECK ELECTRIC THROTTLE CONTROL ACTUATOR VISUALLY

1. Remove the intake air duct.
2. Check if a foreign matter is caught between the throttle valve and the housing.

OK or NG

- OK >> GO TO 2.
 NG >> Remove the foreign matter and clean the electric throttle control actuator inside.

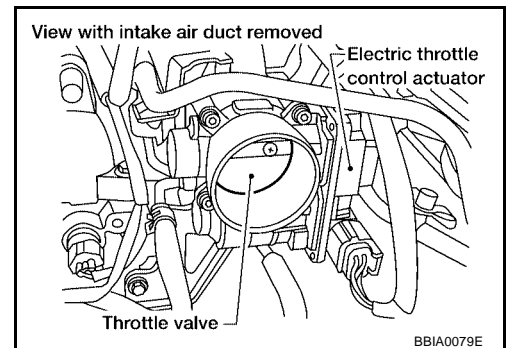

2. REPLACE ELECTRIC THROTTLE CONTROL ACTUATOR

1. Replace the electric throttle control actuator.
2. Perform [EC-93, "Throttle Valve Closed Position Learning"](#) .
3. Perform [EC-93, "Idle Air Volume Learning"](#) .

>> INSPECTION END

DTC P1122 ELECTRIC THROTTLE CONTROL FUNCTION

[QR]

DTC P1122 ELECTRIC THROTTLE CONTROL FUNCTION

PF0:16119

Description

UBS002XW

NOTE:

If DTC P1122 is displayed with DTC P1121 or 1126, first perform the trouble diagnosis for DTC P1121 or P1126. Refer to [EC-386](#) or [EC-394](#).

Electric throttle control actuator consists of throttle control motor, throttle position sensor, etc.

The throttle control motor is operated by the ECM and it opens and closes the throttle valve.

The current opening angle of the throttle valve is detected by the throttle position sensor and it provides feedback to the ECM to control the throttle control motor to make the throttle valve opening angle properly in response to driving condition.

On Board Diagnosis Logic

UBS002XX

This self-diagnosis has the one trip detection logic.

DTC No.	Trouble diagnosis name	DTC detecting condition	Possible cause
P1122 1122	Electric throttle control performance problem	Electric throttle control function does not operate properly.	<ul style="list-style-type: none">● Harness or connectors (Throttle control motor circuit is open or shorted)● Electric throttle control actuator

FAIL-SAFE MODE

When the malfunction is detected, the ECM enters fail-safe mode and the MIL lights up.

Engine operating condition in fail-safe mode

ECM stops the electric throttle control actuator control, throttle valve is maintained at a fixed opening (approx. 5 degrees) by the return spring.

DTC Confirmation Procedure

UBS002XY

NOTE:

If DTC Confirmation Procedure has been previously conducted, always turn ignition switch OFF and wait at least 10 seconds before conducting the next test.

TESTING CONDITION:

Before performing the following procedure, confirm that battery voltage is more than 11V when engine is running.

WITH CONSULT-II

1. Turn ignition switch ON and wait at least 2 seconds.
2. Select "DATA MONITOR" mode with CONSULT-II.
3. Start engine and let it idle for 5 seconds.
4. If DTC is detected, go to [EC-390, "Diagnostic Procedure"](#).

DATA MONITOR	
MONITOR	NO DTC
ENG SPEED	XXX rpm

SEF058Y

WITH GST

Follow the procedure "WITH CONSULT-II" above.

DTC P1122 ELECTRIC THROTTLE CONTROL FUNCTION

[QR]

Wiring Diagram

UBS002XZ

EC-ETC1-01

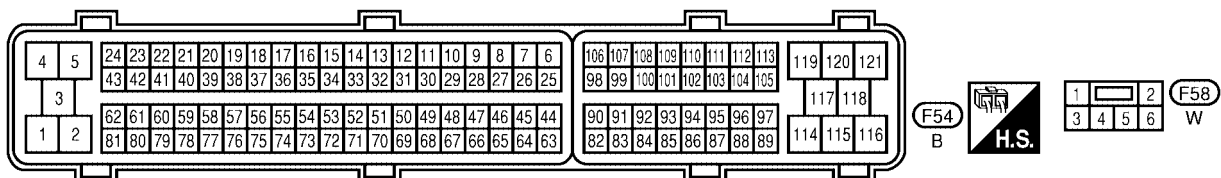
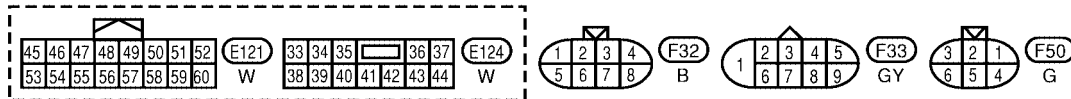
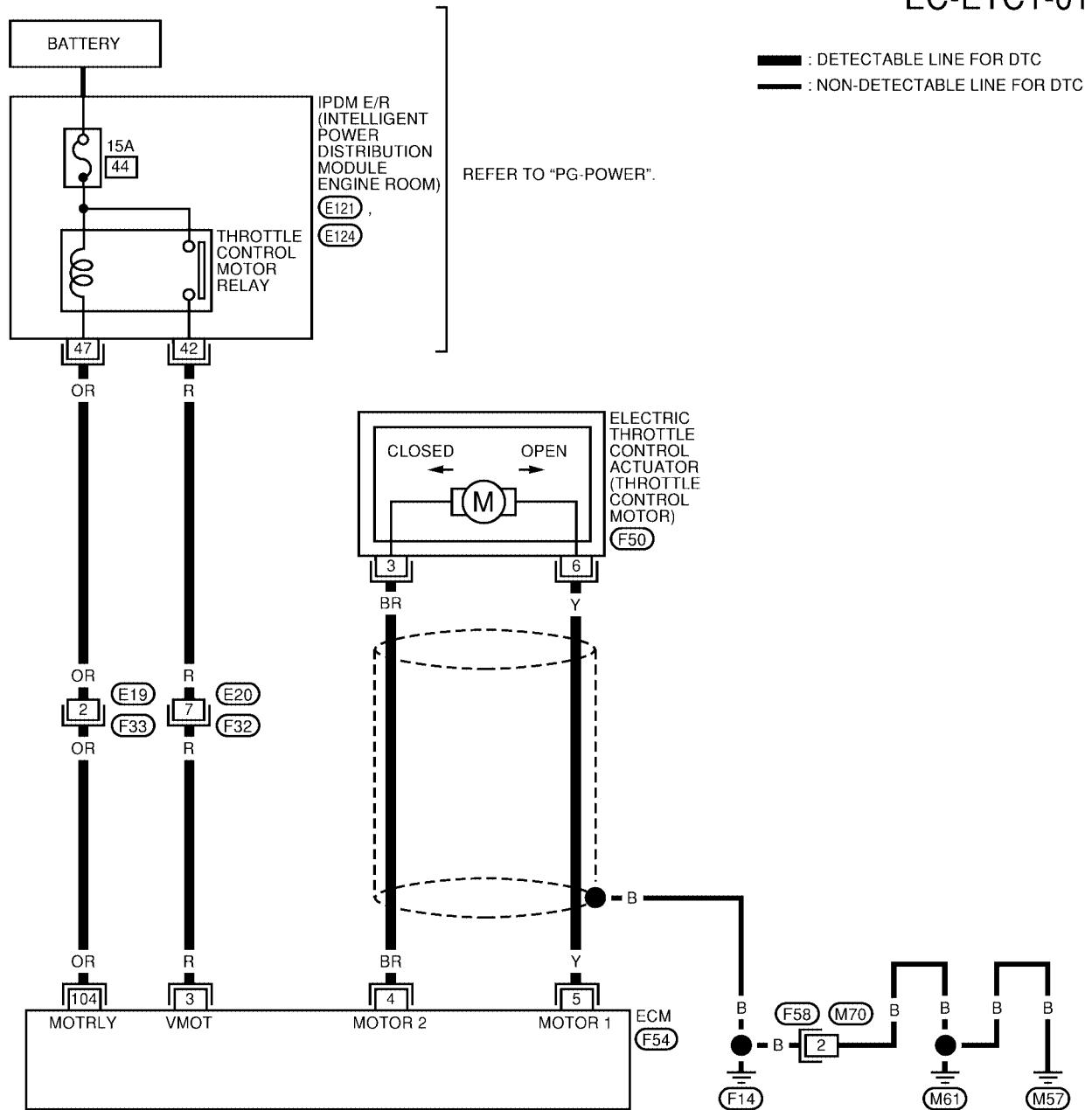

BBWA1236E

DTC P1122 ELECTRIC THROTTLE CONTROL FUNCTION

[QR]

Specification data are reference values and are measured between each terminal and ground.
Pulse signal is measured by CONSULT-II.

CAUTION:

Do not use ECM ground terminals when measuring input/output voltage. Doing so may result in damage to the ECM's transistor. Use a ground other than ECM terminals, such as the ground.

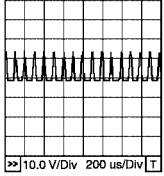
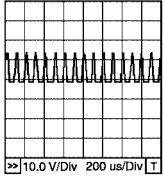
TER-MINAL NO.	WIRE COLOR	ITEM	CONDITION	DATA (DC Voltage)
3	R	Throttle control motor power supply	[Ignition switch: ON]	BATTERY VOLTAGE (11 - 14V)
4	BR	Throttle control motor (Close)	[Ignition switch: ON] ● Engine stopped ● Shift lever: D (A/T), 1ST (M/T) ● Accelerator pedal is released	0 - 14V★  PBI0534E
5	Y	Throttle control motor (Open)	[Ignition switch: ON] ● Engine stopped ● Shift lever: D (A/T), 1ST (M/T) ● Accelerator pedal is fully depressed	0 - 14V★  PBI0533E
104	OR	Throttle control motor relay	[Ignition switch: OFF]	BATTERY VOLTAGE (11 - 14V)
			[Ignition switch: ON]	0 - 1.0V

★: Average voltage for pulse signal (Actual pulse signal can be confirmed by oscilloscope.)

Diagnostic Procedure

UBS002Y0

1. CHECK GROUND CONNECTIONS

1. Turn ignition switch OFF.
2. Loosen and retighten three ground screws on the body. Refer to [EC-164, "Ground Inspection"](#).

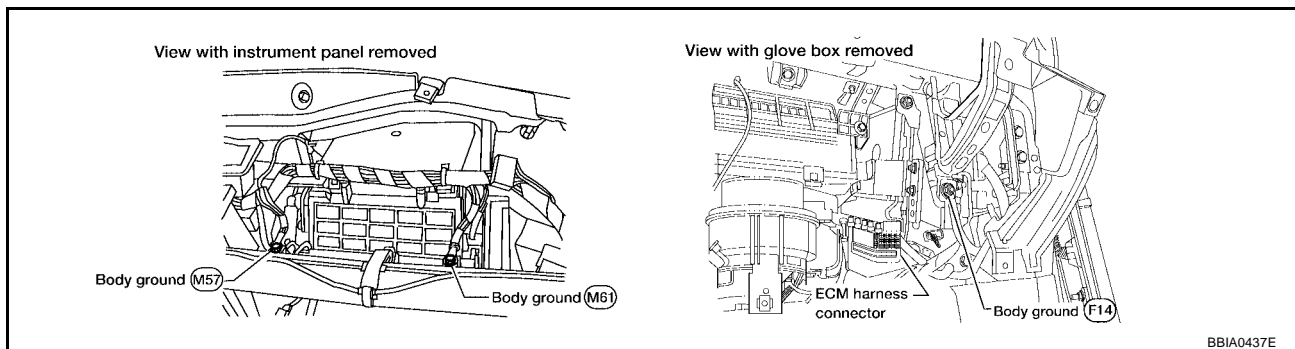

BBI0437E

OK or NG

- OK >> GO TO 2.
- NG >> Repair or replace ground connections.

2. CHECK THROTTLE CONTROL MOTOR RELAY INPUT SIGNAL CIRCUIT-I

1. Check voltage between ECM terminal 3 and ground under the following conditions with CONSULT-II or tester.

Ignition switch	Voltage
OFF	Approximately 0V
ON	Battery voltage (11 - 14V)

OK or NG

- OK >> GO TO 10.
- NG >> GO TO 3.

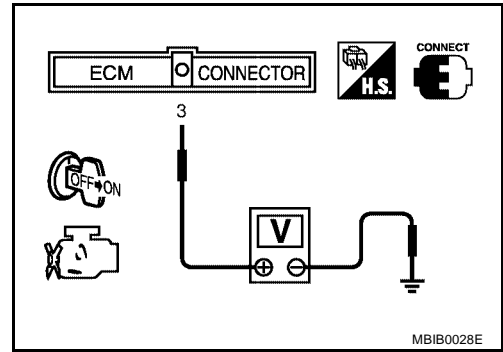

3. CHECK THROTTLE CONTROL MOTOR RELAY INPUT SIGNAL CIRCUIT-II

1. Turn ignition switch OFF.
2. Disconnect ECM harness connector.
3. Disconnect IPDM E/R harness connector E124.
4. Check continuity between ECM terminal 3 and IPDM E/R terminal 42. Refer to Wiring Diagram.

Continuity should exist.

5. Also check harness for short to ground and short to power.

OK or NG

- OK >> GO TO 5.
- NG >> GO TO 4.

4. DETECT MALFUNCTIONING PART

Check the following.

- Harness connectors E20, F32
- Harness for open or short between ECM and IPDM E/R

>> Repair open circuit or short to ground or short to power in harness or connectors.

5. CHECK THROTTLE CONTROL MOTOR RELAY POWER SUPPLY CIRCUIT-I

1. Reconnect all harness connectors disconnected.
2. Check voltage between ECM terminal 104 and ground with CONSULT-II or tester.

Voltage: Battery voltage

OK or NG

- OK >> GO TO 9.
- NG >> GO TO 6.

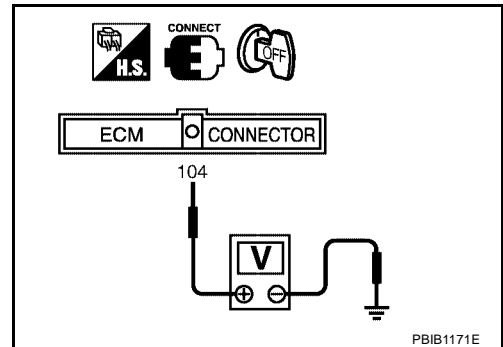

6. CHECK THROTTLE CONTROL MOTOR RELAY POWER SUPPLY CIRCUIT-II

1. Disconnect ECM harness connector.
2. Disconnect IPDM E/R harness connector E121.
3. Check harness continuity between ECM terminal 104 and IPDM E/R terminal 47.
Refer to Wiring Diagram.

Continuity should exist.

4. Also check harness for short to ground and short to power.

OK or NG

- OK >> GO TO 8.
- NG >> GO TO 7.

7. DETECT MALFUNCTIONING PART

Check the following.

- Harness connectors E19, F33
- Harness for open or short between ECM and IPDM E/R

>> Repair open circuit or short to ground or short to power in harness or connectors.

8. CHECK FUSE

1. Disconnect 10A fuse.
2. Check 10A fuse for blown.

OK or NG

- OK >> GO TO 9.
- NG >> Replace 15A fuse.

9. CHECK INTERMITTENT INCIDENT

Refer to [EC-158, "TROUBLE DIAGNOSIS FOR INTERMITTENT INCIDENT"](#) .

OK or NG

- OK >> Replace IPDM E/R. Refer to [PG-15, "IPDM E/R \(INTELLIGENT POWER DISTRIBUTION MODULE ENGINE ROOM\)"](#) .
- NG >> Repair or replace harness or connectors.

10. CHECK THROTTLE CONTROL MOTOR OUTPUT SIGNAL CIRCUIT FOR OPEN OR SHORT

1. Turn ignition switch OFF.
2. Disconnect electric throttle control actuator harness connector.
3. Disconnect ECM harness connector.
4. Check harness continuity between the following terminals.
Refer to Wiring Diagram.

Electric throttle control actuator terminal	ECM terminal	Continuity
3	5	Should not exist
	4	Should exist
6	5	Should exist
	4	Should not exist

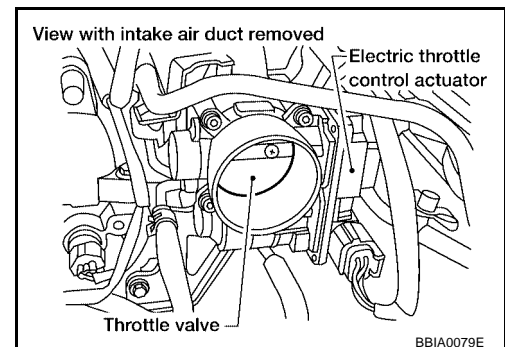

5. Also check harness for short to ground and short to power.

OK or NG

- OK >> GO TO 11.
- NG >> Repair or replace.

11. CHECK ELECTRIC THROTTLE CONTROL ACTUATOR VISUALLY

1. Remove the intake air duct.
2. Check if foreign matter is caught between the throttle valve and the housing.

OK or NG

OK >> GO TO 12.

NG >> Remove the foreign matter and clean the electric throttle control actuator inside.

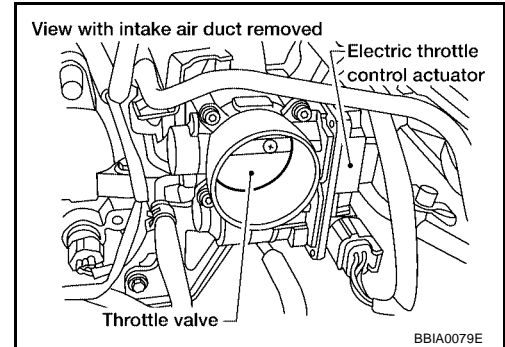

12. CHECK THROTTLE CONTROL MOTOR

Refer to [EC-393, "Component Inspection"](#) .

OK or NG

OK >> GO TO 13.

NG >> GO TO 14.

13. CHECK INTERMITTENT INCIDENT

Refer to [EC-158, "TROUBLE DIAGNOSIS FOR INTERMITTENT INCIDENT"](#) .

OK or NG

OK >> GO TO 14.

NG >> Repair or replace harness or connectors.

14. REPLACE ELECTRIC THROTTLE CONTROL ACTUATOR

1. Replace the electric throttle control actuator.
2. Perform [EC-93, "Throttle Valve Closed Position Learning"](#) .
3. Perform [EC-93, "Idle Air Volume Learning"](#) .

>> INSPECTION END

Component Inspection THROTTLE CONTROL MOTOR

UBS002Y1

1. Disconnect electric throttle control actuator harness connector.
2. Check resistance between terminals 3 and 6.

Resistance: Approximately 1 - 15 Ω [at 25 °C (77°F)]

3. If NG, replace electric throttle control actuator and go to next step.
4. Perform [EC-93, "Throttle Valve Closed Position Learning"](#) .
5. Perform [EC-93, "Idle Air Volume Learning"](#) .

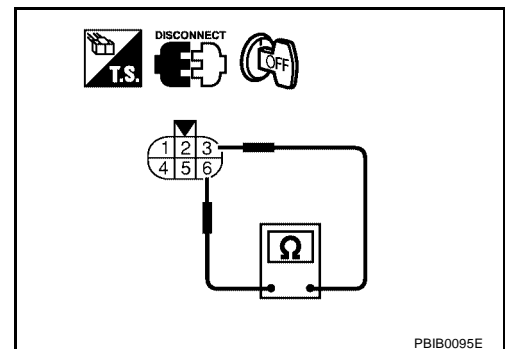

UBS002Y2

Remove and Installation ELECTRIC THROTTLE CONTROL ACTUATOR

Refer to [EM-19, "INTAKE MANIFOLD"](#) .

DTC P1124, P1126 THROTTLE CONTROL MOTOR RELAY

[QR]

DTC P1124, P1126 THROTTLE CONTROL MOTOR RELAY

PF16119

Component Description

UBS002Y3

Power supply for the throttle control motor is provided to the ECM via throttle control motor relay. The throttle control motor relay is ON/OFF controlled by the ECM. When the ignition switch is turned ON, the ECM sends an ON signal to throttle control motor relay and battery voltage is provided to the ECM. When the ignition switch is turned OFF, the ECM sends an OFF signal to throttle control motor relay and battery voltage is not provided to the ECM.

CONSULT-II Reference Value in Data Monitor Mode

UBS002Y4

Specification data are reference values.

MONITOR ITEM	CONDITION	SPECIFICATION
THRTL RELAY	● Ignition switch: ON	ON

On Board Diagnosis Logic

UBS002Y5

These self-diagnoses have one trip detection logic.

DTC No.	Trouble diagnosis name	DTC detecting condition	Possible cause
P1124 1124	Throttle control motor relay circuit short	ECM detects the throttle control motor relay is stuck ON.	<ul style="list-style-type: none"> ● Harness or connectors (Throttle control motor relay circuit is shorted) ● Throttle control motor relay
P1126 1126	Throttle control motor relay circuit open	ECM detects a voltage of power source for throttle control motor is excessively low.	<ul style="list-style-type: none"> ● Harness or connectors (Throttle control motor relay circuit is open) ● Throttle control motor relay

FAIL-SAFE MODE

When the malfunction is detected, ECM enters fail-safe mode and the MIL lights up.

Engine operating condition in fail-safe mode

ECM stops the electric throttle control actuator control, throttle valve is maintained at a fixed opening (approx. 5 degrees) by the return spring.

DTC Confirmation Procedure

UBS002Y6

NOTE:

If DTC Confirmation Procedure has been previously conducted, always turn ignition switch OFF and wait at least 10 seconds before conducting the next test.

PROCEDURE FOR DTC P1124

TESTING CONDITION:

Before performing the following procedure, confirm that battery voltage is more than 8V.

④ With CONSULT-II

1. Turn ignition switch ON and wait at least 1 second.
2. Select "DATA MONITOR" mode with CONSULT-II.
3. If DTC is detected, go to [EC-397, "Diagnostic Procedure"](#).

DATA MONITOR	
MONITOR	NO DTC
ENG SPEED	XXX rpm

SEF058Y

DTC P1124, P1126 THROTTLE CONTROL MOTOR RELAY

[QR]

With GST

Follow the procedure "With CONSULT-II" above.

PROCEDURE FOR DTC P1126

With CONSULT-II

1. Turn ignition switch ON and wait at least 2 seconds.
2. Select "DATA MONITOR" mode with CONSULT-II.
3. Start engine and let it idle for 5 seconds.
4. If DTC is detected, go to [EC-397, "Diagnostic Procedure"](#) .

DATA MONITOR	
MONITOR	NO DTC
ENG SPEED	XXX rpm

SEF058Y

With GST

Follow the procedure "With CONSULT-II" above.

A

EC

C

D

E

F

G

H

I

J

K

L

M

DTC P1124, P1126 THROTTLE CONTROL MOTOR RELAY

[QR]

UBS002Y7

Wiring Diagram

EC-ETC2-01

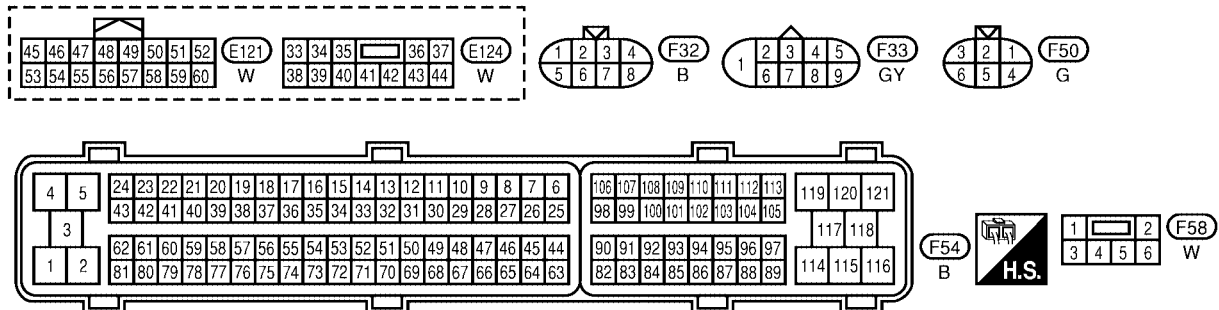
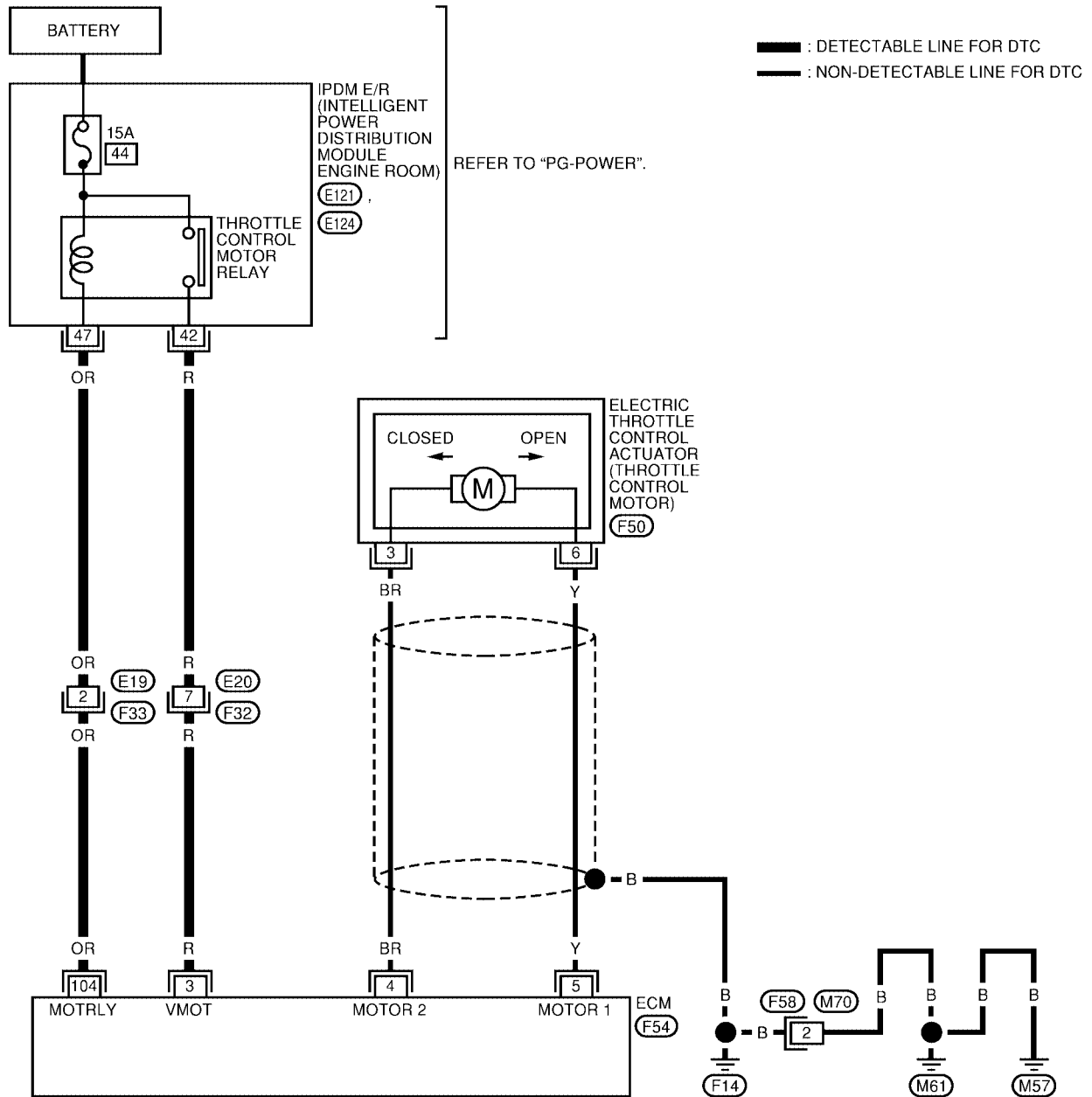

BBWA1237E

DTC P1124, P1126 THROTTLE CONTROL MOTOR RELAY

[QR]

Specification data are reference values and are measured between each terminal and ground.

CAUTION:

Do not use ECM ground terminals when measuring input/output voltage. Doing so may result in damage to the ECM's transistor. Use a ground other than ECM terminals, such as the ground.

TER-MINAL NO.	WIRE COLOR	ITEM	CONDITION	DATA (DC Voltage)
3	R	Throttle control motor power supply	[Ignition switch: ON]	BATTERY VOLTAGE (11 - 14V)
104	OR	Throttle control motor relay	[Ignition switch: OFF]	BATTERY VOLTAGE (11 - 14V)
			[Ignition switch: ON]	0 - 1.0V

Diagnostic Procedure

UBS002Y8

1. CHECK THROTTLE CONTROL MOTOR RELAY POWER SUPPLY CIRCUIT-I

- Turn ignition switch OFF.
- Check voltage between ECM terminal 104 and ground with CONSULT-II or tester.

Voltage: Battery voltage

OK or NG

- OK >> GO TO 5.
- NG >> GO TO 2.

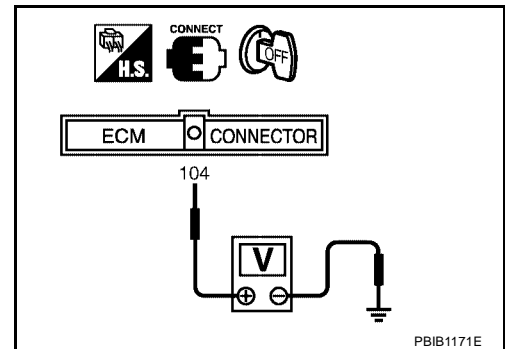

2. CHECK THROTTLE CONTROL MOTOR RELAY POWER SUPPLY CIRCUIT-II

- Disconnect ECM harness connector.
- Disconnect IPDM E/R harness connector E121.
- Check continuity between ECM terminal 104 and IPDM E/R terminal 47. Refer to Wiring Diagram.

Continuity should exist.

- Also check harness for short to ground and short to power.

OK or NG

- OK >> GO TO 4.
- NG >> GO TO 3.

3. DETECT MALFUNCTIONING PART

Check the following.

- Harness connectors E19, F33
- Harness for open or short between ECM and IPDM E/R

>> Repair open circuit or short to ground or short to power in harness or connectors.

4. CHECK FUSE

1. Disconnect 15A fuse.
2. Check 15A fuse for blown.

OK or NG

- OK >> GO TO 8.
 NG >> Replace 15A fuse.

5. CHECK THROTTLE CONTROL MOTOR RELAY INPUT SIGNAL CIRCUIT-I

1. Check voltage between ECM terminal 3 and ground under the following conditions with CONSULT-II or tester.

Ignition switch	Voltage
OFF	Approximately 0V
ON	Battery voltage (11 - 14V)

OK or NG

- OK >> GO TO 8.
 NG >> GO TO 6.

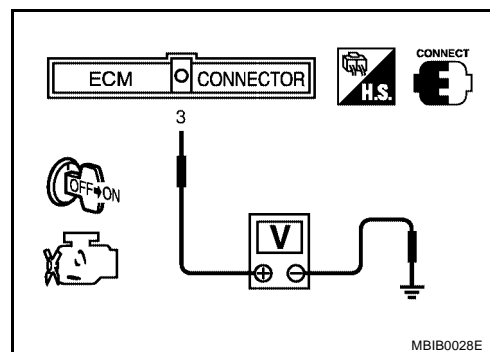

6. CHECK THROTTLE CONTROL MOTOR RELAY INPUT SIGNAL CIRCUIT-II

1. Turn ignition switch OFF.
2. Disconnect ECM harness connector.
3. Disconnect IPDM E/R harness connector E124.
4. Check continuity between ECM terminal 3 and IPDM E/R terminal 42. Refer to Wiring Diagram.

Continuity should exist.

5. Also check harness for short to ground and short to power.

OK or NG

- OK >> GO TO 8.
 NG >> GO TO 7.

7. DETECT MALFUNCTIONING PART

Check the following.

- Harness connectors E20, F32
- Harness for open or short between ECM and IPDM E/R

>> Repair open circuit or short to ground or short to power in harness or connectors.

8. CHECK INTERMITTENT INCIDENT

Refer to [EC-158, "TROUBLE DIAGNOSIS FOR INTERMITTENT INCIDENT"](#) .

OK or NG

- OK >> Replace IPDM E/R. Refer to [PG-15, "IPDM E/R \(INTELLIGENT POWER DISTRIBUTION MODULE ENGINE ROOM\)"](#) .
 NG >> Repair or replace harness or connectors.

DTC P1128 THROTTLE CONTROL MOTOR

[QR]

DTC P1128 THROTTLE CONTROL MOTOR

PF16119

Component Description

UBS002Y9

The throttle control motor is operated by the ECM and it opens and closes the throttle valve. The current opening angle of the throttle valve is detected by the throttle position sensor and it provides feedback to the ECM to control the throttle control motor to make the throttle valve opening angle properly in response to driving condition.

On Board Diagnosis Logic

UBS002YA

This self-diagnosis has the one trip detection logic.

DTC No.	Trouble diagnosis name	DTC detecting condition	Possible cause
P1128 1128	Throttle control motor circuit short	ECM detects short in both circuits between ECM and throttle control motor.	<ul style="list-style-type: none">● Harness or connectors (Throttle control motor circuit is shorted.)● Electric throttle control actuator (Throttle control motor)

FAIL-SAFE MODE

When the malfunction is detected, ECM enters fail-safe mode and the MIL lights up.

Engine operating condition in fail-safe mode

ECM stops the electric throttle control actuator control, throttle valve is maintained at a fixed opening (approx. 5 degrees) by the return spring.

DTC Confirmation Procedure

UBS002YB

NOTE:

If DTC Confirmation Procedure has been previously conducted, always turn ignition switch OFF and wait at least 10 seconds before conducting the next test.

WITH CONSULT-II

1. Turn ignition switch ON and wait at least 2 seconds.
2. Select "DATA MONITOR" mode with CONSULT-II.
3. Start engine and let it idle for 5 seconds.
4. If DTC is detected, go to [EC-401, "Diagnostic Procedure"](#).

DATA MONITOR	
MONITOR	NO DTC
ENG SPEED	XXX rpm

SEF058Y

WITH GST

Follow the procedure "WITH CONSULT-II" above.

DTC P1128 THROTTLE CONTROL MOTOR

[QR]

Wiring Diagram

UBS002YC

EC-ETC3-01

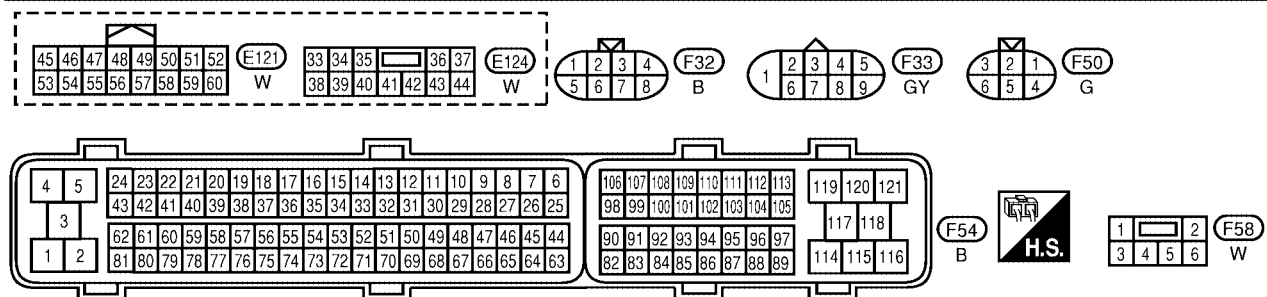
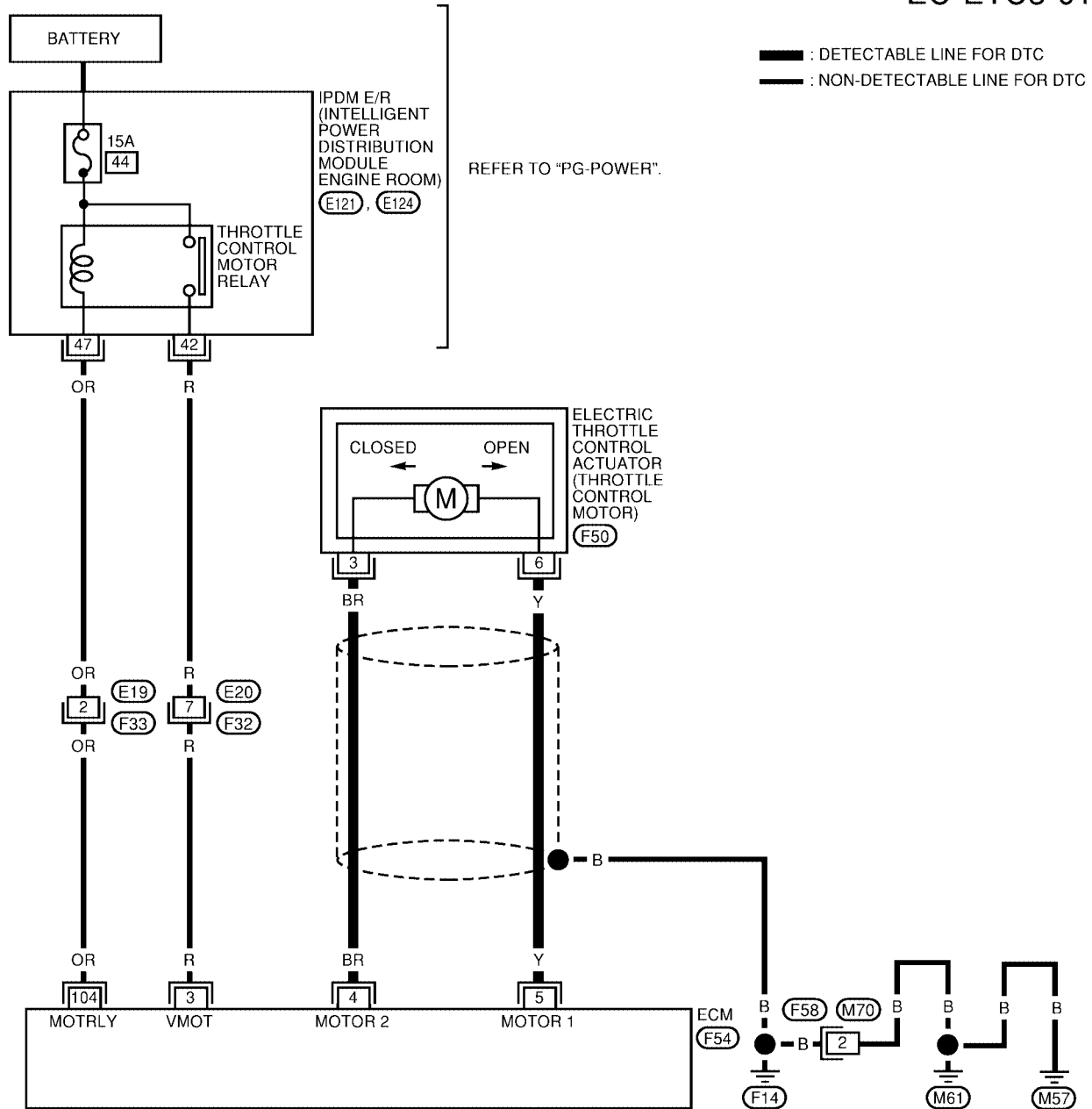

BBWA1238E

DTC P1128 THROTTLE CONTROL MOTOR

[QR]

Specification data are reference values and are measured between each terminal and ground. Pulse signal is measured by CONSULT-II.

CAUTION:

Do not use ECM ground terminals when measuring input/output voltage. Doing so may result in damage to the ECM's transistor. Use a ground other than ECM terminals, such as the ground.

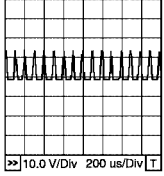
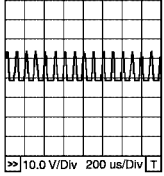
TER-MINAL NO.	WIRE COLOR	ITEM	CONDITION	DATA (DC Voltage)
4	BR	Throttle control motor (Close)	<p>[Ignition switch: ON]</p> <ul style="list-style-type: none"> ● Engine stopped ● Shift lever: D (A/T), 1ST (M/T) ● Accelerator pedal is released 	<p>0 - 14V★</p>  <p>PBIB0534E</p>
5	Y	Throttle control motor (Open)	<p>[Ignition switch: ON]</p> <ul style="list-style-type: none"> ● Engine stopped ● Shift lever: D (A/T), 1ST (M/T) ● Accelerator pedal is fully depressed 	<p>0 - 14V★</p>  <p>PBIB0533E</p>

★: Average voltage for pulse signal (Actual pulse signal can be confirmed by oscilloscope.)

Diagnostic Procedure

UBS002YD

1. CHECK GROUND CONNECTIONS

1. Turn ignition switch OFF.
2. Loosen and retighten three ground screws on the body. Refer to [EC-164, "Ground Inspection"](#).

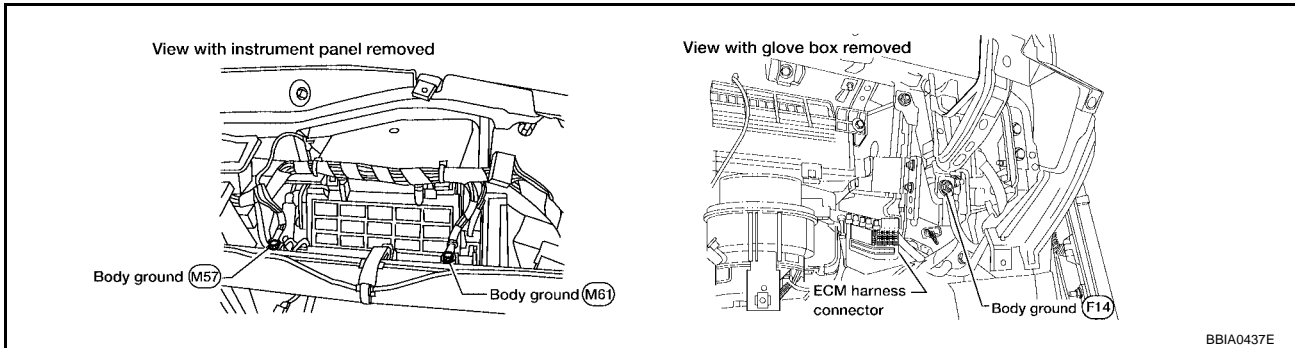

OK or NG

- OK >> GO TO 2.
- NG >> Repair or replace ground connections.

2. CHECK THROTTLE CONTROL MOTOR OUTPUT SIGNAL CIRCUIT FOR OPEN OR SHORT

1. Disconnect electric throttle control actuator harness connector.
2. Disconnect ECM harness connector.
3. Check harness continuity between the following terminals.
Refer to Wiring Diagram.

Electric throttle control actuator terminal	ECM terminal	Continuity
3	5	Should not exist
	4	Should exist
6	5	Should exist
	4	Should not exist

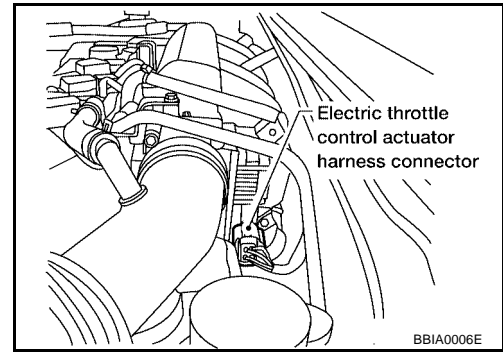

4. Also check harness for short to ground and short to power.

OK or NG

- OK >> GO TO 3.
- NG >> Repair or replace.

3. CHECK THROTTLE CONTROL MOTOR

Refer to [EC-402, "Component Inspection"](#) .

OK or NG

- OK >> GO TO 4.
- NG >> GO TO 5.

4. CHECK INTERMITTENT INCIDENT

Refer to [EC-158, "TROUBLE DIAGNOSIS FOR INTERMITTENT INCIDENT"](#) .

OK or NG

- OK >> GO TO 6.
- NG >> Repair or replace harness or connectors.

5. REPLACE ELECTRIC THROTTLE CONTROL ACTUATOR

1. Replace the electric throttle control actuator.
2. Perform [EC-93, "Throttle Valve Closed Position Learning"](#) .
3. Perform [EC-93, "Idle Air Volume Learning"](#) .

>> INSPECTION END

Component Inspection THROTTLE CONTROL MOTOR

UBS002YE

1. Disconnect electric throttle control actuator harness connector.
2. Check resistance between terminals 3 and 6.

Resistance: Approximately 1 - 15 Ω [at 25 °C (77°F)]

3. If NG, replace electric throttle control actuator and go to next step.
4. Perform [EC-93, "Throttle Valve Closed Position Learning"](#) .
5. Perform [EC-93, "Idle Air Volume Learning"](#) .

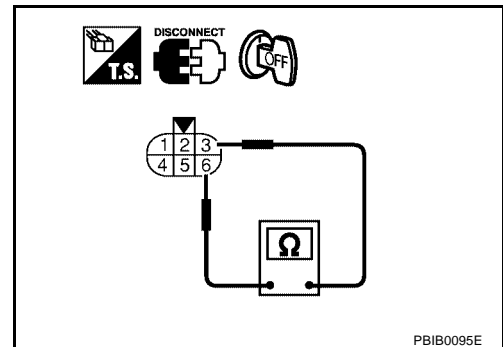

Removal and Installation ELECTRIC THROTTLE CONTROL ACTUATOR

Refer to [EM-19, "INTAKE MANIFOLD"](#) .

A

EC

C

D

E

F

G

H

I

J

K

L

M

DTC P1146 HO2S2

Component Description

UBS002YW

The heated oxygen sensor 2, after three way catalyst (manifold), monitors the oxygen level in the exhaust gas.

Even if switching characteristics of the A/F sensor 1 are shifted, the air-fuel ratio is controlled to stoichiometric, by the signal from the heated oxygen sensor 2.

This sensor is made of ceramic zirconia. The zirconia generates voltage from approximately 1V in richer conditions to 0V in leaner conditions.

Under normal conditions the heated oxygen sensor 2 is not used for engine control operation.

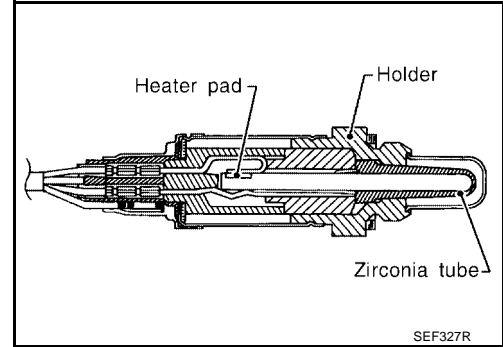

CONSULT-II Reference Value in Data Monitor Mode

UBS002YX

Specification data are reference values.

MONITOR ITEM	CONDITION		SPECIFICATION
HO2S2 (B1)	<ul style="list-style-type: none"> ● Warm-up condition ● After keeping engine speed between 3,500 and 4,000 rpm for 1 minute and at idle for 1 minute under no load. 	Revving engine from idle to 3,000 rpm quickly.	0 - 0.3V ↔ Approx. 0.6 - 1.0V
HO2S2 MNTR (B1)	<ul style="list-style-type: none"> ● Engine: After warming up ● After keeping engine speed between 3,500 and 4,000 rpm for 1 minute and at idle for 1 minute under no load. 	Revving engine from idle to 3,000 rpm quickly.	LEAN ↔ RICH

On Board Diagnosis Logic

UBS002YY

The heated oxygen sensor 2 has a much longer switching time between rich and lean than the A/F sensor 1. The oxygen storage capacity of the three way catalyst (manifold) causes the longer switching time. To judge the malfunctions of heated oxygen sensor 2, ECM monitors whether the minimum voltage of sensor is sufficiently low during the various driving condition such as fuel-cut.

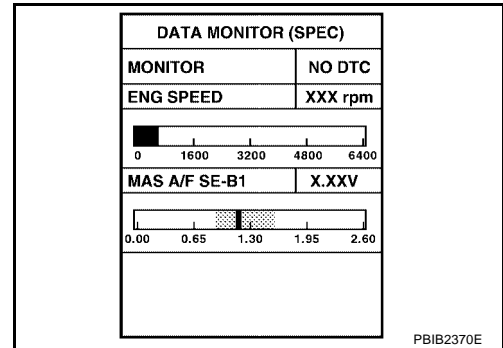

PBIB2370E

DTC No.	Trouble diagnosis name	DTC detecting condition	Possible cause
P1146 1146	Heated oxygen sensor 2 minimum voltage monitoring	The minimum voltage from the sensor is not reached to the specified voltage.	<ul style="list-style-type: none"> ● Harness or connectors (The sensor circuit is open or shorted) ● Heated oxygen sensor 2 ● Fuel pressure ● Fuel injector

DTC Confirmation Procedure

NOTE:

If DTC confirmation Procedure has been previously conducted, always turn ignition switch OFF and wait at least 10 seconds before conducting the next test.

WITH CONSULT-II

TESTING CONDITION:

For the best results, perform DTC WORK SUPPORT at a temperature of 0 to 30°C (32 to 86°F).

1. Turn ignition switch ON and select "DATA MONITOR " mode with CONSULT-II
2. Start engine and warm it up to the normal operating temperature.
3. Turn ignition switch OFF and wait at least 10 seconds.
4. Start engine and keep the engine speed between 3,500 and 4,000 rpm for at least 1 minute under no load.
5. Let engine idle for 1 minute.
6. Make sure that "COOLAN TEMP/S" indicates more than 70°C (158°F).
If not, warm up engine and go to next step when "COOLAN TEMP/S" indication reaches to 70°C (158°F).
7. Open engine hood.
8. Select "HO2S2 (B1) P1146" of "HO2S2" in "DTC WORK SUPPORT" mode with CONSULT-II.
9. Start engine and following the instruction of CONSULT-II.

DATA MONITOR	
MONITOR	NO DTC
ENG SPEED	XXX rpm
COOLAN TEMP/S	XXX °C

SEF174Y

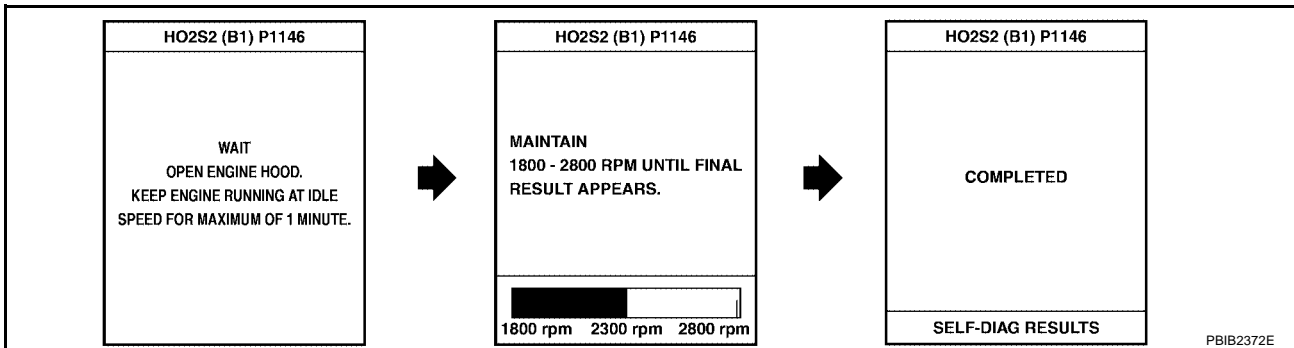

NOTE:

It will take at most 10 minutes until "COMPLETED" is displayed.

10. Make sure that "OK" is displayed after touching "SELF-DIAG RESULTS".
If "NG" is displayed, refer to [EC-408, "Diagnostic Procedure"](#).
If "CAN NOT BE DIAGNOSED" is displayed, perform the following.
 - a. Turn ignition switch OFF and leave the vehicle in a cool place (soak the vehicle).
 - b. Return to step 1.

Overall Function Check

Use this procedure to check the overall function of the heated oxygen sensor 2 circuit. During this check, a 1st trip DTC might not be confirmed.

WITH GST

1. Start engine and warm it up to the normal operating temperature.
2. Turn ignition switch OFF and wait at least 10 seconds.
3. Start engine and keep the engine speed between 3,500 and 4,000 rpm for at least 1 minute under no load.
4. Let engine idle 1 minute.
5. Set voltmeter probes between ECM terminal 74 (HO2S2 signal) and ground.

DTC P1146 HO2S2

[QR]

6. Check the voltage when revving up to 4,000 rpm under no load at least 10 times.
(Depress and release accelerator pedal as soon as possible.)
The voltage should be below 0.18V at least once during this procedure.
If the voltage can be confirmed in step 6, step 7 is not necessary.
7. Keep vehicle at idling for 10 minutes, then check the voltage. Or check the voltage when coasting from 80 km/h (50 MPH) in D position with OD OFF (A/T models) 3rd gear position (M/T models).
The voltage should be below 0.18V at least once during this procedure.
8. If NG, go to [EC-408, "Diagnostic Procedure"](#).

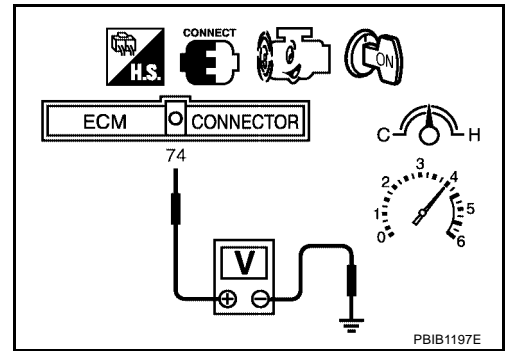

DTC P1146 HO2S2

[QR]

Wiring Diagram

UBS002Z1

EC-HO2S2-01

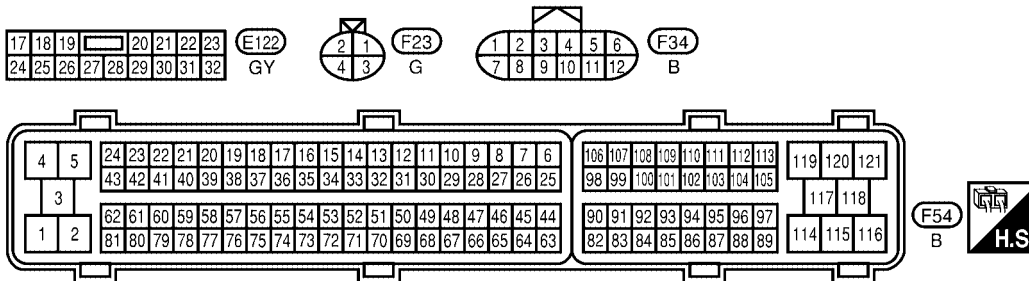
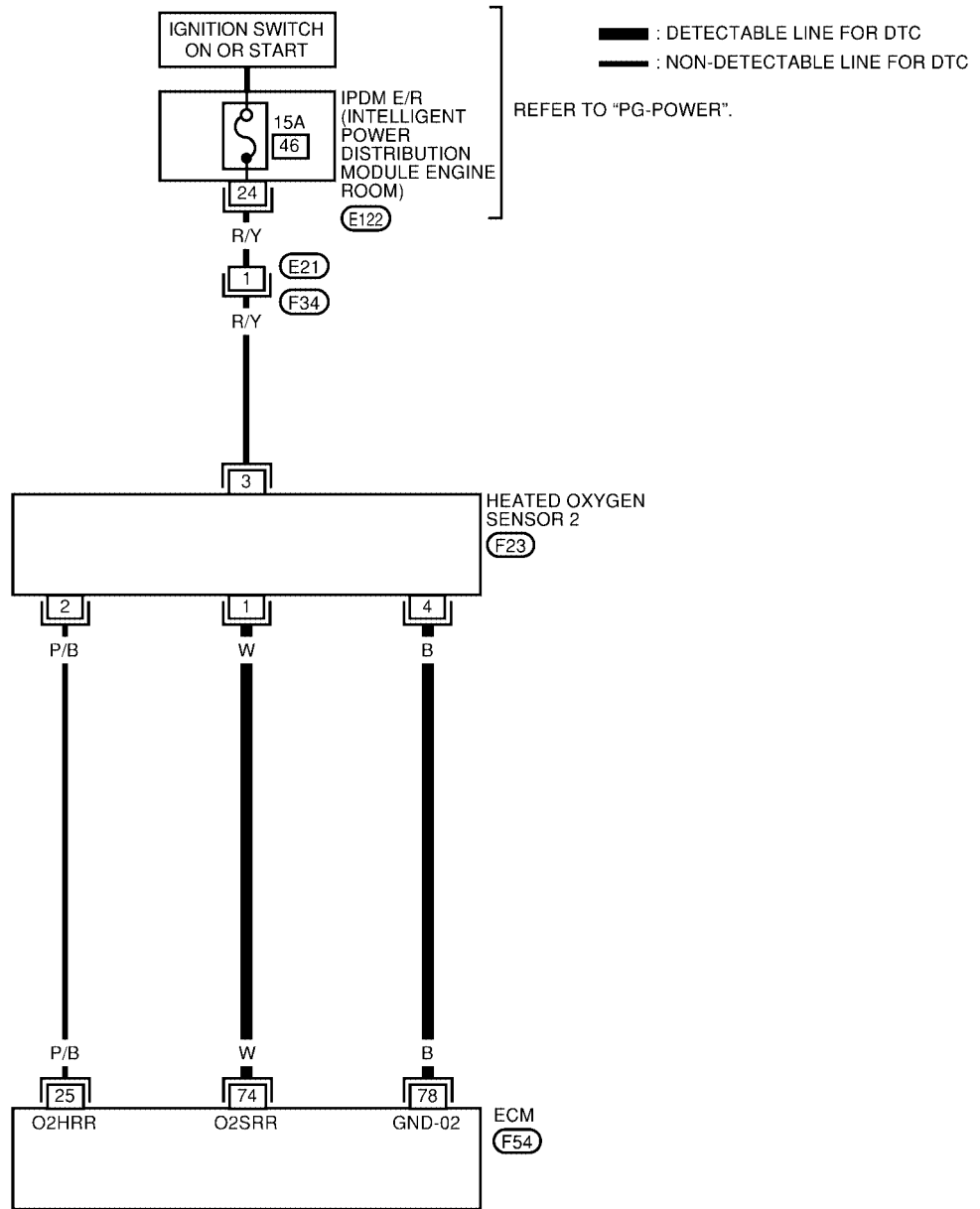

BBWA1220E

Specification data are reference values and are measured between each terminal and ground.

CAUTION:

Do not use ECM ground terminals when measuring input/output voltage. Doing so may result in damage to the ECM's transistor. Use a ground other than ECM terminals, such as the ground.

TER-MINAL NO.	WIRE COLOR	ITEM	CONDITION	DATA (DC Voltage)
74	W	Heated oxygen sensor 2	<p>[Engine is running]</p> <ul style="list-style-type: none"> ● Warm-up condition ● Revving engine from idle up to 3,000 rpm quickly after the following conditions are met. ● Keeping the engine speed between 3,500 and 4,000 rpm for 1 minute and at idle for 1 minute under no load. 	0 - Approximately 1.0V
78	B	Sensor ground (Heated oxygen sensor)	<p>[Engine is running]</p> <ul style="list-style-type: none"> ● Warm-up condition ● Idle speed 	Approximately 0V

Diagnostic Procedure

UBS002Z2

1. CHECK GROUND CONNECTIONS

1. Turn ignition switch OFF.
2. Loosen and retighten three ground screws on the body. Refer to [EC-164, "Ground Inspection"](#) .

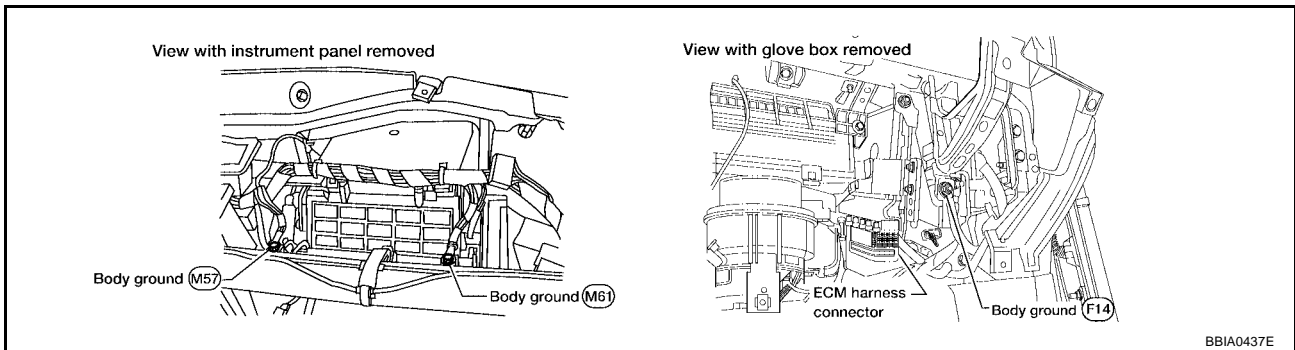

OK or NG

- OK >> GO TO 2.
- NG >> Repair or replace ground connections.

2. CLEAR THE SELF-LEARNING DATA

With CONSULT-II

1. Start engine and warm it up to normal operating temperature.
2. Select "SELF-LEARNING CONT" in "WORK SUPPORT" mode with CONSULT-II.
3. Clear the self-learning control coefficient by touching "CLEAR".
4. Run engine for at least 10 minutes at idle speed.
**Is the 1st trip DTC P0172 detected?
Is it difficult to start engine?**

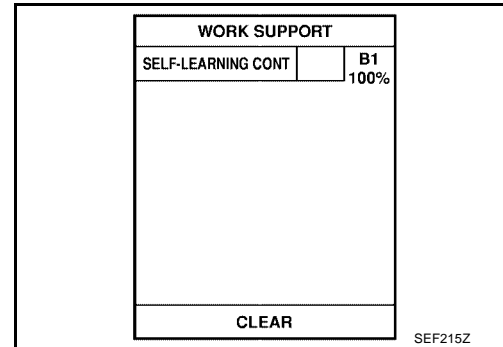

Without CONSULT-II

1. Start engine and warm it up to normal operating temperature.
2. Turn ignition switch OFF.
3. Disconnect mass air flow sensor harness connector, and restart and run engine for at least 5 seconds at idle speed.
4. Stop engine and reconnect mass air flow sensor harness connector.
5. Make sure DTC P0102 is displayed.
6. Erase the DTC memory. Refer to [EC-65, "HOW TO ERASE EMISSION-RELATED DIAGNOSTIC INFORMATION"](#).
7. Make sure DTC P0000 is displayed.
8. Run engine for at least 10 minutes at idle speed.
**Is the 1st trip DTC P0172 detected?
Is it difficult to start engine?**

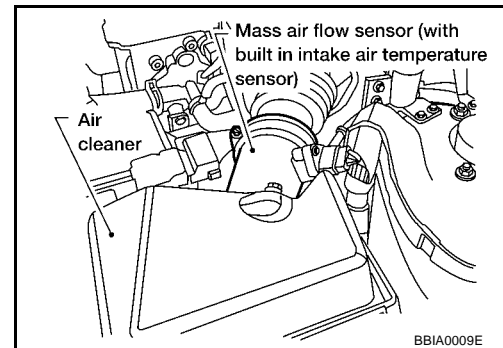

Yes or No

- Yes >> Perform trouble diagnosis for DTC P0172. Refer to [EC-240](#).
- No >> GO TO 3.

3. CHECK HO2S2 GROUND CIRCUIT FOR OPEN AND SHORT

1. Turn ignition switch OFF.
2. Disconnect heated oxygen sensor 2 harness connector.
3. Disconnect ECM harness connector.
4. Check harness continuity between ECM terminal 78 and HO2S2 terminal 4.
Refer to Wiring Diagram.

Continuity should exist.

5. Also check harness for short to ground and short to power.

OK or NG

- OK >> GO TO 4.
- NG >> Repair open circuit or short to ground or short to power in harness or connectors.

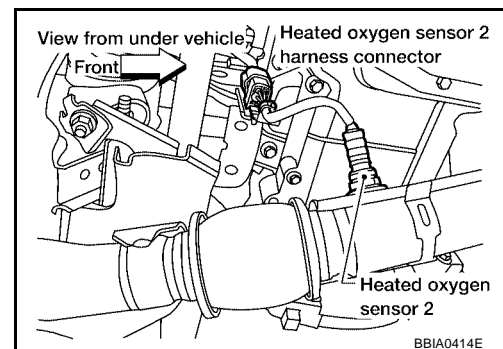

4. CHECK HO2S2 INPUT SIGNAL CIRCUIT FOR OPEN AND SHORT

1. Check harness continuity between ECM terminal 74 and HO2S2 terminal 1.
Refer to Wiring Diagram.

Continuity should exist.

2. Check harness continuity between ECM terminal 74 or HO2S2 terminal 1 and ground.
Refer to Wiring Diagram.

Continuity should not exist.

3. Also check harness for short to power.

OK or NG

OK >> GO TO 5.

NG >> Repair open circuit or short to ground or short to power in harness or connectors.

5. CHECK HEATED OXYGEN SENSOR 2

Refer to [EC-410, "Component Inspection"](#) .

OK or NG

OK >> GO TO 6.

NG >> Replace heated oxygen sensor 2.

6. CHECK INTERMITTENT INCIDENT

Refer to [EC-158, "TROUBLE DIAGNOSIS FOR INTERMITTENT INCIDENT"](#) .

>> INSPECTION END

**Component Inspection
HEATED OXYGEN SENSOR 2**

UBS002Z3

With CONSULT-II

1. Start engine and warm it up to the normal operating temperature.
2. Turn ignition switch OFF and wait at least 10 seconds.
3. Start engine and keep the engine speed between 3,500 and 4,000 rpm for at least 1 minute under no load.
4. Let engine idle for 1 minute.
5. Select "FUEL INJECTION" in "ACTIVE TEST" mode, and select "HO2S2 (B1)" as the monitor item with CONSULT-II.

ACTIVE TEST	
FUEL INJECTION	25 %
MONITOR	
ENG SPEED	XXX rpm
HO2S2 (B1)	XXX V

PBIB1783E

6. Check "HO2S2 (B1)" at idle speed when adjusting "FUEL INJECTION" to $\pm 25\%$.

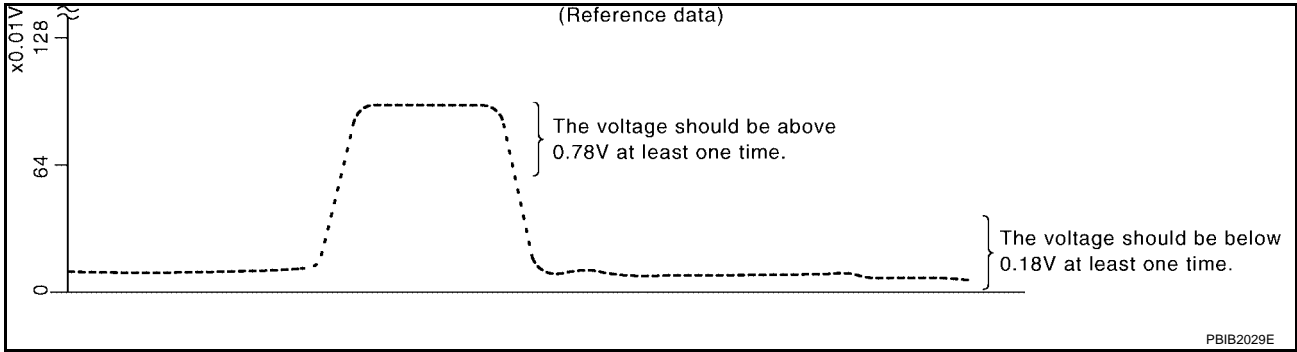

"HO2S2 (B1)" should be above 0.78V at least once when the "FUEL INJECTION" is +25%.
 "HO2S2 (B1)" should be below 0.18V at least once when the "FUEL INJECTION" is -25%.

CAUTION:

- Discard any heated oxygen sensor which has been dropped from a height of more than 0.5 m (19.7 in) onto a hard surface such as a concrete floor; use a new one.
- Before installing new oxygen sensor, clean exhaust system threads using Oxygen Sensor Thread Cleaner tool J-43897-18 or J-43897-12 and approved anti-seize lubricant.

⊗ **Without CONSULT-II**

1. Start engine and warm it up to the normal operating temperature.
2. Turn ignition switch OFF and wait at least 10 seconds.
3. Start engine and keep the engine speed between 3,500 and 4,000 rpm for at least 1 minute under no load.
4. Let engine idle for 1 minute.
5. Set voltmeter probes between ECM terminal 74 (HO2S2 signal) and ground.
6. Check the voltage when revving up to 4,000 rpm under no load at least 10 times.

(Depress and release accelerator pedal as soon as possible.)
The voltage should be above 0.78V at least once during this procedure.
If the voltage is above 0.78V at step 6, step 7 is not necessary.

7. Keep vehicle idling for 10 minutes, then check voltage. Or check the voltage when coasting from 80 km/h (50 MPH) in D position with OD OFF (A/T), 3rd gear position (M/T).
The voltage should be below 0.18V at least once during this procedure.

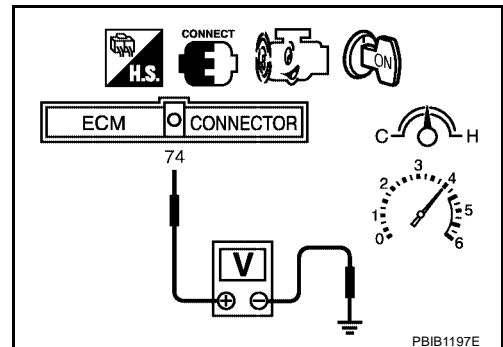

8. If NG, replace heated oxygen sensor 2.

CAUTION:

- Discard any heated oxygen sensor which has been dropped from a height of more than 0.5 m (19.7 in) onto a hard surface such as a concrete floor; use a new one.
- Before installing new oxygen sensor, clean exhaust system threads using Oxygen Sensor Thread Cleaner tool J-43897-18 or J-43897-12 and approved anti-seize lubricant.

**Removal and Installation
 HEATED OXYGEN SENSOR 2**

UBS002Z4

Refer to [EX-3. "EXHAUST SYSTEM \(QR25DE\)"](#).

DTC P1147 HO2S2

Component Description

UBS002Z5

The heated oxygen sensor 2, after three way catalyst (manifold), monitors the oxygen level in the exhaust gas. Even if switching characteristics of the A/F sensor 1 are shifted, the air-fuel ratio is controlled to stoichiometric, by the signal from the heated oxygen sensor 2. This sensor is made of ceramic zirconia. The zirconia generates voltage from approximately 1V in richer conditions to 0V in leaner conditions. Under normal conditions the heated oxygen sensor 2 is not used for engine control operation.

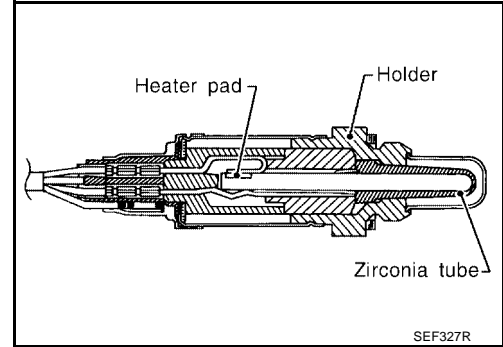

CONSULT-II Reference Value in Data Monitor Mode

UBS002Z6

Specification data are reference values.

MONITOR ITEM	CONDITION		SPECIFICATION
HO2S2 (B1)	<ul style="list-style-type: none"> ● Warm-up condition ● After keeping engine speed between 3,500 and 4,000 rpm for 1 minute and at idle for 1 minute under no load. 	Revving engine from idle to 3,000 rpm quickly.	0 - 0.3V ←→ Approx. 0.6 - 1.0V
HO2S2 MNTR (B1)	<ul style="list-style-type: none"> ● Engine: After warming up ● After keeping engine speed between 3,500 and 4,000 rpm for 1 minute and at idle for 1 minute under no load. 	Revving engine from idle to 3,000 rpm quickly.	LEAN ←→ RICH

On Board Diagnosis Logic

UBS002Z7

The heated oxygen sensor 2 has a much longer switching time between rich and lean than the A/F sensor 1. The oxygen storage capacity before the three way catalyst (manifold) causes the longer switching time. To judge the malfunctions of heated oxygen sensor 2, ECM monitors whether the maximum voltage of the sensor is sufficiently high during the various driving condition such as fuel-cut.

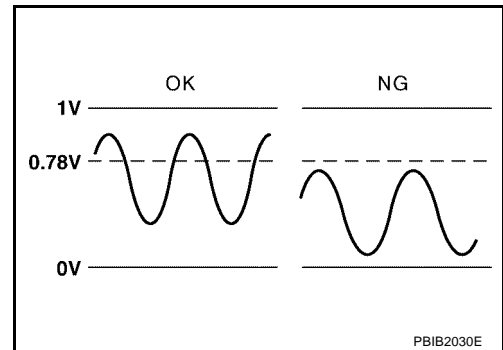

DTC No.	Trouble diagnosis name	DTC detecting condition	Possible cause
P1147 1147	Heated oxygen sensor 2 maximum voltage monitoring	The maximum voltage from the sensor is not reached to the specified voltage.	<ul style="list-style-type: none"> ● Harness or connectors (The sensor circuit is open or shorted) ● Heated oxygen sensor 2 ● Fuel pressure ● Fuel injector ● Intake air leaks

DTC Confirmation Procedure

NOTE:

If DTC confirmation Procedure has been previously conducted, always turn ignition switch OFF and wait at least 10 seconds before conducting the next test.

WITH CONSULT-II

TESTING CONDITION:

For the best results, perform DTC WORK SUPPORT at a temperature of 0 to 30°C (32 to 86°F).

1. Turn ignition switch ON and select "DATA MONITOR" mode with CONSULT-II.
2. Start engine and warm it up to the normal operating temperature.
3. Turn ignition switch OFF and wait at least 10 seconds.
4. Start engine and keep the engine speed between 3,500 and 4,000 rpm for at least 1 minute under no load.
5. Let engine idle for 1 minute.
6. Make sure that "COOLAN TEMP/S" indicates more than 70°C (158°F).
If not, warm up engine and go to next step when "COOLAN TEMP/S" indication reaches to 70°C (158°F).
7. Open engine hood.
8. Select "HO2S2 (B1) P1147" of "HO2S2" in "DTC WORK SUPPORT" mode with CONSULT-II.
9. Start engine and following the instruction of CONSULT-II.

DATA MONITOR	
MONITOR	NO DTC
ENG SPEED	XXX rpm
COOLAN TEMP/S	XXX °C

SEF174Y

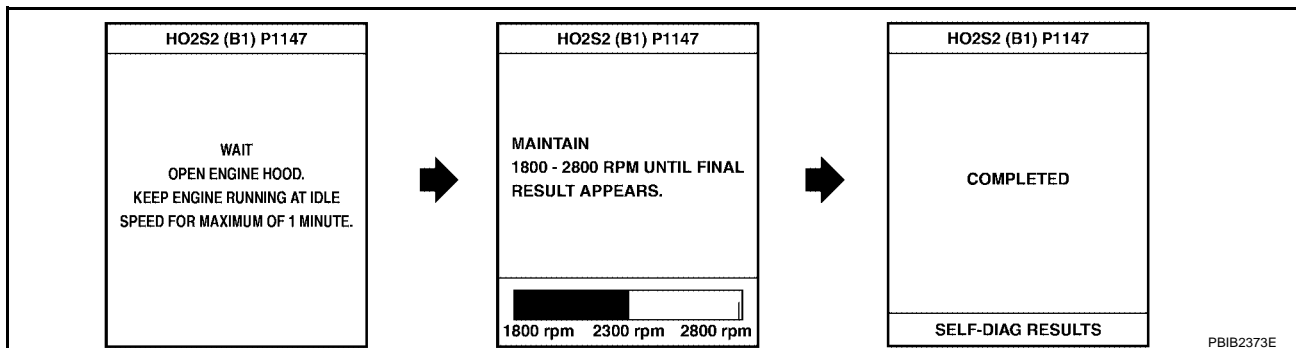

NOTE:

It will take at most 10 minutes until "COMPLETED" is displayed.

10. Make sure that "OK" is displayed after touching "SELF-DIAG RESULTS".
If "NG" is displayed, refer to [EC-416, "Diagnostic Procedure"](#).
If "CAN NOT BE DIAGNOSED" is displayed, perform the following.
 - a. Turn ignition switch OFF and leave the vehicle in a cool place (soak the vehicle).
 - b. Return to step 1.

Overall Function Check

Use this procedure to check the overall function of the heated oxygen sensor 2 circuit. During this check, a 1st trip DTC might not be confirmed.

WITH GST

1. Start engine and warm it up to the normal operating temperature.
2. Turn ignition switch OFF and wait at least 10 seconds.
3. Start engine and keep the engine speed between 3,500 and 4,000 rpm for at least 1 minute under no load.
4. Let engine idle 1 minute.
5. Set voltmeter probes between ECM terminal 74 (HO2S2 signal) and ground.

DTC P1147 HO2S2

[QR]

6. Check the voltage when revving up to 4,000 rpm under no load at least 10 times.
(Depress and release accelerator pedal as soon as possible.)
The voltage should be above 0.78V at least once during this procedure.
If the voltage can be confirmed in step 6, step 7 is not necessary.
7. Keep vehicle idling for 10 minutes, then check the voltage. Or check the voltage when coasting from 80 km/h (50 MPH) in D position with "OD" OFF (A/T models) 3rd gear position (M/T models).
The voltage should be above 0.78V at least once during this procedure.
8. If NG, go to [EC-416, "Diagnostic Procedure"](#).

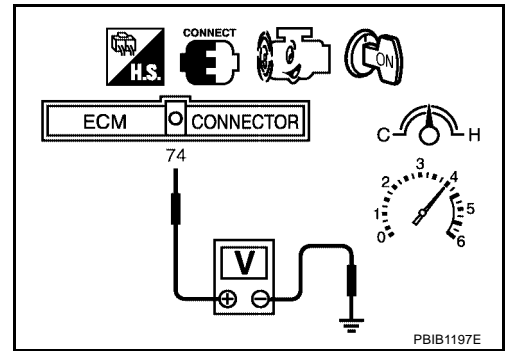

DTC P1147 HO2S2

[QR]

Wiring Diagram

UBS002ZA

EC-HO2S2-01

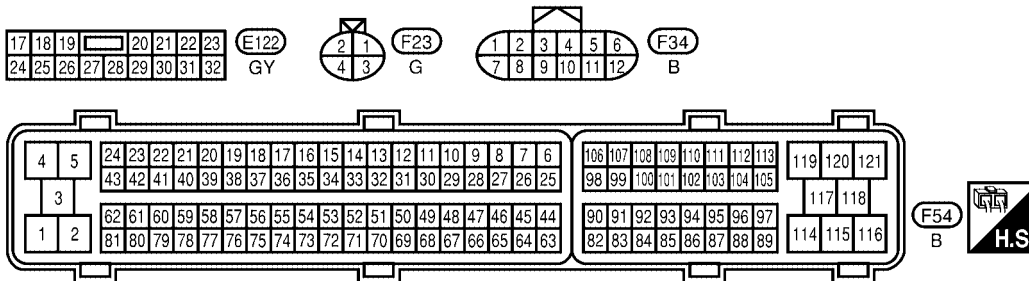
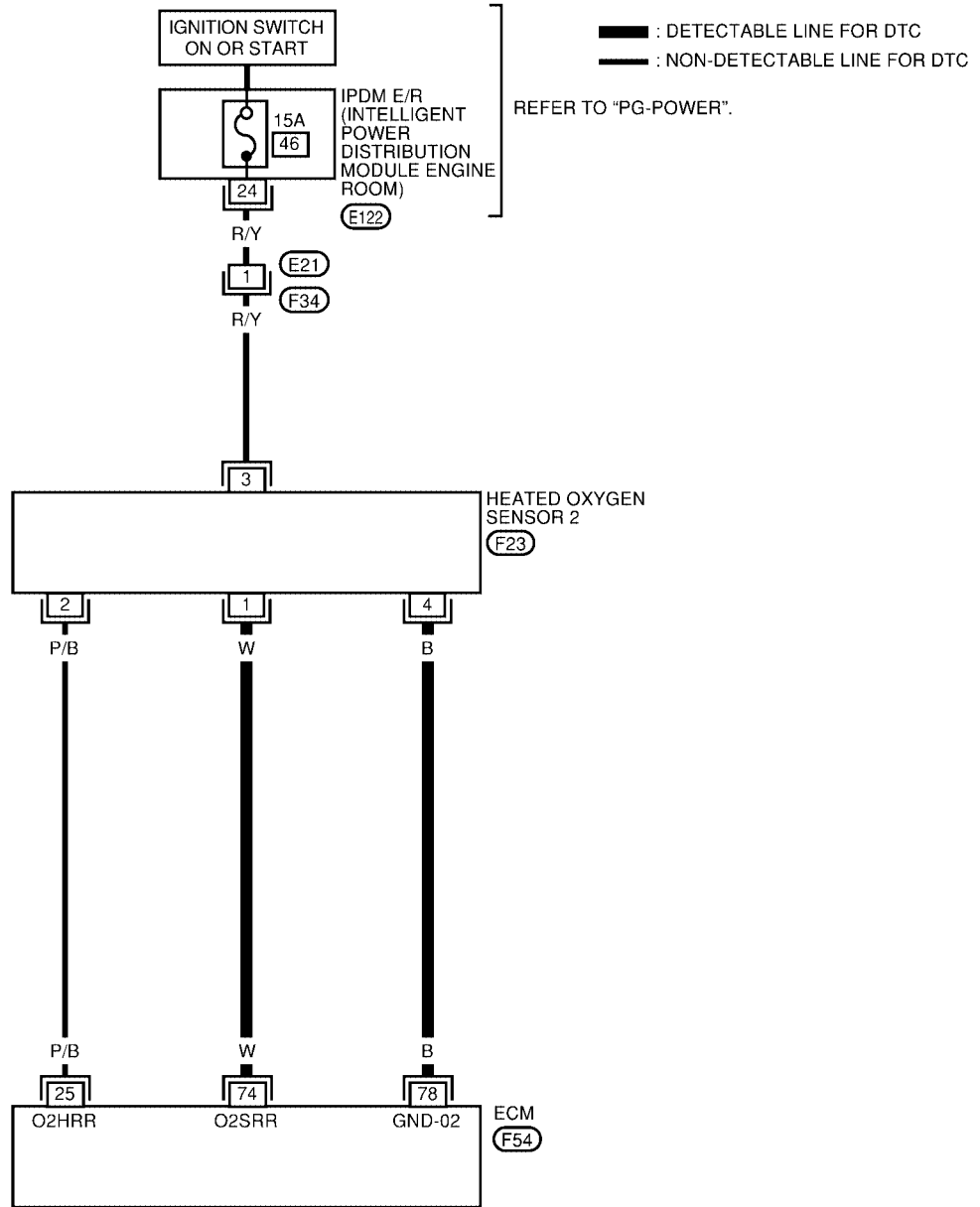

BBWA1220E

Specification data are reference values and are measured between each terminal and ground.

CAUTION:

Do not use ECM ground terminals when measuring input/output voltage. Doing so may result in damage to the ECM's transistor. Use a ground other than ECM terminals, such as the ground.

TER-MINAL NO.	WIRE COLOR	ITEM	CONDITION	DATA (DC Voltage)
74	W	Heated oxygen sensor 2	<p>[Engine is running]</p> <ul style="list-style-type: none"> ● Warm-up condition ● Revving engine from idle up to 3,000 rpm quickly after the following conditions are met. ● Keeping the engine speed between 3,500 and 4,000 rpm for 1 minute and at idle for 1 minute under no load. 	0 - Approximately 1.0V
78	B	Sensor ground (Heated oxygen sensor)	<p>[Engine is running]</p> <ul style="list-style-type: none"> ● Warm-up condition ● Idle speed 	Approximately 0V

Diagnostic Procedure

UBS002ZB

1. CHECK GROUND CONNECTIONS

1. Turn ignition switch OFF.
2. Loosen and retighten three ground screws on the body. Refer to [EC-164, "Ground Inspection"](#).

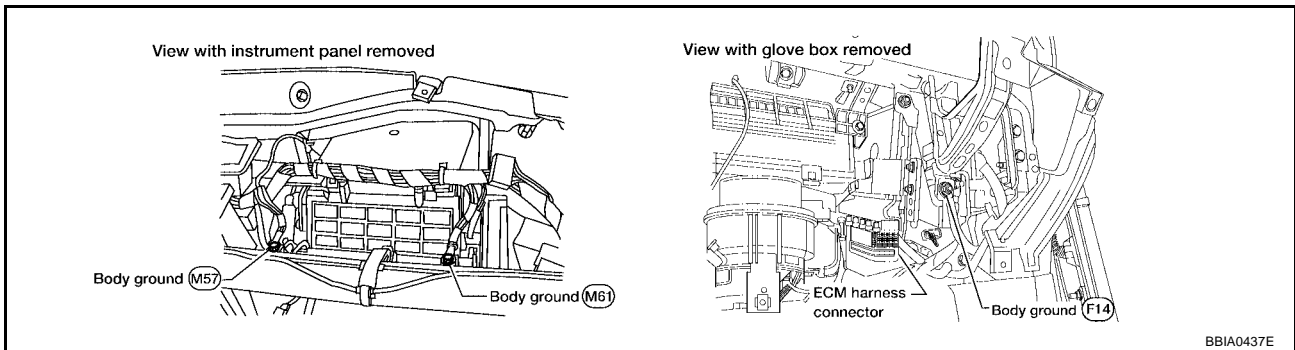

BBIA0437E

OK or NG

- OK >> GO TO 2.
- NG >> Repair or replace ground connections.

2. CLEAR THE SELF-LEARNING DATA

④ With CONSULT-II

1. Start engine and warm it up to normal operating temperature.
2. Select "SELF-LEARNING CONT" in "WORK SUPPORT" mode with CONSULT-II.
3. Clear the self-learning control coefficient by touching "CLEAR".
4. Run engine for at least 10 minutes at idle speed.
**Is the 1st trip DTC P0171 detected?
Is it difficult to start engine?**

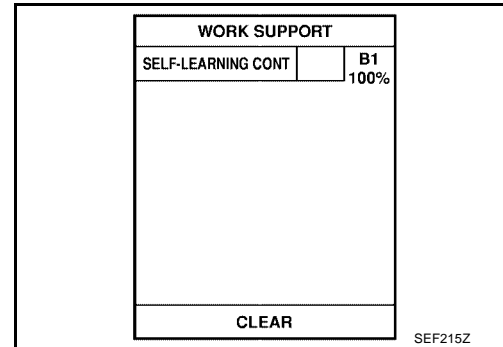

⊗ Without CONSULT-II

1. Start engine and warm it up to normal operating temperature.
2. Turn ignition switch OFF.
3. Disconnect mass air flow sensor harness connector, and restart and run engine for at least 5 seconds at idle speed.
4. Stop engine and reconnect mass air flow sensor harness connector.
5. Make sure DTC P0102 is displayed.
6. Erase the DTC memory. Refer to [EC-65, "HOW TO ERASE EMISSION-RELATED DIAGNOSTIC INFORMATION"](#).
7. Make sure DTC P0000 is displayed.
8. Run engine for at least 10 minutes at idle speed.
**Is the 1st trip DTC P0171 detected?
Is it difficult to start engine?**

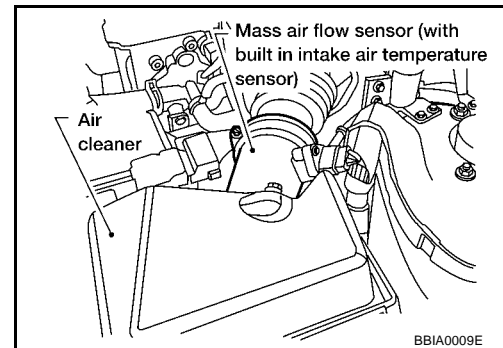

Yes or No

- Yes >> Perform trouble diagnosis for DTC P0171. Refer to [EC-233](#).
- No >> GO TO 3.

3. CHECK HO2S2 GROUND CIRCUIT FOR OPEN AND SHORT

1. Turn ignition switch OFF.
2. Disconnect heated oxygen sensor 2 harness connector.
3. Disconnect ECM harness connector.
4. Check harness continuity between ECM terminal 78 and HO2S2 terminal 4.
Refer to Wiring Diagram.

Continuity should exist.

5. Also check harness for short to ground and short to power.

OK or NG

- OK >> GO TO 4.
- NG >> Repair open circuit or short to ground or short to power in harness or connectors.

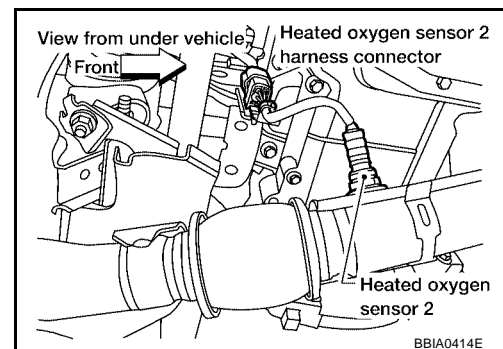

4. CHECK HO2S2 INPUT SIGNAL CIRCUIT FOR OPEN AND SHORT

1. Check harness continuity between ECM terminal 74 and HO2S2 terminal 1.
Refer to Wiring Diagram.

Continuity should exist.

2. Check harness continuity between ECM terminal 74 or HO2S2 terminal 1 and ground.
Refer to Wiring Diagram.

Continuity should not exist.

3. Also check harness for short to power.

OK or NG

OK >> GO TO 5.

NG >> Repair open circuit or short to ground or short to power in harness or connectors.

5. CHECK HEATED OXYGEN SENSOR 2

Refer to [EC-418, "Component Inspection"](#) .

OK or NG

OK >> GO TO 6.

NG >> Replace heated oxygen sensor 2.

6. CHECK INTERMITTENT INCIDENT

Refer to [EC-158, "TROUBLE DIAGNOSIS FOR INTERMITTENT INCIDENT"](#) .

>> INSPECTION END

**Component Inspection
HEATED OXYGEN SENSOR 2**

UBS002ZC

With CONSULT-II

1. Start engine and warm it up to the normal operating temperature.
2. Turn ignition switch OFF and wait at least 10 seconds.
3. Start engine and keep the engine speed between 3,500 and 4,000 rpm for at least 1 minute under no load.
4. Let engine idle for 1 minute.
5. Select "FUEL INJECTION" in "ACTIVE TEST" mode, and select "HO2S2 (B1)" as the monitor item with CONSULT-II.

ACTIVE TEST	
FUEL INJECTION	25 %
MONITOR	
ENG SPEED	XXX rpm
HO2S2 (B1)	XXX V

PBIB1783E

6. Check "HO2S2 (B1)" at idle speed when adjusting "FUEL INJECTION" to $\pm 25\%$.

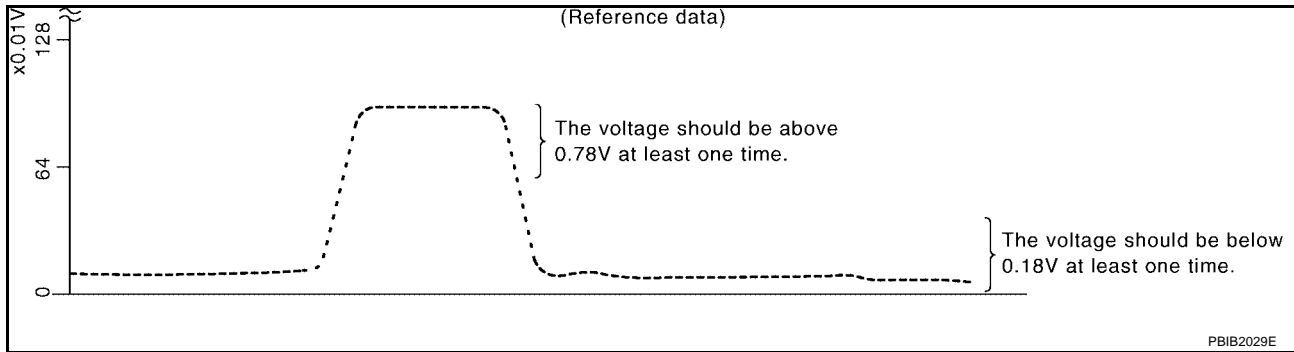

"HO2S2 (B1)" should be above 0.78V at least once when the "FUEL INJECTION" is +25%.
 "HO2S2 (B1)" should be below 0.18V at least once when the "FUEL INJECTION" is -25%.

CAUTION:

- Discard any heated oxygen sensor which has been dropped from a height of more than 0.5 m (19.7 in) onto a hard surface such as a concrete floor; use a new one.
- Before installing new oxygen sensor, clean exhaust system threads using Oxygen Sensor Thread Cleaner tool J-43897-18 or J-43897-12 and approved anti-seize lubricant.

⊗ **Without CONSULT-II**

1. Start engine and warm it up to the normal operating temperature.
2. Turn ignition switch OFF and wait at least 10 seconds.
3. Start engine and keep the engine speed between 3,500 and 4,000 rpm for at least 1 minute under no load.
4. Let engine idle for 1 minute.
5. Set voltmeter probes between ECM terminal 74 (HO2S2 signal) and ground.
6. Check the voltage when revving up to 4,000 rpm under no load at least 10 times.

(Depress and release accelerator pedal as soon as possible.)
The voltage should be above 0.78V at least once during this procedure.
If the voltage is above 0.78V at step 6, step 7 is not necessary.

7. Keep vehicle idling for 10 minutes, then check voltage. Or check the voltage when coasting from 80 km/h (50 MPH) in D position with OD OFF (A/T), 3rd gear position (M/T).
The voltage should be below 0.18V at least once during this procedure.
8. If NG, replace heated oxygen sensor 2.

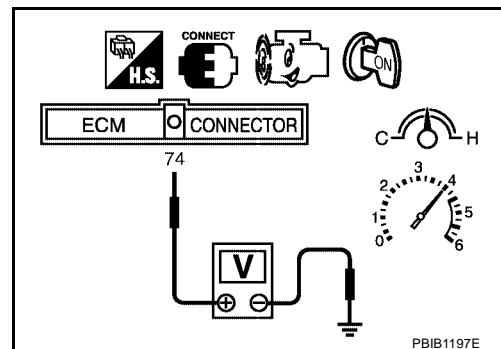

CAUTION:

- Discard any heated oxygen sensor which has been dropped from a height of more than 0.5 m (19.7 in) onto a hard surface such as a concrete floor; use a new one.
- Before installing new oxygen sensor, clean exhaust system threads using Oxygen Sensor Thread Cleaner tool J-43897-18 or J-43897-12 and approved anti-seize lubricant.

**Removal and Installation
 HEATED OXYGEN SENSOR 2**

UBS002ZD

Refer to [EX-3. "EXHAUST SYSTEM \(QR25DE\)"](#).

DTC P1148 CLOSED LOOP CONTROL

[QR]

DTC P1148 CLOSED LOOP CONTROL

PFP:22690

On Board Diagnosis Logic

UBS002ZE

This self-diagnosis has the one trip detection logic.

DTC No.	Trouble diagnosis name	DTC detecting condition	Possible cause
P1148 1148	Closed loop control function	The closed loop control function does not operate even when vehicle is driving in the specified condition.	<ul style="list-style-type: none">● Harness or connectors [The air fuel ratio (A/F) sensor 1 circuit is open or shorted.]● Air fuel ratio (A/F) sensor 1● Air fuel ratio (A/F) sensor 1 heater

DTC P1148 is displayed with another DTC for air fuel ratio (A/F) sensor 1.
Perform the trouble diagnosis for the corresponding DTC.

DTC P1217 ENGINE OVER TEMPERATURE

[QR]

PF0:0000

UBS00ELG

DTC P1217 ENGINE OVER TEMPERATURE

Description SYSTEM DESCRIPTION

NOTE:

If DTC P1217 is displayed with DTC U1000 or U1001, first perform the trouble diagnosis for DTC U1000, U1001. Refer to [EC-166, "DTC U1000, U1001 CAN COMMUNICATION LINE"](#).

Cooling Fan Control

Sensor	Input Signal to ECM	ECM function	Actuator
Crankshaft position sensor (POS) Camshaft position sensor (PHASE)	Engine speed*1	Cooling fan control	IPDM E/R (Cooling fan relay)
Battery	Battery voltage*1		
Wheel sensor	Vehicle speed*2		
Engine coolant temperature sensor	Engine coolant temperature		
Air conditioner switch	Air conditioner ON signal*2		
Refrigerant pressure sensor	Refrigerant pressure		

*1: The ECM determines the start signal status by the signals of engine speed and battery voltage.

*2: This signal is sent to ECM through CAN communication line.

The ECM controls the cooling fan corresponding to the vehicle speed, engine coolant temperature, refrigerant pressure, and air conditioner ON signal. The control system has 4-step control [HIGH/MID/LOW/OFF].

Cooling Fan Operation

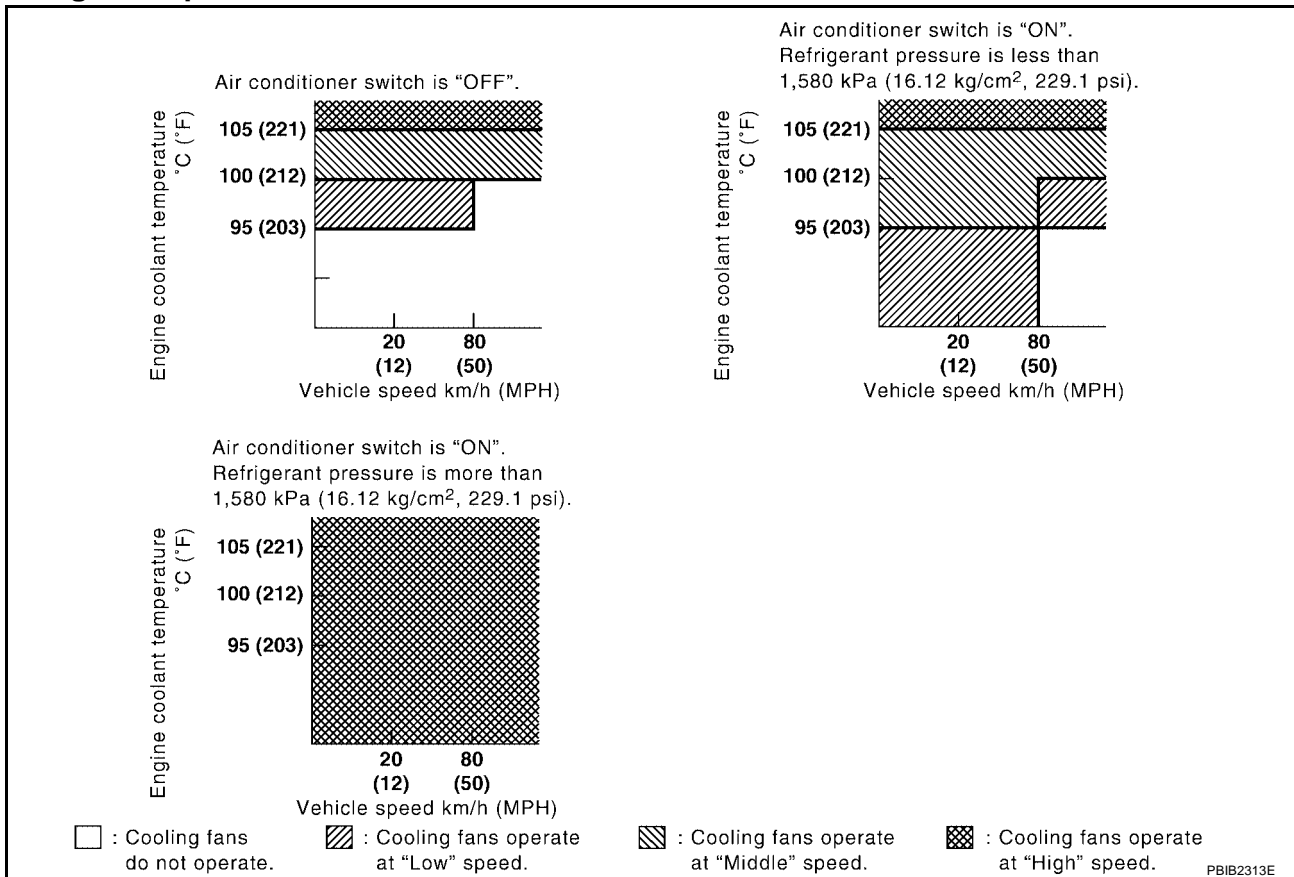

DTC P1217 ENGINE OVER TEMPERATURE

[QR]

Cooling Fan Relay Operation

The ECM controls cooling fan relays in the IPDM E/R through CAN communication line.

Cooling fan speed	Cooling fan relay		
	1	2	3
Stop (OFF)	OFF	OFF	OFF
Low (LOW)	OFF	ON	OFF
Middle (MID)	OFF	OFF	ON
High (HI)	ON	OFF	ON

COMPONENT DESCRIPTION

Cooling Fan Motor

The cooling fan operates at each speed when the current flows in the cooling fan motor as follows.

Cooling fan speed	Cooling fan motor terminals	
	(+)	(-)
Middle (MID)	1	3 and 4
	2	3 and 4
	1 and 2	3
	1 and 2	4
High (HI)	1 and 2	3 and 4

The cooling fan operates at low (LOW) speed when cooling fan motors-1 and -2 are circuited in series under middle speed condition.

CONSULT-II Reference Value in Data Monitor Mode

UBS002ZJ

Specification data are reference values.

MONITOR ITEM	CONDITION		SPECIFICATION
AIR COND SIG	<ul style="list-style-type: none"> Engine: After warming up, idle the engine 	Air conditioner switch: OFF	OFF
		Air conditioner switch: ON (Compressor operates.)	ON
COOLING FAN	<ul style="list-style-type: none"> Engine: After warming up, idle the engine Air conditioner switch: OFF 	Engine coolant temperature is 94°C (201°F) or less	OFF
		Engine coolant temperature is between 95°C (203°F) and 99°C (210°F)	LOW
		Engine coolant temperature is between 100°C (212°F) and 104°C (219°F)	MID
		Engine coolant temperature is 105°C (221°F) or more	HI

On Board Diagnosis Logic

UBS002ZK

If the cooling fan or another component in the cooling system malfunctions, engine coolant temperature will rise. When the engine coolant temperature reaches an abnormally high temperature condition, a malfunction is indicated.

This self-diagnosis has the one trip detection logic.

DTC P1217 ENGINE OVER TEMPERATURE

[QR]

DTC No.	Trouble diagnosis name	DTC detecting condition	Possible cause
P1217 1217	Engine over temperature (Overheat)	<ul style="list-style-type: none"> ● Cooling fan does not operate properly (Overheat). ● Cooling fan system does not operate properly (Overheat). ● Engine coolant was not added to the system using the proper filling method. ● Engine coolant is not within the specified range. 	<ul style="list-style-type: none"> ● Harness or connectors (The cooling fan circuit is open or shorted.) ● IPDM E/R ● Cooling fan ● Radiator hose ● Radiator ● Radiator cap ● Water pump ● Thermostat <p>For more information, refer to EC-432, "Main 12 Causes of Overheating".</p>

CAUTION:

When a malfunction is indicated, be sure to replace the coolant. Refer to [MA-15](#), "[Changing Engine Coolant](#)". Also, replace the engine oil. Refer to [LU-8](#), "[Changing Engine Oil](#)".

1. Fill radiator with coolant up to specified level with a filling speed of 2 liters per minute. Be sure to use coolant with the proper mixture ratio. Refer to [MA-14](#), "[ANTI-FREEZE COOLANT MIXTURE RATIO](#)".
2. After refilling coolant, run engine to ensure that no water-flow noise is emitted.

Overall Function Check

UBS00E46

Use this procedure to check the overall function of the cooling fan. During this check, a DTC might not be confirmed.

WARNING:

Never remove the radiator cap when the engine is hot. Serious burns could be caused by high pressure fluid escaping from the radiator.

Wrap a thick cloth around cap. Carefully remove the cap by turning it a quarter turn to allow built-up pressure to escape. Then turn the cap all the way off.

WITH CONSULT-II

1. Check the coolant level in the reservoir tank and radiator.
Allow engine to cool before checking coolant level.
If the coolant level in the reservoir tank and/or radiator is below the proper range, skip the following steps and go to [EC-427](#), "[Diagnostic Procedure](#)".
2. Confirm whether customer filled the coolant or not. If customer filled the coolant, skip the following steps and go to [EC-427](#), "[Diagnostic Procedure](#)".
3. Turn ignition switch ON.
4. Perform "COOLING FAN" in "ACTIVE TEST" mode with CONSULT-II.
5. If the results are NG, go to [EC-427](#), "[Diagnostic Procedure](#)".

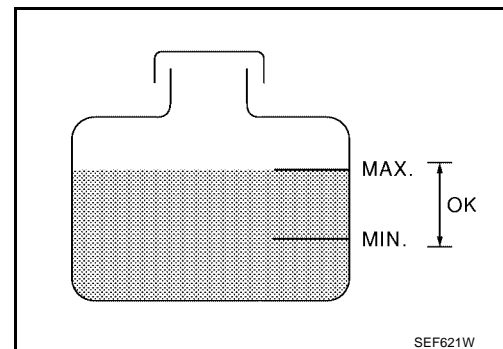

SEF621W

ACTIVE TEST	
COOLING FAN	OFF
MONITOR	
COOLANT TEMP/S	XXX °C

SEF646X

 WITH GST

1. Check the coolant level in the reservoir tank and radiator.
Allow engine to cool before checking coolant level.
If the coolant level in the reservoir tank and/or radiator is below the proper range, skip the following steps and go to [EC-427, "Diagnostic Procedure"](#).
2. Confirm whether customer filled the coolant or not. If customer filled the coolant, skip the following steps and go to [EC-427, "Diagnostic Procedure"](#).
3. Perform IPDM E/R auto active test and check cooling fan motors operation, refer to [PG-21, "Auto Active Test"](#).
4. If NG, go to [EC-427, "Diagnostic Procedure"](#).

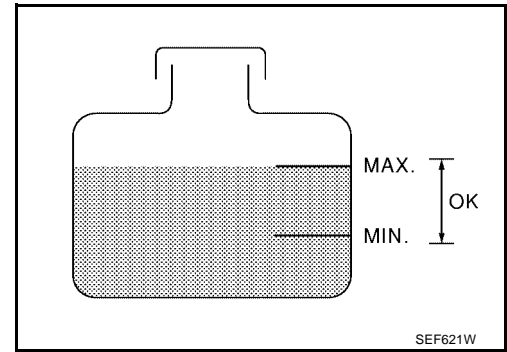



DTC P1217 ENGINE OVER TEMPERATURE

[QR]

Wiring Diagram

UBS002ZM

EC-COOL/F-01

-  : DETECTABLE LINE FOR DTC
-  : NON-DETECTABLE LINE FOR DTC
-  : DATA LINE

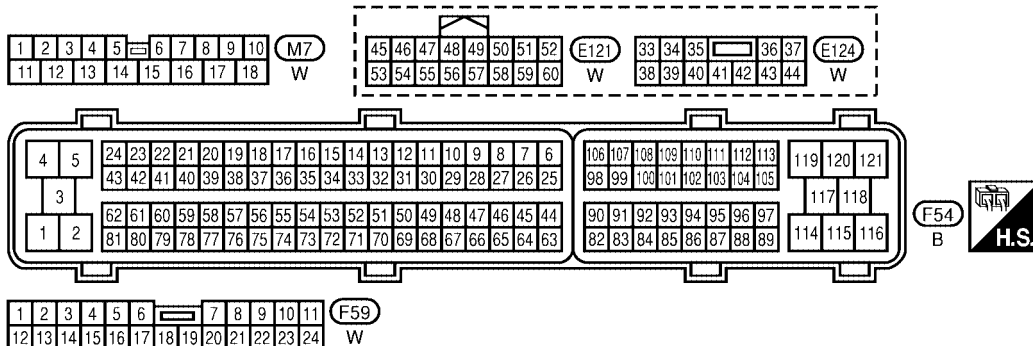
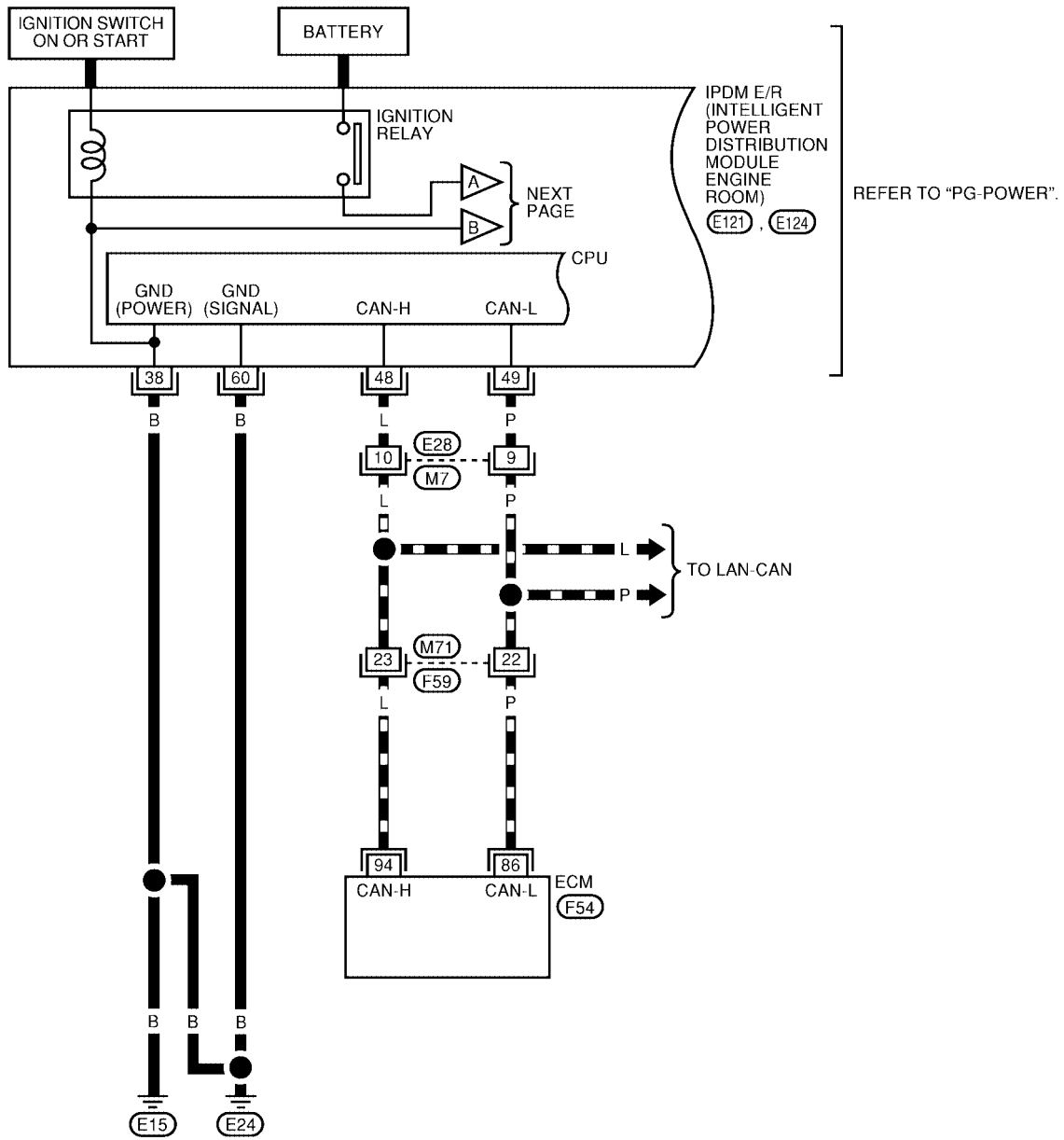

BBWA1239E

Diagnostic Procedure

1. INSPECTION START

Do you have CONSULT-II?

Yes or No

- Yes >> GO TO 2.
- No >> GO TO 3.

2. CHECK COOLING FAN OPERATION

With CONSULT-II

1. Start engine and let it idle.
2. Select "COOLING FAN" in "ACTIVE TEST" mode with CONSULT-II.
3. Make sure that cooling fans-1 and -2 operate at each speed (LOW/MID/HI).

OK or NG

- OK >> GO TO 4.
- NG >> Check cooling fan control circuit. (Go to [EC-429, "PROCEDURE A"](#) .)

ACTIVE TEST	
COOLING FAN	LOW
MONITOR	
COOLAN TEMP/S	XXX °C

SEF784Z

3. CHECK COOLING FAN OPERATION

Without CONSULT-II

1. Perform IPDM E/R auto active test and check cooling fan motors operation, refer to [PG-21, "Auto Active Test"](#) .
2. Make sure that cooling fans-1 and -2 operate at each speed (Low/Middle/High).

OK or NG

- OK >> GO TO 4.
- NG >> Check cooling fan control circuit. (Go to [EC-429, "PROCEDURE A"](#) .)

4. CHECK COOLING SYSTEM FOR LEAK

Apply pressure to the cooling system with a tester, and check if the pressure drops.

Testing pressure: 157 kPa (1.6 kg/cm² , 23 psi)

CAUTION:

Higher than the specified pressure may cause radiator damage. Pressure should not drop.

OK or NG

- OK >> GO TO 5.
- NG >> Check the following for leak. Refer to [CO-9, "CHECKING COOLING SYSTEM FOR LEAKS"](#) .
 - Hose
 - Radiator
 - Water pump

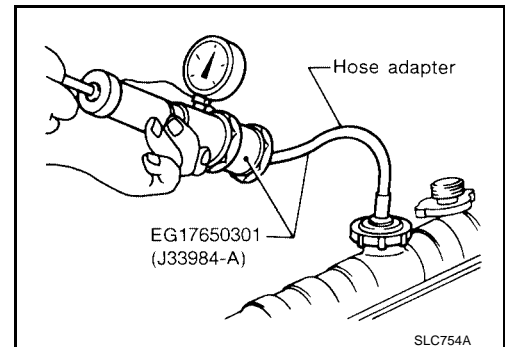

5. CHECK RADIATOR CAP

Apply pressure to cap with a tester.

Radiator cap relief pressure: 59 - 98 kPa (0.6 - 1.0 kg/cm², 9 - 14 psi)

OK or NG

- OK >> GO TO 6.
- NG >> Replace radiator cap.

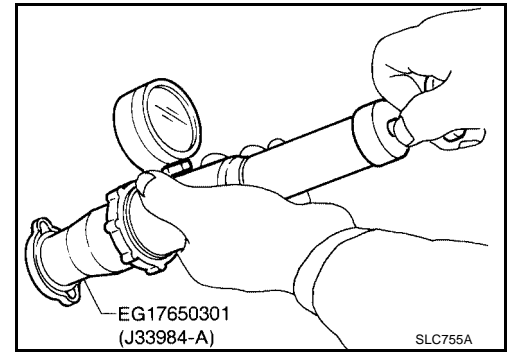

6. CHECK THERMOSTAT

1. Check valve seating condition at normal room temperatures. **It should seat tightly.**
2. Check valve opening temperature and valve lift.

Valve opening temperature: 82°C (180°F) [standard]
Valve lift: More than 8 mm/95°C (0.31 in/203°F)

3. Check if valve is closed at 5°C (9°F) below valve opening temperature. For details, refer to [CO-16, "THERMOSTAT AND THERMOSTAT HOUSING"](#).

OK or NG

- OK >> GO TO 7.
- NG >> Replace thermostat

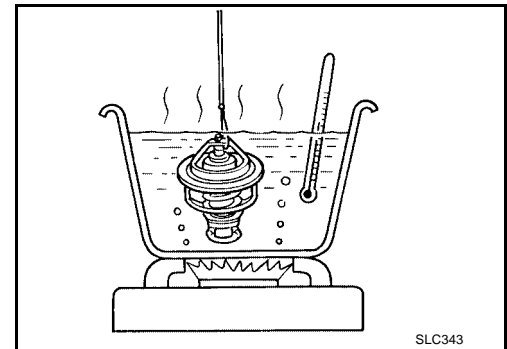

7. CHECK ENGINE COOLANT TEMPERATURE SENSOR

Refer to [EC-432, "Component Inspection"](#).

OK or NG

- OK >> GO TO 8.
- NG >> Replace engine coolant temperature sensor.

8. CHECK MAIN 12 CAUSES

If the cause cannot be isolated, go to [EC-432, "Main 12 Causes of Overheating"](#).

>> **INSPECTION END**

PROCEDURE A**1. CHECK IPDM E/R POWER SUPPLY CIRCUIT**

1. Turn ignition switch OFF.
2. Disconnect IPDM E/R harness connectors E123.
3. Check voltage between IPDM E/R terminal 15 and ground with CONSULT-II or tester.

Voltage: Battery voltage

OK or NG

- OK >> GO TO 3.
 NG >> GO TO 2.

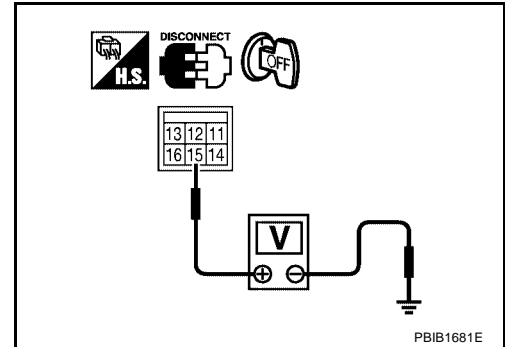
**2. DETECT MALFUNCTIONING PART**

Check the following.

- 40A fusible link
- Harness for open or short between IPDM E/R and battery

>> Repair open circuit or short to ground in harness or connectors.

3. CHECK IPDM E/R GROUND CIRCUIT FOR OPEN AND SHORT

1. Turn ignition switch OFF.
2. Check harness continuity between IPDM E/R terminal 16 and ground. Refer to Wiring Diagram.

Continuity should exist.

3. Also check harness for short to power.

OK or NG

- OK >> GO TO 4.
 NG >> Repair open circuit or short to power in harness or connectors.

4. CHECK COOLING FAN MOTOR-2 POWER SUPPLY CIRCUIT

1. Disconnect cooling fan motor-2 harness connector.

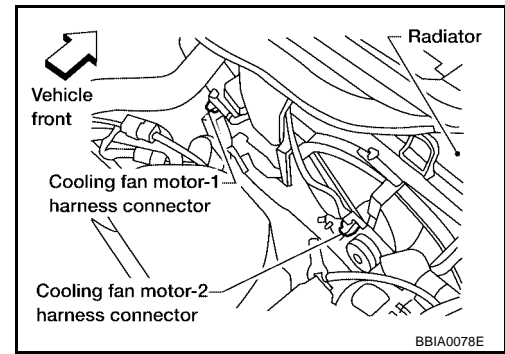

2. Check voltage between cooling fan motor-2 terminals 1, 2 and ground with CONSULT-II or tester.

Voltage: Battery voltage

OK or NG

- OK >> GO TO 6.
- NG >> GO TO 5.

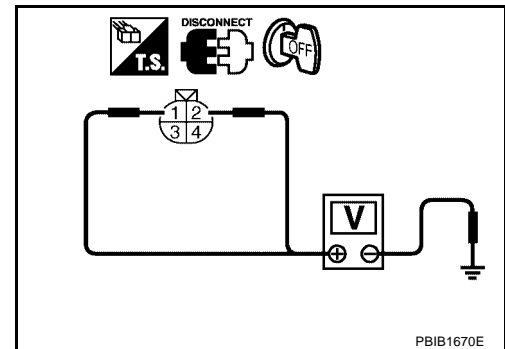

5. DETECT MALFUNCTIONING PART

Check the following.

- 40A fusible link
- Harness for open or short between cooling fan motor-2 and battery

>> Repair open circuit or short to ground in harness or connectors.

6. CHECK COOLING FAN MOTOR-2 GROUND CIRCUIT FOR OPEN AND SHORT

1. Turn ignition switch OFF.
2. Disconnect IPDM E/R harness connector E118.
3. Check harness continuity between the following terminals.
Cooling fan motor-2 terminal 3 and IPDM E/R terminal 8
Cooling fan motor-2 terminal 4 and IPDM E/R terminals 11, 12
Refer to Wiring diagram.

Continuity should exist.

4. Also check harness for short to ground or short to power.

OK or NG

- OK >> GO TO 7.
- NG >> Repair open circuit or short to ground or short to power in harness or connectors.

7. CHECK COOLING FAN MOTOR-1 GROUND CIRCUIT FOR OPEN AND SHORT

1. Turn ignition switch OFF.
2. Disconnect cooling fan motor-1 harness connector.
3. Check harness continuity between cooling fan motor-1 terminals 3, 4 and ground.
Refer to Wiring diagram.

Continuity should exist.

4. Also check harness for short to power.

OK or NG

- OK >> GO TO 8.
- NG >> Repair open circuit or short to power in harness or connectors.

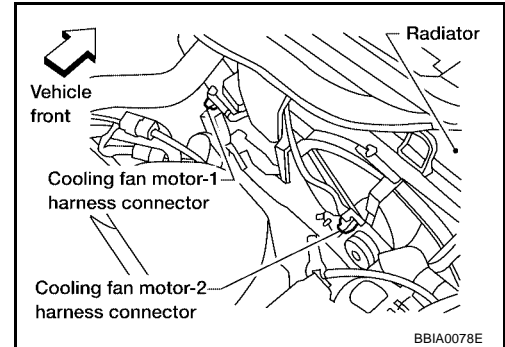

8. CHECK COOLING FAN MOTOR-1 POWER SUPPLY CIRCUIT FOR OPEN AND SHORT

1. Check harness continuity between the following terminals.
Cooling fan motor-1 terminal 2 and IPDM E/R terminal 13
Cooling fan motor-1 terminal 1 and IPDM E/R terminals 10, 14
Refer to Wiring Diagram.

Continuity should exist.

2. Also check harness for short to ground and short to power.

OK or NG

- OK >> GO TO 9.
- NG >> Repair open circuit or short to ground or short to power in harness or connectors.

9. CHECK COOLING FAN MOTORS

Refer to [EC-432, "Component Inspection"](#) .

OK or NG

- OK >> GO TO 10.
- NG >> Replace cooling fan motors.

10. CHECK INTERMITTENT INCIDENT

Perform [EC-158, "TROUBLE DIAGNOSIS FOR INTERMITTENT INCIDENT"](#) .

OK or NG

- OK >> Replace IPDM E/R. Refer to [PG-15, "IPDM E/R \(INTELLIGENT POWER DISTRIBUTION MODULE ENGINE ROOM\)"](#) .
- NG >> Repair or replace harness or connector.

DTC P1217 ENGINE OVER TEMPERATURE

[QR]

Main 12 Causes of Overheating

UBS002ZO

Engine	Step	Inspection item	Equipment	Standard	Reference page
OFF	1	<ul style="list-style-type: none"> Blocked radiator Blocked condenser Blocked radiator grille Blocked bumper 	<ul style="list-style-type: none"> Visual 	No blocking	—
	2	<ul style="list-style-type: none"> Coolant mixture 	<ul style="list-style-type: none"> Coolant tester 	50 - 50% coolant mixture	See MA-14. "ANTI-FREEZE COOLANT MIXTURE RATIO" .
	3	<ul style="list-style-type: none"> Coolant level 	<ul style="list-style-type: none"> Visual 	Coolant up to MAX level in reservoir tank and radiator filler neck	See CO-10. "Refilling Engine Coolant" .
	4	<ul style="list-style-type: none"> Radiator cap 	<ul style="list-style-type: none"> Pressure tester 	59 - 98 kPa (0.6 - 1.0 kg/cm ² , 9 - 14 psi) (Limit)	See CO-9. "CHECKING RADIATOR CAP" .
ON*2	5	<ul style="list-style-type: none"> Coolant leaks 	<ul style="list-style-type: none"> Visual 	No leaks	See CO-9. "CHECKING COOLING SYSTEM FOR LEAKS" .
ON*2	6	<ul style="list-style-type: none"> Thermostat 	<ul style="list-style-type: none"> Touch the upper and lower radiator hoses 	Both hoses should be hot	See CO-16. "THERMOSTAT AND THERMOSTAT HOUSING" , and CO-11. "RADIATOR" .
ON*1	7	<ul style="list-style-type: none"> Cooling fan 	<ul style="list-style-type: none"> CONSULT-II 	Operating	See trouble diagnosis for DTC P1217 (EC-421) .
OFF	8	<ul style="list-style-type: none"> Combustion gas leak 	<ul style="list-style-type: none"> Color checker chemical tester 4 Gas analyzer 	Negative	—
ON*3	9	<ul style="list-style-type: none"> Coolant temperature gauge 	<ul style="list-style-type: none"> Visual 	Gauge less than 3/4 when driving	—
		<ul style="list-style-type: none"> Coolant overflow to reservoir tank 	<ul style="list-style-type: none"> Visual 	No overflow during driving and idling	See CO-10. "Refilling Engine Coolant" .
OFF*4	10	<ul style="list-style-type: none"> Coolant return from reservoir tank to radiator 	<ul style="list-style-type: none"> Visual 	Should be initial level in reservoir tank	See CO-9. "CHECKING RESERVOIR LEVEL" .
OFF	11	<ul style="list-style-type: none"> Cylinder head 	<ul style="list-style-type: none"> Straight gauge feeler gauge 	0.1 mm (0.004 in) Maximum distortion (warping)	See EM-59. "CYLINDER HEAD" .
	12	<ul style="list-style-type: none"> Cylinder block and pistons 	<ul style="list-style-type: none"> Visual 	No scuffing on cylinder walls or piston	See EM-75. "CYLINDER BLOCK" .

*1: Turn the ignition switch ON.

*2: Engine running at 3,000 rpm for 10 minutes.

*3: Drive at 90 km/h (55 MPH) for 30 minutes and then let idle for 10 minutes.

*4: After 60 minutes of cool down time.

For more information, refer to [CO-6. "OVERHEATING CAUSE ANALYSIS"](#) .

Component Inspection COOLING FAN MOTORS-1 AND -2

UBS002ZP

1. Disconnect cooling fan motor harness connectors.
2. Supply cooling fan motor terminals with battery voltage and check operation.

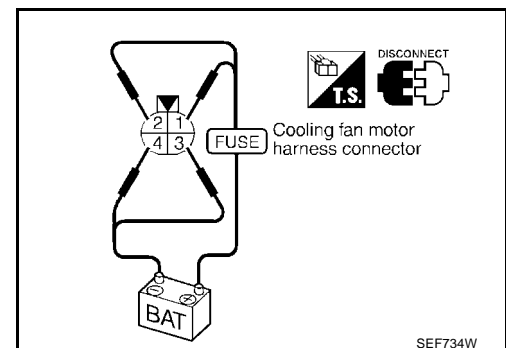

SEF734W

DTC P1217 ENGINE OVER TEMPERATURE

[QR]

Cooling fan speed	Cooling fan motor terminals	
	(+)	(-)
Middle (MID)	1	3 and 4
	2	3 and 4
	1 and 2	3
	1 and 2	4
High (HI)	1 and 2	3 and 4

Cooling fan motor should operate.
If NG, replace cooling fan motor.

A

EC

C

D

E

F

G

H

I

J

K

L

M

DTC P1225 TP SENSOR

Component Description

Electric throttle control actuator consists of throttle control motor, throttle position sensor, etc. The throttle position sensor responds to the throttle valve movement.

The throttle position sensor has the two sensors. These sensors are a kind of potentiometers which transform the throttle valve position into output voltage, and emit the voltage signal to the ECM. In addition, these sensors detect the opening and closing speed of the throttle valve and feed the voltage signals to the ECM. The ECM judges the current opening angle of the throttle valve from these signals and the ECM controls the throttle control motor to make the throttle valve opening angle properly in response to driving condition.

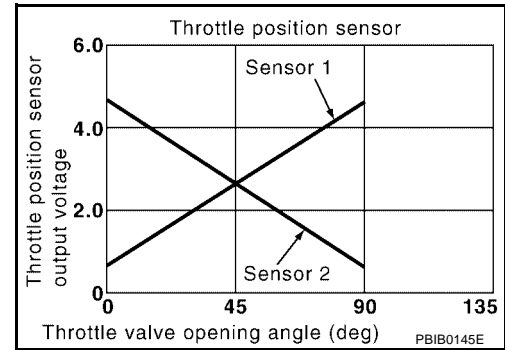

On Board Diagnosis Logic

The MIL will not light up for this diagnosis.

DTC No.	Trouble diagnosis name	DTC detecting condition	Possible cause
P1225 1225	Closed throttle position learning performance problem	Closed throttle position learning value is excessively low.	<ul style="list-style-type: none"> Electric throttle control actuator (TP sensor 1 and 2)

DTC Confirmation Procedure

NOTE:

If DTC Confirmation Procedure has been previously conducted, always turn ignition switch OFF and wait at least 10 seconds before conducting the next test.

TESTING CONDITION:

Before performing the following procedure, confirm that battery voltage is more than 10V at idle.

WITH CONSULT-II

- Turn ignition switch ON.
- Select "DATA MONITOR" mode with CONSULT-II.
- Turn ignition switch OFF, wait at least 10 seconds.
- Turn ignition switch ON.
- If 1st trip DTC is detected, go to [EC-435, "Diagnostic Procedure"](#)

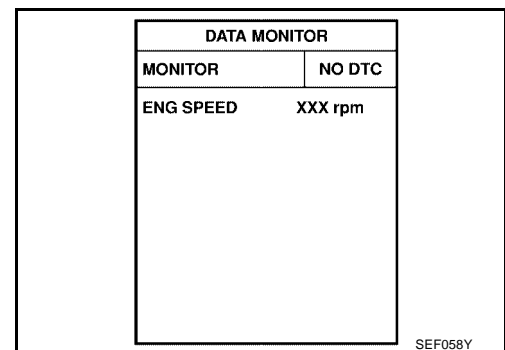

WITH GST

Follow the procedure "With CONSULT-II" above.

Diagnostic Procedure**1. CHECK ELECTRIC THROTTLE CONTROL ACTUATOR VISUALLY**

1. Turn ignition switch OFF.
2. Remove the intake air duct.
3. Check if foreign matter is caught between the throttle valve and the housing.

OK or NG

- OK >> GO TO 2.
 NG >> Remove the foreign matter and clean the electric throttle control actuator inside.

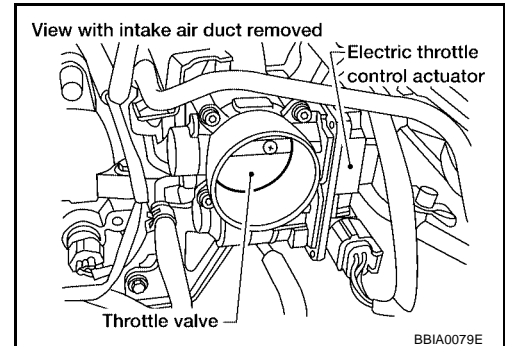
**2. REPLACE ELECTRIC THROTTLE CONTROL ACTUATOR**

1. Replace the electric throttle control actuator.
2. Perform [EC-93, "Throttle Valve Closed Position Learning"](#) .
3. Perform [EC-93, "Idle Air Volume Learning"](#) .

>> INSPECTION END

Remove and Installation
ELECTRIC THROTTLE CONTROL ACTUATOR

Refer to [EM-19, "INTAKE MANIFOLD"](#) .

DTC P1226 TP SENSOR

Component Description

Electric throttle control actuator consists of throttle control motor, throttle position sensor, etc. The throttle position sensor responds to the throttle valve movement.

The throttle position sensor has the two sensors. These sensors are a kind of potentiometers which transform the throttle valve position into output voltage, and emit the voltage signal to the ECM. In addition, these sensors detect the opening and closing speed of the throttle valve and feed the voltage signals to the ECM. The ECM judges the current opening angle of the throttle valve from these signals and the ECM controls the throttle control motor to make the throttle valve opening angle properly in response to driving condition.

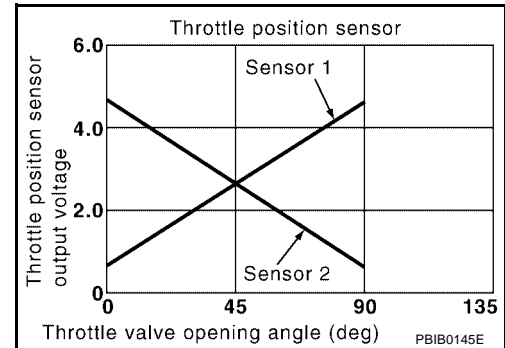

On Board Diagnosis Logic

The MIL will not light up for this diagnosis.

DTC No.	Trouble diagnosis name	DTC detecting condition	Possible cause
P1226 1226	Closed throttle position learning performance problem	Closed throttle position learning is not performed successfully, repeatedly.	<ul style="list-style-type: none"> Electric throttle control actuator (TP sensor 1 and 2)

DTC Confirmation Procedure

NOTE:

If DTC Confirmation Procedure has been previously conducted, always turn ignition switch OFF and wait at least 10 seconds before conducting the next test.

TESTING CONDITION:

Before performing the following procedure, confirm that battery voltage is more than 10V at idle.

WITH CONSULT-II

- Turn ignition switch ON.
- Select "DATA MONITOR" mode with CONSULT-II.
- Turn ignition switch OFF, wait at least 10 seconds.
- Turn ignition switch ON.
- Repeat steps 3 and 4 for 32 times.
- If 1st trip DTC is detected, go to [EC-437, "Diagnostic Procedure"](#)

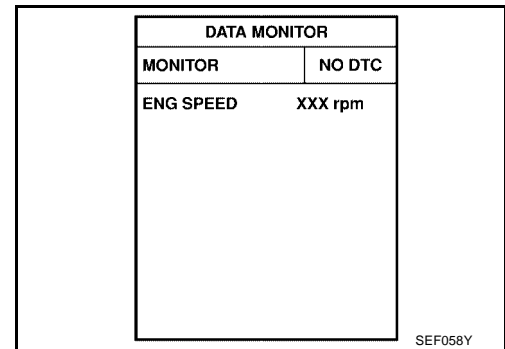

WITH GST

Follow the procedure "With CONSULT-II" above.

Diagnostic Procedure**1. CHECK ELECTRIC THROTTLE CONTROL ACTUATOR VISUALLY**

1. Turn ignition switch OFF.
2. Remove the intake air duct.
3. Check if foreign matter is caught between the throttle valve and the housing.

OK or NG

- OK >> GO TO 2.
 NG >> Remove the foreign matter and clean the electric throttle control actuator inside.

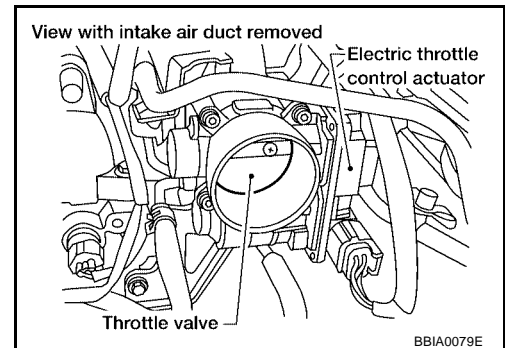
**2. REPLACE ELECTRIC THROTTLE CONTROL ACTUATOR**

1. Replace the electric throttle control actuator.
2. Perform [EC-93, "Throttle Valve Closed Position Learning"](#) .
3. Perform [EC-93, "Idle Air Volume Learning"](#) .

>> INSPECTION END

Remove and Installation
ELECTRIC THROTTLE CONTROL ACTUATOR

Refer to [EM-19, "INTAKE MANIFOLD"](#) .

DTC P1229 SENSOR POWER SUPPLY

[QR]

DTC P1229 SENSOR POWER SUPPLY

PF16119

On Board Diagnosis Logic

UBS0030G

This self-diagnosis has the one trip detection logic.

DTC No.	Trouble diagnosis name	DTC detecting condition	Possible cause
P1229 1229	Sensor power supply circuit short	ECM detects a voltage of power source for sensor is excessively low or high.	<ul style="list-style-type: none"> ● Harness or connectors (APP sensor 1 circuit is shorted.) (PSP sensor circuit is shorted.) (Refrigerant pressure sensor circuit is shorted.) (EVAP control system pressure sensor circuit is shorted.) ● Accelerator pedal position sensor (APP sensor 1) ● Power steering pressure sensor ● Refrigerant pressure sensor ● EVAP control system pressure sensor

FAIL-SAFE MODE

When the malfunction is detected, the ECM enters fail-safe mode and the MIL lights up.

Engine operation condition in fail-safe mode

ECM stops the electric throttle control actuator control, throttle valve is maintained at a fixed opening (approx. 5 degrees) by the return spring.

DTC Confirmation Procedure

UBS0030H

NOTE:

If DTC Confirmation Procedure has been previously conducted, always turn ignition switch OFF and wait at least 10 seconds before conducting the next test.

TESTING CONDITION:

Before performing the following procedure, confirm that battery voltage is more than 10V at idle.

WITH CONSULT-II

1. Turn ignition switch ON.
2. Select "DATA MONITOR" mode with CONSULT-II.
3. Start engine and let it idle for 1 second.
4. If DTC is detected, go to [EC-440, "Diagnostic Procedure"](#).

DATA MONITOR	
MONITOR	NO DTC
ENG SPEED	XXX rpm

SEF058Y

WITH GST

Follow the procedure "WITH CONSULT-II" above.

DTC P1229 SENSOR POWER SUPPLY

[QR]

Wiring Diagram

UBS0030I

EC-SEN/PW-01

- : DETECTABLE LINE FOR DTC
- : NON-DETECTABLE LINE FOR DTC
- A** : WITH A/T

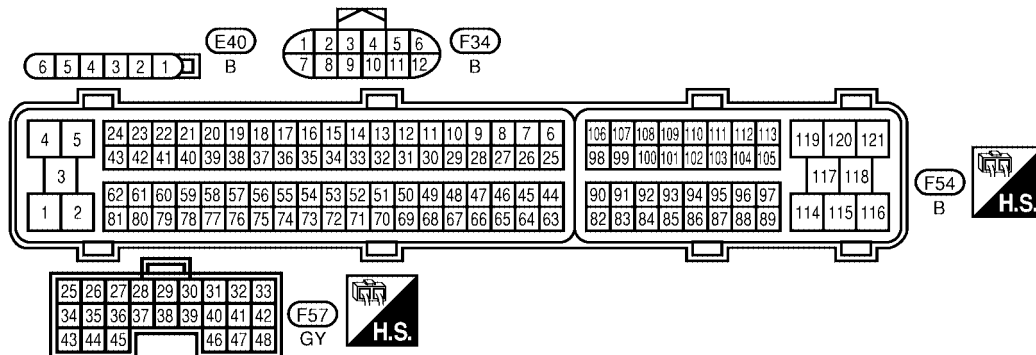
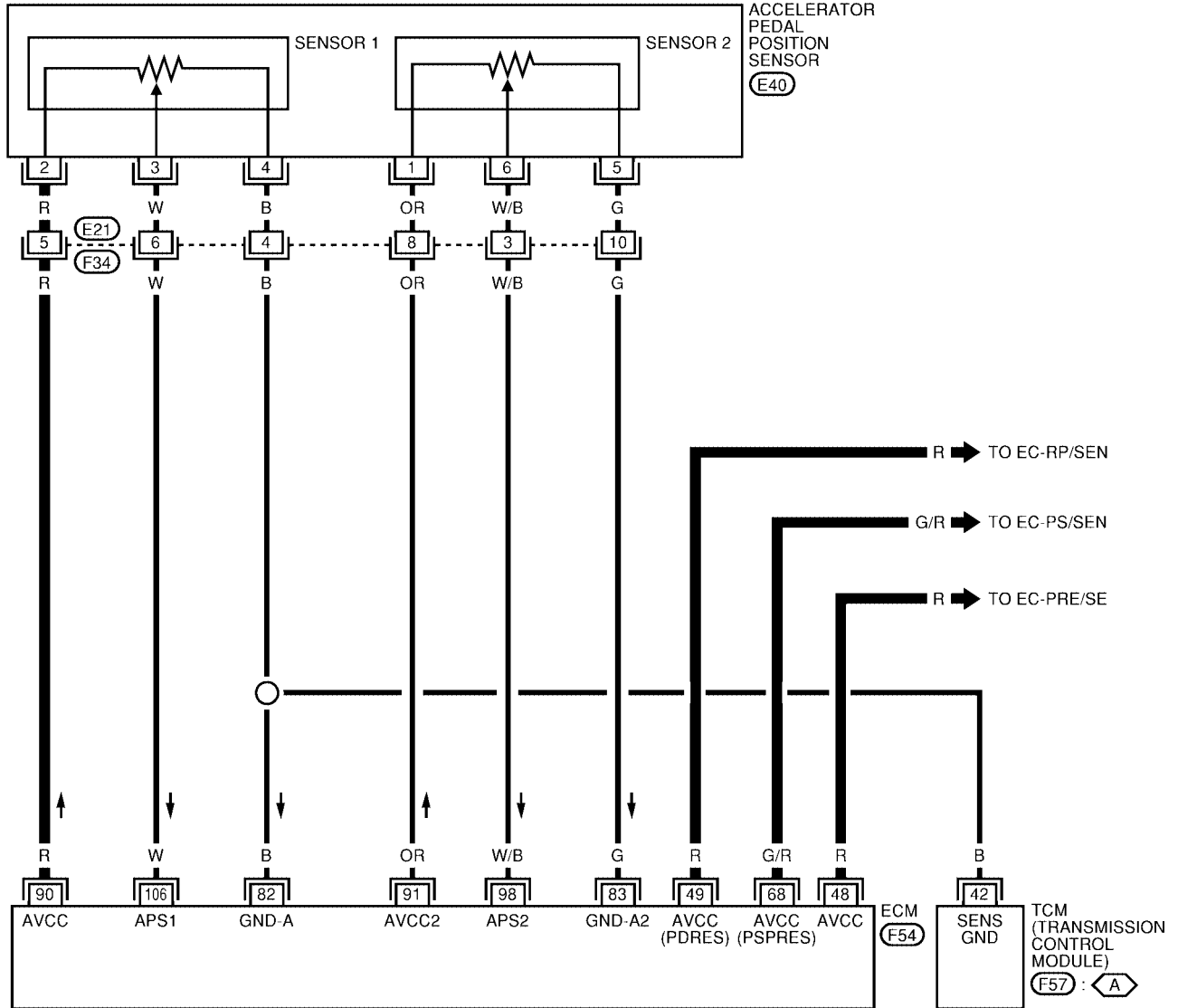

BBWA1241E

DTC P1229 SENSOR POWER SUPPLY

[QR]

Specification data are reference values and are measured between each terminal and ground.

CAUTION:

Do not use ECM ground terminals when measuring input/output voltage. Doing so may result in damage to the ECM's transistor. Use a ground other than ECM terminals, such as the ground.

TER-MINAL NO.	WIRE COLOR	ITEM	CONDITION	DATA (DC Voltage)
48	R	Sensor power supply (EVAP control system pressure sensor)	[Ignition switch: ON]	Approximately 5V
49	R	Sensor power supply (Refrigerant pressure sensor)	[Ignition switch: ON]	Approximately 5V
68	G/R	Sensor power supply (Power steering pressure sensor)	[Ignition switch: ON]	Approximately 5V
90	R	Sensor power supply (Accelerator pedal position sensor 1)	[Ignition switch: ON]	Approximately 5V

Diagnostic Procedure

UBS0030J

1. CHECK GROUND CONNECTIONS

1. Turn ignition switch OFF.
2. Loosen and retighten three ground screws on the body. Refer to [EC-164, "Ground Inspection"](#).

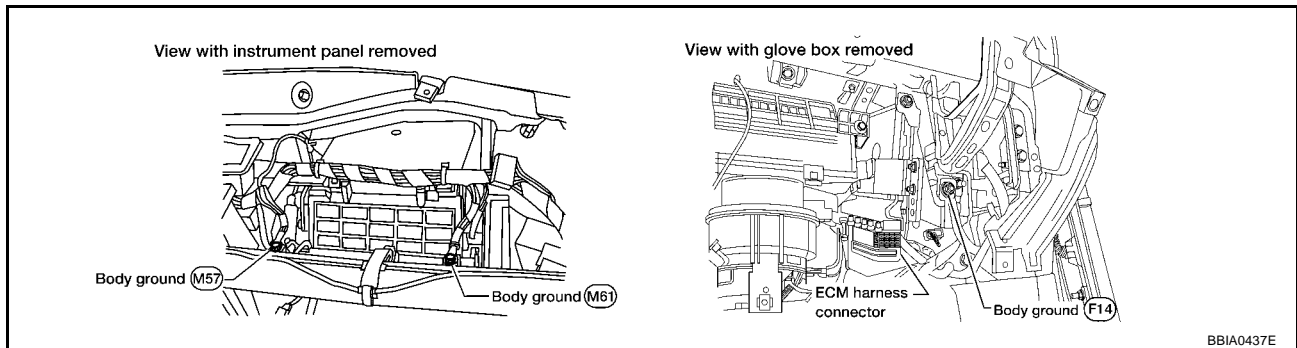

BBI A0437E

OK or NG

- OK >> GO TO 2.
- NG >> Repair or replace ground connections.

2. CHECK ACCELERATOR PEDAL POSITION SENSOR 1 POWER SUPPLY CIRCUIT

1. Disconnect accelerator pedal position (APP) sensor harness connector.
2. Turn ignition switch ON.

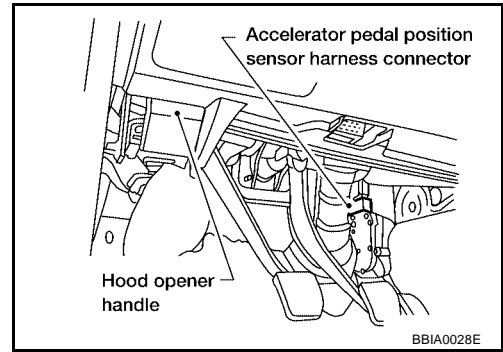

3. Check voltage between APP sensor terminal 2 and ground with CONSULT-II or tester.

Voltage: Approximately 5V

OK or NG

- OK >> GO TO 5.
- NG >> GO TO 3.

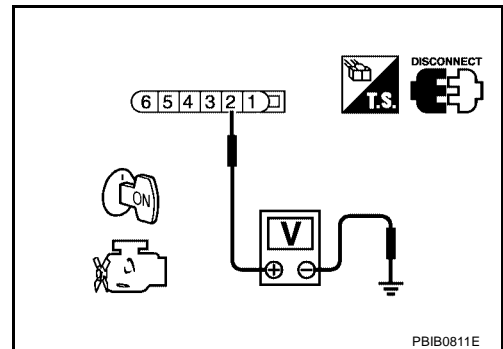

3. CHECK SENSOR POWER SUPPLY CIRCUITS

Check the following.

- Harness for short to power and short to ground, between the following terminals.

ECM terminal	Sensor terminal	Reference Wiring Diagram
90	APP sensor terminal 2	EC-551
48	EVAP control system pressure sensor terminal 3	EC-324
49	Refrigerant pressure sensor terminal 1	EC-606
68	PSP sensor terminal 1	EC-366

OK or NG

- OK >> GO TO 4.
- NG >> Repair short to ground or short to power in harness or connectors.

4. CHECK COMPONENTS

Check the following.

- Refrigerant pressure sensor (Refer to [EC-609](#) .)
- Power steering pressure sensor (Refer to [EC-369](#) .)
- EVAP control system pressure sensor (Refer to [EC-334](#) .)

OK or NG

- OK >> GO TO 7.
- NG >> Replace malfunctioning component.

5. CHECK APP SENSOR

Refer to [EC-556](#), "Component Inspection" .

OK or NG

- OK >> GO TO 7.
- NG >> GO TO 6.

6. REPLACE ACCELERATOR PEDAL ASSEMBLY

1. Replace accelerator pedal assembly.
2. Perform [EC-93, "Accelerator Pedal Released Position Learning"](#) .
3. Perform [EC-93, "Throttle Valve Closed Position Learning"](#) .
4. Perform [EC-93, "Idle Air Volume Learning"](#) .

>> INSPECTION END

7. CHECK INTERMITTENT INCIDENT

Refer to [EC-158, "TROUBLE DIAGNOSIS FOR INTERMITTENT INCIDENT"](#) .

>> INSPECTION END

DTC P1271 A/F SENSOR 1

PFP:22693

UBS00C65

Component Description

The A/F sensor 1 is a planar dual-cell limit current sensor. The sensor element of the A/F sensor 1 is the combination of a Nernst concentration cell (sensor cell) with an oxygen-pump cell, which transports ions. It has a heater in the element.

The sensor is capable of precise measurement $\lambda = 1$, but also in the lean and rich range. Together with its control electronics, the sensor outputs a clear, continuous signal throughout a wide λ range ($0.7 < \lambda < \text{air}$).

The exhaust gas components diffuse through the diffusion gap at the electrode of the oxygen pump and Nernst concentration cell, where they are brought to thermodynamic balance.

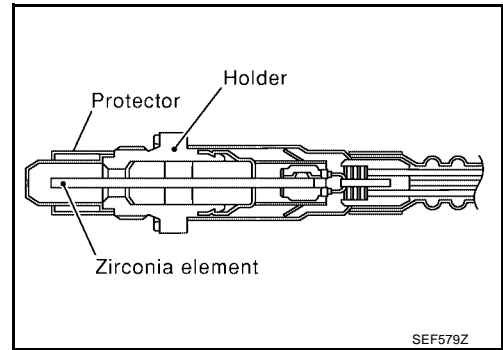

An electronic circuit controls the pump current through the oxygen-pump cell so that the composition of the exhaust gas in the diffusion gap remains constant at $\lambda = 1$. Therefore, the A/F sensor 1 is able to indicate air-fuel ratio by this pumping of current. In addition, a heater is integrated in the sensor to ensure the required operating temperature of 700 - 800°C (1,292 - 1,472°F).

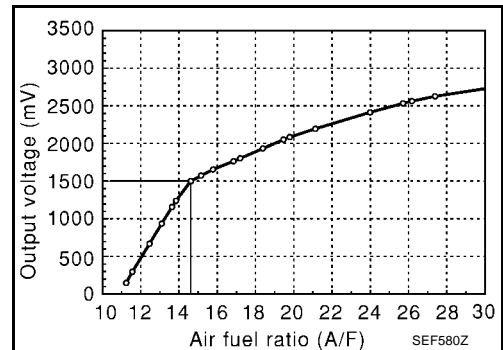

CONSULT-II Reference Value in Data Monitor Mode

UBS00C66

Specification data are reference values.

MONITOR ITEM	CONDITION	SPECIFICATION
A/F SEN1 (B1)	<ul style="list-style-type: none"> Engine: After warming up Maintaining engine speed at 2,000 rpm	Fluctuates around 1.5V

On Board Diagnosis Logic

UBS00C67

To judge the malfunction, the diagnosis checks that the A/F signal computed by ECM from the air fuel ratio (A/F) sensor 1 signal is not inordinately low.

DTC No.	Trouble diagnosis name	DTC detecting condition	Possible Cause
P1271 1271	Air fuel ratio (A/F) sensor 1 circuit no activity detected	<ul style="list-style-type: none"> The A/F signal computed by ECM from the A/F sensor 1 signal is constantly approx. 0V. 	<ul style="list-style-type: none"> Harness or connectors (The sensor circuit is open or shorted.) Air fuel ratio (A/F) sensor 1

DTC Confirmation Procedure

UBS00ELH

NOTE:

If DTC Confirmation Procedure has been previously conducted, always turn ignition switch OFF and wait at least 10 seconds before conducting the next test.

TESTING CONDITION:

Before performing the following procedure, confirm that battery voltage is more than 11V at idle.

WITH CONSULT-II

1. Start engine and warm it up to normal operating temperature.
2. Select "A/F SEN1 (B1)" in "DATA MONITOR" mode with CONSULT-II.

DTC P1271 A/F SENSOR 1

[QR]

3. Check "A/F SEN1 (B1)" indication.
If the indication is constantly approx. 0V, go to [EC-446, "Diagnostic Procedure"](#).
If the indication is not constantly approx. 0V, go to next step.
4. Turn ignition switch OFF, wait at least 10 seconds and then restart engine.
5. Drive and accelerate vehicle to more than 40 km/h (25 MPH) within 20 seconds after restarting engine.
6. Maintain the following conditions for about 20 consecutive seconds.

DATA MONITOR	
MONITOR	NO DTC
ENG SPEED	XXX rpm
COOLAN TEMP/S	XXX °C
A/F SEN1 (B1)	XXX V

SEF581Z

ENG SPEED	1,000 - 3,200 rpm
VHCL SPEED SE	More than 40 km/h (25 MPH)
B/FUEL SCHDL	1.5 - 9.0 msec
COOLANT TEMP/S	Less than 70°C (158°F)
Shift lever	Suitable position

NOTE:

- Keep the accelerator pedal as steady as possible during the cruising.
 - If this procedure is not completed within 1 minute after restarting engine at step 4, return to step 4.
7. If 1st trip DTC is displayed, go to [EC-446, "Diagnostic Procedure"](#).

 **WITH GST**

Follow the procedure "WITH CONSULT-II" above.

DTC P1271 A/F SENSOR 1

[QR]

UBS00C6A

Wiring Diagram

EC-A/F-01

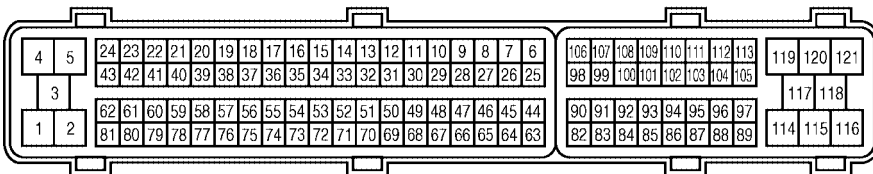
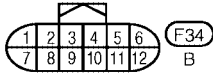
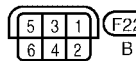
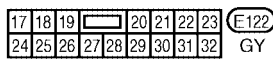
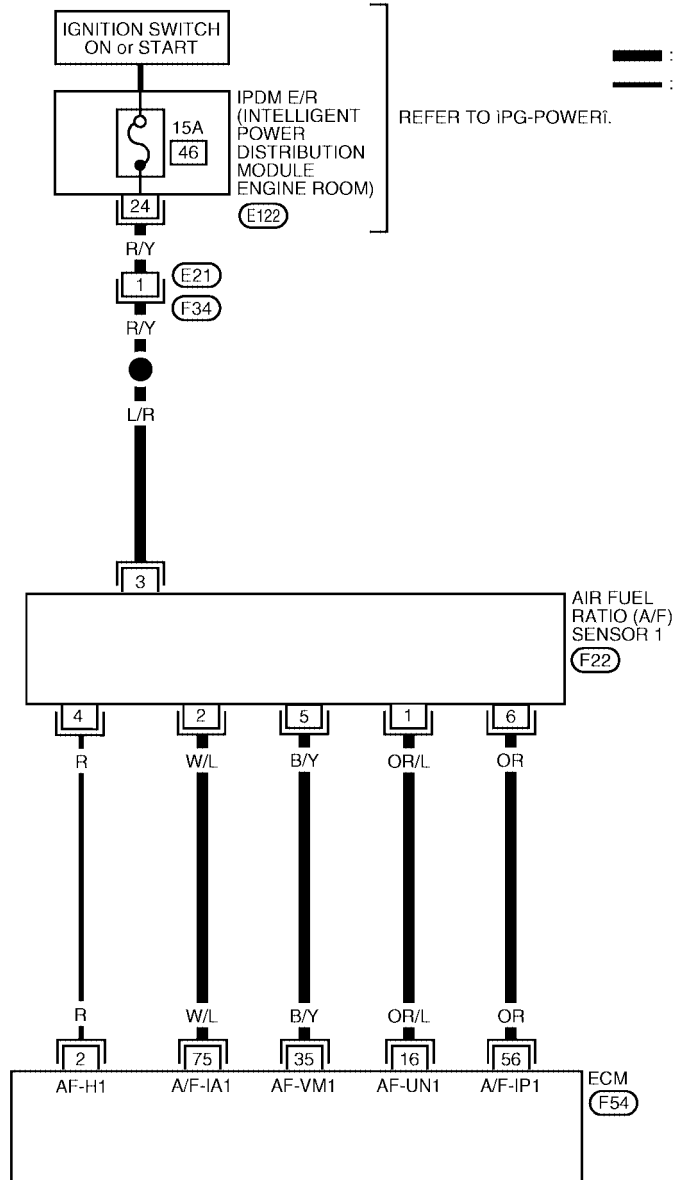

BBWA1242E

DTC P1271 A/F SENSOR 1

[QR]

Specification data are reference values and are measured between each terminal and ground.

CAUTION:

Do not use ECM ground terminals when measuring input/output voltage. Doing so may result in damage to the ECM's transistor. Use a ground other than ECM terminals, such as the ground.

TERMI- NAL NO.	WIRE COLOR	ITEM	CONDITION	DATA (DC Voltage)
16	OR/L	A/F sensor 1	[Engine is running] ● Warm-up condition ● Idle speed	Approximately 3.1V
35	B/Y			Approximately 2.6V
56	OR			2 - 3V
75	W/L			2 - 3V

Diagnostic Procedure

UBS00C6B

1. CHECK GROUND CONNECTIONS

1. Turn ignition switch OFF.
2. Loosen and retighten three ground screws on the body. Refer to [EC-164, "Ground Inspection"](#).

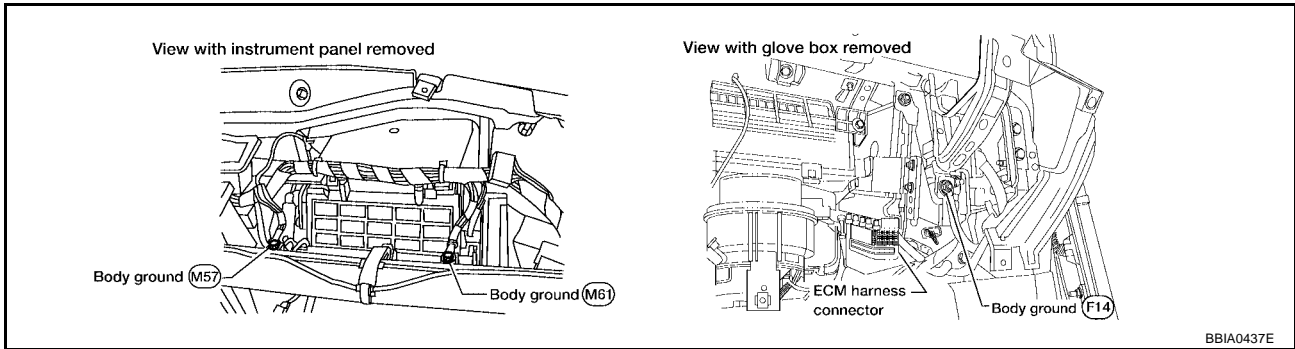

OK or NG

- OK >> GO TO 2.
- NG >> Repair or replace ground connections.

2. CHECK AIR FUEL RATIO (A/F) SENSOR 1 POWER SUPPLY CIRCUIT

1. Disconnect A/F sensor 1 harness connector.
2. Turn ignition switch ON.

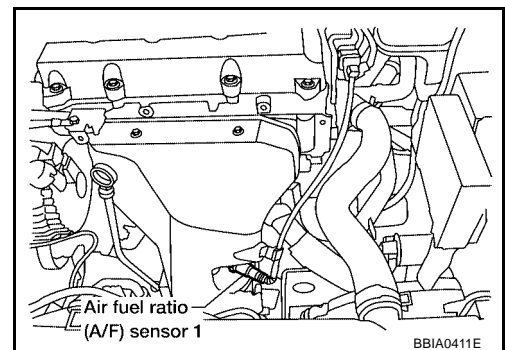

3. Check voltage between A/F sensor 1 terminal 3 and ground with CONSULT-II or tester.

Voltage: Battery voltage

OK or NG

- OK >> GO TO 4.
- NG >> GO TO 3.

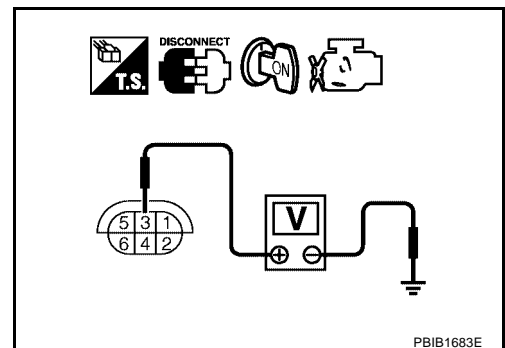

3. DETECT MALFUNCTIONING PART

Check the following.

- Harness connectors E21, F34
- IPDM E/R harness connector E122
- 15A fuse
- Harness for open or short between A/F sensor 1 and fuse

>> Repair or replace harness or connectors.

4. CHECK A/F SENSOR 1 INPUT SIGNAL CIRCUIT FOR OPEN AND SHORT

1. Turn ignition switch OFF.
2. Disconnect ECM harness connector.
3. Check harness continuity between the following terminals. Refer to Wiring Diagram.

A/F sensor 1 terminal	ECM terminal
1	16
5	35
6	56
2	75

Continuity should exist.

4. Check harness continuity between ECM terminals 16, 35, 56, 75 or A/F sensor 1 terminals 1, 2, 5, 6 and ground. Refer to Wiring Diagram.

Continuity should not exist.

5. Also check harness for short to power.

OK or NG

OK >> GO TO 5.

NG >> Repair open circuit or short to ground or short to power in harness or connectors.

5. CHECK INTERMITTENT INCIDENT

Perform [EC-158, "TROUBLE DIAGNOSIS FOR INTERMITTENT INCIDENT"](#) .

OK or NG

OK >> Replace A/F sensor 1.

NG >> Repair or replace.

**Removal and Installation
AIR FUEL RATIO SENSOR**

Refer to [EM-24, "EXHAUST MANIFOLD AND THREE WAY CATALYST"](#) .

UBS00C6C

DTC P1272 A/F SENSOR 1

Component Description

The A/F sensor 1 is a planar dual-cell limit current sensor. The sensor element of the A/F sensor 1 is the combination of a Nernst concentration cell (sensor cell) with an oxygen-pump cell, which transports ions. It has a heater in the element.

The sensor is capable of precise measurement $\lambda = 1$, but also in the lean and rich range. Together with its control electronics, the sensor outputs a clear, continuous signal throughout a wide λ range ($0.7 < \lambda < \text{air}$).

The exhaust gas components diffuse through the diffusion gap at the electrode of the oxygen pump and Nernst concentration cell, where they are brought to thermodynamic balance.

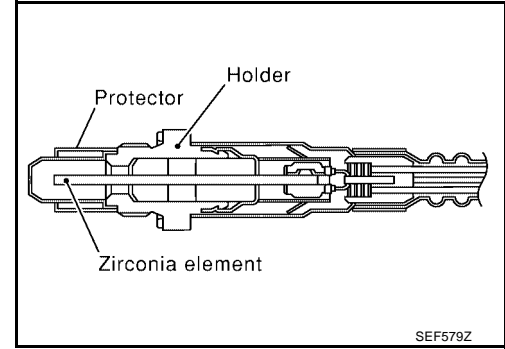

An electronic circuit controls the pump current through the oxygen-pump cell so that the composition of the exhaust gas in the diffusion gap remains constant at $\lambda = 1$. Therefore, the A/F sensor 1 is able to indicate air-fuel ratio by this pumping of current. In addition, a heater is integrated in the sensor to ensure the required operating temperature of 700 - 800°C (1,292 - 1,472°F).

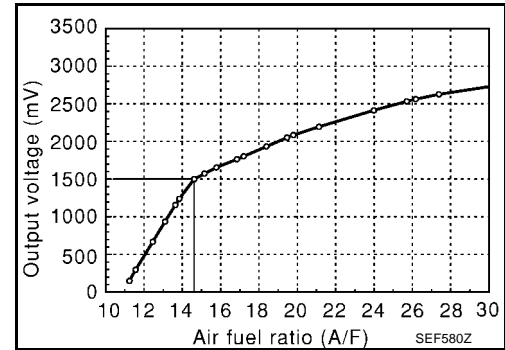

CONSULT-II Reference Value in Data Monitor Mode

Specification data are reference values.

MONITOR ITEM	CONDITION		SPECIFICATION
A/F SEN1 (B1)	<ul style="list-style-type: none"> Engine: After warming up 	Maintaining engine speed at 2,000 rpm	Fluctuates around 1.5V

On Board Diagnosis Logic

To judge the malfunction, the diagnosis checks that the A/F signal computed by ECM from the air fuel ratio (A/F) sensor 1 signal is not inordinately high.

DTC No.	Trouble diagnosis name	DTC detecting condition	Possible Cause
P1272 1272	Air fuel ratio (A/F) sensor 1 circuit no activity detected	<ul style="list-style-type: none"> The A/F signal computed by ECM from the A/F sensor 1 signal is constantly approx. 5V. 	<ul style="list-style-type: none"> Harness or connectors (The sensor circuit is open or shorted.) Air fuel ratio (A/F) sensor 1

DTC Confirmation Procedure

NOTE:

If DTC Confirmation Procedure has been previously conducted, always turn ignition switch OFF and wait at least 10 seconds before conducting the next test.

TESTING CONDITION:

Before performing the following procedure, confirm that battery voltage is more than 11V at idle.

WITH CONSULT-II

1. Start engine and warm it up to normal operating temperature.
2. Select "A/F SEN1 (B1)" in "DATA MONITOR" mode with CONSULT-II.

DTC P1272 A/F SENSOR 1

[QR]

3. Check "A/F SEN1 (B1)" indication.
If the indication is constantly approx. 5V, go to [EC-451, "Diagnostic Procedure"](#).
If the indication is not constantly approx. 5V, go to next step.
4. Turn ignition switch OFF, wait at least 10 seconds and then restart engine.
5. Drive and accelerate vehicle to more than 40 km/h (25 MPH) within 20 seconds after restarting engine.
6. Maintain the following conditions for about 20 consecutive seconds.

DATA MONITOR	
MONITOR	NO DTC
ENG SPEED	XXX rpm
COOLANT TEMP/S	XXX °C
A/F SEN1 (B1)	XXX V

SEF581Z

ENG SPEED	1,000 - 3,200 rpm
VHCL SPEED SE	More than 40 km/h (25 MPH)
B/FUEL SCHDL	1.5 - 9.0 msec
COOLANT TEMP/S	Less than 70°C (158°F)
Shift lever	Suitable position

NOTE:

- Keep the accelerator pedal as steady as possible during the cruising.
- If this procedure is not completed within 1 minute after restarting engine at step 4, return to step 4.

7. If 1st trip DTC is displayed, go to [EC-451, "Diagnostic Procedure"](#).

 **WITH GST**

Follow the procedure "WITH CONSULT-II" above.

A
EC
C
D
E
F
G
H
I
J
K
L
M

DTC P1272 A/F SENSOR 1

[QR]

UBS00C6I

Wiring Diagram

EC-A/F-01

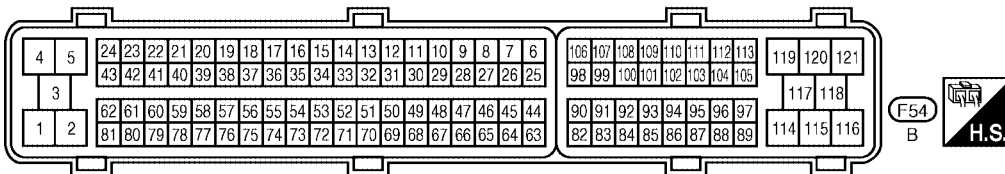
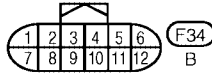
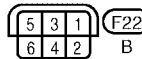
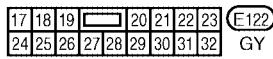
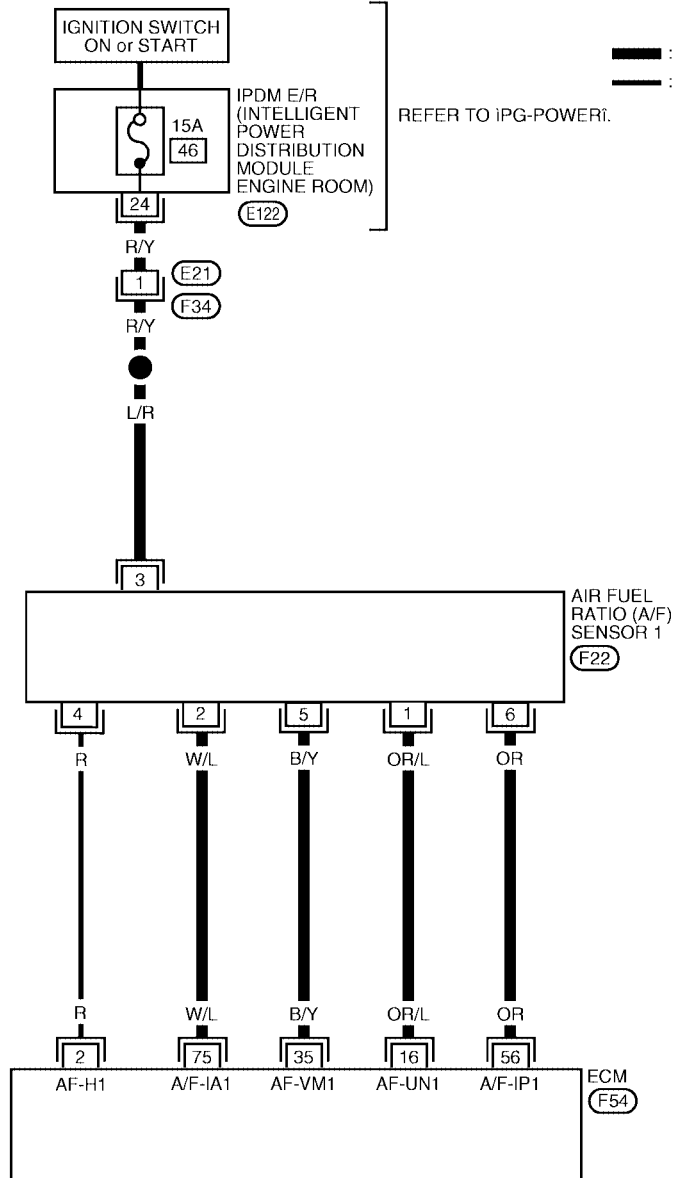

BBWA1242E

DTC P1272 A/F SENSOR 1

[QR]

Specification data are reference values and are measured between each terminal and ground.

CAUTION:

Do not use ECM ground terminals when measuring input/output voltage. Doing so may result in damage to the ECM's transistor. Use a ground other than ECM terminals, such as the ground.

TERMI- NAL NO.	WIRE COLOR	ITEM	CONDITION	DATA (DC Voltage)
16	OR/L	A/F sensor 1	[Engine is running] ● Warm-up condition ● Idle speed	Approximately 3.1V
35	B/Y			Approximately 2.6V
56	OR			2 - 3V
75	W/L			2 - 3V

Diagnostic Procedure

UBS00C6J

1. CHECK GROUND CONNECTIONS

1. Turn ignition switch OFF.
2. Loosen and retighten three ground screws on the body. Refer to [EC-164, "Ground Inspection"](#).

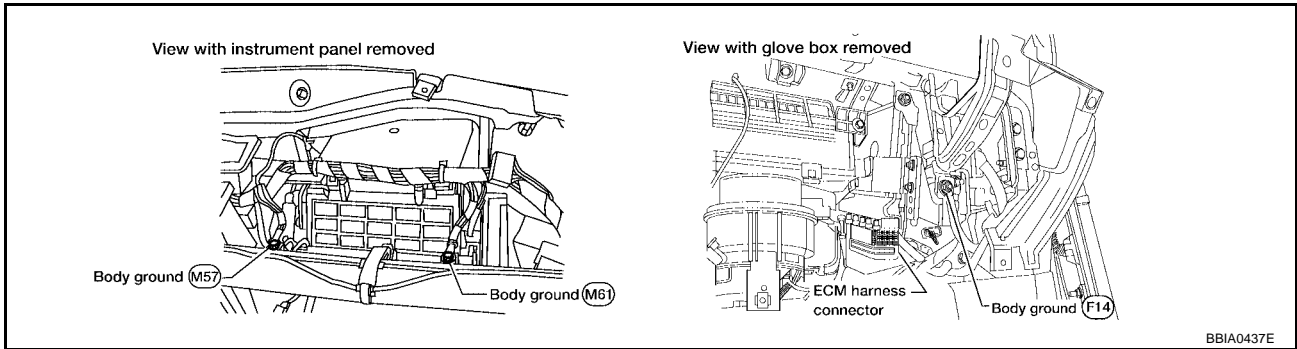

OK or NG

- OK >> GO TO 2.
- NG >> Repair or replace ground connections.

2. CHECK AIR FUEL RATIO (A/F) SENSOR 1 POWER SUPPLY CIRCUIT

1. Disconnect A/F sensor 1 harness connector.
2. Turn ignition switch ON.

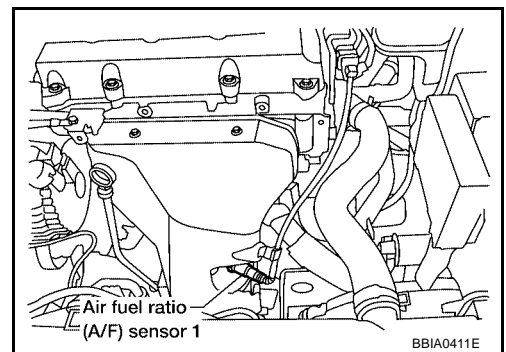

3. Check voltage between A/F sensor 1 terminal 3 and ground with CONSULT-II or tester.

Voltage: Battery voltage

OK or NG

- OK >> GO TO 4.
- NG >> GO TO 3.

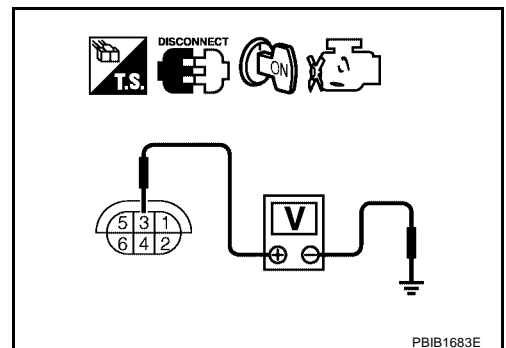

3. DETECT MALFUNCTIONING PART

Check the following.

- Harness connectors E21, F34
- IPDM E/R harness connector E122
- 15A fuse
- Harness for open or short between A/F sensor 1 and fuse

>> Repair or replace harness or connectors.

4. CHECK A/F SENSOR 1 INPUT SIGNAL CIRCUIT FOR OPEN AND SHORT

1. Turn ignition switch OFF.
2. Disconnect ECM harness connector.
3. Check harness continuity between the following terminals. Refer to Wiring Diagram.

A/F sensor 1 terminal	ECM terminal
1	16
5	35
6	56
2	75

Continuity should exist.

4. Check harness continuity between ECM terminals 16, 35, 56, 75 or A/F sensor 1 terminals 1, 2, 5, 6 and ground. Refer to Wiring Diagram.

Continuity should not exist.

5. Also check harness for short to power.

OK or NG

OK >> GO TO 5.

NG >> Repair open circuit or short to ground or short to power in harness or connectors.

5. CHECK INTERMITTENT INCIDENT

Perform [EC-158, "TROUBLE DIAGNOSIS FOR INTERMITTENT INCIDENT"](#) .

OK or NG

OK >> Replace A/F sensor 1.

NG >> Repair or replace.

Removal and Installation AIR FUEL RATIO SENSOR

UBS00C6K

Refer to [EM-24, "EXHAUST MANIFOLD AND THREE WAY CATALYST"](#) .

DTC P1273 A/F SENSOR 1

PFP:22693

UBS00C6L

Component Description

The A/F sensor 1 is a planar dual-cell limit current sensor. The sensor element of the A/F sensor 1 is the combination of a Nernst concentration cell (sensor cell) with an oxygen-pump cell, which transports ions. It has a heater in the element.

The sensor is capable of precise measurement $\lambda = 1$, but also in the lean and rich range. Together with its control electronics, the sensor outputs a clear, continuous signal throughout a wide λ range ($0.7 < \lambda < \text{air}$).

The exhaust gas components diffuse through the diffusion gap at the electrode of the oxygen pump and Nernst concentration cell, where they are brought to thermodynamic balance.

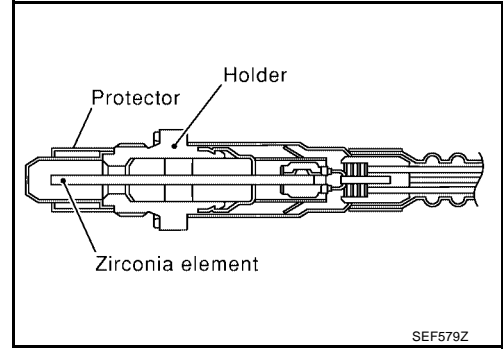

An electronic circuit controls the pump current through the oxygen-pump cell so that the composition of the exhaust gas in the diffusion gap remains constant at $\lambda = 1$. Therefore, the A/F sensor 1 is able to indicate air-fuel ratio by this pumping of current. In addition, a heater is integrated in the sensor to ensure the required operating temperature of 700 - 800°C (1,292 - 1,472°F).

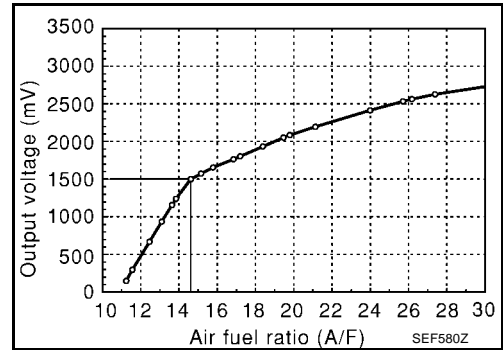

CONSULT-II Reference Value in Data Monitor Mode

UBS00C6M

Specification data are reference values.

MONITOR ITEM	CONDITION		SPECIFICATION
A/F SEN1 (B1)	● Engine: After warming up	Maintaining engine speed at 2,000 rpm	Fluctuates around 1.5V

On Board Diagnosis Logic

UBS00C6N

To judge the malfunction, the A/F signal computed by ECM from the air fuel ratio (A/F) sensor 1 signal is monitored not to be shifted lean side or rich side. When the A/F sensor 1 signal is shifting to the lean side, the malfunction will be detected.

DTC No.	Trouble diagnosis name	DTC detecting condition	Possible Cause
P1273 1273	Air fuel ratio (A/F) sensor 1 lean shift monitoring	● The output voltage computed by ECM from the A/F sensor 1 signal is shifted to the lean side for a specified period.	<ul style="list-style-type: none"> ● Air fuel ratio (A/F) sensor 1 ● Air fuel ratio (A/F) sensor heater 1 ● Fuel pressure ● Fuel injector ● Intake air leaks

DTC Confirmation Procedure

UBS00ELJ

NOTE:

If DTC Confirmation Procedure has been previously conducted, always turn ignition switch OFF and wait at least 10 seconds before conducting the next test.

TESTING CONDITION:

Before performing the following procedure, confirm that battery voltage is more than 11V at idle.

WITH CONSULT-II

1. Start engine and warm it up to normal operating temperature.
2. Turn ignition switch OFF and wait at least 10 seconds.

DTC P1273 A/F SENSOR 1

[QR]

3. Turn ignition switch ON and select "SELF-LEARNING CONT" in "WORK SUPPORT" mode with CONSULT-II.
4. Clear the self-learning coefficient by touching "CLEAR".
5. Turn ignition switch OFF and wait at least 10 seconds.
6. Start engine and keep the engine speed between 3,500 and 4,000 rpm for 1 minute under no load.
7. Let engine idle for 1 minute.
8. Keep engine speed between 2,500 and 3,000 rpm for 20 minutes.
9. If 1st trip DTC is detected, go to [EC-456. "Diagnostic Procedure"](#)

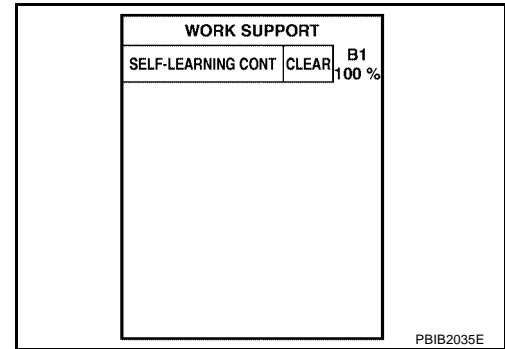

WITH GST

1. Start engine and warm it up to normal operating temperature.
2. Turn ignition switch OFF and wait at least 10 seconds.
3. Disconnect mass air flow sensor harness connector.
4. Start engine and let it idle for at least 5 seconds.
5. Stop engine and reconnect mass air flow sensor harness connector.
6. Select "Service \$03" with GST and make sure that DTC P0102 is detected.
7. Select "Service \$04" with GST and erase the DTC P0102.
8. Start engine and keep the engine speed between 3,500 and 4,000 rpm for 1 minute under no load.
9. Let engine idle for 1 minute.
10. Keep engine speed between 2,500 and 3,000 rpm for 20 minutes.
11. Select "Service \$07" with GST.
If 1st trip DTC is detected, go to [EC-456. "Diagnostic Procedure"](#).

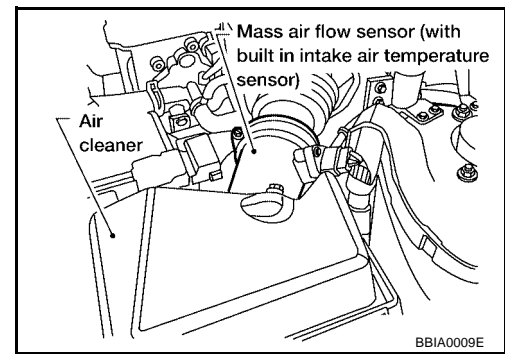

DTC P1273 A/F SENSOR 1

[QR]

Wiring Diagram

UBS00C6Q

EC-A/F-01

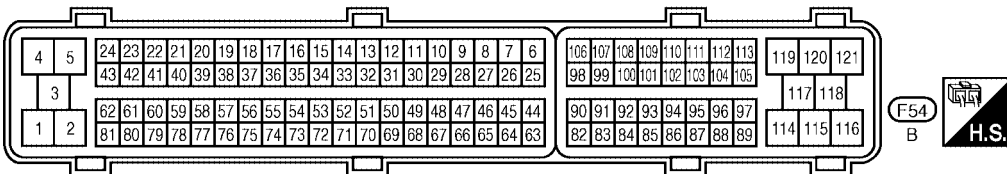
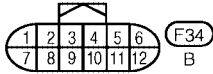
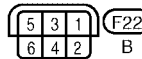
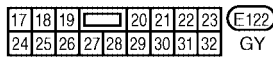
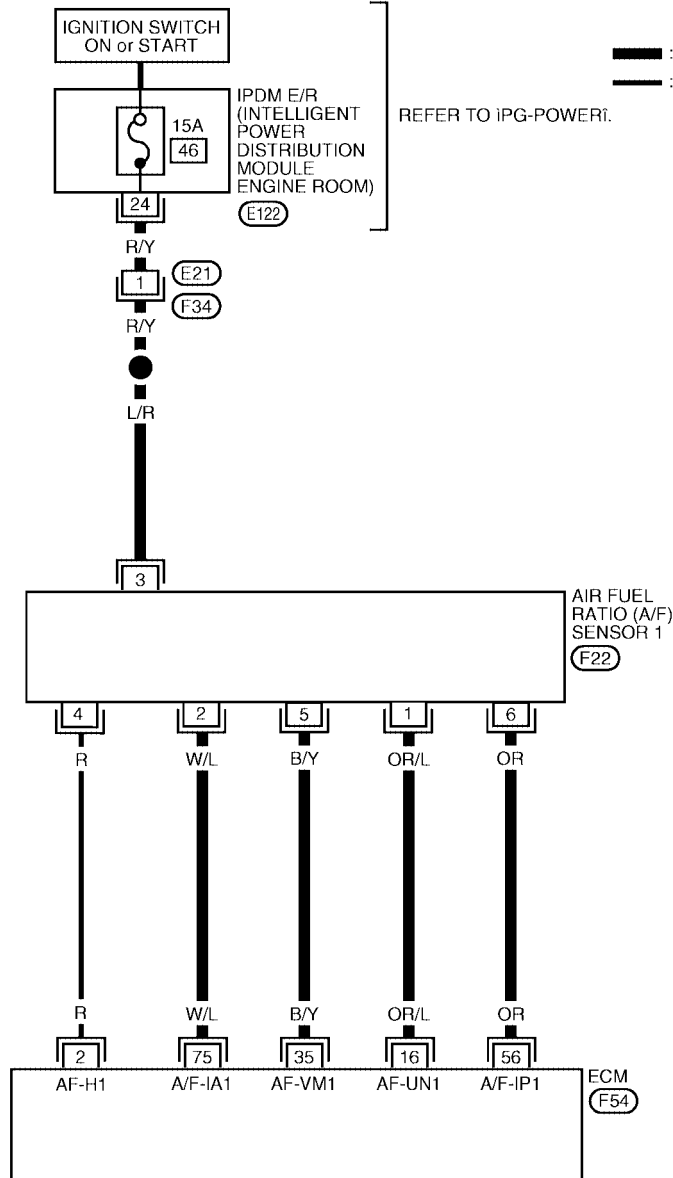

BBWA1242E

DTC P1273 A/F SENSOR 1

[QR]

Specification data are reference values and are measured between each terminal and ground.

CAUTION:

Do not use ECM ground terminals when measuring input/output voltage. Doing so may result in damage to the ECM's transistor. Use a ground other than ECM terminals, such as the ground.

TERMI- NAL NO.	WIRE COLOR	ITEM	CONDITION	DATA (DC Voltage)
16	OR/L	A/F sensor 1	[Engine is running] ● Warm-up condition ● Idle speed	Approximately 3.1V
35	B/Y			Approximately 2.6V
56	OR			2 - 3V
75	W/L			2 - 3V

Diagnostic Procedure

UBS00C6R

1. CHECK GROUND CONNECTIONS

1. Turn ignition switch OFF.
2. Loosen and retighten three ground screws on the body. Refer to [EC-164, "Ground Inspection"](#).

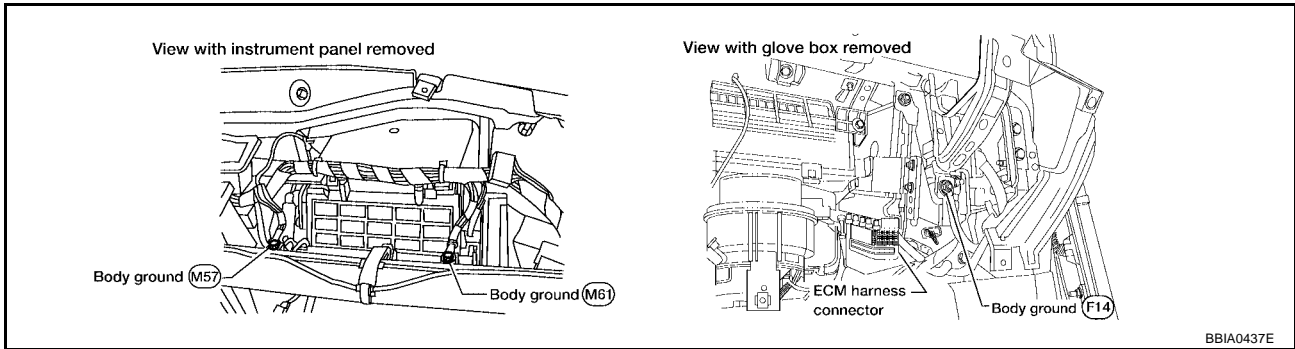

OK or NG

- OK >> GO TO 2.
- NG >> Repair or replace ground connections.

2. RETIGHTEN AIR FUEL RATIO (A/F) SENSOR 1

Loosen and retighten the air fuel ratio (A/F) sensor 1.

Tightening torque: 40 - 60 N-m (4.1 - 6.1 kg-m, 30 - 44 ft-lb)

>> GO TO 3.

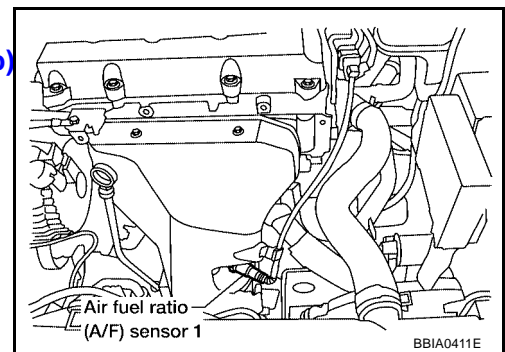

3. CLEAR THE SELF-LEARNING DATA.

With CONSULT-II

1. Start engine and warm it up to normal operating temperature.
2. Select "SELF-LEARNING CONT" in "WORK SUPPORT" mode with CONSULT-II.
3. Clear the self-learning control coefficient by touching "CLEAR".
4. Run engine for at least 10 minutes at idle speed.

Is the 1st trip DTC P0171 detected? Is it difficult to start engine?

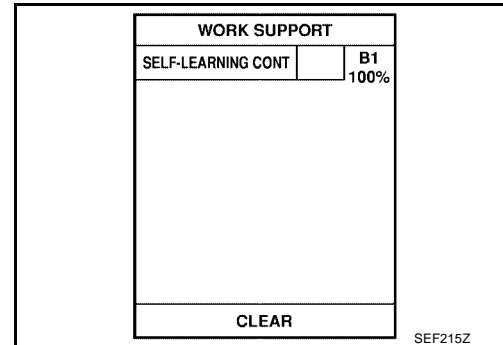

Without CONSULT-II

1. Start engine and warm it up to normal operating temperature.
2. Turn ignition switch OFF.
3. Disconnect mass air flow sensor harness connector, and restart and run engine for at least 3 seconds at idle speed.
4. Stop engine and reconnect mass air flow sensor harness connector.
5. Make sure DTC P0102 is displayed.
6. Erase the DTC memory. Refer to [EC-65, "HOW TO ERASE EMISSION-RELATED DIAGNOSTIC INFORMATION"](#).
7. Make sure DTC P0000 is displayed.
8. Run engine for at least 10 minutes at idle speed.

Is the 1st trip DTC P0171 detected? Is it difficult to start engine?

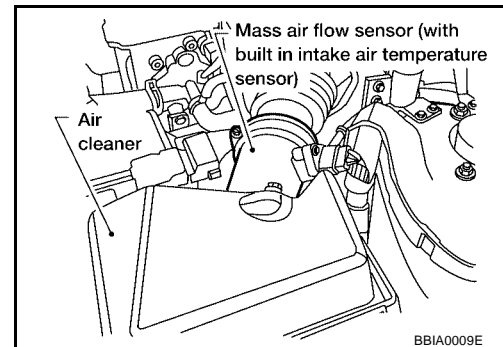

Yes or No

- Yes >> Perform trouble diagnosis for DTC P0171. Refer to [EC-233](#) .
- No >> GO TO 4.

4. CHECK AIR FUEL RATIO (A/F) SENSOR 1 POWER SUPPLY CIRCUIT

1. Turn ignition switch OFF.
2. Disconnect A/F sensor 1 harness connector.
3. Turn ignition switch ON.

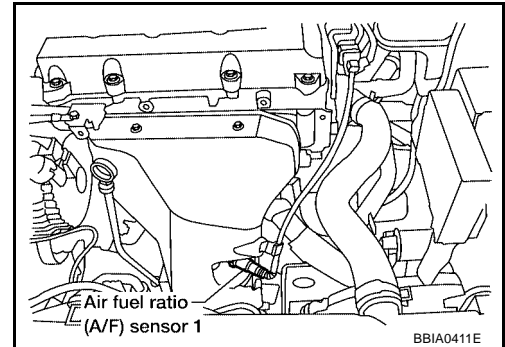

4. Check voltage between A/F sensor 1 terminal 3 and ground with CONSULT-II or tester.

Voltage: Battery voltage

OK or NG

- OK >> GO TO 6.
 NG >> GO TO 5.

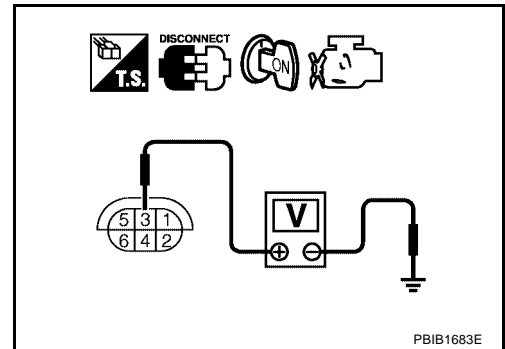

5. DETECT MALFUNCTIONING PART

Check the following.

- Harness connectors E21, F34
- IPDM E/R harness connector E122
- 15A fuse
- Harness for open or short between A/F sensor 1 and fuse

>> Repair or replace harness or connectors.

6. CHECK A/F SENSOR 1 INPUT SIGNAL CIRCUIT FOR OPEN AND SHORT

1. Turn ignition switch OFF.
2. Disconnect ECM harness connector.
3. Check harness continuity between the following terminals. Refer to Wiring Diagram.

A/F sensor 1 terminal	ECM terminal
1	16
5	35
6	56
2	75

Continuity should exist.

4. Check harness continuity between ECM terminals 16, 35, 56, 75 or A/F sensor 1 terminals 1, 2, 5, 6 and ground. Refer to Wiring Diagram.

Continuity should not exist.

5. Also check harness for short to power.

OK or NG

OK >> GO TO 7.

NG >> Repair open circuit or short to ground or short to power in harness or connectors.

7. CHECK A/F SENSOR 1 HEATER

Refer to [EC-377, "Component Inspection"](#) .

OK or NG

OK >> GO TO 8.

NG >> Replace A/F sensor 1.

8. CHECK INTERMITTENT INCIDENT

Perform [EC-158, "TROUBLE DIAGNOSIS FOR INTERMITTENT INCIDENT"](#) .

OK or NG

OK >> Replace A/F sensor 1.

NG >> Repair or replace.

**Removal and Installation
AIR FUEL RATIO SENSOR**

Refer to [EM-24, "EXHAUST MANIFOLD AND THREE WAY CATALYST"](#) .

UBS00C6S

DTC P1274 A/F SENSOR 1

PFP:22693

Component Description

UBS00C6T

The A/F sensor 1 is a planar dual-cell limit current sensor. The sensor element of the A/F sensor 1 is the combination of a Nernst concentration cell (sensor cell) with an oxygen-pump cell, which transports ions. It has a heater in the element.

The sensor is capable of precise measurement $\lambda = 1$, but also in the lean and rich range. Together with its control electronics, the sensor outputs a clear, continuous signal throughout a wide λ range ($0.7 < \lambda < \text{air}$).

The exhaust gas components diffuse through the diffusion gap at the electrode of the oxygen pump and Nernst concentration cell, where they are brought to thermodynamic balance.

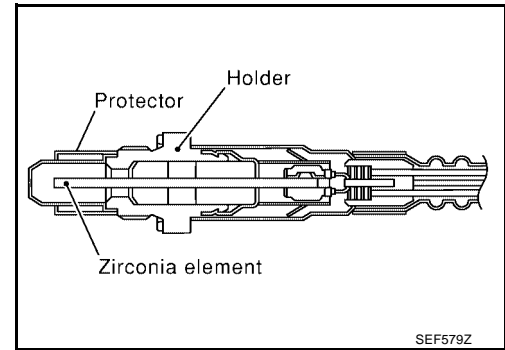

An electronic circuit controls the pump current through the oxygen-pump cell so that the composition of the exhaust gas in the diffusion gap remains constant at $\lambda = 1$. Therefore, the A/F sensor 1 is able to indicate air-fuel ratio by this pumping of current. In addition, a heater is integrated in the sensor to ensure the required operating temperature of 700 - 800°C (1,292 - 1,472°F).

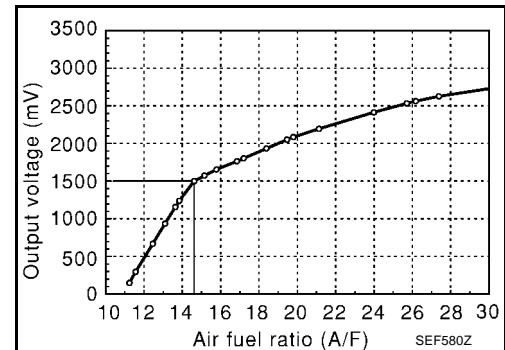

CONSULT-II Reference Value in Data Monitor Mode

UBS00C6U

Specification data are reference values.

MONITOR ITEM	CONDITION		SPECIFICATION
A/F SEN1 (B1)	● Engine: After warming up	Maintaining engine speed at 2,000 rpm	Fluctuates around 1.5V

On Board Diagnosis Logic

UBS00C6V

To judge the malfunction, the A/F signal computed by ECM from the air fuel ratio (A/F) sensor 1 signal is monitored not to be shifted to the lean side or rich side. When the A/F sensor 1 signal is shifting to the rich side, the malfunction will be detected.

DTC No.	Trouble diagnosis name	DTC detecting condition	Possible Cause
P1274 1274	Air fuel ratio (A/F) sensor 1 rich shift monitoring	● The A/F signal computed by ECM from the A/F sensor 1 signal is shifted to the rich side for a specified period.	<ul style="list-style-type: none"> ● Air fuel ratio (A/F) sensor 1 ● Air fuel ratio (A/F) sensor heater 1 ● Fuel pressure ● Fuel Injector

DTC Confirmation Procedure

UBS00ELK

NOTE:

If DTC Confirmation Procedure has been previously conducted, always turn ignition switch OFF and wait at least 10 seconds before conducting the next test.

TESTING CONDITION:

Before performing the following procedure, confirm that battery voltage is more than 11V at idle.

WITH CONSULT-II

1. Start engine and warm it up to normal operating temperature.
2. Turn ignition switch OFF and wait at least 10 seconds.
3. Turn ignition switch ON and select "SELF-LEARNING CONT" in "WORK SUPPORT" mode with CONSULT-II.

DTC P1274 A/F SENSOR 1

[QR]

4. Clear the self-learning coefficient by touching "CLEAR".
5. Turn ignition switch OFF and wait at least 10 seconds.
6. Start engine and keep the engine speed between 3,500 and 4,000 rpm for 1 minute under no load.
7. Let engine idle for 1 minute.
8. Keep engine speed between 2,500 and 3,000 rpm for 20 minutes.
9. If 1st trip DTC is detected, go to [EC-463, "Diagnostic Procedure"](#)

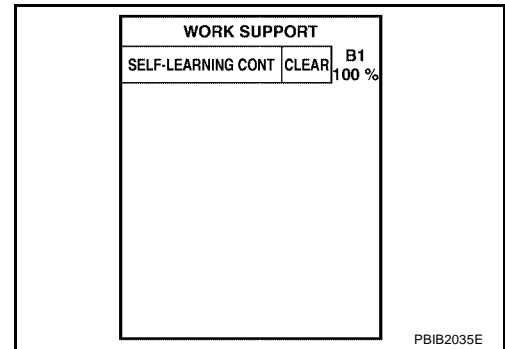

WITH GST

1. Start engine and warm it up to normal operating temperature.
2. Turn ignition switch OFF and wait at least 10 seconds.
3. Disconnect mass air flow sensor harness connector.
4. Start engine and let it idle for at least 5 seconds.
5. Stop engine and reconnect mass air flow sensor harness connector.
6. Select "Service \$03" with GST and make sure that DTC P0102 is detected.
7. Select "Service \$04" with GST and erase the DTC P0102.
8. Start engine and keep the engine speed between 3,500 and 4,000 rpm for 1 minute under no load.
9. Let engine idle for 1 minute.
10. Keep engine speed between 2,500 and 3,000 rpm for 20 minutes.
11. Select "Service \$07" with GST.
If 1st trip DTC is detected, go to [EC-463, "Diagnostic Procedure"](#) .

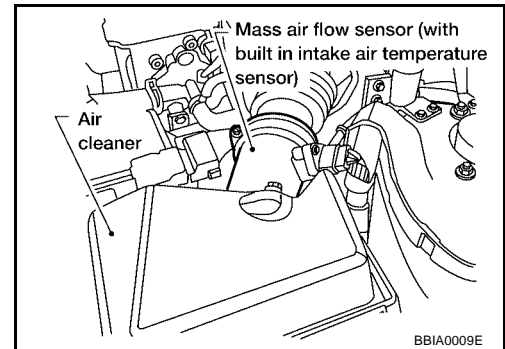

DTC P1274 A/F SENSOR 1

[QR]

Wiring Diagram

UBS00C6Y

EC-A/F-01

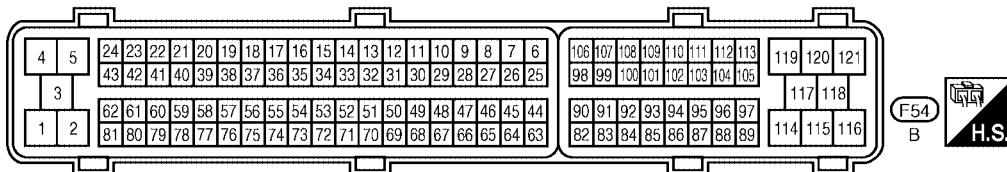
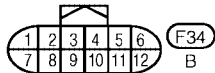
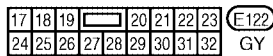
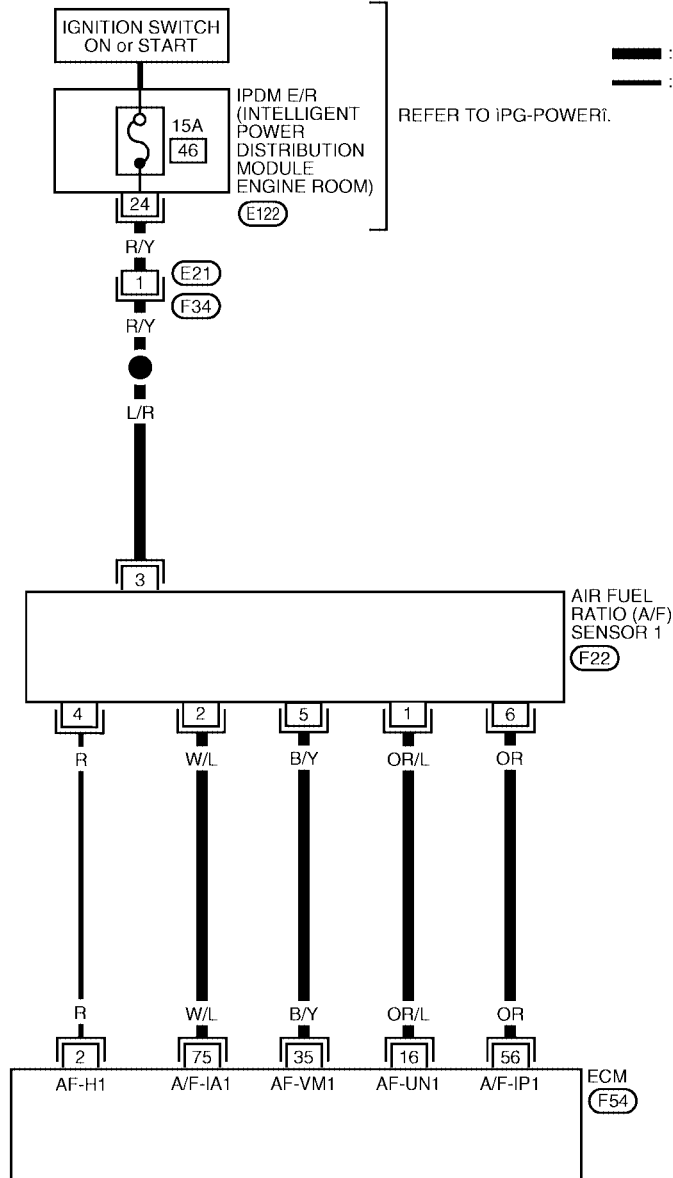

BBWA1242E

DTC P1274 A/F SENSOR 1

[QR]

Specification data are reference values and are measured between each terminal and ground.

CAUTION:

Do not use ECM ground terminals when measuring input/output voltage. Doing so may result in damage to the ECM's transistor. Use a ground other than ECM terminals, such as the ground.

TERMI- NAL NO.	WIRE COLOR	ITEM	CONDITION	DATA (DC Voltage)
16	OR/L	A/F sensor 1	[Engine is running] ● Warm-up condition ● Idle speed	Approximately 3.1V
35	B/Y			Approximately 2.6V
56	OR			2 - 3V
75	W/L			2 - 3V

Diagnostic Procedure

UBS00C6Z

1. CHECK GROUND CONNECTIONS

1. Turn ignition switch OFF.
2. Loosen and retighten three ground screws on the body. Refer to [EC-164, "Ground Inspection"](#).

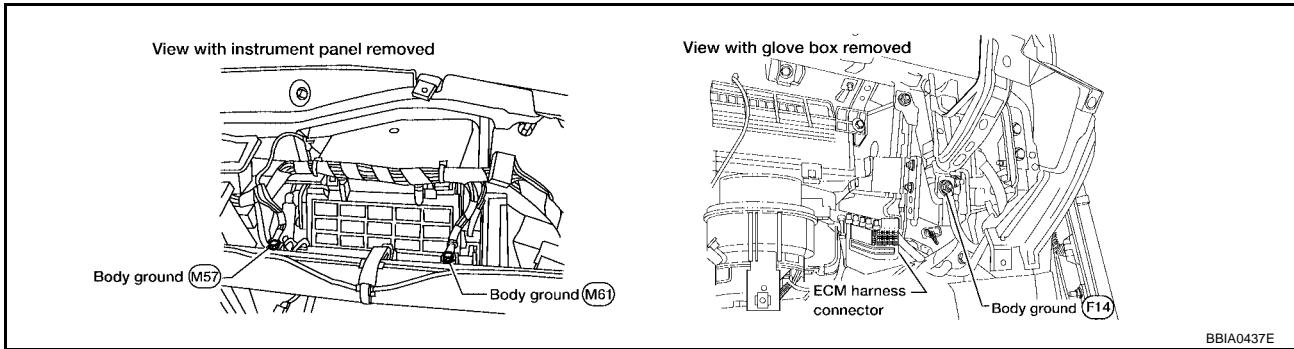

OK or NG

- OK >> GO TO 2.
- NG >> Repair or replace ground connections.

2. RETIGHTEN AIR FUEL RATIO (A/F) SENSOR 1

Loosen and retighten the air fuel ratio (A/F) sensor 1.

Tightening torque: 40 - 60 N-m (4.1 - 6.1 kg-m, 30 - 44 ft-lb)

>> GO TO 3.

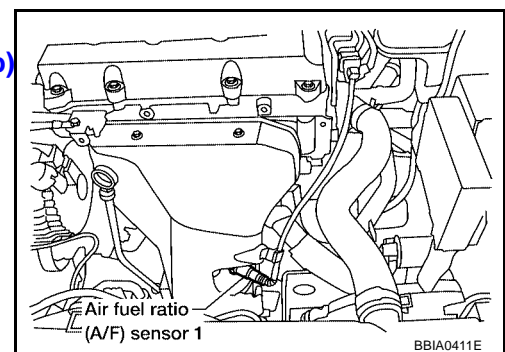

3. CLEAR THE SELF-LEARNING DATA

With CONSULT-II

1. Start engine and warm it up to normal operating temperature.
2. Select "SELF-LEARNING CONT" in "WORK SUPPORT" mode with CONSULT-II.
3. Clear the self-learning control coefficient by touching "CLEAR".
4. Run engine for at least 10 minutes at idle speed.
Is the 1st trip DTC P0172 detected? Is it difficult to start engine?

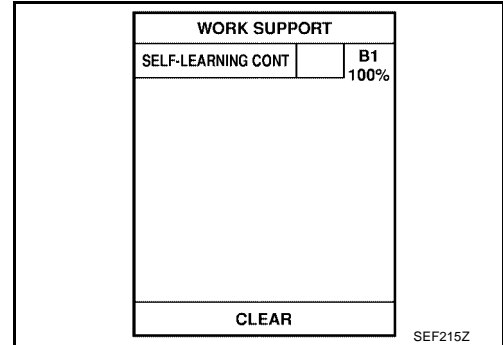

Without CONSULT-II

1. Start engine and warm it up to normal operating temperature.
2. Turn ignition switch OFF.
3. Disconnect mass air flow sensor harness connector, and restart and run engine for at least 3 seconds at idle speed.
4. Stop engine and reconnect mass air flow sensor harness connector.
5. Make sure DTC P0102 is displayed.
6. Erase the DTC memory. Refer to [EC-65, "HOW TO ERASE EMISSION-RELATED DIAGNOSTIC INFORMATION"](#).
7. Make sure DTC P0000 is displayed.
8. Run engine for at least 10 minutes at idle speed.
Is the 1st trip DTC P0172 detected? Is it difficult to start engine?

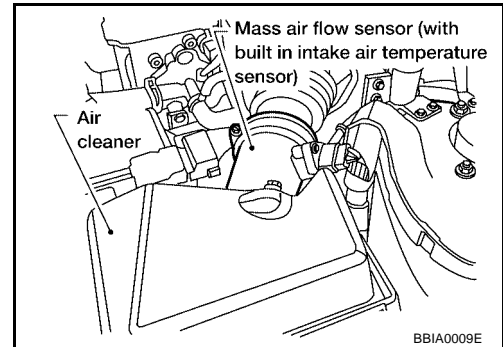

Yes or No

- Yes >> Perform trouble diagnosis for DTC P0172. Refer to [EC-240](#) .
- No >> GO TO 4.

4. CHECK HARNESS CONNECTOR

1. Turn ignition switch OFF.
2. Disconnect A/F sensor 1 harness connector.
3. Check harness connector for water.
Water should not exit.

OK or NG

- OK >> GO TO 5.
- NG >> Repair or replace harness connector.

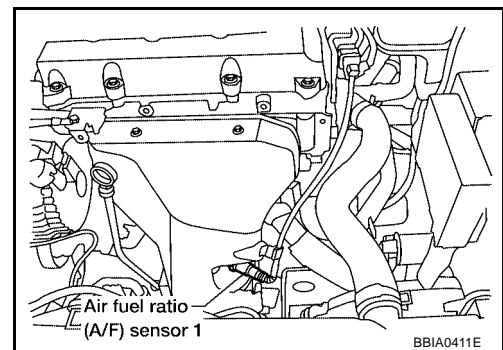

5. CHECK AIR FUEL RATIO (A/F) SENSOR 1 POWER SUPPLY CIRCUIT

1. Turn ignition switch ON.
2. Check voltage between A/F sensor 1 terminal 3 and ground with CONSULT-II or tester.

Voltage: Battery voltage

OK or NG

- OK >> GO TO 7.
- NG >> GO TO 6.

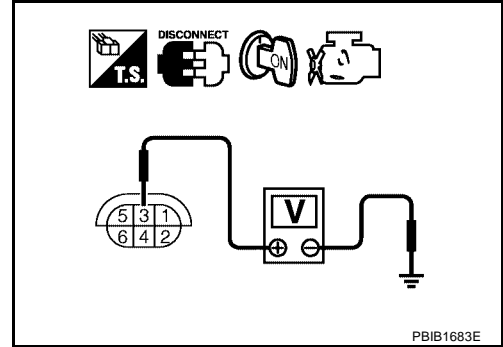

6. DETECT MALFUNCTIONING PART

Check the following.

- Harness connectors E21, F34
- IPDM E/R harness connector E122
- 15A fuse
- Harness for open or short between A/F sensor 1 and fuse

>> Repair or replace harness or connectors.

7. CHECK A/F SENSOR 1 INPUT SIGNAL CIRCUIT FOR OPEN AND SHORT

1. Turn ignition switch OFF.
2. Disconnect ECM harness connector.
3. Check harness continuity between the following terminals. Refer to Wiring Diagram.

A/F sensor 1 terminal	ECM terminal
1	16
5	35
6	56
2	75

Continuity should exist.

4. Check harness continuity between ECM terminals 16, 35, 56, 75 or A/F sensor 1 terminals 1, 2, 5, 6 and ground. Refer to Wiring Diagram.

Continuity should not exist.

5. Also check harness for short to power.

OK or NG

- OK >> GO TO 8.
- NG >> Repair open circuit or short to ground or short to power in harness or connectors.

8. CHECK A/F SENSOR 1 HEATER

Refer to [EC-377, "Component Inspection"](#) .

OK or NG

- OK >> GO TO 9.
- NG >> Replace A/F sensor 1.

9. CHECK INTERMITTENT INCIDENT

Perform [EC-158, "TROUBLE DIAGNOSIS FOR INTERMITTENT INCIDENT"](#) .

OK or NG

OK >> Replace A/F sensor 1.

NG >> Repair or replace.

Removal and Installation
AIR FUEL RATIO SENSOR

UBS00C70

Refer to [EM-24, "EXHAUST MANIFOLD AND THREE WAY CATALYST"](#) .

DTC P1276 A/F SENSOR 1

PFP:22693

UBS00C71

Component Description

The A/F sensor 1 is a planar dual-cell limit current sensor. The sensor element of the A/F sensor 1 is the combination of a Nernst concentration cell (sensor cell) with an oxygen-pump cell, which transports ions. It has a heater in the element.

The sensor is capable of precise measurement $\lambda = 1$, but also in the lean and rich range. Together with its control electronics, the sensor outputs a clear, continuous signal throughout a wide λ range ($0.7 < \lambda < \text{air}$).

The exhaust gas components diffuse through the diffusion gap at the electrode of the oxygen pump and Nernst concentration cell, where they are brought to thermodynamic balance.

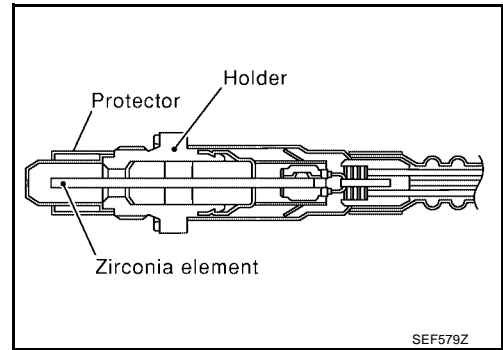

An electronic circuit controls the pump current through the oxygen-pump cell so that the composition of the exhaust gas in the diffusion gap remains constant at $\lambda = 1$. Therefore, the A/F sensor 1 is able to indicate air-fuel ratio by this pumping of current. In addition, a heater is integrated in the sensor to ensure the required operating temperature of 700 - 800°C (1,292 - 1,472°F).

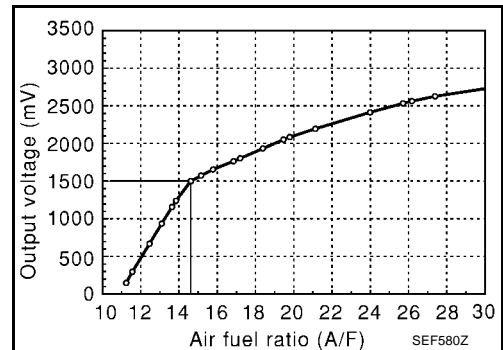

CONSULT-II Reference Value in Data Monitor Mode

UBS00C72

Specification data are reference values.

MONITOR ITEM	CONDITION	SPECIFICATION
A/F SEN1 (B1)	<ul style="list-style-type: none"> Engine: After warming up Maintaining engine speed at 2,000 rpm	Fluctuates around 1.5V

On Board Diagnosis Logic

UBS00C73

To judge the malfunction, the diagnosis checks that the A/F signal computed by ECM from the air fuel ratio (A/F) sensor 1 signal fluctuates according to fuel feedback control.

DTC No.	Trouble diagnosis name	DTC detecting condition	Possible Cause
P1276 1276	Air fuel ratio (A/F) sensor 1 circuit high voltage	<ul style="list-style-type: none"> The A/F signal computed by ECM from the A/F sensor 1 signal is constantly approx. 1.5V. 	<ul style="list-style-type: none"> Harness or connectors (The sensor circuit is open or shorted.) Air fuel ratio (A/F) sensor 1

DTC Confirmation Procedure

UBS00ELL

CAUTION:

Always drive vehicle at a safe speed.

NOTE:

If DTC Confirmation Procedure has been previously conducted, always turn ignition switch OFF and wait at least 10 seconds before conducting the next test.

TESTING CONDITION:

Before performing the following procedure, confirm that battery voltage is more than 11V at idle.

Ⓟ WITH CONSULT-II

- Start engine and warm it up to normal operating temperature.
- Select "A/F SEN1 (B1)" in "DATA MONITOR" mode with CONSULT-II.
- Check "A/F SEN1 (B1)" indication.
If the indication is constantly approx. 1.5V and does not fluctuates, go to [EC-471, "Diagnostic Procedure"](#).

DTC P1276 A/F SENSOR 1

[QR]

If the indication fluctuates around 1.5V, go to next step.

4. Select "A/F SEN1 (B1) P1276" of "A/F SEN1" in "DTC WORK SUPPORT" mode with CONSULT-II.
5. Touch "START".
6. When the following conditions are met, "TESTING" will be displayed on the CONSULT-II screen.

ENG SPEED	1,750 - 2,600 rpm
Vehicle speed	More than 64 km/h (40 MPH)
B/FUEL SCHDL	1.0 - 8.0 msec
COOLANT TEMP/S	More than 70°C (158°F)
Shift lever	D position with OD ON (A/T models)
	5th position (M/T models)

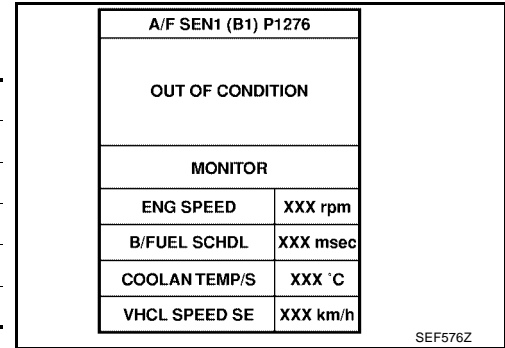

If "TESTING" is not displayed after 20 seconds, retry from step 2.

7. Release accelerator pedal fully.

NOTE:

Never apply brake during releasing the accelerator pedal.

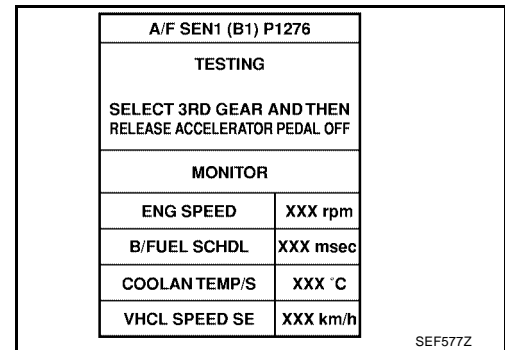

8. Make sure that "TESTING" changes to "COMPLETED".
If "TESTING" changed to "OUT OF CONDITION", retry from step 6.
9. Make sure that "OK" is displayed after touching "SELF-DIAG RESULT".
If "NG" is displayed, go to [EC-471, "Diagnostic Procedure"](#).

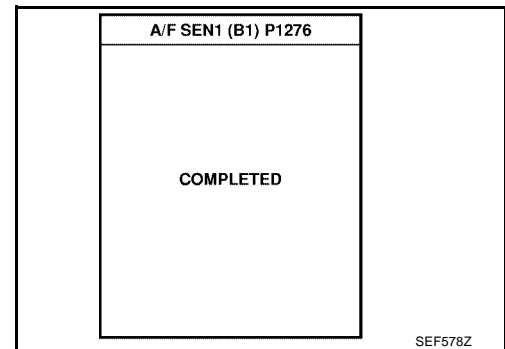

Overall Function Check

UBS00ELM

Use this procedure to check the overall function of the A/F sensor 1 circuit. During this check, a 1st trip DTC might not be confirmed.

 **WITH GST**

1. Start engine and warm it up to normal operating temperature.
2. Drive the vehicle at a speed of 80 km/h (50 MPH) for a few minutes in the suitable gear position.
3. Set D position with "OD" ON (A/T) or 5th position (M/T), then release the accelerator pedal fully until the vehicle speed decreases to 50 km/h (30 MPH).

NOTE:

Never apply brake during releasing the accelerator pedal.

4. Repeat steps 2 to 3 five times.
5. Stop the vehicle and turn ignition switch OFF.
6. Wait at least 10 seconds and restart engine.
7. Repeat steps 2 to 3 five times.

DTC P1276 A/F SENSOR 1

[QR]

-
8. Stop the vehicle and connect GST to the vehicle.
 9. Make sure that no 1st trip DTC is displayed.
If the 1st trip DTC is displayed, go to [EC-471, "Diagnostic Procedure"](#).

A

EC

C

D

E

F

G

H

I

J

K

L

M

DTC P1276 A/F SENSOR 1

[QR]

UBS00C76

Wiring Diagram

EC-A/F-01

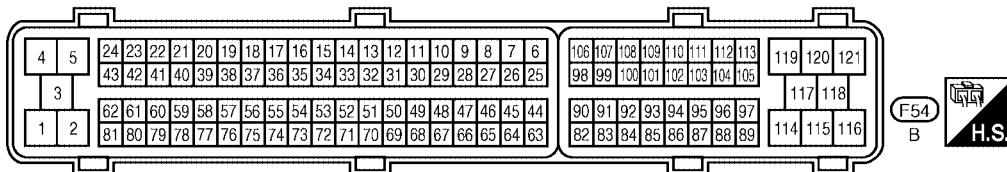
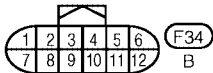
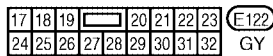
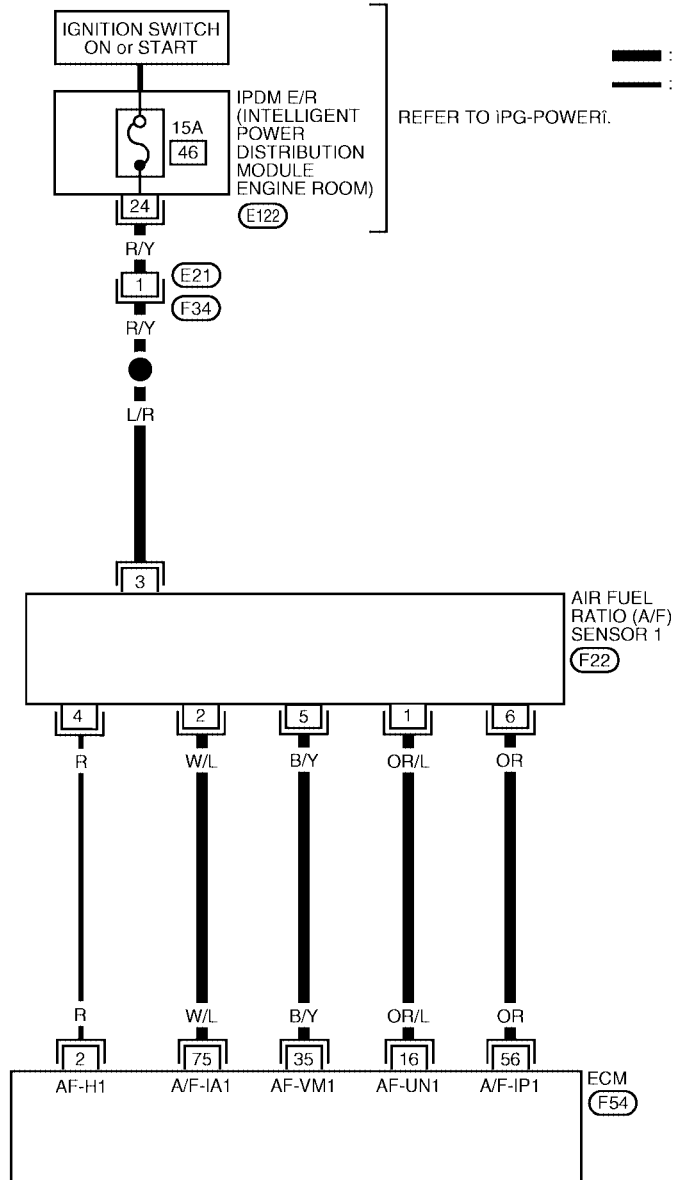

BBWA1242E

DTC P1276 A/F SENSOR 1

[QR]

Specification data are reference values and are measured between each terminal and ground.

CAUTION:

Do not use ECM ground terminals when measuring input/output voltage. Doing so may result in damage to the ECM's transistor. Use a ground other than ECM terminals, such as the ground.

TERMI- NAL NO.	WIRE COLOR	ITEM	CONDITION	DATA (DC Voltage)
16	OR/L	A/F sensor 1	[Engine is running] ● Warm-up condition ● Idle speed	Approximately 3.1V
35	B/Y			Approximately 2.6V
56	OR			2 - 3V
75	W/L			2 - 3V

Diagnostic Procedure

UBS00C77

1. CHECK GROUND CONNECTIONS

- Turn ignition switch OFF.
- Loosen and retighten three ground screws on the body. Refer to [EC-164, "Ground Inspection"](#).

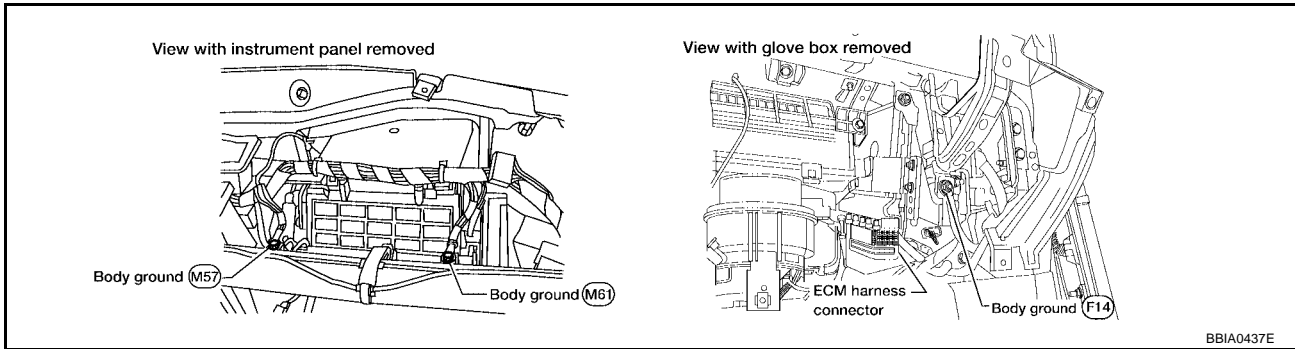

OK or NG

- OK >> GO TO 2.
- NG >> Repair or replace ground connections.

2. CHECK AIR FUEL RATIO (A/F) SENSOR 1 POWER SUPPLY CIRCUIT

- Disconnect A/F sensor 1 harness connector.
- Turn ignition switch ON.

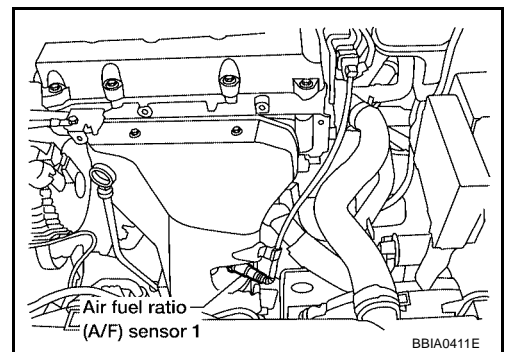

- Check voltage between A/F sensor 1 terminal 3 and ground with CONSULT-II or tester.

Voltage: Battery voltage

OK or NG

- OK >> GO TO 4.
- NG >> GO TO 3.

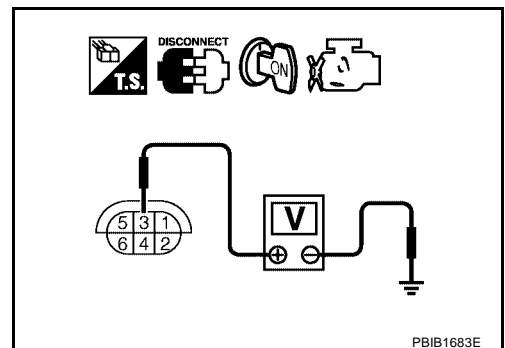

3. DETECT MALFUNCTIONING PART

Check the following.

- Harness connectors E21, F34
- IPDM E/R harness connector E122
- 15A fuse
- Harness for open or short between A/F sensor 1 and fuse

>> Repair or replace harness or connectors.

4. CHECK A/F SENSOR 1 INPUT SIGNAL CIRCUIT FOR OPEN AND SHORT

1. Turn ignition switch OFF.
2. Disconnect ECM harness connector.
3. Check harness continuity between the following terminals. Refer to Wiring Diagram.

A/F sensor 1 terminal	ECM terminal
1	16
5	35
6	56
2	75

Continuity should exist.

4. Check harness continuity between ECM terminals 16, 35, 56, 75 or A/F sensor 1 terminals 1, 2, 5, 6 and ground. Refer to Wiring Diagram.

Continuity should not exist.

5. Also check harness for short to power.

OK or NG

OK >> GO TO 5.

NG >> Repair open circuit or short to ground or short to power in harness or connectors.

5. CHECK INTERMITTENT INCIDENT

Perform [EC-158, "TROUBLE DIAGNOSIS FOR INTERMITTENT INCIDENT"](#) .

OK or NG

OK >> Replace A/F sensor 1.

NG >> Repair or replace.

Removal and Installation AIR FUEL RATIO SENSOR

UBS00C78

Refer to [EM-24, "EXHAUST MANIFOLD AND THREE WAY CATALYST"](#)

DTC P1278 A/F SENSOR 1

Component Description

The A/F sensor 1 is a planar dual-cell limit current sensor. The sensor element of the A/F sensor 1 is the combination of a Nernst concentration cell (sensor cell) with an oxygen-pump cell, which transports ions. It has a heater in the element.

The sensor is capable of precise measurement $\lambda = 1$, but also in the lean and rich range. Together with its control electronics, the sensor outputs a clear, continuous signal throughout a wide λ range ($0.7 < \lambda < \text{air}$).

The exhaust gas components diffuse through the diffusion gap at the electrode of the oxygen pump and Nernst concentration cell, where they are brought to thermodynamic balance.

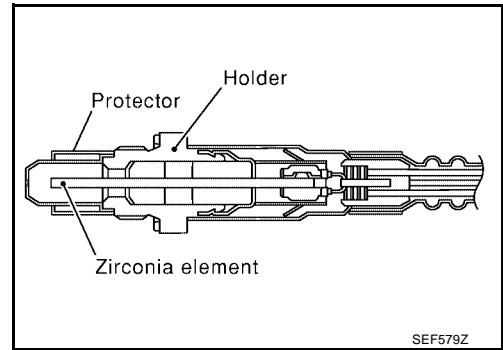

An electronic circuit controls the pump current through the oxygen-pump cell so that the composition of the exhaust gas in the diffusion gap remains constant at $\lambda = 1$. Therefore, the A/F sensor 1 is able to indicate air-fuel ratio by this pumping of current. In addition, a heater is integrated in the sensor to ensure the required operating temperature of 700 - 800°C (1,292 - 1,472°F).

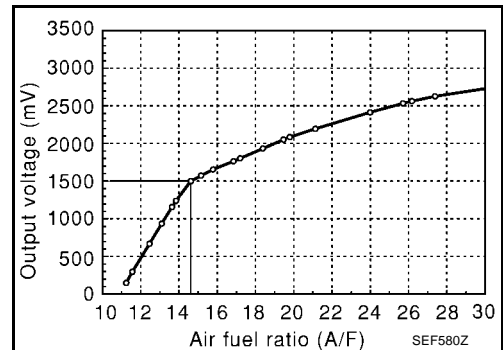

CONSULT-II Reference Value in Data Monitor Mode

Specification data are reference values.

MONITOR ITEM	CONDITION		SPECIFICATION
A/F SEN1 (B1)	● Engine: After warming up	Maintaining engine speed at 2,000 rpm	Fluctuates around 1.5V

On Board Diagnosis Logic

To judge the malfunction of air fuel ratio (A/F) sensor 1, this diagnosis measures response time of the A/F signal computed by ECM from the air fuel ratio (A/F) sensor 1 signal. The time is compensated by engine operating (speed and load), fuel feedback control constant, and the air fuel ratio (A/F) sensor 1 temperature index. Judgment is based on whether the compensated time (the A/F sensor 1 signal cycling time index) is inordinately long or not.

DTC No.	Trouble diagnosis name	DTC detecting condition	Possible Cause
P1278 1278	Air fuel ratio (A/F) sensor 1 circuit slow response	● The response (from RICH to LEAN) of the A/F signal computed by ECM from A/F sensor 1 signal takes more than the specified time.	<ul style="list-style-type: none"> ● Harness or connectors (The sensor circuit is open or shorted.) ● Air fuel ratio (A/F) sensor 1 ● Air fuel ratio (A/F) sensor heater 1 ● Fuel pressure ● Fuel Injector ● Intake air leaks ● Exhaust gas leaks ● PCV ● Mass air flow sensor

DTC Confirmation Procedure

NOTE:

If DTC Confirmation Procedure has been previously conducted, always turn ignition switch OFF and wait at least 10 seconds before conducting the next test.

TESTING CONDITION:

Before performing the following procedure, confirm that battery voltage is more than 11V at idle.

WITH CONSULT-II

1. Start engine and warm it up to normal operating temperature.
2. Turn ignition switch OFF and wait at least 10 seconds.
3. Start engine and keep the engine speed between 3,500 and 4,000 rpm for at least 1 minute under no load.
4. Let engine idle for 1 minute.
5. Select "A/F SEN1(B1) P1278/P1279" of "A/F SEN1" in "DTC WORK SUPPORT" mode with CONSULT-II.
6. Touch "START".
If "COMPLETED" appears on CONSULT-II screen, go to step 10.
If "COMPLETED" does not appear on CONSULT-II screen, go to the following step.

A/F SEN1 (B1) P1278/P1279	
OUT OF CONDITION	
MONITOR	
ENG SPEED	XXX rpm
B/FUEL SCHDL	XXX msec
COOLAN TEMP/S	XXX °C
VHCL SPEED SE	XXX km/h
PBIB0756E	

7. After perform the following procedure, "TESTING" will be displayed on the CONSULT-II screen.
 - a. Increase the engine speed up to 4,000 to 5,000 rpm and keep it for 10 seconds.
 - b. Fully release accelerator pedal and then let engine idle for about 10 seconds.
If "TESTING" is not displayed after 10 seconds, refer to [EC-148, "TROUBLE DIAGNOSIS - SPECIFICATION VALUE"](#).
8. Wait for about 20 seconds at idle at under the condition that "TESTING" is displayed on the CONSULT-II screen.

A/F SEN1 (B1) P1278/P1279	
TESTING	
MONITOR	
ENG SPEED	XXX rpm
B/FUEL SCHDL	XXX msec
COOLAN TEMP/S	XXX °C
VHCL SPEED SE	XXX km/h
PBIB1925E	

9. Make sure that "TESTING" changes to "COMPLETED".
If "TESTING" changed to "OUT OF CONDITION", refer to [EC-148, "TROUBLE DIAGNOSIS - SPECIFICATION VALUE"](#).
10. Make sure that "OK" is displayed after touching "SELF-DIAG RESULT".
If "NG" is displayed, go to [EC-477, "Diagnostic Procedure"](#).

A/F SEN1 (B1) P1278/P1279	
COMPLETED	
PBIB0758E	

WITH GST

1. Start engine and warm it up to normal operating temperature.
2. Select "Service \$01" with GST.
3. Calculate the total value of "Short term fuel trim" and "Long term fuel trim" indications.
Make sure that the total percentage should be within $\pm 15\%$.
If OK, go to the following step.
If NG, check the following.
 - Intake air leaks

DTC P1278 A/F SENSOR 1

[QR]

-
- Exhaust gas leaks
 - Incorrect fuel pressure
 - Lack of fuel
 - Injectors
 - Incorrect PCV hose connection
 - PCV valve
 - Mass air flow sensor
4. Turn ignition switch OFF and wait at least 10 seconds.
 5. Start engine and keep the engine speed between 3,500 and 4,000 rpm for at least 1 minute under no load.
 6. Let engine idle for 1 minute.
 7. Increase the engine speed up to 4,000 to 5,000 rpm and keep it for 10 seconds.
 8. Fully release accelerator pedal and then let engine idle for about 1 minute.
 9. Select "Service \$07" with GST.
If 1st trip DTC is detected, go to [EC-477, "Diagnostic Procedure"](#) .

A

EC

C

D

E

F

G

H

I

J

K

L

M

DTC P1278 A/F SENSOR 1

[QR]

Wiring Diagram

UBS00C7E

EC-A/F-01

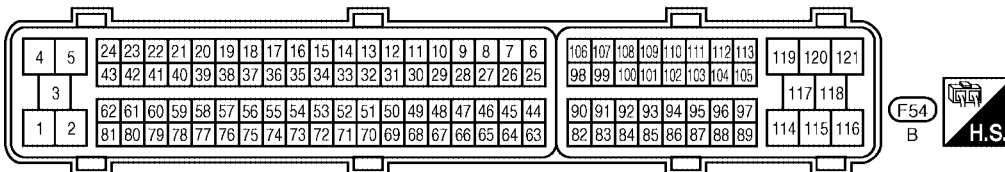
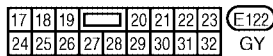
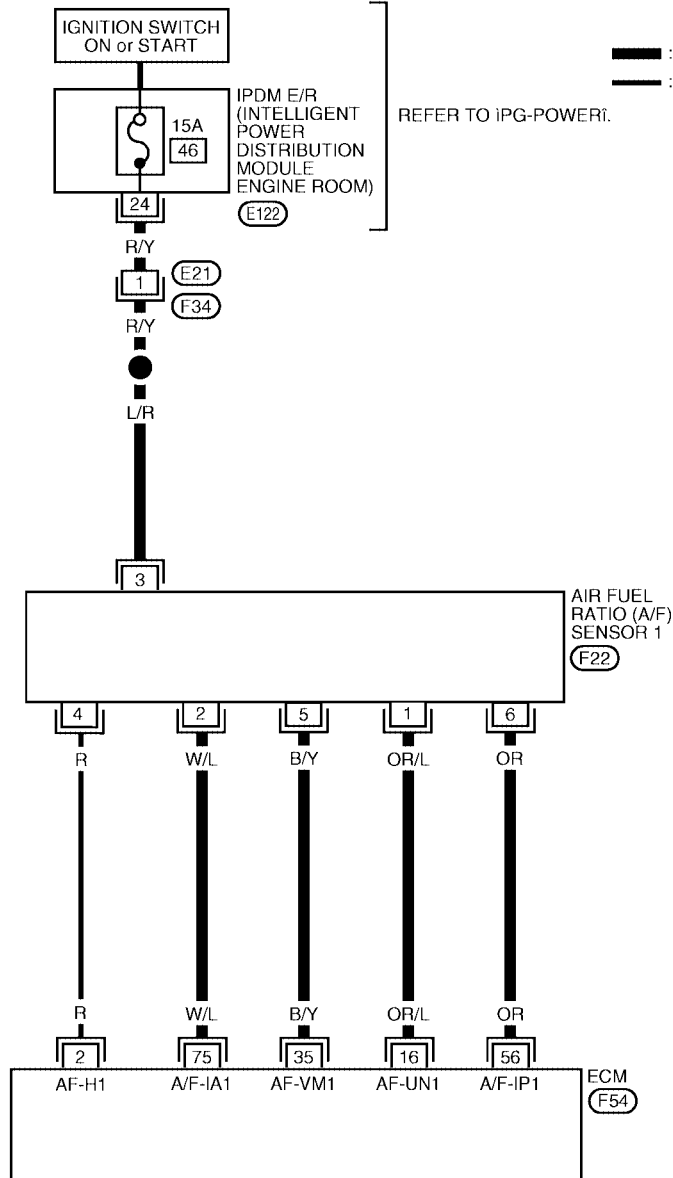

BBWA1242E

DTC P1278 A/F SENSOR 1

[QR]

Specification data are reference values and are measured between each terminal and ground.

CAUTION:

Do not use ECM ground terminals when measuring input/output voltage. Doing so may result in damage to the ECM's transistor. Use a ground other than ECM terminals, such as the ground.

TERMI- NAL NO.	WIRE COLOR	ITEM	CONDITION	DATA (DC Voltage)
16	OR/L	A/F sensor 1	[Engine is running] ● Warm-up condition ● Idle speed	Approximately 3.1V
35	B/Y			Approximately 2.6V
56	OR			2 - 3V
75	W/L			2 - 3V

Diagnostic Procedure

UBS00C7F

1. CHECK GROUND CONNECTIONS

1. Turn ignition switch OFF.
2. Loosen and retighten three ground screws on the body. Refer to [EC-164, "Ground Inspection"](#).

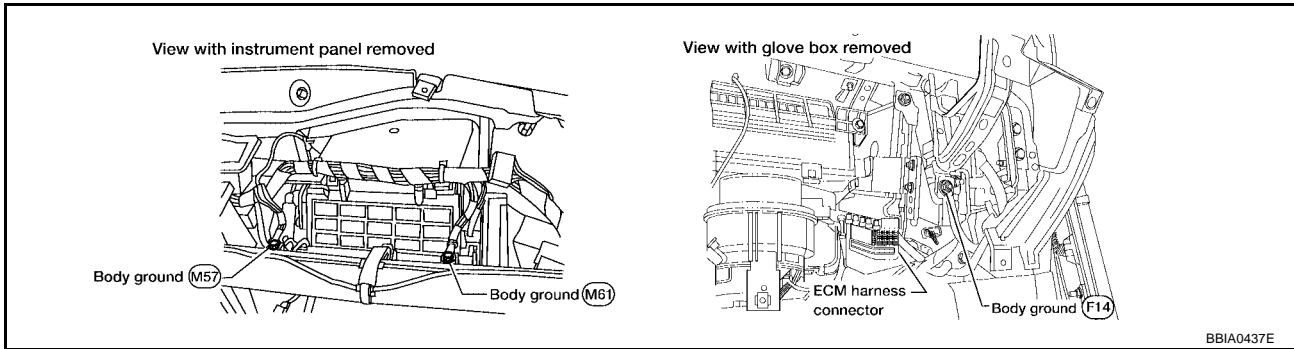

OK or NG

- OK >> GO TO 2.
- NG >> Repair or replace ground connections.

2. RETIGHTEN AIR FUEL RATIO (A/F) SENSOR 1

Loosen and retighten the air fuel ratio (A/F) sensor 1.

Tightening torque: 40 - 60 N-m (4.1 - 6.1 kg-m, 30 - 44 ft-lb)

>> GO TO 3.

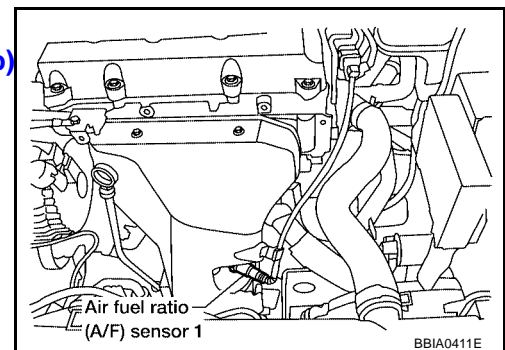

3. CHECK EXHAUST GAS LEAK

1. Start engine and run it at idle.
2. Listen for an exhaust gas leak before three way catalyst (manifold).

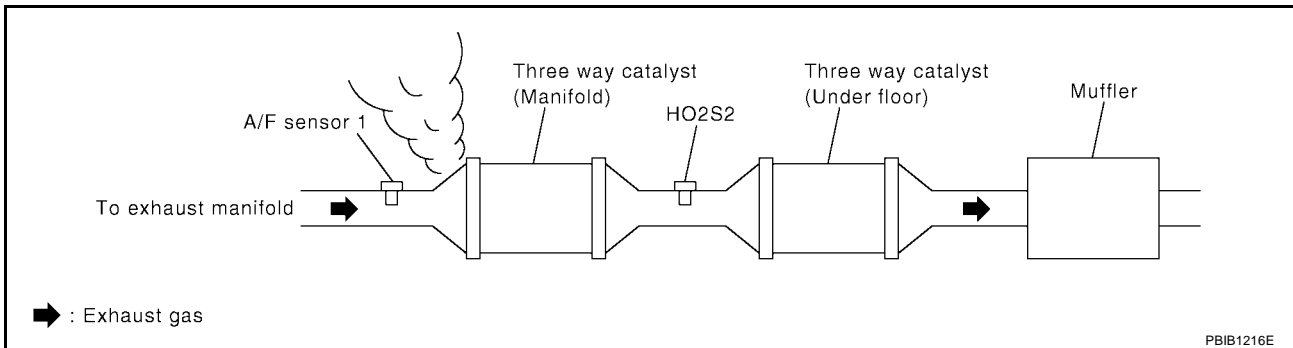

OK or NG

- OK >> GO TO 4.
 NG >> Repair or replace.

4. CHECK FOR INTAKE AIR LEAK

Listen for an intake air leak after the mass air flow sensor.

OK or NG

- OK >> GO TO 5.
 NG >> Repair or replace.

5. CLEAR THE SELF-LEARNING DATA

With CONSULT-II

1. Start engine and warm it up to normal operating temperature.
2. Select "SELF-LEARNING CONT" in "WORK SUPPORT" mode with CONSULT-II.
3. Clear the self-learning control coefficient by touching "CLEAR" or "START".
4. Run engine for at least 10 minutes at idle speed.
Is the 1st trip DTC P0171 or P0172 detected? Is it difficult to start engine?

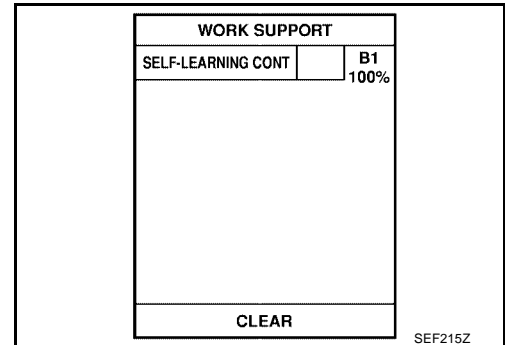

Without CONSULT-II

1. Start engine and warm it up to normal operating temperature.
2. Turn ignition switch OFF.
3. Disconnect mass air flow sensor harness connector, and restart and run engine for at least 3 seconds at idle speed.
4. Stop engine and reconnect mass air flow sensor harness connector.
5. Make sure DTC P0102 is displayed.
6. Erase the DTC memory. Refer to [EC-65, "HOW TO ERASE EMISSION-RELATED DIAGNOSTIC INFORMATION"](#).
7. Make sure DTC P0000 is displayed.
8. Run engine for at least 10 minutes at idle speed.
Is the 1st trip DTC P0171 or P0172 detected? Is it difficult to start engine?

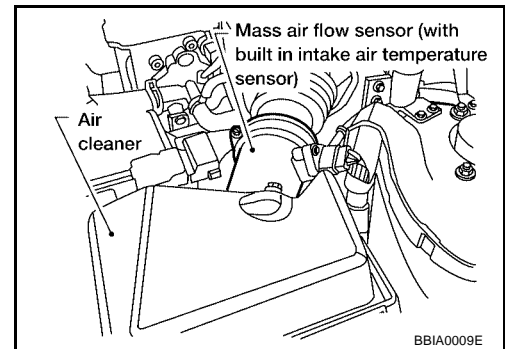

Yes or No

- Yes >> Perform trouble diagnosis for DTC P0171, P0172. Refer to [EC-233](#) , [EC-240](#) .
- No >> GO TO 6.

6. CHECK AIR FUEL RATIO (A/F) SENSOR 1 POWER SUPPLY CIRCUIT

1. Turn ignition switch OFF.
2. Disconnect A/F sensor 1 harness connector.
3. Turn ignition switch ON.

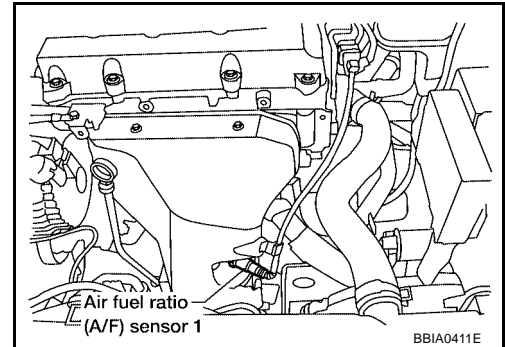

4. Check voltage between A/F sensor 1 terminal 3 and ground with CONSULT-II or tester.

Voltage: Battery voltage

OK or NG

- OK >> GO TO 8.
 NG >> GO TO 7.

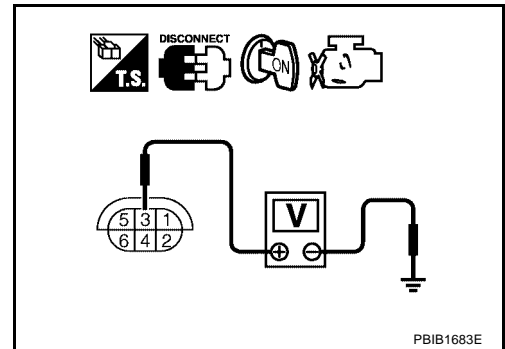

7. DETECT MALFUNCTIONING PART

Check the following.

- Harness connectors E21, F34
- IPDM E/R harness connector E122
- 15A fuse
- Harness for open or short between A/F sensor 1 and fuse

>> Repair or replace harness or connectors.

8. CHECK A/F SENSOR 1 INPUT SIGNAL CIRCUIT FOR OPEN AND SHORT

1. Turn ignition switch OFF.
2. Disconnect ECM harness connector.
3. Check harness continuity between the following terminals. Refer to Wiring Diagram.

A/F sensor 1 terminal	ECM terminal
1	16
5	35
6	56
2	75

Continuity should exist.

4. Check harness continuity between ECM terminals 16, 35, 56, 75 or A/F sensor 1 terminals 1, 2, 5, 6 and ground. Refer to Wiring Diagram.

Continuity should not exist.

5. Also check harness for short to power.

OK or NG

OK >> GO TO 9.

NG >> Repair open circuit or short to ground or short to power in harness or connectors.

9. CHECK AIR FUEL RATIO (A/F) SENSOR 1 HEATER

Refer to [EC-377, "Component Inspection"](#) .

OK or NG

OK >> GO TO 10.

NG >> Replace A/F sensor 1.

10. CHECK MASS AIR FLOW SENSOR

Refer to [EC-184, "Component Inspection"](#) .

OK or NG

OK >> GO TO 11.

NG >> Replace mass air flow sensor.

11. CHECK PCV VALVE

Refer to [EC-50, "Component Inspection"](#) .

OK or NG

OK >> GO TO 12.

NG >> Repair or replace PCV valve.

12. CHECK INTERMITTENT INCIDENT

Perform [EC-158, "TROUBLE DIAGNOSIS FOR INTERMITTENT INCIDENT"](#) .

OK or NG

OK >> Replace A/F sensor 1.

NG >> Repair or replace.

**Removal and Installation
AIR FUEL RATIO SENSOR**

Refer to [EM-24, "EXHAUST MANIFOLD AND THREE WAY CATALYST"](#) .

UBS00C7G

DTC P1279 A/F SENSOR 1

Component Description

The A/F sensor 1 is a planar dual-cell limit current sensor. The sensor element of the A/F sensor 1 is the combination of a Nernst concentration cell (sensor cell) with an oxygen-pump cell, which transports ions. It has a heater in the element.

The sensor is capable of precise measurement $\lambda = 1$, but also in the lean and rich range. Together with its control electronics, the sensor outputs a clear, continuous signal throughout a wide λ range ($0.7 < \lambda < \text{air}$).

The exhaust gas components diffuse through the diffusion gap at the electrode of the oxygen pump and Nernst concentration cell, where they are brought to thermodynamic balance.

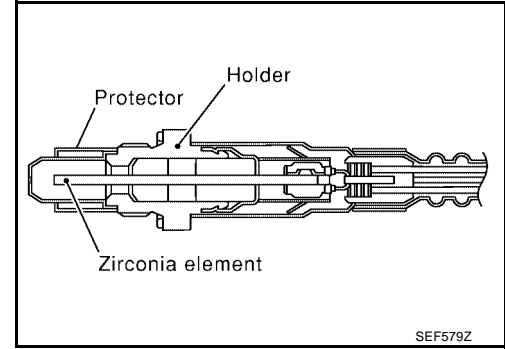

An electronic circuit controls the pump current through the oxygen-pump cell so that the composition of the exhaust gas in the diffusion gap remains constant at $\lambda = 1$. Therefore, the A/F sensor 1 is able to indicate air-fuel ratio by this pumping of current. In addition, a heater is integrated in the sensor to ensure the required operating temperature of 700 - 800°C (1,292 - 1,472°F).

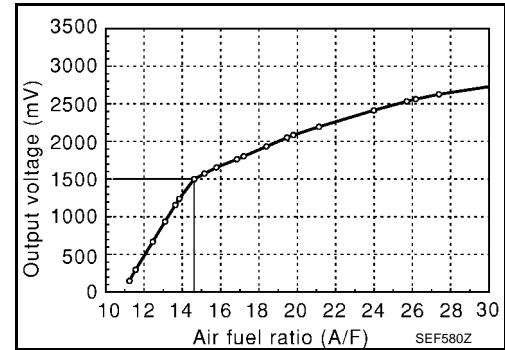

CONSULT-II Reference Value in Data Monitor Mode

Specification data are reference values.

MONITOR ITEM	CONDITION		SPECIFICATION
A/F SEN1 (B1)	<ul style="list-style-type: none"> ● Engine: After warming up 	Maintaining engine speed at 2,000 rpm	Fluctuates around 1.5V

On Board Diagnosis Logic

To judge the malfunction of air fuel ratio (A/F) sensor 1, this diagnosis measures response time of the A/F signals computed by ECM from the air fuel ratio (A/F) sensor 1 signal. The time is compensated by engine operating (speed and load), fuel feedback control constant, and the air fuel ratio (A/F) sensor 1 temperature index. Judgment is based on whether the compensated time (the A/F sensor 1 signal cycling time index) is inordinately long or not.

DTC No.	Trouble diagnosis name	DTC detecting condition	Possible Cause
P1279 1279	Air-fuel ratio (A/F) sensor 1 circuit slow response	<ul style="list-style-type: none"> ● The response (from LEAN to RICH) of the A/F signal computed by ECM from A/F sensor 1 signal takes more than the specified time. 	<ul style="list-style-type: none"> ● Harness or connectors (The sensor circuit is open or shorted.) ● Air-fuel ratio (A/F) sensor 1 ● Air-fuel ratio (A/F) sensor heater 1 ● Fuel pressure ● Fuel Injector ● Intake air leaks ● Exhaust gas leaks ● PCV ● Mass air flow sensor

DTC Confirmation Procedure

NOTE:

If DTC Confirmation Procedure has been previously conducted, always turn ignition switch OFF and wait at least 10 seconds before conducting the next test.

TESTING CONDITION:

Before performing the following procedure, confirm that battery voltage is more than 11V at idle.

WITH CONSULT-II

1. Start engine and warm it up to normal operating temperature.
2. Turn ignition switch OFF and wait at least 10 seconds.
3. Start engine and keep the engine speed between 3,500 and 4,000 rpm for at least 1 minute under no load.
4. Let engine idle for 1 minute.
5. Select "A/F SEN1(B1) P1278/P1279" of "A/F SEN1" in "DTC WORK SUPPORT" mode with CONSULT-II.
6. Touch "START".
If "COMPLETED" appears on CONSULT-II screen, go to step 10.
If "COMPLETED" does not appear on CONSULT-II screen, go to the following step.

A/F SEN1 (B1) P1278/P1279	
OUT OF CONDITION	
MONITOR	
ENG SPEED	XXX rpm
B/FUEL SCHDL	XXX msec
COOLAN TEMP/S	XXX °C
VHCL SPEED SE	XXX km/h

PBIB0756E

7. After perform the following procedure, "TESTING" will be displayed on the CONSULT-II screen.
 - a. Increase the engine speed up to 4,000 to 5,000 rpm and keep it for 10 seconds.
 - b. Fully release accelerator pedal and then let engine idle for about 10 seconds.
If "TESTING" is not displayed after 10 seconds, refer to [EC-148, "TROUBLE DIAGNOSIS - SPECIFICATION VALUE"](#).
8. Wait for about 20 seconds at idle at under the condition that "TESTING" is displayed on the CONSULT-II screen.

A/F SEN1 (B1) P1278/P1279	
TESTING	
MONITOR	
ENG SPEED	XXX rpm
B/FUEL SCHDL	XXX msec
COOLAN TEMP/S	XXX °C
VHCL SPEED SE	XXX km/h

PBIB1925E

9. Make sure that "TESTING" changes to "COMPLETED".
If "TESTING" changed to "OUT OF CONDITION", refer to [EC-148, "TROUBLE DIAGNOSIS - SPECIFICATION VALUE"](#).
10. Make sure that "OK" is displayed after touching "SELF-DIAG RESULT".
If "NG" is displayed, go to [EC-486, "Diagnostic Procedure"](#).

A/F SEN1 (B1) P1278/P1279	
COMPLETED	

PBIB0758E

WITH GST

1. Start engine and warm it up to normal operating temperature.
2. Select "Service \$01" with GST.
3. Calculate the total value of "Short term fuel trim" and "Long term fuel trim" indications.
Make sure that the total percentage should be within $\pm 15\%$.
If OK, go to the following step.
If NG, check the following.
 - Intake air leaks

-
- Exhaust gas leaks
 - Incorrect fuel pressure
 - Lack of fuel
 - Fuel Injector
 - Incorrect PCV hose connection
 - PCV valve
 - Mass air flow sensor
4. Turn ignition switch OFF and wait at least 10 seconds.
 5. Start engine and keep the engine speed between 3,500 and 4,000 rpm for at least 1 minute under no load.
 6. Let engine idle for 1 minute.
 7. Increase the engine speed up to 4,000 to 5,000 rpm and keep it for 10 seconds.
 8. Fully release accelerator pedal and then let engine idle for about 1 minute.
 9. Select "Service \$07" with GST.
If 1st trip DTC is detected, go to [EC-486, "Diagnostic Procedure"](#).

DTC P1279 A/F SENSOR 1

[QR]

Wiring Diagram

UBS00C7M

EC-A/F-01

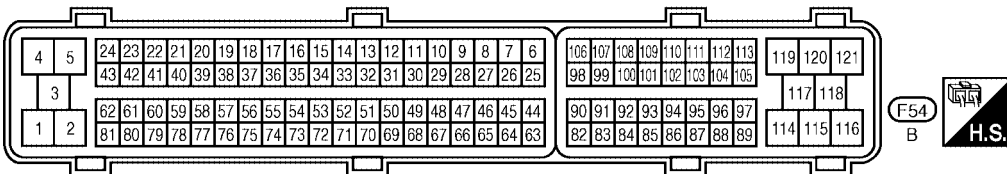
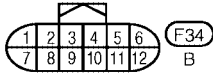
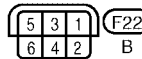
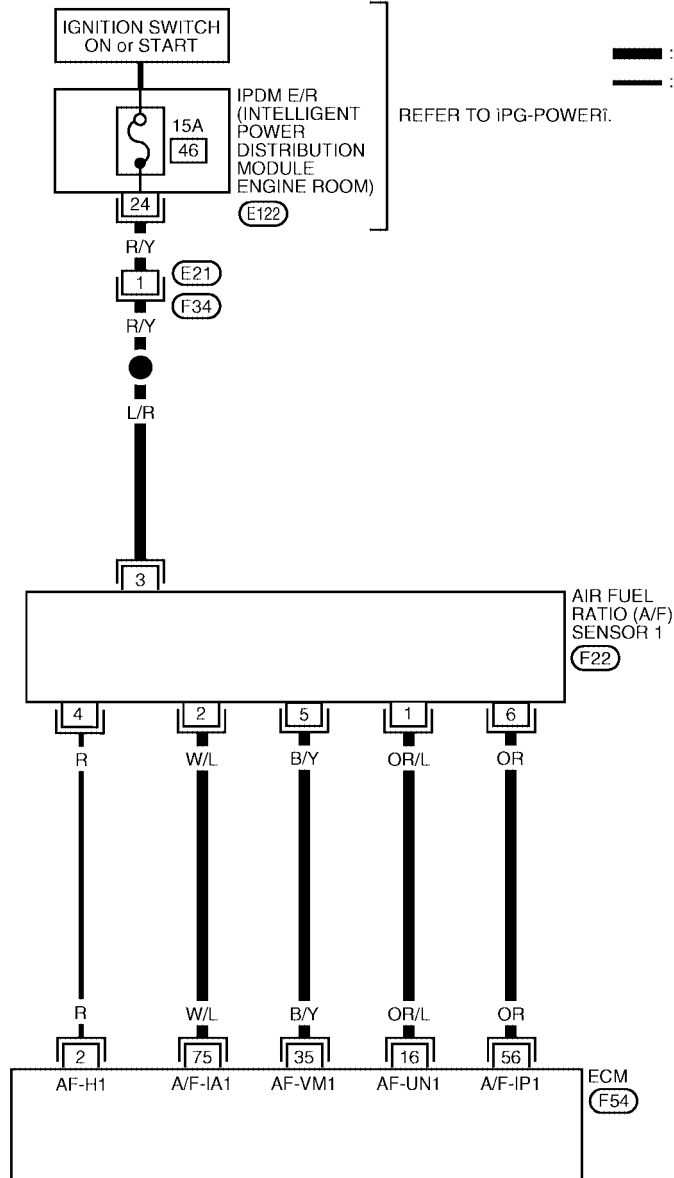

BBWA1242E

DTC P1279 A/F SENSOR 1

[QR]

Specification data are reference values and are measured between each terminal and ground.

CAUTION:

Do not use ECM ground terminals when measuring input/output voltage. Doing so may result in damage to the ECM's transistor. Use a ground other than ECM terminals, such as the ground.

TERMINAL NO.	WIRE COLOR	ITEM	CONDITION	DATA (DC Voltage)
16	OR/L	A/F sensor 1	[Engine is running] ● Warm-up condition ● Idle speed	Approximately 3.1V
35	B/Y			Approximately 2.6V
56	OR			2 - 3V
75	W/L			2 - 3V

Diagnostic Procedure

UBS00C7N

1. CHECK GROUND CONNECTIONS

1. Turn ignition switch OFF.
2. Loosen and retighten three ground screws on the body. Refer to [EC-164, "Ground Inspection"](#).

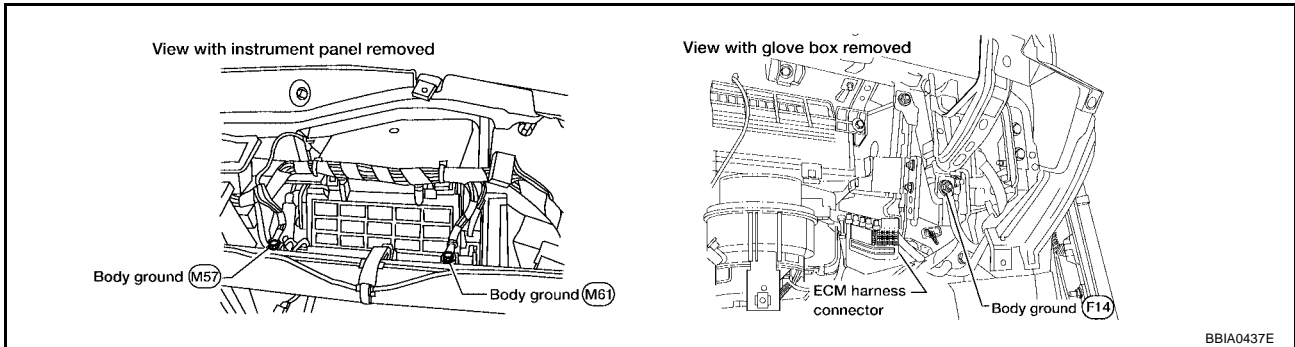

BBIA0437E

OK or NG

- OK >> GO TO 2.
- NG >> Repair or replace ground connections.

2. RETIGHTEN AIR FUEL RATIO (A/F) SENSOR 1

Loosen and retighten the air fuel ratio (A/F) sensor 1.

Tightening torque: 40 - 60 N-m (4.1 - 6.1 kg-m, 30 - 44 ft-lb)

>> GO TO 3.

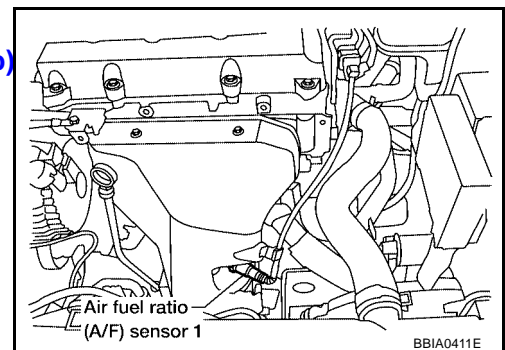

BBIA0411E

3. CHECK EXHAUST GAS LEAK

1. Start engine and run it at idle.
2. Listen for an exhaust gas leak before three way catalyst (manifold).

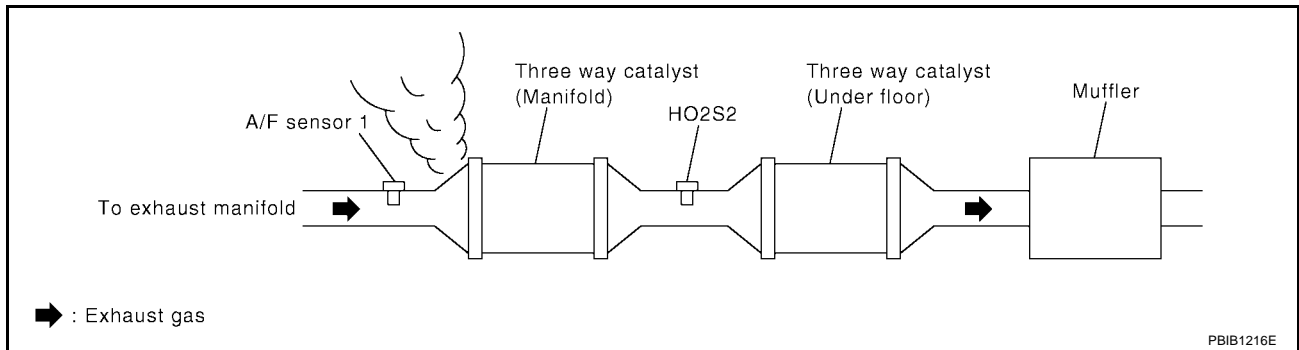

OK or NG

- OK >> GO TO 4.
 NG >> Repair or replace.

4. CHECK FOR INTAKE AIR LEAK

Listen for an intake air leak after the mass air flow sensor.

OK or NG

- OK >> GO TO 5.
 NG >> Repair or replace.

5. CLEAR THE SELF-LEARNING DATA

Ⓜ With CONSULT-II

1. Start engine and warm it up to normal operating temperature.
2. Select "SELF-LEARNING CONT" in "WORK SUPPORT" mode with CONSULT-II.
3. Clear the self-learning control coefficient by touching "CLEAR" or "START".
4. Run engine for at least 10 minutes at idle speed.
Is the 1st trip DTC P0171 or P0172 detected? Is it difficult to start engine?

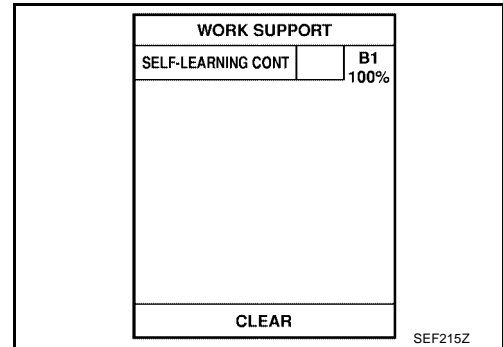

⊗ Without CONSULT-II

1. Start engine and warm it up to normal operating temperature.
2. Turn ignition switch OFF.
3. Disconnect mass air flow sensor harness connector, and restart and run engine for at least 3 seconds at idle speed.
4. Stop engine and reconnect mass air flow sensor harness connector.
5. Make sure DTC P0102 is displayed.
6. Erase the DTC memory. Refer to [EC-65, "HOW TO ERASE EMISSION-RELATED DIAGNOSTIC INFORMATION"](#).
7. Make sure DTC P0000 is displayed.
8. Run engine for at least 10 minutes at idle speed.
Is the 1st trip DTC P0171 or P0172 detected? Is it difficult to start engine?

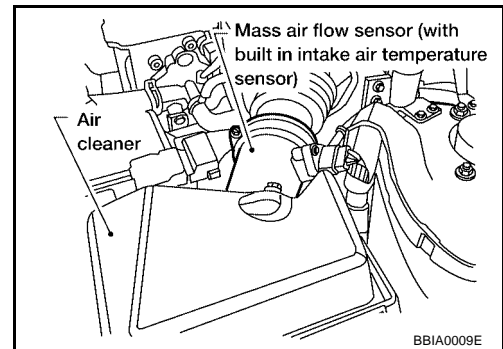

Yes or No

- Yes >> Perform trouble diagnosis for DTC P0171, P0172. Refer to [EC-233](#) , [EC-240](#) .
- No >> GO TO 6.

6. CHECK AIR FUEL RATIO (A/F) SENSOR 1 POWER SUPPLY CIRCUIT

1. Turn ignition switch OFF.
2. Disconnect A/F sensor 1 harness connector.
3. Turn ignition switch ON.

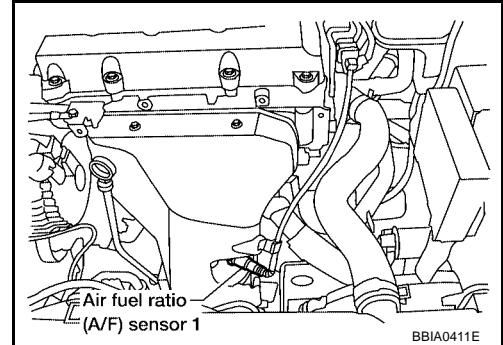

4. Check voltage between A/F sensor 1 terminal 3 and ground with CONSULT-II or tester.

Voltage: Battery voltage

OK or NG

- OK >> GO TO 8.
 NG >> GO TO 7.

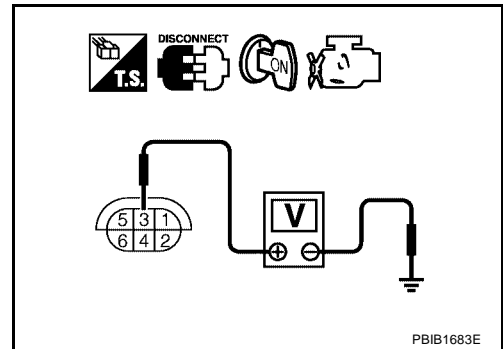

7. DETECT MALFUNCTIONING PART

Check the following.

- Harness connectors E21, F34
- IPDM E/R harness connector E122
- 15A fuse
- Harness for open or short between A/F sensor 1 and fuse

>> Repair or replace harness or connectors.

8. CHECK A/F SENSOR 1 INPUT SIGNAL CIRCUIT FOR OPEN AND SHORT

1. Turn ignition switch OFF.
2. Disconnect ECM harness connector.
3. Check harness continuity between the following terminals. Refer to Wiring Diagram.

A/F sensor 1 terminal	ECM terminal
1	16
5	35
6	56
2	75

Continuity should exist.

4. Check harness continuity between ECM terminals 16, 35, 56, 75 or A/F sensor 1 terminals 1, 2, 5, 6 and ground. Refer to Wiring Diagram.

Continuity should not exist.

5. Also check harness for short to power.

OK or NG

OK >> GO TO 9.

NG >> Repair open circuit or short to ground or short to power in harness or connectors.

9. CHECK AIR FUEL RATIO (A/F) SENSOR 1 HEATER

Refer to [EC-377, "Component Inspection"](#) .

OK or NG

OK >> GO TO 10.

NG >> Replace A/F sensor 1.

10. CHECK MASS AIR FLOW SENSOR

Refer to [EC-184, "Component Inspection"](#) .

OK or NG

OK >> GO TO 11.

NG >> Replace mass air flow sensor.

11. CHECK PCV VALVE

Refer to [EC-50, "POSITIVE CRANKCASE VENTILATION"](#) .

OK or NG

OK >> GO TO 12.

NG >> Repair or replace PCV valve.

12. CHECK INTERMITTENT INCIDENT

Perform [EC-158, "TROUBLE DIAGNOSIS FOR INTERMITTENT INCIDENT"](#) .

OK or NG

OK >> Replace A/F sensor 1.

NG >> Repair or replace.

**Removal and Installation
AIR FUEL RATIO SENSOR**

Refer to [EM-24, "EXHAUST MANIFOLD AND THREE WAY CATALYST"](#) .

UBS00C70

DTC P1444 EVAP CANISTER PURGE VOLUME CONTROL SOLENOID VALVE

[QR]

DTC P1444 EVAP CANISTER PURGE VOLUME CONTROL SOLENOID VALVE

PFP:14920

UBS00CE0

Description SYSTEM DESCRIPTION

Sensor	Input Signal to ECM	ECM function	Actuator
Crankshaft position sensor (POS) Camshaft position sensor (PHASE)	Engine speed*1	EVAP can- ister purge flow control	EVAP canister purge volume control solenoid valve
Mass air flow sensor	Amount of intake air		
Engine coolant temperature sensor	Engine coolant temperature		
Battery	Battery voltage*1		
Throttle position sensor	Throttle position		
Accelerator pedal position sensor	Accelerator pedal position		
Air fuel ratio (A/F) sensor 1	Density of oxygen in exhaust gas (Mixture ratio feedback signal)		
Fuel tank temperature sensor	Fuel temperature in fuel tank		
Vehicle speed sensor	Vehicle speed*2		

*1: ECM determines the start signal status by the signals of engine speed and battery voltage.

*2: This signal is sent to the ECM though CAN communication line.

This system controls flow rate of fuel vapor from the EVAP canister. The opening of the vapor by-pass passage in the EVAP canister purge volume control solenoid valve changes to control the flow rate. The EVAP canister purge volume control solenoid valve repeats ON/OFF operation according to the signal sent from the ECM. The opening of the valve varies for optimum engine control. The optimum value stored in the ECM is determined by considering various engine conditions. When the engine is operating, the flow rate of fuel vapor from the EVAP canister is regulated as the air flow changes.

COMPONENT DESCRIPTION

The EVAP canister purge volume control solenoid valve uses a ON/OFF duty to control the flow rate of fuel vapor from the EVAP canister. The EVAP canister purge volume control solenoid valve is moved by ON/OFF pulses from the ECM. The longer the ON pulse, the greater the amount of fuel vapor that will flow through the valve.

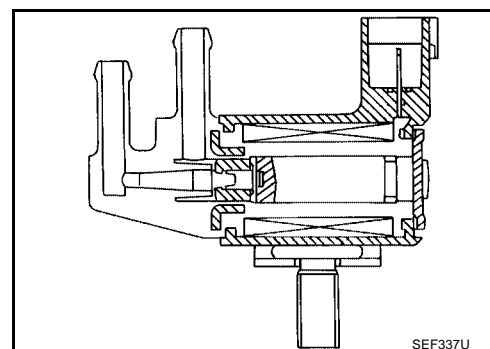

CONSULT-II Reference Value in Data Monitor Mode

UBS00CEP

Specification data are reference values.

MONITOR ITEM	CONDITION	SPECIFICATION
PURG VOL C/V	<ul style="list-style-type: none"> ● Engine: After warming up ● Shift lever: N (A/T), Neutral (M/T) ● Air conditioner switch: OFF ● No-load 	Idle (Accelerator pedal is not depressed even slightly, after engine starting) 2,000 rpm
		0% 20 - 30%

On Board Diagnosis Logic

UBS00CE0

DTC No.	Trouble diagnosis name	DTC detecting condition	Possible cause
P1444 1444	EVAP canister purge volume control solenoid valve	The canister purge flow is detected during the specified driving conditions, even when EVAP canister purge volume control solenoid valve is completely closed.	<ul style="list-style-type: none"> ● EVAP control system pressure sensor ● EVAP canister purge volume control solenoid valve (The valve is stuck open.) ● EVAP canister vent control valve ● EVAP canister ● Hoses (Hoses are connected incorrectly or clogged.)

DTC Confirmation Procedure

UBS00CER

NOTE:

If DTC Confirmation Procedure has been previously conducted, always turn ignition switch OFF and wait at least 10 seconds before conducting the next test.

TESTING CONDITION:

Always perform test at a temperature of 5°C (41°F) or more.

WITH CONSULT-II

1. Start engine and warm it up to normal operating temperature.
2. Turn ignition switch OFF and wait at least 10 seconds.
3. Turn ignition switch ON.
4. Select "PURG VOL CN/V P1444" of "EVAPORATIVE SYSTEM" in "DTC WORK SUPPORT" mode with CONSULT-II.
5. Touch "START".

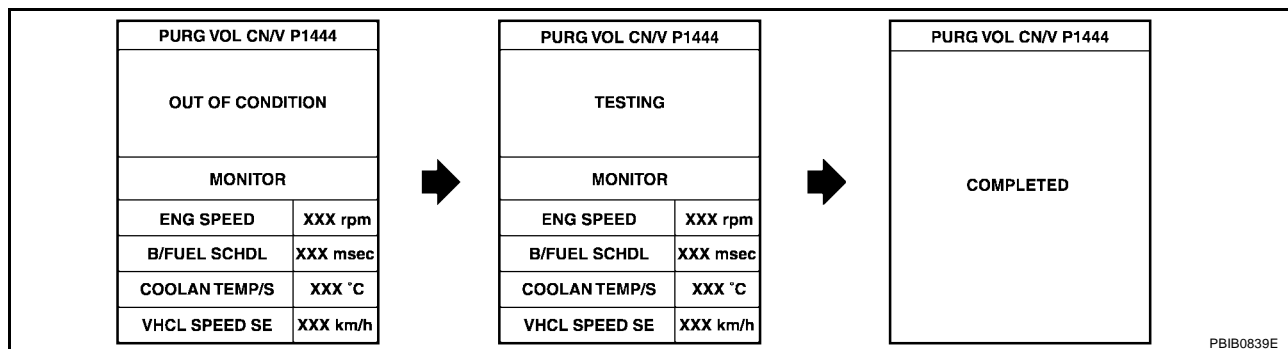

6. Start engine and let it idle until "TESTING" on CONSULT-II changes to "COMPLETED". (It will take approximately 10 seconds.)
If "TESTING" is not displayed after 5 minutes, retry from step 2.
7. Make sure that "OK" is displayed after touching "SELF-DIAG RESULTS". If "NG" is displayed, refer to [EC-494, "Diagnostic Procedure"](#).

WITH GST

1. Start engine and warm it up to normal operating temperature.
2. Turn ignition switch OFF and wait at least 10 seconds.
3. Start engine and let it idle for at least 20 seconds.
4. Select Service \$07 with GST.
5. If 1st trip DTC is detected, go to [EC-494, "Diagnostic Procedure"](#).

DTC P1444 EVAP CANISTER PURGE VOLUME CONTROL SOLENOID VALVE [QR]

UBS00CES

Wiring Diagram

EC-PGC/V-01

A
EC
C
D
E
F
G
H
I
J
K
L
M

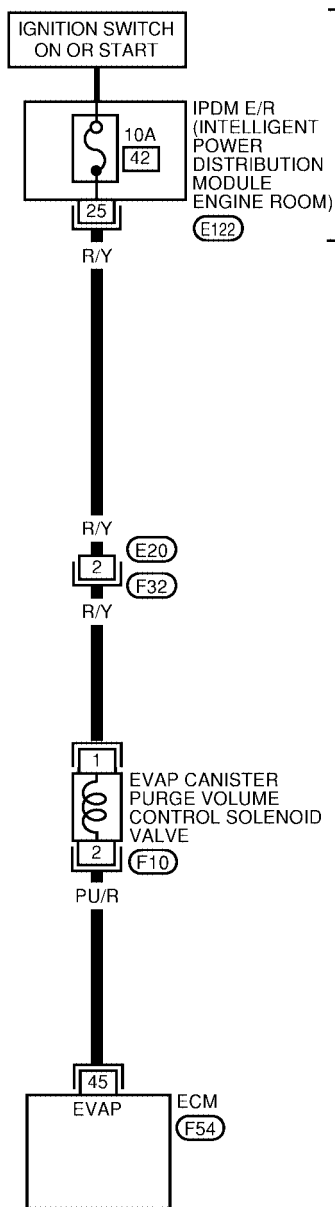

: DETECTABLE LINE FOR DTC
 : NON-DETECTABLE LINE FOR DTC

REFER TO "PG-POWER".

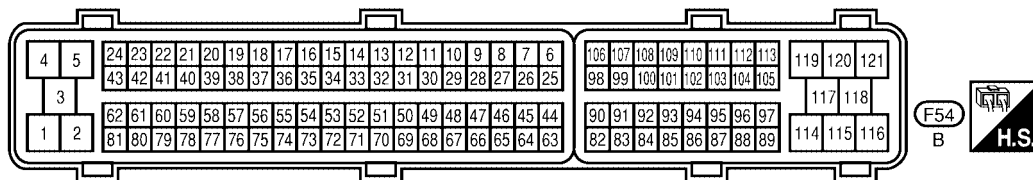

BBWA1227E

DTC P1444 EVAP CANISTER PURGE VOLUME CONTROL SOLENOID VALVE

[QR]

Specification data are reference values and are measured between each terminal and ground.
Pulse signal is measured by CONSULT-II.

CAUTION:

Do not use ECM ground terminals when measuring input/output voltage. Doing so may result in damage to the ECM's transistor. Use a ground other than ECM terminals, such as the ground.

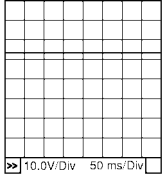
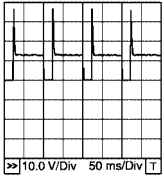
TERMI- NAL NO.	WIRE COLOR	ITEM	CONDITION	DATA (DC Voltage)
45	PU/R	EVAP canister purge vol- ume control solenoid valve	<p>[Engine is running]</p> <ul style="list-style-type: none"> ● Idle speed ● Accelerator pedal is not depressed even slightly, after engine starting 	<p>BATTERY VOLTAGE (11 - 14V)★</p>  <p>PBIB0050E</p>
			<p>[Engine is running]</p> <ul style="list-style-type: none"> ● Engine speed is about 2,000 rpm (More than 100 seconds after starting engine) 	<p>Approximately 10V★</p>  <p>PBIB0520E</p>

★: Average voltage for pulse signal (Actual pulse signal can be confirmed by oscilloscope.)

Diagnostic Procedure

UBS00CET

1. CHECK EVAP CANISTER PURGE VOLUME CONTROL SOLENOID VALVE POWER SUPPLY CIRCUIT

1. Turn ignition switch OFF.
2. Disconnect EVAP canister purge volume control solenoid valve harness connector.
3. Turn ignition switch ON.

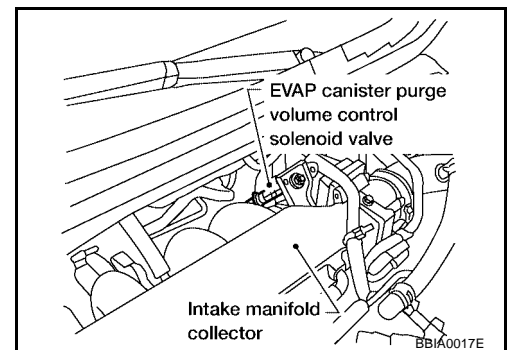

4. Check voltage between EVAP canister purge volume control solenoid valve terminal 1 and ground with CONSULT-II or tester.

Voltage: Battery voltage

OK or NG

- OK >> GO TO 3.
NG >> GO TO 2.

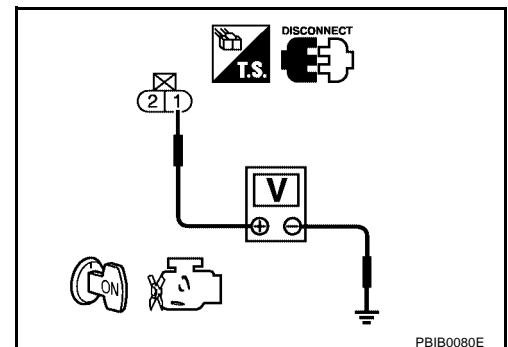

DTC P1444 EVAP CANISTER PURGE VOLUME CONTROL SOLENOID VALVE [QR]

2. DETECT MALFUNCTIONING PART

Check the following.

- Harness connectors E20, F32
- IPDM E/R harness connector E122
- 10A fuse
- Harness for open or short between EVAP canister purge volume control solenoid valve and IPDM E/R

>> Repair open circuit or short to ground or short to power in harness or connectors.

3. CHECK EVAP CANISTER PURGE VOLUME CONTROL SOLENOID VALVE OUTPUT SIGNAL CIRCUIT FOR OPEN AND SHORT

1. Turn ignition switch OFF.
2. Disconnect ECM harness connector.
3. Check harness continuity between ECM terminal 45 and EVAP canister purge volume control solenoid valve terminal 2. Refer to Wiring Diagram.

Continuity should exist.

4. Also check harness for short to ground and short to power.

OK or NG

OK >> GO TO 4.

NG >> Repair open circuit or short to ground or short to power in harness or connectors.

4. CHECK EVAP CONTROL SYSTEM PRESSURE SENSOR CONNECTOR

1. Disconnect EVAP control system pressure sensor harness connector.

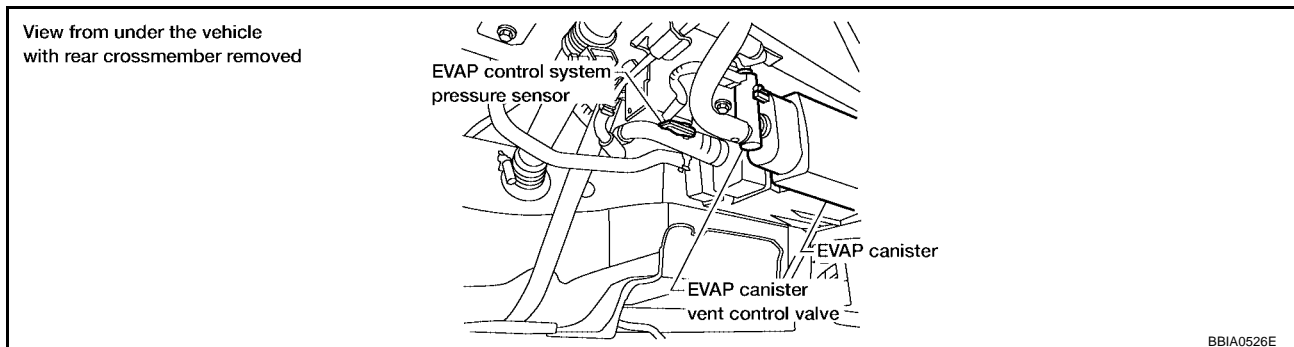

2. Check connectors for water.

Water should not exist.

OK or NG

OK >> GO TO 5.

NG >> Replace EVAP control system pressure sensor.

5. CHECK EVAP CONTROL SYSTEM PRESSURE SENSOR

Refer to [EC-327, "Component Inspection"](#).

OK or NG

OK (With CONSULT-II)>>GO TO 6.

OK (Without CONSULT-II)>>GO TO 7.

NG >> Replace EVAP control system pressure sensor.

6. CHECK EVAP CANISTER PURGE VOLUME CONTROL SOLENOID VALVE

With CONSULT-II

1. Turn ignition switch OFF.
2. Reconnect harness connectors disconnected.
3. Start engine.
4. Perform "PURG VOL CONT/V" in "ACTIVE TEST" mode with CONSULT-II. Check that engine speed varies according to the valve opening.

OK or NG

- OK >> GO TO 8.
 NG >> GO TO 7.

ACTIVE TEST	
PURG VOL CONT/V	XXX %
MONITOR	
ENG SPEED	XXX rpm
A/F ALPHA-B1	XXX %

PBIB1786E

7. CHECK EVAP CANISTER PURGE VOLUME CONTROL SOLENOID VALVE

Refer to [EC-497, "Component Inspection"](#) .

OK or NG

- OK >> GO TO 8.
 NG >> Replace EVAP canister purge volume control solenoid valve.

8. CHECK RUBBER TUBE FOR CLOGGING

1. Disconnect rubber tube connected to EVAP canister vent control valve.
2. Check the rubber tube for clogging.

OK or NG

- OK >> GO TO 9.
 NG >> Clean the rubber tube using an air blower.

9. CHECK EVAP CANISTER VENT CONTROL VALVE

Refer to [EC-317, "Component Inspection"](#) .

OK or NG

- OK >> GO TO 10.
 NG >> Replace EVAP canister vent control valve.

10. CHECK IF EVAP CANISTER SATURATED WITH WATER

1. Remove EVAP canister with EVAP canister vent control valve attached.
2. Check if water will drain from the EVAP canister.

YES or NO

- YES >> GO TO 11.
 NO >> GO TO 13.

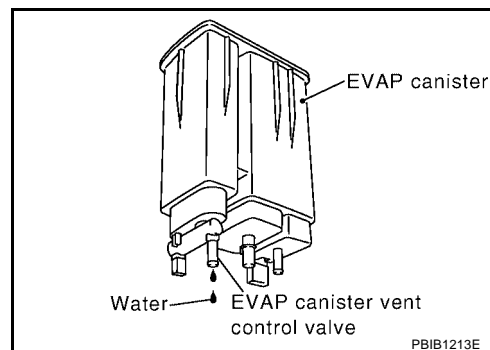

DTC P1444 EVAP CANISTER PURGE VOLUME CONTROL SOLENOID VALVE [QR]

11. CHECK EVAP CANISTER

Weigh the EVAP canister with the EVAP canister vent control valve and EVAP control system pressure sensor attached.

The weight should be less than 2.1 kg (4.6 lb).

OK or NG

- OK >> GO TO 13.
- NG >> GO TO 12.

12. DETECT MALFUNCTIONING PART

Check the following.

- EVAP canister for damage
- EVAP hose between EVAP canister and vehicle frame for clogging or poor connection

>> Repair hose or replace EVAP canister.

13. CHECK INTERMITTENT INCIDENT

Refer to [EC-158, "TROUBLE DIAGNOSIS FOR INTERMITTENT INCIDENT"](#).

>> INSPECTION END

Component Inspection EVAP CANISTER PURGE VOLUME CONTROL SOLENOID VALVE

UBS00CEU

☐ With CONSULT-II

Check air passage continuity of EVAP canister purge volume control solenoid valve under the following conditions.

Condition (PURG VOL CONT/V value)	Air passage continuity between A and B
100%	Yes
0%	No

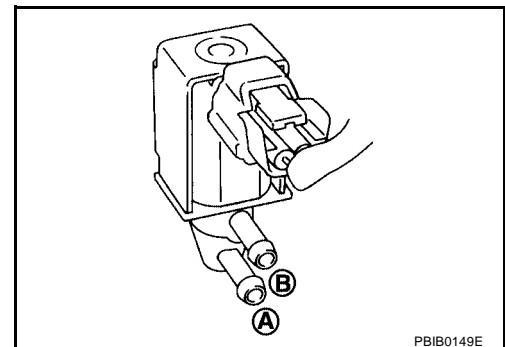

⊗ Without CONSULT-II

Check air passage continuity of EVAP canister purge volume control solenoid valve under the following conditions.

Condition	Air passage continuity between A and B
12V direct current supply between terminals 1 and 2	Yes
No supply	No

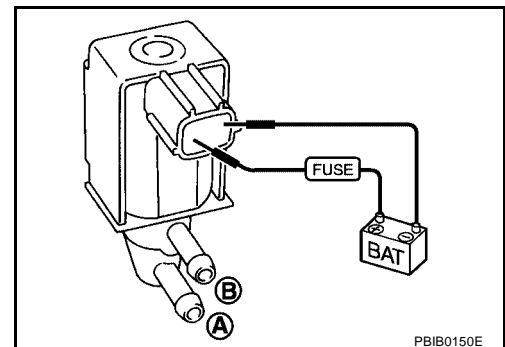

Removal and Installation EVAP CANISTER PURGE VOLUME CONTROL SOLENOID VALVE

UBS00CEV

Refer to [EM-19, "INTAKE MANIFOLD"](#).

DTC P1446 EVAP CANISTER VENT CONTROL VALVE

[QR]

DTC P1446 EVAP CANISTER VENT CONTROL VALVE

PF14935

Component Description

UBS00CEW

The EVAP canister vent control valve is located on the EVAP canister and is used to seal the canister vent.

This solenoid valve responds to signals from the ECM. When the ECM sends an ON signal, the coil in the solenoid valve is energized. A plunger will then move to seal the canister vent. The ability to seal the vent is necessary for the on board diagnosis of other evaporative emission control system components.

This solenoid valve is used only for diagnosis, and usually remains opened.

When the vent is closed, under normal purge conditions, the evaporative emission control system is depressurized and allows "EVAP Control System" diagnoses.

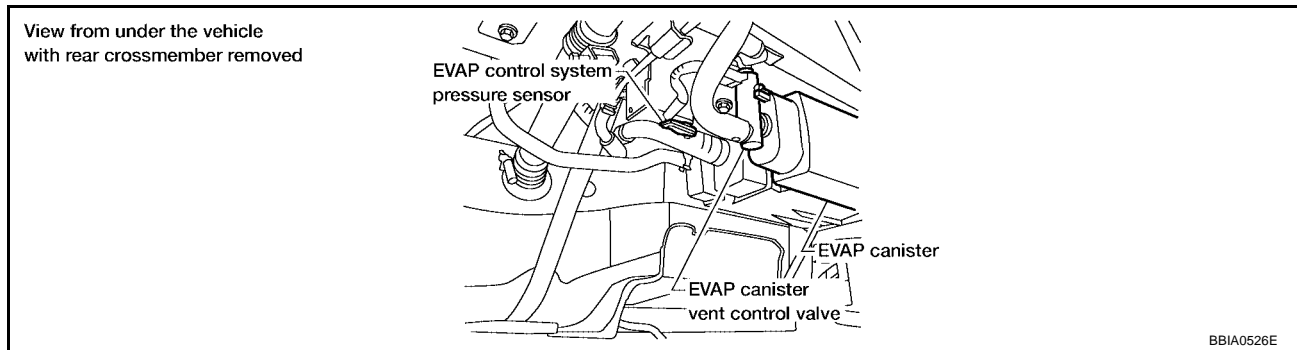
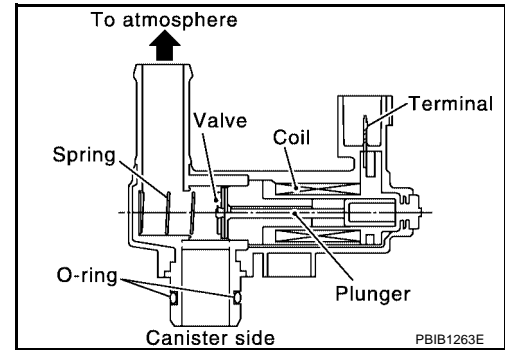

CONSULT-II Reference Value in Data Monitor Mode

UBS00CEX

Specification data are reference values.

MONITOR ITEM	CONDITION	SPECIFICATION
VENT CONT/V	● Ignition switch: ON	OFF

On Board Diagnosis Logic

UBS00CEY

DTC No.	Trouble diagnosis name	DTC detecting condition	Possible cause
P1446 1446	EVAP canister vent control valve close	EVAP canister vent control valve remains closed under specified driving conditions.	<ul style="list-style-type: none"> ● EVAP canister vent control valve ● EVAP control system pressure sensor and the circuit ● Blocked rubber tube to EVAP canister vent control valve ● EVAP canister is saturated with water

DTC Confirmation Procedure

UBS00CEZ

CAUTION:

Always drive vehicle at a safe speed.

NOTE:

If DTC Confirmation Procedure has been previously conducted, always turn ignition switch OFF and wait at least 10 seconds before conducting the next test.

DTC P1446 EVAP CANISTER VENT CONTROL VALVE

[QR]

WITH CONSULT-II

1. Turn ignition switch ON and wait at least 5 seconds.
2. Turn ignition switch OFF and wait at least 10 seconds.
3. Turn ignition switch ON and select "DATA MONITOR" mode with CONSULT-II.
4. Start engine and let it idle for at least 1 minute.
5. Repeat next procedures 3 times.
 - a. Increase the engine speed up to 3,000 to 3,500 rpm and keep it for 2 minutes and 50 seconds to 3 minutes.
Never exceed 3 minutes.
 - b. Fully released accelerator pedal and keep engine idle for about 5 seconds.
6. If 1st trip DTC is detected, go to [EC-501, "Diagnostic Procedure"](#).
If 1st trip DTC is not detected, go to the next step.
7. Repeat next procedure 20 times.
 - a. Quickly increase the engine speed up to 4,000 to 4,500 rpm or more and keep it for 25 to 30 seconds.
 - b. Fully released accelerator pedal and keep engine idle for at least 35 seconds.

DATA MONITOR	
MONITOR	NO DTC
ENG SPEED	XXX rpm

SEF058Y

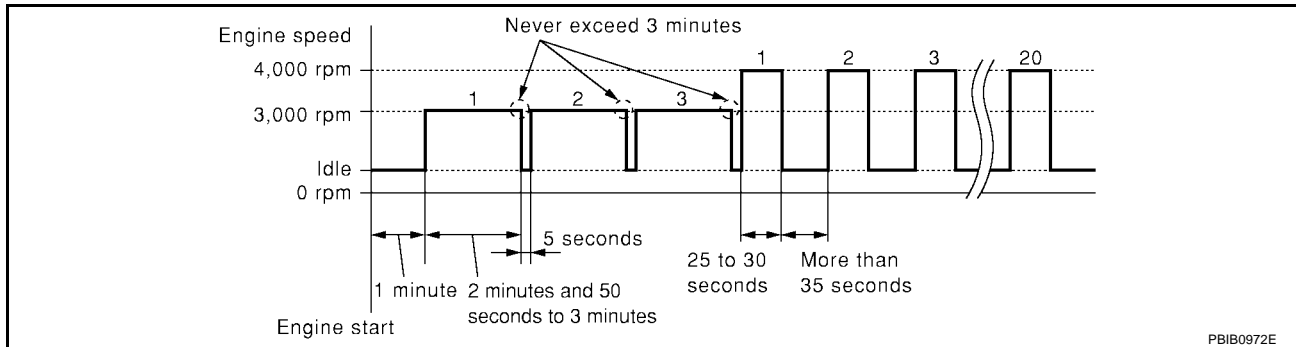

8. If 1st trip DTC is detected, go to [EC-501, "Diagnostic Procedure"](#).

WITH GST

Follow the procedure "WITH CONSULT-II" above.

DTC P1446 EVAP CANISTER VENT CONTROL VALVE

[QR]

Wiring Diagram

UBS00CF0

EC-VENT/V-01

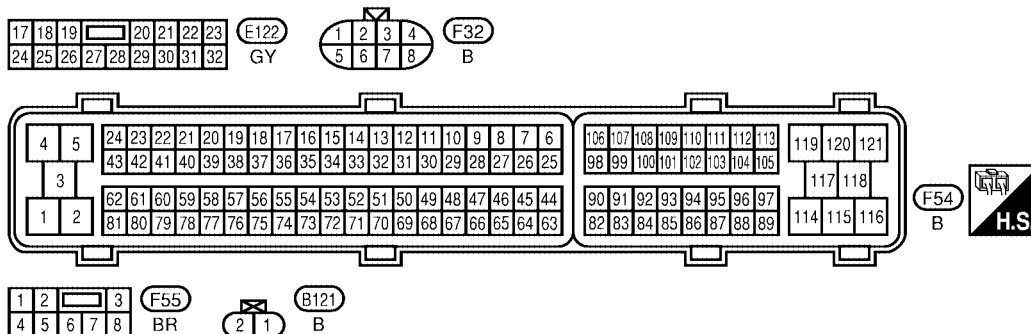
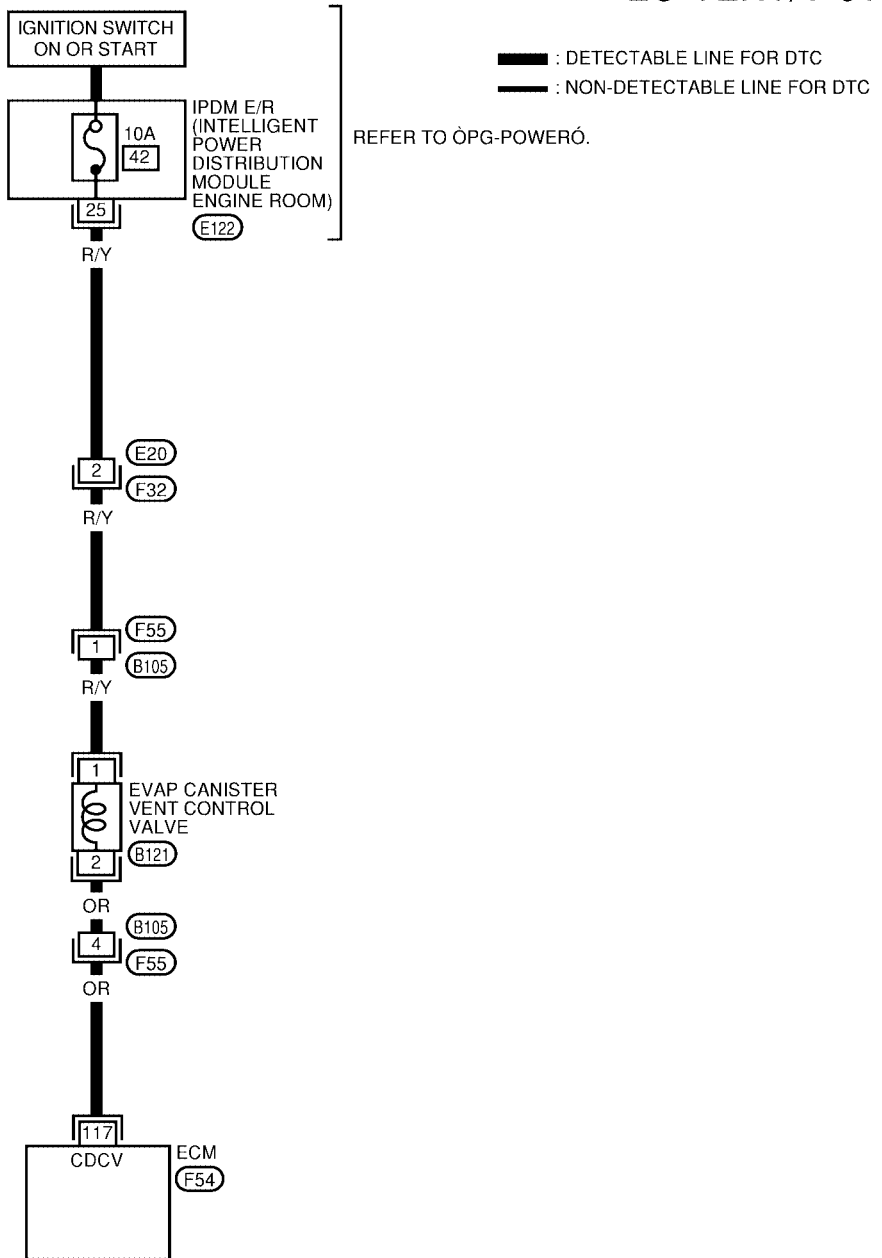

BBWA1228E

DTC P1446 EVAP CANISTER VENT CONTROL VALVE

[QR]

Specification data are reference values and are measured between each terminal and ground.

CAUTION:

Do not use ECM ground terminals when measuring input/output voltage. Doing so may result in damage to the ECM's transistor. Use a ground other than ECM terminals, such as the ground.

TERMI- NAL NO.	WIRE COLOR	ITEM	CONDITION	DATA (DC Voltage)
117	OR	EVAP canister vent control valve	[Ignition switch: ON]	BATTERY VOLTAGE (11 - 14V)

Diagnostic Procedure

UBS00CF1

1. CHECK RUBBER TUBE

1. Turn ignition switch OFF.
2. Disconnect rubber tube connected to EVAP canister vent control valve.
3. Check the rubber tube for clogging.

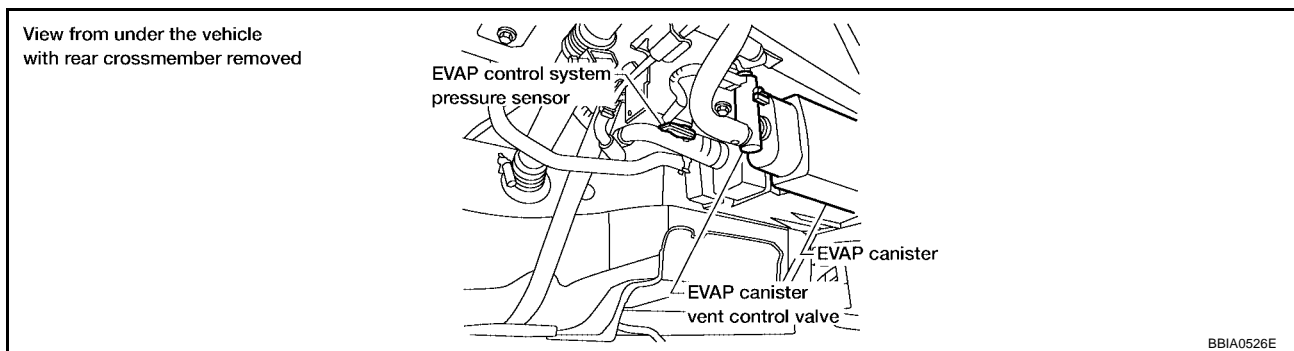

OK or NG

- OK >> GO TO 2.
- NG >> Clean rubber tube using an air blower.

2. CHECK EVAP CANISTER VENT CONTROL VALVE

Refer to [EC-502, "EVAP CANISTER VENT CONTROL VALVE"](#).

OK or NG

- OK >> GO TO 3.
- NG >> Replace EVAP canister vent control valve.

3. CHECK IF EVAP CANISTER SATURATED WITH WATER

1. Remove EVAP canister with EVAP canister vent control valve attached.
2. Check if water will drain from the EVAP canister.

Yes or No

- Yes >> GO TO 4.
- No >> GO TO 6.

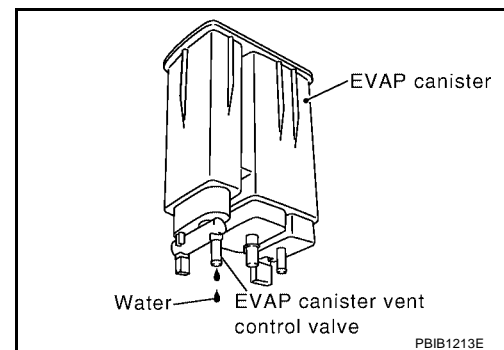

4. CHECK EVAP CANISTER

Weigh the EVAP canister with the EVAP canister vent control valve and EVAP control system pressure sensor attached.

The weight should be less than 2.1 kg (4.6 lb).

OK or NG

- OK >> GO TO 6.
- NG >> GO TO 5.

5. DETECT MALFUNCTIONING PART

Check the following.

- EVAP canister for damage
- EVAP hose between EVAP canister and vehicle frame for clogging or poor connection

>> Repair hose or replace EVAP canister.

6. CHECK EVAP CONTROL SYSTEM PRESSURE SENSOR CONNECTOR

1. Disconnect EVAP control system pressure sensor harness connector.

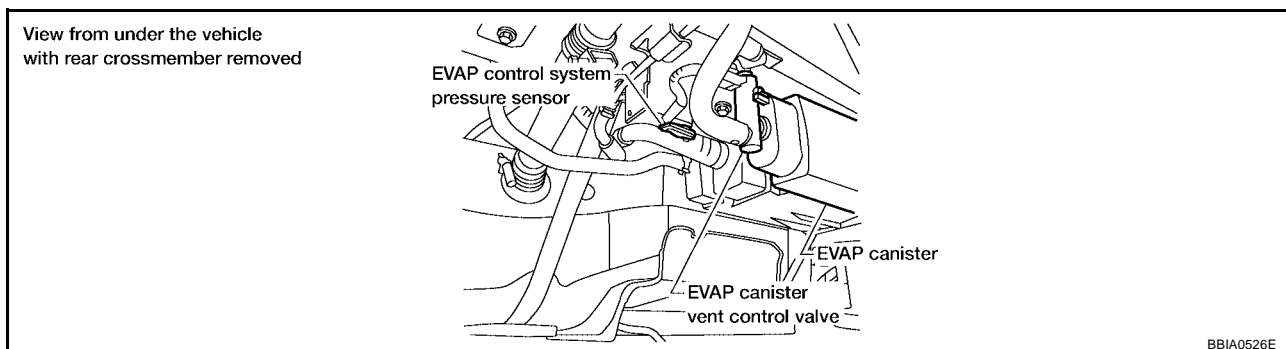

2. Check connectors for water.

Water should not exist.

OK or NG

- OK >> GO TO 7.
- NG >> Replace EVAP control system pressure sensor.

7. CHECK EVAP CONTROL SYSTEM PRESSURE SENSOR

Refer to [EC-334, "Component Inspection"](#) .

OK or NG

- OK >> GO TO 8.
- NG >> Replace EVAP control system pressure sensor.

8. CHECK INTERMITTENT INCIDENT

Refer to [EC-158, "TROUBLE DIAGNOSIS FOR INTERMITTENT INCIDENT"](#) .

>> INSPECTION END

Component Inspection EVAP CANISTER VENT CONTROL VALVE

UBS00CF2

Ⓟ With CONSULT-II

1. Remove EVAP canister vent control valve from EVAP canister.

DTC P1446 EVAP CANISTER VENT CONTROL VALVE

[QR]

2. Check portion **B** of EVAP canister vent control valve for being rusted.
If NG, replace EVAP canister vent control valve.
If OK, go to next step.
3. Reconnect harness connectors disconnected.
4. Turn ignition switch ON.

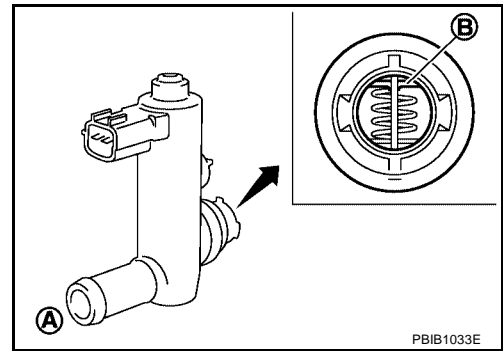

5. Perform "VENT CONTROL/V" in "ACTIVE TEST" mode.
6. Check air passage continuity and operation delay time.

Condition VENT CONTROL/V	Air passage continuity between A and B
ON	No
OFF	Yes

ACTIVE TEST	
VENT CONTROL/V	OFF
MONITOR	
ENG SPEED	XXX rpm
A/F ALPHA-B1	XXX %

PBIB1787E

Operation takes less than 1 second.
Make sure new O-ring is installed properly.
If NG, replace EVAP canister vent control valve.
If OK, go to next step.

7. Clean the air passage (Portion **A** to **B**) of EVAP canister vent control valve using an air blower.
8. Perform step 5 again.

⊗ **Without CONSULT-II**

1. Remove EVAP canister vent control valve from EVAP canister.
2. Check portion **B** of EVAP canister vent control valve for being rusted.

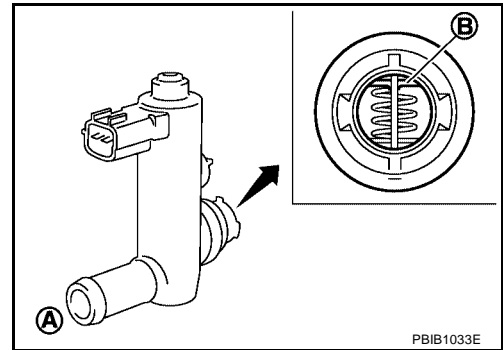

3. Check air passage continuity and operation delay time under the following conditions.

Condition	Air passage continuity between A and B
12V direct current supply between terminals 1 and 2	No
OFF	Yes

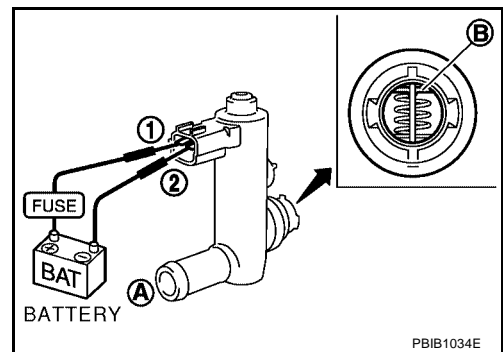

Operation takes less than 1 second.
Make sure new O-ring is installed properly.
If NG, replace EVAP canister vent control valve.
If OK, go to next step.

4. Clean the air passage (Portion **A** to **B**) of EVAP canister vent control valve using an air blower.
5. Perform step 3 again.

DTC P1564 ASCD STEERING SWITCH

[QR]

PFP:25551

DTC P1564 ASCD STEERING SWITCH

Component Description

UBS00320

ASCD steering switch has variant values of electrical resistance for each button. ECM reads voltage variation of switch, and determines which button is operated.

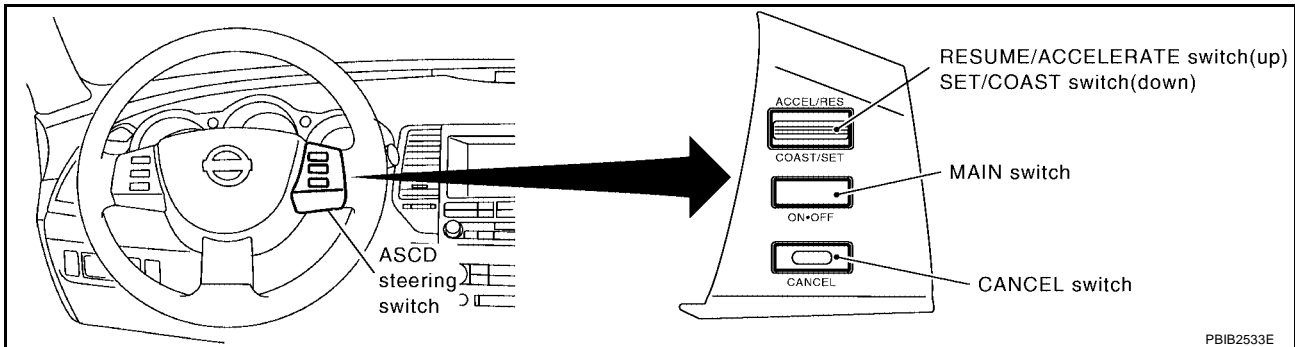

Refer to [EC-34, "AUTOMATIC SPEED CONTROL DEVICE \(ASCD\)"](#) for the ASCD function.

CONSULT-II Reference Value in Data Monitor Mode

UBS00321

Specification data are reference values.

MONITOR ITEM	CONDITION		SPECIFICATION
MAIN SW	● Ignition switch: ON	CRUISE switch: Pressed	ON
		CRUISE switch: Released	OFF
CANCEL SW	● Ignition switch: ON	CANCEL switch: Pressed	ON
		CANCEL switch: Released	OFF
RESUME/ACC SW	● Ignition switch: ON	RESUME/ACCEL switch: Pressed	ON
		RESUME/ACCEL switch: Released	OFF
SET SW	● Ignition switch: ON	SET/COAST switch: Pressed	ON
		SET/COAST switch: Released	OFF

On Board Diagnosis Logic

UBS00322

This self-diagnosis has the one trip detection logic.
The MIL will not light up for this diagnosis.

NOTE:

If DTC P1564 is displayed with DTC P0605, first perform the trouble diagnosis for DTC P0605. Refer to [EC-370](#).

DTC No.	Trouble Diagnosis Name	DTC Detecting Condition	Possible Cause
P1564 1564	ASCD steering switch	<ul style="list-style-type: none"> ● An excessively high voltage signal from the ASCD steering switch is sent to ECM. ● ECM detects that input signal from the ASCD steering switch is out of the specified range. ● ECM detects that the ASCD steering switch is stuck ON. 	<ul style="list-style-type: none"> ● Harness or connectors (The switch circuit is open or shorted.) ● ASCD steering switch ● ECM

DTC Confirmation Procedure

UBS00323

NOTE:

If DTC Confirmation Procedure has been previously conducted, always turn ignition switch OFF and wait at least 10 seconds before conducting the next test.

WITH CONSULT-II

1. Turn ignition switch ON.

DTC P1564 ASCD STEERING SWITCH

[QR]

2. Select "DATA MONITOR" mode with CONSULT-II.
3. Wait at least 10 seconds.
4. Press CRUISE switch for at least 10 seconds, then release it and wait at least 10 seconds.
5. Press RESUME/ACCEL switch for at least 10 seconds, then release it and wait at least 10 seconds.
6. Press SET/COAST switch for at least 10 seconds, then release it and wait at least 10 seconds.
7. Press CANCEL switch for at least 10 seconds, then release it and wait at least 10 seconds.
8. If DTC is detected, go to [EC-508, "Diagnostic Procedure"](#) .

DATA MONITOR	
MONITOR	NO DTC
ENG SPEED	XXX rpm

SEF058Y

WITH GST

Follow the procedure "WITH CONSULT-II" above.

A

EC

C

D

E

F

G

H

I

J

K

L

M

DTC P1564 ASCD STEERING SWITCH

[QR]

Wiring Diagram

UBS00324

EC-ASC/SW-01

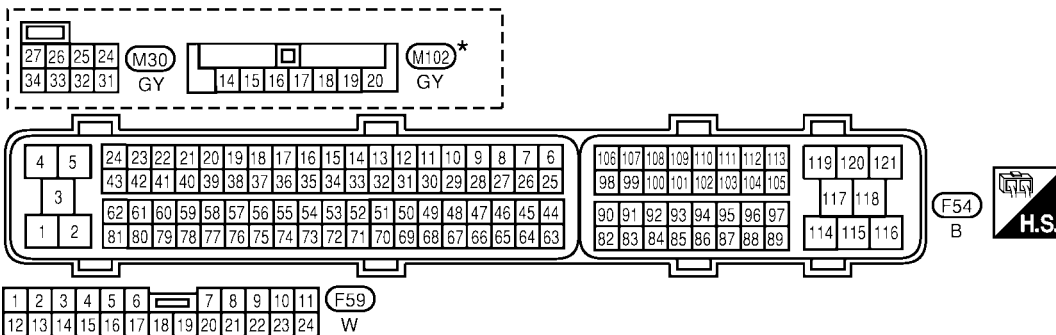
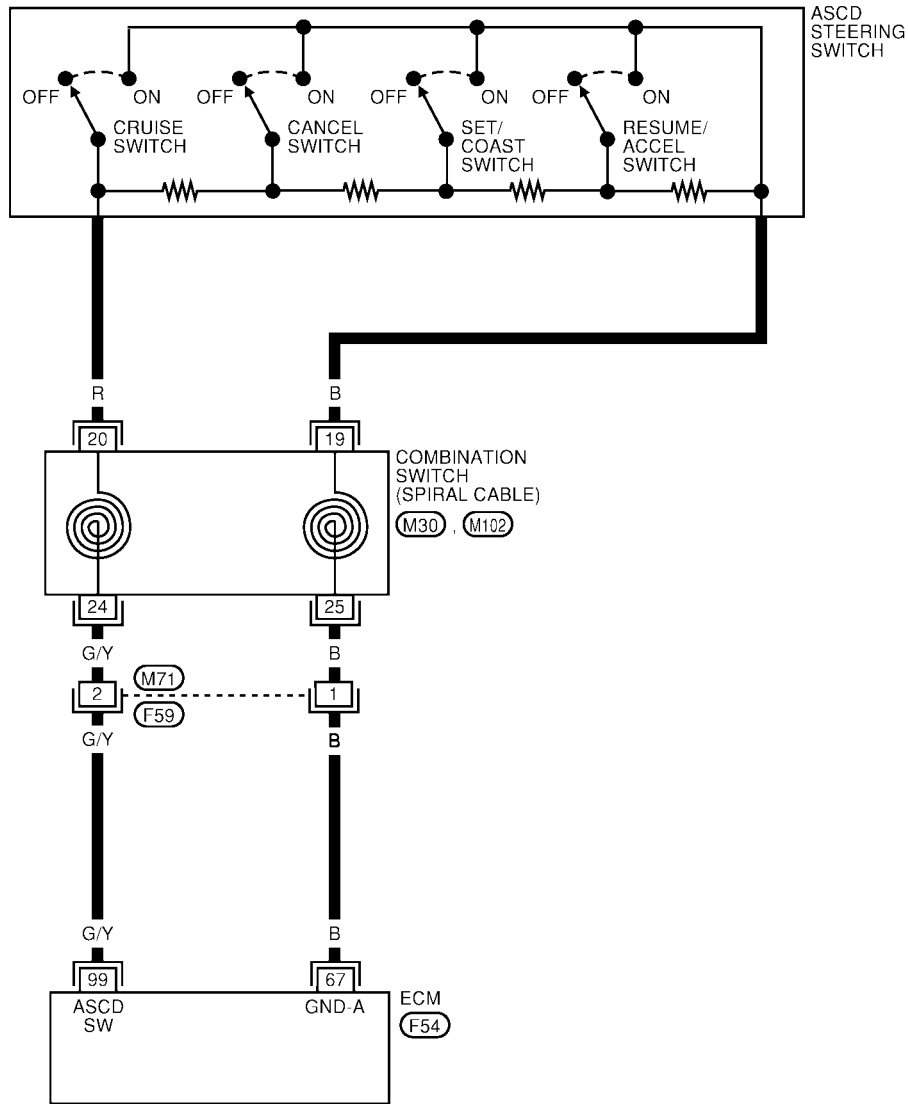

* : This connector is not shown in "HARNESS LAYOUT" of PG section.

BBWA1243E

DTC P1564 ASCD STEERING SWITCH

[QR]

Specification data are reference values and are measured between each terminal and ground.

CAUTION:

Do not use ECM ground terminals when measuring input/output voltage. Doing so may result in damage to the ECM's transistor. Use a ground other than ECM terminals, such as the ground.

TERMI- NAL NO.	WIRE COLOR	ITEM	CONDITION	DATA (DC Voltage)
67	B	Sensor ground	[Engine is running] <ul style="list-style-type: none"> ● Warm-up condition ● Idle speed 	Approximately 0V
99	G/Y	ASCD steering switch	[Ignition switch: ON] <ul style="list-style-type: none"> ● ASCD steering switch: OFF 	Approximately 4V
			[Ignition switch: ON] <ul style="list-style-type: none"> ● CRUISE switch: Pressed 	Approximately 0V
			[Ignition switch: ON] <ul style="list-style-type: none"> ● CANCEL switch: Pressed 	Approximately 1V
			[Ignition switch: ON] <ul style="list-style-type: none"> ● SET/COAST switch: Pressed 	Approximately 2V
			[Ignition switch: ON] <ul style="list-style-type: none"> ● RESUME/ACCEL switch: Pressed 	Approximately 3V

A
EC
C
D
E
F
G
H
I
J
K
L
M

Diagnostic Procedure

1. CHECK ASCD STEERING SWITCH CIRCUIT

With CONSULT-II

1. Turn ignition switch ON.
2. Select "MAIN SW", "RESUME/ACC SW", "SET SW and "CANCEL SW" in "DATA MONITOR" mode with CONSULT-II.
3. Check each item indication under the following conditions.

Switch	Monitor item	Condition	Indication
CRUISE switch	MAIN SW	Pressed	ON
		Released	OFF
SET/COAST switch	SET SW	Pressed	ON
		Released	OFF
RESUME/ACCEL switch	RESUME/ACC SW	Pressed	ON
		Released	OFF
CANCEL switch	CANCEL SW	Pressed	ON
		Released	OFF

DATA MONITOR	
MONITOR	NO DTC
MAIN SW	OFF
CANCEL SW	OFF
RESUME/ACC SW	OFF
SET SW	OFF

SEC006D

Without CONSULT-II

1. Turn ignition switch ON.
2. Check voltage between ECM terminal 99 and ground with pressing each button.

Switch	Condition	Voltage [V]
CRUISE switch	Pressed	Approx. 0
	Released	Approx. 4.0
SET/COAST switch	Pressed	Approx. 2.0
	Released	Approx. 4.0
RESUME/ACCEL switch	Pressed	Approx. 3.0
	Released	Approx. 4.0
CANCEL switch	Pressed	Approx. 1.0
	Released	Approx. 4.0

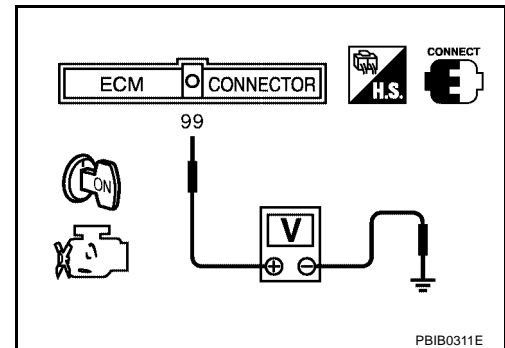

OK or NG

- OK >> GO TO 7.
 NG >> GO TO 2.

2. CHECK ASCD STEERING SWITCH GROUND CIRCUIT FOR OPEN AND SHORT

1. Turn ignition switch OFF.
2. Disconnect combination switch harness connector M102.
3. Disconnect ECM harness connector.
4. Check harness continuity between combination switch terminal 19 and ECM terminal 67.
Refer to Wiring Diagram.

Continuity should exist.

5. Also check harness for short to ground or short to power.

OK or NG

- OK >> GO TO 4.
 NG >> GO TO 3.

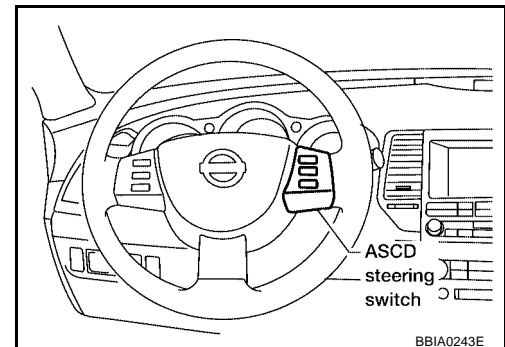

3. DETECT MALFUNCTIONING PART

Check the following.

- Harness connectors M71, F59
- Combination switch (spiral cable)
- Harness for open and short between ECM and combination switch

>> Repair open circuit or short to ground or short to power in harness or connectors.

4. CHECK ASCD STEERING SWITCH INPUT SIGNAL CIRCUIT FOR OPEN AND SHORT

1. Check harness continuity between ECM terminal 99 and combination switch terminal 20. Refer to Wiring Diagram.

Continuity should exist.

2. Also check harness for short to ground and short to power.

OK or NG

- OK >> GO TO 6.
- NG >> GO TO 5.

5. DETECT MALFUNCTIONING PART

Check the following.

- Combination switch (spiral cable)
- Harness for open and short between ECM and combination switch
- Harness connectors M71, F59

>> Repair open circuit or short to ground or short to power in harness or connectors.

6. CHECK ASCD STEERING SWITCH

Refer to [EC-509, "Component Inspection"](#) .

OK or NG

- OK >> GO TO 7.
- NG >> Replace ASCD steering switch.

7. CHECK INTERMITTENT INCIDENT

Refer to [EC-158, "TROUBLE DIAGNOSIS FOR INTERMITTENT INCIDENT"](#) .

>> INSPECTION END

**Component Inspection
ASC D STEERING SWITCH**

UBS00326

1. Disconnect ASCD steering switch.
2. Check continuity between ASCD steering switch terminals 1 and 2 with pushing each switch.

Switch	Condition	Resistance [Ω]
CRUISE switch	Pressed	Approx. 0
	Released	Approx. 4,000
SET SW/COAST switch	Pressed	Approx. 660
	Released	Approx. 4,000
RESUME/ACCEL switch	Pressed	Approx. 1,480
	Released	Approx. 4,000

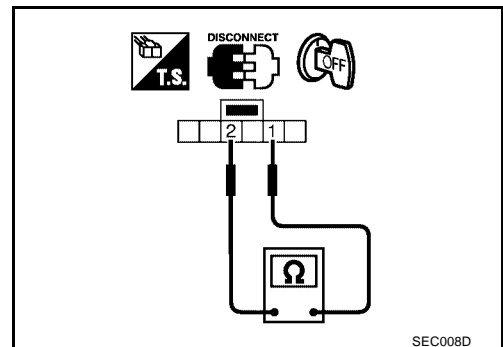

DTC P1564 ASCD STEERING SWITCH

[QR]

Switch	Condition	Resistance [Ω]
CANCEL switch	Pressed	Approx. 250
	Released	Approx. 4,000

If NG, replace ASCD steering switch.

DTC P1572 ASCD BRAKE SWITCH

[QR]

PF2:25320

UBS00327

DTC P1572 ASCD BRAKE SWITCH

Component Description

When the brake pedal is depressed, ASCD brake switch is turned OFF and stop lamp switch is turned ON. ECM detects the state of the brake pedal by this input of two kinds (ON/OFF signal).

Refer to [EC-34, "AUTOMATIC SPEED CONTROL DEVICE \(ASCD\)"](#) for the ASCD function.

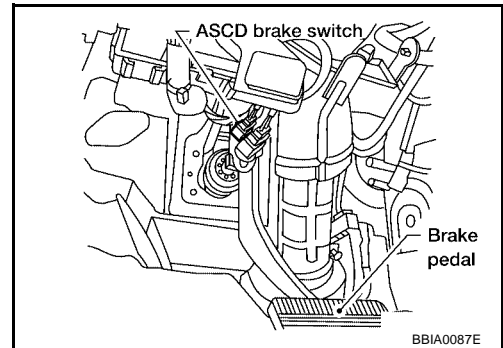

CONSULT-II Reference Value in Data Monitor Mode

UBS00328

Specification data are reference values.

MONITOR ITEM	CONDITION		SPECIFICATION
BRAKE SW1 (ASCD brake switch)	● Ignition switch: ON	● Brake pedal: Fully released ● Clutch pedal: Fully released (M/T)	ON
		● Brake pedal: Slightly depressed ● Clutch pedal: Fully depressed (M/T)	OFF
BRAKE SW2 (STOP lamp switch)	● Ignition switch: ON	Brake pedal: Fully released	OFF
		Brake pedal: Slightly depressed	ON

On Board Diagnosis Logic

UBS00329

This self-diagnosis has the one trip detection logic.
The MIL will not light up for this diagnosis.

NOTE:

- If DTC P1572 is displayed with DTC P0605, first perform the trouble diagnosis for DTC P0605. Refer to [EC-370](#).
- This self-diagnosis has the one trip detection logic. When malfunction A is detected, DTC is not stored in ECM memory. And in that case, 1st trip DTC and 1st trip freeze frame data are displayed. 1st trip DTC is erased when ignition switch OFF. And even when malfunction A is detected in two consecutive trips, DTC is not stored in ECM memory.

DTC P1572 ASCD BRAKE SWITCH

[QR]

DTC No.	Trouble Diagnosis Name	DTC Detecting Condition		Possible Cause
P1572 1572	ASCD brake switch	A)	<ul style="list-style-type: none"> When the vehicle speed is above 30km/h (19 MPH), ON signals from the stop lamp switch and the ASCD brake switch are sent to ECM at the same time. 	<ul style="list-style-type: none"> Harness or connectors (The stop lamp switch circuit is shorted.) Harness or connectors (The ASCD brake switch circuit is shorted.) Harness or connectors (The ASCD clutch switch circuit is shorted.) (M/T models) Stop lamp switch ASCD brake switch ASCD clutch switch (M/T models) Incorrect stop lamp switch installation Incorrect ASCD brake switch installation Incorrect ASCD clutch switch installation (M/T models) ECM
		B)	<ul style="list-style-type: none"> ASCD brake switch signal is not sent to ECM for extremely long time while the vehicle is driving 	

DTC Confirmation Procedure

UBS0032A

CAUTION:

Always drive vehicle at a safe speed.

NOTE:

- If DTC Confirmation Procedure has been previously conducted, always turn ignition switch OFF and wait at least 10 seconds before conducting the next test.
- Procedure for malfunction B is not described here. It takes extremely long time to complete procedure for malfunction B. By performing procedure for malfunction A, the incident that causes malfunction B can be detected.

TESTING CONDITION:

Steps 3 and 4 may be conducted with the drive wheels lifted in the shop or by driving the vehicle. If a road test is expected to be easier, it is unnecessary to lift the vehicle.

WITH CONSULT-II

- Start engine.
- Select "DATA MONITOR" mode with CONSULT-II.
- Press CRUISE switch and make sure that CRUISE indicator lights up.
- Drive the vehicle for at least 5 consecutive seconds under the following condition.

VHCL SPEED SE	More than 30 km/h (19 MPH)
Selector lever	Suitable position

If DTC is detected, go to [EC-515, "Diagnostic Procedure"](#) .
If DTC is not detected, go to the following step.

DATA MONITOR	
MONITOR	NO DTC
ENG SPEED	XXX rpm
VHCL SPEED SE	XXX km/h
CRUISE LAMP	ON
BRAKE SW 1	ON
BRAKE SW 2	OFF

PBIB2386E

- Drive the vehicle for at least 5 consecutive seconds under the following condition.

VHCL SPEED SE	More than 30 km/h (19 MPH)
Selector lever	Suitable position
Driving location	Depress the brake pedal for more than 5 seconds so as not to come off from the above-mentioned condition.

- If 1st trip DTC is detected, go to [EC-515, "Diagnostic Procedure"](#) .

WITH GST

Follow the procedure "WITH CONSULT-II" above.

DTC P1572 ASCD BRAKE SWITCH

[QR]

UBS0032B

Wiring Diagram

EC-ASC/BS-01

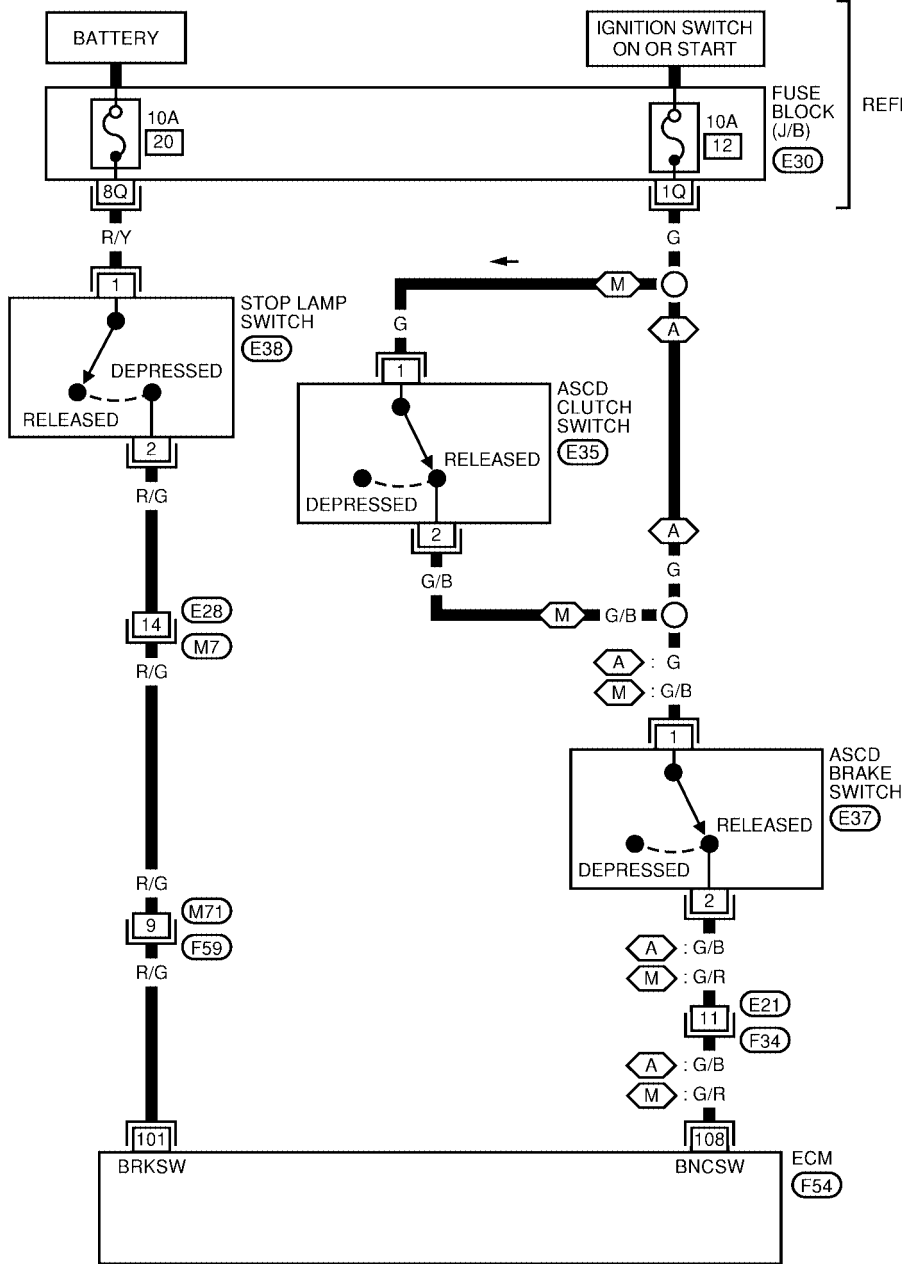

REFER TO "PG-POWER".

(A) : WITH A/T
(M) : WITH M/T

(A) : G
(M) : G/B

(A) : G/B
(M) : G/R

(A) : G/B
(M) : G/R

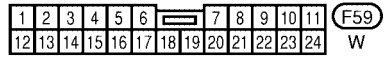
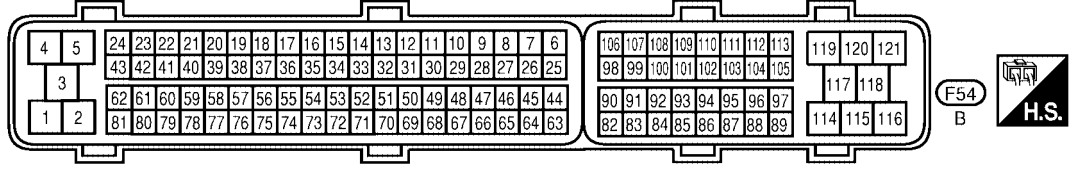
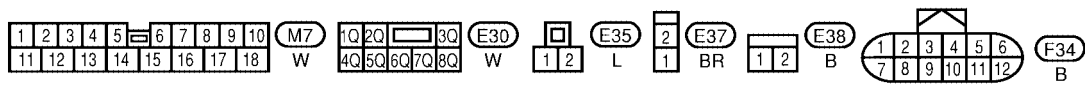

BBWA1244E

DTC P1572 ASCD BRAKE SWITCH

[QR]

Specification data are reference values and are measured between each terminal and ground.

CAUTION:

Do not use ECM ground terminals when measuring input/output voltage. Doing so may result in damage to the ECM's transistor. Use a ground other than ECM terminals, such as the ground.

TERMI- NAL NO.	WIRE COLOR	ITEM	CONDITION	DATA (DC Voltage)
101	R/G	Stop lamp switch	[Ignition switch: ON] <ul style="list-style-type: none"> ● Brake pedal: Fully released 	Approximately 0V
			[Ignition switch: ON] <ul style="list-style-type: none"> ● Brake pedal: Depressed 	BATTERY VOLTAGE (11 - 14V)
108	G/B*1 G/R*2	ASCD brake switch	[Ignition switch: ON] <ul style="list-style-type: none"> ● Brake pedal: Depressed ● Clutch pedal: Depressed (M/T) 	Approximately 0V
			[Ignition switch: ON] <ul style="list-style-type: none"> ● Brake pedal: Fully released ● Clutch pedal: Released (M/T) 	BATTERY VOLTAGE (11 - 14V)

*1: A/T models

*2: M/T models

Diagnostic Procedure

1. CHECK OVERALL FUNCTION-I

With CONSULT-II

1. Turn ignition switch ON.
2. Select "BRAKE SW1" in "DATA MONITOR" mode with CONSULT-II.
3. Check "BRAKE SW1" indication under the following conditions.

M/T models

CONDITION	INDICATION
When clutch pedal or brake pedal: Depressed	OFF
When clutch pedal and brake pedal: Fully released	ON

A/T models

CONDITION	INDICATION
When brake pedal: Depress	OFF
When brake pedal: Fully released	ON

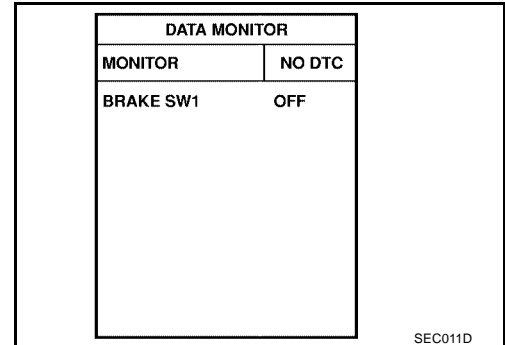

Without CONSULT-II

1. Turn ignition switch ON.
2. Check voltage between ECM terminal 108 and ground under the following conditions.

M/T models

CONDITION	VOLTAGE
When clutch pedal or brake pedal: Depressed	Approximately 0V
When clutch pedal and brake pedal: Fully released	Battery voltage

A/T models

CONDITION	VOLTAGE
When brake pedal: Depress	Approximately 0V
When brake pedal: Fully released	Battery voltage

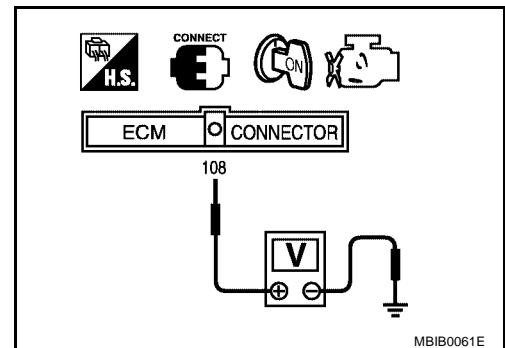

OK or NG

- OK >> GO TO 2.
- NG (M/T models) >>GO TO 3.
- NG (A/T models) >>GO TO 8.

2. CHECK OVERALL FUNCTION-II

① With CONSULT-II

Check "BRAKE SW2" indication in "DATA MONITOR" mode.

CONDITION	INDICATION
When brake pedal: Released	OFF
When brake pedal: Depressed	ON

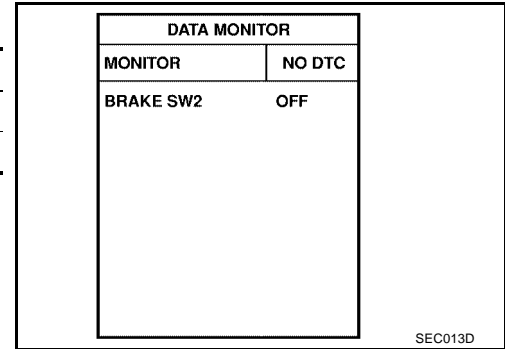

⊗ Without CONSULT-II

Check voltage between ECM terminal 101 and ground under the following conditions.

CONDITION	VOLTAGE
When brake pedal: Released	Approximately 0V
When brake pedal: Depressed	Battery voltage

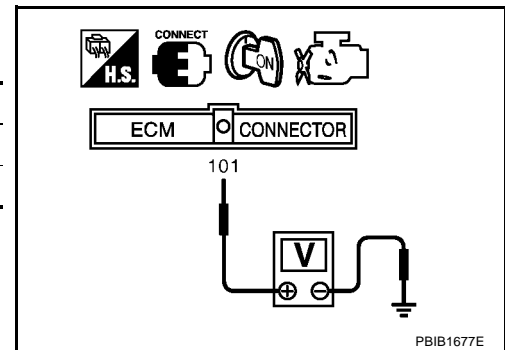

OK or NG

- OK >> GO TO 18.
- NG >> GO TO 13.

3. CHECK ASCD CLUTCH SWITCH CIRCUIT

1. Turn ignition switch OFF.
2. Disconnect ASCD brake switch harness connector.
3. Turn ignition switch ON.

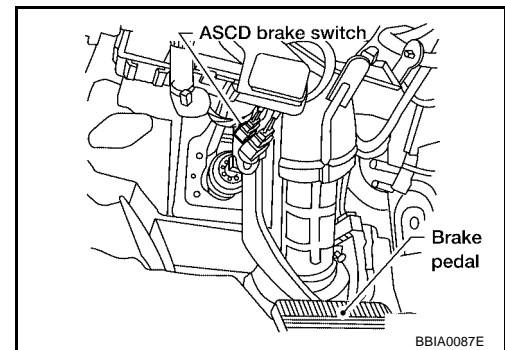

4. Check voltage between ASCD brake switch terminal 1 and ground under the following conditions with CONSULT-II or tester.

CONDITION	VOLTAGE
When clutch pedal: Released	Battery voltage
When clutch pedal: Depressed	Approx. 0V

OK or NG

- OK >> GO TO 10.
- NG >> GO TO 4.

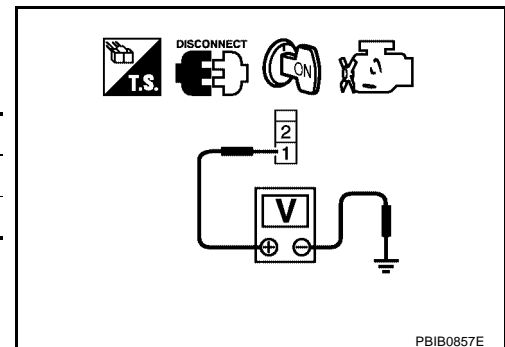

4. CHECK ASCD CLUTCH SWITCH POWER SUPPLY CIRCUIT

1. Turn ignition switch OFF.
2. Disconnect ASCD clutch switch harness connector.
3. Turn ignition switch ON.

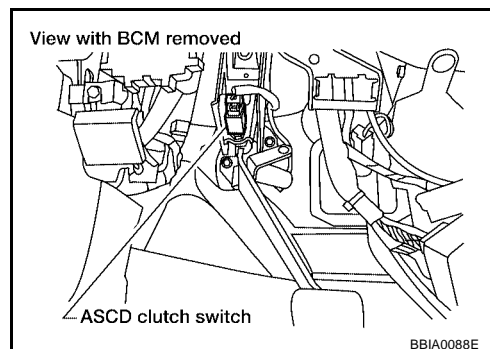

4. Check voltage between ASCD clutch switch terminal 1 and ground with CONSULT-II or tester.

Voltage: Battery voltage

OK or NG

- OK >> GO TO 6.
- NG >> GO TO 5.

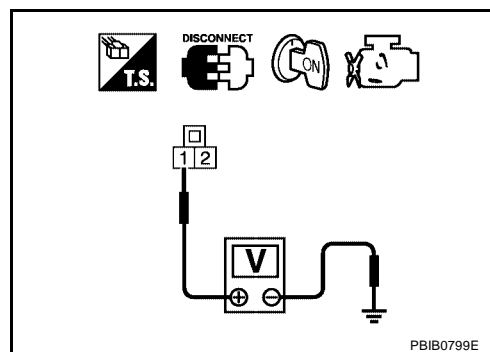

5. DETECT MALFUNCTIONING PART

Check the following.

- Fuse block (J/B) connector E30
- 10A fuse
- Harness for open or short between ASCD clutch switch and fuse

>> Repair open circuit or short to ground or short to power in harness or connectors.

6. CHECK ASCD CLUTCH SWITCH INPUT SIGNAL CIRCUIT FOR OPEN AND SHORT

1. Turn ignition switch OFF.
2. Check harness continuity between ASCD clutch switch terminal 2 and ASCD brake switch terminal 1. Refer to Wiring Diagram.

Continuity should exist.

3. Also check harness for short to ground and short to power.

OK or NG

- OK >> GO TO 7.
- NG >> Repair open circuit or short to ground or short to power in harness or connectors.

7. CHECK ASCD CLUTCH SWITCH

Refer to [EC-520, "Component Inspection"](#)

OK or NG

- OK >> GO TO 18.
- NG >> Replace ASCD clutch switch.

8. CHECK ASCD BRAKE SWITCH POWER SUPPLY CIRCUIT

1. Turn ignition switch OFF.
2. Disconnect ASCD brake switch harness connector.
3. Turn ignition switch ON.

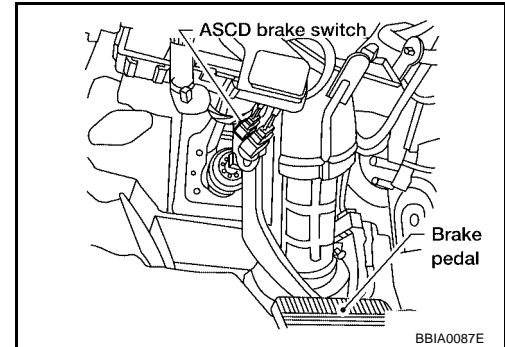

4. Check voltage between ASCD brake switch terminal 1 and ground with CONSULT-II or tester.

Voltage: Battery voltage

OK or NG

- OK >> GO TO 10.
- NG >> GO TO 9.

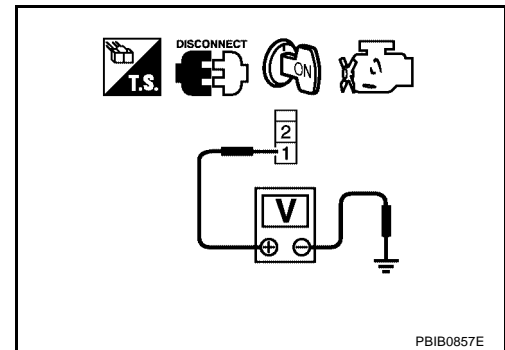

9. DETECT MALFUNCTIONING PART

Check the following.

- Fuse block (J/B) connector E30
- 10A fuse
- Harness for open or short between ASCD brake switch and fuse

>> Repair open circuit or short to ground or short to power in harness or connectors.

10. CHECK ASCD BRAKE SWITCH INPUT SIGNAL CIRCUIT FOR OPEN AND SHORT

1. Turn ignition switch OFF.
2. Disconnect ECM harness connector.
3. Check harness continuity between ECM terminal 108 and ASCD brake switch terminal 2. Refer to Wiring Diagram.

Continuity should exist.

4. Also check harness for short to ground or short to power.

OK or NG

- OK >> GO TO 12.
- NG >> GO TO 11.

11. DETECT MALFUNCTIONING PART

Check the following.

- Harness connectors E21, F34
- Harness for open or short between ECM and ASCD brake switch

>> Repair open circuit or short to ground or short to power in harness or connectors.

12. CHECK ASCD BRAKE SWITCH

Refer to [EC-520, "Component Inspection"](#)

OK or NG

- OK >> GO TO 18.
 NG >> Replace ASCD brake switch.

13. CHECK STOP LAMP SWITCH POWER SUPPLY CIRCUIT

1. Turn ignition switch OFF.
2. Disconnect stop lamp switch harness connector.

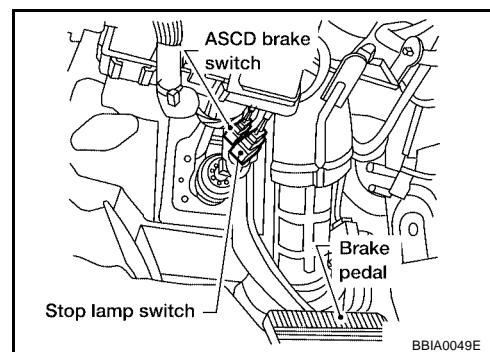

3. Check voltage between stop lamp switch terminal 1 and ground with CONSULT -II or tester.

Voltage: Battery voltage

OK or NG

- OK >> GO TO 15.
 NG >> GO TO 14.

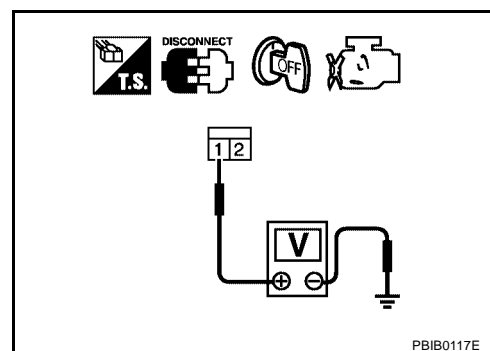

14. DETECT MALFUNCTIONING PART

Check the following.

- Fuse block (J/B) connector E30
- 10A fuse
- Harness for open or short between stop lamp switch and fuse

>> Repair open circuit or short to ground or short to power in harness or connectors.

15. CHECK STOP LAMP SWITCH INPUT SIGNAL CIRCUIT FOR OPEN AND SHORT

1. Disconnect ECM harness connector.
2. Check harness continuity between ECM terminal 101 and stop lamp switch terminal 2. Refer to Wiring Diagram.

Continuity should exist.

3. Also check harness for short to ground and short to power.

OK or NG

- OK >> GO TO 17.
 NG >> GO TO 16.

16. DETECT MALFUNCTIONING PART

Check the following.

- Harness connectors E28, M7
- Harness connectors M71, F59
- Harness for open or short between ECM and stop lamp switch

>> Repair open circuit or short to ground or short to power in harness or connectors.

17. CHECK STOP LAMP SWITCH

Refer to [EC-520, "Component Inspection"](#)

OK or NG

- OK >> GO TO 18.
 NG >> Replace stop lamp switch.

18. CHECK INTERMITTENT INCIDENT

Refer to [EC-158, "TROUBLE DIAGNOSIS FOR INTERMITTENT INCIDENT"](#) .

>> INSPECTION END

Component Inspection ASCD BRAKE SWITCH

UBS0032D

1. Turn ignition switch OFF.
2. Disconnect ASCD brake switch harness connector.
3. Check continuity between ASCD brake switch terminals 1 and 2 under the following conditions.

Condition	Continuity
When brake pedal is fully released.	Should exist.
When brake pedal is depressed.	Should not exist.

If NG, adjust ASCD brake switch installation, refer to [BR-6, "BRAKE PEDAL"](#) , and perform step 3 again.

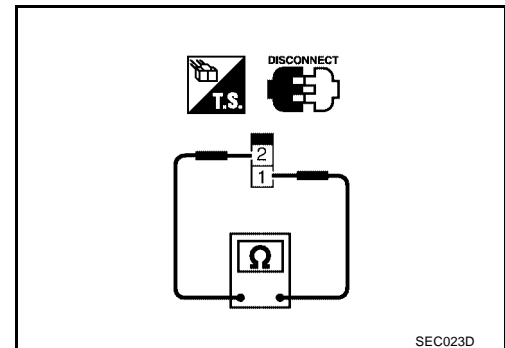

ASCD CLUTCH SWITCH (FOR M/T MODELS)

1. Turn ignition switch OFF.
2. Disconnect ASCD clutch switch harness connector.
3. Check continuity between ASCD clutch switch terminals 1 and 2 under the following conditions.

Condition	Continuity
When clutch pedal is fully released.	Should exist.
When clutch pedal is depressed.	Should not exist.

If NG, adjust ASCD clutch switch installation, refer to [CL-5, "CLUTCH PEDAL"](#) , and perform step 3 again.

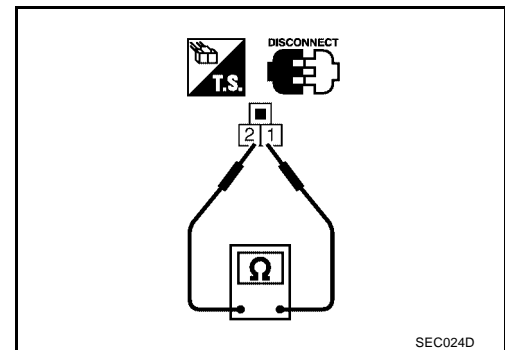

STOP LAMP SWITCH

1. Turn ignition switch OFF.
2. Disconnect stop lamp switch harness connector.
3. Check continuity between stop lamp switch terminals 1 and 2 under the following conditions.

Condition	Continuity
When brake pedal is fully released.	Should not exist.
When brake pedal is depressed.	Should exist.

If NG, adjust stop lamp switch installation, refer to [BR-6](#), "[BRAKE PEDAL](#)", and perform step 3 again.

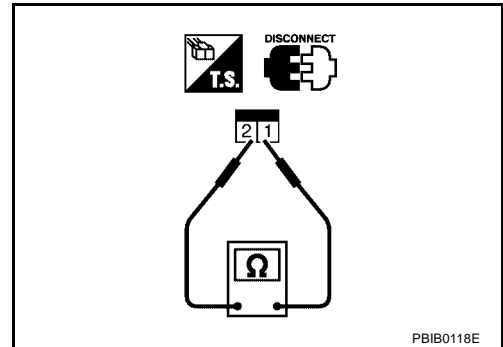

A
EC
C
D
E
F
G
H
I
J
K
L
M

DTC P1574 ASCD VEHICLE SPEED SENSOR

[QR]

DTC P1574 ASCD VEHICLE SPEED SENSOR

PF3:31036

Component Description

UBS0032E

The ECM receives two vehicle speed sensor signals via CAN communication line. One is sent from combination meter, and the other is from TCM (Transmission control module). The ECM uses these signals for ASCD control. Refer to [EC-34, "AUTOMATIC SPEED CONTROL DEVICE \(ASCD\)"](#) for ASCD functions.

On Board Diagnosis Logic

UBS0032F

This self-diagnosis has the one trip detection logic.
The MIL will not light up for this diagnosis.

NOTE:

- If DTC P1574 is displayed with DTC U1000, U1001, first perform the trouble diagnosis for DTC U1000, U1001. Refer to [EC-166, "DTC U1000, U1001 CAN COMMUNICATION LINE"](#).
- If DTC P1574 is displayed with DTC P0500, first perform the trouble diagnosis for DTC P0500. Refer to [EC-359, "DTC P0500 VSS"](#).
- If DTC P1574 is displayed with DTC P0605, first perform the trouble diagnosis for DTC P0605. Refer to [EC-370, "DTC P0605 ECM"](#).

DTC No.	Trouble Diagnosis Name	DTC Detecting Condition	Possible Cause
P1574 1574	ASCD vehicle speed sensor	ECM detects a difference between two vehicle speed signals is out of the specified range.	<ul style="list-style-type: none">● Harness or connectors (The CAN communication line is open or shorted.)● Harness or connectors (The combination meter circuit is open or shorted.)● TCM● Combination meter● Vehicle speed sensor● ECM

DTC Confirmation Procedure

UBS0032G

CAUTION:

Always drive vehicle at a safe speed.

NOTE:

If DTC Confirmation Procedure has been previously conducted, always turn ignition switch OFF and wait at least 10 seconds before conducting the next test.

TESTING CONDITION:

Step 3 may be conducted with the drive wheels lifted in the shop or by driving the vehicle. If a road test is expected to be easier, it is unnecessary to lift the vehicle.

④ WITH CONSULT-II

1. Start engine.
2. Select "DATA MONITOR" mode with CONSULT-II.
3. Drive the vehicle at more than 40 km/h (25MPH).
4. If 1st trip DTC is detected, go to [EC-523, "Diagnostic Procedure"](#).

DATA MONITOR	
MONITOR	NO DTC
ENG SPEED	XXX rpm

SEF058Y

④ WITH GST

Follow the procedure "WITH CONSULT-II" above.

DTC P1574 ASCD VEHICLE SPEED SENSOR

[QR]

UBS0032H

Diagnostic Procedure

1. CHECK DTC WITH TCM

Check DTC with TCM. Refer to [AT-39, "ON BOARD DIAGNOSTIC SYSTEM DESCRIPTION"](#).

OK or NG

OK >> GO TO 2.

NG >> Perform trouble shooting relevant to DTC indicated.

2. CHECK DTC WITH "ABS ACTUATOR AND ELECTRIC UNIT"

Refer to [BRC-8, "TROUBLE DIAGNOSIS"](#).

OK or NG

OK >> GO TO 3.

NG >> Repair or replace.

3. CHECK COMBINATION METER

Check combination meter function.

Refer to [DI-4, "COMBINATION METERS"](#).

>> INSPECTION END

A

EC

C

D

E

F

G

H

I

J

K

L

M

DTC P1706 PNP SWITCH

[QR]

PFP:32006

DTC P1706 PNP SWITCH

Component Description

UBS0032I

When the shift lever position is P (A/T models only) or N, park/neutral position (PNP) switch is ON. ECM detects the position because the continuity of the line (the ON signal) exists.

CONSULT-II Reference Value in Data Monitor Mode

UBS0032J

Specification data are reference values.

MONITOR ITEM	CONDITION		SPECIFICATION
P/N POSI SW	● Ignition switch: ON	Shift lever: P or N (A/T model) Neutral (M/T model)	ON
		Shift lever: Except above	OFF

On Board Diagnosis Logic

UBS0032K

DTC No.	Trouble diagnosis name	DTC detecting condition	Possible cause
P1706 1706	Park/neutral position switch	The signal of the park/neutral position (PNP) switch is not changed in the process of engine starting and driving.	<ul style="list-style-type: none"> ● Harness or connectors [The park/neutral position (PNP) switch circuit is open or shorted.] ● Park/neutral position (PNP) switch

DTC Confirmation Procedure

UBS0032L

CAUTION:

Always drive vehicle at a safe speed.

NOTE:

If DTC Confirmation Procedure has been previously conducted, always turn ignition switch OFF and wait at least 10 seconds before conducting the next test.

WITH CONSULT-II

1. Turn ignition switch ON.
2. Select "P/N POSI SW" in "DATA MONITOR" mode with CONSULT-II. Then check the "P/N POSI SW" signal under the following conditions.

Position (Selector lever)	Known-good signal
P or N position	ON
Except the above position	OFF

If NG, go to [EC-528, "Diagnostic Procedure"](#) .

If OK, go to following step.

3. Select "DATA MONITOR" mode with CONSULT-II.
4. Start engine and warm it up to normal operating temperature.
5. Maintain the following conditions for at least 60 consecutive seconds.

ENG SPEED	More than 1,500 rpm
COOLAN TEMP/S	More than 70°C (158°F)
B/FUEL SCHDL	3.0 - 31.8 msec
VHCL SPEED SE	More than 64 km/h (40 MPH)
Selector lever	Suitable position

6. If 1st trip DTC is detected, go to [EC-528, "Diagnostic Procedure"](#)

DATA MONITOR	
MONITOR	NO DTC
P/N POSI SW	ON

SEF212Y

DATA MONITOR	
MONITOR	NO DTC
ENG SPEED	XXX rpm
COOLAN TEMP/S	XXX °C
VHCL SPEED SE	XXX km/h
P/N POSI SW	OFF
B/FUEL SCHDL	XXX msec

SEF213Y

DTC P1706 PNP SWITCH

[QR]

UBS0032M

Overall Function Check

Use this procedure to check the overall function of the park/neutral position (PNP) switch circuit. During this check, a 1st trip DTC might not be confirmed.

WITH GST

1. Turn ignition switch ON.
2. Check voltage between ECM terminal 102 (PNP switch signal) and ground under the following conditions.

Condition (Gear position)	Voltage V (Known good data)
P or N position (A/T) Neutral position (M/T)	Approx. 0
Except the above position	A/T: Battery voltage M/T: Approximately 5V

3. If NG, go to [EC-528, "Diagnostic Procedure"](#) .

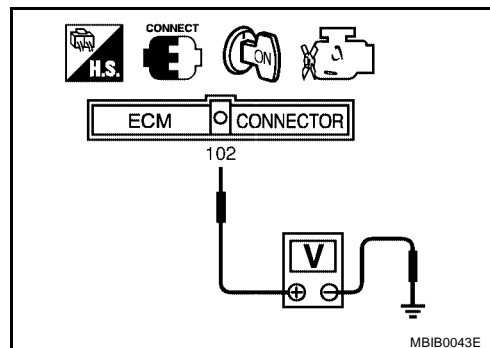

A
EC
C
D
E
F
G
H
I
J
K
L
M

DTC P1706 PNP SWITCH

[QR]

UBS0032N

Wiring Diagram AT MODELS

EC-PNP/SW-01

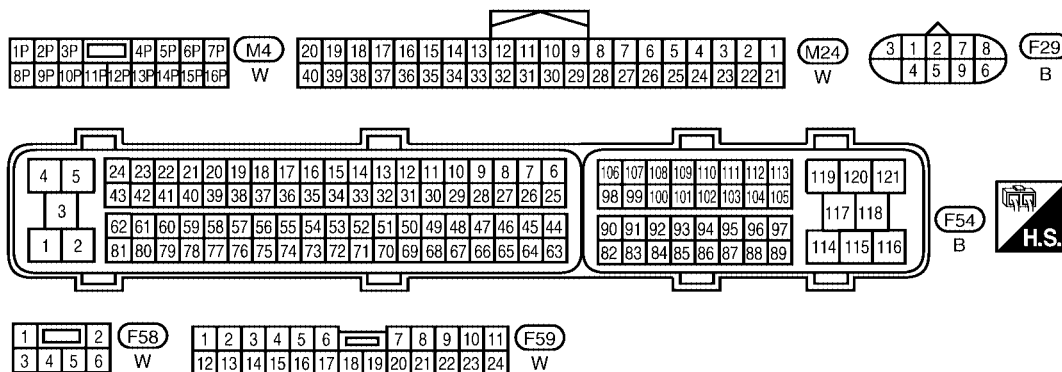
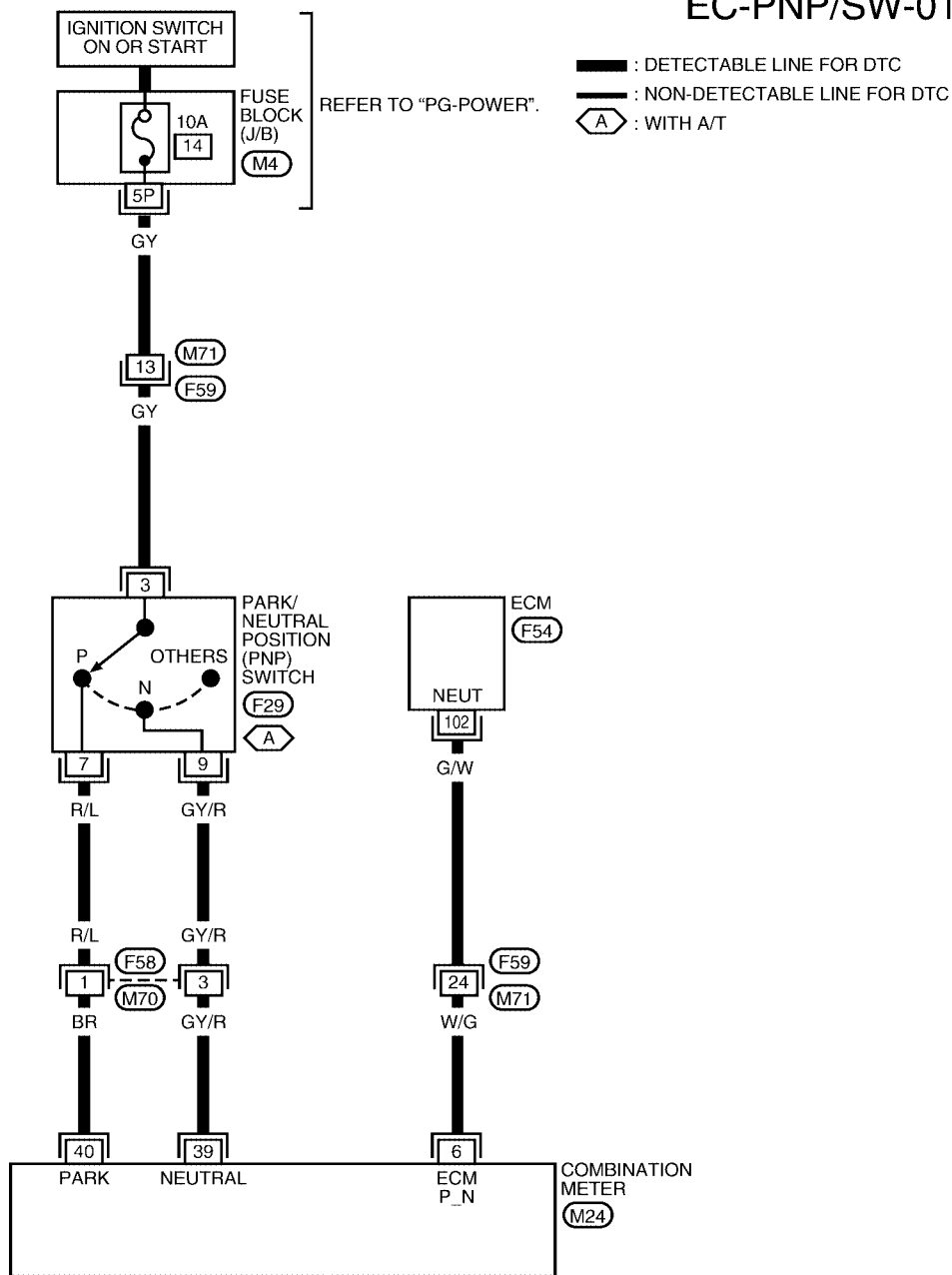

WBWA0109E

DTC P1706 PNP SWITCH

[QR]

MT MODELS

EC-PNP/SW-02

A
EC
C
D
E
F
G
H
I
J
K
L
M

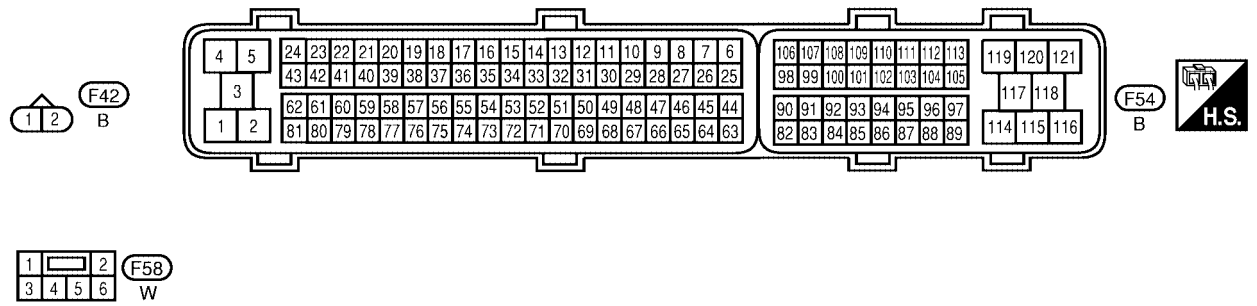
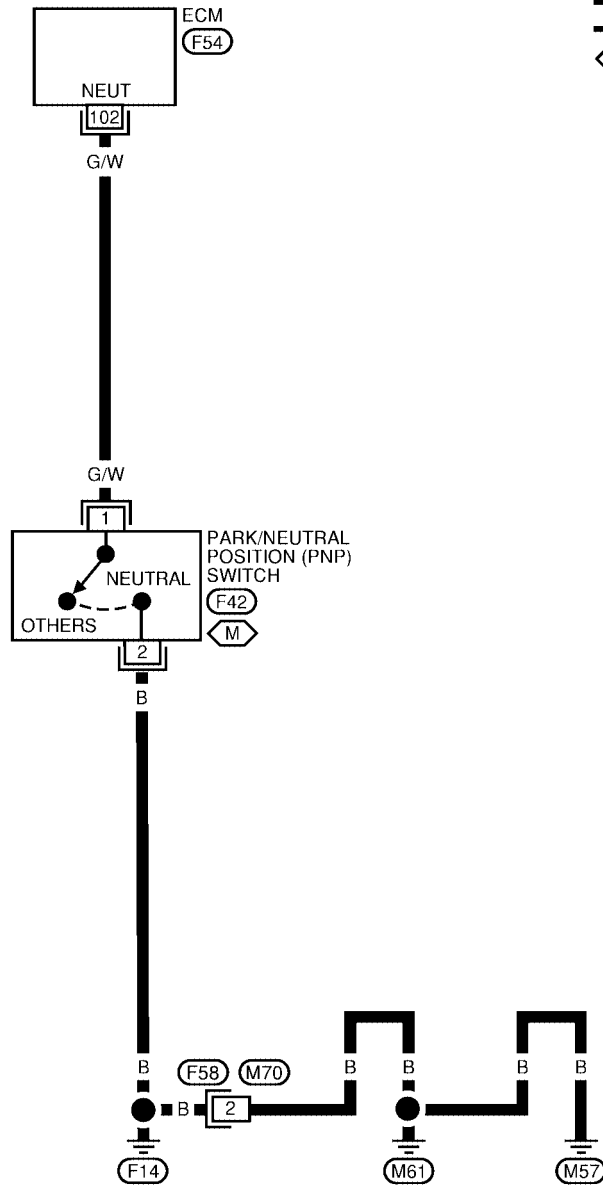

BBWA1246E

DTC P1706 PNP SWITCH

[QR]

Specification data are reference values and are measured between each terminal and ground.

CAUTION:

Do not use ECM ground terminals when measuring input/output voltage. Doing so may result in damage to the ECM's transistor. Use a ground other than ECM terminals, such as the ground.

TER-MINAL NO.	WIRE COLOR	ITEM	CONDITION	DATA (DC Voltage)
102	GW	PNP switch	[Ignition switch: ON] ● Gear position is P or N	Approximately 0V
			[Ignition switch: ON] ● Except the above gear position	A/T models BATTERY VOLTAGE (11 - 14V) M/T models Approximately 5V

Diagnostic Procedure

UBS00CVR

1. CONFIRM THE TRANSMISSION TYPE

Which type of transmission (A/T or M/T) is on the vehicle?

A/T or MT

A/T >> Go to [EC-528, "PROCEDURE A"](#) .

M/T >> Go to [EC-531, "PROCEDURE B"](#) .

PROCEDURE A

1. CHECK STARTING SYSTEM

Turn ignition switch OFF, then turn it to START.

Does starter motor operate?

Yes or No

Yes >> GO TO 2.

No >> Refer to [SC-9, "STARTING SYSTEM"](#) .

2. CHECK PNP SWITCH INPUT SIGNAL CIRCUIT FOR OPEN AND SHORT-I

1. Turn ignition switch OFF.
2. Disconnect combination meter harness connector M24.
3. Turn ignition switch ON.
4. Check voltage between combination meter terminals 39, 40 and ground with CONSULT-II or tester under the following conditions.

Condition (Shift position)	Voltage
P position	BATTERY VOLTAGE (11 - 14V)
N position	BATTERY VOLTAGE (11 - 14V)
Except the above position	Approximately 0 V

OK or NG

OK >> GO TO 9.

NG >> GO TO 3.

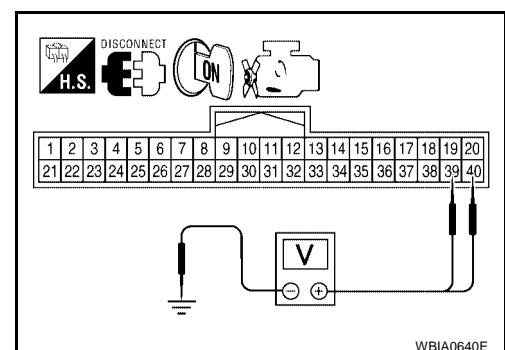

WBIA0640E

3. CHECK PNP SWITCH POWER SUPPLY CIRCUIT

1. Turn ignition switch OFF.
2. Disconnect PNP switch harness connector.
3. Turn ignition switch ON.

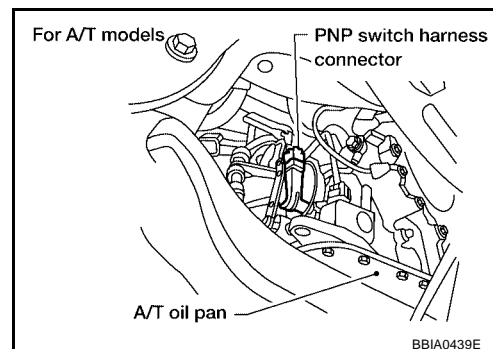

4. Check voltage between PNP switch terminal 3 and ground with CONSULT-II or tester.

Voltage: Battery voltage

OK or NG

- OK >> GO TO 5.
 NG >> GO TO 4.

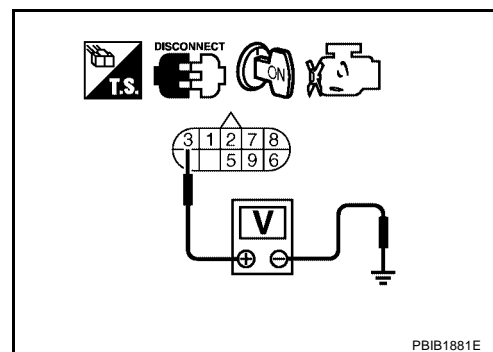

4. DETECT MALFUNCTIONING PART

Check the following.

- Harness connectors M71, F59
- 10A fuse
- Fuse block (J/B) connector M4
- Harness for open or short between PNP switch and fuse

>> Repair open circuit or short to ground or short to power in harness or connectors.

5. CHECK PNP SWITCH INPUT SIGNAL CIRCUIT FOR OPEN AND SHORT-I

1. Check harness continuity between PNP switch terminals 7, 9 and combination meter terminals 39, 40. Refer to Wiring Diagram.

Continuity should exist.

2. Also check harness for short to ground and short to power.

OK or NG

- OK >> GO TO 7.
 NG >> GO TO 6.

6. DETECT MALFUNCTIONING PART

Check the following.

- Harness connectors F58, M70
- Harness for open or short between PNP switch and combination meter

>> Repair open circuit or short to ground or short to power in harness or connectors.

7. CHECK PNP SWITCH

Refer to [AT-105, "DTC P0705 PARK/NEUTRAL POSITION SWITCH"](#) .

OK or NG

- OK >> GO TO 8.
- NG >> Replace PNP switch.

8. CHECK INTERMITTENT INCIDENT

Refer to [EC-158, "TROUBLE DIAGNOSIS FOR INTERMITTENT INCIDENT"](#) .

>> **INSPECTION END**

9. CHECK PNP SWITCH INPUT SIGNAL CIRCUIT FOR OPEN AND SHORT-II

1. Turn ignition switch OFF.
2. Disconnect ECM harness connector.
3. Check harness continuity between ECM terminal 102 and combination meter terminal 6.
Refer to Wiring Diagram.

Continuity should exist.

4. Also check harness for short to ground and short to power.

OK or NG

- OK >> GO TO 11.
- NG >> GO TO 10.

10. DETECT MALFUNCTIONING PART

Check the following.

- Harness connectors M71, F59
- Harness for open or short between ECM and combination meter

>> Repair open circuit or short to ground or short to power in harness or connectors.

11. REPLACE COMBINATION METER

Refer to [DI-4, "COMBINATION METERS"](#) .

OK or NG

- OK >> GO TO 12.
- NG >> Replace combination meter

12. CHECK INTERMITTENT INCIDENT

Refer to [EC-158, "TROUBLE DIAGNOSIS FOR INTERMITTENT INCIDENT"](#) .

>> **INSPECTION END**

PROCEDURE B**1. CHECK PNP SWITCH GROUND CIRCUIT FOR OPEN AND SHORT**

1. Turn ignition switch OFF.
2. Disconnect PNP switch harness connector.
3. Check harness continuity between PNP switch terminal 2 and ground.
Refer to Wiring Diagram.

Continuity should exist.

4. Also check harness for short to power.

OK or NG

- OK >> GO TO 3
NG >> GO TO 2.

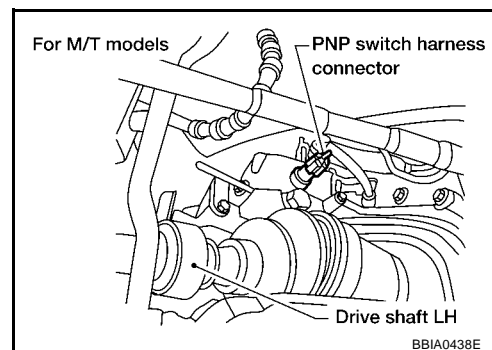
**2. DETECT MALFUNCTIONING PART**

Check the following.

- Harness connectors F58, M70
- Harness for open or short between PNP switch and ground

>> Repair open circuit or short to power in harness or connectors.

3. CHECK PNP SWITCH INPUT SIGNAL CIRCUIT FOR OPEN AND SHORT

1. Disconnect ECM harness connector.
2. Check harness continuity between ECM terminal 102 and PNP switch terminal 1.
Refer to Wiring Diagram.

Continuity should exist.

3. Also check harness for short to ground and short to power.

OK or NG

- OK >> GO TO 4.
NG >> Repair open circuit or short to ground or short to power in harness or connectors.

4. CHECK PNP SWITCH

Refer to [MT-13. "POSITION SWITCH"](#) .

OK or NG

- OK >> GO TO 5.
NG >> Replace PNP switch.

5. CHECK INTERMITTENT INCIDENT

Refer to [EC-158. "TROUBLE DIAGNOSIS FOR INTERMITTENT INCIDENT"](#) .

>> **INSPECTION END**

DTC P1800 VIAS CONTROL SOLENOID VALVE

Component Description

UBS00C7P

The VIAS control solenoid valve cuts the intake manifold vacuum signal for power valve control. It responds to ON/OFF signals from the ECM. When the solenoid is OFF, the vacuum signal from the intake manifold is cut. When the ECM sends an ON signal the coil pulls the plunger downward and feeds the vacuum signal to the power valve actuator.

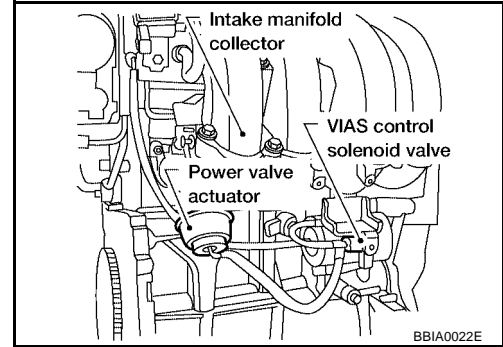

CONSULT-II Reference Value in Data Monitor Mode

UBS00C7Q

Specification data are reference values.

MONITOR ITEM	CONDITION		SPECIFICATION
VIAS S/V	● Engine: After warming up	Idle	OFF
		More than 5,000 rpm	ON

On Board Diagnosis Logic

UBS00C7R

The MIL will not light up for this self-diagnosis.

DTC No.	Trouble diagnosis name	DTC detecting condition	Possible cause
P1800 1800	VIAS control solenoid valve circuit	An excessively low or high voltage signal is sent to ECM through the valve	<ul style="list-style-type: none"> ● Harness or connectors (The solenoid valve circuit is open or shorted.) ● VIAS control solenoid valve

DTC Confirmation Procedure

UBS00C7S

NOTE:

If DTC Confirmation Procedure has been previously conducted, always turn ignition switch OFF and wait at least 10 seconds before conducting the next test.

TESTING CONDITION:

Before performing the following procedure, confirm that battery voltage is between 11V at idle.

WITH CONSULT-II

1. Turn ignition switch ON.
2. Select "DATA MONITOR" mode with CONSULT-II.
3. Start engine and let it idle for at least 5 seconds.
4. If 1st trip DTC is detected, go to [EC-534, "Diagnostic Procedure"](#)

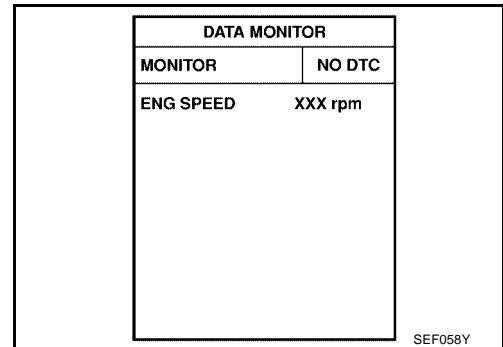

WITH GST

Follow the procedure "WITH CONSULT-II" above.

DTC P1800 VIAS CONTROL SOLENOID VALVE

[QR]

Wiring Diagram

UBS00C7T

EC-VIAS/V

A
EC
C
D
E
F
G
H
I
J
K
L
M

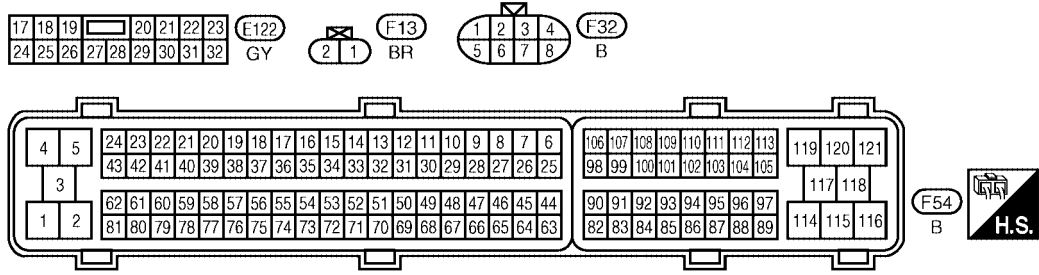
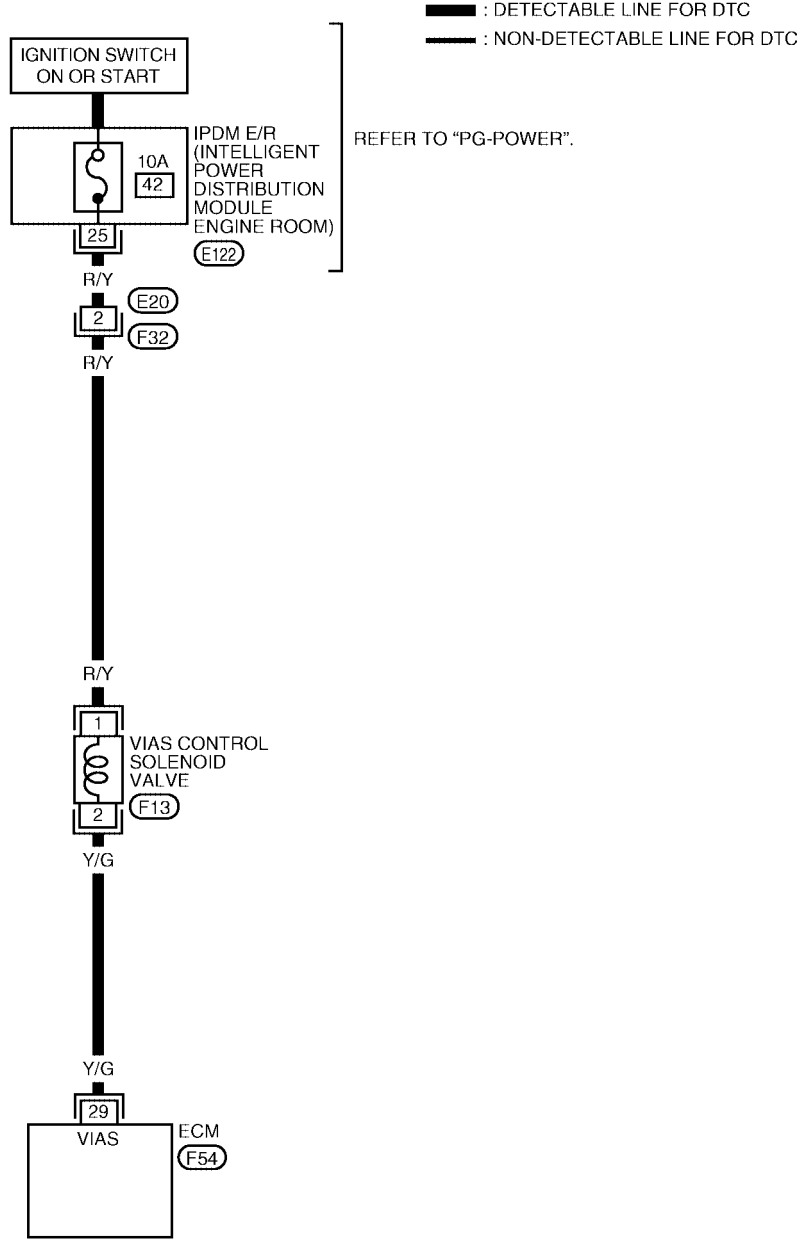

BBWA1256E

DTC P1800 VIAS CONTROL SOLENOID VALVE

[QR]

Specification data are reference values and are measured between each terminal and ground.

CAUTION:

Do not use ECM ground terminals when measuring input/output voltage. Doing so may result in damage to the ECM's transistor. Use a ground other than ECM terminals, such as the ground.

TER-MINAL NO.	WIRE COLOR	ITEM	CONDITION	DATA (DC Voltage)
29	Y/G	VIAS control solenoid valve	[Engine is running] ● Idle speed	BATTERY VOLTAGE (11 - 14V)
			[Engine is running] ● Engine speed is above 5,000 rpm	0 - 1.0V

Diagnostic Procedure

UBS00C7U

1. CHECK VIAS CONTROL SOLENOID VALVE POWER SUPPLY CIRCUIT

1. Turn ignition switch OFF.
2. Disconnect VIAS control solenoid valve harness connector.
3. Turn ignition switch ON.

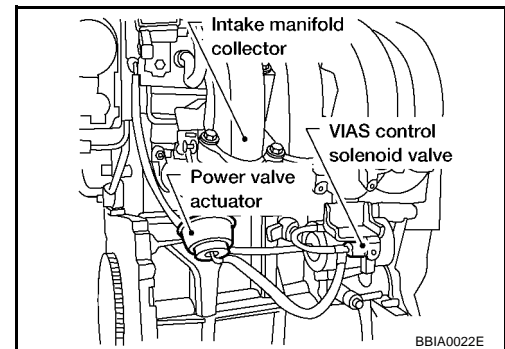

4. Check voltage between terminal 1 and ground with CONSULT-II or tester.

Voltage: Battery voltage

OK or NG

- OK >> GO TO 3.
- NG >> GO TO 2.

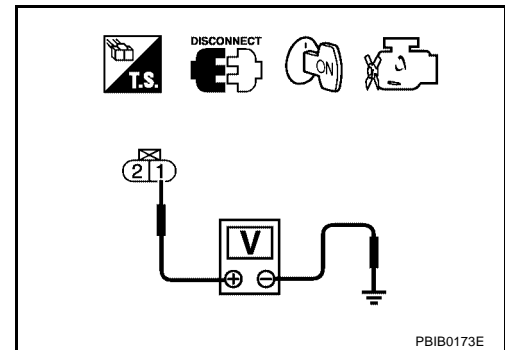

2. DETECT MALFUNCTIONING PART

Check the following.

- Harness connectors E20, F32
- IPDM E/R connector E122
- 10A fuse
- Harness for open or short between IPDM E/R and VIAS control solenoid valve

>> Repair or replace harness or connectors.

3. CHECK VIAS CONTROL SOLENOID VALVE OUTPUT SIGNAL CIRCUIT FOR OPEN AND SHORT

1. Turn ignition switch OFF.
2. Disconnect ECM harness connector.
3. Check harness continuity between ECM terminal 29 and VIAS control solenoid valve terminal 2. Refer to Wiring Diagram.

Continuity should exist.

4. Also check harness for short to ground and short to power.

OK or NG

OK >> GO TO 4.

NG >> Repair open circuit or short to ground or short to power in harness or connectors.

4. CHECK VIAS CONTROL SOLENOID VALVE

Refer to [EC-535, "Component Inspection"](#) .

OK or NG

OK >> GO TO 5.

NG >> Replace VIAS control solenoid valve.

5. CHECK INTERMITTENT INCIDENT

Refer to [EC-158, "TROUBLE DIAGNOSIS FOR INTERMITTENT INCIDENT"](#) .

>> INSPECTION END

Component Inspection VIAS CONTROL SOLENOID VALVE

UBS00C7V

Ⓟ With CONSULT-II

1. Reconnect harness connectors disconnected.
2. Turn ignition switch ON.
3. Perform "VIAS SOL VALVE" in "ACTIVE TEST" mode.
4. Check air passage continuity and operation delay time under the following conditions.

Condition VIAS SOL VALVE	Air passage continuity between A and B	Air passage continuity between A and C
ON	Yes	No
OFF	No	Yes

Operation takes less than 1 second.

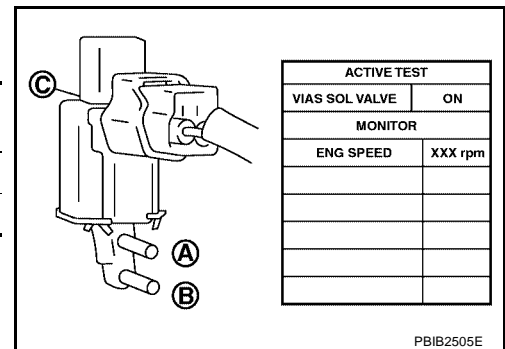

ⓧ Without CONSULT-II

Check air passage continuity and operation delay time under the following conditions.

Condition	Air passage continuity between A and B	Air passage continuity between A and C
12V direct current supply between terminals 1 and 2	Yes	No
No supply	No	Yes

Operation takes less than 1 second.

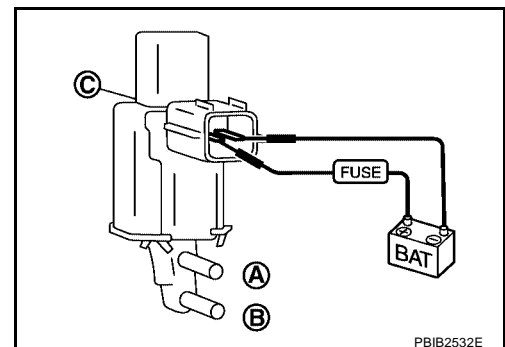

Removal and Installation VIAS CONTROL SOLENOID VALVE

UBS00C7W

Refer to [EM-19, "INTAKE MANIFOLD"](#) .

DTC P1805 BRAKE SWITCH

[QR]

DTC P1805 BRAKE SWITCH

PFP:25320

Description

UBS0032P

Brake switch signal is applied to the ECM through the stop lamp switch when the brake pedal is depressed. This signal is used mainly to decrease the engine speed when the vehicle is driving.

CONSULT-II Reference Value in Data Monitor Mode

UBS0032Q

Specification data are reference values.

MONITOR ITEM	CONDITION		SPECIFICATION
BRAKE SW	● Ignition switch: ON	Brake pedal: Fully released	OFF
		Brake pedal: Slightly depressed	ON

On Board Diagnosis Logic

UBS0032R

The MIL will not light up for this diagnosis.

DTC No.	Trouble diagnosis name	DTC detecting condition	Possible cause
P1805 1805	Brake switch	A brake switch signal is not sent to ECM for extremely long time while the vehicle is driving.	<ul style="list-style-type: none"> ● Harness or connectors (Stop lamp switch circuit is open or shorted.) ● Stop lamp switch

FAIL-SAFE MODE

When the malfunction is detected, the ECM enters fail-safe mode.

Engine operating condition in fail-safe mode	
ECM controls the electric throttle control actuator by regulating the throttle opening to a small range. Therefore, acceleration will be poor.	
Vehicle condition	Driving condition
When engine is idling	Normal
When accelerating	Poor acceleration

DTC Confirmation Procedure

UBS0032S

WITH CONSULT-II

1. Turn ignition switch ON.
2. Fully depress the brake pedal for at least 5 seconds.
3. Erase the DTC with CONSULT-II.
4. Select "DATA MONITOR" mode with CONSULT-II.
5. If 1st trip DTC is detected, go to [EC-539, "Diagnostic Procedure"](#)

DATA MONITOR	
MONITOR	NO DTC
ENG SPEED	XXX rpm
BRAKE SW	ON

PBIB1952E

WITH GST

Follow the procedure "WITH CONSULT-II" above.

DTC P1805 BRAKE SWITCH

[QR]

UBS0032T

Wiring Diagram

EC-BRK/SW-01

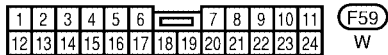
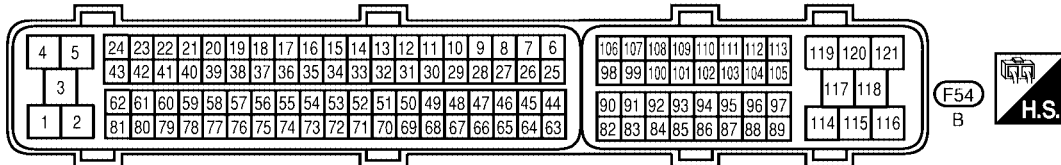
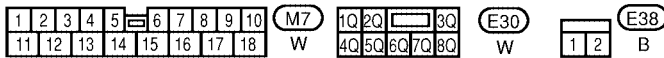
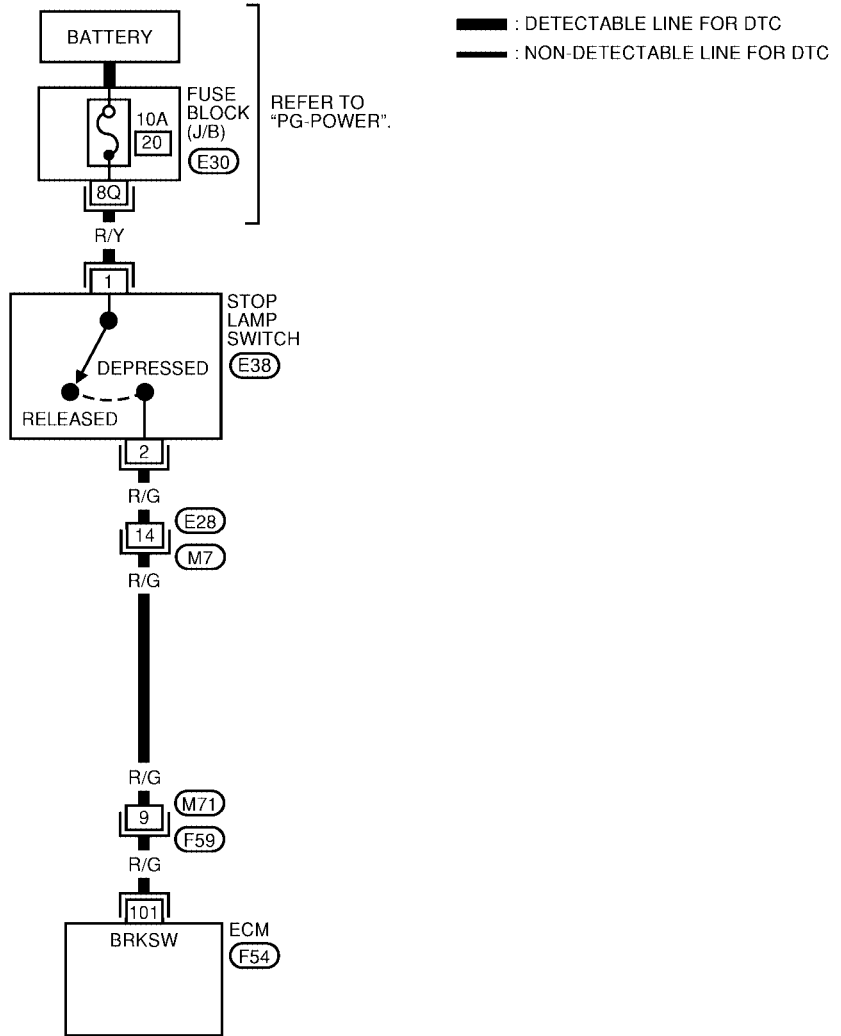

BBWA1247E

DTC P1805 BRAKE SWITCH

[QR]

Specification data are reference values and are measured between each terminal and ground.

CAUTION:

Do not use ECM ground terminals when measuring input/output voltage. Doing so may result in damage to the ECM's transistor. Use a ground other than ECM terminals, such as the ground.

TER-MINAL NO.	WIRE COLOR	ITEM	CONDITION	DATA (DC Voltage)
101	R/G	Stop lamp switch	[Ignition switch: ON] ● Brake pedal: Fully released	Approximately 0V
			[Ignition switch: ON] ● Brake pedal: Depressed	BATTERY VOLTAGE (11 - 14V)

Diagnostic Procedure

UBS0032U

1. CHECK STOP LAMP SWITCH CIRCUIT

- Turn ignition switch OFF.
- Check the stop lamp when depressing and releasing the brake pedal.

Brake pedal	Stop lamp
Fully released	Not illuminated
Depressed	Illuminated

OK or NG

- OK >> GO TO 4.
- NG >> GO TO 2.

2. CHECK STOP LAMP SWITCH POWER SUPPLY CIRCUIT

- Disconnect stop lamp switch harness connector.

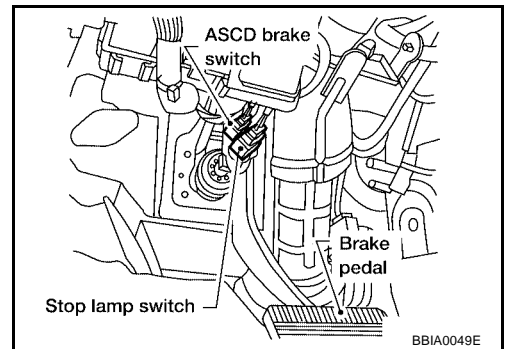

- Check voltage between stop lamp switch terminal 1 and ground with CONSULT-II or tester.

Voltage: Battery voltage

OK or NG

- OK >> GO TO 4.
- NG >> GO TO 3.

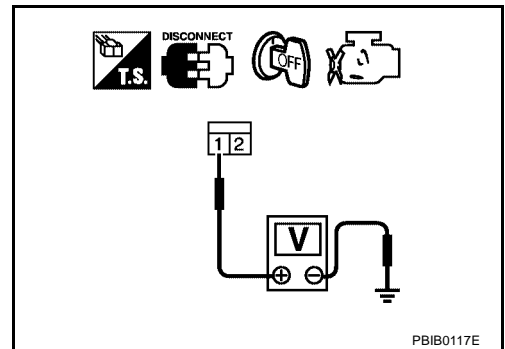

3. DETECT MALFUNCTIONING PART

Check the following.

- 10A fuse
- Fuse block (J/B) connector E30
- Harness for open and short between stop lamp switch and battery

>> Repair open circuit or short to ground or short to power in harness or connectors.

4. CHECK STOP LAMP SWITCH INPUT SIGNAL CIRCUIT FOR OPEN AND SHORT

1. Disconnect ECM harness connector.
2. Check harness continuity between ECM terminal 101 and stop lamp switch terminal 2. Refer to Wiring Diagram.

Continuity should exist.

3. Also check harness for short to ground and short to power.

OK or NG

- OK >> GO TO 6.
NG >> GO TO 5.

5. DETECT MALFUNCTIONING PART

Check the following.

- Harness connectors E28, M7
- Harness connectors M71, F59
- Harness for open or short between ECM and stop lamp switch

>> Repair open circuit or short to ground or short to power in harness or connectors.

6. CHECK STOP LAMP SWITCH

Refer to [EC-540, "Component Inspection"](#) .

OK or NG

- OK >> GO TO 7.
NG >> Replace stop lamp switch.

7. CHECK INTERMITTENT INCIDENT

Refer to [EC-158, "TROUBLE DIAGNOSIS FOR INTERMITTENT INCIDENT"](#) .

>> INSPECTION END

Component Inspection STOP LAMP SWITCH

1. Disconnect stop lamp switch harness connector.

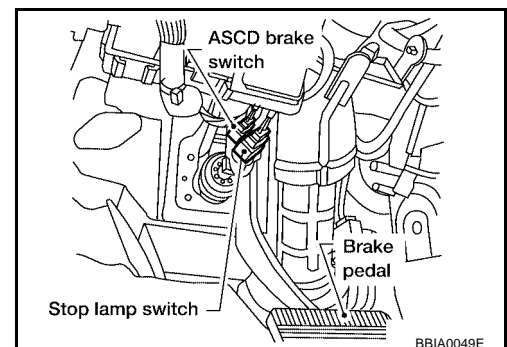

UBS0032V

DTC P1805 BRAKE SWITCH

[QR]

2. Check continuity between stop lamp switch terminals 1 and 2 under the following conditions.

Conditions	Continuity
Brake pedal fully released	Should not exist.
Brake pedal depressed	Should exist.

If NG, adjust brake pedal installation, refer to [BR-6, "BRAKE PEDAL"](#) , and perform step 2 again.

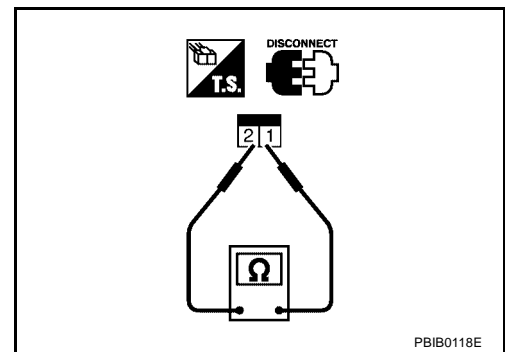

A

EC

C

D

E

F

G

H

I

J

K

L

M

DTC P2122, P2123 APP SENSOR

Component Description

UBS002TV

The accelerator pedal position sensor is installed on the upper end of the accelerator pedal assembly. The sensor detects the accelerator position and sends a signal to the ECM.

Accelerator pedal position sensor has two sensors. These sensors are a kind of potentiometers which transform the accelerator pedal position into output voltage, and emit the voltage signal to the ECM. In addition, these sensors detect the opening and closing speed of the accelerator pedal and feed the voltage signals to the ECM. The ECM judges the current opening angle of the accelerator pedal from these signals and controls the throttle control motor based on these signals.

Idle position of the accelerator pedal is determined by the ECM receiving the signal from the accelerator pedal position sensor. The ECM uses this signal for the engine operation such as fuel cut.

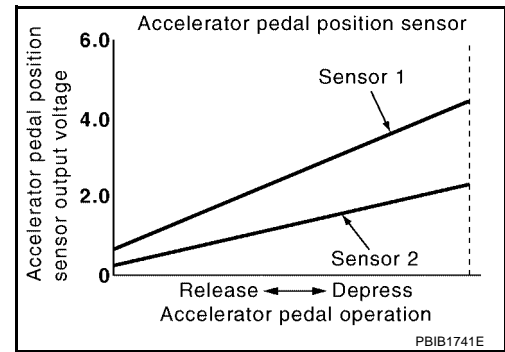

CONSULT-II Reference Value in Data Monitor Mode

UBS002TW

Specification data are reference values.

MONITOR ITEM	CONDITION		SPECIFICATION
ACCEL SEN1	● Ignition switch: ON (Engine stopped)	Accelerator pedal: Fully released	0.65 - 0.87V
		Accelerator pedal: Fully depressed	More than 4.3V
ACCEL SEN2*	● Ignition switch: ON (Engine stopped)	Accelerator pedal: Fully released	0.56 - 0.96V
		Accelerator pedal: Fully depressed	More than 4.0V
CLSD THL POS	● Ignition switch: ON (Engine stopped)	Accelerator pedal: Fully released	ON
		Accelerator pedal: Slightly depressed	OFF

*: Accelerator pedal position sensor 2 signal is converted by ECM internally. Thus, it differs from ECM terminals voltage signal.

On Board Diagnosis Logic

UBS002TX

These self-diagnoses have the one trip detection logic.

NOTE:

If DTC P2122 or P2123 is displayed with DTC P1229, first perform the trouble diagnosis for DTC P1229. Refer to [EC-438](#).

DTC No.	Trouble diagnosis name	DTC detecting condition	Possible cause
P2122 2122	Accelerator pedal position sensor 1 circuit low input	An excessively low voltage from the APP sensor 1 is sent to ECM.	● Harness or connectors (The APP sensor 1 circuit is open or shorted.) ● Accelerator pedal position sensor (Accelerator pedal position sensor 1)
P2123 2123	Accelerator pedal position sensor 1 circuit high input	An excessively high voltage from the APP sensor 1 is sent to ECM.	

FAIL-SAFE MODE

When the malfunction is detected, the ECM enters fail-safe mode and the MIL lights up.

Engine operating condition in fail-safe mode

The ECM controls the electric throttle control actuator in regulating the throttle opening in order for the idle position to be within +10 degrees.

The ECM regulates the opening speed of the throttle valve to be slower than the normal condition.

So, the acceleration will be poor.

DTC Confirmation Procedure

UBS002TY

NOTE:

If DTC Confirmation Procedure has been previously conducted, always turn ignition switch OFF and wait at least 10 seconds before conducting the next test.

TESTING CONDITION:

DTC P2122, P2123 APP SENSOR

[QR]

Before performing the following procedure, confirm that battery voltage is more than 10V at idle.

WITH CONSULT-II

1. Turn ignition switch ON.
2. Select "DATA MONITOR" mode with CONSULT-II.
3. Start engine and let it idle for 1 second.
4. If DTC is detected, go to [EC-545, "Diagnostic Procedure"](#) .

DATA MONITOR	
MONITOR	NO DTC
ENG SPEED	XXX rpm

SEF058Y

WITH GST

Follow the procedure "WITH CONSULT-II" above.

A

EC

C

D

E

F

G

H

I

J

K

L

M

DTC P2122, P2123 APP SENSOR

[QR]

Wiring Diagram

UBS002TZ

EC-APPS1-01

- : DETECTABLE LINE FOR DTC
- : NON-DETECTABLE LINE FOR DTC
- (A)** : WITH A/T

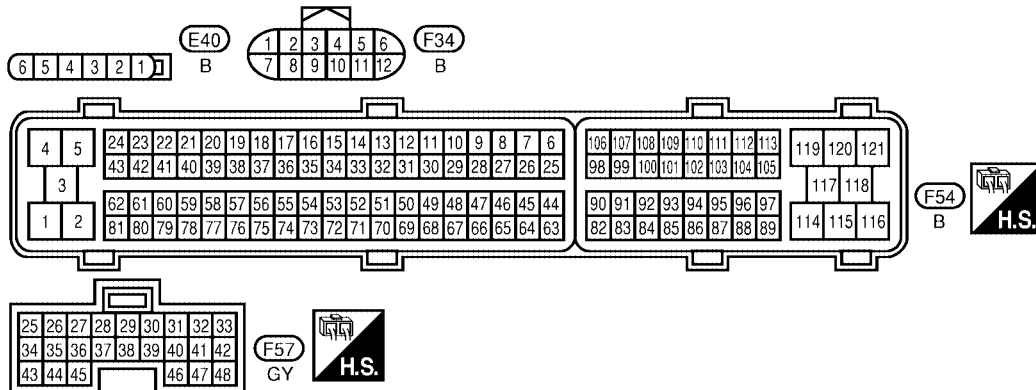
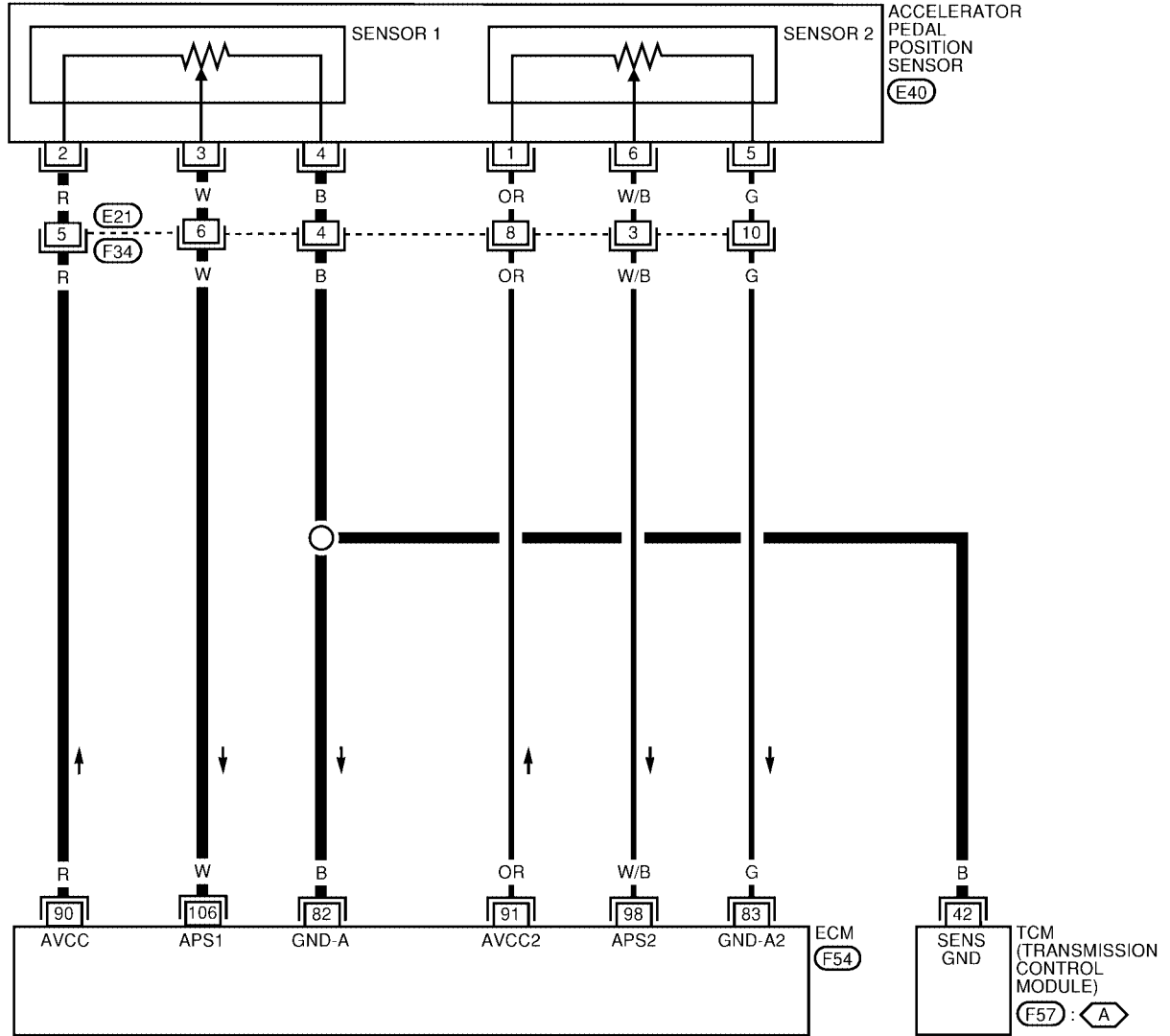

BBWA1249E

DTC P2122, P2123 APP SENSOR

[QR]

Specification data are reference values and are measured between each terminal and ground.

CAUTION:

Do not use ECM ground terminals when measuring input/output voltage. Doing so may result in damage to the ECM's transistor. Use a ground other than ECM terminals, such as the ground.

TERMI- NAL NO.	WIRE COLOR	ITEM	CONDITION	DATA (DC Voltage)
82	B	Sensor ground (Accelerator pedal position sensor 1)	[Engine is running] ● Warm-up condition ● Idle speed	Approximately 0V
83	G	Sensor ground (Accelerator pedal position sensor 2)	[Engine is running] ● Warm-up condition ● Idle speed	Approximately 0V
90	R	Sensor power supply (Accelerator pedal position sensor 1)	[Ignition switch: ON]	Approximately 5V
91	OR	Sensor power supply (Accelerator pedal position sensor 2)	[Ignition switch: ON]	Approximately 5V
98	W/B	Accelerator pedal position sensor 2	[Ignition switch: ON] ● Engine stopped ● Accelerator pedal: Fully released	0.28 - 0.48V
			[Ignition switch: ON] ● Engine stopped ● Accelerator pedal: Fully depressed	More than 2.0V
106	W	Accelerator pedal position sensor 1	[Ignition switch: ON] ● Engine stopped ● Accelerator pedal: Fully released	0.65 - 0.87V
			[Ignition switch: ON] ● Engine stopped ● Accelerator pedal: Fully depressed	More than 4.3V

Diagnostic Procedure

UBS002U0

1. CHECK GROUND CONNECTIONS

1. Turn ignition switch OFF.
2. Loosen and retighten three ground screws on the body. Refer to [EC-164, "Ground Inspection"](#).

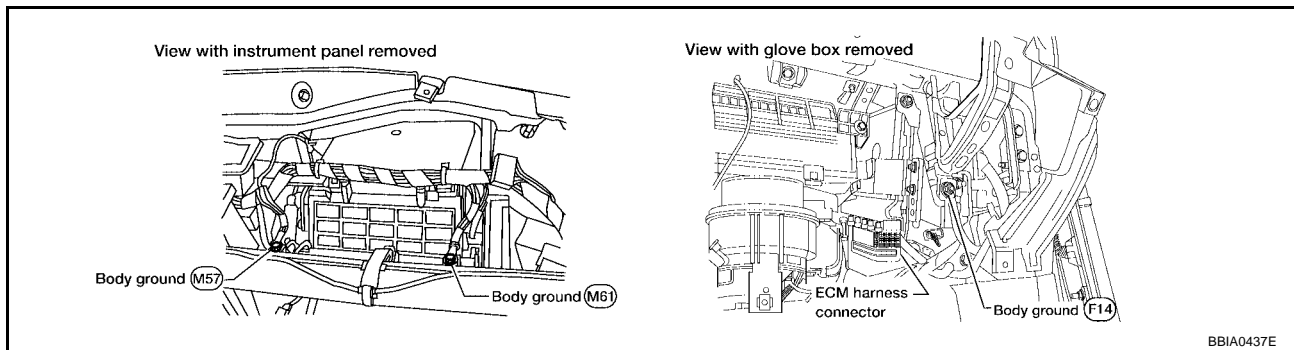

OK or NG

- OK >> GO TO 2.
- NG >> Repair or replace ground connections.

2. CHECK APP SENSOR 1 POWER SUPPLY CIRCUIT

1. Disconnect accelerator pedal position (APP) sensor harness connector.
2. Turn ignition switch ON.

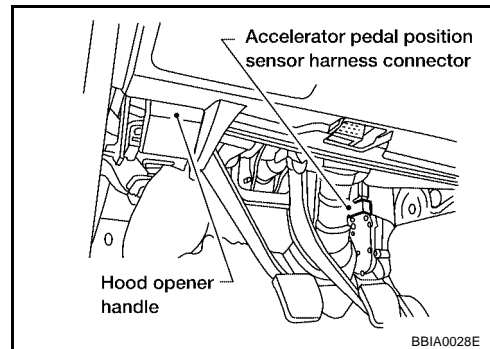

3. Check voltage between APP sensor terminal 2 and ground with CONSULT-II or tester.

Voltage: Approximately 5V

OK or NG

- OK >> GO TO 4.
- NG >> GO TO 3.

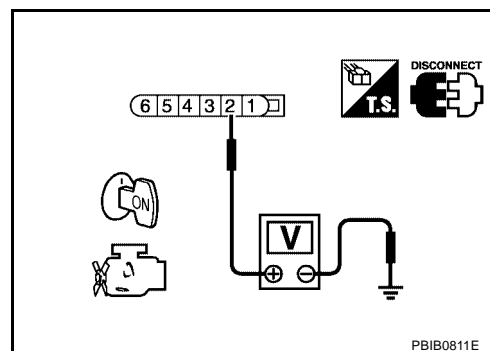

3. DETECT MALFUNCTIONING PART

Check the following.

- Harness connectors E21, F34
- Harness for open or short between ECM and accelerator pedal position sensor

>> Repair open circuit or short to ground or short to power in harness or connectors.

4. CHECK APP SENSOR 1 GROUND CIRCUIT FOR OPEN AND SHORT

1. Turn ignition switch OFF.
2. Disconnect ECM harness connector and TCM harness connector.
3. Check harness continuity between APP sensor terminal 4 and ECM terminal 82, TCM terminal 42. Refer to Wiring Diagram.

Continuity should exist.

4. Also check harness for short to ground and short to power.

OK or NG

- OK >> GO TO 6.
- NG >> GO TO 5.

5. DETECT MALFUNCTIONING PART

Check the following.

- Harness connectors E21, F34
- Harness for open or short between ECM and accelerator pedal position sensor
- Harness for open or short between TCM and accelerator pedal position sensor

>> Repair open circuit or short to ground or short to power in harness or connectors.

6. CHECK APP SENSOR 1 INPUT SIGNAL CIRCUIT FOR OPEN AND SHORT

1. Check harness continuity between ECM terminal 106 and APP sensor terminal 3.
Refer to Wiring Diagram.

Continuity should exist.

2. Also check harness for short to ground and short to power.

OK or NG

- OK >> GO TO 8.
- NG >> GO TO 7.

7. DETECT MALFUNCTIONING PART

Check the following.

- Harness connectors E21, F34
- Harness for open or short between ECM and accelerator pedal position sensor

>> Repair open circuit or short to ground or short to power in harness or connectors.

8. CHECK APP SENSOR

Refer to [EC-571, "Component Inspection"](#) .

OK or NG

- OK >> GO TO 10.
- NG >> GO TO 9.

9. REPLACE ACCELERATOR PEDAL ASSEMBLY

1. Replace accelerator pedal assembly.
2. Perform [EC-93, "Accelerator Pedal Released Position Learning"](#) .
3. Perform [EC-93, "Throttle Valve Closed Position Learning"](#) .
4. Perform [EC-93, "Idle Air Volume Learning"](#) .

>> INSPECTION END

10. CHECK INTERMITTENT INCIDENT

Refer to [EC-158, "TROUBLE DIAGNOSIS FOR INTERMITTENT INCIDENT"](#) .

>> INSPECTION END

**Component Inspection
ACCELERATOR PEDAL POSITION SENSOR**

UBS00CVS

1. Reconnect all harness connectors disconnected.
2. Turn ignition switch ON.
3. Check voltage between ECM terminals 106 (APP sensor 1 signal), 98 (APP sensor 2 signal) and ground under the following conditions.

Terminal	Accelerator pedal	Voltage
106 (Accelerator pedal position sensor 1)	Fully released	0.65 - 0.87V
	Fully depressed	More than 4.3V
98 (Accelerator pedal position sensor 2)	Fully released	0.28 - 0.48V
	Fully depressed	More than 2.0V

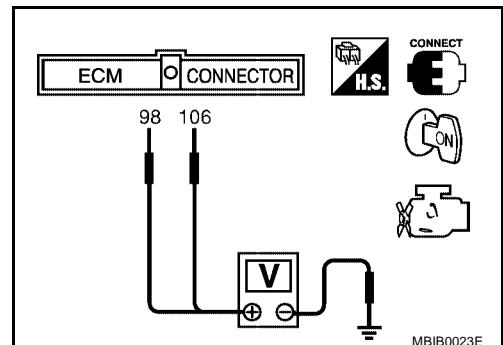

4. If NG, replace accelerator pedal assembly and go to the next step.
5. Perform [EC-93, "Accelerator Pedal Released Position Learning"](#) .
6. Perform [EC-93, "Throttle Valve Closed Position Learning"](#) .
7. Perform [EC-93, "Idle Air Volume Learning"](#) .

Removal and Installation ACCELERATOR PEDAL

UBS002U2

Refer to [ACC-2, "ACCELERATOR CONTROL SYSTEM"](#) .

DTC P2127, P2128 APP SENSOR

Component Description

The accelerator pedal position sensor is installed on the upper end of the accelerator pedal assembly. The sensor detects the accelerator position and sends a signal to the ECM.

Accelerator pedal position sensor has two sensors. These sensors are a kind of potentiometers which transform the accelerator pedal position into output voltage, and emit the voltage signal to the ECM. In addition, these sensors detect the opening and closing speed of the accelerator pedal and feed the voltage signals to the ECM. The ECM judges the current opening angle of the accelerator pedal from these signals and controls the throttle control motor based on these signals.

Idle position of the accelerator pedal is determined by the ECM receiving the signal from the accelerator pedal position sensor. The ECM uses this signal for the engine operation such as fuel cut.

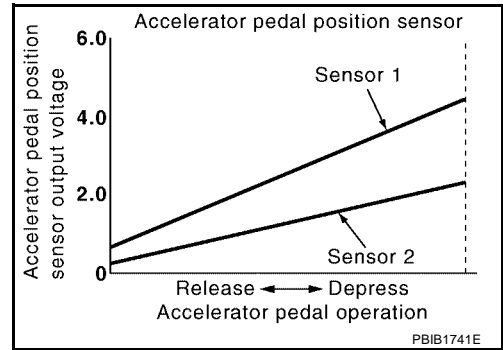

CONSULT-II Reference Value in Data Monitor Mode

Specification data are reference values.

MONITOR ITEM	CONDITION		SPECIFICATION
ACCEL SEN1	● Ignition switch: ON (Engine stopped)	Accelerator pedal: Fully released	0.65 - 0.87V
		Accelerator pedal: Fully depressed	More than 4.3V
ACCEL SEN2*	● Ignition switch: ON (Engine stopped)	Accelerator pedal: Fully released	0.56 - 0.96V
		Accelerator pedal: Fully depressed	More than 4.0V
CLSD THL POS	● Ignition switch: ON (Engine stopped)	Accelerator pedal: Fully released	ON
		Accelerator pedal: Slightly depressed	OFF

*: Accelerator pedal position sensor 2 signal is converted by ECM internally. Thus, it differs from ECM terminals voltage signal.

On Board Diagnosis Logic

These self-diagnoses have the one trip detection logic.

DTC No.	Trouble diagnosis name	DTC detecting condition	Possible cause
P2127 2127	Accelerator pedal position sensor 2 circuit low input	An excessively low voltage from the APP sensor 2 is sent to ECM.	<ul style="list-style-type: none"> ● Harness or connectors (The APP sensor 2 circuit is open or shorted.) (TP sensor circuit is shorted.) ● Accelerator pedal position sensor (Accelerator pedal position sensor 2) ● Electric throttle control actuator (TP sensor 1 and 2)
P2128 2128	Accelerator pedal position sensor 2 circuit high input	An excessively high voltage from the APP sensor 2 is sent to ECM.	

FAIL-SAFE MODE

When the malfunction is detected, the ECM enters fail-safe mode and the MIL lights up.

Engine operating condition in fail-safe mode

The ECM controls the electric throttle control actuator in regulating the throttle opening in order for the idle position to be within +10 degrees.

The ECM regulates the opening speed of the throttle valve to be slower than the normal condition. So, the acceleration will be poor.

DTC Confirmation Procedure

NOTE:

If DTC Confirmation Procedure has been previously conducted, always turn ignition switch OFF and wait at least 10 seconds before conducting the next test.

TESTING CONDITION:

Before performing the following procedure, confirm that battery voltage is more than 10V at idle.

DTC P2127, P2128 APP SENSOR

[QR]

WITH CONSULT-II

1. Turn ignition switch ON.
2. Select "DATA MONITOR" mode with CONSULT-II.
3. Start engine and let it idle for 1 second.
4. If DTC is detected, go to [EC-552, "Diagnostic Procedure"](#) .

DATA MONITOR	
MONITOR	NO DTC
ENG SPEED	XXX rpm

SEF058Y

WITH GST

Follow the procedure "WITH CONSULT-II" above.

DTC P2127, P2128 APP SENSOR

[QR]

Wiring Diagram

UBS0030C

EC-APPS2-01

- : DETECTABLE LINE FOR DTC
- : NON-DETECTABLE LINE FOR DTC
- ⬡** : WITH A/T

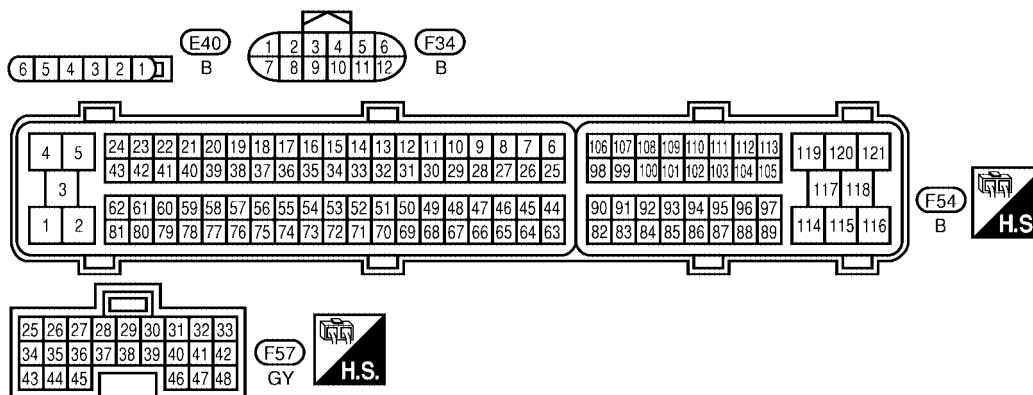
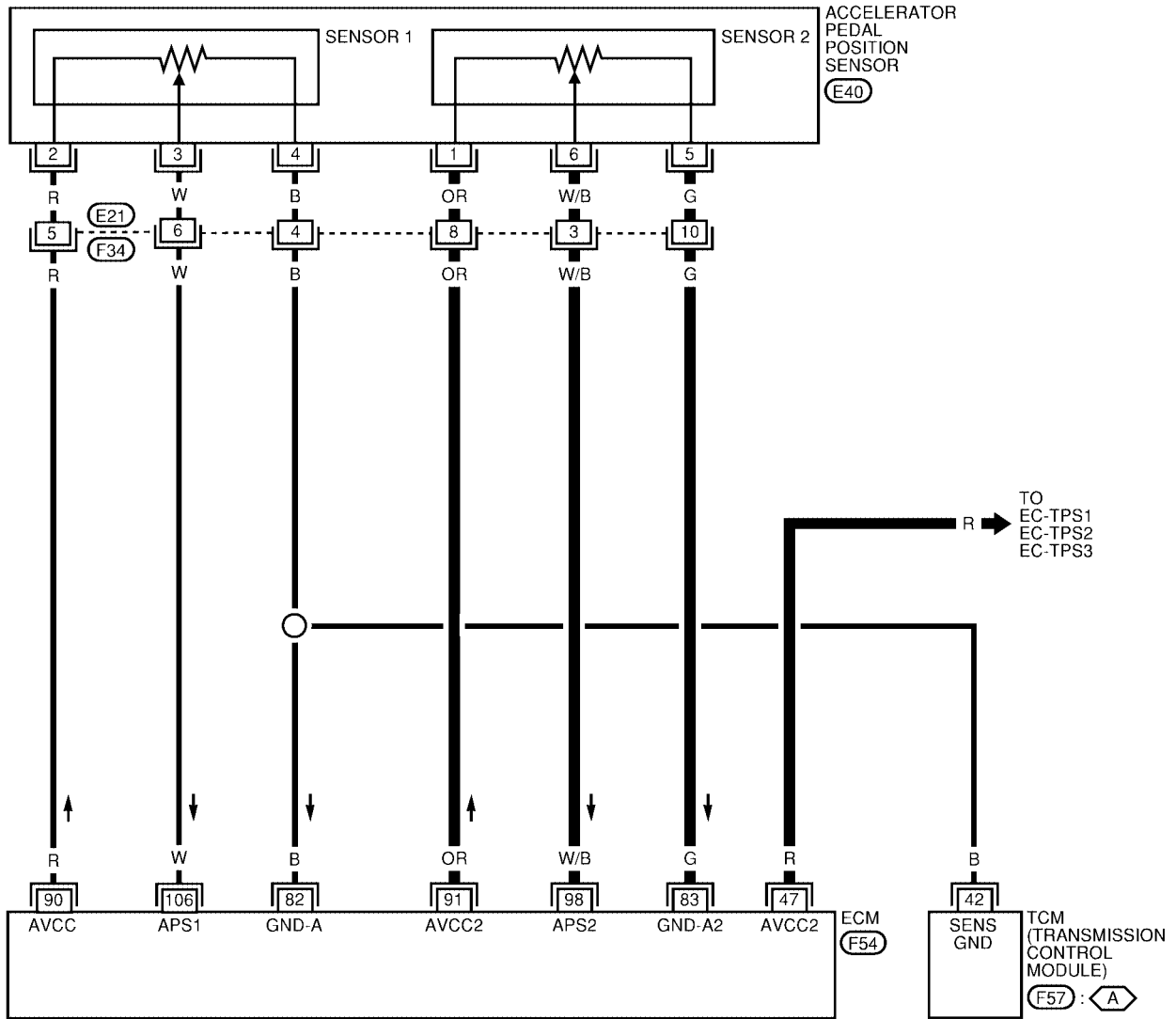

BBWA1250E

DTC P2127, P2128 APP SENSOR

[QR]

Specification data are reference values and are measured between each terminal and ground.

CAUTION:

Do not use ECM ground terminals when measuring input/output voltage. Doing so may result in damage to the ECM's transistor. Use a ground other than ECM terminals, such as the ground.

TER-MINAL NO.	WIRE COLOR	ITEM	CONDITION	DATA (DC Voltage)
47	R	Sensor power supply (Throttle position sensor)	[Ignition switch: ON]	Approximately 5V
82	B	Sensor ground (Accelerator pedal position sensor 1)	[Engine is running] ● Warm-up condition ● Idle speed	Approximately 0V
83	G	Sensor ground (Accelerator pedal position sensor 2)	[Engine is running] ● Warm-up condition ● Idle speed	Approximately 0V
90	R	Sensor power supply (Accelerator pedal position sensor 1)	[Ignition switch: ON]	Approximately 5V
91	OR	Sensor power supply (Accelerator pedal position sensor 2)	[Ignition switch: ON]	Approximately 5V
98	W/B	Accelerator pedal position sensor 2	[Ignition switch: ON] ● Engine stopped ● Accelerator pedal: Fully released	0.28 - 0.48V
			[Ignition switch: ON] ● Engine stopped ● Accelerator pedal: Fully depressed	More than 2.0V
106	W	Accelerator pedal position sensor 1	[Ignition switch: ON] ● Engine stopped ● Accelerator pedal: Fully released	0.65 - 0.87V
			[Ignition switch: ON] ● Engine stopped ● Accelerator pedal: Fully depressed	More than 4.3V

Diagnostic Procedure

UBS0030D

1. CHECK GROUND CONNECTIONS

1. Turn ignition switch OFF.
2. Loosen and retighten three ground screws on the body. Refer to [EC-164, "Ground Inspection"](#) .

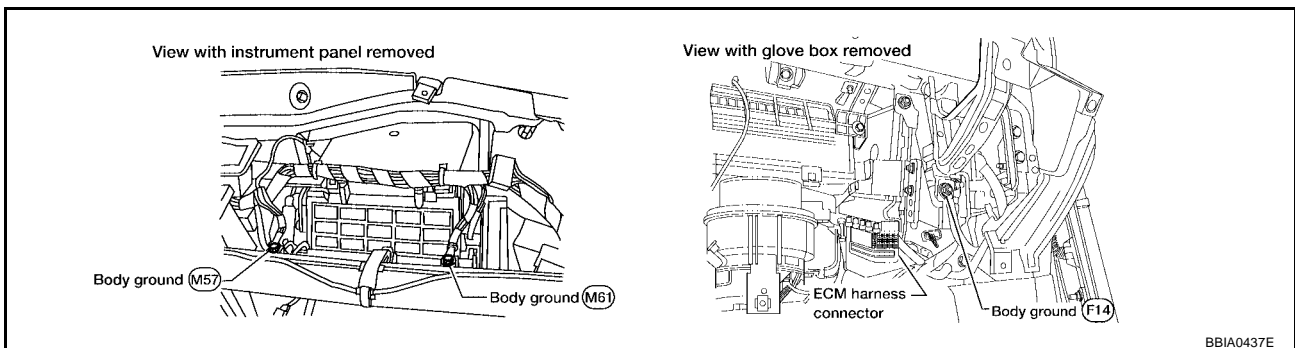

OK or NG

- OK >> GO TO 2.
- NG >> Repair or replace ground connections.

2. CHECK APP SENSOR 2 POWER SUPPLY CIRCUIT-I

1. Disconnect accelerator pedal position (APP) sensor harness connector.
2. Turn ignition switch ON.

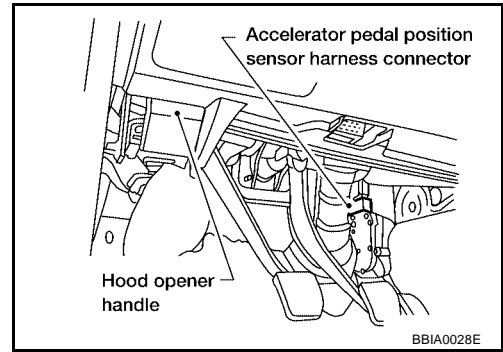

3. Check voltage between APP sensor terminal 1 and ground with CONSULT-II or tester.

Voltage: Approximately 5V

OK or NG

- OK >> GO TO 8.
- NG >> GO TO 3.

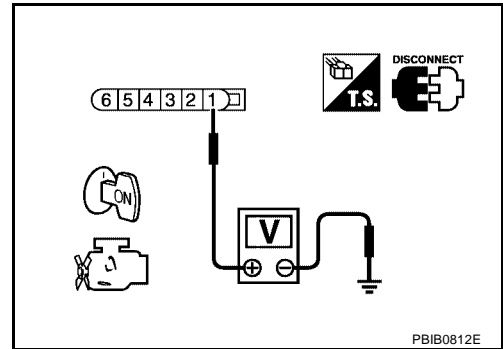

3. CHECK APP SENSOR 2 POWER SUPPLY CIRCUIT-II

1. Turn ignition switch OFF.
2. Disconnect ECM harness connector.
3. Check harness continuity between APP sensor terminal 1 and ECM terminal 91. Refer to Wiring Diagram.

Continuity should exist.

OK or NG

- OK >> GO TO 5.
- NG >> GO TO 4.

4. DETECT MALFUNCTIONING PART

Check the following.

- Harness connectors E21, F34
- Harness for open between ECM and accelerator pedal position sensor

>> Repair or replace open circuit.

5. CHECK APP SENSOR 2 POWER SUPPLY CIRCUIT-III

Check the following.

- Harness for short to power and short to ground, between the following terminals.

ECM terminal	Sensor terminal	Reference Wiring Diagram
91	APP sensor terminal 1	EC-544
47	Electric throttle control actuator terminal 1	EC-396

OK or NG

- OK >> GO TO 6.
- NG >> Repair short to ground or short to power in harness or connectors.

6. CHECK THROTTLE POSITION SENSOR

Refer to [EC-563, "Component Inspection"](#) .

OK or NG

- OK >> GO TO 14.
NG >> GO TO 7.

7. REPLACE ELECTRIC THROTTLE CONTROL ACTUATOR

1. Replace the electric throttle control actuator.
2. Perform [EC-93, "Throttle Valve Closed Position Learning"](#) .
3. Perform [EC-93, "Idle Air Volume Learning"](#) .

>> **INSPECTION END**

8. CHECK APP SENSOR 2 GROUND CIRCUIT FOR OPEN AND SHORT

1. Turn ignition switch OFF.
2. Disconnect ECM harness connector.
3. Check harness continuity between APP sensor terminal 5 and ECM terminal 83.
Refer to Wiring Diagram.

Continuity should exist.

4. Also check harness for short to ground and short to power.

OK or NG

- OK >> GO TO 10.
NG >> GO TO 9.

9. DETECT MALFUNCTIONING PART

Check the following.

- Harness connectors E21, F34
- Harness for open or short between ECM and accelerator pedal position sensor

>> Repair open circuit or short to ground or short to power in harness or connectors.

10. CHECK APP SENSOR 2 INPUT SIGNAL CIRCUIT FOR OPEN AND SHORT

1. Check harness continuity between ECM terminal 98 and APP sensor terminal 6.
Refer to Wiring Diagram.

Continuity should exist.

2. Also check harness for short to ground and short to power.

OK or NG

- OK >> GO TO 12.
NG >> GO TO 11.

11. DETECT MALFUNCTIONING PART

Check the following.

- Harness connectors E21, F34
- Harness for open or short between ECM and accelerator pedal position sensor

>> Repair open circuit or short to ground or short to power in harness or connectors.

12. CHECK APP SENSOR

Refer to [EC-556, "Component Inspection"](#) .

OK or NG

OK >> GO TO 14.

NG >> GO TO 13.

A

EC

13. REPLACE ACCELERATOR PEDAL ASSEMBLY

1. Replace accelerator pedal assembly.
2. Perform [EC-93, "Accelerator Pedal Released Position Learning"](#) .
3. Perform [EC-93, "Throttle Valve Closed Position Learning"](#) .
4. Perform [EC-93, "Idle Air Volume Learning"](#) .

>> INSPECTION END

14. CHECK INTERMITTENT INCIDENT

Refer to [EC-158, "TROUBLE DIAGNOSIS FOR INTERMITTENT INCIDENT"](#) .

>> INSPECTION END

C

D

E

F

G

H

I

J

K

L

M

Component Inspection ACCELERATOR PEDAL POSITION SENSOR

1. Reconnect all harness connectors disconnected.
2. Turn ignition switch ON.
3. Check voltage between ECM terminals 106 (APP sensor 1 signal), 98 (APP sensor 2 signal) and ground under the following conditions.

Terminal	Accelerator pedal	Voltage
106 (Accelerator pedal position sensor 1)	Fully released	0.65 - 0.87V
	Fully depressed	More than 4.3V
98 (Accelerator pedal position sensor 2)	Fully released	0.28 - 0.48V
	Fully depressed	More than 2.0V

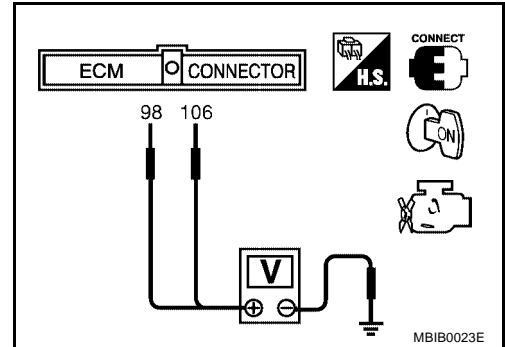

4. If NG, replace accelerator pedal assembly and go to the next step.
5. Perform [EC-93, "Accelerator Pedal Released Position Learning"](#) .
6. Perform [EC-93, "Throttle Valve Closed Position Learning"](#) .
7. Perform [EC-93, "Idle Air Volume Learning"](#) .

Remove and Installation ACCELERATOR PEDAL

Refer to [ACC-2, "ACCELERATOR CONTROL SYSTEM"](#) .

DTC P2135 TP SENSOR

Component Description

Electric throttle control actuator consists of throttle control motor, throttle position sensor, etc. The throttle position sensor responds to the throttle valve movement.

The throttle position sensor has the two sensors. These sensors are a kind of potentiometers which transform the throttle valve position into output voltage, and emit the voltage signal to the ECM. In addition, these sensors detect the opening and closing speed of the throttle valve and feed the voltage signals to the ECM. The ECM judges the current opening angle of the throttle valve from these signals and the ECM controls the throttle control motor to make the throttle valve opening angle properly in response to driving condition.

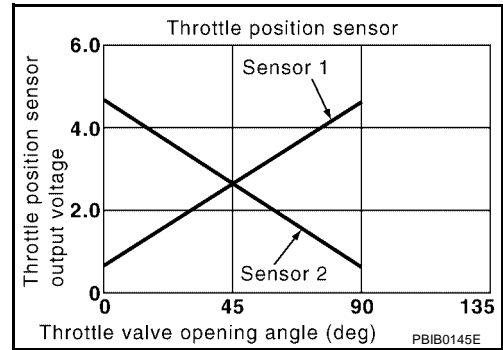

CONSULT-II Reference Value in Data Monitor Mode

Specification data are reference values.

MONITOR ITEM	CONDITION		SPECIFICATION
THRTL SEN1 THRTL SEN2*	<ul style="list-style-type: none"> Ignition switch: ON (Engine stopped) Shift lever: D (A/T), 1ST (M/T) 	Accelerator pedal: Fully released	More than 0.36V
		Accelerator pedal: Fully depressed	Less than 4.75V

*: Throttle position sensor 2 signal is converted by ECM internally. Thus, it differs from ECM terminals voltage signal.

On Board Diagnosis Logic

This self-diagnosis has the one trip detection logic.

DTC No.	Trouble diagnosis name	DTC detecting condition	Possible cause
P0221 0221	Throttle position sensor circuit range/performance problem	Rationally incorrect voltage is sent to ECM compared with the signals from TP sensor 1 and TP sensor 2.	<ul style="list-style-type: none"> Harness or connector (The TP sensor 1 and 2 circuit is open or shorted.) (APP sensor 2 circuit is shorted.) Electric throttle control actuator (TP sensor 1 and 2) Accelerator pedal position sensor

FAIL-SAFE MODE

When the malfunction is detected, the ECM enters fail-safe mode and the MIL lights up.

Engine operation condition in fail-safe mode

The ECM controls the electric throttle control actuator in regulating the throttle opening in order for the idle position to be within +10 degrees.

The ECM regulates the opening speed of the throttle valve to be slower than the normal condition.

So, the acceleration will be poor.

DTC Confirmation Procedure

NOTE:

If DTC Confirmation Procedure has been previously conducted, always turn ignition switch OFF and wait at least 10 seconds before conducting the next test.

TESTING CONDITION:

Before performing the following procedure, confirm that battery voltage is more than 10V at idle.

WITH CONSULT-II

1. Turn ignition switch ON.

DTC P2135 TP SENSOR

[QR]

2. Select "DATA MONITOR" mode with CONSULT-II.
3. Start engine and let it idle for 1 second.
4. If DTC is detected, go to [EC-560, "Diagnostic Procedure"](#) .

DATA MONITOR	
MONITOR	NO DTC
ENG SPEED	XXX rpm

SEF058Y



WITH GST

Follow the procedure "WITH CONSULT-II" above.

DTC P2135 TP SENSOR

[QR]

Wiring Diagram

UBS002TB

EC-TPS3-01

: DETECTABLE LINE FOR DTC
 : NON-DETECTABLE LINE FOR DTC

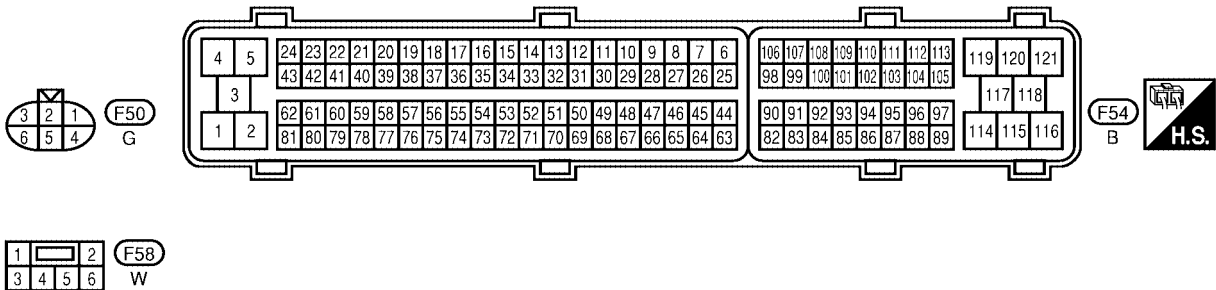
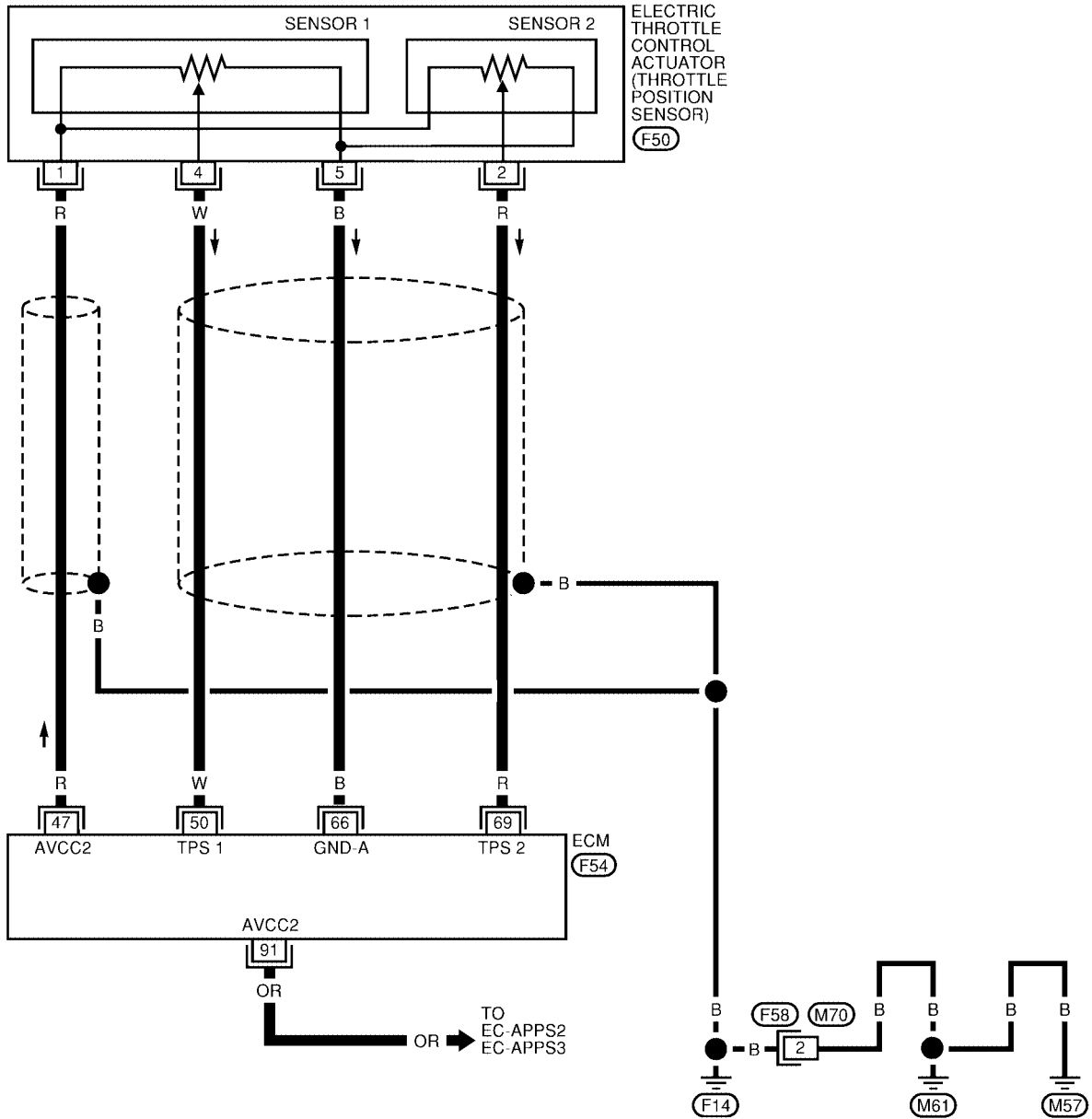

BBWA1251E

DTC P2135 TP SENSOR

[QR]

Specification data are reference values and are measured between each terminal and ground.

CAUTION:

Do not use ECM ground terminals when measuring input/output voltage. Doing so may result in damage to the ECM's transistor. Use a ground other than ECM terminals, such as the ground.

TERMI- NAL NO.	WIRE COLOR	ITEM	CONDITION	DATA (DC Voltage)
47	R	Sensor power supply (Throttle position sensor)	[Ignition switch: ON]	Approximately 5V
50	W	Throttle position sensor 1	[Ignition switch: ON] ● Engine stopped ● Shift lever: D (A/T), 1ST (M/T) ● Accelerator pedal: Fully released	More than 0.36V
			[Ignition switch: ON] ● Engine stopped ● Shift lever: D (A/T), 1ST (M/T) ● Accelerator pedal: Fully depressed	Less than 4.75V
66	B	Sensor ground (Throttle position sensor)	[Engine is running] ● Warm-up condition ● Idle speed	Approximately 0V
69	R	Throttle position sensor 2	[Ignition switch: ON] ● Engine stopped ● Shift lever: D (A/T), 1ST (M/T) ● Accelerator pedal: Fully released	Less than 4.75V
			[Ignition switch: ON] ● Engine stopped ● Shift lever: D (A/T), 1ST (M/T) ● Accelerator pedal: Fully depressed	More than 0.36V
91	OR	Sensor power supply (Accelerator pedal position sensor 2)	[Ignition switch: ON]	Approximately 5V

Diagnostic Procedure

UBS0027C

1. CHECK GROUND CONNECTIONS

1. Turn ignition switch OFF.
2. Loosen and retighten three ground screws on the body. Refer to [EC-164, "Ground Inspection"](#) .

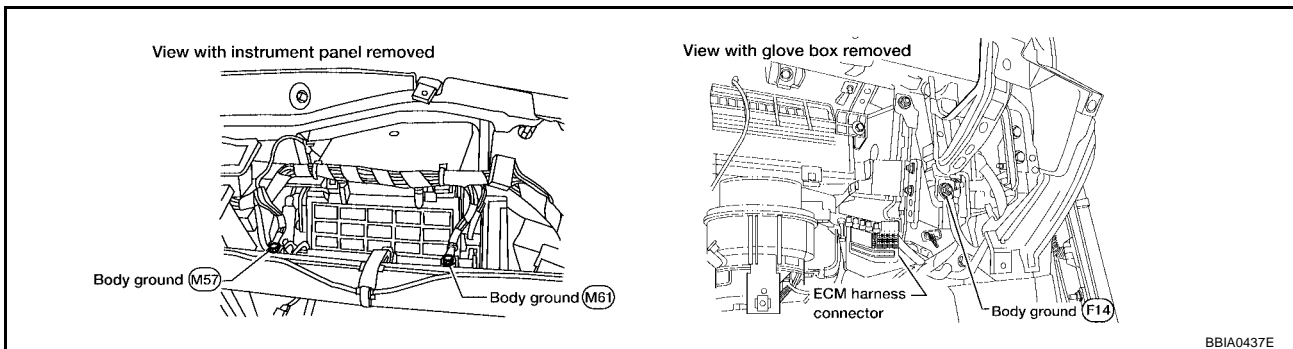

BBA0437E

OK or NG

- OK >> GO TO 2.
- NG >> Repair or replace ground connections.

2. CHECK THROTTLE POSITION SENSOR POWER SUPPLY CIRCUIT-I

1. Disconnect electric throttle control actuator harness connector.
2. Turn ignition switch ON.

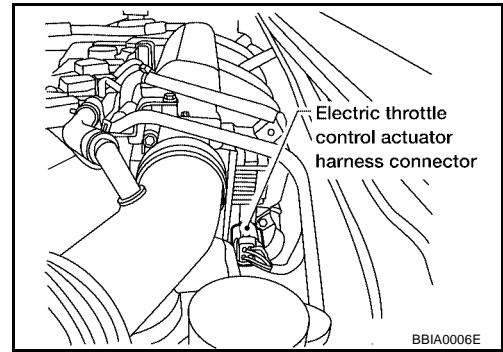

3. Check voltage between electric throttle control actuator terminal 1 and ground with CONSULT-II or tester.

Voltage: Approximately 5V

OK or NG

- OK >> GO TO 7.
- NG >> GO TO 3.

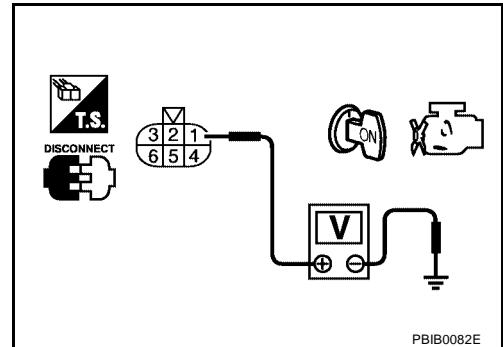

3. CHECK THROTTLE POSITION SENSOR POWER SUPPLY CIRCUIT-II

1. Turn ignition switch OFF.
2. Disconnect ECM harness connector.
3. Check harness continuity between electric throttle control actuator terminal 1 and ECM terminal 47. Refer to Wiring Diagram.

Continuity should exist.

OK or NG

- OK >> GO TO 4.
- NG >> Repair or replace open circuit.

4. CHECK THROTTLE POSITION SENSOR POWER SUPPLY CIRCUIT-III

Check the following.

- Harness for short to power and short to ground, between the following terminals.

ECM terminal	Sensor terminal	Reference Wiring Diagram
47	Electric throttle control actuator terminal 1	EC-400
91	APP sensor terminal 1	EC-544

OK or NG

- OK >> GO TO 5.
- NG >> Repair short to ground or short to power in harness or connectors.

5. CHECK APP SENSOR

Refer to [EC-547, "Component Inspection"](#) .

OK or NG

- OK >> GO TO 11.
- NG >> GO TO 6.

6. REPLACE ACCELERATOR PEDAL ASSEMBLY

1. Replace accelerator pedal assembly.
2. Perform [EC-93, "Accelerator Pedal Released Position Learning"](#) .
3. Perform [EC-93, "Throttle Valve Closed Position Learning"](#) .
4. Perform [EC-93, "Idle Air Volume Learning"](#) .

>> INSPECTION END

7. CHECK THROTTLE POSITION SENSOR GROUND CIRCUIT FOR OPEN AND SHORT

1. Turn ignition switch OFF.
2. Disconnect ECM harness connector.
3. Check harness continuity between electric throttle control actuator terminal 5 and ECM terminal 66.
Refer to Wiring Diagram.

Continuity should exist.

4. Also check harness for short to ground and short to power.

OK or NG

OK >> GO TO 8.

NG >> Repair open circuit or short to ground or short to power in harness or connectors.

8. CHECK THROTTLE POSITION SENSOR INPUT SIGNAL CIRCUIT FOR OPEN AND SHORT

1. Check harness continuity between ECM terminal 50 and electric throttle control actuator terminal 4, ECM terminal 69 and electric throttle control actuator terminal 2.
Refer to Wiring Diagram.

Continuity should exist.

2. Also check harness for short to ground and short to power.

OK or NG

OK >> GO TO 9.

NG >> Repair open circuit or short to ground or short to power in harness or connectors.

9. CHECK THROTTLE POSITION SENSOR

Refer to [EC-563, "Component Inspection"](#) .

OK or NG

OK >> GO TO 11.

NG >> GO TO 10.

10. REPLACE ELECTRIC THROTTLE CONTROL ACTUATOR

1. Replace the electric throttle control actuator.
2. Perform [EC-93, "Throttle Valve Closed Position Learning"](#) .
3. Perform [EC-93, "Idle Air Volume Learning"](#) .

>> INSPECTION END

11. CHECK INTERMITTENT INCIDENT

Refer to [EC-158, "TROUBLE DIAGNOSIS FOR INTERMITTENT INCIDENT"](#) .

>> INSPECTION END

DTC P2135 TP SENSOR

[QR]

UBS002TD

Component Inspection THROTTLE POSITION SENSOR

1. Reconnect all harness connectors disconnected.
2. Perform [EC-93, "Throttle Valve Closed Position Learning"](#) .
3. Turn ignition switch ON.
4. Set shift lever to D position (A/T models) or 1st position (M/T models).
5. Check voltage between ECM terminals 50 (TP sensor 1), 69 (TP sensor 2) and ground under the following conditions.

Terminal	Accelerator pedal	Voltage
50 (Throttle position sensor 1)	Fully released	More than 0.36V
	Fully depressed	Less than 4.75V
69 (Throttle position sensor 2)	Fully released	Less than 4.75V
	Fully depressed	More than 0.36V

6. If NG, replace electric throttle control actuator and go to the next step.
7. Perform [EC-93, "Throttle Valve Closed Position Learning"](#) .
8. Perform [EC-93, "Idle Air Volume Learning"](#) .

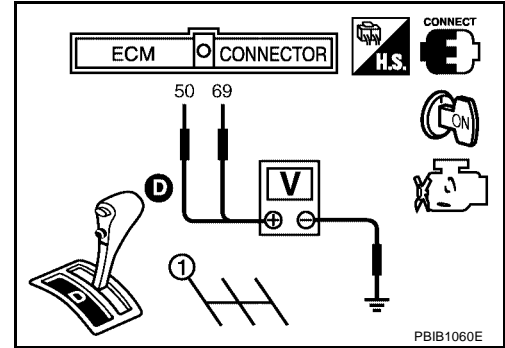

Remove and Installation ELECTRIC THROTTLE CONTROL ACTUATOR

Refer to [EM-19, "INTAKE MANIFOLD"](#) .

UBS002TE

DTC P2138 APP SENSOR

Component Description

UBS002TN

The accelerator pedal position sensor is installed on the upper end of the accelerator pedal assembly. The sensor detects the accelerator position and sends a signal to the ECM.

Accelerator pedal position sensor has two sensors. These sensors are a kind of potentiometers which transform the accelerator pedal position into output voltage, and emit the voltage signal to the ECM. In addition, these sensors detect the opening and closing speed of the accelerator pedal and feed the voltage signals to the ECM. The ECM judges the current opening angle of the accelerator pedal from these signals and controls the throttle control motor based on these signals.

Idle position of the accelerator pedal is determined by the ECM receiving the signal from the accelerator pedal position sensor. The ECM uses this signal for the engine operation such as fuel cut.

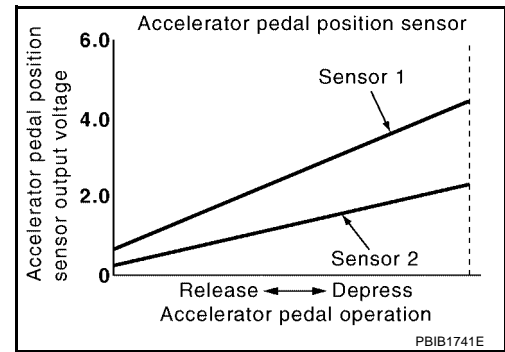

CONSULT-II Reference Value in Data Monitor Mode

UBS002TO

Specification data are reference values.

MONITOR ITEM	CONDITION		SPECIFICATION
ACCEL SEN1	● Ignition switch: ON (Engine stopped)	Accelerator pedal: Fully released	0.65 - 0.87V
		Accelerator pedal: Fully depressed	More than 4.3V
ACCEL SEN2*	● Ignition switch: ON (Engine stopped)	Accelerator pedal: Fully released	0.56 - 0.96V
		Accelerator pedal: Fully depressed	More than 4.0V
CLSD THL POS	● Ignition switch: ON (Engine stopped)	Accelerator pedal: Fully released	ON
		Accelerator pedal: Slightly depressed	OFF

*: Accelerator pedal position sensor 2 signal is converted by ECM internally. Thus, it differs from ECM terminals voltage signal.

On Board Diagnosis Logic

UBS002TP

This self-diagnosis has the one trip detection logic.

NOTE:

If DTC P2138 is displayed with DTC P1229, first perform the trouble diagnosis for DTC P1229. Refer to EC-438.

DTC No.	Trouble diagnosis name	DTC detecting condition	Possible cause
P2138 2138	Accelerator pedal position sensor circuit range/performance problem	Rationally incorrect voltage is sent to ECM compared with the signals from APP sensor 1 and APP sensor 2.	<ul style="list-style-type: none"> ● Harness or connector (The APP sensor 1 and 2 circuit is open or shorted.) (TP sensor circuit is shorted.) ● Accelerator pedal position sensor 1 and 2 ● Electric throttle control actuator (TP sensor 1 and 2)

FAIL-SAFE MODE

When the malfunction is detected, the ECM enters fail-safe mode and the MIL lights up.

Engine operating condition in fail-safe mode

The ECM controls the electric throttle control actuator in regulating the throttle opening in order for the idle position to be within +10 degrees.

The ECM regulates the opening speed of the throttle valve to be slower than the normal condition.

So, the acceleration will be poor.

DTC Confirmation Procedure

NOTE:

If DTC Confirmation Procedure has been previously conducted, always turn ignition switch OFF and wait at least 10 seconds before conducting the next test.

TESTING CONDITION:

Before performing the following procedure, confirm that battery voltage is more than 10V at idle.

WITH CONSULT-II

1. Turn ignition switch ON.
2. Select "DATA MONITOR" mode with CONSULT-II.
3. Start engine and let it idle for 1 second.
4. If DTC is detected, go to [EC-567, "Diagnostic Procedure"](#) .

DATA MONITOR	
MONITOR	NO DTC
ENG SPEED	XXX rpm

SEF058Y

WITH GST

Follow the procedure "WITH CONSULT-II" above.

A
EC
C
D
E
F
G
H
I
J
K
L
M

DTC P2138 APP SENSOR

[QR]

Wiring Diagram

UBS002TR

EC-APPS3-01

- : DETECTABLE LINE FOR DTC
- : NON-DETECTABLE LINE FOR DTC
- (A)** : WITH A/T

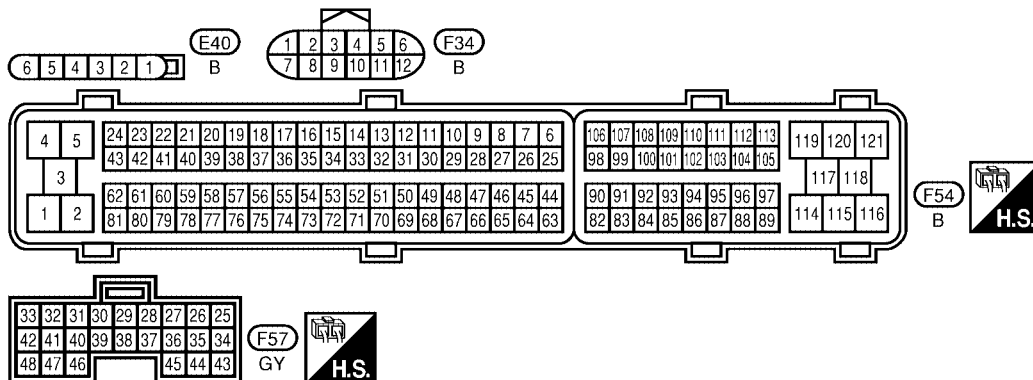
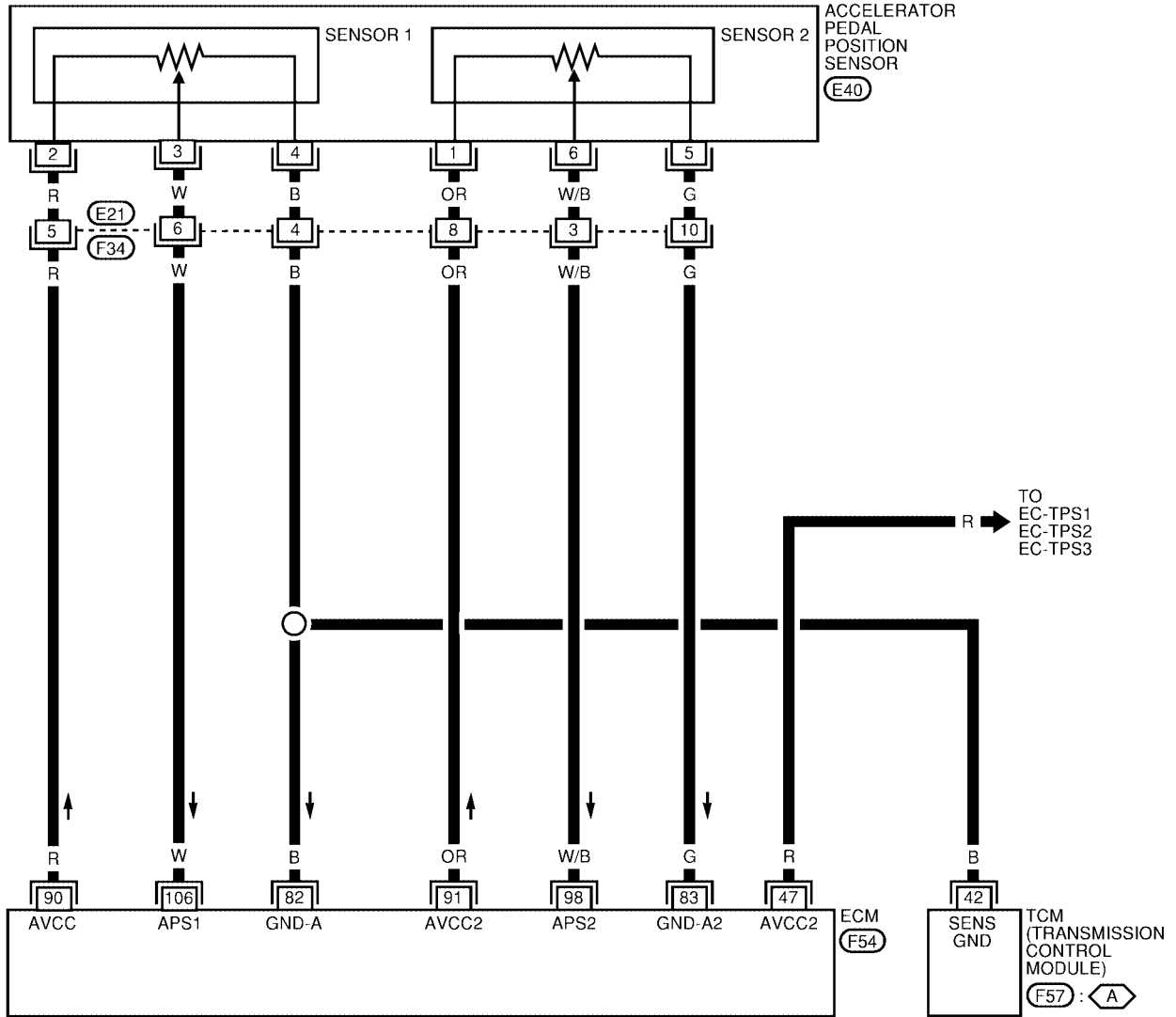

BBWA1248E

DTC P2138 APP SENSOR

[QR]

Specification data are reference values and are measured between each terminal and ground.

CAUTION:

Do not use ECM ground terminals when measuring input/output voltage. Doing so may result in damage to the ECM's transistor. Use a ground other than ECM terminals, such as the ground.

TERMI- NAL NO.	WIRE COLOR	ITEM	CONDITION	DATA (DC Voltage)
47	R	Sensor power supply (Throttle position sensor)	[Ignition switch: ON]	Approximately 5V
82	B	Sensor ground (Accelerator pedal position sensor 1)	[Engine is running] ● Warm-up condition ● Idle speed	Approximately 0V
83	G	Sensor ground (Accelerator pedal position sensor 2)	[Engine is running] ● Warm-up condition ● Idle speed	Approximately 0V
90	R	Sensor power supply (Accelerator pedal position sensor 1)	[Ignition switch: ON]	Approximately 5V
91	OR	Sensor power supply (Accelerator pedal position sensor 2)	[Ignition switch: ON]	Approximately 5V
98	W/B	Accelerator pedal position sensor 2	[Ignition switch: ON] ● Engine stopped ● Accelerator pedal: Fully released	0.28 - 0.48V
			[Ignition switch: ON] ● Engine stopped ● Accelerator pedal: Fully depressed	More than 2.0V
106	W	Accelerator pedal position sensor 1	[Ignition switch: ON] ● Engine stopped ● Accelerator pedal: Fully released	0.65 - 0.87V
			[Ignition switch: ON] ● Engine stopped ● Accelerator pedal: Fully depressed	More than 4.3V

Diagnostic Procedure

UBS002TS

1. CHECK GROUND CONNECTIONS

1. Turn ignition switch OFF.
2. Loosen and retighten three ground screws on the body. Refer to [EC-164, "Ground Inspection"](#).

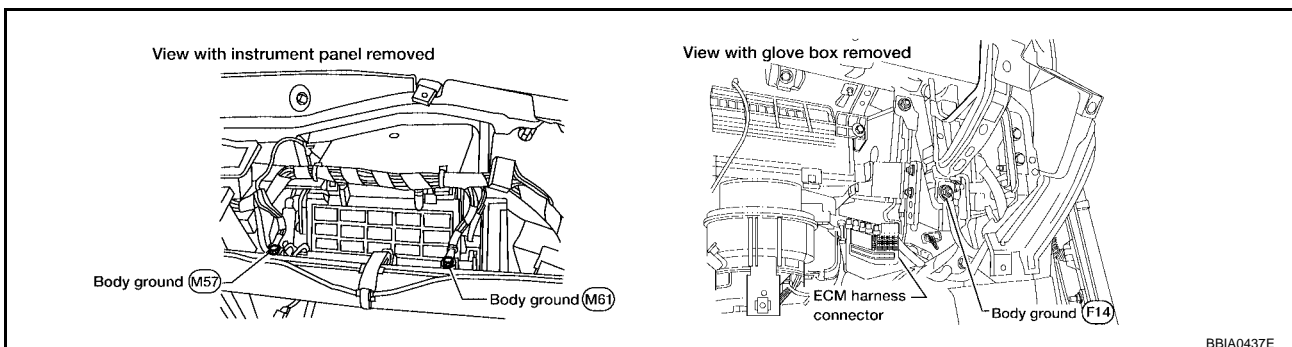

OK or NG

- OK >> GO TO 2.
- NG >> Repair or replace ground connections.

2. CHECK APP SENSOR 1 POWER SUPPLY CIRCUIT

1. Disconnect accelerator pedal position (APP) sensor harness connector.
2. Turn ignition switch ON.

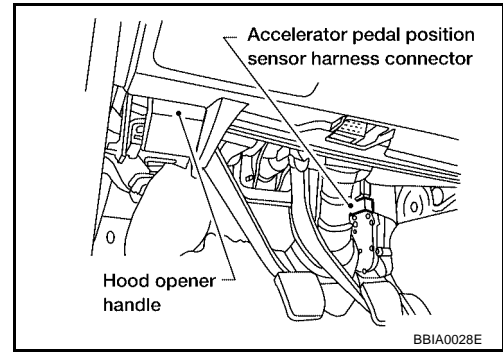

3. Check voltage between APP sensor terminal 2 and ground with CONSULT-II or tester.

Voltage: Approximately 5V

OK or NG

- OK >> GO TO 4.
- NG >> GO TO 3.

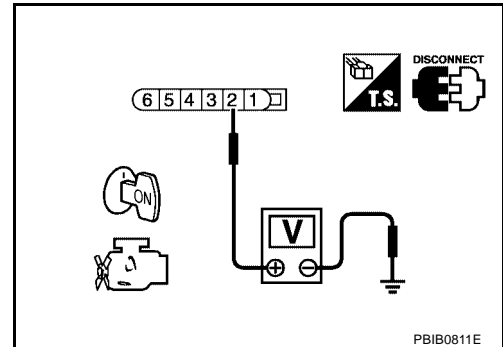

3. DETECT MALFUNCTIONING PART

Check the following.

- Harness connectors E21, F34
- Harness for open or short between ECM and accelerator pedal position sensor

>> Repair open circuit or short to ground or short to power in harness or connectors.

4. CHECK APP SENSOR 2 POWER SUPPLY CIRCUIT-I

Check voltage between APP sensor terminal 1 and ground with CONSULT-II or tester.

Voltage: Approximately 5V

OK or NG

- OK >> GO TO 10.
- NG >> GO TO 5.

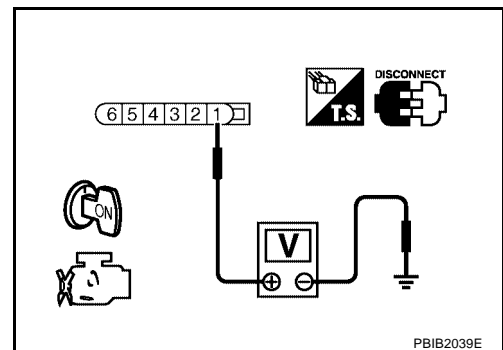

5. CHECK APP SENSOR 2 POWER SUPPLY CIRCUIT-II

1. Turn ignition switch OFF.
2. Disconnect ECM harness connector.
3. Check harness continuity between APP sensor terminal 1 and ECM terminal 91.
Refer to Wiring Diagram.

Continuity should exist.

OK or NG

- OK >> GO TO 7.
NG >> GO TO 6.

6. DETECT MALFUNCTIONING PART

Check the following.

- Harness connectors E21, F34
- Harness for open between ECM and accelerator pedal position sensor

>> Repair or replace open circuit.

7. CHECK APP SENSOR 2 POWER SUPPLY CIRCUIT-III

Check the following.

- Harness for short to power and short to ground, between the following terminals.

ECM terminal	Sensor terminal	Reference Wiring Diagram
91	APP sensor terminal 1	EC-566
47	Electric throttle control actuator terminal 1	EC-400

OK or NG

- OK >> GO TO 8.
NG >> Repair short to ground or short to power in harness or connectors.

8. CHECK THROTTLE POSITION SENSOR

Refer to [EC-563, "Component Inspection"](#) .

OK or NG

- OK >> GO TO 16.
NG >> GO TO 9.

9. REPLACE ELECTRIC THROTTLE CONTROL ACTUATOR

1. Replace the electric throttle control actuator.
2. Perform [EC-93, "Throttle Valve Closed Position Learning"](#) .
3. Perform [EC-93, "Idle Air Volume Learning"](#) .

>> **INSPECTION END**

10. CHECK APP SENSOR GROUND CIRCUIT FOR OPEN AND SHORT

1. Turn ignition switch OFF.
2. Disconnect ECM harness connector.
3. Check harness continuity between APP sensor terminal 4 and ECM terminal 82, APP sensor terminal 5 and ECM terminal 83.
Refer to Wiring Diagram.

Continuity should exist.

4. Also check harness for short to ground and short to power.

OK or NG

- OK >> GO TO 12.
NG >> GO TO 11.

11. DETECT MALFUNCTIONING PART

Check the following.

- Harness connectors E21, F34
- Harness for open or short between ECM and accelerator pedal position sensor
- Harness for open or short between TCM and accelerator pedal position sensor

>> Repair open circuit or short to ground or short to power in harness or connectors.

12. CHECK APP SENSOR INPUT SIGNAL CIRCUIT FOR OPEN AND SHORT

1. Check harness continuity between ECM terminal 106 and APP sensor terminal 3, ECM terminal 98 and APP sensor terminal 6.
Refer to Wiring Diagram.

Continuity should exist.

2. Also check harness for short to ground and short to power.

OK or NG

- OK >> GO TO 14.
NG >> GO TO 13.

13. DETECT MALFUNCTIONING PART

Check the following.

- Harness connectors E21, F34
- Harness for open or short between ECM and accelerator pedal position sensor

>> Repair open circuit or short to ground or short to power in harness or connectors.

14. CHECK APP SENSOR

Refer to [EC-571, "Component Inspection"](#) .

OK or NG

- OK >> GO TO 16.
NG >> GO TO 15.

15. REPLACE ACCELERATOR PEDAL ASSEMBLY

1. Replace accelerator pedal assembly.
2. Perform [EC-93, "Accelerator Pedal Released Position Learning"](#) .
3. Perform [EC-93, "Throttle Valve Closed Position Learning"](#) .
4. Perform [EC-93, "Idle Air Volume Learning"](#) .

>> INSPECTION END

16. CHECK INTERMITTENT INCIDENT

Refer to [EC-158, "TROUBLE DIAGNOSIS FOR INTERMITTENT INCIDENT"](#) .

>> INSPECTION END

**Component Inspection
ACCELERATOR PEDAL POSITION SENSOR**

UBS00CVU

1. Reconnect all harness connectors disconnected.
2. Turn ignition switch ON.
3. Check voltage between ECM terminals 106 (APP sensor 1 signal), 98 (APP sensor 2 signal) and ground under the following conditions.

Terminal	Accelerator pedal	Voltage
106 (Accelerator pedal position sensor 1)	Fully released	0.65 - 0.87V
	Fully depressed	More than 4.3V
98 (Accelerator pedal position sensor 2)	Fully released	0.28 - 0.48V
	Fully depressed	More than 2.0V

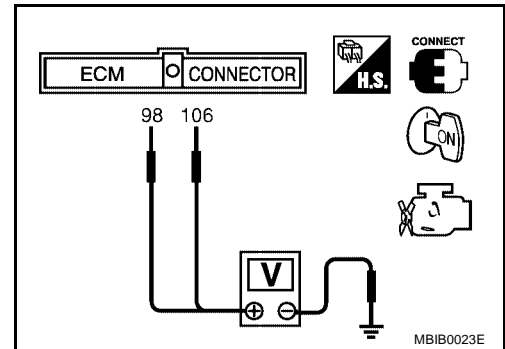

4. If NG, replace accelerator pedal assembly and go to the next step.
5. Perform [EC-93, "Accelerator Pedal Released Position Learning"](#) .
6. Perform [EC-93, "Throttle Valve Closed Position Learning"](#) .
7. Perform [EC-93, "Idle Air Volume Learning"](#) .

**Remove and Installation
ACCELERATOR PEDAL**

UBS002TU

Refer to [ACC-2, "ACCELERATOR CONTROL SYSTEM"](#) .

IGNITION SIGNAL

PFP:22448

Component Description

IGNITION COIL & POWER TRANSISTOR

UBS0032W

The ignition signal from the ECM is sent to and amplified by the power transistor. The power transistor turns ON and OFF the ignition coil primary circuit. This ON-OFF operation induces the proper high voltage in the coil secondary circuit.

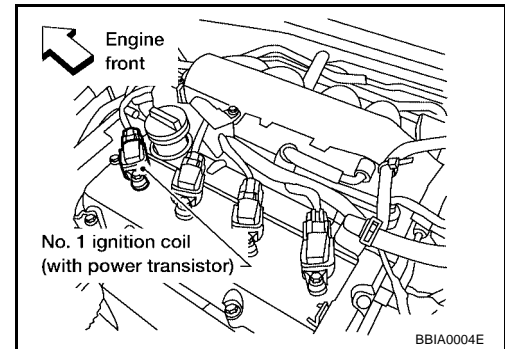

IGNITION SIGNAL

[QR]

Specification data are reference values and are measured between each terminal and ground.

CAUTION:

Do not use ECM ground terminals when measuring input/output voltage. Doing so may result in damage to the ECM's transistor. Use a ground other than ECM terminals, such as the ground.

TERMI- NAL NO.	WIRE COLOR	ITEM	CONDITION	DATA (DC Voltage)
111	W/B	ECM relay (Self shut-off)	[Engine is running] [Ignition switch: OFF] <ul style="list-style-type: none">● A few seconds after turning ignition switch OFF	0 - 1.0V
			[Ignition switch: OFF] <ul style="list-style-type: none">● More than a few seconds after turning ignition switch OFF	BATTERY VOLTAGE (11 - 14V)
119 120	R/G	Power supply for ECM	[Ignition switch: ON]	BATTERY VOLTAGE (11 - 14V)

IGNITION SIGNAL

[QR]

EC-IGNSYS-02

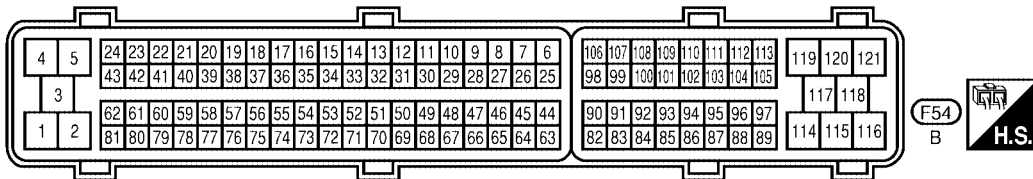
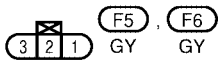
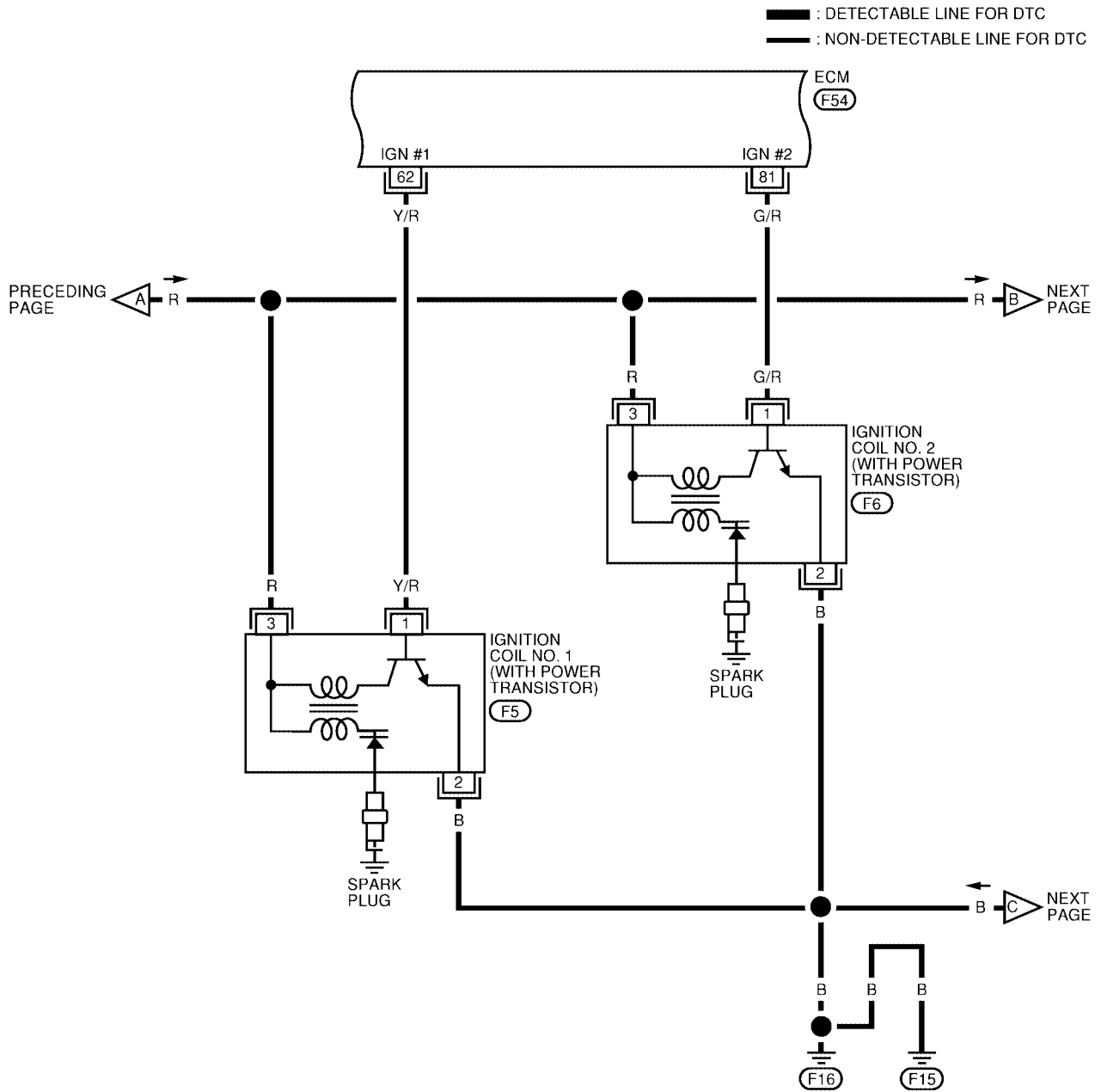

BBWA1253E

IGNITION SIGNAL

[QR]

Specification data are reference values and are measured between each terminal and ground.
Pulse signal is measured by CONSULT-II.

CAUTION:

Do not use ECM ground terminals when measuring input/output voltage. Doing so may result in damage to the ECM's transistor. Use a ground other than ECM terminals, such as the ground.

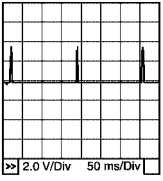
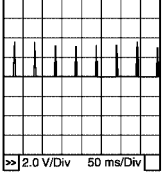
TERMI- NAL NO.	WIRE COLOR	ITEM	CONDITION	DATA (DC Voltage)
62 81	Y/R G/R	Ignition signal No. 1 Ignition signal No. 2	<p>[Engine is running]</p> <ul style="list-style-type: none"> ● Warm-up condition ● Idle speed <p>NOTE: The pulse cycle changes depending on rpm at idle.</p>	<p>0 - 0.1V★</p>  <p>PBIB0521E</p>
			<p>[Engine is running]</p> <ul style="list-style-type: none"> ● Warm-up condition ● Engine speed is 2,000 rpm. 	<p>0 - 0.2V★</p>  <p>PBIB0522E</p>

★: Average voltage for pulse signal (Actual pulse signal can be confirmed by oscilloscope.)

IGNITION SIGNAL

[QR]

EC-IGNSYS-03

A
EC
C
D
E
F
G
H
I
J
K
L
M

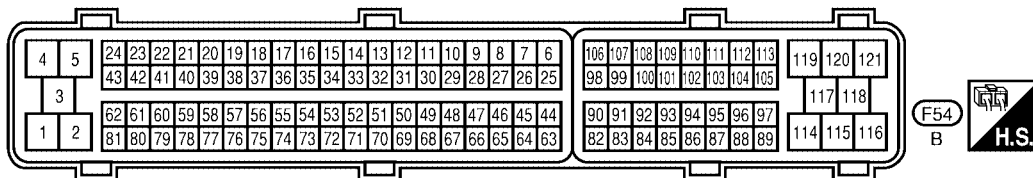
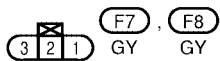
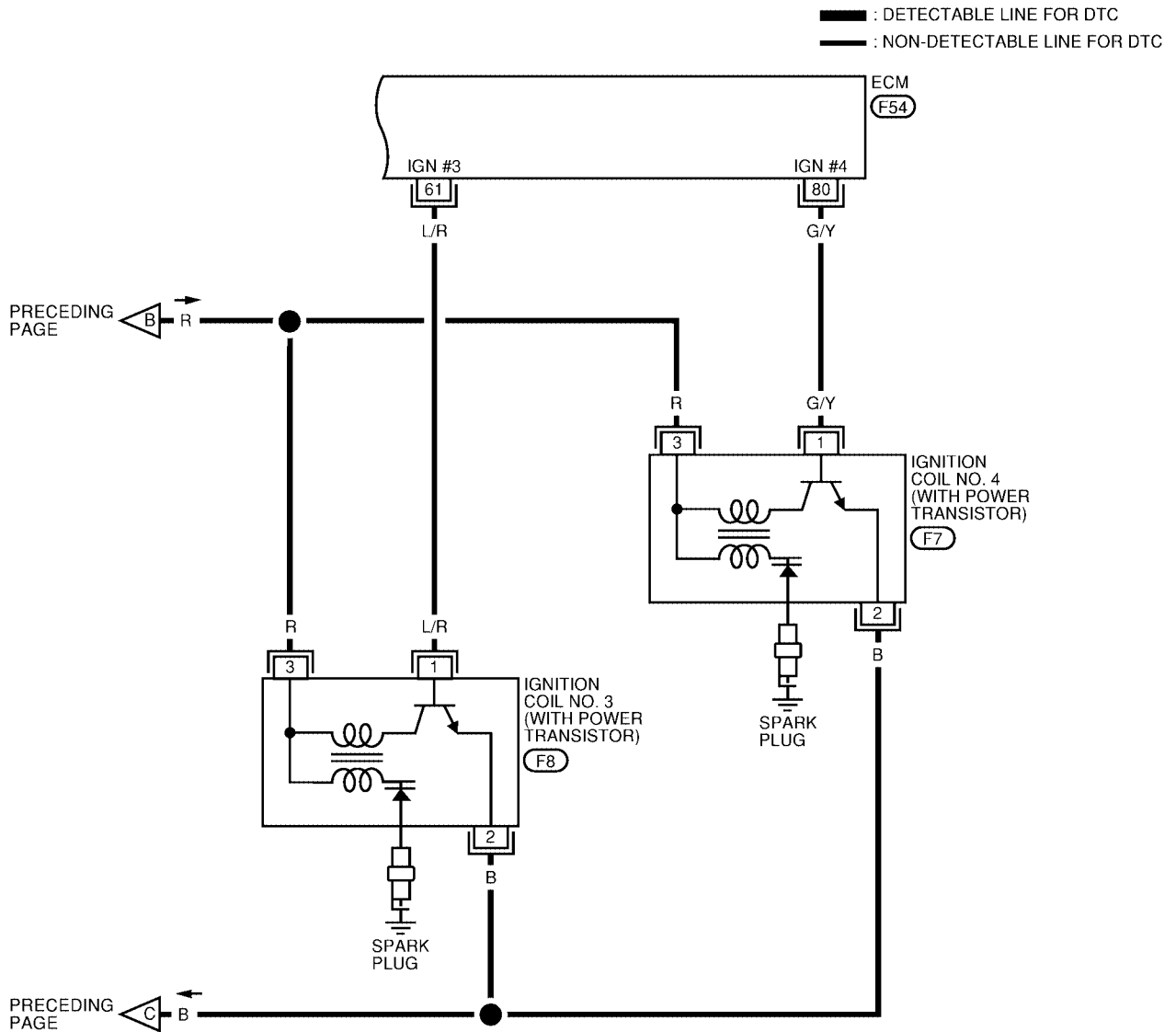

BBWA1254E

IGNITION SIGNAL

[QR]

Specification data are reference values and are measured between each terminal and ground.

CAUTION:

Do not use ECM ground terminals when measuring input/output voltage. Doing so may result in damage to the ECM's transistor. Use a ground other than ECM terminals, such as the ground.

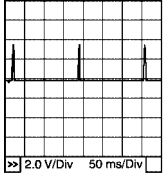
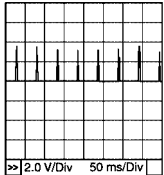
TERMI- NAL NO.	WIRE COLOR	ITEM	CONDITION	DATA (DC Voltage)
61 80	L/R G/Y	Ignition signal No. 3 Ignition signal No. 4	<p>[Engine is running]</p> <ul style="list-style-type: none"> ● Warm-up condition ● Idle speed <p>NOTE: The pulse cycle changes depending on rpm at idle.</p>	<p>0 - 0.1V★</p>  <p>PBIB0521E</p>
			<p>[Engine is running]</p> <ul style="list-style-type: none"> ● Warm-up condition ● Engine speed is 2,000 rpm. 	<p>0 - 0.2V★</p>  <p>PBIB0522E</p>

★: Average voltage for pulse signal (Actual pulse signal can be confirmed by oscilloscope.)

Diagnostic Procedure

UBS00E43

1. CHECK ENGINE START

Turn ignition switch OFF, and restart engine.

Is engine running?

Yes or No

Yes (With CONSULT-II)>>GO TO 2.

Yes (Without CONSULT-II)>>GO TO 3.

No >> GO TO 4.

2. CHECK OVERALL FUNCTION

With CONSULT-II

1. Perform "POWER BALANCE" in "ACTIVE TEST" mode with CONSULT-II.

2. Make sure that all circuits do not produce a momentary engine speed drop.

OK or NG

OK >> **INSPECTION END**

NG >> GO TO 8.

ACTIVE TEST	
POWER BALANCE	
MONITOR	
ENG SPEED	XXX rpm
MAS A/F SE-B1	XXX V

PBIB0133E

3. CHECK OVERALL FUNCTION

⊗ **Without CONSULT-II**

1. Let engine idle.
2. Read the voltage signal between ECM terminals 61, 62, 80, 81 and ground with an oscilloscope.
3. Verify that the oscilloscope screen shows the signal wave as shown below.

NOTE:

The pulse cycle changes depending on rpm at idle.

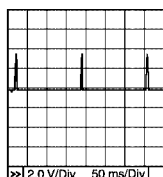

PBIB0521E

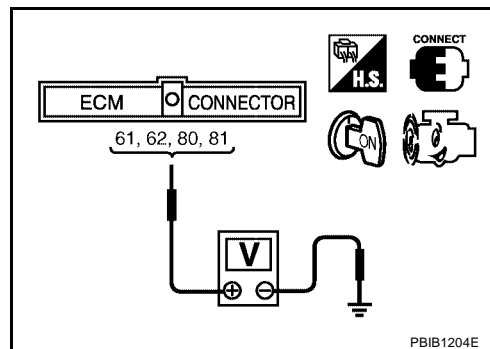

PBIB1204E

OK or NG

- OK >> **INSPECTION END**
 NG >> GO TO 8.

4. CHECK IGNITION COIL POWER SUPPLY CIRCUIT-I

1. Turn ignition switch OFF, wait at least 10 seconds and then turn ignition switch ON.
2. Check voltage between ECM terminals 119, 120 and ground with CONSULT-II or tester.

Voltage: Battery voltage

OK or NG

- OK >> GO TO 5.
 NG >> Go to [EC-159, "POWER SUPPLY AND GROUND CIRCUIT"](#).

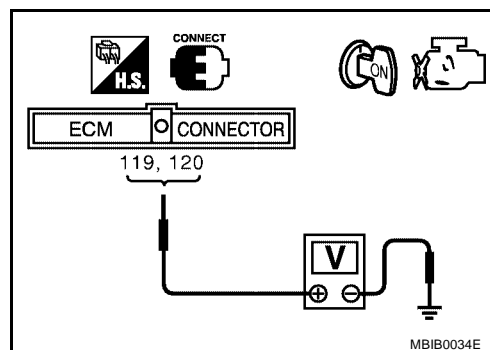

MBIB0034E

5. CHECK CONDENSER CIRCUIT FOR OPEN AND SHORT

1. Turn ignition switch OFF.
2. Disconnect condenser harness connector.
3. Check harness continuity between IPDM E/R terminal 17 and condenser terminal 1, condenser terminal 2 and ground. Refer to Wiring Diagram.

Continuity should exist.

4. Also check harness for short to ground and short to power.

OK or NG

- OK >> GO TO 7.
 NG >> GO TO 6.

6. DETECT MALFUNCTIONING PART

Check the following.

- Harness connector E20, F32
- Harness for open or short between IPDM E/R and condenser
- Harness for open or short between condenser and ground

>> Repair or replace open circuit or short to power in harness or connectors.

7. CHECK CONDENSER

Refer to [EC-581, "Component Inspection"](#) .

OK or NG

- OK >> GO TO 8.
- NG >> Replace condenser.

8. CHECK IGNITION COIL POWER SUPPLY CIRCUIT-V

1. Turn ignition switch OFF.
2. Reconnect all harness connectors disconnected.
3. Disconnect ignition coil harness connector.
4. Turn ignition switch ON.

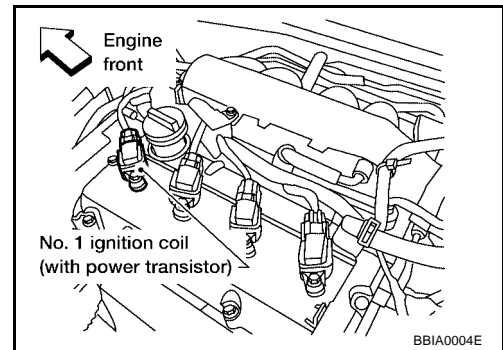

5. Check voltage between ignition coil terminal 3 and ground with CONSULT-II or tester.

Voltage: Battery voltage

OK or NG

- OK >> GO TO 10.
- NG >> GO TO 9.

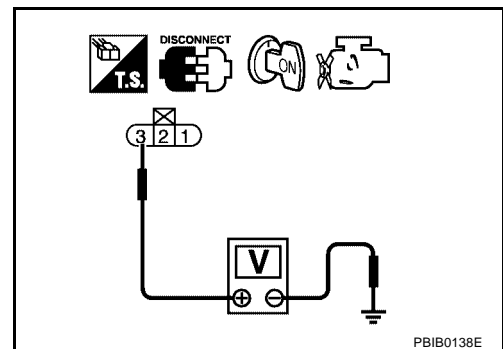

9. DETECT MALFUNCTIONING PART

Check the following.

- Harness connector E20, F32
- Harness for open or short between ignition coil and IPDM E/R

>> Repair or replace harness or connectors.

10. CHECK IGNITION COIL GROUND CIRCUIT FOR OPEN AND SHORT

1. Turn ignition switch OFF.
2. Check harness continuity between ignition coil terminal 2 and ground.
Refer to Wiring Diagram.

Continuity should exist.

3. Also check harness for short to power.

OK or NG

OK >> GO TO 11.

NG >> Repair open circuit or short to power in harness or connectors.

11. CHECK IGNITION COIL OUTPUT SIGNAL CIRCUIT FOR OPEN AND SHORT

1. Disconnect ECM harness connector.
2. Check harness continuity between ECM terminals 61, 62, 80, 81 and ignition coil terminal 1.
Refer to Wiring Diagram.

Continuity should exist.

3. Also check harness for short to ground and short to power.

OK or NG

OK >> GO TO 12.

NG >> Repair open circuit or short to ground or short to power in harness or connectors.

12. CHECK IGNITION COIL WITH POWER TRANSISTOR

Refer to [EC-581, "Component Inspection"](#) .

OK or NG

OK >> GO TO 13.

NG >> Replace ignition coil with power transistor.

13. CHECK INTERMITTENT INCIDENT

Refer to [EC-158, "TROUBLE DIAGNOSIS FOR INTERMITTENT INCIDENT"](#) .

>> INSPECTION END

Component Inspection IGNITION COIL WITH POWER TRANSISTOR

UBS0032Z

1. Turn ignition switch OFF.
2. Disconnect ignition coil harness connector.
3. Check resistance between ignition coil terminals as follows.

Terminal No.	Resistance Ω [at 25°C (77°F)]
1 and 2	Except 0 or ∞
1 and 3	Except 0
2 and 3	

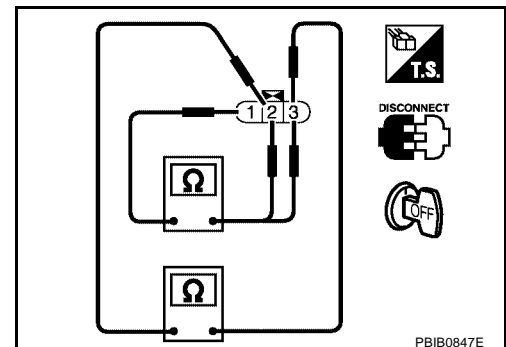

CONDENSER

1. Turn ignition switch OFF.
2. Disconnect condenser harness connector.

IGNITION SIGNAL

[QR]

3. Check resistance between condenser terminals as 1 and 2.

Resistance: Above 1 MΩ at 25°C (77°F)

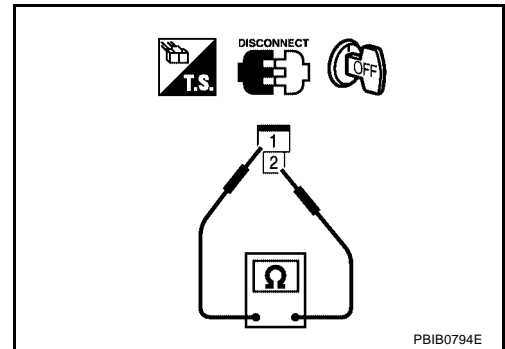

UBS00330

Removal and Installation IGNITION COIL WITH POWER TRANSISTOR

Refer to [EM-29, "IGNITION COIL"](#) .

VIAS

**Description
SYSTEM DESCRIPTION**

Sensor	Input Signal to ECM	ECM function	Actuator
Mass air flow sensor	Amount of intake air	VIAS control	VIAS control solenoid valve
Throttle position sensor	Throttle position		
Accelerator pedal position sensor	Closed throttle position		
Battery	Battery voltage*		
Crankshaft position sensor (POS) Camshaft position sensor (PHASE)	Engine speed*		
Engine coolant temperature sensor	Engine coolant temperature		

*: ECM determines the start signal status by the signals of engine speed and battery voltage.

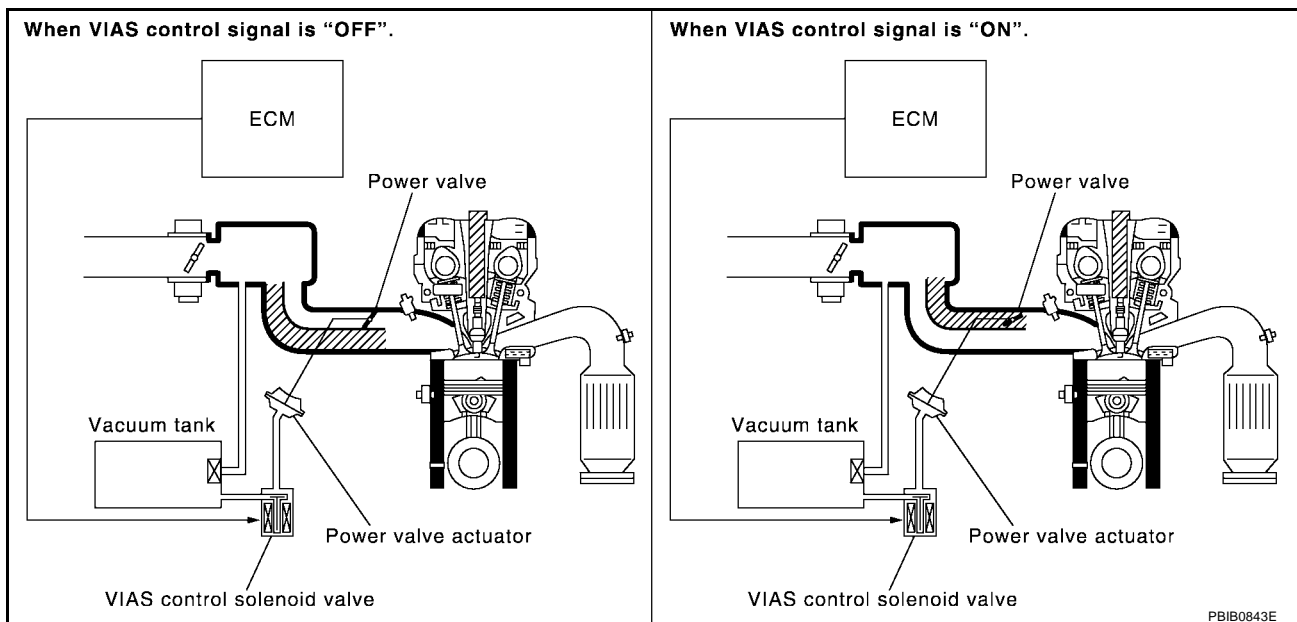

When the engine is running at low or medium speed, the power valve is fully closed. Under this condition, the effective suction port length is equivalent to the total length of the intake manifold collector's suction port including the intake valve. This long suction port provides increased air intake which results in improved suction efficiency and higher torque generation.

The surge tank and one-way valve are provided. When engine is running at high speed, the ECM sends the signal to the VIAS control solenoid valve. This signal introduces the intake manifold vacuum into the power valve actuator and therefore opens the power valve to two suction passages together in the collector.

Under this condition, the effective port length is equivalent to the length of the suction port provided independently for each cylinder. This shortened port length results in enhanced engine output with reduced suction resistance under high speeds.

COMPONENT DESCRIPTION

Power Valve

The power valve is installed in intake manifold collector and used to control the suction passage of the variable induction air control system. It is set in the fully closed or fully opened position by the power valve actuator operated by the vacuum stored in the surge tank. The vacuum in the surge tank is controlled by the VIAS control solenoid valve.

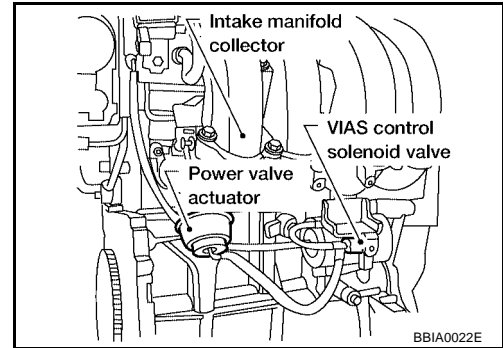

VIAS Control Solenoid Valve

The VIAS control solenoid valve cuts the intake manifold vacuum signal for power valve control. It responds to ON/OFF signals from the ECM. When the solenoid is off, the vacuum signal from the intake manifold is cut. When the ECM sends an ON signal the coil pulls the plunger downward and feeds the vacuum signal to the power valve actuator.

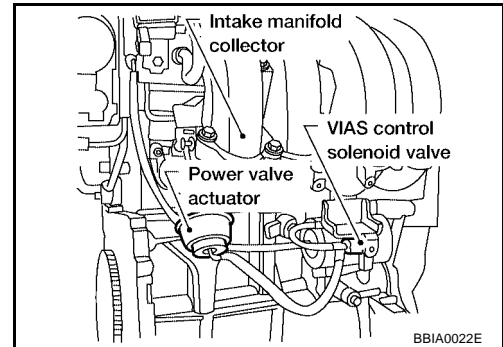

CONSULT-II Reference Value in Data Monitor Mode

UBS00332

MONITOR ITEM	CONDITION		SPECIFICATION
VIAS S/V	● Engine: After warming up	Idle	OFF
		More than 5,000 rpm	ON

Wiring Diagram

UBS00333

EC-VIAS-01

A
EC
C
D
E
F
G
H
I
J
K
L
M

— : DETECTABLE LINE FOR DTC
— : NON-DETECTABLE LINE FOR DTC

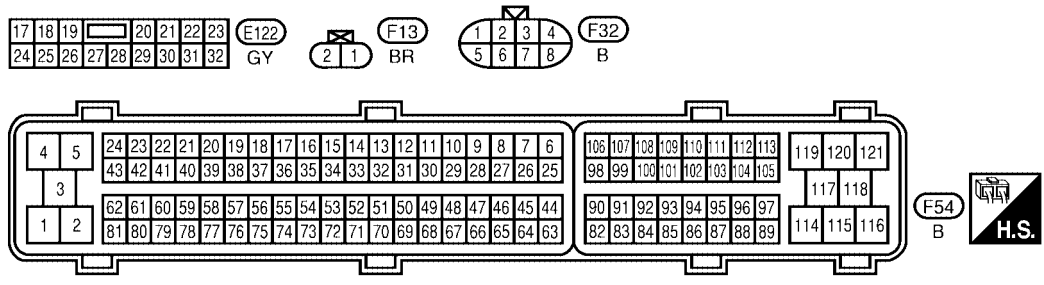
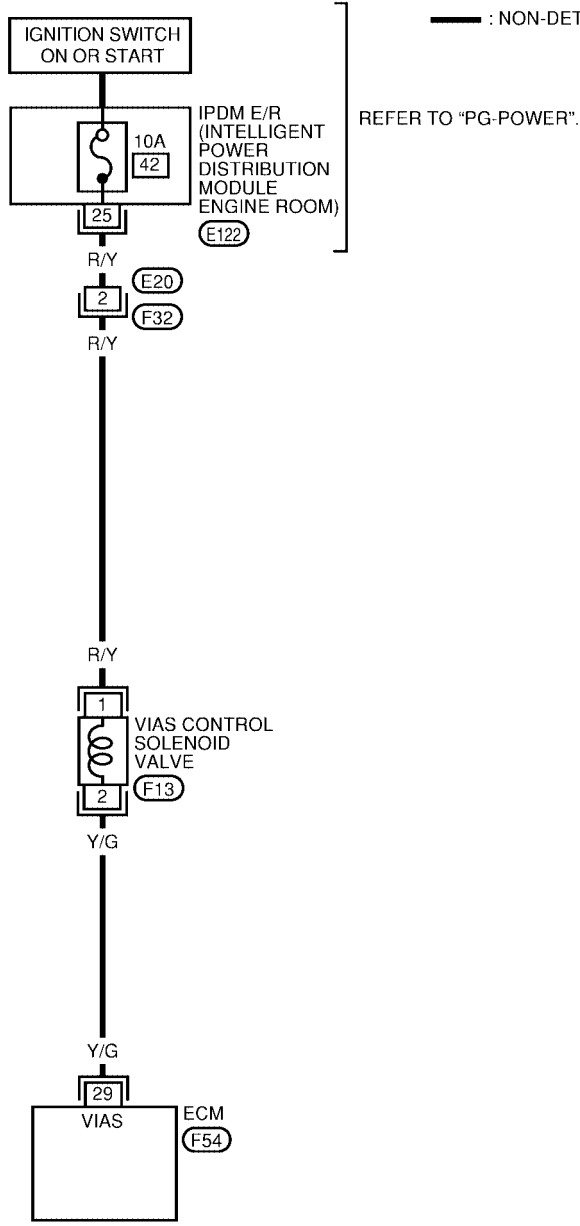

BBWA1255E

VIAS

[QR]

Specification data are reference values and are measured between each terminal and ground.

CAUTION:

Do not use ECM ground terminals when measuring input/output voltage. Doing so may result in damage to the ECM's transistor. Use a ground other than ECM terminals, such as the ground.

TER-MINAL NO.	WIRE COLOR	ITEM	CONDITION	DATA (DC Voltage)
29	Y/G	VIAS control solenoid valve	[Engine is running] <ul style="list-style-type: none">● Idle speed	BATTERY VOLTAGE (11 - 14V)
			[Engine is running] <ul style="list-style-type: none">● Engine speed is above 5,000 rpm	0 - 1.0V

Diagnostic Procedure

1. CHECK OVERALL FUNCTION

With CONSULT-II

1. Start engine and warm it up to normal operating temperature.
2. Perform "VIAS SOL VALVE" in "ACTIVE TEST" mode with CONSULT-II.

ACTIVE TEST	
VIAS SOL VALVE	OFF
MONITOR	
ENG SPEED	XXX rpm

PBI0844E

3. Turn VIAS control solenoid valve ON and OFF, and make sure that power valve actuator rod moves.

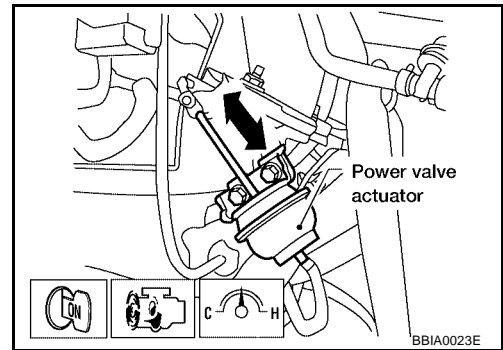

Without CONSULT-II

1. Start engine and warm it up to normal operating temperature.
2. Rev engine quickly up to above 5,000 rpm and make sure that power valve actuator rod moves.

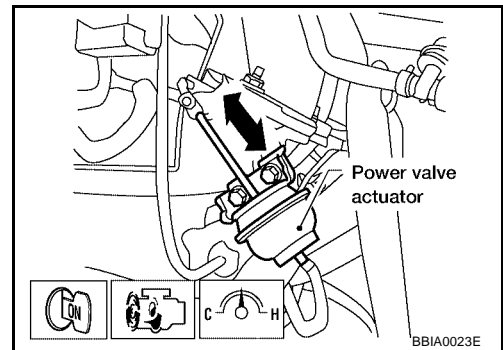

OK or NG

- OK >> **INSPECTION END**
- NG (With CONSULT-II) >>GO TO 2.
- NG (Without CONSULT-II) >>GO TO 3.

A
EC
C
D
E
F
G
H
I
J
K
L
M

2. CHECK VACUUM EXISTENCE

With CONSULT-II

1. Stop engine and disconnect vacuum hose connected to power valve actuator.
2. Start engine and let it idle.
3. Perform "VIAS SOL VALVE" in "ACTIVE TEST" mode with CONSULT-II.
4. Turn VIAS control solenoid valve ON and OFF, and check vacuum existence under the following conditions.

VIAS SOL VALVE	Vacuum
ON	Should exist.
OFF	Should not exist.

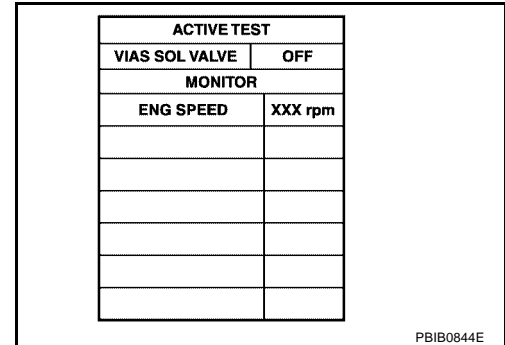

PBIB0844E

OK or NG

- OK >> Repair or replace power valve actuator.
- NG >> GO TO 4.

3. CHECK VACUUM EXISTENCE

Without CONSULT-II

1. Stop engine and disconnect vacuum hose connected to power valve actuator.
2. Disconnect VIAS control solenoid valve harness connector.
3. Start engine and let it idle.
4. Apply 12V of direct current between VIAS control solenoid valve terminals 1 and 2.
5. Check vacuum existence under the following conditions.

Condition	Vacuum
12V direct current supply	Should exist.
No supply	Should not exist.

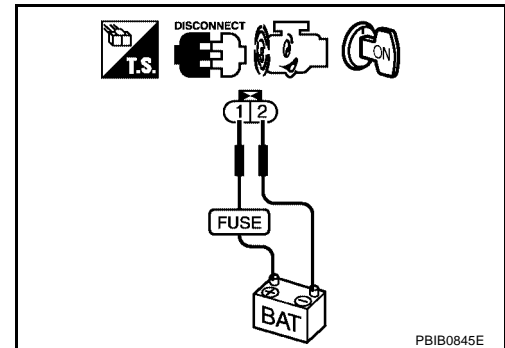

PBIB0845E

OK or NG

- OK >> Repair or replace power valve actuator.
- NG >> GO TO 4.

4. CHECK VACUUM HOSE

1. Stop engine.
2. Check hoses and tubes between intake manifold and power valve actuator for crack, clogging, improper connection or disconnection. Refer to [EC-117, "Vacuum Hose Drawing"](#).

OK or NG

- OK >> GO TO 5.
- NG >> Repair hoses or tubes.

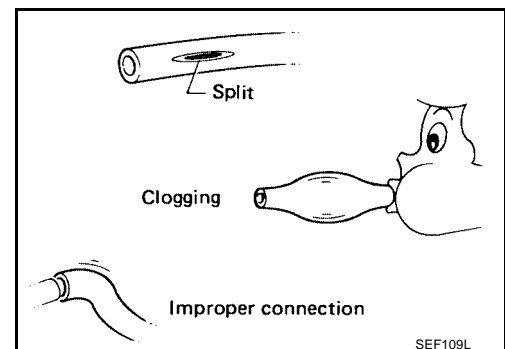

SEF109L

5. CHECK VACUUM TANK

Refer to [EC-590, "Component Inspection"](#) .

OK or NG

- OK >> GO TO 6.
NG >> Replace vacuum tank.

6. CHECK VIAS CONTROL SOLENOID VALVE POWER SUPPLY CIRCUIT

1. Turn ignition switch OFF.
2. Disconnect VIAS control solenoid valve harness connector.
3. Turn ignition switch ON.

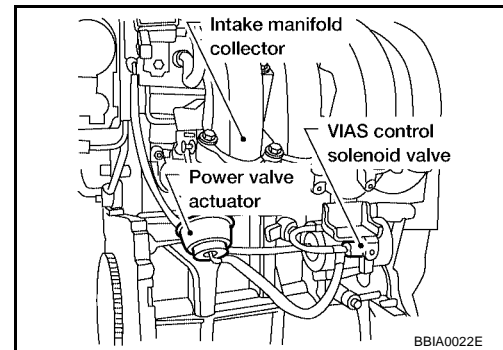

4. Check voltage between VIAS control solenoid valve terminal 1 and ground with CONSULT-II or tester.

Voltage: Battery voltage

OK or NG

- OK >> GO TO 8.
NG >> GO TO 7.

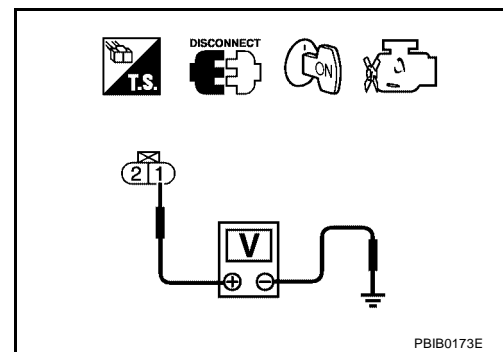

7. DETECT MALFUNCTIONING PART

Check the following.

- Harness connectors E20, F32
- IPDM E/R connector E122
- 10A fuse
- Harness continuity between fuse and VIAS control solenoid valve

>> Repair harness or connectors.

8. CHECK VIAS CONTROL SOLENOID VALVE OUTPUT SIGNAL CIRCUIT FOR OPEN AND SHORT

1. Turn ignition switch OFF.
2. Disconnect ECM harness connector.
3. Check harness continuity between ECM terminal 29 and VIAS control solenoid valve terminal 2. Refer to Wiring Diagram.

Continuity should exist.

4. Also check harness for short to ground and short to power.

OK or NG

- OK >> GO TO 9.
NG >> Repair open circuit or short to ground or short to power in harness or connectors.

9. CHECK VIAS CONTROL SOLENOID VALVE

Refer to [EC-590, "Component Inspection"](#) .

OK or NG

- OK >> GO TO 10.
- NG >> Replace VIAS control solenoid valve.

10. CHECK INTERMITTENT INCIDENT

Refer to [EC-158, "TROUBLE DIAGNOSIS FOR INTERMITTENT INCIDENT"](#) .

>> INSPECTION END

Component Inspection VIAS CONTROL SOLENOID VALVE

UBS00335

Ⓟ With CONSULT-II

1. Reconnect harness connectors disconnected.
2. Turn ignition switch ON.
3. Perform "VIAS SOL VALVE" in "ACTIVE TEST" mode.
4. Check air passage continuity and operation delay time under the following conditions.

Condition VIAS SOL VALVE	Air passage continuity between A and B	Air passage continuity between A and C
ON	Yes	No
OFF	No	Yes

Operation takes less than 1 second.

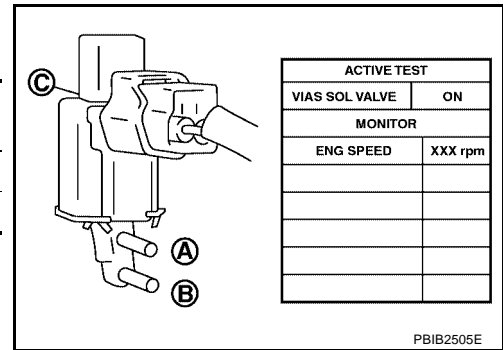

ⓧ Without CONSULT-II

Check air passage continuity and operation delay time under the following conditions.

Condition	Air passage continuity between A and B	Air passage continuity between A and C
12V direct current supply between terminals 1 and 2	Yes	No
No supply	No	Yes

Operation takes less than 1 second.

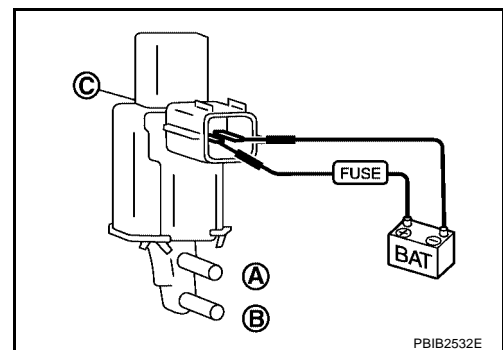

VACUUM TANK

1. Disconnect vacuum hose connected to vacuum tank.
2. Connect a vacuum pump to the port **A** of vacuum pump.
3. Apply vacuum and make sure that vacuum exists at the port **B** .

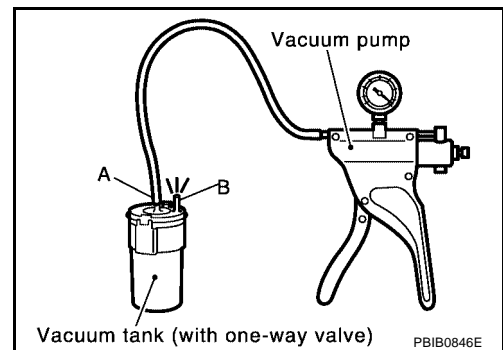

Removal and Installation

VIAS CONTROL SOLENOID VALVE

Refer to [EM-19, "INTAKE MANIFOLD"](#) .

A

EC

C

D

E

F

G

H

I

J

K

L

M

INJECTOR CIRCUIT

Component Description

UBS00337

The fuel injector is a small, precise solenoid valve. When the ECM supplies a ground to the injector circuit, the coil in the injector is energized. The energized coil pulls the needle valve back and allows fuel to flow through the injector into the intake manifold. The amount of fuel injected depends upon the injection pulse duration. Pulse duration is the length of time the injector remains open. The ECM controls the injection pulse duration based on engine fuel needs.

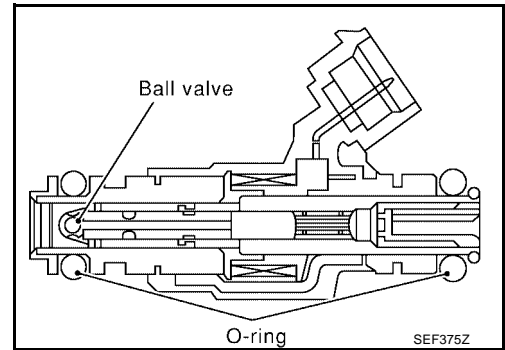

CONSULT-II Reference Value in Data Monitor Mode

UBS00338

Specification data are reference values.

MONITOR ITEM	CONDITION		SPECIFICATION
B/FUEL SCHDL	<ul style="list-style-type: none"> See EC-148. "TROUBLE DIAGNOSIS - SPECIFICATION VALUE". 		
INJ PULSE-B1	<ul style="list-style-type: none"> Engine: After warming up Shift lever: N (A/T), Neutral (M/T) Air conditioner switch: OFF No-load 	Idle	2.0 - 3.0 msec
		2,000 rpm	1.9 - 2.9 msec

INJECTOR CIRCUIT

[QR]

Wiring Diagram

UBS00339

EC-INJECT-01

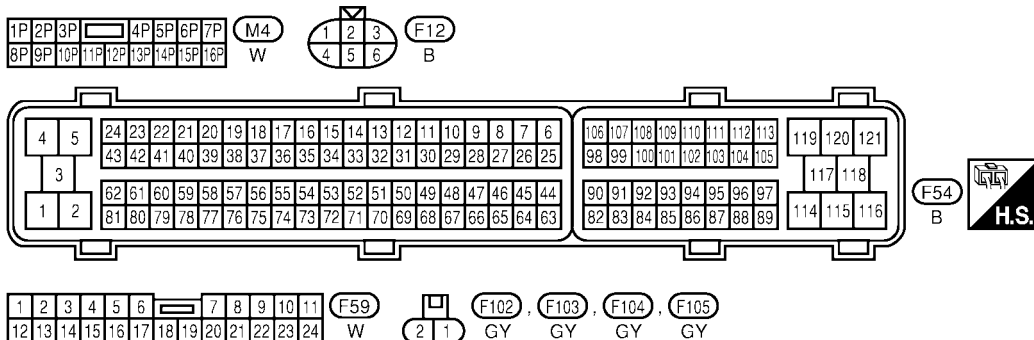
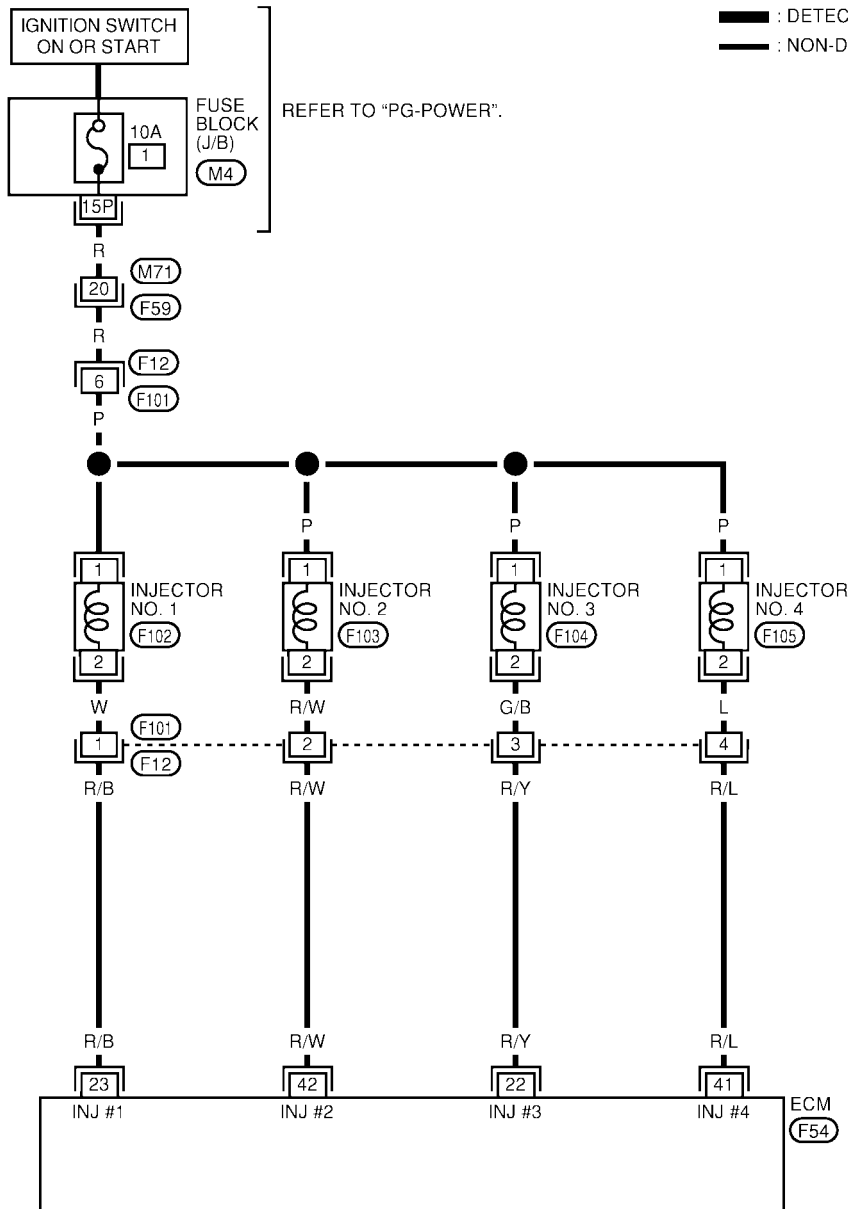

BBWA1257E

INJECTOR CIRCUIT

[QR]

Specification data are reference values and are measured between each terminal and ground.
Pulse signal is measured by CONSULT-II.

CAUTION:

Do not use ECM ground terminals when measuring input/output voltage. Doing so may result in damage to the ECM's transistor. Use a ground other than ECM terminals, such as the ground.

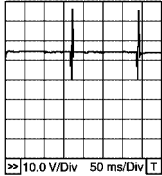
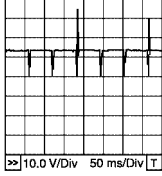
TERMI- NAL NO.	WIRE COLOR	ITEM	CONDITION	DATA (DC Voltage)
22 23 41 42	R/Y R/B R/L R/W	Injector No. 3 Injector No. 1 Injector No. 4 Injector No. 2	<p>[Engine is running]</p> <ul style="list-style-type: none"> ● Warm-up condition ● Idle speed <p>NOTE: The pulse cycle changes depending on rpm at idle.</p>	<p>BATTERY VOLTAGE (11 - 14V)★</p>  <p style="text-align: right; font-size: small;">PBIB0529E</p>
			<p>[Engine is running]</p> <ul style="list-style-type: none"> ● Warm-up condition ● Engine speed is 2,000 rpm 	<p>BATTERY VOLTAGE (11 - 14V)★</p>  <p style="text-align: right; font-size: small;">PBIB0530E</p>

★: Average voltage for pulse signal (Actual pulse signal can be confirmed by oscilloscope.)

Diagnostic Procedure

UBS0033A

1. INSPECTION START

Turn ignition switch to START.

Is any cylinder ignited?

Yes or No

- Yes >> GO TO 2.
- No >> GO TO 3.

2. CHECK OVERALL FUNCTION

④ With CONSULT-II

1. Start engine.
2. Perform "POWER BALANCE" in "ACTIVE TEST" mode with CONSULT-II.
3. Make sure that each circuit produces a momentary engine speed drop.

ACTIVE TEST	
POWER BALANCE	
MONITOR	
ENG SPEED	XXX rpm
MAS A/F SE-B1	XXX V

PBIB0133E

⊗ Without CONSULT-II

1. Start engine.
2. Listen to each injector operating sound.
Clicking noise should be heard.

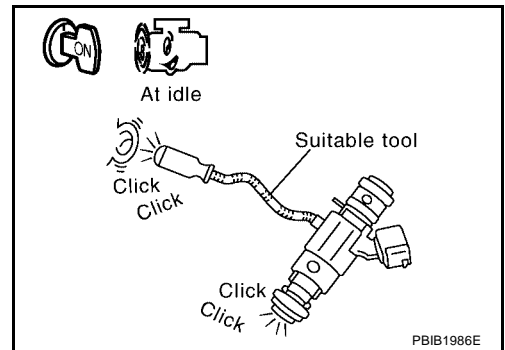

OK or NG

- OK >> **INSPECTION END**
 NG >> **GO TO 3.**

A
EC
C
D
E
F
G
H
I
J
K
L
M

3. CHECK INJECTOR POWER SUPPLY CIRCUIT

1. Turn ignition switch OFF.
2. Disconnect injector harness connector.
3. Turn ignition switch ON.

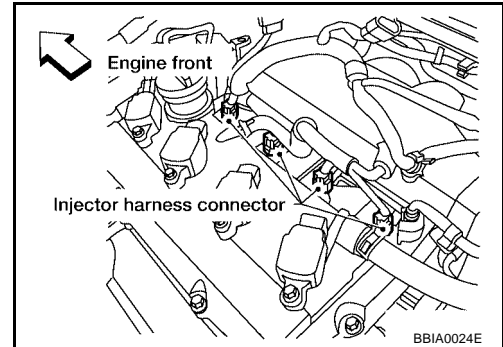

4. Check voltage between injector terminal 1 and ground with CONSULT-II or tester.

Voltage: Battery voltage

OK or NG

- OK >> GO TO 5.
- NG >> GO TO 4.

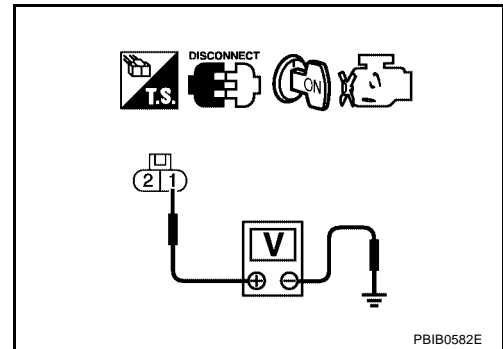

4. DETECT MALFUNCTIONING PART

Check the following.

- Harness connectors M71, F59
- Harness connectors F12, F101
- Fuse block (J/B) connector M4
- 10A fuse
- Harness for open or short between injector and fuse

>> Repair open circuit or short to ground or short to power in harness or connectors.

5. CHECK INJECTOR OUTPUT SIGNAL CIRCUIT FOR OPEN AND SHORT

1. Turn ignition switch OFF.
2. Disconnect ECM harness connector.
3. Check harness continuity between injector terminal 2 and ECM terminals 22, 23, 41, 42. Refer to Wiring Diagram.

Continuity should exist.

4. Also check harness for short to ground and short to power.

OK or NG

- OK >> GO TO 7.
- NG >> GO TO 6.

6. DETECT MALFUNCTIONING PART

Check the following.

- Harness connectors F12, F101
- Harness for open or short between injector and ECM

>> Repair open circuit or short to ground or short to power in harness or connectors.

7. CHECK INJECTOR

Refer to [EC-597, "Component Inspection"](#) .

OK or NG

OK >> GO TO 8.

NG >> Replace injector.

8. CHECK INTERMITTENT INCIDENT

Refer to [EC-158, "TROUBLE DIAGNOSIS FOR INTERMITTENT INCIDENT"](#) .

>> INSPECTION END

Component Inspection INJECTOR

UBS0033B

1. Disconnect injector harness connector.
2. Check resistance between terminals as shown in the figure.

Resistance: 11.6 - 14.9Ω [at 10 - 60°C (50 - 140°F)]

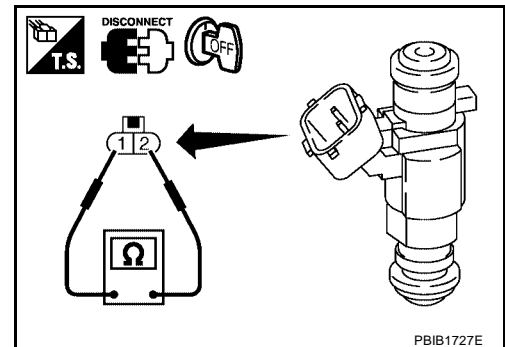

UBS0033C

Removal and Installation INJECTOR

Refer to [EM-32, "FUEL INJECTOR AND FUEL TUBE"](#) .

FUEL PUMP CIRCUIT

[QR]

PF1:17042

UBS00E44

FUEL PUMP CIRCUIT

Description SYSTEM DESCRIPTION

Sensor	Input Signal to ECM	ECM Function	Actuator
Crankshaft position sensor (POS) Camshaft position sensor (PHASE)	Engine speed*	Fuel pump control	Fuel pump relay
Battery	Battery voltage*		

*: ECM determines the start signal status by the signals of engine speed and battery voltage.

The ECM activates the fuel pump for 1 second after the ignition switch is turned ON to improve engine start-ability. If the ECM receives a engine speed signal from the camshaft position sensor (PHASE), it knows that the engine is rotating, and causes the pump to operate. If the engine speed signal is not received when the ignition switch is ON, the engine stalls. The ECM stops pump operation and prevents battery discharging, thereby improving safety. The ECM does not directly drive the fuel pump. It controls the ON/OFF fuel pump relay, which in turn controls the fuel pump.

Condition	Fuel pump operation
Ignition switch is turned to ON.	Operates for 1 second.
Engine running and cranking	Operates.
When engine is stopped	Stops in 1.5 seconds.
Except as shown above	Stops.

COMPONENT DESCRIPTION

A turbine type design fuel pump is used in the fuel tank.

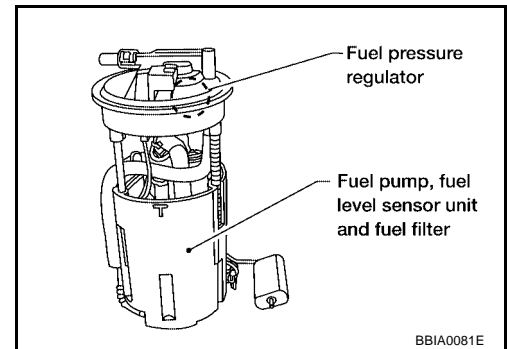

BBIA0081E

CONSULT-II Reference Value in Data Monitor Mode

UBS0033H

Specification data are reference values.

MONITOR ITEM	CONDITION	SPECIFICATION
FUEL PUMP RLY	● For 1 second after turning ignition switch ON	ON
	● Engine running or cranking	
	● Except above conditions	OFF

FUEL PUMP CIRCUIT

[QR]

UBS0033I

Wiring Diagram

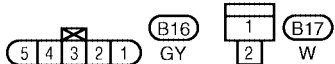
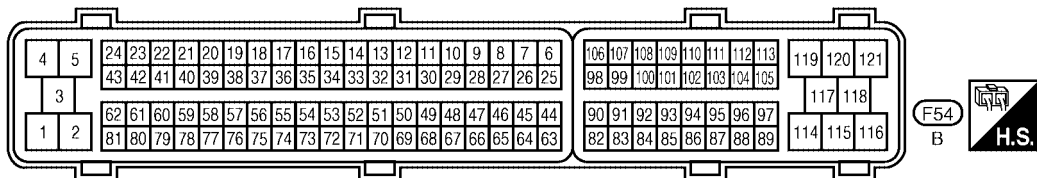
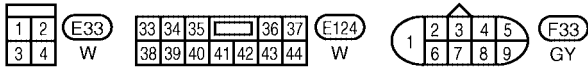
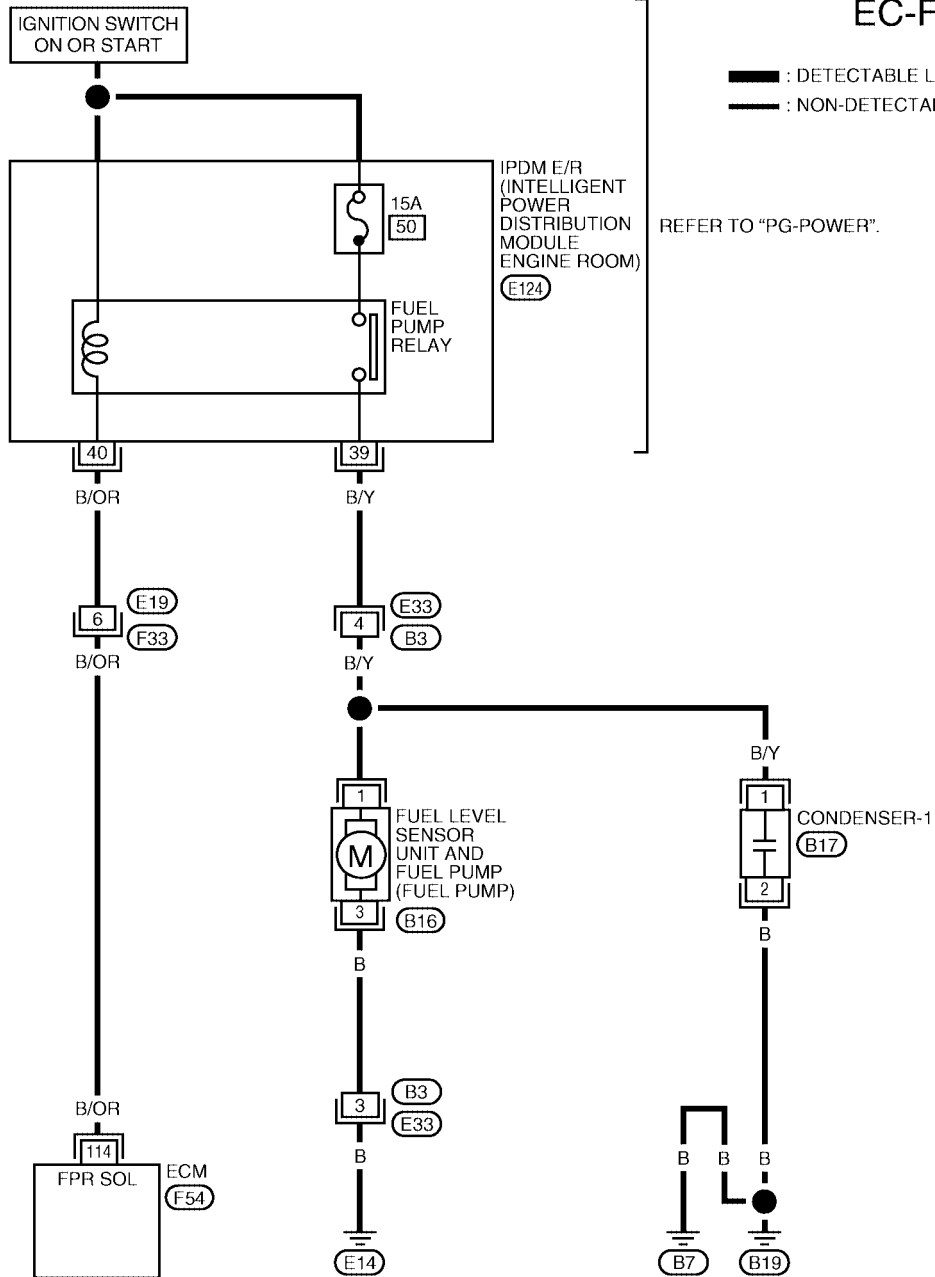

BBWA1258E

FUEL PUMP CIRCUIT

[QR]

Specification data are reference values and are measured between each terminal and ground.

CAUTION:

Do not use ECM ground terminals when measuring input/output voltage. Doing so may result in damage to the ECM's transistor. Use a ground other than ECM terminals, such as the ground.

TER-MINAL NO.	WIRE COLOR	ITEM	CONDITION	DATA (DC Voltage)
114	B/OR	Fuel pump relay	[Ignition switch: ON] ● For 1 second after turning ignition switch ON	0 - 1.0V
			[Engine is running] [Ignition switch: ON] ● More than 1 second after turning ignition switch ON	BATTERY VOLTAGE (11 - 14V)

Diagnostic Procedure

UBS0033J

1. CHECK OVERALL FUNCTION

- Turn ignition switch ON.
- Pinch fuel feed hose with two fingers.
Fuel pressure pulsation should be felt on the fuel hose for 1 second after ignition switch is turned ON.

OK or NG

- OK >> **INSPECTION END**
NG >> GO TO 2.

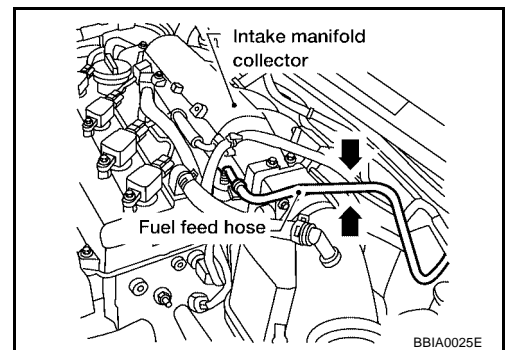

2. CHECK FUEL PUMP POWER SUPPLY CIRCUIT-I

- Turn ignition switch OFF.
- Disconnect ECM harness connector.
- Turn ignition switch ON.

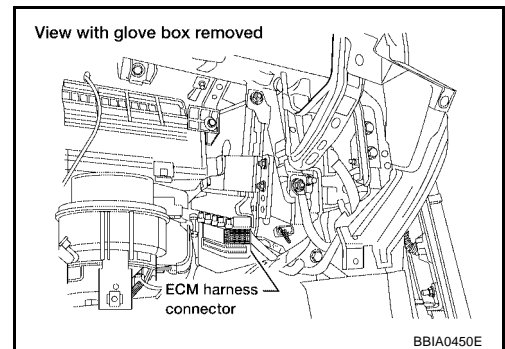

- Check voltage between ECM terminal 114 and ground with CONSULT-II or tester.

Voltage: Battery voltage

OK or NG

- OK >> GO TO 5.
NG >> GO TO 3.

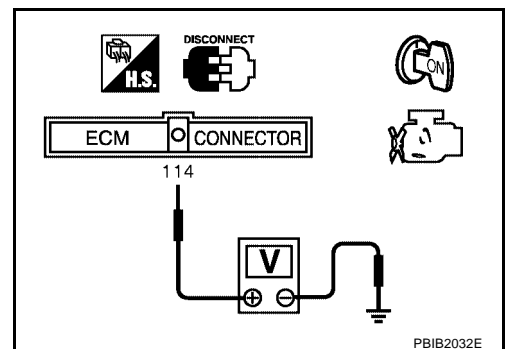

3. CHECK FUEL PUMP POWER SUPPLY CIRCUIT-II

1. Turn ignition switch OFF.
2. Disconnect IPDM E/R harness connector E124.
3. Turn ignition switch ON.
4. Check voltage between IPDM E/R terminal 40 and ground with CONSULT-II or tester.

Voltage: Battery voltage

OK or NG

- OK >> GO TO 4.
- NG >> GO TO 13.

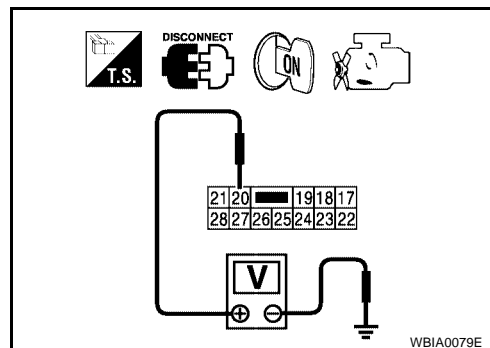

4. DETECT MALFUNCTIONING PART

Check the following.

- Harness or connectors E19, F33
- Harness for open or short between IPDM E/R and ECM

>> Repair harness or connectors.

5. CHECK CONDENSER POWER SUPPLY CIRCUIT-I

1. Turn ignition switch OFF.
2. Reconnect all harness connectors disconnected.
3. Disconnect condenser harness connector.
4. Turn ignition switch ON.

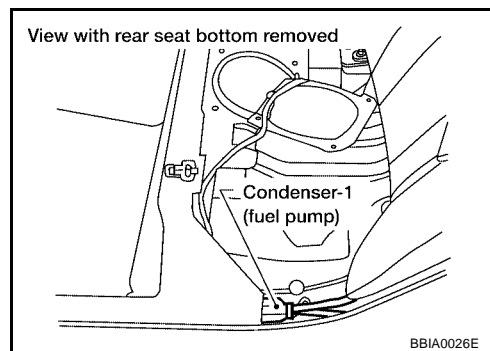

5. Check voltage between condenser terminal 1 and ground with CONSULT-II or tester.

Voltage: Battery voltage should exist for 1 second after ignition switch is turned ON.

OK or NG

- OK >> GO TO 9.
- NG >> GO TO 6.

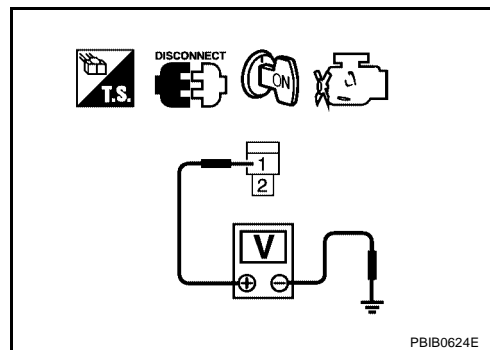

6. CHECK 15A FUSE

1. Turn ignition switch OFF.
2. Disconnect 15A fuse.
3. Check 15A fuse.

OK or NG

- OK >> GO TO 7.
NG >> Replace fuse.

7. CHECK CONDENSER POWER SUPPLY CIRCUIT-II

1. Disconnect IPDM E/R harness connector E124.
2. Check harness continuity between IPDM E/R terminal 39 and condenser terminal 1.
Refer to Wiring Diagram.

Continuity should exist.

3. Also check harness for short to ground and short to power.

OK or NG

- OK >> GO TO 13.
NG >> GO TO 8.

8. DETECT MALFUNCTIONING PART

Check the following.

- Harness or connectors E33, B3
- Harness for open or short between IPDM E/R and condenser

>> Repair harness or connectors.

9. CHECK CONDENSER GROUND CIRCUIT

1. Check harness continuity between condenser terminal 2 and ground.
Refer to Wiring Diagram.

Continuity should exist.

2. Also check harness for short to power.

OK or NG

- OK >> GO TO 10.
NG >> Repair or replace harness or connectors.

10. CHECK CONDENSER

Refer to [EC-603, "Component Inspection"](#) .

OK or NG

- OK >> GO TO 11.
NG >> Replace condenser.

11. CHECK FUEL PUMP POWER SUPPLY AND GROUND CIRCUIT FOR OPEN AND SHORT

1. Turn ignition switch OFF.
2. Disconnect "fuel level sensor unit and fuel pump" harness connector.
3. Check harness continuity between "fuel level sensor unit and fuel pump" terminal 1 and harness connector B3 terminal 4, "fuel level sensor unit and fuel pump" terminal 3 and ground. Refer to Wiring Diagram.

Continuity should exist.

4. Also check harness for short to ground and short to power.

OK or NG

OK >> GO TO 12.

NG >> Repair or replace harness or connectors.

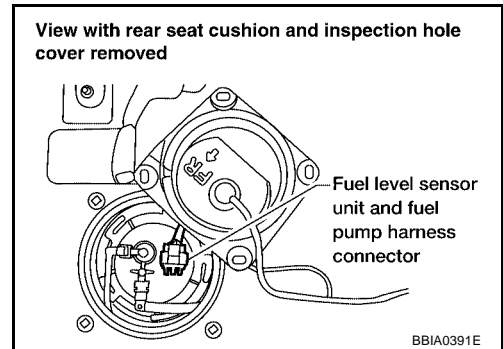

12. CHECK FUEL PUMP

Refer to [EC-603, "Component Inspection"](#) .

OK or NG

OK >> GO TO 13.

NG >> Replace fuel pump.

13. CHECK INTERMITTENT INCIDENT

Refer to [EC-158, "TROUBLE DIAGNOSIS FOR INTERMITTENT INCIDENT"](#) .

OK or NG

OK >> Replace IPDM E/R.

NG >> Repair or replace harness or connectors.

Component Inspection FUEL PUMP

UBS0033K

1. Disconnect "fuel level sensor unit and fuel pump" harness connector.

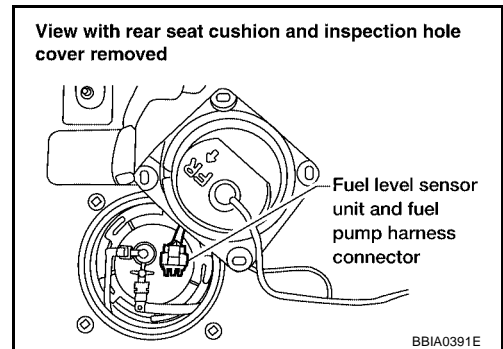

2. Check resistance between "fuel level sensor unit and fuel pump" terminals 1 and 3.

Resistance: 0.2 - 5.0Ω [at 25°C (77°F)]

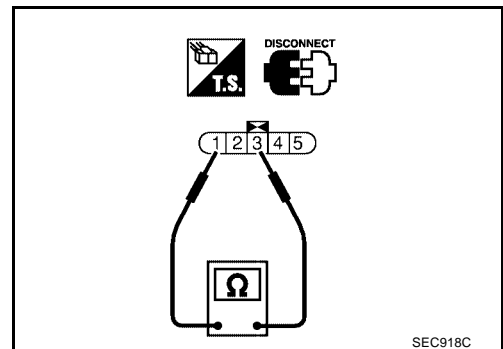

CONDENSER

1. Turn ignition switch OFF.
2. Disconnect condenser harness connector.
3. Check resistance between condenser terminals 1 and 2.

Resistance: Above $1M\Omega$ [at 25°C (77°F)]

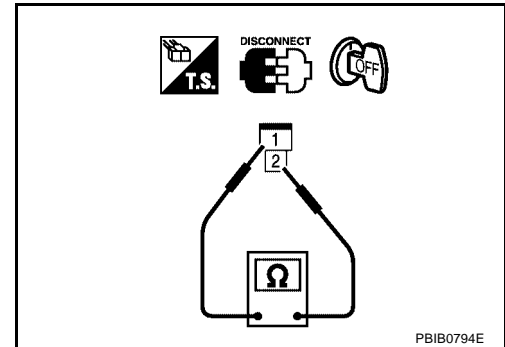

UBS0033L

Removal and Installation FUEL PUMP

Refer to [FL-5, "FUEL LEVEL SENSOR UNIT, FUEL FILTER AND FUEL PUMP ASSEMBLY"](#) .

REFRIGERANT PRESSURE SENSOR

[QR]

REFRIGERANT PRESSURE SENSOR

PFP:92136

UBS0033S

Component Description

The refrigerant pressure sensor is installed at the liquid tank of the air conditioner system. The sensor uses an electrostatic volume pressure transducer to convert refrigerant pressure to voltage. The voltage signal is sent to ECM, and ECM controls cooling fan system.

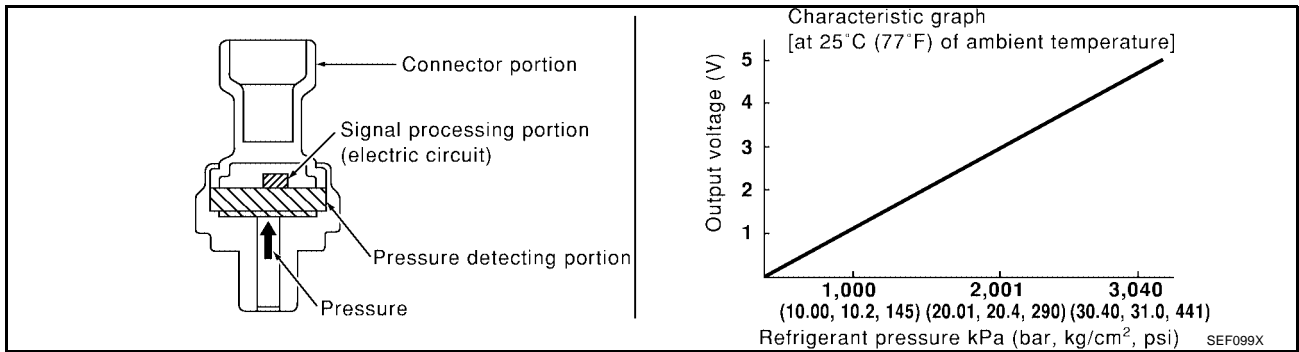
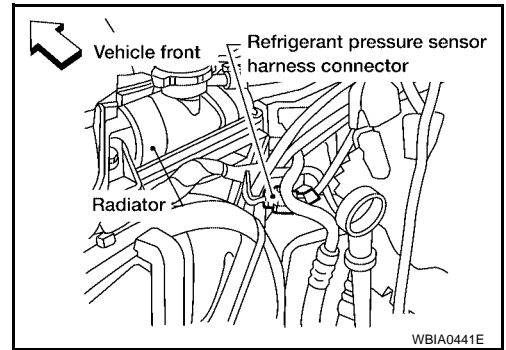

REFRIGERANT PRESSURE SENSOR

[QR]

Wiring Diagram

UBS0033T

EC-RP/SEN-01

: DETECTABLE LINE FOR DTC
 : NON-DETECTABLE LINE FOR DTC

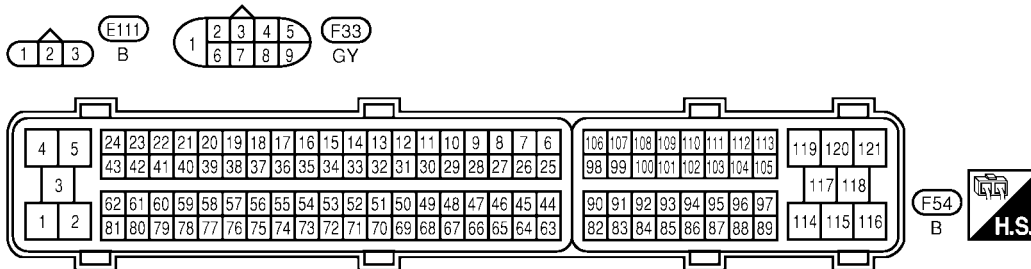
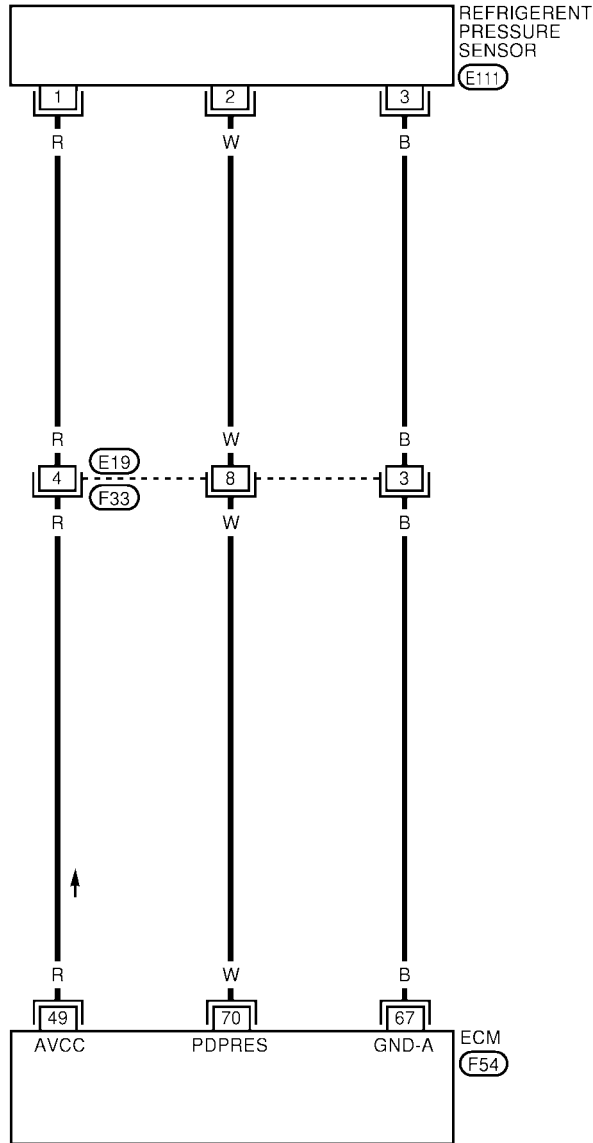

BBWA1259E

REFRIGERANT PRESSURE SENSOR

[QR]

Specification data are reference values and are measured between each terminal and ground.

CAUTION:

Do not use ECM ground terminals when measuring input/output voltage. Doing so may result in damage to the ECM's transistor. Use a ground other than ECM terminals, such as the ground.

TERMI- NAL NO.	WIRE COLOR	ITEM	CONDITION	DATA (DC Voltage)
49	R	Sensor power supply (Refrigerant pressure sensor)	[Ignition switch: ON]	Approximately 5V
67	B	Sensor ground	[Engine is running] ● Warm-up condition ● Idle speed	Approximately 0V
70	W	Refrigerant pressure sensor	[Engine is running] ● Warm-up condition ● Both A/C switch and blower switch are ON (Compressor operates.)	1.0 - 4.0V

Diagnostic Procedure

UBS0033U

1. CHECK REFRIGERANT PRESSURE SENSOR OVERALL FUNCTION

1. Start engine and warm it up to normal operating temperature.
2. Turn A/C switch and blower switch ON.
3. Check voltage between ECM terminal 70 and ground with CONSULT-II or tester.

Voltage: 1.0 - 4.0V

OK or NG

- OK >> INSPECTION END
- NG >> GO TO 2.

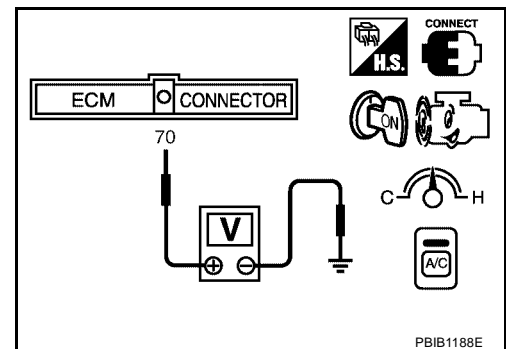

2. CHECK REFRIGERANT PRESSURE SENSOR POWER SUPPLY CIRCUIT

1. Turn A/C switch and blower switch OFF.
2. Stop engine.
3. Disconnect refrigerant pressure sensor harness connector.
4. Turn ignition switch ON.

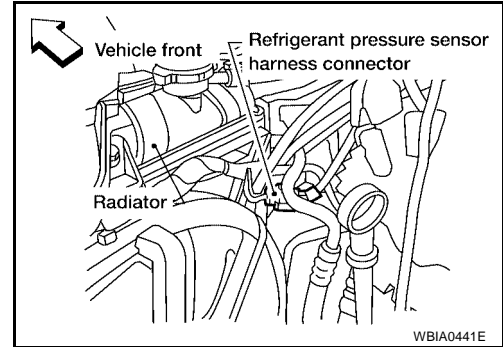

5. Check voltage between refrigerant pressure sensor terminal 1 and ground with CONSULT-II or tester.

Voltage: Approximately 5V

OK or NG

- OK >> GO TO 4.
- NG >> GO TO 3.

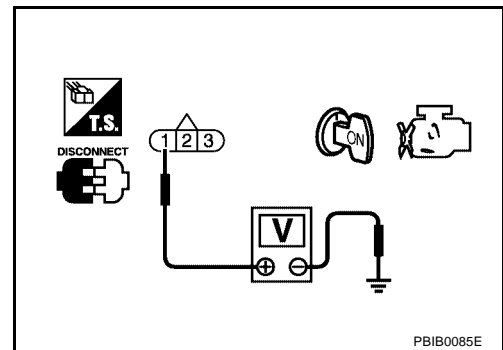

3. DETECT MALFUNCTIONING PART

Check the following.

- Harness connectors E19, F33
- Harness for open or short between ECM and refrigerant pressure sensor

>> Repair open circuit or short to ground or short to power in harness or connectors.

4. CHECK REFRIGERANT PRESSURE SENSOR GROUND CIRCUIT FOR OPEN AND SHORT

1. Turn ignition switch OFF.
2. Disconnect ECM harness connector.
3. Check harness continuity between refrigerant pressure sensor terminal 3 and ECM terminal 67. Refer to Wiring Diagram.

Continuity should exist.

4. Also check harness for short to ground and short to power.

OK or NG

- OK >> GO TO 6.
- NG >> GO TO 5.

5. DETECT MALFUNCTIONING PART

Check the following.

- Harness connectors E19, F33
- Harness for open or short between ECM and refrigerant pressure sensor

>> Repair open circuit or short to ground or short to power in harness or connectors.

REFRIGERANT PRESSURE SENSOR

[QR]

6. CHECK REFRIGERANT PRESSURE SENSOR INPUT SIGNAL CIRCUIT FOR OPEN AND SHORT

1. Check harness continuity between ECM terminal 70 and refrigerant pressure sensor terminal 2.
Refer to Wiring Diagram.

Continuity should exist.

2. Also check harness for short to ground and short to power.

OK or NG

- OK >> GO TO 8.
- NG >> GO TO 7.

7. DETECT MALFUNCTIONING PART

Check the following.

- Harness connectors E19, F33
- Harness for open or short between ECM and refrigerant pressure sensor

>> Repair open circuit or short to ground or short to power in harness or connectors.

8. CHECK INTERMITTENT INCIDENT

Refer to [EC-158, "TROUBLE DIAGNOSIS FOR INTERMITTENT INCIDENT"](#) .

OK or NG

- OK >> Replace refrigerant pressure sensor.
- NG >> Repair or replace.

Removal and Installation REFRIGERANT PRESSURE SENSOR

UBS0033V

Refer to [ATC-113, "Removal and Installation for Refrigerant Pressure Sensor"](#) , [MTC-99, "Removal and Installation for Refrigerant Pressure Sensor"](#) .

ELECTRICAL LOAD SIGNAL

Description

UBS0033W

The electrical load signal (Headlamp switch signal, rear window defogger switch signal, etc.) is transferred through the CAN communication line from BCM to ECM via IPDM E/R.

Diagnostic Procedure

UBS0033X

1. CHECK LOAD SIGNAL CIRCUIT OVERALL FUNCTION-I

1. Turn ignition switch ON.
2. Connect CONSULT-II or GST and select "DATA MONITOR" mode.
3. Select "LOAD SIGNAL" and check indication under the following conditions.

Condition	Indication
Rear window defogger switch ON	ON
Rear window defogger switch OFF	OFF

DATA MONITOR	
MONITORING	NO DTC
LOAD SIGNAL	ON

PBIB0103E

OK or NG

- OK >> GO TO 2.
 NG >> GO TO 3.

2. CHECK LOAD SIGNAL CIRCUIT OVERALL FUNCTION-II

Check "LOAD SIGNAL" indication under the following conditions.

Condition	Indication
Lighting switch ON at 2nd position	ON
Lighting switch OFF	OFF

DATA MONITOR	
MONITORING	NO DTC
LOAD SIGNAL	ON

PBIB0103E

OK or NG

- OK >> **INSPECTION END**
 NG >> GO TO 4.

3. CHECK REAR WINDOW DEFOGGER SYSTEM

Refer to [GW-42, "REAR WINDOW DEFOGGER"](#) .

>> **INSPECTION END**

4. CHECK HEADLAMP SYSTEM

Refer to [LT-6, "HEADLAMP \(FOR USA\)"](#) or [LT-33, "HEADLAMP \(FOR CANADA\) - DAYTIME LIGHT SYSTEM"](#) .

>> **INSPECTION END**

ASCD BRAKE SWITCH

[QR]

PFP:25320

UBS0033Y

ASCD BRAKE SWITCH

Component Description

When depress on the brake pedal, ASCD brake switch is turned OFF and stop lamp switch is turned ON. ECM detects the state of the brake pedal by this input of two kinds (ON/OFF signal)

Refer to [EC-34, "AUTOMATIC SPEED CONTROL DEVICE \(ASCD\)"](#) for the ASCD function.

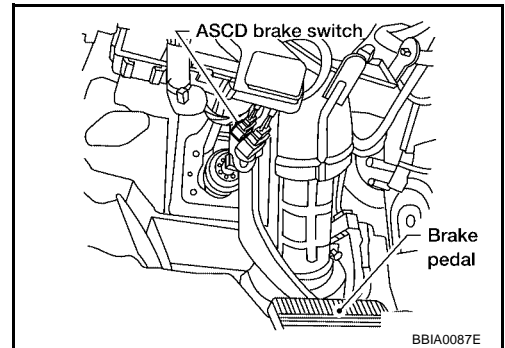

CONSULT-II Reference Value in Data Monitor Mode

UBS0033Z

Specification data are reference values.

MONITOR ITEM	CONDITION		SPECIFICATION
BRAKE SW1 (ASCD brake switch)	● Ignition switch: ON	● Brake pedal: Fully released ● Clutch pedal: Fully released (M/T)	ON
		● Brake pedal: Slightly depressed ● Clutch pedal: Fully depressed (M/T)	OFF
BRAKE SW2 (STOP lamp switch)	● Ignition switch: ON	Brake pedal: Fully released	OFF
		Brake pedal: Slightly depressed	ON

ASCD BRAKE SWITCH

[QR]

UBS00340

Wiring Diagram

EC-ASCBOF-01

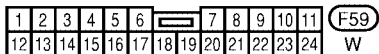
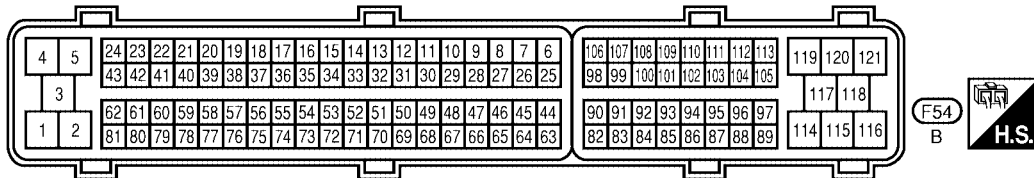
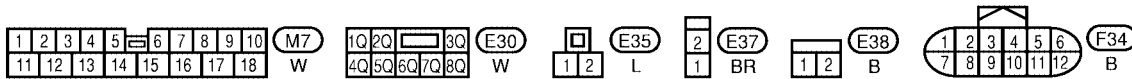
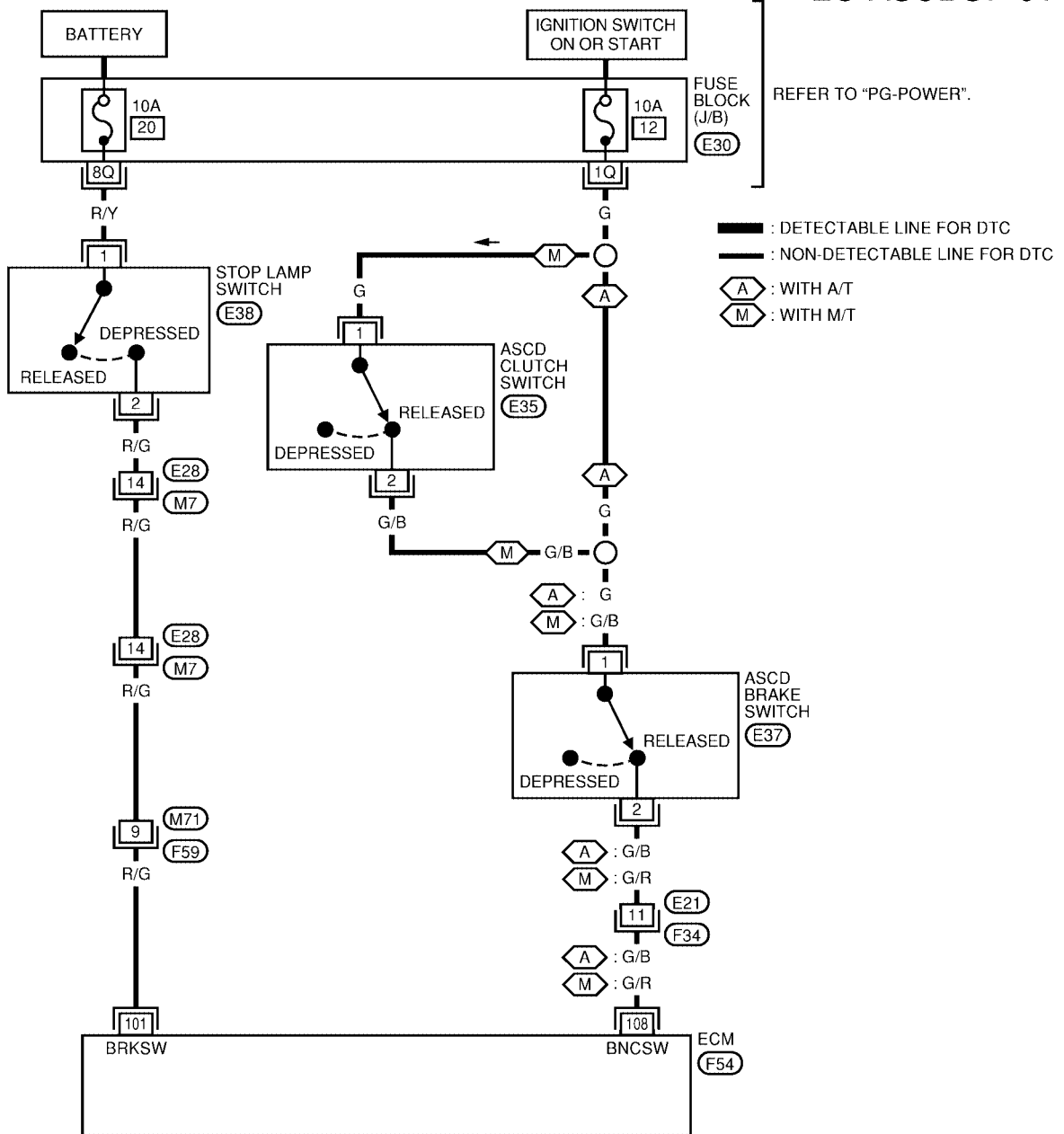

BBWA1260E

ASCD BRAKE SWITCH

[QR]

Specification data are reference values and are measured between each terminal and ground.

CAUTION:

Do not use ECM ground terminals when measuring input/output voltage. Doing so may result in damage to the ECM's transistor. Use a ground other than ECM terminals, such as the ground.

TERMI- NAL NO.	WIRE COLOR	ITEM	CONDITION	DATA (DC Voltage)
101	R/G	Stop lamp switch	[Ignition switch: ON] ● Brake pedal: Fully released	Approximately 0V
			[Ignition switch: ON] ● Brake pedal: Depressed	BATTERY VOLTAGE (11 - 14V)
108	G/B*1 G/R*2	ASCD brake switch	[Ignition switch: ON] ● Brake pedal: Depressed ● Clutch pedal: Depressed (M/T)	Approximately 0V
			[Ignition switch: ON] ● Brake pedal: Fully released ● Clutch pedal: Released (M/T)	BATTERY VOLTAGE (11 - 14V)

*1: A/T models

*2: M/T models

A
EC
C
D
E
F
G
H
I
J
K
L
M

ASCD BRAKE SWITCH

[QR]

UBS00341

Diagnostic Procedure

1. CHECK OVERALL FUNCTION-I

With CONSULT-II

- Turn ignition switch ON.
- Select "BRAKE SW1" in "DATA MONITOR" mode with CONSULT-II.
- Check "BRAKE SW1" indication under the following conditions.
M/T models

CONDITION	INDICATION
When clutch pedal or brake pedal: Depressed	OFF
When clutch pedal and brake pedal: Fully released	ON

A/T models

CONDITION	INDICATION
When brake pedal: Depressed	OFF
When brake pedal: Fully released	ON

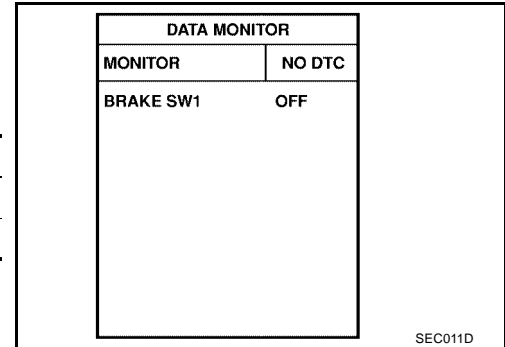

Without CONSULT-II

- Turn ignition switch ON.
- Check voltage between ECM terminal 108 and ground under the following conditions.
M/T models

CONDITION	VOLTAGE
When clutch pedal or brake pedal: Depressed	Approximately 0V
When clutch pedal and brake pedal: Fully released	Battery voltage

A/T models

CONDITION	VOLTAGE
When brake pedal: Depressed	Approximately 0V
When brake pedal: Fully released	Battery voltage

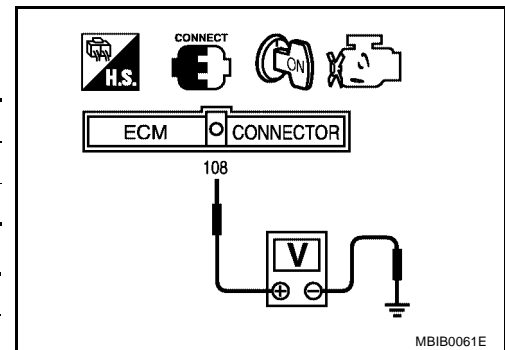

OK or NG

- OK >> GO TO 2.
 NG (M/T models) >>GO TO 3.
 NG (A/T models) >>GO TO 8.

ASCD BRAKE SWITCH

[QR]

2. CHECK OVERALL FUNCTION-II

With CONSULT-II

Check "BRAKE SW2" indication in "DATA MONITOR" mode.

CONDITION	INDICATION
When brake pedal: Released	OFF
When brake pedal: Depressed	ON

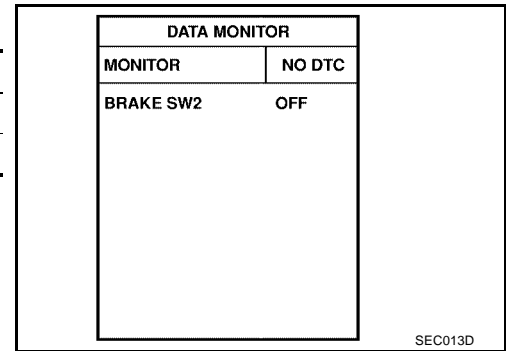

Without CONSULT-II

Check voltage between ECM terminal 101 and ground under the following conditions.

CONDITION	VOLTAGE
When brake pedal: Released	Approximately 0V
When brake pedal: Depressed	Battery voltage

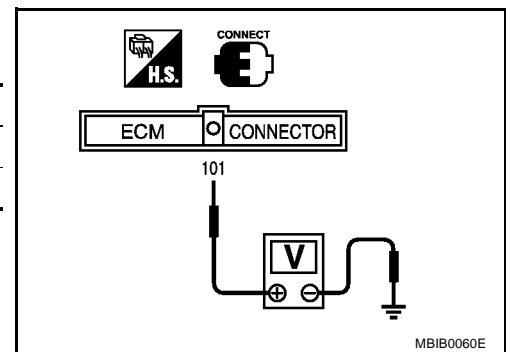

OK or NG

- OK >> **INSPECTION END**
- NG >> GO TO 13.

3. CHECK ASCD CLUTCH SWITCH CIRCUIT

1. Turn ignition switch OFF.
2. Disconnect ASCD brake switch harness connector.
3. Turn ignition switch ON.

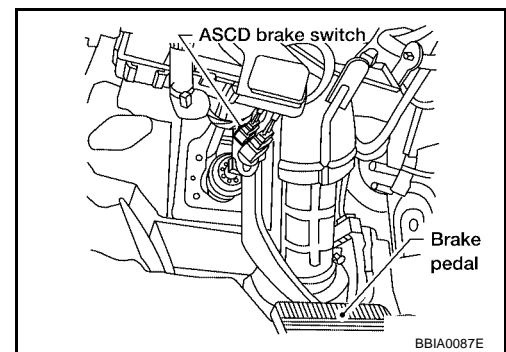

4. Check voltage between ASCD brake switch terminal 1 and ground under the following conditions with CONSULT-II or tester.

CONDITION	VOLTAGE
When clutch pedal: Released	Battery voltage
When clutch pedal: Depressed	Approx. 0V

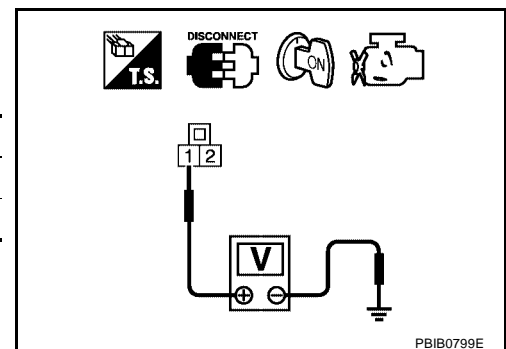

OK or NG

- OK >> GO TO 10.
- NG >> GO TO 4.

4. CHECK ASCD CLUTCH SWITCH POWER SUPPLY CIRCUIT

1. Turn ignition switch OFF.
2. Disconnect ASCD clutch switch harness connector.
3. Turn ignition switch ON.

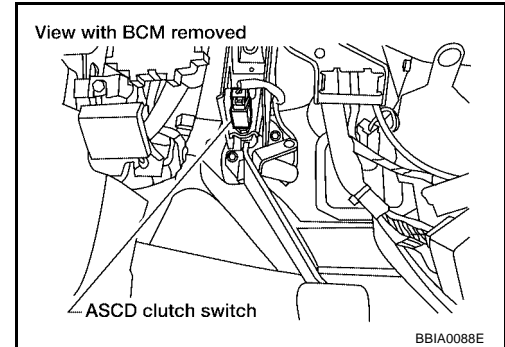

4. Check voltage between ASCD clutch switch terminal 1 and ground with CONSULT-II or tester.

Voltage: Battery voltage

OK or NG

- OK >> GO TO 6.
- NG >> GO TO 5.

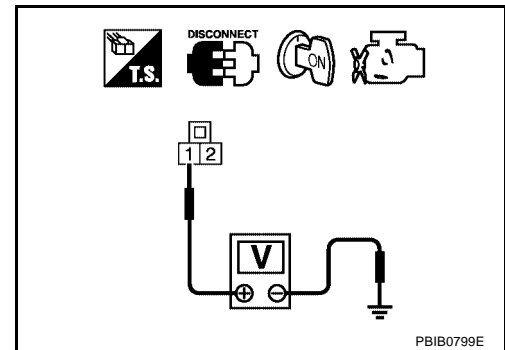

5. DETECT MALFUNCTIONING PART

Check the following.

- Fuse block (J/B) connector E30
- 10A fuse
- Harness for open or short between ASCD clutch switch and fuse

>> Repair open circuit or short to ground or short to power in harness or connectors.

6. CHECK ASCD CLUTCH SWITCH INPUT SIGNAL CIRCUIT FOR OPEN AND SHORT

1. Turn ignition switch OFF.
2. Check harness continuity between ASCD clutch switch terminal 2 and ASCD brake switch terminal 1. Refer to Wiring Diagram.

Continuity should exist.

3. Also check harness for short to ground and short to power.

OK or NG

- OK >> GO TO 7.
- NG >> Repair open circuit or short to ground or short to power in harness or connectors.

7. CHECK ASCD CLUTCH SWITCH

Refer to [EC-520, "Component Inspection"](#)

OK or NG

- OK >> GO TO 18.
- NG >> Replace ASCD clutch switch.

8. CHECK ASCD BRAKE SWITCH POWER SUPPLY CIRCUIT

1. Turn ignition switch OFF.
2. Disconnect ASCD brake switch harness connector.
3. Turn ignition switch ON.

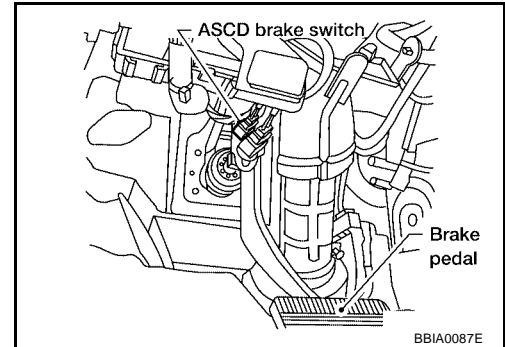

4. Check voltage between ASCD brake switch terminal 1 and ground with CONSULT-II or tester.

Voltage: Battery voltage

OK or NG

- OK >> GO TO 10.
- NG >> GO TO 9.

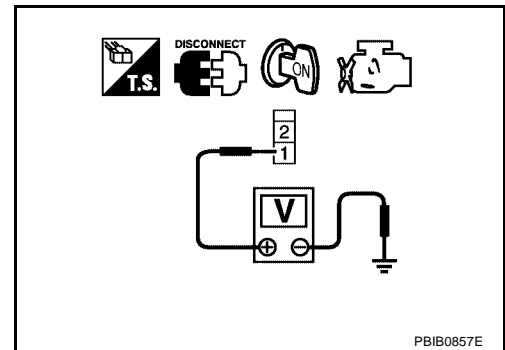

9. DETECT MALFUNCTIONING PART

Check the following.

- Fuse block (J/B) connector E30
- 10A fuse
- Harness for open or short between ASCD brake switch and fuse

>> Repair open circuit or short to ground or short to power in harness or connectors.

10. CHECK ASCD BRAKE SWITCH INPUT SIGNAL CIRCUIT FOR OPEN AND SHORT

1. Turn ignition switch OFF.
2. Disconnect ECM harness connector.
3. Check harness continuity between ECM terminal 101 and ASCD brake switch terminal 2. Refer to Wiring Diagram.

Continuity should exist.

4. Also check harness for short to ground or short to power.

OK or NG

- OK >> GO TO 12.
- NG >> GO TO 11.

11. DETECT MALFUNCTIONING PART

Check the following.

- Harness connectors E21, F34
- Harness for open or short between ECM and ASCD brake switch

>> Repair open circuit or short to ground or short to power in harness or connectors.

12. CHECK ASCD BRAKE SWITCH

Refer to [EC-520, "Component Inspection"](#)

OK or NG

- OK >> GO TO 18.
- NG >> Replace ASCD brake switch.

13. CHECK STOP LAMP SWITCH POWER SUPPLY CIRCUIT

1. Turn ignition switch OFF.
2. Disconnect stop lamp switch harness connector.

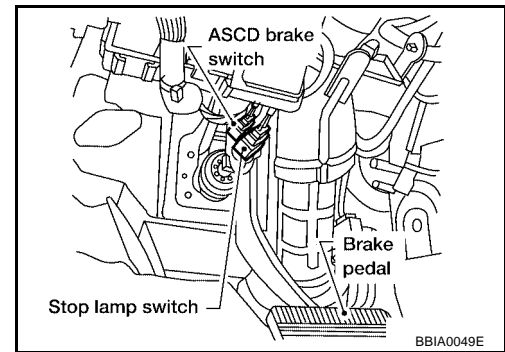

3. Check voltage between stop lamp switch terminal 1 and ground with CONSULT -II or tester.

Voltage: Battery voltage

OK or NG

- OK >> GO TO 15.
- NG >> GO TO 14.

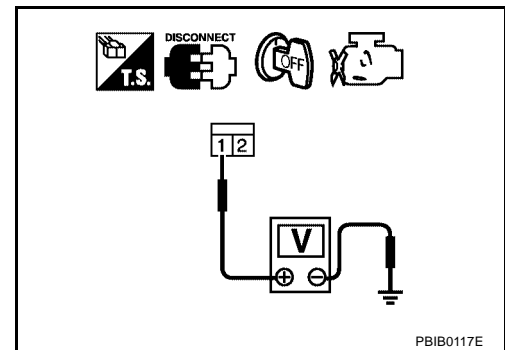

14. DETECT MALFUNCTIONING PART

Check the following.

- Fuse block (J/B) connector E30
- 10A fuse
- Harness for open or short between stop lamp switch and fuse

>> Repair open circuit or short to ground or short to power in harness or connectors.

15. CHECK STOP LAMP SWITCH INPUT SIGNAL CIRCUIT FOR OPEN AND SHORT

1. Disconnect ECM harness connector.
2. Check harness continuity between ECM terminal 101 and stop lamp switch terminal 2. Refer to Wiring Diagram.

Continuity should exist.

3. Also check harness for short to ground and short to power.

OK or NG

- OK >> GO TO 17.
- NG >> GO TO 16.

16. DETECT MALFUNCTIONING PART

Check the following.

- Harness connectors E28, M7
- Harness connectors M71, F59
- Harness for open or short between ECM and stop lamp switch

>> Repair open circuit or short to ground or short to power in harness or connectors.

17. CHECK STOP LAMP SWITCH

Refer to [EC-520, "Component Inspection"](#)

OK or NG

OK >> GO TO 18.

NG >> Replace stop lamp switch.

18. CHECK INTERMITTENT INCIDENT

Refer to [EC-158, "TROUBLE DIAGNOSIS FOR INTERMITTENT INCIDENT"](#) .

>> INSPECTION END

A
EC
C
D
E
F
G
H
I
J
K
L
M

ASC D INDICATOR

Component Description

UBS00342

ASC D indicator lamp illuminates to indicate ASC D operation status. Lamp has two indicators, CRUISE and SET, and is integrated in combination meter.

CRUISE indicator illuminates when CRUISE switch on ASC D steering switch is turned ON to indicate that ASC D system is ready for operation.

SET indicator illuminates when following conditions are met.

- CRUISE indicator is illuminated.
- SET switch on ASC D steering switch is turned ON while vehicle speed is within the range of ASC D setting.

SET indicator remains lit during ASC D control.

Refer to [EC-34, "AUTOMATIC SPEED CONTROL DEVICE \(ASC D\)"](#) for the ASC D function.

CONSULT-II Reference Value in Data Monitor Mode

UBS00343

Specification data are reference value.

MONITOR ITEM	CONDITION		SPECIFICATION
CRUISE LAMP	● Ignition switch: ON	CRUISE switch is pressed at first time → second time	ON → OFF
SET LAMP	● MAIN switch: ON	ASC D is operating	ON
	● When vehicle is between 40 km/h (25 MPH) and 144 km/h (89 MPH)	ASC D is not operating	OFF

ASC D INDICATOR

[QR]

UBS00344

Wiring Diagram

EC-ASCIND-0

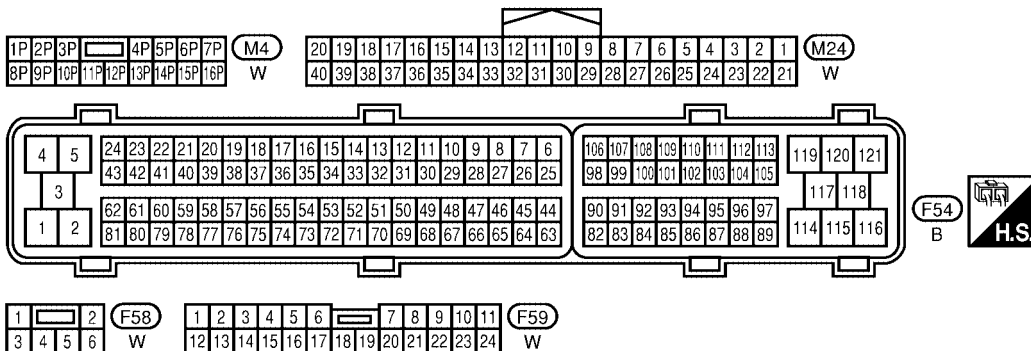
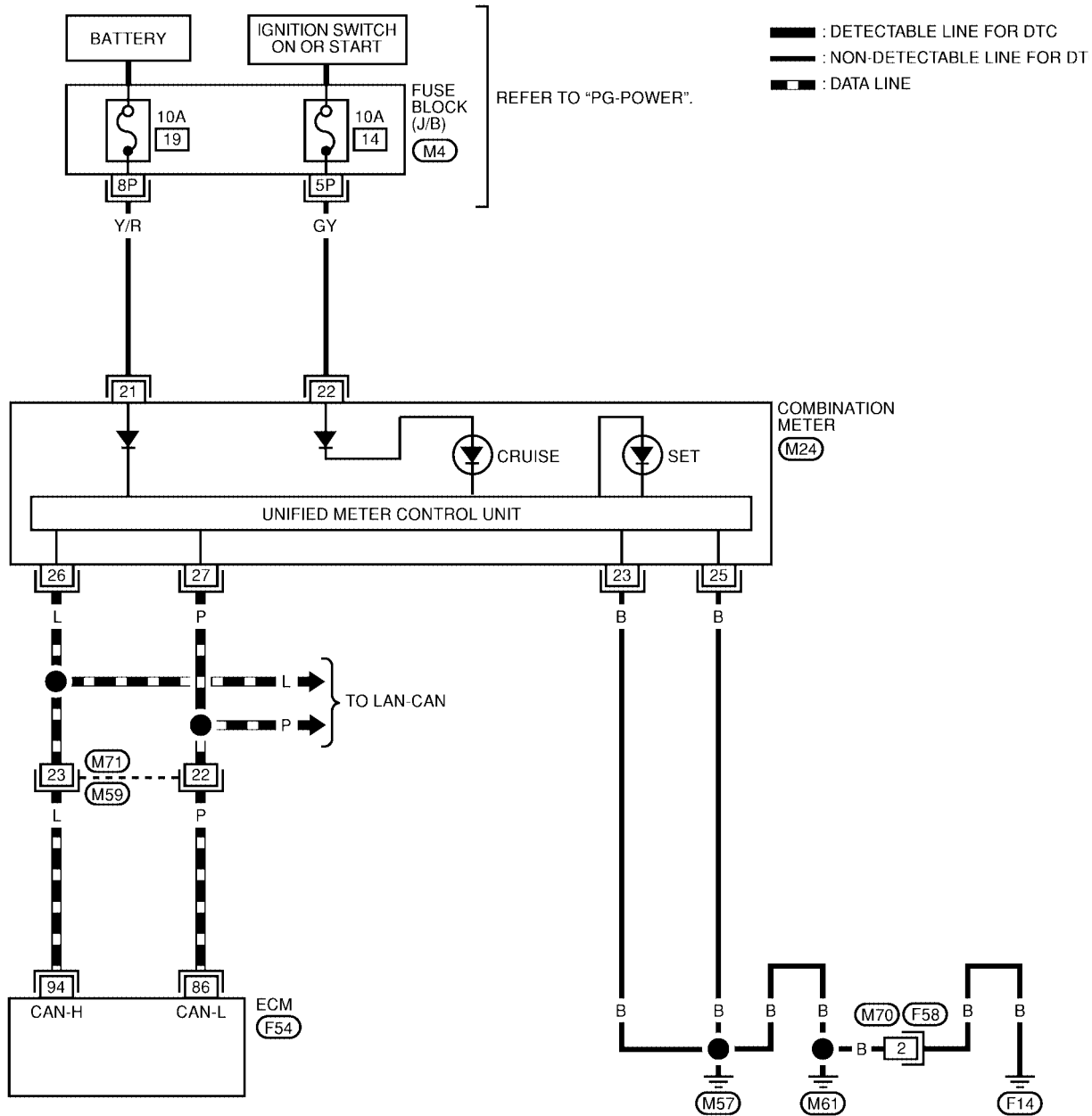

BBWA1261E

Diagnostic Procedure

1. CHECK OVERALL FUNCTION

Check ASC D indicator under the following conditions.

ASC D INDICATOR	CONDITION		SPECIFICATION
CRUISE LAMP	● Ignition switch: ON	CRUISE switch is pressed at first time → second time	ON → OFF
SET LAMP	● MAIN switch: ON	ASC D is operating	ON
	● When vehicle is between 40 km/h (25 MPH) and 144 km/h (89 MPH)	ASC D is not operating	OFF

OK or NG

OK >> **INSPECTION END**

NG >> GO TO 2.

2. CHECK DTC

Check that DTC U1000 or U1001 is not displayed.

Yes or No

Yes >> Perform trouble diagnoses for DTC U1000, U1001, refer to [EC-166, "DTC U1000, U1001 CAN COMMUNICATION LINE"](#) .

No >> GO TO 3.

3. CHECK COMBINATION METER OPERATION

Does combination meter operate normally?

Yes or No

Yes >> GO TO 4.

No >> Check combination meter circuit. Refer to [DI-4, "COMBINATION METERS"](#) .

4. CHECK INTERMITTENT INCIDENT

Refer to [EC-158, "TROUBLE DIAGNOSIS FOR INTERMITTENT INCIDENT"](#) .

>> **INSPECTION END**

MIL AND DATA LINK CONNECTOR

[QR]

MIL AND DATA LINK CONNECTOR

PFP:24814

Wiring Diagram

UBS00ELP

EC-MIL/DL-01

A

EC

C

D

E

F

G

H

I

J

K

L

M

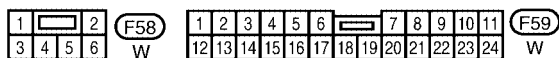
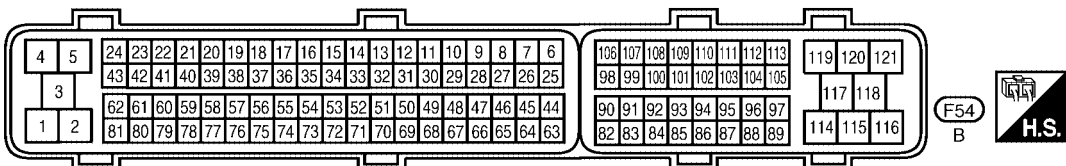
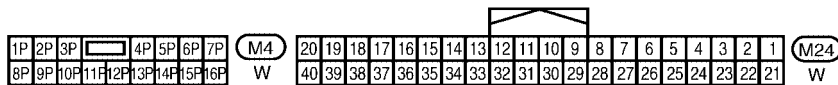
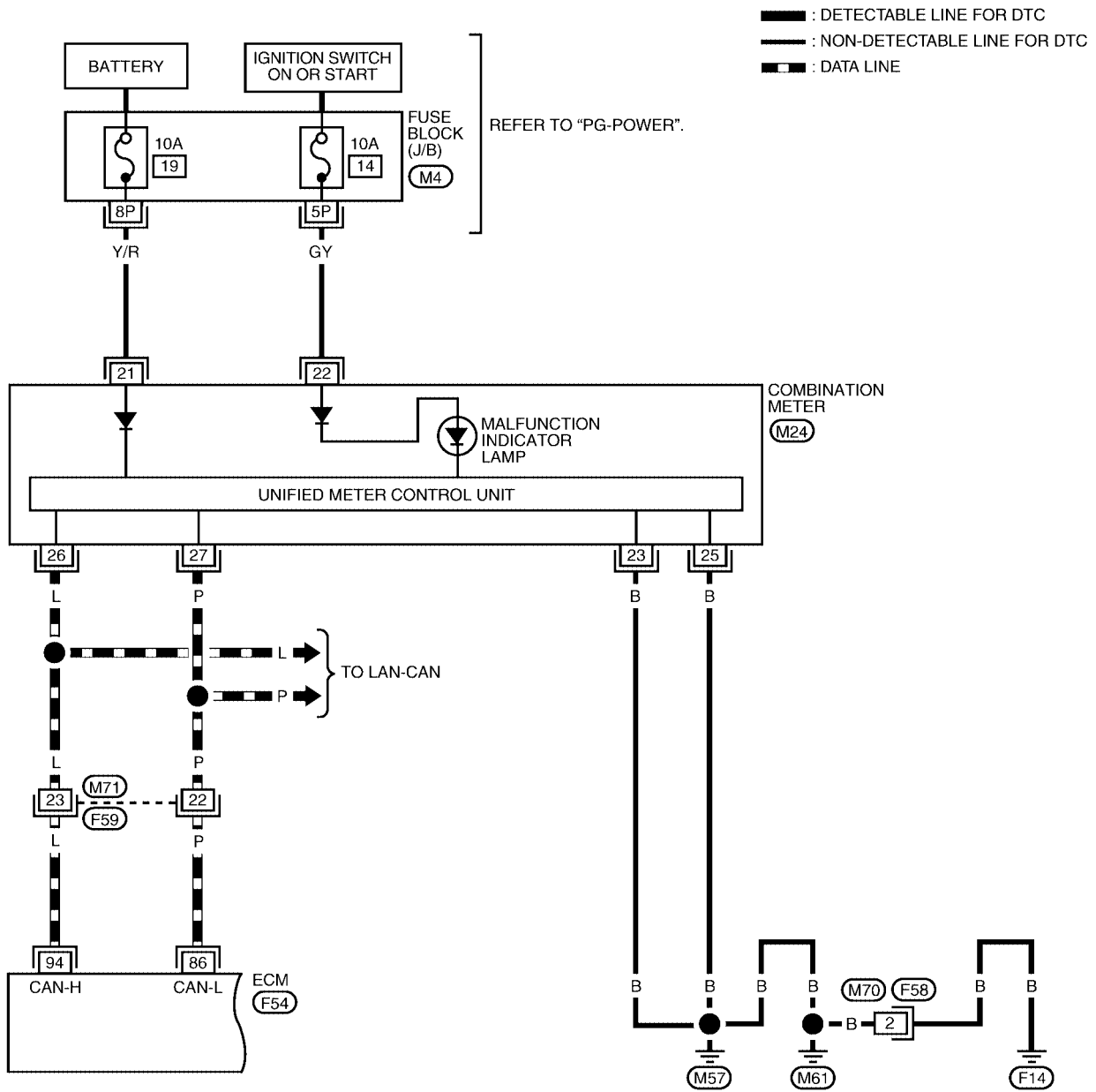

BBWA1232E

MIL AND DATA LINK CONNECTOR

[QR]

EC-MIL/DL-02

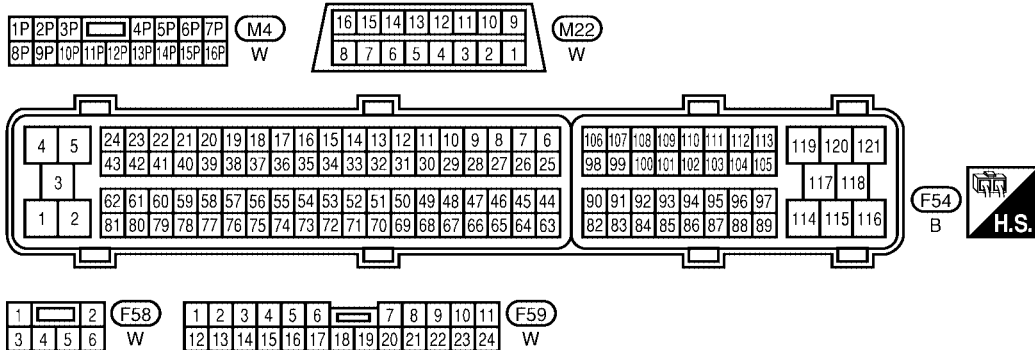
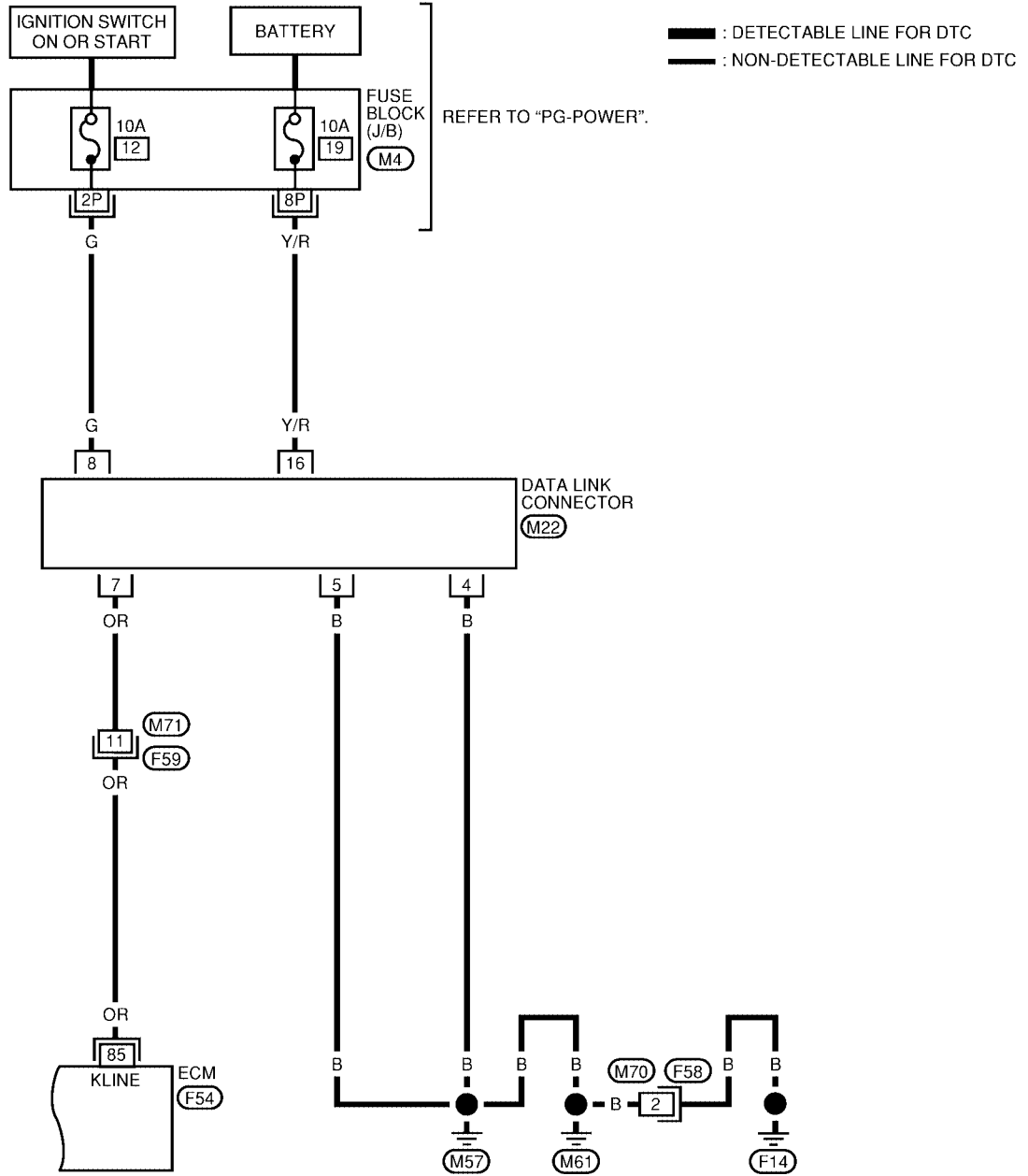

BBWA1262E

SERVICE DATA AND SPECIFICATIONS (SDS)

[QR]

SERVICE DATA AND SPECIFICATIONS (SDS)

PF0:00030

Fuel Pressure

UBS0034H

Fuel pressure at idle	Approximately 350 kPa (3.57kg/cm ² , 51psi)
-----------------------	--

Idle Speed and Ignition Timing

UBS0034I

Target idle speed	No-load* ¹ [in P or N position (A/T) or Neutral position (M/T)]	700±50 rpm
Air conditioner: ON	In P or N position (A/T) or Neutral position (M/T)	800 rpm or more* ²
Ignition timing	In P or N position (A/T) or Neutral position (M/T)	15°± 5° BTDC

*1: Under the following conditions:

- Air conditioner switch: OFF
- Electric load: OFF (Lights, heater fan & rear window defogger)
- Steering wheel: Kept in straight-ahead position

*2: It refrigerant pressure is low, the idle speed may not be increased.

Calculated Load Value

UBS0034J

Conditions	Calculated load value% (Using CONSULT-II or GST)
At idle	10 - 35
At 2,500 rpm	10 - 35

Mass Air Flow Sensor

UBS0034K

Supply voltage	Battery voltage (11 - 14V)
Output voltage at idle	0.9 - 1.2V*
Mass air flow (Using CONSULT-II or GST)	1.0 - 4.0 g·m/sec at idle* 4.0 - 10.0 g·m/sec at 2,500 rpm*

*: Engine is warmed up to normal operating temperature and running under no-load.

Intake Air Temperature Sensor

UBS0034L

Temperature °C (°F)	Resistance kΩ
25 (77)	1.9 - 2.1
80 (176)	0.31 - 0.37

Engine Coolant Temperature Sensor

UBS0034M

Temperature °C (°F)	Resistance kΩ
20 (68)	2.1 - 2.9
50 (122)	0.68 - 1.00
90 (194)	0.236 - 0.260

Air Fuel Ratio (A/F) Sensor 1 Heater

UBS0034N

Resistance [at 25°C (77°F)]	2.3 - 4.3Ω
-----------------------------	------------

Heated Oxygen sensor 2 Heater

UBS0034O

Resistance [at 25°C (77°F)]	5.0 - 7.0Ω
-----------------------------	------------

Crankshaft Position Sensor (POS)

UBS00CV1

Refer to [EC-278, "Component Inspection"](#) .

Camshaft Position Sensor (PHASE)

UBS00CV2

Refer to [EC-285, "Component Inspection"](#) .

SERVICE DATA AND SPECIFICATIONS (SDS)

[QR]

Throttle Control Motor

UBS00CV3

Resistance [at 25°C (77°F)]	Approximately 1 - 15Ω
-----------------------------	-----------------------

Injector

UBS00CV4

Resistance [at 10 - 60°C (50 - 140°F)]	11.6 - 14.9Ω
--	--------------

Fuel Pump

UBS00CV5

Resistance [at 25°C (77°F)]	0.2 - 5.0Ω
-----------------------------	------------

INDEX FOR DTC

[VQ]

INDEX FOR DTC

PFP:00024

DTC No. Index

UBS00HZG

NOTE:

If DTC U1000 or U1001 is displayed with other DTC, first perform the trouble diagnosis for DTC U1000, U1001. Refer to [EC-790. "DTC U1000, U1001 CAN COMMUNICATION LINE"](#) .

DTC*1		Items (CONSULT-II screen terms)	Reference page
CONSULT-II GST*2	ECM*3		
U1000	1000*4	CAN COMM CIRCUIT	EC-790
U1001	1001*4	CAN COMM CIRCUIT	EC-790
P0000	0000	NO DTC IS DETECTED. FURTHER TESTING MAY BE REQUIRED.	—
P0011	0011	INT/V TIM CONT-B1	EC-793
P0021	0021	INT/V TIM CONT-B2	EC-793
P0037	0037	HO2S2 HTR (B1)	EC-797
P0038	0038	HO2S2 HTR (B1)	EC-797
P0057	0057	HO2S2 HTR (B2)	EC-797
P0058	0058	HO2S2 HTR (B2)	EC-797
P0101	0101	MAF SEN/CIRCUIT	EC-806
P0102	0102	MAF SEN/CIRCUIT	EC-815
P0103	0103	MAF SEN/CIRCUIT	EC-815
P0112	0112	IAT SEN/CIRCUIT	EC-822
P0113	0113	IAT SEN/CIRCUIT	EC-822
P0117	0117	ECT SEN/CIRCUIT	EC-826
P0118	0118	ECT SEN/CIRCUIT	EC-826
P0122	0122	TP SEN 2/CIRC	EC-831
P0123	0123	TP SEN 2/CIRC	EC-831
P0125	0125	ECT SENSOR	EC-838
P0127	0127	IAT SENSOR	EC-841
P0128	0128	THERMSTAT FNCTN	EC-844
P0138	0138	HO2S2 (B1)	EC-846
P0139	0139	HO2S2 (B1)	EC-856
P0158	0158	HO2S2 (B2)	EC-846
P0159	0159	HO2S2 (B2)	EC-856
P0171	0171	FUEL SYS-LEAN-B1	EC-868
P0172	0172	FUEL SYS-RICH-B1	EC-879
P0174	0174	FUEL SYS-LEAN-B2	EC-868
P0175	0175	FUEL SYS-RICH-B2	EC-879
P0181	0181	FTT SENSOR	EC-890
P0182	0182	FTT SEN/CIRCUIT	EC-895
P0183	0183	FTT SEN/CIRCUIT	EC-895
P0222	0222	TP SEN 1/CIRC	EC-899
P0223	0223	TP SEN 1/CIRC	EC-899
P0300	0300	MULTI CYL MISFIRE	EC-906
P0301	0301	CYL 1 MISFIRE	EC-906

INDEX FOR DTC

[VQ]

DTC*1		Items (CONSULT-II screen terms)	Reference page
CONSULT-II GST*2	ECM*3		
P0302	0302	CYL 2 MISFIRE	EC-906
P0303	0303	CYL 3 MISFIRE	EC-906
P0304	0304	CYL 4 MISFIRE	EC-906
P0305	0305	CYL 5 MISFIRE	EC-906
P0306	0306	CYL 6 MISFIRE	EC-906
P0327	0327	KNOCK SEN/CIRC-B1	EC-916
P0328	0328	KNOCK SEN/CIRC-B1	EC-916
P0335	0335	CKP SEN/CIRCUIT	EC-921
P0340	0340	CMP SEN/CIRC-B1	EC-928
P0345	0345	CMP SEN/CIRC-B2	EC-928
P0400	0400	EGR SYSTEM	EC-937
P0403	0403	EGR VOL CON/V CIR	EC-945
P0405	0405	EGR TEMP SEN/CIRC	EC-952
P0406	0406	EGR TEMP SEN/CIRC	EC-952
P0420	0420	TW CATALYST SYS-B1	EC-959
P0430	0430	TW CATALYST SYS-B2	EC-959
P0441	0441	EVAP PURG FLOW/MON	EC-964
P0442	0442	EVAP SMALL LEAK	EC-969
P0444	0444	PURG VOLUME CONT/V	EC-977
P0445	0445	PURG VOLUME CONT/V	EC-977
P0447	0447	VENT CONTROL VALVE	EC-984
P0451	0451	EVAP SYS PRES SEN	EC-991
P0452	0452	EVAP SYS PRES SEN	EC-994
P0453	0453	EVAP SYS PRES SEN	EC-1000
P0455	0455	EVAP GROSS LEAK	EC-1008
P0456	0456	EVAP VERY SML LEAK	EC-1016
P0460	0460	FUEL LEV SEN SLOSH	EC-1025
P0461	0461	FUEL LEVEL SENSOR	EC-1027
P0462	0462	FUEL LEVL SEN/CIRC	EC-1029
P0463	0463	FUEL LEVL SEN/CIRC	EC-1029
P0500	0500	VEH SPEED SEN/CIRC*5	EC-1031
P0506	0506	ISC SYSTEM	EC-1033
P0507	0507	ISC SYSTEM	EC-1035
P0550	0550	PW ST P SEN/CIRC	EC-1037
P0605	0605	ECM	EC-1042
P0705	0705	PNP SW/CIRC	AT-471
P0710	0710	ATF TEMP SEN/CIRC	AT-476
P0711	0711	FLUID TEMP SEN	AT-481
P0717	0717	TURBINE SENSOR	AT-486
P0722	0722	VHCL SPEED SEN-AT*5	AT-490
P0731	0731	A/T 1ST GR FNCTN	AT-496
P0732	0732	A/T 2ND GR FNCTN	AT-499

INDEX FOR DTC

[VQ]

DTC*1		Items (CONSULT-II screen terms)	Reference page
CONSULT-II GST*2	ECM*3		
P0733	0733	A/T 3RD GR FNCTN	AT-505
P0734	0734	A/T 4TH GR FNCTN	AT-511
P0735	0735	A/T 5TH GR FNCTN	AT-516
P0744	0744	A/T TCC S/V FNCTN	AT-522
P0745	0745	L/PRESS SOL/CIRC	AT-525
P0750	0750	SFT SOL A/CIRC	AT-530
P0755	0755	SFT SOL B/CIRC	AT-535
P0760	0760	SHIFT SOL C	AT-540
P0762	0762	SFT SOL C STUCK ON	AT-545
P0765	0765	SHIFT SOL D	AT-550
P0770	0770	SHIFT SOL E	AT-555
P0775	0775	PC SOL B(SFT/PRS)	AT-560
P0780	0780	SHIFT	AT-565
P0795	0795	PC SOL C(TCC&SFT)	AT-569
P0797	0797	PC SOL C STC ON	AT-574
P0882	0882	TCM POWER INPT SIG	AT-585
P1031	1031	A/F SEN1 HTR (B1)	EC-1045
P1032	1032	A/F SEN1 HTR (B1)	EC-1045
P1051	1051	A/F SEN1 HTR (B2)	EC-1045
P1052	1052	A/F SEN1 HTR (B2)	EC-1045
P1065	1065	ECM BACK UP/CIRCUIT	EC-1053
P1111	1111	INT/V TIM V/CIR-B1	EC-1057
P1121	1121	ETC ACTR	EC-1066
P1122	1122	ETC FUNCTION/CIRC	EC-1068
P1124	1124	ETC MOT PWR	EC-1074
P1126	1126	ETC MOT PWR	EC-1074
P1128	1128	ETC MOT	EC-1079
P1136	1136	INT/V TIM V/CIR-B2	EC-1057
P1146	1146	HO2S2 (B1)	EC-1084
P1147	1147	HO2S2 (B1)	EC-1096
P1148	1148	CLOSED LOOP-B1	EC-1108
P1166	1166	HO2S2 (B2)	EC-1084
P1167	1167	HO2S2 (B2)	EC-1096
P1168	1168	CLOSED LOOP-B2	EC-1108
P1211	1211	TCS C/U FUNCTN	EC-1109
P1212	1212	TCS/CIRC	EC-1110
P1217	1217	ENG OVER TEMP	EC-1111
P1225	1225	CTP LEARNING	EC-1123
P1226	1226	CTP LEARNING	EC-1125
P1229	1229	SENSOR POWER/CIRC	EC-1127
P1271	1271	A/F SENSOR1 (B1)	EC-1132
P1272	1272	A/F SENSOR1 (B1)	EC-1140

A
EC
C
D
E
F
G
H
I
J
K
L
M

INDEX FOR DTC

[VQ]

DTC*1		Items (CONSULT-II screen terms)	Reference page
CONSULT-II GST*2	ECM*3		
P1273	1273	A/F SENSOR1 (B1)	EC-1148
P1274	1274	A/F SENSOR1 (B1)	EC-1157
P1276	1276	A/F SENSOR1 (B1)	EC-1166
P1278	1278	A/F SENSOR1 (B1)	EC-1175
P1279	1279	A/F SENSOR1 (B1)	EC-1187
P1281	1281	A/F SENSOR1 (B2)	EC-1132
P1282	1282	A/F SENSOR1 (B2)	EC-1140
P1283	1283	A/F SENSOR1 (B2)	EC-1148
P1284	1284	A/F SENSOR1 (B2)	EC-1157
P1286	1286	A/F SENSOR1 (B2)	EC-1166
P1288	1288	A/F SENSOR1 (B2)	EC-1175
P1289	1289	A/F SENSOR1 (B2)	EC-1187
P1402	1402	EGR SYSTEM	EC-1199
P1444	1444	PURG VOLUME CONT/V	EC-1206
P1446	1446	VENT CONTROL VALVE	EC-1214
P1564	1564	ASCD SW	EC-1220
P1572	1572	ASCD BRAKE SW	EC-1227
P1574	1574	ASCD VHL SPD SEN	EC-1238
P1610 - P1615	1610 - 1615	NATS MALFUNCTION	EC-667
P1706	1706	P-N POS SW/CIRCUIT	EC-1240
P1800	1800	VIAS S/V CIRC	EC-1248
P1805	1805	BRAKE SW/CIRCUIT	EC-1253
P2122	2122	APP SEN 1/CIRC	EC-1258
P2123	2123	APP SEN 1/CIRC	EC-1258
P2127	2127	APP SEN 2/CIRC	EC-1265
P2128	2128	APP SEN 2/CIRC	EC-1265
P2135	2135	TP SENSOR	EC-1272
P2138	2138	APP SENSOR	EC-1279

*1: 1st trip DTC No. is the same as DTC No.

*2: This number is prescribed by SAE J2012.

*3: In Diagnostic Test Mode II (Self-diagnostic results), this number is controlled by NISSAN.

*4: The troubleshooting for this DTC needs CONSULT-II.

*5: When the fail-safe operations for both self-diagnoses occur, the MIL illuminates.

Alphabetical Index

UBS00HZF

NOTE:

If DTC U1000 or U1001 is displayed with other DTC, first perform the trouble diagnosis for DTC U1000, U1001. Refer to [EC-790, "DTC U1000, U1001 CAN COMMUNICATION LINE"](#) .

Items (CONSULT-II screen terms)	DTC*1		Reference page
	CONSULT-II GST*2	ECM*3	
A/F SENSOR1 (B1)	P1271	1271	EC-1132
A/F SENSOR1 (B1)	P1272	1272	EC-1140
A/F SENSOR1 (B1)	P1273	1273	EC-1148
A/F SENSOR1 (B1)	P1274	1274	EC-1157

INDEX FOR DTC

[VQ]

Items (CONSULT-II screen terms)	DTC*1		Reference page
	CONSULT-II GST*2	ECM*3	
A/F SENSOR1 (B1)	P1276	1276	EC-1166
A/F SENSOR1 (B1)	P1278	1278	EC-1175
A/F SENSOR1 (B1)	P1279	1279	EC-1187
A/F SENSOR1 (B2)	P1281	1281	EC-1132
A/F SENSOR1 (B2)	P1282	1282	EC-1140
A/F SENSOR1 (B2)	P1283	1283	EC-1148
A/F SENSOR1 (B2)	P1284	1284	EC-1157
A/F SENSOR1 (B2)	P1286	1286	EC-1166
A/F SENSOR1 (B2)	P1288	1288	EC-1175
A/F SENSOR1 (B2)	P1289	1289	EC-1187
A/F SEN1 HTR (B1)	P1031	1031	EC-1045
A/F SEN1 HTR (B1)	P1032	1032	EC-1045
A/F SEN1 HTR (B2)	P1051	1051	EC-1045
A/F SEN1 HTR (B2)	P1052	1052	EC-1045
A/T 1ST GR FNCTN	P0731	0731	AT-496
A/T 2ND GR FNCTN	P0732	0732	AT-499
A/T 3RD GR FNCTN	P0733	0733	AT-505
A/T 4TH GR FNCTN	P0734	0734	AT-511
A/T 5HT GR FNCTN	P0735	0735	AT-516
A/T TCC S/V FNCTN	P0744	0744	AT-522
APP SEN 1/CIRC	P2122	2122	EC-1258
APP SEN 1/CIRC	P2123	2123	EC-1258
APP SEN 2/CIRC	P2127	2127	EC-1265
APP SEN 2/CIRC	P2128	2128	EC-1265
APP SENSOR	P2138	2138	EC-1279
ASCD BRAKE SW	P1572	1572	EC-1227
ASCD SW	P1564	1564	EC-1220
ASCD VHL SPD SEN	P1574	1574	EC-1238
ATF TEMP SEN/CIRC	P0710	0710	AT-476
BRAKE SW/CIRCUIT	P1805	1805	EC-1253
CAN COMM CIRCUIT	U1000	1000*4	EC-790
CAN COMM CIRCUIT	U1001	1001*4	EC-790
CKP SEN/CIRCUIT	P0335	0335	EC-921
CLOSED LOOP-B1	P1148	1148	EC-1108
CLOSED LOOP-B2	P1168	1168	EC-1108
CMP SEN/CIRC-B1	P0340	0340	EC-928
CMP SEN/CIRC-B2	P0345	0345	EC-928
CTP LEARNING	P1225	1225	EC-1123
CTP LEARNING	P1226	1226	EC-1125
CYL 1 MISFIRE	P0301	0301	EC-906
CYL 2 MISFIRE	P0302	0302	EC-906
CYL 3 MISFIRE	P0303	0303	EC-906

A
EC
C
D
E
F
G
H
I
J
K
L
M

INDEX FOR DTC

[VQ]

Items (CONSULT-II screen terms)	DTC*1		Reference page
	CONSULT-II GST*2	ECM*3	
CYL 4 MISFIRE	P0304	0304	EC-906
CYL 5 MISFIRE	P0305	0305	EC-906
CYL 6 MISFIRE	P0306	0306	EC-906
ECM	P0605	0605	EC-1042
ECM BACK UP/CIRCUIT	P1065	1065	EC-1053
ECT SEN/CIRCUIT	P0117	0117	EC-826
ECT SEN/CIRCUIT	P0118	0118	EC-826
ECT SENSOR	P0125	0125	EC-838
EGR SYSTEM	P0400	0400	EC-937
EGR SYSTEM	P1402	1402	EC-1199
EGR TEMP SEN/CIRC	P0405	0405	EC-952
EGR TEMP SEN/CIRC	P0406	0406	EC-952
EGR VOL CON/V CIR	P0403	0403	EC-945
ENG OVER TEMP	P1217	1217	EC-1111
ETC ACTR	P1121	1121	EC-1066
ETC FUNCTION/CIRC	P1122	1122	EC-1068
ETC MOT	P1128	1128	EC-1079
ETC MOT PWR	P1124	1124	EC-1074
ETC MOT PWR	P1126	1126	EC-1074
EVAP GROSS LEAK	P0455	0455	EC-1008
EVAP PURG FLOW/MON	P0441	0441	EC-964
EVAP SMALL LEAK	P0442	0442	EC-969
EVAP SYS PRES SEN	P0451	0451	EC-991
EVAP SYS PRES SEN	P0452	0452	EC-994
EVAP SYS PRES SEN	P0453	0453	EC-1000
EVAP VERY SML LEAK	P0456	0456	EC-1016
FLUID TEMP SEN	P0711	0711	AT-481
FTT SEN/CIRCUIT	P0182	0182	EC-895
FTT SEN/CIRCUIT	P0183	0183	EC-895
FTT SENSOR	P0181	0181	EC-890
FUEL LEV SEN SLOSH	P0460	0460	EC-1025
FUEL LEVEL SENSOR	P0461	0461	EC-1027
FUEL LEVL SEN/CIRC	P0462	0462	EC-1029
FUEL LEVL SEN/CIRC	P0463	0463	EC-1029
FUEL SYS-LEAN-B1	P0171	0171	EC-868
FUEL SYS-LEAN-B2	P0174	0174	EC-868
FUEL SYS-RICH-B1	P0172	0172	EC-879
FUEL SYS-RICH-B2	P0175	0175	EC-879
HO2S2 (B1)	P0138	0138	EC-846
HO2S2 (B1)	P0139	0139	EC-856
HO2S2 (B1)	P1146	1146	EC-1084
HO2S2 (B1)	P1147	1147	EC-1096

INDEX FOR DTC

[VQ]

Items (CONSULT-II screen terms)	DTC*1		Reference page
	CONSULT-II GST*2	ECM*3	
HO2S2 (B2)	P0158	0158	EC-846
HO2S2 (B2)	P0159	0159	EC-856
HO2S2 (B2)	P1166	1166	EC-1084
HO2S2 (B2)	P1167	1167	EC-1096
HO2S2 HTR (B1)	P0037	0037	EC-797
HO2S2 HTR (B1)	P0038	0038	EC-797
HO2S2 HTR (B2)	P0057	0057	EC-797
HO2S2 HTR (B2)	P0058	0058	EC-797
IAT SEN/CIRCUIT	P0112	0112	EC-822
IAT SEN/CIRCUIT	P0113	0113	EC-822
IAT SENSOR	P0127	0127	EC-841
INT/V TIM CONT-B1	P0011	0011	EC-793
INT/V TIM CONT-B2	P0021	0021	EC-793
INT/V TIM V/CIR-B1	P1111	1111	EC-1057
INT/V TIM V/CIR-B2	P1136	1136	EC-1057
ISC SYSTEM	P0506	0506	EC-1033
ISC SYSTEM	P0507	0507	EC-1035
KNOCK SEN/CIRC-B1	P0327	0327	EC-916
KNOCK SEN/CIRC-B1	P0328	0328	EC-916
L/PRESS SOL/CIRC	P0745	0745	AT-525
MAF SEN/CIRCUIT	P0101	0101	EC-806
MAF SEN/CIRCUIT	P0102	0102	EC-815
MAF SEN/CIRCUIT	P0103	0103	EC-815
MULTI CYL MISFIRE	P0300	0300	EC-906
NATS MALFUNCTION	P1610 - P1615	1610 - 1615	EC-667
NO DTC IS DETECTED. FURTHER TESTING MAY BE REQUIRED.	P0000	0000	—
P-N POS SW/CIRCUIT	P1706	1706	EC-1240
PC SOL B(SFT/PRS)	P0775	0775	AT-560
PC SOL C(TCC&SFT)	P0795	0795	AT-569
PC SOL C STC ON	P0797	0797	AT-574
PNP SW/CIRC	P0705	0705	AT-471
PURG VOLUME CONT/V	P0444	0444	EC-977
PURG VOLUME CONT/V	P0445	0445	EC-977
PURG VOLUME CONT/V	P1444	1444	EC-1206
PW ST P SEN/CIRC	P0550	0550	EC-1037
SENSOR POWER/CIRC	P1229	1229	EC-1127
SFT SOL A/CIRC	P0750	0750	AT-530
SFT SOL B/CIRC	P0755	0755	AT-535
SFT SOL C STUCK ON	P0762	0762	AT-545
SHIFT	P0780	0780	AT-565
SHIFT SOL C	P0760	0760	AT-540

INDEX FOR DTC

[VQ]

Items (CONSULT-II screen terms)	DTC*1		Reference page
	CONSULT-II GST*2	ECM*3	
SHIFT SOL D	P0765	0765	AT-550
SHIFT SOL E	P0770	0770	AT-555
TCM POWER INPT SIG	P0882	0882	AT-585
TCS C/U FUNCTN	P1211	1211	EC-1109
TCS/CIRC	P1212	1212	EC-1110
THERMSTAT FNCTN	P0128	0128	EC-844
TP SEN 1/CIRC	P0222	0222	EC-899
TP SEN 1/CIRC	P0223	0223	EC-899
TP SEN 2/CIRC	P0122	0122	EC-831
TP SEN 2/CIRC	P0123	0123	EC-831
TP SENSOR	P2135	2135	EC-1272
TURBINE SENSOR	P0717	0717	AT-486
TW CATALYST SYS-B1	P0420	0420	EC-959
TW CATALYST SYS-B2	P0430	0430	EC-959
VEH SPEED SEN/CIRC*5	P0500	0500	EC-1031
VENT CONTROL VALVE	P0447	0447	EC-984
VENT CONTROL VALVE	P1446	1446	EC-1214
VHCL SPEED SEN-AT*5	P0722	0722	AT-490
VIAS S/V CIRC	P1800	1800	EC-1248

*1: 1st trip DTC No. is the same as DTC No.

*2: This number is prescribed by SAE J2012.

*3: In Diagnostic Test Mode II (Self-diagnostic results), this number is controlled by NISSAN.

*4: The troubleshooting for this DTC needs CONSULT-II.

*5: When the fail-safe operations for both self-diagnoses occur, the MIL illuminates.

PRECAUTIONS

PFP:00001

Precautions for Supplemental Restraint System (SRS) “AIR BAG” and “SEAT BELT PRE-TENSIONER”

UBS00IIZ

The Supplemental Restraint System such as “AIR BAG” and “SEAT BELT PRE-TENSIONER”, used along with a front seat belt, helps to reduce the risk or severity of injury to the driver and front passenger for certain types of collision. This system includes seat belt switch inputs and dual stage front air bag modules. The SRS system uses the seat belt switches to determine the front air bag deployment, and may only deploy one front air bag, depending on the severity of a collision and whether the front occupants are belted or unbelted. Information necessary to service the system safely is included in the SRS and SB section of this Service Manual.

WARNING:

- To avoid rendering the SRS inoperative, which could increase the risk of personal injury or death in the event of a collision which would result in air bag inflation, all maintenance must be performed by an authorized NISSAN/INFINITI dealer.
- Improper maintenance, including incorrect removal and installation of the SRS, can lead to personal injury caused by unintentional activation of the system. For removal of Spiral Cable and Air Bag Module, see the SRS section.
- Do not use electrical test equipment on any circuit related to the SRS unless instructed to in this Service Manual. SRS wiring harnesses can be identified by yellow and/or orange harnesses or harness connectors.

On Board Diagnostic (OBD) System of Engine and A/T

UBS00HZI

The ECM has an on board diagnostic system. It will light up the malfunction indicator lamp (MIL) to warn the driver of a malfunction causing emission deterioration.

CAUTION:

- Be sure to turn the ignition switch OFF and disconnect the negative battery cable before any repair or inspection work. The open/short circuit of related switches, sensors, solenoid valves, etc. will cause the MIL to light up.
- Be sure to connect and lock the connectors securely after work. A loose (unlocked) connector will cause the MIL to light up due to the open circuit. (Be sure the connector is free from water, grease, dirt, bent terminals, etc.)
- Certain systems and components, especially those related to OBD, may use a new style slide-locking type harness connector. For description and how to disconnect, refer to [PG-66, "HARNESS CONNECTOR"](#) .
- Be sure to route and secure the harnesses properly after work. The interference of the harness with a bracket, etc. may cause the MIL to light up due to the short circuit.
- Be sure to connect rubber tubes properly after work. A misconnected or disconnected rubber tube may cause the MIL to light up due to the malfunction of the EVAP system or fuel injection system, etc.
- Be sure to erase the unnecessary malfunction information (repairs completed) from the ECM and TCM (Transmission control module) before returning the vehicle to the customer.

Precaution

UBS00HZJ

- Always use a 12 volt battery as power source.
- Do not attempt to disconnect battery cables while engine is running.
- Before connecting or disconnecting the ECM harness connector, turn ignition switch OFF and disconnect battery ground cable. Failure to do so may damage the ECM because battery voltage is applied to ECM even if ignition switch is turned OFF.
- Before removing parts, turn ignition switch OFF and then disconnect battery ground cable.

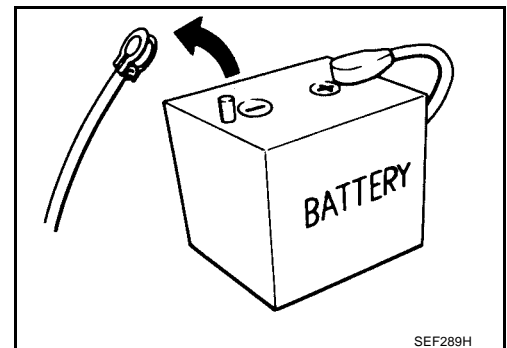

PRECAUTIONS

[VQ]

- Do not disassemble ECM.
- If a battery cable is disconnected, the memory will return to the ECM value.
The ECM will now start to self-control at its initial value. Engine operation can vary slightly when the terminal is disconnected. However, this is not an indication of a malfunction. Do not replace parts because of a slight variation.
- If the battery is disconnected, the following emission-related diagnostic information will be lost within 24 hours.
 - Diagnostic trouble codes
 - 1st trip diagnostic trouble codes
 - Freeze frame data
 - 1st trip freeze frame data
 - System readiness test (SRT) codes
 - Test values
- When connecting ECM harness connector, fasten it securely with levers as far as they will go as shown in the figure.

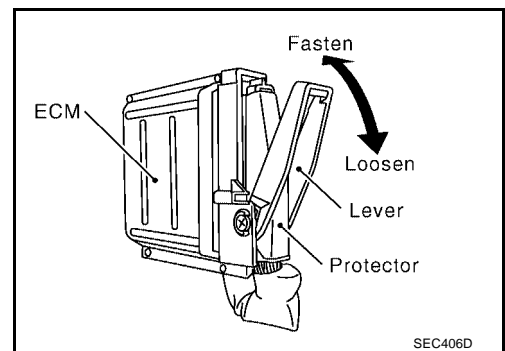
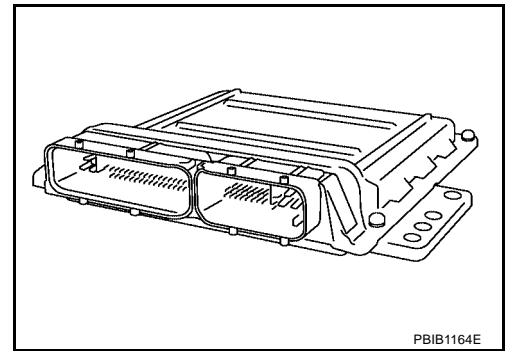

- When connecting or disconnecting pin connectors into or from ECM, take care not to damage pin terminals (bend or break).
Make sure that there are not any bends or breaks on ECM pin terminal, when connecting pin connectors.
- Securely connect ECM harness connectors.
A poor connection can cause an extremely high (surge) voltage to develop in coil and condenser, thus resulting in damage to ICs.
- Keep engine control system harness at least 10 cm (4 in) away from adjacent harness, to prevent engine control system malfunctions due to receiving external noise, degraded operation of ICs, etc.
- Keep engine control system parts and harness dry.
- Before replacing ECM, perform "ECM Terminals and Reference Value" inspection and make sure ECM functions properly. Refer to [EC-740](#).
- Handle mass air flow sensor carefully to avoid damage.
- Do not disassemble mass air flow sensor.
- Do not clean mass air flow sensor with any type of detergent.
- Do not disassemble electric throttle control actuator.
- Even a slight leak in the air intake system can cause serious incidents.
- Do not shock or jar the camshaft position sensor (PHASE), crankshaft position sensor (POS).

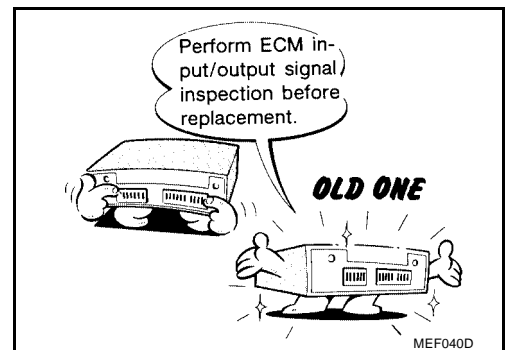
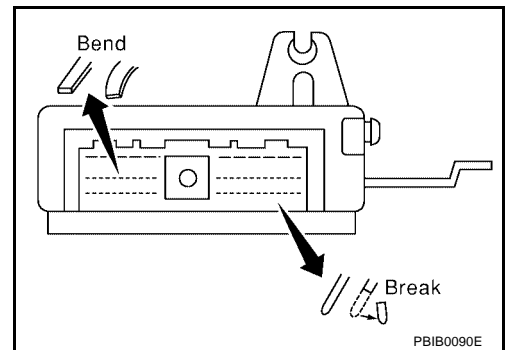

PRECAUTIONS

[VQ]

- After performing each TROUBLE DIAGNOSIS, perform DTC Confirmation Procedure or Overall Function Check. The DTC should not be displayed in the DTC Confirmation Procedure if the repair is completed. The Overall Function Check should be a good result if the repair is completed.

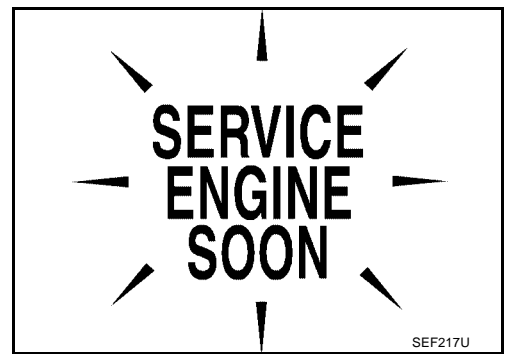

- When measuring ECM signals with a circuit tester, never allow the two tester probes to contact. Accidental contact of probes will cause a short circuit and damage the ECM power transistor.
- Do not use ECM ground terminals when measuring input/output voltage. Doing so may result in damage to the ECM's transistor. Use a ground other than ECM terminals, such as the ground.

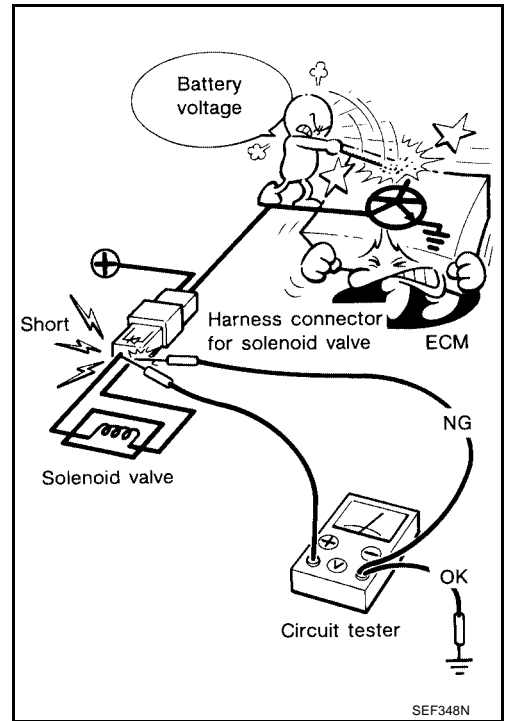

- B1 indicates the bank 1, B2 indicates the bank 2 as shown in the figure.

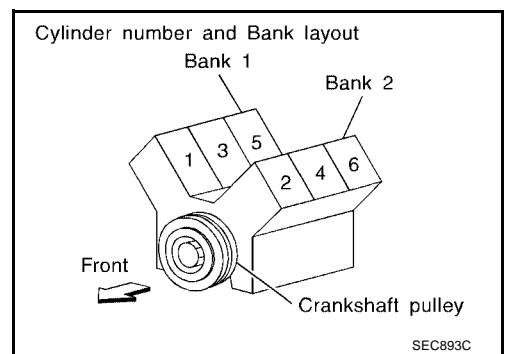

PRECAUTIONS

[VQ]

- Do not operate fuel pump when there is no fuel in lines.
- Tighten fuel hose clamps to the specified torque.

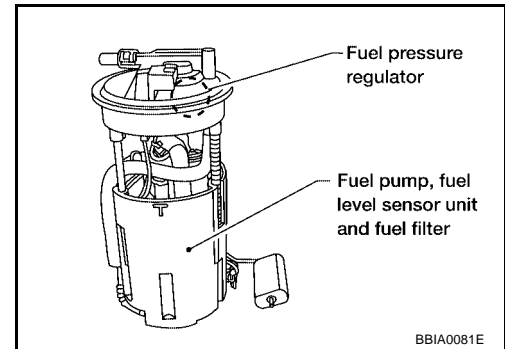

- Do not depress accelerator pedal when starting.
- Immediately after starting, do not rev up engine unnecessarily.
- Do not rev up engine just prior to shutdown.

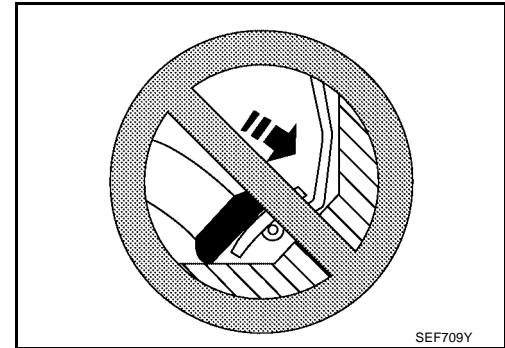

- When installing C.B. ham radio or a mobile phone, be sure to observe the following as it may adversely affect electronic control systems depending on installation location.
 - Keep the antenna as far as possible from the electronic control units.
 - Keep the antenna feeder line more than 20 cm (8 in) away from the harness of electronic controls. Do not let them run parallel for a long distance.
 - Adjust the antenna and feeder line so that the standing-wave ratio can be kept smaller.
 - Be sure to ground the radio to vehicle body.

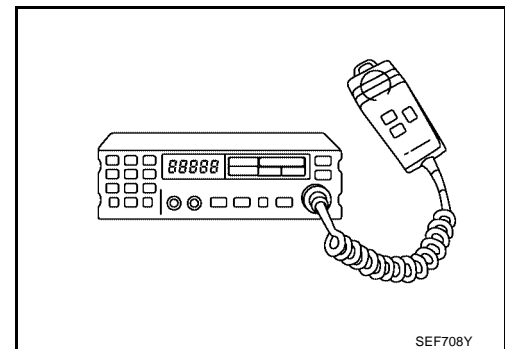

Wiring Diagrams and Trouble Diagnosis

UBS00HZK

When you read wiring diagrams, refer to the following:

- [GI-14, "How to Read Wiring Diagrams"](#)
- [PG-4, "POWER SUPPLY ROUTING CIRCUIT"](#) for power distribution circuit

When you perform trouble diagnosis, refer to the following:

- [GI-10, "HOW TO FOLLOW TEST GROUPS IN TROUBLE DIAGNOSES"](#)
- [GI-26, "How to Perform Efficient Diagnosis for an Electrical Incident"](#)

PREPARATION

[VQ]



PF0:00002

UBS00HZL

PREPARATION

Special Service Tools

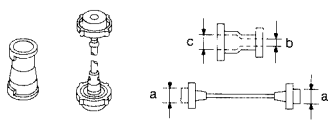
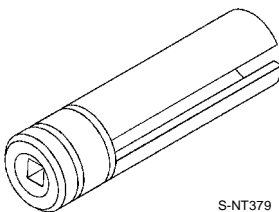
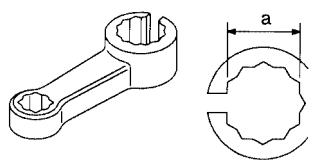
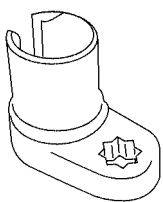
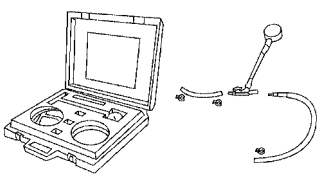
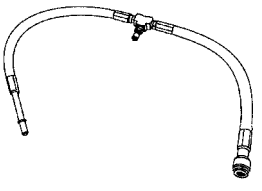
The actual shapes of Kent-Moore tools may differ from those of special service tools illustrated here.

Tool number (Kent-Moore No.) Tool name	Description
EG17650301 (J-33984-A) Radiator cap tester adapter <div style="text-align: center;">  <p>S-NT564</p> </div>	Adapting radiator cap tester to radiator cap and radiator filler neck a: 28 (1.10) dia. b: 31.4 (1.236) dia. c: 41.3 (1.626) dia. Unit: mm (in)
KV10117100 (J-36471-A) Heated oxygen sensor wrench <div style="text-align: center;">  <p>S-NT379</p> </div>	Loosening or tightening heated oxygen sensors with 22 mm (0.87 in) hexagon nut
KV10114400 (J-38365) Heated oxygen sensor wrench <div style="text-align: center;">  <p>S-NT636</p> </div>	Loosening or tightening heated oxygen sensors a: 22 mm (0.87 in)
(J-44626) Air fuel ratio (A/F) sensor wrench <div style="text-align: center;">  <p>LEM054</p> </div>	Loosening or tightening air fuel ratio (A/F) sensor 1
(J-44321) Fuel pressure gauge kit <div style="text-align: center;">  <p>LEC642</p> </div>	Checking fuel pressure
(J-44321-6) Fuel pressure adapter <div style="text-align: center;">  <p>LBIA0376E</p> </div>	Connecting fuel pressure gauge to quick connector type fuel lines.
(J-45488) Quick connector re- lease <div style="text-align: center;">  <p>PBIC0198E</p> </div>	Remove fuel tube quick connectors in engine room

PREPARATION

[VQ]

Tool number (Kent-Moore No.) Tool name	Description
KV109E0010 (J-46209) Break-out box	Measuring the ECM signals with a circuit tester
KV109E0080 (J-45819) Y-cable adapter	Measuring the ECM signals with a circuit tester

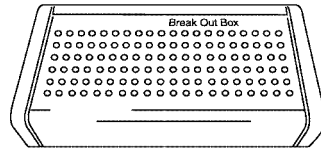

S-NT825

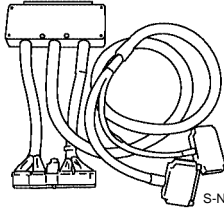

S-NT826

PREPARATION

[VQ]

Commercial Service Tools

UBS00HZM

Tool name (Kent-Moore No.)	Description
Leak detector i.e.: (J-41416)	Locating the EVAP leak
EVAP service port adapter i.e.: (J-41413-OB)	Applying positive pressure through EVAP service port
Fuel filler cap adapter i.e.: (MLR-8382)	Checking fuel tank vacuum relief valve opening pressure
Socket wrench	Removing and installing engine coolant temperature sensor
Oxygen sensor thread cleaner i.e.: (J-43897-18) (J-43897-12)	Reconditioning the exhaust system threads before installing a new oxygen sensor. Use with anti-seize lubricant shown below. a: 18 mm diameter with pitch 1.5 mm for Zirconia Oxygen Sensor b: 12 mm diameter with pitch 1.25 mm for Titania Oxygen Sensor
Anti-seize lubricant i.e.: (Permatex™ 133AR or equivalent meeting MIL specification MIL-A-907)	Lubricating oxygen sensor thread cleaning tool when reconditioning exhaust system threads.

A
EC
C
D
E
F
G
H
I
J
K
L
M

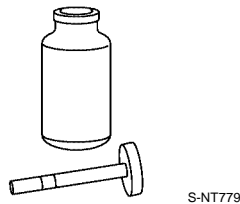
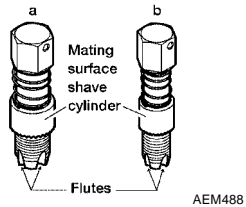
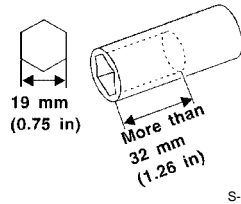
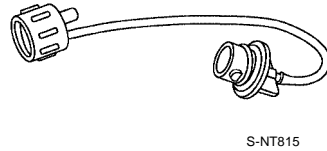
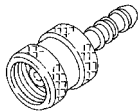
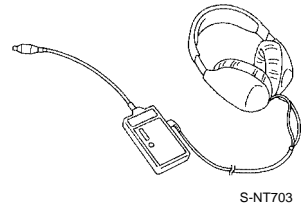

ENGINE CONTROL SYSTEM

PF2:23710

System Diagram

UBS00HZT

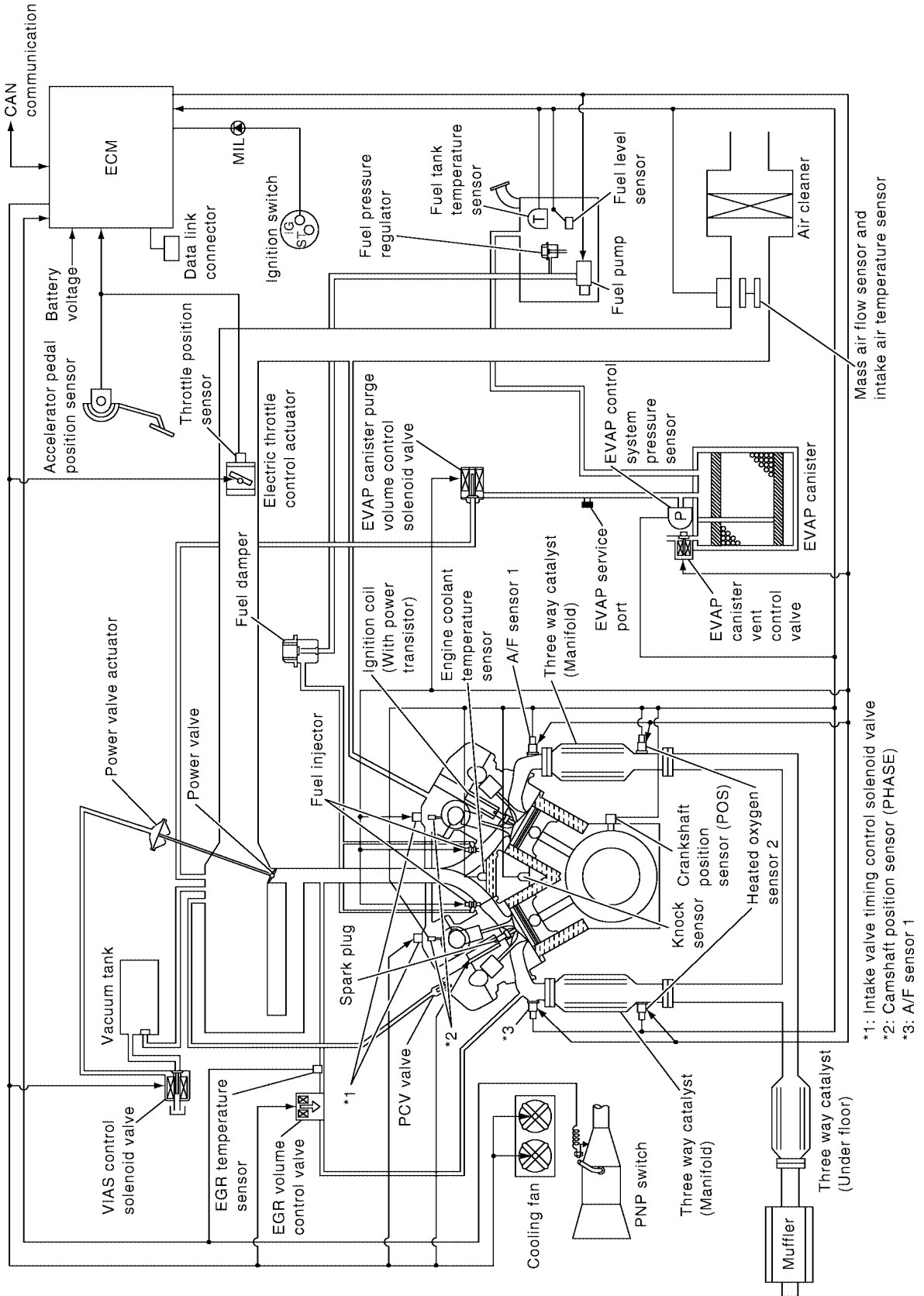

- *1: Intake valve timing control solenoid valve
- *2: Camshaft position sensor (PHASE)
- *3: A/F sensor 1

Multipoint Fuel Injection (MFI) System INPUT/OUTPUT SIGNAL CHART

Sensor	Input Signal to ECM	ECM function	Actuator
Crankshaft position sensor (POS)	Engine speed* ³ Piston position	Fuel injection & mixture ratio control	Fuel injector
Camshaft position sensor (PHASE)			
Mass air flow sensor	Amount of intake air		
Engine coolant temperature sensor	Engine coolant temperature		
Air fuel ratio (A/F) sensor 1	Density of oxygen in exhaust gas		
Throttle position sensor	Throttle position		
Accelerator pedal position sensor	Accelerator pedal position		
Park/neutral position (PNP) switch	Gear position		
Knock sensor	Engine knocking condition		
Battery	Battery voltage* ³		
Power steering pressure sensor	Power steering operation		
Heated oxygen sensor 2* ¹	Density of oxygen in exhaust gas		
Air conditioner switch* ²	Air conditioner operation		
Wheel sensor* ²	Vehicle speed		

*1: This sensor is not used to control the engine system. This is used only for the on board diagnosis.

*2: This signal is sent to the ECM through CAN communication line.

*3: ECM determines the start signal status by the signals of engine speed and battery voltage.

SYSTEM DESCRIPTION

The amount of fuel injected from the fuel injector is determined by the ECM. The ECM controls the length of time the valve remains open (injection pulse duration). The amount of fuel injected is a program value in the ECM memory. The program value is preset by engine operating conditions. These conditions are determined by input signals (for engine speed and intake air) from both the crankshaft position sensor and the mass air flow sensor.

VARIOUS FUEL INJECTION INCREASE/DECREASE COMPENSATION

In addition, the amount of fuel injected is compensated to improve engine performance under various operating conditions as listed below.

<Fuel increase>

- During warm-up
- When starting the engine
- During acceleration
- Hot-engine operation
- When selector lever is changed from N to D (A/T models)
- High-load, high-speed operation

<Fuel decrease>

- During deceleration
- During high engine speed operation

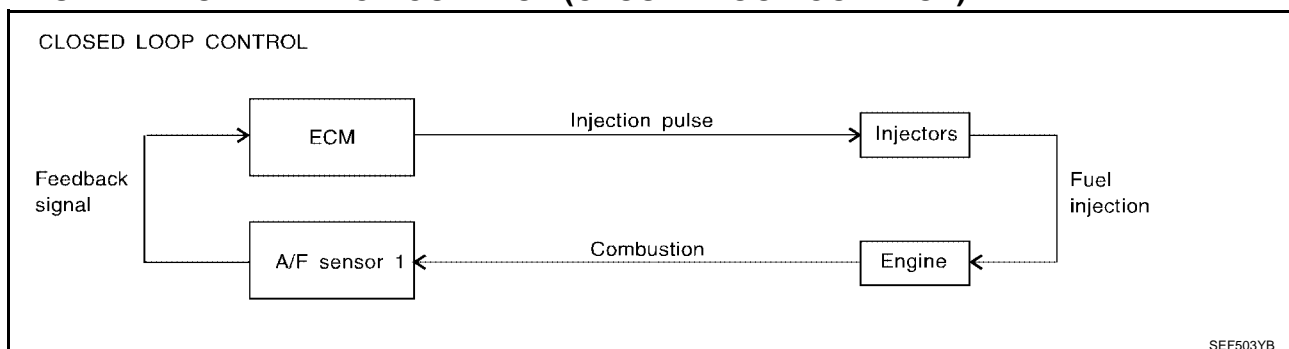
MIXTURE RATIO FEEDBACK CONTROL (CLOSED LOOP CONTROL)

The mixture ratio feedback system provides the best air-fuel mixture ratio for driveability and emission control. The three way catalyst (manifold) can then better reduce CO, HC and NOx emissions. This system uses air fuel ratio (A/F) sensor 1 in the exhaust manifold to monitor whether the engine operation is rich or lean. The ECM adjusts the injection pulse width according to the sensor voltage signal. For more information about air fuel ratio (A/F) sensor 1, refer to [EC-1132, "DTC P1271, P1281 A/F SENSOR 1"](#). This maintains the mixture ratio within the range of stoichiometric (ideal air-fuel mixture).

This stage is referred to as the closed loop control condition.

Heated oxygen sensor 2 is located downstream of the three way catalyst (manifold). Even if the switching characteristics of air fuel ratio (A/F) sensor 1 shift, the air-fuel ratio is controlled to stoichiometric by the signal from heated oxygen sensor 2.

Open Loop Control

The open loop system condition refers to when the ECM detects any of the following conditions. Feedback control stops in order to maintain stabilized fuel combustion.

- Deceleration and acceleration
- High-load, high-speed operation
- Malfunction of A/F sensor 1 or its circuit
- Insufficient activation of A/F sensor 1 at low engine coolant temperature
- High engine coolant temperature
- During warm-up
- After shifting from N to D (A/T models)
- When starting the engine

MIXTURE RATIO SELF-LEARNING CONTROL

The mixture ratio feedback control system monitors the mixture ratio signal transmitted from A/F sensor 1. This feedback signal is then sent to the ECM. The ECM controls the basic mixture ratio as close to the theoretical mixture ratio as possible. However, the basic mixture ratio is not necessarily controlled as originally designed. Both manufacturing differences (i.e., mass air flow sensor hot wire) and characteristic changes during operation (i.e., injector clogging) directly affect mixture ratio.

Accordingly, the difference between the basic and theoretical mixture ratios is monitored in this system. This is then computed in terms of "injection pulse duration" to automatically compensate for the difference between the two ratios.

"Fuel trim" refers to the feedback compensation value compared against the basic injection duration. Fuel trim includes short term fuel trim and long term fuel trim.

"Short term fuel trim" is the short-term fuel compensation used to maintain the mixture ratio at its theoretical value. The signal from A/F sensor 1 indicates whether the mixture ratio is RICH or LEAN compared to the theoretical value. The signal then triggers a reduction in fuel volume if the mixture ratio is rich, and an increase in fuel volume if it is lean.

"Long term fuel trim" is overall fuel compensation carried out long-term to compensate for continual deviation of the short term fuel trim from the central value. Such deviation will occur due to individual engine differences, wear over time and changes in the usage environment.

FUEL INJECTION TIMING

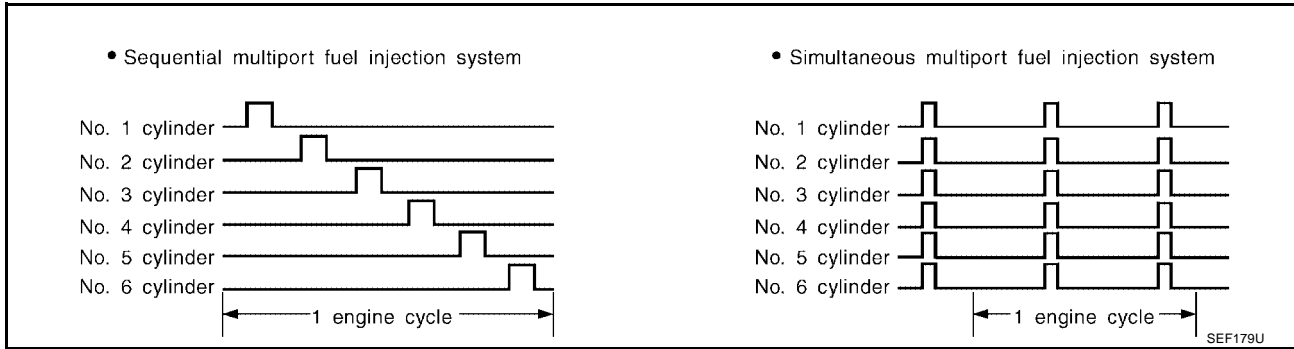

Two types of systems are used.

Sequential Multiport Fuel Injection System

Fuel is injected into each cylinder during each engine cycle according to the firing order. This system is used when the engine is running.

Simultaneous Multiport Fuel Injection System

Fuel is injected simultaneously into all six cylinders twice each engine cycle. In other words, pulse signals of the same width are simultaneously transmitted from the ECM.

The six injectors will then receive the signals two times for each engine cycle.

This system is used when the engine is being started and/or if the fail-safe system (CPU) is operating.

FUEL SHUT-OFF

Fuel to each cylinder is cut off during deceleration, operation of the engine at excessively high speeds or operation of the vehicle at excessively high speeds.

Electronic Ignition (EI) System INPUT/OUTPUT SIGNAL CHART

UBS00HZX

Sensor	Input Signal to ECM	ECM function	Actuator
Crankshaft position sensor (POS)	Engine speed*2 Piston position	Ignition timing control	Power transistor
Camshaft position sensor (PHASE)			
Mass air flow sensor	Amount of intake air		
Engine coolant temperature sensor	Engine coolant temperature		
Throttle position sensor	Throttle position		
Accelerator pedal position sensor	Accelerator pedal position		
Knock sensor	Engine knocking		
Park/neutral position (PNP) switch	Gear position		
Battery	Battery voltage*2		
Wheel sensor*1	Vehicle speed		

*1: This signal is sent to the ECM through CAN communication line.

*2: ECM determines the start signal status by the signals of engine speed and battery voltage.

SYSTEM DESCRIPTION

Firing order: 1 - 2 - 3 - 4 - 5 - 6

The ignition timing is controlled by the ECM to maintain the best air-fuel ratio for every running condition of the engine. The ignition timing data is stored in the ECM.

The ECM receives information such as the injection pulse width and camshaft position sensor (PHASE) signal. Computing this information, ignition signals are transmitted to the power transistor.

During the following conditions, the ignition timing is revised by the ECM according to the other data stored in the ECM.

- At starting
- During warm-up
- At idle
- At low battery voltage

- During acceleration

The knock sensor retard system is designed only for emergencies. The basic ignition timing is programmed within the anti-knocking zone, if recommended fuel is used under dry conditions. The retard system does not operate under normal driving conditions. If engine knocking occurs, the knock sensor monitors the condition. The signal is transmitted to the ECM. The ECM retards the ignition timing to eliminate the knocking condition.

Fuel Cut Control (at No Load and High Engine Speed) INPUT/OUTPUT SIGNAL CHART

UBS00100

Sensor	Input Signal to ECM	ECM function	Actuator
Park/neutral position (PNP) switch	Neutral position	Fuel cut control	Fuel injector
Accelerator pedal position sensor	Accelerator pedal position		
Engine coolant temperature sensor	Engine coolant temperature		
Crankshaft position sensor (POS) Camshaft position sensor (PHASE)	Engine speed		
Wheel sensor*	Vehicle speed		

*: This signal is sent to the ECM through CAN communication line.

SYSTEM DESCRIPTION

If the engine speed is above 1,800 rpm under no load (for example, the shift position is neutral and engine speed over is 1,800 rpm) fuel will be cut off after some time. The exact time when the fuel is cut off varies based on engine speed.

Fuel cut will be operated until the engine speed reaches 1,500 rpm, then fuel cut will be cancelled.

NOTE:

This function is different from deceleration control listed under "Multiport Fuel Injection (MFI) System", [EC-643](#)

AIR CONDITIONING CUT CONTROL

[VQ]

AIR CONDITIONING CUT CONTROL

PFP:23710

Input/Output Signal Chart

UBS00HZZ

Sensor	Input Signal to ECM	ECM function	Actuator
Air conditioner switch*1	Air conditioner ON signal	Air conditioner cut control	Air conditioner relay
Accelerator pedal position sensor	Accelerator pedal position		
Crankshaft position sensor (POS) Camshaft position sensor (PHASE)	Engine speed*2		
Engine coolant temperature sensor	Engine coolant temperature		
Battery	Battery voltage*2		
Refrigerant pressure sensor	Refrigerant pressure		
Power steering pressure sensor	Power steering operation		
Wheel sensor*1	Vehicle speed		

*1: This signal is sent to the ECM through CAN communication line.

*2: ECM determines the start signal status by the signals of engine speed and battery voltage.

System Description

UBS00IIV

This system improves engine operation when the air conditioner is used. Under the following conditions, the air conditioner is turned OFF.

- When the accelerator pedal is fully depressed.
- When cranking the engine.
- At high engine speeds.
- When the engine coolant temperature becomes excessively high.
- When operating power steering during low engine speed or low vehicle speed.
- When engine speed is excessively low.
- When refrigerant pressure is excessively low or high.

AUTOMATIC SPEED CONTROL DEVICE (ASCD)

[VQ]

AUTOMATIC SPEED CONTROL DEVICE (ASCD)

PF1:18930

System Description INPUT/OUTPUT SIGNAL CHART

UBS00IG4

Sensor	Input signal to ECM	ECM function	Actuator
ASCD brake switch	Brake pedal operation	ASCD vehicle speed control	Electric throttle control actuator
Stop lamp switch	Brake pedal operation		
ASCD clutch switch (M/T models)	Clutch pedal operation		
ASCD steering switch	ASCD steering switch operation		
Park/Neutral position (PNP) switch	Gear position		
Combination meter*	Vehicle speed		
TCM* (A/T models)	Powertrain revolution		

*: This signal is sent to the ECM through CAN communication line

BASIC ASCD SYSTEM

Refer to Owner's Manual for ASCD operating instructions.

Automatic Speed Control Device (ASCD) allows a driver to keep vehicle at predetermined constant speed without depressing accelerator pedal. Driver can set vehicle speed in advance between approximately 40 km/h (25 MPH) and 144 km/h (89 MPH).

ECM controls throttle angle of electric throttle control actuator to regulate engine speed.

Operation status of ASCD is indicated by CRUISE indicator and SET indicator in combination meter. If any malfunction occurs in ASCD system, it automatically deactivates control.

SET OPERATION

Press MAIN switch. (The CRUISE indicator in combination meter illuminates.)

When vehicle speed reaches a desired speed between approximately 40 km/h (25 MPH) and 144 km/h (89 MPH), press SET/COAST switch. (Then SET indicator in combination meter illuminates.)

ACCEL OPERATION

If the RESUME/ACCELERATE switch is pressed during cruise control driving, increase the vehicle speed until the switch is released or vehicle speed reaches maximum speed controlled by the system.

And then ASCD will keep the new set speed.

CANCEL OPERATION

When any of following conditions exist, cruise operation will be canceled.

- CANCEL switch is pressed
- More than 2 switches at ASCD steering switch are pressed at the same time (Set speed will be cleared)
- Brake pedal is depressed
- Clutch pedal is depressed or gear position is changed to the neutral position (M/T)
- Selector lever is changed to N, P, R position (A/T)
- Vehicle speed decreased to 13 km/h (8 MPH) lower than the set speed
- TCS system is operated

When the ECM detects any of the following conditions, the ECM will cancel the cruise operation and inform the driver by blinking indicator lamp.

- Engine coolant temperature is slightly higher than the normal operating temperature, CRUISE lamp may blink slowly.
When the engine coolant temperature decreases to the normal operating temperature, CRUISE lamp will stop blinking and the cruise operation will be able to work by pressing SET/COAST switch or RESUME/ACCELERATE switch.
- Malfunction for some self-diagnoses regarding ASCD control: SET lamp will blink quickly.

If MAIN switch is turned to OFF during ASCD is activated, all of ASCD operations will be canceled and vehicle speed memory will be erased.

COAST OPERATION

When the SET/COAST switch is pressed during cruise control driving, decrease vehicle set speed until the switch is released. And then ASCD will keep the new set speed.

A

RESUME OPERATION

When the RESUME/ACCELERATE switch is pressed after cancel operation other than pressing CRUISE switch is performed, vehicle speed will return to last set speed. To resume vehicle set speed, vehicle condition must meet following conditions.

EC

- Brake pedal is released
- Clutch pedal is released (M/T)
- A/T selector lever is in other than P and N positions (A/T)
- Vehicle speed is greater than 40 km/h (25 MPH) and less than 144 km/h (89 MPH)

C

D

Component Description

UBS001G5

ASCD STEERING SWITCH

Refer to [EC-1220](#) .

E

ASCD BRAKE SWITCH

Refer to [EC-1227](#) , and [EC-1333](#) .

F

ASCD CLUTCH SWITCH

Refer to [EC-1227](#) , and [EC-1333](#) .

G

STOP LAMP SWITCH

Refer to [EC-1253](#) .

H

ELECTRIC THROTTLE CONTROL ACTUATOR

Refer to [EC-1066](#) , [EC-1068](#) , [EC-1074](#) and [EC-1079](#) .

I

ASCD INDICATOR

Refer to [EC-1343](#) .

J

K

L

M

CAN COMMUNICATION

PF2:23710

System Description

UBS00101

CAN (Controller Area Network) is a serial communication line for real time application. It is an on-vehicle multiplex communication line with high data communication speed and excellent error detection ability. Many electronic control units are equipped onto a vehicle, and each control unit shares information and links with other control units during operation (not independent). In CAN communication, control units are connected with 2 communication lines (CAN H line, CAN L line) allowing a high rate of information transmission with less wiring. Each control unit transmits/receives data but selectively reads required data only.

Refer to [LAN-21, "CAN COMMUNICATION"](#) , about CAN communication for detail.

EVAPORATIVE EMISSION SYSTEM

PFP:14950

Description SYSTEM DESCRIPTION

UBS001FV

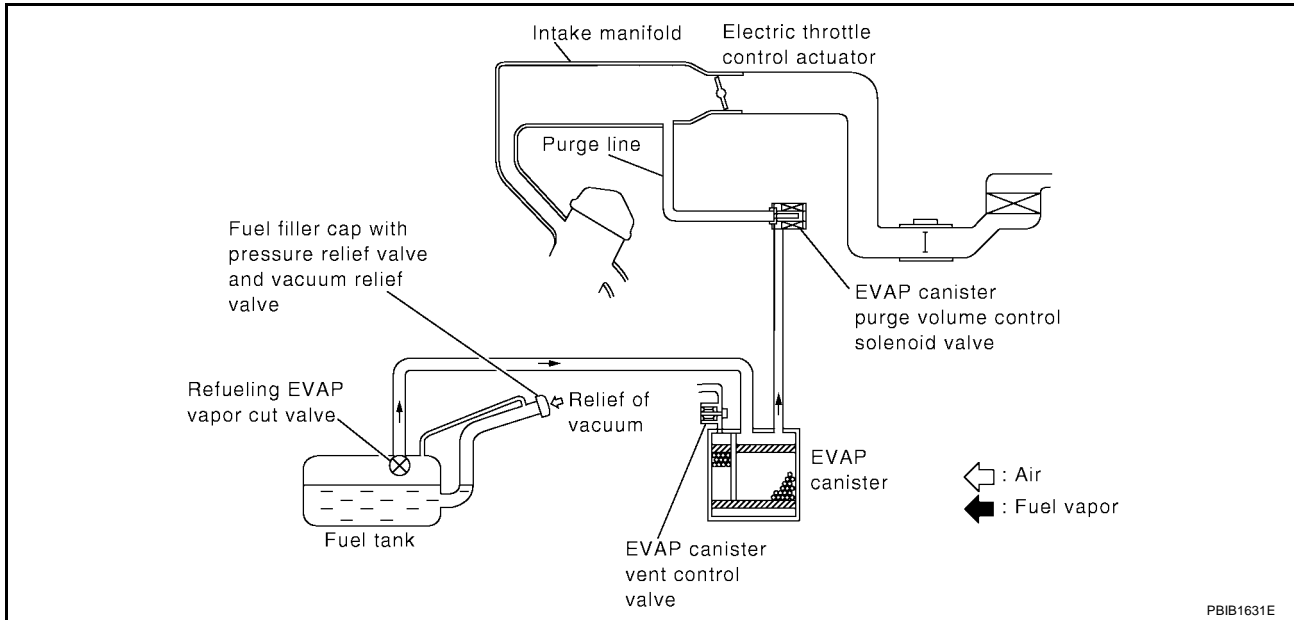

The evaporative emission system is used to reduce hydrocarbons emitted into the atmosphere from the fuel system. This reduction of hydrocarbons is accomplished by activated charcoals in the EVAP canister. The fuel vapor in the sealed fuel tank is led into the EVAP canister which contains activated carbon and the vapor is stored there when the engine is not operating or when refueling to the fuel tank. The vapor in the EVAP canister is purged by the air through the purge line to the intake manifold when the engine is operating. EVAP canister purge volume control solenoid valve is controlled by ECM. When the engine operates, the flow rate of vapor controlled by EVAP canister purge volume control solenoid valve is proportionally regulated as the air flow increases. EVAP canister purge volume control solenoid valve also shuts off the vapor purge line during decelerating and idling.

EVAPORATIVE EMISSION SYSTEM

[VQ]

EVAPORATIVE EMISSION LINE DRAWING (SE-R MODELS)

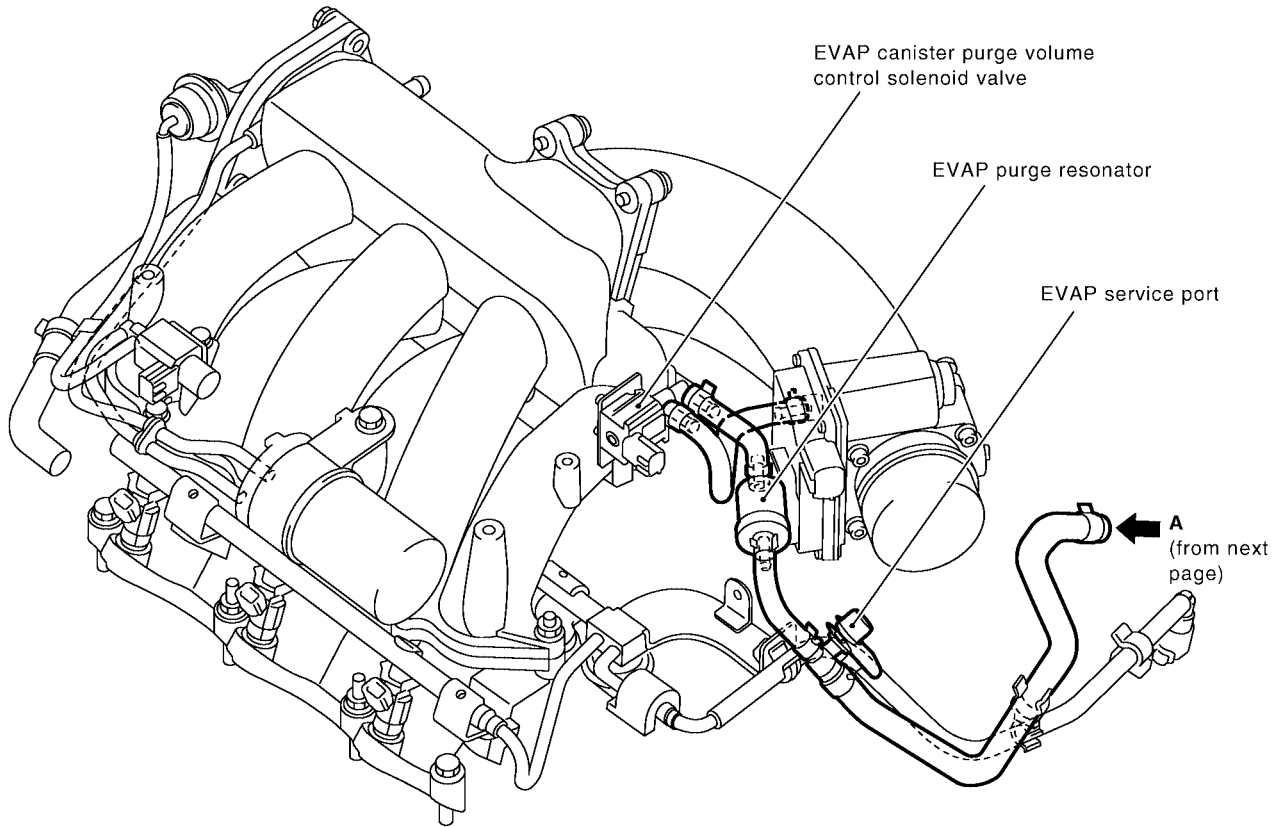

NOTE: Do not use soapy water or any type of solvent while installing vacuum hose or purge hoses.

PBIB2502E

EVAPORATIVE EMISSION SYSTEM

[VQ]

Refer to
previous
page

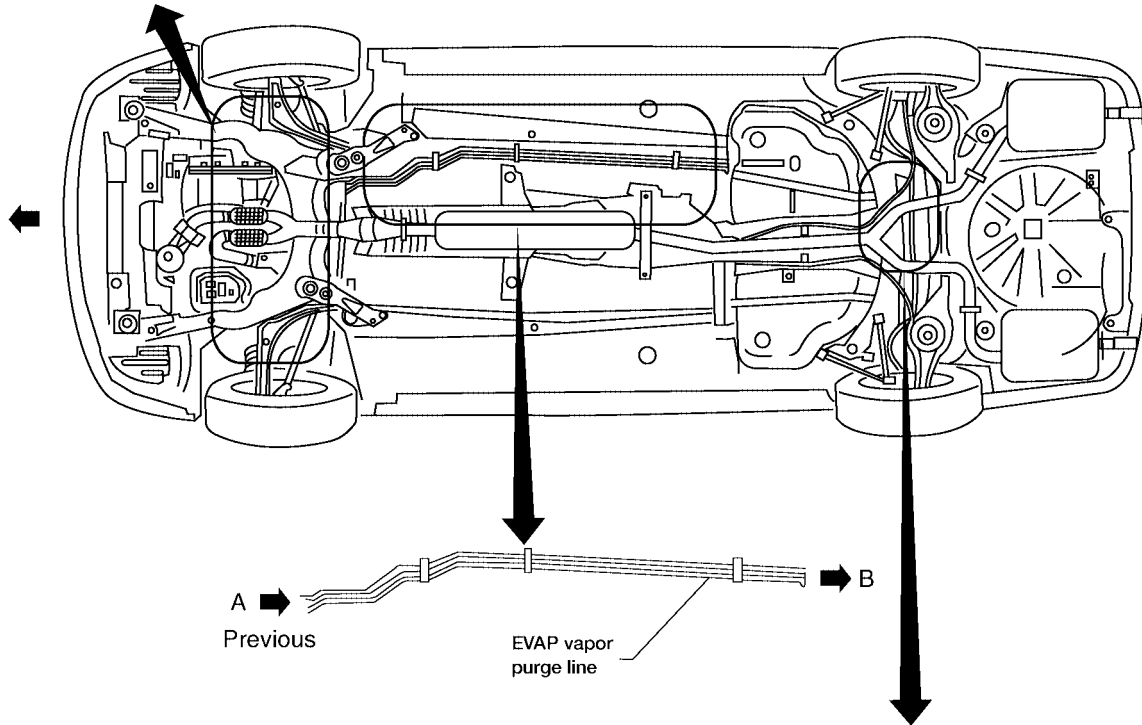

View from under the vehicle with rear crossmember removed

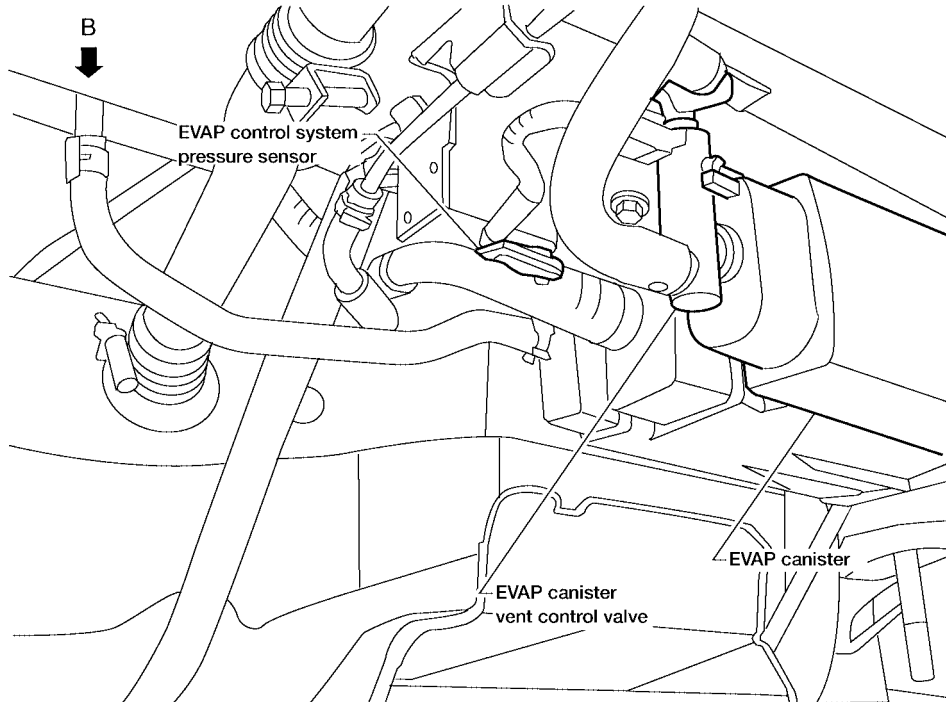

A
EC
C
D
E
F
G
H
I
J
K
L
M

BBIA0525E

EVAPORATIVE EMISSION SYSTEM

[VQ]

EVAPORATIVE EMISSION LINE DRAWING (EXCEPT SE-R MODELS)

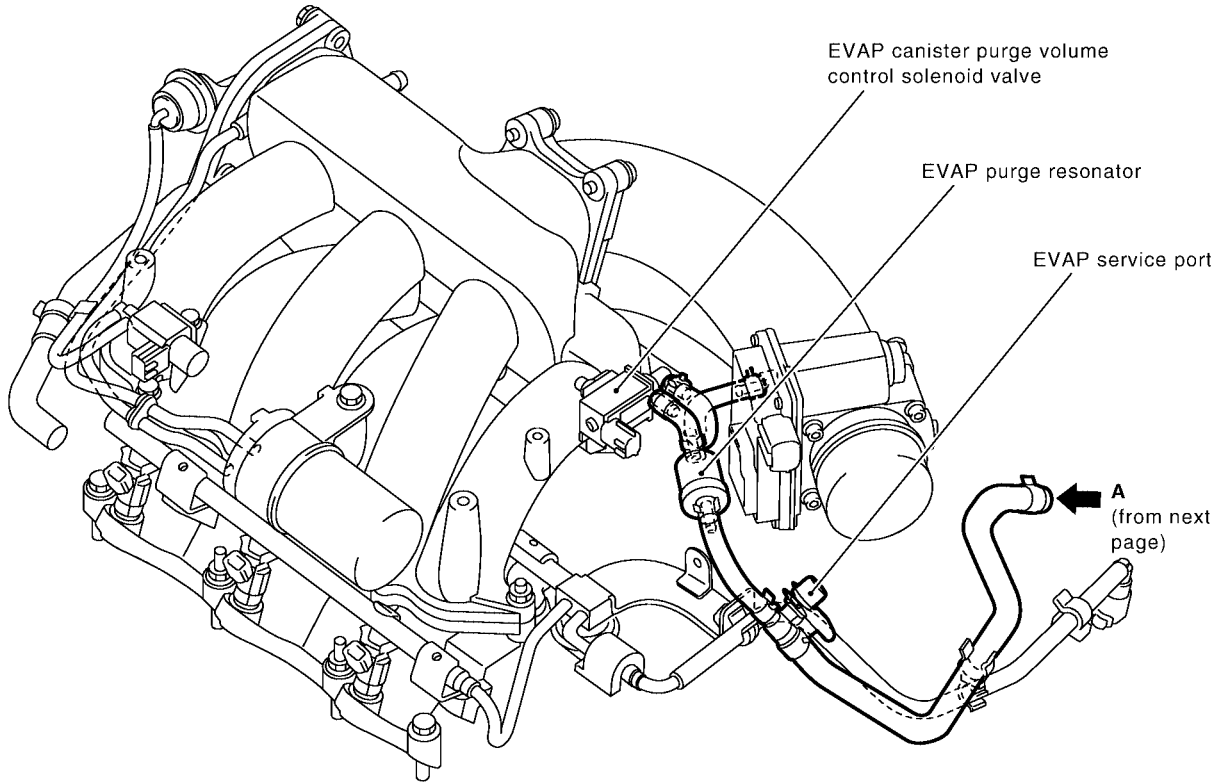

NOTE: Do not use soapy water or any type of solvent while installing vacuum hose or purge hoses.

PBIB2504E

EVAPORATIVE EMISSION SYSTEM

[VQ]

Refer to
previous
page

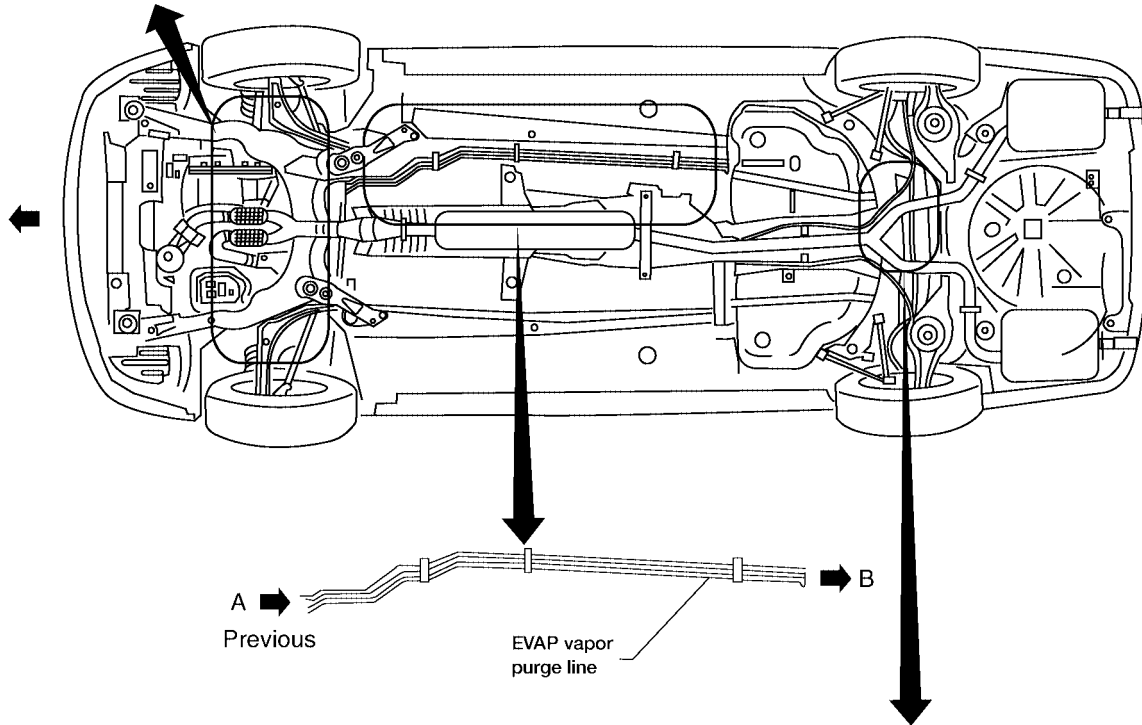

View from under the vehicle with rear crossmember removed

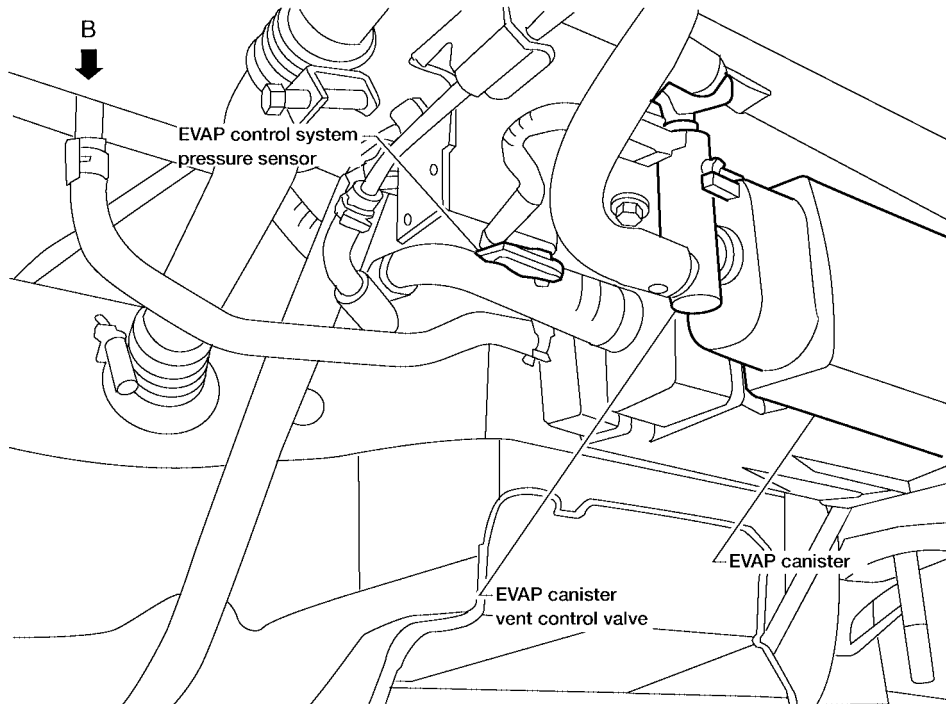

A
EC
C
D
E
F
G
H
I
J
K
L
M

BBIA0525E

Component Inspection EVAP CANISTER

Check EVAP canister as follows:

1. Block port **B** .
2. Blow air into port **A** and check that it flows freely out of port **C** .
3. Release blocked port **B** .
4. Apply vacuum pressure to port **B** and check that vacuum pressure exists at the ports **A** and **C** .
5. Block port **A** and **B** .
6. Apply pressure to port **C** and check that there is no leakage.

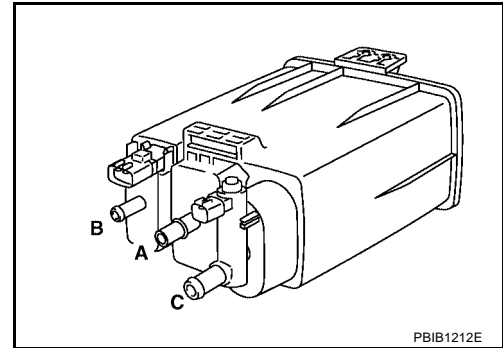

PBIB1212E

FUEL TANK VACUUM RELIEF VALVE (BUILT INTO FUEL FULLER CAP)

1. Wipe clean valve housing.

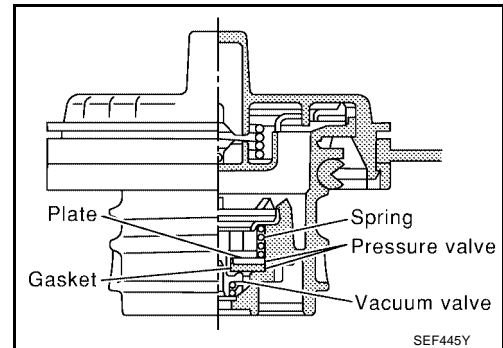

SEF445Y

2. Check valve opening pressure and vacuum.

Pressure: 15.3 - 20.0 kPa (0.156 - 0.204 kg/cm² , 2.22 - 2.90 psi)

Vacuum: -6.0 to -3.3 kPa (-0.061 to -0.034 kg/cm² , -0.87 to -0.48 psi)

3. If out of specification, replace fuel filler cap as an assembly.

CAUTION:

Use only a genuine fuel filler cap as a replacement. If an incorrect fuel filler cap is used, the MIL may come on.

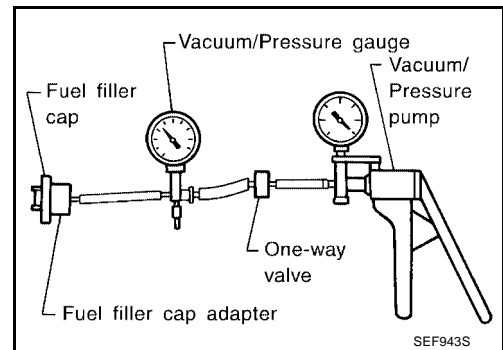

SEF943S

EVAP CANISTER PURGE VOLUME CONTROL SOLENOID VALVE

Refer to [EC-983](#) .

FUEL TANK TEMPERATURE SENSOR

Refer to [EC-898](#) .

EVAP CANISTER VENT CONTROL VALVE

Refer to [EC-989](#) .

EVAP CONTROL SYSTEM PRESSURE SENSOR

Refer to [EC-999](#) .

EVAP SERVICE PORT

Positive pressure is delivered to the EVAP system through the EVAP service port. If fuel vapor leakage in the EVAP system occurs, use a leak detector to locate the leak.

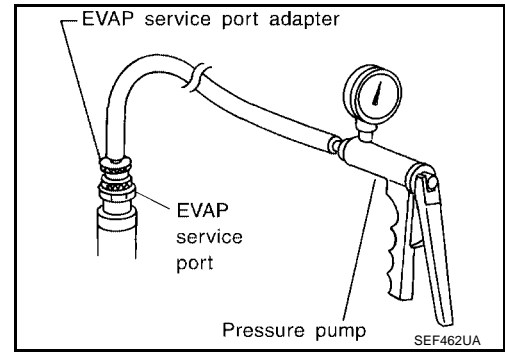

UBS00IFX

Removal and Installation EVAP CANISTER

Tighten EVAP canister as shown in the figure.

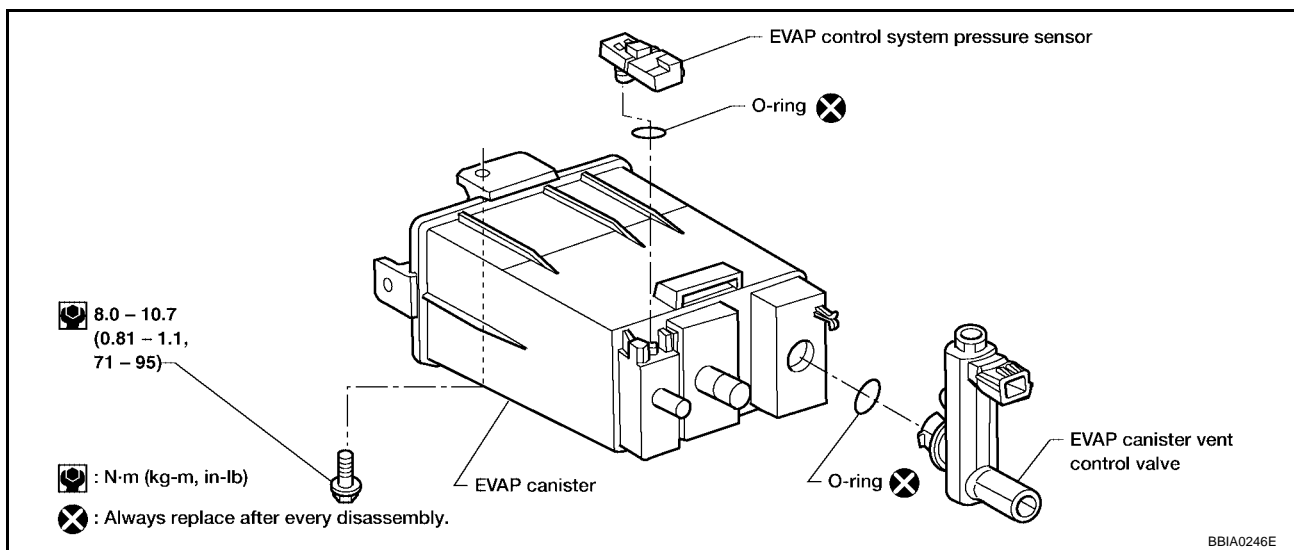

EVAP CANISTER VENT CONTROL VALVE

1. Turn EVAP canister vent control valve clockwise.
 2. Remove the EVAP canister vent control valve.
- Do not reuse the O-ring, replace it with a new one.**

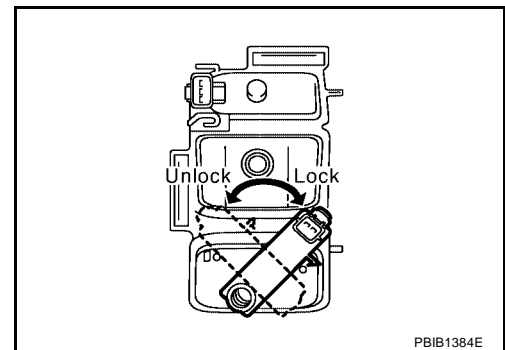

UBS00IFY

How to Detect Fuel Vapor Leakage

CAUTION:

- Never use compressed air or a high pressure pump.
- Do not exceed 4.12 kPa (0.042 kg/cm² , 0.6 psi) of pressure in EVAP system.

NOTE:

- Do not start engine.
- Improper installation of EVAP service port adapter to the EVAP service port may cause a leak.

WITH CONSULT-II

1. Attach the EVAP service port adapter securely to the EVAP service port.
2. Also attach the pressure pump and hose to the EVAP service port adapter.

EVAPORATIVE EMISSION SYSTEM

[VQ]

3. Turn ignition switch ON.
4. Select the "EVAP SYSTEM CLOSE" of "WORK SUPPORT MODE" with CONSULT-II.
5. Touch "START". A bar graph (Pressure indicating display) will appear on the screen.

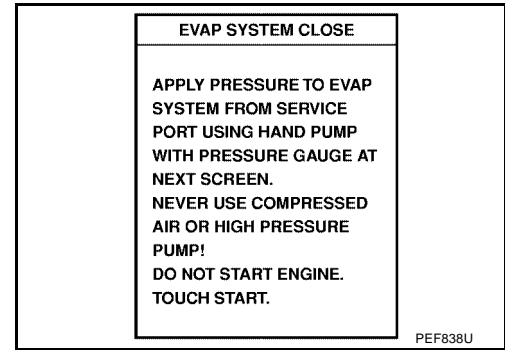

6. Apply positive pressure to the EVAP system until the pressure indicator reaches the middle of the bar graph.
7. Remove EVAP service port adapter and hose with pressure pump.

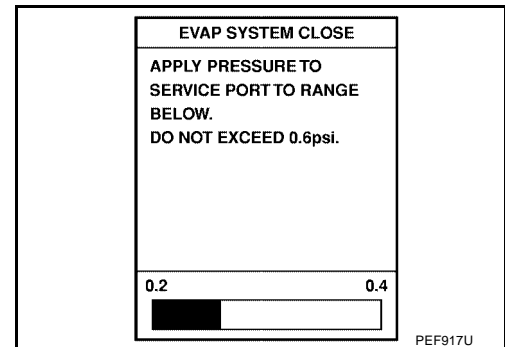

8. Locate the leak using a leak detector. Refer to [EC-652, "EVAPORATIVE EMISSION LINE DRAWING \(SE-R MODELS\)"](#) or [EC-654, "EVAPORATIVE EMISSION LINE DRAWING \(EXCEPT SE-R MODELS\)"](#).

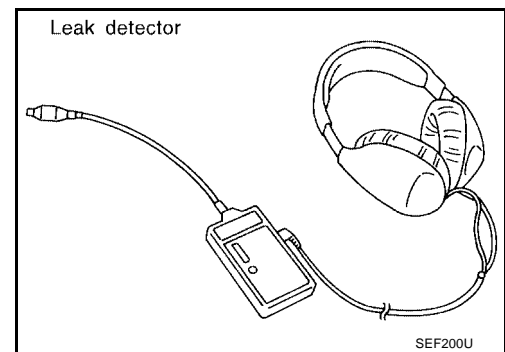

⊗ WITHOUT CONSULT-II

1. Attach the EVAP service port adapter securely to the EVAP service port.
2. Also attach the pressure pump with pressure gauge to the EVAP service port adapter.

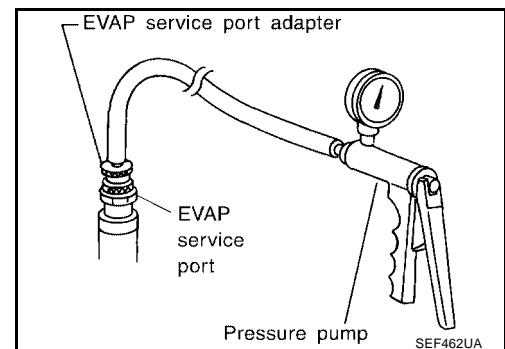

EVAPORATIVE EMISSION SYSTEM

[VQ]

3. Apply battery voltage between the terminals of EVAP canister vent control valve to make a closed EVAP system.

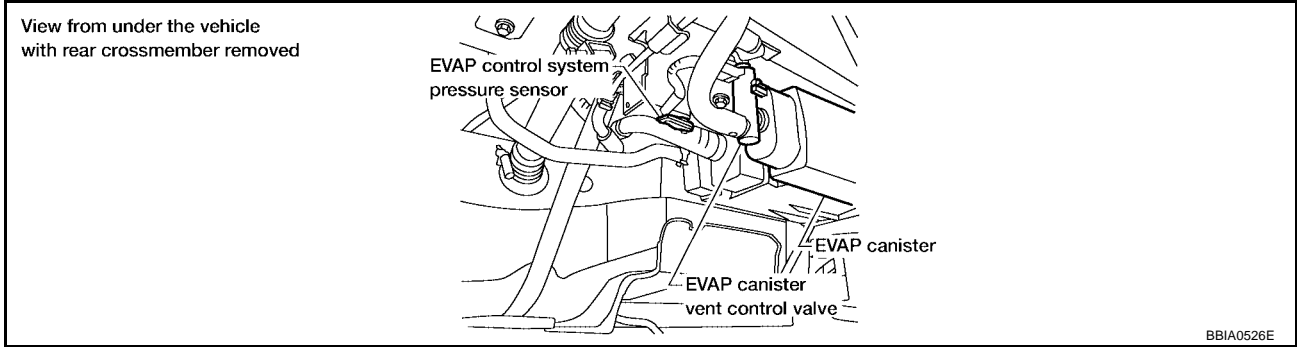

4. To locate the leak, deliver positive pressure to the EVAP system until pressure gauge points reach 1.38 to 2.76 kPa (0.014 to 0.028 kg/cm² , 0.2 to 0.4 psi).
5. Remove EVAP service port adapter and hose with pressure pump.
6. Locate the leak using a leak detector. Refer to [EC-652, "EVAPORATIVE EMISSION LINE DRAWING \(SE-R MODELS\)"](#) or [EC-654, "EVAPORATIVE EMISSION LINE DRAWING \(EXCEPT SE-R MODELS\)"](#) .

ON BOARD REFUELING VAPOR RECOVERY (ORVR)

PFP:00032

System Description

UBS001FZ

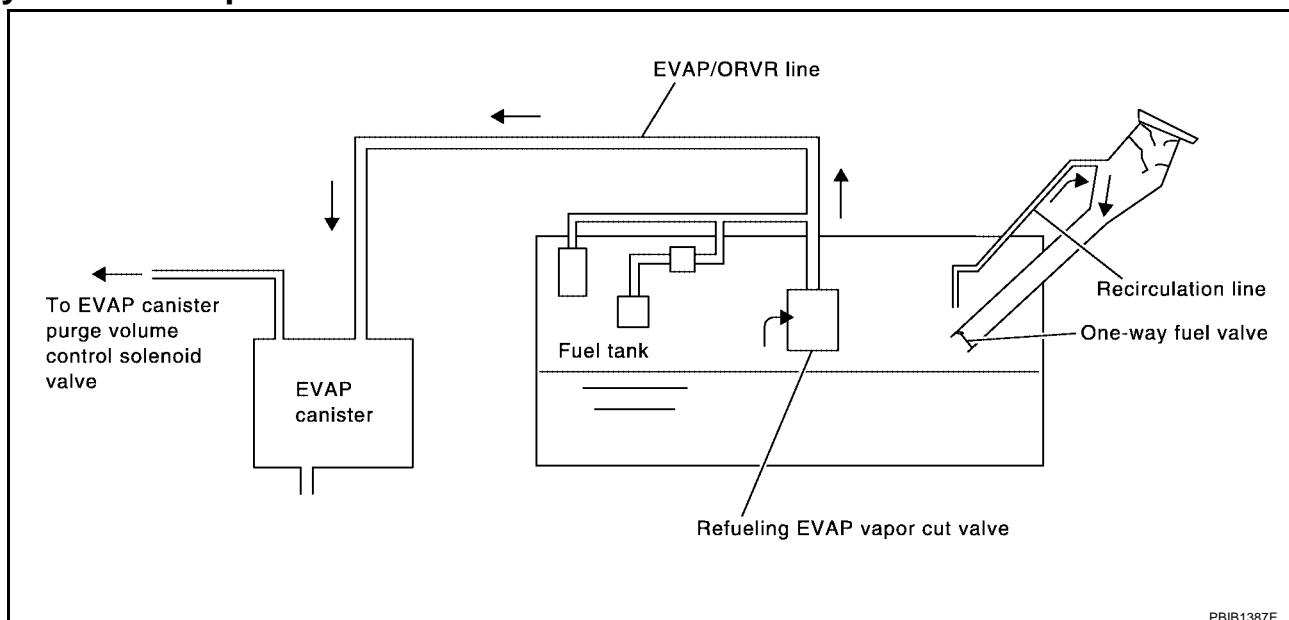

PBIB1387E

From the beginning of refueling, the air and vapor inside the fuel tank go through refueling EVAP vapor cut valve and EVAP/ORVR line to the EVAP canister. The vapor is absorbed by the EVAP canister and the air is released to the atmosphere.

When the refueling has reached the full level of the fuel tank, the refueling EVAP vapor cut valve is closed and refueling is stopped because of auto shut-off. The vapor which was absorbed by the EVAP canister is purged during driving.

WARNING:

When conducting inspections below, be sure to observe the following:

- Put a "CAUTION: INFLAMMABLE" sign in workshop.
- Do not smoke while servicing fuel system. Keep open flames and sparks away from work area.
- Be sure to furnish the workshop with a CO₂ fire extinguisher.

CAUTION:

- Before removing fuel line parts, carry out the following procedures:
 - Put drained fuel in an explosion-proof container and put lid on securely.
 - Release fuel pressure from fuel line. Refer to Fuel Pressure Release, [EC-714](#) .
 - Disconnect battery ground cable.
- Always replace O-ring when the fuel gauge retainer is removed.
- Do not kink or twist hose and tube when they are installed.
- Do not tighten hose and clamps excessively to avoid damaging hoses.
- After installation, run engine and check for fuel leaks at connection.
- Do not attempt to top off the fuel tank after the fuel pump nozzle shuts off automatically. Continued refueling may cause fuel overflow, resulting in fuel spray and possibly a fire.

Diagnostic Procedure

SYMPTOM: FUEL ODOR FROM EVAP CANISTER IS STRONG.

1. CHECK EVAP CANISTER

1. Remove EVAP canister with EVAP canister vent control valve and EVAP control system pressure sensor attached.
2. Weigh the EVAP canister with EVAP canister vent control valve and EVAP control system pressure sensor attached.
The weight should be less than 2.1 kg (4.6 lb).

OK or NG

- OK >> GO TO 2.
 NG >> GO TO 3.

2. CHECK IF EVAP CANISTER SATURATED WITH WATER

Does water drain from the EVAP canister?

Yes or No

- Yes >> GO TO 3.
 No >> GO TO 5.

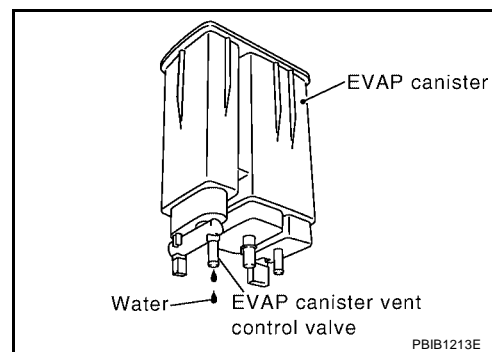

3. REPLACE EVAP CANISTER

Replace EVAP canister with a new one.

>> GO TO 4.

4. DETECT MALFUNCTIONING PART

Check the EVAP hose between EVAP canister and vehicle frame for clogging or poor connection.

>> Repair or replace EVAP hose.

5. CHECK REFUELING EVAP VAPOR CUT VALVE

Refer to [EC-663, "Component Inspection"](#) .

OK or NG

- OK >> **INSPECTION END**
 NG >> Replace refueling EVAP vapor cut valve with fuel tank.

ON BOARD REFUELING VAPOR RECOVERY (ORVR)

[VQ]

SYMPTOM: CANNOT REFUEL/FUEL ODOR FROM THE FUEL FILLER OPENING IS STRONG WHILE REFUELING.

1. CHECK EVAP CANISTER

1. Remove EVAP canister with EVAP canister vent control valve and EVAP control system pressure sensor attached.
2. Weigh the EVAP canister with EVAP canister vent control valve and EVAP control system pressure sensor attached.

The weight should be less than 2.1 kg (4.6 lb).

OK or NG

- OK >> GO TO 2.
NG >> GO TO 3.

2. CHECK IF EVAP CANISTER SATURATED WITH WATER

Does water drain from the EVAP canister?

Yes or No

- Yes >> GO TO 3.
No >> GO TO 5.

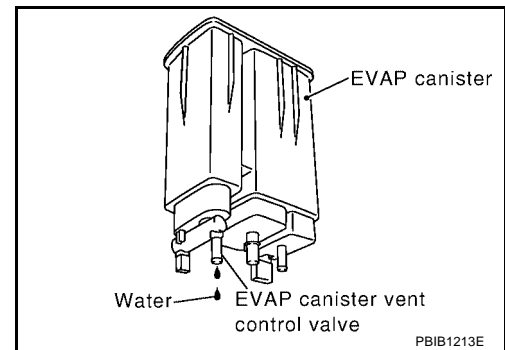

3. REPLACE EVAP CANISTER

Replace EVAP canister with a new one.

>> GO TO 4.

4. DETECT MALFUNCTIONING PART

Check the EVAP hose between EVAP canister and vehicle frame for clogging or poor connection.

>> Repair or replace EVAP hose.

5. CHECK VENT HOSES AND VENT TUBES

Check hoses and tubes between EVAP canister and refueling EVAP vapor cut valve for clogging, kink, looseness and improper connection.

OK or NG

- OK >> GO TO 6.
NG >> Repair or replace hoses and tubes.

6. CHECK FILLER NECK TUBE

Check recirculation line for clogging, dents and cracks.

OK or NG

- OK >> GO TO 7.
NG >> Replace filler neck tube.

7. CHECK REFUELING EVAP VAPOR CUT VALVE

Refer to [EC-663, "Component Inspection"](#) .

OK or NG

- OK >> GO TO 8.
- NG >> Replace refueling EVAP vapor cut valve with fuel tank.

8. CHECK FUEL FILLER TUBE

Check filler neck tube and hose connected to the fuel tank for clogging, dents and cracks.

OK or NG

- OK >> GO TO 9.
- NG >> Replace fuel filler tube.

9. CHECK ONE-WAY FUEL VALVE-I

Check one-way valve for clogging.

OK or NG

- OK >> GO TO 10.
- NG >> Repair or replace one-way fuel valve with fuel tank.

10. CHECK ONE-WAY FUEL VALVE-II

1. Make sure that fuel is drained from the tank.
2. Remove fuel filler tube and hose.
3. Check one-way fuel valve for operation as follows.
When a stick is inserted, the valve should open, when removing stick it should close.

Do not drop any material into the tank.

OK or NG

- OK >> **INSPECTION END**
- NG >> Replace fuel filler tube or replace one-way fuel valve with fuel tank.

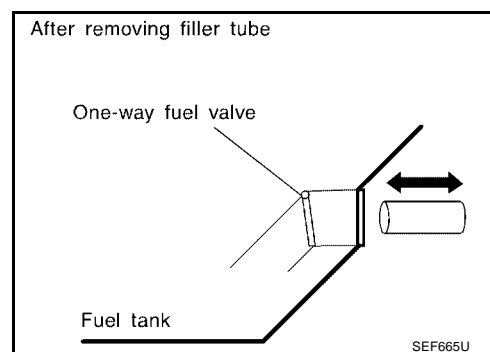

UBS00IG1

**Component Inspection
REFUELING EVAP VAPOR CUT VALVE****ⓐ With CONSULT-II**

1. Remove fuel tank. Refer to [FL-12, "FUEL TANK"](#) .
2. Drain fuel from the tank as follows:
 - a. Remove fuel feed hose located on the fuel gauge retainer.
 - b. Connect a spare fuel hose, one side to fuel gauge retainer where the hose was removed and the other side to a fuel container.
 - c. Drain fuel using "FUEL PUMP RELAY" in "ACTIVE TEST" mode with CONSULT-II.
3. Check refueling EVAP vapor cut valve for being stuck to close as follows.
Blow air into the refueling EVAP vapor cut valve (from the end of EVAP/ORVR line hose), and check that the air flows freely into the tank.
4. Check refueling EVAP vapor cut valve for being stuck to open as follows.
 - a. Connect vacuum pump to hose end.
 - b. Remove fuel gauge retainer with fuel gauge unit.
Always replace O-ring with new one.
 - c. Put fuel tank upside down.

ON BOARD REFUELING VAPOR RECOVERY (ORVR)

[VQ]

- d. Apply vacuum pressure to hose end [-13.3 kPa (-100 mmHg, -3.94 inHg)] with fuel gauge retainer remaining open and check that the pressure is applicable.

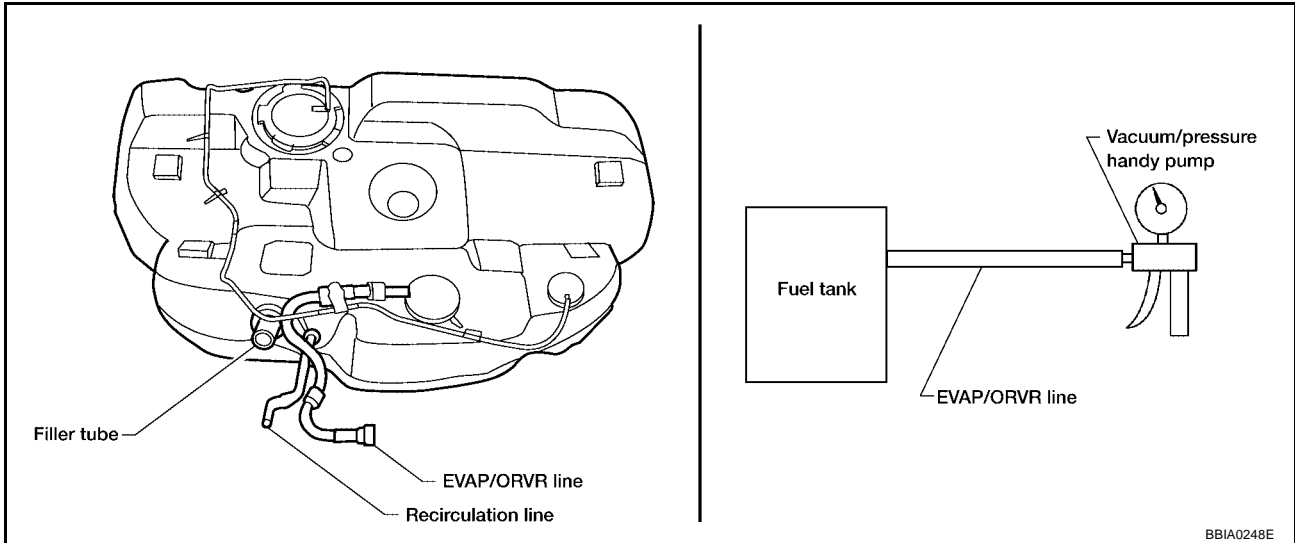

⊗ Without CONSULT-II

1. Remove fuel tank. Refer to [FL-12. "FUEL TANK"](#) .
2. Drain fuel from the tank as follows:
 - a. Remove fuel gauge retainer.
 - b. Drain fuel from the tank using a handy pump into a fuel container.
3. Check refueling EVAP vapor cut valve for being stuck to close as follows.
Blow air into the refueling EVAP vapor cut valve (from the end of EVAP/ORVR line hose), and check that the air flows freely into the tank.
4. Check refueling EVAP vapor cut valve for being stuck to open as follows.
 - a. Connect vacuum pump to hose end.
 - b. Remove fuel gauge retainer with fuel gauge unit.
Always replace O-ring with new one.
 - c. Put fuel tank upside down.
- d. Apply vacuum pressure to hose end [-13.3 kPa (-100 mmHg, -3.94 inHg)] with fuel gauge retainer remaining open and check that the pressure is applicable.

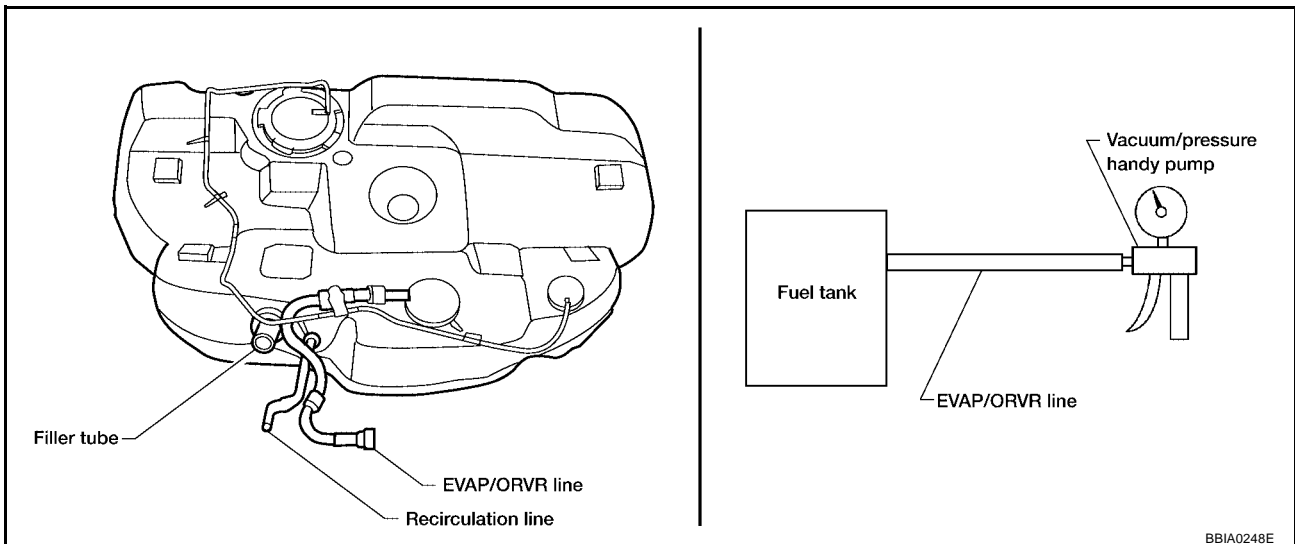

POSITIVE CRANKCASE VENTILATION

PFP:11810

UBS00IG2

Description
SYSTEM DESCRIPTION

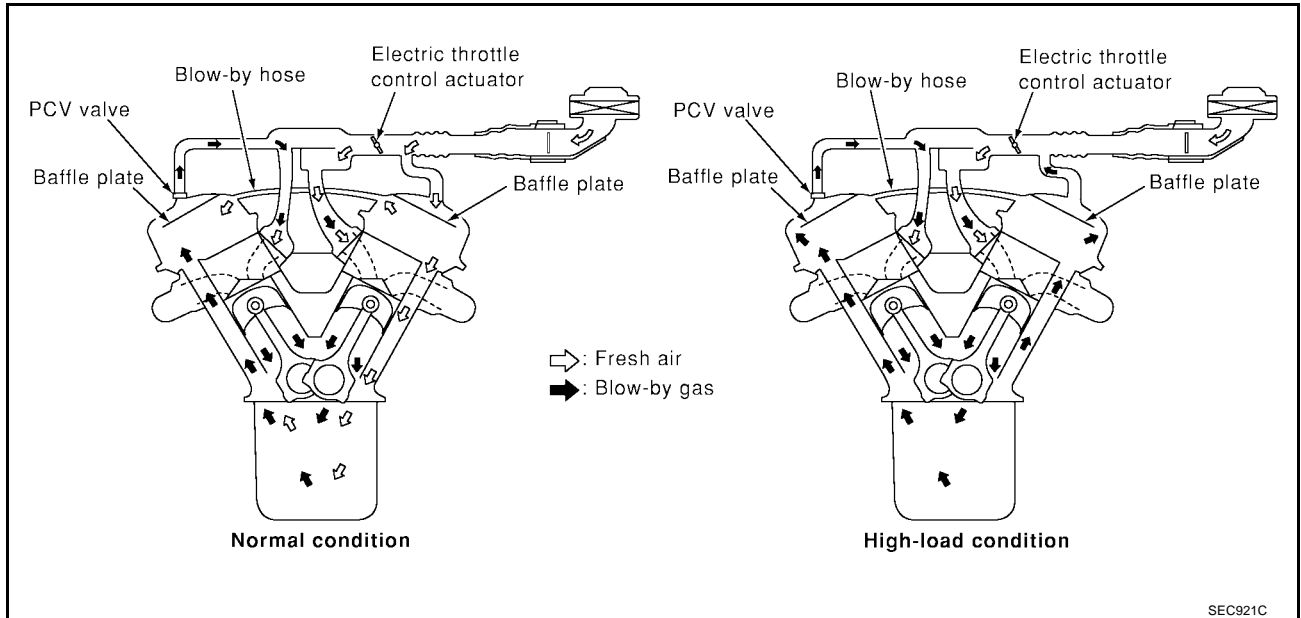

This system returns blow-by gas to the intake manifold.

The positive crankcase ventilation (PCV) valve is provided to conduct crankcase blow-by gas to the intake manifold. During partial throttle operation of the engine, the intake manifold sucks the blow-by gas through the PCV valve. Normally, the capacity of the valve is sufficient to handle any blow-by and a small amount of ventilating air. The ventilating air is then drawn from the air inlet tubes into the crankcase. In this process the air passes through the hose connecting air inlet tubes to rocker cover. Under full-throttle condition, the manifold vacuum is insufficient to draw the blow-by flow through the valve. The flow goes through the hose connection in the reverse direction.

On vehicles with an excessively high blow-by, the valve does not meet the requirement. This is because some of the flow will go through the hose connection to the air inlet tubes under all conditions.

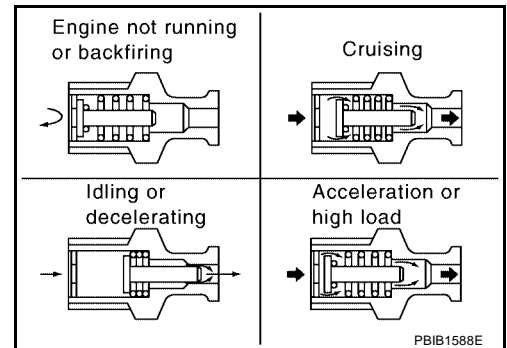

Component Inspection
PCV (POSITIVE CRANKCASE VENTILATION) VALVE

UBS00IG3

With engine running at idle, remove PCV valve from rocker cover. A properly working valve makes a hissing noise as air passes through it. A strong vacuum should be felt immediately when a finger is placed over valve inlet.

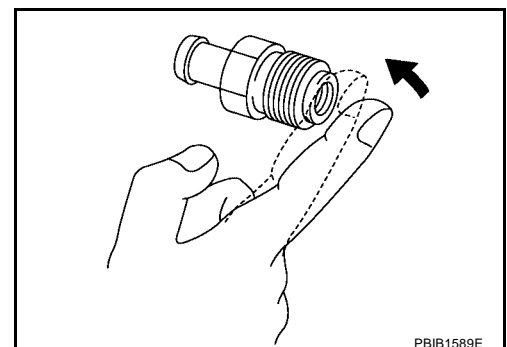

POSITIVE CRANKCASE VENTILATION

[VQ]

PCV VALVE VENTILATION HOSE

1. Check hoses and hose connections for leaks.
2. Disconnect all hoses and clean with compressed air. If any hose cannot be freed of obstructions, replace.

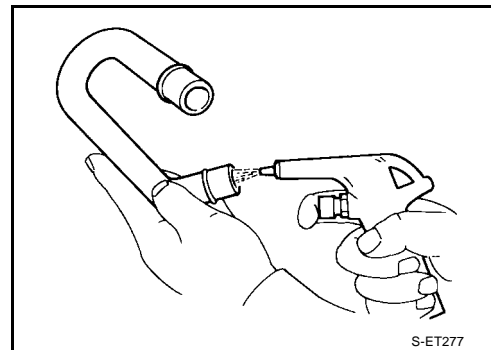

NVIS (NISSAN VEHICLE IMMOBILIZER SYSTEM-NATS)

PFP:25386

UBS00105

Description

- If the security indicator lights up with the ignition switch in the ON position or “NATS MALFUNCTION” is displayed on “SELF-DIAG RESULTS” screen, perform self-diagnostic results mode with CONSULT-II using NATS program card. Refer to [BL-107, "NVIS\(NISSAN Vehicle Immobilizer System-NATS\)"](#).
- Confirm no self-diagnostic results of NVIS (NATS) is displayed before touching “ERASE” in “SELF-DIAG RESULTS” mode with CONSULT-II.
- When replacing ECM, initialization of NVIS (NATS) system and registration of all NVIS (NATS) ignition key IDs must be carried out with CONSULT-II using NATS program card. Therefore, be sure to receive all keys from vehicle owner. Regarding the procedures of NVIS (NATS) initialization and all NVIS (NATS) ignition key ID registration, refer to CONSULT-II Operation Manual, IVIS/NVIS.

SELF DIAG RESULTS	
DTC RESULTS	TIME
NATS MALFUNCTION [P1610]	0

SEF543X

A

EC

C

D

E

F

G

H

I

J

K

L

M

ON BOARD DIAGNOSTIC (OBD) SYSTEM

PFP:00028

Introduction

UBS00102

The ECM has an on board diagnostic system, which detects malfunctions related to engine sensors or actuators. The ECM also records various emission-related diagnostic information including:

Emission-related diagnostic information	Diagnostic service
Diagnostic Trouble Code (DTC)	Service \$03 of SAE J1979
Freeze Frame data	Service \$02 of SAE J1979
System Readiness Test (SRT) code	Service \$01 of SAE J1979
1st Trip Diagnostic Trouble Code (1st Trip DTC)	Service \$07 of SAE J1979
1st Trip Freeze Frame data	
Test values and Test limits	Service \$06 of SAE J1979
Calibration ID	Service \$09 of SAE J1979

The above information can be checked using procedures listed in the table below.

×: Applicable —: Not applicable

	DTC	1st trip DTC	Freeze Frame data	1st trip Freeze Frame data	SRT code	SRT status	Test value
CONSULT-II	×	×	×	×	×	×	—
GST	×	×	×	—	×	×	×
ECM	×	×*	—	—	—	×	—

*: When DTC and 1st trip DTC simultaneously appear on the display, they cannot be clearly distinguished from each other.

The malfunction indicator lamp (MIL) on the instrument panel lights up when the same malfunction is detected in two consecutive trips (Two trip detection logic), or when the ECM enters fail-safe mode. (Refer to [EC-724](#) .)

Two Trip Detection Logic

UBS00103

When a malfunction is detected for the first time, 1st trip DTC and 1st trip Freeze Frame data are stored in the ECM memory. The MIL will not light up at this stage. <1st trip>

If the same malfunction is detected again during the next drive, the DTC and Freeze Frame data are stored in the ECM memory, and the MIL lights up. The MIL lights up at the same time when the DTC is stored. <2nd trip> The “trip” in the “Two Trip Detection Logic” means a driving mode in which self-diagnosis is performed during vehicle operation. Specific on board diagnostic items will cause the ECM to light up or blink the MIL, and store DTC and Freeze Frame data, even in the 1st trip, as shown below.

×: Applicable —: Not applicable

Items	MIL				DTC		1st trip DTC	
	1st trip		2nd trip		1st trip displaying	2nd trip displaying	1st trip displaying	2nd trip displaying
	Blinking	Lighting up	Blinking	Lighting up				
Misfire (Possible three way catalyst damage) — DTC: P0300 - P0306 is being detected	×	—	—	—	—	—	×	—
Misfire (Possible three way catalyst damage) — DTC: P0300 - P0306 is being detected	—	—	×	—	—	×	—	—
One trip detection diagnoses (Refer to EC-669 .)	—	×	—	—	×	—	—	—
Except above	—	—	—	×	—	×	×	—

When there is an open circuit on MIL circuit, the ECM cannot warn the driver by lighting up MIL when there is malfunction on engine control system.

Therefore, when electrical controlled throttle and part of ECM related diagnoses are continuously detected as NG for 5 trips, ECM warns the driver that engine control system malfunctions and MIL circuit is open by means of operating fail-safe function.

ON BOARD DIAGNOSTIC (OBD) SYSTEM

[VQ]

The fail-safe function also operates when above diagnoses except MIL circuit are detected and demands the driver to repair the malfunction.

Engine operating condition in fail-safe mode	Engine speed will not rise more than 2,500 rpm due to the fuel cut
--	--

Emission-related Diagnostic Information EMISSION-RELATED DIAGNOSTIC INFORMATION ITEMS

UBS00104

×:Applicable —: Not applicable

Items (CONSULT-II screen terms)	DTC*1		SRT code	Test value/ Test limit (GST only)	Trip	MIL lighting up	Refer- ence page
	CONSULT-II GST*2	ECM*3					
CAN COMM CIRCUIT	U1000	1000*5	—	—	1 (A/T) 2 (M/T)	× (A/T) — (M/T)	EC-790
CAN COMM CIRCUIT	U1001	1001*5	—	—	2	—	EC-790
NO DTC IS DETECTED. FURTHER TESTING MAY BE REQUIRED.	P0000	0000	—	—	—	Flashing*7	EC-685
INT/V TIM CONT-B1	P0011	0011	—	—	2	×	EC-793
INT/V TIM CONT-B2	P0021	0021	—	—	2	×	EC-793
HO2S2 HTR (B1)	P0037	0037	×	×	2	×	EC-797
HO2S2 HTR (B1)	P0038	0038	×	×	2	×	EC-797
HO2S2 HTR (B2)	P0057	0057	×	×	2	×	EC-797
HO2S2 HTR (B2)	P0058	0058	×	×	2	×	EC-797
MAF SEN/CIRCUIT	P0101	0101	—	—	2	×	EC-806
MAF SEN/CIRCUIT	P0102	0102	—	—	1	×	EC-815
MAF SEN/CIRCUIT	P0103	0103	—	—	1	×	EC-815
IAT SEN/CIRCUIT	P0112	0112	—	—	2	×	EC-822
IAT SEN/CIRCUIT	P0113	0113	—	—	2	×	EC-822
ECT SEN/CIRCUIT	P0117	0117	—	—	1	×	EC-826
ECT SEN/CIRCUIT	P0118	0118	—	—	1	×	EC-826
TP SEN 2/CIRC	P0122	0122	—	—	1	×	EC-831
TP SEN 2/CIRC	P0123	0123	—	—	1	×	EC-831
ECT SENSOR	P0125	0125	—	—	1	×	EC-838
IAT SENSOR	P0127	0127	—	—	2	×	EC-841
THERMSTAT FNCTN	P0128	0128	—	—	2	×	EC-844
HO2S2 (B1)	P0138	0138	—	×	2	×	EC-846
HO2S2 (B1)	P0139	0139	×	×	2	×	EC-856
HO2S2 (B2)	P0158	0158	—	×	2	×	EC-846
HO2S2 (B2)	P0159	0159	×	×	2	×	EC-856
FUEL SYS-LEAN-B1	P0171	0171	—	—	2	×	EC-868
FUEL SYS-RICH-B1	P0172	0172	—	—	2	×	EC-879
FUEL SYS-LEAN-B2	P0174	0174	—	—	2	×	EC-868
FUEL SYS-RICH-B2	P0175	0175	—	—	2	×	EC-879
FTT SENSOR	P0181	0181	—	—	2	×	EC-890
FTT SEN/CIRCUIT	P0182	0182	—	—	2	×	EC-895
FTT SEN/CIRCUIT	P0183	0183	—	—	2	×	EC-895
TP SEN 1/CIRC	P0222	0222	—	—	1	×	EC-899
TP SEN 1/CIRC	P0223	0223	—	—	1	×	EC-899
MULTI CYL MISFIRE	P0300	0300	—	—	2	×	EC-906

ON BOARD DIAGNOSTIC (OBD) SYSTEM

[VQ]

Items (CONSULT-II screen terms)	DTC*1		SRT code	Test value/ Test limit (GST only)	Trip	MIL lighting up	Refer- ence page
	CONSULT-II GST*2	ECM*3					
CYL 1 MISFIRE	P0301	0301	—	—	2	×	EC-906
CYL 2 MISFIRE	P0302	0302	—	—	2	×	EC-906
CYL 3 MISFIRE	P0303	0303	—	—	2	×	EC-906
CYL 4 MISFIRE	P0304	0304	—	—	2	×	EC-906
CYL 5 MISFIRE	P0305	0305	—	—	2	×	EC-906
CYL 6 MISFIRE	P0306	0306	—	—	2	×	EC-906
KNOCK SEN/CIRC-B1	P0327	0327	—	—	2	—	EC-916
KNOCK SEN/CIRC-B1	P0328	0328	—	—	2	—	EC-916
CKP SEN/CIRCUIT	P0335	0335	—	—	2	×	EC-921
CMP SEN/CIRC-B1	P0340	0340	—	—	2	×	EC-928
CMP SEN/CIRC-B2	P0345	0345	—	—	2	×	EC-928
EGR SYSTEM	P0400	0400	×	×	2	×	EC-937
EGR VOL CON/V CIR	P0403	0403	—	—	1	×	EC-945
EGR TEMP SEN/CIRC	P0405	0405	—	—	2	×	EC-952
EGR TEMP SEN/CIRC	P0406	0406	—	—	2	×	EC-952
TW CATALYST SYS-B1	P0420	0420	×	×	2	×	EC-959
TW CATALYST SYS-B2	P0430	0430	×	×	2	×	EC-959
EVAP PURG FLOW/MON	P0441	0441	×	×	2	×	EC-964
EVAP SMALL LEAK	P0442	0442	×	×	2	×	EC-969
PURG VOLUME CONT/V	P0444	0444	—	—	2	×	EC-977
PURG VOLUME CONT/V	P0445	0445	—	—	2	×	EC-977
VENT CONTROL VALVE	P0447	0447	—	—	2	×	EC-984
EVAP SYS PRES SEN	P0451	0451	—	—	2	×	EC-991
EVAP SYS PRES SEN	P0452	0452	—	—	2	×	EC-994
EVAP SYS PRES SEN	P0453	0453	—	—	2	×	EC-1000
EVAP GROSS LEAK	P0455	0455	—	—	2	×	EC-1008
EVAP VERY SML LEAK	P0456	0456	×*4	×	2	×	EC-1016
FUEL LEV SEN SLOSH	P0460	0460	—	—	2	×	EC-1025
FUEL LEVEL SENSOR	P0461	0461	—	—	2	×	EC-1027
FUEL LEVL SEN/CIRC	P0462	0462	—	—	2	×	EC-1029
FUEL LEVL SEN/CIRC	P0463	0463	—	—	2	×	EC-1029
VEH SPEED SEN/CIRC*6	P0500	0500	—	—	2	×	EC-1031
ISC SYSTEM	P0506	0506	—	—	2	×	EC-1033
ISC SYSTEM	P0507	0507	—	—	2	×	EC-1035
PW ST P SEN/CIRC	P0550	0550	—	—	2	—	EC-1037
ECM	P0605	0605	—	—	1 or 2	× or —	EC-1042
PNP SW/CIRC	P0705	0705	—	—	1	×	AT-471
ATF TEMP SEN/CIRC	P0710	0710	—	—	2	×	AT-476
FLUID TEMP SEN	P0711	0711	—	—	2	×	AT-481
TURBINE SENSOR	P0717	0717	—	—	1	×	AT-486
VHCL SPEED SEN.A/T*6	P0722	0722	—	—	1	×	AT-490
A/T 1ST GR FNCTN	P0731	0731	—	—	1	×	AT-496

ON BOARD DIAGNOSTIC (OBD) SYSTEM

[VQ]

Items (CONSULT-II screen terms)	DTC*1		SRT code	Test value/ Test limit (GST only)	Trip	MIL lighting up	Refer- ence page	
	CONSULT-II GST*2	ECM*3						
A/T 2ND GR FNCTN	P0732	0732	—	—	1	×	AT-499	EC
A/T 3RD GR FNCTN	P0733	0733	—	—	1	×	AT-505	
A/T 4TH GR FNCTN	P0734	0734	—	—	1	×	AT-511	
A/T 5TH GR FNCTN	P0735	0735	—	—	1	×	AT-516	C
A/T TCC S/U FNCTN	P0744	0744	—	—	1	×	AT-522	
L/PRESS SOL/CIRC	P0745	0745	—	—	1	×	AT-525	D
SFT SOL A/CIRC	P0750	0750	—	—	1	×	AT-530	
SFT SOL B/CIRC	P0755	0755	—	—	1	×	AT-535	
SHIFT SOL C	P0760	0760	—	—	1	×	AT-540	E
SFT SOL C STUCK ON	P0762	0762	—	—	1	×	AT-545	
SHIFT SOL D	P0765	0765	—	—	1	×	AT-550	
SHIFT SOL E	P0770	0770	—	—	1	×	AT-555	F
PC SOL B (SFT/PRS)	P0775	0775	—	—	1	×	AT-560	
SHIFT	P0780	0780	—	—	1	×	AT-565	G
PC SOL C (TCC&SFT)	P0795	0795	—	—	1	×	AT-569	
PC SOL C STC ON	P0797	0797	—	—	1	×	AT-574	
TCM POWER INPT SIG	P0882	0882	—	—	1	×	AT-585	H
A/F SEN1 HTR (B1)	P1031	1031	×	×	2	×	EC-1045	
A/F SEN1 HTR (B1)	P1032	1032	×	×	2	×	EC-1045	I
A/F SEN1 HTR (B2)	P1051	1051	×	×	2	×	EC-1045	
A/F SEN1 HTR (B2)	P1052	1052	×	×	2	×	EC-1045	J
ECM BACK UP/CIRC	P1065	1065	—	—	2	×	EC-1053	
INT/V TIM V/CIR-B1	P1111	1111	—	—	2	×	EC-1057	
ETC ACTR	P1121	1121	—	—	1	×	EC-1066	K
ETC FUNCTION/CIRC	P1122	1122	—	—	1	×	EC-1068	
ETC MOT PWR	P1124	1124	—	—	1	×	EC-1074	
ETC MOT PWR	P1126	1126	—	—	1	×	EC-1074	L
ETC MOT	P1128	1128	—	—	1	×	EC-1079	
INT/V TIM V/CIR-B2	P1136	1136	—	—	2	×	EC-1057	M
HO2S2 (B1)	P1146	1146	×	×	2	×	EC-1084	
HO2S2 (B1)	P1147	1147	×	×	2	×	EC-1096	
CLOSED LOOP-B1	P1148	1148	—	—	1	×	EC-1108	
HO2S2 (B2)	P1166	1166	×	×	2	×	EC-1084	
HO2S2 (B2)	P1167	1167	×	×	2	×	EC-1096	
CLOSED LOOP-B2	P1168	1168	—	—	1	×	EC-1108	
TCS C/U FUNCTN	P1211	1211	—	—	2	—	EC-1109	
TCS/CIRC	P1212	1212	—	—	2	—	EC-1110	
ENG OVER TEMP	P1217	1217	—	—	1	×	EC-1111	
CTP LEARNING	P1225	1225	—	—	2	—	EC-1123	
CTP LEARNING	P1226	1226	—	—	2	—	EC-1125	
SENSOR POWER/CIRC	P1229	1229	—	—	1	×	EC-1127	
A/F SENSOR1 (B1)	P1271	1271	—	×	2	×	EC-1132	

ON BOARD DIAGNOSTIC (OBD) SYSTEM

[VQ]

Items (CONSULT-II screen terms)	DTC*1		SRT code	Test value/ Test limit (GST only)	Trip	MIL lighting up	Refer- ence page
	CONSULT-II GST*2	ECM*3					
A/F SENSOR1 (B1)	P1272	1272	—	×	2	×	EC-1140
A/F SENSOR1 (B1)	P1273	1273	—	×	2	×	EC-1148
A/F SENSOR1 (B1)	P1274	1274	—	×	2	×	EC-1157
A/F SENSOR1 (B1)	P1276	1276	—	×	2	×	EC-1166
A/F SENSOR1 (B1)	P1278	1278	×	×	2	×	EC-1175
A/F SENSOR1 (B1)	P1279	1279	×	×	2	×	EC-1187
A/F SENSOR1 (B2)	P1281	1281	—	×	2	×	EC-1132
A/F SENSOR1 (B2)	P1282	1282	—	×	2	×	EC-1140
A/F SENSOR1 (B2)	P1283	1283	—	×	2	×	EC-1148
A/F SENSOR1 (B2)	P1284	1284	—	×	2	×	EC-1157
A/F SENSOR1 (B2)	P1286	1286	—	×	2	×	EC-1166
A/F SENSOR1 (B2)	P1288	1288	×	×	2	×	EC-1175
A/F SENSOR1 (B2)	P1289	1289	×	×	2	×	EC-1187
EGR SYSTEM	P1402	1402	×	×	2	×	EC-1199
PURG VOLUME CONT/V	P1444	1444	—	—	2	×	EC-1206
VENT CONTROL VALVE	P1446	1446	—	—	2	×	EC-1214
ASCD SW	P1564	1564	—	—	1	—	EC-1220
ASCD BRAKE SW	P1572	1572	—	—	1	—	EC-1227
ASCD VHL SPD SEN	P1574	1574	—	—	1	—	EC-1238
NATS MALFUNCTION	P1610 - P1615	1610 - 1615	—	—	2	—	EC-667
P-N POS SW/CIRCUIT	P1706	1706	—	—	2	×	EC-1240
VIAS S/V CIRC	P1800	1800	—	—	2	—	EC-1248
BRAKE SW/CIRCUIT	P1805	1805	—	—	2	—	EC-1253
APP SEN 1/CIRC	P2122	2122	—	—	1	×	EC-1258
APP SEN 1/CIRC	P2123	2123	—	—	1	×	EC-1258
APP SEN 2/CIRC	P2127	2127	—	—	1	×	EC-1265
APP SEN 2/CIRC	P2128	2128	—	—	1	×	EC-1265
TP SENSOR	P2135	2135	—	—	1	×	EC-1272
APP SENSOR	P2138	2138	—	—	1	×	EC-1279

*1: 1st trip DTC No. is the same as DTC No.

*2: This number is prescribed by SAE J2012.

*3: In Diagnostic Test Mode II (Self-diagnostic results), this number is controlled by NISSAN.

*4: SRT code will not be set if the self-diagnostic result is NG.

*5: The troubleshooting for this DTC need CONSULT-II.

*6: When the fail-safe operations for both self-diagnoses occur at the same time, the MIL illuminates.

*7: When the ECM is in the mode of displaying SRT status, MIL may flash. For the details, refer to [EC-677, "How to Display SRT Status"](#)

DTC AND 1ST TRIP DTC

The 1st trip DTC (whose number is the same as the DTC number) is displayed for the latest self-diagnostic result obtained. If the ECM memory was cleared previously, and the 1st trip DTC did not reoccur, the 1st trip DTC will not be displayed.

If a malfunction is detected during the 1st trip, the 1st trip DTC is stored in the ECM memory. The MIL will not light up (two trip detection logic). If the same malfunction is not detected in the 2nd trip (meeting the required driving pattern), the 1st trip DTC is cleared from the ECM memory. If the same malfunction is detected in the 2nd trip, both the 1st trip DTC and DTC are stored in the ECM memory and the MIL lights up. In other words,

the DTC is stored in the ECM memory and the MIL lights up when the same malfunction occurs in two consecutive trips. If a 1st trip DTC is stored and a non-diagnostic operation is performed between the 1st and 2nd trips, only the 1st trip DTC will continue to be stored. For malfunctions that blink or light up the MIL during the 1st trip, the DTC and 1st trip DTC are stored in the ECM memory.

Procedures for clearing the DTC and the 1st trip DTC from the ECM memory are described in [EC-682, "HOW TO ERASE EMISSION-RELATED DIAGNOSTIC INFORMATION"](#) .

For malfunctions in which 1st trip DTCs are displayed, refer to [EC-669, "EMISSION-RELATED DIAGNOSTIC INFORMATION ITEMS"](#) . These items are required by legal regulations to continuously monitor the system/component. In addition, the items monitored non-continuously are also displayed on CONSULT-II.

1st trip DTC is specified in Service \$07 of SAE J1979. 1st trip DTC detection occurs without lighting up the MIL and therefore does not warn the driver of a malfunction. However, 1st trip DTC detection will not prevent the vehicle from being tested, for example during Inspection/Maintenance (I/M) tests.

When a 1st trip DTC is detected, check, print out or write down and erase (1st trip) DTC and Freeze Frame data as specified in Work Flow procedure Step II, refer to [EC-717, "WORK FLOW"](#) . Then perform DTC Confirmation Procedure or Overall Function Check to try to duplicate the malfunction. If the malfunction is duplicated, the item requires repair.

How to Read DTC and 1st Trip DTC

DTC and 1st trip DTC can be read by the following methods.

 **With CONSULT-II**

 **With GST**

CONSULT-II or GST (Generic Scan Tool) Examples: P0340, P1148, P1706, etc.

These DTCs are prescribed by SAE J2012.

(CONSULT-II also displays the malfunctioning component or system.)

 **No Tools**

The number of blinks of the MIL in the Diagnostic Test Mode II (Self-Diagnostic Results) indicates the DTC. Example: 0340, 1148, 1706, etc.

These DTCs are controlled by NISSAN.

- **1st trip DTC No. is the same as DTC No.**
- **Output of a DTC indicates a malfunction. However, GST or the Diagnostic Test Mode II do not indicate whether the malfunction is still occurring or has occurred in the past and has returned to normal. CONSULT-II can identify malfunction status as shown below. Therefore, using CONSULT-II (if available) is recommended.**

A sample of CONSULT-II display for DTC and 1st trip DTC is shown below. DTC or 1st trip DTC of a malfunction is displayed in SELF-DIAGNOSTIC RESULTS mode of CONSULT-II. Time data indicates how many times the vehicle was driven after the last detection of a DTC.

If the DTC is being detected currently, the time data will be [0].

If a 1st trip DTC is stored in the ECM, the time data will be [1t].

DTC display	SELF DIAG RESULTS		1st trip DTC display	SELF DIAG RESULTS	
	DTC RESULTS	TIME		DTC RESULTS	TIME
	CKP SEN/CIRCUIT [P0335]	0		CKP SEN/CIRCUIT [P0335]	1t

PBIB0911E

FREEZE FRAME DATA AND 1ST TRIP FREEZE FRAME DATA

The ECM records the driving conditions such as fuel system status, calculated load value, engine coolant temperature, short term fuel trim, long term fuel trim, engine speed, vehicle speed, base fuel schedule and intake air temperature at the moment a malfunction is detected.

Data which are stored in the ECM memory, along with the 1st trip DTC, are called 1st trip freeze frame data. The data, stored together with the DTC data, are called freeze frame data and displayed on CONSULT-II or GST. The 1st trip freeze frame data can only be displayed on the CONSULT-II screen, not on the GST. For details, see [EC-754, "Freeze Frame Data and 1st Trip Freeze Frame Data"](#).

Only one set of freeze frame data (either 1st trip freeze frame data or freeze frame data) can be stored in the ECM. 1st trip freeze frame data is stored in the ECM memory along with the 1st trip DTC. There is no priority for 1st trip freeze frame data and it is updated each time a different 1st trip DTC is detected. However, once freeze frame data (2nd trip detection/MIL on) is stored in the ECM memory, 1st trip freeze frame data is no longer stored. Remember, only one set of freeze frame data can be stored in the ECM. The ECM has the following priorities to update the data.

Priority	Items	
1	Freeze frame data	Misfire — DTC: P0300 - P0306 Fuel Injection System Function — DTC: P0171, P0172, P0174, P0175
2		Except the above items (Includes A/T related items)
3	1st trip freeze frame data	

For example, the EGR malfunction (Priority: 2) was detected and the freeze frame data was stored in the 2nd trip. After that when the misfire (Priority: 1) is detected in another trip, the freeze frame data will be updated from the EGR malfunction to the misfire. The 1st trip freeze frame data is updated each time a different malfunction is detected. There is no priority for 1st trip freeze frame data. However, once freeze frame data is stored in the ECM memory, 1st trip freeze data is no longer stored (because only one freeze frame data or 1st trip freeze frame data can be stored in the ECM). If freeze frame data is stored in the ECM memory and freeze frame data with the same priority occurs later, the first (original) freeze frame data remains unchanged in the ECM memory.

Both 1st trip freeze frame data and freeze frame data (along with the DTCs) are cleared when the ECM memory is erased. Procedures for clearing the ECM memory are described in [EC-682, "HOW TO ERASE EMISSION-RELATED DIAGNOSTIC INFORMATION"](#).

SYSTEM READINESS TEST (SRT) CODE

System Readiness Test (SRT) code is specified in Service \$01 of SAE J1979.

As part of an enhanced emissions test for Inspection & Maintenance (I/M), certain states require the status of SRT be used to indicate whether the ECM has completed self-diagnosis of major emission systems and components. Completion must be verified in order for the emissions inspection to proceed.

If a vehicle is rejected for a State emissions inspection due to one or more SRT items indicating "INCMP", use the information in this Service Manual to set the SRT to "CMPLT".

In most cases the ECM will automatically complete its self-diagnosis cycle during normal usage, and the SRT status will indicate "CMPLT" for each application system. Once set as "CMPLT", the SRT status remains "CMPLT" until the self-diagnosis memory is erased.

Occasionally, certain portions of the self-diagnostic test may not be completed as a result of the customer's normal driving pattern; the SRT will indicate "INCMP" for these items.

NOTE:

The SRT will also indicate "INCMP" if the self-diagnosis memory is erased for any reason or if the ECM memory power supply is interrupted for several hours.

If, during the state emissions inspection, the SRT indicates "CMPLT" for all test items, the inspector will continue with the emissions test. However, if the SRT indicates "INCMP" for one or more of the SRT items the vehicle is returned to the customer untested.

NOTE:

If MIL is ON during the state emissions inspection, the vehicle is also returned to the customer untested even though the SRT indicates "CMPLT" for all test items. Therefore, it is important to check SRT ("CMPLT") and DTC (No DTCs) before the inspection.

ON BOARD DIAGNOSTIC (OBD) SYSTEM

[VQ]

SRT Item

The table below shows required self-diagnostic items to set the SRT to "CMPLT".

SRT item (CONSULT-II indication)	Performance Priority*1	Required self-diagnostic items to set the SRT to "CMPLT"	Corresponding DTC No.
CATALYST	3	Three way catalyst function	P0420, P0430
EVAP SYSTEM	3	EVAP control system purge flow monitoring	P0441
	2	EVAP control system	P0442
	3	EVAP control system	P0456
HO2S	3	A/F sensor 1	P1278, P1288
		A/F sensor 1	P1279, P1289
		Heated oxygen sensor 2	P0139, P0159
		Heated oxygen sensor 2	P1146, P1166
		Heated oxygen sensor 2	P1147, P1167
HO2S HTR	3	A/F sensor 1 heater	P1031, P1032, P1051, P1052
		Heated oxygen sensor 2 heater	P0037, P0038, P0057, P0058
EGR SYSTEM	3	EGR function	P0400
	1	EGR function	P1402

*1: If completion of several SRTs is required, perform driving patterns (DTC confirmation procedure), one by one based on the priority for models with CONSULT-II.

SRT Set Timing

SRT is set as "CMPLT" after self-diagnosis has been performed one or more times. Completion of SRT is done regardless of whether the result is OK or NG. The set timing is different between OK and NG results and is shown in the table below.

Self-diagnosis result		Example					
		Diagnosis	Ignition cycle				
			← ON →	OFF	← ON →	OFF	
All OK	Case 1	P0400	OK (1)	— (1)	OK (2)	— (2)	
		P0402	OK (1)	— (1)	— (1)	OK (2)	
		P1402	OK (1)	OK (2)	— (2)	— (2)	
		SRT of EGR	"CMPLT"	"CMPLT"	"CMPLT"	"CMPLT"	
	Case 2	P0400	OK (1)	— (1)	— (1)	— (1)	
		P0402	— (0)	— (0)	OK (1)	— (1)	
		P1402	OK (1)	OK (2)	— (2)	— (2)	
		SRT of EGR	"INCMP"	"INCMP"	"CMPLT"	"CMPLT"	
NG exists	Case 3	P0400	OK	OK	—	—	
		P0402	—	—	—	—	
		P1402	NG	—	NG		NG (Consecutive NG)
		(1st trip) DTC	1st trip DTC	—	1st trip DTC		DTC (= MIL ON)
		SRT of EGR	"INCMP"	"INCMP"	"INCMP"	"CMPLT"	

OK: Self-diagnosis is carried out and the result is OK.

NG: Self-diagnosis is carried out and the result is NG.

—: Self-diagnosis is not carried out.

When all SRT related self-diagnoses showed OK results in a single cycle (Ignition OFF-ON-OFF), the SRT will indicate "CMPLT". → Case 1 above

ON BOARD DIAGNOSTIC (OBD) SYSTEM

[VQ]

When all SRT related self-diagnoses showed OK results through several different cycles, the SRT will indicate "CMPLT" at the time the respective self-diagnoses have at least one OK result. → Case 2 above
If one or more SRT related self-diagnoses showed NG results in 2 consecutive cycles, the SRT will also indicate "CMPLT". → Case 3 above

The table above shows that the minimum number of cycles for setting SRT as "INCMP" is one (1) for each self-diagnosis (Case 1 & 2) or two (2) for one of self-diagnoses (Case 3). However, in preparation for the state emissions inspection, it is unnecessary for each self-diagnosis to be executed twice (Case 3) for the following reasons:

- The SRT will indicate "CMPLT" at the time the respective self-diagnoses have one (1) OK result.
- The emissions inspection requires "CMPLT" of the SRT only with OK self-diagnosis results.
- When, during SRT driving pattern, 1st trip DTC (NG) is detected prior to "CMPLT" of SRT, the self-diagnosis memory must be erased from ECM after repair.
- If the 1st trip DTC is erased, all the SRT will indicate "INCMP".

NOTE:

SRT can be set as "CMPLT" together with the DTC(s). Therefore, DTC check must always be carried out prior to the state emission inspection even though the SRT indicates "CMPLT".

SRT Service Procedure

If a vehicle has failed the state emissions inspection due to one or more SRT items indicating "INCMP", review the flowchart diagnostic sequence on the next page.

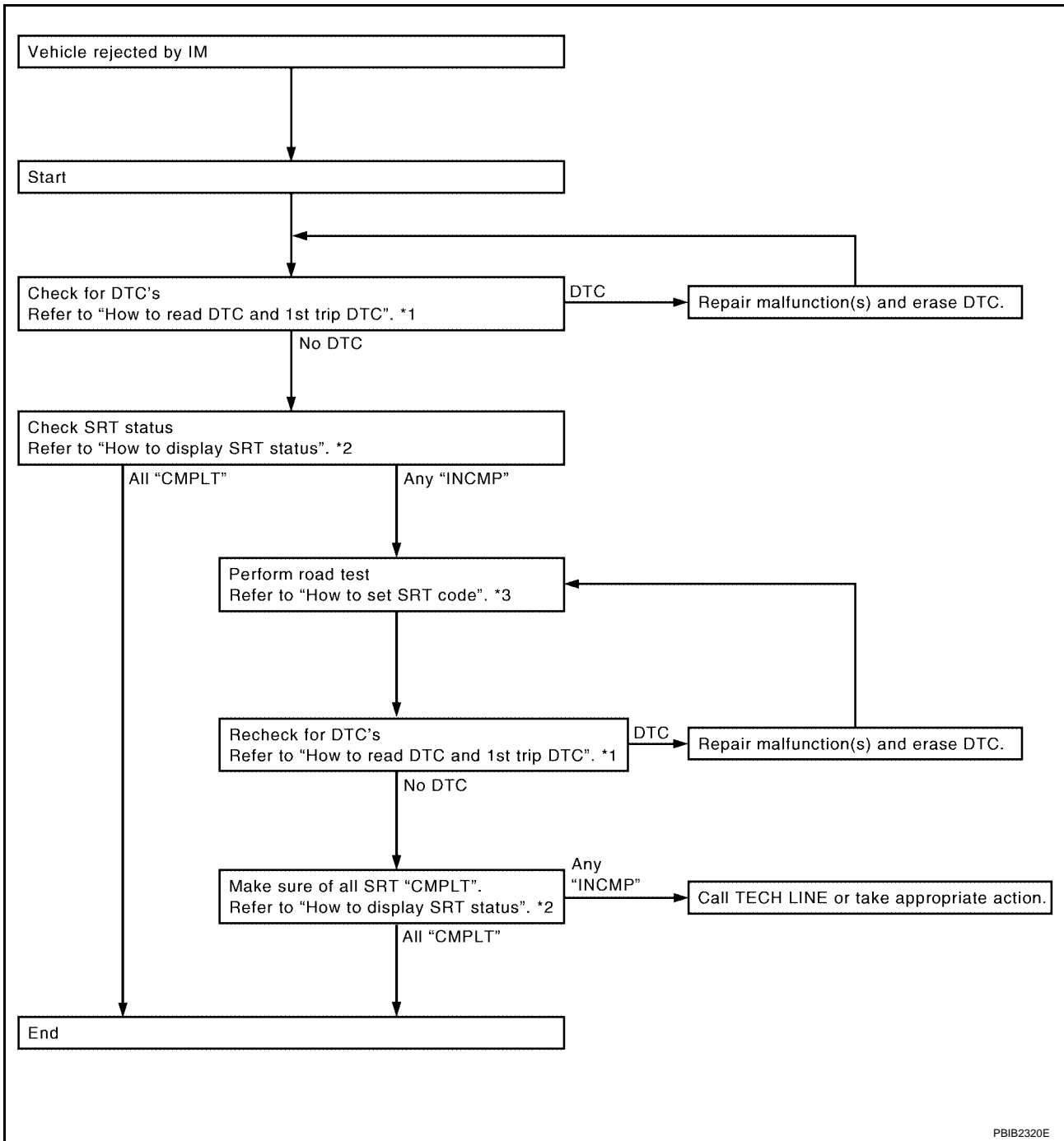

*1 [EC-673](#)

*2 [EC-677](#)

*3 [EC-678](#)

PBIB2320E

How to Display SRT Status

WITH CONSULT-II

Selecting "SRT STATUS" in "DTC CONFIRMATION" mode with CONSULT-II.

For items whose SRT codes are set, a "CMPLT" is displayed on the CONSULT-II screen; for items whose SRT codes are not set, "INCMP" is displayed.

A sample of CONSULT-II display for SRT code is shown in the figure.

"INCMP" means the self-diagnosis is incomplete and SRT is not set.

"CMPLT" means the self-diagnosis is complete and SRT is set.

WITH GST

Selecting Service \$01 with GST (Generic Scan Tool)

SRT STATUS	
CATALYST	CMPLT
EVAP SYSTEM	INCMP
HO2S HTR	CMPLT
HO2S	CMPLT
EGR SYSTEM	INCMP

SEF713Y



NO TOOLS

A SRT code itself can not be displayed while only SRT status can be.

1. Turn ignition switch ON and wait 20 seconds.
2. SRT status is indicated as shown below.
 - When all SRT codes are set, MIL lights up continuously.
 - When any SRT codes are not set, MIL will flash periodically for 10 seconds.

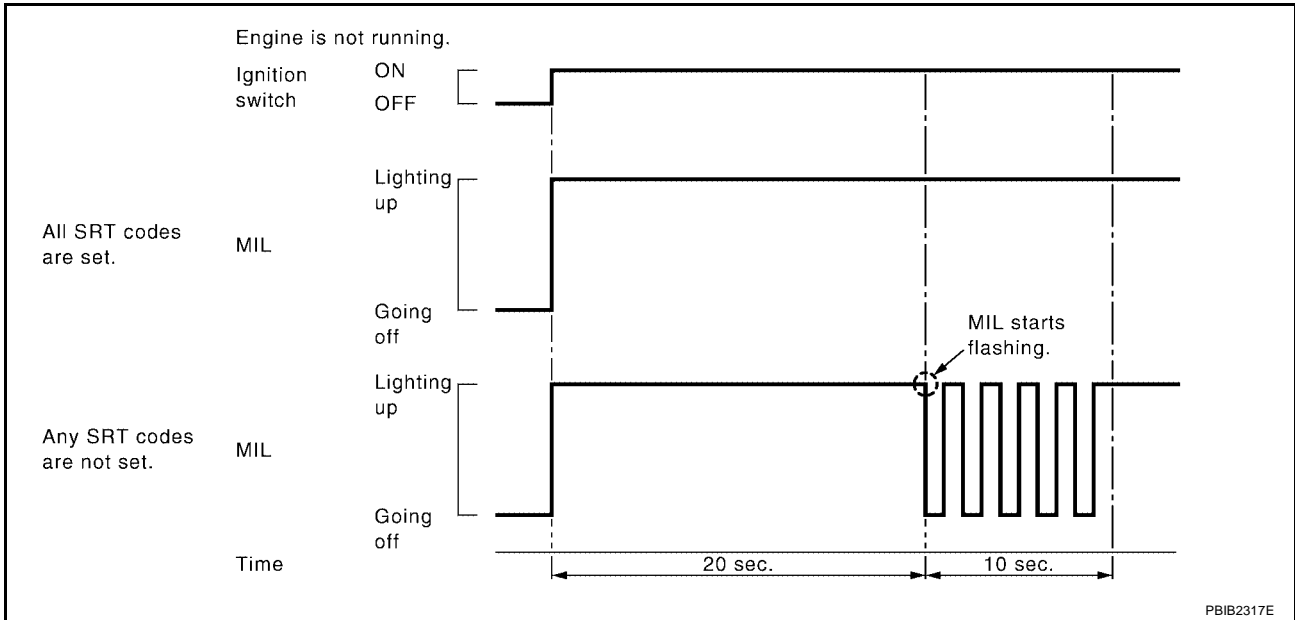

How to Set SRT Code

To set all SRT codes, self-diagnosis for the items indicated above must be performed one or more times. Each diagnosis may require a long period of actual driving under various conditions.

WITH CONSULT-II

Perform corresponding DTC Confirmation Procedure one by one based on Performance Priority in the table on [EC-675, "SRT Item"](#).

WITHOUT CONSULT-II

The most efficient driving pattern in which SRT codes can be properly set is explained on the next page. The driving pattern should be performed one or more times to set all SRT codes.

Driving Pattern

Note: Always drive vehicle in safe manner according to traffic conditions and obey all traffic laws. Refer to next page for more information and explanation of chart.

Driving pattern

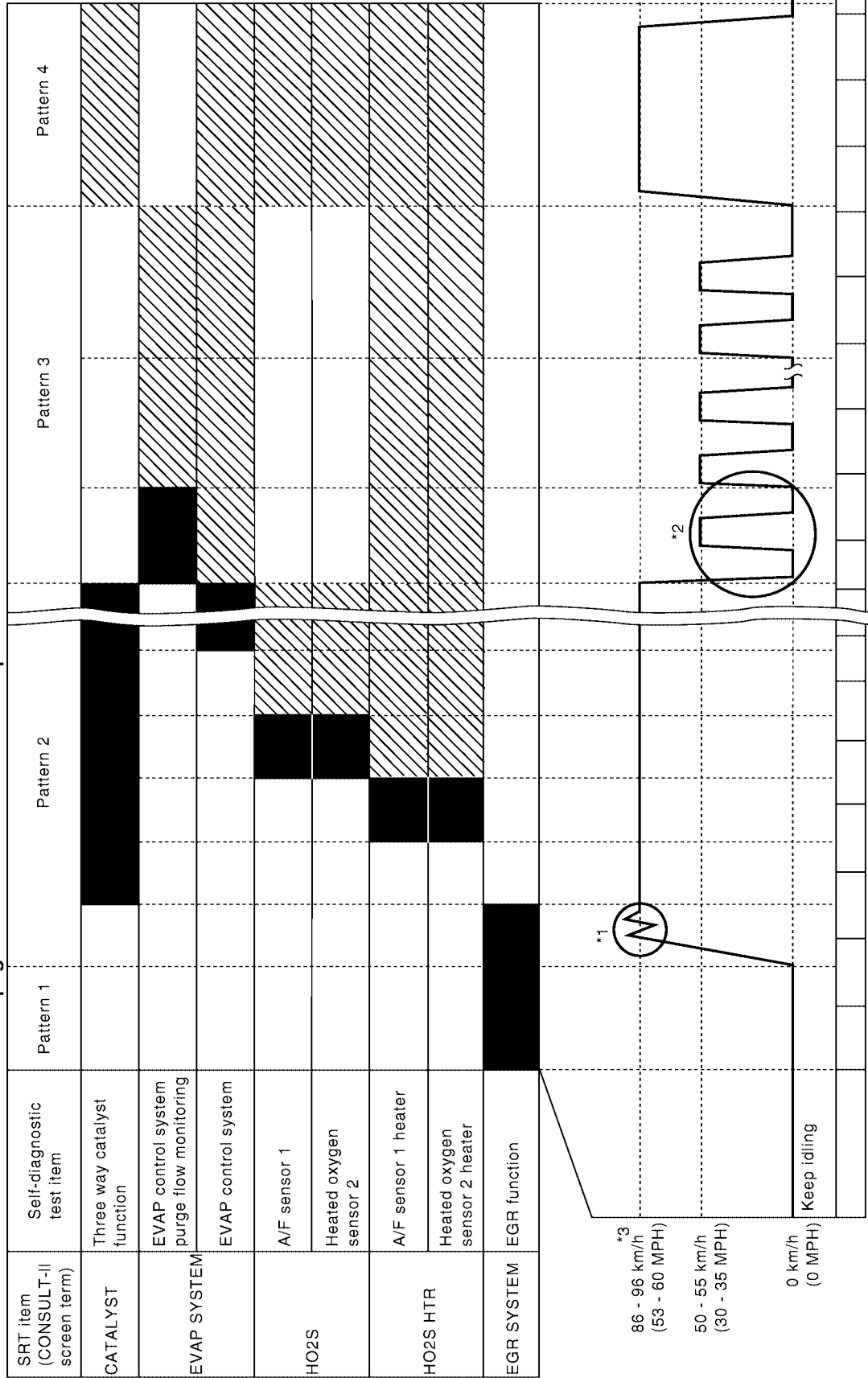

PBIB2273E

A
EC
C
D
E
F
G
H
I
J
K
L
M

ON BOARD DIAGNOSTIC (OBD) SYSTEM

[VQ]

- The time required for each diagnosis varies with road surface conditions, weather, altitude, individual driving habits, etc.
Zone A refers to the range where the time, required for the diagnosis under normal conditions*, is the shortest.
Zone B refers to the range where the diagnosis can still be performed if the diagnosis is not completed within zone A.

*: Normal conditions refer to the following:

- Sea level
- Flat road
- Ambient air temperature: 20 - 30°C (68 - 86°F)
- Diagnosis is performed as quickly as possible under normal conditions.
Under different conditions [For example: ambient air temperature other than 20 - 30°C (68 - 86°F)], diagnosis may also be performed.

Pattern 1:

- **The engine is started at the engine coolant temperature of -10 to 35°C (14 to 95°F) (where the voltage between the ECM terminal 73 and ground is 3.0 - 4.3V).**
- **The engine must be operated at idle speed until the engine coolant temperature is greater than 70°C (158°F) (where the voltage between the ECM terminal 73 and ground is lower than 1.4V).**
- **The engine is started at the fuel tank temperature of warmer than 0°C (32°F) (where the voltage between the ECM terminal 107 and ground is less than 4.1V).**

Pattern 2:

- When steady-state driving is performed again even after it is interrupted, each diagnosis can be conducted. In this case, the time required for diagnosis may be extended.

Pattern 3:

- The driving pattern outlined in *2 must be repeated at least 3 times.

Pattern 4:

- Tests are performed after the engine has been operated for at least 17 minutes.
- The accelerator pedal must be held very steady during steady-state driving.
- If the accelerator pedal is moved, the test must be conducted all over again.

*1: Depress the accelerator pedal until vehicle speed is 90 km/h (56 MPH), then release the accelerator pedal and keep it released for more than 10 seconds. Depress the accelerator pedal until vehicle speed is 90 km/h (56 MPH) again.

*2: Operate the vehicle in the following driving pattern.

1. Decelerate vehicle to 0 km/h (0 MPH) and let engine idle.
2. Repeat driving pattern shown at right at least 10 times.
- **During acceleration, hold the accelerator pedal as steady as possible.**

*3: Checking the vehicle speed with GST is advised.

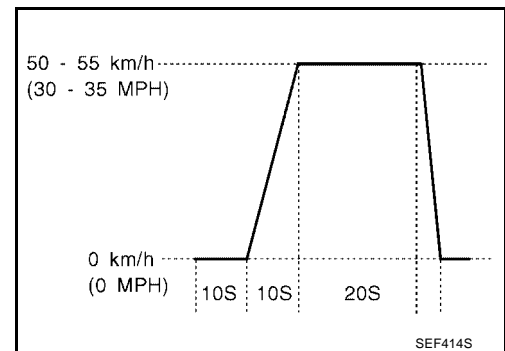

Suggested Transmission Gear Position for A/T Models

Set the selector lever in the D position with the overdrive switch turned ON.

Suggested Upshift Speeds for M/T Models

Shown below are suggested vehicle speeds for shifting into a higher gear. These suggestions relate to fuel economy and vehicle performance. Actual upshift speeds will vary according to road conditions, the weather and individual driving habits.

ON BOARD DIAGNOSTIC (OBD) SYSTEM

[VQ]

	For normal acceleration in low altitude areas [less than 1,219 m (4,000 ft)]:		For quick acceleration in low altitude areas and high altitude areas [over 1,219 m (4,000 ft)]:
Gear change	ACCEL shift point km/h (MPH)	CRUISE shift point km/h (MPH)	km/h (MPH)
1st to 2nd	21 (13)	21 (13)	24 (15)
2nd to 3rd	37 (23)	26 (16)	40 (25)
3rd to 4th	53 (33)	44 (27)	64 (40)
4th to 5th	63 (39)	58 (36)	72 (45)

Suggested Maximum Speed in Each Gear

Downshift to a lower gear if the engine is not running smoothly, or if you need to accelerate.

Do not exceed the maximum suggested speed (shown below) in any gear. For level road driving, use the highest gear suggested for that speed. Always observe posted speed limits and drive according to the road conditions to ensure safe operation. Do not over-rev the engine when shifting to a lower gear as it may cause engine damage or loss of vehicle control.

Gear	km/h (MPH)
1st	55 (35)
2nd	105 (65)
3rd	—
4th	—
5th	—

TEST VALUE AND TEST LIMIT (GST ONLY — NOT APPLICABLE TO CONSULT-II)

The following is the information specified in Service \$06 of SAE J1979.

The test value is a parameter used to determine whether a system/circuit diagnostic test is OK or NG while being monitored by the ECM during self-diagnosis. The test limit is a reference value which is specified as the maximum or minimum value and is compared with the test value being monitored.

These data (test value and test limit) are specified by Test ID (TID) and Component ID (CID) and can be displayed on the GST screen.

Item	Self-diagnostic test item	DTC	Test value (GST display)		Test limit	Conversion
			TID	CID		
CATALYST	Three way catalyst function (Bank 1)	P0420	01H	01H	Max.	1/128
		P0420	02H	81H	Min.	1
	Three way catalyst function (Bank 2)	P0430	03H	02H	Max.	1/128
		P0430	04H	82H	Min.	1
EVAP SYSTEM	EVAP control system (Small leak)	P0442	05H	03H	Max.	1/128 mm ²
	EVAP control system purge flow monitoring	P0441	06H	83H	Min.	20 mV
	EVAP control system (Very small leak)	P0456	07H	03H	Max.	1/128 mm ²

ON BOARD DIAGNOSTIC (OBD) SYSTEM

[VQ]

Item	Self-diagnostic test item	DTC	Test value (GST display)		Test limit	Conversion	
			TID	CID			
HO2S	A/F sensor 1 (Bank 1)	P1271	41H	8EH	Min.	5mV	
		P1272	42H	0EH	Max.	5mV	
		P1273	43H	0EH	Max.	0.002	
		P1274	44H	8EH	Min.	0.002	
		P1278	45H	8EH	Min.	0.004	
		P1276	46H	0EH	Max.	5mV	
		P1276	47H	8EH	Min.	5mV	
		P1279	48H	8EH	Min.	0.004	
	A/F sensor 1 (Bank 2)	P1281	4CH	8FH	Min.	5mV	
		P1282	4DH	0FH	Max.	5mV	
		P1283	4EH	0FH	Max.	0.002	
		P1284	4FH	8FH	Min.	0.002	
		P1288	50H	8FH	Min.	0.004	
		P1286	51H	0FH	Max.	5mV	
		P1286	52H	8FH	Min.	5mV	
		P1289	53H	8FH	Min.	0.004	
	Heated oxygen sensor 2 (Bank 1)	P0138	1CH	06H	Max.	10mV	
		P0139	19H	86H	Min.	10mV/500 ms	
		P1147	1AH	86H	Min.	10 mV	
		P1146	1BH	06H	Max.	10 mV	
	Heated oxygen sensor 2 (Bank 2)	P0158	24H	07H	Max.	10mV	
		P0159	21H	87H	Min.	10 mV/500 ms	
		P1167	22H	87H	Min.	10 mV	
		P1166	23H	07H	Max.	10 mV	
	HO2S HEATER	A/F sensor 1 heater (Bank 1)	P1032	57H	10H	Max.	5 mV
			P1031	58H	90H	Min.	5 mV
		A/F sensor 1 heater (Bank 2)	P1052	59H	11H	Max.	5 mV
			P1051	5AH	91H	Min.	5 mV
Heated oxygen sensor 2 heater (Bank 1)		P0038	2DH	0AH	Max.	20 mV	
		P0037	2EH	8AH	Min.	20 mV	
Heated oxygen sensor 2 heater (Bank 2)		P0058	2FH	0BH	Max.	20 mV	
		P0057	30H	8BH	Min.	20 mV	
EGR SYSTEM	EGR function	P0400	31H	8CH	Min.	1°C	
		P0400	32H	8CH	Min.	1°C	
		P0400	33H	8CH	Min.	1°C	
		P0400	34H	8CH	Min.	1°C	
		P1402	35H	0CH	Max.	1°C	

HOW TO ERASE EMISSION-RELATED DIAGNOSTIC INFORMATION

How to Erase DTC

WITH CONSULT-II

The emission related diagnostic information in the ECM can be erased by selecting “ERASE” in the “SELF-DIAG RESULTS” mode with CONSULT-II.

If DTCs are displayed for both ECM and TCM (Transmission control module), they need to be erased individually from the ECM and TCM (Transmission control module).

NOTE:

If the DTC is not for A/T related items (see [EC-627, "INDEX FOR DTC"](#)), skip steps 2 through 4.

1. If the ignition switch stays ON after repair work, be sure to turn ignition switch OFF once. Wait at least 10 seconds and then turn it ON (engine stopped) again.
2. Turn CONSULT-II ON and touch "TRANSMISSION".
3. Touch "SELF-DIAG RESULTS".
4. Touch "ERASE". [The DTC in the TCM (Transmission control module) will be erased.] Then touch "BACK" twice.
5. Touch "ENGINE".
6. Touch "SELF-DIAG RESULTS".
7. Touch "ERASE". (The DTC in the ECM will be erased.)

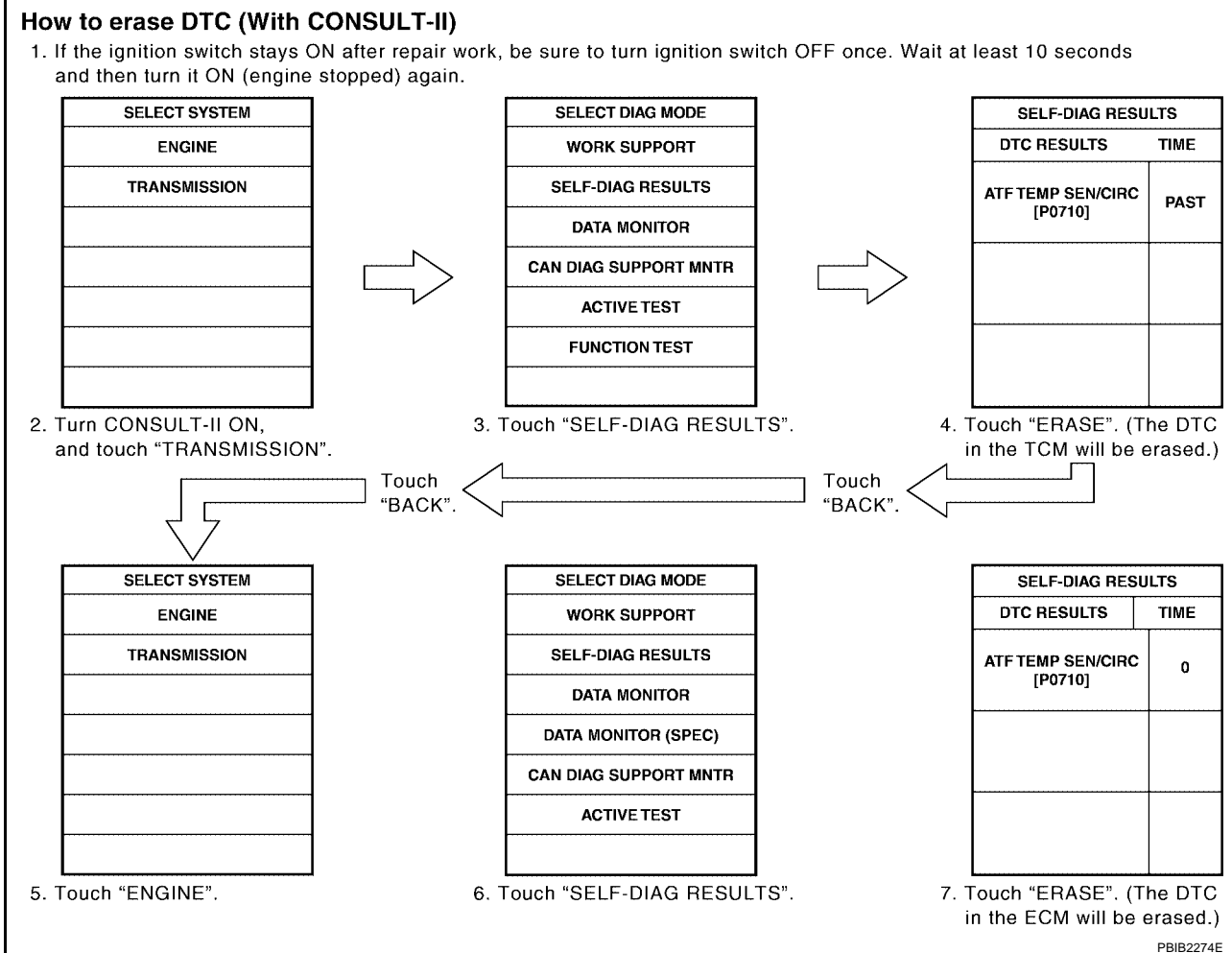

WITH GST

The emission related diagnostic information in the ECM can be erased by selecting Service \$04 with GST.

NOTE:

If the DTC is not for A/T related items (see [EC-627, "INDEX FOR DTC"](#)), skip step 2.

1. If the ignition switch stays ON after repair work, be sure to turn ignition switch OFF once. Wait at least 10 seconds and then turn it ON (engine stopped) again.
2. Perform [AT-423, "HOW TO ERASE DTC \(WITH GST\)"](#) . (The DTC in TCM will be erased)
3. Select Service \$04 with GST (Generic Scan Tool).

No Tools

NOTE:

If the DTC is not for AT related items (see [EC-627, "INDEX FOR DTC"](#)), skip step 2.

1. If the ignition switch stays ON after repair work, be sure to turn ignition switch OFF once. Wait at least 10 seconds and then turn it ON (engine stopped) again.

ON BOARD DIAGNOSTIC (OBD) SYSTEM

[VQ]

2. Perform [AT-424, "HOW TO ERASE DTC \(NO TOOLS\)"](#) . (The DTC in the TCM will be erased.)
3. Change the diagnostic test mode from Mode II to Mode I by depressing the accelerator pedal. Refer to [EC-686, "HOW TO SWITCH DIAGNOSTIC TEST MODE"](#) .
 - **If the battery is disconnected, the emission-related diagnostic information will be lost within 24 hours.**
 - **The following data are cleared when the ECM memory is erased.**
 - Diagnostic trouble codes
 - 1st trip diagnostic trouble codes
 - Freeze frame data
 - 1st trip freeze frame data
 - System readiness test (SRT) codes
 - Test values

Actual work procedures are explained using a DTC as an example. Be careful so that not only the DTC, but all of the data listed above, are cleared from the ECM memory during work procedures.

Malfunction Indicator Lamp (MIL)

DESCRIPTION



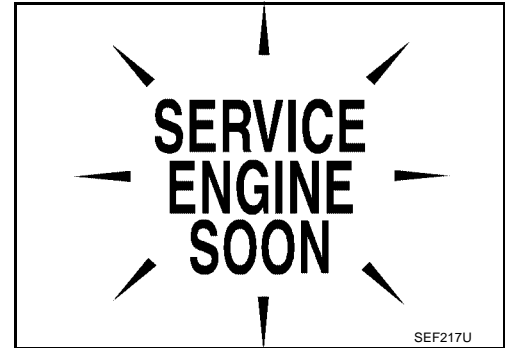

The MIL is located on the instrument panel.

1. The MIL will light up when the ignition switch is turned ON without the engine running. This is a bulb check.
If the MIL does not light up, refer to [DI-30, "WARNING LAMPS"](#), or see [EC-1346](#).
2. When the engine is started, the MIL should go off.
If the MIL remains on, the on board diagnostic system has detected an engine system malfunction.



ON BOARD DIAGNOSTIC SYSTEM FUNCTION

The on board diagnostic system has the following three functions.

Diagnostic Test Mode	KEY and ENG. Status	Function	Explanation of Function
Mode I	Ignition switch in ON position  Engine stopped 	BULB CHECK	This function checks the MIL bulb for damage (blown, open circuit, etc.). If the MIL does not come on, check MIL circuit.
	Engine running 	MALFUNCTION WARNING	This is a usual driving condition. When a malfunction is detected twice in two consecutive driving cycles (two trip detection logic), the MIL will light up to inform the driver that a malfunction has been detected. The following malfunctions will light up or blink the MIL in the 1st trip. <ul style="list-style-type: none"> ● Misfire (Possible three way catalyst damage) ● One trip detection diagnoses
Mode II	Ignition switch in ON position  Engine stopped 	SELF-DIAGNOSTIC RESULTS	This function allows DTCs and 1st trip DTCs to be read.

When there is an open circuit on MIL circuit, the ECM cannot warn the driver by lighting up MIL when there is malfunction on engine control system.

Therefore, when electrical controlled throttle and part of ECM related diagnoses are continuously detected as NG for 5 trips, ECM warns the driver that engine control system malfunctions and MIL circuit is open by means of operating fail-safe function.

The fail-safe function also operates when above diagnoses except MIL circuit are detected and demands the driver to repair the malfunction.

Engine operating condition in fail-safe mode	Engine speed will not rise more than 2,500 rpm due to the fuel cut
--	--

MIL Flashing Without DTC

When any SRT codes are not set, MIL may flash without DTC. For the details, refer to [EC-677, "How to Display SRT Status"](#).

HOW TO SWITCH DIAGNOSTIC TEST MODE

NOTE:

- It is better to count the time accurately with a clock.
- It is impossible to switch the diagnostic mode when an accelerator pedal position sensor circuit has a malfunction.
- Always ECM returns to Diagnostic Test Mode I after ignition switch is turned OFF.

How to Set Diagnostic Test Mode II (Self-diagnostic Results)

1. Confirm that accelerator pedal is fully released, turn ignition switch ON and wait 3 seconds.
2. Repeat the following procedure quickly 5 times within 5 seconds.
 - a. Fully depress the accelerator pedal.
 - b. Fully release the accelerator pedal.
3. Wait 7 seconds, fully depress the accelerator pedal and keep it for approx. 10 seconds until the MIL starts blinking.

NOTE:

Do not release the accelerator pedal for 10 seconds if MIL may start blinking on the halfway of this 10 seconds. This blinking is displaying SRT status and is continued for another 10 seconds. For the details, refer to [EC-677, "How to Display SRT Status"](#).

4. Fully release the accelerator pedal.
ECM has entered to Diagnostic Test Mode II (Self-diagnostic results).

NOTE:

Wait until the same DTC (or 1st trip DTC) appears to confirm all DTCs certainly.

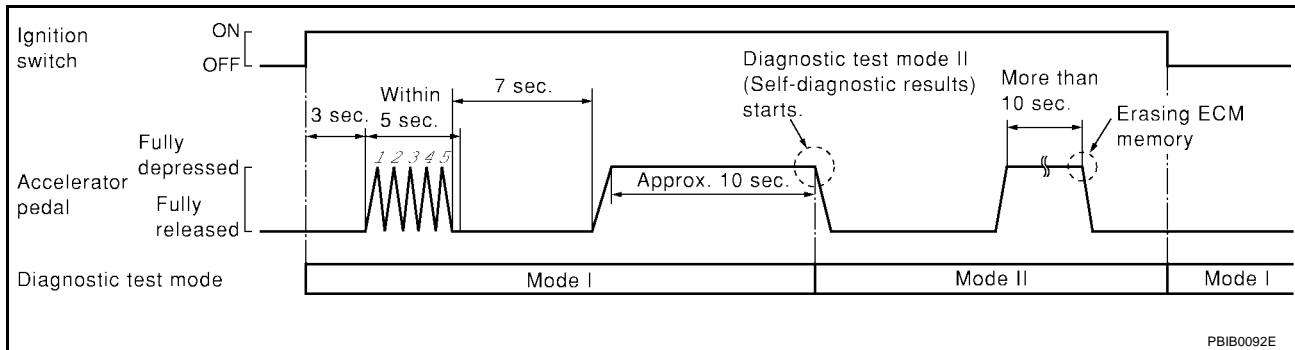

How to Erase Diagnostic Test Mode II (Self-diagnostic Results)

1. Set ECM in Diagnostic Test Mode II (Self-diagnostic results). Refer to [EC-686, "How to Set Diagnostic Test Mode II \(Self-diagnostic Results\)"](#).
2. Fully depress the accelerator pedal and keep it for more than 10 seconds.
The emission-related diagnostic information has been erased from the backup memory in the ECM.
3. Fully release the accelerator pedal, and confirm the DTC 0000 is displayed.

DIAGNOSTIC TEST MODE I — BULB CHECK

In this mode, the MIL on the instrument panel should stay ON. If it remains OFF, check the bulb. Refer to [DI-30, "WARNING LAMPS"](#) or see [EC-1346](#).

DIAGNOSTIC TEST MODE I — MALFUNCTION WARNING

MIL	Condition
ON	When the malfunction is detected.
OFF	No malfunction.

This DTC number is clarified in Diagnostic Test Mode II (SELF-DIAGNOSTIC RESULTS)

DIAGNOSTIC TEST MODE II — SELF-DIAGNOSTIC RESULTS

In this mode, the DTC and 1st trip DTC are indicated by the number of blinks of the MIL as shown below. The DTC and 1st trip DTC are displayed at the same time. If the MIL does not illuminate in diagnostic test mode I (Malfunction warning), all displayed items are 1st trip DTCs. If only one code is displayed when the MIL illuminates in diagnostic test mode II (SELF-DIAGNOSTIC RESULTS), it is a DTC; if two or more codes are displayed, they may be either DTCs or 1st trip DTCs. DTC No. is same as that of 1st trip DTC. These uniden-

tified codes can be identified by using the CONSULT-II or GST. A DTC will be used as an example for how to read a code.

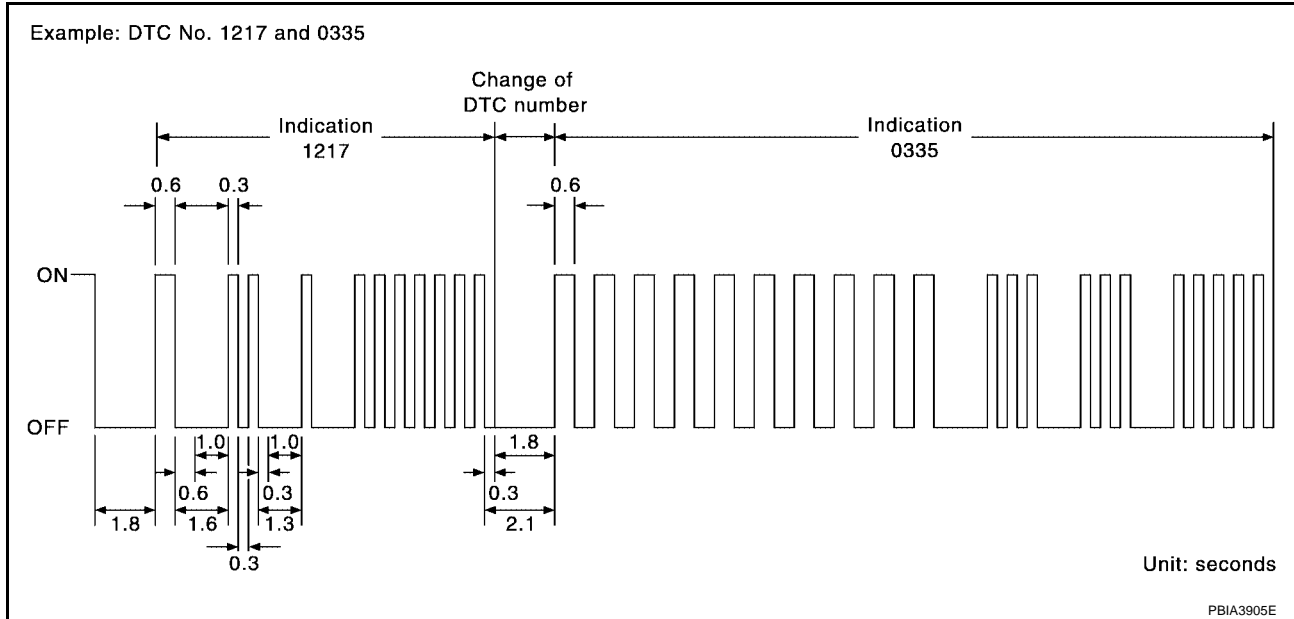

A particular trouble code can be identified by the number of four-digit numeral flashes. The “zero” is indicated by the number of ten flashes. The length of time the 1,000th-digit numeral flashes on and off is 1.2 seconds consisting of an ON (0.6-second) - OFF (0.6-second) cycle.

The 100th-digit numeral and lower digit numerals consist of a 0.3-second ON and 0.3-second OFF cycle.

A change from one digit numeral to another occurs at an interval of 1.0-second OFF. In other words, the later numeral appears on the display 1.3 seconds after the former numeral has disappeared.

A change from one trouble code to another occurs at an interval of 1.8-second OFF.

In this way, all the detected malfunctions are classified by their DTC numbers. The DTC 0000 refers to no malfunction. (See [EC-627, "INDEX FOR DTC"](#))

How to Erase Diagnostic Test Mode II (Self-diagnostic Results)

The DTC can be erased from the back up memory in the ECM by depressing accelerator pedal. Refer to [EC-686, "How to Erase Diagnostic Test Mode II \(Self-diagnostic Results\)"](#).

- If the battery is disconnected, the DTC will be lost from the backup memory within 24 hours.
- Be careful not to erase the stored memory before starting trouble diagnoses.

OBD System Operation Chart

UBS00107

RELATIONSHIP BETWEEN MIL, 1ST TRIP DTC, DTC, AND DETECTABLE ITEMS

- When a malfunction is detected for the first time, the 1st trip DTC and the 1st trip freeze frame data are stored in the ECM memory.
- When the same malfunction is detected in two consecutive trips, the DTC and the freeze frame data are stored in the ECM memory, and the MIL will come on. For details, refer to [EC-668, "Two Trip Detection Logic"](#).
- The MIL will go off after the vehicle is driven 3 times (driving pattern B) with no malfunction. The drive is counted only when the recorded driving pattern is met (as stored in the ECM). If another malfunction occurs while counting, the counter will reset.
- The DTC and the freeze frame data will be stored until the vehicle is driven 40 times (driving pattern A) without the same malfunction recurring (except for Misfire and Fuel Injection System). For Misfire and Fuel Injection System, the DTC and freeze frame data will be stored until the vehicle is driven 80 times (driving pattern C) without the same malfunction recurring. The “TIME” in “SELF-DIAGNOSTIC RESULTS” mode of CONSULT-II will count the number of times the vehicle is driven.
- The 1st trip DTC is not displayed when the self-diagnosis results in OK for the 2nd trip.

ON BOARD DIAGNOSTIC (OBD) SYSTEM

[VQ]

SUMMARY CHART

Items	Fuel Injection System	Misfire	Other
MIL (goes off)	3 (pattern B)	3 (pattern B)	3 (pattern B)
DTC, Freeze Frame Data (no display)	80 (pattern C)	80 (pattern C)	40 (pattern A)
1st Trip DTC (clear)	1 (pattern C), *1	1 (pattern C), *1	1 (pattern B)
1st Trip Freeze Frame Data (clear)	*1, *2	*1, *2	1 (pattern B)

For details about patterns B and C under "Fuel Injection System" and "Misfire", see [EC-690](#) .

For details about patterns A and B under Other, see [EC-692](#) .

*1: Clear timing is at the moment OK is detected.

*2: Clear timing is when the same malfunction is detected in the 2nd trip.

RELATIONSHIP BETWEEN MIL, DTC, 1ST TRIP DTC AND DRIVING PATTERNS FOR "MISFIRE" <EXHAUST QUALITY DETERIORATION>, "FUEL INJECTION SYSTEM"

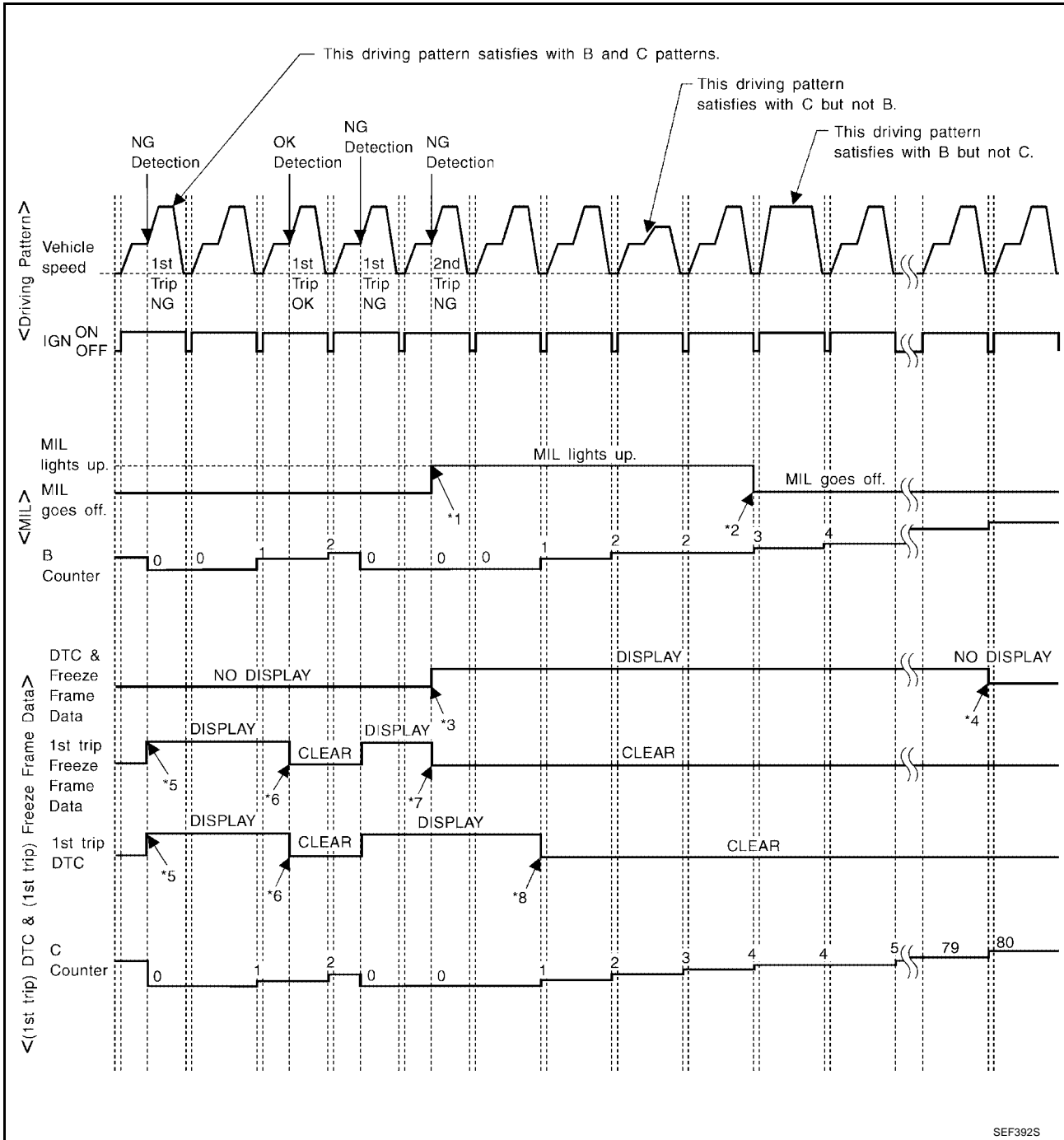

*1: When the same malfunction is detected in two consecutive trips, MIL will light up.

*2: MIL will go off after vehicle is driven 3 times (pattern B) without any malfunctions.

*3: When the same malfunction is detected in two consecutive trips, the DTC and the freeze frame data will be stored in ECM.

*4: The DTC and the freeze frame data will not be displayed any longer after vehicle is driven 80 times (pattern C) without the same malfunction. (The DTC and the freeze frame data still remain in ECM.)

*5: When a malfunction is detected for the first time, the 1st trip DTC and the 1st trip freeze frame data will be stored in ECM.

*6: The 1st trip DTC and the 1st trip freeze frame data will be cleared at the moment OK is detected.

*7: When the same malfunction is detected in the 2nd trip, the 1st trip freeze frame data will be cleared.

*8: 1st trip DTC will be cleared when vehicle is driven once (pattern C) without the same malfunction after DTC is stored in ECM.

EXPLANATION FOR DRIVING PATTERNS FOR “MISFIRE <EXHAUST QUALITY DETERIORATION>”, “FUEL INJECTION SYSTEM”

<Driving Pattern B>

Driving pattern B means the vehicle operation as follows:

All components and systems should be monitored at least once by the OBD system.

- The B counter will be cleared when the malfunction is detected once regardless of the driving pattern.
- The B counter will be counted up when driving pattern B is satisfied without any malfunction.
- The MIL will go off when the B counter reaches 3. (*2 in “OBD SYSTEM OPERATION CHART”)

<Driving Pattern C>

Driving pattern C means the vehicle operation as follows:

The following conditions should be satisfied at the same time:

Engine speed: (Engine speed in the freeze frame data) ± 375 rpm

Calculated load value: (Calculated load value in the freeze frame data) $\times (1 \pm 0.1)$ [%]

Engine coolant temperature (T) condition:

- When the freeze frame data shows lower than 70°C (158°F), T should be lower than 70°C (158°F).
- When the freeze frame data shows higher than or equal to 70°C (158°F), T should be higher than or equal to 70°C (158°F).

Example:

If the stored freeze frame data is as follows:

Engine speed: 850 rpm, Calculated load value: 30%, Engine coolant temperature: 80°C (176°F)

To be satisfied with driving pattern C, the vehicle should run under the following conditions:

Engine speed: 475 - 1,225 rpm, Calculated load value: 27 - 33%, Engine coolant temperature: more than 70°C (158°F)

- The C counter will be cleared when the malfunction is detected regardless of vehicle conditions above.
- The C counter will be counted up when vehicle conditions above is satisfied without the same malfunction.
- The DTC will not be displayed after C counter reaches 80.
- The 1st trip DTC will be cleared when C counter is counted once without the same malfunction after DTC is stored in ECM.

RELATIONSHIP BETWEEN MIL, DTC, 1ST TRIP DTC AND DRIVING PATTERNS EXCEPT FOR "MISFIRE <EXHAUST QUALITY DETERIORATION>", "FUEL INJECTION SYSTEM"

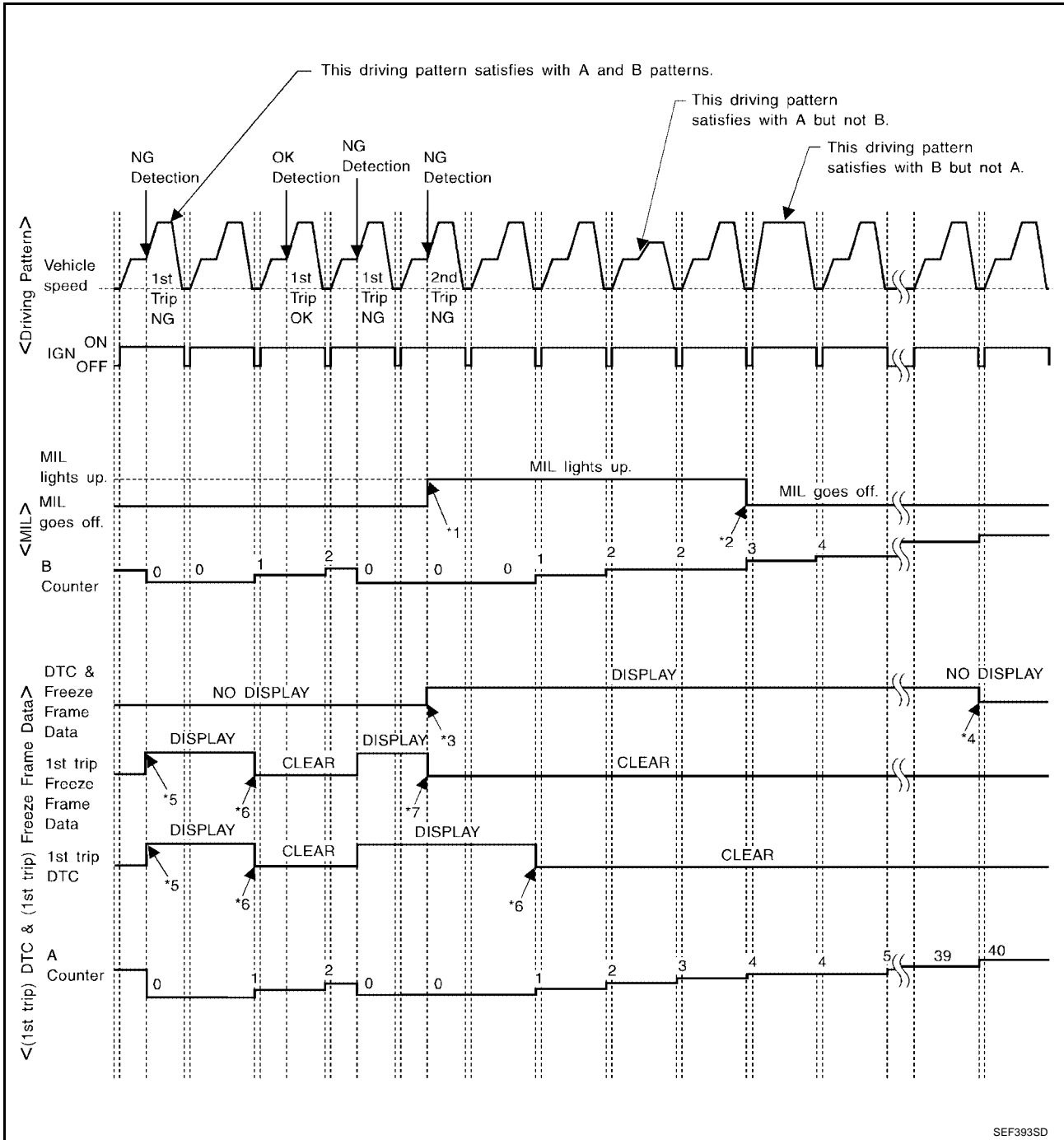

- *1: When the same malfunction is detected in two consecutive trips, MIL will light up.
- *2: MIL will go off after vehicle is driven 3 times (pattern B) without any malfunctions.
- *3: When the same malfunction is detected in two consecutive trips, the DTC and the freeze frame data will be stored in ECM.
- *4: The DTC and the freeze frame data will not be displayed any longer after vehicle is driven 40 times (pattern A) without the same malfunction. (The DTC and the freeze frame data still remain in ECM.)
- *5: When a malfunction is detected for the first time, the 1st trip DTC and the 1st trip freeze frame data will be stored in ECM.
- *6: 1st trip DTC will be cleared after vehicle is driven once (pattern B) without the same malfunction.
- *7: When the same malfunction is detected in the 2nd trip, the 1st trip freeze frame data will be cleared.

EXPLANATION FOR DRIVING PATTERNS EXCEPT FOR "MISFIRE <EXHAUST QUALITY DETERIORATION>", "FUEL INJECTION SYSTEM"

<Driving Pattern A>

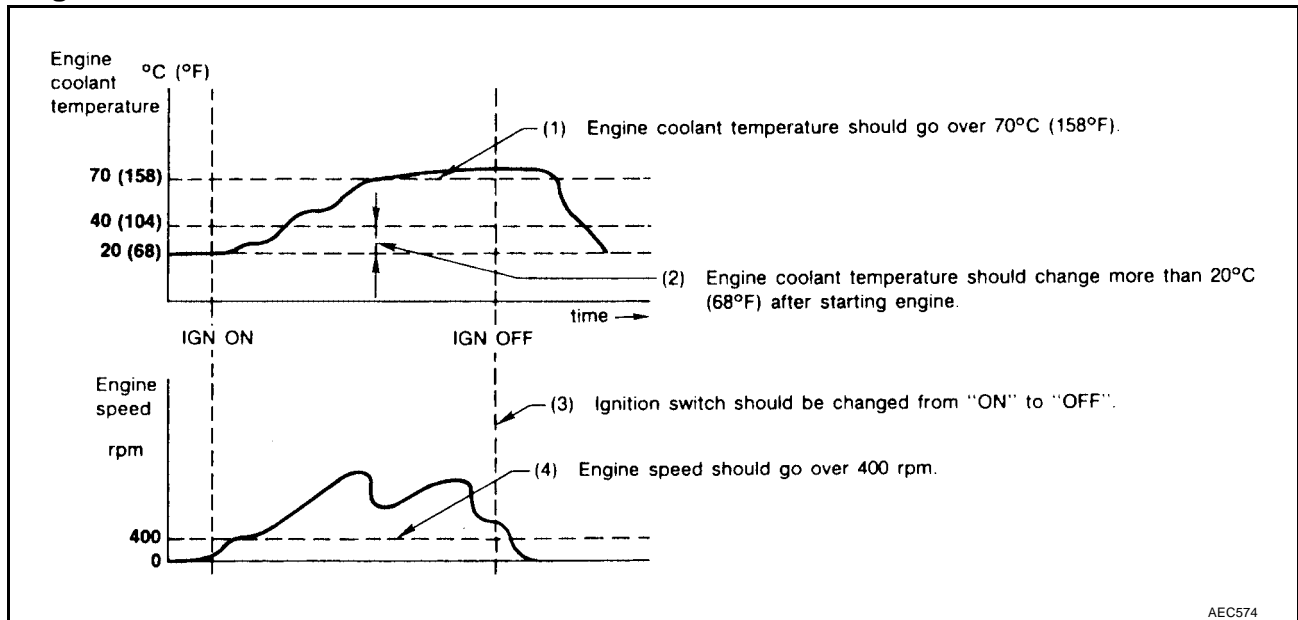

- The A counter will be cleared when the malfunction is detected regardless of (1) - (4).
- The A counter will be counted up when (1) - (4) are satisfied without the same malfunction.
- The DTC will not be displayed after the A counter reaches 40.

<Driving Pattern B>

Driving pattern B means the vehicle operation as follows:

All components and systems should be monitored at least once by the OBD system.

- The B counter will be cleared when the malfunction is detected once regardless of the driving pattern.
- The B counter will be counted up when driving pattern B is satisfied without any malfunctions.
- The MIL will go off when the B counter reaches 3 (*2 in OBD SYSTEM OPERATION CHART).

BASIC SERVICE PROCEDURE

PFP:00018

UBS0010B

Basic Inspection

1. INSPECTION START

1. Check service records for any recent repairs that may indicate a related malfunction, or a current need for scheduled maintenance.
2. Open engine hood and check the following:
 - Harness connectors for improper connections
 - Wiring harness for improper connections, pinches and cut
 - Vacuum hoses for splits, kinks and improper connections
 - Hoses and ducts for leaks
 - Air cleaner clogging
 - Gasket
3. Confirm that electrical or mechanical loads are not applied.
 - Headlamp switch is OFF.
 - Air conditioner switch is OFF.
 - Rear window defogger switch is OFF.
 - Steering wheel is in the straight-ahead position, etc.
4. Start engine and warm it up until engine coolant temperature indicator points the middle of gauge. Ensure engine stays below 1,000 rpm.

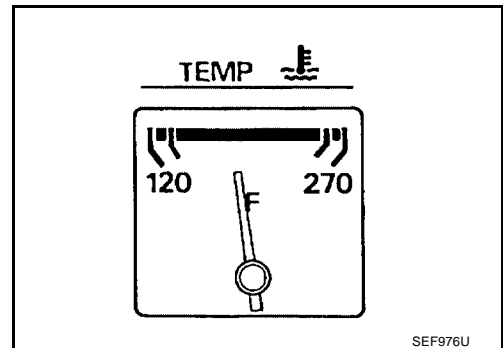
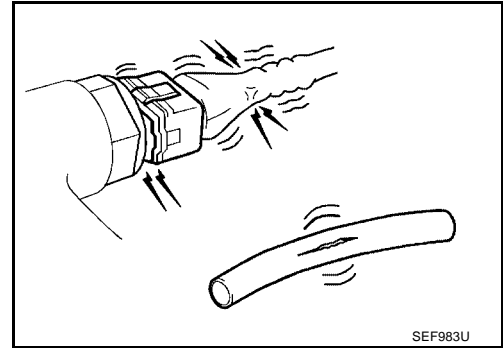

5. Run engine at about 2,000 rpm for about 2 minutes under no-load.
6. Make sure that no DTC is displayed with CONSULT-II or GST.

OK or NG

- OK >> GO TO 3.
- NG >> GO TO 2.

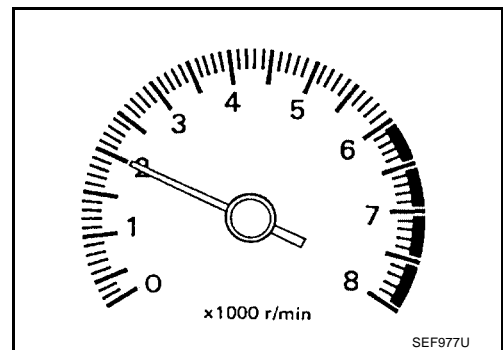

2. REPAIR OR REPLACE

Repair or replace components as necessary according to corresponding Diagnostic Procedure.

>> GO TO 3.

3. CHECK TARGET IDLE SPEED

With CONSULT-II

1. Run engine at about 2,000 rpm for about 2 minutes under no-load.
2. Rev engine (2,000 to 3,000 rpm) 2 or 3 times under no-load, then run engine at idle speed for about 1 minute.

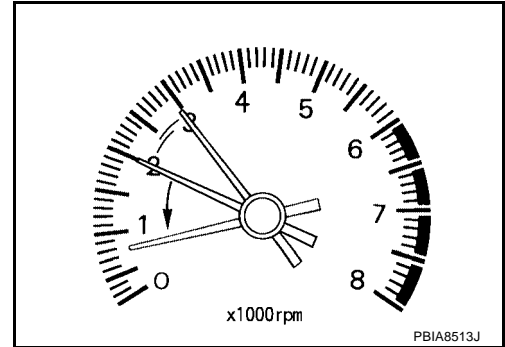

3. Read idle speed in "DATA MONITOR" mode with CONSULT-II. Refer to [EC-698, "IDLE SPEED"](#) .

A/T: 675 ± 50 rpm (in P or N position)

M/T: 625 ± 50 rpm (in neutral position)

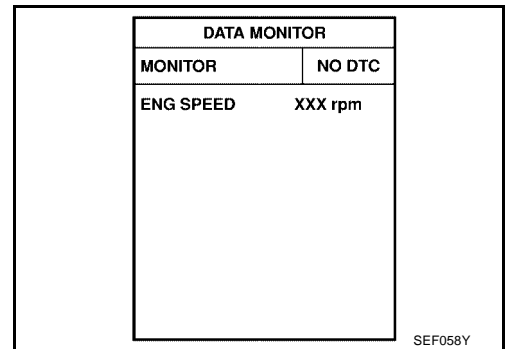

Without CONSULT-II

1. Run engine at about 2,000 rpm for about 2 minutes under no-load.
2. Rev engine (2,000 to 3,000 rpm) 2 or 3 times under no-load, then run engine at idle speed for about 1 minute.
3. Check idle speed. Refer to [EC-698, "IDLE SPEED"](#) .

A/T: 675 ± 50 rpm (in P or N position)

M/T: 625 ± 50 rpm (in neutral position)

OK or NG

- OK >> GO TO 10.
- NG >> GO TO 4.

4. PERFORM ACCELERATOR PEDAL RELEASED POSITION LEARNING

1. Stop engine.
2. Perform [EC-711, "Accelerator Pedal Released Position Learning"](#) .

>> GO TO 5.

5. PERFORM THROTTLE VALVE CLOSED POSITION LEARNING

Perform [EC-711, "Throttle Valve Closed Position Learning"](#) .

>> GO TO 6.

6. PERFORM IDLE AIR VOLUME LEARNING

Refer to [EC-712, "Idle Air Volume Learning"](#) .

Is Idle Air Volume Learning carried out successfully?

Yes or No

- Yes >> GO TO 7.
- No >> 1. Follow the instruction of Idle Air Volume Learning.
2. GO TO 4.

7. CHECK TARGET IDLE SPEED AGAIN

Ⓜ With CONSULT-II

1. Start engine and warm it up to normal operating temperature.
2. Read idle speed in "DATA MONITOR" mode with CONSULT-II. Refer to [EC-698, "IDLE SPEED"](#) .

A/T: 675 ± 50 rpm (in P or N position)

M/T: 625 ± 50 rpm (in neutral position)

ⓧ Without CONSULT-II

1. Start engine and warm it up to normal operating temperature.
2. Check idle speed. Refer to [EC-698, "IDLE SPEED"](#) .

A/T: 675 ± 50 rpm (in P or N position)

M/T: 625 ± 50 rpm (in neutral position)

DATA MONITOR	
MONITOR	NO DTC
ENG SPEED	XXX rpm
COOLAN TEMP/S	XXX °C

SEF174Y

OK or NG

- OK >> GO TO 10.
- NG >> GO TO 8.

8. DETECT MALFUNCTIONING PART

Check the following.

- Check camshaft position sensor (PHASE) and circuit. Refer to [EC-928](#) .
- Check crankshaft position sensor (POS) and circuit. Refer to [EC-921](#) .

OK or NG

- OK >> GO TO 9.
- NG >> 1. Repair or replace.
2. GO TO 4.

9. CHECK ECM FUNCTION

1. Substitute another known-good ECM to check ECM function. (ECM may be the cause of an incident, but this is a rare case.)
2. Perform initialization of NVIS (NATS) system and registration of all NVIS (NATS) ignition key IDs. Refer to [EC-667, "Description"](#) .

>> GO TO 4.

10. CHECK IGNITION TIMING

1. Run engine at idle.
2. Check ignition timing with a timing light. Refer to [EC-698, "IGNITION TIMING"](#).

A/T: $15 \pm 5^\circ$ BTDC (in P or N position)

M/T: $15 \pm 5^\circ$ BTDC (in neutral position)

OK or NG

OK >> GO TO 19.

NG >> GO TO 11.

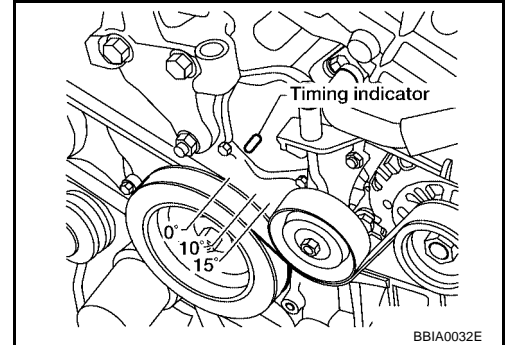

11. PERFORM ACCELERATOR PEDAL RELEASED POSITION LEARNING

1. Stop engine.
2. Perform [EC-711, "Accelerator Pedal Released Position Learning"](#).

>> GO TO 12.

12. PERFORM THROTTLE VALVE CLOSED POSITION LEARNING

Perform [EC-711, "Throttle Valve Closed Position Learning"](#).

>> GO TO 13.

13. PERFORM IDLE AIR VOLUME LEARNING

Refer to [EC-712, "Idle Air Volume Learning"](#).

Is Idle Air Volume Learning carried out successfully?

Yes or No

Yes >> GO TO 14.

No >> 1. Follow the instruction of Idle Air Volume Learning.
2. GO TO 4.

14. CHECK TARGET IDLE SPEED AGAIN

With CONSULT-II

1. Start engine and warm it up to normal operating temperature.
2. Read idle speed in "DATA MONITOR" mode with CONSULT-II. Refer to [EC-698, "IDLE SPEED"](#).

A/T: 675 ± 50 rpm (in P or N position)

M/T: 625 ± 50 rpm (in neutral position)

Without CONSULT-II

1. Start engine and warm it up to normal operating temperature.
2. Check idle speed. Refer to [EC-698, "IDLE SPEED"](#).

A/T: 675 ± 50 rpm (in P or N position)

M/T: 625 ± 50 rpm (in neutral position)

OK or NG

OK >> GO TO 15.

NG >> GO TO 17.

DATA MONITOR	
MONITOR	NO DTC
ENG SPEED	XXX rpm
COOLAN TEMP/S	XXX °C

SEF174Y

15. CHECK IGNITION TIMING AGAIN

1. Run engine at idle.
2. Check ignition timing with a timing light. Refer to [EC-698, "IGNITION TIMING"](#).

A/T: $15 \pm 5^\circ$ BTDC (in P or N position)

M/T: $15 \pm 5^\circ$ BTDC (in neutral position)

OK or NG

OK >> GO TO 19.

NG >> GO TO 16.

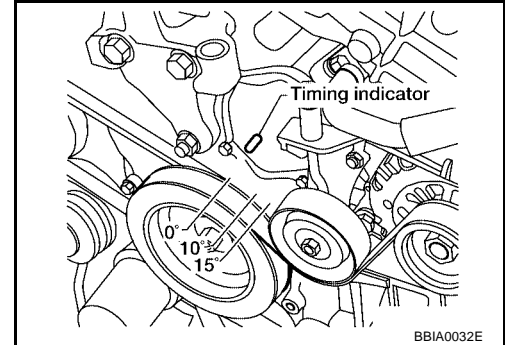

16. CHECK TIMING CHAIN INSTALLATION

Check timing chain installation. Refer to [EM-161, "TIMING CHAIN"](#).

OK or NG

OK >> GO TO 17.

NG >> 1. Repair the timing chain installation.
2. GO TO 4.

17. DETECT MALFUNCTIONING PART

Check the following.

- Check camshaft position sensor (PHASE) and circuit. Refer to [EC-928](#).
- Check crankshaft position sensor (POS) and circuit. Refer to [EC-921](#).

OK or NG

OK >> GO TO 18.

NG >> 1. Repair or replace.
2. GO TO 4.

18. CHECK ECM FUNCTION

1. Substitute another known-good ECM to check ECM function. (ECM may be the cause of an incident, but this is a rare case.)
2. Perform initialization of NVIS (NATS) system and registration of all NVIS (NATS) ignition key IDs. Refer to [EC-667, "Description"](#).

>> GO TO 4.

19. INSPECTION END

Did you replace ECM, referring this Basic Inspection procedure?

Yes or No

Yes >> 1. Perform [EC-711, "VIN Registration"](#).
2. **INSPECTION END**

No >> **INSPECTION END**

Idle Speed and Ignition Timing Check IDLE SPEED

With CONSULT-II

Check idle speed in "DATA MONITOR" mode with CONSULT-II.

DATA MONITOR	
MONITOR	NO DTC
ENG SPEED	XXX rpm

SEF058Y

With GST

Check idle speed in "Service \$01" with GST.

IGNITION TIMING

Method A

1. Attach timing light to loop wire as shown.

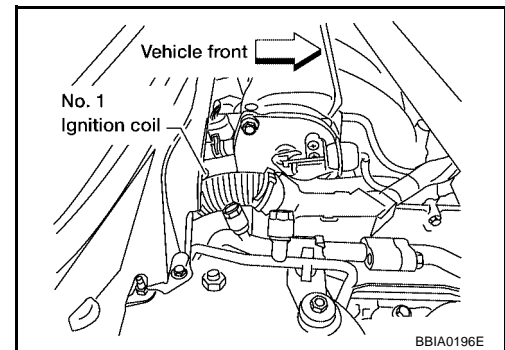

2. Check ignition timing.

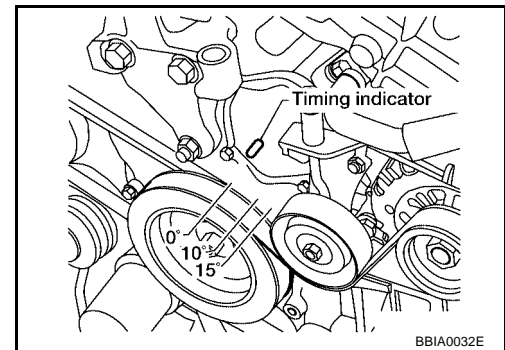

Method B

1. Remove No.1 ignition coil.

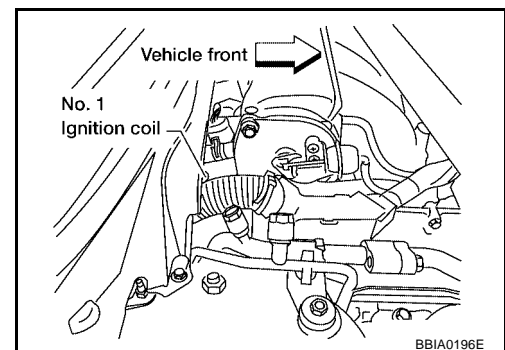

BASIC SERVICE PROCEDURE

[VQ]

2. Connect No.1 ignition coil and spark plug with suitable high-tension wire as shown, and attach timing light clamp to this wire.

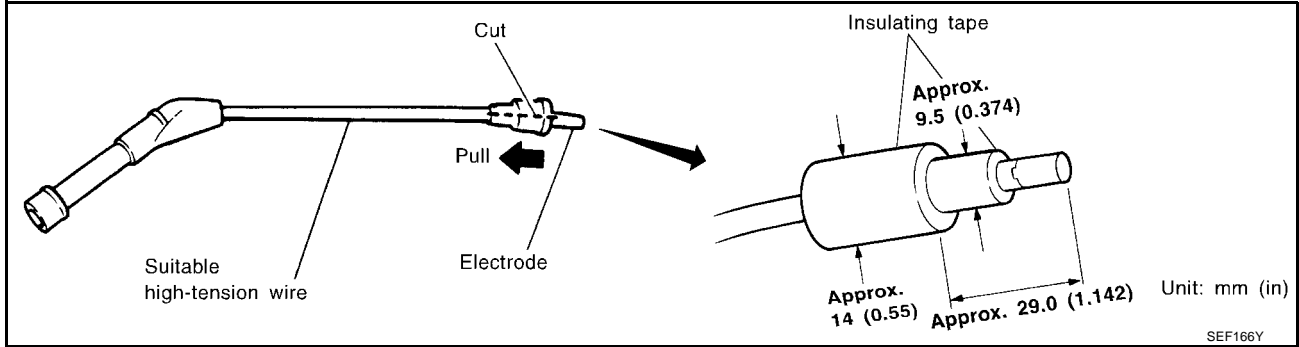
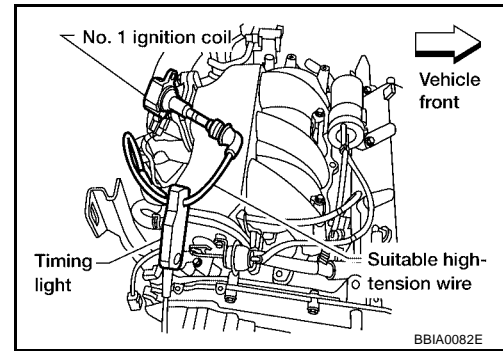

3. Check ignition timing.

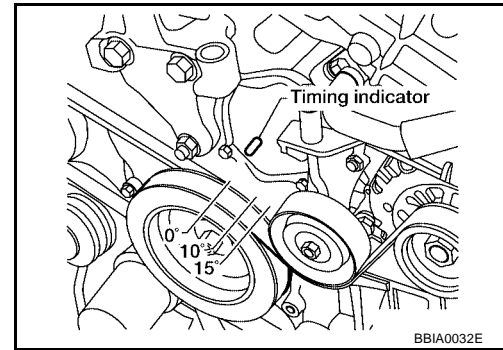

Idle Mixture Ratio Adjustment

PREPARATION

1. Make sure that the following parts are in good order.
 - Battery
 - Ignition system
 - Engine oil and coolant levels
 - Fuses
 - ECM harness connector
 - Vacuum hoses
 - Air intake system
(Oil filler cap, oil level gauge, etc.)
 - Fuel pressure
 - Engine compression
 - EGR volume control valve operation
 - Throttle valve
 - Evaporative emission system
2. On air conditioner equipped models, checks should be carried out while the air conditioner is OFF.
3. On automatic transmission equipped models, when checking idle rpm, ignition timing and mixture ratio, checks should be carried out while selector lever is in N position.
4. When measuring CO percentage, insert probe more than 40 cm (15.7 in) into tail pipe.
5. Turn OFF headlamp, heater blower, rear window defogger.
6. Keep front wheels pointed straight ahead.

OVERALL SEQUENCE

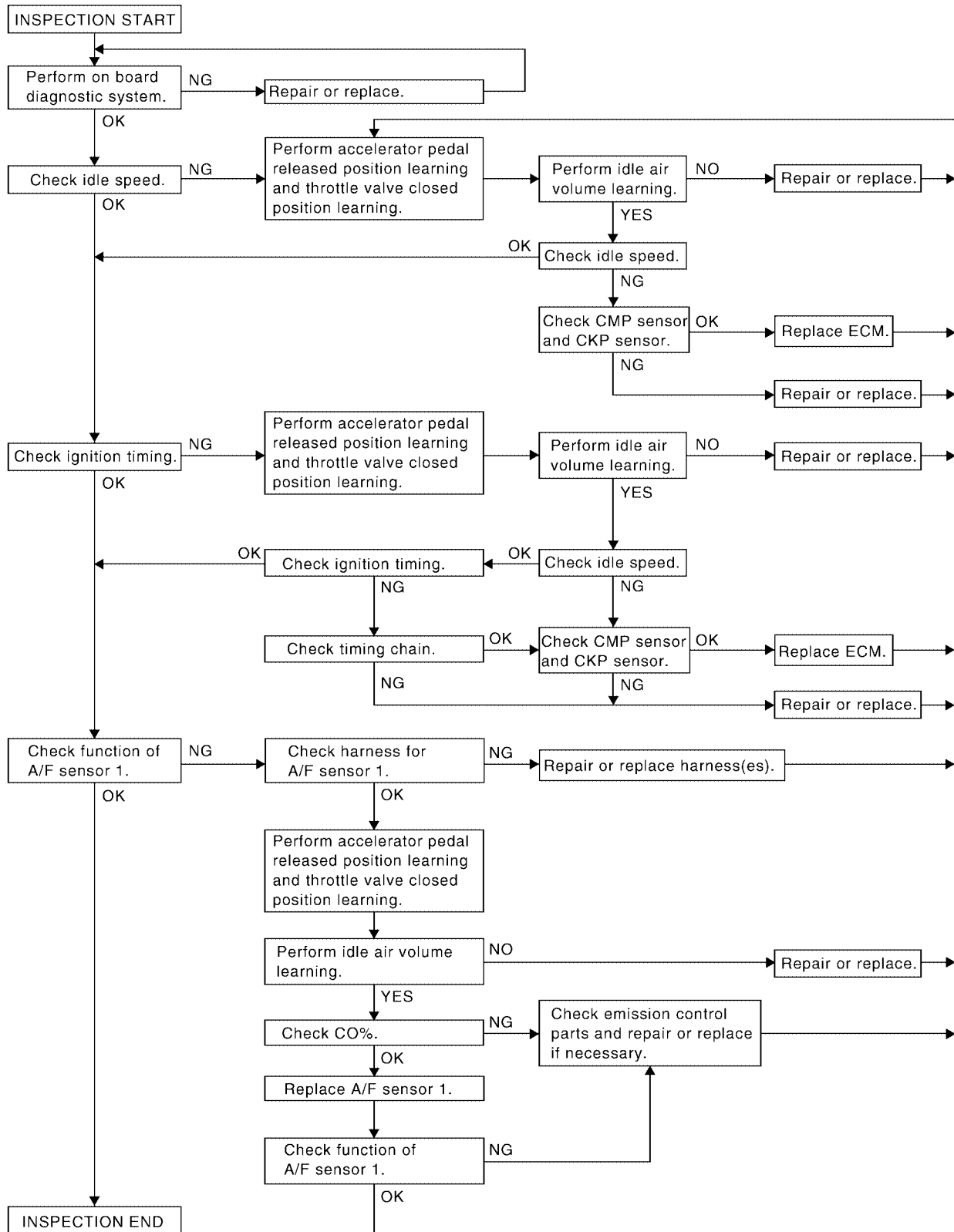

NOTE:

If a vehicle contains a part which is operating outside of design specifications with no MIL illumination, the part shall not be replaced prior to emission testing unless it is determined that the part has been tampered with or abused in such a way that the diagnostic system cannot reasonably be expected to detect the resulting malfunction.

PBIB2086E

DETAILED PROCEDURE

1. INSPECTION START

1. Check service records for any recent repairs that may indicate a related malfunction, or a current need for scheduled maintenance.
2. Open engine hood and check the following:
 - Harness connectors for improper connections
 - Wiring harness for improper connections, pinches and cut
 - Vacuum hoses for splits, kinks and improper connections
 - Hoses and ducts for leaks
 - Air cleaner clogging
 - Gasket
3. Confirm that electrical or mechanical loads are not applied.
 - Head lamp switch is OFF.
 - Air conditioner switch is OFF.
 - Rear window defogger switch is OFF.
 - Steering wheel is in the straight-ahead position, etc.
4. Start engine and warm it up until engine coolant temperature indicator points the middle of gauge. Ensure engine stays below 1,000 rpm.

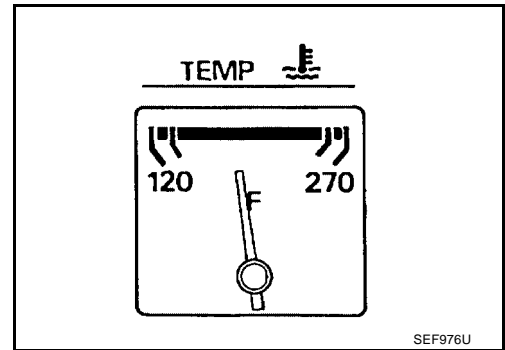
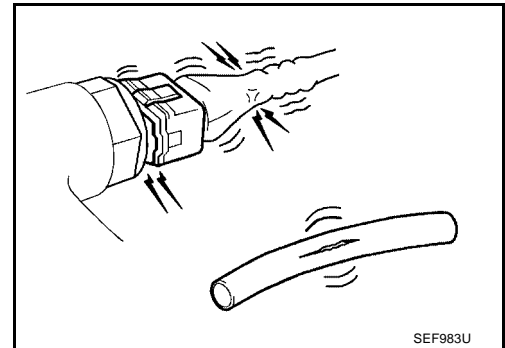

5. Run engine at about 2,000 rpm for about 2 minutes under no-load.
6. Make sure that no DTC is displayed with CONSULT-II or GST.

OK or NG

- OK >> GO TO 3.
- NG >> GO TO 2.

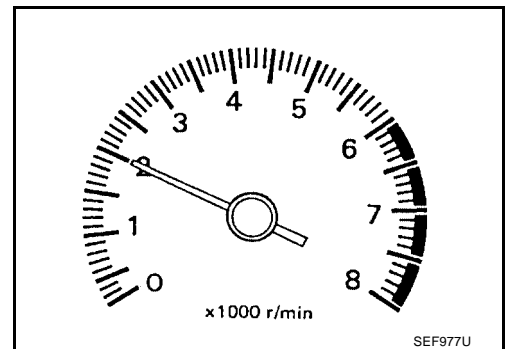

2. REPAIR OR REPLACE

Repair or replace components as necessary according to corresponding Diagnostic Procedure.

>> GO TO 3.

3. CHECK TARGET IDLE SPEED

Ⓟ With CONSULT-II

1. Run engine at about 2,000 rpm for about 2 minutes under no-load.
2. Rev engine (2,000 to 3,000 rpm) 2 or 3 times under no-load, then run engine at idle speed for about 1 minute.

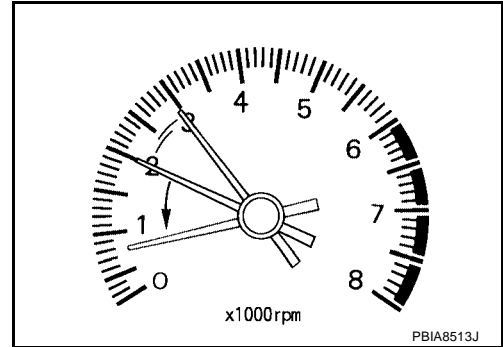

3. Read idle speed in "DATA MONITOR" mode with CONSULT-II. Refer to [EC-698, "IDLE SPEED"](#) .

A/T: 675 ± 50 rpm (in P or N position)
M/T: 625 ± 50 rpm (in neutral position)

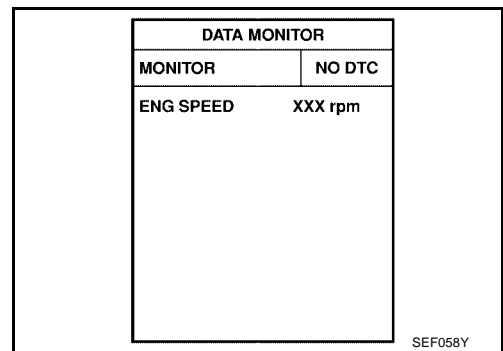

ⓧ Without CONSULT-II

1. Run engine at about 2,000 rpm for about 2 minutes under no-load.
2. Rev engine (2,000 to 3,000 rpm) 2 or 3 times under no-load, then run engine at idle speed for about 1 minute.
3. Check idle speed. Refer to [EC-698, "IDLE SPEED"](#) .

A/T: 675 ± 50 rpm (in P or N position)
M/T: 625 ± 50 rpm (in neutral position)

OK or NG

- OK >> GO TO 10.
- NG >> GO TO 4.

4. PERFORM ACCELERATOR PEDAL RELEASED POSITION LEARNING

1. Stop engine.
2. Perform [EC-711, "Accelerator Pedal Released Position Learning"](#) .

>> GO TO 5.

5. PERFORM THROTTLE VALVE CLOSED POSITION LEARNING

Perform [EC-711, "Throttle Valve Closed Position Learning"](#) .

>> GO TO 6.

6. PERFORM IDLE AIR VOLUME LEARNING

Perform [EC-712, "Idle Air Volume Learning"](#) .

Is Idle Air Volume Learning carried out successfully?

Yes or No

- Yes >> GO TO 7.
 No >> 1. Follow the instruction of Idle Air Volume Learning.
 2. GO TO 4.

7. CHECK TARGET IDLE SPEED AGAIN

Ⓟ With CONSULT-II

1. Start engine and warm it up to normal operating temperature.
2. Read idle speed in "DATA MONITOR" mode with CONSULT-II. Refer to [EC-698, "IDLE SPEED"](#) .

A/T: 675 ± 50 rpm (in P or N position)

M/T: 625 ± 50 rpm (in neutral position)

ⓧ Without CONSULT-II

1. Start engine and warm it up to normal operating temperature.
2. Check idle speed. Refer to [EC-698, "IDLE SPEED"](#) .

A/T: 675 ± 50 rpm (in P or N position)

M/T: 625 ± 50 rpm (in neutral position)

DATA MONITOR	
MONITOR	NO DTC
ENG SPEED	XXX rpm
COOLAN TEMP/S	XXX °C

SEF174Y

OK or NG

- OK >> GO TO 10.
 NG >> GO TO 8.

8. DETECT MALFUNCTIONING PART

Check the following.

- Check camshaft position sensor (PHASE) and circuit. Refer to [EC-928](#) .
- Check crankshaft position sensor (POS) and circuit. Refer to [EC-921](#) .

OK or NG

- OK >> GO TO 9.
 NG >> 1. Repair or replace.
 2. GO TO 4.

9. CHECK ECM FUNCTION

1. Substitute another known-good ECM to check ECM function. (ECM may be the cause of an incident, but this is a rare case.)
2. Perform initialization of NVIS (NATS) system and registration of all NVIS (NATS) ignition key IDs. Refer to [BL-109, "ECM Re-communicating Function"](#) .

>> GO TO 4.

10. CHECK IGNITION TIMING

1. Run engine at idle.
2. Check ignition timing with a timing light. Refer to [EC-698, "IGNITION TIMING"](#).

A/T: 15 ± 5° BTDC (in P or N position)

M/T: 15 ± 5° BTDC (in neutral position)

OK or NG

OK (With CONSULT-II)>>GO TO 19.

OK (Without CONSULT-II)>>GO TO 20.

NG >> GO TO 11.

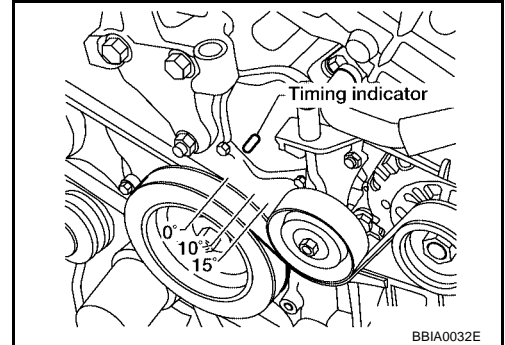

11. PERFORM ACCELERATOR PEDAL RELEASED POSITION LEARNING

1. Stop engine.
2. Perform [EC-711, "Accelerator Pedal Released Position Learning"](#).

>> GO TO 12.

12. PERFORM THROTTLE VALVE CLOSED POSITION LEARNING

Perform [EC-711, "Throttle Valve Closed Position Learning"](#).

>> GO TO 13.

13. PERFORM IDLE AIR VOLUME LEARNING

Perform [EC-712, "Idle Air Volume Learning"](#).

Is Idle Air Volume Learning carried out successfully?

Yes or No

Yes >> GO TO 14.

No >> 1. Follow the instruction of Idle Air Volume Learning.
2. GO TO 4.

14. CHECK TARGET IDLE SPEED AGAIN

With CONSULT-II

1. Start engine and warm it up to normal operating temperature.
2. Read idle speed in "DATA MONITOR" mode with CONSULT-II. Refer to [EC-698, "IDLE SPEED"](#).

A/T: 675 ± 50 rpm (in P or N position)

M/T: 625 ± 50 rpm (in neutral position)

Without CONSULT-II

1. Start engine and warm it up to normal operating temperature.
2. Check idle speed. Refer to [EC-698, "IDLE SPEED"](#).

A/T: 675 ± 50 rpm (in P or N position)

M/T: 625 ± 50 rpm (in neutral position)

OK or NG

OK >> GO TO 15.

NG >> GO TO 17.

DATA MONITOR	
MONITOR	NO DTC
ENG SPEED	XXX rpm
COOLAN TEMP/S	XXX °C

SEF174Y

15. CHECK IGNITION TIMING AGAIN

1. Run engine at idle.
2. Check ignition timing with a timing light. Refer to [EC-698, "IGNITION TIMING"](#) .

A/T: $15 \pm 5^\circ$ BTDC (in P or N position)

M/T: $15 \pm 5^\circ$ BTDC (in neutral position)

OK or NG

OK (With CONSULT-II)>>GO TO 19.

OK (Without CONSULT-II)>>GO TO 20.

NG >> GO TO 16.

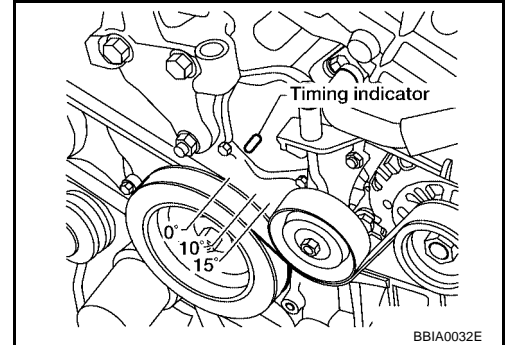

16. CHECK TIMING CHAIN INSTALLATION

Check timing chain installation. Refer to [EM-161, "TIMING CHAIN"](#) .

OK or NG

OK >> GO TO 17.

NG >> 1. Repair the timing chain installation.

2. GO TO 4.

17. DETECT MALFUNCTIONING PART

Check the following.

- Check camshaft position sensor (PHASE) and circuit. Refer to [EC-928](#) .
- Check crankshaft position sensor (POS) and circuit. Refer to [EC-921](#) .

OK or NG

OK >> GO TO 18.

NG >> 1. Repair or replace.

2. GO TO 4.

18. CHECK ECM FUNCTION

1. Substitute another known-good ECM to check ECM function. (ECM may be the cause of an incident, but this is a rare case.)
2. Perform initialization of NVIS (NATS) system and registration of all NVIS (NATS) ignition key IDs. Refer to [BL-109, "ECM Re-communicating Function"](#) .

>> GO TO 4.

19. CHECK AIR FUEL RATIO (A/F) SENSOR 1 FUNCTION

 **With CONSULT-II**

1. Turn ignition switch OFF and wait at a least 10 seconds.
2. Start engine and warm it up to normal operating temperature.
3. Drive the vehicle at a speed of 80 km/h (50 MPH) for a few minutes in D position (A/T) or 5th positin (M/T).

NOTE:

Keep the accelerator pedal as steady as possible during the cruising.

4. Then release the accelerator pedal fully until the vehicle speed decreases to 50 km/h (30 MPH).

NOTE:

Never apply brake during releasing the accelerator pedal.

5. Repeat steps 3 to 4 for 5 times.
6. Stop the vehicle and connect CONSULT-II to the vehicle.
7. Make sure that no (1st trip) DTC is displayed in "SELF-DIAG RESULTS" mode.

OK or NG

- OK >> **INSPECTION END**
 NG >> GO TO 21.

20. CHECK AIR FUEL RATIO (A/F) SENSOR 1 FUNCTION

 **With GST**

1. Turn ignition switch OFF and wait at a least 10 seconds.
2. Start engine and warm it up to normal operating temperature.
3. Drive the vehicle at a speed of 80 km/h (50 MPH) for a few minutes in D position (A/T) or 5th positin (M/T).

NOTE:

Keep the accelerator pedal as steady as possible during the cruising.

4. Then release the accelerator pedal fully until the vehicle speed decreases to 50 km/h (30 MPH).

NOTE:

Never apply brake during releasing the accelerator pedal.

5. Repeat steps 3 to 4 for 5 times.
6. Stop the vehicle and connect GST to the vehicle.
7. Make sure that no (1st trip) DTC is displayed.

OK or NG

- OK >> **INSPECTION END**
 NG >> GO TO 21.

A
EC
C
D
E
F
G
H
I
J
K
L
M

21. CHECK AIR FUEL RATIO (A/F) SENSOR 1 HARNESS

1. Turn ignition switch OFF and disconnect battery ground cable.
2. Disconnect ECM harness connector.
3. Disconnect A/F sensor 1 harness connector.
4. Check harness continuity between the following terminals. Refer to [EC-1134, "Wiring Diagram"](#) .

Bank 1		Bank 2	
A/F sensor 1 terminal	ECM terminal	A/F sensor 1 terminal	ECM terminal
1	16	1	76
2	75	2	77
4	2	4	24
5	35	5	57
6	56	6	58

Continuity should exist.

5. Also check harness for short to ground and short to power.

OK or NG

OK >> GO TO 22.

NG >> 1. Repair open circuit or short to ground or short to power in harness or connectors between ECM and A/F sensor 1.

2. GO TO 4.

22. PERFORM ACCELERATOR PEDAL RELEASED POSITION LEARNING

1. Reconnect ECM harness connector.
2. Perform [EC-711, "Accelerator Pedal Released Position Learning"](#) .

>> GO TO 23.

23. PERFORM THROTTLE VALVE CLOSED POSITION LEARNING

Perform [EC-711, "Throttle Valve Closed Position Learning"](#) .

>> GO TO 24.

24. PERFORM IDLE AIR VOLUME LEARNING

Refer to [EC-712, "Idle Air Volume Learning"](#) .

Is Idle Air Volume Learning carried out successfully?

Yes or No

Yes (With CONSULT-II)>>GO TO 25.

Yes (Without CONSULT-II)>>GO TO 26.

No >> 1. Follow the instruction of Idle Air Volume Learning.
 2. GO TO 4.

25. CHECK CO%

With CONSULT-II

1. Start engine and warm it up until engine coolant temperature indicator points the middle of gauge.
2. Turn ignition switch OFF, wait at least 10 seconds and then turn ON.
3. Select "ENG COOLANT TEMP" in "ACTIVE TEST" mode.
4. Set "ENG COOLANT TEMP" to 5°C (41°F) by touching "DOWN" and "Qd".
5. Start engine and rev it (2,000 to 3,000 rpm) two or three times under no load, then run engine at idle speed.
6. Check CO%.

Idle CO: 0.7 – 9.9% and engine runs smoothly.

OK or NG

- OK >> GO TO 28.
- NG >> GO TO 27.

ACTIVE TEST	
ENG COOLANT TEMP	XXX °C
MONITOR	
ENG SPEED	XXX rpm
INJ PULSE-B1	XXX msec
IGN TIMING	XXX BTDC

SEF172Y

26. CHECK CO%

Without CONSULT-II

1. Start engine and warm it up until engine coolant temperature indicator points to the middle of gauge.
2. Turn ignition switch OFF.
3. Disconnect engine coolant temperature sensor harness connector.
4. Connect a resistor (4.4 kΩ) between terminals of engine coolant temperature sensor harness connector.
5. Start engine and rev it (2,000 to 3,000 rpm) 2 or 3 times under no load, then run engine at idle speed.
6. Check CO%.

Idle CO: 0.7 – 9.9% and engine runs smoothly.

7. After checking CO%, turn ignition switch OFF, disconnect the resistor from the terminals of engine coolant temperature sensor harness connector, and then connect engine coolant temperature sensor harness connector to engine coolant temperature sensor.

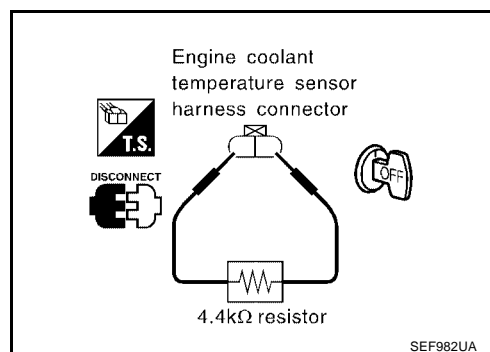

OK or NG

- OK >> GO TO 28.
- NG >> GO TO 27.

27. RECONNECT AIR FUEL RATIO (A/F) SENSOR 1 HARNESS CONNECTOR

1. Turn ignition switch OFF.
2. Reconnect A/F sensor 1 harness connector.

>> GO TO 31.

28. REPLACE AIR FUEL RATIO (A/F) SENSOR 1

1. Stop engine.
2. Replace A/F sensor 1 on the malfunctioning bank.

With CONSULT-II>>GO TO 29.
With GST>>GO TO 30.

29. CHECK AIR FUEL RATIO (A/F) SENSOR 1 FUNCTION

With CONSULT-II

1. Turn ignition switch OFF and wait at a least 10 seconds.
2. Start engine and warm it up to normal operating temperature.
3. Drive the vehicle at a speed of 80 km/h (50 MPH) for a few minutes in D position (A/T) or 5th positin (M/T).

NOTE:

Keep the accelerator pedal as steady as possible during the cruising.

4. Then release the accelerator pedal fully until the vehicle speed decreases to 50 km/h (30 MPH).

NOTE:

Never apply brake during releasing the accelerator pedal.

5. Repeat steps 3 to 4 for 5 times.
6. Stop the vehicle and connect CONSULT-II to the vehicle.
7. Make sure that no (1st trip) DTC is displayed in "SELF-DIAG RESULTS" mode.

OK or NG

- OK >> GO TO 4.
NG >> GO TO 31.

30. CHECK AIR FUEL RATIO (A/F) SENSOR 1 FUNCTION

With GST

1. Turn ignition switch OFF and wait at a least 10 seconds.
2. Start engine and warm it up to normal operating temperature.
3. Drive the vehicle at a speed of 80 km/h (50 MPH) for a few minutes in D position (A/T) or 5th positin (M/T).

NOTE:

Keep the accelerator pedal as steady as possible during the cruising.

4. Then release the accelerator pedal fully until the vehicle speed decreases to 50 km/h (30 MPH).

NOTE:

Never apply brake during releasing the accelerator pedal.

5. Repeat steps 3 to 4 for 5 times.
6. Stop the vehicle and connect GST to the vehicle.
7. Make sure that no (1st trip) DTC is displayed.

OK or NG

- OK >> GO TO 4.
NG >> GO TO 31.

31. DETECT MALFUNCTIONING PART

Check the following.

- Check fuel pressure regulator, and repair or replace if necessary. Refer to [EC-714, "Fuel Pressure Check"](#).
- Check mass air flow sensor and its circuit, and repair or replace if necessary. Refer to [EC-806](#) and [EC-815](#).
- Check injector and its circuit, and repair or replace if necessary. Refer to [EC-1308](#).
- Check engine coolant temperature sensor and its circuit, and repair or replace if necessary. Refer to [EC-826](#) and [EC-838](#).

OK or NG

- OK >> GO TO 33.
NG >> 1. Repair or replace.
2. GO TO 32.

32. ERASE UNNECESSARY DTC

After this inspection, unnecessary DTC might be displayed. Erase the stored memory in ECM and TCM. Refer to [EC-682, "How to Erase DTC"](#) and [AT-422, "HOW TO ERASE DTC"](#).

>> GO TO 4.

33. CHECK ECM FUNCTION

1. Substitute another known-good ECM to check ECM function. (ECM may be the cause of an incident, but this is a rare case.)
2. Perform initialization of NVIS (NATS) system and registration of all NVIS (NATS) ignition key IDs. Refer to [BL-109, "ECM Re-communicating Function"](#).

>> GO TO 4.

VIN Registration DESCRIPTION

UBS00110

VIN Registration is an operation to registering VIN in ECM. It must be performed each time ECM is replaced.

NOTE:

Accurate VIN which is registered in ECM may be required for Inspection & Maintenance (I/M).

OPERATION PROCEDURE

Ⓟ **With CONSULT-II**

1. Check the VIN of the vehicle and note it. Refer to [GI-46, "IDENTIFICATION INFORMATION"](#).
2. Turn ignition switch ON and engine stopped.
3. Select "VIN REGISTRATION" in "WORK SUPPORT" mode.
4. Follow the instruction of CONSULT-II display.

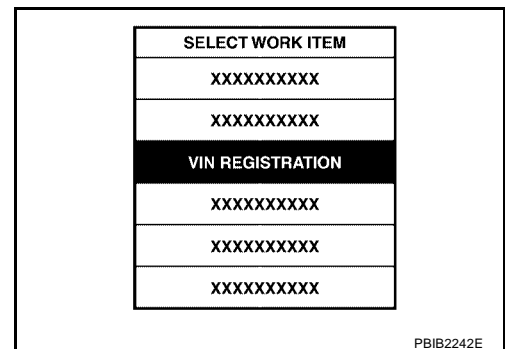

Accelerator Pedal Released Position Learning DESCRIPTION

UBS00HZP

Accelerator Pedal Released Position Learning is an operation to learn the fully released position of the accelerator pedal by monitoring the accelerator pedal position sensor output signal. It must be performed each time harness connector of accelerator pedal position sensor or ECM is disconnected.

OPERATION PROCEDURE

1. Make sure that accelerator pedal is fully released.
2. Turn ignition switch ON and wait at least 2 seconds.
3. Turn ignition switch OFF and wait at least 10 seconds.
4. Turn ignition switch ON and wait at least 2 seconds.
5. Turn ignition switch OFF and wait at least 10 seconds.

Throttle Valve Closed Position Learning DESCRIPTION

UBS00HZQ

Throttle Valve Closed Position Learning is an operation to learn the fully closed position of the throttle valve by monitoring the throttle position sensor output signal. It must be performed each time harness connector of electric throttle control actuator or ECM is disconnected.

OPERATION PROCEDURE

1. Make sure that accelerator pedal is fully released.
2. Turn ignition switch ON.
3. Turn ignition switch OFF wait at least 10 seconds.
Make sure that throttle valve moves during above 10 seconds by confirming the operating sound.

Idle Air Volume Learning DESCRIPTION

UBS00HZR

Idle Air Volume Learning is an operation to learn the idle air volume that keeps each engine within the specific range. It must be performed under any of the following conditions:

- Each time electric throttle control actuator or ECM is replaced.
- Idle speed or ignition timing is out of specification.

PREPARATION

Before performing Idle Air Volume Learning, make sure that all of the following conditions are satisfied. Learning will be cancelled if any of the following conditions are missed for even a moment.

- Battery voltage: More than 12.9V (At idle)
- Engine coolant temperature: 70 - 100°C (158 - 212°F)
- PNP switch: ON
- Electric load switch: OFF
(Air conditioner, headlamp, rear window defogger)
On vehicles equipped with daytime light systems, if the parking brake is applied before the engine is start the headlamp will not be illuminated.
- Steering wheel: Neutral (Straight-ahead position)
- Vehicle speed: Stopped
- Transmission: Warmed-up
For A/T models with CONSULT-II, drive vehicle until "FLUID TEMP SE" in "DATA MONITOR" mode of "A/T" system indicates less than 0.9V.
For A/T models without CONSULT-II and M/T models, drive vehicle for 10 minutes.

OPERATION PROCEDURE

With CONSULT-II

1. Perform [EC-711, "Accelerator Pedal Released Position Learning"](#) .
2. Perform [EC-711, "Throttle Valve Closed Position Learning"](#) .
3. Start engine and warm it up to normal operating temperature.
4. Check that all items listed under the topic PREPARATION (previously mentioned) are in good order.
5. Select "IDLE AIR VOL LEARN" in "WORK SUPPORT" mode.

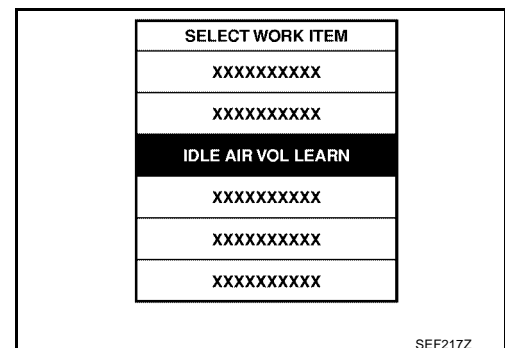

BASIC SERVICE PROCEDURE

[VQ]

6. Touch "START" and wait 20 seconds.

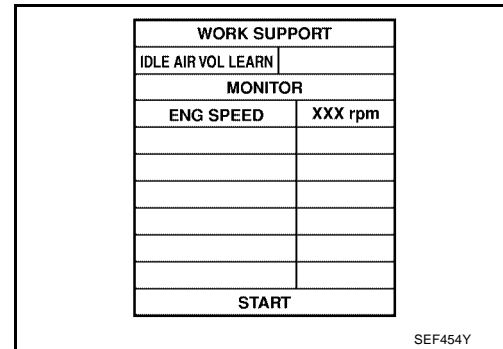

7. Make sure that "CMPLT" is displayed on CONSULT-II screen. If "CMPLT" is not displayed, Idle Air Volume Learning will not be carried out successfully. In this case, find the cause of the incident by referring to the DIAGNOSTIC PROCEDURE below.

8. Rev up the engine 2 or 3 times and make sure that idle speed and ignition timing are within the specifications.

ITEM	SPECIFICATION
Idle speed	A/T: 675 ± 50 rpm (in P or N position) M/T: 625 ± 50 rpm (in neutral position)
Ignition timing	A/T: 15 ± 5° BTDC (in P or N position) M/T: 15 ± 5° BTDC (in neutral position)

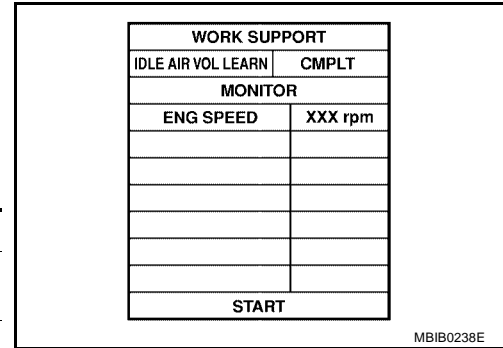

⊗ Without CONSULT-II

NOTE:

- It is better to count the time accurately with a clock.
 - It is impossible to switch the diagnostic mode when an accelerator pedal position sensor circuit has a malfunction.
1. Perform [EC-711, "Accelerator Pedal Released Position Learning"](#) .
 2. Perform [EC-711, "Throttle Valve Closed Position Learning"](#) .
 3. Start engine and warm it up to normal operating temperature.
 4. Check that all items listed under the topic PREPARATION (previously mentioned) are in good order.
 5. Turn ignition switch OFF and wait at least 10 seconds.
 6. Confirm that accelerator pedal is fully released, turn ignition switch ON and wait 3 seconds.
 7. Repeat the following procedure quickly 5 times within 5 seconds.
 - a. Fully depress the accelerator pedal.
 - b. Fully release the accelerator pedal.
 8. Wait 7 seconds, fully depress the accelerator pedal and keep it for approx. 20 seconds until the MIL stops blinking and turned ON.
 9. Fully release the accelerator pedal within 3 seconds after the MIL turned ON.
 10. Start engine and let it idle.
 11. Wait 20 seconds.

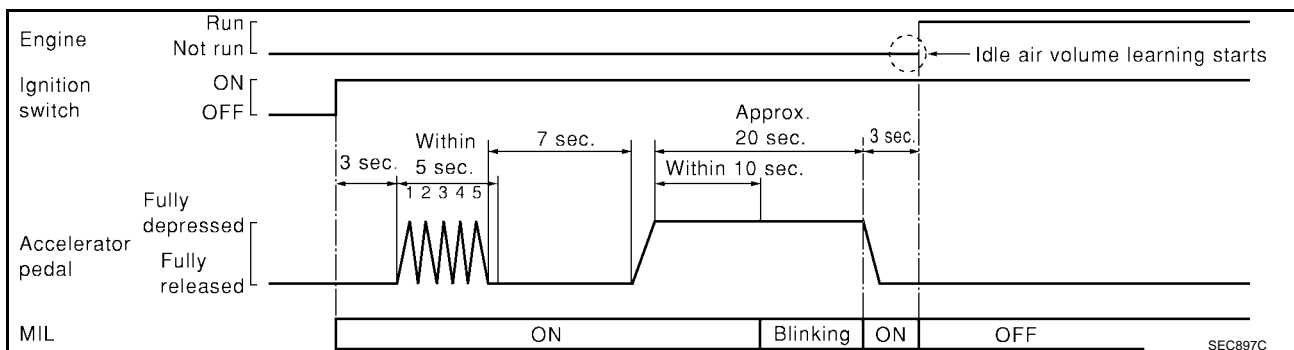

12. Rev up the engine 2 or 3 times and make sure that idle speed and ignition timing are within the specifications.

ITEM	SPECIFICATION
Idle speed	A/T: 675 ± 50 rpm (in P or N position) M/T: 625 ± 50 rpm (in neutral position)
Ignition timing	A/T: 15 ± 5° BTDC (in P or N position) M/T: 15 ± 5° BTDC (in neutral position)

13. If idle speed and ignition timing are not within the specification, Idle Air Volume Learning will not be carried out successfully. In this case, find the cause of the incident by referring to the DIAGNOSTIC PROCEDURE below.

DIAGNOSTIC PROCEDURE

If idle air volume learning cannot be performed successfully, proceed as follows:

1. Check that throttle valve is fully closed.
2. Check PCV valve operation.
3. Check that downstream of throttle valve is free from air leakage.
4. When the above three items check out OK, engine component parts and their installation condition are questionable. Check and eliminate the cause of the incident.
It is useful to perform [EC-772, "TROUBLE DIAGNOSIS - SPECIFICATION VALUE"](#).
5. If any of the following conditions occur after the engine has started, eliminate the cause of the incident and perform "Idle Air Volume Learning" all over again:
 - Engine stalls.
 - Erroneous idle.

Fuel Pressure Check FUEL PRESSURE RELEASE

UBS00HZS

④ With CONSULT-II

1. Turn ignition switch ON.
2. Perform "FUEL PRESSURE RELEASE" in "WORK SUPPORT" mode with CONSULT-II.
3. Start engine.
4. After engine stalls, crank it 2 or 3 times to release all fuel pressure.
5. Turn ignition switch OFF.

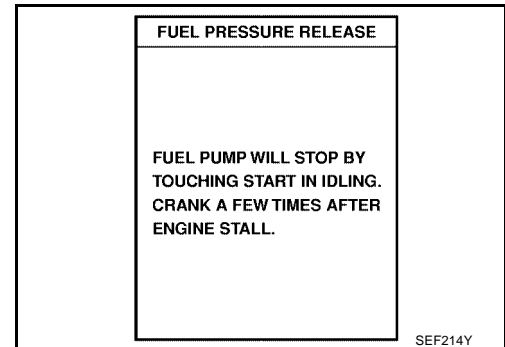

⊗ Without CONSULT-II

1. Remove fuel pump fuse located in IPDM E/R.
2. Start engine.
3. After engine stalls, crank it 2 or 3 times to release all fuel pressure.
4. Turn ignition switch OFF.
5. Reinstall fuel pump fuse after servicing fuel system.

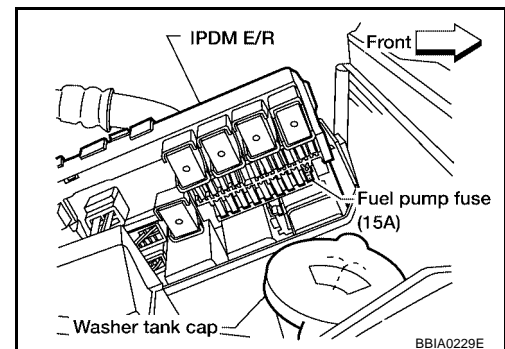

FUEL PRESSURE CHECK

CAUTION:

- Be careful not to scratch or get the fuel hose connection area dirty when servicing, so that the quick connector o-ring maintains sealability.

BASIC SERVICE PROCEDURE

[VQ]

- Use Fuel Pressure Gauge Kit J-44321 and Fuel Pressure Adapter J-44321-6 to check fuel pressure.
- Do not perform fuel pressure check with electrical system operating (i.e. lights, rear defog, A/C, etc.). Fuel pressure gauge may indicate false readings due to varying engine loads and changes in manifold vacuum.

NOTE:

Prepare pans or saucers under the disconnected fuel line because the fuel may spill out. The fuel pressure cannot be completely released because L31 models do not have fuel return system.

1. Release fuel pressure to zero. Refer to [EC-714, "FUEL PRESSURE RELEASE"](#).
2. Remove fuel hose using Quick Connector Release J-45488. Refer to [EM-122, "INTAKE MANIFOLD COLLECTOR"](#).
 - Do not twist or kink fuel hose because it is plastic hose.
 - Do not remove fuel hose from quick connector.
 - Keep fuel hose connections clean.
3. Install Fuel Pressure Adapter J-44321-6 and Fuel Pressure Gauge (from kit J-44321) as shown in figure.
 - Do not distort or bend fuel rail tube when installing fuel pressure gauge adapter.
 - When reconnecting fuel hose, check the original fuel hose for damage and abnormality.
4. Turn ignition switch ON (reactivate fuel pump), and check for fuel leakage.
5. Start engine and check for fuel leakage.
6. Read the indication of fuel pressure gauge.
 - During fuel pressure check, check for fuel leakage from fuel connection every 3 minutes.

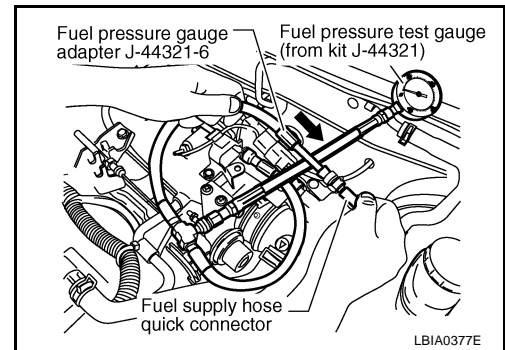

At idling: Approximately 350 kPa (3.57 kg/cm² , 51 psi)

7. If result is unsatisfactory, go to next step.
8. Check the following.
 - Fuel hoses and fuel tubes for clogging
 - Fuel filter for clogging
 - Fuel pump
 - Fuel pressure regulator for cloggingIf OK, replace fuel pressure regulator.
If NG, repair or replace.
9. Before disconnecting Fuel Pressure Gauge and Fuel Pressure Adapter J-44321-6, release fuel pressure to zero. Refer to [EC-714, "FUEL PRESSURE RELEASE"](#).

TROUBLE DIAGNOSIS

Trouble Diagnosis Introduction INTRODUCTION

The engine has an ECM to control major systems such as fuel control, ignition control, idle air control system, etc. The ECM accepts input signals from sensors and instantly drives actuators. It is essential that both input and output signals are proper and stable. At the same time, it is important that there are no malfunctions such as vacuum leaks, fouled spark plugs, or other malfunctions with the engine.

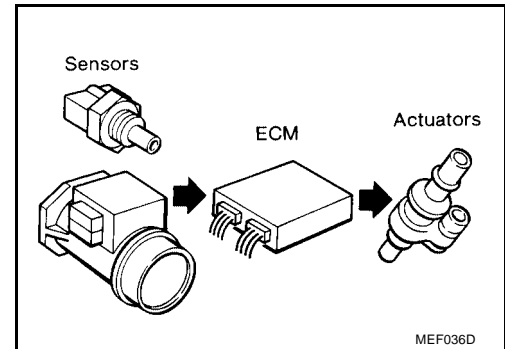

It is much more difficult to diagnose an incident that occurs intermittently rather than continuously. Most intermittent incidents are caused by poor electric connections or improper wiring. In this case, careful checking of suspected circuits may help prevent the replacement of good parts.

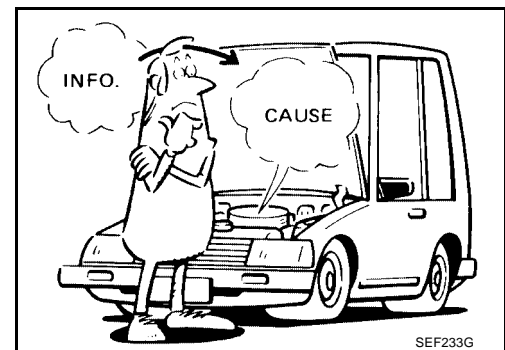

A visual check only may not find the cause of the incidents. A road test with CONSULT-II (or GST) or a circuit tester connected should be performed. Follow the WORK FLOW on [EC-717](#).

Before undertaking actual checks, take a few minutes to talk with a customer who approaches with a driveability complaint. The customer can supply good information about such incidents, especially intermittent ones. Find out what symptoms are present and under what conditions they occur. A DIAGNOSTIC WORKSHEET like the example on [EC-721](#) should be used.

Start your diagnosis by looking for conventional malfunctions first. This will help troubleshoot driveability malfunctions on an electronically controlled engine vehicle.

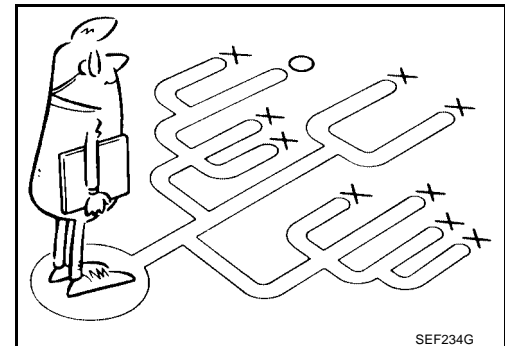

TROUBLE DIAGNOSIS

[VQ]

WORK FLOW Overall Sequence

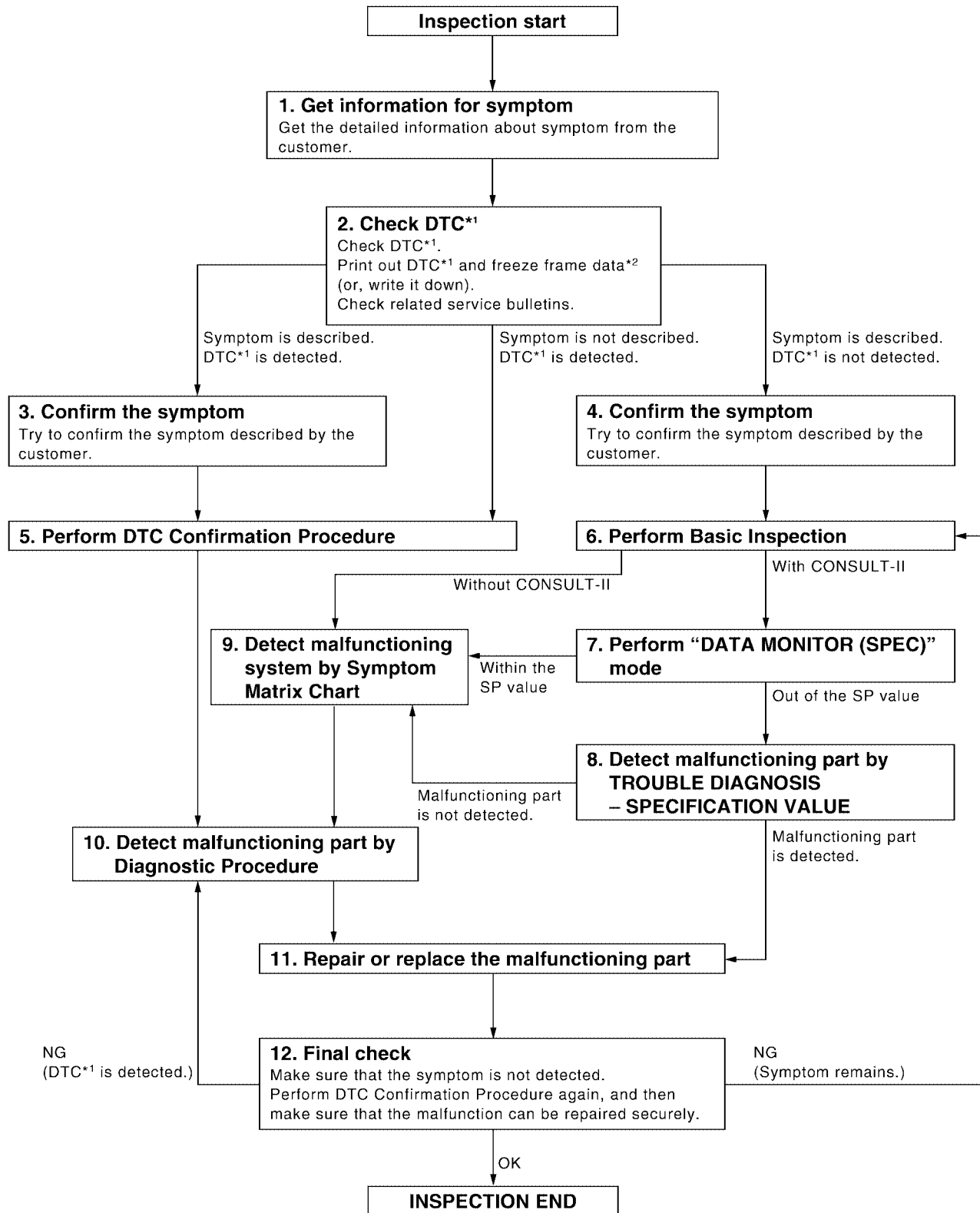

*1: Include 1st trip DTC.

*2: Include 1st trip freeze frame data.

PBIB2267E

Detailed Flow**1. GET INFORMATION FOR SYMPTOM**

Get the detailed information from the customer about the symptom (the condition and the environment when the incident/malfunction occurred) using the [EC-720, "DIAGNOSTIC WORKSHEET"](#) .

>> GO TO 2.

2. CHECK DTC*¹

1. Check DTC*¹ .
2. Perform the following procedure if DTC*¹ is displayed.
 - Record DTC*¹ and freeze frame data*² . (Print them out with CONSULT-II or GST.)
 - Erase DTC*¹ . (Refer to [EC-682, "HOW TO ERASE EMISSION-RELATED DIAGNOSTIC INFORMATION"](#) .)
 - Study the relationship between the cause detected by DTC*¹ and the symptom described by the customer. (Symptom Matrix Chart is useful. Refer to [EC-725](#) .)
3. Check related service bulletins for information.

Is any symptom described and any DTC detected?

Symptom is described, DTC*¹ is displayed>>GO TO 3.

Symptom is described, DTC*¹ is not displayed>>GO TO 4.

Symptom is not described, DTC*¹ is displayed>>GO TO 5.

3. CONFIRM THE SYMPTOM

Try to confirm the symptom described by the customer (except MIL ON).

DIAGNOSIS WORK SHEET is useful to verify the incident.

Connect CONSULT-II to the vehicle in DATA MONITOR (AUTO TRIG) mode and check real time diagnosis results.

Verify relation between the symptom and the condition when the symptom is detected.

>> GO TO 5.

4. CONFIRM THE SYMPTOM

Try to confirm the symptom described by the customer.

DIAGNOSIS WORK SHEET is useful to verify the incident.

Connect CONSULT-II to the vehicle in DATA MONITOR (AUTO TRIG) mode and check real time diagnosis results.

Verify relation between the symptom and the condition when the symptom is detected.

>> GO TO 6.

5. PERFORM DTC CONFIRMATION PROCEDURE

Perform DTC Confirmation Procedure for the displayed DTC*1 , and then make sure that DTC*1 is detected again.

At this time, always connect CONSULT-II to the vehicle, and check diagnostic results in real time on “DATA MONITOR (AUTO TRIG)”.

If two or more DTCs*1 are detected, refer to [EC-722, "DTC Inspection Priority Chart"](#) and determine trouble diagnosis order.

NOTE:

- Freeze frame data*2 is useful if the DTC*1 is not detected.
- Perform Overall Function Check if DTC Confirmation Procedure is not included on Service Manual. This simplified check procedure is an effective alternative though DTC*1 cannot be detected during this check. If the result of Overall Function Check is NG, it is the same as the detection of DTC*1 by DTC Confirmation Procedure.

Is DTC*1 detected?

Yes >> GO TO 10.

No >> Check according to [EC-782, "TROUBLE DIAGNOSIS FOR INTERMITTENT INCIDENT"](#) .

6. PERFORM BASIC INSPECTION

Perform [EC-693, "Basic Inspection"](#) .

With CONSULT-II>>GO TO 7.

Without CONSULT-II>>GO TO 9.

7. PERFORM DATA MONITOR (SPEC) MODE

Ⓜ With CONSULT-II

Make sure that “MAS A/F SE-B1”, “B/FUEL SCHDL”, and “A/F ALPHA-B1”, “A/F ALPHA-B2” are within the SP value using CONSULT-II “DATA MONITOR (SPEC)” mode. Refer to [EC-773, "Diagnostic Procedure"](#) .

Are they within the SP value?

Yes >> GO TO 9.

No >> GO TO 8.

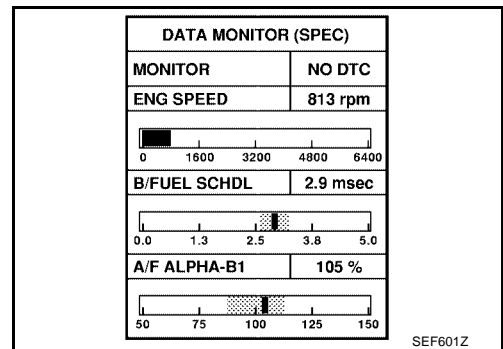

8. DETECT MALFUNCTIONING PART BY TROUBLE DIAGNOSIS - SPECIFICATION VALUE

Detect malfunctioning part according to [EC-772, "TROUBLE DIAGNOSIS - SPECIFICATION VALUE"](#) .

Is malfunctioning part detected?

Yes >> GO TO 11.

No >> GO TO 9.

9. DETECT MALFUNCTIONING SYSTEM BY SYMPTOM MATRIX CHART

Detect malfunctioning system according to [EC-725, "Symptom Matrix Chart"](#) based on the confirmed symptom in step 4, and determine the trouble diagnosis order based on possible causes and symptom.

>> GO TO 10.

10. DETECT MALFUNCTIONING PART BY DIAGNOSTIC PROCEDURE

Inspect according to Diagnostic Procedure of the system.

NOTE:

The Diagnostic Procedure in EC section described based on open circuit inspection. A short circuit inspection is also required for the circuit check in the Diagnostic Procedure. For details, refer to Circuit Inspection in [GI-26, "How to Perform Efficient Diagnosis for an Electrical Incident"](#).

Is malfunctioning part detected?

Yes >> GO TO 11.

No >> Monitor input data from related sensors or check voltage of related ECM terminals using CONSULT-II. Refer to [EC-766, "CONSULT-II Reference Value in Data Monitor"](#), [EC-740, "ECM Terminals and Reference Value"](#).

11. REPAIR OR REPLACE THE MALFUNCTIONING PART

1. Repair or replace the malfunctioning part.
2. Reconnect parts or connectors disconnected during Diagnostic Procedure again after repair and replacement.
3. Check DTC. If DTC is displayed, erase it, refer to [EC-682, "HOW TO ERASE EMISSION-RELATED DIAGNOSTIC INFORMATION"](#).

>> GO TO 12.

12. FINAL CHECK

When DTC was detected in step 2, perform DTC Confirmation Procedure or Overall Function Check again, and then make sure that the malfunction have been repaired securely.

When symptom was described from the customer, refer to confirmed symptom in step 3 or 4, and make sure that the symptom is not detected.

OK or NG

NG (DTC*¹ is detected)>>GO TO 10.

NG (Symptom remains)>>GO TO 6.

OK >> 1. Before returning the vehicle to the customer, make sure to erase unnecessary DTC*¹ in ECM and TCM (Transmission Control Module). (Refer to [EC-682, "HOW TO ERASE EMISSION-RELATED DIAGNOSTIC INFORMATION"](#) and [AT-422, "HOW TO ERASE DTC"](#).)

2. If the completion of SRT is needed, drive vehicle under the specific driving pattern. Refer to [EC-679, "Driving Pattern"](#).

3. INSPECTION END

*1: Include 1st trip DTC.

*2: Include 1st trip freeze frame data.

DIAGNOSTIC WORKSHEET

Description

There are many operating conditions that lead to the malfunction of engine components. A good grasp of such conditions can make troubleshooting faster and more accurate.

In general, each customer feels differently about a incident. It is important to fully understand the symptoms or conditions for a customer complaint.

Utilize a diagnostic worksheet like the one on the next page in order to organize all the information for troubleshooting.

Some conditions may cause the MIL to come on steady or blink and DTC to be detected. Examples:

- Vehicle ran out of fuel, which caused the engine to misfire.
- Fuel filler cap was left off or incorrectly screwed on, allowing fuel to evaporate into the atmosphere.

KEY POINTS

WHAT Vehicle & engine model
WHEN Date, Frequencies
WHERE..... Road conditions
HOW Operating conditions,
 Weather conditions,
 Symptoms

SEF907L

DTC Inspection Priority Chart

If some DTCs are displayed at the same time, perform inspections one by one based on the following priority chart.

NOTE:

If DTC U1000 and/or U1001 is displayed with other DTC, first perform the trouble diagnosis for DTC U1000, U1001. Refer to [EC-790](#) .

Priority	Detected items (DTC)
1	<ul style="list-style-type: none"> ● U1000 U1001 CAN communication line ● P0101 P0102 P0103 Mass air flow sensor ● P0112 P0113 P0127 Intake air temperature sensor ● P0117 P0118 P0125 Engine coolant temperature sensor ● P0122 P0123 P0222 P0223 P1225 P1226 P2135 Throttle position sensor ● P0128 Thermostat function ● P0181 P0182 P0183 Fuel tank temperature sensor ● P0327 P0328 Knock sensor ● P0335 Crankshaft position sensor (POS) ● P0340 P0345 Camshaft position sensor (PHASE) ● P0403 EGR volume control valve ● P0460 P0461 P0462 P0463 Fuel level sensor ● P0500 Vehicle speed sensor ● P0605 ECM ● P0705 Park/Neutral position (PNP) switch ● P1229 Sensor power supply ● P1610 - P1615 NATS ● P1706 Park/Neutral position (PNP) switch ● P2122 P2123 P2127 P2128 P2138 Accelerator pedal position sensor

TROUBLE DIAGNOSIS

[VQ]

Priority	Detected items (DTC)	
2	● P0037 P0038 P0057 P0058 Heated oxygen sensor 2 heater	A
	● P0138 P0139 P0158 P0159 P1146 P1147 P1166 P1167 Heated oxygen sensor 2	
	● P0405 P0406 EGR temperature sensor	EC
	● P0441 EVAP control system purge flow monitoring	
	● P0444 P0445 P1444 EVAP canister purge volume control solenoid valve	
	● P0447 P1446 EVAP canister vent control valve	C
	● P0451 P0452 P0453 EVAP control system pressure sensor	
	● P0550 Power steering pressure sensor	
	● P1031 P1032 P1051 P1052 A/F sensor 1 heater	D
	● P1065 ECM power supply	
	● P1111 P1136 Intake valve timing control solenoid valve	
	● P1122 Electric throttle control function	E
	● P1124 P1126 P1128 Electric throttle control actuator	
	● P1217 Engine over temperature (OVERHEAT)	
	● P1271 P1272 P1273 P1274 P1276 P1278 P1279 P1281 P1282 P1283 P1284 P1286 P1288 P1289 A/F sensor 1	F
	● P1800 VIAS control solenoid valve	
	● P1805 Brake switch	
3	● P0011 P0021 Intake valve timing control	G
	● P0171 P0172 P0174 P0175 Fuel injection system function	
	● P0300 - P0306 Misfire	
	● P0400 P1402 EGR system	H
	● P0420 P0430 Three way catalyst function	
	● P0442 P0455 P0456 EVAP control system	
	● P0506 P0507 Idle speed control system	I
	● P0710 - P0882 A/T related sensors, solenoid valves and switches	
	● P1121 Electric throttle control actuator	
	● P1148 P1168 Closed loop control	J
	● P1211 TCS control unit	
	● P1212 TCS communication line	
	● P1564 ASCD steering switch	K
	● P1572 ASCD brake switch	
	● P1574 ASCD vehicle speed sensor	L
	M	

TROUBLE DIAGNOSIS

[VQ]

UBS0010A

Fail-safe Chart

When the DTC listed below is detected, the ECM enters fail-safe mode and the MIL lights up.

DTC No.	Detected items	Engine operating condition in fail-safe mode								
P0102 P0103	Mass air flow sensor circuit	Engine speed will not rise more than 2,400 rpm due to the fuel cut.								
P0117 P0118	Engine coolant temperature sensor circuit	<p>Engine coolant temperature will be determined by ECM based on the time after turning ignition switch ON or START. CONSULT-II displays the engine coolant temperature decided by ECM.</p> <table border="1" style="width: 100%; border-collapse: collapse;"> <thead> <tr> <th style="text-align: center;">Condition</th> <th style="text-align: center;">Engine coolant temperature decided (CONSULT-II display)</th> </tr> </thead> <tbody> <tr> <td>Just as ignition switch is turned ON or START</td> <td style="text-align: center;">40°C (104°F)</td> </tr> <tr> <td>More than approx. 4 minutes after ignition ON or START</td> <td style="text-align: center;">80°C (176°F)</td> </tr> <tr> <td>Except as shown above</td> <td style="text-align: center;">40 - 80°C (104 - 176°F) (Depends on the time)</td> </tr> </tbody> </table> <p>When the fail-safe system for engine coolant temperature sensor is activated, the cooling fan operates while engine is running.</p>	Condition	Engine coolant temperature decided (CONSULT-II display)	Just as ignition switch is turned ON or START	40°C (104°F)	More than approx. 4 minutes after ignition ON or START	80°C (176°F)	Except as shown above	40 - 80°C (104 - 176°F) (Depends on the time)
Condition	Engine coolant temperature decided (CONSULT-II display)									
Just as ignition switch is turned ON or START	40°C (104°F)									
More than approx. 4 minutes after ignition ON or START	80°C (176°F)									
Except as shown above	40 - 80°C (104 - 176°F) (Depends on the time)									
P0122 P0123 P0222 P0223 P2135	Throttle position sensor	<p>The ECM controls the electric throttle control actuator in regulating the throttle opening in order for the idle position to be within +10 degrees. The ECM regulates the opening speed of the throttle valve to be slower than the normal condition. So, the acceleration will be poor.</p>								
P1121	Electric throttle control actuator	<p>(When electric throttle control actuator does not function properly due to the return spring malfunction:) ECM controls the electric throttle actuator by regulating the throttle opening around the idle position. The engine speed will not rise more than 2,000 rpm.</p> <p>(When throttle valve opening angle in fail-safe mode is not in specified range:) ECM controls the electric throttle control actuator by regulating the throttle opening to 20 degrees or less.</p> <p>(When ECM detects the throttle valve is stuck open:) While the vehicle is driving, it slows down gradually by fuel cut. After the vehicle stops, the engine stalls. The engine can restart in N or P position (A/T), neutral position (M/T), and engine speed will not exceed 1,000 rpm or more.</p>								
P1122	Electric throttle control function	ECM stops the electric throttle control actuator control, throttle valve is maintained at a fixed opening (approx. 5 degrees) by the return spring.								
P1124 P1126	Throttle control motor relay	ECM stops the electric throttle control actuator control, throttle valve is maintained at a fixed opening (approx. 5 degrees) by the return spring.								
P1128	Throttle control motor	ECM stops the electric throttle control actuator control, throttle valve is maintained at a fixed opening (approx. 5 degrees) by the return spring.								
P1229	Sensor power supply	ECM stops the electric throttle control actuator control, throttle valve is maintained at a fixed opening (approx. 5 degrees) by the return spring.								
P2122 P2123 P2127 P2128 P2138	Accelerator pedal position sensor	<p>The ECM controls the electric throttle control actuator in regulating the throttle opening in order for the idle position to be within +10 degrees. The ECM regulates the opening speed of the throttle valve to be slower than the normal condition. So, the acceleration will be poor.</p>								

- When there is an open circuit on MIL circuit, the ECM cannot warn the driver by lighting up MIL when there is malfunction on engine control system.
Therefore, when electrical controlled throttle and part of ECM related diagnoses are continuously detected as NG for 5 trips, ECM warns the driver that engine control system malfunctions and MIL circuit is open by means of operating fail-safe function.
The fail-safe function also operates when above diagnoses except MIL circuit are detected and demands the driver to repair the malfunction.

Engine operating condition in fail-safe mode	Engine speed will not rise more than 2,500 rpm due to the fuel cut
--	--

TROUBLE DIAGNOSIS

[VQ]

UBS0010C

Symptom Matrix Chart SYSTEM — BASIC ENGINE CONTROL SYSTEM

		SYMPTOM												Reference page	
		HARD/NO START/RESTART (EXCP. HA)	ENGINE STALL	HESITATION/SURGING/FLAT SPOT	SPARK KNOCK/DETONATION	LACK OF POWER/POOR ACCELERATION	HIGH IDLE/LOW IDLE	ROUGH IDLE/HUNTING	IDLING VIBRATION	SLOW/NO RETURN TO IDLE	OVERHEATS/WATER TEMPERATURE HIGH	EXCESSIVE FUEL CONSUMPTION	EXCESSIVE OIL CONSUMPTION		BATTERY DEAD (UNDER CHARGE)
Warranty symptom code		AA	AB	AC	AD	AE	AF	AG	AH	AJ	AK	AL	AM	HA	
Fuel	Fuel pump circuit	1	1	2	3	2		2	2			3		2	EC-1316
	Fuel pressure regulator system	3	3	4	4	4	4	4	4	4		4			EC-714
	Injector circuit	1	1	2	3	2		2	2			2			EC-1308
	Evaporative emission system	3	3	4	4	4	4	4	4	4	4	4			EC-651
Air	Positive crankcase ventilation system	3	3	4	4	4	4	4	4	4		4	1		EC-665
	Incorrect idle speed adjustment						1	1	1	1		1			EC-700
	Electric throttle control actuator	1	1	2	3	3	2	2	2	2		2		2	EC-1066 , EC-1068
Ignition	Incorrect ignition timing adjustment	3	3	1	1	1		1	1			1			EC-700
	Ignition circuit	1	1	2	2	2		2	2			2			EC-1287
EGR	EGR volume control valve circuit		2												EC-945
	EGR system	2	1	2	3	3	3	2	2	3		3			EC-937 , EC-1199
Main power supply and ground circuit		2	2	3	3	3		3	3		2	3			EC-783
Mass air flow sensor circuit		1			2										EC-806 , EC-815
Engine coolant temperature sensor circuit								3			3				EC-826 , EC-838
A/F sensor 1 circuit			1	2	3	2		2	2			2			EC-1132 , EC-1140 , EC-1148 , EC-1157 , EC-1166 , EC-1175 , EC-1187
Throttle position sensor circuit							2			2					EC-831 , EC-899 , EC-1123 , EC-1125 , EC-1272
Accelerator pedal position sensor circuit				3	2	1									EC-1127 , EC-1258 , EC-1265 , EC-1279
Knock sensor circuit				2								3			EC-916

A
EC
C
D
E
F
G
H
I
J
K
L
M

TROUBLE DIAGNOSIS

[VQ]

	SYMPTOM												Refer- ence page	
	HARD/NO START/RESTART (EXCP. HA)	ENGINE STALL	HESITATION/SURGING/FLAT SPOT	SPARK KNOCK/DETONATION	LACK OF POWER/POOR ACCELERATION	HIGH IDLE/LOW IDLE	ROUGH IDLE/HUNTING	IDLING VIBRATION	SLOW/NO RETURN TO IDLE	OVERHEATS/WATER TEMPERATURE HIGH	EXCESSIVE FUEL CONSUMPTION	EXCESSIVE OIL CONSUMPTION		BATTERY DEAD (UNDER CHARGE)
Warranty symptom code	AA	AB	AC	AD	AE	AF	AG	AH	AJ	AK	AL	AM	HA	
Crankshaft position sensor (POS) circuit	2	2												EC-921
Camshaft position sensor (PHASE) circuit	3	2												EC-928
Vehicle speed signal circuit		2	3		3						3			EC-1031
Power steering pressure sensor circuit		2					3	3						EC-1037
ECM	2	2	3	3	3	3	3	3	3	3	3			EC-1042 , EC-1053
Intake valve timing control solenoid valve circuit		3	2		1	3	2	2	3		3			EC-1057
PNP switch circuit			3		3		3	3			3			EC-1240
VIAS control solenoid valve circuit					1									EC-1248
Refrigerant pressure sensor circuit		2				3			3		4			EC-1327
Electrical load signal circuit							3							EC-1332
Air conditioner circuit	2	2	3	3	3	3	3	3	3		3		2	ATC-28 , MTC-28
ABS actuator and electric unit (control unit)			4											BRC-8 or BRC-51

1 - 6: The numbers refer to the order of inspection.
(continued on next page)

TROUBLE DIAGNOSIS

[VQ]

SYSTEM — ENGINE MECHANICAL & OTHER

		SYMPTOM											Reference page		
		HARD/NO START/RESTART (EXCP. HA)	ENGINE STALL	HESITATION/SURGING/FLAT SPOT	SPARK KNOCK/DETONATION	LACK OF POWER/POOR ACCELERATION	HIGH IDLE/LOW IDLE	ROUGH IDLE/HUNTING	IDLING VIBRATION	SLOW/NO RETURN TO IDLE	OVERHEATS/WATER TEMPERATURE HIGH	EXCESSIVE FUEL CONSUMPTION		EXCESSIVE OIL CONSUMPTION	BATTERY DEAD (UNDER CHARGE)
Warranty symptom code		AA	AB	AC	AD	AE	AF	AG	AH	AJ	AK	AL	AM	HA	
Fuel	Fuel tank	5												FL-12	
	Fuel piping			5	5	5		5	5			5		EM-147	
	Vapor lock		5											—	
	Valve deposit													—	
	Poor fuel (Heavy weight gasoline, Low octane)	5		5	5	5		5	5			5		—	
Air	Air duct													EM-120	
	Air cleaner													EM-120	
	Air leakage from air duct (Mass air flow sensor — electric throttle control actuator)		5	5		5		5	5			5		EM-120	
	Electric throttle control actuator	5			5		5			5				EM-122	
	Air leakage from intake manifold/Collector/Gasket													EM-122 , EM-129	
Cranking	Battery	1	1	1		1		1	1					1	SC-4
	Generator circuit														SC-21
	Starter circuit	3										1			SC-9
	Signal plate	6													EM-224
	PNP switch	4													AT-471
Engine	Cylinder head	5	5	5	5	5		5	5			5			EM-200
	Cylinder head gasket										4		3		
	Cylinder block														
	Piston												4		
	Piston ring														
	Connecting rod	6	6	6	6	6		6	6			6			EM-224
	Bearing														
	Crankshaft														
Valve mechanism	Timing chain														EM-161
	Camshaft														EM-182
	Intake valve timing control	5	5	5	5	5		5	5			5		EM-161	
	Intake valve												3		EM-200
	Exhaust valve														

TROUBLE DIAGNOSIS

[VQ]

		SYMPTOM												Reference page	
		HARD/NO START/RESTART (EXCP. HA)	ENGINE STALL	HESITATION/SURGING/FLAT SPOT	SPARK KNOCK/DETONATION	LACK OF POWER/POOR ACCELERATION	HIGH IDLE/LOW IDLE	ROUGH IDLE/HUNTING	IDLING VIBRATION	SLOW/NO RETURN TO IDLE	OVERHEATS/WATER TEMPERATURE HIGH	EXCESSIVE FUEL CONSUMPTION	EXCESSIVE OIL CONSUMPTION		BATTERY DEAD (UNDER CHARGE)
Warranty symptom code		AA	AB	AC	AD	AE	AF	AG	AH	AJ	AK	AL	AM	HA	
Exhaust	Exhaust manifold/Tube/Muffler/Gasket	5	5	5	5	5		5	5			5			EM-134 , EX-6
	Three way catalyst														
Lubrica- tion	Oil pan/Oil strainer/Oil pump/Oil filter/Oil gallery/Oil cooler	5	5	5	5	5		5	5			5			EM-138 , LU-24 , LU-23 , LU-27
	Oil level (Low)/Filthy oil														LU-20
Cooling	Radiator/Hose/Radiator filler cap														CO-30
	Thermostat									5					CO-42
	Water pump														CO-37
	Water gallery	5	5	5	5	5		5	5		4	5			CO-44
	Cooling fan									5					CO-31
	Coolant level (Low)/Contami- nated coolant									5					CO-28
NVIS (NISSAN Vehicle Immobilizer System — NATS)		1	1												BL-107

1 - 6: The numbers refer to the order of inspection.

Engine Control Component Parts Location

UBS0010D

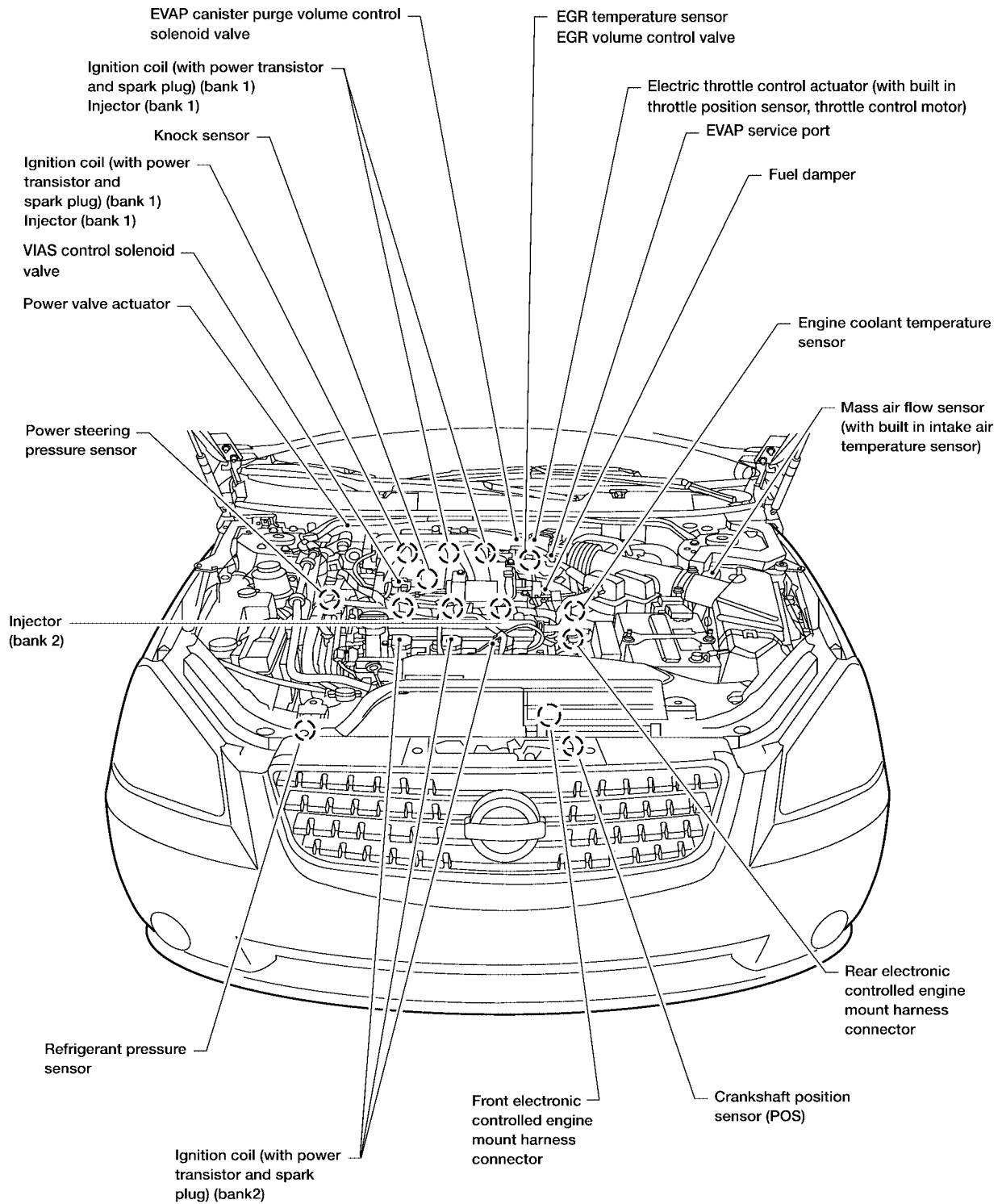

A
EC
C
D
E
F
G
H
I
J
K
L
M

BBIA0454E

TROUBLE DIAGNOSIS

[VQ]

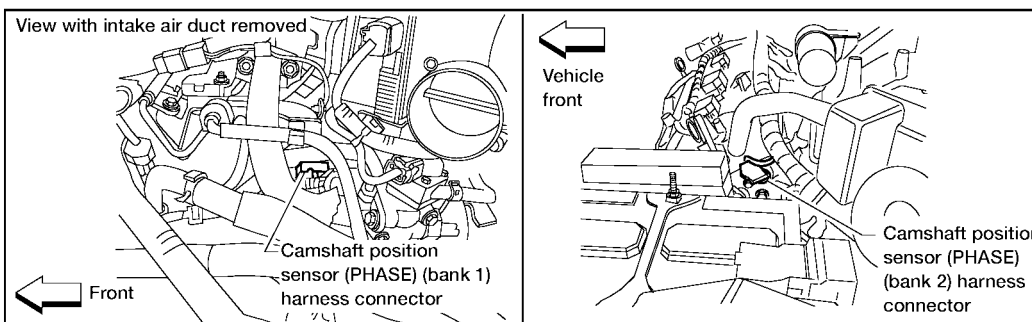
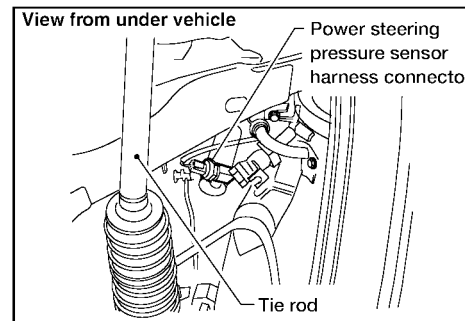
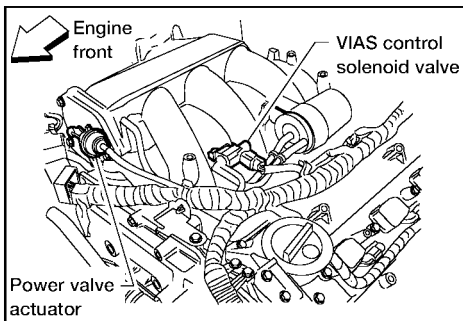
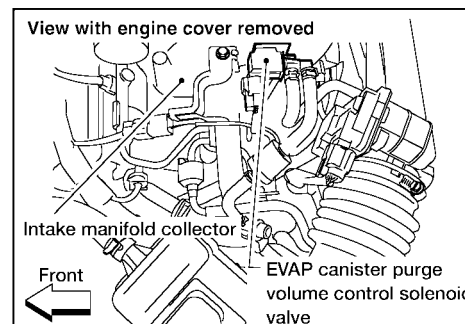
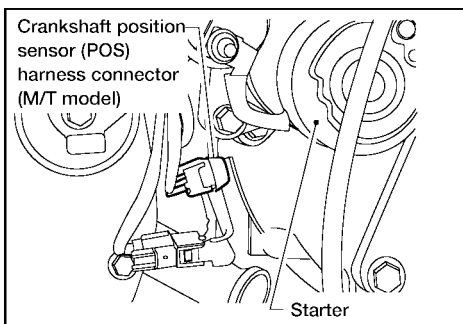
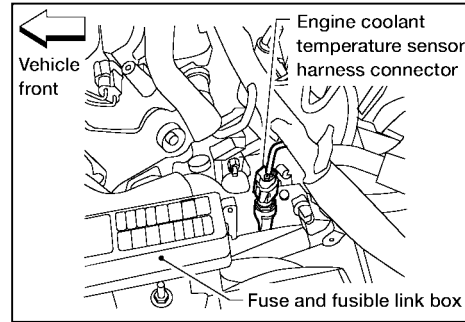
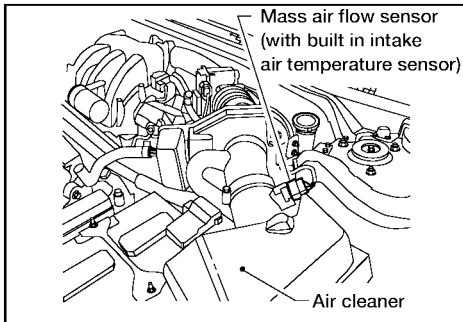

BBIA0527E

TROUBLE DIAGNOSIS

[VQ]

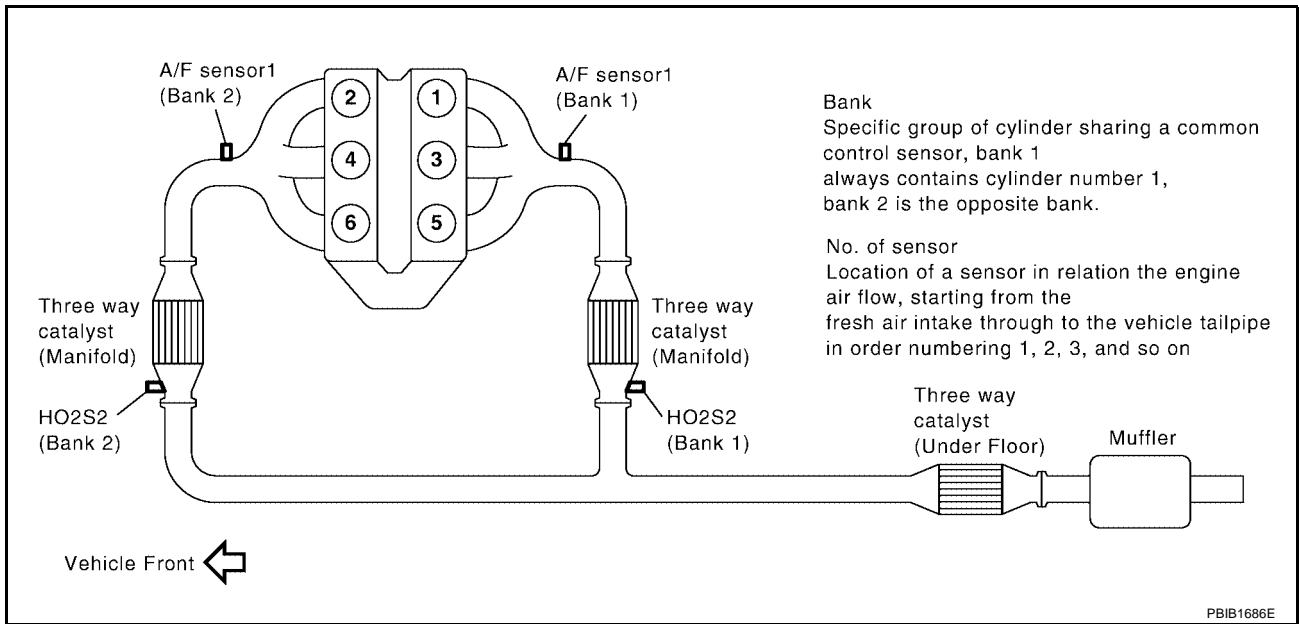

A

EC

C

D

E

F

G

H

I

J

K

L

M

TROUBLE DIAGNOSIS

[VQ]

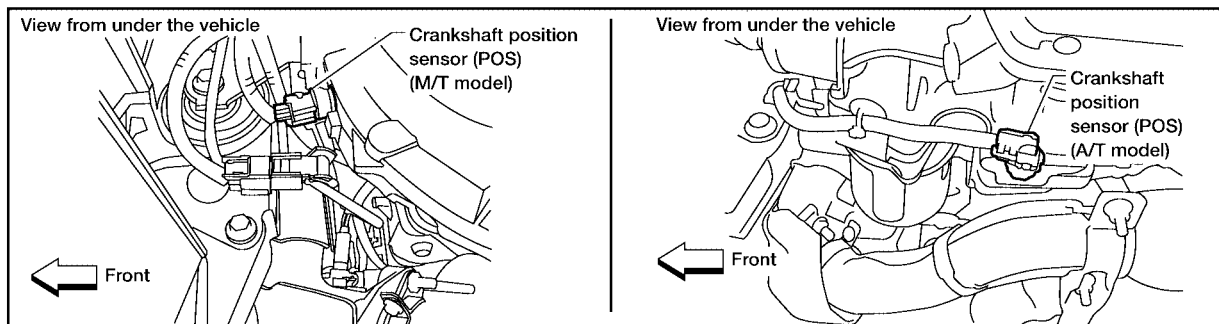
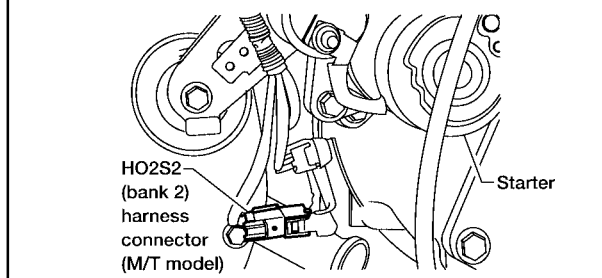
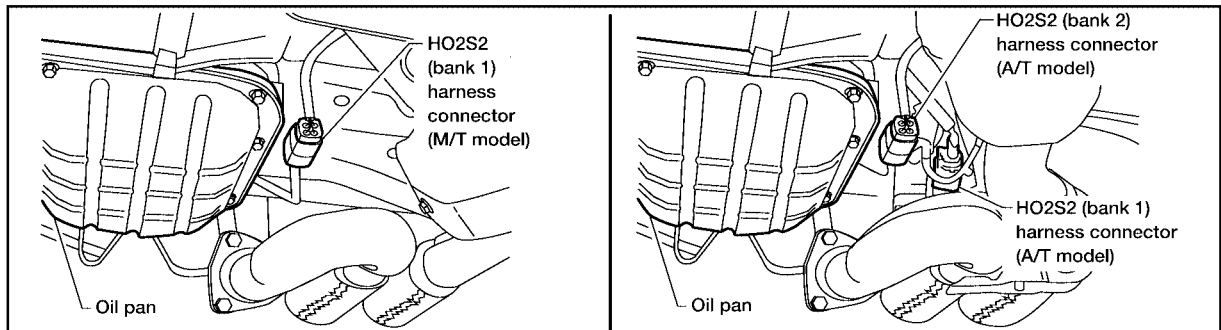
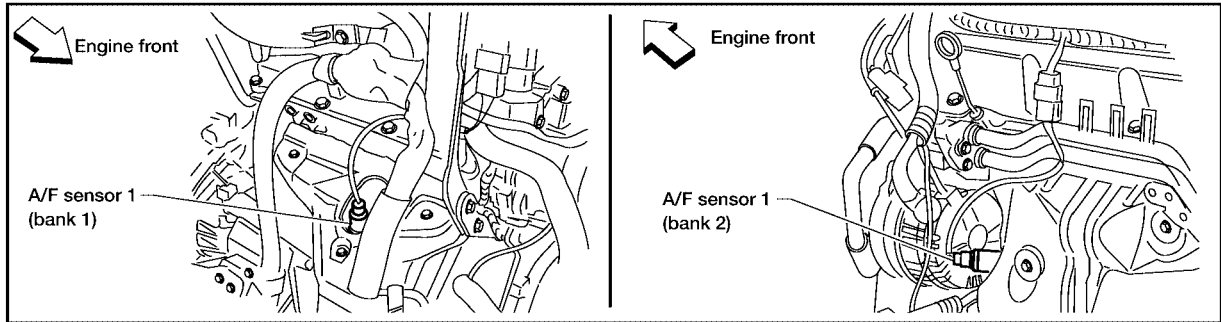

BBIA0455E

TROUBLE DIAGNOSIS

[VQ]

A

EC

C

D

E

F

G

H

I

J

K

L

M

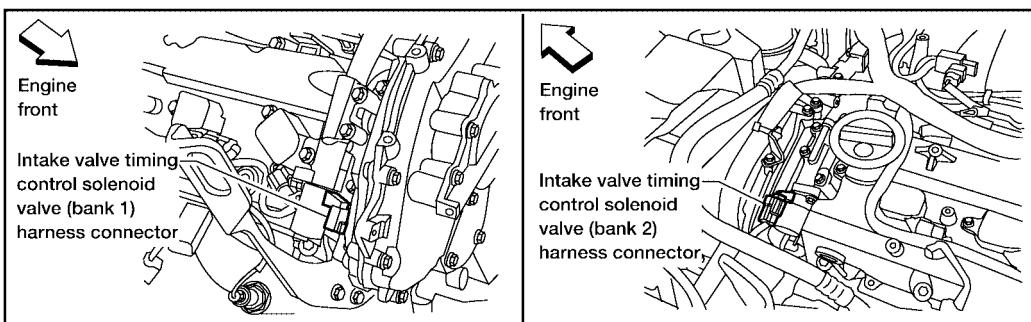
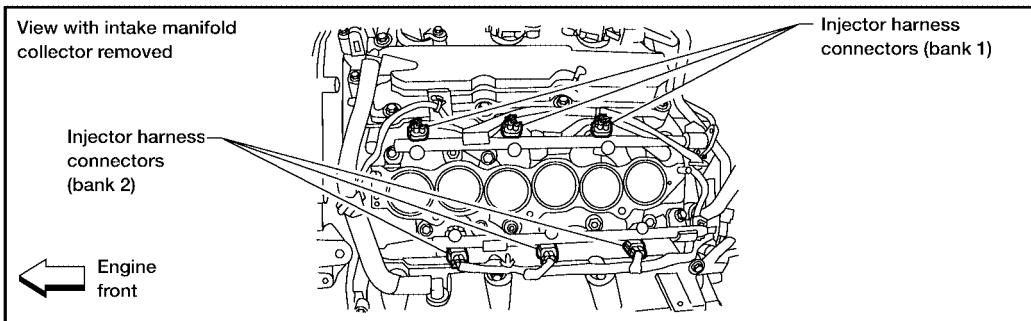
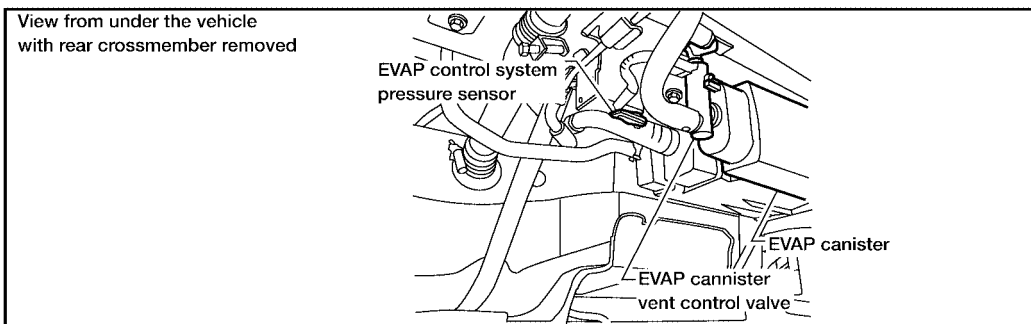
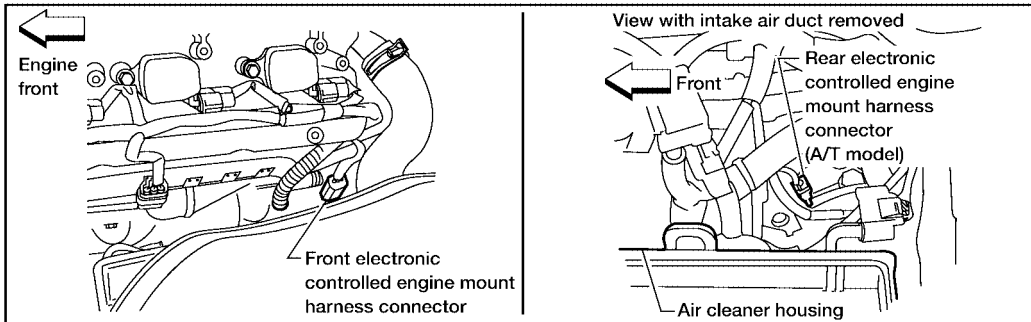

BBA0457E

TROUBLE DIAGNOSIS

[VQ]

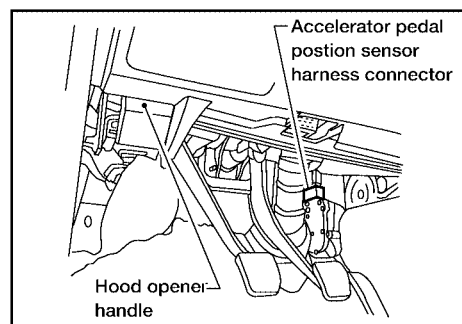
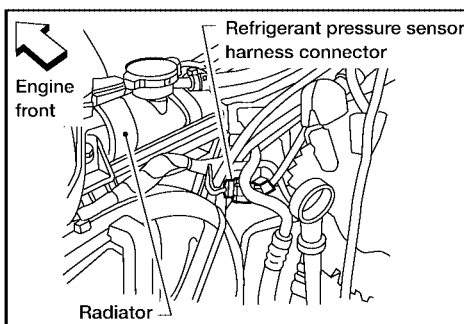
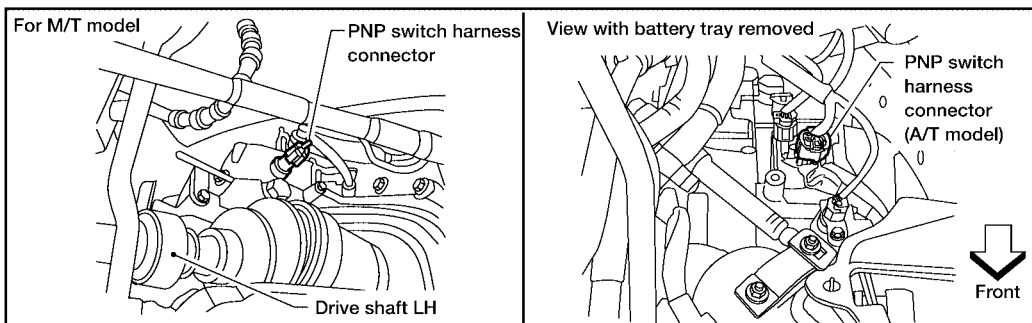
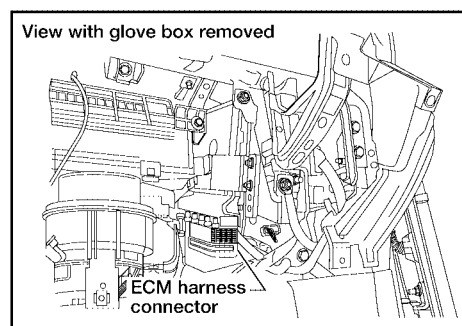
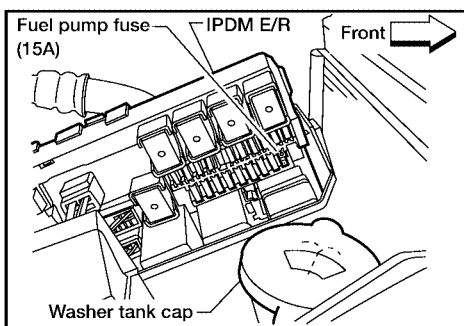
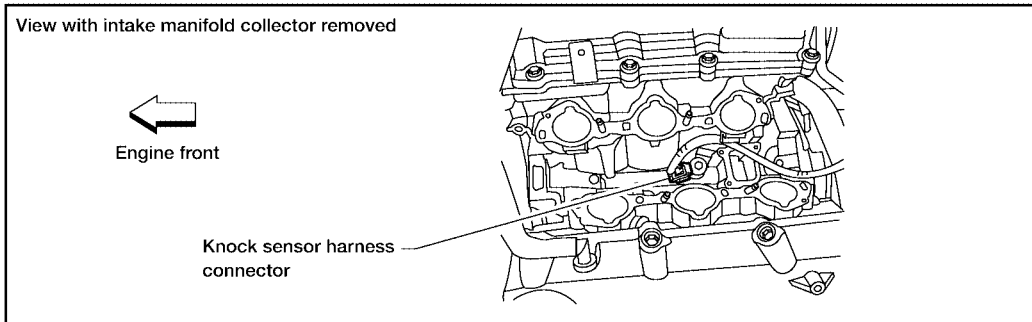

BBA0458E

A

EC

C

D

E

F

G

H

I

J

K

L

M

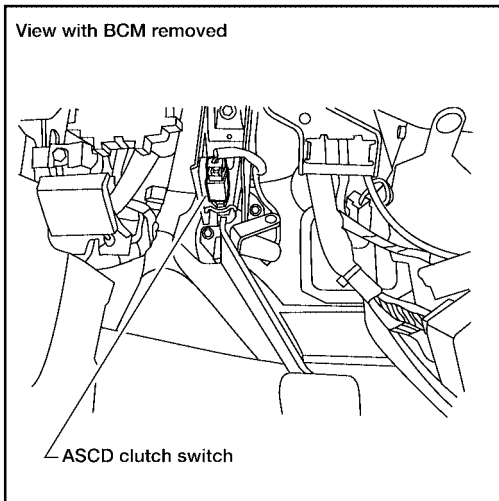
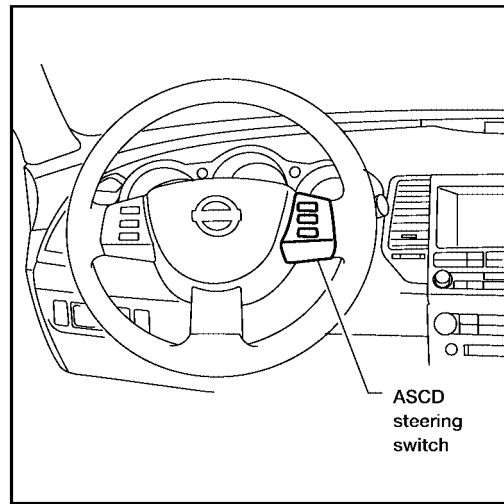
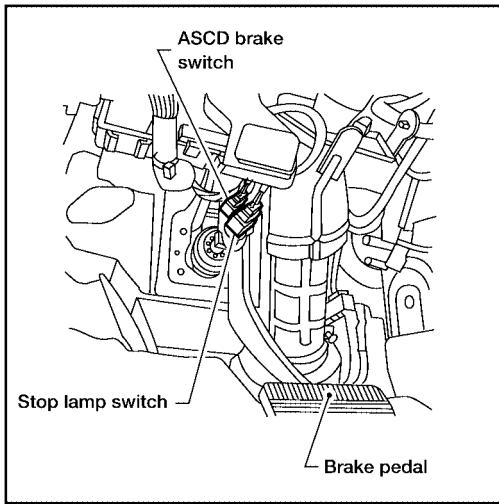

Vacuum Hose Drawing SE-R MODELS

UBS00HZU

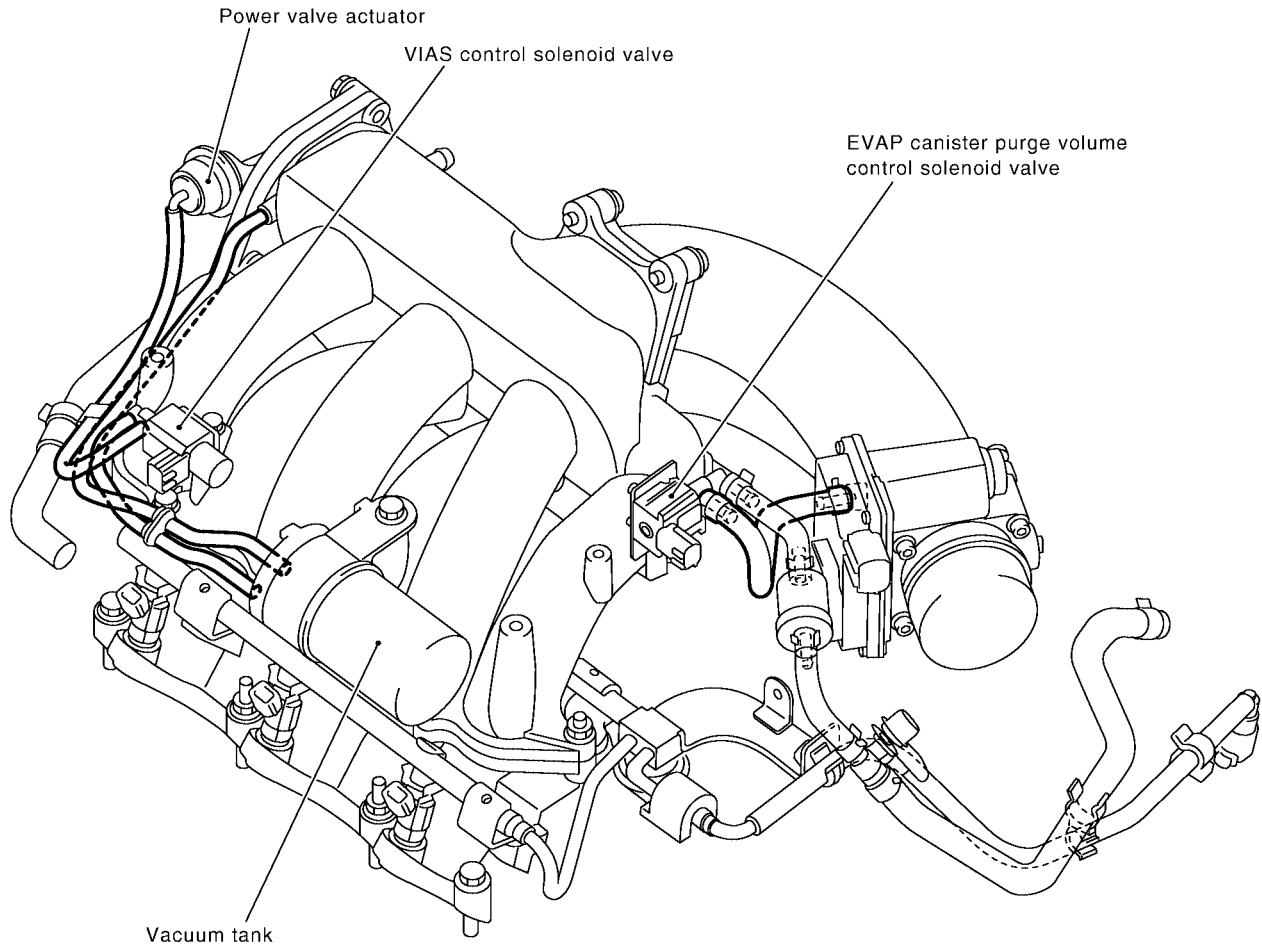

NOTE: Do not use soapy water or any type of solvent while installing vacuum hose or purge hoses.

Refer to [EC-642, "System Diagram"](#) for Vacuum Control System.

PBIB2501E

EXCEPT SE-R MODELS

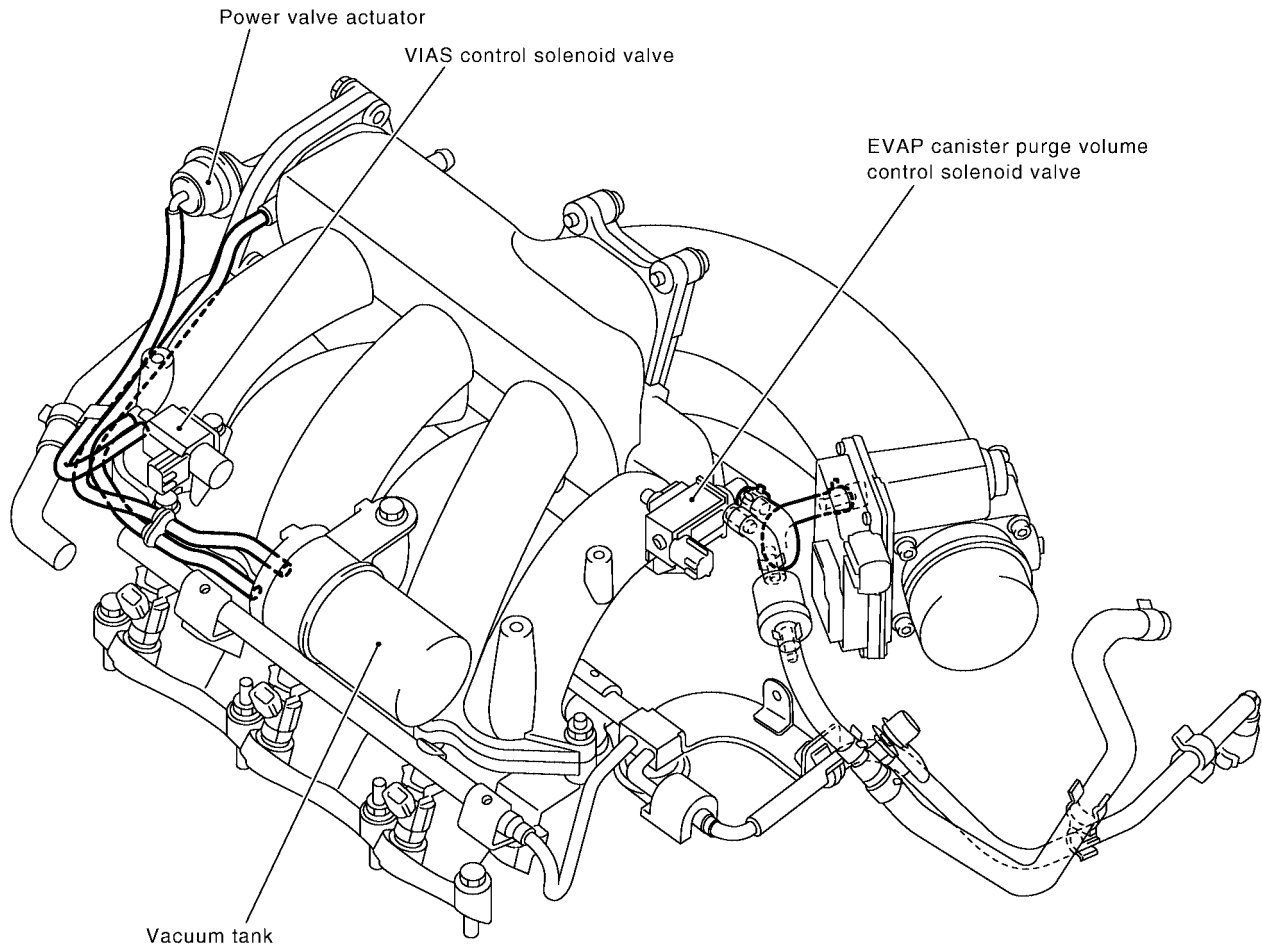

NOTE: Do not use soapy water or any type of solvent while installing vacuum hose or purge hoses.

Refer to [EC-642, "System Diagram"](#) for Vacuum Control System.

PBIB2503E

Circuit Diagram

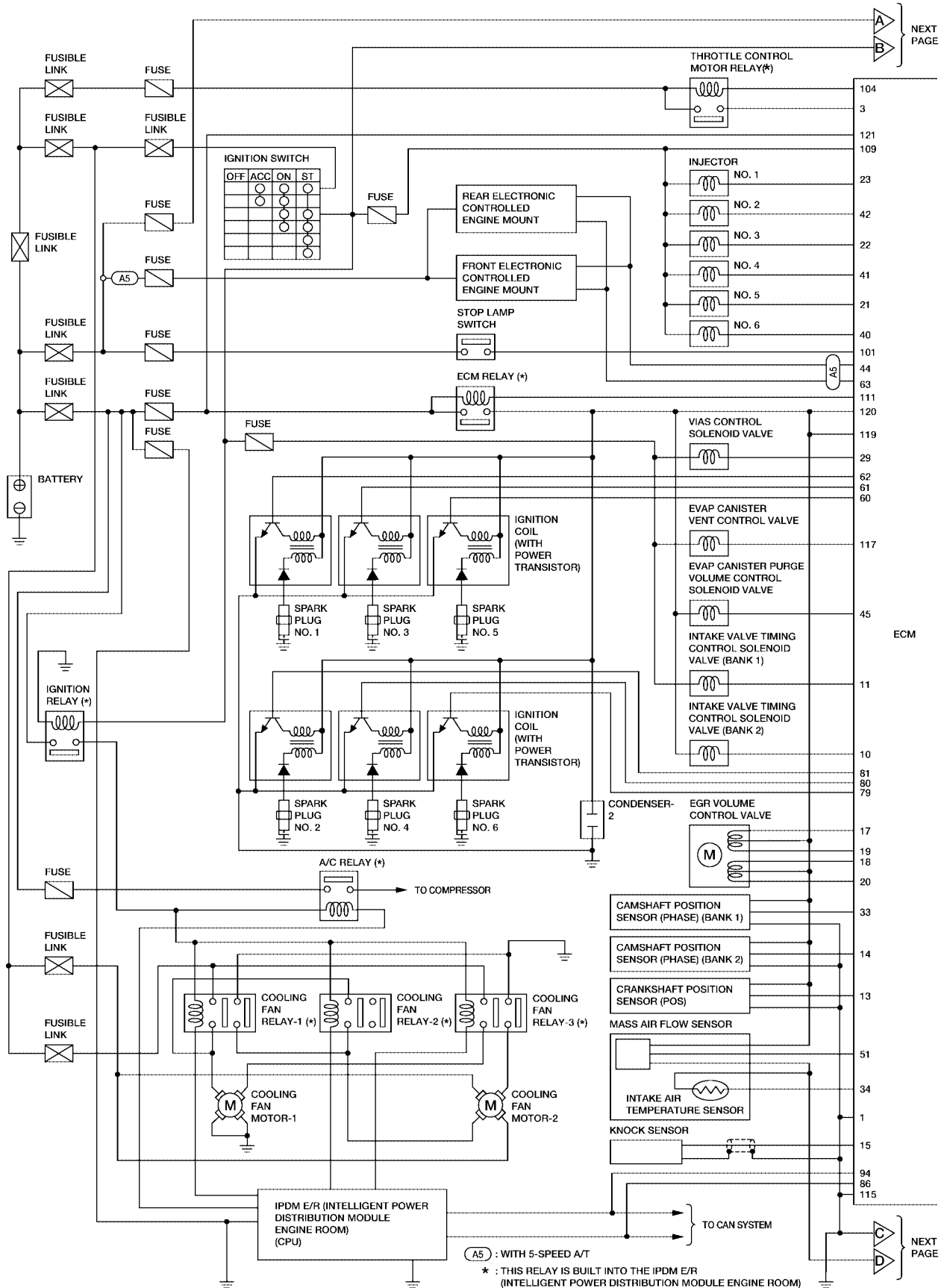

TROUBLE DIAGNOSIS

[VQ]

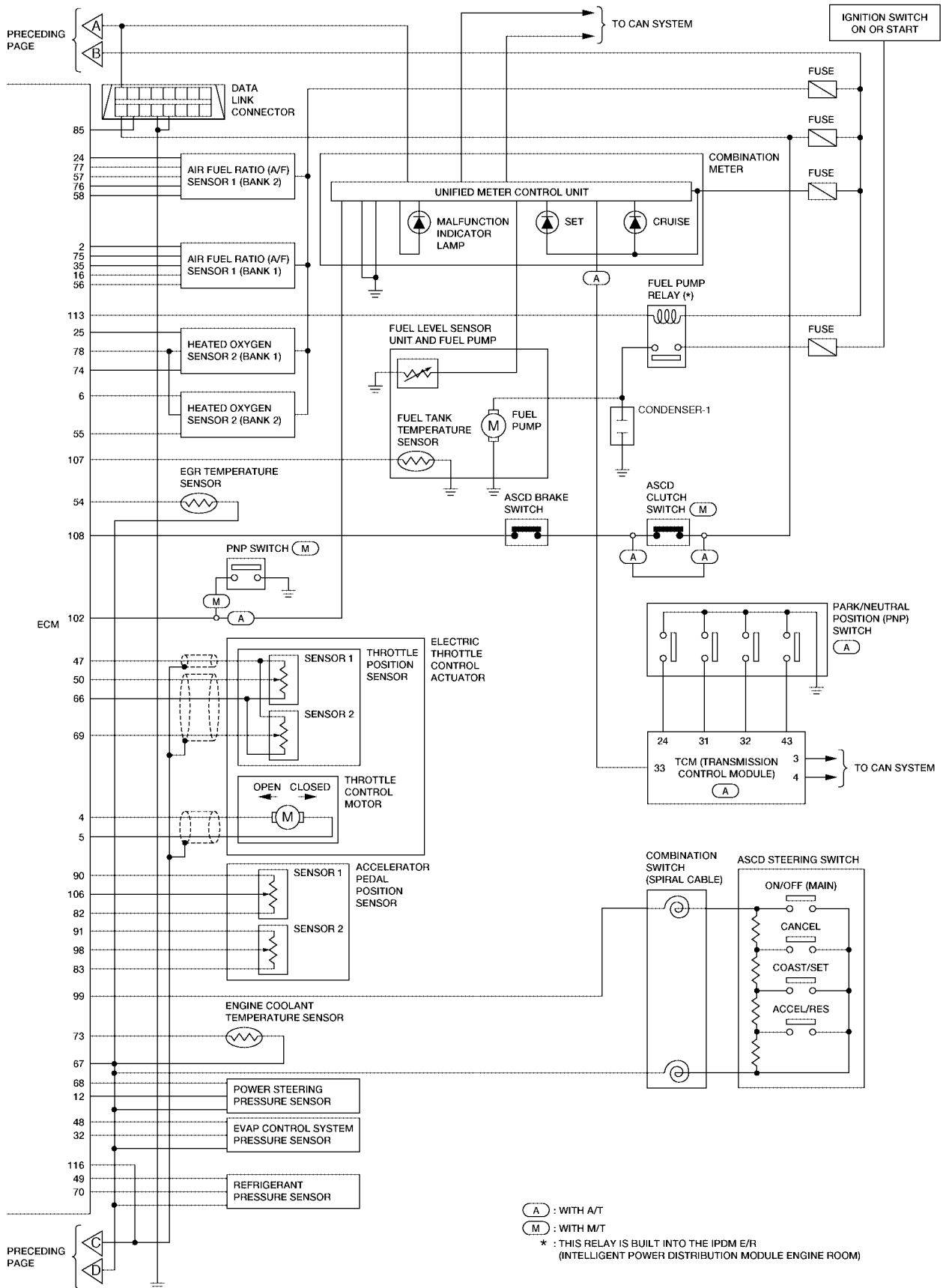

ECM Harness Connector Terminal Layout

UBS0010F

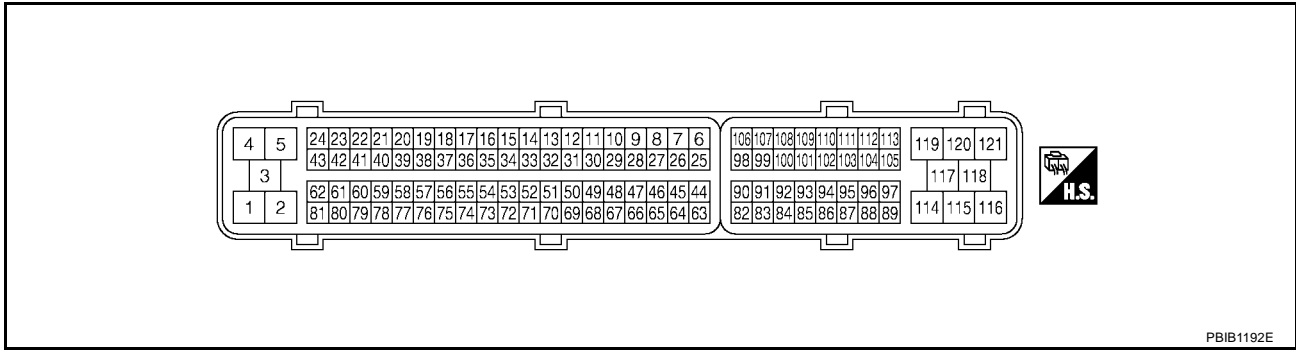

ECM Terminals and Reference Value PREPARATION

UBS0010G

1. ECM is located behind the glove box. For this inspection, remove glove box.
2. Remove ECM harness connector.

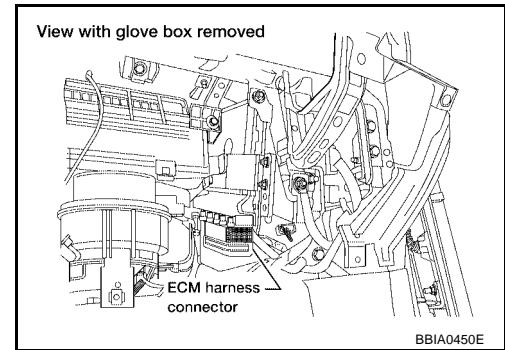

3. When disconnecting ECM harness connector, loosen it with levers as far as they will go as shown at right.
4. Connect a break-out box (SST) and Y-cable adapter (SST) between the ECM and ECM harness connector.
 - Use extreme care not to touch 2 pins at one time.
 - Data is for comparison and may not be exact.

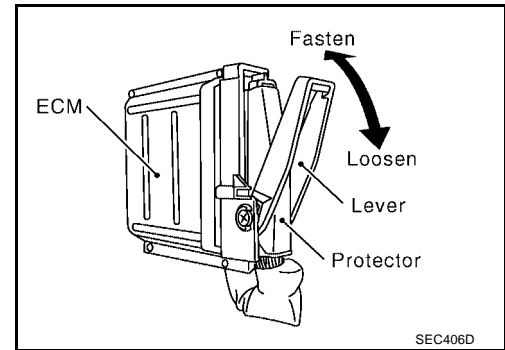

ECM INSPECTION TABLE

Specification data are reference values and are measured between each terminal and ground. Pulse signal is measured by CONSULT-II.

CAUTION:

Do not use ECM ground terminals when measuring input/output voltage. Doing so may result in damage to the ECMs transistor. Use a ground other than ECM terminals, such as the ground.

TER-MINAL NO.	WIRE COLOR	ITEM	CONDITION	DATA (DC Voltage)
1	B	ECM ground	[Engine is running] ● Idle speed	Body ground
2	W	A/F sensor 1 heater (bank 1)	[Engine is running] ● Warm-up condition ● Idle speed	Approximately 5V★

PBIB1584E

TROUBLE DIAGNOSIS

[VQ]

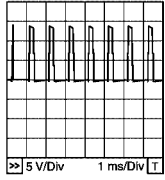
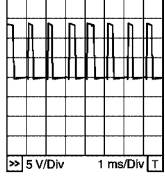
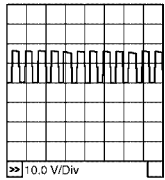
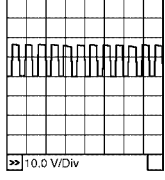
TER-MINAL NO.	WIRE COLOR	ITEM	CONDITION	DATA (DC Voltage)
3	R	Throttle control motor relay power supply	[Ignition switch: ON]	BATTERY VOLTAGE (11 - 14V)
4	BR	Throttle control motor (Close)	[Ignition switch: ON] <ul style="list-style-type: none"> ● Engine stopped ● Shift lever: D (A/T) or 1st (M/T) ● Accelerator pedal: Released 	0 - 14V★  <small>PBIB1104E</small>
5	Y	Throttle control motor (Open)	[Ignition switch: ON] <ul style="list-style-type: none"> ● Engine stopped ● Shift lever: D (A/T) or 1st (M/T) ● Accelerator pedal: Fully depressed 	0 - 14V★  <small>PBIB1105E</small>
6	R/L	Heated oxygen sensor 2 heater (bank 2)	[Engine is running] <ul style="list-style-type: none"> ● Engine speed is below 3,600 rpm after the following conditions are met <ul style="list-style-type: none"> - Engine: after warming up - Keeping the engine speed between 3,500 and 4,000 rpm for 1 minute and at idle for 1 minute under no load 	0 - 1.0V
			[Ignition switch: ON] <ul style="list-style-type: none"> ● Engine stopped [Engine is running] <ul style="list-style-type: none"> ● Engine speed is above 3,600 rpm 	BATTERY VOLTAGE (11 - 14V)
10	Y	Intake valve timing control solenoid valve (bank 2)	[Engine is running] <ul style="list-style-type: none"> ● Warm-up condition ● Idle speed 	BATTERY VOLTAGE (11 - 14V)
			[Engine is running] <ul style="list-style-type: none"> ● Warm-up condition ● Engine speed is 2,000 rpm 	7 - 12V★  <small>PBIB1790E</small>
11	R/L	Intake valve timing control solenoid valve (bank 1)	[Engine is running] <ul style="list-style-type: none"> ● Warm-up condition ● Idle speed 	BATTERY VOLTAGE (11 - 14V)
			[Engine is running] <ul style="list-style-type: none"> ● Warm-up condition ● Engine speed is 2,000 rpm 	7 - 12V★  <small>PBIB1790E</small>

A
EC
C
D
E
F
G
H
I
J
K
L
M

TROUBLE DIAGNOSIS

[VQ]

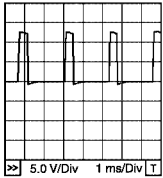
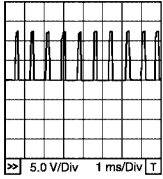
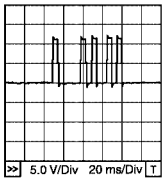
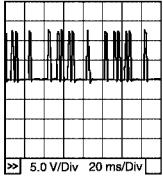
TER-MINAL NO.	WIRE COLOR	ITEM	CONDITION	DATA (DC Voltage)
12	W	Power steering pressure sensor	[Engine is running] ● Steering wheel: Being turned	0.5 - 4.5V
			[Engine is running] ● Steering wheel: Not being turned	0.4 - 0.8V
13	W	Crankshaft position sensor (POS)	[Engine is running] ● Warm-up condition ● Idle speed NOTE: The pulse cycle changes depending on rpm at idle	Approximately 10V★  PBIB1041E
			[Engine is running] ● Engine speed is 2,000 rpm	Approximately 10V★  PBIB1042E
14	W	Camshaft position sensor (PHASE) (bank 2)	[Engine is running] ● Warm-up condition ● Idle speed NOTE: The pulse cycle changes depending on rpm at idle	1.0 - 4.0V★  PBIB1039E
			[Engine is running] ● Engine speed is 2,000 rpm	1.0 - 4.0V★  PBIB1040E
15	W	Knock sensor	[Engine is running] ● Idle speed	Approximately 2.5V
16	OR	A/F sensor 1 (Bank 1)	[Engine is running] ● Warm-up condition ● Idle speed	Approximately 3.1V
35	W/R			Approximately 2.6V
56	LG/R			Approximately 2.3V
75	LG			Approximately 2.3V
17 18 19 20	P/B LG L L/W	EGR volume control valve	[Engine is running] ● Idle speed	0.1 - 14V

TROUBLE DIAGNOSIS

[VQ]

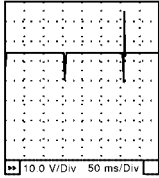
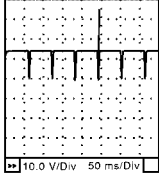
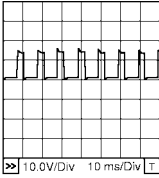
TER-MINAL NO.	WIRE COLOR	ITEM	CONDITION	DATA (DC Voltage)
21 22 23	L/W R/Y R/B	Injector No. 5 Injector No. 3 Injector No. 1	<p>[Engine is running]</p> <ul style="list-style-type: none"> ● Warm-up condition ● Idle speed <p>NOTE: The pulse cycle changes depending on rpm at idle</p>	<p>BATTERY VOLTAGE (11 - 14V)★</p>  <p style="text-align: right; font-size: small;">SEC984C</p>
			<p>[Engine is running]</p> <ul style="list-style-type: none"> ● Warm-up condition ● Engine speed is 2,000 rpm 	<p>BATTERY VOLTAGE (11 - 14V)★</p>  <p style="text-align: right; font-size: small;">SEC985C</p>
24	R/G	A/F sensor 1 heater (Bank 2)	<p>[Engine is running]</p> <ul style="list-style-type: none"> ● Warm-up condition ● Idle speed 	<p>Approximately 5V★</p>  <p style="text-align: right; font-size: small;">PBIB1584E</p>
25	P/B	Heated oxygen sensor 2 heater (bank 1)	<p>[Engine is running]</p> <ul style="list-style-type: none"> ● Engine speed is below 3,600 rpm after the following conditions are met <ul style="list-style-type: none"> - Engine: after warming up - Keeping the engine speed between 3,500 and 4,000 rpm for 1 minute and at idle for 1 minute under no load 	0 - 1.0V
			<p>[Ignition switch: ON]</p> <ul style="list-style-type: none"> ● Engine stopped <p>[Engine is running]</p> <ul style="list-style-type: none"> ● Engine speed is above 3,600 rpm 	BATTERY VOLTAGE (11 - 14V)
29	Y/G	VIAS control solenoid valve	<p>[Engine is running]</p> <ul style="list-style-type: none"> ● Idle speed 	BATTERY VOLTAGE (11 - 14V)
			<p>[Engine is running]</p> <ul style="list-style-type: none"> ● Engine speed is between 1,800 and 3,600 rpm 	0 - 1.0V
32	W	EVAP control system pressure sensor	[Ignition switch: ON]	Approximately 1.8 - 4.8V

A

EC

C

D

E

F

G

H

I

J

K

L

M

TROUBLE DIAGNOSIS

[VQ]

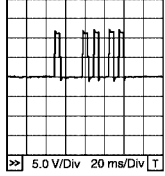
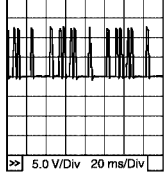
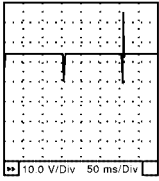
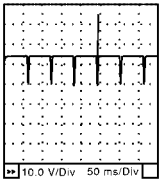
TER-MINAL NO.	WIRE COLOR	ITEM	CONDITION	DATA (DC Voltage)
33	R/Y	Camshaft position sensor (PHASE) (bank 1)	<p>[Engine is running]</p> <ul style="list-style-type: none"> ● Warm-up condition ● Idle speed <p>NOTE: The pulse cycle changes depending on rpm at idle</p>	<p>1.0 - 4.0V★</p>  <p style="text-align: right; font-size: small;">PBIB1039E</p>
			<p>[Engine is running]</p> <ul style="list-style-type: none"> ● Engine speed is 2,000 rpm 	<p>1.0 - 4.0V★</p>  <p style="text-align: right; font-size: small;">PBIB1040E</p>
34	Y/G	Intake air temperature sensor	<p>[Engine is running]</p>	<p>Approximately 0 - 4.8V Output voltage varies with intake air temperature.</p>
40 41 42	PU/R R/L R/W	Injector No. 6 Injector No. 4 Injector No. 2	<p>[Engine is running]</p> <ul style="list-style-type: none"> ● Warm-up condition ● Idle speed <p>NOTE: The pulse cycle changes depending on rpm at idle</p>	<p>BATTERY VOLTAGE (11 - 14V)★</p>  <p style="text-align: right; font-size: small;">SEC984C</p>
			<p>[Engine is running]</p> <ul style="list-style-type: none"> ● Warm-up condition ● Engine speed is 2,000 rpm 	<p>BATTERY VOLTAGE (11 - 14V)★</p>  <p style="text-align: right; font-size: small;">SEC985C</p>
44	W	Electronic controlled engine mount-1	<p>[Engine is running]</p> <ul style="list-style-type: none"> ● Idle speed 	<p>0 - 3.0V</p>
			<p>[Engine is running]</p> <ul style="list-style-type: none"> ● Except the above 	<p>BATTERY VOLTAGE (11 - 14V)</p>

TROUBLE DIAGNOSIS

[VQ]

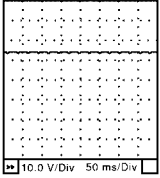
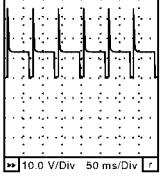
TER-MINAL NO.	WIRE COLOR	ITEM	CONDITION	DATA (DC Voltage)
45	PU/R	EVAP canister purge volume control solenoid valve	<p>[Engine is running]</p> <ul style="list-style-type: none"> ● Idle speed 	<p>BATTERY VOLTAGE (11 - 14V)★</p> 
			<p>[Engine is running]</p> <ul style="list-style-type: none"> ● Engine speed is about 2,000 rpm (More than 100 seconds after starting engine) 	<p>BATTERY VOLTAGE (11 - 14V)★</p> 
47	R	Sensor power supply (Throttle position sensor)	[Ignition switch: ON]	Approximately 5V
48	R	Sensor power supply (EVAP control system pressure sensor)	[Ignition switch: ON]	Approximately 5V
49	R	Sensor power supply (Refrigerant pressure sensor)	[Ignition switch: ON]	Approximately 5V
50	W	Throttle position sensor 1	<p>[Ignition switch: ON]</p> <ul style="list-style-type: none"> ● Engine stopped ● Shift lever: D (A/T) or 1st (M/T) ● Accelerator pedal: Fully released 	More than 0.36V
			<p>[Ignition switch: ON]</p> <ul style="list-style-type: none"> ● Engine stopped ● Shift lever: D (A/T) or 1st (M/T) ● Accelerator pedal: Fully depressed 	Less than 4.75V
51	W	Mass air flow sensor	<p>[Engine is running]</p> <ul style="list-style-type: none"> ● Warm-up condition ● Idle speed 	1.0 - 1.2V
			<p>[Engine is running]</p> <ul style="list-style-type: none"> ● Warm-up condition ● Engine speed is 2,500 rpm 	1.6 - 2.0V
54	P/L	EGR temperature sensor	<p>[Ignition switch: ON]</p>	Less than 4.5V
			<p>[Engine is running]</p> <ul style="list-style-type: none"> ● Warm-up condition ● EGR system is operating 	0 - 1.5V
55	W	Heated oxygen sensor 2 (bank 2)	<p>[Engine is running]</p> <ul style="list-style-type: none"> ● Warm-up condition ● Revving engine from idle to 3,000 rpm quickly after the following conditions are met. – After keeping the engine speed between 3,500 and 4,000 rpm for 1 minute and at idle for 1 minute under no load 	0 - Approximately 1.0V

TROUBLE DIAGNOSIS

[VQ]

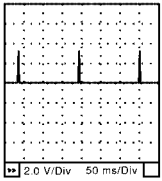
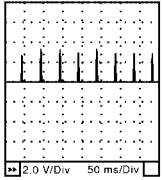
TER-MINAL NO.	WIRE COLOR	ITEM	CONDITION	DATA (DC Voltage)
57	OR/B	A/F sensor 1 (Bank 2)	[Engine is running] <ul style="list-style-type: none"> ● Warm-up condition ● Idle speed 	Approximately 2.6V
58	PU			Approximately 2.3V
76	BR			Approximately 3.1V
77	G/W			Approximately 2.3V
60 61 62	PU/W L/R Y/R	Ignition signal No. 5 Ignition signal No. 3 Ignition signal No. 1	[Engine is running] <ul style="list-style-type: none"> ● Warm-up condition ● Idle speed NOTE: The pulse cycle changes depending on rpm at idle	0 - 0.3V★ 
			[Engine is running] <ul style="list-style-type: none"> ● Warm-up condition ● Engine speed is 2,500 rpm 	0.1 - 0.6V★ 
63	W/R	Electronic controlled engine mount-2	[Engine is running] <ul style="list-style-type: none"> ● Idle speed 	BATTERY VOLTAGE (11 - 14V)
			[Engine is running] <ul style="list-style-type: none"> ● Except the above 	0 - 3.0V
66	B	Sensor ground (Throttle position sensor)	[Engine is running] <ul style="list-style-type: none"> ● Warm-up condition ● Idle speed 	Approximately 0V
67	B	Sensor ground	[Engine is running] <ul style="list-style-type: none"> ● Warm-up condition ● Idle speed 	Approximately 0V
68	R	Sensor power supply (PSP sensor)	[Ignition switch: ON]	Approximately 5V
69	R	Throttle position sensor 2	[Ignition switch: ON] <ul style="list-style-type: none"> ● Engine stopped ● Shift lever: D (A/T) or 1st (M/T) ● Accelerator pedal: Fully released 	Less than 4.75V
			[Ignition switch: ON] <ul style="list-style-type: none"> ● Engine stopped ● Shift lever: D (A/T) or 1st (M/T) ● Accelerator pedal: Fully depressed 	More than 0.36V
70	W	Refrigerant pressure sensor	[Engine is running] <ul style="list-style-type: none"> ● Warm-up condition ● Both A/C switch and blower switch are ON (Compressor operates.) 	1.0 - 4.0V
73	Y	Engine coolant temperature sensor	[Engine is running]	Approximately 0 - 4.8V Output voltage varies with engine coolant temperature.

TROUBLE DIAGNOSIS

[VQ]

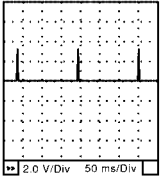
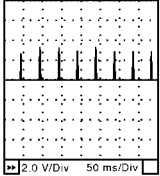
TER-MINAL NO.	WIRE COLOR	ITEM	CONDITION	DATA (DC Voltage)	
74	W	Heated oxygen sensor 2 (bank 1)	[Engine is running] <ul style="list-style-type: none"> ● Warm-up condition ● Revving engine from idle to 3,000 rpm quickly after the following conditions are met <ul style="list-style-type: none"> – After keeping the engine speed between 3,500 and 4,000 rpm for 1 minute and at idle for 1 minute under no load 	0 - Approximately 1.0V	A EC C
78	B	Sensor ground (Heated oxygen sensor 2)	[Engine is running] <ul style="list-style-type: none"> ● Warm-up condition ● Idle speed 	Approximately 0V	D E
79 80 81	GY/R GY G/R	Ignition signal No. 6 Ignition signal No. 4 Ignition signal No. 2	[Engine is running] <ul style="list-style-type: none"> ● Warm-up condition ● Idle speed <p>NOTE: The pulse cycle changes depending on rpm at idle</p>	0 - 0.3V★ 	F G
			[Engine is running] <ul style="list-style-type: none"> ● Warm-up condition ● Engine speed is 2,500 rpm 	0.1 - 0.6V★ 	H I
82	B	Sensor ground (APP sensor 1)	[Engine is running] <ul style="list-style-type: none"> ● Warm-up condition ● Idle speed 	Approximately 0V	J
83	G	Sensor ground (APP sensor 2)	[Engine is running] <ul style="list-style-type: none"> ● Warm-up condition ● Idle speed 	Approximately 0V	K
85	OR	Data link connector	[Ignition switch: ON] <ul style="list-style-type: none"> ● CONSULT-II or GST is disconnected 	Approximately 5V - Battery voltage (11 - 14V)	L
86	P	CAN communication line	[Ignition switch: ON]	Approximately 1.1 - 2.3V Output voltage varies with the communication status	M
90	R	Sensor power supply (APP sensor 1)	[Ignition switch: ON]	Approximately 5V	
91	OR	Sensor power supply (APP sensor 2)	[Ignition switch: ON]	Approximately 5V	
94	L	CAN communication line	[Ignition switch: ON]	Approximately 2.6 - 3.2V Output voltage varies with the communication status.	
98	W/B	Accelerator pedal position sensor 2	[Ignition switch: ON] <ul style="list-style-type: none"> ● Engine stopped ● Accelerator pedal: Fully released 	0.28 - 0.48V	
			[Ignition switch: ON] <ul style="list-style-type: none"> ● Engine stopped ● Accelerator pedal: Fully depressed 	More than 2.0V	

TROUBLE DIAGNOSIS

[VQ]

TER-MINAL NO.	WIRE COLOR	ITEM	CONDITION	DATA (DC Voltage)
99	G/Y	ASCD steering switch	[Ignition switch: ON] ● ASCD steering switch: OFF	Approximately 4V
			[Ignition switch: ON] ● MAIN switch: Pressed	Approximately 0V
			[Ignition switch: ON] ● CANCEL switch: Pressed	Approximately 1V
			[Ignition switch: ON] ● RESUME/ACCELERATE switch: Pressed	Approximately 3V
			[Ignition switch: ON] ● SET/COAST switch: Pressed	Approximately 2V
101	R/G	Stop lamp switch	[Ignition switch: OFF] ● Brake pedal: Fully released	Approximately 0V
			[Ignition switch: OFF] ● Brake pedal: Slightly depressed	BATTERY VOLTAGE (11 - 14V)
102	G/R (A/T) G/W (M/T)	PNP switch	[Ignition switch: ON] ● Shift lever: P or N (A/T), Neutral (M/T)	Approximately 0V
			[Ignition switch: ON] ● Shift lever: Except above	BATTERY VOLTAGE (11 - 14V)
104	OR	Throttle control motor relay	[Ignition switch: OFF]	BATTERY VOLTAGE (11 - 14V)
			[Ignition switch: ON]	0 - 1.0V
106	W	Accelerator pedal position sensor 1	[Ignition switch: ON] ● Engine stopped ● Accelerator pedal: Fully released	0.65 - 0.87V
			[Ignition switch: ON] ● Engine stopped ● Accelerator pedal: Fully depressed	More than 4.3V
107	P/L	Fuel tank temperature sensor	[Engine is running]	Approximately 0 - 4.8V Output voltage varies with fuel tank temperature.
108	G/B (A/T) G/R (M/T)	ASCD brake switch	[Ignition switch: ON] ● Brake pedal: Slightly depressed (A/T) ● Clutch pedal and/or clutch pedal: Slightly depressed (M/T)	Approximately 0V
			[Ignition switch: ON] ● Brake pedal: Fully released (A/T) ● Clutch pedal and brake pedal: Fully released (M/T)	BATTERY VOLTAGE (11 - 14V)
109	R	Ignition switch	[Ignition switch: OFF]	0V
			[Ignition switch: ON]	BATTERY VOLTAGE (11 - 14V)
111	W/B	ECM relay (Self shut-off)	[Engine is running] [Ignition switch: OFF] ● For a few seconds after turning ignition switch OFF	0 - 1.5V
			[Ignition switch: OFF] ● More than a few seconds after turning ignition switch OFF	BATTERY VOLTAGE (11 - 14V)

TROUBLE DIAGNOSIS

[VQ]

TER-MINAL NO.	WIRE COLOR	ITEM	CONDITION	DATA (DC Voltage)	A
113	B/OR	Fuel pump relay	[Ignition switch: ON] ● For 1 second after turning ignition switch ON [Engine is running]	0 - 1.5V	EC
			[Ignition switch: ON] ● More than 1 second after turning ignition switch ON	BATTERY VOLTAGE (11 - 14V)	C
115 116	B B	ECM ground	[Engine is running] ● Idle speed	Body ground	D
117	OR	EVAP canister vent control valve	[Ignition switch: ON]	BATTERY VOLTAGE (11 - 14V)	E
119 120	R/G R/G	Power supply for ECM	[Ignition switch: ON]	BATTERY VOLTAGE (11 - 14V)	F
121	W/L	Power supply for ECM (Back-up)	[Ignition switch: OFF]	BATTERY VOLTAGE (11 - 14V)	G

★: Average voltage for pulse signal (Actual pulse signal can be confirmed by oscilloscope.)

A
EC
C
D
E
F
G
H
I
J
K
L
M

TROUBLE DIAGNOSIS

[VQ]

UBS0010H

CONSULT-II Function (ENGINE) FUNCTION

Diagnostic test mode	Function
Work support	This mode enables a technician to adjust some devices faster and more accurately by following the indications on the CONSULT-II unit.
Self-diagnostic results	Self-diagnostic results such as 1st trip DTC, DTCs and 1st trip freeze frame data or freeze frame data can be read and erased quickly.*
Data monitor	Input/Output data in the ECM can be read.
Data monitor (SPEC)	Input/Output of the specification for Basic fuel schedule, AFM, A/F feedback control value and the other data monitor items can be read.
CAN diagnostic support monitor	The results of transmit/receive diagnosis of CAN communication can be read.
Active test	Diagnostic Test Mode in which CONSULT-II drives some actuators apart from the ECMs and also shifts some parameters in a specified range.
DTC & SRT confirmation	The status of system monitoring tests and the self-diagnosis status/result can be confirmed.
Function test	This mode is used to inform customers when their vehicle condition requires periodic maintenance.
ECM part number	ECM part number can be read.

*: The following emission-related diagnostic information is cleared when the ECM memory is erased.

- Diagnostic trouble codes
- 1st trip diagnostic trouble codes
- Freeze frame data
- 1st trip freeze frame data
- System readiness test (SRT) codes
- Test values

TROUBLE DIAGNOSIS

[VQ]

ENGINE CONTROL COMPONENT PARTS/CONTROL SYSTEMS APPLICATION

Item		DIAGNOSTIC TEST MODE								
		WORK SUP-PORT	SELF-DIAGNOSTIC RESULTS		DATA MONI-TOR	DATA MONI-TOR (SPEC)	ACTIVE TEST	DTC & SRT CONFIRMATION		
			DTC*1	FREEZE FRAME DATA*2				SRT STATUS	DTC WORK SUP-PORT	
ENGINE CONTROL COMPONENT PARTS INPUT	Crankshaft position sensor (POS)		×	×	×	×			A	
	Camshaft position sensor (PHASE)		×	×	×	×			B	
	Mass air flow sensor		×		×	×			C	
	Engine coolant temperature sensor		×	×	×	×	×		D	
	A/F sensor 1		×		×	×		×	E	
	Heated oxygen sensor 2		×		×	×		×	F	
	Wheel sensor		×	×	×	×			G	
	Accelerator pedal position sensor		×		×	×			H	
	Throttle position sensor		×		×	×			I	
	Fuel tank temperature sensor		×		×	×	×		J	
	EVAP control system pressure sensor		×		×	×			K	
	Intake air temperature sensor		×	×	×	×			L	
	EGR temperature sensor		×		×	×			M	
	Knock sensor		×							N
	Refrigerant pressure sensor				×	×				O
	Closed throttle position switch (accelerator pedal position sensor signal)				×	×				P
	Air conditioner switch				×	×				Q
	Park/neutral position (PNP) switch		×		×	×				R
	Stop lamp switch		×		×	×				S
	Power steering pressure sensor		×		×	×				T
Battery voltage				×	×				U	
Load signal				×	×				V	
Fuel level sensor		×		×	×				W	
ASCD steering switch		×		×	×				X	
ASCD brake switch		×		×	×				Y	
ASCD clutch switch		×		×	×				Z	

TROUBLE DIAGNOSIS

[VQ]

Item		DIAGNOSTIC TEST MODE							
		WORK SUP-PORT	SELF-DIAGNOSTIC RESULTS		DATA MONI-TOR	DATA MONI-TOR (SPEC)	ACTIVE TEST	DTC & SRT CONFIRMATION	
			DTC*1	FREEZE FRAME DATA*2				SRT STATUS	DTC WORK SUP-PORT
ENGINE CONTROL COMPONENT PARTS OUTPUT	Fuel injector				×	×	×		
	Power transistor (Ignition timing)				×	×	×		
	Throttle control motor relay		×		×	×			
	Throttle control motor		×						
	EVAP canister purge volume control solenoid valve		×		×	×	×		×
	Air conditioner relay				×	×			
	Fuel pump relay	×			×	×	×		
	Cooling fan relay		×		×	×	×		
	EGR volume control valve		×		×	×	×		
	A/F sensor 1 heater		×		×	×		×	
	Heated oxygen sensor 2 heater		×		×	×		×	
	EVAP canister vent control valve	×	×		×	×	×		
	Intake valve timing control solenoid valve		×		×	×	×		
	VIAS control solenoid valve		×		×	×	×		
	Electronic controlled engine mount				×	×	×		
Calculated load value			×	×	×				

X: Applicable

*1: This item includes 1st trip DTCs.

*2: This mode includes 1st trip freeze frame data or freeze frame data. The items appear on CONSULT-II screen in freeze frame data mode only if a 1st trip DTC or DTC is detected. For details, refer to [EC-674](#).

INSPECTION PROCEDURE

CAUTION:

If CONSULT-II is used with no connection of CONSULT-II CONVERTER, malfunctions might be detected in self-diagnosis depending on control unit which carry out CAN communication.

1. Turn ignition switch OFF.
2. Connect "CONSULT-II" and "CONSULT-II CONVERTER" to data link connector, which is located under LH dash panel near the hood opener handle.
3. Turn ignition switch ON.

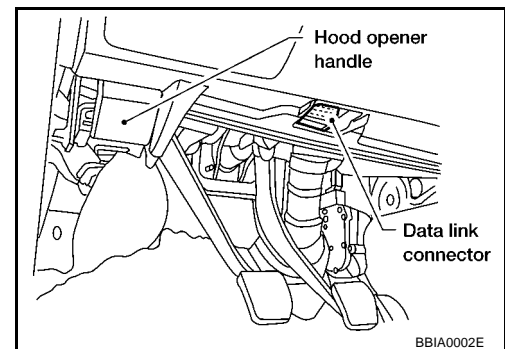

TROUBLE DIAGNOSIS

[VQ]

4. Touch "START (NISSAN BASED VHCL)".

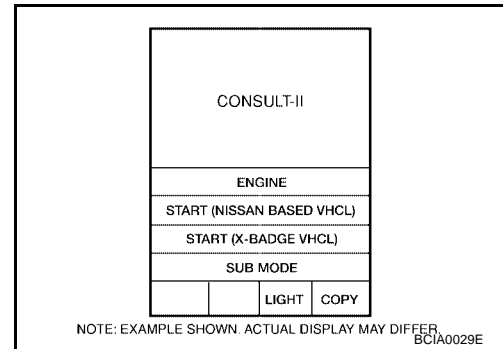

5. Touch "ENGINE".
If "ENGINE" is not indicated, go to [GI-39, "Consult-II Data Link Connector \(DLC\) Circuit"](#).

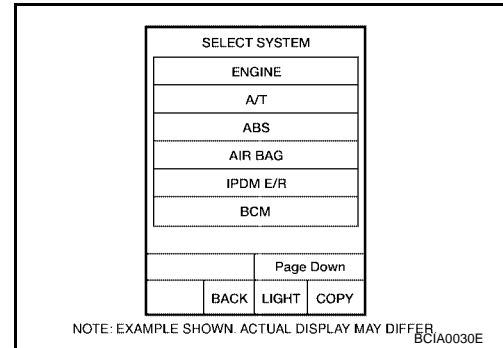

6. Perform each diagnostic test mode according to each service procedure.
For further information, see the CONSULT-II Operation Manual.

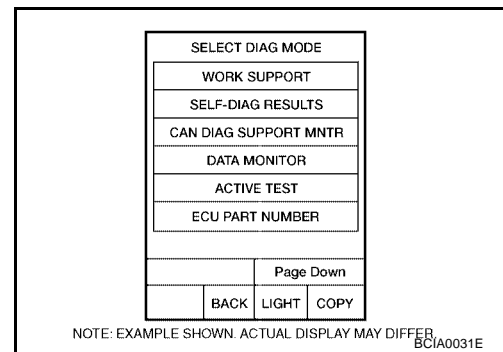

WORK SUPPORT MODE

Work Item

WORK ITEM	CONDITION	USAGE
FUEL PRESSURE RELEASE	<ul style="list-style-type: none"> FUEL PUMP WILL STOP BY TOUCHING "START" DURING IDLING. CRANK A FEW TIMES AFTER ENGINE STALLS. 	When releasing fuel pressure from fuel line
IDLE AIR VOL LEARN	<ul style="list-style-type: none"> THE IDLE AIR VOLUME THAT KEEPS THE ENGINE WITHIN THE SPECIFIED RANGE IS MEMORIZED IN ECM. 	When learning the idle air volume
SELF-LEARNING CONT	<ul style="list-style-type: none"> THE COEFFICIENT OF SELF-LEARNING CONTROL MIXTURE RATIO RETURNS TO THE ORIGINAL COEFFICIENT. 	When clearing the coefficient of self-learning control value

TROUBLE DIAGNOSIS

[VQ]

WORK ITEM	CONDITION	USAGE
EVAP SYSTEM CLOSE	<p>CLOSE THE EVAP CANISTER VENT CONTROL VALVE IN ORDER TO MAKE EVAP SYSTEM CLOSE UNDER THE FOLLOWING CONDITIONS.</p> <ul style="list-style-type: none"> ● IGN SW ON ● ENGINE NOT RUNNING ● AMBIENT TEMPERATURE IS ABOVE 0°C (32°F). ● NO VACUUM AND NO HIGH PRESSURE IN EVAP SYSTEM ● FUEL TANK TEMP. IS MORE THAN 0°C (32°F). ● WITHIN 10 MINUTES AFTER STARTING “EVAP SYSTEM CLOSE” ● WHEN TRYING TO EXECUTE “EVAP SYSTEM CLOSE” UNDER THE CONDITION EXCEPT ABOVE, CONSULT-II WILL DISCONTINUE IT AND DISPLAY APPROPRIATE INSTRUCTION. <p>NOTE: WHEN STARTING ENGINE, CONSULT-II MAY DISPLAY “BATTERY VOLTAGE IS LOW. CHARGE BATTERY”, EVEN IN USING CHARGED BATTERY.</p>	When detecting EVAP vapor leak point of EVAP system
VIN REGISTRATION	<ul style="list-style-type: none"> ● IN THIS MODE, VIN IS REGISTERED IN ECM 	When registering VIN in ECM
TARGET IDLE RPM ADJ*	<ul style="list-style-type: none"> ● IDLE CONDITION 	When setting target idle speed
TARGET IGN TIM ADJ*	<ul style="list-style-type: none"> ● IDLE CONDITION 	When adjusting target ignition timing

*: This function is not necessary in the usual service procedure.

SELF-DIAG RESULTS MODE

Self Diagnostic Item

Regarding items of “DTC and 1st trip DTC”, refer to [EC-627, "INDEX FOR DTC"](#) .

Freeze Frame Data and 1st Trip Freeze Frame Data

Freeze frame data item*	Description
DIAG TROUBLE CODE [PXXXX]	<ul style="list-style-type: none"> ● The engine control component part/control system has a trouble code, it is displayed as “PXXXX”. (Refer to EC-627, "INDEX FOR DTC" .)
FUEL SYS-B1	<ul style="list-style-type: none"> ● “Fuel injection system status” at the moment a malfunction is detected is displayed.
FUEL SYS-B2	<ul style="list-style-type: none"> ● One mode in the following is displayed. “Mode2”: Open loop due to detected system malfunction “Mode3”: Open loop due to driving conditions (power enrichment, deceleration enrichment) “Mode4”: Closed loop - using oxygen sensor(s) as feedback for fuel control “Mode5”: Open loop - has not yet satisfied condition to go to closed loop
CAL/LD VALUE [%]	<ul style="list-style-type: none"> ● The calculated load value at the moment a malfunction is detected is displayed.
COOLANT TEMP [°C] or [°F]	<ul style="list-style-type: none"> ● The engine coolant temperature at the moment a malfunction is detected is displayed.
L-FUEL TRM-B1 [%]	<ul style="list-style-type: none"> ● “Long-term fuel trim” at the moment a malfunction is detected is displayed.
L-FUEL TRM-B2 [%]	<ul style="list-style-type: none"> ● The long-term fuel trim indicates much more gradual feedback compensation to the base fuel schedule than short-term fuel trim.
S-FUEL TRM-B1 [%]	<ul style="list-style-type: none"> ● “Short-term fuel trim” at the moment a malfunction is detected is displayed.
S-FUEL TRM-B2 [%]	<ul style="list-style-type: none"> ● The short-term fuel trim indicates dynamic or instantaneous feedback compensation to the base fuel schedule.
ENGINE SPEED [rpm]	<ul style="list-style-type: none"> ● The engine speed at the moment a malfunction is detected is displayed.
VEHICL SPEED [km/h] or [mph]	<ul style="list-style-type: none"> ● The vehicle speed at the moment a malfunction is detected is displayed.

TROUBLE DIAGNOSIS

[VQ]

Freeze frame data item*	Description
B/FUEL SCHDL [msec]	<ul style="list-style-type: none"> The base fuel schedule at the moment a malfunction is detected is displayed.
INT/A TEMP SE [°C] or [°F]	<ul style="list-style-type: none"> The intake air temperature at the moment a malfunction is detected is displayed.

*: The items are the same as those of 1st trip freeze frame data.

DATA MONITOR MODE

Monitored Item

×: Applicable

Monitored item [Unit]	ECM INPUT SIGNALS	MAIN SIGNALS	Description	Remarks
ENG SPEED [rpm]	×	×	<ul style="list-style-type: none"> Indicates the engine speed computed from the signal of the crankshaft position sensor (POS) and camshaft position sensor (PHASE). 	<ul style="list-style-type: none"> Accuracy becomes poor if engine speed drops below the idle rpm. If the signal is interrupted while the engine is running, an abnormal value may be indicated.
MAS A/F SE-B1 [V]	×	×	<ul style="list-style-type: none"> The signal voltage of the mass air flow sensor is displayed. 	<ul style="list-style-type: none"> When the engine is stopped, a certain value is indicated.
B/FUEL SCHDL [msec]		×	<ul style="list-style-type: none"> Base fuel schedule indicates the fuel injection pulse width programmed into ECM, prior to any learned on board correction. 	
A/F ALPHA-B1 [%]		×	<ul style="list-style-type: none"> The mean value of the air-fuel ratio feedback correction factor per cycle is indicated. 	<ul style="list-style-type: none"> When the engine is stopped, a certain value is indicated. This data also includes the data for the air-fuel ratio learning control.
A/F ALPHA-B2 [%]		×		
COOLAN TEMP/S [°C] or [°F]	×	×	<ul style="list-style-type: none"> The engine coolant temperature (determined by the signal voltage of the engine coolant temperature sensor) is displayed. 	<ul style="list-style-type: none"> When the engine coolant temperature sensor is open or short-circuited, ECM enters fail-safe mode. The engine coolant temperature determined by the ECM is displayed.
A/F SEN1 (B1) [V]	×	×	<ul style="list-style-type: none"> The A/F signal computed from the input signal of the A/F sensor 1 is displayed. 	
A/F SEN1 (B2) [V]	×			
HO2S2 (B1) [V]	×		<ul style="list-style-type: none"> The signal voltage of the heated oxygen sensor 2 is displayed. 	
HO2S2 (B2) [V]	×			
HO2S2 MNTR (B1) [RICH/LEAN]	×		<ul style="list-style-type: none"> Display of heated oxygen sensor 2 signal: RICH: means the amount of oxygen after three way catalyst is relatively small. LEAN: means the amount of oxygen after three way catalyst is relatively large. 	<ul style="list-style-type: none"> When the engine is stopped, a certain value is indicated.
HO2S2 MNTR (B2) [RICH/LEAN]	×			
VHCL SPEED SE [km/h] or [mph]	×	×	<ul style="list-style-type: none"> The vehicle speed computed from the vehicle speed signal sent from combination meter is displayed. 	
BATTERY VOLT [V]	×	×	<ul style="list-style-type: none"> The power supply voltage of ECM is displayed. 	
ACCEL SEN 1 [V]	×	×	<ul style="list-style-type: none"> The accelerator pedal position sensor signal voltage is displayed. 	<ul style="list-style-type: none"> ACCEL SEN2 signal is converted by ECM internally. Thus, it differs from ECM terminal voltage signal.
ACCEL SEN 2 [V]	×			
THRTL SEN 1 [V]	×	×	<ul style="list-style-type: none"> The throttle position sensor signal voltage is displayed. 	<ul style="list-style-type: none"> THRTL SEN2 signal is converted by ECM internally. Thus, it differs from ECM terminal voltage signal.
THRTL SEN 2 [V]	×			
FUEL T/TMP SE [°C] or [°F]	×		<ul style="list-style-type: none"> The fuel temperature (determined by the signal voltage of the fuel tank temperature sensor) is displayed. 	

TROUBLE DIAGNOSIS

[VQ]

Monitored item [Unit]	ECM INPUT SIGNALS	MAIN SIGNALS	Description	Remarks
INT/A TEMP SE [°C] or [°F]	×	×	<ul style="list-style-type: none"> The intake air temperature (determined by the signal voltage of the intake air temperature sensor) is indicated. 	
EGR TEMP SEN [V]	×	×	<ul style="list-style-type: none"> The signal voltage of EGR temperature sensor is displayed 	
EVAP SYS PRES [V]	×		<ul style="list-style-type: none"> The signal voltage of EVAP control system pressure sensor is displayed. 	
FUEL LEVEL SE [V]	×		<ul style="list-style-type: none"> The signal voltage of the fuel level sensor is displayed. 	
START SIGNAL [ON/OFF]	×	×	<ul style="list-style-type: none"> Indicates start signal status [ON/OFF] computed by the ECM according to the signals of engine speed and battery voltage. 	<ul style="list-style-type: none"> After starting the engine, [OFF] is displayed regardless of the starter signal.
CLSD THL POS [ON/OFF]	×	×	<ul style="list-style-type: none"> Indicates idle position [ON/OFF] computed by ECM according to the accelerator pedal position sensor signal. 	
AIR COND SIG [ON/OFF]	×	×	<ul style="list-style-type: none"> Indicates [ON/OFF] condition of the air conditioner switch as determined by the air conditioner signal. 	
P/N POSI SW [ON/OFF]	×	×	<ul style="list-style-type: none"> Indicates [ON/OFF] condition from the park/neutral position (PNP) switch signal. 	
PW/ST SIGNAL [ON/OFF]	×	×	<ul style="list-style-type: none"> [ON/OFF] condition of the power steering system (determined by the signal voltage of the power steering pressure sensor signal) is indicated. 	
LOAD SIGNAL [ON/OFF]	×	×	<ul style="list-style-type: none"> Indicates [ON/OFF] condition from the electrical load signal. ON: Rear window defogger switch is ON and/or lighting switch is in 2nd position. OFF: Both rear window defogger switch and lighting switch are OFF. 	
IGNITION SW [ON/OFF]	×		<ul style="list-style-type: none"> Indicates [ON/OFF] condition from ignition switch signal. 	
HEATER FAN SW [ON/OFF]	×		<ul style="list-style-type: none"> Indicates [ON/OFF] condition from heater fan switch signal. 	
BRAKE SW [ON/OFF]	×		<ul style="list-style-type: none"> Indicates [ON/OFF] condition from the stop lamp switch signal. 	
INJ PULSE-B1 [msec]		×	<ul style="list-style-type: none"> Indicates the actual fuel injection pulse width compensated by ECM according to the input signals. 	<ul style="list-style-type: none"> When the engine is stopped, a certain computed value is indicated.
INJ PULSE-B2 [msec]				
IGN TIMING [BTDC]		×	<ul style="list-style-type: none"> Indicates the ignition timing computed by ECM according to the input signals. 	<ul style="list-style-type: none"> When the engine is stopped, a certain value is indicated.
CAL/LD VALUE [%]			<ul style="list-style-type: none"> "Calculated load value" indicates the value of the current air flow divided by peak air flow. 	
MASS AIRFLOW [g·m/s]			<ul style="list-style-type: none"> Indicates the mass air flow computed by ECM according to the signal voltage of the mass air flow sensor. 	
PURG VOL C/V [%]			<ul style="list-style-type: none"> Indicates the EVAP canister purge volume control solenoid valve control value computed by the ECM according to the input signals. The opening becomes larger as the value increases. 	

TROUBLE DIAGNOSIS

[VQ]

Monitored item [Unit]	ECM INPUT SIGNALS	MAIN SIGNALS	Description	Remarks	
EGR VOL CON/V [step]		×	<ul style="list-style-type: none"> Indicates the EGR volume control value computed by the ECM according to the input signals. The opening becomes larger as the value increases. 		A EC
INT/V TIM (B1) [°CA]			<ul style="list-style-type: none"> Indicates [°CA] of intake camshaft advanced angle. 		C
INT/V TIM (B2) [°CA]				D	
INT/V SOL (B1) [%]			<ul style="list-style-type: none"> The control condition of the intake valve timing control solenoid valve (determined by ECM according to the input signals) is indicated. The advance angle becomes larger as the value increases. 		E
INT/V SOL (B2) [%]				F	
VIAS S/V [ON/OFF]			<ul style="list-style-type: none"> The control condition of the VIAS control solenoid valve (determined by ECM according to the input signals) is indicated. ON: VIAS control solenoid valve is operating. OFF: VIAS control solenoid valve is not operating. 		G H
AIR COND RLY [ON/OFF]		×	<ul style="list-style-type: none"> The air conditioner relay control condition (determined by ECM according to the input signals) is indicated. 		I
ENGINE MOUNT [IDLE/TRVL]			<ul style="list-style-type: none"> The control condition of the electronic controlled engine mount (determined by ECM according to the input signals) is indicated. IDLE: Idle condition TRVL: Driving condition 		J
FUEL PUMP RLY [ON/OFF]		×	<ul style="list-style-type: none"> Indicates the fuel pump relay control condition determined by ECM according to the input signals. 		K
VENT CONT/V [ON/OFF]			<ul style="list-style-type: none"> The control condition of the EVAP canister vent control valve (determined by ECM according to the input signals) is indicated. ON: Closed OFF: Open 		L
THRTL RELAY [ON/OFF]		×	<ul style="list-style-type: none"> Indicates the throttle control motor relay control condition determined by the ECM according to the input signals. 		M
COOLING FAN [HI/MID/LOW/OFF]			<ul style="list-style-type: none"> The control condition of the cooling fan (determined by ECM according to the input signals) is indicated. HI: High speed operation MID: Middle speed operation LOW: Low speed operation OFF: Stop 		
HO2S2 HTR (B1) [ON/OFF]			<ul style="list-style-type: none"> Indicates [ON/OFF] condition of heated oxygen sensor 2 heater determined by ECM according to the input signals. 		
HO2S2 HTR (B2) [ON/OFF]					
I/P PULLY SPD [rpm]			<ul style="list-style-type: none"> Indicates the engine speed computed from the turbine revolution sensor signal. 		
VEHICLE SPEED [km/h] or [MPH]			<ul style="list-style-type: none"> Indicates the vehicle speed computed from the revolution sensor signal. 		

TROUBLE DIAGNOSIS

[VQ]

Monitored item [Unit]	ECM INPUT SIGNALS	MAIN SIGNALS	Description	Remarks
IDL A/V LEARN [YET/CMPLT]			<ul style="list-style-type: none"> Display the condition of idle air volume learning YET: Idle Air Volume Learning has not been performed yet. CMPLT: Idle Air Volume Learning has already been performed successfully. 	
TRVL AFTER MIL [km] or [mile]			<ul style="list-style-type: none"> Distance traveled while MIL is activated. 	
A/F S1 HTR (B1) [%]			<ul style="list-style-type: none"> A/F sensor 1 heater control value computed by ECM according to the input signals. 	
A/F S1 HTR (B2) [%]			<ul style="list-style-type: none"> The current flow to the heater becomes larger as the value increases. 	
AC PRESS SEN [V]			<ul style="list-style-type: none"> The signal voltage from the refrigerant pressure sensor is displayed. 	
VHCL SPEED SE [km/h] or [mph]			<ul style="list-style-type: none"> The vehicle speed computed from the vehicle speed signal sent from TCM is displayed. 	
SET VHCL SPD [km/h] or [mph]			<ul style="list-style-type: none"> The preset vehicle speed is displayed. 	
MAIN SW [ON/OFF]			<ul style="list-style-type: none"> Indicates [ON/OFF] condition from MAIN switch signal. 	
CANCEL SW [ON/OFF]			<ul style="list-style-type: none"> Indicates [ON/OFF] condition from CANCEL switch signal. 	
RESUME/ACC SW [ON/OFF]			<ul style="list-style-type: none"> Indicates [ON/OFF] condition from RESUME/ACCELERATE switch signal. 	
SET SW [ON/OFF]			<ul style="list-style-type: none"> Indicates [ON/OFF] condition from SET/COAST switch signal. 	
BRAKE SW1 [ON/OFF]			<ul style="list-style-type: none"> Indicates [ON/OFF] condition from ASCD brake switch signal. 	
BRAKE SW2 [ON/OFF]			<ul style="list-style-type: none"> Indicates [ON/OFF] condition of stop lamp switch signal. 	
VHCL SPD CUT [NON/CUT]			<ul style="list-style-type: none"> Indicates the vehicle cruise condition. NON: Vehicle speed is maintained at the ASCD set speed. CUT: Vehicle speed increased to excessively high compared with the ASCD set speed, and ASCD operation is cut off. 	
LO SPEED CUT [NON/CUT]			<ul style="list-style-type: none"> Indicates the vehicle cruise condition. NON: Vehicle speed is maintained at the ASCD set speed. CUT: Vehicle speed decreased to excessively low compared with the ASCD set speed, and ASCD operation is cut off. 	
AT OD MONITOR [ON/OFF]			<ul style="list-style-type: none"> Indicates [ON/OFF] condition of A/T O/D according to the input signal from the TCM. 	
AT OD CANCEL [ON/OFF]			<ul style="list-style-type: none"> Indicates [ON/OFF] condition of A/T O/D cancel signal sent from the TCM. 	
CRUISE LAMP [ON/OFF]			<ul style="list-style-type: none"> Indicates [ON/OFF] condition of CRUISE lamp determined by the ECM according to the input signals. 	
SET LAMP [ON/OFF]			<ul style="list-style-type: none"> Indicates [ON/OFF] condition of SET lamp determined by the ECM according to the input signals. 	

TROUBLE DIAGNOSIS

[VQ]

Monitored item [Unit]	ECM INPUT SIGNALS	MAIN SIGNALS	Description	Remarks
Voltage [V]			<ul style="list-style-type: none"> ● Voltage, frequency, duty cycle or pulse width measured by the probe. 	<ul style="list-style-type: none"> ● Only # is displayed if item is unable to be measured. ● Figures with #s are temporary ones. They are the same figures as an actual piece of data which was just previously measured.
Frequency [msec], [Hz] or [%]				
DUTY-HI				
DUTY-LOW				
PLS WIDTH-HI				
PLS WIDTH-LOW				

NOTE:

Any monitored item that does not match the vehicle being diagnosed is deleted from the display automatically.

DATA MONITOR (SPEC) MODE

Monitored Item

Monitored item [Unit]	ECM input signals	Main signals	Description	Remarks
ENG SPEED [rpm]	×	×	<ul style="list-style-type: none"> ● Indicates the engine speed computed from the signal of the crankshaft position sensor (POS) and camshaft position sensor (PHASE). 	
MAS A/F SE-B1 [V]	×	×	<ul style="list-style-type: none"> ● The signal voltage of the mass air flow sensor specification is displayed. 	<ul style="list-style-type: none"> ● When engine is running specification range is indicated.
B/FUEL SCHDL [msec]		×	<ul style="list-style-type: none"> ● Base fuel schedule indicates the fuel injection pulse width programmed into ECM, prior to any learned on board correction. 	<ul style="list-style-type: none"> ● When engine is running specification range is indicated.
A/F ALPHA-B1 [%] A/F ALPHA-B2 [%]		×	<ul style="list-style-type: none"> ● The mean value of the air-fuel ratio feedback correction factor per cycle is indicated. 	<ul style="list-style-type: none"> ● When engine is running specification range is indicated. ● This data also includes the data for the air-fuel ratio learning control.

NOTE:

Any monitored item that does not match the vehicle being diagnosed is deleted from the display automatically.

ACTIVE TEST MODE

Test Item

TEST ITEM	CONDITION	JUDGEMENT	CHECK ITEM (REMEDY)
FUEL INJECTION	<ul style="list-style-type: none"> ● Engine: Return to the original trouble condition ● Change the amount of fuel injection using CONSULT-II. 	If trouble symptom disappears, see CHECK ITEM.	<ul style="list-style-type: none"> ● Harness and connectors ● Fuel injector ● Air fuel ratio (A/F) sensor 1
IGNITION TIMING	<ul style="list-style-type: none"> ● Engine: Return to the original trouble condition ● Timing light: Set ● Retard the ignition timing using CONSULT-II. 	If trouble symptom disappears, see CHECK ITEM.	<ul style="list-style-type: none"> ● Perform Idle Air Volume Learning.
POWER BALANCE	<ul style="list-style-type: none"> ● Engine: After warming up, idle the engine. ● A/C switch: OFF ● Shift lever: P or N (A/T), Neutral (M/T) ● Cut off each injector signal one at a time using CONSULT-II. 	Engine runs rough or dies.	<ul style="list-style-type: none"> ● Harness and connectors ● Compression ● Fuel injector ● Power transistor ● Spark plug ● Ignition coil

TROUBLE DIAGNOSIS

[VQ]

TEST ITEM	CONDITION	JUDGEMENT	CHECK ITEM (REMEDY)
COOLING FAN*	<ul style="list-style-type: none"> ● Ignition switch: ON ● Turn the cooling fan "HI", "LOW" and "OFF" using CONSULT-II. 	Cooling fan moves and stops.	<ul style="list-style-type: none"> ● Harness and connectors ● Cooling fan motor ● IPDM E/R
ENG COOLANT TEMP	<ul style="list-style-type: none"> ● Engine: Return to the original trouble condition ● Change the engine coolant temperature using CONSULT-II. 	If trouble symptom disappears, see CHECK ITEM.	<ul style="list-style-type: none"> ● Harness and connectors ● Engine coolant temperature sensor ● Fuel injector
FUEL PUMP RELAY	<ul style="list-style-type: none"> ● Ignition switch: ON (Engine stopped) ● Turn the fuel pump relay ON and OFF using CONSULT-II and listen to operating sound. 	Fuel pump relay makes the operating sound.	<ul style="list-style-type: none"> ● Harness and connectors ● Fuel pump relay
EGR VOL CONT/V	<ul style="list-style-type: none"> ● Ignition switch: ON (Engine stopped) ● Change the EGR volume control valve opening step using CONSULT-II. 	EGR volume control valve makes an operating sound.	<ul style="list-style-type: none"> ● Harness and connectors ● EGR volume control valve
VIAS SOL VALVE	<ul style="list-style-type: none"> ● Ignition switch: ON ● Turn solenoid valve "ON" and "OFF" using CONSULT-II and listen to operating sound. 	Solenoid valve makes the operating sound.	<ul style="list-style-type: none"> ● Harness and connectors ● Solenoid valve
ENGINE MOUNTING	<ul style="list-style-type: none"> ● Ignition switch: ON ● Turn electronic controlled engine mount "IDLE" and "TRVL" with the CONSULT-II. 	Electronic controlled engine mount makes the operating sound.	<ul style="list-style-type: none"> ● Harness and connectors ● Electronic controlled engine mount
PURG VOL CONT/V	<ul style="list-style-type: none"> ● Engine: After warming up, run engine at 1,500 rpm. ● Change the EVAP canister purge volume control solenoid valve opening percent using CONSULT-II. 	Engine speed changes according to the opening percent.	<ul style="list-style-type: none"> ● Harness and connectors ● Solenoid valve
FUEL/T TEMP SEN	<ul style="list-style-type: none"> ● Change the fuel tank temperature using CONSULT-II. 		
VENT CONTROL/V	<ul style="list-style-type: none"> ● Ignition switch: ON (Engine stopped) ● Turn solenoid valve "ON" and "OFF" with the CONSULT-II and listen to operating sound. 	Solenoid valve makes an operating sound.	<ul style="list-style-type: none"> ● Harness and connectors ● Solenoid valve
V/T ASSIGN ANGLE	<ul style="list-style-type: none"> ● Engine: Return to the original trouble condition ● Change intake valve timing using CONSULT-II. 	If trouble symptom disappears, see CHECK ITEM.	<ul style="list-style-type: none"> ● Harness and connectors ● Intake valve timing control solenoid valve

*: Leaving cooling fan OFF with CONSULT-II while engine is running may cause the engine to overheat.

DTC & SRT CONFIRMATION MODE

SRT STATUS Mode

For details, refer to [EC-674, "SYSTEM READINESS TEST \(SRT\) CODE"](#) .

SRT WORK SUPPORT Mode

This mode enables a technician to drive a vehicle to set the SRT while monitoring the SRT status.

TROUBLE DIAGNOSIS

[VQ]

DTC WORK SUPPORT Mode

Test mode	Test item	Condition	Reference page
EVAPORATIVE SYSTEM	PURG FLOW P0441	Refer to corresponding trouble diagnosis for DTC.	EC-964
	EVP SML LEAK P0442/P1442*		EC-969
	EVP V/S LEAK P0456/P1456*		EC-1016
	PURG VOL CN/V P1444		EC-1206
A/F SEN1	A/F SEN1 (B1) P1276		EC-1166
	A/F SEN1 (B2) P1286		EC-1166
	A/F SEN1 (B1) P1278/1279		EC-1175, EC-1187
	A/F SEN1 (B2) P1288/1289		EC-1175, EC-1187
HO2S2	HO2S2 (B1) P0139		EC-856
	HO2S2 (B1) P1146		EC-1084
	HO2S2 (B1) P1147		EC-1096
	HO2S2 (B2) P0159		EC-856
	HO2S2 (B2) P1166	EC-1084	
	HO2S2 (B2) P1167	EC-1096	
EGR SYSTEM	EGR SYSTEM P0400	EC-937	
	EGR SYSTEM P1402	EC-1199	

*: DTC P1442 and P1456 does not apply to L31 models but appears in DTC WORK SUPPORT Mode screens.

REAL TIME DIAGNOSIS IN DATA MONITOR MODE (RECORDING VEHICLE DATA)

Description

CONSULT-II has two kinds of triggers and they can be selected by touching "SETTING" in "DATA MONITOR" mode.

1. "AUTO TRIG" (Automatic trigger):

- The malfunction will be identified on the CONSULT-II screen in real time.

In other words, DTC/1st trip DTC and malfunction item will be displayed if the malfunction is detected by ECM.

At the moment a malfunction is detected by ECM, "MONITOR" in "DATA MONITOR" screen is changed to "Recording Data ... xx%" as shown at right, and the data after the malfunction detection is recorded. Then when the percentage reached 100%, "REAL-TIME DIAG" screen is displayed. If "STOP" is touched on the screen during "Recording Data ... xx%", "REAL-TIME DIAG" screen is also displayed.

The recording time after the malfunction detection and the recording speed can be changed by "TRIGGER POINT" and "Recording Speed". Refer to CONSULT-II Operation Manual.

2. "MANU TRIG" (Manual trigger):

- DTC/1st trip DTC and malfunction item will not be displayed automatically on CONSULT-II screen even though a malfunction is detected by ECM. DATA MONITOR can be performed continuously even though a malfunction is detected.

DATA MONITOR	
Recording Data...11%	NO DTC
ENG SPEED	XXX rpm
MAS A/F SE-B1	XXX V
COOLAN TEMP/S	XXX °C
HO2S1 (B1)	XXX V
VHCL SPEED SE	XXX km/h

SEF705Y

SET RECORDING CONDITION				
AUTO TRIG				
MANU TRIG				
TRIGGER POINT				
<div style="display: flex; justify-content: space-between; width: 100%;"> 0% 20% 40% 60% 80% 100% </div>				
RECORDING SPEED				
<table style="width: 100%; border-collapse: collapse;"> <tr> <td style="width: 50%; text-align: left;">MIN</td> <td style="width: 50%; text-align: right;">MAX</td> </tr> <tr> <td style="border: 1px solid black; height: 15px;"></td> <td style="border: 1px solid black; height: 15px;"></td> </tr> </table>	MIN	MAX		
MIN	MAX			
/64 /32 /16 /8 /4 /2 FULL				

SEF707X

Operation

1. "AUTO TRIG"

- While trying to detect the DTC/1st trip DTC by performing the DTC Confirmation Procedure, be sure to select to "DATA MONITOR (AUTO TRIG)" mode. You can confirm the malfunction at the moment it is detected.
- While narrowing down the possible causes, CONSULT-II should be set in "DATA MONITOR (AUTO TRIG)" mode, especially in case the incident is intermittent.
When you are inspecting the circuit by gently shaking (or twisting) the suspicious connectors, components and harness in the DTC Confirmation Procedure, the moment a malfunction is found the DTC/1st trip DTC will be displayed. (Refer to "INCIDENT SIMULATION TESTS" in [GI-26, "How to Perform Efficient Diagnosis for an Electrical Incident"](#) .)

2. "MANU TRIG"

- If the malfunction is displayed as soon as "DATA MONITOR" is selected, reset CONSULT-II to "MANU TRIG". By selecting "MANU TRIG" you can monitor and store the data. The data can be utilized for further diagnosis, such as a comparison with the value for the normal operating condition.

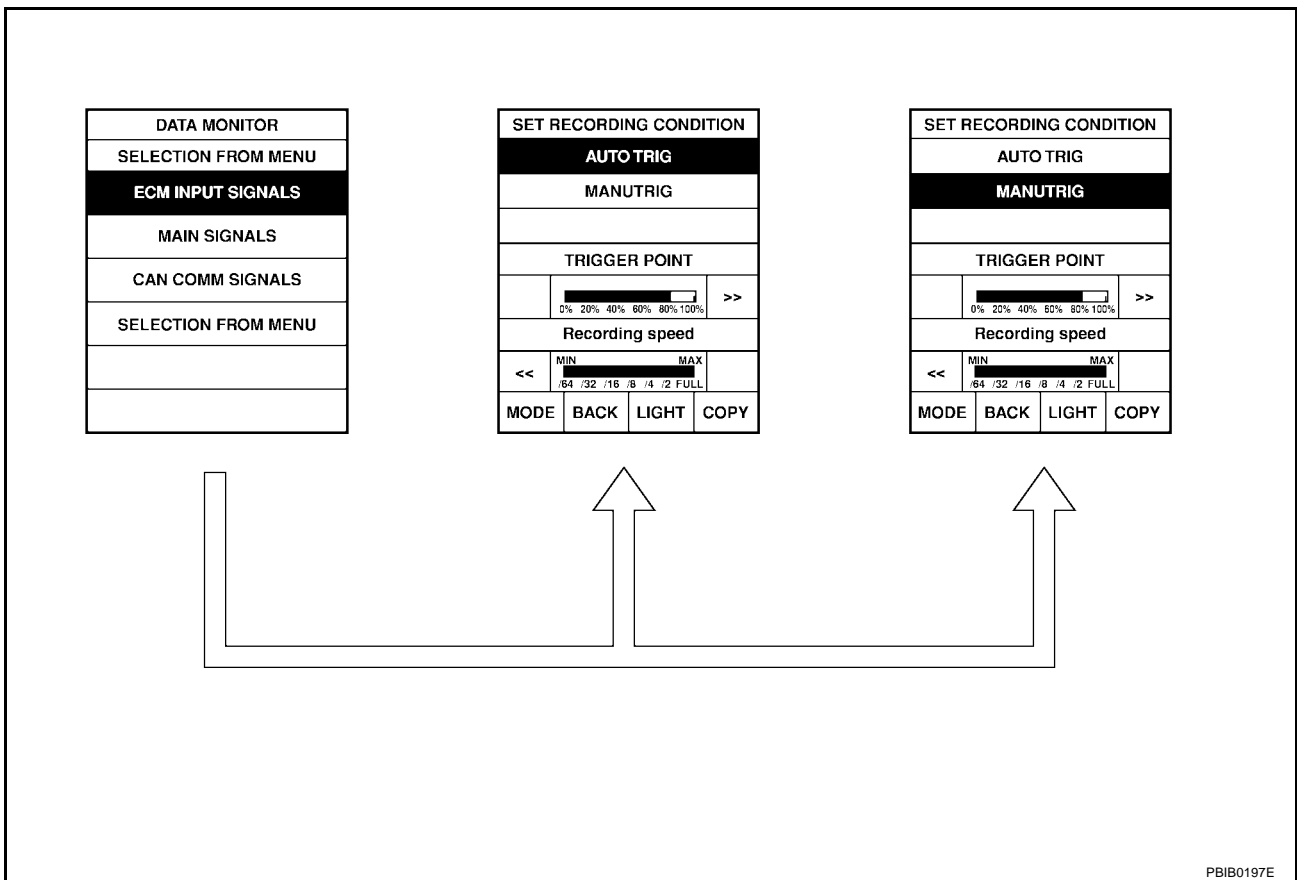

Generic Scan Tool (GST) Function DESCRIPTION

UBS00101

Generic Scan Tool (OBDII scan tool) complying with SAE J1978 has 8 different functions explained below. ISO9141 is used as the protocol. The name GST or Generic Scan Tool is used in this service manual.

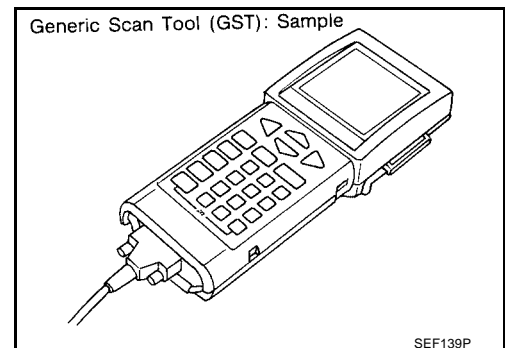

TROUBLE DIAGNOSIS

[VQ]

FUNCTION

Diagnostic test mode		Function
Service \$01	READINESS TESTS	This diagnostic service gains access to current emission-related data values, including analog inputs and outputs, digital inputs and outputs, and system status information.
Service \$02	(FREEZE DATA)	This diagnostic service gains access to emission-related data value which were stored by ECM during the freeze frame. For details, refer to EC-674, "FREEZE FRAME DATA AND 1ST TRIP FREEZE FRAME DATA" .
Service \$03	DTCs	This diagnostic service gains access to emission-related power train trouble codes which were stored by ECM.
Service \$04	CLEAR DIAG INFO	This diagnostic service can clear all emission-related diagnostic information. This includes: <ul style="list-style-type: none"> ● Clear number of diagnostic trouble codes (Service \$01) ● Clear diagnostic trouble codes (Service \$03) ● Clear trouble code for freeze frame data (Service \$01) ● Clear freeze frame data (Service \$02) ● Reset status of system monitoring test (Service \$01) ● Clear on board monitoring test results (Service \$06 and \$07)
Service \$06	(ON BOARD TESTS)	This diagnostic service accesses the results of on board diagnostic monitoring tests of specific components/systems that are not continuously monitored.
Service \$07	(ON BOARD TESTS)	This diagnostic service enables the off board test drive to obtain test results for emission-related powertrain components/systems that are continuously monitored during normal driving conditions.
Service \$08	—	This diagnostic service can close EVAP system in ignition switch ON position (Engine stopped). When this diagnostic service is performed, the EVAP canister vent control valve can be closed. In the following conditions, this diagnostic service cannot function. <ul style="list-style-type: none"> ● Low ambient temperature ● Low battery voltage ● Engine running ● Ignition switch OFF ● Low fuel temperature ● Too much pressure is applied to EVAP system
Service \$09	(CALIBRATION ID)	This diagnostic service enables the off-board test device to request specific vehicle information such as Vehicle Identification Number (VIN) and Calibration IDs.

INSPECTION PROCEDURE

1. Turn ignition switch OFF.
2. Connect GST to data link connector, which is located under LH dash panel near the hood opener handle.

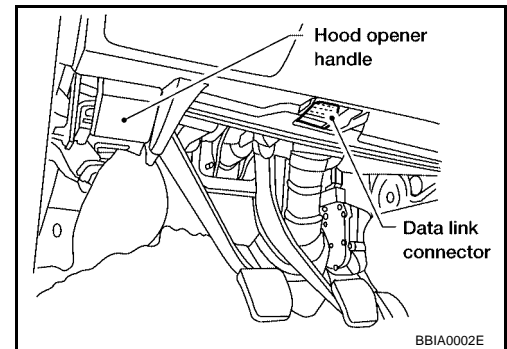

TROUBLE DIAGNOSIS

[VQ]

3. Turn ignition switch ON.
4. Enter the program according to instruction on the screen or in the operation manual.
(*: Regarding GST screens in this section, sample screens are shown.)

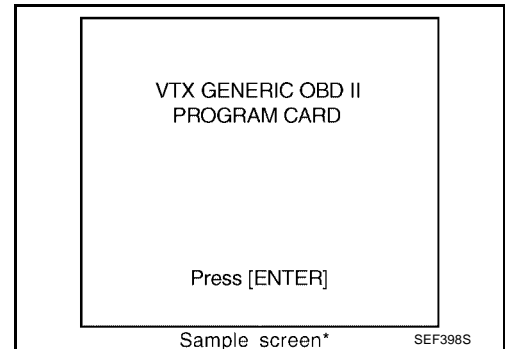

5. Perform each diagnostic service according to each service procedure.
For further information, see the GST Operation Manual of the tool maker.

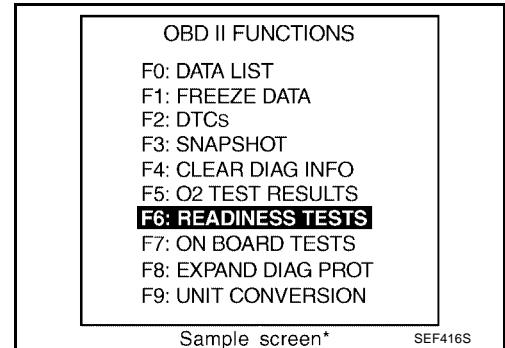

A

EC

C

D

E

F

G

H

I

J

K

L

M

TROUBLE DIAGNOSIS

[VQ]

UBS0010J

CONSULT-II Reference Value in Data Monitor

Remarks:

- Specification data are reference values.
- Specification data are output/input values which are detected or supplied by the ECM at the connector.
- * Specification data may not be directly related to their components signals/values/operations.
 - i.e. Adjust ignition timing with a timing light before monitoring IGN TIMING, because the monitor may show the specification data in spite of the ignition timing not being adjusted to the specification data. This IGN TIMING monitors the data calculated by the ECM according to the signals input from the camshaft position sensor and other ignition timing related sensors.

MONITOR ITEM	CONDITION		SPECIFICATION
ENG SPEED	● Run engine and compare CONSULT-II value with the tachometer indication.		Almost the same speed as the tachometer indication.
MAS A/F SE-B1	See EC-772, "TROUBLE DIAGNOSIS - SPECIFICATION VALUE" .		
B/FUEL SCHDL	See EC-772, "TROUBLE DIAGNOSIS - SPECIFICATION VALUE" .		
A/F ALPHA-B1 A/F ALPHA-B2	See EC-772, "TROUBLE DIAGNOSIS - SPECIFICATION VALUE" .		
COOLAN TEMP/S	● Engine: After warming up		More than 70°C (158°F)
A/F SEN1 (B1) A/F SEN1 (B2)	● Engine: After warming up	Maintaining engine speed at 2,000 rpm	Fluctuates around 1.5 V
HO2S2 (B1) HO2S2 (B2)	● Warm-up condition ● After keeping engine speed between 3,500 and 4,000 rpm for 1 minute and at idle for 1 minute under no load	Revving engine from idle to 3,000 rpm quickly	0 - 0.3V ↔ Approx. 0.6 - 1.0V
HO2S2 MNTR (B1) HO2S2 MNTR (B2)	● Warm-up condition ● After keeping engine speed between 3,500 and 4,000 rpm for 1 minute and at idle for 1 minute under no load.	Revving engine from idle to 3,000 rpm quickly.	LEAN ↔ RICH
VEH SPEED SE	● Turn drive wheels and compare CONSULT-II value with the speedometer indication.		Almost the same speed as the speedometer indication
BATTERY VOLT	● Ignition switch: ON (Engine stopped)		11 - 14V
ACCEL SEN1	● Ignition switch: ON (Engine stopped)	Accelerator pedal: Fully released	0.65 - 0.87V
		Accelerator pedal: Fully depressed	More than 4.3V
ACCEL SEN2*	● Ignition switch: ON (Engine stopped)	Accelerator pedal: Fully released	0.56 - 0.96V
		Accelerator pedal: Fully depressed	More than 4.0V
THRTL SEN1 THRTL SEN2*	● Ignition switch: ON (Engine stopped) ● Shift lever: D (A/T) or 1st (M/T)	Accelerator pedal: Fully released	More than 0.36V
		Accelerator pedal: Fully depressed	Less than 4.75V
EGR TEMP SEN	● Engine: After warming up		Less than 4.5V
EVAP SYS PRES	● Ignition switch: ON		Approx. 1.8 - 4.8V
START SIGNAL	● Ignition switch: ON → START → ON		OFF → ON → OFF
CLSD THL POS	● Ignition switch: ON (Engine stopped)	Accelerator pedal: Fully released	ON
		Accelerator pedal: Slightly depressed	OFF
AIR COND SIG	● Engine: After warming up, idle the engine	Air conditioner switch: OFF	OFF
		Air conditioner switch: ON (Compressor operates.)	ON
P/N POSI SW	● Ignition switch: ON	Shift lever: P or N (A/T), Neutral (M/T)	ON
		Shift lever: Except above	OFF
PW/ST SIGNAL	● Engine: After warming up, idle the engine	Steering wheel: Not being turned (Forward direction)	OFF
		Steering wheel: Being turned	ON

TROUBLE DIAGNOSIS

[VQ]

MONITOR ITEM	CONDITION	SPECIFICATION
LOAD SIGNAL	<ul style="list-style-type: none"> ● Ignition switch: ON 	Rear window defogger switch is ON and/or lighting switch is in 2nd. ON
		Rear window defogger switch is OFF and lighting switch is OFF. OFF
IGNITION SW	<ul style="list-style-type: none"> ● Ignition switch: ON → OFF → ON 	ON → OFF → ON
BRAKE SW	<ul style="list-style-type: none"> ● Ignition switch: ON 	Brake pedal: Fully released OFF
		Brake pedal: Slightly depressed ON
INJ PULSE-B1 INJ PULSE-B2	<ul style="list-style-type: none"> ● Engine: After warming up ● Shift lever: P or N (A/T), Neutral (M/T) ● Air conditioner switch: OFF ● No-load 	Idle 2.0 - 3.0 msec
		2,000 rpm 1.9 - 2.9 msec
IGN TIMING	<ul style="list-style-type: none"> ● Engine: After warming up ● Shift lever: P or N (A/T), Neutral (M/T) ● Air conditioner switch: OFF ● No-load 	Idle 13° - 18° BTDC
		2,000 rpm 25° - 45° BTDC
CAL/LD VALUE	<ul style="list-style-type: none"> ● Engine: After warming up ● Shift lever: P or N (A/T), Neutral (M/T) ● Air conditioner switch: OFF ● No-load 	Idle 5% - 35%
		2,500 rpm 5% - 35%
MASS AIRFLOW	<ul style="list-style-type: none"> ● Engine: After warming up ● Shift lever: P or N (A/T), Neutral (M/T) ● Air conditioner switch: OFF ● No-load 	Idle 2.0 - 6.0 g·m/s
		2,500 rpm 7.0 - 20.0 g·m/s
PURG VOL C/V	<ul style="list-style-type: none"> ● Engine: After warming up ● Shift lever: P or N (A/T), Neutral (M/T) ● Air conditioner switch: OFF ● No-load 	Idle 0%
		2,000 rpm —
EGR VOLCON/V	<ul style="list-style-type: none"> ● Engine: After warming up ● Shift lever: P or N (A/T), Neutral (M/T) ● Air conditioner switch: OFF ● No load 	Idle 0 step
		Revving engine from idle up to 3,000 rpm quickly 10 - 55 step
INT/V TIM (B1) INT/V TIM (B2)	<ul style="list-style-type: none"> ● Engine: After warming up ● Shift lever: P or N (A/T), Neutral (M/T) ● Air conditioner switch: OFF ● No-load 	Idle -5° - 5°CA
		2,000 rpm Approx. 0° - 30°CA
INT/V SOL (B1) INT/V SOL (B2)	<ul style="list-style-type: none"> ● Engine: After warming up ● Shift lever: P or N (A/T), Neutral (M/T) ● Air conditioner switch: OFF ● No-load 	Idle 0% - 2%
		2,000 rpm Approx. 0% - 50%
VIAS S/V	<ul style="list-style-type: none"> ● Engine: After warming up 	1,800 - 3,600 rpm ON
		Except above conditions OFF

A
EC
C
D
E
F
G
H
I
J
K
L
M

TROUBLE DIAGNOSIS

[VQ]

MONITOR ITEM	CONDITION	SPECIFICATION	
AIR COND RLY	<ul style="list-style-type: none"> ● Engine: After warming up, idle the engine 	Air conditioner switch: OFF	OFF
		Air conditioner switch: ON (Compressor operates)	ON
ENGINE MOUNT	<ul style="list-style-type: none"> ● Engine: After warming up 	Idle (with vehicle stopped)	IDLE
		Except above conditions	TRVL
FUEL PUMP RLY	<ul style="list-style-type: none"> ● For 1 second after turning ignition switch ON ● Engine running or cranking 		ON
		● Except above conditions	OFF
VENT CONT/V	<ul style="list-style-type: none"> ● Ignition switch: ON 		OFF
THRTL RELAY	<ul style="list-style-type: none"> ● Ignition switch: ON 		ON
COOLING FAN	<ul style="list-style-type: none"> ● Engine: After warming up, idle the engine ● Air conditioner switch: OFF 	Engine coolant temperature is 94°C (201°F) or less	OFF
		Engine coolant temperature is between 95°C (203°F) and 99°C (210°F)	LOW
		Engine coolant temperature is between 100°C (212°F) and 104°C (219°F)	MID
		Engine coolant temperature is 105°C (221°F) or more	HI
HO2S2 HTR (B1) HO2S2 HTR (B2)	<ul style="list-style-type: none"> ● Engine speed is below 3,600 rpm after the following conditions are met. <ul style="list-style-type: none"> – Engine: After warming up – Keeping the engine speed between 3,500 and 4,000 rpm for 1 minute and at idle for 1 minute under no load ● Engine speed: Above 3,600 rpm 		ON
			OFF
I/P PULLY SPD	<ul style="list-style-type: none"> ● Vehicle speed: More than 20 km/h (12 MPH) 		Almost the same speed as the tachometer indication
VEHICLE SPEED	<ul style="list-style-type: none"> ● Turn drive wheels and compare CONSULT-II value with the speedometer indication. 		Almost the same speed as the speedometer indication
TRVL AFTER MIL	<ul style="list-style-type: none"> ● Ignition switch: ON 	Vehicle has traveled after MIL has turned ON.	0 - 65,535 km (0 - 40,723 mile)
A/F S1 HTR (B1) A/F S1 HTR (B2)	<ul style="list-style-type: none"> ● Engine: After warming up, idle the engine 		0 - 100%
AC PRESS SEN	<ul style="list-style-type: none"> ● Ignition switch: ON (Engine stopped) ● Engine: Idle ● Air conditioner switch: ON 		Approx. 0V
			1.0 - 4.0V
VEH SPEED SE	<ul style="list-style-type: none"> ● Turn drive wheels and compare CONSULT-II value with the speedometer indication. 		Almost the same speed as the speedometer indication
SET VHCL SPD	<ul style="list-style-type: none"> ● Engine: Running 	ASCD: Operating.	The preset vehicle speed is displayed.
MAIN SW	<ul style="list-style-type: none"> ● Ignition switch: ON 	MAIN switch: Pressed	ON
		MAIN switch: Released	OFF
CANCEL SW	<ul style="list-style-type: none"> ● Ignition switch: ON 	CANCEL switch: Pressed	ON
		CANCEL switch: Released	OFF
RESUME/ACC SW	<ul style="list-style-type: none"> ● Ignition switch: ON 	RESUME/ACCELERATE switch: Pressed	ON
		RESUME/ACCELERATE switch: Released	OFF
SET SW	<ul style="list-style-type: none"> ● Ignition switch: ON 	SET/COAST switch: Pressed	ON
		SET/COAST switch: Released	OFF

TROUBLE DIAGNOSIS

[VQ]

MONITOR ITEM	CONDITION		SPECIFICATION
BRAKE SW1	● Ignition switch: ON	Clutch pedal (M/T) and brake pedal: Fully released	ON
		Clutch pedal (M/T) and/or brake pedal: Slightly depressed	OFF
BRAKE SW2	● Ignition switch: ON	Brake pedal: Fully released	OFF
		Brake pedal: Slightly depressed	ON
CRUISE LAMP	● Ignition switch: ON	MAIN switch: Pressed at the 1st time → at the 2nd time	ON → OFF
SET LAMP	● MAIN switch: ON ● When vehicle speed is between 40 km/h (25 MPH) and 144 km/h (89 MPH)	ASCD is operating	ON
		ASCD is not operating	OFF

*: Accelerator pedal position sensor 2 signal and throttle position sensor 2 signal are converted by ECM internally. Thus, they differ from ECM terminals voltage signal.

A
EC
C
D
E
F
G
H
I
J
K
L
M

Major Sensor Reference Graph in Data Monitor Mode

The following are the major sensor reference graphs in "DATA MONITOR" mode.

CLSD THL POS, ACCEL SEN 1, THRTL SEN 1

Below is the data for "CLSD THL POS", "ACCEL SEN 1" and "THRTL SEN 1" when depressing the accelerator pedal with the ignition switch ON and with shift lever in D position (A/T), 1st position (M/T).

The signal of "ACCEL SEN 1" and "THRTL SEN 1" should rise gradually without any intermittent drop or rise after "CLSD THL POS" is changed from ON to OFF.

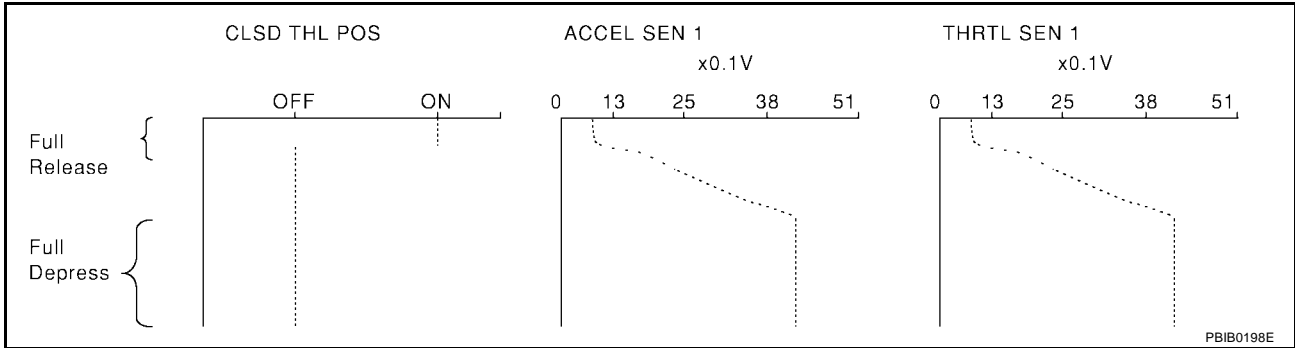

ENG SPEED, MAS A/F SE-B1, THRTL SEN 1, HO2S2 (B1), INJ PULSE-B1

Below is the data for "ENG SPEED", "MAS A/F SE-B1", "THRTL SEN 1", "HO2S2 (B1)" and "INJ PULSE-B1" when revving engine quickly up to 4,800 rpm under no load after warming up engine sufficiently.

Each value is for reference, the exact value may vary.

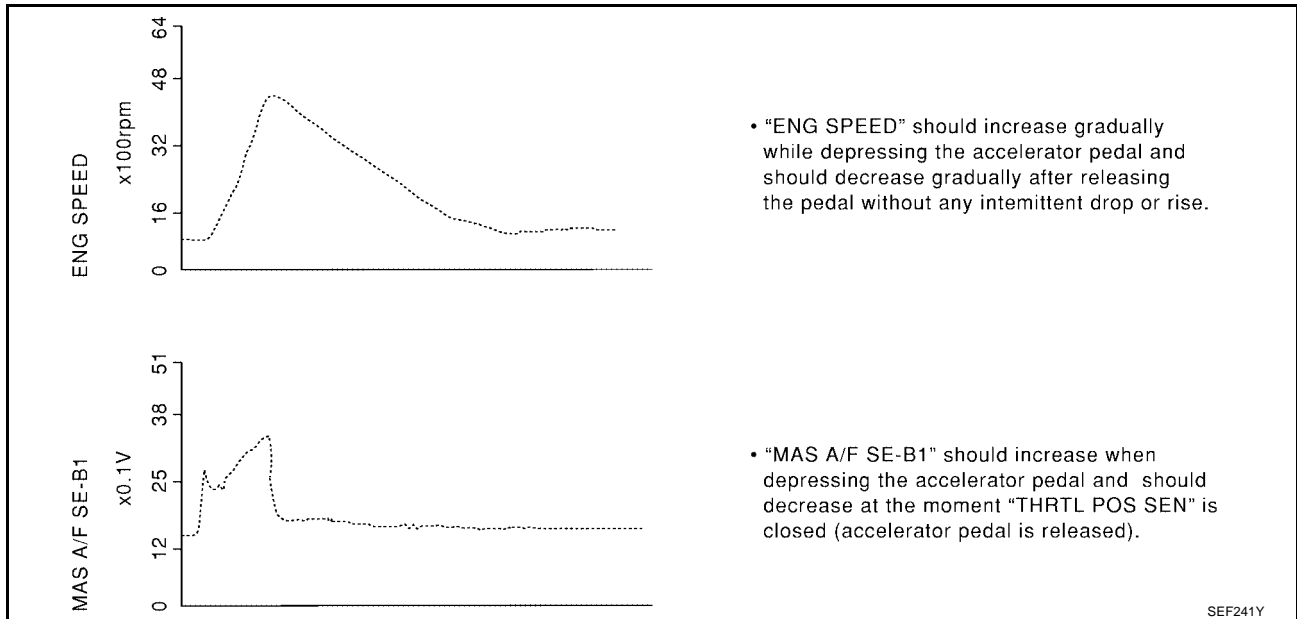

A

EC

C

D

E

F

G

H

I

J

K

L

M

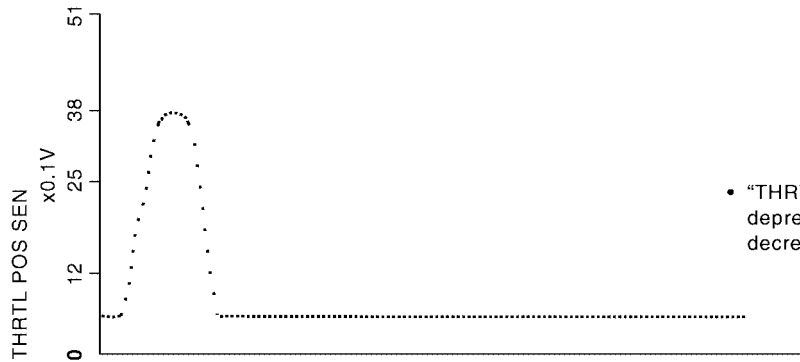

- "THRTL SEN1" should increase while depressing the accelerator pedal and should decrease while releasing it.

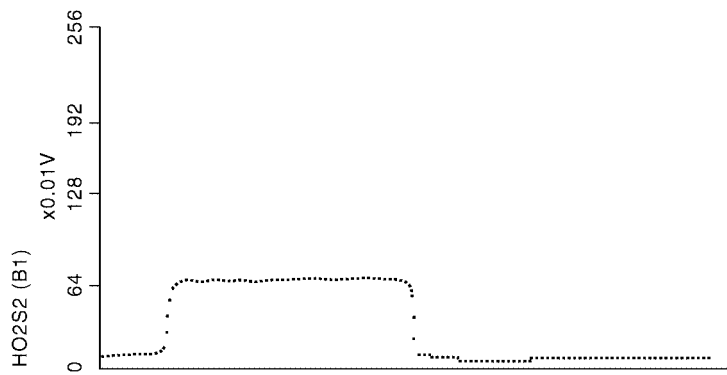

TROUBLE DIAGNOSIS - SPECIFICATION VALUE

PFP:00031

Description

UBS0010L

The specification (SP) value indicates the tolerance of the value that is displayed in “DATA MONITOR (SPEC)” mode of CONSULT-II during normal operation of the Engine Control System. When the value in “DATA MONITOR (SPEC)” mode is within the SP value, the Engine Control System is confirmed OK. When the value in “DATA MONITOR (SPEC)” mode is NOT within the SP value, the Engine Control System may have one or more malfunctions.

The SP value is used to detect malfunctions that may affect the Engine Control System, but will not light the MIL.

The SP value will be displayed for the following three items:

- B/FUEL SCHDL (The fuel injection pulse width programmed into ECM prior to any learned on board correction)
- A/F ALPHA-B1/B2 (The mean value of air-fuel ratio feedback correction factor per cycle)
- MAS A/F SE-B1 (The signal voltage of the mass air flow sensor)

Testing Condition

UBS0010M

- Vehicle driven distance: More than 5,000 km (3,017 miles)
- Barometric pressure: 98.3 - 104.3 kPa (1.003 - 1.064 kg/cm² , 14.25 - 15.12 psi)
- Atmospheric temperature: 20 - 30°C (68 - 86°F)
- Engine coolant temperature: 75 - 95°C (167 - 203°F)
- Transmission: Warmed-up*¹
- Electrical load: Not applied*²
- Engine speed: Idle

*1: After the engine is warmed up to normal operating temperature, drive vehicle until “FLUID TEMP SE” (A/T fluid temperature sensor signal) indicates more than 60°C (140°F).

*2: Rear window defogger switch, air conditioner switch, lighting switch are OFF. Steering wheel is straight ahead.

Inspection Procedure

UBS0010N

NOTE:

Perform “DATA MONITOR (SPEC)” mode in maximum scale display.

1. Perform [EC-693, "Basic Inspection"](#) .
2. Confirm that the testing conditions indicated above are met.
3. Select “B/FUEL SCHDL”, “A/F ALPHA-B1”, “A/F ALPHA-B2” and “MAS A/F SE-B1” in “DATA MONITOR (SPEC)” mode with CONSULT-II.
4. Make sure that monitor items are within the SP value.
5. If NG, go to [EC-773, "Diagnostic Procedure"](#) .

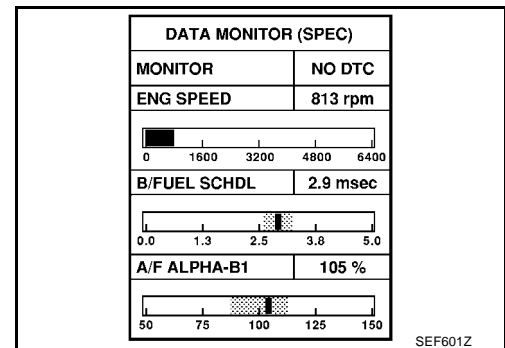

Diagnostic Procedure OVERALL SEQUENCE

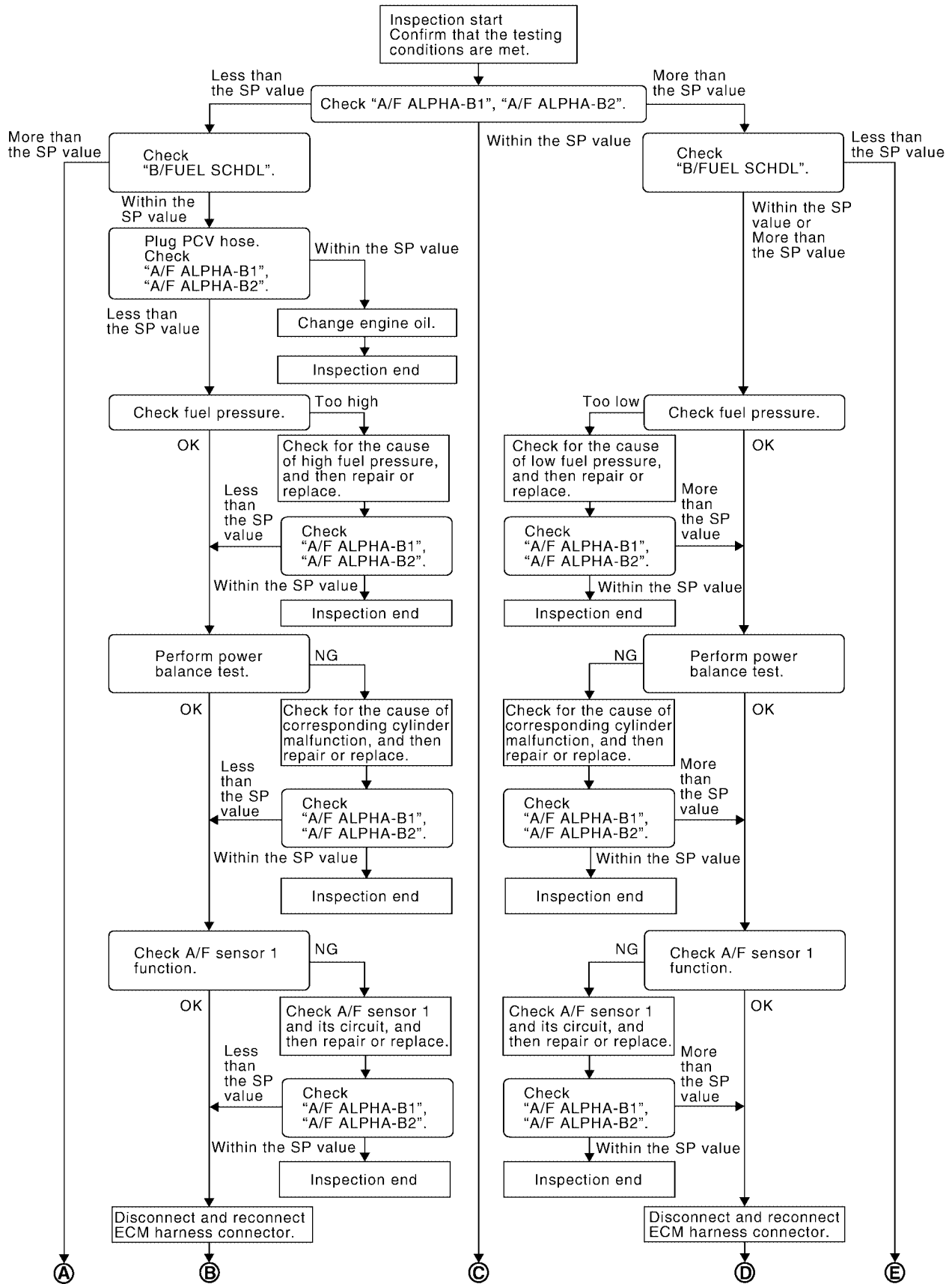

DETAILED PROCEDURE

1. CHECK "A/F ALPHA-B1", "A/F ALPHA-B2"

1. Start engine.
2. Confirm that the testing conditions are met. Refer to [EC-772, "Testing Condition"](#).
3. Select "A/F ALPHA-B1", "A/F ALPHA-B2" in "DATA MONITOR (SPEC)" mode, and make sure that the each indication is within the SP value.

NOTE:

Check "A/F ALPHA-B1", "A/F ALPHA-B2" for approximately 1 minute because they may fluctuate. It is NG if the indication is out of the SP value even a little.

OK or NG

- OK >> GO TO 17.
- NG (Less than the SP value)>>GO TO 2.
- NG (More than the SP value)>>GO TO 3.

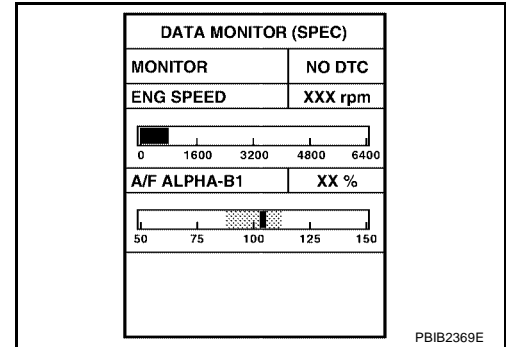

2. CHECK "B/FUEL SCHDL"

Select "B/FUEL SCHDL" in "DATA MONITOR (SPEC)" mode, and make sure that the indication is within the SP value.

OK or NG

- OK >> GO TO 4.
- NG (More than the SP value)>>GO TO 19.

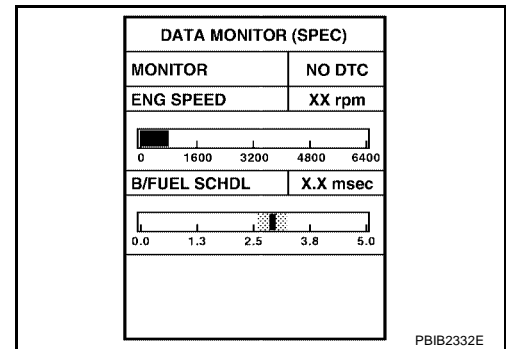

3. CHECK "B/FUEL SCHDL"

Select "B/FUEL SCHDL" in "DATA MONITOR (SPEC)" mode, and make sure that the indication is within the SP value.

OK or NG

- OK >> GO TO 6.
- NG (More than the SP value)>>GO TO 6.
- NG (Less than the SP value)>>GO TO 25.

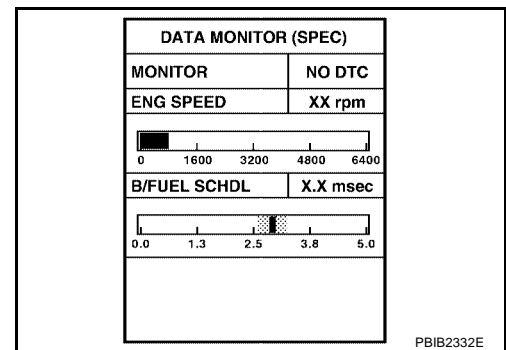

4. CHECK "A/F ALPHA-B1", "A/F ALPHA-B2"

1. Stop the engine.
2. Disconnect PCV hose, and then plug it.
3. Start engine.
4. Select "A/F ALPHA-B1", "A/F ALPHA-B2" in "DATA MONITOR (SPEC)" mode, and make sure that the each indication is within the SP value.

OK or NG

- OK >> GO TO 5.
- NG >> GO TO 6.

5. CHANGE ENGINE OIL

1. Stop the engine.
2. Change engine oil.

NOTE:

This symptom may occur when a large amount of gasoline is mixed with engine oil because of driving conditions (such as when engine oil temperature does not rise enough since a journey distance is too short during winter). The symptom will not be detected after changing engine oil or changing driving condition.

>> **INSPECTION END**

6. CHECK FUEL PRESSURE

Check fuel pressure. (Refer to [EC-714, "Fuel Pressure Check"](#) .)

OK or NG

OK >> GO TO 9.

NG (Fuel pressure is too high)>>Replace fuel pressure regulator, refer to [EC-714](#) . GO TO 8.

NG (Fuel pressure is too low)>>GO TO 7.

7. DETECT MALFUNCTIONING PART

1. Check the following.
 - Clogged and bent fuel hose and fuel tube
 - Clogged fuel filter
 - Fuel pump and its circuit (Refer to [EC-1316](#) .)
2. If NG, repair or replace the malfunctioning part. (Refer to [EC-714](#) .)
If OK, replace fuel pressure regulator.

>> GO TO 8.

8. CHECK "A/F ALPHA-B1", "A/F ALPHA-B2"

1. Start engine.
2. Select "A/F ALPHA-B1", "A/F ALPHA-B2" in "DATA MONITOR (SPEC)" mode, and make sure that the each indication is within the SP value.

OK or NG

OK >> **INSPECTION END**

NG >> GO TO 9.

9. PERFORM POWER BALANCE TEST

1. Perform "POWER BALANCE" in "ACTIVE TEST" mode.
2. Make sure that the each cylinder produces a momentary engine speed drop.

OK or NG

OK >> GO TO 12.

NG >> GO TO 10.

ACTIVE TEST	
POWER BALANCE	
MONITOR	
ENG SPEED	XXX rpm
MAS A/F SE-B1	XXX V

PBIB0133E

10. DETECT MALFUNCTIONING PART

1. Check the following.
 - Ignition coil and its circuit (Refer to [EC-1287](#) .)
 - Fuel injector and its circuit (Refer to [EC-1308](#) .)
 - Intake air leakage
 - Low compression pressure (Refer to [EM-200](#) .)
2. If NG, repair or replace the malfunctioning part.
If OK, replace fuel injector. (It may be caused by leakage from fuel injector or clogging.)

>> GO TO 11.

11. CHECK "A/F ALPHA-B1", "A/F ALPHA-B2"

1. Start engine.
2. Select "A/F ALPHA-B1", "A/F ALPHA-B2" in "DATA MONITOR (SPEC)" mode, and make sure that the each indication is within the SP value.

OK or NG

- OK >> **INSPECTION END**
 NG >> GO TO 12.

12. CHECK A/F SENSOR 1 FUNCTION

Perform all DTC Confirmation Procedure related with A/F sensor 1.

- For DTC P1271, P1281, refer to [EC-1132, "DTC Confirmation Procedure"](#) .
- For DTC P1272, P1282, refer to [EC-1140, "DTC Confirmation Procedure"](#) .
- For DTC P1273, P1283, refer to [EC-1148, "DTC Confirmation Procedure"](#) .
- For DTC P1274, P1284, refer to [EC-1157, "DTC Confirmation Procedure"](#) .
- For DTC P1276, P1286, refer to [EC-1166, "DTC Confirmation Procedure"](#) .
- For DTC P1278, P1288, refer to [EC-1176, "DTC Confirmation Procedure"](#) .
- For DTC P1279, P1289, refer to [EC-1188, "DTC Confirmation Procedure"](#) .

OK or NG

- OK >> GO TO 15.
 NG >> GO TO 13.

13. CHECK A/F SENSOR 1 CIRCUIT

Perform Diagnostic Procedure according to corresponding DTC.

>> GO TO 14.

14. CHECK "A/F ALPHA-B1", "A/F ALPHA-B2"

1. Start engine.
2. Select "A/F ALPHA-B1", "A/F ALPHA-B2" in "DATA MONITOR (SPEC)" mode, and make sure that the each indication is within the SP value.

OK or NG

- OK >> **INSPECTION END**
 NG >> GO TO 15.

15. DISCONNECT AND RECONNECT ECM HARNESS CONNECTOR

1. Stop the engine.
2. Disconnect ECM harness connector. Check pin terminal and connector for damage, and then reconnect it.

>> GO TO 16.

16. CHECK "A/F ALPHA-B1", "A/F ALPHA-B2"

1. Start engine.
2. Select "A/F ALPHA-B1", "A/F ALPHA-B2" in "DATA MONITOR (SPEC)" mode, and make sure that the each indication is within the SP value.

OK or NG

OK >> **INSPECTION END**

NG >> Detect malfunctioning part according to [EC-725, "Symptom Matrix Chart"](#) .

17. CHECK "B/FUEL SCHDL"

Select "B/FUEL SCHDL" in "DATA MONITOR (SPEC)" mode, and make sure that the indication is within the SP value.

OK or NG

OK >> **INSPECTION END**

NG (More than the SP value)>>GO TO 18.

NG (Less than the SP value)>>GO TO 25.

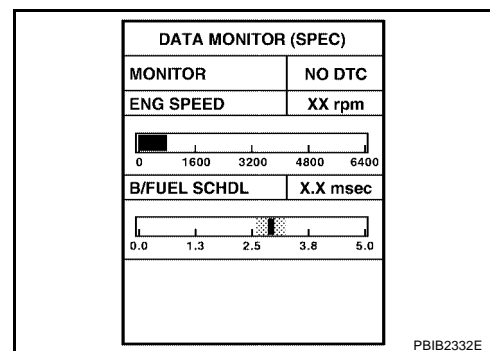
**18. DETECT MALFUNCTIONING PART**

1. Check for the cause of large engine friction. Refer to the following.
 - Engine oil level is too high
 - Engine oil viscosity
 - Belt tension of power steering, alternator, A/C compressor, etc. is excessive
 - Noise from engine
 - Noise from transmission, etc.
2. Check for the cause of insufficient combustion. Refer to the following.
 - EGR valve stuck
 - Valve clearance malfunction
 - Intake valve timing control function malfunction
 - Camshaft sprocket installation malfunction, etc.

>> Repair or replace malfunctioning part, and then GO TO 30.

19. CHECK INTAKE SYSTEM

Check for the cause of uneven air flow through mass air flow sensor. Refer to the following.

- Crushed air ducts
- Malfunctioning seal of air cleaner element
- Uneven dirt of air cleaner element
- Improper specification of intake air system

OK or NG

OK >> GO TO 21.

NG >> Repair or replace malfunctioning part, and then GO TO 20.

20. CHECK "A/F ALPHA-B1", "A/F ALPHA-B2", AND "B/FUEL SCHDL"

Select "A/F ALPHA-B1", "A/F ALPHA-B2", and "B/FUEL SCHDL" in "DATA MONITOR (SPEC)" mode, and make sure that the each indication is within the SP value.

OK or NG

OK >> **INSPECTION END**

NG ("B/FUEL SCHDL" is more, "A/F ALPHA-B1", "A/F ALPHA-B2" are less than the SP value)>>GO TO 21.

21. DISCONNECT AND RECONNECT MASS AIR FLOW SENSOR HARNESS CONNECTOR

1. Stop the engine.
2. Disconnect mass air flow sensor harness connector. Check pin terminal and connector for damage and then reconnect it again.

>> GO TO 22.

22. CHECK "A/F ALPHA-B1", "A/F ALPHA-B2"

1. Start engine.
2. Select "A/F ALPHA-B1", "A/F ALPHA-B2" in "DATA MONITOR (SPEC)" mode, and make sure that the each indication is within the SP value.

OK or NG

OK >> 1. Detect malfunctioning part of mass air flow sensor circuit and repair it. Refer to [EC-815](#).
2. GO TO 29.

NG >> GO TO 23.

23. CHECK "MAS A/F SE-B1"

Select "MAS A/F SE-B1" in "DATA MONITOR (SPEC)" mode, and make sure that the indication is within the SP value.

OK or NG

OK >> GO TO 24.

NG (More than the SP value)>>Replace mass air flow sensor, and then GO TO 29.

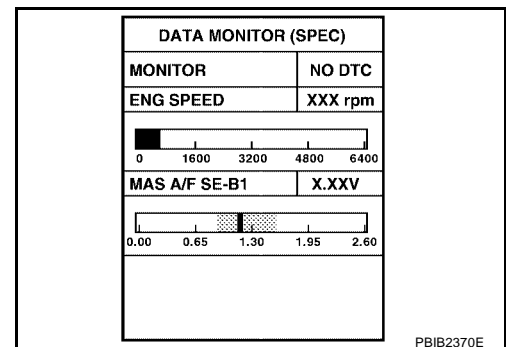

24. REPLACE ECM

1. Replace ECM.
2. Perform initialization of NVIS(NATS) system and registration of all NVIS(NATS) ignition key IDs. Refer to [BL-109, "ECM Re-communicating Function"](#) .
3. Perform [EC-711, "VIN Registration"](#) .
4. Perform [EC-711, "Accelerator Pedal Released Position Learning"](#) .
5. Perform [EC-711, "Throttle Valve Closed Position Learning"](#) .
6. Perform [EC-712, "Idle Air Volume Learning"](#) .

>> GO TO 29.

25. CHECK INTAKE SYSTEM

Check for the cause of uneven air flow through mass air flow sensor. Refer to the following.

- Crushed air ducts
- Malfunctioning seal of air cleaner element
- Uneven dirt of air cleaner element
- Improper specification of intake air system

OK or NG

OK >> GO TO 27.

NG >> Repair or replace malfunctioning part, and then GO TO 26.

26. CHECK "B/FUEL SCHDL"

Select "B/FUEL SCHDL" in "DATA MONITOR (SPEC)" mode, and make sure that the indication is within the SP value.

OK or NG

OK >> **INSPECTION END**

NG (Less than the SP value)>>GO TO 27.

27. CHECK "MAS A/F SE-B1"

Select "MAS A/F SE-B1" in "DATA MONITOR (SPEC)" mode, and make sure that the indication is within the SP value.

OK or NG

OK >> GO TO 28.

NG (Less than the SP value)>>Replace mass air flow sensor, and then GO TO 30.

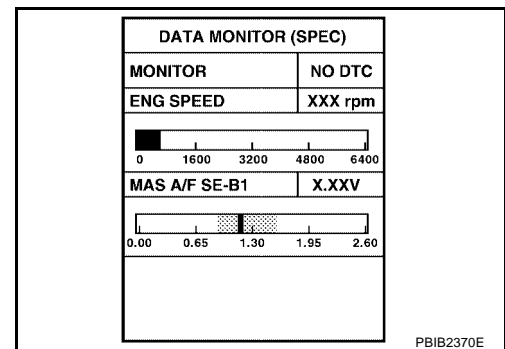

28. CHECK INTAKE SYSTEM

Check for the cause of air leak after the mass air flow sensor. Refer to the following.

- Disconnection, looseness, and cracks in air duct
- Looseness of oil filler cap
- Disconnection of oil level gauge
- Open stuck, breakage, hose disconnection, or cracks of PCV valve
- Disconnection or cracks of EVAP purge hose, open stuck of EVAP canister purge volume control solenoid valve
- Malfunctioning seal of rocker cover gasket
- Disconnection, looseness, or cracks of hoses, such as vacuum hose, connecting to intake air system parts
- Malfunctioning seal of intake air system, etc.

>> GO TO 30.

29. CHECK "A/F ALPHA-B1", "A/F ALPHA-B2", AND "B/FUEL SCHDL"

Select "A/F ALPHA-B1", "A/F ALPHA-B2", and "B/FUEL SCHDL" in "DATA MONITOR (SPEC)" mode, and make sure that the each indication is within the SP value.

OK or NG

OK >> **INSPECTION END**

NG >> Detect malfunctioning part according to [EC-725, "Symptom Matrix Chart"](#) .

30. CHECK "B/FUEL SCHDL"

Select "B/FUEL SCHDL" in "DATA MONITOR (SPEC)" mode, and then make sure that the indication is within the SP value.

OK or NG

OK >> **INSPECTION END**

NG >> Detect malfunctioning part according to [EC-725, "Symptom Matrix Chart"](#) .

TROUBLE DIAGNOSIS FOR INTERMITTENT INCIDENT

PFP:00006

Description

UBS0010P

Intermittent incidents may occur. In many cases, the malfunction resolves itself (the part or circuit function returns to normal without intervention). It is important to realize that the symptoms described in the customer's complaint often do not recur on (1st trip) DTC visits. Realize also that the most frequent cause of intermittent incidents occurrences is poor electrical connections. Because of this, the conditions under which the incident occurred may not be clear. Therefore, circuit checks made as part of the standard diagnostic procedure may not indicate the specific malfunctioning area.

Common Intermittent Incidents Report Situations

STEP in Work Flow	Situation
2	The CONSULT-II is used. The SELF-DIAG RESULTS screen shows time data other than [0] or [1t].
3 or 4	The symptom described by the customer does not recur.
5	(1st trip) DTC does not appear during the DTC Confirmation Procedure.
10	The Diagnostic Procedure for PXXXX does not indicate the malfunctioning area.

Diagnostic Procedure

UBS0010Q

1. INSPECTION START

Erase (1st trip) DTCs. Refer to [EC-682, "HOW TO ERASE EMISSION-RELATED DIAGNOSTIC INFORMATION"](#) .

>> GO TO 2.

2. CHECK GROUND TERMINALS

Check ground terminals for corroding or loose connection.
Refer to [EC-789, "Ground Inspection"](#) .

OK or NG

OK >> GO TO 3.
NG >> Repair or replace.

3. SEARCH FOR ELECTRICAL INCIDENT

Perform [GI-26, "How to Perform Efficient Diagnosis for an Electrical Incident"](#) , "INCIDENT SIMULATION TESTS".

OK or NG

OK >> GO TO 4.
NG >> Repair or replace.

4. CHECK CONNECTOR TERMINALS

Refer to [GI-23, "How to Check Terminal"](#) , "HOW TO PROBE CONNECTORS", "How to Check Enlarged Contact Spring of Terminal".

OK or NG

OK >> **INSPECTION END**
NG >> Repair or replace connector.

POWER SUPPLY AND GROUND CIRCUIT

[VQ]

POWER SUPPLY AND GROUND CIRCUIT

PFV:24110

Wiring Diagram

UBS0010R

EC-MAIN-01

— : DETECTABLE LINE FOR DTC
 - - - : NON-DETECTABLE LINE FOR DTC

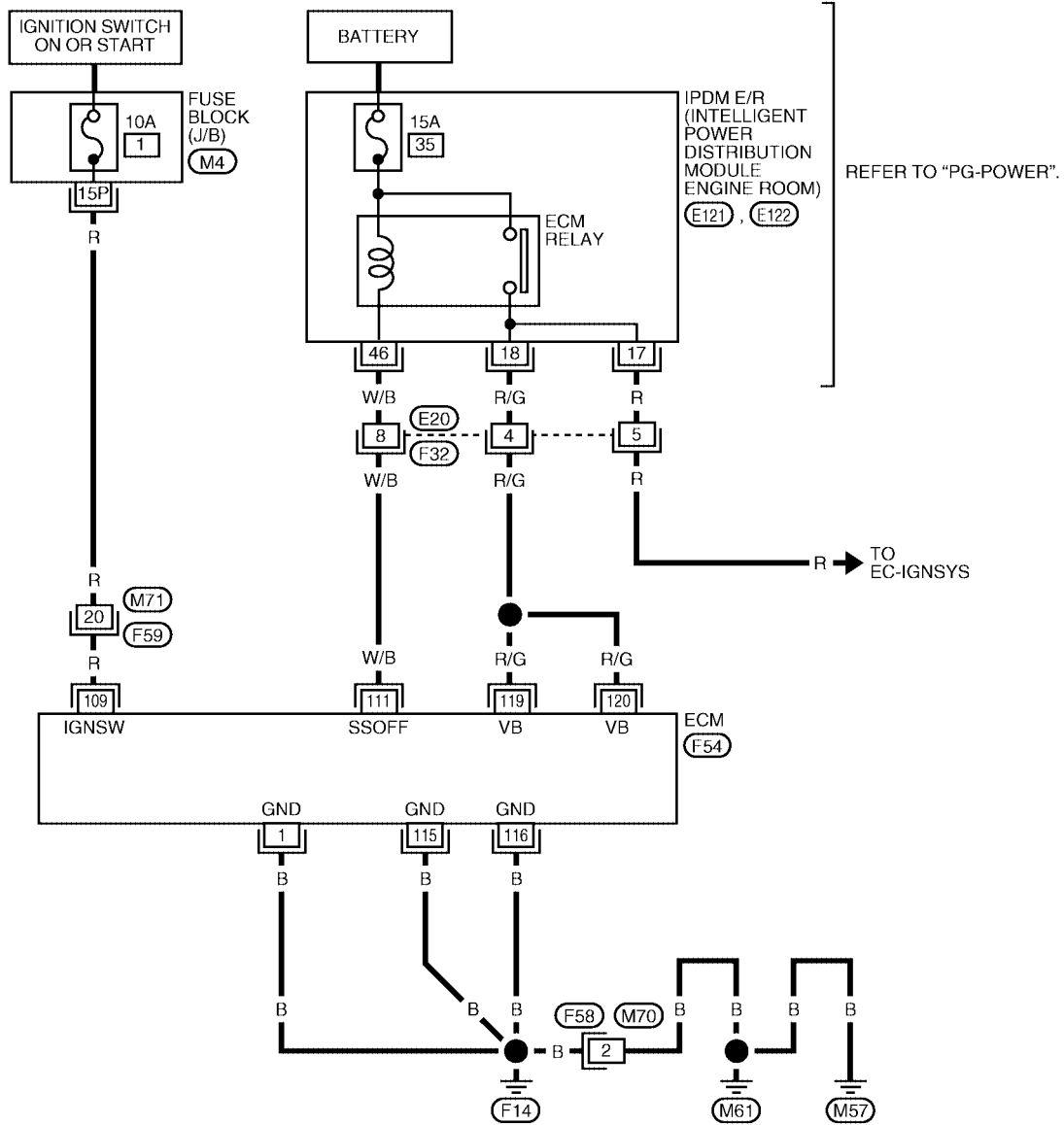

REFER TO "PG-POWER".

TO EC-IGNSYS

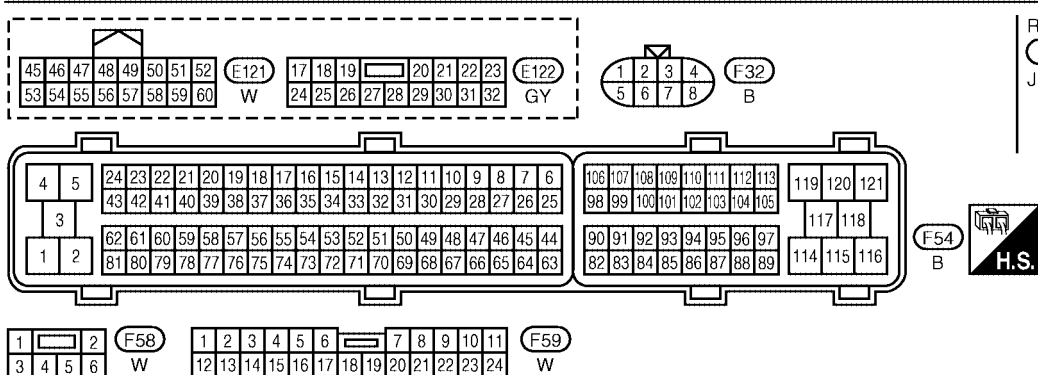

REFER TO THE FOLLOWING.

(M4) - FUSE BLOCK - JUNCTION BOX (J/B)

BBWA1554E

POWER SUPPLY AND GROUND CIRCUIT

[VQ]

Specification data are reference values and are measured between each terminal and ground.

CAUTION:

Do not use ECM ground terminals when measuring input/output voltage. Doing so may result in damage to the ECM's transistor. Use a ground other than ECM terminals, such as the ground.

TER-MINAL NO.	WIRE COLOR	ITEM	CONDITION	DATA (DC Voltage)
1	B	ECM ground	[Engine is running] ● Idle speed	Body ground
109	R	Ignition switch	[Ignition switch: OFF]	0V
			[Ignition switch: ON]	BATTERY VOLTAGE (11 - 14V)
111	W/B	ECM relay (Self shut-off)	[Engine is running] [Ignition switch: OFF] ● For a few seconds after turning ignition switch OFF	0 - 1.5V
			[Ignition switch: OFF] ● More than a few seconds after turning ignition switch OFF	BATTERY VOLTAGE (11 - 14V)
115 116	B B	ECM ground	[Engine is running] ● Idle speed	Body ground
119 120	R/G R/G	Power supply for ECM	[Ignition switch: ON]	BATTERY VOLTAGE (11 - 14V)

Diagnostic Procedure

UBS0010S

1. INSPECTION START

Start engine.

Is engine running?

Yes or No

Yes >> GO TO 8.

No >> GO TO 2.

2. CHECK ECM POWER SUPPLY CIRCUIT-I

1. Turn ignition switch OFF and then ON.
2. Check voltage between ECM terminal 109 and ground with CONSULT-II or tester.

Voltage: Battery voltage

OK or NG

OK >> GO TO 4.

NG >> GO TO 3.

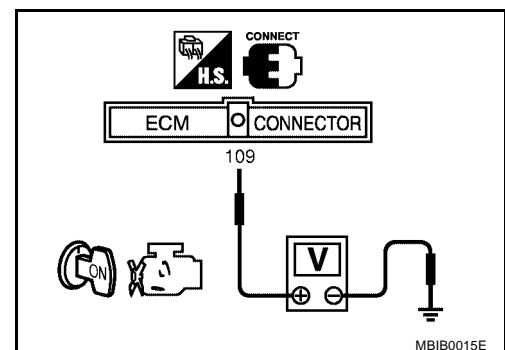

MBIB0015E

3. DETECT MALFUNCTIONING PART

Check the following.

- Harness connectors M71, F59
- Fuse block (J/B) connector M4
- 10A fuse
- Harness for open or short between ECM and fuse

>> Repair open circuit or short to power in harness or connectors.

4. CHECK GROUND CONNECTIONS

1. Turn ignition switch OFF.
2. Loosen and retighten three ground screws on the body.
Refer to [EC-789, "Ground Inspection"](#).

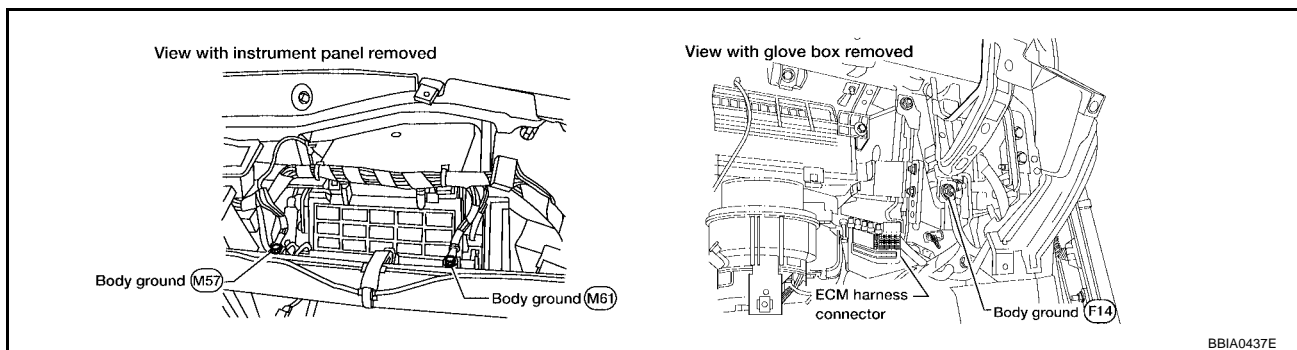

OK or NG

- OK >> GO TO 5.
NG >> Repair or replace ground connections.

5. CHECK ECM GROUND CIRCUIT FOR OPEN AND SHORT-I

1. Disconnect ECM harness connector.
2. Check harness continuity between ECM terminals 1, 115, 116 and ground.
Refer to Wiring Diagram.

Continuity should exist.

3. Also check harness for short to power.

OK or NG

- OK >> GO TO 7.
NG >> GO TO 6.

6. DETECT MALFUNCTIONING PART

Check the following.

- Harness connectors F58, M70
- Harness for open or short between ECM and ground

>> Repair open circuit or short to power in harness or connectors.

7. CHECK ECM POWER SUPPLY CIRCUIT-II

1. Reconnect ECM harness connector.
2. Turn ignition switch ON.
3. Check voltage between IPDM E/R terminal 17 and ground with CONSULT-II or tester.

Voltage: Battery voltage

OK or NG

- OK >> Go to [EC-1287, "IGNITION SIGNAL"](#) .
 NG >> GO TO 8.

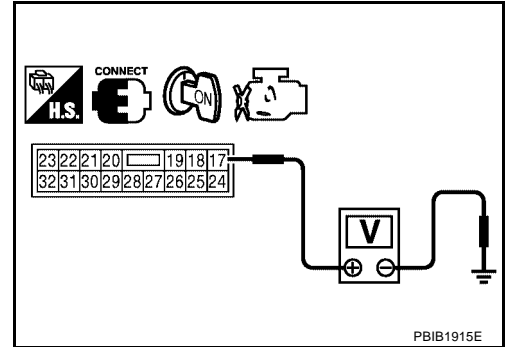

8. CHECK ECM POWER SUPPLY CIRCUIT-III

1. Turn ignition switch OFF and wait at least 10 seconds.
2. Turn ignition switch ON and then OFF.
3. Check voltage between ECM terminals 119, 120 and ground with CONSULT-II or tester.

Voltage: After turning ignition switch OFF, battery voltage will exist for a few seconds, then drop approximately 0V.

OK or NG

- OK >> GO TO 15.
 NG (Battery voltage does not exist.)>>GO TO 9.
 NG (Battery voltage exists for more than a few seconds.)>>GO TO 12.

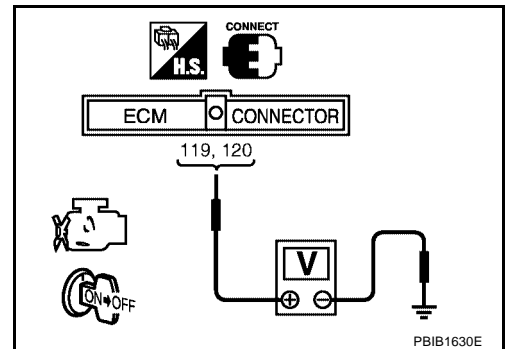

9. CHECK ECM POWER SUPPLY CIRCUIT-V

Check voltage between ECM terminal 111 and ground with CONSULT-II or tester.

Voltage: Battery voltage

OK or NG

- OK >> GO TO 10.
 NG >> GO TO 12.

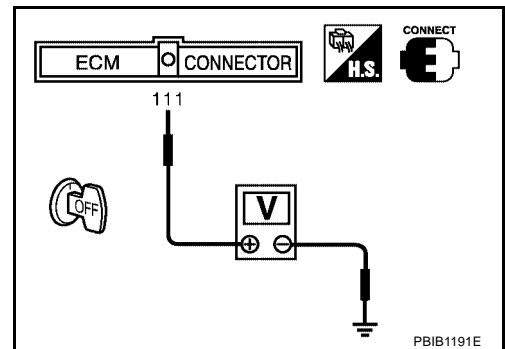

10. CHECK ECM POWER SUPPLY CIRCUIT-VI

1. Disconnect ECM harness connector.
2. Disconnect IPDM E/R harness connector E122.
3. Check harness continuity between ECM terminals 119, 120 and IPDM E/R terminal 18. Refer to Wiring Diagram.

Continuity should exist.

4. Also check harness for short to ground and short to power.

OK or NG

- OK >> GO TO 15.
 NG >> GO TO 11.

11. DETECT MALFUNCTIONING PART

Check the following.

- Harness or connectors E20, F32
- Harness for open or short between ECM and IPDM E/R

>> Repair open circuit or short to ground or short to power in harness or connectors.

12. CHECK ECM POWER SUPPLY CIRCUIT-VII

1. Disconnect ECM harness connector.
2. Disconnect IPDM E/R harness connector E121.
3. Check harness continuity between ECM terminal 111 and IPDM E/R terminal 46.
Refer to Wiring Diagram.

Continuity should exist.

4. Also check harness for short to ground and short to power.

OK or NG

- OK >> GO TO 14.
- NG >> GO TO 13.

13. DETECT MALFUNCTIONING PART

Check the following.

- Harness or connectors E20, F32
- Harness for open or short between ECM and IPDM E/R

>> Repair open circuit or short to ground or short to power in harness or connectors.

14. CHECK 15A FUSE

1. Disconnect 15A fuse from IPDM E/R.
2. Check 15A fuse.

OK or NG

- OK >> GO TO 18.
- NG >> Replace 15A fuse.

15. CHECK GROUND CONNECTIONS

1. Turn ignition switch OFF.
2. Loosen and retighten three ground screws on the body.
Refer to [EC-789, "Ground Inspection"](#) .

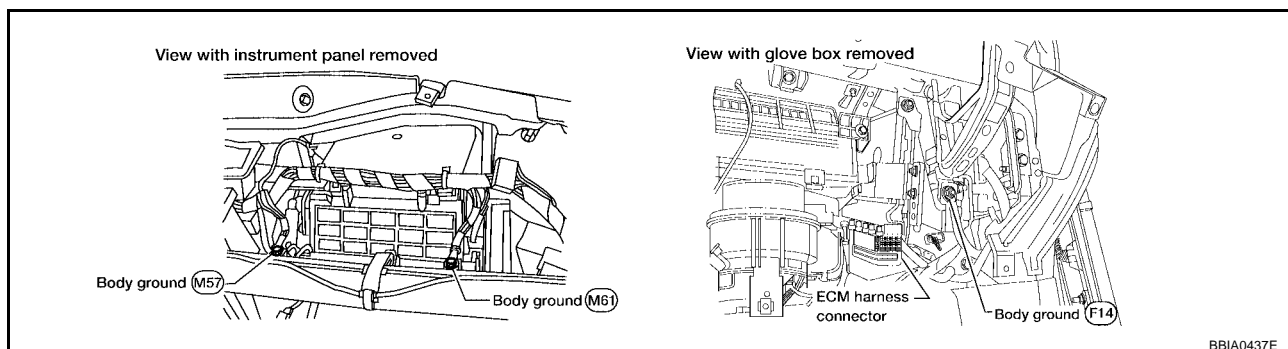

OK or NG

- OK >> GO TO 16.
- NG >> Repair or replace ground connections.

16. CHECK ECM GROUND CIRCUIT FOR OPEN AND SHORT-II

1. Disconnect ECM harness connector.
2. Check harness continuity between ECM terminals 1, 115, 116 and ground.
Refer to Wiring Diagram.

Continuity should exist.

3. Also check harness for short to power.

OK or NG

- OK >> GO TO 18.
- NG >> GO TO 17.

17. DETECT MALFUNCTIONING PART

Check the following.

- Harness connectors F58, M70
- Harness for open or short between ECM and ground

>> Repair open circuit or short to power in harness or connectors.

18. CHECK INTERMITTENT INCIDENT

Refer to [EC-782, "TROUBLE DIAGNOSIS FOR INTERMITTENT INCIDENT"](#) .

OK or NG

- OK >> Replace IPDM E/R.
- NG >> Repair open circuit or short to ground or short to power in harness or connectors.

Ground Inspection

Ground connections are very important to the proper operation of electrical and electronic circuits. Ground connections are often exposed to moisture, dirt and other corrosive elements. The corrosion (rust) can become an unwanted resistance. This unwanted resistance can change the way a circuit works.

Electronically controlled circuits are very sensitive to proper grounding. A loose or corroded ground can drastically affect an electronically controlled circuit. A poor or corroded ground can easily affect the circuit. Even when the ground connection looks clean, there can be a thin film of rust on the surface.

When inspecting a ground connection follow these rules:

- Remove the ground bolt or screw.
- Inspect all mating surfaces for tarnish, dirt, rust, etc.
- Clean as required to assure good contact.
- Reinstall bolt or screw securely.
- Inspect for "add-on" accessories which may be interfering with the ground circuit.
- If several wires are crimped into one ground eyelet terminal, check for proper crimps. Make sure all of the wires are clean, securely fastened and providing a good ground path. If multiple wires are cased in one eyelet make sure no ground wires have excess wire insulation.

For detailed ground distribution information, refer to [PG-28, "Ground Distribution"](#) .

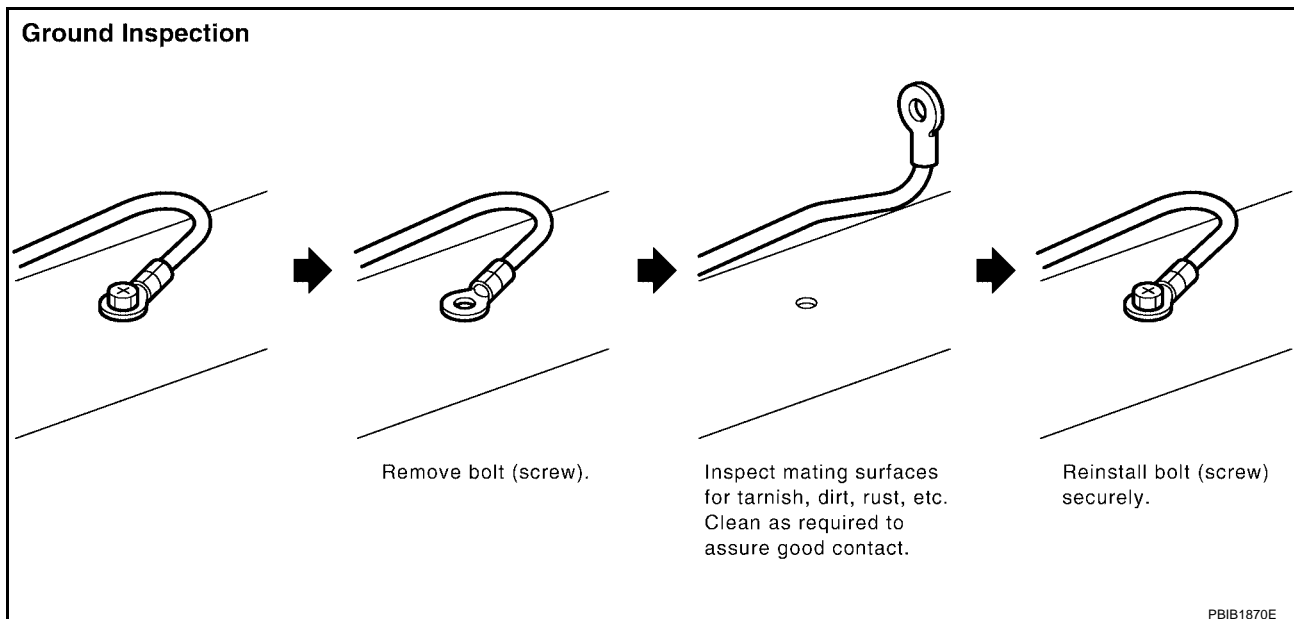

DTC U1000, U1001 CAN COMMUNICATION LINE

[VQ]

DTC U1000, U1001 CAN COMMUNICATION LINE

PFP:23710

Description

UBS0010U

CAN (Controller Area Network) is a serial communication line for real time application. It is an on-vehicle multiplex communication line with high data communication speed and excellent error detection ability. Many electronic control units are equipped onto a vehicle, and each control unit shares information and links with other control units during operation (not independent). In CAN communication, control units are connected with 2 communication lines (CAN H line, CAN L line) allowing a high rate of information transmission with less wiring. Each control unit transmits/receives data but selectively reads required data only.

On Board Diagnosis Logic

UBS0010V

DTC No.	Trouble diagnosis name	DTC detecting condition	Possible cause
U1000*1 1000*1	CAN communication line	<ul style="list-style-type: none">● ECM cannot communicate to other control units.● ECM cannot communicate for more than the specified time.	<ul style="list-style-type: none">● Harness or connectors (CAN communication line is open or shorted)
U1001*2 1001*2			

*1: This self-diagnosis has the one trip detection logic. (A/T)

The MIL will not light up for this diagnosis. (M/T)

*2: The MIL will not light up for this diagnosis.

DTC Confirmation Procedure

UBS0010W

1. Turn ignition switch ON and wait at least 3 seconds.
2. Select "DATA MONITOR" mode with CONSULT-II.
3. If 1st trip DTC is detected, go to [EC-792, "Diagnostic Procedure"](#).



DTC U1000, U1001 CAN COMMUNICATION LINE

[VQ]

Wiring Diagram

UBS0010X

EC-CAN-01

-  : DETECTABLE LINE FOR DTC
-  : NON-DETECTABLE LINE FOR DTC
-  : DATA LINE

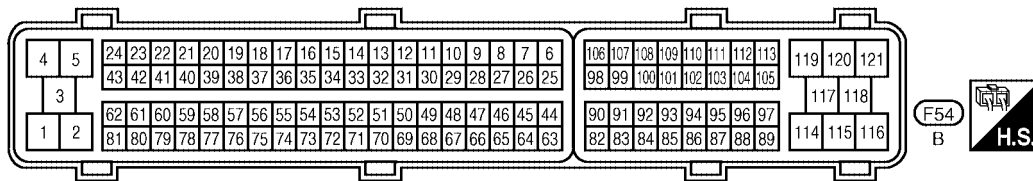
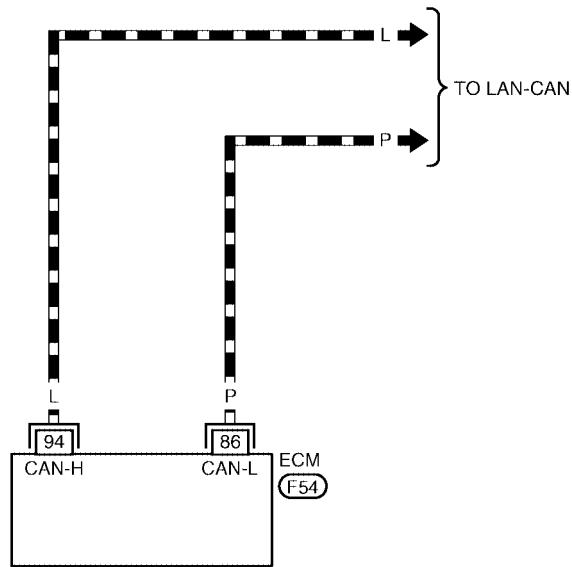

BBWA1264E

Diagnostic Procedure

UBS0010Y

Go to [LAN-4, "Precautions When Using CONSULT-II"](#) .

DTC P0011, P0021 IVT CONTROL

PFP:23796

Description
SYSTEM DESCRIPTION

UBS0010Z

Sensor	Input signal to ECM	ECM function	Actuator
Crankshaft position sensor (POS)	Engine speed Piston position	Intake valve timing control	Intake valve timing control solenoid valve
Camshaft position sensor (PHASE)			
Engine coolant temperature sensor	Engine coolant temperature		
Wheel sensor*	Vehicle speed		

*: This signal is sent to the ECM through CAN Communication line

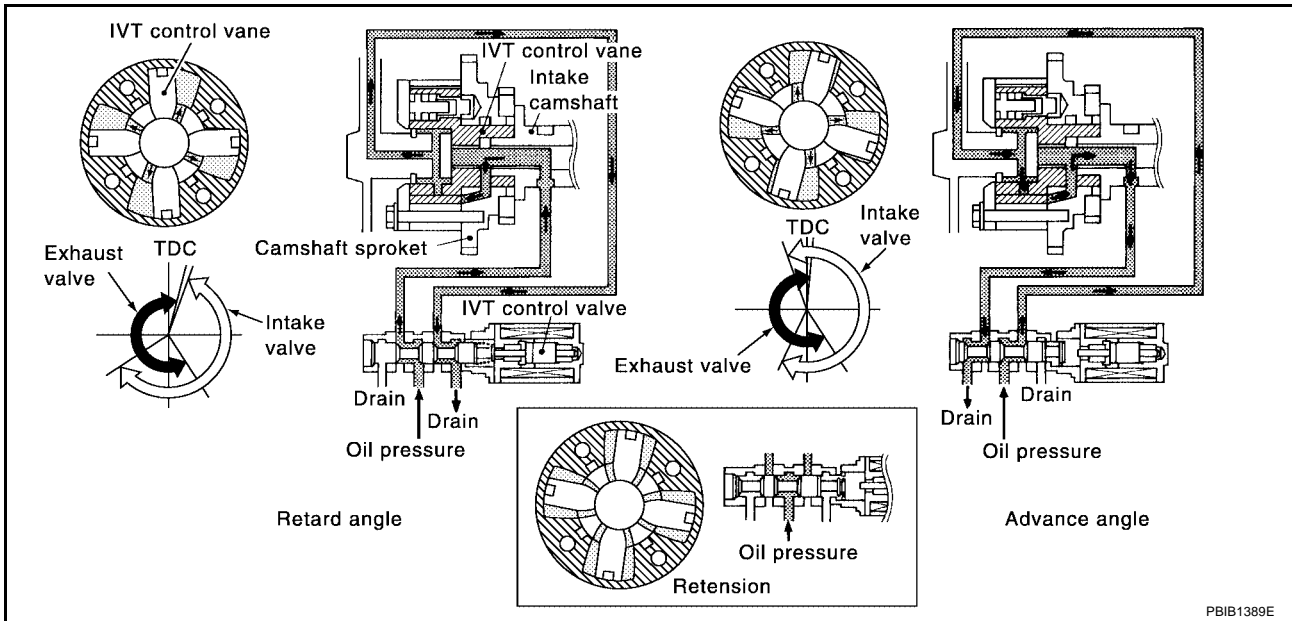

This mechanism hydraulically controls cam phases continuously with the fixed operating angle of the intake valve.

The ECM receives signals such as crankshaft position, camshaft position, engine speed, and engine coolant temperature. Then, the ECM sends ON/OFF pulse duty signals to the intake valve timing control solenoid valve depending on driving status. This makes it possible to control the shut/open timing of the intake valve to increase engine torque in low/mid speed range and output in high-speed range.

CONSULT-II Reference Value in Data Monitor Mode

UBS00110

Specification data are reference values.

MONITOR ITEM	CONDITION	SPECIFICATION
INT/V TIM (B1) INT/V TIM (B2)	● Engine: After warming up ● Shift lever: P or N (A/T), Neutral (M/T) ● Air conditioner switch: OFF ● No-load	Idle -5° - 5°CA
		2,000 rpm Approx. 0° - 30°CA
INT/V SOL (B1) INT/V SOL (B2)	● Engine: After warming up ● Shift lever: P or N (A/T), Neutral (M/T) ● Air conditioner switch: OFF ● No-load	Idle 0% - 2%
		2,000 rpm Approx. 0% - 50%

On Board Diagnosis Logic

DTC No.	Trouble diagnosis name	Detecting condition	Possible cause
P0011 0011 (Bank 1)	Intake valve timing control performance	There is a gap between angle of target and phase-control angle degree.	<ul style="list-style-type: none"> ● Crankshaft position sensor (POS) ● Camshaft position sensor (PHASE) ● Intake valve control solenoid valve ● Accumulation of debris to the signal pick-up portion of the camshaft ● Timing chain installation ● Foreign matter caught in the oil groove for intake valve timing control
P0021 0021 (Bank 2)			

FAIL-SAFE MODE

When the malfunction is detected, the ECM enters fail-safe mode.

Detected items	Engine operating condition in fail-safe mode
Intake valve timing control	The signal is not energized to the solenoid valve and the valve control does not function.

DTC Confirmation Procedure

CAUTION:

Always drive at a safe speed.

NOTE:

- If DTC P0011 or P0021 is displayed with DTC P1111 or P1136, first perform trouble diagnosis for DTC P1111 or P1136. Refer to [EC-1057](#).
- If DTC Confirmation Procedure has been previously conducted, always turn ignition switch OFF and wait at least 10 seconds before conducting the next test.

TESTING CONDITION:

Before performing the following procedure, confirm that battery voltage is between 10V and 16V at idle.

Ⓟ WITH CONSULT-II

1. Turn ignition switch ON and select "DATA MONITOR" mode with CONSULT-II.
2. Start engine and warm it up to the normal operating temperature.
3. Maintain the following conditions for at least 6 consecutive seconds.
Hold the accelerator pedal as steady as possible.

ENG SPEED	1,200 - 2,000 rpm (A constant rotation is maintained.)
COOLAN TEMP/S	60 - 120°C (140 - 248°F)
B/FUEL SCHDL	More than 3.38 msec
Shift lever	P or N position (A/T) Neutral position (M/T)

DATA MONITOR	
MONITOR	NO DTC
ENG SPEED	XXX rpm
COOLAN TEMP/S	XXX °C
VHCL SPEED SE	XXX km/h
B/FUEL SCHDL	XXX msec

PBIB0164E

4. Let engine idle for 10 seconds.
5. If the 1st trip DTC is detected, go to [EC-795, "Diagnostic Procedure"](#).
If the 1st trip DTC is not detected, go to next step.
6. Maintain the following conditions for at least 20 consecutive seconds.

ENG SPEED	1,700 - 3,175 rpm (A constant rotation is maintained.)
COOLANT TEMPS	70 - 105°C (158 - 221°F)
Shift lever	1st or 2nd position
Driving location uphill	Driving vehicle uphill (Increased engine load will help maintain the driving conditions required for this test.)

7. If the 1st trip DTC is detected, go to [EC-795, "Diagnostic Procedure"](#).

WITH GST

Follow the procedure "WITH CONSULT-II" above.

Diagnostic Procedure

UBS00113

1. CHECK OIL PRESSURE WARNING LAMP

1. Start engine.
2. Check oil pressure warning lamp and confirm it is not illuminated.

OK or NG

- OK >> GO TO 2.
 KG >> Go to [LU-21, "OIL PRESSURE CHECK"](#).

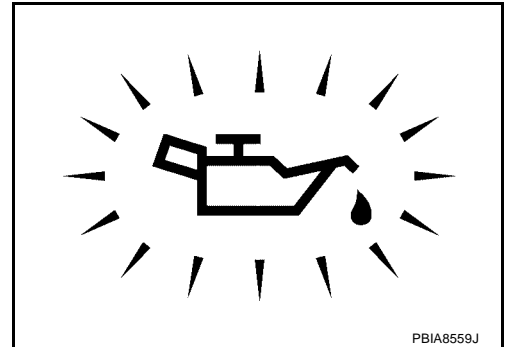

2. CHECK INTAKE VALVE TIMING CONTROL SOLENOID VALVE

Refer to [EC-796, "Component Inspection"](#).

OK or NG

- OK >> GO TO 3.
 NG >> Replace intake valve timing control solenoid valve.

3. CHECK CRANKSHAFT POSITION SENSOR (POS)

Refer to [EC-927, "Component Inspection"](#).

OK or NG

- OK >> GO TO 4.
 NG >> Replace crankshaft position sensor (POS).

4. CHECK CAMSHAFT POSITION SENSOR (PHASE)

Refer to [EC-936, "Component Inspection"](#).

OK or NG

- OK >> GO TO 5.
 NG >> Replace camshaft position sensor (PHASE).

5. CHECK CAMSHAFT (INTAKE)

Check the following.

- Accumulation of debris to the signal plate of camshaft rear end
- Chipping signal plate of camshaft rear end

OK or NG

- OK >> GO TO 6.
 NG >> Remove debris and clean the signal plate of camshaft rear end or replace camshaft.

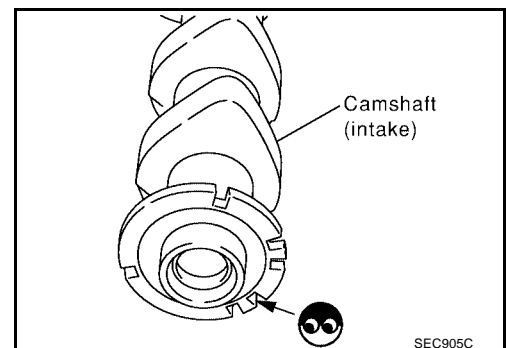

6. CHECK TIMING CHAIN INSTALLATION

Check service records for any recent repairs that may cause timing chain misaligned.

OK or NG

- OK >> Check timing chain installation. Refer to [EM-161, "TIMING CHAIN"](#) .
- NG >> GO TO 7.

7. CHECK LUBRICATION CIRCUIT

Refer to [EM-187, "INSPECTION AFTER REMOVAL"](#) .

OK or NG

- OK >> GO TO 8.
- NG >> Clean lubrication line.

8. CHECK INTERMITTENT INCIDENT

Refer to [EC-782, "TROUBLE DIAGNOSIS FOR INTERMITTENT INCIDENT"](#) .

For Wiring Diagram, refer to [EC-923](#) for CKP sensor (POS) and [EC-930](#) for CMP sensor (PHASE).

>> INSPECTION END

Component Inspection INTAKE VALVE TIMING CONTROL SOLENOID VALVE

UBS001IP

1. Disconnect intake valve timing control solenoid valve harness connector.
2. Check resistance between intake valve timing control solenoid valve as follows.

Terminal	Resistance
1 and 2	7.0 - 7.7Ω [at 20°C (68°F)]
1 or 2 and ground	(Continuity should not exist.)

If NG, replace intake valve timing control solenoid valve.
If OK, go to next step.

3. Remove intake valve timing control solenoid valve.
4. Provide 12V DC between intake valve timing control solenoid valve terminals and then interrupt it. Make sure that the plunger moves as shown in the figure.

CAUTION:

Do not apply 12V DC continuously for 5 seconds or more. Doing so may result in damage to the coil in intake valve timing control solenoid valve.

If NG, replace intake valve timing control solenoid valve.

NOTE:

Always replace O-ring when intake valve timing control solenoid valve is removed.

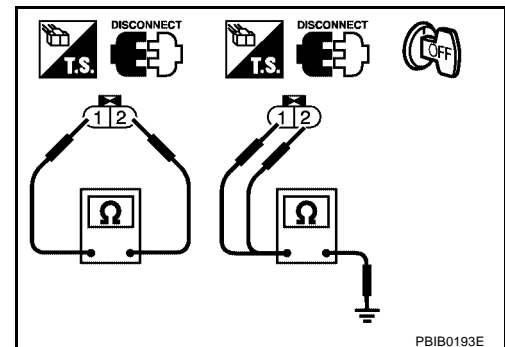

PBIB0193E

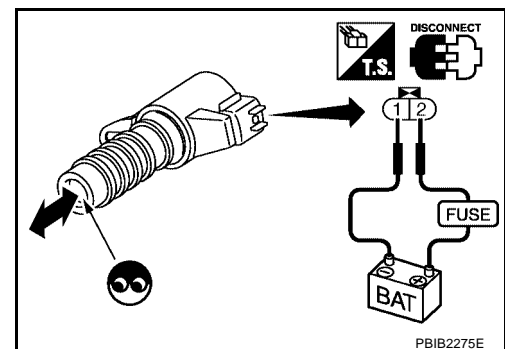

PBIB2275E

Removal and Installation INTAKE VALVE TIMING CONTROL SOLENOID VALVE

UBS001IQ

Refer to [EM-161, "TIMING CHAIN"](#) .

DTC P0037, P0038, P0057, P0058 HO2S2 HEATER

[VQ]

DTC P0037, P0038, P0057, P0058 HO2S2 HEATER

PFV:226A0

Description SYSTEM DESCRIPTION

UBS00114

Sensor	Input signal to ECM	ECM function	Actuator
Camshaft position sensor (PHASE)	Engine speed	Heated oxygen sensor 2 heater control	Heated oxygen sensor 2 heater
Crankshaft position sensor (POS)			
Engine coolant temperature sensor	Engine coolant temperature		
Mass air flow sensor	Amount of intake air		

The ECM performs ON/OFF control of the heated oxygen sensor 2 heater corresponding to the engine speed, amount of intake air and engine coolant temperature.

OPERATION

Engine speed rpm	Heated oxygen sensor 2 heater
Above 3,600	OFF
Below 3,600 rpm after the following conditions are met. <ul style="list-style-type: none"> ● Engine: After warming up ● Keeping the engine speed between 3,500 and 4,000 rpm for 1 minute and at idle for 1 minute under no load 	ON

CONSULT-II Reference Value in Data Monitor Mode

UBS00115

Specification data are reference values.

MONITOR ITEM	CONDITION	SPECIFICATION
HO2S2 HTR (B1) HO2S2 HTR (B2)	<ul style="list-style-type: none"> ● Engine speed is below 3,600 rpm after the following conditions are met. <ul style="list-style-type: none"> – Engine: After warming up – Keeping the engine speed between 3,500 and 4,000 rpm for 1 minute and at idle for 1 minute under no load 	ON
	<ul style="list-style-type: none"> ● Engine speed: Above 3,600 rpm 	OFF

On Board Diagnosis Logic

UBS00116

DTC No.	Trouble diagnosis name	DTC detecting condition	Possible cause
P0037 0037 (Bank 1)	Heated oxygen sensor 2 heater control circuit low	The current amperage in the heated oxygen sensor 2 heater circuit is out of the normal range. (An excessively low voltage signal is sent to ECM through the heated oxygen sensor 2 heater.)	<ul style="list-style-type: none"> ● Harness or connectors (The heated oxygen sensor 2 heater circuit is open or shorted.) ● Heater oxygen sensor 2 heater
P0057 0057 (Bank 2)			
P0038 0038 (Bank 1)	Heated oxygen sensor 2 heater control circuit high	The current amperage in the heated oxygen sensor 2 heater circuit is out of the normal range. (An excessively high voltage signal is sent to ECM through the heated oxygen sensor 2 heater.)	<ul style="list-style-type: none"> ● Harness or connectors (The heated oxygen sensor 2 heater circuit is shorted.) ● Heater oxygen sensor 2 heater
P0058 0058 (Bank 2)			

DTC Confirmation Procedure

NOTE:

If DTC Confirmation Procedure has been previously conducted, always turn ignition switch OFF and wait at least 10 seconds before conducting the next test.

TESTING CONDITION:

Before performing the following procedure, confirm that battery voltage is between 11.0V and 16V at idle.

WITH CONSULT-II

1. Turn ignition switch ON and select "DATA MONITOR" mode with CONSULT-II.
2. Start engine and warm it up to the normal operating temperature.
3. Turn ignition switch OFF and wait at least 10 seconds.
4. Start the engine and keep the engine speed between 3,500 rpm and 4,000 rpm for at least 1 minute under no load.
5. Let engine idle for 1 minute.
6. If 1st trip DTC is detected, go to [EC-802. "Diagnostic Procedure"](#)

DATA MONITOR	
MONITOR	NO DTC
ENG SPEED	XXX rpm
COOLANT TEMP/S	XXX °C

SEF174Y

WITH GST

Follow the procedure "WITH CONSULT-II" above.

DTC P0037, P0038, P0057, P0058 HO2S2 HEATER

[VQ]

Wiring Diagram BANK 1

UBS00118

EC-O2H2B1-01

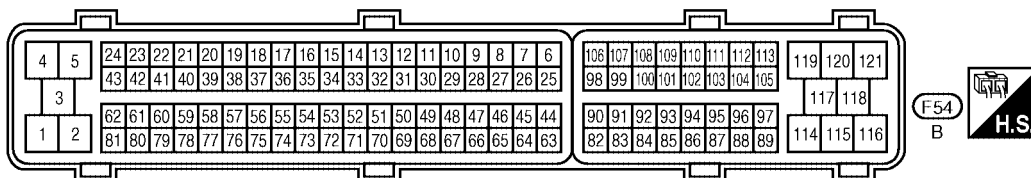
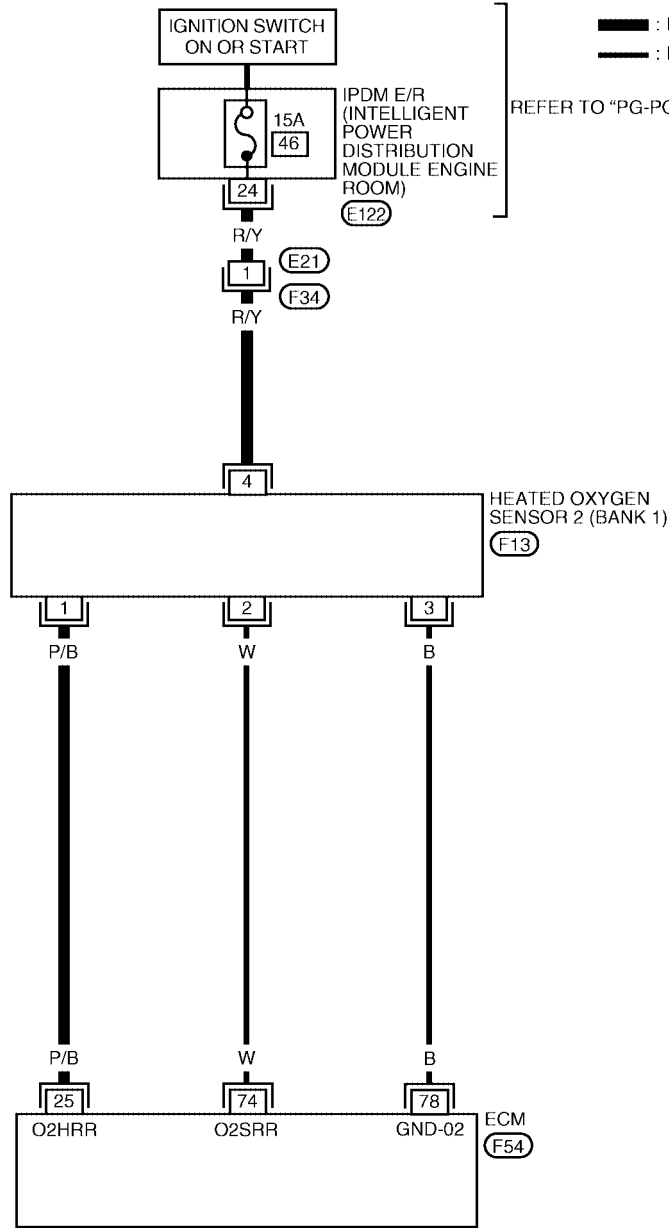

BBWA1663E

DTC P0037, P0038, P0057, P0058 HO2S2 HEATER

[VQ]

Specification data are reference values and are measured between each terminal and ground.

CAUTION:

Do not use ECM ground terminals when measuring input/output voltage. Doing so may result in damage to the ECM's transistor. Use a ground other than ECM terminals, such as the ground.

TER-MINAL NO.	WIRE COLOR	ITEM	CONDITION	DATA (DC Voltage)
25	P/B	Heated oxygen sensor 2 heater (bank 1)	[Engine is running] <ul style="list-style-type: none"> ● Engine speed is below 3,600 rpm after the following conditions are met. <ul style="list-style-type: none"> - Engine: after warming up - Keeping the engine speed between 3,500 and 4,000 rpm for 1 minute and at idle for 1 minute under no load. 	0 - 1.0V
			[Ignition switch: ON] <ul style="list-style-type: none"> ● Engine stopped [Engine is running] <ul style="list-style-type: none"> ● Engine speed is above 3,600 rpm. 	BATTERY VOLTAGE (11 - 14V)

DTC P0037, P0038, P0057, P0058 HO2S2 HEATER

[VQ]

BANK 2

EC-O2H2B2-01

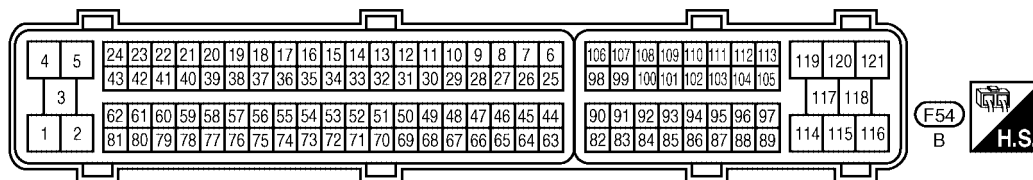
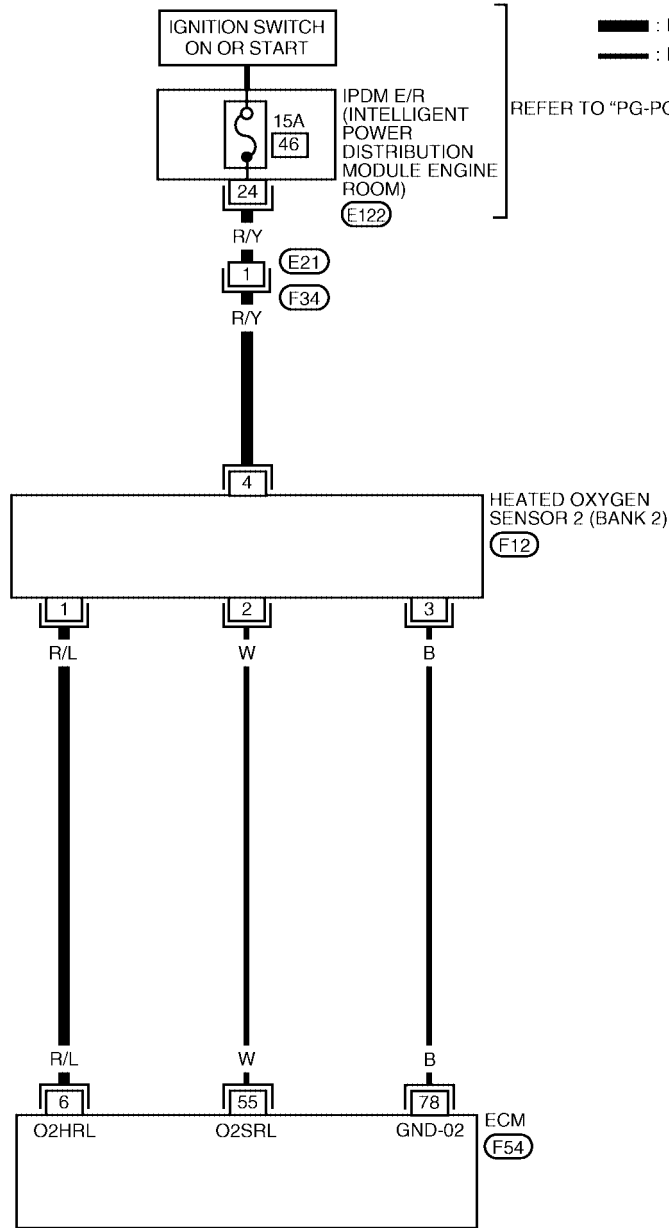

BBWA1664E

DTC P0037, P0038, P0057, P0058 HO2S2 HEATER

[VQ]

Specification data are reference values and are measured between each terminal and ground.

CAUTION:

Do not use ECM ground terminals when measuring input/output voltage. Doing so may result in damage to the ECM's transistor. Use a ground other than ECM terminals, such as the ground.

TER-MINAL NO.	WIRE COLOR	ITEM	CONDITION	DATA (DC Voltage)
6	R/L	Heated oxygen sensor 2 heater (bank 2)	[Engine is running] <ul style="list-style-type: none"> Engine speed is below 3,600 rpm after the following conditions are met. <ul style="list-style-type: none"> Engine: after warming up Keeping the engine speed between 3,500 and 4,000 rpm for 1 minute and at idle for 1 minute under no load. 	0 - 1.0V
			[Ignition switch: ON] <ul style="list-style-type: none"> Engine stopped [Engine is running] <ul style="list-style-type: none"> Engine speed is above 3,600 rpm. 	BATTERY VOLTAGE (11 - 14V)

Diagnostic Procedure

UBS00119

1. CHECK GROUND CONNECTIONS

- Turn ignition switch OFF.
- Loosen and retighten three ground screws on the body.
Refer to [EC-789, "Ground Inspection"](#).

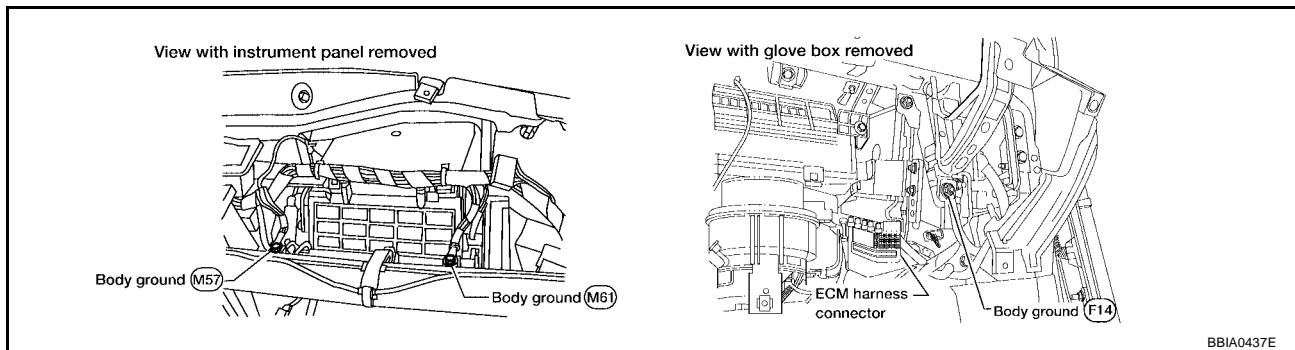

BBI40437E

OK or NG

- OK >> GO TO 2.
- NG >> Repair or replace ground connections.

2. CHECK HO2S2 POWER SUPPLY CIRCUIT

1. Disconnect heated oxygen sensor 2 harness connector.

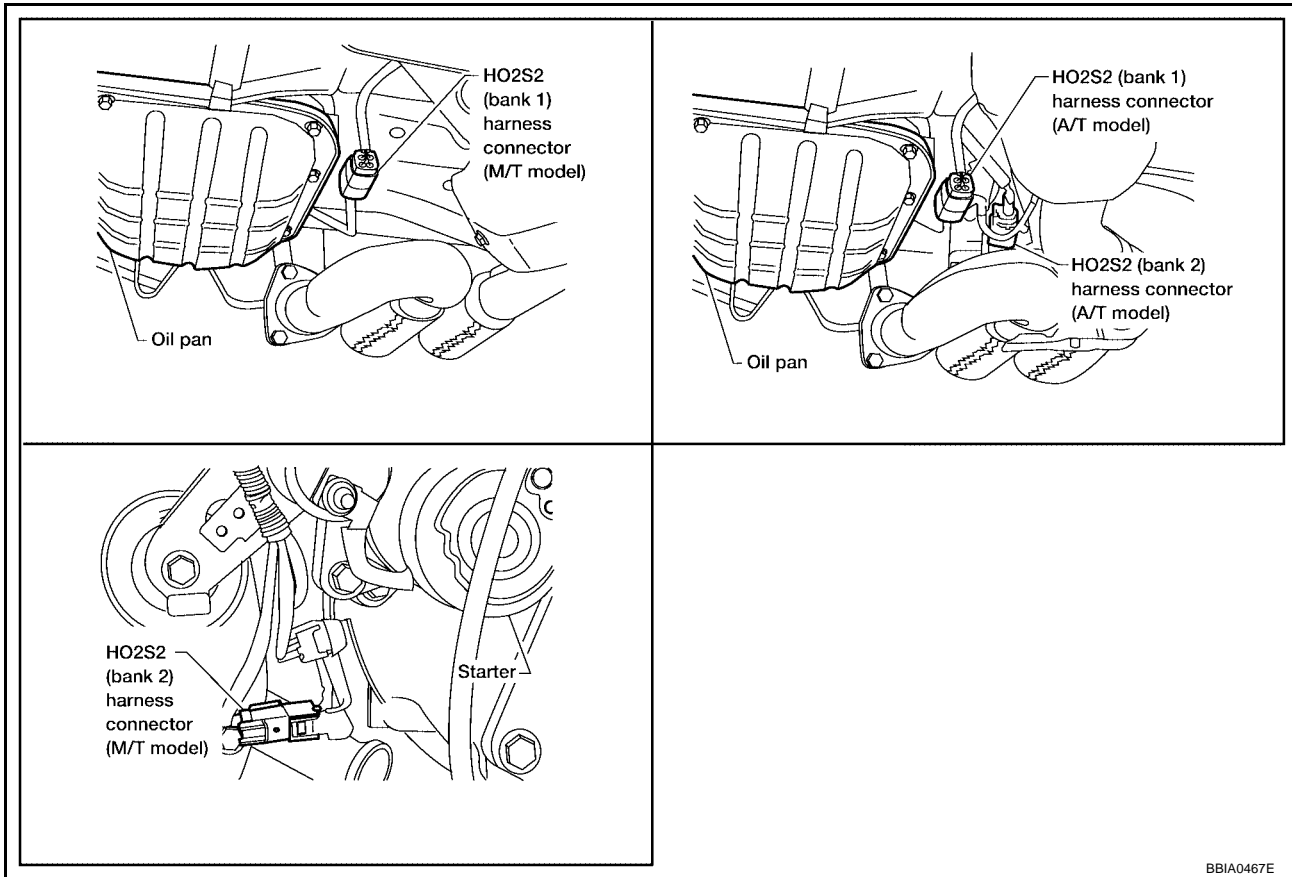

2. Turn ignition switch ON.
3. Check voltage between HO2S2 terminal 4 and ground with CONSULT-II or tester.

Voltage: Battery voltage

OK or NG

- OK >> GO TO 4.
- NG >> GO TO 3.

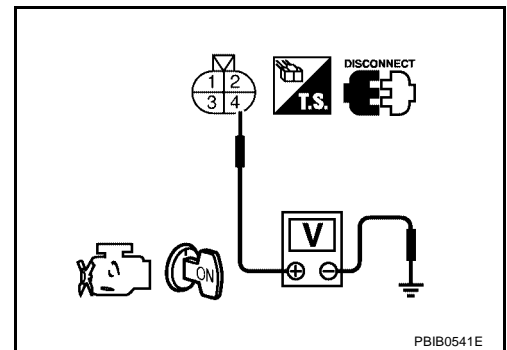

3. DETECT MALFUNCTIONING PART

Check the following.

- Harness connectors E21, F34
- IPDM E/R harness connector E122
- 15A fuse
- Harness for open or short between heated oxygen sensor 2 and fuse

>> Repair harness or connectors.

4. CHECK HO2S2 OUTPUT SIGNAL CIRCUIT FOR OPEN AND SHORT

1. Turn ignition switch OFF.
2. Disconnect ECM harness connector.
3. Check harness continuity between ECM terminal and HO2S2 terminal as follows.
Refer to Wiring Diagram.

DTC	Terminals		Bank
	ECM	Sensor	
P0037, P0038	25	1	1
P0057, P0058	6	1	2

Continuity should exist.

4. Also check harness for short to ground and short to power.

OK or NG

- OK >> GO TO 5.
- NG >> Repair open circuit or short to ground or short to power in harness or connectors.

5. CHECK HEATED OXYGEN SENSOR 2 HEATER

Refer to [EC-804, "Component Inspection"](#) .

OK or NG

- OK >> GO TO 6.
- NG >> Replace malfunctioning heated oxygen sensor 2.

6. CHECK INTERMITTENT INCIDENT

Refer to [EC-782, "TROUBLE DIAGNOSIS FOR INTERMITTENT INCIDENT"](#) .

>> **INSPECTION END**

Component Inspection HEATED OXYGEN SENSOR 2 HEATER

UBS0011A

1. Check resistance between HO2S2 terminals as follows.

Terminal No.	Resistance
1 and 4	5.0 - 7.0 Ω [at 25°C (77°F)]
2 and 1, 3, 4	∞ Ω (Continuity should not exist)
3 and 1, 2, 4	

2. If NG, replace heated oxygen sensor 2.

CAUTION:

- Discard any heated oxygen sensor which has been dropped from a height of more than 0.5 m (19.7 in) onto a hard surface such as a concrete floor; use a new one.
- Before installing new oxygen sensor, clean exhaust system threads using Oxygen Sensor Thread Cleaner tool J-43897-18 or J-43897-12 and approved anti-seize lubricant.

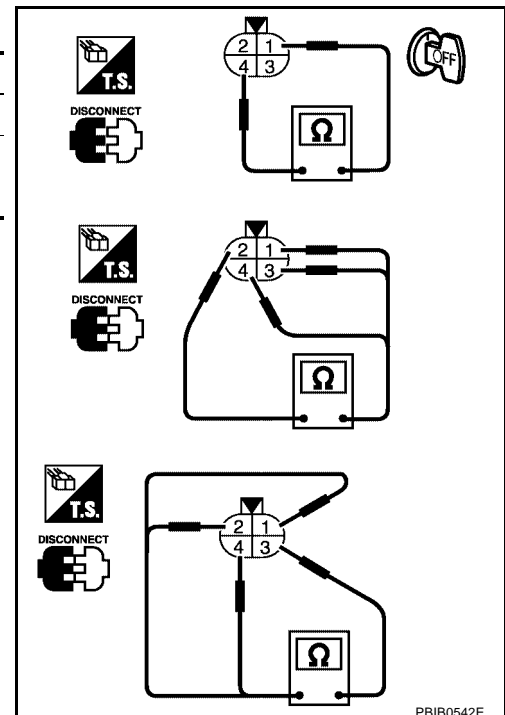

PBIB0542E

Removal and Installation
HEATED OXYGEN SENSOR 2

Refer to [EM-134, "EXHAUST MANIFOLD AND THREE WAY CATALYST"](#) .

A

EC

C

D

E

F

G

H

I

J

K

L

M

DTC P0101 MAF SENSOR

Component Description

The mass air flow sensor is placed in the stream of intake air. It measures the intake flow rate by measuring a part of the entire intake flow. The mass air flow sensor controls the temperature of the hot wire to a certain amount. The heat generated by the hot wire is reduced as the intake air flows around it. The more air, the greater the heat loss.

Therefore, the electric current supplied to hot wire is changed to maintain the temperature of the hot wire as air flow increases. The ECM detects the air flow by means of this current change.

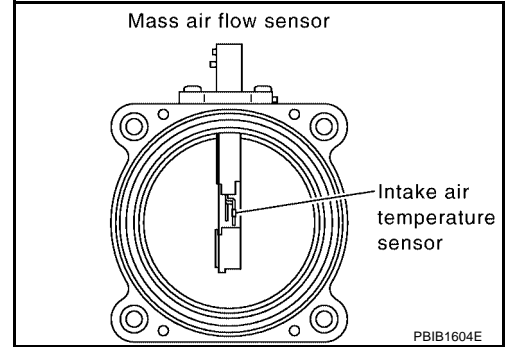

CONSULT-II Reference Value in Data Monitor Mode

Specification data are reference values.

MONITOR ITEM	CONDITION	SPECIFICATION
MAS A/F SE-B1	See EC-772, "TROUBLE DIAGNOSIS - SPECIFICATION VALUE" .	
CAL/LD VALUE	<ul style="list-style-type: none"> ● Engine: After warming up ● Shift lever: P or N (A/T), Neutral (M/T) ● Air conditioner switch: OFF ● No-load 	Idle 5% - 35%
		2,500 rpm 5% - 35%
MASS AIRFLOW	<ul style="list-style-type: none"> ● Engine: After warming up ● Shift lever: P or N (A/T), Neutral (M/T) ● Air conditioner switch: OFF ● No-load 	Idle 2.0 - 6.0 g-m/s
		2,500 rpm 7.0 - 20.0 g-m/s

On Board Diagnosis Logic

DTC No.	Trouble diagnosis name	DTC detecting condition		Possible cause
P0101 0101	Mass air flow sensor circuit range/performance problem	A)	A high voltage from the sensor is sent to ECM under light load driving condition.	<ul style="list-style-type: none"> ● Harness or connectors (The sensor circuit is open or shorted.) ● Mass air flow sensor ● EVAP control system pressure sensor ● Intake air temperature sensor
		B)	A low voltage from the sensor is sent to ECM under heavy load driving condition.	<ul style="list-style-type: none"> ● Harness or connectors (The sensor circuit is open or shorted.) ● Intake air leaks ● Mass air flow sensor ● EVAP control system pressure sensor ● Intake air temperature sensor

DTC Confirmation Procedure

Perform **PROCEDURE FOR MALFUNCTION A** first.

If the DTC cannot be confirmed, perform **PROCEDURE FOR MALFUNCTION B**.

NOTE:

If DTC Confirmation Procedure has been previously conducted, always turn ignition switch OFF and wait at least 10 seconds before conducting the next test.

PROCEDURE FOR MALFUNCTION A

NOTE:

If engine will not start or stops soon, wait at least 10 seconds with engine stopped (Ignition switch ON) instead of running engine at idle speed.

With CONSULT-II

1. Turn ignition switch ON.
2. Select "DATA MONITOR" mode with CONSULT-II.
3. Start engine and warm it up to normal operating temperature.
4. Run engine for at least 10 seconds at idle speed.
5. If 1st trip DTC is detected, go to [EC-810, "Diagnostic Procedure"](#)

DATA MONITOR	
MONITOR	NO DTC
ENG SPEED	XXX rpm
COOLAN TEMP/S	XXX °C

SEF174Y

With GST

Follow the procedure "With CONSULT-II" above.

PROCEDURE FOR MALFUNCTION B

CAUTION:

Always drive vehicle at a safe speed.

With CONSULT-II

1. Turn ignition switch ON.
2. Start engine and warm it up to normal operating temperature.
If engine cannot be started, go to [EC-810, "Diagnostic Procedure"](#).
3. Select "DATA MONITOR" mode with CONSULT-II.
4. Check the voltage of "MAS A/F SE-B1" with "DATA MONITOR".
5. Increases engine speed to about 4,000 rpm.
6. Monitor the linear voltage rise in response to engine speed increases.
If NG, go to [EC-810, "Diagnostic Procedure"](#).
If OK, go to following step.

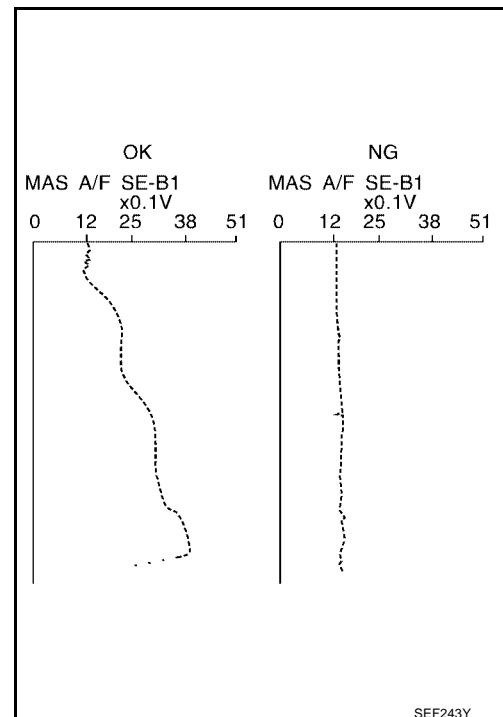

DTC P0101 MAF SENSOR

[VQ]

7. Maintain the following conditions for at least 10 consecutive seconds.

ENG SPEED	More than 2,000 rpm
THRTL SEN 1	More than 3V
THRTL SEN 2	More than 3V
Shift lever	Suitable position
Driving location	Driving vehicle uphill (Increased engine load) will help maintain the driving conditions required for this test.

DATA MONITOR	
MONITOR	NO DTC
ENG SPEED	XXX rpm
VHCL SPEED SE	XXX km/h
THRTL SEN 1	XXX V
THRTL SEN 2	XXX V

PBIB0199E

8. If 1st trip DTC is detected, go to [EC-810, "Diagnostic Procedure"](#)

Overall Function Check PROCEDURE FOR MALFUNCTION B

UBS0011G

Use this procedure to check the overall function of the mass air flow sensor circuit. During this check, a 1st trip DTC might not be confirmed.

With GST

1. Start engine and warm it up to normal operating temperature.
2. Select Service \$01 with GST.
3. Check the mass air flow sensor signal with Service \$01.
4. Check for linear mass air flow sensor signal value rise in response to increases to about 4,000 rpm in engine speed.
5. If NG, go to [EC-810, "Diagnostic Procedure"](#).

CALC LOAD	20%
COOLANT TEMP	95°C
SHORT FT #1	2%
LONG FT #1	0%
SHORT FT #2	4%
LONG FT #2	0%
ENGINE SPD	2637RPM
VEHICLE SPD	0MPH
IGN ADVANCE	41.0°
INTAKE AIR	41°C
MAF	14.1gm/sec
THROTTLE POS	3%

SEF534P

DTC P0101 MAF SENSOR

[VQ]

UBS0011H

Wiring Diagram

EC-MAFS-01

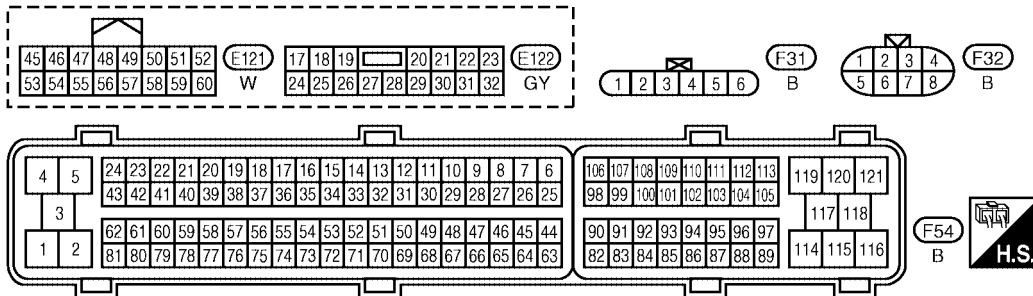
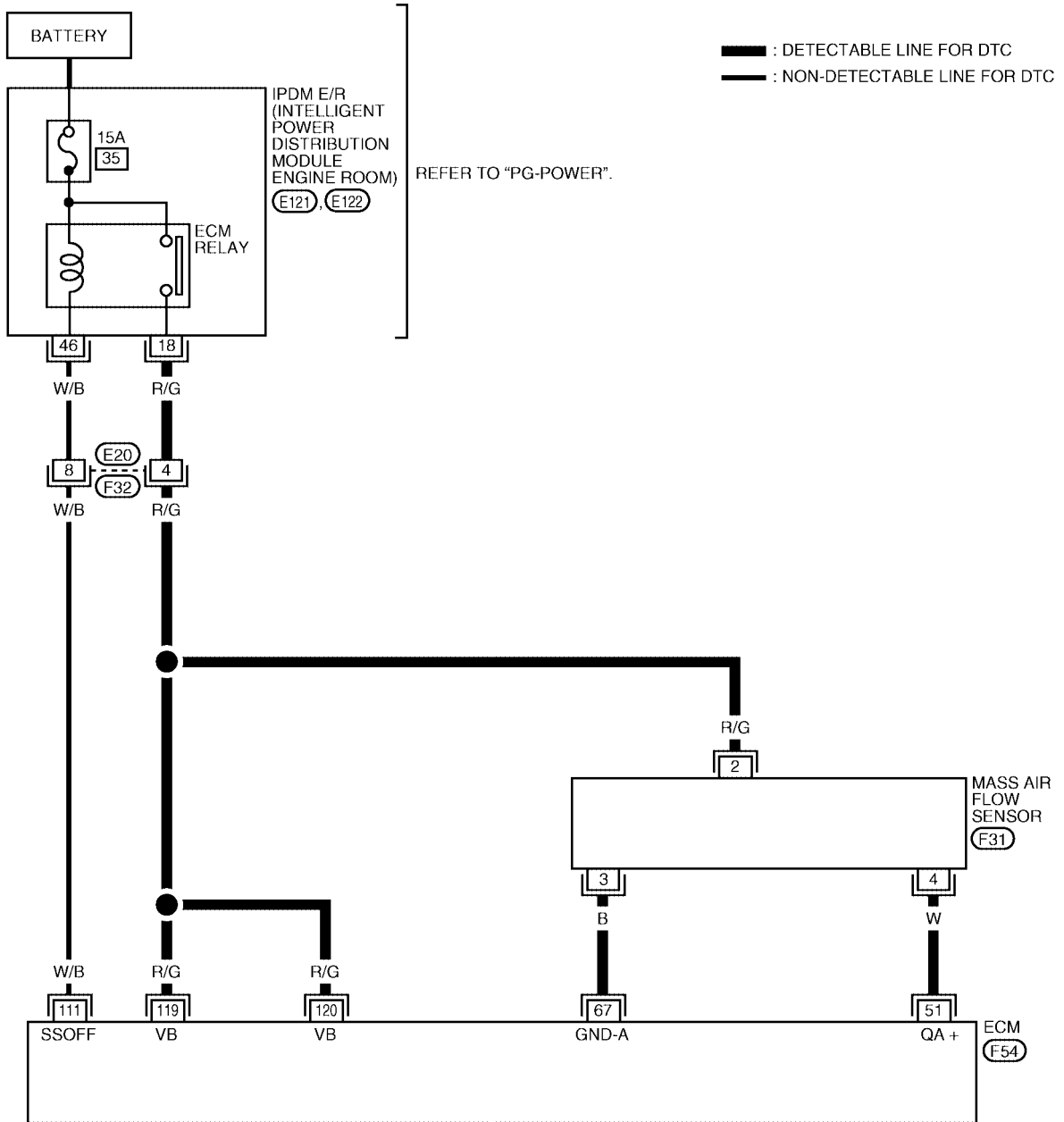

BBWA1271E

DTC P0101 MAF SENSOR

[VQ]

Specification data are reference values and are measured between each terminal and ground.

CAUTION:

Do not use ECM ground terminals when measuring input/output voltage. Doing so may result in damage to the ECM's transistor. Use a ground other than ECM terminals, such as the ground.

TER-MINAL NO.	WIRE COLOR	ITEM	CONDITION	DATA (DC Voltage)
51	W	Mass air flow sensor	[Engine is running] ● Warm-up condition ● Idle speed	1.0 - 1.2V
			[Engine is running] ● Warm-up condition ● Engine speed is 2,500 rpm.	1.6 - 2.0V
67	B	Sensor ground	[Engine is running] ● Warm-up condition ● Idle speed	Approximately 0V
111	W/B	ECM relay (Self shut-off)	[Engine is running] [Ignition switch: OFF] ● For a few seconds after turning ignition switch OFF	0 - 1.5V
			[Ignition switch: OFF] ● More than a few seconds after turning ignition switch OFF	BATTERY VOLTAGE (11 - 14V)
119 120	R/G R/G	Power supply for ECM	[Ignition switch: ON]	BATTERY VOLTAGE (11 - 14V)

Diagnostic Procedure

UBS00111

1. INSPECTION START

Which malfunction (A or B) is duplicated?

A or B

- A >> GO TO 3.
- B >> GO TO 2.

2. CHECK INTAKE SYSTEM

Check the following for connection.

- Air duct
- Vacuum hoses
- Intake air passage between air duct and intake manifold

OK or NG

- OK >> GO TO 3.
- NG >> Reconnect the parts.

3. CHECK GROUND CONNECTIONS

1. Turn ignition switch OFF.
2. Loosen and retighten three ground screws on the body.
Refer to [EC-789, "Ground Inspection"](#) .

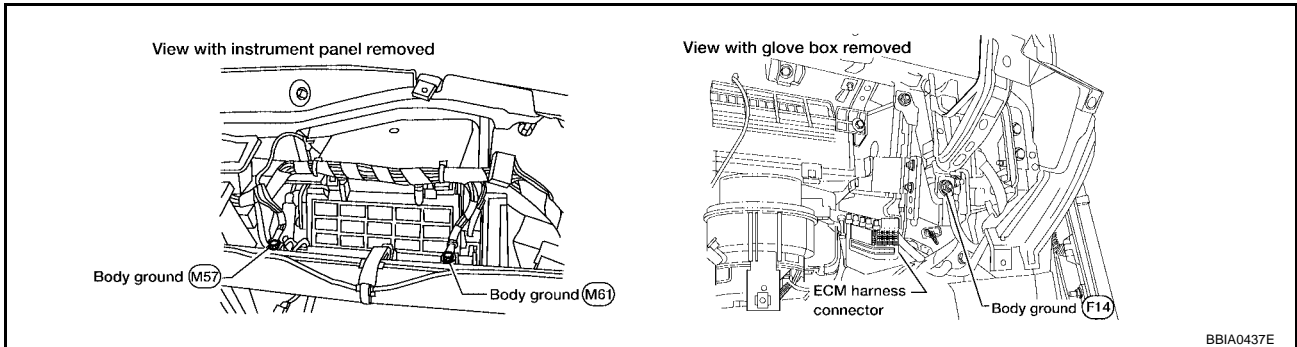

OK or NG

- OK >> GO TO 4.
- NG >> Repair or replace ground connections.

4. CHECK MAF SENSOR POWER SUPPLY CIRCUIT

1. Disconnect mass air flow (MAF) sensor harness connector.
2. Turn ignition switch ON.

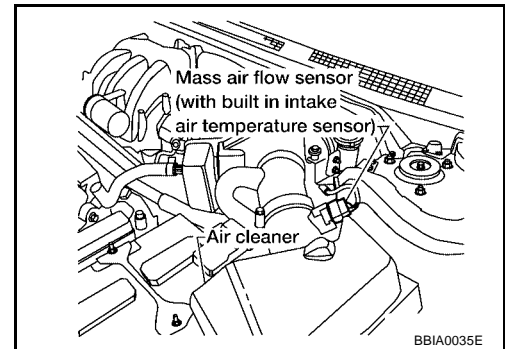

3. Check voltage between MAF sensor terminal 2 and ground with CONSULT-II or tester.

Voltage: Battery voltage

OK or NG

- OK >> GO TO 6.
- NG >> GO TO 5.

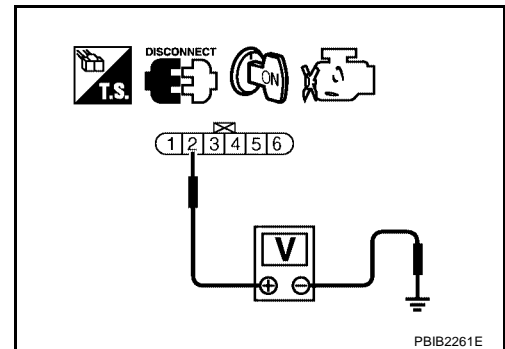

5. DETECT MALFUNCTIONING PART

Check the following.

- Harness connectors E20, F32
- Harness for open or short between IPDM E/R and mass air flow sensor
- Harness for open or short between mass air flow sensor and ECM

>> Repair open circuit or short to ground or short to power in harness or connectors.

6. CHECK MAF SENSOR GROUND CIRCUIT FOR OPEN AND SHORT

1. Turn ignition switch OFF.
2. Disconnect ECM harness connector.
3. Check harness continuity between MAF sensor terminal 3 and ECM terminal 67.
Refer to Wiring Diagram.

Continuity should exist.

4. Also check harness for short to ground and short to power.

OK or NG

- OK >> GO TO 7.
NG >> Repair open circuit or short to ground or short to power in harness or connectors.

7. CHECK MAF SENSOR INPUT SIGNAL CIRCUIT FOR OPEN AND SHORT

1. Check harness continuity between MAF sensor terminal 4 and ECM terminal 51.
Refer to Wiring Diagram.

Continuity should exist.

2. Also check harness for short to ground and short to power.

OK or NG

- OK >> GO TO 8.
NG >> Repair open circuit or short to ground or short to power in harness or connectors.

8. CHECK INTAKE AIR TEMPERATURE SENSOR

Refer to [EC-825, "Component Inspection"](#) .

OK or NG

- OK >> GO TO 9.
NG >> Replace intake air temperature sensor.

9. CHECK EVAP CONTROL SYSTEM PRESSURE SENSOR

Refer to [EC-993, "Component Inspection"](#) .

OK or NG

- OK >> GO TO 10.
NG >> Replace EVAP control system pressure sensor.

10. CHECK MASS AIR FLOW SENSOR

Refer to [EC-812, "Component Inspection"](#) .

OK or NG

- OK >> GO TO 9.
NG >> Replace mass air flow sensor.

11. CHECK INTERMITTENT INCIDENT

Refer to [EC-782, "TROUBLE DIAGNOSIS FOR INTERMITTENT INCIDENT"](#) .

>> INSPECTION END

Component Inspection MASS AIR FLOW SENSOR

UBS001J

With CONSULT-II

1. Reconnect all harness connectors disconnected.
2. Start engine and warm it up to normal operating temperature.
3. Connect CONSULT-II and select "DATA MONITOR" mode.

DTC P0101 MAF SENSOR

[VQ]

4. Select "MAS A/F SE-B1" and check indication under the following conditions.

Condition	MAS A/F SE-B1 (V)
Ignition switch ON (Engine stopped.)	Approx. 0.4
Idle (Engine is warmed-up to normal operating temperature.)	1.0 - 1.2
2,500 rpm (Engine is warmed-up to normal operating temperature.)	1.6 - 2.0
Idle to about 4,000 rpm	1.0 - 1.2 to Approx. 2.4*

*: Check for linear voltage rise in response to engine being increased to about 4,000 rpm.

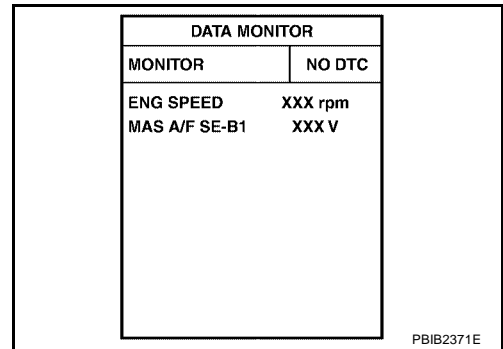

5. If the voltage is out of specification, proceed the following.
- Check for the cause of uneven air flow through mass air flow sensor. Refer to following.
 - Crushed air ducts
 - Malfunctioning seal of air cleaner element
 - Uneven dirt of air cleaner element
 - Improper specification of intake air system parts
 - If NG, repair or replace malfunctioning part and perform step 2 to 4 again. If OK, go to next step.
- Turn ignition switch OFF.
 - Disconnect mass air flow sensor harness connector and reconnect it again.
 - Perform step 2 to 4 again.
 - If NG, clean or replace mass air flow sensor.

⊗ **Without CONSULT-II**

- Reconnect all harness connectors disconnected.
- Start engine and warm it up to normal operating temperature.
- Check voltage between ECM terminal 51 (Mass air flow sensor signal) and ground.

Condition	Voltage V
Ignition switch ON (Engine stopped.)	Approx. 0.4
Idle (Engine is warmed-up to normal operating temperature.)	1.0 - 1.2
2,500 rpm (Engine is warmed-up to normal operating temperature.)	1.6 - 2.0
Idle to about 4,000 rpm	1.0 - 1.2 to Approx. 2.4*

*: Check for linear voltage rise in response to engine being increased to about 4,000 rpm.

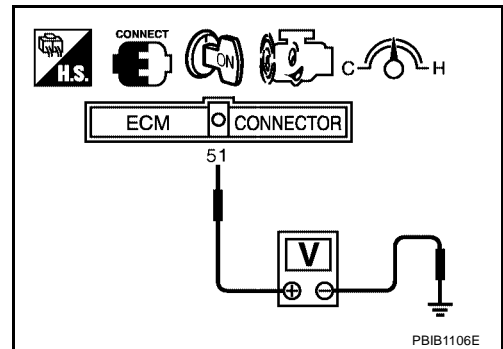

- If the voltage is out of specification, proceed the following.
 - Check for the cause of uneven air flow through mass air flow sensor. Refer to following.
 - Crushed air ducts
 - Malfunctioning seal of air cleaner element
 - Uneven dirt of air cleaner element
 - Improper specification of intake air system parts
 - If NG, repair or replace malfunctioning part and perform step 2 to 4 again. If OK, go to next step.
- Turn ignition switch OFF.
- Disconnect mass air flow sensor harness connector and reconnect it again.
- Perform step 2 and 3 again.
- If NG, clean or replace mass air flow sensor.

Removal and Installation
MASS AIR FLOW SENSOR

Refer to [EM-120, "AIR CLEANER AND AIR DUCT"](#) .

DTC P0102, P0103 MAF SENSOR

Component Description

The mass air flow sensor is placed in the stream of intake air. It measures the intake flow rate by measuring a part of the entire intake flow. The mass air flow sensor controls the temperature of the hot wire to a certain amount. The heat generated by the hot wire is reduced as the intake air flows around it. The more air, the greater the heat loss.

Therefore, the electric current supplied to hot wire is changed to maintain the temperature of the hot wire as air flow increases. The ECM detects the air flow by means of this current change.

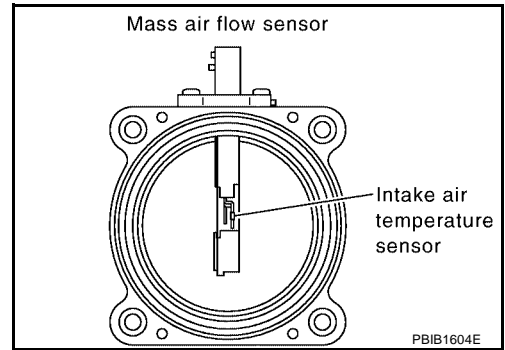

CONSULT-II Reference Value in Data Monitor Mode

Specification data are reference values.

MONITOR ITEM	CONDITION		SPECIFICATION
MAS A/F SE-B1	See EC-772. "TROUBLE DIAGNOSIS - SPECIFICATION VALUE" .		
CAL/LD VALUE	<ul style="list-style-type: none"> ● Engine: After warming up ● Shift lever: P or N (A/T), Neutral (M/T) ● Air conditioner switch: OFF ● No-load 	Idle	5% - 35%
		2,500 rpm	5% - 35%
MASS AIRFLOW	<ul style="list-style-type: none"> ● Engine: After warming up ● Shift lever: P or N (A/T), Neutral (M/T) ● Air conditioner switch: OFF ● No-load 	Idle	2.0 - 6.0 g-m/s
		2,500 rpm	7.0 - 20.0 g-m/s

On Board Diagnosis Logic

These self-diagnoses have the one trip detection logic.

DTC No.	Trouble diagnosis name	DTC detecting condition	Possible cause
P0102 0102	Mass air flow sensor circuit low input	An excessively low voltage from the sensor is sent to ECM.	<ul style="list-style-type: none"> ● Harness or connectors (The sensor circuit is open or shorted.) ● Intake air leaks ● Mass air flow sensor
P0103 0103	Mass air flow sensor circuit high input	An excessively high voltage from the sensor is sent to ECM.	<ul style="list-style-type: none"> ● Harness or connectors (The sensor circuit is open or shorted.) ● Mass air flow sensor

FAIL-SAFE MODE

When the malfunction is detected, the ECM enters fail-safe mode and the MIL lights up.

Detected items	Engine operating condition in fail-safe mode
Mass air flow sensor circuit	Engine speed will not rise more than 2,400 rpm due to the fuel cut.

DTC Confirmation Procedure

NOTE:

If DTC Confirmation Procedure has been previously conducted, always turn ignition switch OFF and wait at least 10 seconds before conducting the next test.

PROCEDURE FOR DTC P0102

 **With CONSULT-II**

1. Turn ignition switch ON.
2. Select "DATA MONITOR" mode with CONSULT-II.
3. Start engine and wait at least 5 seconds.
4. If DTC is detected, go to [EC-818, "Diagnostic Procedure"](#) .

DATA MONITOR	
MONITOR	NO DTC
ENG SPEED	XXX rpm

SEF058Y

 **With GST**

Follow the procedure "With CONSULT-II" above.

PROCEDURE FOR DTC P0103

 **With CONSULT-II**

1. Turn ignition switch ON.
2. Select "DATA MONITOR" mode with CONSULT-II.
3. Wait at least 5 seconds.
4. If DTC is detected, go to [EC-818, "Diagnostic Procedure"](#) .
If DTC is not detected, go to next step.
5. Start engine and wait at least 5 seconds.
6. If DTC is detected, go to [EC-818, "Diagnostic Procedure"](#) .

DATA MONITOR	
MONITOR	NO DTC
ENG SPEED	XXX rpm

SEF058Y

 **With GST**

Follow the procedure "With CONSULT-II" above.

DTC P0102, P0103 MAF SENSOR

[VQ]

UBS0011P

Wiring Diagram

EC-MAFS-01

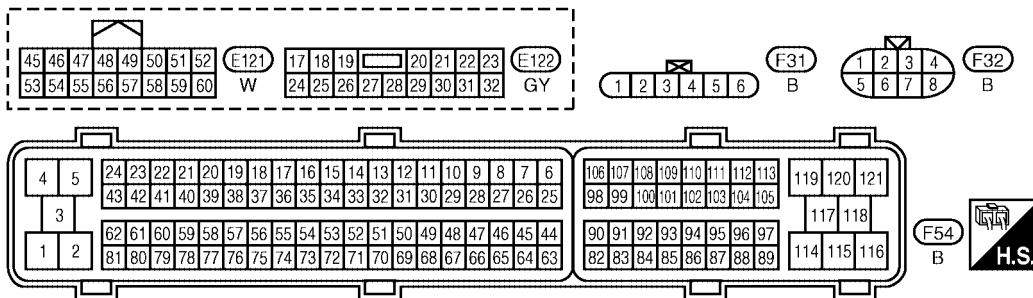
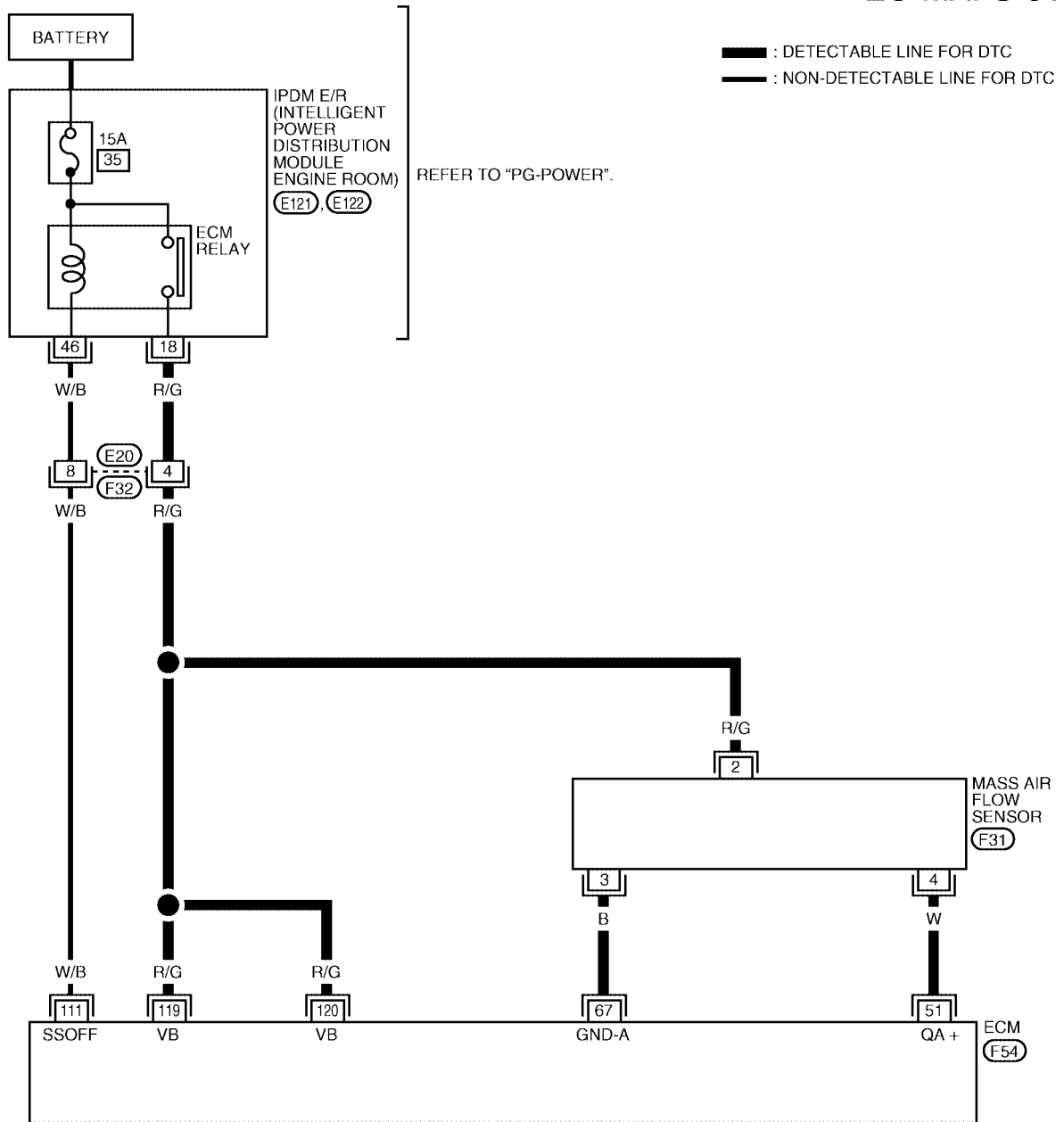

BBWA1271E

DTC P0102, P0103 MAF SENSOR

[VQ]

Specification data are reference values and are measured between each terminal and ground.

CAUTION:

Do not use ECM ground terminals when measuring input/output voltage. Doing so may result in damage to the ECM's transistor. Use a ground other than ECM terminals, such as the ground.

TER-MINAL NO.	WIRE COLOR	ITEM	CONDITION	DATA (DC Voltage)
51	W	Mass air flow sensor	[Engine is running] ● Warm-up condition ● Idle speed	1.0 - 1.2V
			[Engine is running] ● Warm-up condition ● Engine speed is 2,500 rpm.	1.6 - 2.0V
67	B	Sensor ground	[Engine is running] ● Warm-up condition ● Idle speed	Approximately 0V
111	W/B	ECM relay (Self shut-off)	[Engine is running] [Ignition switch: OFF] ● For a few seconds after turning ignition switch OFF	0 - 1.5V
			[Ignition switch: OFF] ● More than a few seconds after turning ignition switch OFF	BATTERY VOLTAGE (11 - 14V)
119 120	R/G R/G	Power supply for ECM	[Ignition switch: ON]	BATTERY VOLTAGE (11 - 14V)

Diagnostic Procedure

UBS0011Q

1. INSPECTION START

Which malfunction (P0102 or P0103) is duplicated?

P0102 or P0103

P0102 >> GO TO 3.

P0103 >> GO TO 2.

2. CHECK INTAKE SYSTEM

Check the following for connection.

- Air duct
- Vacuum hoses
- Intake air passage between air duct and intake manifold

OK or NG

OK >> GO TO 3.

NG >> Reconnect the parts.

3. CHECK GROUND CONNECTIONS

1. Turn ignition switch OFF.
2. Loosen and retighten three ground screws on the body.
Refer to [EC-789, "Ground Inspection"](#) .

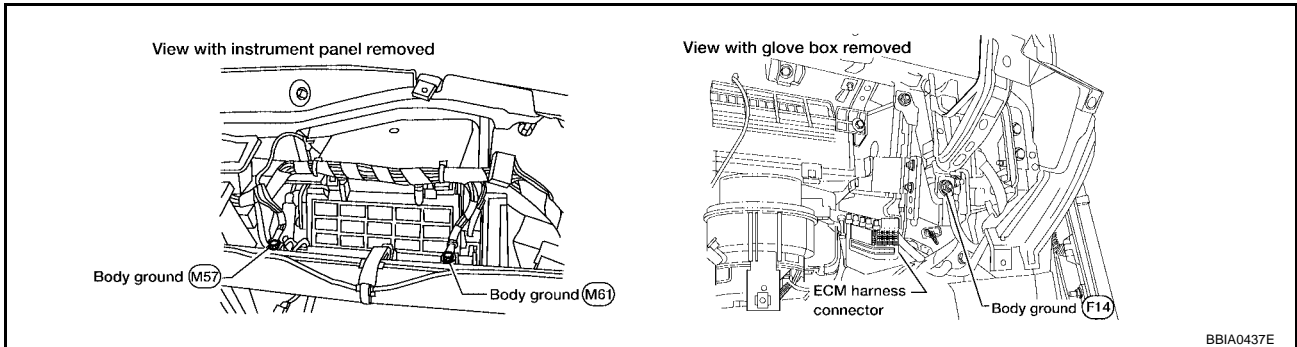

OK or NG

- OK >> GO TO 4.
- NG >> Repair or replace ground connections.

4. CHECK MAF SENSOR POWER SUPPLY CIRCUIT

1. Disconnect mass air flow (MAF) sensor harness connector.
2. Turn ignition switch ON.

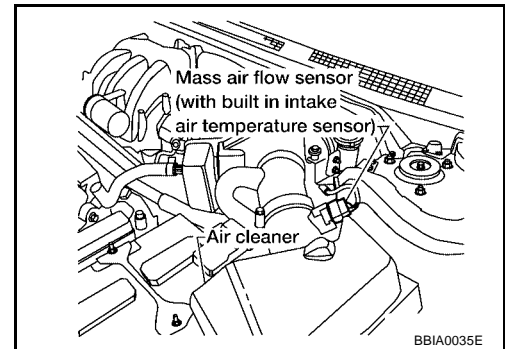

3. Check voltage between MAF sensor terminal 2 and ground with CONSULT-II or tester.

Voltage: Battery voltage

OK or NG

- OK >> GO TO 6.
- NG >> GO TO 5.

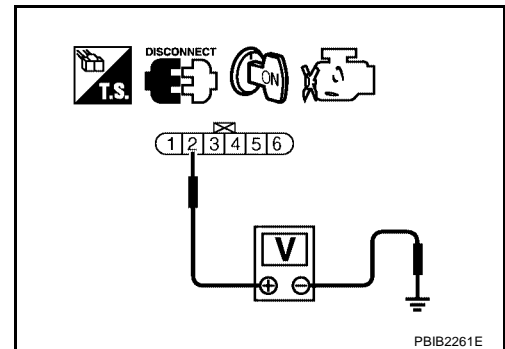

5. DETECT MALFUNCTIONING PART

Check the following.

- Harness connectors E20, F32
- Harness for open or short between IPDM E/R and mass air flow sensor
- Harness for open or short between mass air flow sensor and ECM

>> Repair open circuit or short to ground or short to power in harness or connectors.

6. CHECK MAF SENSOR GROUND CIRCUIT FOR OPEN AND SHORT

1. Turn ignition switch OFF.
2. Disconnect ECM harness connector.
3. Check harness continuity between MAF sensor terminal 3 and ECM terminal 67.
Refer to Wiring Diagram.

Continuity should exist.

4. Also check harness for short to ground and short to power.

OK or NG

- OK >> GO TO 7.
- NG >> Repair open circuit or short to ground or short to power in harness or connectors.

7. CHECK MAF SENSOR INPUT SIGNAL CIRCUIT FOR OPEN AND SHORT

1. Check harness continuity between MAF sensor terminal 4 and ECM terminal 51.
Refer to Wiring Diagram.

Continuity should exist.

2. Also check harness for short to ground and short to power.

OK or NG

- OK >> GO TO 8.
- NG >> Repair open circuit or short to ground or short to power in harness or connectors.

8. CHECK MASS AIR FLOW SENSOR

Refer to [EC-812, "Component Inspection"](#) .

OK or NG

- OK >> GO TO 9.
- NG >> Replace mass air flow sensor.

9. CHECK INTERMITTENT INCIDENT

Refer to [EC-782, "TROUBLE DIAGNOSIS FOR INTERMITTENT INCIDENT"](#) .

>> INSPECTION END

**Component Inspection
MASS AIR FLOW SENSOR**

UBS0011R

With CONSULT-II

1. Reconnect all harness connectors disconnected.
2. Start engine and warm it up to normal operating temperature.
3. Connect CONSULT-II and select "DATA MONITOR" mode.
4. Select "MAS A/F SE-B1" and check indication under the following conditions.

Condition	MAS A/F SE-B1 (V)
Ignition switch ON (Engine stopped.)	Approx. 0.4
Idle (Engine is warmed-up to normal operating temperature.)	1.0 - 1.2
2,500 rpm (Engine is warmed-up to normal operating temperature.)	1.6 - 2.0
Idle to about 4,000 rpm	1.0 - 1.2 to Approx. 2.4*

*: Check for linear voltage rise in response to engine being increased to about 4,000 rpm.

5. If the voltage is out of specification, proceed the following.

DATA MONITOR	
MONITOR	NO DTC
ENG SPEED	XXX rpm
MAS A/F SE-B1	XXX V

PBIB2371E

DTC P0102, P0103 MAF SENSOR

[VQ]

- a. Check for the cause of uneven air flow through mass air flow sensor. Refer to following.
 - Crushed air ducts
 - Malfunctioning seal of air cleaner element
 - Uneven dirt of air cleaner element
 - Improper specification of intake air system parts
- b. If NG, repair or replace malfunctioning part and perform step 2 to 4 again. If OK, go to next step.
6. Turn ignition switch OFF.
7. Disconnect mass air flow sensor harness connector and reconnect it again.
8. Perform step 2 to 4 again.
9. If NG, clean or replace mass air flow sensor.

⊗ Without CONSULT-II

1. Reconnect all harness connectors disconnected.
2. Start engine and warm it up to normal operating temperature.
3. Check voltage between ECM terminal 51 (Mass air flow sensor signal) and ground.

Condition	Voltage V
Ignition switch ON (Engine stopped.)	Approx. 0.4
Idle (Engine is warmed-up to normal operating temperature.)	1.0 - 1.2
2,500 rpm (Engine is warmed-up to normal operating temperature.)	1.6 - 2.0
Idle to about 4,000 rpm	1.0 - 1.2 to Approx. 2.4*

*: Check for linear voltage rise in response to engine being increased to about 4,000 rpm.

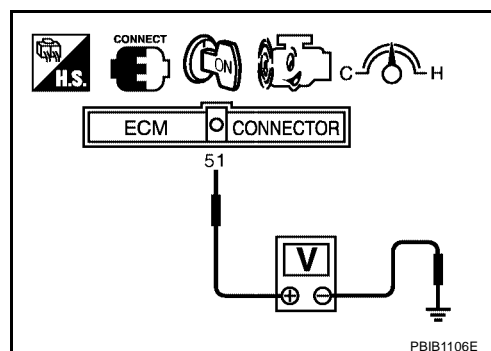

4. If the voltage is out of specification, proceed the following.
 - a. Check for the cause of uneven air flow through mass air flow sensor. Refer to following.
 - Crushed air ducts
 - Malfunctioning seal of air cleaner element
 - Uneven dirt of air cleaner element
 - Improper specification of intake air system parts
 - b. If NG, repair or replace malfunctioning part and perform step 2 to 4 again. If OK, go to next step.
 5. Turn ignition switch OFF.
 6. Disconnect mass air flow sensor harness connector and reconnect it again.
 7. Perform step 2 and 3 again.
 8. If NG, clean or replace mass air flow sensor.

Removal and Installation MASS AIR FLOW SENSOR

Refer to [EM-120, "AIR CLEANER AND AIR DUCT"](#) .

UBS0011S

DTC P0112, P0113 IAT SENSOR

PFP:22630

Component Description

UBS0011T

The intake air temperature sensor is built-into mass air flow sensor. The sensor detects intake air temperature and transmits a signal to the ECM.

The temperature sensing unit uses a thermistor which is sensitive to the change in temperature. Electrical resistance of the thermistor decreases in response to the temperature rise.

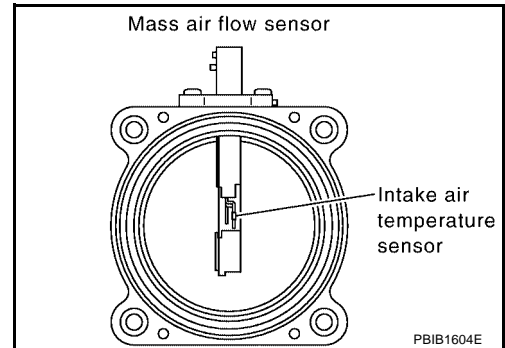

<Reference data>

Intake air temperature °C (°F)	Voltage* V	Resistance kΩ
25 (77)	3.32	1.94 - 2.06
80 (176)	1.23	0.295 - 0.349

*: This data is reference value and is measured between ECM terminal 34 (Intake air temperature sensor) and ground.

CAUTION:

Do not use ECM ground terminals when measuring input/output voltage. Doing so may result in damage to the ECM's transistor. Use a ground other than ECM terminals, such as the ground.

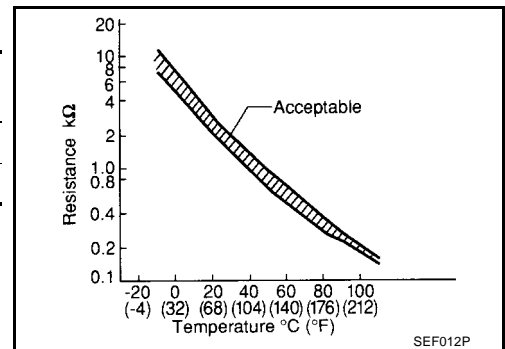

On Board Diagnosis Logic

UBS0011U

DTC No.	Trouble diagnosis name	DTC detecting condition	Possible cause
P0112 0112	Intake air temperature sensor circuit low input	An excessively low voltage from the sensor is sent to ECM.	<ul style="list-style-type: none"> ● Harness or connectors (The sensor circuit is open or shorted.) ● Intake air temperature sensor
P0113 0113	Intake air temperature sensor circuit high input	An excessively high voltage from the sensor is sent to ECM.	

DTC Confirmation Procedure

UBS0011V

NOTE:

If DTC Confirmation Procedure has been previously conducted, always turn ignition switch OFF and wait at least 10 seconds before conducting the next test.

WITH CONSULT-II

1. Turn ignition switch ON.
2. Select "DATA MONITOR" mode with CONSULT-II.
3. Wait at least 5 seconds.
4. If 1st trip DTC is detected, go to [EC-824, "Diagnostic Procedure"](#)

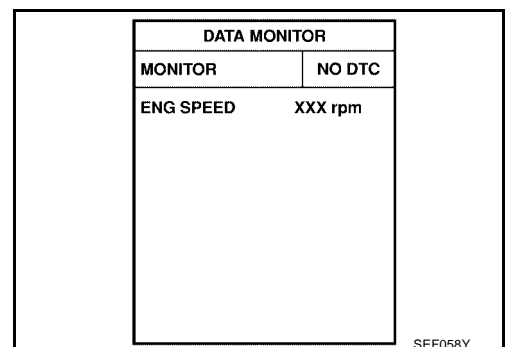

WITH GST

Follow the procedure "WITH CONSULT-II" above.

DTC P0112, P0113 IAT SENSOR

[VQ]

Wiring Diagram

UBS0011W

EC-IATS-01

A
EC
C
D
E
F
G
H
I
J
K
L
M

— : DETECTABLE LINE FOR DTC
— : NON-DETECTABLE LINE FOR DTC

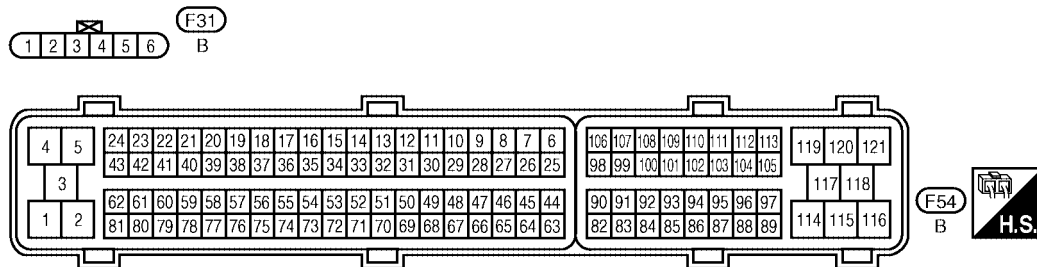
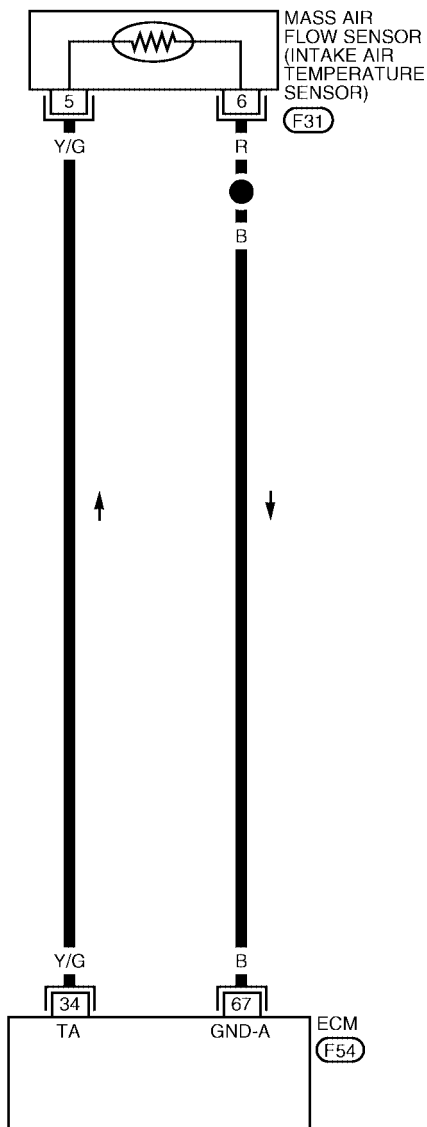

BBWA1272E

Diagnostic Procedure

1. CHECK GROUND CONNECTIONS

1. Turn ignition switch OFF.
2. Loosen and retighten three ground screws on the body.
Refer to [EC-789, "Ground Inspection"](#).

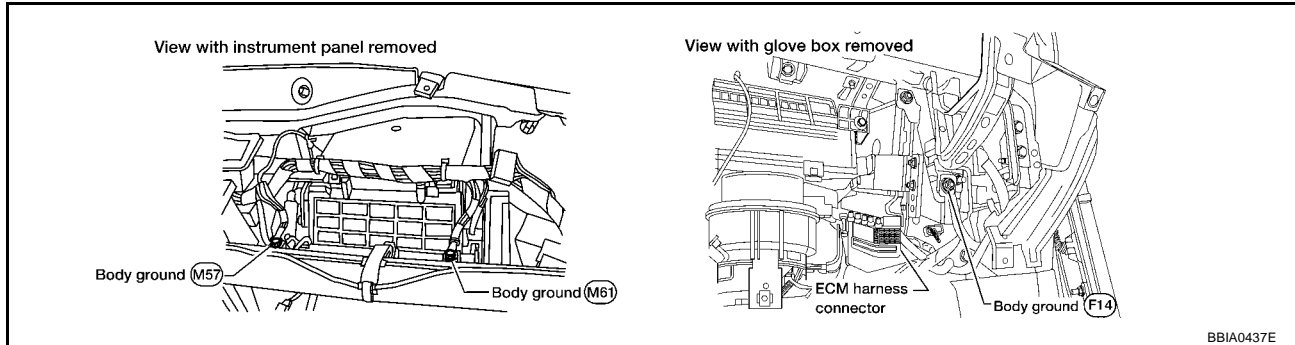

OK or NG

- OK >> GO TO 2.
NG >> Repair or replace ground connections.

2. CHECK INTAKE AIR TEMPERATURE SENSOR POWER SUPPLY CIRCUIT

1. Disconnect mass air flow sensor (intake air temperature sensor is built-into) harness connector.
2. Turn ignition switch ON.

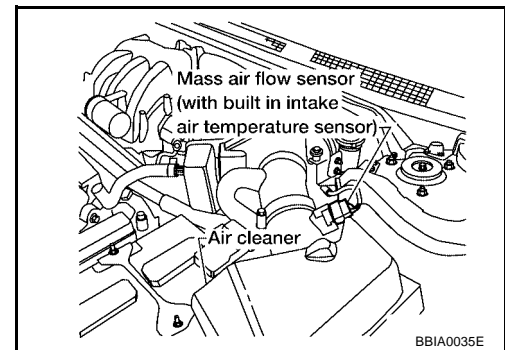

3. Check voltage between mass air flow sensor terminal 5 and ground.

Voltage: Approximately 5V

OK or NG

- OK >> GO TO 3.
NG >> Repair open circuit or short to ground or short to power in harness or connectors.

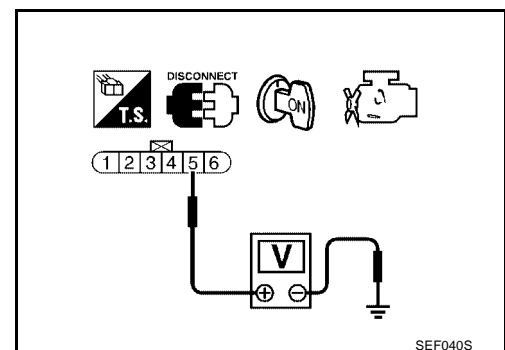

3. CHECK INTAKE AIR TEMPERATURE SENSOR GROUND CIRCUIT FOR OPEN AND SHORT

1. Turn ignition switch OFF.
2. Disconnect ECM harness connector.
3. Check harness continuity between mass air flow sensor terminal 6 and ECM terminal 67.
Refer to Wiring Diagram.

Continuity should exist.

4. Also check harness for short to ground and short to power.

OK or NG

- OK >> GO TO 4.
- NG >> Repair open circuit or short to ground or short to power in harness or connectors.

4. CHECK INTAKE AIR TEMPERATURE SENSOR

Refer to [EC-825, "Component Inspection"](#) .

OK or NG

- OK >> GO TO 5.
- NG >> Replace mass air flow sensor (with intake air temperature sensor).

5. CHECK INTERMITTENT INCIDENT

Refer to [EC-782, "TROUBLE DIAGNOSIS FOR INTERMITTENT INCIDENT"](#) .

>> INSPECTION END

**Component Inspection
INTAKE AIR TEMPERATURE SENSOR**

UBS0011Y

1. Check resistance between mass air flow sensor terminals 5 and 6 under the following conditions.

Intake air temperature °C (°F)	Resistance kΩ
25 (77)	1.94 - 2.06

2. If NG, replace mass air flow sensor (with intake air temperature sensor).

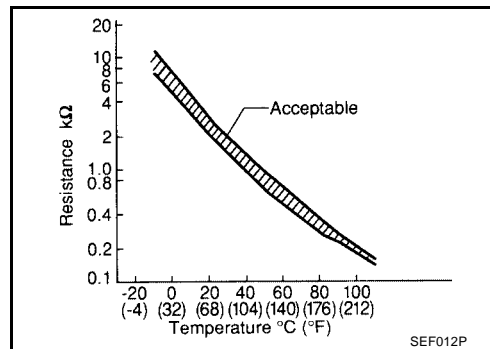
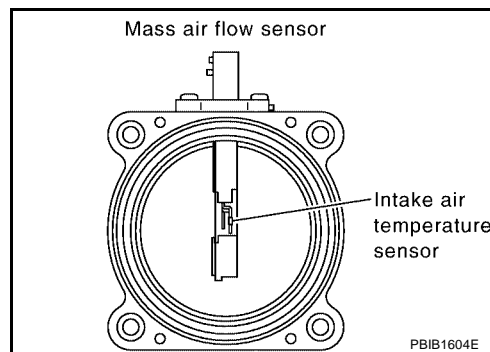

**Removal and Installation
MASS AIR FLOW SENSOR**

UBS0011Z

Refer to [EM-120, "AIR CLEANER AND AIR DUCT"](#) .

DTC P0117, P0118 ECT SENSOR

[VQ]

PFP:22630

UBS00120

DTC P0117, P0118 ECT SENSOR

Component Description

The engine coolant temperature sensor is used to detect the engine coolant temperature. The sensor modifies a voltage signal from the ECM. The modified signal returns to the ECM as the engine coolant temperature input. The sensor uses a thermistor which is sensitive to the change in temperature. The electrical resistance of the thermistor decreases as temperature increases.

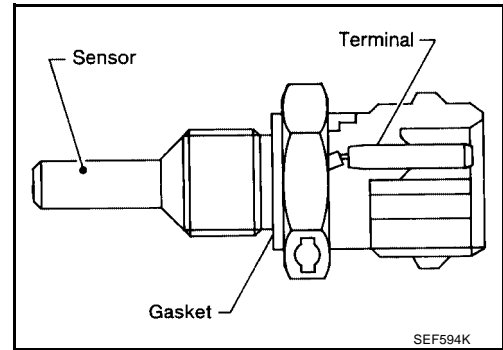

<Reference data>

Engine coolant temperature °C (°F)	Voltage* V	Resistance kΩ
-10 (14)	4.4	7.0 - 11.4
20 (68)	3.5	2.1 - 2.9
50 (122)	2.2	0.68 - 1.00
90 (194)	0.9	0.236 - 0.260

*: This data is reference value and is measured between ECM terminal 73 (Engine coolant temperature sensor) and ground.

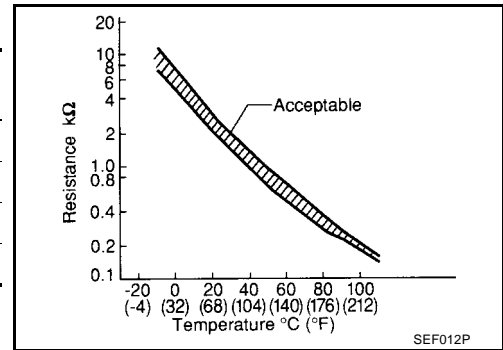

CAUTION:

Do not use ECM ground terminals when measuring input/output voltage. Doing so may result in damage to the ECM's transistor. Use a ground other than ECM terminals, such as the ground.

On Board Diagnosis Logic

UBS00121

These self-diagnoses have the one trip detection logic.

DTC No.	Trouble Diagnosis Name	DTC Detecting Condition	Possible Cause
P0117 0117	Engine coolant temperature sensor circuit low input	An excessively low voltage from the sensor is sent to ECM.	<ul style="list-style-type: none"> ● Harness or connectors (The sensor circuit is open or shorted.) ● Engine coolant temperature sensor
P0118 0118	Engine coolant temperature sensor circuit high input	An excessively high voltage from the sensor is sent to ECM.	

FAIL-SAFE MODE

When the malfunction is detected, the ECM enters fail-safe mode and the MIL lights up.

Detected items	Engine operating condition in fail-safe mode	
Engine coolant temperature sensor circuit	Engine coolant temperature will be determined by ECM based on the time after turning ignition switch ON or START. CONSULT-II displays the engine coolant temperature decided by ECM.	
	Condition	Engine coolant temperature decided (CONSULT-II display)
	Just as ignition switch is turned ON or START	40°C (104°F)
	More than approx. 4 minutes after ignition ON or START	80°C (176°F)
	Except as shown above	40 - 80°C (104 - 176°F) (Depends on the time)
When the fail-safe system for engine coolant temperature sensor is activated, the cooling fan operates while engine is running.		

DTC Confirmation Procedure

NOTE:

If DTC Confirmation Procedure has been previously conducted, always turn ignition switch OFF and wait at least 10 seconds before conducting the next test.

WITH CONSULT-II

1. Turn ignition switch ON.
2. Select "DATA MONITOR" mode with CONSULT-II.
3. Wait at least 5 seconds.
4. If DTC is detected, go to [EC-829, "Diagnostic Procedure"](#) .

DATA MONITOR	
MONITOR	NO DTC
ENG SPEED	XXX rpm
<small>SEF058Y</small>	

WITH GST

Follow the procedure "WITH CONSULT-II" above.

A
EC
C
D
E
F
G
H
I
J
K
L
M

DTC P0117, P0118 ECT SENSOR

[VQ]

Wiring Diagram

UBS00123

EC-ECTS-01

: DETECTABLE LINE FOR DTC
 : NON-DETECTABLE LINE FOR DTC

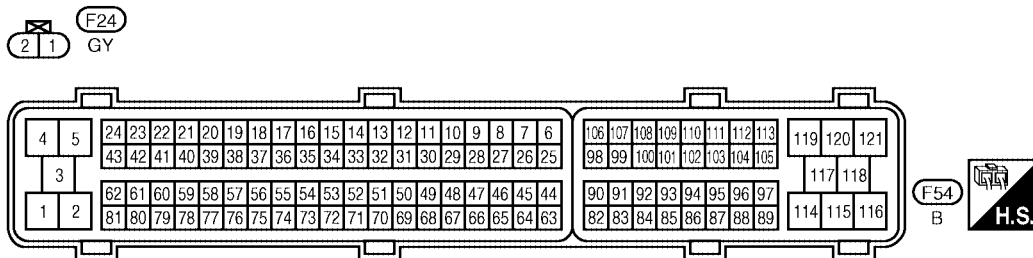
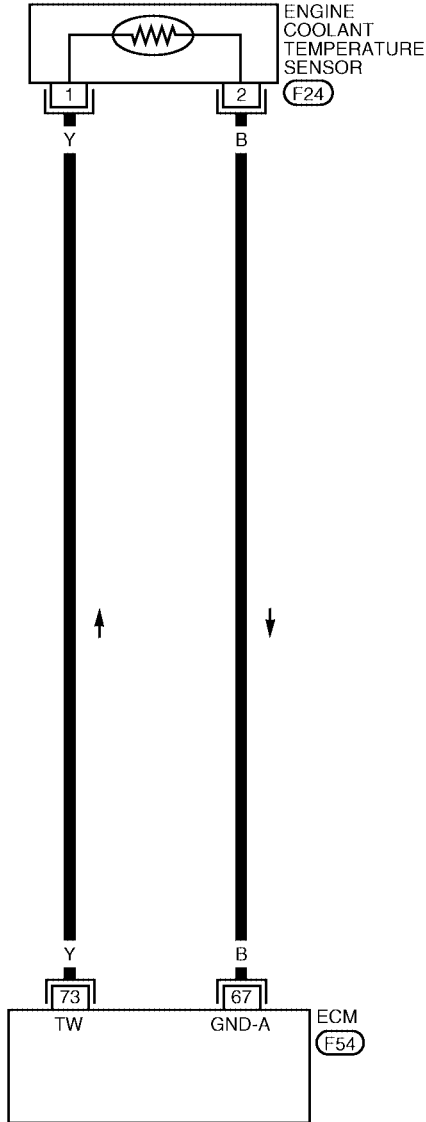

BBWA1273E

Diagnostic Procedure

1. CHECK GROUND CONNECTIONS

1. Turn ignition switch OFF.
2. Loosen and retighten three ground screws on the body.
Refer to [EC-789, "Ground Inspection"](#).

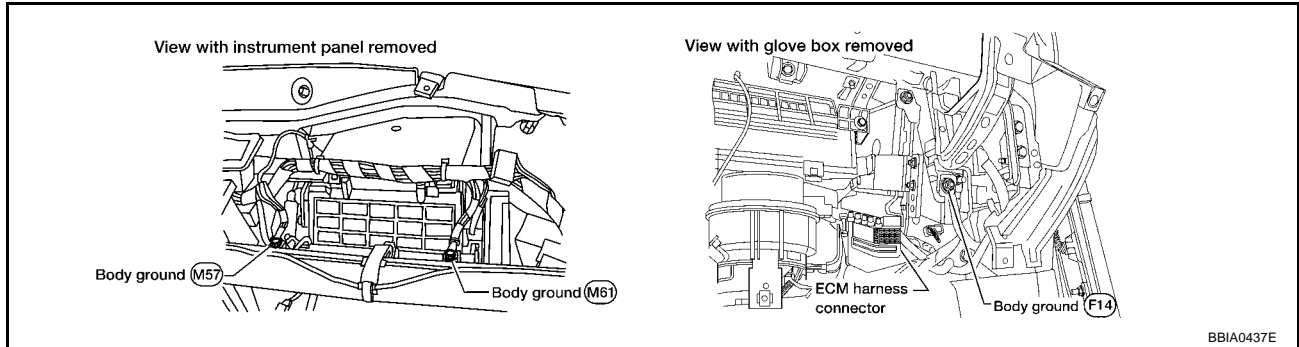

OK or NG

- OK >> GO TO 2.
- NG >> Repair or replace ground connections.

2. CHECK ECT SENSOR POWER SUPPLY CIRCUIT

1. Disconnect engine coolant temperature (ECT) sensor harness connector.
2. Turn ignition switch ON.

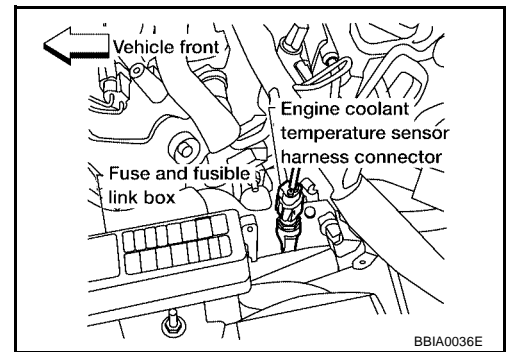

3. Check voltage between ECT sensor terminal 1 and ground with CONSULT-II or tester.

Voltage: Approximately 5V

OK or NG

- OK >> GO TO 3.
- NG >> Repair open circuit or short to ground or short to power in harness or connectors.

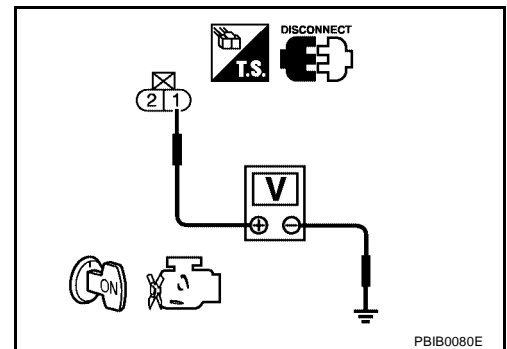

3. CHECK ECT SENSOR GROUND CIRCUIT FOR OPEN AND SHORT

1. Turn ignition switch OFF.
2. Disconnect ECM harness connector.
3. Check harness continuity between ECT sensor terminal 2 and ECM terminal 67.
Refer to Wiring Diagram.

Continuity should exist.

4. Also check harness for short to ground and short to power.

OK or NG

- OK >> GO TO 4.
- NG >> Repair open circuit or short to ground or short to power in harness or connectors.

4. CHECK ENGINE COOLANT TEMPERATURE SENSOR

Refer to [EC-830, "Component Inspection"](#) .

OK or NG

- OK >> GO TO 5.
- NG >> Replace engine coolant temperature sensor.

5. CHECK INTERMITTENT INCIDENT

Refer to [EC-782, "TROUBLE DIAGNOSIS FOR INTERMITTENT INCIDENT"](#) .

>> INSPECTION END

Component Inspection ENGINE COOLANT TEMPERATURE SENSOR

UBS00I25

1. Check resistance between engine coolant temperature sensor terminals 1 and 2 as shown in the figure.

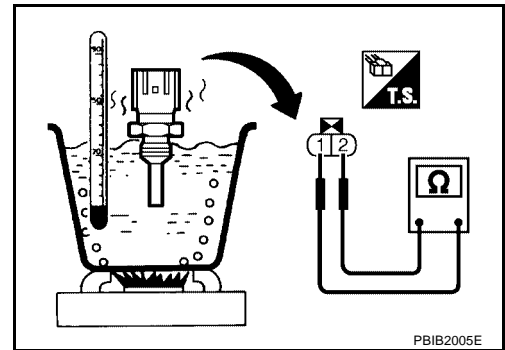

<Reference data>

Engine coolant temperature °C (°F)	Resistance kΩ
20 (68)	2.1 - 2.9
50 (122)	0.68 - 1.00
90 (194)	0.236 - 0.260

2. If NG, replace engine coolant temperature sensor.

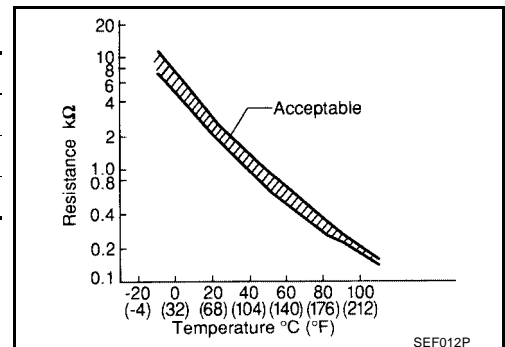

SEF012P

Removal and Installation ENGINE COOLANT TEMPERATURE SENSOR

UBS00I26

Refer to [CO-44, "WATER OUTLET AND WATER PIPING"](#) .

DTC P0122, P0123 TP SENSOR

PF:16119

Component Description

UBS00127

Electric throttle control actuator consists of throttle control motor, throttle position sensor, etc. The throttle position sensor responds to the throttle valve movement.

The throttle position sensor has the two sensors. These sensors are a kind of potentiometers which transform the throttle valve position into output voltage, and emit the voltage signal to the ECM. In addition, these sensors detect the opening and closing speed of the throttle valve and feed the voltage signals to the ECM. The ECM judges the current opening angle of the throttle valve from these signals and the ECM controls the throttle control motor to make the throttle valve opening angle properly in response to driving condition.

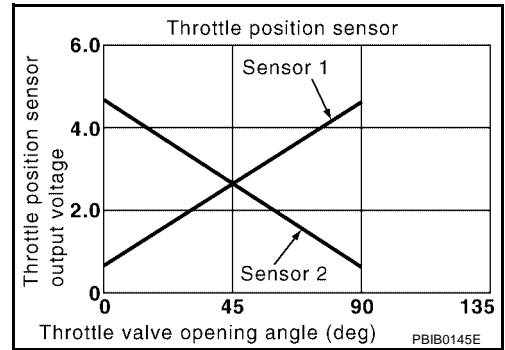

CONSULT-II Reference Value in Data Monitor Mode

UBS00128

Specification data are reference values.

MONITOR ITEM	CONDITION		SPECIFICATION
THRTL SEN1 THRTL SEN2*	● Ignition switch: ON (Engine stopped)	Accelerator pedal: Fully released	More than 0.36V
	● Shift lever: D (A/T), 1st (M/T)	Accelerator pedal: Fully depressed	Less than 4.75V

*: Throttle position sensor 2 signal is converted by ECM internally. Thus, it differs from ECM terminal voltage signal.

On Board Diagnosis Logic

UBS00129

These self-diagnoses have the one trip detection logic.

DTC No.	Trouble diagnosis name	DTC detecting condition	Possible cause
P0122 0122	Throttle position sensor 2 circuit low input	An excessively low voltage from the TP sensor 2 is sent to ECM.	<ul style="list-style-type: none"> ● Harness or connectors (The TP sensor 2 circuit is open or shorted.) (APP sensor 2 circuit is shorted) ● Electric throttle control actuator (TP sensor 2) ● Accelerator pedal position sensor (APP sensor 2)
P0123 0123	Throttle position sensor 2 circuit high input	An excessively high voltage from the TP sensor 2 is sent to ECM.	

FAIL-SAFE MODE

When the malfunction is detected, ECM enters fail-safe mode and the MIL lights up.

Engine operation condition in fail-safe mode

The ECM controls the electric throttle control actuator in regulating the throttle opening in order for the idle position to be within +10 degrees.

The ECM regulates the opening speed of the throttle valve to be slower than the normal condition.

So, the acceleration will be poor.

DTC Confirmation Procedure

NOTE:

If DTC Confirmation Procedure has been previously conducted, always turn ignition switch OFF and wait at least 10 seconds before conducting the next test.

TESTING CONDITION:

Before performing the following procedure, confirm that battery voltage is more than 10V at idle.

WITH CONSULT-II

1. Turn ignition switch ON.
2. Select "DATA MONITOR" mode with CONSULT-II.
3. Start engine and let it idle for 1 second.
4. If DTC is detected, go to [EC-834, "Diagnostic Procedure"](#) .

DATA MONITOR	
MONITOR	NO DTC
ENG SPEED	XXX rpm

SEF058Y

WITH GST

Follow the procedure "WITH CONSULT-II" above.

DTC P0122, P0123 TP SENSOR

[VQ]

Wiring Diagram

UBS0012B

EC-TPS2-01

: DETECTABLE LINE FOR DTC
 : NON-DETECTABLE LINE FOR DTC

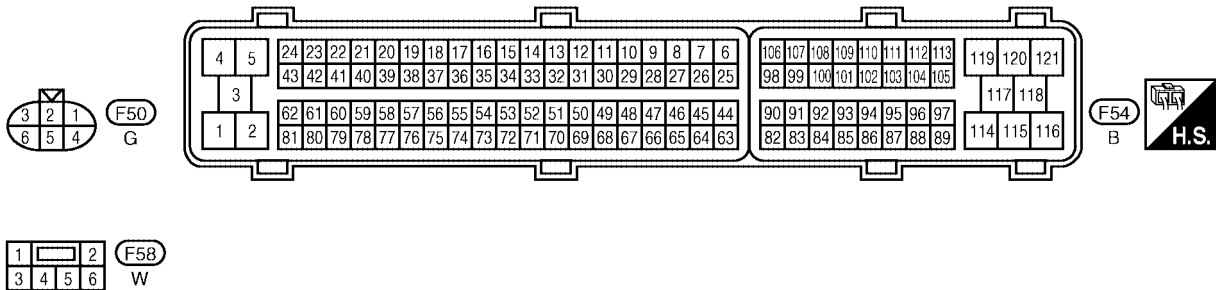
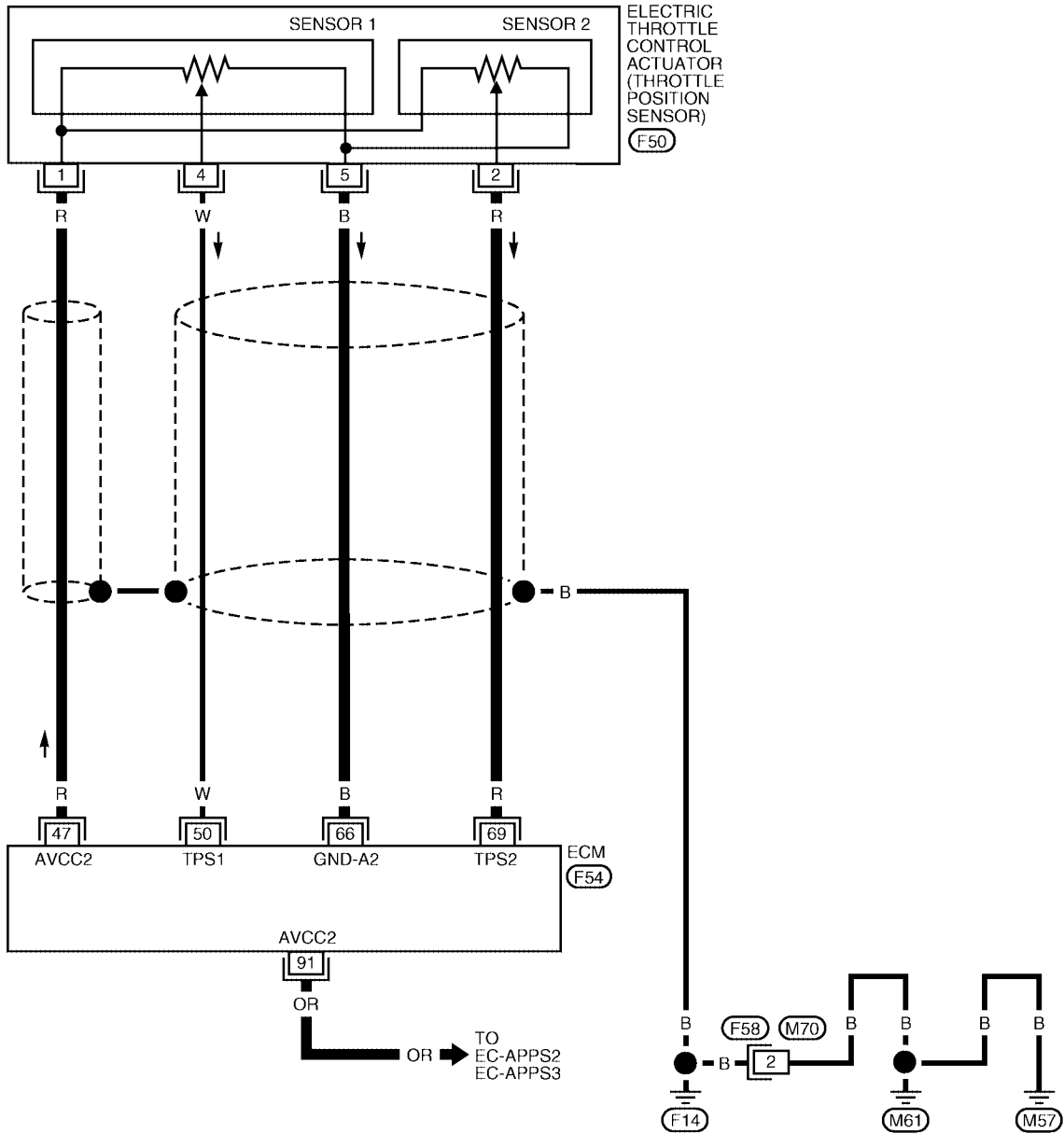

BBWA1555E

DTC P0122, P0123 TP SENSOR

[VQ]

Specification data are reference values and are measured between each terminal and ground.

CAUTION:

Do not use ECM ground terminals when measuring input/output voltage. Doing so may result in damage to the ECM's transistor. Use a ground other than ECM terminals, such as the ground.

TER-MINAL NO.	WIRE COLOR	ITEM	CONDITION	DATA (DC Voltage)
47	R	Sensor power supply (Throttle position sensor)	[Ignition switch: ON]	Approximately 5V
50	W	Throttle position sensor 1	[Ignition switch: ON] <ul style="list-style-type: none"> ● Engine stopped ● Shift lever: D (A/T) or 1st (M/T) ● Accelerator pedal: Fully released 	More than 0.36V
			[Ignition switch: ON] <ul style="list-style-type: none"> ● Engine stopped ● Shift lever: D (A/T) or 1st (M/T) ● Accelerator pedal: Fully depressed 	Less than 4.75V
66	B	Sensor ground (Throttle position sensor)	[Engine is running] <ul style="list-style-type: none"> ● Warm-up condition ● Idle speed 	Approximately 0V
69	R	Throttle position sensor 2	[Ignition switch: ON] <ul style="list-style-type: none"> ● Engine stopped ● Shift lever: D (A/T) or 1st (M/T) ● Accelerator pedal: Fully released 	Less than 4.75V
			[Ignition switch: ON] <ul style="list-style-type: none"> ● Engine stopped ● Shift lever: D (A/T) or 1st (M/T) ● Accelerator pedal: Fully depressed 	More than 0.36V
91	OR	Sensor power supply (APP sensor 2)	[Ignition switch: ON]	Approximately 5V

Diagnostic Procedure

UBS0012C

1. CHECK GROUND CONNECTIONS

1. Turn ignition switch OFF.
2. Loosen and retighten three ground screws on the body.
Refer to [EC-789, "Ground Inspection"](#).

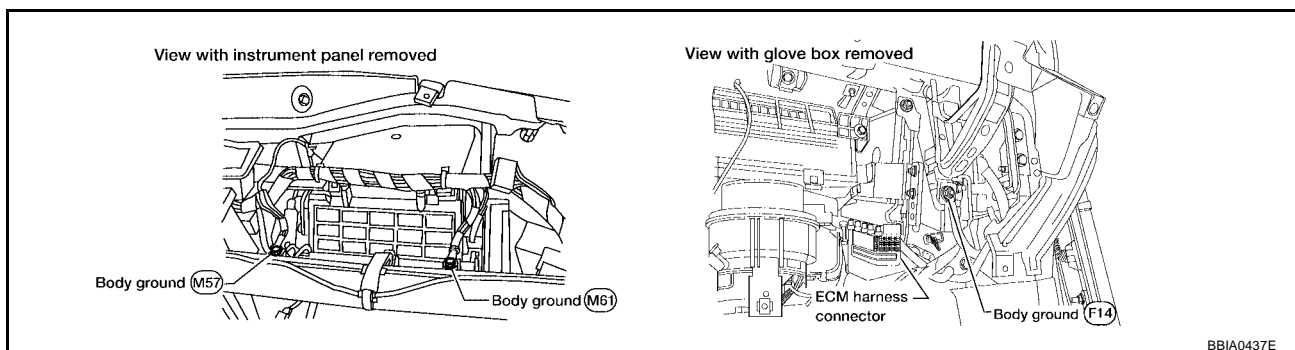

BBI40437E

OK or NG

- OK >> GO TO 2.
 NG >> Repair or replace ground connections.

2. CHECK THROTTLE POSITION SENSOR 2 POWER SUPPLY CIRCUIT-I

1. Disconnect electric throttle control actuator harness connector.
2. Turn ignition switch ON.

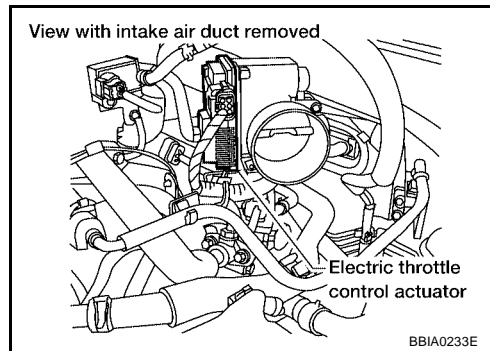

3. Check voltage between electric throttle control actuator terminal 1 and ground with CONSULT-II or tester.

Voltage: Approximately 5V

OK or NG

- OK >> GO TO 7.
- NG >> GO TO 3.

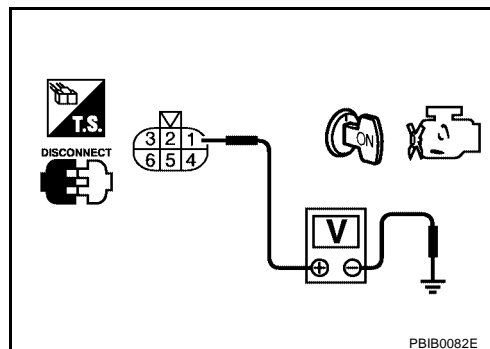

3. CHECK THROTTLE POSITION SENSOR 2 POWER SUPPLY CIRCUIT-II

1. Turn ignition switch OFF.
2. Disconnect ECM harness connector.
3. Check harness continuity between electric throttle control actuator terminal 1 and ECM terminal 47. Refer to Wiring Diagram.

Continuity should exist.

OK or NG

- OK >> GO TO 4.
- NG >> Repair or replace open circuit.

4. CHECK THROTTLE POSITION SENSOR 2 POWER SUPPLY CIRCUIT-III

Check harness for short to power and short to ground, between the following terminals.

ECM terminal	Sensor terminal	Reference Wiring Diagram
47	Electric throttle control actuator terminal 1	EC-833
91	APP sensor terminal 1	EC-1267

OK or NG

- OK >> GO TO 5.
- NG >> Repair short to ground or short to power in harness or connectors.

5. CHECK APP SENSOR

Refer to [EC-1271, "Component Inspection"](#) .

OK or NG

- OK >> GO TO 11.
- NG >> GO TO 6.

6. REPLACE ACCELERATOR PEDAL ASSEMBLY

1. Replace accelerator pedal assembly.
2. Perform [EC-711, "Accelerator Pedal Released Position Learning"](#) .
3. Perform [EC-711, "Throttle Valve Closed Position Learning"](#) .
4. Perform [EC-712, "Idle Air Volume Learning"](#) .

>> INSPECTION END

7. CHECK THROTTLE POSITION SENSOR 2 GROUND CIRCUIT FOR OPEN AND SHORT

1. Turn ignition switch OFF.
2. Disconnect ECM harness connector.
3. Check harness continuity between electric throttle control actuator terminal 5 and ECM terminal 66. Refer to Wiring Diagram.

Continuity should exist.

4. Also check harness for short to ground and short to power.

OK or NG

OK >> GO TO 8.

NG >> Repair open circuit or short to ground or short to power in harness or connectors.

8. CHECK THROTTLE POSITION SENSOR 2 INPUT SIGNAL CIRCUIT FOR OPEN AND SHORT

1. Check harness continuity between ECM terminal 69 and electric throttle control actuator terminal 2. Refer to Wiring Diagram.

Continuity should exist.

2. Also check harness for short to ground and short to power.

OK or NG

OK >> GO TO 9.

NG >> Repair open circuit or short to ground or short to power in harness or connectors.

9. CHECK THROTTLE POSITION SENSOR

Refer to [EC-837, "Component Inspection"](#) .

OK or NG

OK >> GO TO 11.

NG >> GO TO 10.

10. REPLACE ELECTRIC THROTTLE CONTROL ACTUATOR

1. Replace the electric throttle control actuator.
2. Perform [EC-711, "Throttle Valve Closed Position Learning"](#) .
3. Perform [EC-712, "Idle Air Volume Learning"](#) .

>> INSPECTION END

11. CHECK INTERMITTENT INCIDENT

Refer to [EC-782, "TROUBLE DIAGNOSIS FOR INTERMITTENT INCIDENT"](#) .

>> INSPECTION END

Component Inspection
THROTTLE POSITION SENSOR

1. Reconnect all harness connectors disconnected.
2. Perform [EC-711, "Throttle Valve Closed Position Learning"](#) .
3. Turn ignition switch ON.
4. Set Shift lever to D (A/T) or 1st (M/T) position.
5. Check voltage between ECM terminals 50 (TP sensor 1 signal), 69 (TP sensor 2 signal) and ground under the following conditions.

Terminal	Accelerator pedal	Voltage
50 (Throttle position sensor 1)	Fully released	More than 0.36V
	Fully depressed	Less than 4.75V
69 (Throttle position sensor 2)	Fully released	Less than 4.75V
	Fully depressed	More than 0.36V

6. If NG, replace electric throttle control actuator and go to the next step.
7. Perform [EC-711, "Throttle Valve Closed Position Learning"](#) .
8. Perform [EC-712, "Idle Air Volume Learning"](#) .

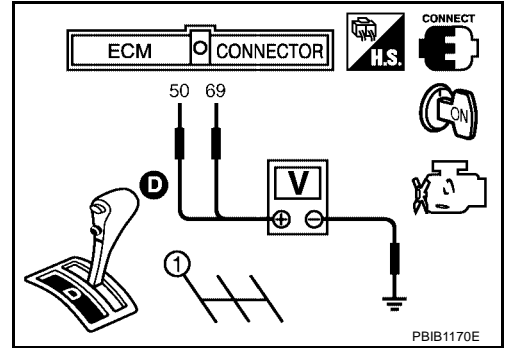

Removal and Installation
ELECTRIC THROTTLE CONTROL ACTUATOR

Refer to [EM-122, "INTAKE MANIFOLD COLLECTOR"](#) .

A
EC
C
D
E
F
G
H
I
J
K
L
M

DTC P0125 ECT SENSOR

Component Description

NOTE:

If DTC P0125 is displayed with P0117 or P0118, first perform the trouble diagnosis for DTC P0117 or P0118. Refer to [EC-826. "DTC P0117, P0118 ECT SENSOR"](#).

The engine coolant temperature sensor is used to detect the engine coolant temperature. The sensor modifies a voltage signal from the ECM. The modified signal returns to the ECM as the engine coolant temperature input. The sensor uses a thermistor which is sensitive to the change in temperature. The electrical resistance of the thermistor decreases as temperature increases.

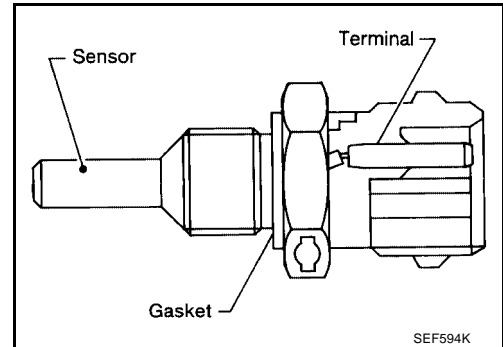

<Reference data>

Engine coolant temperature °C (°F)	Voltage* V	Resistance kΩ
-10 (14)	4.4	7.0 - 11.4
20 (68)	3.5	2.1 - 2.9
50 (122)	2.2	0.68 - 1.00
90 (194)	0.9	0.236 - 0.260

*: This data is reference value and is measured between ECM terminal 73 (Engine coolant temperature sensor) and ground.

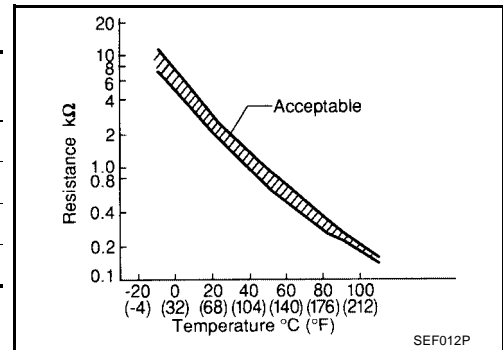

CAUTION:

Do not use ECM ground terminals when measuring input/output voltage. Doing so may result in damage to the ECM's transistor. Use a ground other than ECM terminals, such as the ground.

On Board Diagnosis Logic

This self-diagnosis has the one trip detection logic.

DTC No.	Trouble diagnosis name	DTC detecting condition	Possible cause
P0125 0125	Insufficient engine coolant temperature for closed loop fuel control	<ul style="list-style-type: none"> ● Voltage sent to ECM from the sensor is not practical, even when some time has passed after starting the engine. ● Engine coolant temperature is insufficient for closed loop fuel control. 	<ul style="list-style-type: none"> ● Harness or connectors (High resistance in the circuit) ● Engine coolant temperature sensor ● Thermostat

DTC Confirmation Procedure

CAUTION:

Be careful not to overheat engine.

NOTE:

If DTC Confirmation Procedure has been previously conducted, always turn ignition switch OFF and wait at least 10 seconds before conducting the next test.

WITH CONSULT-II

1. Turn ignition switch ON.
2. Select "DATA MONITOR" mode with CONSULT-II.
3. Check that "COOLAN TEMP/S" is above 10°C (50°F).
If it is above 10°C (50°F), the test result will be OK.
If it is below 10°C (50°F), go to following step.
4. Start engine and run it for 65 minutes at idle speed.
If "COOLAN TEMP/S" increases to more than 10°C (50°F) within 65 minutes, stop engine because the test result will be OK.
5. If 1st trip DTC is detected, go to [EC-839, "Diagnostic Procedure"](#)

DATA MONITOR	
MONITOR	NO DTC
ENG SPEED	XXX rpm
COOLAN TEMP/S	XXX °C

SEF174Y

WITH GST

Follow the procedure "WITH CONSULT-II" above.

Diagnostic Procedure

1. CHECK GROUND CONNECTIONS

1. Turn ignition switch OFF.
2. Loosen and retighten three ground screws on the body.
Refer to [EC-789, "Ground Inspection"](#) .

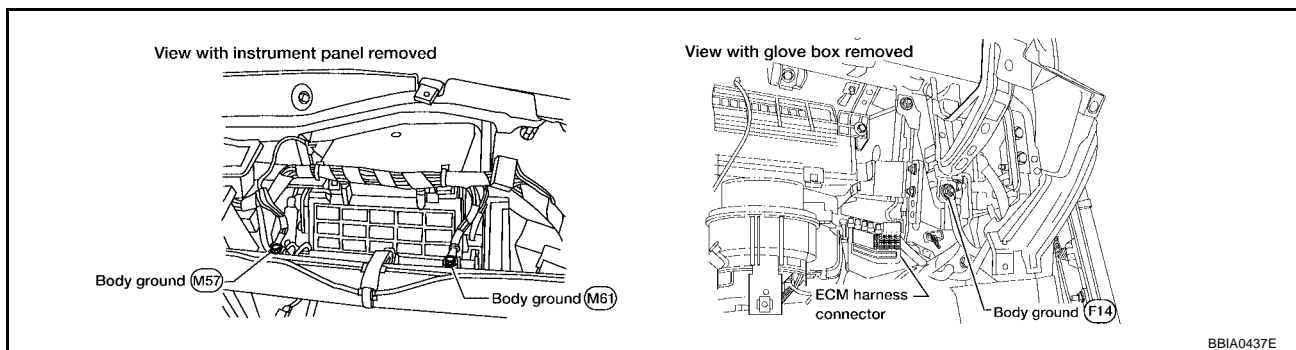

OK or NG

- OK >> GO TO 2.
- NG >> Repair or replace ground connections.

2. CHECK ENGINE COOLANT TEMPERATURE SENSOR

Refer to [EC-840, "Component Inspection"](#) .

OK or NG

- OK >> GO TO 3.
- NG >> Replace engine coolant temperature sensor.

3. CHECK THERMOSTAT OPERATION

When the engine is cold [lower than 70°C (158°F)] condition, grasp lower radiator hose and confirm the engine coolant does not flow.

OK or NG

OK >> GO TO 4.

NG >> Repair or replace thermostat. Refer to [CO-42, "THERMOSTAT AND THERMOSTAT HOUSING"](#) .

4. CHECK INTERMITTENT INCIDENT

Refer to [EC-782, "TROUBLE DIAGNOSIS FOR INTERMITTENT INCIDENT"](#) .

For circuit, refer to [EC-828, "Wiring Diagram"](#) .

>> INSPECTION END

Component Inspection ENGINE COOLANT TEMPERATURE SENSOR

UBS0012J

1. Check resistance between engine coolant temperature sensor terminals 1 and 2 as shown in the figure.

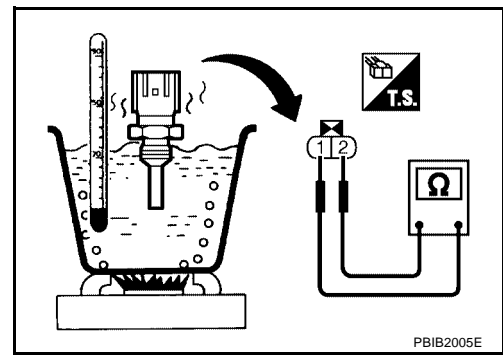

PBIB2005E

<Reference data>

Engine coolant temperature °C (°F)	Resistance kΩ
20 (68)	2.1 - 2.9
50 (122)	0.68 - 1.00
90 (194)	0.236 - 0.260

2. If NG, replace engine coolant temperature sensor.

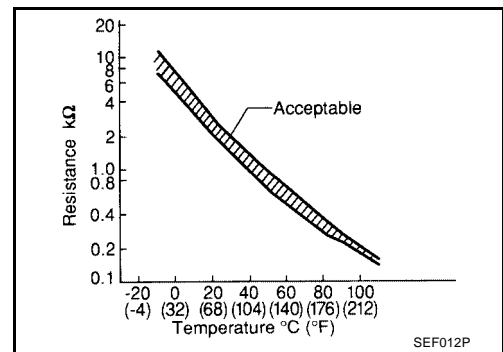

SEF012P

Removal and Installation ENGINE COOLANT TEMPERATURE SENSOR

UBS0012K

Refer to [CO-44, "WATER OUTLET AND WATER PIPING"](#) .

DTC P0127 IAT SENSOR

Component Description

The intake air temperature sensor is built into mass air flow sensor. The sensor detects intake air temperature and transmits a signal to the ECM.

The temperature sensing unit uses a thermistor which is sensitive to the change in temperature. Electrical resistance of the thermistor decreases in response to the temperature rise.

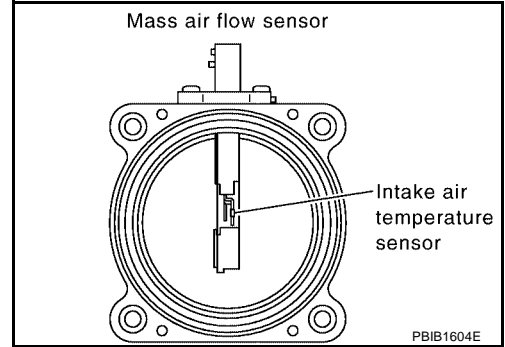

<Reference data>

Intake air temperature °C (°F)	Voltage* V	Resistance kΩ
25 (77)	3.32	1.94 - 2.06
80 (176)	1.23	0.295 - 0.349

*: This data is reference value and is measured between ECM terminal 34 (Intake air temperature sensor) and ground.

CAUTION:

Do not use ECM ground terminals when measuring input/output voltage. Doing so may result in damage to the ECM's transistor. Use a ground other than ECM terminals, such as the ground.

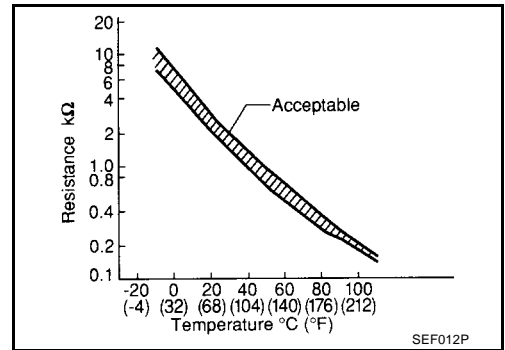

On Board Diagnosis Logic

DTC No.	Trouble diagnosis name	DTC detecting condition	Possible cause
P0127 0127	Intake air temperature too high	Rationally incorrect voltage from the sensor is sent to ECM, compared with the voltage signal from engine coolant temperature sensor.	<ul style="list-style-type: none"> ● Harness or connectors (The sensor circuit is open or shorted) ● Intake air temperature sensor

DTC Confirmation Procedure

NOTE:

If DTC Confirmation Procedure has been previously conducted, always turn ignition switch OFF and wait at least 10 seconds before conducting the next test.

CAUTION:

Always drive vehicle at a safe speed.

TESTING CONDITION:

This test may be conducted with the drive wheels lifted in the shop or by driving the vehicle. If a road test is expected to be easier, it is unnecessary to lift the vehicle.

WITH CONSULT-II

1. Wait until engine coolant temperature is less than 90°C (194°F)
 - a. Turn ignition switch ON.

DTC P0127 IAT SENSOR

[VQ]

- b. Select "DATA MONITOR" mode with CONSULT-II.
- c. Check the engine coolant temperature.
- d. If the engine coolant temperature is not less than 90°C (194°F), turn ignition switch OFF and cool down engine.
 - Perform the following steps before engine coolant temperature is above 90°C (194°F).
2. Turn ignition switch ON.
3. Select "DATA MONITOR" mode with CONSULT-II.
4. Start engine.
5. Hold vehicle speed at more than 70 km/h (43 MPH) for 100 consecutive seconds.
6. If 1st trip DTC is detected, go to [EC-842, "Diagnostic Procedure"](#).

DATA MONITOR	
MONITOR	NO DTC
ENG SPEED	XXX rpm
COOLAN TEMP/S	XXX °C
VHCL SPEED SE	XXX km/h
B/FUEL SCHDL	XXX msec

SEF189Y

WITH GST

Follow the procedure "WITH CONSULT-II" above.

Diagnostic Procedure

UBS00/20

1. CHECK GROUND CONNECTIONS

1. Turn ignition switch OFF.
2. Loosen and retighten three ground screws on the body. Refer to [EC-789, "Ground Inspection"](#).

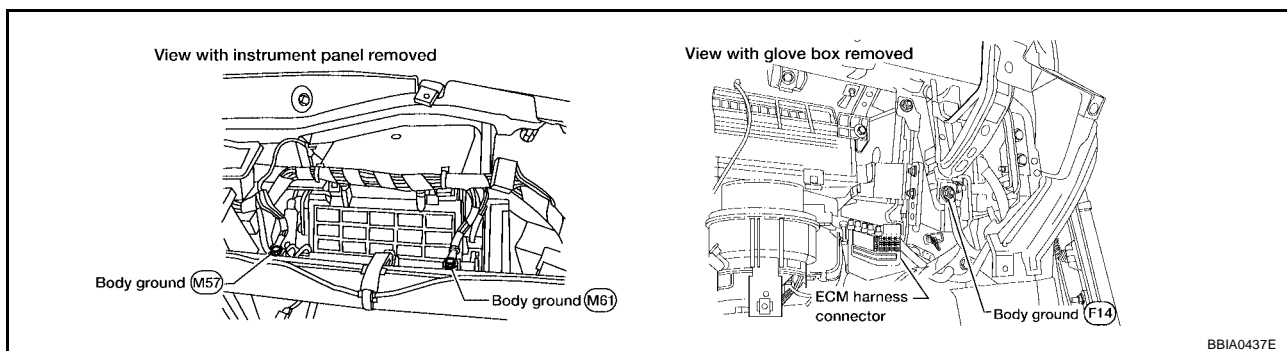

OK or NG

- OK >> GO TO 2.
- NG >> Repair or replace ground connections.

2. CHECK INTAKE AIR TEMPERATURE SENSOR

Refer to [EC-843, "Component Inspection"](#).

OK or NG

- OK >> GO TO 3.
- NG >> Replace mass air flow sensor (with intake air temperature sensor).

3. CHECK INTERMITTENT INCIDENT

Refer to [EC-782, "TROUBLE DIAGNOSIS FOR INTERMITTENT INCIDENT"](#).

Refer to [EC-823, "Wiring Diagram"](#).

>> INSPECTION END

Component Inspection
INTAKE AIR TEMPERATURE SENSOR

1. Check resistance between intake air temperature sensor terminals 5 and 6 under the following conditions.

Intake air temperature °C (°F)	Resistance kΩ
25 (77)	1.94 - 2.06

2. If NG, replace mass air flow sensor (with intake air temperature sensor).

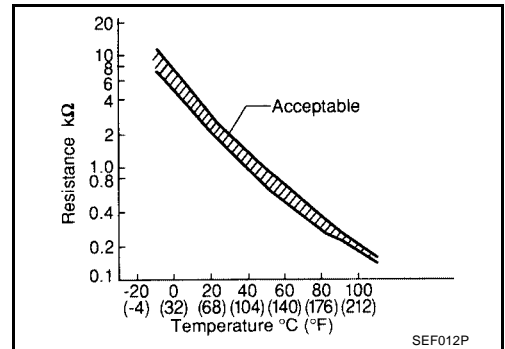
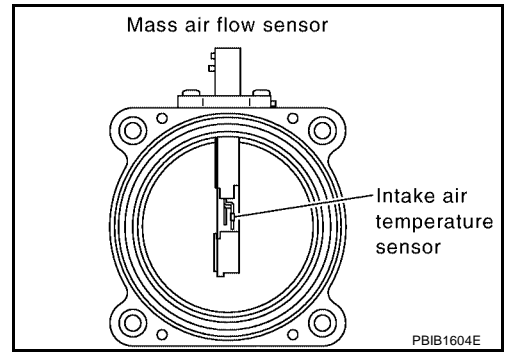

Removal and Installation
MASS AIR FLOW SENSOR

Refer to [EM-120, "AIR CLEANER AND AIR DUCT"](#) .

A
 EC
 C
 D
 E
 F
 G
 H
 I
 J
 K
 L
 M

DTC P0128 THERMOSTAT FUNCTION

[VQ]

DTC P0128 THERMOSTAT FUNCTION

PFV:21200

On Board Diagnosis Logic

UBS0012R

Engine coolant temperature has not risen enough to open the thermostat even though the engine has run long enough.

This is due to a leak in the seal or the thermostat stuck open.

DTC No.	Trouble diagnosis name	DTC detecting condition	Possible cause
P0128 0128	Thermostat function	The engine coolant temperature does not reach to specified temperature even though the engine has run long enough.	<ul style="list-style-type: none">● Thermostat● Leakage from sealing portion of thermostat● Engine coolant temperature sensor

DTC Confirmation Procedure

UBS0012S

NOTE:

If DTC Confirmation Procedure has been previously conducted, always turn ignition switch OFF and wait at least 10 seconds before conducting the next test.

TESTING CONDITION:

- For best results, perform at ambient temperature of -10°C (14°F) or higher.
- For best results, perform at engine coolant temperature of -10°C (14°F) to 60°C (140°F).

WITH CONSULT-II

1. Replace thermostat with new one. Refer to [CO-42, "THERMOSTAT AND THERMOSTAT HOUSING"](#). Use only a genuine NISSAN thermostat as a replacement. If an incorrect thermostat is used, the MIL may come on.
2. Turn ignition switch ON.
3. Select "COOLAN TEMP/S" in "DATA MONITOR" mode with CONSULT-II.
4. Check that the "COOLAN TEMP/S" is above 60°C (140°F).
If it is below 60°C (140°F), go to following step.
If it is above 60°C (140°F), cool down the engine to less than 60°C (140°F), then retry from step 1.
5. Drive vehicle for 10 consecutive minutes under the following conditions.

VHCL SPEED SE	80 - 120 km/h (50 - 75 MPH)
---------------	-----------------------------

If 1st trip DTC is detected, go to [EC-844, "Diagnostic Procedure"](#).

DATA MONITOR	
MONITOR	NO DTC
COOLAN TEMP/S	XXX °C
VHCL SPEED SE	XXX km/h

SEF176Y

WITH GST

1. Follow the procedure "WITH CONSULT-II" above.

Diagnostic Procedure

UBS0012T

1. CHECK ENGINE COOLANT TEMPERATURE SENSOR

Refer to [EC-845, "Component Inspection"](#).

OK or NG

- OK >> **INSPECTION END**
NG >> Replace engine coolant temperature sensor.

DTC P0128 THERMOSTAT FUNCTION

[VQ]

UBS0012U

Component Inspection ENGINE COOLANT TEMPERATURE SENSOR

Check resistance as shown in the figure.

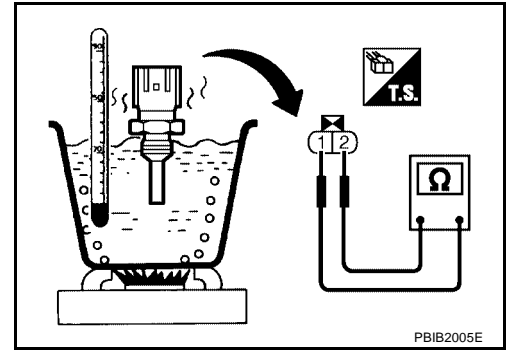

<Reference data>

Temperature °C (°F)	Resistance kΩ
20 (68)	2.1 - 2.9
50 (122)	0.68 - 1.0
90 (194)	0.236 - 0.260

If NG, replace engine coolant temperature sensor.

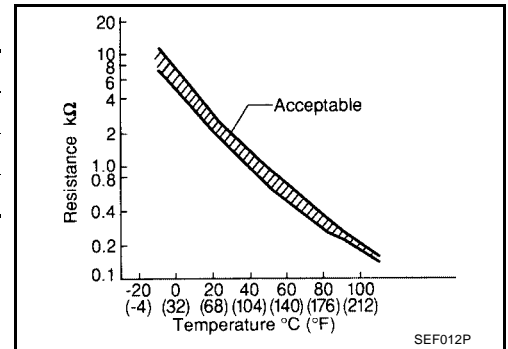

Removal and Installation ENGINE COOLANT TEMPERATURE SENSOR

Refer to [CO-44, "WATER OUTLET AND WATER PIPING"](#).

UBS0012V

DTC P0138, P0158 HO2S2

Component Description

UBS0012W

The heated oxygen sensor 2, after three way catalyst (manifold), monitors the oxygen level in the exhaust gas on each bank. Even if switching characteristics of the air fuel ratio (A/F) sensor 1 are shifted, the air-fuel ratio is controlled to stoichiometric, by the signal from the heated oxygen sensor 2. This sensor is made of ceramic zirconia. The zirconia generates voltage from approximately 1V in richer conditions to 0V in leaner conditions. Under normal conditions the heated oxygen sensor 2 is not used for engine control operation.

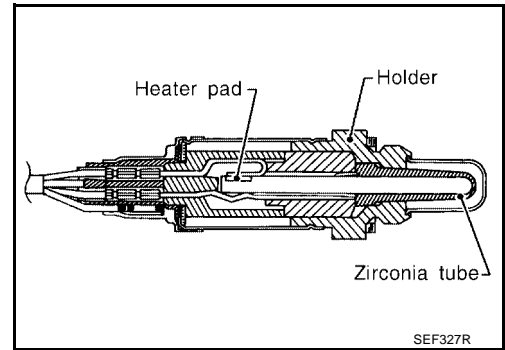

CONSULT-II Reference Value in Data Monitor Mode

UBS0012X

Specification data are reference values.

MONITOR ITEM	CONDITION		SPECIFICATION
HO2S2 (B1) HO2S2 (B2)	<ul style="list-style-type: none"> Warm-up condition After keeping engine speed between 3,500 and 4,000 rpm for 1 minute and at idle for 1 minute under no load. 	Revsing engine from idle to 3,000 rpm quickly.	0 - 0.3V ↔ Approx. 0.6 - 1.0V
HO2S2 MNTR (B1) HO2S2 MNTR (B2)			LEAN ↔ RICH

On Board Diagnosis Logic

UBS0012Y

The heated oxygen sensor 2 has a much longer switching time between rich and lean than the air fuel ratio (A/F) sensor 1. The oxygen storage capacity of the three way catalyst (manifold) causes the longer switching time. To judge the malfunctions of heated oxygen sensor 2, ECM monitors whether the voltage is unusually high during the various driving condition such as fuel-cut.

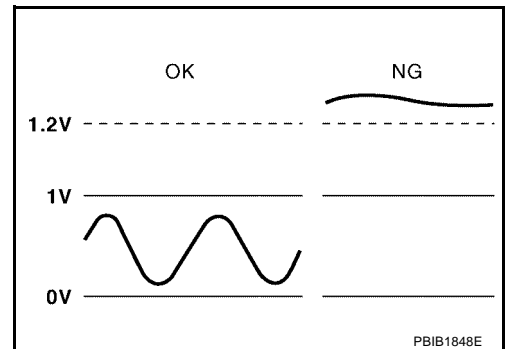

DTC No.	Trouble diagnosis name	DTC detecting condition	Possible cause
P0138 0138 (Bank 1)	Heated oxygen sensor 2 circuit high voltage	An excessively high voltage from the sensor is sent to ECM.	<ul style="list-style-type: none"> Harness or connectors (The sensor circuit is open or shorted) Heated oxygen sensor 2
P0158 0158 (Bank 2)			

DTC Confirmation Procedure

NOTE:

If DTC Confirmation Procedure has been previously conducted, always turn ignition switch OFF and wait at least 10 seconds before conducting the next test.

WITH CONSULT-II

1. Turn ignition switch ON and select "DATA MONITOR" mode with CONSULT-II.
2. Start engine and warm it up to the normal operating temperature.
3. Turn ignition switch OFF and wait at least 10 seconds.
4. Start engine and keep the engine speed between 3,500 and 4,000 rpm for at least 1 minute under no load.
5. Let engine idle for 2 minutes.
6. If 1st trip DTC is detected, go to [EC-851, "Diagnostic Procedure"](#)

DATA MONITOR	
MONITOR	NO DTC
ENG SPEED	XXX rpm
COOLAN TEMP/S	XXX °C

SEF174Y

WITH GST

Follow the procedure "WITH CONSULT-II" above.

A
EC
C
D
E
F
G
H
I
J
K
L
M

Wiring Diagram
BANK 1

EC-O2S2B1-01

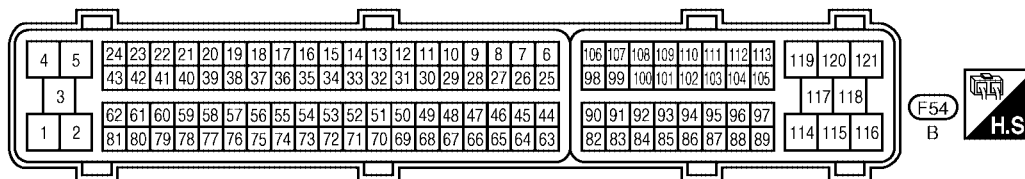
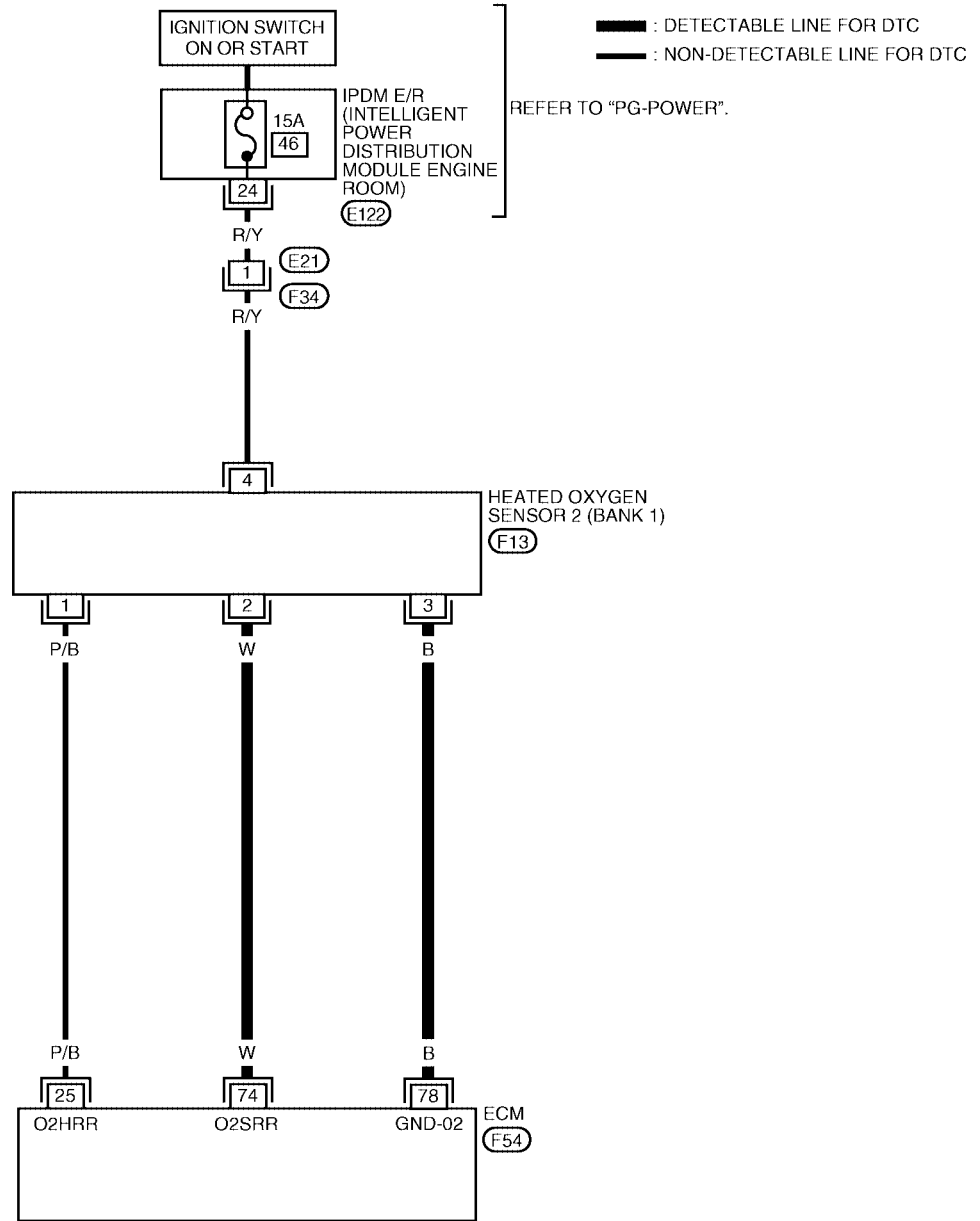

DTC P0138, P0158 HO2S2

[VQ]

Specification data are reference values and are measured between each terminal and ground.

CAUTION:

Do not use ECM ground terminals when measuring input/output voltage. Doing so may result in damage to the ECM's transistor. Use a ground other than ECM terminals, such as the ground.

TER-MINAL NO.	WIRE COLOR	ITEM	CONDITION	DATA (DC Voltage)
74	W	Heated oxygen sensor 2 (bank 1)	<p>[Engine is running]</p> <ul style="list-style-type: none"> ● Warm-up condition ● Revving engine from idle to 3,000 rpm quickly after the following conditions are met. – After keeping the engine speed between 3,500 and 4,000 rpm for 1 minute and at idle for 1 minute under no load. 	0 - Approximately 1.0V
78	B	Sensor ground (Heated oxygen sensor 2)	<p>[Engine is running]</p> <ul style="list-style-type: none"> ● Warm-up condition ● Idle speed 	Approximately 0V

A
EC
C
D
E
F
G
H
I
J
K
L
M

BANK 2

EC-O2S2B2-01

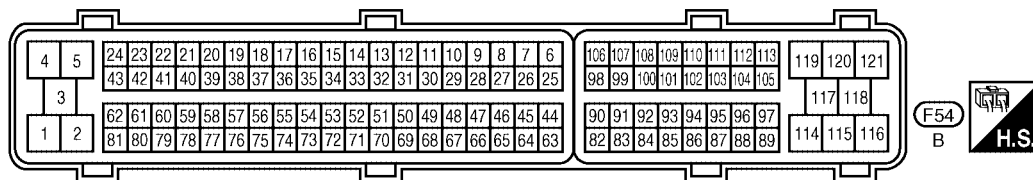
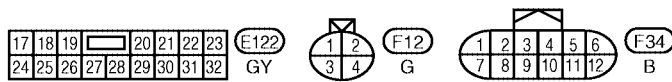
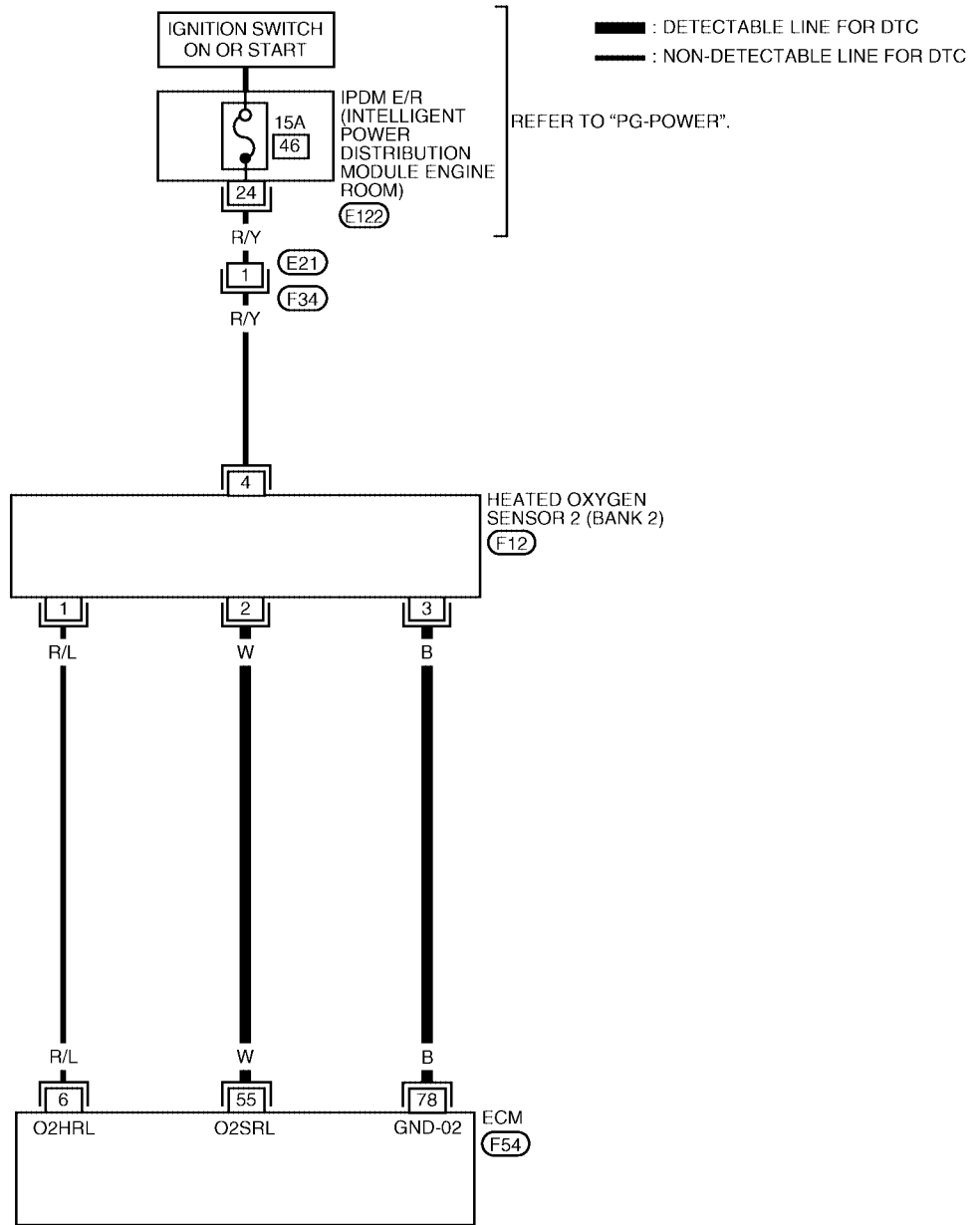

Specification data are reference values and are measured between each terminal and ground.

CAUTION:

Do not use ECM ground terminals when measuring input/output voltage. Doing so may result in damage to the ECM's transistor. Use a ground other than ECM terminals, such as the ground.

TER-MINAL NO.	WIRE COLOR	ITEM	CONDITION	DATA (DC Voltage)
55	W	Heated oxygen sensor 2 (bank 2)	<p>[Engine is running]</p> <ul style="list-style-type: none"> ● Warm-up condition ● Revving engine from idle to 3,000 rpm quickly after the following conditions are met. – After keeping the engine speed between 3,500 and 4,000 rpm for 1 minute and at idle for 1 minute under no load. 	0 - Approximately 1.0V
78	B	Sensor ground (Heated oxygen sensor 2)	<p>[Engine is running]</p> <ul style="list-style-type: none"> ● Warm-up condition ● Idle speed 	Approximately 0V

Diagnostic Procedure

UBS00131

1. CHECK GROUND CONNECTIONS

1. Turn ignition switch OFF.
2. Loosen and retighten three ground screws on the body.
Refer to [EC-789, "Ground Inspection"](#).

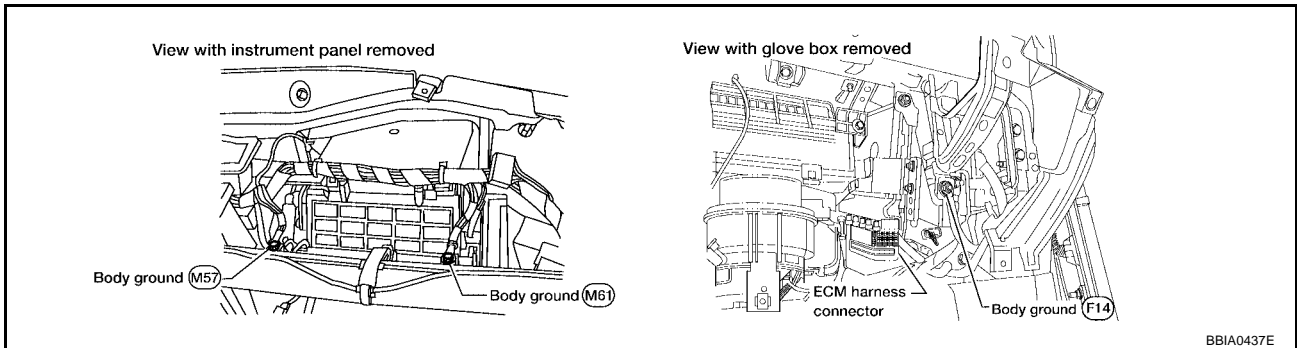

OK or NG

- OK >> GO TO 2.
- NG >> Repair or replace ground connections.

2. CHECK HO2S2 GROUND CIRCUIT FOR OPEN AND SHORT

1. Disconnect ECM harness connector.
2. Disconnect heated oxygen sensor 2 harness connector.

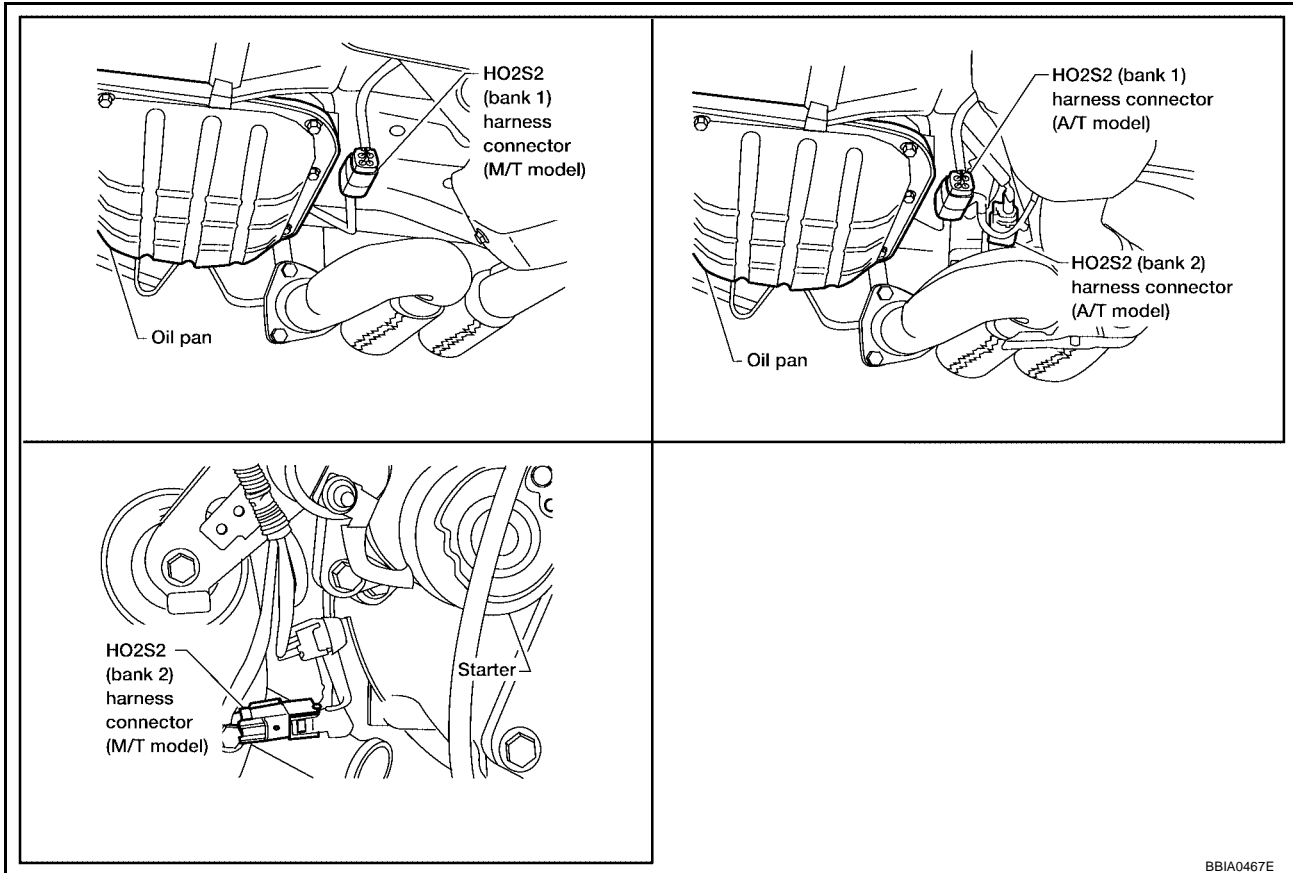

3. Check harness continuity between HO2S2 terminal 3 and ECM terminal 78.
Refer to Wiring Diagram.

Continuity should exist.

4. Also check harness for short to ground and short to power.

OK or NG

OK >> GO TO 3.

NG >> Repair open circuit or short to ground or short to power in harness or connectors.

3. CHECK HO2S2 INPUT SIGNAL CIRCUIT FOR OPEN AND SHORT

1. Check harness continuity between ECM terminal and HO2S2 terminal as follows. Refer to Wiring Diagram.

DTC	Terminals		Bank
	ECM	Sensor	
P0138	74	2	1
P0158	55	2	2

Continuity should exist.

2. Check harness continuity between the following terminals and ground. Refer to Wiring Diagram.

DTC	Terminals		Bank
	ECM	Sensor	
P0138	74	2	1
P0158	55	2	2

Continuity should not exist.

3. Also check harness for short to power.

OK or NG

OK >> GO TO 4.

NG >> Repair open circuit or short to ground or short to power in harness or connectors.

4. CHECK HO2S2 CONNECTOR FOR WATER

Check heated oxygen sensor 2 harness connectors for water.

Water should not exist.

OK or NG

OK >> GO TO 5.

NG >> Repair or replace harness or connectors.

5. CHECK HEATED OXYGEN SENSOR 2

Refer to [EC-854, "Component Inspection"](#) .

OK or NG

OK >> GO TO 6.

NG >> Replace malfunctioning heated oxygen sensor 2.

6. CHECK INTERMITTENT INCIDENT

Refer to [EC-782, "TROUBLE DIAGNOSIS FOR INTERMITTENT INCIDENT"](#) .

>> INSPECTION END

Component Inspection
HEATED OXYGEN SENSOR 2

With CONSULT-II

1. Turn ignition switch ON and select "DATA MONITOR" mode with CONSULT-II.
2. Start engine and warm it up to the normal operating temperature.
3. Turn ignition switch OFF and wait at least 10 seconds.
4. Start engine and keep the engine speed between 3,500 and 4,000 rpm for at least 1 minute under no load.
5. Let engine idle for 1 minute.

DATA MONITOR	
MONITOR	NO DTC
ENG SPEED	XXX rpm
COOLAN TEMP/S	XXX °C

SEF174Y

6. Select "FUEL INJECTION" in "ACTIVE TEST" mode, and select "HO2S2 (B1)/(B2)" as the monitor item with CONSULT-II.

ACTIVE TEST	
FUEL INJECTION	25 %
MONITOR	
ENG SPEED	XXX rpm
HO2S1 (B1)	XXX V
HO2S2 (B1)	XXX V
HO2S1 MNTR (B1)	RICH
HO2S2 MNTR (B1)	RICH

SEF662Y

7. Check "HO2S2 (B1)/(B2)" at idle speed when adjusting "FUEL INJECTION" to ±25%.

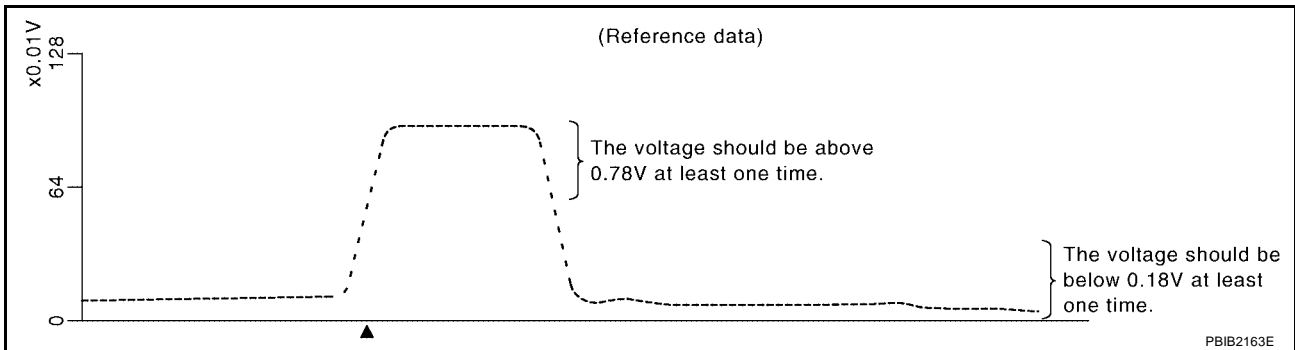

"HO2S2 (B1)/(B2)" should be above 0.78V at least once when the "FUEL INJECTION" is +25%.
 "HO2S2 (B1)/(B2)" should be below 0.18V at least once when the "FUEL INJECTION" is -25%.

CAUTION:

- Discard any heated oxygen sensor which has been dropped from a height of more than 0.5 m (19.7 in) onto a hard surface such as a concrete floor; use a new one.
- Before installing new oxygen sensor, clean exhaust system threads using Oxygen Sensor Thread Cleaner tool J-43897-18 or J-43897-12 and approved anti-seize lubricant.

Without CONSULT-II

1. Start engine and warm it up to the normal operating temperature.
2. Turn ignition switch OFF and wait at least 10 seconds.
3. Start engine and keep the engine speed between 3,500 and 4,000 rpm for at least 1 minute under no load.
4. Let engine idle for 1 minute.
5. Set voltmeter probes between ECM terminal 74 [HO2S2 (B1) signal] or 55 [HO2S2 (B2) signal] and ground.

6. Check the voltage when revving up to 4,000 rpm under no load at least 10 times.
(Depress and release accelerator pedal as soon as possible.)
The voltage should be above 0.78V at least once during this procedure.
If the voltage is above 0.78V at step 6, step 7 is not necessary.
7. Keep vehicle at idling for 10 minutes, then check voltage. Or check the voltage when coasting from 80 km/h (50 MPH) in D position with "OD" OFF (A/T), 3rd gear position (M/T).
The voltage should be below 0.18V at least once during this procedure.
8. If NG, replace heated oxygen sensor 2.

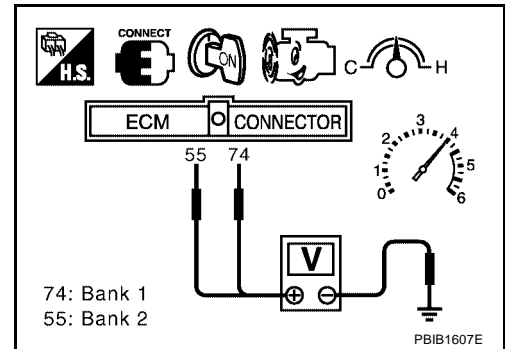
**CAUTION:**

- Discard any heated oxygen sensor which has been dropped from a height of more than 0.5 m (19.7 in) onto a hard surface such as a concrete floor; use a new one.
- Before installing new oxygen sensor, clean exhaust system threads using Oxygen Sensor Thread Cleaner tool J-43897-18 or J-43897-12 and approved anti-seize lubricant.

Removal and Installation

HEATED OXYGEN SENSOR 2

UBS00133

Refer to [EM-134, "EXHAUST MANIFOLD AND THREE WAY CATALYST"](#) .

DTC P0139, P0159 HO2S2

Component Description

UBS00134

The heated oxygen sensor 2, after three way catalyst (manifold), monitors the oxygen level in the exhaust gas on each bank. Even if switching characteristics of the air fuel ratio (A/F) sensor 1 are shifted, the air-fuel ratio is controlled to stoichiometric, by the signal from the heated oxygen sensor 2. This sensor is made of ceramic zirconia. The zirconia generates voltage from approximately 1V in richer conditions to 0V in leaner conditions. Under normal conditions the heated oxygen sensor 2 is not used for engine control operation.

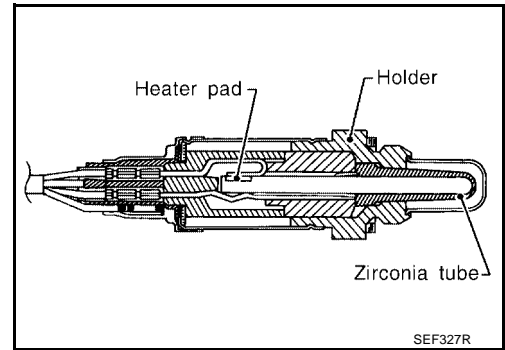

CONSULT-II Reference Value in Data Monitor Mode

UBS00135

Specification data are reference values.

MONITOR ITEM	CONDITION		SPECIFICATION
HO2S2 (B1) HO2S2 (B2)	<ul style="list-style-type: none"> Warm-up condition After keeping engine speed between 3,500 and 4,000 rpm for 1 minute and at idle for 1 minute under no load. 	Revving engine from idle to 3,000 rpm quickly.	0 - 0.3V ↔ Approx. 0.6 - 1.0V
HO2S2 MNTR (B1) HO2S2 MNTR (B2)			LEAN ↔ RICH

On Board Diagnosis Logic

UBS00136

The heated oxygen sensor 2 has a much longer switching time between rich and lean than the air fuel ratio (A/F) sensor 1. The oxygen storage capacity before the three way catalyst (manifold) causes the longer switching time. To judge the malfunctions of heated oxygen sensor 2, ECM monitors whether the switching response of the sensor's voltage is faster than specified during the various driving condition such as fuel-cut.

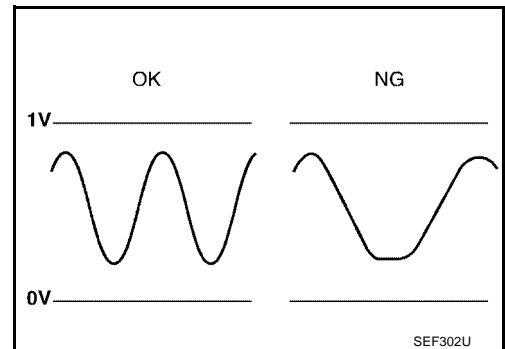

DTC No.	Trouble diagnosis name	DTC detecting condition	Possible cause
P0139 0139 (Bank 1)	Heated oxygen sensor 2 circuit slow response	It takes more time for the sensor to respond between rich and lean than the specified time.	<ul style="list-style-type: none"> Harness or connectors (The sensor circuit is open or shorted) Heated oxygen sensor 2 Fuel pressure Fuel injector Intake air leaks
P0159 0159 (Bank 2)			

DTC Confirmation Procedure

NOTE:

If DTC Confirmation Procedure has been previously conducted, always turn ignition switch OFF and wait at least 10 seconds before conducting the next test.

WITH CONSULT-II

TESTING CONDITION:

For better results, perform "DTC WORK SUPPORT" at a temperature of 0 to 30 °C (32 to 86 °F).

1. Turn ignition switch ON and select "DATA MONITOR" mode with CONSULT-II.
2. Start engine and warm it up to the normal operating temperature.
3. Turn ignition switch OFF and wait at least 10 seconds.
4. Start engine and keep the engine speed between 3,500 and 4,000 rpm for at least 1 minute under no load.
5. Let engine idle for 1 minute.
6. Make sure that "COOLAN TEMP/S" indicates more than 70°C (158°F).
If not, warm up engine and go to next step when "COOLAN TEMP/S" indication reaches to 70°C (158°F).
7. Select "HO2S2 (B1) P0139" or "HO2S2 (B2) P0159" of "HO2S2" in "DTC WORK SUPPORT" mode with CONSULT-II.
8. Start engine and following the instruction of CONSULT-II.

DATA MONITOR	
MONITOR	NO DTC
ENG SPEED	XXX rpm
COOLAN TEMP/S	XXX °C

SEF174Y

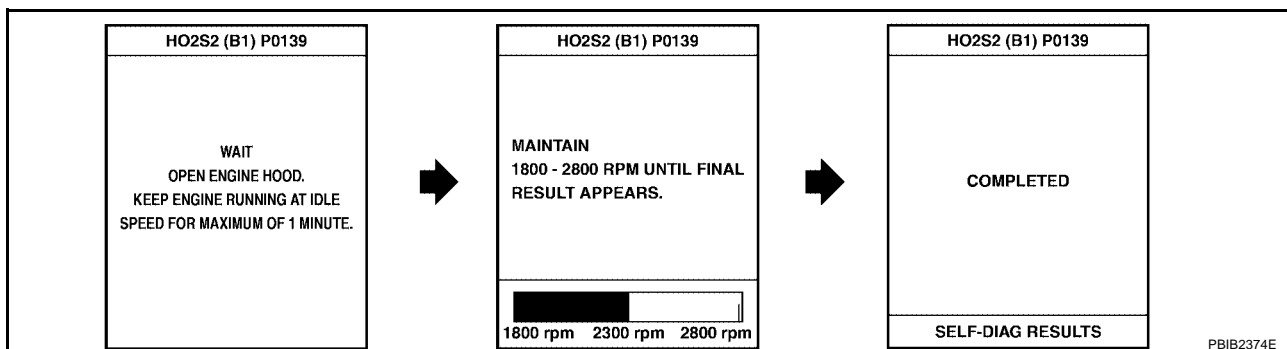

NOTE:

It will take at most 10 minutes until "COMPLETED" is displayed.

9. Make sure that "OK" is displayed after touching "SELF-DIAG RESULTS".
If "NG" is displayed, refer to [EC-862, "Diagnostic Procedure"](#).
If "CAN NOT BE DIAGNOSED" is displayed, perform the following.
 - a. Turn ignition switch OFF and leave the vehicle in a cool place (soak the vehicle).
 - b. Return to step 1.

Overall Function Check

Use this procedure to check the overall function of the heated oxygen sensor 2 circuit. During this check, a 1st trip DTC might not be confirmed.

WITH GST

1. Start engine and warm it up to the normal operating temperature.
2. Turn ignition switch OFF and wait at least 10 seconds.
3. Start engine and keep the engine speed between 3,500 and 4,000 rpm for at least 1 minute under no load.
4. Let engine idle for 1 minute.
5. Set voltmeter probes between ECM terminal 74 [HO2S2 (B1) signal] or 55 [HO2S2 (B2) signal] and ground.

DTC P0139, P0159 HO2S2

[VQ]

6. Check the voltage when revving up to 4,000 rpm under no load at least 10 times.
(Depress and release accelerator pedal as soon as possible.)
A change of voltage should be more than 0.06V for 1 second during this procedure.
If the voltage can be confirmed in step 6, step 7 is not necessary.
7. Keep vehicle at idling for 10 minutes, then check the voltage. Or check the voltage when coasting from 80 km/h (50 MPH) in D position with "OD" OFF (A/T), 3rd gear position (M/T).
A change of voltage should be more than 0.06V for 1 second during this procedure.
8. If NG, go to [EC-862, "Diagnostic Procedure"](#).

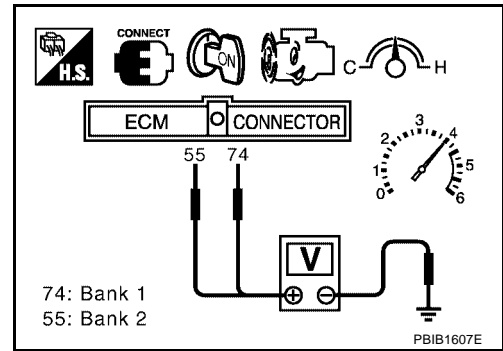

Wiring Diagram
BANK 1

UBS00139

EC-O2S2B1-01

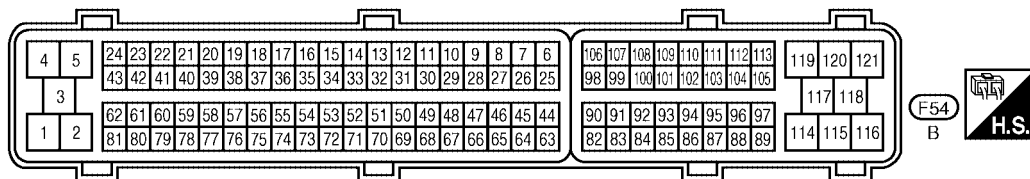
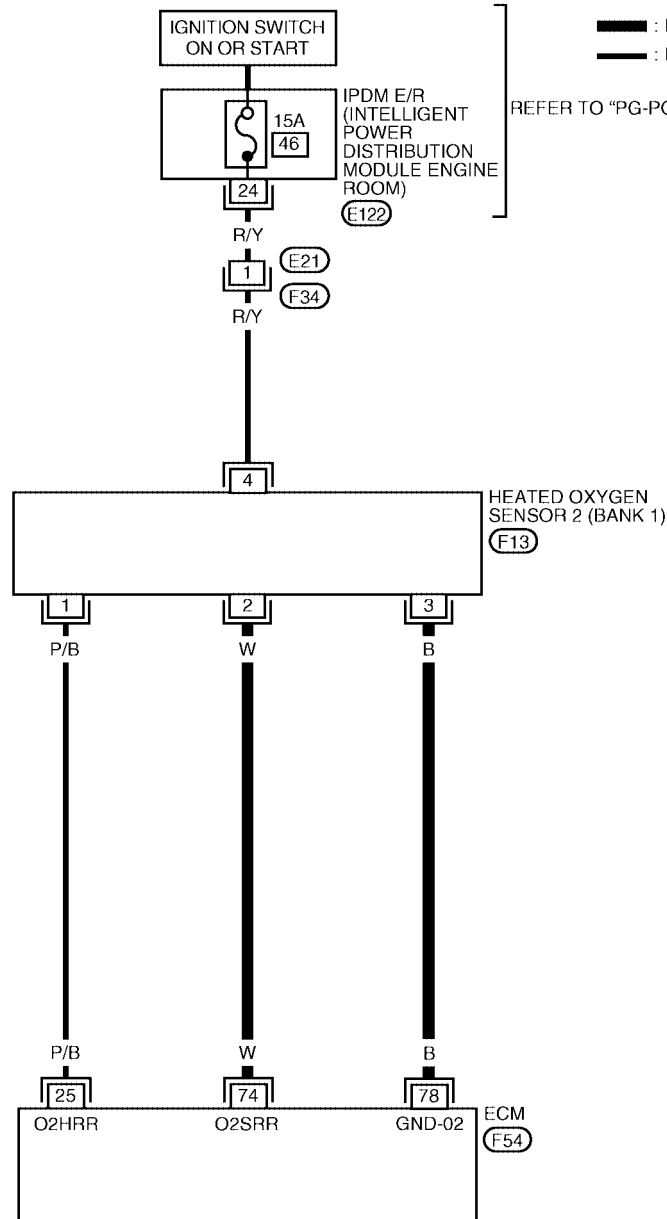

DTC P0139, P0159 HO2S2

[VQ]

Specification data are reference values and are measured between each terminal and ground.

CAUTION:

Do not use ECM ground terminals when measuring input/output voltage. Doing so may result in damage to the ECM's transistor. Use a ground other than ECM terminals, such as the ground.

TER-MINAL NO.	WIRE COLOR	ITEM	CONDITION	DATA (DC Voltage)
74	W	Heated oxygen sensor 2 (bank 1)	[Engine is running] <ul style="list-style-type: none"> ● Warm-up condition ● Revving engine from idle to 3,000 rpm quickly after the following conditions are met. – After keeping the engine speed between 3,500 and 4,000 rpm for 1 minute and at idle for 1 minute under no load. 	0 - Approximately 1.0V
78	B	Sensor ground (Heated oxygen sensor 2)	[Engine is running] <ul style="list-style-type: none"> ● Warm-up condition ● Idle speed 	Approximately 0V

DTC P0139, P0159 HO2S2

[VQ]

BANK 2

EC-O2S2B2-01

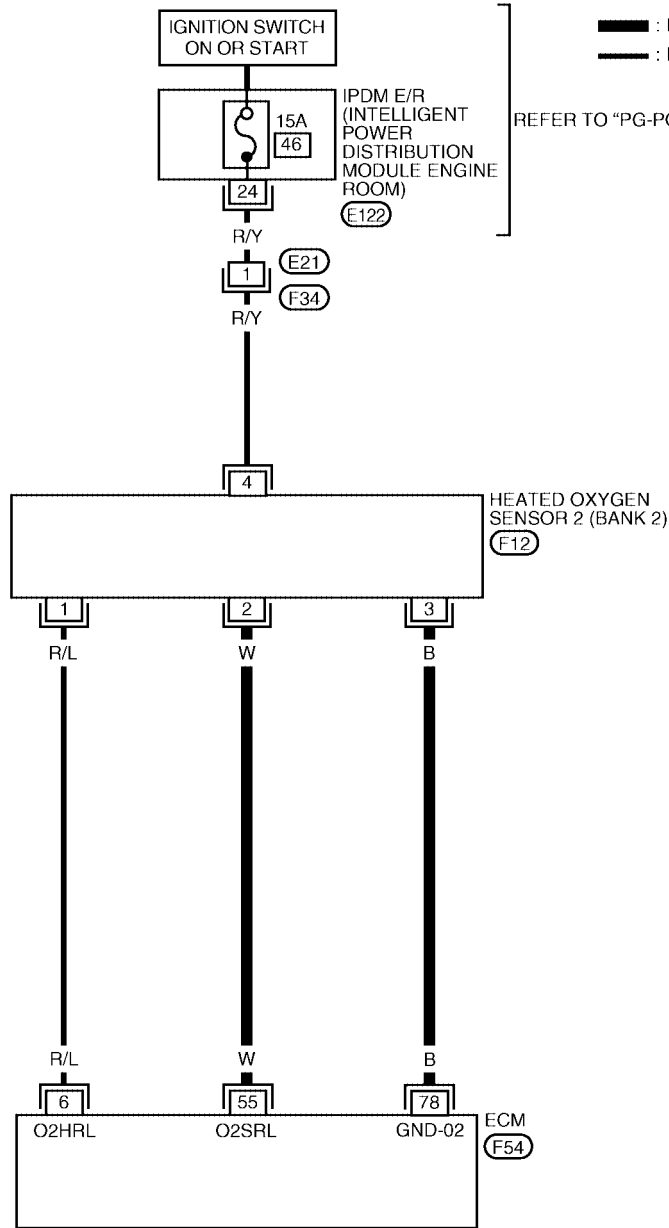

— : DETECTABLE LINE FOR DTC
 — : NON-DETECTABLE LINE FOR DTC

REFER TO "PG-POWER".

A
 EC
 C
 D
 E
 F
 G
 H
 I
 J
 K
 L
 M

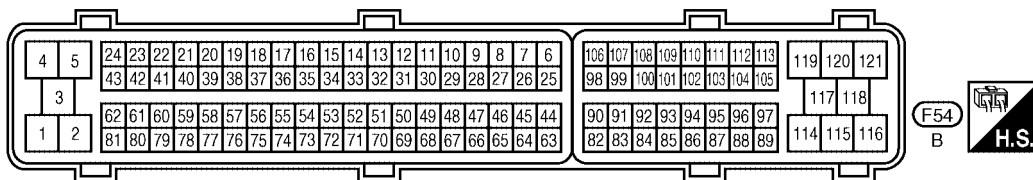
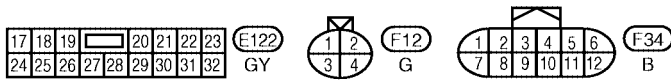

BBWA1556E

Specification data are reference values and are measured between each terminal and ground.

CAUTION:

Do not use ECM ground terminals when measuring input/output voltage. Doing so may result in damage to the ECM's transistor. Use a ground other than ECM terminals, such as the ground.

TER-MINAL NO.	WIRE COLOR	ITEM	CONDITION	DATA (DC Voltage)
55	W	Heated oxygen sensor 2 (bank 2)	<p>[Engine is running]</p> <ul style="list-style-type: none"> ● Warm-up condition ● Revving engine from idle to 3,000 rpm quickly after the following conditions are met. - After keeping the engine speed between 3,500 and 4,000 rpm for 1 minute and at idle for 1 minute under no load. 	0 - Approximately 1.0V
78	B	Sensor ground (Heated oxygen sensor 2)	<p>[Engine is running]</p> <ul style="list-style-type: none"> ● Warm-up condition ● Idle speed 	Approximately 0V

Diagnostic Procedure

UBS0013A

1. CHECK GROUND CONNECTIONS

1. Turn ignition switch OFF.
2. Loosen and retighten three ground screws on the body.
Refer to [EC-789, "Ground Inspection"](#).

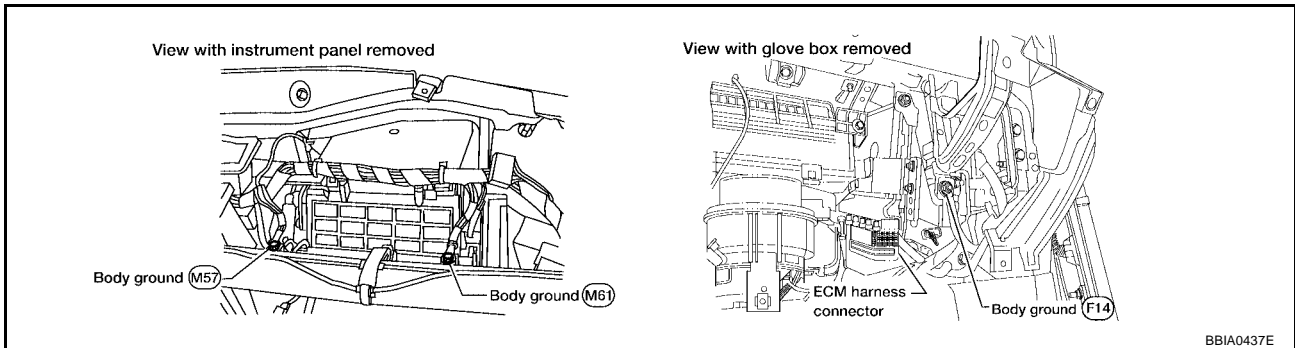

BBIA0437E

OK or NG

- OK >> GO TO 2.
- NG >> Repair or replace ground connections.

2. CLEAR THE SELF-LEARNING DATA

Ⓟ With CONSULT-II

1. Start engine and warm it up to normal operating temperature.
2. Select "SELF-LEARNING CONT" in "WORK SUPPORT" mode with CONSULT-II.
3. Clear the self-learning control coefficient by touching "CLEAR".
4. Run engine for at least 10 minutes at idle speed.
**Is the 1st trip DTC P0171, P0172, P0174 or P0175 detected?
Is it difficult to start engine?**

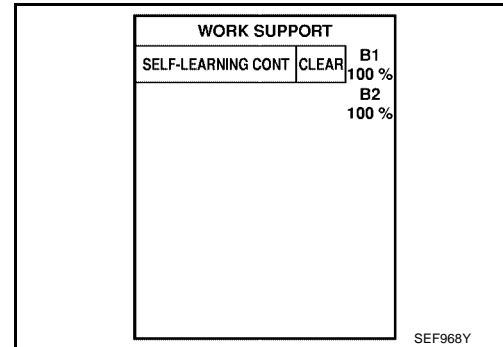

⊗ Without CONSULT-II

1. Start engine and warm it up to normal operating temperature.
2. Turn ignition switch OFF.
3. Disconnect mass air flow sensor harness connector, and restart and run engine for at least 5 seconds at idle speed.
4. Stop engine and reconnect mass air flow sensor harness connector.
5. Make sure DTC P0102 is displayed.
6. Erase the DTC memory. Refer to [EC-682, "HOW TO ERASE EMISSION-RELATED DIAGNOSTIC INFORMATION"](#).
7. Make sure DTC P0000 is displayed.
8. Run engine for at least 10 minutes at idle speed.
**Is the 1st trip DTC P0171, P0172, P0174 or P0175 detected?
Is it difficult to start engine?**

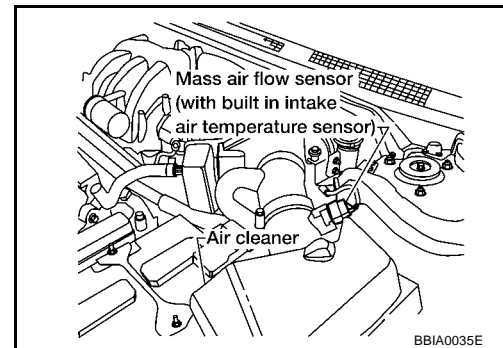

Yes or No

- Yes >> Perform trouble diagnosis for DTC P0171, P0174 or P0172, P0175. Refer to [EC-868, "DTC P0171, P0174 FUEL INJECTION SYSTEM FUNCTION"](#) or [EC-879, "DTC P0172, P0175 FUEL INJECTION SYSTEM FUNCTION"](#).
- No >> GO TO 3.

3. CHECK HO2S2 GROUND CIRCUIT FOR OPEN AND SHORT

1. Turn ignition switch OFF.
2. Disconnect ECM harness connector.
3. Disconnect heated oxygen sensor 2 harness connector.

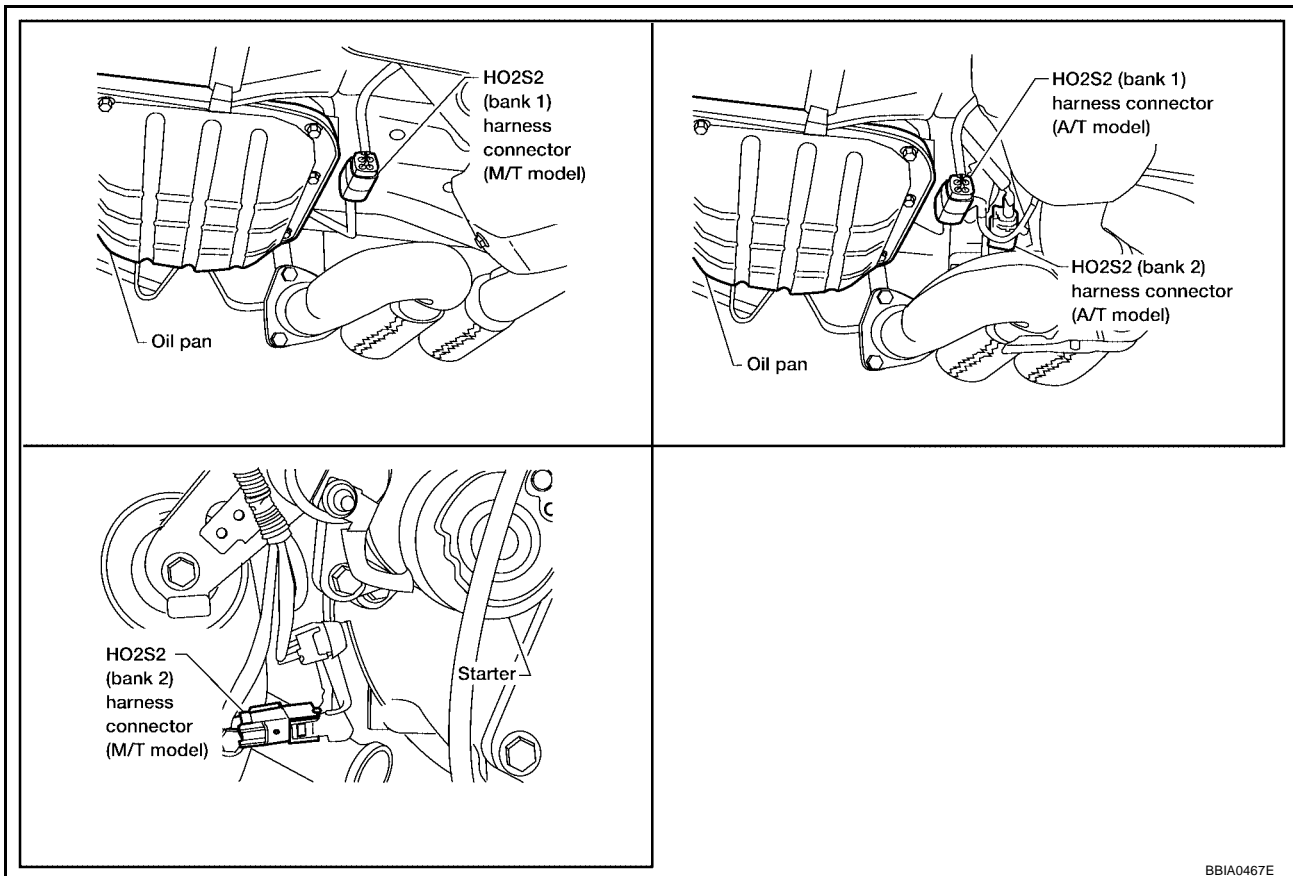

4. Check harness continuity between HO2S2 terminal 3 and ECM terminal 78. Refer to Wiring Diagram.

Continuity should exist.

5. Also check harness for short to ground and short to power.

OK or NG

OK >> GO TO 4.

NG >> Repair open circuit or short to ground or short to power in harness or connectors.

4. CHECK HO2S2 INPUT SIGNAL CIRCUIT FOR OPEN AND SHORT

1. Check harness continuity between ECM terminal and HO2S2 terminal as follows. Refer to Wiring Diagram.

DTC	Terminals		Bank
	ECM	Sensor	
P0139	74	2	1
P0159	55	2	2

Continuity should exist.

2. Check harness continuity between the following terminals and ground. Refer to Wiring Diagram.

DTC	Terminals		Bank
	ECM	Sensor	
P0139	74	2	1
P0159	55	2	2

Continuity should not exist.

3. Also check harness for short to power.

OK or NG

OK >> GO TO 5.

NG >> Repair open circuit or short to ground or short to power in harness or connectors.

5. CHECK HEATED OXYGEN SENSOR 2

Refer to [EC-865, "Component Inspection"](#) .

OK or NG

OK >> GO TO 6.

NG >> Replace malfunctioning heated oxygen sensor 2.

6. CHECK INTERMITTENT INCIDENT

Refer to [EC-782, "TROUBLE DIAGNOSIS FOR INTERMITTENT INCIDENT"](#) .

>> INSPECTION END

**Component Inspection
HEATED OXYGEN SENSOR 2**

UBS0013B

With CONSULT-II

1. Turn ignition switch ON and select "DATA MONITOR" mode with CONSULT-II.
2. Start engine and warm it up to the normal operating temperature.
3. Turn ignition switch OFF and wait at least 10 seconds.
4. Start engine and keep the engine speed between 3,500 and 4,000 rpm for at least 1 minute under no load.
5. Let engine idle for 1 minute.

DATA MONITOR	
MONITOR	NO DTC
ENG SPEED	XXX rpm
COOLAN TEMP/S	XXX °C

SEF174Y

- Select "FUEL INJECTION" in "ACTIVE TEST" mode, and select "HO2S2 (B1)/(B2)" as the monitor item with CONSULT-II.

ACTIVE TEST	
FUEL INJECTION	25 %
MONITOR	
ENG SPEED	XXX rpm
HO2S1 (B1)	XXX V
HO2S2 (B1)	XXX V
HO2S1 MNTR (B1)	RICH
HO2S2 MNTR (B1)	RICH

SEF662Y

- Check "HO2S2 (B1)/(B2)" at idle speed when adjusting "FUEL INJECTION" to $\pm 25\%$.

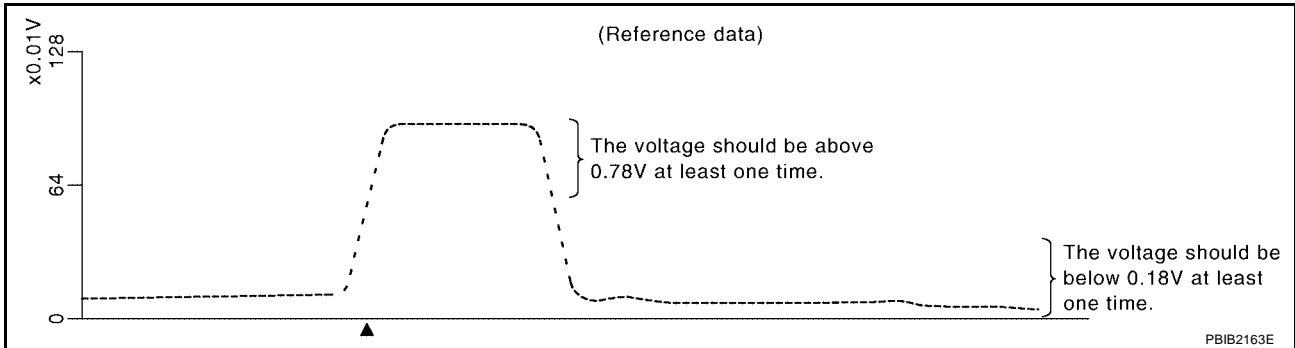

"HO2S2 (B1)/(B2)" should be above 0.78V at least once when the "FUEL INJECTION" is +25%.
 "HO2S2 (B1)/(B2)" should be below 0.18V at least once when the "FUEL INJECTION" is -25%.

CAUTION:

- Discard any heated oxygen sensor which has been dropped from a height of more than 0.5 m (19.7 in) onto a hard surface such as a concrete floor; use a new one.
- Before installing new oxygen sensor, clean exhaust system threads using Oxygen Sensor Thread Cleaner tool J-43897-18 or J-43897-12 and approved anti-seize lubricant.

Without CONSULT-II

- Start engine and warm it up to the normal operating temperature.
- Turn ignition switch OFF and wait at least 10 seconds.
- Start engine and keep the engine speed between 3,500 and 4,000 rpm for at least 1 minute under no load.
- Let engine idle for 1 minute.
- Set voltmeter probes between ECM terminal 74 [HO2S2 (B1) signal] or 55 [HO2S2 (B2) signal] and ground.
- Check the voltage when revving up to 4,000 rpm under no load at least 10 times.
 (Depress and release accelerator pedal as soon as possible.)
The voltage should be above 0.78V at least once during this procedure.
If the voltage is above 0.78V at step 6, step 7 is not necessary.
- Keep vehicle at idling for 10 minutes, then check voltage. Or check the voltage when coasting from 80 km/h (50 MPH) in D position with "OD" OFF (A/T), 3rd gear position (M/T).
The voltage should be below 0.18V at least once during this procedure.
- If NG, replace heated oxygen sensor 2.

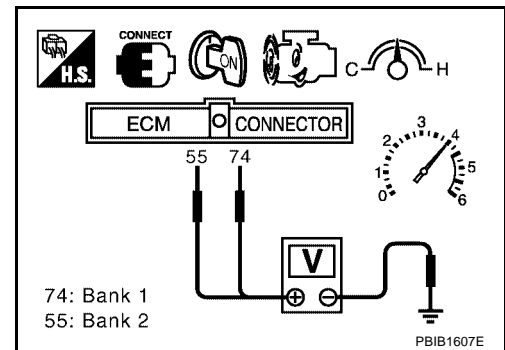

CAUTION:

- Discard any heated oxygen sensor which has been dropped from a height of more than 0.5 m (19.7 in) onto a hard surface such as a concrete floor; use a new one.
- Before installing new oxygen sensor, clean exhaust system threads using Oxygen Sensor Thread Cleaner tool J-43897-18 or J-43897-12 and approved anti-seize lubricant.

Removal and Installation
HEATED OXYGEN SENSOR 2

Refer to [EM-134, "EXHAUST MANIFOLD AND THREE WAY CATALYST"](#) .

A

EC

C

D

E

F

G

H

I

J

K

L

M

DTC P0171, P0174 FUEL INJECTION SYSTEM FUNCTION

[VQ]

DTC P0171, P0174 FUEL INJECTION SYSTEM FUNCTION

PF16600

On Board Diagnosis Logic

UBS0013D

With the Air/Fuel Mixture Ratio Self-Learning Control, the actual mixture ratio can be brought closely to the theoretical mixture ratio based on the mixture ratio feedback signal from the A/F sensors 1. The ECM calculates the necessary compensation to correct the offset between the actual and the theoretical ratios. In case the amount of the compensation value is extremely large (The actual mixture ratio is too lean.), the ECM judges the condition as the fuel injection system malfunction and lights up the MIL (2 trip detection logic).

Sensor	Input signal to ECM	ECM function	Actuator
A/F sensor 1	Density of oxygen in exhaust gas (Mixture ratio feedback signal)	Fuel injection control	Fuel injector

DTC No.	Trouble diagnosis name	DTC detecting condition	Possible cause
P0171 0171 (Bank 1)	Fuel injection system too lean	<ul style="list-style-type: none"> Fuel injection system does not operate properly. The amount of mixture ratio compensation is too large. (The mixture ratio is too lean.) 	<ul style="list-style-type: none"> Intake air leaks A/F sensor 1 Fuel injector Exhaust gas leaks Incorrect fuel pressure Lack of fuel Mass air flow sensor Incorrect PCV hose connection
P0174 0174 (Bank 2)			

DTC Confirmation Procedure

UBS0013E

NOTE:

If DTC Confirmation Procedure has been previously conducted, always turn ignition switch OFF and wait at least 10 seconds before conducting the next test.

④ WITH CONSULT-II

- Start engine and warm it up to normal operating temperature.
- Turn ignition switch OFF and wait at least 10 seconds.
- Turn ignition switch ON and select "SELF-LEARNING CONT" in "WORK SUPPORT" mode with CONSULT-II.
- Clear the self-learning control coefficient by touching "CLEAR".
- Select "DATA MONITOR" mode with CONSULT-II.
- Start engine again and let it idle for at least 10 minutes. The 1st trip DTC P0171 or P0174 should be detected at this stage, if a malfunction exists. If so, go to [EC-872, "Diagnostic Procedure"](#).

NOTE:

If 1st trip DTC is not detected during above procedure, performing the following procedure is advised.

- Turn ignition switch OFF and wait at least 10 seconds.
- Start engine and drive the vehicle under the similar conditions to (1st trip) Freeze Frame Data for 10 minutes. Refer to the table below. **Hold the accelerator pedal as steady as possible.**

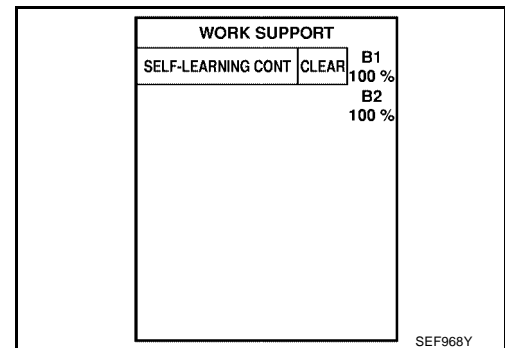

The similar conditions to (1st trip) Freeze Frame Data means the vehicle operation that the following conditions should be satisfied at the same time.

Engine speed	Engine speed in the freeze frame data \pm 400 rpm
Vehicle speed	Vehicle speed in the freeze frame data \pm 10 km/h (6 MPH)
Engine coolant temperature (T) condition	When the freeze frame data shows lower than 70 °C (158 °F), T should be lower than 70 °C (158 °F).
	When the freeze frame data shows higher than or equal to 70 °C (158 °F), T should be higher than or equal to 70 °C (158 °F).

DTC P0171, P0174 FUEL INJECTION SYSTEM FUNCTION

[VQ]

7. If it is difficult to start engine at step 6, the fuel injection system has a malfunction, too.
8. Crank engine while depressing accelerator pedal. If engine starts, go to [EC-872, "Diagnostic Procedure"](#). If engine does not start, check exhaust and intake air leak visually.

WITH GST

1. Start engine and warm it up to normal operating temperature.
2. Turn ignition switch OFF and wait at least 10 seconds.
3. Disconnect mass air flow sensor harness connector.
4. Restart engine and let it idle for at least 5 seconds.
5. Stop engine and reconnect mass air flow sensor harness connector.
6. Select Service \$03 with GST. Make sure DTC P0102 is detected.
7. Select Service \$04 with GST and erase the DTC P0102.
8. Start engine again and let it idle for at least 10 minutes.
9. Select Service \$07 with GST. The 1st trip DTC P0171 or P0174 should be detected at this stage, if a malfunction exists. If so, go to [EC-872, "Diagnostic Procedure"](#).

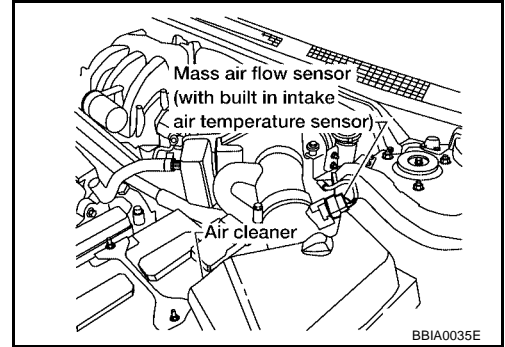

NOTE:

If 1st trip DTC is not detected during above procedure, performing the following procedure is advised.

- a. Turn ignition switch OFF and wait at least 10 seconds.
- b. Start engine and drive the vehicle under the similar conditions to (1st trip) Freeze Frame Data for 10 minutes. Refer to the table below.

Hold the accelerator pedal as steady as possible.

The similar conditions to (1st trip) Freeze Frame Data means the vehicle operation that the following conditions should be satisfied at the same time.

Engine speed	Engine speed in the freeze frame data \pm 400 rpm
Vehicle speed	Vehicle speed in the freeze frame data \pm 10 km/h (6 MPH)
Engine coolant temperature (T) condition	When the freeze frame data shows lower than 70 °C (158 °F), T should be lower than 70 °C (158 °F).
	When the freeze frame data shows higher than or equal to 70 °C (158 °F), T should be higher than or equal to 70 °C (158 °F).

10. If it is difficult to start engine at step 8, the fuel injection system has a malfunction.
11. Crank engine while depressing accelerator pedal. If engine starts, go to [EC-872, "Diagnostic Procedure"](#). If engine does not start, check exhaust and intake air leak visually.

DTC P0171, P0174 FUEL INJECTION SYSTEM FUNCTION

[VQ]

UBS0013F

Wiring Diagram BANK 1

EC-FUELB1-01

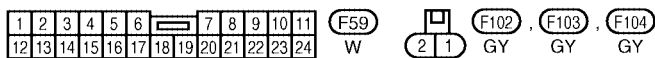
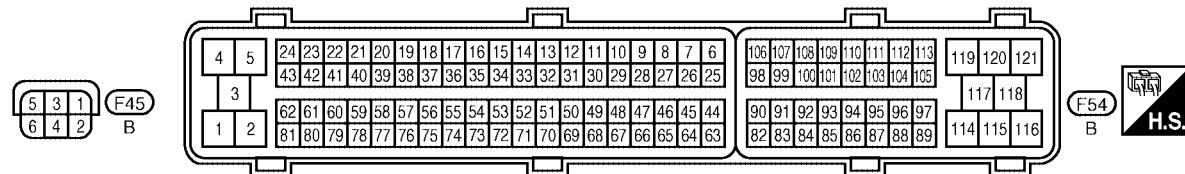
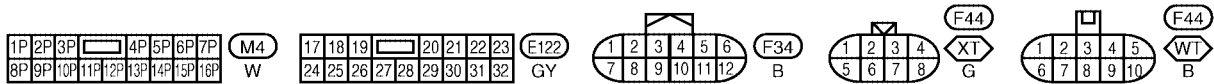
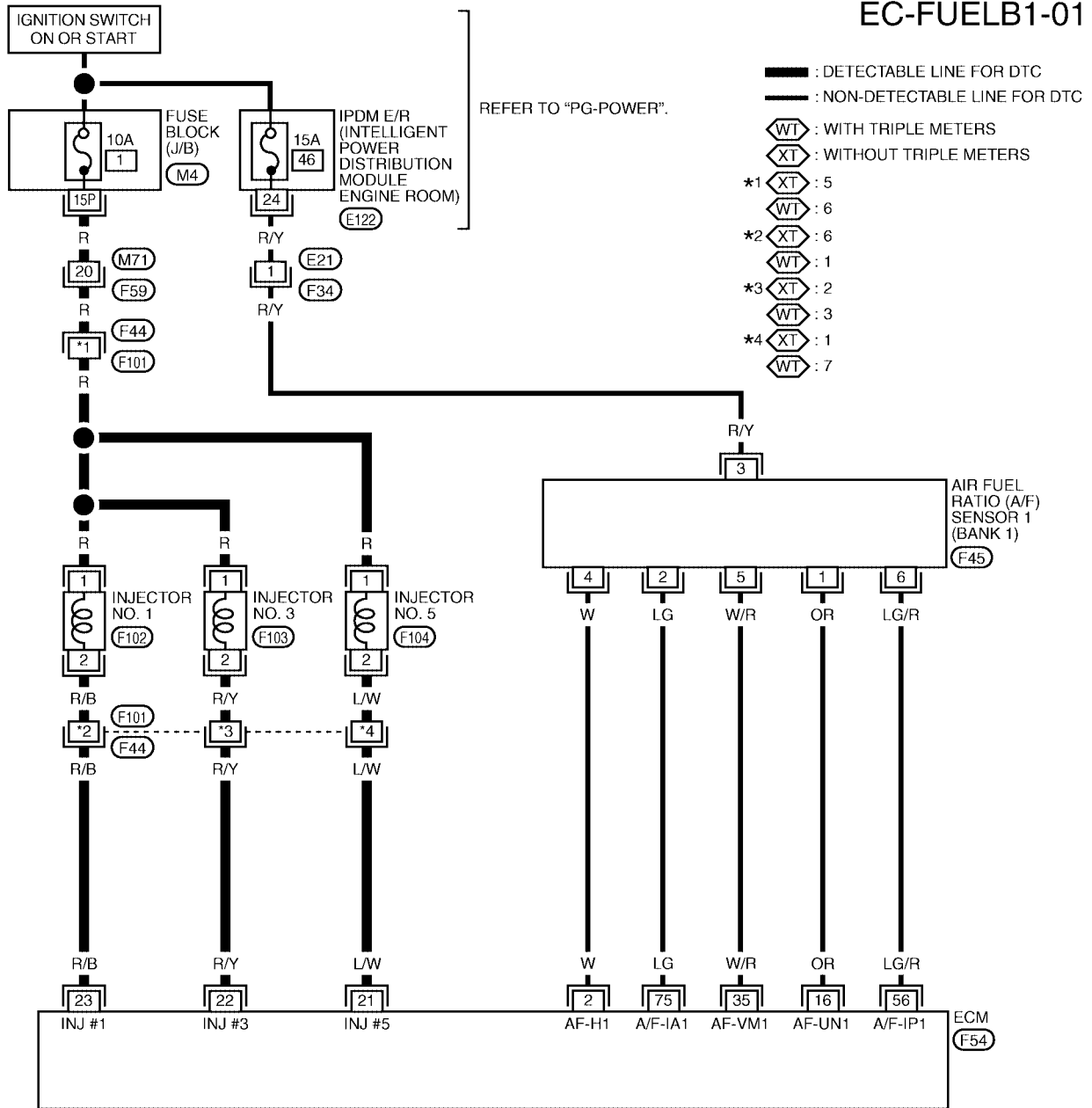

BBWA1557E

DTC P0171, P0174 FUEL INJECTION SYSTEM FUNCTION

[VQ]

BANK 2

EC-FUELB2-01

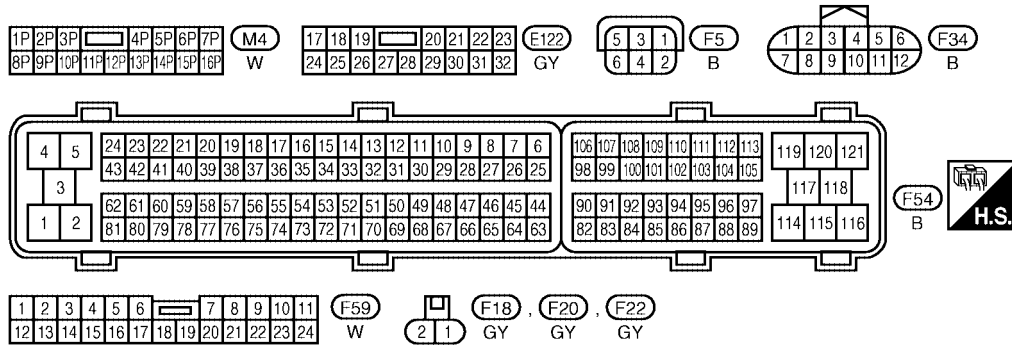
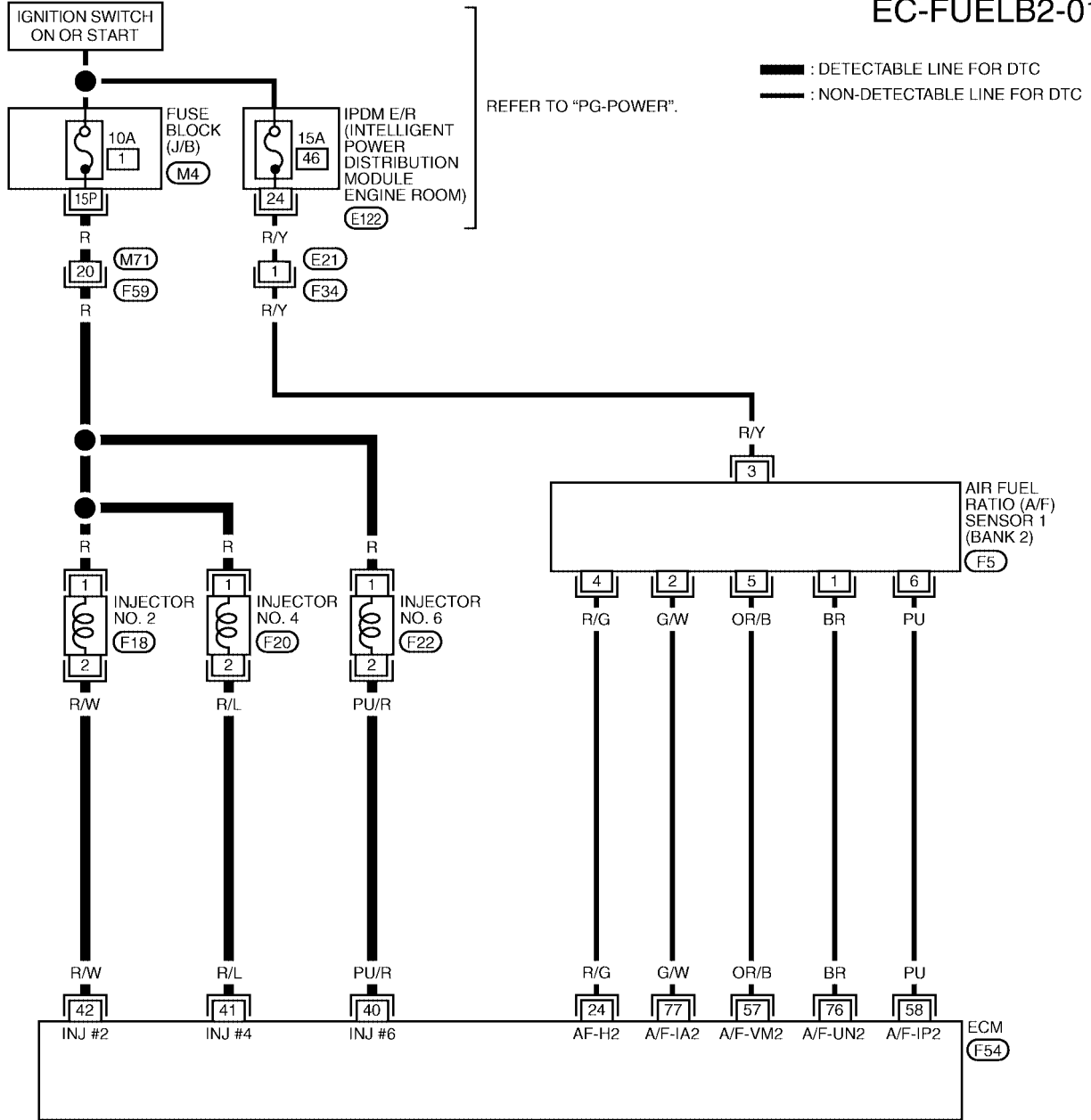

BBWA1558E

Diagnostic Procedure

1. CHECK EXHAUST GAS LEAK

1. Start engine and run it at idle.
2. Listen for an exhaust gas leak before three way catalyst (manifold).

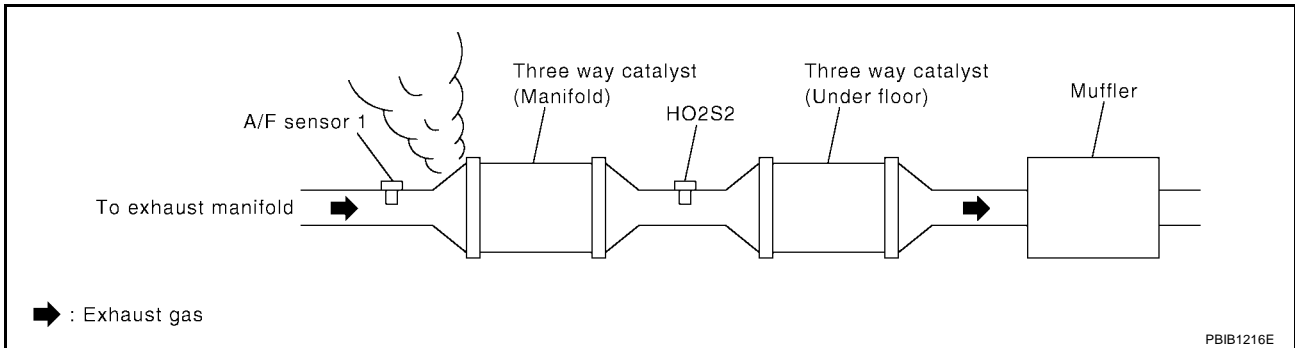

OK or NG

- OK >> GO TO 2.
- NG >> Repair or replace.

2. CHECK FOR INTAKE AIR LEAK

1. Listen for an intake air leak after the mass air flow sensor.
2. Check PCV hose connection.

OK or NG

- OK >> GO TO 3.
- NG >> Repair or replace.

3. CHECK A/F SENSOR 1 INPUT SIGNAL CIRCUIT

1. Turn ignition switch OFF.
2. Disconnect corresponding A/F sensor 1 harness connector.

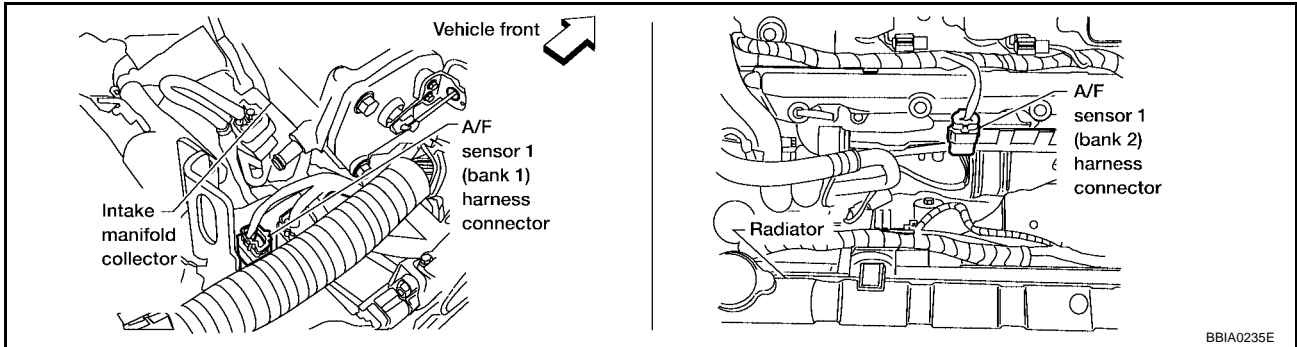

3. Disconnect ECM harness connector.
4. Check harness continuity between the following terminals. Refer to Wiring Diagram.

	A/F sensor 1 terminal	ECM terminal
Bank 1	1	16
	2	75
	5	35
	6	56
Bank 2	1	76
	2	77
	5	57
	6	58

Continuity should exist.

5. Check harness continuity between the following terminals and ground. Refer to Wiring Diagram.

Bank 1		Bank 2	
A/F sensor 1 terminal	ECM terminal	A/F sensor 1 terminal	ECM terminal
1	16	1	76
2	75	2	77
5	35	5	57
6	56	6	58

Continuity should not exist.

6. Also check harness for short to power.

OK or NG

OK >> GO TO 4.

NG >> Repair open circuit or short to ground or short to power in harness or connectors.

4. CHECK FUEL PRESSURE

1. Release fuel pressure to zero. Refer to [EC-714, "FUEL PRESSURE RELEASE"](#) .
2. Install fuel pressure gauge and check fuel pressure. Refer to [EC-714, "FUEL PRESSURE CHECK"](#) .

At idling: Approx. 350 kPa (3.57 kg/cm² , 51 psi)

OK or NG

- OK (With CONSULT-II)>>GO TO 6.
 OK (Without CONSULT-II)>>GO TO 7.
 NG >> GO TO 5.

5. DETECT MALFUNCTIONING PART

Check the following.

- Fuel pump and circuit (Refer to [EC-1316, "FUEL PUMP CIRCUIT"](#) .)
- Fuel pressure regulator (Refer to [EC-714, "FUEL PRESSURE CHECK"](#) .)
- Fuel lines (Refer to [MA-24, "Checking Fuel Lines"](#))
- Fuel filter for clogging

>> Repair or replace.

6. CHECK MASS AIR FLOW SENSOR

Ⓟ With CONSULT-II

1. Install all removed parts.
2. Check "MASS AIR FLOW" in "DATA MONITOR" mode with CONSULT-II.

2.0 - 6.0 g-m/sec: at idling
7.0 - 20.0 g-m/sec: at 2,500 rpm

OK or NG

- OK >> GO TO 8.
 NG >> Check connectors for rusted terminals or loose connections in the mass air flow sensor circuit or ground. Refer to [EC-806](#) .

7. CHECK MASS AIR FLOW SENSOR

Ⓢ With GST

1. Install all removed parts.
2. Check mass air flow sensor signal in Service \$01 with GST.

2.0 - 6.0 g-m/sec: at idling
7.0 - 20.0 g-m/sec: at 2,500 rpm

OK or NG

- OK (P0171)>>GO TO 9.
 OK (P0174)>>GO TO 11.
 NG >> Check connectors for rusted terminals or loose connections in the mass air flow sensor circuit or ground. Refer to [EC-806](#) .

8. CHECK FUNCTION OF INJECTOR

④ With CONSULT-II

1. Start engine.
2. Perform "POWER BALANCE" in "ACTIVE TEST" mode with CONSULT-II.
3. Make sure that each circuit produces a momentary engine speed drop.

ACTIVE TEST	
POWER BALANCE	
MONITOR	
ENG SPEED	XXX rpm
MAS A/F SE-B1	XXX V

PBIB0133E

OK or NG

- OK >> GO TO 12.
 NG >> Perform trouble diagnosis for INJECTOR CIRCUIT, refer to [EC-1308](#) .

A
 EC
 C
 D
 E
 F
 G
 H
 I
 J
 K
 L
 M

9. CHECK FUNCTION OF INJECTOR-I

⊗ **Without CONSULT-II**

1. Stop engine.
2. Disconnect harness connector F44, F101
3. Turn ignition switch ON.

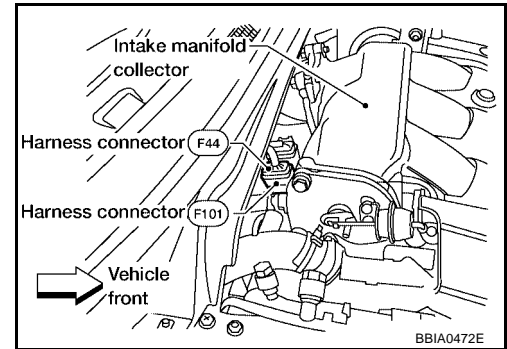

4. Check voltage between harness connector F44 terminal 6 (with triple meters) or 5 (without triple meters) and ground with CONSULT-II or tester.

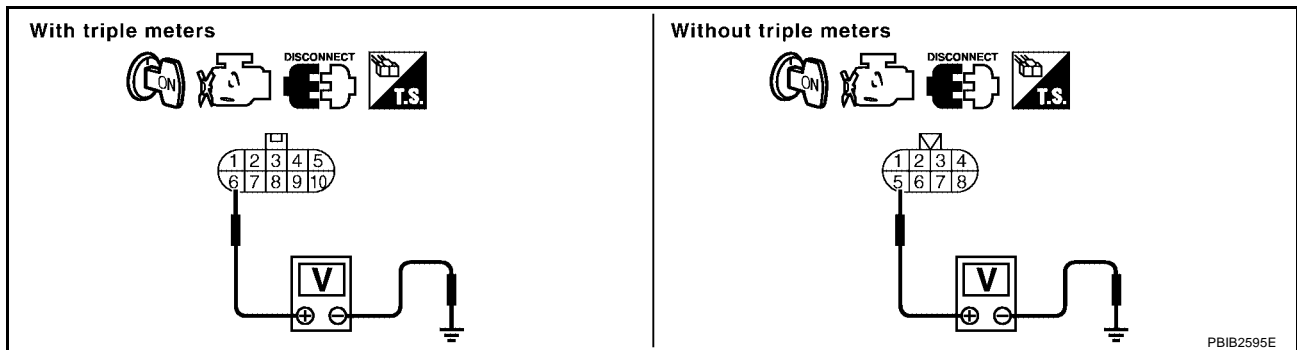

Voltage: Battery voltage

5. Turn ignition switch OFF.
6. Disconnect ECM harness connector.
7. Check harness continuity between harness connector F44 and ECM as follows. Refer to Wiring Diagram.

With triple meters

Cylinder	Harness connector F44 terminal	ECM terminal
1	1	23
3	3	22
5	7	21

Without triple meters

Cylinder	Harness connector F44 terminal	ECM terminal
1	6	23
3	2	22
5	1	21

Continuity should exist.

8. Also check harness for short to ground and short to power.

OK or NG

- OK >> GO TO 10.
- NG >> Perform trouble diagnosis for INJECTOR CIRCUIT, refer to [EC-1308](#).

10. CHECK FUNCTION OF INJECTOR-II

Provide battery voltage between harness connector F101 as follows and then interrupt it. Listen to each injector operating sound.

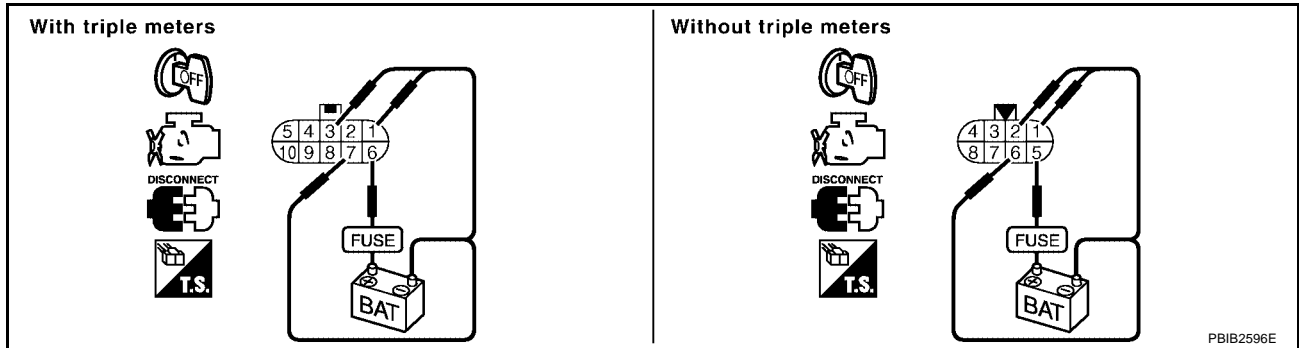

With triple meters

Cylinder	Harness connector F101 terminal	
	(+)	(-)
1	6	1
3	6	3
5	6	7

Without triple meters

Cylinder	Harness connector F101 terminal	
	(+)	(-)
1	5	6
3	5	2
5	5	1

Operating sound should exist.

OK or NG

OK >> GO TO 12.

NG >> Perform trouble diagnosis for INJECTOR CIRCUIT, refer to [EC-1308](#).

11. CHECK FUNCTION OF INJECTOR

1. Start engine.
2. Listen to injectors No.2, No.4, No.6 operating sound.

Clicking noise should exist.

OK or NG

OK >> GO TO 12.

NG >> Perform trouble diagnosis for INJECTOR CIRCUIT, refer to [EC-1308](#).

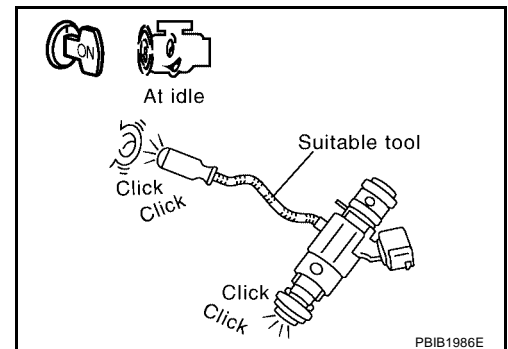

12. CHECK INJECTOR

1. Confirm that the engine is cooled down and there are no fire hazards near the vehicle.
2. Turn ignition switch OFF.
3. Disconnect all injector harness connectors.
4. Remove injector gallery assembly. Refer to [EM-147, "FUEL INJECTOR AND FUEL TUBE"](#) .
Keep fuel hose and all injectors connected to injector gallery.
5. For DTC P0171, reconnect injector harness connectors on bank 1.
For DTC P0174, reconnect injector harness connectors on bank 2.
6. Disconnect all ignition coil harness connectors.
7. Prepare pans or saucers under each injector.
8. Crank engine for about 3 seconds.
For DTC P0171, make sure that fuel sprays out from injectors on bank 1.
For DTC P0174, make sure that fuel sprays out from injectors on bank 2.

Fuel should be sprayed evenly for each injector.

OK or NG

- OK >> GO TO 13.
NG >> Replace injectors from which fuel does not spray out.
Always replace O-ring with new ones.

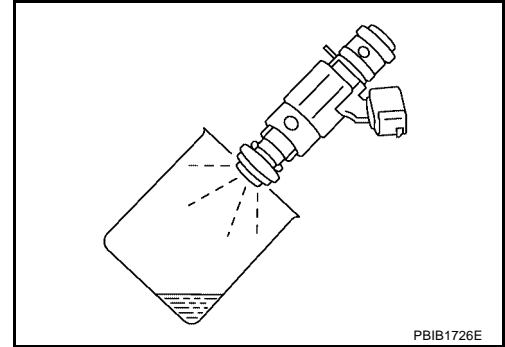

13. CHECK INTERMITTENT INCIDENT

Refer to [EC-782, "TROUBLE DIAGNOSIS FOR INTERMITTENT INCIDENT"](#) .

>> **INSPECTION END**

DTC P0172, P0175 FUEL INJECTION SYSTEM FUNCTION

[VQ]

DTC P0172, P0175 FUEL INJECTION SYSTEM FUNCTION

PFV:16600

On Board Diagnosis Logic

UBS0013H

With the Air/Fuel Mixture Ratio Self-Learning Control, the actual mixture ratio can be brought closely to the theoretical mixture ratio based on the mixture ratio feedback signal from the A/F sensors 1. The ECM calculates the necessary compensation to correct the offset between the actual and the theoretical ratios. In case the amount of the compensation value is extremely large (The actual mixture ratio is too rich.), the ECM judges the condition as the fuel injection system malfunction and lights up the MIL (2 trip detection logic).

Sensor	Input signal to ECM	ECM function	Actuator
A/F sensor 1	Density of oxygen in exhaust gas (Mixture ratio feedback signal)	Fuel injection control	Fuel injector

DTC No.	Trouble diagnosis name	DTC detecting condition	Possible cause
P0172 0172 (Bank 1)	Fuel injection system too rich	<ul style="list-style-type: none"> Fuel injection system does not operate properly. The amount of mixture ratio compensation is too large. (The mixture ratio is too rich.) 	<ul style="list-style-type: none"> A/F sensor 1 Fuel injector Exhaust gas leaks Incorrect fuel pressure Mass air flow sensor
P0175 0175 (Bank 2)			

DTC Confirmation Procedure

UBS0013I

NOTE:

If DTC Confirmation Procedure has been previously conducted, always turn ignition switch OFF and wait at least 10 seconds before conducting the next test.

WITH CONSULT-II

- Start engine and warm it up to normal operating temperature.
- Turn ignition switch OFF and wait at least 10 seconds.
- Turn ignition switch ON and select "SELF-LEARNING CONT" in "WORK SUPPORT" mode with CONSULT-II.
- Clear the self-learning control coefficient by touching "CLEAR".
- Select "DATA MONITOR" mode with CONSULT-II.
- Start engine again and let it idle for at least 10 minutes. The 1st trip DTC P0172, P0175 should be detected at this stage, if a malfunction exists. If so, go to [EC-883, "Diagnostic Procedure"](#).

NOTE:

If 1st trip DTC is not detected during above procedure, performing the following procedure is advised.

- Turn ignition switch OFF and wait at least 10 seconds.
- Start engine and drive the vehicle under the similar conditions to (1st trip) Freeze Frame Data for a certain time. Refer to the table below. **Hold the accelerator pedal as steady as possible.**

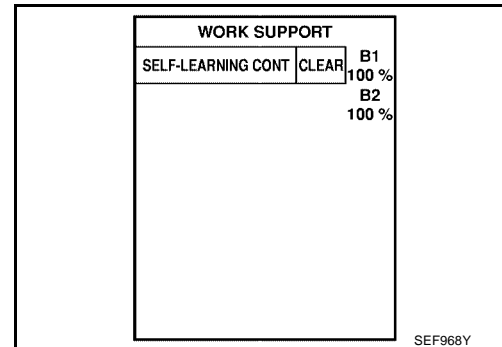

The similar conditions to (1st trip) Freeze Frame Data means the vehicle operation that the following conditions should be satisfied at the same time.

Engine speed	Engine speed in the freeze frame data \pm 400 rpm
Vehicle speed	Vehicle speed in the freeze frame data \pm 10 km/h (6 MPH)
Engine coolant temperature (T) condition	When the freeze frame data shows lower than 70 °C (158 °F), T should be lower than 70 °C (158 °F).
	When the freeze frame data shows higher than or equal to 70 °C (158 °F), T should be higher than or equal to 70 °C (158 °F).

- If it is difficult to start engine at step 6, the fuel injection system has a malfunction, too.
- Crank engine while depressing accelerator pedal.

DTC P0172, P0175 FUEL INJECTION SYSTEM FUNCTION

[VQ]

If engine starts, go to [EC-883, "Diagnostic Procedure"](#) . If engine does not start, remove ignition plugs and check for fouling, etc.

WITH GST

1. Start engine and warm it up to normal operating temperature.
2. Turn ignition switch OFF and wait at least 10 seconds.
3. Disconnect mass air flow sensor harness connector. Then restart and run engine for at least 5 seconds at idle speed.
4. Stop engine and reconnect mass air flow sensor harness connector.
5. Select Service \$03 with GST. Make sure DTC P0102 is detected.
6. Select Service \$04 with GST and erase the DTC P0102.
7. Start engine again and let it idle for at least 10 minutes.
8. Select Service \$07 with GST. The 1st trip DTC P0172 or P0175 should be detected at this stage, if a malfunction exists. If so, go to [EC-883, "Diagnostic Procedure"](#) .

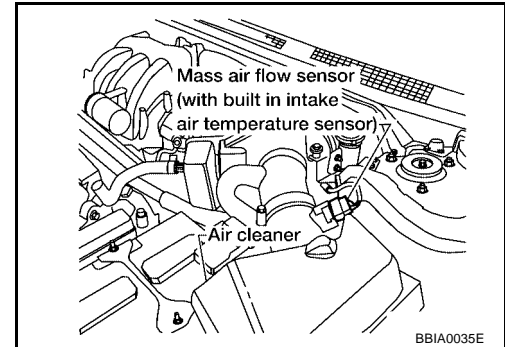

NOTE:

If 1st trip DTC is not detected during above procedure, performing the following procedure is advised.

- a. Turn ignition switch OFF and wait at least 10 seconds.
- b. Start engine and drive the vehicle under the similar conditions to (1st trip) Freeze Frame Data for a certain time. Refer to the table below.

Hold the accelerator pedal as steady as possible.

The similar conditions to (1st trip) Freeze Frame Data means the vehicle operation that the following conditions should be satisfied at the same time.

Engine speed	Engine speed in the freeze frame data \pm 400 rpm
Vehicle speed	Vehicle speed in the freeze frame data \pm 10 km/h (6 MPH)
Engine coolant temperature (T) condition	When the freeze frame data shows lower than 70 °C (158 °F), T should be lower than 70 °C (158 °F).
	When the freeze frame data shows higher than or equal to 70 °C (158 °F), T should be higher than or equal to 70 °C (158 °F).

9. If it is difficult to start engine at step 7, the fuel injection system has a malfunction.
10. Crank engine while depressing accelerator pedal.
If engine starts, go to [EC-883, "Diagnostic Procedure"](#) . If engine does not start, remove ignition plugs and check for fouling, etc.

DTC P0172, P0175 FUEL INJECTION SYSTEM FUNCTION

[VQ]

UBS0013J

Wiring Diagram BANK 1

EC-FUELB1-01

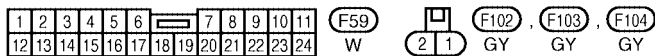
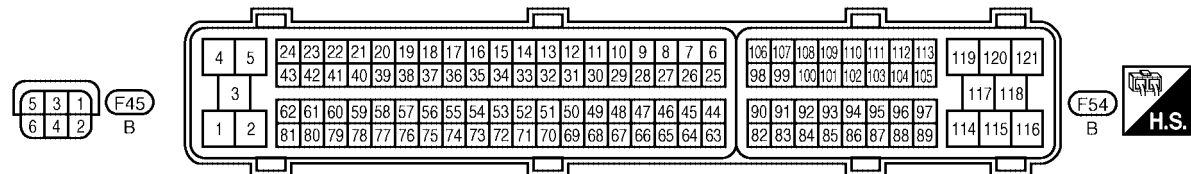
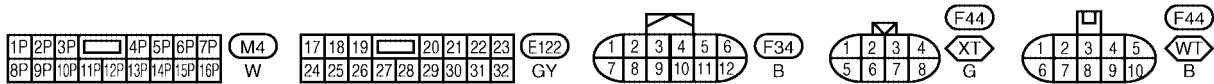
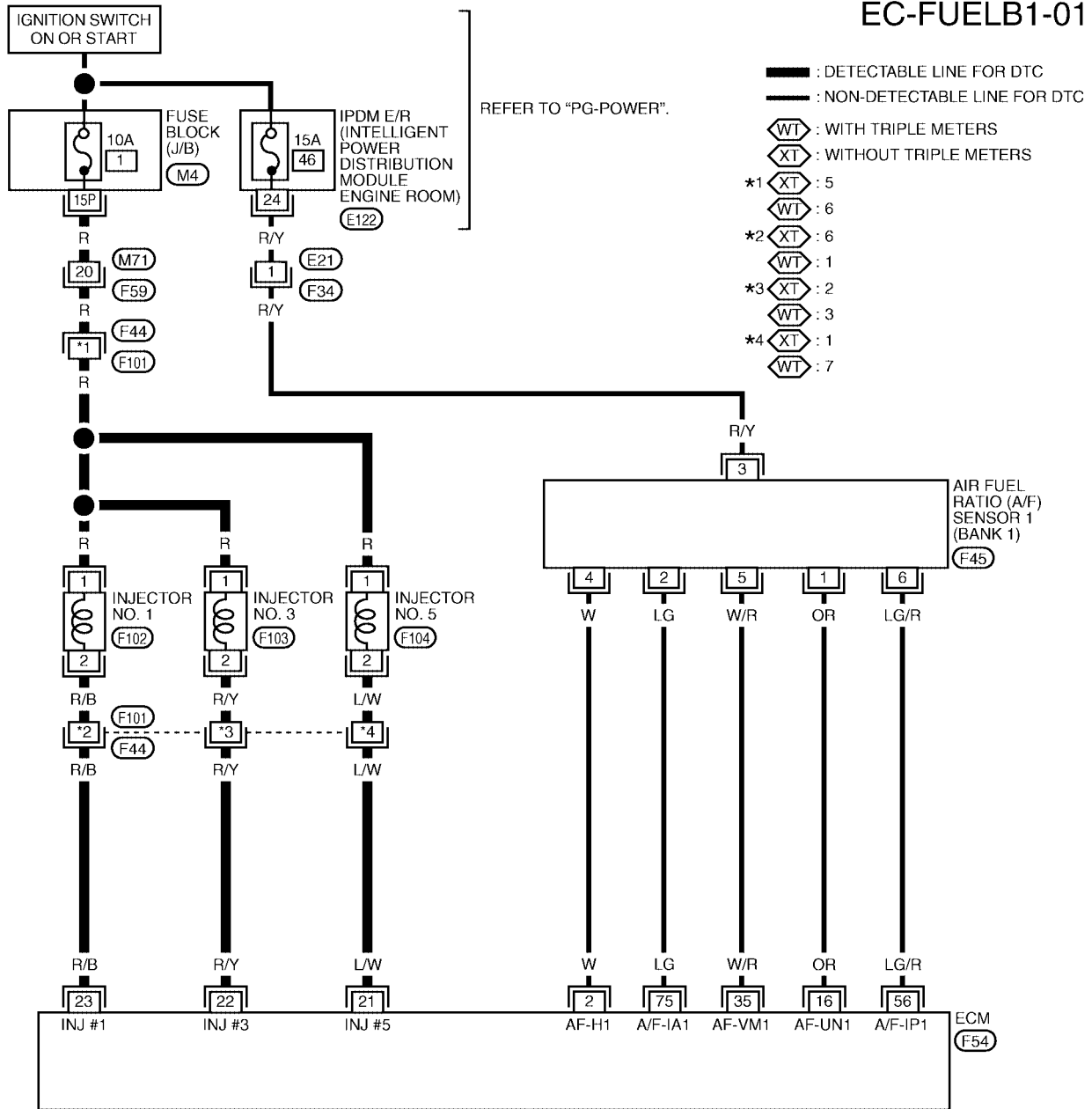

BBWA1557E

DTC P0172, P0175 FUEL INJECTION SYSTEM FUNCTION

[VQ]

BANK 2

EC-FUELB2-01

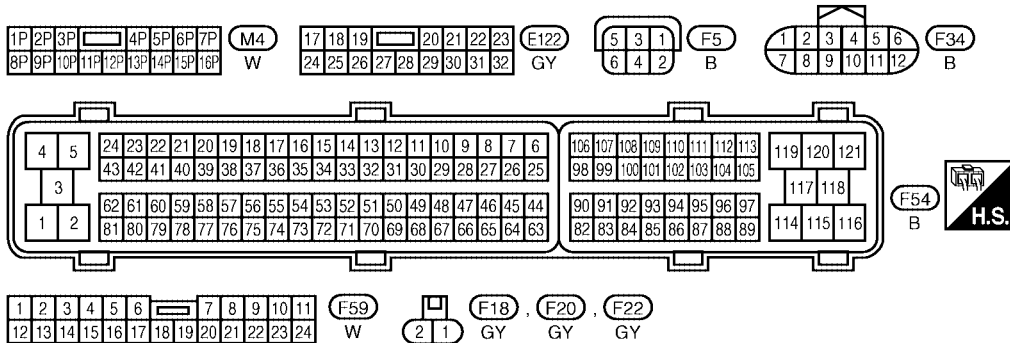
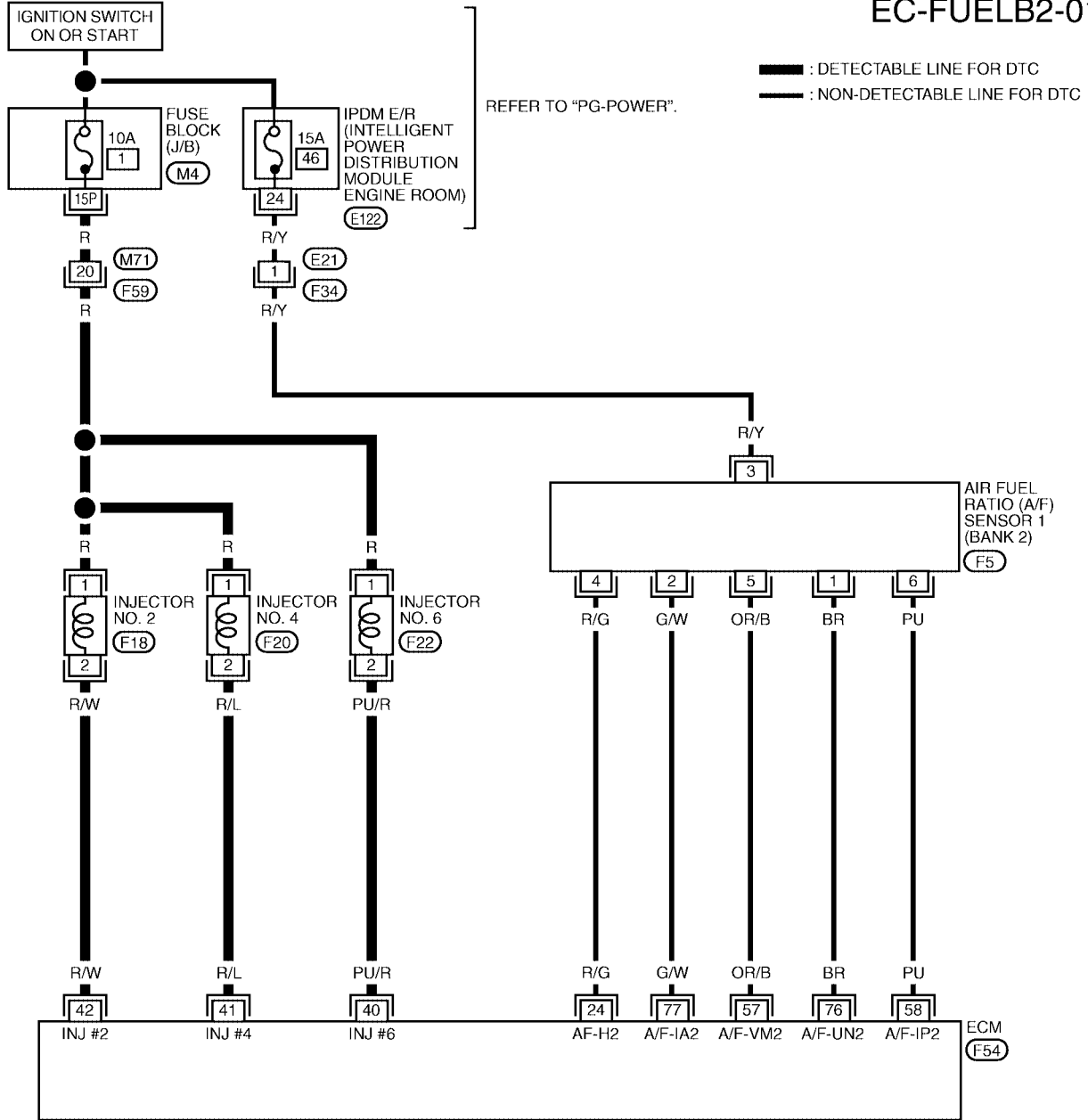

BBWA1558E

Diagnostic Procedure

1. CHECK EXHAUST GAS LEAK

1. Start engine and run it at idle.
2. Listen for an exhaust gas leak before three way catalyst (manifold).

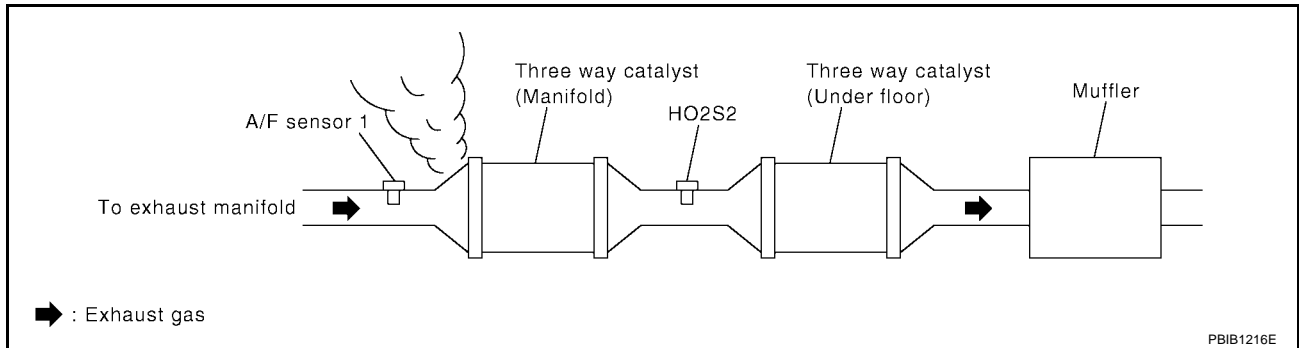

OK or NG

- OK >> GO TO 2.
- NG >> Repair or replace.

2. CHECK FOR INTAKE AIR LEAK

Listen for an intake air leak after the mass air flow sensor.

OK or NG

- OK >> GO TO 3.
- NG >> Repair or replace.

A
EC
C
D
E
F
G
H
I
J
K
L
M

3. CHECK A/F SENSOR 1 INPUT SIGNAL CIRCUIT

1. Turn ignition switch OFF.
2. Disconnect corresponding A/F sensor 1 harness connector.

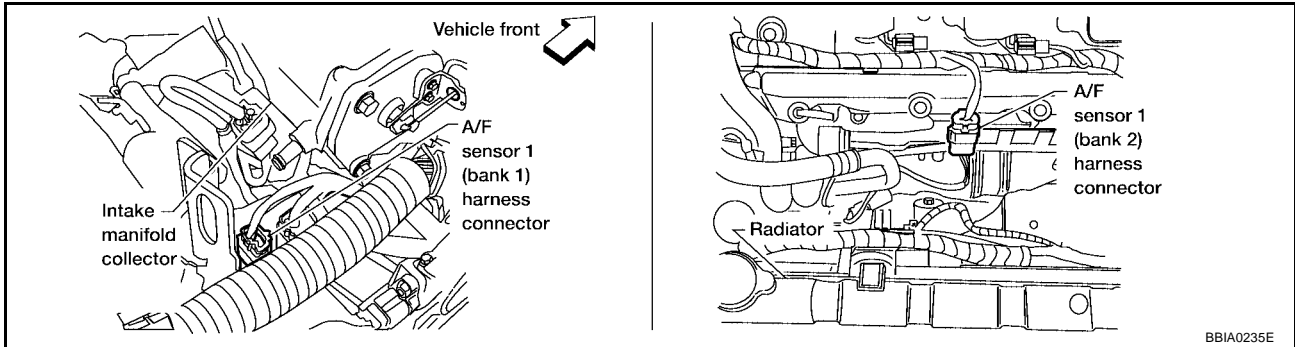

3. Disconnect ECM harness connector.
4. Check harness continuity between the following terminals. Refer to Wiring Diagram.

	A/F sensor 1 terminal	ECM terminal
Bank 1	1	16
	2	75
	5	35
	6	56
Bank 2	1	76
	2	77
	5	57
	6	58

Continuity should exist.

5. Check harness continuity between the following terminals and ground. Refer to Wiring Diagram.

Bank 1		Bank 2	
A/F sensor 1 terminal	ECM terminal	A/F sensor 1 terminal	ECM terminal
1	16	1	76
2	75	2	77
5	35	5	57
6	56	6	58

Continuity should not exist.

6. Also check harness for short to power.

OK or NG

OK >> GO TO 4.

NG >> Repair open circuit or short to ground or short to power in harness or connectors.

4. CHECK FUEL PRESSURE

1. Release fuel pressure to zero. Refer to [EC-714, "FUEL PRESSURE RELEASE"](#) .
2. Install fuel pressure gauge and check fuel pressure. Refer to [EC-714, "FUEL PRESSURE CHECK"](#) .

At idling: Approx. 350 kPa (3.57 kg/cm² , 51 psi)

OK or NG

OK (With CONSULT-II)>>GO TO 6.

OK (Without CONSULT-II)>>GO TO 7.

NG >> GO TO 5.

5. DETECT MALFUNCTIONING PART

Check the following.

- Fuel pump and circuit (Refer to, [EC-1316, "FUEL PUMP CIRCUIT"](#) .)
- Fuel pressure regulator (Refer to [EC-714, "FUEL PRESSURE CHECK"](#) .)

>> Repair or replace.

6. CHECK MASS AIR FLOW SENSOR

 **With CONSULT-II**

1. Install all removed parts.
2. Check "MASS AIR FLOW" in "DATA MONITOR" mode with CONSULT-II.

2.0 - 6.0 g-m/sec: at idling

7.0 - 20.0 g-m/sec: at 2,500 rpm

OK or NG

OK >> GO TO 8.

NG >> Check connectors for rusted terminals or loose connections in the mass air flow sensor circuit or ground. Refer to [EC-806](#) .

7. CHECK MASS AIR FLOW SENSOR

 **With GST**

1. Install all removed parts.
2. Check mass air flow sensor signal in Service \$01 with GST.

2.0 - 6.0 g-m/sec: at idling

7.0 - 20.0 g-m/sec: at 2,500 rpm

OK or NG

OK (P0172)>>GO TO 9.

OK (P0175)>>GO TO 11.

NG >> Check connectors for rusted terminals or loose connections in the mass air flow sensor circuit or ground. Refer to [EC-806](#) .

8. CHECK FUNCTION OF INJECTOR

⑧ With CONSULT-II

1. Start engine.
2. Perform "POWER BALANCE" in "ACTIVE TEST" mode with CONSULT-II.
3. Make sure that each circuit produces a momentary engine speed drop.

ACTIVE TEST	
POWER BALANCE	
MONITOR	
ENG SPEED	XXX rpm
MAS A/F SE-B1	XXX V

PBIB0133E

OK or NG

- OK >> GO TO 12.
 NG >> Perform trouble diagnosis for INJECTOR CIRCUIT, refer to [EC-1308](#) .

9. CHECK FUNCTION OF INJECTOR-I

⊗ Without CONSULT-II

1. Stop engine.
2. Disconnect harness connector F44, F101
3. Turn ignition switch ON.

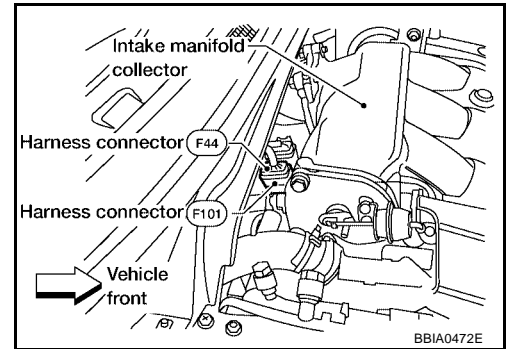

4. Check voltage between harness connector F44 terminal 6 (with triple meters) or 5 (without triple meters) and ground with CONSULT-II or tester.

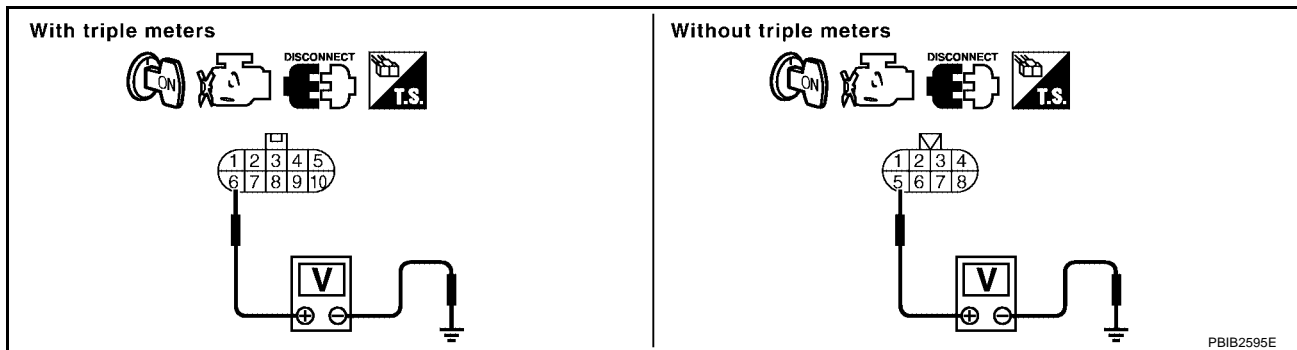

Voltage: Battery voltage

5. Turn ignition switch OFF.
6. Disconnect ECM harness connector.
7. Check harness continuity between harness connector F44 and ECM as follows. Refer to Wiring Diagram.

With triple meters

Cylinder	Harness connector F44 terminal	ECM terminal
1	1	23
3	3	22
5	7	21

Without triple meters

Cylinder	Harness connector F44 terminal	ECM terminal
1	6	23
3	2	22
5	1	21

Continuity should exist.

8. Also check harness for short to ground and short to power.

OK or NG

OK >> GO TO 10.

NG >> Perform trouble diagnosis for INJECTOR CIRCUIT, refer to [EC-1308](#).

10. CHECK FUNCTION OF INJECTOR-II

Provide battery voltage between harness connector F101 as follows and then interrupt it. Listen to each injector operating sound.

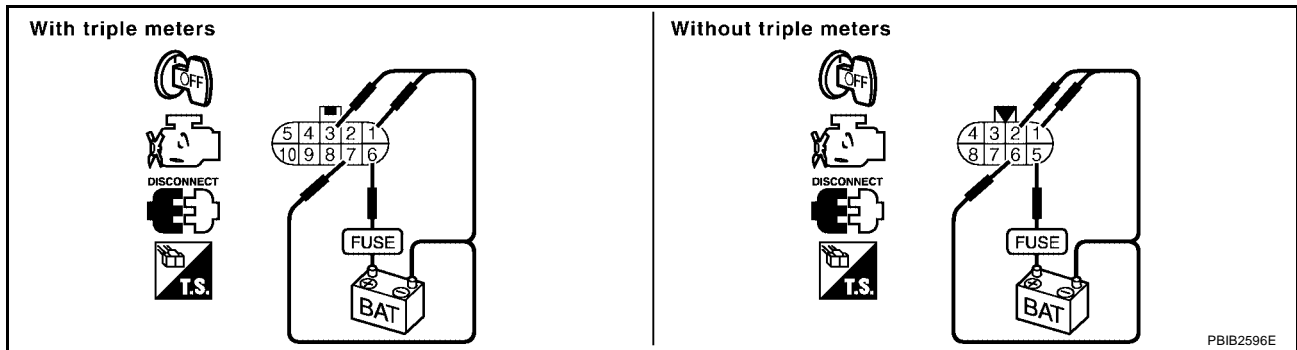

With triple meters

Cylinder	Harness connector F101 terminal	
	(+)	(-)
1	6	1
3	6	3
5	6	7

Without triple meters

Cylinder	Harness connector F101 terminal	
	(+)	(-)
1	5	6
3	5	2
5	5	1

Operating sound should exist.

OK or NG

OK >> GO TO 12.

NG >> Perform trouble diagnosis for INJECTOR CIRCUIT, refer to [EC-1308](#).

11. CHECK FUNCTION OF INJECTOR

1. Start engine.
2. Listen to injectors No.2, No.4, No.6 operating sound.

Clicking noise should exist.

OK or NG

OK >> GO TO 12.

NG >> Perform trouble diagnosis for INJECTOR CIRCUIT, refer to [EC-1308](#).

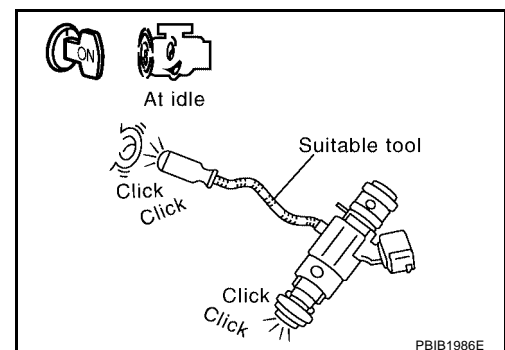

12. CHECK INJECTOR

1. Remove injector assembly. Refer to [EM-147, "FUEL INJECTOR AND FUEL TUBE"](#) .
Keep fuel hose and all injectors connected to injector gallery.
2. Confirm that the engine is cooled down and there are no fire hazards near the vehicle.
3. Disconnect all injector harness connectors.
4. Disconnect all ignition coil harness connectors.
5. Prepare pans or saucers under each injectors.
6. Crank engine for about 3 seconds.
Make sure fuel does not drip from injector.

OK or NG

OK (Does not drip.)>>GO TO 13.

NG (Drips.)>>Replace the injectors from which fuel is dripping. Always replace O-ring with new one.

13. CHECK INTERMITTENT INCIDENT

Refer to [EC-782, "TROUBLE DIAGNOSIS FOR INTERMITTENT INCIDENT"](#) .

>> INSPECTION END

A

EC

C

D

E

F

G

H

I

J

K

L

M

DTC P0181 FTT SENSOR

Component Description

The fuel tank temperature sensor is used to detect the fuel temperature inside the fuel tank. The sensor modifies a voltage signal from the ECM. The modified signal returns to the ECM as the fuel temperature input. The sensor uses a thermistor which is sensitive to the change in temperature. The electrical resistance of the thermistor decreases as temperature increases.

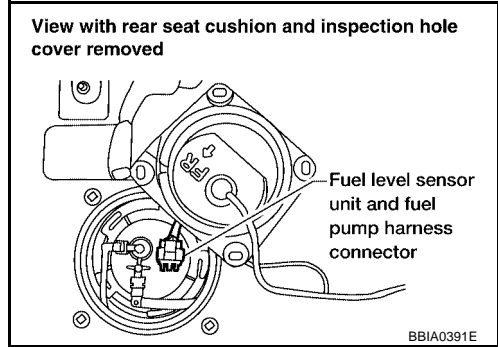

<Reference data>

Fluid temperature °C (°F)	Voltage* V	Resistance kΩ
20 (68)	3.5	2.3 - 2.7
50 (122)	2.2	0.79 - 0.90

*: This data is reference value and is measured between ECM terminal 107 (Fuel tank temperature sensor) and ground.

CAUTION:

Do not use ECM ground terminals when measuring input/output voltage. Doing so may result in damage to the ECM's transistor. Use a ground other than ECM terminals, such as the ground.

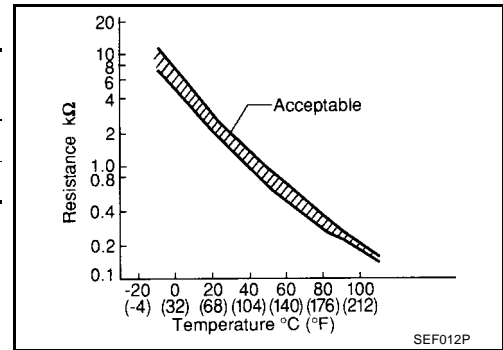

On Board Diagnosis Logic

DTC No.	Trouble diagnosis name	DTC detecting condition	Possible cause
P0181 0181	Fuel tank temperature sensor circuit range/performance	Rationally incorrect voltage from the sensor is sent to ECM, compared with the voltage signals from engine coolant temperature sensor and intake air temperature sensor.	<ul style="list-style-type: none"> ● Harness or connectors (The sensor circuit is open or shorted) ● Fuel tank temperature sensor

DTC Confirmation Procedure

NOTE:

If DTC Confirmation Procedure has been previously conducted, always turn ignition switch OFF and wait at least 10 seconds before conducting the next test.

WITH CONSULT-II

1. Turn ignition switch ON.
2. Select "DATA MONITOR" mode with CONSULT-II.
3. Wait at least 10 seconds.
If the result is NG, go to [EC-893, "Diagnostic Procedure"](#).
If the result is OK, go to following step.
4. Check "COOLAN TEMP/S" value.
If "COOLAN TEMP/S" is less than 60°C (140°F), the result will be OK.
If "COOLAN TEMP/S" is above 60°C (140°F), go to the following step.
5. Cool engine down until "COOLAN TEMP/S" is less than 60°C (140°F).
6. Wait at least 10 seconds.
7. If 1st trip DTC is detected, go to [EC-893, "Diagnostic Procedure"](#).

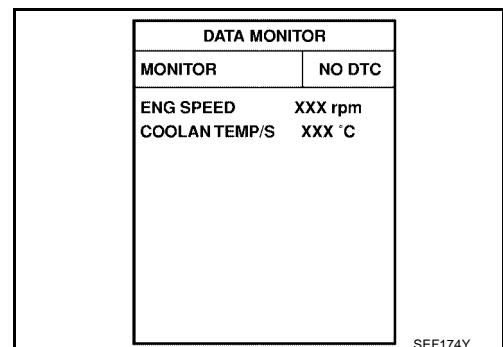

DTC P0181 FTT SENSOR

[VQ]



WITH GST

Follow the procedure "WITH CONSULT-II" above.

A

EC

C

D

E

F

G

H

I

J

K

L

M

DTC P0181 FTT SENSOR

[VQ]

Wiring Diagram

UBS00130

EC-FTTS-01

— : DETECTABLE LINE FOR DTC
 - - - : NON-DETECTABLE LINE FOR DTC

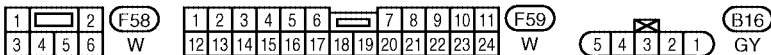
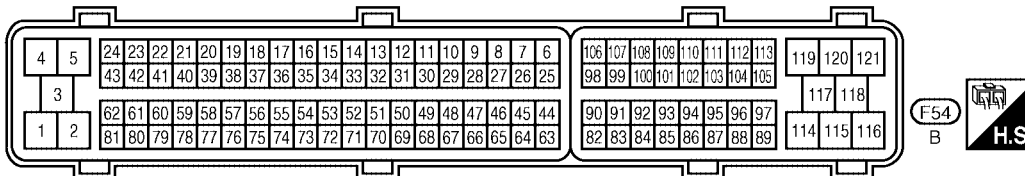
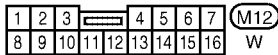
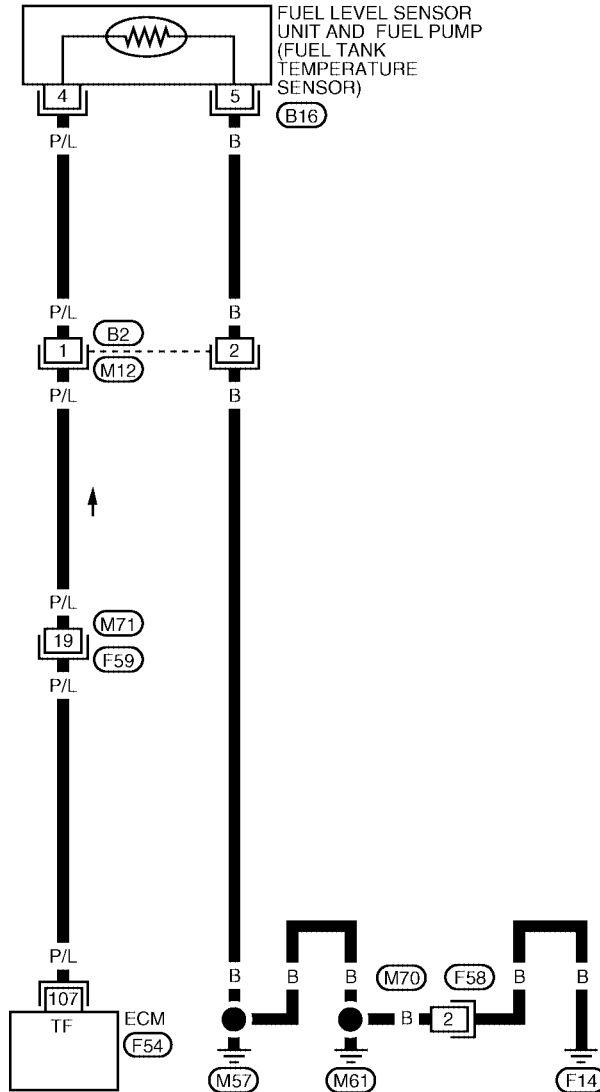

BBWA1559E

Diagnostic Procedure

1. CHECK GROUND CONNECTIONS

1. Turn ignition switch OFF.
2. Loosen and retighten three ground screws on the body.
Refer to [EC-789, "Ground Inspection"](#).

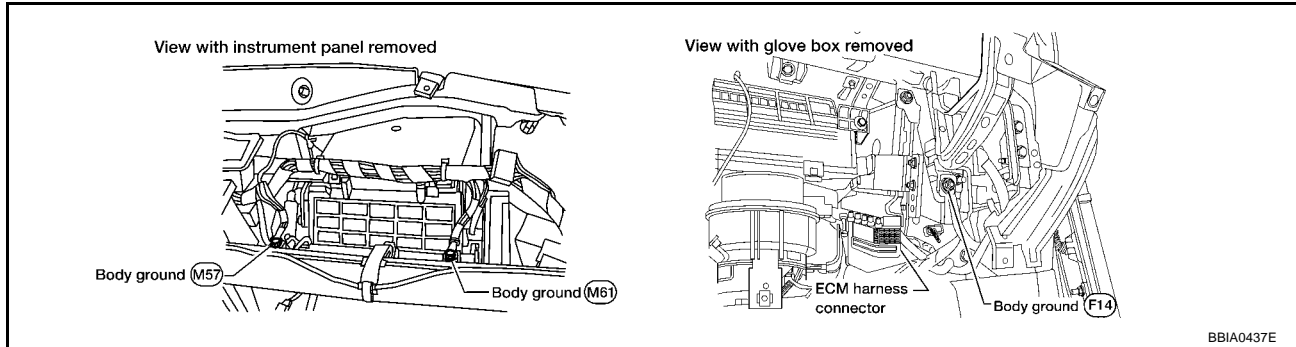

OK or NG

- OK >> GO TO 2.
- NG >> Repair or replace ground connections.

2. CHECK FUEL TANK TEMPERATURE SENSOR POWER SUPPLY CIRCUIT

1. Disconnect "fuel level sensor unit and fuel pump" harness connector.
2. Turn ignition switch ON.

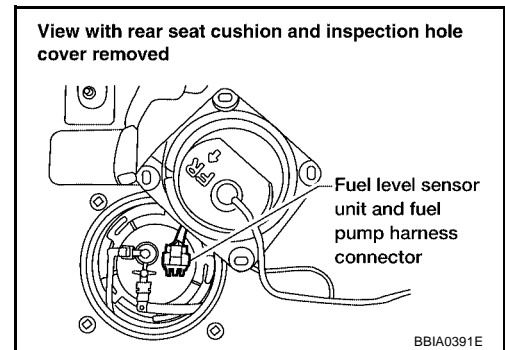

3. Check voltage between "fuel level sensor unit and fuel pump" terminal 4 and ground with CONSULT-II or tester.

Voltage: Approximately 5V

OK or NG

- OK >> GO TO 4.
- NG >> GO TO 3.

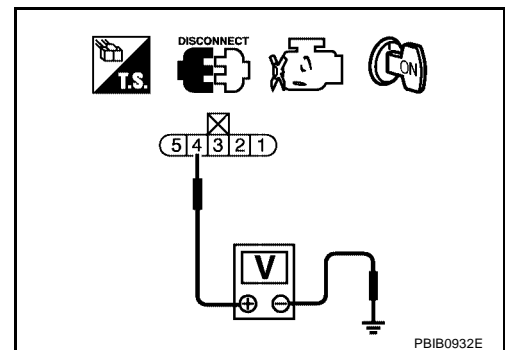

3. DETECT MALFUNCTIONING PART

Check the following.

- Harness connectors B2, M12
- Harness connectors M71, F59
- Harness for open or short between ECM and "fuel level sensor unit and fuel pump"

>> Repair open circuit or short to power in harness or connector.

4. CHECK FUEL TANK TEMPERATURE SENSOR GROUND CIRCUIT FOR OPEN AND SHORT

1. Turn ignition switch OFF.
2. Check harness continuity between “fuel level sensor unit and fuel pump” terminal 5 and ground. Refer to Wiring Diagram.

Continuity should exist.

3. Also check harness for short to power.

OK or NG

- OK >> GO TO 6.
- NG >> GO TO 5.

5. DETECT MALFUNCTIONING PART

Check the following.

- Harness connectors B2, M12
- Harness connectors M70, F58
- Harness for open or short between “fuel level sensor unit and fuel pump” and ground

>> Repair open circuit or short to power in harness or connector.

6. CHECK FUEL TANK TEMPERATURE SENSOR

Refer to [EC-894, "Component Inspection"](#) .

OK or NG

- OK >> GO TO 7.
- NG >> Replace fuel level sensor unit.

7. CHECK INTERMITTENT INCIDENT

Refer to [EC-782, "TROUBLE DIAGNOSIS FOR INTERMITTENT INCIDENT"](#) .

>> **INSPECTION END**

**Component Inspection
FUEL TANK TEMPERATURE SENSOR**

UBS0013Q

1. Remove fuel level sensor unit.
2. Check resistance between “fuel level sensor unit and fuel pump” terminals 4 and 5 by heating with hot water or heat gun as shown in the figure.

Temperature °C (°F)	Resistance kΩ
20 (68)	2.3 - 2.7
50 (122)	0.79 - 0.90

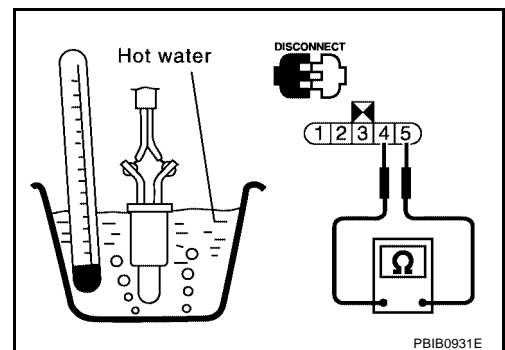

UBS0013R

**Removal and Installation
FUEL TANK TEMPERATURE SENSOR**

Refer to [FL-5, "FUEL LEVEL SENSOR UNIT, FUEL FILTER AND FUEL PUMP ASSEMBLY"](#) .

DTC P0182, P0183 FTT SENSOR

Component Description

The fuel tank temperature sensor is used to detect the fuel temperature inside the fuel tank. The sensor modifies a voltage signal from the ECM. The modified signal returns to the ECM as the fuel temperature input. The sensor uses a thermistor which is sensitive to the change in temperature. The electrical resistance of the thermistor decreases as temperature increases.

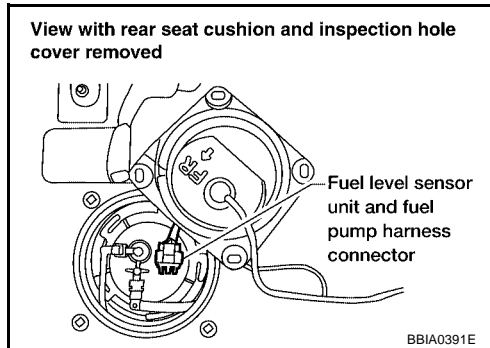

<Reference data>

Fluid temperature °C (°F)	Voltage* V	Resistance kΩ
20 (68)	3.5	2.3 - 2.7
50 (122)	2.2	0.79 - 0.90

*: This data is reference value and is measured between ECM terminal 107 (Fuel tank temperature sensor) and ground.

CAUTION:
Do not use ECM ground terminals when measuring input/output voltage. Doing so may result in damage to the ECM's transistor. Use a ground other than ECM terminals, such as the ground.

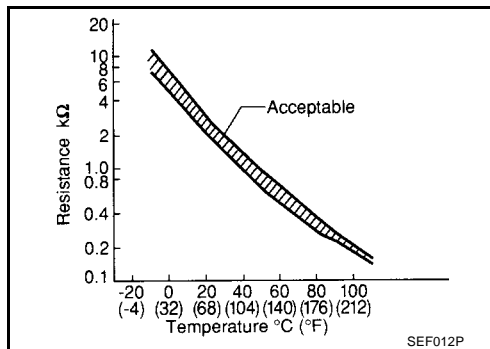

On Board Diagnosis Logic

DTC No.	Trouble diagnosis name	DTC detecting condition	Possible cause
P0182 0182	Fuel tank temperature sensor circuit low input	An excessively low voltage from the sensor is sent to ECM.	<ul style="list-style-type: none"> ● Harness or connectors (The sensor circuit is open or shorted.) ● Fuel tank temperature sensor
P0183 0183	Fuel tank temperature sensor circuit high input	An excessively high voltage from the sensor is sent to ECM.	

DTC Confirmation Procedure

NOTE:

If DTC Confirmation Procedure has been previously conducted, always turn ignition switch OFF and wait at least 10 seconds before conducting the next test.

WITH CONSULT-II

1. Turn ignition switch ON.
2. Select "DATA MONITOR" mode with CONSULT-II.
3. Wait at least 5 seconds.
4. If 1st trip DTC is detected, go to [EC-897, "Diagnostic Procedure"](#)

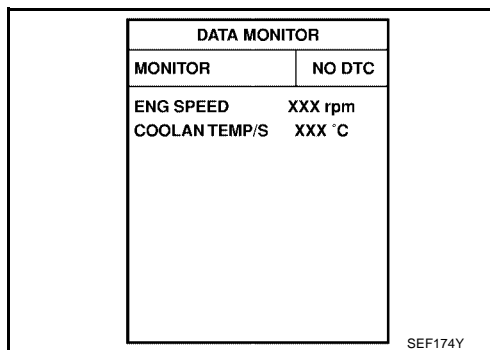

WITH GST

Follow the procedure "WITH CONSULT-II" above.

DTC P0182, P0183 FTT SENSOR

[VQ]

Wiring Diagram

UBS0013V

EC-FTTS-01

— : DETECTABLE LINE FOR DTC
 - - - : NON-DETECTABLE LINE FOR DTC

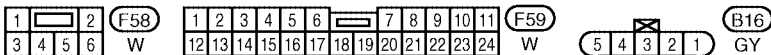
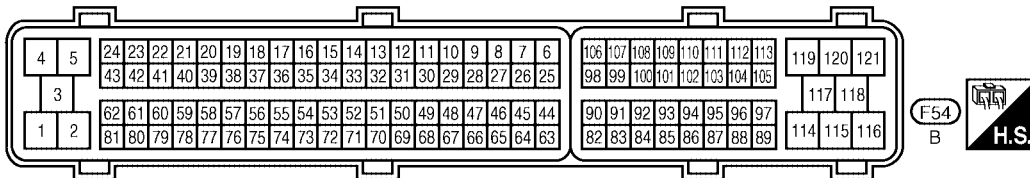
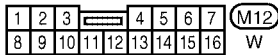
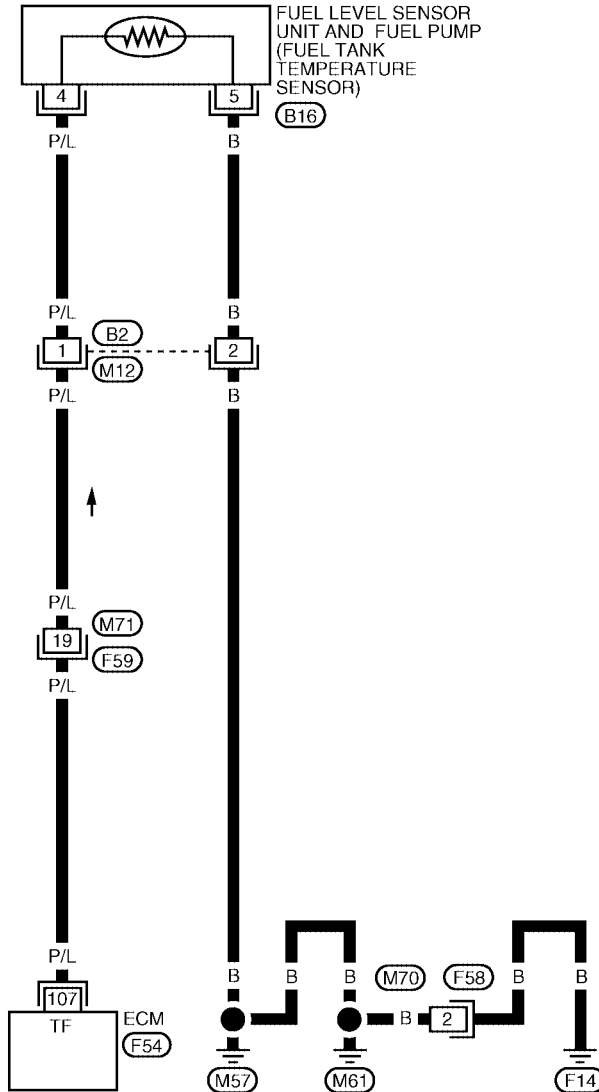

BBWA1559E

Diagnostic Procedure

1. CHECK GROUND CONNECTIONS

1. Turn ignition switch OFF.
2. Loosen and retighten three ground screws on the body.
Refer to [EC-789, "Ground Inspection"](#).

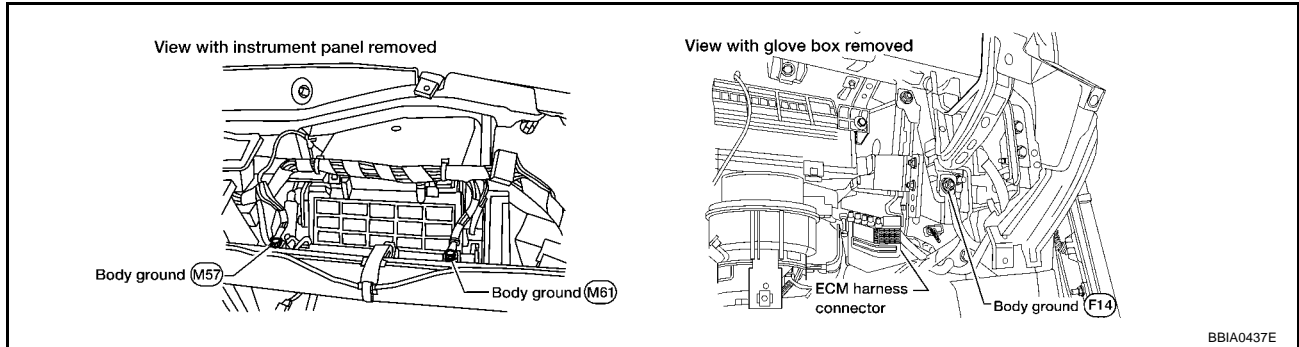

OK or NG

- OK >> GO TO 2.
- NG >> Repair or replace ground connections.

2. CHECK FUEL TANK TEMPERATURE SENSOR POWER SUPPLY CIRCUIT

1. Disconnect "fuel level sensor unit and fuel pump" harness connector.
2. Turn ignition switch ON.

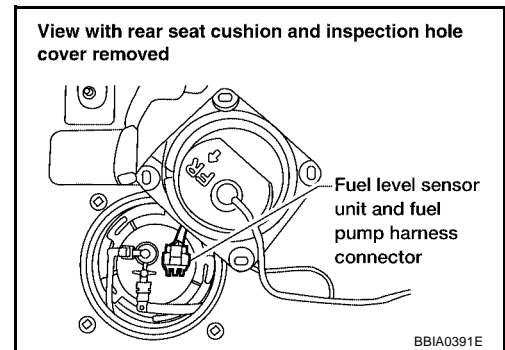

3. Check voltage between "fuel level sensor unit and fuel pump" terminal 4 and ground with CONSULT-II or tester.

Voltage: Approximately 5V

OK or NG

- OK >> GO TO 4.
- NG >> GO TO 3.

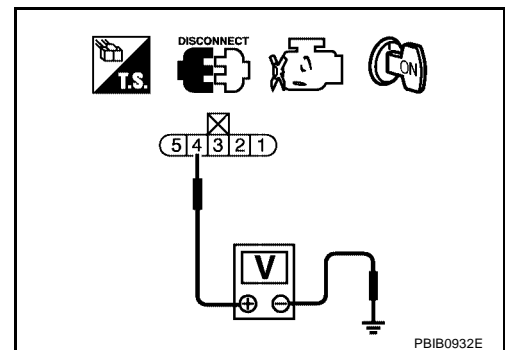

3. DETECT MALFUNCTIONING PART

Check the following.

- Harness connectors B2, M12
- Harness connectors M71, F59
- Harness for open or short between ECM and "fuel level sensor unit and fuel pump"

>> Repair open circuit or short to power in harness or connector.

4. CHECK FUEL TANK TEMPERATURE SENSOR GROUND CIRCUIT FOR OPEN AND SHORT

1. Turn ignition switch OFF.
2. Check harness continuity between “fuel level sensor unit and fuel pump” terminal 5 and ground. Refer to Wiring Diagram.

Continuity should exist.

3. Also check harness for short to power.

OK or NG

- OK >> GO TO 6.
- NG >> GO TO 5.

5. DETECT MALFUNCTIONING PART

Check the following.

- Harness connectors B2, M12
- Harness connectors M70, F58
- Harness for open or short between “fuel level sensor unit and fuel pump” and ground

>> Repair open circuit or short to power in harness or connector.

6. CHECK FUEL TANK TEMPERATURE SENSOR

Refer to [EC-894, "Component Inspection"](#) .

OK or NG

- OK >> GO TO 7.
- NG >> Replace fuel level sensor unit.

7. CHECK INTERMITTENT INCIDENT

Refer to [EC-782, "TROUBLE DIAGNOSIS FOR INTERMITTENT INCIDENT"](#) .

>> **INSPECTION END**

**Component Inspection
FUEL TANK TEMPERATURE SENSOR**

UBS0013X

1. Remove fuel level sensor unit.
2. Check resistance between “fuel level sensor unit and fuel pump” terminals 4 and 5 by heating with hot water or heat gun as shown in the figure.

Temperature °C (°F)	Resistance kΩ
20 (68)	2.3 - 2.7
50 (122)	0.79 - 0.90

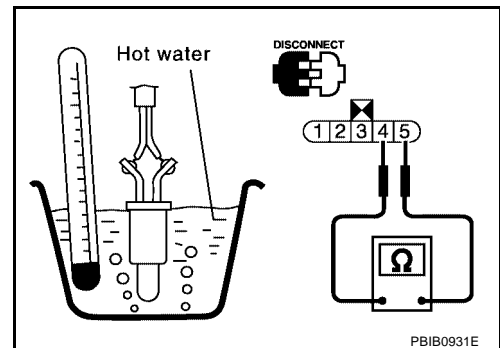

UBS0013Y

**Removal and Installation
FUEL TANK TEMPERATURE SENSOR**

Refer to [FL-5, "FUEL LEVEL SENSOR UNIT, FUEL FILTER AND FUEL PUMP ASSEMBLY"](#) .

DTC P0222, P0223 TP SENSOR

PF1:16119

Component Description

UBS0013Z

Electric throttle control actuator consists of throttle control motor, throttle position sensor, etc. The throttle position sensor responds to the throttle valve movement.

The throttle position sensor has the two sensors. These sensors are a kind of potentiometers which transform the throttle valve position into output voltage, and emit the voltage signal to the ECM. In addition, these sensors detect the opening and closing speed of the throttle valve and feed the voltage signals to the ECM. The ECM judges the current opening angle of the throttle valve from these signals and the ECM controls the throttle control motor to make the throttle valve opening angle properly in response to driving condition.

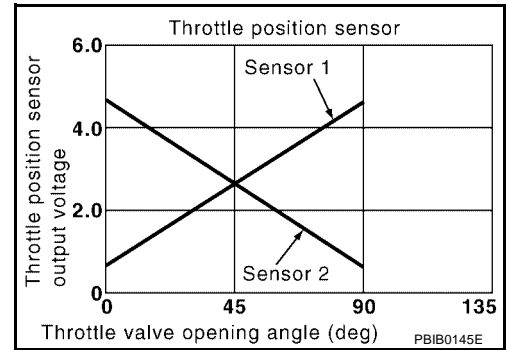

CONSULT-II Reference Value in Data Monitor Mode

UBS00140

Specification data are reference values.

MONITOR ITEM	CONDITION		SPECIFICATION
THRTL SEN1 THRTL SEN2*	● Ignition switch: ON (Engine stopped)	Accelerator pedal: Fully released	More than 0.36V
	● Shift lever: D (A/T), 1st (M/T)	Accelerator pedal: Fully depressed	Less than 4.75V

*: Throttle position sensor 2 signal is converted by ECM internally. Thus, it differs from ECM terminal voltage signal.

On Board Diagnosis Logic

UBS00141

These self-diagnoses have the one trip detection logic.

DTC No.	Trouble diagnosis name	DTC detecting condition	Possible cause
P0222 0222	Throttle position sensor 1 circuit low input	An excessively low voltage from the TP sensor 1 is sent to ECM.	<ul style="list-style-type: none"> ● Harness or connectors (The TP sensor 1 circuit is open or shorted.) (APP sensor 2 circuit is shorted.) ● Electric throttle control actuator (TP sensor 1) ● Accelerator pedal position sensor (APP sensor 2)
P0223 0223	Throttle position sensor 1 circuit high input	An excessively high voltage from the TP sensor 1 is sent to ECM.	

FAIL-SAFE MODE

When the malfunction is detected, ECM enters fail-safe mode and the MIL lights up.

Engine operation condition in fail-safe mode

The ECM controls the electric throttle control actuator in regulating the throttle opening in order for the idle position to be within +10 degrees.

The ECM regulates the opening speed of the throttle valve to be slower than the normal condition.

So, the acceleration will be poor.

DTC Confirmation Procedure

NOTE:

If DTC Confirmation Procedure has been previously conducted, always turn ignition switch OFF and wait at least 10 seconds before conducting the next test.

TESTING CONDITION:

Before performing the following procedure, confirm that battery voltage is more than 10V at idle.

WITH CONSULT-II

1. Turn ignition switch ON.
2. Select "DATA MONITOR" mode with CONSULT-II.
3. Start engine and let it idle for 1 second.
4. If DTC is detected, go to [EC-902, "Diagnostic Procedure"](#) .

DATA MONITOR	
MONITOR	NO DTC
ENG SPEED	XXX rpm

SEF058Y

WITH GST

Follow the procedure WITH CONSULT-II above.

DTC P0222, P0223 TP SENSOR

[VQ]

Wiring Diagram

UBS00143

EC-TPS1-01

: DETECTABLE LINE FOR DTC
 : NON-DETECTABLE LINE FOR DTC

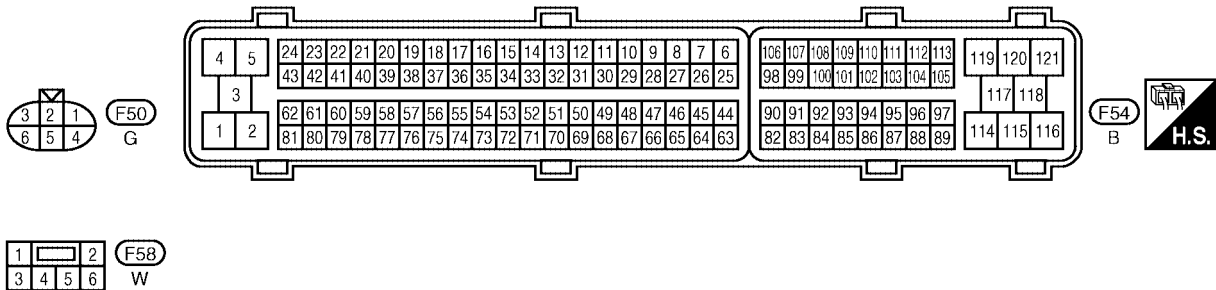
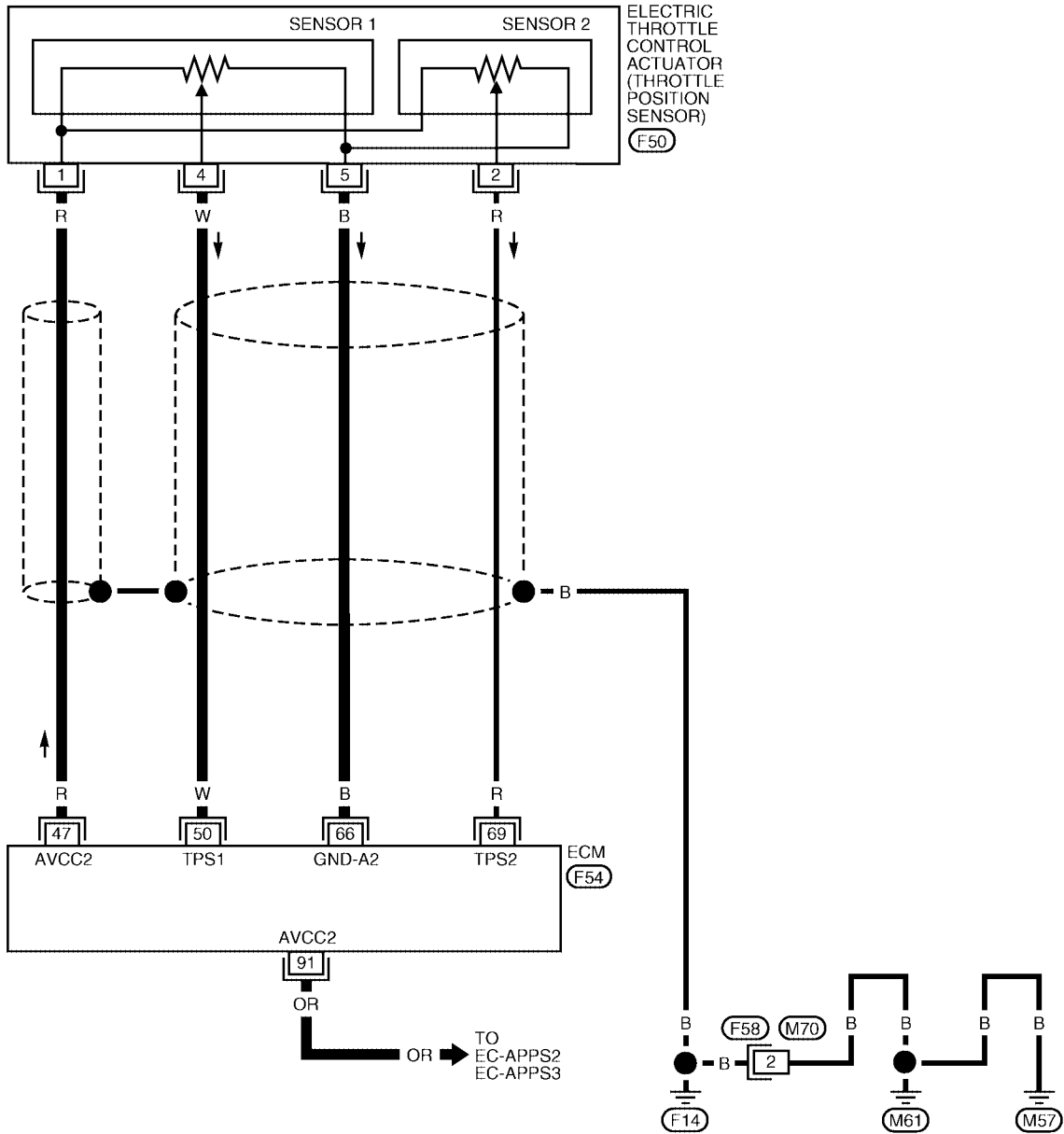

BBWA1591E

DTC P0222, P0223 TP SENSOR

[VQ]

Specification data are reference values and are measured between each terminal and ground.

CAUTION:

Do not use ECM ground terminals when measuring input/output voltage. Doing so may result in damage to the ECM's transistor. Use a ground other than ECM terminals, such as the ground.

TER-MINAL NO.	WIRE COLOR	ITEM	CONDITION	DATA (DC Voltage)
47	R	Sensor power supply (Throttle position sensor)	[Ignition switch: ON]	Approximately 5V
50	W	Throttle position sensor 1	[Ignition switch: ON] <ul style="list-style-type: none"> ● Engine stopped ● Shift lever: D (A/T) or 1st (M/T) ● Accelerator pedal: Fully released 	More than 0.36V
			[Ignition switch: ON] <ul style="list-style-type: none"> ● Engine stopped ● Shift lever: D (A/T) or 1st (M/T) ● Accelerator pedal: Fully depressed 	Less than 4.75V
66	B	Sensor ground (Throttle position sensor)	[Engine is running] <ul style="list-style-type: none"> ● Warm-up condition ● Idle speed 	Approximately 0V
69	R	Throttle position sensor 2	[Ignition switch: ON] <ul style="list-style-type: none"> ● Engine stopped ● Shift lever: D (A/T) or 1st (M/T) ● Accelerator pedal: Fully released 	Less than 4.75V
			[Ignition switch: ON] <ul style="list-style-type: none"> ● Engine stopped ● Shift lever: D (A/T) or 1st (M/T) ● Accelerator pedal: Fully depressed 	More than 0.36V
91	OR	Sensor power supply (APP sensor 2)	[Ignition switch: ON]	Approximately 5V

Diagnostic Procedure

UBS00144

1. CHECK GROUND CONNECTIONS

1. Turn ignition switch OFF.
2. Loosen and retighten three ground screws on the body.
Refer to [EC-789, "Ground Inspection"](#).

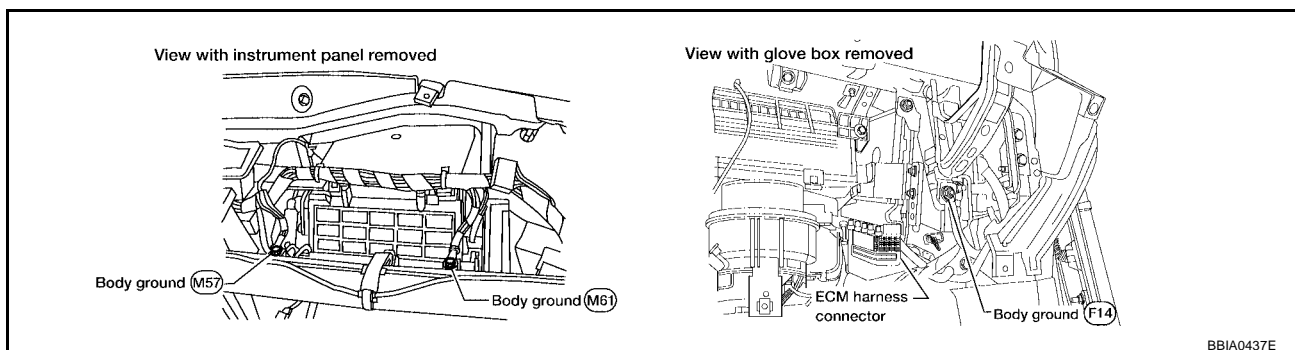

BBI40437E

OK or NG

- OK >> GO TO 2.
- NG >> Repair or replace ground connections.

2. CHECK THROTTLE POSITION SENSOR 1 POWER SUPPLY CIRCUIT-I

1. Disconnect electric throttle control actuator harness connector.
2. Turn ignition switch ON.

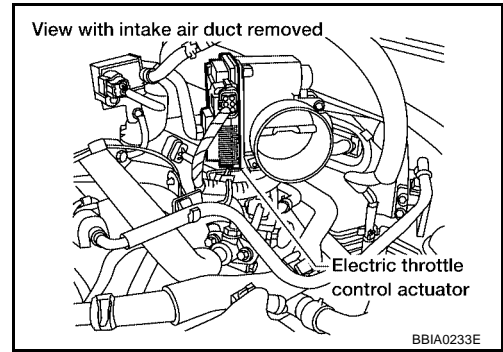

3. Check voltage between electric throttle control actuator terminal 1 and ground with CONSULT-II or tester.

Voltage: Approximately 5V

OK or NG

- OK >> GO TO 7.
- NG >> GO TO 3.

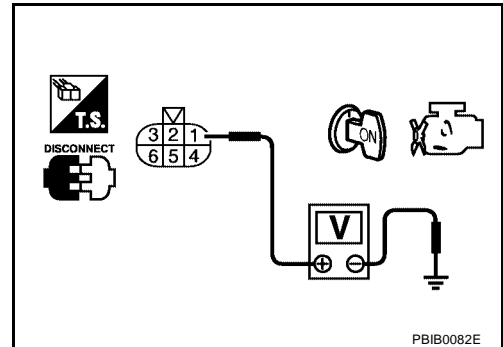

3. CHECK THROTTLE POSITION SENSOR 1 POWER SUPPLY CIRCUIT-II

1. Turn ignition switch OFF.
2. Disconnect ECM harness connector.
3. Check harness continuity between electric throttle control actuator terminal 1 and ECM terminal 47. Refer to Wiring Diagram.

Continuity should exist.

OK or NG

- OK >> GO TO 4.
- NG >> Repair or replace open circuit.

4. CHECK THROTTLE POSITION SENSOR 1 POWER SUPPLY CIRCUIT-III

Check harness for short to power and short to ground, between the following terminals.

ECM terminal	Sensor terminal	Reference Wiring Diagram
47	Electric throttle control actuator terminal 1	EC-901
91	APP sensor terminal 1	EC-1267

OK or NG

- OK >> GO TO 5.
- NG >> Repair short to ground or short to power in harness or connectors.

5. CHECK APP SENSOR

Refer to [EC-1271, "Component Inspection"](#) .

OK or NG

- OK >> GO TO 11.
- NG >> GO TO 6.

6. REPLACE ACCELERATOR PEDAL ASSEMBLY

1. Replace accelerator pedal assembly.
2. Perform [EC-711, "Accelerator Pedal Released Position Learning"](#) .
3. Perform [EC-711, "Throttle Valve Closed Position Learning"](#) .
4. Perform [EC-712, "Idle Air Volume Learning"](#) .

>> INSPECTION END

7. CHECK THROTTLE POSITION SENSOR 1 GROUND CIRCUIT FOR OPEN AND SHORT

1. Turn ignition switch OFF.
2. Disconnect ECM harness connector.
3. Check harness continuity between electric throttle control actuator terminal 5 and ECM terminal 66.
Refer to Wiring Diagram.

Continuity should exist.

4. Also check harness for short to ground and short to power.

OK or NG

OK >> GO TO 8.

NG >> Repair open circuit or short to ground or short to power in harness or connectors.

8. CHECK THROTTLE POSITION SENSOR 1 INPUT SIGNAL CIRCUIT FOR OPEN AND SHORT

1. Check harness continuity between ECM terminal 50 and electric throttle control actuator terminal 4.
Refer to Wiring Diagram.

Continuity should exist.

2. Also check harness for short to ground and short to power.

OK or NG

OK >> GO TO 9.

NG >> Repair open circuit or short to ground or short to power in harness or connectors.

9. CHECK THROTTLE POSITION SENSOR

Refer to [EC-837, "Component Inspection"](#) .

OK or NG

OK >> GO TO 11.

NG >> GO TO 10.

10. REPLACE ELECTRIC THROTTLE CONTROL ACTUATOR

1. Replace the electric throttle control actuator.
2. Perform [EC-711, "Throttle Valve Closed Position Learning"](#) .
3. Perform [EC-712, "Idle Air Volume Learning"](#) .

>> INSPECTION END

11. CHECK INTERMITTENT INCIDENT

Refer to [EC-782, "TROUBLE DIAGNOSIS FOR INTERMITTENT INCIDENT"](#) .

>> INSPECTION END

Component Inspection
THROTTLE POSITION SENSOR

1. Reconnect all harness connectors disconnected.
2. Perform [EC-711, "Throttle Valve Closed Position Learning"](#) .
3. Turn ignition switch ON.
4. Set Shift lever to D (A/T) or 1st (M/T) position.
5. Check voltage between ECM terminals 50 (TP sensor 1 signal), 69 (TP sensor 2 signal) and ground under the following conditions.

Terminal	Accelerator pedal	Voltage
50 (Throttle position sensor 1)	Fully released	More than 0.36V
	Fully depressed	Less than 4.75V
69 (Throttle position sensor 2)	Fully released	Less than 4.75V
	Fully depressed	More than 0.36V

6. If NG, replace electric throttle control actuator and go to the next step.
7. Perform [EC-711, "Throttle Valve Closed Position Learning"](#) .
8. Perform [EC-712, "Idle Air Volume Learning"](#) .

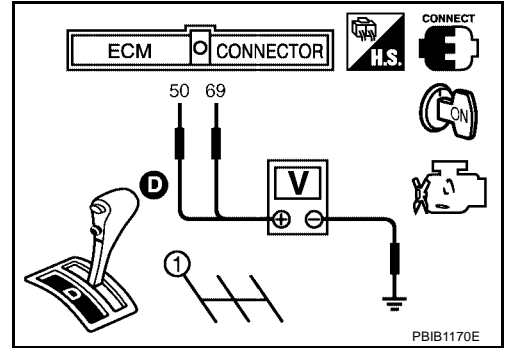

Removal and Installation

ELECTRIC THROTTLE CONTROL ACTUATOR

Refer to [EM-122, "INTAKE MANIFOLD COLLECTOR"](#) .

A
EC
C
D
E
F
G
H
I
J
K
L
M

DTC P0300 - P0306 MULTIPLE CYLINDER MISFIRE, NO. 1 - 6 CYLINDER MISFIRE

[VQ]

DTC P0300 - P0306 MULTIPLE CYLINDER MISFIRE, NO. 1 - 6 CYLINDER MISFIRE

PFP:00000

On Board Diagnosis Logic

UBS00147

When a misfire occurs, engine speed will fluctuate. If the engine speed fluctuates enough to cause the crankshaft position (CKP) sensor (POS) signal to vary, ECM can determine that a misfire is occurring.

Sensor	Input Signal to ECM	ECM function
Crankshaft position sensor (POS)	Engine speed	On board diagnosis of misfire

The misfire detection logic consists of the following two conditions.

- One Trip Detection Logic (Three Way Catalyst Damage)**
On the first trip that a misfire condition occurs that can damage the three way catalyst (TWC) due to overheating, the MIL will blink.
When a misfire condition occurs, the ECM monitors the CKP sensor signal every 200 engine revolutions for a change.
When the misfire condition decreases to a level that will not damage the TWC, the MIL will turn off.
If another misfire condition occurs that can damage the TWC on a second trip, the MIL will blink.
When the misfire condition decreases to a level that will not damage the TWC, the MIL will remain on.
If another misfire condition occurs that can damage the TWC, the MIL will begin to blink again.
- Two Trip Detection Logic (Exhaust quality deterioration)**
For misfire conditions that will not damage the TWC (but will affect vehicle emissions), the MIL will only light when the misfire is detected on a second trip. During this condition, the ECM monitors the CKP sensor signal every 1,000 engine revolutions.
A misfire malfunction can be detected on any one cylinder or on multiple cylinders.

DTC No.	Trouble diagnosis name	DTC detecting condition	Possible cause
P0300 0300	Multiple cylinder misfire detected	Multiple cylinder misfire.	<ul style="list-style-type: none">● Improper spark plug● Insufficient compression● Incorrect fuel pressure● The injector circuit is open or shorted● Fuel injector● Intake air leak● The ignition signal circuit is open or shorted● Lack of fuel● Signal plate● Air fuel ratio (A/F) sensor 1● Incorrect PCV hose connection
P0301 0301	No. 1 cylinder misfire detected	No. 1 cylinder misfires.	
P0302 0302	No. 2 cylinder misfire detected	No. 2 cylinder misfires.	
P0303 0303	No. 3 cylinder misfire detected	No. 3 cylinder misfires.	
P0304 0304	No. 4 cylinder misfire detected	No. 4 cylinder misfires.	
P0305 0305	No. 5 cylinder misfire detected	No. 5 cylinder misfires.	
P0306 0306	No. 6 cylinder misfire detected	No. 6 cylinder misfires.	

DTC Confirmation Procedure

UBS00148

CAUTION:

Always drive vehicle in safe manner according to traffic conditions and obey all traffic laws when driving.

NOTE:

If DTC Confirmation Procedure has been previously conducted, always turn ignition switch OFF and wait at least 10 seconds before conducting the next test.

WITH CONSULT-II

1. Turn ignition switch ON, and select "DATA MONITOR" mode with CONSULT-II.
2. Start engine and warm it up to normal operating temperature.
3. Turn ignition switch OFF and wait at least 10 seconds.
4. Restart engine and let it idle for about 15 minutes.
5. If 1st trip DTC is detected, go to [EC-907, "Diagnostic Procedure"](#).

DATA MONITOR	
MONITOR	NO DTC
ENG SPEED	XXX rpm
COOLAN TEMP/S	XXX °C
VHCL SPEED SE	XXX km/h
B/FUEL SCHDL	XXX msec

PBIB0164E

NOTE:

If 1st trip DTC is not detected during above procedure, performing the following procedure is advised.

- a. Turn ignition switch OFF and wait at least 10 seconds.
- b. Start engine and drive the vehicle under the similar conditions to (1st trip) Freeze Frame Data for a certain time. Refer to the table below.

Hold the accelerator pedal as steady as possible.

The similar conditions to (1st trip) Freeze Frame Data means the vehicle operation that the following conditions should be satisfied at the same time.

Engine speed	Engine speed in the freeze frame data ± 400 rpm
Vehicle speed	Vehicle speed in the freeze frame data ± 10 km/h (6 MPH)
Engine coolant temperature (T) condition	When the freeze frame data shows lower than 70 °C (158 °F), T should be lower than 70 °C (158 °F).
	When the freeze frame data shows higher than or equal to 70 °C (158 °F), T should be higher than or equal to 70 °C (158 °F).

The time to driving varies according to the engine speed in the freeze frame data.

Engine speed	Time
Around 1,000 rpm	Approximately 10 minutes
Around 2,000 rpm	Approximately 5 minutes
More than 3,000 rpm	Approximately 3.5 minutes

WITH GST

Follow the procedure "WITH CONSULT-II" above.

Diagnostic Procedure

UBS00149

1. CHECK FOR INTAKE AIR LEAK AND PCV HOSE

1. Start engine and run it at idle speed.
2. Listen for the sound of the intake air leak.
3. Check PCV hose connection.

OK or NG

- OK >> GO TO 2.
 NG >> Discover air leak location and repair.

2. CHECK FOR EXHAUST SYSTEM CLOGGING

Stop engine and visually check exhaust tube, three way catalyst and muffler for dents.

OK or NG

- OK (With CONSULT-II)>>GO TO 3.
 OK (Without CONSULT-II)>>GO TO 4.
 NG >> Repair or replace it.

3. PERFORM POWER BALANCE TEST

With CONSULT-II

1. Perform "POWER BALANCE" in "ACTIVE TEST" mode.
2. Is there any cylinder which does not produce a momentary engine speed drop?

ACTIVE TEST	
POWER BALANCE	
MONITOR	
ENG SPEED	XXX rpm
MAS A/F SE-B1	XXX V

PBIB0133E

Yes or No

- Yes >> GO TO 4.
- No >> GO TO 10.

4. CHECK FUNCTION OF INJECTOR-I

1. Stop engine.
2. Disconnect harness connector F44, F101.
3. Turn ignition switch ON.

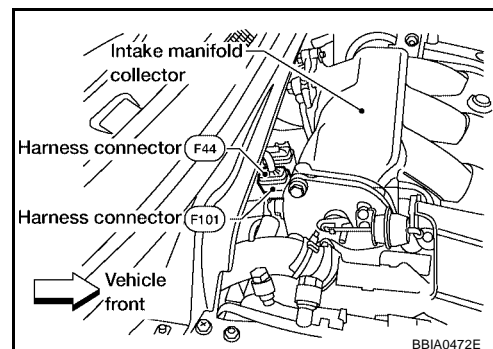

4. Check voltage between harness connector F44 terminal 6 (with triple meters) or 5 (without triple meters) and ground with CONSULT-II or tester.

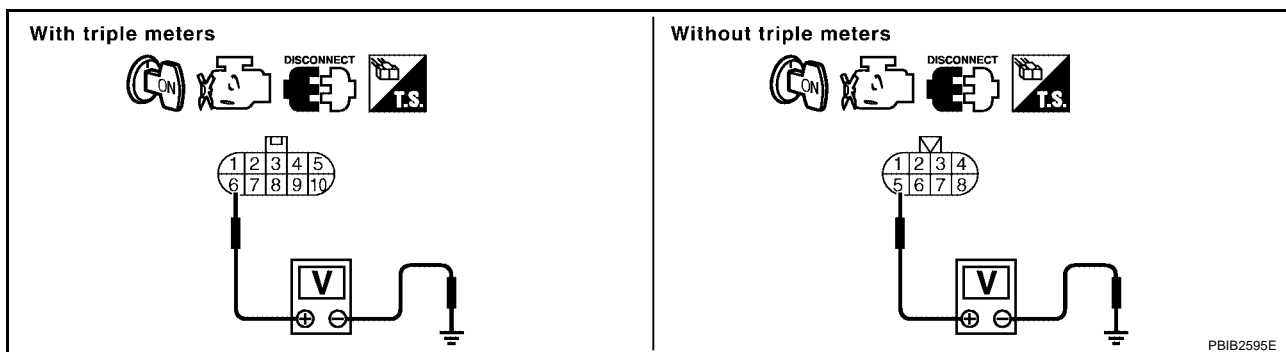

Voltage: Battery voltage

5. Turn ignition switch OFF.
6. Disconnect ECM harness connector.
7. Check harness continuity between harness connector F44 and ECM as follows. Refer to Wiring Diagram.

With triple meters

Cylinder	Harness connector F44 terminal	ECM terminal
1	1	23
3	3	22
5	7	21

Without triple meters

Cylinder	Harness connector F44 terminal	ECM terminal
1	6	23
3	2	22
5	1	21

Continuity should exist.

8. Also check harness for short to ground and short to power.

OK or NG

OK >> GO TO 5.

NG >> Perform trouble diagnosis for INJECTOR CIRCUIT, refer to [EC-1308](#).

5. CHECK FUNCTION OF INJECTOR-II

Provide battery voltage between harness connector F101 as follows and then interrupt it. Listen to each injector operating sound.

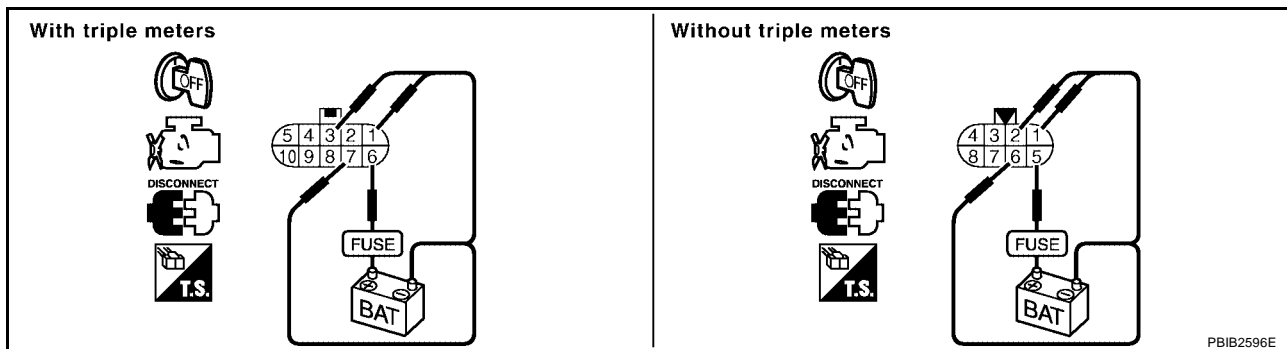

With triple meters

Cylinder	Harness connector F101 terminal	
	(+)	(-)
1	6	1
3	6	3
5	6	7

Without triple meters

Cylinder	Harness connector F101 terminal	
	(+)	(-)
1	5	6
3	5	2
5	5	1

Operating sound should exist.

OK or NG

OK >> GO TO 6.

NG >> Perform trouble diagnosis for INJECTOR CIRCUIT, refer to [EC-1308](#) .

6. CHECK FUNCTION OF INJECTOR-III

1. Reconnect all harness connector disconnected.
2. Start engine.
3. Listen to injectors No. 2, No. 4, No.6 operating sound.

Clicking noise should exist.

OK or NG

OK >> GO TO 7.

NG >> Perform trouble diagnosis for INJECTOR CIRCUIT, refer to [EC-1308](#) .

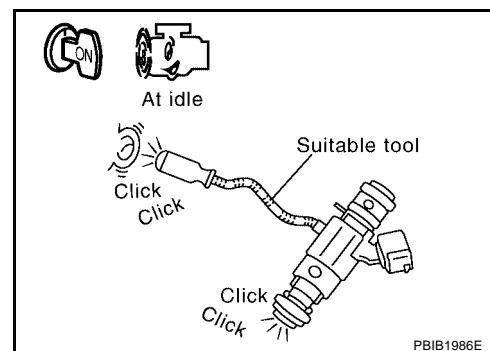

7. CHECK FUNCTION OF IGNITION COIL-I

CAUTION:

Do the following procedure in the place where ventilation is good without the combustible.

1. Turn ignition switch OFF.
2. Remove fuel pump fuse in IPDM E/R to release fuel pressure.
NOTE:
Do not use CONSULT-II to release fuel pressure, or fuel pressure applies again during the following procedure.
3. Start engine.
4. After engine stalls, crank it 2 or 3 times to release all fuel pressure.
5. Turn ignition switch OFF.
6. Remove all ignition coil harness connectors to avoid the electrical discharge from the ignition coils.
7. Remove ignition coil and spark plug of the cylinder to be checked.
8. Crank engine for 5 seconds or more to remove combustion gas in the cylinder.
9. Connect spark plug and harness connector to ignition coil.
10. Fix ignition coil using a rope etc. with gap of 13 - 17 mm between the edge of the spark plug and grounded metal portion as shown in the figure.
11. Crank engine for about three seconds, and check whether spark is generated between the spark plug and the grounded metal portion.

Spark should be generated.

CAUTION:

- Do not approach to the spark plug and the ignition coil within 50cm. Be careful not to get an electrical shock while checking, because the electrical discharge voltage becomes 20kV or more.

- It might cause to damage the ignition coil if the gap of 17 mm or more is taken.

NOTE:

When the gap is 13 mm or less, the spark might be generated even if the coil is malfunctioning.

OK or NG

- OK >> GO TO 11.
- NG >> GO TO 8.

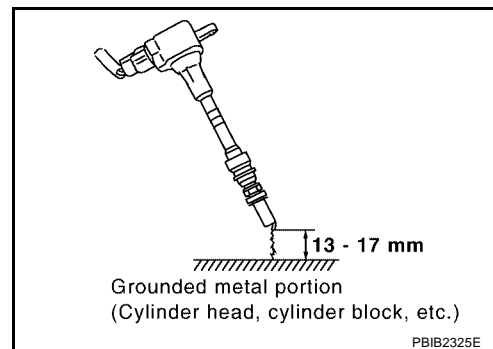
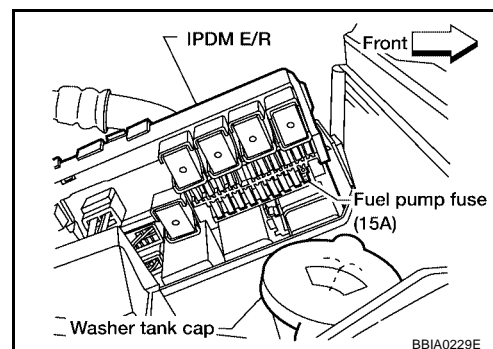

8. CHECK FUNCTION OF IGNITION COIL-II

1. Turn ignition switch OFF.
2. Disconnect spark plug and connect a known-good spark plug.
3. Crank engine for about 3 seconds, and recheck whether spark is generated between the spark plug and the grounded metal portion.

Spark should be generated.

OK or NG

- OK >> GO TO 9.
- NG >> Check ignition coil, power transistor and their circuits. Refer to [EC-1287, "IGNITION SIGNAL"](#).

9. CHECK SPARK PLUG

Check the initial spark plug for fouling, etc.

OK or NG

- OK >> Replace spark plug(s) with standard type one(s). For spark plug type, refer to [MA-26](#) .
- NG >> 1. Repair or clean spark plug.
2. GO TO 10.

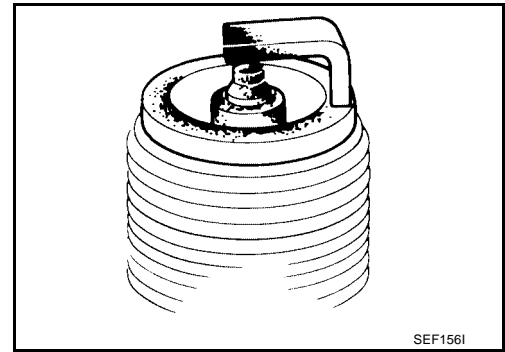

10. CHECK FUNCTION OF IGNITION COIL-III

1. Reconnect the initial spark plugs.
2. Crank engine for about 3 seconds, and recheck whether spark is generated between the spark plug and the grounded portion.

Spark should be generated.

OK or NG

- OK >> **INSPECTION END**
- NG >> Replace spark plug(s) with standard type one(s). For spark plug type, refer to [MA-26](#) .

11. CHECK COMPRESSION PRESSURE

Check compression pressure. Refer to [EM-200, "CHECKING COMPRESSION PRESSURE"](#) .

Standard:	1,275 kPa (13.0 kg/cm² , 185 psi)/300 rpm
Minimum:	981 kPa (10.0 kg/cm² , 142 psi)/300 rpm
Difference between each cylinder:	98 kPa (1.0 kg/cm² , 14 psi)/300 rpm

OK or NG

- OK >> GO TO 12.
- NG >> Check pistons, piston rings, valves, valve seats and cylinder head gaskets.

12. CHECK FUEL PRESSURE

1. Install all removed parts.
2. Release fuel pressure to zero. Refer to [EC-714, "FUEL PRESSURE RELEASE"](#) .
3. Install fuel pressure gauge and check fuel pressure. Refer to [EC-714, "FUEL PRESSURE CHECK"](#) .

At idle: Approx. 350 kPa (3.57 kg/cm² , 51 psi)

OK or NG

- OK >> GO TO 14.
- NG >> GO TO 13.

13. DETECT MALFUNCTIONING PART

Check the following.

- Fuel pump and circuit (Refer to [EC-1316, "FUEL PUMP CIRCUIT"](#) .)
- Fuel pressure regulator (Refer to [EC-714, "FUEL PRESSURE CHECK"](#) .)
- Fuel lines (Refer to [MA-24, "Checking Fuel Lines"](#))
- Fuel filter for clogging

>> Repair or replace.

14. CHECK IGNITION TIMING

Check the following items. Refer to [EC-693, "Basic Inspection"](#) .

Items	Specifications
Target idle speed	A/T: 675 ± 50 rpm (in P or N position) M/T: 625 ± 50 rpm (in neutral position)
Ignition timing	A/T: 15 ± 5° BTDC (in P or N position) M/T: 15 ± 5° BTDC (in neutral position)

OK or NG

OK >> GO TO 15.

NG >> Follow the [EC-693, "Basic Inspection"](#) .

A
EC
C
D
E
F
G
H
I
J
K
L
M

15. CHECK A/F SENSOR 1 INPUT SIGNAL

1. Turn ignition switch OFF.
2. Disconnect A/F sensor 1 harness connector.

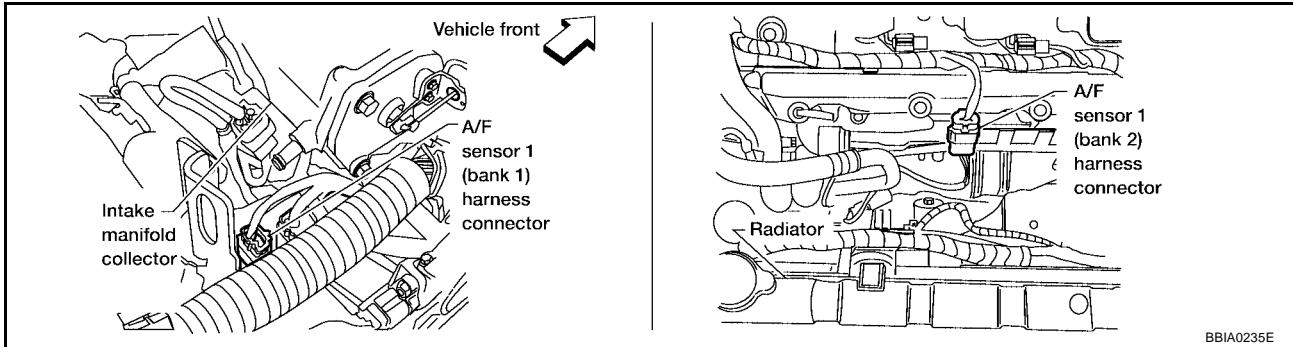

3. Disconnect ECM harness connector.
4. Check harness continuity between the following terminals. Refer to Wiring Diagram.

	A/F sensor 1 terminal	ECM terminal
Bank 1	1	16
	2	75
	5	35
	6	56
Bank 2	1	76
	2	77
	5	57
	6	58

Continuity should exist.

5. Check harness continuity between the following terminals and ground. Refer to Wiring Diagram.

Bank 1		Bank 2	
A/F sensor 1 terminal	ECM terminal	A/F sensor 1 terminal	ECM terminal
1	16	1	76
2	75	2	77
5	35	5	57
6	56	6	58

Continuity should not exist.

6. Also check harness for short to power.

OK or NG

OK >> GO TO 16.

NG >> Repair open circuit or short to ground or short to power in harness or connectors between ECM and A/F sensor 1.

16. CHECK A/F SENSOR 1 HEATER

Refer to [EC-1052, "Component Inspection"](#).

OK or NG

OK >> GO TO 17.

NG >> Replace (malfunctioning) A/F sensor 1.

17. CHECK MASS AIR FLOW SENSOR

 **With CONSULT-II**

Check mass air flow sensor signal in "DATA MONITOR" mode with CONSULT-II.

2.0 - 6.0 g-m/sec: at idling
7.0 - 20.0 g-m/sec: at 2,500 rpm

 **With GST**

Check mass air flow sensor signal in Service \$01 with GST.

2.0 - 6.0 g-m/sec: at idling
7.0 - 20.0 g-m/sec: at 2,500 rpm

OK or NG

OK >> GO TO 18.

NG >> Check connectors for rusted terminals or loose connections in the mass air flow sensor circuit or ground. Refer to [EC-806, "DTC P0101 MAF SENSOR"](#) .

18. CHECK SYMPTOM MATRIX CHART

Check items on the rough idle symptom in [EC-725, "Symptom Matrix Chart"](#) .

OK or NG

OK >> GO TO 19.

NG >> Repair or replace.

19. ERASE THE 1ST TRIP DTC

Some tests may cause a 1st trip DTC to be set.

Erase the 1st trip DTC from the ECM memory after performing the tests. Refer to [EC-682, "HOW TO ERASE EMISSION-RELATED DIAGNOSTIC INFORMATION"](#) .

>> GO TO 20.

20. CHECK INTERMITTENT INCIDENT

Refer to [EC-782, "TROUBLE DIAGNOSIS FOR INTERMITTENT INCIDENT"](#) .

>> **INSPECTION END**

DTC P0327, P0328 KS

PFP:22060

Component Description

UBS0014A

The knock sensor is attached to the cylinder block. It senses engine knocking using a piezoelectric element. A knocking vibration from the cylinder block is sensed as vibrational pressure. This pressure is converted into a voltage signal and sent to the ECM.

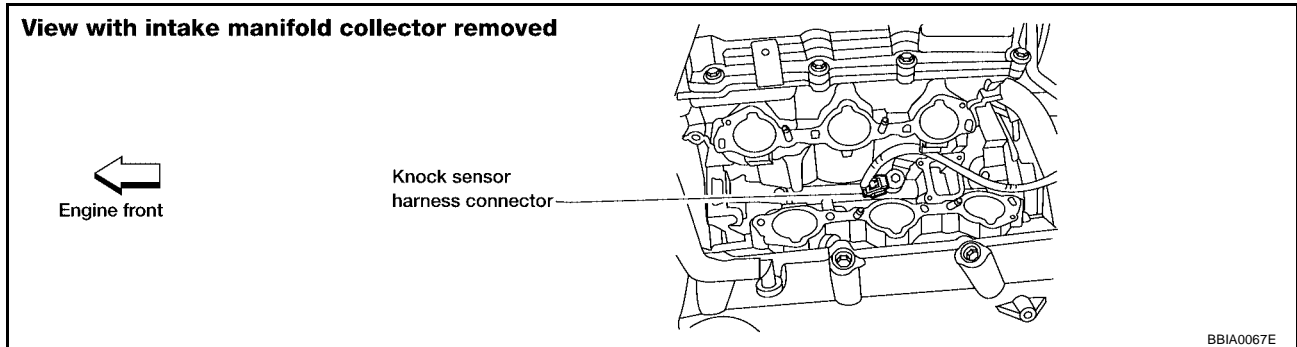

On Board Diagnosis Logic

UBS0014B

The MIL will not light up for these diagnoses.

DTC No.	Trouble diagnosis name	DTC detected condition	Possible cause
P0327 0327	Knock sensor circuit low input	An excessively low voltage from the sensor is sent to ECM.	<ul style="list-style-type: none"> ● Harness or connectors (The sensor circuit is open or shorted.) ● Knock sensor
P0328 0328	Knock sensor circuit high input	An excessively high voltage from the sensor is sent to ECM.	

DTC Confirmation Procedure

UBS0014C

NOTE:

If DTC Confirmation Procedure has been previously conducted, always turn ignition switch OFF and wait at least 10 seconds before conducting the next test.

TESTING CONDITION:

Before performing the following procedure, confirm that battery voltage is more than 10V at idle.

WITH CONSULT-II

1. Turn ignition switch ON and select "DATA MONITOR" mode with CONSULT-II.
2. Start engine and run it for at least 5 seconds at idle speed.
3. If 1st trip DTC is detected, go to [EC-918, "Diagnostic Procedure"](#)

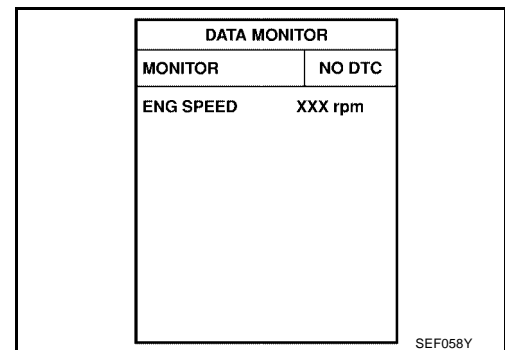

WITH GST

Follow the procedure "WITH CONSULT-II" above.

Specification data are reference values and are measured between each terminal and ground.

CAUTION:

Do not use ECM ground terminals when measuring input/output voltage. Doing so may result in damage to the ECM's transistor. Use a ground other than ECM terminals, such as the ground.

TER-MINAL NO.	WIRE COLOR	ITEM	CONDITION	DATA (DC Voltage)
15	W	Knock sensor	[Engine is running] ● Idle speed	Approximately 2.5V

Diagnostic Procedure

UBS0014E

1. CHECK KNOCK SENSOR INPUT SIGNAL CIRCUIT FOR OPEN AND SHORT-I

1. Turn ignition switch OFF.
2. Disconnect ECM harness connector.
3. Check resistance between ECM terminal 15 and ground. Refer to Wiring Diagram.

NOTE:

It is necessary to use an ohmmeter which can measure more than 10 MΩ.

Resistance: Approximately 532 - 588 kΩ [at 20°C (68°F)]

4. Also check harness for short to ground and short to power.

OK or NG

- OK >> GO TO 4.
- NG >> GO TO 2.

2. CHECK KNOCK SENSOR INPUT SIGNAL CIRCUIT FOR OPEN AND SHORT-II

1. Disconnect knock sensor harness connector.

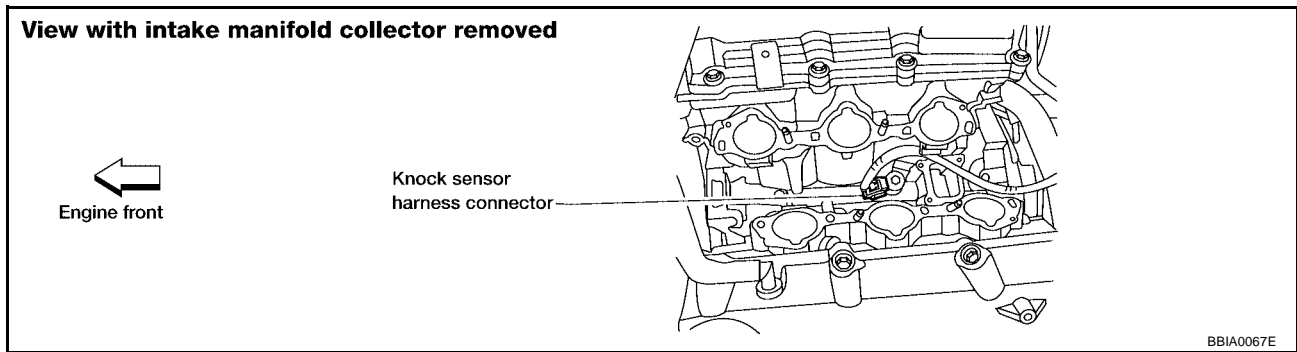

BBI A0067E

2. Check harness continuity between ECM terminal 15 and knock sensor terminal 2. Refer to Wiring Diagram.

Continuity should exist.

3. Also check harness for short to ground and short to power.

OK or NG

- OK >> GO TO 4.
- NG >> GO TO 3.

3. DETECT MALFUNCTIONING PART

Check the following.

- Harness connectors F26, F301
- Harness for open or short between ECM and knock sensor

>> Repair open circuit or short to ground or short to power in harness or connectors.

4. CHECK KNOCK SENSOR

Refer to [EC-920, "Component Inspection"](#) .

OK or NG

OK >> GO TO 5.

NG >> Replace knock sensor.

5. CHECK GROUND CONNECTIONS

Loosen and retighten three ground screws on the body.

Refer to [EC-789, "Ground Inspection"](#) .

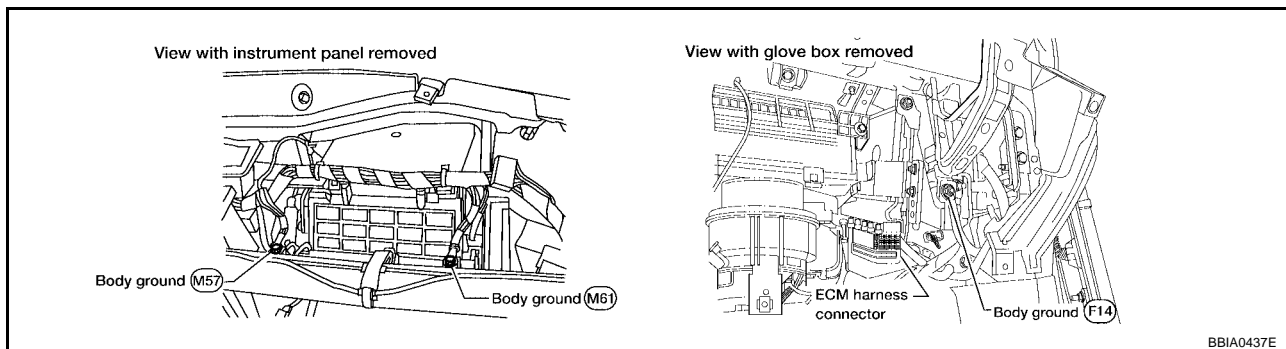

OK or NG

OK >> GO TO 6.

NG >> Repair or replace ground connections.

6. CHECK KNOCK SENSOR SHIELD CIRCUIT FOR OPEN AND SHORT

1. Disconnect knock sensor harness connector.
2. Check harness continuity between knock sensor terminal 1 and ground. Refer to Wiring Diagram.

Continuity should exist.

3. Also check for short to power.

OK or NG

OK >> GO TO 8.

NG >> GO TO 7.

7. DETECT MALFUNCTIONING PART

Check the following.

- Harness connectors F26, F301
- Harness connectors F58, M70
- Harness for open or short between knock sensor terminal 2 and ground

>> Repair open circuit or short power in harness or connectors.

8. CHECK INTERMITTENT INCIDENT

Refer to [EC-782, "TROUBLE DIAGNOSIS FOR INTERMITTENT INCIDENT"](#) .

>> INSPECTION END

Component Inspection KNOCK SENSOR

Check resistance between knock sensor terminal 2 and ground.

NOTE:

It is necessary to use an ohmmeter which can measure more than 10 M Ω .

Resistance: Approximately 532 - 588 k Ω [at 20°C (68°F)]

CAUTION:

Do not use any knock sensors that have been dropped or physically damaged. Use only new ones.

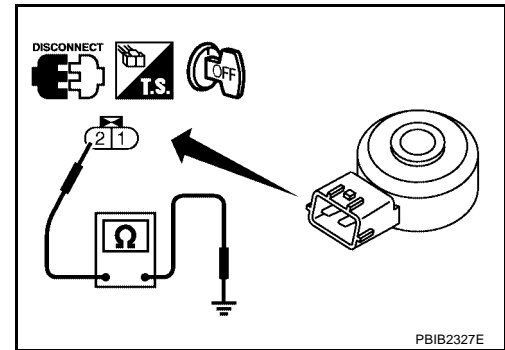

Removal and Installation KNOCK SENSOR

Refer to [EM-224, "CYLINDER BLOCK"](#) .

DTC P0335 CKP SENSOR (POS)

[VQ]

DTC P0335 CKP SENSOR (POS)

PFP:23731

UBS0014H

Component Description

The crankshaft position sensor (POS) is located on the oil pan facing the gear teeth (cogs) of the signal plate. It detects the fluctuation of the engine revolution.

The sensor consists of a permanent magnet and Hall IC.

When the engine is running, the high and low parts of the teeth cause the gap with the sensor to change.

The changing gap causes the magnetic field near the sensor to change.

Due to the changing magnetic field, the voltage from the sensor changes.

The ECM receives the voltage signal and detects the fluctuation of the engine revolution.

ECM receives the signals as shown in the figure.

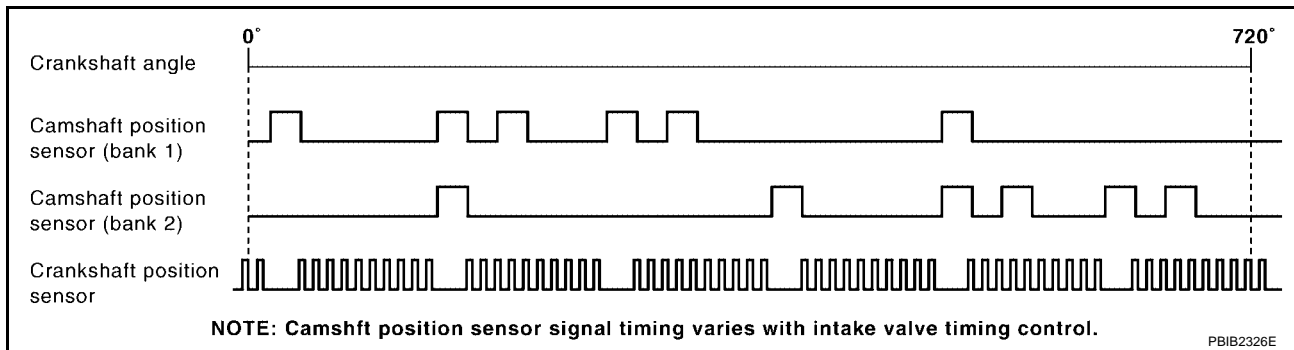
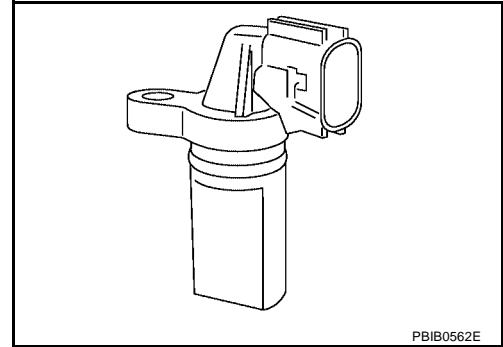

CONSULT-II Reference Value in Data Monitor Mode

UBS0014I

Specification data are reference values.

MONITOR ITEM	CONDITION	SPECIFICATION
ENG SPEED	<ul style="list-style-type: none"> Run engine and compare CONSULT-II value with the tachometer indication. 	Almost the same speed as the tachometer indication.

On Board Diagnosis Logic

UBS0014J

DTC No.	Trouble diagnosis name	DTC detecting condition	Possible cause
P0335 0335	Crankshaft position sensor (POS) circuit	<ul style="list-style-type: none"> The crankshaft position sensor (POS) signal is not detected by the ECM during the first few seconds of engine cranking. The proper pulse signal from the crankshaft position sensor (POS) is not sent to ECM while the engine is running. The crankshaft position sensor (POS) signal is not in the normal pattern during engine running. 	<ul style="list-style-type: none"> Harness or connectors (The sensor circuit is open or shorted) Crankshaft position sensor (POS) Signal plate

DTC Confirmation Procedure

UBS0014K

NOTE:

If DTC Confirmation Procedure has been previously conducted, always turn ignition switch OFF and wait at least 10 seconds before conducting the next test.

TESTING CONDITION:

Before performing the following procedure, confirm that battery voltage is more than 10.5V with ignition switch ON.

DTC P0335 CKP SENSOR (POS)

[VQ]

WITH CONSULT-II

1. Turn ignition switch ON and select "DATA MONITOR" mode with CONSULT-II.
2. Crank engine for at least 2 seconds and run it for at least 5 seconds at idle speed.
3. If 1st trip DTC is detected, go to [EC-924, "Diagnostic Procedure"](#).
If 1st trip DTC is not detected, go to next step.
4. Maintaining engine speed at more than 800 rpm for at least 5 seconds.
5. If 1st trip DTC is detected, go to [EC-924, "Diagnostic Procedure"](#).

DATA MONITOR	
MONITOR	NO DTC
ENG SPEED	XXX rpm

SEF058Y

WITH GST

Follow the procedure "WITH CONSULT-II" above.

DTC P0335 CKP SENSOR (POS)

[VQ]

Wiring Diagram

UBS0014L

EC-POS-01

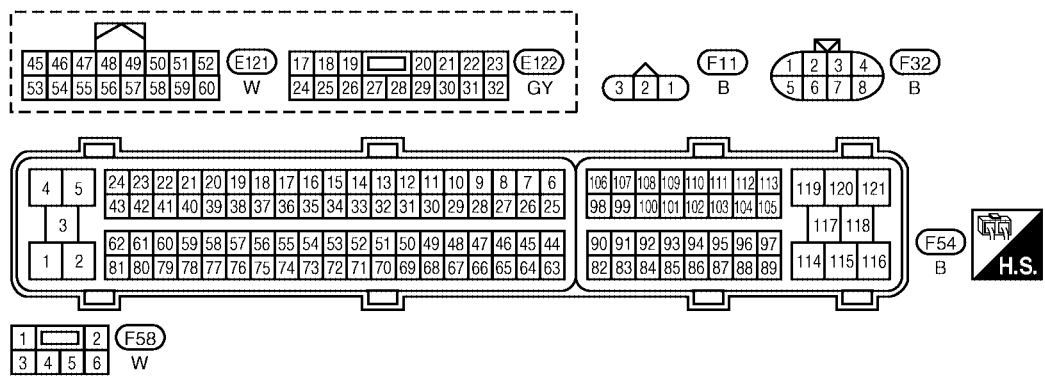
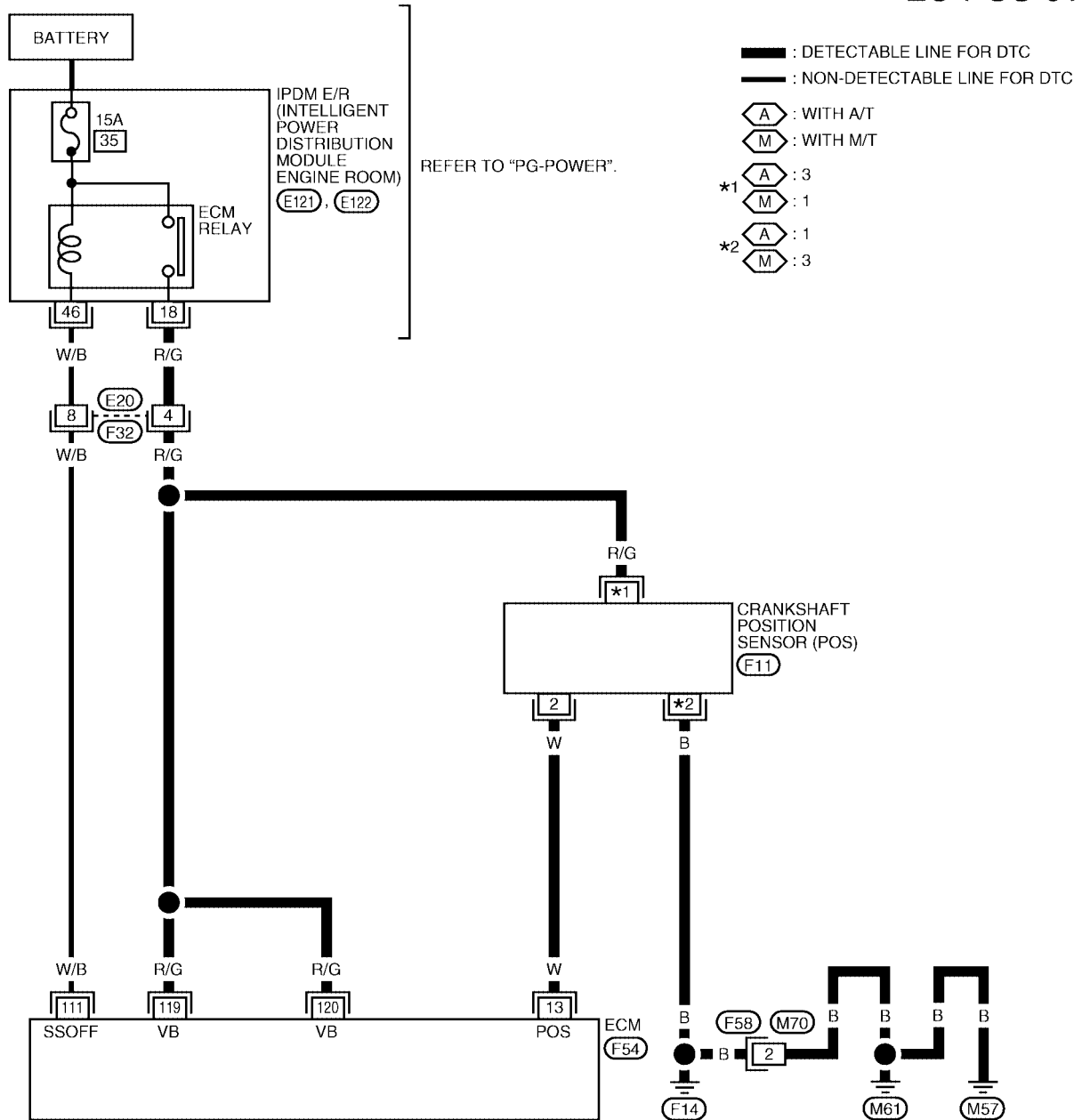

DTC P0335 CKP SENSOR (POS)

[VQ]

Specification data are reference values and are measured between each terminal and ground.
Pulse signal is measured by CONSULT-II.

CAUTION:

Do not use ECM ground terminals when measuring input/output voltage. Doing so may result in damage to the ECM's transistor. Use a ground other than ECM terminals, such as the ground.

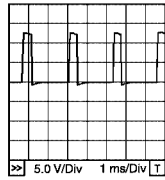
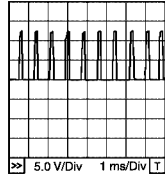
TER-MINAL NO.	WIRE COLOR	ITEM	CONDITION	DATA (DC Voltage)
13	W	Crankshaft position sensor (POS)	<p>[Engine is running]</p> <ul style="list-style-type: none"> ● Warm-up condition ● Idle speed <p>NOTE: The pulse cycle changes depending on rpm at idle</p>	<p>Approximately 1.6V★</p>  <p>PBIB1041E</p>
			<p>[Engine is running]</p> <ul style="list-style-type: none"> ● Engine speed is 2,000 rpm. 	<p>Approximately 1.4V★</p>  <p>PBIB1042E</p>

★: Average voltage for pulse signal (Actual pulse signal can be confirmed by oscilloscope.)

Diagnostic Procedure

UBS0014M

1. CHECK GROUND CONNECTIONS

1. Turn ignition switch OFF.
2. Loosen and retighten three ground screws on the body.
Refer to [EC-789, "Ground Inspection"](#).

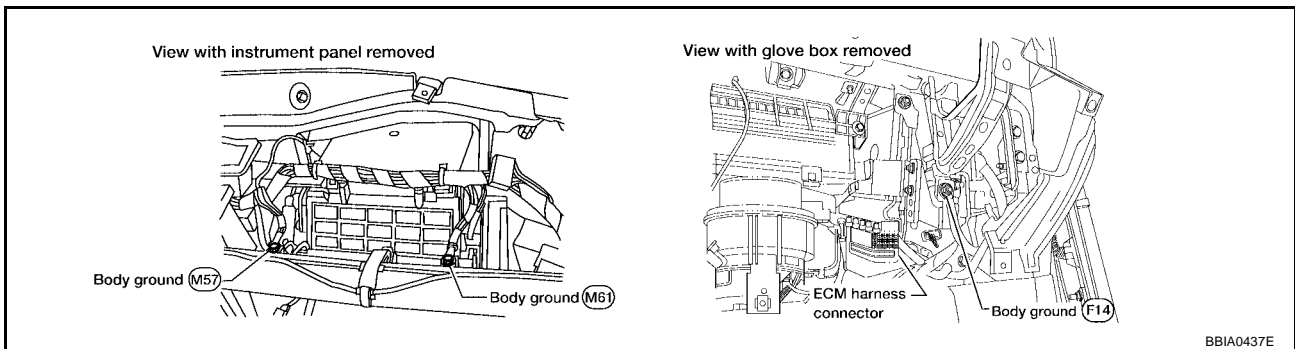

BBIA0437E

OK or NG

- OK >> GO TO 2.
- NG >> Repair or replace ground connections.

2. CHECK CRANKSHAFT POSITION (CKP) SENSOR (POS) POWER SUPPLY CIRCUIT

1. Disconnect crankshaft position (CKP) sensor (POS) harness connector.

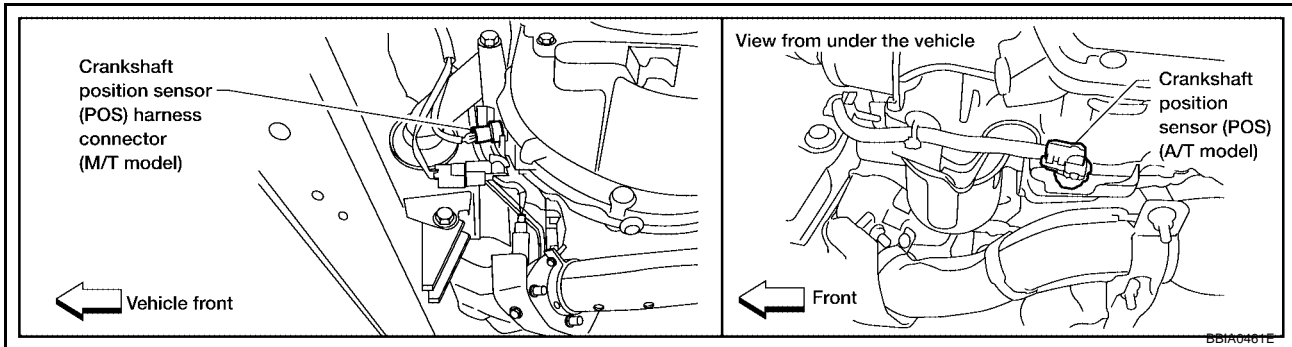

2. Turn ignition switch ON.
3. Check voltage between CKP sensor (POS) terminal 3 (A/T models) or 1 (M/T models) and ground with CONSULT-II or tester.

Voltage: Battery voltage

4. Also check harness for short to ground and short to power.

OK or NG

- OK >> GO TO 4.
- NG >> GO TO 3.

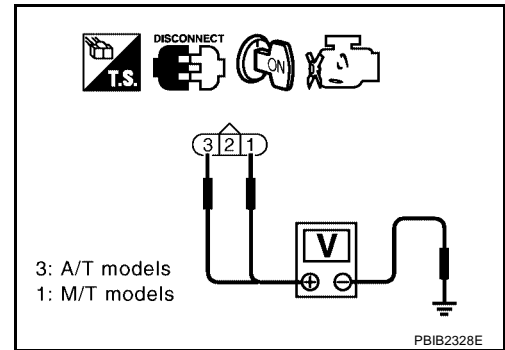

3. DETECT MALFUNCTIONING PART

Check the following.

- Harness connectors E20, F32
- Harness for open or short between crankshaft position sensor (POS) and ECM
- Harness for open or short between crankshaft position sensor (POS) and IPDM E/R

>> Repair open circuit or short to ground or short to power in harness or connectors.

4. CHECK CKP SENSOR (POS) GROUND CIRCUIT FOR OPEN AND SHORT

1. Turn ignition switch OFF.
2. Check harness continuity between CKP sensor (POS) terminal 1 (A/T models) or 3 (M/T models) and ground. Refer to Wiring Diagram.

Continuity should exist.

3. Also check harness for short to power.

OK or NG

- OK >> GO TO 6.
- NG >> GO TO 5.

5. DETECT MALFUNCTIONING PART

Check the following.

- Harness connectors F58, M70
- Harness for open or short between crankshaft position sensor (POS) and ground

>> Repair open circuit or short to power in harness or connectors.

6. CHECK CKP SENSOR (POS) INPUT SIGNAL CIRCUIT FOR OPEN AND SHORT

1. Disconnect ECM harness connector.
2. Check harness continuity between ECM terminal 13 and CKP sensor (POS) terminal 2.
Refer to Wiring Diagram.

Continuity should exist.

3. Also check harness for short to ground and short to power.

OK or NG

OK >> GO TO 7.

NG >> Repair open circuit or short to ground or short to power in harness or connectors.

7. CHECK CRANKSHAFT POSITION SENSOR (POS)

Refer to [EC-927, "Component Inspection"](#) .

OK or NG

OK >> GO TO 8.

NG >> Replace crankshaft position sensor (POS).

8. CHECK GEAR TOOTH

Visually check for chipping signal plate gear tooth.

OK or NG

OK >> GO TO 9.

NG >> Replace the signal plate.

9. CHECK INTERMITTENT INCIDENT

Refer to [EC-782, "TROUBLE DIAGNOSIS FOR INTERMITTENT INCIDENT"](#) .

>> **INSPECTION END**

Component Inspection CRANKSHAFT POSITION SENSOR (POS)

1. Loosen the fixing bolt of the sensor.
2. Disconnect crankshaft position sensor (POS) harness connector.
3. Remove the sensor.
4. Visually check the sensor for chipping.

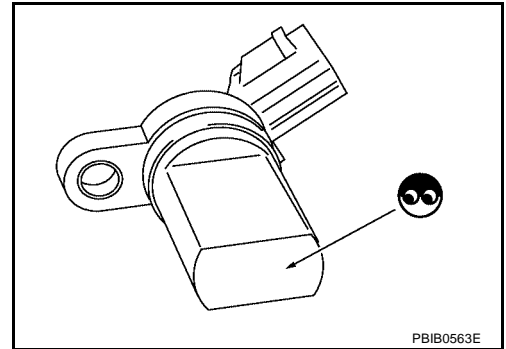

PBIB0563E

5. Check resistance as shown in the figure.

Terminal No. (Polarity)	Resistance Ω [at 25°C (77°F)]
1 (+) - 2 (-)	Except 0 or ∞
1 (+) - 3 (-)	
2 (+) - 3 (-)	

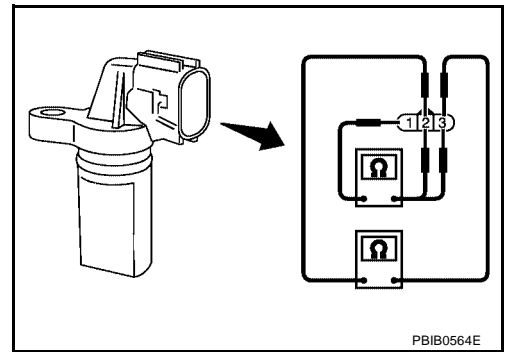

PBIB0564E

Removal and Installation CRANKSHAFT POSITION SENSOR (POS)

Refer to [EM-138, "OIL PAN AND OIL STRAINER"](#) .

DTC P0340, P0345 CMP SENSOR (PHASE)

Component Description

The camshaft position sensor (PHASE) senses the retraction of camshaft (intake) to identify a particular cylinder. The camshaft position sensor (PHASE) senses the piston position.

When the crankshaft position sensor (POS) system becomes inoperative, the camshaft position sensor (PHASE) provides various controls of engine parts instead, utilizing timing of cylinder identification signals.

The sensor consists of a permanent magnet and Hall IC.

When engine is running, the high and low parts of the teeth cause the gap with the sensor to change.

The changing gap causes the magnetic field near the sensor to change.

Due to the changing magnetic field, the voltage from the sensor changes. ECM receives the signals as shown in the figure.

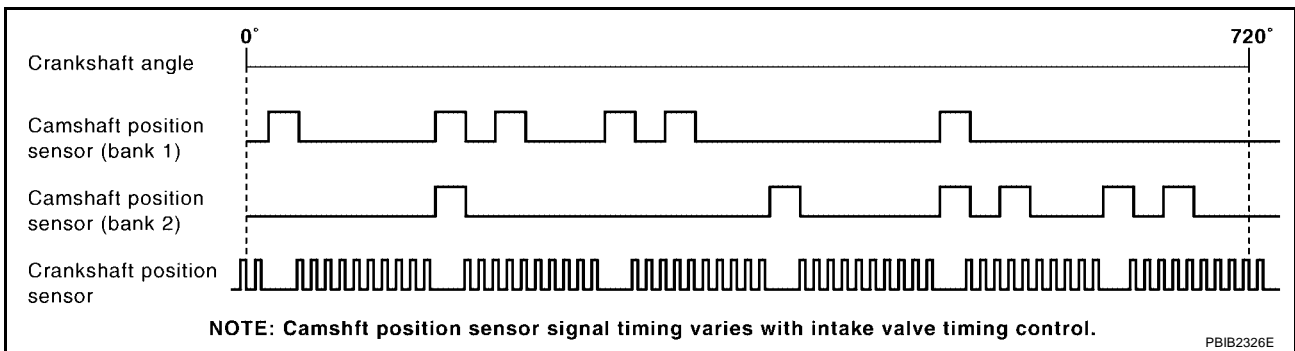
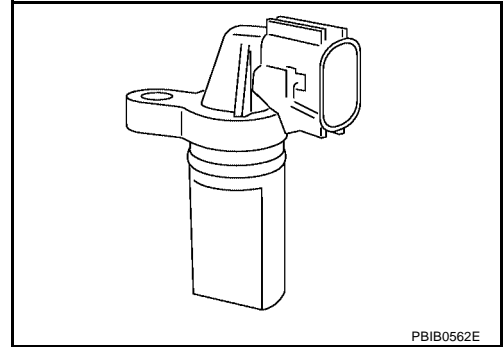

On Board Diagnosis Logic

DTC No.	Trouble diagnosis name	DTC detecting condition	Possible cause
P0340 0340 (Bank 1)	Camshaft position sensor (PHASE) circuit	<ul style="list-style-type: none"> The cylinder No. signal is not sent to ECM for the first few seconds during engine cranking. 	<ul style="list-style-type: none"> Harness or connectors (The sensor circuit is open or shorted) Camshaft position sensor (PHASE)
P0345 0345 (Bank 2)		<ul style="list-style-type: none"> The cylinder No. signal is not sent to ECM during engine running. The cylinder No. signal is not in the normal pattern during engine running. 	<ul style="list-style-type: none"> Camshaft (Intake) Starter motor (Refer to SC-9 .) Starting system circuit (Refer to SC-9 .) Dead (Weak) battery

DTC Confirmation Procedure

NOTE:

If DTC Confirmation Procedure has been previously conducted, always turn ignition switch OFF and wait at least 10 seconds before conducting the next test.

TESTING CONDITION:

Before performing the following procedure, confirm that battery voltage is more than 10.5V with ignition switch ON.

Ⓟ WITH CONSULT-II

1. Turn ignition switch ON.

DTC P0340, P0345 CMP SENSOR (PHASE)

[VQ]

2. Select "DATA MONITOR" mode with CONSULT-II.
3. Crank engine for at least 2 seconds and run it for at least 5 seconds at idle speed.
4. If 1st trip DTC is detected, go to [EC-933, "Diagnostic Procedure"](#).
If 1st trip DTC is not detected, go to next step.
5. Maintaining engine speed at more than 800 rpm for at least 5 seconds.
6. If 1st trip DTC is detected, go to [EC-933, "Diagnostic Procedure"](#).

DATA MONITOR	
MONITOR	NO DTC
ENG SPEED	XXX rpm

SEF058Y

WITH GST

Follow the procedure "WITH CONSULT-II" above.

A

EC

C

D

E

F

G

H

I

J

K

L

M

DTC P0340, P0345 CMP SENSOR (PHASE)

[VQ]

UBS0014S

Wiring Diagram BANK 1

EC-PHSB1-01

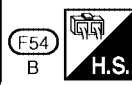
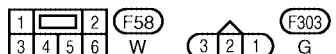
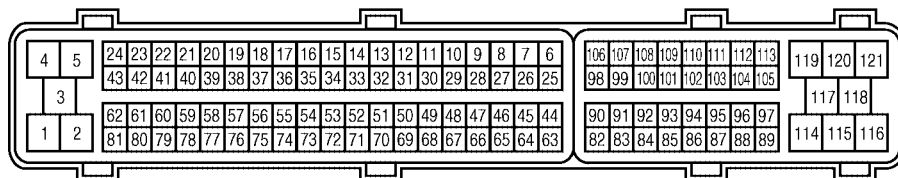
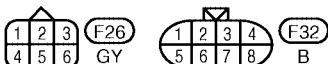
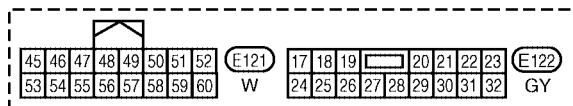
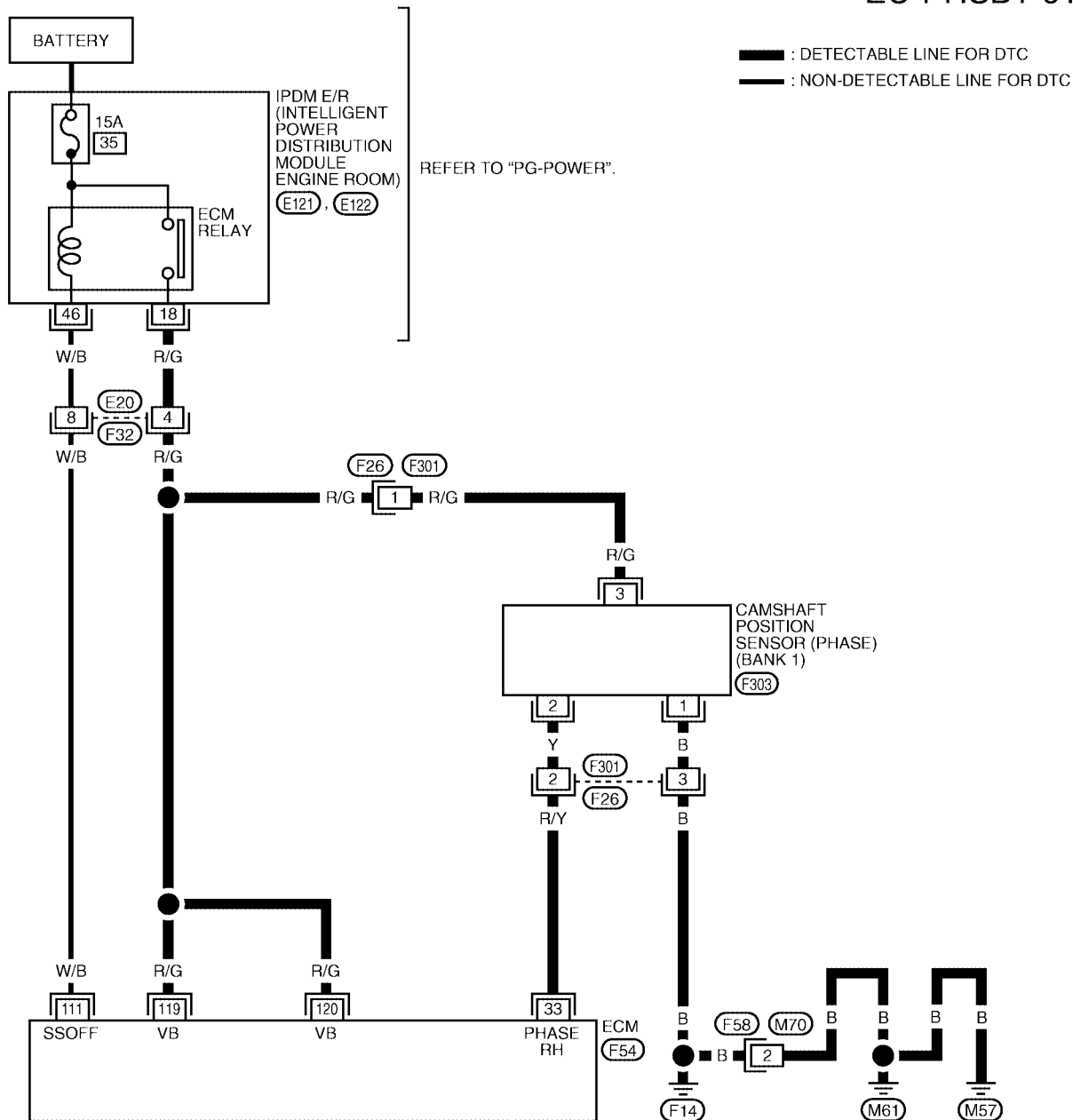

BBWA1560E

DTC P0340, P0345 CMP SENSOR (PHASE)

[VQ]

Specification data are reference values and are measured between each terminal and ground.
Pulse signal is measured by CONSULT-II.

CAUTION:

Do not use ECM ground terminals when measuring input/output voltage. Doing so may result in damage to the ECM's transistor. Use a ground other than ECM terminals, such as the ground.

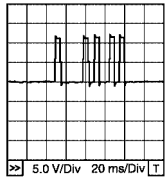
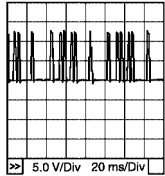
TER-MINAL NO.	WIRE COLOR	ITEM	CONDITION	DATA (DC Voltage)
33	R/Y	Camshaft position sensor (PHASE) (bank 1)	<p>[Engine is running]</p> <ul style="list-style-type: none"> ● Warm-up condition ● Idle speed <p>NOTE: The pulse cycle changes depending on rpm at idle</p>	<p>1.0 - 4.0V★</p>  <p>PBIB1039E</p>
			<p>[Engine is running]</p> <ul style="list-style-type: none"> ● Engine speed is 2,000 rpm. 	<p>1.0 - 4.0V★</p>  <p>PBIB1040E</p>

★: Average voltage for pulse signal (Actual pulse signal can be confirmed by oscilloscope.)

DTC P0340, P0345 CMP SENSOR (PHASE)

[VQ]

BANK 2

EC-PHSB2-01

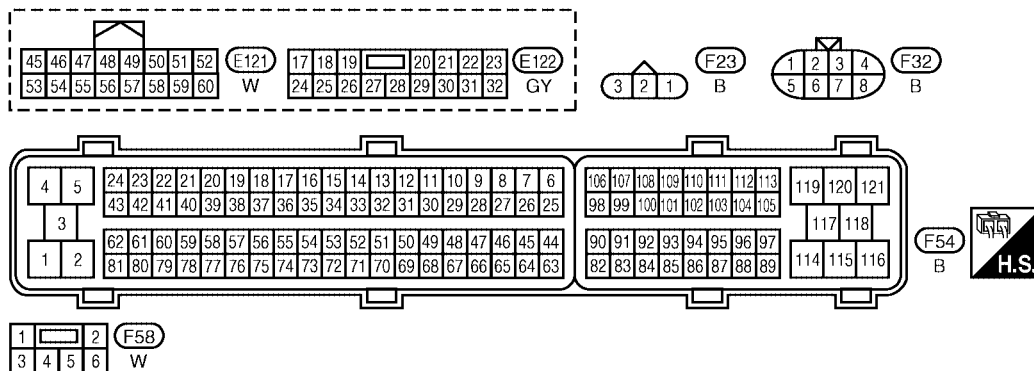
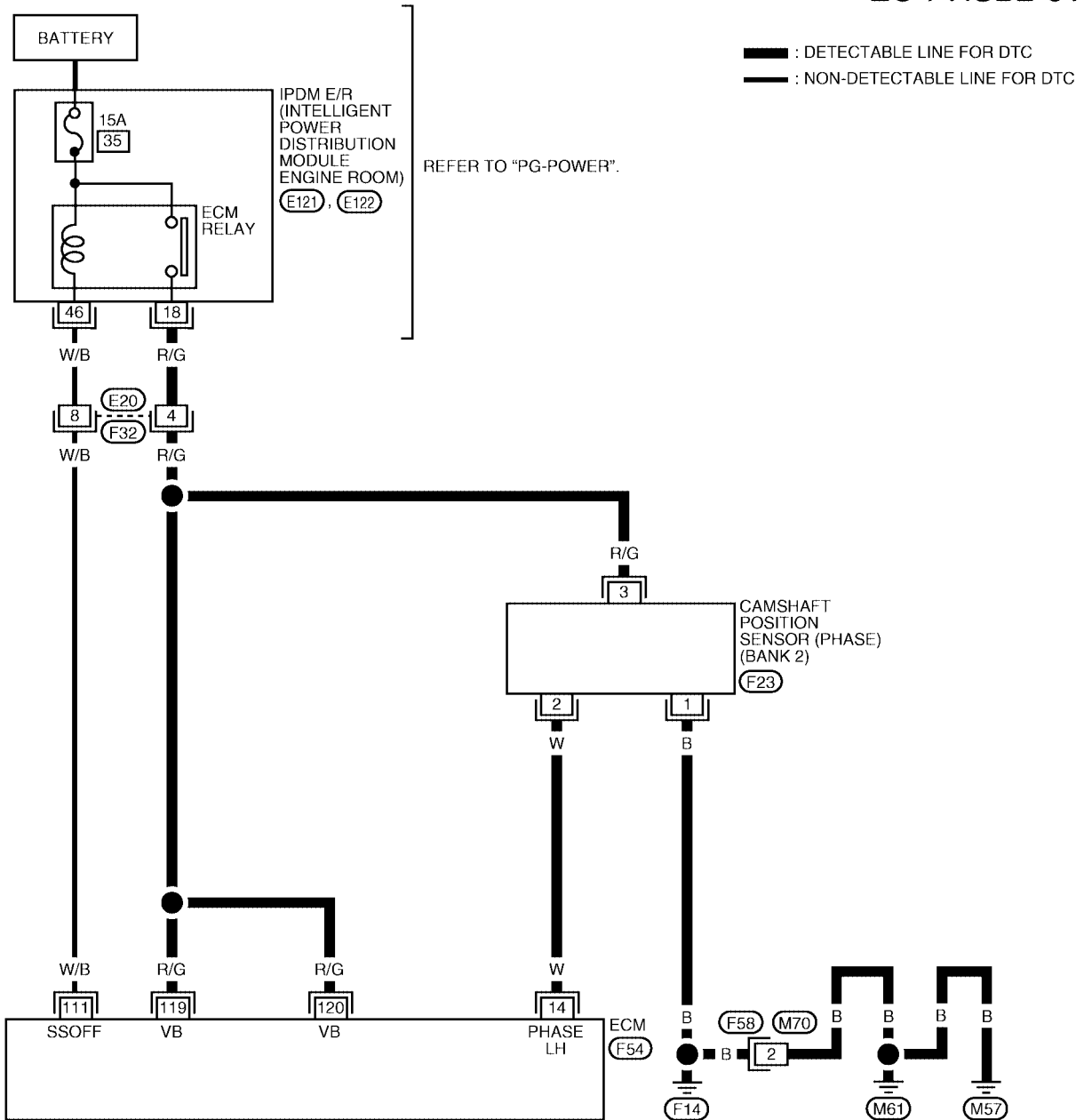

BBWA1288E

DTC P0340, P0345 CMP SENSOR (PHASE)

[VQ]

Specification data are reference values and are measured between each terminal and ground.
Pulse signal is measured by CONSULT-II.

CAUTION:

Do not use ECM ground terminals when measuring input/output voltage. Doing so may result in damage to the ECM's transistor. Use a ground other than ECM terminals, such as the ground.

TER-MINAL NO.	WIRE COLOR	ITEM	CONDITION	DATA (DC Voltage)
14	W	Camshaft position sensor (PHASE) (bank 2)	<p>[Engine is running]</p> <ul style="list-style-type: none"> ● Warm-up condition ● Idle speed <p>NOTE: The pulse cycle changes depending on rpm at idle</p>	<p>1.0 - 4.0V★</p> <p>PBIB1039E</p>
			<p>[Engine is running]</p> <ul style="list-style-type: none"> ● Engine speed is 2,000 rpm. 	<p>1.0 - 4.0V★</p> <p>PBIB1040E</p>

★: Average voltage for pulse signal (Actual pulse signal can be confirmed by oscilloscope.)

Diagnostic Procedure

UBS0014T

1. CHECK STARTING SYSTEM

Turn ignition switch to START position.

Does the engine turn over?

Does the starter motor operate?

Yes or No

Yes >> GO TO 2.

No >> Check starting system. (Refer to [SC-9, "STARTING SYSTEM"](#) .)

2. CHECK GROUND CONNECTIONS

1. Turn ignition switch OFF.
2. Loosen and retighten three ground screws on the body.
Refer to [EC-789, "Ground Inspection"](#) .

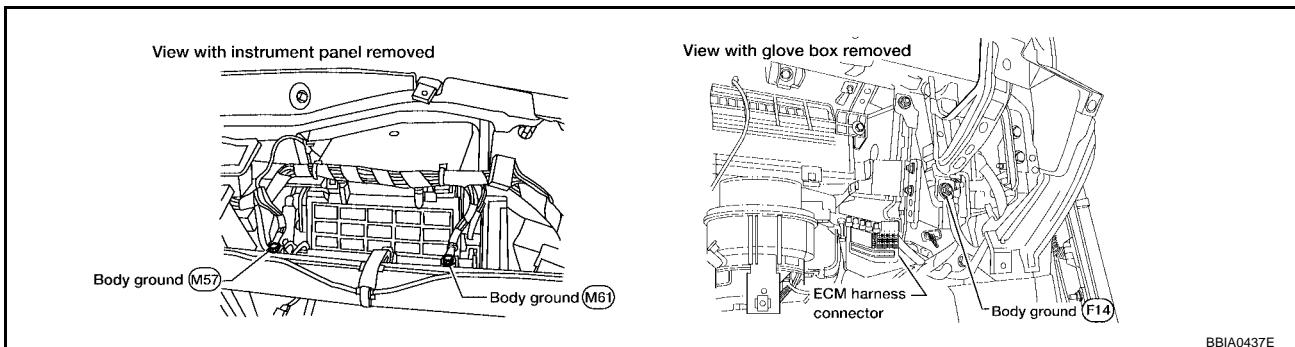

OK or NG

OK >> GO TO 3.

NG >> Repair or replace ground connections.

3. CHECK CAMSHAFT POSITION (CMP) SENSOR (PHASE) POWER SUPPLY CIRCUIT

1. Disconnect camshaft position (CMP) sensor (PHASE) harness connector.

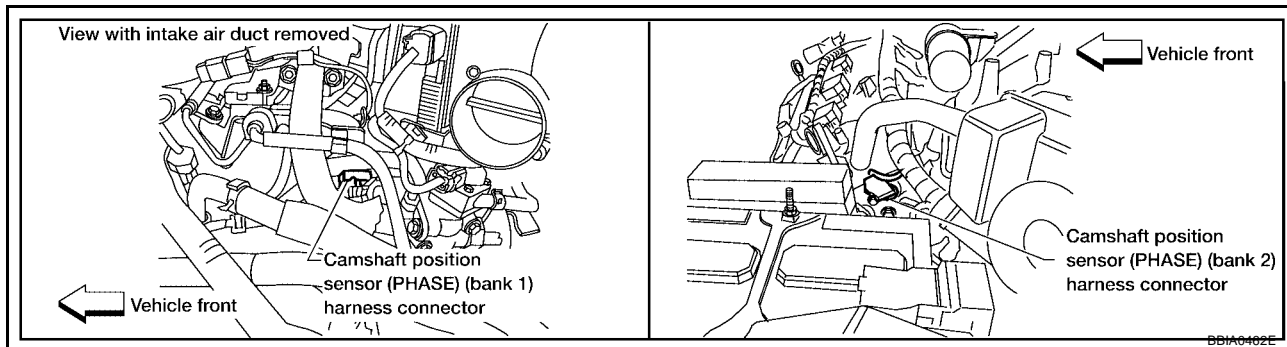

2. Turn ignition switch ON.
3. Check voltage between CMP sensor (PHASE) terminal 3 and ground with CONSULT-II or tester.

Voltage: Battery voltage

4. Also check harness for short to ground and short to power.

OK or NG

- OK >> GO TO 5.
- NG >> GO TO 4.

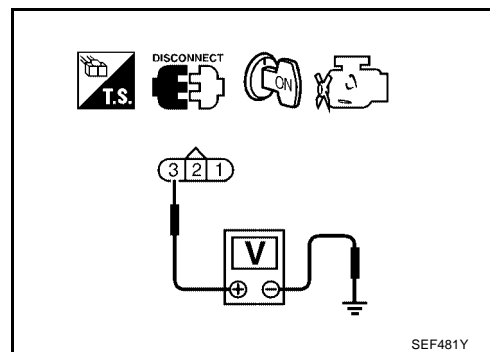

4. DETECT MALFUNCTIONING PART

Check the following.

- Harness connectors E20, F32
- Harness connectors F26, F301 (bank 1)
- Harness for open or short between camshaft position sensor (PHASE) and ECM
- Harness for open or short between camshaft position sensor (PHASE) and IPDM E/R

>> Repair open circuit or short to ground or short to power in harness or connectors.

5. CHECK CMP SENSOR (PHASE) GROUND CIRCUIT FOR OPEN AND SHORT

1. Turn ignition switch OFF.
2. Check harness continuity between CMP sensor (PHASE) terminal 1 and ground.

Continuity should exist.

3. Also check harness for short to power.

OK or NG

- OK >> GO TO 7.
- NG >> GO TO 6.

6. DETECT MALFUNCTIONING PART

Check the following.

- Harness connectors F58, M70
- Harness connectors F301, F26 (bank 1)
- Harness for open or short between CMP sensor (PHASE) and ground

>> Repair open circuit or short to power in harness or connectors.

7. CHECK CMP SENSOR (PHASE) INPUT SIGNAL CIRCUIT FOR OPEN AND SHORT

1. Disconnect ECM harness connector.
2. Check harness continuity between ECM terminal 33 (bank 1) or 14 (bank 2) and CMP sensor (PHASE) terminal 2.
Refer to Wiring Diagram.

Continuity should exist.

3. Also check harness for short to ground and short to power.

OK or NG

OK >> GO TO 9.

NG >> GO TO 8.

8. DETECT MALFUNCTIONING PART

Check the following.

- Harness connectors F26, F301 (bank 1)
- Harness for open or short between CMP sensor (PHASE) and ECM

>> Repair open circuit or short to ground or short to power in harness or connectors.

9. CHECK CAMSHAFT POSITION SENSOR (PHASE)

Refer to [EC-936, "Component Inspection"](#) .

OK or NG

OK >> GO TO 10.

NG >> Replace camshaft position sensor (PHASE).

10. CHECK CAMSHAFT (INTAKE)

Check the following.

- Accumulation of debris to the signal plate of camshaft rear end
- Chipping signal plate of camshaft rear end

OK or NG

OK >> GO TO 11.

NG >> Remove debris and clean the signal plate of camshaft rear end or replace camshaft.

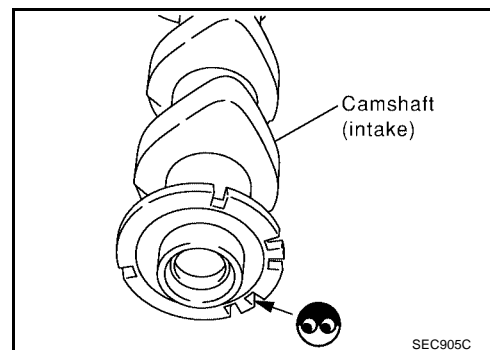

11. CHECK INTERMITTENT INCIDENT

Refer to [EC-782, "TROUBLE DIAGNOSIS FOR INTERMITTENT INCIDENT"](#) .

>> INSPECTION END

Component Inspection
CAMSHAFT POSITION SENSOR (PHASE)

1. Loosen the fixing bolt of the sensor.
2. Disconnect camshaft position sensor (PHASE) harness connector.
3. Remove the sensor.
4. Visually check the sensor for chipping.

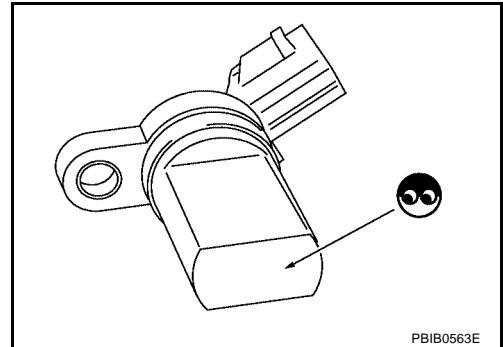

PBIB0563E

5. Check resistance as shown in the figure.

Terminal No. (Polarity)	Resistance Ω [at 25°C (77°F)]
1 (+) - 2 (-)	Except 0 or ∞
1 (+) - 3 (-)	
2 (+) - 3 (-)	

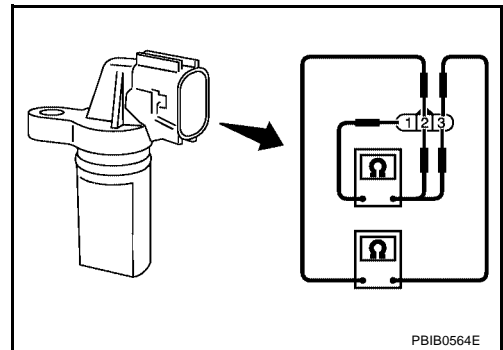

PBIB0564E

Removal and Installation
CAMSHAFT POSITION SENSOR (PHASE)

Refer to [EM-182, "CAMSHAFT"](#) .

DTC P0400 EGR FUNCTION

Description SYSTEM DESCRIPTION

Sensor	Input Signal to ECM	ECM function	Actuator
Camshaft position sensor (PHASE)	Engine speed*2 Piston position	EGR volume control	EGR volume control valve
Crankshaft position sensor (POS)			
Mass air flow sensor	Amount of intake air		
Engine coolant temperature sensor	Engine coolant temperature		
Throttle position sensor	Throttle position		
Accelerator pedal position sensor	Accelerator pedal position		
Park/neutral position (PNP) switch	Gear position		
Battery	Battery voltage*2		
Air conditioner switch*1	Air conditioner operation		
Power steering pressure sensor	Power steering operation		
Electrical load*1	Electrical load signal		
Wheel sensor*1	Vehicle speed		
TCM*1 (A/T models)	Gear position, shifting signal		

*1: This signal is sent to the ECM through CAN communication line.

*2: ECM determines the start signal status by the signals of engine speed and battery voltage.

This system controls flow rate of EGR led from exhaust manifold to intake manifold. The opening of the EGR by-pass passage in the EGR volume control valve changes to control the flow rate. A built-in step motor moves the valve in steps corresponding to the ECM output pulses. The opening of the valve varies for optimum engine control. The optimum value stored in the ECM is determined by considering various engine conditions. The EGR volume control valve remains closed under the following conditions.

- Engine stopped
- Engine starting
- Engine idling
- Low engine coolant temperature
- Excessively high engine coolant temperature
- High engine speed
- Wide open throttle
- Low battery voltage

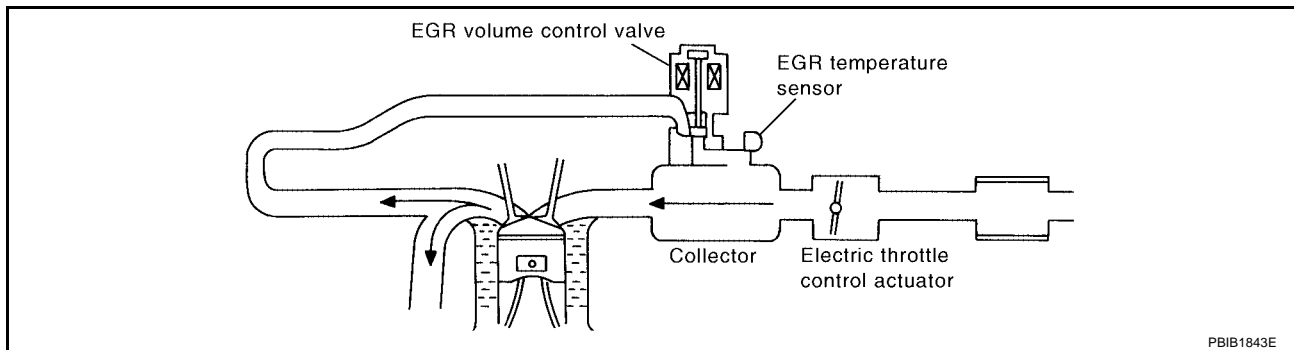

COMPONENT DESCRIPTION

EGR volume control valve

The EGR volume control valve uses a step motor to control the flow rate of EGR from exhaust manifold. This motor has four winding phases. It operates according to the output pulse signal of the ECM. Two windings are turned ON and OFF in sequence. Each time an ON pulse is issued, the valve opens or closes, changing the flow rate. When no change in the flow rate is needed, the ECM does not issue the pulse signal. A certain voltage signal is issued so that the valve remains at that particular opening.

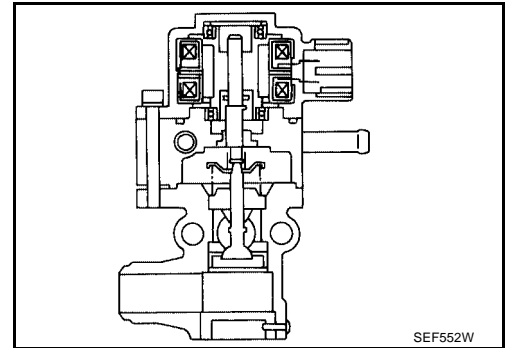

EGR Temperature Sensor

The EGR temperature sensor detects temperature changes in the EGR passageway. When the EGR volume control valve opens, hot exhaust gases flow, and the temperature in the passageway changes. The EGR temperature sensor is a thermistor that modifies a voltage signal sent from the ECM. This modified signal then returns to the ECM as an input signal. As the temperature increases, EGR temperature sensor resistance decreases. This sensor is not directly used to control the engine system. It is used only for the on board diagnosis.

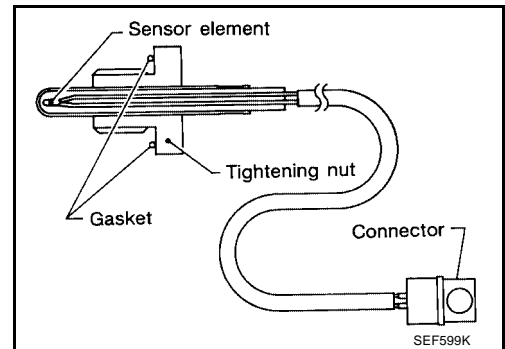

<Reference data>

EGR temperature °C (°F)	Voltage* V	Resistance MΩ
0 (32)	4.59	0.73 - 0.88
50 (122)	2.32	0.074 - 0.082
100 (212)	0.62	0.011 - 0.014

*: This data is reference values and are measured between ECM terminal 54 (EGR temperature sensor) and ground.

CAUTION:

Do not use ECM ground terminals when measuring input/output voltage. Doing so may damage the ECM's transistor. Use a ground other than ECM terminals, such as the ground.

When EGR system is operating.

Voltage: 0 - 1.5V

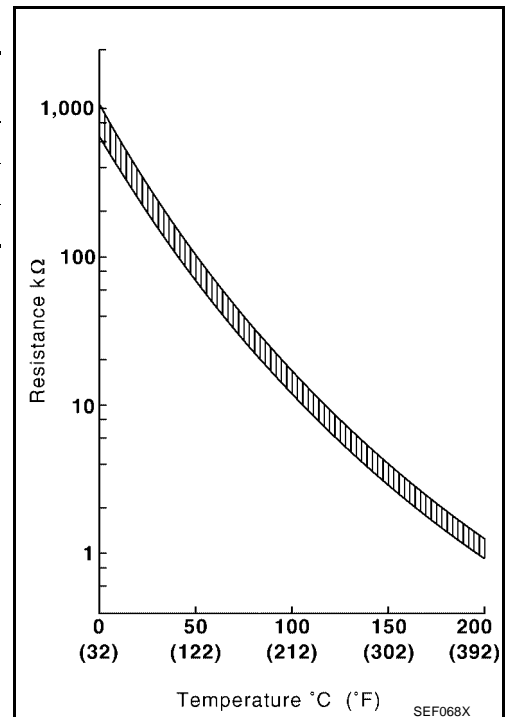

CONSULT-II Reference Value in Data Monitor Mode

UBS0014X

Specification data are reference values.

MONITOR ITEM	CONDITION	SPECIFICATION
EGR TEMP SEN	<ul style="list-style-type: none"> ● Engine: After warming up 	Less than 4.5V
EGR VOL CON/V	<ul style="list-style-type: none"> ● Engine: After warming up ● Air conditioner switch: OFF ● Shift lever: P or N (A/T), Neutral (M/T) ● No load 	Idle 0 step
	<ul style="list-style-type: none"> ● Revving engine up to 3,000 rpm quickly 	10 - 55 step

On Board Diagnosis Logic

UBS0014Y

If the absence of EGR flow is detected by EGR temperature sensor under the condition that calls for EGR, a low-flow malfunction is diagnosed.

DTC No.	Trouble diagnosis name	DTC detecting condition	Possible cause
P0400 0400	EGR function (Close)	No EGR flow is detected under the condition that calls for EGR.	<ul style="list-style-type: none"> ● Harness or connectors (The EGR volume control valve circuit is open or shorted.) ● EGR volume control valve stuck closed ● Dead (Weak) battery ● EGR passage clogged ● EGR temperature sensor and circuit ● Exhaust gas leaks

DTC Confirmation Procedure

UBS0014Z

CAUTION:

Always drive vehicle at a safe speed.

NOTE:

- If DTC Confirmation Procedure has been previously conducted, always turn ignition switch OFF and wait at least 5 seconds before conducting the next test.
- P0400 will not be displayed at "SELF-DIAG RESULTS" mode with CONSULT-II even though DTC work support test result is NG.

TESTING CONDITION:

- **Before performing the following procedure, confirm battery voltage is more than 10V at idle, then stop engine immediately.**
- **For best results, perform the test at a temperature of 5°C (41°F) or higher.**

WITH CONSULT-II

1. Turn ignition switch OFF, wait at least 10 seconds and then turn ON.
2. Check "COOLAN TEMP/S" in "DATA MONITOR" mode with CONSULT-II.
Confirm "COOLAN TEMP/S" value is within the range listed below.

COOLAN TEMP/S: Less than 40°C (104°F)

If the value is out of range, park the vehicle in a cool place and allow the engine temperature to stabilize. Do not attempt to lower the engine coolant temperature with a fan or means other than ambient air. Doing so may produce an inaccurate diagnostic result.

3. Start engine and let it idle monitoring "COOLAN TEMP/S" value. When the "COOLAN TEMP/S" value reaches 70°C (158°F), immediately go to the next step.
4. Select "EGR SYSTEM P0400" of "EGR SYSTEM" in "DTC WORK SUPPORT" mode with CONSULT-II.
5. Touch "START".
6. Accelerate vehicle to a speed of 40 km/h (25 MPH) once and then stop vehicle with engine running.

DATA MONITOR	
MONITOR	NO DTC
COOLAN TEMP/S	XXX °C

SEF013Y

DTC P0400 EGR FUNCTION

[VQ]

If "COMPLETED" appears on CONSULT-II screen, go to step 8.
If "COMPLETED" does not appear on CONSULT-II screen, go to the following step.

7. When the following conditions are met, "TESTING" will be displayed on the CONSULT-II screen. Maintain the conditions until "TESTING" changes to "COMPLETED". (It will take approximately 30 seconds or more.)

ENG SPEED	1,200 - 2,800 rpm
Vehicle speed	More than 10 km/h (6 MPH)
B/FUEL SCHDL	4.0 - 9.0 msec
Shift lever	Suitable position

EGR SYSTEM P0400	
OUT OF CONDITION	
MONITOR	
ENG SPEED	XXX rpm
B/FUEL SCHDL	XXX msec
COOLANT TEMP/S	XXX °C
VHCL SPEED SE	XXX km/h

SEF845Y

If "TESTING" is not displayed after 5 minutes, retry from step 2.

8. Make sure that "OK" is displayed after touching "SELF-DIAG RESULTS". If "NG" is displayed, refer to [EC-942, "Diagnostic Procedure"](#).

WITH GST

- Turn ignition switch OFF, wait at least 10 seconds and then turn ON.
- Check engine coolant temperature in Service \$01 with GST.
Engine coolant temperature: Less than 40°C (104°F)
If the value is out of range, park the vehicle in a cool place and allow the engine temperature to stabilize. Do not attempt to lower the coolant temperature with a fan or means other than ambient air. Doing so may produce an inaccurate diagnostic result.
- Start engine and let it idle monitoring the engine coolant temperature value. When the engine coolant temperature reaches 70°C (158°F), immediately go to the next step.
- Maintain the following conditions for at least 1 minute.
Engine speed: 1,200 - 2,800 rpm
Vehicle speed: More than 10 km/h (6 MPH)
Shift lever: Suitable position
- Select Service \$07 with GST.
- If 1st trip DTC is detected, go to [EC-942, "Diagnostic Procedure"](#).

DTC P0400 EGR FUNCTION

[VQ]

Wiring Diagram

UBS00150

EC-EGRC1-01

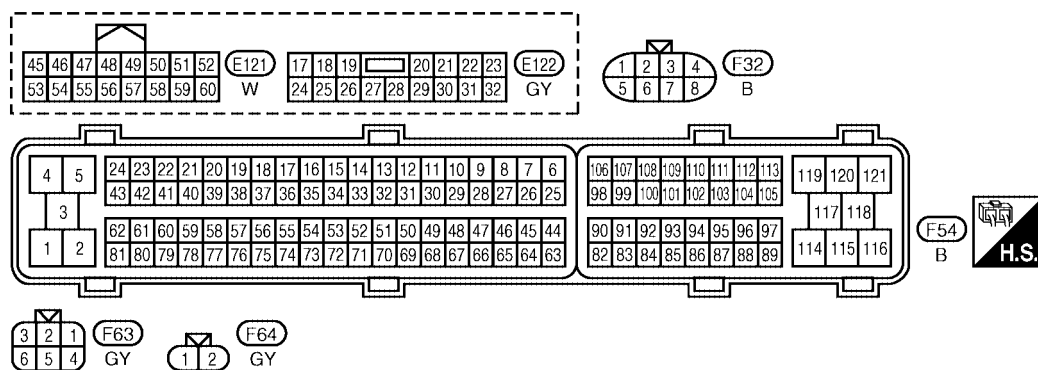
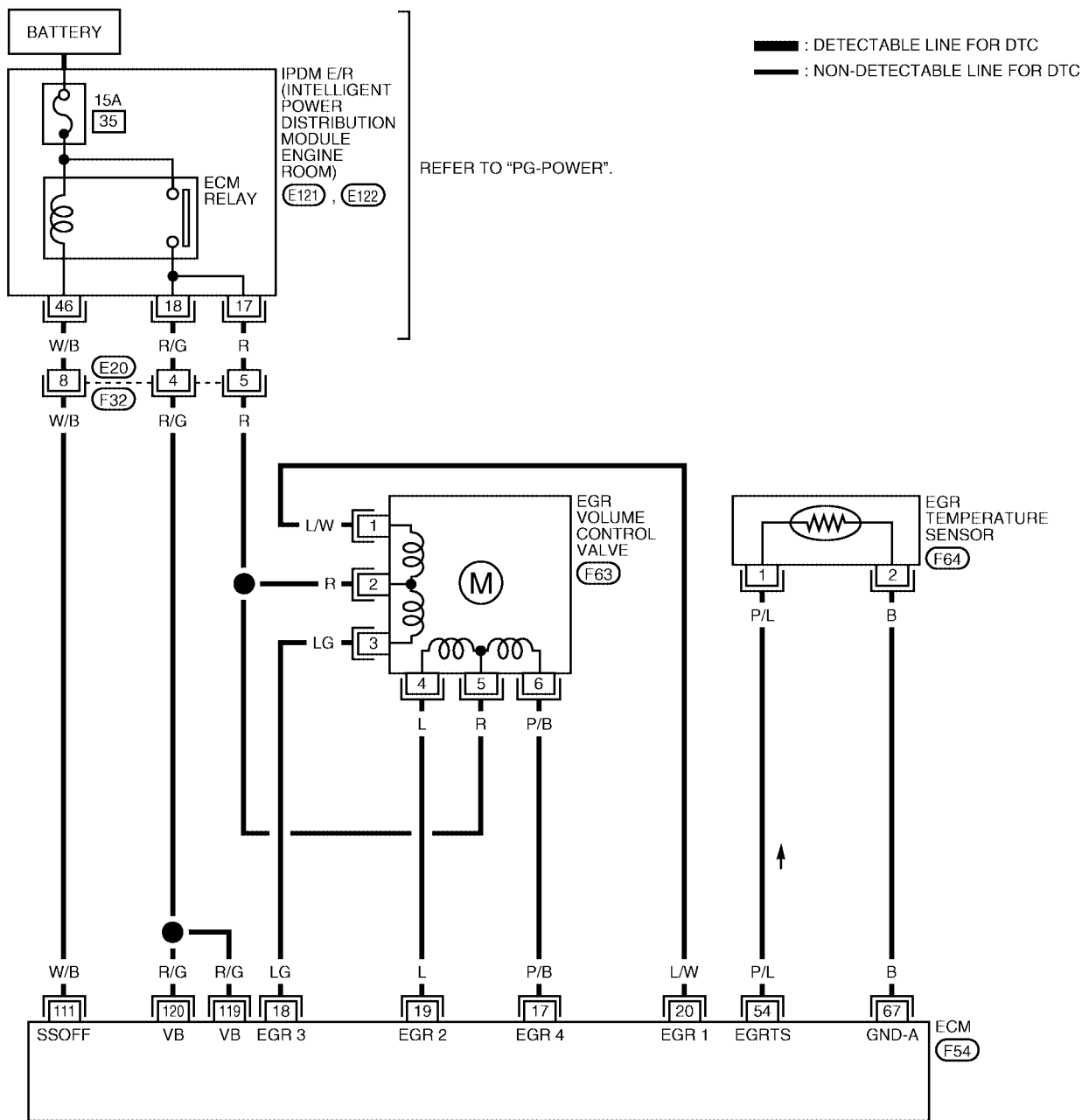

BBWA1561E

DTC P0400 EGR FUNCTION

[VQ]

Specification data are reference values and are measured between each terminal and ground.

CAUTION:

Do not use ECM ground terminals when measuring input/output voltage. Doing so may result in damage to the ECM's transistor. Use a ground other than ECM terminals, such as the ground.

TER-MINAL NO.	WIRE COLOR	ITEM	CONDITION	DATA (DC Voltage)
17 18 19 20	P/B LG L L/W	EGR volume control valve	[Engine is running] ● Idle speed	0.1 - 14V
111	W/B	ECM relay (Self shut-off)	[Engine is running] [Ignition switch: OFF] ● For a few seconds after turning ignition switch OFF	0 - 1.5V
			[Ignition switch: OFF] ● More than a few seconds after turning ignition switch OFF	BATTERY VOLTAGE (11 - 14V)
119 120	R/G R/G	Power supply for ECM	[Ignition switch: ON]	BATTERY VOLTAGE (11 - 14V)

Diagnostic Procedure

UBS00151

1. CHECK EXHAUST SYSTEM

1. Start engine.
2. Check exhaust pipes and muffler for leaks.

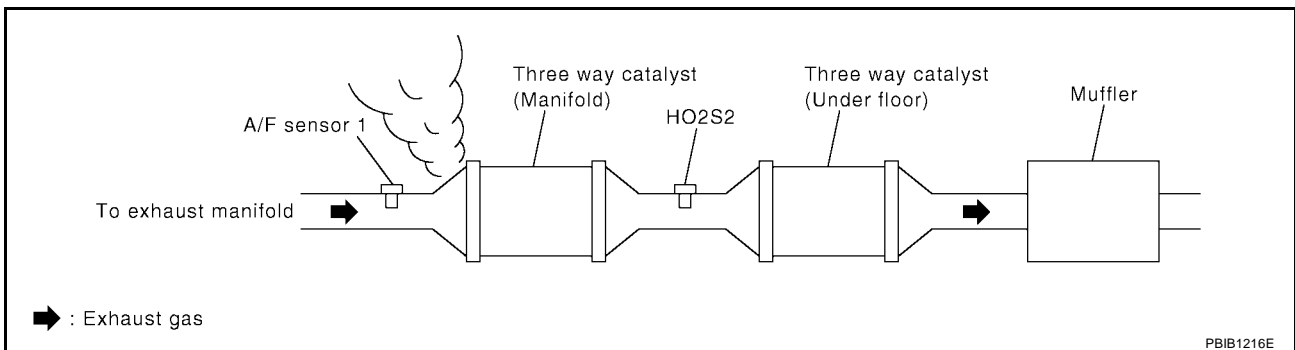

PBIB1216E

OK or NG

- OK >> GO TO 2.
- NG >> Repair or replace exhaust system.

2. CHECK EGR VOLUME CONTROL VALVE POWER SUPPLY CIRCUIT

1. Turn ignition switch OFF.
2. Disconnect EGR volume control valve harness connector.
3. Turn ignition switch ON.

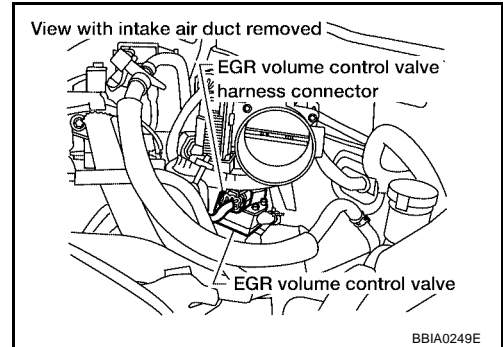

4. Check voltage between EGR volume control valve terminals 2, 5 and ground with CONSULT-II or tester.

Voltage: Battery voltage

OK or NG

- OK >> GO TO 4.
- NG >> GO TO 3.

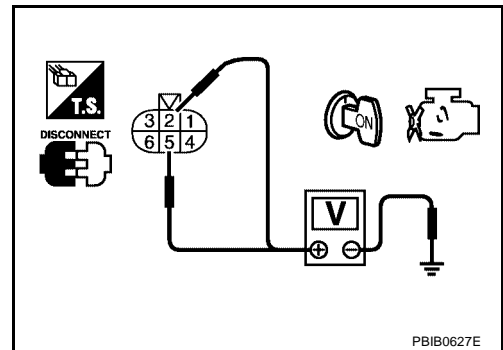

3. DETECT MALFUNCTIONING PART

Check the following.

- Harness connectors E20, F32
- IPDM E/R harness connector E122
- Harness for open or short between EGR volume control valve and IPDM E/R

>> Repair open circuit or short to ground or short to power in harness or connectors.

4. CHECK EGR VOLUME CONTROL VALVE OUTPUT SIGNAL CIRCUIT FOR OPEN AND SHORT

1. Turn ignition switch OFF.
2. Disconnect ECM harness connector.
3. Check harness continuity between ECM terminals and EGR volume control valve terminals as follows. Refer to Wiring Diagram.

ECM terminal	EGR volume control valve
17	6
18	3
19	4
20	1

Continuity should exist.

4. Also check harness for short to ground and short to power.

OK or NG

- OK >> GO TO 5.
- NG >> Repair open circuit or short to ground or short to power in harness or connectors.

5. CHECK EGR PASSAGE

Check EGR passage for clogging and cracks.

OK or NG

OK >> GO TO 6.

NG >> Repair or replace EGR passage.

6. CHECK EGR VOLUME CONTROL VALVE

Refer to [EC-949, "Component Inspection"](#) .

OK or NG

OK >> GO TO 7.

NG >> Replace EGR volume control valve.

7. CHECK EGR TEMPERATURE SENSOR AND CIRCUIT

Perform DTC Confirmation Procedure for DTC P 0405, P0406. Refer to [EC-953, "DTC Confirmation Procedure"](#) .

OK or NG

OK >> GO TO 8.

NG >> Repair or replace malfunctioning part.

8. CHECK INTERMITTENT INCIDENT

Refer to [EC-782, "TROUBLE DIAGNOSIS FOR INTERMITTENT INCIDENT"](#) .

>> **INSPECTION END**

DTC P0403 EGR VOLUME CONTROL VALVE

[VQ]

PF:14710

UBS00152

DTC P0403 EGR VOLUME CONTROL VALVE

Description SYSTEM DESCRIPTION

Sensor	Input Signal to ECM	ECM function	Actuator
Camshaft position sensor (PHASE)	Engine speed*2 Piston position	EGR volume control	EGR volume control valve
Crankshaft position sensor (POS)			
Mass air flow sensor	Amount of intake air		
Engine coolant temperature sensor	Engine coolant temperature		
Throttle position sensor	Throttle position		
Accelerator pedal position sensor	Accelerator pedal position		
Park/neutral position (PNP) switch	Gear position		
Battery	Battery voltage*2		
Air conditioner switch*1	Air conditioner operation		
Power steering pressure sensor	Power steering operation		
Electrical load*1	Electrical load signal		
Wheel sensor*1	Vehicle speed		
TCM*1 (A/T models)	Gear position, shifting signal		

*1: This signal is sent to the ECM through CAN communication line.

*2: ECM determines the start signal status by the signals of engine speed and battery voltage.

This system controls flow rate of EGR led from exhaust manifold to intake manifold. The opening of the EGR by-pass passage in the EGR volume control valve changes to control the flow rate. A built-in step motor moves the valve in steps corresponding to the ECM output pulses. The opening of the valve varies for optimum engine control. The optimum value stored in the ECM is determined by considering various engine conditions. The EGR volume control valve remains close under the following conditions.

- Engine stopped
- Engine starting
- Engine idling
- Low engine coolant temperature
- Excessively high engine coolant temperature
- High engine speed
- Wide open throttle
- Low battery voltage

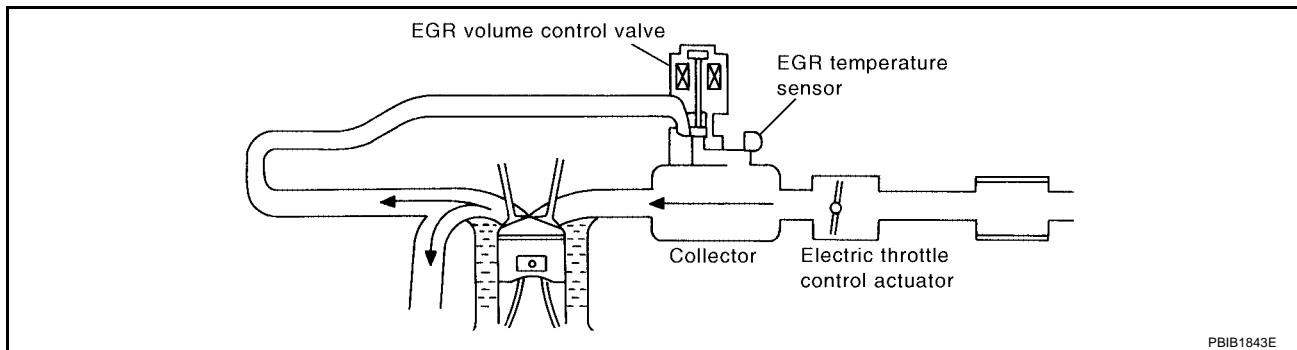

PBIB1843E

COMPONENT DESCRIPTION

EGR volume control valve

The EGR volume control valve uses a step motor to control the flow rate of EGR from exhaust manifold. This motor has four winding phases. It operates according to the output pulse signal of the ECM. Two windings are turned ON and OFF in sequence. Each time an ON pulse is issued, the valve opens or closes, changing the flow rate. When no change in the flow rate is needed, the ECM does not issue the pulse signal. A certain voltage signal is issued so that the valve remains at that particular opening.

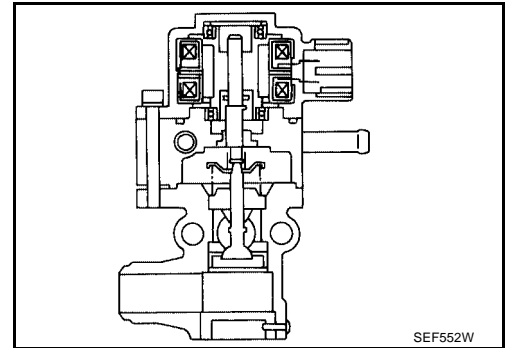

CONSULT-II Reference Value in Data Monitor Mode

UBS00153

Specification data are reference values.

MONITOR ITEM	CONDITION	SPECIFICATION
EGR VOL CON/V	<ul style="list-style-type: none"> ● Engine: After warming up ● Air conditioner switch: OFF ● Shift lever: P or N (A/T), Neutral (M/T) ● No load 	Idle
	<ul style="list-style-type: none"> ● Revving engine up to 3,000 rpm quickly 	0 step
		10 - 55 step

On Board Diagnosis Logic

UBS00154

This self-diagnosis has the one trip detection logic.

DTC No.	Trouble diagnosis name	DTC detecting condition	Possible cause
P0403 0403	EGR volume control valve circuit	An improper voltage signal is sent to ECM through the valve	<ul style="list-style-type: none"> ● Harness or connectors (The EGR volume control valve circuit is open or shorted.) ● EGR volume control valve

DTC Confirmation Procedure

UBS00155

NOTE:

If DTC Confirmation Procedure has been previously conducted, always turn ignition switch OFF and wait at least 10 seconds before conducting the next test.

TESTING CONDITION:

Before performing the following procedure, confirm that battery voltage is more than 10V at idle.

Ⓜ WITH CONSULT-II

1. Turn ignition switch ON and select "DATA MONITOR" mode with CONSULT-II.
2. Start engine and warm it up to normal operating temperature.
3. Rev engine from idle to 2,000 rpm 10 times.
4. If DTC is detected, go to [EC-948, "Diagnostic Procedure"](#) .

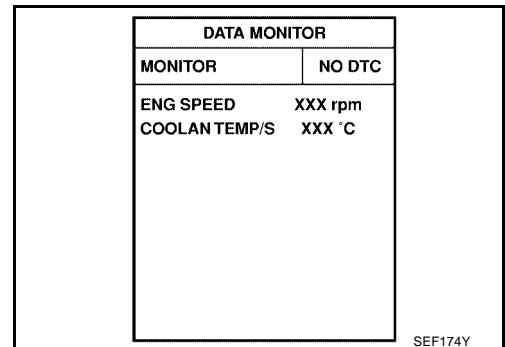

Ⓜ WITH GST

Follow the procedure "WITH CONSULT-II" above.

DTC P0403 EGR VOLUME CONTROL VALVE

[VQ]

UBS00156

Wiring Diagram

EC-EGVC/V-01

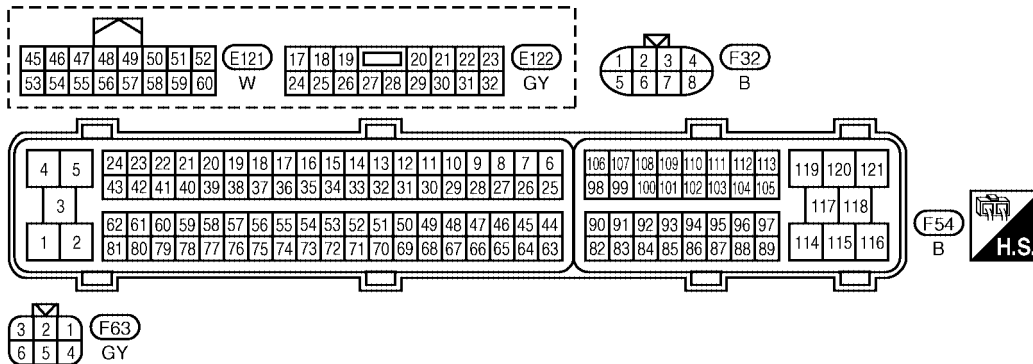
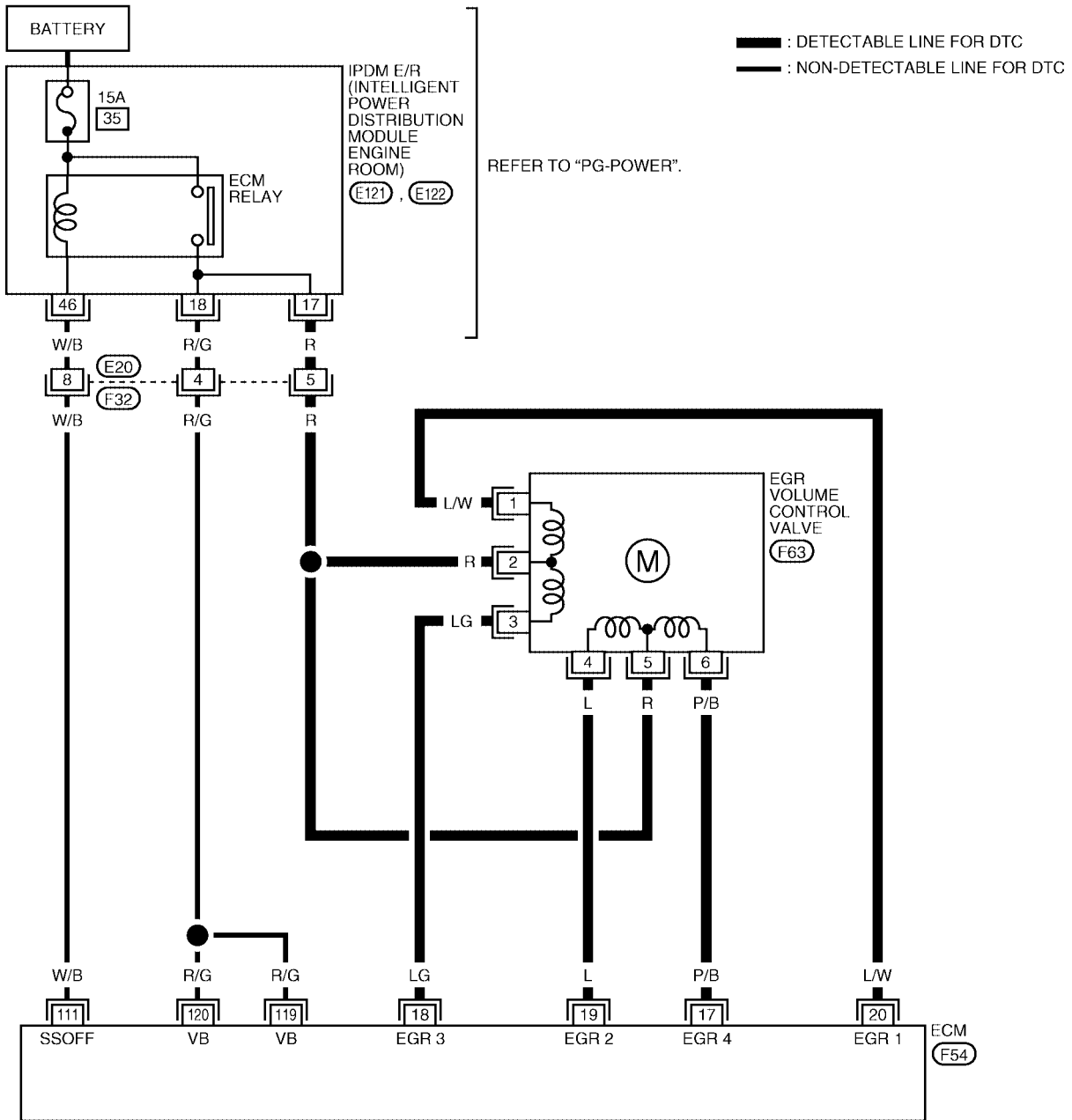

DTC P0403 EGR VOLUME CONTROL VALVE

[VQ]

Specification data are reference values and are measured between each terminal and ground.

CAUTION:

Do not use ECM ground terminals when measuring input/output voltage. Doing so may result in damage to the ECM's transistor. Use a ground other than ECM terminals, such as the ground.

TER-MINAL NO.	WIRE COLOR	ITEM	CONDITION	DATA (DC Voltage)
17 18 19 20	P/B LG L L/W	EGR volume control valve	[Engine is running] ● Idle speed	0.1 - 14V
111	W/B	ECM relay (Self shut-off)	[Engine is running] [Ignition switch: OFF] ● For a few seconds after turning ignition switch OFF	0 - 1.5V
			[Ignition switch: OFF] ● More than a few seconds after turning ignition switch OFF	BATTERY VOLTAGE (11 - 14V)
119 120	R/G R/G	Power supply for ECM	[Ignition switch: ON]	BATTERY VOLTAGE (11 - 14V)

Diagnostic Procedure

UBS00157

1. CHECK EGR VOLUME CONTROL VALVE POWER SUPPLY CIRCUIT

1. Turn ignition switch OFF.
2. Disconnect EGR volume control valve harness connector.
3. Turn ignition switch ON.

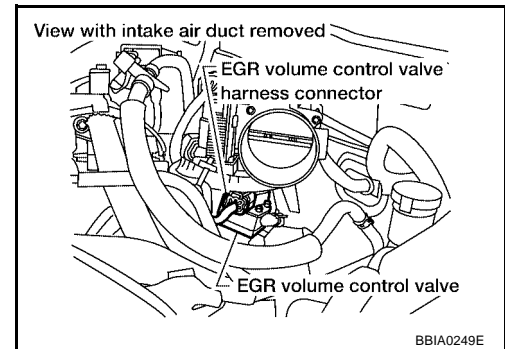

4. Check voltage between EGR volume control valve terminals 2, 5 and ground with CONSULT-II or tester.

Voltage: Battery voltage

OK or NG

- OK >> GO TO 3.
- NG >> GO TO 2.

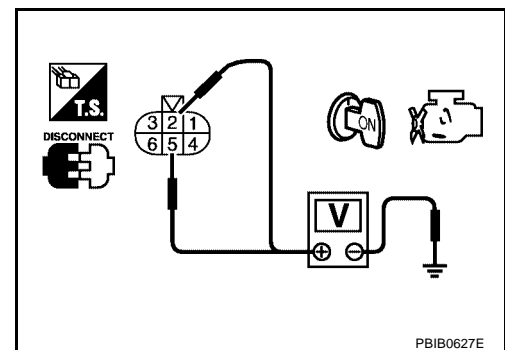

2. DETECT MALFUNCTIONING PART

Check the following.

- Harness connectors E20, F32
- IPDM E/R harness connector E122
- Harness for open or short between EGR volume control valve and IPDM E/R

>> Repair open circuit or short to ground or short to power in harness or connectors.

DTC P0403 EGR VOLUME CONTROL VALVE

[VQ]

3. CHECK EGR VOLUME CONTROL VALVE OUTPUT SIGNAL CIRCUIT FOR OPEN AND SHORT

1. Turn ignition switch OFF.
2. Disconnect ECM harness connector.
3. Check harness continuity between ECM terminals and EGR volume control valve terminals as follows. Refer to Wiring Diagram.

ECM terminal	EGR volume control valve
17	6
18	3
19	4
20	1

Continuity should exist.

4. Also check harness for short to ground and short to power.

OK or NG

OK >> GO TO 4.

NG >> Repair open circuit or short to ground or short to power in harness or connectors.

4. CHECK EGR VOLUME CONTROL VALVE

Refer to [EC-949, "Component Inspection"](#) .

OK or NG

OK >> GO TO 5.

NG >> Replace EGR volume control valve.

5. CHECK INTERMITTENT INCIDENT

Refer to [EC-782, "TROUBLE DIAGNOSIS FOR INTERMITTENT INCIDENT"](#) .

>> INSPECTION END

Component Inspection EGR VOLUME CONTROL VALVE

UBS00158

 With CONSULT-II

1. Turn ignition switch OFF.
2. Disconnect EGR volume control valve harness connector.

DTC P0403 EGR VOLUME CONTROL VALVE

[VQ]

3. Check resistance between EGR volume control valve terminal 2 and terminals 1, 3, terminal 5 and terminals 4, 6.

Resistance: 20 - 24 Ω [at 20°C (68°F)]

If NG, replace EGR volume control valve.
If OK, go to next step.

4. Remove EGR volume control valve.
5. Reconnect ECM harness connector and EGR volume control valve harness connector.
6. Turn ignition switch ON.

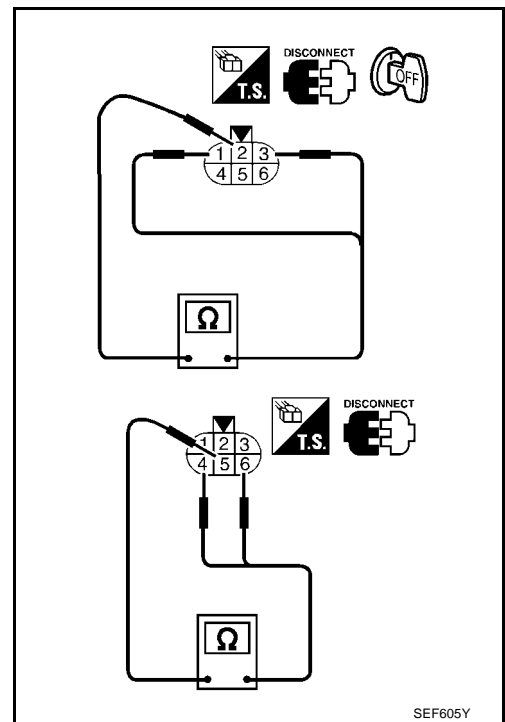

7. Perform "EGR VOL CONT/V" in "ACTIVE TEST" mode with CONSULT-II.

ACTIVE TEST	
EGR VOL CONT/V	20 step
MONITOR	
ENG SPEED	XXX rpm
EGR TEMP SEN	XXX V

SEF015Y

8. Check that EGR volume control valve shaft moves smoothly forward and backward according to the valve opening steps.
If NG, replace EGR volume control valve.

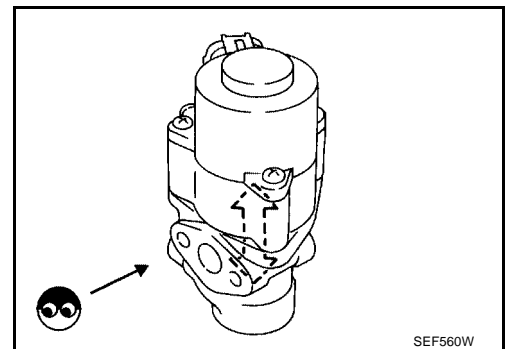

⊗ Without CONSULT-II

1. Turn ignition switch OFF.
2. Disconnect EGR volume control valve harness connector.

DTC P0403 EGR VOLUME CONTROL VALVE

[VQ]

3. Check resistance between EGR volume control valve terminal 2 and terminals 1, 3, terminal 5 and terminals 4, 6.

Resistance: 20 - 24 Ω [at 20°C (68F°)]

If NG, replace EGR volume control valve.
If OK, go to next step.

4. Remove EGR volume control valve.
5. Reconnect ECM harness connector and EGR volume control valve harness connector.
6. Turn ignition switch ON and OFF.

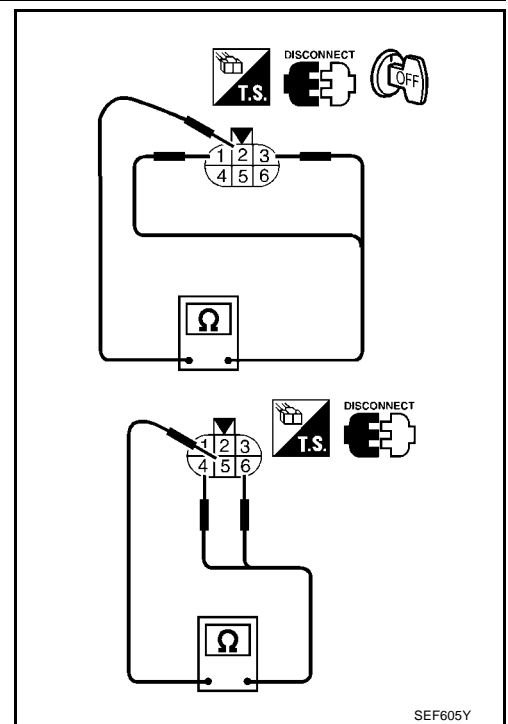

SEF605Y

7. Check that EGR volume control valve shaft moves smoothly forward and backward according to the ignition switch position.

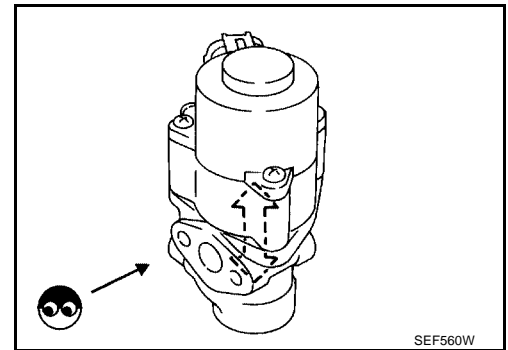

SEF560W

UBS00159

Removal and Installation EGR VOLUME CONTROL VALVE

Refer to [EM-126. "EGR VOLUME CONTROL VALVE"](#) .

DTC P0405, P0406 EGRT SENSOR

Component Description

The EGR temperature sensor detects temperature changes in the EGR passageway. When the EGR volume control valve opens, hot exhaust gases flow, and the temperature in the passageway changes. The EGR temperature sensor is a thermistor that modifies a voltage signal sent from the ECM. This modified signal then returns to the ECM as an input signal. As the temperature increases, EGR temperature sensor resistance decreases.

This sensor is not directly used to control the engine system. It is used only for the on board diagnosis.

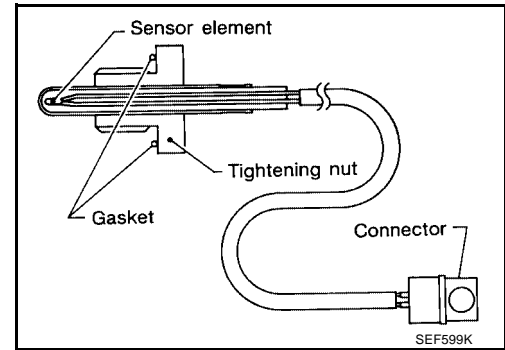

<Reference data>

EGR temperature °C (°F)	Voltage* V	Resistance MΩ
0 (32)	4.59	0.73 - 0.88
50 (122)	2.32	0.074 - 0.082
100 (212)	0.62	0.011 - 0.014

*: This data is reference value and is measured between ECM terminal 54 (EGR temperature sensor) and ground.

CAUTION:

Do not use ECM ground terminals when measuring input/output voltage. Doing so may damage the ECM's transistor. Use a ground other than ECM terminals, such as the ground.

When EGR system is operating.

Voltage: 0 - 1.5V

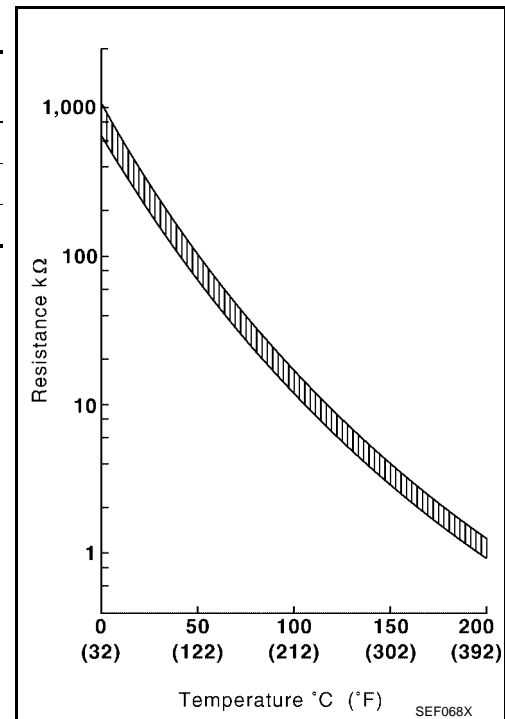

On Board Diagnosis Logic

DTC No.	Trouble Diagnosis Name	DTC Detecting Condition	Possible Cause
P0405 0405	EGR temperature sensor circuit low input	An excessively low voltage from the EGR temperature sensor is sent to ECM even when engine coolant temperature is low.	<ul style="list-style-type: none"> ● Harness or connectors (The EGR temperature sensor circuit is shorted.) ● EGR temperature sensor ● Malfunction of EGR function
P0406 0406	EGR temperature sensor circuit high input	An excessively high voltage from the EGR temperature sensor is sent to ECM even when engine coolant temperature is high.	<ul style="list-style-type: none"> ● Harness or connectors (The EGR temperature sensor circuit is open.) ● EGR temperature sensor ● Malfunction of EGR function

DTC Confirmation Procedure

NOTE:

If DTC Confirmation Procedure has been previously conducted, always turn ignition switch OFF and wait at least 10 seconds before conducting the next test.

PROCEDURE FOR DTC P0405

With CONSULT-II

1. Turn ignition switch ON.
2. Select "DATA MONITOR" mode with CONSULT-II.
3. Verify that "COOLAN TEMP/S" indicates less than 50°C (122°F).
If the engine coolant temperature is above the range, cool the engine down.
4. Start engine and let it idle for at least 8 seconds.
5. If 1st trip DTC is detected, go to [EC-956, "Diagnostic Procedure"](#)

DATA MONITOR	
MONITOR	NO DTC
ENG SPEED	XXX rpm
COOLAN TEMP/S	XXX °C

SEF174Y

With GST

Follow the procedure "With CONSULT-II" above.

PROCEDURE FOR DTC P0406

CAUTION:

Always drive vehicle at a safe speed.

TESTING CONDITION:

Always perform the test at a temperature above -10°C (14°F).

With CONSULT-II

1. Start engine and warm it up to normal operating temperature.
2. Select "EGR VOL CONT/V" in "ACTIVE TEST" mode with CONSULT-II.
3. Hold engine speed at 1,500 rpm.
4. Touch "Qu" and set the EGR volume control valve opening to 50 step and check "EGR TEMP SEN" indication.
"EGR TEMP SEN" indication should decrease to less than 1.0V.
If the check result is NG, go to [EC-956, "Diagnostic Procedure"](#).
If the check result is OK, go to the following step.
5. Turn ignition switch OFF and wait at least 10 seconds.
6. Turn ignition switch ON and select "DATA MONITOR" mode with CONSULT-II.
7. Start engine and maintain the following conditions for at least 5 consecutive seconds.

ENG SPEED	1,200 - 2,800 rpm
VHCL SPEED SE	More than 10 km/h (6 MPH)
B/FUEL SCHDL	4 - 9 msec
Shift lever	Suitable position

8. If 1st trip DTC is detected, go to [EC-956, "Diagnostic Procedure"](#)

ACTIVE TEST	
EGR VOL CONT/V	20 step
MONITOR	
ENG SPEED	XXX rpm
EGR TEMP SEN	XXX V

SEF015Y

DATA MONITOR	
MONITOR	NO DTC
ENG SPEED	XXX rpm
COOLAN TEMP/S	XXX °C
VHCL SPEED SE	XXX km/h
B/FUEL SCHDL	XXX msec

PBIB0164E

With GST

1. Start engine and warm it up to normal operating temperature.
2. Turn ignition switch OFF, wait at least 10 seconds and then turn ON.
3. Select Service \$01 with GST and maintain the following conditions for at least 5 consecutive seconds.

DTC P0405, P0406 EGRT SENSOR

[VQ]

Engine speed	1,200 - 2,800 rpm
Vehicle speed	More than 10 km/h (6 MPH)
Shift lever	Suitable position

4. Select Service \$07 with GST.
5. If 1st trip DTC is detected, go to [EC-956, "Diagnostic Procedure"](#).



DTC P0405, P0406 EGRT SENSOR

[VQ]

Wiring Diagram

UBS0015D

EC-EGR/TS-01

 : DETECTABLE LINE FOR DTC
 : NON-DETECTABLE LINE FOR DTC

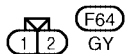
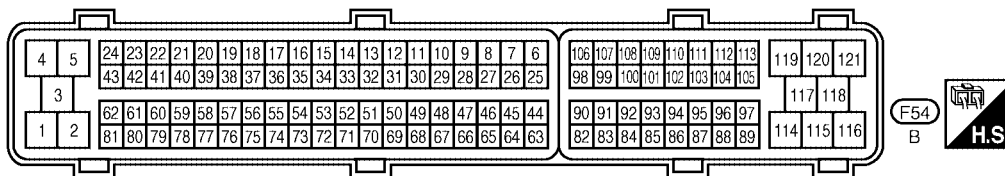
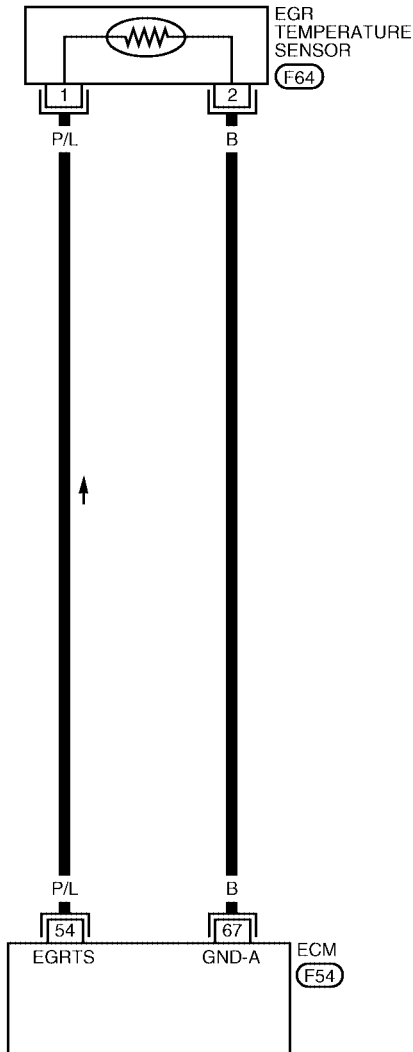

BBWA1562E

Diagnostic Procedure

1. CHECK GROUND CONNECTIONS

1. Turn ignition switch OFF.
2. Loosen and retighten three ground screws on the body.
Refer to [EC-789, "Ground Inspection"](#).

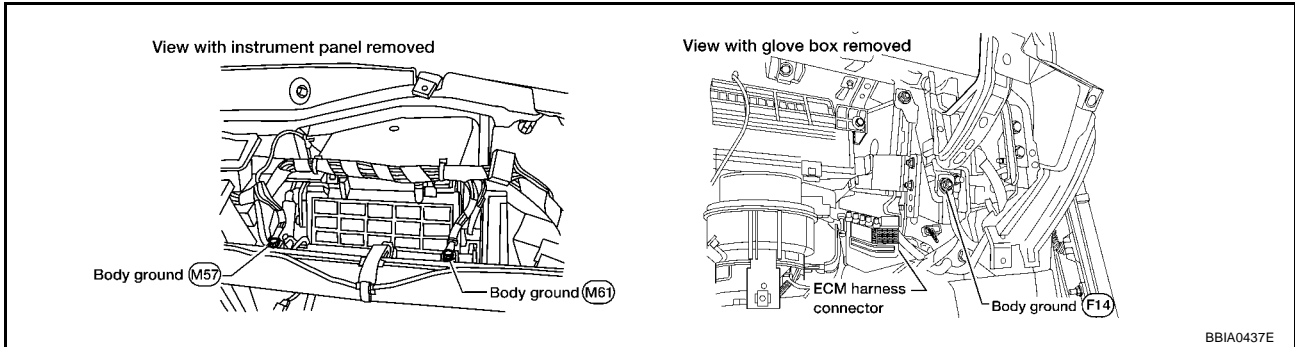

BBIA0437E

OK or NG

- OK >> GO TO 2.
- NG >> Repair or replace ground connections.

2. CHECK EGR TEMPERATURE SENSOR POWER SUPPLY CIRCUIT

1. Disconnect EGR temperature sensor harness connector.
2. Turn ignition switch ON.

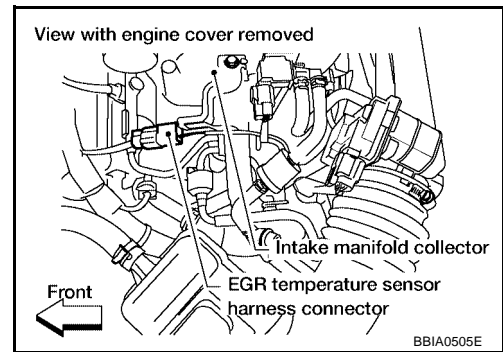

BBIA0505E

3. Check voltage between EGR temperature sensor terminal 1 and ground with CONSULT-II or tester.

Voltage: Approximately 5V

OK or NG

- OK >> GO TO 3.
- NG >> Repair or replace harness or connectors.

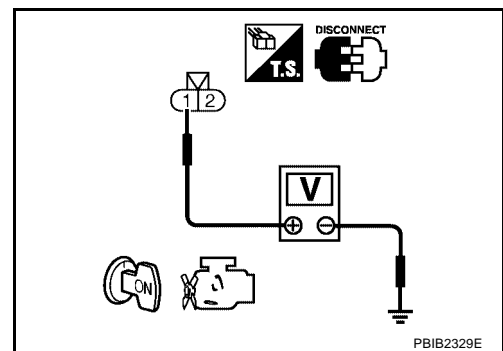

PBIB2329E

3. CHECK EGR TEMPERATURE SENSOR GROUND CIRCUIT FOR OPEN AND SHORT

1. Turn ignition switch OFF.
2. Disconnect ECM harness connector.
3. Check harness continuity between EGR temperature sensor terminal 2 and ECM terminal 67.
Refer to Wiring Diagram.

Continuity should exist.

4. Also check harness for short to ground and short to power.

OK or NG

OK >> GO TO 4.

NG >> Repair open circuit or short to ground or short to power in harness or connector.

4. CHECK EGR TEMPERATURE SENSOR

Refer to [EC-957, "Component Inspection"](#) .

OK or NG

OK >> GO TO 5.

NG >> Replace EGR temperature sensor.

5. CHECK EGR VOLUME CONTROL VALVE

Refer to [EC-949, "Component Inspection"](#) .

OK or NG

OK >> GO TO 6.

NG >> Replace EGR volume control valve.

6. CHECK INTERMITTENT INCIDENT

Refer to [EC-782, "TROUBLE DIAGNOSIS FOR INTERMITTENT INCIDENT"](#) .

>> **INSPECTION END**

Component Inspection

EGR TEMPERATURE SENSOR

UBS0015F

1. Turn ignition switch OFF.
2. Disconnect EGR temperature sensor harness connector.
3. Check resistance between EGR temperature sensor terminals 1 and 2 as shown in the figure.

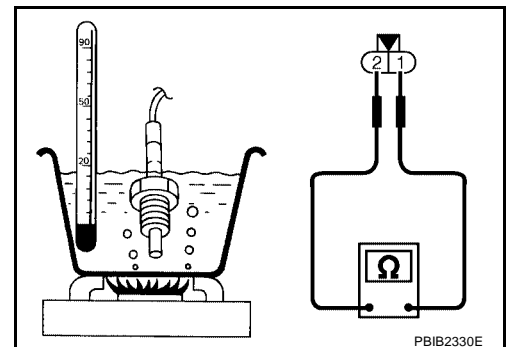

PBIB2330E

DTC P0405, P0406 EGRT SENSOR

[VQ]

<Reference data>

EGR temperature °C (°F)	Resistance MΩ
0 (32)	0.73 - 0.88
50 (122)	0.074 - 0.082
100 (212)	0.011 - 0.014

4. If NG, replace EGR temperature sensor.

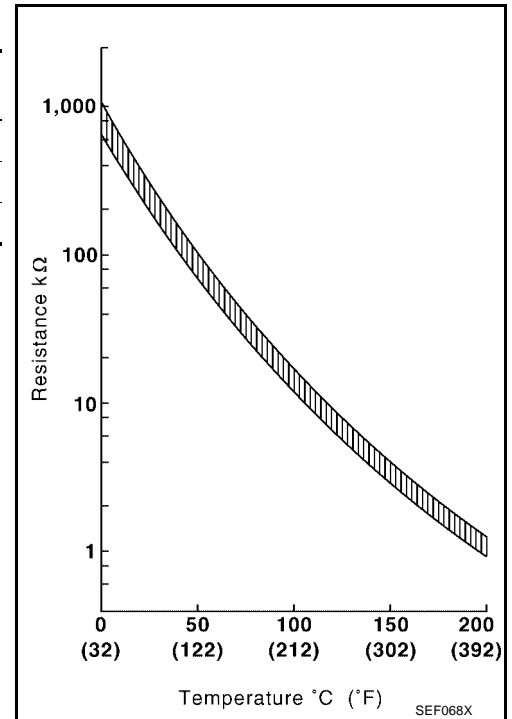

UBS0015G

Removal and Installation EGR TEMPERATURE SENSOR

Refer to [EM-126, "EGR VOLUME CONTROL VALVE"](#) .

DTC P0420, P0430 THREE WAY CATALYST FUNCTION

[VQ]

DTC P0420, P0430 THREE WAY CATALYST FUNCTION

PFP:20905

On Board Diagnosis Logic

UBS0015H

The ECM monitors the switching frequency ratio of air fuel ratio (A/F) sensor 1 and heated oxygen sensor 2.

A three way catalyst (manifold) with high oxygen storage capacity will indicate a low switching frequency of heated oxygen sensor 2. As oxygen storage capacity decreases, the heated oxygen sensor 2 switching frequency will increase.

When the frequency ratio of air fuel ration (A/F) sensor 1 and heated oxygen sensor 2 approaches a specified limit value, the three way catalyst (manifold) malfunction is diagnosed.

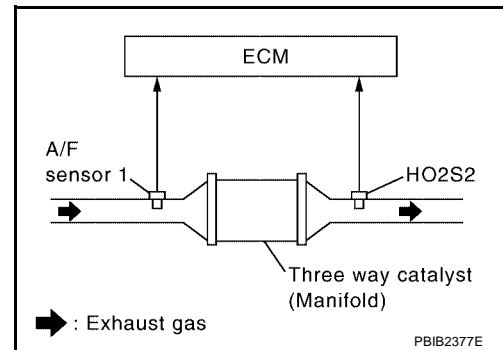

DTC No.	Trouble diagnosis name	DTC detecting condition	Possible cause
P0420 0420 (Bank 1)	Catalyst system efficiency below threshold	<ul style="list-style-type: none"> Three way catalyst (manifold) does not operate properly. Three way catalyst (manifold) does not have enough oxygen storage capacity. 	<ul style="list-style-type: none"> Three way catalyst (manifold) Exhaust tube Intake air leaks Fuel injector Fuel injector leaks Spark plug Improper ignition timing
P0430 0430 (Bank 2)			

DTC Confirmation Procedure

UBS0015I

NOTE:

If DTC Confirmation Procedure has been previously conducted, always turn ignition switch OFF and wait at least 10 seconds before conducting the next test.

WITH CONSULT-II

TESTING CONDITION:

Do not hold engine speed for more than the specified minutes below.

- Turn ignition switch ON and select "DATA MONITOR" mode with CONSULT-II.
- Start engine and warm it up to the normal operating temperature.
- Turn ignition switch OFF and wait at least 10 seconds.
- Start engine and keep the engine speed between 3,500 and 4,000 rpm for at least 1 minute under no load.
- Let engine idle for 1 minute.
- Make sure that "COOLAN TEMP/S" indicates more than 70°C (158°F).
If not, warm up engine and go to next step when "COOLAN TEMP/S" indication reaches to 70°C (158°F).
- Open engine hood.

DATA MONITOR	
MONITOR	NO DTC
ENG SPEED	XXX rpm
COOLAN TEMP/S	XXX °C
VHCL SPEED SE	XXX km/h
B/FUEL SCHDL	XXX msec

SEF189Y

DTC P0420, P0430 THREE WAY CATALYST FUNCTION

[VQ]

8. Select "DTC & SRT CONFIRMATION" then "SRT WORK SUPPORT" mode with CONSULT-II.
9. Rev engine up to 2,000 to 3,000 rpm and hold it for 3 consecutive minutes then release the accelerator pedal completely. If "INCMP" of "CATALYST" changed to "CMPLT", go to step 12.
10. Wait 5 seconds at idle.

SRT WORK SUPPORT	
CATALYST	INCMP
EVAP SYSTEM	INCMP
HO2S HTR	CMPLT
HO2S	INCMP
EGR SYSTEM	INCMP
MONITOR	
ENG SPEED	XXX rpm
MAS A/F SE-B1	XXX V
B/FUEL SCHDL	XXX msec
A/F ALPHA-B1	XXX V
COOLAN TEMP/S	XX °C
A/F SEN1 (B1)	XXX V

SEF533Z

11. Rev engine up to 2,000 to 3,000 rpm and maintain it until "INCMP" of "CATALYST" changes to "CMPLT" (It will take approximately 5 minutes). If not "CMPLT", stop engine and cool it down to less than 70°C (158°F) and then retest from step 1.

SRT WORK SUPPORT	
CATALYST	CMPLT
EVAP SYSTEM	INCMP
HO2S HTR	CMPLT
HO2S	INCMP
EGR SYSTEM	INCMP
MONITOR	
ENG SPEED	XXX rpm
MAS A/F SE-B1	XXX V
B/FUEL SCHDL	XXX msec
A/F ALPHA-B1	XXX V
COOLAN TEMP/S	XX °C
A/F SEN1 (B1)	XXX V

SEF534Z

12. Select "SELF-DIAG RESULTS" mode with CONSULT-II.
13. Confirm that the 1st trip DTC is not detected. If the 1st trip DTC is detected, go to [EC-961, "Diagnostic Procedure"](#).

SELF DIAG RESULTS	
DTC RESULTS	TIME
NO DTC IS DETECTED. FURTHER TESTING MAY BE REQUIRED.	

SEF535Z

Overall Function Check

UBS0015J

Use this procedure to check the overall function of the three way catalyst (manifold). During this check, a 1st trip DTC might not be confirmed.

WITH GST

1. Start engine and warm it up to the normal operating temperature.
2. Turn ignition switch OFF and wait at least 10 seconds.
3. Start engine and keep the engine speed between 3,500 and 4,000 rpm for at least 1 minute under no load.
4. Let engine idle for 1 minute.
5. Open engine hood.
6. Set voltmeter probe between ECM terminals 74 [HO2S2 (bank 1) signal], 55 [HO2S2 (bank 2) signal] and ground.
7. Keep engine speed at 2,500 rpm constant under no load.
8. Make sure that the voltage does not vary for more than 5 seconds.

If the voltage fluctuation cycle takes less than 5 seconds, go to [EC-961, "Diagnostic Procedure"](#).

- 1 cycle: 0.6 - 1.0 → 0 - 0.3 → 0.6 - 1.0

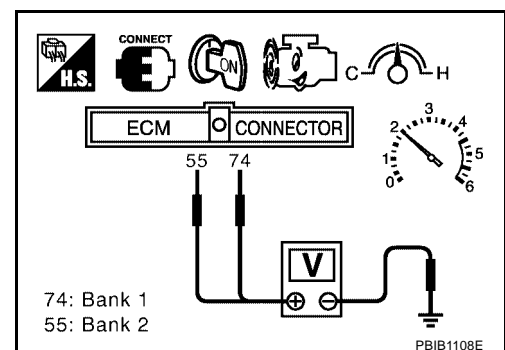

Diagnostic Procedure

1. CHECK EXHAUST SYSTEM

Visually check exhaust tubes and muffler for dent.

OK or NG

- OK >> GO TO 2.
- NG >> Repair or replace.

2. CHECK EXHAUST GAS LEAK

1. Start engine and run it at idle.
2. Listen for an exhaust gas leak before the three way catalyst (manifold).

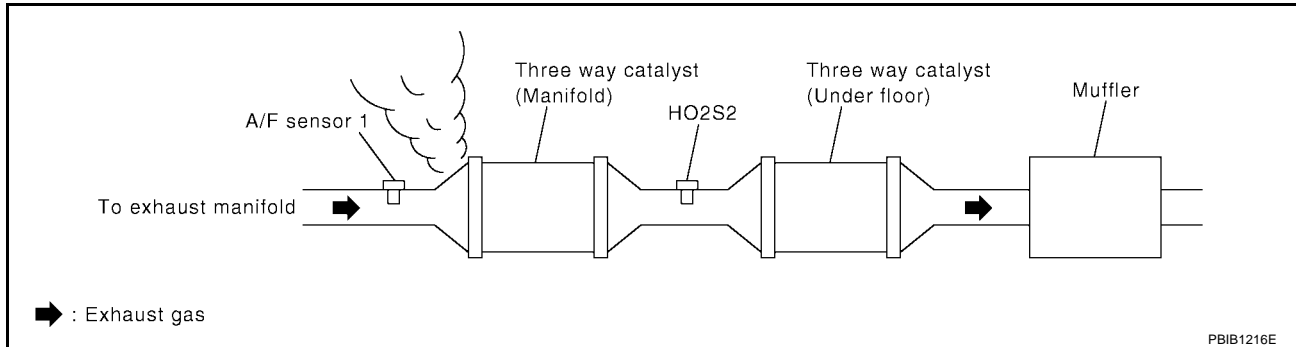

OK or NG

- OK >> GO TO 3.
- NG >> Repair or replace.

3. CHECK INTAKE AIR LEAK

Listen for an intake air leak after the mass air flow sensor.

OK or NG

- OK >> GO TO 4.
- NG >> Repair or replace.

4. CHECK IGNITION TIMING

Check the following items. Refer to [EC-693, "Basic Inspection"](#) .

Items	Specifications
Target idle speed	A/T: 675 ± 50 rpm (in P or N position) M/T: 625 ± 50 rpm (in neutral position)
Ignition timing	A/T: 15 ± 5° BTDC (in P or N position) M/T: 15 ± 5° BTDC (in neutral position)

OK or NG

- OK >> GO TO 5.
- NG >> Follow the [EC-693, "Basic Inspection"](#) .

5. CHECK INJECTOR

1. Stop engine and then turn ignition switch ON.
2. Check voltage between ECM terminals 21, 22, 23, 40, 41, 42 and ground with CONSULT-II or tester.
Refer to Wiring Diagram for Injectors, [EC-1309](#).

Voltage: Battery voltage

OK or NG

- OK >> GO TO 6.
NG >> Perform [EC-1310, "Diagnostic Procedure"](#).

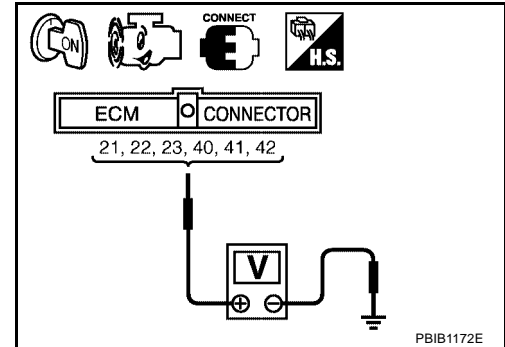

6. CHECK FUNCTION OF IGNITION COIL-I

CAUTION:

Do the following procedure in the place where ventilation is good without the combustible.

1. Turn ignition switch OFF.
2. Remove fuel pump fuse in IPDM E/R to release fuel pressure.
NOTE:
Do not use CONSULT-II to release fuel pressure, or fuel pressure applies again during the following procedure.
3. Start engine.
4. After engine stalls, crank it 2 or 3 times to release all fuel pressure.
5. Turn ignition switch OFF.
6. Remove all ignition coil harness connectors to avoid the electrical discharge from the ignition coils.
7. Remove ignition coil and spark plug of the cylinder to be checked.
8. Crank engine for 5 seconds or more to remove combustion gas in the cylinder.
9. Connect spark plug and harness connector to ignition coil.
10. Fix ignition coil using a rope etc. with gap of 13 - 17 mm between the edge of the spark plug and grounded metal portion as shown in the figure.
11. Crank engine for about three seconds, and check whether spark is generated between the spark plug and the grounded metal portion.

Spark should be generated.

CAUTION:

- Do not approach to the spark plug and the ignition coil within 50cm. Be careful not to get an electrical shock while checking, because the electrical discharge voltage becomes 20kV or more.
- It might cause to damage the ignition coil if the gap of 17 mm or more is taken.

NOTE:

When the gap is 13 mm or less, the spark might be generated even if the coil is malfunctioning.

OK or NG

- OK >> GO TO 10.
NG >> GO TO 7.

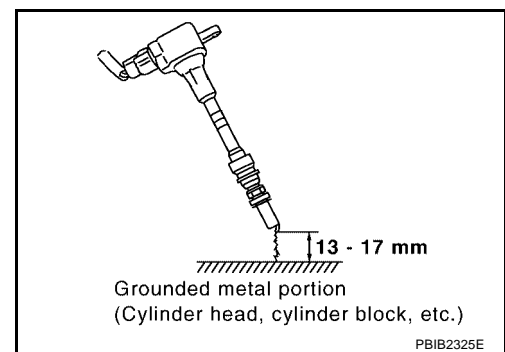
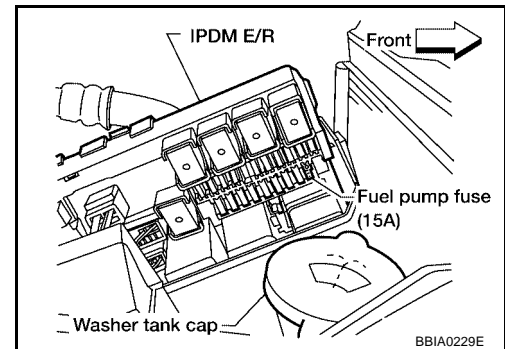

7. CHECK FUNCTION OF IGNITION COIL-II

1. Turn ignition switch OFF.
2. Disconnect spark plug and connect a known-good spark plug.
3. Crank engine for about 3 seconds, and recheck whether spark is generated between the spark plug and the grounded metal portion.

Spark should be generated.

OK or NG

OK >> GO TO 8.

NG >> Check ignition coil, power transistor and their circuits. Refer to [EC-1287](#).

8. CHECK SPARK PLUG

Check the initial spark plug for fouling, etc.

OK or NG

OK >> Replace spark plug(s) with standard type one(s). For spark plug type, refer to [MA-26, "Changing Spark Plugs \(Platinum - Tipped Type\)"](#).

NG >> 1. Repair or clean spark plug.
2. GO TO 9.

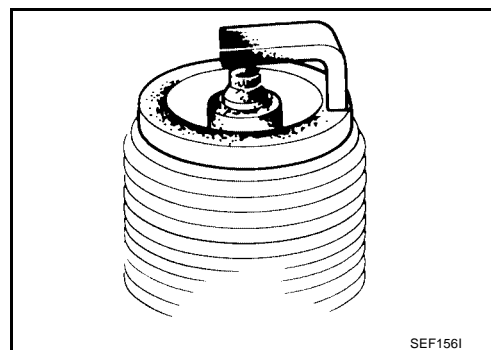
**9. CHECK FUNCTION OF IGNITION COIL-III**

1. Reconnect the initial spark plugs.
2. Crank engine for about 3 seconds, and recheck whether spark is generated between the spark plug and the grounded portion.

Spark should be generated.

OK or NG

OK >> **INSPECTION END**

NG >> Replace spark plug(s) with standard type one(s). For spark plug type, refer to [MA-26](#).

10. CHECK INJECTOR

1. Turn ignition switch OFF.
2. Remove injector assembly.
Refer to [EM-147, "FUEL INJECTOR AND FUEL TUBE"](#).
Keep fuel hose and all injectors connected to injector gallery.
3. Reconnect all injector harness connectors.
4. Disconnect all ignition coil harness connectors.
5. Turn ignition switch ON.
Make sure fuel does not drip from injector.

OK or NG

OK (Does not drip.)>>GO TO 11.

NG (Drips.)>>Replace the injector(s) from which fuel is dripping.

11. CHECK INTERMITTENT INCIDENT

Refer to [EC-782, "TROUBLE DIAGNOSIS FOR INTERMITTENT INCIDENT"](#).

Trouble is fixed.>>**INSPECTION END**

Trouble is not fixed.>>Replace three way catalyst (manifold).

DTC P0441 EVAP CONTROL SYSTEM

System Description

NOTE:

If DTC P0441 is displayed with other DTC such as P2122, P2123, P2127, P2128 or P2138, first perform trouble diagnosis for other DTC.

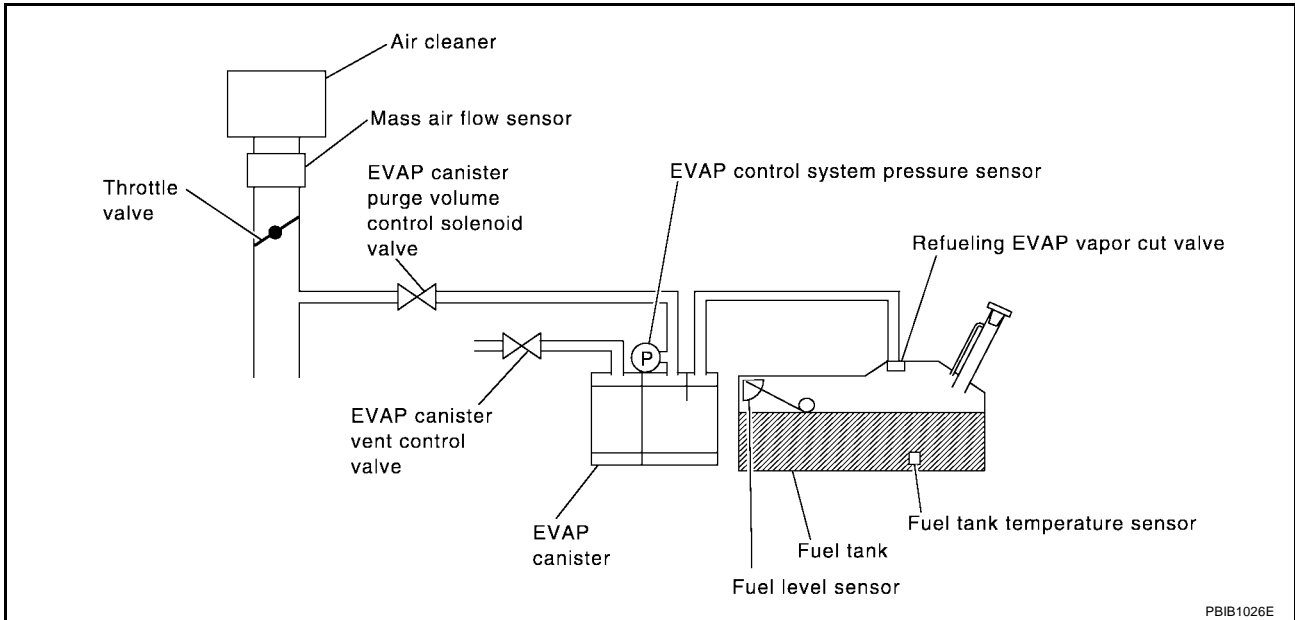

PBIB1026E

In this evaporative emission (EVAP) control system, purge flow occurs during non-closed throttle conditions. Purge volume is related to air intake volume. Under normal purge conditions (non-closed throttle), the EVAP canister purge volume control solenoid valve is open to admit purge flow. Purge flow exposes the EVAP control system pressure sensor to intake manifold vacuum.

On Board Diagnosis Logic

Under normal conditions (non-closed throttle), sensor output voltage indicates if pressure drop and purge flow are adequate. If not, a malfunction is determined.

DTC No.	Trouble diagnosis name	DTC detecting condition	Possible cause
P0441 0441	EVAP control system incorrect purge flow	EVAP control system does not operate properly, EVAP control system has a leak between intake manifold and EVAP control system pressure sensor.	<ul style="list-style-type: none"> ● EVAP canister purge volume control solenoid valve stuck closed ● EVAP control system pressure sensor and the circuit ● Loose, disconnected or improper connection of rubber tube ● Blocked rubber tube ● Cracked EVAP canister ● EVAP canister purge volume control solenoid valve circuit ● Accelerator pedal position sensor ● Blocked purge port ● EVAP canister vent control valve

DTC Confirmation Procedure

CAUTION:

Always drive vehicle at a safe speed.

NOTE:

If DTC Confirmation Procedure has been previously conducted, always turn ignition switch OFF and wait at least 10 seconds before conducting the next test.

TESTING CONDITION:

Always perform test at a temperature of 5°C (41°F) or more.

WITH CONSULT-II

1. Start engine and warm it up to normal operating temperature.
2. Turn ignition switch OFF and wait at least 10 seconds.
3. Start engine and let it idle for at least 70 seconds.
4. Select "PURG FLOW P0441" of "EVAPORATIVE SYSTEM" in "DTC CONFIRMATION" mode with CONSULT-II.
5. Touch "START".
If "COMPLETED" is displayed, go to step 7.
6. When the following conditions are met, "TESTING" will be displayed on the CONSULT-II screen. Maintain the conditions continuously until "TESTING" changes to "COMPLETED". (It will take at least 35 seconds.)

Shift lever	Suitable position
Vehicle speed	32 - 120 km/h (20 - 75 MPH)
ENG SPEED	500 - 3,000 rpm
B/FUEL SCHDL	1.3 - 9.0 msec
Engine coolant temperature	70 - 100°C (158 - 212°F)

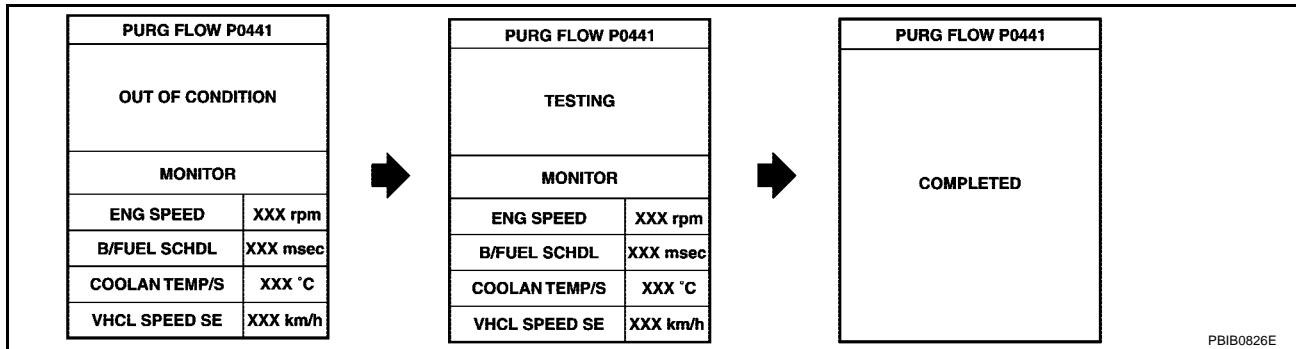

If "TESTING" is not changed for a long time, retry from step 2.

7. Make sure that "OK" is displayed after touching "SELF-DIAG RESULTS". If "NG" is displayed, refer to [EC-966, "Diagnostic Procedure"](#).

Overall Function Check

UBS00150

Use this procedure to check the overall monitoring function of the EVAP control system purge flow monitoring. During this check, a 1st trip DTC might not be confirmed.

WITH GST

1. Lift up drive wheels.
2. Start engine (TCS switch OFF) and warm it up to normal operating temperature.
3. Turn ignition switch OFF, wait at least 10 seconds.
4. Start engine and wait at least 70 seconds.
5. Set voltmeter probes to ECM terminals 32 (EVAP control system pressure sensor signal) and ground.
6. Check EVAP control system pressure sensor value at idle speed and note it.
7. Establish and maintain the following conditions for at least 1 minute.

Air conditioner switch	ON
Headlamp switch	ON
Rear window defogger switch	ON
Engine speed	Approx. 3,000 rpm
Shift lever	Any position other than P, N or R

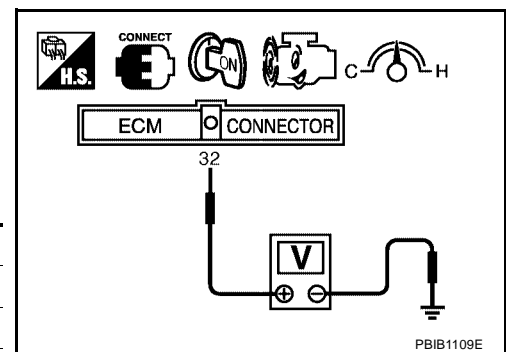

8. Verify that EVAP control system pressure sensor value stays 0.1V less than the value at idle speed (measured at step 6) for at least 1 second.

9. If NG, go to [EC-966, "Diagnostic Procedure"](#) .

Diagnostic Procedure

UBS0015P

1. CHECK EVAP CANISTER

1. Turn ignition switch OFF.
2. Check EVAP canister for cracks.

OK or NG

- OK (With CONSULT-II)>>GO TO 2.
- OK (Without CONSULT-II)>>GO TO 3.
- NG >> Replace EVAP canister.

2. CHECK PURGE FLOW

Ⓟ With CONSULT-II

1. Disconnect vacuum hose connected to EVAP canister purge volume control solenoid valve at EVAP service port and install vacuum gauge. For the location of EVAP service port, refer to [EC-652, "EVAPORATIVE EMISSION LINE DRAWING \(SE-R MODELS\)"](#) or [EC-654, "EVAPORATIVE EMISSION LINE DRAWING \(EXCEPT SE-R MODELS\)"](#) .
2. Start engine and let it idle.
3. Select "PURG VOL CONT/V" in "ACTIVE TEST" mode with CONSULT-II.
4. Rev engine up to 2,000 rpm.
5. Touch "Qd" and "Qu" on CONSULT-II screen to adjust "PURG VOL CONT/V" opening and check vacuum existence.

PURG VOL CONT/V	Vacuum
100%	Should exist.
0%	Should not exist.

OK or NG

- OK >> GO TO 7.
- NG >> GO TO 4.

ACTIVE TEST	
PURG VOL CONT/V	XXX %
MONITOR	
ENG SPEED	XXX rpm
A/F ALPHA-B1	XX %
A/F ALPHA-B2	XX %

PBIB1678E

3. CHECK PURGE FLOW

ⓧ Without CONSULT-II

1. Start engine and warm it up to normal operating temperature.
2. Stop engine.
3. Disconnect vacuum hose connected to EVAP canister purge volume control solenoid valve at EVAP service port and install vacuum gauge. For the location of EVAP service port, refer to [EC-652, "EVAPORATIVE EMISSION LINE DRAWING \(SE-R MODELS\)"](#) or [EC-654, "EVAPORATIVE EMISSION LINE DRAWING \(EXCEPT SE-R MODELS\)"](#) .
4. Start engine and let it idle for at least 80 seconds.
5. Check vacuum gauge indication when revving engine up to 2,000 rpm.

Vacuum should exist.

6. Release the accelerator pedal fully and let idle.

Vacuum should not exist.

OK or NG

- OK >> GO TO 7.
- NG >> GO TO 4.

4. CHECK EVAP PURGE LINE

1. Turn ignition switch OFF.
2. Check EVAP purge line for improper connection or disconnection.
Refer to [EC-652, "EVAPORATIVE EMISSION LINE DRAWING \(SE-R MODELS\)"](#) or [EC-654, "EVAPORATIVE EMISSION LINE DRAWING \(EXCEPT SE-R MODELS\)"](#).

OK or NG

- OK >> GO TO 5.
- NG >> Repair it.

5. CHECK EVAP PURGE HOSE AND PURGE PORT

1. Disconnect purge hoses connected to EVAP service port **A** and EVAP canister purge volume control solenoid valve **B**.
2. Blow air into each hose and EVAP purge port **C**.

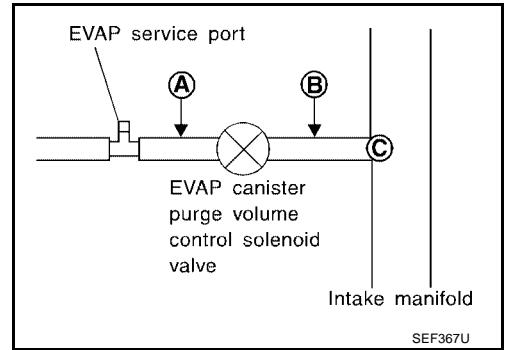

3. Check that air flows freely.

OK or NG

- OK (With CONSULT-II)>>GO TO 6.
- OK (Without CONSULT-II)>>GO TO 7.
- NG >> Repair or clean hoses and/or purge port.

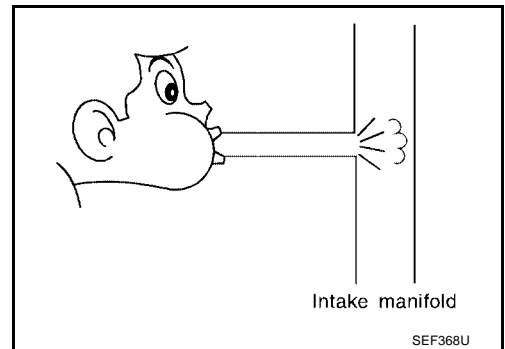

6. CHECK EVAP CANISTER PURGE VOLUME CONTROL SOLENOID VALVE

With CONSULT-II

1. Start engine.
2. Perform "PURG VOL CONT/V" in "ACTIVE TEST" mode with CONSULT-II. Check that engine speed varies according to the valve opening.

OK or NG

- OK >> GO TO 8.
- NG >> GO TO 7.

ACTIVE TEST	
PURG VOL CONT/V	XXX %
MONITOR	
ENG SPEED	XXX rpm
A/F ALPHA-B1	XX %
A/F ALPHA-B2	XX %

PBIB1678E

7. CHECK EVAP CANISTER PURGE VOLUME CONTROL SOLENOID VALVE

Refer to [EC-983, "Component Inspection"](#).

OK or NG

- OK >> GO TO 8.
- NG >> Replace EVAP canister purge volume control solenoid valve.

8. CHECK EVAP CONTROL SYSTEM PRESSURE SENSOR CONNECTOR

1. Disconnect EVAP control system pressure sensor harness connector.
2. Check connectors for water.

Water should not exist.

OK or NG

- OK >> GO TO 9.
NG >> Replace EVAP control system pressure sensor.

9. CHECK EVAP CONTROL SYSTEM PRESSURE SENSOR FUNCTION

Refer to DTC Confirmation Procedure for DTC P0452 [EC-995](#) , P0453 [EC-1001](#) .

OK or NG

- OK >> GO TO 10.
NG >> Replace EVAP control system pressure sensor.

10. CHECK RUBBER TUBE FOR CLOGGING

1. Disconnect rubber tube connected to EVAP canister vent control valve.
2. Check the rubber tube for clogging.

OK or NG

- OK >> GO TO 11.
NG >> Clean the rubber tube using an air blower.

11. CHECK EVAP CANISTER VENT CONTROL VALVE

Refer to [EC-989, "Component Inspection"](#) .

OK or NG

- OK >> GO TO 12.
NG >> Replace EVAP canister vent control valve.

12. CHECK EVAP PURGE LINE

Inspect EVAP purge line (pipe and rubber tube). Check for evidence of leaks.

Refer to [EC-652, "EVAPORATIVE EMISSION LINE DRAWING \(SE-R MODELS\)"](#) or [EC-654, "EVAPORATIVE EMISSION LINE DRAWING \(EXCEPT SE-R MODELS\)"](#) .

OK or NG

- OK >> GO TO 13.
NG >> Replace it.

13. CLEAN EVAP PURGE LINE

Clean EVAP purge line (pipe and rubber tube) using air blower.

>> GO TO 14.

14. CHECK INTERMITTENT INCIDENT

Refer to [EC-782, "TROUBLE DIAGNOSIS FOR INTERMITTENT INCIDENT"](#) .

>> INSPECTION END

DTC P0442 EVAP CONTROL SYSTEM

PFP:14950

On Board Diagnosis Logic

UBS0015Q

This diagnosis detects leaks in the EVAP purge line using engine intake manifold vacuum. If pressure does not increase, the ECM will check for leaks in the line between the fuel tank and EVAP canister purge volume control solenoid valve, under the following Vacuum test conditions. The EVAP canister vent control valve is closed to shut the EVAP purge line off. The EVAP canister purge volume control solenoid valve will then be opened to depressurize the EVAP purge line using intake manifold vacuum. After this occurs, the EVAP canister purge volume control solenoid valve will be closed.

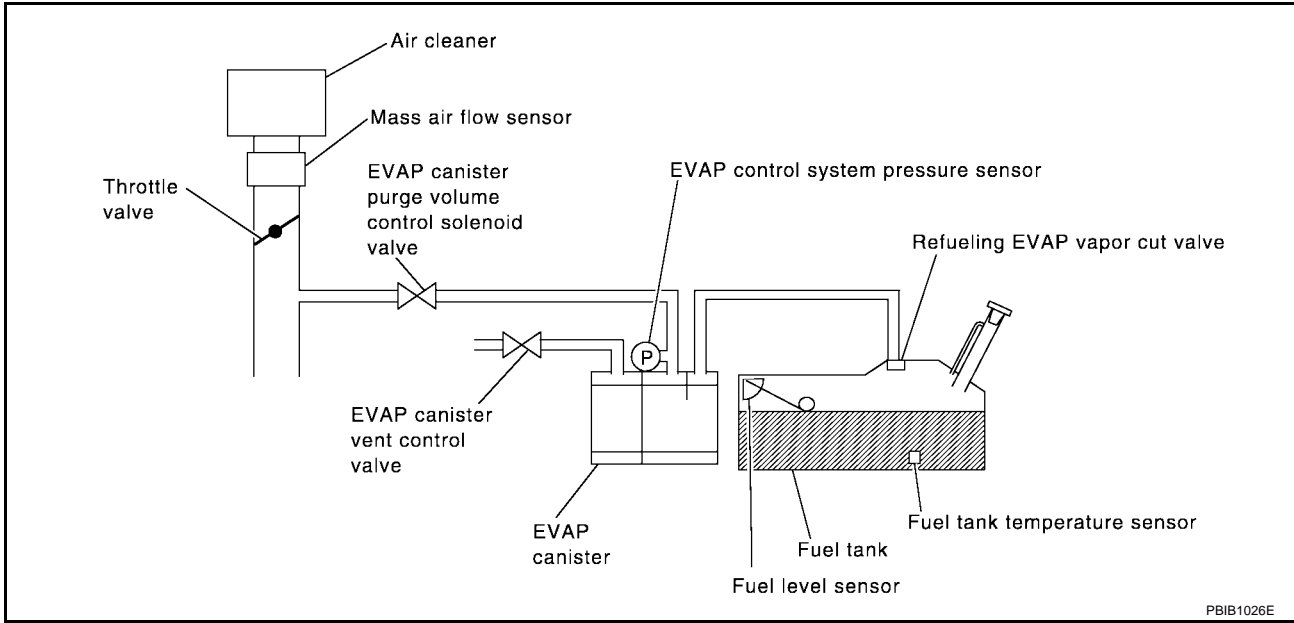

DTC No.	Trouble diagnosis name	DTC detecting condition	Possible cause
P0442 0442	EVAP control system small leak detected (negative pressure)	EVAP control system has a leak, EVAP control system does not operate properly.	<ul style="list-style-type: none"> ● Incorrect fuel tank vacuum relief valve ● Incorrect fuel filler cap used ● Fuel filler cap remains open or fails to close. ● Foreign matter caught in fuel filler cap. ● Leak is in line between intake manifold and EVAP canister purge volume control solenoid valve. ● Foreign matter caught in EVAP canister vent control valve. ● EVAP canister or fuel tank leaks ● EVAP purge line (pipe and rubber tube) leaks ● EVAP purge line rubber tube bent ● Loose or disconnected rubber tube ● EVAP canister vent control valve and the circuit ● EVAP canister purge volume control solenoid valve and the circuit ● Fuel tank temperature sensor ● O-ring of EVAP canister vent control valve is missing or damaged ● EVAP canister is saturated with water ● EVAP control system pressure sensor ● Fuel level sensor and the circuit ● Refueling EVAP vapor cut valve ● ORVR system leaks

CAUTION:

- Use only a genuine NISSAN fuel filler cap as a replacement. If an incorrect fuel filler cap is used, the MIL may come on.
- If the fuel filler cap is not tightened properly, the MIL may come on.
- Use only a genuine NISSAN rubber tube as a replacement.

DTC Confirmation Procedure

UBS0015R

NOTE:

- If DTC Confirmation Procedure has been previously conducted, always turn ignition switch OFF and wait at least 10 seconds before conducting the next test.

TESTING CONDITION:

- Perform “DTC WORK SUPPORT” when the fuel level is between 1/4 and 3/4 full, and vehicle is placed on flat level surface.
- Always perform test at a temperature of 0 to 30°C (32 to 86°F).

WITH CONSULT-II

1. Turn ignition switch ON.
2. Turn ignition switch OFF and wait at least 10 seconds.
3. Turn ignition switch ON and select “DATA MONITOR” mode with CONSULT-II.
4. Make sure that the following conditions are met.
COOLANT TEMP/S: 0 - 70°C (32 - 158°F)
INT/A TEMP SE: 0 - 30°C (32 - 86°F)
5. Select “EVAP SML LEAK P0442/P1442” of “EVAPORATIVE SYSTEM” in “DTC WORK SUPPORT” mode with CONSULT-II.
 Follow the instruction displayed.

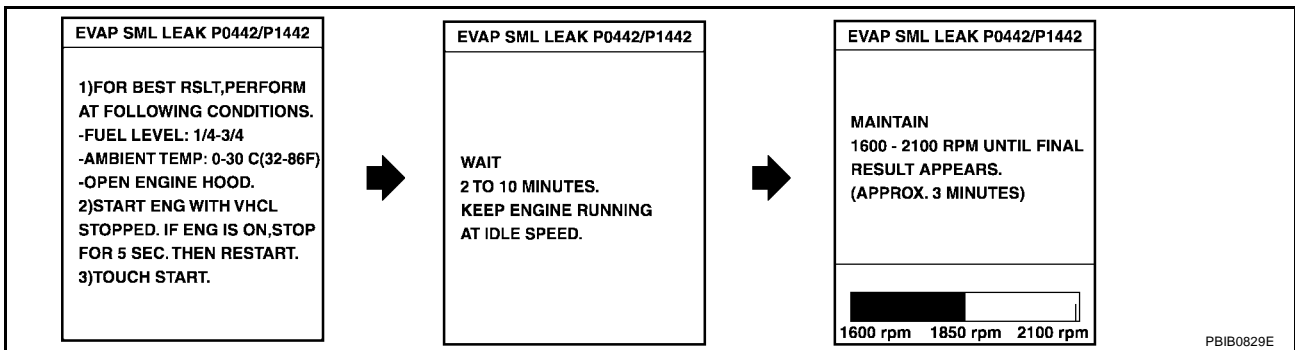

NOTE:

If the engine speed cannot be maintained within the range displayed on the CONSULT-II screen, go to [EC-693, "Basic Inspection"](#).

6. Make sure that “OK” is displayed.
 If “NG” is displayed, refer to [EC-971, "Diagnostic Procedure"](#).

NOTE:

Make sure that EVAP hoses are connected to EVAP canister purge volume control solenoid valve properly.

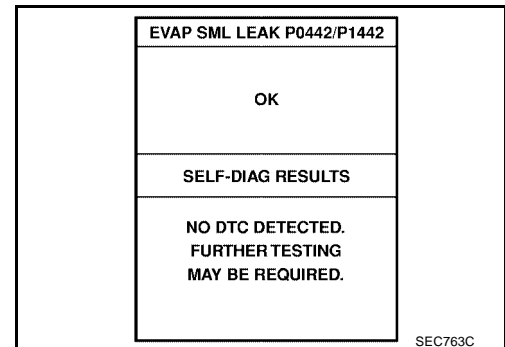

WITH GST**NOTE:**

Be sure to read the explanation of Driving Pattern on [EC-679](#) before driving vehicle.

1. Start engine.
2. Drive vehicle according to Driving Pattern, [EC-679](#) .
3. Stop vehicle.
4. Turn ignition switch OFF, wait at least 10 seconds and then turn ON.
5. Select Service \$07 with GST.
 - If P0442 is displayed on the screen, go to [EC-971, "Diagnostic Procedure"](#) .
 - If P0441 is displayed on the screen, go to "Diagnostic Procedure" for DTC P0441, [EC-966](#) .

Diagnostic Procedure

UBS0015S

1. CHECK FUEL FILLER CAP DESIGN

1. Turn ignition switch OFF.
2. Check for genuine NISSAN fuel filler cap design.

OK or NG

- OK >> GO TO 2.
 NG >> Replace with genuine NISSAN fuel filler cap.

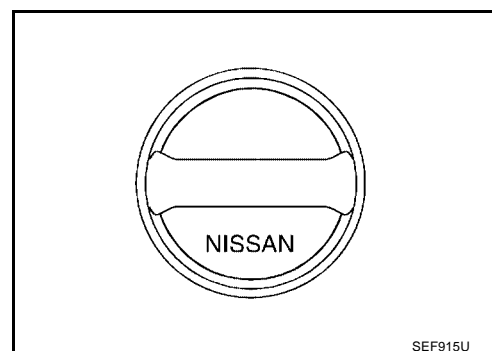
**2. CHECK FUEL FILLER CAP INSTALLATION**

Check that the cap is tightened properly by rotating the cap clockwise.

OK or NG

- OK >> GO TO 3.
 NG >> 1. Open fuel filler cap, then clean cap and fuel filler neck threads using air blower.
 2. Retighten until ratcheting sound is heard.

3. CHECK FUEL FILLER CAP FUNCTION

Check for air releasing sound while opening the fuel filler cap.

OK or NG

- OK >> GO TO 5.
 NG >> GO TO 4.

4. CHECK FUEL TANK VACUUM RELIEF VALVE

Refer to [EC-656, "FUEL TANK VACUUM RELIEF VALVE \(BUILT INTO FUEL FULLER CAP\)"](#) .

OK or NG

- OK >> GO TO 5.
 NG >> Replace fuel filler cap with a genuine one.

5. INSTALL THE PRESSURE PUMP

To locate the EVAP leak, install EVAP service port adapter and pressure pump to EVAP service port securely. For the location of EVAP service port, refer to [EC-652, "EVAPORATIVE EMISSION LINE DRAWING \(SE-R MODELS\)"](#) or [EC-654, "EVAPORATIVE EMISSION LINE DRAWING \(EXCEPT SE-R MODELS\)"](#).

NOTE:

Improper installation of the EVAP service port adapter to the EVAP service port may cause leaking.

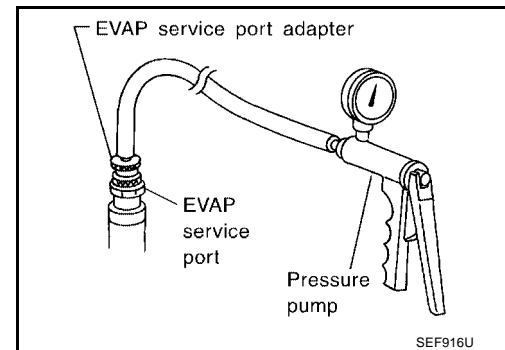
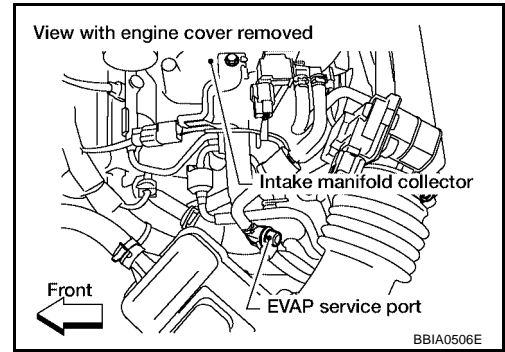

With CONSULT-II>>GO TO 6.
Without CONSULT-II>>GO TO 7.

6. CHECK FOR EVAP LEAK

Ⓟ With CONSULT-II

1. Turn ignition switch ON.
2. Select "EVAP SYSTEM CLOSE" of "WORK SUPPORT" mode with CONSULT-II.
3. Touch "START" and apply pressure into the EVAP line until the pressure indicator reaches the middle of the bar graph.

NOTE:

- Never use compressed air or a high pressure pump.
- Do not exceed 4.12 kPa (0.042 kg/cm², 0.6 psi) of pressure in the system.

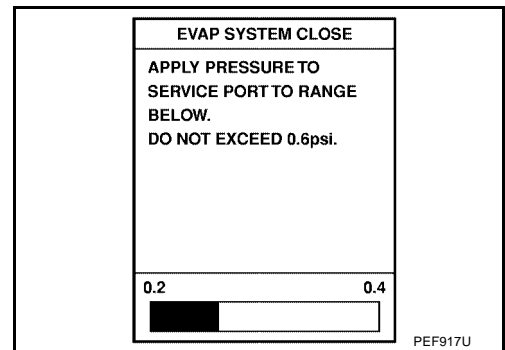

4. Using EVAP leak detector, locate the EVAP leak. For the leak detector, refer to the instruction manual for more details. Refer to [EC-652, "EVAPORATIVE EMISSION LINE DRAWING \(SE-R MODELS\)"](#) or [EC-654, "EVAPORATIVE EMISSION LINE DRAWING \(EXCEPT SE-R MODELS\)"](#).

OK or NG

- OK >> GO TO 8.
- NG >> Repair or replace.

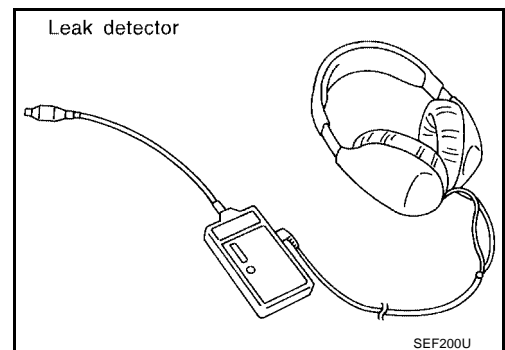

7. CHECK FOR EVAP LEAK

⊗ Without CONSULT-II

1. Turn ignition switch OFF.
2. Apply 12 volts DC to EVAP canister vent control valve. The valve will close. (Continue to apply 12 volts until the end of test.)

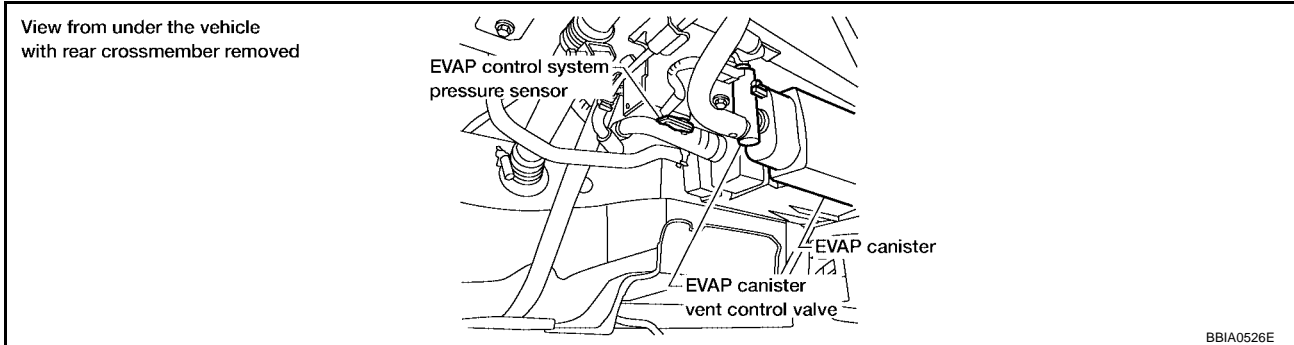

3. Pressurize the EVAP line using pressure pump with 1.3 to 2.7 kPa (10 to 20 mmHg, 0.39 to 0.79 inHg), then remove pump and EVAP service port adapter.

NOTE:

- Never use compressed air or a high pressure pump.
- Do not exceed 4.12 kPa (0.042 kg/cm² , 0.6 psi) of pressure in the system.

4. Using EVAP leak detector, locate the EVAP leak. For the leak detector, refer to the instruction manual for more details.

Refer to [EC-652, "EVAPORATIVE EMISSION LINE DRAWING \(SE-R MODELS\)"](#) or [EC-654, "EVAPORATIVE EMISSION LINE DRAWING \(EXCEPT SE-R MODELS\)"](#) .

OK or NG

- OK >> GO TO 8.
- NG >> Repair or replace.

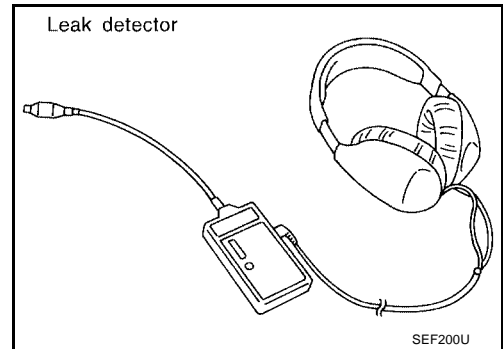

8. CHECK EVAP CANISTER VENT CONTROL VALVE

Check the following.

- EVAP canister vent control valve is installed properly.
Refer to [EC-657, "Removal and Installation"](#) .
- EVAP canister vent control valve.
Refer to [EC-989, "Component Inspection"](#) .

OK or NG

- OK >> GO TO 9.
- NG >> Repair or replace EVAP canister vent control valve and O-ring.

9. CHECK IF EVAP CANISTER SATURATED WITH WATER

1. Remove EVAP canister with EVAP canister vent control valve and EVAP control system pressure sensor attached.
2. Does water drain from the EVAP canister?

Yes or No

- Yes >> GO TO 10.
- No (With CONSULT-II)>>GO TO 12.
- No (Without CONSULT-II)>>GO TO 13.

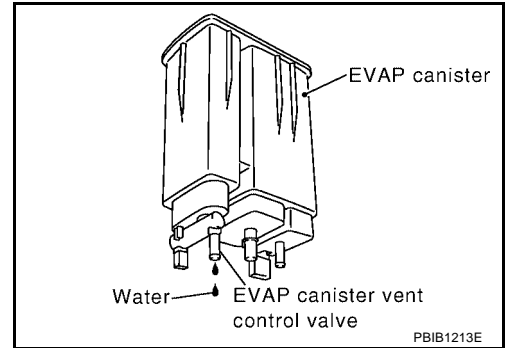

10. CHECK EVAP CANISTER

Weigh the EVAP canister with the EVAP canister vent control valve and EVAP control system pressure sensor attached.

The weight should be less than 2.1 kg (4.6 lb).

OK or NG

- OK (With CONSULT-II)>>GO TO 12.
- OK (Without CONSULT-II)>>GO TO 13.
- NG >> GO TO 11.

11. DETECT MALFUNCTIONING PART

Check the following.

- EVAP canister for damage
- EVAP hose between EVAP canister and vehicle frame for clogging or poor connection

>> Repair hose or replace EVAP canister.

12. CHECK EVAP CANISTER PURGE VOLUME CONTROL SOLENOID VALVE OPERATION

Ⓟ With CONSULT-II

1. Disconnect vacuum hose to EVAP canister purge volume control solenoid valve at EVAP service port.
2. Start engine.
3. Perform "PURG VOL CONT/V" in "ACTIVE TEST" mode.
4. Touch "Qu" on CONSULT-II screen to increase "PURG VOL CONT/V" opening to 100%.
5. Check vacuum hose for vacuum when revving engine up to 2,000 rpm.

OK or NG

- OK >> GO TO 15.
- NG >> GO TO 14.

ACTIVE TEST	
PURG VOL CONT/V	XXX %
MONITOR	
ENG SPEED	XXX rpm
A/F ALPHA-B1	XX %
A/F ALPHA-B2	XX %

PBIB1678E

13. CHECK EVAP CANISTER PURGE VOLUME CONTROL SOLENOID VALVE OPERATION**⊗ Without CONSULT-II**

1. Start engine and warm it up to normal operating temperature.
2. Stop engine.
3. Disconnect vacuum hose to EVAP canister purge volume control solenoid valve at EVAP service port.
4. Start engine and let it idle for at least 80 seconds.
5. Check vacuum hose for vacuum when revving engine up to 2,000 rpm.

Vacuum should exist.

OK or NG

- OK >> GO TO 16.
 NG >> GO TO 14.

14. CHECK VACUUM HOSE

Check vacuum hoses for clogging or disconnection. Refer to [EC-736, "Vacuum Hose Drawing"](#).

OK or NG

- OK >> GO TO 15.
 NG >> Repair or reconnect the hose.

15. CHECK EVAP CANISTER PURGE VOLUME CONTROL SOLENOID VALVE

Refer to [EC-983, "Component Inspection"](#).

OK or NG

- OK >> GO TO 16.
 NG >> Replace EVAP canister purge volume control solenoid valve.

16. CHECK FUEL TANK TEMPERATURE SENSOR

Refer to [EC-894, "Component Inspection"](#).

OK or NG

- OK >> GO TO 17.
 NG >> Replace fuel level sensor unit.

17. CHECK EVAP CONTROL SYSTEM PRESSURE SENSOR

Refer to [EC-999, "Component Inspection"](#).

OK or NG

- OK >> GO TO 18.
 NG >> Replace EVAP control system pressure sensor.

18. CHECK EVAP PURGE LINE

Check EVAP purge line (pipe, rubber tube, fuel tank and EVAP canister) for cracks or improper connection. Refer to [EC-652, "EVAPORATIVE EMISSION LINE DRAWING \(SE-R MODELS\)"](#) or [EC-654, "EVAPORATIVE EMISSION LINE DRAWING \(EXCEPT SE-R MODELS\)"](#).

OK or NG

- OK >> GO TO 19.
 NG >> Repair or reconnect the hose.

19. CLEAN EVAP PURGE LINE

Clean EVAP purge line (pipe and rubber tube) using air blower.

>> GO TO 20.

20. CHECK EVAP/ORVR LINE

Check EVAP/ORVR line between EVAP canister and fuel tank for clogging, kink, looseness and improper connection. For location, refer to [EC-660, "ON BOARD REFUELING VAPOR RECOVERY \(ORVR\)"](#) .

OK or NG

- OK >> GO TO 21.
- NG >> Repair or replace hoses and tubes.

21. CHECK RECIRCULATION LINE

Check recirculation line between filler neck tube and fuel tank for clogging, kink, cracks, looseness and improper connection.

OK or NG

- OK >> GO TO 22.
- NG >> Repair or replace hose, tube or filler neck tube.

22. CHECK REFUELING EVAP VAPOR CUT VALVE

Refer to [EC-663, "REFUELING EVAP VAPOR CUT VALVE"](#) .

OK or NG

- OK >> GO TO 23.
- NG >> Replace refueling EVAP vapor cut valve with fuel tank.

23. CHECK FUEL LEVEL SENSOR

Refer to [DI-18, "FUEL LEVEL SENSOR UNIT CHECK"](#) .

OK or NG

- OK >> GO TO 24.
- NG >> Replace fuel level sensor unit.

24. CHECK INTERMITTENT INCIDENT

Refer to [EC-782, "TROUBLE DIAGNOSIS FOR INTERMITTENT INCIDENT"](#) .

>> INSPECTION END

DTC P0444, P0445 EVAP CANISTER PURGE VOLUME CONTROL SOLENOID VALVE

[VQ]

DTC P0444, P0445 EVAP CANISTER PURGE VOLUME CONTROL SOLENOID VALVE

PFP:14920

Description SYSTEM DESCRIPTION

UBS0015T

Sensor	Input Signal to ECM	ECM function	Actuator
Crankshaft position sensor (POS) Camshaft position sensor (PHASE)	Engine speed* ¹ Piston position	EVAP canister purge flow control	EVAP canister purge vol- ume control solenoid valve
Mass air flow sensor	Amount of intake air		
Engine coolant temperature sensor	Engine coolant temperature		
Battery	Battery voltage* ¹		
Throttle position sensor	Throttle position		
Accelerator pedal position sensor	Accelerator pedal position		
Air fuel ratio (A/F) sensor 1	Density of oxygen in exhaust gas (Mixture ratio feedback signal)		
Fuel tank temperature sensor	Fuel temperature in fuel tank		
Wheel sensor* ²	Vehicle speed		

*1: ECM determines the start signal status by the signals of engine speed and battery voltage.

*2: This signal is sent to the ECM through CAN communication line.

This system controls flow rate of fuel vapor from the EVAP canister. The opening of the vapor by-pass passage in the EVAP canister purge volume control solenoid valve changes to control the flow rate. The EVAP canister purge volume control solenoid valve repeats ON/OFF operation according to the signal sent from the ECM. The opening of the valve varies for optimum engine control. The optimum value stored in the ECM is determined by considering various engine conditions. When the engine is operating, the flow rate of fuel vapor from the EVAP canister is regulated as the air flow changes.

COMPONENT DESCRIPTION

The EVAP canister purge volume control solenoid valve uses a ON/OFF duty to control the flow rate of fuel vapor from the EVAP canister. The EVAP canister purge volume control solenoid valve is moved by ON/OFF pulses from the ECM. The longer the ON pulse, the greater the amount of fuel vapor that will flow through the valve.

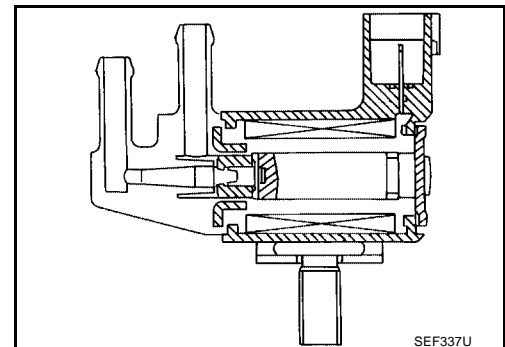

CONSULT-II Reference Value in Data Monitor Mode

UBS0015U

Specification data are reference values.

MONITOR ITEM	CONDITION	SPECIFICATION
PURG VOL C/V	<ul style="list-style-type: none"> ● Engine: After warming up ● Shift lever: P or N (A/T), Neutral (M/T) 	Idle
	<ul style="list-style-type: none"> ● Air conditioner switch: OFF ● No-load 	2,000 rpm
		0%
		—

DTC P0444, P0445 EVAP CANISTER PURGE VOLUME CONTROL SOLENOID VALVE

[VQ]

On Board Diagnosis Logic

UBS0015V

DTC No.	Trouble diagnosis name	DTC detecting condition	Possible cause
P0444 0444	EVAP canister purge volume control solenoid valve circuit open	An excessively low voltage signal is sent to ECM through the valve	<ul style="list-style-type: none"> ● Harness or connectors (The solenoid valve circuit is open or shorted.) ● EVAP canister purge volume control solenoid valve
P0445 0445	EVAP canister purge volume control solenoid valve circuit shorted	An excessively high voltage signal is sent to ECM through the valve	<ul style="list-style-type: none"> ● Harness or connectors (The solenoid valve circuit is shorted.) ● EVAP canister purge volume control solenoid valve

DTC Confirmation Procedure

UBS0015W

NOTE:

If DTC Confirmation Procedure has been previously conducted, always turn ignition switch OFF and wait at least 10 seconds before conducting the next test.

TESTING CONDITION:

Before performing the following procedure, confirm battery voltage is more than 11V at idle.

WITH CONSULT-II

1. Turn ignition switch ON.
2. Select "DATA MONITOR" mode with CONSULT-II.
3. Start engine and let it idle for at least 13 seconds.
4. If 1st trip DTC is detected, go to [EC-981, "Diagnostic Procedure"](#)

DATA MONITOR	
MONITOR	NO DTC
ENG SPEED	XXX rpm

SEF058Y

WITH GST

Follow the procedure "WITH CONSULT-II" above.

DTC P0444, P0445 EVAP CANISTER PURGE VOLUME CONTROL SOLENOID VALVE

[VQ]

Wiring Diagram

UBS0015X

EC-PGC/V-01

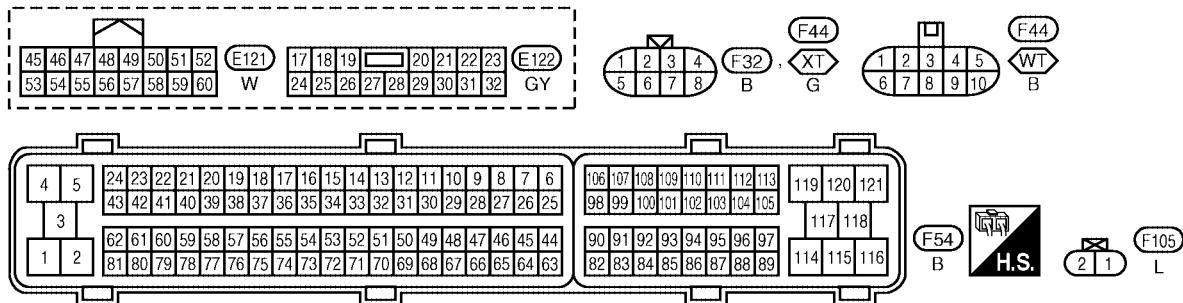
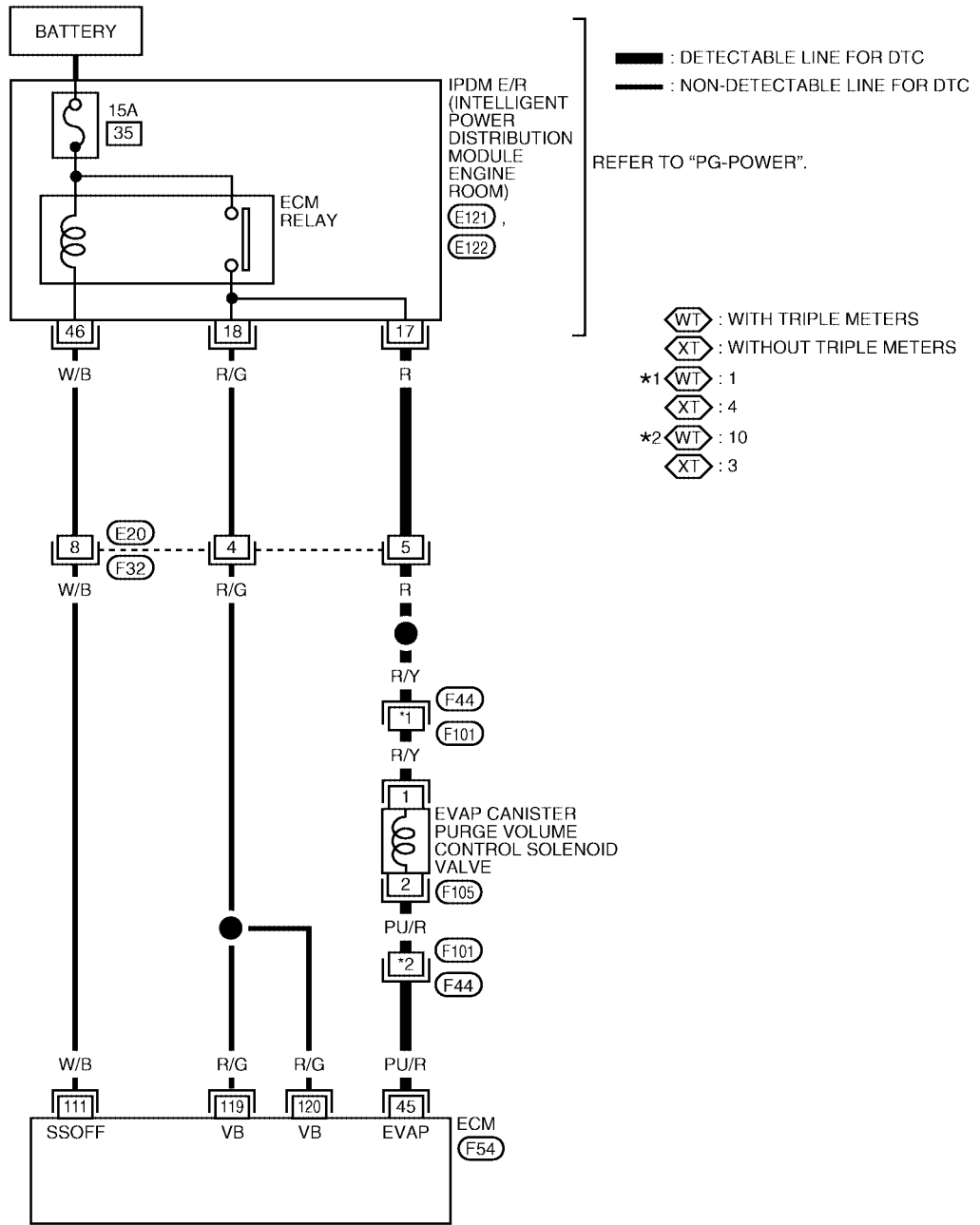

BBWA1563E

DTC P0444, P0445 EVAP CANISTER PURGE VOLUME CONTROL SOLENOID VALVE

[VQ]

Specification data are reference values and are measured between each terminal and ground.
Pulse signal is measured by CONSULT-II.

CAUTION:

Do not use ECM ground terminals when measuring input/output voltage. Doing so may result in damage to the ECM's transistor. Use a ground other than ECM terminals, such as the ground.

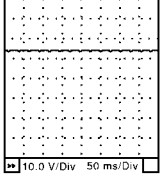
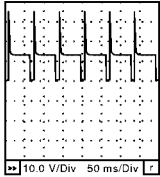
TER-MINAL NO.	WIRE COLOR	ITEM	CONDITION	DATA (DC Voltage)
45	PU/R	EVAP canister purge volume control solenoid valve	<p>[Engine is running]</p> <ul style="list-style-type: none"> ● Idle speed 	<p>BATTERY VOLTAGE (11 - 14V)★</p>  <p style="text-align: right;">SEC990C</p>
			<p>[Engine is running]</p> <ul style="list-style-type: none"> ● Engine speed is about 2,000 rpm (More than 100 seconds after starting engine) 	<p>BATTERY VOLTAGE (11 - 14V)★</p>  <p style="text-align: right;">SEC991C</p>
111	W/B	ECM relay (Self shut-off)	<p>[Engine is running] [Ignition switch: OFF]</p> <ul style="list-style-type: none"> ● For a few seconds after turning ignition switch OFF 	0 - 1.5V
			<p>[Ignition switch: OFF]</p> <ul style="list-style-type: none"> ● More than a few seconds after turning ignition switch OFF 	BATTERY VOLTAGE (11 - 14V)
119 120	R/G R/G	Power supply for ECM	[Ignition switch: ON]	BATTERY VOLTAGE (11 - 14V)

★: Average voltage for pulse signal (Actual pulse signal can be confirmed by oscilloscope.)

DTC P0444, P0445 EVAP CANISTER PURGE VOLUME CONTROL SOLENOID VALVE

[VQ]

UBS0015Y

Diagnostic Procedure

1. CHECK EVAP CANISTER PURGE VOLUME CONTROL SOLENOID VALVE POWER SUPPLY CIRCUIT

1. Turn ignition switch OFF.
2. Disconnect EVAP canister purge volume control solenoid valve harness connector.
3. Turn ignition switch ON.

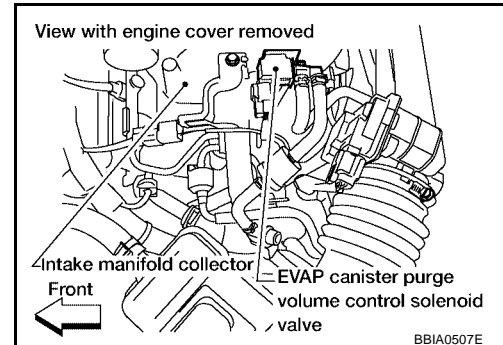

4. Check voltage between EVAP canister purge volume control solenoid valve terminal 1 and ground with CONSULT-II or tester.

Voltage: Battery voltage

OK or NG

- OK >> GO TO 3.
- NG >> GO TO 2.

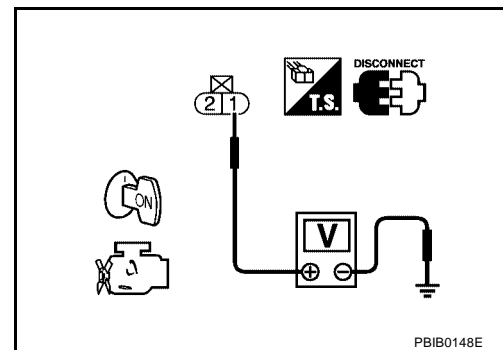

2. DETECT MALFUNCTIONING PART

Check the following.

- Harness connectors E20, F32
- Harness connectors F44, F101
- IPDM E/R harness connector E122
- Harness for open or short between EVAP canister purge volume control solenoid valve and IPDM E/R

>> Repair open circuit or short to ground or short to power in harness connectors.

3. CHECK EVAP CANISTER PURGE VOLUME CONTROL SOLENOID VALVE OUTPUT SIGNAL CIRCUIT FOR OPEN AND SHORT

1. Turn ignition switch OFF.
2. Disconnect ECM harness connector.
3. Check harness continuity between ECM terminal 45 and EVAP canister purge volume control solenoid valve terminal 2. Refer to Wiring Diagram.

Continuity should exist.

4. Also check harness for short to ground and short to power.

OK or NG

- OK (With CONSULT-II)>>GO TO 5.
- OK (Without CONSULT-II)>>GO TO 6.
- NG >> GO TO 4.

DTC P0444, P0445 EVAP CANISTER PURGE VOLUME CONTROL SOLENOID VALVE

[VQ]

4. DETECT MALFUNCTIONING PART

Check the following.

- Harness connectors F101, F44
- Harness for open or short between EVAP canister purge volume control solenoid valve and ECM

>> Repair open circuit or short to ground or short to power in harness connectors.

5. CHECK EVAP CANISTER PURGE VOLUME CONTROL SOLENOID VALVE OPERATION

④ With CONSULT-II

1. Reconnect all harness connectors disconnected.
2. Start engine.
3. Perform "PURG VOL CONT/V" in "ACTIVE TEST" mode with CONSULT-II. Check that engine speed varies according to the valve opening.

OK or NG

- OK >> GO TO 7.
- NG >> GO TO 6.

ACTIVE TEST	
PURG VOL CONT/V	XXX %
MONITOR	
ENG SPEED	XXX rpm
A/F ALPHA-B1	XX %
A/F ALPHA-B2	XX %

PBIB1678E

6. CHECK EVAP CANISTER PURGE VOLUME CONTROL SOLENOID VALVE

Refer to [EC-983, "Component Inspection"](#) .

OK or NG

- OK >> GO TO 7.
- NG >> Replace EVAP canister purge volume control solenoid valve.

7. CHECK INTERMITTENT INCIDENT

Refer to [EC-782, "TROUBLE DIAGNOSIS FOR INTERMITTENT INCIDENT"](#) .

>> INSPECTION END

DTC P0444, P0445 EVAP CANISTER PURGE VOLUME CONTROL SOLENOID VALVE

[VQ]

UBS0015Z

Component Inspection

EVAP CANISTER PURGE VOLUME CONTROL SOLENOID VALVE

With CONSULT-II

Check air passage continuity of EVAP canister purge volume control solenoid valve under the following conditions.

Condition (PURG VOL CONT/V value)	Air passage continuity between A and B
100%	Yes
0%	No

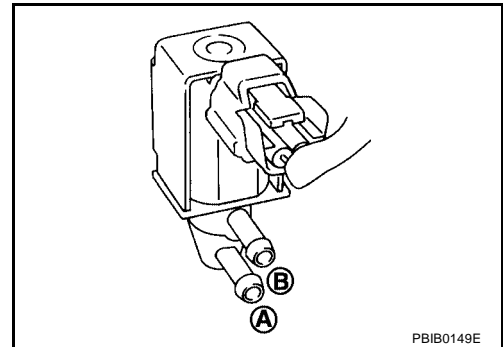

Without CONSULT-II

Check air passage continuity of EVAP canister purge volume control solenoid valve under the following conditions.

Condition	Air passage continuity between A and B
12V direct current supply between terminals 1 and 2	Yes
No supply	No

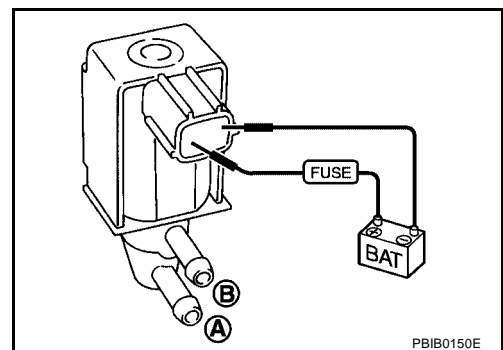

Removal and Installation

EVAP CANISTER PURGE VOLUME CONTROL SOLENOID VALVE

Refer to [EM-122, "INTAKE MANIFOLD COLLECTOR"](#).

UBS00160

DTC P0447 EVAP CANISTER VENT CONTROL VALVE

[VQ]

DTC P0447 EVAP CANISTER VENT CONTROL VALVE

PF1:14935

Component Description

UBS00161

The EVAP canister vent control valve is located on the EVAP canister and is used to seal the canister vent.

This solenoid valve responds to signals from the ECM. When the ECM sends an ON signal, the coil in the solenoid valve is energized. A plunger will then move to seal the canister vent. The ability to seal the vent is necessary for the on board diagnosis of other evaporative emission control system components.

This solenoid valve is used only for diagnosis, and usually remains opened.

When the vent is closed, under normal purge conditions, the evaporative emission control system is depressurized and allows EVAP Control System diagnosis.

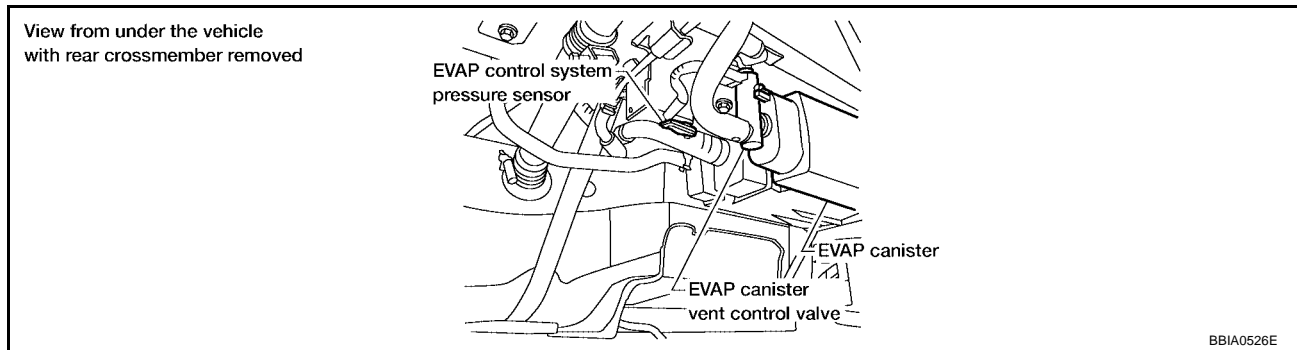
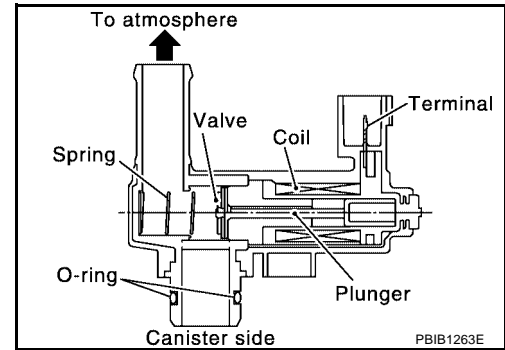

CONSULT-II Reference Value in Data Monitor Mode

UBS00162

Specification data are reference values.

MONITOR ITEM	CONDITION	SPECIFICATION
VENT CONT/V	● Ignition switch: ON	OFF

On Board Diagnosis Logic

UBS00163

DTC No.	Trouble diagnosis name	DTC detecting condition	Possible cause
P0447 0447	EVAP canister vent control valve circuit open	An improper voltage signal is sent to ECM through EVAP canister vent control valve.	<ul style="list-style-type: none"> ● Harness or connectors (The valve circuit is open or shorted.) ● EVAP canister vent control valve

DTC Confirmation Procedure

NOTE:

If DTC Confirmation Procedure has been previously conducted, always turn ignition switch OFF and wait at least 10 seconds before conducting the next test.

TESTING CONDITION:

Before performing the following procedure, confirm battery voltage is more than 11V at idle.

WITH CONSULT-II

1. Turn ignition switch ON.
2. Select "DATA MONITOR" mode with CONSULT-II.
3. Start engine and wait at least 8 seconds.
4. If 1st trip DTC is detected, go to [EC-987, "Diagnostic Procedure"](#)

DATA MONITOR	
MONITOR	NO DTC
ENG SPEED	XXX rpm
<small>SEF058Y</small>	

WITH GST

Follow the procedure "WITH CONSULT-II" above.

A
EC
C
D
E
F
G
H
I
J
K
L
M

DTC P0447 EVAP CANISTER VENT CONTROL VALVE

[VQ]

Wiring Diagram

UBS00165

EC-VENT/V-01

: DETECTABLE LINE FOR DTC
 : NON-DETECTABLE LINE FOR DTC

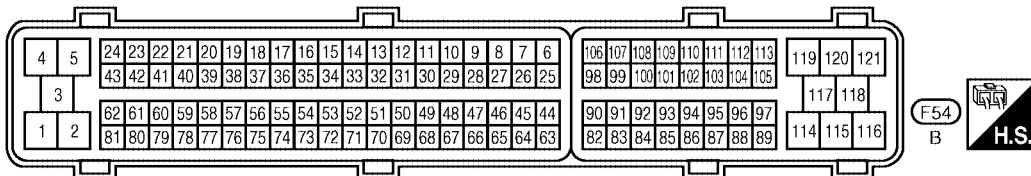
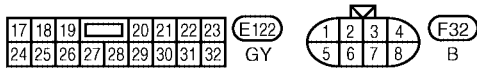
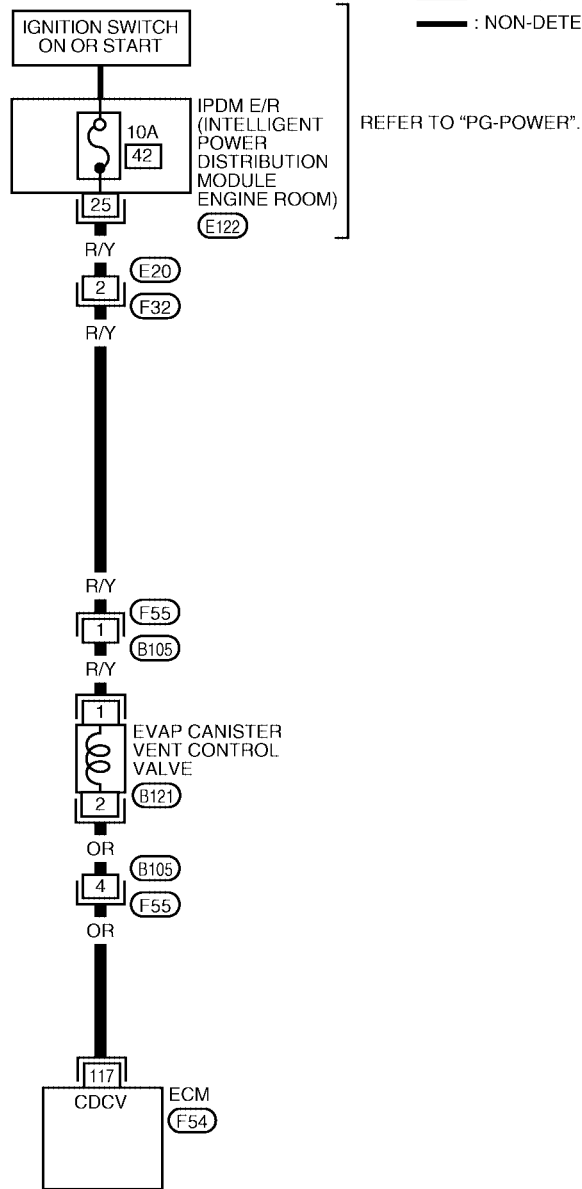

BBWA1665E

DTC P0447 EVAP CANISTER VENT CONTROL VALVE

[VQ]

Specification data are reference values and are measured between each terminal and ground.

CAUTION:

Do not use ECM ground terminals when measuring input/output voltage. Doing so may result in damage to the ECM's transistor. Use a ground other than ECM terminals, such as the ground.

TER-MINAL NO.	WIRE COLOR	ITEM	CONDITION	DATA (DC Voltage)
117	OR	EVAP canister vent control valve	[Ignition switch: ON]	BATTERY VOLTAGE (11 - 14V)

Diagnostic Procedure

UBS00166

1. INSPECTION START

Do you have CONSULT-II?

Yes or No

- Yes >> GO TO 2.
- No >> GO TO 3.

2. CHECK EVAP CANISTER VENT CONTROL VALVE CIRCUIT

 **With CONSULT-II**

1. Turn ignition switch OFF and then turn ON.
2. Select "VENT CONTROL/V" in "ACTIVE TEST" mode with CONSULT-II.
3. Touch "ON/OFF" on CONSULT-II screen.
4. Check for operating sound of the valve.

Clicking noise should be heard.

OK or NG

- OK >> GO TO 7.
- NG >> GO TO 3.

ACTIVE TEST	
VENT CONTROL/V	OFF
MONITOR	
ENG SPEED	XXX rpm
A/F ALPHA-B1	XXX %
A/F ALPHA-B2	XXX %

PBIB1679E

3. CHECK EVAP CANISTER VENT CONTROL VALVE POWER SUPPLY CIRCUIT

1. Turn ignition switch OFF.
2. Disconnect EVAP canister vent control valve harness connector.

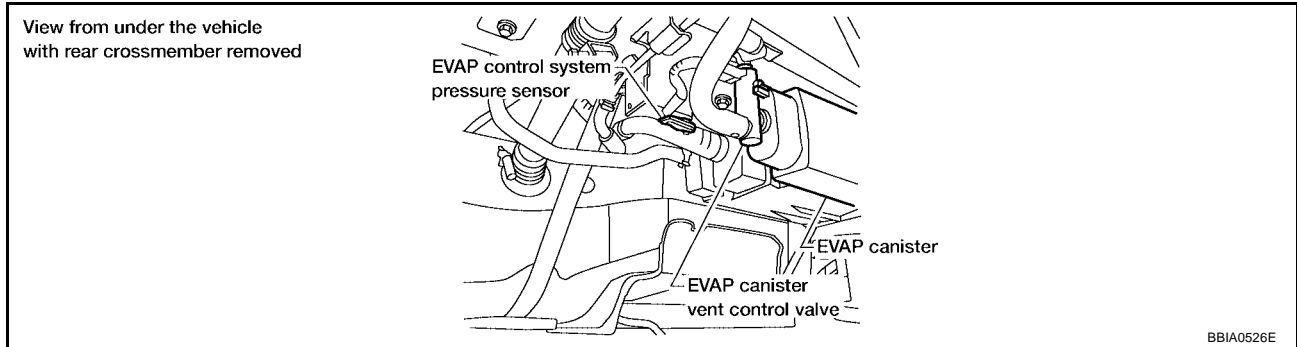

3. Turn ignition switch ON.
4. Check voltage between EVAP canister vent control valve terminal 1 and ground with CONSULT-II or tester.

Voltage: Battery voltage

OK or NG

- OK >> GO TO 5.
NG >> GO TO 4.

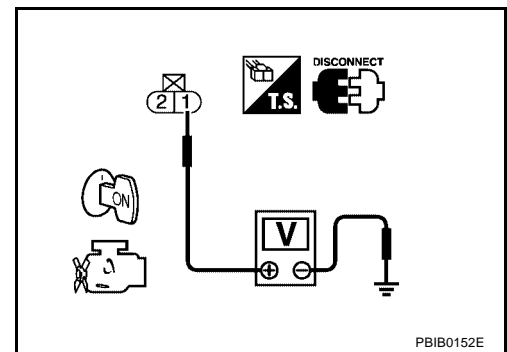

4. DETECT MALFUNCTIONING PART

Check the following.

- Harness connectors E20, F32
- Harness connectors F55, B105
- IPDM E/R harness connector E122
- Harness for open or short between EVAP canister vent control valve and IPDM E/R

>> Repair open circuit or short to ground or short to power in harness or connectors.

5. CHECK EVAP CANISTER VENT CONTROL VALVE OUTPUT SIGNAL CIRCUIT FOR OPEN AND SHORT

1. Turn ignition switch OFF.
2. Disconnect ECM harness connector.
3. Check harness continuity between ECM terminal 117 and EVAP canister vent control valve terminal 2. Refer to Wiring Diagram.

Continuity should exist.

4. Also check harness for short to ground and short to power.

OK or NG

- OK >> GO TO 7.
NG >> GO TO 6.

6. DETECT MALFUNCTIONING PART

Check the following.

- Harness connectors B105, F55
- Harness for open or short between EVAP canister vent control valve and ECM

>> Repair open circuit or short to ground or short to power in harness or connectors.

7. CHECK RUBBER TUBE FOR CLOGGING

1. Disconnect rubber tube connected to EVAP canister vent control valve.
2. Check the rubber tube for clogging.

OK or NG

- OK >> GO TO 8.
- NG >> Clean the rubber tube using an air blower.

8. CHECK EVAP CANISTER VENT CONTROL VALVE

Refer to [EC-989, "Component Inspection"](#) .

OK or NG

- OK >> GO TO 9.
- NG >> Replace EVAP canister vent control valve.

9. CHECK INTERMITTENT INCIDENT

Refer to [EC-782, "TROUBLE DIAGNOSIS FOR INTERMITTENT INCIDENT"](#) .

>> INSPECTION END

**Component Inspection
EVAP CANISTER VENT CONTROL VALVE**

UBS00167

With CONSULT-II

1. Remove EVAP canister vent control valve from EVAP canister.
2. Check portion **B** of EVAP canister vent control valve for being rusted.
If NG, replace EVAP canister vent control valve.
If OK, go to next step.
3. Reconnect harness connectors disconnected.
4. Turn ignition switch ON.

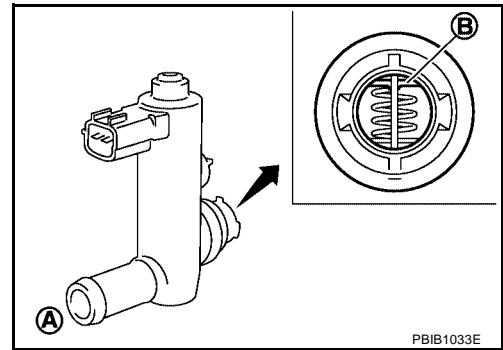

PBIB1033E

5. Perform "VENT CONTROL/V" in "ACTIVE TEST" mode.
6. Check air passage continuity and operation delay time.
Make sure new O-ring is installed properly.

Condition VENT CONTROL/V	Air passage continuity between A and B
ON	No
OFF	Yes

Operation takes less than 1 second.

- If NG, replace EVAP canister vent control valve.
- If OK, go to next step.

ACTIVE TEST	
VENT CONTROL/V	OFF
MONITOR	
ENG SPEED	XXX rpm
A/F ALPHA-B1	XXX %
A/F ALPHA-B2	XXX %

PBIB1679E

7. Clean the air passage (Portion **A** to **B**) of EVAP canister vent control valve using an air blower.

DTC P0447 EVAP CANISTER VENT CONTROL VALVE

[VQ]

8. Perform step 6 again.

⊗ **Without CONSULT-II**

1. Remove EVAP canister vent control valve from EVAP canister.
2. Check portion **B** of EVAP canister vent control valve for being rusted.

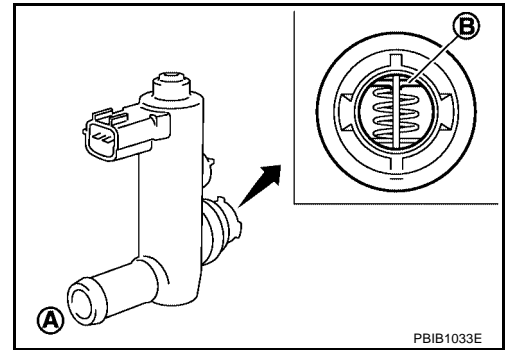

3. Check air passage continuity and operation delay time under the following conditions.

Make sure new O-ring is installed properly.

Condition	Air passage continuity between A and B
12V direct current supply between terminals 1 and 2	No
OFF	Yes

Operation takes less than 1 second.

If NG, replace EVAP canister vent control valve.
If OK, go to next step.

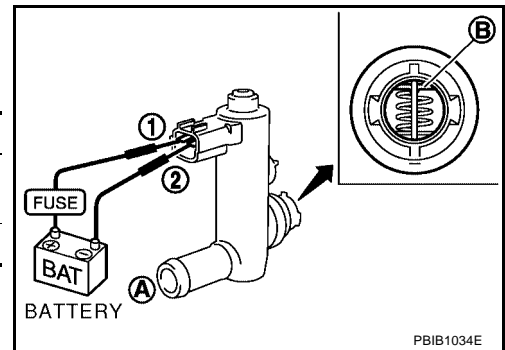

4. Clean the air passage (Portion **A** to **B**) of EVAP canister vent control valve using an air blower.
5. Perform step 3 again.

DTC P0451 EVAP CONTROL SYSTEM PRESSURE SENSOR

[VQ]

DTC P0451 EVAP CONTROL SYSTEM PRESSURE SENSOR

PFP:22365

Component Description

UBS00168

The EVAP control system pressure sensor detects pressure in the purge line. The sensor output voltage to the ECM increases as pressure increases.

View from under the vehicle
with rear crossmember removed

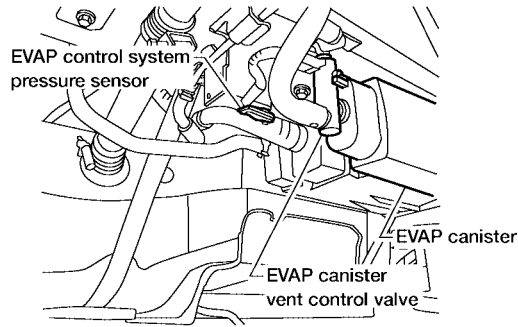

BBIA0526E

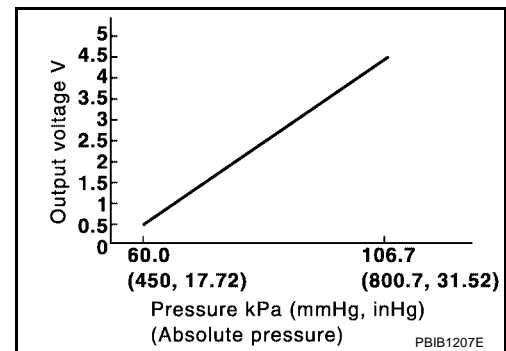

CONSULT-II Reference Value in Data Monitor Mode

UBS00169

Specification data are reference values.

MONITOR ITEM	CONDITION	SPECIFICATION
EVAP SYS PRES	● Ignition switch: ON	Approx. 1.8 - 4.8V

On Board Diagnosis Logic

UBS0016A

NOTE:

If DTC P0451 is displayed with DTC P1229, first perform the trouble diagnosis for DTC P1229. Refer to [EC-1127](#).

DTC No.	Trouble diagnosis name	DTC detecting condition	Possible cause
P0451 0451	EVAP control system pressure sensor performance	ECM detects a sloshing signal from the EVAP control system pressure sensor	<ul style="list-style-type: none"> ● Harness or connectors ● EVAP control system pressure sensor

DTC Confirmation Procedure

NOTE:

If DTC Confirmation Procedure has been previously conducted, always turn ignition switch OFF and wait at least 10 seconds before conducting the next test.

WITH CONSULT-II

1. Turn ignition switch OFF and wait at least 10 seconds.
2. Turn ignition switch ON and select "DATA MONITOR" mode with CONSULT-II.
3. Start engine and wait at least 40 seconds.

NOTE:

Do not depress accelerator pedal even slightly.

If 1st trip DTC is detected, go to [EC-992, "Diagnostic Procedure"](#)

DATA MONITOR	
MONITOR	NO DTC
ENG SPEED	XXX rpm
COOLANT TEMP/S	XXX °C
FUEL T/TMP SE	XXX °C

SEF194Y

WITH GST

Follow the procedure "WITH CONSULT-II" above.

Diagnostic Procedure

1. CHECK GROUND CONNECTIONS

1. Turn ignition switch OFF.
2. Loosen and retighten three ground screws on the body.
Refer to [EC-789, "Ground Inspection"](#) .

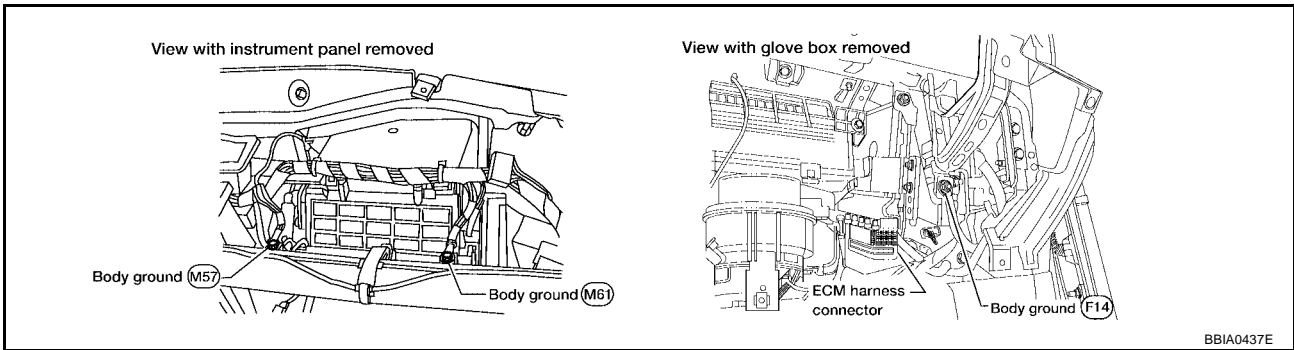

BBIA0437E

OK or NG

- OK >> GO TO 2.
- NG >> Repair or replace ground connections.

2. CHECK EVPA CONTROL SYSTEM PRESSURE SENSOR CONNECTOR FOR WATER

1. Disconnect EVAP control system pressure sensor harness connector.

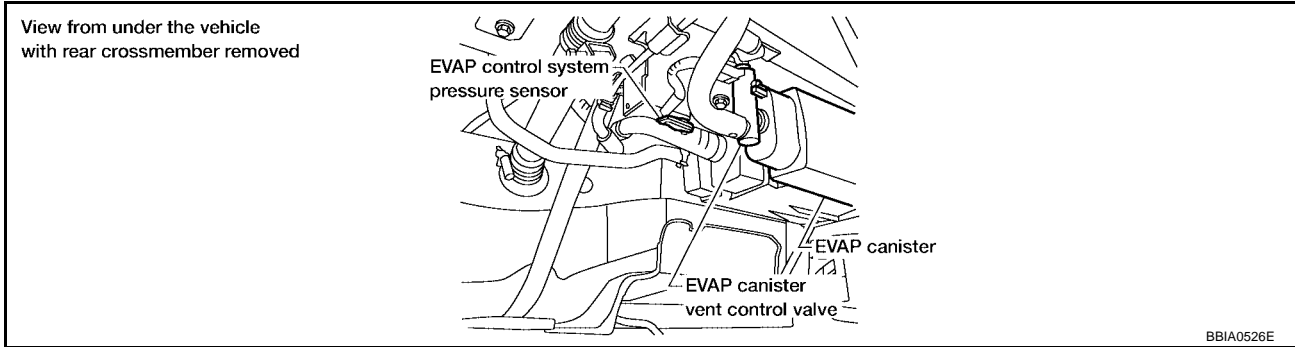

2. Check sensor harness connector for water.

Water should not exist.

OK or NG

- OK >> GO TO 3.
- NG >> Repair or replace harness connector.

3. CHECK EVAP CONTROL SYSTEM PRESSURE SENSOR

Refer to [EC-993, "Component Inspection"](#) .

OK or NG

- OK >> GO TO 4.
- NG >> Replace EVAP control system pressure sensor.

4. CHECK INTERMITTENT INCIDENT

Refer to [EC-782, "TROUBLE DIAGNOSIS FOR INTERMITTENT INCIDENT"](#) .
For wiring diagram, refer to [EC-996](#) .

>> INSPECTION END

Component Inspection EVAP CONTROL SYSTEM PRESSURE SENSOR

UBS0016D

1. Remove EVAP control system pressure sensor with its harness connector connected from EVAP canister.
Do not reuse the O-ring, replace it with a new one.
2. Install a vacuum pump to EVAP control system pressure sensor.
3. Turn ignition switch ON and check output voltage between ECM terminal 32 and ground under the following conditions.

Applied vacuum kPa (mmHg, inHg)	Voltage V
Not applied	1.8 - 4.8
-26.7 (-200, -7.87)	2.1 to 2.5V lower than above value

CAUTION:

- Always calibrate the vacuum pump gauge when using it.
- Do not apply below -93.3 kPa (-700 mmHg, -27.56 inHg) or pressure over 101.3 kPa (760 mmHg, 29.92 inHg).

4. If NG, replace EVAP control system pressure sensor.

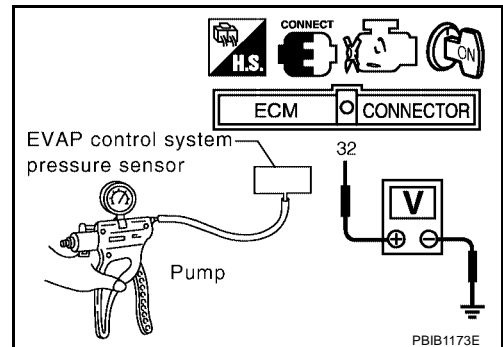

DTC P0452 EVAP CONTROL SYSTEM PRESSURE SENSOR

[VQ]

DTC P0452 EVAP CONTROL SYSTEM PRESSURE SENSOR

PFP:25085

Component Description

UBS0016E

The EVAP control system pressure sensor detects pressure in the purge line. The sensor output voltage to the ECM increases as pressure increases.

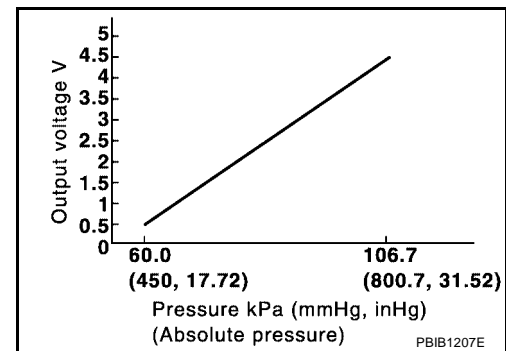
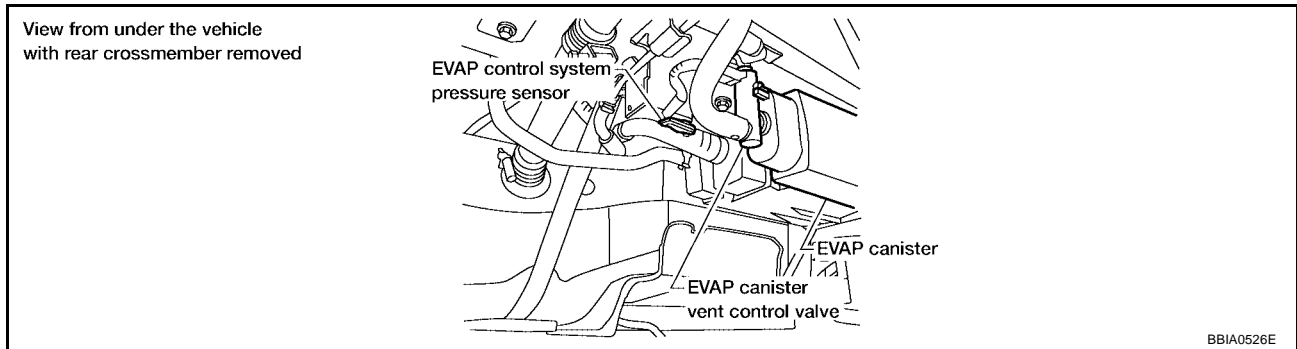

CONSULT-II Reference Value in Data Monitor Mode

UBS0016F

Specification data are reference values.

MONITOR ITEM	CONDITION	SPECIFICATION
EVAP SYS PRES	● Ignition switch: ON	Approx. 1.8 - 4.8V

On Board Diagnosis Logic

UBS0016G

NOTE:

If DTC P0452 is displayed with DTC P1229, first perform the trouble diagnosis for DTC P1229. Refer to [EC-1127](#).

DTC No.	Trouble diagnosis name	DTC detecting condition	Possible cause
P0452 0452	EVAP control system pressure sensor low input	An excessively low voltage from the sensor is sent to ECM.	<ul style="list-style-type: none"> ● Harness or connectors (The sensor circuit is open or shorted.) ● EVAP control system pressure sensor

DTC Confirmation Procedure

NOTE:

If DTC Confirmation Procedure has been previously conducted, always turn ignition switch OFF and wait at least 10 seconds before conducting the next test.

TESTING CONDITION:

Always perform test at a temperature of 5°C (41°F) or more.

WITH CONSULT-II

1. Start engine and warm it up to normal operating temperature.
2. Turn ignition switch OFF and wait at least 10 seconds.
3. Turn ignition switch ON.
4. Select "DATA MONITOR" mode with CONSULT-II.
5. Make sure that "FUEL T/TMP SE" is more than 0°C (32°F).
6. Start engine and wait at least 20 seconds.
If 1st trip DTC is detected, go to [EC-997, "Diagnostic Procedure"](#)

DATA MONITOR	
MONITOR	NO DTC
ENG SPEED	XXX rpm
COOLAN TEMP/S	XXX °C
FUEL T/TMP SE	XXX °C

SEF194Y

WITH GST

1. Start engine and warm it up to normal operating temperature.
2. Check that voltage between ECM terminal 107 (Fuel tank temperature sensor signal) and ground is less than 4.2V.
3. Turn ignition switch OFF and wait at least 10 seconds.
4. Start engine and wait at least 20 seconds.
5. Select Service \$07 with GST.
If 1st trip DTC is detected, go to [EC-997, "Diagnostic Procedure"](#)

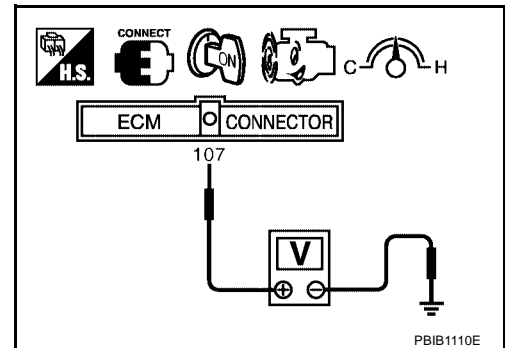

DTC P0452 EVAP CONTROL SYSTEM PRESSURE SENSOR

[VQ]

Wiring Diagram

UBS0016I

EC-PRE/SE-01

: DETECTABLE LINE FOR DTC
 : NON-DETECTABLE LINE FOR DTC

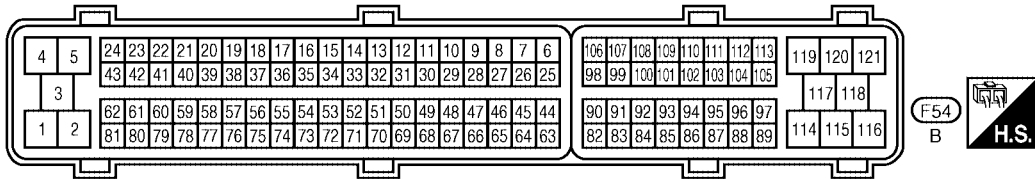
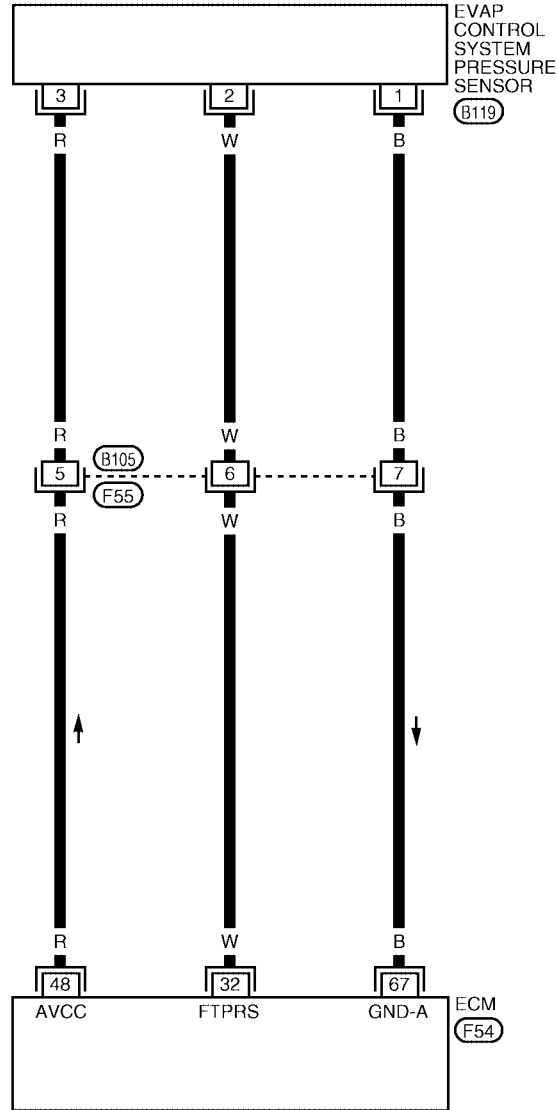

BBWA1666E

DTC P0452 EVAP CONTROL SYSTEM PRESSURE SENSOR

[VQ]

Specification data are reference values and are measured between each terminal and ground.

CAUTION:

Do not use ECM ground terminals when measuring input/output voltage. Doing so may result in damage to the ECM's transistor. Use a ground other than ECM terminals, such as the ground.

TER-MINAL NO.	WIRE COLOR	ITEM	CONDITION	DATA (DC Voltage)
32	W	EVAP control system pressure sensor	[Ignition switch: ON]	Approximately 1.8 - 4.8V
48	R	Sensor power supply (EVAP control system pressure sensor)	[Ignition switch: ON]	Approximately 5V
67	B	Sensor ground	[Engine is running] ● Warm-up condition ● Idle speed	Approximately 0V

Diagnostic Procedure

UBS0016J

1. CHECK GROUND CONNECTIONS

1. Turn ignition switch OFF.
2. Loosen and retighten three ground screws on the body.
Refer to [EC-789, "Ground Inspection"](#).

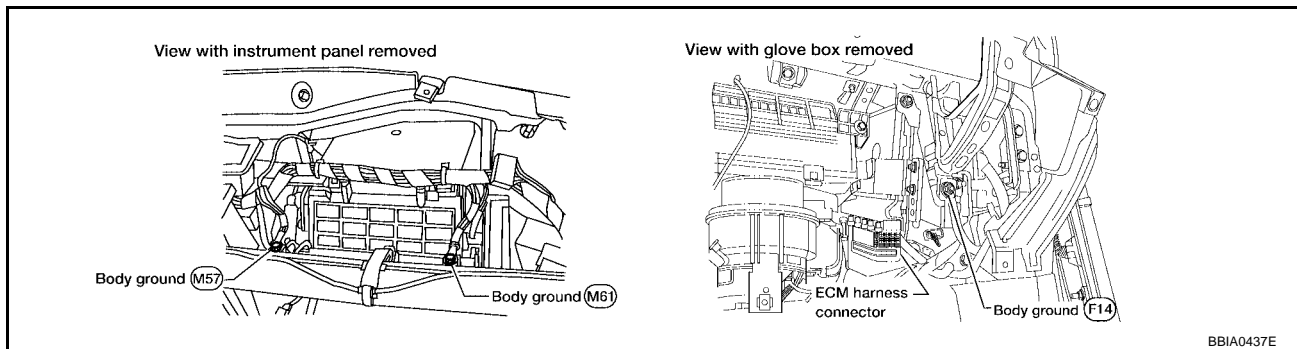

OK or NG

- OK >> GO TO 2.
- NG >> Repair or replace ground connections.

2. CHECK CONNECTOR

1. Disconnect EVAP control system pressure sensor harness connector.

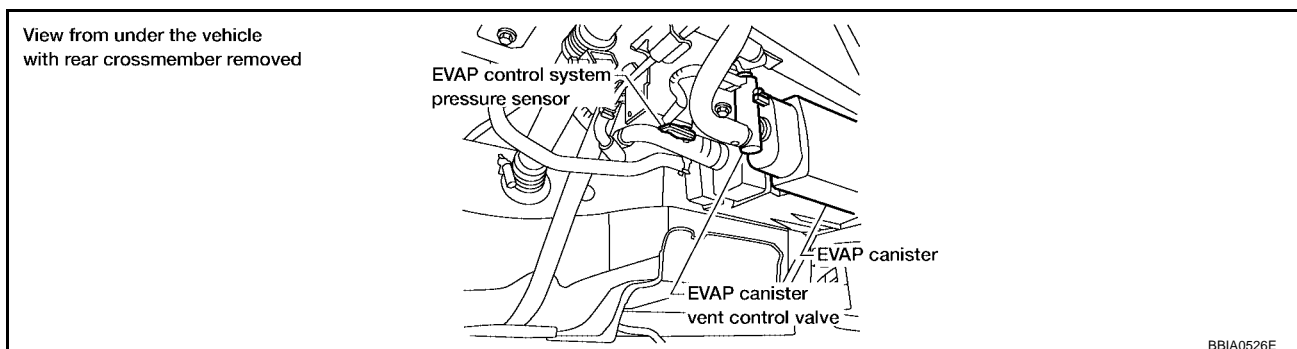

2. Check sensor harness connector for water.

Water should not exist.

OK or NG

- OK >> GO TO 3.
- NG >> Repair or replace harness connector.

3. CHECK EVAP CONTROL SYSTEM PRESSURE SENSOR POWER SUPPLY CIRCUIT

1. Turn ignition switch ON.
2. Check voltage between EVAP control system pressure sensor terminal 3 and ground with CONSULT-II or tester.

Voltage: Approximately 5V

OK or NG

- OK >> GO TO 5.
- NG >> GO TO 4.

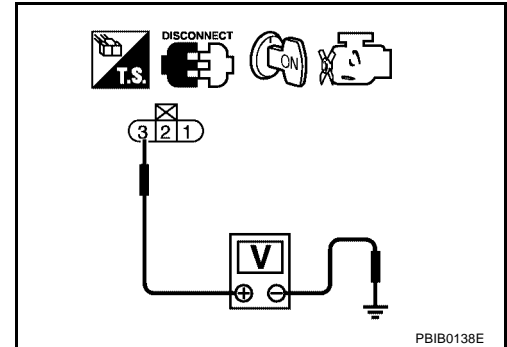

4. DETECT MALFUNCTIONING PART

Check the following.

- Harness connectors B105, F55
- Harness for open or short between EVAP control system pressure sensor and ECM

>> Repair open circuit or short to ground or short to power in harness or connectors.

5. CHECK EVAP CONTROL SYSTEM PRESSURE SENSOR GROUND CIRCUIT FOR OPEN AND SHORT

1. Turn ignition switch OFF.
2. Disconnect ECM harness connector.
3. Check harness continuity between EVAP control system pressure sensor terminal 1 and ECM terminal 67.
Refer to Wiring Diagram.

Continuity should exist.

4. Also check harness for short to ground and short to power.

OK or NG

- OK >> GO TO 7.
- NG >> GO TO 6.

6. DETECT MALFUNCTIONING PART

Check the following.

- Harness connectors B105, F55
- Harness for open or short between EVAP control system pressure sensor and ECM

>> Repair open circuit or short to ground or short to power in harness or connectors.

DTC P0452 EVAP CONTROL SYSTEM PRESSURE SENSOR

[VQ]

7. CHECK EVAP CONTROL SYSTEM PRESSURE SENSOR INPUT SIGNAL CIRCUIT FOR OPEN AND SHORT

1. Check harness continuity between ECM terminal 32 and EVAP control system pressure sensor terminal 2.
Refer to Wiring Diagram.

Continuity should exist.

2. Also check harness for short to ground and short to power.

OK or NG

- OK >> GO TO 9.
- NG >> GO TO 8.

8. DETECT MALFUNCTIONING PART

Check the following.

- Harness connectors B105, F55
- Harness for open or short between EVAP control system pressure sensor and ECM

>> Repair open circuit or short to ground or short to power in harness or connectors.

9. CHECK EVAP CONTROL SYSTEM PRESSURE SENSOR

Refer to [EC-999, "Component Inspection"](#) .

OK or NG

- OK >> GO TO 10.
- NG >> Replace EVAP control system pressure sensor.

10. CHECK INTERMITTENT INCIDENT

Refer to [EC-782, "TROUBLE DIAGNOSIS FOR INTERMITTENT INCIDENT"](#) .

>> **INSPECTION END**

Component Inspection EVAP CONTROL SYSTEM PRESSURE SENSOR

UBS0016K

1. Remove EVAP control system pressure sensor with its harness connector connected from EVAP canister.
Do not reuse the O-ring, replace it with a new one.
2. Install a vacuum pump to EVAP control system pressure sensor.
3. Turn ignition switch ON and check output voltage between ECM terminal 32 and ground under the following conditions.

Applied vacuum kPa (mmHg, inHg)	Voltage V
Not applied	1.8 - 4.8
-26.7 (-200, -7.87)	2.1 to 2.5V lower than above value

CAUTION:

- Always calibrate the vacuum pump gauge when using it.
 - Do not apply below -93.3 kPa (-700 mmHg, -27.56 inHg) or pressure over 101.3 kPa (760 mmHg, 29.92 inHg).
4. If NG, replace EVAP control system pressure sensor.

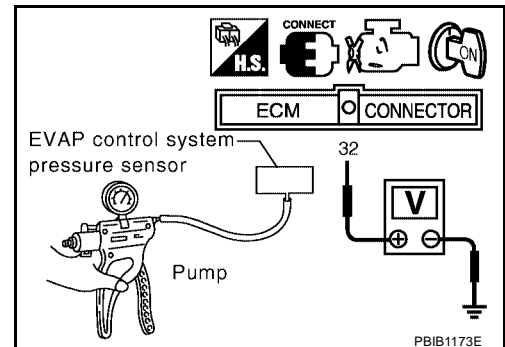

DTC P0453 EVAP CONTROL SYSTEM PRESSURE SENSOR

[VQ]

DTC P0453 EVAP CONTROL SYSTEM PRESSURE SENSOR

PFP:25085

Component Description

UBS0016L

The EVAP control system pressure sensor detects pressure in the purge line. The sensor output voltage to the ECM increases as pressure increases.

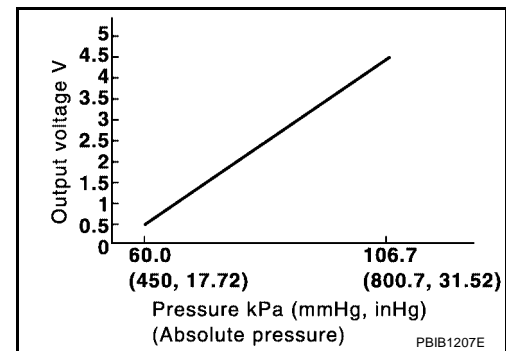
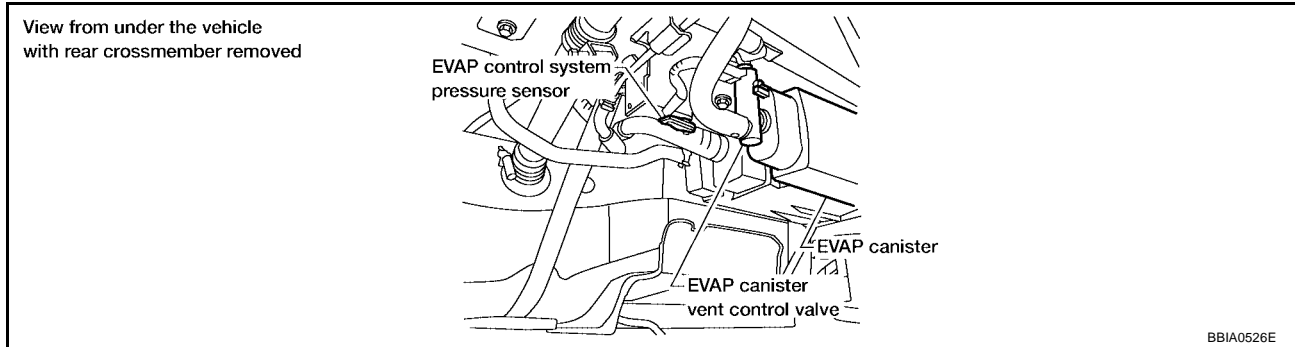

CONSULT-II Reference Value in Data Monitor Mode

UBS0016M

Specification data are reference values.

MONITOR ITEM	CONDITION	SPECIFICATION
EVAP SYS PRES	● Ignition switch: ON	Approx. 1.8 - 4.8V

On Board Diagnosis Logic

UBS0016N

NOTE:

If DTC P0453 is displayed with DTC P1229, first perform the trouble diagnosis for DTC P1229. Refer to [EC-1127](#).

DTC No.	Trouble diagnosis name	DTC detecting condition	Possible cause
P0453 0453	EVAP control system pressure sensor high input	An excessively high voltage from the sensor is sent to ECM.	<ul style="list-style-type: none"> ● Harness or connectors (The sensor circuit is open or shorted.) ● EVAP control system pressure sensor ● EVAP canister vent control valve ● EVAP canister ● Rubber hose from EVAP canister vent control valve to vehicle frame

DTC Confirmation Procedure

NOTE:

If DTC Confirmation Procedure has been previously conducted, always turn ignition switch OFF and wait at least 10 seconds before conducting the next test.

TESTING CONDITION:

Always perform test at a temperature of 5°C (41°F) or more.

WITH CONSULT-II

1. Start engine and warm it up to normal operating temperature.
2. Turn ignition switch OFF and wait at least 10 seconds.
3. Turn ignition switch ON.
4. Select "DATA MONITOR" mode with CONSULT-II.
5. Make sure that "FUEL T/TEMP SE" is more than 0°C (32°F).
6. Wait at least 10 seconds.
7. If 1st trip DTC is detected, go to [EC-1003, "Diagnostic Procedure"](#).

DATA MONITOR	
MONITOR	NO DTC
ENG SPEED	XXX rpm
COOLAN TEMP/S	XXX °C
FUEL T/TMP SE	XXX °C

SEF194Y

WITH GST

1. Start engine and warm it up to normal operating temperature.
2. Check that voltage between ECM terminal 107 (Fuel tank temperature sensor signal) and ground is less than 4.2V.
3. Turn ignition switch OFF and wait at least 10 seconds.
4. Turn ignition switch ON and wait at least 10 seconds.
5. Select Service \$07 with GST.
If 1st trip DTC is detected, go to [EC-1003, "Diagnostic Procedure"](#).

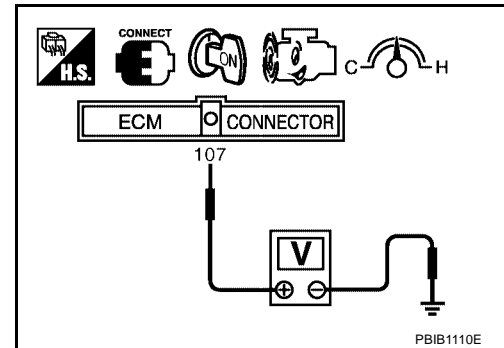

DTC P0453 EVAP CONTROL SYSTEM PRESSURE SENSOR

[VQ]

Wiring Diagram

UBS0016P

EC-PRE/SE-01

: DETECTABLE LINE FOR DTC
 : NON-DETECTABLE LINE FOR DTC

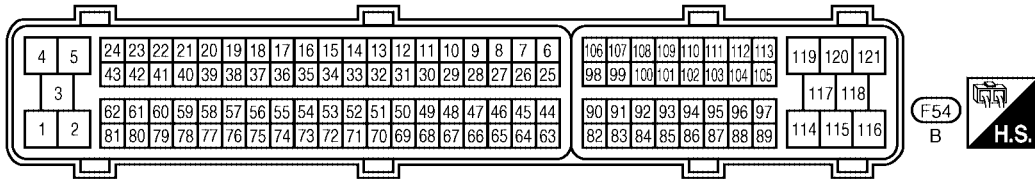
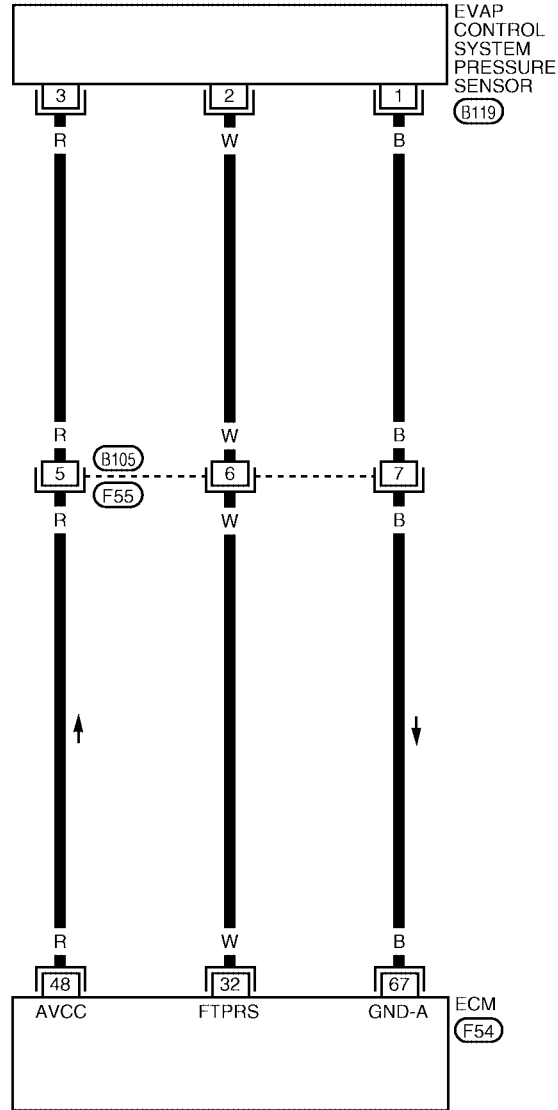

BBWA1666E

DTC P0453 EVAP CONTROL SYSTEM PRESSURE SENSOR

[VQ]

Specification data are reference values and are measured between each terminal and ground.

CAUTION:

Do not use ECM ground terminals when measuring input/output voltage. Doing so may result in damage to the ECM's transistor. Use a ground other than ECM terminals, such as the ground.

TER-MINAL NO.	WIRE COLOR	ITEM	CONDITION	DATA (DC Voltage)
32	W	EVAP control system pressure sensor	[Ignition switch: ON]	Approximately 1.8 - 4.8V
48	R	Sensor power supply (EVAP control system pressure sensor)	[Ignition switch: ON]	Approximately 5V
67	B	Sensor ground	[Engine is running] ● Warm-up condition ● Idle speed	Approximately 0V

Diagnostic Procedure

UBS0016Q

1. CHECK GROUND CONNECTIONS

1. Turn ignition switch OFF.
2. Loosen and retighten three ground screws on the body.
Refer to [EC-789, "Ground Inspection"](#).

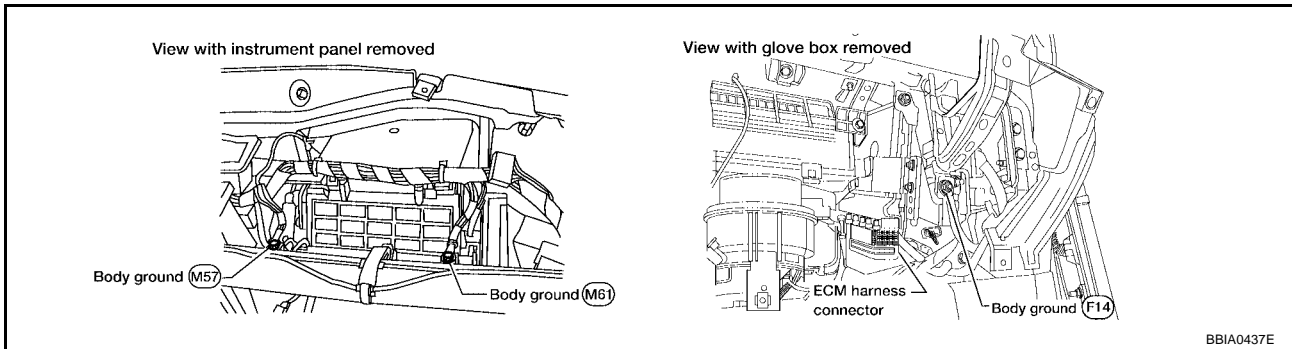

OK or NG

- OK >> GO TO 2.
- NG >> Repair or replace ground connections.

2. CHECK CONNECTOR

1. Disconnect EVAP control system pressure sensor harness connector.

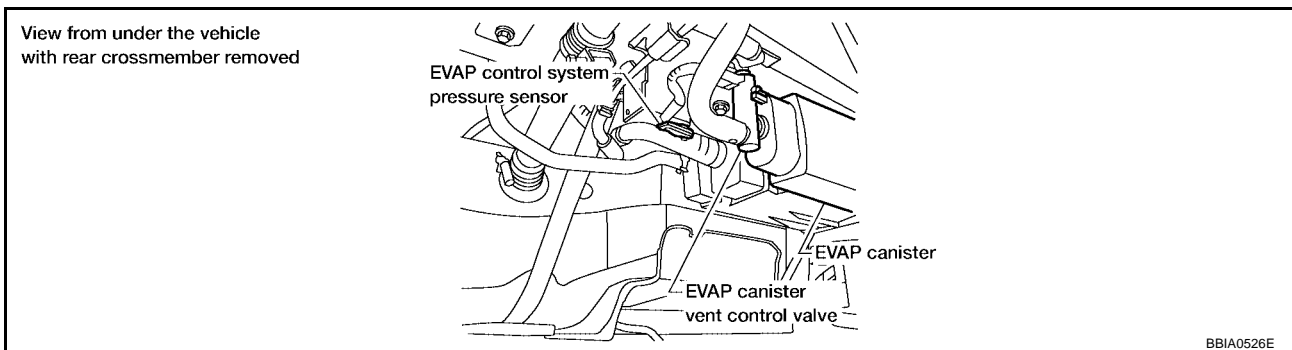

2. Check sensor harness connector for water.

Water should not exist.

OK or NG

- OK >> GO TO 3.
- NG >> Repair or replace harness connector.

3. CHECK EVAP CONTROL SYSTEM PRESSURE SENSOR POWER SUPPLY CIRCUIT

1. Turn ignition switch ON.
2. Check voltage between EVAP control system pressure sensor terminal 3 and ground with CONSULT-II or tester.

Voltage: Approximately 5V

OK or NG

- OK >> GO TO 5.
NG >> GO TO 4.

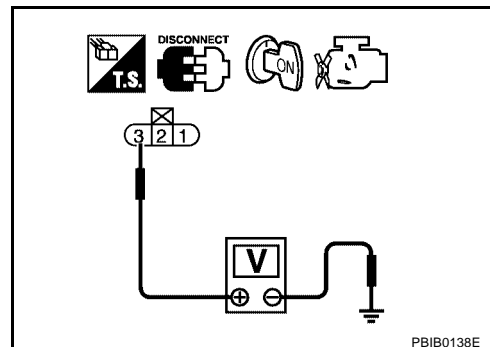

4. DETECT MALFUNCTIONING PART

Check the following.

- Harness connectors B105, F55
- Harness for open or short between EVAP control system pressure sensor and ECM

>> Repair open circuit or short to ground or short to power in harness or connectors.

5. CHECK EVAP CONTROL SYSTEM PRESSURE SENSOR GROUND CIRCUIT FOR OPEN AND SHORT

1. Turn ignition switch OFF.
2. Disconnect ECM harness connector.
3. Check harness continuity between EVAP control system pressure sensor terminal 1 and ECM terminal 67.
Refer to Wiring Diagram.

Continuity should exist.

4. Also check harness for short to ground and short to power.

OK or NG

- OK >> GO TO 7.
NG >> GO TO 6.

6. DETECT MALFUNCTIONING PART

Check the following.

- Harness connectors B105, F55
- Harness for open or short between EVAP control system pressure sensor and ECM

>> Repair open circuit or short to ground or short to power in harness or connectors.

7. CHECK EVAP CONTROL SYSTEM PRESSURE SENSOR INPUT SIGNAL CIRCUIT FOR OPEN AND SHORT

1. Check harness continuity between ECM terminal 32 and EVAP control system pressure sensor terminal 2.
Refer to Wiring Diagram.

Continuity should exist.

2. Also check harness for short to ground and short to power.

OK or NG

- OK >> GO TO 9.
NG >> GO TO 8.

8. DETECT MALFUNCTIONING PART

Check the following.

- Harness connectors B105, F55
- Harness for open or short between EVAP control system pressure sensor and ECM

>> Repair open circuit or short to ground or short to power in harness or connectors.

9. CHECK RUBBER TUBE

1. Disconnect rubber tube connected to EVAP canister vent control valve.
2. Check the rubber tube for clogging, vent and kinked.

OK or NG

- OK >> GO TO 10.
NG >> Clean the rubber tube using an air blower, repair or replace rubber tube.

10. CHECK EVAP CANISTER VENT CONTROL VALVE

Refer to [EC-989, "Component Inspection"](#) .

OK or NG

- OK >> GO TO 11.
NG >> Replace EVAP canister vent control valve.

11. CHECK EVAP CONTROL SYSTEM PRESSURE SENSOR

Refer to [EC-1007, "Component Inspection"](#) .

OK or NG

- OK >> GO TO 12.
NG >> Replace EVAP control system pressure sensor.

12. CHECK IF EVAP CANISTER SATURATED WITH WATER

1. Remove EVAP canister with EVAP canister vent control valve and EVAP control system pressure sensor attached.
2. Check if water will drain from the EVAP canister.

Yes or No

- Yes >> GO TO 13.
No >> GO TO 15.

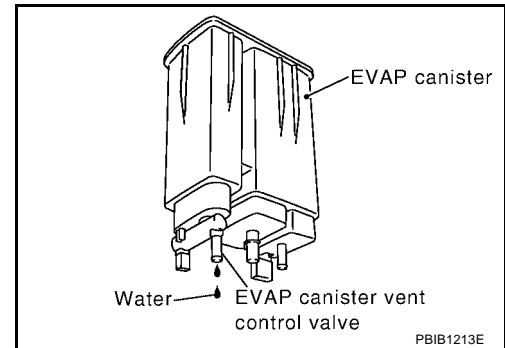

13. CHECK EVAP CANISTER

Weigh the EVAP canister with the EVAP canister vent control valve and EVAP control system pressure sensor attached.

The weight should be less than 2.1 kg (4.6 lb).

OK or NG

- OK >> GO TO 15.
NG >> GO TO 14.

14. DETECT MALFUNCTIONING PART

Check the following.

- EVAP canister for damage
- EVAP hose between EVAP canister and vehicle frame for clogging or poor connection

>> Repair hose or replace EVAP canister.

15. CHECK INTERMITTENT INCIDENT

Refer to [EC-782. "TROUBLE DIAGNOSIS FOR INTERMITTENT INCIDENT"](#) .

>> **INSPECTION END**

DTC P0453 EVAP CONTROL SYSTEM PRESSURE SENSOR

[VQ]

UBS0016R

Component Inspection EVAP CONTROL PRESSURE SENSOR

1. Remove EVAP control system pressure sensor with its harness connector connected from EVAP canister.
Do not reuse the O-ring, replace it with a new one.
2. Install a vacuum pump to EVAP control system pressure sensor.
3. Turn ignition switch ON and check output voltage between ECM terminal 32 and ground under the following conditions.

Applied vacuum kPa (mmHg, inHg)	Voltage V
Not applied	1.8 - 4.8
-26.7 (-200, -7.87)	2.1 to 2.5V lower than above value

CAUTION:

- Always calibrate the vacuum pump gauge when using it.
 - Do not apply below -93.3 kPa (-700 mmHg, -27.56 inHg) or pressure over 101.3 kPa (760 mmHg, 29.92 inHg).
4. If NG, replace EVAP control system pressure sensor.

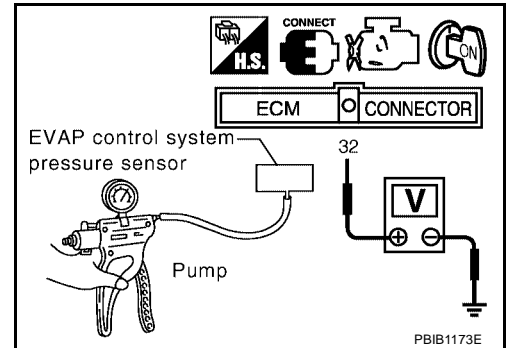

DTC P0455 EVAP CONTROL SYSTEM

On Board Diagnosis Logic

This diagnosis detects a very large leak (fuel filler cap fell off etc.) in EVAP system between the fuel tank and EVAP canister purge volume control solenoid valve.

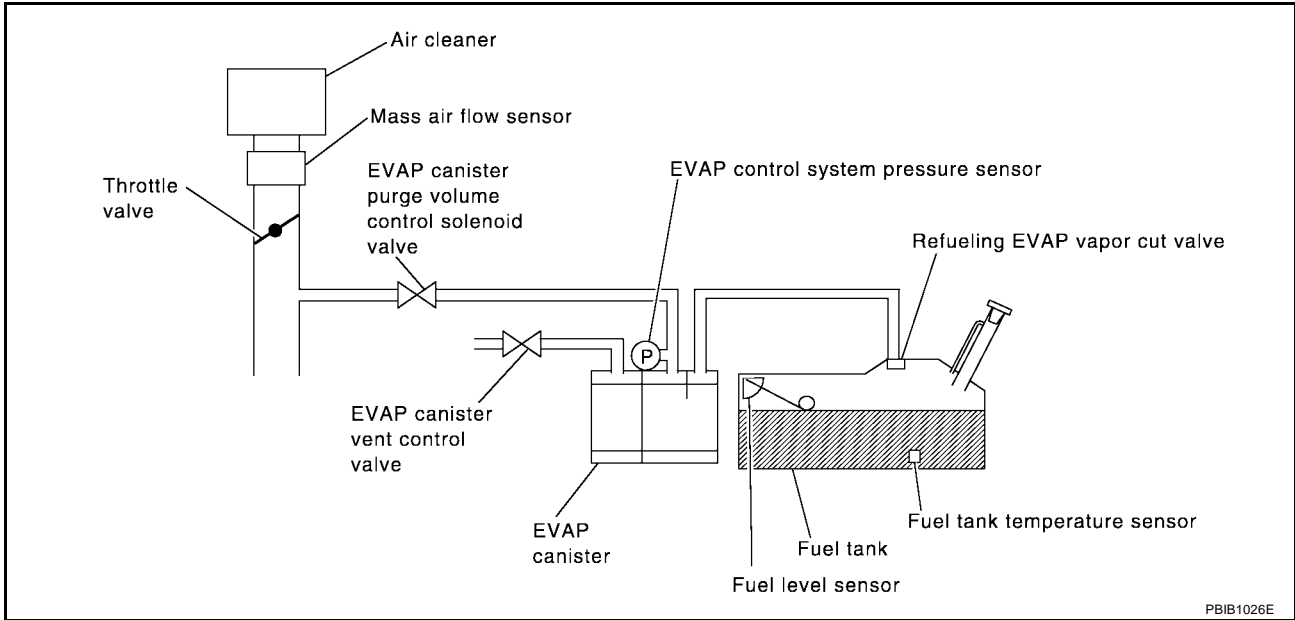

DTC No.	Trouble diagnosis name	DTC detecting condition	Possible cause
P0455 0455	EVAP control system gross leak detected	EVAP control system has a very large leak such as fuel filler cap fell off, EVAP control system does not operate properly.	<ul style="list-style-type: none"> ● Fuel filler cap remains open or fails to close. ● Incorrect fuel tank vacuum relief valve ● Incorrect fuel filler cap used ● Foreign matter caught in fuel filler cap. ● Leak is in line between intake manifold and EVAP canister purge volume control solenoid valve. ● Foreign matter caught in EVAP canister vent control valve. ● EVAP canister or fuel tank leaks ● EVAP purge line (pipe and rubber tube) leaks ● EVAP purge line rubber tube bent. ● Loose or disconnected rubber tube ● EVAP canister vent control valve and the circuit ● EVAP canister purge volume control solenoid valve and the circuit ● Fuel tank temperature sensor ● O-ring of EVAP canister vent control valve is missing or damaged. ● EVAP control system pressure sensor ● Refueling EVAP vapor cut valve ● ORVR system leaks

CAUTION:

- Use only a genuine NISSAN fuel filler cap as a replacement. If an incorrect fuel filler cap is used, the MIL may come on.
- If the fuel filler cap is not tightened properly, the MIL may come on.
- Use only a genuine NISSAN rubber tube as a replacement.

DTC Confirmation Procedure

CAUTION:

Never remove fuel filler cap during the DTC Confirmation Procedure.

NOTE:

- Make sure that EVAP hoses are connected to EVAP canister purge volume control solenoid valve properly.
- If DTC Confirmation Procedure has been previously conducted, always turn ignition switch OFF and wait at least 10 seconds before conducting the next test.

TESTING CONDITION:

- Perform “DTC WORK SUPPORT” when the fuel level is between 1/4 and 3/4 full, and vehicle is placed on flat level surface.
- Open engine hood before conducting the following procedures.

WITH CONSULT-II

1. Tighten fuel filler cap securely until ratcheting sound is heard.
2. Turn ignition switch ON.
3. Turn ignition switch OFF and wait at least 10 seconds.
4. Turn ignition switch ON and select “DATA MONITOR” mode with CONSULT-II.
5. Make sure that the following conditions are met.
COOLAN TEMP/S: 0 - 70°C (32 - 158°F)
INT/A TEMP SE: 0 - 60°C (32 - 140°F)
6. Select “EVAP SML LEAK P0442/P1442” of “EVAPORATIVE SYSTEM” in “DTC WORK SUPPORT” mode with CONSULT-II.
 Follow the instruction displayed.

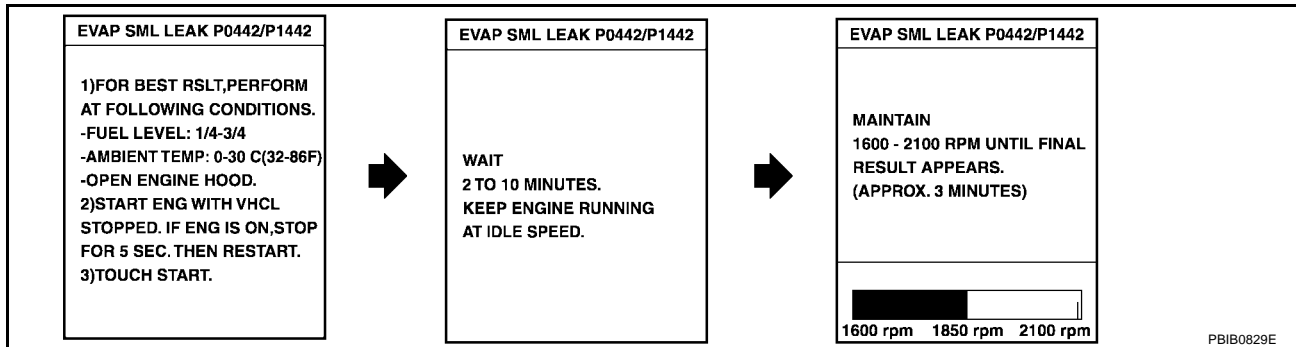

NOTE:

If the engine speed cannot be maintained within the range displayed on the CONSULT-II screen, go to [EC-693, "Basic Inspection"](#) .

7. Make sure that “OK” is displayed.
 If “NG” is displayed, select “SELF-DIAG RESULTS” mode and make sure that “EVAP GROSS LEAK [P0455]” is displayed. If it is displayed, refer to [EC-1010, "Diagnostic Procedure"](#) .
 If P0442 is displayed, perform Diagnostic Procedure for DTC P0442 [EC-971, "Diagnostic Procedure"](#) .

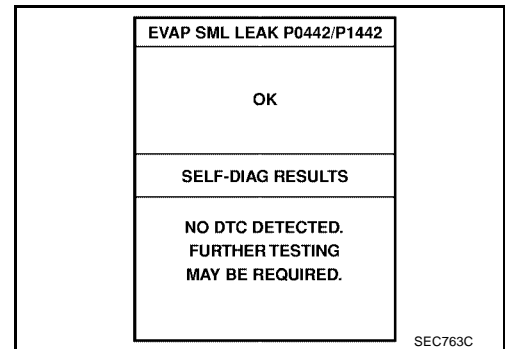

WITH GST**NOTE:**

Be sure to read the explanation of Driving Pattern on [EC-679](#) before driving vehicle.

1. Start engine.
2. Drive vehicle according to Driving Pattern, [EC-679](#) .
3. Stop vehicle.
4. Turn ignition switch OFF, wait at least 10 seconds and then turn ON.
5. Select Service \$07 with GST.
 - If P0455 is displayed on the screen, go to [EC-1010, "Diagnostic Procedure"](#) .
 - If P0442 is displayed on the screen, go to Diagnostic Procedure, for DTC P0442, [EC-971](#) .
 - If P0441 is displayed on the screen, go to Diagnostic Procedure for DTC P0441, [EC-966](#) .

Diagnostic Procedure

UBS0016U

1. CHECK FUEL FILLER CAP DESIGN

1. Turn ignition switch OFF.
2. Check for genuine NISSAN fuel filler cap design.

OK or NG

- OK >> GO TO 2.
 NG >> Replace with genuine NISSAN fuel filler cap.

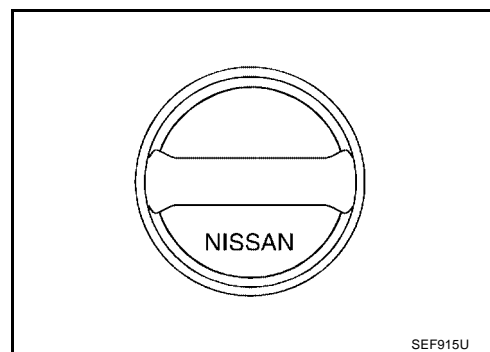

SEF915U

2. CHECK FUEL FILLER CAP INSTALLATION

Check that the cap is tightened properly by rotating the cap clockwise.

OK or NG

- OK >> GO TO 3.
 NG >> 1. Open fuel filler cap, then clean cap and fuel filler neck threads using air blower.
 2. Retighten until ratcheting sound is heard.

3. CHECK FUEL FILLER CAP FUNCTION

Check for air releasing sound while opening the fuel filler cap.

OK or NG

- OK >> GO TO 5.
 NG >> GO TO 4.

4. CHECK FUEL TANK VACUUM RELIEF VALVE

Refer to [EC-656, "FUEL TANK VACUUM RELIEF VALVE \(BUILT INTO FUEL FULLER CAP\)"](#) .

OK or NG

- OK >> GO TO 5.
 NG >> Replace fuel filler cap with a genuine one.

5. CHECK EVAP PURGE LINE

Check EVAP purge line (pipe, rubber tube, fuel tank and EVAP canister) for cracks, improper connection or disconnection.

Refer to [EC-652, "EVAPORATIVE EMISSION LINE DRAWING \(SE-R MODELS\)"](#) or [EC-654, "EVAPORATIVE EMISSION LINE DRAWING \(EXCEPT SE-R MODELS\)"](#).

OK or NG

- OK >> GO TO 6.
- NG >> Repair or reconnect the hose.

6. CLEAN EVAP PURGE LINE

Clean EVAP purge line (pipe and rubber tube) using air blower.

>> GO TO 7.

7. CHECK EVAP CANISTER VENT CONTROL VALVE

Check the following.

- EVAP canister vent control valve is installed properly.
Refer to [EC-657, "Removal and Installation"](#).
- EVAP canister vent control valve.
Refer to [EC-989, "Component Inspection"](#).

OK or NG

- OK >> GO TO 8.
- NG >> Repair or replace EVAP canister vent control valve and O-ring.

8. INSTALL THE PRESSURE PUMP

To locate the EVAP leak, install EVAP service port adapter and pressure pump to EVAP service port securely.

Refer to [EC-652, "EVAPORATIVE EMISSION LINE DRAWING \(SE-R MODELS\)"](#) or [EC-654, "EVAPORATIVE EMISSION LINE DRAWING \(EXCEPT SE-R MODELS\)"](#).

NOTE:

Improper installation of the EVAP service port adapter to the EVAP service port may cause leaking.

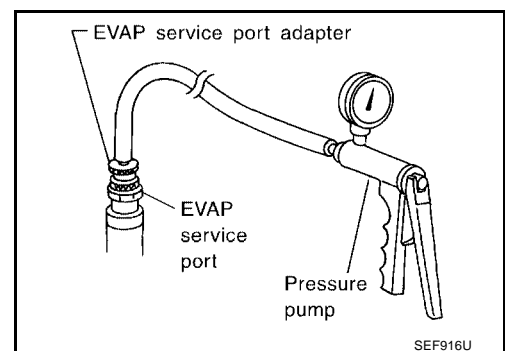
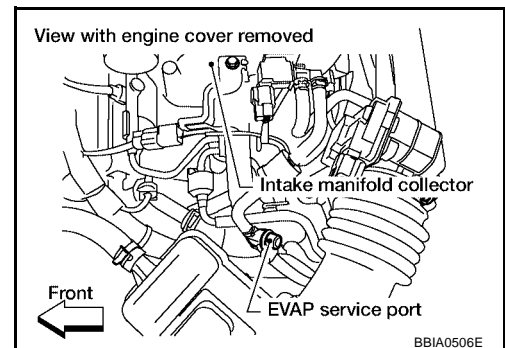

With CONSULT-II>>GO TO 9.
Without CONSULT-II>>GO TO 10.

9. CHECK FOR EVAP LEAK

With CONSULT-II

1. Turn ignition switch ON.
2. Select "EVAP SYSTEM CLOSE" of "WORK SUPPORT" mode with CONSULT-II.
3. Touch "START" and apply pressure into the EVAP line until the pressure indicator reaches the middle of the bar graph.

NOTE:

- **Never use compressed air or a high pressure pump.**
- **Do not exceed 4.12 kPa (0.042 kg/cm² , 0.6 psi) of pressure in the system.**

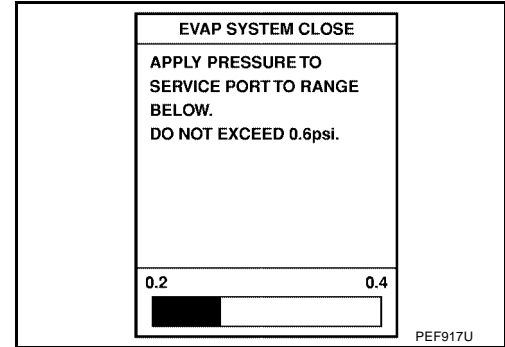

4. Using EVAP leak detector, locate the EVAP leak. For the leak detector, refer to the instruction manual for more details. Refer to [EC-652, "EVAPORATIVE EMISSION LINE DRAWING \(SE-R MODELS\)"](#) or [EC-654, "EVAPORATIVE EMISSION LINE DRAWING \(EXCEPT SE-R MODELS\)"](#).

OK or NG

- OK >> GO TO 11.
 NG >> Repair or replace.

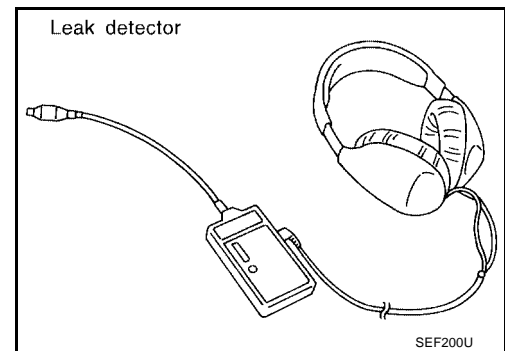

10. CHECK FOR EVAP LEAK

⊗ Without CONSULT-II

1. Turn ignition switch OFF.
2. Apply 12 volts DC to EVAP canister vent control valve. The valve will close. (Continue to apply 12 volts until the end of test.)

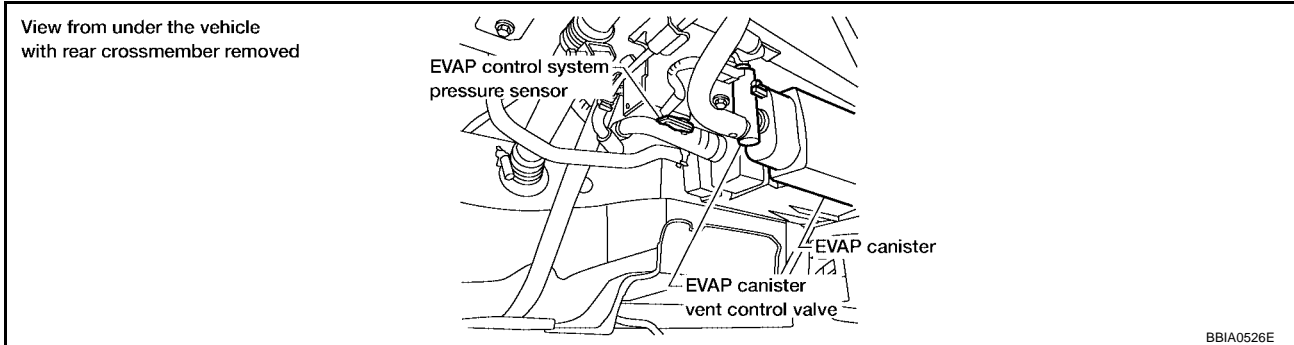

3. Pressurize the EVAP line using pressure pump with 1.3 to 2.7 kPa (10 to 20 mmHg, 0.39 to 0.79 inHg), then remove pump and EVAP service port adapter.

NOTE:

- Never use compressed air or a high pressure pump.
- Do not exceed 4.12 kPa (0.042 kg/cm² , 0.6 psi) of pressure in the system.

4. Using EVAP leak detector, locate the EVAP leak. For the leak detector, refer to the instruction manual for more details. Refer to [EC-652, "EVAPORATIVE EMISSION LINE DRAWING \(SE-R MODELS\)"](#) or [EC-654, "EVAPORATIVE EMISSION LINE DRAWING \(EXCEPT SE-R MODELS\)"](#) .

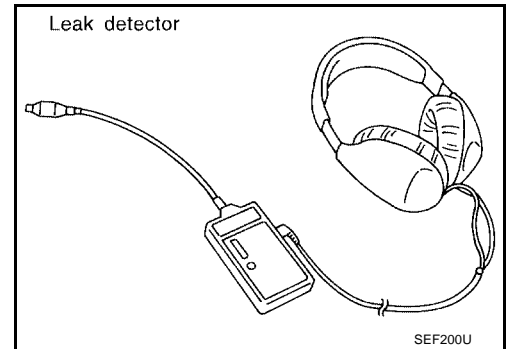

OK or NG

- OK >> GO TO 12.
- NG >> Repair or replace.

11. CHECK EVAP CANISTER PURGE VOLUME CONTROL SOLENOID VALVE OPERATION

Ⓟ With CONSULT-II

1. Disconnect vacuum hose to EVAP canister purge volume control solenoid valve at EVAP service port.
2. Start engine.
3. Perform "PURG VOL CONT/V" in "ACTIVE TEST" mode.
4. Touch "Qu" on CONSULT-II screen to increase "PURG VOL CONT/V" opening to 100%.
5. Check vacuum hose for vacuum when revving engine up to 2,000 rpm.

OK or NG

- OK >> GO TO 14.
- NG >> GO TO 13.

ACTIVE TEST	
PURG VOL CONT/V	XXX %
MONITOR	
ENG SPEED	XXX rpm
A/F ALPHA-B1	XX %
A/F ALPHA-B2	XX %

PBIB1678E

12. CHECK EVAP CANISTER PURGE VOLUME CONTROL SOLENOID VALVE OPERATION

⊗ **Without CONSULT-II**

1. Start engine and warm it up to normal operating temperature.
2. Stop engine.
3. Disconnect vacuum hose to EVAP canister purge volume control solenoid valve at EVAP service port.
4. Start engine and let it idle for at least 80 seconds.
5. Check vacuum hose for vacuum when revving engine up to 2,000 rpm.

Vacuum should exist.

OK or NG

- OK >> GO TO 15.
- NG >> GO TO 13.

13. CHECK VACUUM HOSE

Check vacuum hoses for clogging or disconnection. Refer to [EC-736, "Vacuum Hose Drawing"](#) .

OK or NG

- OK (With CONSULT-II)>>GO TO 14.
- OK (Without CONSULT-II)>>GO TO 15.
- NG >> Repair or reconnect the hose.

14. CHECK EVAP CANISTER PURGE VOLUME CONTROL SOLENOID VALVE

Ⓟ **With CONSULT-II**

1. Start engine.
2. Perform "PURG VOL CONT/V" in "ACTIVE TEST" mode with CONSULT-II. Check that engine speed varies according to the valve opening.

OK or NG

- OK >> GO TO 16.
- NG >> GO TO 15.

ACTIVE TEST	
PURG VOL CONT/V	XXX %
MONITOR	
ENG SPEED	XXX rpm
A/F ALPHA-B1	XX %
A/F ALPHA-B2	XX %

PBIB1678E

15. CHECK EVAP CANISTER PURGE VOLUME CONTROL SOLENOID VALVE

Refer to [EC-983, "Component Inspection"](#) .

OK or NG

- OK >> GO TO 16.
- NG >> Replace EVAP canister purge volume control solenoid valve.

16. CHECK FUEL TANK TEMPERATURE SENSOR

Refer to [EC-894, "Component Inspection"](#) .

OK or NG

- OK >> GO TO 17.
- NG >> Replace fuel level sensor unit.

17. CHECK EVAP CONTROL SYSTEM PRESSURE SENSOR

Refer to [EC-999, "Component Inspection"](#) .

OK or NG

OK >> GO TO 18.

NG >> Replace EVAP control system pressure sensor.

18. CHECK EVAP/ORVR LINE

Check EVAP/ORVR line between EVAP canister and fuel tank for clogging, kink, looseness and improper connection. For location, refer to [EC-660, "ON BOARD REFUELING VAPOR RECOVERY \(ORVR\)"](#) .

OK or NG

OK >> GO TO 19.

NG >> Repair or replace hoses and tubes.

19. CHECK RECIRCULATION LINE

Check recirculation line between filler neck tube and fuel tank for clogging, kink, cracks, looseness and improper connection.

OK or NG

OK >> GO TO 20.

NG >> Repair or replace hose, tube or filler neck tube.

20. CHECK REFUELING EVAP VAPOR CUT VALVE

Refer to [EC-663, "REFUELING EVAP VAPOR CUT VALVE"](#) .

OK or NG

OK >> GO TO 21.

NG >> Replace refueling EVAP vapor cut valve with fuel tank.

21. CHECK INTERMITTENT INCIDENT

Refer to [EC-782, "TROUBLE DIAGNOSIS FOR INTERMITTENT INCIDENT"](#) .

>> **INSPECTION END**

A

EC

C

D

E

F

G

H

I

J

K

L

M

DTC P0456 EVAP CONTROL SYSTEM

PFP:14950

On Board Diagnosis Logic

UBS0016V

This diagnosis detects very small leaks in the EVAP line between fuel tank and EVAP canister purge volume control solenoid valve, using the intake manifold vacuum in the same way as conventional EVAP small leak diagnosis.

If ECM judges a leak which corresponds to a very small leak, the very small leak P0456 will be detected.

If ECM judges a leak equivalent to a small leak, EVAP small leak P0442 will be detected.

If ECM judges there are no leaks, the diagnosis will be OK.

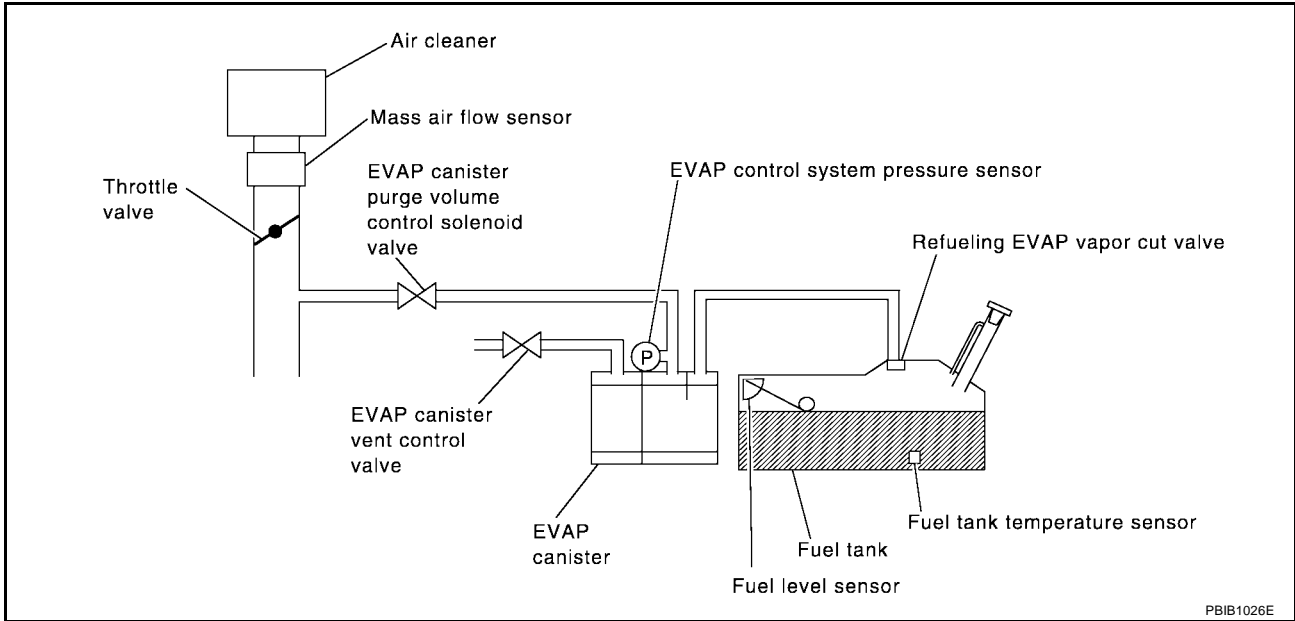

DTC No.	Trouble diagnosis name	DTC detecting condition	Possible cause
P0456 0456	Evaporative emission control system very small leak (negative pressure check)	<ul style="list-style-type: none"> ● EVAP system has a very small leak. ● EVAP system does not operate properly. 	<ul style="list-style-type: none"> ● Incorrect fuel tank vacuum relief valve ● Incorrect fuel filler cap used ● Fuel filler cap remains open or fails to close. ● Foreign matter caught in fuel filler cap. ● Leak is in line between intake manifold and EVAP canister purge volume control solenoid valve. ● Foreign matter caught in EVAP canister vent control valve. ● EVAP canister or fuel tank leaks ● EVAP purge line (pipe and rubber tube) leaks ● EVAP purge line rubber tube bent ● Loose or disconnected rubber tube ● EVAP canister vent control valve and the circuit ● EVAP canister purge volume control solenoid valve and the circuit ● Fuel tank temperature sensor ● O-ring of EVAP canister vent control valve is missing or damaged ● EVAP canister is saturated with water ● EVAP control system pressure sensor ● Refueling EVAP vapor cut valve ● ORVR system leaks ● Fuel level sensor and the circuit ● Foreign matter caught in EVAP canister purge volume control solenoid valve

CAUTION:

- Use only a genuine NISSAN fuel filler cap as a replacement. If an incorrect fuel filler cap is used, the MIL may come on.
- If the fuel filler cap is not tightened properly, the MIL may come on.
- Use only a genuine NISSAN rubber tube as a replacement.

DTC Confirmation Procedure

UBS0016W

NOTE:

- If DTC P0456 is displayed with P0442, first perform trouble diagnosis for DTC P0456.
- After repair, make sure that the hoses and clips are installed properly.
- If DTC Confirmation Procedure has been previously conducted, always turn ignition switch OFF and wait at least 10 seconds before conducting the next test.

TESTING CONDITION:

- Open engine hood before conducting following procedure.
- If any of following conditions are met just before the DTC confirmation procedure, leave the vehicle for more than 1 hour.
 - Fuel filler cap is removed.
 - Refilled or drained the fuel.
 - EVAP component parts is/are removed.
- Before performing the following procedure, confirm that battery voltage is more than 11V at idle.

WITH CONSULT-II

1. Turn ignition switch ON and select "DATA MONITOR" mode with CONSULT-II.
2. Make sure the following conditions are met.
FUEL LEVEL SE: 0.25 - 1.4V
COOLAN TEMP/S: 0 - 32°C (32 - 90°F)
FUEL T/TMP SE: 0 - 35°C (32 - 95°F)
INT A/TEMP SE: More than 0°C (32°F)
 If NG, turn ignition switch OFF and leave the vehicle in a cool place (soak the vehicle) or refilling/draining fuel until the output voltage condition of the "FUEL LEVEL SE" meets within the range above and leave the vehicle for more than 1 hour. Then start from step 1).
3. Turn ignition switch OFF and wait at least 10 seconds.
4. Turn ignition switch ON.
5. Select "EVAP V/S LEAK P0456/P1456" of "EVAPORATIVE SYSTEM" in "DTC WORK SUPPORT" mode with CONSULT-II.
Follow the instruction displayed.

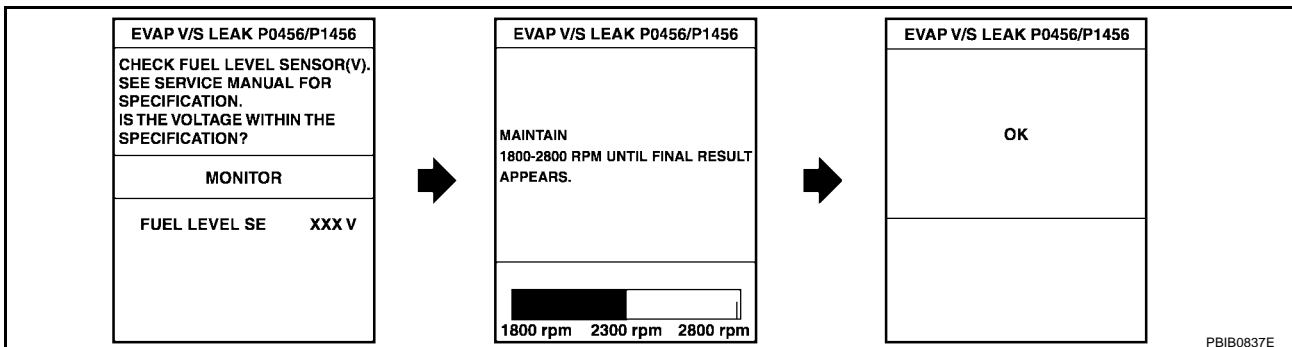

6. Make sure that "OK" is displayed.
If "NG" is displayed, refer to [EC-1019, "Diagnostic Procedure"](#).

NOTE:

- If the engine speed cannot be maintained within the range displayed on CONSULT-II screen, go to [EC-693, "Basic Inspection"](#).
- Make sure that EVAP hoses are connected to EVAP canister purge volume control solenoid valve properly.

Overall Function Check

WITH GST

Use this procedure to check the overall function of the EVAP very small leak function. During this check, a 1st trip DTC might not be confirmed.

CAUTION:

- Never use compressed air, doing so may damage the EVAP system.
- Do not start engine.
- Do not exceeded 4.12 kPa (0.042 kg/cm² , 0.6 psi).

1. Attach the EVAP service port adapter securely to the EVAP service port.

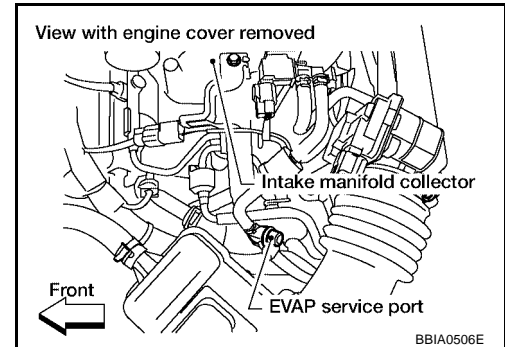

2. Set the pressure pump and a hose.
3. Also set a vacuum gauge via 3-way connector and a hose.
4. Turn ignition switch ON.
5. Connect GST and select Service \$08.
6. Using Service \$08 control the EVAP canister vent control valve (close).
7. Apply pressure and make sure the following conditions are satisfied.

Pressure to be applied: 2.7 kPa (20 mmHg, 0.79 inHg)

Time to be waited after the pressure drawn in to the EVAP system and the pressure to be dropped: 60 seconds and the pressure should not be dropped more than 0.4 kPa (3 mmHg, 0.12 inHg).

If NG, go to [EC-1019, "Diagnostic Procedure"](#).

If OK, go to next step.

8. Disconnect GST.
9. Start engine and warm it up to normal operating temperature.
10. Turn ignition switch OFF and wait at least 10 seconds.
11. Restart engine and let it idle for 90 seconds.
12. Keep engine speed at 2,000 rpm for 30 seconds.
13. Turn ignition switch OFF.

NOTE:

For more information, refer to GST Instruction Manual.

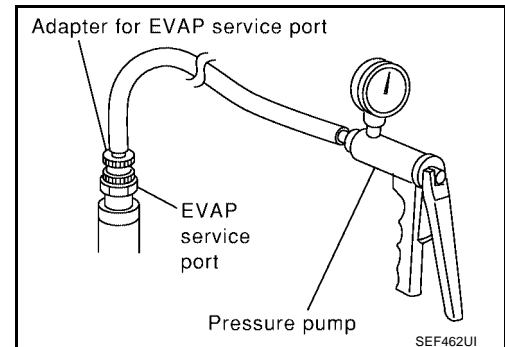

Diagnostic Procedure**1. CHECK FUEL FILLER CAP DESIGN**

1. Turn ignition switch OFF.
2. Check for genuine NISSAN fuel filler cap design.

OK or NG

- OK >> GO TO 2.
 NG >> Replace with genuine NISSAN fuel filler cap.

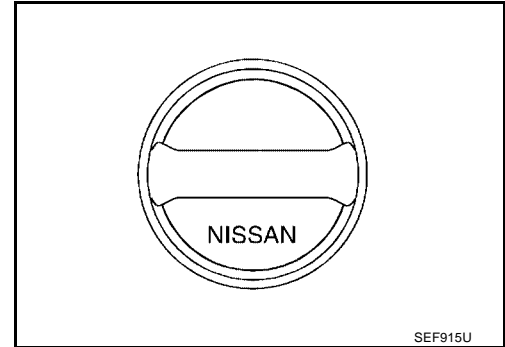
**2. CHECK FUEL FILLER CAP INSTALLATION**

Check that the cap is tightened properly by rotating the cap clockwise.

OK or NG

- OK >> GO TO 3.
 NG >> 1. Open fuel filler cap, then clean cap and fuel filler neck threads using air blower.
 2. Retighten until ratcheting sound is heard.

3. CHECK FUEL FILLER CAP FUNCTION

Check for air releasing sound while opening the fuel filler cap.

OK or NG

- OK >> GO TO 5.
 NG >> GO TO 4.

4. CHECK FUEL TANK VACUUM RELIEF VALVE

Refer to [EC-656, "FUEL TANK VACUUM RELIEF VALVE \(BUILT INTO FUEL FULLER CAP\)"](#).

OK or NG

- OK >> GO TO 5.
 NG >> Replace fuel filler cap with a genuine one.

5. INSTALL THE PRESSURE PUMP

To locate the EVAP leak, install EVAP service port adapter and pressure pump to EVAP service port securely.

For the location of EVAP service port, refer to [EC-652, "EVAPORATIVE EMISSION LINE DRAWING \(SE-R MODELS\)"](#) or [EC-654, "EVAPORATIVE EMISSION LINE DRAWING \(EXCEPT SE-R MODELS\)"](#).

NOTE:

Improper installation of the EVAP service port adapter to the EVAP service port may cause leaking.

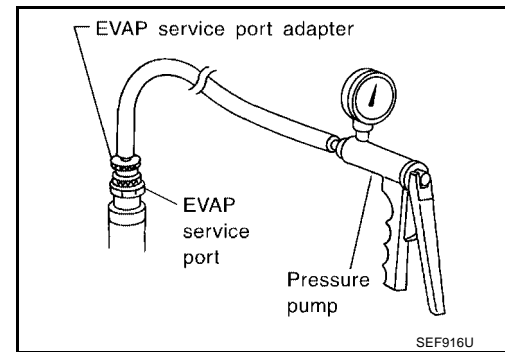
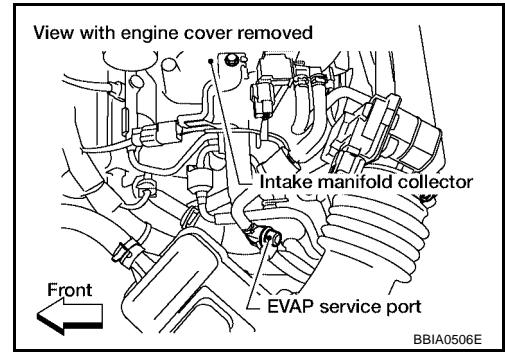

With CONSULT-II>>GO TO 6.
Without CONSULT-II>>GO TO 7.

6. CHECK FOR EVAP LEAK

Ⓟ With CONSULT-II

1. Turn ignition switch ON.
2. Select "EVAP SYSTEM CLOSE" of "WORK SUPPORT" mode with CONSULT-II.
3. Touch "START" and apply pressure into the EVAP line until the pressure indicator reaches the middle of the bar graph.

NOTE:

- Never use compressed air or a high pressure pump.
- Do not exceed 4.12 kPa (0.042 kg/cm² , 0.6 psi) of pressure in the system.

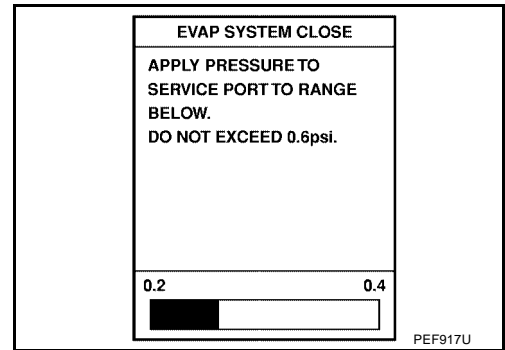

4. Using EVAP leak detector, locate the EVAP leak. For the leak detector, refer to the instruction manual for more details. Refer to [EC-652, "EVAPORATIVE EMISSION LINE DRAWING \(SE-R MODELS\)"](#) or [EC-654, "EVAPORATIVE EMISSION LINE DRAWING \(EXCEPT SE-R MODELS\)"](#).

OK or NG

- OK >> GO TO 8.
- NG >> Repair or replace.

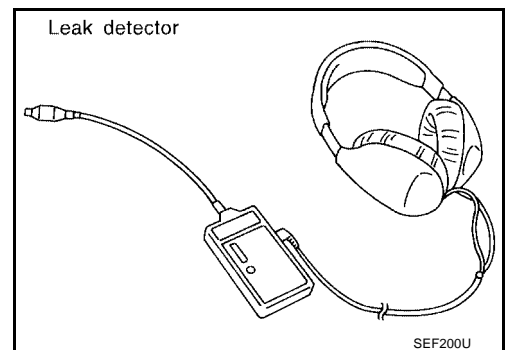

7. CHECK FOR EVAP LEAK

⊗ Without CONSULT-II

1. Turn ignition switch OFF.
2. Apply 12 volts DC to EVAP canister vent control valve. The valve will close. (Continue to apply 12 volts until the end of test.)

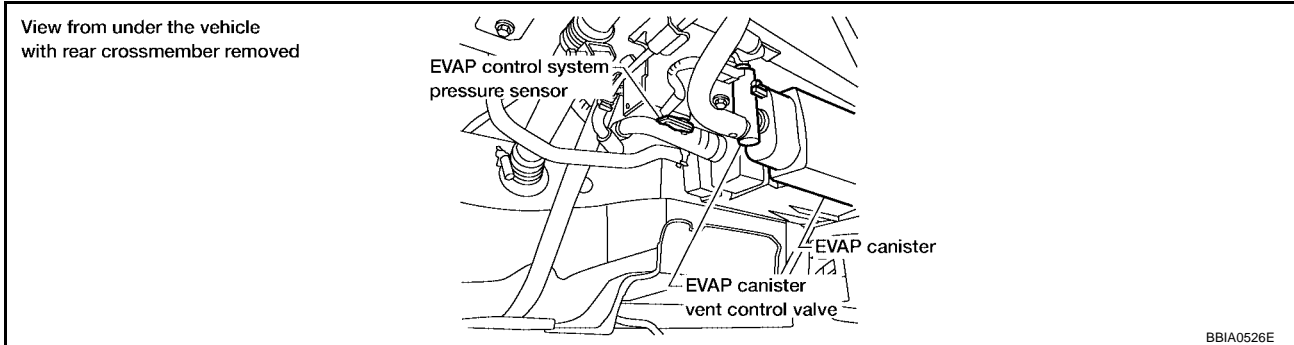

3. Pressurize the EVAP line using pressure pump with 1.3 to 2.7 kPa (10 to 20 mmHg, 0.39 to 0.79 inHg), then remove pump and EVAP service port adapter.

NOTE:

- Never use compressed air or a high pressure pump.
- Do not exceed 4.12 kPa (0.042 kg/cm² , 0.6 psi) of pressure in the system.

4. Using EVAP leak detector, locate the EVAP leak. For the leak detector, refer to the instruction manual for more details. Refer to [EC-652, "EVAPORATIVE EMISSION LINE DRAWING \(SE-R MODELS\)"](#) or [EC-654, "EVAPORATIVE EMISSION LINE DRAWING \(EXCEPT SE-R MODELS\)"](#) .

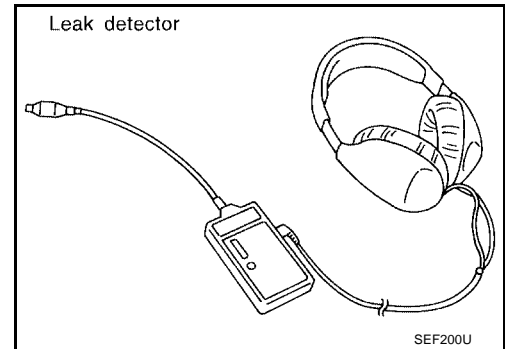

OK or NG

- OK >> GO TO 8.
- NG >> Repair or replace.

8. CHECK EVAP CANISTER VENT CONTROL VALVE

Check the following.

- EVAP canister vent control valve is installed properly. Refer to [EC-657, "Removal and Installation"](#) .
- EVAP canister vent control valve. Refer to [EC-989, "Component Inspection"](#) .

OK or NG

- OK >> GO TO 9.
- NG >> Repair or replace EVAP canister vent control valve and O-ring.

9. CHECK IF EVAP CANISTER SATURATED WITH WATER

1. Remove EVAP canister with EVAP canister vent control valve and EVAP control system pressure sensor attached.
2. Does water drain from the EVAP canister?

Yes or No

- Yes >> GO TO 10.
- No (With CONSULT-II)>>GO TO 12.
- No (Without CONSULT-II)>>GO TO 13.

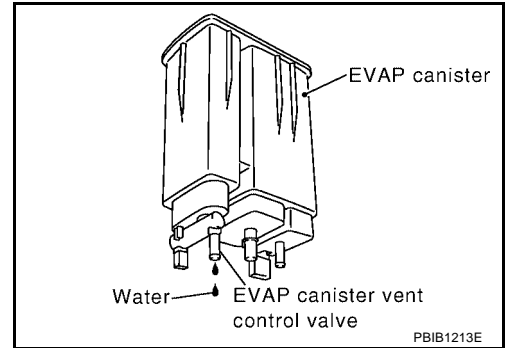

10. CHECK EVAP CANISTER

Weigh the EVAP canister with the EVAP canister vent control valve and EVAP control system pressure sensor attached.

The weight should be less than 2.1 kg (4.6 lb).

OK or NG

- OK (With CONSULT-II)>>GO TO 12.
- OK (Without CONSULT-II)>>GO TO 13.
- NG >> GO TO 11.

11. DETECT MALFUNCTIONING PART

Check the following.

- EVAP canister for damage
- EVAP hose between EVAP canister and vehicle frame for clogging or poor connection

>> Repair hose or replace EVAP canister.

12. CHECK EVAP CANISTER PURGE VOLUME CONTROL SOLENOID VALVE OPERATION

Ⓟ With CONSULT-II

1. Disconnect vacuum hose to EVAP canister purge volume control solenoid valve at EVAP service port.
2. Start engine.
3. Perform "PURG VOL CONT/V" in "ACTIVE TEST" mode.
4. Touch "Qu" on CONSULT-II screen to increase "PURG VOL CONT/V" opening to 100%.
5. Check vacuum hose for vacuum when revving engine up to 2,000 rpm.

OK or NG

- OK >> GO TO 15.
- NG >> GO TO 14.

ACTIVE TEST	
PURG VOL CONT/V	XXX %
MONITOR	
ENG SPEED	XXX rpm
A/F ALPHA-B1	XX %
A/F ALPHA-B2	XX %

PBIB1678E

13. CHECK EVAP CANISTER PURGE VOLUME CONTROL SOLENOID VALVE OPERATION**⊗ Without CONSULT-II**

1. Start engine and warm it up to normal operating temperature.
2. Stop engine.
3. Disconnect vacuum hose to EVAP canister purge volume control solenoid valve at EVAP service port.
4. Start engine and let it idle for at least 80 seconds.
5. Check vacuum hose for vacuum when revving engine up to 2,000 rpm.

Vacuum should exist.

OK or NG

- OK >> GO TO 16.
 NG >> GO TO 14.

14. CHECK VACUUM HOSE

Check vacuum hoses for clogging or disconnection. Refer to [EC-736, "Vacuum Hose Drawing"](#).

OK or NG

- OK >> GO TO 15.
 NG >> Repair or reconnect the hose.

15. CHECK EVAP CANISTER PURGE VOLUME CONTROL SOLENOID VALVE

Refer to [EC-983, "Component Inspection"](#).

OK or NG

- OK >> GO TO 16.
 NG >> Replace EVAP canister purge volume control solenoid valve.

16. CHECK FUEL TANK TEMPERATURE SENSOR

Refer to [EC-894, "Component Inspection"](#).

OK or NG

- OK >> GO TO 17.
 NG >> Replace fuel level sensor unit.

17. CHECK EVAP CONTROL SYSTEM PRESSURE SENSOR

Refer to [EC-999, "Component Inspection"](#).

OK or NG

- OK >> GO TO 18.
 NG >> Replace EVAP control system pressure sensor.

18. CHECK EVAP PURGE LINE

Check EVAP purge line (pipe, rubber tube, fuel tank and EVAP canister) for cracks or improper connection. Refer to [EC-652, "EVAPORATIVE EMISSION LINE DRAWING \(SE-R MODELS\)"](#) or [EC-654, "EVAPORATIVE EMISSION LINE DRAWING \(EXCEPT SE-R MODELS\)"](#).

OK or NG

- OK >> GO TO 19.
 NG >> Repair or reconnect the hose.

19. CLEAN EVAP PURGE LINE

Clean EVAP purge line (pipe and rubber tube) using air blower.

>> GO TO 20.

20. CHECK EVAP/ORVR LINE

Check EVAP/ORVR line between EVAP canister and fuel tank for clogging, kink, looseness and improper connection. For location, refer to [EC-660, "ON BOARD REFUELING VAPOR RECOVERY \(ORVR\)"](#) .

OK or NG

- OK >> GO TO 21.
- NG >> Repair or replace hoses and tubes.

21. CHECK RECIRCULATION LINE

Check recirculation line between filler neck tube and fuel tank for clogging, kink, cracks, looseness and improper connection.

OK or NG

- OK >> GO TO 22.
- NG >> Repair or replace hose, tube or filler neck tube.

22. CHECK REFUELING EVAP VAPOR CUT VALVE

Refer to [EC-663, "Component Inspection"](#) .

OK or NG

- OK >> GO TO 23.
- NG >> Replace refueling EVAP vapor cut valve with fuel tank.

23. CHECK FUEL LEVEL SENSOR

Refer to [DI-18, "FUEL LEVEL SENSOR UNIT CHECK"](#) .

OK or NG

- OK >> GO TO 24.
- NG >> Replace fuel level sensor unit.

24. CHECK INTERMITTENT INCIDENT

Refer to [EC-782, "TROUBLE DIAGNOSIS FOR INTERMITTENT INCIDENT"](#) .

>> **INSPECTION END**

DTC P0460 FUEL LEVEL SENSOR

PF:25060

Component Description

UBS0016Z

The fuel level sensor is mounted in the fuel level sensor unit. The sensor detects a fuel level in the fuel tank and transmits a signal to the combination meter. The combination meter sends the fuel level sensor signal to the ECM through CAN communication line. It consists of two parts, one is mechanical float and the other is variable resistor. Fuel level sensor output voltage changes depending on the movement of the fuel mechanical float.

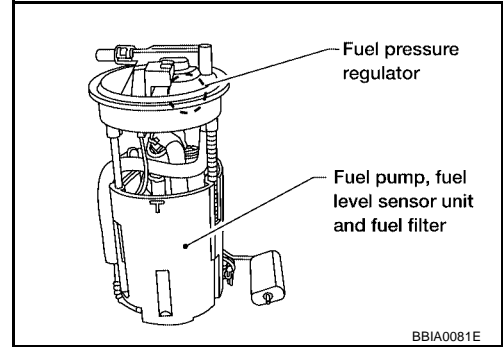

UBS00170

On Board Diagnosis Logic

NOTE:

If DTC P0460 is displayed with DTC U1000 or U1001, first perform the trouble diagnosis for DTC U1000, U1001. Refer to [EC-790](#) .

When the vehicle is parked, naturally the fuel level in the fuel tank is stable. It means that output signal of the fuel level sensor does not change. If ECM senses sloshing signal from the sensor, fuel level sensor malfunction is detected.

DTC No.	Trouble diagnosis name	DTC detecting condition	Possible cause
P0460 0460	Fuel level sensor circuit noise	Even though the vehicle is parked, a signal being varied is sent from the fuel level sensor to ECM.	<ul style="list-style-type: none"> ● Harness or connectors (The CAN communication line is open or shorted) ● Harness or connectors (The sensor circuit is open or shorted) ● Combination meter ● Fuel level sensor

DTC Confirmation Procedure

UBS00171

NOTE:

If DTC Confirmation Procedure has been previously conducted, always turn ignition switch OFF and wait at least 10 seconds before conducting the next test.

WITH CONSULT-II

1. Turn ignition switch ON.
2. Select "DATA MONITOR" mode with CONSULT-II.
3. Start engine and wait maximum of 2 consecutive minutes.
4. If 1st trip DTC is detected, go to [EC-1026, "Diagnostic Procedure"](#) .

DATA MONITOR	
MONITOR	NO DTC
FUEL T/TMP SE	XXX °C
FUEL LEVEL SE	XXX V

SEF195Y

WITH GST

Follow the procedure "WITH CONSULT-II" above.

DTC P0460 FUEL LEVEL SENSOR

[VQ]

UBS00172

Diagnostic Procedure

1. CHECK COMBINATION METER FUNCTION

Refer to [DI-7, "Combination Meter"](#) .

OK or NG

OK >> GO TO 2.

NG >> Go to [DI-14, "Fuel System"](#) .

2. CHECK INTERMITTENT INCIDENT

Refer to [EC-782, "TROUBLE DIAGNOSIS FOR INTERMITTENT INCIDENT"](#) .

>> INSPECTION END

Removal and Installation FUEL LEVEL SENSOR

UBS00173

Refer to [FL-5, "FUEL LEVEL SENSOR UNIT, FUEL FILTER AND FUEL PUMP ASSEMBLY"](#) .

DTC P0461 FUEL LEVEL SENSOR

Component Description

The fuel level sensor is mounted in the fuel level sensor unit. The sensor detects a fuel level in the fuel tank and transmits a signal to the combination meter. The combination meter sends the fuel level sensor signal to the ECM through CAN communication line. It consists of two parts, one is mechanical float and the other is variable resistor. Fuel level sensor output voltage changes depending on the movement of the fuel mechanical float.

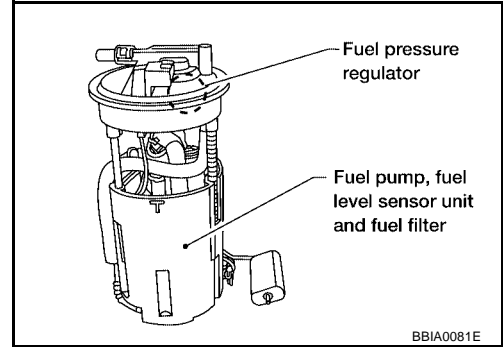

On Board Diagnosis Logic

NOTE:

If DTC P0461 is displayed with DTC U1000 or U1001, first perform the trouble diagnosis for DTC U1000, U1001. Refer to [EC-790, "DTC U1000, U1001 CAN COMMUNICATION LINE"](#).

Driving long distances naturally affect fuel gauge level.

This diagnosis detects the fuel gauge malfunction of the gauge not moving even after a long distance has been driven.

DTC No.	Trouble diagnosis name	DTC detecting condition	Possible cause
P0461 0461	Fuel level sensor circuit range/performance	The output signal of the fuel level sensor does not change within the specified range even though the vehicle has been driven a long distance.	<ul style="list-style-type: none"> ● Harness or connectors (The CAN communication line is open or shorted) ● Harness or connectors (The sensor circuit is open or shorted) ● Combination meter ● Fuel level sensor

Overall Function Check

Use this procedure to check the overall function of the fuel level sensor function. During this check, a 1st trip DTC might not be confirmed.

WARNING:

When performing following procedure, be sure to observe the handling of the fuel. Refer to [FL-12, "FUEL TANK"](#).

TESTING CONDITION:

Before starting overall function check, preparation of draining fuel and refilling fuel is required.

WITH CONSULT-II

NOTE:

Start from step 10, if it is possible to confirm that the fuel cannot be drained by 30 ℓ (7-7/8 US gal, 6-5/8 Imp gal) in advance.

1. Prepare a fuel container and a spare hose.
2. Release fuel pressure from fuel line, refer to [EC-714, "FUEL PRESSURE RELEASE"](#).
3. Remove the fuel feed hose on the fuel level sensor unit.
4. Connect a spare fuel hose where the fuel feed hose was removed.
5. Turn ignition switch OFF and wait at least 10 seconds then turn ON.
6. Select "FUEL LEVEL SE" in "DATA MONITOR" mode with CONSULT-II.

DTC P0461 FUEL LEVEL SENSOR

[VQ]

7. Check "FUEL LEVEL SE" output voltage and note it.
8. Select "FUEL PUMP" in "ACTIVE TEST" mode with CONSULT-II.
9. Touch ON and drain fuel approximately 30 ℓ (7-7/8 US gal, 6-5/8 Imp gal) and stop it.
10. Check "FUEL LEVEL SE" output voltage and note it.
11. Fill fuel into the fuel tank for 30 ℓ (7-7/8 US gal, 6-5/8 Imp gal).
12. Check "FUEL LEVEL SE" output voltage and note it.
13. Confirm whether the voltage changes more than 0.03V during step 7 to 10 and 10 to 12.
If NG, go to [EC-1028, "Diagnostic Procedure"](#) .

DATA MONITOR	
MONITOR	NO DTC
FUEL T/TMP SE	XXX °C
FUEL LEVEL SE	XXX V

SEP195Y

WITH GST

NOTE:

Start from step 8, if it is possible to confirm that the fuel cannot be drained by 30 ℓ (7-7/8 US gal, 6-5/8 Imp gal) in advance.

1. Prepare a fuel container and a spare hose.
2. Release fuel pressure from fuel line. Refer to [EC-714, "FUEL PRESSURE RELEASE"](#) .
3. Remove the fuel feed hose on the fuel level sensor unit.
4. Connect a spare fuel hose where the fuel feed hose was removed.
5. Turn ignition switch ON.
6. Drain fuel by 30 ℓ (7-7/8 US gal, 6-5/8 Imp gal) from the fuel tank using proper equipment.
7. Confirm that the fuel gauge indication varies.
8. Fill fuel into the fuel tank for 30 ℓ (7-7/8 US gal, 6-5/8 Imp gal).
9. Confirm that the fuel gauge indication varies.
10. If NG, go to [EC-1028, "Diagnostic Procedure"](#) .

Diagnostic Procedure

UBS00177

1. CHECK COMBINATION METER FUNCTION

Refer to [DI-7, "Combination Meter"](#) .

OK or NG

- OK >> GO TO 2.
- NG >> Go to [DI-14, "Fuel System"](#) .

2. CHECK INTERMITTENT INCIDENT

Refer to [EC-782, "TROUBLE DIAGNOSIS FOR INTERMITTENT INCIDENT"](#) .

>> INSPECTION END

Removal and Installation FUEL LEVEL SENSOR

UBS00178

Refer to [FL-5, "FUEL LEVEL SENSOR UNIT, FUEL FILTER AND FUEL PUMP ASSEMBLY"](#) .

DTC P0462, P0463 FUEL LEVEL SENSOR

PFP:25060

Component Description

UBS00179

The fuel level sensor is mounted in the fuel level sensor unit. The sensor detects a fuel level in the fuel tank and transmits a signal to the combination meter. The combination meter sends the fuel level sensor signal to the ECM through CAN communication line. It consists of two parts, one is mechanical float and the other is variable resistor. Fuel level sensor output voltage changes depending on the movement of the fuel mechanical float.

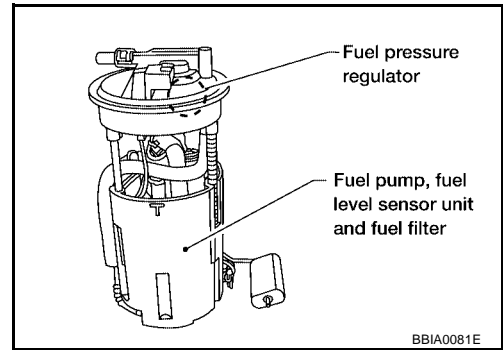

UBS0017A

On Board Diagnosis Logic

NOTE:

If DTC P0462 or P0463 is displayed with DTC U1000 or U1001, first perform the trouble diagnosis for DTC U1000, U1001. Refer to [EC-790, "DTC U1000, U1001 CAN COMMUNICATION LINE"](#).

This diagnosis indicates the former, to detect open or short circuit malfunction.

DTC No.	Trouble diagnosis name	DTC detecting condition	Possible cause
P0462 0462	Fuel level sensor circuit low input	An excessively low voltage from the sensor is sent to ECM.	<ul style="list-style-type: none"> ● Harness or connectors (The CAN communication line is open or shorted) ● Harness or connectors (The sensor circuit is open or shorted) ● Combination meter ● Fuel level sensor
P0463 0463	Fuel level sensor circuit high input	An excessively high voltage from the sensor is sent to ECM.	

DTC Confirmation Procedure

UBS0017B

NOTE:

If DTC Confirmation Procedure has been previously conducted, always turn ignition switch OFF and wait at least 10 seconds before conducting the next test.

TESTING CONDITION:

Before performing the following procedure, confirm that battery voltage is more than 11V at ignition switch ON.

Ⓟ WITH CONSULT-II

1. Turn ignition switch ON.
2. Select "DATA MONITOR" mode with CONSULT-II.
3. Wait at least 5 seconds.
4. If 1st trip DTC is detected, go to [EC-1030, "Diagnostic Procedure"](#).

DATA MONITOR	
MONITOR	NO DTC
FUEL T/TMP SE	XXX °C
FUEL LEVEL SE	XXX V

SEF195Y

Ⓞ WITH GST

Follow the procedure "WITH CONSULT-II" above.

Diagnostic Procedure

1. CHECK DTC WITH COMBINATION METER

Refer to [DI-7, "Combination Meter"](#) .

OK or NG

OK >> GO TO 2.

NG >> Go to [DI-16, "Tachometer System"](#) .

2. CHECK INTERMITTENT INCIDENT

Refer to [EC-782, "TROUBLE DIAGNOSIS FOR INTERMITTENT INCIDENT"](#) .

>> INSPECTION END

Removal and Installation FUEL LEVEL SENSOR

Refer to [FL-5, "FUEL LEVEL SENSOR UNIT, FUEL FILTER AND FUEL PUMP ASSEMBLY"](#) .

DTC P0500 VSS

Description

UBS0017E

NOTE:

If DTC P0500 is displayed with DTC U1000 or U1001, first perform the trouble diagnosis for DTC U1000, U1001. Refer to [EC-790, "DTC U1000, U1001 CAN COMMUNICATION LINE"](#).

The vehicle speed signal is sent to the combination meter from the or "ABS actuator and electric unit (control unit)" by CAN communication line. The combination meter then sends a signal to the ECM by CAN communication line.

On Board Diagnosis Logic

UBS0017F

DTC No.	Trouble diagnosis name	DTC detecting condition	Possible cause
P0500 0500	Vehicle speed sensor	The almost 0 km/h (0 MPH) signal from vehicle speed sensor is sent to ECM even when vehicle is being driven.	<ul style="list-style-type: none"> ● Harness or connectors (The CAN communication line is open or shorted) ● Harness or connectors (The vehicle speed signal circuit is open or shorted) ● Wheel sensor ● Combination meter ● ABS actuator and electric unit (control unit)

DTC Confirmation Procedure

UBS0017G

CAUTION:

Always drive vehicle at a safe speed.

NOTE:

If DTC Confirmation Procedure has been previously conducted, always turn ignition switch OFF and wait at least 10 seconds before conducting the next test.

TESTING CONDITION:

Steps 1 and 2 may be conducted with the drive wheels lifted in the shop or by driving the vehicle. If a road test is expected to be easier, it is unnecessary to lift the vehicle.

WITH CONSULT-II

1. Start engine.
2. Read "VHCL SPEED SE" in "DATA MONITOR" mode with CONSULT-II. The vehicle speed on CONSULT-II should exceed 10 km/h (6 MPH) when rotating wheels with suitable gear position.
If NG, go to [EC-1032, "Diagnostic Procedure"](#).
If OK, go to following step.
3. Select "DATA MONITOR" mode with CONSULT-II.
4. Warm engine up to normal operating temperature.
5. Maintain the following conditions for at least 60 consecutive seconds.

ENG SPEED	1,600 - 6,000 rpm (A/T, 6M/T) 1,800 - 6,000 rpm (5M/T)
COOLAN TEMP/S	More than 70°C (158°F)
B/FUEL SCHDL	4.4 - 31.8 msec (A/T) 5.3 - 31.8 msec (M/T)
Shift lever	Except P or N position (A/T) Except Neutral position (M/T)
PW/ST SIGNAL	OFF

DATA MONITOR	
MONITOR	NO DTC
ENG SPEED	XXX rpm
COOLAN TEMP/S	XXX °C
B/FUEL SCHDL	XXX msec
PW/ST SIGNAL	OFF
VHCL SPEED SE	XXX km/h

SEF196Y

6. If 1st trip DTC is detected, go to [EC-1032, "Diagnostic Procedure"](#).

Overall Function Check

UBS0017H

Use this procedure to check the overall function of the vehicle speed sensor circuit. During this check, a 1st trip DTC might not be confirmed.

 **WITH GST**

1. Lift up drive wheels.
2. Start engine.
3. Read vehicle speed sensor signal in Service \$01 with GST.
The vehicle speed sensor on GST should be able to exceed 10 km/h (6 MPH) when rotating wheels with suitable gear position.
4. If NG, go to [EC-1032, "Diagnostic Procedure"](#) .

Diagnostic Procedure

UBS0071

1. CHECK DTC WITH "ABS ACTUATOR AND ELECTRIC UNIT (CONTROL UNIT)"

Refer to [BRC-8, "TROUBLE DIAGNOSIS"](#) (models without TCS) or [BRC-51, "TROUBLE DIAGNOSIS"](#) (models with TCS).

OK or NG

- OK >> GO TO 2.
NG >> Repair or replace.

2. CHECK COMBINATION METER FUNCTION

Refer to [DI-7, "Combination Meter"](#) .

>> **INSPECTION END**

DTC P0506 ISC SYSTEM

Description

UBS0017J

NOTE:

If DTC P0506 is displayed with other DTC, first perform the trouble diagnosis for the other DTC.

The ECM controls the engine idle speed to a specified level through the fine adjustment of the air, which is let into the intake manifold, by operating the electric throttle control actuator. The operating of the throttle valve is varied to allow for optimum control of the engine idling speed. The crankshaft position sensor (POS) detects the actual engine speed and sends a signal to the ECM.

The ECM controls the electric throttle control actuator so that the engine speed coincides with the target value memorized in the ECM. The target engine speed is the lowest speed at which the engine can operate steadily. The optimum value stored in the ECM is determined by taking into consideration various engine conditions, such as during warming up, deceleration, and engine load (air conditioner, power steering and cooling fan operation, etc.).

On Board Diagnosis Logic

UBS0017K

DTC No.	Trouble diagnosis name	DTC detecting condition	Possible cause
P0506 0506	Idle speed control system RPM lower than expected	The idle speed is less than the target idle speed by 100 rpm or more.	<ul style="list-style-type: none"> ● Electric throttle control actuator ● Intake air leak

DTC Confirmation Procedure

UBS0017L

NOTE:

- If DTC Confirmation Procedure has been previously conducted, always turn ignition switch OFF and wait at least 10 seconds before conducting the next test.
- If the target idle speed is out of the specified value, perform [EC-712. "Idle Air Volume Learning"](#) , before conducting DTC Confirmation Procedure. For the target idle speed, refer to the [EC-1348. "SERVICE DATA AND SPECIFICATIONS \(SDS\)"](#) .

TESTING CONDITION:

- Before performing the following procedure, confirm that battery voltage is more than 11V at idle.
- Always perform the test at a temperature above -10°C (14°F).

 WITH CONSULT-II

1. Open engine hood.
2. Start engine and warm it up to normal operating temperature.
3. Turn ignition switch OFF and wait at least 10 seconds.
4. Turn ignition switch ON again and select "DATA MONITOR" mode with CONSULT-II.
5. Start engine and run it for at least 1 minute at idle speed.
6. If 1st trip DTC is detected, go to [EC-1034. "Diagnostic Procedure"](#) .

DATA MONITOR	
MONITOR	NO DTC
ENG SPEED	XXX rpm
COOLAN TEMP/S	XXX °C

SEF174Y

 WITH GST

Follow the procedure "WITH CONSULT-II" above.

Diagnostic Procedure**1. CHECK INTAKE AIR LEAK**

1. Start engine and let it idle.
2. Listen for an intake air leak after the mass air flow sensor.

OK or NG

- OK >> GO TO 2.
NG >> Discover air leak location and repair.

2. REPLACE ECM

1. Stop engine.
2. Replace ECM.
3. Perform initialization of NVIS(NATS) system and registration of all NVIS(NATS) ignition key IDs. Refer to [BL-109, "ECM Re-communicating Function"](#) .
4. Perform [EC-711, "VIN Registration"](#) .
5. Perform [EC-711, "Accelerator Pedal Released Position Learning"](#) .
6. Perform [EC-711, "Throttle Valve Closed Position Learning"](#) .
7. Perform [EC-712, "Idle Air Volume Learning"](#) .

>> **INSPECTION END**

DTC P0507 ISC SYSTEM

Description

UBS0017N

NOTE:

If DTC P0507 is displayed with other DTC, first perform the trouble diagnosis for the other DTC.

The ECM controls the engine idle speed to a specified level through the fine adjustment of the air, which is let into the intake manifold, by operating the electric throttle control actuator. The operating of the throttle valve is varied to allow for optimum control of the engine idling speed. The crankshaft position sensor (POS) detects the actual engine speed and sends a signal to the ECM.

The ECM controls the electric throttle control actuator so that the engine speed coincides with the target value memorized in the ECM. The target engine speed is the lowest speed at which the engine can operate steadily. The optimum value stored in the ECM is determined by taking into consideration various engine conditions, such as during warming up, deceleration, and engine load (air conditioner, power steering and cooling fan operation, etc.).

On Board Diagnosis Logic

UBS0017O

DTC No.	Trouble diagnosis name	DTC detecting condition	Possible cause
P0507 0507	Idle speed control system RPM higher than expected	The idle speed is more than the target idle speed by 200 rpm or more.	<ul style="list-style-type: none"> ● Electric throttle control actuator ● Intake air leak ● PCV system

DTC Confirmation Procedure

UBS0017P

NOTE:

- If DTC Confirmation Procedure has been previously conducted, always turn ignition switch OFF and wait at least 10 seconds before conducting the next test.
- **If the target idle speed is out of the specified value, perform [EC-712. "Idle Air Volume Learning"](#), before conducting DTC Confirmation Procedure. For the target idle speed, refer to the [EC-1348. "SERVICE DATA AND SPECIFICATIONS \(SDS\)"](#).**

TESTING CONDITION:

- Before performing the following procedure, confirm that battery voltage is more than 11V at idle.
- Always perform the test at a temperature above -10°C (14°F).

WITH CONSULT-II

1. Open engine hood.
2. Start engine and warm it up to normal operating temperature.
3. Turn ignition switch OFF and wait at least 10 seconds.
4. Turn ignition switch ON again and select "DATA MONITOR" mode with CONSULT-II.
5. Start engine and run it for at least 1 minute at idle speed.
6. If 1st trip DTC is detected, go to [EC-1036. "Diagnostic Procedure"](#).

DATA MONITOR	
MONITOR	NO DTC
ENG SPEED	XXX rpm
COOLAN TEMP/S	XXX °C

SEF174Y

WITH GST

Follow the procedure "WITH CONSULT-II" above.

Diagnostic Procedure**1. CHECK PCV HOSE CONNECTION**

Confirm that PCV hose is connected correctly.

OK or NG

OK >> GO TO 2.

NG >> Repair or replace.

2. CHECK INTAKE AIR LEAK

1. Start engine and let it idle.
2. Listen for an intake air leak after the mass air flow sensor.

OK or NG

OK >> GO TO 3.

NG >> Discover air leak location and repair.

3. REPLACE ECM

1. Stop engine.
2. Replace ECM.
3. Perform initialization of NVIS(NATS) system and registration of all NVIS(NATS) ignition key IDs. Refer to [BL-109, "ECM Re-communicating Function"](#) .
4. Perform [EC-711, "VIN Registration"](#) .
5. Perform [EC-711, "Accelerator Pedal Released Position Learning"](#) .
6. Perform [EC-711, "Throttle Valve Closed Position Learning"](#) .
7. Perform [EC-712, "Idle Air Volume Learning"](#) .

>> **INSPECTION END**

DTC P0550 PSP SENSOR

Component Description

Power steering pressure (PSP) sensor is installed to the power steering high-pressure tube and detects a power steering load. This sensor is a potentiometer which transforms the power steering load into output voltage, and emits the voltage signal to the ECM. The ECM controls the electric throttle control actuator and adjusts the throttle valve opening angle to increase the engine speed and adjusts the idle speed for the increased load.

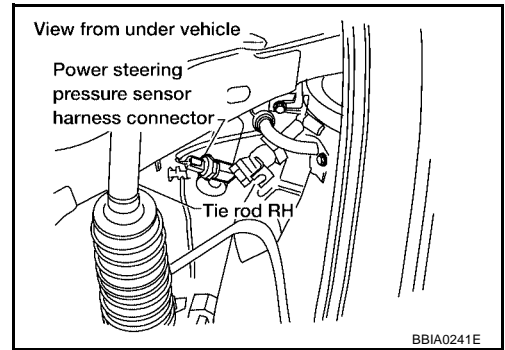

CONSULT-II Reference Value in Data Monitor Mode

Specification data are reference values.

MONITOR ITEM	CONDITION		SPECIFICATION
PW/ST SIGNAL	<ul style="list-style-type: none"> Engine: After warming up, idle the engine 	Steering wheel: Not being turned (Forward direction)	OFF
		Steering wheel: Being turned	ON

On Board Diagnosis Logic

The MIL will not light up for this diagnosis.

NOTE:

If DTC P0550 is displayed with DTC P1229, first perform the trouble diagnosis for DTC P1229. Refer to [EC-1127](#).

DTC No.	Trouble diagnosis name	DTC detecting condition	Possible cause
P0550 0550	Power steering pressure sensor circuit	An excessively low or high voltage from the sensor is sent to ECM.	<ul style="list-style-type: none"> Harness or connectors (The sensor circuit is open or shorted) Power steering pressure sensor

DTC Confirmation Procedure

NOTE:

If DTC Confirmation Procedure has been previously conducted, always turn ignition switch OFF and wait at least 10 seconds before conducting the next test.

WITH CONSULT-II

- Turn ignition switch ON.
- Select "DATA MONITOR" mode with CONSULT-II.
- Start engine and let it idle for at least 5 seconds.
- If 1st trip DTC is detected, go to [EC-1039, "Diagnostic Procedure"](#).

DATA MONITOR	
MONITOR	NO DTC
ENG SPEED	XXX rpm

SEF058Y

WITH GST

Follow the procedure "WITH CONSULT-II" above.

DTC P0550 PSP SENSOR

[VQ]

Wiring Diagram

UBS0017V

EC-PS/SEN-01

: DETECTABLE LINE FOR DTC
 : NON-DETECTABLE LINE FOR DTC

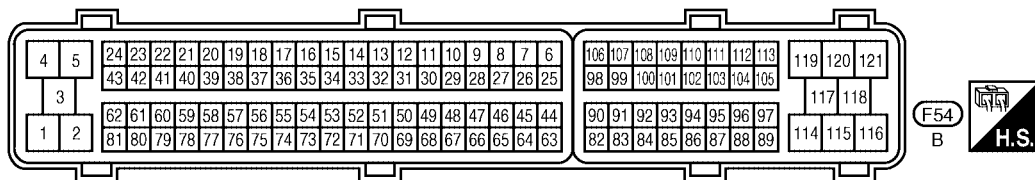
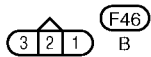
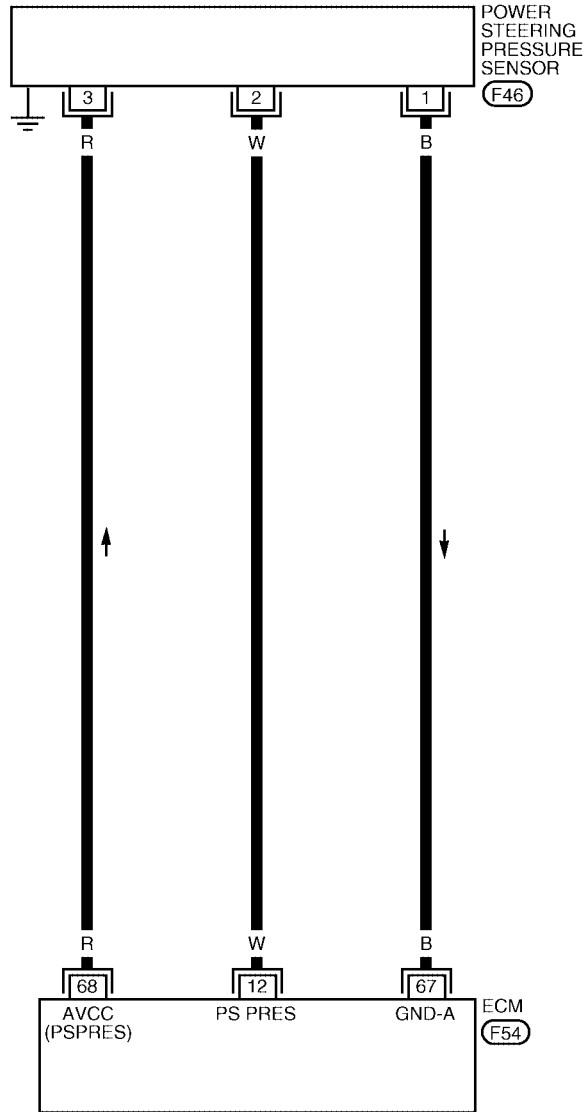

BBWA1586E

DTC P0550 PSP SENSOR

[VQ]

Specification data are reference values and are measured between each terminal and ground.

CAUTION:

Do not use ECM ground terminals when measuring input/output voltage. Doing so may result in damage to the ECM's transistor. Use a ground other than ECM terminals, such as the ground.

TER-MINAL NO.	WIRE COLOR	ITEM	CONDITION	DATA (DC Voltage)
12	W	Power steering pressure sensor	[Engine is running] ● Steering wheel: Being turned	0.5 - 4.5V
			[Engine is running] ● Steering wheel: Not being turned	0.4 - 0.8V
67	B	Sensor ground	[Engine is running] ● Warm-up condition ● Idle speed	Approximately 0V
68	R	Sensor power supply (PSP sensor)	[Ignition switch: ON]	Approximately 5V

Diagnostic Procedure

UBS0017W

1. CHECK GROUND CONNECTIONS

1. Turn ignition switch OFF.
2. Loosen and retighten three ground screws on the body.
Refer to [EC-789, "Ground Inspection"](#).

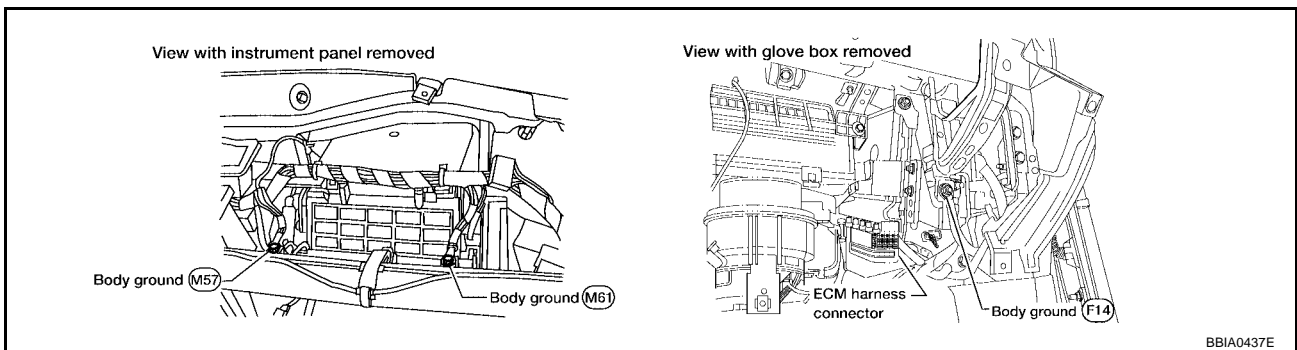

OK or NG

- OK >> GO TO 2.
- NG >> Repair or replace ground connections.

2. CHECK PSP SENSOR POWER SUPPLY CIRCUIT

1. Disconnect PSP sensor harness connector.
2. Turn ignition switch ON.

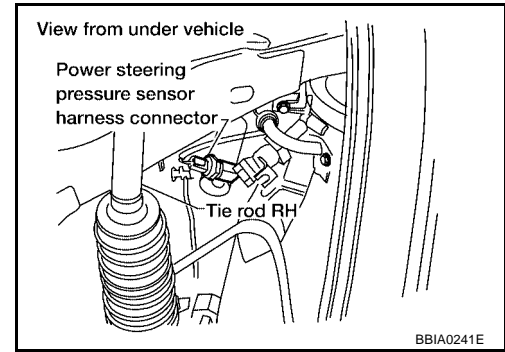

3. Check voltage between PSP sensor terminal 3 and ground with CONSULT-II or tester.

Voltage: Approximately 5V

OK or NG

- OK >> GO TO 3.
 NG >> Repair open circuit or short to ground or short to power in harness or connectors.

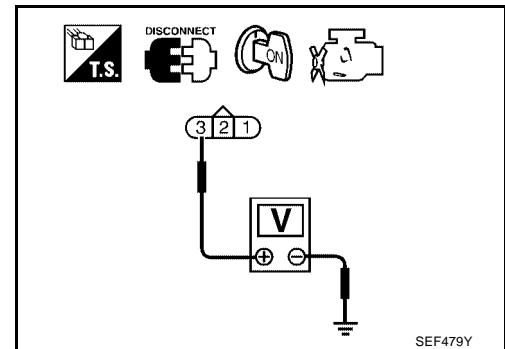

3. CHECK PSP SENSOR GROUND CIRCUIT FOR OPEN AND SHORT

1. Turn ignition switch OFF.
2. Disconnect ECM harness connector.
3. Check harness continuity between PSP sensor terminal 1 and ECM terminal 67. Refer to Wiring Diagram.

Continuity should exist.

4. Also check harness for short to ground and short to power.

OK or NG

- OK >> GO TO 5.
 NG >> Repair open circuit or short to ground or short to power in harness or connectors.

4. CHECK PSP SENSOR INPUT SIGNAL CIRCUIT FOR OPEN AND SHORT

1. Check harness continuity between ECM terminal 12 and PSP sensor terminal 2.

Continuity should exist.

2. Also check harness for short to ground and short to power.

OK or NG

- OK >> GO TO 5.
 NG >> Repair open circuit or short to ground or short to power in harness or connectors.

5. CHECK PSP SENSOR

Refer to [EC-1041, "Component Inspection"](#).

OK or NG

- OK >> GO TO 6.
 NG >> Replace PSP sensor.

6. CHECK INTERMITTENT INCIDENT

Refer to [EC-782, "TROUBLE DIAGNOSIS FOR INTERMITTENT INCIDENT"](#) .

>> INSPECTION END

**Component Inspection
POWER STEERING PRESSURE SENSOR**

UBS0017X

1. Reconnect all harness connectors disconnected.
2. Start engine and let it idle.
3. Check voltage between ECM terminal 12 and ground under the following conditions.

Condition	Voltage
Steering wheel: Being turned.	0.5 - 4.5V
Steering wheel: Not being turned.	0.4 - 0.8V

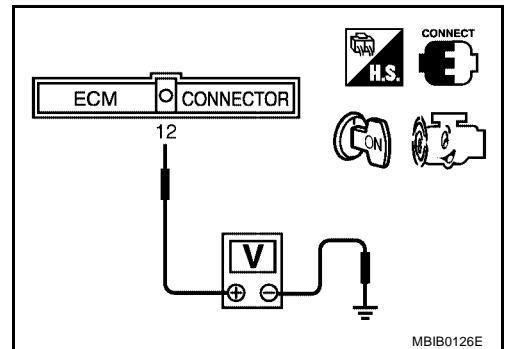

A
EC
C
D
E
F
G
H
I
J
K
L
M

DTC P0605 ECM

Component Description

UBS0017Y

The ECM consists of a microcomputer and connectors for signal input and output and for power supply. The ECM controls the engine.

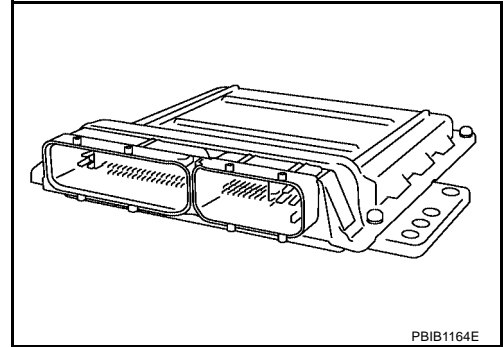

UBS0017Z

On Board Diagnosis Logic

This self-diagnosis has one or two trip detection logic.

DTC No.	Trouble diagnosis name	DTC detecting condition		Possible cause
P0605 0605	Engine control module	A)	ECM calculation function is malfunctioning.	● ECM
		B)	ECM EEP-ROM system is malfunctioning.	
		C)	ECM self shut-off function is malfunctioning.	

FAIL-SAFE MODE

ECM enters fail-safe mode when the malfunction A is detected.

Detected items	Engine operation condition in fail-safe mode
Malfunction A	<ul style="list-style-type: none"> ● ECM stops the electric throttle control actuator control, throttle valve is maintained at a fixed opening (approx. 5 degrees) by the return spring. ● ECM deactivates ASCD operation.

DTC Confirmation Procedure

UBS00180

Perform **PROCEDURE FOR MALFUNCTION A** first. If the 1st trip DTC cannot be confirmed, perform **PROCEDURE FOR MALFUNCTION B**. If there is no malfunction on **PROCEDURE FOR MALFUNCTION B**, perform **PROCEDURE FOR MALFUNCTION C**.

NOTE:

If DTC Confirmation Procedure has been previously conducted, always turn ignition switch OFF and wait at least 10 seconds before conducting the next test.

PROCEDURE FOR MALFUNCTION A

Ⓟ **With CONSULT-II**

1. Turn ignition switch ON.
2. Select "DATA MONITOR" mode with CONSULT-II.
3. If 1st trip DTC is detected, go to [EC-1043, "Diagnostic Procedure"](#).

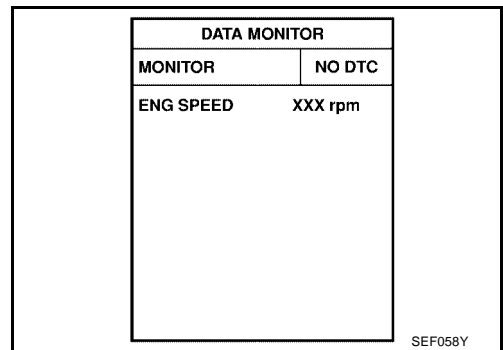

Ⓟ **With GST**

Follow the procedure "With CONSULT-II" above.

PROCEDURE FOR MALFUNCTION B

With CONSULT-II

1. Turn ignition switch ON and wait at least 1 second.
2. Select "DATA MONITOR" mode with CONSULT-II.
3. Turn ignition switch OFF, wait at least 10 seconds, and then turn ON.
4. If 1st trip DTC is detected, go to [EC-1043, "Diagnostic Procedure"](#) .

DATA MONITOR	
MONITOR	NO DTC
ENG SPEED	XXX rpm

SEF058Y

With GST

Follow the procedure "With CONSULT-II" above.

PROCEDURE FOR MALFUNCTION C

With CONSULT-II

1. Turn ignition switch ON and wait at least 1 second.
2. Select "DATA MONITOR" mode with CONSULT-II.
3. Turn ignition switch OFF, wait at least 10 seconds, and then turn ON.
4. Repeat step 3 for 32 times.
5. If 1st trip DTC is detected, go to [EC-1043, "Diagnostic Procedure"](#) .

DATA MONITOR	
MONITOR	NO DTC
ENG SPEED	XXX rpm

SEF058Y

With GST

Follow the procedure "With CONSULT-II" above.

Diagnostic Procedure

1. INSPECTION START

With CONSULT-II

1. Turn ignition switch ON.
2. Select "SELF DIAG RESULTS" mode with CONSULT-II.
3. Touch "ERASE".
4. **Perform DTC Confirmation Procedure.**
See [EC-1042](#) .
5. Is the 1st trip DTC P0605 displayed again?

With GST

1. Turn ignition switch ON.
2. Select Service \$04 with GST.
3. Touch "ERASE".
4. **Perform DTC Confirmation Procedure.**
See [EC-1042](#) .
5. Is the 1st trip DTC P0605 displayed again?

Yes or No

Yes >> GO TO 2.

No >> **INSPECTION END**

A
EC
C
D
E
F
G
H
I
J
K
L
M

2. REPLACE ECM

1. Replace ECM.
2. Perform initialization of NVIS(NATS) system and registration of all NVIS(NATS) ignition key IDs. Refer to [BL-109, "ECM Re-communicating Function"](#) .
3. Perform [EC-711, "VIN Registration"](#) .
4. Perform [EC-711, "Accelerator Pedal Released Position Learning"](#) .
5. Perform [EC-711, "Throttle Valve Closed Position Learning"](#) .
6. Perform [EC-712, "Idle Air Volume Learning"](#) .

>> INSPECTION END

DTC P1031, P1032, P1051, P1052 A/F SENSOR 1 HEATER

[VQ]

DTC P1031, P1032, P1051, P1052 A/F SENSOR 1 HEATER

PFP:22693

Description SYSTEM DESCRIPTION

UBS00182

Sensor	Input Signal to ECM	ECM function	Actuator
Camshaft position sensor (PHASE) Crankshaft position sensor (POS)	Engine speed	Air fuel ratio (A/F) sensor 1 heater control	Air fuel ratio (A/F) sensor 1 heater
Mass air flow sensor	Amount of intake air		

The ECM performs ON/OFF duty control of the A/F sensor 1 heater corresponding to the engine operating condition to keep the temperature of A/F sensor 1 element at the specified range.

CONSULT-II Reference Value in Data Monitor Mode

UBS00183

Specification data are reference values.

MONITOR ITEM	CONDITION	SPECIFICATION
A/F S1 HTR (B1) A/F S1 HTR (B2)	● Engine: After warming up, idle the engine	0 - 100%

On Board Diagnosis Logic

UBS00184

DTC No.	Trouble diagnosis name	DTC detecting condition	Possible cause
P1031 1031 (Bank 1)	Air fuel ratio (A/F) sensor 1 heater control circuit low	The current amperage in the heated air fuel ratio (A/F) sensor 1 heater circuit is out of the normal range. (An excessively low voltage signal is sent to ECM through the heated air fuel ratio (A/F) sensor 1 heater.)	<ul style="list-style-type: none"> ● Harness or connectors (The A/F sensor 1 heater circuit is open or shorted.) ● A/F sensor 1 heater
P1051 1051 (Bank 2)			
P1032 1032 (Bank 1)	Air fuel ratio (A/F) sensor 1 heater control circuit high	The current amperage in the heated air fuel ratio (A/F) sensor 1 heater circuit is out of the normal range. (An excessively high voltage signal is sent to ECM through the heated air fuel ratio (A/F) sensor 1 heater.)	<ul style="list-style-type: none"> ● Harness or connectors (The A/F sensor 1 heater circuit is shorted.) ● A/F sensor 1 heater
P1052 1052 (Bank 2)			

DTC Confirmation Procedure

UBS00185

NOTE:

If DTC Confirmation Procedure has been previously conducted, always turn ignition switch OFF and wait at least 10 seconds before conducting the next test.

TESTING CONDITION:

Before performing the following procedure, confirm that battery voltage is between 10.5V and 16V at idle.

With CONSULT-II

WITH CONSULT-II

1. Turn ignition switch ON and select "DATA MONITOR" mode with CONSULT-II.
2. Start engine and let it idle for at least 10 seconds.
3. If 1st trip DTC is detected, go to [EC-1050, "Diagnostic Procedure"](#).

DATA MONITOR	
MONITOR	NO DTC
ENG SPEED	XXX rpm

SEF058Y

DTC P1031, P1032, P1051, P1052 A/F SENSOR 1 HEATER

[VQ]



WITH GST

Follow the procedure "WITH CONSULT-II" above.

DTC P1031, P1032, P1051, P1052 A/F SENSOR 1 HEATER

[VQ]

UBS00186

Wiring Diagram BANK 1

EC-AF1HB1-01

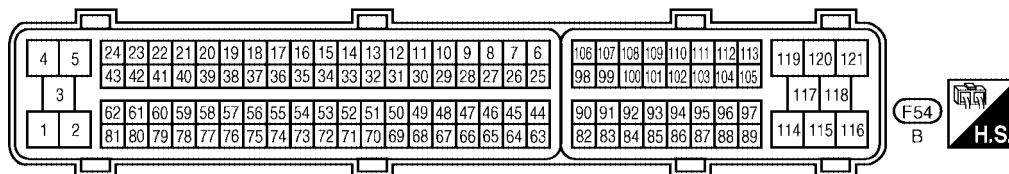
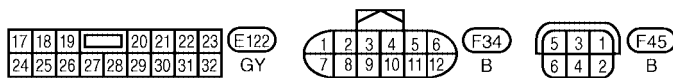
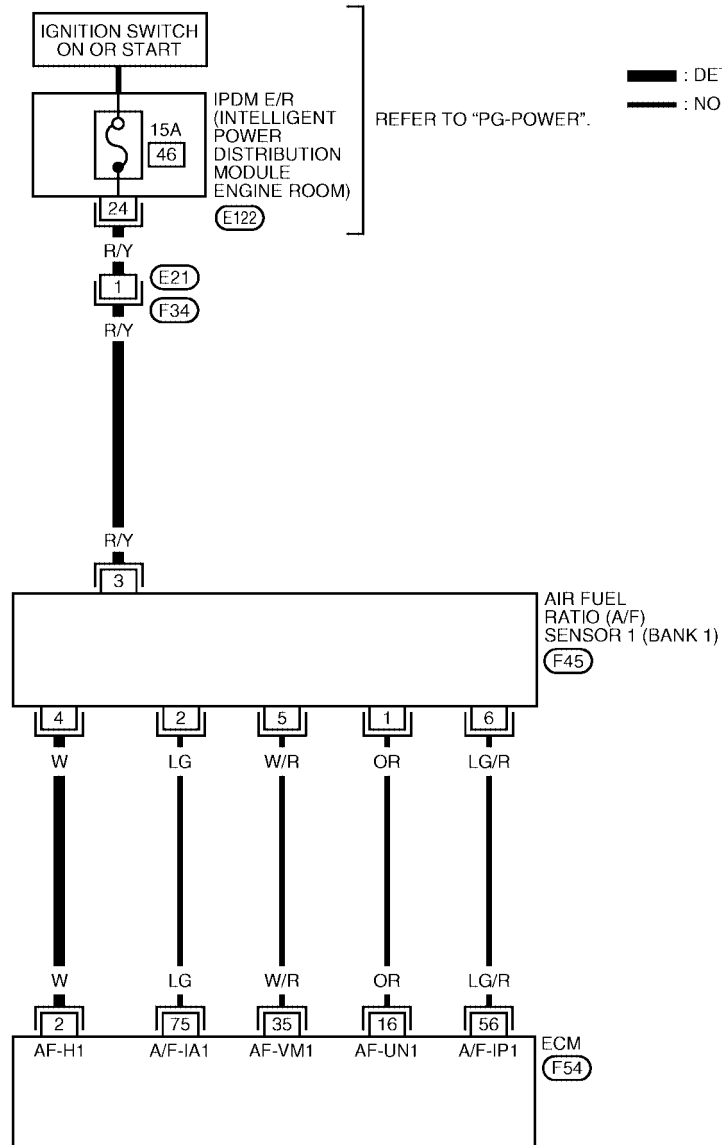

BBWA1274E

DTC P1031, P1032, P1051, P1052 A/F SENSOR 1 HEATER

[VQ]

Specification data are reference values and are measured between each terminal and ground.
Pulse signal is measured by CONSULT-II.

CAUTION:

Do not use ECM ground terminals when measuring input/output voltage. Doing so may result in damage to the ECM's transistor. Use a ground other than ECM terminals, such as the ground.

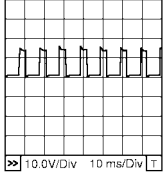
TERMI- NAL NO.	WIRE COLOR	ITEM	CONDITION	DATA (DC Voltage)
2	W	A/F sensor 1 heater (Bank 1)	<p>[Engine is running]</p> <ul style="list-style-type: none"> ● Warm-up condition ● Idle speed 	<p>Approximately 5V★</p>  <p>10.0V/Div 10 ms/Div</p>

PBIB1584E

★: Average voltage for pulse signal (Actual pulse signal can be confirmed by oscilloscope.)

DTC P1031, P1032, P1051, P1052 A/F SENSOR 1 HEATER

[VQ]

BANK 2

EC-AF1HB2-01

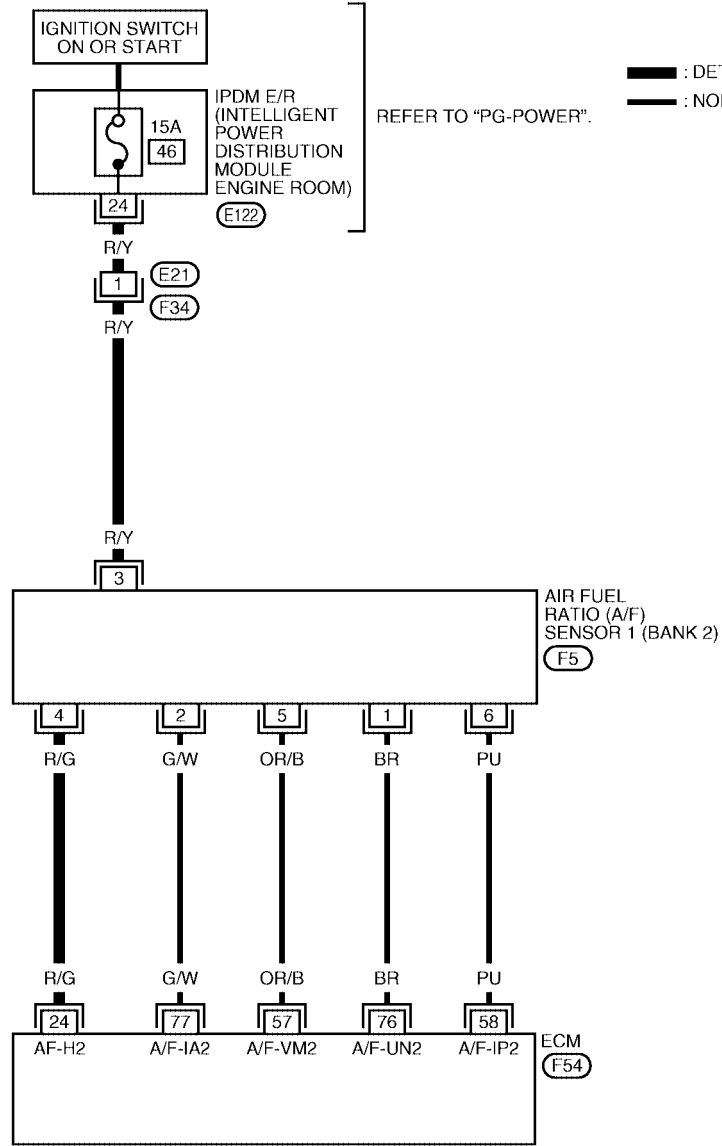

— : DETECTABLE LINE FOR DTC
 — : NON-DETECTABLE LINE FOR DTC

A
 EC
 C
 D
 E
 F
 G
 H
 I
 J
 K
 L
 M

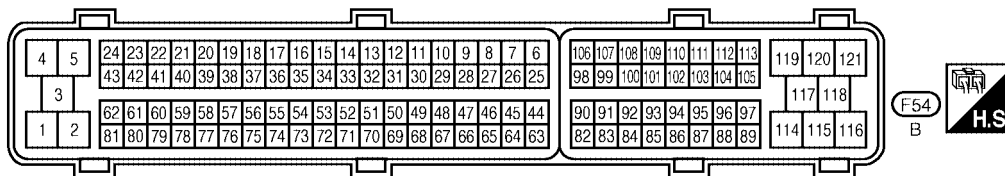
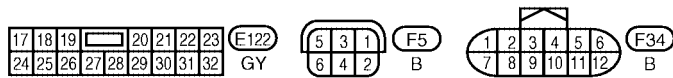

BBWA1564E

DTC P1031, P1032, P1051, P1052 A/F SENSOR 1 HEATER

[VQ]

Specification data are reference values and are measured between each terminal and ground.
Pulse signal is measured by CONSULT-II.

CAUTION:

Do not use ECM ground terminals when measuring input/output voltage. Doing so may result in damage to the ECM's transistor. Use a ground other than ECM terminals, such as the ground.

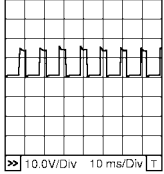
TERMI- NAL NO.	WIRE COLOR	ITEM	CONDITION	DATA (DC Voltage)
24	R/G	A/F sensor 1 heater (Bank 2)	<p>[Engine is running]</p> <ul style="list-style-type: none"> ● Warm-up condition ● Idle speed 	<p>Approximately 5V★</p>  <p>PBIB1584E</p>

★: Average voltage for pulse signal (Actual pulse signal can be confirmed by oscilloscope.)

Diagnostic Procedure

UBS00187

1. CHECK GROUND CONNECTIONS

1. Turn ignition switch OFF.
2. Loosen and retighten three ground screws on the body.
Refer to [EC-789, "Ground Inspection"](#).

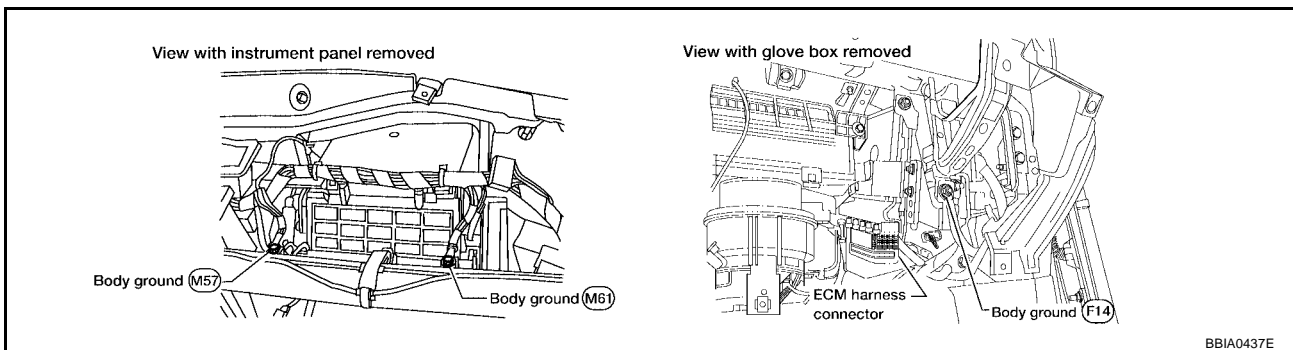

BBA0437E

OK or NG

- OK >> GO TO 2.
NG >> Repair or replace ground connections.

2. CHECK AIR FUEL RATIO (A/F) SENSOR 1 POWER SUPPLY CIRCUIT

1. Disconnect air fuel ratio (A/F) sensor 1 harness connector.

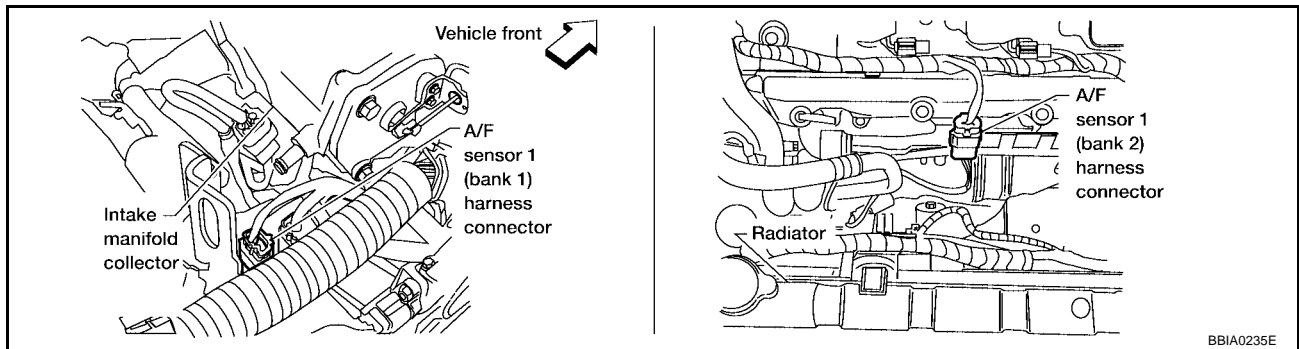

2. Turn ignition switch ON.
3. Check voltage between A/F sensor 1 terminal 3 and ground with CONSULT-II or tester.

Voltage: Battery voltage

OK or NG

- OK >> GO TO 4.
- NG >> GO TO 3.

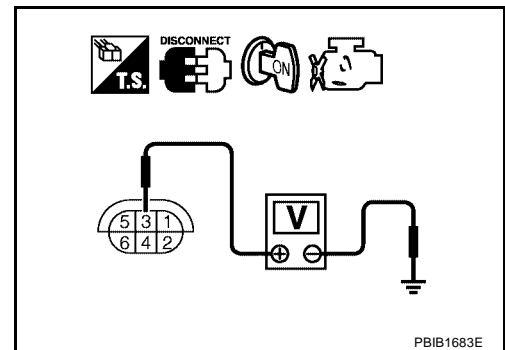

3. DETECT MALFUNCTIONING PART

Check the following.

- Harness connectors E21, F34
- IPDM E/R harness connector E122
- 15A fuse
- Harness for open or short between A/F sensor 1 and fuse

>> Repair or replace harness or connectors.

4. CHECK A/F SENSOR 1 HEATER OUTPUT SIGNAL CIRCUIT

1. Turn ignition switch OFF.
2. Disconnect ECM harness connector.
3. Check harness continuity between ECM terminal 2 (bank 1) or 24 (bank 2) and A/F sensor 1 terminal 4. Refer to Wiring Diagram.

Continuity should exist.

4. Also check harness for short to ground and short to power.

OK or NG

- OK >> GO TO 5.
- NG >> Repair open circuit or short to ground or short to power in harness or connectors.

5. CHECK A/F SENSOR 1 HEATER

Refer to [EC-1052, "Component Inspection"](#) .

OK or NG

- OK >> GO TO 6.
- NG >> Replace A/F sensor 1.

6. CHECK INTERMITTENT INCIDENT

Perform [EC-782, "TROUBLE DIAGNOSIS FOR INTERMITTENT INCIDENT"](#) .

OK or NG

OK >> Replace A/F sensor 1.

NG >> Repair or replace.

Component Inspection AIR FUEL RATIO (A/F) SENSOR 1 HEATER

UBS00188

Check resistance between terminals 3 and 4.

Resistance: 2.3 - 4.3Ω [at 25°C (77°F)]

Check continuity between terminals 3 and 1, 2, 5, 6, terminals 4 and 1, 2, 5, 6.

Continuity should not exist.

If NG, replace the A/F sensor 1.

CAUTION:

- Discard any A/F sensor which has been dropped from a height of more than 0.5 m (19.7 in) onto a hard surface such as a concrete floor; use a new one.
- Before installing new A/F sensor, clean exhaust system threads using Heated Oxygen Sensor Thread Cleaner tool J-43897-18 or J-43897-12 and approved anti-seize lubricant.

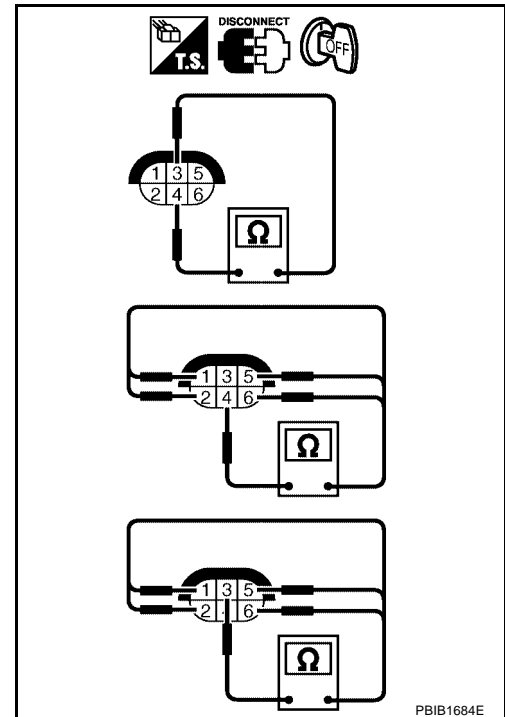

Removal and Installation AIR FUEL RATIO (A/F) SENSOR 1

UBS00189

Refer to [EM-134, "EXHAUST MANIFOLD AND THREE WAY CATALYST"](#) .

DTC P1065 ECM POWER SUPPLY

PFP:23710

Component Description

UBS0018A

Battery voltage is supplied to the ECM even when the ignition switch is turned OFF for the ECM memory function of the DTC memory, the air-fuel ratio feedback compensation value memory, the Idle Air Volume Learning value memory, etc.

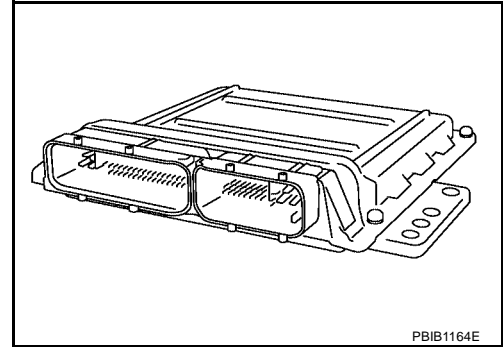

On Board Diagnosis Logic

UBS0018B

DTC No.	Trouble diagnosis name	DTC detecting condition	Possible cause
P1065 1065	ECM power supply circuit	ECM back-up RAM system does not function properly.	<ul style="list-style-type: none"> ● Harness or connectors [ECM power supply (back-up) circuit is open or shorted.] ● ECM

DTC Confirmation Procedure

UBS0018C

NOTE:

If DTC Confirmation Procedure has been previously conducted, always turn ignition switch OFF and wait at least 10 seconds before conducting the next test.

WITH CONSULT-II

1. Turn ignition switch ON and wait at least 1 second.
2. Select "DATA MONITOR" mode with CONSULT-II.
3. Start engine and let it idle for 1 second.
4. Turn ignition switch OFF, wait at least 10 seconds, and then turn ON.
5. Repeat steps 3 and 4 for 4 times.
6. If 1st trip DTC is detected, go to [EC-1055, "Diagnostic Procedure"](#) .

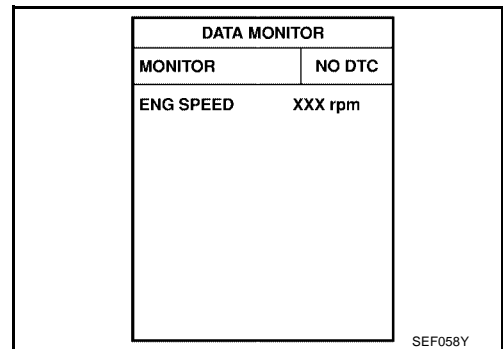

WITH GST

Follow the procedure "WITH CONSULT-II" above.

DTC P1065 ECM POWER SUPPLY

[VQ]

Wiring Diagram

UBS0018D

EC-ECM/PW-01

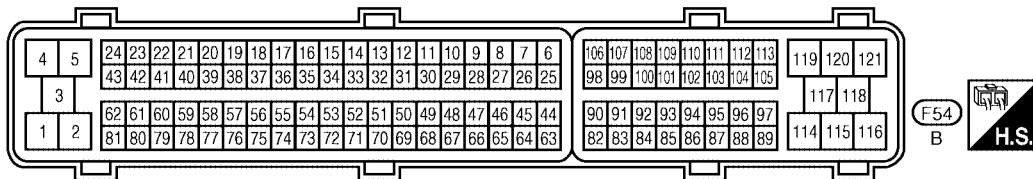
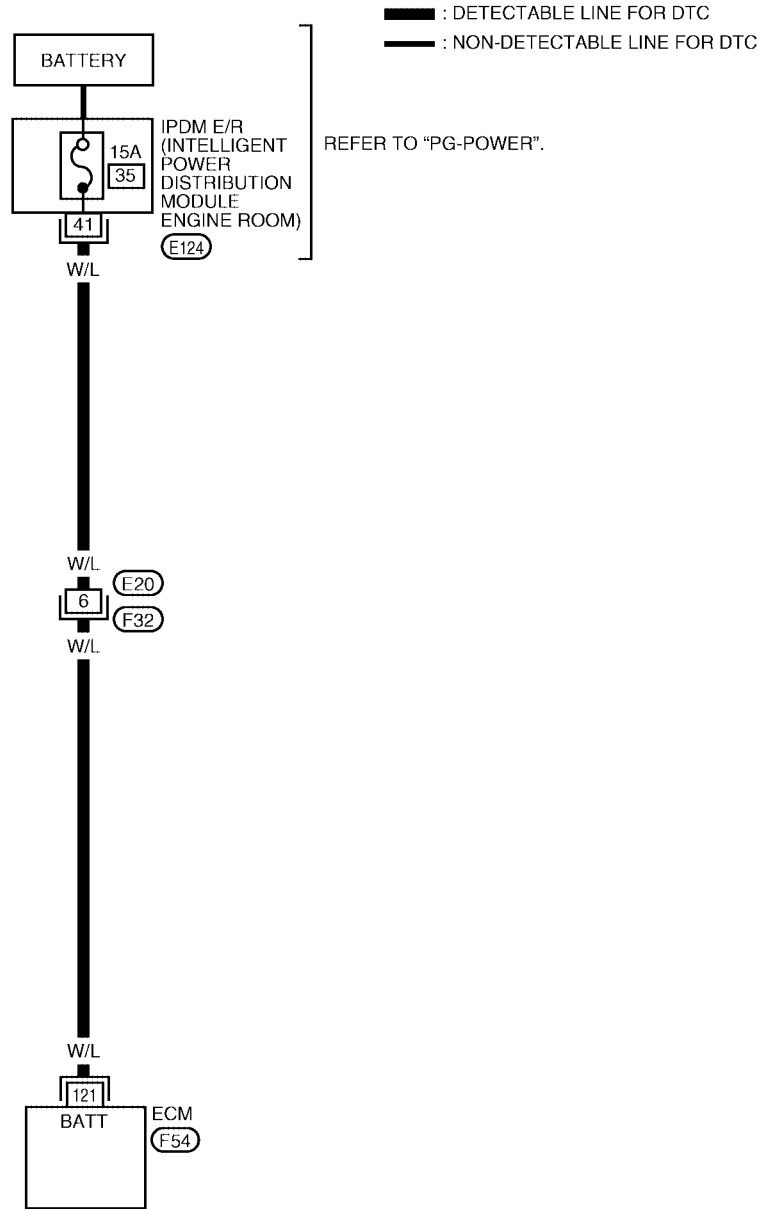

BBWA1667E

DTC P1065 ECM POWER SUPPLY

[VQ]

Specification data are reference values and are measured between each terminal and ground.

CAUTION:

Do not use ECM ground terminals when measuring input/output voltage. Doing so may result in damage to the ECM's transistor. Use a ground other than ECM terminals, such as the ground.

TER-MINAL NO.	WIRE COLOR	ITEM	CONDITION	DATA (DC Voltage)
121	W/L	Power supply for ECM (Back-up)	[Ignition switch: OFF]	BATTERY VOLTAGE (11 - 14V)

Diagnostic Procedure

UBS0018E

1. CHECK ECM POWER SUPPLY

1. Turn ignition switch OFF.
2. Check voltage between ECM terminal 121 and ground with CONSULT-II or tester.

Voltage: Battery voltage

OK or NG

- OK >> GO TO 3.
- NG >> GO TO 2.

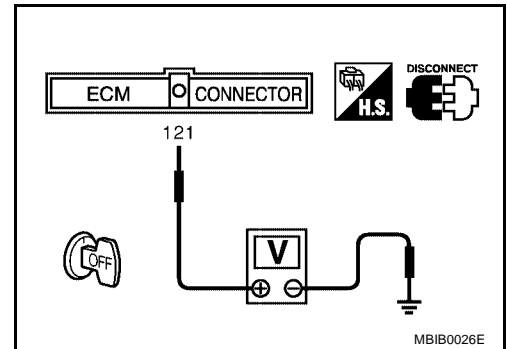

2. DETECT MALFUNCTIONING PART

Check the following.

- Harness connectors E20, F32
- IPDM E/R harness connector E124
- 15A fuse
- Harness for open or short between ECM and battery

>> Repair or replace harness or connectors.

3. CHECK INTERMITTENT INCIDENT

Refer to [EC-782, "TROUBLE DIAGNOSIS FOR INTERMITTENT INCIDENT"](#) .

OK or NG

- OK >> GO TO 4.
- NG >> Repair or replace harness or connectors.

4. PERFORM DTC CONFIRMATION PROCEDURE

 **With CONSULT-II**

1. Turn ignition switch ON.
2. Select "SELF DIAG RESULTS" mode with CONSULT-II.
3. Touch "ERASE".
4. **Perform DTC Confirmation Procedure.**
See [EC-1053](#) .
5. Is the 1st trip DTC P1065 displayed again?

 **With GST**

1. Turn ignition switch ON.
2. Select Service \$04 with GST.
3. Touch "ERASE".
4. **Perform DTC Confirmation Procedure.**
See [EC-1053](#) .
5. Is the 1st trip DTC P1065 displayed again?

Yes or No

Yes >> GO TO 5.

No >> **INSPECTION END**

5. REPLACE ECM

1. Replace ECM.
2. Perform initialization of NVIS(NATS) system and registration of all NVIS(NATS) ignition key IDs. Refer to [BL-109, "ECM Re-communicating Function"](#) .
3. Perform [EC-711, "VIN Registration"](#) .
4. Perform [EC-711, "Accelerator Pedal Released Position Learning"](#) .
5. Perform [EC-711, "Throttle Valve Closed Position Learning"](#) .
6. Perform [EC-712, "Idle Air Volume Learning"](#) .

>> **INSPECTION END**

DTC P1111, P1136 IVT CONTROL SOLENOID VALVE

PFP:23796

Component Description

UBS0018F

Intake valve timing control solenoid valve is activated by ON/OFF pulse duty (ratio) signals from the ECM.

The intake valve timing control solenoid valve changes the oil amount and direction of flow through intake valve timing control unit or stops oil flow.

The longer pulse width advances valve angle.

The shorter pulse width retards valve angle.

When ON and OFF pulse widths become equal, the solenoid valve stops oil pressure flow to fix the intake valve angle at the control position.

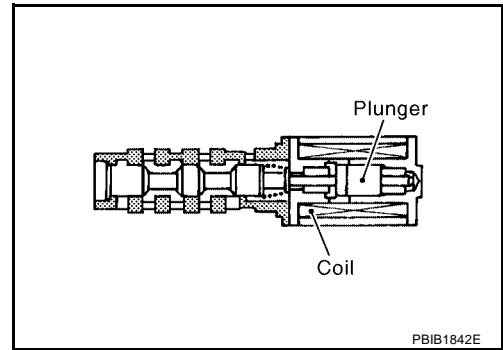

CONSULT-II Reference Value in Data Monitor Mode

UBS0018G

Specification data are reference values.

MONITOR ITEM	CONDITION	SPECIFICATION
INT/V SOL (B1) INT/V SOL (B2)	<ul style="list-style-type: none"> ● Engine: After warming up ● Shift lever: P or N (A/T), Neutral (M/T) 	Idle
	<ul style="list-style-type: none"> ● Air conditioner switch: OFF ● No-load 	2,000 rpm
		0% - 2%
		Approx. 0% - 50%

On Board Diagnosis Logic

UBS0018H

DTC No.	Trouble diagnosis name	DTC detecting condition	Possible cause
P1111 1111 (Bank 1)	Intake valve timing control solenoid valve circuit	An improper voltage is sent to the ECM through intake valve timing control solenoid valve.	<ul style="list-style-type: none"> ● Harness or connectors (Intake valve timing control solenoid valve circuit is open or shorted.) ● Intake valve timing control solenoid valve
P1136 1136 (Bank 2)			

DTC Confirmation Procedure

UBS0018I

NOTE:

If DTC Confirmation Procedure has been previously conducted, always turn ignition switch OFF and wait at least 10 seconds before conducting the next test.

④ WITH CONSULT-II

1. Turn ignition switch ON.
2. Select "DATA MONITOR" mode with CONSULT-II.
3. Start engine and let it idle for 5 seconds.
4. If 1st trip DTC is detected, go to [EC-1061, "Diagnostic Procedure"](#).

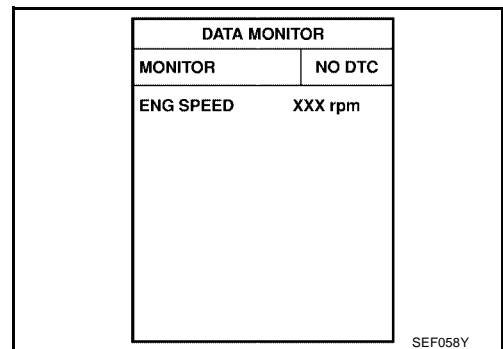

④ WITH GST

Following the procedure "WITH CONSULT-II" above.

DTC P1111, P1136 IVT CONTROL SOLENOID VALVE

[VQ]

UBS0018J

Wiring Diagram BANK 1

EC-IVCB1-01

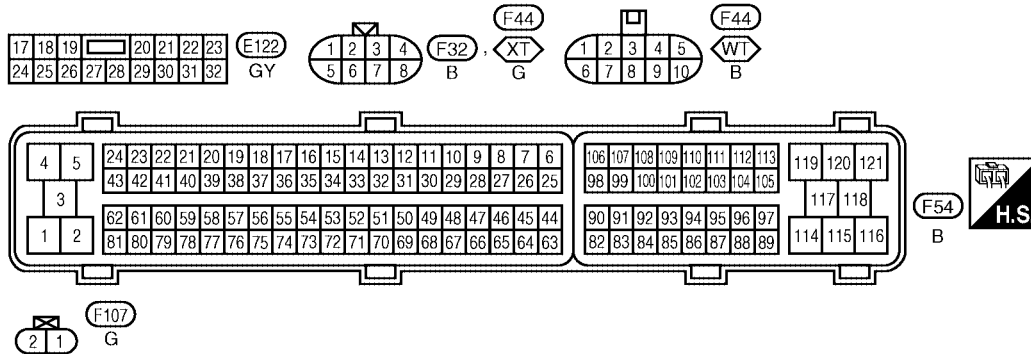
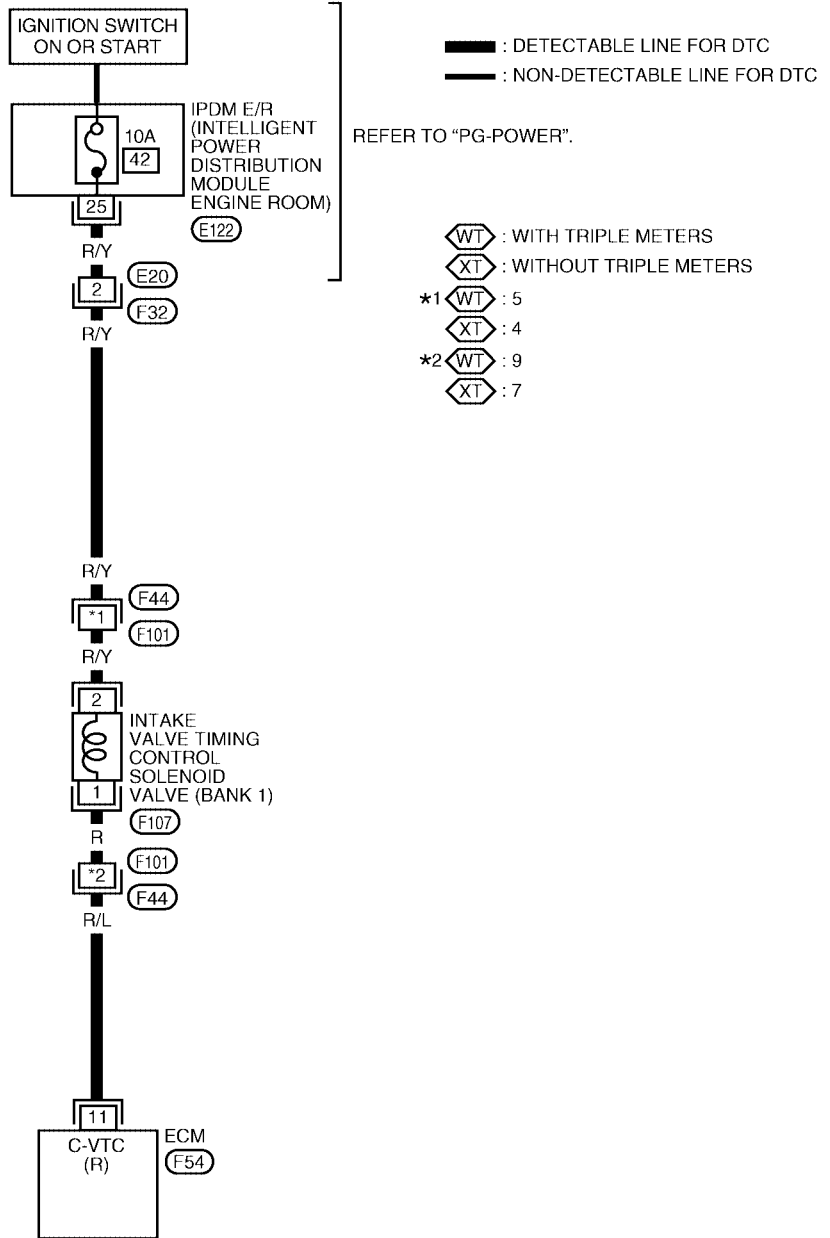

BBWA1565E

DTC P1111, P1136 IVT CONTROL SOLENOID VALVE

[VQ]

Specification data are reference values and are measured between each terminal and ground.
Pulse signal is measured by CONSULT-II.

CAUTION:

Do not use ECM ground terminals when measuring input/output voltage. Doing so may result in damage to the ECM's transistor. Use a ground other than ECM terminals, such as the ground.

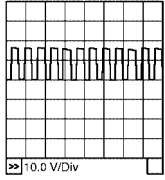
TER-MINAL NO.	WIRE COLOR	ITEM	CONDITION	DATA (DC Voltage)
11	R/L	Intake valve timing control solenoid valve (bank 1)	[Engine is running] <ul style="list-style-type: none"> ● Warm-up condition ● Idle speed 	BATTERY VOLTAGE (11 - 14V)
			[Engine is running] <ul style="list-style-type: none"> ● Warm-up condition ● Engine speed is 2,000 rpm. 	7 - 12V★ 

★: Average voltage for pulse signal (Actual pulse signal can be confirmed by oscilloscope.)

DTC P1111, P1136 IVT CONTROL SOLENOID VALVE

[VQ]

BANK 2

EC-IVCB2-01

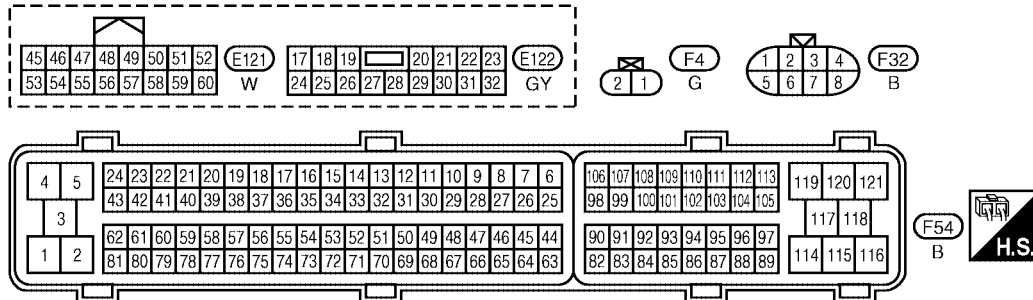
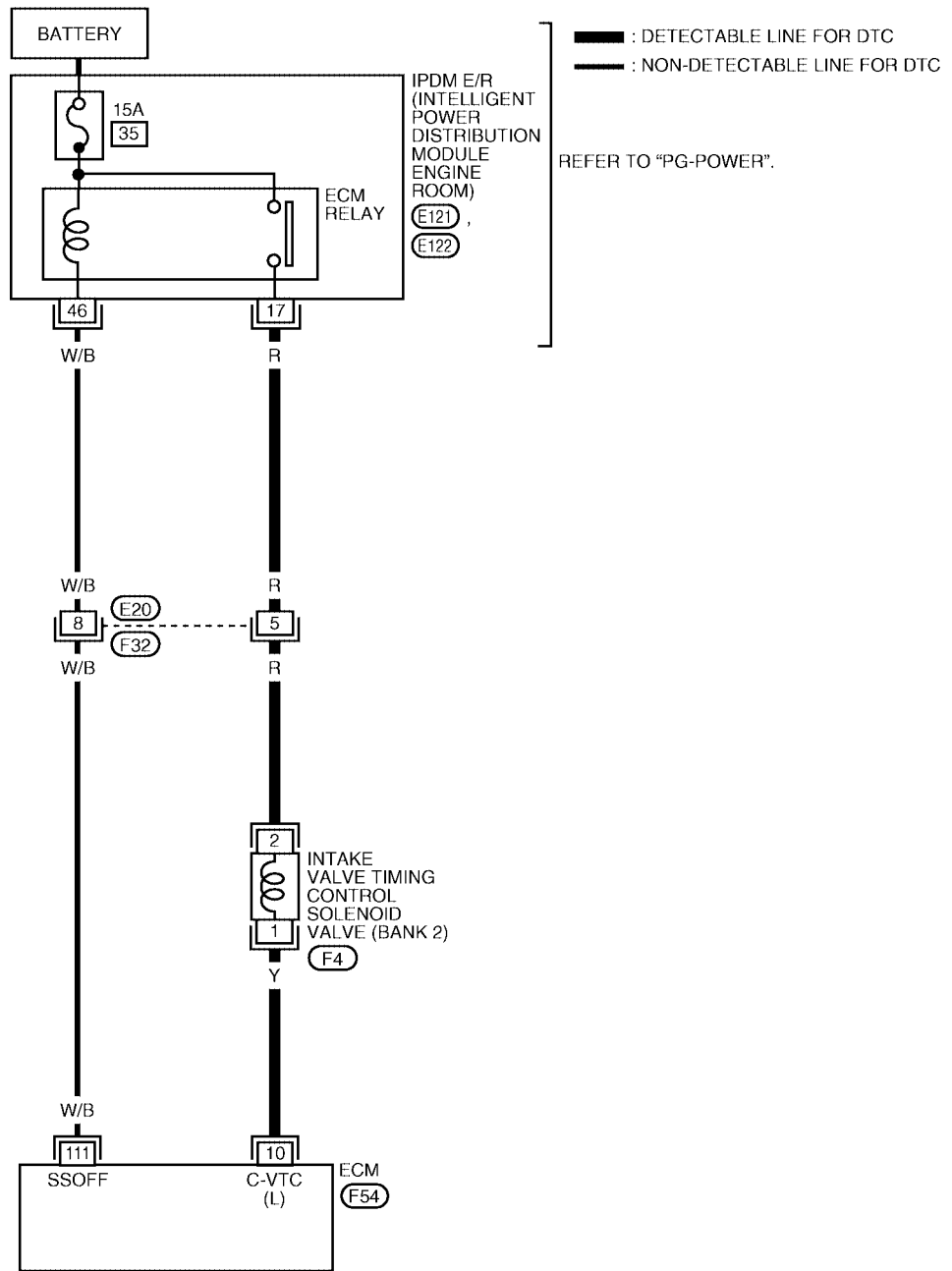

BBWA1566E

DTC P1111, P1136 IVT CONTROL SOLENOID VALVE

[VQ]

Specification data are reference values and are measured between each terminal and ground.
Pulse signal is measured by CONSULT-II.

CAUTION:

Do not use ECM ground terminals when measuring input/output voltage. Doing so may result in damage to the ECM's transistor. Use a ground other than ECM terminals, such as the ground.

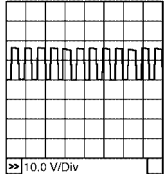
TER-MINAL NO.	WIRE COLOR	ITEM	CONDITION	DATA (DC Voltage)
10	Y	Intake valve timing control solenoid valve (bank 2)	[Engine is running] <ul style="list-style-type: none"> ● Warm-up condition ● Idle speed 	BATTERY VOLTAGE (11 - 14V)
			[Engine is running] <ul style="list-style-type: none"> ● Warm-up condition ● Engine speed is 2,000 rpm. 	7 - 12V★ 

★: Average voltage for pulse signal (Actual pulse signal can be confirmed by oscilloscope.)

Diagnostic Procedure

UBS0018K

1. INSPECTION START

Which malfunction (P1111 or P1136) is duplicated?

P1111 or P1136

- P1111 >> Go to [EC-1062, "PROCEDURE FOR P1111"](#).
- P1136 >> Go to [EC-1063, "PROCEDURE FOR P1136"](#).

PROCEDURE FOR P1111

1. CHECK INTAKE VALVE TIMING CONTROL SOLENOID VALVE POWER SUPPLY CIRCUIT

1. Turn ignition switch OFF.
2. Disconnect intake valve timing control solenoid valve harness connector.

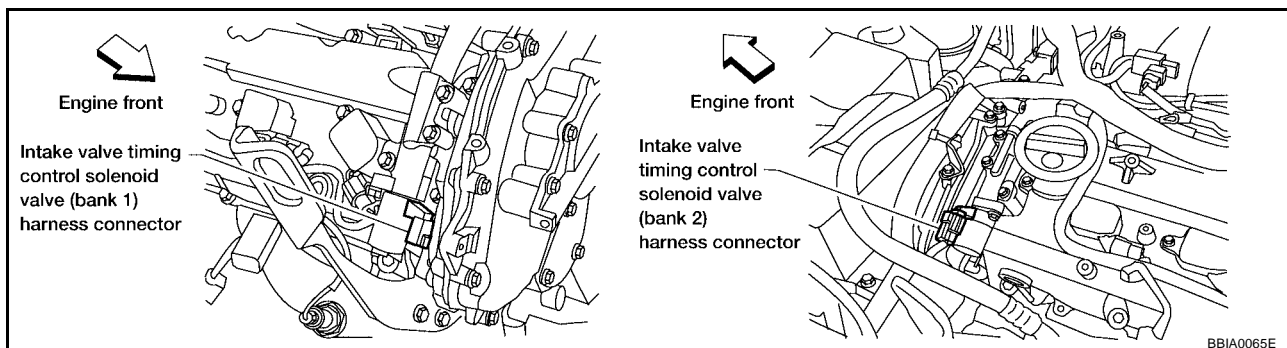

3. Turn ignition switch ON.
4. Check voltage between intake valve timing control solenoid valve terminal 2 and ground with CONSULT-II or tester.

Voltage: Battery voltage

OK or NG

- OK >> GO TO 3.
 NG >> GO TO 2.

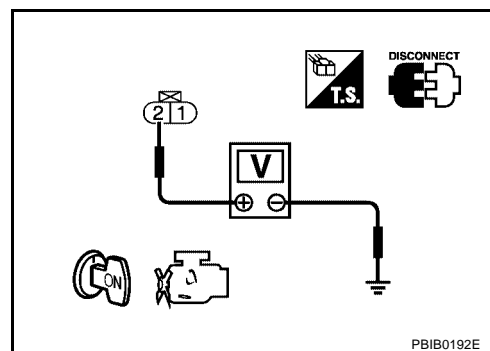

2. DETECT MALFUNCTIONING PART

Check the following.

- Harness connectors E20, F32
- Harness connectors F44, F101
- IPDM E/R harness connector E122
- Harness for open or short between intake valve timing control solenoid valve and fuse

>> Repair open circuit or short to ground or short to power in harness or connectors.

3. CHECK INTAKE VALVE TIMING CONTROL SOLENOID VALVE OUTPUT SIGNAL CIRCUIT FOR OPEN AND SHORT

1. Turn ignition switch OFF.
2. Disconnect ECM harness connector.
3. Check harness continuity between ECM terminal 11 and intake valve timing control solenoid valve terminal 1. Refer to Wiring Diagram.

Continuity should exist.

4. Also check harness for short to ground and short to power.

OK or NG

- OK >> GO TO 5.
 NG >> GO TO 4.

4. DETECT MALFUNCTIONING PART

Check the following.

- Harness connectors F101, F44
- Harness for open and short between ECM and intake valve timing control solenoid valve

>> Repair open circuit or short to ground or short to power in harness or connectors.

5. CHECK INTAKE VALVE TIMING CONTROL SOLENOID VALVE

Refer to [EC-1064, "Component Inspection"](#) .

OK or NG

- OK >> GO TO 6.
- NG >> Replace intake valve timing control solenoid valve.

6. CHECK INTERMITTENT INCIDENT

Refer to [EC-782, "TROUBLE DIAGNOSIS FOR INTERMITTENT INCIDENT"](#) .

>> INSPECTION END

PROCEDURE FOR P1136

1. CHECK INTAKE VALVE TIMING CONTROL SOLENOID VALVE POWER SUPPLY CIRCUIT

1. Turn ignition switch OFF.
2. Disconnect intake valve timing control solenoid valve harness connector.

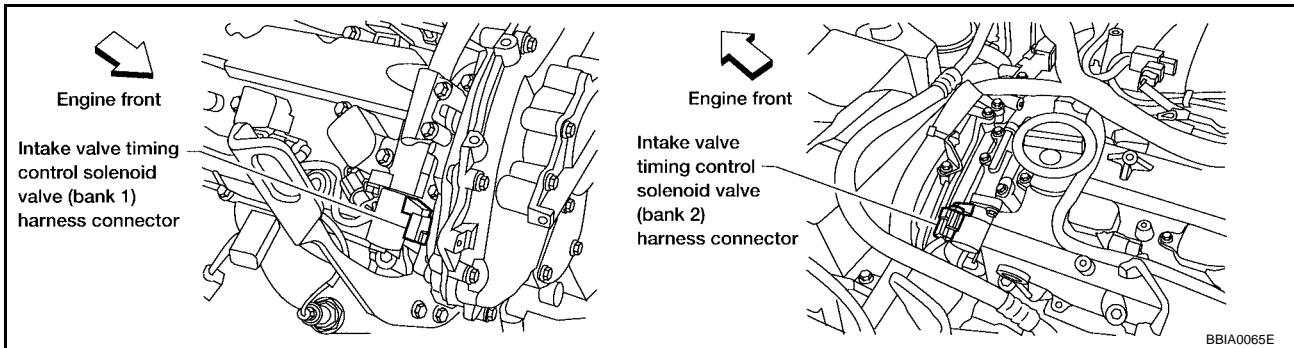

3. Turn ignition switch ON.
4. Check voltage between intake valve timing control solenoid valve terminal 2 and ground with CONSULT-II or tester.

Voltage: Battery voltage

OK or NG

- OK >> GO TO 3.
- NG >> GO TO 2.

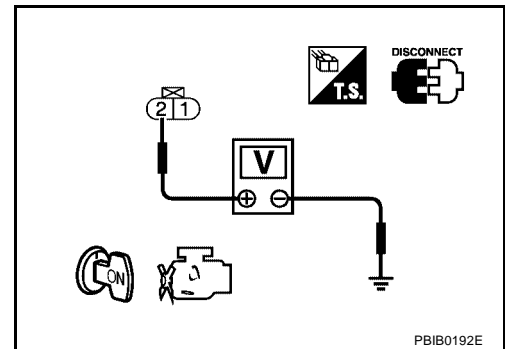

2. DETECT MALFUNCTIONING PART

Check the following.

- Harness connectors E20, F32
- IPDM E/R harness connector E122
- Harness for open or short between intake valve timing control solenoid valve and IPDM E/R

>> Repair open circuit or short to ground or short to power in harness or connectors.

3. CHECK INTAKE VALVE TIMING CONTROL SOLENOID VALVE OUTPUT SIGNAL CIRCUIT FOR OPEN AND SHORT

1. Turn ignition switch OFF.
2. Disconnect ECM harness connector.
3. Check harness continuity between ECM terminal 10 and intake valve timing control solenoid valve terminal 1. Refer to Wiring Diagram.

Continuity should exist.

4. Also check harness for short to ground and short to power.

OK or NG

OK >> GO TO 4.

NG >> Repair open circuit or short to ground or short to power in harness or connectors.

4. CHECK INTAKE VALVE TIMING CONTROL SOLENOID VALVE

Refer to [EC-1064, "Component Inspection"](#) .

OK or NG

OK >> GO TO 5.

NG >> Replace intake valve timing control solenoid valve.

5. CHECK INTERMITTENT INCIDENT

Refer to [EC-782, "TROUBLE DIAGNOSIS FOR INTERMITTENT INCIDENT"](#) .

>> INSPECTION END

Component Inspection INTAKE VALVE TIMING CONTROL SOLENOID VALVE

UBS0018L

1. Disconnect intake valve timing control solenoid valve harness connector.
2. Check resistance between intake valve timing control solenoid valve as follows.

Terminal	Resistance
1 and 2	7.0 - 7.7Ω [at 20°C (68°F)]
1 or 2 and ground	∞Ω (Continuity should not exist.)

If NG, replace intake valve timing control solenoid valve.
If OK, go to next step.

3. Remove intake valve timing control solenoid valve.

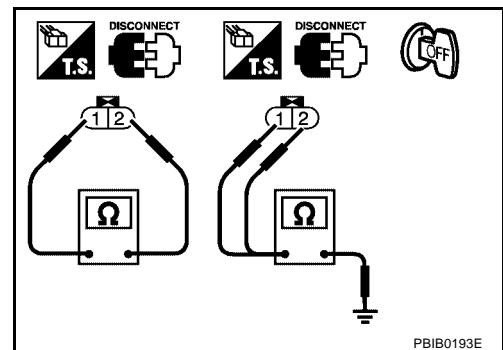

DTC P1111, P1136 IVT CONTROL SOLENOID VALVE

[VQ]

4. Provide 12V DC between intake valve timing control solenoid valve terminals and then interrupt it. Make sure that the plunger moves as shown in the figure.

CAUTION:

Do not apply 12V DC continuously for 5 seconds or more. Doing so may result in damage to the coil in intake valve timing control solenoid valve.

If NG, replace intake valve timing control solenoid valve.

NOTE:

Always replace O-ring when intake valve timing control solenoid valve is removed.

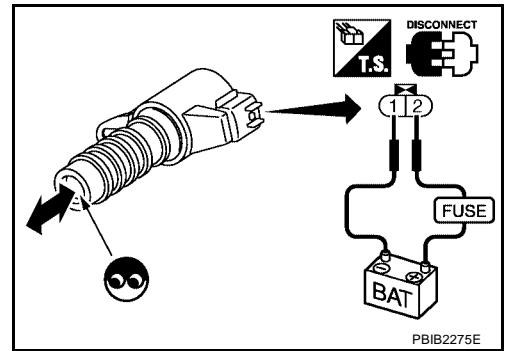

Removal and Installation

INTAKE VALVE TIMING CONTROL SOLENOID VALVE

Refer to [EM-161, "TIMING CHAIN"](#) .

A
EC
C
D
E
F
G
H
I
J
K
L
M

UBS0018M

DTC P1121 ELECTRIC THROTTLE CONTROL ACTUATOR

[VQ]

DTC P1121 ELECTRIC THROTTLE CONTROL ACTUATOR

PF16119

Component Description

UBS0018N

Electric throttle control actuator consists of throttle control motor, throttle position sensor, etc. The throttle control motor is operated by the ECM and it opens and closes the throttle valve. The throttle position sensor detects the throttle valve position, and the opening and closing speed of the throttle valve and feeds the voltage signals to the ECM. The ECM judges the current opening angle of the throttle valve from these signals and the ECM controls the throttle control motor to make the throttle valve opening angle properly in response to driving condition.

On Board Diagnosis Logic

UBS0018O

This self-diagnosis has the one trip detection logic.

DTC No.	Trouble diagnosis name	DTC detecting condition		Possible cause
P1121 1121	Electric throttle control actuator	A)	Electric throttle control actuator does not function properly due to the return spring malfunction.	● Electric throttle control actuator
		B)	Throttle valve opening angle in fail-safe mode is not in specified range.	
		C)	ECM detects the throttle valve is stuck open.	

FAIL-SAFE MODE

When the malfunction is detected, the ECM enters fail-safe mode and the MIL lights up.

Detected items	Engine operating condition in fail-safe mode
Malfunction A	ECM controls the electric throttle actuator by regulating the throttle opening around the idle position. The engine speed will not rise more than 2,000 rpm.
Malfunction B	ECM controls the electric throttle control actuator by regulating the throttle opening to 20 degrees or less.
Malfunction C	While the vehicle is driving, it slows down gradually by fuel cut. After the vehicle stops, the engine stalls. The engine can restart in N or P position (A/T), neutral position (M/T), and engine speed will not exceed 1,000 rpm or more.

DTC Confirmation Procedure

UBS0018P

NOTE:

- Perform **PROCEDURE FOR MALFUNCTION A AND B** first. If the DTC cannot be confirmed, perform **PROCEDURE FOR MALFUNCTION C**.
- If DTC Confirmation Procedure has been previously conducted, always turn ignition switch OFF and wait at least 10 seconds before conducting the next test.

PROCEDURE FOR MALFUNCTION A AND B

④ With CONSULT-II

1. Turn ignition switch ON and wait at least 1 second.
2. Select "DATA MONITOR" mode with CONSULT-II.
3. Shift selector lever to D position (A/T) or 1st position (M/T) and wait at least 3 seconds.
4. Shift selector lever to P position (A/T) or neutral position (M/T).
5. Turn ignition switch OFF and wait at least 10 seconds.
6. Turn ignition switch ON and wait at least 1 second.
7. Shift selector lever to D position (A/T) or 1st position (M/T) and wait at least 3 seconds.
8. Shift selector lever to P position (A/T) or neutral position (M/T).
9. Turn ignition switch OFF, wait at least 10 seconds, and then turn ON.
10. If DTC is detected, go to [EC-1067, "Diagnostic Procedure"](#).

DATA MONITOR	
MONITOR	NO DTC
ENG SPEED	XXX rpm

SEF058Y

With GST

Follow the procedure "With CONSULT-II" above.

PROCEDURE FOR MALFUNCTION C

With CONSULT-II

1. Turn ignition switch ON and wait at least 1 second.
2. Select "DATA MONITOR" mode with CONSULT-II.
3. Shift selector lever to D position (A/T) or 1st position (M/T) and wait at least 3 seconds.
4. Shift selector lever to P or N position (A/T) or neutral position (M/T).
5. Start engine and let it idle for 3 seconds.
6. If DTC is detected, go to [EC-1067, "Diagnostic Procedure"](#) .

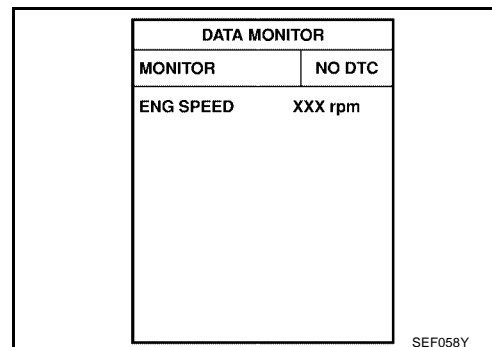

With GST

Follow the procedure "With CONSULT-II" above.

Diagnostic Procedure

1. CHECK ELECTRIC THROTTLE CONTROL ACTUATOR VISUALLY

1. Remove the intake air duct.
2. Check if a foreign matter is caught between the throttle valve and the housing.

OK or NG

- OK >> GO TO 2.
- NG >> Remove the foreign matter and clean the electric throttle control actuator inside.

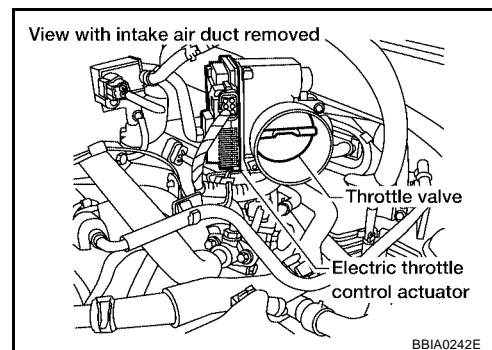

2. REPLACE ELECTRIC THROTTLE CONTROL ACTUATOR

1. Replace the electric throttle control actuator.
2. Perform [EC-711, "Throttle Valve Closed Position Learning"](#) .
3. Perform [EC-712, "Idle Air Volume Learning"](#) .

>> INSPECTION END

DTC P1122 ELECTRIC THROTTLE CONTROL FUNCTION

[VQ]

DTC P1122 ELECTRIC THROTTLE CONTROL FUNCTION

PF0:16119

Description

UBS0018R

NOTE:

If DTC P1122 is displayed with DTC P1121 or 1126, first perform the trouble diagnosis for DTC P1121 or P1126. Refer to [EC-1066](#) or [EC-1074](#).

Electric throttle control actuator consists of throttle control motor, throttle position sensor, etc.

The throttle control motor is operated by the ECM and it opens and closes the throttle valve.

The current opening angle of the throttle valve is detected by the throttle position sensor and it provides feedback to the ECM to control the throttle control motor to make the throttle valve opening angle properly in response to driving condition.

On Board Diagnosis Logic

UBS0018S

This self-diagnosis has the one trip detection logic.

DTC No.	Trouble diagnosis name	DTC detecting condition	Possible cause
P1122 1122	Electric throttle control performance problem	Electric throttle control function does not operate properly.	<ul style="list-style-type: none">● Harness or connectors (Throttle control motor circuit is open or shorted)● Electric throttle control actuator

FAIL-SAFE MODE

When the malfunction is detected, ECM enters fail-safe mode and the MIL lights up.

Engine operating condition in fail-safe mode

ECM stops the electric throttle control actuator control, throttle valve is maintained at a fixed opening (approx. 5 degrees) by the return spring.

DTC Confirmation Procedure

UBS0018T

TESTING CONDITION:

- Before performing the following procedure, confirm that battery voltage is more than 11V at idle.

NOTE:

If DTC Confirmation Procedure has been previously conducted, always turn ignition switch OFF and wait at least 10 seconds before conducting the next test.

WITH CONSULT-II

1. Turn ignition switch ON and wait at least 2 seconds.
2. Select "DATA MONITOR" mode with CONSULT-II.
3. Start engine and let it idle for 5 seconds.
4. If DTC is detected, go to [EC-1070, "Diagnostic Procedure"](#).

DATA MONITOR	
MONITOR	NO DTC
ENG SPEED	XXX rpm

SEF058Y

WITH GST

Follow the procedure "WITH CONSULT-II" above.

DTC P1122 ELECTRIC THROTTLE CONTROL FUNCTION

[VQ]

Wiring Diagram

UBS0018U

EC-ETC1-01

A
EC
C
D
E
F
G
H
I
J
K
L
M

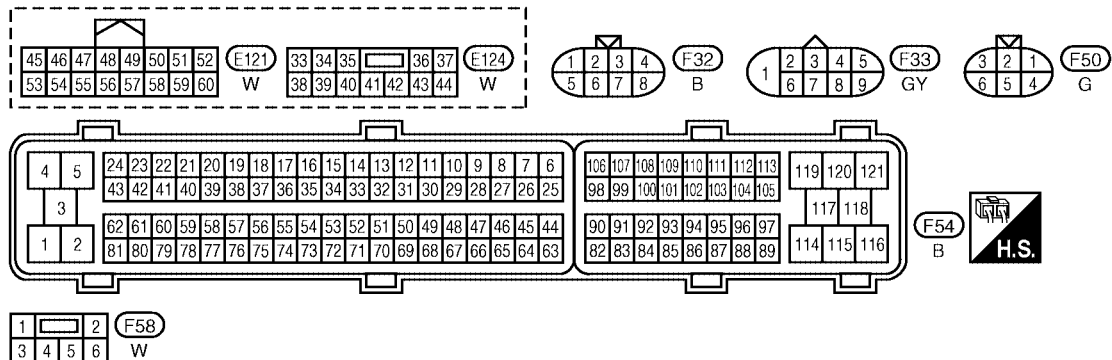
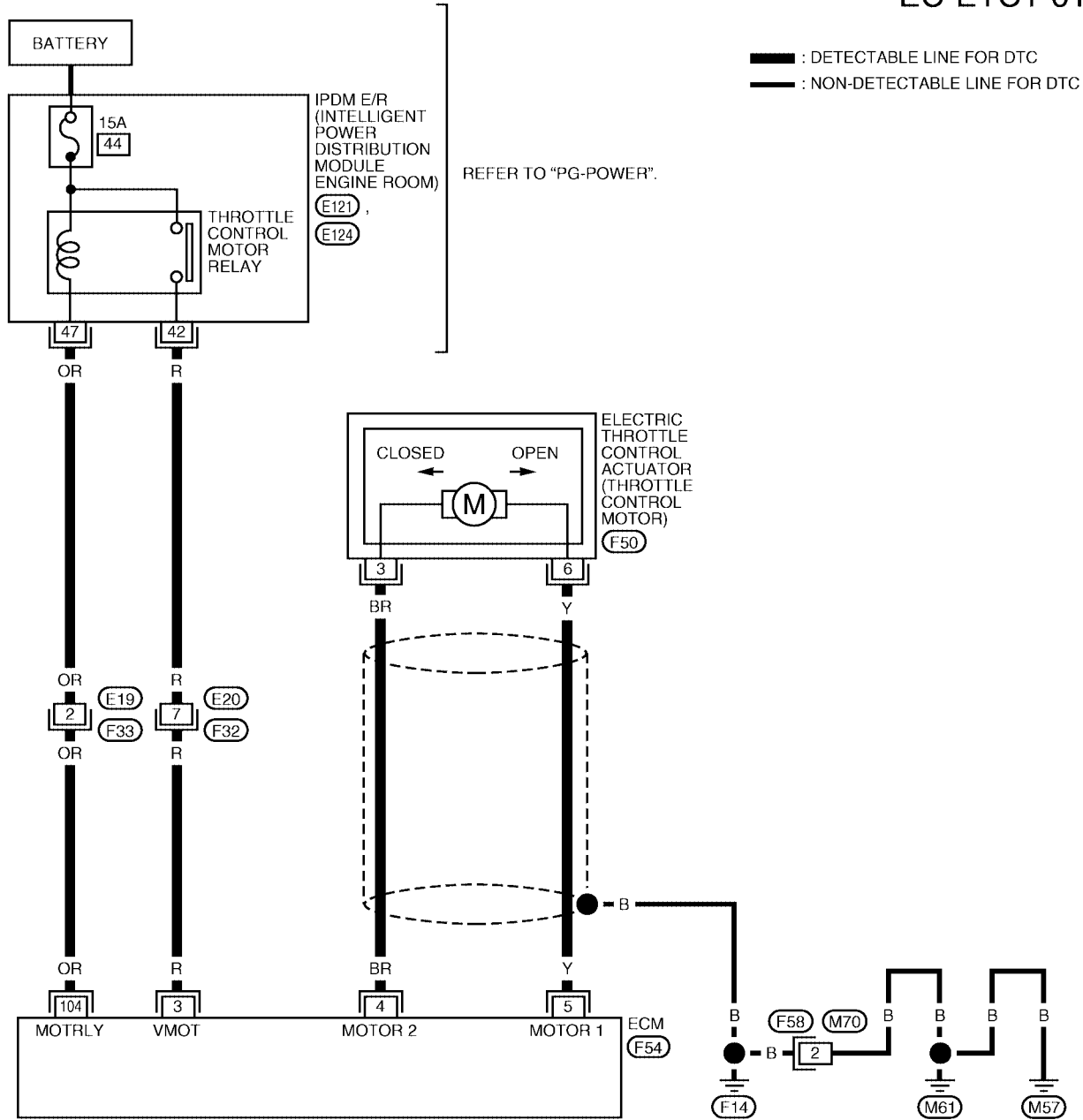

BBWA1567E

DTC P1122 ELECTRIC THROTTLE CONTROL FUNCTION

[VQ]

Specification data are reference values and are measured between each terminal and ground.
Pulse signal is measured by CONSULT-II.

CAUTION:

Do not use ECM ground terminals when measuring input/output voltage. Doing so may result in damage to the ECM's transistor. Use a ground other than ECM terminals, such as the ground.

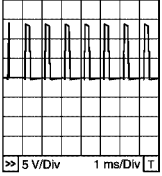
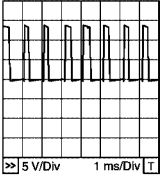
TER-MINAL NO.	WIRE COLOR	ITEM	CONDITION	DATA (DC Voltage)
3	R	Throttle control motor relay power supply	[Ignition switch: ON]	BATTERY VOLTAGE (11 - 14V)
4	BR	Throttle control motor (Close)	[Ignition switch: ON] <ul style="list-style-type: none"> ● Engine stopped ● Shift lever: D (A/T) or 1st (M/T) ● Accelerator pedal: Released 	0 - 14V★  PBIB1104E
5	Y	Throttle control motor (Open)	[Ignition switch: ON] <ul style="list-style-type: none"> ● Engine stopped ● Shift lever: D (A/T) or 1st (M/T) ● Accelerator pedal: Fully depressed 	0 - 14V★  PBIB1105E
104	OR	Throttle control motor relay	[Ignition switch: OFF]	BATTERY VOLTAGE (11 - 14V)
			[Ignition switch: ON]	0 - 1.0V

★: Average voltage for pulse signal (Actual pulse signal can be confirmed by oscilloscope.)

Diagnostic Procedure

UBS0018V

1. CHECK GROUND CONNECTIONS

1. Turn ignition switch OFF.
2. Loosen and retighten three ground screws on the body.
Refer to [EC-789, "Ground Inspection"](#) .

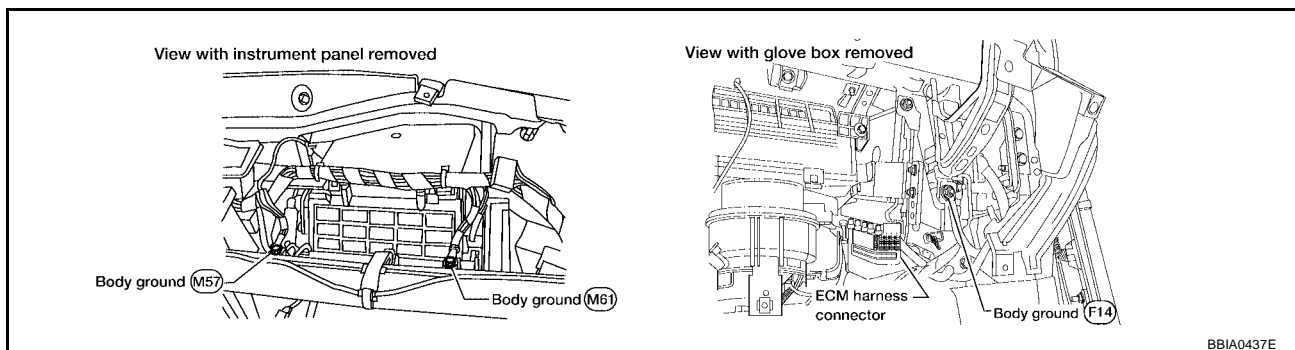

BBIA0437E

OK or NG

- OK >> GO TO 2.
- NG >> Repair or replace ground connections.

2. CHECK THROTTLE CONTROL MOTOR RELAY INPUT SIGNAL CIRCUIT-I

1. Check voltage between ECM terminal 3 and ground under the following conditions with CONSULT-II or tester.

Ignition switch	Voltage
OFF	Approximately 0V
ON	Battery voltage (11 - 14V)

OK or NG

- OK >> GO TO 10.
- NG >> GO TO 3.

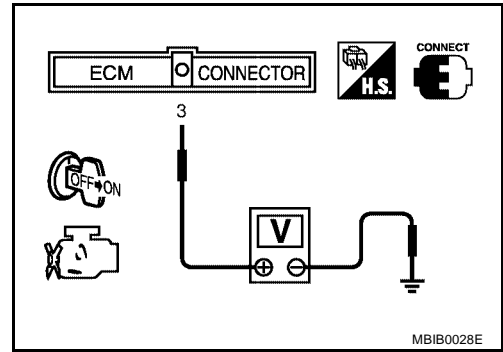

3. CHECK THROTTLE CONTROL MOTOR RELAY INPUT SIGNAL CIRCUIT-II

1. Turn ignition switch OFF.
2. Disconnect ECM harness connector.
3. Disconnect IPDM E/R harness connector E124.
4. Check continuity between ECM terminal 3 and IPDM E/R terminal 42. Refer to Wiring Diagram.

Continuity should exist.

5. Also check harness for short to ground and short to power.

OK or NG

- OK >> GO TO 5.
- NG >> GO TO 4.

4. DETECT MALFUNCTIONING PART

Check the following.

- Harness connectors E20, F32
- Harness for open or short between ECM and IPDM E/R

>> Repair open circuit or short to ground or short to power in harness or connectors.

5. CHECK THROTTLE CONTROL MOTOR RELAY POWER SUPPLY CIRCUIT-I

1. Reconnect all harness connectors disconnected.
2. Check voltage between ECM terminal 104 and ground with CONSULT-II or tester.

Voltage: Battery voltage

OK or NG

- OK >> GO TO 9.
- NG >> GO TO 6.

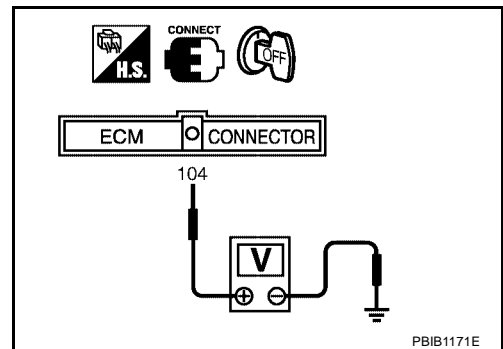

6. CHECK THROTTLE CONTROL MOTOR RELAY POWER SUPPLY CIRCUIT-II

1. Disconnect ECM harness connector.
2. Disconnect IPDM E/R harness connector E121.
3. Check continuity between ECM terminal 104 and IPDM E/R terminal 47.
Refer to Wiring Diagram.

Continuity should exist.

4. Also check harness for short to ground and short to power.

OK or NG

- OK >> GO TO 8.
- NG >> GO TO 7.

7. DETECT MALFUNCTIONING PART

Check the following.

- Harness connectors E19, F33
- Harness for open or short between ECM and IPDM E/R

>> Repair open circuit or short to ground or short to power in harness or connectors.

8. CHECK FUSE

1. Disconnect 15A fuse.
2. Check 15A fuse for blown.

OK or NG

- OK >> GO TO 9.
- NG >> Replace 15A fuse.

9. CHECK INTERMITTENT INCIDENT

Refer to [EC-782, "TROUBLE DIAGNOSIS FOR INTERMITTENT INCIDENT"](#) .

OK or NG

- OK >> Replace IPDM E/R. Refer to [PG-15, "IPDM E/R \(INTELLIGENT POWER DISTRIBUTION MODULE ENGINE ROOM\)"](#) .
- NG >> Repair or replace harness or connectors.

10. CHECK THROTTLE CONTROL MOTOR OUTPUT SIGNAL CIRCUIT FOR OPEN OR SHORT

1. Turn ignition switch OFF.
2. Disconnect electric throttle control actuator harness connector.
3. Disconnect ECM harness connector.
4. Check harness continuity between the following terminals.
Refer to Wiring Diagram.

Electric throttle control actuator terminal	ECM terminal	Continuity
3	5	Should not exist
	4	Should exist
6	5	Should exist
	4	Should not exist

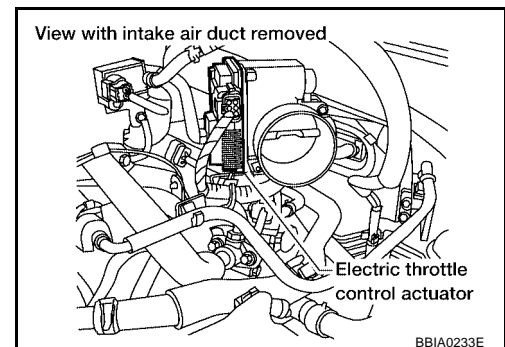

5. Also check harness for short to ground and short to power.

OK or NG

- OK >> GO TO 11.
- NG >> Repair or replace.

11. CHECK ELECTRIC THROTTLE CONTROL ACTUATOR VISUALLY

1. Remove the intake air duct.
2. Check if foreign matter is caught between the throttle valve and the housing.

OK or NG

OK >> GO TO 12.

NG >> Remove the foreign matter and clean the electric throttle control actuator inside.

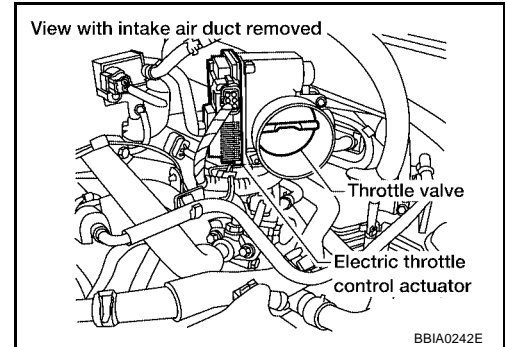

12. CHECK THROTTLE CONTROL MOTOR

Refer to [EC-1073, "Component Inspection"](#) .

OK or NG

OK >> GO TO 13.

NG >> GO TO 14.

13. CHECK INTERMITTENT INCIDENT

Refer to [EC-782, "TROUBLE DIAGNOSIS FOR INTERMITTENT INCIDENT"](#) .

OK or NG

OK >> GO TO 14.

NG >> Repair or replace harness or connectors.

14. REPLACE ELECTRIC THROTTLE CONTROL ACTUATOR

1. Replace the electric throttle control actuator.
2. Perform [EC-711, "Throttle Valve Closed Position Learning"](#) .
3. Perform [EC-712, "Idle Air Volume Learning"](#) .

>> INSPECTION END

Component Inspection THROTTLE CONTROL MOTOR

UBS0018W

1. Disconnect electric throttle control actuator harness connector.
2. Check resistance between terminals 3 and 6.

Resistance: Approximately 1 - 15 Ω [at 25 °C (77°F)]

3. If NG, replace electric throttle control actuator and go to next step.
4. Perform [EC-711, "Throttle Valve Closed Position Learning"](#) .
5. Perform [EC-712, "Idle Air Volume Learning"](#) .

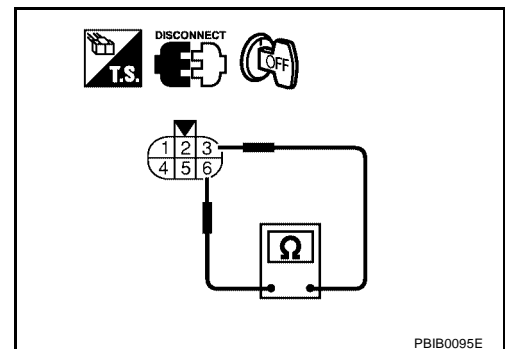

PBIB0095E

Remove and Installation ELECTRIC THROTTLE CONTROL ACTUATOR

UBS0018X

Refer to [EM-122, "INTAKE MANIFOLD COLLECTOR"](#) .

DTC P1124, P1126 THROTTLE CONTROL MOTOR RELAY

[VQ]

DTC P1124, P1126 THROTTLE CONTROL MOTOR RELAY

PF16119

Component Description

UBS0018Y

Power supply for the throttle control motor is provided to the ECM via throttle control motor relay. The throttle control motor relay is ON/OFF controlled by the ECM. When the ignition switch is turned ON, the ECM sends an ON signal to throttle control motor relay and battery voltage is provided to the ECM. When the ignition switch is turned OFF, the ECM sends an OFF signal to throttle control motor relay and battery voltage is not provided to the ECM.

CONSULT-II Reference Value in Data Monitor Mode

UBS0018Z

Specification data are reference values.

MONITOR ITEM	CONDITION	SPECIFICATION
THRTL RELAY	● Ignition switch: ON	ON

On Board Diagnosis Logic

UBS00190

These self-diagnoses have the one trip detection logic.

DTC No.	Trouble diagnosis name	DTC detecting condition	Possible cause
P1124 1124	Throttle control motor relay circuit short	ECM detects the throttle control motor relay is stuck ON.	<ul style="list-style-type: none">● Harness or connectors (Throttle control motor relay circuit is shorted)● Throttle control motor relay
P1126 1126	Throttle control motor relay circuit open	ECM detects a voltage of power source for throttle control motor is excessively low.	<ul style="list-style-type: none">● Harness or connectors (Throttle control motor relay circuit is open)● Throttle control motor relay

FAIL-SAFE MODE

When the malfunction is detected, ECM enters fail-safe mode and the MIL lights up.

Engine operating condition in fail-safe mode

ECM stops the electric throttle control actuator control, throttle valve is maintained at a fixed opening (approx. 5 degrees) by the return spring.

DTC Confirmation Procedure

UBS00191

NOTE:

If DTC Confirmation Procedure has been previously conducted, always turn ignition switch OFF and wait at least 10 seconds before conducting the next test.

PROCEDURE FOR DTC P1124

TESTING CONDITION:

Before performing the following procedure, confirm that battery voltage is more than 8V.

④ With CONSULT-II

1. Turn ignition switch ON and wait at least 1 second.
2. Select "DATA MONITOR" mode with CONSULT-II.
3. If DTC is detected, go to [EC-1077, "Diagnostic Procedure"](#).

DATA MONITOR	
MONITOR	NO DTC
ENG SPEED	XXX rpm

SEF058Y

DTC P1124, P1126 THROTTLE CONTROL MOTOR RELAY

[VQ]

With GST

Follow the procedure "With CONSULT-II" above.

PROCEDURE FOR DTC P1126

With CONSULT-II

1. Turn ignition switch ON and wait at least 2 seconds.
2. Select "DATA MONITOR" mode with CONSULT-II.
3. Start engine and let it idle for 5 seconds.
4. If DTC is detected, go to [EC-1077, "Diagnostic Procedure"](#) .

DATA MONITOR	
MONITOR	NO DTC
ENG SPEED	XXX rpm

SEF058Y

With GST

Follow the procedure "With CONSULT-II" above.

A

EC

C

D

E

F

G

H

I

J

K

L

M

DTC P1124, P1126 THROTTLE CONTROL MOTOR RELAY

[VQ]

Wiring Diagram

UBS00192

EC-ETC2-01

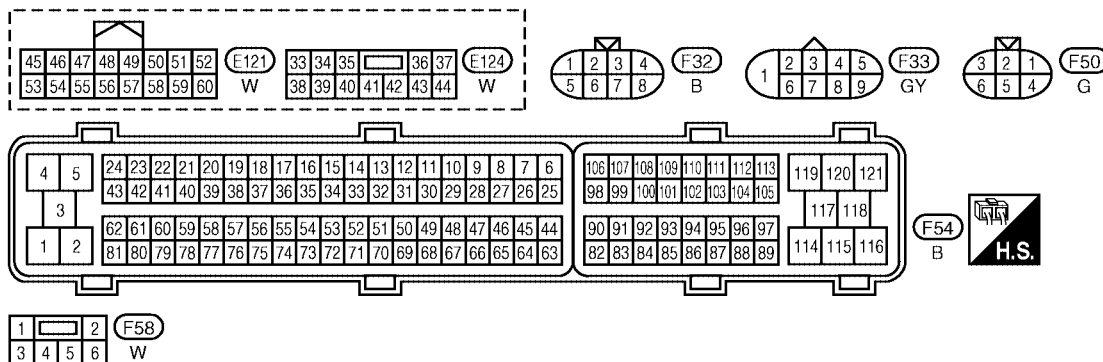
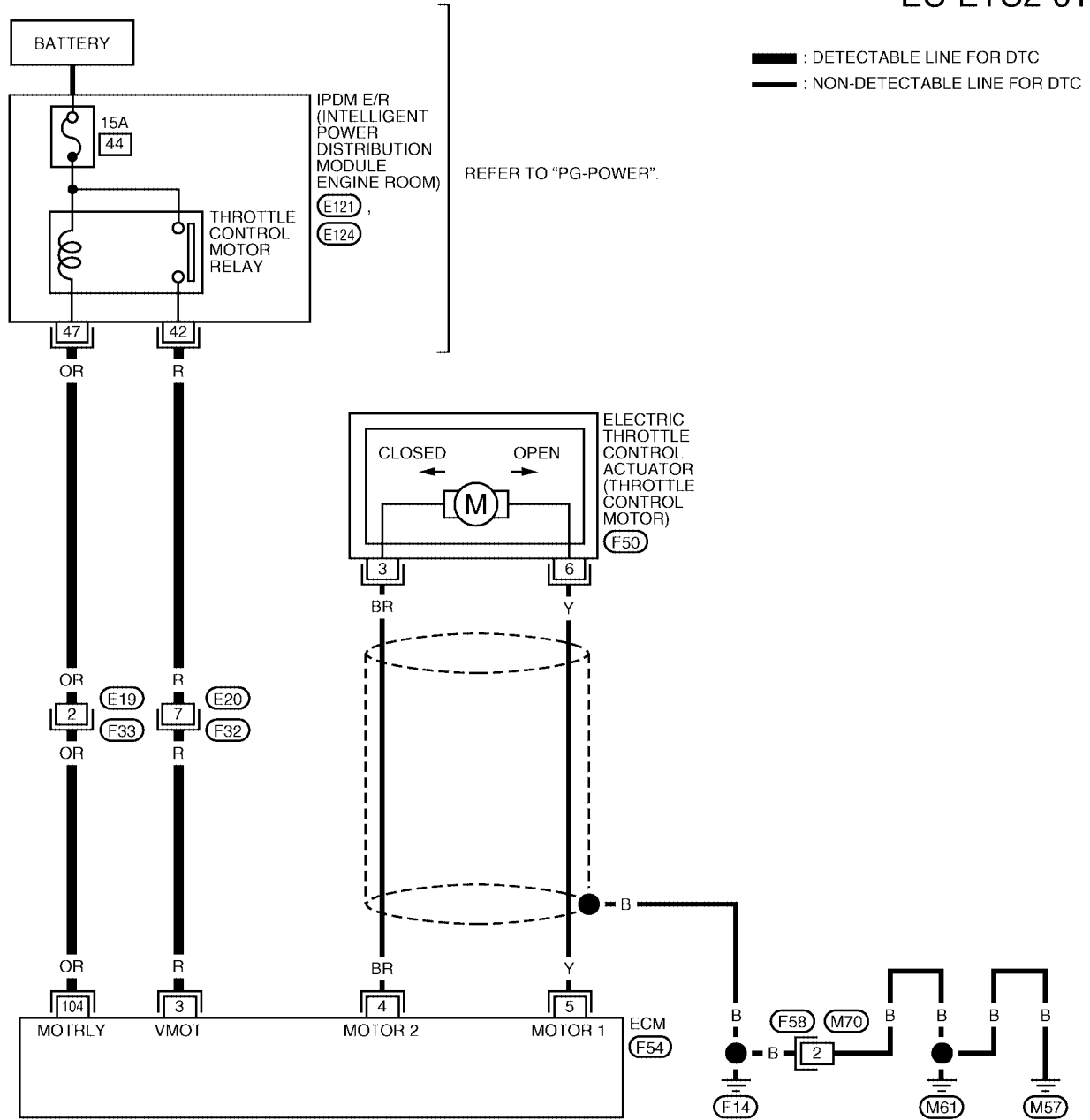

BBWA1568E

DTC P1124, P1126 THROTTLE CONTROL MOTOR RELAY

[VQ]

Specification data are reference values and are measured between each terminal and ground.

CAUTION:

Do not use ECM ground terminals when measuring input/output voltage. Doing so may result in damage to the ECM's transistor. Use a ground other than ECM terminals, such as the ground.

TER-MINAL NO.	WIRE COLOR	ITEM	CONDITION	DATA (DC Voltage)
3	R	Throttle control motor relay power supply	[Ignition switch: ON]	BATTERY VOLTAGE (11 - 14V)
104	OR	Throttle control motor relay	[Ignition switch: OFF]	BATTERY VOLTAGE (11 - 14V)
			[Ignition switch: ON]	0 - 1.0V

Diagnostic Procedure

UBS00193

1. CHECK THROTTLE CONTROL MOTOR RELAY POWER SUPPLY CIRCUIT-I

- Turn ignition switch OFF.
- Check voltage between ECM terminal 104 and ground with CONSULT-II or tester.

Voltage: Battery voltage

OK or NG

- OK >> GO TO 5.
- NG >> GO TO 2.

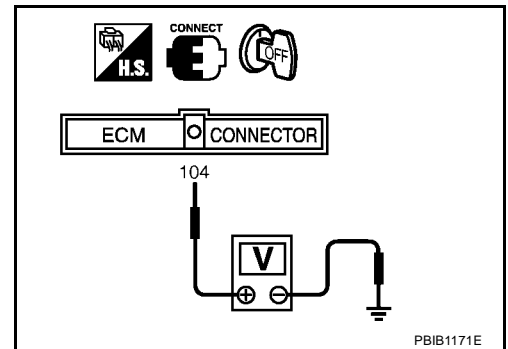

2. CHECK THROTTLE CONTROL MOTOR RELAY POWER SUPPLY CIRCUIT-II

- Disconnect ECM harness connector.
- Disconnect IPDM E/R harness connector E121.
- Check continuity between ECM terminal 104 and IPDM E/R terminal 47. Refer to Wiring Diagram.

Continuity should exist.

- Also check harness for short to ground and short to power.

OK or NG

- OK >> GO TO 4.
- NG >> GO TO 3.

3. DETECT MALFUNCTIONING PART

Check the following.

- Harness connectors E19, F33
- Harness for open or short between ECM and IPDM E/R

>> Repair open circuit or short to ground or short to power in harness or connectors.

4. CHECK FUSE

1. Disconnect 15A fuse.
2. Check 15A fuse for blown.

OK or NG

- OK >> GO TO 8.
 NG >> Replace 15A fuse.

5. CHECK THROTTLE CONTROL MOTOR RELAY INPUT SIGNAL CIRCUIT-I

1. Check voltage between ECM terminal 3 and ground under the following conditions with CONSULT-II or tester.

Ignition switch	Voltage
OFF	Approximately 0V
ON	Battery voltage (11 - 14V)

OK or NG

- OK >> GO TO 8.
 NG >> GO TO 6.

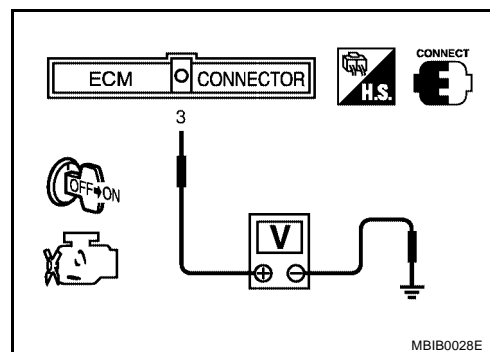

6. CHECK THROTTLE CONTROL MOTOR RELAY INPUT SIGNAL CIRCUIT-II

1. Turn ignition switch OFF.
2. Disconnect ECM harness connector.
3. Disconnect IPDM E/R harness connector E124.
4. Check continuity between ECM terminal 3 and IPDM E/R terminal 42. Refer to Wiring Diagram.

Continuity should exist.

5. Also check harness for short to ground and short to power.

OK or NG

- OK >> GO TO 8.
 NG >> GO TO 7.

7. DETECT MALFUNCTIONING PART

Check the following.

- Harness connectors E20, F32
- Harness for open or short between ECM and IPDM E/R

>> Repair open circuit or short to ground or short to power in harness or connectors.

8. CHECK INTERMITTENT INCIDENT

Refer to [EC-782, "TROUBLE DIAGNOSIS FOR INTERMITTENT INCIDENT"](#) .

OK or NG

- OK >> Replace IPDM E/R. Refer to [PG-15, "IPDM E/R \(INTELLIGENT POWER DISTRIBUTION MODULE ENGINE ROOM\)"](#) .
 NG >> Repair or replace harness or connectors.

DTC P1128 THROTTLE CONTROL MOTOR

[VQ]

DTC P1128 THROTTLE CONTROL MOTOR

PFP:16119

Component Description

UBS00194

The throttle control motor is operated by the ECM and it opens and closes the throttle valve. The current opening angle of the throttle valve is detected by the throttle position sensor and it provides feedback to the ECM to control the throttle control motor to make the throttle valve opening angle properly in response to driving condition.

On Board Diagnosis Logic

UBS00195

This self-diagnosis has the one trip detection logic.

DTC No.	Trouble diagnosis name	DTC detecting condition	Possible cause
P1128 1128	Throttle control motor circuit short	ECM detects short in both circuits between ECM and throttle control motor.	<ul style="list-style-type: none">● Harness or connectors (Throttle control motor circuit is shorted.)● Electric throttle control actuator (Throttle control motor)

FAIL-SAFE MODE

When the malfunction is detected, the ECM enters fail-safe mode and the MIL lights up.

Engine operating condition in fail-safe mode

ECM stops the electric throttle control actuator control, throttle valve is maintained at a fixed opening (approx. 5 degrees) by the return spring.

DTC Confirmation Procedure

UBS00196

NOTE:

If DTC Confirmation Procedure has been previously conducted, always turn ignition switch OFF and wait at least 10 seconds before conducting the next test.

WITH CONSULT-II

1. Turn ignition switch ON and wait at least 2 seconds.
2. Select "DATA MONITOR" mode with CONSULT-II.
3. Start engine and let it idle for 5 seconds.
4. If DTC is detected, go to [EC-1081, "Diagnostic Procedure"](#).

DATA MONITOR	
MONITOR	NO DTC
ENG SPEED	XXX rpm

SEF058Y

WITH GST

Follow the procedure "WITH CONSULT-II" above.

DTC P1128 THROTTLE CONTROL MOTOR

[VQ]

Wiring Diagram

UBS00197

EC-ETC3-01

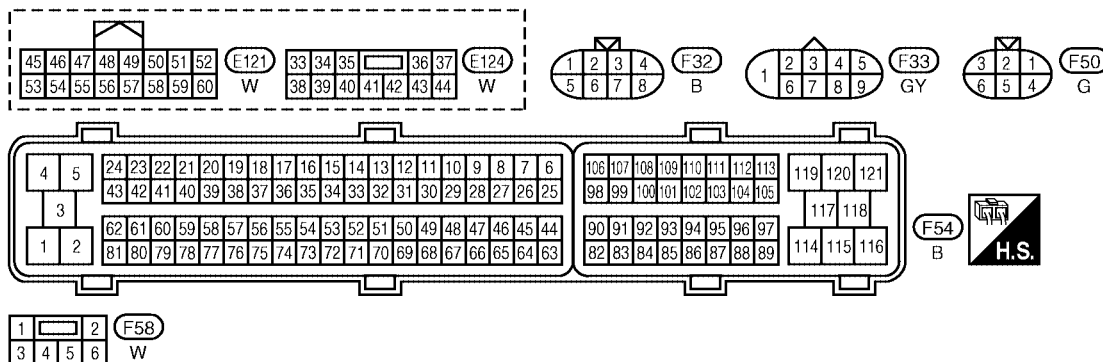
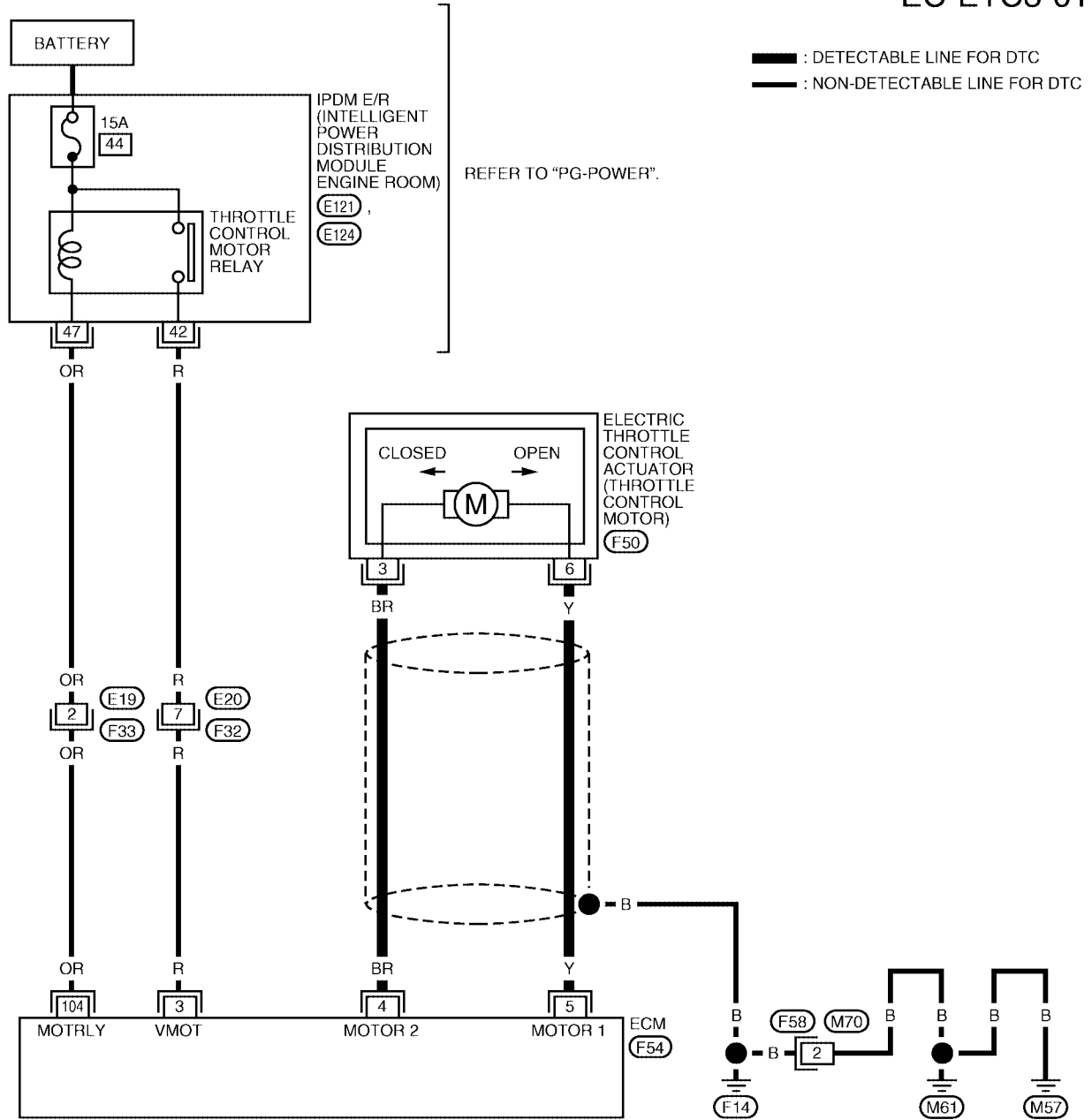

BBWA1569E

DTC P1128 THROTTLE CONTROL MOTOR

[VQ]

Specification data are reference values and are measured between each terminal and ground. Pulse signal is measured by CONSULT-II.

CAUTION:

Do not use ECM ground terminals when measuring input/output voltage. Doing so may result in damage to the ECM's transistor. Use a ground other than ECM terminals, such as the ground.

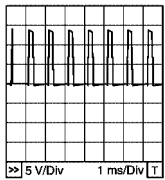
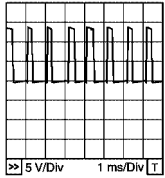
TER-MINAL NO.	WIRE COLOR	ITEM	CONDITION	DATA (DC Voltage)
4	BR	Throttle control motor (Close)	<p>[Ignition switch: ON]</p> <ul style="list-style-type: none"> ● Engine stopped ● Shift lever: D (A/T) or 1st (M/T) ● Accelerator pedal: Released 	<p>0 - 14V★</p>  <p>PBIB1104E</p>
5	Y	Throttle control motor (Open)	<p>[Ignition switch: ON]</p> <ul style="list-style-type: none"> ● Engine stopped ● Shift lever: D (A/T) or 1st (M/T) ● Accelerator pedal: Fully depressed 	<p>0 - 14V★</p>  <p>PBIB1105E</p>

★: Average voltage for pulse signal (Actual pulse signal can be confirmed by oscilloscope.)

Diagnostic Procedure

UBS00198

1. CHECK GROUND CONNECTIONS

1. Turn ignition switch OFF.
2. Loosen and retighten three ground screws on the body. Refer to [EC-789, "Ground Inspection"](#).

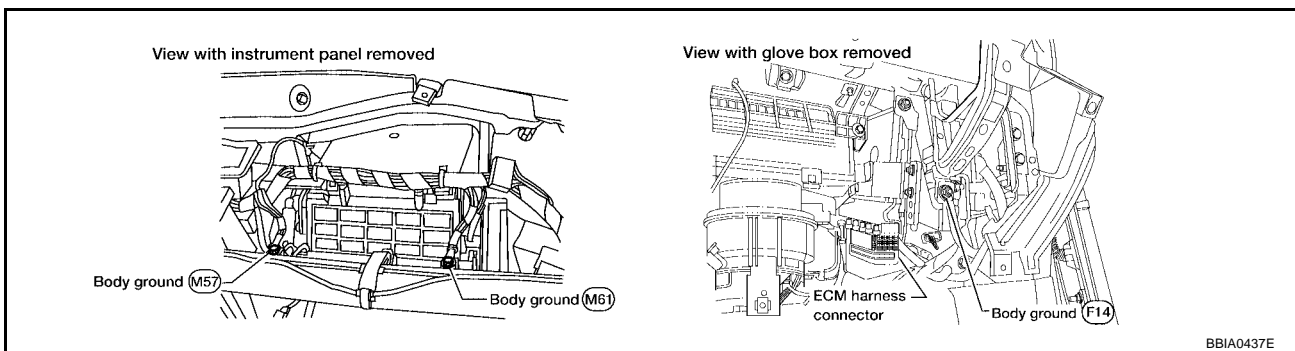

OK or NG

- OK >> GO TO 2.
- NG >> Repair or replace ground connections.

2. CHECK THROTTLE CONTROL MOTOR OUTPUT SIGNAL CIRCUIT FOR OPEN OR SHORT

1. Disconnect electric throttle control actuator harness connector.
2. Disconnect ECM harness connector.
3. Check harness continuity between the following terminals.
Refer to Wiring Diagram.

Electric throttle control actuator terminal	ECM terminal	Continuity
3	5	Should not exist
	4	Should exist
6	5	Should exist
	4	Should not exist

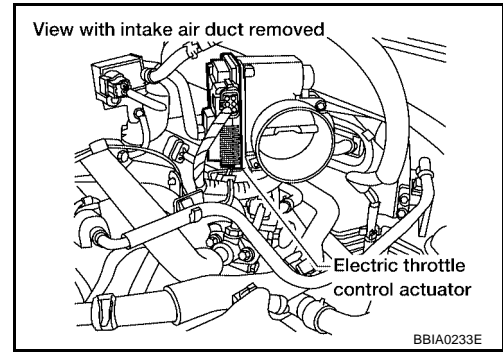

4. Also check harness for short to ground and short to power.

OK or NG

- OK >> GO TO 3.
- NG >> Repair or replace.

3. CHECK THROTTLE CONTROL MOTOR

Refer to [EC-1082, "Component Inspection"](#) .

OK or NG

- OK >> GO TO 4.
- NG >> GO TO 5.

4. CHECK INTERMITTENT INCIDENT

Refer to [EC-782, "TROUBLE DIAGNOSIS FOR INTERMITTENT INCIDENT"](#) .

OK or NG

- OK >> GO TO 5.
- NG >> Repair or replace harness or connectors.

5. REPLACE ELECTRIC THROTTLE CONTROL ACTUATOR

1. Replace the electric throttle control actuator.
2. Perform [EC-711, "Throttle Valve Closed Position Learning"](#) .
3. Perform [EC-712, "Idle Air Volume Learning"](#) .

>> INSPECTION END

Component Inspection THROTTLE CONTROL MOTOR

UBS00199

1. Disconnect electric throttle control actuator harness connector.
2. Check resistance between terminals 3 and 6.

Resistance: Approximately 1 - 15 Ω [at 25 °C (77°F)]

3. If NG, replace electric throttle control actuator and go to next step.
4. Perform [EC-711, "Throttle Valve Closed Position Learning"](#) .
5. Perform [EC-712, "Idle Air Volume Learning"](#) .

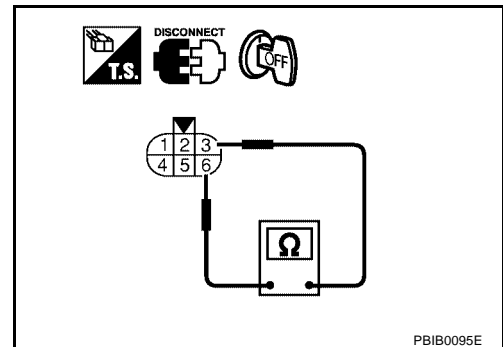

PBIB0095E

DTC P1128 THROTTLE CONTROL MOTOR

[VQ]

UBS0019A

Removal and Installation ELECTRIC THROTTLE CONTROL ACTUATOR

Refer to [EM-122, "INTAKE MANIFOLD COLLECTOR"](#) .

A

EC

C

D

E

F

G

H

I

J

K

L

M

DTC P1146, P1166 HO2S2

Component Description

UBS0019B

The heated oxygen sensor 2, after three way catalyst (manifold), monitors the oxygen level in the exhaust gas on each bank. Even if switching characteristics of the air fuel ratio (A/F) sensor 1 are shifted, the air-fuel ratio is controlled to stoichiometric, by the signal from the heated oxygen sensor 2. This sensor is made of ceramic zirconia. The zirconia generates voltage from approximately 1V in richer conditions to 0V in leaner conditions. Under normal conditions the heated oxygen sensor 2 is not used for engine control operation.

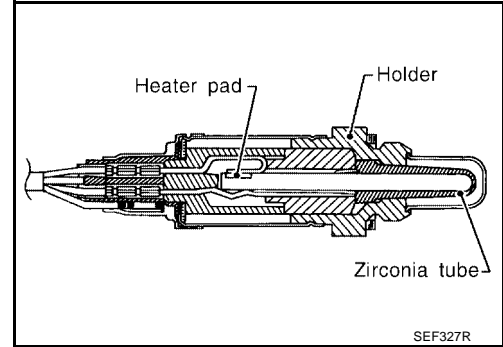

CONSULT-II Reference Value in Data Monitor Mode

UBS0019C

Specification data are reference values.

MONITOR ITEM	CONDITION		SPECIFICATION
HO2S2 (B1) HO2S2 (B2)	<ul style="list-style-type: none"> Warm-up condition After keeping engine speed between 3,500 and 4,000 rpm for 1 minute and at idle for 1 minute under no load. 	Revving engine from idle to 3,000 rpm quickly.	0 - 0.3V ↔ Approx. 0.6 - 1.0V
HO2S2 MNTR (B1) HO2S2 MNTR (B2)			LEAN ↔ RICH

On Board Diagnosis Logic

UBS0019D

The heated oxygen sensor 2 has a much longer switching time between rich and lean than the air fuel ratio (A/F) sensor 1. The oxygen storage capacity of the three way catalyst (manifold) causes the longer switching time. To judge the malfunctions of heated oxygen sensor 2, ECM monitors whether the minimum voltage of sensor is sufficiently low during the various driving condition such as fuel-cut.

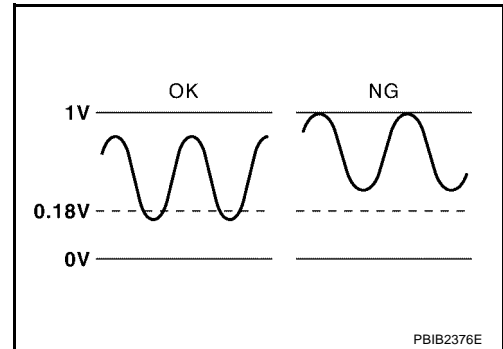

DTC No.	Trouble diagnosis name	DTC detecting condition	Possible cause
P1146 1146 (Bank 1)	Heated oxygen sensor 2 minimum voltage monitoring	The minimum voltage from the sensor is not reached to the specified voltage.	<ul style="list-style-type: none"> Harness or connectors (The sensor circuit is open or shorted) Heated oxygen sensor 2 Fuel pressure Fuel injector
P1166 1166 (Bank 2)			

DTC Confirmation Procedure

NOTE:

If DTC confirmation Procedure has been previously conducted, always turn ignition switch OFF and wait at least 10 seconds before conducting the next test.

WITH CONSULT-II

TESTING CONDITION:

For better results, perform DTC WORK SUPPORT at a temperature of 0 to 30 °C (32 to 86 °F).

1. Turn ignition switch ON and select "DATA MONITOR" mode with CONSULT-II.
2. Start engine and warm it up to the normal operating temperature.
3. Turn ignition switch OFF and wait at least 10 seconds.
4. Start engine and keep the engine speed between 3,500 and 4,000 rpm for at least 1 minute under no load.
5. Let engine idle for 1 minute.
6. Make sure that "COOLAN TEMP/S" indicates more than 70°C (158°F).
If not, warm up engine and go to next step when "COOLAN TEMP/S" indication reaches to 70°C (158°F).
7. Open engine hood.
8. Select "HO2S2 (B1) P1146" or "HO2S2 (B2) P1166" of "HO2S2" in "DTC WORK SUPPORT" mode with CONSULT-II.
9. Start engine and following the instruction of CONSULT-II.

DATA MONITOR	
MONITOR	NO DTC
ENG SPEED	XXX rpm
COOLAN TEMP/S	XXX °C

SEF174Y

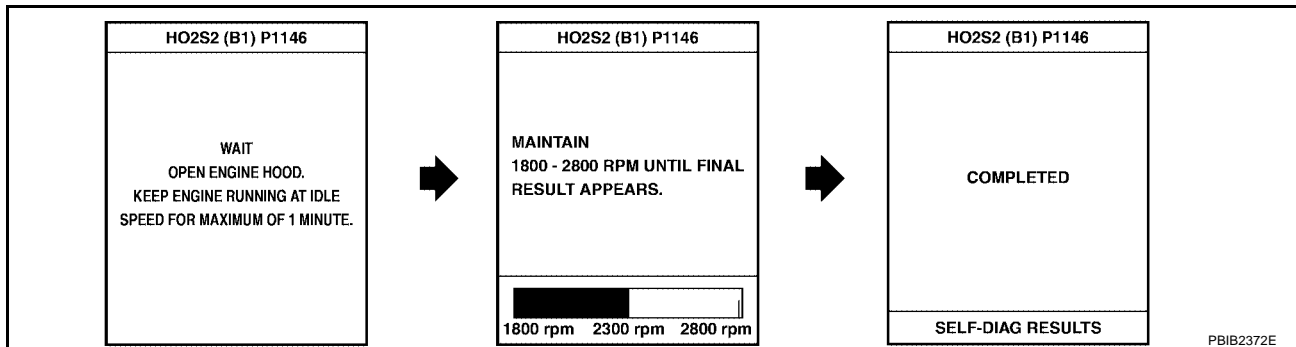

NOTE:

It will take at most 10 minutes until "COMPLETED" is displayed.

10. Make sure that "OK" is displayed after touching "SELF-DIAG RESULTS".
If "NG" is displayed, refer to [EC-1090, "Diagnostic Procedure"](#).
If "CAN NOT BE DIAGNOSED" is displayed, perform the following.
 - a. Turn ignition switch OFF and leave the vehicle in a cool place (soak the vehicle).
 - b. Return to step 1.

Overall Function Check

Use this procedure to check the overall function of the heated oxygen sensor 2 circuit. During this check, a 1st trip DTC might not be confirmed.

WITH GST

1. Start engine and warm it up to the normal operating temperature.
2. Turn ignition switch OFF and wait at least 10 seconds.
3. Start engine and keep the engine speed between 3,500 and 4,000 rpm for at least 1 minute under no load.
4. Let engine idle for 1 minute.
5. Set voltmeter probes between ECM terminal 74 [HO2S2 (B1) signal] or 55 [HO2S2 (B2) signal] and ground.

DTC P1146, P1166 HO2S2

[VQ]

6. Check the voltage when revving up to 4,000 rpm under no load at least 10 times.
(Depress and release accelerator pedal as soon as possible.)
The voltage should be below 0.18V at least once during this procedure.
If the voltage can be confirmed in step 6, step 7 is not necessary.
7. Keep vehicle at idling for 10 minutes, then check the voltage. Or check the voltage when coasting from 80 km/h (50 MPH) in D position with "OD" OFF (A/T), 3rd gear position (M/T).
The voltage should be below 0.18V at least once during this procedure.
8. If NG, go to [EC-1090, "Diagnostic Procedure"](#).

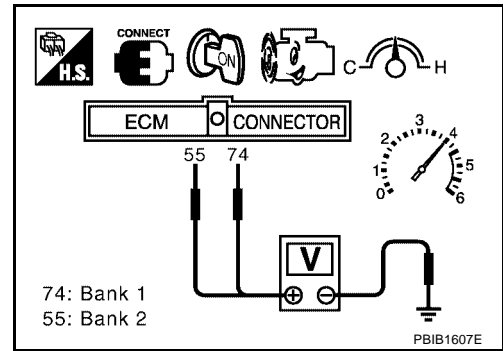

Wiring Diagram
BANK 1

EC-O2S2B1-01

A
EC
C
D
E
F
G
H
I
J
K
L
M

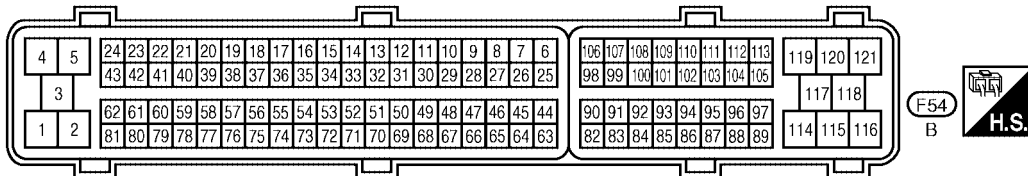
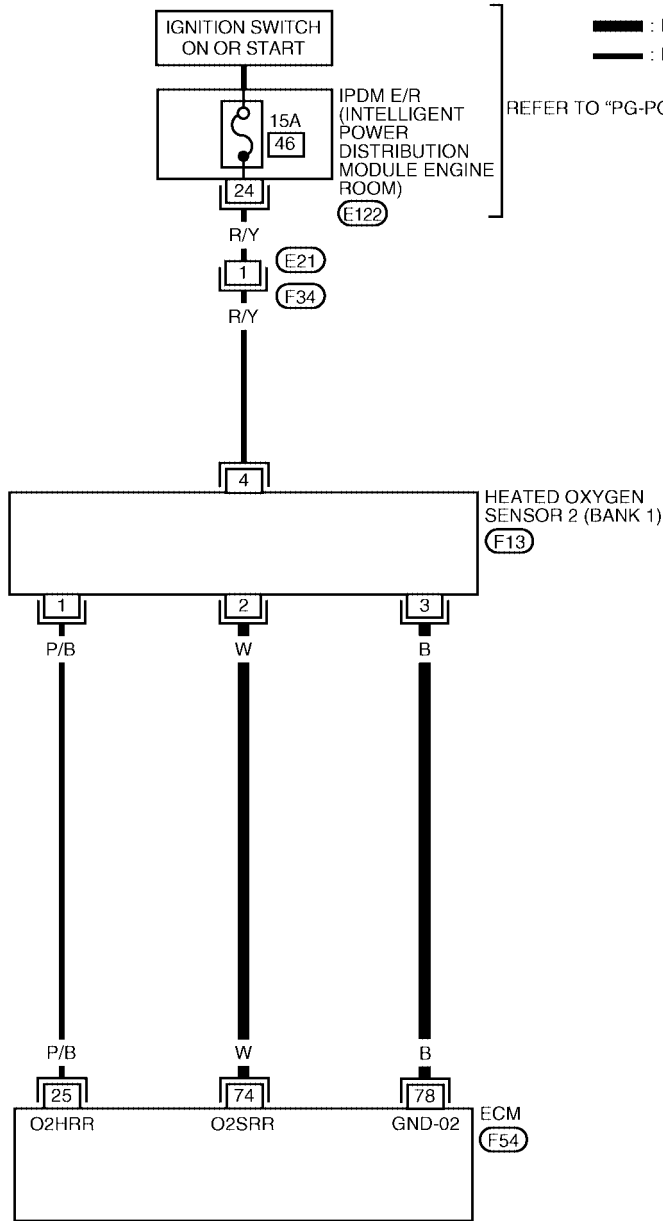

DTC P1146, P1166 HO2S2

[VQ]

Specification data are reference values and are measured between each terminal and ground.

CAUTION:

Do not use ECM ground terminals when measuring input/output voltage. Doing so may result in damage to the ECM's transistor. Use a ground other than ECM terminals, such as the ground.

TER-MINAL NO.	WIRE COLOR	ITEM	CONDITION	DATA (DC Voltage)
74	W	Heated oxygen sensor 2 (bank 1)	<p>[Engine is running]</p> <ul style="list-style-type: none"> ● Warm-up condition ● Revving engine from idle to 3,000 rpm quickly after the following conditions are met <ul style="list-style-type: none"> – After keeping the engine speed between 3,500 and 4,000 rpm for 1 minute and at idle for 1 minute under no load 	0 - Approximately 1.0V
78	B	Sensor ground (Heated oxygen sensor 2)	<p>[Engine is running]</p> <ul style="list-style-type: none"> ● Warm-up condition ● Idle speed 	Approximately 0V

DTC P1146, P1166 HO2S2

[VQ]

BANK 2

EC-O2S2B2-01

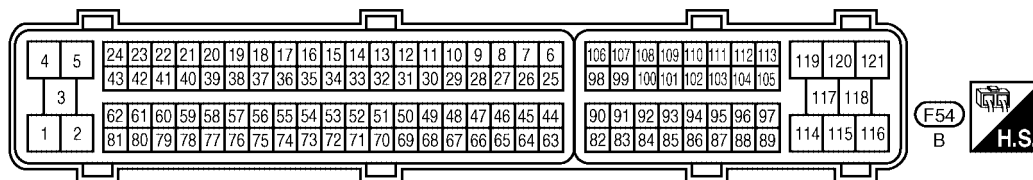
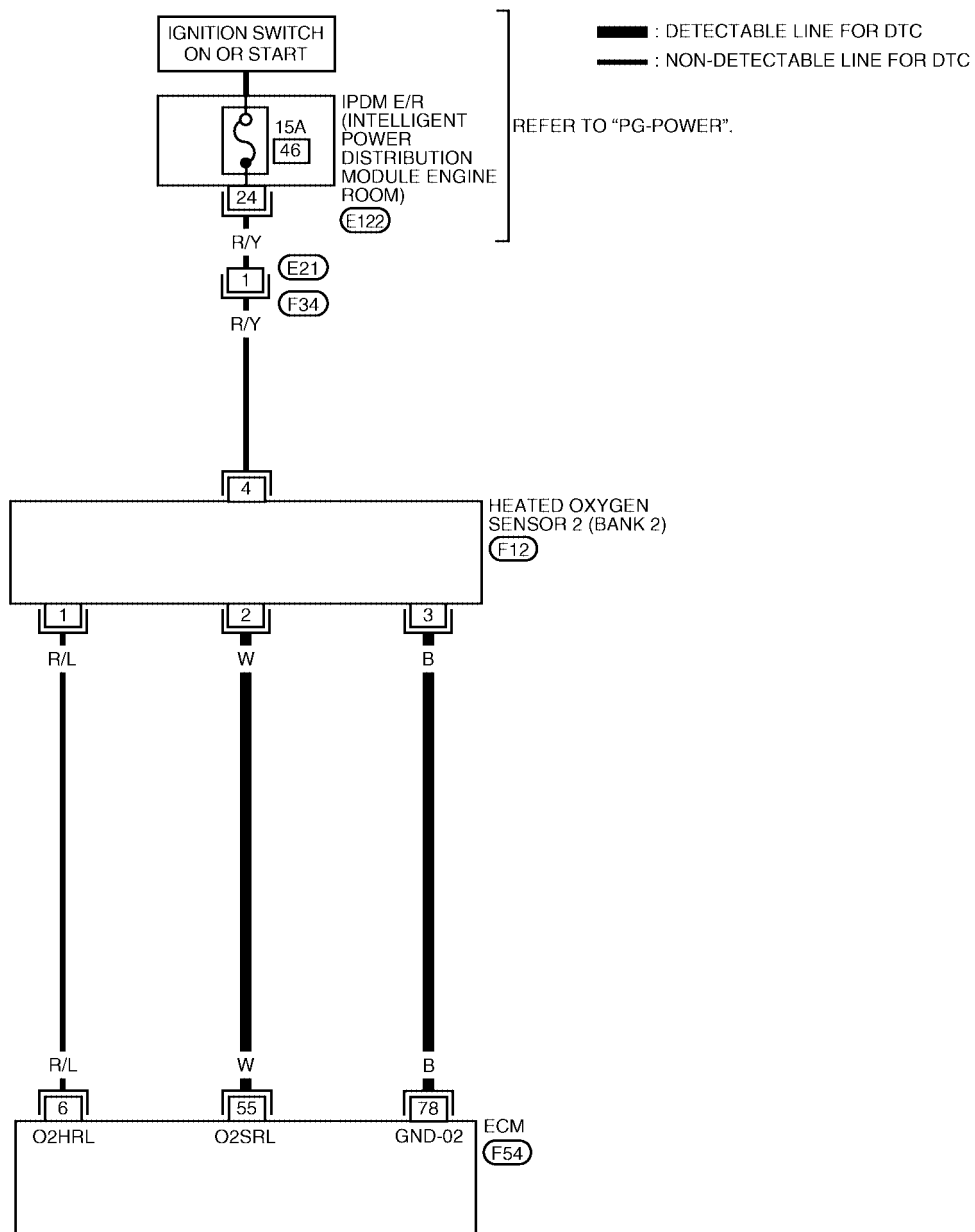

BBWA1556E

Specification data are reference values and are measured between each terminal and ground.

CAUTION:

Do not use ECM ground terminals when measuring input/output voltage. Doing so may result in damage to the ECM's transistor. Use a ground other than ECM terminals, such as the ground.

TER-MINAL NO.	WIRE COLOR	ITEM	CONDITION	DATA (DC Voltage)
55	W	Heated oxygen sensor 2 (bank 2)	<p>[Engine is running]</p> <ul style="list-style-type: none"> ● Warm-up condition ● Revving engine from idle to 3,000 rpm quickly after the following conditions are met <ul style="list-style-type: none"> - After keeping the engine speed between 3,500 and 4,000 rpm for 1 minute and at idle for 1 minute under no load 	0 - Approximately 1.0V
78	B	Sensor ground (Heated oxygen sensor 2)	<p>[Engine is running]</p> <ul style="list-style-type: none"> ● Warm-up condition ● Idle speed 	Approximately 0V

Diagnostic Procedure

UBS0019H

1. CHECK GROUND CONNECTIONS

1. Turn ignition switch OFF.
2. Loosen and retighten three ground screws on the body. Refer to [EC-789, "Ground Inspection"](#) .

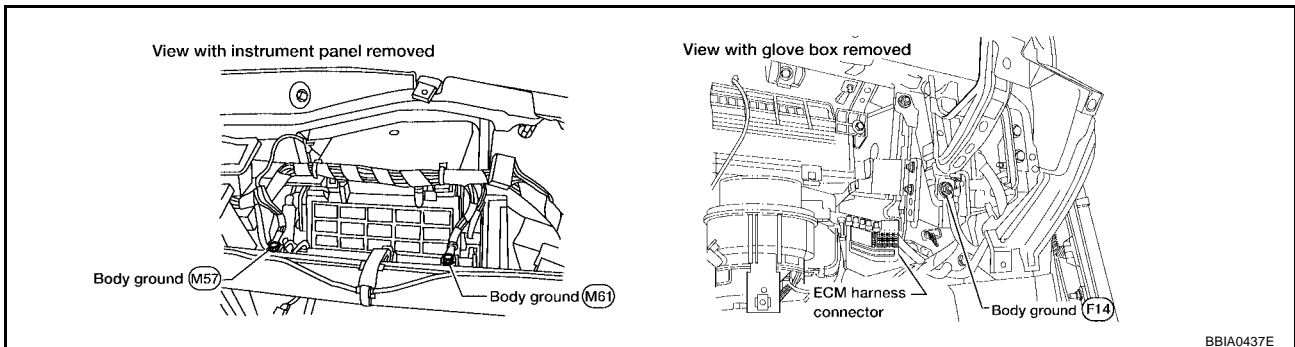

BBIA0437E

OK or NG

- OK >> GO TO 2.
- NG >> Repair or replace ground connections.

2. CLEAR THE SELF-LEARNING DATA

With CONSULT-II

1. Start engine and warm it up to normal operating temperature.
2. Select "SELF-LEARNING CONT" in "WORK SUPPORT" mode with CONSULT-II.
3. Clear the self-learning control coefficient by touching "CLEAR".
4. Run engine for at least 10 minutes at idle speed.
**Is the 1st trip DTC P0172 or P0175 detected?
Is it difficult to start engine?**

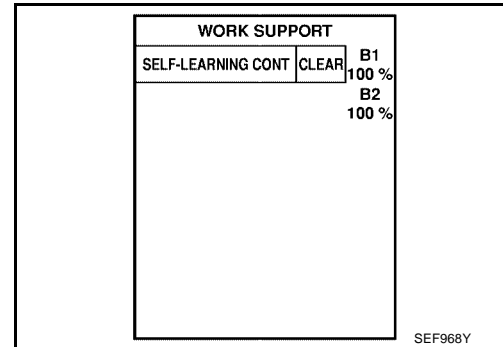

Without CONSULT-II

1. Start engine and warm it up to normal operating temperature.
2. Turn ignition switch OFF.
3. Disconnect mass air flow sensor harness connector, and restart and run engine for at least 5 seconds at idle speed.
4. Stop engine and reconnect mass air flow sensor harness connector.
5. Make sure DTC P0102 is displayed.
6. Erase the DTC memory. Refer to [EC-682, "HOW TO ERASE EMISSION-RELATED DIAGNOSTIC INFORMATION"](#).
7. Make sure DTC P0000 is displayed.
8. Run engine for at least 10 minutes at idle speed.
**Is the 1st trip DTC P0172 or P0175 detected?
Is it difficult to start engine?**

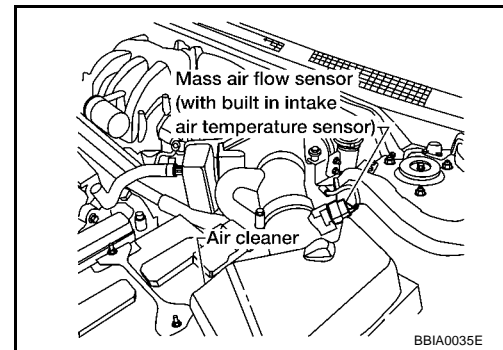

Yes or No

- Yes >> Perform trouble diagnosis for DTC P0172, P0175. Refer to [EC-879](#).
- No >> GO TO 3.

3. CHECK HO2S2 GROUND CIRCUIT FOR OPEN AND SHORT

1. Turn ignition switch OFF.
2. Disconnect ECM harness connector.
3. Disconnect heated oxygen sensor 2 harness connector.

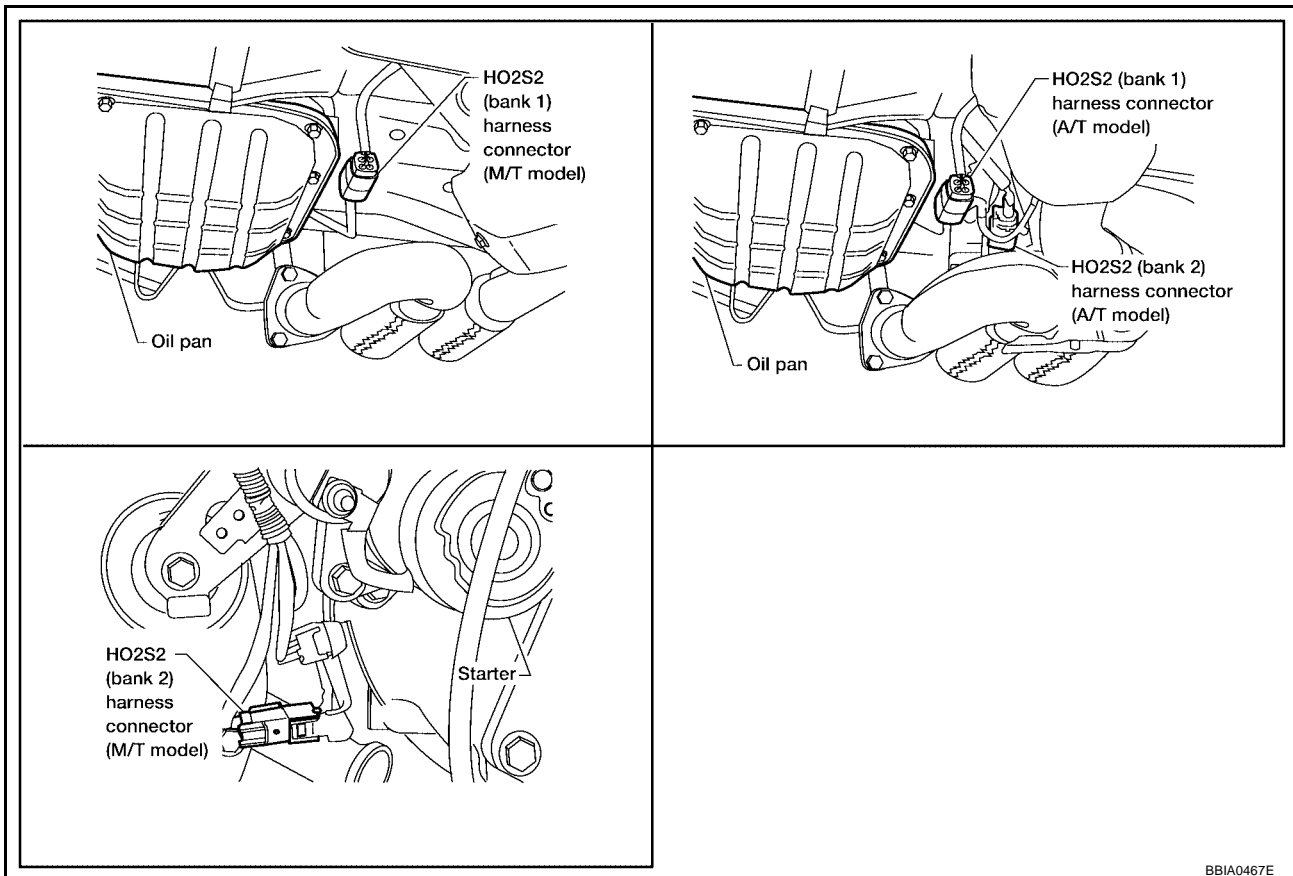

BBIA0467E

4. Check harness continuity between HO2S2 terminal 3 and ECM terminal 78. Refer to Wiring Diagram.

Continuity should exist.

5. Also check harness for short to ground and short to power.

OK or NG

OK >> GO TO 4.

NG >> Repair open circuit or short to ground or short to power in harness or connectors.

4. CHECK HO2S2 INPUT SIGNAL CIRCUIT FOR OPEN AND SHORT

1. Check harness continuity between ECM terminal and HO2S2 terminal as follows.
Refer to Wiring Diagram.

DTC	Terminals		Bank
	ECM	Sensor	
P1146	74	2	1
P1166	55	2	2

Continuity should exist.

2. Check harness continuity between the following terminals and ground.
Refer to Wiring Diagram.

DTC	Terminals		Bank
	ECM	Sensor	
P1146	74	2	1
P1166	55	2	2

Continuity should not exist.

3. Also check harness for short to power.

OK or NG

OK >> GO TO 5.

NG >> Repair open circuit or short to ground or short to power in harness or connectors.

5. CHECK HEATED OXYGEN SENSOR 2

Refer to [EC-1093, "Component Inspection"](#) .

OK or NG

OK >> GO TO 6.

NG >> Replace malfunctioning heated oxygen sensor 2.

6. CHECK INTERMITTENT INCIDENT

Refer to [EC-782, "TROUBLE DIAGNOSIS FOR INTERMITTENT INCIDENT"](#) .

>> INSPECTION END

**Component Inspection
HEATED OXYGEN SENSOR 2**

UBS0019I

With CONSULT-II

1. Turn ignition switch ON and select "DATA MONITOR" mode with CONSULT-II.
2. Start engine and warm it up to the normal operating temperature.
3. Turn ignition switch OFF and wait at least 10 seconds.
4. Start engine and keep the engine speed between 3,500 and 4,000 rpm for at least 1 minute under no load.
5. Let engine idle for 1 minute.

DATA MONITOR	
MONITOR	NO DTC
ENG SPEED	XXX rpm
COOLAN TEMP/S	XXX °C

SEF174Y

- Select "FUEL INJECTION" in "ACTIVE TEST" mode, and select "HO2S2 (B1)/(B2)" as the monitor item with CONSULT-II.

ACTIVE TEST	
FUEL INJECTION	25 %
MONITOR	
ENG SPEED	XXX rpm
HO2S2 (B1)	XXX V
HO2S2 (B2)	XXX V

PBIB1672E

- Check "HO2S2 (B1)/(B2)" at idle speed when adjusting "FUEL INJECTION" to $\pm 25\%$.

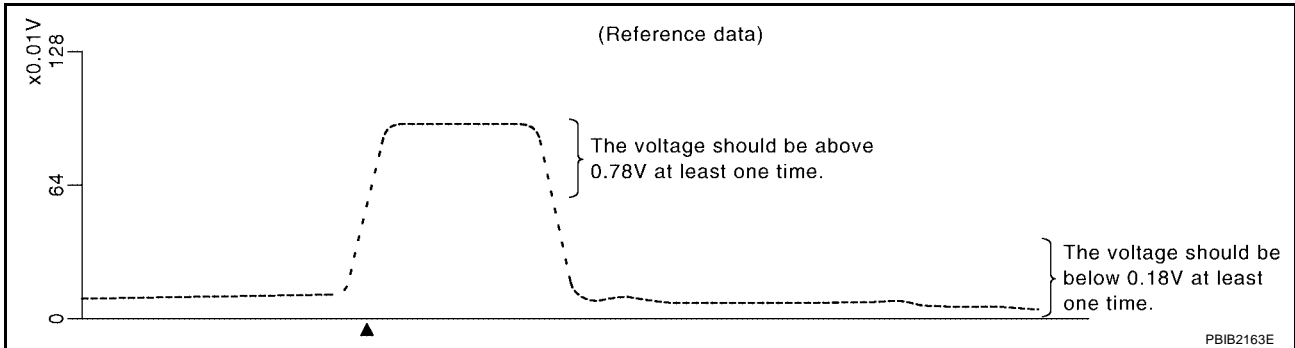

"HO2S2 (B1)/(B2)" should be above 0.78V at least once when the "FUEL INJECTION" is +25%.
 "HO2S2 (B1)/(B2)" should be below 0.18V at least once when the "FUEL INJECTION" is -25%.

CAUTION:

- Discard any heated oxygen sensor which has been dropped from a height of more than 0.5 m (19.7 in) onto a hard surface such as a concrete floor; use a new one.
- Before installing new oxygen sensor, clean exhaust system threads using Oxygen Sensor Thread Cleaner tool J-43897-18 or J-43897-12 and approved anti-seize lubricant.

Without CONSULT-II

- Start engine and warm it up to the normal operating temperature.
- Turn ignition switch OFF and wait at least 10 seconds.
- Start engine and keep the engine speed between 3,500 and 4,000 rpm for at least 1 minute under no load.
- Let engine idle for 1 minute.
- Set voltmeter probes between ECM terminal 74 [HO2S2 (B1) signal] or 55 [HO2S2 (B2) signal] and ground.
- Check the voltage when revving up to 4,000 rpm under no load at least 10 times.
 (Depress and release accelerator pedal as soon as possible.)
The voltage should be above 0.78V at least once during this procedure.
If the voltage is above 0.78V at step 6, step 7 is not necessary.
- Keep vehicle at idling for 10 minutes, then check voltage. Or check the voltage when coasting from 80 km/h (50 MPH) in D position with "OD" OFF (A/T), 3rd gear position (M/T).
The voltage should be below 0.18V at least once during this procedure.
- If NG, replace heated oxygen sensor 2.

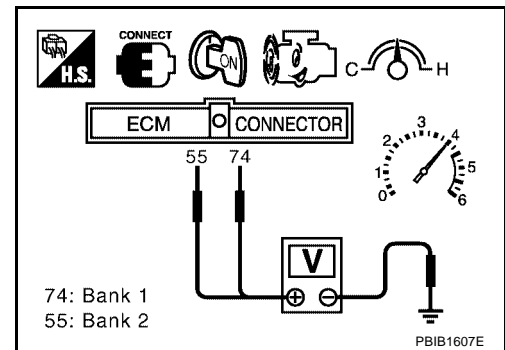

CAUTION:

- Discard any heated oxygen sensor which has been dropped from a height of more than 0.5 m (19.7 in) onto a hard surface such as a concrete floor; use a new one.
- Before installing new oxygen sensor, clean exhaust system threads using Oxygen Sensor Thread Cleaner tool J-43897-18 or J-43897-12 and approved anti-seize lubricant.

Removal and Installation
HEATED OXYGEN SENSOR 2

Refer to [EM-134, "EXHAUST MANIFOLD AND THREE WAY CATALYST"](#) .

A

EC

C

D

E

F

G

H

I

J

K

L

M

DTC P1147, P1167 HO2S2

Component Description

UBS0019K

The heated oxygen sensor 2, after three way catalyst (manifold), monitors the oxygen level in the exhaust gas on each bank. Even if switching characteristics of the air fuel ratio (A/F) sensor 1 are shifted, the air-fuel ratio is controlled to stoichiometric, by the signal from the heated oxygen sensor 2. This sensor is made of ceramic zirconia. The zirconia generates voltage from approximately 1V in richer conditions to 0V in leaner conditions. Under normal conditions the heated oxygen sensor 2 is not used for engine control operation.

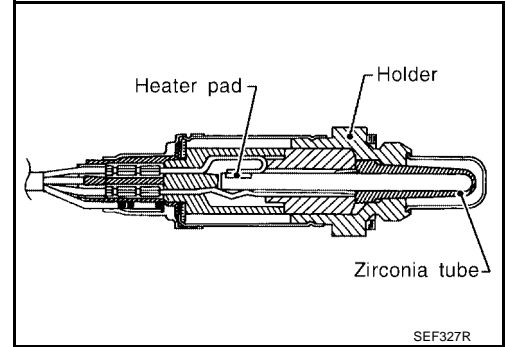

CONSULT-II Reference Value in Data Monitor Mode

UBS0019L

Specification data are reference values.

MONITOR ITEM	CONDITION		SPECIFICATION
HO2S2 (B1) HO2S2 (B2)	<ul style="list-style-type: none"> Warm-up condition After keeping engine speed between 3,500 and 4,000 rpm for 1 minute and at idle for 1 minute under no load. 	Revving engine from idle to 3,000 rpm quickly.	0 - 0.3V ↔ Approx. 0.6 - 1.0V
HO2S2 MNTR (B1) HO2S2 MNTR (B2)			LEAN ↔ RICH

On Board Diagnosis Logic

UBS0019M

The heated oxygen sensor 2 has a much longer switching time between rich and lean than the air fuel ratio (A/F) sensor 1. The oxygen storage capacity before the three way catalyst (manifold) causes the longer switching time. To judge the malfunctions of heated oxygen sensor 2, ECM monitors whether the maximum voltage of the sensor is sufficiently high during the various driving condition such as fuel-cut.

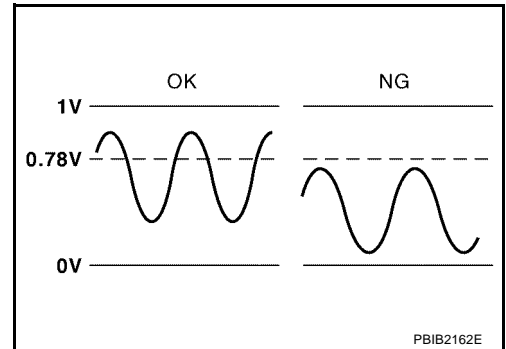

DTC No.	Trouble diagnosis name	DTC detecting condition	Possible cause
P1147 1147 (Bank 1)	Heated oxygen sensor 2 maximum voltage monitoring	The maximum voltage from the sensor is not reached to the specified voltage.	<ul style="list-style-type: none"> Harness or connectors (The sensor circuit is open or shorted) Heated oxygen sensor 2 Fuel pressure Fuel injector Intake air leaks
P1167 1167 (Bank 2)			

DTC Confirmation Procedure

NOTE:

If DTC confirmation Procedure has been previously conducted, always turn ignition switch OFF and wait at least 10 seconds before conducting the next test.

WITH CONSULT-II

TESTING CONDITION:

For better results, perform "DTC WORK SUPPORT" at a temperature of 0 to 30 °C (32 to 86 °F).

1. Turn ignition switch ON and select "DATA MONITOR" mode with CONSULT-II.
2. Start engine and warm it up to the normal operating temperature.
3. Turn ignition switch OFF and wait at least 10 seconds.
4. Start engine and keep the engine speed between 3,500 and 4,000 rpm for at least 1 minute under no load.
5. Let engine idle for 1 minute.
6. Make sure that "COOLAN TEMP/S" indicates more than 70°C (158°F).
If not, warm up engine and go to next step when "COOLAN TEMP/S" indication reaches to 70°C (158°F).
7. Open engine hood.
8. Select "HO2S2 (B1) P1147" or "HO2S2 (B2) P1167" of "HO2S2" in "DTC WORK SUPPORT" mode with CONSULT-II.
9. Start engine and following the instruction of CONSULT-II.

DATA MONITOR	
MONITOR	NO DTC
ENG SPEED	XXX rpm
COOLAN TEMP/S	XXX °C

SEF174Y

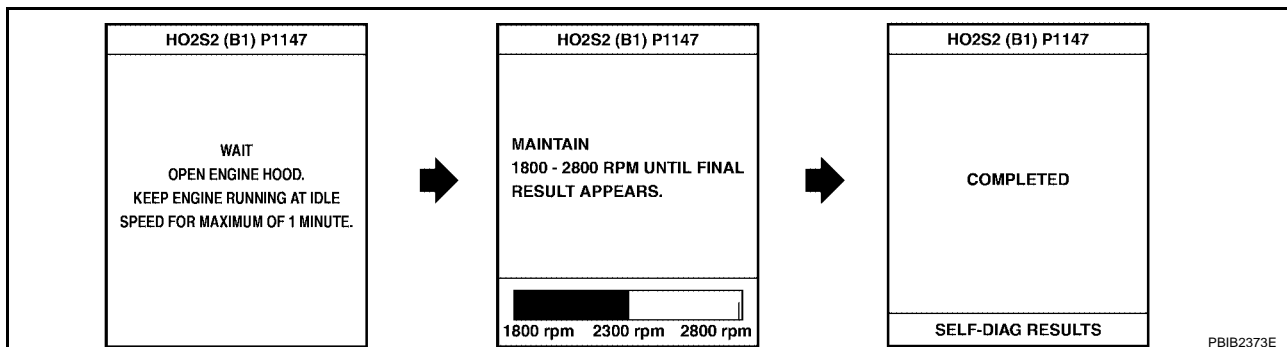

NOTE:

It will take at most 10 minutes until "COMPLETED" is displayed.

10. Make sure that "OK" is displayed after touching "SELF-DIAG RESULTS".
If "NG" is displayed, refer to [EC-1102, "Diagnostic Procedure"](#).
If "CAN NOT BE DIAGNOSED" is displayed, perform the following.
 - a. Turn ignition switch OFF and leave the vehicle in a cool place (soak the vehicle).
 - b. Return to step 1.

Overall Function Check

Use this procedure to check the overall function of the heated oxygen sensor 2 circuit. During this check, a 1st trip DTC might not be confirmed.

WITH GST

1. Start engine and warm it up to the normal operating temperature.
2. Turn ignition switch OFF and wait at least 10 seconds.
3. Start engine and keep the engine speed between 3,500 and 4,000 rpm for at least 1 minute under no load.
4. Let engine idle for 1 minute.
5. Set voltmeter probes between ECM terminal 74 [HO2S2 (B1) signal] or 55 [HO2S2 (B2) signal] and ground.

DTC P1147, P1167 HO2S2

[VQ]

6. Check the voltage when revving up to 4,000 rpm under no load at least 10 times.
(Depress and release accelerator pedal as soon as possible.)
The voltage should be above 0.78V at least once during this procedure.
If the voltage can be confirmed in step 6, step 7 is not necessary.
7. Keep vehicle at idling for 10 minutes, then check the voltage. Or check the voltage when coasting from 80 km/h (50 MPH) in D position with "OD" OFF (A/T), 3rd gear position (M/T).
The voltage should be above 0.78V at least once during this procedure.
8. If NG, go to [EC-1102, "Diagnostic Procedure"](#).

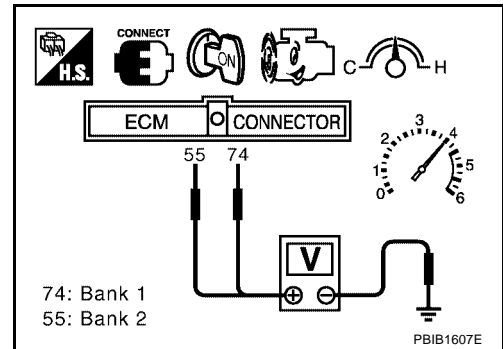

Wiring Diagram
BANK 1

UBS0019P

EC-O2S2B1-01

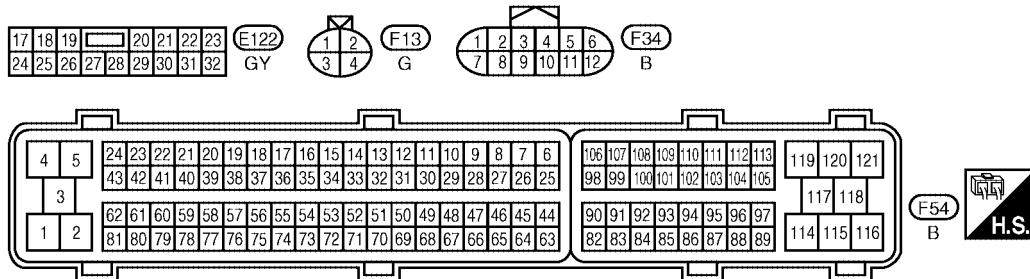
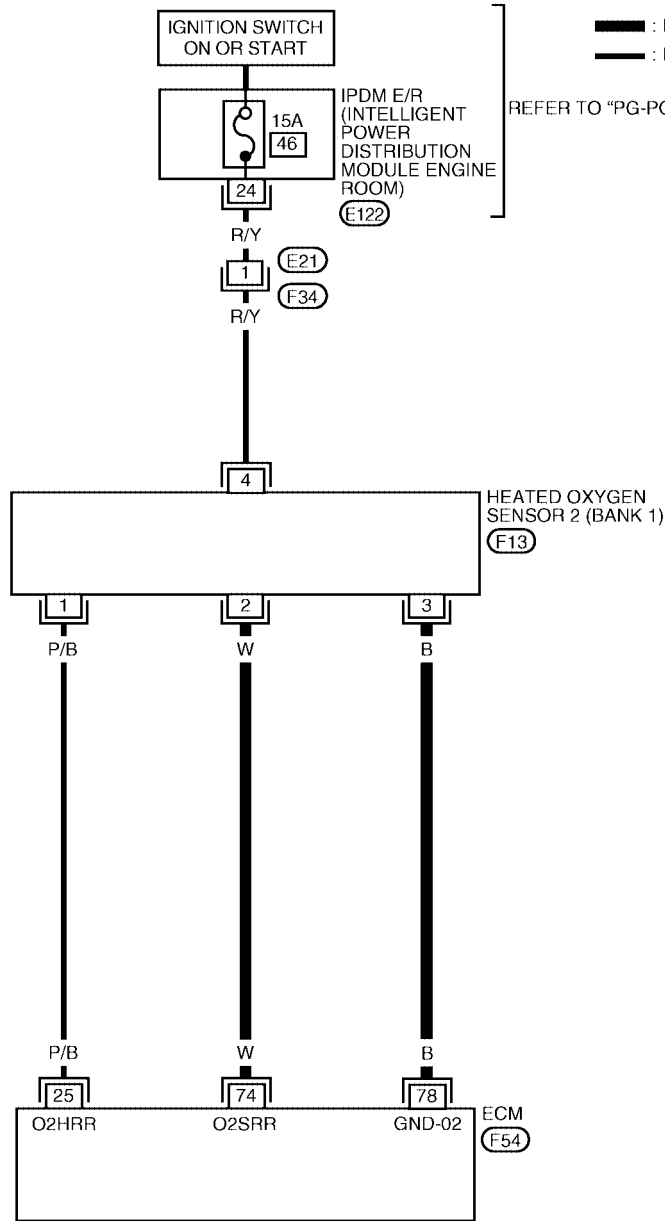

DTC P1147, P1167 HO2S2

[VQ]

Specification data are reference values and are measured between each terminal and ground.

CAUTION:

Do not use ECM ground terminals when measuring input/output voltage. Doing so may result in damage to the ECM's transistor. Use a ground other than ECM terminals, such as the ground.

TER-MINAL NO.	WIRE COLOR	ITEM	CONDITION	DATA (DC Voltage)
74	W	Heated oxygen sensor 2 (bank 1)	[Engine is running] <ul style="list-style-type: none"> ● Warm-up condition ● Revving engine from idle to 3,000 rpm quickly after the following conditions are met <ul style="list-style-type: none"> - After keeping the engine speed between 3,500 and 4,000 rpm for 1 minute and at idle for 1 minute under no load 	0 - Approximately 1.0V
78	B	Sensor ground (Heated oxygen sensor 2)	[Engine is running] <ul style="list-style-type: none"> ● Warm-up condition ● Idle speed 	Approximately 0V

DTC P1147, P1167 HO2S2

[VQ]

BANK 2

EC-O2S2B2-01

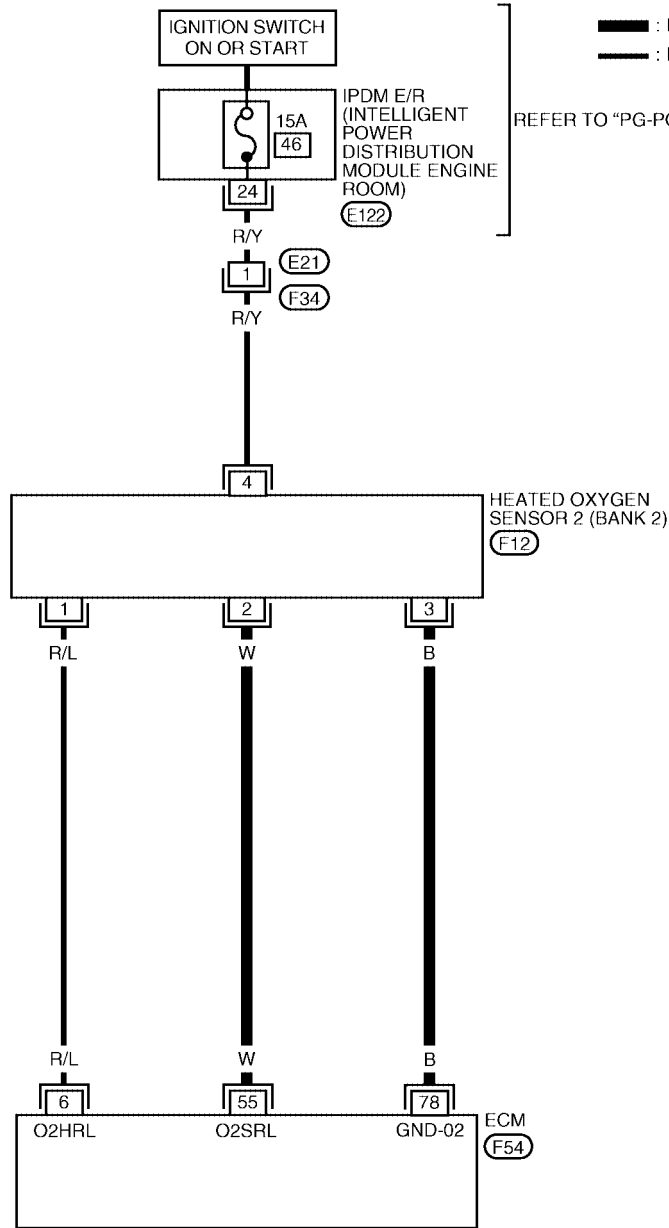

— : DETECTABLE LINE FOR DTC
 - - - : NON-DETECTABLE LINE FOR DTC

REFER TO "PG-POWER".

A
 EC
 C
 D
 E
 F
 G
 H
 I
 J
 K
 L
 M

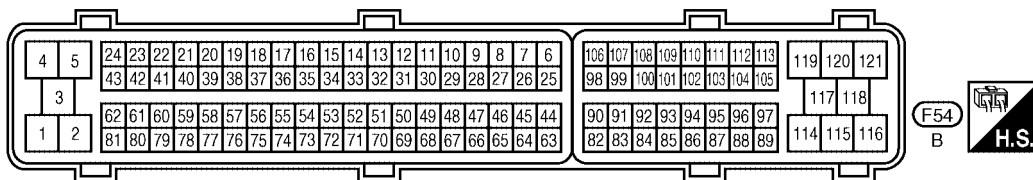
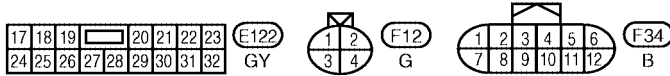

BBWA1556E

Specification data are reference values and are measured between each terminal and ground.

CAUTION:

Do not use ECM ground terminals when measuring input/output voltage. Doing so may result in damage to the ECM's transistor. Use a ground other than ECM terminals, such as the ground.

TER-MINAL NO.	WIRE COLOR	ITEM	CONDITION	DATA (DC Voltage)
55	W	Heated oxygen sensor 2 (bank 2)	<p>[Engine is running]</p> <ul style="list-style-type: none"> ● Warm-up condition ● Revving engine from idle to 3,000 rpm quickly after the following conditions are met <ul style="list-style-type: none"> - After keeping the engine speed between 3,500 and 4,000 rpm for 1 minute and at idle for 1 minute under no load 	0 - Approximately 1.0V
78	B	Sensor ground (Heated oxygen sensor 2)	<p>[Engine is running]</p> <ul style="list-style-type: none"> ● Warm-up condition ● Idle speed 	Approximately 0V

Diagnostic Procedure

UBS0019Q

1. CHECK GROUND CONNECTIONS

1. Turn ignition switch OFF.
2. Loosen and retighten three ground screws on the body. Refer to [EC-789, "Ground Inspection"](#) .

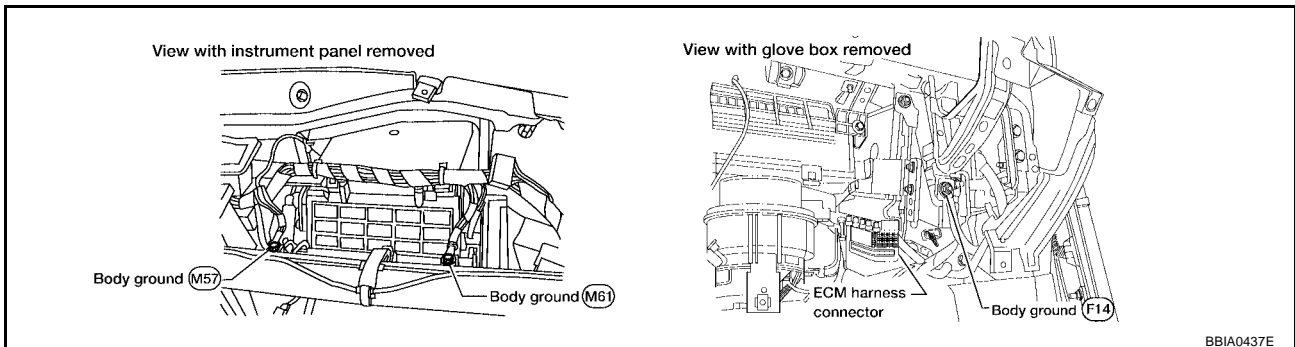

BBIA0437E

OK or NG

- OK >> GO TO 2.
- NG >> Repair or replace ground connections.

2. CLEAR THE SELF-LEARNING DATA

With CONSULT-II

1. Start engine and warm it up to normal operating temperature.
2. Select "SELF-LEARNING CONT" in "WORK SUPPORT" mode with CONSULT-II.
3. Clear the self-learning control coefficient by touching "CLEAR".
4. Run engine for at least 10 minutes at idle speed.
Is the 1st trip DTC P0171 or P0174 detected?
Is it difficult to start engine?

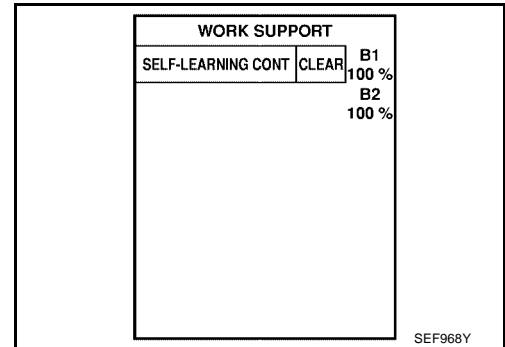

Without CONSULT-II

1. Start engine and warm it up to normal operating temperature.
2. Turn ignition switch OFF.
3. Disconnect mass air flow sensor harness connector, and restart and run engine for at least 5 seconds at idle speed.
4. Stop engine and reconnect mass air flow sensor harness connector.
5. Make sure DTC P0102 is displayed.
6. Erase the DTC memory. Refer to [EC-682, "HOW TO ERASE EMISSION-RELATED DIAGNOSTIC INFORMATION"](#).
7. Make sure DTC P0000 is displayed.
8. Run engine for at least 10 minutes at idle speed.
Is the 1st trip DTC P0171 or P0174 detected?
Is it difficult to start engine?

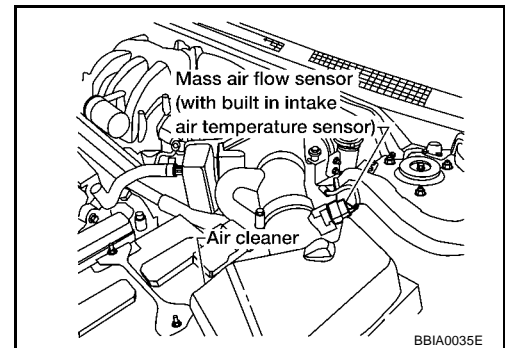

Yes or No

- Yes >> Perform trouble diagnosis for DTC P0171 or P0174. Refer to [EC-868](#).
- No >> GO TO 3.

3. CHECK HO2S2 GROUND CIRCUIT FOR OPEN AND SHORT

1. Turn ignition switch OFF.
2. Disconnect ECM harness connector.
3. Disconnect heated oxygen sensor 2 harness connector.

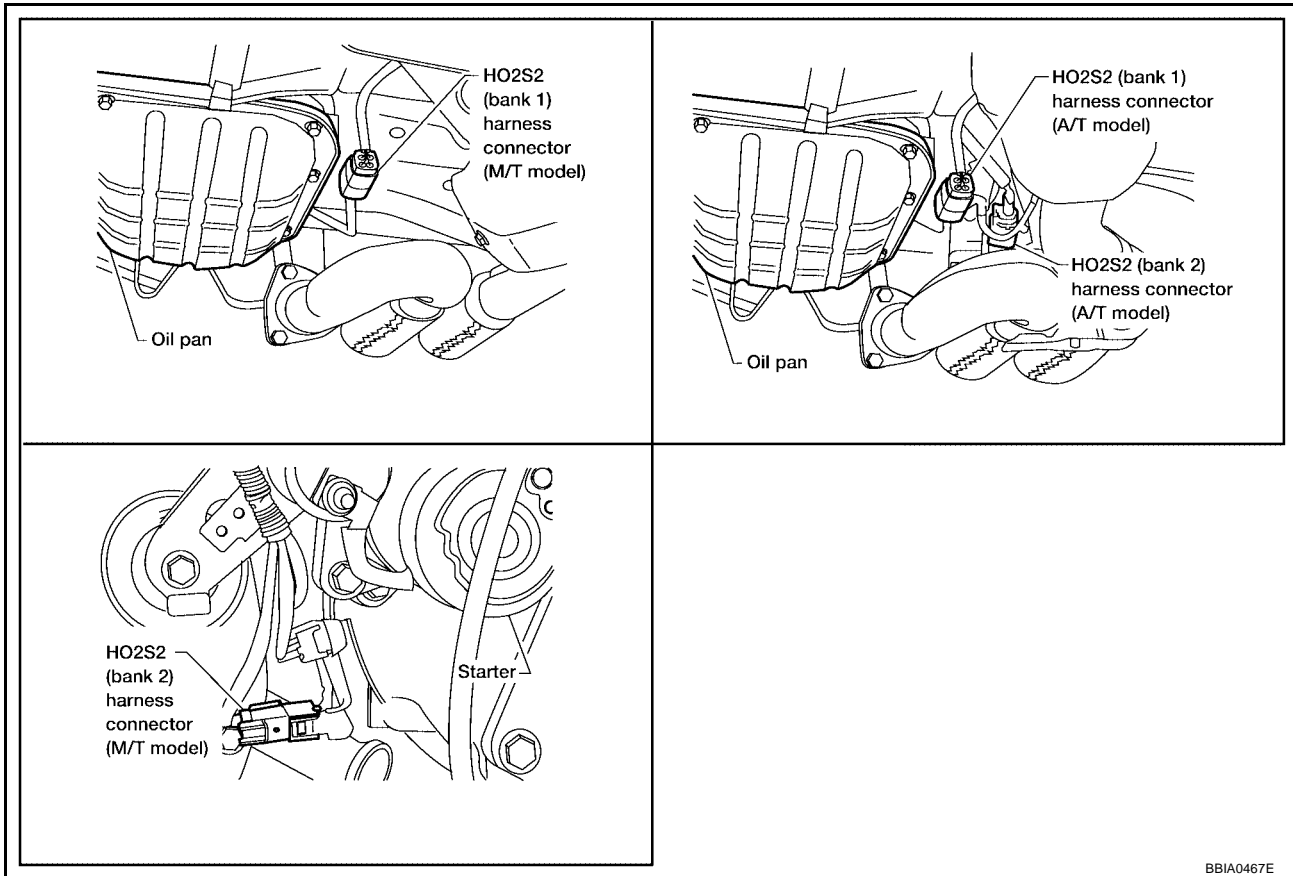

4. Check harness continuity between HO2S2 terminal 3 and ECM terminal 78. Refer to Wiring Diagram.

Continuity should exist.

5. Also check harness for short to ground and short to power.

OK or NG

OK >> GO TO 4.

NG >> Repair open circuit or short to ground or short to power in harness or connectors.

4. CHECK HO2S2 INPUT SIGNAL CIRCUIT FOR OPEN AND SHORT

1. Check harness continuity between ECM terminal and HO2S2 terminal as follows.
Refer to Wiring Diagram.

DTC	Terminals		Bank
	ECM	Sensor	
P1147	74	2	1
P1167	55	2	2

Continuity should exist.

2. Check harness continuity between the following terminals and ground.
Refer to Wiring Diagram.

DTC	Terminals		Bank
	ECM	Sensor	
P1147	74	2	1
P1167	55	2	2

Continuity should not exist.

3. Also check harness for short to power.

OK or NG

OK >> GO TO 5.

NG >> Repair open circuit or short to ground or short to power in harness or connectors.

5. CHECK HEATED OXYGEN SENSOR 2

Refer to [EC-1105, "Component Inspection"](#) .

OK or NG

OK >> GO TO 6.

NG >> Replace malfunctioning heated oxygen sensor 2.

6. CHECK INTERMITTENT INCIDENT

Refer to [EC-782, "TROUBLE DIAGNOSIS FOR INTERMITTENT INCIDENT"](#) .

>> INSPECTION END

**Component Inspection
HEATED OXYGEN SENSOR 2**

UBS0019R

With CONSULT-II

1. Turn ignition switch ON and select "DATA MONITOR" mode with CONSULT-II.
2. Start engine and warm it up to the normal operating temperature.
3. Turn ignition switch OFF and wait at least 10 seconds.
4. Start engine and keep the engine speed between 3,500 and 4,000 rpm for at least 1 minute under no load.
5. Let engine idle for 1 minute.

DATA MONITOR	
MONITOR	NO DTC
ENG SPEED	XXX rpm
COOLAN TEMP/S	XXX °C

SEF174Y

- Select "FUEL INJECTION" in "ACTIVE TEST" mode, and select "HO2S2 (B1)/(B2)" as the monitor item with CONSULT-II.

ACTIVE TEST	
FUEL INJECTION	25 %
MONITOR	
ENG SPEED	XXX rpm
HO2S2 (B1)	XXX V
HO2S2 (B2)	XXX V

PBIB1672E

- Check "HO2S2 (B1)/(B2)" at idle speed when adjusting "FUEL INJECTION" to $\pm 25\%$.

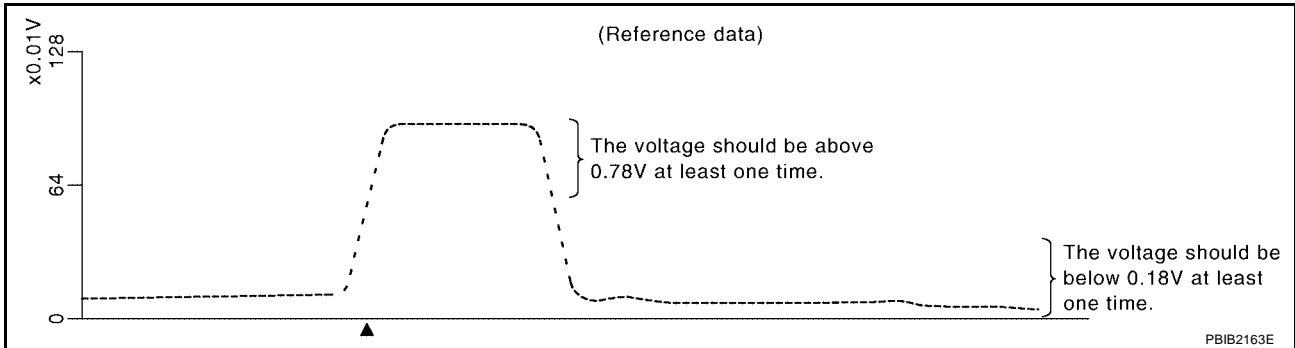

"HO2S2 (B1)/(B2)" should be above 0.78V at least once when the "FUEL INJECTION" is +25%.
 "HO2S2 (B1)/(B2)" should be below 0.18V at least once when the "FUEL INJECTION" is -25%.

CAUTION:

- Discard any heated oxygen sensor which has been dropped from a height of more than 0.5 m (19.7 in) onto a hard surface such as a concrete floor; use a new one.
- Before installing new oxygen sensor, clean exhaust system threads using Oxygen Sensor Thread Cleaner tool J-43897-18 or J-43897-12 and approved anti-seize lubricant.

Without CONSULT-II

- Start engine and warm it up to the normal operating temperature.
- Turn ignition switch OFF and wait at least 10 seconds.
- Start engine and keep the engine speed between 3,500 and 4,000 rpm for at least 1 minute under no load.
- Let engine idle for 1 minute.
- Set voltmeter probes between ECM terminal 74 [HO2S2 (B1) signal] or 55 [HO2S2 (B2) signal] and ground.
- Check the voltage when revving up to 4,000 rpm under no load at least 10 times.
 (Depress and release accelerator pedal as soon as possible.)
The voltage should be above 0.78V at least once during this procedure.
If the voltage is above 0.78V at step 6, step 7 is not necessary.
- Keep vehicle at idling for 10 minutes, then check voltage. Or check the voltage when coasting from 80 km/h (50 MPH) in D position with "OD" OFF (A/T), 3rd gear position (M/T).
The voltage should be below 0.18V at least once during this procedure.
- If NG, replace heated oxygen sensor 2.

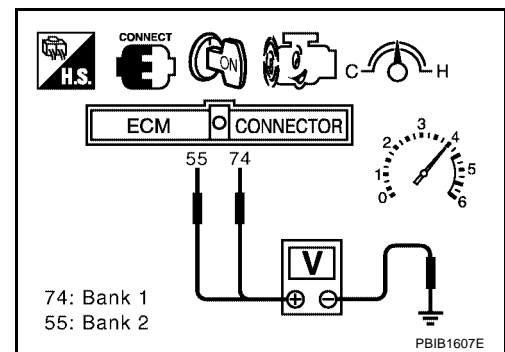

CAUTION:

- Discard any heated oxygen sensor which has been dropped from a height of more than 0.5 m (19.7 in) onto a hard surface such as a concrete floor; use a new one.
- Before installing new oxygen sensor, clean exhaust system threads using Oxygen Sensor Thread Cleaner tool J-43897-18 or J-43897-12 and approved anti-seize lubricant.

Removal and Installation
HEATED OXYGEN SENSOR 2

Refer to [EM-134, "EXHAUST MANIFOLD AND THREE WAY CATALYST"](#) .

A

EC

C

D

E

F

G

H

I

J

K

L

M

DTC P1148, P1168 CLOSED LOOP CONTROL

[VQ]

DTC P1148, P1168 CLOSED LOOP CONTROL

PF2:22690

On Board Diagnosis Logic

UBS0019T

These self-diagnoses have the one trip detection logic.

DTC No.	Trouble diagnosis name	DTC detecting condition	Possible cause
P1148 1148 (Bank 1)	Closed loop control function	The closed loop control function for bank 1 does not operate even when vehicle is driving in the specified condition.	<ul style="list-style-type: none">● Harness or connectors [The air fuel ratio (A/F) sensor 1 circuit is open or shorted.]● Air fuel ratio (A/F) sensor 1● Air fuel ratio (A/F) sensor 1 heater
P1168 1168 (Bank 2)		The closed loop control function for bank 2 does not operate even when vehicle is driving in the specified condition.	

DTC P1148 or P1168 is displayed with another DTC for air fuel ratio (A/F) sensor 1.
Perform the trouble diagnosis for the corresponding DTC.

DTC P1211 TCS CONTROL UNIT

[VQ]

DTC P1211 TCS CONTROL UNIT

PFP:47850

Description

UBS0019U

The malfunction information related to TCS is transferred through the CAN communication line from “ABS actuator and electric unit (control unit)” to ECM.

Be sure to erase the malfunction information such as DTC not only for “ABS actuator and electric unit (control unit)” but also for ECM after TCS related repair.

On Board Diagnosis Logic

UBS0019V

Freeze frame data is not stored in the ECM for this self-diagnosis. The MIL will not light up for this self-diagnosis.

DTC No.	Trouble diagnosis name	DTC detecting condition	Possible cause
P1211 1211	TCS control unit	ECM receives a malfunction information from “ABS actuator and electric unit (control unit)”.	<ul style="list-style-type: none">● ABS actuator and electric unit (control unit)● TCS related parts

DTC Confirmation Procedure

UBS0019W

TESTING CONDITION:

Before performing the following procedure, confirm that battery voltage is more than 10.5V at idle.

WITH CONSULT-II

1. Turn ignition switch ON.
2. Select “DATA MONITOR” mode with CONSULT-II.
3. Start engine and let it idle for at least 60 seconds.
4. If 1st trip DTC is detected, go to [EC-1109, "Diagnostic Procedure"](#) .

DATA MONITOR	
MONITOR	NO DTC
ENG SPEED	XXX rpm

SEF058Y

WITH GST

Follow the procedure “WITH CONSULT-II” above.

Diagnostic Procedure

UBS0019X

Go to [BRC-51, "TROUBLE DIAGNOSIS"](#) .

DTC P1212 TCS COMMUNICATION LINE

[VQ]

DTC P1212 TCS COMMUNICATION LINE

PFP:47850

Description

UBS0019Y

NOTE:

If DTC P1212 is displayed with DTC U1000 or U1001, first perform the trouble diagnosis for DTC U1000, U1001. Refer to [EC-790, "DTC U1000, U1001 CAN COMMUNICATION LINE"](#).

This CAN communication line is used to control the smooth engine operation during the TCS operation. Pulse signals are exchanged between ECM and "ABS actuator and electric unit (control unit)".

Be sure to erase the malfunction information such as DTC not only for "ABS actuator and electric unit (control unit)" but also for ECM after TCS related repair.

On Board Diagnosis Logic

UBS0019Z

Freeze frame data is not stored in the ECM for this self-diagnosis. The MIL will not light up for this self-diagnosis.

DTC No.	Trouble diagnosis name	DTC detecting condition	Possible cause
P1212 1212	TCS communication line	ECM can not receive the information from "ABS actuator and electric unit (control unit)" continuously.	<ul style="list-style-type: none">● Harness or connectors (The CAN communication line is open or shorted.)● ABS actuator and electric unit (control unit)● Dead (Weak) battery

DTC Confirmation Procedure

UBS001A0

TESTING CONDITION:

Before performing the following procedure, confirm that battery voltage is more than 10.5V at idle.

④ WITH CONSULT-II

1. Turn ignition switch ON.
2. Select "DATA MONITOR" mode with CONSULT-II.
3. Start engine and let it idle for at least 10 seconds.
4. If a 1st trip DTC is detected, go to [EC-1110, "Diagnostic Procedure"](#).

DATA MONITOR	
MONITOR	NO DTC
ENG SPEED	XXX rpm

SEF058Y

④ WITH GST

Follow the procedure "WITH CONSULT-II" above.

Diagnostic Procedure

UBS001A1

Go to [BRC-51, "TROUBLE DIAGNOSIS"](#).

DTC P1217 ENGINE OVER TEMPERATURE

[VQ]

DTC P1217 ENGINE OVER TEMPERATURE

PFP:00000

Description SYSTEM DESCRIPTION

UBS001A2

NOTE:

If DTC P1217 is displayed with DTC U1000 or U1001, first perform the trouble diagnosis for DTC U1000, U1001. Refer to [EC-790, "DTC U1000, U1001 CAN COMMUNICATION LINE"](#).

Cooling Fan Control

Sensor	Input Signal to ECM	ECM function	Actuator
Crankshaft position sensor (POS) Camshaft position sensor (PHASE)	Engine speed*1	Cooling fan control	IPDM E/R (Cooling fan relay)
Battery	Battery voltage*1		
Wheel sensor	Vehicle speed*2		
Engine coolant temperature sensor	Engine coolant temperature		
Air conditioner switch	Air conditioner ON signal*2		
Refrigerant pressure sensor	Refrigerant pressure		

*1: The ECM determines the start signal status by the signals of engine speed and battery voltage.

*2: This signal is sent to ECM through CAN communication line.

The ECM controls the cooling fan corresponding to the vehicle speed, engine coolant temperature, refrigerant pressure, and air conditioner ON signal. The control system has 4-step control [HIGH/MIDDLE/LOW/OFF]. The ECM control cooling fan relays through CAN communication line.

Cooling Fan Operation

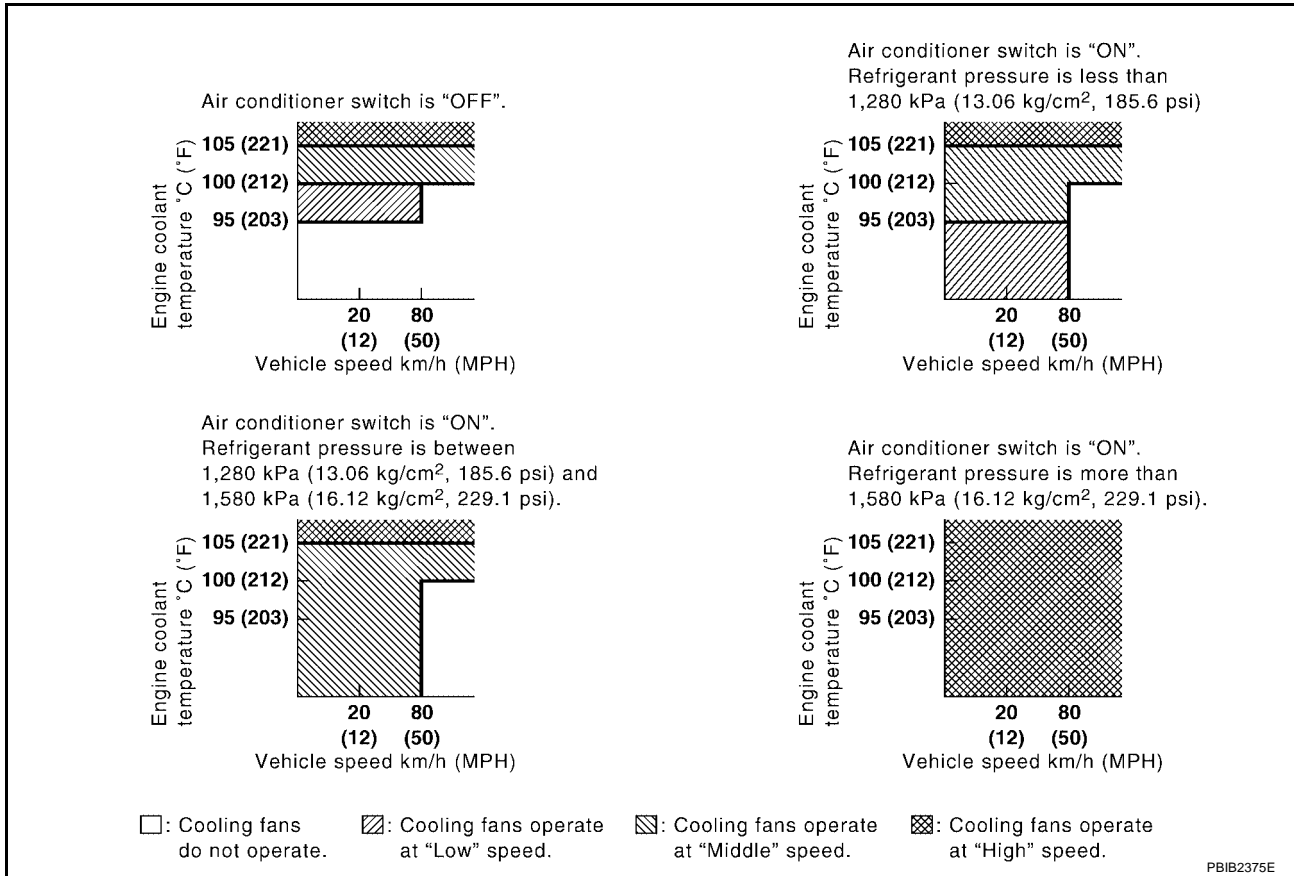

DTC P1217 ENGINE OVER TEMPERATURE

[VQ]

Cooling Fan Relay Operation

The ECM controls cooling fan relays in the IPDM E/R through CAN communication line.

Cooling fan speed	Cooling fan relay		
	1	2	3
Stop (OFF)	OFF	OFF	OFF
Low (LOW)	OFF	ON	OFF
Middle (MID)	OFF	OFF	ON
High (HI)	ON	OFF	ON

COMPONENT DESCRIPTION

Cooling Fan Motor

The cooling fan operates at each speed when the current flows in the cooling fan motor as follows.

Cooling fan speed	Cooling fan motor terminals	
	(+)	(-)
Middle (MID)	1	3 and 4
	2	3 and 4
	1 and 2	3
	1 and 2	4
High (HI)	1 and 2	3 and 4

The cooling fan operates at low (LOW) speed when cooling fan motors-1 and -2 are circuited in series under middle speed condition.

CONSULT-II Reference Value in Data Monitor Mode

UBS001A3

Specification data are reference values.

MONITOR ITEM	CONDITION	SPECIFICATION
AIR COND SIG	● Engine: After warming up, idle the engine	Air conditioner switch: OFF OFF
		Air conditioner switch: ON (Compressor operates.) ON
COOLING FAN	● Engine: After warming up, idle the engine ● Air conditioner switch: OFF	Engine coolant temperature is 94°C (201°F) or less OFF
		Engine coolant temperature is between 95°C (203°F) and 99°C (210°F) LOW
		Engine coolant temperature is between 100°C (212°F) and 104°C (219°F) MID
		Engine coolant temperature is 105°C (221°F) or more HI

On Board Diagnosis Logic

If the cooling fan or another component in the cooling system malfunctions, engine coolant temperature will rise.

When the engine coolant temperature reaches an abnormally high temperature condition, a malfunction is indicated.

This self-diagnosis has the one trip detection logic.

DTC No.	Trouble diagnosis name	DTC detecting condition	Possible cause
P1217 1217	Engine over temperature (Overheat)	<ul style="list-style-type: none"> ● Cooling fan does not operate properly (Overheat). ● Cooling fan system does not operate properly (Overheat). ● Engine coolant level was not added to the system using the proper filling method. ● Engine coolant is not within the specified range. 	<ul style="list-style-type: none"> ● Harness or connectors (The cooling fan circuit is open or shorted.) ● Cooling fan ● IPDM E/R (Cooling fan relay) ● Radiator hose ● Radiator ● Radiator cap ● Water pump ● Thermostat <p>For more information, refer to EC-1122, "Main 12 Causes of Overheating".</p>

CAUTION:

When a malfunction is indicated, be sure to replace the coolant. Refer to [MA-22](#), "[Changing Engine Coolant](#)". Also, replace the engine oil. Refer to [MA-25](#), "[Changing Engine Oil](#)".

1. Fill radiator with coolant up to specified level with a filling speed of 2 liters per minute. Be sure to use coolant with the proper mixture ratio. Refer to [MA-14](#), "[ANTI-FREEZE COOLANT MIXTURE RATIO](#)".
2. After refilling coolant, run engine to ensure that no water-flow noise is emitted.

Overall Function Check

Use this procedure to check the overall function of the cooling fan. During this check, a DTC might not be confirmed.

WARNING:

Never remove the radiator cap when the engine is hot. Serious burns could be caused by high pressure fluid escaping from the radiator.

Wrap a thick cloth around cap. Carefully remove the cap by turning it a quarter turn to allow built-up pressure to escape. Then turn the cap all the way off.

WITH CONSULT-II

1. Check the coolant level in the reservoir tank and radiator.
Allow engine to cool before checking coolant level.
If the coolant level in the reservoir tank and/or radiator is below the proper range, skip the following steps and go to [EC-1117](#), "[Diagnostic Procedure](#)".
2. Confirm whether customer filled the coolant or not. If customer filled the coolant, skip the following steps and go to [EC-1117](#), "[Diagnostic Procedure](#)".
3. Turn ignition switch ON.

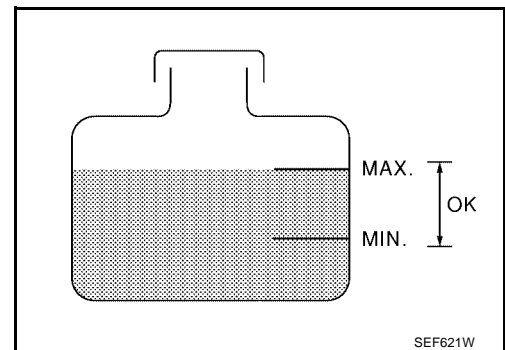

SEF621W

DTC P1217 ENGINE OVER TEMPERATURE

[VQ]

4. Perform "COOLING FAN" in "ACTIVE TEST" mode with CONSULT-II.
5. If the results are NG, go to [EC-1117, "Diagnostic Procedure"](#) .

ACTIVE TEST	
COOLING FAN	OFF
MONITOR	
COOLAN TEMP/S	XXX °C

SEF646X

WITH GST

1. Check the coolant level in the reservoir tank and radiator.
Allow engine to cool before checking coolant level.
If the coolant level in the reservoir tank and/or radiator is below the proper range, skip the following steps and go to [EC-1117, "Diagnostic Procedure"](#) .
2. Confirm whether customer filled the coolant or not. If customer filled the coolant, skip the following steps and go to [EC-1117, "Diagnostic Procedure"](#) .
3. Perform IPDM E/R auto active test and check cooling fan motors operation, refer to [PG-21, "Auto Active Test"](#)
4. If NG, go to [EC-1117, "Diagnostic Procedure"](#) .

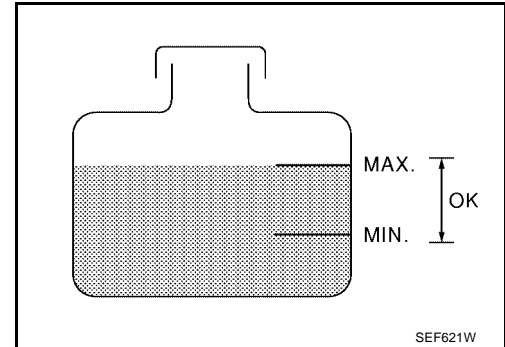

DTC P1217 ENGINE OVER TEMPERATURE

[VQ]

EC-COOL/F-02

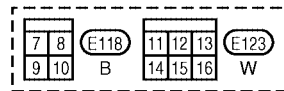
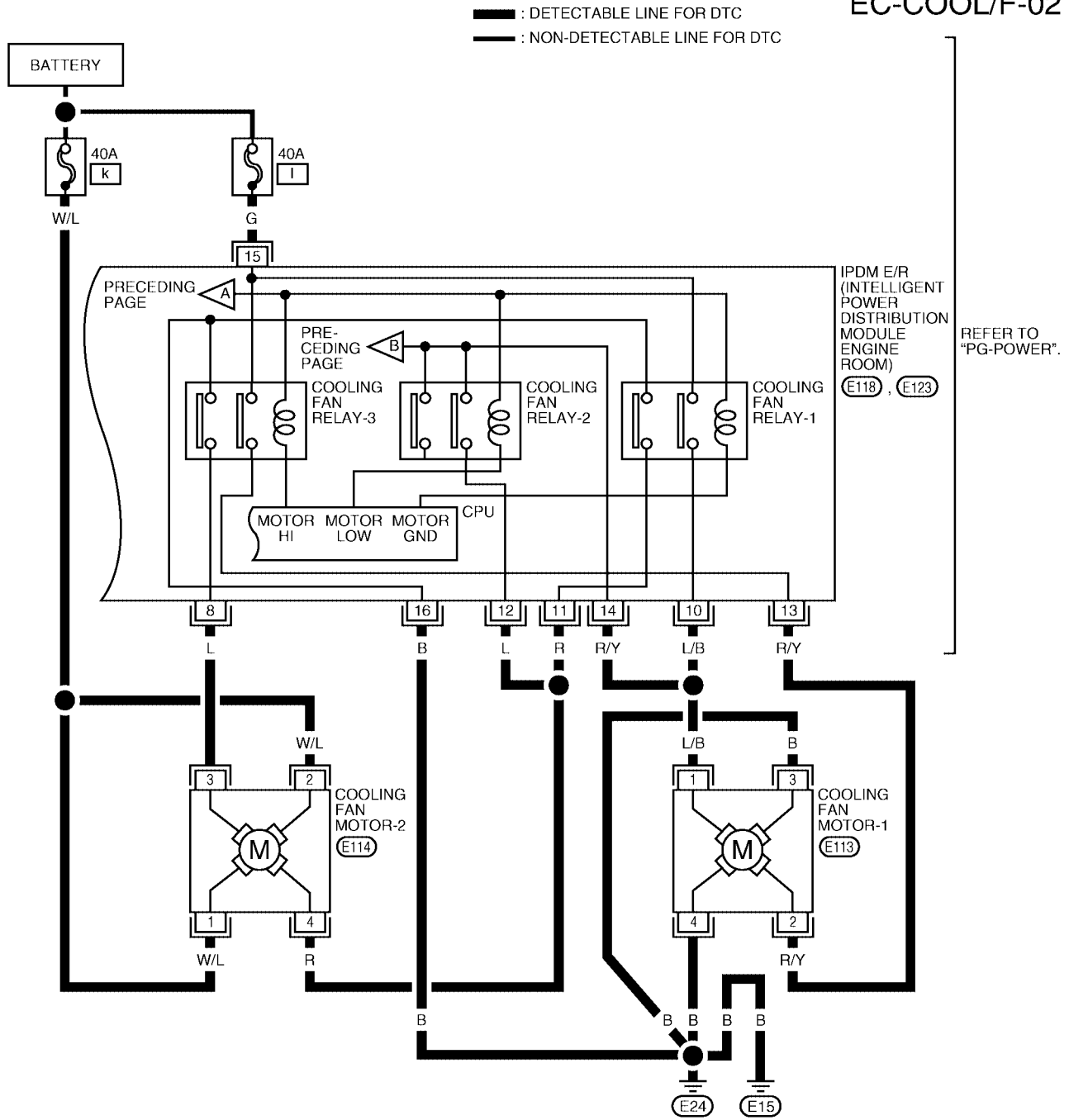

BBWA1571E

Diagnostic Procedure

1. INSPECTION START

Do you have CONSULT-II?

Yes or No

- Yes >> GO TO 2.
- No >> GO TO 3.

2. CHECK COOLING FAN OPERATION

With CONSULT-II

1. Start engine and let it idle.
2. Select "COOLING FAN" in "ACTIVE TEST" mode with CONSULT-II.
3. Make sure that cooling fans-1 and -2 operate at each speed (LOW/MID/HI).

OK or NG

- OK >> GO TO 4.
- NG >> Check cooling fan control circuit. (Go to [EC-1119, "PROCEDURE A"](#).)

ACTIVE TEST	
COOLING FAN	LOW
MONITOR	
COOLAN TEMP/S	XXX °C

SEF784Z

3. CHECK COOLING FAN OPERATION

Without CONSULT-II

1. Perform IPDM E/R auto active test and check cooling fan motors operation, refer to [PG-21, "Auto Active Test"](#).
2. Make sure that cooling fans-1 and -2 operate at each speed (Low/Middle/High).

OK or NG

- OK >> GO TO 4.
- NG >> Check cooling fan control circuit. (Go to [EC-1119, "PROCEDURE A"](#).)

4. CHECK COOLING SYSTEM FOR LEAK

Apply pressure to the cooling system with a tester, and check if the pressure drops.

Testing pressure: 157 kPa (1.6 kg/cm² , 23 psi)

CAUTION:

Higher than the specified pressure may cause radiator damage. Pressure should not drop.

OK or NG

- OK >> GO TO 5.
- NG >> Check the following for leak. Refer to [CO-28, "CHECKING COOLING SYSTEM FOR LEAKS"](#).

- Hose
- Radiator
- Water pump

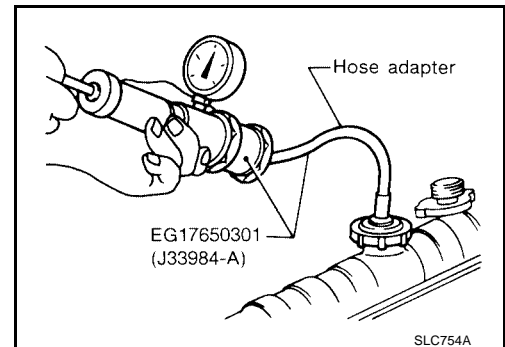

5. CHECK RADIATOR CAP

Apply pressure to cap with a tester.

Radiator cap relief pressure: **59 - 98 kPa (0.6 - 1.0 kg/cm², 9 - 14 psi)**

OK or NG

- OK >> GO TO 6.
- NG >> Replace radiator cap.

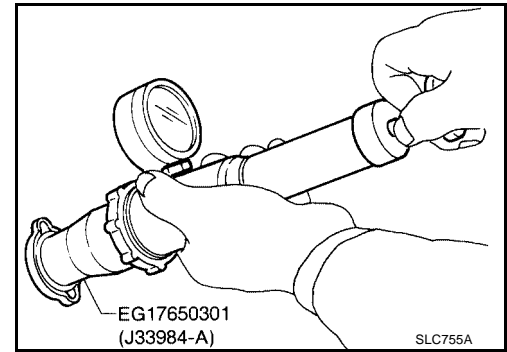

6. CHECK THERMOSTAT

1. Check valve seating condition at normal room temperatures.
It should seat tightly.
2. Check valve opening temperature and valve lift.

Valve opening temperature: **82°C (180°F) [standard]**
Valve lift: **More than 8.6 mm/95°C (0.339 in/203°F)**

3. Check if valve is closed at 5°C (9°F) below valve opening temperature.
For details, refer to [CO-42, "THERMOSTAT AND THERMOSTAT HOUSING"](#).

OK or NG

- OK >> GO TO 7.
- NG >> Replace thermostat

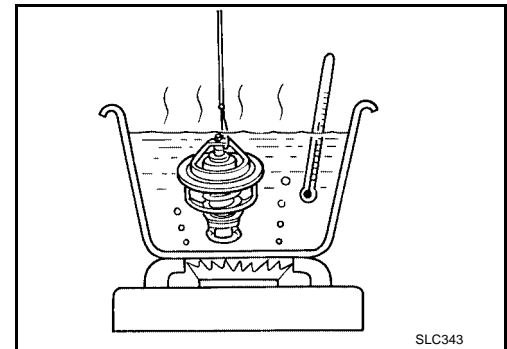

7. CHECK ENGINE COOLANT TEMPERATURE SENSOR

Refer to [EC-830, "Component Inspection"](#).

OK or NG

- OK >> GO TO 8.
- NG >> Replace engine coolant temperature sensor.

8. CHECK MAIN 12 CAUSES

If the cause cannot be isolated, go to [EC-1122, "Main 12 Causes of Overheating"](#).

>> INSPECTION END

PROCEDURE A

1. CHECK IPDM E/R POWER SUPPLY CIRCUIT

1. Turn ignition switch OFF.
2. Disconnect IPDM E/R harness connector E123.
3. Check voltage between IPDM E/R terminal 15 and ground with CONSULT-II or tester.

Voltage: Battery voltage

OK or NG

- OK >> GO TO 3.
- NG >> GO TO 2.

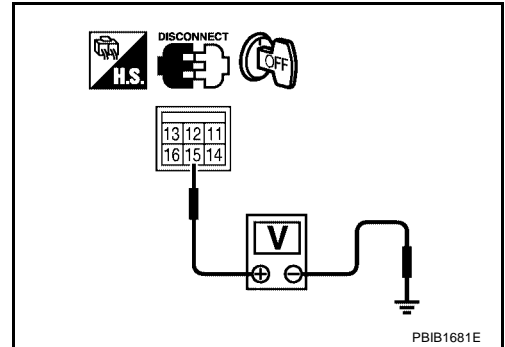

2. DETECT MALFUNCTIONING PART

Check the following.

- 40A fusible link
- Harness for open or short between IPDM E/R and battery

>> Repair open circuit or short to ground or short to power in harness or connectors.

3. CHECK IPDM E/R GROUND CIRCUIT FOR OPEN AND SHORT

1. Turn ignition switch OFF.
2. Disconnect IPDM E/R harness connectors E121, E124.
3. Check harness continuity between IPDM E/R terminals 16, 38, 60 and ground. Refer to Wiring Diagram.

Continuity should exist.

4. Also check harness for short to power.

OK or NG

- OK >> GO TO 4.
- NG >> Repair open circuit or short to ground or short to power in harness or connectors.

4. CHECK COOLING FAN MOTOR-2 POWER SUPPLY CIRCUIT

1. Disconnect cooling fan motor-2 harness connector.

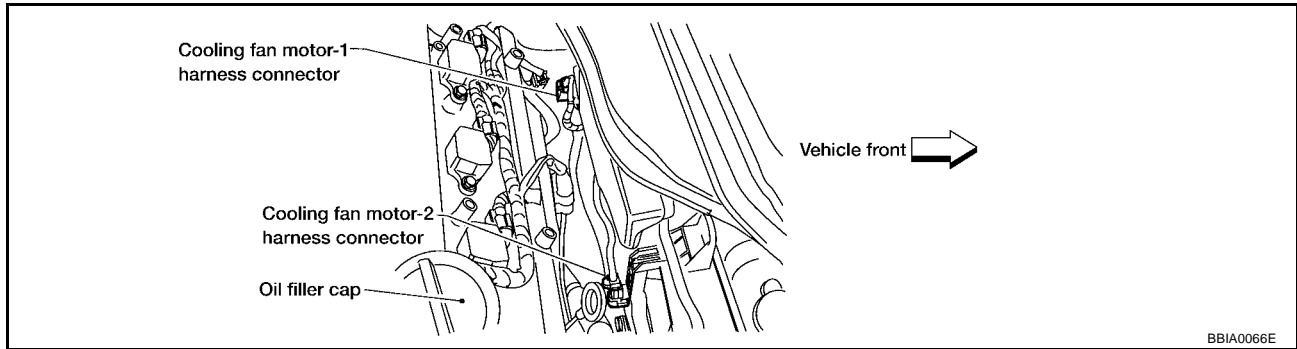

2. Check voltage between cooling fan motor-2 terminals 1, 2 and ground with CONSULT-II or tester.

Voltage: Battery voltage

OK or NG

- OK >> GO TO 6.
- NG >> GO TO 5.

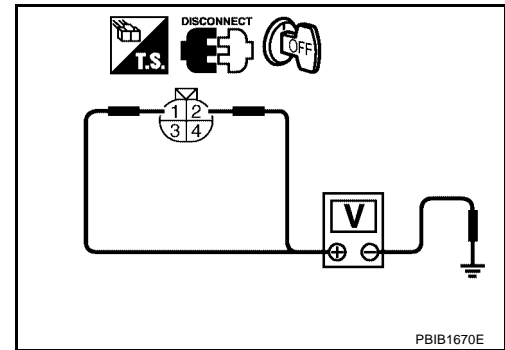

5. DETECT MALFUNCTIONING PART

Check the following.

- 40A fusible link
- Harness for open or short between cooling fan motor-2 and battery

>> Repair open circuit or short to ground or short to power in harness or connectors.

6. CHECK COOLING FAN MOTOR-2 GROUND CIRCUIT FOR OPEN AND SHORT

1. Disconnect IPDM E/R harness connector E118.
2. Check harness continuity between the following terminals.
Cooling fan motor-2 terminal 3 and IPDM E/R terminal 8
Cooling fan motor-2 terminal 4 and IPDM E/R terminals 11, 12
Refer to Wiring diagram.

Continuity should exist.

3. Also check harness for short to ground and short to power.

OK or NG

- OK >> GO TO 7.
- NG >> Repair open circuit or short to ground or short to power in harness or connectors.

7. CHECK COOLING FAN MOTOR-1 GROUND CIRCUIT FOR OPEN AND SHORT

1. Disconnect cooling fan motor-1 harness connector.

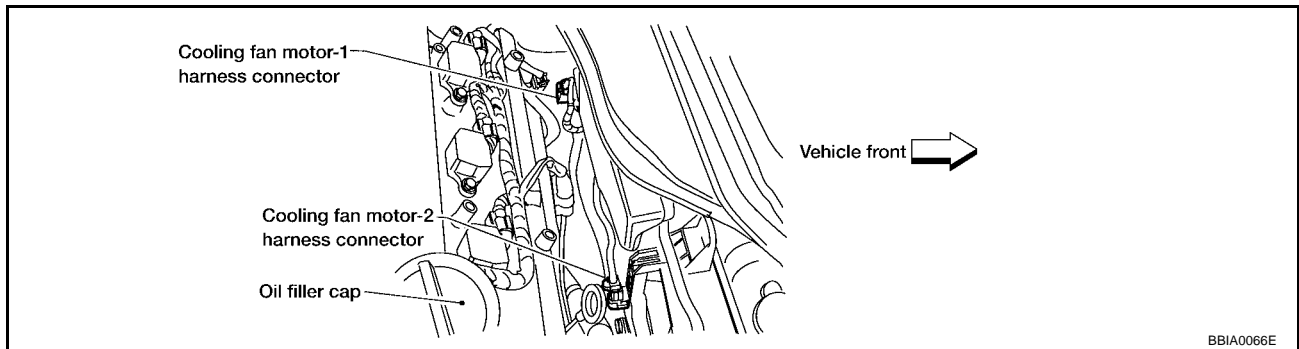

2. Check harness continuity between cooling fan motor-1 terminals 3, 4 and ground. Refer to Wiring diagram.

Continuity should exist.

3. Also check harness for short to power.

OK or NG

OK >> GO TO 8.

NG >> Repair open circuit or short to power in harness or connectors.

8. CHECK COOLING FAN MOTOR-1 POWER SUPPLY CIRCUIT FOR OPEN AND SHORT

1. Check harness continuity between the following terminals.
Cooling fan motor-1 terminal 2 and IPDM E/R terminal 13
Cooling fan motor-1 terminal 1 and IPDM E/R terminals 10, 14
Refer to Wiring Diagram.

Continuity should exist.

2. Also check harness for short to ground and short to power.

OK or NG

OK >> GO TO 9.

NG >> Repair open circuit or short to ground or short to power in harness or connectors.

9. CHECK COOLING FAN MOTORS

Refer to [EC-1122, "Component Inspection"](#) .

OK or NG

OK >> GO TO 10.

NG >> Replace cooling fan motors.

10. CHECK INTERMITTENT INCIDENT

Perform [EC-782, "TROUBLE DIAGNOSIS FOR INTERMITTENT INCIDENT"](#) .

OK or NG

OK >> Replace IPDM E/R. Refer to [PG-15, "IPDM E/R \(INTELLIGENT POWER DISTRIBUTION MODULE ENGINE ROOM\)"](#) .

NG >> Repair or replace harness or connector.

DTC P1217 ENGINE OVER TEMPERATURE

[VQ]

UBS001A8

Main 12 Causes of Overheating

Engine	Step	Inspection item	Equipment	Standard	Reference page
OFF	1	<ul style="list-style-type: none"> Blocked radiator Blocked condenser Blocked radiator grille Blocked bumper 	<ul style="list-style-type: none"> Visual 	No blocking	—
	2	<ul style="list-style-type: none"> Coolant mixture 	<ul style="list-style-type: none"> Coolant tester 	50 - 50% coolant mixture	MA-14
	3	<ul style="list-style-type: none"> Coolant level 	<ul style="list-style-type: none"> Visual 	Coolant up to MAX level in reservoir tank and radiator filler neck	CO-28
	4	<ul style="list-style-type: none"> Radiator cap 	<ul style="list-style-type: none"> Pressure tester 	59 - 98 kPa (0.6 - 1.0 kg/cm ² , 9 - 14 psi) (Limit)	CO-28
ON*2	5	<ul style="list-style-type: none"> Coolant leaks 	<ul style="list-style-type: none"> Visual 	No leaks	CO-28
ON*2	6	<ul style="list-style-type: none"> Thermostat 	<ul style="list-style-type: none"> Touch the upper and lower radiator hoses 	Both hoses should be hot	CO-42
ON*1	7	<ul style="list-style-type: none"> Cooling fan 	<ul style="list-style-type: none"> CONSULT-II 	Operating	See trouble diagnosis for DTC P1217 (EC-1111).
OFF	8	<ul style="list-style-type: none"> Combustion gas leak 	<ul style="list-style-type: none"> Color checker chemical tester 4 Gas analyzer 	Negative	—
ON*3	9	<ul style="list-style-type: none"> Coolant temperature gauge 	<ul style="list-style-type: none"> Visual 	Gauge less than 3/4 when driving	—
		<ul style="list-style-type: none"> Coolant overflow to reservoir tank 	<ul style="list-style-type: none"> Visual 	No overflow during driving and idling	CO-28
OFF*4	10	<ul style="list-style-type: none"> Coolant return from reservoir tank to radiator 	<ul style="list-style-type: none"> Visual 	Should be initial level in reservoir tank	CO-28
OFF	11	<ul style="list-style-type: none"> Cylinder head 	<ul style="list-style-type: none"> Straight gauge feeler gauge 	0.1 mm (0.004 in) Maximum distortion (warping)	EM-200
	12	<ul style="list-style-type: none"> Cylinder block and pistons 	<ul style="list-style-type: none"> Visual 	No scuffing on cylinder walls or piston	EM-224

*1: Turn the ignition switch ON.

*2: Engine running at 3,000 rpm for 10 minutes.

*3: Drive at 90 km/h (55 MPH) for 30 minutes and then let idle for 10 minutes.

*4: After 60 minutes of cool down time.

For more information, refer to [CO-24, "OVERHEATING CAUSE ANALYSIS"](#).

Component Inspection COOLING FAN MOTORS-1 AND -2

UBS001A9

- Disconnect cooling fan motor harness connectors.
- Supply cooling fan motor terminals with battery voltage and check operation.

Cooling fan speed	Cooling fan motor terminals	
	(+)	(-)
Middle (MID)	1	3 and 4
	2	3 and 4
	1 and 2	3
	1 and 2	4
High (HI)	1 and 2	3 and 4

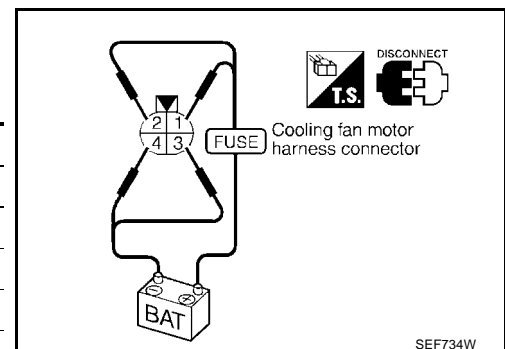

Cooling fan motor should operate.
If NG, replace cooling fan motor.

DTC P1225 TP SENSOR

Component Description

Electric throttle control actuator consists of throttle control motor, throttle position sensor, etc. The throttle position sensor responds to the throttle valve movement.

The throttle position sensor has the two sensors. These sensors are a kind of potentiometers which transform the throttle valve position into output voltage, and emit the voltage signal to the ECM. In addition, these sensors detect the opening and closing speed of the throttle valve and feed the voltage signals to the ECM. The ECM judges the current opening angle of the throttle valve from these signals and the ECM controls the throttle control motor to make the throttle valve opening angle properly in response to driving condition.

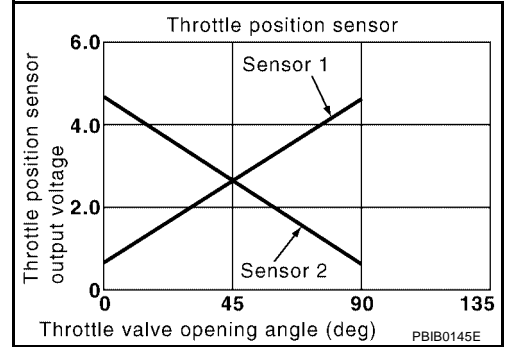

On Board Diagnosis Logic

The MIL will not light up for this diagnosis.

DTC No.	Trouble diagnosis name	DTC detecting condition	Possible cause
P1225 1225	Closed throttle position learning performance problem	Closed throttle position learning value is excessively low.	<ul style="list-style-type: none"> Electric throttle control actuator (TP sensor 1 and 2)

DTC Confirmation Procedure

NOTE:

If DTC Confirmation Procedure has been previously conducted, always turn ignition switch OFF and wait at least 10 seconds before conducting the next test.

TESTING CONDITION:

Before performing the following procedure, confirm that battery voltage is more than 10V at idle.

WITH CONSULT-II

1. Turn ignition switch ON.
2. Select "DATA MONITOR" mode with CONSULT-II.
3. Turn ignition switch OFF, wait at least 10 seconds.
4. Turn ignition switch ON.
5. If 1st trip DTC is detected, go to [EC-1124, "Diagnostic Procedure"](#).

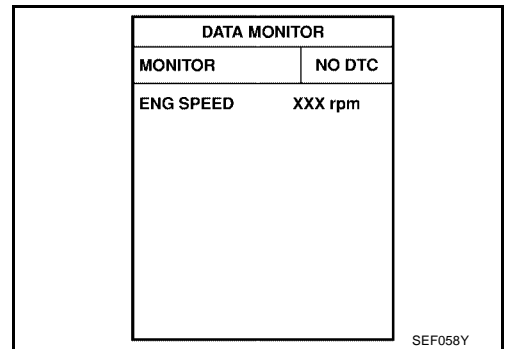

WITH GST

Follow the procedure "WITH CONSULT-II" above.

Diagnostic Procedure**1. CHECK ELECTRIC THROTTLE CONTROL ACTUATOR VISUALLY**

1. Turn ignition switch OFF.
2. Remove the intake air duct.
3. Check if foreign matter is caught between the throttle valve and the housing.

OK or NG

- OK >> GO TO 2.
NG >> Remove the foreign matter and clean the electric throttle control actuator inside.

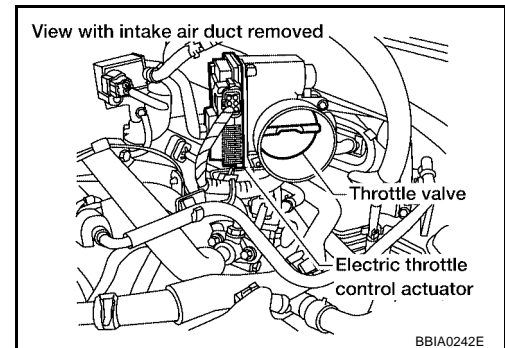
**2. REPLACE ELECTRIC THROTTLE CONTROL ACTUATOR**

1. Replace the electric throttle control actuator.
2. Perform [EC-711, "Throttle Valve Closed Position Learning"](#) .
3. Perform [EC-712, "Idle Air Volume Learning"](#) .

>> INSPECTION END

**Removal and Installation
ELECTRIC THROTTLE CONTROL ACTUATOR**

Refer to [EM-122, "INTAKE MANIFOLD COLLECTOR"](#) .

DTC P1226 TP SENSOR

Component Description

Electric throttle control actuator consists of throttle control motor, throttle position sensor, etc. The throttle position sensor responds to the throttle valve movement.

The throttle position sensor has the two sensors. These sensors are a kind of potentiometers which transform the throttle valve position into output voltage, and emit the voltage signal to the ECM. In addition, these sensors detect the opening and closing speed of the throttle valve and feed the voltage signals to the ECM. The ECM judges the current opening angle of the throttle valve from these signals and the ECM controls the throttle control motor to make the throttle valve opening angle properly in response to driving condition.

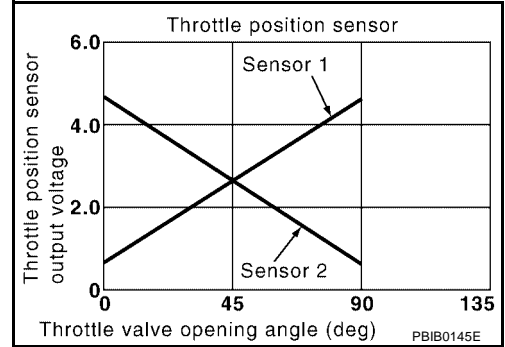

On Board Diagnosis Logic

The MIL will not light up for this diagnosis.

DTC No.	Trouble diagnosis name	DTC detecting condition	Possible cause
P1226 1226	Closed throttle position learning performance problem	Closed throttle position learning is not performed successfully, repeatedly.	<ul style="list-style-type: none"> Electric throttle control actuator (TP sensor 1 and 2)

DTC Confirmation Procedure

NOTE:

If DTC Confirmation Procedure has been previously conducted, always turn ignition switch OFF and wait at least 10 seconds before conducting the next test.

TESTING CONDITION:

Before performing the following procedure, confirm that battery voltage is more than 10V at idle.

WITH CONSULT-II

- Turn ignition switch ON.
- Select "DATA MONITOR" mode with CONSULT-II.
- Turn ignition switch OFF, wait at least 10 seconds.
- Turn ignition switch ON.
- Repeat steps 3 and 4 for 32 times.
- If 1st trip DTC is detected, go to [EC-1126, "Diagnostic Procedure"](#).

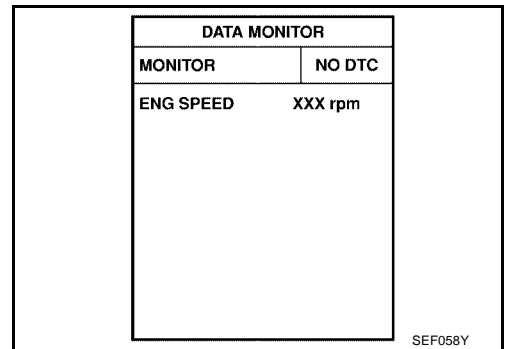

WITH GST

Follow the procedure "WITH CONSULT-II" above.

Diagnostic Procedure**1. CHECK ELECTRIC THROTTLE CONTROL ACTUATOR VISUALLY**

1. Turn ignition switch OFF.
2. Remove the intake air duct.
3. Check if foreign matter is caught between the throttle valve and the housing.

OK or NG

- OK >> GO TO 2.
NG >> Remove the foreign matter and clean the electric throttle control actuator inside.

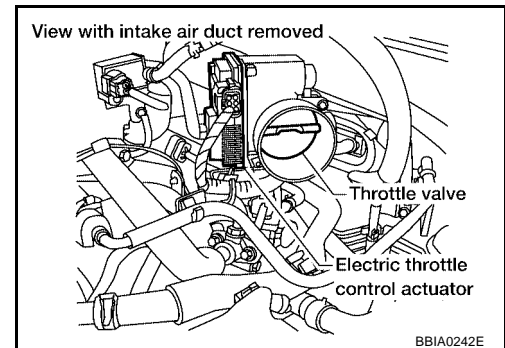
**2. REPLACE ELECTRIC THROTTLE CONTROL ACTUATOR**

1. Replace the electric throttle control actuator.
2. Perform [EC-711, "Throttle Valve Closed Position Learning"](#) .
3. Perform [EC-712, "Idle Air Volume Learning"](#) .

>> INSPECTION END

**Removal and Installation
ELECTRIC THROTTLE CONTROL ACTUATOR**

Refer to [EM-122, "INTAKE MANIFOLD COLLECTOR"](#) .

DTC P1229 SENSOR POWER SUPPLY

[VQ]

DTC P1229 SENSOR POWER SUPPLY

PF16119

On Board Diagnosis Logic

UBS001AK

This self-diagnosis has the one trip detection logic.

DTC No.	Trouble diagnosis name	DTC detecting condition	Possible cause
P1229 1229	Sensor power supply circuit short	ECM detects a voltage of power source for sensor is excessively low or high.	<ul style="list-style-type: none"> ● Harness or connectors (APP sensor 1 circuit is shorted.) (PSP sensor circuit is shorted.) (EVAP control system pressure sensor is shorted.) (Refrigerant pressure sensor circuit is shorted.) ● Accelerator pedal position sensor (APP sensor 1) ● Power steering pressure sensor ● EVAP control system pressure sensor ● Refrigerant pressure sensor

FAIL-SAFE MODE

When the malfunction is detected, ECM enters fail-safe mode and the MIL lights up.

Engine operation condition in fail-safe mode

ECM stops the electric throttle control actuator control, throttle valve is maintained at a fixed opening (approx. 5 degrees) by the return spring.

DTC Confirmation Procedure

UBS001AL

NOTE:

If DTC Confirmation Procedure has been previously conducted, always turn ignition switch OFF and wait at least 10 seconds before conducting the next test.

TESTING CONDITION:

Before performing the following procedure, confirm that battery voltage is more than 10V at idle.

WITH CONSULT-II

1. Turn ignition switch ON.
2. Select "DATA MONITOR" mode with CONSULT-II.
3. Start engine and let it idle for 1 second.
4. If DTC is detected, go to [EC-1129, "Diagnostic Procedure"](#).

DATA MONITOR	
MONITOR	NO DTC
ENG SPEED	XXX rpm

SEF058Y

WITH GST

Follow the procedure "WITH CONSULT-II" above.

DTC P1229 SENSOR POWER SUPPLY

[VQ]

Wiring Diagram

UBS00IAM

EC-SEN/PW-01

: DETECTABLE LINE FOR DTC
 : NON-DETECTABLE LINE FOR DTC

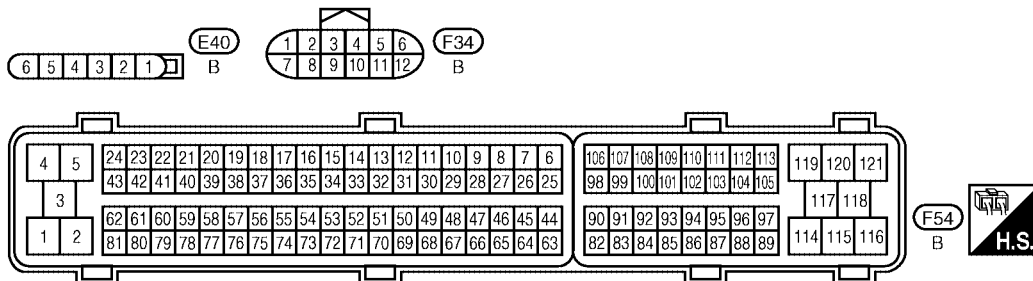
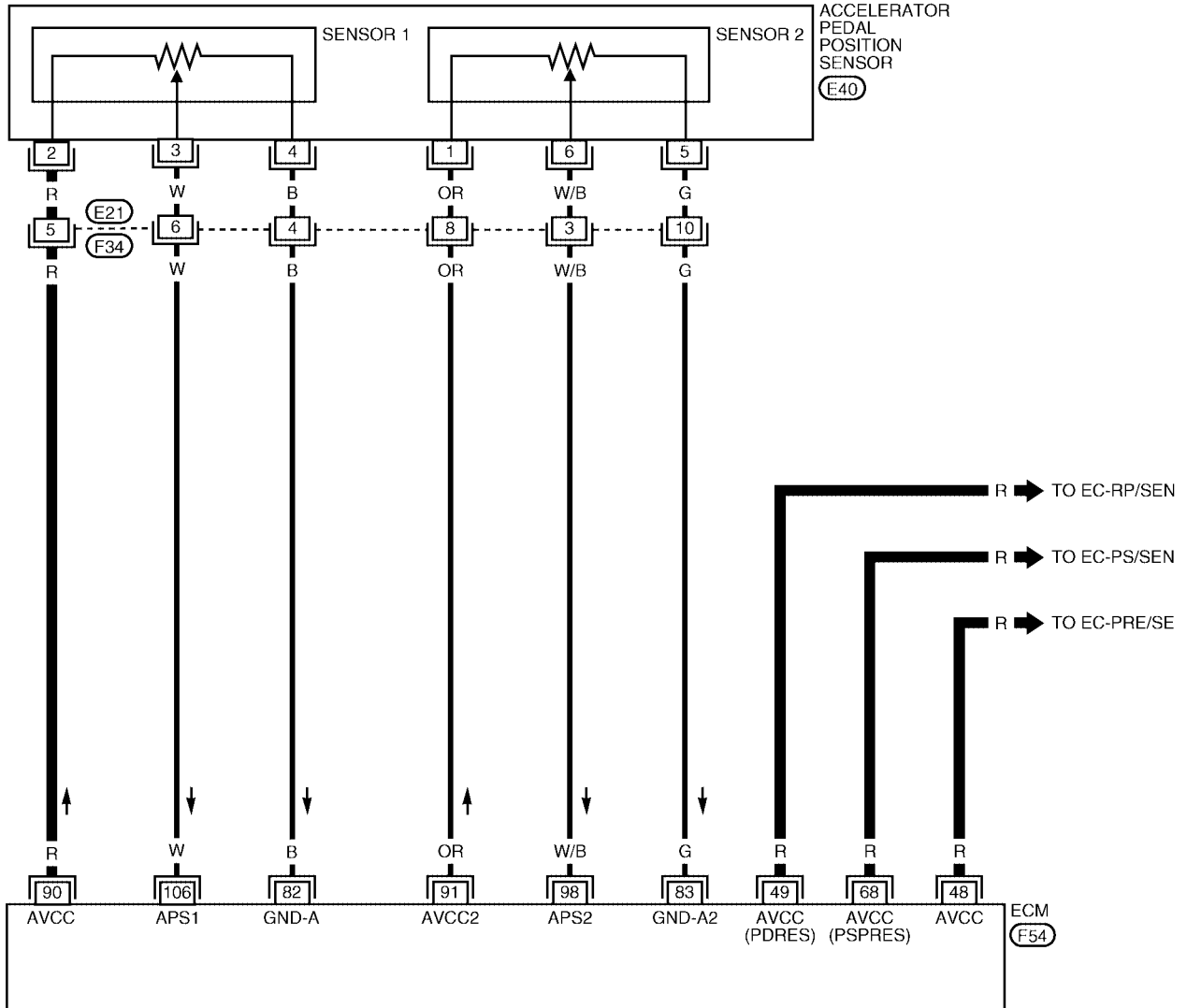

BBWA1303E

DTC P1229 SENSOR POWER SUPPLY

[VQ]

Specification data are reference values and are measured between each terminal and ground.

CAUTION:

Do not use ECM ground terminals when measuring input/output voltage. Doing so may result in damage to the ECM's transistor. Use a ground other than ECM terminals, such as the ground.

TER-MINAL NO.	WIRE COLOR	ITEM	CONDITION	DATA (DC Voltage)
48	R	Sensor power supply (EVAP control system pressure sensor)	[Ignition switch: ON]	Approximately 5V
49	R	Sensor power supply (Refrigerant pressure sensor)	[Ignition switch: ON]	Approximately 5V
68	R	Sensor power supply (Power steering pressure sensor)	[Ignition switch: ON]	Approximately 5V
90	R	Sensor power supply (APP sensor 1)	[Ignition switch: ON]	Approximately 5V

Diagnostic Procedure

UBS001AN

1. CHECK GROUND CONNECTIONS

1. Turn ignition switch OFF.
2. Loosen and retighten three ground screws on the body.
Refer to [EC-789, "Ground Inspection"](#).

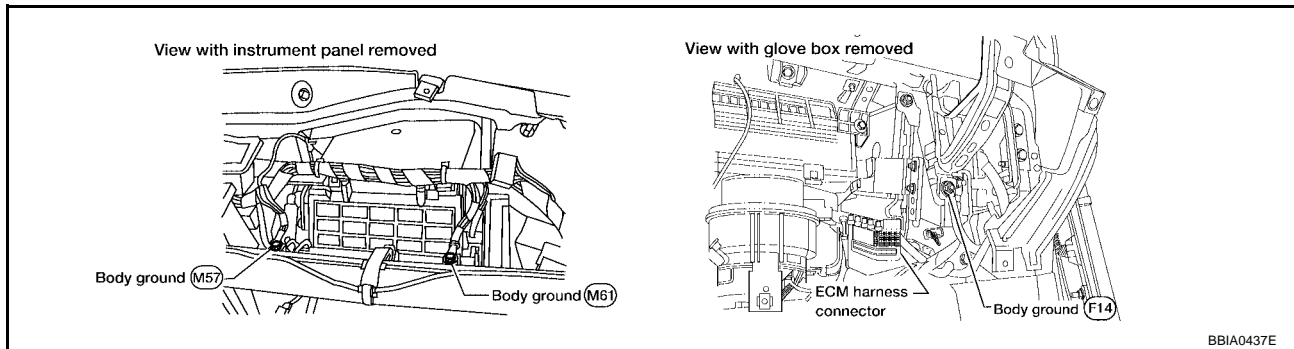

OK or NG

- OK >> GO TO 2.
- NG >> Repair or replace ground connections.

2. CHECK ACCELERATOR PEDAL POSITION SENSOR 1 POWER SUPPLY CIRCUIT

1. Disconnect accelerator pedal position (APP) sensor harness connector.
2. Turn ignition switch ON.

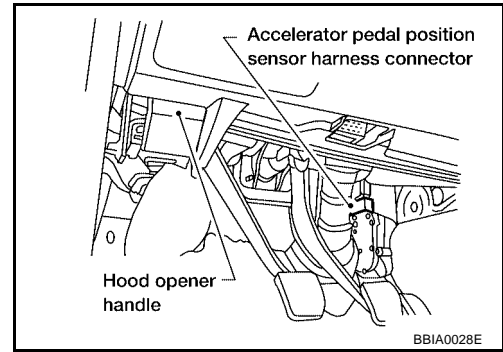

3. Check voltage between APP sensor terminal 2 and ground with CONSULT-II or tester.

Voltage: Approximately 5V

OK or NG

- OK >> GO TO 5.
- NG >> GO TO 3.

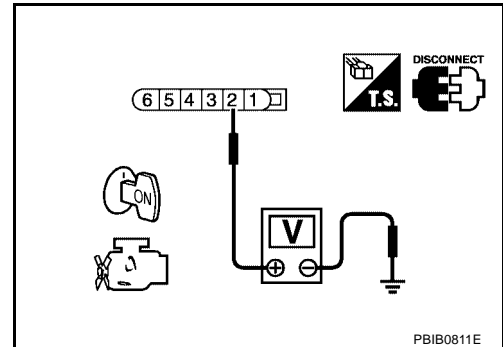

3. CHECK SENSOR POWER SUPPLY CIRCUITS

Check harness for short to power and short to ground, between the following terminals.

ECM terminal	Sensor terminal	Reference Wiring Diagram
90	APP sensor terminal 2	EC-1128
48	EVAP control system pressure sensor terminal 3	EC-996
49	Refrigerant pressure sensor terminal 1	EC-1328
68	PSP sensor terminal 3	EC-1038

OK or NG

- OK >> GO TO 4.
- NG >> Repair short to ground or short to power in harness or connectors.

4. CHECK COMPONENTS

Check the following.

- EVAP control system pressure sensor (Refer to [EC-993, "Component Inspection"](#) .)
- Refrigerant pressure sensor (Refer to [ATC-66, "COMPONENT INSPECTION"](#) .)
- Power steering pressure sensor (Refer to [EC-1041, "Component Inspection"](#) .)

OK or NG

- OK >> GO TO 7.
- NG >> Replace malfunctioning component.

5. CHECK APP SENSOR

Refer to [EC-1263, "Component Inspection"](#) .

OK or NG

- OK >> GO TO 7.
- NG >> GO TO 6.

6. REPLACE ACCELERATOR PEDAL ASSEMBLY

1. Replace accelerator pedal assembly.
2. Perform [EC-711, "Accelerator Pedal Released Position Learning"](#) .
3. Perform [EC-711, "Throttle Valve Closed Position Learning"](#) .
4. Perform [EC-712, "Idle Air Volume Learning"](#) .

>> INSPECTION END

7. CHECK INTERMITTENT INCIDENT

Refer to [EC-782, "TROUBLE DIAGNOSIS FOR INTERMITTENT INCIDENT"](#) .

>> INSPECTION END

A
EC
C
D
E
F
G
H
I
J
K
L
M

DTC P1271, P1281 A/F SENSOR 1

PFP:22693

Component Description

UBS001A0

The A/F sensor is a planar dual-cell limit current sensor. The sensor element of the A/F sensor is the combination of a Nernst concentration cell (sensor cell) with an oxygen-pump cell, which transports ions. It has a heater in the element.

The sensor is capable of precise measurement $\lambda = 1$, but also in the lean and rich range. Together with its control electronics, the sensor outputs a clear, continuous signal throughout a wide λ range ($0.7 < \lambda < \text{air}$).

The exhaust gas components diffuse through the diffusion gap at the electrode of the oxygen pump and Nernst concentration cell, where they are brought to thermodynamic balance.

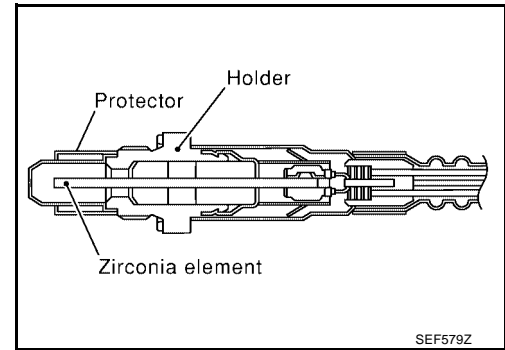

An electronic circuit controls the pump current through the oxygen-pump cell so that the composition of the exhaust gas in the diffusion gap remains constant at $\lambda = 1$. Therefore, the A/F sensor is able to indicate air/fuel ratio by this pumping of current. In addition, a heater is integrated in the sensor to ensure the required operating temperature of 700 - 800°C (1,292 - 1,472°F).

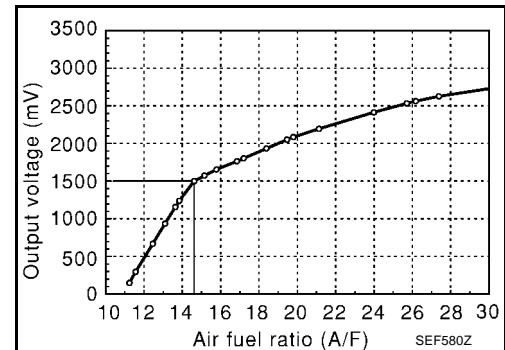

CONSULT-II Reference Value in Data Monitor Mode

UBS001A0

Specification data are reference values.

MONITOR ITEM	CONDITION	SPECIFICATION
A/F SEN1 (B1) A/F SEN1 (B2)	<ul style="list-style-type: none"> ● Engine: After warming up Maintaining engine speed at 2,000 rpm	Fluctuates around 1.5V

On Board Diagnosis Logic

UBS001A0

To judge the malfunction, the diagnosis checks that the A/F signal computed by ECM from the air fuel ratio (A/F) sensor 1 signal is not inordinately low.

DTC No.	Trouble diagnosis name	DTC detecting condition	Possible Cause
P1271 1271 (Bank 1)	Air fuel ratio (A/F) sensor 1 circuit no activity detected	<ul style="list-style-type: none"> ● The A/F signal computed by ECM from the A/F sensor 1 signal is constantly approx. 0V. 	<ul style="list-style-type: none"> ● Harness or connectors (The A/F sensor 1 circuit is open or shorted.) ● Air fuel ratio (A/F) sensor 1
P1281 1281 (Bank 2)			

DTC Confirmation Procedure

UBS001A0

NOTE:

If DTC Confirmation Procedure has been previously conducted, always turn ignition switch OFF and wait at least 10 seconds before conducting the next test.

TESTING CONDITION:

Before performing the following procedure, confirm that battery voltage is more than 11V at idle.

WITH CONSULT-II

1. Start engine and warm it up to normal operating temperature.
2. Select "A/F SEN1 (B1)" or "A/F SEN1 (B2)" in "DATA MONITOR" mode with CONSULT-II.

DTC P1271, P1281 A/F SENSOR 1

[VQ]

3. Check "A/F SEN1 (B1)" or "A/F SEN1 (B2)" indication.
If the indication is constantly approx. 0V, go to [EC-1137, "Diagnostic Procedure"](#).
If the indication is not constantly approx. 0V, go to next step.
4. Turn ignition switch OFF, wait at least 10 seconds and then restart engine.
5. Drive and accelerate vehicle to more than 40 km/h (25 MPH) within 20 seconds after restarting engine.
6. Maintain the following conditions for about 20 consecutive seconds.

DATA MONITOR	
MONITOR	NO DTC
ENG SPEED	XXX rpm
COOLANT TEMP/S	XXX °C
A/F SEN1 (B1)	XXX V

SEF581Z

ENG SPEED	1,000 - 3,200 rpm
VHCL SPEED SE	More than 40 km/h (25 MPH)
B/FUEL SCHDL	1.5 - 9.0 msec
Shift lever	Suitable position

NOTE:

- Keep the accelerator pedal as steady as possible during the cruising.
 - If this procedure is not completed within 1 minute after restarting engine at step 4, return to step 4.
7. If 1st trip DTC is displayed, go to [EC-1137, "Diagnostic Procedure"](#).

 **WITH GST**

Follow the procedure "WITH CONSULT-II" above.

A
EC
C
D
E
F
G
H
I
J
K
L
M

DTC P1271, P1281 A/F SENSOR 1

[VQ]

UBS001AS

Wiring Diagram BANK 1

EC-AF1B1-01

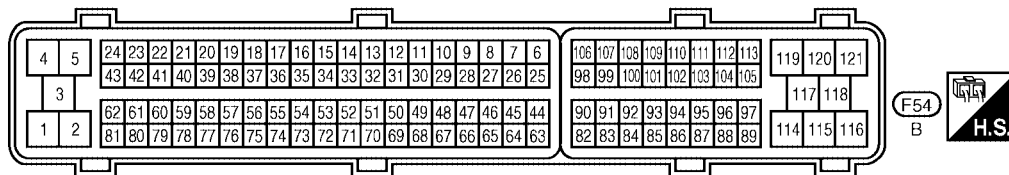
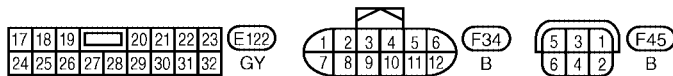
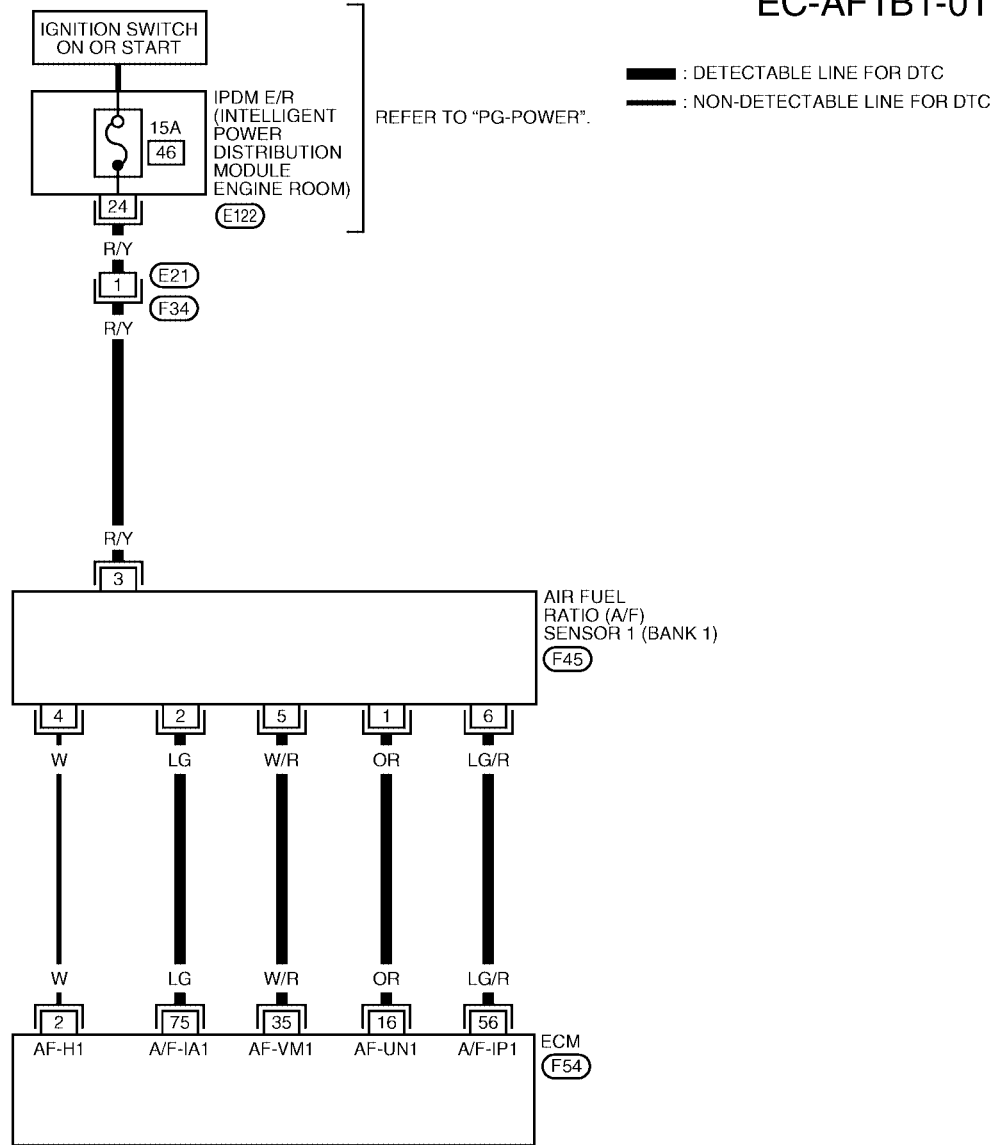

BBWA1267E

DTC P1271, P1281 A/F SENSOR 1

[VQ]

Specification data are reference values and are measured between each terminal and ground.

CAUTION:

Do not use ECM ground terminals when measuring input/output voltage. Doing so may result in damage to the ECM's transistor. Use a ground other than ECM terminals, such as the ground.

TERMI- NAL NO.	WIRE COLOR	ITEM	CONDITION	DATA (DC Voltage)
16	OR	A/F sensor 1 (Bank 1)	[Engine is running] ● Warm-up condition ● Idle speed	Approximately 3.1V
35	W/R			Approximately 2.6V
56	LG/R			Approximately 2.3V
75	LG			Approximately 2.3V

A
EC
C
D
E
F
G
H
I
J
K
L
M

DTC P1271, P1281 A/F SENSOR 1

[VQ]

BANK 2

EC-AF1B2-01

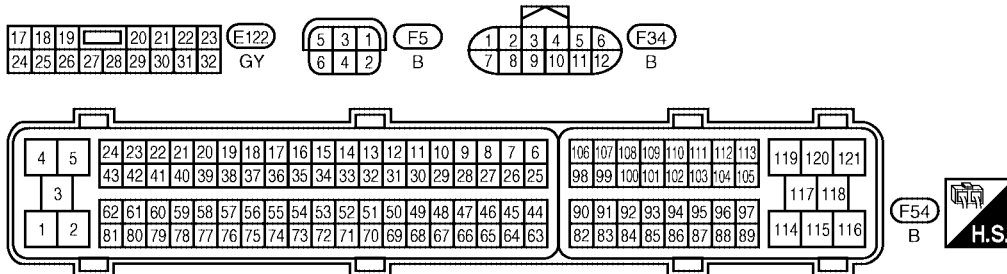
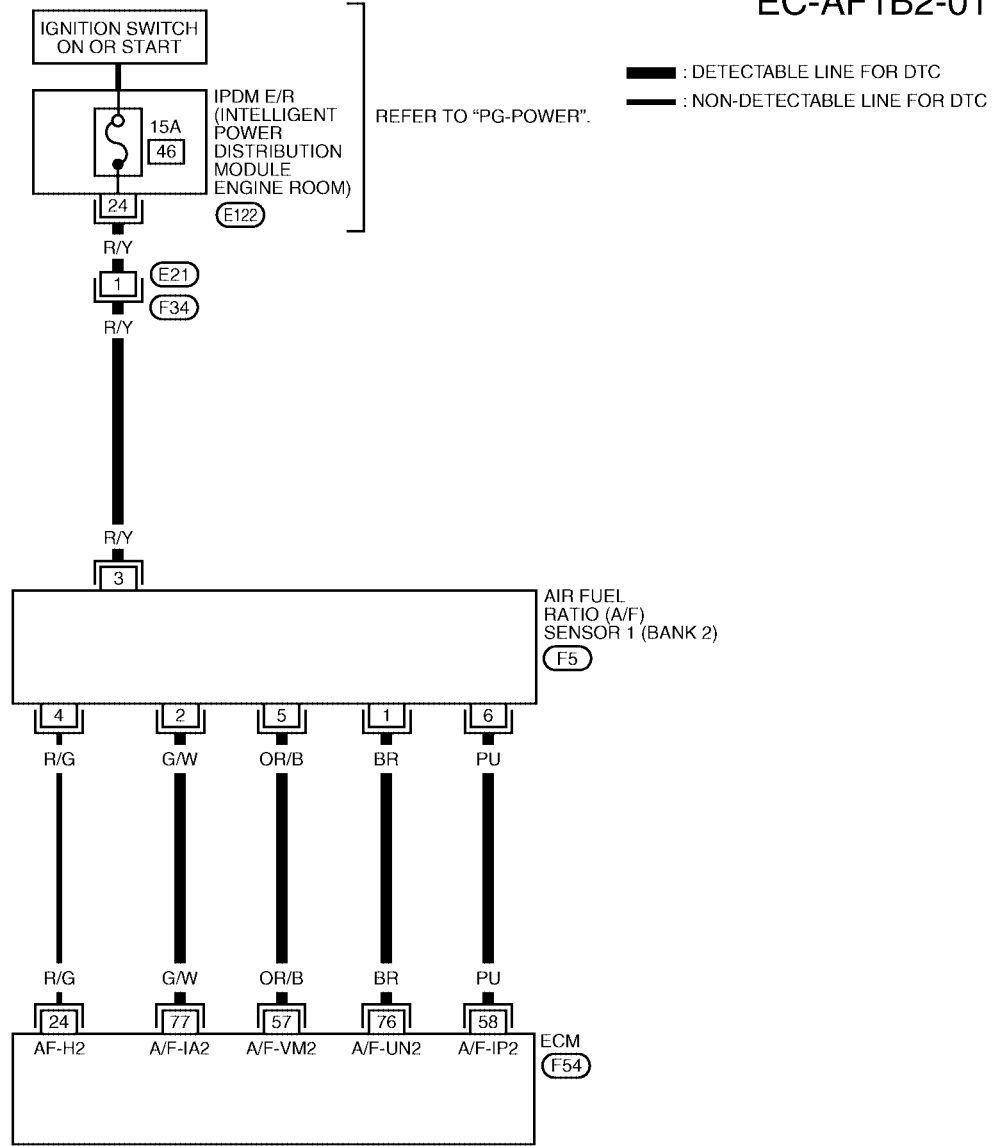

BBWA1572E

DTC P1271, P1281 A/F SENSOR 1

[VQ]

Specification data are reference values and are measured between each terminal and ground.

CAUTION:

Do not use ECM ground terminals when measuring input/output voltage. Doing so may result in damage to the ECM's transistor. Use a ground other than ECM terminals, such as the ground.

TERMI- NAL NO.	WIRE COLOR	ITEM	CONDITION	DATA (DC Voltage)
57	OR/B	A/F sensor 1 (Bank 2)	[Engine is running] ● Warm-up condition ● Idle speed	Approximately 2.6V
58	PU			Approximately 2.3V
76	BR			Approximately 3.1V
77	G/W			Approximately 2.3V

Diagnostic Procedure

UBS001AT

1. CHECK GROUND CONNECTIONS

1. Turn ignition switch OFF.
2. Loosen and retighten three ground screws on the body.
Refer to [EC-789, "Ground Inspection"](#).

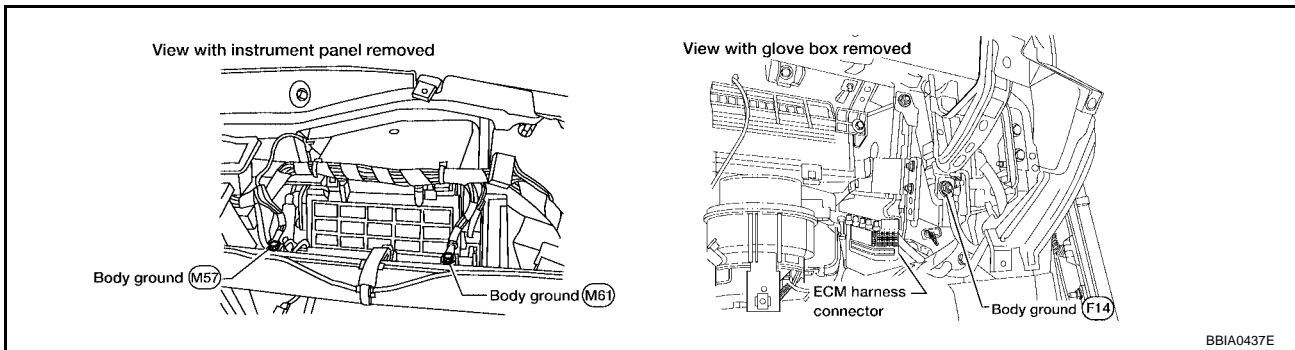

OK or NG

- OK >> GO TO 2.
- NG >> Repair or replace ground connections.

2. CHECK AIR FUEL RATIO (A/F) SENSOR 1 POWER SUPPLY CIRCUIT

1. Disconnect air fuel ratio (A/F) sensor 1 harness connector.

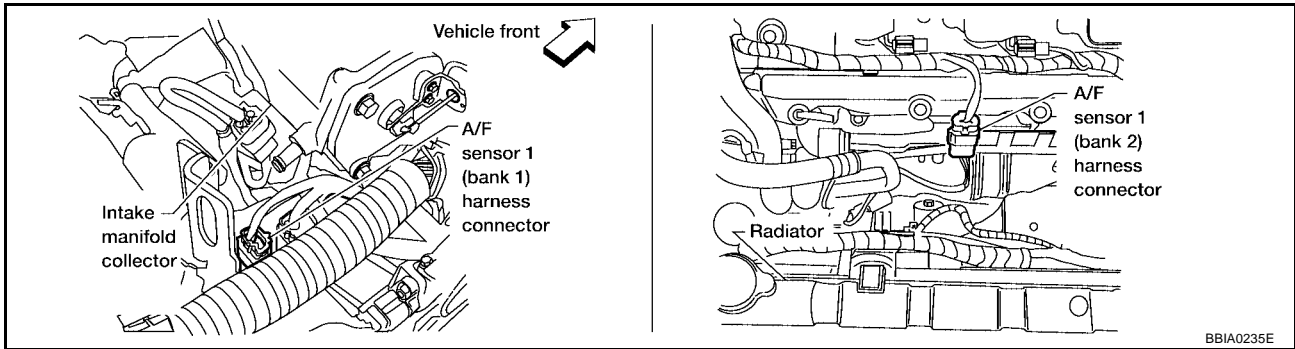

2. Turn ignition switch ON.
3. Check voltage between A/F sensor 1 terminal 3 and ground with CONSULT-II or tester.

Voltage: Battery voltage

OK or NG

- OK >> GO TO 4.
- NG >> GO TO 3.

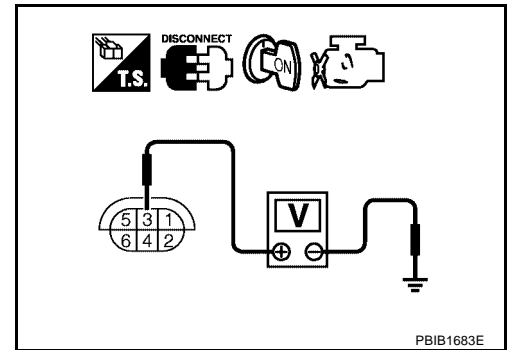

3. DETECT MALFUNCTIONING PART

Check the following.

- Harness connectors E21, F34
- IPDM E/R harness connector E122
- 15A fuse
- Harness for open or short between A/F sensor 1 and fuse

>> Repair or replace harness or connectors.

4. CHECK A/F SENSOR 1 INPUT SIGNAL CIRCUIT

1. Turn ignition switch OFF.
2. Disconnect ECM harness connector.
3. Check harness continuity between the following terminals.
Refer to Wiring Diagram.

	A/F sensor 1 terminal	ECM terminal
Bank1	1	16
	2	75
	5	35
	6	56
Bank 2	1	76
	2	77
	5	57
	6	58

Continuity should exist.

4. Check harness continuity between the following terminals and ground.
Refer to Wiring Diagram.

Bank 1		Bank 2	
A/F sensor 1 terminal	ECM terminal	A/F sensor 1 terminal	ECM terminal
1	16	1	76
2	75	2	77
5	35	5	57
6	56	6	58

Continuity should not exist.

5. Also check harness for short to power.

OK or NG

OK >> GO TO 5.

NG >> Repair open circuit or short to ground or short to power in harness or connectors.

5. CHECK INTERMITTENT INCIDENT

Perform [EC-782, "TROUBLE DIAGNOSIS FOR INTERMITTENT INCIDENT"](#) .

OK or NG

OK >> Replace A/F sensor 1.

NG >> Repair or replace.

**Removal and Installation
AIR FUEL RATIO (A/F) SENSOR 1**

UBS00IAU

Refer to [EM-134, "EXHAUST MANIFOLD AND THREE WAY CATALYST"](#) .

DTC P1272, P1282 A/F SENSOR 1

Component Description

The A/F sensor is a planar dual-cell limit current sensor. The sensor element of the A/F sensor is the combination of a Nernst concentration cell (sensor cell) with an oxygen-pump cell, which transports ions. It has a heater in the element.

The sensor is capable of precise measurement $\lambda = 1$, but also in the lean and rich range. Together with its control electronics, the sensor outputs a clear, continuous signal throughout a wide λ range ($0.7 < \lambda < \text{air}$).

The exhaust gas components diffuse through the diffusion gap at the electrode of the oxygen pump and Nernst concentration cell, where they are brought to thermodynamic balance.

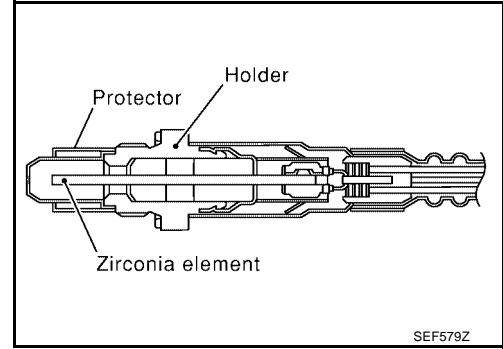

An electronic circuit controls the pump current through the oxygen-pump cell so that the composition of the exhaust gas in the diffusion gap remains constant at $\lambda = 1$. Therefore, the A/F sensor is able to indicate air/fuel ratio by this pumping of current. In addition, a heater is integrated in the sensor to ensure the required operating temperature of 700 - 800°C (1,292 - 1,472°F).

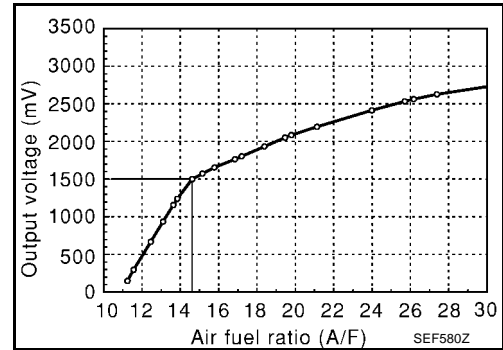

CONSULT-II Reference Value in Data Monitor Mode

Specification data are reference values.

MONITOR ITEM	CONDITION		SPECIFICATION
A/F SEN1 (B1) A/F SEN1 (B2)	● Engine: After warming up	Maintaining engine speed at 2,000 rpm	Fluctuates around 1.5V

On Board Diagnosis Logic

To judge the malfunction, the diagnosis checks that the A/F signal computed by ECM from the air fuel ratio (A/F) sensor 1 signal is not inordinately high.

DTC No.	Trouble diagnosis name	DTC detecting condition	Possible Cause
P1272 1272 (Bank 1)	Air fuel ratio (A/F) sensor 1 circuit no activity detected	● The A/F signal computed by ECM from the A/F sensor 1 signal is constantly approx. 5V.	<ul style="list-style-type: none"> ● Harness or connectors (The A/F sensor 1 circuit is open or shorted.) ● Air fuel ratio (A/F) sensor 1
P1282 1282 (Bank 2)			

DTC Confirmation Procedure

NOTE:

If DTC Confirmation Procedure has been previously conducted, always turn ignition switch OFF and wait at least 10 seconds before conducting the next test.

TESTING CONDITION:

Before performing the following procedure, confirm that battery voltage is more than 11V at idle.

WITH CONSULT-II

1. Start engine and warm it up to normal operating temperature.
2. Select "A/F SEN1 (B1)" or "A/F SEN1 (B2)" in "DATA MONITOR" mode with CONSULT-II.

DTC P1272, P1282 A/F SENSOR 1

[VQ]

3. Check "A/F SEN1 (B1)" or "A/F SEN1 (B2)" indication.
If the indication is constantly approx. 5V, go to [EC-1145, "Diagnostic Procedure"](#).
If the indication is not constantly approx. 5V, go to next step.
4. Turn ignition switch OFF, wait at least 10 seconds and then restart engine.
5. Drive and accelerate vehicle to more than 40 km/h (25 MPH) within 20 seconds after restarting engine.
6. Maintain the following conditions for about 20 consecutive seconds.

DATA MONITOR	
MONITOR	NO DTC
ENG SPEED	XXX rpm
COOLANT TEMP/S	XXX °C
A/F SEN1 (B1)	XXX V

SEF581Z

ENG SPEED	1,000 - 3,200 rpm
VHCL SPEED SE	More than 40 km/h (25 MPH)
B/FUEL SCHDL	1.5 - 9.0 msec
Shift lever	Suitable position

NOTE:

- Keep the accelerator pedal as steady as possible during the cruising.
 - If this procedure is not completed within 1 minute after restarting engine at step 4, return to step 4.
7. If 1st trip DTC is displayed, go to [EC-1145, "Diagnostic Procedure"](#).

 **WITH GST**

Follow the procedure "WITH CONSULT-II" above.

A
EC
C
D
E
F
G
H
I
J
K
L
M

DTC P1272, P1282 A/F SENSOR 1

[VQ]

UBS00IAZ

Wiring Diagram BANK 1

EC-AF1B1-01

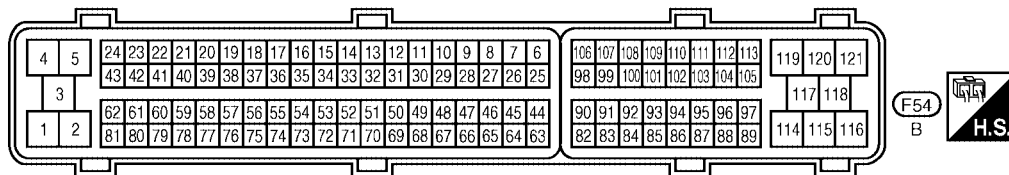
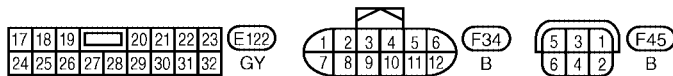
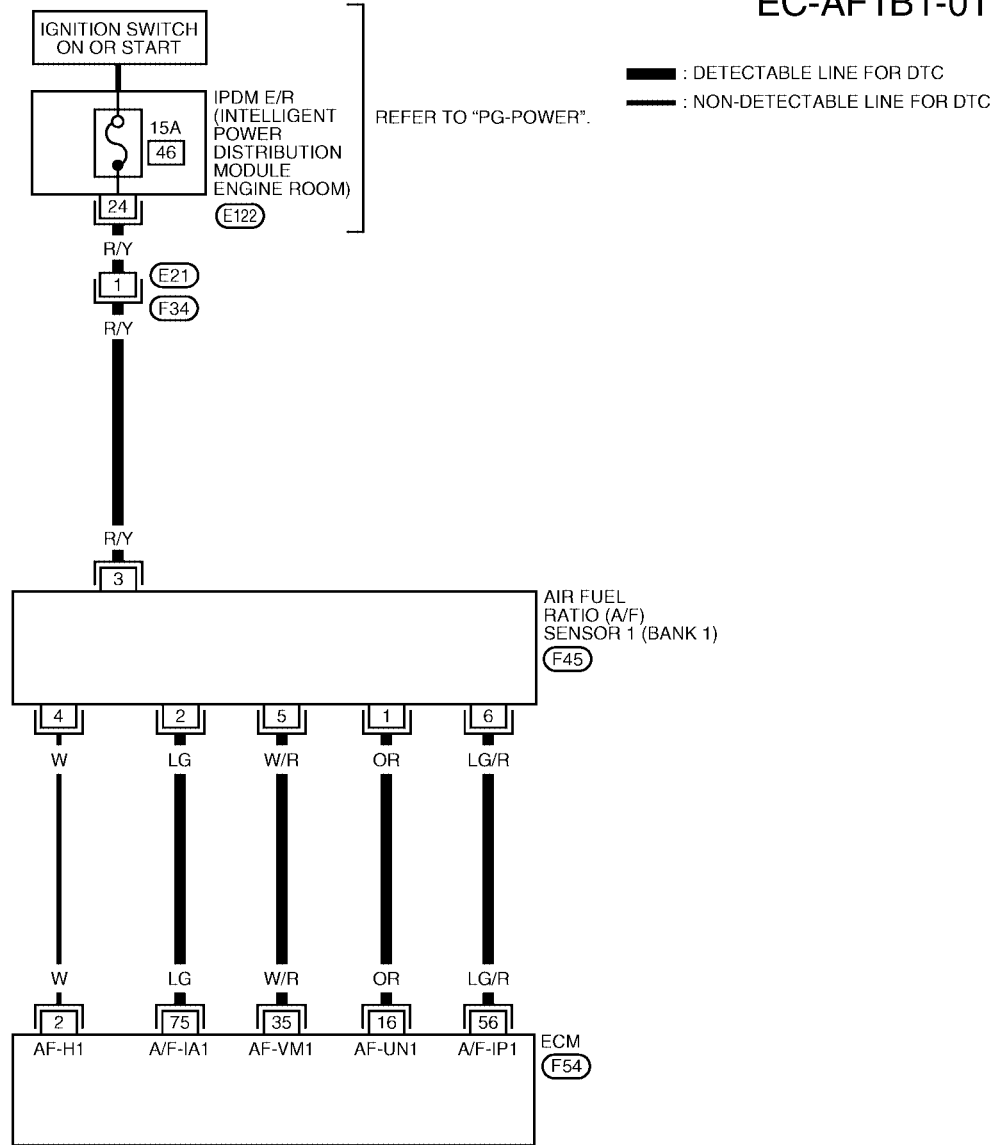

BBWA1267E

DTC P1272, P1282 A/F SENSOR 1

[VQ]

Specification data are reference values and are measured between each terminal and ground.

CAUTION:

Do not use ECM ground terminals when measuring input/output voltage. Doing so may result in damage to the ECM's transistor. Use a ground other than ECM terminals, such as the ground.

TERMI- NAL NO.	WIRE COLOR	ITEM	CONDITION	DATA (DC Voltage)
16	OR	A/F sensor 1 (Bank 1)	[Engine is running] ● Warm-up condition ● Idle speed	Approximately 3.1V
35	W/R			Approximately 2.6V
56	LG/R			Approximately 2.3V
75	LG			Approximately 2.3V

A
EC
C
D
E
F
G
H
I
J
K
L
M

DTC P1272, P1282 A/F SENSOR 1

[VQ]

BANK 2

EC-AF1B2-01

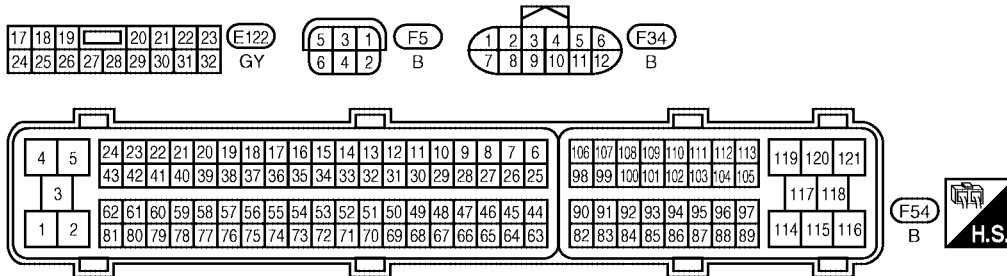
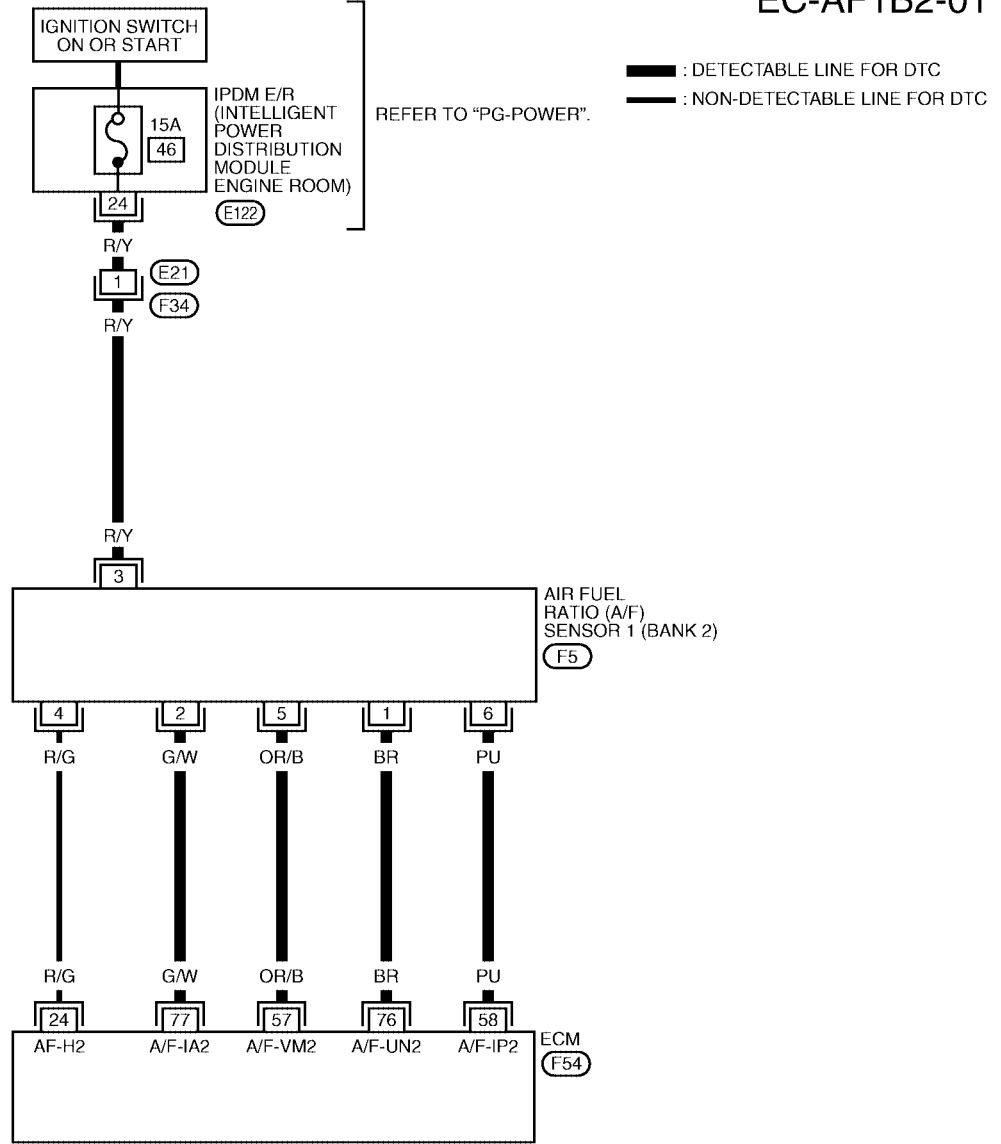

BBWA1572E

DTC P1272, P1282 A/F SENSOR 1

[VQ]

Specification data are reference values and are measured between each terminal and ground.

CAUTION:

Do not use ECM ground terminals when measuring input/output voltage. Doing so may result in damage to the ECM's transistor. Use a ground other than ECM terminals, such as the ground.

TERMI- NAL NO.	WIRE COLOR	ITEM	CONDITION	DATA (DC Voltage)
57	OR/B	A/F sensor 1 (Bank 2)	[Engine is running] ● Warm-up condition ● Idle speed	Approximately 2.6V
58	PU			Approximately 2.3V
76	BR			Approximately 3.1V
77	G/W			Approximately 2.3V

Diagnostic Procedure

UBS001B0

1. CHECK GROUND CONNECTIONS

1. Turn ignition switch OFF.
2. Loosen and retighten three ground screws on the body.
Refer to [EC-789, "Ground Inspection"](#).

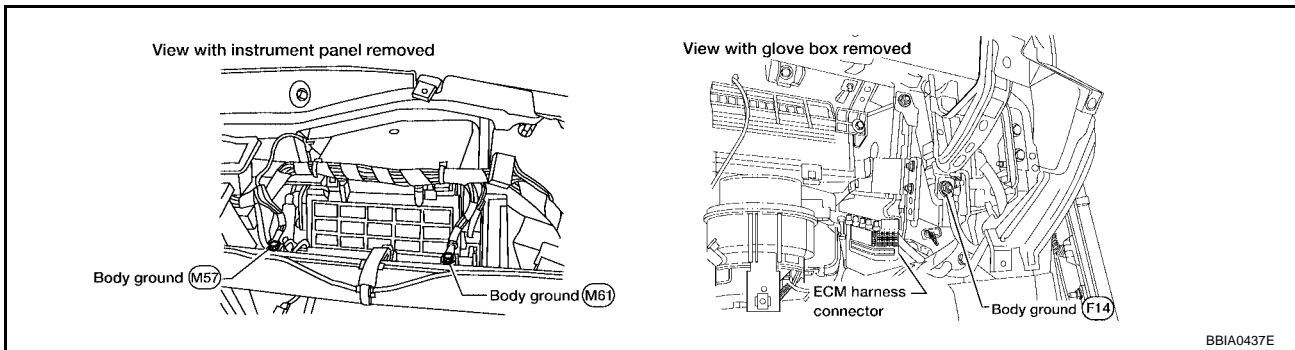

OK or NG

- OK >> GO TO 2.
- NG >> Repair or replace ground connections.

2. CHECK AIR FUEL RATIO (A/F) SENSOR 1 POWER SUPPLY CIRCUIT

1. Disconnect air fuel ratio (A/F) sensor 1 harness connector.

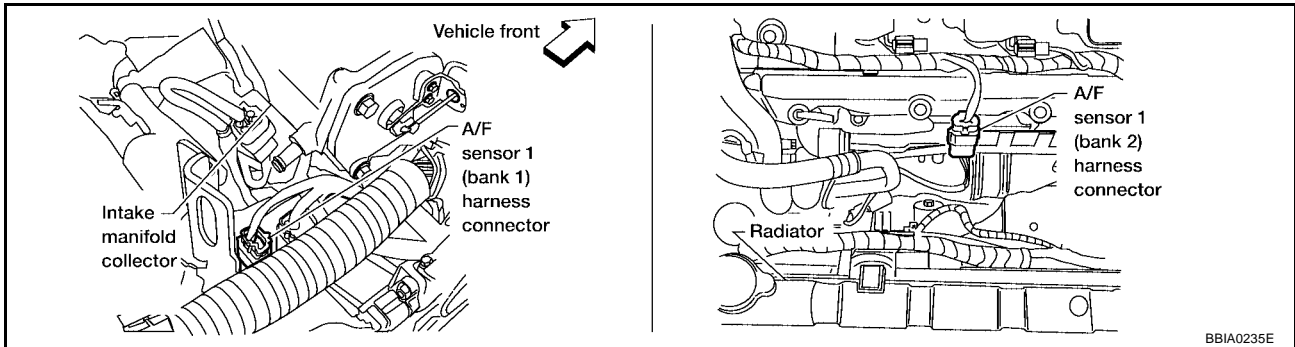

2. Turn ignition switch ON.
3. Check voltage between A/F sensor 1 terminal 3 and ground with CONSULT-II or tester.

Voltage: Battery voltage

OK or NG

- OK >> GO TO 4.
- NG >> GO TO 3.

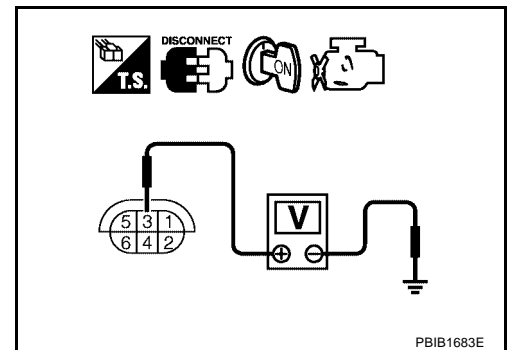

3. DETECT MALFUNCTIONING PART

Check the following.

- Harness connectors E21, F34
- IPDM E/R harness connector E122
- 15A fuse
- Harness for open or short between A/F sensor 1 and fuse

>> Repair or replace harness or connectors.

4. CHECK A/F SENSOR 1 INPUT SIGNAL CIRCUIT

1. Turn ignition switch OFF.
2. Disconnect ECM harness connector.
3. Check harness continuity between the following terminals.
Refer to Wiring Diagram.

	A/F sensor 1 terminal	ECM terminal
Bank 1	1	16
	2	75
	5	35
	6	56
Bank 2	1	76
	2	77
	5	57
	6	58

Continuity should exist.

4. Check harness continuity between the following terminals and ground.
Refer to Wiring Diagram.

Bank 1		Bank 2	
A/F sensor 1 terminal	ECM terminal	A/F sensor 1 terminal	ECM terminal
1	16	1	76
2	75	2	77
5	35	5	57
6	56	6	58

Continuity should not exist.

5. Also check harness for short to power.

OK or NG

OK >> GO TO 5.

NG >> Repair open circuit or short to ground or short to power in harness or connectors.

5. CHECK INTERMITTENT INCIDENT

Perform [EC-782, "TROUBLE DIAGNOSIS FOR INTERMITTENT INCIDENT"](#) .

OK or NG

OK >> Replace A/F sensor 1.

NG >> Repair or replace.

**Removal and Installation
AIR FUEL RATIO (A/F) SENSOR 1**

UBS001B1

Refer to [EM-134, "EXHAUST MANIFOLD AND THREE WAY CATALYST"](#) .

DTC P1273, P1283 A/F SENSOR 1

PFP:22693

Component Description

UBS001B2

The A/F sensor is a planar dual-cell limit current sensor. The sensor element of the A/F sensor is the combination of a Nernst concentration cell (sensor cell) with an oxygen-pump cell, which transports ions. It has a heater in the element.

The sensor is capable of precise measurement $\lambda = 1$, but also in the lean and rich range. Together with its control electronics, the sensor outputs a clear, continuous signal throughout a wide λ range ($0.7 < \lambda < \text{air}$).

The exhaust gas components diffuse through the diffusion gap at the electrode of the oxygen pump and Nernst concentration cell, where they are brought to thermodynamic balance.

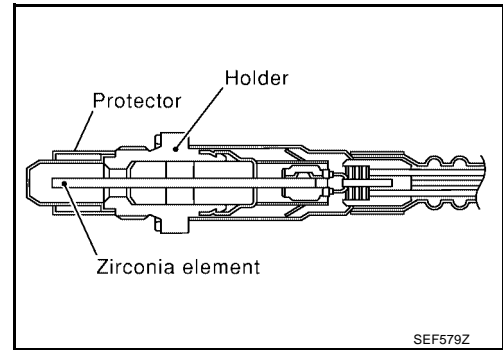

An electronic circuit controls the pump current through the oxygen-pump cell so that the composition of the exhaust gas in the diffusion gap remains constant at $\lambda = 1$. Therefore, the A/F sensor is able to indicate air/fuel ratio by this pumping of current. In addition, a heater is integrated in the sensor to ensure the required operating temperature of 700 - 800°C (1,292 - 1,472°F).

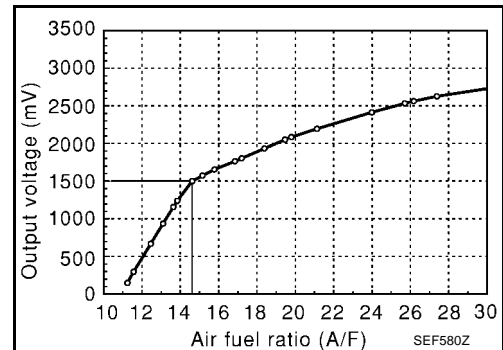

CONSULT-II Reference Value in Data Monitor Mode

UBS001B3

Specification data are reference values.

MONITOR ITEM	CONDITION	SPECIFICATION
A/F SEN1 (B1) A/F SEN1 (B2)	<ul style="list-style-type: none"> ● Engine: After warming up Maintaining engine speed at 2,000 rpm	Fluctuates around 1.5V

On Board Diagnosis Logic

UBS001B4

To judge the malfunction, the A/F signal computed by ECM from the air fuel ratio (A/F) sensor 1 signal is monitored not to be shifted LEAN side or RICH side.

DTC No.	Trouble diagnosis name	DTC detecting condition	Possible Cause
P1273 1273 (Bank 1)	Air fuel ratio (A/F) sensor 1 lean shift monitoring	<ul style="list-style-type: none"> ● The output voltage computed by ECM from the A/F sensor 1 signal is shifted to the lean side for a specified period. 	<ul style="list-style-type: none"> ● Air fuel ratio (A/F) sensor 1 ● Air fuel ratio (A/F) sensor 1 heater ● Fuel pressure ● Fuel injector ● Intake air leaks
P1283 1283 (Bank 2)			

DTC Confirmation Procedure

UBS001B5

NOTE:

If DTC Confirmation Procedure has been previously conducted, always turn ignition switch OFF and wait at least 10 seconds before conducting the next test.

TESTING CONDITION:

Before performing the following procedure, confirm that battery voltage is more than 11V at idle.

WITH CONSULT-II

1. Start engine and warm it up to normal operating temperature.
2. Turn ignition switch OFF and wait at least 10 seconds.
3. Turn ignition switch ON and select "SELF-LEARNING CONT" in "WORK SUPPORT" mode with CONSULT-II.

DTC P1273, P1283 A/F SENSOR 1

[VQ]

4. Clear the self-learning coefficient by touching "CLEAR".
5. Turn ignition switch OFF and wait at least 10 seconds.
6. Start engine and keep the engine speed between 3,500 and 4,000 rpm for 1 minute under no load.
7. Let engine idle for 1 minute.
8. Keep engine speed between 2,500 and 3,000 rpm for 20 minutes.
9. If 1st trip DTC is detected, go to [EC-1153, "Diagnostic Procedure"](#).

WORK SUPPORT		
SELF-LEARNING CONT	CLEAR	B1 100 %
		B2 100 %

SEF968Y

WITH GST

1. Start engine and warm it up to normal operating temperature.
2. Turn ignition switch OFF and wait at least 10 seconds.
3. Disconnect mass air flow sensor harness connector.
4. Start engine and let it idle for at least 5 seconds.
5. Stop engine and reconnect mass air flow sensor harness connector.
6. Select Service \$03 with GST and make sure that DTC P0102 is detected.
7. Select Service \$04 with GST and erase the DTC P0102.
8. Start engine and keep the engine speed between 3,500 and 4,000 rpm for 1 minute under no load.
9. Let engine idle for 1 minute.
10. Keep engine speed between 2,500 and 3,000 rpm for 20 minutes.
11. Select Service \$07 with GST.
If 1st trip DTC is detected, go to [EC-1153, "Diagnostic Procedure"](#).

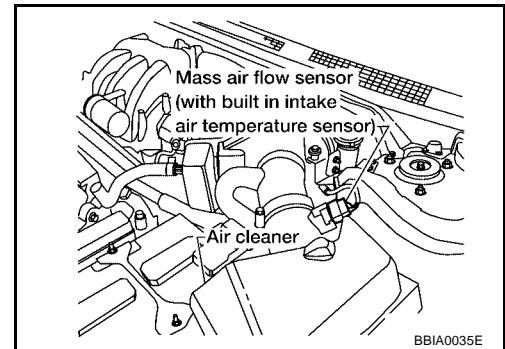

DTC P1273, P1283 A/F SENSOR 1

[VQ]

UBS001B6

Wiring Diagram BANK 1

EC-AF1B1-01

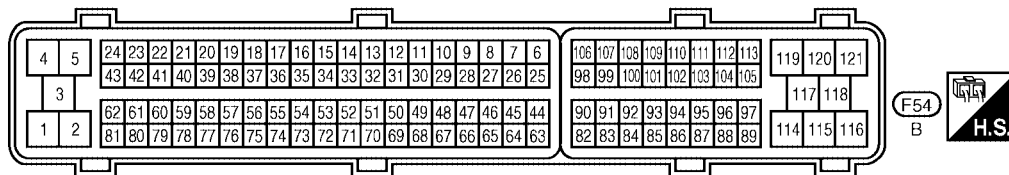
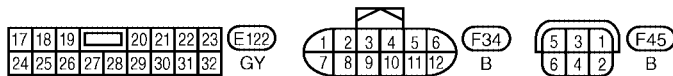
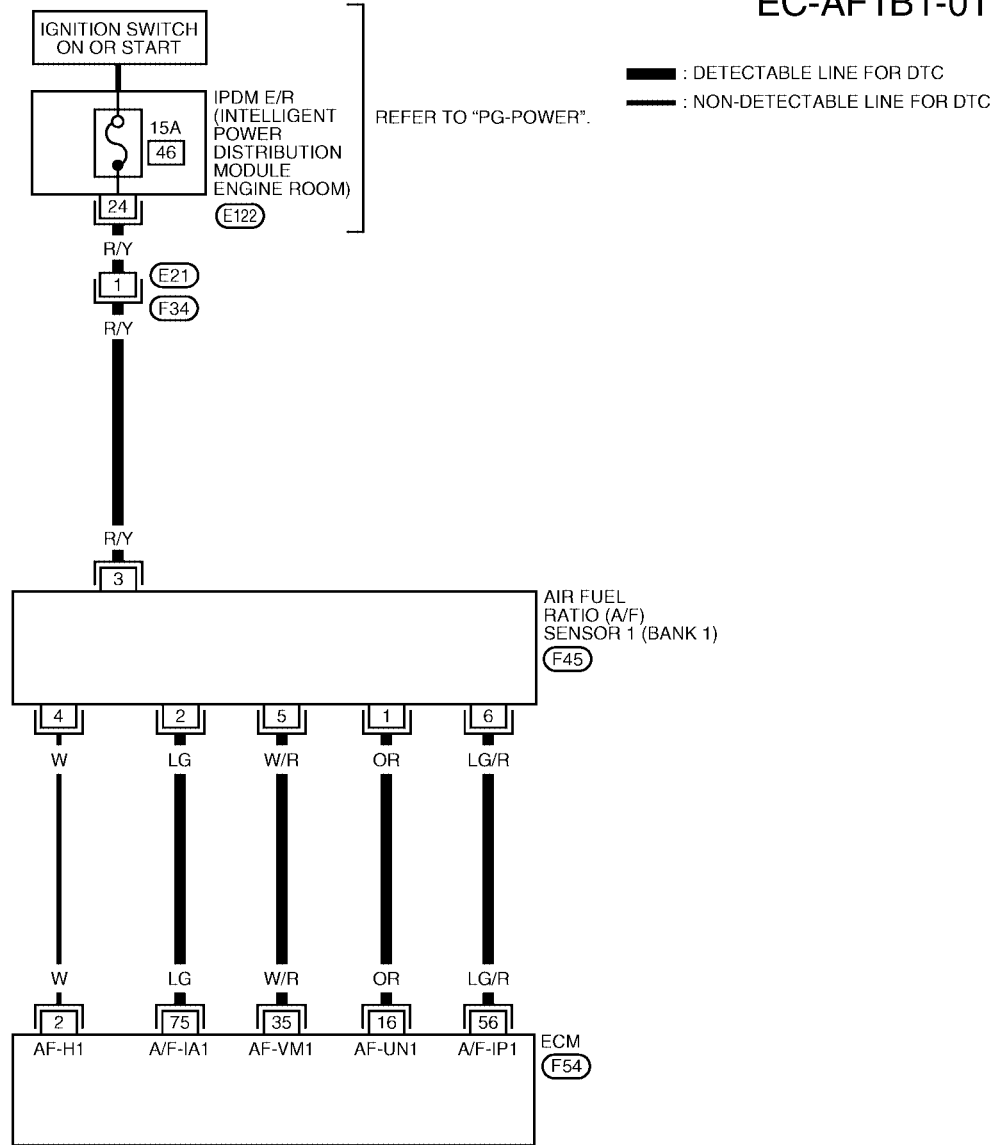

BBWA1267E

DTC P1273, P1283 A/F SENSOR 1

[VQ]

Specification data are reference values and are measured between each terminal and ground.

CAUTION:

Do not use ECM ground terminals when measuring input/output voltage. Doing so may result in damage to the ECM's transistor. Use a ground other than ECM terminals, such as the ground.

TERMI- NAL NO.	WIRE COLOR	ITEM	CONDITION	DATA (DC Voltage)
16	OR	A/F sensor 1 (Bank 1)	[Engine is running] ● Warm-up condition ● Idle speed	Approximately 3.1V
35	W/R			Approximately 2.6V
56	LG/R			Approximately 2.3V
75	LG			Approximately 2.3V

A
EC
C
D
E
F
G
H
I
J
K
L
M

DTC P1273, P1283 A/F SENSOR 1

[VQ]

BANK 2

EC-AF1B2-01

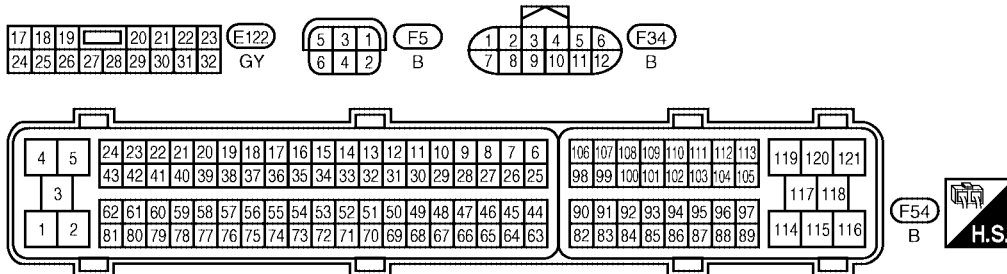
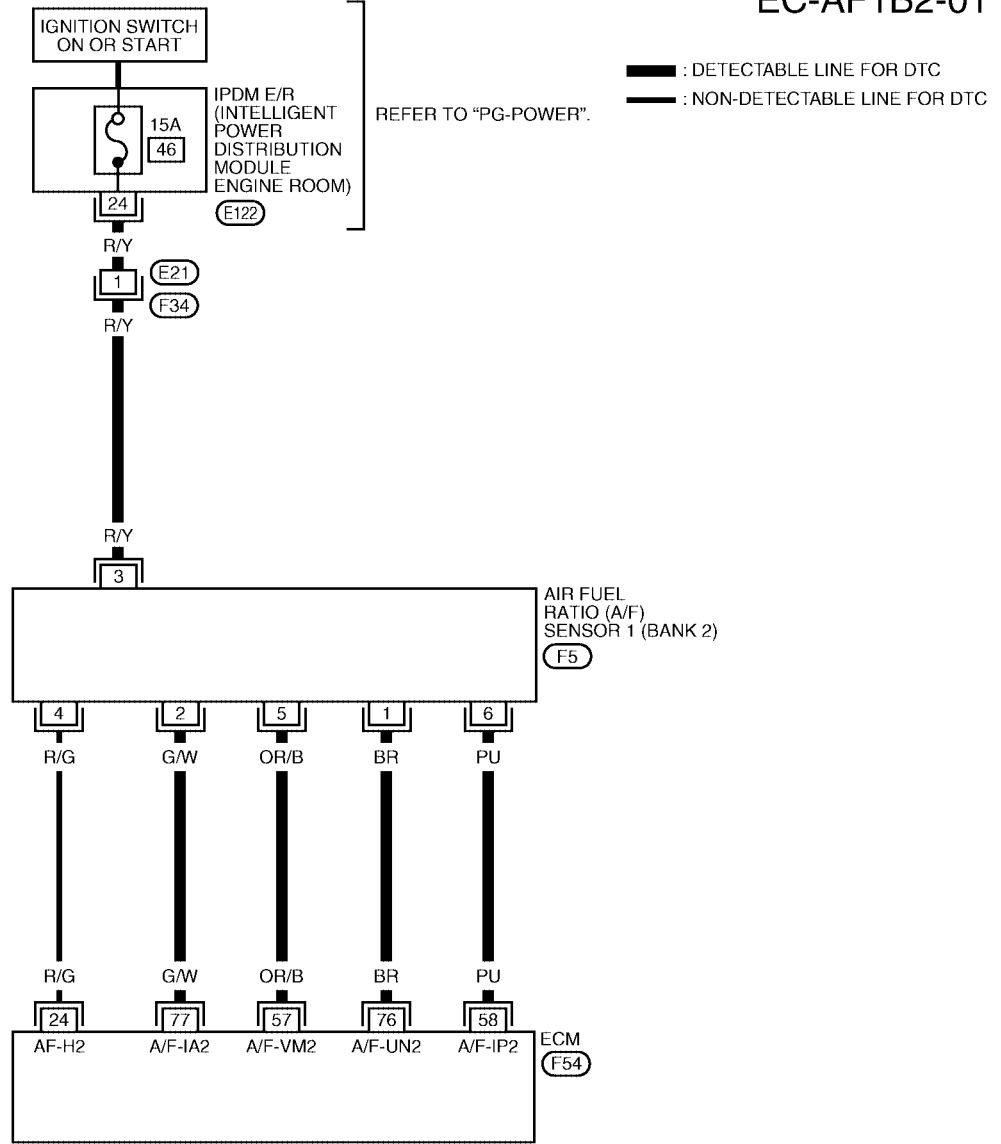

BBWA1572E

DTC P1273, P1283 A/F SENSOR 1

[VQ]

Specification data are reference values and are measured between each terminal and ground.

CAUTION:

Do not use ECM ground terminals when measuring input/output voltage. Doing so may result in damage to the ECM's transistor. Use a ground other than ECM terminals, such as the ground.

TERMI- NAL NO.	WIRE COLOR	ITEM	CONDITION	DATA (DC Voltage)
57	OR/B	A/F sensor 1 (Bank 2)	[Engine is running] ● Warm-up condition ● Idle speed	Approximately 2.6V
58	PU			Approximately 2.3V
76	BR			Approximately 3.1V
77	G/W			Approximately 2.3V

Diagnostic Procedure

UBS001B7

1. CHECK GROUND CONNECTIONS

1. Turn ignition switch OFF.
2. Loosen and retighten three ground screws on the body.
Refer to [EC-789, "Ground Inspection"](#).

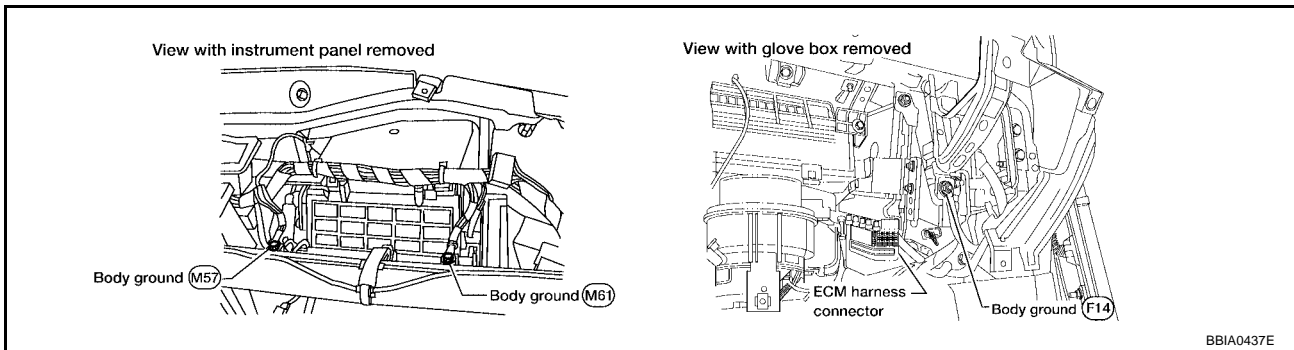

OK or NG

- OK >> GO TO 2.
- NG >> Repair or replace ground connections.

2. RETIGHTEN AIR FUEL RATIO (A/F) SENSOR 1

Loosen and retighten the air fuel ratio (A/F) sensor 1.

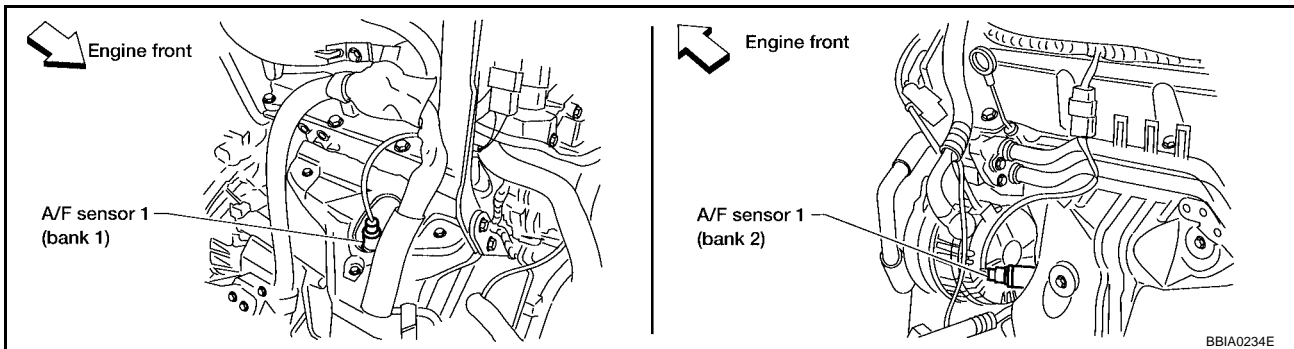

Tightening torque: 40 - 60 N-m (4.1 - 6.1 kg-m, 30 - 44 ft-lb)

>> GO TO 3.

3. CLEAR THE SELF-LEARNING DATA.

With CONSULT-II

1. Start engine and warm it up to normal operating temperature.
2. Select "SELF-LEARNING CONT" in "WORK SUPPORT" mode with CONSULT-II.
3. Clear the self-learning control coefficient by touching "CLEAR".
4. Run engine for at least 10 minutes at idle speed.
Is the 1st trip DTC P0171 or P0174 detected?
Is it difficult to start engine?

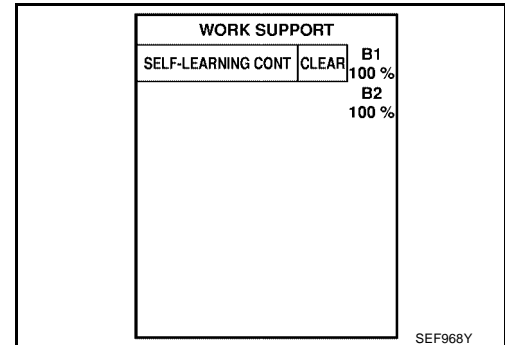

Without CONSULT-II

1. Start engine and warm it up to normal operating temperature.
2. Turn ignition switch OFF.
3. Disconnect mass air flow sensor harness connector.
4. Restart engine and let it idle for at least 3 seconds.
5. Stop engine and reconnect mass air flow sensor harness connector.
6. Make sure DTC P0102 is displayed.
7. Erase the DTC memory. Refer to [EC-682, "HOW TO ERASE EMISSION-RELATED DIAGNOSTIC INFORMATION"](#) .
8. Make sure DTC P0000 is displayed.
9. Run engine for at least 10 minutes at idle speed.
Is the 1st trip DTC P0171 or P0174 detected?
Is it difficult to start engine?

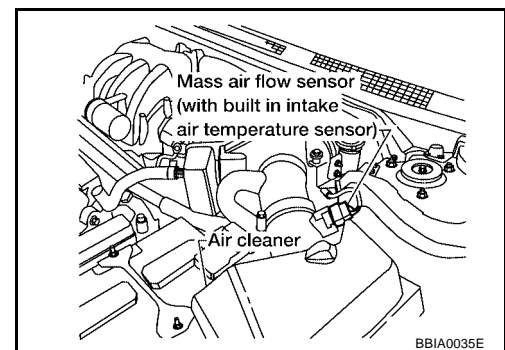

Yes or No

- Yes >> Perform trouble diagnosis for DTC P0171 or P0174. Refer to [EC-868](#) .
- No >> GO TO 4.

4. CHECK AIR FUEL RATIO (A/F) SENSOR 1 POWER SUPPLY CIRCUIT

1. Turn ignition switch OFF.
2. Disconnect air fuel ratio (A/F) sensor 1 harness connector.

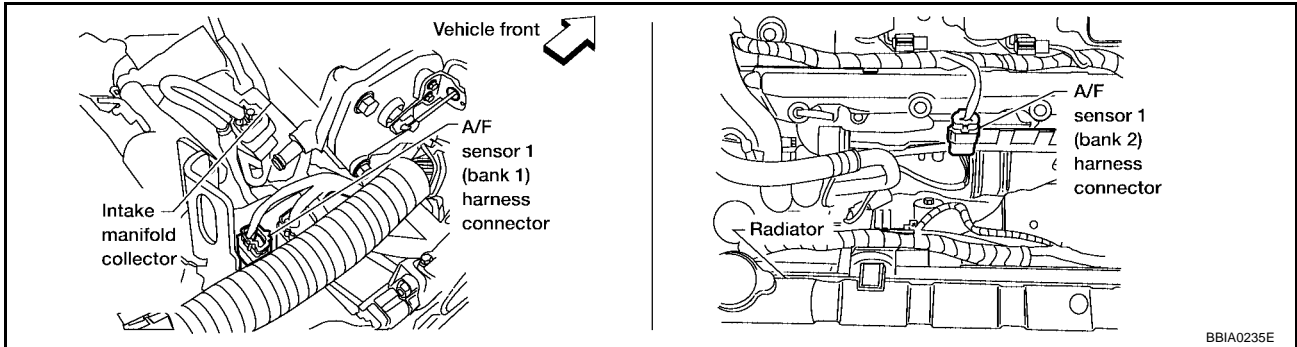

3. Turn ignition switch ON.
4. Check voltage between A/F sensor 1 terminal 3 and ground with CONSULT-II or tester.

Voltage: Battery voltage

OK or NG

- OK >> GO TO 6.
- NG >> GO TO 5.

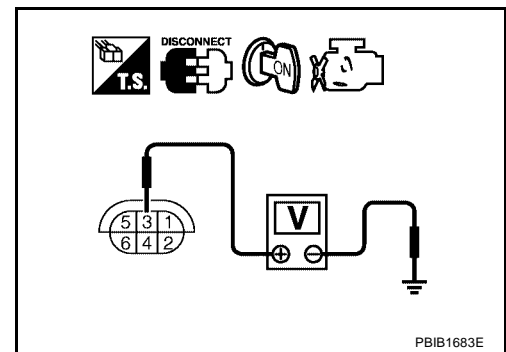

5. DETECT MALFUNCTIONING PART

Check the following.

- Harness connectors E21, F34
- IPDM E/R harness connector E122
- 15A fuse
- Harness for open or short between A/F sensor 1 and fuse

>> Repair or replace harness or connectors.

6. CHECK A/F SENSOR 1 INPUT SIGNAL CIRCUIT

1. Turn ignition switch OFF.
2. Disconnect ECM harness connector.
3. Check harness continuity between the following terminals.
Refer to Wiring Diagram.

	A/F sensor 1 terminal	ECM terminal
Bank 1	1	16
	2	75
	5	35
	6	56
Bank 2	1	76
	2	77
	5	57
	6	58

Continuity should exist.

4. Check harness continuity between the following terminals and ground.
Refer to Wiring Diagram.

Bank 1		Bank 2	
A/F sensor 1 terminal	ECM terminal	A/F sensor 1 terminal	ECM terminal
1	16	1	76
2	75	2	77
5	35	5	57
6	56	6	58

Continuity should not exist.

5. Also check harness for short to power.

OK or NG

OK >> GO TO 7.

NG >> Repair open circuit or short to ground or short to power in harness or connectors.

7. CHECK A/F SENSOR 1 HEATER

Refer to [EC-1052, "Component Inspection"](#) .

OK or NG

OK >> GO TO 8.

NG >> Replace A/F sensor 1.

8. CHECK INTERMITTENT INCIDENT

Perform [EC-782, "TROUBLE DIAGNOSIS FOR INTERMITTENT INCIDENT"](#) .

OK or NG

OK >> Replace A/F sensor 1.

NG >> Repair or replace.

Removal and Installation AIR FUEL RATIO (A/F) SENSOR 1

Refer to [EM-134, "EXHAUST MANIFOLD AND THREE WAY CATALYST"](#) .

UBS001B8

DTC P1274, P1284 A/F SENSOR 1

PFP:22693

Component Description

UBS001B9

The A/F sensor is a planar dual-cell limit current sensor. The sensor element of the A/F sensor is the combination of a Nernst concentration cell (sensor cell) with an oxygen-pump cell, which transports ions. It has a heater in the element.

The sensor is capable of precise measurement $\lambda = 1$, but also in the lean and rich range. Together with its control electronics, the sensor outputs a clear, continuous signal throughout a wide λ range ($0.7 < \lambda < \text{air}$).

The exhaust gas components diffuse through the diffusion gap at the electrode of the oxygen pump and Nernst concentration cell, where they are brought to thermodynamic balance.

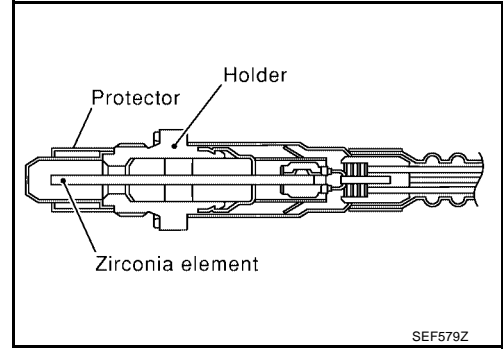

An electronic circuit controls the pump current through the oxygen-pump cell so that the composition of the exhaust gas in the diffusion gap remains constant at $\lambda = 1$. Therefore, the A/F sensor is able to indicate air/fuel ratio by this pumping of current. In addition, a heater is integrated in the sensor to ensure the required operating temperature of 700 - 800°C (1,292 - 1,472°F).

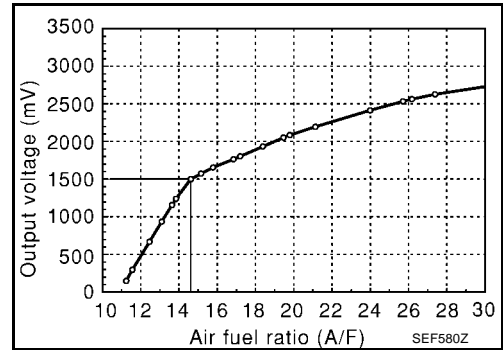

CONSULT-II Reference Value in Data Monitor Mode

UBS001BA

Specification data are reference values.

MONITOR ITEM	CONDITION	SPECIFICATION
A/F SEN1 (B1) A/F SEN1 (B2)	<ul style="list-style-type: none"> Engine: After warming up Maintaining engine speed at 2,000 rpm	Fluctuates around 1.5V

On Board Diagnosis Logic

UBS001BB

To judge the malfunction, the A/F signal computed by ECM from the air fuel ratio (A/F) sensor 1 signal is monitored not to be shifted to the LEAN side or RICH side.

DTC No.	Trouble diagnosis name	DTC detecting condition	Possible Cause
P1274 1274 (Bank 1)	Air fuel ratio (A/F) sensor 1 rich shift monitoring	<ul style="list-style-type: none"> The A/F signal computed by ECM from the A/F sensor 1 signal is shifted to the rich side for a specified period. 	<ul style="list-style-type: none"> Air fuel ratio (A/F) sensor 1 Air fuel ratio (A/F) sensor 1 heater Fuel pressure Fuel injector
P1284 1244 (Bank 2)			

DTC Confirmation Procedure

UBS001BC

NOTE:

If DTC Confirmation Procedure has been previously conducted, always turn ignition switch OFF and wait at least 10 seconds before conducting the next test.

TESTING CONDITION:

Before performing the following procedure, confirm that battery voltage is more than 11V at idle.

WITH CONSULT-II

- Start engine and warm it up to normal operating temperature.
- Turn ignition switch OFF and wait at least 10 seconds.
- Turn ignition switch ON and select "SELF-LEARNING CONT" in "WORK SUPPORT" mode with CONSULT-II.

DTC P1274, P1284 A/F SENSOR 1

[VQ]

4. Clear the self-learning coefficient by touching "CLEAR".
5. Turn ignition switch OFF and wait at least 10 seconds.
6. Start engine and keep the engine speed between 3,500 and 4,000 rpm for 1 minute under no load.
7. Let engine idle for 1 minute.
8. Keep engine speed between 2,500 and 3,000 rpm for 20 minutes.
9. If 1st trip DTC is detected, go to [EC-1162, "Diagnostic Procedure"](#).

WORK SUPPORT		
SELF-LEARNING CONT	CLEAR	B1 100 %
		B2 100 %

SEF968Y

WITH GST

1. Start engine and warm it up to normal operating temperature.
2. Turn ignition switch OFF and wait at least 10 seconds.
3. Disconnect mass air flow sensor harness connector.
4. Start engine and let it idle for at least 5 seconds.
5. Stop engine and reconnect mass air flow sensor harness connector.
6. Select Service \$03 with GST and make sure that DTC P0102 is detected.
7. Select Service \$04 with GST and erase the DTC P0102.
8. Start engine and keep the engine speed between 3,500 and 4,000 rpm for 1 minute under no load.
9. Let engine idle for 1 minute.
10. Keep engine speed between 2,500 and 3,000 rpm for 20 minutes.
11. Select Service \$07 with GST.
If 1st trip DTC is detected, go to [EC-1162, "Diagnostic Procedure"](#).

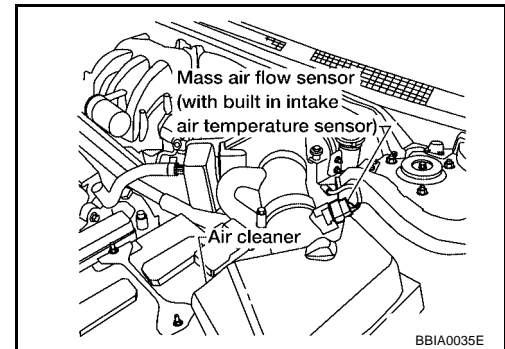

DTC P1274, P1284 A/F SENSOR 1

[VQ]

UBS001BD

Wiring Diagram BANK 1

EC-AF1B1-01

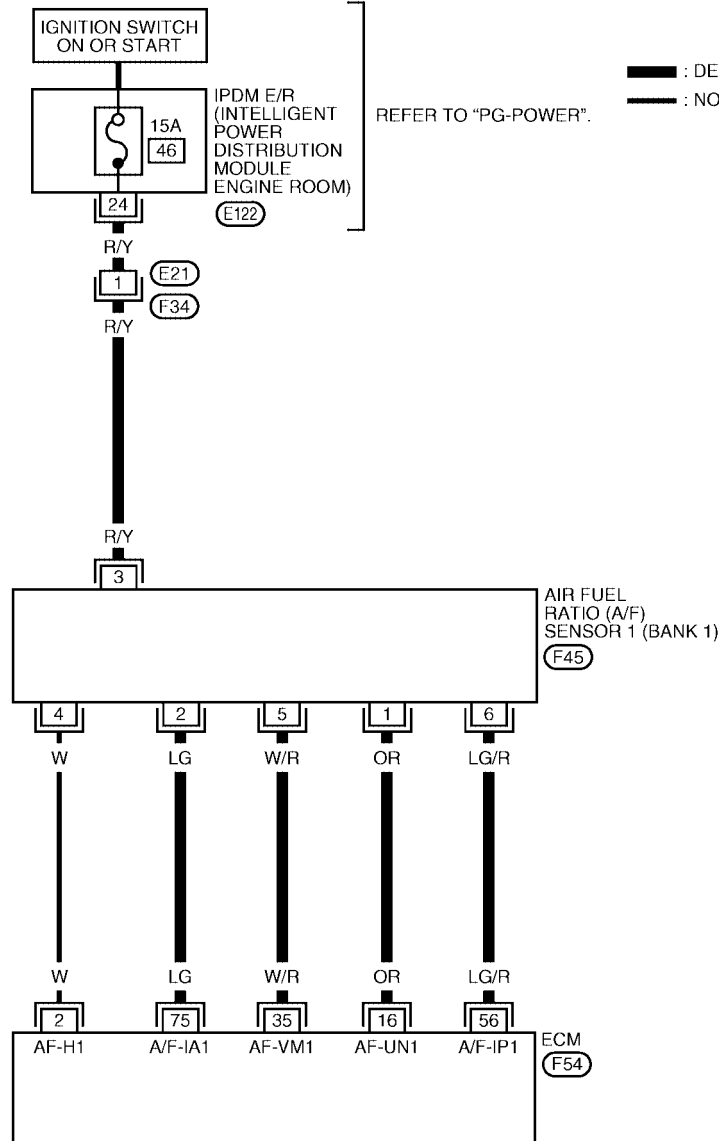

— : DETECTABLE LINE FOR DTC
— : NON-DETECTABLE LINE FOR DTC

A
EC
C
D
E
F
G
H
I
J
K
L
M

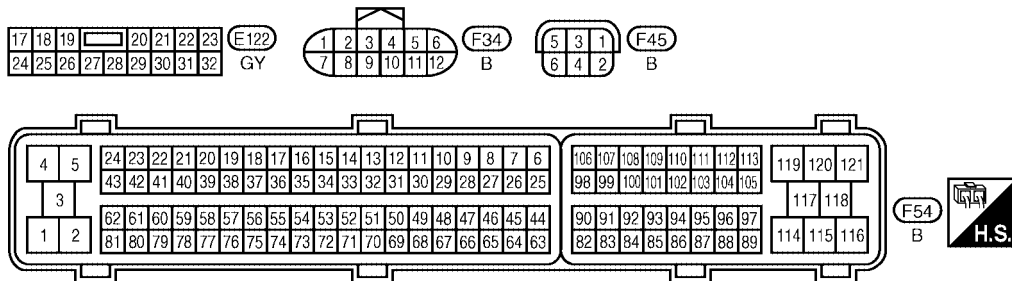

BBWA1267E

DTC P1274, P1284 A/F SENSOR 1

[VQ]

Specification data are reference values and are measured between each terminal and ground.

CAUTION:

Do not use ECM ground terminals when measuring input/output voltage. Doing so may result in damage to the ECM's transistor. Use a ground other than ECM terminals, such as the ground.

TERMI- NAL NO.	WIRE COLOR	ITEM	CONDITION	DATA (DC Voltage)
16	OR	A/F sensor 1 (Bank 1)	[Engine is running] <ul style="list-style-type: none">● Warm-up condition● Idle speed	Approximately 3.1V
35	W/R			Approximately 2.6V
56	LG/R			Approximately 2.3V
75	LG			Approximately 2.3V

DTC P1274, P1284 A/F SENSOR 1

[VQ]

BANK 2

EC-AF1B2-01

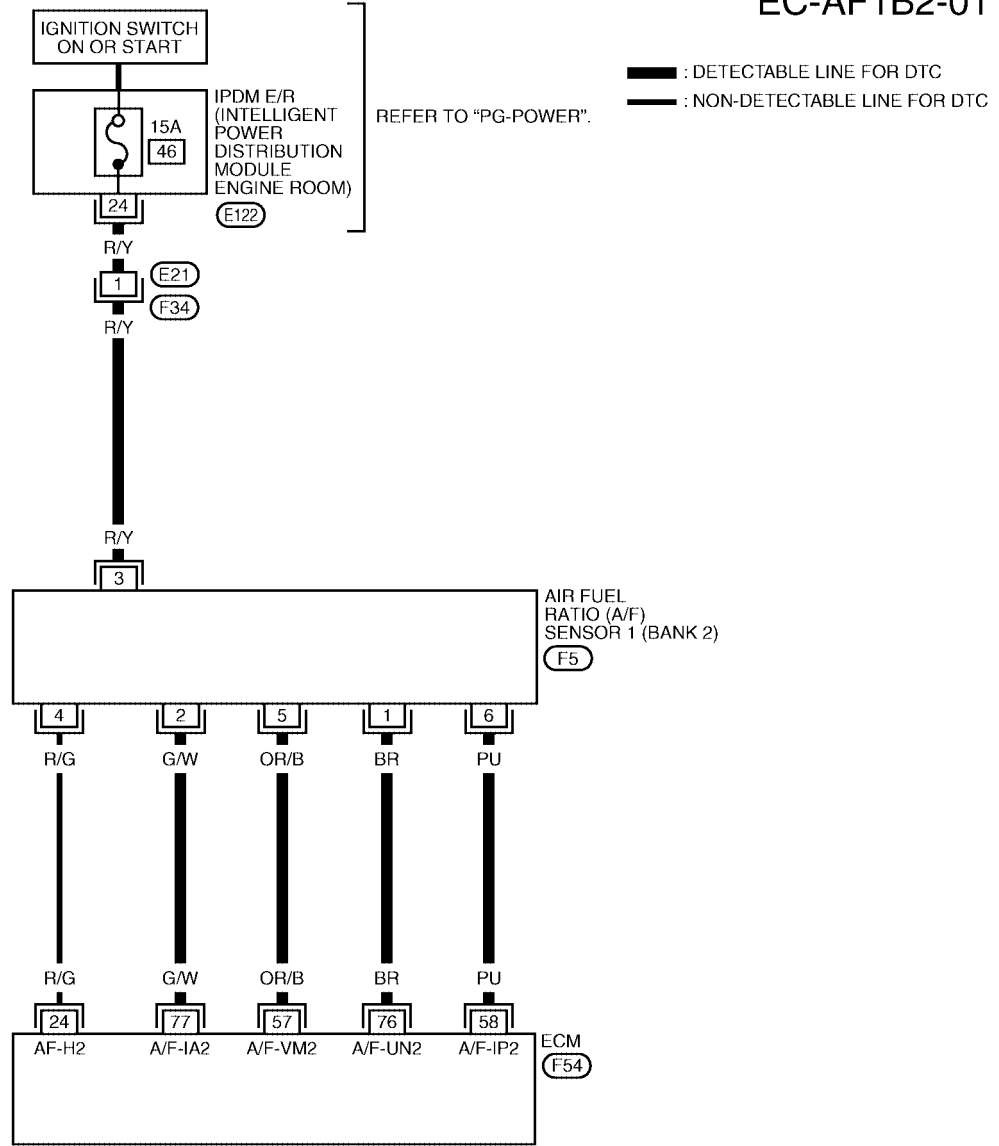

A
EC
C
D
E
F
G
H
I
J
K
L
M

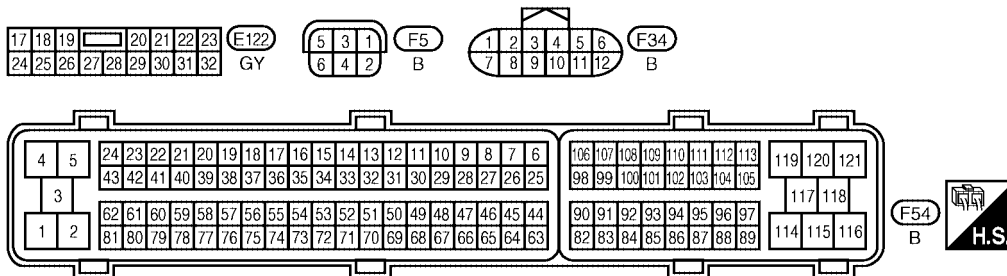

BBWA1572E

DTC P1274, P1284 A/F SENSOR 1

[VQ]

Specification data are reference values and are measured between each terminal and ground.

CAUTION:

Do not use ECM ground terminals when measuring input/output voltage. Doing so may result in damage to the ECM's transistor. Use a ground other than ECM terminals, such as the ground.

TERMI- NAL NO.	WIRE COLOR	ITEM	CONDITION	DATA (DC Voltage)
57	OR/B	A/F sensor 1 (Bank 2)	[Engine is running] ● Warm-up condition ● Idle speed	Approximately 2.6V
58	PU			Approximately 2.3V
76	BR			Approximately 3.1V
77	G/W			Approximately 2.3V

Diagnostic Procedure

UBS001BE

1. CHECK GROUND CONNECTIONS

1. Turn ignition switch OFF.
2. Loosen and retighten three ground screws on the body.
Refer to [EC-789, "Ground Inspection"](#).

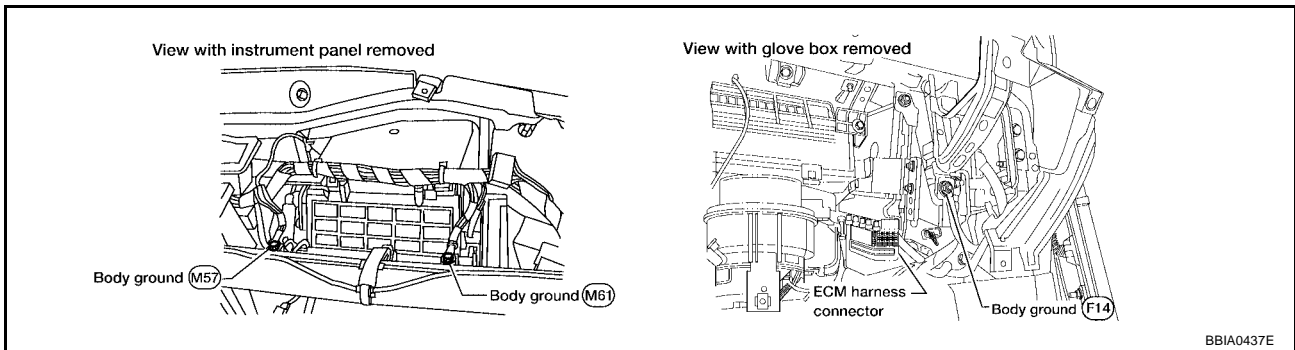

OK or NG

- OK >> GO TO 2.
- NG >> Repair or replace ground connections.

2. RETIGHTEN AIR FUEL RATIO (A/F) SENSOR 1

Loosen and retighten the air fuel ratio (A/F) sensor 1.

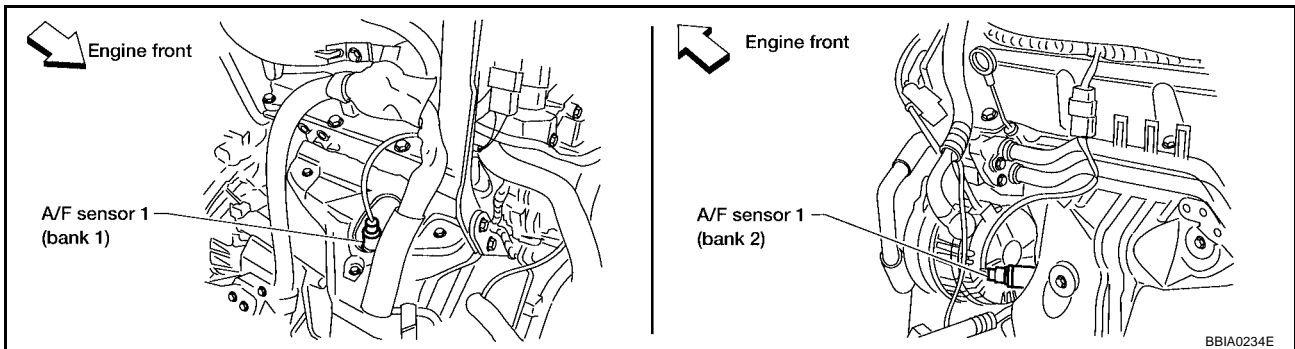

Tightening torque: 40 - 60 N-m (4.1 - 6.1 kg-m, 30 - 44 ft-lb)

>> GO TO 3.

3. CLEAR THE SELF-LEARNING DATA.

With CONSULT-II

1. Start engine and warm it up to normal operating temperature.
2. Select "SELF-LEARNING CONT" in "WORK SUPPORT" mode with CONSULT-II.
3. Clear the self-learning control coefficient by touching "CLEAR".
4. Run engine for at least 10 minutes at idle speed.
Is the 1st trip DTC P0172 or P0175 detected?
Is it difficult to start engine?

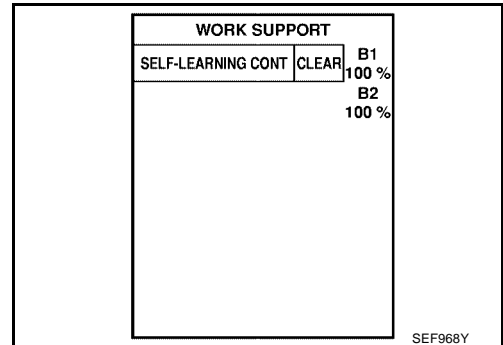

Without CONSULT-II

1. Start engine and warm it up to normal operating temperature.
2. Turn ignition switch OFF.
3. Disconnect mass air flow sensor harness connector.
4. Restart engine and let it idle for at least 3 seconds.
5. Stop engine and reconnect mass air flow sensor harness connector.
6. Make sure DTC P0102 is displayed.
7. Erase the DTC memory. Refer to [EC-682. "HOW TO ERASE EMISSION-RELATED DIAGNOSTIC INFORMATION"](#) .
8. Make sure DTC P0000 is displayed.
9. Run engine for at least 10 minutes at idle speed.
Is the 1st trip DTC P0172 or P0175 detected?
Is it difficult to start engine?

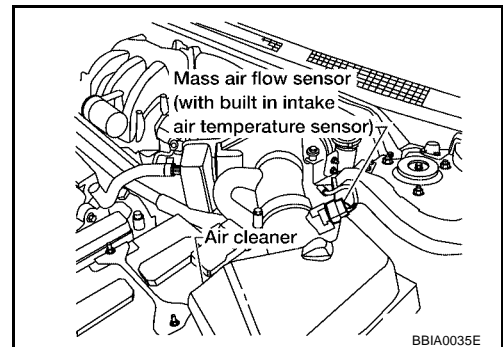

Yes or No

- Yes >> Perform trouble diagnosis for DTC P0172 or P0175. Refer to [EC-879](#) .
- No >> GO TO 4.

A
EC
C
D
E
F
G
H
I
J
K
L
M

4. CHECK HARNESS CONNECTOR

1. Turn ignition switch OFF.
2. Disconnect A/F sensor 1 harness connector.

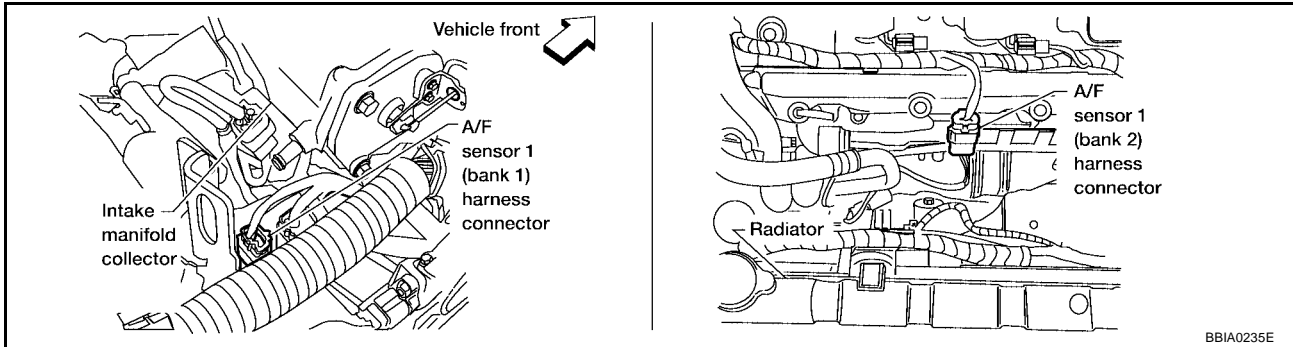

3. Check harness connector for water.
Water should not exit.

OK or NG

- OK >> GO TO 5.
NG >> Repair or replace harness connector.

5. CHECK AIR FUEL RATIO (A/F) SENSOR 1 POWER SUPPLY CIRCUIT

1. Turn ignition switch ON.
2. Check voltage between A/F sensor 1 terminal 3 and ground with CONSULT-II or tester.

Voltage: Battery voltage

OK or NG

- OK >> GO TO 7.
NG >> GO TO 6.

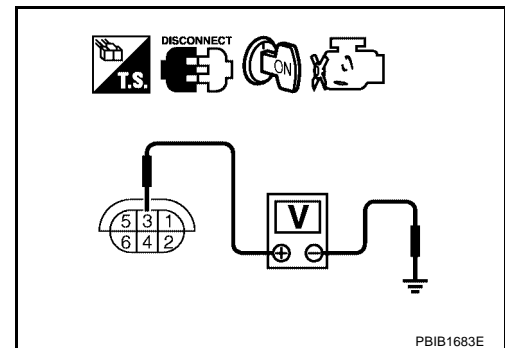

6. DETECT MALFUNCTIONING PART

Check the following.

- Harness connectors E21, F34
- IPDM E/R harness connector E122
- 15A fuse
- Harness for open or short between A/F sensor 1 and fuse

>> Repair or replace harness or connectors.

7. CHECK A/F SENSOR 1 INPUT SIGNAL CIRCUIT

1. Turn ignition switch OFF.
2. Disconnect ECM harness connector.
3. Check harness continuity between the following terminals.
Refer to Wiring Diagram.

	A/F sensor 1 terminal	ECM terminal
Bank 1	1	16
	2	75
	5	35
	6	56
Bank 2	1	76
	2	77
	5	57
	6	58

Continuity should exist.

4. Check harness continuity between the following terminals and ground.
Refer to Wiring Diagram.

Bank 1		Bank 2	
A/F sensor 1 terminal	ECM terminal	A/F sensor 1 terminal	ECM terminal
1	16	1	76
2	75	2	77
5	35	5	57
6	56	6	58

Continuity should not exist.

5. Also check harness for short to power.

OK or NG

OK >> GO TO 8.

NG >> Repair open circuit or short to ground or short to power in harness or connectors.

8. CHECK A/F SENSOR 1 HEATER

Refer to [EC-1052, "Component Inspection"](#) .

OK or NG

OK >> GO TO 9.

NG >> Replace A/F sensor 1.

9. CHECK INTERMITTENT INCIDENT

Perform [EC-782, "TROUBLE DIAGNOSIS FOR INTERMITTENT INCIDENT"](#) .

OK or NG

OK >> Replace A/F sensor 1.

NG >> Repair or replace.

Removal and Installation AIR FUEL RATIO (A/F) SENSOR 1

Refer to [EM-134, "EXHAUST MANIFOLD AND THREE WAY CATALYST"](#) .

UBS00IBF

DTC P1276, P1286 A/F SENSOR 1

PFP:22693

Component Description

UBS00IBG

The A/F sensor is a planar dual-cell limit current sensor. The sensor element of the A/F sensor is the combination of a Nernst concentration cell (sensor cell) with an oxygen-pump cell, which transports ions. It has a heater in the element.

The sensor is capable of precise measurement $\lambda = 1$, but also in the lean and rich range. Together with its control electronics, the sensor outputs a clear, continuous signal throughout a wide λ range ($0.7 < \lambda < \text{air}$).

The exhaust gas components diffuse through the diffusion gap at the electrode of the oxygen pump and Nernst concentration cell, where they are brought to thermodynamic balance.

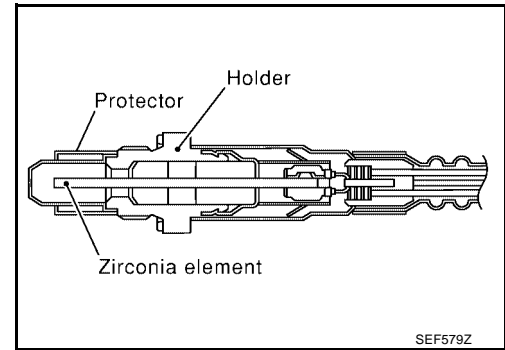

An electronic circuit controls the pump current through the oxygen-pump cell so that the composition of the exhaust gas in the diffusion gap remains constant at $\lambda = 1$. Therefore, the A/F sensor is able to indicate air/fuel ratio by this pumping of current. In addition, a heater is integrated in the sensor to ensure the required operating temperature of 700 - 800°C (1,292 - 1,472°F).

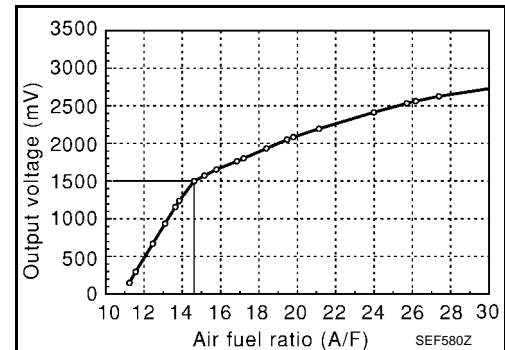

CONSULT-II Reference Value in Data Monitor Mode

UBS00IBH

Specification data are reference values.

MONITOR ITEM	CONDITION		SPECIFICATION
A/F SEN1 (B1) A/F SEN1 (B2)	● Engine: After warming up	Maintaining engine speed at 2,000 rpm	Fluctuates around 1.5V

On Board Diagnosis Logic

UBS00IBI

To judge the malfunction, the diagnosis checks that the A/F signal computed by ECM from the air fuel ratio (A/F) sensor 1 signal fluctuates according to fuel feedback control.

DTC No.	Trouble diagnosis name	DTC detecting condition	Possible Cause
P1276 1276 (Bank 1)	Air fuel ratio (A/F) sensor 1 circuit high voltage	● The A/F signal computed by ECM from the A/F sensor 1 signal is constantly approx. 1.5V.	<ul style="list-style-type: none"> ● Harness or connectors (The A/F sensor 1 circuit is open or shorted.) ● Air fuel ratio (A/F) sensor 1
P1286 1286 (Bank 2)			

DTC Confirmation Procedure

UBS00IBJ

CAUTION:

Always drive vehicle at a safe speed.

NOTE:

If DTC Confirmation Procedure has been previously conducted, always turn ignition switch OFF and wait at least 10 seconds before conducting the next test.

TESTING CONDITION:

Before performing the following procedure, confirm that battery voltage is more than 11V at idle.

WITH CONSULT-II

1. Start engine and warm it up to normal operating temperature.
2. Select "A/F SEN1 (B1)" or "A/F SEN1 (B2)" in "DATA MONITOR" mode with CONSULT-II.
3. Check "A/F SEN1 (B1)" or "A/F SEN1 (B2)" indication.

DTC P1276, P1286 A/F SENSOR 1

[VQ]

If the indication is constantly approx. 1.5V and does not fluctuates, go to [EC-1172, "Diagnostic Procedure"](#)

If the indication fluctuates around 1.5V, go to next step.

4. Select "A/F SEN1 (B1) P1276" or "A/F SEN1 (B2) P1286" of "A/F SEN1" in "DTC WORK SUPPORT" mode with CONSULT-II.
5. Touch "START".
6. When the following conditions are met, "TESTING" will be displayed on the CONSULT-II screen.

ENG SPEED	1,750 - 3,200 rpm
Vehicle speed	More than 64 km/h (40MPH)
B/FUEL SCHDL	1.0 - 8.0 msec
Shift lever	D position (A/T) 5th position (M/T)

If "TESTING" is not displayed after 20 seconds, retry from step 2.

A/F SEN1 (B1) P1276	
OUT OF CONDITION	
MONITOR	
ENG SPEED	XXX rpm
B/FUEL SCHDL	XXX msec
COOLANTEMP/S	XXX °C
VHCL SPEED SE	XXX km/h

SEF576Z

7. Release accelerator pedal fully.

NOTE:

Never apply brake during releasing the accelerator pedal.

A/F SEN1 (B1) P1276	
TESTING	
SELECT 3RD GEAR AND THEN RELEASE ACCELERATOR PEDAL OFF	
MONITOR	
ENG SPEED	XXX rpm
B/FUEL SCHDL	XXX msec
COOLANTEMP/S	XXX °C
VHCL SPEED SE	XXX km/h

SEF577Z

8. Make sure that "TESTING" changes to "COMPLETED".
If "TESTING" changed to "OUT OF CONDITION", retry from step 6.
9. Make sure that "OK" is displayed after touching "SELF-DIAG RESULT".
If "NG" is displayed, go to [EC-1172, "Diagnostic Procedure"](#).

A/F SEN1 (B1) P1276	
COMPLETED	

SEF578Z

Overall Function Check

UBS001BK

Use this procedure to check the overall function of the A/F sensor 1 circuit.

 **WITH GST**

1. Start engine and warm it up to normal operating temperature.
2. Drive the vehicle at a speed of 80 km/h (50 MPH) for a few minutes in the suitable gear position.
3. Set D position, then release the accelerator pedal fully until the vehicle speed decreases to 50 km/h (30 MPH).

NOTE:

Never apply brake during releasing the accelerator pedal.

4. Repeat steps 2 to 3 for 5 times.
5. Stop the vehicle and turn ignition switch OFF.
6. Wait at least 10 seconds and restart engine.
7. Repeat steps 2 to 3 for 5 times.

DTC P1276, P1286 A/F SENSOR 1

[VQ]

-
8. Stop the vehicle and connect GST to the vehicle.
 9. Make sure that no DTC is displayed.
If the DTC is displayed, go to [EC-1172, "Diagnostic Procedure"](#) .

DTC P1276, P1286 A/F SENSOR 1

[VQ]

Wiring Diagram BANK 1

UBS001BL

EC-AF1B1-01

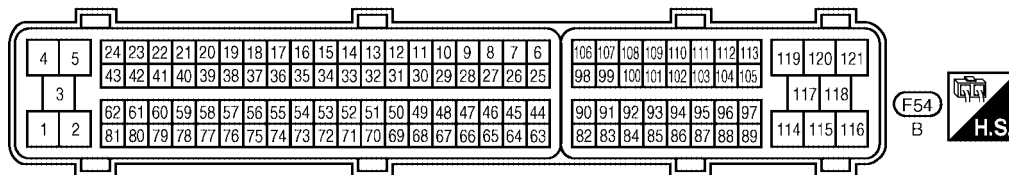
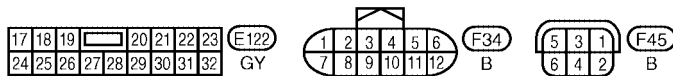
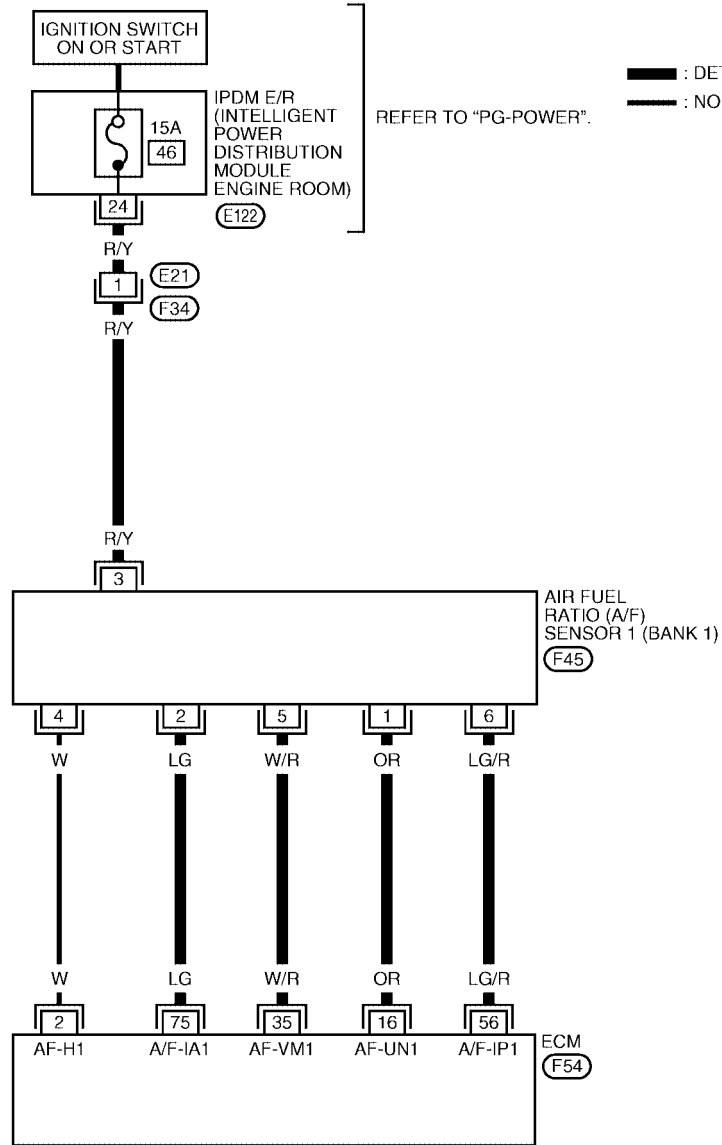

BBWA1267E

DTC P1276, P1286 A/F SENSOR 1

[VQ]

Specification data are reference values and are measured between each terminal and ground.

CAUTION:

Do not use ECM ground terminals when measuring input/output voltage. Doing so may result in damage to the ECM's transistor. Use a ground other than ECM terminals, such as the ground.

TERMI- NAL NO.	WIRE COLOR	ITEM	CONDITION	DATA (DC Voltage)
16	OR	A/F sensor 1 (Bank 1)	[Engine is running] <ul style="list-style-type: none">● Warm-up condition● Idle speed	Approximately 3.1V
35	W/R			Approximately 2.6V
56	LG/R			Approximately 2.3V
75	LG			Approximately 2.3V

DTC P1276, P1286 A/F SENSOR 1

[VQ]

BANK 2

EC-AF1B2-01

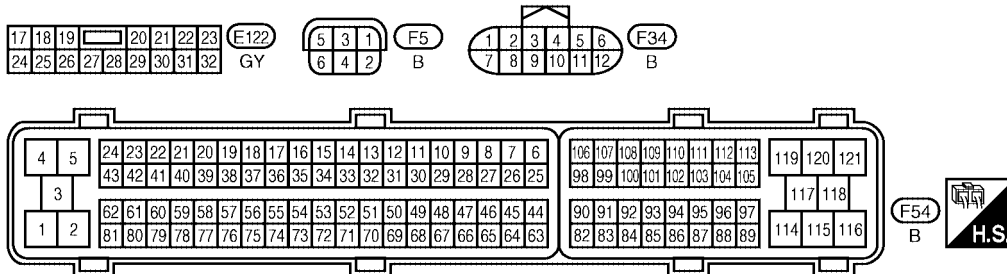
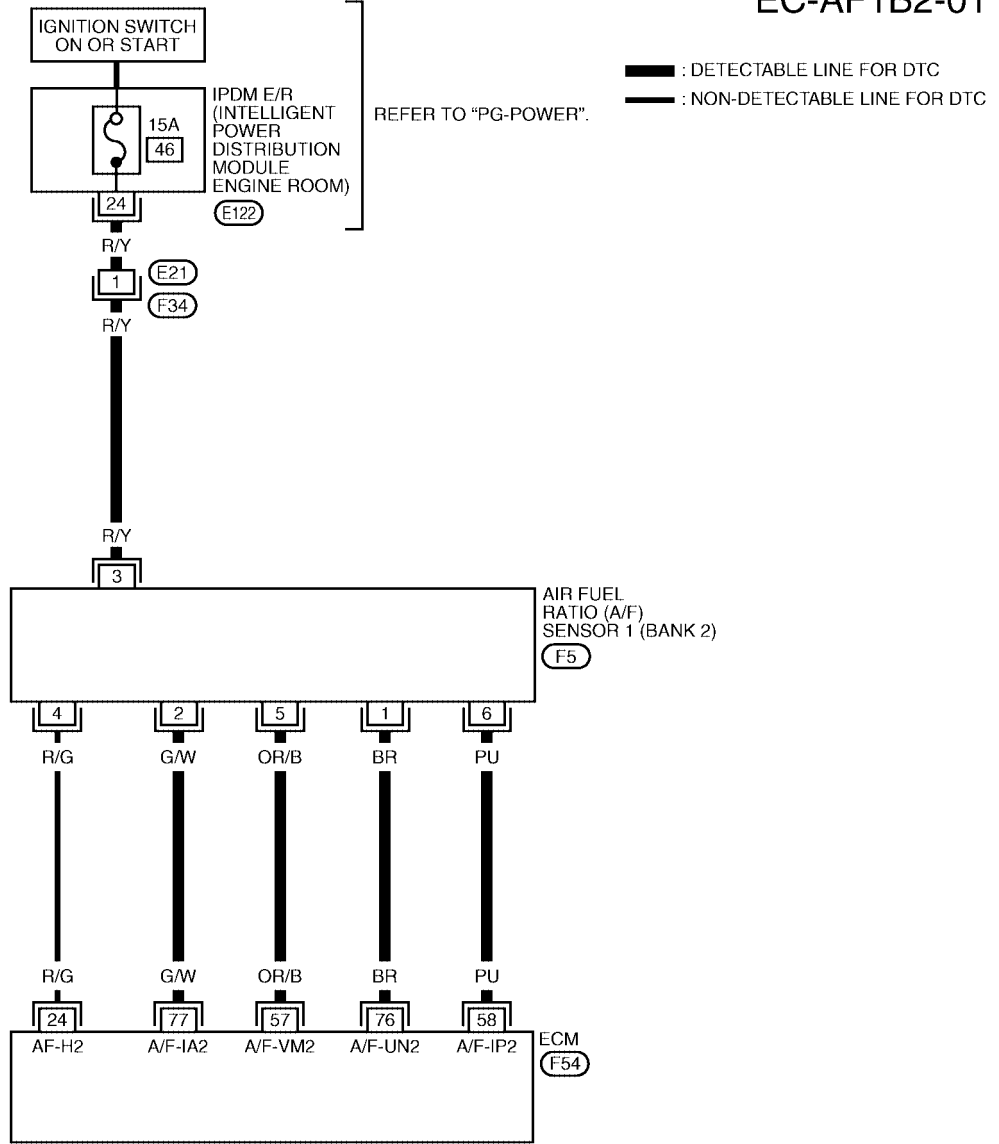

BBWA1572E

DTC P1276, P1286 A/F SENSOR 1

[VQ]

Specification data are reference values and are measured between each terminal and ground.

CAUTION:

Do not use ECM ground terminals when measuring input/output voltage. Doing so may result in damage to the ECM's transistor. Use a ground other than ECM terminals, such as the ground.

TERMI- NAL NO.	WIRE COLOR	ITEM	CONDITION	DATA (DC Voltage)
57	OR/B	A/F sensor 1 (Bank 2)	[Engine is running] ● Warm-up condition ● Idle speed	Approximately 2.6V
58	PU			Approximately 2.3V
76	BR			Approximately 3.1V
77	G/W			Approximately 2.3V

Diagnostic Procedure

UBS001BM

1. CHECK GROUND CONNECTIONS

1. Turn ignition switch OFF.
2. Loosen and retighten three ground screws on the body.
Refer to [EC-789, "Ground Inspection"](#).

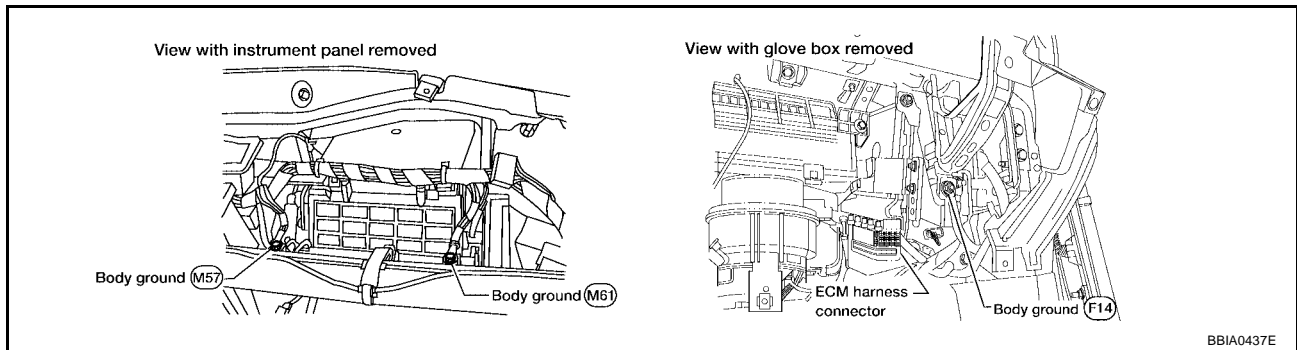

BBA0437E

OK or NG

- OK >> GO TO 2.
- NG >> Repair or replace ground connections.

2. CHECK AIR FUEL RATIO (A/F) SENSOR 1 POWER SUPPLY CIRCUIT

1. Disconnect air fuel ratio (A/F) sensor 1 harness connector.

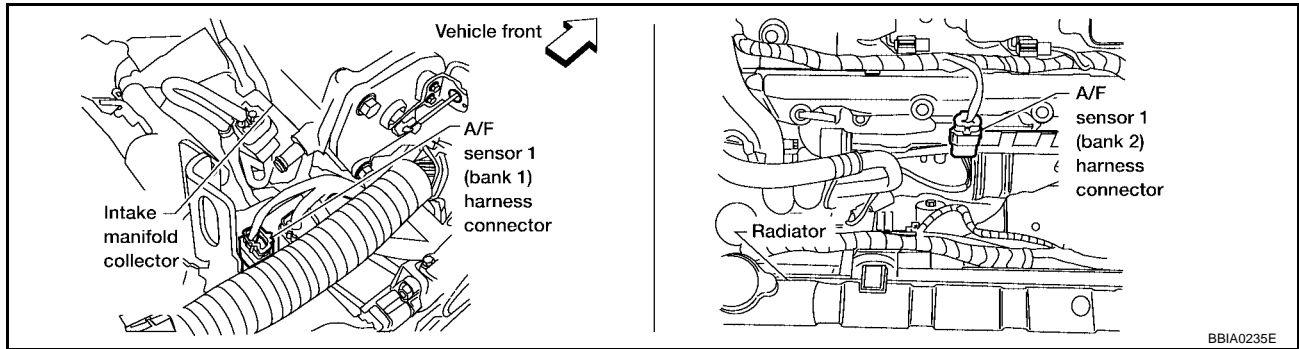

2. Turn ignition switch ON.
3. Check voltage between A/F sensor 1 terminal 3 and ground with CONSULT-II or tester.

Voltage: Battery voltage

OK or NG

- OK >> GO TO 4.
- NG >> GO TO 3.

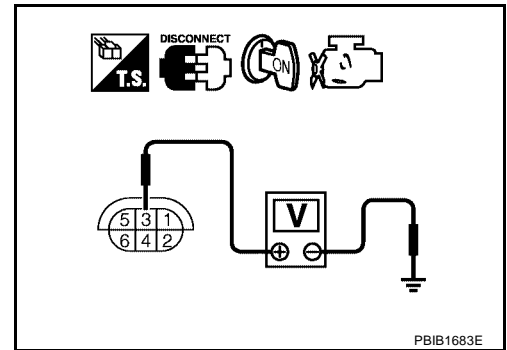

3. DETECT MALFUNCTIONING PART

Check the following.

- Harness connectors E21, F34
- IPDM E/R harness connector E122
- 15A fuse
- Harness for open or short between A/F sensor 1 and fuse

>> Repair or replace harness or connectors.

4. CHECK A/F SENSOR 1 INPUT SIGNAL CIRCUIT

1. Turn ignition switch OFF.
2. Disconnect ECM harness connector.
3. Check harness continuity between the following terminals.
Refer to Wiring Diagram.

	A/F sensor 1 terminal	ECM terminal
Bank 1	1	16
	2	75
	5	35
	6	56
Bank 2	1	76
	2	77
	5	57
	6	58

Continuity should exist.

4. Check harness continuity between the following terminals and ground.
Refer to Wiring Diagram.

Bank 1		Bank 2	
A/F sensor 1 terminal	ECM terminal	A/F sensor 1 terminal	ECM terminal
1	16	1	76
2	75	2	77
5	35	5	57
6	56	6	58

Continuity should not exist.

5. Also check harness for short to power.

OK or NG

OK >> GO TO 5.

NG >> Repair open circuit or short to ground or short to power in harness or connectors.

5. CHECK INTERMITTENT INCIDENT

Perform [EC-782, "TROUBLE DIAGNOSIS FOR INTERMITTENT INCIDENT"](#) .

OK or NG

OK >> Replace A/F sensor 1.

NG >> Repair or replace.

Removal and Installation AIR FUEL RATIO (A/F) SENSOR 1

UBS001BN

Refer to [EM-134, "EXHAUST MANIFOLD AND THREE WAY CATALYST"](#) .

DTC P1278, P1288 A/F SENSOR 1

PFP:22693

UBS00IB0

Component Description

The air fuel ratio (A/F) sensor 1 is a planar dual-cell limit current sensor. The sensor element of the A/F sensor 1 is the combination of a Nernst concentration cell (sensor cell) with an oxygen-pump cell, which transports ions. It has a heater in the element.

The sensor is capable of precise measurement $\lambda = 1$, but also in the lean and rich range. Together with its control electronics, the sensor outputs a clear, continuous signal throughout a wide λ range ($0.7 < \lambda < \text{air}$).

The exhaust gas components diffuse through the diffusion gap at the electrode of the oxygen pump and Nernst concentration cell, where they are brought to thermodynamic balance.

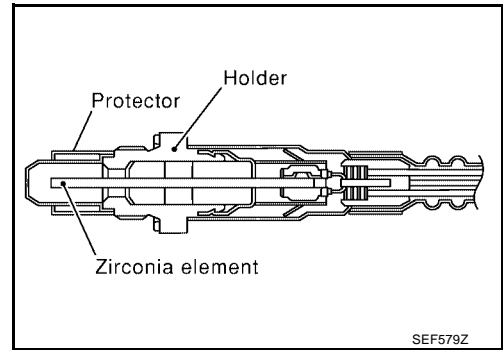

An electronic circuit controls the pump current through the oxygen-pump cell so that the composition of the exhaust gas in the diffusion gap remains constant at $\lambda = 1$. Therefore, the A/F sensor 1 is able to indicate air/fuel ratio by this pumping of current. In addition, a heater is integrated in the sensor to ensure the required operating temperature of 700 - 800°C (1,292 - 1,472°F).

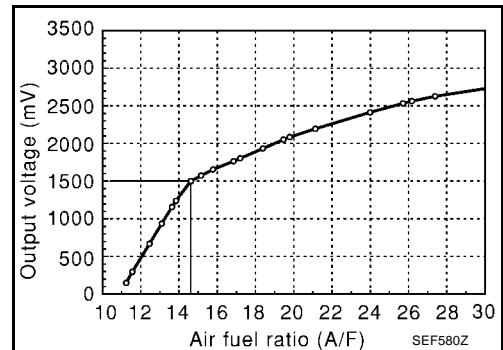

CONSULT-II Reference Value in Data Monitor Mode

UBS00IBP

Specification data are reference values.

MONITOR ITEM	CONDITION		SPECIFICATION
A/F SEN1 (B1) A/F SEN1 (B2)	● Engine: After warming up	Maintaining engine speed at 2,000 rpm	Fluctuates around 1.5V

On Board Diagnosis Logic

UBS00IBQ

To judge the malfunction of A/F sensor 1, this diagnosis measures response time of the A/F signal computed by ECM from the A/F sensor 1 signal. The time is compensated by engine operating (speed and load), fuel feedback control constant, and the A/F sensor 1 temperature index. Judgment is based on whether the compensated time (the A/F signal cycling time index) is inordinately long or not.

DTC No.	Trouble diagnosis name	DTC detecting condition	Possible Cause
P1278 1278 (Bank 1)	Air fuel ratio (A/F) sensor 1 circuit slow response	● The response (from RICH to LEAN) of the A/F signal computed by ECM from A/F sensor 1 signal takes more than the specified time.	<ul style="list-style-type: none"> ● Harness or connectors (The A/F sensor 1 circuit is open or shorted.) ● Air fuel ratio (A/F) sensor 1 ● Air fuel ratio (A/F) sensor 1 heater ● Fuel pressure ● Fuel injector ● Intake air leaks ● Exhaust gas leaks ● PCV ● Mass air flow sensor
P1288 1288 (Bank 2)			

DTC Confirmation Procedure

NOTE:

If DTC Confirmation Procedure has been previously conducted, always turn ignition switch OFF and wait at least 10 seconds before conducting the next test.

TESTING CONDITION:

Before performing the following procedure, confirm that battery voltage is more than 11V at idle.

WITH CONSULT-II

1. Start engine and warm it up to normal operating temperature.
2. Turn ignition switch OFF and wait at least 10 seconds.
3. Start engine and keep the engine speed between 3,500 and 4,000 rpm for at least 1 minute under no load.
4. Let engine idle for 1 minute.
5. Select "A/F SEN1(B1) P1278/P1279" or "A/F SEN1(B1) P1288/P1289" of "A/F SEN1" in "DTC WORK SUPPORT" mode with CONSULT-II.
6. Touch "START".
 If "COMPLETED" appears on CONSULT-II screen, go to step 10.
 If "COMPLETED" does not appear on CONSULT-II screen, go to the following step.

A/F SEN1 (B1) P1278/P1279	
OUT OF CONDITION	
MONITOR	
ENG SPEED	XXX rpm
B/FUEL SCHDL	XXX msec
COOLAN TEMP/S	XXX °C
VHCL SPEED SE	XXX km/h
PBIB0756E	

7. After perform the following procedure, "TESTING" will be displayed on the CONSULT-II screen.
 - a. Increase the engine speed up to 4,000 to 5,000 rpm and keep it for 10 seconds.
 - b. Fully release accelerator pedal and then let engine idle for about 10 seconds.
If "TESTING" is not displayed after 10 seconds, refer to [EC-772, "TROUBLE DIAGNOSIS - SPECIFICATION VALUE"](#) .
8. Wait for about 20 seconds at idle at under the condition that "TESTING" is displayed on the CONSULT-II screen.

A/F SEN1 (B1) P1278/P1279	
TESTING	
MONITOR	
ENG SPEED	XXX rpm
B/FUEL SCHDL	XXX msec
COOLAN TEMP/S	XXX °C
VHCL SPEED SE	XXX km/h
PBIB1925E	

9. Make sure that "TESTING" changes to "COMPLETED".
If "TESTING" changed to "OUT OF CONDITION", refer to [EC-772, "TROUBLE DIAGNOSIS - SPECIFICATION VALUE"](#) .
10. Make sure that "OK" is displayed after touching "SELF-DIAG RESULT".
 If "NG" is displayed, go to [EC-1181, "Diagnostic Procedure"](#) .

A/F SEN1 (B1) P1278/P1279	
COMPLETED	
PBIB0758E	

**WITH GST**

- | | |
|--|----|
| 1. Start engine and warm it up to normal operating temperature. | A |
| 2. Select "Service \$01" with GST. | |
| 3. Calculate the total value of "Short term fuel trim" and "Long term fuel trim" indications. Make sure that the total percentage should be within $\pm 15\%$.
If OK, go to the following step.
If NG, check the following. | EC |
| ● Intake air leaks | C |
| ● Exhaust gas leaks | |
| ● Incorrect fuel pressure | D |
| ● Lack of fuel | |
| ● Fuel injector | E |
| ● Incorrect PCV hose connection | |
| ● PCV valve | F |
| ● Mass air flow sensor | |
| 4. Turn ignition switch OFF and wait at least 10 seconds. | F |
| 5. Start engine and keep the engine speed between 3,500 and 4,000 rpm for at least 1 minute under no load. | |
| 6. Let engine idle for 1 minute. | G |
| 7. Increase the engine speed up to 4,000 to 5,000 rpm and keep it for 10 seconds. | |
| 8. Fully release accelerator pedal and then let engine idle for about 1 minute. | H |
| 9. Select "Service \$07" with GST.
If 1st trip DTC is detected, go to EC-1181, "Diagnostic Procedure" . | H |
| | I |
| | J |
| | K |
| | L |
| | M |

DTC P1278, P1288 A/F SENSOR 1

[VQ]

UBS00IBS

Wiring Diagram BANK 1

EC-AF1B1-01

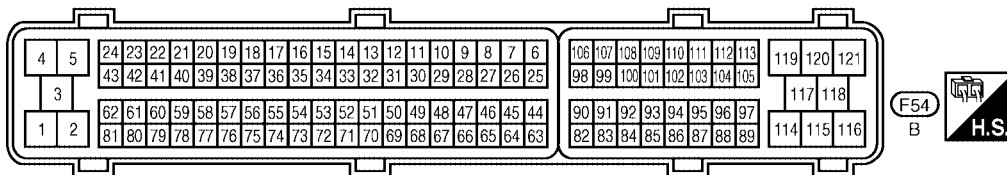
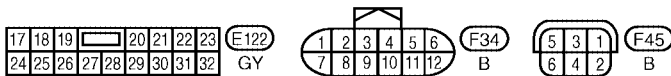
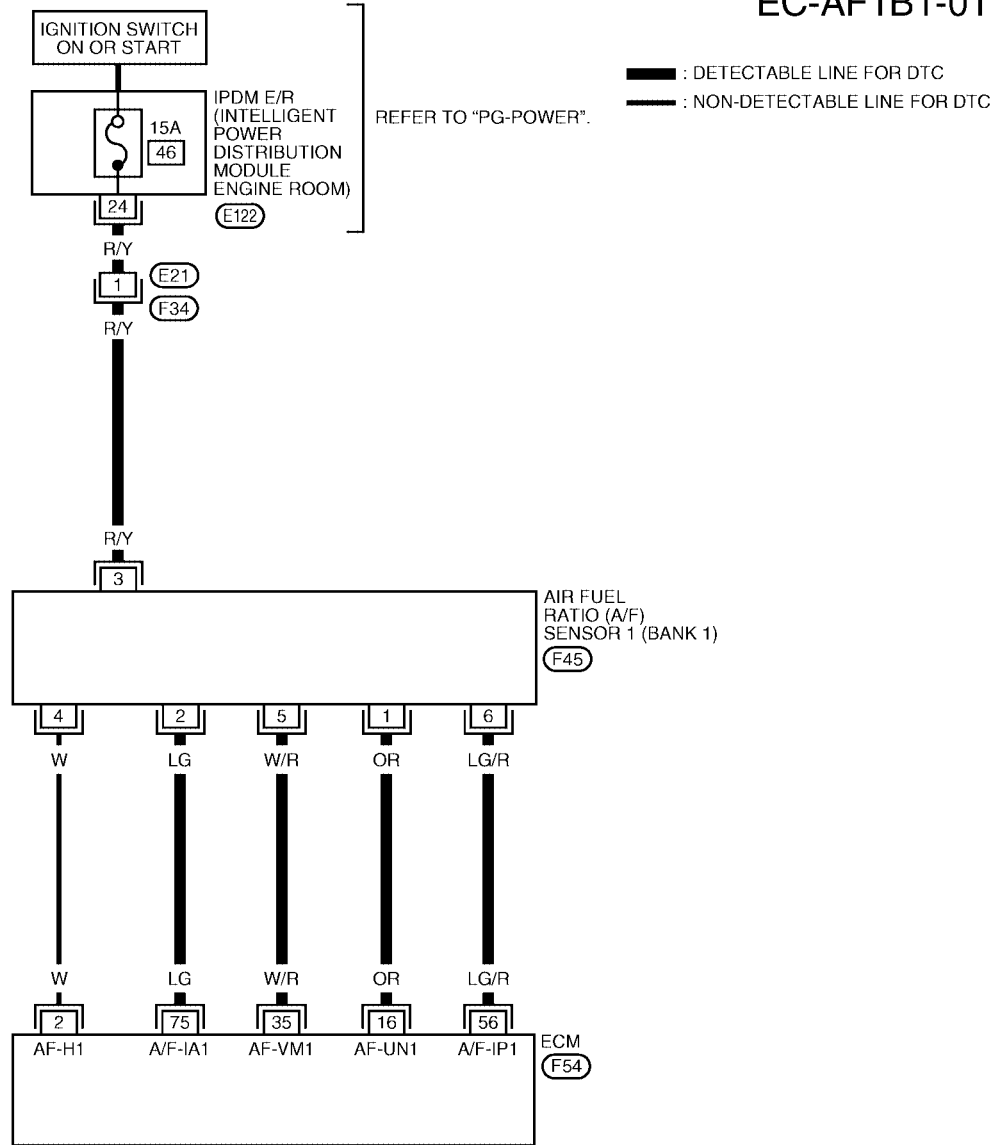

BBWA1267E

DTC P1278, P1288 A/F SENSOR 1

[VQ]

Specification data are reference values and are measured between each terminal and ground.

CAUTION:

Do not use ECM ground terminals when measuring input/output voltage. Doing so may result in damage to the ECM's transistor. Use a ground other than ECM terminals, such as the ground.

TER-MINAL NO.	WIRE COLOR	ITEM	CONDITION	DATA (DC Voltage)
16	OR	A/F sensor 1 (Bank 1)	[Engine is running] ● Warm-up condition ● Idle speed	Approximately 3.1V
35	W/R			Approximately 2.6V
56	LG/R			Approximately 2.3V
75	LG			Approximately 2.3V

A
EC
C
D
E
F
G
H
I
J
K
L
M

DTC P1278, P1288 A/F SENSOR 1

[VQ]

BANK 2

EC-AF1B2-01

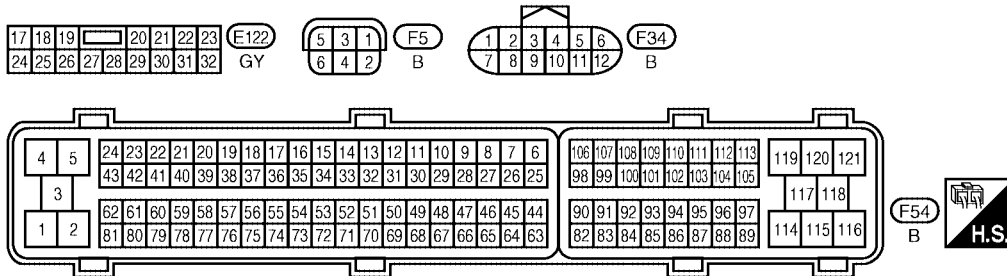
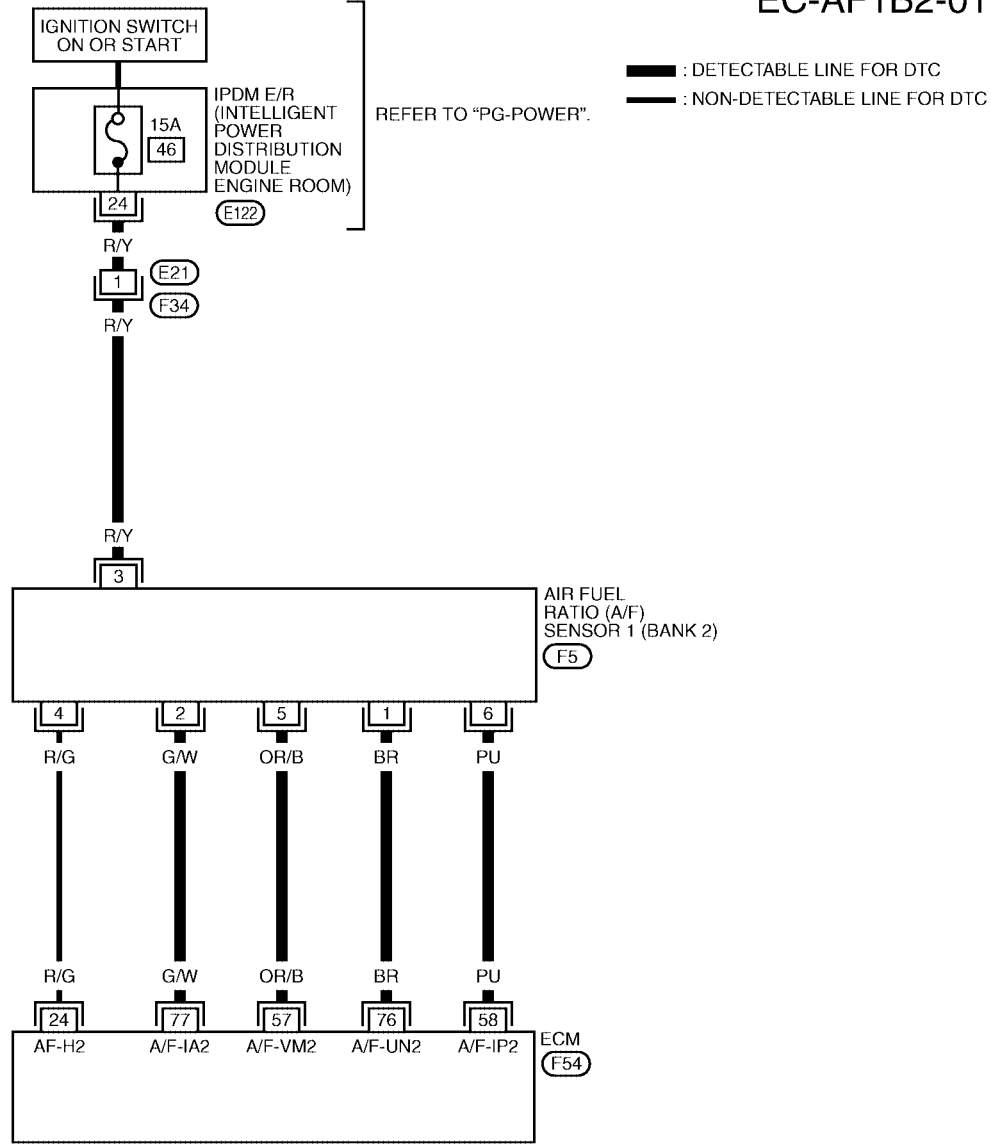

BBWA1572E

DTC P1278, P1288 A/F SENSOR 1

[VQ]

Specification data are reference values and are measured between each terminal and ground.

CAUTION:

Do not use ECM ground terminals when measuring input/output voltage. Doing so may result in damage to the ECM's transistor. Use a ground other than ECM terminals, such as the ground.

TER-MINAL NO.	WIRE COLOR	ITEM	CONDITION	DATA (DC Voltage)
57	OR/B	A/F sensor 1 (Bank 2)	[Engine is running] ● Warm-up condition ● Idle speed	Approximately 2.6V
58	PU			Approximately 2.3V
76	BR			Approximately 3.1V
77	G/W			Approximately 2.3V

Diagnostic Procedure

UBS001BT

1. CHECK GROUND CONNECTIONS

1. Turn ignition switch OFF.
2. Loosen and retighten three ground screws on the body.
Refer to [EC-789, "Ground Inspection"](#).

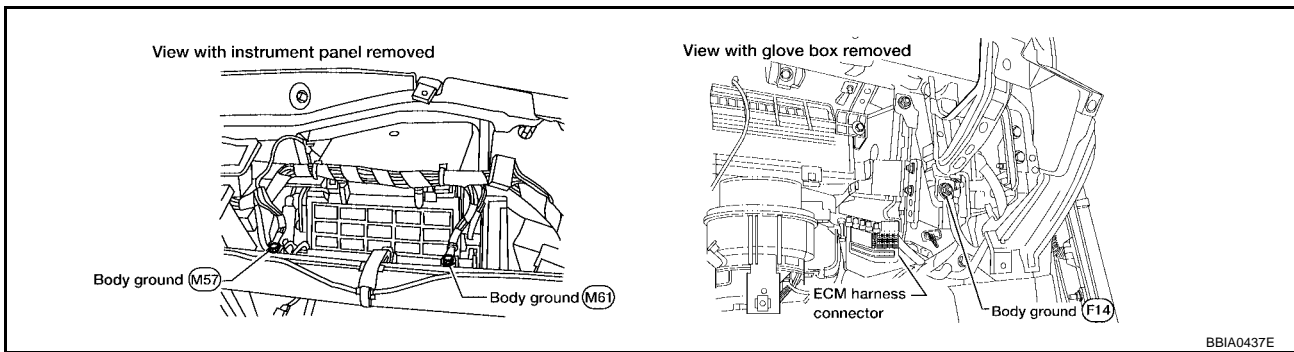

OK or NG

- OK >> GO TO 2.
- NG >> Repair or replace ground connections.

2. RETIGHTEN A/F SENSOR 1

Loosen and retighten the A/F sensor 1.

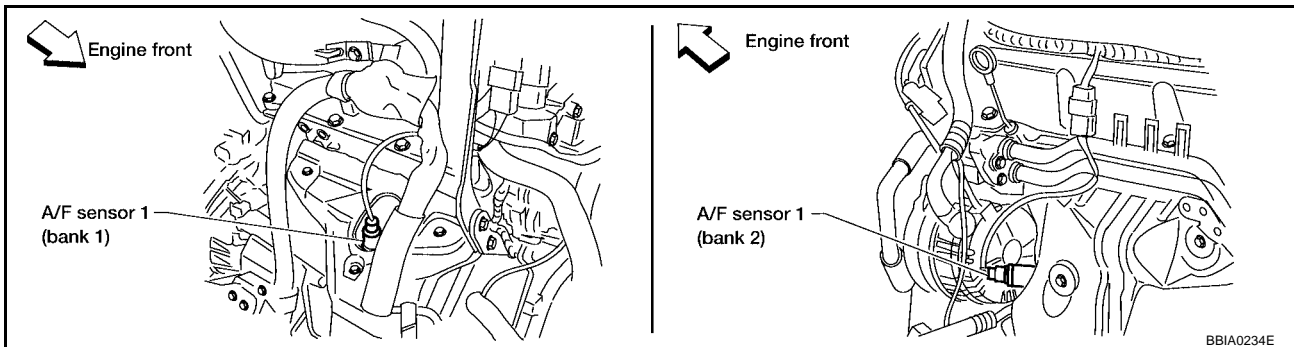

Tightening torque: 40 - 60 N-m (4.1 - 6.1 kg-m, 30 - 44 ft-lb)

>> GO TO 3.

3. CHECK EXHAUST GAS LEAK

1. Start engine and run it at idle.
2. Listen for an exhaust gas leak before three way catalyst (manifold).

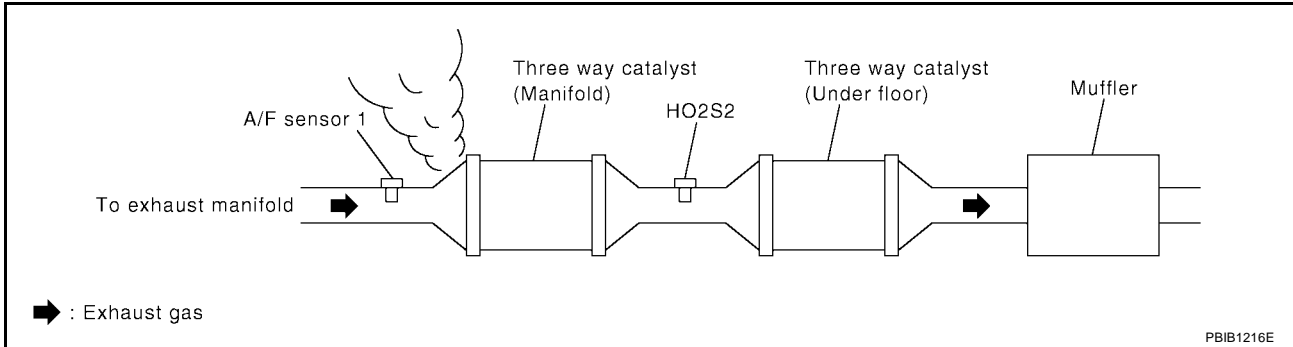

OK or NG

- OK >> GO TO 4.
 NG >> Repair or replace.

4. CHECK FOR INTAKE AIR LEAK

Listen for an intake air leak after the mass air flow sensor.

OK or NG

- OK >> GO TO 5.
 NG >> Repair or replace.

5. CLEAR THE SELF-LEARNING DATA

With CONSULT-II

1. Start engine and warm it up to normal operating temperature.
2. Select "SELF-LEARNING CONT" in "WORK SUPPORT" mode with CONSULT-II.
3. Clear the self-learning control coefficient by touching "CLEAR" or "START".
4. Run engine for at least 10 minutes at idle speed.
**Is the 1st trip DTC P0171, P172, P0174 or P0175 detected?
 Is it difficult to start engine?**

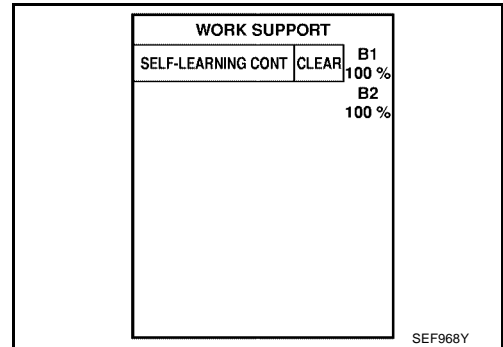

Without CONSULT-II

1. Start engine and warm it up to normal operating temperature.
2. Turn ignition switch OFF.
3. Disconnect mass air flow sensor harness connector.
4. Restart engine and let it idle for at least 5 seconds.
5. Stop engine and reconnect mass air flow sensor harness connector.
6. Make sure DTC P0102 is displayed.
7. Erase the DTC memory. Refer to [EC-682, "HOW TO ERASE EMISSION-RELATED DIAGNOSTIC INFORMATION"](#).
8. Make sure DTC P0000 is displayed.
9. Run engine for at least 10 minutes at idle speed.
**Is the 1st trip DTC P0171, P0172, P0174 or P0175 detected?
 Is it difficult to start engine?**

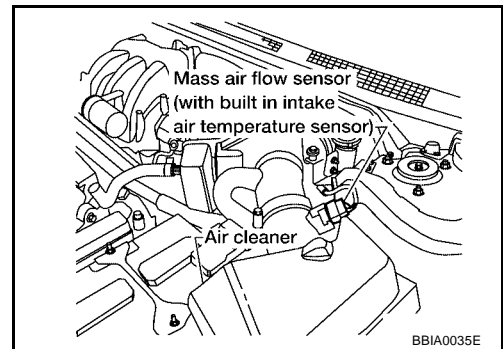

Yes or No

- Yes >> Perform trouble diagnosis for DTC P0171, P0174 or P0172, P0175. Refer to [EC-868, "DTC P0171, P0174 FUEL INJECTION SYSTEM FUNCTION"](#) or [EC-879, "DTC P0172, P0175 FUEL INJECTION SYSTEM FUNCTION"](#).
- No >> GO TO 6.

A
EC
C
D
E
F
G
H
I
J
K
L
M

6. CHECK A/F SENSOR 1 POWER SUPPLY CIRCUIT

1. Turn ignition switch OFF.
2. Disconnect A/F sensor 1 harness connector.

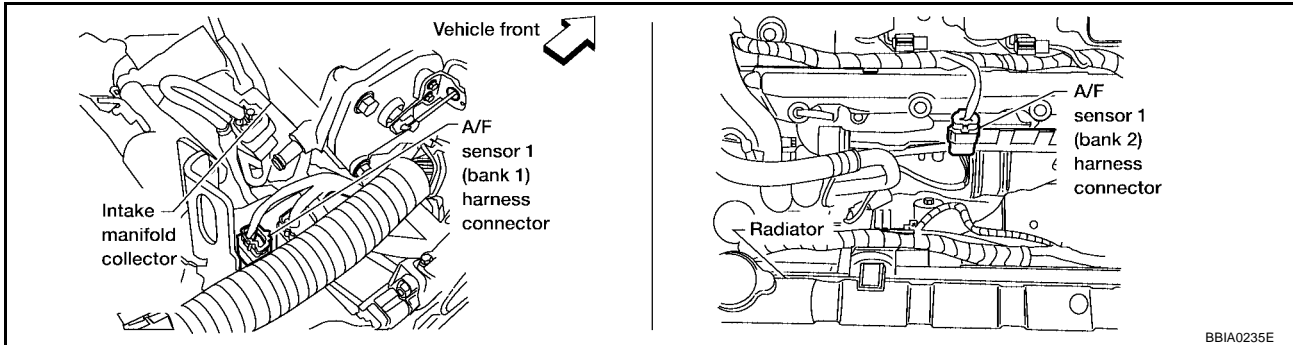

3. Turn ignition switch ON.
4. Check voltage between A/F sensor 1 terminal 3 and ground with CONSULT-II or tester.

Voltage: Battery voltage

OK or NG

- OK >> GO TO 8.
NG >> GO TO 7.

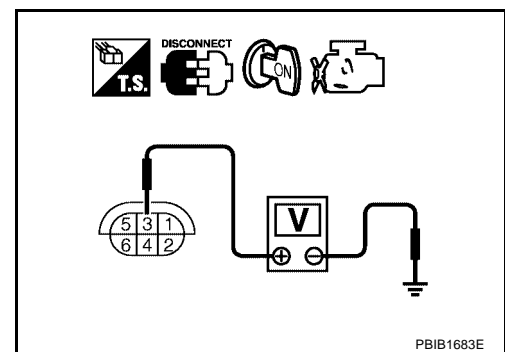

7. DETECT MALFUNCTIONING PART

Check the following.

- Harness connectors E21, F34
- IPDM E/R harness connector E122
- 15A fuse
- Harness for open or short between A/F sensor 1 and fuse

>> Repair or replace harness or connectors.

8. CHECK A/F SENSOR 1 INPUT SIGNAL CIRCUIT FOR OPEN AND SHORT

1. Turn ignition switch OFF.
2. Disconnect ECM harness connector.
3. Check harness continuity between the following terminals.
Refer to Wiring Diagram.

	A/F sensor 1 terminal	ECM terminal
Bank 1	1	16
	2	75
	5	35
	6	56
Bank 2	1	76
	2	77
	5	57
	6	58

Continuity should exist.

4. Check harness continuity between the following terminals and ground.
Refer to Wiring Diagram.

Bank 1		Bank 2	
A/F sensor 1 terminal	ECM terminal	A/F sensor 1 terminal	ECM terminal
1	16	1	76
2	75	2	77
5	35	5	57
6	56	6	58

Continuity should not exist.

5. Also check harness for short to power.

OK or NG

OK >> GO TO 9.

NG >> Repair open circuit or short to ground or short to power in harness or connectors.

9. CHECK AIR FUEL RATIO (A/F) SENSOR 1 HEATER

Refer to [EC-1052, "Component Inspection"](#) .

OK or NG

OK >> GO TO 10.

NG >> Replace A/F sensor 1.

10. CHECK MASS AIR FLOW SENSOR

Refer to [EC-812, "Component Inspection"](#) .

OK or NG

OK >> GO TO 11.

NG >> Replace mass air flow sensor.

11. CHECK PCV VALVE

Refer to [EC-665, "POSITIVE CRANKCASE VENTILATION"](#) .

OK or NG

OK >> GO TO 12.

NG >> Repair or replace PCV valve.

12. CHECK INTERMITTENT INCIDENT

Perform [EC-782, "TROUBLE DIAGNOSIS FOR INTERMITTENT INCIDENT"](#) .

OK or NG

OK >> Replace A/F sensor 1.

NG >> Repair or replace.

Removal and Installation **AIR FUEL RATIO (A/F) SENSOR 1**

UBS001BU

Refer to [EM-134, "EXHAUST MANIFOLD AND THREE WAY CATALYST"](#) .

DTC P1279, P1289 A/F SENSOR 1

PFP:22693

UBS001BV

Component Description

The air fuel ratio (A/F) sensor 1 is a planar dual-cell limit current sensor. The sensor element of the A/F sensor 1 is the combination of a Nernst concentration cell (sensor cell) with an oxygen-pump cell, which transports ions. It has a heater in the element.

The sensor is capable of precise measurement $\lambda = 1$, but also in the lean and rich range. Together with its control electronics, the sensor outputs a clear, continuous signal throughout a wide λ range ($0.7 < \lambda < \text{air}$).

The exhaust gas components diffuse through the diffusion gap at the electrode of the oxygen pump and Nernst concentration cell, where they are brought to thermodynamic balance.

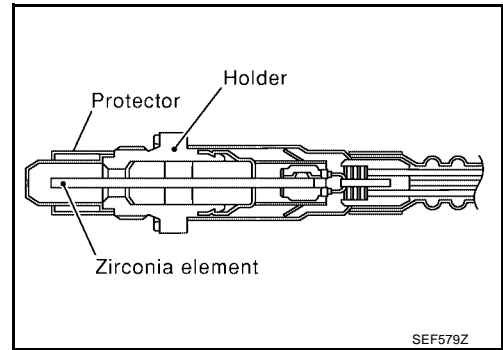

An electronic circuit controls the pump current through the oxygen-pump cell so that the composition of the exhaust gas in the diffusion gap remains constant at $\lambda = 1$. Therefore, the A/F sensor 1 is able to indicate air/fuel ratio by this pumping of current. In addition, a heater is integrated in the sensor to ensure the required operating temperature of 700 - 800°C (1,292 - 1,472°F).

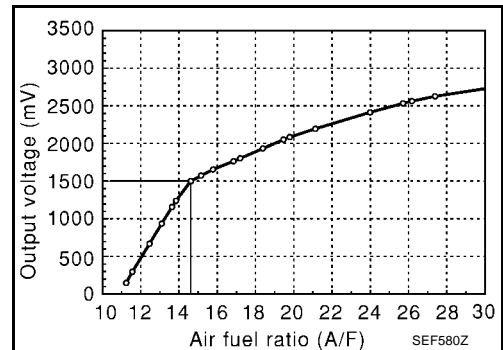

CONSULT-II Reference Value in Data Monitor Mode

UBS001BW

Specification data are reference values.

MONITOR ITEM	CONDITION		SPECIFICATION
A/F SEN1 (B1) A/F SEN1 (B2)	● Engine: After warming up	Maintaining engine speed at 2,000 rpm	Fluctuates around 1.5V

On Board Diagnosis Logic

UBS001BX

To judge the malfunction of A/F sensor 1, this diagnosis measures response time of the A/F signal computed by ECM from the air fuel ration A/F sensor 1 signal. The time is compensated by engine operating (speed and load), fuel feedback control constant, and the A/F sensor 1 temperature index. Judgment is based on whether the compensated time (the A/F signal cycling time index) is inordinately long or not.

DTC No.	Trouble diagnosis name	DTC detecting condition	Possible Cause
P1279 1279 (Bank 1)	Air fuel ratio (A/F) sensor 1 circuit slow response	● The response (from LEAN to RICH) of the A/F signal computed by ECM from A/F sensor 1 signal takes more than the specified time.	<ul style="list-style-type: none"> ● Harness or connectors (The A/F sensor 1 circuit is open or shorted.) ● Air fuel ratio (A/F) sensor 1 ● Air fuel ratio (A/F) sensor 1 heater ● Fuel pressure ● Fuel injector ● Intake air leaks ● Exhaust gas leaks ● PCV ● Mass air flow sensor
P1289 1289 (Bank 2)			

DTC Confirmation Procedure

NOTE:

If DTC Confirmation Procedure has been previously conducted, always turn ignition switch OFF and wait at least 10 seconds before conducting the next test.

TESTING CONDITION:

Before performing the following procedure, confirm that battery voltage is more than 11V at idle.

WITH CONSULT-II

1. Start engine and warm it up to normal operating temperature.
2. Turn ignition switch OFF and wait at least 10 seconds.
3. Start engine and keep the engine speed between 3,500 and 4,000 rpm for at least 1 minute under no load.
4. Let engine idle for 1 minute.
5. Select "A/F SEN1(B1) P1278/P1279" or "A/F SEN1(B1) P1288/P1289" of "A/F SEN1" in "DTC WORK SUPPORT" mode with CONSULT-II.
6. Touch "START".
 If "COMPLETED" appears on CONSULT-II screen, go to step 10.
 If "COMPLETED" does not appear on CONSULT-II screen, go to the following step.

A/F SEN1 (B1) P1278/P1279	
OUT OF CONDITION	
MONITOR	
ENG SPEED	XXX rpm
B/FUEL SCHDL	XXX msec
COOLAN TEMP/S	XXX °C
VHCL SPEED SE	XXX km/h
PBIB0756E	

7. After perform the following procedure, "TESTING" will be displayed on the CONSULT-II screen.
 - a. Increase the engine speed up to 4,000 to 5,000 rpm and keep it for 10 seconds.
 - b. Fully release accelerator pedal and then let engine idle for about 10 seconds.
If "TESTING" is not displayed after 10 seconds, refer to [EC-772, "TROUBLE DIAGNOSIS - SPECIFICATION VALUE"](#) .
8. Wait for about 20 seconds at idle at under the condition that "TESTING" is displayed on the CONSULT-II screen.

A/F SEN1 (B1) P1278/P1279	
TESTING	
MONITOR	
ENG SPEED	XXX rpm
B/FUEL SCHDL	XXX msec
COOLAN TEMP/S	XXX °C
VHCL SPEED SE	XXX km/h
PBIB1925E	

9. Make sure that "TESTING" changes to "COMPLETED".
If "TESTING" changed to "OUT OF CONDITION", refer to [EC-772, "TROUBLE DIAGNOSIS - SPECIFICATION VALUE"](#) .
10. Make sure that "OK" is displayed after touching "SELF-DIAG RESULT".
 If "NG" is displayed, go to [EC-1193, "Diagnostic Procedure"](#) .

A/F SEN1 (B1) P1278/P1279	
COMPLETED	
PBIB0758E	



WITH GST

- | | |
|---|--|
| <ol style="list-style-type: none"> 1. Start engine and warm it up to normal operating temperature. 2. Select "Service \$01" with GST. 3. Calculate the total value of "Short term fuel trim" and "Long term fuel trim" indications. Make sure that the total percentage should be within $\pm 15\%$.
If OK, go to the following step.
If NG, check the following. <ul style="list-style-type: none"> ● Intake air leaks ● Exhaust gas leaks ● Incorrect fuel pressure ● Lack of fuel ● Fuel injector ● Incorrect PCV hose connection ● PCV valve ● Mass air flow sensor 4. Turn ignition switch OFF and wait at least 10 seconds. 5. Start engine and keep the engine speed between 3,500 and 4,000 rpm for at least 1 minute under no load. 6. Let engine idle for 1 minute. 7. Increase the engine speed up to 4,000 to 5,000 rpm and keep it for 10 seconds. 8. Fully release accelerator pedal and then let engine idle for about 1 minute. 9. Select "Service \$07" with GST.
If 1st trip DTC is detected, go to EC-1193, "Diagnostic Procedure". | <p>A</p> <p>EC</p> <p>C</p> <p>D</p> <p>E</p> <p>F</p> <p>G</p> <p>H</p> <p>I</p> <p>J</p> <p>K</p> <p>L</p> <p>M</p> |
|---|--|

DTC P1279, P1289 A/F SENSOR 1

[VQ]

UBS00IBZ

Wiring Diagram BANK 1

EC-AF1B1-01

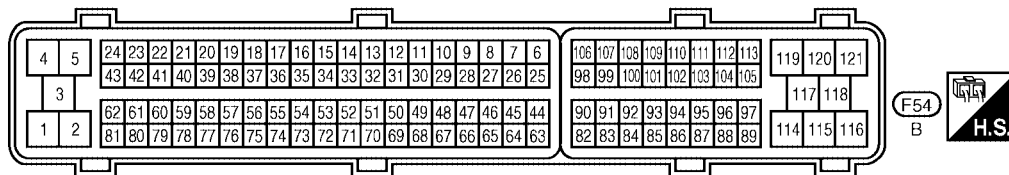
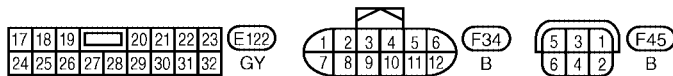
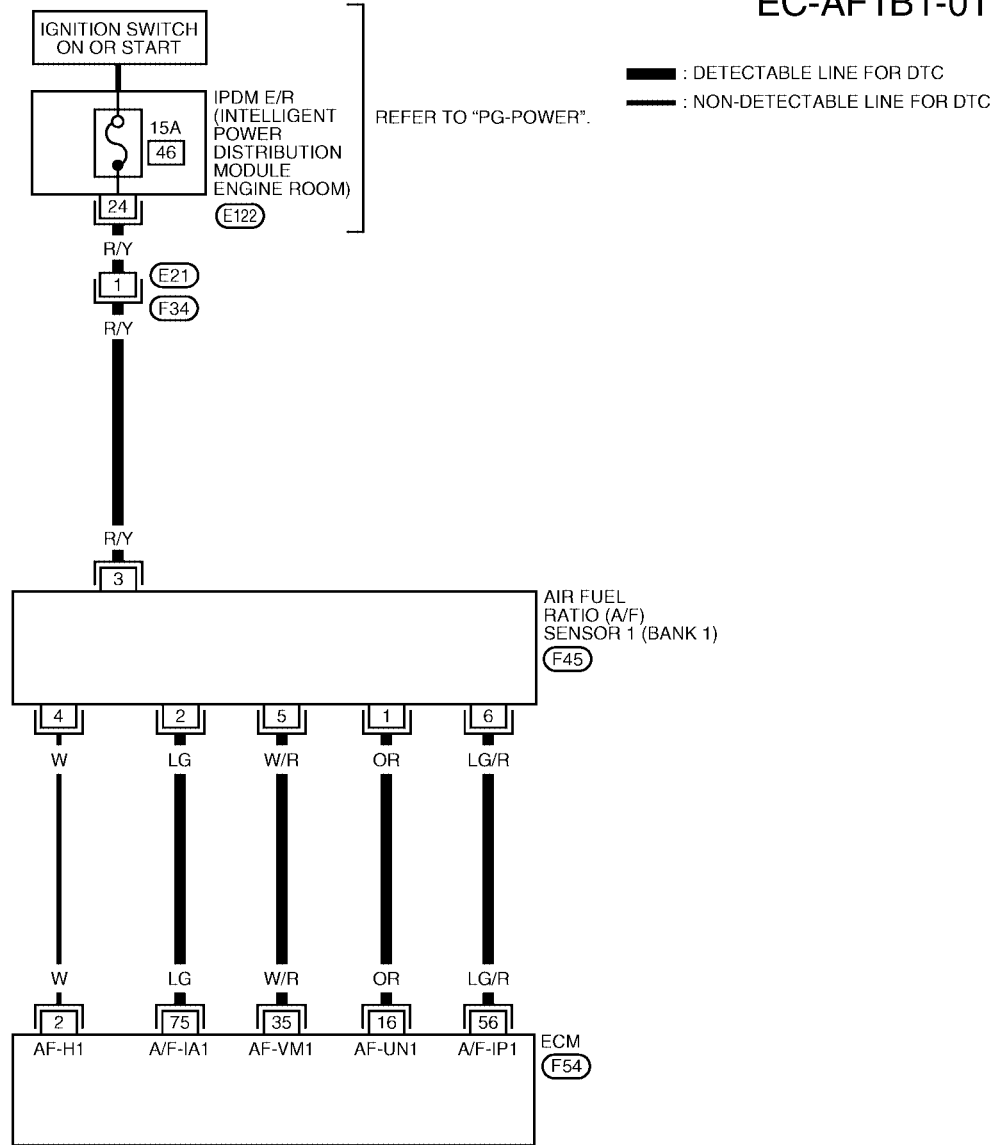

BBWA1267E

DTC P1279, P1289 A/F SENSOR 1

[VQ]

Specification data are reference values and are measured between each terminal and ground.

CAUTION:

Do not use ECM ground terminals when measuring input/output voltage. Doing so may result in damage to the ECM's transistor. Use a ground other than ECM terminals, such as the ground.

TER-MINAL NO.	WIRE COLOR	ITEM	CONDITION	DATA (DC Voltage)
16	OR	A/F sensor 1 (Bank 1)	[Engine is running] ● Warm-up condition ● Idle speed	Approximately 3.1V
35	W/R			Approximately 2.6V
56	LG/R			Approximately 2.3V
75	LG			Approximately 2.3V

A
EC
C
D
E
F
G
H
I
J
K
L
M

DTC P1279, P1289 A/F SENSOR 1

[VQ]

BANK 2

EC-AF1B2-01

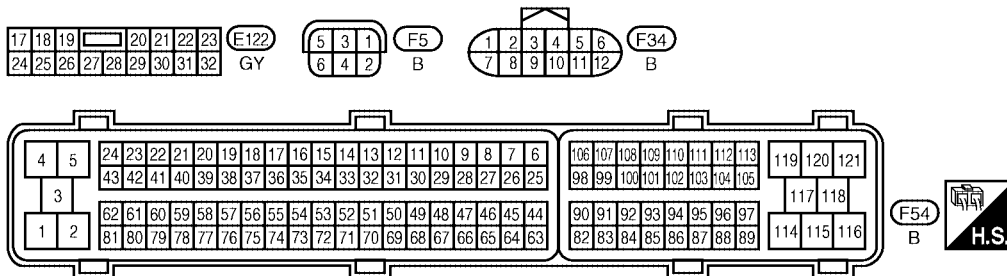
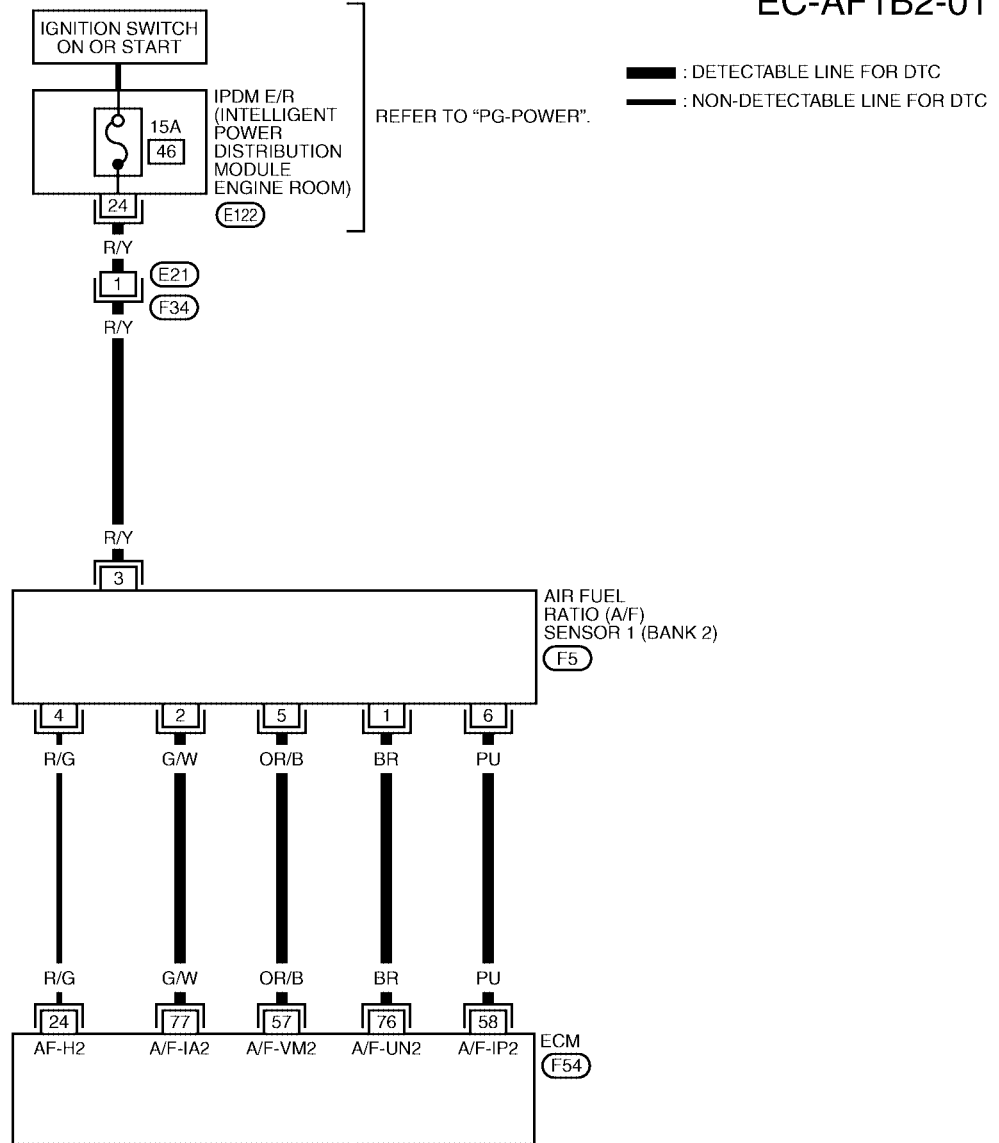

BBWA1572E

DTC P1279, P1289 A/F SENSOR 1

[VQ]

Specification data are reference values and are measured between each terminal and ground.

CAUTION:

Do not use ECM ground terminals when measuring input/output voltage. Doing so may result in damage to the ECM's transistor. Use a ground other than ECM terminals, such as the ground.

TER-MINAL NO.	WIRE COLOR	ITEM	CONDITION	DATA (DC Voltage)
57	OR/B	A/F sensor 1 (Bank 2)	[Engine is running] ● Warm-up condition ● Idle speed	Approximately 2.6V
58	PU			Approximately 2.3V
76	BR			Approximately 3.1V
77	G/W			Approximately 2.3V

Diagnostic Procedure

UBS001C0

1. CHECK GROUND CONNECTIONS

1. Turn ignition switch OFF.
2. Loosen and retighten three ground screws on the body.
Refer to [EC-789, "Ground Inspection"](#).

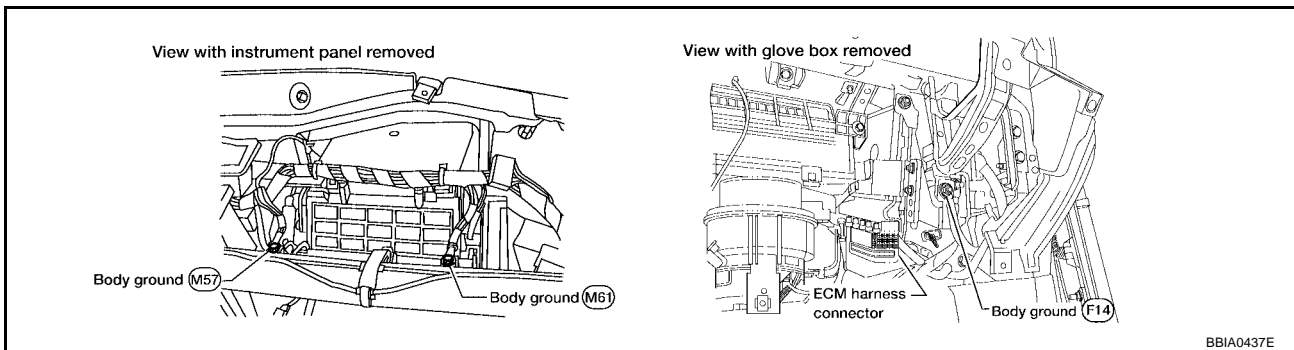

OK or NG

- OK >> GO TO 2.
- NG >> Repair or replace ground connections.

2. RETIGHTEN A/F SENSOR 1

Loosen and retighten the A/F sensor 1.

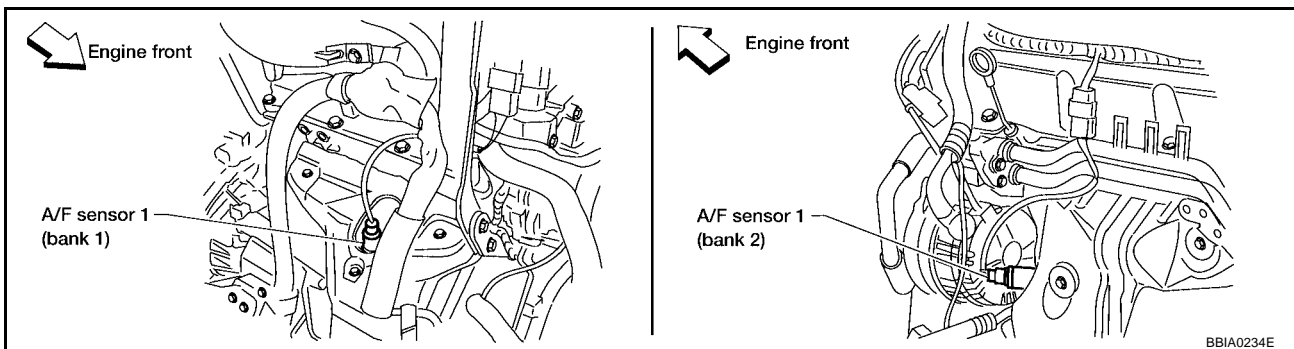

Tightening torque: 40 - 60 N-m (4.1 - 6.1 kg-m, 30 - 44 ft-lb)

>> GO TO 3.

3. CHECK EXHAUST GAS LEAK

1. Start engine and run it at idle.
2. Listen for an exhaust gas leak before three way catalyst (manifold).

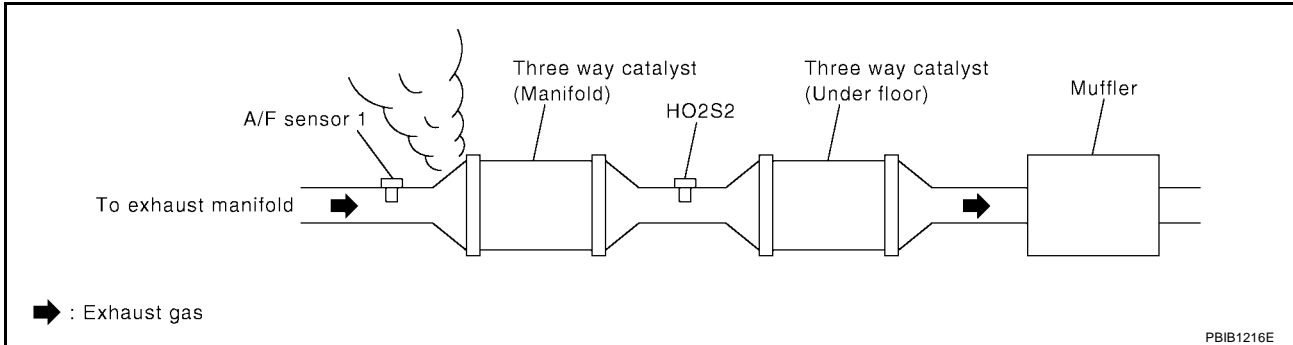

OK or NG

- OK >> GO TO 4.
- NG >> Repair or replace.

4. CHECK FOR INTAKE AIR LEAK

Listen for an intake air leak after the mass air flow sensor.

OK or NG

- OK >> GO TO 5.
- NG >> Repair or replace.

5. CLEAR THE SELF-LEARNING DATA

Ⓜ With CONSULT-II

1. Start engine and warm it up to normal operating temperature.
2. Select "SELF-LEARNING CONT" in "WORK SUPPORT" mode with CONSULT-II.
3. Clear the self-learning control coefficient by touching "CLEAR" or "START".
4. Run engine for at least 10 minutes at idle speed.
Is the 1st trip DTC P0171, P172, P0174 or P0175 detected?
Is it difficult to start engine?

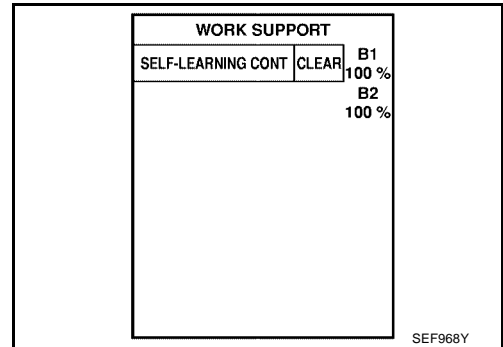

⊗ Without CONSULT-II

1. Start engine and warm it up to normal operating temperature.
2. Turn ignition switch OFF.
3. Disconnect mass air flow sensor harness connector.
4. Restart engine and let it idle for at least 5 seconds.
5. Stop engine and reconnect mass air flow sensor harness connector.
6. Make sure DTC P0102 is displayed.
7. Erase the DTC memory. Refer to [EC-682, "HOW TO ERASE EMISSION-RELATED DIAGNOSTIC INFORMATION"](#) .
8. Make sure DTC P0000 is displayed.
9. Run engine for at least 10 minutes at idle speed.
Is the 1st trip DTC P0171, P0172, P0174 or P0175 detected?
Is it difficult to start engine?

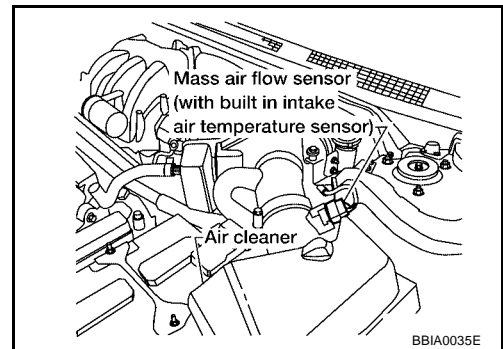

Yes or No

- Yes >> Perform trouble diagnosis for DTC P0171, P0174 or P0172, P0175. Refer to [EC-868, "DTC P0171, P0174 FUEL INJECTION SYSTEM FUNCTION"](#) or [EC-879, "DTC P0172, P0175 FUEL INJECTION SYSTEM FUNCTION"](#) .
- No >> GO TO 6.

A
EC
C
D
E
F
G
H
I
J
K
L
M

6. CHECK A/F SENSOR 1 POWER SUPPLY CIRCUIT

1. Turn ignition switch OFF.
2. Disconnect A/F sensor 1 harness connector.

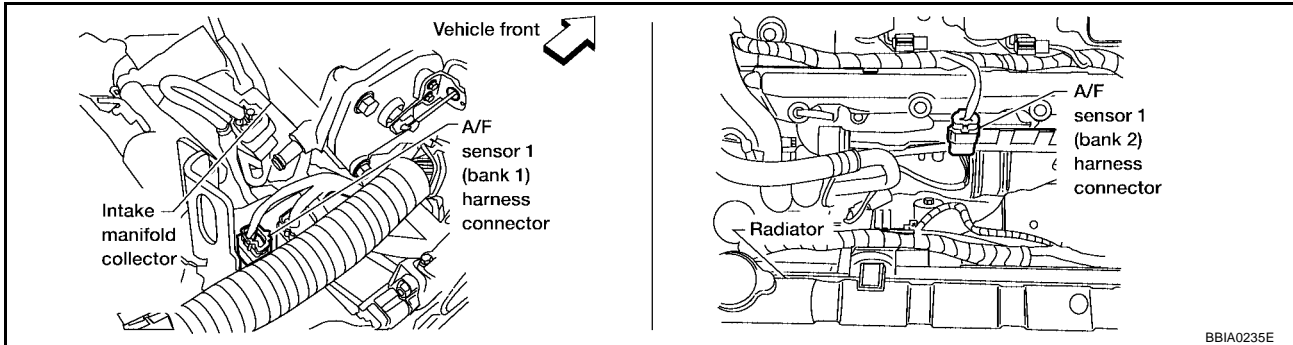

3. Turn ignition switch ON.
4. Check voltage between A/F sensor 1 terminal 3 and ground with CONSULT-II or tester.

Voltage: Battery voltage

OK or NG

- OK >> GO TO 8.
NG >> GO TO 7.

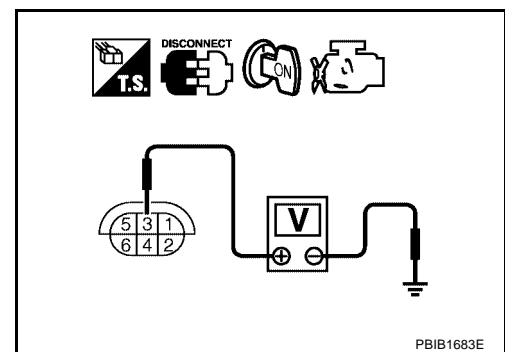

7. DETECT MALFUNCTIONING PART

Check the following.

- Harness connectors E21, F34
- IPDM E/R harness connector E122
- 15A fuse
- Harness for open or short between A/F sensor 1 and fuse

>> Repair or replace harness or connectors.

8. CHECK A/F SENSOR 1 INPUT SIGNAL CIRCUIT FOR OPEN AND SHORT

1. Turn ignition switch OFF.
2. Disconnect ECM harness connector.
3. Check harness continuity between the following terminals.
Refer to Wiring Diagram.

	A/F sensor 1 terminal	ECM terminal
Bank 1	1	16
	2	75
	5	35
	6	56
Bank 2	1	76
	2	77
	5	57
	6	58

Continuity should exist.

4. Check harness continuity between the following terminals and ground.
Refer to Wiring Diagram.

Bank 1		Bank 2	
A/F sensor 1 terminal	ECM terminal	A/F sensor 1 terminal	ECM terminal
1	16	1	76
2	75	2	77
5	35	5	57
6	56	6	58

Continuity should not exist.

5. Also check harness for short to power.

OK or NG

OK >> GO TO 9.

NG >> Repair open circuit or short to ground or short to power in harness or connectors.

9. CHECK AIR FUEL RATIO (A/F) SENSOR 1 HEATER

Refer to [EC-1052, "Component Inspection"](#) .

OK or NG

OK >> GO TO 10.

NG >> Replace A/F sensor 1.

10. CHECK MASS AIR FLOW SENSOR

Refer to [EC-820, "Component Inspection"](#) .

OK or NG

OK >> GO TO 11.

NG >> Replace mass air flow sensor.

11. CHECK PCV VALVE

Refer to [EC-665, "POSITIVE CRANKCASE VENTILATION"](#) .

OK or NG

OK >> GO TO 12.

NG >> Repair or replace PCV valve.

12. CHECK INTERMITTENT INCIDENT

Perform [EC-782, "TROUBLE DIAGNOSIS FOR INTERMITTENT INCIDENT"](#) .

OK or NG

OK >> Replace A/F sensor 1.

NG >> Repair or replace.

Removal and Installation **AIR FUEL RATIO (A/F) SENSOR 1**

UBS001C1

Refer to [EM-134, "EXHAUST MANIFOLD AND THREE WAY CATALYST"](#)

DTC P1402 EGR FUNCTION

Description SYSTEM DESCRIPTION

Sensor	Input Signal to ECM	ECM function	Actuator
Camshaft position sensor (PHASE)	Engine speed*2 Piston position	EGR volume control	EGR volume control valve
Crankshaft position sensor (POS)			
Mass air flow sensor	Amount of intake air		
Engine coolant temperature sensor	Engine coolant temperature		
Throttle position sensor	Throttle position		
Accelerator pedal position sensor	Accelerator pedal position		
Park/neutral position (PNP) switch	Gear position		
Battery	Battery voltage*2		
Air conditioner switch*1	Air conditioner operation		
Power steering pressure sensor	Power steering operation		
Electrical load*1	Electrical load signal		
Wheel sensor*1	Vehicle speed		
TCM*1 (A/T models)	Gear position, shifting signal		

*1: This signal is sent to the ECM through CAN communication line.

*2: ECM determines the start signal status by the signals of engine speed and battery voltage.

This system controls flow rate of EGR led from exhaust manifold to intake manifold. The opening of the EGR by-pass passage in the EGR volume control valve changes to control the flow rate. A built-in step motor moves the valve in steps corresponding to the ECM output pulses. The opening of the valve varies for optimum engine control. The optimum value stored in the ECM is determined by considering various engine conditions. The EGR volume control valve remains closed under the following conditions.

- Engine stopped
- Engine starting
- Engine idling
- Low engine coolant temperature
- Excessively high engine coolant temperature
- High engine speed
- Wide open throttle
- Low battery voltage

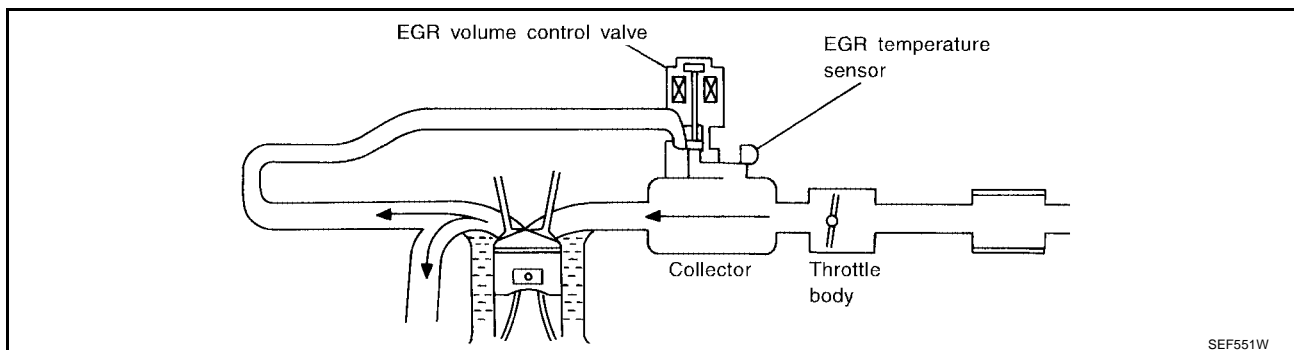

SEF551W

COMPONENT DESCRIPTION

EGR Volume Control Valve

The EGR volume control valve uses a step motor to control the flow rate of EGR from exhaust manifold. This motor has four winding phases. It operates according to the output pulse signal of the ECM. Two windings are turned ON and OFF in sequence. Each time an ON pulse is issued, the valve opens or closes, changing the flow rate. When no change in the flow rate is needed, the ECM does not issue the pulse signal. A certain voltage signal is issued so that the valve remains at that particular opening.

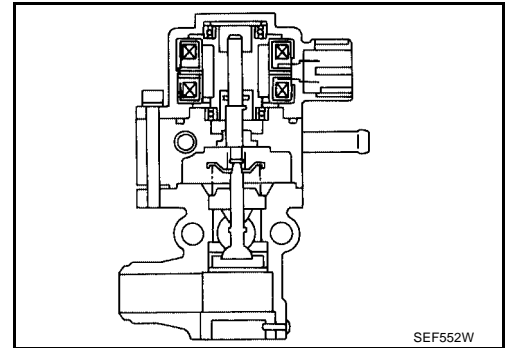

EGR Temperature Sensor

The EGR temperature sensor detects temperature changes in the EGR passageway. When the EGR volume control valve opens, hot exhaust gases flow, and the temperature in the passageway changes. The EGR temperature sensor is a thermistor that modifies a voltage signal sent from the ECM. This modified signal then returns to the ECM as an input signal. As the temperature increases, EGR temperature sensor resistance decreases. This sensor is not directly used to control the engine system. It is used only for the on board diagnosis.

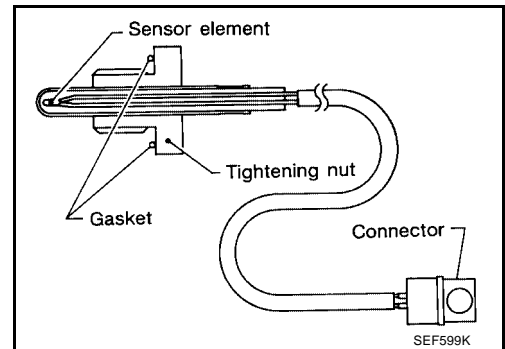

<Reference data>

EGR temperature °C (°F)	Voltage* V	Resistance MΩ
0 (32)	4.59	0.73 - 0.88
50 (122)	2.32	0.074 - 0.082
100 (212)	0.62	0.011 - 0.014

*: This data is reference value and is measured between ECM terminal 54 (EGR temperature sensor) and ground.

CAUTION:

Do not use ECM ground terminals when measuring input/output voltage. Doing so may damage the ECM's transistor. Use a ground other than ECM terminals, such as the ground.

When EGR system is operating.

Voltage: 0 - 1.5V

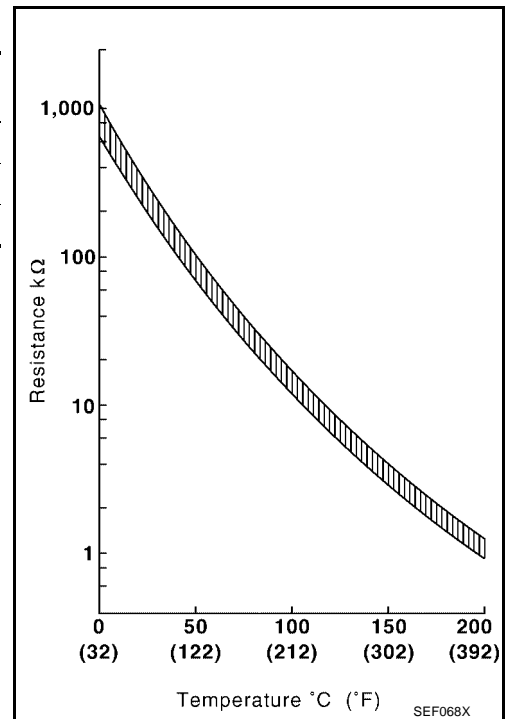

CONSULT-II Reference Value in Data Monitor Mode

UBS001C3

Specification data are reference values.

MONITOR ITEM	CONDITION	SPECIFICATION
EGR TEMP SEN	● Engine: After warming up	Less than 4.5V
EGR VOL CON/V	● Engine: After warming up ● Air conditioner switch: OFF	Idle 0 step
	● Shift lever: P or N (A/T), Neutral (M/T) ● No load	Revsing engine up to 3,000 rpm quickly 10 - 55 step

On Board Diagnosis Logic

UBS001C4

If the EGR temperature sensor detects EGR flow under the condition that does not call for EGR, a high-flow malfunction is diagnosed.

DTC No.	Trouble diagnosis name	DTC detecting condition	Possible cause
P1402 1402	EGR function (Open)	EGR flow is detected under the condition that does not call for EGR.	<ul style="list-style-type: none"> ● Harness or connectors (The EGR volume control valve circuit is open or shorted.) ● EGR volume control valve leaking or stuck open ● EGR temperature sensor

DTC Confirmation Procedure

UBS001C5

NOTE:

- Diagnosis for this DTC will occur when engine coolant temperature is below 50 to 60°C (122 to 140°F). Therefore, it will be better to turn ignition switch ON (start engine) at the engine coolant temperature below 30°C (86°F) when starting DTC confirmation procedure.
- If DTC Confirmation Procedure has been previously conducted, always turn ignition switch OFF and wait at least 10 seconds before conducting the next test.

TESTING CONDITION:

- Always perform the test at a temperature above -10°C (14°F).
- Engine coolant temperature and EGR temperature must be verified in "DATA MONITOR" mode with CONSULT-II before starting DTC WORK SUPPORT test. If it is out of range below, the test cannot be conducted.

COOLAN TEMP/S : -10 to 50°C (14 to 122°F)*

EGR TEMP SEN : Less than 4.8V

If the values are out of the ranges indicated above, park the vehicle in a cool place and allow the engine temperature to stabilize. Do not attempt to reduce the engine coolant temperature or EGR temperature with a fan or means other than ambient air. Doing so may produce an inaccurate diagnostic result.

*: Although CONSULT-II screen displays "-10 to 40°C (14 to 104°F)" as a range of engine coolant temperature, ignore it.

WITH CONSULT-II

1. Turn ignition switch OFF, and wait at least 10 seconds, and then turn ON.
2. Select "EGR SYSTEM P1402" of "EGR SYSTEM" in "DTC WORK SUPPORT" mode with CONSULT-II.
3. Touch "START".

DATA MONITOR	
MONITOR	NO DTC
COOLAN TEMP/S	XXX °C
EGR TEMP SEN	XXX V

SEF202Y

DTC P1402 EGR FUNCTION

[VQ]

4. Start engine and let it idle until "TESTING" on CONSULT-II screen is turned to "COMPLETED". (It will take 60 seconds or more.)

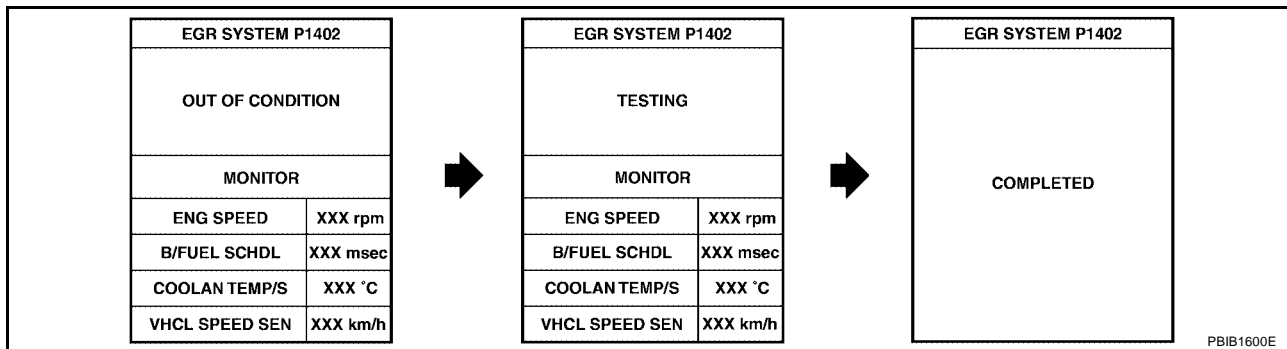

If "TESTING" is not displayed after 5 minutes, turn ignition OFF and cool the engine coolant temperature to the range of -10 to 50°C (14 to 122°F). Retry from step 1.

5. Make sure that "OK" is displayed after touching "SELF-DIAG RESULTS". If "NG" is displayed, refer to [EC-1204, "Diagnostic Procedure"](#).

WITH GST

1. Turn ignition switch ON and select Service \$01 with GST.
2. Check that engine coolant temperature is within the range of -10 to 50°C (14 to 122°F).
3. Check that voltage between ECM terminal 54 (EGR temperature sensor signal) and ground is less than 4.8V.
4. Start engine and let it idle for at least 60 seconds.
5. Stop engine.
6. Turn ignition switch OFF, wait at least 10 seconds and then turn ON.
7. Select Service \$07 with GST.
8. If 1st trip DTC is detected, go to [EC-1204, "Diagnostic Procedure"](#).

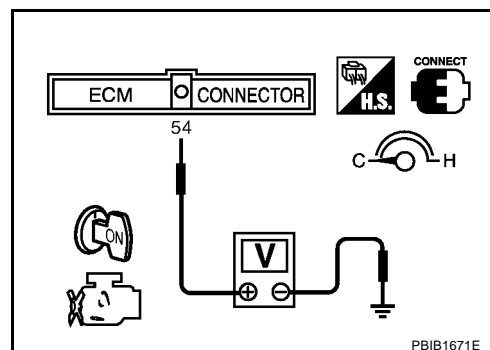

DTC P1402 EGR FUNCTION

[VQ]

Wiring Diagram

UBS001C6

EC-EGRC1-01

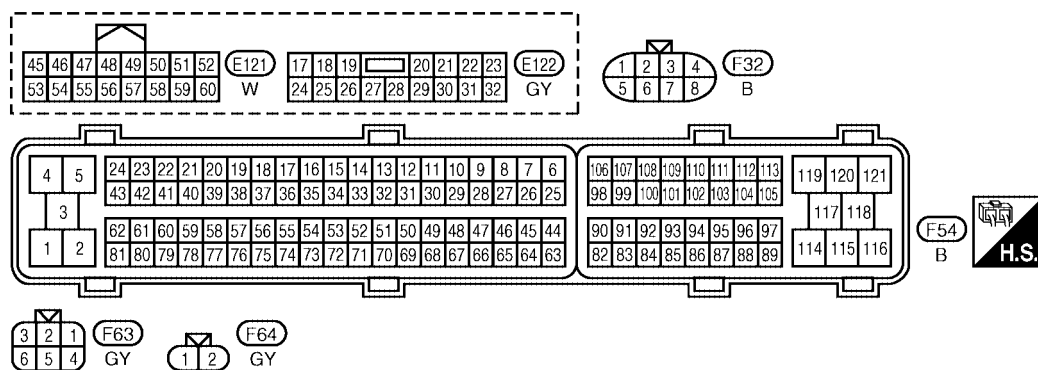
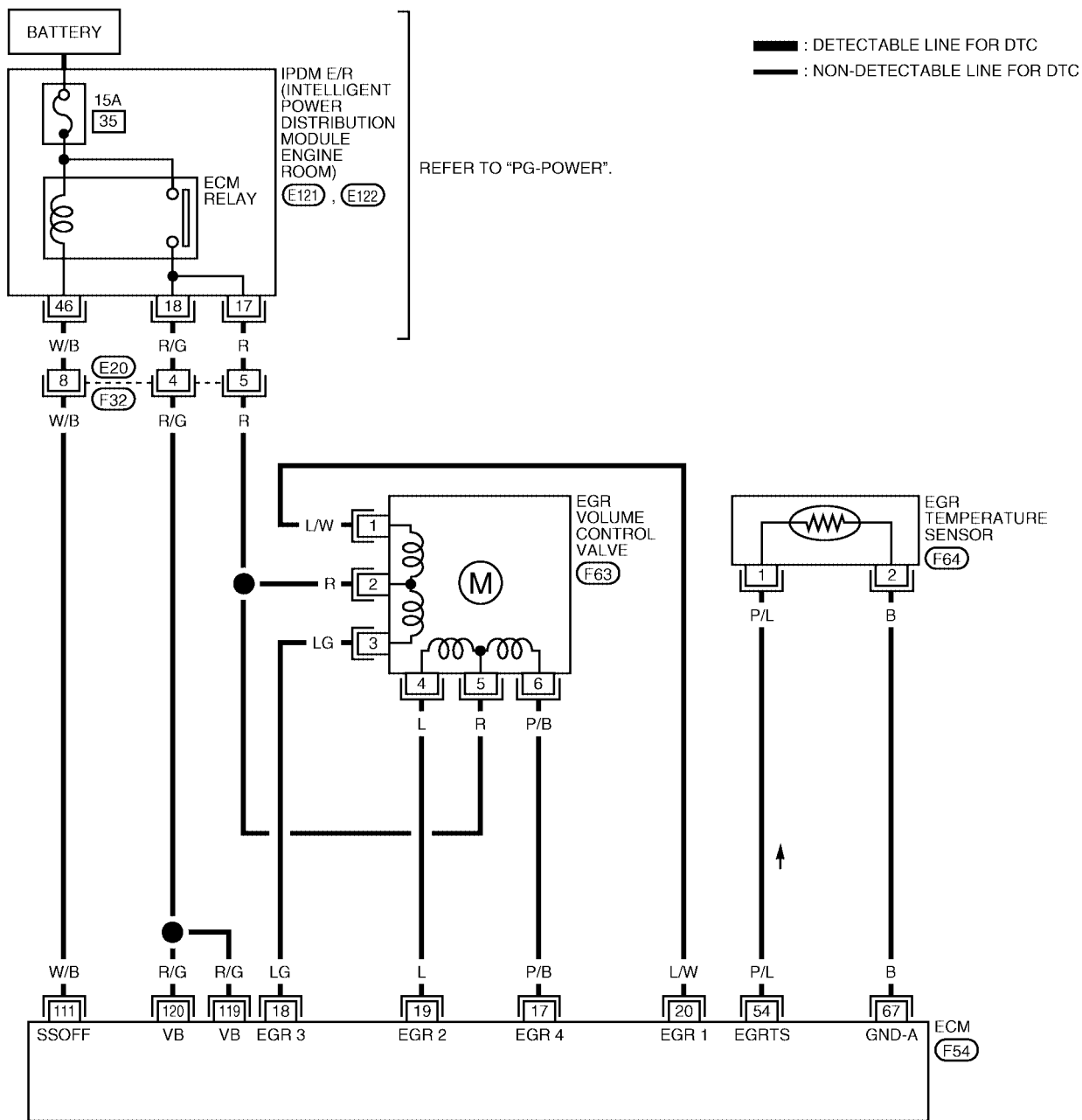

BBWA1561E

DTC P1402 EGR FUNCTION

[VQ]

Specification data are reference values and are measured between each terminal and ground.

CAUTION:

Do not use ECM ground terminals when measuring input/output voltage. Doing so may result in damage to the ECM's transistor. Use a ground other than ECM terminals, such as the ground.

TER-MINAL NO.	WIRE COLOR	ITEM	CONDITION	DATA (DC Voltage)
17 18 19 20	P/B LG L L/W	EGR volume control valve	[Engine is running] ● Idle speed	0.1 - 14V
54	P/L	EGR temperature sensor	[Ignition switch: ON]	Less than 4.5V
			[Engine is running] ● Warm-up condition ● EGR system is operating	0 - 1.5V
67	B	Sensor ground	[Engine is running] ● Warm-up condition ● Idle speed	Approximately 0V
111	W/B	ECM relay (Self shut-off)	[Engine is running] [Ignition switch: OFF] ● For a few seconds after turning ignition switch OFF	0 - 1.5V
			[Ignition switch: OFF] ● More than a few seconds after turning ignition switch OFF	BATTERY VOLTAGE (11 - 14V)
119 120	R/G R/G	Power supply for ECM	[Ignition switch: ON]	BATTERY VOLTAGE (11 - 14V)

Diagnostic Procedure

UBS00IC7

1. CHECK EGR VOLUME CONTROL VALVE POWER SUPPLY CIRCUIT

1. Turn ignition switch OFF.
2. Disconnect EGR volume control valve harness connector.
3. Turn ignition switch ON.

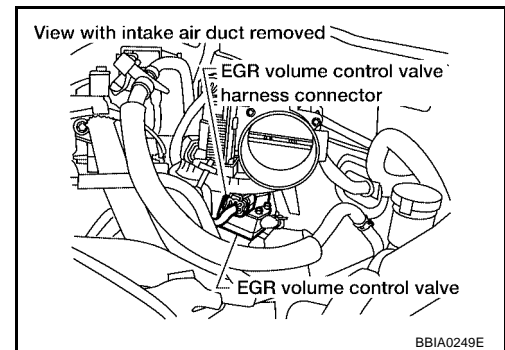

4. Check voltage between EGR volume control valve terminals 2, 5 and ground with CONSULT-II or tester.

Voltage: Battery voltage

OK or NG

- OK >> GO TO 3.
NG >> GO TO 2.

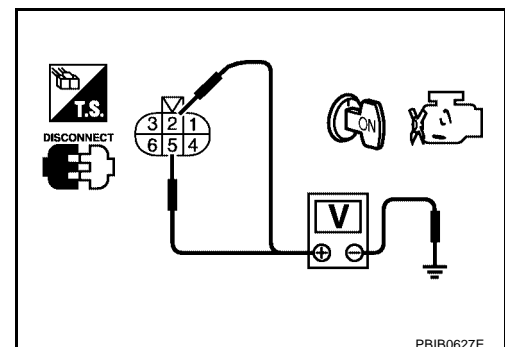

2. DETECT MALFUNCTIONING PART

Check the following.

- Harness connectors E20, F32
- IPDM E/R harness connector E122
- Harness for open or short between EGR volume control valve and IPDM E/R

>> Repair harness or connectors.

3. CHECK EGR VOLUME CONTROL VALVE OUTPUT SIGNAL CIRCUIT FOR OPEN AND SHORT

1. Turn ignition switch OFF.
2. Disconnect ECM harness connector.
3. Check harness continuity between ECM terminals and EGR volume control valve terminals as follows. Refer to Wiring Diagram.

ECM terminal	EGR volume control valve
17	6
18	3
19	4
20	1

Continuity should exist.

4. Also check harness for short to ground and short to power.

OK or NG

- OK >> GO TO 4.
- NG >> Repair open circuit or short to ground or short to power in harness or connectors.

4. CHECK EGR VOLUME CONTROL VALVE

Refer to [EC-949, "Component Inspection"](#) .

OK or NG

- OK >> GO TO 5.
- NG >> Replace EGR volume control valve.

5. CHECK EGR TEMPERATURE SENSOR

Refer to [EC-957, "Component Inspection"](#) .

OK or NG

- OK >> GO TO 6.
- NG >> Replace EGR temperature sensor.

6. CHECK INTERMITTENT INCIDENT

Refer to [EC-782, "TROUBLE DIAGNOSIS FOR INTERMITTENT INCIDENT"](#) .

>> **INSPECTION END**

DTC P1444 EVAP CANISTER PURGE VOLUME CONTROL SOLENOID VALVE

[VQ]

DTC P1444 EVAP CANISTER PURGE VOLUME CONTROL SOLENOID VALVE

PFV:14920

Description SYSTEM DESCRIPTION

UBS00IC8

Sensor	Input Signal to ECM	ECM function	Actuator
Crankshaft position sensor (POS) Camshaft position sensor (PHASE)	Engine speed* ¹	EVAP canister purge flow control	EVAP canister purge vol- ume control solenoid valve
Mass air flow sensor	Amount of intake air		
Engine coolant temperature sensor	Engine coolant temperature		
Battery	Battery voltage* ¹		
Throttle position sensor	Throttle position		
Accelerator pedal position sensor	Accelerator pedal position		
Air fuel ratio (A/F) sensor 1	Density of oxygen in exhaust gas (Mixture ratio feedback signal)		
Fuel tank temperature sensor	Fuel temperature in fuel tank		
Wheel sensor* ²	Vehicle speed		

*1: ECM determines the start signal status by the signals of engine speed and battery voltage.

*2: This signal is sent to the ECM through CAN communication line.

This system controls flow rate of fuel vapor from the EVAP canister. The opening of the vapor by-pass passage in the EVAP canister purge volume control solenoid valve changes to control the flow rate. The EVAP canister purge volume control solenoid valve repeats ON/OFF operation according to the signal sent from the ECM. The opening of the valve varies for optimum engine control. The optimum value stored in the ECM is determined by considering various engine conditions. When the engine is operating, the flow rate of fuel vapor from the EVAP canister is regulated as the air flow changes.

COMPONENT DESCRIPTION

The EVAP canister purge volume control solenoid valve uses a ON/OFF duty to control the flow rate of fuel vapor from the EVAP canister. The EVAP canister purge volume control solenoid valve is moved by ON/OFF pulses from the ECM. The longer the ON pulse, the greater the amount of fuel vapor that will flow through the valve.

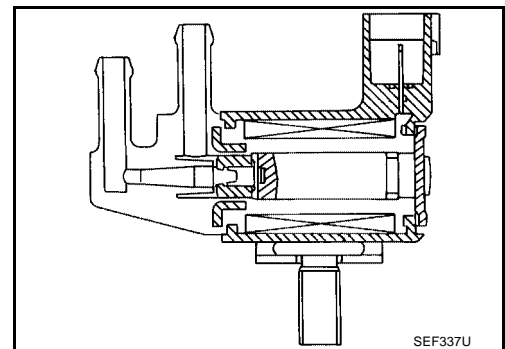

CONSULT-II Reference Value in Data Monitor Mode

UBS00IC9

Specification data are reference values.

MONITOR ITEM	CONDITION	SPECIFICATION
PURG VOL C/V	● Engine: After warming up ● Shift lever: P or N (A/T), Neutral (M/T) ● Air conditioner switch: OFF ● No-load	Idle
		2,000 rpm
		0%
		—

DTC P1444 EVAP CANISTER PURGE VOLUME CONTROL SOLENOID VALVE [VQ]

UBS001CA

On Board Diagnosis Logic

DTC No.	Trouble diagnosis name	DTC detecting condition	Possible cause
P1444 1444	EVAP canister purge volume control solenoid valve	The canister purge flow is detected during the specified driving conditions, even when EVAP canister purge volume control solenoid valve is completely closed.	<ul style="list-style-type: none"> ● EVAP control system pressure sensor ● EVAP canister purge volume control solenoid valve (The valve is stuck open.) ● EVAP canister vent control valve ● EVAP canister ● Hoses (Hoses are connected incorrectly or clogged.)

DTC Confirmation Procedure

UBS001CB

NOTE:

If DTC Confirmation Procedure has been previously conducted, always turn ignition switch OFF and wait at least 10 seconds before conducting the next test.

TESTING CONDITION:

Always perform test at a temperature of 5°C (41°F) or more.

WITH CONSULT-II

1. Start engine and warm it up to normal operating temperature.
2. Turn ignition switch OFF and wait at least 10 seconds.
3. Turn ignition switch ON.
4. Select "PURG VOL CN/V P1444" of "EVAPORATIVE SYSTEM" in "DTC WORK SUPPORT" mode with CONSULT-II.
5. Touch "START".

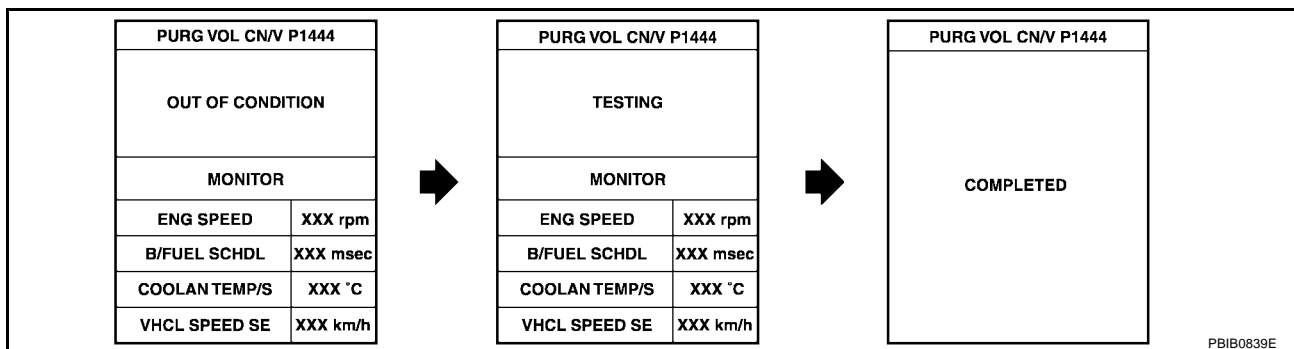

6. Start engine and let it idle until "TESTING" on CONSULT-II changes to "COMPLETED". (It will take approximately 10 seconds.)
If "TESTING" is not displayed after 5 minutes, retry from step 2.
7. Make sure that "OK" is displayed after touching "SELF-DIAG RESULTS". If "NG" is displayed, refer to [EC-1210, "Diagnostic Procedure"](#).

WITH GST

1. Start engine and warm it up to normal operating temperature.
2. Turn ignition switch OFF and wait at least 10 seconds.
3. Start engine and let it idle for at least 20 seconds.
4. Select Service \$07 with GST.
5. If 1st trip DTC is detected, go to [EC-1210, "Diagnostic Procedure"](#).

DTC P1444 EVAP CANISTER PURGE VOLUME CONTROL SOLENOID VALVE [VQ]

UBS00ICC

Wiring Diagram

EC-PGC/V-01

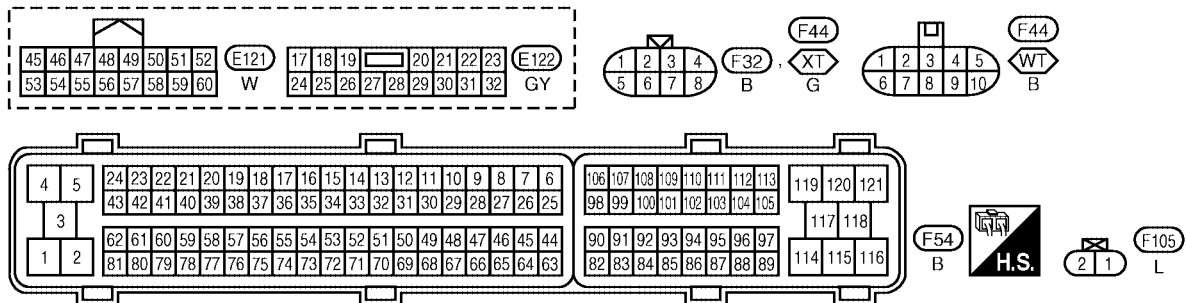
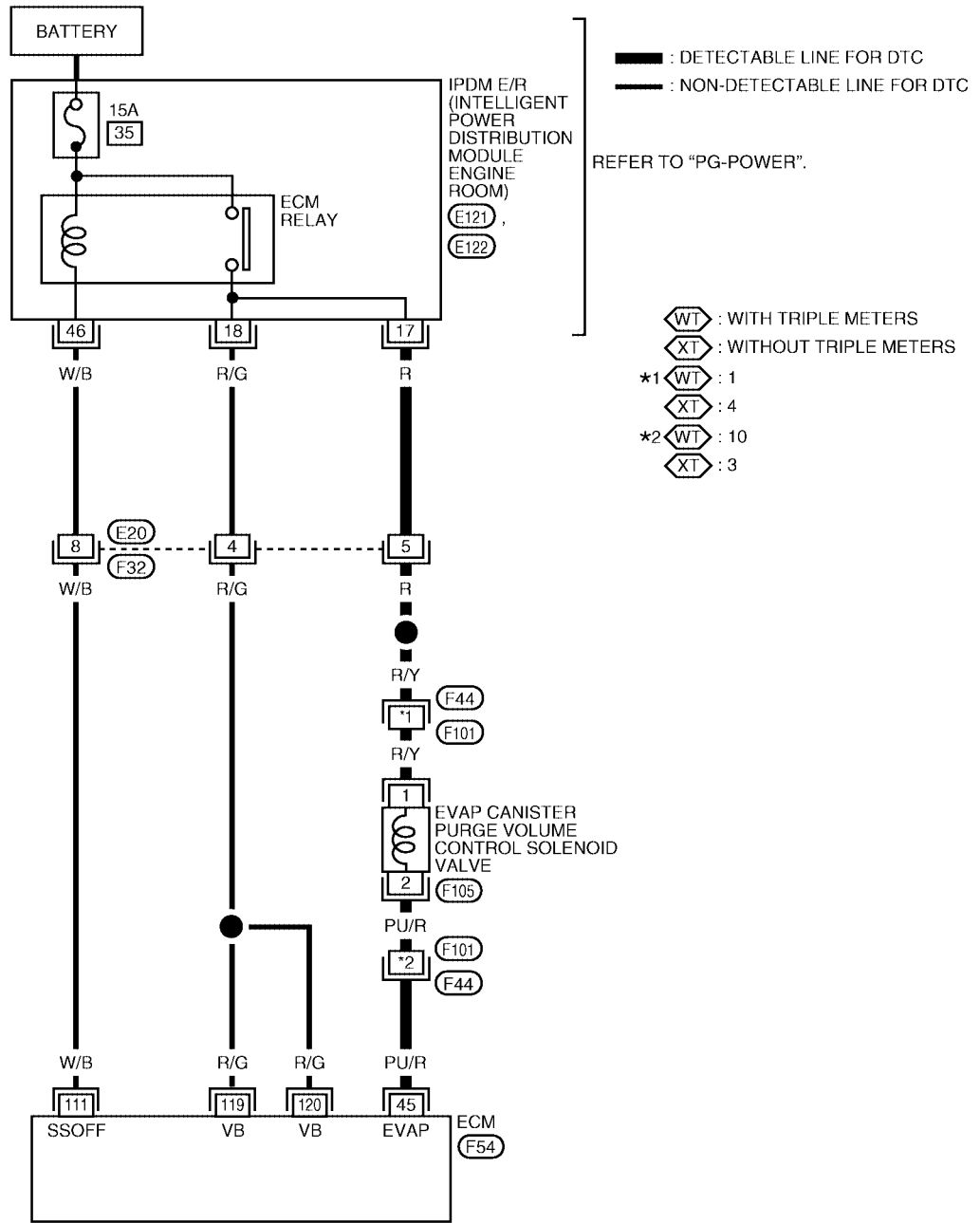

BBWA1563E

DTC P1444 EVAP CANISTER PURGE VOLUME CONTROL SOLENOID VALVE [VQ]

Specification data are reference values and are measured between each terminal and ground. Pulse signal is measured by CONSULT-II.

CAUTION:

Do not use ECM ground terminals when measuring input/output voltage. Doing so may result in damage to the ECM's transistor. Use a ground other than ECM terminals, such as the ground.

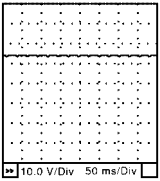
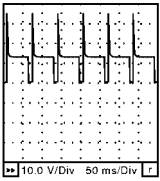
TER-MINAL NO.	WIRE COLOR	ITEM	CONDITION	DATA (DC Voltage)
45	PU/R	EVAP canister purge volume control solenoid valve	[Engine is running] <ul style="list-style-type: none"> ● Idle speed 	BATTERY VOLTAGE (11 - 14V) [★] 
			[Engine is running] <ul style="list-style-type: none"> ● Engine speed is about 2,000 rpm (More than 100 seconds after starting engine). 	BATTERY VOLTAGE (11 - 14V) [★] 
111	W/B	ECM relay (Self shut-off)	[Engine is running] [Ignition switch: OFF] <ul style="list-style-type: none"> ● For a few seconds after turning ignition switch OFF 	0 - 1.5V
			[Ignition switch: OFF] <ul style="list-style-type: none"> ● More than a few seconds after turning ignition switch OFF 	BATTERY VOLTAGE (11 - 14V)
119 120	R/G R/G	Power supply for ECM	[Ignition switch: ON]	BATTERY VOLTAGE (11 - 14V)

★: Average voltage for pulse signal (Actual pulse signal can be confirmed by oscilloscope.)

DTC P1444 EVAP CANISTER PURGE VOLUME CONTROL SOLENOID VALVE

[VQ]

Diagnostic Procedure

UBS00ICD

1. CHECK EVAP CANISTER PURGE VOLUME CONTROL SOLENOID VALVE POWER SUPPLY CIRCUIT

1. Turn ignition switch OFF.
2. Disconnect EVAP canister purge volume control solenoid valve harness connector.
3. Turn ignition switch ON.

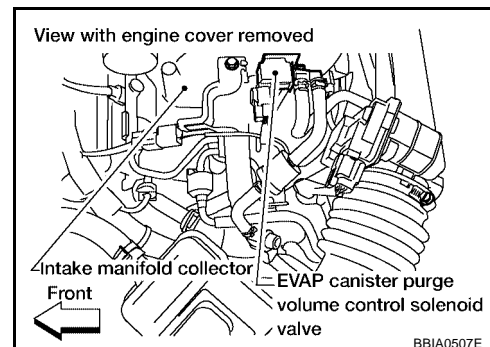

4. Check voltage between EVAP canister purge volume control solenoid valve terminal 1 and ground with CONSULT-II or tester.

Voltage: Battery voltage

OK or NG

- OK >> GO TO 3.
NG >> GO TO 2.

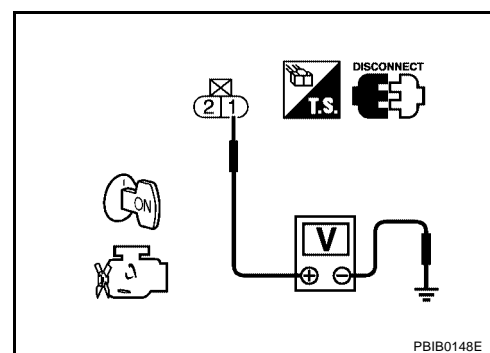

2. DETECT MALFUNCTIONING PART

Check the following.

- Harness connectors E20, F32
- Harness connectors F44, F101
- IPDM E/R harness connector E122
- Harness for open or short between EVAP canister purge volume control solenoid valve and IPDM E/R

>> Repair open circuit or short to ground or short to power in harness or connectors.

3. CHECK EVAP CANISTER PURGE VOLUME CONTROL SOLENOID VALVE OUTPUT SIGNAL CIRCUIT FOR OPEN AND SHORT

1. Turn ignition switch OFF.
2. Disconnect ECM harness connector.
3. Check harness continuity between ECM terminal 45 and EVAP canister purge volume control solenoid valve terminal 2. Refer to Wiring Diagram.

Continuity should exist.

4. Also check harness for short to ground and short to power.

OK or NG

- OK >> GO TO 5.
NG >> GO TO 4.

DTC P1444 EVAP CANISTER PURGE VOLUME CONTROL SOLENOID VALVE [VQ]

4. DETECT MALFUNCTIONING PART

Check the following.

- Harness connectors F101, F44
- Harness for open or short between EVAP canister purge volume control solenoid valve and ECM

>> Repair open circuit or short to ground or short to power in harness or connectors.

5. CHECK EVAP CONTROL SYSTEM PRESSURE SENSOR CONNECTOR

1. Disconnect EVAP control system pressure sensor harness connector.

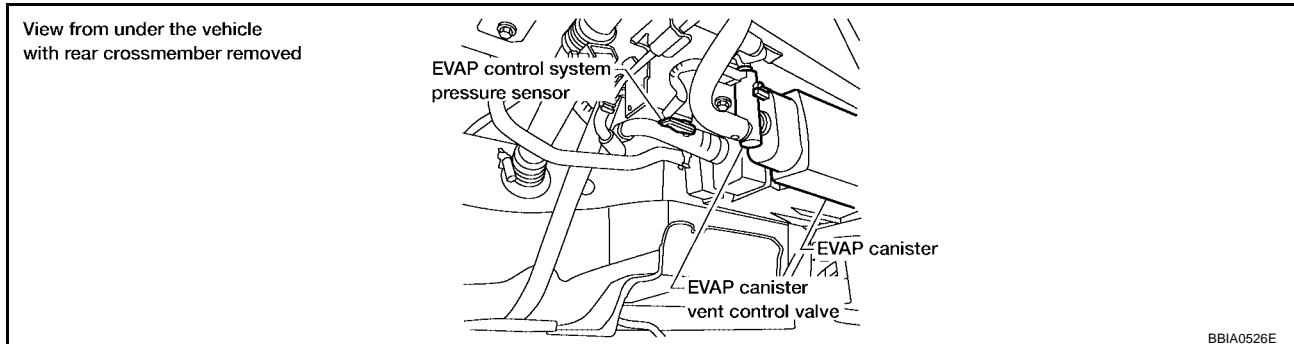

2. Check connectors for water.

Water should not exist.

OK or NG

- OK >> GO TO 6.
- NG >> Replace EVAP control system pressure sensor.

6. CHECK EVAP CONTROL SYSTEM PRESSURE SENSOR

Refer to [EC-999, "Component Inspection"](#).

OK or NG

- OK (With CONSULT-II)>>GO TO 7.
- OK (Without CONSULT-II)>>GO TO 8.
- NG >> Replace EVAP control system pressure sensor.

7. CHECK EVAP CANISTER PURGE VOLUME CONTROL SOLENOID VALVE

Ⓜ With CONSULT-II

1. Turn ignition switch OFF.
2. Reconnect harness connectors disconnected.
3. Start engine.
4. Perform "PURG VOL CONT/V" in "ACTIVE TEST" mode with CONSULT-II. Check that engine speed varies according to the valve opening.

OK or NG

- OK >> GO TO 9.
- NG >> GO TO 8.

ACTIVE TEST	
PURG VOL CONT/V	XXX %
MONITOR	
ENG SPEED	XXX rpm
A/F ALPHA-B1	XX %
A/F ALPHA-B2	XX %

PBIB1678E

DTC P1444 EVAP CANISTER PURGE VOLUME CONTROL SOLENOID VALVE [VQ]

8. CHECK EVAP CANISTER PURGE VOLUME CONTROL SOLENOID VALVE

Refer to [EC-1213, "Component Inspection"](#) .

OK or NG

- OK >> GO TO 9.
- NG >> Replace EVAP canister purge volume control solenoid valve.

9. CHECK RUBBER TUBE FOR CLOGGING

1. Disconnect rubber tube connected to EVAP canister vent control valve.
2. Check the rubber tube for clogging.

OK or NG

- OK >> GO TO 10.
- NG >> Clean the rubber tube using an air blower.

10. CHECK EVAP CANISTER VENT CONTROL VALVE

Refer to [EC-989, "Component Inspection"](#) .

OK or NG

- OK >> GO TO 11.
- NG >> Replace EVAP canister vent control valve.

11. CHECK IF EVAP CANISTER SATURATED WITH WATER

1. Remove EVAP canister with EVAP canister vent control valve and EVAP control system pressure sensor attached.
2. Check if water will drain from the EVAP canister.

Yes or No

- Yes >> GO TO 12.
- No >> GO TO 14.

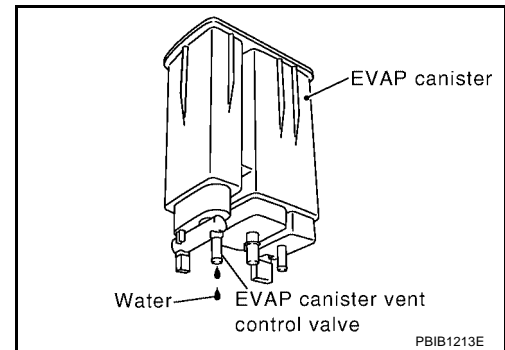

12. CHECK EVAP CANISTER

Weigh the EVAP canister with the EVAP canister vent control valve and EVAP control system pressure sensor attached.

The weight should be less than 2.1 kg (4.6 lb).

OK or NG

- OK >> GO TO 14.
- NG >> GO TO 13.

13. DETECT MALFUNCTIONING PART

Check the following.

- EVAP canister for damage
- EVAP hose between EVAP canister and vehicle frame for clogging or poor connection

>> Repair hose or replace EVAP canister.

DTC P1444 EVAP CANISTER PURGE VOLUME CONTROL SOLENOID VALVE [VQ]

14. CHECK INTERMITTENT INCIDENT

Refer to [EC-782, "TROUBLE DIAGNOSIS FOR INTERMITTENT INCIDENT"](#) .

>> INSPECTION END

Component Inspection EVAP CANISTER PURGE VOLUME CONTROL SOLENOID VALVE

UBS00ICE

With CONSULT-II

Check air passage continuity of EVAP canister purge volume control solenoid valve under the following conditions.

Condition (PURG VOL CONT/V value)	Air passage continuity between A and B
100%	Yes
0%	No

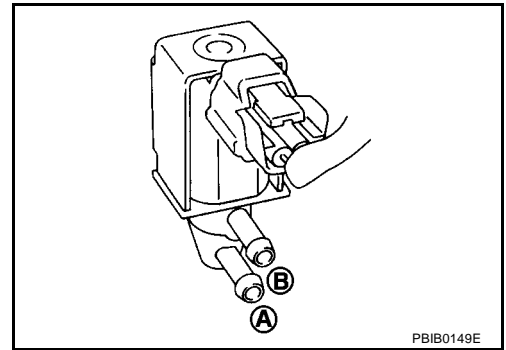

Without CONSULT-II

Check air passage continuity of EVAP canister purge volume control solenoid valve under the following conditions.

Condition	Air passage continuity between A and B
12V direct current supply between terminals 1 and 2	Yes
No supply	No

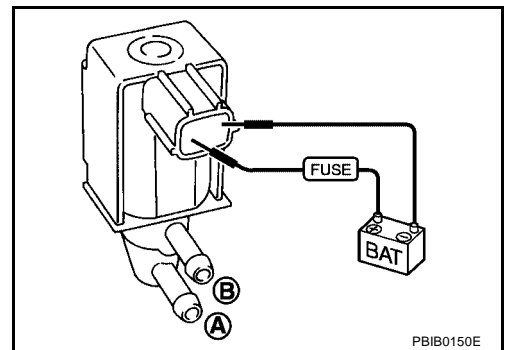

Removal and Installation EVAP CANISTER PURGE VOLUME CONTROL SOLENOID VALVE

UBS00ICF

Refer to [EM-122, "INTAKE MANIFOLD COLLECTOR"](#) .

DTC P1446 EVAP CANISTER VENT CONTROL VALVE

[VQ]

DTC P1446 EVAP CANISTER VENT CONTROL VALVE

PF14935

Component Description

UBS001CG

The EVAP canister vent control valve is located on the EVAP canister and is used to seal the canister vent.

This solenoid valve responds to signals from the ECM. When the ECM sends an ON signal, the coil in the solenoid valve is energized. A plunger will then move to seal the canister vent. The ability to seal the vent is necessary for the on board diagnosis of other evaporative emission control system components.

This solenoid valve is used only for diagnosis, and usually remains opened.

When the vent is closed, under normal purge conditions, the evaporative emission control system is depressurized and allows EVAP Control System diagnosis.

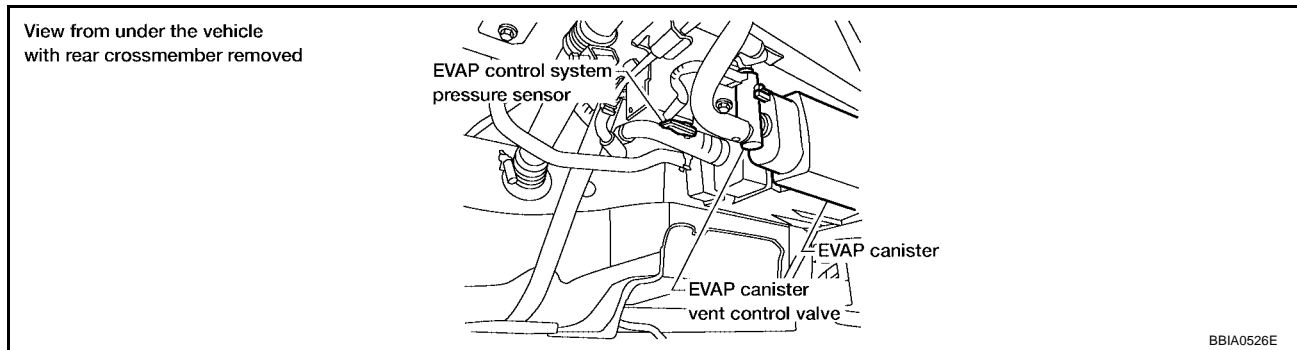
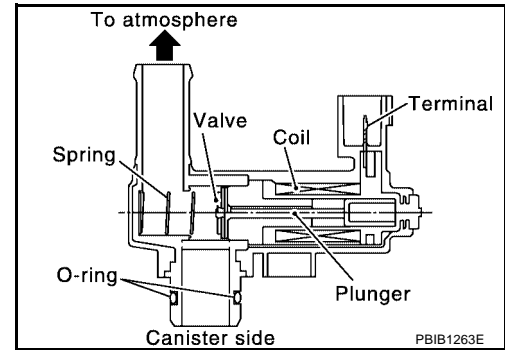

CONSULT-II Reference Value in Data Monitor Mode

UBS001CH

Specification data are reference values.

MONITOR ITEM	CONDITION	SPECIFICATION
VENT CONT/V	● Ignition switch: ON	OFF

On Board Diagnosis Logic

UBS001CI

DTC No.	Trouble diagnosis name	DTC detecting condition	Possible cause
P1446 1446	EVAP canister vent control valve close	EVAP canister vent control valve remains closed under specified driving conditions.	<ul style="list-style-type: none"> ● EVAP canister vent control valve ● EVAP control system pressure sensor and the circuit ● Blocked rubber tube to EVAP canister vent control valve ● EVAP canister is saturated with water

DTC Confirmation Procedure

NOTE:

If DTC Confirmation Procedure has been previously conducted, always turn ignition switch OFF and wait at least 10 seconds before conducting the next test.

WITH CONSULT-II

1. Turn ignition switch ON and wait at least 5 seconds.
2. Turn ignition switch OFF and wait at least 10 seconds.
3. Turn ignition switch ON and select "DATA MONITOR" mode with CONSULT-II.
4. Start engine and let it idle for at least 1 minute.
5. Repeat next procedures 3 times.
 - a. Increase the engine speed up to 3,000 to 3,500 rpm and keep it for 2 minutes and 50 seconds to 3 minutes.
Never exceed 3 minutes.
 - b. Fully released accelerator pedal and keep engine idle for about 5 seconds.
6. If 1st trip DTC is detected, go to [EC-1217, "Diagnostic Procedure"](#).
If 1st trip DTC is not detected, go to the next step.
7. Repeat next procedure 20 times.
 - a. Quickly increase the engine speed up to 4,000 to 4,500 rpm or more and keep it for 25 to 30 seconds.
 - b. Fully released accelerator pedal and keep engine idle for at least 35 seconds.

DATA MONITOR	
MONITOR	NO DTC
ENG SPEED	XXX rpm

SEF058Y

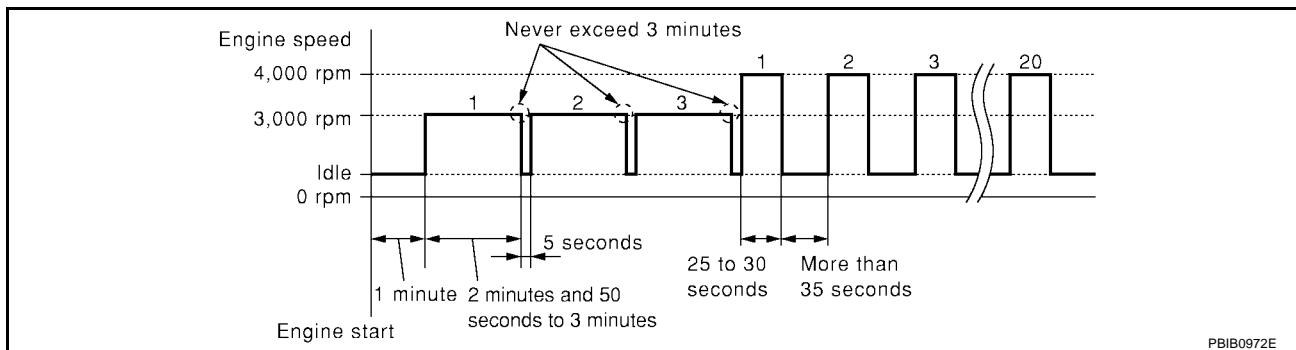

8. If 1st trip DTC is detected, go to [EC-1217, "Diagnostic Procedure"](#).

WITH GST

Follow the procedure "WITH CONSULT-II" above.

DTC P1446 EVAP CANISTER VENT CONTROL VALVE

[VQ]

Wiring Diagram

UBS001CK

EC-VENT/V-01

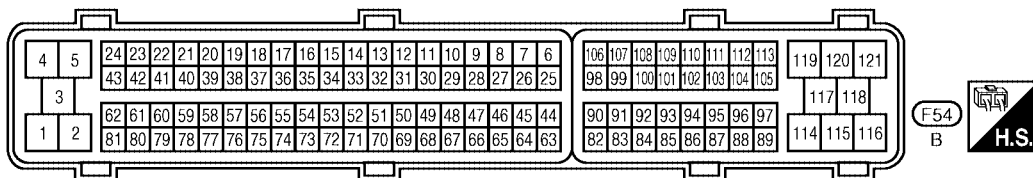
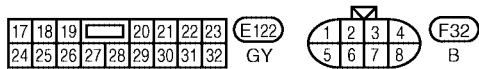
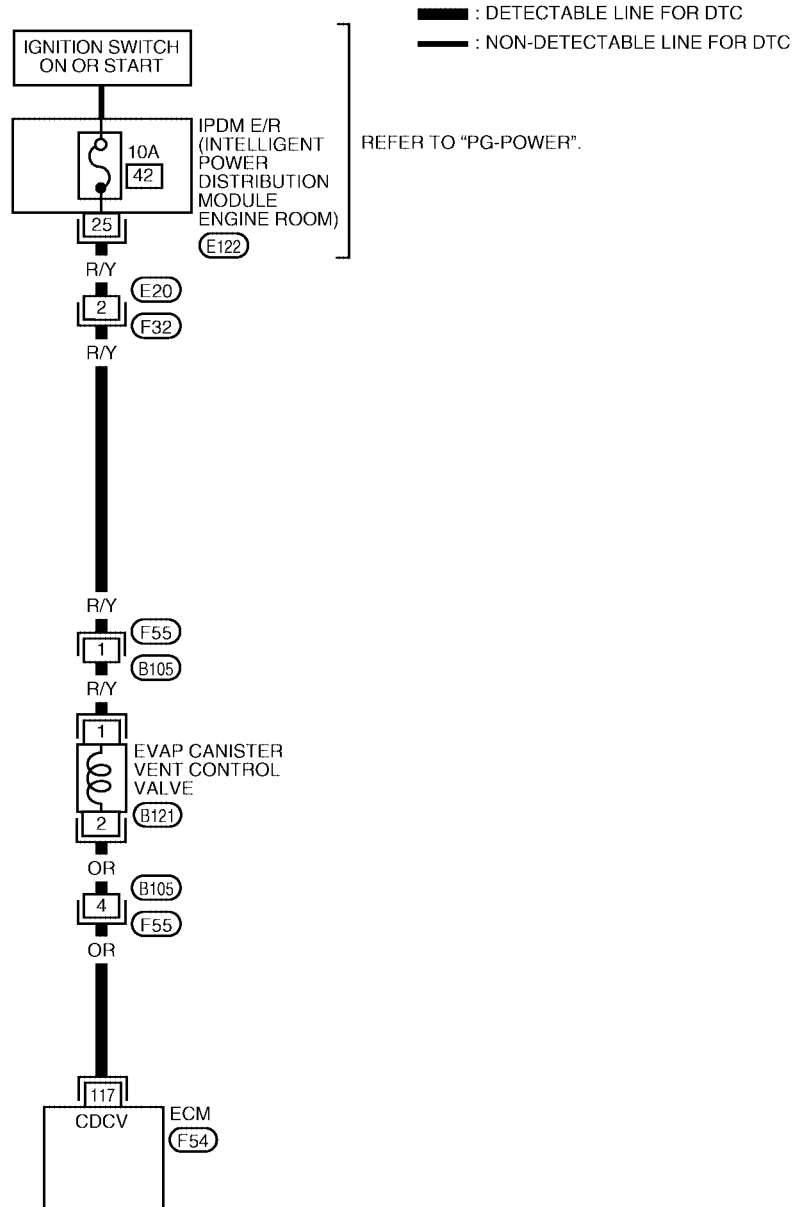

BBWA1665E

DTC P1446 EVAP CANISTER VENT CONTROL VALVE

[VQ]

Specification data are reference values and are measured between each terminal and ground.

CAUTION:

Do not use ECM ground terminals when measuring input/output voltage. Doing so may result in damage to the ECM's transistor. Use a ground other than ECM terminals, such as the ground.

TER-MINAL NO.	WIRE COLOR	ITEM	CONDITION	DATA (DC Voltage)
117	OR	EVAP canister vent control valve	[Ignition switch: ON]	BATTERY VOLTAGE (11 - 14V)

Diagnostic Procedure

UBS001CL

1. CHECK RUBBER TUBE

1. Turn ignition switch OFF.
2. Disconnect rubber tube connected to EVAP canister vent control valve.

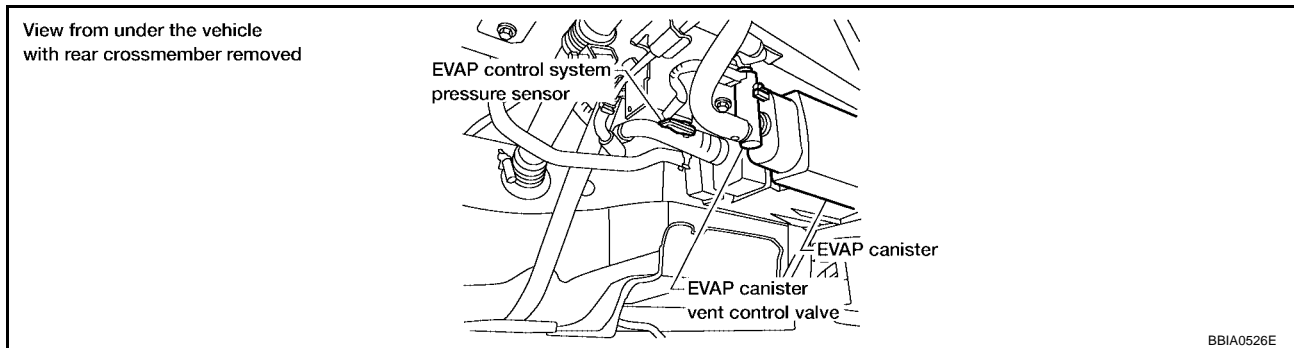

3. Check the rubber tube for clogging.

OK or NG

- OK >> GO TO 2.
- NG >> Clean rubber tube using an air blower.

2. CHECK EVAP CANISTER VENT CONTROL VALVE

Refer to [EC-1218, "EVAP CANISTER VENT CONTROL VALVE"](#).

OK or NG

- OK >> GO TO 3.
- NG >> Replace EVAP canister vent control valve.

3. CHECK IF EVAP CANISTER SATURATED WITH WATER

1. Remove EVAP canister with EVAP canister vent control valve and EVAP control system pressure sensor attached.
2. Check if water will drain from the EVAP canister.

Yes or No

- Yes >> GO TO 4.
- No >> GO TO 6.

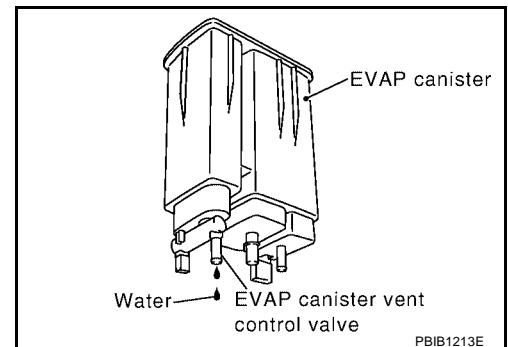

4. CHECK EVAP CANISTER

Weigh the EVAP canister with the EVAP canister vent control valve and EVAP control system pressure sensor attached.

The weight should be less than 2.1 kg (4.6 lb).

OK or NG

- OK >> GO TO 6.
- NG >> GO TO 5.

5. DETECT MALFUNCTIONING PART

Check the following.

- EVAP canister for damage
- EVAP hose between EVAP canister and vehicle frame for clogging or poor connection

>> Repair hose or replace EVAP canister.

6. CHECK EVAP CONTROL SYSTEM PRESSURE SENSOR CONNECTOR

1. Disconnect EVAP control system pressure sensor harness connector.
2. Check connectors for water.

Water should not exist.

OK or NG

- OK >> GO TO 7.
- NG >> Replace EVAP control system pressure sensor.

7. CHECK EVAP CONTROL SYSTEM PRESSURE SENSOR

Refer to [EC-999, "Component Inspection"](#) .

OK or NG

- OK >> GO TO 8.
- NG >> Replace EVAP control system pressure sensor.

8. CHECK INTERMITTENT INCIDENT

Refer to [EC-782, "TROUBLE DIAGNOSIS FOR INTERMITTENT INCIDENT"](#) .

>> **INSPECTION END**

Component Inspection EVAP CANISTER VENT CONTROL VALVE

UBS00/CM

Ⓟ With CONSULT-II

1. Remove EVAP canister vent control valve from EVAP canister.
2. Check portion **B** of EVAP canister vent control valve for being rusted.
If NG, replace EVAP canister vent control valve.
If OK, go to next step.
3. Reconnect harness connectors disconnected.
4. Turn ignition switch ON.

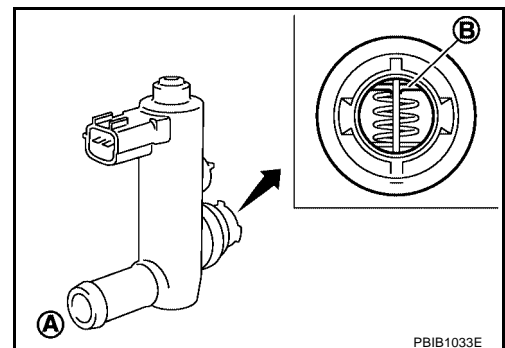

PBIB1033E

DTC P1446 EVAP CANISTER VENT CONTROL VALVE

[VQ]

- Perform "VENT CONTROL/V" in "ACTIVE TEST" mode.
- Check air passage continuity and operation delay time.
Make sure new O-ring is installed properly.

Condition VENT CONTROL/V	Air passage continuity between A and B
ON	No
OFF	Yes

Operation takes less than 1 second.

If NG, replace EVAP canister vent control valve.
If OK, go to next step.

- Clean the air passage (Portion **A** to **B**) of EVAP canister vent control valve using an air blower.
- Perform step 5 again.

⊗ **Without CONSULT-II**

- Remove EVAP canister vent control valve from EVAP canister.
- Check portion **B** of EVAP canister vent control valve for being rusted.

ACTIVE TEST	
VENT CONTROL/V	OFF
MONITOR	
ENG SPEED	XXX rpm
A/F ALPHA-B1	XXX %
A/F ALPHA-B2	XXX %

PBIB1679E

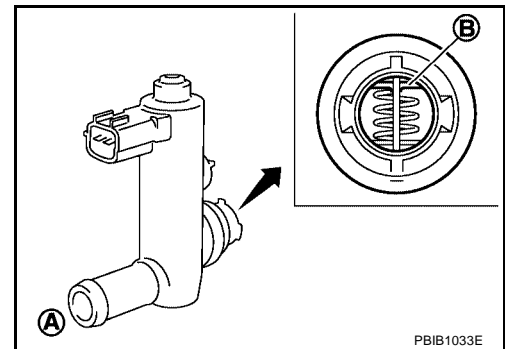

- Check air passage continuity and operation delay time under the following conditions.
Make sure new O-ring is installed properly.

Condition	Air passage continuity between A and B
12V direct current supply between terminals 1 and 2	No
OFF	Yes

Operation takes less than 1 second.

If NG, replace EVAP canister vent control valve.
If OK, go to next step.

- Clean the air passage (Portion **A** to **B**) of EVAP canister vent control valve using an air blower.
- Perform step 3 again.

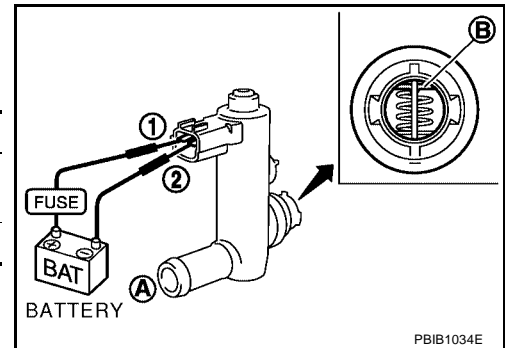

DTC P1564 ASCD STEERING SWITCH

[VQ]

PFP:25551

DTC P1564 ASCD STEERING SWITCH

Component Description

UBS00ICN

ASCD steering switch has variant values of electrical resistance for each button. ECM reads voltage variation of switch, and determines which button is operated.

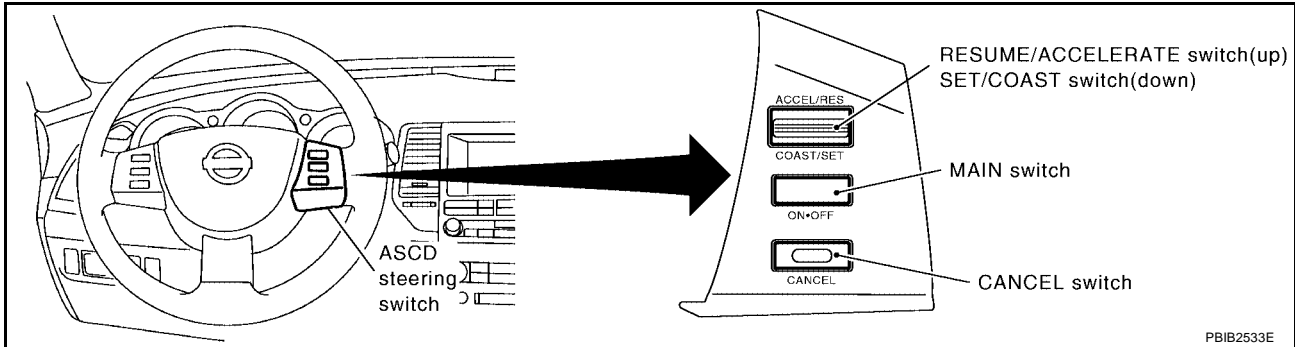

Refer to [EC-648, "AUTOMATIC SPEED CONTROL DEVICE \(ASCD\)"](#) for the ASCD function.

CONSULT-II Reference Value in Data Monitor Mode

UBS00ICO

Specification data are reference values.

MONITOR ITEM	CONDITION		SPECIFICATION
MAIN SW	● Ignition switch: ON	MAIN switch: Pressed	ON
		MAIN switch: Released	OFF
CANCEL SW	● Ignition switch: ON	CANCEL switch: Pressed	ON
		CANCEL switch: Released	OFF
RESUME/ACC SW	● Ignition switch: ON	RESUME/ACCELERATE switch: Pressed	ON
		RESUME/ACCELERATE switch: Released	OFF
SET SW	● Ignition switch: ON	SET/COAST switch: Pressed	ON
		SET/COAST switch: Released	OFF

On Board Diagnosis Logic

UBS00ICP

This self-diagnosis has the one trip detection logic.
The MIL will not light up for this diagnosis.

NOTE:

If DTC P1564 is displayed with DTC P0605, first perform the trouble diagnosis for DTC P0605. Refer to [EC-1042](#).

DTC No.	Trouble Diagnosis Name	DTC Detecting Condition	Possible Cause
P1564 1564	ASCD steering switch	<ul style="list-style-type: none"> ● An excessively high voltage signal from the ASCD steering switch is sent to ECM. ● ECM detects that input signal from the ASCD steering switch is out of the specified range. ● ECM detects that the ASCD steering switch is stuck ON. 	<ul style="list-style-type: none"> ● Harness or connectors (The switch circuit is open or shorted.) ● ASCD steering switch ● ECM

DTC Confirmation Procedure

NOTE:

If DTC Confirmation Procedure has been previously conducted, always turn ignition switch OFF and wait at least 10 seconds before conducting the next test.

 **WITH CONSULT-II**

1. Turn ignition switch ON.
2. Select "DATA MONITOR" mode with CONSULT-II.
3. Wait at least 10 seconds.
4. Press MAIN switch for at least 10 seconds, then release it and wait at least 10 seconds.
5. Press CANCEL switch for at least 10 seconds, then release it and wait at least 10 seconds.
6. Press RESUME/ACCELERATE switch for at least 10 seconds, then release it and wait at least 10 seconds.
7. Press SET/COAST switch for at least 10 seconds, then release it and wait at least 10 seconds.
8. If DTC is detected, go to [EC-1223, "Diagnostic Procedure"](#) .

 **WITH GST**

Follow the procedure "WITH CONSULT-II" above.

A
EC
C
D
E
F
G
H
I
J
K
L
M

DTC P1564 ASCD STEERING SWITCH

[VQ]

Specification data are reference values and are measured between each terminal and ground.

CAUTION:

Do not use ECM ground terminals when measuring input/output voltage. Doing so may result in damage to the ECM's transistor. Use a ground other than ECM terminals, such as the ground.

TER-MINAL NO.	WIRE COLOR	ITEM	CONDITION	DATA (DC Voltage)
67	B	Sensor ground	[Engine is running] <ul style="list-style-type: none"> ● Warm-up condition ● Idle speed 	Approximately 0V
99	G/Y	ASCD steering switch	[Ignition switch: ON] <ul style="list-style-type: none"> ● ASCD steering switch: OFF 	Approximately 4V
			[Ignition switch: ON] <ul style="list-style-type: none"> ● MAIN switch: Pressed 	Approximately 0V
			[Ignition switch: ON] <ul style="list-style-type: none"> ● CANCEL switch: Pressed 	Approximately 1V
			[Ignition switch: ON] <ul style="list-style-type: none"> ● RESUME/ACCELERATE switch: Pressed 	Approximately 3V
			[Ignition switch: ON] <ul style="list-style-type: none"> ● SET/COAST switch: Pressed 	Approximately 2V

Diagnostic Procedure

UBS001CS

1. CHECK GROUND CONNECTIONS

1. Turn ignition switch OFF.
2. Loosen and retighten three ground screws on the body.
Refer to [EC-789, "Ground Inspection"](#) .

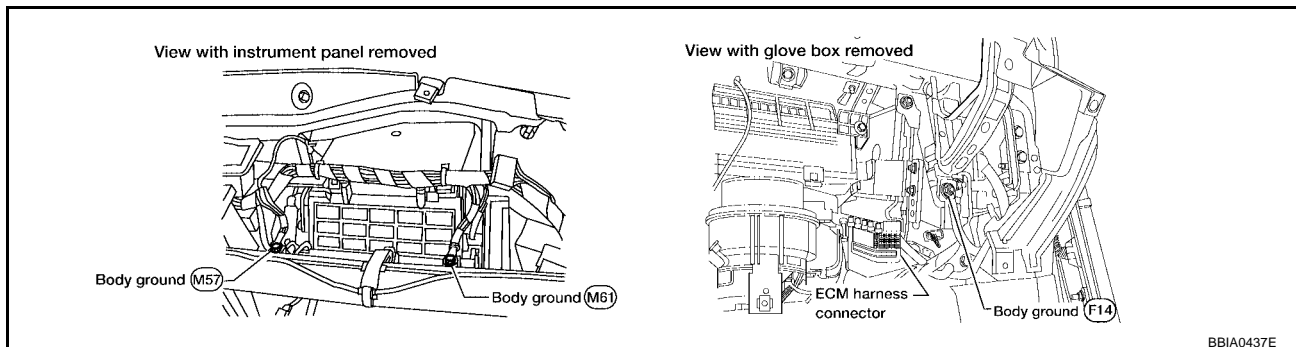

OK or NG

- OK >> GO TO 2.
- NG >> Repair or replace ground connections.

2. CHECK ASCD STEERING SWITCH CIRCUIT

④ With CONSULT-II

1. Turn ignition switch ON.
2. Select "MAIN SW", "RESUME/ACC SW", "SET SW" and "CANCEL SW" in "DATA MONITOR" mode with CONSULT-II.
3. Check each item indication under the following conditions.

Switch	Monitor item	Condition	Indication
MAIN switch	MAIN SW	Pressed	ON
		Released	OFF
CANCEL switch	CANCEL SW	Pressed	ON
		Released	OFF
RESUME/ACCELERATE switch	RESUME/ACC SW	Pressed	ON
		Released	OFF
SET/COAST switch	SET SW	Pressed	ON
		Released	OFF

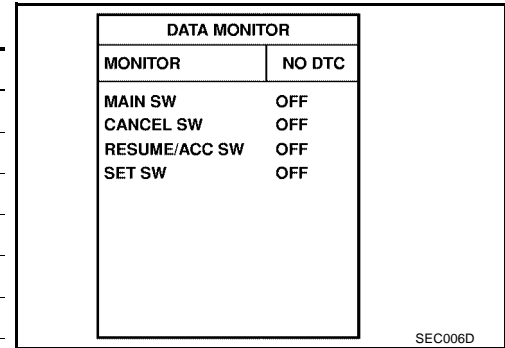

⊗ Without CONSULT-II

1. Turn ignition switch ON.
2. Check voltage between ECM terminal 99 and ground with pressing each button.

Switch	Condition	Voltage [V]
MAIN switch	Pressed	Approx. 0
	Released	Approx. 4
CANCEL switch	Pressed	Approx. 1
	Released	Approx. 4
RESUME/ACCELERATE switch	Pressed	Approx. 3
	Released	Approx. 4
SET/COAST switch	Pressed	Approx. 2
	Released	Approx. 4

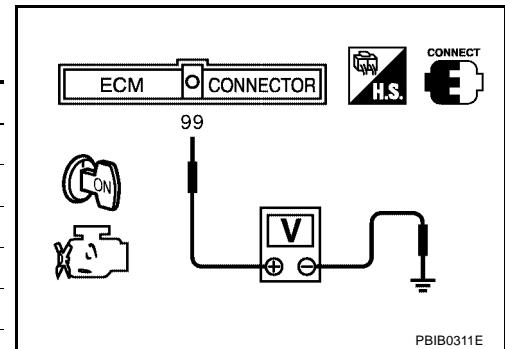

OK or NG

- OK >> GO TO 8.
- NG >> GO TO 3.

3. CHECK ASCD STEERING SWITCH GROUND CIRCUIT FOR OPEN AND SHORT

1. Turn ignition switch OFF.
2. Disconnect ECM harness connector.
3. Disconnect combination switch harness connector M102.
4. Check harness continuity between combination switch terminal 19 and ECM terminal 67. Refer to Wiring Diagram.

Continuity should exist.

5. Also check harness for short to ground and short to power.

OK or NG

- OK >> GO TO 5.
- NG >> GO TO 4.

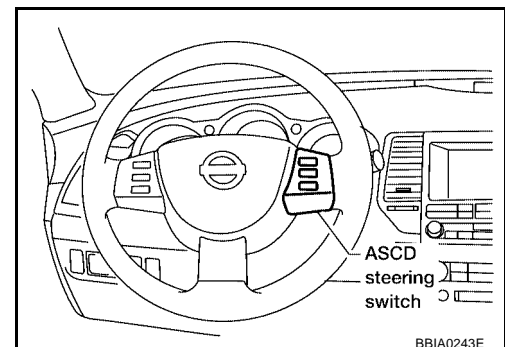

4. DETECT MALFUNCTIONING PART

Check the following.

- Harness connectors M71, F59
- Combination switch (spiral cable)
- Harness for open and short between ECM and combination switch

>> Repair open circuit or short to ground or short to power in harness or connectors.

5. CHECK ASCD STEERING SWITCH INPUT SIGNAL CIRCUIT FOR OPEN AND SHORT

1. Check harness continuity between ECM terminal 99 and combination switch terminal 20. Refer to Wiring Diagram.

Continuity should exist.

2. Also check harness for short to ground and short to power.

OK or NG

- OK >> GO TO 7.
- NG >> GO TO 6.

6. DETECT MALFUNCTIONING PART

Check the following.

- Harness connectors M71, F59
- Combination switch (spiral cable)
- Harness for open and short between ECM and combination switch

>> Repair open circuit or short to ground or short to power in harness or connectors.

7. CHECK ASCD STEERING SWITCH

Refer to [EC-1226, "Component Inspection"](#) .

OK or NG

- OK >> GO TO 8.
- NG >> Replace steering wheel.

8. CHECK INTERMITTENT INCIDENT

Refer to [EC-782, "TROUBLE DIAGNOSIS FOR INTERMITTENT INCIDENT"](#) .

>> **INSPECTION END**

DTC P1564 ASCD STEERING SWITCH

[VQ]

UBS00ICT

Component Inspection ASCD STEERING SWITCH

1. Disconnect combination switch (spiral cable).
2. Check continuity between combination switch (spiral cable) terminals 14 and 15 with pushing each switch.

Switch	Condition	Resistance [Ω]
MAIN switch	Pressed	Approx. 0
	Released	Approx. 4,000
CANCEL switch	Pressed	Approx. 250
	Released	Approx. 4,000
RESUME/ACCELERATE switch	Pressed	Approx. 1,480
	Released	Approx. 4,000
SET/COAST switch	Pressed	Approx. 660
	Released	Approx. 4,000

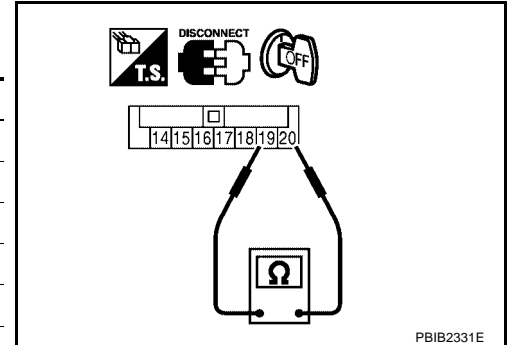

DTC P1572 ASCD BRAKE SWITCH

PFP:25320

Component Description

UBS001CU

When the brake pedal is depressed, ASCD brake switch is turned OFF and stop lamp switch is turned ON. ECM detects the state of the brake pedal by this input of two kinds (ON/OFF signal).

Refer to [EC-648](#), "AUTOMATIC SPEED CONTROL DEVICE (ASCD)" for the ASCD function.

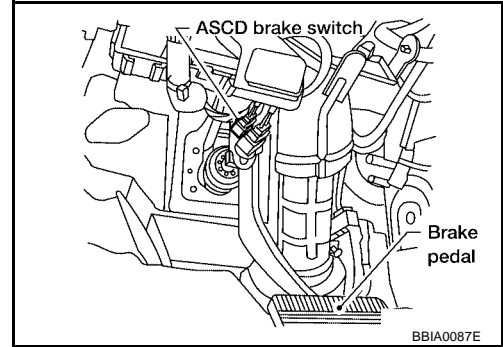

CONSULT-II Reference Value in Data Monitor Mode

UBS001CV

Specification data are reference values.

MONITOR ITEM	CONDITION		SPECIFICATION
BRAKE SW1 (ASCD brake switch)	● Ignition switch: ON	Clutch pedal (M/T) and brake pedal: Fully released	ON
		Clutch pedal (M/T) and/or brake pedal: Slightly depressed	OFF
BRAKE SW2 (Stop lamp switch)	● Ignition switch: ON	Brake pedal: Fully released	OFF
		Brake pedal: Slightly depressed	ON

On Board Diagnosis Logic

UBS001CW

This self-diagnosis has the one trip detection logic.
The MIL will not light up for this diagnosis.

NOTE:

- If DTC P 1572 is displayed with DTC P0605, first perform the trouble diagnosis for DTC P0605. Refer to [EC-1042](#)
- This self-diagnosis has the one trip detection logic. When malfunction A is detected, DTC is not stored in ECM memory. And in that case, 1st trip DTC and 1st trip freeze frame data are displayed. 1st trip DTC is erased when ignition switch OFF. And even when malfunction A is detected in two consecutive trips, DTC is not stored in ECM memory.

DTC No.	Trouble Diagnosis Name	DTC Detecting Condition		Possible Cause
P1572 1572	ASCD brake switch	A)	<ul style="list-style-type: none"> ● When the vehicle speed is above 30km/h (19 MPH), ON signals from the stop lamp switch and the ASCD brake switch are sent to ECM at the same time. 	<ul style="list-style-type: none"> ● Harness or connectors (The stop lamp switch circuit is shorted.) ● Harness or connectors (The ASCD brake switch circuit is shorted.) ● Harness or connectors (The ASCD clutch switch circuit is shorted.) (M/T models) ● Stop lamp switch ● ASCD brake switch ● ASCD clutch switch (M/T models) ● Incorrect stop lamp switch installation ● Incorrect ASCD brake switch installation ● Incorrect ASCD clutch switch installation (M/T models) ● ECM
		B)	<ul style="list-style-type: none"> ● ASCD brake switch signal is not sent to ECM for extremely long time while the vehicle is driving 	

DTC Confirmation Procedure

CAUTION:

Always drive vehicle at a safe speed.

NOTE:

- If DTC Confirmation Procedure has been previously conducted, always turn ignition switch OFF and wait at least 10 seconds before conducting the next test.
- Procedure for malfunction B is not described here. It takes extremely long time to complete procedure for malfunction B. By performing procedure for malfunction A, the incident that causes malfunction B can be detected.

TESTING CONDITION:

Steps 4 and 5 may be conducted with the drive wheels lifted in the shop or by driving the vehicle. If a road test is expected to be easier, it is unnecessary to lift the vehicle.

WITH CONSULT-II

1. Start engine (TCS switch OFF).
2. Select "DATA MONITOR" mode with CONSULT-II.
3. Press MAIN switch and make sure that CRUISE indicator lights up.
4. Drive the vehicle for at least 5 consecutive seconds under the following condition.

VHCL SPEED SE	More than 30 km/h (19 MPH)
Selector lever	Suitable position

If 1st trip DTC is detected, go to [EC-1231, "Diagnostic Procedure"](#).

If 1st trip DTC is not detected, go to the following step.

5. Drive the vehicle for at least 5 consecutive seconds under the following condition.

VHCL SPEED SE	More than 30 km/h (19 MPH)
Selector lever	Suitable position
Driving location	Depress the brake pedal for more than five seconds so as not to come off from the above-mentioned vehicle speed.

6. If 1st trip DTC is detected, go to [EC-1231, "Diagnostic Procedure"](#).

WITH GST

Follow the procedure "WITH CONSULT-II" above.

DATA MONITOR	
MONITOR	NO DTC
ENG SPEED	XXX rpm
VHCL SPEED SE	XXX km/h
CRUISE LAMP	ON
BRAKE SW 1	ON
BRAKE SW 2	OFF

PBIB2386E

DTC P1572 ASCD BRAKE SWITCH

[VQ]

Wiring Diagram

UBS001CY

EC-ASC/BS-01

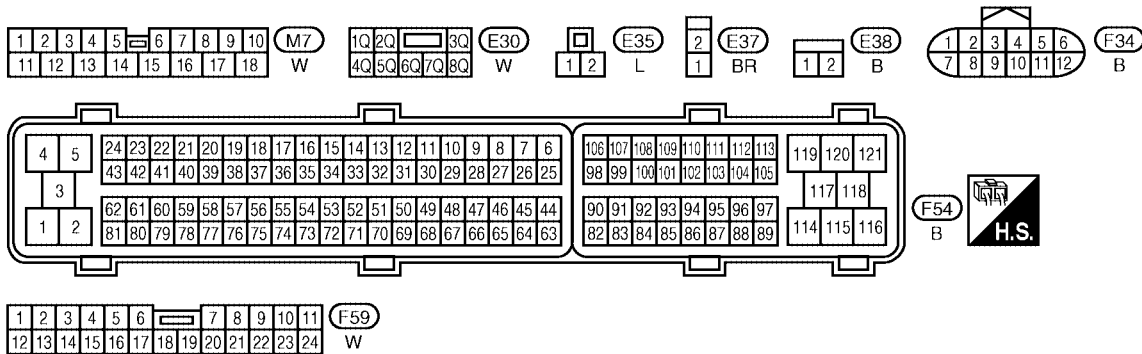
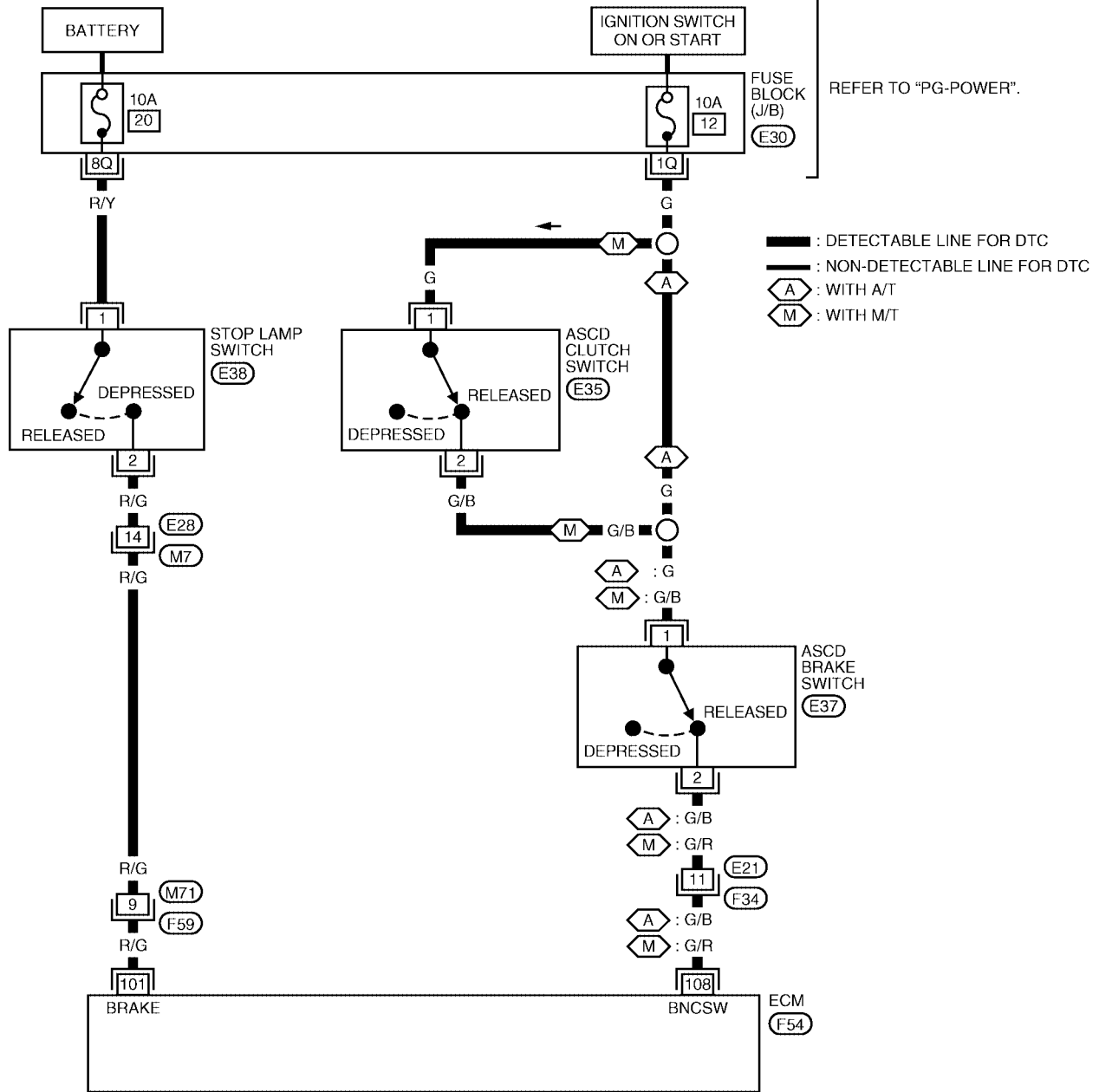

DTC P1572 ASCD BRAKE SWITCH

[VQ]

Specification data are reference values and are measured between each terminal and ground.

CAUTION:

Do not use ECM ground terminals when measuring input/output voltage. Doing so may result in damage to the ECM's transistor. Use a ground other than ECM terminals, such as the ground.

TER-MINAL NO.	WIRE COLOR	ITEM	CONDITION	DATA (DC Voltage)
101	R/G	Stop lamp switch	[Ignition switch: OFF] <ul style="list-style-type: none"> ● Brake pedal: Fully released 	Approximately 0V
			[Ignition switch: OFF] <ul style="list-style-type: none"> ● Brake pedal: Slightly depressed 	BATTERY VOLTAGE (11 - 14V)
108	G/B (A/T) G/R (M/T)	ASCD brake switch	[Ignition switch: ON] <ul style="list-style-type: none"> ● Brake pedal: Slightly depressed (A/T) ● Clutch pedal and/or clutch pedal: Slightly depressed (M/T) 	Approximately 0V
			[Ignition switch: ON] <ul style="list-style-type: none"> ● Brake pedal: Fully released (A/T) ● Clutch pedal and brake pedal: Fully released (M/T) 	BATTERY VOLTAGE (11 - 14V)

DTC P1572 ASCD BRAKE SWITCH

[VQ]

UBS00ICZ

Diagnostic Procedure

1. CHECK OVERALL FUNCTION-I

With CONSULT-II

1. Turn ignition switch ON.
2. Select "BRAKE SW1" in "DATA MONITOR" mode with CONSULT-II.
3. Check "BRAKE SW1" indication under the following conditions.

A/T models

CONDITION	INDICATION
Brake pedal: Slightly depressed	OFF
Brake pedal: Fully released	ON

M/T models

CONDITION	INDICATION
Clutch pedal and/or brake pedal: Slightly depressed	OFF
Clutch pedal and brake pedal: Fully released	ON

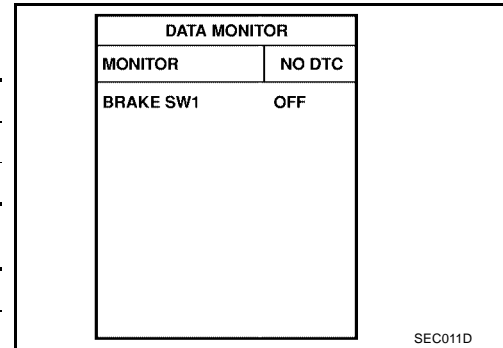

Without CONSULT-II

1. Turn ignition switch ON.
2. Check voltage between ECM terminal 108 and ground under the following conditions.

A/T models

CONDITION	VOLTAGE
Brake pedal: Slightly depressed	Approximately 0V
Brake pedal: Fully released	Battery voltage

M/T models

CONDITION	VOLTAGE
Clutch pedal and/or brake pedal: Slightly depressed	Approximately 0V
Clutch pedal and brake pedal: Fully released	Battery voltage

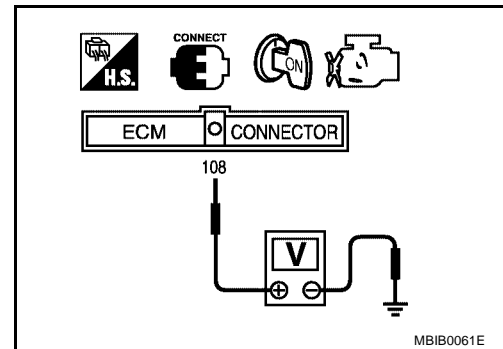

OK or NG

- OK >> GO TO 2.
- NG (M/T models)>>GO TO 3.
- NG (A/T models)>>GO TO 8.

DTC P1572 ASCD BRAKE SWITCH

[VQ]

2. CHECK OVERALL FUNCTION-II

With CONSULT-II

Check "BRAKE SW2" indication in "DATA MONITOR" mode.

CONDITION	INDICATION
Brake pedal: Fully released	OFF
Brake pedal: Slightly depressed	ON

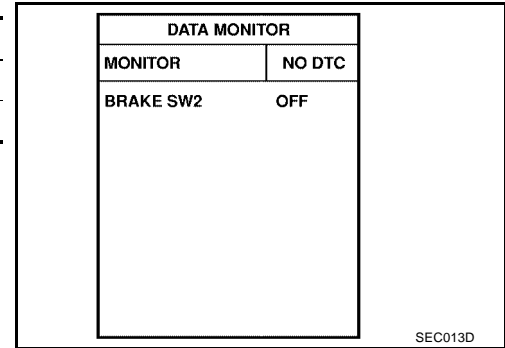

Without CONSULT-II

Check voltage between ECM terminal 101 and ground under the following conditions.

CONDITION	VOLTAGE
Brake pedal: Fully released	Approximately 0V
Brake pedal: Slightly depressed	Battery voltage

OK or NG

- OK >> GO TO 18.
- NG >> GO TO 13.

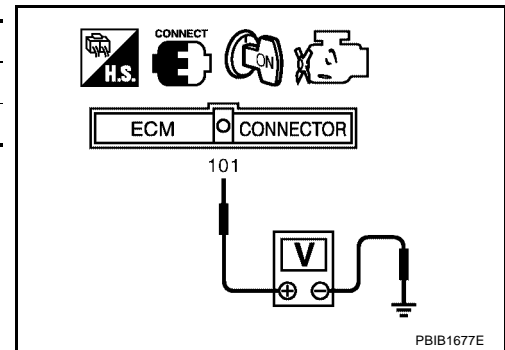

3. CHECK ASCD CLUTCH SWITCH CIRCUIT

1. Turn ignition switch OFF.
2. Disconnect ASCD brake switch harness connector.
3. Turn ignition switch ON.

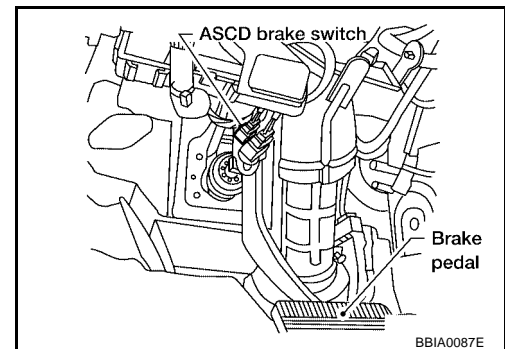

4. Check voltage between ASCD brake switch terminal 1 and ground under the following conditions with CONSULT-II or tester.

CONDITION	VOLTAGE
Clutch pedal: Slightly depressed	Approximately 0V
Clutch pedal: Fully released	Battery voltage

OK or NG

- OK >> GO TO 10.
- NG >> GO TO 4.

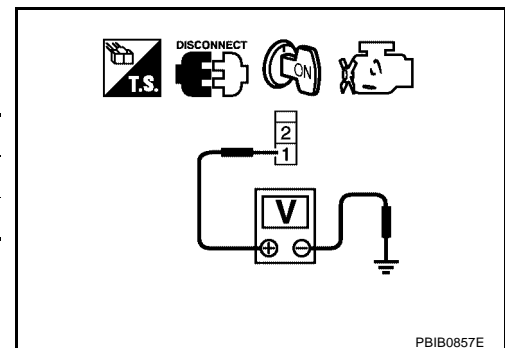

4. CHECK ASCD CLUTCH SWITCH POWER SUPPLY CIRCUIT

1. Turn ignition switch OFF.
2. Disconnect ASCD clutch switch harness connector.
3. Turn ignition switch ON.

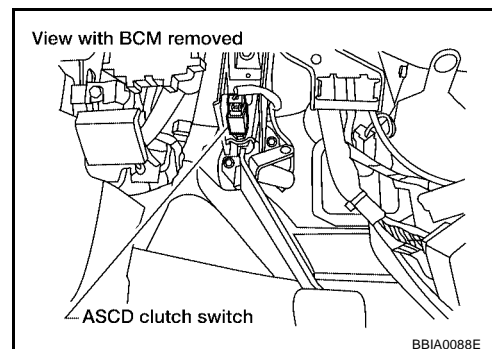

4. Check voltage between ASCD clutch switch terminal 1 and ground with CONSULT-II or tester.

Voltage: Battery voltage

OK or NG

- OK >> GO TO 6.
NG >> GO TO 5.

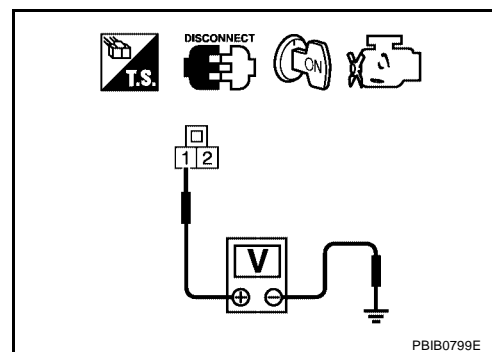

5. DETECT MALFUNCTIONING PART

Check the following.

- Fuse block (J/B) connector E30
- 10A fuse
- Harness for open or short between ASCD clutch switch and fuse

>> Repair open circuit or short to ground or short to power in harness or connectors.

6. CHECK ASCD CLUTCH SWITCH INPUT SIGNAL CIRCUIT FOR OPEN AND SHORT

1. Turn ignition switch OFF.
2. Check harness continuity between ASCD clutch switch terminal 2 and ASCD brake switch terminal 1. Refer to Wiring Diagram.

Continuity should exist.

3. Also check harness for short to ground and short to power.

OK or NG

- OK >> GO TO 7.
NG >> Repair open circuit or short to ground or short to power in harness or connectors.

7. CHECK ASCD CLUTCH SWITCH

Refer to [EC-1236, "Component Inspection"](#)

OK or NG

- OK >> GO TO 18.
NG >> Replace ASCD clutch switch.

8. CHECK ASCD BRAKE SWITCH POWER SUPPLY CIRCUIT

1. Turn ignition switch OFF.
2. Disconnect ASCD brake switch harness connector.
3. Turn ignition switch ON.

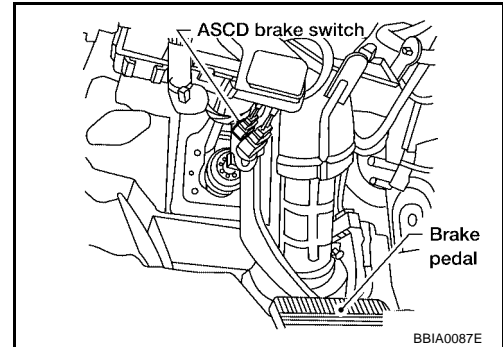

4. Check voltage between ASCD brake switch terminal 1 and ground with CONSULT-II or tester.

Voltage: Battery voltage

OK or NG

- OK >> GO TO 10.
NG >> GO TO 9.

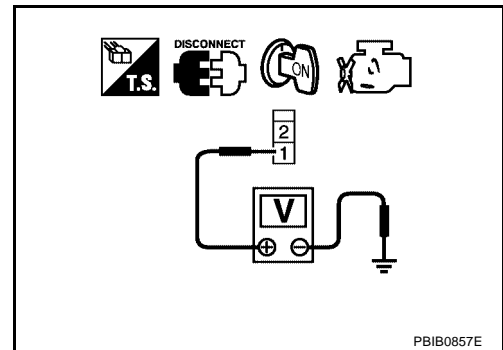

9. DETECT MALFUNCTIONING PART

Check the following.

- Fuse block (J/B) connector E30
- 10A fuse
- Harness for open or short between ASCD brake switch and fuse

>> Repair open circuit or short to ground or short to power in harness or connectors.

10. CHECK ASCD BRAKE SWITCH INPUT SIGNAL CIRCUIT FOR OPEN AND SHORT

1. Turn ignition switch OFF.
2. Disconnect ECM harness connector.
3. Check harness continuity between ECM terminal 108 and ASCD brake switch terminal 2. Refer to Wiring Diagram.

Continuity should exist.

4. Also check harness for short to ground and short to power.

OK or NG

- OK >> GO TO 12.
NG >> GO TO 11.

11. DETECT MALFUNCTIONING PART

Check the following.

- Harness connectors E21, F34
- Harness for open or short between ECM and ASCD brake switch

>> Repair open circuit or short to ground or short to power in harness or connectors.

12. CHECK ASCD BRAKE SWITCH

Refer to [EC-1236, "Component Inspection"](#)

OK or NG

- OK >> GO TO 18.
 NG >> Replace ASCD brake switch.

13. CHECK STOP LAMP SWITCH POWER SUPPLY CIRCUIT

- Turn ignition switch OFF.
- Disconnect stop lamp switch harness connector.

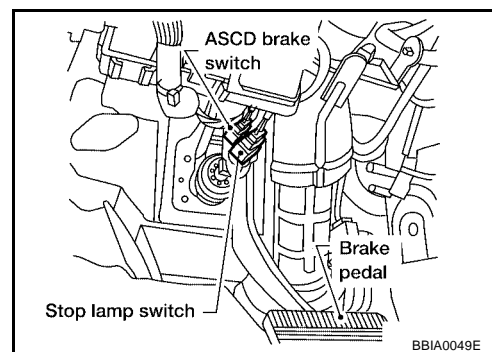

- Check voltage between stop lamp switch terminal 1 and ground with CONSULT -II or tester.

Voltage: Battery voltage

OK or NG

- OK >> GO TO 15.
 NG >> GO TO 14.

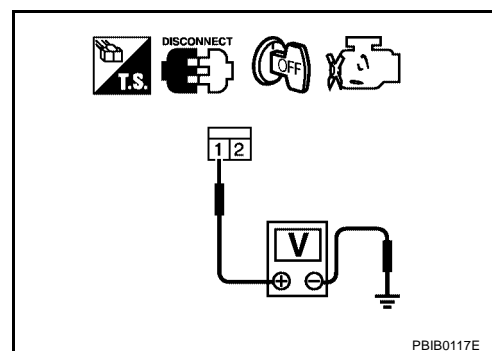

14. DETECT MALFUNCTIONING PART

Check the following.

- Fuse block (J/B) connector E30
- 10A fuse
- Harness for open or short between stop lamp switch and battery

>> Repair open circuit or short to ground or short to power in harness or connectors.

15. CHECK STOP LAMP SWITCH INPUT SIGNAL CIRCUIT FOR OPEN AND SHORT

- Disconnect ECM harness connector.
- Check harness continuity between ECM terminal 101 and stop lamp switch terminal 2. Refer to Wiring Diagram.

Continuity should exist.

- Also check harness for short to ground and short to power.

OK or NG

- OK >> GO TO 17.
 NG >> GO TO 16.

16. DETECT MALFUNCTIONING PART

Check the following.

- Harness connectors E28, M7
- Harness connectors M71, F59
- Harness for open or short between ECM and stop lamp switch

>> Repair open circuit or short to ground or short to power in harness or connectors.

17. CHECK STOP LAMP SWITCH

Refer to [EC-1236, "Component Inspection"](#)

OK or NG

- OK >> GO TO 18.
- NG >> Replace stop lamp switch.

18. CHECK INTERMITTENT INCIDENT

Refer to [EC-782, "TROUBLE DIAGNOSIS FOR INTERMITTENT INCIDENT"](#) .

>> INSPECTION END

Component Inspection ASC D BRAKE SWITCH

UBS001D0

1. Turn ignition switch OFF.
2. Disconnect ASCD brake switch harness connector.
3. Check continuity between ASCD brake switch terminals 1 and 2 under the following conditions.

Condition	Continuity
Brake pedal: Fully released	Should exist.
Brake pedal: Slightly depressed	Should not exist.

If NG, adjust ASCD brake switch installation, refer to [BR-6, "BRAKE PEDAL"](#) , and perform step 3 again.

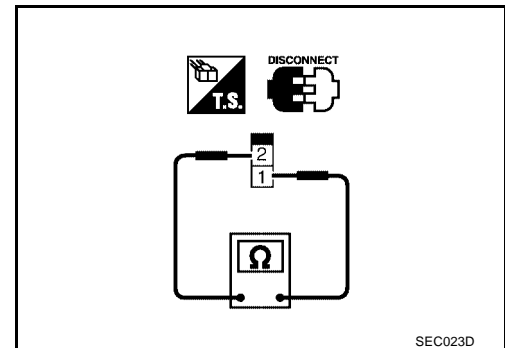

ASC D CLUTCH SWITCH

1. Turn ignition switch OFF.
2. Disconnect ASCD clutch switch harness connector.
3. Check harness continuity between ASCD clutch switch terminals 1 and 2 under the following conditions.

Condition	Continuity
Clutch pedal: Fully released	Should exist.
Clutch pedal: Slightly depressed	Should not exist.

If NG, adjust ASCD clutch switch installation, refer to [CL-5, "CLUTCH PEDAL"](#) , and perform step 3 again.

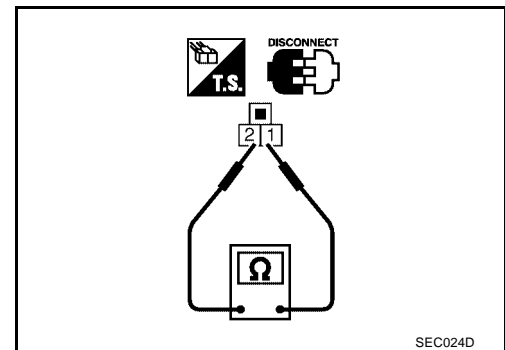

STOP LAMP SWITCH

1. Turn ignition switch OFF.
2. Disconnect stop lamp switch harness connector.
3. Check continuity between stop lamp switch terminals 1 and 2 under the following conditions.

Condition	Continuity
Brake pedal: Fully released	Should not exist.
Brake pedal: Slightly depressed	Should exist.

If NG, adjust stop lamp switch installation, refer to [BR-6](#), "[BRAKE PEDAL](#)", and perform step 3 again.

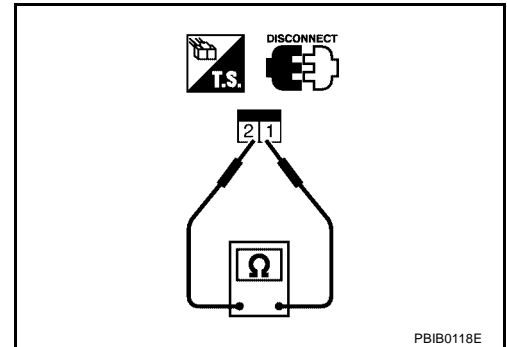

A
EC
C
D
E
F
G
H
I
J
K
L
M

DTC P1574 ASCD VEHICLE SPEED SENSOR

[VQ]

DTC P1574 ASCD VEHICLE SPEED SENSOR

PF3:31036

Component Description

UBS001D1

The ECM receives two vehicle speed sensor signals via CAN communication line. One is sent from combination meter, and the other is from TCM (Transmission control module). The ECM uses these signals for ASCD control. Refer to [EC-648, "AUTOMATIC SPEED CONTROL DEVICE \(ASCD\)"](#) for ASCD functions.

On Board Diagnosis Logic

UBS001D2

This self-diagnosis has the one trip detection logic.
The MIL will not light up for this diagnosis.

NOTE:

- If DTC P1574 is displayed with DTC U1000, U1001, first perform the trouble diagnosis for DTC U1000, U1001. Refer to [EC-790, "DTC U1000, U1001 CAN COMMUNICATION LINE"](#).
- If DTC P1574 is displayed with DTC P0500, first perform the trouble diagnosis for DTC P0500. Refer to [EC-1031, "DTC P0500 VSS"](#).
- If DTC P1574 is displayed with DTC P0605, first perform the trouble diagnosis for DTC P0605. Refer to [EC-1042, "DTC P0605 ECM"](#).

DTC No.	Trouble Diagnosis Name	DTC Detecting Condition	Possible Cause
P1574 1574	ASCD vehicle speed sensor	ECM detects a difference between two vehicle speed signals is out of the specified range.	<ul style="list-style-type: none">● Harness or connectors (The CAN communication line is open or shorted.)● Combination meter● ABS actuator and electric unit (control unit)● Wheel sensor● TCM (A/T models)● ECM

DTC Confirmation Procedure

UBS001D3

CAUTION:

Always drive vehicle at a safe speed.

NOTE:

If DTC Confirmation Procedure has been previously conducted, always turn ignition switch OFF and wait at least 10 seconds before conducting the next test.

TESTING CONDITION:

Step 3 may be conducted with the drive wheels lifted in the shop or by driving the vehicle. If a road test is expected to be easier, it is unnecessary to lift the vehicle.

WITH CONSULT-II

1. Start engine.
2. Select "DATA MONITOR" mode with CONSULT-II.
3. Drive the vehicle at more than 40 km/h (25 MPH).
4. If DTC is detected, go to [EC-1239, "Diagnostic Procedure"](#).

DATA MONITOR	
MONITOR	NO DTC
ENG SPEED	XXX rpm

SEF058Y

WITH GST

Follow the procedure "WITH CONSULT-II" above.

Diagnostic Procedure**1. CHECK DTC WITH TCM**

Check DTC with TCM. Refer to [AT-425, "TROUBLE DIAGNOSIS"](#) .

OK or NG

OK >> GO TO 2.

NG >> Perform trouble shooting relevant to DTC indicated.

2. CHECK DTC WITH "ABS ACTUATOR AND ELECTRIC UNIT (CONTROL UNIT)"

Refer to [BRC-8, "TROUBLE DIAGNOSIS"](#) (models without TCS) or [BRC-51, "TROUBLE DIAGNOSIS"](#) (models with TCS).

OK or NG

OK >> GO TO 3.

NG >> Repair or replace.

3. CHECK COMBINATION METER FUNCTION

Refer to [DI-4, "COMBINATION METERS"](#) .

>> INSPECTION END

A

EC

C

D

E

F

G

H

I

J

K

L

M

DTC P1706 PNP SWITCH

[VQ]

PF3:32006

DTC P1706 PNP SWITCH

Component Description

UBS001D5

When the shift position is P or N (A/T), Neutral (M/T), park/neutral position (PNP) switch is ON. ECM detects the position because the continuity of the line (the ON signal) exists.

CONSULT-II Reference Value in Data Monitor Mode

UBS001D6

Specification data are reference values.

MONITOR ITEM	CONDITION		SPECIFICATION
P/N POSI SW	● Ignition switch: ON	Shift lever: P or N (A/T), Neutral (M/T)	ON
		Shift lever: Except above	OFF

On Board Diagnosis Logic

UBS001D7

DTC No.	Trouble diagnosis name	DTC detecting condition	Possible cause
P1706 1706	Park/neutral position switch	The signal of the park/neutral position (PNP) switch is not changed in the process of engine starting and driving.	<ul style="list-style-type: none"> ● Harness or connectors [The park/neutral position (PNP) switch circuit is open or shorted.] ● Park/neutral position (PNP) switch ● Combination meter (A/T models) ● TCM (A/T models)

DTC Confirmation Procedure

UBS001D8

CAUTION:

Always drive vehicle at a safe speed.

NOTE:

If DTC Confirmation Procedure has been previously conducted, always turn ignition switch OFF and wait at least 10 seconds before conducting the next test.

④ WITH CONSULT-II

1. Turn ignition switch ON.
2. Select "P/N POSI SW" in "DATA MONITOR" mode with CONSULT-II. Then check the "P/N POSI SW" signal under the following conditions.

Position (Shift lever)	Known-good signal
P or N position (A/T)	ON
Neutral position (M/T)	ON
Except the above position	OFF

If NG, go to [EC-1245, "Diagnostic Procedure"](#).

If OK, go to following step.

3. Select "DATA MONITOR" mode with CONSULT-II.
4. Start engine and warm it up to normal operating temperature.
5. Maintain the following conditions for at least 60 consecutive seconds.

ENG SPEED	1,400 - 6375 rpm
COOLAN TEMP/S	More than 70°C (158°F)
B/FUEL SCHDL	2.0 - 31.8 msec
VHCL SPEED SE	More than 64 km/h (40 MPH)
Shift lever	Suitable position

6. If 1st trip DTC is detected, go to [EC-1245, "Diagnostic Procedure"](#).

DATA MONITOR	
MONITOR	NO DTC
P/N POSI SW	ON

SEF212Y

DATA MONITOR	
MONITOR	NO DTC
ENG SPEED	XXX rpm
COOLAN TEMP/S	XXX °C
VHCL SPEED SE	XXX km/h
P/N POSI SW	OFF
B/FUEL SCHDL	XXX msec

SEF213Y

Overall Function Check

Use this procedure to check the overall function of the park/neutral position (PNP) switch circuit. During this check, a 1st trip DTC might not be confirmed.

WITH GST

1. Turn ignition switch ON.
2. Check voltage between ECM terminal 102 (PNP switch signal) and ground under the following conditions.

Condition (Shift lever)	Voltage (Known good data)
P or N position (A/T) Neutral position (M/T)	Approx. 0V
Except the above position	BATTERY VOLTAGE (11 - 14V)

3. If NG, go to [EC-1245, "Diagnostic Procedure"](#) .

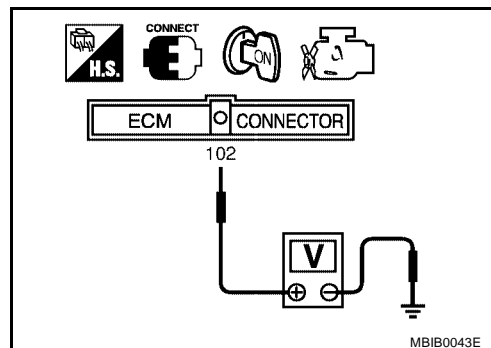

A
EC
C
D
E
F
G
H
I
J
K
L
M

DTC P1706 PNP SWITCH

[VQ]

UBS00IDA

Wiring Diagram A/T MODELS

EC-PNP/SW-01

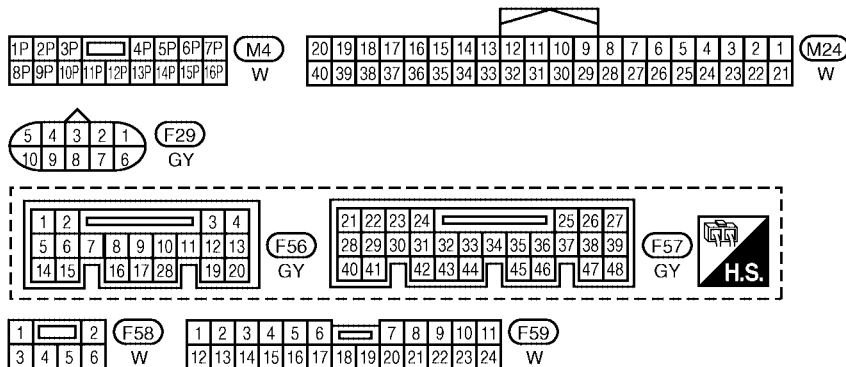
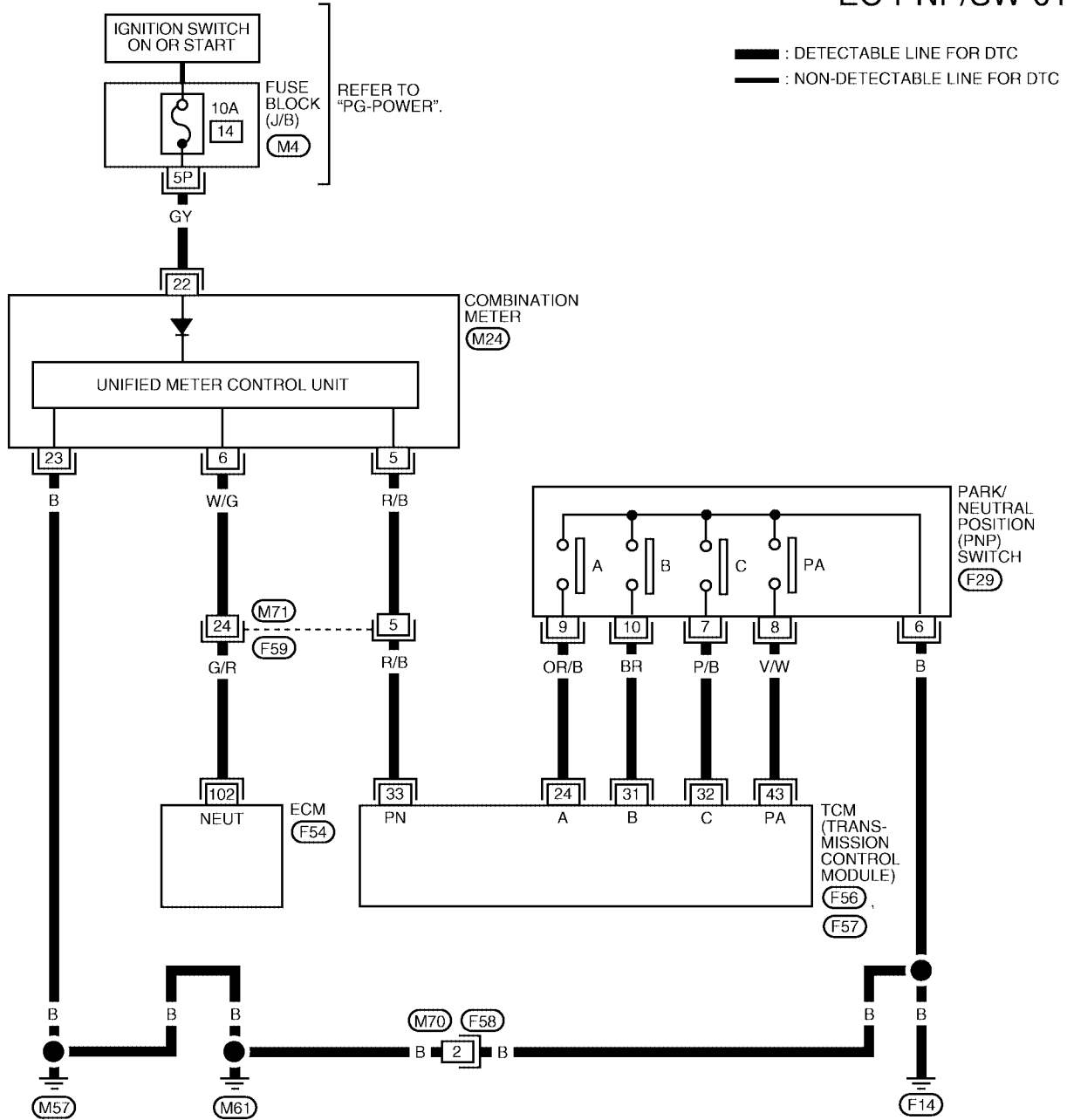

REFER TO THE FOLLOWING.
(F54) - ELECTRICAL UNITS

BBWA1589E

DTC P1706 PNP SWITCH

[VQ]

Specification data are reference values and are measured between each terminal and ground.

CAUTION:

Do not use ECM ground terminals when measuring input/output voltage. Doing so may result in damage to the ECM's transistor. Use a ground other than ECM terminals, such as the ground.

TER-MINAL NO.	WIRE COLOR	ITEM	CONDITION	DATA (DC Voltage)
102	G/R	PNP switch	[Ignition switch: ON] ● Shift lever: P or N	Approximately 0V
			[Ignition switch: ON] ● Shift lever: Except above	BATTERY VOLTAGE (11 - 14V)

A
EC
C
D
E
F
G
H
I
J
K
L
M

DTC P1706 PNP SWITCH

[VQ]

M/T MODELS

EC-PNP/SW-02

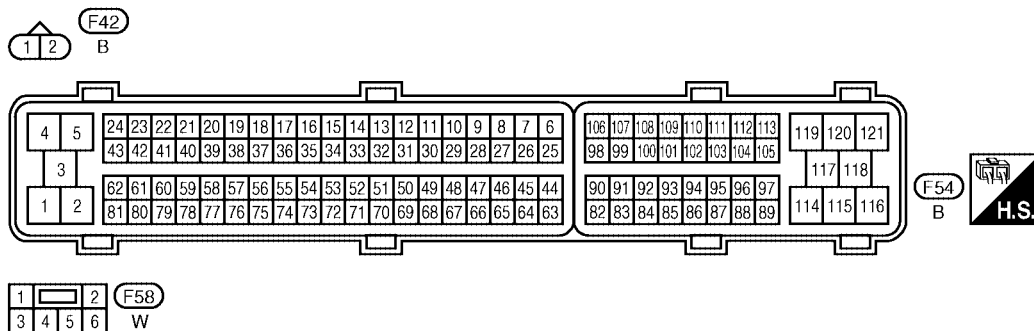
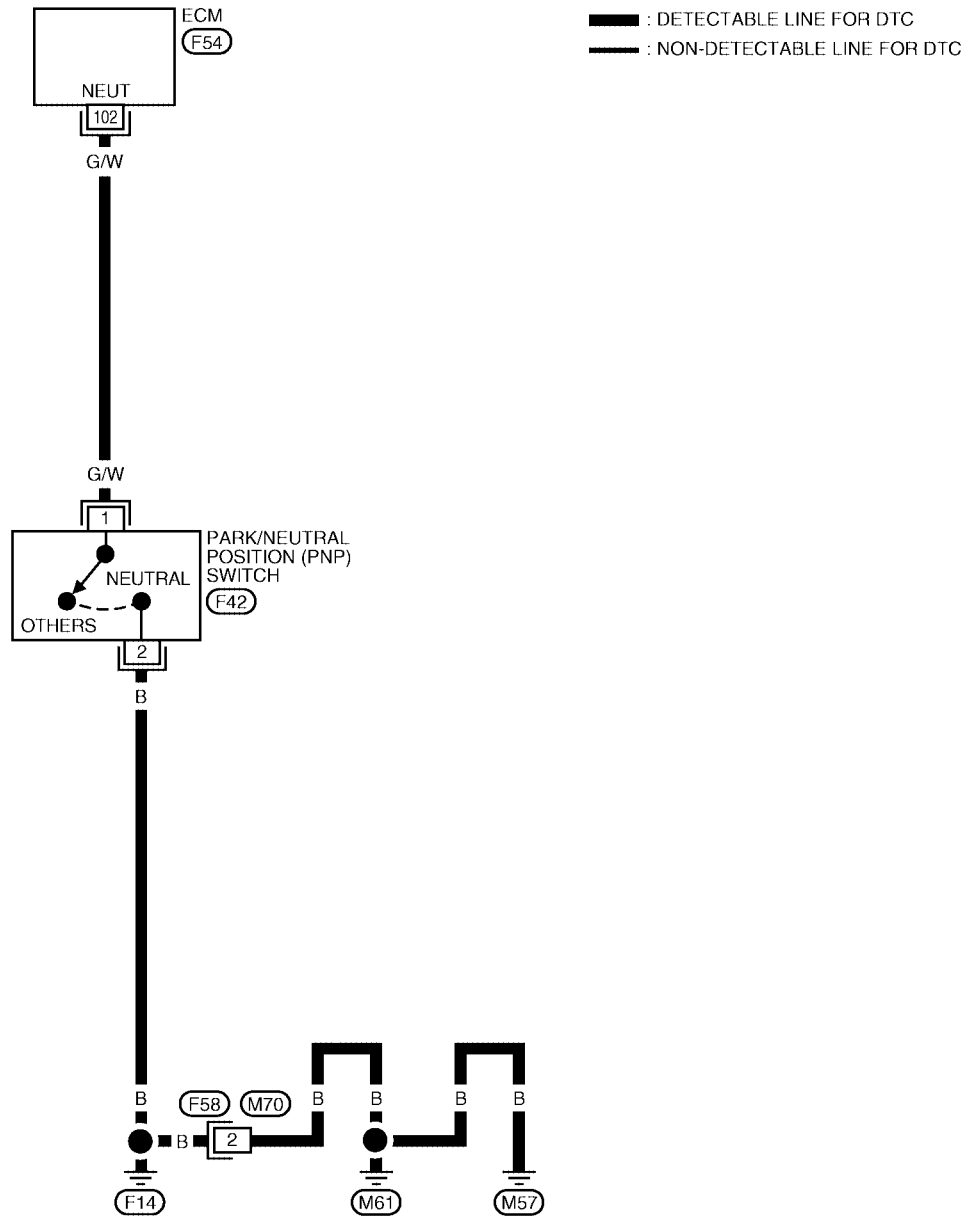

BBWA1588E

DTC P1706 PNP SWITCH

[VQ]

Specification data are reference values and are measured between each terminal and ground.

CAUTION:

Do not use ECM ground terminals when measuring input/output voltage. Doing so may result in damage to the ECM's transistor. Use a ground other than ECM terminals, such as the ground.

TER-MINAL NO.	WIRE COLOR	ITEM	CONDITION	DATA (DC Voltage)
102	G/W	PNP switch	[Ignition switch: ON] ● Shift lever: Neutral	Approximately 0V
			[Ignition switch: ON] ● Shift lever: Except above	BATTERY VOLTAGE (11 - 14V)

Diagnostic Procedure A/T MODELS

UBS00IDB

1. CHECK DTC WITH TCM

Refer to [AT-425, "TROUBLE DIAGNOSIS"](#).

OK or NG

OK >> GO TO 2.

NG >> Repair or replace.

2. CHECK PNP SWITCH INPUT SIGNAL CIRCUIT FOR OPEN AND SHORT-I

1. Turn ignition switch OFF.
2. Disconnect TCM harness connector.
3. Disconnect combination meter harness connector.
4. Check harness continuity between TCM terminal 33 and combination meter terminal 5.
Refer to Wiring Diagram.

Continuity should exist.

5. Also check harness for short to ground and short to power.

OK or NG

OK >> GO TO 4.

NG >> GO TO 3.

3. DETECT MALFUNCTIONING PART

Check the following.

- Harness connectors M71, F59
- Harness for open or short between TCM and combination meter

>> Repair open circuit or short to ground or short to power in harness or connectors.

4. CHECK PNP SWITCH INPUT SIGNAL CIRCUIT FOR OPEN AND SHORT-II

1. Disconnect ECM harness connector.
2. Check harness continuity between ECM terminal 102 and combination meter terminal 6.
Refer to Wiring Diagram.

Continuity should exist.

3. Also check harness for short to ground and short to power.

OK or NG

OK >> GO TO 6.

NG >> GO TO 5.

5. DETECT MALFUNCTIONING PART

Check the following.

- Harness connectors M71, F59
- Harness for open or short between ECM and combination meter

>> Repair open circuit or short to ground or short to power in harness or connectors.

6. CHECK INTERMITTENT INCIDENT

Refer to [EC-782, "TROUBLE DIAGNOSIS FOR INTERMITTENT INCIDENT"](#) .

OK or NG

- OK >> GO TO 7.
 NG >> Repair or replace.

7. REPLACE COMBINATION METER

Refer to [DI-4, "COMBINATION METERS"](#) .

>> INSPECTION END

M/T MODELS

1. CHECK PNP SWITCH GROUND CIRCUIT

1. Turn ignition switch OFF.
2. Disconnect PNP switch harness connector.
3. Check harness continuity between PNP switch terminal 2 and ground.
Refer to Wiring Diagram.

Continuity should exist.

4. Also check harness for short to power.

OK or NG

- OK >> GO TO 3
 NG >> GO TO 2.

2. DETECT MALFUNCTIONING PART

Check the following.

- Harness connector F58, M70
- Harness for open or short between PNP switch and ground

>> Repair open circuit or short to power in harness or connectors.

3. CHECK PNP SWITCH INPUT SIGNAL CIRCUIT

1. Disconnect ECM harness connector.
2. Check harness continuity between ECM terminal 102 and PNP switch terminal 1.
Refer to Wiring Diagram.

Continuity should exist.

3. Also check harness for short to ground and short to power.

OK or NG

- OK >> GO TO 4.
 NG >> Repair open circuit or short to ground or short to power in harness or connectors.

DTC P1706 PNP SWITCH

[VQ]

4. CHECK PNP SWITCH

Refer to [MT-77, "PARK/NEUTRAL POSITION SWITCH"](#) .

OK or NG

OK >> GO TO 5.

NG >> Replace PNP switch.

5. CHECK INTERMITTENT INCIDENT

Refer to [EC-782, "TROUBLE DIAGNOSIS FOR INTERMITTENT INCIDENT"](#) .

>> **INSPECTION END**

A

EC

C

D

E

F

G

H

I

J

K

L

M

DTC P1800 VIAS CONTROL SOLENOID VALVE

PFP:14955

Component Description

UBS001DC

The VIAS control solenoid valve cuts the intake manifold vacuum signal for power valve actuator. It responds to ON/OFF signals from the ECM. When the solenoid is off, the vacuum signal from the intake manifold is cut. When the ECM sends an ON signal the coil pulls the plunger downward and feeds the vacuum signal to the power valve actuator.

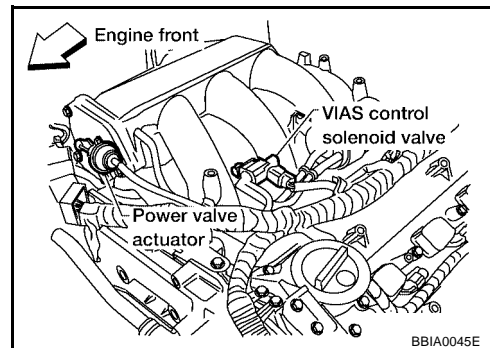

CONSULT-II Reference Value in Data Monitor Mode

UBS001DD

Specification data are reference values.

MONITOR ITEM	CONDITION		SPECIFICATION
VIAS S/V	● Engine: After warming up	1,800 - 3,600 rpm	ON
		Except above conditions	OFF

On Board Diagnosis Logic

UBS001DE

The MIL will not light up for this self-diagnosis.

DTC No.	Trouble diagnosis name	DTC detecting condition	Possible cause
P1800 1800	VIAS control solenoid valve circuit	An excessively low or high voltage signal is sent to ECM through the valve	<ul style="list-style-type: none"> ● Harness or connectors (The solenoid valve circuit is open or shorted.) ● VIAS control solenoid valve

DTC Confirmation Procedure

UBS001DF

NOTE:

If DTC Confirmation Procedure has been previously conducted, always turn ignition switch OFF and wait at least 10 seconds before conducting the next test.

TESTING CONDITION:

Before performing the following procedure, confirm that battery voltage is between 11V at idle.

WITH CONSULT-II

1. Turn ignition switch ON.
2. Select "DATA MONITOR" mode with CONSULT-II.
3. Start engine and let it idle for at least 5 seconds.
4. If 1st trip DTC is detected, go to [EC-1250, "Diagnostic Procedure"](#).

DATA MONITOR	
MONITOR	NO DTC
ENG SPEED	XXX rpm

SEF058Y

WITH GST

Follow the procedure "WITH CONSULT-II" above.

DTC P1800 VIAS CONTROL SOLENOID VALVE

[VQ]

Wiring Diagram

UBS00IDG

EC-VIAS/V-01

A
EC
C
D
E
F
G
H
I
J
K
L
M

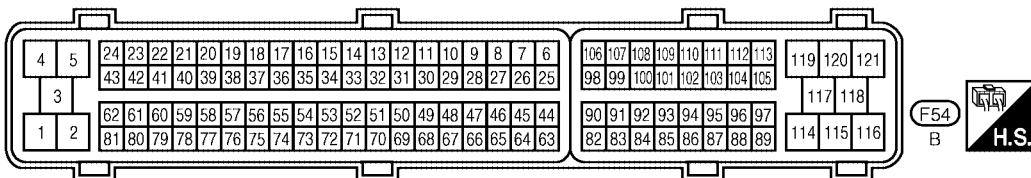
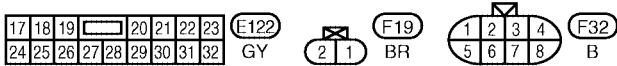
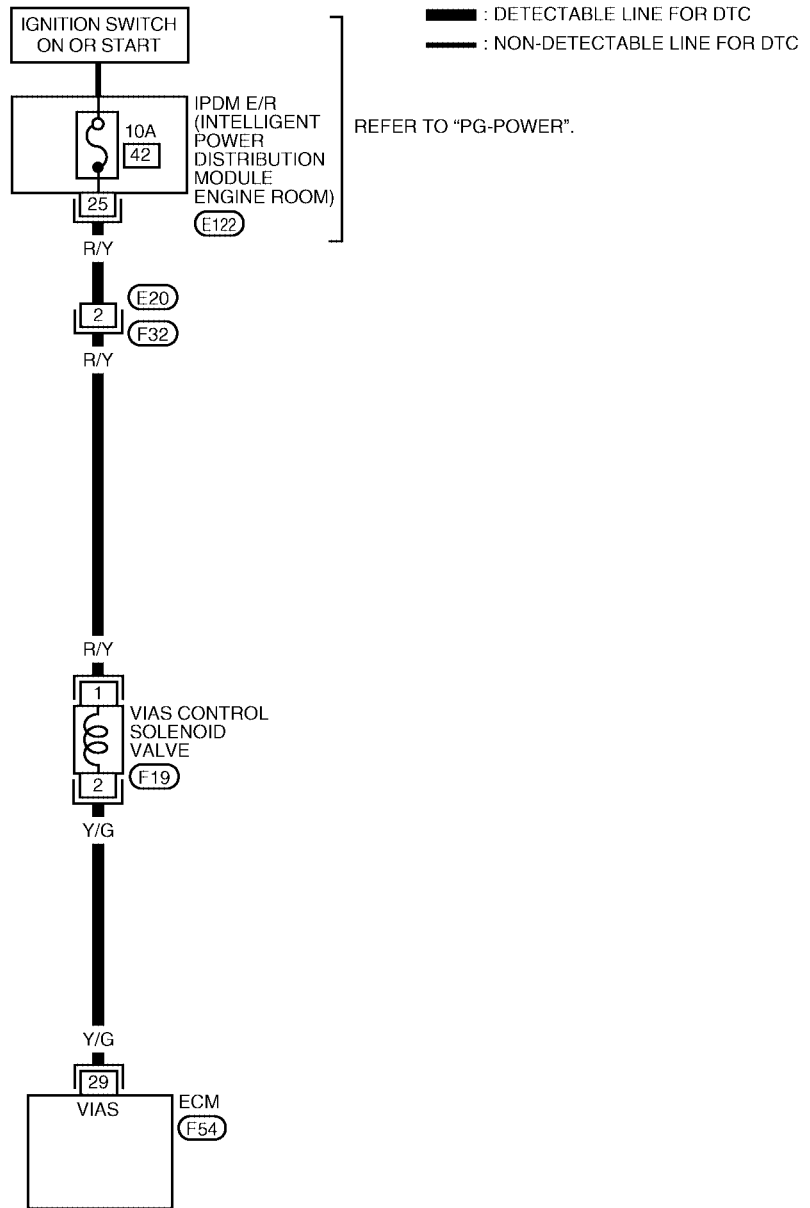

BBWA1573E

DTC P1800 VIAS CONTROL SOLENOID VALVE

[VQ]

Specification data are reference values and are measured between each terminal and ground.

CAUTION:

Do not use ECM ground terminals when measuring input/output voltage. Doing so may result in damage to the ECM's transistor. Use a ground other than ECM terminals, such as the ground.

TER-MINAL NO.	WIRE COLOR	ITEM	CONDITION	DATA (DC Voltage)
29	Y/G	VIAS control solenoid valve	[Engine is running] ● Idle speed	BATTERY VOLTAGE (11 - 14V)
			[Engine is running] ● Engine speed is between 1,800 and 3,600 rpm.	0 - 1.0V

Diagnostic Procedure

UBS00IDH

1. CHECK VIAS CONTROL SOLENOID VALVE POWER SUPPLY CIRCUIT

1. Turn ignition switch OFF.
2. Disconnect VIAS control solenoid valve harness connector.
3. Turn ignition switch ON.

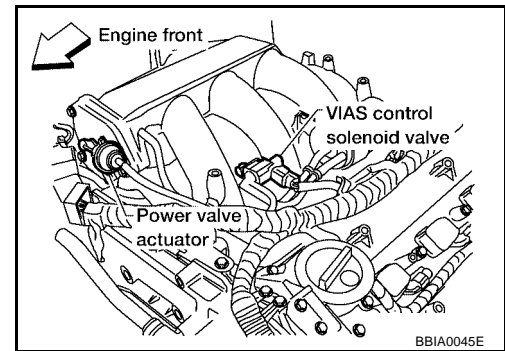

4. Check voltage between terminal 1 and ground with CONSULT-II or tester.

Voltage: Battery voltage

OK or NG

- OK >> GO TO 3.
- NG >> GO TO 2.

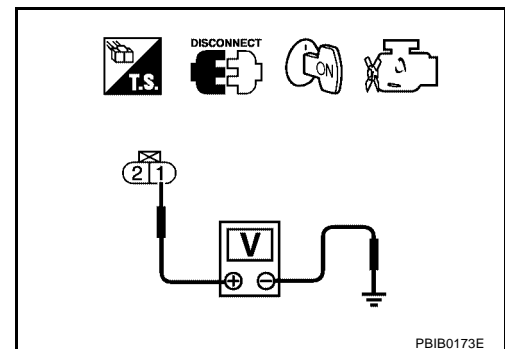

2. DETECT MALFUNCTIONING PART

Check the following.

- Harness connectors E20, F32
- IPDM E/R connector E122
- 10A fuse
- Harness for open or short between VIAS control solenoid valve and fuse

>> Repair open circuit or short to ground or short to power in harness or connectors.

3. CHECK VIAS CONTROL SOLENOID VALVE OUTPUT SIGNAL CIRCUIT FOR OPEN AND SHORT

1. Turn ignition switch OFF.
2. Disconnect ECM harness connector.
3. Check harness continuity between ECM terminal 29 and VIAS control solenoid valve terminal 2. Refer to Wiring Diagram.

Continuity should exist.

4. Also check harness for short to ground and short to power.

OK or NG

OK >> GO TO 4.

NG >> Repair open circuit or short to ground or short to power in harness or connectors.

4. CHECK VIAS CONTROL SOLENOID VALVE

Refer to [EC-1251, "Component Inspection"](#) .

OK or NG

OK >> GO TO 5.

NG >> Replace VIAS control solenoid valve.

5. CHECK INTERMITTENT INCIDENT

Refer to [EC-782, "TROUBLE DIAGNOSIS FOR INTERMITTENT INCIDENT"](#) .

>> INSPECTION END

Component Inspection VIAS CONTROL SOLENOID VALVE

UBS001DI

Ⓟ With CONSULT-II

1. Reconnect harness connectors disconnected.
2. Turn ignition switch ON.
3. Perform "VIAS SOL VALVE" in "ACTIVE TEST" mode.
4. Check air passage continuity and operation delay time under the following conditions.

Condition VIAS SOL VALVE	Air passage continuity between A and B	Air passage continuity between A and C
ON	Yes	No
OFF	No	Yes

Operation takes less than 1 second.

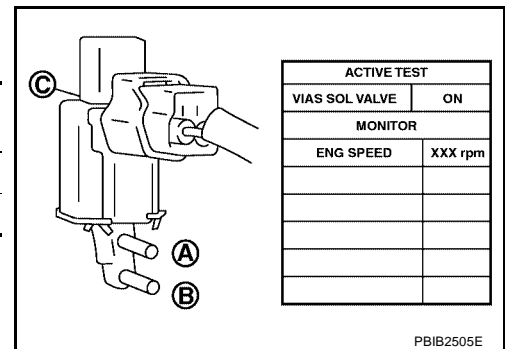

Ⓢ With GST

Check air passage continuity and operation delay time under the following conditions.

Condition	Air passage continuity between A and B	Air passage continuity between A and C
12V direct current supply between terminals 1 and 2	Yes	No
No supply	No	Yes

Operation takes less than 1 second.

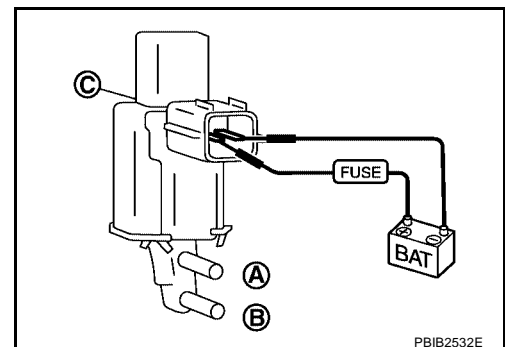

Removal and Installation

VIAS CONTROL SOLENOID VALVE

Refer to [EM-129, "INTAKE MANIFOLD"](#) .

DTC P1805 BRAKE SWITCH

[VQ]

DTC P1805 BRAKE SWITCH

PFP:25320

Description

UBS001DK

Brake switch signal is applied to the ECM through the stop lamp switch when the brake pedal is depressed. This signal is used mainly to decrease the engine speed when the vehicle is driving.

CONSULT-II Reference Value in Data Monitor Mode

UBS001DL

Specification data are reference values.

MONITOR ITEM	CONDITION		SPECIFICATION
BRAKE SW	● Ignition switch: ON	Brake pedal: Fully released	OFF
		Brake pedal: Slightly depressed	ON

On Board Diagnosis Logic

UBS001DM

The MIL will not light up for this diagnosis.

DTC No.	Trouble diagnosis name	DTC detecting condition	Possible cause
P1805 1805	Brake switch	A brake switch signal is not sent to ECM for extremely long time while the vehicle is driving.	<ul style="list-style-type: none"> ● Harness or connectors (Stop lamp switch circuit is open or shorted.) ● Stop lamp switch

FAIL-SAFE MODE

When the malfunction is detected, the ECM enters fail-safe mode.

Engine operating condition in fail-safe mode	
ECM controls the electric throttle control actuator by regulating the throttle opening to a small range. Therefore, acceleration will be poor.	
Vehicle condition	Driving condition
When engine is idling	Normal
When accelerating	Poor acceleration

DTC Confirmation Procedure

UBS001DN

WITH CONSULT-II

1. Turn ignition switch ON.
2. Fully depress the brake pedal for at least 5 seconds.
3. Erase the DTC with CONSULT-II.
4. Select "DATA MONITOR" mode with CONSULT-II.
5. If 1st trip DTC is detected, go to [EC-1255, "Diagnostic Procedure"](#).

DATA MONITOR	
MONITOR	NO DTC
ENG SPEED	XXX rpm

SEF058Y

WITH GST

Follow the procedure "WITH CONSULT-II" above.

DTC P1805 BRAKE SWITCH

[VQ]

Wiring Diagram

UBS001D0

EC-BRK/SW-01

: DETECTABLE LINE FOR DTC
 : NON-DETECTABLE LINE FOR DTC

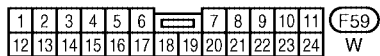
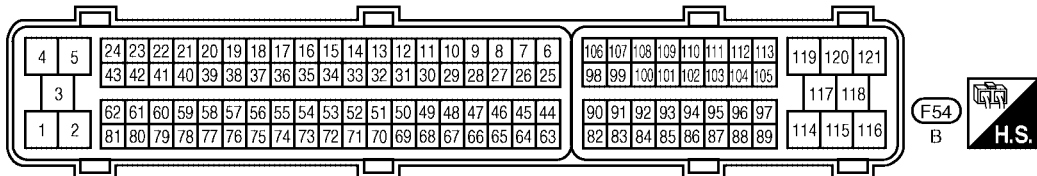
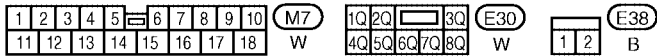
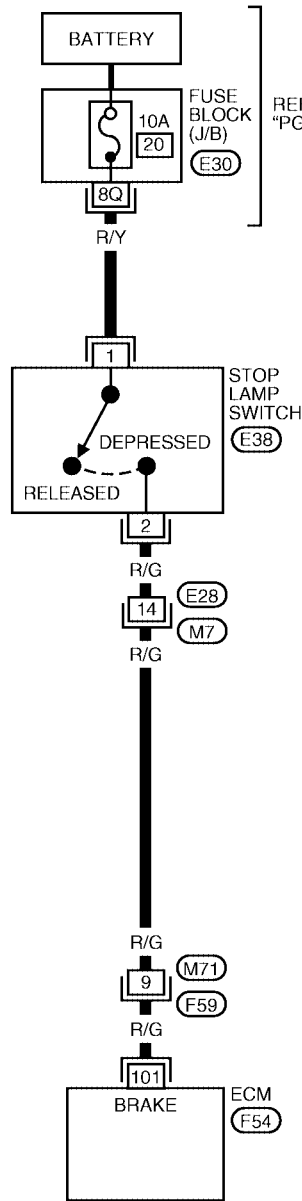

BBWA1574E

DTC P1805 BRAKE SWITCH

[VQ]

Specification data are reference values and are measured between each terminal and ground.

CAUTION:

Do not use ECM ground terminals when measuring input/output voltage. Doing so may result in damage to the ECM's transistor. Use a ground other than ECM terminals, such as the ground.

TER-MINAL NO.	WIRE COLOR	ITEM	CONDITION	DATA (DC Voltage)
101	R/G	Stop lamp switch	[Ignition switch: OFF] ● Brake pedal: Fully released	Approximately 0V
			[Ignition switch: OFF] ● Brake pedal: Slightly depressed	BATTERY VOLTAGE (11 - 14V)

Diagnostic Procedure

UBS00IDP

1. CHECK STOP LAMP SWITCH CIRCUIT

- Turn ignition switch OFF.
- Check the stop lamp when depressing and releasing the brake pedal.

Brake pedal	Stop lamp
Fully released	Not illuminated
Slightly depressed	Illuminated

OK or NG

- OK >> GO TO 4.
- NG >> GO TO 2.

2. CHECK STOP LAMP SWITCH POWER SUPPLY CIRCUIT

- Disconnect stop lamp switch harness connector.

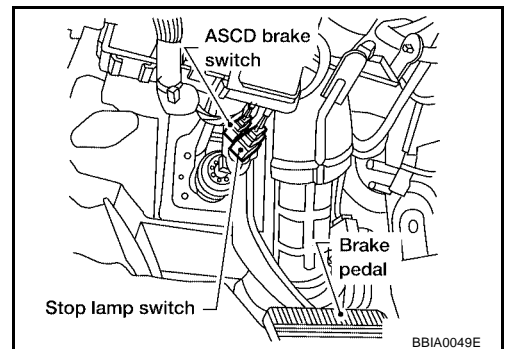

- Check voltage between stop lamp switch terminal 1 and ground with CONSULT-II or tester.

Voltage: Battery voltage

OK or NG

- OK >> GO TO 4.
- NG >> GO TO 3.

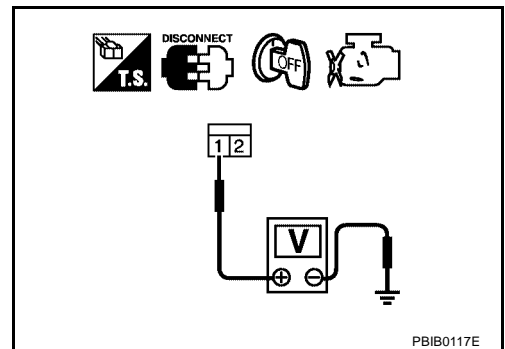

3. DETECT MALFUNCTIONING PART

Check the following.

- 10A fuse
- Fuse block (J/B) connector E30
- Harness for open and short between stop lamp switch and battery

>> Repair open circuit or short to ground or short to power in harness or connectors.

4. CHECK STOP LAMP SWITCH INPUT SIGNAL CIRCUIT FOR OPEN AND SHORT

1. Turn ignition switch OFF.
2. Disconnect ECM harness connector.
3. Check harness continuity between ECM terminal 101 and stop lamp switch terminal 2.
Refer to Wiring Diagram.

Continuity should exist.

4. Also check harness for short to ground and short to power.

OK or NG

- OK >> GO TO 6.
NG >> GO TO 5.

5. DETECT MALFUNCTIONING PART

Check the following.

- Harness connectors E28, M7
- Harness connectors M71, F59
- Harness for open or short between ECM and stop lamp switch

>> Repair open circuit or short to ground or short to power in harness or connectors.

6. CHECK STOP LAMP SWITCH

Refer to [EC-1257, "Component Inspection"](#) .

OK or NG

- OK >> GO TO 7.
NG >> Replace stop lamp switch.

7. CHECK INTERMITTENT INCIDENT

Refer to [EC-782, "TROUBLE DIAGNOSIS FOR INTERMITTENT INCIDENT"](#) .

>> **INSPECTION END**

Component Inspection STOP LAMP SWITCH

1. Disconnect stop lamp switch harness connector.

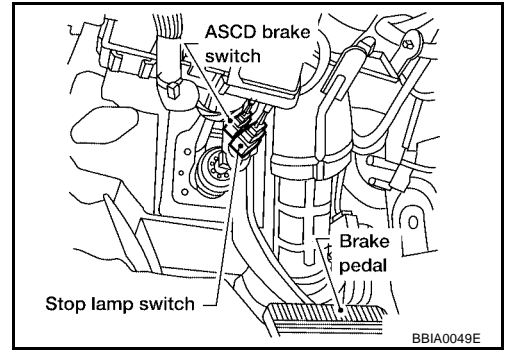

2. Check continuity between stop lamp switch terminals 1 and 2 under the following conditions.

Conditions	Continuity
Brake pedal: Fully released	Should not exist.
Brake pedal: Slightly depressed	Should exist.

3. If NG, adjust stop lamp switch installation, refer to [BR-6](#), "[BRAKE PEDAL](#)", and perform step 2 again.

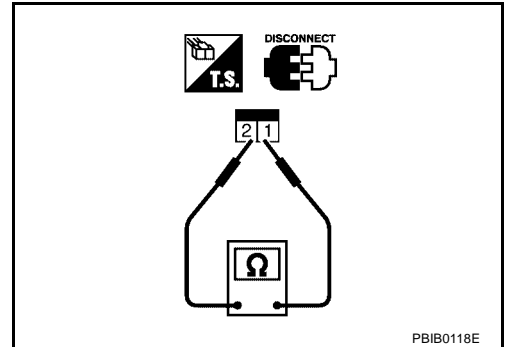

A
EC
C
D
E
F
G
H
I
J
K
L
M

DTC P2122, P2123 APP SENSOR

Component Description

The accelerator pedal position sensor is installed on the upper end of the accelerator pedal assembly. The sensor detects the accelerator position and sends a signal to the ECM.

Accelerator pedal position sensor has two sensors. These sensors are a kind of potentiometers which transform the accelerator pedal position into output voltage, and emit the voltage signal to the ECM. In addition, these sensors detect the opening and closing speed of the accelerator pedal and feed the voltage signals to the ECM. The ECM judges the current opening angle of the accelerator pedal from these signals and controls the throttle control motor based on these signals.

Idle position of the accelerator pedal is determined by the ECM receiving the signal from the accelerator pedal position sensor. The ECM uses this signal for the engine operation such as fuel cut.

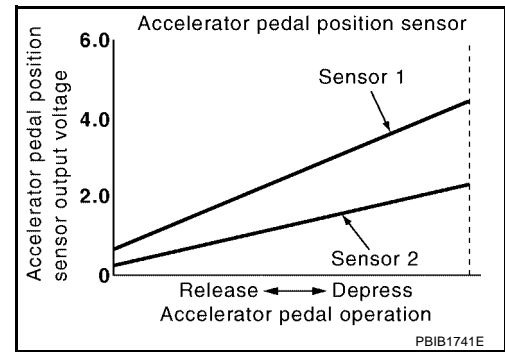

CONSULT-II Reference Value in Data Monitor Mode

Specification data are reference values.

MONITOR ITEM	CONDITION		SPECIFICATION
ACCEL SEN1	● Ignition switch: ON (Engine stopped)	Accelerator pedal: Fully released	0.65 - 0.87V
		Accelerator pedal: Fully depressed	More than 4.3V
ACCEL SEN2*	● Ignition switch: ON (Engine stopped)	Accelerator pedal: Fully released	0.56 - 0.96V
		Accelerator pedal: Fully depressed	More than 4.0V
CLSD THL POS	● Ignition switch: ON (Engine stopped)	Accelerator pedal: Fully released	ON
		Accelerator pedal: Slightly depressed	OFF

*: Accelerator pedal position sensor 2 signal is converted by ECM internally. Thus, it differ from ECM terminal voltage.

On Board Diagnosis Logic

These self-diagnoses have the one trip detection logic.

NOTE:

If DTC P2122 or P2123 is displayed with DTC P1229, first perform the trouble diagnosis for DTC P1229. Refer to [EC-1127](#).

DTC No.	Trouble diagnosis name	DTC detecting condition	Possible cause
P2122 2122	Accelerator pedal position sensor 1 circuit low input	An excessively low voltage from the APP sensor 1 is sent to ECM.	● Harness or connectors (The APP sensor 1 circuit is open or shorted.) ● Accelerator pedal position sensor (Accelerator pedal position sensor 1)
P2123 2123	Accelerator pedal position sensor 1 circuit high input	An excessively high voltage from the APP sensor 1 is sent to ECM.	

FAIL-SAFE MODE

When the malfunction is detected, ECM enters fail-safe mode and the MIL lights up.

Engine operating condition in fail-safe mode

The ECM controls the electric throttle control actuator in regulating the throttle opening in order for the idle position to be within +10 degrees.

The ECM regulates the opening speed of the throttle valve to be slower than the normal condition.

So, the acceleration will be poor.

DTC Confirmation Procedure

NOTE:

If DTC Confirmation Procedure has been previously conducted, always turn ignition switch OFF and wait at least 10 seconds before conducting the next test.

TESTING CONDITION:

Before performing the following procedure, confirm that battery voltage is more than 10V at idle.

WITH CONSULT-II

1. Turn ignition switch ON.
2. Select "DATA MONITOR" mode with CONSULT-II.
3. Start engine and let it idle for 1 second.
4. If DTC is detected, go to [EC-1261, "Diagnostic Procedure"](#) .

DATA MONITOR	
MONITOR	NO DTC
ENG SPEED	XXX rpm
<small>SEF058Y</small>	

WITH GST

Follow the procedure "WITH CONSULT-II" above.

A
EC
C
D
E
F
G
H
I
J
K
L
M

DTC P2122, P2123 APP SENSOR

[VQ]

Wiring Diagram

UBS00IDV

EC-APPS1-01

: DETECTABLE LINE FOR DTC
 : NON-DETECTABLE LINE FOR DTC

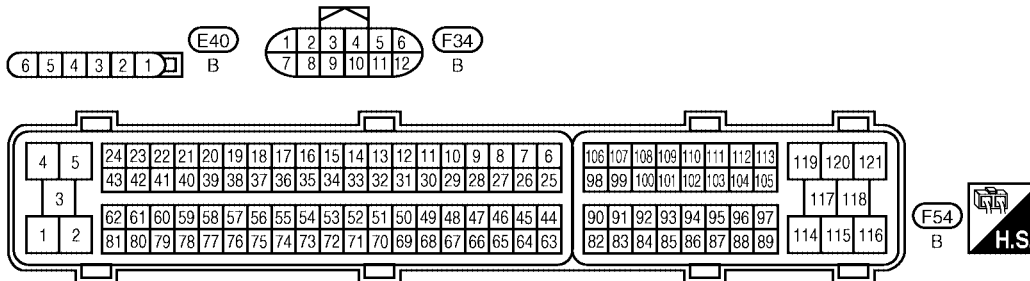
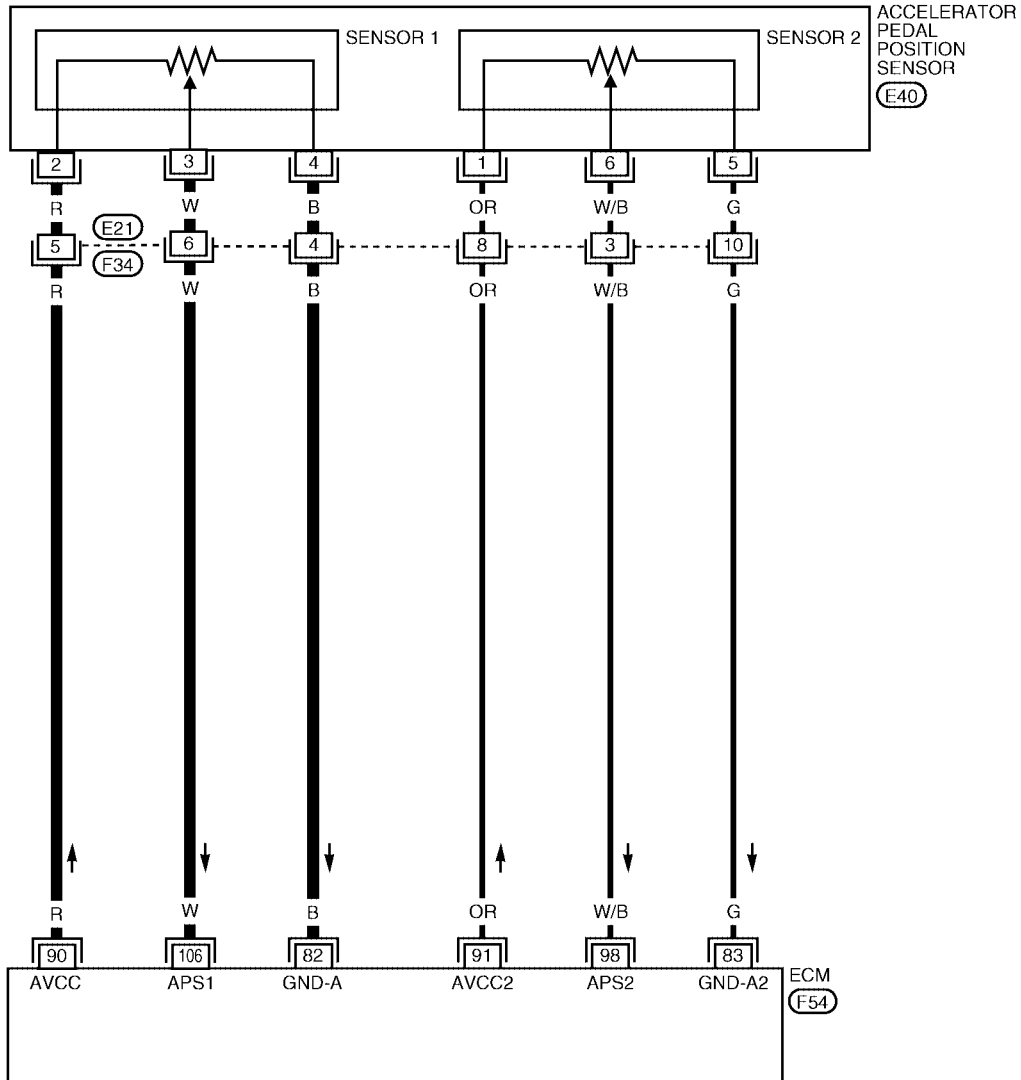

BBWA1284E

DTC P2122, P2123 APP SENSOR

[VQ]

Specification data are reference values and are measured between each terminal and ground.

CAUTION:

Do not use ECM ground terminals when measuring input/output voltage. Doing so may result in damage to the ECM's transistor. Use a ground other than ECM terminals, such as the ground.

TER-MINAL NO.	WIRE COLOR	ITEM	CONDITION	DATA (DC Voltage)
82	B	Sensor ground (APP sensor 1)	[Engine is running] ● Warm-up condition ● Idle speed	Approximately 0V
83	G	Sensor ground (APP sensor 2)	[Engine is running] ● Warm-up condition ● Idle speed	Approximately 0V
90	R	Sensor power supply (APP sensor 1)	[Ignition switch: ON]	Approximately 5V
91	OR	Sensor power supply (APP sensor 2)	[Ignition switch: ON]	Approximately 5V
98	W/B	Accelerator pedal position sensor 2	[Ignition switch: ON] ● Engine stopped ● Accelerator pedal: Fully released	0.28 - 0.48V
			[Ignition switch: ON] ● Engine stopped ● Accelerator pedal: Fully depressed	More than 2.0V
106	W	Accelerator pedal position sensor 1	[Ignition switch: ON] ● Engine stopped ● Accelerator pedal: Fully released	0.65 - 0.87V
			[Ignition switch: ON] ● Engine stopped ● Accelerator pedal: Fully depressed	More than 4.3V

Diagnostic Procedure

UBS001DW

1. CHECK GROUND CONNECTIONS

1. Turn ignition switch OFF.
2. Loosen and retighten three ground screws on the body.
Refer to [EC-789, "Ground Inspection"](#).

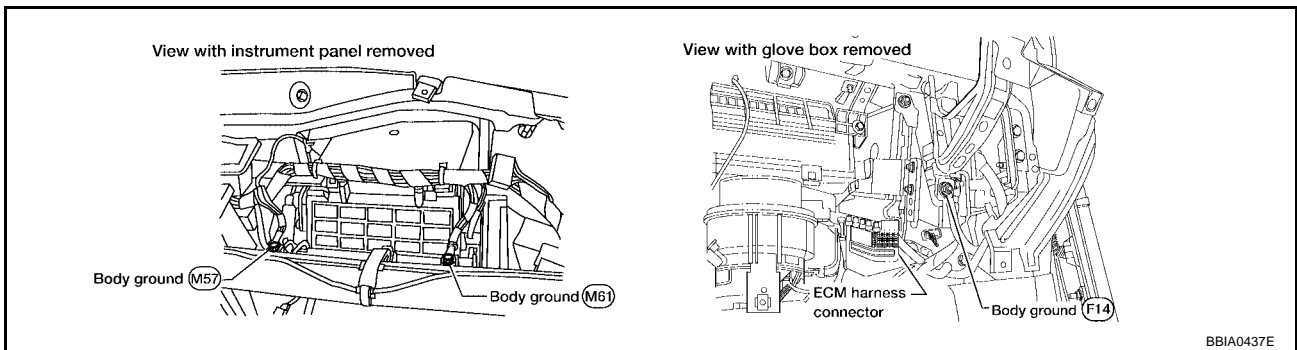

OK or NG

- OK >> GO TO 2.
- NG >> Repair or replace ground connections.

2. CHECK APP SENSOR 1 POWER SUPPLY CIRCUIT

1. Disconnect accelerator pedal position (APP) sensor harness connector.
2. Turn ignition switch ON.

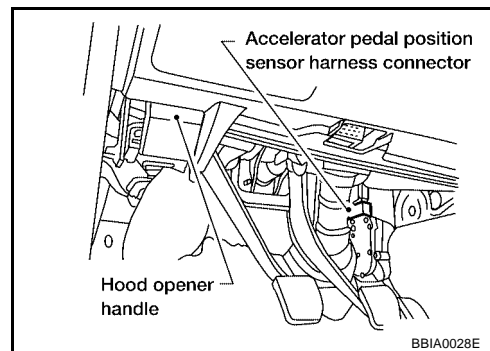

3. Check voltage between APP sensor terminal 2 and ground with CONSULT-II or tester.

Voltage: Approximately 5V

OK or NG

- OK >> GO TO 4.
NG >> GO TO 3.

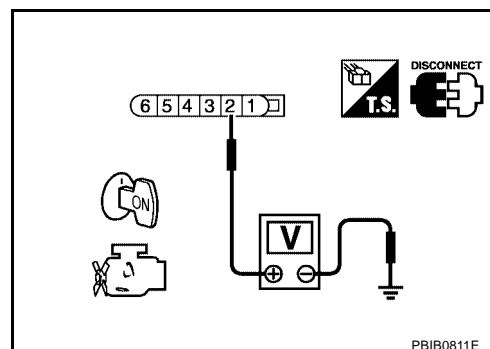

3. DETECT MALFUNCTIONING PART

Check the following.

- Harness connectors E21, F34
- Harness for open or short between ECM and accelerator pedal position sensor

>> Repair open circuit or short to ground or short to power in harness or connectors.

4. CHECK APP SENSOR 1 GROUND CIRCUIT FOR OPEN AND SHORT

1. Turn ignition switch OFF.
2. Disconnect ECM harness connector.
3. Check harness continuity between APP sensor terminal 4 and ECM terminal 82. Refer to Wiring Diagram.

Continuity should exist.

4. Also check harness for short to ground and short to power.

OK or NG

- OK >> GO TO 6.
NG >> GO TO 5.

5. DETECT MALFUNCTIONING PART

Check the following.

- Harness connectors E21, F34
- Harness for open or short between ECM and accelerator pedal position sensor

>> Repair open circuit or short to ground or short to power in harness or connectors.

6. CHECK APP SENSOR INPUT SIGNAL CIRCUIT FOR OPEN AND SHORT

1. Check harness continuity between ECM terminal 106 and APP sensor terminal 3.
Refer to Wiring Diagram.

Continuity should exist.

2. Also check harness for short to ground and short to power.

OK or NG

- OK >> GO TO 8.
- NG >> GO TO 7.

7. DETECT MALFUNCTIONING PART

Check the following.

- Harness connectors E21, F34
- Harness for open or short between ECM and accelerator pedal position sensor

>> Repair open circuit or short to ground or short to power in harness or connectors.

8. CHECK APP SENSOR

Refer to [EC-1263, "Component Inspection"](#) .

OK or NG

- OK >> GO TO 10.
- NG >> GO TO 9.

9. REPLACE ACCELERATOR PEDAL ASSEMBLY

1. Replace accelerator pedal assembly.
2. Perform [EC-711, "Accelerator Pedal Released Position Learning"](#) .
3. Perform [EC-711, "Throttle Valve Closed Position Learning"](#) .
4. Perform [EC-712, "Idle Air Volume Learning"](#) .

>> INSPECTION END

10. CHECK INTERMITTENT INCIDENT

Refer to [EC-782, "TROUBLE DIAGNOSIS FOR INTERMITTENT INCIDENT"](#) .

>> INSPECTION END

**Component Inspection
ACCELERATOR PEDAL POSITION SENSOR**

UBS001DX

1. Reconnect all harness connectors disconnected.
2. Turn ignition switch ON.
3. Check voltage between ECM terminals 106 (APP sensor 1 signal), 98 (APP sensor 2 signal) and ground under the following conditions.

Terminal	Accelerator pedal	Voltage
106 (Accelerator pedal position sensor 1)	Fully released	0.65 - 0.87V
	Fully depressed	More than 4.3V
98 (Accelerator pedal position sensor 2)	Fully released	0.28 - 0.48V
	Fully depressed	More than 2.0V

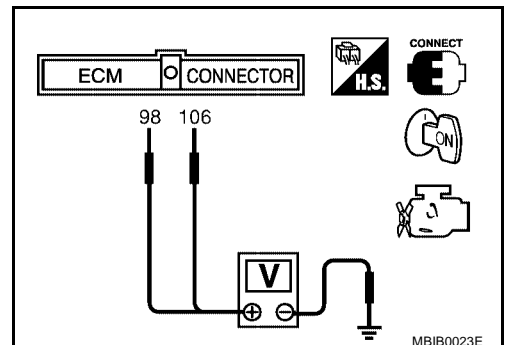

4. If NG, replace accelerator pedal assembly and go to next step.
5. Perform [EC-711, "Accelerator Pedal Released Position Learning"](#) .
6. Perform [EC-711, "Throttle Valve Closed Position Learning"](#) .
7. Perform [EC-712, "Idle Air Volume Learning"](#) .

Removal and Installation ACCELERATOR PEDAL

UBS00IDY

Refer to [ACC-2, "ACCELERATOR CONTROL SYSTEM"](#) .

DTC P2127, P2128 APP SENSOR

Component Description

The accelerator pedal position sensor is installed on the upper end of the accelerator pedal assembly. The sensor detects the accelerator position and sends a signal to the ECM.

Accelerator pedal position sensor has two sensors. These sensors are a kind of potentiometers which transform the accelerator pedal position into output voltage, and emit the voltage signal to the ECM. In addition, these sensors detect the opening and closing speed of the accelerator pedal and feed the voltage signals to the ECM. The ECM judges the current opening angle of the accelerator pedal from these signals and controls the throttle control motor based on these signals.

Idle position of the accelerator pedal is determined by the ECM receiving the signal from the accelerator pedal position sensor. The ECM uses this signal for the engine operation such as fuel cut.

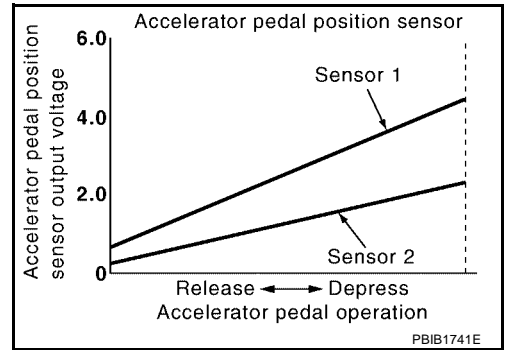

CONSULT-II Reference Value in Data Monitor Mode

Specification data are reference values.

MONITOR ITEM	CONDITION		SPECIFICATION
ACCEL SEN1	● Ignition switch: ON (Engine stopped)	Accelerator pedal: Fully released	0.65 - 0.87V
		Accelerator pedal: Fully depressed	More than 4.3V
ACCEL SEN2*	● Ignition switch: ON (Engine stopped)	Accelerator pedal: Fully released	0.56 - 0.96V
		Accelerator pedal: Fully depressed	More than 4.0V
CLSD THL POS	● Ignition switch: ON (Engine stopped)	Accelerator pedal: Fully released	ON
		Accelerator pedal: Slightly depressed	OFF

*: Accelerator pedal position sensor 2 signal is converted by ECM internally. Thus, it differ from ECM terminal voltage.

On Board Diagnosis Logic

These self-diagnoses have the one trip detection logic.

DTC No.	Trouble diagnosis name	DTC detecting condition	Possible cause
P2127 2127	Accelerator pedal position sensor 2 circuit low input	An excessively low voltage from the APP sensor 2 is sent to ECM.	<ul style="list-style-type: none"> ● Harness or connectors (The APP sensor 2 circuit is open or shorted.) (TP sensor circuit is shorted.) ● Accelerator pedal position sensor (Accelerator pedal position sensor 2) ● Electric throttle control actuator (TP sensor 1 and 2)
P2128 2128	Accelerator pedal position sensor 2 circuit high input	An excessively high voltage from the APP sensor 2 is sent to ECM.	

FAIL-SAFE MODE

When the malfunction is detected, ECM enters fail-safe mode and the MIL lights up.

Engine operating condition in fail-safe mode

The ECM controls the electric throttle control actuator in regulating the throttle opening in order for the idle position to be within +10 degrees.

The ECM regulates the opening speed of the throttle valve to be slower than the normal condition. So, the acceleration will be poor.

DTC Confirmation Procedure

NOTE:

If DTC Confirmation Procedure has been previously conducted, always turn ignition switch OFF and wait at least 10 seconds before conducting the next test.

TESTING CONDITION:

Before performing the following procedure, confirm that battery voltage is more than 10V at idle.

WITH CONSULT-II

1. Turn ignition switch ON.
2. Select "DATA MONITOR" mode with CONSULT-II.
3. Start engine and let it idle for 1 second.
4. If DTC is detected, go to [EC-1268, "Diagnostic Procedure"](#) .

DATA MONITOR	
MONITOR	NO DTC
ENG SPEED	XXX rpm
<small>SEF058Y</small>	

WITH GST

Follow the procedure "WITH CONSULT-II" above.

DTC P2127, P2128 APP SENSOR

[VQ]

Wiring Diagram

UBS001E3

EC-APPS2-01

— : DETECTABLE LINE FOR DTC
 - - - : NON-DETECTABLE LINE FOR DTC

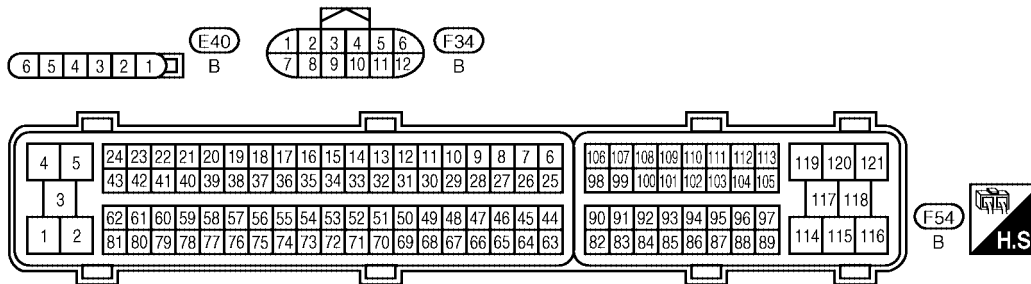
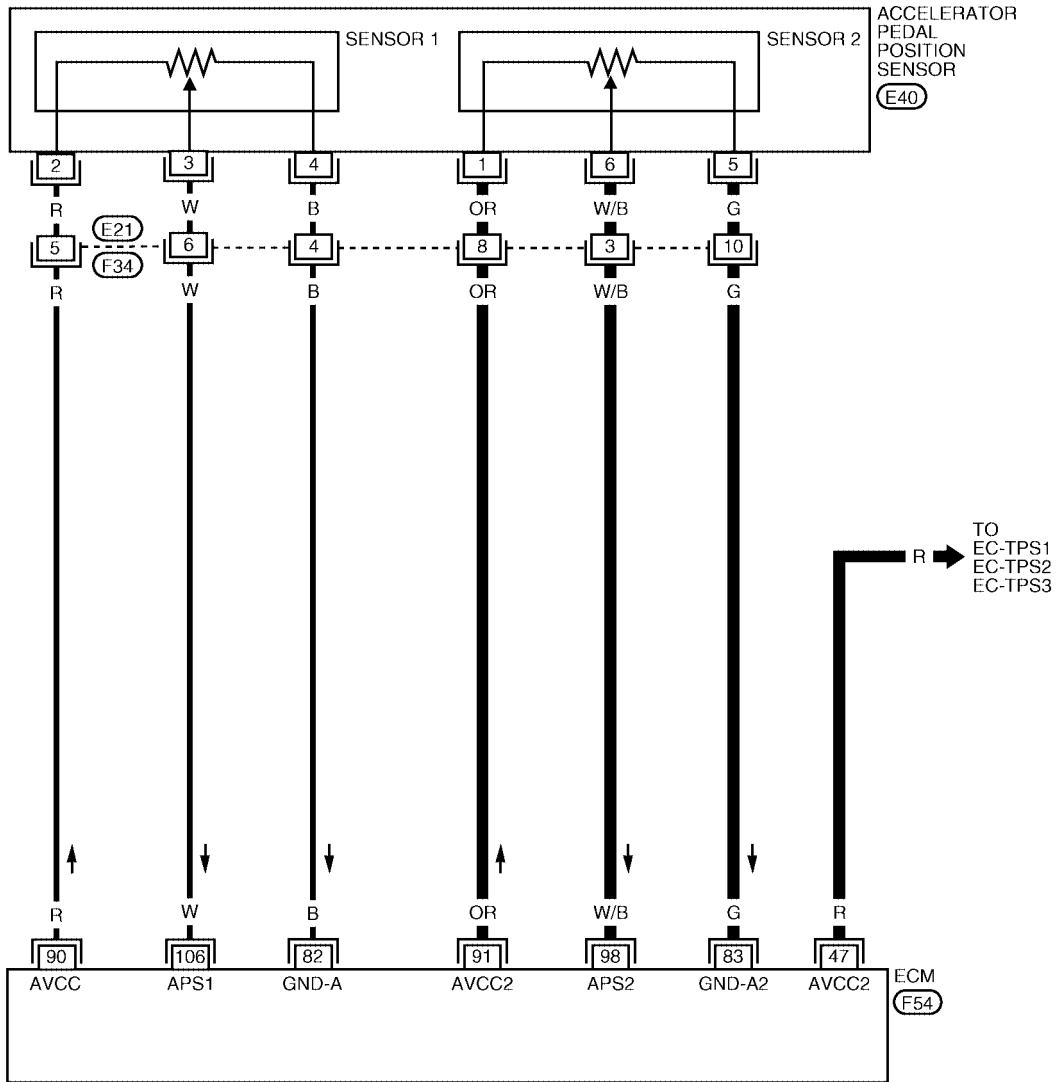

BBWA1302E

DTC P2127, P2128 APP SENSOR

[VQ]

Specification data are reference values and are measured between each terminal and ground.

CAUTION:

Do not use ECM ground terminals when measuring input/output voltage. Doing so may result in damage to the ECM's transistor. Use a ground other than ECM terminals, such as the ground.

TER-MINAL NO.	WIRE COLOR	ITEM	CONDITION	DATA (DC Voltage)
47	R	Sensor power supply (Throttle position sensor)	[Ignition switch: ON]	Approximately 5V
82	B	Sensor ground (APP sensor 1)	[Engine is running] ● Warm-up condition ● Idle speed	Approximately 0V
83	G	Sensor ground (APP sensor 2)	[Engine is running] ● Warm-up condition ● Idle speed	Approximately 0V
90	R	Sensor power supply (APP sensor 1)	[Ignition switch: ON]	Approximately 5V
91	OR	Sensor power supply (APP sensor 2)	[Ignition switch: ON]	Approximately 5V
98	W/B	Accelerator pedal position sensor 2	[Ignition switch: ON] ● Engine stopped ● Accelerator pedal: Fully released	0.28 - 0.48V
			[Ignition switch: ON] ● Engine stopped ● Accelerator pedal: Fully depressed	More than 2.0V
106	W	Accelerator pedal position sensor 1	[Ignition switch: ON] ● Engine stopped ● Accelerator pedal: Fully released	0.65 - 0.87V
			[Ignition switch: ON] ● Engine stopped ● Accelerator pedal: Fully depressed	More than 4.3V

Diagnostic Procedure

UBS001E4

1. CHECK GROUND CONNECTIONS

1. Turn ignition switch OFF.
2. Loosen and retighten three ground screws on the body.
Refer to [EC-789, "Ground Inspection"](#).

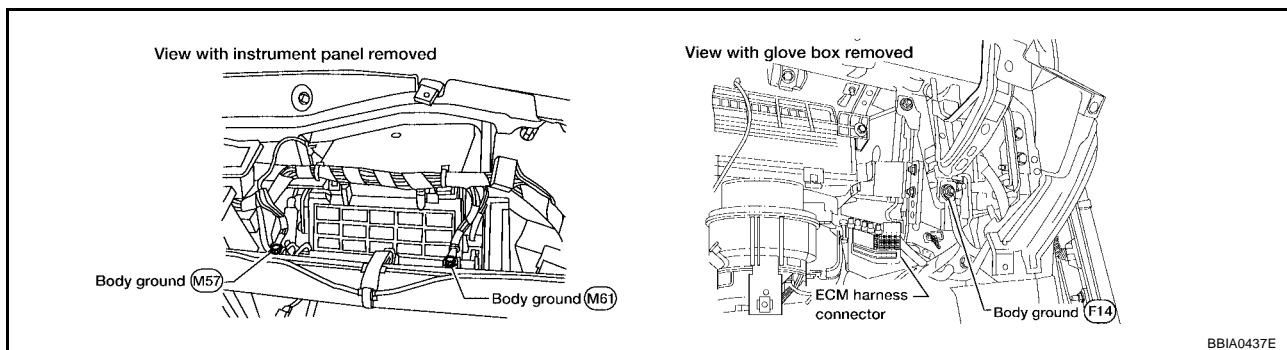

BBI40437E

OK or NG

- OK >> GO TO 2.
- NG >> Repair or replace ground connections.

2. CHECK APP SENSOR 2 POWER SUPPLY CIRCUIT-I

1. Disconnect accelerator pedal position (APP) sensor harness connector.
2. Turn ignition switch ON.

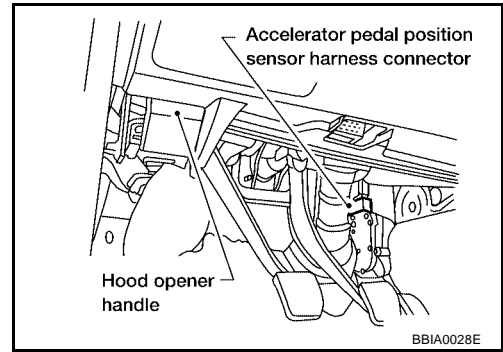

3. Check voltage between APP sensor terminal 1 and ground with CONSULT-II or tester.

Voltage: Approximately 5V

OK or NG

- OK >> GO TO 8.
- NG >> GO TO 3.

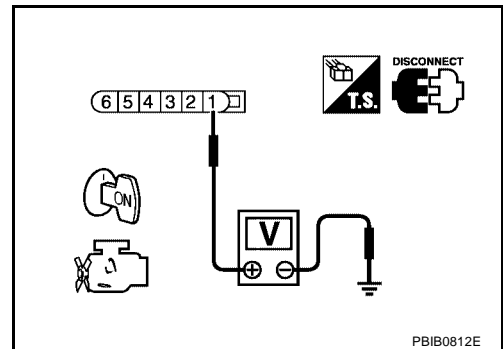

3. CHECK APP SENSOR 2 POWER SUPPLY CIRCUIT-II

1. Turn ignition switch OFF.
2. Disconnect ECM harness connector.
3. Check harness continuity between APP sensor terminal 1 and ECM terminal 91. Refer to wiring diagram.

Continuity should exist.

OK or NG

- OK >> GO TO 5.
- NG >> GO TO 4.

4. DETECT MALFUNCTIONING PART

Check the following.

- Harness connectors E21, F34
- Harness for open or short between accelerator pedal position sensor and ECM

>> Repair open circuit or short to ground or short to power in harness or connectors.

5. CHECK THROTTLE POSITION SENSOR 2 POWER SUPPLY CIRCUIT-III

Check harness for short to power and short to ground, between the following terminals.

ECM terminal	Sensor terminal	Reference Wiring Diagram
91	APP sensor terminal 1	EC-1267
47	Electric throttle control actuator terminal 1	EC-1274

OK or NG

- OK >> GO TO 6.
- NG >> Repair short to ground or short to power in harness or connectors.

6. CHECK THROTTLE POSITION SENSOR

Refer to [EC-905, "Component Inspection"](#) .

OK or NG

- OK >> GO TO 14.
NG >> GO TO 7.

7. REPLACE ELECTRIC THROTTLE CONTROL ACTUATOR

1. Replace electric throttle control actuator.
2. Perform [EC-711, "Throttle Valve Closed Position Learning"](#) .
3. Perform [EC-712, "Idle Air Volume Learning"](#) .

>> **INSPECTION END**

8. CHECK APP SENSOR 2 GROUND CIRCUIT FOR OPEN AND SHORT

1. Turn ignition switch OFF.
2. Disconnect ECM harness connector.
3. Check harness continuity between APP sensor terminal 5 and ECM terminal 83.
Refer to Wiring Diagram.

Continuity should exist.

4. Also check harness for short to ground and short to power.

OK or NG

- OK >> GO TO 10.
NG >> GO TO 9.

9. DETECT MALFUNCTIONING PART

Check the following.

- Harness connectors E21, F34
- Harness for open or short between ECM and accelerator pedal position sensor

>> Repair open circuit or short to ground or short to power in harness or connectors.

10. CHECK APP SENSOR 2 INPUT SIGNAL CIRCUIT FOR OPEN AND SHORT

1. Check harness continuity between ECM terminal 98 and APP sensor terminal 6.
Refer to Wiring Diagram.

Continuity should exist.

2. Also check harness for short to ground and short to power.

OK or NG

- OK >> GO TO 12.
NG >> GO TO 11.

11. DETECT MALFUNCTIONING PART

Check the following.

- Harness connectors E21, F34
- Harness for open or short between ECM and accelerator pedal position sensor

>> Repair open circuit or short to ground or short to power in harness or connectors.

12. CHECK APP SENSOR

Refer to [EC-1271, "Component Inspection"](#) .

OK or NG

- OK >> GO TO 14.
- NG >> GO TO 13.

13. REPLACE ACCELERATOR PEDAL ASSEMBLY

1. Replace accelerator pedal assembly.
2. Perform [EC-711, "Accelerator Pedal Released Position Learning"](#) .
3. Perform [EC-711, "Throttle Valve Closed Position Learning"](#) .
4. Perform [EC-712, "Idle Air Volume Learning"](#) .

>> INSPECTION END

14. CHECK INTERMITTENT INCIDENT

Refer to [EC-782, "TROUBLE DIAGNOSIS FOR INTERMITTENT INCIDENT"](#) .

>> INSPECTION END

**Component Inspection
ACCELERATOR PEDAL POSITION SENSOR**

UBS001E5

1. Reconnect all harness connectors disconnected.
2. Turn ignition switch ON.
3. Check voltage between ECM terminals 106 (APP sensor 1 signal), 98 (APP sensor 2 signal) and ground under the following conditions.

Terminal	Accelerator pedal	Voltage
106 (Accelerator pedal position sensor 1)	Fully released	0.65 - 0.87V
	Fully depressed	More than 4.3V
98 (Accelerator pedal position sensor 2)	Fully released	0.28 - 0.48V
	Fully depressed	More than 2.0V

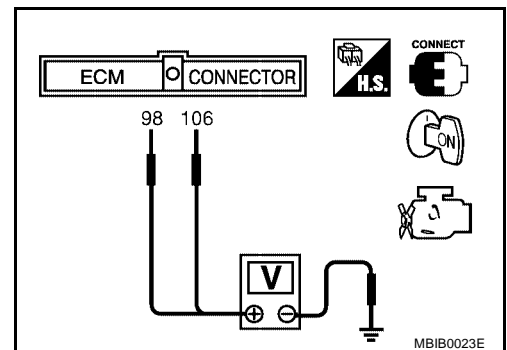

4. If NG, replace accelerator pedal assembly and go to next step.
5. Perform [EC-711, "Accelerator Pedal Released Position Learning"](#) .
6. Perform [EC-711, "Throttle Valve Closed Position Learning"](#) .
7. Perform [EC-712, "Idle Air Volume Learning"](#) .

**Removal and Installation
ACCELERATOR PEDAL**

UBS001E6

Refer to [ACC-2, "ACCELERATOR CONTROL SYSTEM"](#) .

DTC P2135 TP SENSOR

Component Description

UBS001E7

Electric throttle control actuator consists of throttle control motor, throttle position sensor, etc. The throttle position sensor responds to the throttle valve movement.

The throttle position sensor has the two sensors. These sensors are a kind of potentiometers which transform the throttle valve position into output voltage, and emit the voltage signal to the ECM. In addition, these sensors detect the opening and closing speed of the throttle valve and feed the voltage signals to the ECM. The ECM judges the current opening angle of the throttle valve from these signals and the ECM controls the throttle control motor to make the throttle valve opening angle properly in response to driving condition.

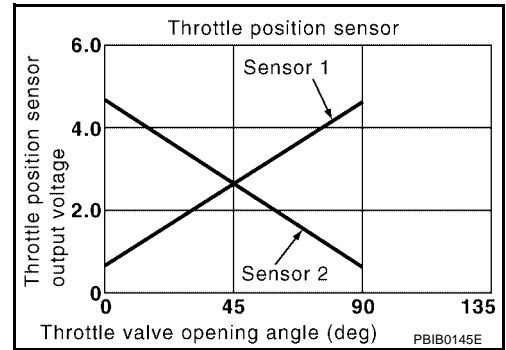

CONSULT-II Reference Value in Data Monitor Mode

UBS001E8

Specification data are reference values.

MONITOR ITEM	CONDITION		SPECIFICATION
THRTL SEN1 THRTL SEN2*	● Ignition switch: ON (Engine stopped)	Accelerator pedal: Fully released	More than 0.36V
	● Shift lever: D (A/T), 1st (M/T)	Accelerator pedal: Fully depressed	Less than 4.75V

*: Throttle position sensor 2 signal is converted by ECM internally. Thus, it differs from ECM terminal voltage signal.

On Board Diagnosis Logic

UBS001E9

This self-diagnosis has the one trip detection logic.

DTC No.	Trouble diagnosis name	DTC detecting condition	Possible cause
P2135 2135	Throttle position sensor circuit range/performance problem	Rationally incorrect voltage is sent to ECM compared with the signals from TP sensor 1 and TP sensor 2.	<ul style="list-style-type: none"> ● Harness or connector (The TP sensor 1 and 2 circuit is open or shorted.) (APP sensor 2 circuit is shorted) ● Electric throttle control actuator (TP sensor 1 and 2) ● Accelerator pedal position sensor (APP sensor 2)

FAIL-SAFE MODE

When the malfunction is detected, the ECM enters fail-safe mode and the MIL lights up.

Engine operation condition in fail-safe mode

The ECM controls the electric throttle control actuator in regulating the throttle opening in order for the idle position to be within +10 degrees.

The ECM regulates the opening speed of the throttle valve to be slower than the normal condition.

So, the acceleration will be poor.

DTC Confirmation Procedure

NOTE:

If DTC Confirmation Procedure has been previously conducted, always turn ignition switch OFF and wait at least 10 seconds before conducting the next test.

TESTING CONDITION:

Before performing the following procedure, confirm that battery voltage is more than 10V at idle.

WITH CONSULT-II

1. Turn ignition switch ON.
2. Select "DATA MONITOR" mode with CONSULT-II.
3. Start engine and let it idle for 1 second.
4. If DTC is detected, go to [EC-1275, "Diagnostic Procedure"](#) .

DATA MONITOR	
MONITOR	NO DTC
ENG SPEED	XXX rpm

SEF058Y

WITH GST

Follow the procedure "WITH CONSULT-II" above.

A
EC
C
D
E
F
G
H
I
J
K
L
M

DTC P2135 TP SENSOR

[VQ]

UBS001EB

Wiring Diagram

EC-TPS3-01

: DETECTABLE LINE FOR DTC
 : NON-DETECTABLE LINE FOR DTC

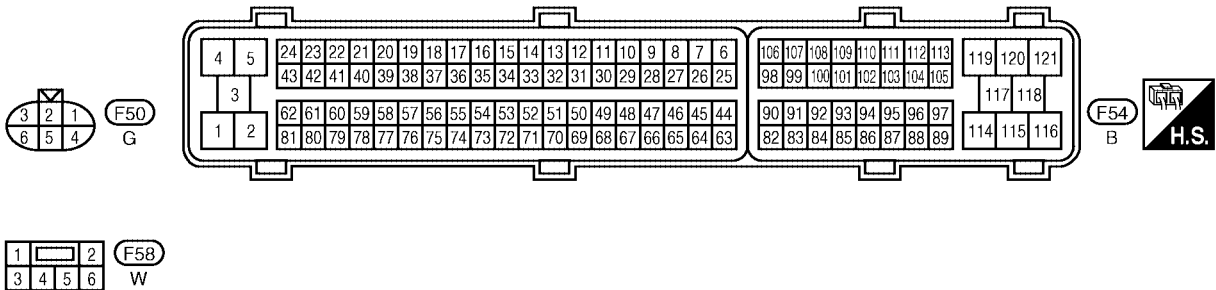
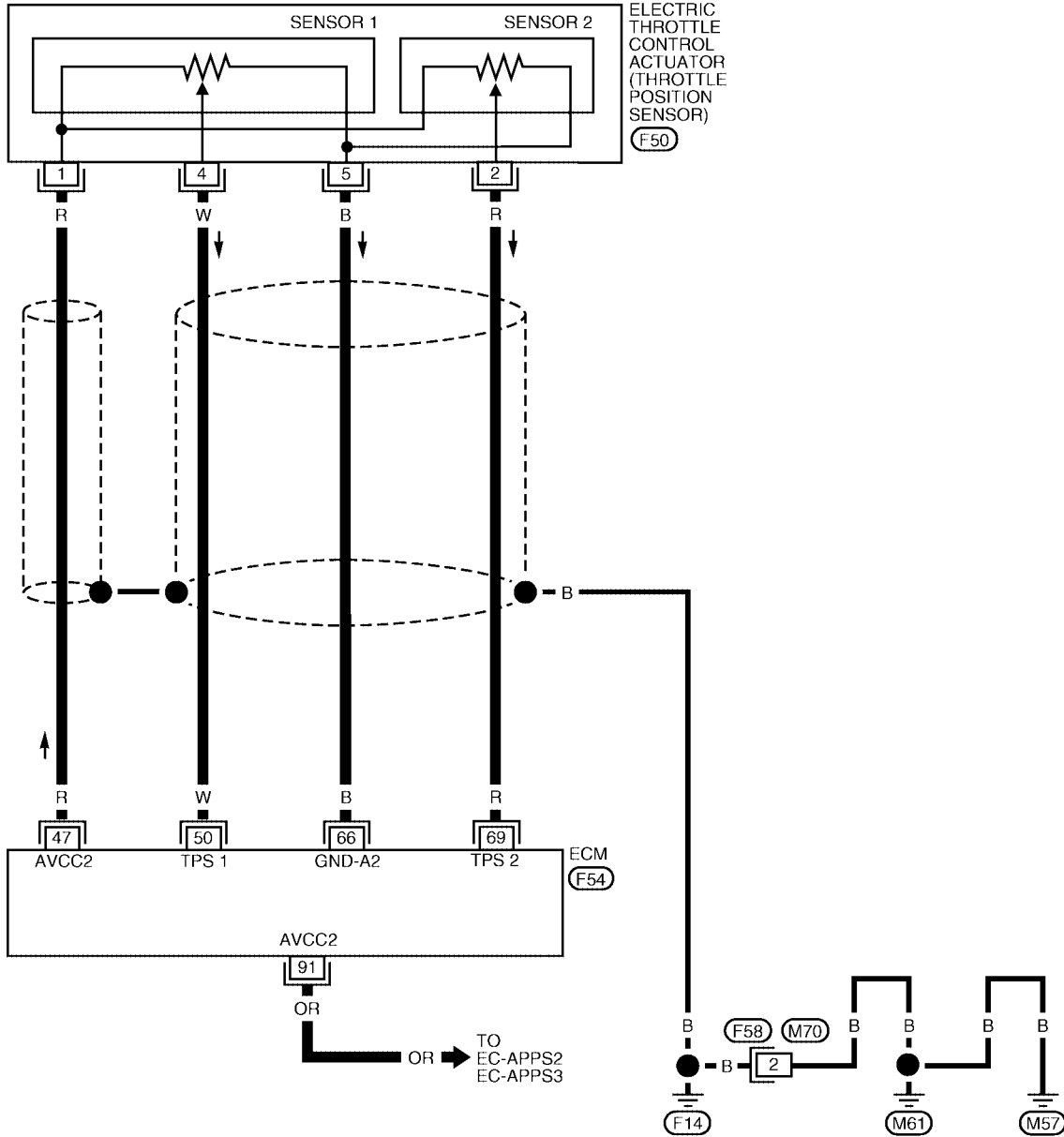

BBWA1575E

DTC P2135 TP SENSOR

[VQ]

Specification data are reference values and are measured between each terminal and ground.

CAUTION:

Do not use ECM ground terminals when measuring input/output voltage. Doing so may result in damage to the ECM's transistor. Use a ground other than ECM terminals, such as the ground.

TER-MINAL NO.	WIRE COLOR	ITEM	CONDITION	DATA (DC Voltage)
47	R	Sensor power supply (Throttle position sensor)	[Ignition switch: ON]	Approximately 5V
50	W	Throttle position sensor 1	[Ignition switch: ON] <ul style="list-style-type: none"> ● Engine stopped ● Shift lever: D (A/T) or 1st (M/T) ● Accelerator pedal: Fully released 	More than 0.36V
			[Ignition switch: ON] <ul style="list-style-type: none"> ● Engine stopped ● Shift lever: D (A/T) or 1st (M/T) ● Accelerator pedal: Fully depressed 	Less than 4.75V
66	B	Sensor ground (Throttle position sensor)	[Engine is running] <ul style="list-style-type: none"> ● Warm-up condition ● Idle speed 	Approximately 0V
69	R	Throttle position sensor 2	[Ignition switch: ON] <ul style="list-style-type: none"> ● Engine stopped ● Shift lever: D (A/T) or 1st (M/T) ● Accelerator pedal: Fully released 	Less than 4.75V
			[Ignition switch: ON] <ul style="list-style-type: none"> ● Engine stopped ● Shift lever: D (A/T) or 1st (M/T) ● Accelerator pedal: Fully depressed 	More than 0.36V
91	OR	Sensor power supply (APP sensor 2)	[Ignition switch: ON]	Approximately 5V

Diagnostic Procedure

UBS001EC

1. CHECK GROUND CONNECTIONS

1. Turn ignition switch OFF.
2. Loosen and retighten three ground screws on the body. Refer to [EC-789, "Ground Inspection"](#).

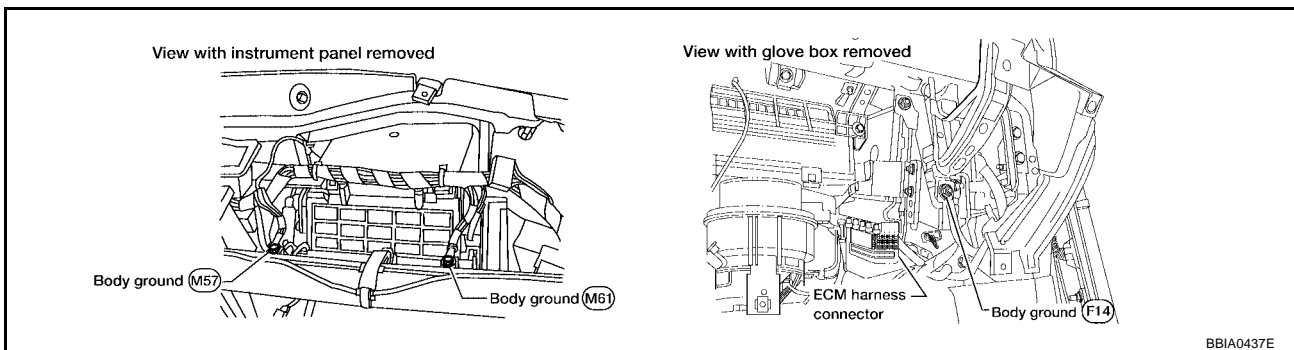

OK or NG

- OK >> GO TO 2.
- NG >> Repair or replace ground connections.

2. CHECK THROTTLE POSITION SENSOR POWER SUPPLY CIRCUIT-I

1. Disconnect electric throttle control actuator harness connector.
2. Turn ignition switch ON.

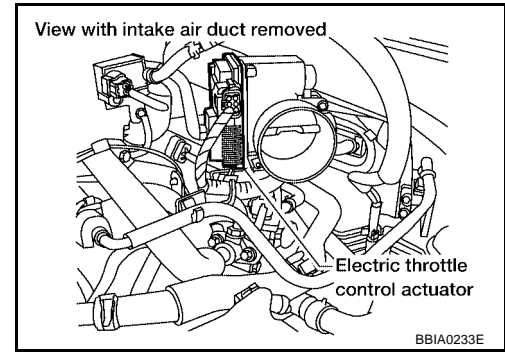

3. Check voltage between electric throttle control actuator terminal 1 and ground with CONSULT-II or tester.

Voltage: Approximately 5V

OK or NG

- OK >> GO TO 7.
 NG >> GO TO 3.

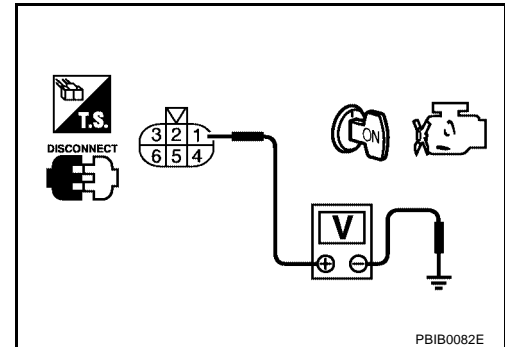

3. CHECK THROTTLE POSITION SENSOR POWER SUPPLY CIRCUIT-II

1. Turn ignition switch OFF.
2. Disconnect ECM harness connector.
3. Check harness continuity between electric throttle control actuator terminal 1 and ECM terminal 47. Refer to Wiring Diagram.

Continuity should exist.

OK or NG

- OK >> GO TO 4.
 NG >> Repair or replace open circuit.

4. CHECK THROTTLE POSITION SENSOR POWER SUPPLY CIRCUIT-III

Check harness for short to power and short to ground, between the following terminals.

ECM terminal	Sensor terminal	Reference Wiring Diagram
47	Electric throttle control actuator terminal 1	EC-1274
91	APP sensor terminal 1	EC-1267

OK or NG

- OK >> GO TO 5.
 NG >> Repair short to ground or short to power in harness or connectors.

5. CHECK APP SENSOR

Refer to [EC-1271, "Component Inspection"](#).

OK or NG

- OK >> GO TO 11.
 NG >> GO TO 6.

6. REPLACE ACCELERATOR PEDAL ASSEMBLY

1. Replace accelerator pedal assembly.
2. Perform [EC-711, "Accelerator Pedal Released Position Learning"](#) .
3. Perform [EC-711, "Throttle Valve Closed Position Learning"](#) .
4. Perform [EC-712, "Idle Air Volume Learning"](#) .

>> INSPECTION END

7. CHECK THROTTLE POSITION SENSOR GROUND CIRCUIT FOR OPEN AND SHORT

1. Turn ignition switch OFF.
2. Disconnect ECM harness connector.
3. Check harness continuity between electric throttle control actuator terminal 5 and ECM terminal 66.
Refer to Wiring Diagram.

Continuity should exist.

4. Also check harness for short to ground and short to power.

OK or NG

OK >> GO TO 8.

NG >> Repair open circuit or short to ground or short to power in harness or connectors.

8. CHECK THROTTLE POSITION SENSOR INPUT SIGNAL CIRCUIT FOR OPEN AND SHORT

1. Check harness continuity between ECM terminal 50 and electric throttle control actuator terminal 4, ECM terminal 69 and electric throttle control actuator terminal 2.
Refer to Wiring Diagram.

Continuity should exist.

2. Also check harness for short to ground and short to power.

OK or NG

OK >> GO TO 9.

NG >> Repair open circuit or short to ground or short to power in harness or connectors.

9. CHECK THROTTLE POSITION SENSOR

Refer to [EC-1278, "Component Inspection"](#) .

OK or NG

OK >> GO TO 11.

NG >> GO TO 10.

10. REPLACE ELECTRIC THROTTLE CONTROL ACTUATOR

1. Replace the electric throttle control actuator.
2. Perform [EC-711, "Throttle Valve Closed Position Learning"](#) .
3. Perform [EC-712, "Idle Air Volume Learning"](#) .

>> INSPECTION END

11. CHECK INTERMITTENT INCIDENT

Refer to [EC-782, "TROUBLE DIAGNOSIS FOR INTERMITTENT INCIDENT"](#) .

>> INSPECTION END

Component Inspection
THROTTLE POSITION SENSOR

1. Reconnect all harness connectors disconnected.
2. Perform [EC-711, "Throttle Valve Closed Position Learning"](#) .
3. Turn ignition switch ON.
4. Set shift lever to D position (A/T) or 1st position (M/T).
5. Check voltage between ECM terminals 50 (TP sensor 1 signal), 69 (TP sensor 2 signal) and ground under the following conditions.

Terminal	Accelerator pedal	Voltage
50 (Throttle position sensor 1)	Fully released	More than 0.36V
	Fully depressed	Less than 4.75V
69 (Throttle position sensor 2)	Fully released	Less than 4.75V
	Fully depressed	More than 0.36V

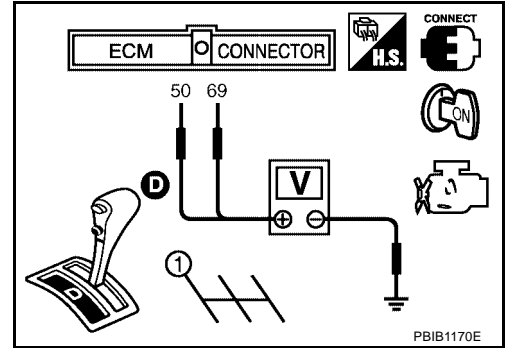

6. If NG, replace electric throttle control actuator and go to the next step.
7. Perform [EC-711, "Throttle Valve Closed Position Learning"](#) .
8. Perform [EC-712, "Idle Air Volume Learning"](#) .

Removal and Installation
ELECTRIC THROTTLE CONTROL ACTUATOR

Refer to [EM-122, "INTAKE MANIFOLD COLLECTOR"](#) .

DTC P2138 APP SENSOR

Component Description

The accelerator pedal position sensor is installed on the upper end of the accelerator pedal assembly. The sensor detects the accelerator position and sends a signal to the ECM.

Accelerator pedal position sensor has two sensors. These sensors are a kind of potentiometers which transform the accelerator pedal position into output voltage, and emit the voltage signal to the ECM. In addition, these sensors detect the opening and closing speed of the accelerator pedal and feed the voltage signals to the ECM. The ECM judges the current opening angle of the accelerator pedal from these signals and controls the throttle control motor based on these signals.

Idle position of the accelerator pedal is determined by the ECM receiving the signal from the accelerator pedal position sensor. The ECM uses this signal for the engine operation such as fuel cut.

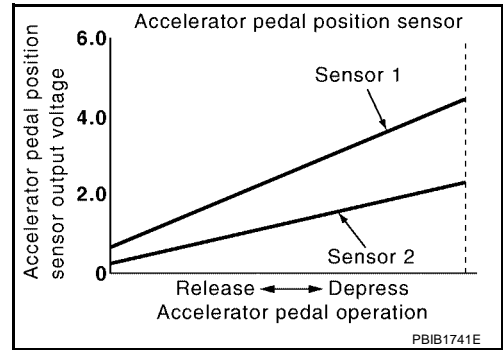

CONSULT-II Reference Value in Data Monitor Mode

Specification data are reference values.

MONITOR ITEM	CONDITION		SPECIFICATION
ACCEL SEN1	● Ignition switch: ON (Engine stopped)	Accelerator pedal: Fully released	0.65 - 0.87V
		Accelerator pedal: Fully depressed	More than 4.3V
ACCEL SEN2*	● Ignition switch: ON (Engine stopped)	Accelerator pedal: Fully released	0.56 - 0.96V
		Accelerator pedal: Fully depressed	More than 4.0V
CLSD THL POS	● Ignition switch: ON (Engine stopped)	Accelerator pedal: Fully released	ON
		Accelerator pedal: Slightly depressed	OFF

*: Accelerator pedal position sensor 2 signal is converted by ECM internally. Thus, it differ from ECM terminal voltage.

On Board Diagnosis Logic

This self-diagnosis has the one trip detection logic.

NOTE:

If DTC P2138 is displayed with DTC P1229, first perform the trouble diagnosis for DTC P1229. Refer to [EC-1127](#).

DTC No.	Trouble diagnosis name	DTC detecting condition	Possible cause
P2138 2138	Accelerator pedal position sensor circuit range/performance problem	Rationally incorrect voltage is sent to ECM compared with the signals from APP sensor 1 and APP sensor 2.	<ul style="list-style-type: none"> ● Harness or connector (The APP sensor 1 and 2 circuit is open or shorted.) (TP sensor circuit is shorted) ● Accelerator pedal position sensor 1 and 2 ● Electric throttle control actuator (TP sensor 1 and 2)

FAIL-SAFE MODE

When the malfunction is detected, ECM enters fail-safe mode and the MIL lights up.

Engine operating condition in fail-safe mode

The ECM controls the electric throttle control actuator in regulating the throttle opening in order for the idle position to be within +10 degrees.

The ECM regulates the opening speed of the throttle valve to be slower than the normal condition.

So, the acceleration will be poor.

DTC Confirmation Procedure

NOTE:

If DTC Confirmation Procedure has been previously conducted, always turn ignition switch OFF and wait at least 10 seconds before conducting the next test.

TESTING CONDITION:

Before performing the following procedure, confirm that battery voltage is more than 10V at idle.

WITH CONSULT-II

1. Turn ignition switch ON.
2. Select "DATA MONITOR" mode with CONSULT-II.
3. Start engine and let it idle for 1 second.
4. If DTC is detected, go to [EC-1282, "Diagnostic Procedure"](#) .

DATA MONITOR	
MONITOR	NO DTC
ENG SPEED	XXX rpm

SEF058Y

WITH GST

Follow the procedure "WITH CONSULT-II" above.

DTC P2138 APP SENSOR

[VQ]

Wiring Diagram

UBS001EJ

EC-APPS3-01

: DETECTABLE LINE FOR DTC
 : NON-DETECTABLE LINE FOR DTC

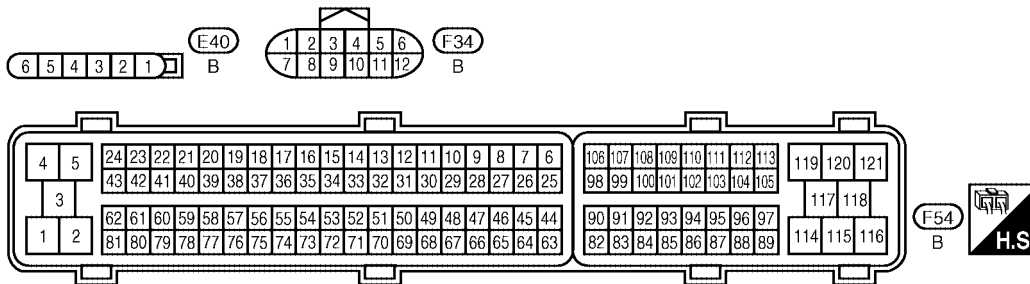
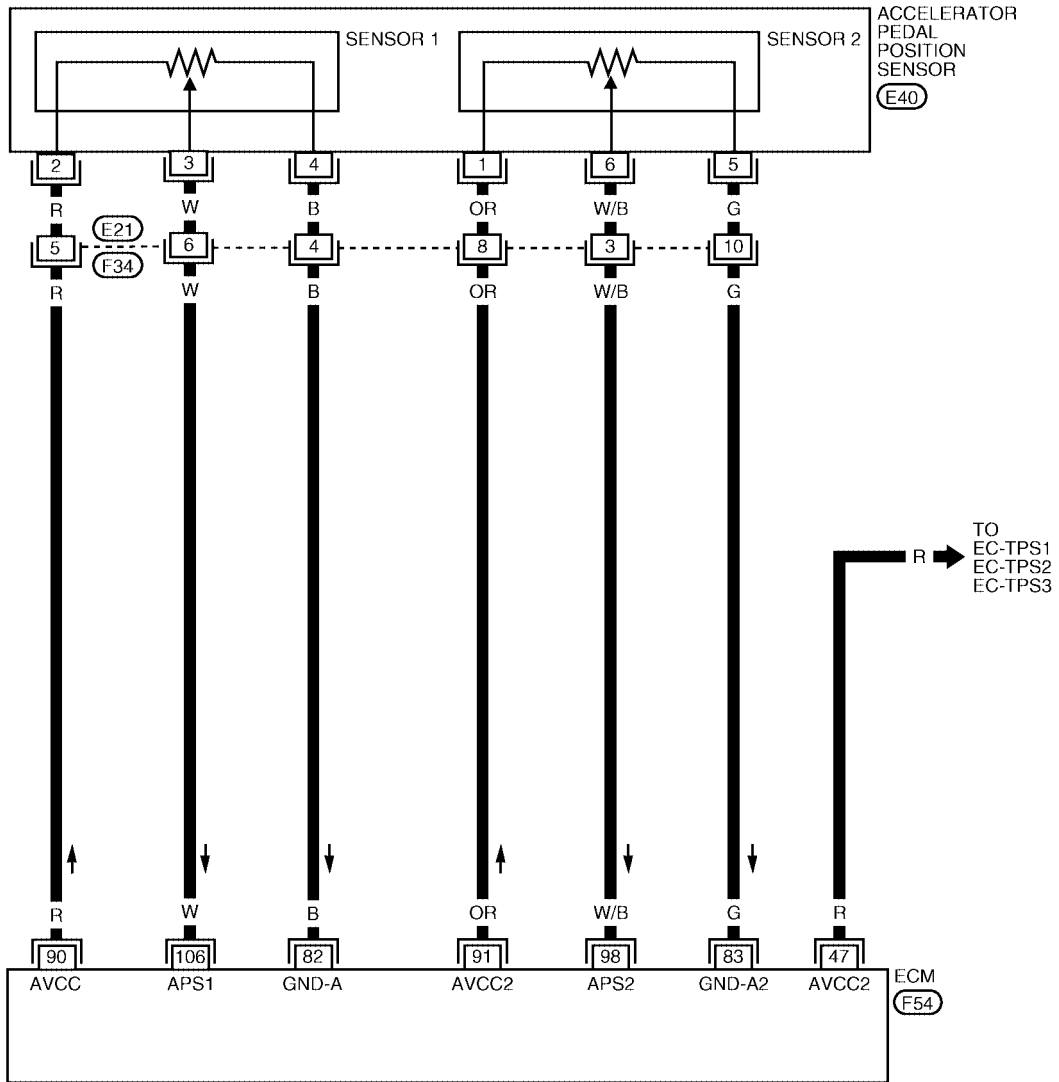

BBWA1283E

DTC P2138 APP SENSOR

[VQ]

Specification data are reference values and are measured between each terminal and ground.

CAUTION:

Do not use ECM ground terminals when measuring input/output voltage. Doing so may result in damage to the ECM's transistor. Use a ground other than ECM terminals, such as the ground.

TER-MINAL NO.	WIRE COLOR	ITEM	CONDITION	DATA (DC Voltage)
47	R	Sensor power supply (Throttle position sensor)	[Ignition switch: ON]	Approximately 5V
82	B	Sensor ground (APP sensor 1)	[Engine is running] ● Warm-up condition ● Idle speed	Approximately 0V
83	G	Sensor ground (APP sensor 2)	[Engine is running] ● Warm-up condition ● Idle speed	Approximately 0V
90	R	Sensor power supply (APP sensor 1)	[Ignition switch: ON]	Approximately 5V
91	OR	Sensor power supply (APP sensor 2)	[Ignition switch: ON]	Approximately 5V
98	W/B	Accelerator pedal position sensor 2	[Ignition switch: ON] ● Engine stopped ● Accelerator pedal: Fully released	0.28 - 0.48V
			[Ignition switch: ON] ● Engine stopped ● Accelerator pedal: Fully depressed	More than 2.0V
106	W	Accelerator pedal position sensor 1	[Ignition switch: ON] ● Engine stopped ● Accelerator pedal: Fully released	0.65 - 0.87V
			[Ignition switch: ON] ● Engine stopped ● Accelerator pedal: Fully depressed	More than 4.3V

Diagnostic Procedure

UBS001EK

1. CHECK GROUND CONNECTIONS

1. Turn ignition switch OFF.
2. Loosen and retighten three ground screws on the body.
Refer to [EC-789, "Ground Inspection"](#).

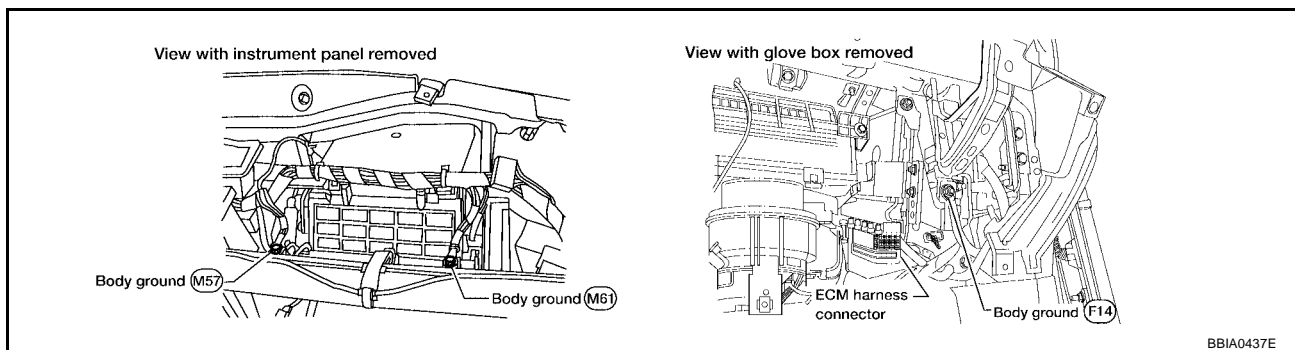

BBA0437E

OK or NG

- OK >> GO TO 2.
- NG >> Repair or replace ground connections.

2. CHECK APP SENSOR 1 POWER SUPPLY CIRCUIT

1. Disconnect accelerator pedal position (APP) sensor harness connector.
2. Turn ignition switch ON.

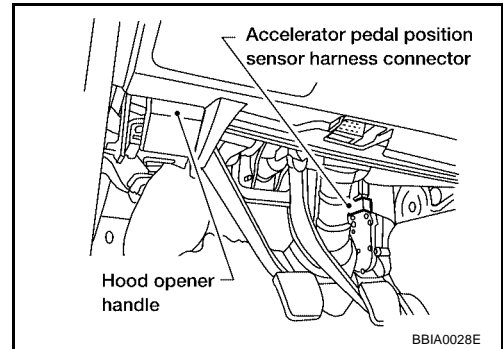

3. Check voltage between APP sensor terminals 2 and ground with CONSULT-II or tester.

Voltage: Approximately 5V

OK or NG

- OK >> GO TO 4.
- NG >> GO TO 3.

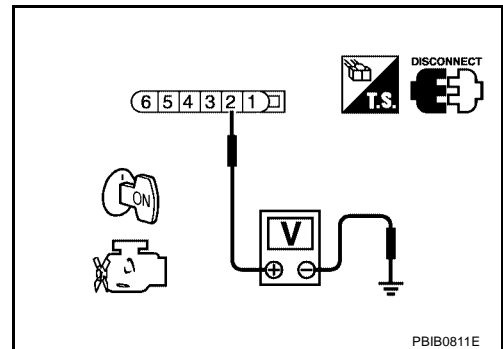

3. DETECT MALFUNCTIONING PART

Check the following.

- Harness connectors E21, F34
- Harness for open or short between accelerator pedal position sensor and ECM

>> Repair open circuit or short to ground or short to power in harness or connectors.

4. CHECK APP SENSOR 2 POWER SUPPLY CIRCUIT-I

Check voltage between APP sensor terminal 1 and ground with CONSULT-II or tester.

Voltage: Approximately 5V

OK or NG

- OK >> GO TO 10.
- NG >> GO TO 5.

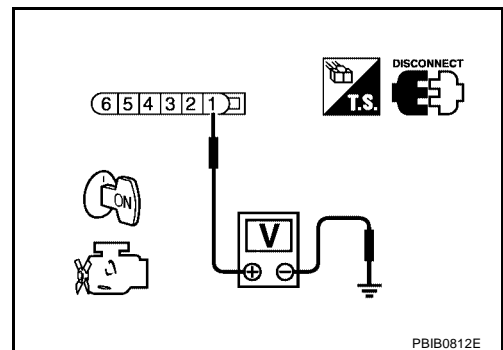

5. CHECK APP SENSOR 2 POWER SUPPLY CIRCUIT-II

1. Turn ignition switch OFF.
2. Disconnect ECM harness connector.
3. Check harness continuity between APP sensor terminal 1 and ECM terminal 91.
Refer to wiring diagram.

Continuity should exist.

OK or NG

- OK >> GO TO 7.
NG >> GO TO 6.

6. DETECT MALFUNCTIONING PART

Check the following.

- Harness connectors E21, F34
- Harness for open or short between accelerator pedal position sensor and ECM

>> Repair open circuit or short to ground or short to power in harness or connectors.

7. CHECK APP SENSOR 2 POWER SUPPLY CIRCUIT-III

Check harness for short to power and short to ground, between the following terminals.

ECM terminal	Sensor terminal	Reference Wiring Diagram
91	APP sensor terminal 1	EC-1281
47	Electric throttle control actuator terminal 1	EC-1274

OK or NG

- OK >> GO TO 8.
NG >> Repair short to ground or short to power in harness or connectors.

8. CHECK THROTTLE POSITION SENSOR

Refer to [EC-1278, "Component Inspection"](#) .

OK or NG

- OK >> GO TO 16.
NG >> GO TO 9.

9. REPLACE ELECTRIC THROTTLE CONTROL ACTUATOR

1. Replace electric throttle control actuator.
2. Perform [EC-711, "Throttle Valve Closed Position Learning"](#) .
3. Perform [EC-712, "Idle Air Volume Learning"](#) .

>> **INSPECTION END**

10. CHECK APP SENSOR GROUND CIRCUIT FOR OPEN AND SHORT

1. Turn ignition switch OFF.
2. Disconnect ECM harness connector.
3. Check harness continuity between APP sensor terminal 5 and ECM terminal 83, APP sensor terminal 4 and ECM terminal 82.
Refer to Wiring Diagram.

Continuity should exist.

4. Also check harness for short to ground and short to power.

OK or NG

- OK >> GO TO 12.
NG >> GO TO 11.

11. DETECT MALFUNCTIONING PART

Check the following.

- Harness connectors E21, F34
- Harness for open or short between accelerator pedal position sensor and ECM

>> Repair open circuit or short to ground or short to power in harness or connectors.

12. CHECK APP SENSOR INPUT SIGNAL CIRCUIT FOR OPEN AND SHORT

1. Check harness continuity between ECM terminal 106 and APP sensor terminal 3, ECM terminal 98 and APP sensor terminal 6.
Refer to Wiring Diagram.

Continuity should exist.

2. Also check harness for short to ground and short to power.

OK or NG

- OK >> GO TO 14.
NG >> GO TO 13.

13. DETECT MALFUNCTIONING PART

Check the following.

- Harness connectors E21, F34
- Harness for open or short between accelerator pedal position sensor and ECM

>> Repair open circuit or short to ground or short to power in harness or connectors.

14. CHECK APP SENSOR

Refer to [EC-1286, "Component Inspection"](#) .

OK or NG

- OK >> GO TO 16.
NG >> GO TO 15.

15. REPLACE ACCELERATOR PEDAL ASSEMBLY

1. Replace accelerator pedal assembly.
2. Perform [EC-711, "Accelerator Pedal Released Position Learning"](#) .
3. Perform [EC-711, "Throttle Valve Closed Position Learning"](#) .
4. Perform [EC-712, "Idle Air Volume Learning"](#) .

>> INSPECTION END

16. CHECK INTERMITTENT INCIDENT

Refer to [EC-782, "TROUBLE DIAGNOSIS FOR INTERMITTENT INCIDENT"](#) .

>> INSPECTION END

Component Inspection ACCELERATOR PEDAL POSITION SENSOR

UBS001EL

1. Reconnect all harness connectors disconnected.
2. Turn ignition switch ON.
3. Check voltage between ECM terminals 106 (APP sensor 1 signal), 98 (APP sensor 2 signal) and ground under the following conditions.

Terminal	Accelerator pedal	Voltage
106 (Accelerator pedal position sensor 1)	Fully released	0.65 - 0.87V
	Fully depressed	More than 4.3V
98 (Accelerator pedal position sensor 2)	Fully released	0.28 - 0.48V
	Fully depressed	More than 2.0V

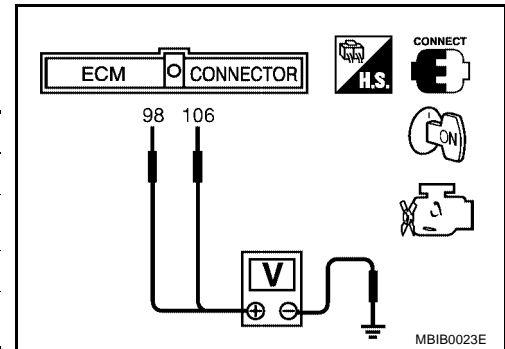

4. If NG, replace accelerator pedal assembly and go to next step.
5. Perform [EC-711, "Accelerator Pedal Released Position Learning"](#) .
6. Perform [EC-711, "Throttle Valve Closed Position Learning"](#) .
7. Perform [EC-712, "Idle Air Volume Learning"](#) .

Removal and Installation ACCELERATOR PEDAL

UBS001EM

Refer to [ACC-2, "ACCELERATOR CONTROL SYSTEM"](#) .

IGNITION SIGNAL

Component Description

IGNITION COIL & POWER TRANSISTOR

The ignition signal from the ECM is sent to and amplified by the power transistor. The power transistor turns ON and OFF the ignition coil primary circuit. This ON/OFF operation induces the proper high voltage in the coil secondary circuit.

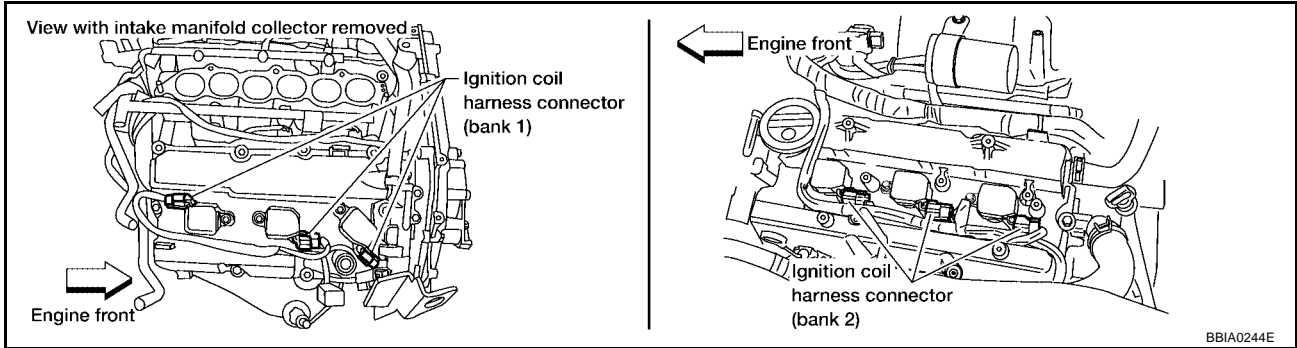

A
EC
C
D
E
F
G
H
I
J
K
L
M

IGNITION SIGNAL

[VQ]

Wiring Diagram

UBS001EO

EC-IGNSYS-01

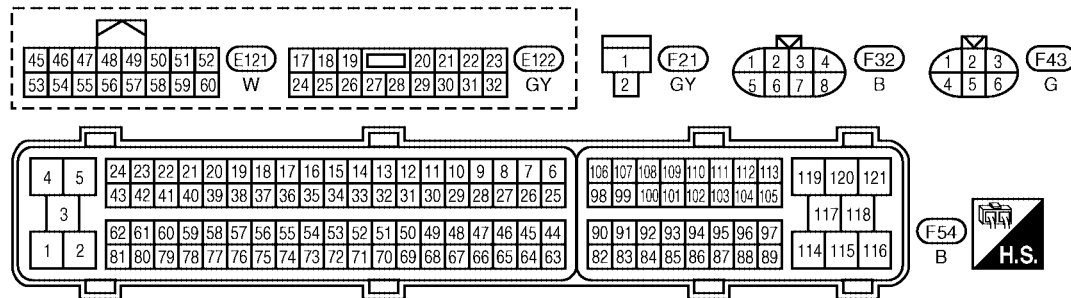
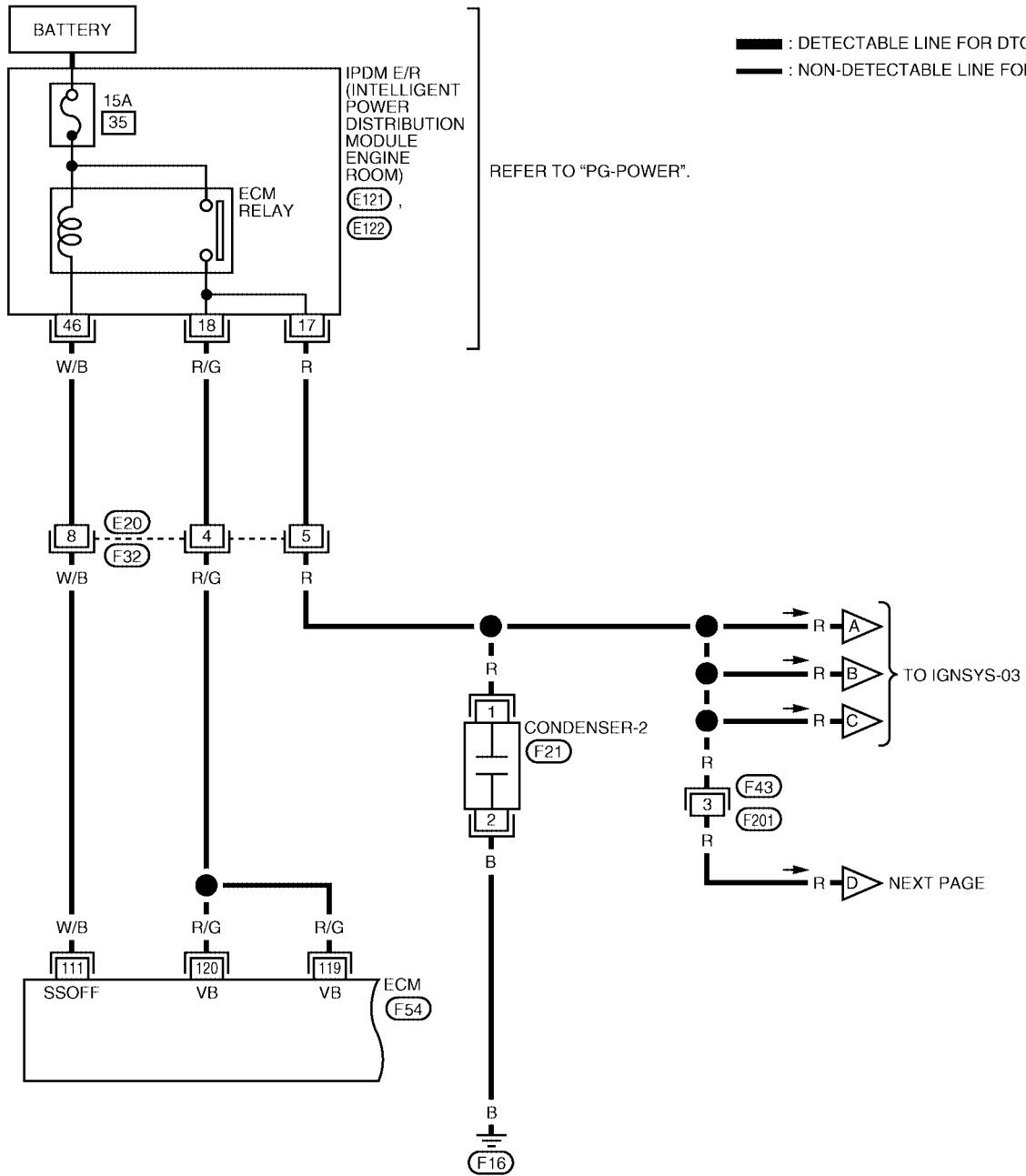

BBWA1576E

IGNITION SIGNAL

[VQ]

Specification data are reference values and are measured between each terminal and ground.

CAUTION:

Do not use ECM ground terminals when measuring input/output voltage. Doing so may result in damage to the ECM's transistor. Use a ground other than ECM terminals, such as the ground.

TER-MINAL NO.	WIRE COLOR	ITEM	CONDITION	DATA (DC Voltage)
111	W/B	ECM relay (Self shut-off)	[Engine is running] [Ignition switch: OFF] ● For a few seconds after turning ignition switch OFF	0 - 1.5V
			[Ignition switch: OFF] ● More than a few seconds after turning ignition switch OFF	BATTERY VOLTAGE (11 - 14V)
119 120	R/G R/G	Power supply for ECM	[Ignition switch: ON]	BATTERY VOLTAGE (11 - 14V)

A
EC
C
D
E
F
G
H
I
J
K
L
M

IGNITION SIGNAL

[VQ]

EC-IGNSYS-02

— : DETECTABLE LINE FOR DTC
 - - - : NON-DETECTABLE LINE FOR DTC

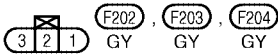
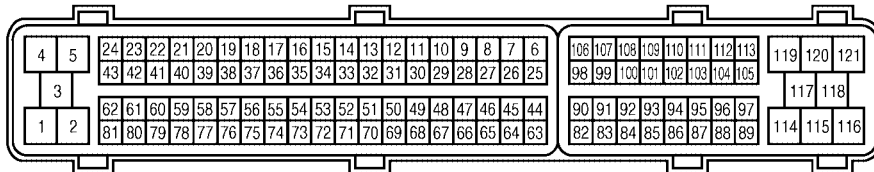
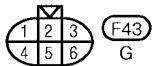
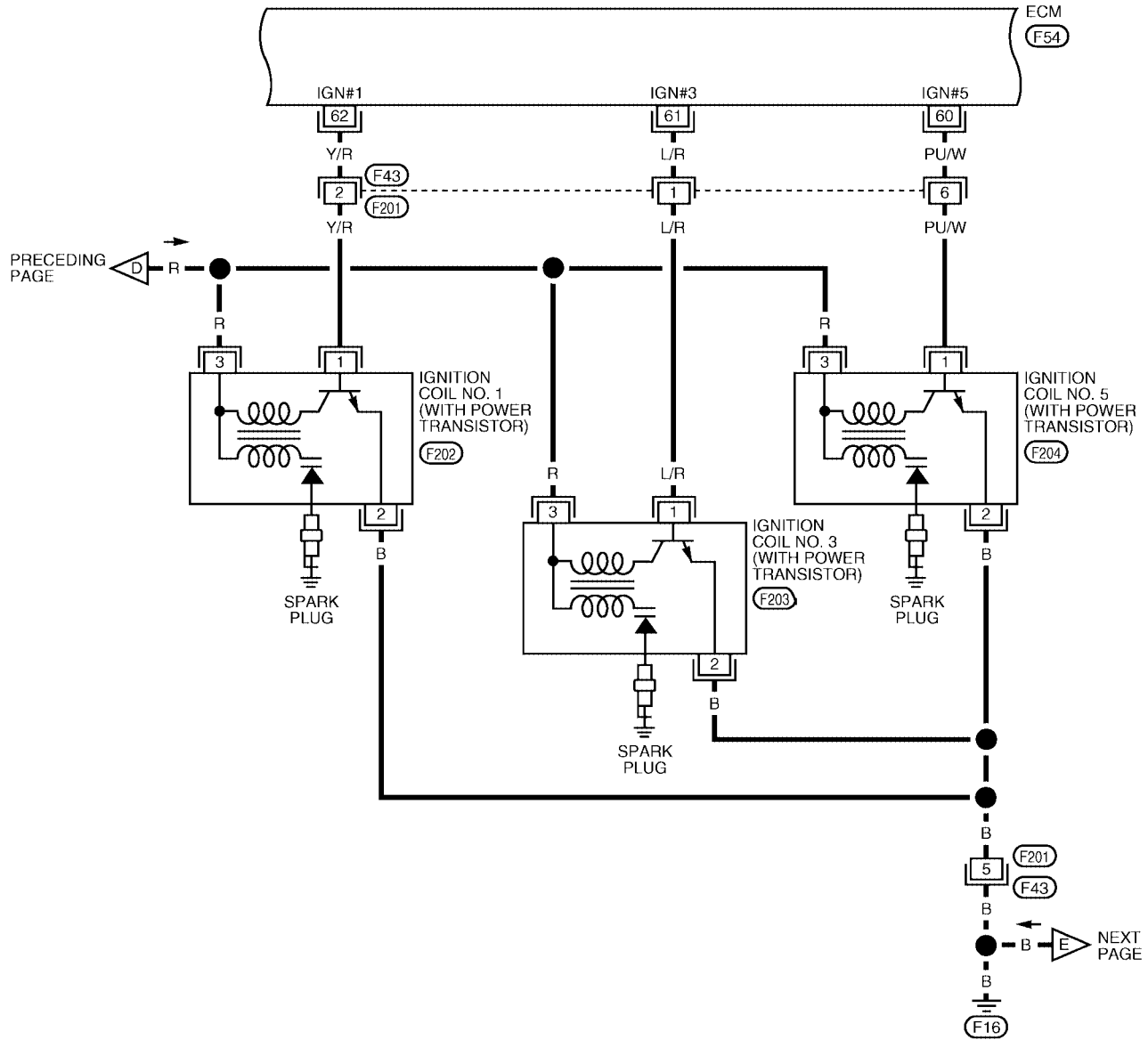

BBWA1311E

IGNITION SIGNAL

[VQ]

Specification data are reference values and are measured between each terminal and ground.
Pulse signal is measured by CONSULT-II.

CAUTION:

Do not use ECM ground terminals when measuring input/output voltage. Doing so may result in damage to the ECM's transistor. Use a ground other than ECM terminals, such as the ground.

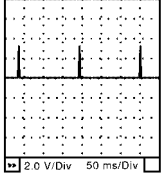
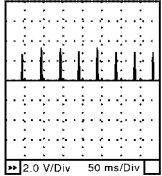
TER-MINAL NO.	WIRE COLOR	ITEM	CONDITION	DATA (DC Voltage)
60 61 62	PU/W L/R Y/R	Ignition signal No. 5 Ignition signal No. 3 Ignition signal No. 1	<p>[Engine is running]</p> <ul style="list-style-type: none"> ● Warm-up condition ● Idle speed <p>NOTE: The pulse cycle changes depending on rpm at idle.</p>	<p>0 - 0.3V★</p> 
			<p>[Engine is running]</p> <ul style="list-style-type: none"> ● Warm-up condition ● Engine speed is 2,500 rpm. 	<p>0.1 - 0.6V★</p> 

★: Average voltage for pulse signal (Actual pulse signal can be confirmed by oscilloscope.)

IGNITION SIGNAL

[VQ]

EC-IGNSYS-03

— : DETECTABLE LINE FOR DTC
 - - - : NON-DETECTABLE LINE FOR DTC

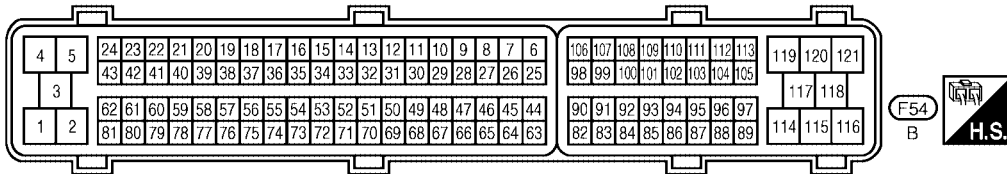
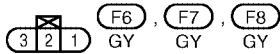
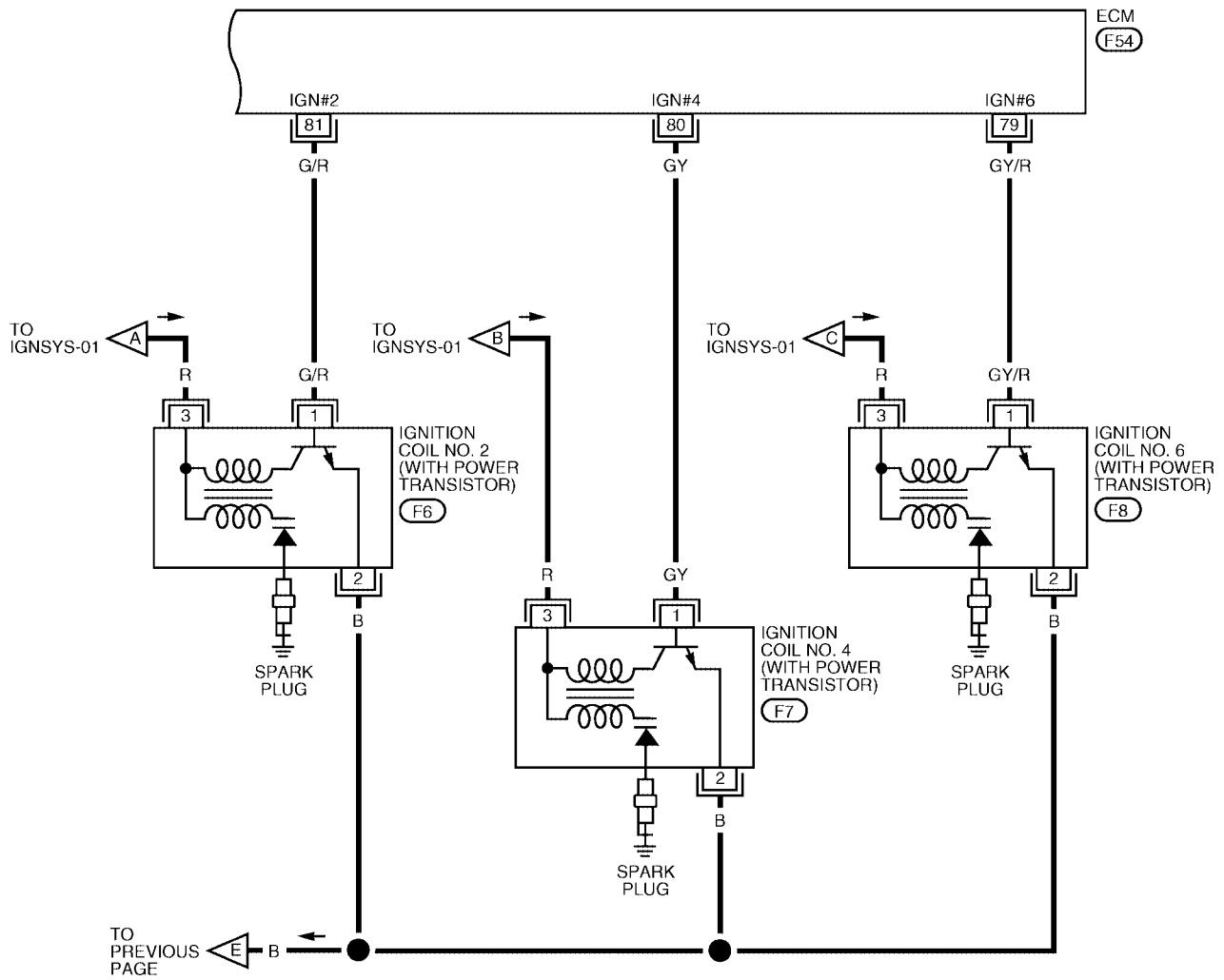

BBWA1312E

IGNITION SIGNAL

[VQ]

Specification data are reference values and are measured between each terminal and ground.
Pulse signal is measured by CONSULT-II.

CAUTION:

Do not use ECM ground terminals when measuring input/output voltage. Doing so may result in damage to the ECM's transistor. Use a ground other than ECM terminals, such as the ground.

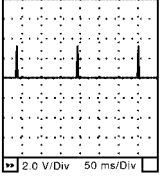
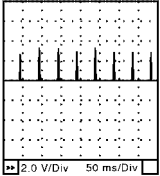
TER-MINAL NO.	WIRE COLOR	ITEM	CONDITION	DATA (DC Voltage)
79 80 81	GY/R GY G/R	Ignition signal No. 6 Ignition signal No. 4 Ignition signal No. 2	<p>[Engine is running]</p> <ul style="list-style-type: none"> ● Warm-up condition ● Idle speed <p>NOTE: The pulse cycle changes depending on rpm at idle.</p>	<p>0 - 0.3V★</p> 
			<p>[Engine is running]</p> <ul style="list-style-type: none"> ● Warm-up condition ● Engine speed is 2,500 rpm. 	<p>0.1 - 0.6V★</p> 

★: Average voltage for pulse signal (Actual pulse signal can be confirmed by oscilloscope.)

Diagnostic Procedure

UBS001EP

1. CHECK ENGINE START

Turn ignition switch OFF, and restart engine.

Is engine running?

Yes or No

- Yes (With CONSULT-II)>>GO TO 2.
- Yes (Without CONSULT-II)>>GO TO 3.
- No >> GO TO 4.

2. CHECK OVERALL FUNCTION

With CONSULT-II

- Perform "POWER BALANCE" in "ACTIVE TEST" mode with CONSULT-II.
- Make sure that each circuit produces a momentary engine speed drop.

OK or NG

- OK >> **INSPECTION END**
- NG >> GO TO 10.

ACTIVE TEST	
POWER BALANCE	
MONITOR	
ENG SPEED	XXX rpm
MAS A/F SE-B1	XXX V

PBIB0133E

3. CHECK OVERALL FUNCTION

⊗ **Without CONSULT-II**

1. Let engine idle.
2. Read the voltage signal between ECM terminals 60, 61, 62, 79, 80, 81 and ground with an oscilloscope.
3. Verify that the oscilloscope screen shows the signal wave as shown below.

NOTE:

The pulse cycle changes depending on rpm at idle.

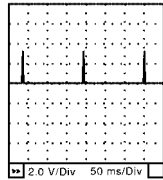

SEC986C

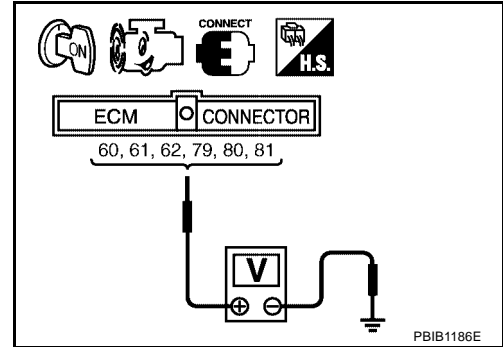

PBIB1186E

OK or NG

- OK >> **INSPECTION END**
 NG >> GO TO 10.

4. CHECK IGNITION COIL POWER SUPPLY CIRCUIT-I

1. Turn ignition switch OFF, wait at least 10 seconds and then turn ON.
2. Check voltage between ECM terminals 119, 120 and ground with CONSULT-II or tester.

Voltage: Battery voltage

OK or NG

- OK >> GO TO 5.
 NG >> Go to [EC-783, "POWER SUPPLY AND GROUND CIRCUIT"](#).

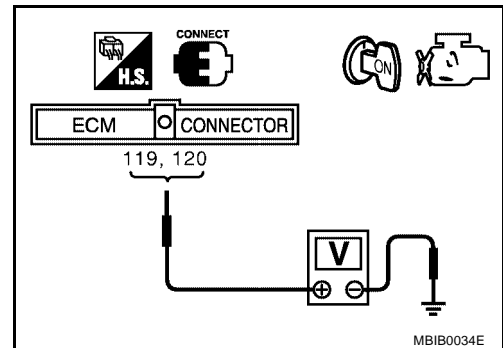

MBIB0034E

5. CHECK IGNITION COIL POWER SUPPLY CIRCUIT-II

1. Turn ignition switch OFF.
2. Disconnect condenser harness connector.
3. Turn ignition switch ON.

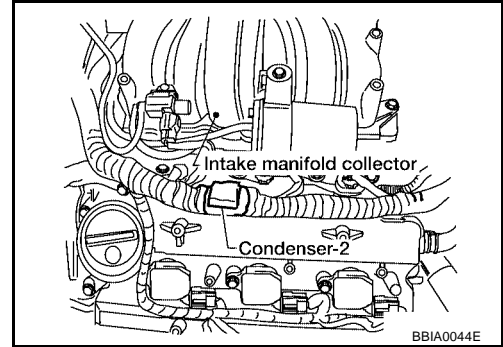

4. Check voltage between condenser terminal 1 and ground with CONSULT-II or tester.

Voltage: Battery voltage

OK or NG

- OK >> GO TO 8.
- NG >> GO TO 6.

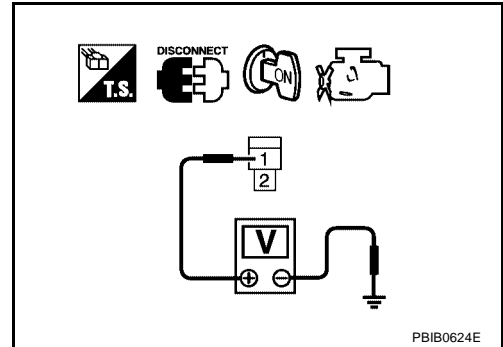

6. CHECK IGNITION COIL POWER SUPPLY CIRCUIT-III

1. Turn ignition switch OFF.
2. Disconnect IPDM E/R harness connector E122.
3. Check harness continuity between IPDM E/R terminal 17 and condenser terminal 1. Refer to Wiring Diagram.

Continuity should exist.

4. Also check harness for short to ground and short to power.

OK or NG

- OK >> GO TO 17.
- NG >> GO TO 7.

7. DETECT MALFUNCTIONING PART

Check the following.

- Harness connectors E20, F32
- Harness for open or short between IPDM E/R and condenser

>> Repair open circuit or short to ground or short to power in harness or connectors.

8. CHECK CONDENSER GROUND CIRCUIT FOR OPEN AND SHORT

1. Turn ignition switch OFF.
2. Check harness continuity between condenser terminal 2 and ground.
Refer to Wiring Diagram.

Continuity should exist.

3. Also check harness for short to power.

OK or NG

OK >> GO TO 9.

NG >> Repair open circuit or short to power in harness or connectors.

9. CHECK CONDENSER

Refer to [EC-1298, "Component Inspection"](#) .

OK or NG

OK >> GO TO 10.

NG >> Replace condenser.

10. CHECK IGNITION COIL POWER SUPPLY CIRCUIT-IV

1. Turn ignition switch OFF.
2. Reconnect all harness connectors disconnected.
3. Disconnect ignition coil harness connector.

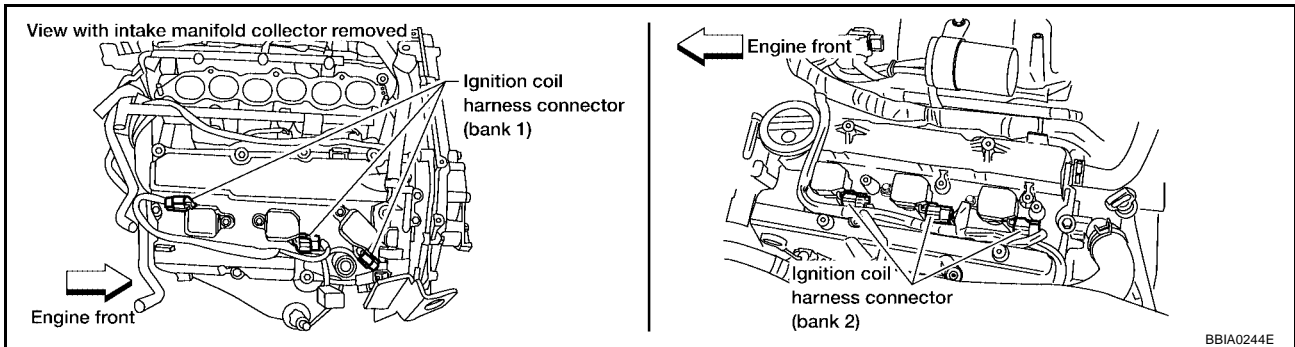

4. Turn ignition switch ON.
5. Check voltage between ignition coil terminal 3 and ground with CONSULT-II or tester.

Voltage: Battery voltage

OK or NG

OK >> GO TO 12.

NG >> GO TO 11.

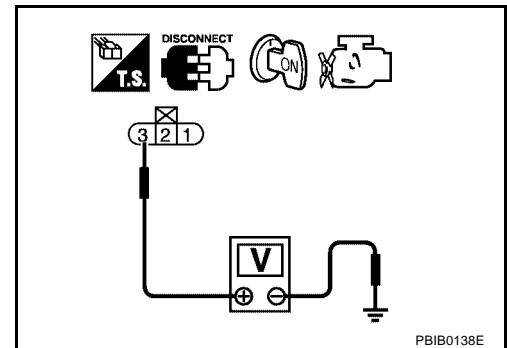

11. DETECT MALFUNCTIONING PART

Check the following.

- Harness connectors F43, F201
- Harness for open or short between ignition coil and harness connector F32

>> Repair or replace harness or connectors.

12. CHECK IGNITION COIL GROUND CIRCUIT FOR OPEN AND SHORT

1. Turn ignition switch OFF.
2. Check harness continuity between ignition coil terminal 2 and ground.
Refer to Wiring Diagram.

Continuity should exist.

3. Also check harness for short to power.

OK or NG

- OK >> GO TO 14.
- NG >> GO TO 13.

13. DETECT MALFUNCTIONING PART

Check the following.

- Harness connectors F43, F201
- Harness for open or short between ignition coil and ground

>> Repair open circuit or short to power in harness or connectors.

14. CHECK IGNITION COIL OUTPUT SIGNAL CIRCUIT FOR OPEN AND SHORT

1. Disconnect ECM harness connector.
2. Check harness continuity between ECM terminals 60, 61, 62, 79, 80, 81 and ignition coil terminal 1.
Refer to Wiring Diagram.

Continuity should exist.

3. Also check harness for short to ground and short to power.

OK or NG

- OK >> GO TO 16.
- NG >> GO TO 15.

15. DETECT MALFUNCTIONING PART

Check the following.

- Harness connectors F43, F201
- Harness for open or short between ignition coil and ECM

>> Repair open circuit or short to ground or short to power in harness or connectors.

16. CHECK IGNITION COIL WITH POWER TRANSISTOR

Refer to [EC-1298, "Component Inspection"](#) .

OK or NG

- OK >> GO TO 17.
- NG >> Replace ignition coil with power transistor.

17. CHECK INTERMITTENT INCIDENT

Refer to [EC-782, "TROUBLE DIAGNOSIS FOR INTERMITTENT INCIDENT"](#) .

OK or NG

- OK >> Replace IPDM E/R.
- NG >> Repair open circuit or short to ground or short to power in harness connectors.

Component Inspection IGNITION COIL WITH POWER TRANSISTOR

CAUTION:

Do the following procedure in the place where ventilation is good without the combustible.

1. Turn ignition switch OFF.
2. Disconnect ignition coil harness connector.
3. Check resistance between ignition coil terminals as follows.

Terminal No. (Polarity)	Resistance Ω [at 25°C (77°F)]
1 and 2	Except 0 or ∞
1 and 3	Except 0
2 and 3	

4. If NG, Replace ignition coil with power transistor.
If OK, go to next step.
5. Turn ignition switch OFF.
6. Reconnect all harness connectors disconnected.
7. Remove fuel pump fuse in IPDM E/R to release fuel pressure.

NOTE:

Do not use CONSULT-II to release fuel pressure, or fuel pressure applies again during the following procedure.

8. Start engine.
9. After engine stalls, crank it 2 or 3 times to release all fuel pressure.
10. Turn ignition switch OFF.
11. Remove ignition coil harness connectors to avoid the electrical discharge from the ignition coils.
12. Remove ignition coil and spark plug of the cylinder to be checked.
13. Crank engine for 5 seconds or more to remove combustion gas in the cylinder.
14. Connect spark plug and harness connector to ignition coil.
15. Fix ignition coil using a rope etc. with gap of 13 - 17 mm between the edge of the spark plug and grounded metal portion as shown in the figure.
16. Crank engine for about three seconds, and check whether spark is generated between the spark plug and the grounded part.

Spark should be generated.

CAUTION:

- Do not approach to the spark plug and the ignition coil within 50cm. Be careful not to get an electrical shock while checking, because the electrical discharge voltage becomes 20kV or more.

- It might cause to damage the ignition coil if the gap of 17 mm or more is taken.

NOTE:

When the gap is 13 mm or less, the spark might be generated even if the coil is malfunctioning.

17. If NG, Replace ignition coil with power transistor.

CONDENSER

1. Turn ignition switch OFF.
2. Disconnect condenser harness connector.

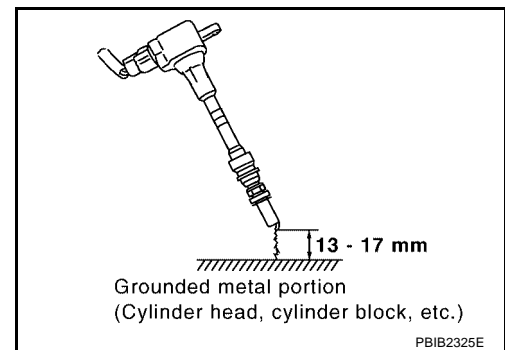
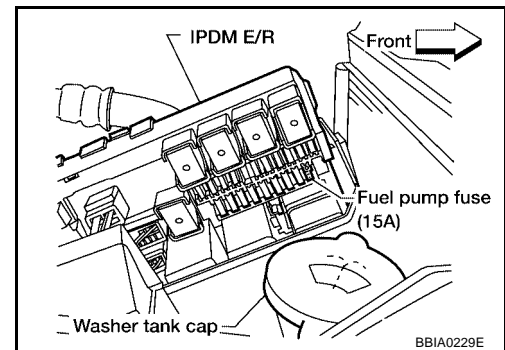
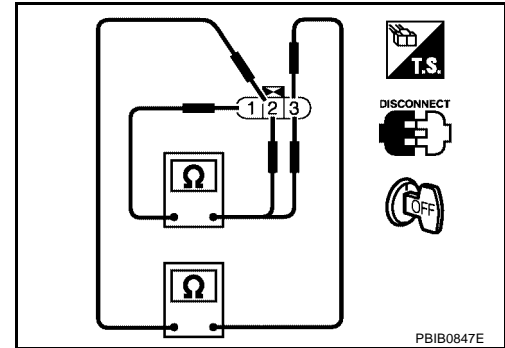

IGNITION SIGNAL

[VQ]

3. Check resistance between condenser terminals 1 and 2.

Resistance : Above 1 MΩ [at 25°C (77°F)]

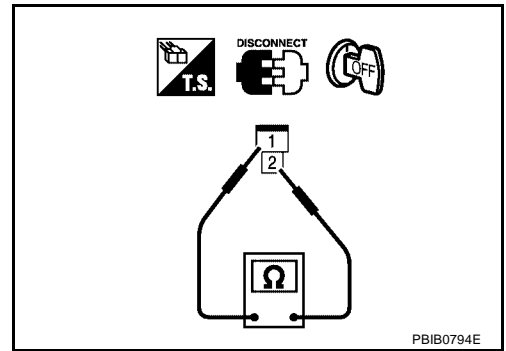

Removal and Installation IGNITION COIL WITH POWER TRANSISTOR

Refer to [EM-144, "IGNITION COIL"](#) .

A
EC
C
D
E
F
G
H
I
J
K
L
M

VIAS

**Description
SYSTEM DESCRIPTION**

Sensor	Input Signal to ECM	ECM function	Actuator
Crankshaft position sensor (POS) Camshaft position sensor (PHASE)	Engine speed*	VIAS control	VIAS control solenoid valve
Mass air flow sensor	Amount of intake air		
Engine coolant temperature sensor	Engine coolant temperature		
Throttle position sensor	Throttle position		
Accelerator pedal position sensor	Accelerator pedal position		
Battery	Battery voltage*		

*: ECM determines the start signal status by the signals of engine speed and battery voltage.

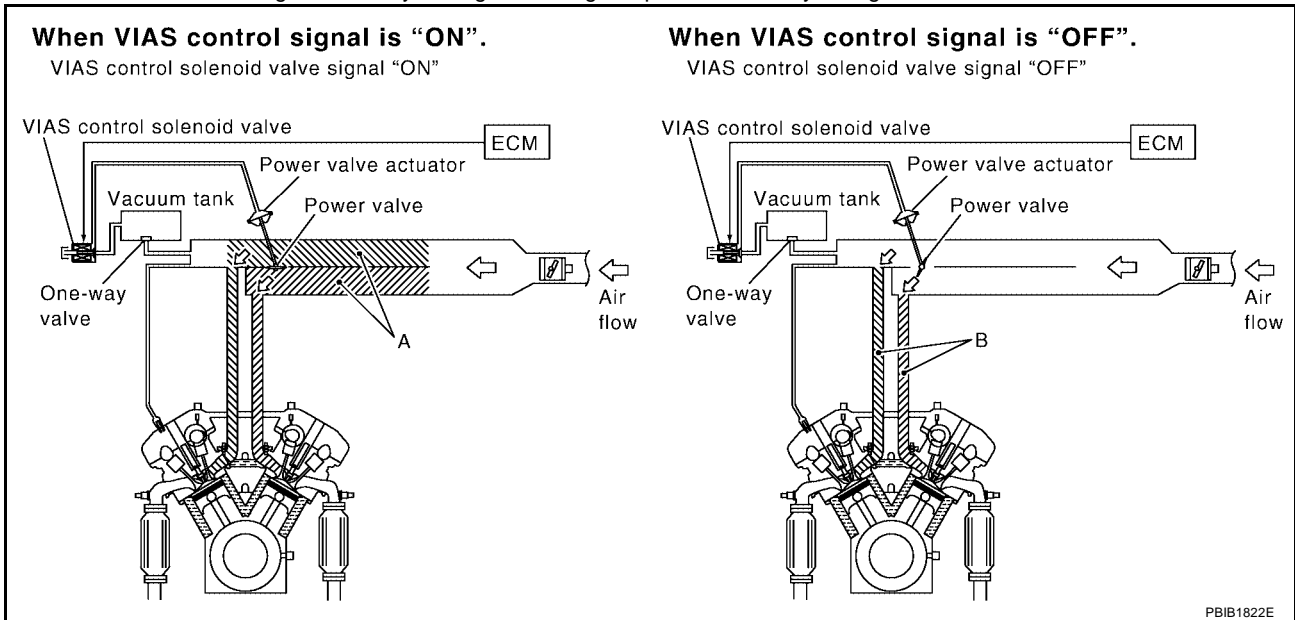

When the engine is running at medium speed, the ECM sends the ON signal to the VIAS control solenoid valve. This signal introduces the intake manifold vacuum into the power valve actuator and therefore closes the power valve.

Under this condition, the effective intake manifold length is equivalent to the total length of passage A and passage B. This long intake manifold provides increased amount of intake air, which results in improved suction efficiency and higher torque.

When engine is running at low or high speed, the ECM sends the OFF signal to the VIAS control solenoid valve and the power valve is opened.

Under this condition, the effective intake manifold length is equivalent to the length of passage B. This shortened intake manifold length results in enhanced engine output due to reduced suction resistance under high speeds.

COMPONENT DESCRIPTION

Power Valve

The power valve is installed in intake manifold collector and used to control the suction passage of the variable induction air control system. It is set in the fully closed or fully opened position by the power valve actuator operated by the vacuum stored in the surge tank. The vacuum in the surge tank is controlled by the VIAS control solenoid valve.

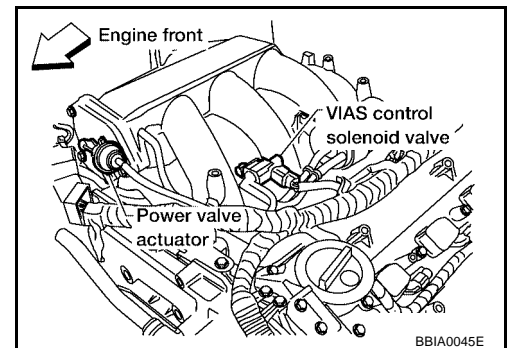

VIAS Control Solenoid Valve

The VIAS control solenoid valve cuts the intake manifold vacuum signal for power valve actuator. It responds to ON/OFF signals from the ECM. When the solenoid is off, the vacuum signal from the intake manifold is cut. When the ECM sends an ON signal the coil pulls the plunger downward and feeds the vacuum signal to the power valve actuator.

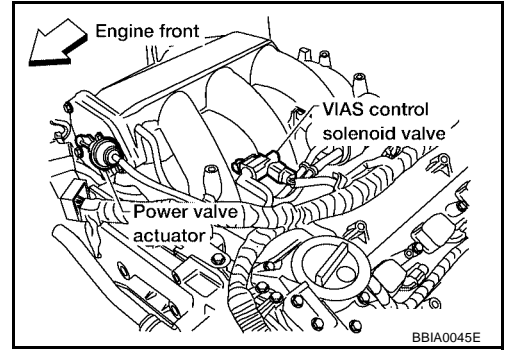

CONSULT-II Reference Value in Data Monitor Mode

UBS001ET

Specification data are reference values.

MONITOR ITEM	CONDITION		SPECIFICATION
VIAS S/V	● Engine: After warming up	1,800 - 3,600 rpm	ON
		Except above conditions	OFF

A
EC
C
D
E
F
G
H
I
J
K
L
M

Wiring Diagram

UBS001EU

EC-VIAS-01

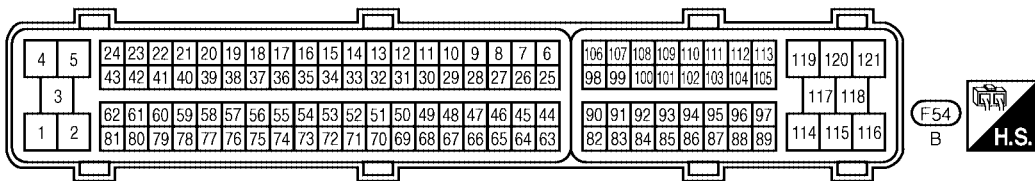
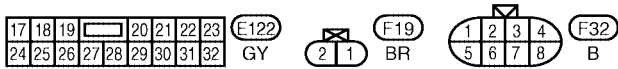
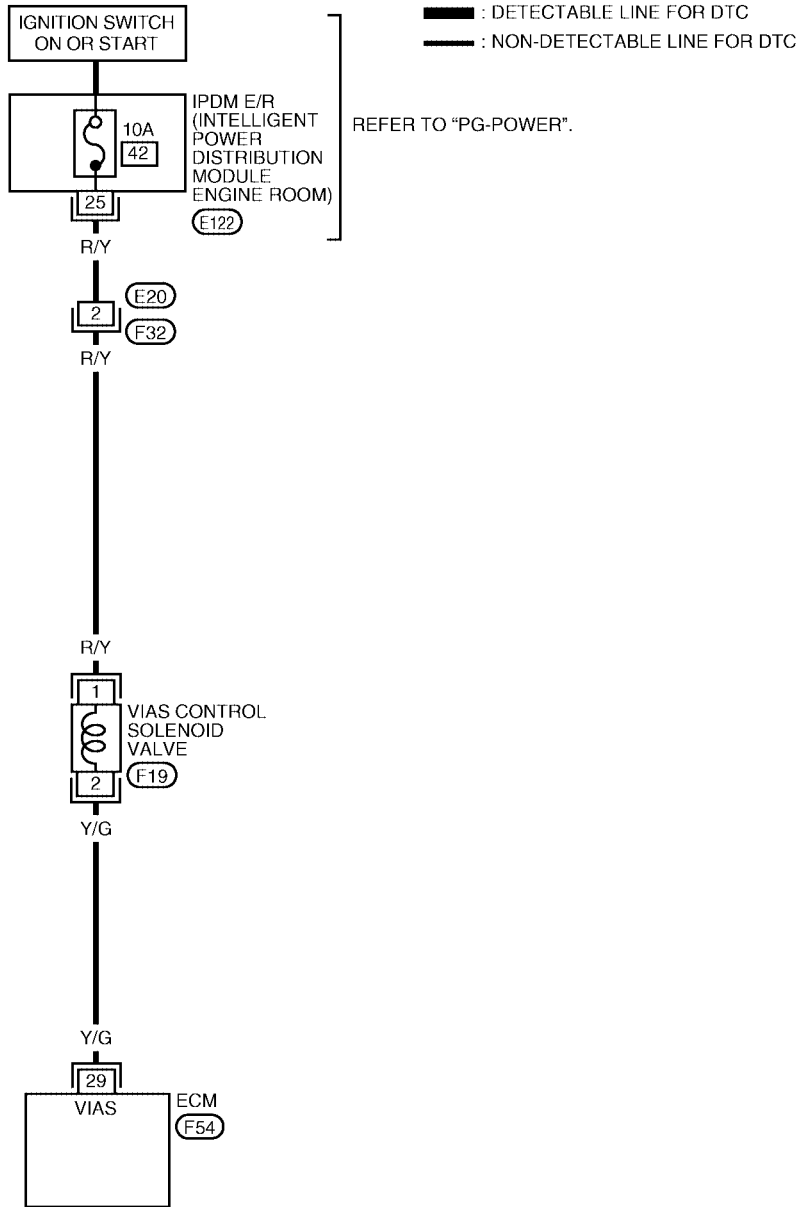

BBWA1313E

Specification data are reference values and are measured between each terminal and ground.

CAUTION:

Do not use ECM ground terminals when measuring input/output voltage. Doing so may result in damage to the ECM's transistor. Use a ground other than ECM terminals, such as the ground.

TER-MINAL NO.	WIRE COLOR	ITEM	CONDITION	DATA (DC Voltage)
29	Y/G	VIAS control solenoid valve	[Engine is running] ● Idle speed	BATTERY VOLTAGE (11 - 14V)
			[Engine is running] ● Engine speed is between 1,800 and 3,600 rpm.	0 - 1.0V

Diagnostic Procedure

UBS001EV

1. CHECK OVERALL FUNCTION

With CONSULT-II

1. Start engine and warm it up to normal operating temperature.
2. Perform "VIAS SOL VALVE" in "ACTIVE TEST" mode with CONSULT-II.
3. Turn VIAS control solenoid valve "ON" and "OFF", and make sure that power valve actuator rod moves.

ACTIVE TEST	
VIAS SOL VALVE	OFF
MONITOR	
ENG SPEED	XXX rpm

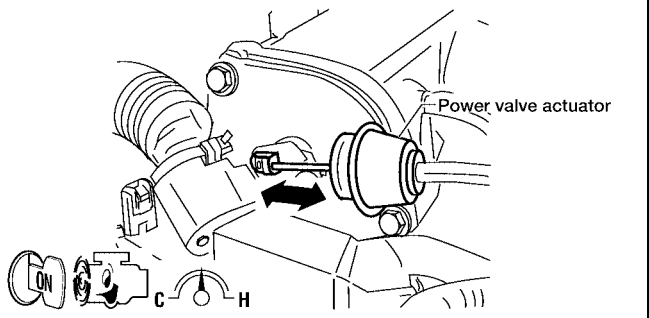

BBIA0252E

Without CONSULT-II

1. Start engine and warm it up to normal operating temperature.
2. Rev engine up to 3,600 rpm and make sure that power valve actuator rod moves.

OK or NG

- OK >> **INSPECTION END**
- NG (With CONSULT-II) >>GO TO 2.
- NG (Without CONSULT-II) >>GO TO 3.

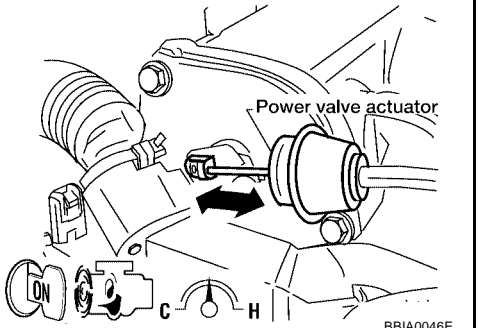

BBIA0046E

2. CHECK VACUUM EXISTENCE

With CONSULT-II

1. Stop engine and disconnect vacuum hose connected to power valve actuator.
2. Start engine and let it idle.
3. Perform "VIAS SOL VALVE" in "ACTIVE TEST" mode with CONSULT-II.
4. Turn VIAS control solenoid valve "ON" and "OFF", and check vacuum existence under the following conditions.

ACTIVE TEST	
VIAS SOL VALVE	OFF
MONITOR	
ENG SPEED	XXX rpm

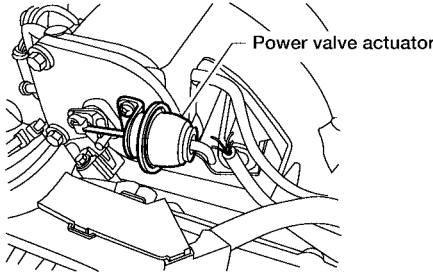

BBIA0253E

VIAS SOL VALVE	Vacuum
ON	Should exist.
OFF	Should not exist.

OK or NG

- OK >> Repair or replace power valve actuator.
- NG >> GO TO 4.

3. CHECK VACUUM EXISTENCE

Without CONSULT-II

1. Stop engine and disconnect vacuum hose connected to power valve actuator.
2. Disconnect VIAS control solenoid valve harness connector.
3. Start engine and let it idle.
4. Apply 12V of direct current between VIAS control solenoid valve terminals 1 and 2.

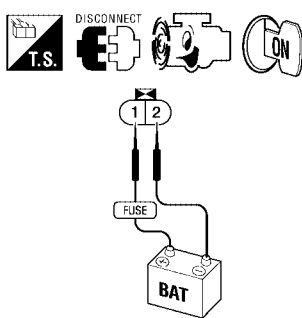
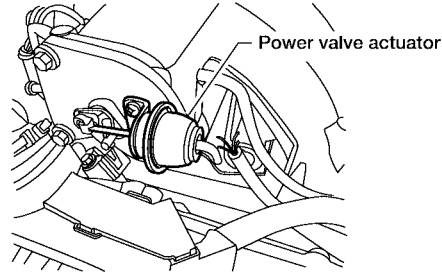
BBIA0254E

5. Check vacuum existence under the following conditions.

Condition	Vacuum
12V direct current supply	Should exist.
No supply	Should not exist.

OK or NG

- OK >> Repair or replace power valve actuator.
- NG >> GO TO 4.

4. CHECK VACUUM HOSE

1. Stop engine.
2. Check hoses and tubes between intake manifold and power valve actuator for crack, clogging, improper connection or disconnection. Refer to [EC-736, "Vacuum Hose Drawing"](#).

OK or NG

- OK >> GO TO 5.
 NG >> Repair hoses or tubes.

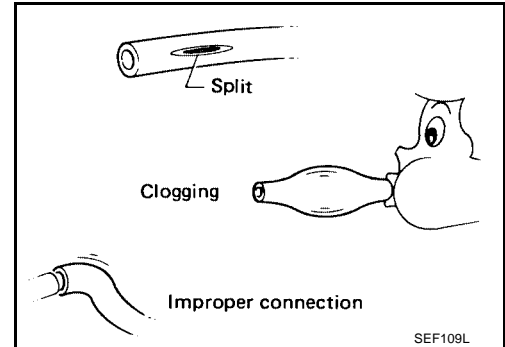

5. CHECK VACUUM TANK

Refer to [EC-1306, "Component Inspection"](#).

OK or NG

- OK >> GO TO 6.
 NG >> Replace vacuum tank.

6. CHECK VIAS CONTROL SOLENOID VALVE POWER SUPPLY CIRCUIT

1. Turn ignition switch OFF.
2. Disconnect VIAS control solenoid valve harness connector.
3. Turn ignition switch ON.

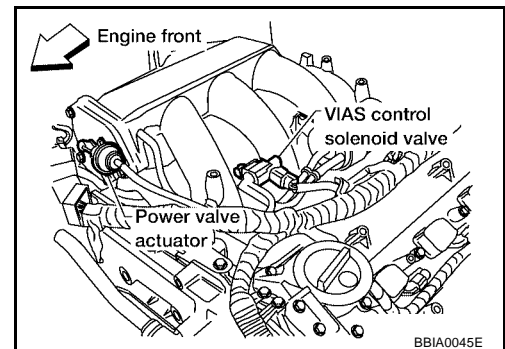

4. Check voltage between terminal 1 and ground with CONSULT-II or tester.

Voltage: Battery voltage

OK or NG

- OK >> GO TO 8.
 NG >> GO TO 7.

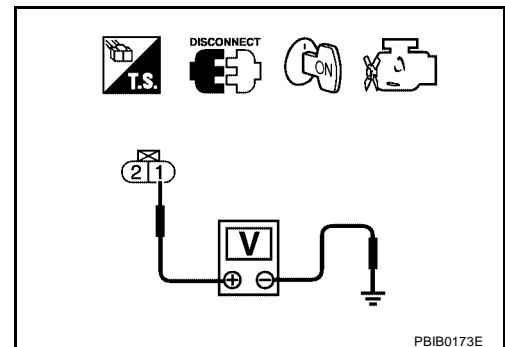

7. DETECT MALFUNCTIONING PART

Check the following.

- Harness connectors E20, F32
- IPDM E/R connector E122
- 10A fuse
- Harness for open or short between VIAS control solenoid valve and fuse

>> Repair open circuit or short to ground or short to power in harness or connectors.

8. CHECK VIAS CONTROL SOLENOID VALVE OUTPUT SIGNAL CIRCUIT FOR OPEN AND SHORT

1. Turn ignition switch OFF.
2. Disconnect ECM harness connector.
3. Check harness continuity between ECM terminal 29 and VIAS control solenoid valve terminal 2. Refer to Wiring Diagram.

Continuity should exist.

4. Also check harness for short to ground and short to power.

OK or NG

OK >> GO TO 9.

NG >> Repair open circuit or short to ground or short to power in harness or connectors.

9. CHECK VIAS CONTROL SOLENOID VALVE

Refer to [EC-1306, "Component Inspection"](#) .

OK or NG

OK >> GO TO 10.

NG >> Replace VIAS control solenoid valve.

10. CHECK INTERMITTENT INCIDENT

Refer to [EC-782, "TROUBLE DIAGNOSIS FOR INTERMITTENT INCIDENT"](#) .

>> **INSPECTION END**

Component Inspection VIAS CONTROL SOLENOID VALVE

UBS001EW

Ⓟ With CONSULT-II

1. Reconnect harness connectors disconnected.
2. Turn ignition switch ON.
3. Perform "VIAS SOL VALVE" in "ACTIVE TEST" mode.
4. Check air passage continuity and operation delay time under the following conditions.

Condition VIAS SOL VALVE	Air passage continuity between A and B	Air passage continuity between A and C
ON	Yes	No
OFF	No	Yes

Operation takes less than 1 second.

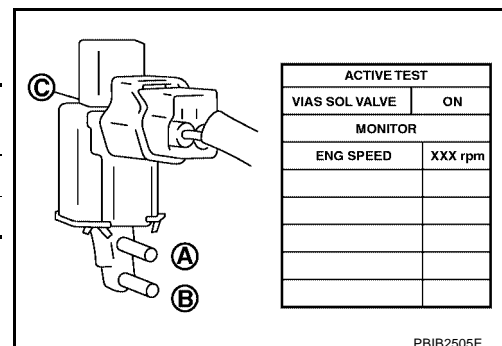

⊗ **Without CONSULT-II**

Check air passage continuity and operation delay time under the following conditions.

Condition	Air passage continuity between A and B	Air passage continuity between A and C
12V direct current supply between terminals 1 and 2	Yes	No
No supply	No	Yes

Operation takes less than 1 second.

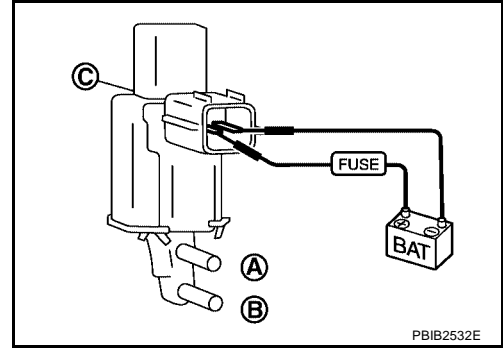

VACUUM TANK

1. Disconnect vacuum hose connected to vacuum tank.
2. Connect a vacuum pump to the port A of vacuum tank.
3. Apply vacuum and make sure that vacuum exists at the port B.

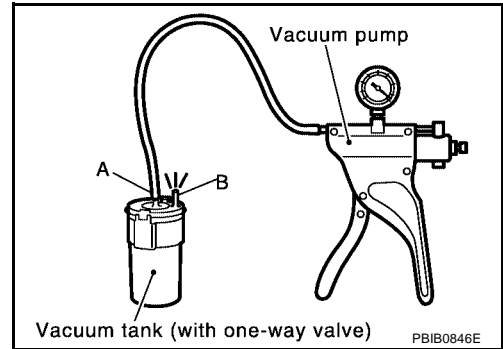

**Removal and Installation
VIAS CONTROL SOLENOID VALVE**

Refer to [EM-129, "INTAKE MANIFOLD"](#) .

A
EC
C
D
E
F
G
H
I
J
K
L
M

INJECTOR CIRCUIT

[VQ]

PFP:16600

UBS001EY

INJECTOR CIRCUIT

Component Description

The fuel injector is a small, precise solenoid valve. When the ECM supplies a ground to the injector circuit, the coil in the injector is energized. The energized coil pulls the ball valve back and allows fuel to flow through the injector into the intake manifold. The amount of fuel injected depends upon the injection pulse duration. Pulse duration is the length of time the injector remains open. The ECM controls the injection pulse duration based on engine fuel needs.

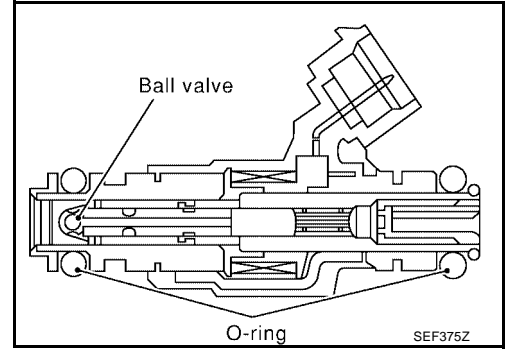

CONSULT-II Reference Value in Data Monitor Mode

UBS001EZ

Specification data are reference values.

MONITOR ITEM	CONDITION	SPECIFICATION
B/FUEL SCHDL	See EC-772, "TROUBLE DIAGNOSIS - SPECIFICATION VALUE" .	
INJ PULSE-B1 INJ PULSE-B2	● Engine: After warming up ● Shift lever: P or N (A/T), Neutral (M/T) ● Air conditioner switch: OFF ● No-load	Idle
	2,000 rpm	2.0 - 3.0 msec 1.9 - 2.9 msec

INJECTOR CIRCUIT

[VQ]

Wiring Diagram

UBS001F0

EC-INJECT-01

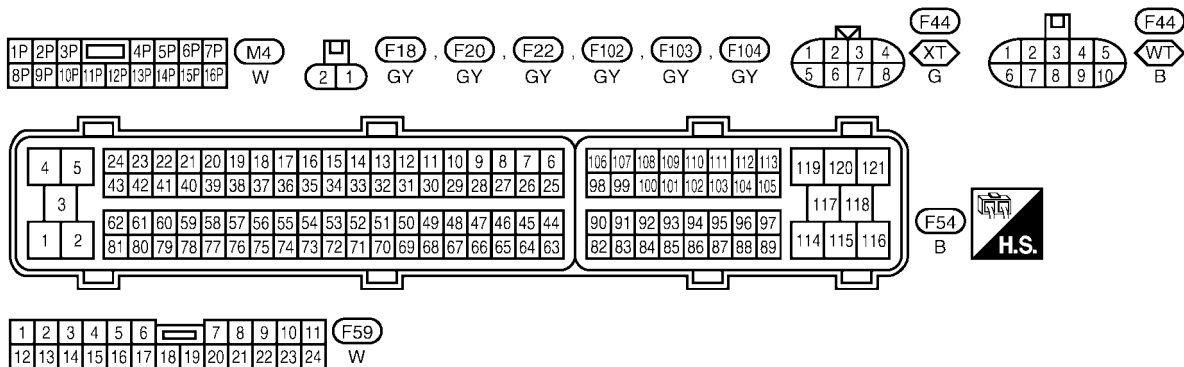
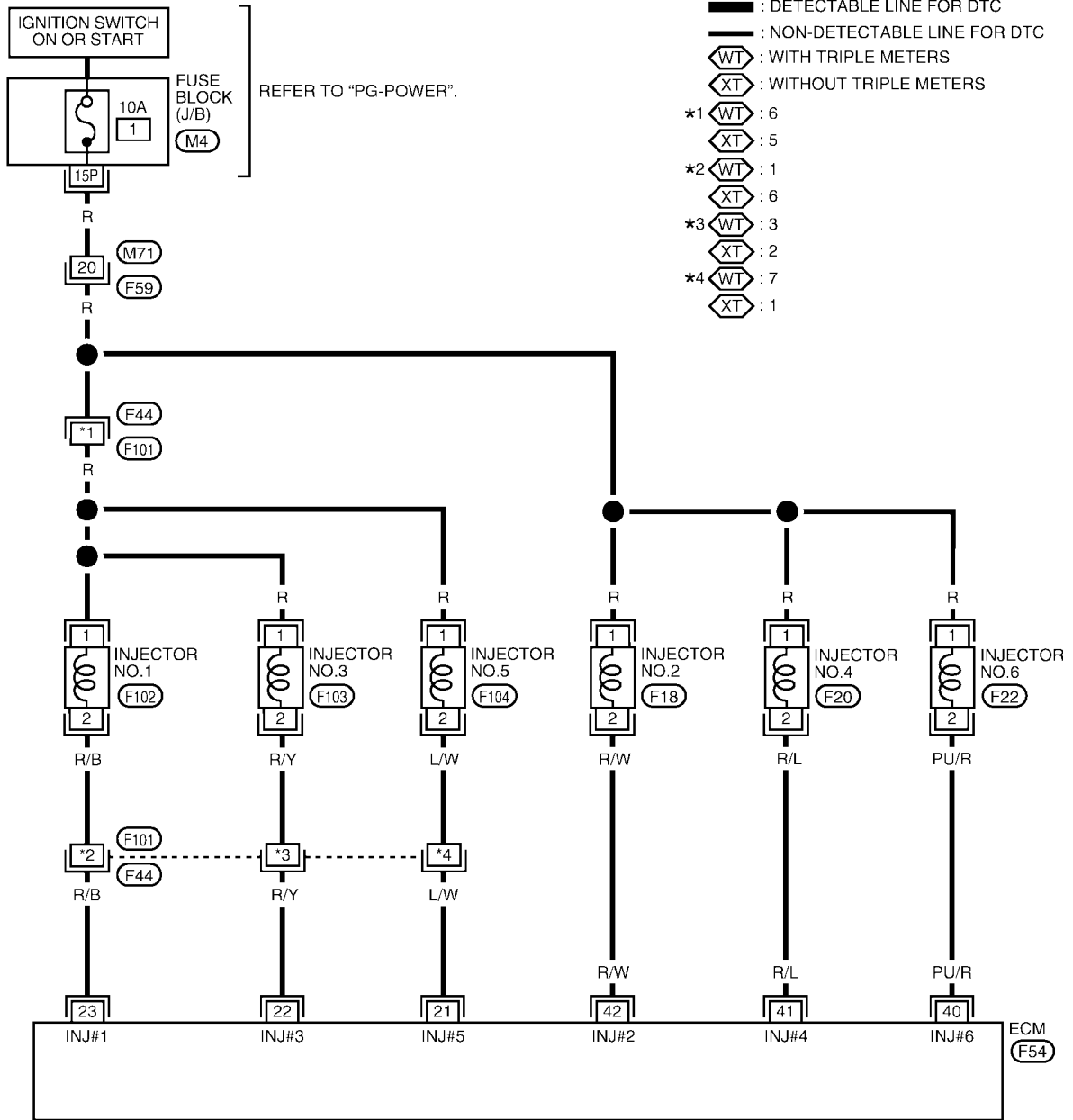

INJECTOR CIRCUIT

[VQ]

Specification data are reference values and are measured between each terminal and ground.
Pulse signal is measured by CONSULT-II.

CAUTION:

Do not use ECM ground terminals when measuring input/output voltage. Doing so may result in damage to the ECM's transistor. Use a ground other than ECM terminals, such as the ground.

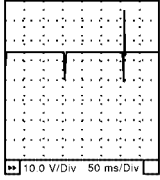
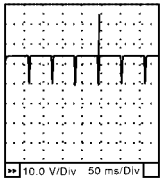
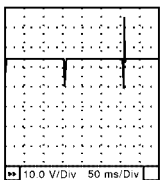
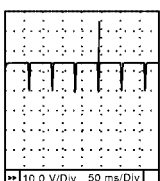
TER-MINAL NO.	WIRE COLOR	ITEM	CONDITION	DATA (DC Voltage)
21 22 23	L/W R/Y R/B	Injector No. 5 Injector No. 3 Injector No. 1	<p>[Engine is running]</p> <ul style="list-style-type: none"> ● Warm-up condition ● Idle speed <p>NOTE: The pulse cycle changes depending on rpm at idle.</p>	<p>BATTERY VOLTAGE (11 - 14V)★</p>  <p>SEC984C</p>
			<p>[Engine is running]</p> <ul style="list-style-type: none"> ● Warm-up condition ● Engine speed is 2,000 rpm. 	<p>BATTERY VOLTAGE (11 - 14V)★</p>  <p>SEC985C</p>
40 41 42	PU/R R/L R/W	Injector No. 6 Injector No. 4 Injector No. 2	<p>[Engine is running]</p> <ul style="list-style-type: none"> ● Warm-up condition ● Idle speed <p>NOTE: The pulse cycle changes depending on rpm at idle.</p>	<p>BATTERY VOLTAGE (11 - 14V)★</p>  <p>SEC984C</p>
			<p>[Engine is running]</p> <ul style="list-style-type: none"> ● Warm-up condition ● Engine speed is 2,000 rpm 	<p>BATTERY VOLTAGE (11 - 14V)★</p>  <p>SEC985C</p>

★: Average voltage for pulse signal (Actual pulse signal can be confirmed by oscilloscope.)

Diagnostic Procedure

UBS00IF1

1. INSPECTION START

Turn ignition switch to START.

Is any cylinder ignited?

Yes or No

- Yes (With CONSULT-II)>>GO TO 2.
- Yes (Without CONSULT-II)>>GO TO 3.
- No >> GO TO 7.

2. CHECK OVERALL FUNCTION

④ With CONSULT-II

1. Start engine.
2. Perform "POWER BALANCE" in "ACTIVE TEST" mode with CONSULT-II.
3. Make sure that each circuit produces a momentary engine speed drop.

ACTIVE TEST	
POWER BALANCE	
MONITOR	
ENG SPEED	XXX rpm
MAS A/F SE-B1	XXX V

PBIB0133E

OK or NG

- OK >> **INSPECTION END**
 NG >> GO TO 7.

A
EC
C
D
E
F
G
H
I
J
K
L
M

3. CHECK FUNCTION OF INJECTOR-I

⊗ **Without CONSULT-II**

1. Stop engine.
2. Disconnect harness connector F44, F101.
3. Turn ignition switch ON.

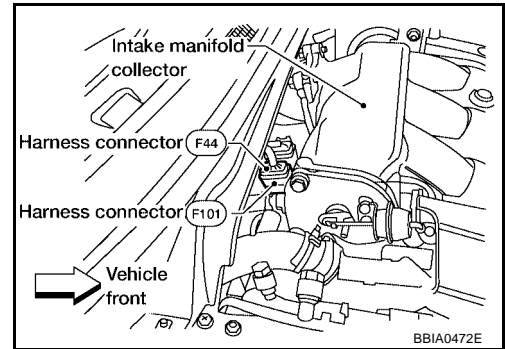

4. Check voltage between harness connector F44 terminal 6 (with triple meters) or 5 (without triple meters) and ground with CONSULT-II or tester.

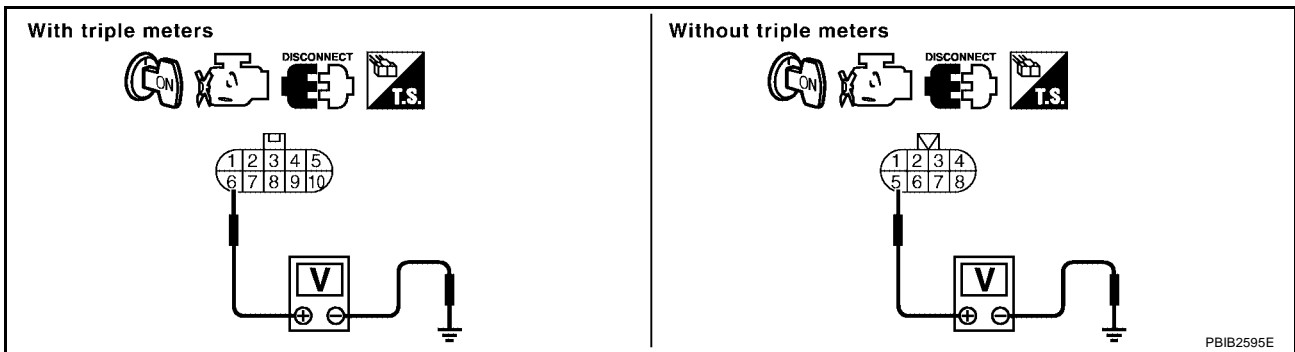

Voltage: Battery voltage

5. Turn ignition switch OFF.
6. Disconnect ECM harness connector.
7. Check harness continuity between harness connector F44 and ECM as follows. Refer to Wiring Diagram.

With triple meters

Cylinder	Harness connector F44 terminal	ECM terminal
1	1	23
3	3	22
5	7	21

Without triple meters

Cylinder	Harness connector F44 terminal	ECM terminal
1	6	23
3	2	22
5	1	21

Continuity should exist.

8. Also check harness for short to ground and short to power.

OK or NG

- OK >> GO TO 5.
- NG >> GO TO 4.

4. DETECT MALFUNCTIONING PART

Check the following.

- Harness connectors M71, F59
- Fuse block (J/B) connector M4
- 10A fuse
- Harness for open or short between harness connector F44 and fuse
- Harness for open or short between harness connector F101 and injector

>> Repair open circuit or short to ground or short to power in harness or connectors.

5. CHECK FUNCTION OF INJECTOR-II

Provide battery voltage between harness connector F101 as follows and then interrupt it. Listen to each injector operating sound.

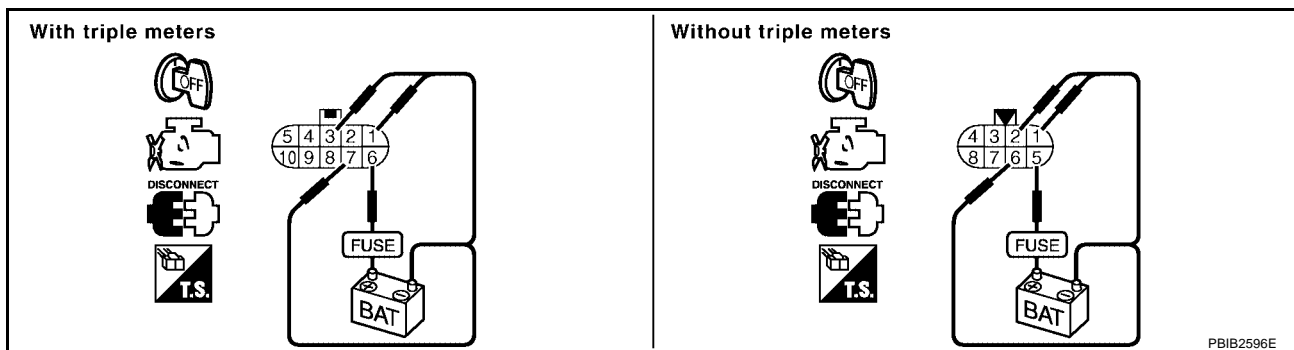

With triple meters

Cylinder	Harness connector F101 terminal	
	(+)	(-)
1	6	1
3	6	3
5	6	7

Without triple meters

Cylinder	Harness connector F101 terminal	
	(+)	(-)
1	5	6
3	5	2
5	5	1

Operating sound should exist.

OK or NG

- OK >> GO TO 6.
- NG >> GO TO 7.

6. CHECK FUNCTION OF INJECTOR-III

1. Reconnect all harness connector disconnected.
2. Start engine.
3. Listen to injectors No. 2, No. 4, No.6 operating sound.

Clicking noise should exist.

OK or NG

- OK >> **INSPECTION END**
 NG >> GO TO 7.

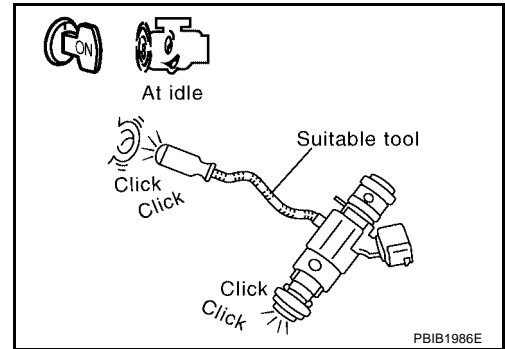

7. CHECK INJECTOR POWER SUPPLY CIRCUIT

1. Turn ignition switch OFF.
2. Disconnect injector harness connector.

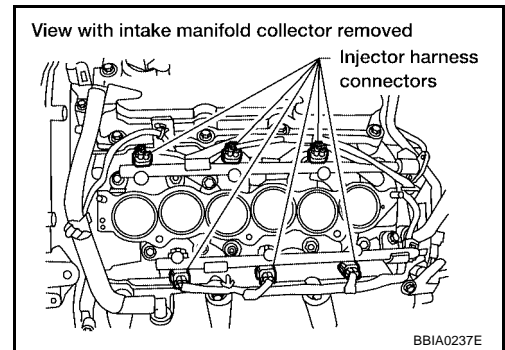

3. Turn ignition switch ON.
4. Check voltage between injector terminal 1 and ground with CONSULT-II or tester.

Voltage: Battery voltage

OK or NG

- OK >> GO TO 9.
 NG >> GO TO 8.

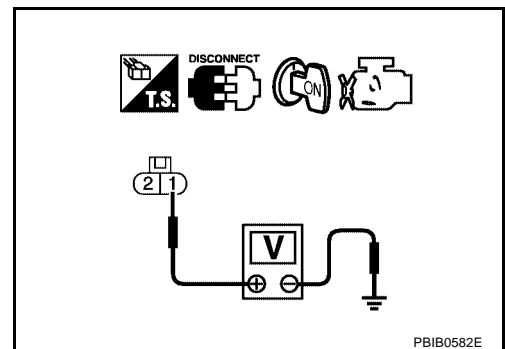

8. DETECT MALFUNCTIONING PART

Check the following.

- Harness connectors M71, F59
- Harness connectors F44, F101
- Fuse block (J/B) connector M4
- 10A fuse
- Harness for open or short between injector and fuse

>> Repair open circuit or short to ground or short to power in harness or connectors.

9. CHECK INJECTOR OUTPUT SIGNAL CIRCUIT FOR OPEN AND SHORT

1. Turn ignition switch OFF.
2. Disconnect ECM harness connector.
3. Check harness continuity between injector terminal 2 and ECM terminals 21, 22, 23, 40, 41, 42.
Refer to Wiring Diagram.

Continuity should exist.

4. Also check harness for short to ground and short to power.

OK or NG

- OK >> GO TO 11.
- NG >> GO TO 10.

10. DETECT MALFUNCTIONING PART

Check the following.

- Harness connectors F101, F44
- Harness for open or short between injector and ECM

>> Repair open circuit or short to ground or short to power in harness or connectors.

11. CHECK INJECTOR

Refer to [EC-1315, "Component Inspection"](#) .

OK or NG

- OK >> GO TO 12.
- NG >> Replace injector.

12. CHECK INTERMITTENT INCIDENT

Refer to [EC-782, "TROUBLE DIAGNOSIS FOR INTERMITTENT INCIDENT"](#) .

>> INSPECTION END

Component Inspection INJECTOR

UBS001F2

1. Disconnect injector harness connector.
2. Check resistance between terminals as shown in the figure.

Resistance: 11.5 - 15.5Ω [at 10 - 88°C (50 - 190°F)]

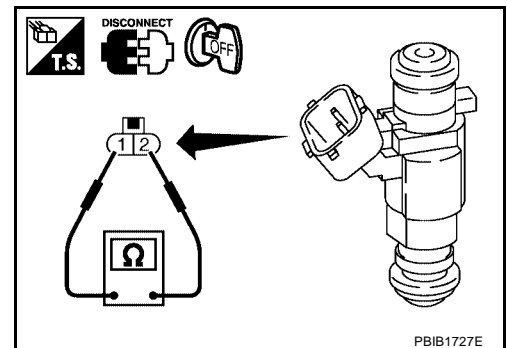

UBS001F3

Removal and Installation INJECTOR

Refer to [EM-147, "FUEL INJECTOR AND FUEL TUBE"](#) .

FUEL PUMP CIRCUIT

[VQ]

PF1:17042

UBS001F4

FUEL PUMP CIRCUIT

Description SYSTEM DESCRIPTION

Sensor	Input Signal to ECM	ECM Function	Actuator
Crankshaft position sensor (POS) Camshaft position sensor (PHASE)	Engine speed*	Fuel pump control	Fuel pump relay
Battery	Battery voltage*		

*: ECM determines the start signal status by the signals of engine speed and battery voltage.

The ECM activates the fuel pump for 1 second after the ignition switch is turned ON to improve engine start-ability. If the ECM receives a engine speed signal from the camshaft position sensor (PHASE), it knows that the engine is rotating, and causes the pump to operate. If the engine speed signal is not received when the ignition switch is ON, the engine stalls. The ECM stops pump operation and prevents battery discharging, thereby improving safety. The ECM does not directly drive the fuel pump. It controls the ON/OFF fuel pump relay, which in turn controls the fuel pump.

Condition	Fuel pump operation
Ignition switch is turned to ON.	Operates for 1 second.
Engine running and cranking	Operates.
When engine is stopped	Stops in 1.5 seconds.
Except as shown above	Stops.

COMPONENT DESCRIPTION

A turbine type design fuel pump is used in the fuel tank.

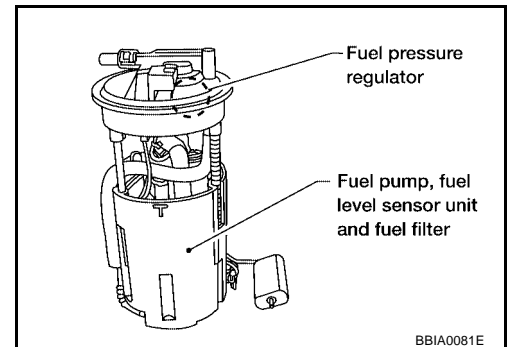

BBIA0081E

CONSULT-II Reference Value in Data Monitor Mode

UBS001F5

Specification data are reference values.

MONITOR ITEM	CONDITION	SPECIFICATION
FUEL PUMP RLY	<ul style="list-style-type: none"> For 1 second after turning ignition switch ON Engine running or cranking 	ON
	<ul style="list-style-type: none"> Except above conditions 	OFF

FUEL PUMP CIRCUIT

[VQ]

Wiring Diagram

UBS001F6

EC-F/PUMP-01

: DETECTABLE LINE FOR DTC
 : NON-DETECTABLE LINE FOR DTC

REFER TO "PG-POWER".

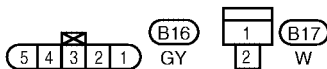
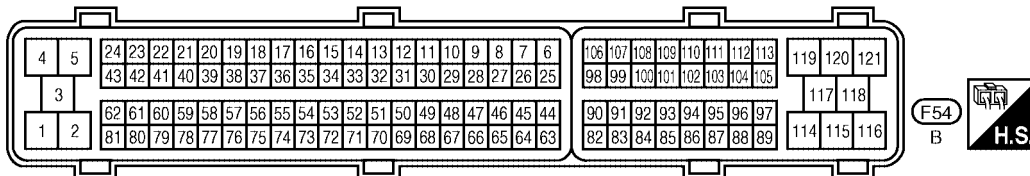
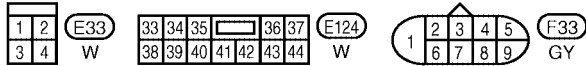
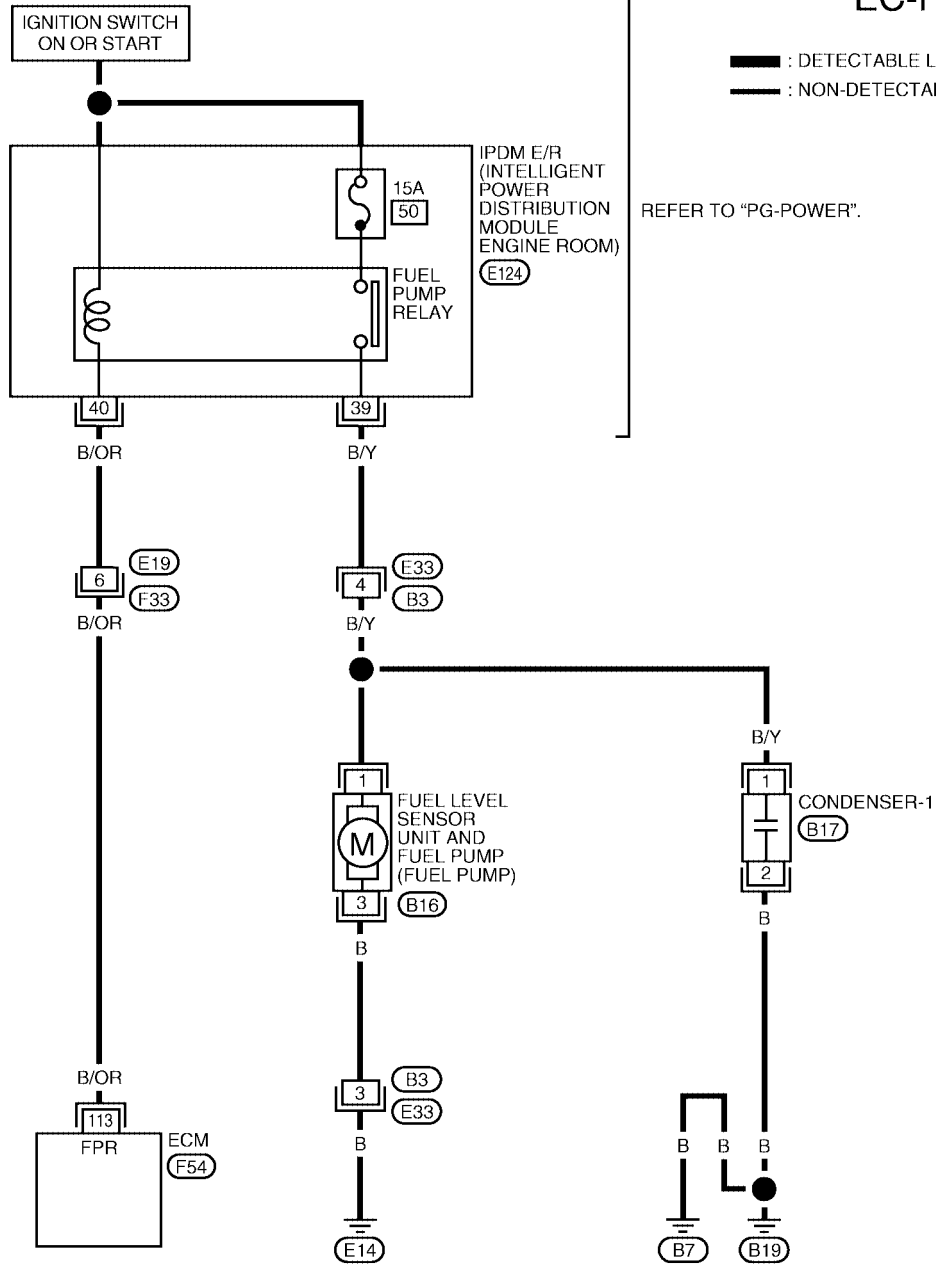

BBWA1578E

FUEL PUMP CIRCUIT

[VQ]

Specification data are reference values and are measured between each terminal and ground.

CAUTION:

Do not use ECM ground terminals when measuring input/output voltage. Doing so may result in damage to the ECM's transistor. Use a ground other than ECM terminals, such as the ground.

TER-MINAL NO.	WIRE COLOR	ITEM	CONDITION	DATA (DC Voltage)
113	B/OR	Fuel pump relay	[Ignition switch: ON] ● For 1 second after turning ignition switch ON	0 - 1.5V
			[Engine is running] [Ignition switch: ON] ● More than 1 second after turning ignition switch ON.	BATTERY VOLTAGE (11 - 14V)

Diagnostic Procedure

UBS00IF7

1. CHECK OVERALL FUNCTION

- Turn ignition switch ON.
- Pinch fuel feed hose with two fingers.
Fuel pressure pulsation should be felt on the fuel feed hose for 1 second after ignition switch is turned ON.

OK or NG

- OK >> **INSPECTION END**
NG >> GO TO 2.

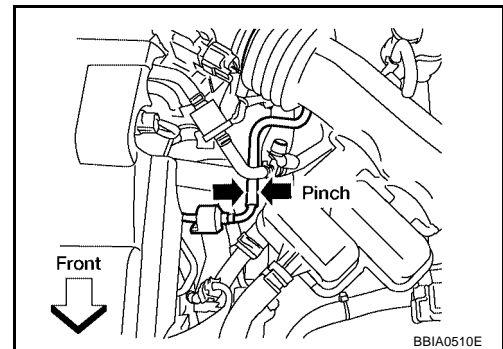

2. CHECK FUEL PUMP POWER SUPPLY CIRCUIT-I

- Turn ignition switch OFF.
- Disconnect ECM harness connector.
- Turn ignition switch ON.
- Check voltage between ECM terminal 113 and ground with CONSULT-II or tester.

Voltage: Battery voltage

OK or NG

- OK >> GO TO 5.
NG >> GO TO 3.

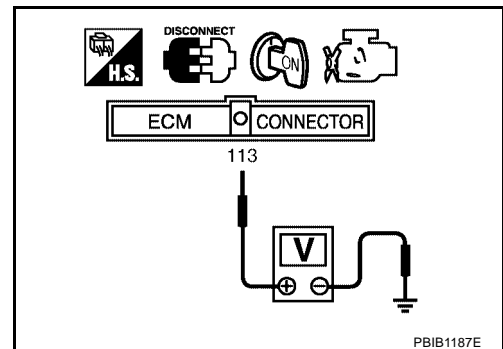

3. CHECK FUEL PUMP POWER SUPPLY CIRCUIT-I

1. Turn ignition switch OFF.
2. Disconnect IPDM E/R harness connector E124.
3. Turn ignition switch ON.
4. Check voltage between IPDM E/R terminal 40 and ground with CONSULT-II or tester.

Voltage: Battery voltage

OK or NG

- OK >> GO TO 4.
- NG >> GO TO 14.

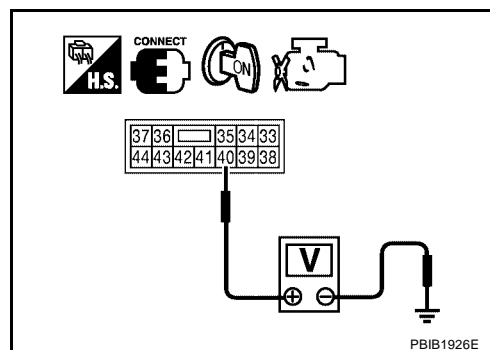

4. DETECT MALFUNCTIONING PART

Check the following.

- Harness connectors E19, F33
- Harness for open or short between IPDM E/R and ECM

>> Repair open circuit or short to ground or short to power in harness or connectors.

5. CHECK CONDENSER POWER SUPPLY CIRCUIT-I

1. Turn ignition switch OFF.
2. Reconnect all harness connectors disconnected.
3. Disconnect condenser harness connector.
4. Turn ignition switch ON.
5. Check voltage between condenser terminal 1 and ground with CONSULT-II or tester.

Voltage: Battery voltage should exist for 1 second after ignition switch is turned ON.

6. Also check harness for short to ground and short to power.

OK or NG

- OK >> GO TO 9.
- NG >> GO TO 6.

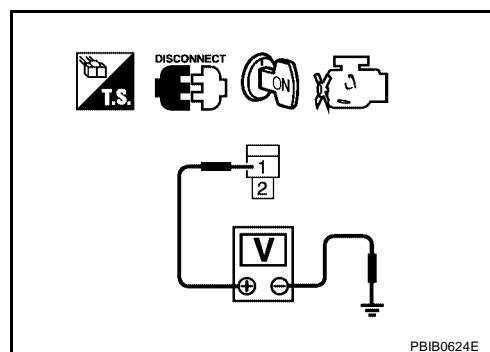

6. CHECK 15A FUSE

1. Turn ignition switch OFF.
2. Disconnect 15A fuse.
3. Check 15A fuse.

OK or NG

- OK >> GO TO 7.
- NG >> Replace fuse.

7. CHECK CONDENSER POWER SUPPLY CIRCUIT-II

1. Disconnect IPDM E/R harness connector E124.
2. Check harness continuity between IPDM E/R terminal 39 and condenser terminal 1.
Refer to Wiring Diagram.

Continuity should exist.

3. Also check harness for short to ground and short to power.

OK or NG

- OK >> GO TO 14.
- NG >> GO TO 8.

8. DETECT MALFUNCTIONING PART

Check the following.

- Harness connectors E33, B3
- Harness for open or short between IPDM E/R and condenser

>> Repair open circuit or short to ground or short to power in harness or connectors.

9. CHECK CONDENSER GROUND CIRCUIT

1. Check harness continuity between condenser terminal 2 and ground.
Refer to Wiring Diagram.

Continuity should exist.

2. Also check harness for short to power.

OK or NG

- OK >> GO TO 10.
- NG >> Repair open circuit or short to power in harness or connectors.

10. CHECK CONDENSER

Refer to [EC-1321, "Component Inspection"](#) .

OK or NG

- OK >> GO TO 11.
- NG >> Replace condenser.

11. CHECK FUEL PUMP POWER SUPPLY AND GROUND CIRCUIT FOR OPEN AND SHORT

1. Turn ignition switch OFF.
2. Disconnect "fuel level sensor unit and fuel pump" harness connector.
3. Disconnect harness connectors E33, B3
4. Check harness continuity between "fuel level sensor unit and fuel pump" terminal 1 and harness connector B3 terminal 4, "fuel level sensor unit and fuel pump" terminal 3 and ground.
Refer to Wiring Diagram.

Continuity should exist.

5. Also check harness for short to ground and short to power.

OK or NG

- OK >> GO TO 13.
- NG >> GO TO 12.

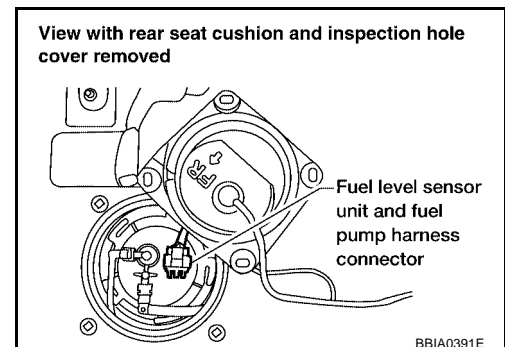

12. DETECT MALFUNCTIONING PART

Check the following.

- Harness connectors E33, B3
- Harness for open or short between “fuse level sensor unit and fuse pump” and harness connector B3
- Harness for open or short between “fuse level sensor unit and fuse pump” and ground

>> Repair open circuit or short to ground or short to power in harness or connectors.

13. CHECK FUEL PUMP

Refer to [EC-1321, "Component Inspection"](#) .

OK or NG

OK >> GO TO 14.

NG >> Replace fuel pump.

14. CHECK INTERMITTENT INCIDENT

Refer to [EC-782, "TROUBLE DIAGNOSIS FOR INTERMITTENT INCIDENT"](#) .

OK or NG

OK >> Replace IPDM E/R.

NG >> Repair or replace harness or connectors.

Component Inspection

FUEL PUMP

1. Disconnect “fuel level sensor unit and fuel pump” harness connector.
2. Check resistance between “fuel level sensor unit and fuel pump” terminals 1 and 3.

Resistance: Approximately 0.2 - 5.0Ω [at 25°C (77°F)]

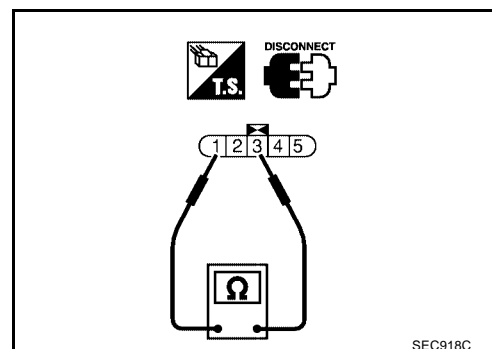

CONDENSER

1. Turn ignition switch OFF.
2. Disconnect condenser harness connector.
3. Check resistance between condenser terminals 1 and 2.

Resistance : Above 1 MΩ [at 25°C (77°F)]

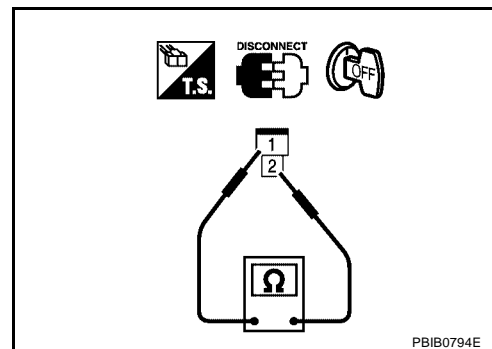

Removal and Installation

FUEL PUMP

Refer to [FL-5, "FUEL LEVEL SENSOR UNIT, FUEL FILTER AND FUEL PUMP ASSEMBLY"](#) .

ELECTRONIC CONTROLLED ENGINE MOUNT

[VQ]

ELECTRONIC CONTROLLED ENGINE MOUNT

PF1:11270

System Description

UBS001FA

Sensor	Input Signal to ECM	ECM function	Actuator
Crankshaft position sensor (POS) Camshaft position sensor (PHASE)	Engine speed	Engine mount control	Electronic controlled engine mount
Wheel sensor*	Vehicle speed		

*: This signal is sent to the ECM through CAN communication line.

The ECM controls the engine mount operation corresponding to the engine speed and the vehicle speed. The control system has 2-step control [Soft/Hard]

Vehicle condition	Engine mount control
Idle (with vehicle stopped)	Soft
Except above conditions	Hard

CONSULT-II Reference Value in Data Monitor Mode

UBS001FB

Specification data are reference values.

MONITOR ITEM	CONDITION	SPECIFICATION	
ENGINE MOUNT	● Engine: After warming up	Idle (with vehicle stopped)	IDLE
		Except above conditions	TRVL

ELECTRONIC CONTROLLED ENGINE MOUNT

[VQ]

Wiring Diagram

UBS001FC

EC-EMNT-01

— : DETECTABLE LINE FOR DTC
 - - - : NON-DETECTABLE LINE FOR DTC

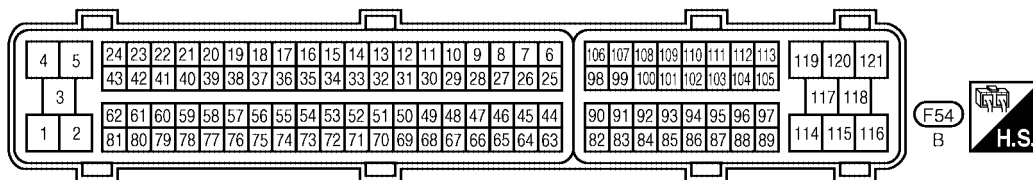
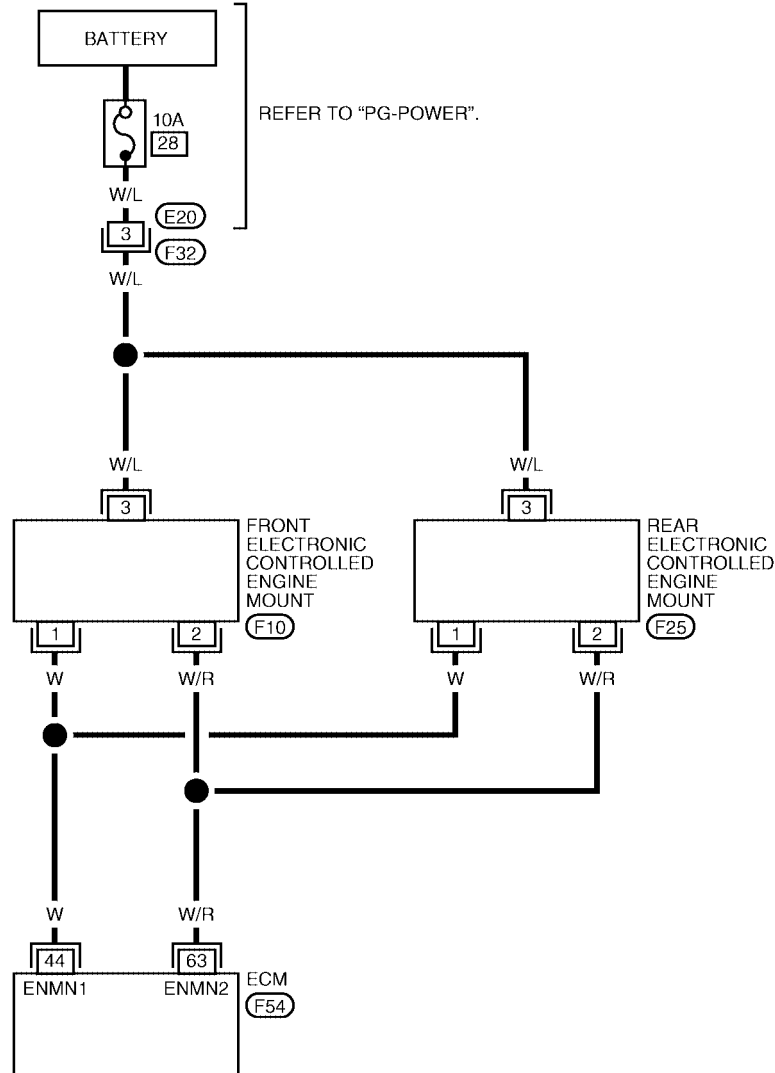

BBWA1579E

ELECTRONIC CONTROLLED ENGINE MOUNT

[VQ]

Specification data are reference values and are measured between each terminal and ground.

CAUTION:

Do not use ECM ground terminals when measuring input/output voltage. Doing so may result in damage to the ECM's transistor. Use a ground other than ECM terminals, such as the ground.

TER-MINAL NO.	WIRE COLOR	ITEM	CONDITION	DATA (DC Voltage)
44	W	Electronic controlled engine mount-1	[Engine is running] ● Idle speed (with vehicle stopped)	0 - 3.0V
			[Engine is running] ● Except above conditions	BATTERY VOLTAGE (11 - 14V)
63	W/R	Electronic controlled engine mount-2	[Engine is running] ● Idle speed (with vehicle stopped)	BATTERY VOLTAGE (11 - 14V)
			[Engine is running] ● Except above conditions	0 - 3.0V

Diagnostic Procedure

UBS001FD

1. INSPECTION START

Do you have CONSULT-II?

Yes or No

- Yes >> GO TO 2.
- No >> GO TO 3.

2. CHECK OVERALL FUNCTION

① With CONSULT-II

1. Turn ignition switch ON.
2. Select "ENGINE MOUNTING" in "ACTIVE TEST" mode with CONSULT-II and touch "ON/OFF" on the CONSULT-II screen.
3. Check that the motor operating sound is heard from front electronic controlled engine mount and rear electronic controlled engine mount for about 0.5 seconds according to the switching condition of "ENGINE MOUNTING".

OK or NG

- OK >> **INSPECTION END**
- NG >> GO TO 4.

ACTIVE TEST	
ENGINE MOUNTING	IDLE
MONITOR	
ENG SPEED	XXX rpm
COOLAN TEMP/S	XXX °C

SEC237C

3. CHECK OVERALL FUNCTION

⊗ Without CONSULT-II

1. Make sure that gear position is P or N.
2. Start engine and let it idle.
3. Change the engine speed from idle to more than 1,000 rpm and then return to idle (with vehicle stopped).
4. Check that the motor operating sound is heard from front electronic controlled engine mount and rear electronic controlled engine mount for about 0.5 seconds when changing engine speed.
It is better to hear the operating sound around the left side front wheel house.

OK or NG

- OK >> **INSPECTION END**
- NG >> GO TO 4.

4. CHECK ELECTRONIC CONTROLLED ENGINE MOUNT POWER SUPPLY CIRCUIT

1. Turn ignition switch OFF.
2. Disconnect front and rear electronic controlled engine mount harness connector.

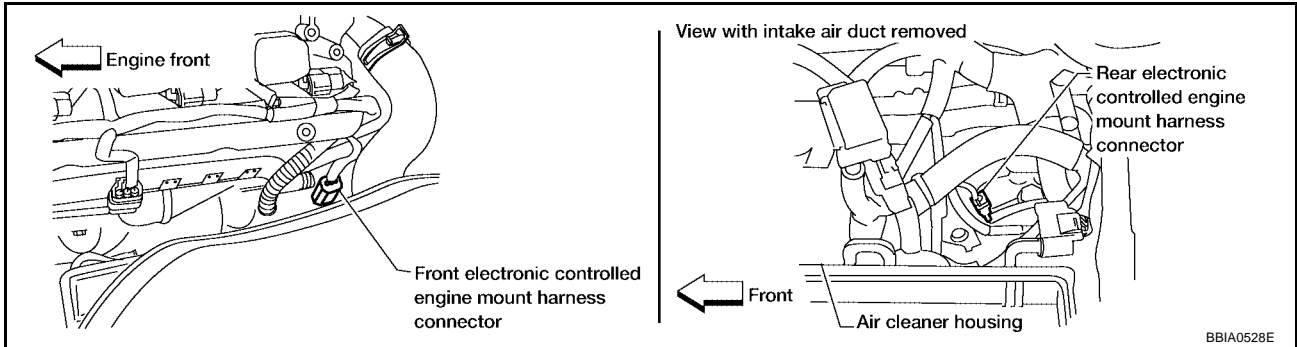

3. Check voltage between electronic controlled engine mount terminal 3 and ground with CONSULT-II or tester.

Voltage: Battery voltage

OK or NG

- OK >> GO TO 6.
- NG >> GO TO 5.

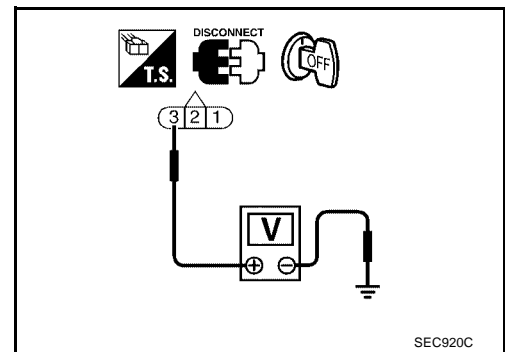

5. DETECT MALFUNCTIONING PART

Check the following.

- Harness connectors E20, F32
- 10A fuse
- Harness for open and short between electronic controlled engine mount and battery

>> Repair open circuit or short to ground or short to power in harness or connectors.

6. CHECK ELECTRONIC CONTROLLED ENGINE MOUNT OUTPUT SIGNAL CIRCUIT FOR OPEN AND SHORT

1. Turn ignition switch OFF.
2. Disconnect ECM harness connector.
3. Check harness continuity between ECM terminals and electronic engine mount terminals as follows. Refer to Wiring Diagram.

ECM terminal	Front electronic controlled engine mount terminal	Rear electronic controlled engine mount terminal
44	1	1
63	2	2

Continuity should exist.

4. Also check harness for short to ground and short to power.

OK or NG

- OK >> GO TO 7.
- NG >> Repair open circuit or short to ground or short to power in harness or connectors.

7. CHECK ELECTRONIC CONTROLLED ENGINE MOUNT

Visually check front and rear electronic controlled engine mount.

OK or NG

OK >> GO TO 8.

NG >> Replace front or rear electronic controlled engine mount.

8. CHECK INTERMITTENT INCIDENT

Refer to [EC-782, "TROUBLE DIAGNOSIS FOR INTERMITTENT INCIDENT"](#) .

>> **INSPECTION END**

REFRIGERANT PRESSURE SENSOR

[VQ]

REFRIGERANT PRESSURE SENSOR

PFP:92136

UBS001FE

Component Description

The refrigerant pressure sensor is installed at the liquid tank of the air conditioner system. The sensor uses an electrostatic volume pressure transducer to convert refrigerant pressure to voltage. The voltage signal is sent to ECM, and ECM controls cooling fan system.

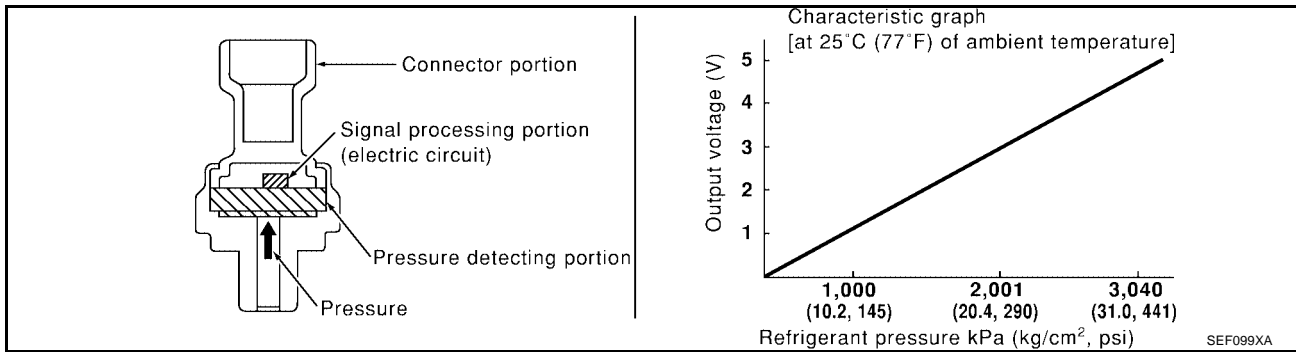
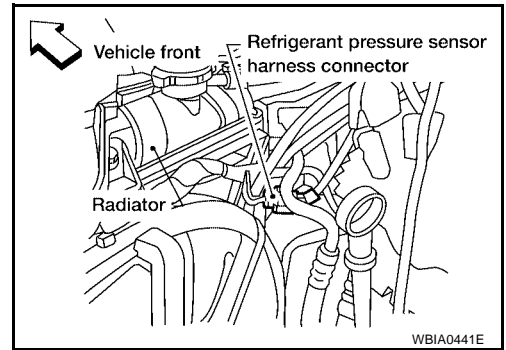

REFRIGERANT PRESSURE SENSOR

[VQ]

Wiring Diagram

UBS001FF

EC-RP/SEN-01

: DETECTABLE LINE FOR DTC
 : NON-DETECTABLE LINE FOR DTC

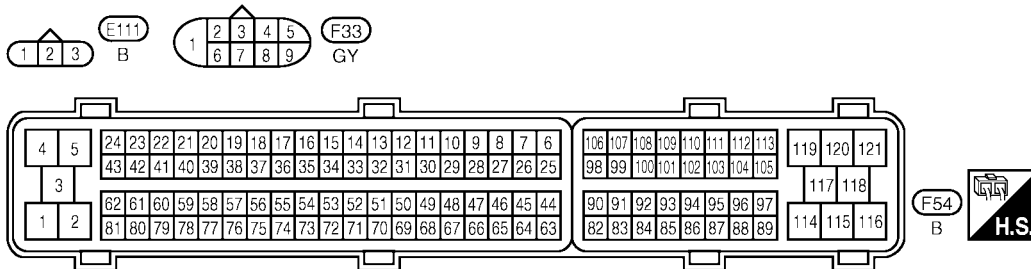
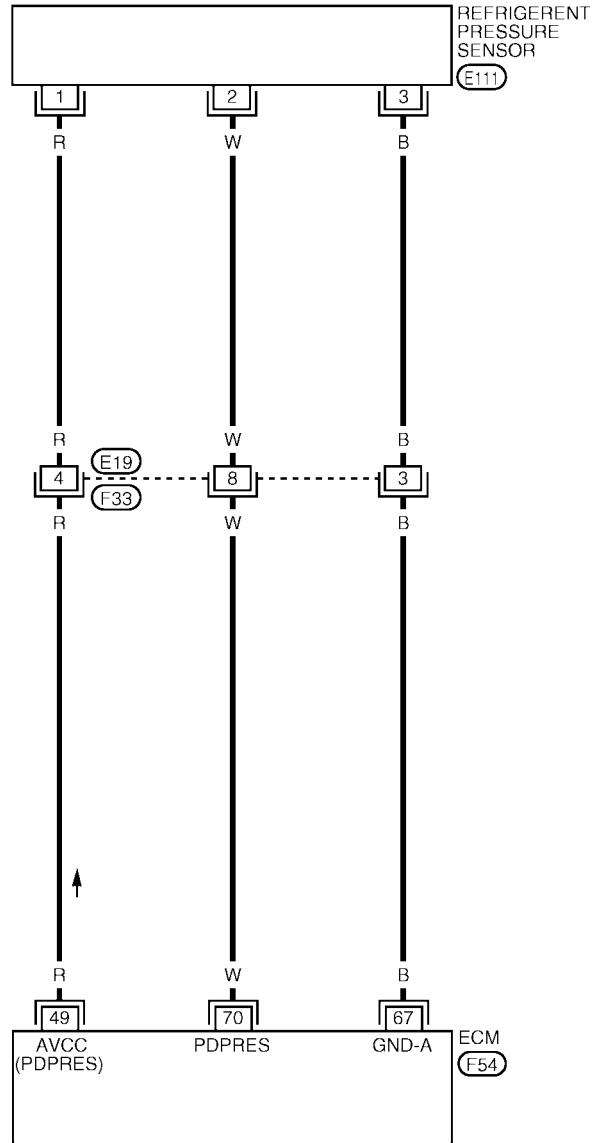

BBWA1580E

REFRIGERANT PRESSURE SENSOR

[VQ]

Specification data are reference values and are measured between each terminal and ground.

CAUTION:

Do not use ECM ground terminals when measuring input/output voltage. Doing so may result in damage to the ECM's transistor. Use a ground other than ECM terminals, such as the ground.

TER-MINAL NO.	WIRE COLOR	ITEM	CONDITION	DATA (DC Voltage)
49	R	Sensor power supply (Refrigerant pressure sensor)	[Ignition switch: ON]	Approximately 5V
67	B	Sensor ground	[Engine is running] ● Warm-up condition ● Idle speed	Approximately 0V
70	W	Refrigerant pressure sensor	[Engine is running] ● Warm-up condition ● Both A/C switch and blower switch are ON. (Compressor operates.)	1.0 - 4.0V

Diagnostic Procedure

UBS00IFG

1. CHECK REFRIGERANT PRESSURE SENSOR OVERALL FUNCTION

1. Start engine and warm it up to normal operating temperature.
2. Turn A/C switch and blower switch ON.
3. Check voltage between ECM terminal 70 and ground with CONSULT-II or tester.

Voltage: 1.0 - 4.0V

OK or NG

- OK >> **INSPECTION END**
- NG >> GO TO 2.

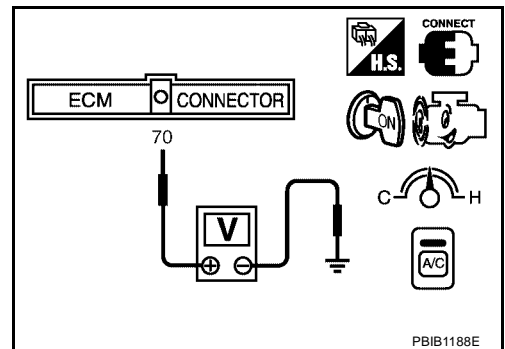

PBIB1188E

2. CHECK GROUND CONNECTIONS

1. Turn A/C switch and blower switch OFF.
2. Turn ignition switch OFF.
3. Loosen and retighten three ground screws on the body. Refer to [EC-789, "Ground Inspection"](#).

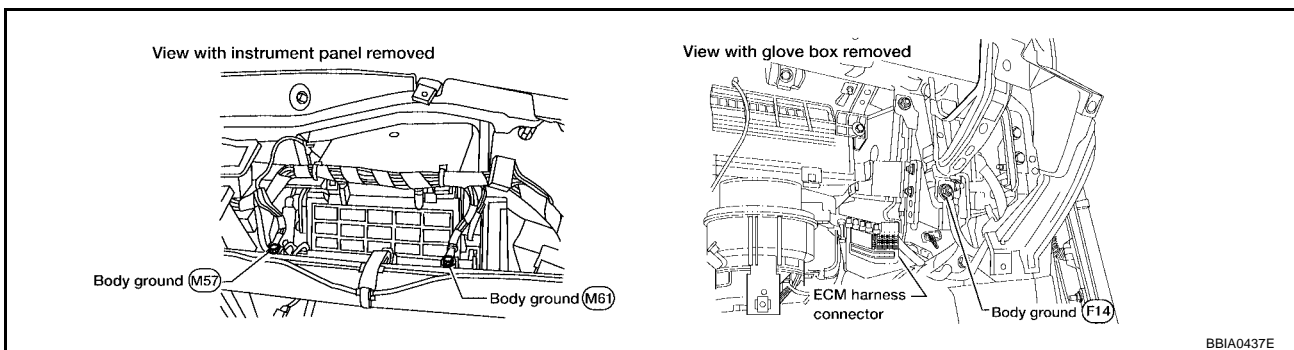

OK or NG

- OK >> GO TO 3.
- NG >> Repair or replace ground connections.

3. CHECK REFRIGERANT PRESSURE SENSOR POWER SUPPLY CIRCUIT

1. Disconnect refrigerant pressure sensor harness connector.
2. Turn ignition switch ON.

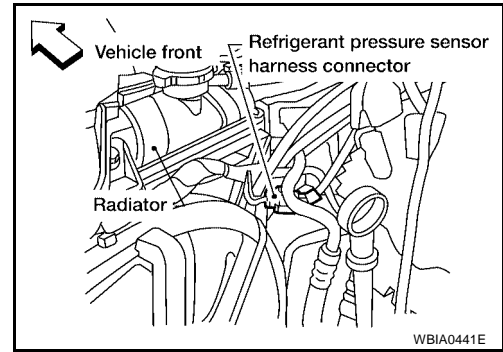

3. Check voltage between refrigerant pressure sensor terminal 1 and ground with CONSULT-II or tester.

Voltage: Approximately 5V

OK or NG

- OK >> GO TO 5.
- NG >> GO TO 4.

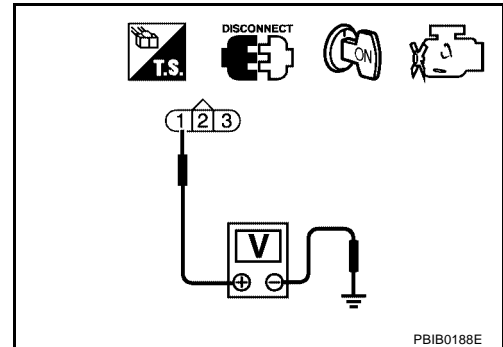

4. DETECT MALFUNCTIONING PART

Check the following.

- Harness connectors E19, F33
- Harness for open or short between ECM and refrigerant pressure sensor

>> Repair open circuit or short to ground or short to power in harness or connectors.

5. CHECK REFRIGERANT PRESSURE SENSOR GROUND CIRCUIT FOR OPEN AND SHORT

1. Turn ignition switch OFF.
2. Disconnect ECM harness connector.
3. Check harness continuity between refrigerant pressure sensor terminal 3 and ECM terminal 67. Refer to Wiring Diagram.

Continuity should exist.

4. Also check harness for short to ground and short to power.

OK or NG

- OK >> GO TO 7.
- NG >> GO TO 6.

6. DETECT MALFUNCTIONING PART

Check the following.

- Harness connectors E19, F33
- Harness for open or short between ECM and refrigerant pressure sensor

>> Repair open circuit or short to ground or short to power in harness or connectors.

REFRIGERANT PRESSURE SENSOR

[VQ]

7. CHECK REFRIGERANT PRESSURE SENSOR INPUT SIGNAL CIRCUIT FOR OPEN AND SHORT

1. Check harness continuity between ECM terminal 70 and refrigerant pressure sensor terminal 2.
Refer to Wiring Diagram.

Continuity should exist.

2. Also check harness for short to ground and short to power.

OK or NG

- OK >> GO TO 9.
NG >> GO TO 8.

8. DETECT MALFUNCTIONING PART

Check the following.

- Harness connectors E19, F33
- Harness for open or short between ECM and refrigerant pressure sensor

>> Repair open circuit or short to ground or short to power in harness or connectors.

9. CHECK INTERMITTENT INCIDENT

Refer to [EC-782, "TROUBLE DIAGNOSIS FOR INTERMITTENT INCIDENT"](#) .

OK or NG

- OK >> Replace refrigerant pressure sensor.
NG >> Repair or replace.

Removal and Installation REFRIGERANT PRESSURE SENSOR

UBS00IFH

Refer to [ATC-113, "Removal and Installation for Refrigerant Pressure Sensor"](#) .

ELECTRICAL LOAD SIGNAL

[VQ]

ELECTRICAL LOAD SIGNAL

PFV:25350

Description

UBS001FI

The electrical load signal (Headlamp switch signal, rear window defogger switch signal, etc.) is transferred through the CAN communication line from BCM to ECM via IPDM E/R.

CONSULT-II Reference Value in Data Monitor Mode

UBS001FJ

Specification data are reference values.

MONITOR ITEM	CONDITION		SPECIFICATION
LOAD SIGNAL	● Ignition switch: ON	Rear window defogger switch: ON and/or Lighting switch: 2nd position	ON
		Rear window defogger switch and lighting switch: OFF.	OFF

Diagnostic Procedure

UBS001FK

1. CHECK LOAD SIGNAL CIRCUIT OVERALL FUNCTION-I

1. Turn ignition switch ON.
2. Connect CONSULT-II and select "DATA MONITOR" mode.
3. Select "LOAD SIGNAL" and check indication under the following conditions.

Condition	Indication
Rear window defogger switch: ON	ON
Rear window defogger switch: OFF	OFF

OK or NG

- OK >> GO TO 2.
NG >> GO TO 3.

DATA MONITOR	
MONITORING	NO DTC
LOAD SIGNAL	ON

PBIB0103E

2. CHECK LOAD SIGNAL CIRCUIT OVERALL FUNCTION-II

Check "LOAD SIGNAL" indication under the following conditions.

Condition	Indication
Lighting switch: ON at 2nd position	ON
Lighting switch: OFF	OFF

OK or NG

- OK >> **INSPECTION END**
NG >> GO TO 4.

DATA MONITOR	
MONITORING	NO DTC
LOAD SIGNAL	ON

PBIB0103E

3. CHECK REAR WINDOW DEFOGGER SYSTEM

Refer to [GW-42, "REAR WINDOW DEFOGGER"](#) .

>> **INSPECTION END**

4. CHECK HEADLAMP SYSTEM

Refer to [LT-6, "HEADLAMP \(FOR USA\)"](#) or [LT-33, "HEADLAMP \(FOR CANADA\) - DAYTIME LIGHT SYSTEM -"](#) .

>> **INSPECTION END**

ASCD BRAKE SWITCH

[VQ]

PFP:25320

UBS00IFL

ASCD BRAKE SWITCH

Component Description

When the brake pedal is depressed, ASCD brake switch is turned OFF and stop lamp switch is turned ON. ECM detects the state of the brake pedal by this input of two kinds (ON/OFF signal).

Refer to [EC-648, "AUTOMATIC SPEED CONTROL DEVICE \(ASCD\)"](#) for the ASCD function.

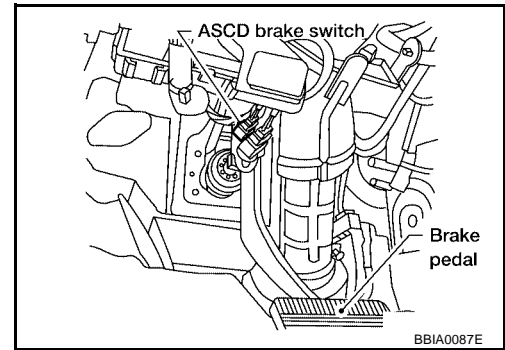

CONSULT-II Reference Value in Data Monitor Mode

UBS00IFM

Specification data are reference values.

MONITOR ITEM	CONDITION		SPECIFICATION
BRAKE SW1 (ASCD brake switch)	● Ignition switch: ON	Clutch pedal (M/T) and brake pedal: Fully released	ON
		Clutch pedal (M/T) and/or brake pedal: Slightly depressed	OFF
BRAKE SW2 (Stop lamp switch)	● Ignition switch: ON	Brake pedal: Fully released	OFF
		Brake pedal: Slightly depressed	ON

ASC D BRAKE SWITCH

[VQ]

Wiring Diagram

UBS001FN

EC-ASCBOF-01

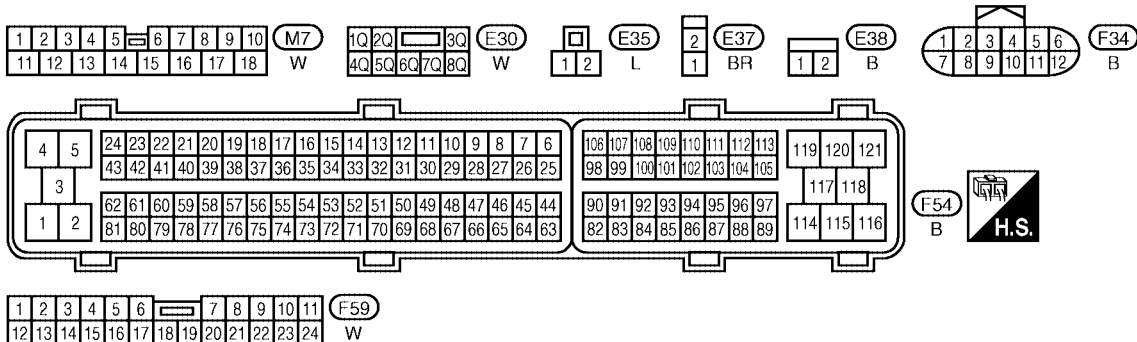
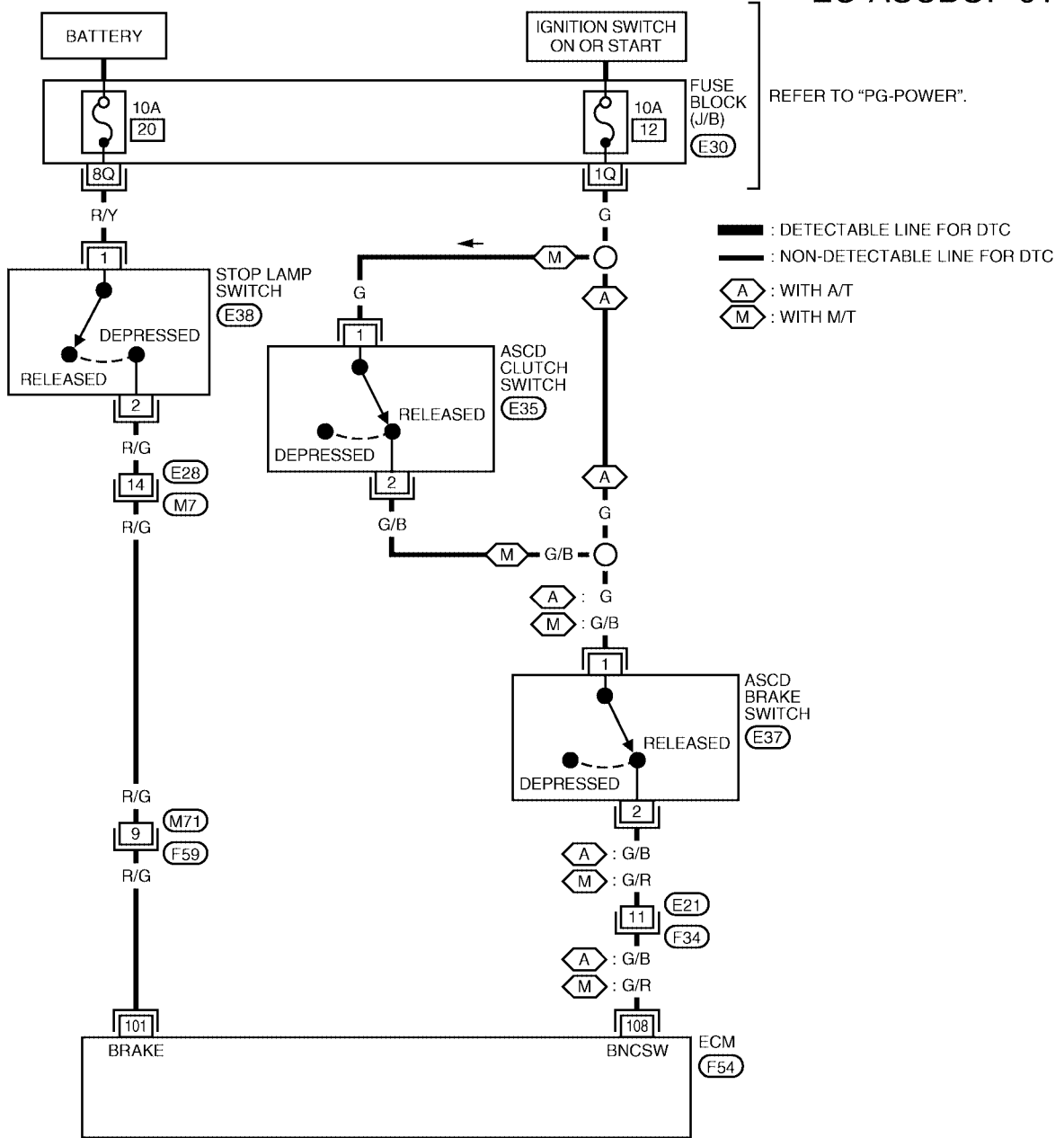

BBWA1581E

ASCD BRAKE SWITCH

[VQ]

Specification data are reference values and are measured between each terminal and ground.

CAUTION:

Do not use ECM ground terminals when measuring input/output voltage. Doing so may result in damage to the ECM's transistor. Use a ground other than ECM terminals, such as the ground.

TER-MINAL NO.	WIRE COLOR	ITEM	CONDITION	DATA (DC Voltage)
101	R/G	Stop lamp switch	[Ignition switch: OFF] ● Brake pedal: Fully released	Approximately 0V
			[Ignition switch: OFF] ● Brake pedal: Slightly depressed	BATTERY VOLTAGE (11 - 14V)
108	G/B (A/T) G/R (M/T)	ASCD brake switch	[Ignition switch: ON] ● Brake pedal: Slightly depressed (A/T) ● Clutch pedal and/or clutch pedal: Slightly depressed (M/T)	Approximately 0V
			[Ignition switch: ON] ● Brake pedal: Fully released (A/T) ● Clutch pedal and brake pedal: Fully released (M/T)	BATTERY VOLTAGE (11 - 14V)

A
EC
C
D
E
F
G
H
I
J
K
L
M

ASCD BRAKE SWITCH

[VQ]

UBS00IFO

Diagnostic Procedure

1. CHECK OVERALL FUNCTION-I

With CONSULT-II

1. Turn ignition switch ON.
2. Select "BRAKE SW1" in "DATA MONITOR" mode with CONSULT-II.
3. Check "BRAKE SW1" indication under the following conditions.

A/T models

CONDITION	INDICATION
Brake pedal: Slightly depressed	OFF
Brake pedal: Fully released	ON

M/T models

CONDITION	INDICATION
Clutch pedal and/or brake pedal: Slightly depressed	OFF
Clutch pedal and brake pedal: Fully released	ON

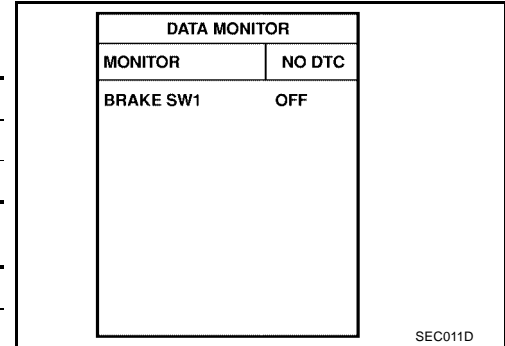

Without CONSULT-II

1. Turn ignition switch ON.
2. Check voltage between ECM terminal 108 and ground under the following conditions.

A/T models

CONDITION	VOLTAGE
Brake pedal: Slightly depressed	Approximately 0V
Brake pedal: Fully released	Battery voltage

M/T models

CONDITION	VOLTAGE
Clutch pedal and/or brake pedal: Slightly depressed	Approximately 0V
Clutch pedal and brake pedal: Fully released	Battery voltage

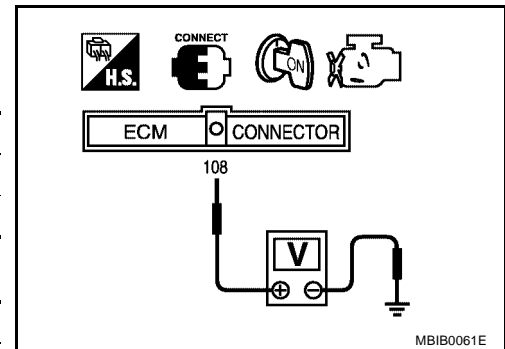

OK or NG

- OK >> GO TO 2.
 NG (M/T models)>>GO TO 3.
 NG (A/T models)>>GO TO 8.

ASCD BRAKE SWITCH

[VQ]

2. CHECK OVERALL FUNCTION-II

With CONSULT-II

Check "BRAKE SW2" indication in "DATA MONITOR" mode.

CONDITION	INDICATION
Brake pedal: Fully released	OFF
Brake pedal: Slightly depressed	ON

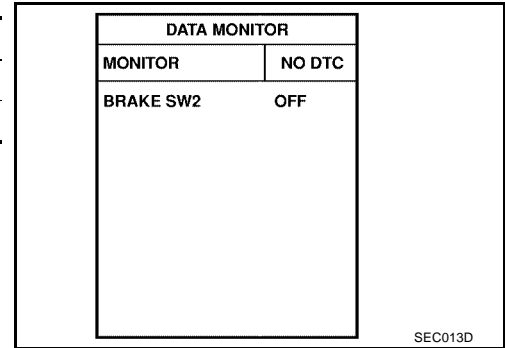

Without CONSULT-II

Check voltage between ECM terminal 101 and ground under the following conditions.

CONDITION	VOLTAGE
Brake pedal: Fully released	Approximately 0V
Brake pedal: Slightly depressed	Battery voltage

OK or NG

- OK >> **INSPECTION END**
- NG >> GO TO 13.

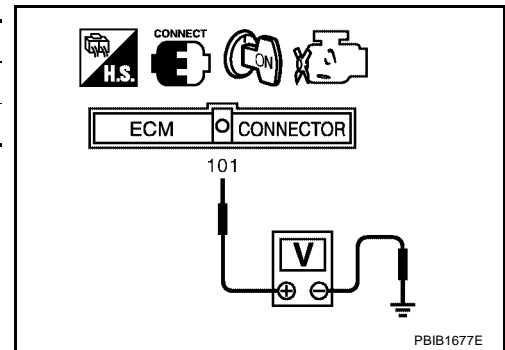

3. CHECK ASCD CLUTCH SWITCH CIRCUIT

1. Turn ignition switch OFF.
2. Disconnect ASCD brake switch harness connector.
3. Turn ignition switch ON.

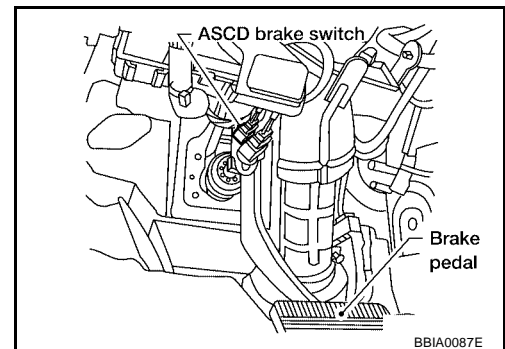

4. Check voltage between ASCD brake switch terminal 1 and ground under the following conditions with CONSULT-II or tester.

CONDITION	VOLTAGE
Clutch pedal: Slightly depressed	Approximately 0V
Clutch pedal: Fully released	Battery voltage

OK or NG

- OK >> GO TO 10.
- NG >> GO TO 4.

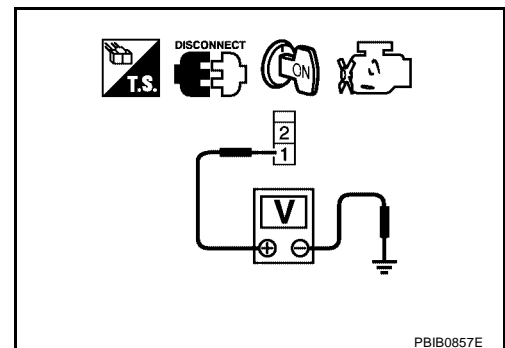

4. CHECK ASCD CLUTCH SWITCH POWER SUPPLY CIRCUIT

1. Turn ignition switch OFF.
2. Disconnect ASCD clutch switch harness connector.
3. Turn ignition switch ON.

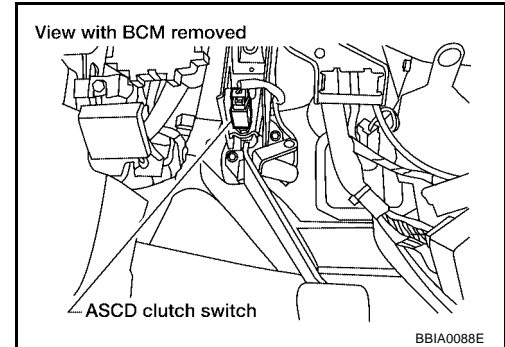

4. Check voltage between ASCD clutch switch terminal 1 and ground with CONSULT-II or tester.

Voltage: Battery voltage

OK or NG

- OK >> GO TO 6.
- NG >> GO TO 5.

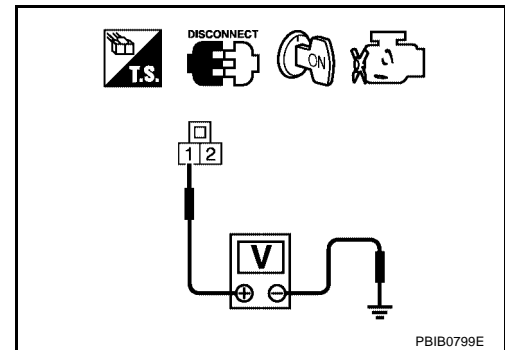

5. DETECT MALFUNCTIONING PART

Check the following.

- Fuse block (J/B) connector E30
- 10A fuse
- Harness for open or short between ASCD clutch switch and fuse

>> Repair open circuit or short to ground or short to power in harness or connectors.

6. CHECK ASCD CLUTCH SWITCH INPUT SIGNAL CIRCUIT FOR OPEN AND SHORT

1. Turn ignition switch OFF.
2. Check harness continuity between ASCD clutch switch terminal 2 and ASCD brake switch terminal 1. Refer to Wiring Diagram.

Continuity should exist.

3. Also check harness for short to ground and short to power.

OK or NG

- OK >> GO TO 7.
- NG >> Repair open circuit or short to ground or short to power in harness or connectors.

7. CHECK ASCD CLUTCH SWITCH

Refer to [EC-1341, "Component Inspection"](#)

OK or NG

- OK >> GO TO 18.
- NG >> Replace ASCD clutch switch.

8. CHECK ASCD BRAKE SWITCH POWER SUPPLY CIRCUIT

1. Turn ignition switch OFF.
2. Disconnect ASCD brake switch harness connector.
3. Turn ignition switch ON.

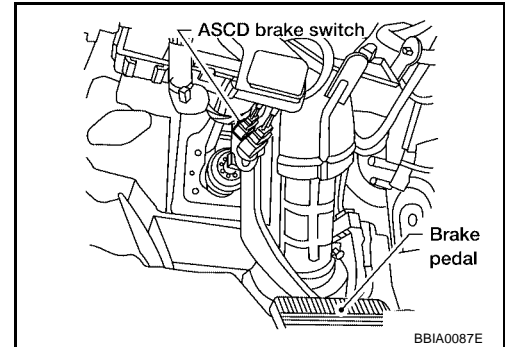

4. Check voltage between ASCD brake switch terminal 1 and ground with CONSULT-II or tester.

Voltage: Battery voltage

OK or NG

- OK >> GO TO 10.
- NG >> GO TO 9.

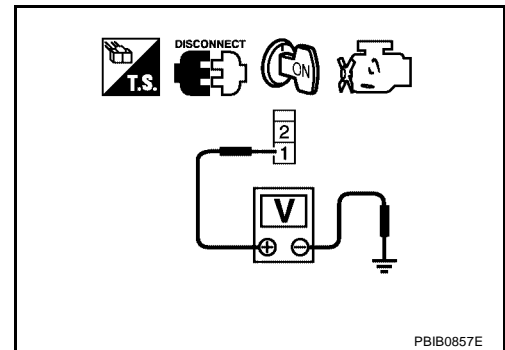

9. DETECT MALFUNCTIONING PART

Check the following.

- Fuse block (J/B) connector E30
- 10A fuse
- Harness for open or short between ASCD brake switch and fuse

>> Repair open circuit or short to ground or short to power in harness or connectors.

10. CHECK ASCD BRAKE SWITCH INPUT SIGNAL CIRCUIT FOR OPEN AND SHORT

1. Turn ignition switch OFF.
2. Disconnect ECM harness connector.
3. Check harness continuity between ECM terminal 108 and ASCD brake switch terminal 2. Refer to Wiring Diagram.

Continuity should exist.

4. Also check harness for short to ground and short to power.

OK or NG

- OK >> GO TO 12.
- NG >> GO TO 11.

11. DETECT MALFUNCTIONING PART

Check the following.

- Harness connectors E21, F34
- Harness for open or short between ECM and ASCD brake switch

>> Repair open circuit or short to ground or short to power in harness or connectors.

12. CHECK ASCD BRAKE SWITCH

Refer to [EC-1341, "Component Inspection"](#)

OK or NG

- OK >> GO TO 18.
- NG >> Replace ASCD brake switch.

13. CHECK STOP LAMP SWITCH POWER SUPPLY CIRCUIT

1. Turn ignition switch OFF.
2. Disconnect stop lamp switch harness connector.

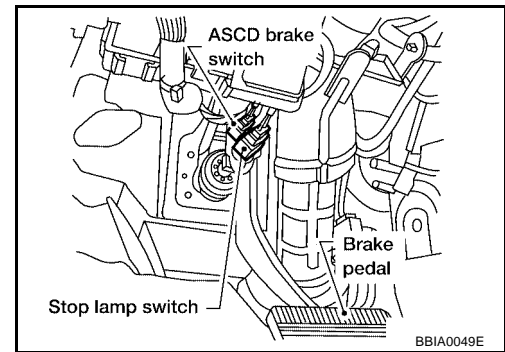

3. Check voltage between stop lamp switch terminal 1 and ground with CONSULT -II or tester.

Voltage: Battery voltage

OK or NG

- OK >> GO TO 15.
- NG >> GO TO 14.

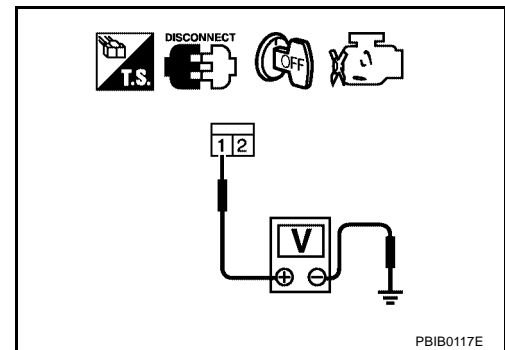

14. DETECT MALFUNCTIONING PART

Check the following.

- Fuse block (J/B) connector E30
- 10A fuse
- Harness for open or short between stop lamp switch and battery

>> Repair open circuit or short to ground or short to power in harness or connectors.

15. CHECK STOP LAMP SWITCH INPUT SIGNAL CIRCUIT FOR OPEN AND SHORT

1. Disconnect ECM harness connector.
2. Check harness continuity between ECM terminal 101 and stop lamp switch terminal 2. Refer to Wiring Diagram.

Continuity should exist.

3. Also check harness for short to ground and short to power.

OK or NG

- OK >> GO TO 17.
- NG >> GO TO 16.

16. DETECT MALFUNCTIONING PART

Check the following.

- Harness connectors E28, M7
- Harness connectors M71, F59
- Harness for open or short between ECM and stop lamp switch

>> Repair open circuit or short to ground or short to power in harness or connectors.

17. CHECK STOP LAMP SWITCH

Refer to [EC-1341, "Component Inspection"](#)

OK or NG

- OK >> GO TO 18.
- NG >> Replace stop lamp switch.

18. CHECK INTERMITTENT INCIDENT

Refer to [EC-782, "TROUBLE DIAGNOSIS FOR INTERMITTENT INCIDENT"](#) .

>> INSPECTION END

Component Inspection ASC D BRAKE SWITCH

UBS00IFP

1. Turn ignition switch OFF.
2. Disconnect ASCD brake switch harness connector.
3. Check continuity between ASCD brake switch terminals 1 and 2 under the following conditions.

Condition	Continuity
Brake pedal: Fully released	Should exist.
Brake pedal: Slightly depressed	Should not exist.

If NG, adjust ASCD brake switch installation, refer to [BR-6, "BRAKE PEDAL"](#) , and perform step 3 again.

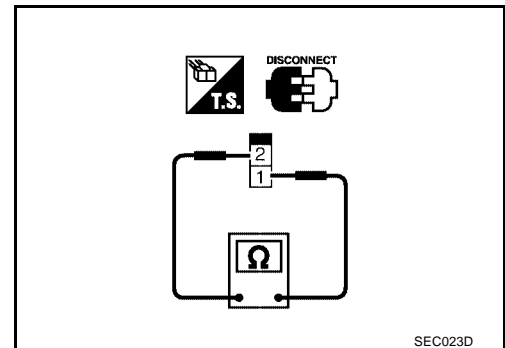

ASC D CLUTCH SWITCH

1. Turn ignition switch OFF.
2. Disconnect ASCD clutch switch harness connector.
3. Check harness continuity between ASCD clutch switch terminals 1 and 2 under the following conditions.

Condition	Continuity
Clutch pedal: Fully released	Should exist.
Clutch pedal: Slightly depressed	Should not exist.

If NG, adjust ASCD clutch switch installation, refer to [CL-5, "CLUTCH PEDAL"](#) , and perform step 3 again.

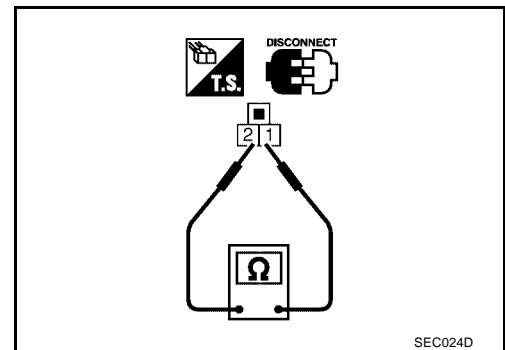

STOP LAMP SWITCH

1. Turn ignition switch OFF.
2. Disconnect stop lamp switch harness connector.
3. Check continuity between stop lamp switch terminals 1 and 2 under the following conditions.

Condition	Continuity
Brake pedal: Fully released	Should not exist.
Brake pedal: Slightly depressed	Should exist.

If NG, adjust stop lamp switch installation, refer to [BR-6](#), "[BRAKE PEDAL](#)", and perform step 3 again.

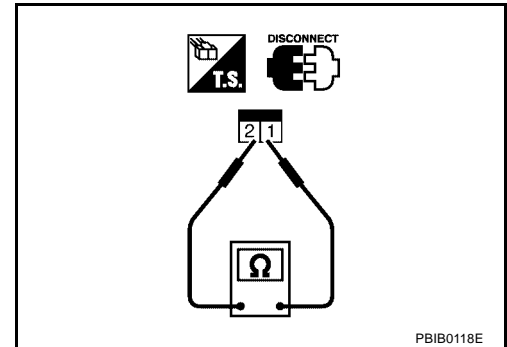

ASC D INDICATOR

Component Description

UBS001FQ

ASC D indicator lamp illuminates to indicate ASC D operation status. Lamp has two indicators, CRUISE and SET, and is integrated in combination meter.

CRUISE indicator illuminates when MAIN switch on ASC D steering switch is turned ON to indicate that ASC D system is ready for operation.

SET indicator illuminates when following conditions are met.

- CRUISE indicator is illuminated.
- SET/COAST switch on ASC D steering switch is turned ON while vehicle speed is within the range of ASC D setting.

SET indicator remains lit during ASC D control.

Refer to [EC-648, "AUTOMATIC SPEED CONTROL DEVICE \(ASC D\)"](#) for the ASC D function.

CONSULT-II Reference Value in Data Monitor Mode

UBS001FR

Specification data are reference value.

MONITOR ITEM	CONDITION		SPECIFICATION
CRUISE LAMP	● Ignition switch: ON	MAIN switch: Pressed at the 1st time → at the 2nd time	ON → OFF
SET LAMP	● MAIN switch: ON	ASC D is operating	ON
	● When vehicle speed is between 40 km/h (25 MPH) and 144 km/h (89 MPH)	ASC D is not operating	OFF

ASC D INDICATOR

[VQ]

UBS001FS

Wiring Diagram

EC-ASCIND-01

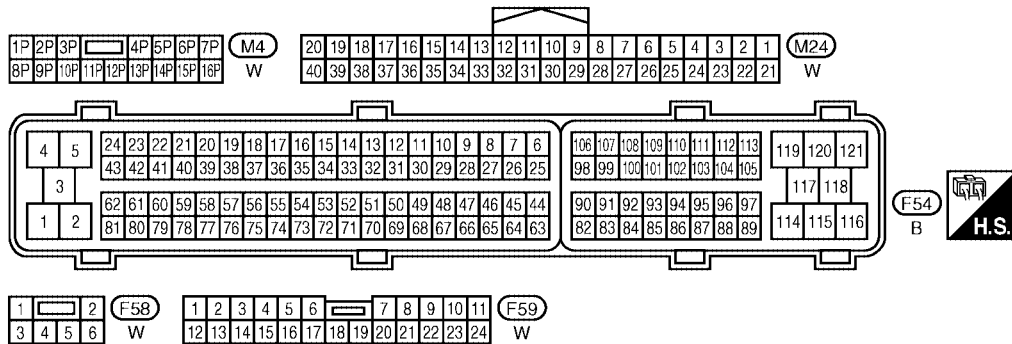
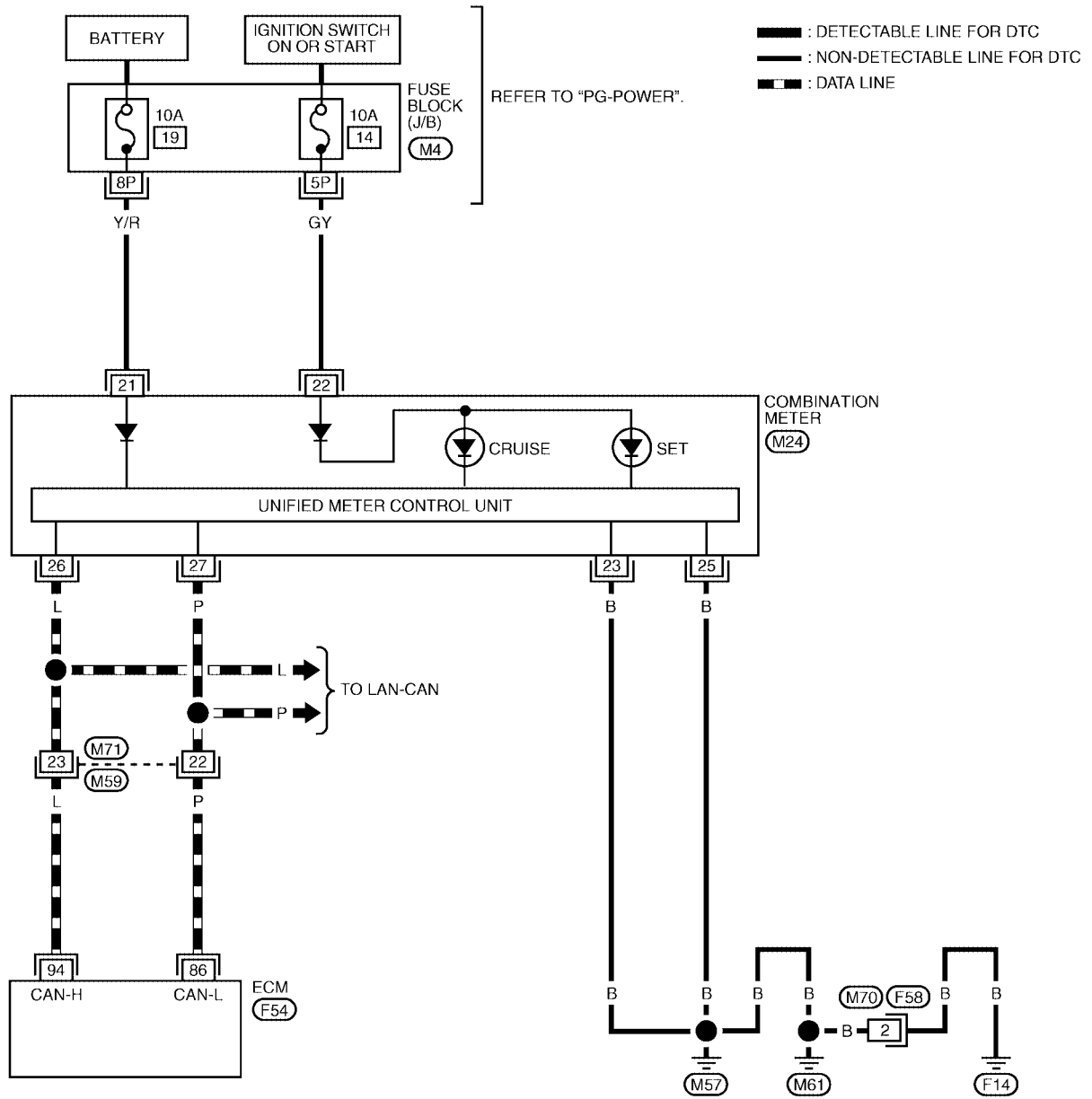

BBWA1582E

ASCD INDICATOR

[VQ]

UBS00IFT

Diagnostic Procedure

1. CHECK OVERALL FUNCTION

Check ASCD indicator under the following conditions.

MONITOR ITEM	CONDITION		SPECIFICATION
CRUISE LAMP	● Ignition switch: ON	MAIN switch: Pressed at the 1st time → at the 2nd time	ON → OFF
SET LAMP	● MAIN switch: ON ● When vehicle speed is between 40 km/h (25 MPH) and 144 km/h (89 MPH)	ASCD is operating	ON
		ASCD is not operating	OFF

OK or NG

OK >> **INSPECTION END**
NG >> GO TO 2.

2. CHECK DTC

Check that DTC U1000 or U1001 is not displayed.

OK or NG

OK >> GO TO 3.
NG >> Perform trouble diagnoses for DTC U1000, U1001. Refer to [EC-790, "DTC U1000, U1001 CAN COMMUNICATION LINE"](#).

3. CHECK COMBINATION METER FUNCTION

Does combination meter operate normally?.

Yes or No

Yes >> GO TO 4.
No >> Go to [DI-7, "Combination Meter"](#).

4. CHECK INTERMITTENT INCIDENT

Refer to [EC-782, "TROUBLE DIAGNOSIS FOR INTERMITTENT INCIDENT"](#).

>> **INSPECTION END**

MIL AND DATA LINK CONNECTOR

[VQ]

MIL AND DATA LINK CONNECTOR

PFV:24814

Wiring Diagram

UBS00IFU

EC-MIL/DL-01

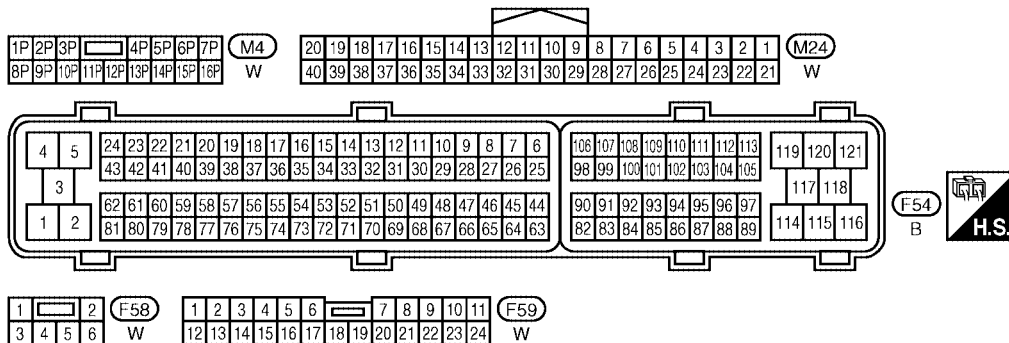
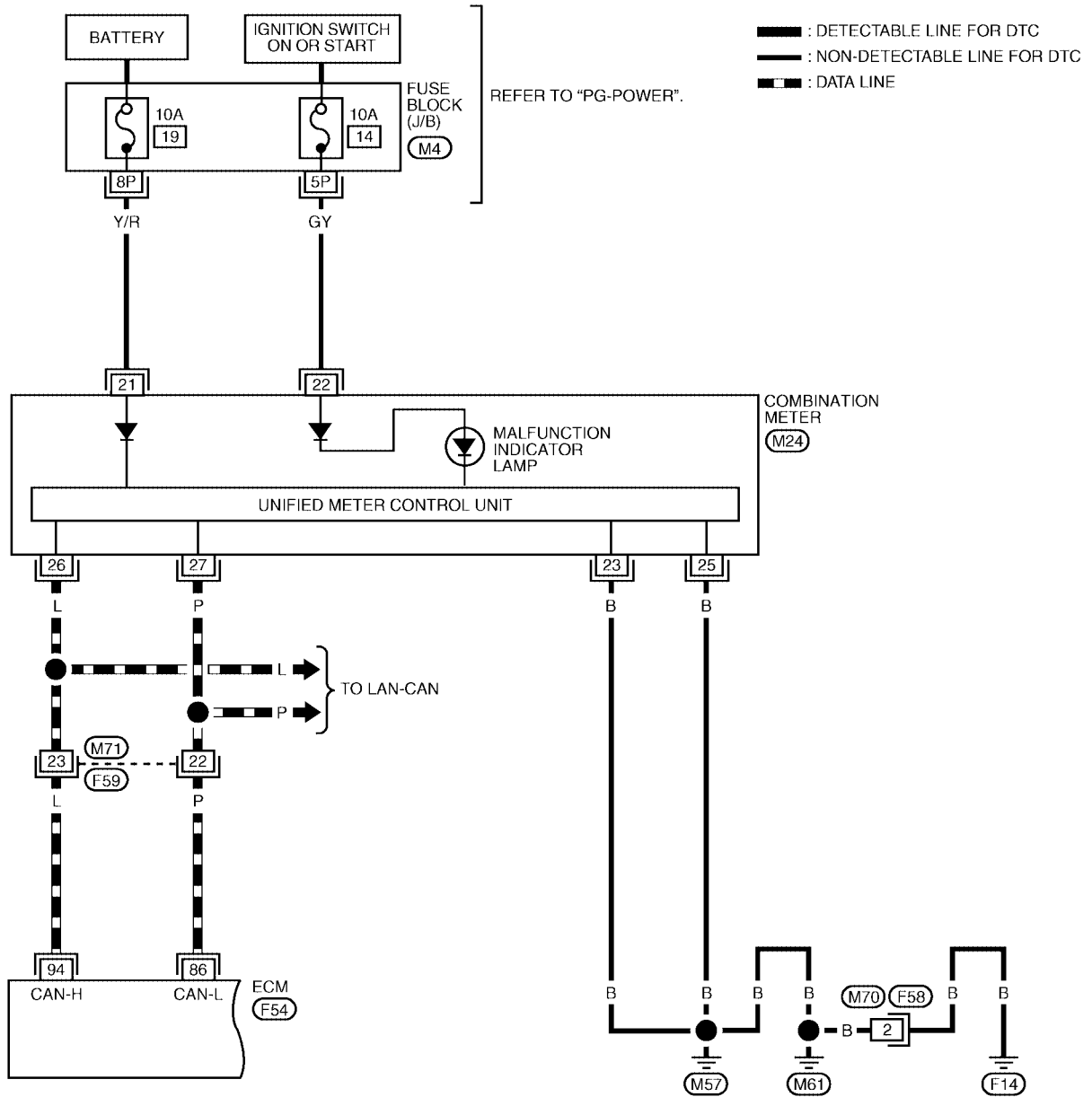

BBWA1583E

MIL AND DATA LINK CONNECTOR

[VQ]

EC-MIL/DL-02

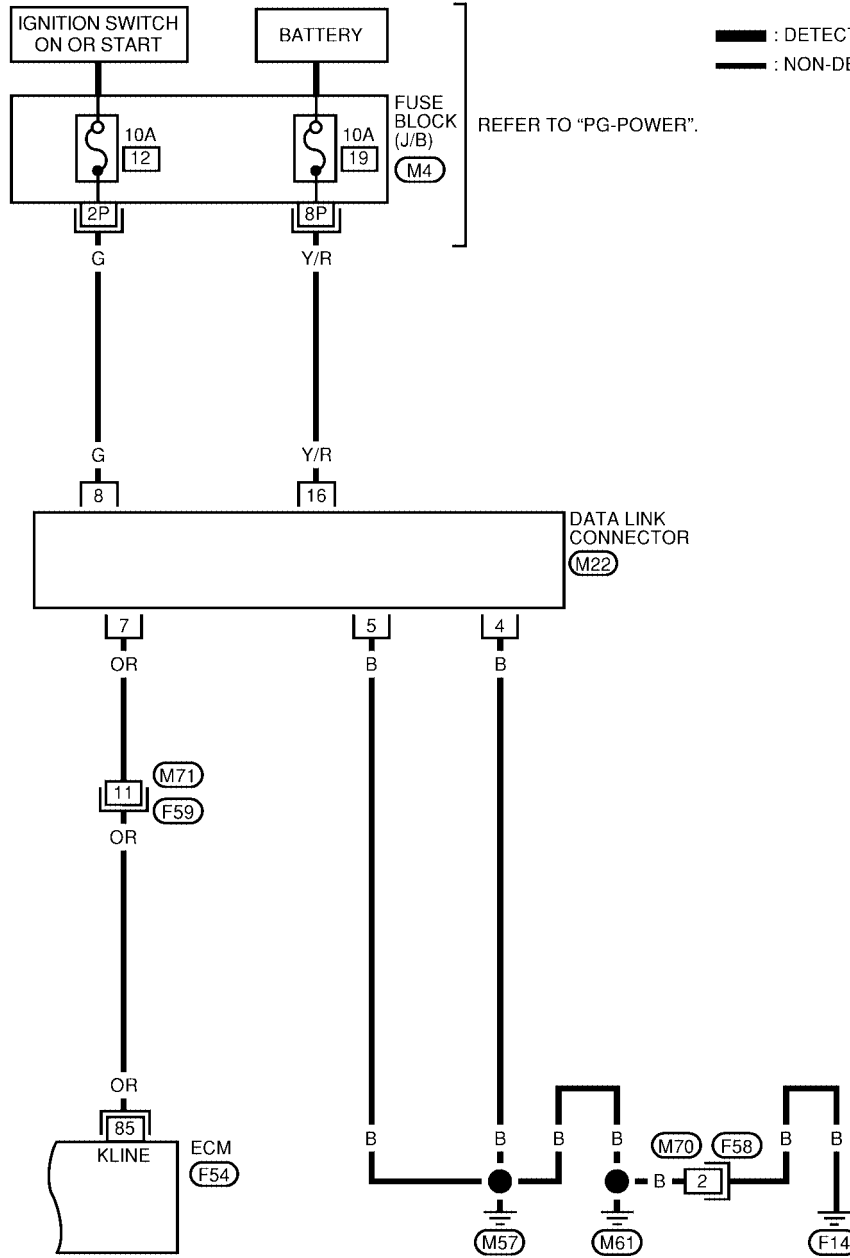

A
 EC
 C
 D
 E
 F
 G
 H
 I
 J
 K
 L
 M

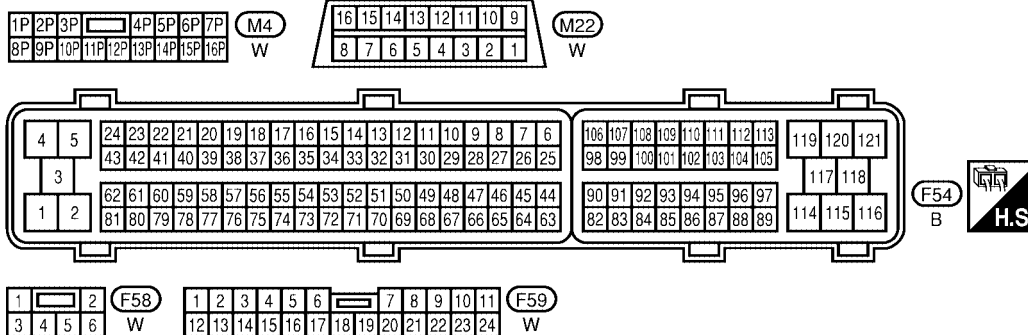

BBWA1320E

SERVICE DATA AND SPECIFICATIONS (SDS)

[VQ]

SERVICE DATA AND SPECIFICATIONS (SDS)

PFP:00030

Fuel Pressure

UBS00IG6

Fuel pressure at idling kPa (kg/cm ² , psi)	Approximately 350 (3.57, 51)
--	------------------------------

Idle Speed and Ignition Timing

UBS00IG7

Target idle speed	No-load* ¹ [in P or N position (A/T) or neutral position (M/T)]	A/T: 675±50 rpm M/T: 625±50 rpm
Air conditioner: ON	In P or N position (A/T) or neutral position (M/T)	700 rpm or more
Ignition timing	In P or N position (A/T) or neutral position (M/T)	15° ± 5° BTDC

*1: Under the following conditions:

- Air conditioner switch: OFF
- Electric load: OFF (Lights, heater fan & rear window defogger)
- Steering wheel: Kept in straight-ahead position

Calculated Load Value

UBS00IG8

Conditions	Calculated load value % (Using CONSULT-II or GST)
At idle	5 - 35
At 2,500 rpm	5 - 35

Mass Air Flow Sensor

UBS00IG9

Supply voltage	Battery voltage (11 - 14V)
Output voltage at idle	1.0 - 1.2V*
Mass air flow (Using CONSULT-II or GST)	2.0 - 6.0 g·m/sec at idle* 7.0 - 20.0 g·m/sec at 2,500 rpm*

*: Engine is warmed up to normal operating temperature and running under no-load.

Intake Air Temperature Sensor

UBS00IGA

Temperature °C (°F)	Resistance kΩ
25 (77)	1.94 - 2.06
80 (176)	0.295 - 0.349

Engine Coolant Temperature Sensor

UBS00IGB

Temperature °C (°F)	Resistance kΩ
20 (68)	2.1 - 2.9
50 (122)	0.68 - 1.00
90 (194)	0.236 - 0.260

EGR Temperature Sensor

UBS00IIR

Temperature °C (°F)	Resistance MΩ
0 (32)	0.73 - 0.88
50 (122)	0.074 - 0.082
100 (212)	0.011 - 0.014

Air Fuel Ratio (A/F) Sensor 1 Heater

UBS00IGC

Resistance [at 25°C (77°F)]	2.3 - 4.3Ω
-----------------------------	------------

Heated Oxygen Sensor 2 Heater

UBS00IGD

Resistance [at 25°C (77°F)]	5.0 - 7.0Ω
-----------------------------	------------

SERVICE DATA AND SPECIFICATIONS (SDS)

[VQ]

Crankshaft Position Sensor (POS)

UBS00IGE

Refer to [EC-927, "Component Inspection"](#) .

A

Camshaft Position Sensor (PHASE)

UBS00IGF

Refer to [EC-936, "Component Inspection"](#) .

EC

Throttle Control Motor

UBS00IGG

Resistance [at 25°C (77°F)]	Approximately 1 - 15Ω
-----------------------------	-----------------------

C

Injector

UBS00IGH

Resistance [at 10 - 60°C (50 -140°F)]	11.1 - 14.5Ω
---------------------------------------	--------------

D

Fuel Pump

UBS00IGI

Resistance [at 25°C (77°F)]	Approximately 0.2 - 5.0Ω
-----------------------------	--------------------------

E

F

G

H

I

J

K

L

M

