

SECTION **MTC**

MANUAL AIR CONDITIONER

A
B
C
D
E
F
G
H
I
J
K
L
M

CONTENTS

<p>PRECAUTIONS 4</p> <p> Precautions for Supplemental Restraint System (SRS) "AIR BAG" and "SEAT BELT PRE-TENSIONER" 4</p> <p> Precautions for Working with HFC-134a (R-134a).... 4</p> <p> Contaminated Refrigerant 4</p> <p> General Refrigerant Precautions 5</p> <p> Precautions for Leak Detection Dye 5</p> <p> A/C Identification Label 6</p> <p> Precautions for Refrigerant Connection 6</p> <p> FEATURES OF NEW TYPE REFRIGERANT CONNECTION 6</p> <p> O-RING AND REFRIGERANT CONNECTION..... 7</p> <p> Precautions for Servicing Compressor 10</p> <p> Precautions for Service Equipment 10</p> <p> RECOVERY/RECYCLING EQUIPMENT 10</p> <p> ELECTRONIC LEAK DETECTOR 10</p> <p> VACUUM PUMP 11</p> <p> MANIFOLD GAUGE SET 11</p> <p> SERVICE HOSES 11</p> <p> SERVICE COUPLERS 12</p> <p> REFRIGERANT WEIGHT SCALE 12</p> <p> CHARGING CYLINDER 12</p> <p> Wiring Diagrams and Trouble Diagnosis 12</p> <p>PREPARATION 13</p> <p> Special Service Tools 13</p> <p> HFC-134a (R-134a) Service Tools and Equipment.. 13</p> <p> Commercial Service Tools 16</p> <p>REFRIGERATION SYSTEM 17</p> <p> Refrigerant Cycle 17</p> <p> REFRIGERANT FLOW 17</p> <p> Refrigerant System Protection 17</p> <p> REFRIGERANT PRESSURE SENSOR 17</p> <p> PRESSURE RELIEF VALVE 17</p> <p> Component Layout 18</p> <p>LUBRICANT 19</p> <p> Maintenance of Lubricant Quantity in Compressor.. 19</p> <p> LUBRICANT 19</p> <p> CHECKING AND ADJUSTING 19</p> <p>AIR CONDITIONER CONTROL 21</p>	<p> Overview Air Conditioner LAN Control System 21</p> <p> System Construction 21</p> <p> OPERATION 21</p> <p> TRANSMISSION DATA AND TRANSMISSION ORDER 22</p> <p> AIR MIX DOOR CONTROL 22</p> <p> FAN SPEED CONTROL 23</p> <p> INTAKE DOOR CONTROL 23</p> <p> MODE DOOR CONTROL 23</p> <p> MAGNET CLUTCH CONTROL 23</p> <p> Overview of Control system 23</p> <p> Control Operation 24</p> <p> AIR CONDITIONER (A/C) SWITCH 25</p> <p> TEMPERATURE DIAL (POTENTIO TEMPERATURE CONTROL) 25</p> <p> FAN DIAL/OFF SWITCH 25</p> <p> RECIRCULATION (REC) SWITCH 25</p> <p> DEFROSTER SWITCH 25</p> <p> MODE DIAL 25</p> <p> REAR WINDOW DEFOGGER SWITCH 25</p> <p> Discharge Air Flow 26</p> <p> System Description 27</p> <p> SWITCHES AND THEIR CONTROL FUNCTION.. 27</p> <p> CAN Communication System Description 27</p> <p>TROUBLE DIAGNOSIS 28</p> <p> How to Perform Trouble Diagnoses for Quick and Accurate Repair 28</p> <p> WORK FLOW 28</p> <p> SYMPTOM TABLE 28</p> <p> Component Parts and Harness Connector Location.. 29</p> <p> ENGINE COMPARTMENT 29</p> <p> PASSENGER COMPARTMENT 31</p> <p> Circuit Diagram 32</p> <p> Wiring Diagram — HEATER — 33</p> <p> Wiring Diagram — A/C,M — 35</p> <p> Front Air Control Terminals and Reference Value... 38</p> <p> INSPECTION OF FRONT AIR CONTROL 38</p> <p> FRONT AIR CONTROL HARNESS CONNECTOR TERMINAL LAYOUT 38</p> <p> FRONT AIR CONTROL INSPECTION TABLE ... 38</p>
---	---

MTC

Operational Check	40	BLOWER MOTOR	79
CONDITIONS:	40	Removal and Installation	79
PROCEDURE:	40	REMOVAL	79
Power Supply and Ground Circuit for Front Air Control	42	INSTALLATION	79
COMPONENT DESCRIPTION	42	IN-CABIN MICROFILTER	80
DIAGNOSTIC PROCEDURE	42	Removal and Installation	80
LAN System Circuit	44	FUNCTION	80
DIAGNOSTIC PROCEDURE	44	REPLACEMENT TIMING	80
Mode Door Motor Circuit	47	REPLACEMENT PROCEDURES	80
INSPECTION FLOW	47	HEATER & COOLING UNIT ASSEMBLY	81
SYSTEM DESCRIPTION	48	Removal and Installation	81
COMPONENT DESCRIPTION	48	REMOVAL	81
DIAGNOSTIC PROCEDURE	48	INSTALLATION	81
Air Mix Door Motor Circuit	49	HEATER CORE	82
INSPECTION FLOW	49	Removal and Installation	82
SYSTEM DESCRIPTION	50	REMOVAL	82
COMPONENT DESCRIPTION	50	INSTALLATION	82
DIAGNOSTIC PROCEDURE	50	INTAKE DOOR MOTOR	83
Intake Door Motor Circuit	51	Removal and Installation	83
INSPECTION FLOW	51	REMOVAL	83
SYSTEM DESCRIPTION	52	INSTALLATION	83
COMPONENT DESCRIPTION	52	MODE DOOR MOTOR	84
DIAGNOSTIC PROCEDURE	52	Removal and Installation	84
Blower Motor Circuit	53	REMOVAL	84
INSPECTION FLOW	53	INSTALLATION	84
SYSTEM DESCRIPTION	54	AIR MIX DOOR MOTOR	85
COMPONENT DESCRIPTION	54	Removal and Installation	85
DIAGNOSTIC PROCEDURE	54	REMOVAL	85
COMPONENT INSPECTION	58	INSTALLATION	85
Magnet Clutch Circuit	59	FAN CONTROL AMPLIFIER	86
INSPECTION FLOW	59	Removal and Installation	86
SYSTEM DESCRIPTION	60	REMOVAL	86
DIAGNOSTIC PROCEDURE	60	INSTALLATION	86
COMPONENT INSPECTION	62	DUCTS AND GRILLES	87
Insufficient Cooling	64	Removal and Installation	87
INSPECTION FLOW	64	REMOVAL	87
PERFORMANCE TEST ANALYSIS	65	INSTALLATION	88
PERFORMANCE CHART	67	REFRIGERANT LINES	89
TROUBLE DIAGNOSIS FOR ABNORMAL PRESSURE	67	HFC-134a (R-134a) Service Procedure	89
Insufficient Heating	71	SETTING OF SERVICE TOOLS AND EQUIPMENT	89
INSPECTION FLOW	71	Components	91
Noise	72	Removal and Installation for Compressor —	
INSPECTION FLOW	72	QR25DE Models	93
Intake Sensor Circuit	73	REMOVAL	93
COMPONENT DESCRIPTION	73	INSTALLATION	93
DIAGNOSTIC PROCEDURE	73	Removal and Installation for Compressor —	
CONTROL UNIT	76	VQ35DE Models	94
Removal and Installation	76	REMOVAL	94
FRONT AIR CONTROL	76	INSTALLATION	94
INTAKE SENSOR	77	Removal and Installation for Compressor Clutch ...	94
Removal and Installation	77	REMOVAL	94
REMOVAL	77	INSPECTION AFTER REMOVAL	96
INSTALLATION	77	INSTALLATION	96
BLOWER UNIT	78	INSPECTION AFTER INSTALLATION	97
Removal and Installation	78	BREAK-IN OPERATION	97
REMOVAL	78	Removal and Installation for Low-pressure Flexible	
INSTALLATION	78	Hose	98
		REMOVAL	98

INSTALLATION	98	Removal and Installation for Expansion Valve	101	
Removal and Installation for High-pressure Flexible Hose	98	REMOVAL	101	A
REMOVAL	98	INSTALLATION	102	
INSTALLATION	98	Checking for Refrigerant Leaks	102	
Removal and Installation for High-pressure Pipe	98	Checking System for Leaks Using the Fluorescent Leak Detector	102	B
REMOVAL	98	Dye Injection	102	
INSTALLATION	98	Electronic Refrigerant Leak Detector	103	
Removal and Installation for Refrigerant Pressure Sensor	99	PRECAUTIONS FOR HANDLING THE LEAK DETECTOR	103	C
REMOVAL	99	CHECKING PROCEDURE	104	
INSTALLATION	99	SERVICE DATA AND SPECIFICATIONS (SDS) ...	106	D
Removal and Installation for Condenser	99	Service Data and Specifications (SDS)	106	
REMOVAL	99	COMPRESSOR	106	
INSTALLATION	100	LUBRICANT	106	E
Removal and Installation for Evaporator	100	REFRIGERANT	106	
REMOVAL	100	ENGINE IDLING SPEED	106	
INSTALLATION	101	BELT TENSION	106	F
				G
				H
				I
				MTC
				K
				L
				M

PRECAUTIONS

PRECAUTIONS

PFP:00001

Precautions for Supplemental Restraint System (SRS) “AIR BAG” and “SEAT BELT PRE-TENSIONER”

EJS002RO

The Supplemental Restraint System such as “AIR BAG” and “SEAT BELT PRE-TENSIONER”, used along with a front seat belt, helps to reduce the risk or severity of injury to the driver and front passenger for certain types of collision. This system includes seat belt switch inputs and dual stage front air bag modules. The SRS system uses the seat belt switches to determine the front air bag deployment, and may only deploy one front air bag, depending on the severity of a collision and whether the front occupants are belted or unbelted. Information necessary to service the system safely is included in the SRS and SB section of this Service Manual.

WARNING:

- To avoid rendering the SRS inoperative, which could increase the risk of personal injury or death in the event of a collision which would result in air bag inflation, all maintenance must be performed by an authorized NISSAN/INFINITI dealer.
- Improper maintenance, including incorrect removal and installation of the SRS, can lead to personal injury caused by unintentional activation of the system. For removal of Spiral Cable and Air Bag Module, see the SRS section.
- Do not use electrical test equipment on any circuit related to the SRS unless instructed to in this Service Manual. SRS wiring harnesses can be identified by yellow and/or orange harnesses or harness connectors.

Precautions for Working with HFC-134a (R-134a)

EJS002RP

WARNING:

- CFC-12 (R-12) refrigerant and HFC-134a (R-134a) refrigerant are not compatible. If the refrigerants are mixed compressor failure is likely to occur. Refer [MTC-4, "Contaminated Refrigerant"](#) . To determine the purity of HFC-134a (R-134a) in the vehicle and recovery tank, use Refrigerant Recovery/Recycling Recharging equipment and Refrigerant Identifier.
- Use only specified lubricant for the HFC-134a (R-134a) A/C system and HFC-134a (R-134a) components. If lubricant other than that specified is used, compressor failure is likely to occur.
- The specified HFC-134a (R-134a) lubricant rapidly absorbs moisture from the atmosphere. The following handling precautions must be observed:
 - When removing refrigerant components from a vehicle, immediately cap (seal) the component to minimize the entry of moisture from the atmosphere.
 - When installing refrigerant components to a vehicle, do not remove the caps (unseal) until just before connecting the components. Connect all refrigerant loop components as quickly as possible to minimize the entry of moisture into system.
 - Only use the specified lubricant from a sealed container. Immediately reseal containers of lubricant. Without proper sealing, lubricant will become moisture saturated and should not be used.
 - Avoid breathing A/C refrigerant and lubricant vapor or mist. Exposure may irritate eyes, nose and throat. Remove HFC-134a (R-134a) from the A/C system using certified service equipment meeting requirements of SAE J2210 [HFC-134a (R-134a) recycling equipment], or J2209 [HFC-134a (R-134a) recycling equipment], If accidental system discharge occurs, ventilate work area before resuming service. Additional health and safety information may be obtained from refrigerant and lubricant manufacturers.
 - Do not allow A/C lubricant to come in contact with styrofoam parts. Damage may result.

Contaminated Refrigerant

EJS002RO

If a refrigerant other than pure HFC-134a (R-134a) is identified in a vehicle, your options are:

- Explain to the customer that environmental regulations prohibit the release of contaminated refrigerant into the atmosphere.
- Explain that recovery of the contaminated refrigerant could damage your service equipment and refrigerant supply.
- Suggest the customer return the vehicle to the location of previous service where the contamination may have occurred.
- If you choose to perform the repair, recover the refrigerant using only **dedicated equipment and containers**. **Do not recover contaminated refrigerant into your existing service equipment**. If your facility

PRECAUTIONS

does not have dedicated recovery equipment, you may contact a local refrigerant product retailer for available service. This refrigerant must be disposed of in accordance with all federal and local regulations. In addition, replacement of all refrigerant system components on the vehicle is recommended.

- If the vehicle is within the warranty period, the air conditioner warranty is void. Please contact NISSAN Customer Affairs for further assistance.

General Refrigerant Precautions

EJS002RR

WARNING:

- Do not release refrigerant into the air. Use approved recovery/recycling equipment to capture the refrigerant every time an air conditioning system is discharged.
- Always wear eye and hand protection (goggles and gloves) when working with any refrigerant or air conditioning system.
- Do not store or heat refrigerant containers above 52°C (125°F).
- Do not heat a refrigerant container with an open flame; if container warming is required, place the bottom of the container in a warm pail of water.
- Do not intentionally drop, puncture, or incinerate refrigerant containers.
- Keep refrigerant away from open flames: poisonous gas will be produced if refrigerant burns.
- Refrigerant will displace oxygen, therefore be certain to work in well ventilated areas to prevent suffocation.
- Do not pressure test or leak test HFC-134a (R-134a) service equipment and/or vehicle air conditioning systems with compressed air during repair. Some mixtures of air and HFC-134a (R-134a) have been shown to be combustible at elevated pressures. These mixtures, if ignited, may cause injury or property damage. Additional health and safety information may be obtained from refrigerant manufacturers.

Precautions for Leak Detection Dye

EJS002RS

- The A/C system contains a fluorescent leak detection dye used for locating refrigerant leaks. An ultraviolet (UV) lamp is required to illuminate the dye when inspecting for leaks.
- Always wear fluorescence enhancing UV safety goggles to protect your eyes and enhance the visibility of the fluorescent dye.
- A compressor shaft seal should not be repaired because of dye seepage. The compressor shaft seal should only be repaired after confirming the leak with an electronic refrigerant leak detector (J-41995).
- Always remove any dye from the leak area after repairs are complete to avoid a misdiagnosis during a future service.
- Do not allow dye to come into contact with painted body panels or interior components. If dye is spilled, clean immediately with the approved dye cleaner. Fluorescent dye left on a surface for an extended period of time **cannot be removed**.
- Do not spray the fluorescent dye cleaning agent on hot surfaces (engine exhaust manifold, etc.).
- Do not use more than one refrigerant dye bottle (1/4 ounce / 7.4 cc) per A/C system.
- Leak detection dyes for HFC-134a (R-134a) and CFC-12 (R-12) A/C systems are different. Do not use HFC-134a (R-134a) leak detection dye in CFC-12 (R-12) A/C systems or CFC-12 (R-12) leak detection dye in HFC-134a (R-134a) A/C systems or A/C system damage may result.
- The fluorescent properties of the dye will remain for over three (3) years unless a compressor failure occurs.

PRECAUTIONS

EJS002RT

A/C Identification Label

Vehicles with factory installed fluorescent dye have this green identification label on the underside of hood.

AIR CONDITIONER NISSAN		
	REFRIGERANT	COMPRESSOR LUBRICANT
TYPE (PART NO.)	HFC134a (R134a)	NISSAN LUMINOUS OIL TYPE DH-PS (KLH00-PAGS0)
AMOUNT	0.50 ± .025 kg (1.10 ± 0.055lbs)	150ml (5.03 oz)

CAUTION PRECAUTION

- REFRIGERANT UNDER HIGH PRESSURE.
- SYSTEM TO BE SERVICED BY QUALIFIED PERSONNEL.
- IMPROPER SERVICE METHODS MAY CAUSE PERSONAL INJURY.
- CONSULT SERVICE MANUAL.
- THIS AIR CONDITIONER SYSTEM COMPLIES WITH SAE J-639.

Nissan Motor Corporation in USA, Carson, CA

WJIA0713E

Precautions for Refrigerant Connection

EJS002RU

A new type refrigerant connection has been introduced to all refrigerant lines except the following locations.

- Expansion valve to cooling unit
- Evaporator pipes to evaporator (inside cooling unit)
- Refrigerant pressure sensor

FEATURES OF NEW TYPE REFRIGERANT CONNECTION

- The O-ring has been relocated. It has also been provided with a groove for proper installation. This eliminates the chance of the O-ring being caught in, or damaged by, the mating part. The sealing direction of the O-ring is now set vertically in relation to the contacting surface of the mating part to improve sealing characteristics.
- The reaction force of the O-ring will not occur in the direction that causes the joint to pull out, thereby facilitating piping connections.

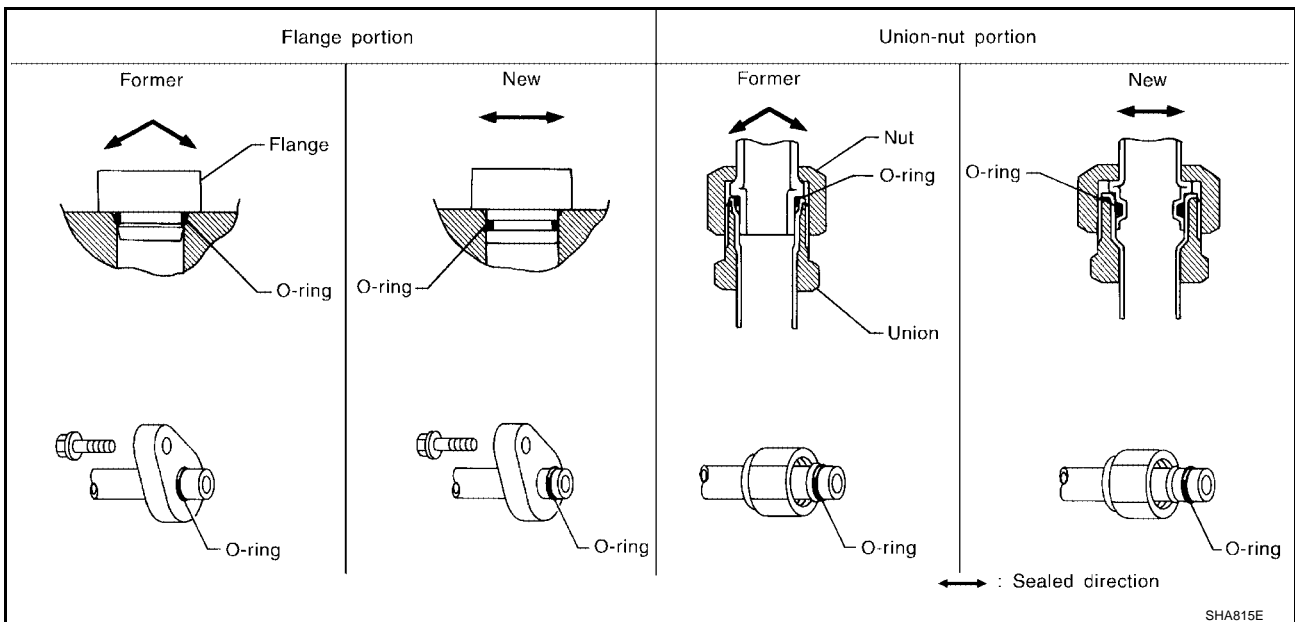

PRECAUTIONS

O-RING AND REFRIGERANT CONNECTION

QR25DE

SEC. 214 • 271 • 274 • 276

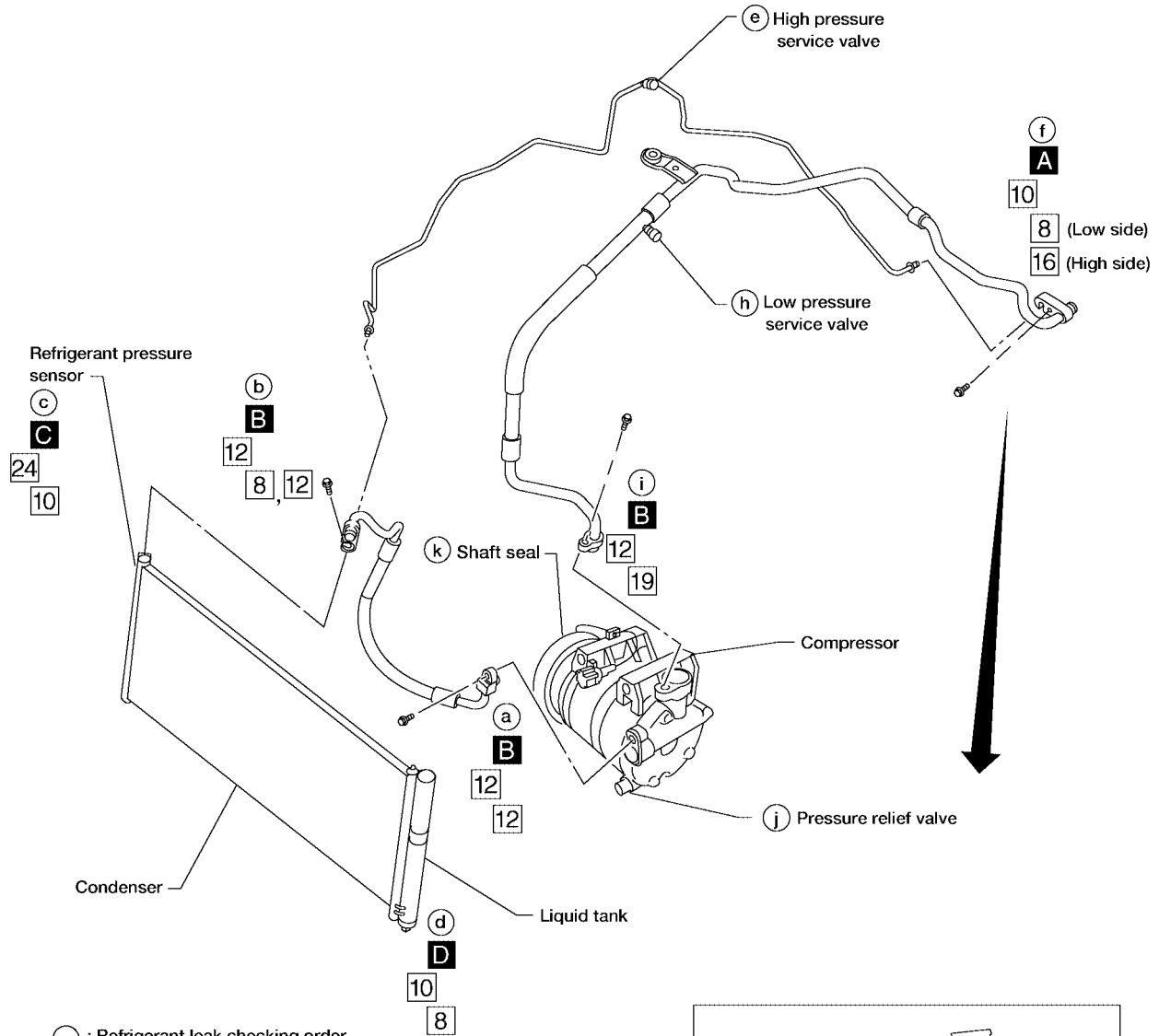

- : Refrigerant leak checking order
- : (Tightening torque)
- □ : (Wrench size)
- : (O-ring size)
- ⊗ : N·m (kg·m, in·lb)
- ⊕ : N·m (kg·m, ft·lb)
- A** ⊗ : 2.9 – 5.9 (0.29 – 0.60, 26 – 52)
- B** ⊗ : 7.8 – 19.6 (0.8 – 1.9, 69 – 173)
- C** ⊗ : 9.8 – 11.7 (1.0 – 1.1, 7.3 – 8.6)
- D** ⊗ : 5.0 – 6.47 (0.51 – 0.65, 45 – 57)

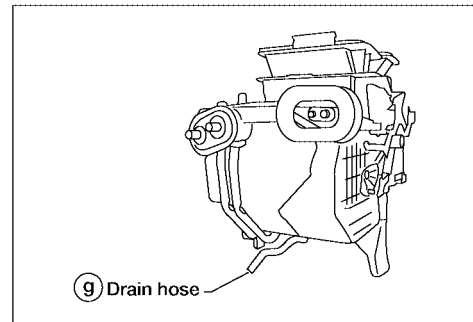

A
B
C
D
E
F
G
H
I
MTC
K
L
M

WJIA0981E

PRECAUTIONS

VQ35DE

SEC. 214 • 271 • 274 • 276

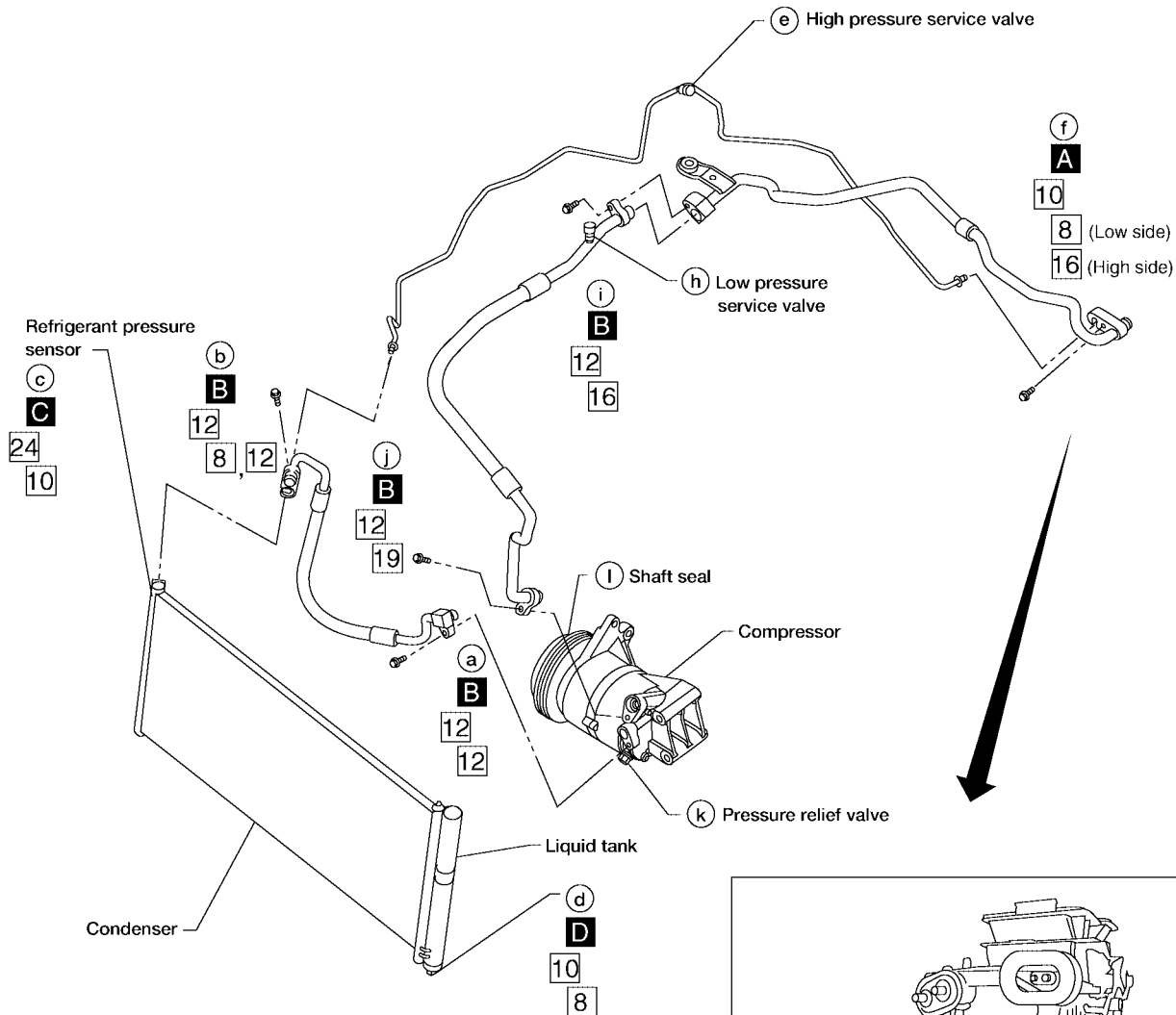

- : Refrigerant leak checking order
- : (Tightening torque)
- □ : (Wrench size)
- : (O-ring size)
- ⊗ : N·m (kg-m, in-lb)
- ⊙ : N·m (kg-m, ft-lb)
- A** ⊗ : 2.9 – 5.9 (0.29 – 0.60, 26 – 52)
- B** ⊗ : 7.8 – 19.6 (0.8 – 1.9, 69 – 173)
- C** ⊗ : 9.8 – 11.7 (1.0 – 1.1, 7.3 – 8.6)
- D** ⊗ : 5.0 – 6.47 (0.51 – 0.65, 45 – 57)

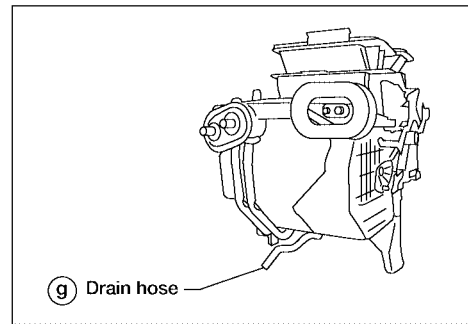

WJIA0982E

CAUTION:

The new and former refrigerant connections use different O-ring configurations. Do not confuse O-rings since they are not interchangeable. If a wrong O-ring is installed, refrigerant will leak at, or around, the connection.

PRECAUTIONS

O-Ring Part Numbers and Specifications

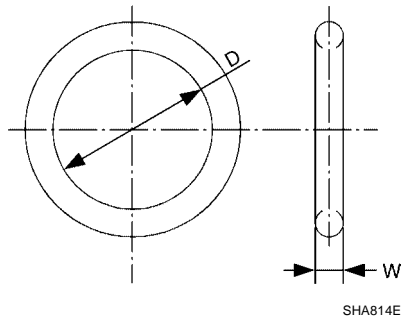

Conne- tion type	O-ring size	Part number*	D mm (in)	W mm (in)
New	8	92471 N8210	6.8 (0.268)	1.85 (0.0728)
Former	10	J2476 89956	9.25 (0.3642)	1.78 (0.0701)
New	12	92472 N8210	10.9 (0.429)	2.43 (0.0957)
Former		92475 71L00	11.0 (0.433)	2.4 (0.094)
New	16	92473 N8210	13.6 (0.535)	2.43 (0.0957)
Former		92475 72L00	14.3 (0.563)	2.3 (0.091)
New	19	92474 N8210	16.5 (0.650)	2.43 (0.0957)
Former		92477 N8200	17.12 (0.6740)	1.78 (0.0701)
New	24	92195 AH300	21.8 (0.858)	2.4 (0.094)

*: Always check with the Parts Department for the latest parts information.

WARNING:

Make sure all refrigerant is discharged into the recycling equipment and the pressure in the system is less than atmospheric pressure. Then gradually loosen the discharge side hose fitting and remove it.

CAUTION:

When replacing or cleaning refrigerant cycle components, observe the following.

- When the compressor is removed, store it in the same position as it is when mounted on the car. Failure to do so will cause lubricant to enter the low pressure chamber.
- When connecting tubes, always use a torque wrench and a back-up wrench.
- After disconnecting tubes, immediately plug all openings to prevent entry of dirt and moisture.
- When installing an air conditioner in the vehicle, connect the pipes as the final stage of the operation. Do not remove the seal caps of pipes and other components until just before required for connection.
- Allow components stored in cool areas to warm to working area temperature before removing seal caps. This prevents condensation from forming inside A/C components.
- Thoroughly remove moisture from the refrigeration system before charging the refrigerant.
- Always replace used O-rings.
- When connecting tube, apply lubricant to circle of the O-rings shown in illustration. Be careful not to apply lubricant to threaded portion.
Lubricant name: NISSAN A/C System Lubricant Type DH-PS or equivalent
Part number: KLH00-PAGS0
- O-ring must be closely attached to grooved portion of tube.
- When replacing the O-ring, be careful not to damage O-ring and tube.
- Connect tube until you hear it click, then tighten the nut or bolt by hand until snug. Make sure that the O-ring is installed to tube correctly.

PRECAUTIONS

- After connecting line, conduct leak test and make sure that there is no leakage from connections. When the gas leaking point is found, disconnect that line and replace the O-ring. Then tighten connections of seal seat to the specified torque.

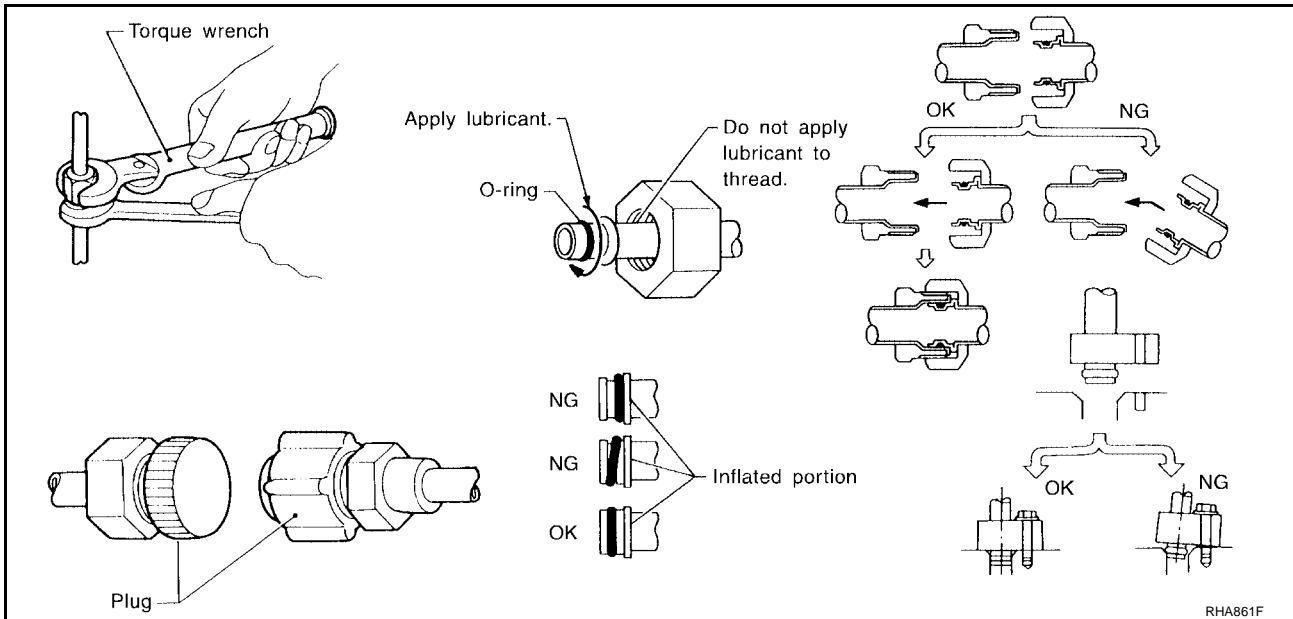

Precautions for Servicing Compressor

EJS002RV

- Plug all openings to prevent moisture and foreign matter from entering.
- When the compressor is removed, store it in the same position as it is when mounted on the car.
- When replacing or repairing compressor, follow "Maintenance of Lubricant Quantity in Compressor" exactly. Refer to [MTC-19, "Maintenance of Lubricant Quantity in Compressor"](#).
- Keep friction surfaces between clutch and pulley clean. If the surface is contaminated, with lubricant, wipe it off by using a clean waste cloth moistened with thinner.
- After compressor service operation, turn the compressor shaft by hand more than 5 turns in both directions. This will equally distribute lubricant inside the compressor. After the compressor is installed, let the engine idle and operate the compressor for 1 hour.
- After replacing the compressor magnet clutch, apply voltage to the new one and check for normal operation. [Gap between clutch disc and pulley is 0.3 - 0.6 mm (0.012 - 0.024 in)]

Precautions for Service Equipment RECOVERY/RECYCLING EQUIPMENT

EJS002RW

Follow the manufacturer's instructions for machine operation and machine maintenance. Never introduce any refrigerant other than that specified into the machine.

ELECTRONIC LEAK DETECTOR

Follow the manufacturer's instructions for tester operation and tester maintenance.

PRECAUTIONS

VACUUM PUMP

The lubricant contained inside the vacuum pump is not compatible with the specified lubricant for HFC-134a (R-134a) A/C systems. The vent side of the vacuum pump is exposed to atmospheric pressure so the vacuum pump lubricant may migrate out of the pump into the service hose. This is possible when the pump is switched off after evacuation (vacuuming) and hose is connected to it. To prevent this migration, use a manual valve situated near the hose-to-pump connection, as follows.

- Usually vacuum pumps have a manual isolator valve as part of the pump. Close this valve to isolate the service hose from the pump.
- For pumps without an isolator, use a hose equipped with a manual shut-off valve near the pump end. Close the valve to isolate the hose from the pump.
- If the hose has an automatic shut off valve, disconnect the hose from the pump: as long as the hose is connected, the valve is open and lubricating oil may migrate.

Some one-way valves open when vacuum is applied and close under a no vacuum condition. Such valves may restrict the pump's ability to pull a deep vacuum and are not recommended.

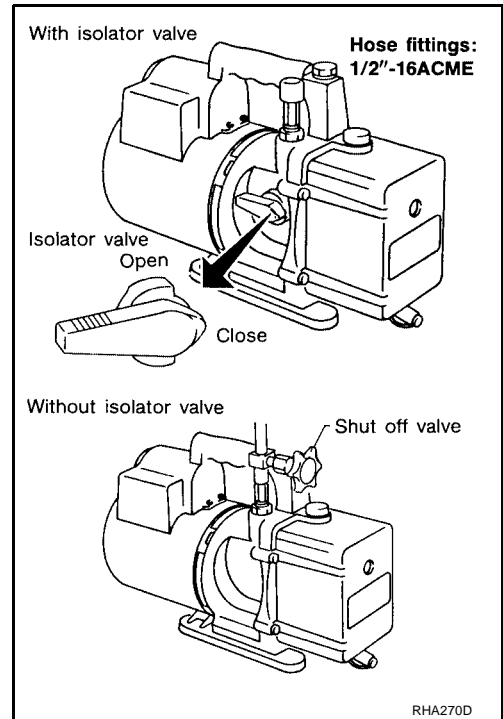

MANIFOLD GAUGE SET

Be certain that the gauge face indicates R-134a or 134a. Make sure the gauge set has 1/2"-16 ACME threaded connections for service hoses. Confirm the set has been used only with refrigerant HFC-134a (R-134a) along with specified lubricant.

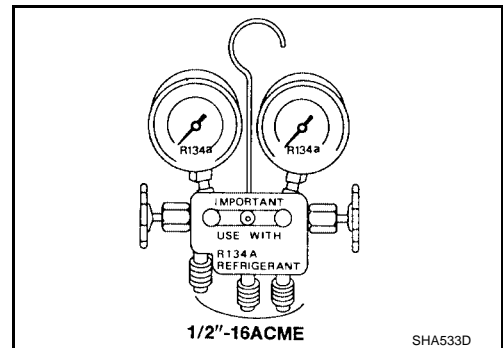

SERVICE HOSES

Be certain that the service hoses display the markings described (colored hose with black stripe). All hoses must include positive shut-off devices (either manual or automatic) near the end of the hoses opposite the manifold gauge.

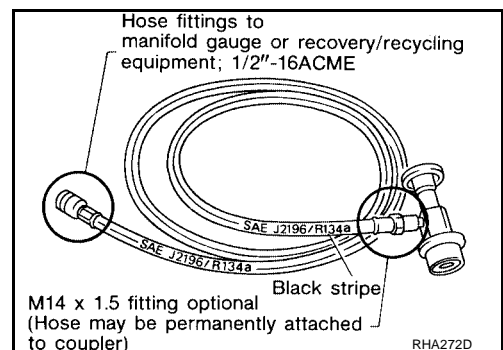

A
B
C
D
E
F
G
H
I
K
L
M

MTC

PRECAUTIONS

SERVICE COUPLERS

Never attempt to connect HFC-134a (R-134a) service couplers to a CFC-12 (R-12) A/C system. The HFC-134a (R-134a) couplers will not properly connect to the CFC-12 (R-12) system. However, if an improper connection is attempted, discharging and contamination may occur.

Shut-off valve rotation	A/C service valve
Clockwise	Open
Counterclockwise	Close

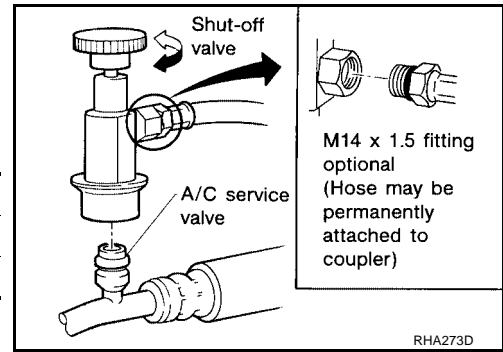

REFRIGERANT WEIGHT SCALE

Verify that no refrigerant other than HFC134a (R-134a) and specified lubricants have been used with the scale. If the scale controls refrigerant flow electronically, the hose fitting must be 1/2"-16 ACME.

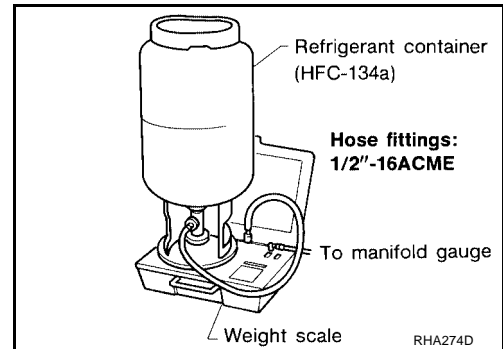

CHARGING CYLINDER

Using a charging cylinder is not recommended. Refrigerant may be vented into air from cylinder's top valve when filling the cylinder with refrigerant. Also, the accuracy of the cylinder is generally less than that of an electronic scale or of quality recycle/recharge equipment.

Wiring Diagrams and Trouble Diagnosis

EJS002RX

When you read wiring diagrams, refer to the following:

- [GI-14, "How to Read Wiring Diagrams"](#)
- [PG-4, "POWER SUPPLY ROUTING CIRCUIT"](#)

When you perform trouble diagnosis, refer to the following:

- [GI-9, "How to Follow Trouble Diagnoses"](#)
- [GI-26, "How to Perform Efficient Diagnosis for an Electrical Incident"](#)

PREPARATION

PREPARATION

PF0:00002

Special Service Tools

EJS003GJ

The actual shapes of Kent-Moore tools may differ from those of special service tools illustrated here.

Tool number (Kent-Moore No.) Tool name	Description
— (J-38873-A) Drive plate installer	Installing pulley and drive plate
KV99233130 (J-29884) Pulley puller	Removing pulley

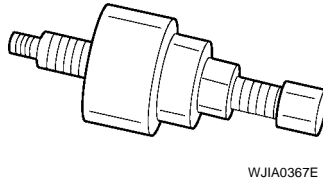

WJIA0367E

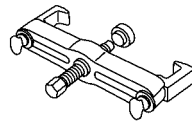

LHA172

HFC-134a (R-134a) Service Tools and Equipment

EJS003GK

Never mix HFC-134a refrigerant and/or its specified lubricant with CFC-12 (R-12) refrigerant and/or its lubricant.

Separate and non-interchangeable service equipment must be used for handling each type of refrigerant/lubricant.

Refrigerant container fittings, service hose fittings and service equipment fittings (equipment which handles refrigerant and/or lubricant) are different between CFC-12 (R-12) and HFC-134a (R-134a). This is to avoid mixed use of the refrigerants/lubricant.

Adapters that convert one size fitting to another must never be used: refrigerant/lubricant contamination will occur and compressor failure will result.

Tool number (Kent-Moore No.) Tool name	Description
— (—) Refrigerant HFC-134a (R-134a)	Container color: Light blue Container marking: HFC-134a (R-134a) Fitting size: Thread size ● large container 1/2 in -16 ACME
KLH00-PAGS0 (—) Genuine NISSAN A/C System Lubricant Type DH-PS	Type: Poly alkaline glycol oil (PAG), type DH-PS Application: HFC-134a (R-134a) vane rotary compressors (NISSAN only) Lubricity: 40 mℓ (1.4 US fl oz, 1.4 Imp fl oz)
K991J0130 (ACR2005-NI) ACR A/C Service Center	Refrigerant recovery, recycling and recharging

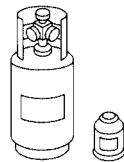

S-NT196





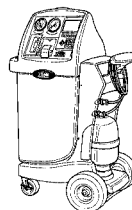

S-NT197

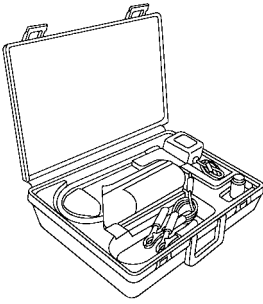
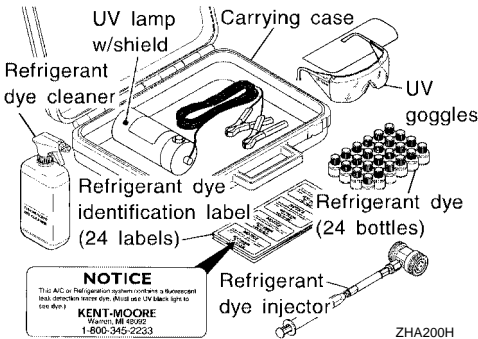
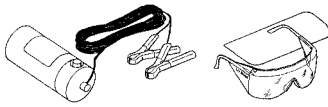

WJIA0293E

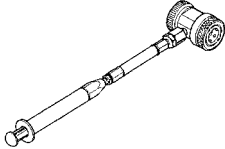
PREPARATION

Tool number (Kent-Moore No.) Tool name	Description
<p>— (J-41995) Electronic refrigerant leak detector</p>	<p>Power supply: ● DC 12V (Battery terminal)</p>  <p style="text-align: right;">AHA281A</p>
<p>— (J-43926) Refrigerant dye leak detection kit Kit includes: (J-42220) UV lamp and UV safety goggles (J-41459) Refrigerant dye injector (J-41447) qty. 24 HFC-134a (R-134a) refrigerant dye (J-43872) Refrigerant dye cleaner</p>	<p>Power supply: DC 12V (Battery terminal)</p>  <p style="text-align: right;">ZHA200H</p>
<p>— (J-42220) Fluorescent dye leak detector</p>	<p>Power supply: DC 12V (Battery terminal) For checking refrigerant leak when fluorescent dye is installed in A/C system. Includes: UV lamp and UV safety goggles</p>  <p style="text-align: right;">SHA438F</p>
<p>— (J-41447) HFC-134a (R-134a) Fluorescent leak detection dye (Box of 24, 1/4 ounce bottles)</p>	<p>Application: For HFC-134a (R-134a) PAG oil Container: 1/4 ounce (7.4cc) bottle (Includes self-adhesive dye identification labels for affixing to vehicle after charging system with dye.)</p>  <p style="text-align: right;">SHA439F</p>
<p>— (J-41459) HFC-134a (R-134a) Dye injector Use with J-41447, 1/4 ounce bottle</p>	<p>For injecting 1/4 ounce of fluorescent leak detection dye into A/C system.</p>  <p style="text-align: right;">SHA440F</p>
<p>— (J-43872) Refrigerant dye cleaner</p>	<p>For cleaning dye spills.</p>  <p style="text-align: right;">SHA441F</p>

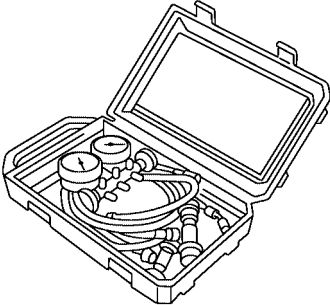
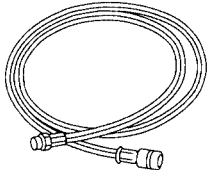
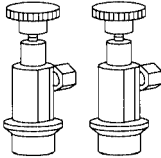
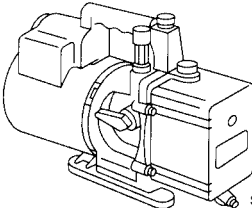

PREPARATION

Tool number (Kent-Moore No.) Tool name	Description	
<p>— (J-39183-C) Manifold gauge set (with hoses and couplers)</p>  <p style="text-align: right; font-size: small;">RJIA0196E</p>	<p>Identification:</p> <ul style="list-style-type: none"> ● The gauge face indicates R-134a. <li style="padding-left: 20px;">Fitting size: Thread size ● 1/2 in -16 ACME 	<p>A</p> <p>B</p> <p>C</p> <p>D</p>
<p>Service hoses</p> <ul style="list-style-type: none"> ● (J-39500-72B) High side hose ● (J-39500-72R) Low side hose ● (J-39500-72Y) Utility hose  <p style="text-align: right; font-size: small;">S-NT201</p>	<p>Hose color:</p> <ul style="list-style-type: none"> ● Low side hose: Blue with black stripe ● High side hose: Red with black stripe ● Utility hose: Yellow with black stripe or green with black stripe <p>Hose fitting to gauge:</p> <ul style="list-style-type: none"> ● 1/2 in -16 ACME 	<p>E</p> <p>F</p> <p>G</p>
<p>Service couplers</p> <ul style="list-style-type: none"> ● (J-39500-20A) High side coupler ● (J-39500-24A) Low side coupler  <p style="text-align: right; font-size: small;">S-NT202</p>	<p>Hose fitting to service hose:</p> <ul style="list-style-type: none"> ● M14 x 1.5 fitting is optional or permanently attached. 	<p>H</p> <p>I</p>
<p>— (J-39649) Vacuum pump (Including the isolator valve)</p>  <p style="text-align: right; font-size: small;">S-NT203</p>	<p>Capacity:</p> <ul style="list-style-type: none"> ● Air displacement: 4 CFM ● Micron rating: 20 microns ● Oil capacity: 482 g (17 oz) <li style="padding-left: 20px;">Fitting size: Thread size ● 1/2 in -16 ACME 	<p style="background-color: black; color: white; padding: 2px;">MTC</p> <p>K</p> <p>L</p> <p>M</p>

PREPARATION

Commercial Service Tools

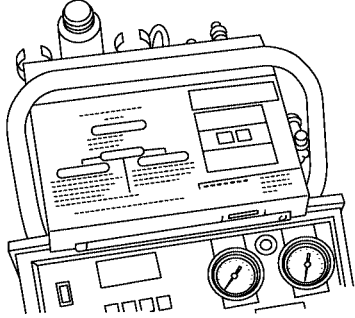
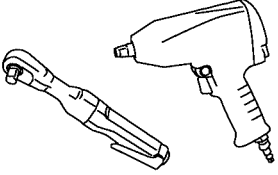
EJS003GL

Tool number Tool name	Description
<p>J-41810-NI Refrigerant identifier equipment HFC 134a (R-134a)</p>  <p>RJIA0197E</p>	<p>Checking refrigerant purity and system contamination</p>
<p>Power tool</p>  <p>PBIC0190E</p>	<p>Removing bolts and nuts</p>
<p>J-44614 Clutch disc holding tool</p>  <p>WHA230</p>	<p>Holding clutch disc for removal and installation</p>

REFRIGERATION SYSTEM

PFP:KA990

REFRIGERATION SYSTEM

Refrigerant Cycle REFRIGERANT FLOW

EJS002S1

The refrigerant flows in the standard pattern, that is, through the compressor, the condenser with liquid tank, through the evaporator, and back to the compressor. The refrigerant evaporation through the evaporator coil is controlled by an externally equalized expansion valve, located inside the evaporator case.

Refrigerant System Protection REFRIGERANT PRESSURE SENSOR

EJS002S2

The refrigerant system is protected against excessively high or low pressures by the refrigerant pressure sensor, located on the condenser. If the system pressure rises above or falls below the specifications, the refrigerant pressure sensor detects the pressure inside the refrigerant line and sends the voltage signal to the ECM. The ECM then signals the BCM (via CAN communication lines) to cease supplying power to the A/C relay which disengages and stops the compressor. This occurs when pressure on the high pressure side (as detected by refrigerant pressure sensor) is over approximately 2,746 kPa (28 kg/cm², 398 psi), or below approximately 120 kPa (1.22 kg/cm², 17.4 psi).

PRESSURE RELIEF VALVE

The refrigerant system is also protected by a pressure relief valve, located in the rear head of the compressor. When the refrigerant pressure in the system increases to an abnormal level [more than 3,727 kPa (38 kg/cm², 540 psi)], the release port on the pressure relief valve automatically opens and releases refrigerant into the atmosphere.

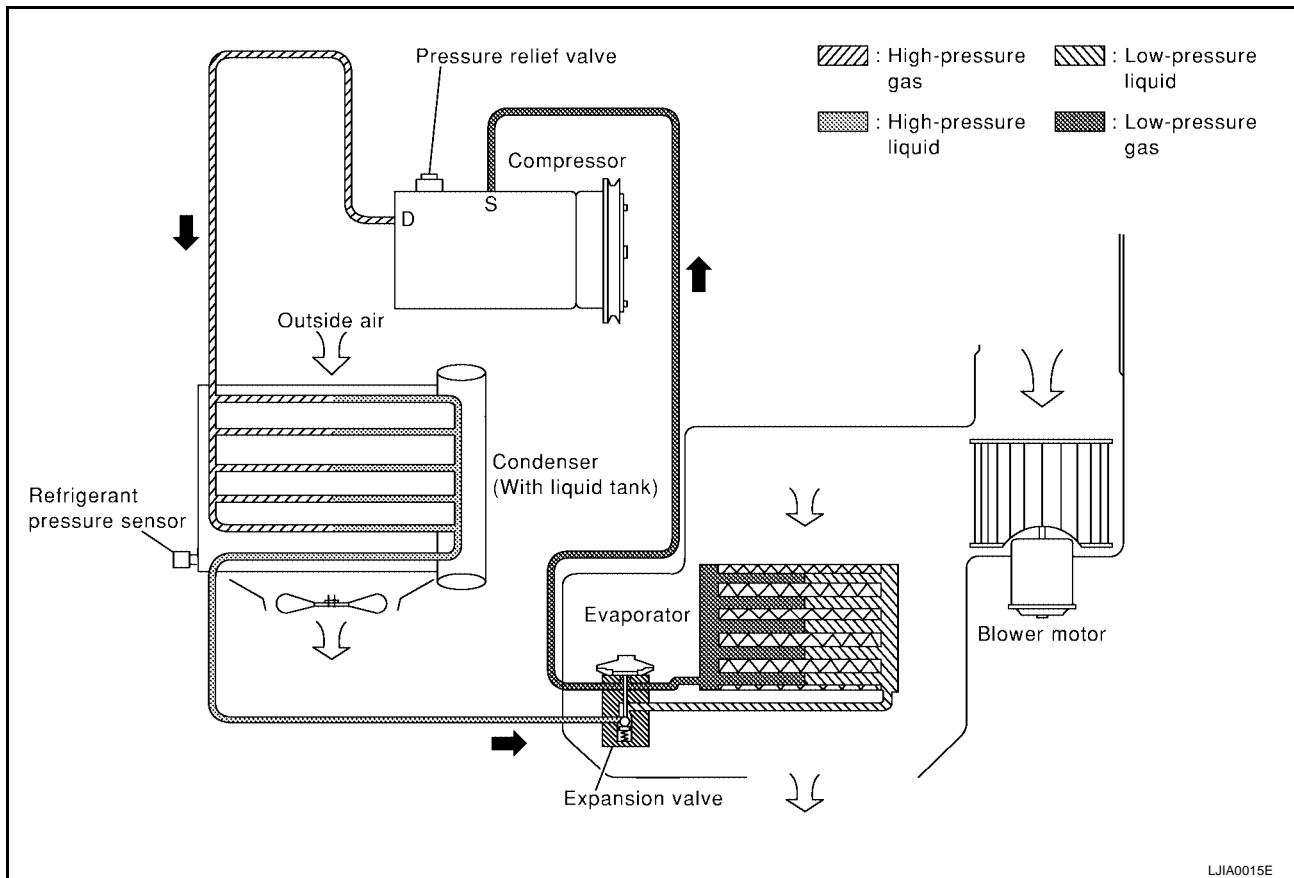

REFRIGERATION SYSTEM

EJS002S3

Component Layout

SEC. 270 • 271 • 272 • 273

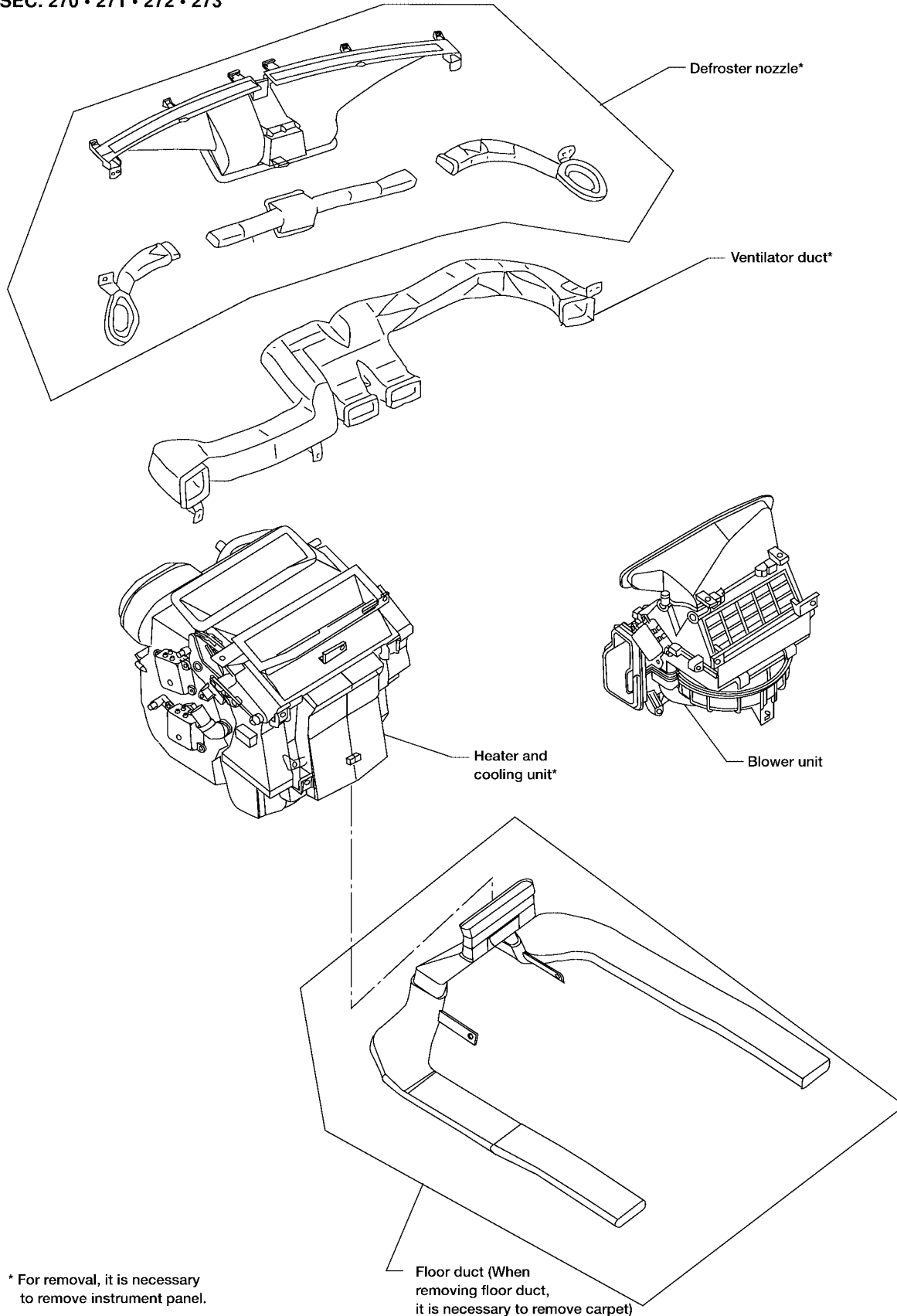

* For removal, it is necessary to remove instrument panel.

WJIA0979E

LUBRICANT

Maintenance of Lubricant Quantity in Compressor

EJS002S4

The lubricant in the compressor circulates through the system with the refrigerant. Add lubricant to compressor when replacing any component or after a large refrigerant leakage has occurred. It is important to maintain the specified amount.

If lubricant quantity is not maintained properly, the following malfunctions may result:

- Lack of lubricant: May lead to a seized compressor
- Excessive lubricant: Inadequate cooling (thermal exchange interference)

LUBRICANT

Lubricant type : NISSAN A/C System Lubricant Type DH-PS or equivalent

Part number : KLH00-PAGS0

CHECKING AND ADJUSTING

CAUTION:

If excessive lubricant leakage is noted, do not perform the lubricant return operation.

Start the engine and set the following conditions:

Test Condition

- Engine speed: Idling to 1,200 rpm
- A/C switch: On
- Blower speed: Max. position
- Temp. control: Optional [Set so that intake air temperature is 25° to 30° C (77° to 86°F).]
- Intake position: Recirculation ()
- Perform lubricant return operation for about ten minutes

Adjust the lubricant quantity according to the following table.

Lubricant Adjusting Procedure for Components Replacement Except Compressor

After replacing any of the following major components, add the correct amount of lubricant to the system.

Amount of Lubricant to be Added

Part replaced	Lubricant to be added to system	
	Amount of lubricant m ℓ (US fl oz, Imp fl oz)	Remarks
Evaporator	75 (2.5, 2.6)	—
Condenser	75 (2.5, 2.6)	—
Liquid tank	5 (0.2, 0.2)	Add if compressor is not replaced.
In case of refrigerant leak	30 (1.0, 1.1)	Large leak
	—	Small leak *1

- *1: If refrigerant leak is small, no addition of lubricant is needed.

Lubricant Adjustment Procedure for Compressor Replacement

1. Before connecting recovery/recycling equipment to vehicle, check recovery/recycling equipment gauges. No refrigerant pressure should be displayed. If NG, recover refrigerant from equipment lines.
2. Connect recovery/recycling equipment to vehicle. Confirm refrigerant purity in supply tank using recovery/recycling equipment and refrigerant identifier. If NG, refer to [MTC-4, "Contaminated Refrigerant"](#) .
3. Confirm refrigerant purity in vehicle A/C system using recovery/recycling equipment and refrigerant identifier. If NG, refer to [MTC-4, "Contaminated Refrigerant"](#) .
4. Discharge refrigerant into the refrigerant recovery/recycling equipment. Measure lubricant discharged into the recovery/recycling equipment.
5. Drain the lubricant from the “old” (removed) compressor into a graduated container and recover the amount of lubricant drained.
6. Drain the lubricant from the “new” compressor into a separate, clean container.

LUBRICANT

7. Measure an amount of new lubricant installed equal to amount drained from “old” compressor. Add this lubricant to “new” compressor through the suction port opening.
8. Measure an amount of new lubricant equal to the amount recovered during discharging. Add this lubricant to “new” compressor through the suction port opening.
9. If the liquid tank also needs to be replaced, add an additional 5 mℓ (0.2 US fl oz, 0.2 Imp fl oz) of lubricant at this time.

CAUTION:

Do not add this 5 mℓ (0.2 US fl oz, 0.2 Imp fl oz) of lubricant if only replacing the compressor and not the liquid tank.

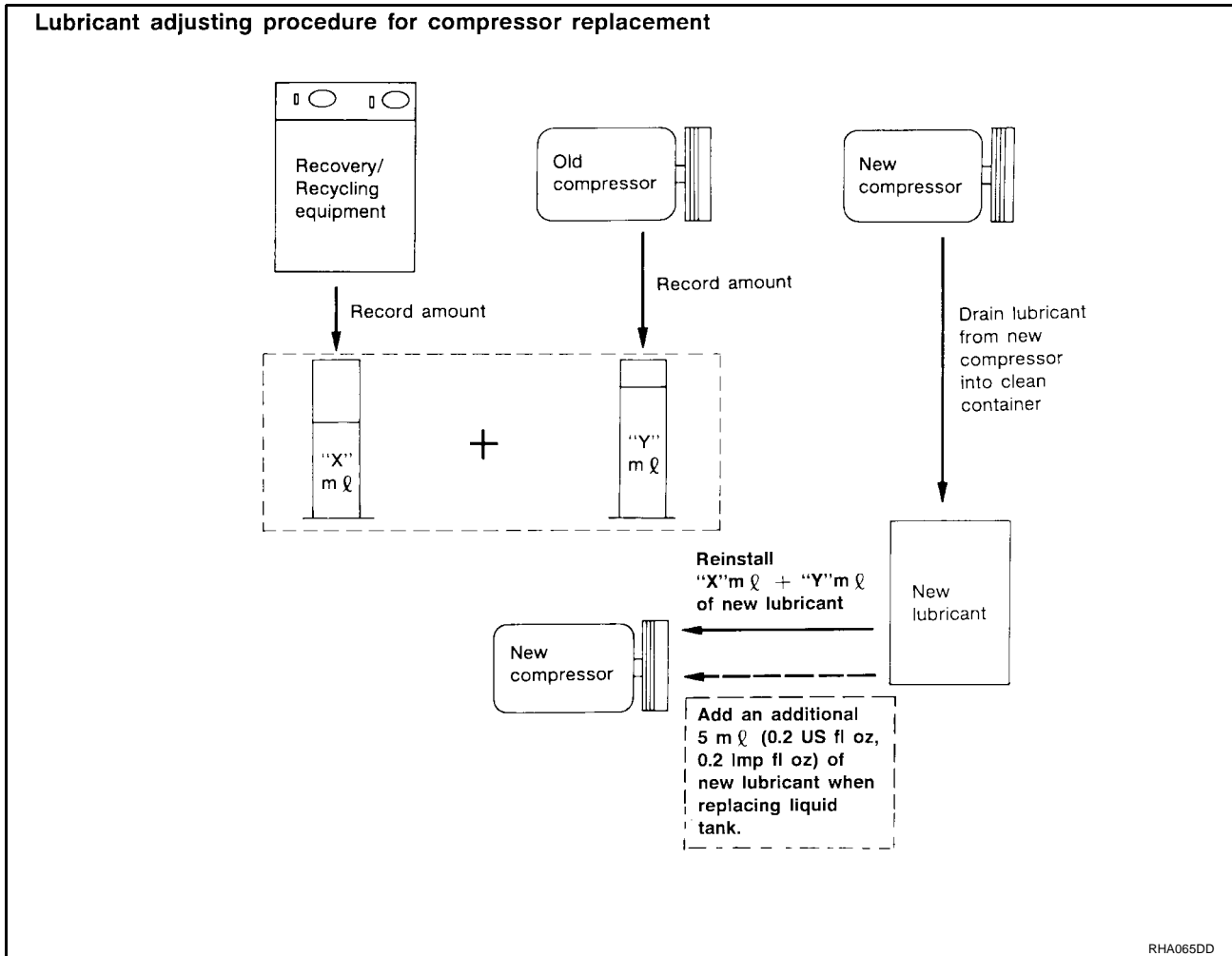

AIR CONDITIONER CONTROL

AIR CONDITIONER CONTROL

PFP:27500

Overview Air Conditioner LAN Control System

EJS002S5

The LAN (local area network) system consists of front air control, air mix door motor, intake door motor, and mode door motor.

A configuration of these components is shown in the diagram below.

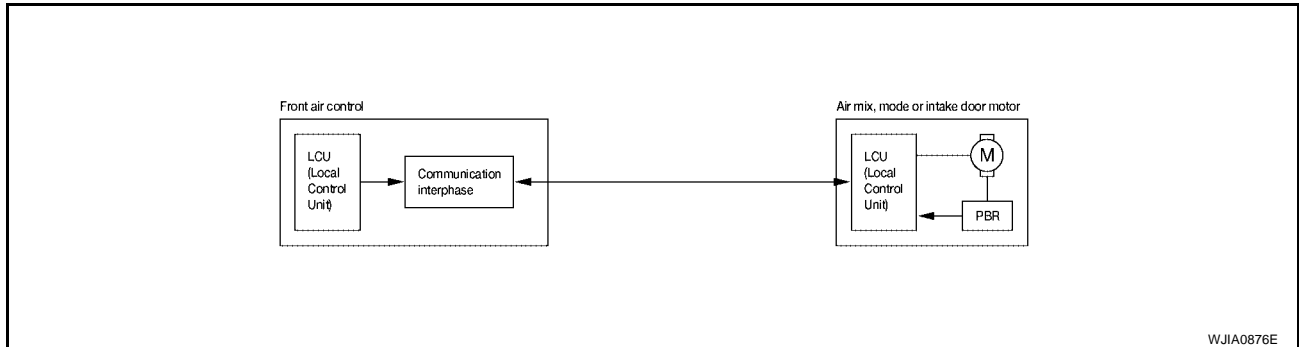

System Construction

EJS002S6

A small network is constructed between the front air control, air mix door motor, intake door motor, and mode door motor. The front air control and motors are connected by data transmission lines and motor power supply lines. The LAN network is built through the ground circuits of the two motors.

Addresses, motor opening angle signals, motor stop signals and error checking messages are all transmitted through the data transmission lines connecting the front air control and each motor.

The following functions are contained in LCUs built into the air mix door motor, intake door motor, and the mode door motor.

- Address
- Motor opening angle signals
- Data transmission
- Motor stop and drive decision
- Opening angle sensor (PBR function)
- Comparison
- Decision (front air control indicated value and motor opening angle comparison)

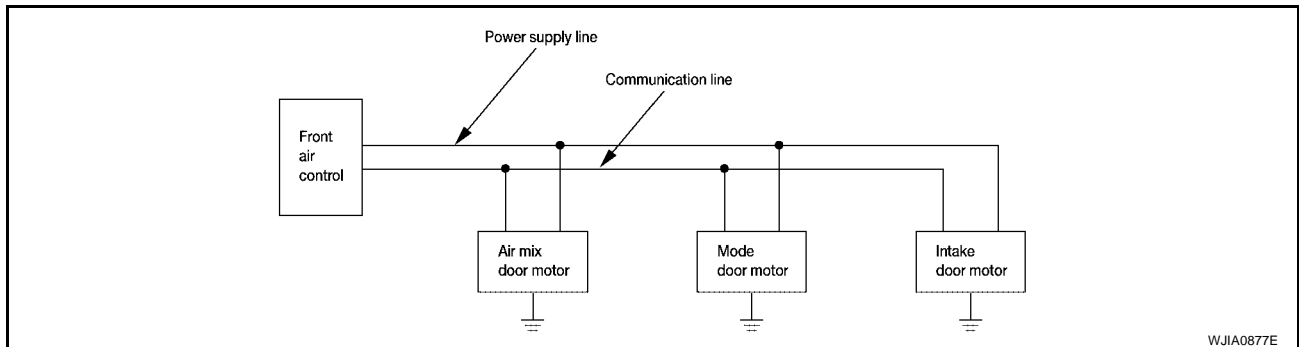

OPERATION

The front air control receives signals from its various dials and switches. The front air control then sends air mix door, mode door and intake door opening angle data to the air mix door motor LCU, mode door motor LCU and intake door motor LCU.

The air mix door motor, mode door motor and intake door motor read their respective signals according to the address signal. Opening angle indication signals received from the front air control and each of the motor position sensors are compared by the LCUs in each motor with the existing decision and opening angles. Subse-

A
B
C
D
E
F
G
H
I
K
L
M

MTC

AIR CONDITIONER CONTROL

quently, HOT/COLD, DEFROST/VENT or FRESH/RECIRCULATION operation is selected. The new selection data is returned to the front air control.

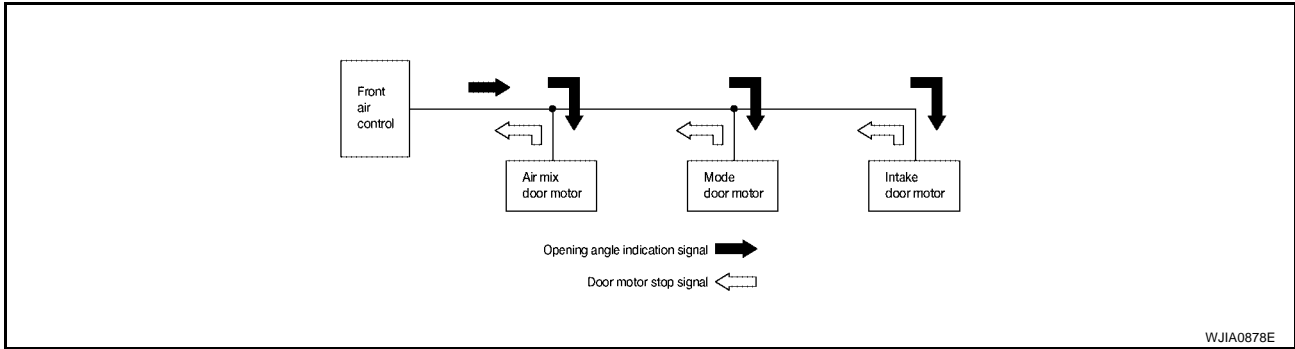

TRANSMISSION DATA AND TRANSMISSION ORDER

Front air control data is transmitted consecutively to each of the door motors following the form shown in figure below.

Start: Initial compulsory signal sent to each of the door motors.

Address: Data sent from the front air control is selected according to data-based decisions made by the air mix door motor, mode door motor and intake door motor.

If the addresses are identical, the opening angle data and error check signals are received by the door motor LCUs. The LCUs then make the appropriate error decision. If the opening angle data is normal, door control begins.

If an error exists, the received data is rejected and corrected data received. Finally, door control is based upon the corrected opening angle data.

Opening angle: Data that shows the indicated door opening angle of each door motor.

Error check: Procedure by which sent and received data is checked for errors. Error data is then compiled. The error check prevents corrupted data from being used by the air mix door motor, mode door motor and intake door motor. Error data can be related to the following problems.

- Abnormal electrical frequency
- Poor electrical connections
- Interference from other signal transmission lines
- Signal level fluctuation

Stop signal: At the end of each transmission, a stop operation, in-operation, or internal problem message is delivered to the front air control. This completes one data transmission and control cycle.

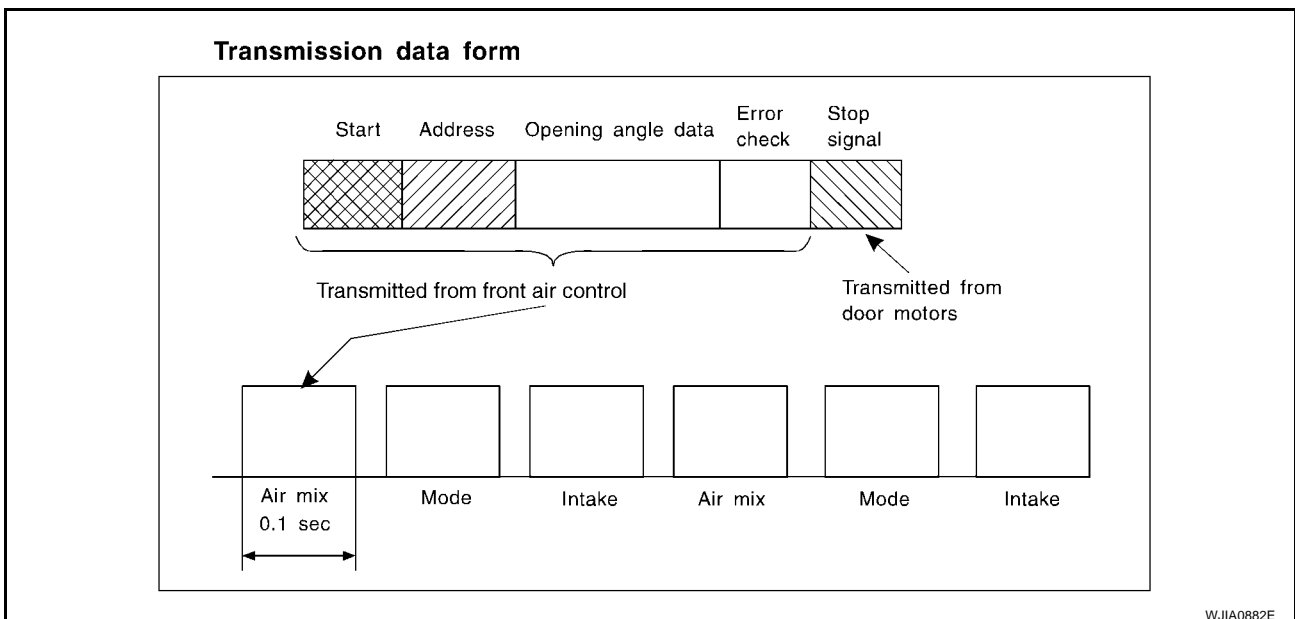

AIR MIX DOOR CONTROL

The air mix door is controlled by the front air control based on input from the temperature dial setting.

AIR CONDITIONER CONTROL

FAN SPEED CONTROL

Blower speed is controlled by the front air control based on the position of the fan dial. With the fan dial set to any position except OFF, the blower will begin to operate.

INTAKE DOOR CONTROL

The intake door is controlled by the front air control based on input from the recirculation switch setting, and the MAX A/C switch setting.

MODE DOOR CONTROL

The mode door is controlled by the front air control based on input from the mode dial setting.

MAGNET CLUTCH CONTROL

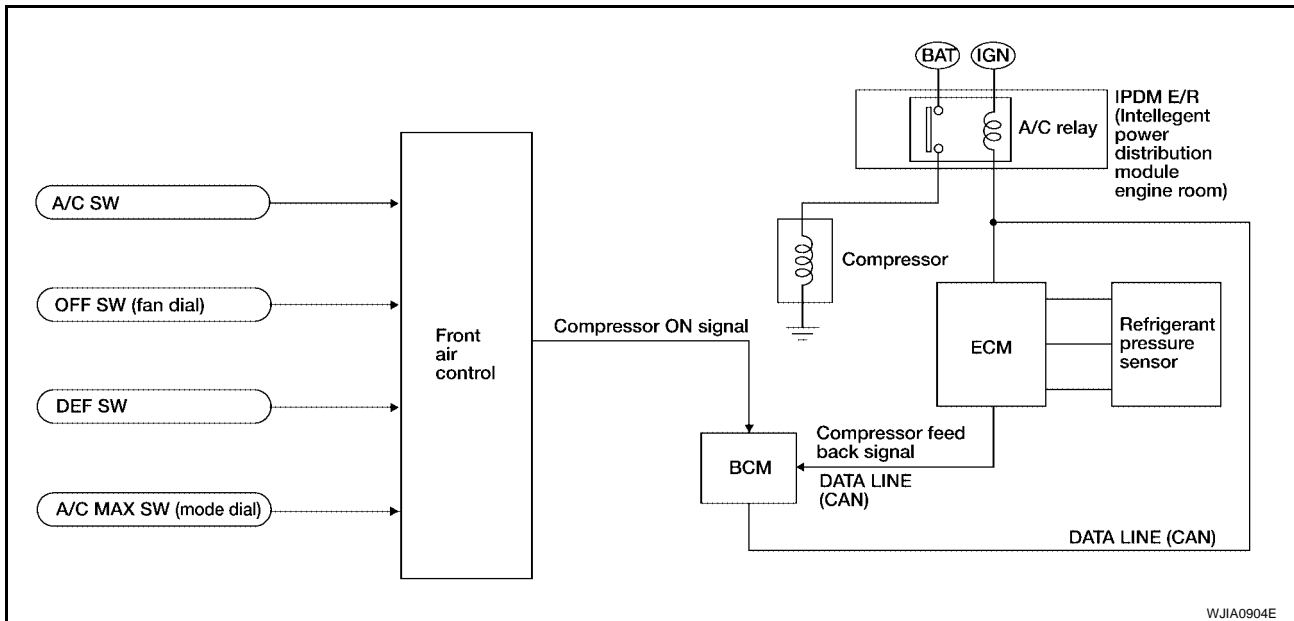

The ECM controls compressor operation using input signals from the throttle position sensor and front air control.

Overview of Control system

The control system consists of an input sensor, switches, the front air control and outputs.

A
B
C
D
E
F
G
H
I
MTC
K
L
M

AIR CONDITIONER CONTROL

The relationship of these components is shown in the diagram below:

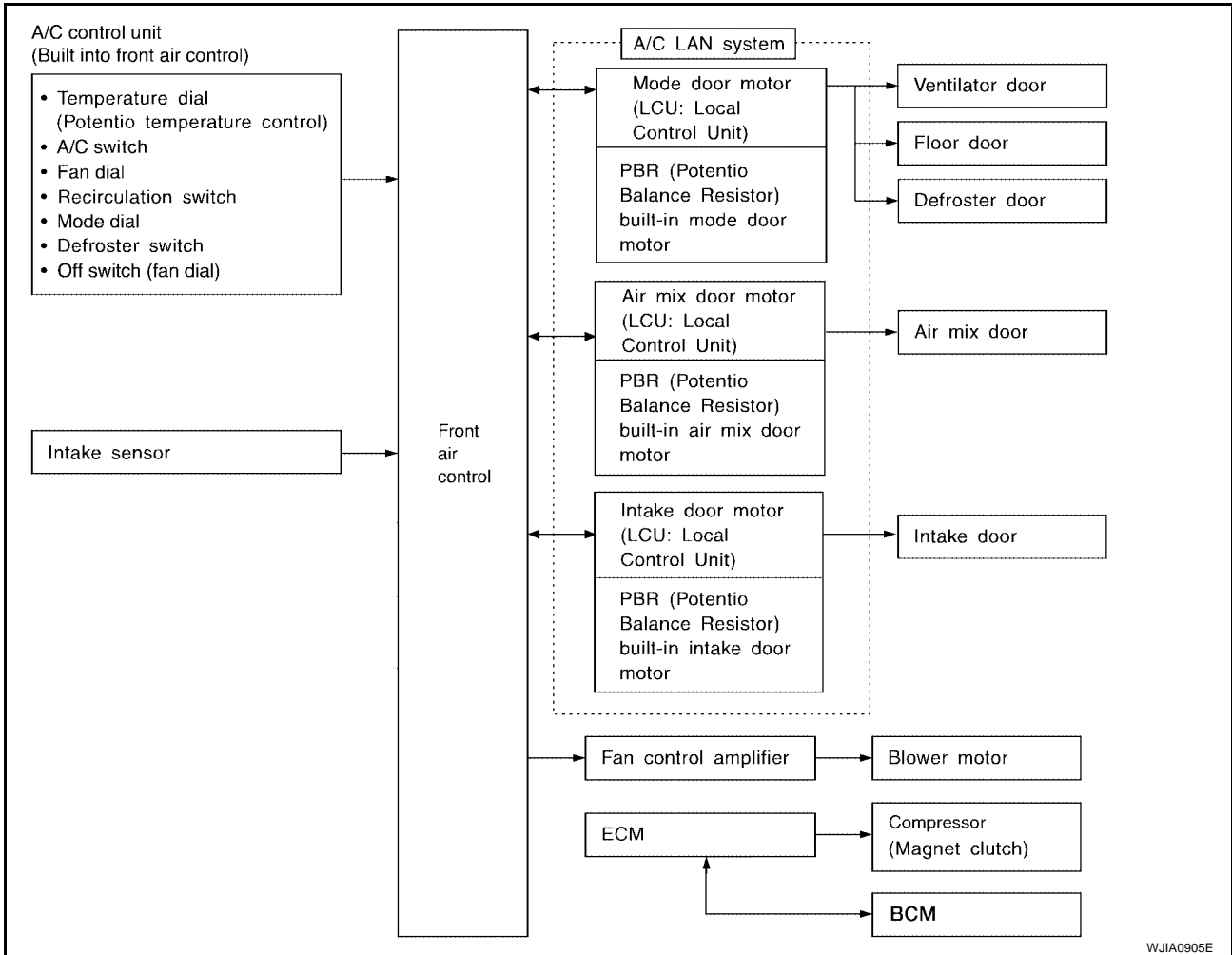

Control Operation

E/JS002S8

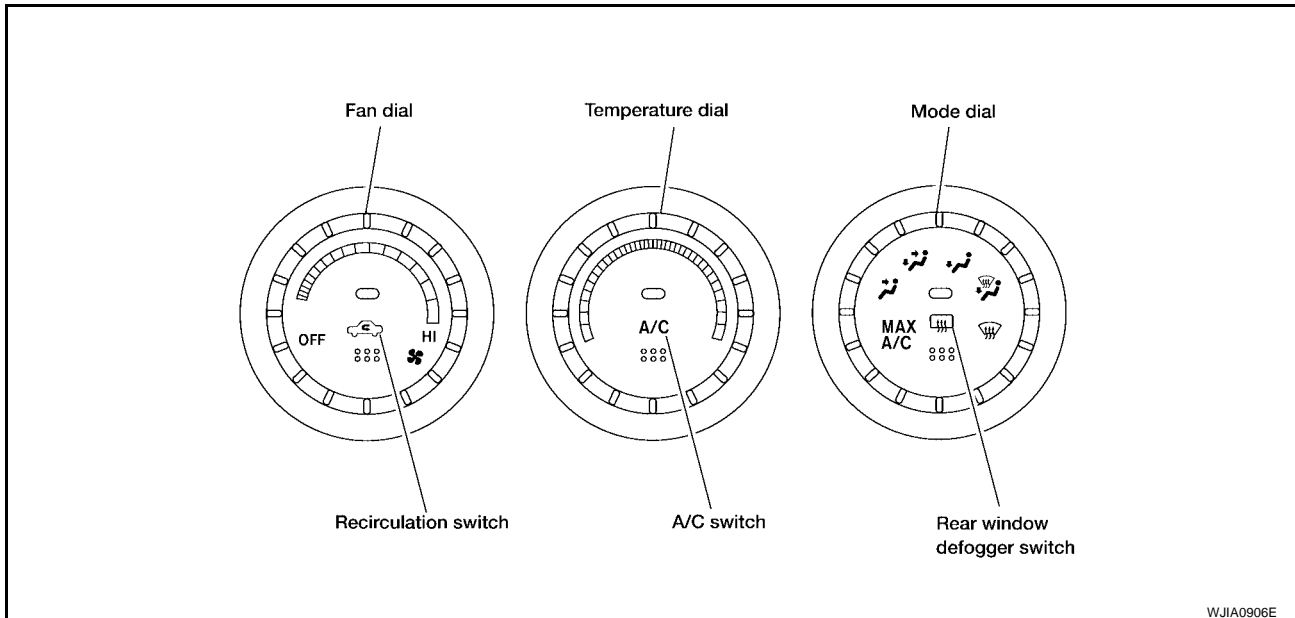

AIR CONDITIONER CONTROL

AIR CONDITIONER (A/C) SWITCH

The air conditioner switch controls the A/C system. When the switch is pressed with the fan ON, the compressor will turn ON. The indicator lamp will also illuminate.

The air conditioner cooling function operates only when the engine is running.

TEMPERATURE DIAL (POTENTIO TEMPERATURE CONTROL)

Increases or decreases the set temperature.

FAN DIAL/OFF SWITCH

Manually controls the blower speed.

In the off position, the compressor and blower are OFF, the intake door is set to the outside air position, and the air mode doors are set to the foot (80% foot and 20% defrost) position.

RECIRCULATION (REC) SWITCH

OFF position: Outside air is drawn into the passenger compartment.

ON position: Interior air is recirculated inside the vehicle.

DEFROSTER SWITCH

Positions the air mode doors to the defrost position. Also positions the intake doors to the outside air position. The compressor remains ON until the ignition is turned OFF.

MODE DIAL

Controls the air discharge through control of mode door, also controls MAX A/C function.

REAR WINDOW DEFOGGER SWITCH

This switch turns the rear window defogger ON and OFF.

A

B

C

D

E

F

G

H

I

MTC

K

L

M

AIR CONDITIONER CONTROL

EJS002S9

Discharge Air Flow

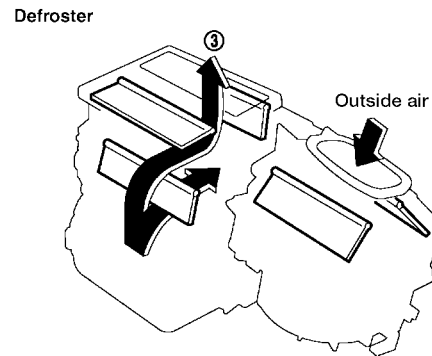
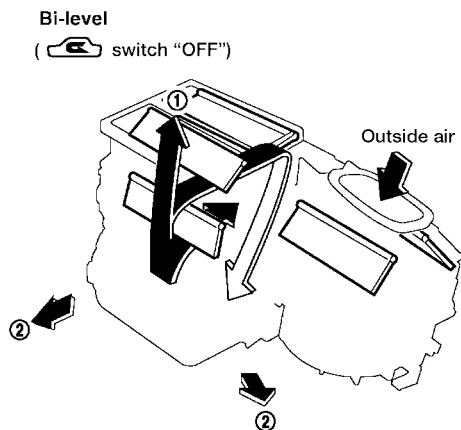
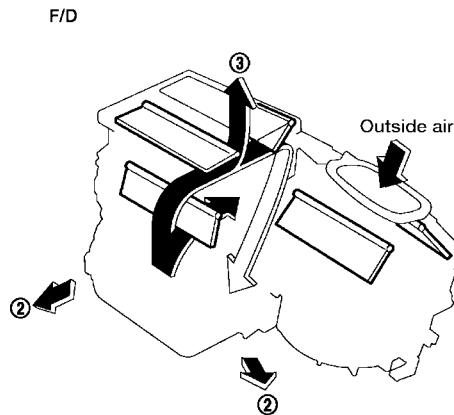
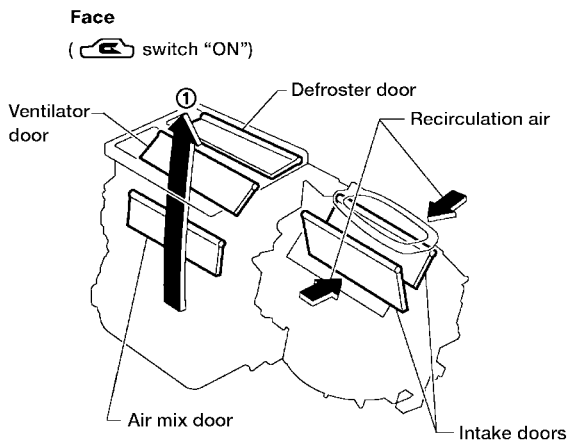
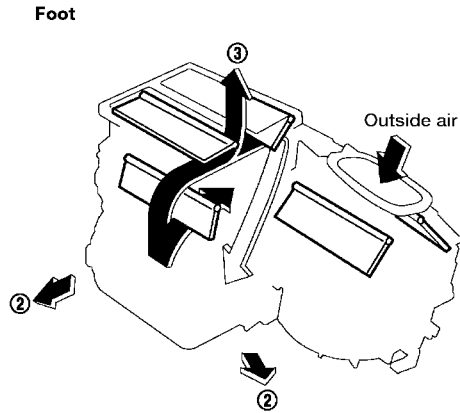
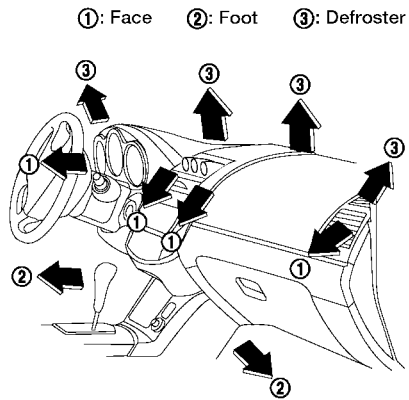

- ①: To face
- ②: To foot
- ③: To defroster

For air flow %, refer to "Operational Check", "TROUBLE DIAGNOSES".

WJIA1185E

AIR CONDITIONER CONTROL

EJS002SA

System Description SWITCHES AND THEIR CONTROL FUNCTION

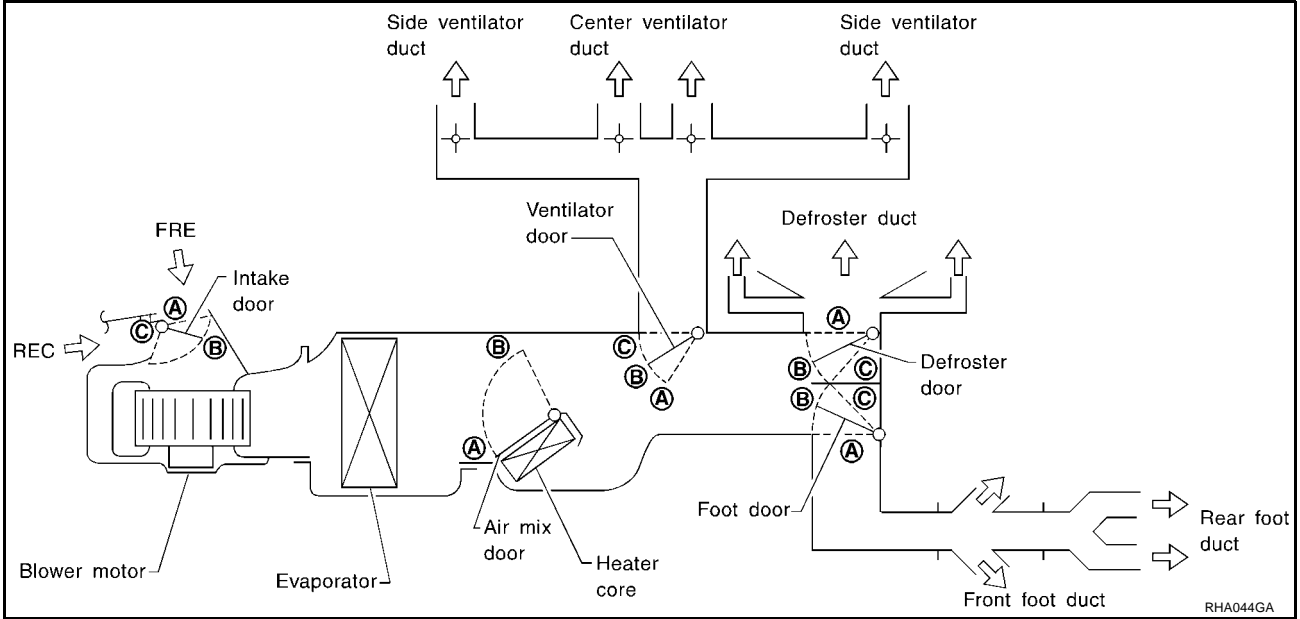

RHA044GA

Position or switch	MODE DIAL						REC SW		Temperature DIAL		
	VENT	B/L	FOOT	D/F	DEF	MAX A/C	ON	OFF			
Door						MAX A/C			COLD	—	HOT
Ventilator door	A	B	C	C	C	A	—	—	—		
Foot door	A	B	C	C	A	A	—	—	—		
Defroster door	A	A	B	C	C	A	—	—	—		
Air mix door	—						—	—	A	—	B
Intake door	—				C	A	A	C	—		

WJJA0907E

CAN Communication System Description

EJS002SB

Refer to [LAN-21, "CAN COMMUNICATION"](#).

A
B
C
D
E
F
G
H
I
MTC
K
L
M

TROUBLE DIAGNOSIS

TROUBLE DIAGNOSIS

PFP:00004

How to Perform Trouble Diagnoses for Quick and Accurate Repair WORK FLOW

EJS002SC

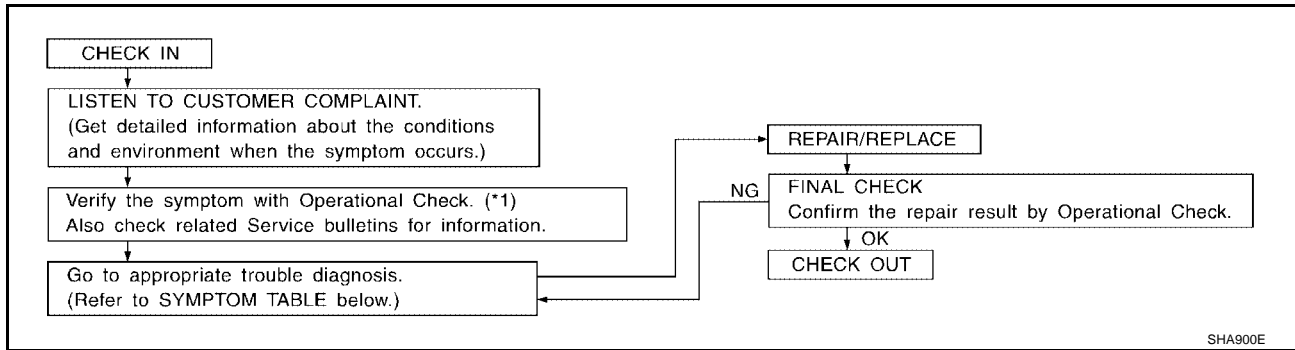

SHA900E

*1: [MTC-40](#)

SYMPTOM TABLE

Symptom		Reference Page
● A/C system does not come on.	● Go to Trouble Diagnosis Procedure for A/C system.	MTC-42
● Air outlet does not change.		
● Mode door motor does not operate normally.	● Go to Trouble Diagnosis Procedure for Mode Door Motor. (LAN)	MTC-47
● Discharge air temperature does not change.		
● Air mix door motor does not operate normally.	● Go to Trouble Diagnosis Procedure for Air Mix Door Motor. (LAN)	MTC-49
● Intake door does not change.		
● Intake door motor does not operate normally.	● Go to Trouble Diagnosis Procedure for Intake Door Motor. (LAN)	MTC-51
● Blower motor operation is malfunctioning.	● Go to Trouble Diagnosis Procedure for Blower Motor.	MTC-53
● Magnet clutch does not engage.	● Go to Trouble Diagnosis Procedure for Magnet Clutch.	MTC-59
● Insufficient cooling.	● Go to Trouble Diagnosis Procedure for Insufficient Cooling.	MTC-64
● Insufficient heating.	● Go to Trouble Diagnosis Procedure for Insufficient Heating.	MTC-71
● Noise.	● Go to Trouble Diagnosis Procedure for Noise.	MTC-72

TROUBLE DIAGNOSIS

Component Parts and Harness Connector Location ENGINE COMPARTMENT

EJS002SD

QR25DE Models

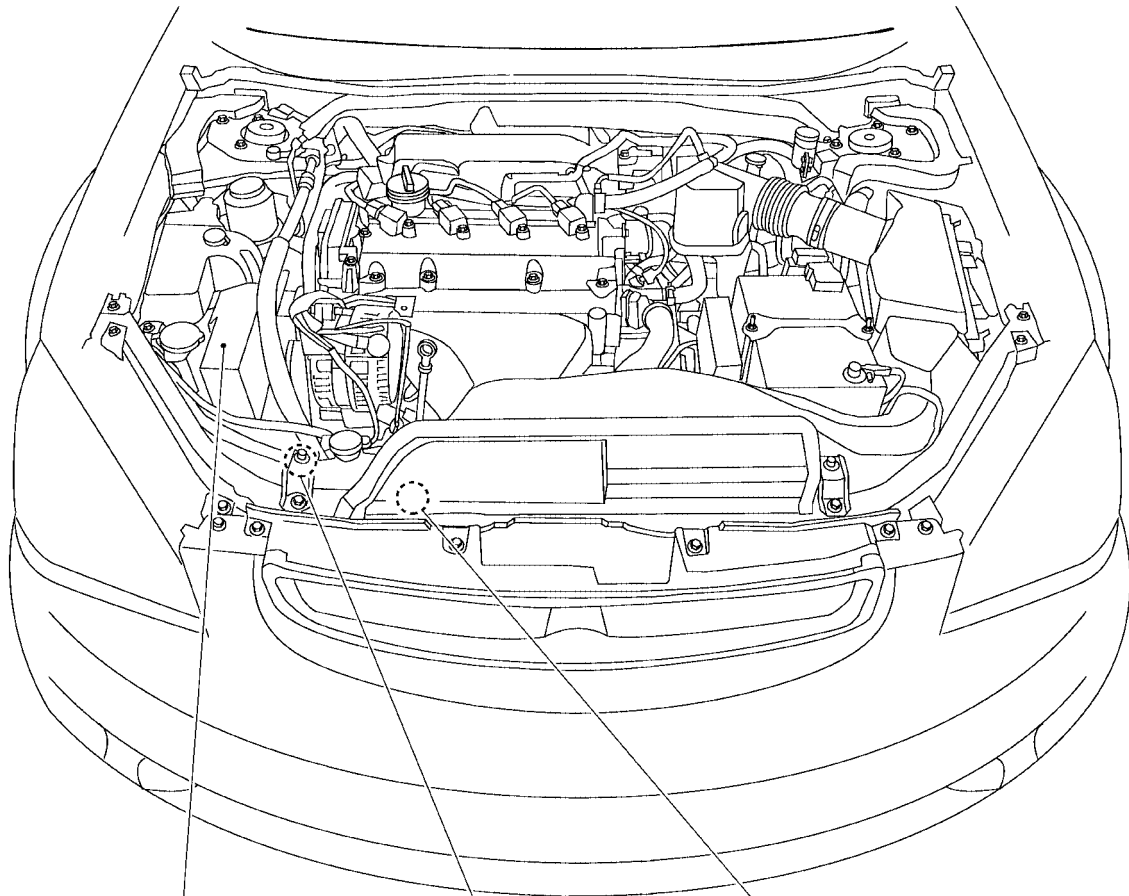
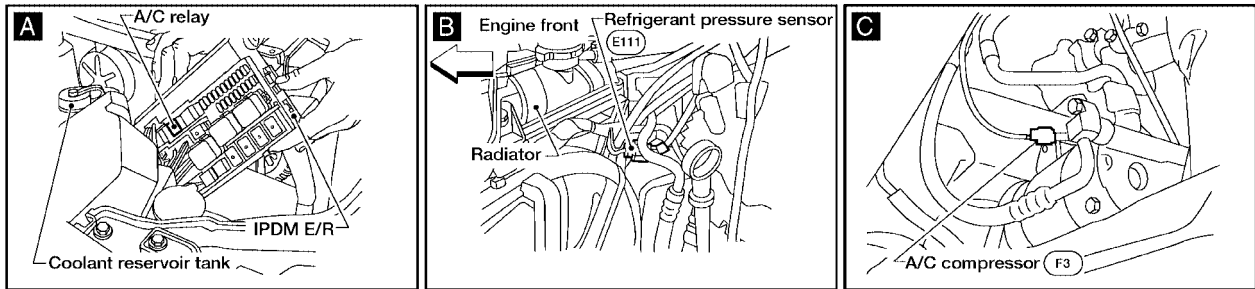

A IPDM E/R
(A/C relay)

B Refrigerant pressure sensor

C A/C compressor

A
B
C
D
E
F
G
H
I
MTC
K
L
M

TROUBLE DIAGNOSIS

VQ35DE Model

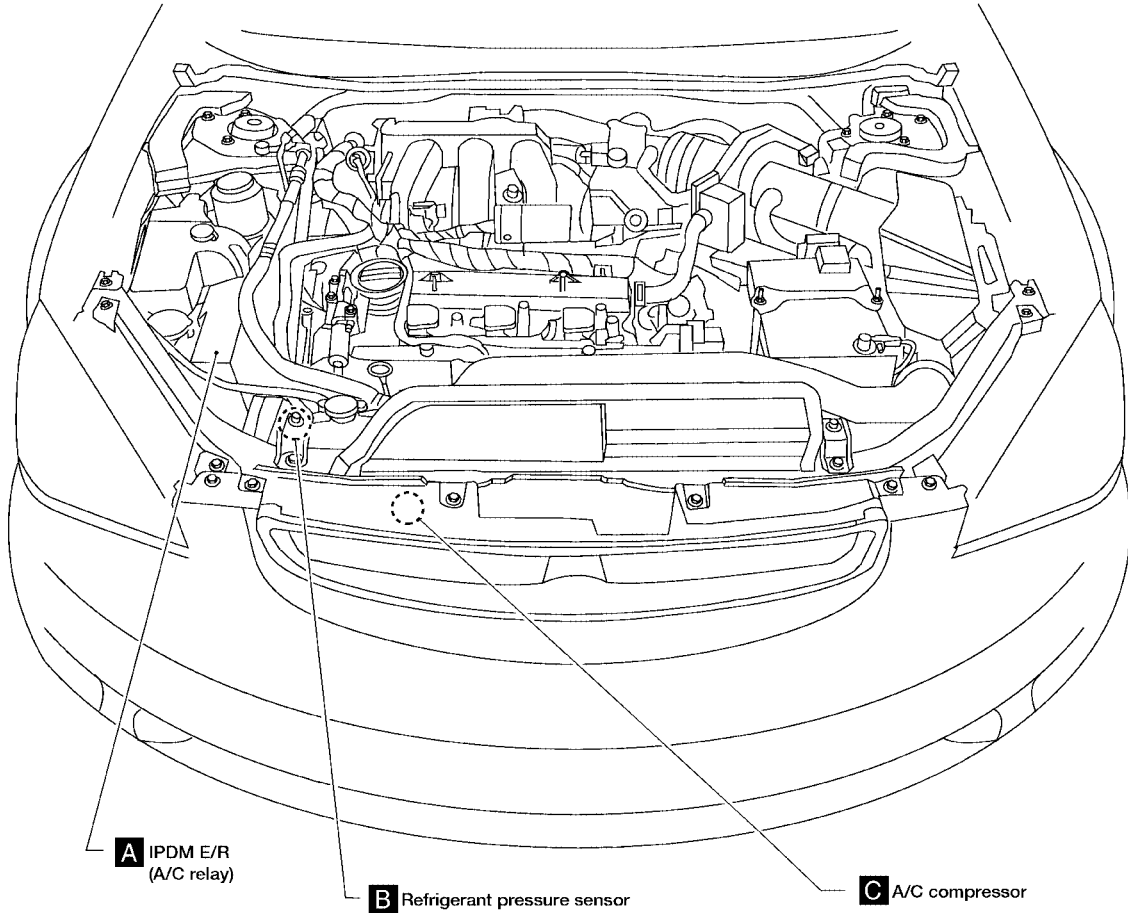
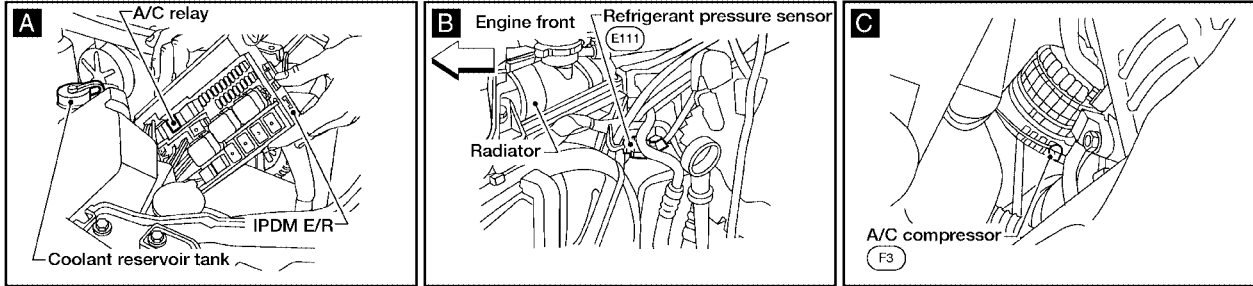

WJIA0137E

TROUBLE DIAGNOSIS

PASSENGER COMPARTMENT

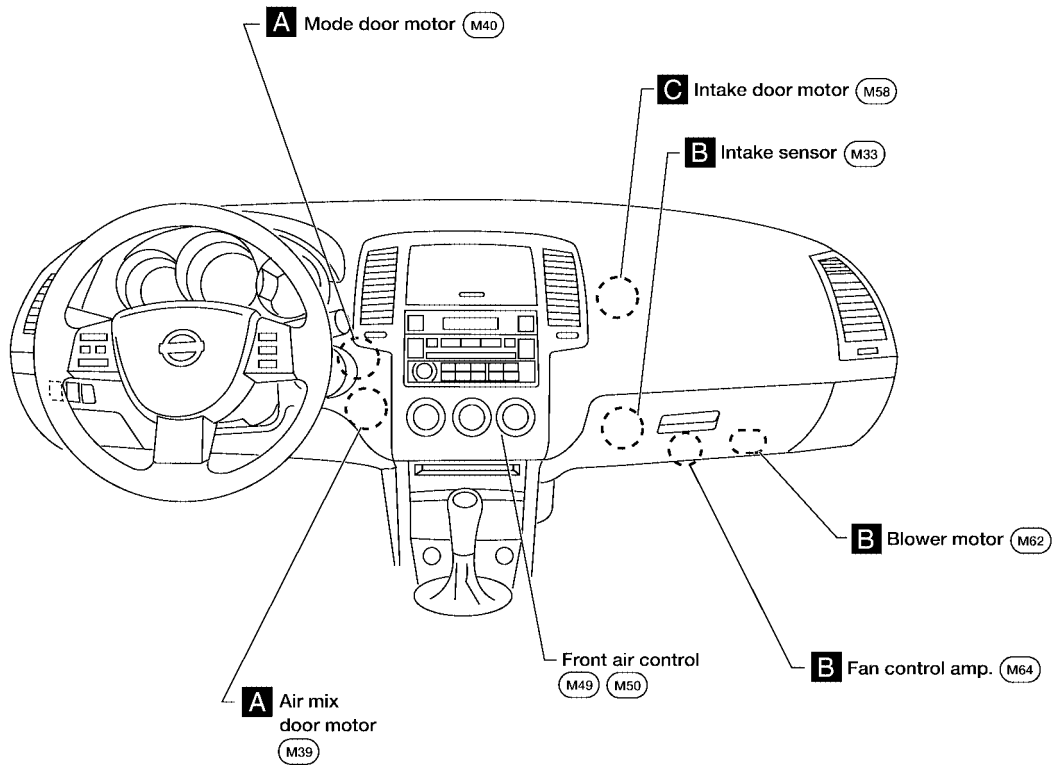
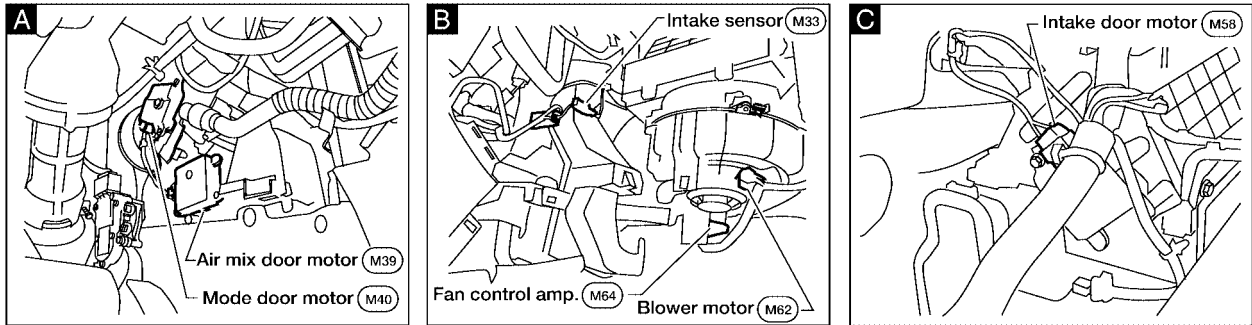

A
B
C
D
E
F
G
H
I
MTC
K
L
M

WJIA1559E

TROUBLE DIAGNOSIS

Circuit Diagram

EJS002SE

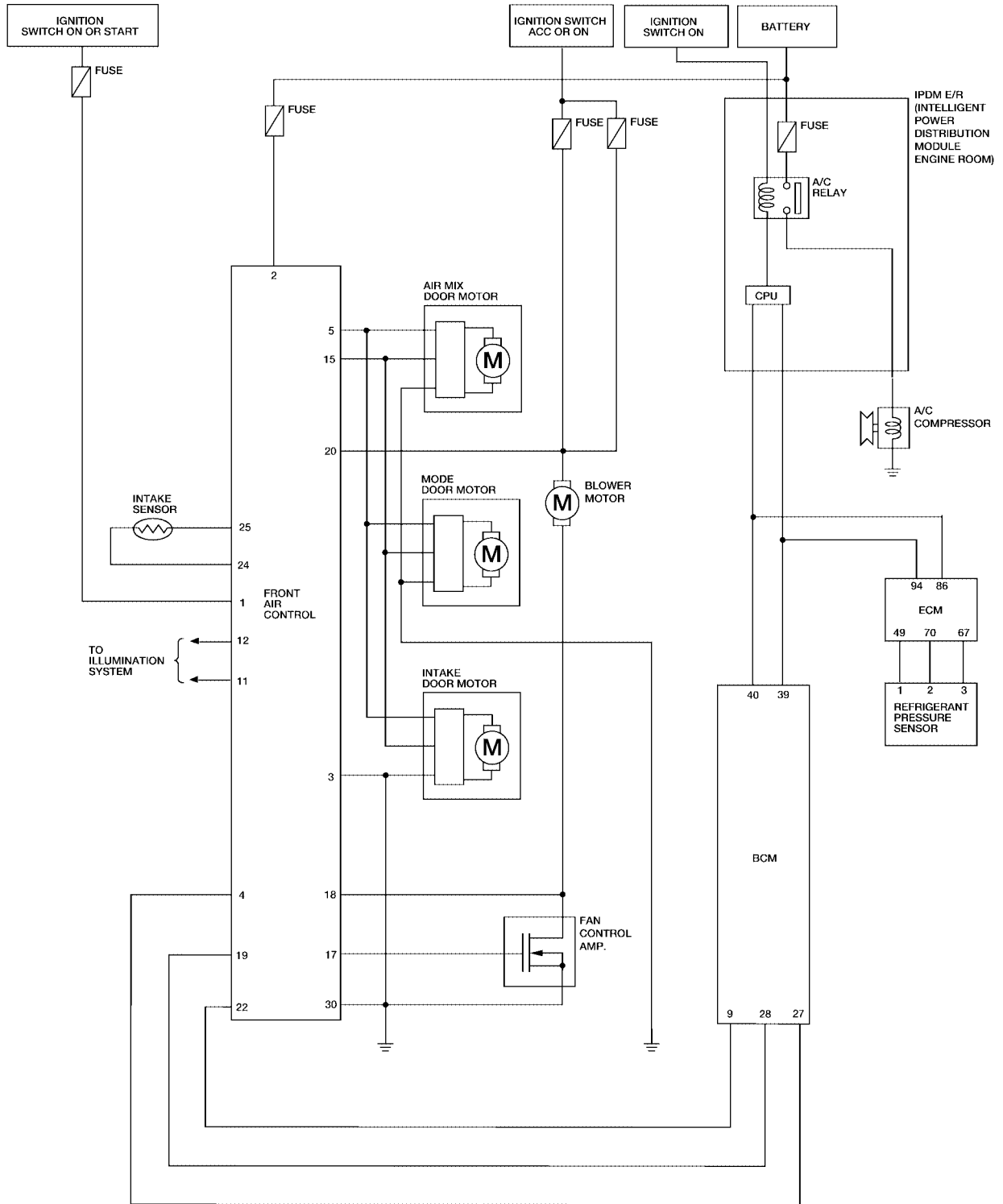

WJWA0137E

TROUBLE DIAGNOSIS

Wiring Diagram — HEATER —

EJS002SF

MTC-HEATER-01

— — — — — : DATA LINE

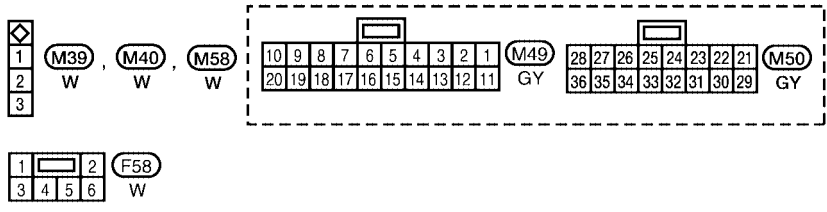
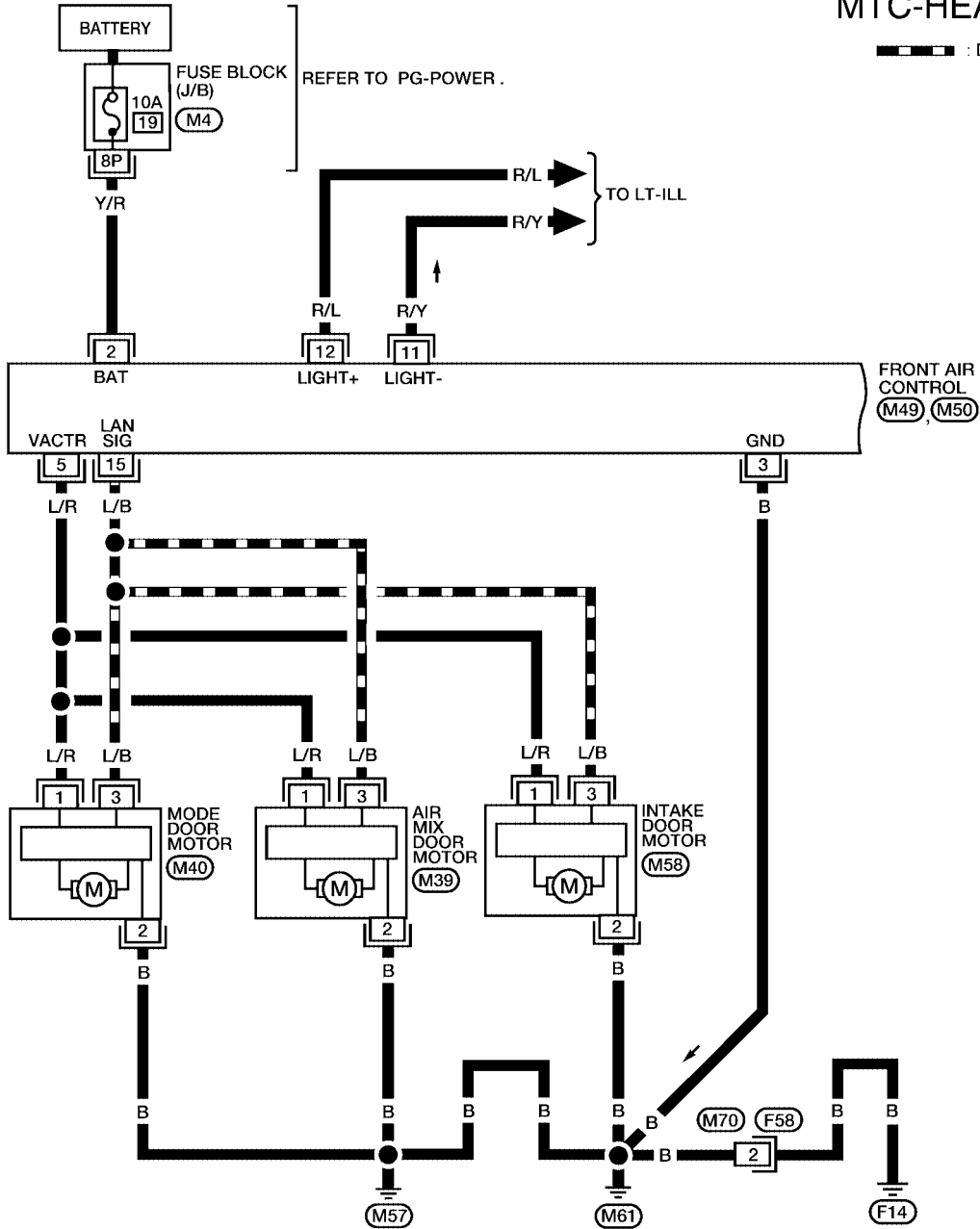

REFER TO THE FOLLOWING.
 (M4) - FUSE BLOCK
 - JUNCTION BOX (J/B)

A
B
C
D
E
F
G
H
I
MTC
K
L
M

TROUBLE DIAGNOSIS

MTC-HEATER-02

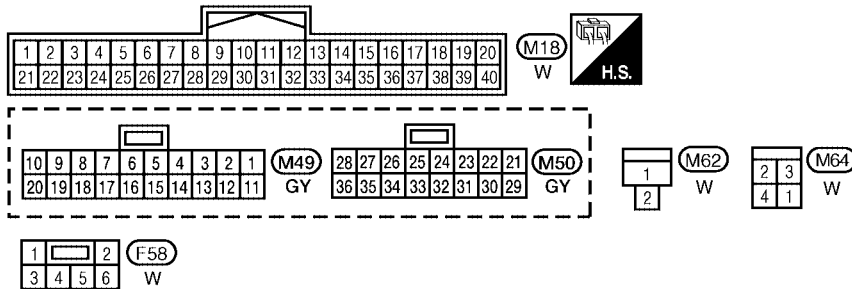
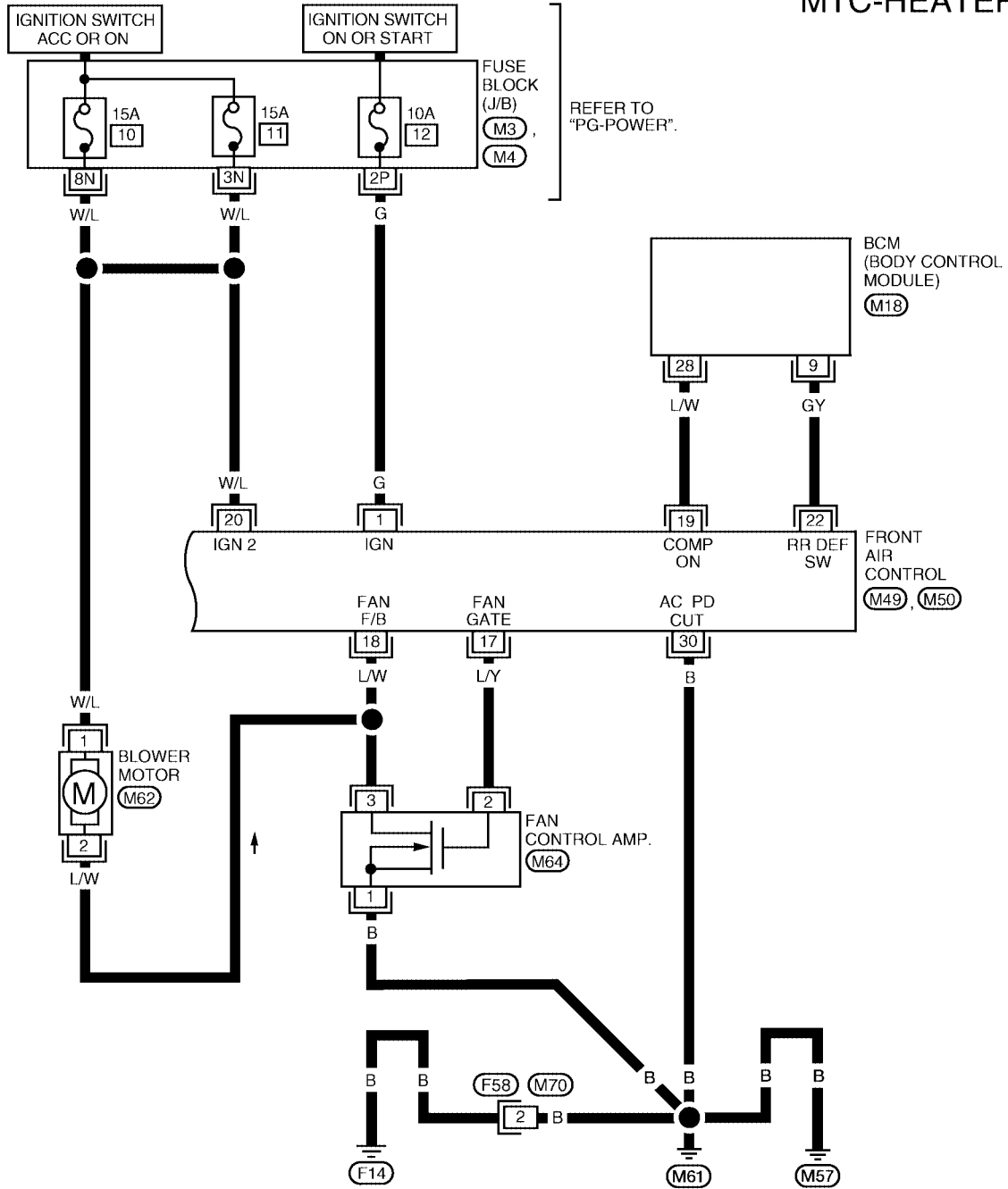

REFER TO THE FOLLOWING.
 (M3), (M4)

WJWA0275E

TROUBLE DIAGNOSIS

Wiring Diagram — A/C,M —

EJS003GP

MTC-A/C,M-01

— — — — — : DATA LINE

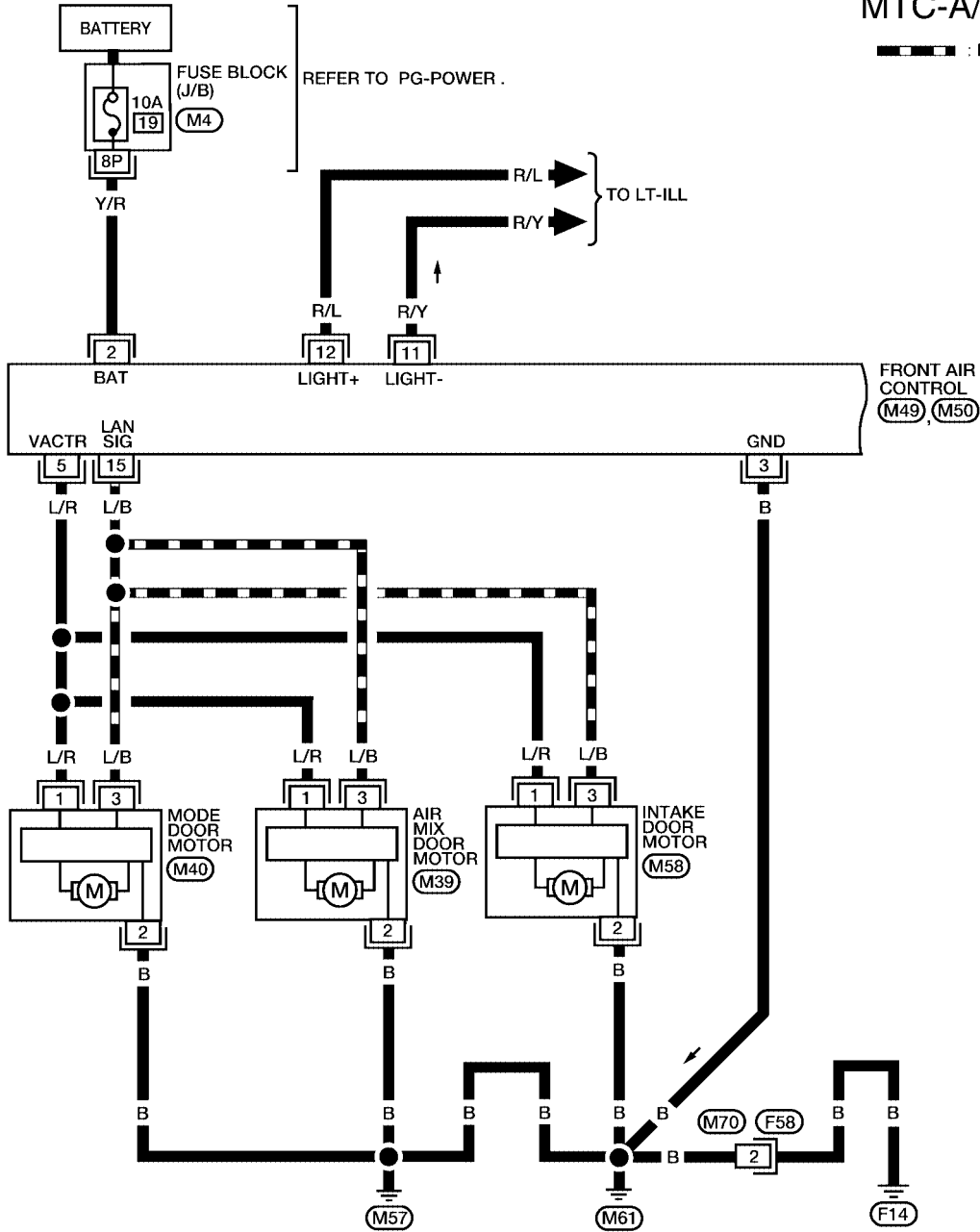

(M39), (M40), (M58)
W W W

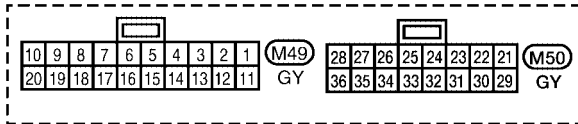

REFER TO THE FOLLOWING.

(M4) - FUSE BLOCK
- JUNCTION BOX (J/B)

A
B
C
D
E
F
G
H
I
MTC
K
L
M

TROUBLE DIAGNOSIS

MTC-A/C,M-02

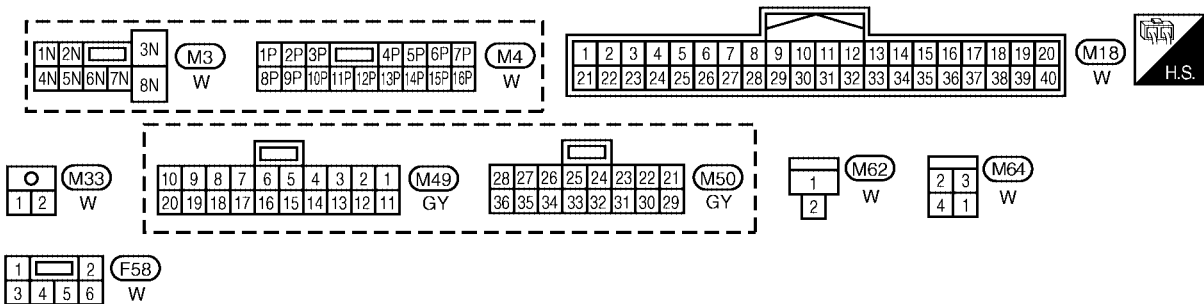
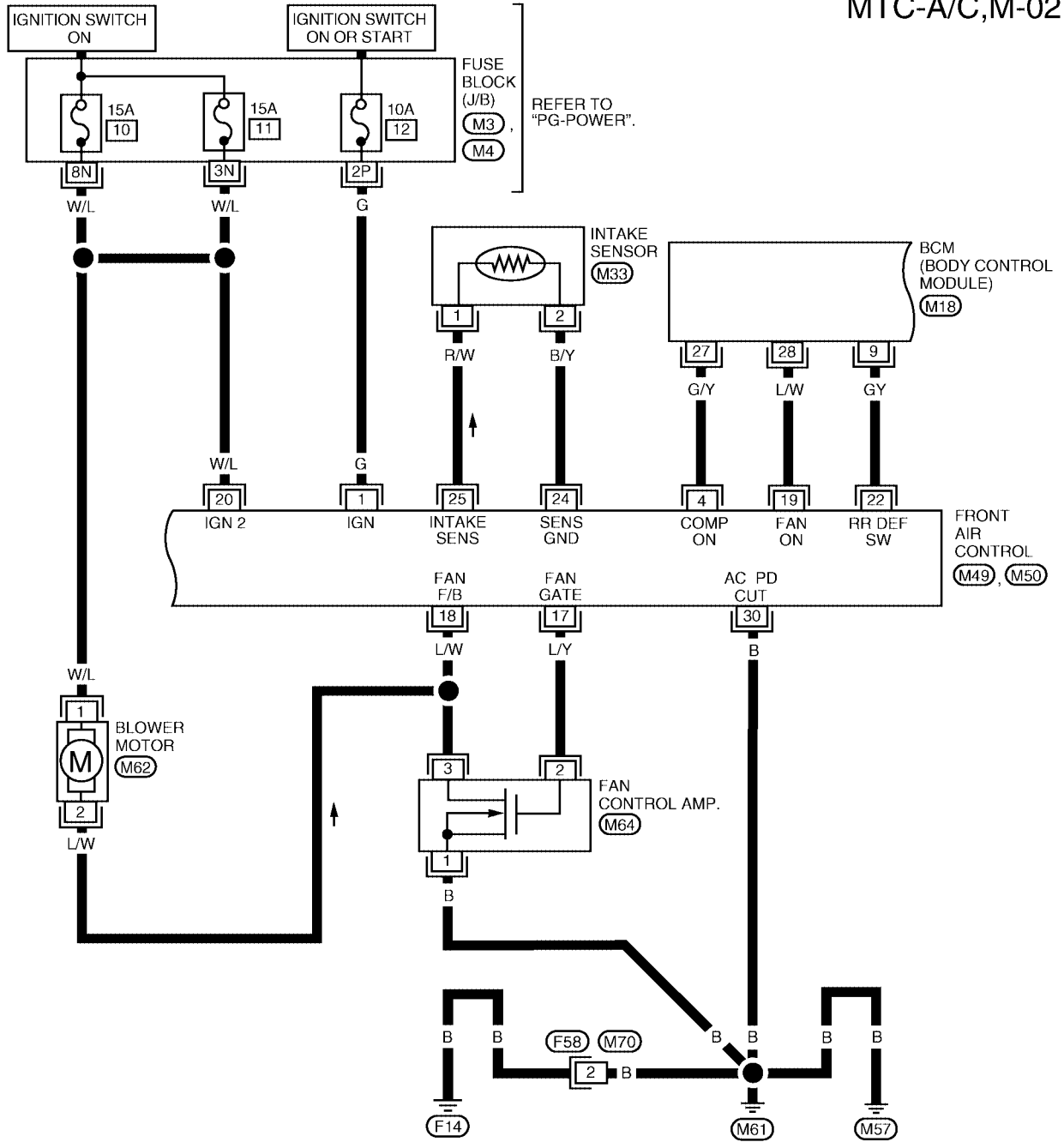

WJWA0177E

TROUBLE DIAGNOSIS

MTC-A/C,M-03

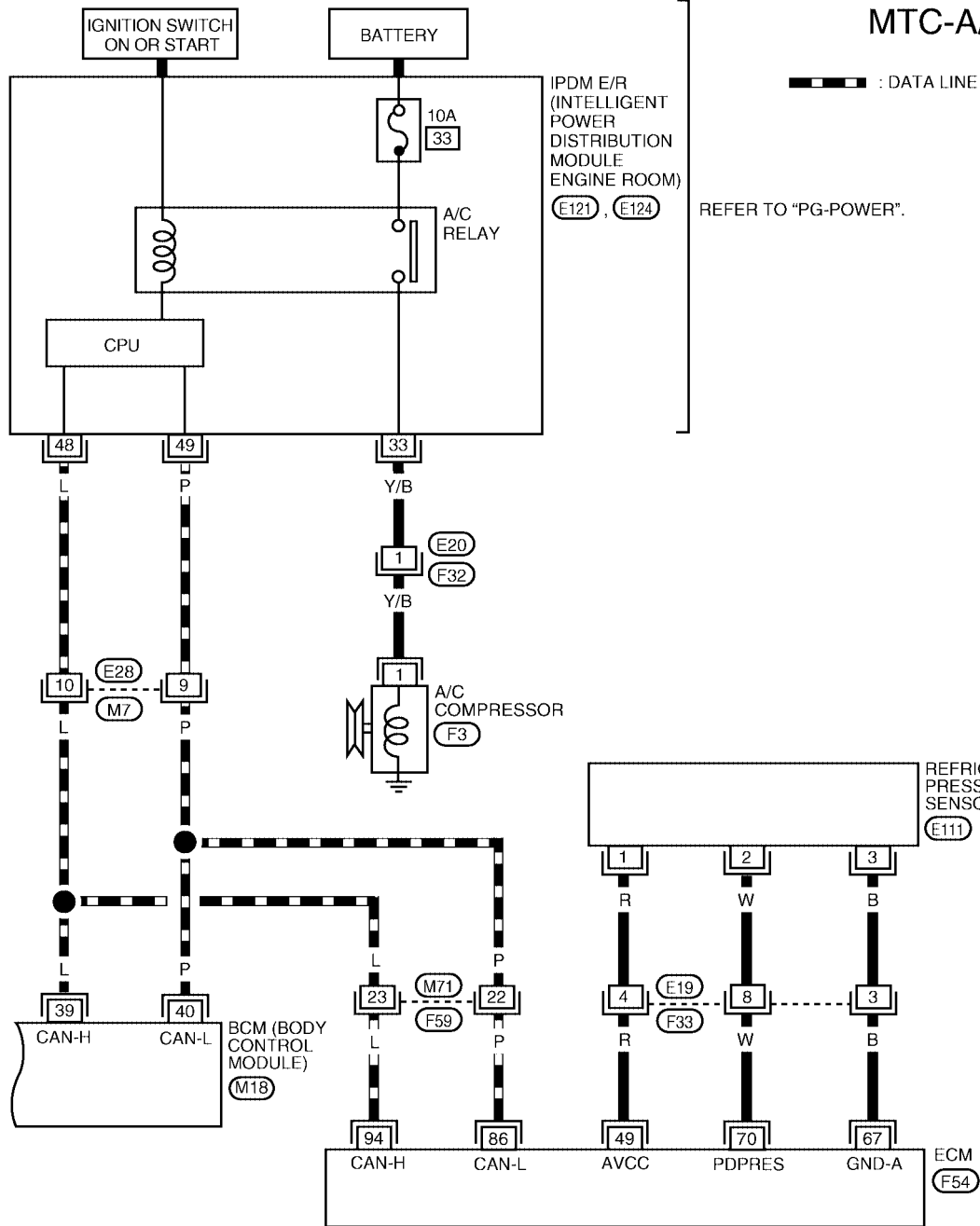

A
B
C
D
E
F
G
H
I
MTC
K
L
M

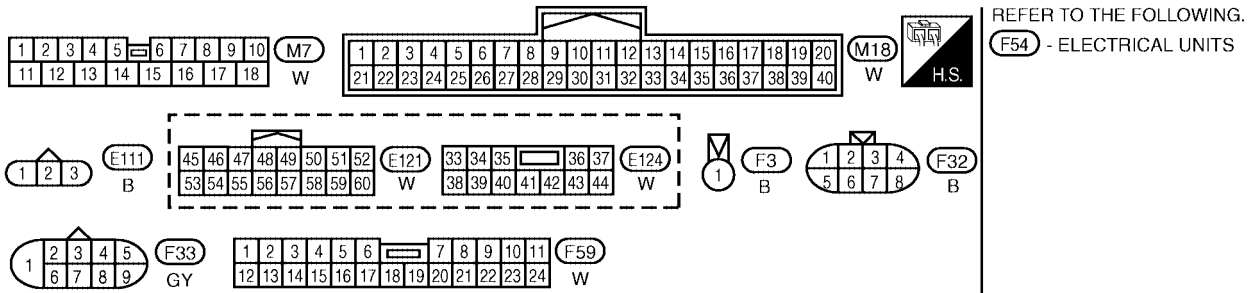

WJWA0142E

TROUBLE DIAGNOSIS

EJS002SG

Front Air Control Terminals and Reference Value INSPECTION OF FRONT AIR CONTROL

- Measure voltage between each terminal and body ground by following "FRONT AIR CONTROL INSPECTION TABLE". [MTC-38](#), "[FRONT AIR CONTROL INSPECTION TABLE](#)"

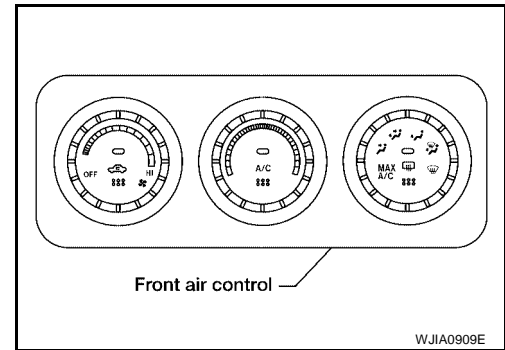

FRONT AIR CONTROL HARNESS CONNECTOR TERMINAL LAYOUT

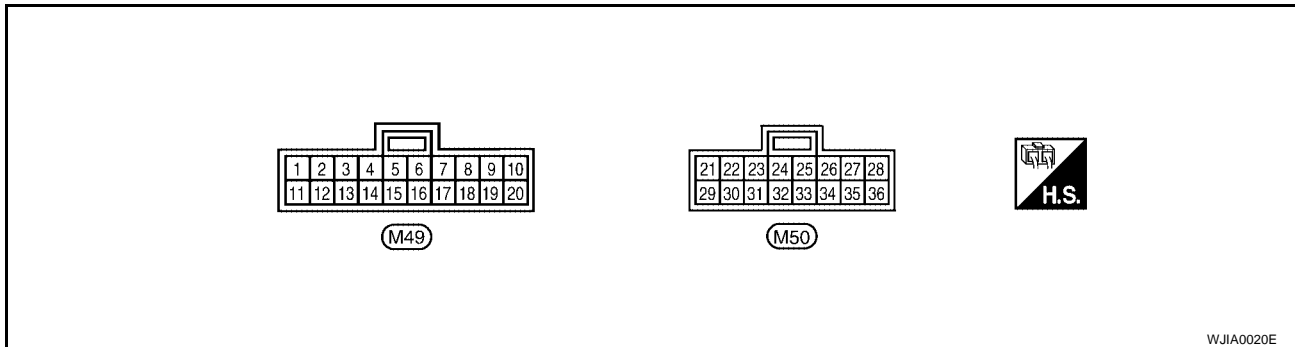

FRONT AIR CONTROL INSPECTION TABLE

Terminal No.	Wire color	Item	Ignition switch	Condition	Voltage (V) (Approx.)	
1	G	Power supply for IGN		—	12	
2	Y/R	Power supply for BAT	—	—	12	
3	B	Ground			0	
4	G/Y	Compressor ON signal		Compressor	ON OFF	0 5
5	L/R	Power supply for mode door motor, intake door motor, and air mix door motor		—	12	
11	R/Y	Light (-)		—	0	
12	R/L	Light (+)		Lighting switch	OFF 1st position	0 12
15	L/B	A/C LAN signal		—	5.5	
17	L/Y	Fan control AMP. control signal		Fan speed	Any speed except high High Low	2.5 - 3 9 - 10 7.0 - 10.0
18	L/W	Blower motor feed back		Fan	ON OFF	0 5
19	L/W	Fan ON signal			—	12
20	W/L	Power supply for IGN		—	—	12

TROUBLE DIAGNOSIS

Terminal No.	Wire color	Item	Ignition switch	Condition		Voltage (V) (Approx.)	
				Defroster switch			
22	GY	Rear defrost ON signal		Defroster switch	ON	0	A
					OFF	5	B
24	B/Y	Sensor ground			—	0	
25	R/W	Intake sensor			—	0 - 5	
30	B	AC PD cut			—	—	C

A

B

C

D

E

F

G

H

I

MTC

K

L

M

TROUBLE DIAGNOSIS

EJS002SH

Operational Check

The purpose of the operational check is to confirm that the system operates properly.

CONDITIONS:

- Engine running and at normal operating temperature.

PROCEDURE:

1. Check Blower

1. Turn fan dial clockwise, blower should operate on low speed.
2. Continue turning fan dial clockwise, and continue checking blower speeds until all speeds are checked.
3. Leave blower on HI speed.

If NG, go to [MTC-53, "Blower Motor Circuit"](#) .

If OK, continue with next check.

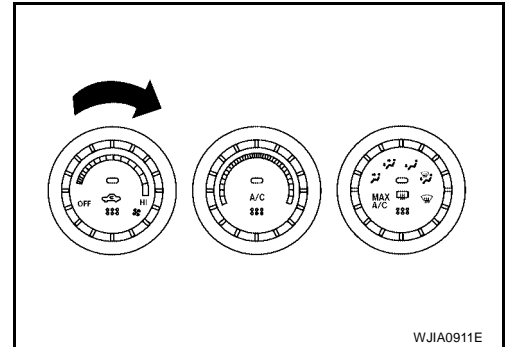

WJIA0911E

2. Check Discharge Air

1. Turn mode switch clockwise five positions.

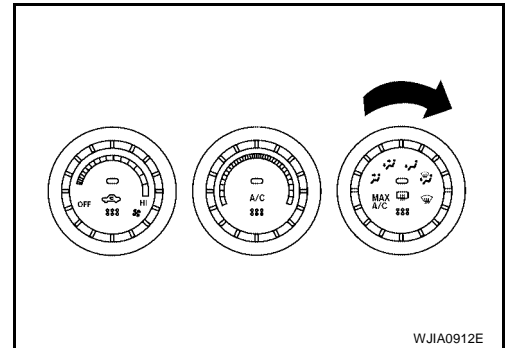

WJIA0912E

2. Confirm that discharge air comes out according to the air distribution table.

Refer to [MTC-26, "Discharge Air Flow"](#) .

NOTE:

Confirm that the compressor clutch is engaged (audio or visual inspection) and intake door position is at FRESH when the DEF





 is selected.

Intake door position is checked in the next step.

If NG, go to [MTC-47, "Mode Door Motor Circuit"](#) .

If OK, continue with next check.

Discharge air flow

Mode control dial	Air outlet/distribution		
	Face	Foot	Defroster
	100%	—	—
	60%	40%	—
	—	80%	20%
	—	60%	40%
	—	—	100%

WJIA0910E

3. Check Recirculation

1. Press REC  switch.

TROUBLE DIAGNOSIS

Recirculation indicator should illuminate.

2. Press REC  switch a second time.
Recirculation indicator should turn off.
3. Listen for intake door position change (you should hear blower sound change slightly).

If NG, go to [MTC-51, "Intake Door Motor Circuit"](#) .

If OK, continue with next check.

4. Check Temperature Decrease

1. Turn the temperature dial fully counterclockwise.
2. Check for cold air at discharge air outlets.

If NG, go to [MTC-64, "Insufficient Cooling"](#) .

If OK, continue with next check.

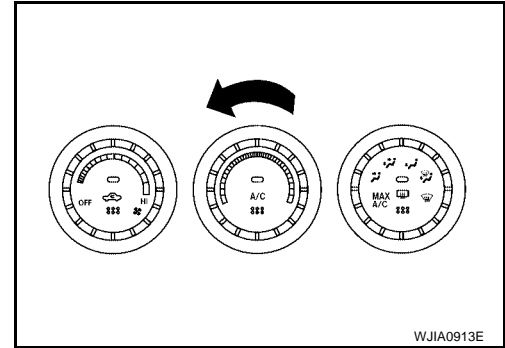

5. Check Temperature Increase

1. Turn the temperature dial fully clockwise.
2. Check for hot air at discharge air outlets.

If NG, go to [MTC-71, "Insufficient Heating"](#) .

If OK, continue with next check.

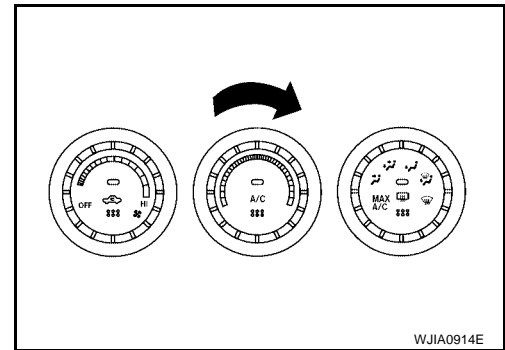

6. Check Air Conditioner Switch

1. Turn fan dial to the desired position and push the air conditioner switch (if equipped) to turn ON the air conditioner.
2. Confirm that the A/C indicator lamp illuminates and that the compressor clutch engages (audio or visual inspection).

If NG, go to [MTC-42, "Power Supply and Ground Circuit for Front Air Control"](#) , then if necessary, [MTC-59, "Magnet Clutch Circuit"](#) .

If all operational checks are OK (symptom can not be duplicated), go to [GI-26, "How to Perform Efficient Diagnosis for an Electrical Incident"](#) and perform tests as outlined to simulate driving condition environment. If symptom appears, refer to [MTC-28, "SYMPTOM TABLE"](#) and perform applicable trouble diagnosis procedures.

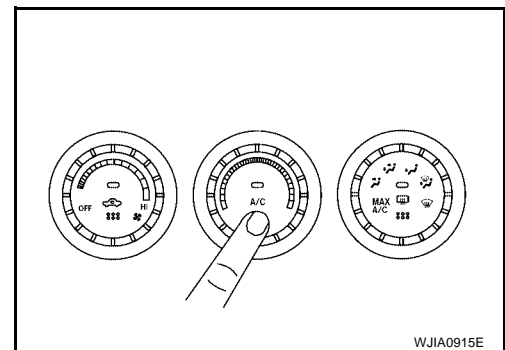

A
B
C
D
E
F
G
H
I
K
L
M

MTC

TROUBLE DIAGNOSIS

EJS002SI

Power Supply and Ground Circuit for Front Air Control

SYMPTOM:

- A/C system does not come on.

INSPECTION FLOW

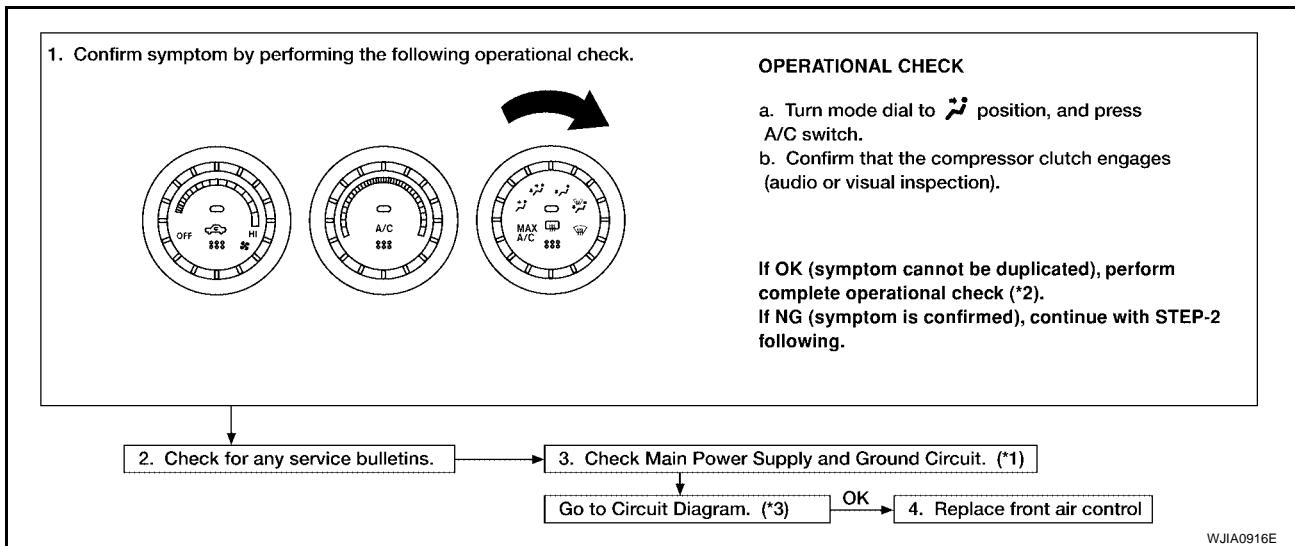

*1: [MTC-42](#)

*2: [MTC-40](#)

*3: [MTC-42](#)

COMPONENT DESCRIPTION

FRONT AIR CONTROL

The front air control has a built-in microcomputer which processes information sent from intake sensor, temperature dial, and various switches needed for air conditioner operation. The air mix door motor, mode door motor, intake door motor, blower motor and compressor are then controlled.

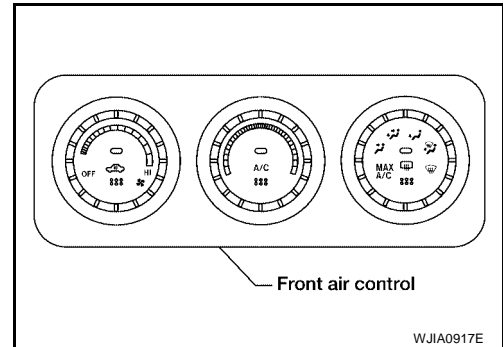

POTENTIAL TEMPERATURE CONTROL (PTC)

The PTC is built into the front air control.

DIAGNOSTIC PROCEDURE

SYMPTOM:

- A/C system does not come on.

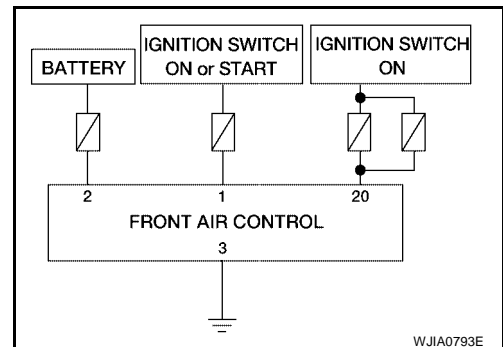

TROUBLE DIAGNOSIS

1. CHECK POWER SUPPLY CIRCUIT FOR FRONT AIR CONTROL

1. Disconnect front air control connector M49.
2. Turn ignition switch ON.
3. Check voltage between front air control connector M49 terminals 1 (G), 2 (Y/R), and 20 (W/L), and ground.

Terminals		Voltage (V) (Approx.)
(+)	(-)	
Connector - Terminal	Wire colors	Body ground 12V
M49-1	G	
M49-2	Y/R	
M49-20	W/L	

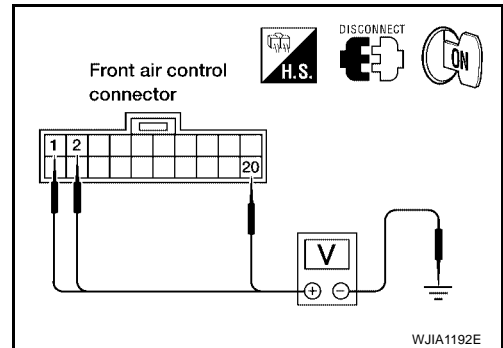

OK or NG

OK >> GO TO 2.

NG >> Check the following.

- 10A fuse [Nos. 12 and 19, located in the fuse block (J/B)] and 15A fuses [Nos. 10 and 11, located in the fuse block (J/B)].
- If fuses are OK, check for open circuit in wiring harness. Repair or replace as necessary.
- If fuses are NG, replace fuse and check wiring harness for short circuit. Repair or replace as necessary.

2. CHECK BODY GROUND CIRCUIT FOR FRONT AIR CONTROL

1. Turn ignition switch OFF.
2. Check continuity between front air control connector M49 terminal 3 (B) and ground.

Terminal		Continuity
(+)	(-)	
Connector - Terminal	Wire colors	Body ground Yes
M49-3	B	

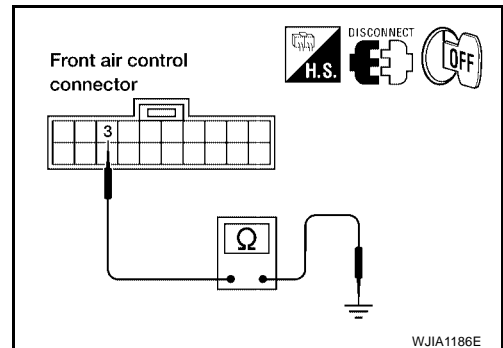

OK or NG

OK >> ● Replace front air control. Refer to [MTC-76, "FRONT AIR CONTROL"](#).

- Inspection End.

NG >> Repair or replace harness.

TROUBLE DIAGNOSIS

EJS002SJ

LAN System Circuit

SYMPTOM: Mode door motor, intake door motor and/or air mix door motor do not operate normally.

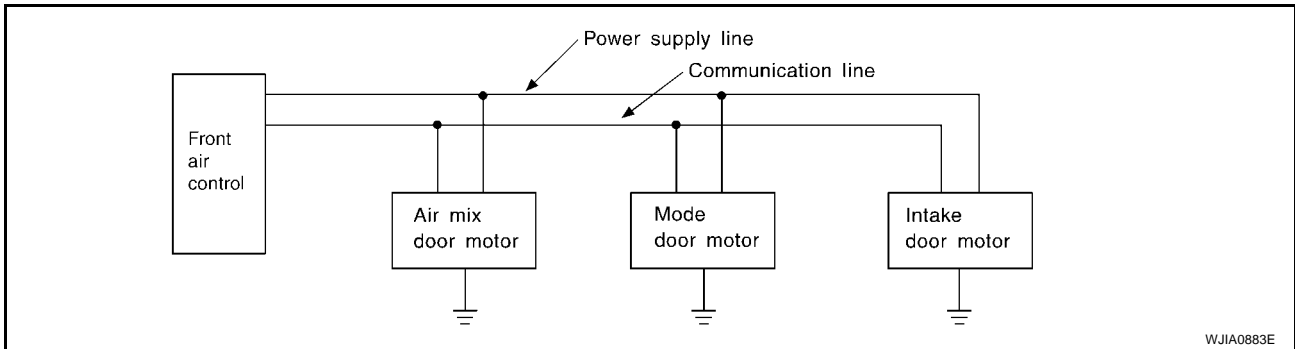

WJIA0883E

DIAGNOSTIC PROCEDURE

1. CHECK POWER SUPPLY FOR DOOR MOTORS

1. Turn ignition switch ON.
2. Check voltage between front air control connector M49 terminal 5 (L/R) and ground.

Terminals		(-)	Voltage (V) (Approx.)
(+) Connector			
Wire color			
M49-5	L/R	Body ground	12V

OK or NG

- OK >> GO TO 2.
 NG >> Replace front air control. Refer to [MTC-76, "FRONT AIR CONTROL"](#).

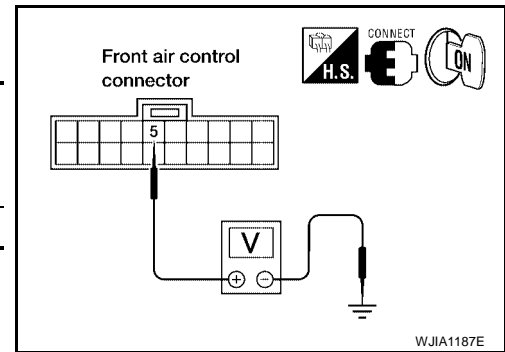

WJIA1187E

2. CHECK SIGNAL FOR DOOR MOTORS

Check voltage between front air control connector M49 terminal 15 (L/B) and ground.

Terminals		(-)	Voltage (V) (Approx.)
(+) Connector			
Wire color			
M49-15	L/B	Ground	5.5V

OK or NG

- OK >> GO TO 3.
 NG >> Replace front air control. Refer to [MTC-76, "FRONT AIR CONTROL"](#).

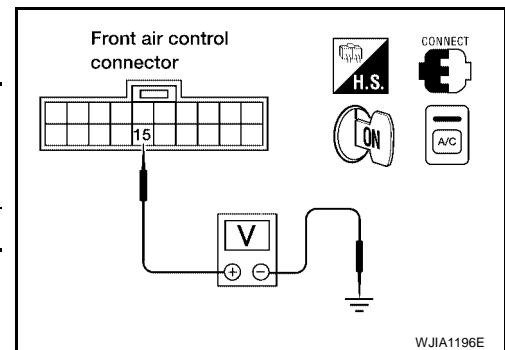

WJIA1196E

TROUBLE DIAGNOSIS

3. CHECK POWER SUPPLY FOR MOTOR

Check voltage between mode door motor connector M40 terminal 1 (L/R) and ground, between air mix door motor connector M39 terminal 1 (L/R) and ground, and between intake door motor connector M58 terminal 1 (L/R) and ground.

Door motors	Terminals		Voltage (V) (Approx.)	
	(+)			(-)
	Connector	wire colors		
Mode	M40-1	L/R	Body ground 12V	
Air mix	M39-1	L/R		
Intake	M58-1	L/R		

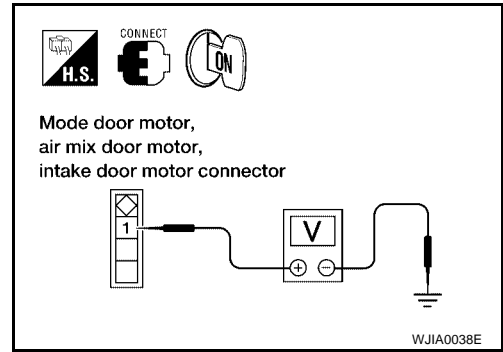

OK or NG

- OK >> GO TO 4.
- NG >> Replace harness or connector.

4. CHECK SIGNAL FOR MOTOR

Check voltage between mode door motor connector M40 terminal 3 (L/B) and ground, between air mix door motor connector M39 terminal 3 (L/B) and ground, and between intake door motor connector M58 terminal 3 (L/B) and ground.

Door motors	Terminals		Voltage (V) (Approx.)	
	(+)			(-)
	Connectors	wire colors		
Mode	M40-3	L/B	Body ground 5.5V	
Air mix	M39-3	L/B		
Intake	M58-3	L/B		

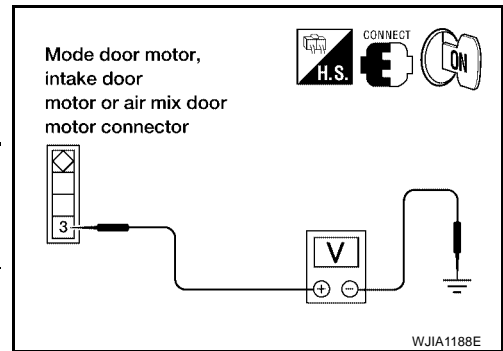

OK or NG

- OK >> GO TO 5.
- NG >> Replace harness or connector.

5. CHECK MOTOR GROUND CIRCUIT

1. Turn ignition switch OFF.
2. Disconnect door motor connectors.
3. Check continuity between mode door motor connector M40 terminal 2 (B) and ground, between air mix door motor connector M39 terminal 2 (B) and ground, and between intake door motor connector M58 terminal 2 (B) and ground.

Door motors	Terminals		Continuity	
	(+)			(-)
	Connector	wire colors		
Mode	M40-2	B	Body ground Yes	
Air mix	M39-2	B		
Intake	M58-2	B		

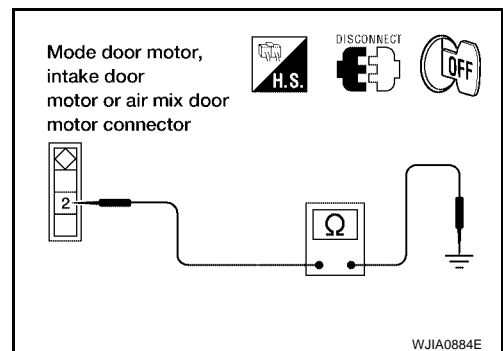

OK or NG

- OK >> GO TO 6.
- NG >> Replace harness or connector.

TROUBLE DIAGNOSIS

6. CHECK MOTOR OPERATION

Disconnect and reconnect the motor connectors and confirm the motor operation.

OK or NG

- OK >> (Returns to normal operation.)
- Motor connector contacts dirty or damaged
- NG >> (Does not operate normally.)
- GO TO 7.

7. CHECK MODE DOOR MOTOR AND AIR MIX DOOR MOTOR OPERATION

1. Disconnect the intake door motor connector.
2. Reconnect the mode door motor connector and air mix door motor connector, confirm the mode door motor and air mix door motor operation.

OK or NG

- OK >> (Mode door motor and air mix door motor operate normally.)
- Replace the intake door motor. refer to [ATC-97, "Removal and Installation"](#)
- NG >> (Mode door motor and air mix door motor do not operate normally.)
- GO TO 8.

8. CHECK AIR MIX DOOR MOTOR AND INTAKE DOOR MOTOR OPERATION

1. Disconnect mode door motor connector.
2. Reconnect the intake door motor connector, confirm the air mix door motor and intake door motor operation.

OK or NG

- OK >> (Air mix door motor and intake door motor operate normally.)
- Replace mode door motor. Refer to [ATC-98, "Removal and Installation"](#)
- NG >> (Air mix door motor and intake door motor do not operate normally.)
- GO TO 9.

9. CHECK INTAKE DOOR MOTOR AND MODE DOOR MOTOR OPERATION

1. Disconnect air mix door motor connector.
2. Reconnect mode door motor connector, confirm the intake door motor and mode door motor operation.

OK or NG

- OK >> (Intake door motor and mode door motor operate normally.)
- Replace air mix door motor. refer to [MTC-85, "Removal and Installation"](#)
- NG >> (Intake door motor and mode door motor do not operate normally.)
- Replace front air control. Refer to [MTC-76, "FRONT AIR CONTROL"](#) .

TROUBLE DIAGNOSIS

EJS002SK

Mode Door Motor Circuit

SYMPTOM:

- Air outlet does not change.
- Mode door motor does not operate normally.

INSPECTION FLOW

1. Confirm symptom by performing the following operational check.

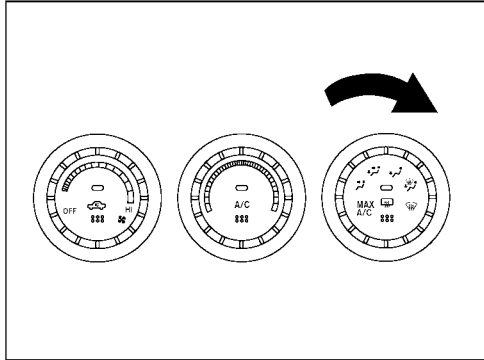

OPERATIONAL CHECK – Discharge air

- Turn mode dial five positions.
- Confirm that discharge air comes out according to the air distribution table.
Refer to “Discharge Air Flow” (*1).

NOTE:

- If OK (symptom cannot be duplicated), perform complete operational check (*2).
- If NG (symptom is confirmed), continue with STEP-2 following.
- Confirm that the compressor clutch is engaged (visual inspection) and intake door position is at FRESH when DEF is selected.
Intake door position is checked in the next step.

2. Check for any service bulletins.

OK

3. Check mode door control linkage.

NG

Repair or adjust control linkage.

OK

4. Check LAN system circuit. (* 3)

OK

If the symptom still exists, perform a complete operational check (*2) and check for other symptoms.
[Refer to symptom table, (* 4).]
Does another symptom exist?

Yes

Go to Trouble Diagnosis for related symptoms.

[Another symptom exists.]

No

Replace front air control

Inspection End

*1 [MTC-26, "Discharge Air Flow"](#)

*2 [MTC-40, "Operational Check"](#)

*3 [MTC-44, "LAN System Circuit"](#)

*4 [MTC-28, "SYMPTOM TABLE"](#)

WJIA0919E

TROUBLE DIAGNOSIS

SYSTEM DESCRIPTION

Component Parts

Mode door control system components are:

- Front air control
- Mode door motor (LCU)

System Operation

The front air control receives signals from its various dials and switches. The front air control then sends air mix door, mode door and intake door motor opening angle data to the air mix door motor LCU, mode door motor LCU and intake door motor LCU.

The mode door motor reads their respective signals according to the address signal. Opening angle indication signals received from the front air control and each of the motor position sensors are compared by the LCU's in each motor with the existing decision and opening angles. Subsequently, HOT/COLD or DEFROST/VENT or FRESH/RECIRCULATION operation is selected. The new selection data is returned to the front air control.

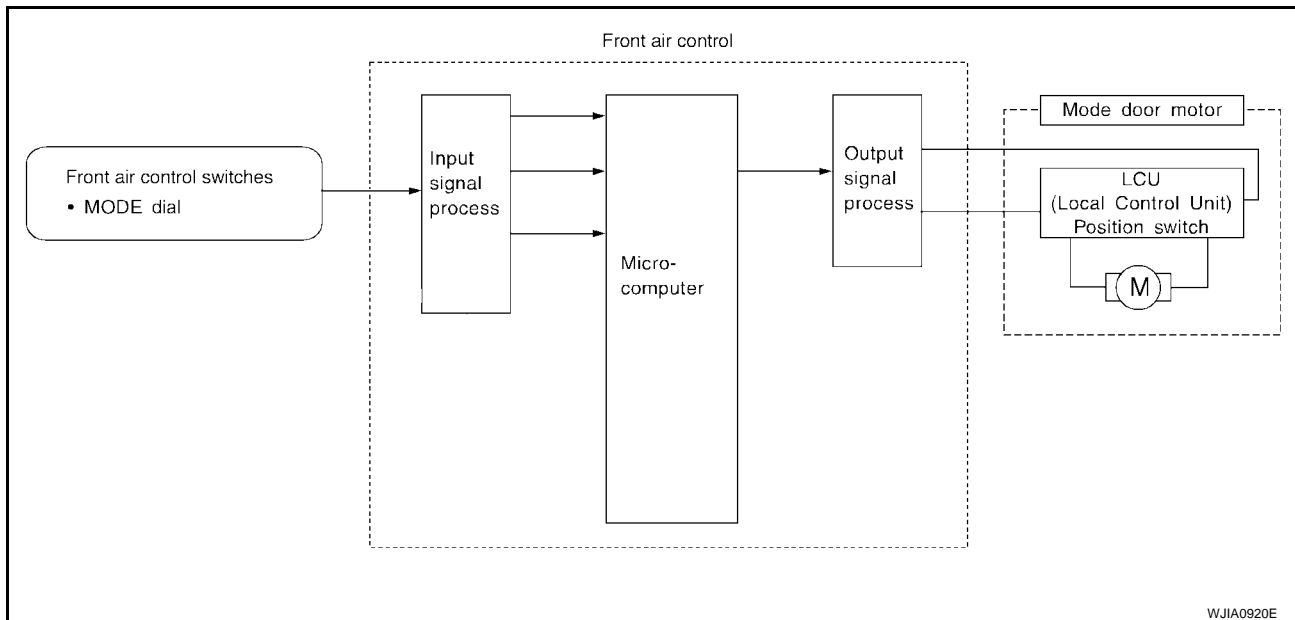

COMPONENT DESCRIPTION

Mode Door Motor

The mode door motor is attached to the heater and cooling unit. It rotates so that air is discharged from the outlet set by the front air control. Motor rotation is conveyed to a link which activates the mode door.

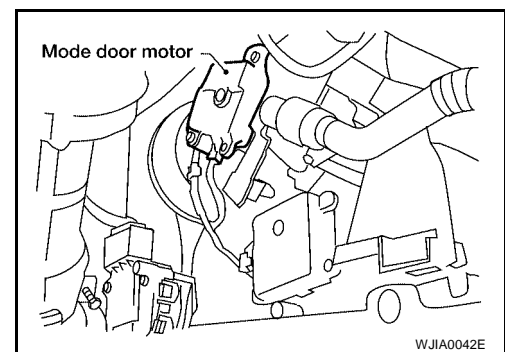

DIAGNOSTIC PROCEDURE

SYMPTOM: Mode door motor and/or air mix door motor does not operate normally.

Perform diagnostic procedure for LAN system circuit. Refer to [MTC-44, "LAN System Circuit"](#).

TROUBLE DIAGNOSIS

EJS002SL

Air Mix Door Motor Circuit

SYMPTOM:

- Discharge air temperature does not change.
- Air mix door motor does not operate.

INSPECTION FLOW

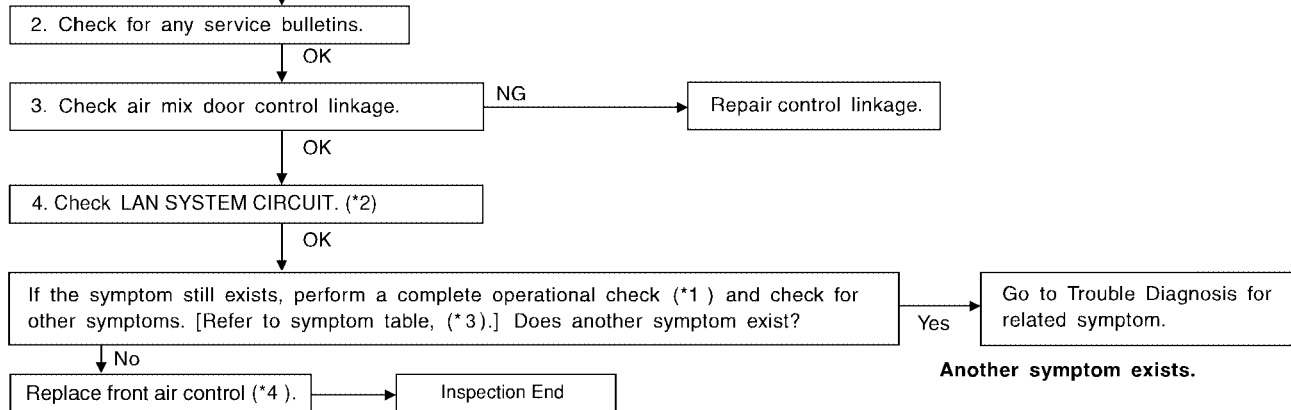
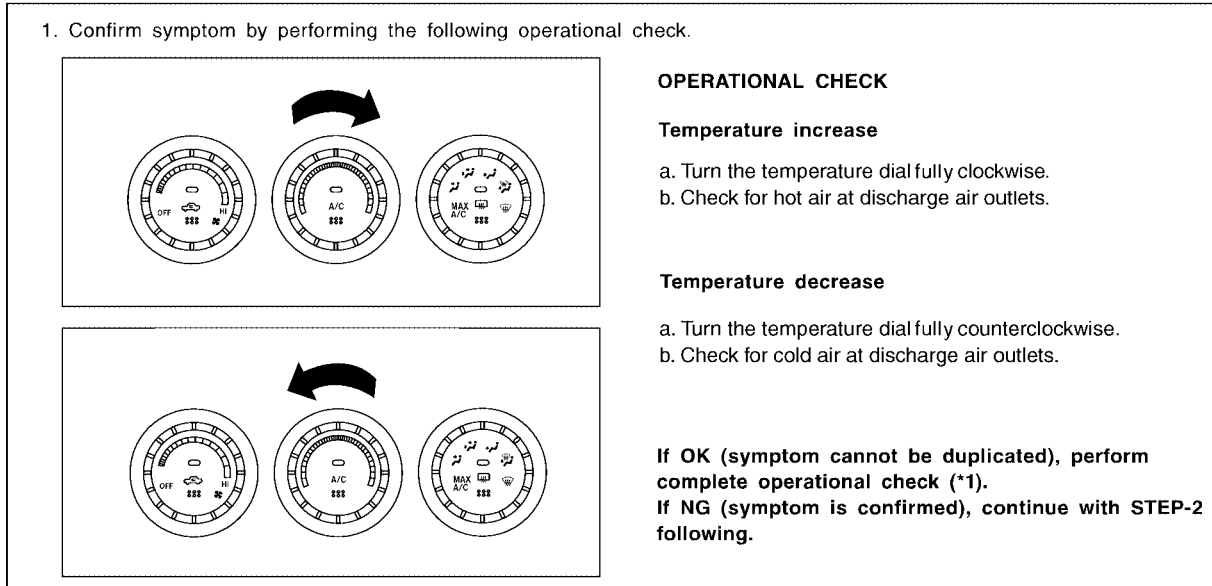

A
B
C
D
E
F
G
H
I
MTC
K
L
M

*1 [MTC-40. "Operational Check"](#)

*2 [MTC-44. "LAN System Circuit"](#)

*3 [MTC-28. "SYMPTOM TABLE"](#)

*4 [MTC-76. "FRONT AIR CONTROL"](#)

WJIA1644E

TROUBLE DIAGNOSIS

SYSTEM DESCRIPTION

Component Parts

Air mix door control system components are:

- Front air control
- Air mix door motor (LCU)

System Operation

The front air control receives signals from its various dials and switches. The front air control then sends air mix door, mode door and intake door motor opening angle data to the air mix door motor LCU, mode door motor LCU and intake door motor LCU.

The air mix door motor, mode door motor and intake door motor read their respective signals according to the address signal. Opening angle indication signals received from the front air control and each of the motor position sensors are compared by the LCUs in each motor with the existing decision and opening angles. Subsequently, HOT/COLD or DEFROST/VENT or FRESH/RECIRCULATION operation is selected. The new selection data is returned to the front air control.

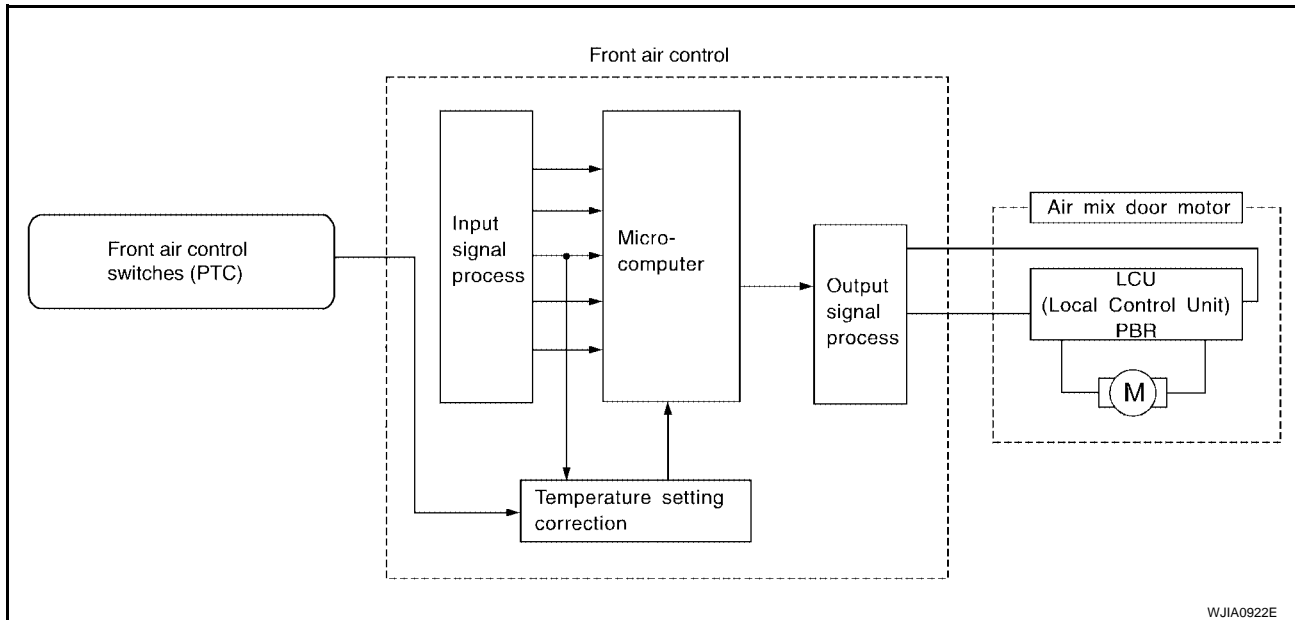

COMPONENT DESCRIPTION

Air Mix Door Motor

The air mix door motor is attached to the heater and cooling unit. It rotates so that the air mix door is opened or closed to a position set by the front air control. Motor rotation is then conveyed through a shaft and the air mix door position is then fed back to the front air control by PBR built-in air mix door motor.

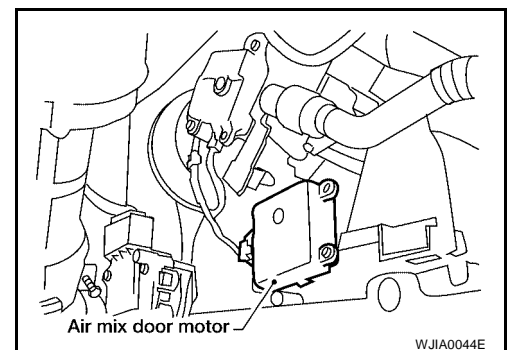

DIAGNOSTIC PROCEDURE

SYMPTOM: Discharge air temperature does not change.

Perform diagnostic procedure for LAN system circuit. Refer to [MTC-44, "LAN System Circuit"](#).

TROUBLE DIAGNOSIS

EJS002SM

Intake Door Motor Circuit

SYMPTOM:

- Intake door does not change.
- Intake door motor does not operate normally.

INSPECTION FLOW

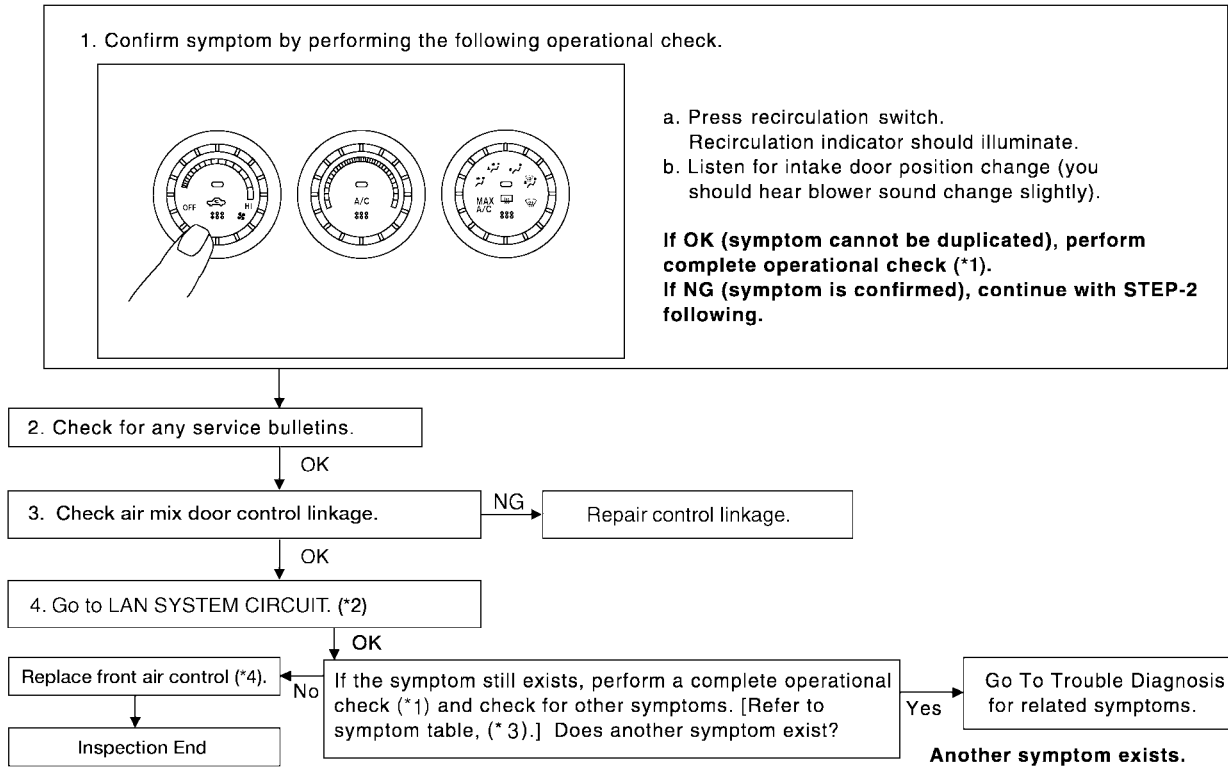

*1 [MTC-40, "Operational Check"](#)

*2 [MTC-44, "LAN System Circuit"](#)

*3 [MTC-28, "SYMPTOM TABLE"](#)

*4 [MTC-76, "FRONT AIR CONTROL"](#)

WJIA1645E

TROUBLE DIAGNOSIS

SYSTEM DESCRIPTION

Component Parts

Intake door control system components are:

- Front air control
- Intake door motor

System Operation

The intake door control determines intake door position based on the ambient temperature, the intake air temperature and the in-vehicle temperature. When the front air control is set to DEFROST, or OFF, the front air control sets the intake door at the fresh position.

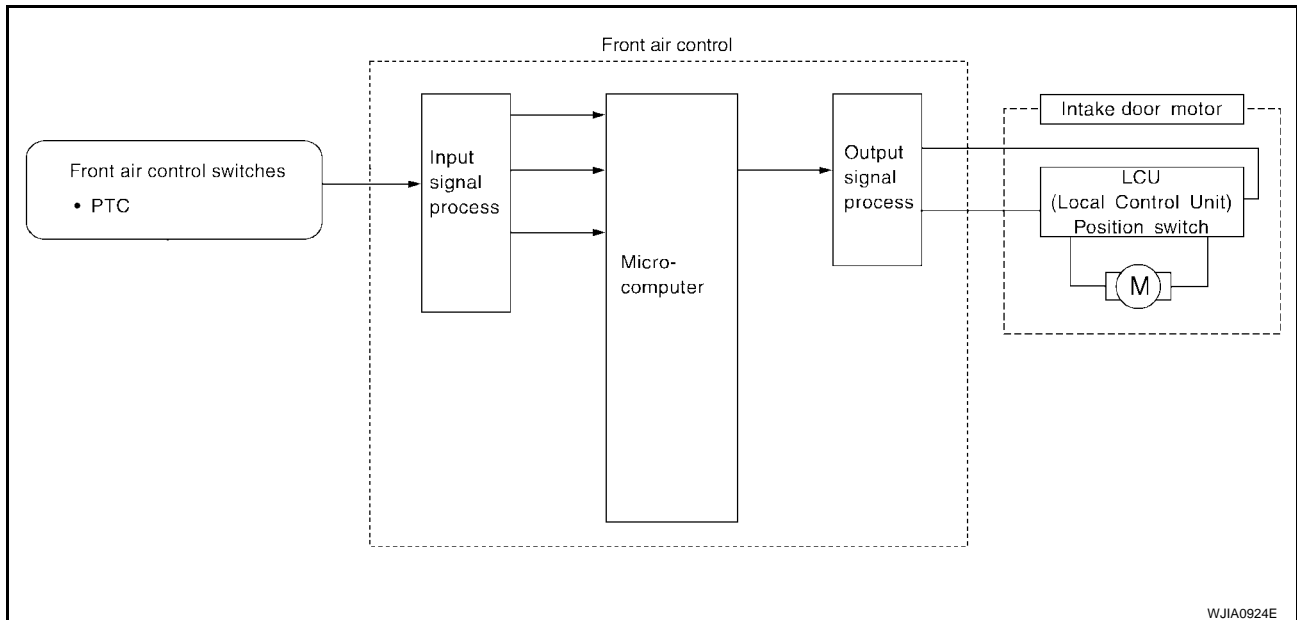

COMPONENT DESCRIPTION

Intake door motor

The intake door motor is attached to the intake unit. It rotates so that air is drawn from inlets set by the front air control. Motor rotation is conveyed to a lever which activates the intake door. Door position is then fed back to the front air control by PBR built-in air mix door motor.

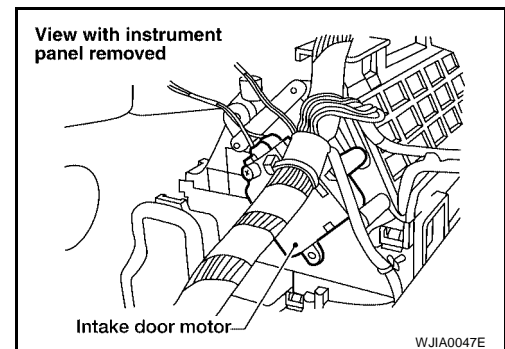

DIAGNOSTIC PROCEDURE

SYMPTOM: Intake door motor does not operate normally.

Perform diagnostic procedure for LAN system circuit. Refer to [MTC-44, "LAN System Circuit"](#) .

TROUBLE DIAGNOSIS

EJS002SN

Blower Motor Circuit

SYMPTOM:

- Blower motor operation is malfunctioning.

INSPECTION FLOW

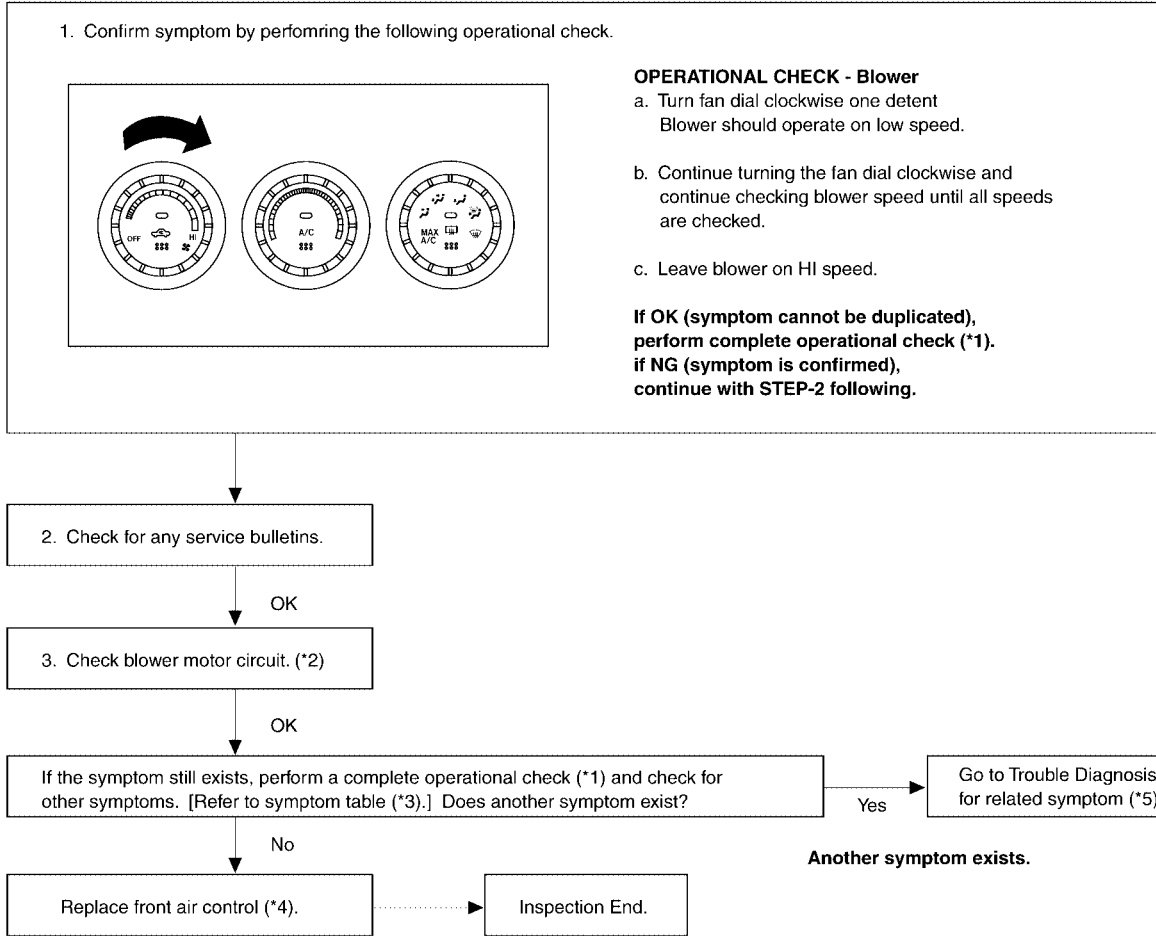

*1 [MTC-40, "Operational Check"](#)

*2 [MTC-53, "Blower Motor Circuit"](#)

*3 [MTC-28, "SYMPTOM TABLE"](#)

*4 [MTC-76, "FRONT AIR CONTROL"](#)

*5 [MTC-28, "SYMPTOM TABLE"](#)

WJIA1647E

TROUBLE DIAGNOSIS

SYSTEM DESCRIPTION

Component Parts

Fan speed control system components are:

- Front air control
- Blower motor
- Fan control amplifier

System Operation

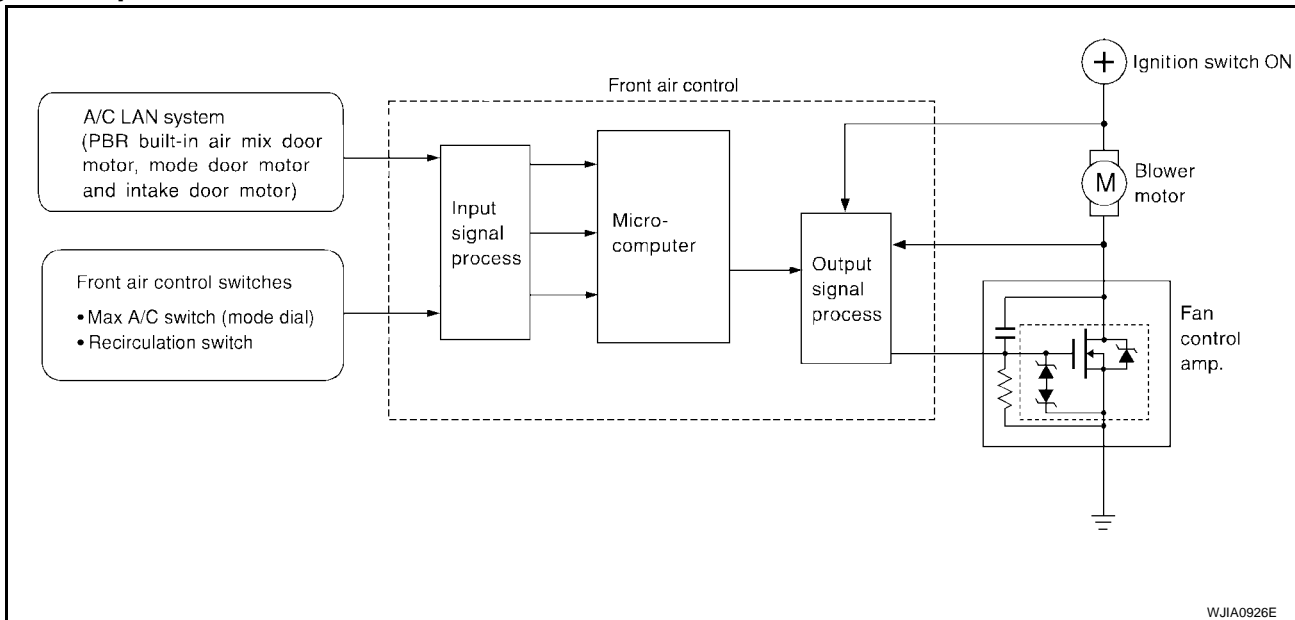

COMPONENT DESCRIPTION

Fan Control Amplifier

The fan control amplifier is located on the cooling unit. The fan control amp. receives a gate voltage from the front air control to smoothly maintain the blower fan motor voltage in the 5 to the 12V range (approx.).

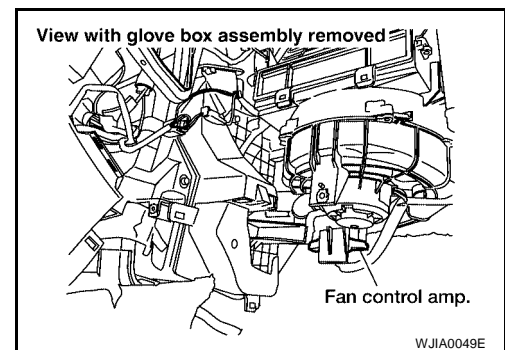

DIAGNOSTIC PROCEDURE

SYMPTOM: Blower motor is malfunctioning.

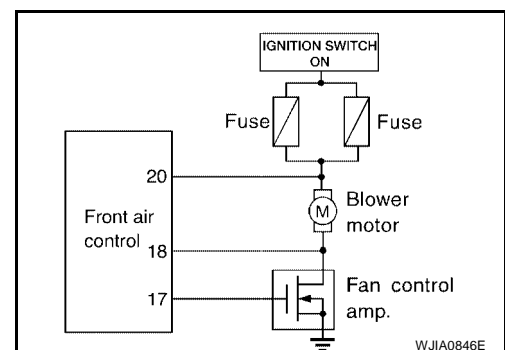

TROUBLE DIAGNOSIS

1. CHECK POWER SUPPLY FOR FAN CONTROL AMP.

1. Disconnect fan control amp. connector.
2. Turn ignition switch ON.
3. Check voltage between fan control amp. harness connector M64 terminal 3 (L/W) and ground.

Terminal		(-)	Voltage (V) (Approx.)
(+)			
Connector - Terminal	Wire color	Body ground	12V
M64-3	L/W		

OK or NG

- OK >> GO TO 2.
 NG >> GO TO 7.

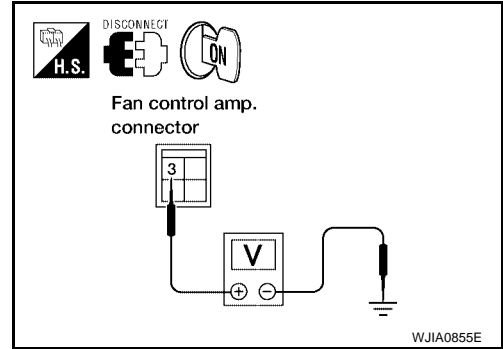

2. CHECK FAN FEEDBACK CIRCUIT

1. Disconnect front air control connector.
2. Check voltage between front air control harness connector M49 terminal 18 (L/W) and ground.

Terminal		(-)	Voltage (V) (Approx.)
(+)			
Connector - Terminal	Wire color	Body ground	12V
M49-18	L/W		

OK or NG

- OK >> GO TO 3.
 NG >> Check for open circuit in wiring harness. Repair or replace as necessary.

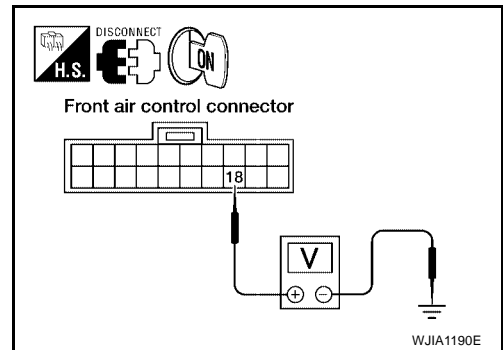

3. CHECK BODY GROUND CIRCUIT FOR FAN CONTROL AMP.

1. Turn ignition switch OFF.
2. Check continuity between fan control amp. harness connector M64 terminal 1 (B) and ground.

Terminal		Body ground	Continuity
Connector - Terminal	Wire color		
M64-1	B	Yes	

OK or NG

- OK >> Reconnect fan control amp. harness connector and GO TO 4.
 NG >> Repair harness or connector.

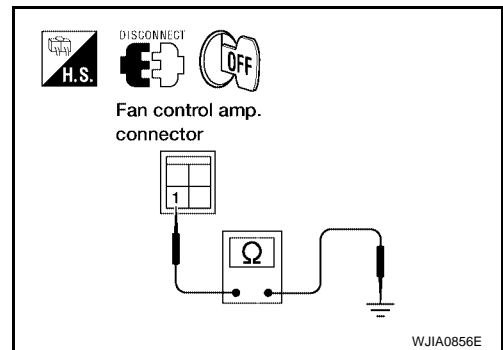

A
B
C
D
E
F
G
H
I
K
L
M

MTC

TROUBLE DIAGNOSIS

4. CHECK VOLTAGE FOR FAN CONTROL AMP.

1. Turn ignition switch ON.
2. Turn fan dial to any position except OFF or AUTO.
3. Check voltage between fan control amp. harness connector M64 terminal 2 L/Y and ground.

Terminal		Voltage (V) (Approx.)
(+)		
Connector - Terminal	Wire color	(-)
M64-2	L/Y	Body ground
		12V

OK or NG

- OK >> 1. Replace fan control amp.
2. Confirm that blower motor operation is normal.
- NG >> GO TO 5.

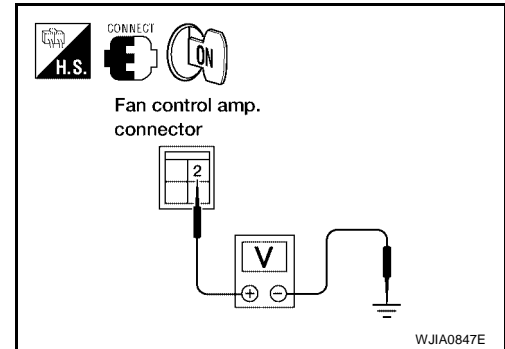

5. CHECK FAN CONTROL AMP. CIRCUIT BETWEEN FAN CONTROL AMP. AND FRONT AIR CONTROL

1. Turn ignition switch OFF.
2. Disconnect front air control and fan control amp. harness connectors.
3. Check continuity between fan control amp. harness connector M64 terminal 2 (L/Y) and front air control harness connector M49 terminal 17 (L/Y).

Terminals				Continuity
Connector - Terminal	Wire color	Connector - Terminal	Wire color	Yes
M64-2	L/Y	M49-17	L/Y	

Continuity should exist.

If OK, check harness for short.

OK or NG

- OK >> GO TO 6.
- NG >> Repair harness or connector.

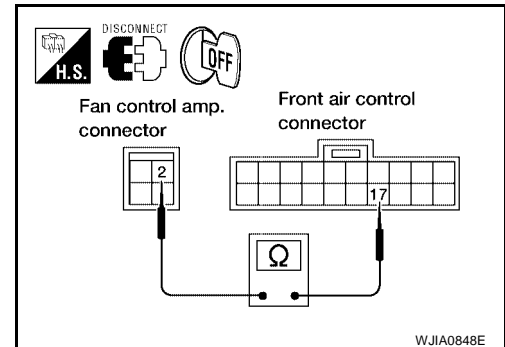

TROUBLE DIAGNOSIS

6. CHECK POWER SUPPLY FOR FRONT AIR CONTROL

1. Turn ignition switch ON.
2. Check voltage between front air control harness connector M49 terminal 2 (Y/R) and ground.

Terminal		Voltage (V) (Approx.)
(+)	(-)	
Connector - Terminal	Wire color	Body ground 12V
M49-2	Y/R	

OK or NG

- OK >> 1. Replace front air control. Refer to [MTC-76, "Removal and Installation"](#) .
2. Confirm that blower motor operation is normal.
- NG >> ● Check for open circuit in wiring harness.
Repair or replace as necessary.
- If OK, replace fuse and check wiring harness for short circuit.
Repair or replace an necessary.

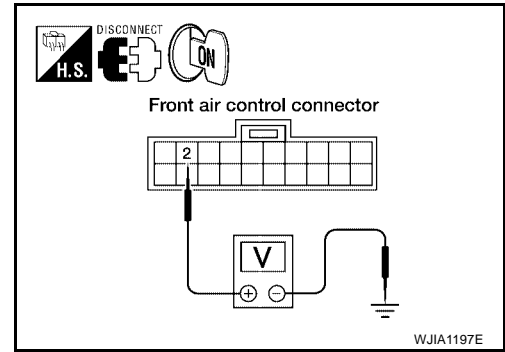

7. CHECK POWER SUPPLY FOR BLOWER MOTOR

1. Turn ignition OFF.
2. Disconnect blower motor harness connector.
3. Turn ignition switch ON.
4. Check voltage between blower motor harness connector M62 terminal 1 (W/L) and ground.

Terminal		Voltage (V) (Approx.)
(+)	(-)	
Connector - Terminal	Wire color	Body ground 12V
M62-1	W/L	

OK or NG

- OK >> GO TO 8.
- NG >> Check power supply circuit and 15A fuses [Nos. 10 and 11, located in the fuse block (J/B)].
- If OK, check for open circuit in wiring harness.
Repair or replace as necessary.
- If OK, replace fuse and check wiring harness for short circuit.
Repair or replace as necessary.

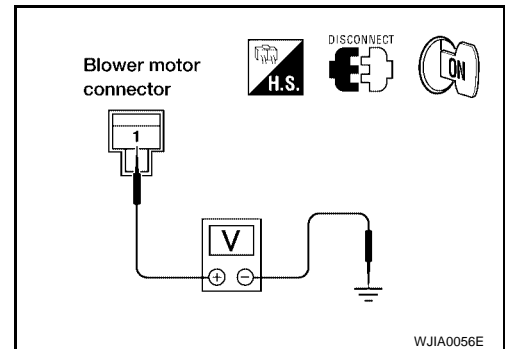

TROUBLE DIAGNOSIS

8. CHECK CIRCUIT CONTINUITY BETWEEN BLOWER MOTOR AND FAN CONTROL AMP.

1. Turn ignition switch OFF.
2. Disconnect front air control connector.
3. Check continuity between blower motor harness connector M62 terminal 2 (L/W) and fan control amp. harness connector M64 terminal 3 (L/W).

Terminals				Continuity
Connector - Terminal	Wire color	Connector - Terminal	Wire color	
M62-2	L/W	M64-3	L/W	Yes

OK or NG

OK >> Check blower motor. Refer to [MTC-58, "Blower Motor"](#).

1. If NG, replace blower motor.
2. Confirm that blower motor operation is normal.

NG >> Repair harness or connector.

COMPONENT INSPECTION

Blower Motor

Confirm smooth rotation of the blower motor.

- Ensure that there are no foreign particles inside the intake unit.

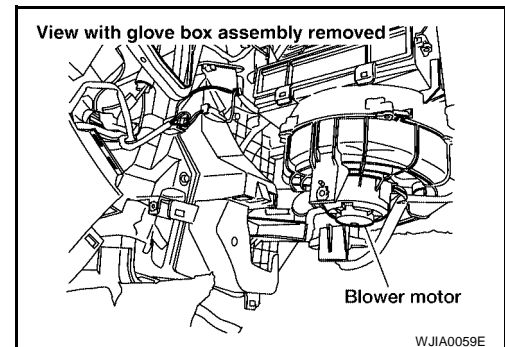
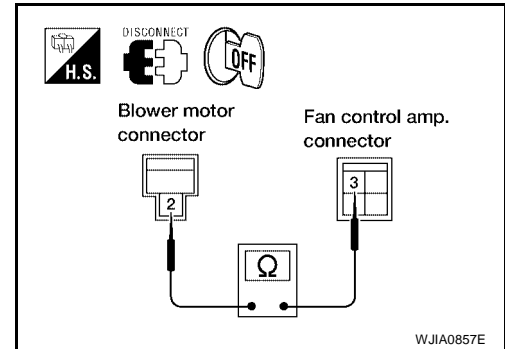

TROUBLE DIAGNOSIS

EJS002SO

Magnet Clutch Circuit

SYMPTOM: Magnet clutch does not engage.

INSPECTION FLOW

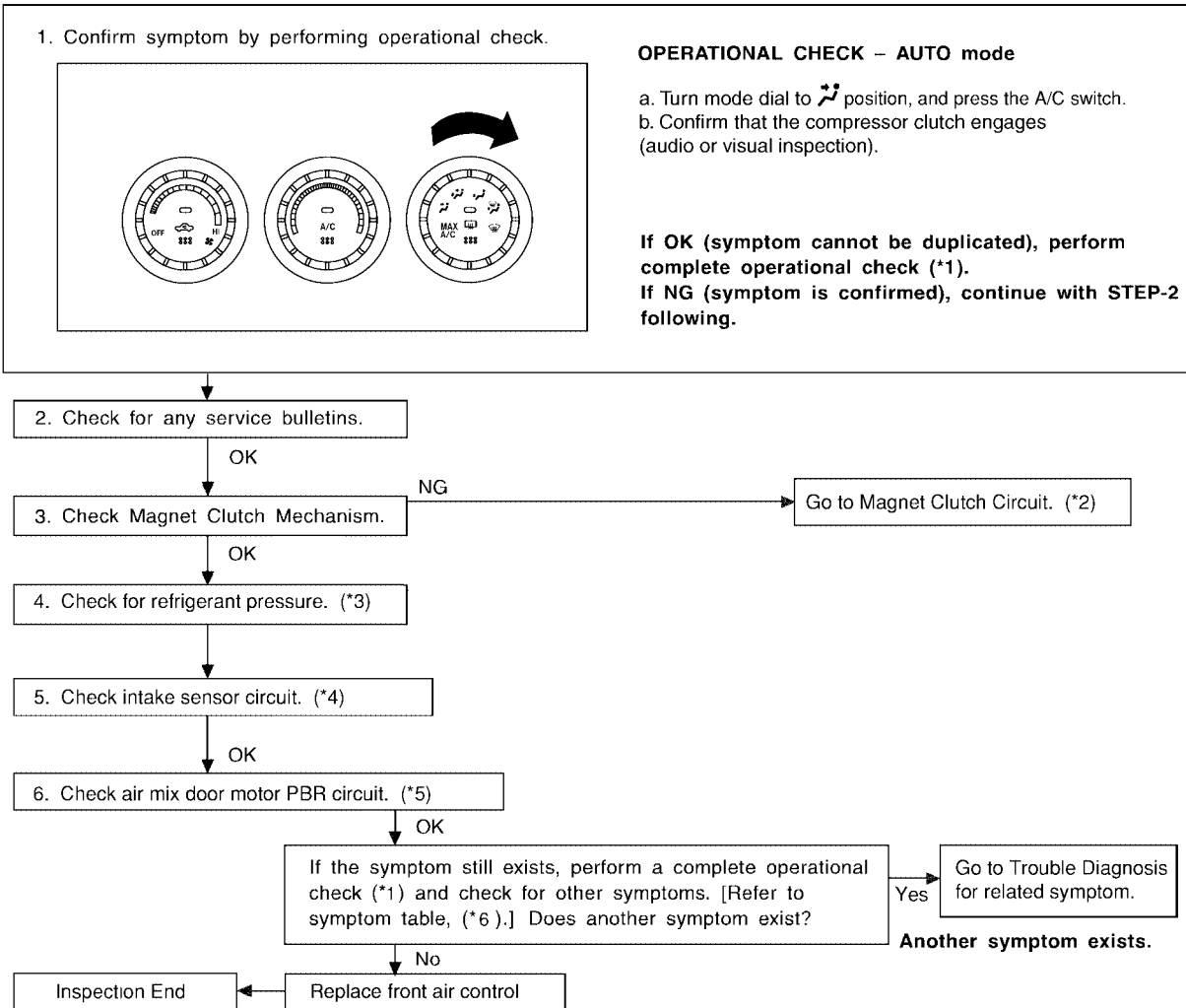

*1 [MTC-40, "Operational Check"](#)

*2 [MTC-59, "Magnet Clutch Circuit"](#)

*3 [MTC-62, "Refrigerant Pressure Sensor"](#)

*4 [MTC-73, "Intake Sensor Circuit"](#)

*5 [MTC-44, "LAN System Circuit"](#)

*6 [MTC-28, "SYMPTOM TABLE"](#)

WJIA0927E

TROUBLE DIAGNOSIS

SYSTEM DESCRIPTION

Front air control controls compressor operation by intake sensor signal and signal from ECM.

DIAGNOSTIC PROCEDURE

SYMPTOM: Magnet clutch does not engage when A/C switch is ON.

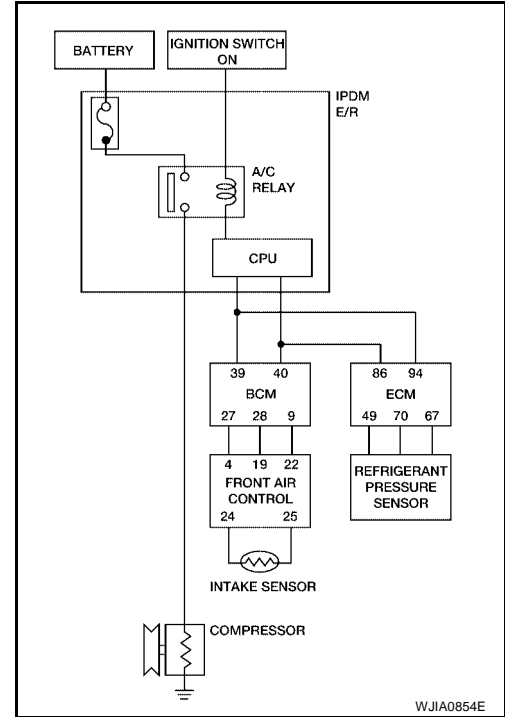

1. CHECK CIRCUIT CONTINUITY BETWEEN A/C RELAY IN IPDM E/R AND COMPRESSOR

1. Disconnect IPDM E/R connector E124 and compressor connector.
2. Check continuity between compressor harness connector F3 terminal 1 (Y/B) and IPDM E/R harness connector E124 terminal 33 (Y/B).

Terminals				Continuity
Connector - Terminal	Wire color	Connector - Terminal	Wire color	
F3-1	Y/B	E124-33	Y/B	Yes

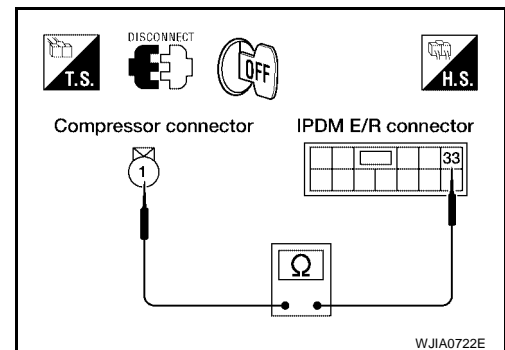

If OK, check harness for short to ground.

OK or NG

OK >> GO TO 2.

NG >> Repair harness or connector.

TROUBLE DIAGNOSIS

2. CHECK POWER SUPPLY FOR COMPRESSOR

1. Reconnect IPDM E/R harness connectors.
2. Start engine and press A/C switch.
3. Check voltage between compressor harness connector F3 terminal 1 (Y/B) and ground.

Terminal		Voltage (V) (Approx.)
(+)	(-)	
Connector - Terminal	Wire color	Body ground 12V
F3-1	Y/B	

OK or NG

OK >> Check magnet clutch coil.

1. If NG, replace magnet clutch. Refer to [MTC-94, "Removal and Installation for Compressor Clutch"](#).

2. If OK, check compressor mounting points for looseness or corrosion and repair as necessary.

NG >> GO TO 3.

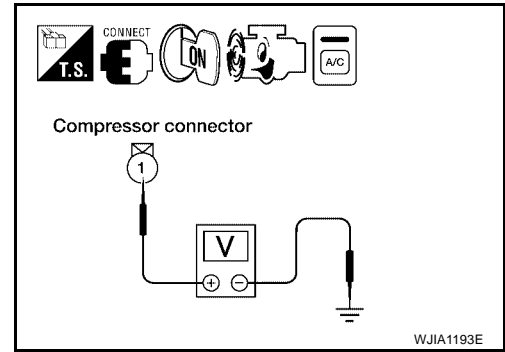

3. CHECK FUSE IN IPDM E/R

Check 10A fuse [No. 33 located at the IPDM E/R].

OK or NG

OK >> GO TO 4.

NG >> Replace fuse and check IPDM E/R for short circuit. Replace if necessary.

4. CHECK CONTINUITY BETWEEN BCM AND FRONT AIR CONTROL

1. Disconnect BCM connector M18 and front air control connector M49.
2. Check continuity between BCM harness connector M18 terminals 27 (G/Y), 28 (L/W) and front air control connector M49 terminals 4 (G/Y), 19 (L/W).

Terminals				Continuity
Connector - Terminal	Wire color	Connector - Terminal	Wire color	
M18-27	G/Y	M49-4	G/Y	Yes
M18-28	L/W	M49-19	L/W	

OK or NG

OK >> GO TO 5.

NG >> Repair harness or connector.

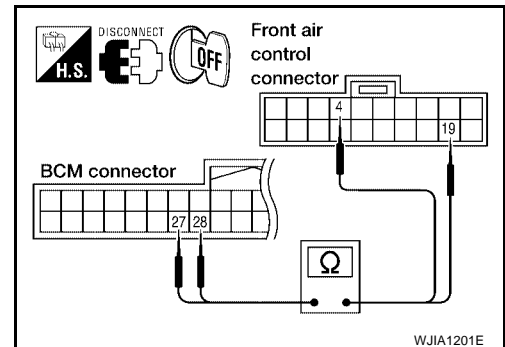

5. CHECK REFRIGERANT PRESSURE SENSOR INPUT SIGNAL

Check voltage between ECM harness connector F54 terminal 70 (W) and ground.

Terminal		Voltage (V) (Approx.)
(+)	(-)	
Connector - Terminal	Wire color	Body ground 12V
F54-70	W	

OK or NG

OK >> GO TO 6.

NG >> 1. Repair harness or connector.

2. Confirm that magnet clutch operation is normal.

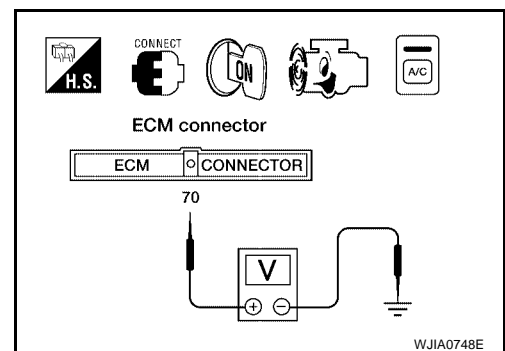

TROUBLE DIAGNOSIS

6. CHECK REFRIGERANT PRESSURE SENSOR

Refer to [MTC-62, "Refrigerant Pressure Sensor"](#) .

OK or NG

OK >> GO TO 7.

NG >> Replace refrigerant pressure sensor. Refer to [MTC-99, "Removal and Installation for Refrigerant Pressure Sensor"](#)

7. CHECK COMPRESSOR ON SIGNAL

Check voltage between front air control connector M49 terminal 4 (G/Y) and ground, with A/C compressor ON and with A/C compressor OFF.

Terminal		Voltage (V) (Approx.)
(+)	(-)	
Connector - Terminal	Wire color	Compressor ON: 0V Compressor OFF: 5V
M49-4	G/Y	

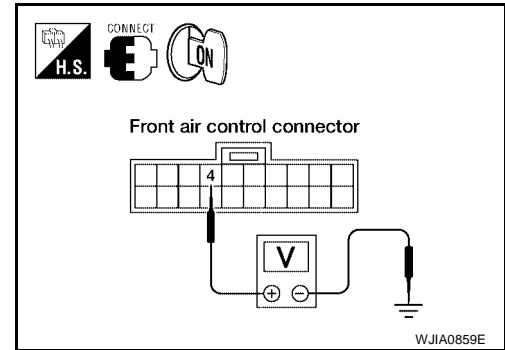

OK or NG

OK >> GO TO 8.

NG >> ● When compressor is ON and voltage is not approx. 0V, Replace front air control. Refer to [MTC-76, "Removal and Installation"](#) .

● When compressor is OFF and voltage is not approx. 5V, BCM is malfunctioning.

8. CHECK CAN COMMUNICATION CIRCUITS

Check CAN communication circuits between BCM to ECM and between ECM to IPDM E/R. Refer to [LAN-21, "CAN COMMUNICATION"](#) .

OK or NG

OK >> ECM malfunctioning.

NG >> Repair or replace component based on the result of diagnosis.

COMPONENT INSPECTION

Refrigerant Pressure Sensor

The refrigerant pressure sensor is attached to the condenser.

● Refer to [MTC-17, "Refrigerant pressure sensor"](#) .

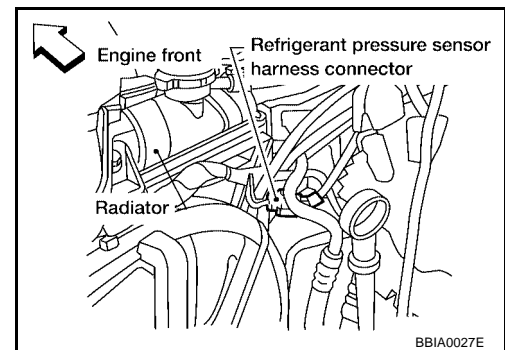

TROUBLE DIAGNOSIS

- Make sure that the A/C refrigerant pressure and the sensor output voltage are within the specified range as shown in the A/C operating condition figure.

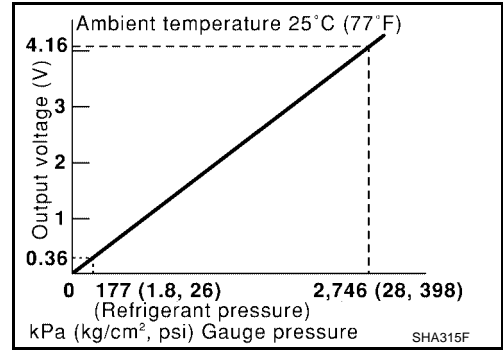

A
B
C
D
E
F
G
H
I
MTC
K
L
M

TROUBLE DIAGNOSIS

EJS002SP

Insufficient Cooling

SYMPTOM: Insufficient cooling

INSPECTION FLOW

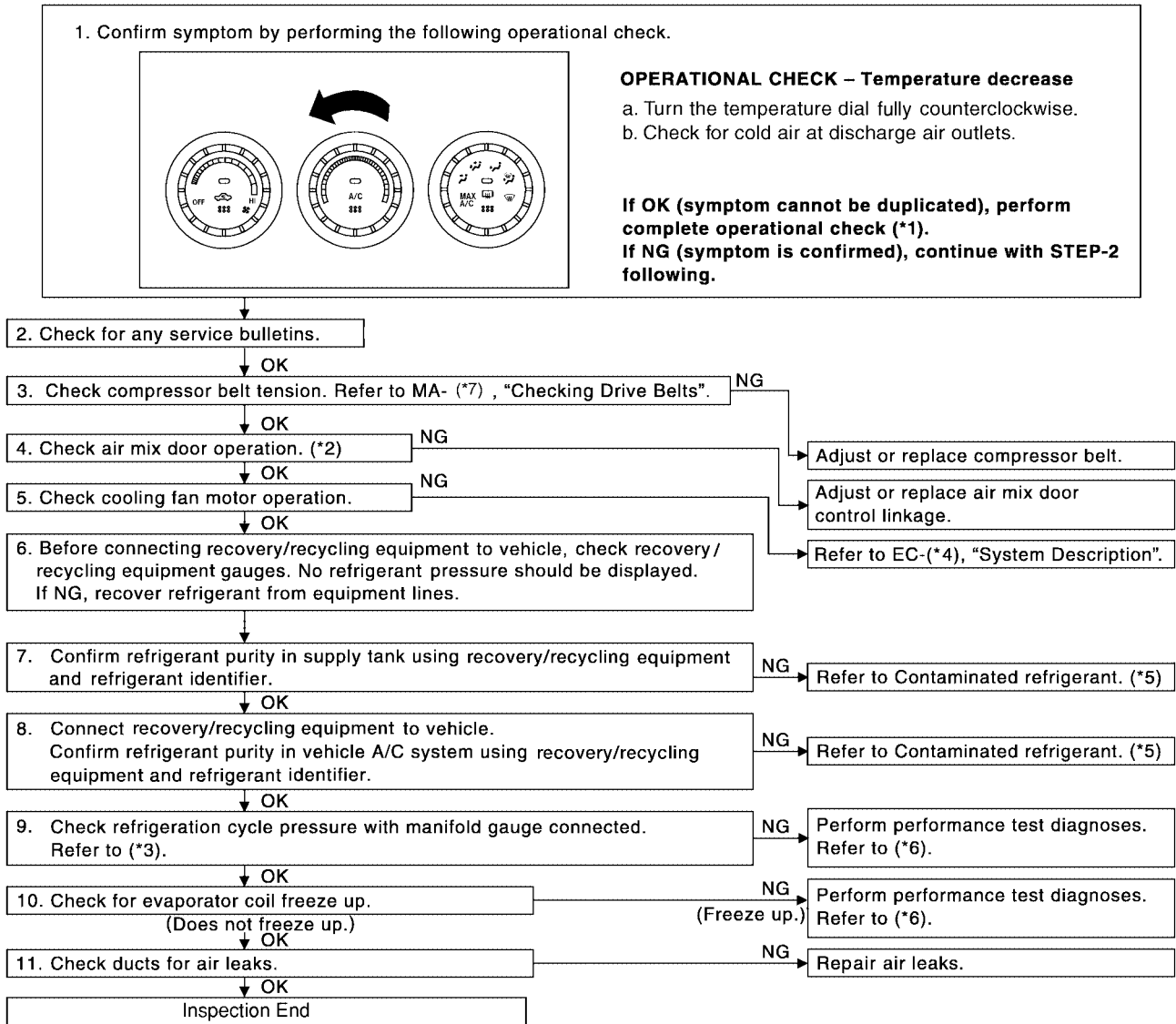

WJIA1194E

*1 [MTC-40, "Operational Check"](#)

*2 [MTC-49, "Air Mix Door Motor Circuit"](#)

*3 [MTC-67, "PERFORMANCE CHART"](#)

*4 [EC-1327, "Component Description"](#)
(VQ) [EC-421, "Description"](#) (QR)

*5 [MTC-4, "Contaminated Refrigerant"](#)

*6 [MTC-65, "PERFORMANCE TEST ANALYSIS"](#)

*7 [EM-15, "Checking Drive Belts"](#) (QR)
[EM-119, "Checking Drive Belts"](#)
(VQ)

TROUBLE DIAGNOSIS

PERFORMANCE TEST ANALYSIS

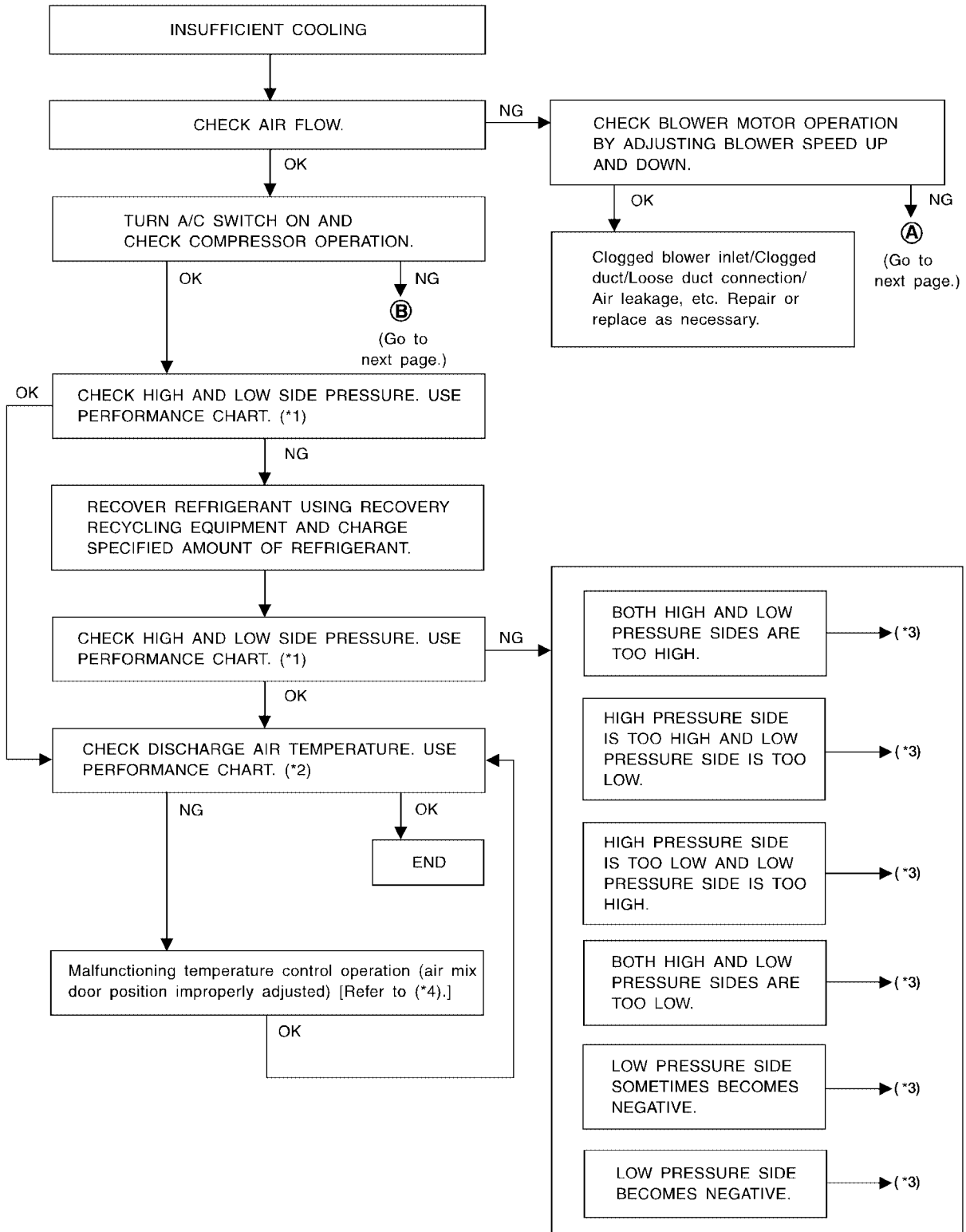

WJIA0198E

*1 [MTC-67, "PERFORMANCE CHART"](#) *2 [MTC-67, "PERFORMANCE CHART"](#) *3 [MTC-67, "TROUBLE DIAGNOSIS FOR ABNORMAL PRESSURE"](#)
 *4 [MTC-49, "Air Mix Door Motor Circuit"](#)

TROUBLE DIAGNOSIS

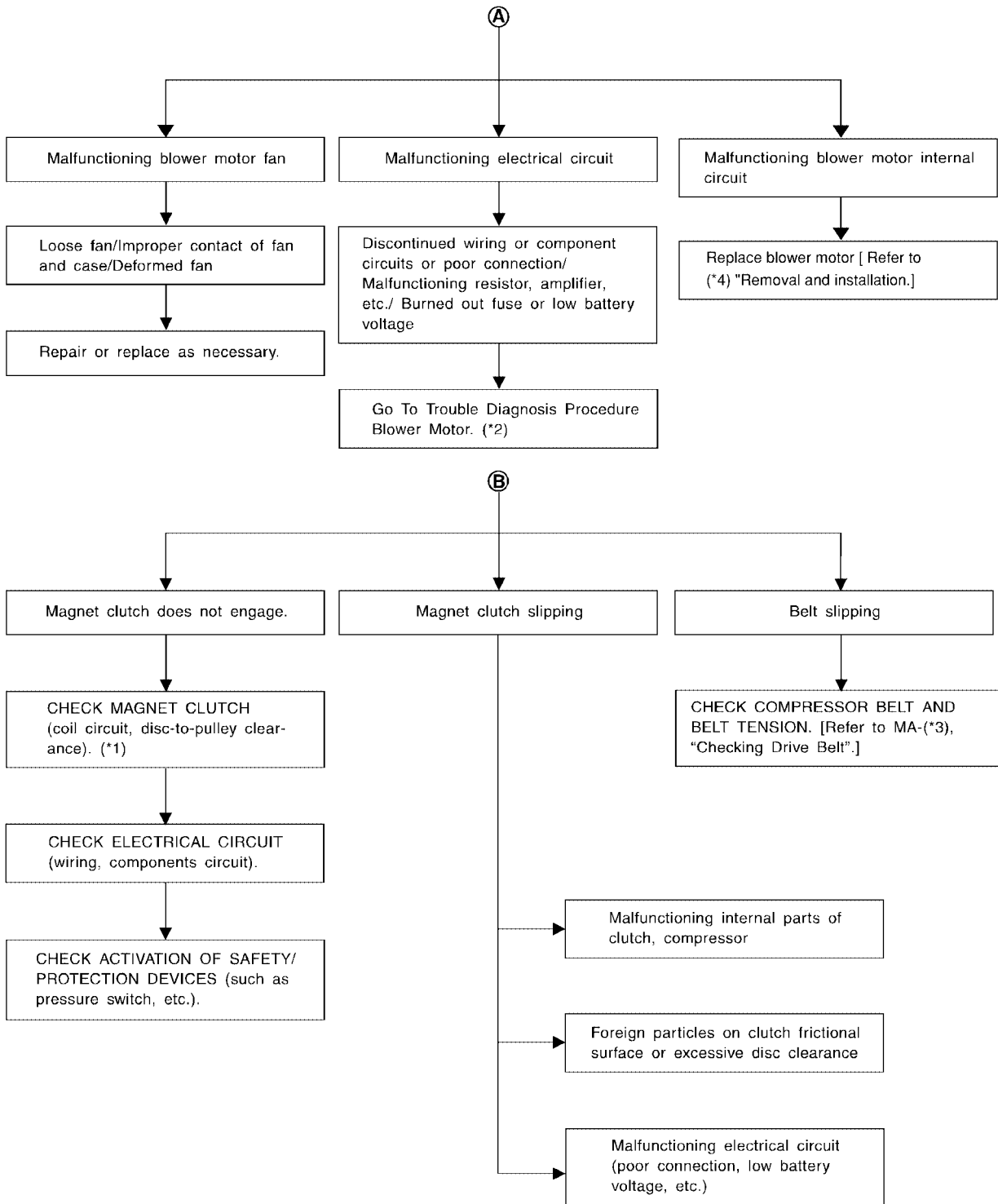

*1 [MTC-96, "INSTALLATION"](#)

*2 [MTC-53, "Blower Motor Circuit"](#)

*3 [EM-15, "Checking Drive Belts" \(QR\)](#)
[EM-119, "Checking Drive Belts" \(VQ\)](#)

*4 [MTC-79, "Removal and Installation"](#)



WJIA0749E

TROUBLE DIAGNOSIS

PERFORMANCE CHART

Test Condition

Testing must be performed as follows:

Vehicle location	Indoors or in the shade (in a well-ventilated place)
Doors	Closed
Door windows	Open
Hood	Open
TEMP.	Max. COLD
Mode switch	 (Ventilation) set
Intake switch	 (Recirculation) set
 (blower) speed	Max. speed set
Engine speed	Idle speed

Operate the air conditioning system for 10 minutes before taking measurements.

Test Reading

Recirculating-to-discharge Air Temperature Table

Inside air (Recirculating air) at blower assembly inlet		Discharge air temperature at center ventilator °C (°F)
Relative humidity %	Air temperature °C (°F)	
50 - 60	25 (77)	10.0 - 12.3 (50 - 54)
	30 (86)	13.2 - 15.3 (56 - 60)
	35 (95)	17.2 - 21.0 (63 - 70)
60 - 70	25 (77)	12.3 - 14.9 (54 - 59)
	30 (86)	15.3 - 19.3 (60 - 67)
	35 (95)	21.0 - 24.4 (70 - 76)

Ambient Air Temperature-to-operating Pressure Table

Ambient air		High-pressure (Discharge side) kPa (kg/cm ² , psi)	Low-pressure (Suction side) kPa (kg/cm ² , psi)
Relative humidity %	Air temperature °C (°F)		
50 - 70	30 (86)	1,220 - 1,500 (12.44 - 15.30, 176.9 - 217.5)	240 - 295 (2.45 - 3.01, 34.8 - 42.8)
	35 (95)	1,360 - 1,690 (13.87 - 17.24, 197.2 - 245.1)	275 - 335 (2.81 - 3.42, 39.9 - 48.6)
	40 (104)	1,500 - 1,830 (12.44 - 18.67, 176.9 - 265.4)	310 - 375 (3.16 - 3.83, 45.0 - 54.4)

TROUBLE DIAGNOSIS FOR ABNORMAL PRESSURE

Whenever system's high and/or low side pressure is abnormal, diagnose using a manifold gauge. The marker above the gauge scale in the following tables indicates the standard (normal) pressure range. Since the standard (normal) pressure differs from vehicle to vehicle, refer to Ambient Air Temperature-to-operating Pressure Table above.

TROUBLE DIAGNOSIS

Both High- and Low-pressure Sides are Too High

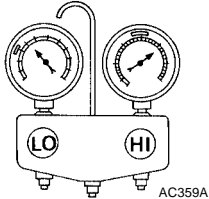
Gauge indication	Refrigerant cycle	Probable cause	Corrective action
<p>Both high and low-pressure sides are too high.</p> 	Pressure is reduced soon after water is splashed on condenser.	Excessive refrigerant charge in refrigeration cycle	Reduce refrigerant until specified pressure is obtained.
	Air suction by cooling fan is insufficient.	Insufficient condenser cooling performance ↓ 1. Condenser fins are clogged. 2. Improper fan rotation of cooling fan	<ul style="list-style-type: none"> Clean condenser. Check and repair cooling fan as necessary.
	<ul style="list-style-type: none"> Low-pressure pipe is not cold. When compressor is stopped high-pressure value quickly drops by approximately 196 kPa (2 kg/cm², 28 psi). It then decreases gradually thereafter. 	Poor heat exchange in condenser (After compressor operation stops, high pressure decreases too slowly.) ↓ Air in refrigeration cycle	Evacuate repeatedly and recharge system.
	Engine tends to overheat.	Engine cooling systems malfunction.	Check and repair each engine cooling system.
	<ul style="list-style-type: none"> An area of the low-pressure pipe is colder than areas near the evaporator outlet. Plates are sometimes covered with frost. 	<ul style="list-style-type: none"> Excessive liquid refrigerant on low-pressure side Excessive refrigerant discharge flow Expansion valve is open a little compared with the specification. ↓ 1. Improper thermal valve installation 2. Improper expansion valve adjustment	Replace expansion valve.

High-pressure Side is Too High and Low-pressure Side is Too Low

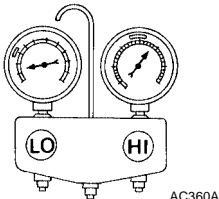
Gauge indication	Refrigerant cycle	Probable cause	Corrective action
<p>High-pressure side is too high and low-pressure side is too low.</p> 	Upper side of condenser and high-pressure side are hot, however, liquid tank is not so hot.	High-pressure tube or parts located between compressor and condenser are clogged or crushed.	<ul style="list-style-type: none"> Check and repair or replace malfunctioning parts. Check lubricant for contamination.

High-pressure Side is Too Low and Low-pressure Side is Too High

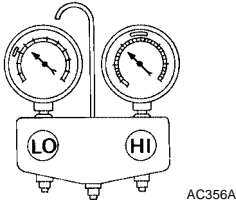
Gauge indication	Refrigerant cycle	Probable cause	Corrective action
<p>High-pressure side is too low and low-pressure side is too high.</p> 	High and low-pressure sides become equal soon after compressor operation stops.	Compressor pressure operation is improper. ↓ Damaged inside compressor pickings	Replace compressor.
	No temperature difference between high and low-pressure sides	Compressor pressure operation is improper. ↓ Damaged inside compressor pickings.	Replace compressor.

TROUBLE DIAGNOSIS

Both High- and Low-pressure Sides are Too Low

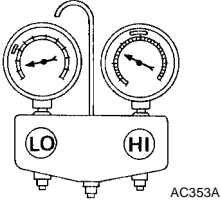
Gauge indication	Refrigerant cycle	Probable cause	Corrective action
<p>Both high- and low-pressure sides are too low.</p>  <p style="text-align: right; font-size: small;">AC353A</p>	<ul style="list-style-type: none"> There is a big temperature difference between receiver drier outlet and inlet. Outlet temperature is extremely low. Liquid tank inlet and expansion valve are frosted. 	Liquid tank inside is slightly clogged.	<ul style="list-style-type: none"> Replace desiccant assembly. Check lubricant for contamination.
	<ul style="list-style-type: none"> Temperature of expansion valve inlet is extremely low as compared with areas near liquid tank. Expansion valve inlet may be frosted. Temperature difference occurs somewhere in high-pressure side 	High-pressure pipe located between receiver drier and expansion valve is clogged.	<ul style="list-style-type: none"> Check and repair malfunctioning parts. Check lubricant for contamination.
	Expansion valve and liquid tank are warm or only cool when touched.	Low refrigerant charge ↓ Leaking fittings or components	Check refrigerant for leaks. Refer to Checking Refrigerant Leaks, MTC-102. "Checking for Refrigerant Leaks" and MTC-103. "Electronic Refrigerant Leak Detector" .
	There is a big temperature difference between expansion valve inlet and outlet while the valve itself is frosted.	Expansion valve closes a little compared with the specification. ↓ 1. Improper expansion valve adjustment 2. Malfunctioning thermal valve 3. Outlet and inlet may be clogged.	<ul style="list-style-type: none"> Remove foreign particles by using compressed air. Check lubricant for contamination.
	An area of the low-pressure pipe is colder than areas near the evaporator outlet.	Low-pressure pipe is clogged or crushed.	<ul style="list-style-type: none"> Check and repair malfunctioning parts. Check lubricant for contamination.
	Air flow volume is not enough or is too low.	Evaporator is frozen.	<ul style="list-style-type: none"> Check thermo control amp. and intake sensor operation. Replace compressor.

Low-pressure Side Sometimes Becomes Negative

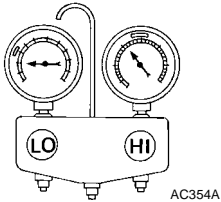
Gauge indication	Refrigerant cycle	Probable cause	Corrective action
<p>Low-pressure side sometimes becomes negative.</p>  <p style="text-align: right; font-size: small;">AC354A</p>	<ul style="list-style-type: none"> Air conditioning system does not function and does not cyclically cool the compartment air. The system constantly functions for a certain period of time after compressor is stopped and restarted. 	Refrigerant does not discharge cyclically. ↓ Moisture is frozen at expansion valve outlet and inlet. ↓ Water is mixed with refrigerant.	<ul style="list-style-type: none"> Drain water from refrigerant or replace refrigerant. Replace desiccant assembly.

A
B
C
D
E
F
G
H
I
K
L
M

MTC

TROUBLE DIAGNOSIS

Low-pressure Side Becomes Negative

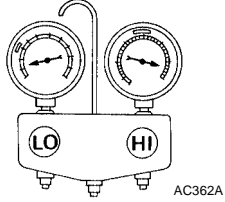
Gauge indication	Refrigerant cycle	Probable cause	Corrective action
<p>Low-pressure side becomes negative.</p>  <p style="text-align: right; font-size: small;">AC362A</p>	<p>Liquid tank or front/rear side of expansion valve's pipe is frosted or dewed.</p>	<p>High-pressure side is closed and refrigerant does not flow. ↓ Expansion valve or liquid tank is frosted.</p>	<p>Leave the system at rest until no frost is present. Start it again to check whether or not the problem is caused by water or foreign particles.</p> <ul style="list-style-type: none"> ● If water is the cause, initially cooling is okay. Then the water freezes causing a blockage. Drain water from refrigerant or replace refrigerant. ● If due to foreign particles, remove expansion valve and remove the particles with dry and compressed air (not shop air). ● If either of the above methods cannot correct the problem, replace expansion valve. ● Replace desiccant assembly. ● Check lubricant for contamination.

TROUBLE DIAGNOSIS

EJS002SQ

Insufficient Heating

SYMPTOM: Insufficient heating

INSPECTION FLOW

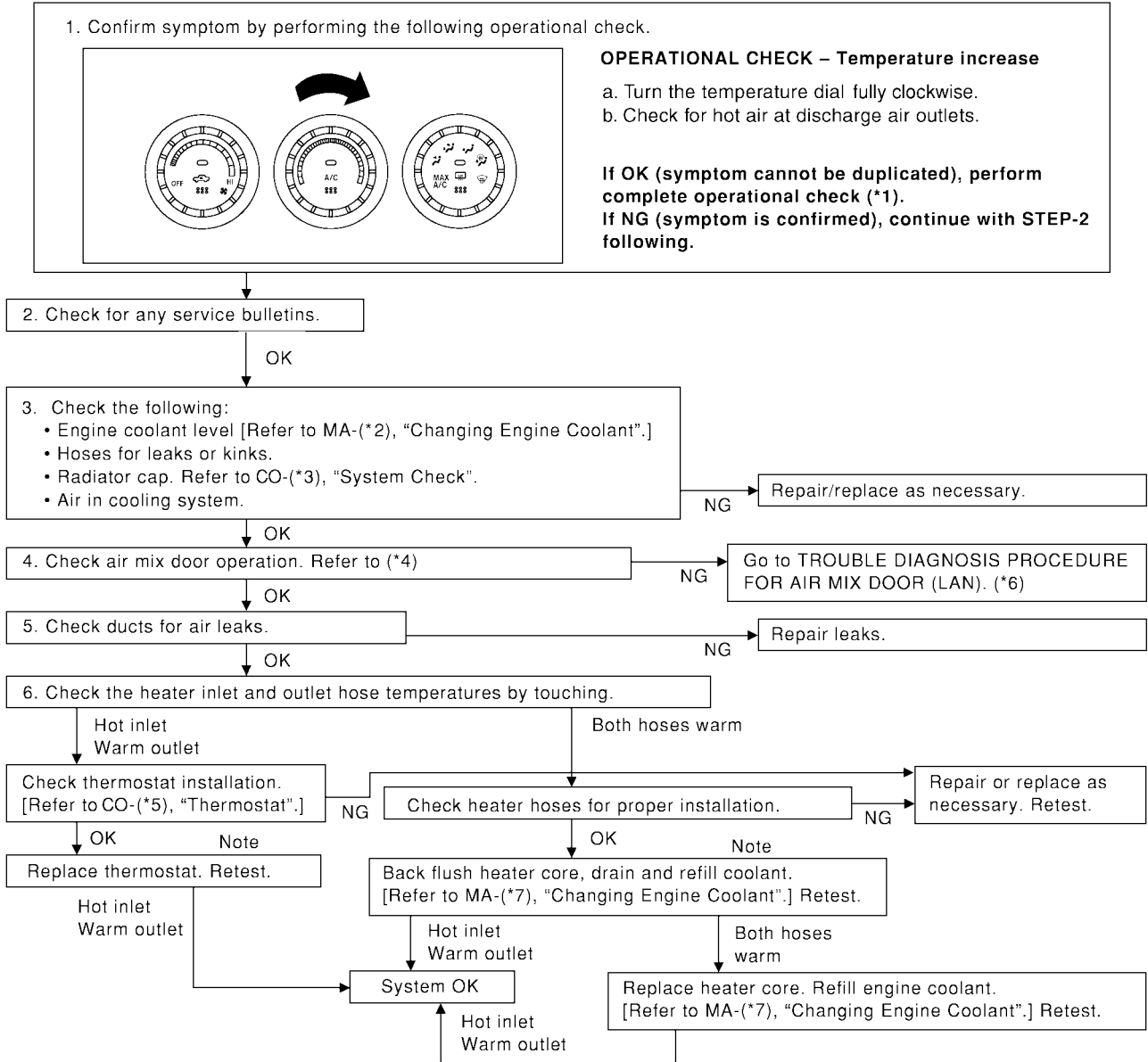

A
B
C
D
E
F
G
H
I
MTC
K
L
M

WJIA1646E

- *1 [MTC-40, "Operational Check"](#)
- *2 [MA-22, "Changing Engine Coolant"](#)
- *3 [CO-9, "CHECKING RADIATOR CAP"](#)
- *4 [MTC-49, "Air Mix Door Motor Circuit"](#)
- *5 [CO-42, "THERMOSTAT AND THERMOSTAT HOUSING"](#)
- *6 [MTC-44, "LAN System Circuit"](#)
- *7 [MA-22, "Changing Engine Coolant"](#)

TROUBLE DIAGNOSIS

EJS002SR

Noise

SYMPTOM: Noise

INSPECTION FLOW

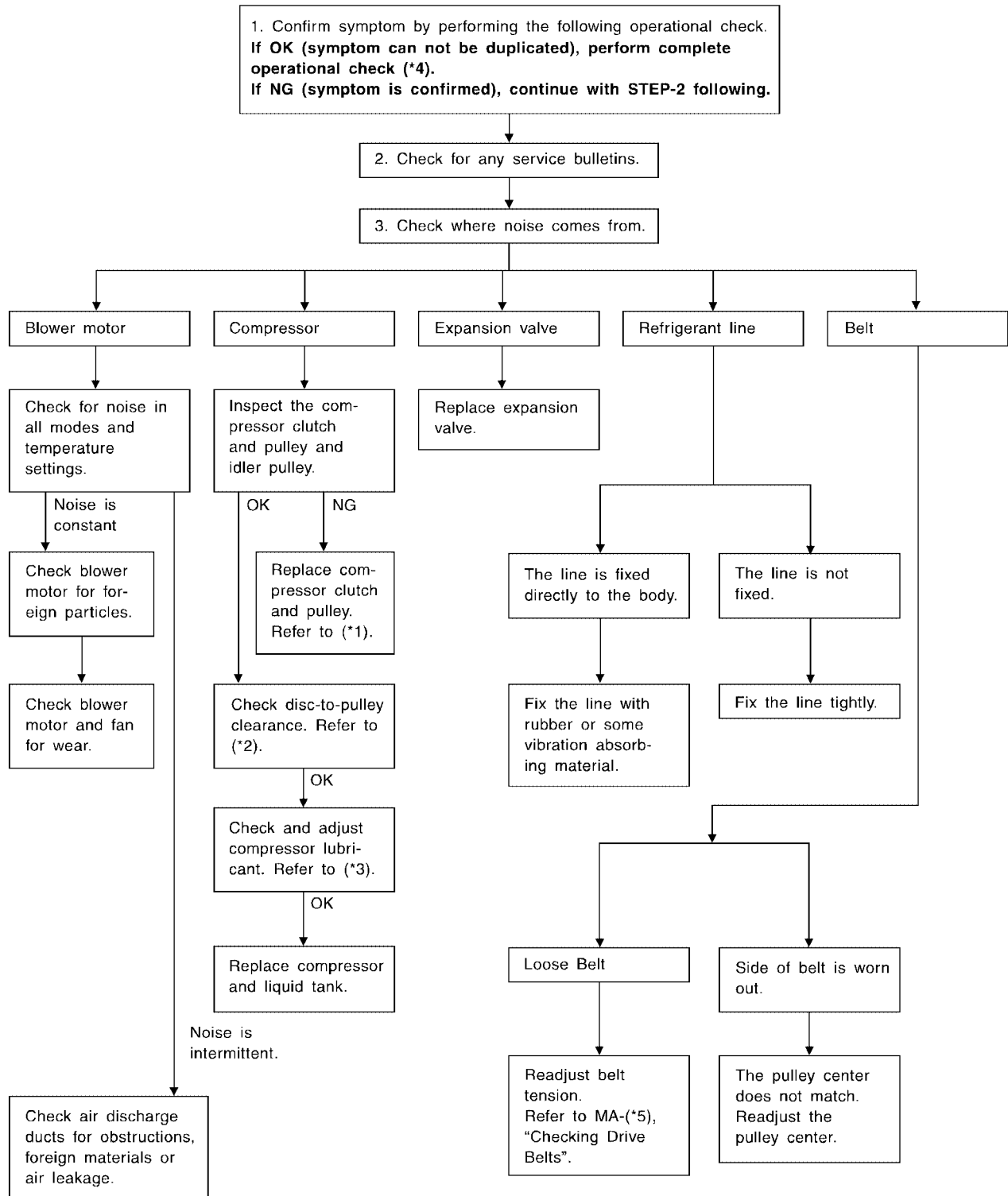

SHA331F

TROUBLE DIAGNOSIS

- *1 [MTC-94, "Removal and Installation for Compressor Clutch"](#)
- *2 [MTC-97, "INSPECTION AFTER INSTALLATION"](#)
- *3 [MTC-19, "LUBRICANT"](#)
- *4 [MTC-40, "Operational Check"](#)
- *5 [EM-15, "Checking Drive Belts" \(QR\)](#)
[EM-119, "Checking Drive Belts" \(VQ\)](#)

EJS002SS

Intake Sensor Circuit COMPONENT DESCRIPTION

Intake Sensor

The intake sensor is located on the heater and cooling unit. It converts temperature of air after it passes through the evaporator into a resistance value which is then input to the front air control. After disconnecting intake sensor harness connector, measure resistance between terminals 1 and 2 at sensor harness side, using the table below.

Temperature °C (°F)	Resistance kΩ
-15 (5)	12.34
-10 (14)	9.62
-5 (23)	7.56
0 (32)	6.00
5 (41)	4.80
10 (50)	3.87
15 (59)	3.15
20 (68)	2.57
25 (77)	2.12
30 (86)	1.76
35 (95)	1.47
40 (104)	1.23
45 (113)	1.04

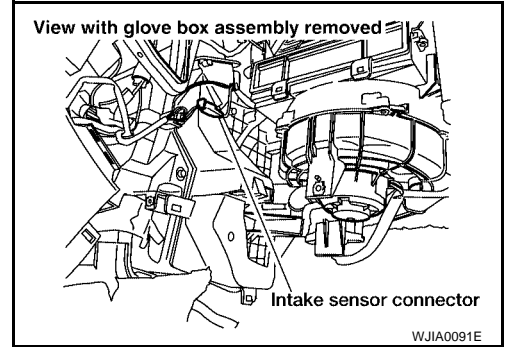

If NG, replace intake sensor.

DIAGNOSTIC PROCEDURE

SYMPTOM: Intake sensor circuit is open or shorted.

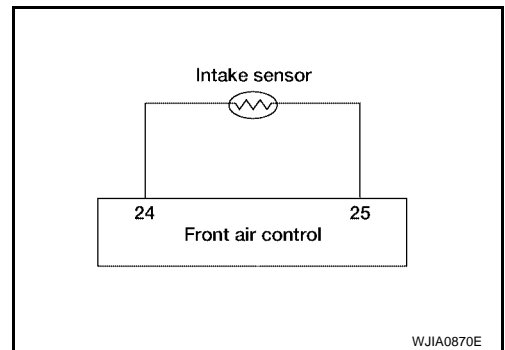

A
B
C
D
E
F
G
H
I
K
L
M

MTC

TROUBLE DIAGNOSIS

1. CHECK INTAKE SENSOR CIRCUIT BETWEEN INTAKE SENSOR AND BODY GROUND

1. Disconnect intake sensor connector.
2. Turn ignition switch ON.
3. Check voltage between intake sensor connector M33 terminal 1 (R/W) and ground.

Terminal		Voltage (V) (Approx.)
(+)	(-)	
Connector - Terminal	Wire color	Body ground 5V
M33-1	R/W	

OK or NG

- OK >> GO TO 2.
NG >> GO TO 4.

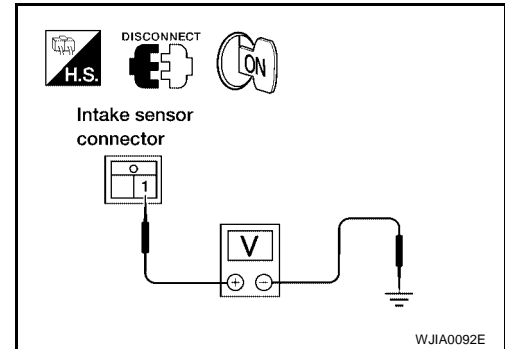

2. CHECK INTAKE SENSOR GROUND CIRCUIT BETWEEN INTAKE SENSOR AND FRONT AIR CONTROL

1. Turn ignition switch OFF.
2. Disconnect front air control connector M50.
3. Check continuity between front air control connector M50 terminal 24 (B/Y) and intake sensor harness connector M33 terminal 2 (B/Y).

Terminals				Continuity
Connector - Terminal	Wire color	Connector - Terminal	Wire color	
M50-24	B/Y	M33-2	B/Y	Yes

If OK, check harness for short.

OK or NG

- OK >> GO TO 3.
NG >> Repair harness or connector.

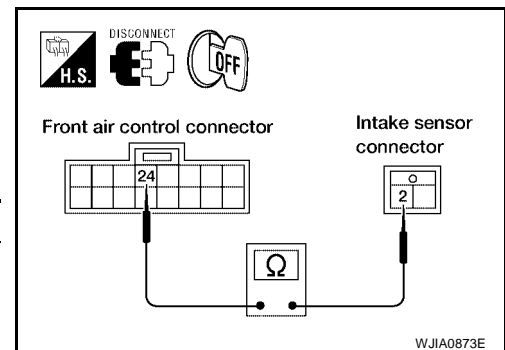

3. CHECK INTAKE SENSOR

Refer to [MTC-73, "Intake Sensor"](#) .

OK or NG

- OK >> 1. Replace front air control. Refer to [MTC-76, "Removal and Installation"](#) .
2. Confirm system operation.
NG >> 1. Replace intake sensor.
2. Confirm system operation.

TROUBLE DIAGNOSIS

4. CHECK INTAKE SENSOR CIRCUIT BETWEEN INTAKE SENSOR AND FRONT AIR CONTROL

1. Turn ignition switch OFF.
2. Disconnect front air control connector M50.
3. Check continuity between front air control connector M50 terminal 25 (R/W) and intake sensor harness connector M33 terminal 1 (R/W).

Terminals				Continuity
Connector - Terminal	Wire color	Connector - Terminal	Wire color	
M33-1	R/W	M50-25	R/W	Yes

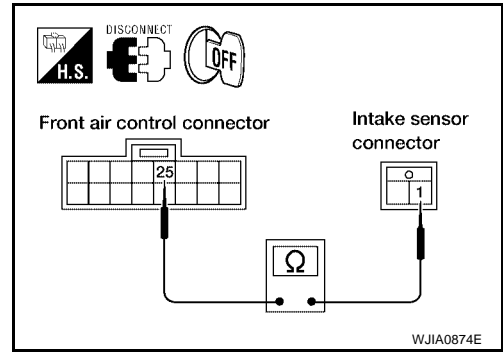

If OK, check harness for short.

OK or NG

- OK >> 1. Replace front air control, Refer to [MTC-76, "Removal and Installation"](#) .
 2. Confirm system operation.
- NG >> Repair harness or connector.

A
B
C
D
E
F
G
H
I

MTC

K
L
M

CONTROL UNIT

CONTROL UNIT

PF2:27500

Removal and Installation FRONT AIR CONTROL

EJS002ST

Removal

1. Remove cluster lid D. Refer to [JP-12, "Cluster Lid D"](#).
2. Remove the two screws and remove the front air control.

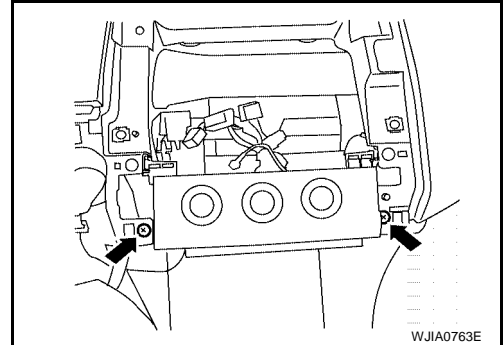

Installation

Installation is in the reverse order of removal.

INTAKE SENSOR

PFP:27723

EJS002SU

INTAKE SENSOR

Removal and Installation

REMOVAL

1. Remove the evaporator. Refer to [MTC-100, "Removal and Installation for Evaporator"](#).
2. Remove the intake sensor clip and then the sensor.

CAUTION:

Be careful not to damage the core surface.

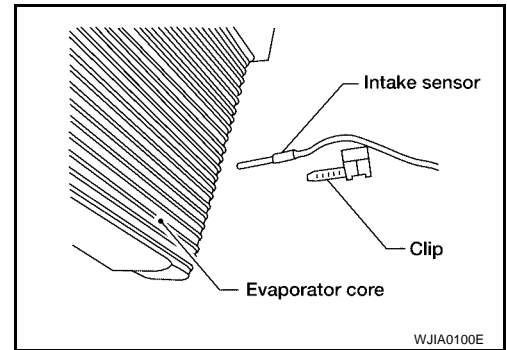

INSTALLATION

Installation is in the reverse order of removal.

A
B
C
D
E
F
G
H
I
M

MTC

BLOWER UNIT

BLOWER UNIT

PFP:27200

Removal and Installation

EJS002SV

REMOVAL

1. Remove the glove box assembly. Refer to [IP-14, "Instrument Lower Cover RH and Glove Box"](#).
2. Remove the ECM.
3. Disconnect the blower motor, intake door motor and fan control amplifier connector.
4. Remove the two bolts and one screw from the blower unit, then remove it.

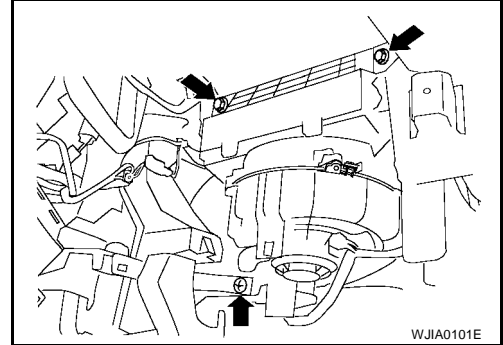

INSTALLATION

Installation is in the reverse order of removal.

BLOWER MOTOR

BLOWER MOTOR

PFP:27226

Removal and Installation

EJS002SW

REMOVAL

1. Remove the blower unit. Refer to [MTC-78, "Removal and Installation"](#).
2. Release the eight tabs attaching blower motor to blower unit case and then remove it.

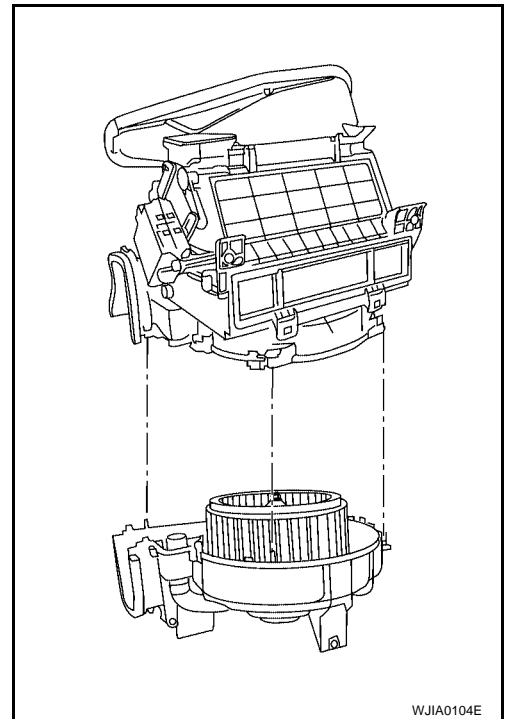

INSTALLATION

Installation is in the reverse order of removal.

A
B
C
D
E
F
G
H
I

MTC

K
L
M

IN-CABIN MICROFILTER

PFP:27277

EJS002SX

IN-CABIN MICROFILTER

Removal and Installation FUNCTION

Air inside passenger compartment is kept clean at either recirculation or fresh mode by installing in-cabin microfilter into blower unit.

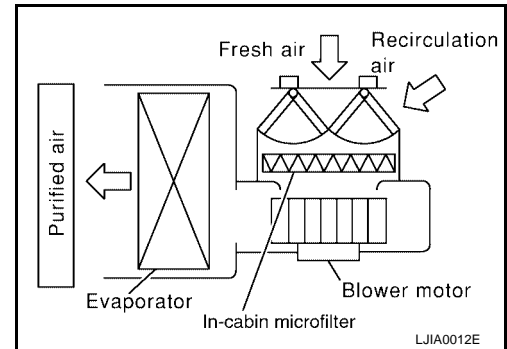

REPLACEMENT TIMING

Replace in-cabin microfilter.

Refer to [MA-7, "SCHEDULE 1"](#) and [MA-10, "SCHEDULE 2"](#).

Caution label is fixed inside the glove box.

REPLACEMENT PROCEDURES

1. Remove the glove box pins. Refer to [IP-14, "Instrument Lower Cover RH and Glove Box"](#).
2. Press in the sides of the glove box door to release the glove box door from the glove box housing.
3. Disconnect the glove box damper cord to remove the glove box door.
4. Disengage the two filter cover tabs to remove the filter cover.
5. Remove the in-cabin microfilter from the blower unit.
6. Install the new in-cabin microfilter into the blower unit.

CAUTION:

- Insert the new filter with the "UP" arrow in the correct orientation.
 - Insert the new filter with the "UP" arrow side of the filter facing the rear of the vehicle.
7. Install the filter cover on the blower unit.
 8. Connect the glove box damper cord to the glove box door.
 9. Press in the sides of the glove box door to install the glove box door into the glove box housing.
 10. Install the glove box pins.

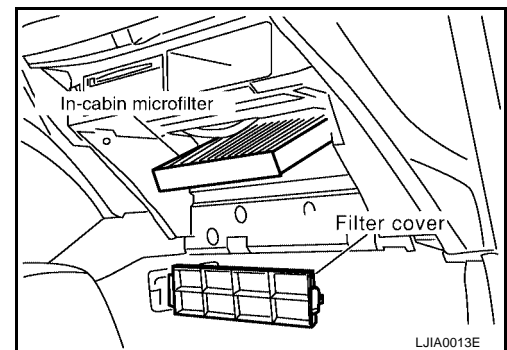

HEATER & COOLING UNIT ASSEMBLY

HEATER & COOLING UNIT ASSEMBLY

PF27110

Removal and Installation

EJS002SY

REMOVAL

1. Discharge the refrigerant from the A/C system. Refer to [MTC-89, "HFC-134a \(R-134a\) Service Procedure"](#).
2. Drain the engine coolant from the cooling system. Refer to [MA-15, "DRAINING ENGINE COOLANT"](#) (QR25DE) or [MA-22, "DRAINING ENGINE COOLANT"](#) (VQ35DE).
3. Remove the wiper motor and linkage. Refer to [WW-28, "REMOVAL"](#).
4. Remove the fasteners and the cowl top. Refer to [EI-19, "Removal and Installation"](#).
5. Disconnect the heater hoses from the heater core pipes.

CAUTION:

Cap or wrap the joint of the pipe with suitable material such as vinyl tape to avoid entry of contaminants.

6. Disconnect the refrigerant lines from the evaporator. Refer to [MTC-89, "REFRIGERANT LINES"](#).

CAUTION:

Cap or wrap the joint of the pipe with suitable material such as vinyl tape to avoid entry of contaminants.

7. Remove the steering member. Refer to [IP-10, "INSTRUMENT PANEL ASSEMBLY"](#).
8. Remove the blower unit. Refer to [MTC-78, "Removal and Installation"](#).
9. Disconnect the air mix door motor connector.

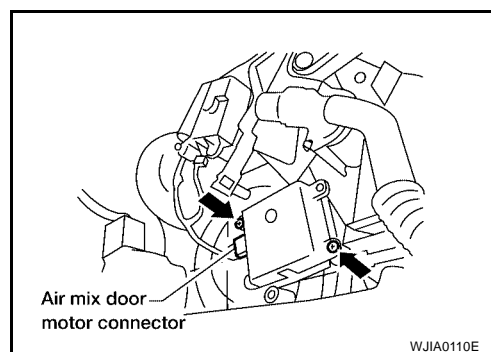

10. Disconnect the mode door motor connector.
11. Remove the heater and cooling unit.

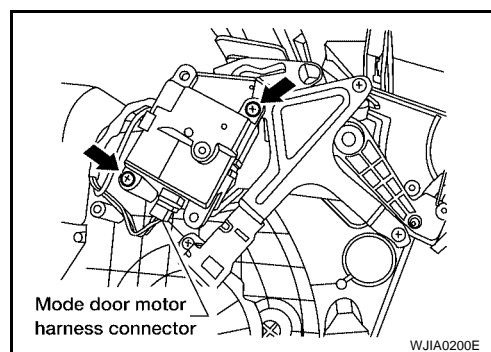

INSTALLATION

Installation is in the reverse order of removal.

- Fill the radiator with the specified water and coolant mixture. Refer to [MA-16, "REFILLING ENGINE COOLANT"](#) (QR25DE) or [MA-23, "REFILLING ENGINE COOLANT"](#) (VQ35DE).
- Recharge the A/C system. Refer to [MTC-89, "HFC-134a \(R-134a\) Service Procedure"](#).

HEATER CORE

HEATER CORE

PFP:27140

Removal and Installation

EJS002SZ

REMOVAL

1. Remove the heater and cooling unit. Refer to [MTC-81, "Removal and Installation"](#).
2. Remove the heater core pipe support screws and then remove it.

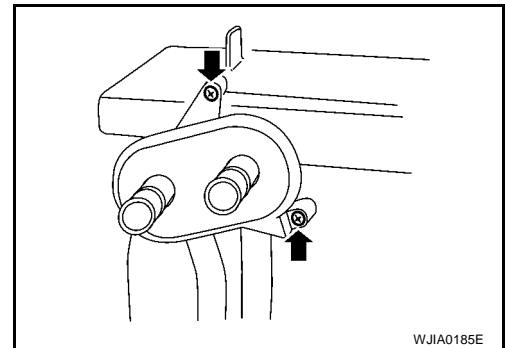

3. Remove the heater core cover screws and then remove it.

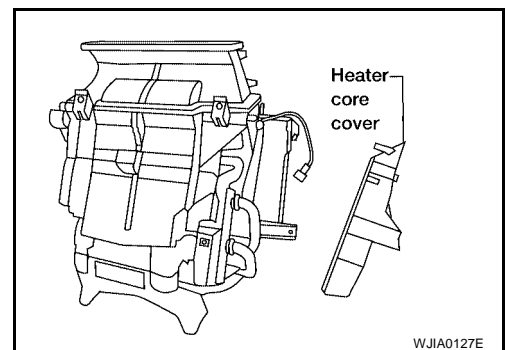

4. Remove the heater core.

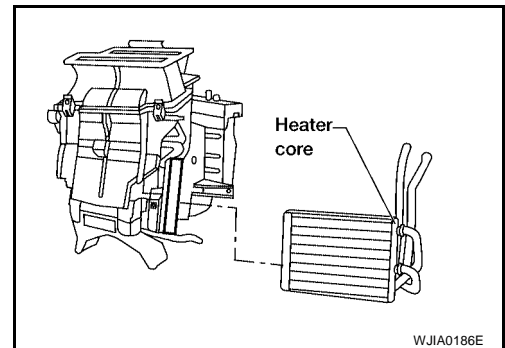

INSTALLATION

Installation is in the reverse order of removal.

INTAKE DOOR MOTOR

INTAKE DOOR MOTOR

PFP:27730

Removal and Installation

EJS00270

REMOVAL

1. Remove the blower unit. Refer to [MTC-78, "Removal and Installation"](#).
2. Remove the screws and then the intake door motor from the blower unit.

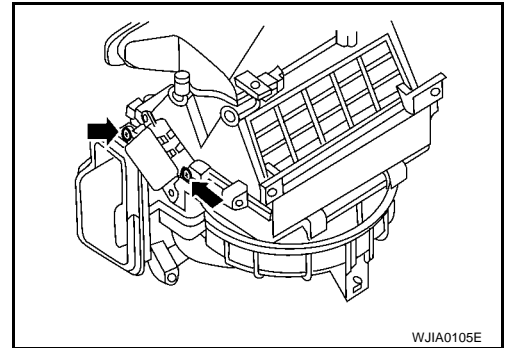

INSTALLATION

Installation is in the reverse order of removal.

A

B

C

D

E

F

G

H

I

MTC

K

L

M

MODE DOOR MOTOR

MODE DOOR MOTOR

PF2:27731

Removal and Installation

EJS002T1

REMOVAL

1. Disconnect the mode door motor connector.
2. Remove the mode door motor screws and then remove the mode door motor.

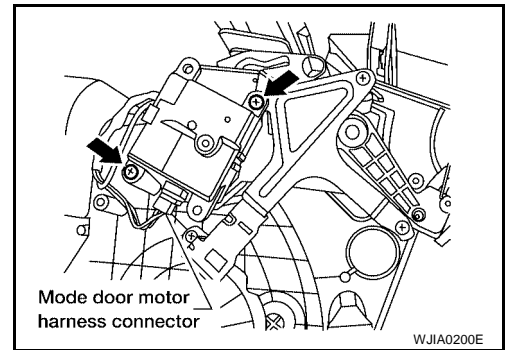

INSTALLATION

Installation is in the reverse order of removal.

AIR MIX DOOR MOTOR

AIR MIX DOOR MOTOR

PFP:27732

Removal and Installation

EJS00272

REMOVAL

1. Remove the driver lower instrument panel assembly. Refer to [IP-12, "Instrument Lower Cover LH"](#).
2. Disconnect the air mix door motor connector.
3. Remove the air mix door motor screws and then remove the air mix door motor.

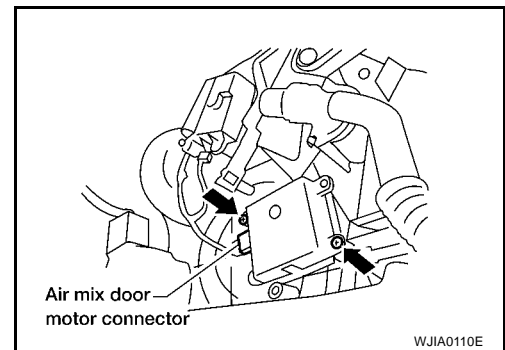

INSTALLATION

Installation is in the reverse order of removal.

A
B
C
D
E
F
G
H
I
MTC
K
L
M

FAN CONTROL AMPLIFIER

FAN CONTROL AMPLIFIER

PF2:27761

Removal and Installation

EJS00402

REMOVAL

1. Remove the glove box assembly. Refer to [IP-14, "Instrument Lower Cover RH and Glove Box"](#).
2. Disconnect the fan control amplifier connector.
3. Remove the screws from the fan control amplifier and then remove the fan control amplifier.

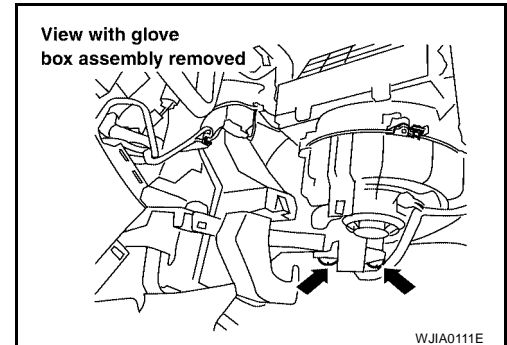

INSTALLATION

Installation is in the reverse order of removal.

DUCTS AND GRILLES

PFP:27860

EJS002T4

DUCTS AND GRILLES

Removal and Installation

Ventilator Duct, Defroster Nozzle, Defroster Ducts, and Grilles

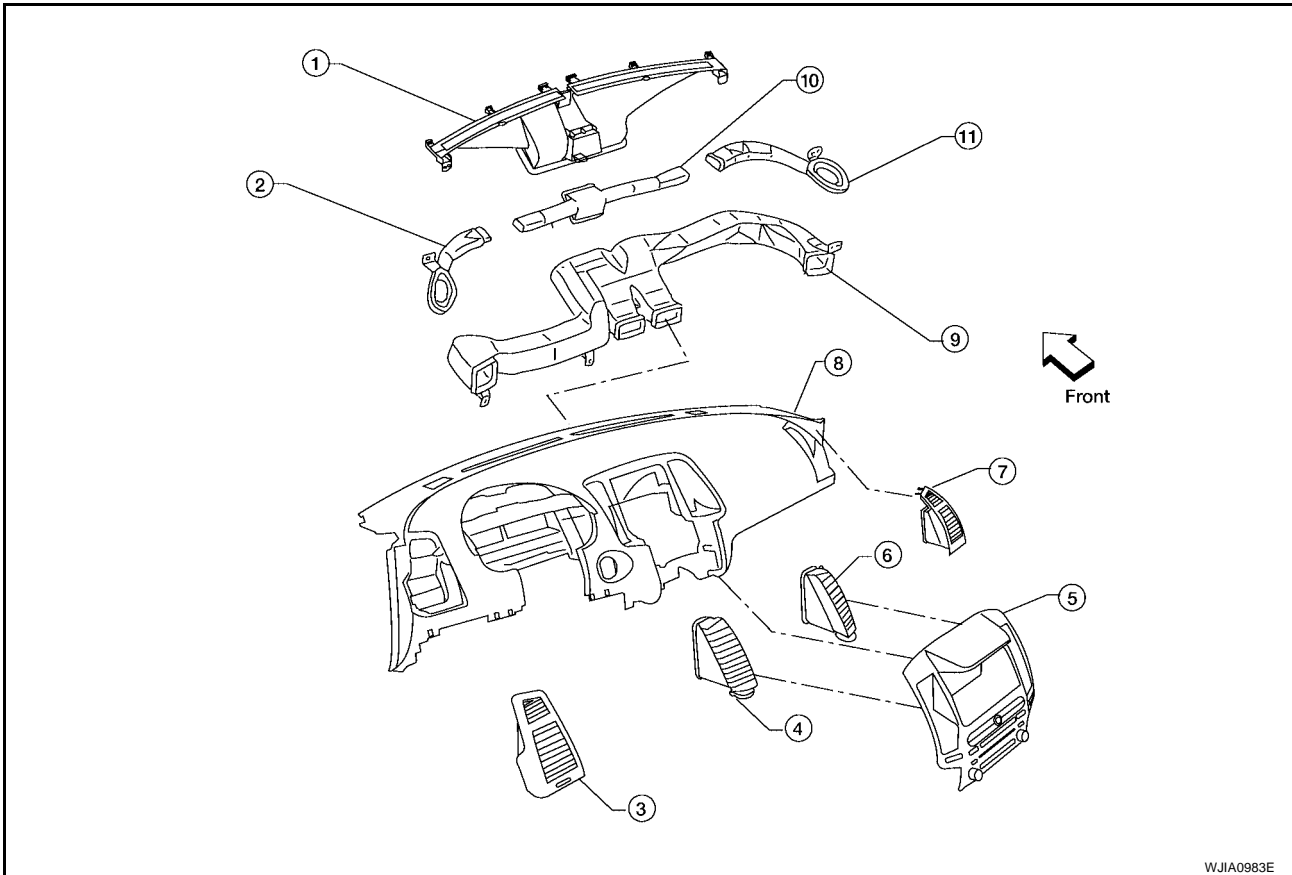

- | | | |
|--------------------------------|----------------------------|--------------------------------|
| 1. Center defroster nozzle | 2. Side defroster duct LH | 3. Side ventilator grille LH |
| 4. Center ventilator grille LH | 5. Cluster lid D | 6. Center ventilator grille RH |
| 7. Side ventilator grille RH | 8. Instrument panel | 9. Ventilator duct |
| 10. Side defroster duct CENTER | 11. Side defroster duct RH | |

REMOVAL

Center Ventilator Grille RH, LH

1. Remove cluster lid D. Refer to [IP-12, "Cluster Lid D"](#).
2. Remove the two center ventilator grille screws.
3. Release the two tabs and then remove the center ventilator grille.

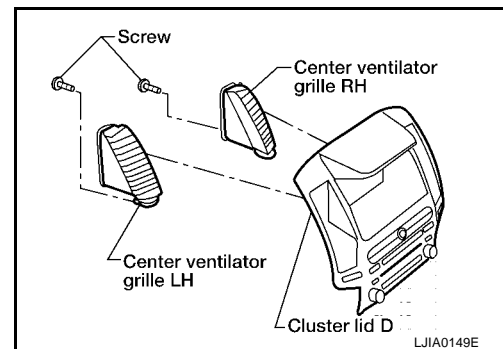

Side Ventilator Grille LH

1. Remove the instrument lower cover LH. Refer to [IP-12, "Instrument Lower Cover LH"](#).

A
B
C
D
E
F
G
H
I

MTC

K

L

M

DUCTS AND GRILLES

2. Remove the side ventilator grille LH.

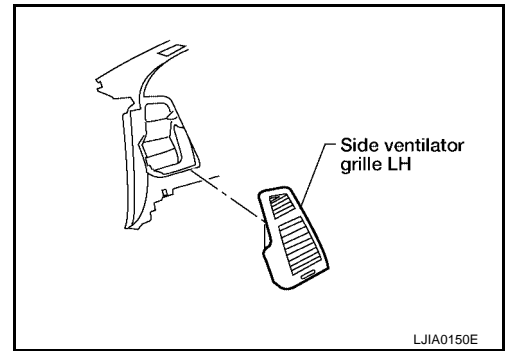

Side Ventilator Grille RH

1. Remove the instrument lower cover RH and glove box. Refer to [IP-14, "Instrument Lower Cover RH and Glove Box"](#).
2. Remove side ventilator grille RH.

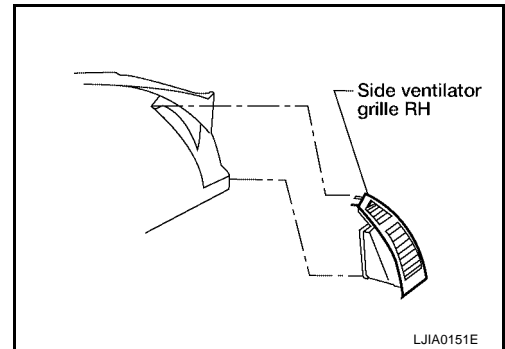

Floor Duct

1. Remove the floor carpet. Refer to [EI-35, "FLOOR TRIM"](#).
2. Release the foam tape and slide the floor duct rearward to release it from the clips.

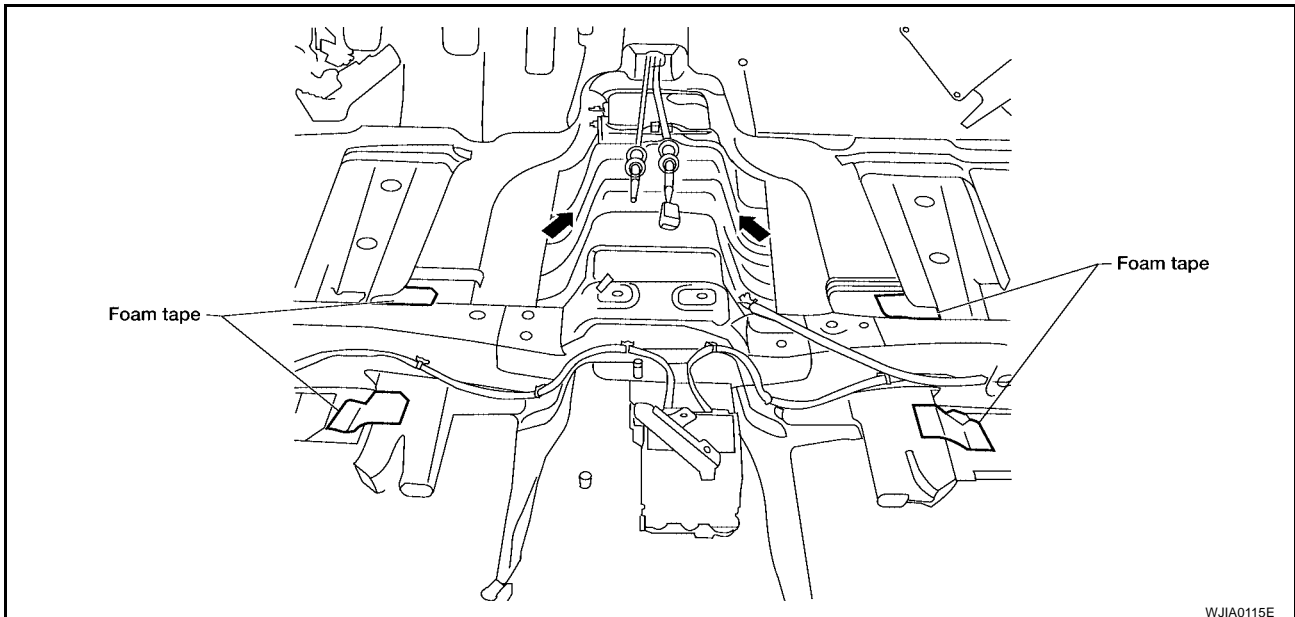

INSTALLATION

Installation is in the reverse order of removal.

REFRIGERANT LINES

REFRIGERANT LINES

PFP:92600

HFC-134a (R-134a) Service Procedure SETTING OF SERVICE TOOLS AND EQUIPMENT

EJS00275

WARNING:

Avoid breathing the A/C refrigerant and lubricant vapor or mist. Exposure may irritate eyes, nose, and throat. Remove the HFC-134a (R-134a) from the A/C system using certified service equipment meeting the requirements of SAE J2210 (R-134a recycling equipment) or J2201 (R-134a recovery equipment). If an accidental system discharge occurs, ventilate the work area before resuming service. Additional health and safety information may be obtained from the refrigerant and lubricant manufacturers.

Discharging Refrigerant

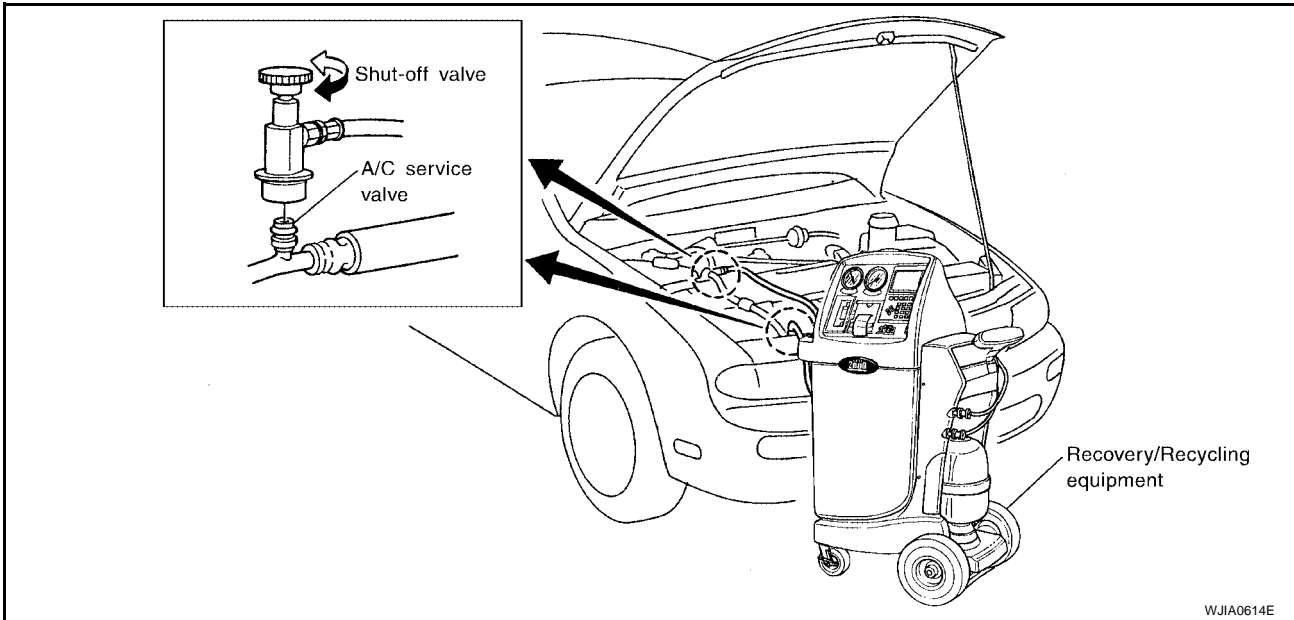

Evacuating System and Charging Refrigerant

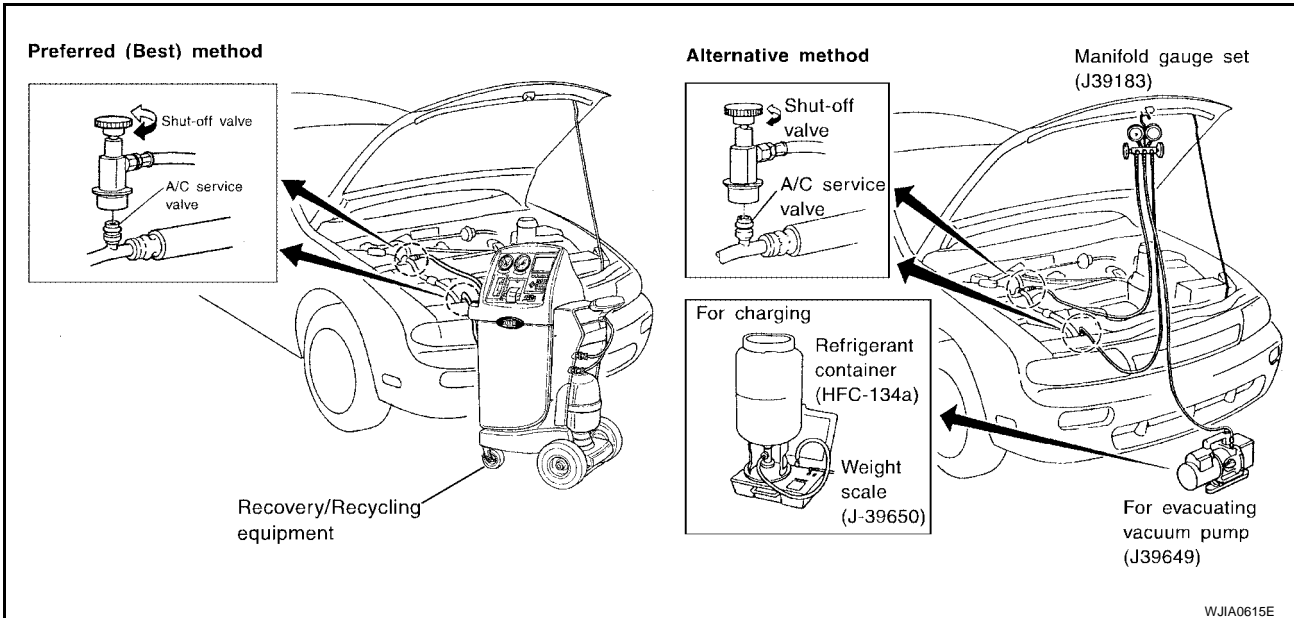

A

B

C

D

E

F

G

H

I

MTC

K

L

M

REFRIGERANT LINES

Discharging, Evacuating, and Recharging the A/C System

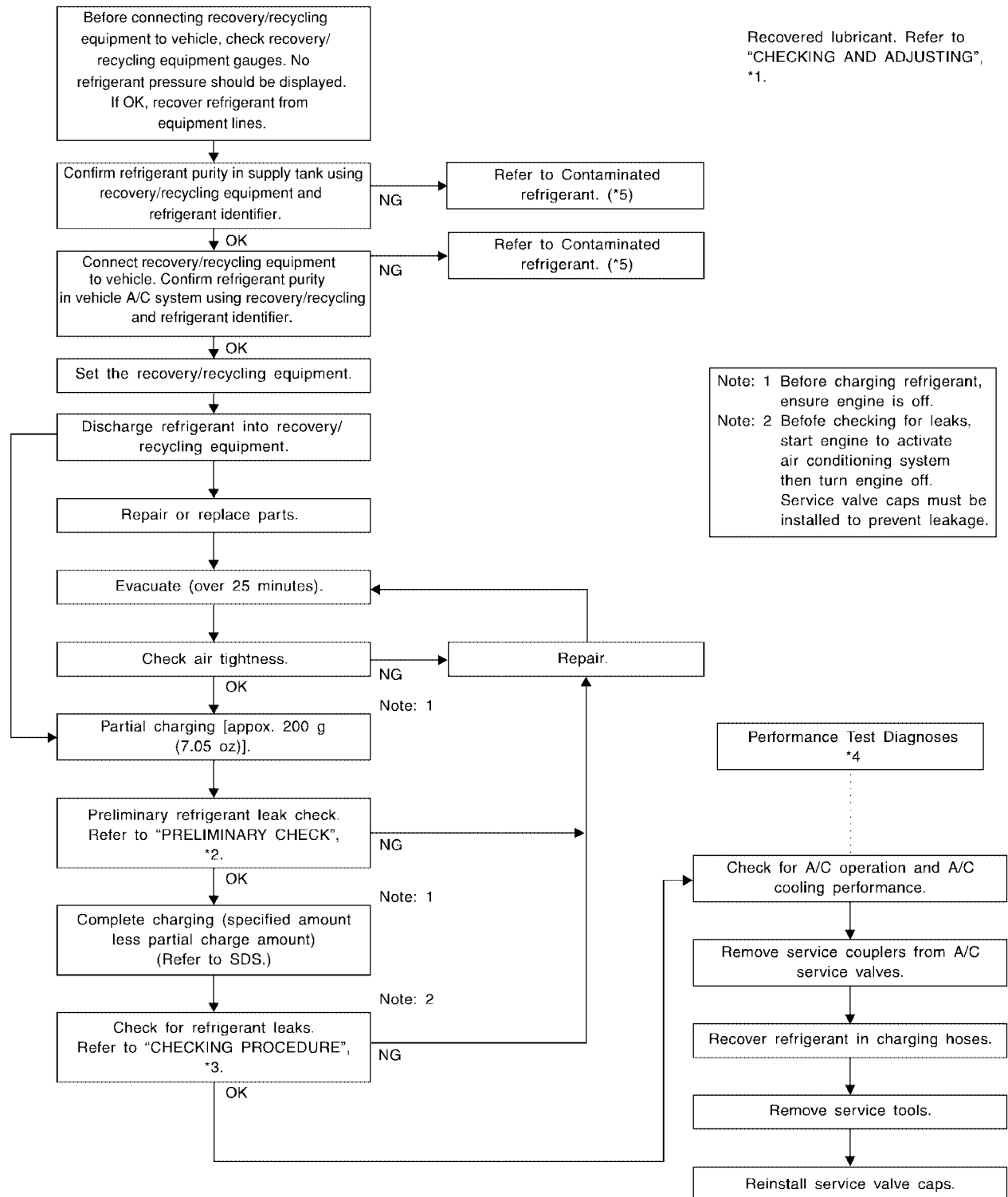

*1 [MTC-19, "CHECKING AND ADJUSTING"](#)

*2 [MTC-102, "Checking for Refrigerant Leaks"](#)

*3 [MTC-102, "Checking for Refrigerant Leaks"](#)

*4 [MTC-65, "PERFORMANCE TEST ANALYSIS"](#)

*5 [MTC-4, "Contaminated Refrigerant"](#)

WJJA0530E

REFRIGERANT LINES

EJS00276

Components

QR25DE Models

SEC. 214 • 271 • 274 • 276

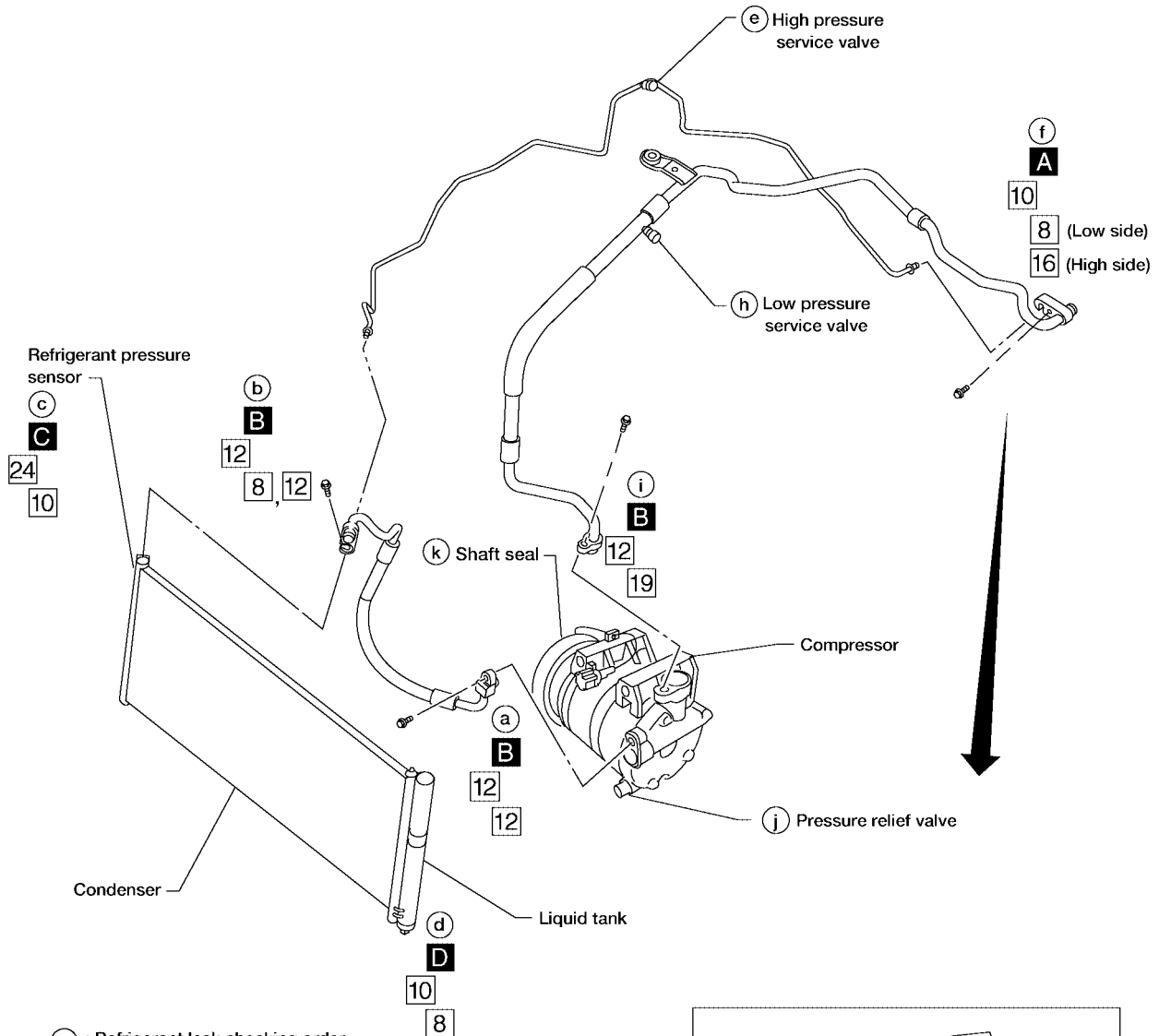

- : Refrigerant leak checking order
- : (Tightening torque)
- □ : (Wrench size)
- : (O-ring size)
- ⊗ : N·m (kg-m, in-lb)
- ⊗ : N·m (kg-m, ft-lb)
- A** ⊗ : 2.9 – 5.9 (0.29 – 0.60, 26 – 52)
- B** ⊗ : 7.8 – 19.6 (0.8 – 1.9, 69 – 173)
- C** ⊗ : 9.8 – 11.7 (1.0 – 1.1, 7.3 – 8.6)
- D** ⊗ : 5.0 – 6.47 (0.51 – 0.65, 45 – 57)

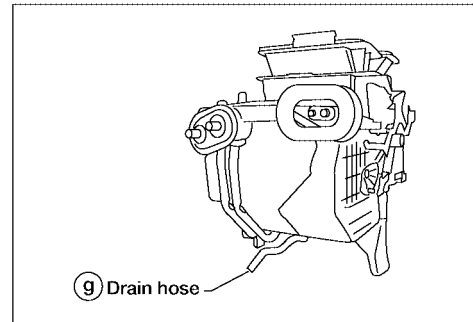

WJIA0981E

REFRIGERANT LINES

VQ35DE Models

SEC. 214 • 271 • 274 • 276

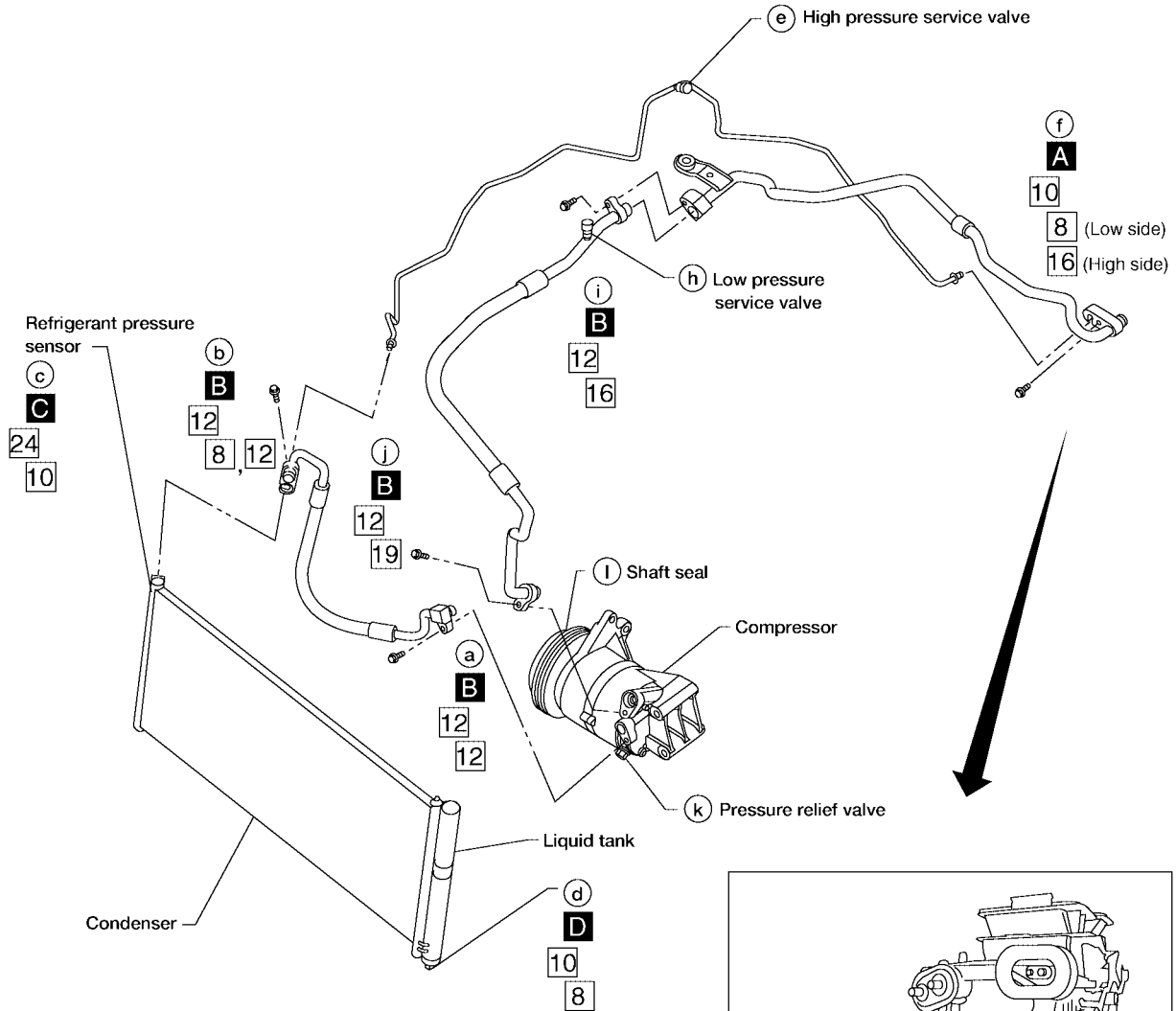

- : Refrigerant leak checking order
- : (Tightening torque)
- □ : (Wrench size)
- : (O-ring size)
- ⊗ : N·m (kg·m, in-lb)
- ⊙ : N·m (kg·m, ft-lb)
- A** ⊗ : 2.9 – 5.9 (0.29 – 0.60, 26 – 52)
- B** ⊗ : 7.8 – 19.6 (0.8 – 1.9, 69 – 173)
- C** ⊗ : 9.8 – 11.7 (1.0 – 1.1, 7.3 – 8.6)
- D** ⊗ : 5.0 – 6.47 (0.51 – 0.65, 45 – 57)

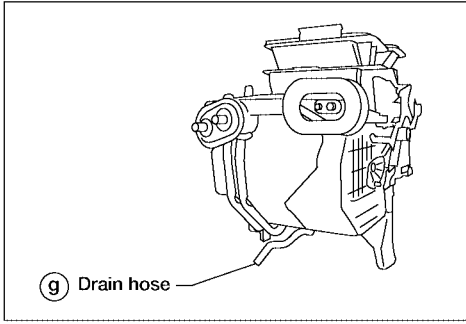

WJIA0982E

NOTE:
Refer to [MTC-6, "Precautions for Refrigerant Connection"](#).

REFRIGERANT LINES

Removal and Installation for Compressor — QR25DE Models

EJS00277

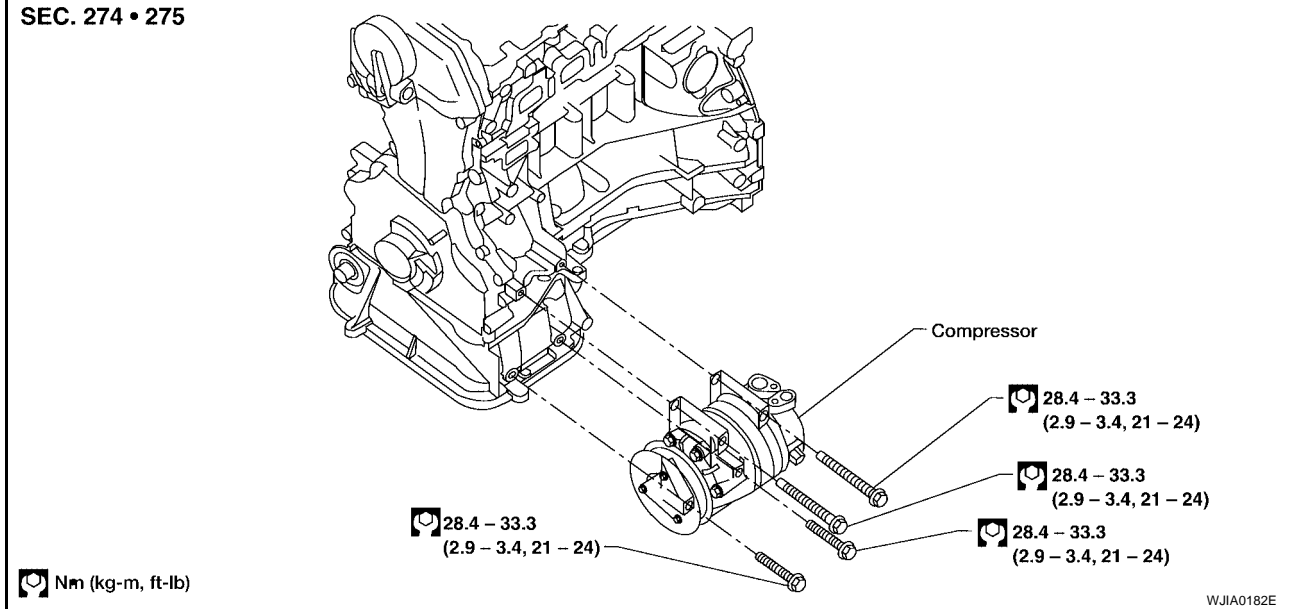

REMOVAL

1. Discharge the refrigerant. Refer to [MTC-89, "HFC-134a \(R-134a\) Service Procedure"](#).
2. Remove the drive belt. Refer to [EM-15, "Removal and Installation"](#).
3. Disconnect the compressor connector.
4. Remove the high-pressure flexible hose and low-pressure flexible hose.

CAUTION:

Cap or wrap the joint of the hose with a suitable material such as vinyl tape to avoid the entry of any contaminants.

5. Remove the compressor bolts, then remove the compressor using power tools.

INSTALLATION

CAUTION:

- Replace the O-ring of the low-pressure flexible hose and high-pressure flexible hose with new ones, then apply A/C lubricant to them for installation.
- After charging the A/C refrigerant, check for leaks. Refer to [MTC-102, "Checking for Refrigerant Leaks"](#).

Compressor bolts : 28.4 - 33.3 N·m (2.9 - 3.4 kg-m, 21 - 24 ft-lb)

High and low-pressure flexible hose bolts : 7.8 - 19.6 N·m (0.8 - 1.9 kg-m, 69 - 173 in-lb)

REFRIGERANT LINES

Removal and Installation for Compressor — VQ35DE Models

EJS002T8

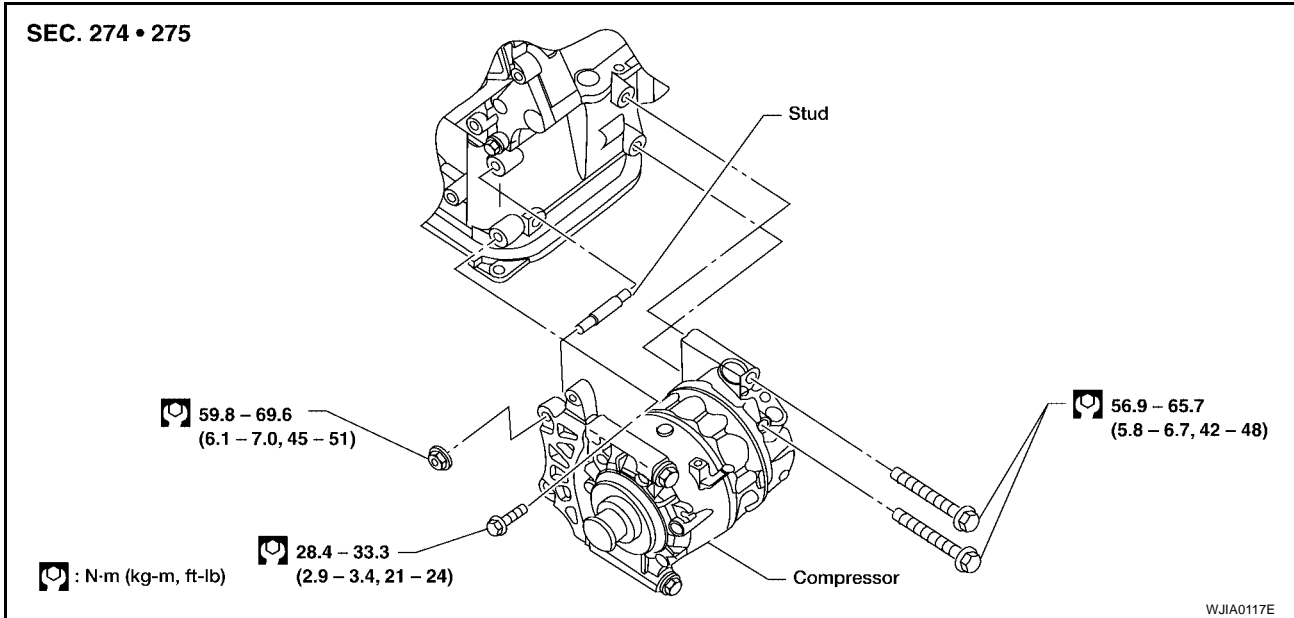

REMOVAL

1. Discharge the refrigerant. Refer to [MTC-89, "HFC-134a \(R-134a\) Service Procedure"](#).
2. Remove the drive belt. Refer to [MA-22, "Checking Drive Belts"](#).
3. Remove the coolant pipe bracket bolt using power tools.
4. Remove the compressor mounting stud.
5. Disconnect the compressor connector.
6. Remove the high-pressure flexible hose and low-pressure flexible hose.

CAUTION:

Cap or wrap the joint of the hose with suitable material such as vinyl tape to avoid the entry of any contaminants.

7. Remove the compressor bolts and nut using power tools, and then remove the compressor.

INSTALLATION

Installation is in the reverse order of removal.

Compressor (rear side) bolt	: 56.9 - 65.7 N-m (5.8 - 6.8 kg-m, 42 - 48 ft-lb)
Compressor (front side) bolt	: 28.4 - 33.3 N-m (2.9 - 3.4 kg-m, 21 - 24 ft-lb)
Compressor (front side) nut	: 59.8 - 69.6 N-m (6.1 - 7.0 kg-m, 45 - 51 ft-lb)
High and low-pressure flexible hose bolts	: 7.8 - 19.6 N-m (0.8 - 1.9 kg-m, 69 - 173 in-lb)

CAUTION:

- Replace the O-rings on the low-pressure flexible hose and high-pressure flexible hose with new ones, then apply A/C lubricant to them for installation.
- After charging the A/C refrigerant, check for leaks. Refer to [MTC-102, "Checking for Refrigerant Leaks"](#).

Removal and Installation for Compressor Clutch

EJS002T9

REMOVAL

1. Remove the compressor. Refer to [MTC-93, "Removal and Installation for Compressor — QR25DE Models"](#) (QR25DE), [MTC-94, "Removal and Installation for Compressor — VQ35DE Models"](#) (VQ35DE).

REFRIGERANT LINES

- Remove the center bolt by holding the clutch disc steady using Tool.

Tool number : (J-44614)

- Remove the clutch disc.

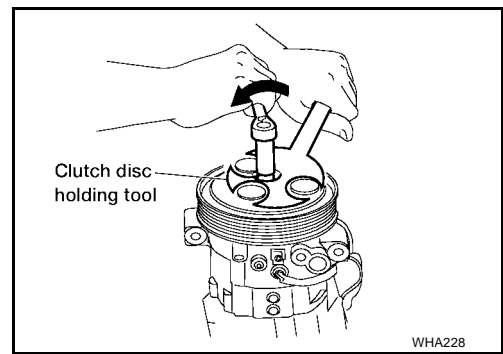

- Remove the snap ring using external snap ring pliers.

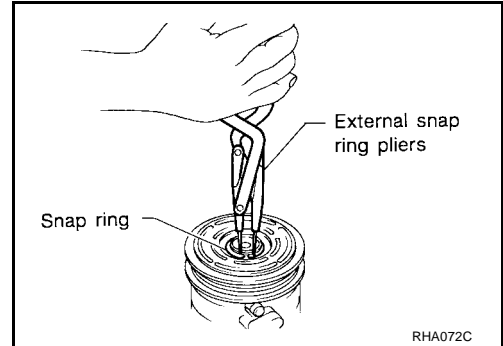

- Remove the pulley assembly using Tool.

- Use a pulley puller with a small adapter. Position the small adapter on the end of the compressor shaft and the center of the puller on the small adapter as shown.

Tool number : KV99233130 (J-29884)

CAUTION:

To prevent deformation of the pulley groove, the puller claws should be hooked under (not into) the pulley groove.

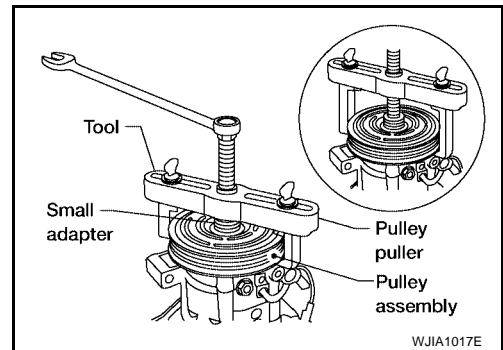

- Remove the snap ring using external snap ring pliers.

- Remove the magnet coil harness clip using a screwdriver.

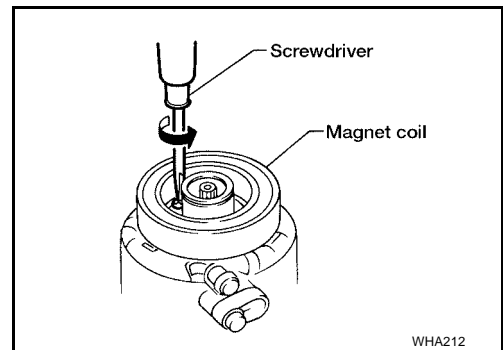

A
B
C
D
E
F
G
H
I
K
L
M

MTC

REFRIGERANT LINES

- Remove the three magnet coil screws and remove the magnet coil.

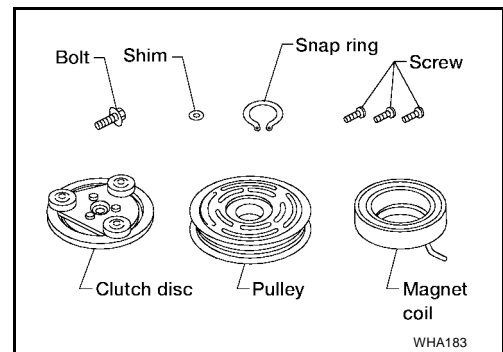

INSPECTION AFTER REMOVAL

Clutch Disc

If the contact surface shows signs of damage due to excessive heat, replace clutch disc and pulley.

Pulley

Check the appearance of the pulley assembly. If the contact surface of the pulley shows signs of excessive grooving, replace the clutch disc and pulley. The contact surfaces of the pulley assembly should be cleaned with a suitable solvent before installation.

Coil

Check the magnet coil for a loose connection or cracked insulation.

INSTALLATION

- Install the magnet coil.

CAUTION:

Be sure to align the magnet coil pin with the hole in the compressor front head.

- Install the magnet coil harness clip using a screwdriver.

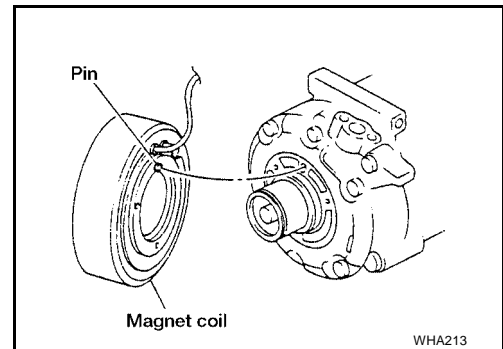

- Install the pulley assembly using Tool and a wrench, and then install the snap ring using snap ring pliers.

Tool number : — (J-38873-A)

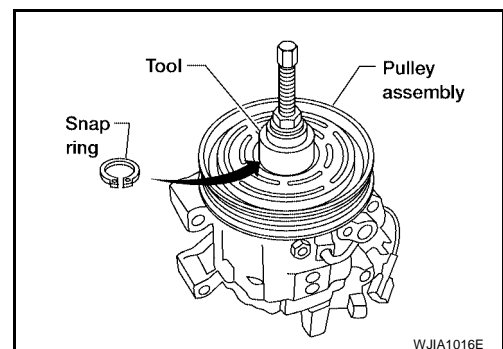

- Install the clutch disc on the drive shaft, together with the original shim(s). Press the clutch disc down using the drive plate installer.

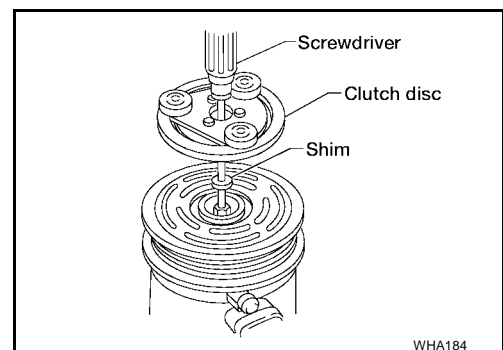

REFRIGERANT LINES

5. Install the center bolt using Tool.

Center bolt : 12 N·m (1.2 kg·m, 9 ft·lb).

Tool number : (J-44614)

- After tightening the center bolt to specification, check that the pulley rotates smoothly.

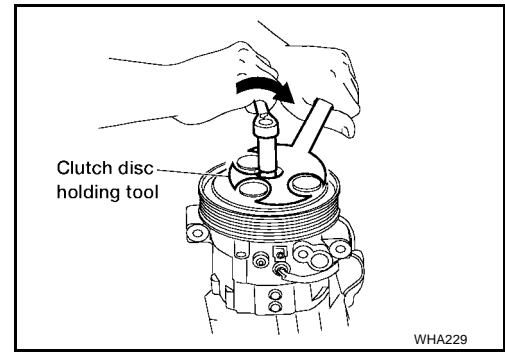

INSPECTION AFTER INSTALLATION

Check the clearance all the way around the clutch disc as shown.

Clutch disc-to-pulley clearance : 0.3 - 0.6 mm
(0.012 - 0.024 in)

If the specified clearance is not obtained, replace the adjusting spacer and recheck the clearance.

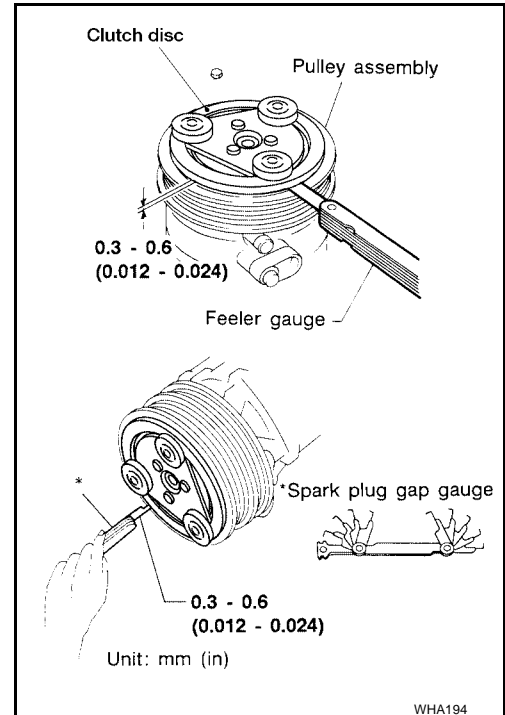

BREAK-IN OPERATION

When replacing compressor clutch assembly, always conduct the break-in operation. This is done by engaging and disengaging the clutch about 30 times. Break-in operation raises the level of transmitted torque.

REFRIGERANT LINES

Removal and Installation for Low-pressure Flexible Hose

EJS0027A

REMOVAL

1. Discharge the refrigerant. Refer to [MTC-89, "HFC-134a \(R-134a\) Service Procedure"](#) .
2. Remove the refrigerant pressure sensor.
3. Remove the low-pressure flexible hose. Refer to [MTC-91, "Components"](#) .

CAUTION:

Cap or wrap the joint of the hose with a suitable material such as vinyl tape to avoid the entry of contaminants.

INSTALLATION

Installation is in the reverse order of removal.

Low-pressure flexible hose (evaporator side) bolt	: 2.9 - 5.9 N-m (0.29 - 0.60 kg-m, 26 - 52 in-lb)
Low-pressure flexible hose (compressor side) bolt	: 7.8 - 19.6 N-m (0.8 - 1.9 kg-m, 69 - 173 in-lb)
Low-pressure flexible hose (in-line connection) bolt	: 7.8 - 19.6 N-m (0.8 - 1.9 kg-m, 69 - 173 in-lb)

CAUTION:

- Replace the O-ring on the low-pressure flexible hose with a new one, then apply A/C lubricant to it for installation.
- After recharging the refrigerant, check for leaks. Refer to [MTC-102, "Checking for Refrigerant Leaks"](#) .

Removal and Installation for High-pressure Flexible Hose

EJS0027B

REMOVAL

1. Discharge the refrigerant. Refer to [MTC-89, "HFC-134a \(R-134a\) Service Procedure"](#) .
2. Reposition the engine coolant reservoir out of the way without disconnecting the hose.
3. Reposition the power steering reservoir out of the way without disconnecting the hose.
4. Remove the high-pressure flexible hose. Refer to [MTC-91, "Components"](#) .

CAUTION:

Cap or wrap the joint of the hose with a suitable material such as vinyl tape to avoid the entry of contaminants.

INSTALLATION

Installation is in the reverse order of removal.

High-pressure flexible hose bolt	: 7.8 - 19.6 N-m (0.8 - 1.9 kg-m, 69 - 173 in-lb)
----------------------------------	---

CAUTION:

- Replace the O-ring of the high-pressure flexible hose with a new one, then apply A/C lubricant to it for installation.
- After charging the refrigerant, check for leaks. Refer to [MTC-102, "Checking for Refrigerant Leaks"](#) .

Removal and Installation for High-pressure Pipe

EJS0027C

REMOVAL

1. Discharge the refrigerant. Refer to [MTC-89, "HFC-134a \(R-134a\) Service Procedure"](#) .
2. Reposition the engine coolant reservoir out of the way without disconnecting the hose.
3. Reposition the power steering reservoir out of the way without disconnecting the hose.
4. Remove the high-pressure pipe. Refer to [MTC-91, "Components"](#) .

CAUTION:

Cap or wrap the joint of the pipe with suitable material such as vinyl tape to avoid the entry of air.

INSTALLATION

Installation is in the reverse order of removal.

REFRIGERANT LINES

High-pressure pipe (evaporator side) bolt : 2.9 - 5.9 N-m (0.29 - 0.60 kg-m, 26 - 52 in-lb)

High-pressure pipe (condenser side) bolt : 7.8 - 19.6 N-m (0.8 - 1.9 kg-m, 69 - 173 in-lb)

CAUTION:

- Replace the O-ring of the high-pressure pipe with a new one, then apply compressor oil to it when installing it.
- After charging the refrigerant, check for leaks. Refer to [MTC-102, "Checking for Refrigerant Leaks"](#)

Removal and Installation for Refrigerant Pressure Sensor

EJS002TD

REMOVAL

1. Discharge the refrigerant. Refer to [MTC-89, "HFC-134a \(R-134a\) Service Procedure"](#).
2. Disconnect the refrigerant pressure sensor connector and remove the refrigerant pressure sensor from the condenser.

CAUTION:

Do not damage the condenser fins.

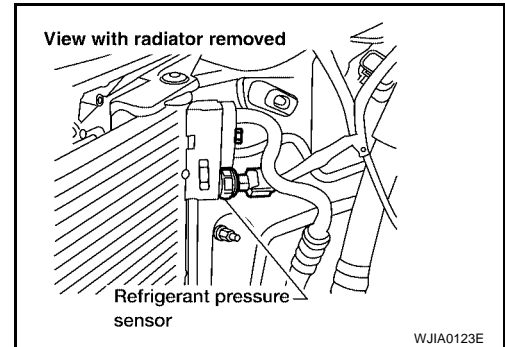

INSTALLATION

Installation is in the reverse order of removal.

Refrigerant pressure sensor : 9.8 - 11.7 N-m (1.0 - 1.2 kg-m, 7.3 - 8.6 ft-lb)

CAUTION:

Replace the O-ring of the refrigerant pressure sensor with a new one, then apply compressor oil to it when installing it.

Removal and Installation for Condenser

EJS002TE

REMOVAL

1. Discharge the refrigerant. Refer to [MTC-89, "HFC-134a \(R-134a\) Service Procedure"](#).
2. Remove the radiator. Refer to [CO-30, "RADIATOR"](#).

CAUTION:

Be careful not to damage the core surface of the condenser and the radiator.

3. Disconnect the high-pressure flexible hose and the high-pressure pipe from the condenser.

CAUTION:

Cap or wrap the joint of the pipe and hose with suitable material such as vinyl tape to avoid the entry of contaminants.

4. Disconnect the refrigerant pressure sensor connector.
5. Remove the front fascia. Refer to [EI-14, "FRONT BUMPER"](#).

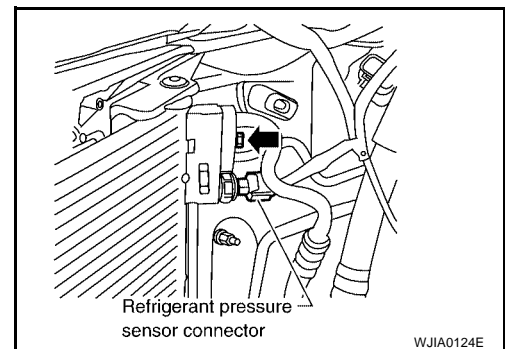

A
B
C
D
E
F
G
H
I
MTC
K
L
M

REFRIGERANT LINES

6. Remove the mounting nuts from condenser mounting brackets.
7. Remove the condenser.

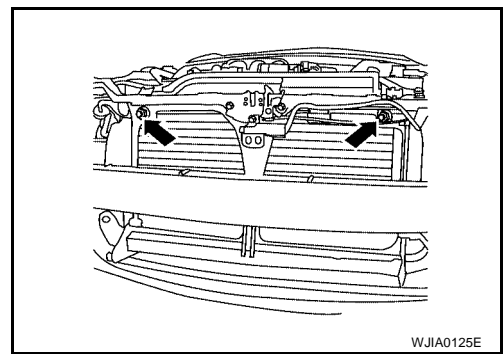

INSTALLATION

Installation is in the reverse order of removal.

High-pressure flexible hose and pipe bolt : 7.8 - 19.6 N-m (0.8 - 1.9 kg-m, 69 - 173 in-lb)
Condenser nuts : 5.0 - 6.79 N-m (0.51 - 0.69 kg-m, 45 - 60 in-lb)

CAUTION:

- Replace the O-rings of the high-pressure pipe, refrigerant pressure sensor, and high-pressure flexible hose with new ones, then apply A/C lubricant to them after installing them.
- When charging refrigerant, check for leaks. Refer to [MTC-102, "Checking for Refrigerant Leaks"](#) .

Removal and Installation for Evaporator

EJS003GN

REMOVAL

1. Evacuate and recover the A/C system refrigerant. Refer to [MTC-89, "HFC-134a \(R-134a\) Service Procedure"](#) .
2. Disconnect the battery negative terminal.
3. Disconnect the air cleaner to electronic throttle control actuator tube. Refer to [EM-17, "AIR CLEANER AND AIR DUCT"](#) (QR25DE), [EM-120, "AIR CLEANER AND AIR DUCT"](#) (VQ35DE).

NOTE:

The tube is located between the air cleaner assembly and the intake manifold and is removed to access the expansion valve.

4. Disconnect the A/C pipe from the expansion valve.

CAUTION:

Cap or wrap the joint of the pipe with suitable material such as vinyl tape to avoid the entry of air.

5. Remove the expansion valve.
6. Remove the center console side finisher RH. Refer to [IP-15, "Center Console"](#) .
7. Remove the glove box assembly. Refer to [IP-14, "Instrument Lower Cover RH and Glove Box"](#) .
8. Remove the ECM.
 - Disconnect the ECM connector.
 - Remove the wire harness from the ECM mounting bracket.
 - Remove the two ECM mounting bracket nuts and disconnect the ground wire.
9. Remove the blower unit. Refer to [MTC-78, "BLOWER UNIT"](#) .

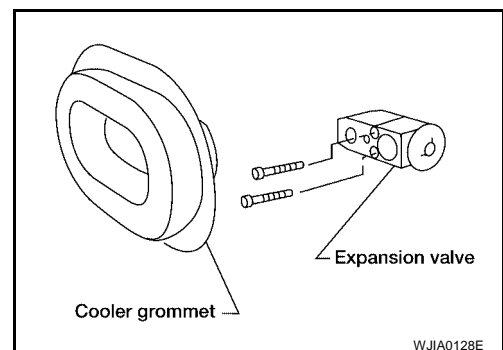

REFRIGERANT LINES

10. Remove the heater core cover.

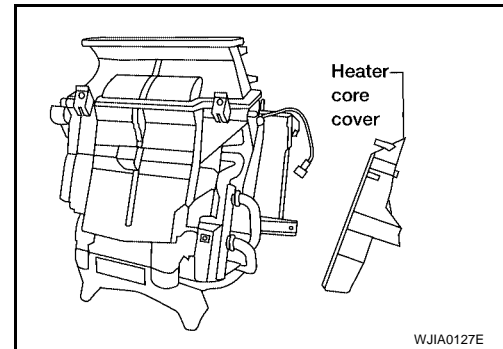

11. Remove the evaporator cover.

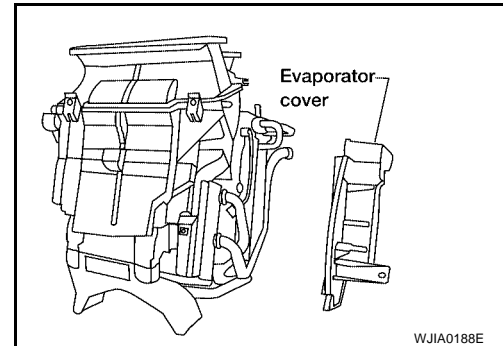

12. Remove the evaporator.

- Remove the thermo control amplifier.
- Remove the intake sensor.

CAUTION:

- Mark the mounting position of the intake sensor and thermo control amplifier.

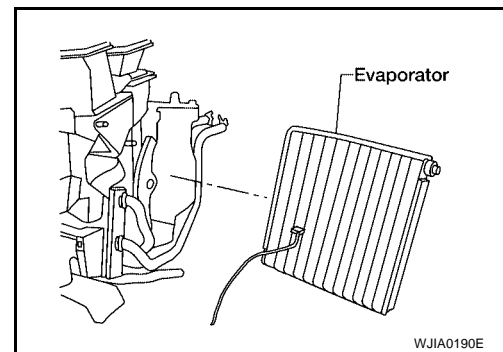

INSTALLATION

Installation is in the reverse order of removal.

Expansion valve mounting bolts : 2.9 - 5.0 N-m (0.29 - 0.51 kg-m, 26 - 44 in-lb)

CAUTION:

- Replace the O-rings with new ones, then apply compressor oil to them when installing them.

Removal and Installation for Expansion Valve

EJS003G0

REMOVAL

1. Evacuate and recover the A/C system refrigerant. Refer to [MTC-89, "HFC-134a \(R-134a\) Service Procedure"](#).
2. Disconnect the air cleaner to electronic throttle control actuator tube. Refer to [EM-17, "AIR CLEANER AND AIR DUCT"](#) (QR25DE), [EM-120, "AIR CLEANER AND AIR DUCT"](#) (VQ35DE).

NOTE:

The tube is located between the air cleaner assembly and the intake manifold and is removed to access the expansion valve.

3. Disconnect the A/C pipe from the expansion valve.

CAUTION:

Cap or wrap the joint of the pipe with suitable material such as vinyl tape to avoid the entry of air.

A
B
C
D
E
F
G
H
I
MTC
K
L
M

REFRIGERANT LINES

4. Remove the expansion valve.

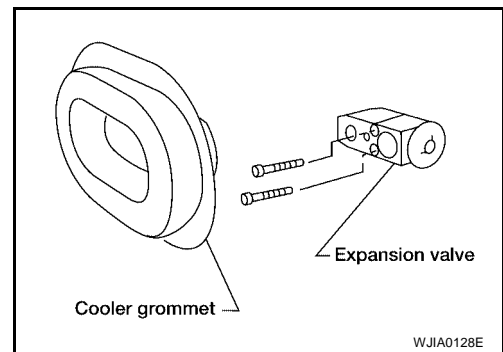

INSTALLATION

Installation is in the reverse order of removal.

Expansion valve mounting bolts : 2.9 - 5.0 N-m (0.29 - 0.51 kg-m, 26 - 44 in-lb)

CAUTION:

- Replace the O-rings with new ones, then apply compressor oil to them when installing them.

Checking for Refrigerant Leaks

EJS002TH

Perform a visual inspection of all refrigeration parts, fittings, hoses and components for signs of A/C lubricant leakage, damage and corrosion. A/C lubricant leakage may indicate an area of refrigerant leakage. Allow extra inspection time in these areas when using either an electronic refrigerant leak detector or fluorescent dye leak detector.

If dye is observed, confirm the leak with an electronic refrigerant leak detector. It is possible a prior leak was repaired and not properly cleaned.

When searching for leaks, do not stop when one leak is found but continue to check for additional leaks at all system components and connections.

When searching for refrigerant leaks using an electronic leak detector, move the probe along the suspected leak area at 25 - 50 mm (1 - 2 in) per second and no further than 6 mm (1/4 in) from the component.

CAUTION:

Moving the electronic leak detector probe slower and closer to the suspected leak area will improve the chances of finding a leak.

Checking System for Leaks Using the Fluorescent Leak Detector

EJS002TI

1. Check A/C system for leaks using the UV lamp and safety goggles (J-42220) in a low sunlight area (area without windows preferable). Illuminate all components, fittings and lines. The dye will appear as a bright green/yellow area at the point of leakage. Fluorescent dye observed at the evaporator drain opening indicates an evaporator core assembly (tubes, core or TXV) leak.
2. If the suspected area is difficult to see, use an adjustable mirror or wipe the area with a clean shop rag or cloth, with the UV lamp for dye residue.
3. After the leak is repaired, remove any residual dye using refrigerant dye cleaner (J-43872) to prevent future misdiagnosis.
4. Perform a system performance check and verify the leak repair with an approved electronic refrigerant leak detector.

NOTE:

Other gases in the work area or substances on the A/C components, for example, anti-freeze, windshield washer fluid, solvents and lubricants, may falsely trigger the leak detector. Make sure the surfaces to be checked are clean.

Clean with a dry cloth or blow off with shop air.

Do not allow the sensor tip of the detector to contact with any substance. This can also cause false readings and may damage the detector.

Dye Injection

EJS002TJ

NOTE:

This procedure is only necessary when recharging the A/C system or when the compressor has seized and has been replaced.

1. Check the A/C system static (at rest) pressure. Pressure must be at least 345 kPa (3.52 kg/cm², 50 psi).

REFRIGERANT LINES

2. Pour one bottle (1/4 ounce / 7.4 cc) of the A/C refrigerant dye into the injector tool (J-41459).

CAUTION:

If repairing the A/C system or replacing a component, pour the dye directly into the open system connection and proceed with the service procedures.

3. Connect the injector tool to the A/C LOW PRESSURE side service valve.
4. Start the engine and switch the A/C ON and fan ON.
5. While the A/C is operating (compressor running), inject one bottle (1/4 ounce / 7.4 cc) of fluorescent dye through the low-pressure service valve using dye injector tool (J-41459), refer to the manufacturer's operating instructions.
6. With the engine still running, disconnect the injector tool from the low-pressure service valve.
7. Operate the A/C system for a minimum of 20 minutes to mix the dye with the system lubricant. Depending on the leak size, operating conditions and location of the leak, it may take from a few minutes to a few days for the dye to penetrate the leak and become visible.

Electronic Refrigerant Leak Detector

EJS002TK

PRECAUTIONS FOR HANDLING THE LEAK DETECTOR

When performing a refrigerant leak check, use a electronic refrigerant leak detector (J-41995) or equivalent. Ensure that the instrument is calibrated and set properly per the manufacturer's operating instructions.

The leak detector is a delicate device. In order to use the leak detector properly, read the manufacturer's operating instructions and perform any specified maintenance.

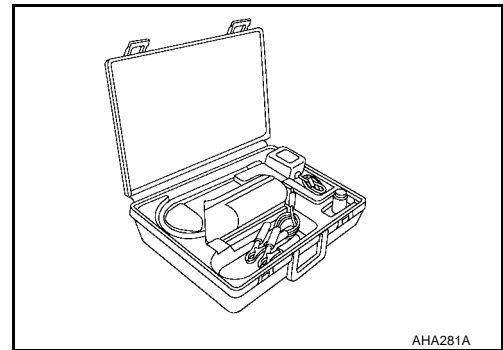

1. Position the leak detector probe approximately 5 mm (3/16 in) away from the point to be checked.

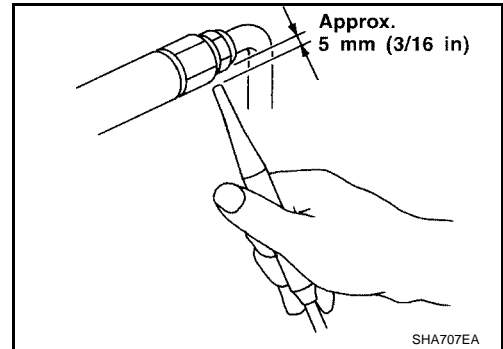

2. When testing, circle each fitting completely with the leak detector probe.

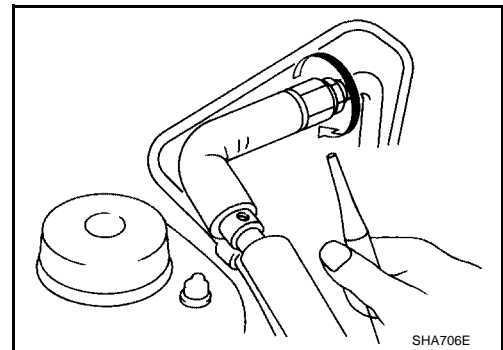

A
B
C
D
E
F
G
H
I
MTC
K
L
M

REFRIGERANT LINES

3. Move the leak detector probe along the component at approximately 25 to 50 mm (1 to 2 in)/sec.

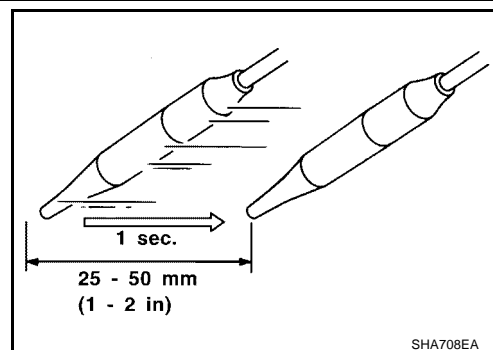

CHECKING PROCEDURE

NOTE:

To prevent inaccurate or false readings, make sure there is no refrigerant vapor, shop chemicals, or cigarette smoke in the vicinity of the vehicle. Perform the leak test in a calm area (low air/wind movement) so that the leaking refrigerant is not dispersed.

1. Turn engine OFF.
2. Connect a suitable A/C manifold gauge set to the A/C service ports.
3. Check if the A/C refrigerant pressure is at least 345 kPa (3.52 kg/cm², 50 psi) above 16°C (61°F). If less than specification, recover/evacuate and recharge the system with the specified amount of refrigerant.

NOTE:

At temperatures below 16°C (61°F), leaks may not be detected since the system may not reach 345 kPa (3.52 kg/cm², 50 psi) pressure.

4. Conduct the leak test from the high side (compressor discharge to evaporator inlet) to the low side (evaporator drain hose to the compressor shaft seal). Refer to [MTC-91, "Components"](#). Clean the component to be checked and move the leak detector probe completely around the connection/component. Perform a leak check for the following areas:

- Compressor
- High and low-pressure hose fittings, relief valve and shaft seal.
- Liquid tank
- Refrigerant pressure sensor
- Service valves

NOTE:

- Check that all the service valve caps are secure on the service valves (to prevent leaks).
- After removing A/C manifold gauge set from service valves, wipe any residue from the valves to prevent any false readings by the leak detector.

- Cooling unit (evaporator)

NOTE:

- With engine OFF, turn blower fan on "High" for at least 15 seconds to dissipate any refrigerant trace in the cooling unit. Wait a minimum of 10 minutes accumulation time (refer to the manufacturer's recommended procedure for actual wait time) before inserting the leak detector probe into the drain hose.
- Keep the probe inserted for at least 10 seconds. Use caution not to contaminate the probe tip with water or dirt that may be in the drain hose.

5. If a leak detector detects a leak, verify at least once by blowing compressed air into area of suspected leak, then repeat check as outlined above.
6. Do not stop when one leak is found. Continue to check for additional leaks at all system components. If no leaks are found, perform steps 7 - 10.
7. Start engine.
8. Set the front air control as follows;
 - a. A/C switch: ON
 - b. Mode: face
 - c. Intake position: Recirculation

REFRIGERANT LINES

- d. Temperature: MAX cold
- e. Fan speed: High
9. Run engine at 1,500 rpm for at least 2 minutes.
10. Turn engine off and perform leak check again following steps 4 through 6 above.

Refrigerant leaks should be checked immediately after stopping the engine. Begin with the leak detector at the compressor. The pressure on the high pressure side will gradually drop after refrigerant circulation stops and pressure on the low pressure side will gradually rise, as shown in the graph. Some leaks are more easily detected when pressure is high.

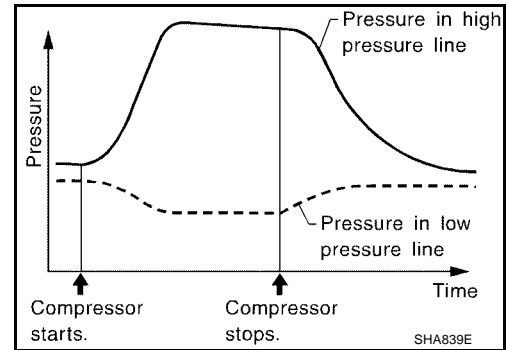

11. Before connecting the recovery/recycling equipment to the A/C system, check the recovery/recycling equipment gauges. No refrigerant pressure should be displayed. If pressure is displayed, recover the refrigerant from the equipment lines and then check the refrigerant purity.
12. Confirm the refrigerant purity in the supply tank using the recovery/recycling equipment and the refrigerant identifier equipment.
13. Confirm the refrigerant purity in the A/C system using the recovery/recycling equipment and the refrigerant identifier equipment.
14. Discharge the A/C system using approved refrigerant recovery equipment. Repair the leaking fitting or component as necessary.
15. Evacuate and recharge the A/C system and perform the leak test to confirm there are no refrigerant leaks.
16. Conduct the A/C performance test to ensure that the system works properly. Refer to [MTC-67, "PERFORMANCE CHART"](#).

A
B
C
D
E
F
G
H
I

MTC

K
L
M

SERVICE DATA AND SPECIFICATIONS (SDS)

SERVICE DATA AND SPECIFICATIONS (SDS)

PFP:00030

Service Data and Specifications (SDS) COMPRESSOR

EJS0027L

Model	CALSONIC KANSEI
Type	DKS-17D
Displacement	175.5 cm ³ (10.7 in ³) / revolution
Cylinder bore × stroke	30.5 mm (1.201 in) x 21.4 mm (0.84 in)
Direction of rotation	Clockwise (viewed from drive end)
Drive belt	Poly V

LUBRICANT

Model	CALSONIC KANSEI (type DKS-17D)	
Name	NISSAN A/C System Lubricant Type DH-PS or equivalent	
Part number	KLH00-PAGS0	
Capacity	Total in system	150 mℓ (5.03 US fl oz, 5.3 Imp fl oz)
	Compressor (service part) charging amount	Refer to MTC-19, "Lubricant Adjustment Procedure for Compressor Replacement" .

REFRIGERANT

Type	HFC-134a (R-134a)
Capacity	0.50 ± 0.025 kg (1.10 ± 0.055 lb)

ENGINE IDLING SPEED

Refer to [EC-80, "Idle Speed and Ignition Timing Check"](#) (QR25DE) or [EC-698, "Idle Speed and Ignition Timing Check"](#) (VQ35DE).

BELT TENSION

Refer to [MA-15, "ENGINE MAINTENANCE \(QR25DE ENGINE\)"](#) or [MA-22, "ENGINE MAINTENANCE \(VQ35DE ENGINE\)"](#).