

SECTION **PG**

POWER SUPPLY, GROUND & CIRCUIT ELEMENTS

CONTENTS

PRECAUTIONS	3	GROUND CIRCUIT	28
Precautions for Supplemental Restraint System (SRS) "AIR BAG" and "SEAT BELT PRE-TENSIONER"	3	Ground Distribution	28
Wiring Diagrams and Trouble Diagnosis	3	MAIN HARNESS	28
POWER SUPPLY ROUTING CIRCUIT	4	ENGINE ROOM HARNESS	30
Schematic	4	ENGINE CONTROL HARNESS (QR25DE)	32
Wiring Diagram — POWER —	6	ENGINE CONTROL HARNESS (VQ35DE)	34
BATTERY POWER SUPPLY — IGNITION SW. IN ANY POSITION	6	BODY HARNESS	36
ACCESSORY POWER SUPPLY — IGNITION SW. IN ACC OR ON	10	BODY NO. 2 HARNESS	37
IGNITION POWER SUPPLY — IGNITION SW. IN ON	11	HARNESS	39
IGNITION POWER SUPPLY — IGNITION SW. IN ON AND/OR START	12	Harness Layout	39
IPDM E/R (INTELLIGENT POWER DISTRIBUTION MODULE ENGINE ROOM)	15	HOW TO READ HARNESS LAYOUT	39
System Description	15	OUTLINE	40
SYSTEMS CONTROLLED BY IPDM E/R	15	MAIN HARNESS	41
CAN COMMUNICATION LINE CONTROL	15	ENGINE ROOM HARNESS (LH VIEW)	43
IPDM E/R STATUS CONTROL	16	ENGINE ROOM HARNESS (RH VIEW)	46
CAN Communication System Description	16	ENGINE CONTROL HARNESS (QR25DE)	48
Function of Detecting Ignition Relay Malfunction ...	16	ENGINE CONTROL HARNESS (VQ35DE)	50
CONSULT-II Function (IPDM E/R)	17	BODY HARNESS	52
CONSULT-II BASIC OPERATION	17	BODY NO. 2 HARNESS	54
SELF-DIAGNOSTIC RESULTS	18	ROOM LAMP HARNESS	56
DATA MONITOR	18	FRONT DOOR LH HARNESS	57
ACTIVE TEST	20	FRONT DOOR RH HARNESS	57
Auto Active Test	21	REAR DOOR LH HARNESS	58
DESCRIPTION	21	REAR DOOR RH HARNESS	58
OPERATION PROCEDURE	21	Wiring Diagram Codes (Cell Codes)	59
INSPECTION IN AUTO ACTIVE TEST MODE... ..	21	ELECTRICAL UNITS LOCATION	62
Schematic	23	Electrical Units Location	62
IPDM E/R TERMINAL ARRANGEMENT	24	ENGINE COMPARTMENT	62
IPDM E/R Power/Ground Circuit Inspection	25	PASSENGER COMPARTMENT	63
Inspection with CONSULT-II (Self-Diagnosis)	26	Fuse	65
Removal and Installation of IPDM E/R	27	Fusible Link	65
REMOVAL	27	Circuit Breaker (Built Into BCM)	65
INSTALLATION	27	HARNESS CONNECTOR	66
		Description	66
		HARNESS CONNECTOR (TAB-LOCKING TYPE)	66
		HARNESS CONNECTOR (SLIDE-LOCKING TYPE)	67
		HARNESS CONNECTOR (DIRECT-CONNECT SRS COMPONENT TYPE)	68

ELECTRICAL UNITS	69	MIXED TYPE RELAYS	70
Terminal Arrangement	69	TYPE OF STANDARDIZED RELAYS	70
STANDARDIZED RELAY	70	FUSE BLOCK-JUNCTION BOX(J/B)	72
Description	70	Terminal Arrangement	72
NORMAL OPEN, NORMAL CLOSED AND		FUSE AND FUSIBLE LINK BOX	73
		Terminal Arrangement	73

PRECAUTIONS

PRECAUTIONS

PFP:00011

Precautions for Supplemental Restraint System (SRS) “AIR BAG” and “SEAT BELT PRE-TENSIONER”

EKS008UA

The Supplemental Restraint System such as “AIR BAG” and “SEAT BELT PRE-TENSIONER”, used along with a front seat belt, helps to reduce the risk or severity of injury to the driver and front passenger for certain types of collision. This system includes seat belt switch inputs and dual stage front air bag modules. The SRS system uses the seat belt switches to determine the front air bag deployment, and may only deploy one front air bag, depending on the severity of a collision and whether the front occupants are belted or unbelted. Information necessary to service the system safely is included in the SRS and SB section of this Service Manual.

WARNING:

- To avoid rendering the SRS inoperative, which could increase the risk of personal injury or death in the event of a collision which would result in air bag inflation, all maintenance must be performed by an authorized NISSAN/INFINITI dealer.
- Improper maintenance, including incorrect removal and installation of the SRS, can lead to personal injury caused by unintentional activation of the system. For removal of Spiral Cable and Air Bag Module, see the SRS section.
- Do not use electrical test equipment on any circuit related to the SRS unless instructed to in this Service Manual. SRS wiring harnesses can be identified by yellow and/or orange harnesses or harness connectors.

Wiring Diagrams and Trouble Diagnosis

EKS008UB

When you read wiring diagrams, refer to the following:

- [GI-14, "How to Read Wiring Diagrams"](#)
- [PG-4, "POWER SUPPLY ROUTING CIRCUIT"](#)

When you perform trouble diagnosis, refer to the following:

- [GI-10, "HOW TO FOLLOW TEST GROUPS IN TROUBLE DIAGNOSES"](#)
- [GI-26, "How to Perform Efficient Diagnosis for an Electrical Incident"](#)

A

B

C

D

E

F

G

H

I

J

PG

L

M

POWER SUPPLY ROUTING CIRCUIT

PF024110

EKS008UC

POWER SUPPLY ROUTING CIRCUIT

Schematic

For detailed ground distribution, refer to [PG-28, "Ground Distribution"](#).

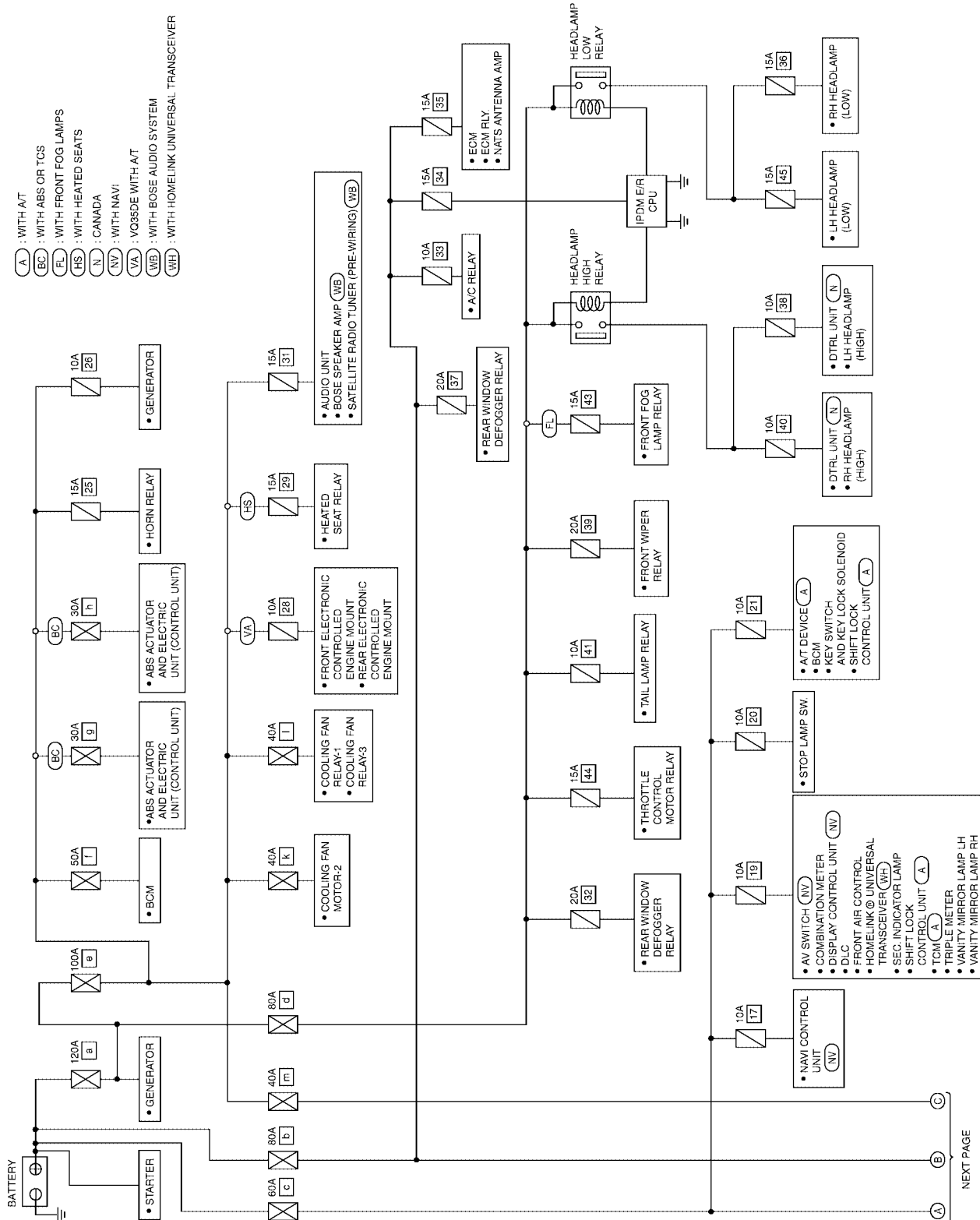

WKWA3028E

POWER SUPPLY ROUTING CIRCUIT

EKS008UD

Wiring Diagram — POWER — BATTERY POWER SUPPLY — IGNITION SW. IN ANY POSITION

PG-POWER-01

ⓀC : WITH ABS OR TCS

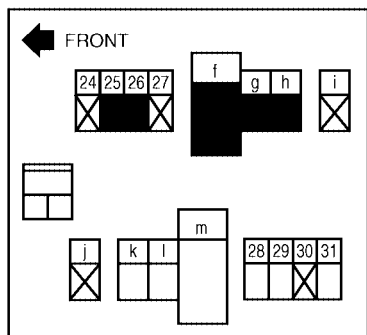
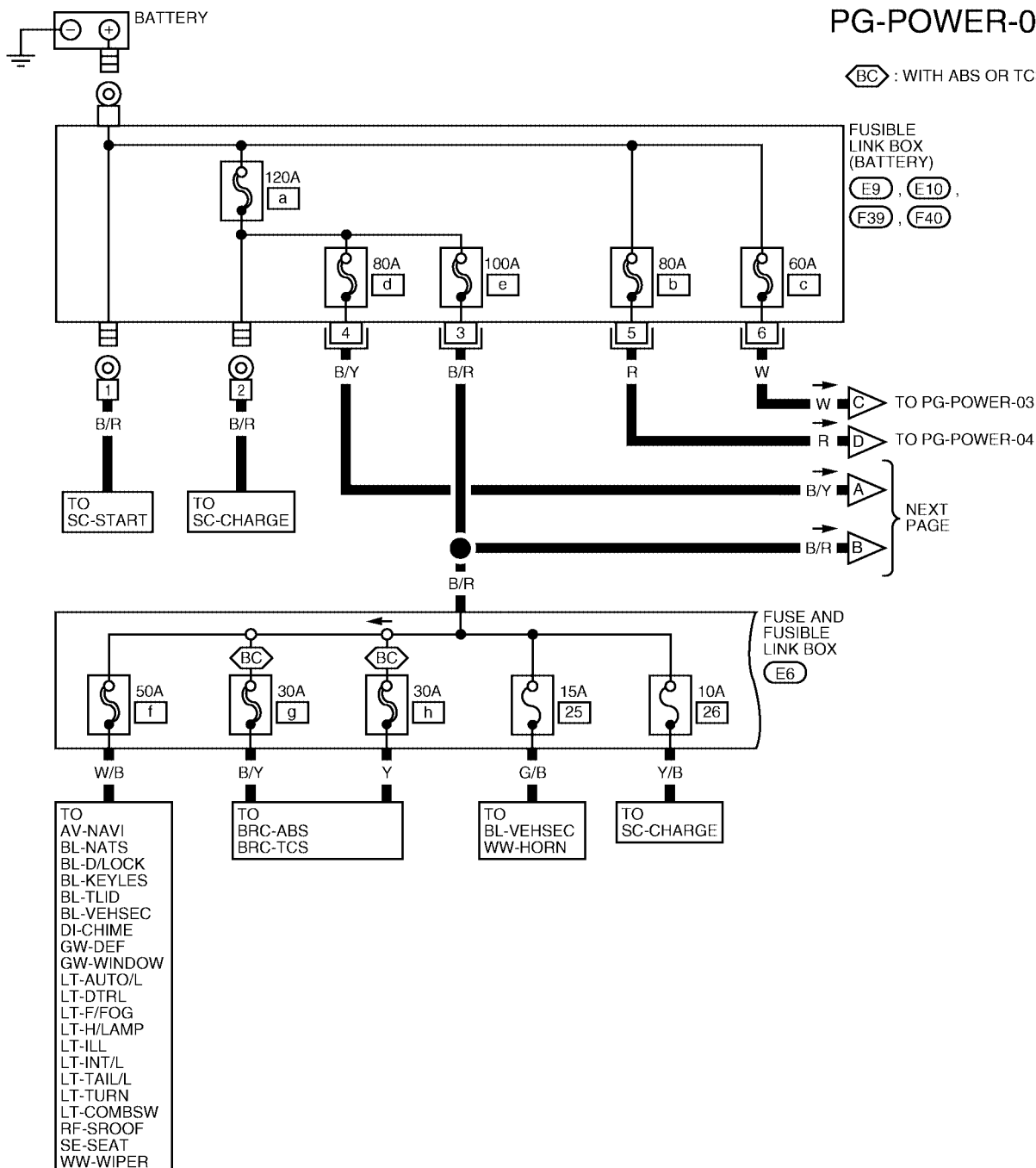

E6

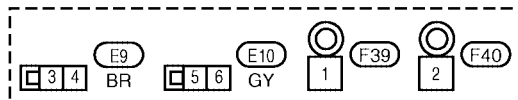

WKWA1465E

POWER SUPPLY ROUTING CIRCUIT

PG-POWER-02

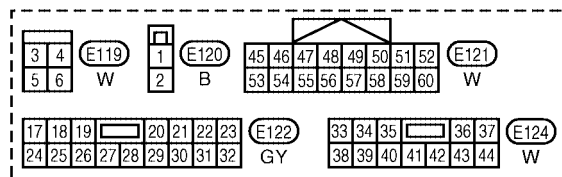
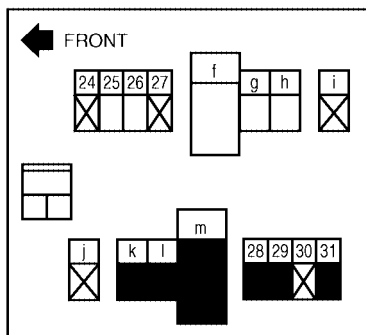
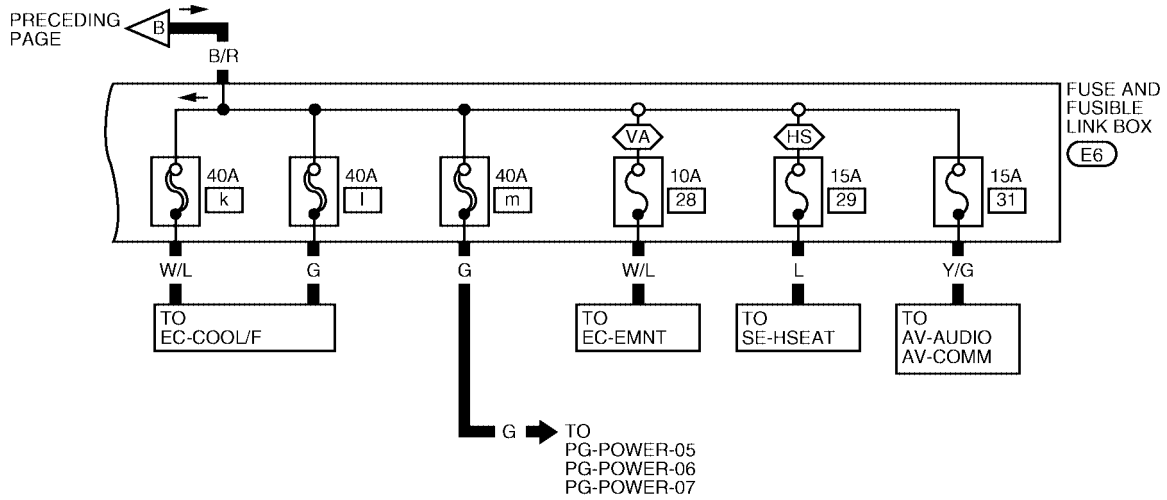
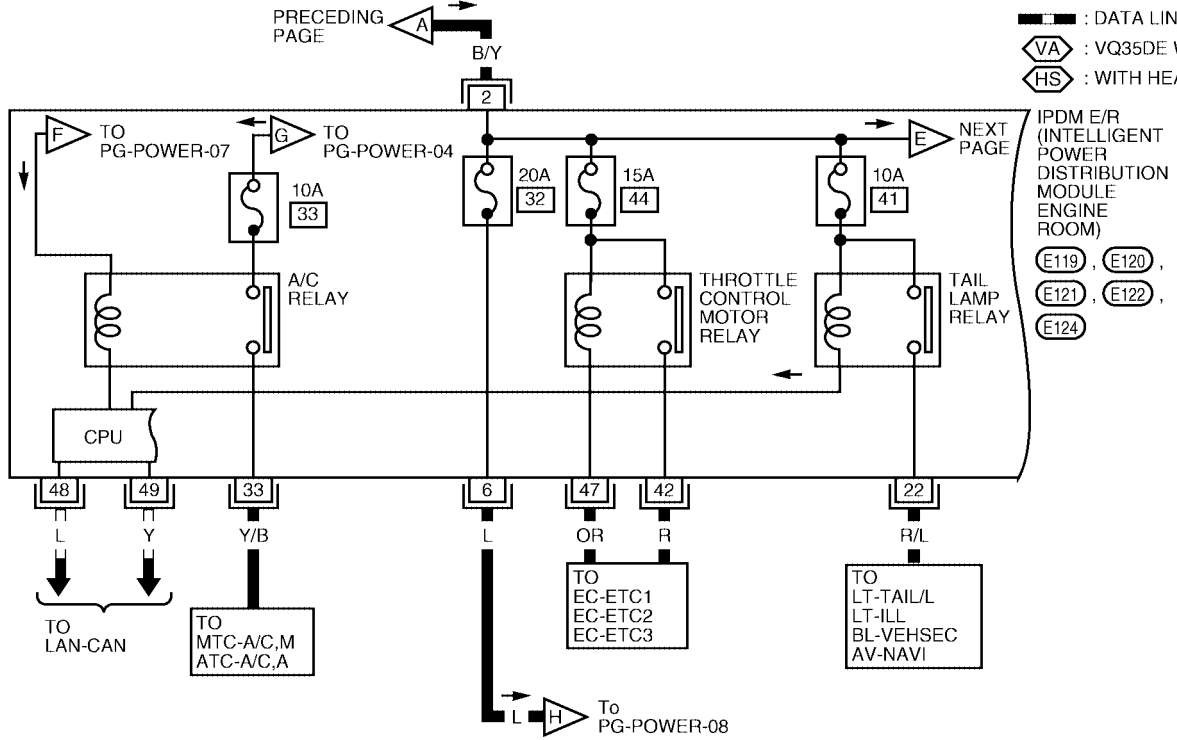

WKWA1466E

POWER SUPPLY ROUTING CIRCUIT

⬡ : WITH FRONT FOG LAMPS

PG-POWER-03

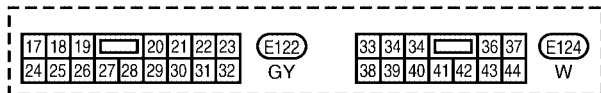
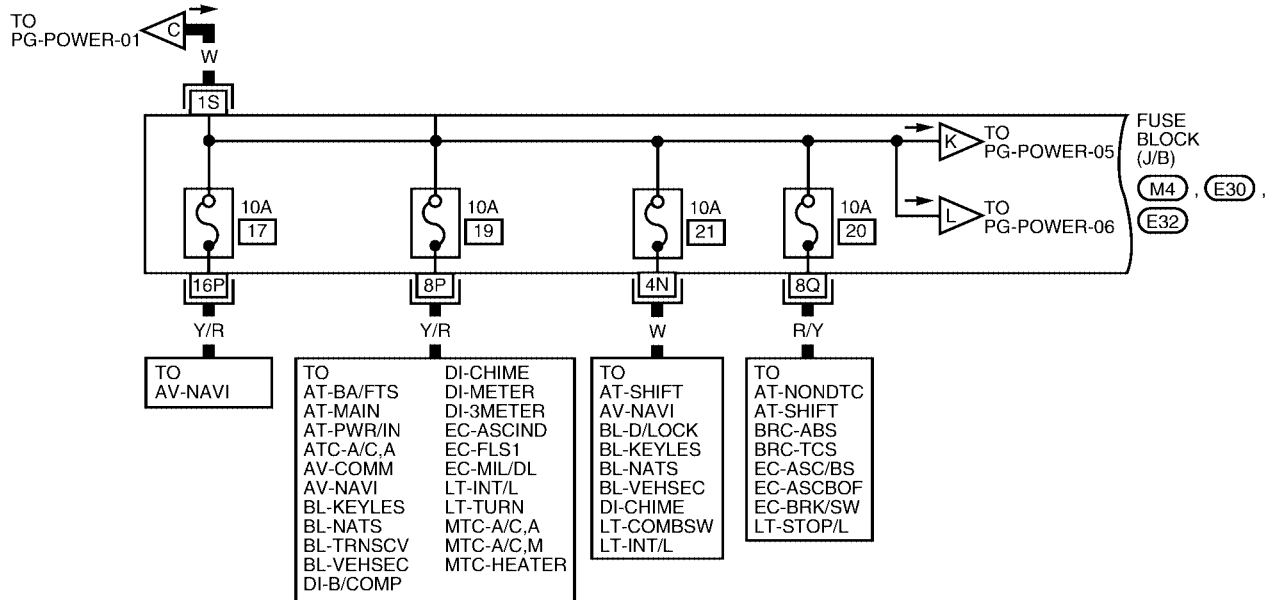
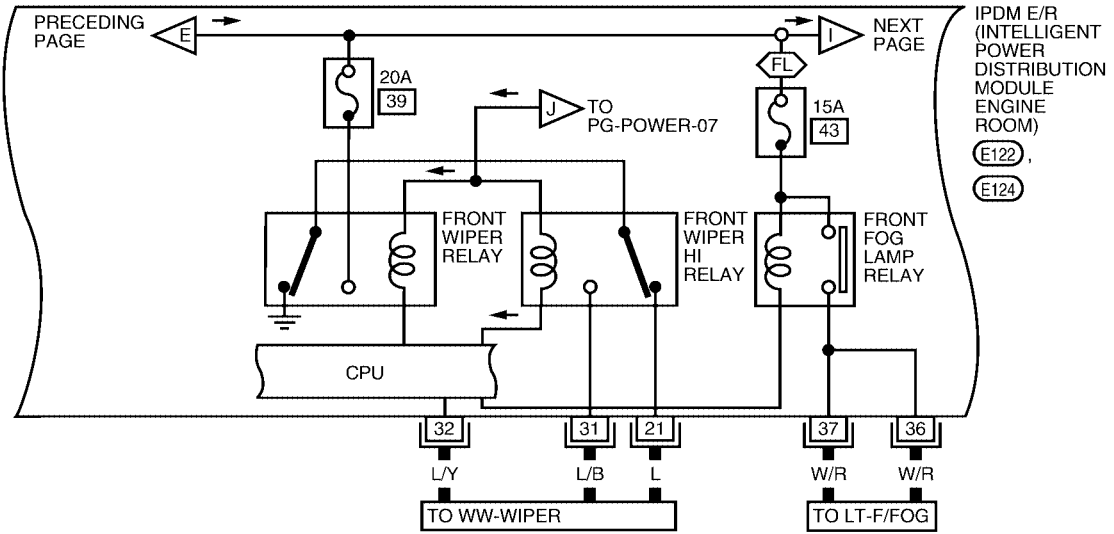

REFER TO THE FOLLOWING.

M4, E30, E32 UP
- FUSE BLOCK -
JUNCTION BOX (J/B)

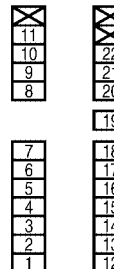

WKWA1844E

POWER SUPPLY ROUTING CIRCUIT

PG-POWER-04

A
B
C
D
E
F
G
H
I
J
PG
L
M

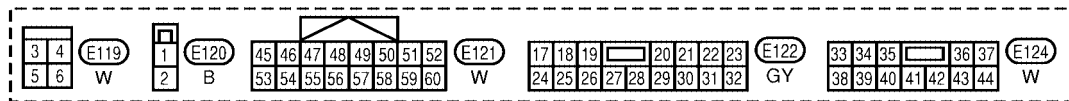
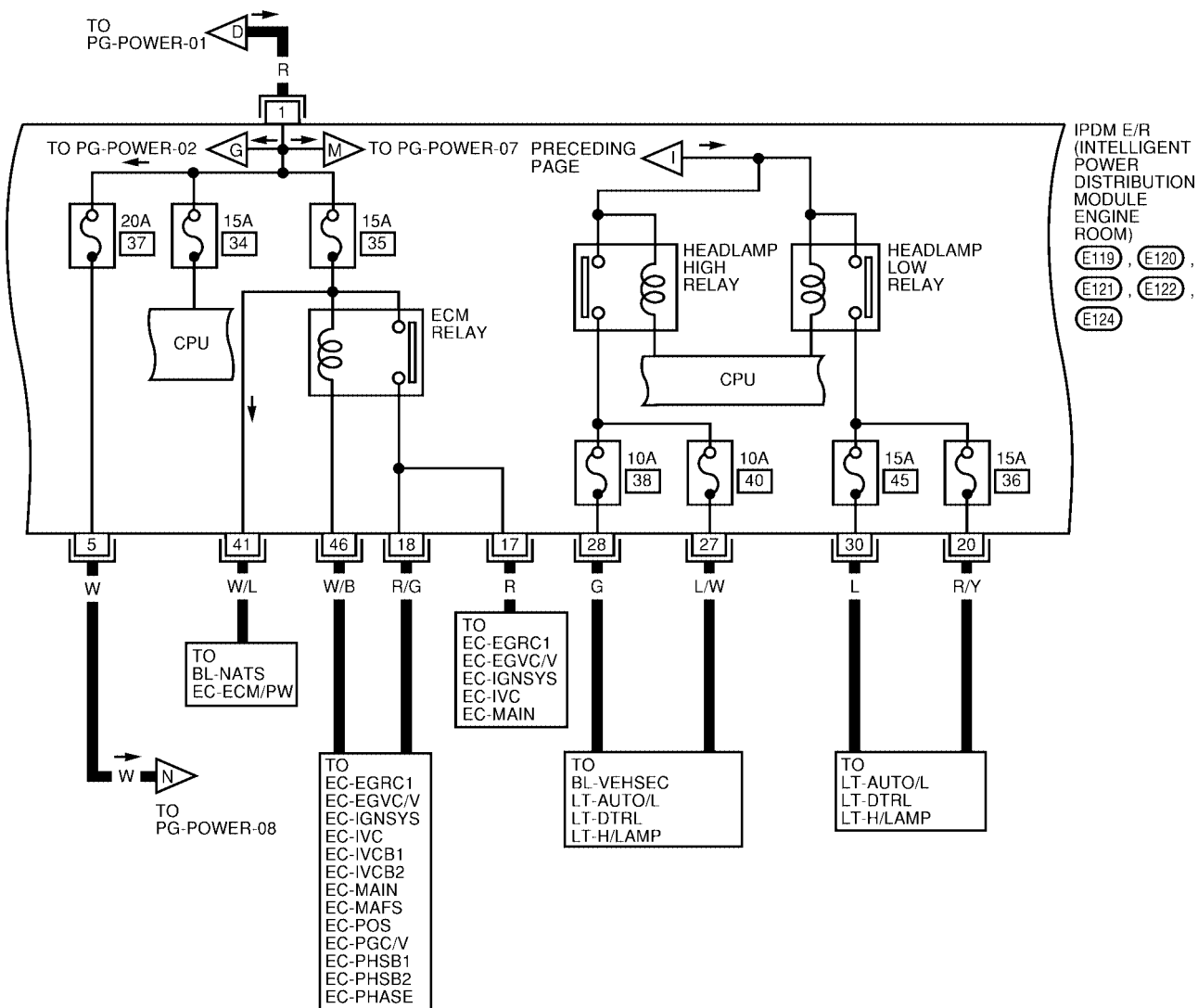

WKWA1468E

POWER SUPPLY ROUTING CIRCUIT

ACCESSORY POWER SUPPLY — IGNITION SW. IN ACC OR ON

PG-POWER-05

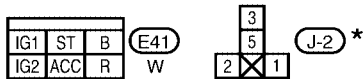
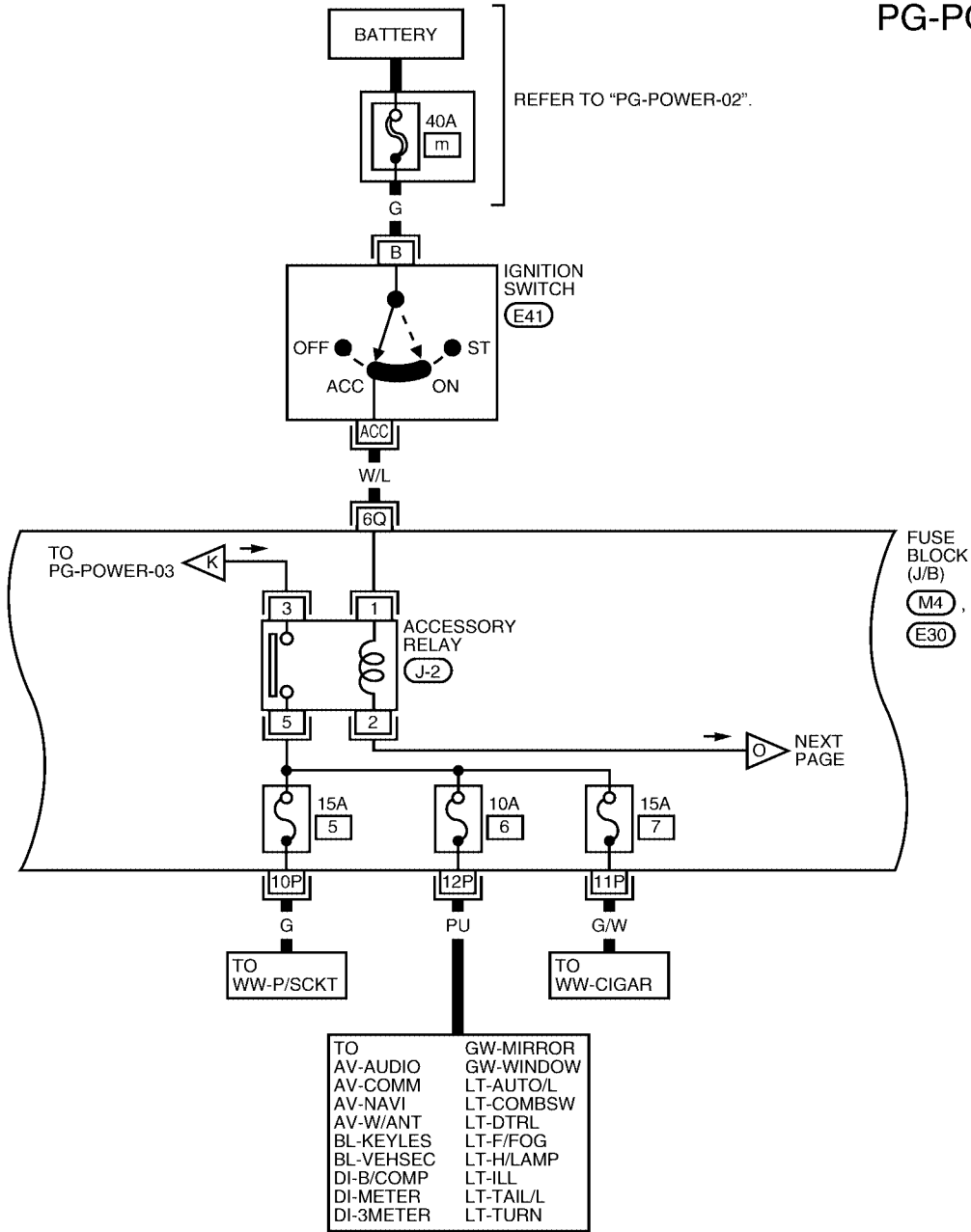

*: THIS CONNECTOR IS NOT SHOWN IN "HARNESS LAYOUT".

REFER TO THE FOLLOWING.

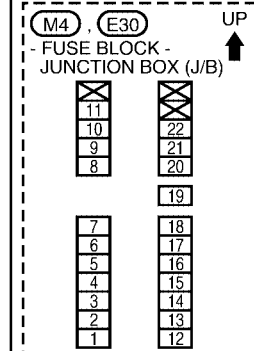

WKWA2110E

POWER SUPPLY ROUTING CIRCUIT

IGNITION POWER SUPPLY — IGNITION SW. IN ON

PG-POWER-06

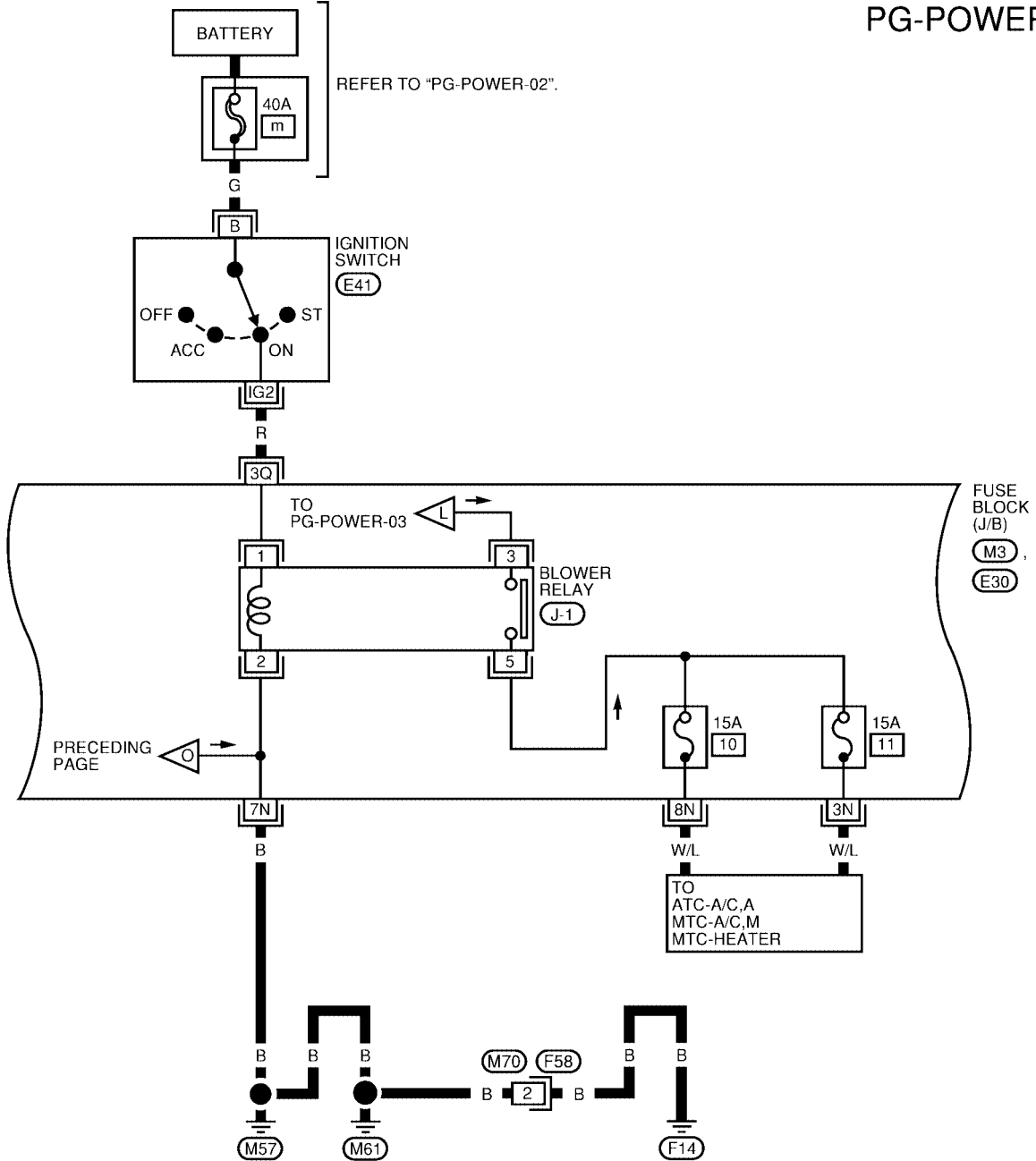

A
B
C
D
E
F
G
H
I
J
PG
L
M

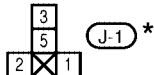
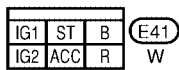

* : THIS CONNECTOR IS NOT SHOWN IN "HARNESS LAYOUT".

REFER TO THE FOLLOWING.

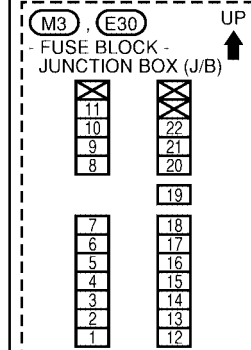

WKWA1470E

POWER SUPPLY ROUTING CIRCUIT

IGNITION POWER SUPPLY — IGNITION SW. IN ON AND/OR START

PG-POWER-07

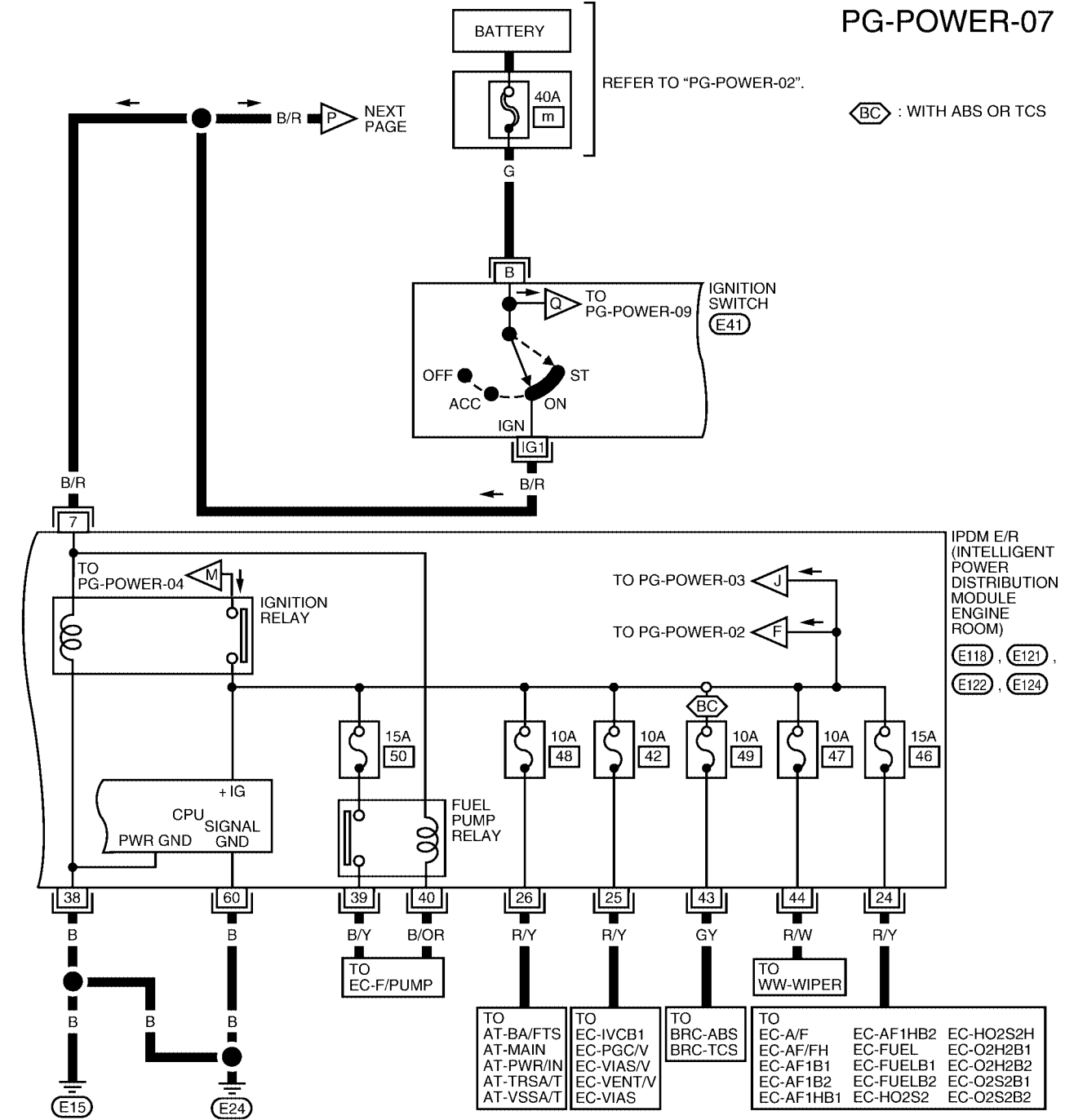

IG1	ST	B	(E41)	(E118)										(E121)	(E122)										(E124)																
IG2	ACC	R	W	7	8	9	10	B	45	46	47	48	49	50	51	52	W	17	18	19	20	21	22	23	W	24	25	26	27	28	29	30	31	32	GY	33	34	35	36	37	W

WKWA3030E

POWER SUPPLY ROUTING CIRCUIT

PG-POWER-08

A
B
C
D
E
F
G
H
I
J
L
M

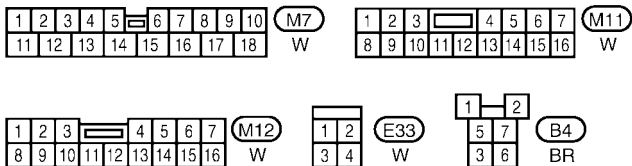
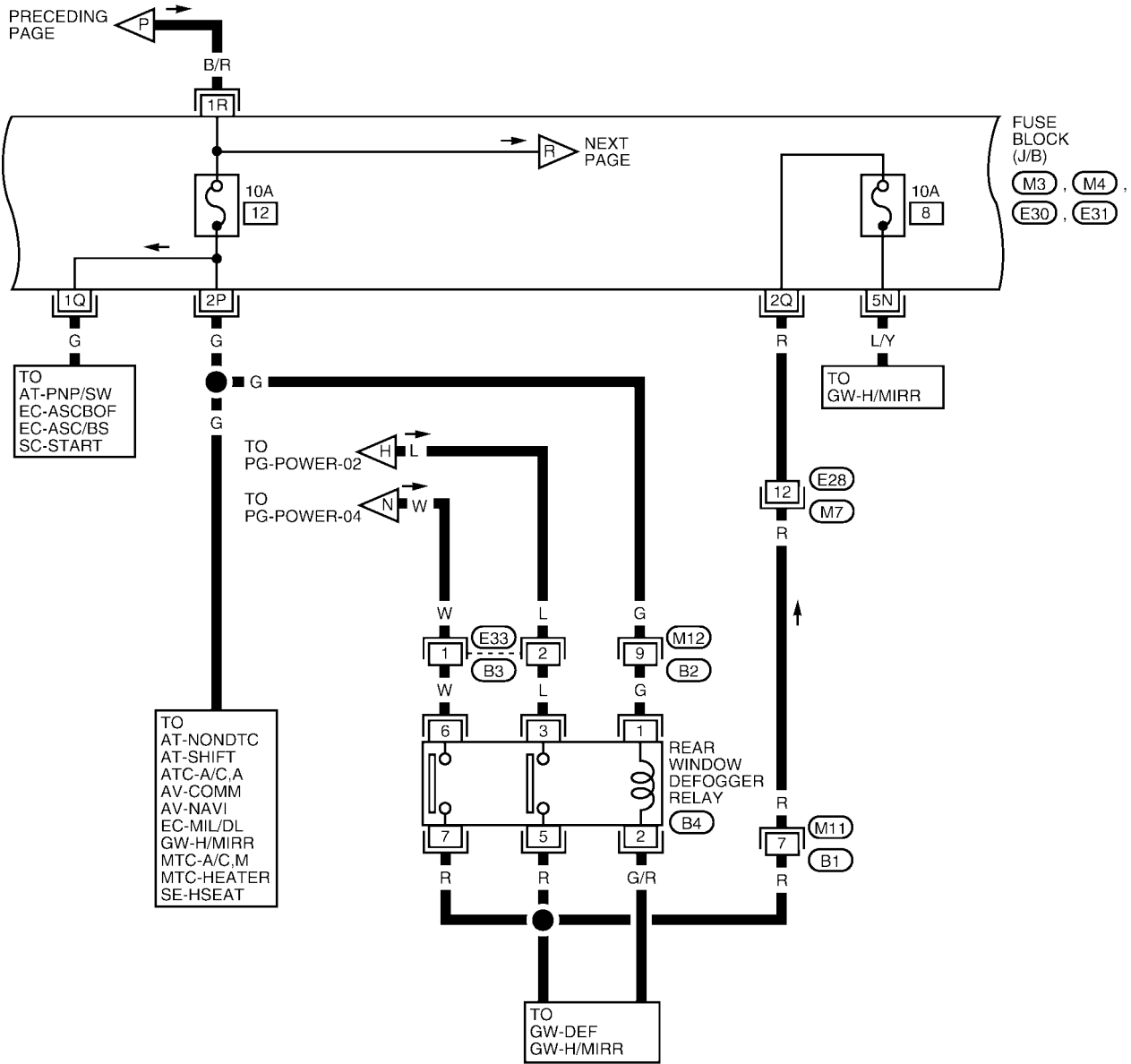

REFER TO THE FOLLOWING.

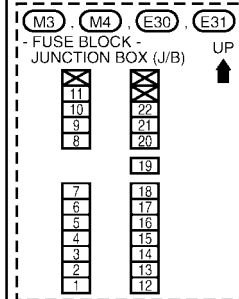

WKWA3031E

POWER SUPPLY ROUTING CIRCUIT

PG-POWER-09

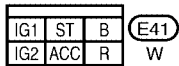
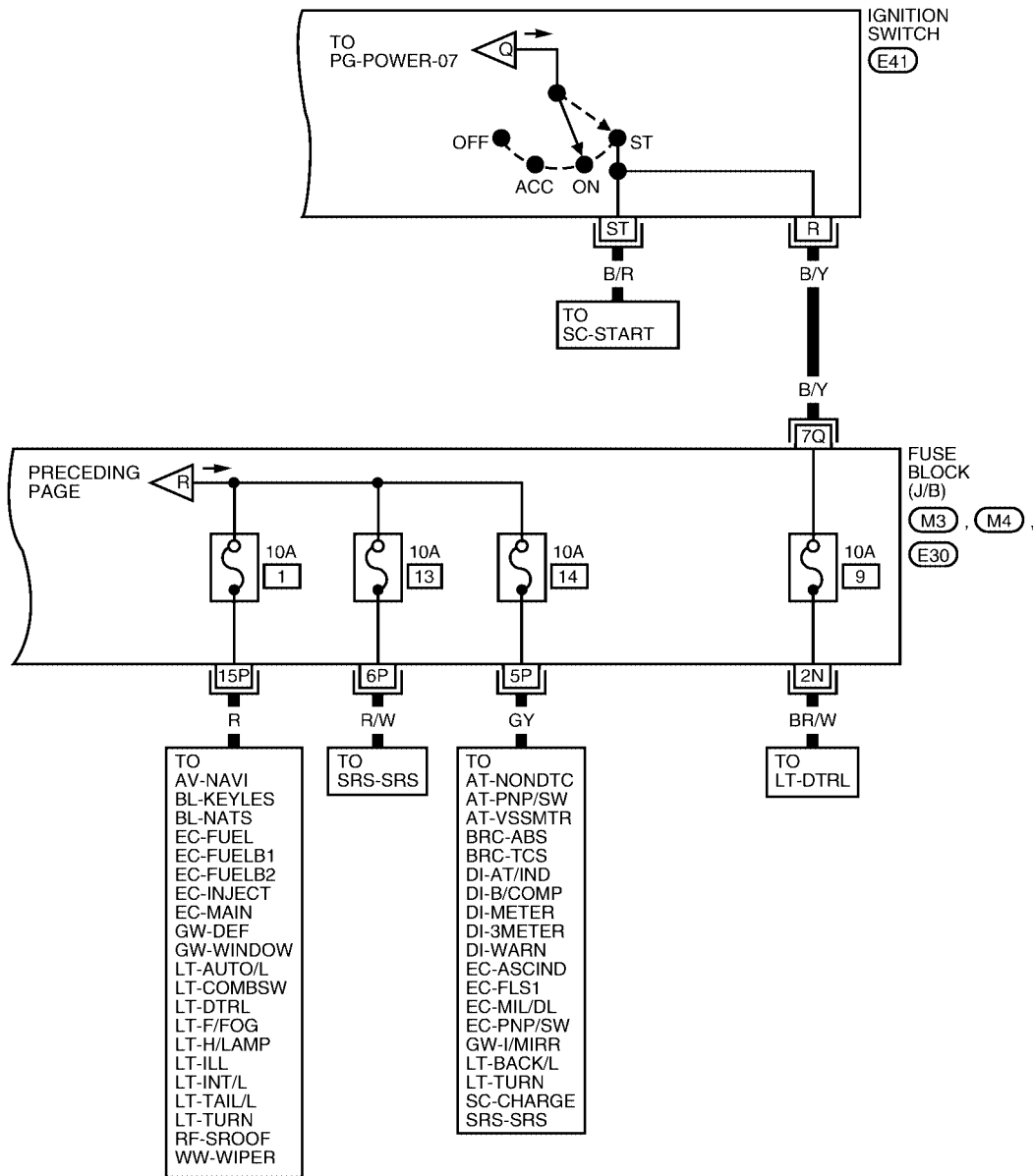

REFER TO THE FOLLOWING.

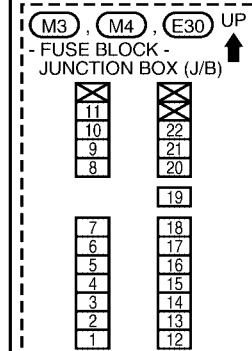

WKWA3032E

IPDM E/R (INTELLIGENT POWER DISTRIBUTION MODULE ENGINE ROOM)

IPDM E/R (INTELLIGENT POWER DISTRIBUTION MODULE ENGINE ROOM)

PF:284B7

EKS008UE

System Description

- IPDM E/R (Intelligent Power Distribution Module Engine Room) integrates the relay box and fuse block which were originally placed in engine compartment. It controls integrated relays via IPDM E/R control circuits.
- IPDM E/R-integrated control circuits perform ON-OFF operation of relays, CAN communication control, oil pressure switch signal reception, etc.
- It controls operation of each electrical component via BCM and CAN communication lines.

CAUTION:

None of the IPDM E/R-integrated relays can be individually removed.

SYSTEMS CONTROLLED BY IPDM E/R

1. Lamp control

Using CAN communication lines, it receives signals from the BCM and controls the following lamps:

- Headlamps (Hi, Lo)
- Parking lamps
- Tail lamps
- Front fog lamps

2. Wiper control

Using CAN communication lines, it receives signals from the BCM and controls the front wipers.

3. Rear window defogger relay control

Using CAN communication lines, it receives signals from the BCM and controls the rear window defogger relay.

4. A/C compressor control

Using CAN communication lines, it receives signals from the ECM and controls the A/C compressor magnetic clutch).

5. Cooling fan control

Using CAN communication lines, it receives signals from the ECM and controls the cooling fan relays.

6. Horn control

Using CAN communication lines, it receives signals from the BCM and controls the horn relay.

CAN COMMUNICATION LINE CONTROL

With CAN communication, by connecting each control unit using two communication lines (CAN L-line, CAN H-line), it is possible to transmit maximum amount of information with minimum wiring. Each control unit can transmit and receive data, and read necessary information only.

1. Fail-safe control

- When CAN communication with other control units is impossible, IPDM E/R performs fail-safe control. After CAN communication recovers normally, it also returns to normal control.
- Operation of control parts by IPDM E/R during fail-safe mode is as follows:

Controlled system	Fail-safe mode
Headlamp	<ul style="list-style-type: none">● With the ignition switch ON, the headlamp (low) is ON.● With the ignition switch OFF, the headlamp (low) is OFF.
Tail and parking lamps	<ul style="list-style-type: none">● With the ignition switch ON, the tail and parking lamps are ON.● With the ignition switch OFF, the tail and parking lamps are OFF.
Cooling fan	<ul style="list-style-type: none">● With the ignition switch ON, the cooling fan HI operates.● With the ignition switch OFF, the cooling fan stops.
Front wiper	Until the ignition switch is turned off, the front wiper LO and HI remains in the same status it was in just before fail-safe control was initiated.
Rear window defogger	Rear window defogger relay OFF
A/C compressor	A/C compressor OFF
Front fog lamps	Front fog lamp relay OFF

A
B
C
D
E
F
G
H
I
J
PG

L
M

IPDM E/R (INTELLIGENT POWER DISTRIBUTION MODULE ENGINE ROOM)

IPDM E/R STATUS CONTROL

In order to save power, IPDM E/R switches status by itself based on each operating condition.

1. CAN communication status
 - CAN communication is normally performed with other control units.
 - Individual unit control by IPDM E/R is normally performed.
 - When sleep request signal is received from BCM, mode is switched to sleep waiting status.
2. Sleep waiting status
 - Process to stop CAN communication is activated.
 - All systems controlled by IPDM E/R are stopped. When 1 second has elapsed after CAN communication with other control units is stopped, mode switches to sleep status.
3. Sleep status
 - IPDM E/R operates in low current-consumption mode.
 - CAN communication is stopped.
 - When a change in CAN communication signal is detected, mode switches to CAN communication status.
 - When a change in ignition switch signal is detected, mode switches to CAN communication status.

CAN Communication System Description

EKS008UF

Refer to [LAN-21, "CAN COMMUNICATION"](#) .

Function of Detecting Ignition Relay Malfunction

EKS008UG

- When the integrated ignition relay is stuck in a "closed contact" position and cannot be turned OFF, IPDM E/R turns ON tail and parking lamps for 10 minutes to indicate IPDM E/R malfunction.
- When the state of the integrated ignition relay does not agree with the state of the ignition switch signal received via CAN communication, the IPDM E/R activates the tail lamp relay.

Ignition switch signal	Ignition relay status	Tail lamp relay
ON	ON	—
OFF	OFF	—
ON	OFF	—
OFF	ON	ON (10 minutes)

NOTE:

When the ignition switch is turned ON, the tail lamps are OFF.

IPDM E/R (INTELLIGENT POWER DISTRIBUTION MODULE ENGINE ROOM)

EKS008UH

CONSULT-II Function (IPDM E/R)

CONSULT-II can display each diagnostic item using the diagnostic test modes shown following.

Inspection Item, Diagnosis Mode	Description
SELF-DIAG RESULTS	The IPDM E/R performs diagnosis of CAN communication and self-diagnosis.
DATA MONITOR	The input/output data of the IPDM E/R is displayed in real time.
ACTIVE TEST	The IPDM E/R sends a drive signal to electronic components to check their operation.
CAN DIAG SUPPORT MNTR	The results of transmit/receive diagnosis of CAN communication can be read.

CONSULT-II BASIC OPERATION

CAUTION:

If CONSULT-II is used with no connection of CONSULT-II CONVERTER, malfunctions might be detected in self-diagnosis depending on control unit which carries out CAN communication.

1. With the ignition switch OFF, connect CONSULT-II and CONSULT-II CONVERTER to the data link connector, then turn ignition switch ON.

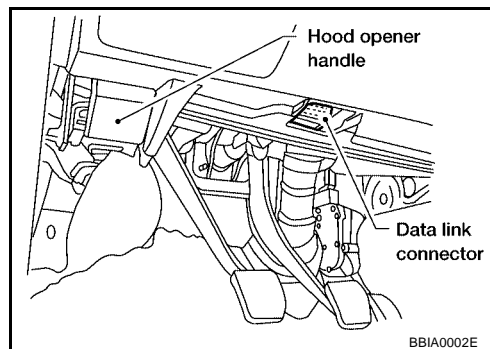

2. Touch "START (NISSAN BASED VHCL)".

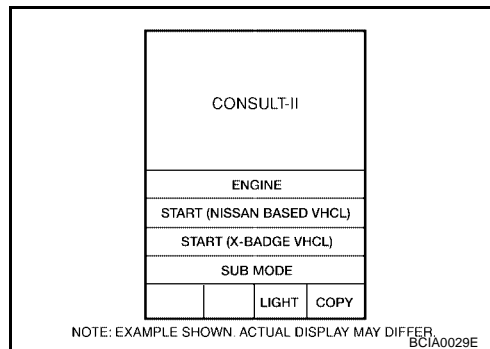

3. Touch "IPDM E/R" on "SELECT SYSTEM" screen.
 - If "IPDM E/R" is not displayed, print "SELECT SYSTEM" screen, then refer to [GI-39, "Consult-II Data Link Connector \(DLC\) Circuit"](#).

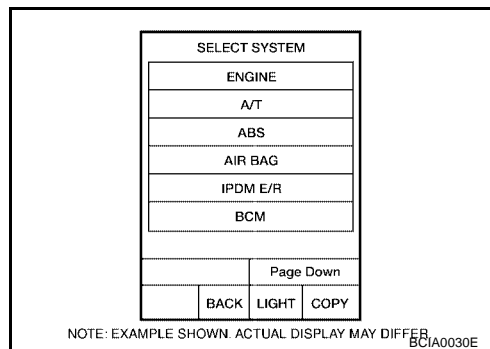

IPDM E/R (INTELLIGENT POWER DISTRIBUTION MODULE ENGINE ROOM)

- Select the desired part to be diagnosed on the "SELECT DIAG MODE" screen.

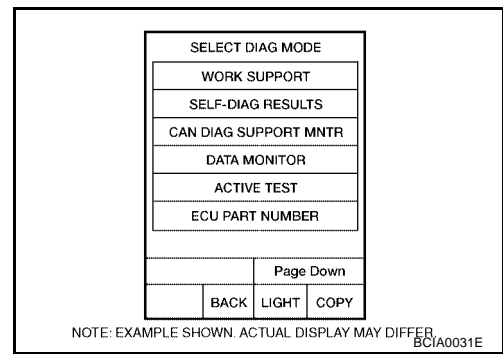

SELF-DIAGNOSTIC RESULTS

Operation Procedure

- Touch "SELF-DIAG RESULTS" on "SELECT DIAG MODE" screen.
- Self-diagnosis results are displayed.

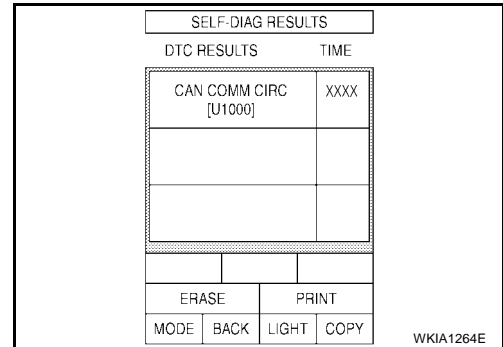

Display Item List

Display items	CONSULT-II display code	Malfunction detection	TIME		Possible causes
			CRNT	PAST	
NO DTC IS DETECTED. FURTHER TESTING MAY BE REQUIRED.	—	—	—	—	—
CAN COMM CIRC	U1000	<ul style="list-style-type: none"> If CAN communication reception/transmission data has a malfunction, or if any of the control units fail, data reception/transmission cannot be confirmed. When the data in CAN communication is not received before the specified time. 	X	X	Any of items listed below have errors: <ul style="list-style-type: none"> TRANSMIT DIAG ECM BCM/SEC

NOTE:

The details for display of the period are as follows:

- CRNT: Error currently detected with IPDM E/R.
- PAST: Error detected in the past and placed in IPDM E/R memory.

DATA MONITOR

Operation Procedure

- Touch "DATA MONITOR" on "SELECT DIAG MODE" screen.
- Touch "ALL SIGNALS", "MAIN SIGNALS" or "SELECT FROM MENU" on the "DATA MONITOR" screen.

ALL SIGNALS	All signals will be monitored.
MAIN SIGNALS	Monitors the predetermined item(s).
SELECT FROM MENU	Selects and monitors individual signal(s).

- Touch "START".
- Touch the required monitoring item on "SELECT ITEM MENU".

IPDM E/R (INTELLIGENT POWER DISTRIBUTION MODULE ENGINE ROOM)

5. Touch "RECORD" while monitoring to record the status of the item being monitored. To stop recording, touch "STOP".

A

B

C

D

E

F

G

H

I

J

PG

L

M

IPDM E/R (INTELLIGENT POWER DISTRIBUTION MODULE ENGINE ROOM)

All Signals, Main Signals, Select From Menu

Item name	CONSULT-II screen display	Display or unit	Monitor item selection			Description
			ALL SIGNALS	MAIN SIGNALS	SELECT FROM MENU	
Motor fan request	MOTOR FAN REQ	1/2/3/4	X	X	X	Signal status input from ECM
Compressor request	AC COMP REQ	ON/OFF	X	X	X	Signal status input from ECM
Tail & clear request	TAIL & CLR REQ	ON/OFF	X	X	X	Signal status input from BCM
H/L LO request	HL LO REQ	ON/OFF	X	X	X	Signal status input from BCM
H/L HI request	HL HI REQ	ON/OFF	X	X	X	Signal status input from BCM
FR fog request	FR FOG REQ	ON/OFF	X	X	X	Signal status input from BCM
FR wiper request	FR WIP REQ	STOP/1LO/LO/HI	X	X	X	Signal status input from BCM
Wiper auto stop	WIP AUTO STOP	ACT P/STOP P	X	X	X	Output status of IPDM E/R
Wiper protection	WIP PROT	OFF/LS/HS/Block	X	X	X	Control status of IPDM E/R
Starter request	ST RLY REQ	ON/OFF	X		X	Status of input signal ^{NOTE}
Ignition relay status	IGN RLY	ON/OFF	X	X	X	Ignition relay status monitored with IPDM E/R
Rear defogger request	RR DEF REQ	ON/OFF	X	X	X	Signal status input from BCM
Oil pressure switch	OIL P SW	OPEN/CLOSE	X		X	Signal status input from IPDM E/R
Hood switch	HOOD SW	OFF	X			Signal status input from IPDM E/R (function is not enabled)
Theft warning horn request	THFT HRN REQ	ON/OFF	X		X	Signal status input from BCM
Horn chirp	HORN CHIRP	ON/OFF	X		X	Output status of IPDM E/R

NOTE:

Perform monitoring of IPDM E/R data with the ignition switch ON. When the ignition switch is in ACC position, display may not be correct.

ACTIVE TEST

Operation Procedure

1. Touch "ACTIVE TEST" on "SELECT DIAG-MODE" screen.
2. Touch item to be tested, and check operation.
3. Touch "START".
4. Touch "STOP" while testing to stop the operation.

Test name	CONSULT-II screen display	Description
Tail lamp output	TAIL LAMP	With a certain ON-OFF operation, the tail lamp relay can be operated.
Rear defogger output	REAR DEFOGGER	With a certain ON-OFF operation, the rear defogger relay can be operated.
Front wiper (HI, LO) output	FRONT WIPER	With a certain operation (OFF, HI ON, LO ON), the front wiper relay (Lo, Hi) can be operated.
Cooling fan output	MOTOR FAN	With a certain operation (1, 2, 3, 4), the cooling fan can be operated.
Lamp (HI, LO, FOG) output	LAMPS	With a certain operation (OFF, HI ON, LO ON, FOG ON), the lamp relay (Lo, Hi, Fog) can be operated.
Horn output	HORN	With a certain ON-OFF operation, the horn relay can be operated.

IPDM E/R (INTELLIGENT POWER DISTRIBUTION MODULE ENGINE ROOM)

EKS008UI

Auto Active Test

DESCRIPTION

- In auto active test mode, operation inspection can be performed when IPDM E/R sends a drive signal to the following systems:
 - Rear window defogger
 - Front wipers
 - Tail and parking lamps
 - Front fog lamps
 - Headlamps (Hi, Lo)
 - A/C compressor (magnetic clutch)
 - Cooling fan

OPERATION PROCEDURE

1. Close hood and front door RH, and lift wiper arms away from windshield (to prevent glass damage by wiper operation).

NOTE:

When auto active test is performed with hood opened, sprinkle water on windshield beforehand.

2. Turn ignition switch OFF.
3. Turn ignition switch ON and, within 20 seconds, press front door switch LH 10 times. Then turn ignition switch OFF.
4. Turn ignition switch ON within 10 seconds after ignition switch OFF.
5. When auto active test mode is actuated, horn chirps once.
6. After a series of operations is repeated three times, auto active test is completed.

NOTE:

When auto active test mode has to be cancelled halfway, turn ignition switch OFF.

CAUTION:

Be sure to perform **BL-30, "Door Switch Check"** when the auto active test cannot be performed.

INSPECTION IN AUTO ACTIVE TEST MODE

- When auto active test mode is actuated, the following eight steps are repeated three times.

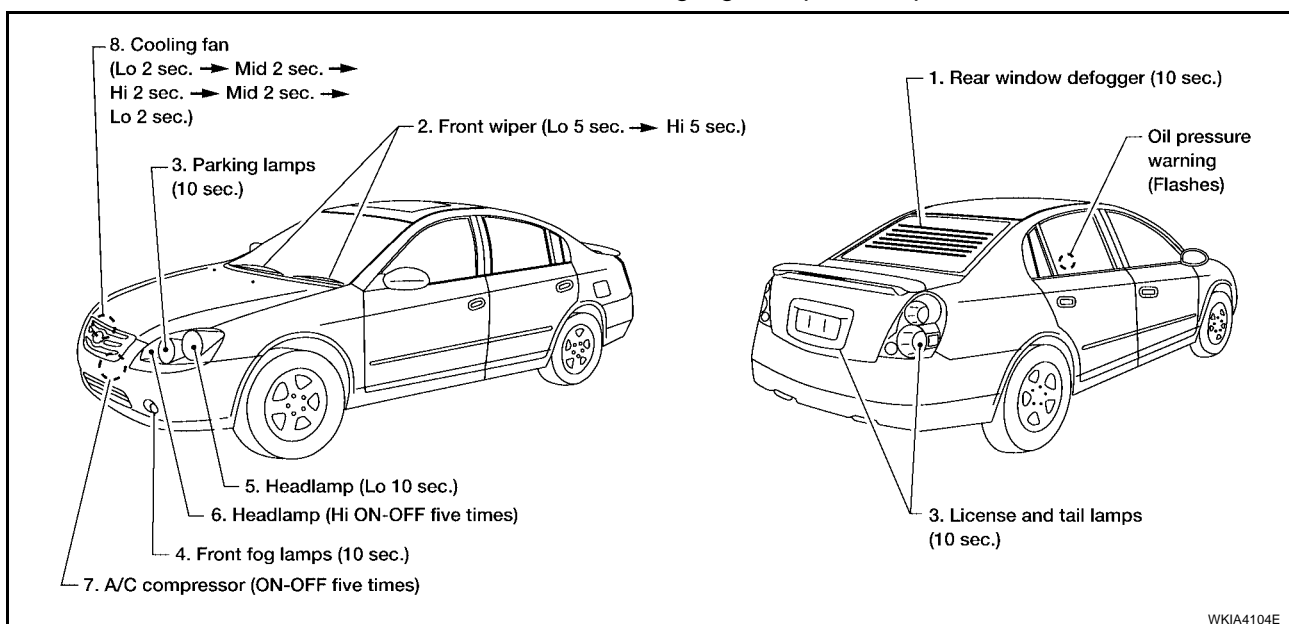

Concept of Auto Active Test

- IPDM E/R actuates auto active test mode when it receives door switch signal from BCM via CAN communication line. Therefore, when auto active test mode is activated successfully, CAN communication between IPDM E/R and BCM is normal.
- If any of systems controlled by IPDM E/R cannot be operated, possible cause can be easily diagnosed using auto active test.

IPDM E/R (INTELLIGENT POWER DISTRIBUTION MODULE ENGINE ROOM)

Diagnosis chart in auto active test mode

Symptom	Inspection contents	Possible cause	
Rear window defogger does not operate.	Perform auto active test. Does rear window defogger operate?	YES	<ul style="list-style-type: none"> ● BCM signal input circuit
		NO	<ul style="list-style-type: none"> ● Rear window defogger relay ● Open circuit of rear window defogger ● IPDM E/R malfunction ● Harness or connector malfunction between IPDM E/R and rear window defogger
Any of front wipers, tail and parking lamps, front fog lamps, and headlamps (Hi, Lo) do not operate.	Perform auto active test. Does system in question operate?	YES	<ul style="list-style-type: none"> ● BCM signal input system
		NO	<ul style="list-style-type: none"> ● Lamp/wiper motor malfunction ● Lamp/wiper motor ground circuit malfunction ● Harness/connector malfunction between IPDM E/R and system in question ● IPDM E/R (integrated relay) malfunction
A/C compressor does not operate.	Perform auto active test. Does magnetic clutch operate?	YES	<ul style="list-style-type: none"> ● BCM signal input circuit ● CAN communication signal between BCM and ECM. ● CAN communication signal between ECM and IPDM E/R
		NO	<ul style="list-style-type: none"> ● Magnetic clutch malfunction ● Harness/connector malfunction between IPDM E/R and magnetic clutch ● IPDM E/R (integrated relay) malfunction
Cooling fan does not operate.	Perform auto active test. Does cooling fan operate?	YES	<ul style="list-style-type: none"> ● ECM signal input circuit ● CAN communication signal between ECM and IPDM E/R
		NO	<ul style="list-style-type: none"> ● Cooling fan motor malfunction ● Harness/connector malfunction between IPDM E/R and cooling fan motor ● IPDM E/R (integrated relay) malfunction
Oil pressure warning lamp does not operate.	Perform auto active test. Does oil pressure warning lamp blink?	YES	<ul style="list-style-type: none"> ● Harness/connector malfunction between IPDM E/R and oil pressure switch ● Oil pressure switch malfunction ● IPDM E/R
		NO	<ul style="list-style-type: none"> ● CAN communication signal between BCM and Combination Meter ● Combination meter

IPDM E/R (INTELLIGENT POWER DISTRIBUTION MODULE ENGINE ROOM)

Schematic

EKS008UJ

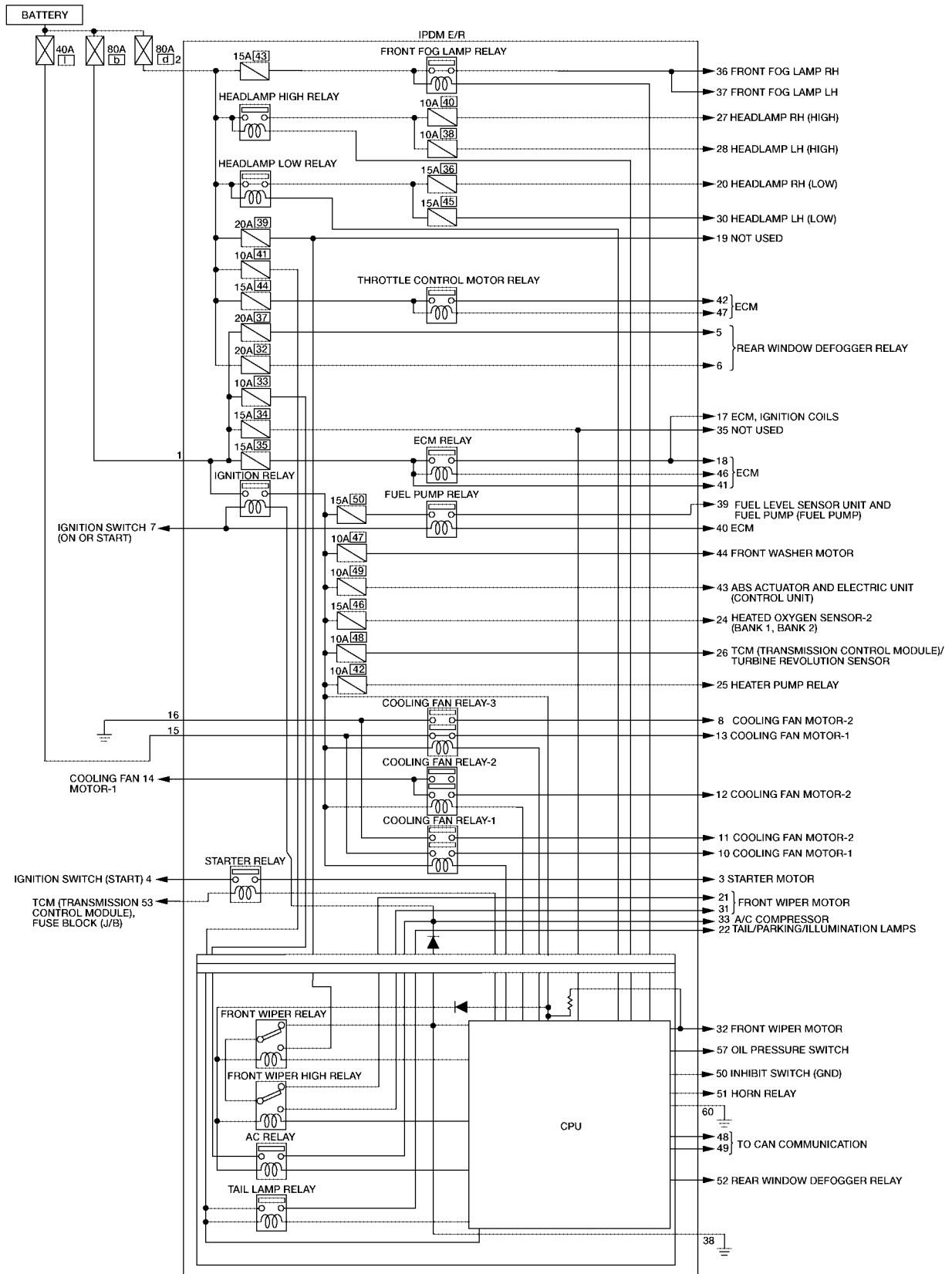

WKWA1575E

IPDM E/R (INTELLIGENT POWER DISTRIBUTION MODULE ENGINE ROOM)

IPDM E/R TERMINAL ARRANGEMENT

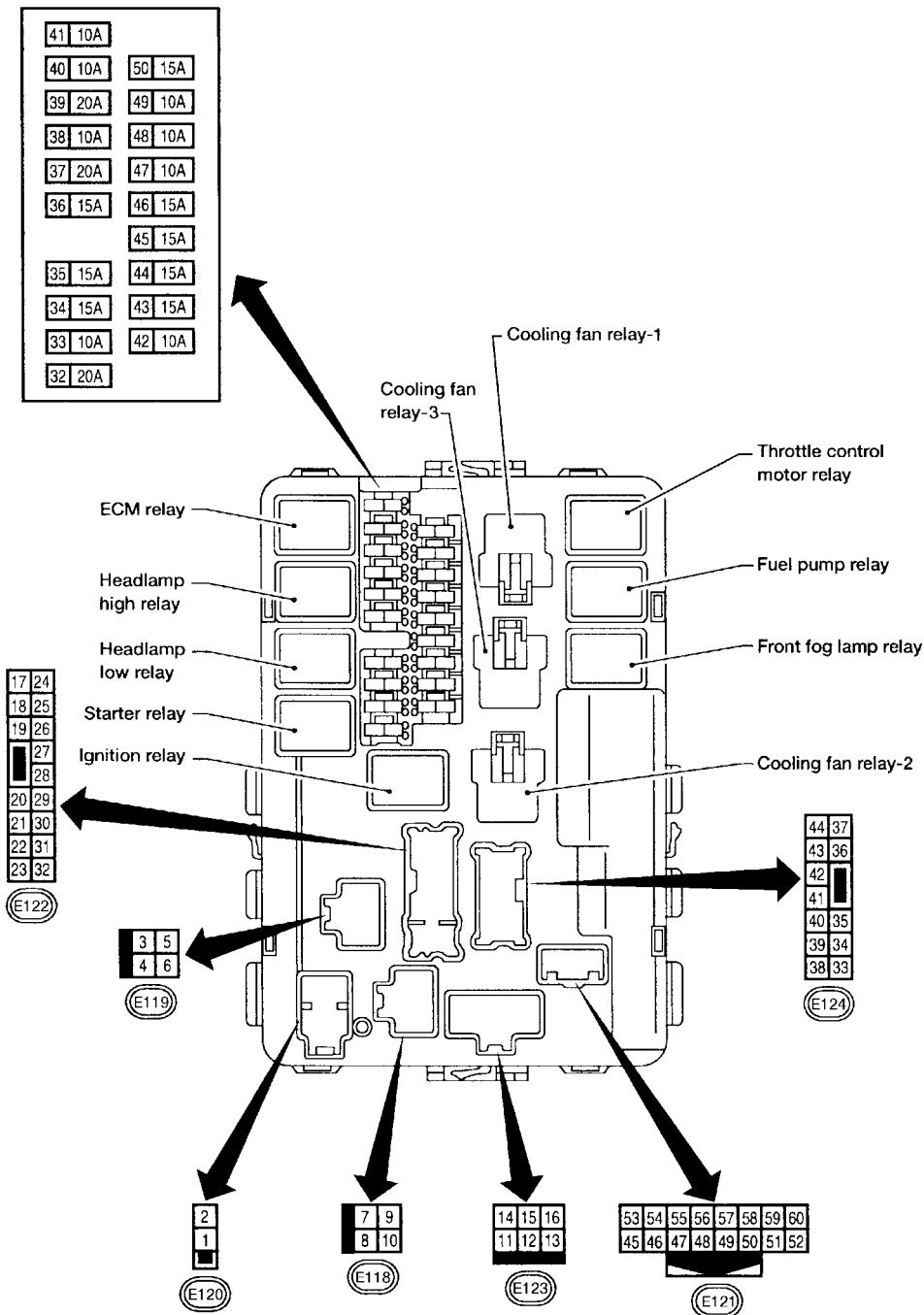

IPDM E/R (INTELLIGENT POWER DISTRIBUTION MODULE ENGINE ROOM)

IPDM E/R Power/Ground Circuit Inspection

EKS00FPL

1. FUSE AND FUSIBLE LINK INSPECTION

Check that the following fusible links are not blown.

Terminal No.	Signal name	Fusible link No.
1, 2	Battery power	a, b, d

OK or NG

- OK >> GO TO 2.
- NG >> Replace fusible link.

2. POWER CIRCUIT INSPECTION

- Disconnect IPDM E/R harness connector E120.
- Check voltage between IPDM E/R harness connector and ground.

Terminals		(-)	Voltage (Approx.)
(+)			
IPDM E/R connector	Terminal		
E120	1, 2	Ground	Battery voltage

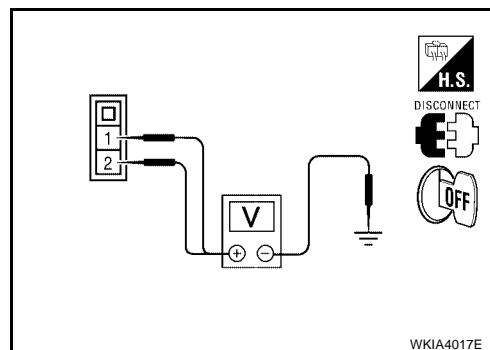

OK or NG

- OK >> GO TO 3.
- NG >> Repair or replace IPDM E/R power circuit harness.

3. GROUND CIRCUIT INSPECTION

- Disconnect IPDM E/R harness connectors E121 and E124.
- Check continuity between IPDM E/R harness connectors and ground.

A		B		Continuity
Connector	Terminal	Connector	Terminal	
IPDM E/R: E121	60	IPDM E/R: E124	38	Yes

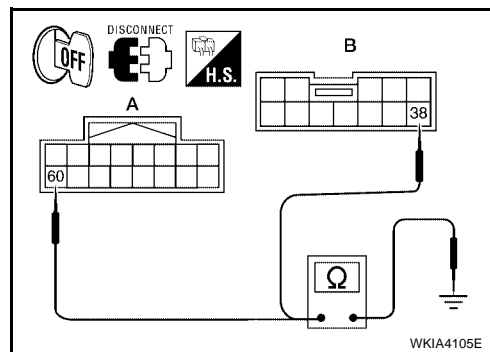

OK or NG

- OK >> Inspection End.
- NG >> Repair or replace ground circuit harness of IPDM E/R.

IPDM E/R (INTELLIGENT POWER DISTRIBUTION MODULE ENGINE ROOM)

Inspection with CONSULT-II (Self-Diagnosis)

EKS008UL

CAUTION:

If a CONSULT-II is used with no connection of CONSULT-II CONVERTER, malfunctions might be detected in self-diagnosis depending on which control unit(s) carry out CAN communication.

1. SELF-DIAGNOSIS RESULT CHECK

1. Connect CONSULT-II and select "IPDM E/R" on the Diagnosis System Selection screen.
2. Select "SELF-DIAG RESULTS" on the diagnosis mode selection screen.
3. Check display content in self-diagnosis results.

CONSULT-II Display	CONSULT-II display code	TIME		Details of diagnosis result
		CRNT	PAST	
NO DTC IS DETECTED. FURTHER TESTING MAY BE REQUIRED.	—	—	—	No malfunction
CAN COMM CIRC	U1000	X	X	Any of items listed below have errors: <ul style="list-style-type: none">● TRANSMIT DIAG● ECM● BCM/SEC

NOTE:

The Details for Display for the Period are as follows:

- CRNT: Error currently detected by IPDM E/R.
- PAST: Error detected in the past and stored in IPDM E/R memory.

Contents displayed

NO DTC DETECTED. FURTHER TESTING MAY BE REQUIRED.>>INSPECTION END.

CAN COMM CIRC>>Print out the self-diagnosis result and refer to [LAN-21, "CAN COMMUNICATION"](#) .

IPDM E/R (INTELLIGENT POWER DISTRIBUTION MODULE ENGINE ROOM)

EKS008UM

Removal and Installation of IPDM E/R

REMOVAL

1. Disconnect the negative battery cable.
2. Remove 2 bolts and position coolant reservoir aside.
3. Remove IPDM E/R upper cover.
4. Remove IPDM E/R harness cover.

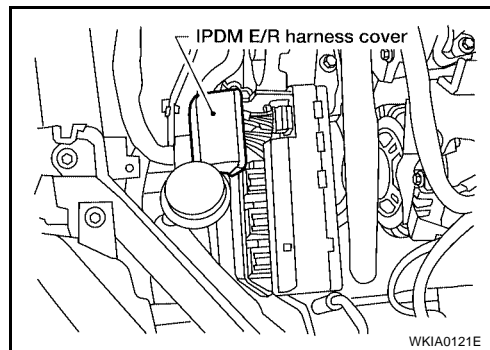
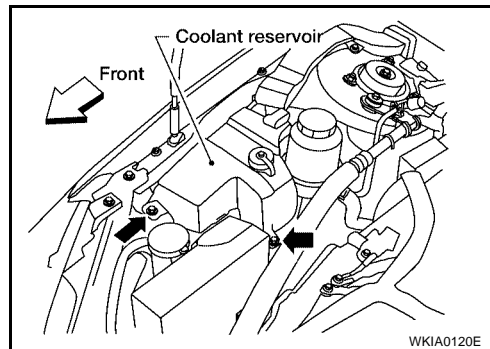

5. Release 2 clips and pull IPDM E/R up from case.
6. Disconnect IPDM E/R connectors and then remove the IPDM E/R.

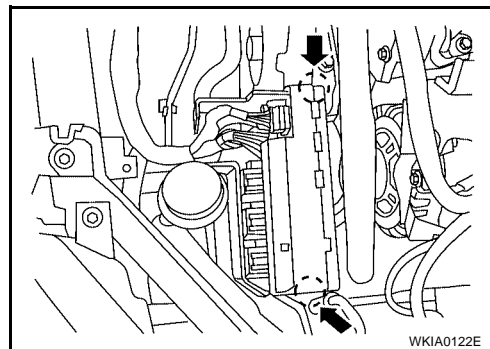

INSTALLATION

Installation is in the reverse order of removal.

A
B
C
D
E
F
G
H
I
J
PG
L
M

GROUND CIRCUIT

PFP:24080

EKS008UN

GROUND CIRCUIT Ground Distribution MAIN HARNESS

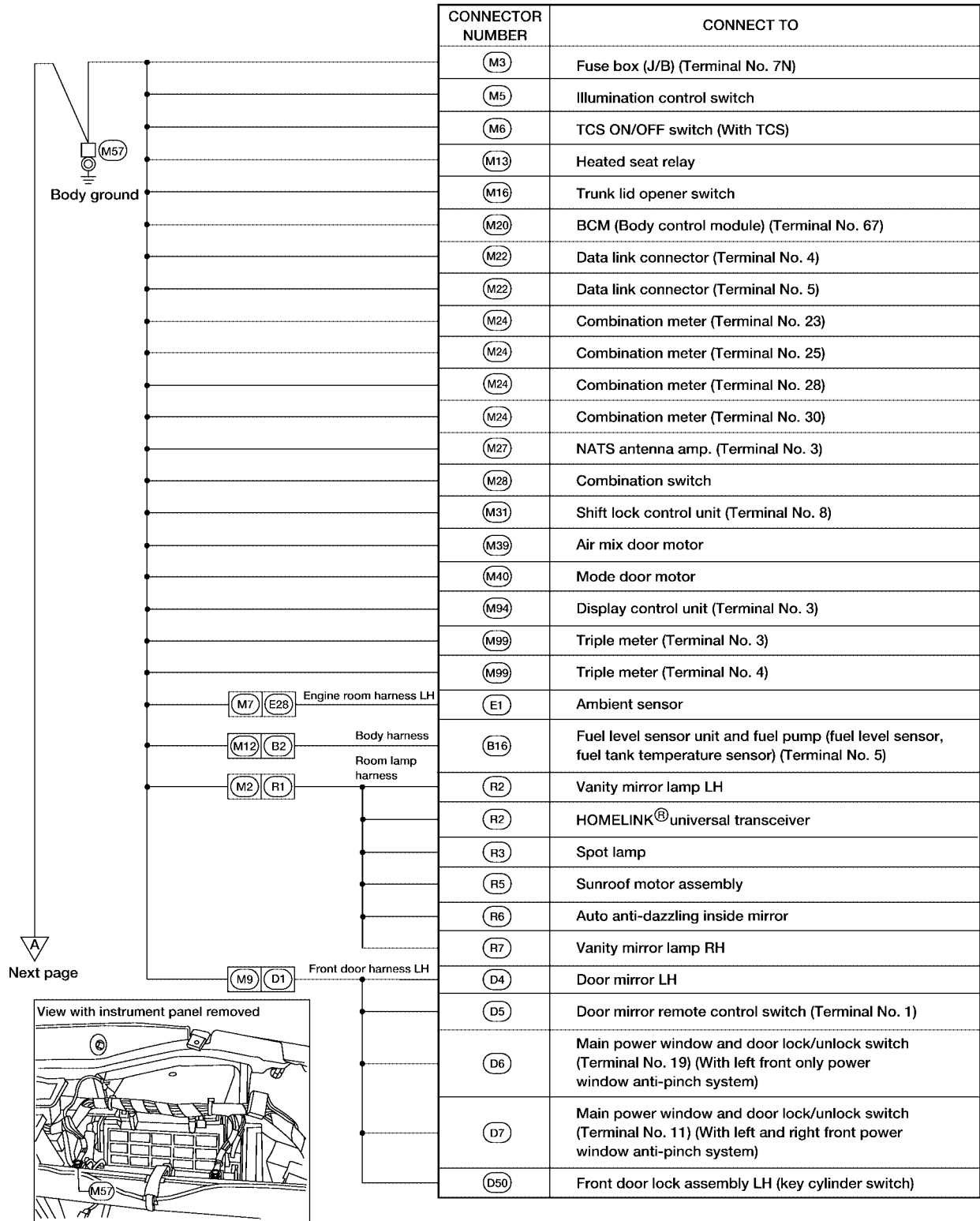

Next page

WKIA4106E

GROUND CIRCUIT

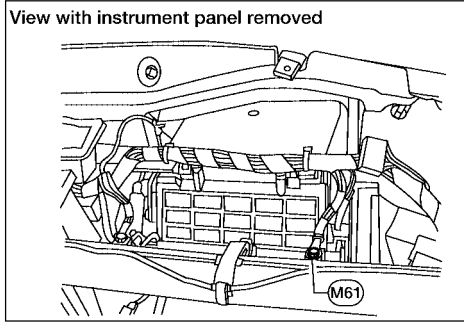

QR : WITH QR25DE
VQ : WITH VQ35DE

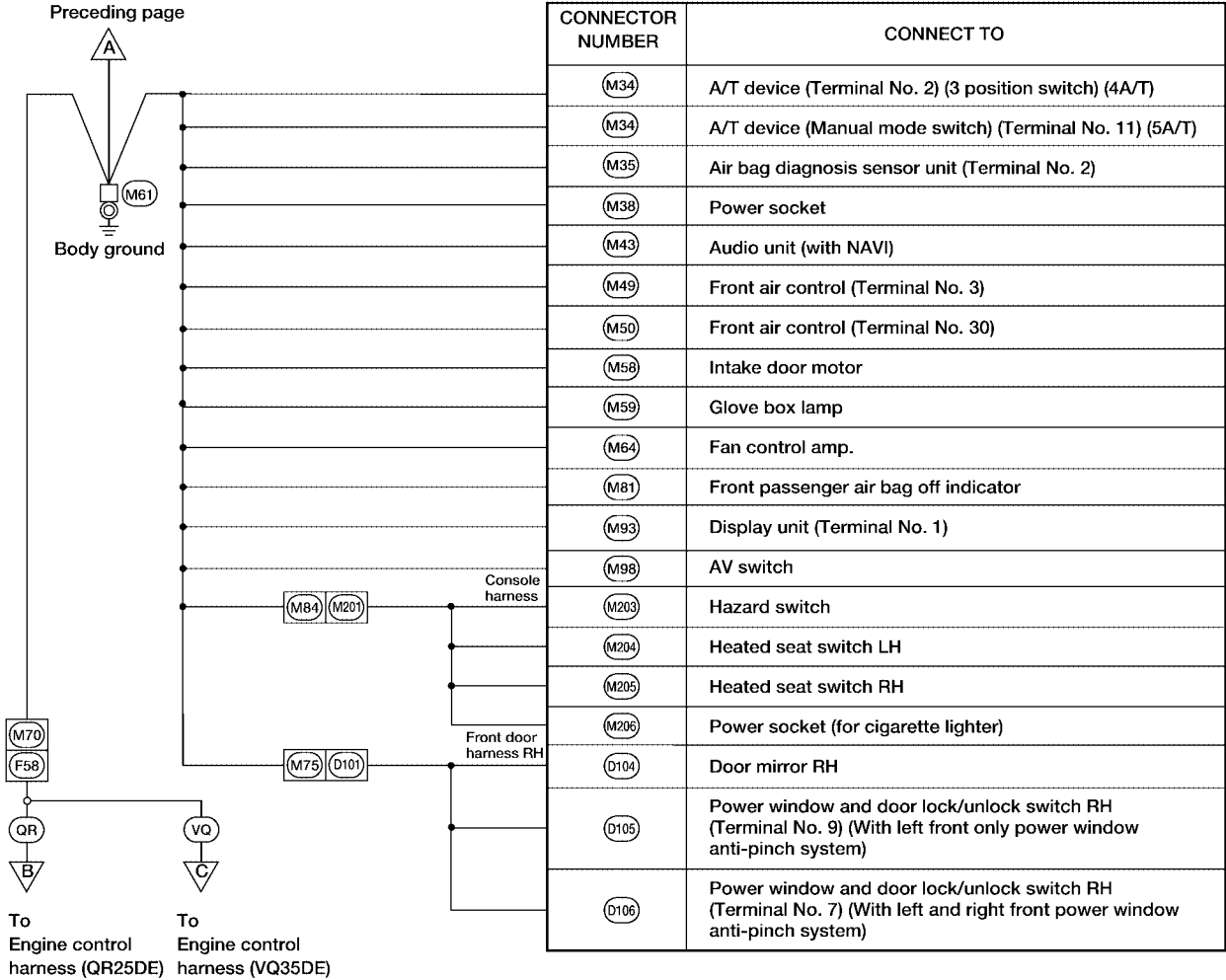

A
B
C
D
E
F
G
H
I
J
PG
L
M

WKIA3144E

GROUND CIRCUIT

ENGINE ROOM HARNESS

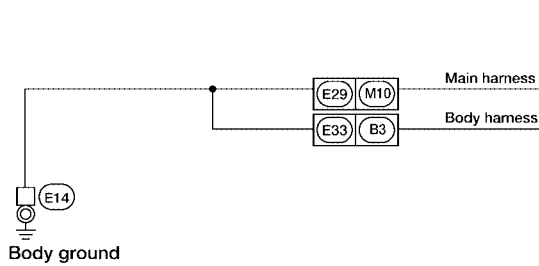
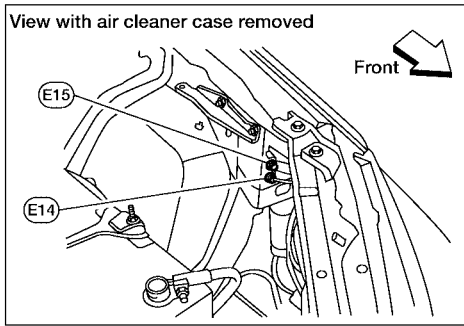

CONNECTOR NUMBER	CONNECT TO
(M35)	Air bag diagnosis sensor unit (Shield wire) (Terminal No.16)
(B16)	Fuel level sensor unit and fuel pump (Fuel Pump)

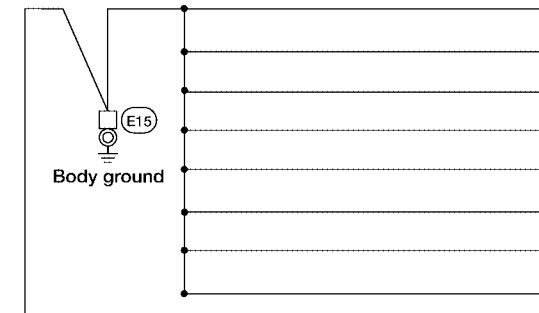

CONNECTOR NUMBER	CONNECT TO
(E2)	Front fog lamp LH
(E11)	Headlamp LH (High)
(E12)	Front combination lamp LH
(E13)	Headlamp LH (Low)
(E16)	Brake fluid level switch
(E23)	Front wiper motor
(E34)	Clutch interlock switch (With M/T)
(E124)	IPDM E/R (Terminal No. 38)

D
Next page

GROUND CIRCUIT

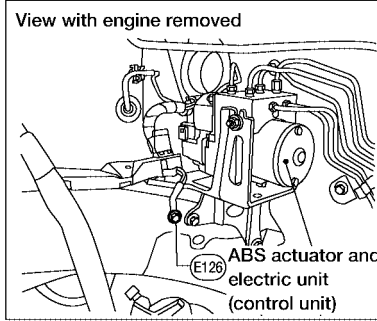
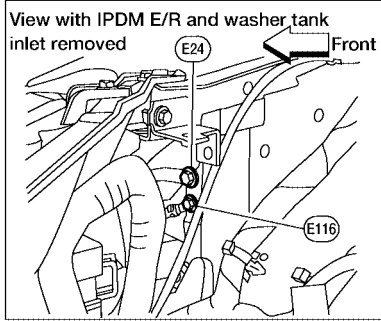

Preceding page

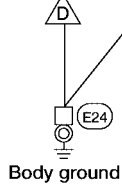

CONNECTOR NUMBER	CONNECT TO
E101	Front fog lamp RH
E103	Daytime light control unit (Canada only) (Terminal No. 14)
E104	Daytime light control unit (Canada only) (Terminal No. 13)
E104	Daytime light control unit (Canada only) (Terminal No. 16)
E106	Washer fluid level sensor
E107	Headlamp RH (Low)
E109	Front combination lamp RH
E110	Headlamp RH (High)
E113	Cooling fan motor 1 (Terminal No. 3)
E113	Cooling fan motor 1 (Terminal No. 4)
E121	IPDM E/R (Terminal No. 60)
E123	IPDM E/R (Cooling fan relay-1, cooling fan relay-3) (Terminal No. 16)

CONNECTOR NUMBER	CONNECT TO
E112	Generator

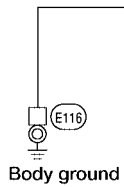

CONNECTOR NUMBER	CONNECT TO
E125	ABS actuator and electric unit (control unit) (Terminal No. 16)
E125	ABS actuator and electric unit (control unit) (Terminal No. 19)

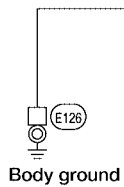

WKIA2755E

GROUND CIRCUIT

ENGINE CONTROL HARNESS (QR25DE)

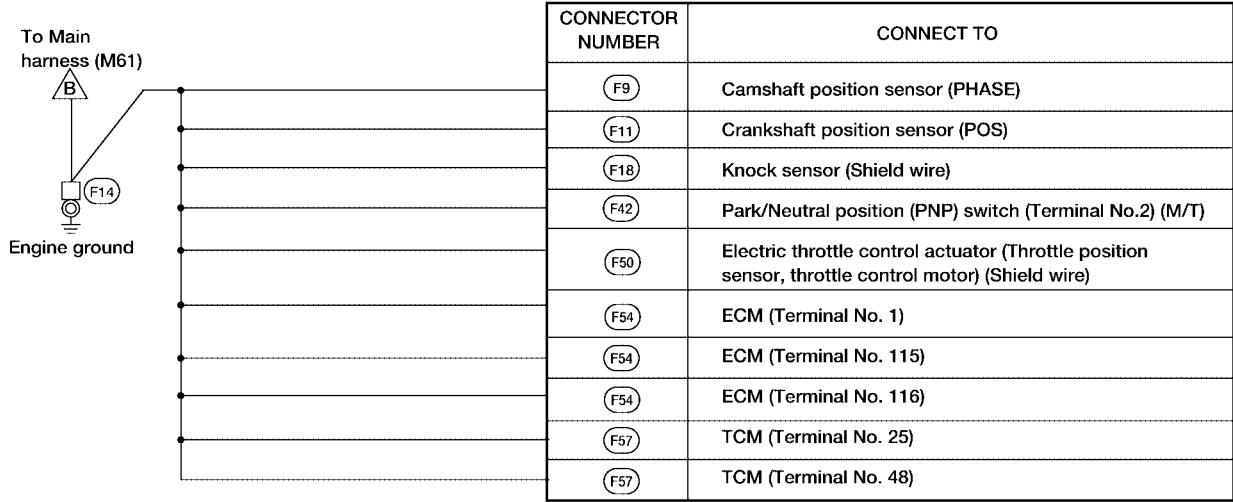
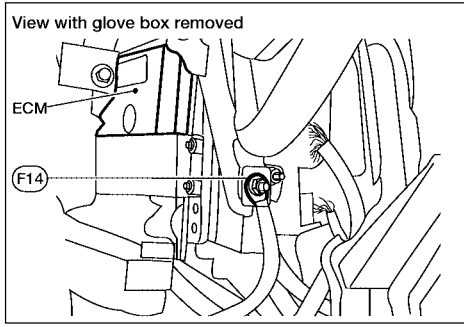

WKIA2756E

GROUND CIRCUIT

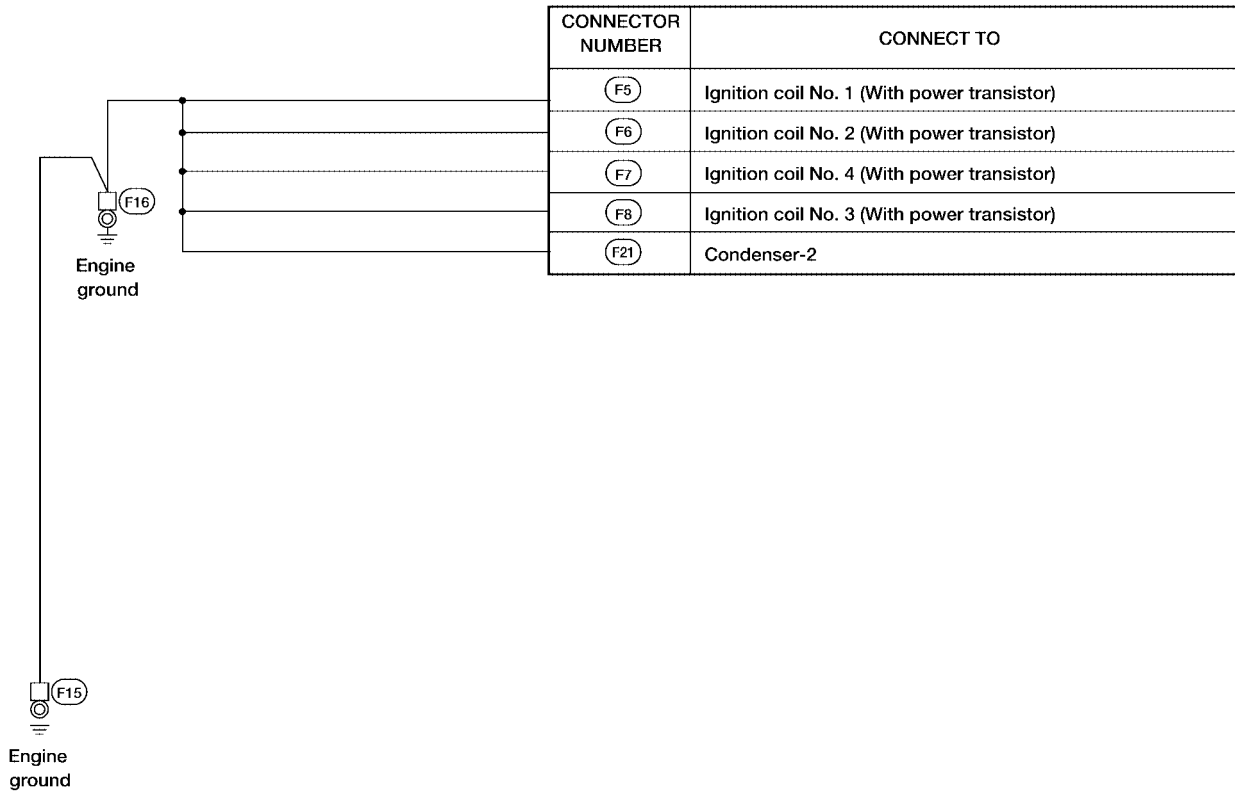
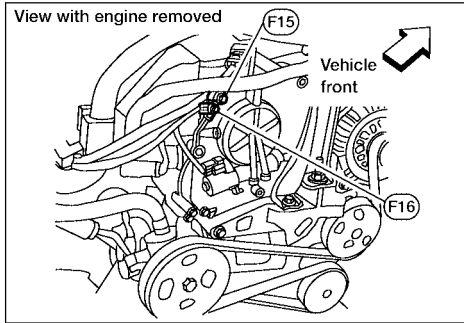

A
B
C
D
E
F
G
H
I
J
L
M

PG

WKIA2757E

GROUND CIRCUIT

ENGINE CONTROL HARNESS (VQ35DE)

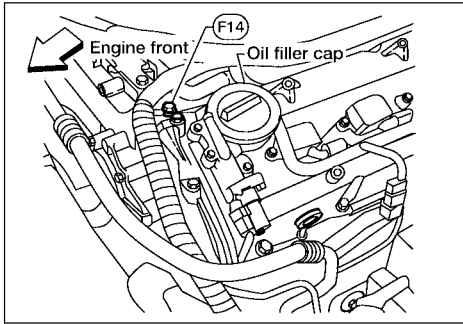

To Main
Harness (M61)

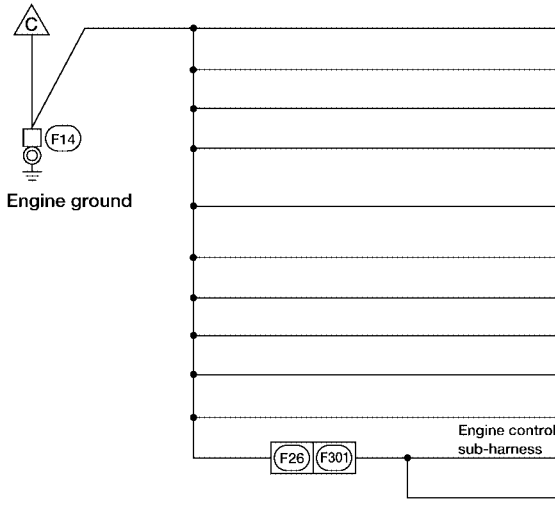

CONNECTOR NUMBER	CONNECT TO
F11	Crankshaft position sensor (POS)
F23	Camshaft position sensor (PHASE) (Bank 2)
F29	Park/Neutral Position (PNP) switch (Terminal No. 6)
F42	Park/Neutral Position (PNP) switch (M/T)
F50	Electric throttle control actuator (Throttle control motor, throttle position sensor) (Shield wire)
F54	ECM (Terminal No. 1)
F54	ECM (Terminal No. 115)
F54	ECM (Terminal No. 116)
F56	TCM (Terminal No. 14)
F57	TCM (Terminal No. 48)
F302	Knock sensor (Shield wire)
F303	Camshaft position sensor (PHASE) (Bank 1)

WKIA3347E

GROUND CIRCUIT

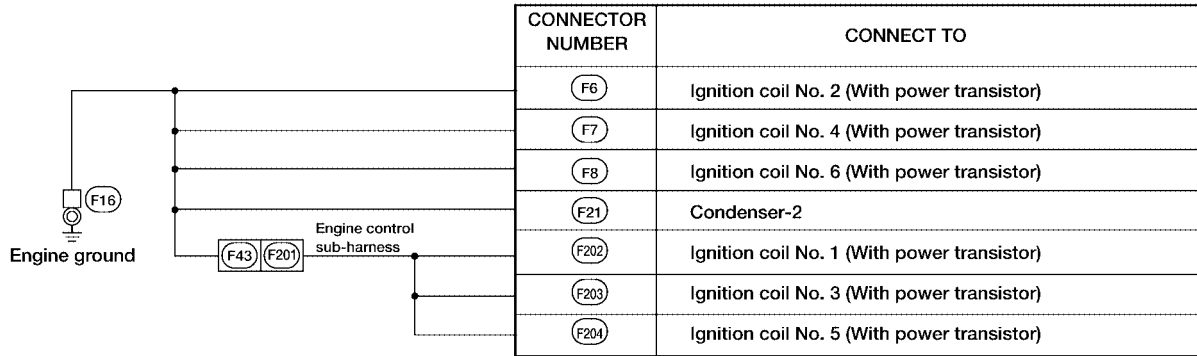
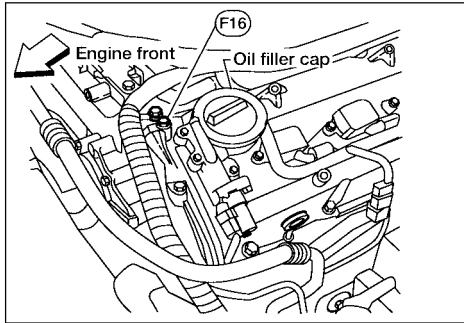

A
B
C
D
E
F
G
H
I
J
PG
L
M

WKIA2759E

GROUND CIRCUIT

BODY HARNESS

View with center pillar garnish LH removed

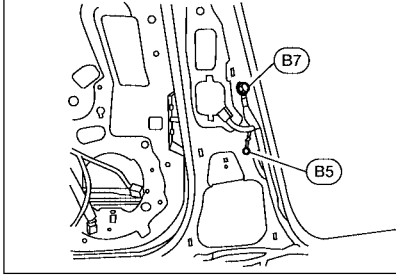

View with rear seatback removed

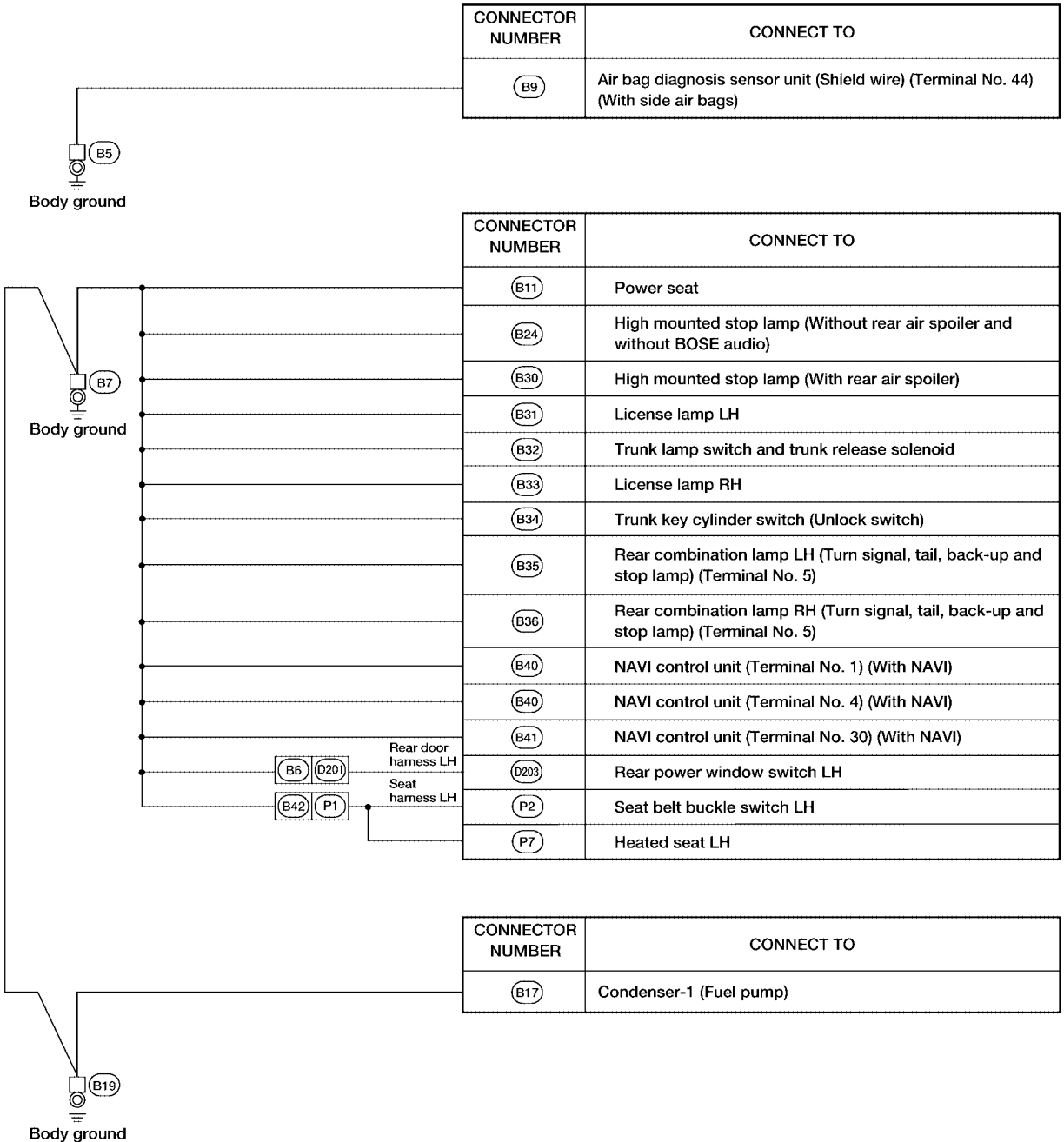
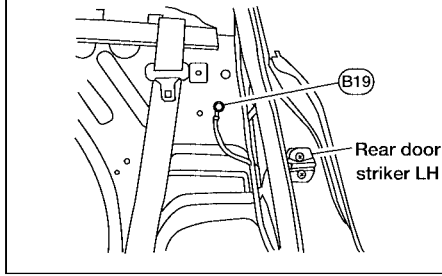

WKIA3145E

GROUND CIRCUIT

BODY NO. 2 HARNESS

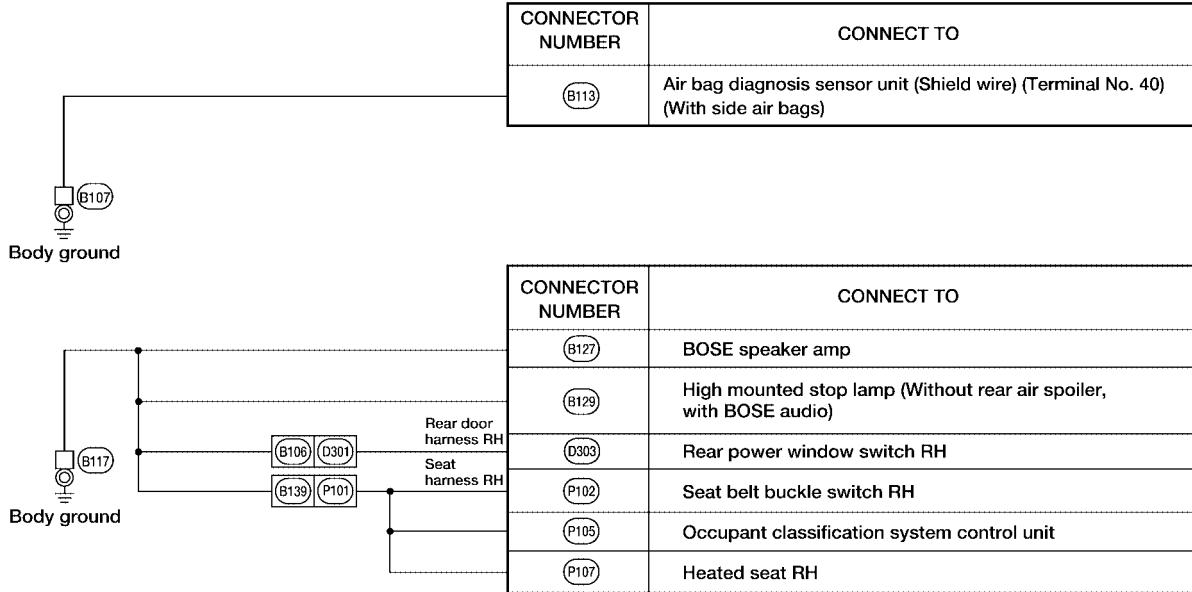
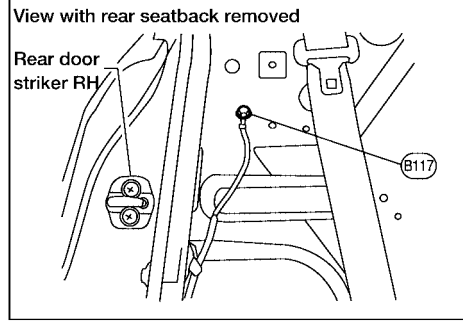
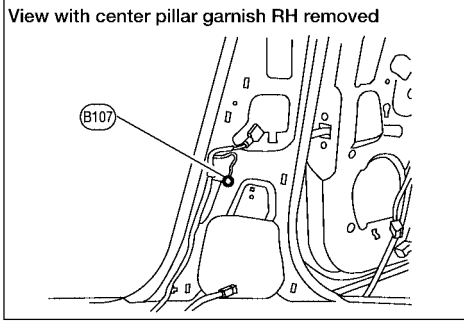

A
B
C
D
E
F
G
H
I
J
PG
L
M

GROUND CIRCUIT

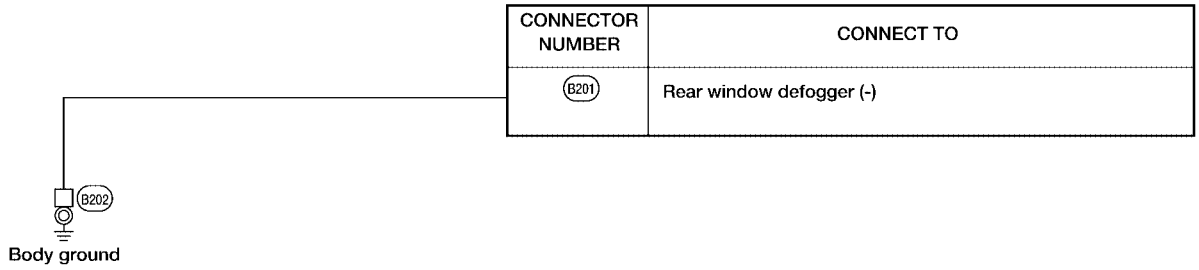
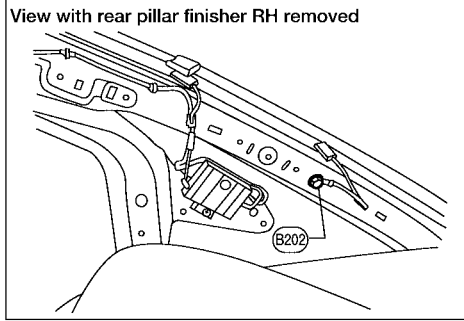

WKIA2762E

HARNESS

PFP:24010

EKS008UO

HARNESS

Harness Layout

HOW TO READ HARNESS LAYOUT

The following Harness Layouts use a map style grid to help locate connectors on the drawings:

- Main Harness and Console Sub-harness
- Engine Room Harness LH (Engine Compartment)
- Engine Room Harness RH (Engine Compartment)
- Engine Control Harness and Engine Control Sub-Harness (QR25DE)
- Engine Control Harness, Engine Control Sub-harness-1, Engine Control Sub-Harness-2, and Engine Control Sub-harness-3 (VQ35DE)
- Body Harness
- Body No. 2 Harness

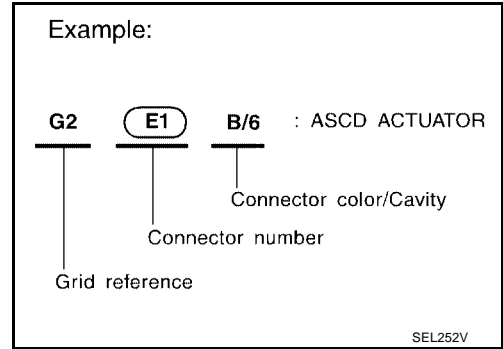

To use the grid reference

1. Find the desired connector number on the connector list.
2. Find the grid reference.
3. On the drawing, find the crossing of the grid reference letter column and number row.
4. Find the connector number in the crossing zone.
5. Follow the line (if used) to the connector.

CONNECTOR SYMBOL

Main symbols of connector (in Harness Layout) are indicated below.

Connector type	Water proof type		Standard type	
	Male	Female	Male	Female
<ul style="list-style-type: none"> ● Cavity: 4 or Less ● Relay connector 				
<ul style="list-style-type: none"> ● Cavity: From 5 to 8 				
<ul style="list-style-type: none"> ● Cavity: 9 or More 				
<ul style="list-style-type: none"> ● Ground terminal etc. 	—			

HARNESS

OUTLINE

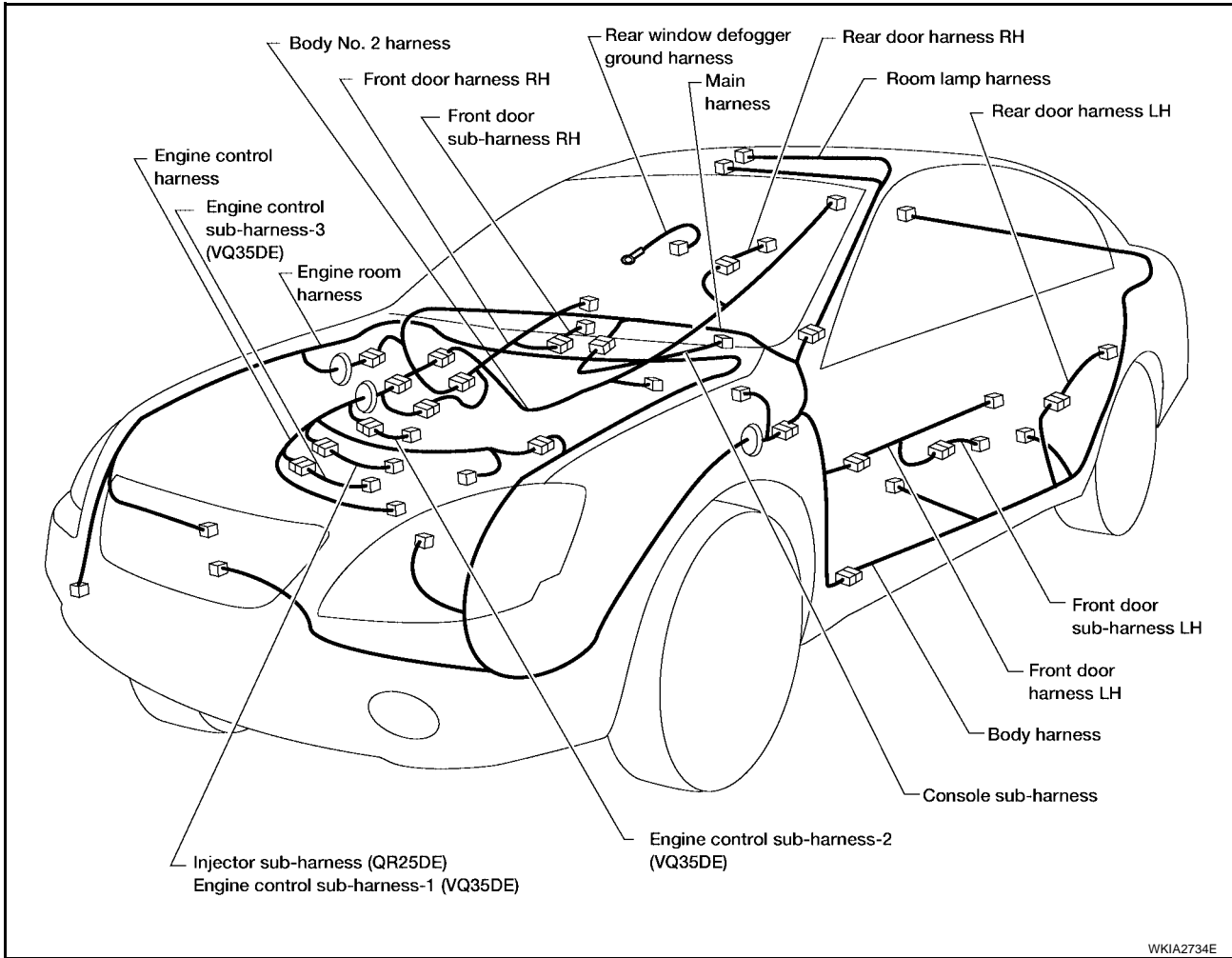

HARNESS

MAIN HARNESS

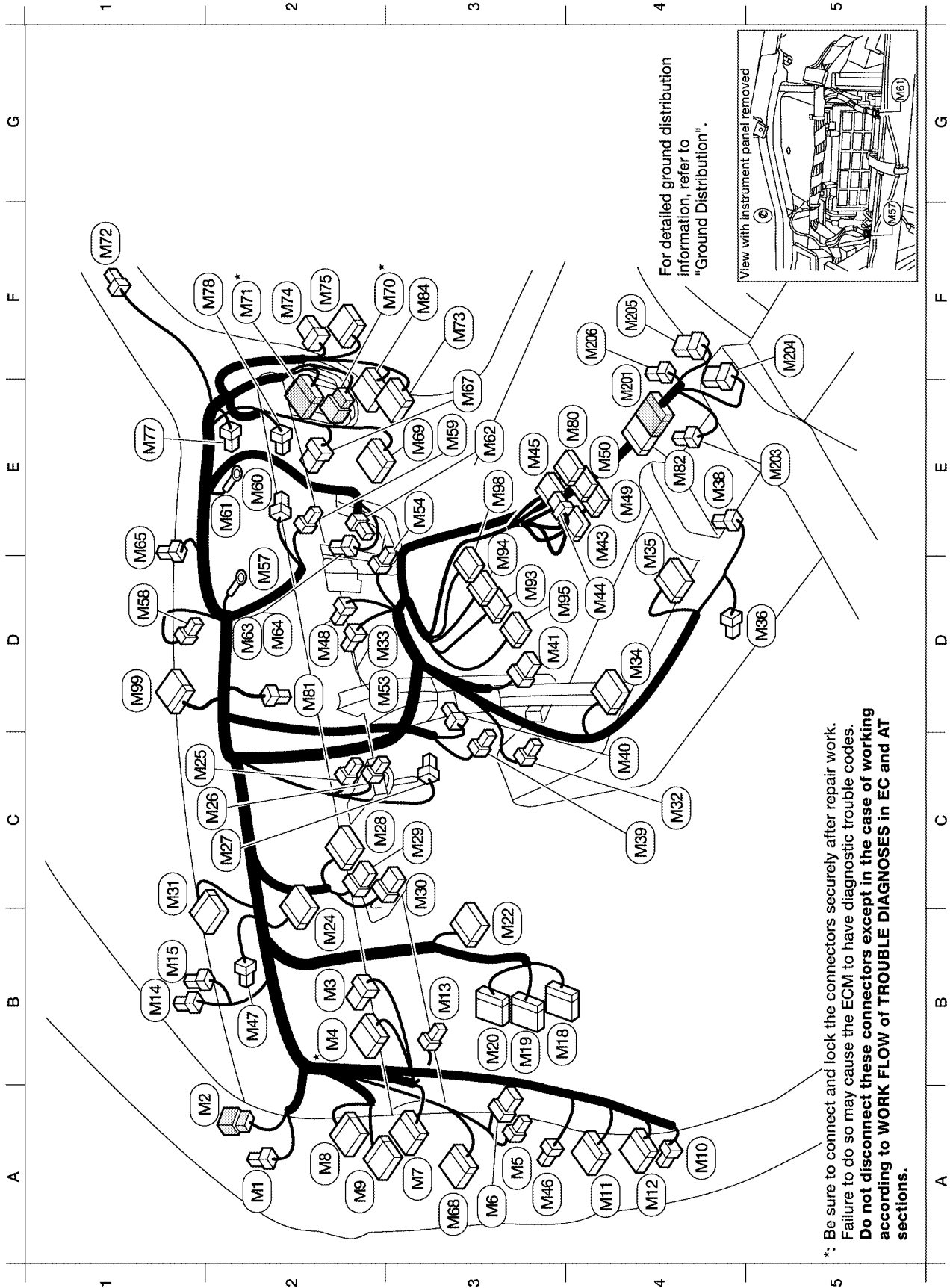

*: Be sure to connect and lock the connectors securely after repair work. Failure to do so may cause the ECM to have diagnostic trouble codes. Do not disconnect these connectors except in the case of working according to WORK FLOW of TROUBLE DIAGNOSES in EC and AT sections.

WKIA4107E

HARNESSES

A2	(M1)	BR/2	: Tweeter LH	C4	(M32)	W/2	: In-vehicle sensor (with auto A/C)	D2	(M64)	W/4	: Fan control amp. (with auto A/C)
A2	(M2)	W/6	: To (E1)(without vanity mirror lamps)	D2	(M33)	W/2	: Intake sensor (with auto A/C)	E1	(M65)	B/2	: Sunload sensor (with auto A/C)
A2	(M2)	W/8	: To (E1)(with vanity mirror lamps)	D4	(M34)	W/16	: A/T device	E3	(M67)	W/8	: To (E13)
B2	(M3)	W/8	: Fuse block (J/B)	E4	(M35)	Y/28	: Air bag diagnosis sensor unit	A3	(M68)	BR/16	: To (G38)
B2 *	(M4)	W/16	: Fuse block (J/B)	D5	(M38)	B/1	: Parking brake switch	E3	(M69)	W/16	: To (G10)
A3	(M5)	W/3	: Illumination control switch	E4	(M38)	B/2	: Power socket	F3	(M70)	W/6	: To (F58)
A3	(M6)	GY/6	: TCS ON/OFF switch (with TCS)	C4	(M39)	W/3	: Air mix door motor (with auto A/C)	F2	(M71)	W/24	: To (F59)
A3	(M7)	W/18	: To (E28)	C4	(M40)	W/3	: Mode door motor	F1	(M72)	BR/2	: Tweeter RH
A2	(M8)	W/16	: To (D2)	D3	(M41)	W/6	: Fan switch (with manual A/C or heater only)	F3	(M73)	W/12	: To (G103)
A2	(M9)	W/12	: To (D1)	E4	(M43)	W/10	: Audio unit	F2	(M74)	W/8	: To (G102)
A4	(M10)	Y/4	: To (E29)	E4	(M44)	W/6	: Audio unit	F2	(M75)	W/10	: To (G101)
A4	(M11)	W/16	: To (B1)	E3	(M45)	W/16	: Audio unit	E1	(M77)	Y/2	: Front passenger air bag module
A4	(M12)	W/16	: To (B2)	A3	(M46)	B/2	: To (E7)	F1	(M78)	OR/2	: Front passenger air bag module
B3	(M13)	L/4	: Heated seat relay	B2	(M47)	W/4	: Remote keyless entry receiver	E4	(M80)	W/12	: Audio unit
B1	(M14)	BR/2	: Security indicator lamp	D2	(M48)	W/2	: Antenna amplifier	D2	(M81)	W/3	: Front passenger air bag off indicator
B1	(M15)	W/3	: Auto light sensor (w/auto light system)	E4	(M49)	GY/20	: Front air control	E4	(M82)	W/10	: To (M231)
B3	(M18)	W/40	: BCM (Body control module)	E4	(M50)	GY/16	: Front air control	F3	(M84)	W/12	: To (G133)
B3	(M19)	W/15	: BCM (Body control module)	D2	(M53)	W/2	: Intake sensor (with manual A/C)	D3	(M83)	W/24	: Display unit
B3	(M20)	B/15	: BCM (Body control module)	E3	(M54)	W/2	: Trunk lid opener cancel switch	E3	(M84)	W/24	: Display control unit (with NAVI)
B3	(M22)	W/16	: Data link connector	D2	(M57)	-	: Body ground	D3	(M85)	W/32	: Display control unit (with NAVI)
B2	(M24)	W/40	: Combination meter	D1	(M58)	W/3	: Intake door motor	E3	(M88)	W/16	: AV switch
C2	(M25)	W/2	: Ignition key illumination	E3	(M59)	BR/2	: Glove box lamp	D1	(M89)	W/12	: Triple meter
C2	(M26)	W/4	: Key switch and key lock solenoid	E2	(M60)	Y/4	: Front passenger air bag service replacement connector	Console sub-harness			
C2	(M27)	W/4	: NATS antenna amp	E2	(M61)	-	: Body ground	E4	(M231)	W/12	: To (M84)
C2	(M28)	W/16	: Combination switch	E3	(M62)	W/2	: Blower motor	E5	(M233)	W/4	: Hazard switch
C3	(M29)	Y/6	: Combination switch	D2	(M63)	BR/2	: To (G132)	F5	(M234)	W/6	: Heated seat switch LH
C3	(M30)	GY/8	: Combination switch	D2	(M63)	BR/2	: To (G132)	F4	(M235)	BR/6	: Heated seat switch RH
C1	(M31)	GY/10	: Shift lock control unit (with A/T)	E2	(M61)	-	: Body ground	F4	(M236)	B/2	: Power socket (for cigarette lighter)

*: Be sure to connect and lock the connectors securely after repair work.
Failure to do so may cause the ECM to have diagnostic trouble codes.
Do not disconnect these connectors except in the case of working according to WORK FLOW of TROUBLE DIAGNOSES in EC and AT sections.

HARNESS

ENGINE ROOM HARNESS (LH VIEW)

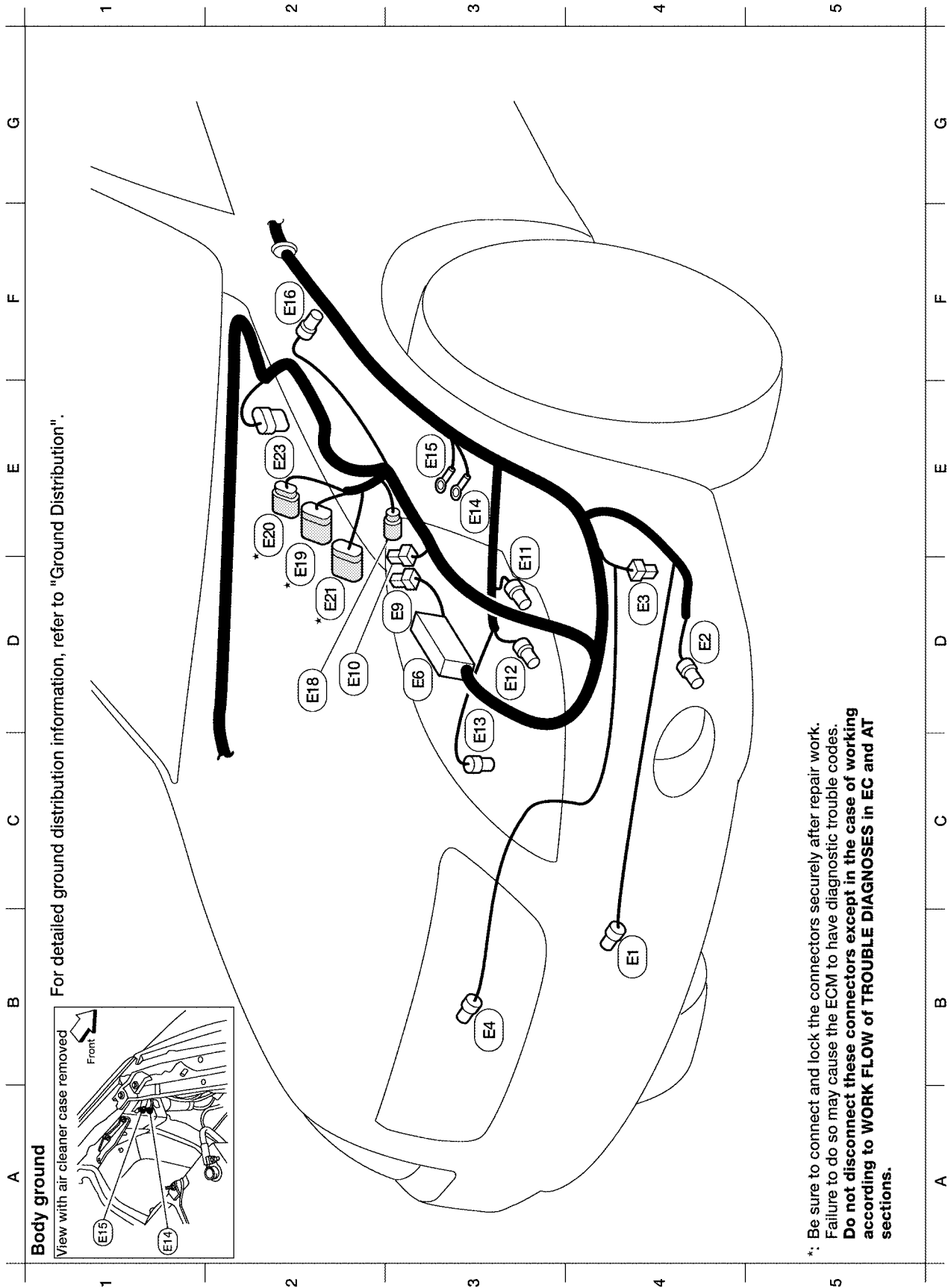

Refer to [PG-46, "ENGINE ROOM HARNESS \(RH VIEW\)"](#) for continuation of engine room harness.

HARNESS

B4	(E1)	B/2	: Ambient sensor
D4	(E2)	B/2	: Front fog lamp LH
D4	(E3)	B/1	: Horn (low)
B3	(E4)	Y/2	: Crash zone sensor
D3	(E6)	-	: Fuse and fusible link box
	(H-1)	W/3	: Horn relay (inside fuse and fusible link box)
D3	(E9)	BR/2	: Fusible link box (battery)
D2	(E10)	GY/2	: Fusible link box (battery)
E3	(E11)	B/2	: Headlamp LH (high)
D3	(E12)	B/3	: Front combination lamp LH
D3	(E13)	B/2	: Headlamp LH (low) (conventional type)
D3	(E13)	BR/2	: Headlamp LH (low) (xenon type)
E3	(E14)	-	: Body ground
E3	(E15)	-	: Body ground
F2	(E16)	GY/2	: Brake fluid level switch
D2	(E18)	BR/2	: Front wheel sensor LH
D2	*(E19)	GY/9	: To (F33)
E2	*(E20)	B/8	: To (F32)
D2	*(E21)	B/12	: To (F34)
E2	(E23)	GY/6	: Wiper motor

*: Be sure to connect and lock the connectors securely after repair work.
 Failure to do so may cause the ECM to have diagnostic trouble codes.
Do not disconnect these connectors except in the case of working according to WORK FLOW of TROUBLE DIAGNOSES in EC and AT sections.

WKIA2738E

HARNESS

PASSENGER COMPARTMENT

- E7 B/2 : To (M46)
- * E28 W/18 : To (M7)
- E29 Y/4 : To (M1D)
- E30 W/8 : Fuse block J/B
- E31 B/2 : Fuse block J/B
- E32 B/1 : Fuse block J/B
- E33 W/4 : To (B3)
- E34 L/2 : Clutch interlock switch (with M/T)
- E35 L/2 : ASCD clutch switch (with M/T and ASCD)
- E36 B/3 : Diode-1 (with DTRL)
- E37 BR/2 : ASCD brake switch
- E38 B/2 : Stop lamp switch
- * E40 B/6 : Accelerator pedal position sensor
- E41 W/6 : Ignition switch
- E102 GY/4 : Daytime light control unit (for Canada)
- E103 GY/6 : Daytime light control unit (for Canada)
- E104 GY/8 : Daytime light control unit (for Canada)

* : Be sure to connect and lock the connectors securely after repair work. Failure to do so may cause the ECM to have diagnostic trouble codes.
Do not disconnect these connectors except in the case of working according to WORK FLOW of TROUBLE DIAGNOSES in EC and AT sections.

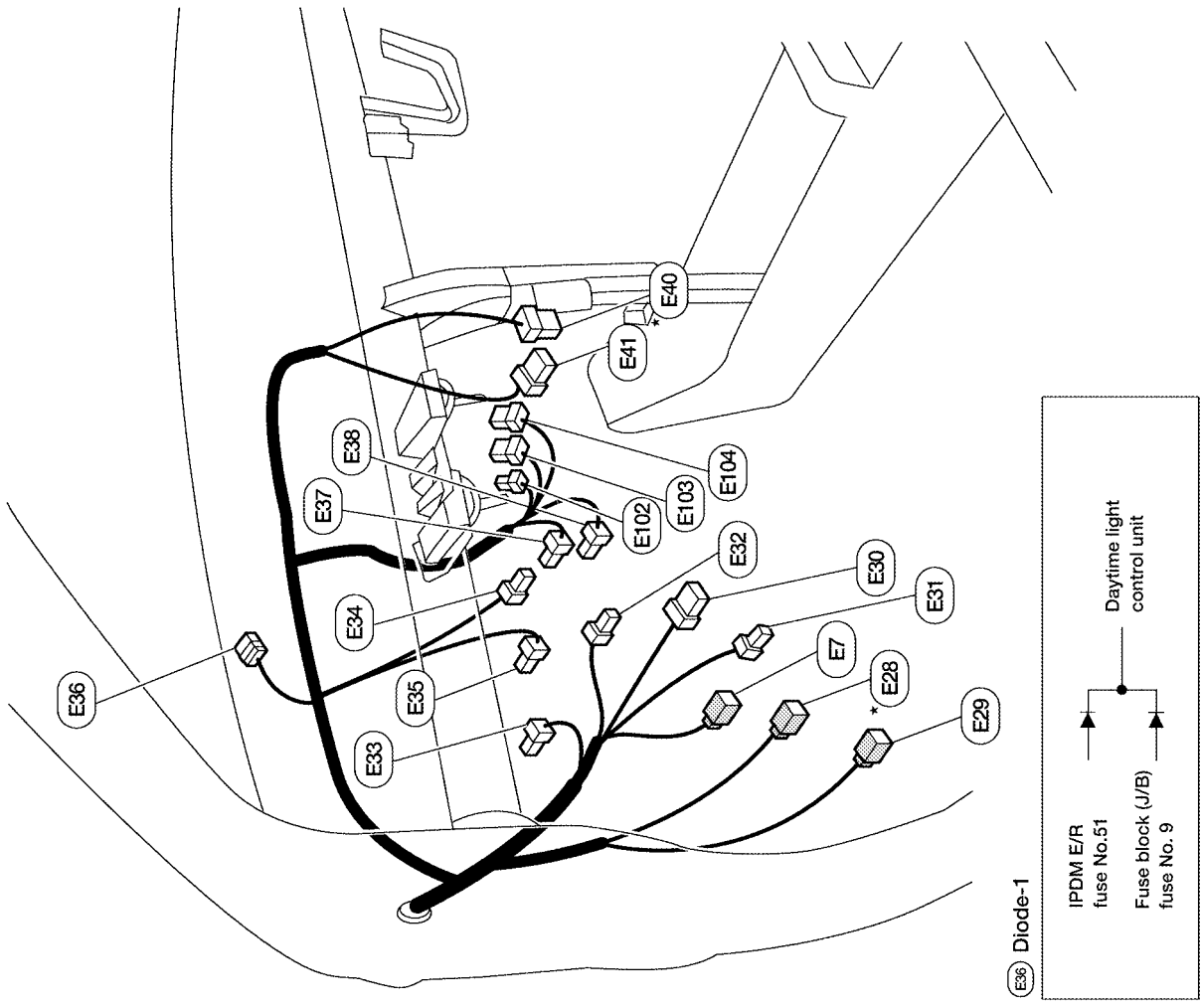

A
B
C
D
E
F
G
H
I
J
L
M

PG

WKIA4110E

HARNESS

ENGINE ROOM HARNESS (RH VIEW)

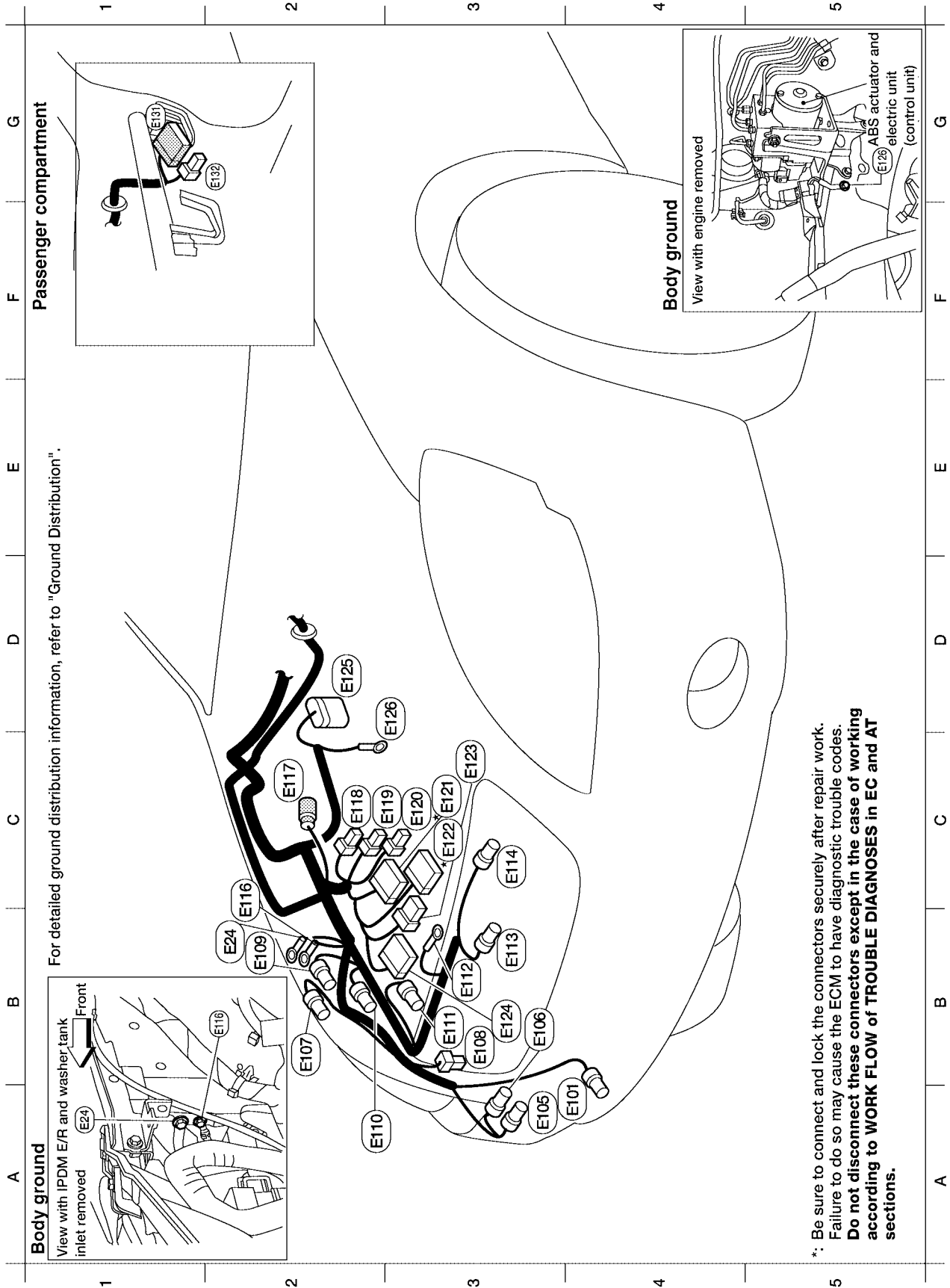

Refer to [PG-43. "ENGINE ROOM HARNESS \(LH VIEW\)"](#) for continuation of engine room harness.

WKIA2740E

HARNESSES

B2	(E24)	-	: Body ground
A4	(E10)	B/2	: Front fog lamp RH
A3	(E105)	GY/2	: Front washer motor
B3	(E106)	BR/2	: Washer fluid level sensor
B2	(E107)	B/2	: Headlamp RH (low) (conventional type)
B2	(E107)	BR/2	: Headlamp RH (low) (xenon type)
B3	(E108)	B/1	: Horn (high)
B2	(E109)	B/3	: Front combination lamp RH
A2	(E110)	B/2	: Headlamp RH (high)
B3	(E111)	B/3	: Refrigerant pressure sensor
B3	(E112)	-	: Generator (ground)
B3	(E113)	GY/4	: Cooling fan motor-1
C3	(E114)	GY/4	: Cooling fan motor-2
C2	(E116)	-	: Body ground
C2	(E117)	GY/2	: Front wheel sensor RH
C2	(E116)	B/4	: IPDM E/R (Intelligent Power Distribution Module Engine Room)
C3	(E119)	W/4	: IPDM E/R (Intelligent Power Distribution Module Engine Room)
C3	(E120)	B/2	: IPDM E/R (Intelligent Power Distribution Module Engine Room)
C3	(E121)	W/16	: IPDM E/R (Intelligent Power Distribution Module Engine Room)
C3	(E122)	GY/16	: IPDM E/R (Intelligent Power Distribution Module Engine Room)
C3	(E123)	W/6	: IPDM E/R (Intelligent Power Distribution Module Engine Room)
B3	(E124)	W/12	: IPDM E/R (Intelligent Power Distribution Module Engine Room)
D2	(E125)	B/31	: ABS actuator and electric unit (with ABS or TCS)
D3	(E126)	-	: Body ground
G1	(E131)	W/8	: To (W/8) (With ABS or TCS)
G2	(E132)	W/4	: To (G1/3) (With ABS or TCS)

*: Be sure to connect and lock the connectors securely after repair work. Failure to do so may cause the ECM to have diagnostic trouble codes. Do not disconnect these connectors except in the case of working according to WORK FLOW of TROUBLE DIAGNOSES in EC and AT sections.

WKIA3356E

HARNESS

ENGINE CONTROL HARNESS (QR25DE)

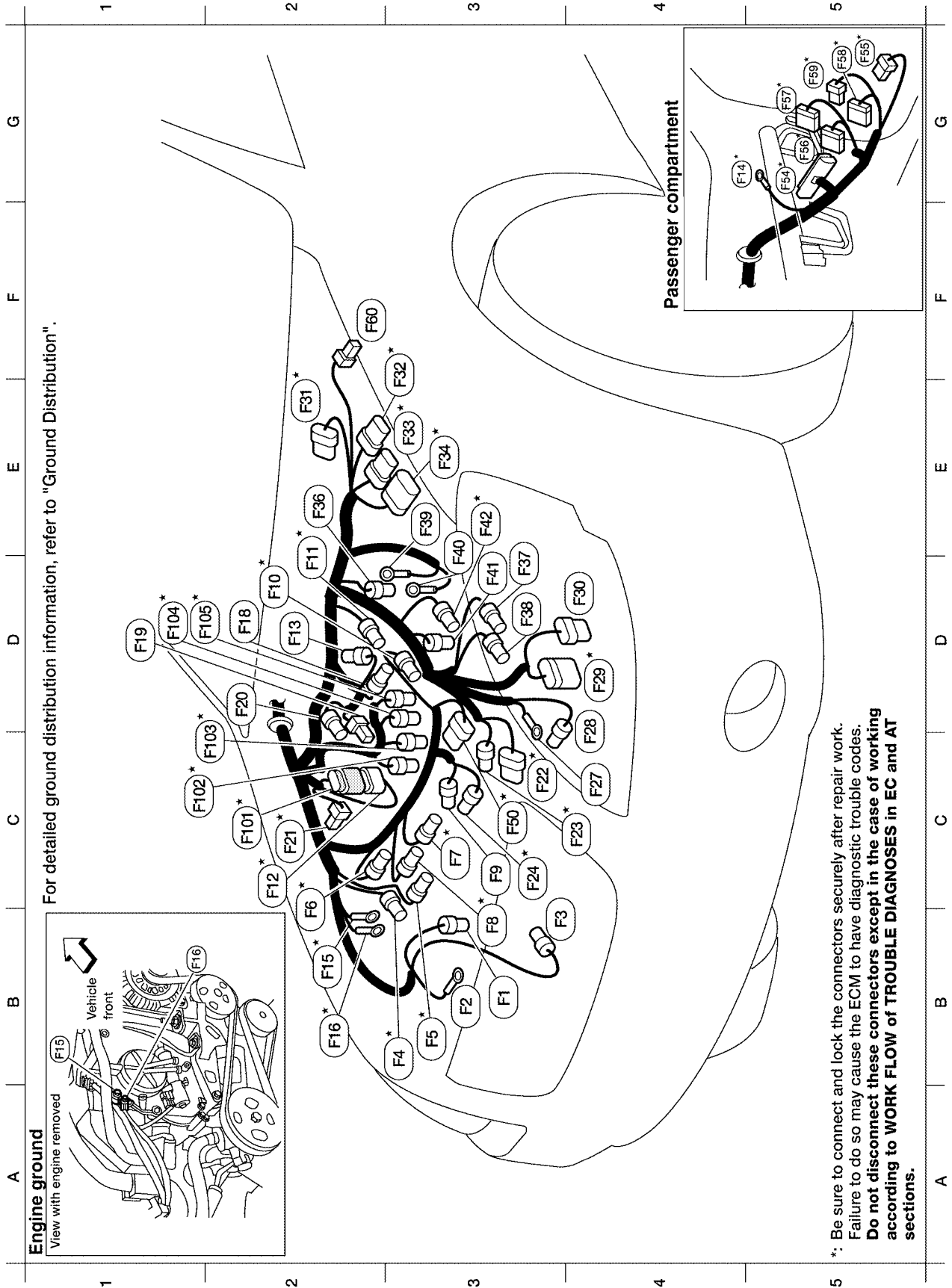

*: Be sure to connect and lock the connectors securely after repair work. Failure to do so may cause the ECM to have diagnostic trouble codes. Do not disconnect these connectors except in the case of working according to **WORK FLOW of TROUBLE DIAGNOSES in EC and AT sections.**

WKIA4111E

B3	(F1)	GY/2	: Generator	E2	*(F31)	B/6	: Mass air flow sensor
B3	(F2)	-	: Generator	F3	*(F32)	B/8	: To (E20)
B3	(F3)	B/1	: A/C compressor	E3	*(F33)	GY/9	: To (E19)
B3	*(F4)	G/2	: Intake valve timing control solenoid valve	E3	*(F34)	B/12	: To (E21)
B3	*(F5)	GY/3	: Ignition coil No. 1 (with power transistor)	E2	(F36)	GY/2	: Vehicle speed sensor
C2	*(F6)	GY/3	: Ignition coil No. 2 (with power transistor)	D3	(F37)	B/3	: Turbine revolution sensor (with A/T)
C3	(F7)	GY/3	: Ignition coil No. 4 (with power transistor)	D3	(F38)	B/3	: Revolution sensor (with A/T)
B3	*(F8)	GY/3	: Ignition coil No. 3 (with power transistor)	E3	(F39)	-	: Battery (positive)
C3	*(F9)	B/3	: Camshaft position sensor (PHASE)	D3	(F40)	-	: Fusible link box (battery)
D2	*(F10)	L/2	: EVAP canister purge volume control solenoid valve	D3	(F41)	B/2	: Back-up lamp switch (with M/T)
D2	*(F11)	B/3	: Crankshaft position sensor	E3	*(F42)	B/2	: Park/neutral position (PNP) switch (with M/T)
C2	*(F12)	B/6	: To (F101)	C3	*(F50)	G/6	: Electric throttle control actuator
D2	(F13)	BR/2	: VIAS control solenoid valve	G5	*(F54)	SMJ	: ECM
G4	*(F14)	-	: Engine ground	G5	*(F55)	BR/8	: To (B105)
B2	*(F15)	-	: Engine ground	G5	*(F56)	W/24	: TCM (transmission control module) (with A/T)
B2	*(F16)	-	: Engine ground	G5	*(F57)	GY/24	: TCM (transmission control module) (with A/T)
D2	(F18)	B/2	: Knock sensor	G5	*(F58)	W/6	: To (M70)
D1	(F19)	GY/1	: Oil pressure switch	G5	*(F59)	W/24	: To (M71)
D2	(F20)	B/3	: Power steering pressure sensor	F2	(F60)	GY/2	: Dropping resistor
C2	*(F21)	W/2	: Condenser-2	Engine control sub-harness			
C3	*(F22)	G/6	: Air fuel ratio (A/F) sensor	C2	*(F101)	B/6	: To (F12)
C4	*(F23)	G/4	: Heated oxygen sensor 2 (Rear)	C2	*(F102)	GY/2	: Injector No. 1
C3	*(F24)	GY/2	: Engine coolant temperature sensor	C2	*(F103)	GY/2	: Injector No. 2
C4	(F27)	-	: Starter motor	D1	*(F104)	GY/2	: Injector No. 3
C4	(F28)	GY/1	: Starter motor	D2	*(F105)	GY/2	: Injector No. 4
D4	*(F29)	B/10	: Park/neutral position (PNP) switch (with A/T)				
D4	(F30)	B/8	: Terminal cord assembly (with A/T)				

*: Be sure to connect and lock the connectors securely after repair work. Failure to do so may cause the ECM to have diagnostic trouble codes. **Do not disconnect these connectors except in the case of working according to WORK FLOW of TROUBLE DIAGNOSES in EC and AT sections.**

WKIA4112E

HARNESS

ENGINE CONTROL HARNESS (VQ35DE)

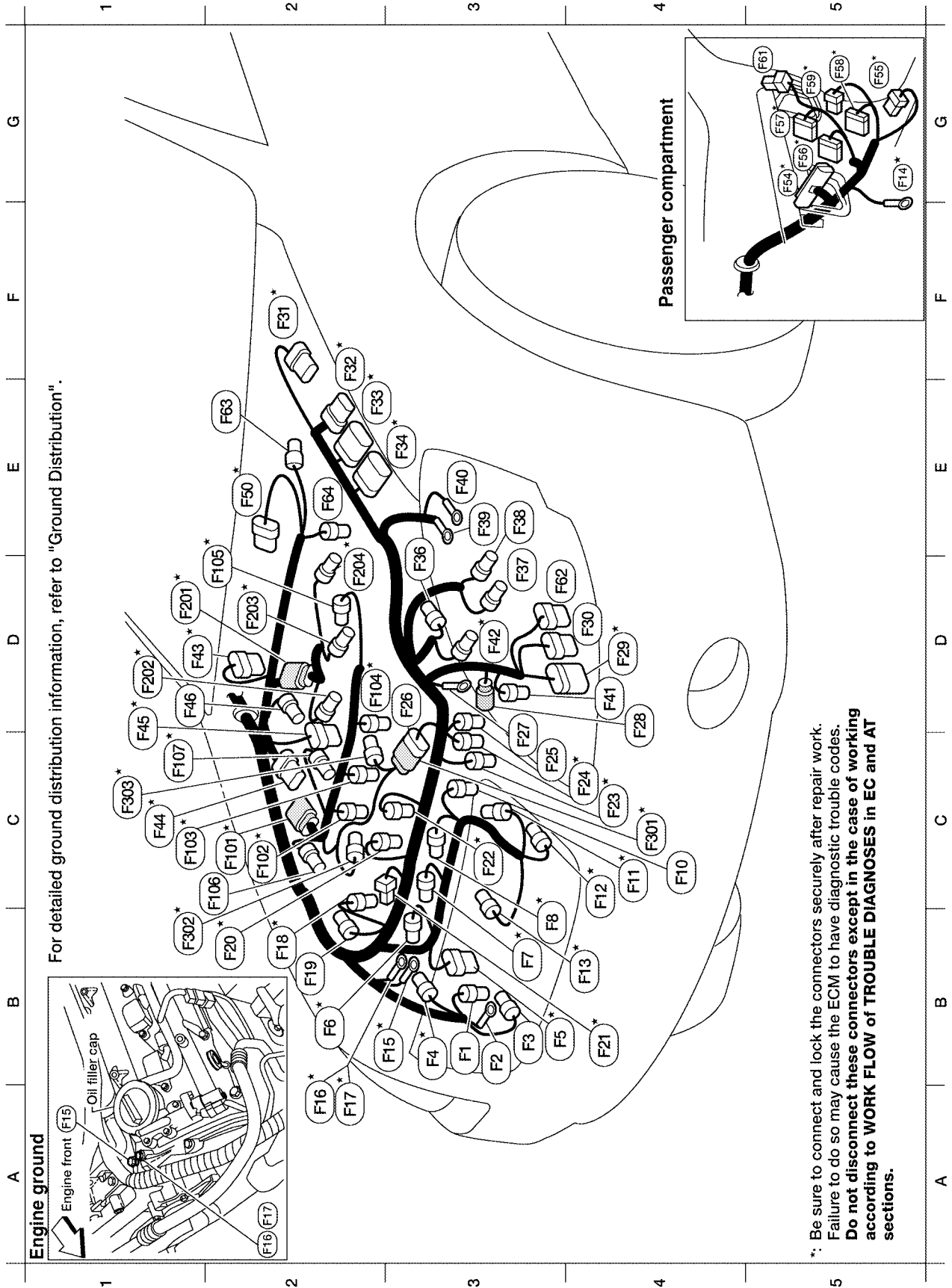

WKIA4113E

B3	(F1)	GY/2	: Generator	D3	(F26)	GY/6	: To (F30)
B3	(F2)	-	: Generator	C3	(F27)	-	: Starter motor
B3	(F3)	B/1	: A/C compressor	D4	(F28)	GY/1	: Starter motor
B3*	(F4)	G/2	: Intake valve timing control solenoid valve (Bank 2)	D4	(F29)	GY/10	: Park/neutral position (PNP) switch (with A/T)
B3*	(F5)	B/6	: Air fuel ratio (A/F) sensor (Bank 2)	D4	(F30)	BR/8	: Terminal cord assembly (with A/T)
B2*	(F6)	GY/3	: Ignition coil No. 2 (with power transistor)	F2	(F31)	B/6	: Mass air flow sensor
B3*	(F7)	GY/3	: Ignition coil No. 4 (with power transistor)	F2	(F32)	B/8	: To (E20)
B3*	(F8)	GY/3	: Ignition coil No. 6 (with power transistor)	E2	(F33)	GY/9	: To (E19)
C4	(F10)	BR/3	: Front electronic controlled engine mount	E3	(F34)	B/12	: To (E21)
C4*	(F11)	B/3	: Crankshaft position sensor	D3	(F36)	GY/2	: Vehicle speed sensor (with M/T)
C4*	(F12)	G/4	: Heated oxygen sensor 2 (Rear) (Bank 2) (with M/T)	D3	(F37)	B/3	: Turbine revolution sensor (with A/T)
(F12)	L/4		: Heated oxygen sensor 2 (Rear) (Bank 2) (with A/T)	E3	(F38)	B/3	: Revolution sensor (with A/T)
B4*	(F13)	G/4	: Heated oxygen sensor 2 (Rear) (Bank 1)	E3	(F39)	-	: Battery (positive)
G5*	(F14)	-	: Engine ground	E3	(F40)	-	: Fusible link box (battery)
B3*	(F15)	-	: Engine ground	D4	(F41)	B/2	: Back-up lamp switch (with M/T)
A2*	(F16)	-	: Engine ground	D3	(F42)	B/2	: Park/neutral position (PNP) switch (with M/T)
A2*	(F17)	-	: Engine ground	D2	(F43)	G/6	: To (F20)
B2*	(F18)	GY/2	: Injector No. 2	C1	(F44)	G/8	: To (F10)
B2	(F19)	B/2	: VIAS control solenoid valve	C1	(F45)	G/6	: Air fuel ratio (A/F) sensor (Bank 1)
B2*	(F20)	GY/2	: Injector No. 4	D1	(F46)	B/3	: Power steering oil pressure sensor
B4*	(F21)	GY/2	: Condenser 2	E2	(F50)	G/6	: Electric throttle control actuator
C3*	(F22)	GY/2	: Injector No. 6	G5	(F54)	SMJ	: ECM
C4*	(F23)	B/3	: Camshaft position sensor (PHASE) (Bank 2)	G5	(F55)	BR/8	: To (E105)
C4*	(F24)	GY/2	: Engine coolant temperature sensor	G5	(F56)	W/20	: TCM (transmission control module) (with A/T)
D3	(F25)	BR/3	: Rear electronic controlled engine mount	G5	(F57)	GY/28	: TCM (transmission control module) (with A/T)
				G5	(F58)	W/6	: To (M70)
				G5	(F59)	W/24	: To (M71)
				G5	(F61)	L/4	: A/T PV IGN relay
				D3	(F62)	GY/8	: Terminal cord assembly (with A/T)

*: Be sure to connect and lock the connectors securely after repair work. Failure to do so may cause the ECM to have diagnostic trouble codes.
Do not disconnect these connectors except in the case of working according to WORK FLOW of TROUBLE DIAGNOSES in EC and AT sections.

E2 (F63) GY/6 : EGR volume control valve
 E2 (F64) GY/2 : EGR Temperature sensor

Engine control sub-harness-1

C2 (F10) G/8 : To (F44)
 C2 (F102) GY/2 : Injector No. 1
 C1 (F103) GY/2 : Injector No. 3
 D2 (F104) GY/2 : Injector No. 5
 D2 (F105) L/2 : EVAP canister purge volume control solenoid valve
 C2 (F106) B/1 : Oil pressure switch
 C1 (F107) G/2 : Intake valve timing control solenoid valve (Bank 1)

Engine control sub-harness-2

D1 (F201) G/6 : To (F43)
 D1 (F202) GY/3 : Ignition coil No. 1 (with power transistor)
 D2 (F203) GY/3 : Ignition coil No. 3 (with power transistor)
 D2 (F204) GY/3 : Ignition coil No. 5 (with power transistor)

Engine control sub-harness-3

C4 (F301) GY/6 : To (F26)
 B1 (F302) GY/2 : Knock sensor
 C1 (F303) G/3 : Camshaft position sensor (PHASE) (Bank 1)



HARNESS

BODY HARNESS

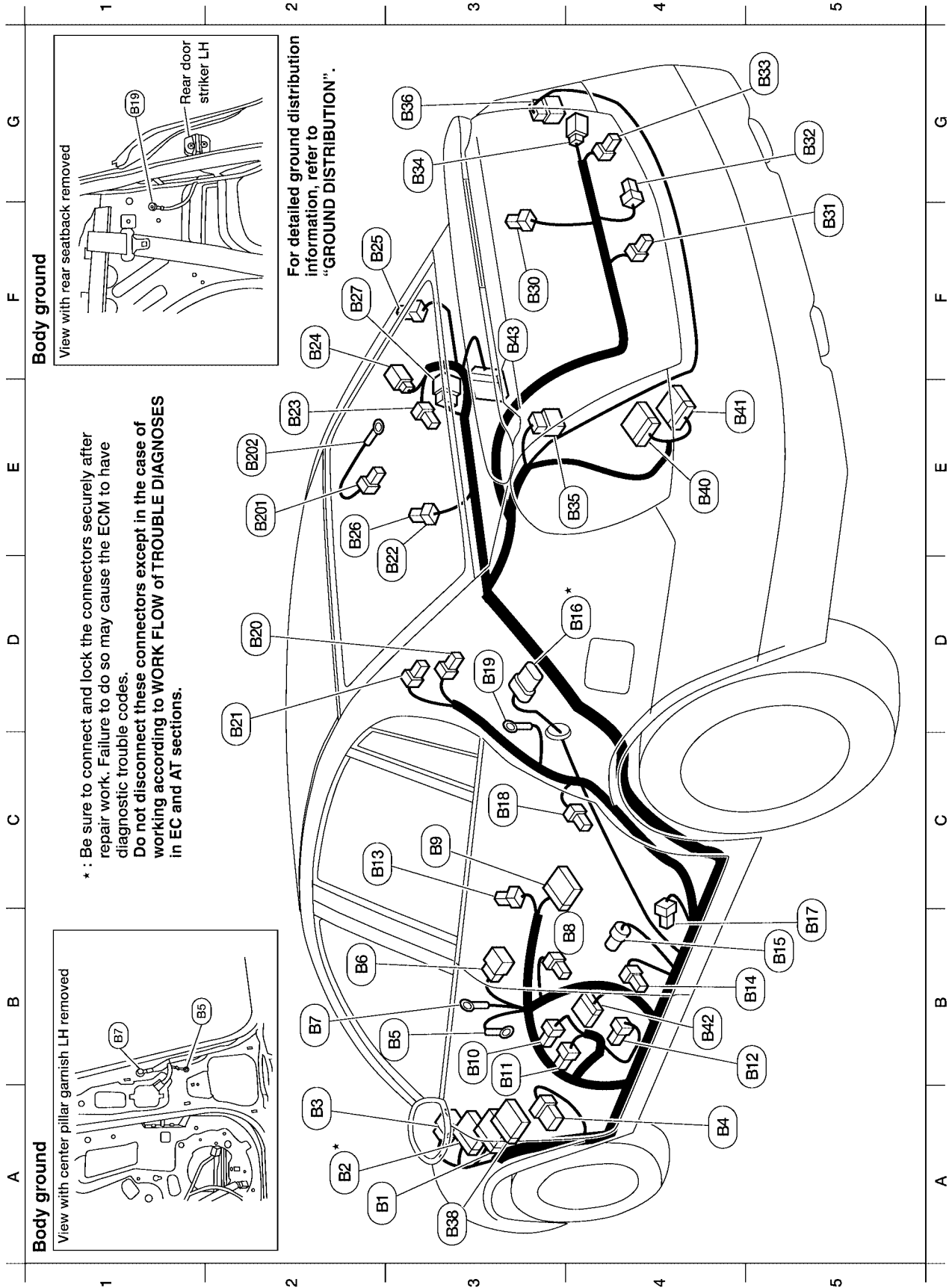

WKIA4115E

HARNESS

A2	(B1)	W/16	: To (M11)	D2	(B20)	Y/2	: LH side curtain air bag module
A2 *	(B2)	W/16	: To (M12)	D2	(B21)	W/1	: Rear window defogger condenser
A2	(B3)	W/6	: To (E30)	D3	(B22)	BR/2	: Rear speaker LH (without Bose audio system)
A4	(B4)	BR/6	: Rear window defogger relay	E2	(B23)	W/2	: Trunk room lamp (without Bose audio system)
B3	(B5)	-	: Body ground	F2	(B24)	W/2	: High mounted stop lamp (without rear spoiler and without Bose audio system)
B2	(B6)	W/8	: To (D201)	F2	(B25)	BR/2	: Rear speaker RH (without Bose audio system)
B2	(B7)	-	: Body ground	E2	(B26)	W/2	: Subwoofer LH (with Bose audio system)
B4	(B8)	W/3	: Front door switch LH	F2	(B27)	W/8	: To (B131) (with Bose audio system)
C3	(B9)	Y/12	: Air bag diagnosis sensor unit	F3	(B30)	BR/2	: High mounted stop lamp (with rear spoiler)
B3	(B10)	Y/2	: Front LH side air bag module	F5	(B31)	BR/2	: License lamp LH
B3	(B11)	W/2	: Power seat	G5	(B32)	W/4	: Trunk lamp switch and trunk release solenoid
B5	(B12)	W/3	: Seat belt buckle switch LH	G5	(B33)	BR/2	: License lamp RH
C2	(B13)	W/3	: Heated seat switch	G3	(B34)	W/2	: Trunk key cylinder switch
B5	(B14)	Y/2	: Front LH seat belt pre-tensioner	E4	(B35)	W/6	: Rear combination lamp LH
B5	(B15)	Y/2	: LH side airbag (satellite) sensor	G3	(B36)	W/6	: Rear combination lamp RH
D4 *	(B16)	GY/5	: Fuel level sensor unit and fuel pump	A3	(B38)	BR/16	: To (M66)
B5	(B17)	W/2	: Condenser-1	E4	(B40)	W/24	: NAVI control unit (with NAVI)
C3	(B18)	W/1	: Rear door switch LH	E4	(B41)	GY/24	: NAVI control unit (with NAVI)
D3	(B19)	-	: Body ground	B4	(B42)	W/8	: To (F1)
				F3	(B43)	GY/2	: NAVI control unit (GPS antenna) (with NAVI)
				E2	(B201)	B/1	: Rear window defogger
				E2	(B202)	-	: Body ground

* : Be sure to connect and lock the connectors securely after repair work. Failure to do so may cause the ECM to have diagnostic trouble codes.
Do not disconnect these connectors except in the case of working according to WORK FLOW of TROUBLE DIAGNOSES in EC and AT sections.

WKIA3362E

HARNESS

BODY NO. 2 HARNESS

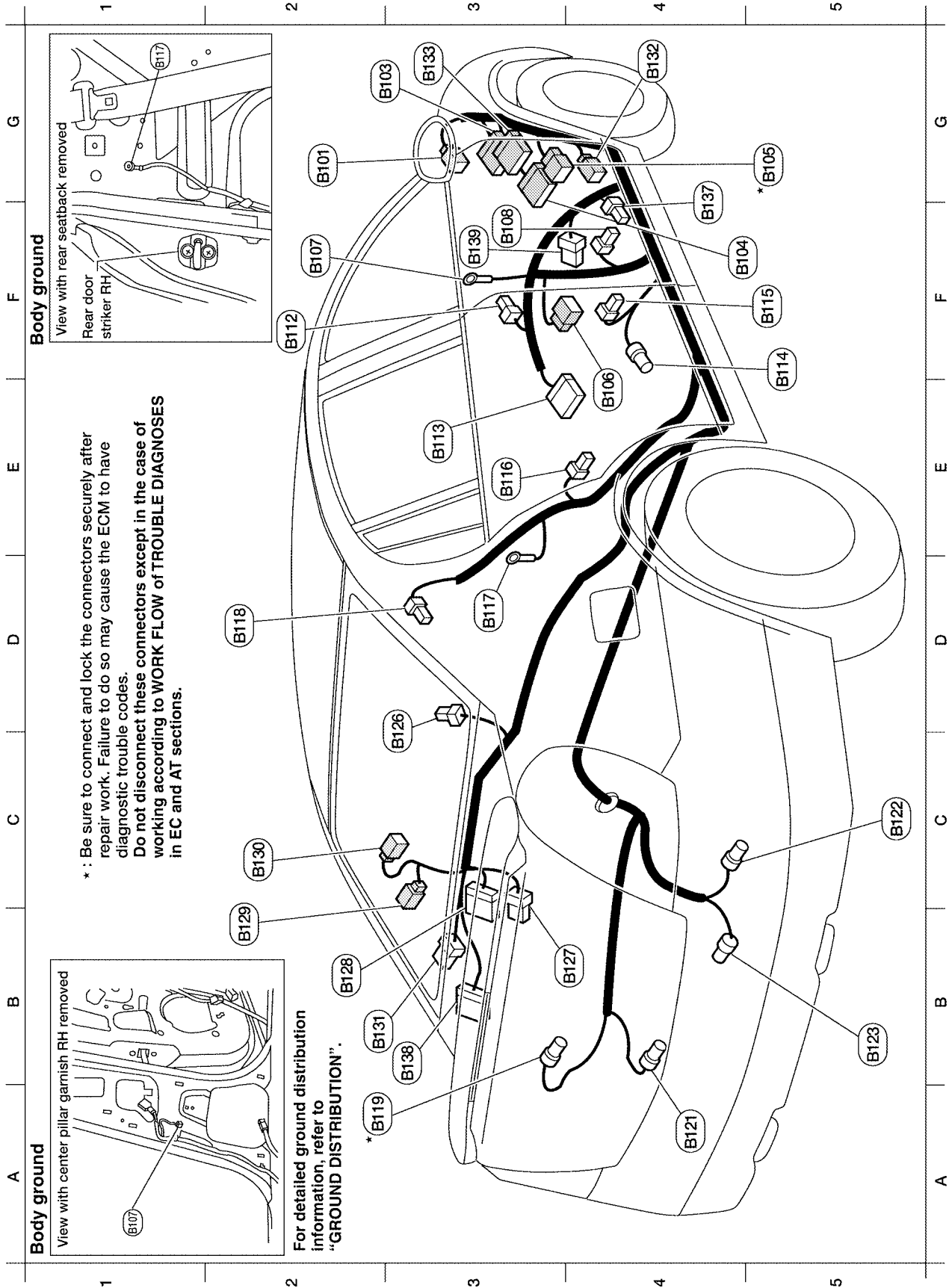

WKIA3149E

G2	(8101)	W/4	: To (E32)
G2	(8103)	W/12	: To (W73)
F4	(8104)	W/16	: To (M69)
G5	(8105)	BR/8	: To (F55)
F4	(8106)	W/8	: To (D301)
F2	(8107)	-	: Body ground
F3	(8109)	W/3	: Heated seat switch RH
F2	(8112)	Y/2	: Front RH side air bag module
E3	(8113)	Y/12	: Air bag diagnosis sensor unit
F5	(8114)	Y/2	: RH side air bag (satellite) sensor
F5	(8115)	Y/2	: Front RH seat belt pre-tensioner
E3	(8116)	W/1	: Rear door switch RH
D3	(8117)	-	: Body ground
D2	(8118)	Y/2	: RH side curtain air bag module
A2	(8119)	GY/3	: EVAP control system pressure sensor
A4	(8121)	B/2	: EVAP canister vent control valve
C5	(8122)	GY/2	: Rear wheel sensor RH
B5	(8123)	BR/2	: Rear wheel sensor LH
C3	(8126)	W/2	: Subwoofer RH (with Bose audio system)
B4	(8127)	GY/8	: Bose Speaker Amp.
B2	(8128)	B/24	: Bose Speaker Amp.
B2	(8129)	W/2	: High mounted stop lamp (without rear spoiler and with Bose audio system)
C2	(8130)	W/2	: Trunk room lamp (with Bose audio system)
B2	(8131)	W/8	: To (B27) (with Bose audio system)
G4	(8132)	BR/2	: To (M63)
G3	(8133)	W/10	: To (M82)
F4	(8137)	B/3	: Belt tension sensor
B3	(8138)	W/16	: Satellite radio tuner (Pre-wiring)
F3	(8139)	W/6	: To (P101)

* : Be sure to connect and lock the connectors securely after repair work. Failure to do so may cause the ECM to have diagnostic trouble codes.
Do not disconnect these connectors except in the case of working according to WORK FLOW of TROUBLE DIAGNOSES in EC and AT sections.

HARNESS

ROOM LAMP HARNESS

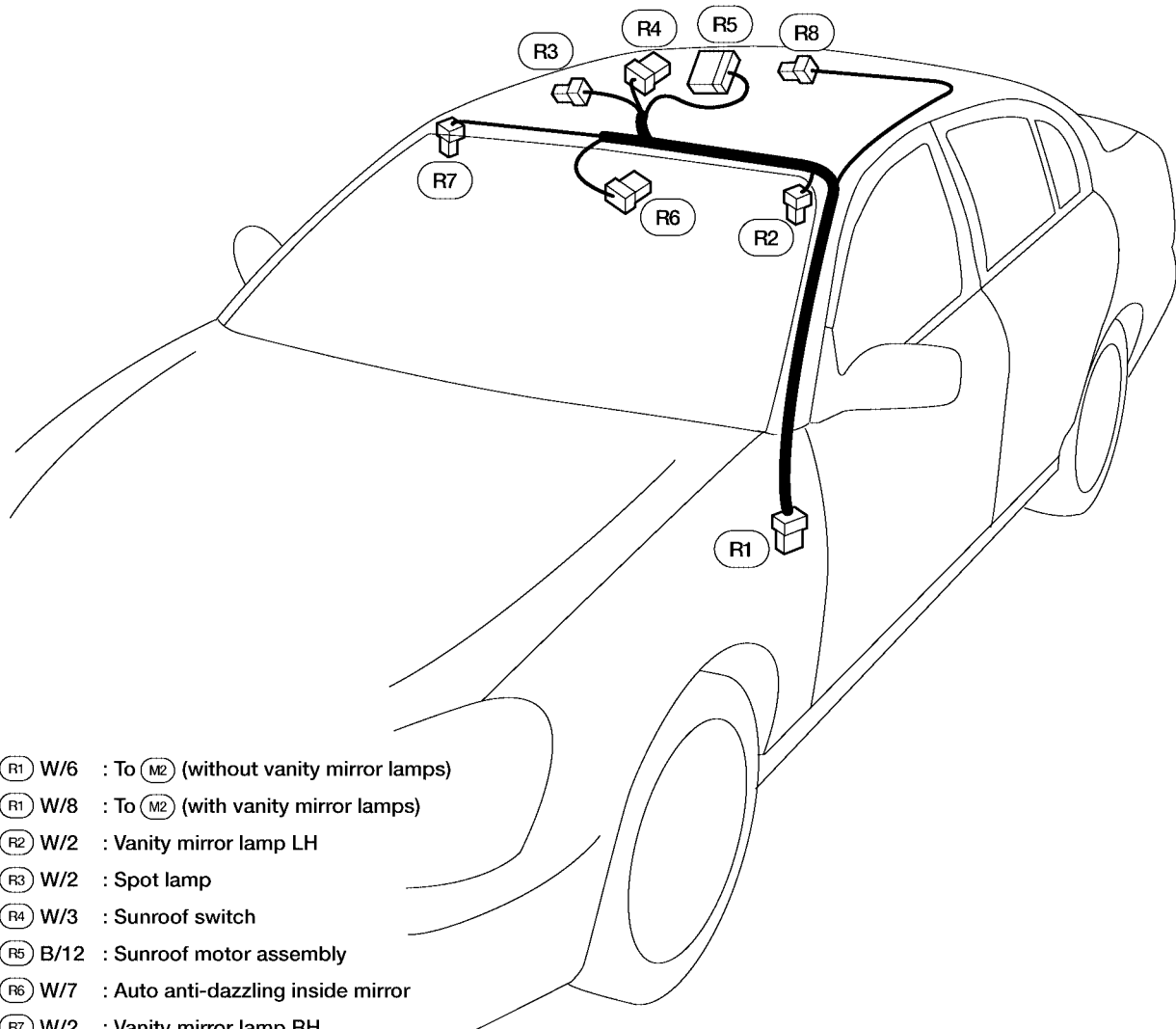

- Ⓡ1 W/6 : To Ⓜ2 (without vanity mirror lamps)
- Ⓡ1 W/8 : To Ⓜ2 (with vanity mirror lamps)
- Ⓡ2 W/2 : Vanity mirror lamp LH
- Ⓡ3 W/2 : Spot lamp
- Ⓡ4 W/3 : Sunroof switch
- Ⓡ5 B/12 : Sunroof motor assembly
- Ⓡ6 W/7 : Auto anti-dazzling inside mirror
- Ⓡ7 W/2 : Vanity mirror lamp RH
- Ⓡ8 W/2 : Room lamp

WKIA2748E

HARNESS

FRONT DOOR LH HARNESS

- (D1) W/12 : To (M9)
 - (D2) W/16 : To (M8)
 - (D3) W/2 : Front door speaker LH (without BOSE)
 - (D3) BR/2 : Front door speaker LH (with BOSE)
 - (D4) W/6 : Door mirror LH
 - (D5) W/10 : Door mirror switch
 - (D6) W/3 : Main power window and door lock/unlock switch
 - (D7) W/16 : Main power window and door lock/unlock switch (With left and right front power window anti-pinch system)
 - (D7) BR/16 : Main power window and door lock/unlock switch (With left front only power window anti-pinch system)
 - (D8) W/6 : Front power window motor LH
 - (D10) W/6 : To (D50)
 - (D11) W/2 : Step lamp LH
- Front door LH sub-harness**
- (D50) W/6 : To (D10)
 - (D51) GY/4 : Front door lock actuator LH

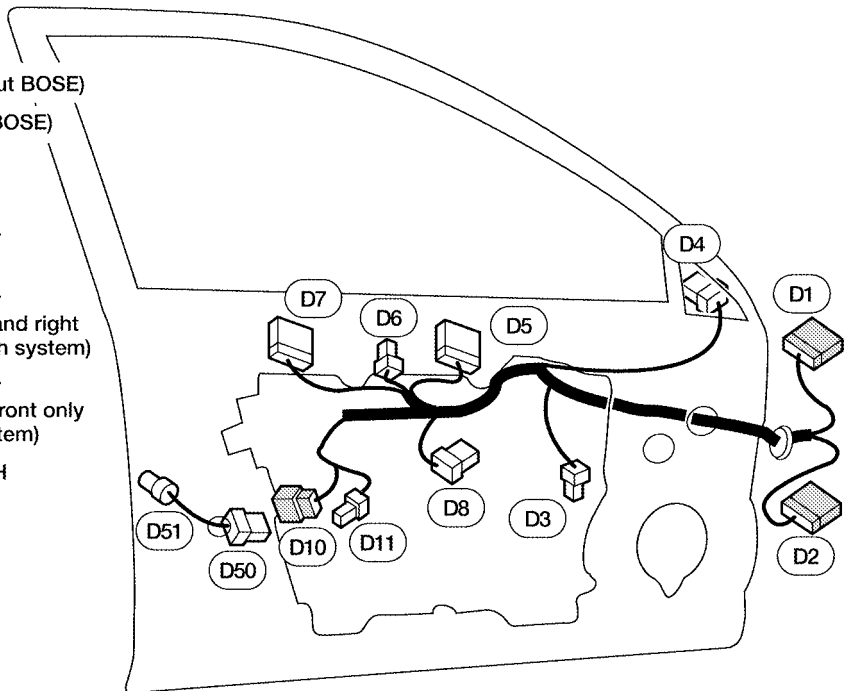

WKIA4117E

FRONT DOOR RH HARNESS

- (D101) W/10 : To (M75)
 - (D102) W/8 : To (M74)
 - (D103) W/2 : Front door speaker RH (without BOSE)
 - (D103) BR/2 : Front door speaker (with BOSE)
 - (D104) W/6 : Door mirror RH
 - (D105) W/12 : Front power window switch RH
 - (D106) BR/8 : Front power window switch RH (With left front only power window anti-pinch system)
 - (D106) W/8 : Front power window switch RH (With left and right power window anti-pinch system)
 - (D107) W/6 : Front power window motor RH (With left and right power window anti-pinch system)
 - (D107) W/2 : Front power window motor RH (With left front only power window anti-pinch system)
 - (D108) W/2 : To (D150)
 - (D109) W/2 : Step lamp RH
- Front door RH sub-harness**
- (D150) W/6 : To (D108)
 - (D151) GY/4 : Front door lock actuator RH

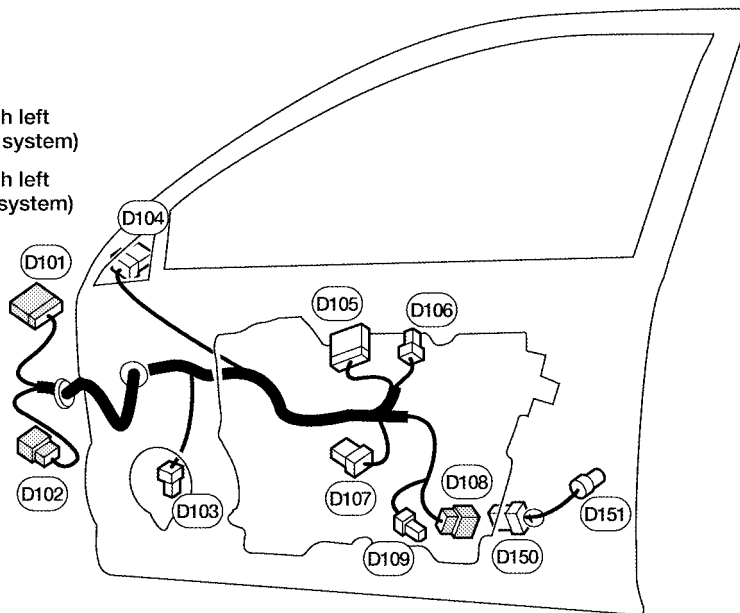

WKIA4118E

HARNESS

REAR DOOR LH HARNESS

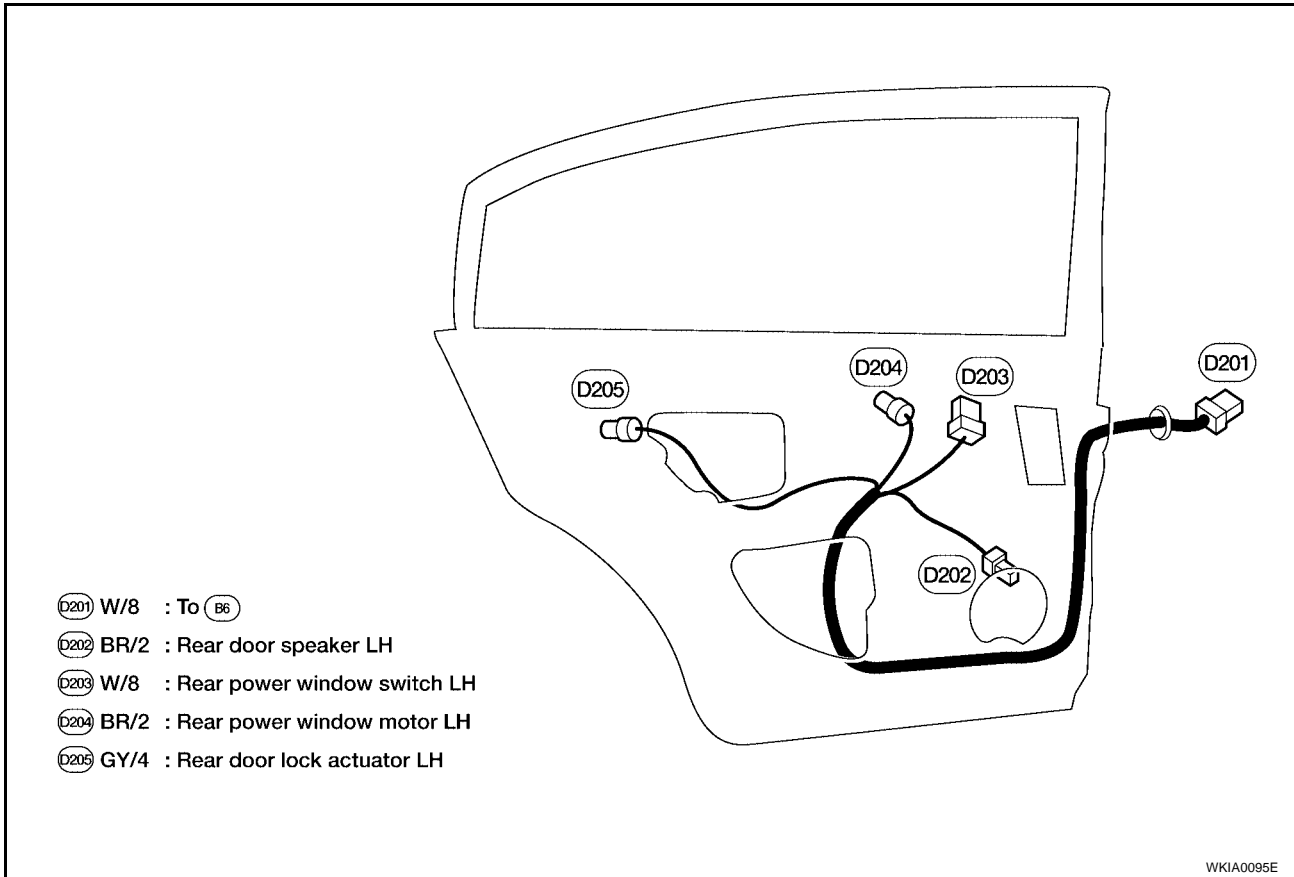

REAR DOOR RH HARNESS

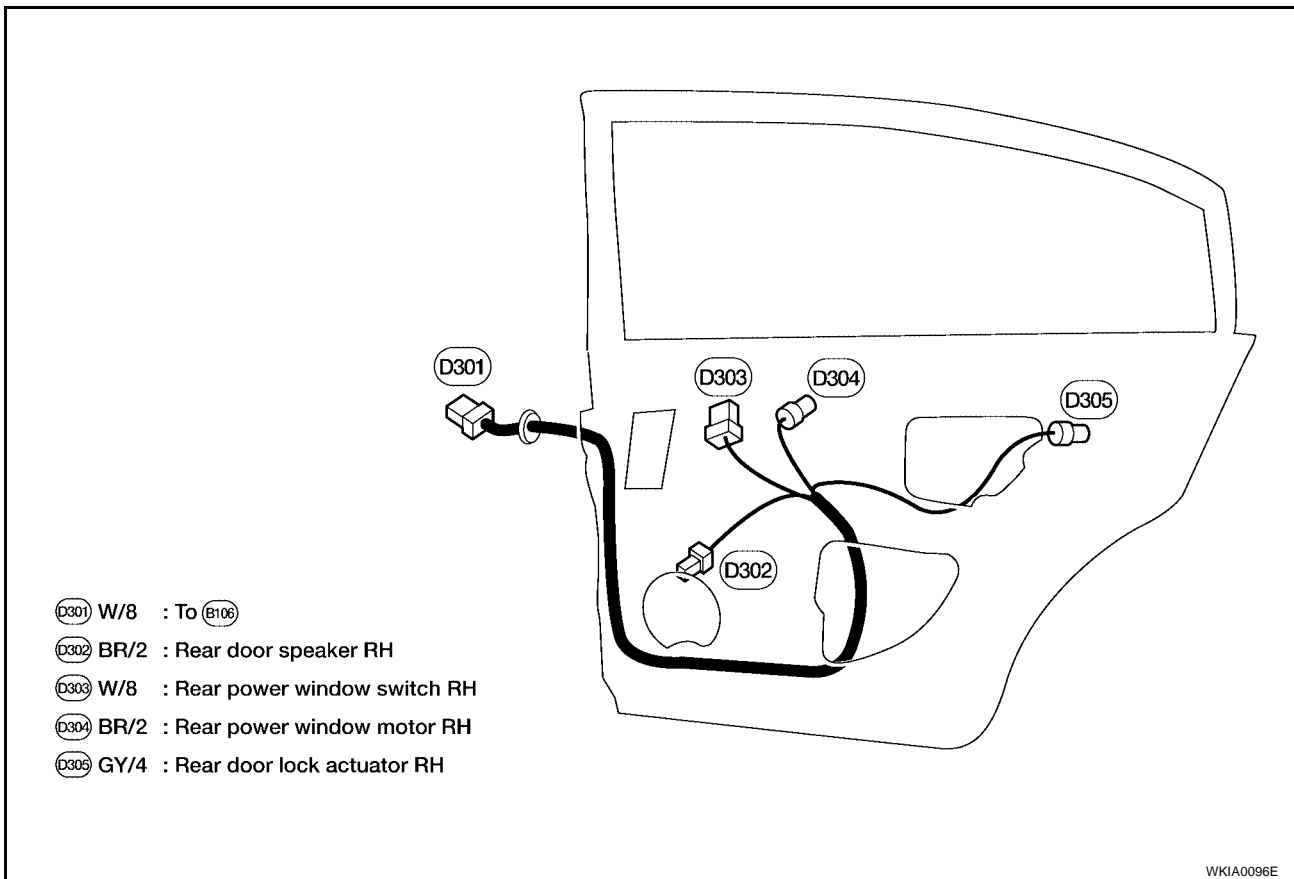

HARNESSES

EKS008UP

Wiring Diagram Codes (Cell Codes)

Use the chart below to find out what each wiring diagram code stands for.

Refer to the wiring diagram code in the alphabetical index to find the location (page number) of each wiring diagram.

Code	Section	Wiring Diagram Name
1STSIG	AT	A/T 1st Signal
2NDSIG	AT	A/T 2nd Signal
3METER	DI	Triple Meter
3RDSIG	AT	A/T 3rd Signal
4THSIG	AT	A/T 4th Signal
5THSIG	AT	A/T 5th Signal
A/C,A	ATC	Auto Air Conditioner
A/C,M	MTC	Manual Air Conditioner
A/F	EC	Air Fuel Ratio Sensor
AF/FH	EC	Air Fuel Ratio Sensor
AF1B1	EC	Air Fuel Ratio Sensor 1 Bank 1
AF1B2	EC	Air Fuel Ratio Sensor 1 Bank 2
AF1HB1	EC	Air Fuel Ratio Sensor 1 Heater Bank 1
AF1HB2	EC	Air Fuel Ratio Sensor 1 Heater Bank 2
ABS	BRC	Anti-Lock Brake System
APPS1	EC	Accelerator Pedal Position Sensor
APPS2	EC	Accelerator Pedal Position Sensor
APPS3	EC	Accelerator Pedal Position Sensor
ASCBOF	EC	ASCD Brake Switch
ASC/BS	EC	ASCD Brake Switch
ASCIND	EC	ASCD Indicator
ASC/SW	EC	ASCD Steering Switch
AT/IND	DI	A/T Indicator Lamp
AUDIO	AV	Audio
AUTO/L	LT	Auto Light System
B/COMP	DI	Board Computer
BA/FTS	AT	A/T Fluid Temperature Sensor and TCM Power Supply
BACK/L	LT	Back-up Lamp
BRK/SW	EC	Brake Switch
CAN	AT	CAN Communication Line
CAN	EC	CAN Communication Line
CAN	LAN	CAN System
CHARGE	SC	Charging System
COMBSW	LT	Combination Switch
COMM	AV	Audio Visual Communication System
CHIME	DI	Warning Chime
CIGAR	WW	Cigarette Lighter
COOL/F	EC	Cooling Fan Control
D/LOCK	BL	Power Door Lock
DEF	GW	Rear Window Defogger
DTRL	LT	Headlamp - With Daytime Light System
ECM/PW	EC	ECM Power Supply for Back-Up
ECTS	EC	Engine Coolant Temperature Sensor
ENGSS	AT	Engine Speed Signal
EGRC1	EC	EGR Function
EGR/TS	EC	EGR Temperature Sensor
EGVC/V	EC	EGR Volume Control Valve

HARNESSES

EMNT	EC	Engine Mount
ETC1	EC	Electric Throttle Control Function
ETC2	EC	Throttle Control Motor Relay
ETC3	EC	Throttle Control Motor
F/FOG	LT	Front Fog Lamp
F/PUMP	EC	Fuel Pump
FLS1	EC	Fuel Level Sensor Function (SLOSH)
FTS	AT	A/T Fluid Temperature Sensor
FTSP	AT	A/T Fluid Temperature Sensor Failure
FTTS	EC	Fuel Tank Temperature Sensor
FUEL	EC	Fuel Injection System Function
FUELB1	EC	Fuel Injection System Function (Bank 1)
FUELB2	EC	Fuel Injection System Function (Bank 2)
H/LAMP	LT	Headlamp
H/MIRR	GW	Door Mirror with Heated Mirror
HEATER	MTC	Heater System
HO2S2	EC	Heated Oxygen Sensor 2 (Rear)
HO2S2H	EC	Heated Oxygen Sensor 2 (Rear) Heater
HORN	WW	Horn
HSEAT	SE	Heated Seat
I/MIRR	GW	Inside Mirror (Auto-Anti Dazzling Mirror)
IATS	EC	Intake Air Temperature Sensor
IGNSYS	EC	Ignition System
ILL	LT	Illumination
INJECT	EC	Injector
INT/L	LT	Spot, Vanity Mirror and Trunk Room Lamps
IVC	EC	Intake Valve Timing Control Solenoid Valve
IVCB1	EC	Intake Valve Timing Control Solenoid Valve Bank 1
IVCB2	EC	Intake Valve Timing Control Solenoid Valve Bank 2
KEYLES	BL	Remote Keyless Entry System
KS	EC	Knock Sensor
LPSV	AT	Line Pressure Solenoid Valve
MAFS	EC	Mass Air Flow Sensor
MAIN	AT	Main Power Supply and Ground Circuit
MAIN	EC	Main Power Supply and Ground Circuit
METER	DI	Speedometer, Tachometer, Temp., Oil and Fuel Gauges
MIL/DL	EC	Malfunction Indicator Lamp
MIRROR	GW	Door Mirror
MMSW	AT	Manual Mode Switch
NATS	BL	Nissan Anti-Theft System
NAVI	AV	Navigation System
NONDTC	AT	Non-detective Items
O2H2B1	EC	Rear Heated Oxygen Sensor 2 (Rear) Heater Bank 1
O2H2B2	EC	Rear Heated Oxygen Sensor 2 (Rear) Heater Bank 2
O2S2B1	EC	Heated Oxygen Sensor 2 (Rear) Bank 1
O2S2B2	EC	Heated Oxygen Sensor 2 (Rear) Bank 2
OVRCV	AT	Over Run Clutch Solenoid Valve
PC/A	AT	Line Pressure Solenoid Valve
PC/B	AT	Shift Pressure Solenoid Valve
PC/C	AT	Pressure Control Solenoid Valve Failure
PC/CS	AT	Line Pressure Solenoid Valve
P/SCKT	WW	Power Socket

HARNESSES

PGC/V	EC	EVAP Canister Purge Volume Control Solenoid Valve	A
PHASE	EC	Camshaft Position Sensor (PHASE)	
PHSB1	EC	Camshaft Position Sensor (PHASE) (Bank 1)	
PHSB2	EC	Camshaft Position Sensor (PHASE) (Bank 2)	
PNP/SW	AT	Park/Neutral Position Switch	B
PNP/SW	EC	Park/Neutral Position Switch	
POS	EC	Crankshaft Position Sensor (CKPS) (POS)	
POWER	PG	Power Supply Routing	C
PRE/SE	EC	EVAP Control System Pressure Sensor	
PS/SEN	EC	Power Steering Oil Pressure Sensor	D
PWR/IN	AT	TCM Ignition Power	
RP/SEN	EC	Refrigerant Pressure Sensor	
SEAT	SE	Power Seat	E
SEN/PW	EC	Sensor Power Supply	
SFTFNC	AT	Unusual Shifting	
SHIFT	AT	A/T Shift Lock System	F
SROOF	RF	Sunroof	
SRS	SRS	Supplemental Restraint System	
SSV/A	AT	Shift Solenoid Valve A	G
SSV/B	AT	Shift Solenoid Valve B	
SSV/C	AT	Shift Solenoid Valve C	
SSV/CS	AT	Shift Solenoid Valve Failure	H
SSV/D	AT	Shift Solenoid Valve D	
SSV/E	AT	Shift Solenoid Valve E	
START	SC	Starting System	I
STOP/L	LT	Stop Lamp	
TLID	BL	Trunk Lid Opener	
TAIL/L	LT	Parking, License and Tail Lamps	J
TCCSIG	AT	A/T TCC Signal (Lock Up)	
TCS	BRC	Traction Control System	
TCV	AT	Torque Converter Clutch Solenoid Valve	PG
TPS	AT	Throttle Position Sensor	
TPS1	EC	Throttle Position Sensor	
TPS2	EC	Throttle Position Sensor	L
TPS3	EC	Throttle Position Sensor	
TRNSCV	BL	HOMELINK® Universal Transceiver	
TRSA/T	AT	Turbine Revolution Sensor	M
TRSC	AT	Turbine Revolution Sensor	
TURN	LT	Turn Signal and Hazard Warning Lamps	
VEHSEC	BL	Vehicle Security System	
VENT/V	EC	EVAP Canister Vent Control Valve	
VIAS	EC	Variable Air Induction Control System	
VIAS/V	EC	Variable Air Induction Control System Valve	
VSSA/T	AT	Vehicle Speed Sensor A/T (Revolution Sensor)	
VSSATC	AT	Revolution Sensor	
VSSMTR	AT	Vehicle Speed Sensor Meter	
W/ANT	AV	Audio Antenna	
WARN	DI	Warning Lamps	
WINDOW	GW	Power Window	
WIPER	WW	Front Wiper and Washer	

ELECTRICAL UNITS LOCATION

ELECTRICAL UNITS LOCATION

PF2:25230

Electrical Units Location ENGINE COMPARTMENT

EKS008UQ

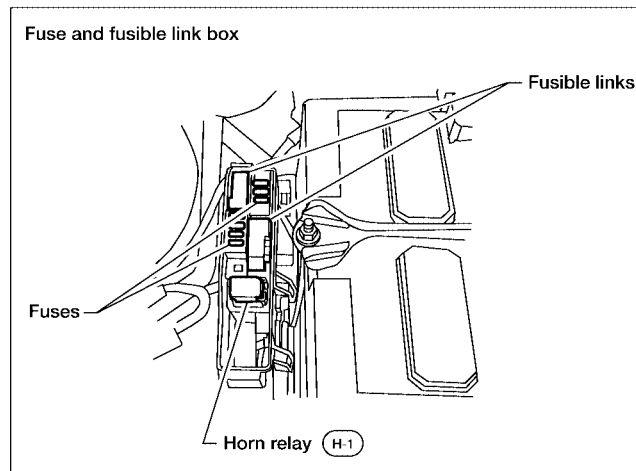
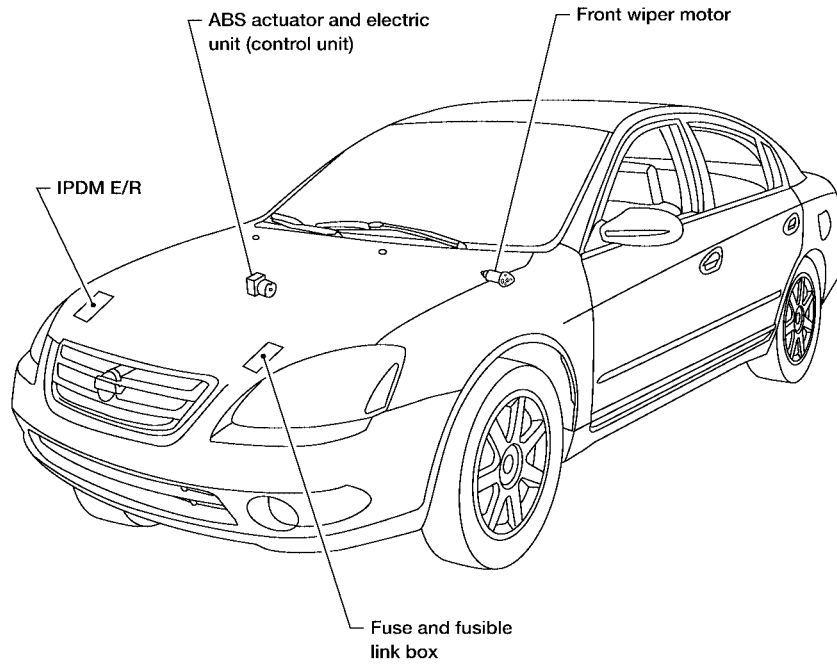

WKIA4119E

ELECTRICAL UNITS LOCATION

PASSENGER COMPARTMENT

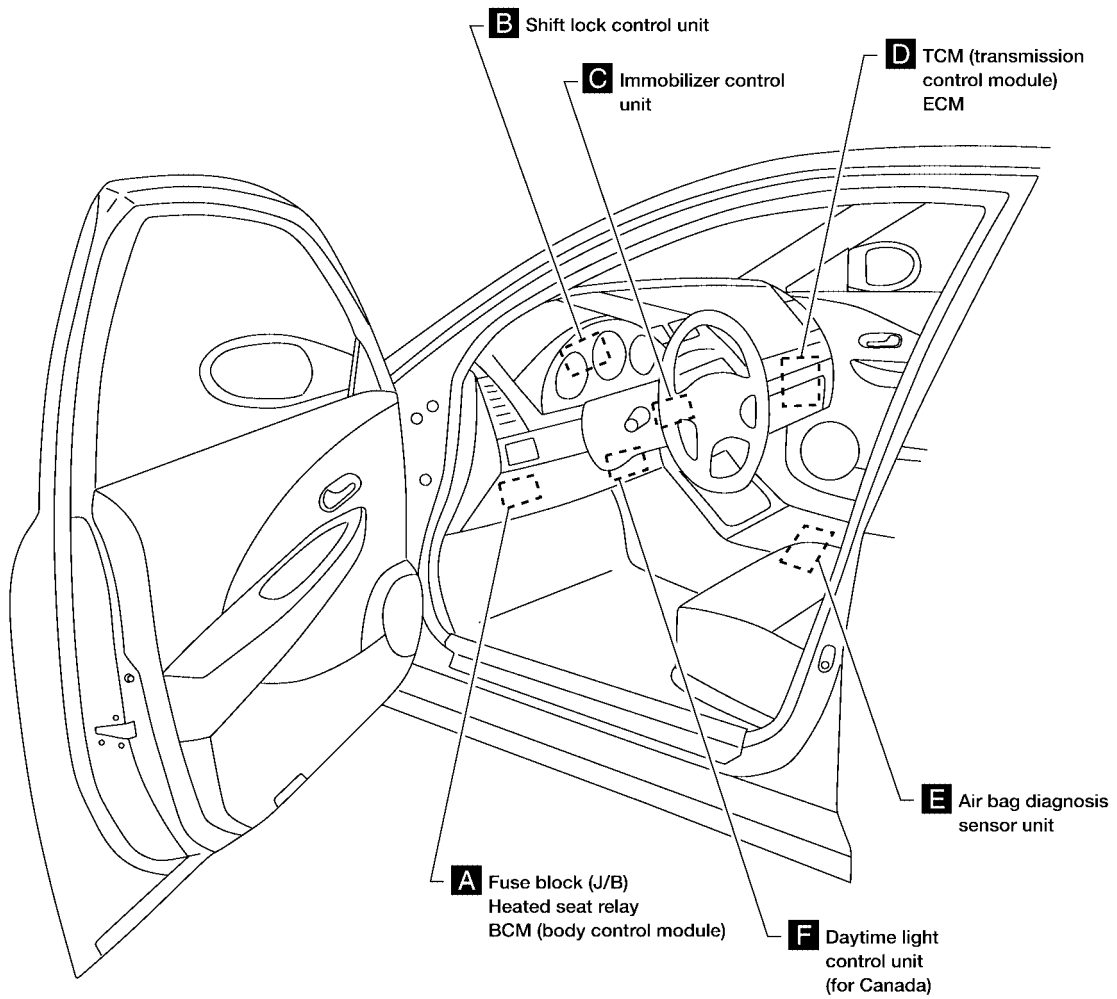

A Instrument panel lower LH

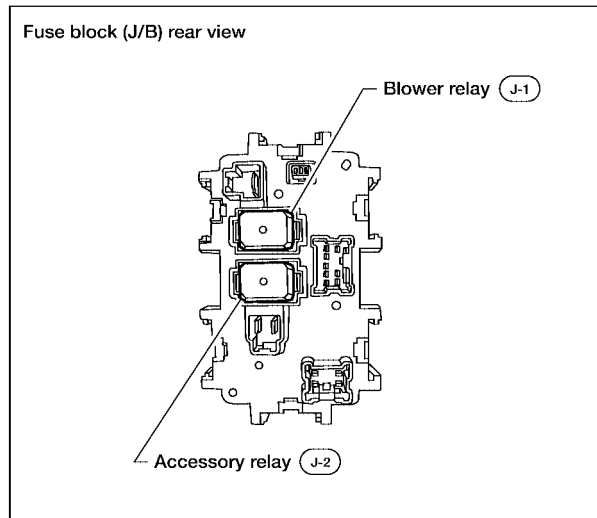
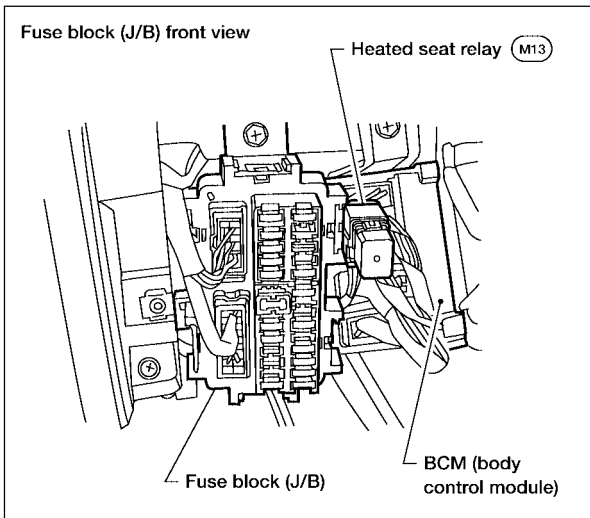

WKIA4120E

ELECTRICAL UNITS LOCATION

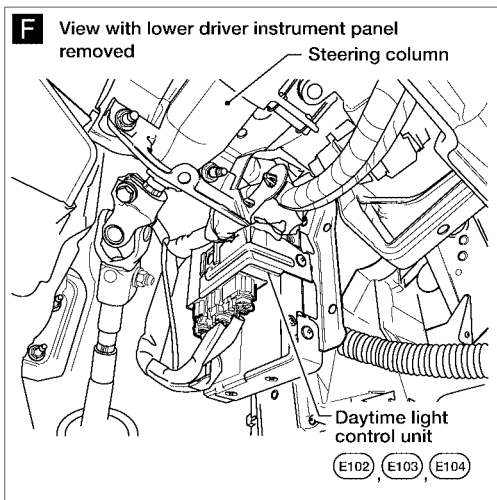
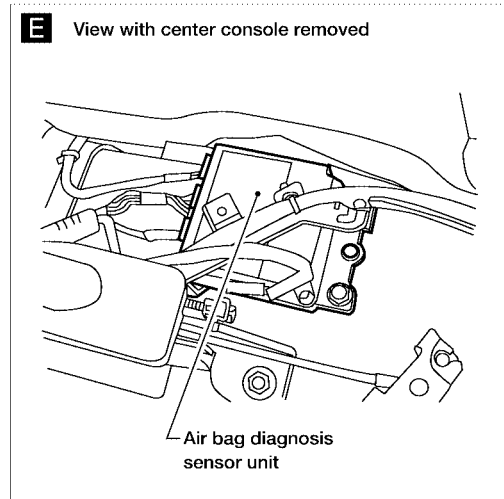
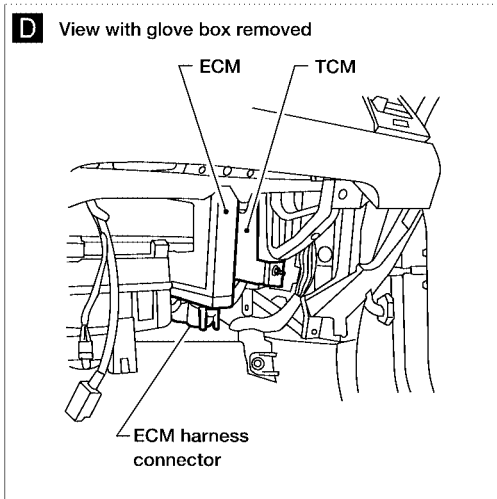
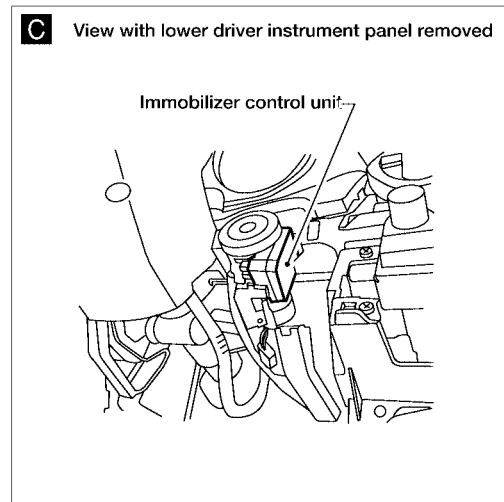
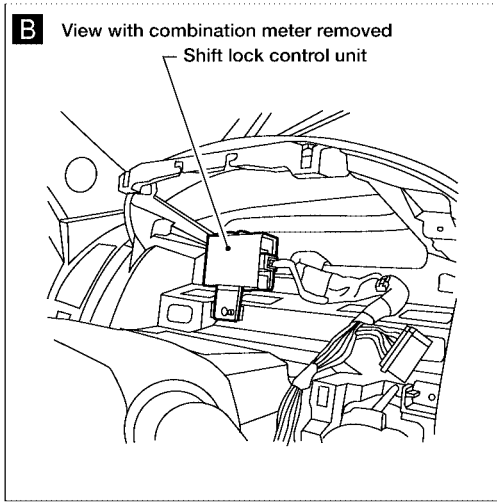

WKIA2765E

ELECTRICAL UNITS LOCATION

Fuse

EKS008UR

- If fuse is blown, be sure to eliminate cause of incident before installing new fuse.
- Use fuse of specified rating. Never use fuse of more than specified rating.
- Do not partially install fuse; always insert it into fuse holder properly.
- Remove fuse for "ELECTRICAL PARTS (BAT)" if vehicle is not used for a long period of time.

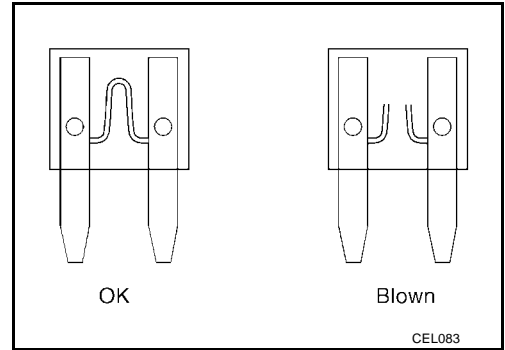

Fusible Link

EKS008US

A melted fusible link can be detected either by visual inspection or by feeling with finger tip. If its condition is questionable, use circuit tester or test lamp.

CAUTION:

- If fusible link should melt, it is possible that critical circuit (power supply or large current carrying circuit) is shorted. In such a case, carefully check and eliminate cause of incident.
- Never wrap outside of fusible link with vinyl tape. Important: Never let fusible link touch any other wiring harness, vinyl or rubber parts.

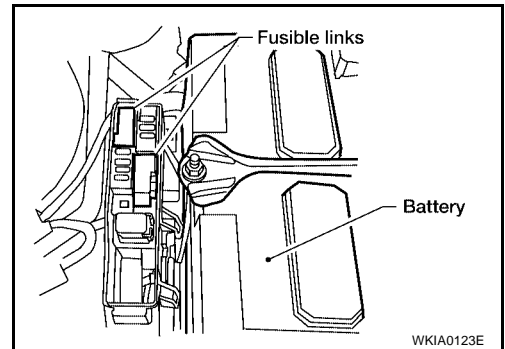

Circuit Breaker (Built Into BCM)

EKS008UT

For example, when current is 30A, the circuit is broken within 8 to 20 seconds.

A circuit breaker is used for the following systems:

- Power seat
- Power windows
- Power door locks
- Remote keyless entry system

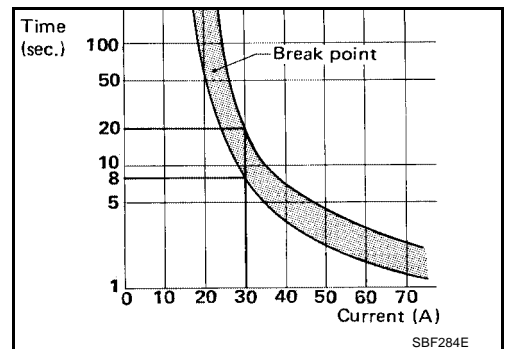

A
B
C
D
E
F
G
H
I
J
PG
L
M

HARNESS CONNECTOR

PFP:B4341

EKS008UU

HARNESS CONNECTOR

Description

HARNESS CONNECTOR (TAB-LOCKING TYPE)

- The tab-locking type connectors help prevent accidental looseness or disconnection.
- The tab-locking type connectors are disconnected by pushing or lifting the locking tab(s). Refer to the illustration below.

Refer to the next page for description of the slide-locking type connector.

CAUTION:

Do not pull the harness or wires when disconnecting the connector.

[Example]

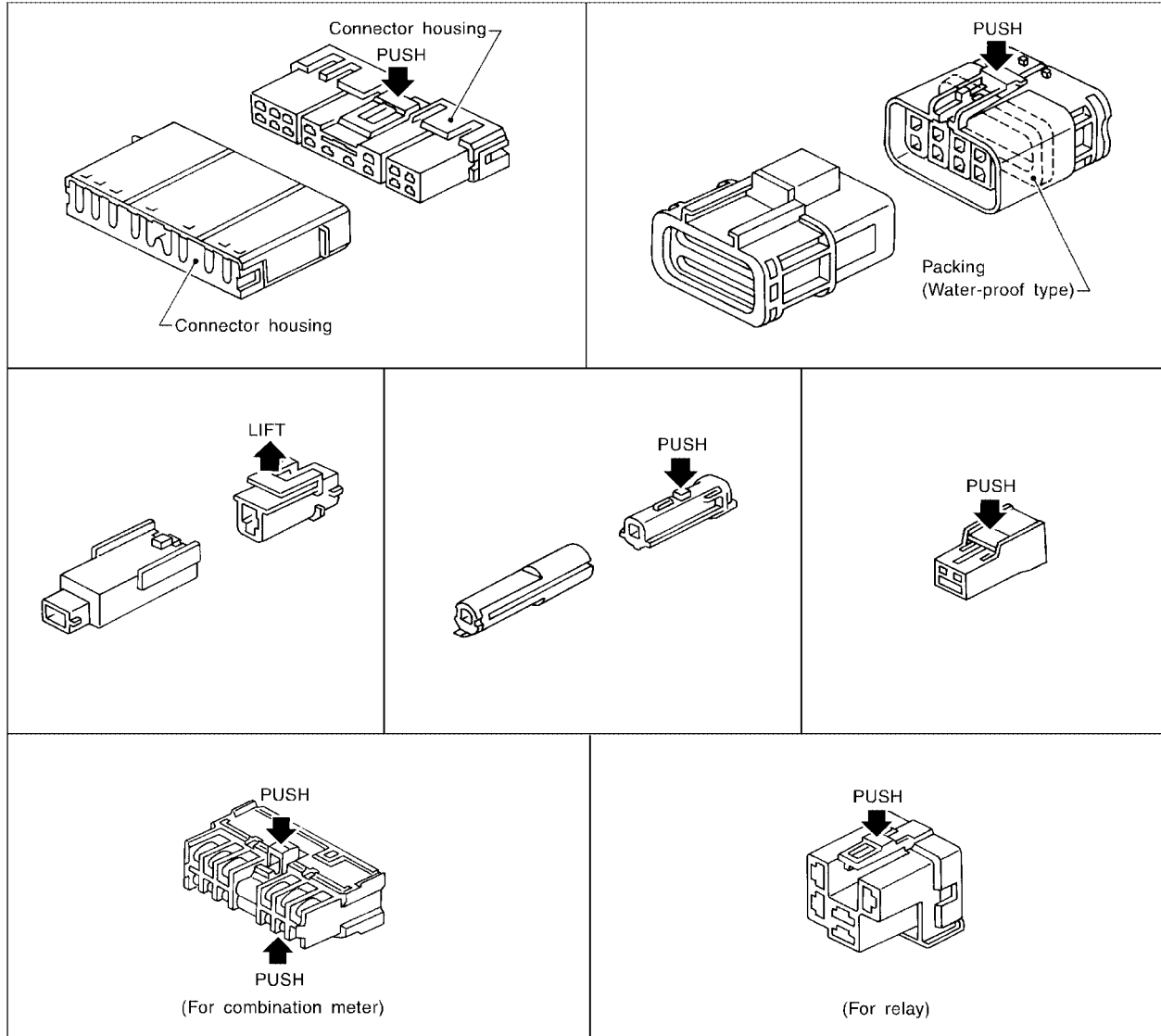

SEL769DA

HARNESS CONNECTOR

HARNESS CONNECTOR (SLIDE-LOCKING TYPE)

- A new style slide-locking type connector is used on certain systems and components, especially those related to OBD.
- The slide-locking type connectors help prevent incomplete locking and accidental looseness or disconnection.
- The slide-locking type connectors are disconnected by pushing or pulling the slider. Refer to the illustration below.

CAUTION:

- Do not pull the harness or wires when disconnecting the connector.
- Be careful not to damage the connector support bracket when disconnecting the connector.

[Example]

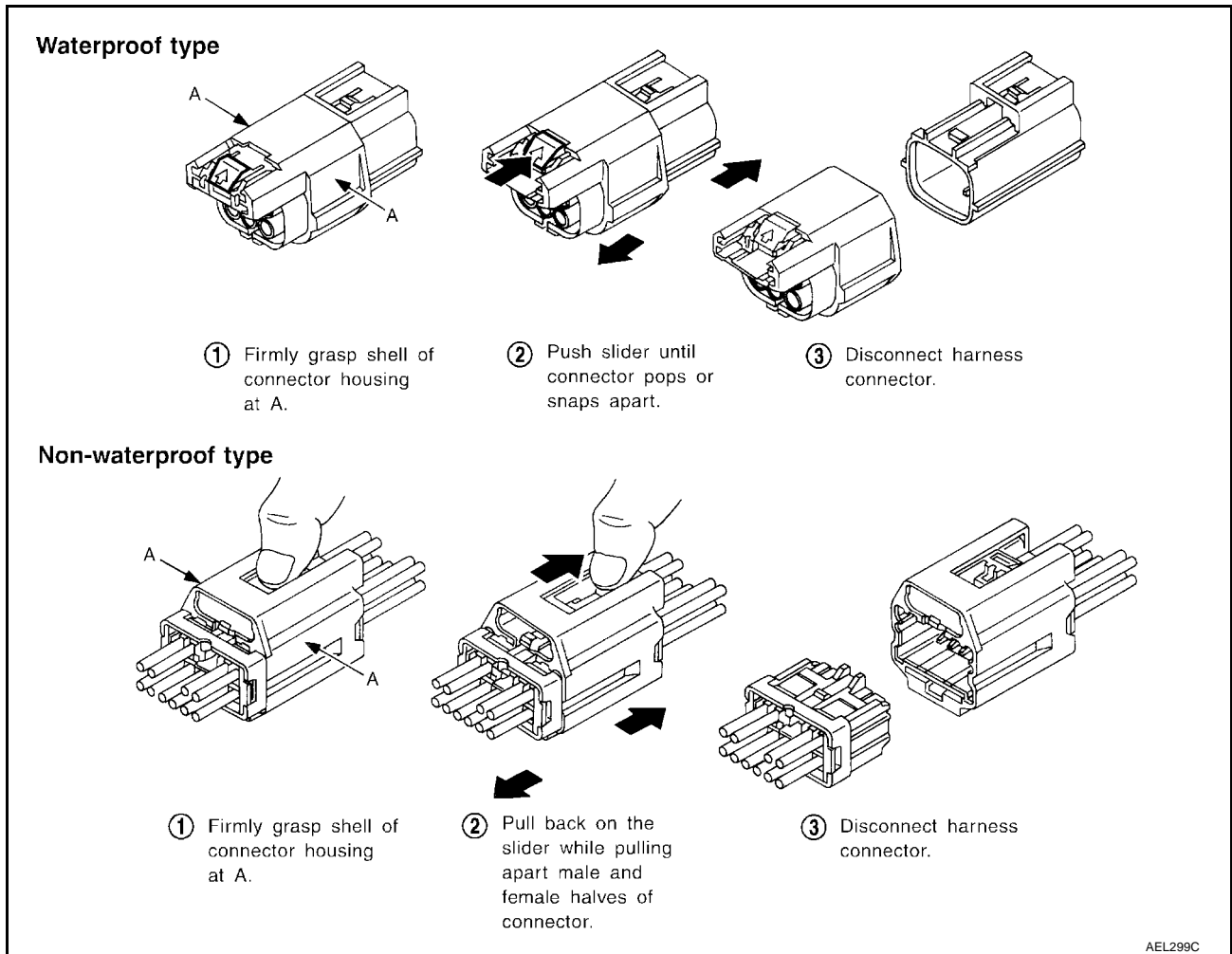

HARNES CONNECTOR

HARNES CONNECTOR (DIRECT-CONNECT SRS COMPONENT TYPE)

- SRS direct-connect type harness connectors are used on certain SRS components such as air bag modules and seat belt pre-tensioners.
- Always pull up to release black locking tab prior to removing connector from SRS component.
- Always push down to lock black locking tab after installing connector to SRS component. When locked, the black locking tab is level with the connector housing.

CAUTION:

- **Do not pull the harness or wires when removing connectors from SRS components.**

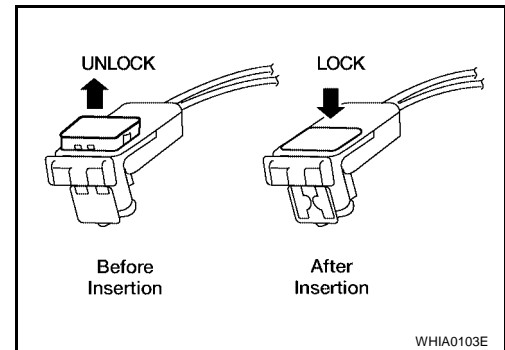



ELECTRICAL UNITS

ELECTRICAL UNITS Terminal Arrangement

PFP:23710

EKS008UV

 : WITH 4-SPEED A/T

 : WITH 5-SPEED A/T

BCM (BODY CONTROL MODULE)

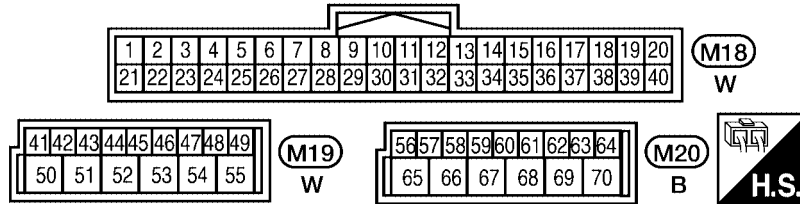

ABS ACTUATOR AND ELECTRIC UNIT (CONTROL UNIT)

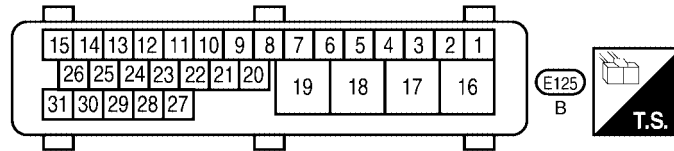

ECM

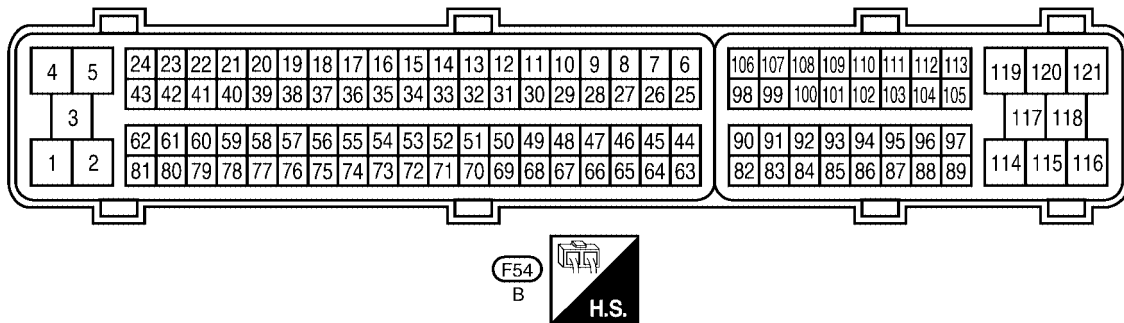

TCM (TRANSMISSION CONTROL MODULE)

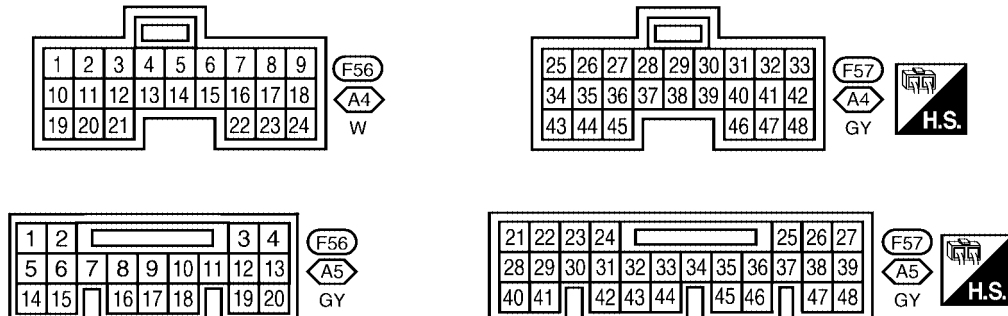

WKIA3348E

STANDARDIZED RELAY

PFP:25230

EKS008UW

STANDARDIZED RELAY

Description

NORMAL OPEN, NORMAL CLOSED AND MIXED TYPE RELAYS

Relays can mainly be divided into three types: normal open, normal closed and mixed type relays.

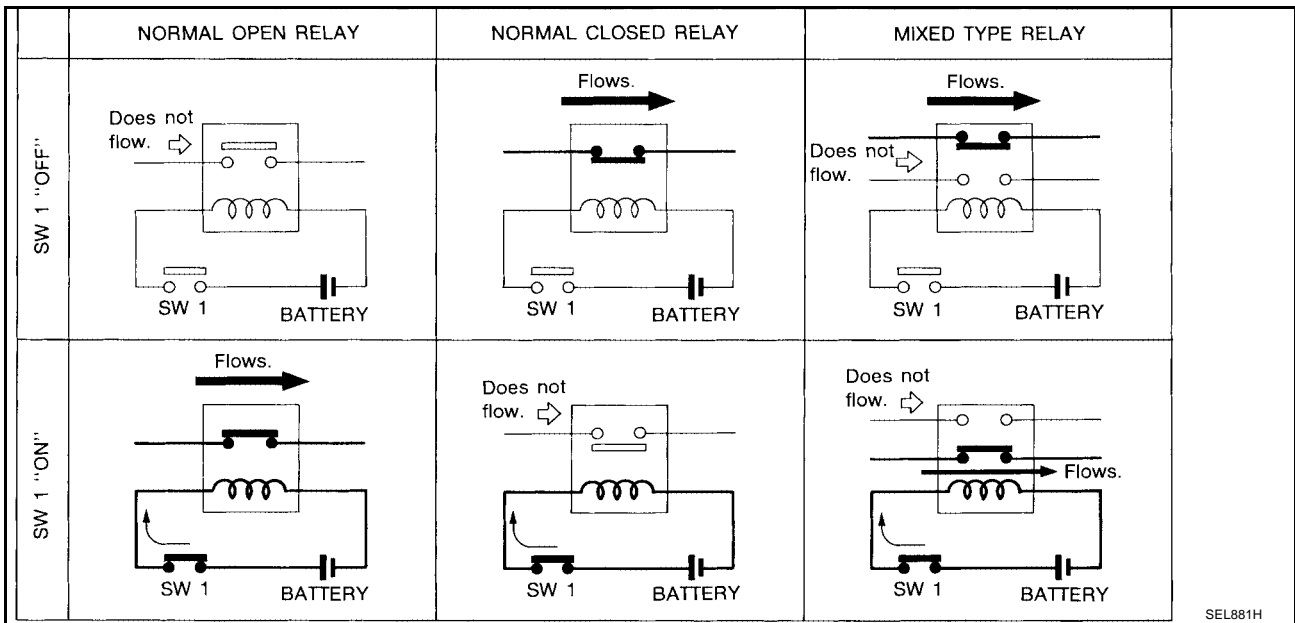

TYPE OF STANDARDIZED RELAYS

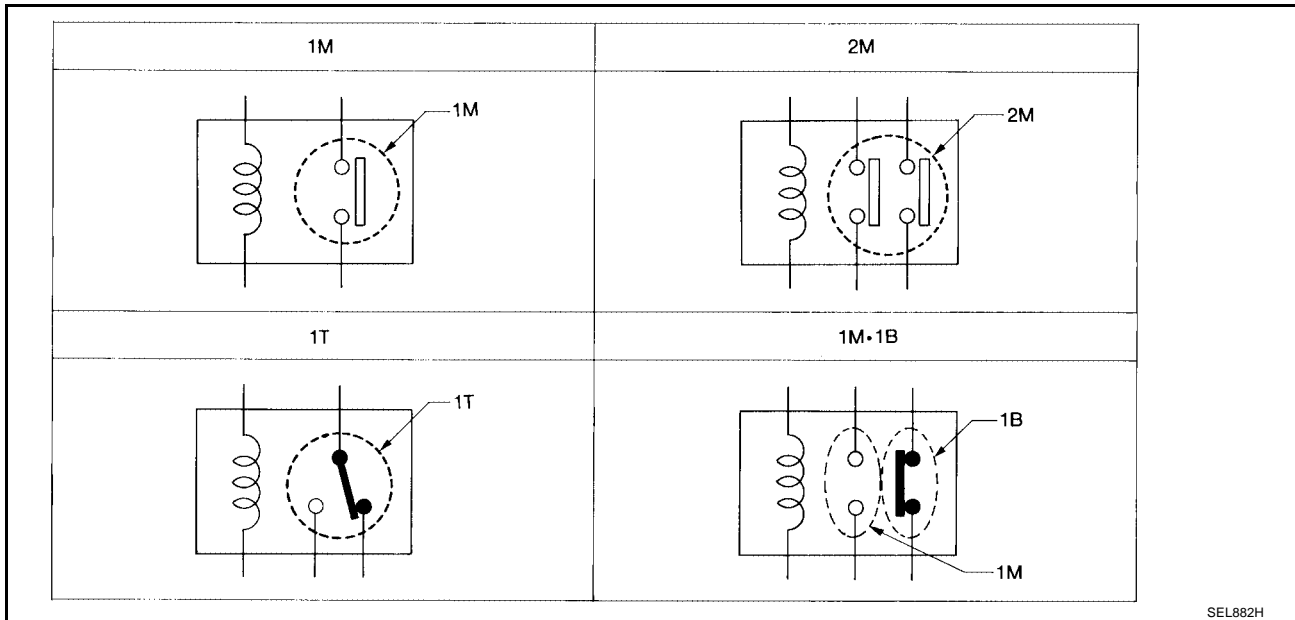

1M	1 Make	2M	2 Make
1T	1 Transfer	1M-1B	1 Make 1 Break

STANDARDIZED RELAY

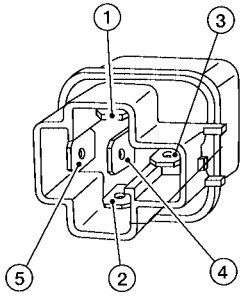
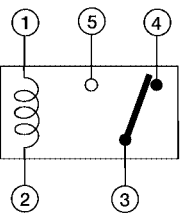
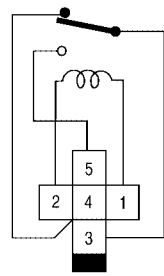
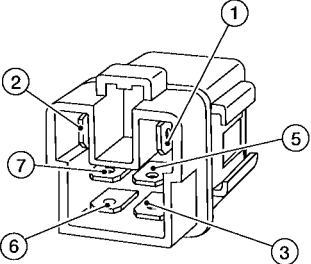
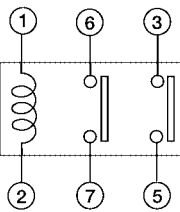
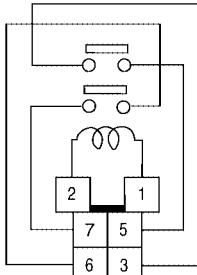
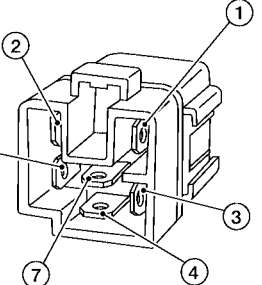
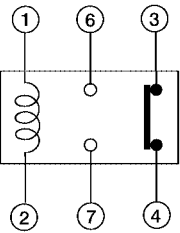
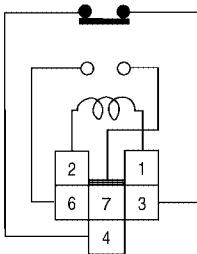
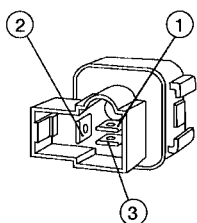
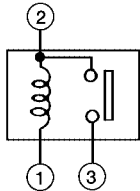
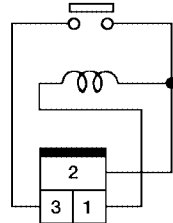
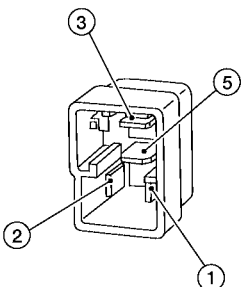
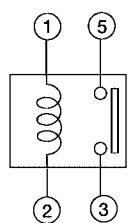
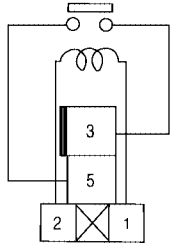
Type	Outer view	Circuit	Connector Symbol and connection	Case color
1T				BLACK
2M				BROWN
1M-1B				GRAY
1M				BLACK
				BLUE

The arrangement of terminal numbers on the actual relays may differ from those shown above.

WKIA0253E

A
B
C
D
E
F
G
H
I
J
PG
L
M

FUSE BLOCK-JUNCTION BOX(J/B)

PF24350

EKS008UX

FUSE BLOCK-JUNCTION BOX(J/B)

Terminal Arrangement

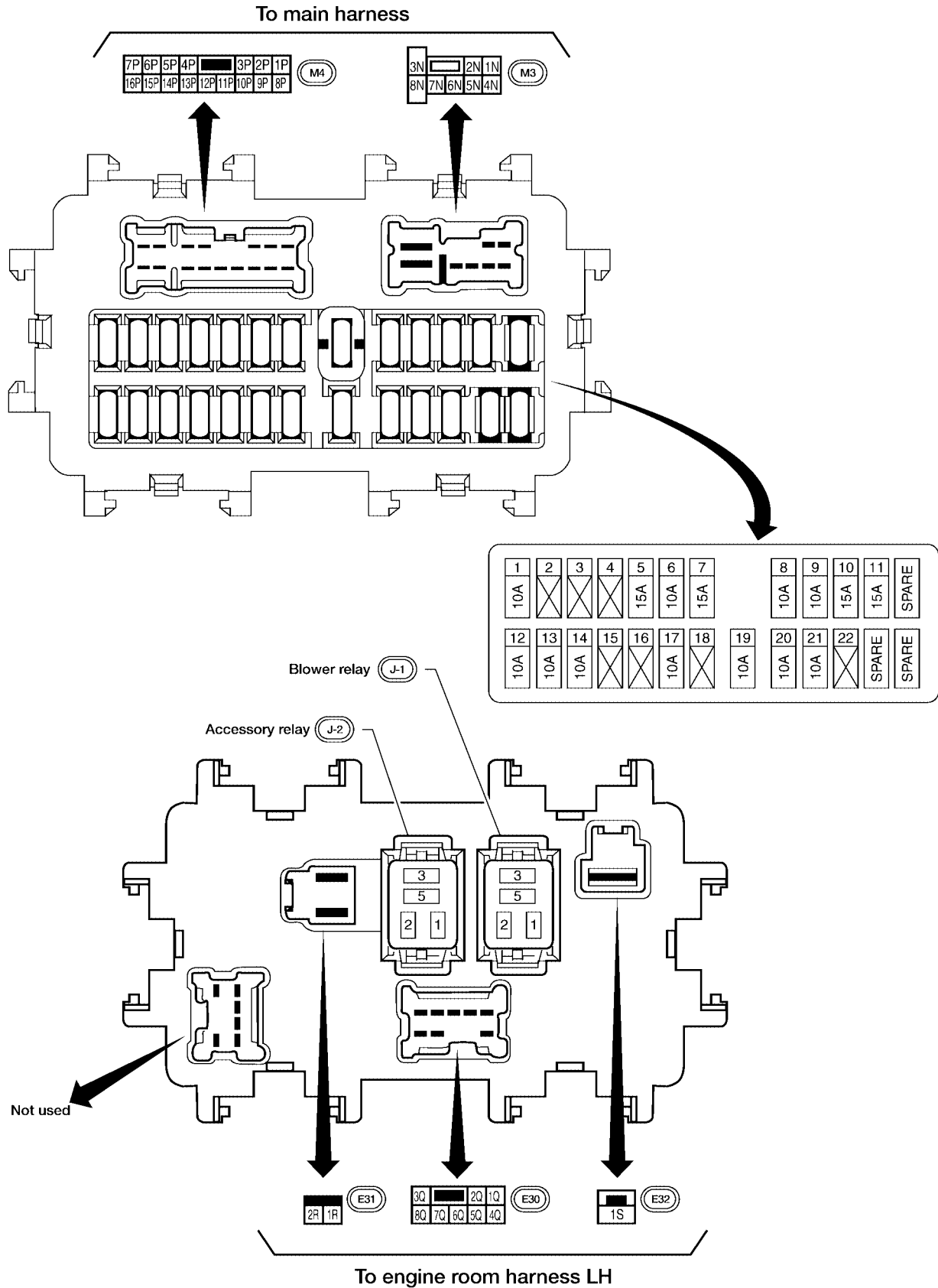

WKIA4121E

FUSE AND FUSIBLE LINK BOX

FUSE AND FUSIBLE LINK BOX

PF24381

Terminal Arrangement

EKS008UY

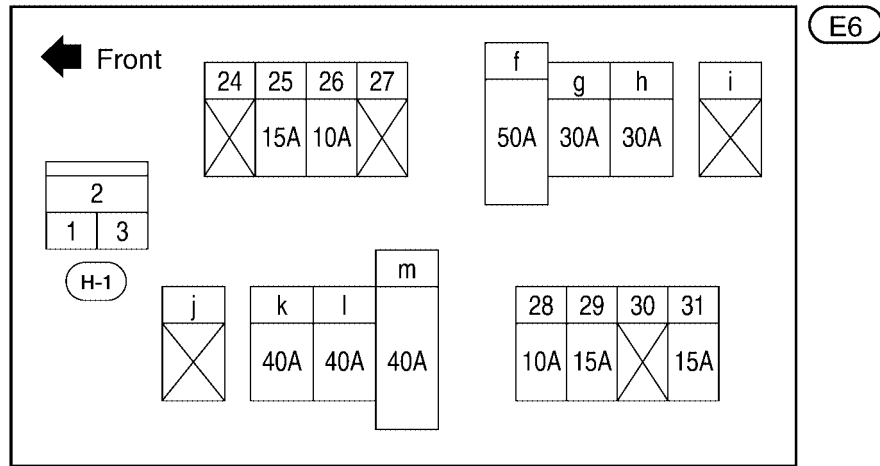

24 - 31: FUSE f - m: FUSIBLE LINK

A
B
C
D
E
F
G
H
I
J
L
M

PG

FUSE AND FUSIBLE LINK BOX
