

SECTION **MA**
 MAINTENANCE

A
B
C
D
E
F
G
H
I
J
K
L
M
N
O

CONTENTS

| | | | |
|--|----|---|----|
| PREPARATION | 3 | SPARK PLUG (PLATINUM-TIPPED TYPE) : Re- removal and Installation | 18 |
| PREPARATION | 3 | EVAP VAPOR LINES | 20 |
| Special Service Tool | 3 | EVAP VAPOR LINES : Inspection | 20 |
| Commercial Service Tool | 3 | ENGINE MAINTENANCE (VQ35DE) | 21 |
| ON-VEHICLE MAINTENANCE | 4 | DRIVE BELTS | 21 |
| GENERAL MAINTENANCE | 4 | DRIVE BELTS : Checking Drive Belts | 21 |
| Explanation General Maintenance | 4 | DRIVE BELTS : Tension Adjustment | 21 |
| PERIODIC MAINTENANCE | 6 | ENGINE COOLANT | 21 |
| Introduction of Periodic Maintenance | 6 | ENGINE COOLANT : Changing Engine Coolant | 21 |
| Schedule 1 | 6 | FUEL LINES | 23 |
| Schedule 2 | 9 | FUEL LINES : Inspection | 23 |
| RECOMMENDED FLUIDS AND LUBRI- CANTS | 11 | AIR CLEANER FILTER | 23 |
| Fluids and Lubricants | 11 | AIR CLEANER FILTER : Removal and Installation | 24 |
| SAE Viscosity Number | 11 | ENGINE OIL | 24 |
| ENGINE MAINTENANCE (QR25DE) | 13 | ENGINE OIL : Changing Engine Oil | 24 |
| DRIVE BELTS | 13 | OIL FILTER | 25 |
| DRIVE BELTS : Checking Drive Belts | 13 | OIL FILTER : Removal and Installation | 25 |
| DRIVE BELTS : Tension Adjustment | 13 | SPARK PLUG (PLATINUM-TIPPED TYPE) | 26 |
| ENGINE COOLANT | 13 | SPARK PLUG (PLATINUM-TIPPED TYPE) : Re- removal and Installation | 26 |
| ENGINE COOLANT : Changing Engine Coolant | 13 | EVAP VAPOR LINES | 27 |
| FUEL LINES | 15 | EVAP VAPOR LINES : Inspection | 27 |
| FUEL LINES : Inspection | 15 | CHASSIS AND BODY MAINTENANCE | 28 |
| AIR CLEANER FILTER | 15 | IN-CABIN MICROFILTER | 28 |
| AIR CLEANER FILTER : Removal and Installation | 16 | IN-CABIN MICROFILTER : Removal and Installa- tion | 28 |
| ENGINE OIL | 16 | EXHAUST SYSTEM | 28 |
| ENGINE OIL : Changing Engine Oil | 16 | EXHAUST SYSTEM : Inspection | 28 |
| OIL FILTER | 17 | CVT FLUID | 28 |
| OIL FILTER : Removal and Installation | 17 | | |
| SPARK PLUG (PLATINUM-TIPPED TYPE) | 18 | | |

MA

| | | | |
|--|-----------|---|-----------|
| CVT FLUID : RE0F09B | 28 | DISC BRAKE : Front Brake Rotor | 35 |
| CVT FLUID : Inspection | 28 | DISC BRAKE : Inspection | 35 |
| CVT FLUID : Changing | 29 | DISC BRAKE : Rear Brake Pad | 36 |
| CVT FLUID : RE0F10A | 30 | DISC BRAKE : Inspection | 36 |
| CVT FLUID : Inspection | 30 | DISC BRAKE : Rear Brake Rotor | 36 |
| CVT FLUID : Changing | 31 | DISC BRAKE : Inspection | 36 |
| M/T OIL | 32 | STEERING GEAR AND LINKAGE | 37 |
| M/T OIL : Draining | 32 | STEERING GEAR AND LINKAGE : Inspection | 37 |
| M/T OIL : Refilling | 32 | POWER STEERING FLUID AND LINES | 37 |
| M/T OIL : Inspection | 32 | POWER STEERING FLUID AND LINES : Inspec- tion | 37 |
| WHEELS | 33 | AXLE AND SUSPENSION PARTS | 38 |
| WHEELS : Inspection | 33 | AXLE AND SUSPENSION PARTS : Inspection | 38 |
| BRAKE FLUID LEVEL AND LEAKS | 34 | DRIVE SHAFT | 38 |
| BRAKE FLUID LEVEL AND LEAKS : Inspection ... | 34 | DRIVE SHAFT : Inspection | 39 |
| BRAKE LINES AND CABLES | 34 | LOCKS, HINGES AND HOOD LATCH | 39 |
| BRAKE LINES AND CABLES : Inspection | 34 | LOCKS, HINGES AND HOOD LATCH : Lubricat- ing | 39 |
| BRAKE FLUID | 34 | SEAT BELT, BUCKLES, RETRACTORS, AN- CHORS AND ADJUSTERS | 39 |
| BRAKE FLUID : Draining | 34 | SEAT BELT, BUCKLES, RETRACTORS, AN- CHORS AND ADJUSTERS : Inspection | 39 |
| BRAKE FLUID : Refilling | 35 | | |
| DISC BRAKE | 35 | | |
| DISC BRAKE : Front Brake Pad | 35 | | |
| DISC BRAKE : Inspection | 35 | | |

PREPARATION

< PREPARATION >

PREPARATION

PREPARATION

Special Service Tool

INFOID:000000000995572

The actual shapes of Kent-Moore tools may differ from those of special service tools illustrated here.

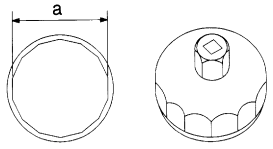
| Tool number (Kent-Moore No.) Tool name | Description |
|--|--|
| KV10115801 (J38956) Oil filter wrench  <p style="text-align: right;">S-NT375</p> | Removing and installing oil filter a: 64.3 mm (2.531 in) |

Commercial Service Tool

INFOID:000000000995573

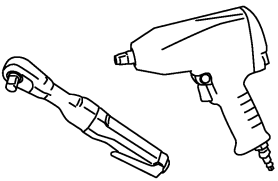
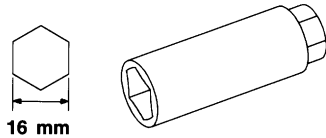
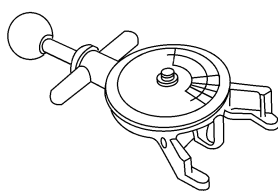
| Tool name (Kent-Moore No.) | Description |
|---|--------------------------------------|
| Power tool (—)  <p style="text-align: right;">PBIC0190E</p> | Loosening nuts and bolts |
| Spark plug wrench (—)  <p>16 mm (0.63 in)</p> <p style="text-align: right;">S-NT047</p> | Removing and installing spark plug |
| Belt tension gauge (BT3373-F)  <p style="text-align: right;">AMA126</p> | Checking drive belt tension (VQ35DE) |

A
B
C
D
E
F
G
H
I
J
K
L
M
N
O

MA

GENERAL MAINTENANCE

< ON-VEHICLE MAINTENANCE >

ON-VEHICLE MAINTENANCE

GENERAL MAINTENANCE

Explanation General Maintenance

INFOID:000000000995574

General maintenance includes those items which should be checked during the normal day-to-day operation of the vehicle. They are essential if the vehicle is to continue operating properly. The owners can perform checks and inspections themselves or have their **NISSAN** dealers do them.

OUTSIDE THE VEHICLE

The maintenance items listed here should be performed from time to time, unless otherwise specified.

| Item | | Reference page |
|--|--|--|
| Tires | Check the pressure with a gauge, including the spare, at least once a month and always prior to a long distance trips. Adjust to the specified pressure if necessary. Check carefully for damage, cuts or excessive wear. | WT-37 |
| Wheel nuts | When checking the tires, make sure no nuts are missing, and check for any loose nuts. Tighten if necessary. | WT-33 |
| Windshield | Clean the windshield on a regular basis. Check the windshield at least every six months for cracks or other damage. Repair as necessary. | — |
| Tire rotation | Tires should be rotated every 12,000 km (7,500 miles). | WT-33 |
| Transmitter component in tire pressure monitoring system (TPMS) | Replace grommet seal, valve core and cap of the transmitter in TPMS every tire replacement by reaching wear limit of tire. | WT-9 |
| Wheel alignment and balance | If the vehicle pulls to either side while driving on a straight and level road, or if you detect uneven or abnormal tire wear, there may be a need for wheel alignment. If the steering wheel or seat vibrates at normal highway speeds, wheel balancing may be needed. | FSU-15 and WT-31 |
| Windshield wiper blades | Check for cracks or wear if they do not wipe properly. | — |
| Doors and engine hood | Check that all doors and the engine hood operate smoothly as well as the trunk lid. Also make sure that all latches lock securely. Lubricate if necessary. Make sure that the secondary latch keeps the hood from opening when the primary latch is released. When driving in areas using road salt or other corrosive materials, check lubrication frequently. | MA-39 |
| Lamps | Make sure that the headlamps, stop lamps, tail lamps, turn signal lamps, and other lamps are all operating properly and installed securely. Also check headlamp aim. Clean the headlamps on a regular basis. | — |

INSIDE THE VEHICLE

The maintenance items listed here should be checked on a regular basis, such as when performing periodic maintenance, cleaning the vehicle, etc.

| Item | | Reference page |
|------------------------------------|---|----------------|
| Warning lamps and chimes | Make sure that all warning lamps and chimes are operating properly. | — |
| Windshield wiper and washer | Check that the wipers and washer operate properly and that the wipers do not streak. | — |
| Windshield defroster | Check that the air comes out of the defroster outlets properly and in sufficient quantity when operating the heater or air conditioner. | — |
| Steering wheel | Check that it has the specified play. Be sure to check for changes in the steering condition, such as excessive play, hard steering or strange noises. Free play: Less than 35 mm (1.38 in) | — |
| Seats | Check seat position controls such as seat adjusters, seatback recliner, etc. to make sure they operate smoothly and that all latches lock securely in every position. Check that the head restraints move up and down smoothly and that the locks (if equipped) hold securely in all latched positions. Check that the latches lock securely for folding-down rear seatbacks. | — |

GENERAL MAINTENANCE

< ON-VEHICLE MAINTENANCE >

| Item | | Reference page | |
|--|---|--|---|
| Seat belts | Check that all parts of the seat belt system (e.g. buckles, anchors, adjusters and retractors) operate properly and smoothly, and are installed securely. Check the belt webbing for cuts, fraying, wear or damage. | SB-3 | A |
| Accelerator pedal | Check the pedal for smooth operation and make sure the pedal does not catch or require uneven effort. Keep the floor mats away from the pedal. | — | B |
| Brakes | Check that the brake does not pull the vehicle to one side when applied. | — | C |
| Brake pedal and booster | Check the pedal for smooth operation and make sure it has the proper distance under it when depressed fully. Check the brake booster function. Be sure to keep the floor mats away from the pedal. | BR-9 , BR-12 | D |
| Parking brake | Check that the lever or pedal has the proper travel and make sure that the vehicle is held securely on a fairly steep hill when only the parking brake is applied. | PB-2 (lever) PB-2 (pedal) | E |
| CVT P (Park) position mechanism | On a fairly steep hill check that the vehicle is held securely with the selector lever in the P (Park) position without applying any brakes. | — | F |

UNDER THE HOOD AND VEHICLE

The maintenance items listed here should be checked periodically (e.g. each time you check the engine oil or refuel).

| Item | | Reference page | |
|---|--|---|----|
| Windshield washer fluid | Check that there is adequate fluid in the tank. | — | G |
| Engine coolant level | Check the coolant level when the engine is cold. | CO-11 (QR25DE) CO-32 (VQ35DE) | H |
| Radiator and hoses | Check the front of the radiator and clean off any dirt, insects, leaves, etc., that may have accumulated. Make sure the hoses have no cracks, deformation, deterioration or loose connections. | — | I |
| Brake fluid level | Make sure that the brake fluid level is between the “MAX” and “MIN” lines on the reservoir. | BR-14 | J |
| Battery | Check the fluid level in each cell. It should be between the “MAX” and “MIN” lines. Vehicles operated in high temperatures or under severe conditions require frequent checks of the battery fluid level. | PG-2 | K |
| Engine drive belts | Make sure that no belt is frayed, worn, cracked or oily. | EM-16 (QR25DE) EM-124 (VQ35DE) | L |
| Engine oil level | Check the level on the oil level gauge after parking the vehicle on a level spot and turning off the engine. | LU-8 (QR25DE) LU-20 (VQ35DE) | M |
| Power steering fluid level and lines | Check the level on the dipstick with the engine off. Check the lines for improper attachment, leaks, cracks, etc. | MA-37 | N |
| Exhaust system | Make sure there are no loose supports, cracks or holes. If the sound of the exhaust seems unusual or there is a smell of exhaust fumes, immediately locate the trouble and correct it. | MA-28 | O |
| Underbody | The underbody is frequently exposed to corrosive substances such as those used on icy roads or to control dust. It is very important to remove these substances, otherwise rust will form on the floor pan, frame, fuel lines and around the exhaust system. At the end of winter, the underbody should be thoroughly flushed with plain water, being careful to clean those areas where mud and dirt can easily accumulate. | — | MA |
| Fluid leaks | Check under the vehicle for fuel, oil, water or other fluid leaks after the vehicle has been parked for a while. Water dripping from the air conditioner after use is normal. If you should notice any leaks or gasoline fumes are evident, check for the cause and correct it immediately. | — | |

PERIODIC MAINTENANCE

< ON-VEHICLE MAINTENANCE >

PERIODIC MAINTENANCE

Introduction of Periodic Maintenance

INFOID:000000000995575

Two different maintenance schedules are provided, and should be used, depending upon the conditions in which the vehicle is mainly operated. **After 60,000 miles (96,000 km) or 48 months, continue the periodic maintenance at the same mileage/time intervals.**

| | | | |
|------------|--|-------------------------------------|----------------------|
| Schedule 1 | Follow Periodic Maintenance Schedule 1 if the driving habits frequently include one or more of the following driving conditions: <ul style="list-style-type: none"> • Repeated short trips of less than 5 miles (8 km). • Repeated short trips of less than 10 miles (16 km) with outside temperatures remaining below freezing. • Operating in hot weather in stop-and-go “rush hour” traffic. • Extensive idling and/or low speed driving for long distances, such as police, taxi or door-to-door delivery use. • Driving in dusty conditions. • Driving on rough, muddy, or salt spread roads. • Towing a trailer, using a camper or a car-top carrier. | Emission Control System Maintenance | MA-6 |
| | | Chassis and Body Maintenance | MA-6 |
| Schedule 2 | Follow Periodic Maintenance Schedule 2 if none of driving conditions shown in Schedule 1 apply to the driving habits. | Emission Control System Maintenance | MA-9 |
| | | Chassis and Body Maintenance | MA-9 |

Schedule 1

INFOID:000000000995576

EMISSION CONTROL SYSTEM

Abbreviations: R = Replace. I = Inspect. Correct or replace if necessary. []: At the mileage intervals only

| MAINTENANCE OPERATION | | MAINTENANCE INTERVAL | | | | | | | | Reference Section - Page or - Content Title |
|--|---|----------------------|-------------------|--------------------|------------------|---------------------|--------------------|---------------------|------------------|--|
| Perform at number of miles, kilometers or months, whichever comes first. | Miles x 1,000 (km x 1,000) Months | 3.75 (6) 3 | 7.50 (12) 6 | 11.25 (18) 9 | 15 (24) 12 | 18.75 (30) 15 | 22.5 (36) 18 | 26.25 (42) 21 | 30 (48) 24 | |
| Drive belts | NOTE (1) | | | | | | | | | MA-13 (QR25DE) MA-21 (VQ35DE) |
| Air cleaner filter | NOTE (2) | | | | | | | | [R] | MA-16 (QR25DE) MA-24 (VQ35DE) |
| EVAP vapor lines | | | | | | | | | I* | MA-20 (QR25DE) MA-27 (VQ35DE) |
| Fuel lines | | | | | | | | | I* | MA-15 (QR25DE) MA-23 (VQ35DE) |
| Fuel filter | NOTE (3) | | | | | | | | | — |
| Engine coolant | NOTE (4) | | | | | | | | | MA-13 (QR25DE) MA-21 (VQ35DE) |
| Engine oil | | R | R | R | R | R | R | R | R | MA-16 (QR25DE) MA-24 (VQ35DE) |

PERIODIC MAINTENANCE

< ON-VEHICLE MAINTENANCE >

| MAINTENANCE OPERATION | | MAINTENANCE INTERVAL | | | | | | | | Reference Section - Page or - Content Title |
|--|--------------------------------------|---|----------------|-----------------|---------------|------------------|-----------------|------------------|---------------|--|
| Perform at number of miles, kilometers or months, whichever comes first. | Miles x 1,000 (km x 1,000) Months | 3.75 (6) 3 | 7.50 (12) 6 | 11.25 (18) 9 | 15 (24) 12 | 18.75 (30) 15 | 22.5 (36) 18 | 26.25 (42) 21 | 30 (48) 24 | |
| Engine oil filter [Use part No. 15208 65F01 or equivalent.] | | R | R | R | R | R | R | R | R | MA-17 (QR25DE) MA-25 (VQ35DE) |
| Spark plugs (Iridium and platinum-tipped type) | | Replace every 105,000 miles (169,000 km). | | | | | | | | MA-18 (QR25DE) MA-26 (VQ35DE) |
| Intake & exhaust valve clearance* | NOTE (5) | | | | | | | | | EM-101 , "Standard and Limit" (QR25DE) EM-225 , "Standard and Limit" (VQ35DE) |

| MAINTENANCE OPERATION | | MAINTENANCE INTERVAL | | | | | | | | Reference Section - Page or - Content Title |
|--|--------------------------------------|----------------------|-----------------|------------------|---------------|------------------|-----------------|------------------|---------------|--|
| Perform at number of miles, kilometers or months, whichever comes first. | Miles x 1,000 (km x 1,000) Months | 33.75 (54) 27 | 37.5 (60) 30 | 41.25 (66) 33 | 45 (72) 36 | 48.75 (78) 39 | 52.5 (84) 42 | 56.25 (90) 45 | 60 (96) 48 | |
| Drive belts | NOTE (1) | | | | | | | | I* | MA-13 (QR25DE) MA-21 (VQ35DE) |
| Air cleaner filter | NOTE (2) | | | | | | | | [R] | MA-16 (QR25DE) MA-24 (VQ35DE) |
| EVAP vapor lines | | | | | | | | | I* | MA-20 (QR25DE) MA-27 (VQ35DE) |
| Fuel lines | | | | | | | | | I* | MA-15 (QR25DE) MA-23 (VQ35DE) |
| Fuel filter | NOTE (3) | | | | | | | | | — |
| Engine coolant | NOTE (4) | | | | | | | | R* | MA-13 (QR25DE) MA-21 (VQ35DE) |
| Engine oil | | R | R | R | R | R | R | R | R | MA-16 (QR25DE) MA-24 (VQ35DE) |
| Engine oil filter [Use part No. 15208 31U01 or equivalent.] | | R | R | R | R | R | R | R | R | MA-17 (QR25DE) MA-25 (VQ35DE) |

A
B
C
D
E
F
G
H
I
J
K
L
M
N
O
MA

PERIODIC MAINTENANCE

< ON-VEHICLE MAINTENANCE >

| MAINTENANCE OPERATION | | MAINTENANCE INTERVAL | | | | | | | | Reference Section - Page or - Content Title |
|--|--------------------------------------|---|-----------------|------------------|---------------|------------------|-----------------|------------------|---------------|--|
| Perform at number of miles, kilometers or months, whichever comes first. | Miles x 1,000 (km x 1,000) Months | 33.75 (54) 27 | 37.5 (60) 30 | 41.25 (66) 33 | 45 (72) 36 | 48.75 (78) 39 | 52.5 (84) 42 | 56.25 (90) 45 | 60 (96) 48 | |
| Spark plugs (Iridium and platinum-tipped type) | | Replace every 105,000 miles (169,000 km). | | | | | | | | MA-18 (QR25DE) MA-26 (VQ35DE) |
| Intake & exhaust valve clearance* | NOTE (5) | | | | | | | | | EM-101 , "Standard and Limit" (QR25DE) EM-225 , "Standard and Limit" (VQ35DE) |

NOTE:

- (1) After 60,000 miles (96,000 km) or 48 months, inspect every 15,000 miles (24,000 km) or 12 months. Replace the drive belts if found damaged.
- (2) If operating mainly in dusty conditions, more frequent maintenance may be required.
- (3) Maintenance-free item. For service procedures, refer to FL section.
- (4) After 60,000 miles (96,000 km) or 48 months, replace every 30,000 miles (48,000 km) or 24 months.
- (5) If valve noise increases, inspect valve clearance.

* Maintenance items and intervals with "*" are recommended by NISSAN for reliable vehicle operation. The owner need not perform such maintenance in order to maintain the emission warranty or manufacturer recall liability. Other maintenance items and intervals are required.

CHASSIS AND BODY

Abbreviations: R = Replace. I = Inspect. Correct or replace if necessary.

| MAINTENANCE OPERATION | | MAINTENANCE INTERVAL | | | | | | | | Reference Section - Page or - Content Title |
|--|--------------------------------------|----------------------|----------------|-----------------|---------------|------------------|-----------------|------------------|---------------|--|
| Perform at number of miles, kilometers or months, whichever comes first. | Miles x 1,000 (km x 1,000) Months | 3.75 (6) 3 | 7.50 (12) 6 | 11.25 (18) 9 | 15 (24) 12 | 18.75 (30) 15 | 22.5 (36) 18 | 26.25 (42) 21 | 30 (48) 24 | |
| Brake lines & cables | | | | | I | | | | I | MA-34 |
| Brake pads & rotors | | | I | | I | | I | | I | MA-35 , MA-36 |
| CVT fluid | NOTE (1) | | | | I | | | | I | MA-28 (RE0F09B) MA-30 (RE0F10B) |
| Manual transaxle oil | NOTE (2) | | | | I | | | | I | MA-32 |
| Steering gear and linkage, axle & suspension parts | | | | | I | | | | | MA-37 |
| Tire rotation | NOTE (3) | | | | | | | | | MA-28 |
| Exhaust system | | | I | | I | | I | | I | MA-39 |
| Front drive shaft boot | | | I | | I | | I | | I | MA-39 |
| In-cabin microfilter | | | | | R | | | | R | MA-34 |

| MAINTENANCE OPERATION | | MAINTENANCE INTERVAL | | | | | | | | Reference Section - Page or - Content Title |
|--|--------------------------------------|----------------------|-----------------|------------------|---------------|------------------|-----------------|------------------|---------------|--|
| Perform at number of miles, kilometers or months, whichever comes first. | Miles x 1,000 (km x 1,000) Months | 33.75 (54) 27 | 37.5 (60) 30 | 41.25 (66) 33 | 45 (72) 36 | 48.75 (78) 39 | 52.5 (84) 42 | 56.25 (90) 45 | 60 (96) 48 | |
| Brake lines & cables | | | | | I | | | | I | MA-34 |
| Brake pads & rotors | | | I | | I | | I | | I | MA-35 , MA-36 |

PERIODIC MAINTENANCE

< ON-VEHICLE MAINTENANCE >

| MAINTENANCE OPERATION | | MAINTENANCE INTERVAL | | | | | | | | Reference Section - Page or - Content Title |
|--|-----------------------------------|----------------------|-----------------|------------------|---------------|------------------|-----------------|------------------|---------------|--|
| Perform at number of miles, kilometers or months, whichever comes first. | Miles x 1,000 (km x 1,000) Months | 33.75 (54) 27 | 37.5 (60) 30 | 41.25 (66) 33 | 45 (72) 36 | 48.75 (78) 39 | 52.5 (84) 42 | 56.25 (90) 45 | 60 (96) 48 | |
| CVT fluid | NOTE (1) | | | | I | | | | I | MA-28 (RE0F09B) MA-30 (RE0F10B) |
| Manual transaxle oil | NOTE (2) | | | | I | | | | I | MA-32 |
| Tire rotation | NOTE (3) | | | | | | | | | MA-37 |
| Exhaust system | | | I | | I | | I | | I | MA-28 |
| Front drive shaft boot | | | I | | I | | I | | I | MA-39 |
| In-cabin microfilter | | | | | R | | | | R | MA-39 |

NOTE:

(1) If towing a trailer, or using a car-top carrier, or driving on rough or muddy roads, inspect CVT fluid deterioration with Consult-III every 60,000 miles (96,000 km), then change the CVT fluid NS-2 if necessary. (Refer to [MA-28, "CVT FLUID : Inspection"](#) RE0F09B or [MA-30, "CVT FLUID : Inspection"](#) RE0F10B.) **Using transmission fluid other than Genuine NISSAN CVT NS-2 will damage the CVT, which is not covered by the NISSAN new vehicle limited warranty.**

(2) If towing a trailer, or using a car-top carrier, or driving on rough or muddy roads, change (not just inspect) oil at every 30,000 miles (48,000 km) or 24 months.

(3) Refer to "Tire rotation" under the "General maintenance" heading earlier in this section.

Schedule 2

INFOID:000000000995577

EMISSION CONTROL SYSTEM

Abbreviations: R = Replace. I = Inspect. Correct or replace if necessary. []: At the mileage intervals only

| MAINTENANCE OPERATION | | MAINTENANCE INTERVAL | | | | | | | | Reference Section - Page or - Content Title |
|--|-----------------------------------|----------------------|---------------|-----------------|---------------|-----------------|---------------|-----------------|---------------|--|
| Perform at number of miles, kilometers or months, whichever comes first. | Miles x 1,000 (km x 1,000) Months | 7.5 (12) 6 | 15 (24) 12 | 22.5 (36) 18 | 30 (48) 24 | 37.5 (60) 30 | 45 (72) 36 | 52.5 (84) 42 | 60 (96) 48 | |
| Drive belts | NOTE (1) | | | | | | | | I* | MA-13 (QR25DE) MA-21 (VQ35DE) |
| Air cleaner filter | | | | | [R] | | | | [R] | MA-16 (QR25DE) MA-24 (VQ35DE) |
| EVAP vapor lines | | | | | I* | | | | I* | MA-20 (QR25DE) MA-27 (VQ35DE) |
| Fuel lines | | | | | I* | | | | I* | MA-15 (QR25DE) MA-23 (VQ35DE) |
| Fuel filter | NOTE (2) | | | | | | | | | — |
| Engine coolant | NOTE (3) | | | | | | | | R* | MA-13 (QR25DE) MA-21 (VQ35DE) |
| Engine oil | | R | R | R | R | R | R | R | R | MA-16 (QR25DE) MA-24 (VQ35DE) |

PERIODIC MAINTENANCE

< ON-VEHICLE MAINTENANCE >

| MAINTENANCE OPERATION | | MAINTENANCE INTERVAL | | | | | | | | Reference Section - Page or - Content Title |
|--|---|---|------------------|--------------------|------------------|--------------------|------------------|--------------------|------------------|---|
| Perform at number of miles, kilometers or months, whichever comes first. | Miles x 1,000 (km x 1,000) Months | 7.5 (12) 6 | 15 (24) 12 | 22.5 (36) 18 | 30 (48) 24 | 37.5 (60) 30 | 45 (72) 36 | 52.5 (84) 42 | 60 (96) 48 | |
| Engine oil filter [Use part No. 15208 65F01 or equivalent.] | | R | R | R | R | R | R | R | R | MA-17 (QR25DE) MA-25 (VQ35DE) |
| Spark plugs (Iridium and platinum-tipped type) | | Replace every 105,000 miles (169,000 km). | | | | | | | | MA-18 (QR25DE) MA-26 (VQ35DE) |
| Intake & exhaust valve clearance* | NOTE (4) | | | | | | | | | EM-101, "Standard and Limit" (QR25DE) EM-225, "Standard and Limit" (VQ35DE) |

NOTE:

- (1) After 60,000 miles (96,000 km) or 48 months, inspect every 15,000 miles (24,000 km) or 12 months. Replace the drive belts if found damaged.
- (2) Maintenance-free item. For service procedures, refer to FL section.
- (3) After 60,000 miles (96,000 km) or 48 months, replace every 30,000 miles (48,000 km) or 24 months.
- (4) If valve noise increases, inspect valve clearance.

* Maintenance items and intervals with "*" are recommended by NISSAN for reliable vehicle operation. The owner need not perform such maintenance in order to maintain the emission warranty or manufacturer recall liability. Other maintenance items and intervals are required

CHASSIS AND BODY

Abbreviations: R = Replace. I = Inspect. Correct or replace if necessary.

| MAINTENANCE OPERATION | | MAINTENANCE INTERVAL | | | | | | | | Reference Section - Page or - Content Title |
|--|---|----------------------|------------------|--------------------|------------------|--------------------|------------------|--------------------|------------------|--|
| Perform at number of miles, kilometers or months, whichever comes first. | Miles x 1,000 (km x 1,000) Months | 7.5 (12) 6 | 15 (24) 12 | 22.5 (36) 18 | 30 (48) 24 | 37.5 (60) 30 | 45 (72) 36 | 52.5 (84) 42 | 60 (96) 48 | |
| Brake lines and cables | | | I | | I | | I | | I | MA-34 |
| Brake pads & rotors | | | I | | I | | I | | I | MA-35 , MA-36 |
| CVT fluid | NOTE (1) | | I | | I | | I | | I | MA-28 (RE0F09B) MA-30 (RE0F10B) |
| Steering gear and linkage, axle & suspension parts | | | I | | I | | I | | I | MA-37 |
| Manual transaxle oil | | | I | | I | | I | | I | MA-32 |
| Tire rotation | NOTE (2) | | | | | | | | | MA-28 |
| Exhaust system | | | | | I | | | | I | MA-39 |
| Front drive shaft boot | | | I | | I | | I | | I | MA-39 |
| In-cabin microfilter | | | R | | R | | R | | R | MA-34 |

NOTE:

- (1) Using transmission fluid other than Genuine NISSAN CVT NS-2 will damage the CVT, which is not covered by the NISSAN new vehicle limited warranty.
- (2) Refer to "Tire rotation" under the "General maintenance" heading earlier in this section.

RECOMMENDED FLUIDS AND LUBRICANTS

< ON-VEHICLE MAINTENANCE >

RECOMMENDED FLUIDS AND LUBRICANTS

Fluids and Lubricants

INFOID:000000000995578

| Description | | Capacity (Approximate) | | | Recommended Fluids/Lubricants |
|---------------------------------------|---------------------------------|------------------------|-----------------|-----------------|--|
| | | US measure | Imp measure | Liter | |
| Fuel | QR25DE | 20 gal | 16-5/8 gal | 75.6 | Unleaded gasoline with an octane rating of at least 87 AKI (RON 91) |
| | VQ35DE | 20 gal | 16-5/8 gal | 75.6 | Unleaded gasoline with an octane rating of at least 91 AKI (RON 96) |
| Engine oil Drain and refill | With oil filter change | QR25DE | 4-7/8 qt | 4 qt | Engine oil with • API Certification Mark *1 • Viscosity SAE 5W-30 *1 |
| | | VQ35DE | 4-1/2 qt | 3-3/4 qt | |
| | Without oil filter change | QR25DE | 4-1/2 qt | 3-3/4 qt | |
| | | VQ35DE | 4-1/4 qt | 3-1/2 qt | |
| Dry engine (Overhaul) | QR25DE | 5-3/4 qt | 4-3/4 qt | 5.4 | |
| | VQ35DE | 4-7/8 qt | 4 qt | 4.6 | |
| Cooling system with reservoir tank | QR25DE | 2 gal | 1-5/8 gal | 7.6 | Genuine NISSAN Long Life Antifreeze/ Coolant or equivalent |
| | VQ35DE | 2-1/8 gal | 1-3/4 gal | 8.2 | |
| CVT fluid | RE0F09B | 10-6/8 qt | 9 qt | 10.2 | Genuine NISSAN CVT Fluid NS-2 *2 |
| | RE0F10A | 8-3/4 qt | 7-1/4 | 8.3 | |
| Manual transaxle fluid (MTF) | | 3-5/8 pt | 3 pt | 1.7 | Genuine NISSAN Manual Transmission Fluid (MTF) HQ Multi 75W-85 or API GL-4, Viscosity SAE 75W-85 |
| Power steering fluid (PSF) | | 1-1/8 qt | 7/8 qt | 1.0 | Genuine NISSAN PSF or equivalent*3 |
| Brake and clutch fluids | | — | — | — | Genuine NISSAN Super Heavy Duty Brake Fluid*4 or equivalent DOT 3 (US FMVSS No. 116) |
| Brake grease | | — | — | — | PBC (poly butyl cuprysil) |
| Brake pad plate grease | | — | — | — | Molykote AS880N grease or equivalent |
| Multi-purpose grease | | — | — | — | NLGI No. 2 (Lithium soap base) |
| Air conditioning system refrigerant | | 1.10 ± 0.055 lb | 0.50 ± 0.025 kg | 0.50 ± 0.025 kg | HFC-134a (R-134a) *3 |
| Air conditioning system oil | | 5.03 fl oz | 5.3 fl oz | 150 mℓ | NISSAN A/C System Oil Type S (DH- PS) or equivalent *3 |
| Windshield washer fluid | | — | — | — | Genuine NISSAN Windshield Washer Concentrate Cleaner & Antifreeze or equivalent |

*1: For further details, see "SAE Viscosity Number".

***2: Using automatic transmission fluid other than Genuine NISSAN CVT Fluid NS-2 will damage the CVT, which is not covered by the NISSAN new vehicle limited warranty.**

*3: For Canada, NISSAN Automatic Transmission Fluid (ATF), DEXRON™ III/ MERCON™, or equivalent ATF may also be used.

*4: Available in mainland U.S.A. through your NISSAN dealer.

*5: For further details, see "Air conditioning specification label".

SAE Viscosity Number

INFOID:000000000995579

GASOLINE ENGINE OIL

A
B
C
D
E
F
G
H
I
J
K
L
M
N
O

MA

RECOMMENDED FLUIDS AND LUBRICANTS

< ON-VEHICLE MAINTENANCE >

NISSAN recommends the use of an energy conserving oil in order to improve fuel economy. Select only engine oils that meet the American Petroleum Institute (API) certification and International Lubricant Standardization and Approval Committee (ILSAC) certification and SAE viscosity standard (2). These oils have the API certification mark (1) on the front of the container. Oils which do not have the specified quality label should not be used as they could cause engine damage.

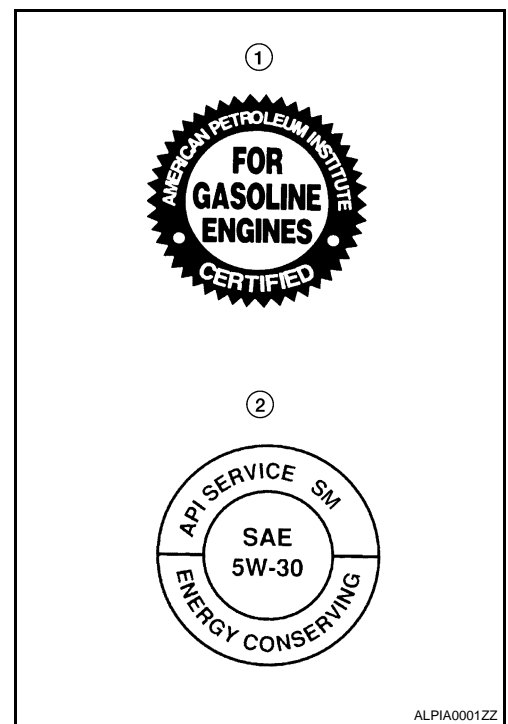

ANTI-FREEZE COOLANT MIXTURE RATIO

The engine cooling system is filled at the factory with a high-quality, year-round, anti-freeze coolant solution. The anti-freeze solution contains rust and corrosion inhibitors. Therefore, additional cooling system additives are not necessary.

CAUTION:

When adding or replacing coolant, be sure to use only Genuine NISSAN Long Life Antifreeze/ Coolant or equivalent with the proper mixture ratio of 50% anti-freeze and 50% demineralized water/distilled water.

Other types of coolant solutions may damage your cooling system.

| Outside temperature down to | | Anti-freeze | Demineralized water or distilled water |
|-----------------------------|-----|-------------|--|
| °C | °F | | |
| -35 | -30 | 50% | 50% |

SMA947CA

ENGINE MAINTENANCE (QR25DE)

< ON-VEHICLE MAINTENANCE >

ENGINE MAINTENANCE (QR25DE)

DRIVE BELTS

DRIVE BELTS : Checking Drive Belts

INFOID:000000000995580

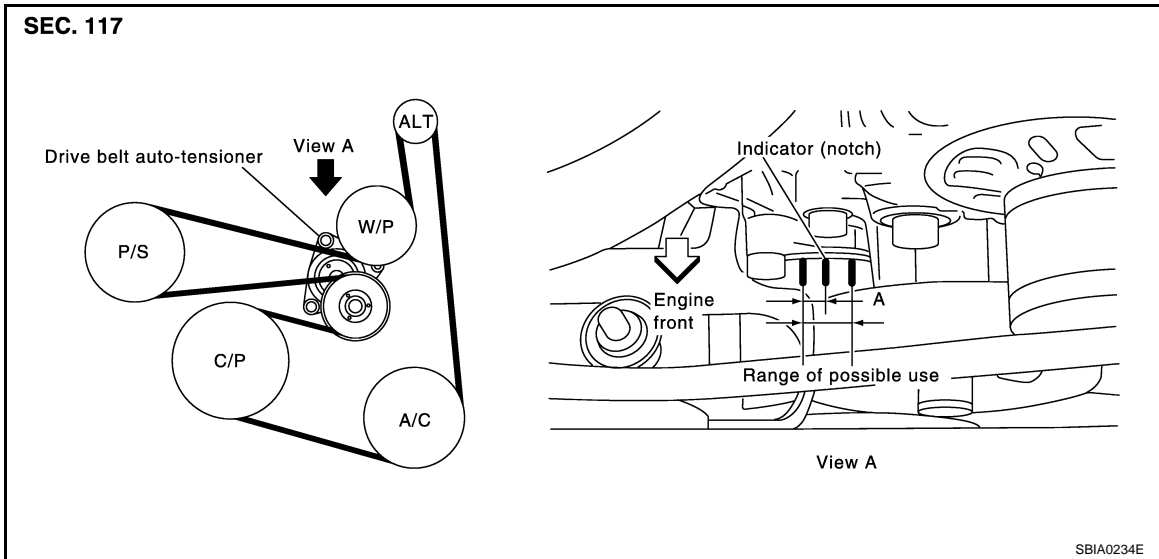

WARNING:

Inspect the drive belt only when the engine is stopped.

NOTE:

On vehicles not equipped with A/C, there is an idler pulley in the position for the drive belt routing.

- Make sure that the stamp mark of drive belt auto-tensioner is within the usable range.

NOTE:

- Check the drive belt auto-tensioner indicator (notch) when the engine is cold.
- When the new drive belt is installed, the range should be "A" as shown.
- Visually check entire belt for wear, damage or cracks.
- If the indicator is out of allowable use range or belt is damaged, replace the belt.

DRIVE BELTS : Tension Adjustment

INFOID:000000000995581

- Belt tension is not manually adjustable, it is automatically adjusted by the drive belt auto-tensioner.

ENGINE COOLANT

ENGINE COOLANT : Changing Engine Coolant

INFOID:000000000995582

WARNING:

- To avoid being scalded, never change the coolant when the engine is hot.
- Wrap a thick cloth around cap and carefully remove the cap. First, turn the cap a quarter of a turn to release built-up pressure. Then push down and turn the cap all the way to remove.

DRAINING ENGINE COOLANT

1. Remove the engine undercover using power tool.
2. Open the radiator drain plug at the bottom of the radiator, and remove the radiator filler cap. This is the only step required when partially draining the cooling system (radiator only).

CAUTION:

Do not to allow the coolant to contact the drive belts.

3. Follow this step for heater core removal/replacement only. Disconnect the upper heater hose at the engine side and apply moderate air pressure [103.46 kPa (15 psi, 1.055 kg/cm²) maximum air pressure] into the hose for 30 seconds to blow the excess coolant out of the heater core.
4. When draining all of the coolant in the system, remove the reservoir tank and drain the coolant, then clean the reservoir tank before installation.

A
B
C
D
E
F
G
H
I
J
K
L
M
N
O

ENGINE MAINTENANCE (QR25DE)

< ON-VEHICLE MAINTENANCE >

- When draining all of the coolant in the system for engine removal or repair, open the drain plug on the cylinder block.

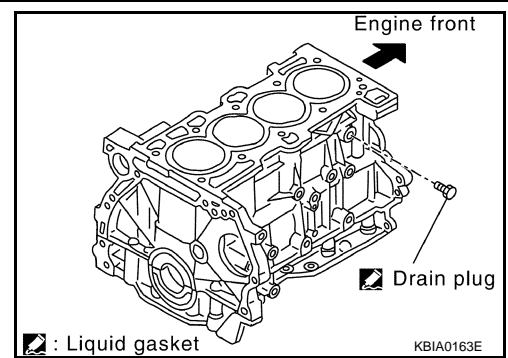

- Check the drained coolant for contaminants such as rust, corrosion or discoloration. If the coolant is contaminated, flush the engine cooling system. Refer to "FLUSHING COOLING SYSTEM".

REFILLING ENGINE COOLANT

- Install the radiator drain plug. Install the reservoir tank and cylinder block drain plug, if removed for a total system drain or for engine removal or repair.
 - The radiator must be completely empty of coolant and water.
 - Apply sealant to the threads of the cylinder block drain plugs. Use Genuine High Performance Thread Sealant or equivalent. Refer to [GI-15, "Recommended Chemical Products and Sealants"](#).

Radiator drain plug : Refer to [CO-15, "Removal and Installation"](#).

Cylinder block drain plug : Refer to [EM-77, "Disassembly and Assembly"](#).

- If disconnected, reattach the upper radiator hose at the engine side.
- Set the vehicle heater controls to the full HOT and heater ON position. Turn the vehicle ignition ON with the engine OFF as necessary to activate the heater mode.
- Install the Tool by installing the radiator cap adapter onto the radiator neck opening. Then attach the gauge body assembly with the refill tube and the venturi assembly to the radiator cap adapter.

Tool number : KV991J0070 (J-45695)

- Insert the refill hose into the coolant mixture container that is placed at floor level. Make sure the ball valve is in the closed position.
 - Use Genuine NISSAN Long Life Anti-freeze coolant or equivalent, mixed 50/50 with distilled water or demineralized water.Refer to [MA-11, "SAE Viscosity Number"](#).

Engine coolant capacity (with reservoir tank) : Refer to [MA-11, "Fluids and Lubricants"](#).

- Install an air hose to the venturi assembly, the air pressure must be within specification.

Compressed air supply pressure : 5.7 - 8.5 kPa (5.6 - 8.4 kg/cm², 80 - 120 psi)

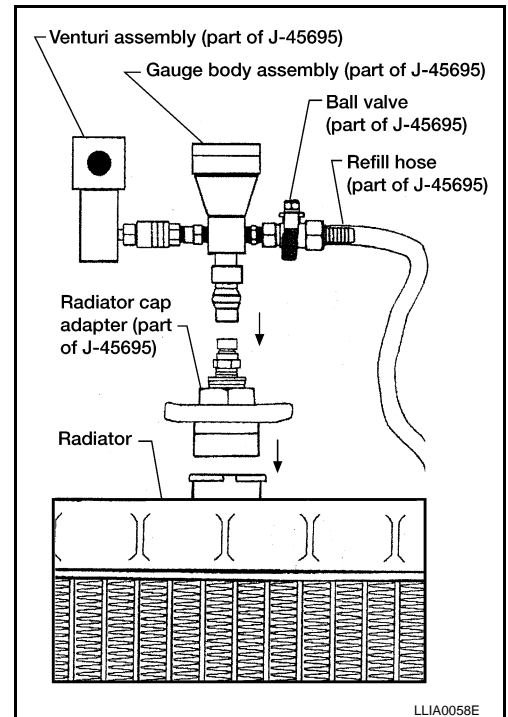

CAUTION:

The compressed air supply must be equipped with an air dryer.

- The vacuum gauge will begin to rise and there will be an audible hissing noise. During this process open the ball valve on the refill hose slightly. Coolant will be visible rising in the refill hose. Once the refill hose is full of coolant, close the ball valve. This will purge any air trapped in the refill hose.

ENGINE MAINTENANCE (QR25DE)

< ON-VEHICLE MAINTENANCE >

8. Continue to draw the vacuum until the gauge reaches 28 inches of vacuum. The gauge may not reach 28 inches in high altitude locations, refer to the vacuum specifications based on the altitude above sea level.

| Altitude above sea level | Vacuum gauge reading |
|--------------------------|----------------------------|
| 0 - 100 m (328 ft) | : 28 inches of vacuum |
| 300 m (984 ft) | : 27 inches of vacuum |
| 500 m (1,641 ft) | : 26 inches of vacuum |
| 1,000 m (3,281 ft) | : 24 - 25 inches of vacuum |

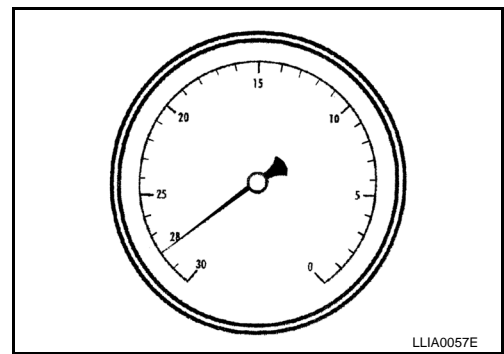

9. When the vacuum gauge has reached the specified amount, disconnect the air hose and wait 20 seconds to see if the system loses any vacuum. If the vacuum level drops, perform any necessary repairs to the system and repeat steps 6 - 8 to bring the vacuum to the specified amount. Recheck for any leaks.
10. Place the coolant container (with the refill hose inserted) at the same level as the top of the radiator. Then open the ball valve on the refill hose so the coolant will be drawn up to fill the cooling system. The cooling system is full when the vacuum gauge reads zero.

CAUTION:

Do not allow the coolant container to get too low when filling, to avoid air from being drawn into the cooling system.

11. Remove the Tool from the radiator neck opening.
12. Fill the cooling system reservoir tank to the specified level and install the radiator cap. Run the engine to warm up the cooling system and top up the system as necessary.

FLUSHING COOLING SYSTEM

1. Fill the radiator from the filler cap above the radiator upper hose and reservoir tank, with water and reinstall the filler cap above the radiator upper hose.
2. Run the engine until it reaches normal operating temperature.
3. Press the engine accelerator two or three times under no-load.
4. Stop the engine and wait until it cools down.
5. Drain the water.
6. Repeat steps 1 through 5 until clear water begins to drain from the radiator.

FUEL LINES

FUEL LINES : Inspection

Inspect fuel lines, fuel filler cap and fuel tank for improper attachment, leaks, cracks, damage, loose connections, chafing or deterioration.

If necessary, repair or replace damaged parts.

INFOID:000000000995583

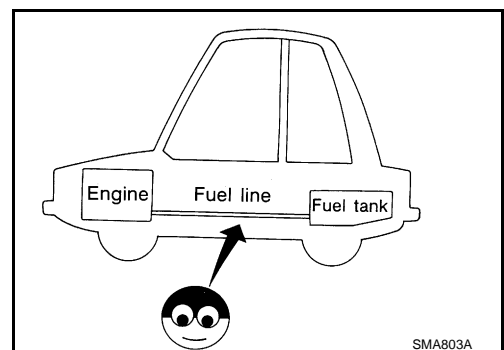

AIR CLEANER FILTER

A
B
C
D
E
F
G
H
I
J
K
L
M
N
O
MA

ENGINE MAINTENANCE (QR25DE)

< ON-VEHICLE MAINTENANCE >

AIR CLEANER FILTER : Removal and Installation

INFOID:000000000995584

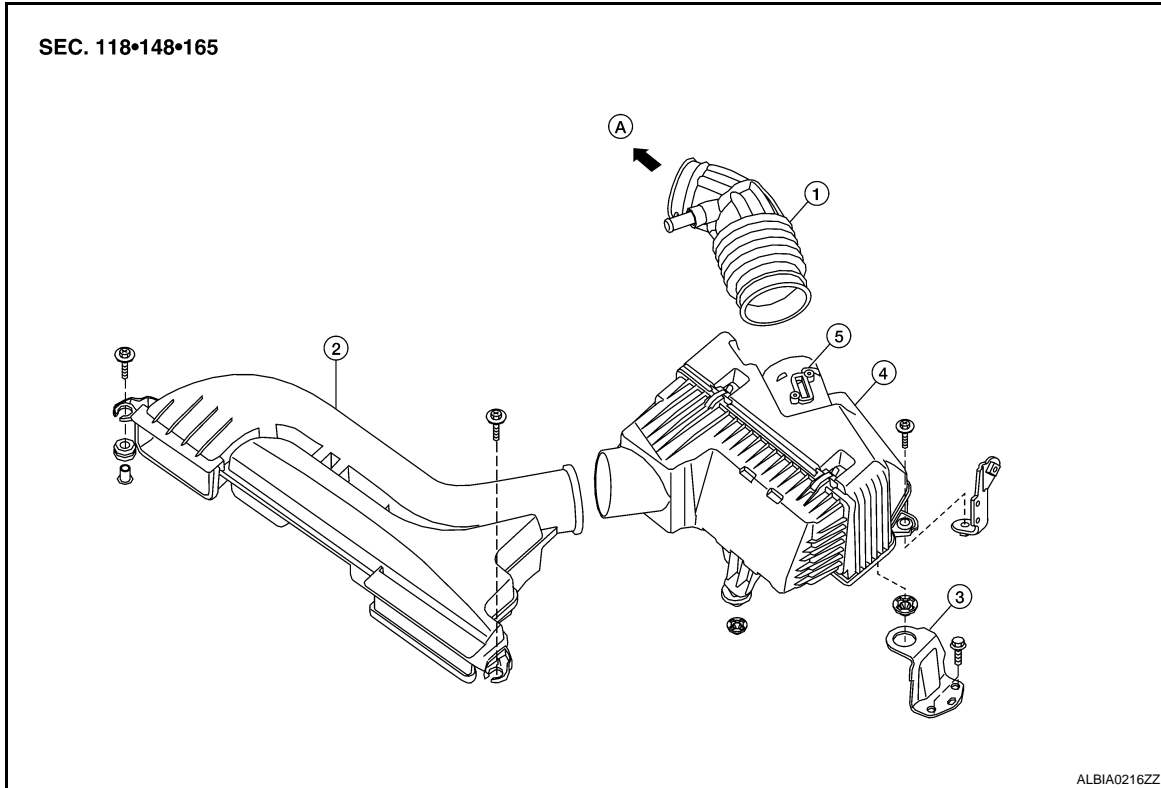

- | | | |
|-------------------------|-------------------------|--|
| 1. Air duct hose | 2. Front air duct | 3. Air cleaner mounting bracket |
| 4. Air cleaner assembly | 5. Mass air flow sensor | A. To electronic throttle control actuator |

REMOVAL

1. Remove front air duct.
2. Disconnect the tube clamp at the electronic throttle control actuator and the air cleaner assembly.
3. Remove fresh air intake hose.
4. Disconnect the mass air flow sensor
5. Remove mass air flow sensor from air cleaner case (upper), as necessary.

CAUTION:

Handle the mass air flow sensor with care:

- Do not shock it.
- Do not disassemble it.
- Do not touch the internal sensor.

6. Remove the air cleaner assembly, as necessary.

INSTALLATION

Installation is in the reverse order of removal.

CHANGING THE AIR CLEANER ELEMENT

1. Unhook the air cleaner case side clips.
2. Remove the air cleaner element.
3. Install a new air cleaner element.
4. Installation is in the reverse order of removal.

ENGINE OIL

ENGINE OIL : Changing Engine Oil

INFOID:000000000995585

WARNING:

- Be careful not to burn yourself, as the engine oil may be hot.

ENGINE MAINTENANCE (QR25DE)

< ON-VEHICLE MAINTENANCE >

- **Prolonged and repeated contact with used engine oil may cause skin cancer: try to avoid direct skin contact with used oil. If skin contact is made, wash thoroughly with soap or hand cleaner as soon as possible.**

1. Position the vehicle so it is level on the hoist.
2. Warm up the engine, and check for oil leaks from the engine.
3. Stop engine and wait for 10 minutes.
4. Remove the oil pan drain plug and oil filler cap.
5. Drain the engine oil.
6. Install the oil pan drain plug with a new washer and refill the engine with new engine oil.
 - Oil specification and viscosity. Refer to [MA-11. "SAE Viscosity Number"](#).

Oil Capacity (Approximate)

| | | |
|------------------------------|---------------------------|-----------------------------------|
| Drain and refill | With oil filter change | 4.6 ℓ (4 7/8 US qt, 4 Imp qt) |
| | Without oil filter change | 4.3 ℓ (4 1/2 US qt, 3 3/4 Imp qt) |
| Dry engine (engine overhaul) | | 5.4 ℓ (5 3/4 US qt, 4 3/4 Imp qt) |

CAUTION:

- Be sure to clean the drain plug and install using a new washer.

Oil pan drain plug : 34.3 N·m (3.5 kg·m, 25 ft·lb)

- The refill capacity depends on the oil temperature and drain time. Use these specifications for reference only. Always use the dipstick to determine when the proper amount of oil is in the engine.

7. Warm up the engine and check the area around the drain plug and oil filter for oil leakage.
8. Stop the engine and wait for 10 minutes.
9. Check the oil level using the dipstick.

CAUTION:

Do not overfill the engine oil.

OIL FILTER

OIL FILTER : Removal and Installation

INFOID:000000000995586

REMOVAL

1. Remove the oil filter using Tool.

Tool number : KV10115801 (J-38956)

CAUTION:

- Be careful not to get burned when the engine and engine oil are hot.
- When removing, prepare a shop cloth to absorb any oil leakage or spillage.
- Do not allow engine oil to adhere to the drive belts.
- Completely wipe off any oil that adheres to the engine and the vehicle.

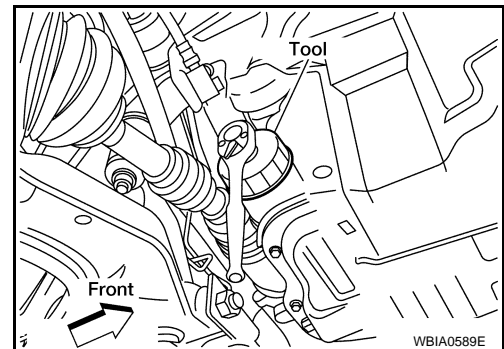

ENGINE MAINTENANCE (QR25DE)

< ON-VEHICLE MAINTENANCE >

- The oil filter has a built in pressure relief valve. Use a genuine NISSAN oil filter or equivalent

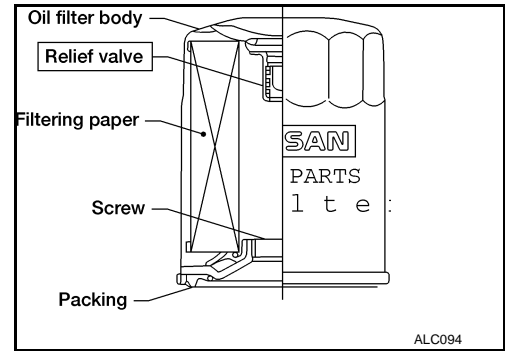

INSTALLATION

1. Clean off any foreign materials adhering to the oil filter installation surface.
2. Apply engine oil to the oil seal surface of the new oil filter.

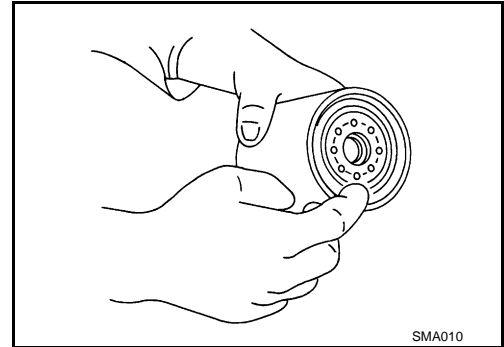

3. Screw the oil filter manually until it touches the installation surface, then tighten it by 2/3 turn. Or tighten to specification below.

Oil filter : 17.6 N·m (1.8 kg·m, 13 ft-lb)

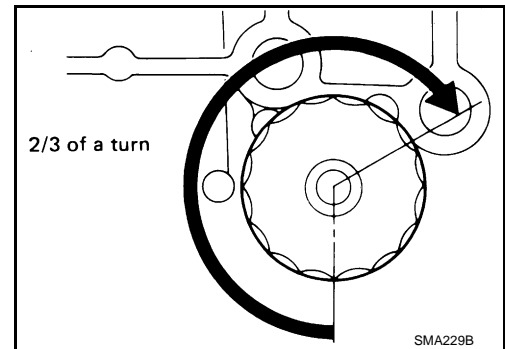

4. Check oil level and add engine oil as necessary. Refer to [LU-8](#).
5. After warming up the engine, check for oil leaks.

SPARK PLUG (PLATINUM-TIPPED TYPE)

SPARK PLUG (PLATINUM-TIPPED TYPE) : Removal and Installation

INFOID:000000000995587

ENGINE MAINTENANCE (QR25DE)

< ON-VEHICLE MAINTENANCE >

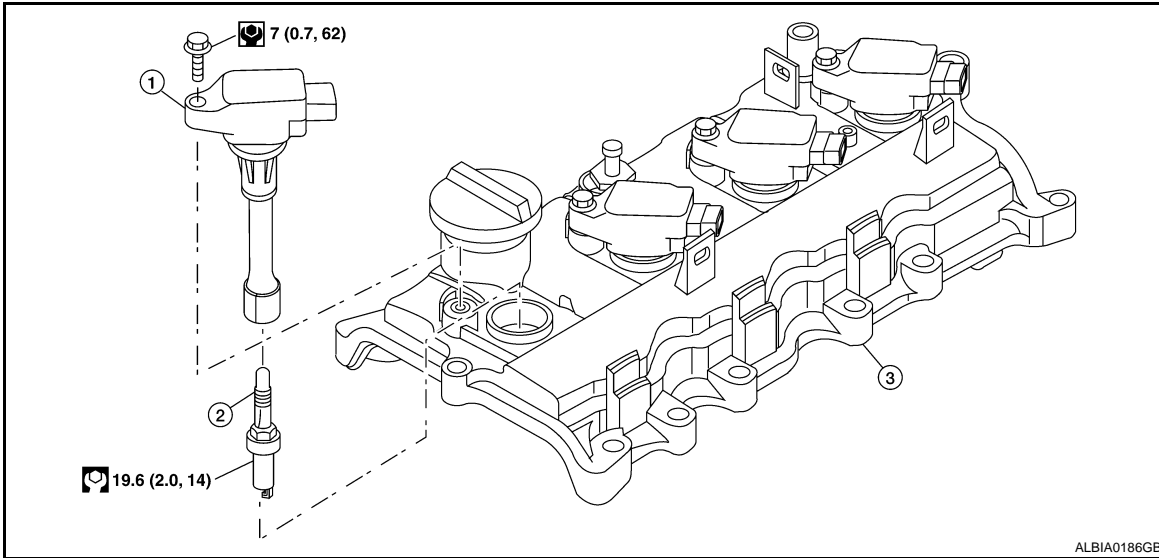

1. Ignition coil

2. Spark plug

3. Rocker cover

REMOVAL

1. Remove the ignition coil. Refer to [EM-34, "Removal and Installation"](#).
2. Remove the spark plug with a suitable spark plug wrench.

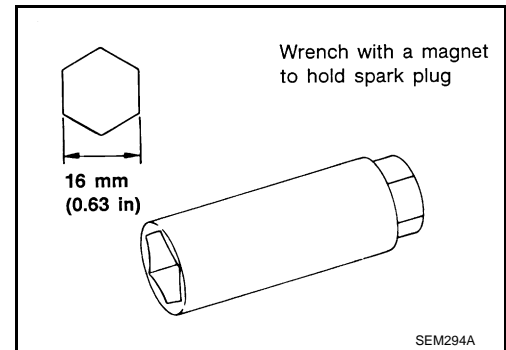

INSPECTION AFTER REMOVAL

- Do not use a wire brush for cleaning the spark plugs. Replace as necessary.

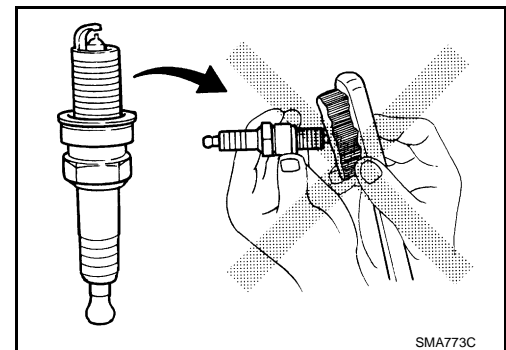

- If plug is covered with carbon, a spark plug cleaner may be used.

Cleaner air pressure : less than 588 kPa (6 kg/cm², 85 psi)

Cleaning time : less than 20 seconds

A
B
C
D
E
F
G
H
I
J
K
L
M
N
O

ENGINE MAINTENANCE (QR25DE)

< ON-VEHICLE MAINTENANCE >

- Checking and adjusting plug gap is not required between change intervals. If the gap is out of specification, replace the spark plug.

Gap (nominal) : 1.1 mm (0.043 in)

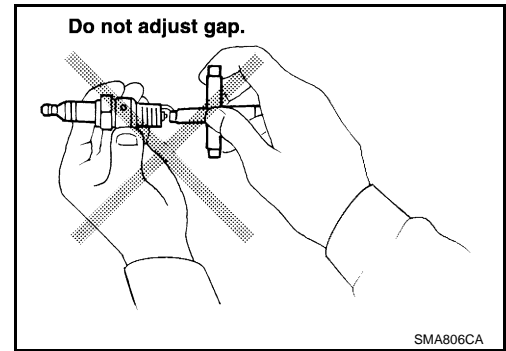

INSTALLATION

Installation is in the reverse order of removal.

| | |
|-------------------|-------------------|
| Temperature range | NGK |
| Standard type | DILKAR6A-11 |
| Gap (nominal) | 1.1 mm (0.043 in) |

EVAP VAPOR LINES

EVAP VAPOR LINES : Inspection

INFOID:000000000995588

1. Visually inspect EVAP vapor lines for improper attachment and for cracks, damage, loose connections, chafing and deterioration.
2. Inspect fuel tank filler cap vacuum relief valve for clogging, sticking, etc.

ENGINE MAINTENANCE (VQ35DE)

< ON-VEHICLE MAINTENANCE >

ENGINE MAINTENANCE (VQ35DE)

DRIVE BELTS

DRIVE BELTS : Checking Drive Belts

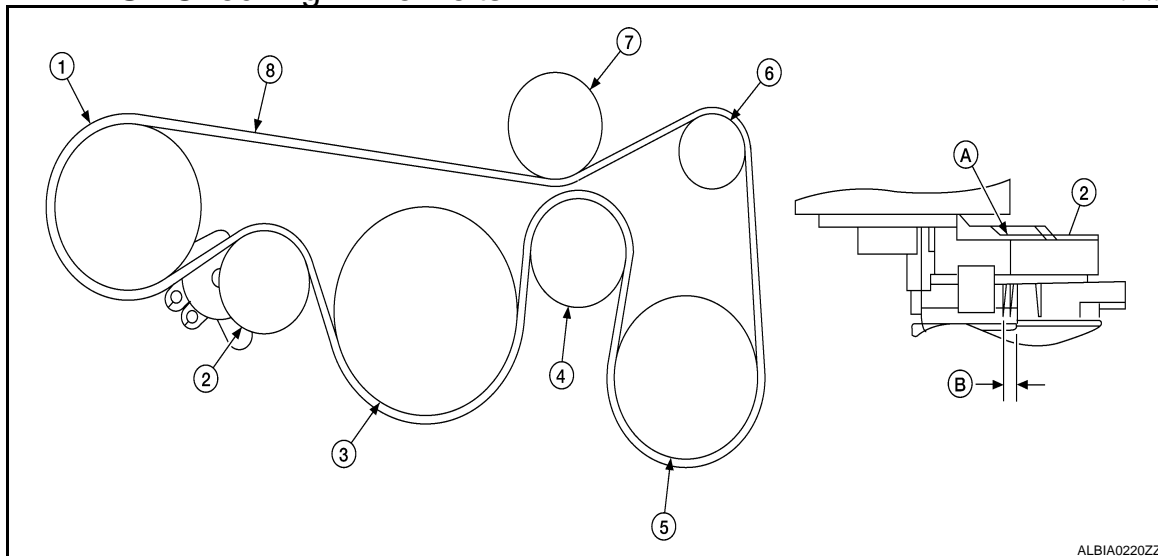

- | | | |
|------------------------|------------------------------|----------------------|
| 1. Power steering pump | 2. Drive belt auto-tensioner | 3. Crankshaft |
| 4. Idler pulley | 5. A/C compressor pulley | 6. Alternator pulley |
| 7. Idler pulley | 8. Drive belt | A. Indicator |
| B. Possible use range | | |

WARNING:

Inspect and check the drive belts with the engine off.

1. Inspect belt for cracks, fraying, wear or oil adhesion. If necessary, replace with a new one.
2. Rotate the crankshaft pulley two times then check the belt tension using Tool.

NOTE:

- Inspect drive belt tension when engine is cold.

DRIVE BELTS : Tension Adjustment

INFOID:000000000995590

- Belt tension is not manually adjustable, it is automatically adjusted by the drive belt auto-tensioner.

ENGINE COOLANT

ENGINE COOLANT : Changing Engine Coolant

INFOID:000000000995591

WARNING:

- **To avoid being scalded, never change the coolant when the engine is hot.**
- **Wrap a thick cloth around cap and carefully remove the cap. First, turn the cap a quarter of a turn to release built-up pressure. Then turn the cap all the way.**

DRAINING ENGINE COOLANT

1. Open radiator drain plug at the bottom of radiator and remove the radiator filler cap. This is the only step required for a partial cooling system drain.
2. If removing the heater core, remove the upper heater hose from the engine coolant outlet and apply moderate air pressure of 15 psi (103.46 kPa, 1.055 kg-cm²) maximum for 30 seconds into the hose to blow out excess coolant from the core.
3. For a complete cooling system drain, remove the reservoir tank and drain the coolant, and then clean the reservoir tank before installation.
 - Do not allow coolant to spill on the drive belts.
4. When performing a complete cooling system drain (to remove the engine or for engine repair), remove the cylinder block front drain plug and the cylinder block RH drain plug.
5. Check the drained coolant for contaminants such as rust, corrosion or discoloration.

ENGINE MAINTENANCE (VQ35DE)

< ON-VEHICLE MAINTENANCE >

- If contaminated, flush the engine cooling system. Refer to "FLUSHING COOLING SYSTEM".

REFILLING ENGINE COOLANT

1. Install the radiator drain plug. If the cooling system was drained completely, install the reservoir tank and the cylinder block drain plugs.
 - The radiator must be completely empty of coolant and water.
 - Apply sealant to the threads of the cylinder block drain plugs. Use Genuine High Performance Thread Sealant or equivalent. Refer to [GI-15, "Recommended Chemical Products and Sealants"](#).

Radiator drain plug : Refer to [CO-36, "Removal and Installation"](#).

Cylinder block front drain plug : Refer to [EM-204, "Disassembly and Assembly"](#).

Cylinder block RH drain plug : Refer to [EM-204, "Disassembly and Assembly"](#).

2. If disconnected, reattach the upper radiator hose at the engine side.
3. Set the vehicle heater controls to the full HOT and heater ON position. Turn the vehicle ignition ON with the engine OFF as necessary to activate the heater mode.
4. Install the Tool by installing the radiator cap adapter onto the radiator neck opening. Then attach the gauge body assembly with the refill tube and the venturi assembly to the radiator cap adapter.

Tool number : KV991J0070 (J-45695)

5. Insert the refill hose into the coolant mixture container that is placed at floor level. Make sure the ball valve is in the closed position.
 - Use Genuine NISSAN Long Life Anti-freeze coolant or equivalent, mixed 50/50 with distilled water or demineralized water. Refer to [MA-11, "SAE Viscosity Number"](#).

Engine coolant capacity (with reservoir tank) : Refer to [MA-11, "Fluids and Lubricants"](#).

6. Install an air hose to the venturi assembly, the air pressure must be within specification.

Compressed air supply pressure : 5.7 - 8.5 kPa (5.6 - 8.4 kg/cm², 80 - 120 psi)

CAUTION:

The compressed air supply must be equipped with an air dryer.

7. The vacuum gauge will begin to rise and there will be an audible hissing noise. During this process open the ball valve on the refill hose slightly. Coolant will be visible rising in the refill hose. Once the refill hose is full of coolant, close the ball valve. This will purge any air trapped in the refill hose.

8. Continue to draw the vacuum until the gauge reaches 28 inches of vacuum. The gauge may not reach 28 inches in high altitude locations, refer to the vacuum specifications based on the altitude above sea level.

| Altitude above sea level | Vacuum gauge reading |
|--------------------------|----------------------------|
| 0 - 100 m (328 ft) | : 28 inches of vacuum |
| 300 m (984 ft) | : 27 inches of vacuum |
| 500 m (1,641 ft) | : 26 inches of vacuum |
| 1,000 m (3,281 ft) | : 24 - 25 inches of vacuum |

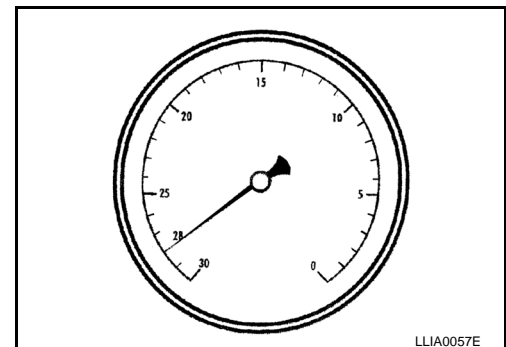
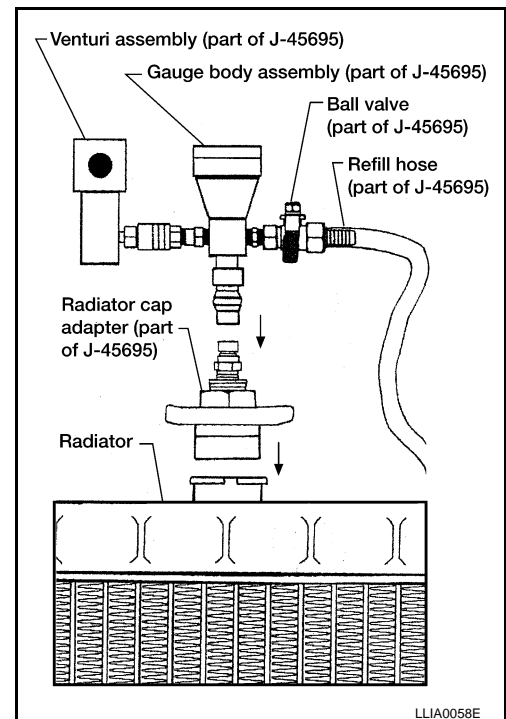

ENGINE MAINTENANCE (VQ35DE)

< ON-VEHICLE MAINTENANCE >

9. When the vacuum gauge has reached the specified amount, disconnect the air hose and wait 20 seconds to see if the system loses any vacuum. If the vacuum level drops, perform any necessary repairs to the system and repeat steps 6 - 8 to bring the vacuum to the specified amount. Recheck for any leaks.
10. Place the coolant container (with the refill hose inserted) at the same level as the top of the radiator. Then open the ball valve on the refill hose so the coolant will be drawn up to fill the cooling system. The cooling system is full when the vacuum gauge reads zero.

CAUTION:

Do not allow the coolant container to get too low when filling, to avoid air from being drawn into the cooling system.

11. Remove the Tool from the radiator neck opening.
12. Fill the cooling system reservoir tank to the specified level and install the radiator cap. Run the engine to warm up the cooling system and top up the system as necessary.

FLUSHING COOLING SYSTEM

1. Fill the radiator from the filler neck above the radiator upper hose and reservoir tank with clean water and reinstall radiator filler cap.
2. Run the engine and warm it up to normal operating temperature.
3. Rev the engine two or three times under no-load.
4. Stop the engine and wait until it cools down.
5. Drain the water from the system. Refer to "DRAINING ENGINE COOLANT".
6. Repeat steps 1 through 5 until clear water begins to drain from the radiator.

FUEL LINES

FUEL LINES : Inspection

Inspect fuel lines, filler cap and tank for improper attachment, leaks, cracks, damage, loose connections, chafing or deterioration. If necessary, repair or replace damaged parts.

INFOID:000000000995592

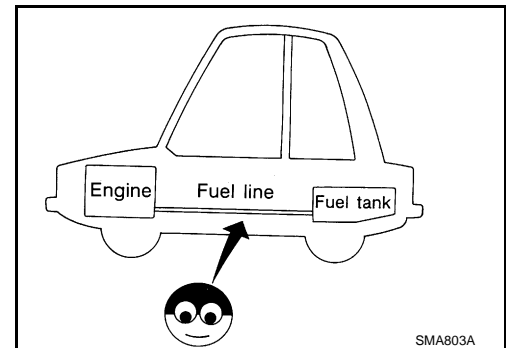

AIR CLEANER FILTER

A
B
C
D
E
F
G
H
I
J
K
L
M
N
O

MA

ENGINE MAINTENANCE (VQ35DE)

< ON-VEHICLE MAINTENANCE >

AIR CLEANER FILTER : Removal and Installation

INFOID:000000000995593

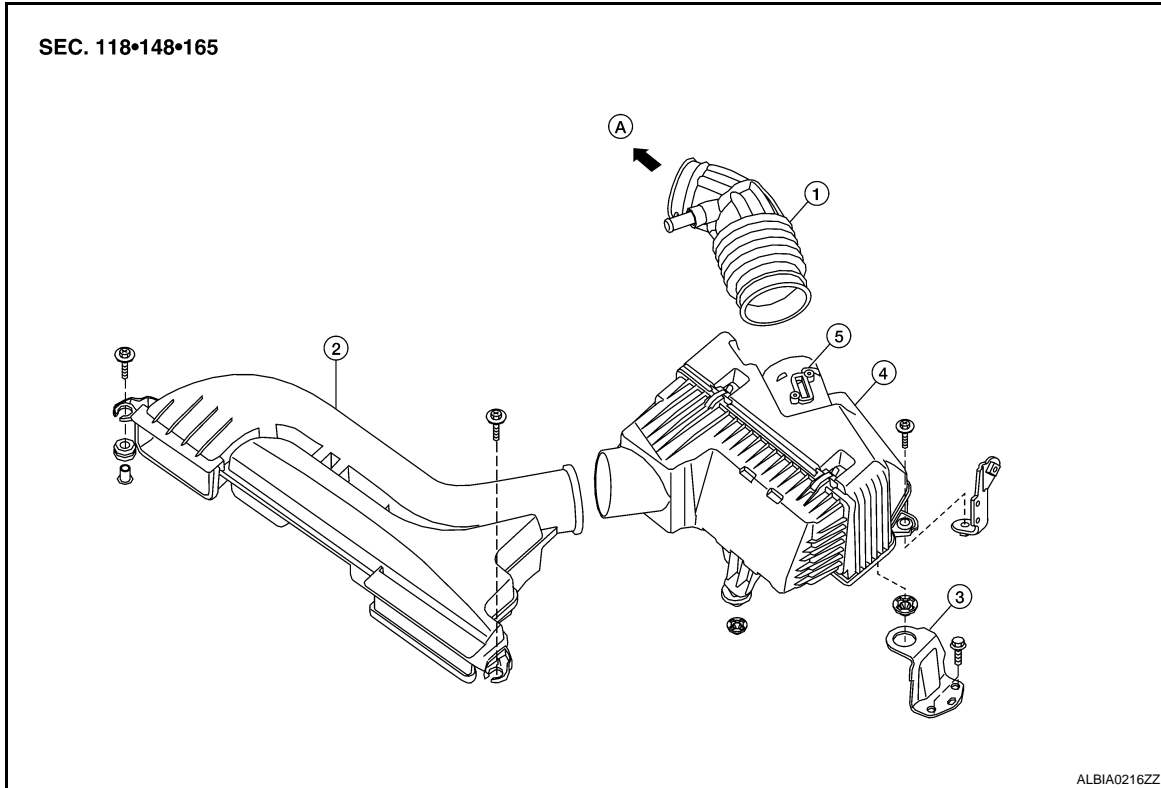

- | | | |
|-------------------------|-------------------------|--|
| 1. Air duct hose | 2. Front air duct | 3. Air cleaner mounting bracket |
| 4. Air cleaner assembly | 5. Mass air flow sensor | A. To electronic throttle control actuator |

CHANGING THE AIR CLEANER ELEMENT

1. Unhook the air cleaner case side clips.
2. Remove the air cleaner element.
3. Install a new air cleaner element.
4. Installation is in the reverse order of removal.

ENGINE OIL

ENGINE OIL : Changing Engine Oil

INFOID:000000000995594

WARNING:

- Be careful not to burn yourself, as the engine oil may be hot.
- Prolonged and repeated contact with used engine oil may cause skin cancer; try to avoid direct skin contact with used oil. If skin contact is made, wash thoroughly with soap or hand cleaner as soon as possible.

1. Position the vehicle so it is level on the hoist.
2. Warm up the engine and check for oil leaks from the engine.
3. Stop engine and wait for 10 minutes.
4. Remove the oil pan drain plug and oil filler cap.
5. Drain the engine oil.
6. Install the oil pan drain plug with a new washer and refill the engine with new engine oil.

Oil pan drain plug : 34.3 N-m (3.5 kg-m, 25 ft-lb)

- Refer to [EM-142, "Removal and Installation"](#).

Oil Capacity (Approximate)

ENGINE MAINTENANCE (VQ35DE)

< ON-VEHICLE MAINTENANCE >

ℓ (US qt, Imp qt)

| | | |
|------------------------------|---------------------------|------------------------------------|
| Drain and refill | With oil filter change | Approximately 4.2 ℓ (4 1/2, 3 3/4) |
| | Without oil filter change | Approximately 4.0 ℓ (4 1/4, 3 1/2) |
| Dry engine (engine overhaul) | | Approximately 4.6 ℓ (4 7/8, 4) |

CAUTION:

- Be sure to clean the oil pan drain plug and install with a new washer.
- The refill capacity depends on the oil temperature and drain time. Use these specifications for reference only. Always use the dipstick to determine when the proper amount of oil is in the engine.

7. Warm up the engine and check around the oil pan drain plug and oil filter for oil leaks.
8. Stop engine and wait for 10 minutes.
9. Check the engine oil level using the dipstick.

CAUTION:

Do not overfill the engine oil.

OIL FILTER

OIL FILTER : Removal and Installation

INFOID:000000000995595

REMOVAL

1. Remove the oil filter using Tool as shown.

Tool number : KV10115801 (J-38956)

CAUTION:

- Be careful not to get burned, the engine oil may be hot.
- When removing, prepare a shop cloth to absorb any oil leakage or spillage.
- Do not allow engine oil to adhere to the drive belts.
- Completely wipe off any oil that adheres to the engine and the vehicle.

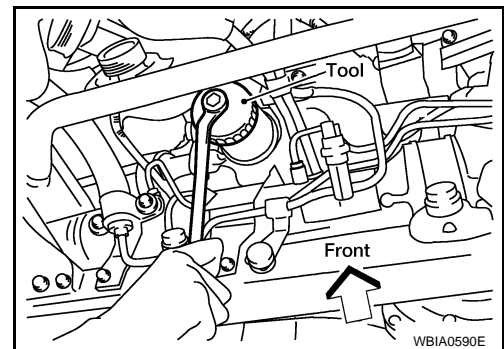

- The oil filter is provided with a relief valve. Use a genuine NISSAN oil filter or equivalent

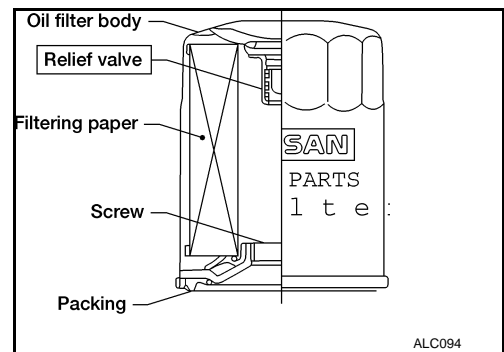

INSTALLATION

1. Remove foreign materials adhering to the oil filter installation surface.

A
B
C
D
E
F
G
H
I
J
K
L
M
N
O

MA

ENGINE MAINTENANCE (VQ35DE)

< ON-VEHICLE MAINTENANCE >

2. Apply clean engine oil to the oil seal contact surface of the new oil filter.

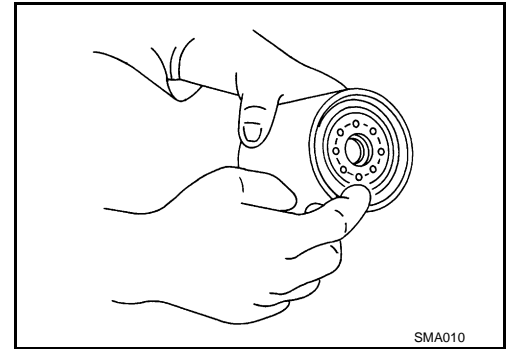

3. Screw the oil filter manually until it touches the installation surface, then tighten it by turning another 2/3 turn, or tighten to specification.

Oil filter : 17.6 N·m (1.8 kg·m, 13 ft·lb)

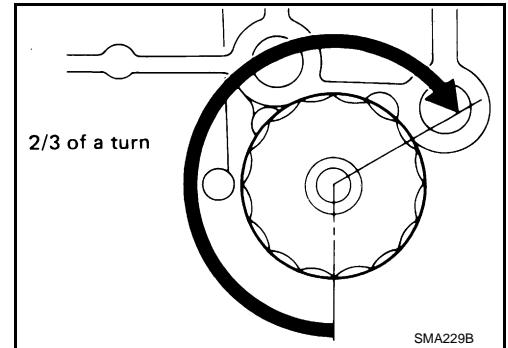

4. Check the oil level and add engine oil as necessary. Refer to [LU-20](#).
5. After warming up the engine, check for any engine oil leaks.

SPARK PLUG (PLATINUM-TIPPED TYPE)

SPARK PLUG (PLATINUM-TIPPED TYPE) : Removal and Installation

INFOID:000000000995596

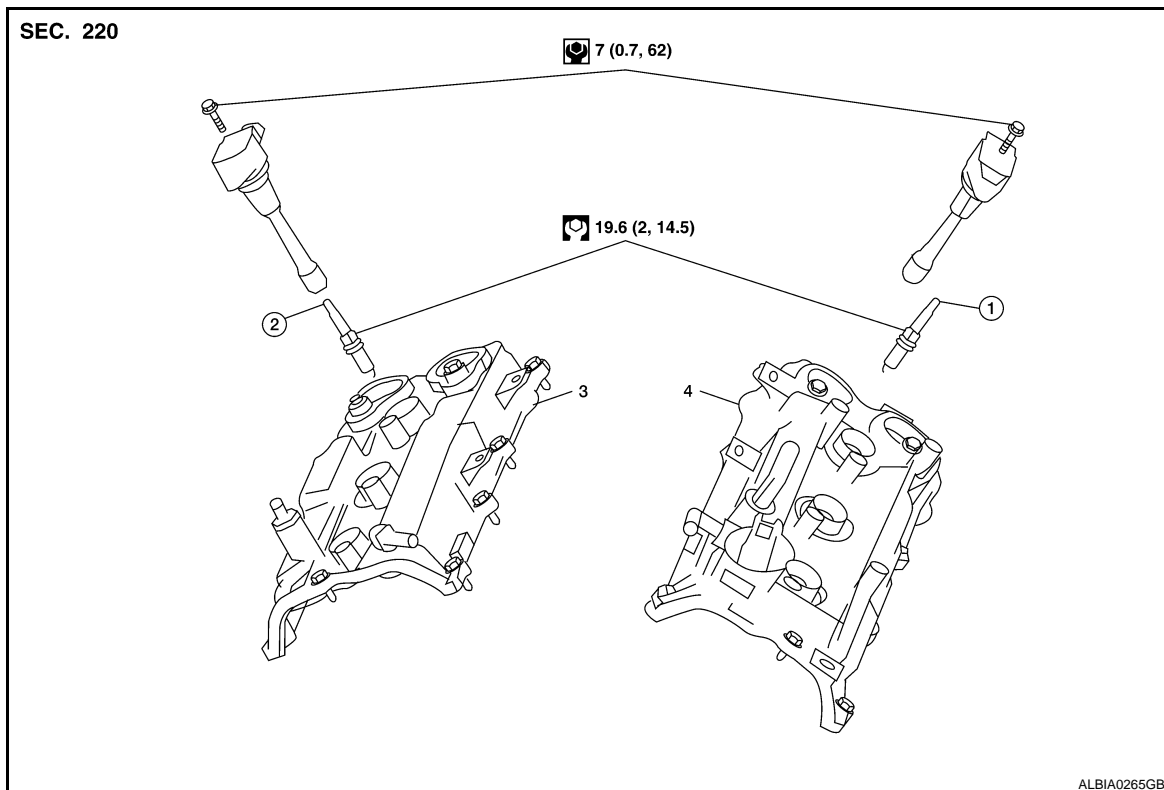

1. Ignition coil
2. Spark plug
3. Rocker cover RH
4. Rocker cover LH

ENGINE MAINTENANCE (VQ35DE)

< ON-VEHICLE MAINTENANCE >

REMOVAL

1. Remove the ignition coil. Refer to [EM-148. "Removal and Installation"](#).
2. Remove the spark plug with a suitable spark plug wrench.

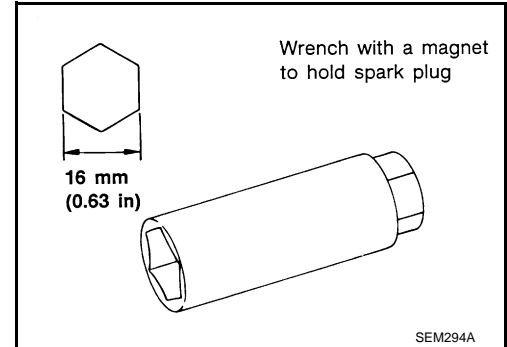

INSPECTION AFTER REMOVAL

- Do not use a wire brush for cleaning the spark plugs. Replace as necessary.

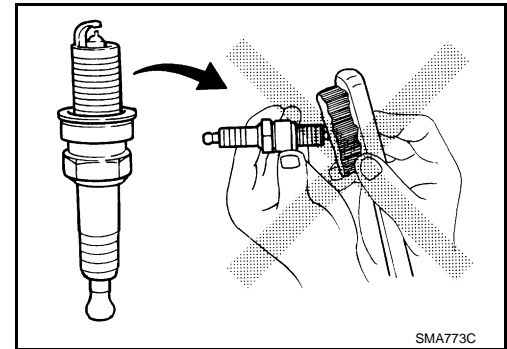

- If plug is covered with carbon, a spark plug cleaner may be used.

Cleaner air pressure : less than 588 kPa (6 kg/cm², 85 psi)

Cleaning time : less than 20 seconds

- Checking and adjusting plug gap is not required between change intervals. If the gap is out of specification, replace the spark plug.

Gap (nominal) : 1.1 mm (0.043 in)

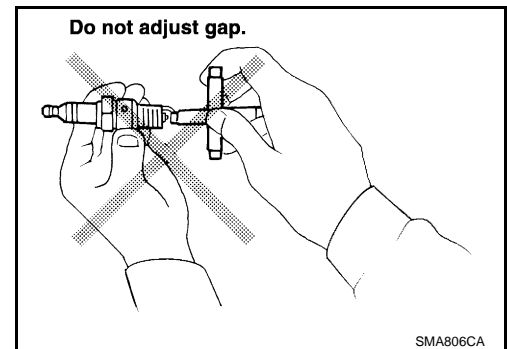

INSTALLATION

Installation is in the reverse order of removal.

| | |
|-------------------|-------------------|
| Temperature range | DENSO |
| Standard type | FXE20HR11 |
| Gap (nominal) | 1.1 mm (0.043 in) |

EVAP VAPOR LINES

EVAP VAPOR LINES : Inspection

INFOID:000000000995597

1. Visually inspect EVAP vapor lines for improper attachment and for cracks, damage, loose connections, chafing and deterioration.
2. Inspect fuel tank filler cap vacuum relief valve for clogging, sticking, etc.

A
B
C
D
E
F
G
H
I
J
K
L
M
N
O

CHASSIS AND BODY MAINTENANCE

< ON-VEHICLE MAINTENANCE >

CHASSIS AND BODY MAINTENANCE

IN-CABIN MICROFILTER

IN-CABIN MICROFILTER : Removal and Installation

INFOID:000000000995598

REMOVAL

1. Remove the instrument panel assembly. Refer to [VTL-12. "Removal and Installation"](#).
2. Disconnect the intake door motor connector (1).
3. Remove the intake door motor screws (A) and remove intake door motor from the blower unit.

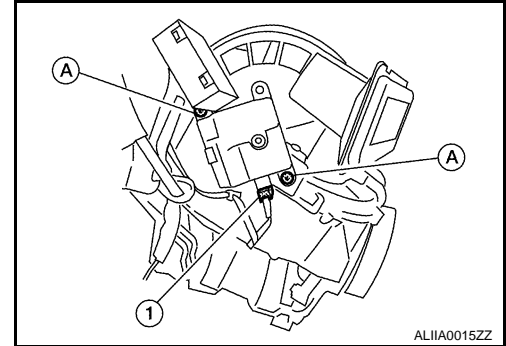

INSTALLATION

Installation is in the reverse order of removal.

EXHAUST SYSTEM

EXHAUST SYSTEM : Inspection

INFOID:000000000995599

Check exhaust pipes, muffler and mounting for improper attachment, leaks, cracks, damage, chafing or deterioration.

- If anything is found, repair or replace damaged parts.

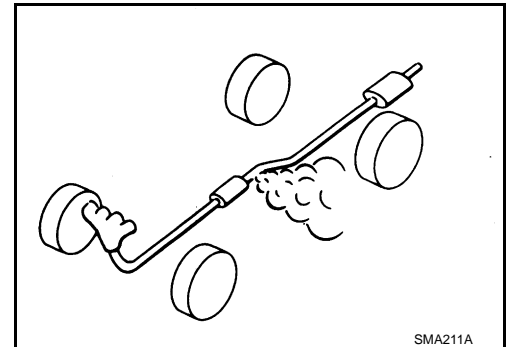

CVT FLUID

CVT FLUID : RE0F09B

INFOID:000000000995600

CVT FLUID : Inspection

INFOID:000000000995601

CHECKING CVT FLUID

Fluid level should be checked with the fluid warmed up to 50 to 80°C (122 to 176°F). The fluid level check procedure is as follows:

1. Check for fluid leakage.
2. With the engine warmed up, drive the vehicle in an urban area. When ambient temperature is 20°C (68°F), it takes about 10 minutes for the CVT fluid to warm up to 50 to 80°C (122 to 176°F).
3. Park the vehicle on a level surface.
4. Apply parking brake firmly.
5. With engine at idle, while depressing brake pedal, move shift selector throughout the entire shift range.

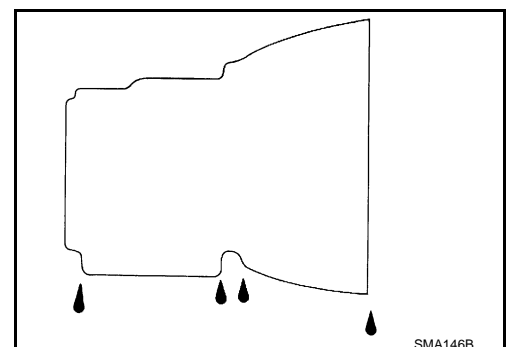

CHASSIS AND BODY MAINTENANCE

< ON-VEHICLE MAINTENANCE >

6. Pull out the CVT fluid level gauge from the CVT fluid charging pipe after pressing the tab on the CVT fluid level gauge to release the lock.

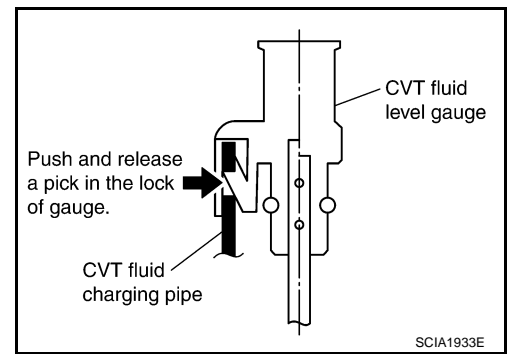

7. Wipe fluid off the CVT fluid level gauge. Insert the CVT fluid level gauge rotating 180° from the originally installed position, then securely push the CVT fluid level gauge until it meets the top end of the CVT fluid charging pipe.

CAUTION:

When wiping away the CVT fluid level gauge, always use lint-free paper, not a cloth rag.

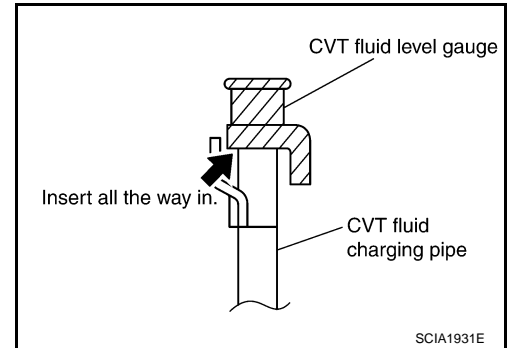

8. Place the selector lever in "P" or "N" and make sure the fluid level is within the specified range.

CAUTION:

When reinstalling CVT fluid level gauge, insert it into the CVT fluid charging pipe and rotate it to the original installation position until it is securely locked.

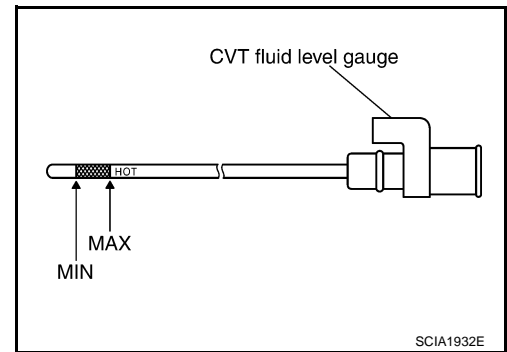

CVT FLUID CONDITION

Check CVT fluid condition.

- If CVT fluid is very dark or smells burned, check operation of CVT. Flush cooling system after repair of CVT.
- If CVT fluid contains frictional material (clutches, brakes, etc.), replace radiator and flush cooler line using cleaning solvent and compressed air after repair of CVT. Refer to [CO-36, "Removal and Installation"](#) and [TM-216, "Cleaning"](#).

| Fluid status | Conceivable cause | Required operation |
|---------------------------------------|--|---|
| Varnished (viscous varnish state) | Clutch, brake scorched | Replace the CVT fluid and check the CVT main unit and the vehicle for malfunctions (wire harnesses, cooler pipes, etc.) |
| Milky white or cloudy | Water in the fluid | Replace the CVT fluid and check for places where water is getting in. |
| Large amount of metal powder mixed in | Unusual wear of sliding parts within CVT | Replace the CVT fluid and check for improper operation of the CVT. |

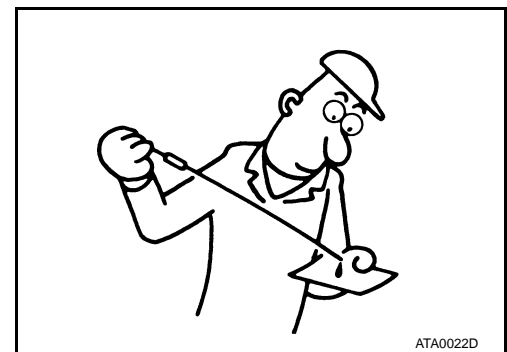

CVT FLUID : Changing

INFOID:000000000995602

A
B
C
D
E
F
G
H
I
J
K
L
M
N
O

CHASSIS AND BODY MAINTENANCE

< ON-VEHICLE MAINTENANCE >

1. Warm up CVT fluid by driving the vehicle for 10 minutes.
 - ⇐: Vehicle front
 - Radiator (2)
 - CVT fluid cooler hose (inlet side) (3)
 - Transaxle assembly (4)
2. Drain CVT fluid from CVT fluid cooler hose (outlet side) (1) and refill with new CVT fluid at CVT fluid charging pipe with the engine running at idle speed.
3. Refill until new CVT fluid comes out from CVT fluid cooler hose (outlet side) (1).
About 30 to 50% extra fluid will be required for this procedure.

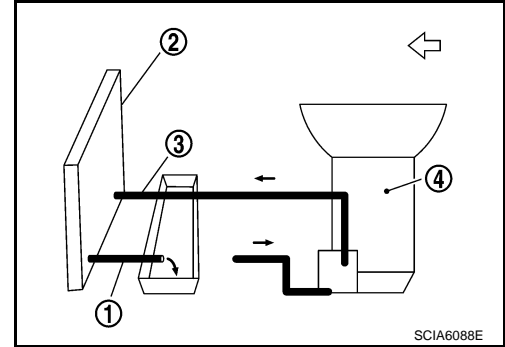

CVT fluid:

Genuine NISSAN CVT Fluid NS-2

Fluid capacity:

Approx. 10.2 ℓ (10-6/8 US qt, 9 Imp qt)

CAUTION:

- Use only Genuine NISSAN CVT Fluid NS-2. Do not mix with other fluid.
 - Using CVT fluid other than Genuine NISSAN CVT Fluid NS-2 will deteriorate in driveability and CVT durability, and may damage the CVT, which is not covered by the warranty.
 - When filling CVT fluid, take care not to scatter heat generating parts such as exhaust.
 - Delete CVT fluid deterioration date with CONSULT-III after changing CVT fluid. Refer to [TM-112, "CONSULT-III Function \(TRANSMISSION\)"](#).
4. Check fluid level and condition. Refer to [TM-214, "Inspection"](#).

CVT FLUID : RE0F10A

INFOID:000000000995603

CVT FLUID : Inspection

INFOID:000000000995604

CHECKING CVT FLUID

Fluid level should be checked with the fluid warmed up to 50 to 80°C (122 to 176°F). The fluid level check procedure is as follows:

1. Check for fluid leakage.
2. With the engine warmed up, drive the vehicle in an urban area. When ambient temperature is 20°C (68°F), it takes about 10 minutes for the CVT fluid to warm up to 50 to 80°C (122 to 176°F).
3. Park the vehicle on a level surface.
4. Apply parking brake firmly.
5. With engine at idle, while depressing brake pedal, move shift selector throughout the entire shift range.
6. Pull out the CVT fluid level gauge from the CVT fluid charging pipe after pressing the tab on the CVT fluid level gauge to release the lock.

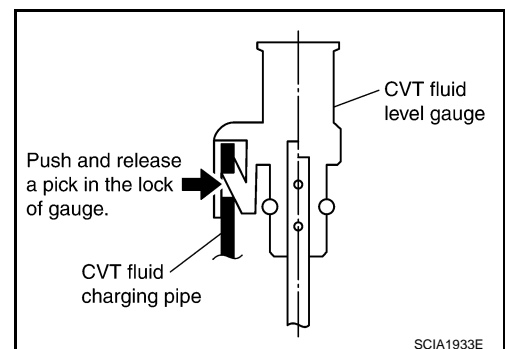
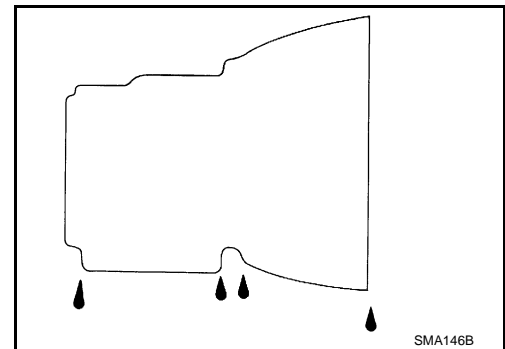

CHASSIS AND BODY MAINTENANCE

< ON-VEHICLE MAINTENANCE >

- Wipe fluid off the CVT fluid level gauge. Insert the CVT fluid level gauge rotating 180° from the originally installed position, then securely push the CVT fluid level gauge until it meets the top end of the CVT fluid charging pipe.

CAUTION:

When wiping away the CVT fluid level gauge, always use lint-free paper, not a cloth rag.

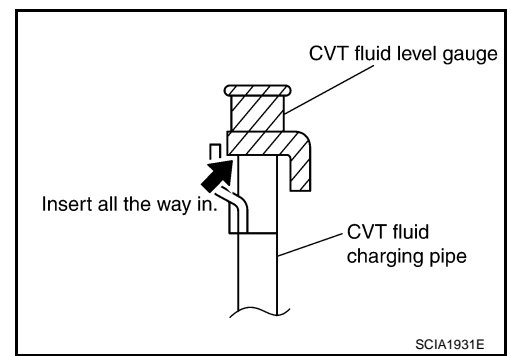

- Place the selector lever in "P" or "N" and make sure the fluid level is within the specified range.

CAUTION:

When reinstalling CVT fluid level gauge, insert it into the CVT fluid charging pipe and rotate it to the original installation position until it is securely locked.

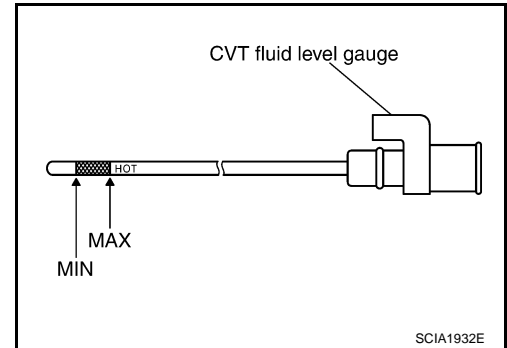

CVT FLUID CONDITION

Check CVT fluid condition.

- If CVT fluid is very dark or smells burned, check operation of CVT. Flush cooling system after repair of CVT.
- If CVT fluid contains frictional material (clutches, brakes, etc.), replace radiator and flush cooler line using cleaning solvent and compressed air after repair of CVT. Refer to [CO-15, "Removal and Installation"](#) and [TM-370, "Cleaning"](#).

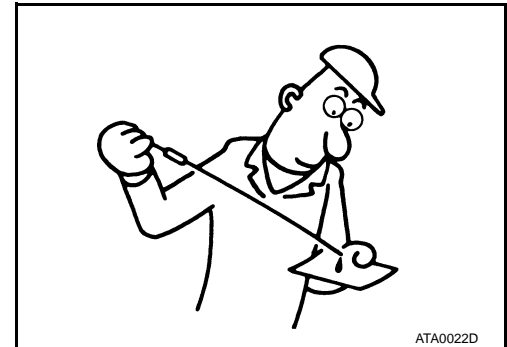

| Fluid status | Conceivable cause | Required operation |
|---------------------------------------|---|---|
| Varnished (viscous varnish state) | CVT fluid become degraded due to high temperatures. | Replace the CVT fluid and check the CVT main unit and the vehicle for malfunctions (wire harnesses, cooler pipes, etc.) |
| Milky white or cloudy | Water in the fluid | Replace the CVT fluid and check for places where water is getting in. |
| Large amount of metal powder mixed in | Unusual wear of sliding parts within CVT | Replace the CVT fluid and check for improper operation of the CVT. |

CVT FLUID : Changing

INFOID:000000000995605

- Remove drain plug, and then drain CVT fluid from oil pan.
- Install drain plug to oil pan.

CAUTION:

Do not reuse drain plug gasket.

34.3 N-m (3.5 kg-m, 25 ft-lb)

- Fill CVT fluid from CVT fluid charging pipe to the specified level.
- With the engine warmed up, drive the vehicle in an urban area. When ambient temperature is 20°C (68°F), it takes about 10 minutes for the CVT fluid to warm up to 50 to 80°C (122 to 176°F).
- Check CVT fluid level and condition.
- Repeat steps 1 to 5 if CVT fluid has been contaminated.

CHASSIS AND BODY MAINTENANCE

< ON-VEHICLE MAINTENANCE >

CVT fluid:

Genuine NISSAN CVT Fluid NS-2

Fluid capacity:

Approx. 8.3 ℓ (7-1/4 Imp qt)

CAUTION:

- Use only Genuine NISSAN CVT Fluid NS-2. Do not mix with other fluid.
- Using CVT fluid other than Genuine NISSAN CVT Fluid NS-2 will deteriorate in driveability and CVT durability, and may damage the CVT, which is not covered by the warranty.
- When filling CVT fluid, take care not to scatter heat generating parts such as exhaust.
- Sufficiently shake the container of CVT fluid before using.
- Delete CVT fluid deterioration date with CONSULT-III after changing CVT fluid.

M/T OIL

M/T OIL : Draining

INFOID:000000000995606

1. Start engine and let it run to warm up transaxle oil.
2. Stop engine and remove the drain plug to drain the oil.
3. Install the drain plug with a new gasket to the transaxle case. Tighten the drain plug to the specified torque. Refer to [TM-78, "Exploded View"](#).

CAUTION:

Do not reuse gasket.

M/T OIL : Refilling

INFOID:000000000995607

1. Remove the plug and fill transaxle with new oil.

Oil grade and capacity: Refer to [MA-11, "Fluids and Lubricants"](#).

2. After refilling oil, measure oil level to check if it is within the specification using suitable gauge as shown.

CAUTION:

Do not start engine while checking oil level.

Oil level "L": 55.0 - 61.0 mm (2.17 - 2.40 in)

3. Install the plug with a new O-ring to the clutch housing.

CAUTION:

Do not reuse O-ring.

4. Tighten plug to the specified torque. Refer to [TM-49, "Adjustment"](#).

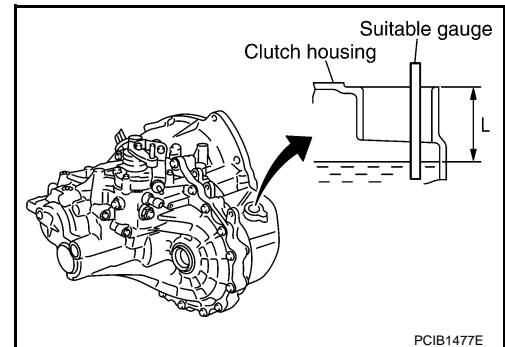

M/T OIL : Inspection

INFOID:000000000995608

LEAKAGE

- Make sure that oil is not leaking from transaxle or around it.

LEVEL

- Remove the plug.
- Measure oil level to check if it is within the specification using a suitable gauge as shown.

CAUTION:

CHASSIS AND BODY MAINTENANCE

< ON-VEHICLE MAINTENANCE >

Do not start engine while checking oil level.

Oil level "L": 55.0 - 61.0 mm (2.17 - 2.40 in)

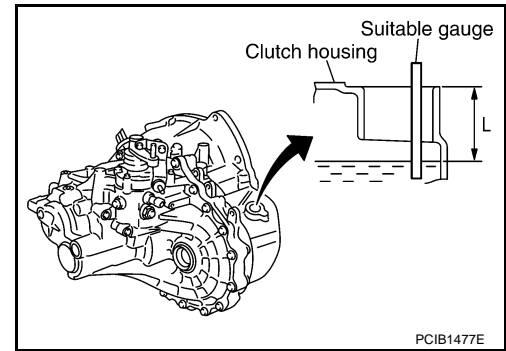

- Install the plug with a new O-ring to the clutch housing.
- CAUTION:**
Do not reuse O-ring.
- Tighten plug to the specified torque. Refer to [TM-49. "Adjustment"](#).

WHEELS

WHEELS : Inspection

INFOID:000000000995609

ALUMINUM WHEEL

1. Check tires for wear and improper inflation.
2. Check wheels for deformation, cracks and other damage. If deformed, remove wheel and check wheel runout.
 - a. Remove tire from aluminum wheel and mount on a tire balance machine.
 - b. Set dial indicator as shown in the figure.

Wheel runout (Dial indicator value):
Refer to [WT-37](#).

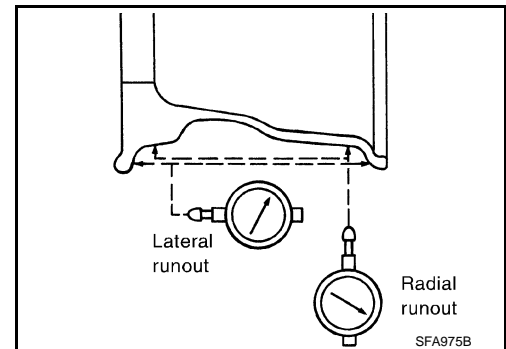

STEEL WHEEL

1. Check tires for wear and improper inflation.
2. Check wheels for deformation, cracks and other damage. If deformed, remove wheel and check wheel runout.
 - a. Remove tire from steel wheel and mount on a tire balance machine.

CHASSIS AND BODY MAINTENANCE

< ON-VEHICLE MAINTENANCE >

- Set two dial indicators as shown in the figure.
- Set each dial indicator to 0.
- Rotate wheel and check dial indicators at several points around the circumference of the wheel.
- Calculate runout at each point as shown below.

$$\text{Radial runout} = (A+B)/2$$

$$\text{Lateral runout} = (C+D)/2$$

- Select maximum positive runout value and the maximum negative value.
Add the two values to determine total runout.
In case a positive or negative value is not available, use the maximum value (negative or positive) for total runout.
If the total runout value exceeds the limit, replace steel wheel.

Wheel runout : Refer to [WT-37](#).

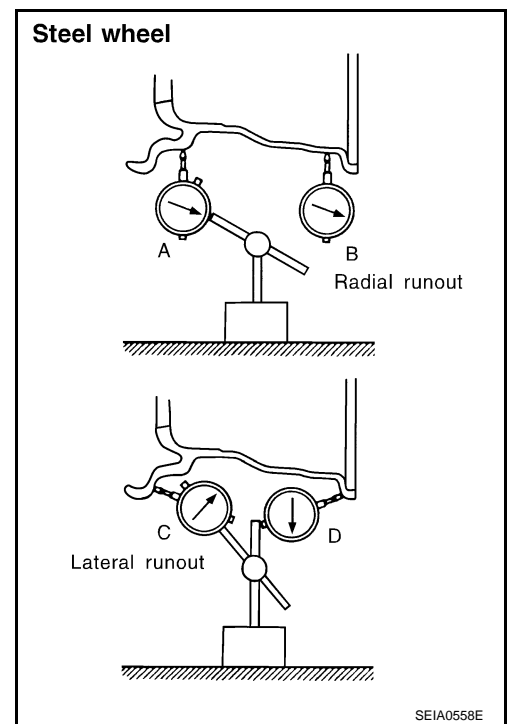

BRAKE FLUID LEVEL AND LEAKS

BRAKE FLUID LEVEL AND LEAKS : Inspection

INFOID:000000000995610

- If fluid level is extremely low, check brake system for leaks.

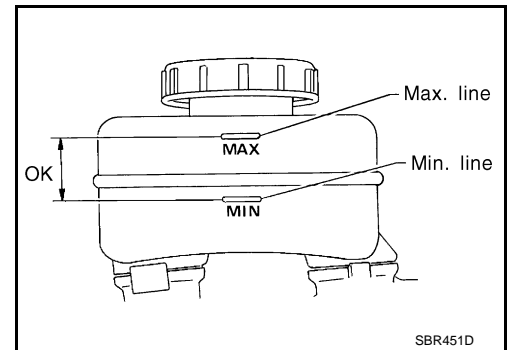

BRAKE LINES AND CABLES

BRAKE LINES AND CABLES : Inspection

INFOID:000000000995611

- Check brake fluid lines and parking brake cables for improper attachment, leaks, chafing, abrasions, deterioration, etc.

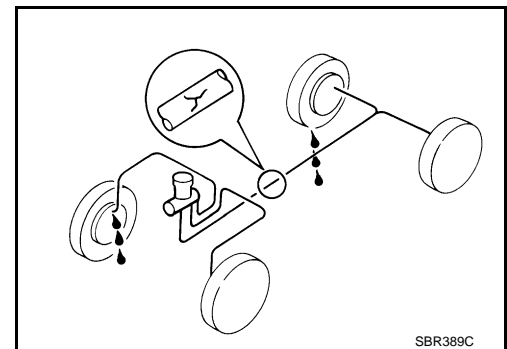

BRAKE FLUID

BRAKE FLUID : Draining

INFOID:000000000995612

DRAINING

CAUTION:

CHASSIS AND BODY MAINTENANCE

< ON-VEHICLE MAINTENANCE >

- Be careful not to splash brake fluid on painted areas; it may cause paint damage. If brake fluid is splashed on painted areas, wash it away with water immediately.
 - Before working, disconnect connectors of ABS actuator and electric unit (control unit) or battery cable from the negative terminal.
1. Connect a vinyl tube to bleed valve.
 2. Depress brake pedal, loosen bleed valve, and gradually remove brake fluid.

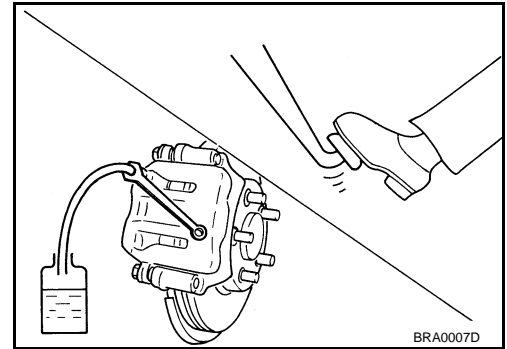

INFOID:000000000995613

BRAKE FLUID : Refilling

REFILLING

CAUTION:

- Refill with new brake fluid "DOT 3".
 - Never reuse drained brake fluid.
 - Before working, disconnect connectors of ABS actuator and electric unit (control unit) or battery cable from the negative terminal.
1. Make sure there is no foreign material in the reservoir tank, and refill with new brake fluid.
 2. Loosen bleed valve, depress brake pedal slowly to full stroke and then release it. Repeat the procedure every 2 or 3 seconds until the new brake fluid comes out, then close the bleed valve while depressing the pedal. Repeat the same work for each wheel.
 3. Bleed air. Refer to [BR-15. "Bleeding Brake System"](#).

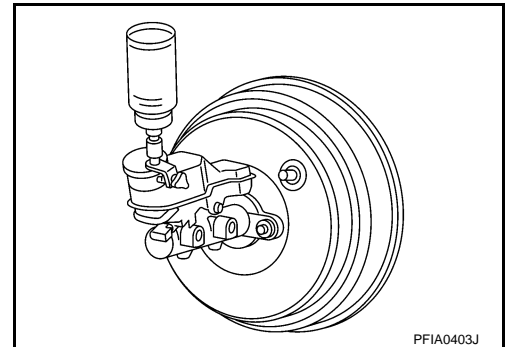

INFOID:000000000995614

DISC BRAKE

DISC BRAKE : Front Brake Pad

INFOID:000000000995615

DISC BRAKE : Inspection

PAD WEAR

Check pad thickness from an inspection hole on cylinder body. Check using a scale if necessary.

Standard

Standard thickness

: Refer to [BR-44. "Front Disc Brake"](#)

Limit

Wear limit thickness

: Refer to [BR-44. "Front Disc Brake"](#)

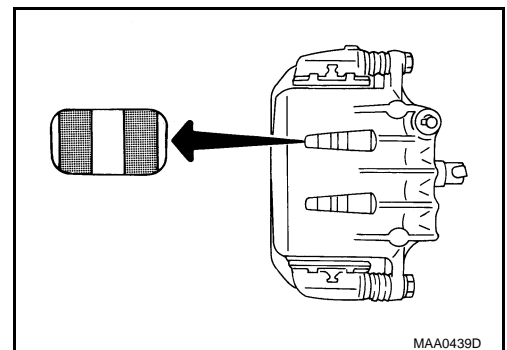

INFOID:000000000995616

DISC BRAKE : Front Brake Rotor

DISC BRAKE : Inspection

INFOID:000000000995617

A
B
C
D
E
F
G
H
I
J
K
L
M
N
O

CHASSIS AND BODY MAINTENANCE

< ON-VEHICLE MAINTENANCE >

VISUAL

Check surface of disc rotor for uneven wear, cracks, and serious damage. Replace if there are.

RUNOUT

1. Fix disc rotor to wheel hub using wheel nuts (2 or more positions).
2. Inspect runout using a dial gauge. [Measured at 10 mm (0.39 in) inside the disc edge.]

Runout limit : 0.035 mm (0.0014 in)
(with it attached to the vehicle)

NOTE:

Before measuring, make sure that wheel bearing axial end play is within the specification. Refer to [FAX-5. "Inspection"](#).

3. When runout exceeds limit value, displace mounting positions of disc rotor by one hole. And then find a position of the minimum value for runout.
4. Replace or lathe disc rotor if runout is outside the specified value after performing the above operation.

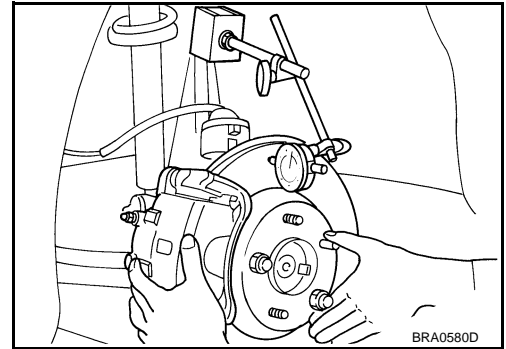

THICKNESS

Check thickness of the disc rotor using a micrometer. Replace disc rotor if thickness is under the wear limit.

Standard thickness : 26.0 mm (1.024 in)
Wear limit : 24.0 mm (0.945 in)
Thickness variation (Measured at 8 positions) : 0.015 mm (0.0006 in)

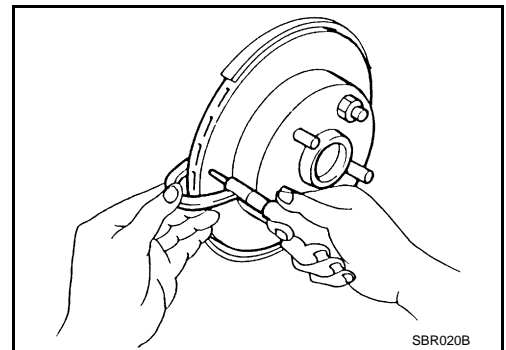

DISC BRAKE : Rear Brake Pad

INFOID:000000000995618

DISC BRAKE : Inspection

INFOID:000000000995619

PAD WEAR

- Check pad thickness from an inspection hole on cylinder body. Check using a scale if necessary.

Standard
Standard thickness : 8.5 mm (0.335 in)
Repair limit thickness : 1.0 mm (0.039 in)

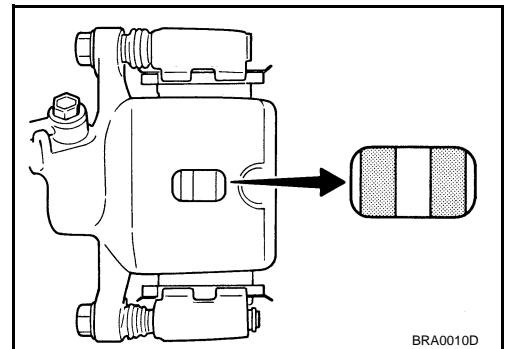

DISC BRAKE : Rear Brake Rotor

INFOID:000000000995620

DISC BRAKE : Inspection

INFOID:000000000995621

VISUAL

Check surface of disc rotor for uneven wear, cracks, and serious damage. Replace if there are.

RUNOUT

CHASSIS AND BODY MAINTENANCE

< ON-VEHICLE MAINTENANCE >

1. Fix disc rotor to wheel hub using wheel nuts (2 or more positions).
2. Inspect runout using dial gauge. [Measured at 10 mm (0.39 in) inside disc edge.]

Runout limit : 0.05 mm (0.002 in)
(With it attached to the vehicle)

NOTE:

Before measuring, make sure that wheel bearing axial end play is within the specification. Refer to [FAX-5, "Inspection"](#).

3. When runout exceeds limit value, displace mounting positions of disc rotor by one hole. And then find a position of the minimum value for runout.
4. Replace disc rotor if it is outside repair limit after performing the above operation.

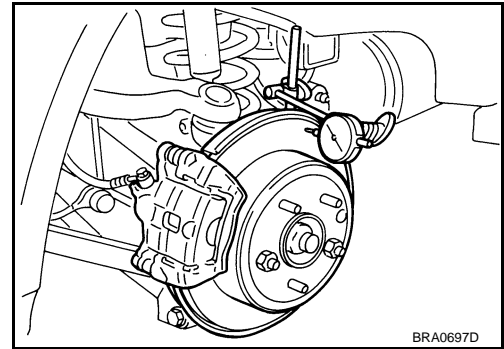

THICKNESS

Check the thickness of the disc rotor using a micrometer. Replace disc rotor if the thickness is under the wear limit.

Standard thickness : 9.0 mm (0.354 in)
Wear limit : 8.0 mm (0.315 in)
Thickness variation (Measured at 8 positions) : 0.015 mm (0.0006 in)

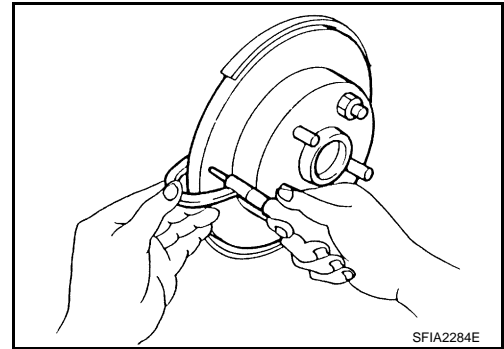

STEERING GEAR AND LINKAGE

STEERING GEAR AND LINKAGE : Inspection

INFOID:000000000995622

STEERING GEAR

- Check gear housing and boots for looseness, damage and grease leakage.
- Check connection with steering column for looseness.

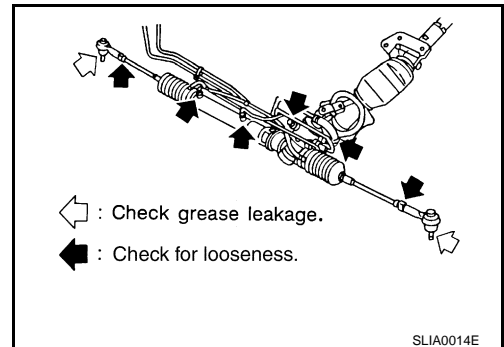

STEERING LINKAGE

Check ball joint, dust cover and other component parts for looseness, wear, damage and grease leakage.

POWER STEERING FLUID AND LINES

POWER STEERING FLUID AND LINES : Inspection

INFOID:000000000995623

FLUID LEVEL

- Check fluid level with engine stopped.

A
B
C
D
E
F
G
H
I
J
K
L
M
N
O

MA

CHASSIS AND BODY MAINTENANCE

< ON-VEHICLE MAINTENANCE >

- Make sure that fluid level is between MIN and MAX.
- Fluid levels at HOT (A) and COLD (B) are different. Do not confuse them.

HOT (A) : Fluid temperature 50 - 80 °C (122 - 176°F)

COLD (B) : Fluid temperature 0 - 30°C (32 - 86°F)

CAUTION:

- The fluid level should not exceed the MAX line. Excessive fluid will cause fluid leakage from the cap.
- Do not reuse drained power steering fluid.
- Recommended fluid is Genuine Nissan PSF or equivalent.

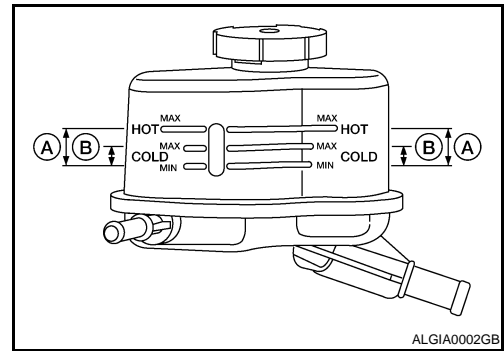

FLUID LEAKAGE

Check hydraulic connections for fluid leakage, cracks, damage, looseness, or wear.

1. Run engine until the fluid temperature reaches 50 to 80° C (122 to 176°F) in reservoir tank, and keep engine speed idle.
2. Turn steering wheel several times from full left stop to full right stop.
3. Hold steering wheel at each lock position for five seconds and carefully, check for fluid leakage.

CAUTION:

Do not hold the steering wheel in a locked position for more than 10 seconds. (There is the possibility that oil pump may be damaged.)

4. If fluid leakage at connections is noticed, then loosen flare nut and then retighten. Do not overtighten connector as this can damage O-ring, washer and connector.
5. If fluid leakage from oil pump is noticed, check oil pump. Refer to [ST-12](#).
6. Check steering gear boots for accumulation of fluid indicating from steering gear.

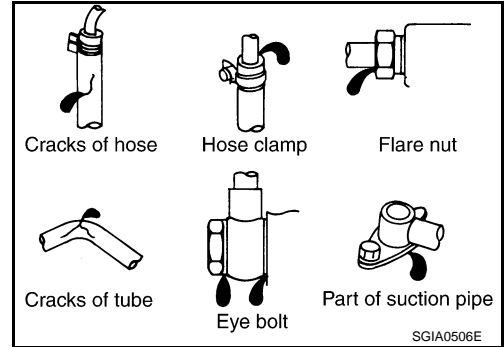

AXLE AND SUSPENSION PARTS

AXLE AND SUSPENSION PARTS : Inspection

INFOID:000000000995624

Check front and rear axle and suspension parts for excessive play, cracks, wear or other damage.

- Shake each wheel to check for excessive play.
- Check wheel bearings for smooth operation.
- Check axle and suspension nuts and bolts for looseness.
- Check strut (shock absorber) for oil leakage or other damage.
- Check suspension ball joint for grease leakage and ball joint dust cover for cracks or other damage.

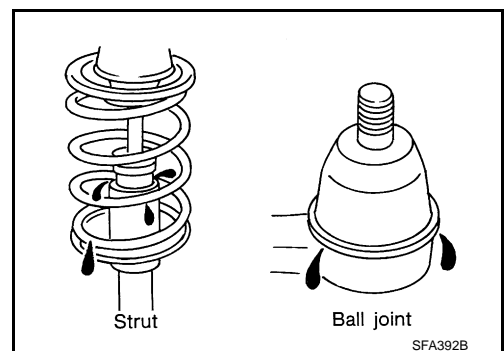
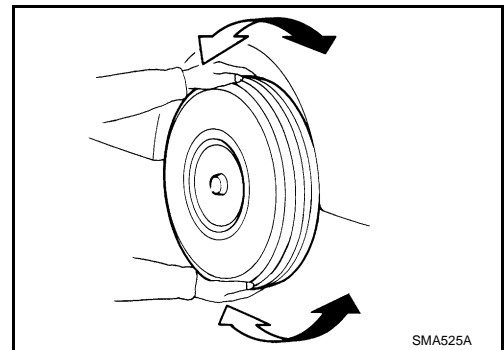

DRIVE SHAFT

CHASSIS AND BODY MAINTENANCE

< ON-VEHICLE MAINTENANCE >

DRIVE SHAFT : Inspection

INFOID:000000000995625

Check boot and drive shaft for cracks, wear, damage and grease leakage.

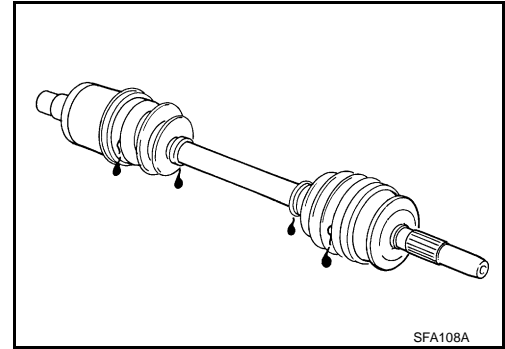

LOCKS, HINGES AND HOOD LATCH

LOCKS, HINGES AND HOOD LATCH : Lubricating

INFOID:000000000995626

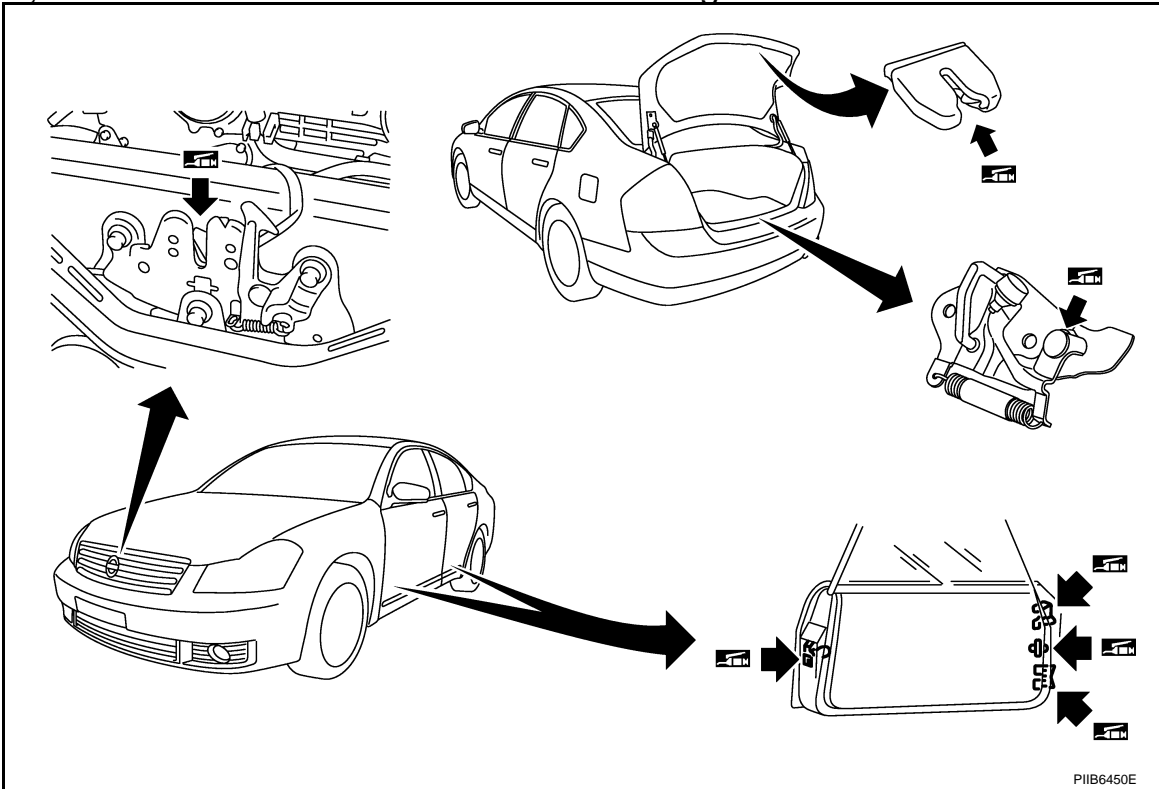

SEAT BELT, BUCKLES, RETRACTORS, ANCHORS AND ADJUSTERS

SEAT BELT, BUCKLES, RETRACTORS, ANCHORS AND ADJUSTERS : Inspection

INFOID:000000000995627

CAUTION:

- After any collision, inspect all seat belt assemblies, including retractors and other attached hardware (i.e. anchor bolt, guide rail set). Nissan recommends to replace all seat belt assemblies in use during a collision, unless not damaged and properly operating after minor collision. Also inspect seat belt assemblies not in use during a collision, and replace if damaged or improperly operating. Seat belt pre-tensioner should be replaced even if the seat belts are not in use during a frontal collision where the driver and passenger air bags are deployed.
- If any component of seat belt assembly is questionable, do not repair. Replace as seat belt assembly.
- If webbing is cut, frayed, or damaged, replace belt assembly.
- Never oil tongue and buckle.
- Use a genuine NISSAN seat belt assembly.

A
B
C
D
E
F
G
H
I
J
K
L
M
N
O

CHASSIS AND BODY MAINTENANCE

< ON-VEHICLE MAINTENANCE >

For details, refer to [SB-3. "Inspection"](#) in SB section.

- Check anchors for loose mounting
- Check belts for damage
- Check retractor for smooth operation
- Check function of buckles and tongues when buckled and released