

SECTION **CHG**
CHARGING SYSTEM

A

B

C

D

E

CONTENTS

BASIC INSPECTION	2	Description	12	F
DIAGNOSIS AND REPAIR WORKFLOW	2	Diagnosis Procedure	12	
Work Flow	2	CHARGING SYSTEM	13	G
FUNCTION DIAGNOSIS	5	Wiring Diagram - Coupe	13	
CHARGING SYSTEM	5	Wiring Diagram - Sedan	18	
System Diagram	5	SYMPTOM DIAGNOSIS	23	H
System Description	5	CHARGING SYSTEM	23	
Component Description	5	Symptom Table	23	I
POWER GENERATION VOLTAGE VARIABLE CONTROL SYSTEM	6	PRECAUTION	24	
System Diagram	6	PRECAUTIONS	24	J
System Description	6	Supplemental Restraint System (SRS) "AIR BAG" and "SEAT BELT PRE-TENSIONER"	24	
Component Description	6	Precaution for Power Generation Voltage Variable Control System	24	K
COMPONENT DIAGNOSIS	7	PREPARATION	25	L
CHARGING SYSTEM PRELIMINARY INSPECTION	7	PREPARATION	25	
Inspection Procedure	7	Special Service Tool	25	
POWER GENERATION VOLTAGE VARIABLE CONTROL SYSTEM OPERATION INSPECTION	8	Commercial Service Tool	25	CHG
Inspection Procedure	8	ON-VEHICLE REPAIR	26	
B TERMINAL CIRCUIT	10	GENERATOR	26	N
Description	10	Removal and Installation	26	
Diagnosis Procedure	10	Inspection	27	
L TERMINAL CIRCUIT	11	SERVICE DATA AND SPECIFICATIONS (SDS)	28	O
Description	11	SERVICE DATA AND SPECIFICATIONS (SDS)	28	P
Diagnosis Procedure	11	Generator	28	
S TERMINAL CIRCUIT	12			

DIAGNOSIS AND REPAIR WORKFLOW

< BASIC INSPECTION >

BASIC INSPECTION

DIAGNOSIS AND REPAIR WORKFLOW

Work Flow

INFOID:000000001345214

OVERALL SEQUENCE

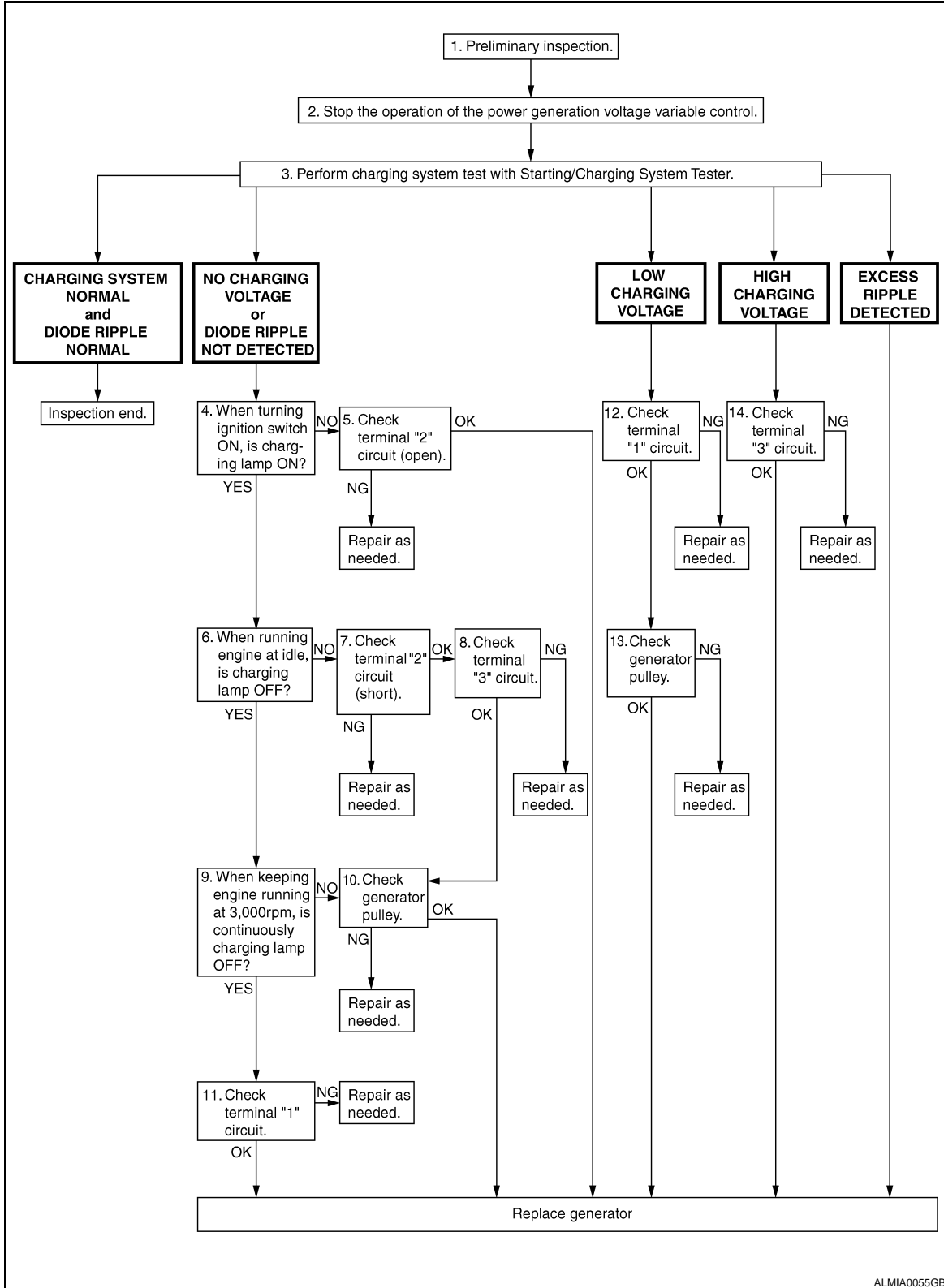

ALMIA0055GB

DETAILED FLOW

DIAGNOSIS AND REPAIR WORKFLOW

< BASIC INSPECTION >

NOTE:

To ensure a complete and thorough diagnosis, the battery, starter and generator test segments must be done as a set from start to finish.

1. PRELIMINARY INSPECTION

Perform the preliminary inspection. Refer to [CHG-7, "Inspection Procedure"](#).

>> GO TO 2

2. DISABLE THE POWER GENERATION VOLTAGE VARIABLE CONTROL SYSTEM

Disable the power generation voltage variable control with either of the following procedures.

- After selecting "ENGINE" on the "SELECT SYSTEM" screen of CONSULT-III, set the "ALTERNATOR DUTY" value to 0 % by selecting "ALTERNATOR DUTY" with "Active Test". Continue "Active Test" until the end of inspection. (When the DUTY value is 0 or 100 %, the normal power generation is performed according to the characteristic of the IC regulator of the generator.)
- Turn the ignition switch OFF, disconnect the battery current sensor connector and leave it disconnected during the course of the test.

NOTE:

Running the engine with the battery current sensor disconnected will cause DTC's (P1550-P1554) to set. After finishing the inspection, connect the battery current sensor connector and erase the self-diagnostic results history of the engine using CONSULT-III.

>> GO TO 3

3. DIAGNOSIS WITH STARTING/CHARGING SYSTEM TESTER

Perform the charging system test using Starting/Charging System Tester (J-44373). For details and operating instructions, refer to Technical Service Bulletin.

Test result

CHARGING SYSTEM NOMAL>>Charging system is normal and will also show "DIODE RIPPLE" test result.

NO CHARGING VOLTAGE>>GO TO 4

LOW CHARGING VOLTAGE>>GO TO 12

HIGH CHARGING VOLTAGE>>GO TO 14

DIODE RIPPLE NORMAL>>Diode ripple is OK and will also show "CHARGING VOLTAGE" test result.

EXCESS RIPPLE DETECTED>>Replace the generator. Perform "DIODE RIPPLE" test again using Starting/Charging System Tester (J-44373) to confirm repair.

DIODE RIPPLE NOT DETECTED>>GO TO 4

4. INSPECTION WITH CHARGE WARNING LAMP (IGNITION SWITCH IS ON)

Turn the ignition switch ON.

Does the charge warning lamp illuminate?

YES >> GO TO 6

NO >> GO TO 5

5. TERMINAL "2" (OPEN) CIRCUIT INSPECTION

Check terminal "2" circuit for open circuits. Refer to [CHG-11, "Diagnosis Procedure"](#).

Is the terminal "2" circuit normal?

YES >> Replace generator.

NO >> Repair as needed.

6. INSPECTION WITH CHARGE WARNING LAMP (IDLING)

Start the engine and run it at idle.

Does the charge warning lamp turn OFF?

YES >> GO TO 9

NO >> GO TO 7

7. TERMINAL "2"(SHORT) CIRCUIT INSPECTION

Check terminal "2" circuit for short to ground. Refer to [CHG-11, "Diagnosis Procedure"](#).

Is the terminal "2" circuit normal?

DIAGNOSIS AND REPAIR WORKFLOW

< BASIC INSPECTION >

YES >> GO TO 8
NO >> Repair as needed.

8. TERMINAL "3" CIRCUIT INSPECTION

Check terminal "3" circuit. Refer to [CHG-12, "Diagnosis Procedure"](#).

Is the terminal "3" circuit normal?

YES >> GO TO 10
NO >> Repair as needed.

9. INSPECTION WITH CHARGE WARNING LAMP (ENGINE AT 3,000 RPM)

Increase and maintain the engine speed at 3,000 rpm.

Does the charge warning lamp remain off?

YES >> GO TO 11
NO >> GO TO 10

10. INSPECTION OF GENERATOR PULLEY

Check generator pulley. Refer to [CHG-27, "Inspection"](#).

Is generator pulley normal?

YES >> Replace generator. Refer to [CHG-26, "Removal and Installation"](#).
NO >> Repair as needed.

11. TERMINAL "1" CIRCUIT INSPECTION

Check terminal "1" circuit. Refer to [CHG-10, "Diagnosis Procedure"](#).

Is terminal "1" circuit normal?

YES >> Replace generator. Refer to [CHG-26, "Removal and Installation"](#).
NO >> Repair as needed.

12. TERMINAL "1" CIRCUIT INSPECTION

Check terminal "1" circuit. Refer to [CHG-10, "Diagnosis Procedure"](#).

Is terminal "1" circuit normal?

YES >> GO TO 13
NO >> Repair as needed.

13. INSPECTION OF GENERATOR PULLEY

Check generator pulley. Refer to [CHG-27, "Inspection"](#).

Is generator pulley normal?

YES >> Replace generator. Refer to [CHG-26, "Removal and Installation"](#).
NO >> Repair as needed.

14. TERMINAL "3" CIRCUIT INSPECTION

Check terminal "3" circuit. Refer to [CHG-12, "Diagnosis Procedure"](#).

Is the terminal "3" circuit normal?

YES >> Replace generator. Refer to [CHG-26, "Removal and Installation"](#).
NO >> Repair as needed.

CHARGING SYSTEM

< FUNCTION DIAGNOSIS >

FUNCTION DIAGNOSIS

CHARGING SYSTEM

System Diagram

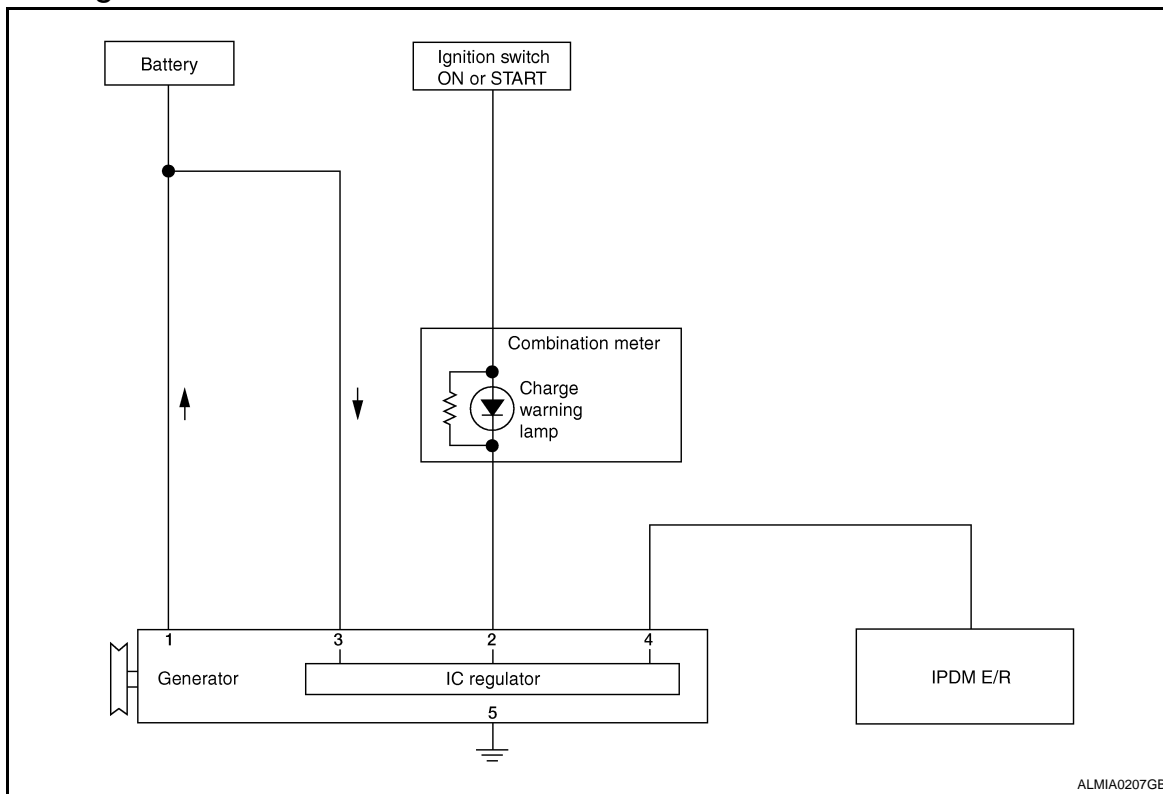

System Description

INFOID:000000001345216

The generator provides DC voltage to operate the vehicle's electrical system and to keep the battery charged. The voltage output is controlled by the IC regulator.

Component Description

INFOID:000000001345217

Component part		Description
Generator	Terminal "1"	Refer to CHG-10, "Description" .
	Terminal "2"	Refer to CHG-12, "Description" .
	Terminal "3"	Refer to CHG-11, "Description" .
	Terminal "4"	Used for the power generation voltage variable control system. Refer to CHG-6, "System Description" .
Combination meter (Charge warning lamp)		The IC regulator warning function activates to illuminate the charge warning lamp if any of the following symptoms occur while generator is operating: <ul style="list-style-type: none"> Excessive voltage is produced. No voltage is produced.
IPDM E/R		Used for the power generation voltage variable control system. Refer to CHG-6, "System Description" .

A

B

C

D

E

F

G

H

I

J

K

L

CHG

N

O

P

POWER GENERATION VOLTAGE VARIABLE CONTROL SYSTEM

< FUNCTION DIAGNOSIS >

POWER GENERATION VOLTAGE VARIABLE CONTROL SYSTEM

System Diagram

INFOID:000000001345218

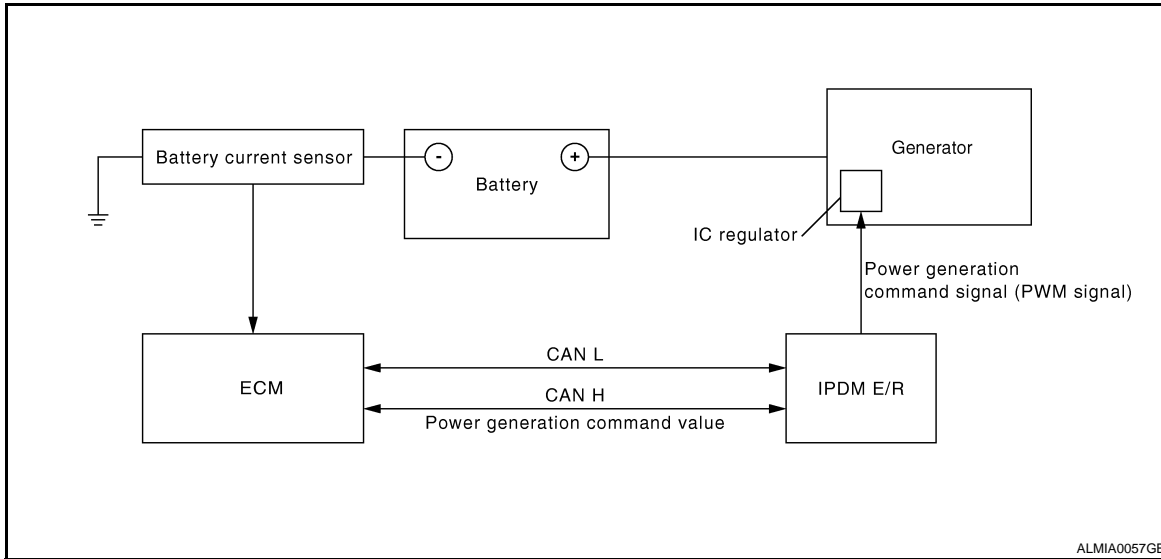

ALMIA0057GB

System Description

INFOID:000000001345219

Power generation variable voltage control system has been adopted. By varying the voltage to the generator, engine load due to power generation of the generator is reduced and fuel consumption is decreased.

NOTE:

When any malfunction is detected in the power generation variable voltage control system, power generation is performed according to the characteristic of the IC regulator in the generator.

Component Description

INFOID:000000001345220

Component part	Description
Battery current sensor	The battery current sensor is installed on the battery cable at the negative terminal. The battery current sensor detects the charging/discharging current of the battery and sends a voltage signal to the ECM according to the current value detected.
ECM	The battery current sensor detects the charging/discharging current of the battery. The ECM judges the battery condition based on this signal. The ECM judges whether to request more output via the power generation voltage variable control according to the battery condition. When performing the power generation voltage variable control, the ECM calculates the target power generation voltage according to the battery condition and sends the calculated value as the power generation command value to the IPDM E/R.
IPDM E/R	The IPDM E/R converts the received power generation command value into a pulse width modulated (PWM) command signal and sends it to the IC regulator.
Generator (IC regulator)	The IC regulator controls the power generation voltage by the target power generation voltage based on the received PWM command signal. When there is no PWM command signal, the generator performs the normal power generation according to the characteristic of the IC regulator.

CHARGING SYSTEM PRELIMINARY INSPECTION

< COMPONENT DIAGNOSIS >

COMPONENT DIAGNOSIS

CHARGING SYSTEM PRELIMINARY INSPECTION

Inspection Procedure

INFOID:000000001345221

1. CHECK BATTERY TERMINALS CONNECTION

Check if battery terminals are clean and tight.

Is the inspection result normal?

YES >> GO TO 2

NO >> Repair battery terminals connection.

2. CHECK FUSE

Check for blown fuse and fusible link.

Unit	Power source (Power supply terminals)	Fuse or Fusible Link
Generator	Battery (terminal 3)	Fuse 29
	Battery (terminal 1)	Fusible Link A
Combination meter	Ignition switch ON (terminal 2)	Fuse 4

Is the inspection result normal?

YES >> GO TO 3

NO >> Be sure to eliminate cause of malfunction before installing new fuse or fusible link.

3. CHECK GENERATOR GROUND TERMINAL CONNECTION

Check if connector E230 terminal 5 (generator ground harness) is clean and tight.

Is the inspection result normal?

YES >> GO TO 4

NO >> Repair connection.

4. CHECK DRIVE BELT TENSION

Check drive belt tension. Refer to [CHG-27. "Inspection"](#).

Is the inspection result normal?

YES >> INSPECTION END.

NO >> Repair as needed.

A
B
C
D
E
F
G
H
I
J
K
L
N
O
P

CHG

POWER GENERATION VOLTAGE VARIABLE CONTROL SYSTEM OPERATION INSPECTION

< COMPONENT DIAGNOSIS >

POWER GENERATION VOLTAGE VARIABLE CONTROL SYSTEM OPERATION INSPECTION

Inspection Procedure

INFOID:000000001345222

CAUTION:

When performing this inspection, always use a charged battery that has completed the battery inspection. (When the charging rate of the battery is low, the response speed of the voltage change will become slow. This can cause an incorrect inspection.)

1.CHECK ECM (CONSULT-III)

Perform ECM self-diagnosis with CONSULT-III. Refer to [EC-1123, "CONSULT-III Function"](#).

Self-diagnostic results content

No malfunction detected>> GO TO 2

Malfunction detected>> Check applicable parts, and repair or replace corresponding parts.

2.CHECK OPERATION OF POWER GENERATION VOLTAGE VARIABLE CONTROL SYSTEM

1. Connect CONSULT-III and start the engine.
2. The selector lever is in "P" or "N" position and all of the electric loads and A/C, etc. are turned OFF.
3. Select "ALTERNATOR DUTY" in "Active Test" of "ENGINE", and then check the value of "BATTERY VOLT" monitor when DUTY value of "ALTERNATOR DUTY" is set to 40.0 %.

"BATTERY VOLT"

2 seconds after setting the DUTY value of "ALTERNATOR DUTY" to 40.0 % : 12 - 13.6 V

4. Check the value of "BATTERY VOLT" monitor when DUTY value of "ALTERNATOR DUTY" is set to 80.0%.

"BATTERY VOLT"

20 seconds after setting the DUTY value of "ALTERNATOR DUTY" to 80.0 % : +0.5 V or more against the value of "BATTERY VOLT" monitor when DUTY value is 40.0 %

Is the measurement value within the specification?

YES >> INSPECTION END.

NO >> GO TO 3

3.CHECK IPDM E/R (CONSULT-III)

Perform IPDM E/R self-diagnosis with CONSULT-III. Refer to [PCS-13, "CONSULT - III Function \(IPDM E/R\)"](#).

Self-diagnostic results content

No malfunction detected>> GO TO 4

Malfunction detected>> Check applicable parts, and repair or replace corresponding parts.

4.CHECK HARNESS BETWEEN GENERATOR AND IPDM E/R

1. Turn ignition switch OFF.
2. Disconnect generator connector and IPDM E/R connector.

POWER GENERATION VOLTAGE VARIABLE CONTROL SYSTEM OPERATION INSPECTION

< COMPONENT DIAGNOSIS >

3. Check continuity between generator harness connector F7 (A) terminal 4 and IPDM E/R harness connector F10 (B) terminal 76.

A		B		Continuity
Connector	Terminal	Connector	Terminal	
F7	4	F10	76	Yes

4. Check continuity between generator harness connector F7 (A) terminal 4 and ground.

A		—	Continuity
Connector	Terminal		
F7	4	Ground	Yes

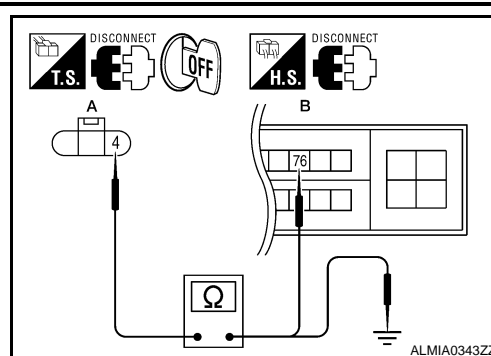

Is the inspection result normal?

- YES >> Replace IPDM E/R. Refer to [PCS-43. "Removal and Installation"](#).
 NO >> Repair harness or connector between IPDM E/R and generator.

A
B
C
D
E
F
G
H
I
J
K
L

CHG

N
O
P

B TERMINAL CIRCUIT

< COMPONENT DIAGNOSIS >

B TERMINAL CIRCUIT

Description

INFOID:000000001345223

The terminal "1" circuit supplies power to charge the battery and operate the vehicles electrical system.

Diagnosis Procedure

INFOID:000000001345224

1.CHECK TERMINAL "1" CONNECTION

1. Turn ignition switch OFF.
2. Check if terminal "1" is clean and tight.

Is the inspection result normal?

YES >> GO TO 2

NO >> Repair terminal "1" connection. Confirm repair by performing complete Starting/Charging system test. Refer to Technical Service Bulletin.

2.CHECK TERMINAL "1" CIRCUIT

Check voltage between generator connector F6 terminal 1 and ground.

1 - ground

Battery voltage

Is the inspection result normal?

YES >> GO TO 3

NO >> Check harness for open between generator and fusible link.

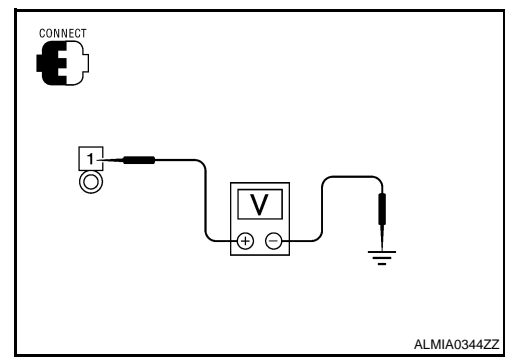

3.CHECK TERMINAL "1" CONNECTION (VOLTAGE DROP TEST)

1. Start engine, then engine running at idle and warm.
2. Check voltage between battery positive terminal and generator connector F6 terminal 1.

1 - B+

Less than 0.2V

Is the inspection result normal?

YES >> Terminal "1" circuit is normal. Refer to [CHG-2. "Work Flow"](#).

NO >> Check harness between battery and generator for high resistance.

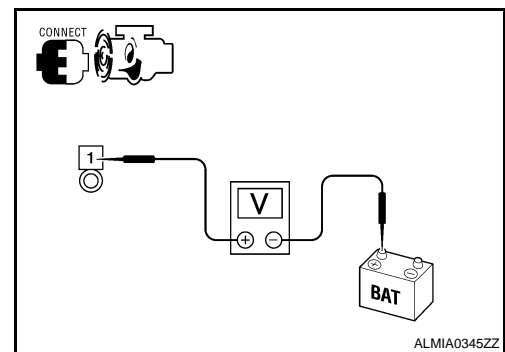

L TERMINAL CIRCUIT

< COMPONENT DIAGNOSIS >

L TERMINAL CIRCUIT

Description

INFOID:000000001345225

The terminal "2" (L) circuit controls the charge warning lamp. The charge warning lamp illuminates when the ignition switch is set to ON or START. When the generator is providing sufficient voltage with the engine running, the charge warning lamp will go off. If the charge warning lamp illuminates with the engine running, a malfunction is indicated.

Diagnosis Procedure

INFOID:000000001345226

1. CHECK CHARGE WARNING LAMP CIRCUIT CONNECTION

Check to see if generator connector F7 terminal 2 is clean and tight.

Is the connection secure?

YES >> GO TO 2

NO >> Repair the connection. Confirm repair by performing complete Starting/Charging system test. Refer to Technical Service Bulletin.

2. CHECK CHARGE WARNING LAMP CIRCUIT

1. Disconnect generator connector F7.
2. Apply ground to generator harness connector F7 terminal 2 with the ignition switch in the ON position.

Charge lamp should illuminate

Does it illuminate?

YES >> Check generator function. Refer to [CHG-2, "Work Flow"](#).

NO >> GO TO 3

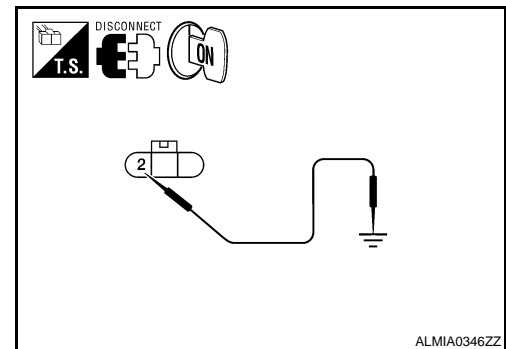

3. CHECK HARNESS CONTINUITY (OPEN CIRCUIT)

1. Turn ignition switch OFF.
2. Disconnect the generator connector F7.
3. Disconnect the combination meter connector M24.
4. Check continuity between generator harness connector F7 (A) terminal 2 and combination meter harness connector M24 (B) terminal 25.

A		B		Continuity
Connector	Terminal	Connector	Terminal	
F7	2	M24	25	Yes

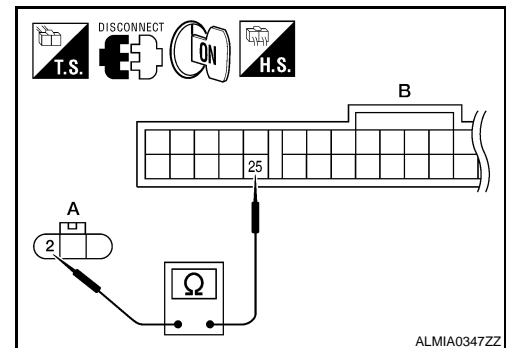

Is continuity present?

YES >> Replace the combination meter. Refer to [MWI-172, "Removal and Installation"](#).

NO >> Repair the harness or connector.

A
B
C
D
E
F
G
H
I
J
K
L
N
O
P

CHG

S TERMINAL CIRCUIT

< COMPONENT DIAGNOSIS >

S TERMINAL CIRCUIT

Description

INFOID:000000001345227

The output voltage of the generator is controlled by the IC regulator at terminal "3" (S) detecting the input voltage. Terminal "3" circuit detects the battery voltage to adjust the generator output voltage with the IC regulator.

Diagnosis Procedure

INFOID:000000001345228

1. CHECK VOLTAGE REGULATOR CIRCUIT CONNECTION

Check to see if connector F7 terminal 3 is clean and tight.

Is the inspection result normal?

YES >> GO TO 2

NO >> Repair terminal connection. Confirm repair by performing complete Starting/Charging system test.
Refer to Technical Service Bulletin.

2. CHECK VOLTAGE REGULATOR CIRCUIT

Check voltage between generator harness connector F7 terminal 3 and ground.

3 - ground

Battery voltage

Does battery voltage exist?

YES >> Refer to [CHG-2. "Work Flow"](#).

NO >> Check harness for open between generator and fuse.

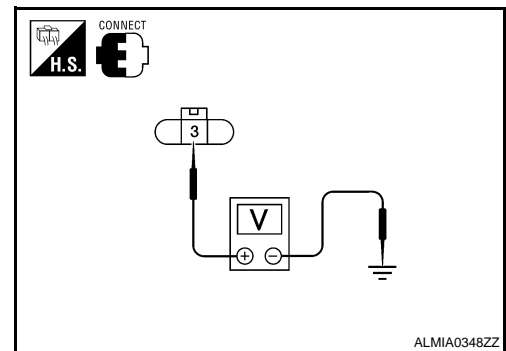

CHARGING SYSTEM

< COMPONENT DIAGNOSIS >

CHARGING SYSTEM

Wiring Diagram - Coupe

INFOID:000000001345229

--- : DATA LINE

CHARGING SYSTEM

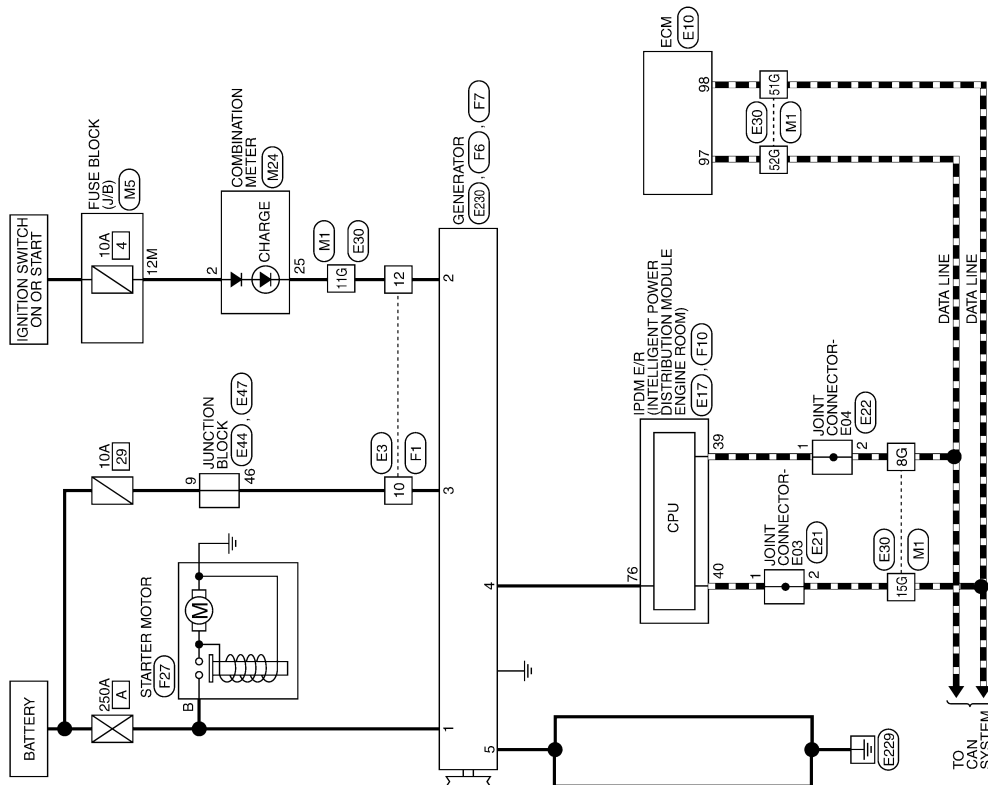

A
B
C
D
E
F
G
H
I
J
K
L
N
O
P

CHG

AWMWA0029G

CHARGING SYSTEM

< COMPONENT DIAGNOSIS >

CHARGING SYSTEM CONNECTORS

Connector No.	M1
Connector Name	WIRE TO WIRE
Connector Color	WHITE

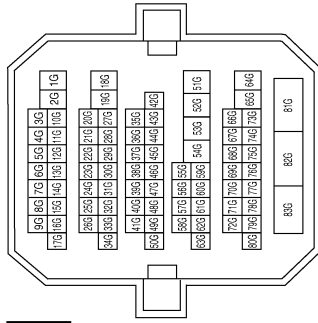

Terminal No.	Color of Wire	Signal Name
8G	P	—
11G	BR	—
15G	L	—
51G	L	—
52G	P	—

Connector No.	M5
Connector Name	FUSE BLOCK (J/B)
Connector Color	WHITE

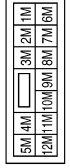

Terminal No.	Color of Wire	Signal Name
12M	P	—

Connector No.	M24
Connector Name	COMBINATION METER
Connector Color	WHITE

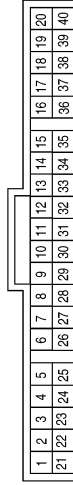

Connector No.	E3
Connector Name	WIRE TO WIRE
Connector Color	WHITE

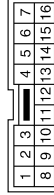

Terminal No.	Color of Wire	Signal Name
2	O	IGN
25	BR	CHG

Terminal No.	Color of Wire	Signal Name
10	Y/B	—
12	BR	—

ALMIA0063GB

CHARGING SYSTEM

< COMPONENT DIAGNOSIS >

Connector No.	E10
Connector Name	ECM
Connector Color	BLACK

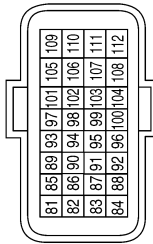

Terminal No.	Color of Wire	Signal Name
97	P	CAN-L
98	L	CAN-H

Connector No.	E17
Connector Name	IPDM E/R (INTELLIGENT POWER DISTRIBUTION MODULE ENGINE ROOM)
Connector Color	WHITE

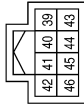

Terminal No.	Color of Wire	Signal Name
39	P	CAN-L
40	L	CAN-H

Connector No.	E21
Connector Name	JOINT CONNECTOR-E03
Connector Color	WHITE



Terminal No.	Color of Wire	Signal Name
1	L	—
2	L	—

Connector No.	E22
Connector Name	JOINT CONNECTOR-E04
Connector Color	WHITE



Terminal No.	Color of Wire	Signal Name
1	P	—
2	P	—

Connector No.	E30
Connector Name	WIRE TO WIRE
Connector Color	WHITE

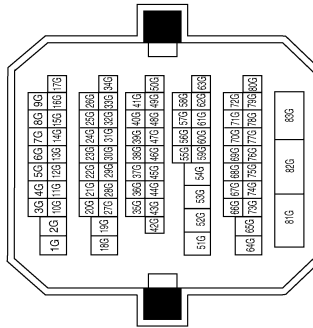

Terminal No.	Color of Wire	Signal Name
8G	P	—
11G	BR	—
15G	L	—
51G	L	—
52G	P	—

ALMIA0064GB

A
B
C
D
E
F
G
H
I
J
K
L
N
O
P

CHG

CHARGING SYSTEM

< COMPONENT DIAGNOSIS >

Connector No.	E230
Connector Name	GENERATOR
Connector Color	—



Terminal No.	Color of Wire	Signal Name
5	B	GND

Connector No.	E47
Connector Name	JUNCTION BLOCK
Connector Color	WHITE

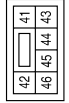

Terminal No.	Color of Wire	Signal Name
46	Y/B	—

Connector No.	E44
Connector Name	JUNCTION BLOCK
Connector Color	BROWN

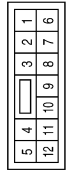

Terminal No.	Color of Wire	Signal Name
9	Y/B	—

Connector No.	F7
Connector Name	GENERATOR
Connector Color	BLACK



Terminal No.	Color of Wire	Signal Name
2	BR	CHG
3	Y/B	BATT
4	GR	—

Connector No.	F6
Connector Name	GENERATOR
Connector Color	—



Terminal No.	Color of Wire	Signal Name
1	B/R	BATT

Connector No.	F1
Connector Name	WIRE TO WIRE
Connector Color	WHITE

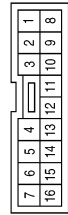

Terminal No.	Color of Wire	Signal Name
10	Y/B	—
12	BR	—

ALMIA0065GB

CHARGING SYSTEM

< COMPONENT DIAGNOSIS >

Connector No.	F27
Connector Name	STARTER MOTOR
Connector Color	—



Terminal No.	Color of Wire	Signal Name
B	B/R	BATT

Connector No.	F10
Connector Name	IPDM E/R (INTELLIGENT POWER DISTRIBUTION MODULE ENGINE ROOM)
Connector Color	WHITE

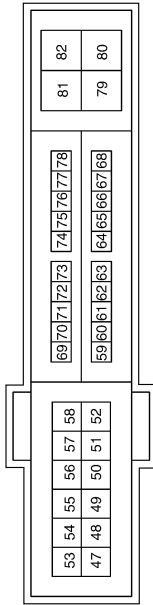

Terminal No.	Color of Wire	Signal Name
76	GR	ALT_C

A
B
C
D
E
F
G
H
I
J
K
L
N
O
P

CHG

ALMIA0066GB

CHARGING SYSTEM

< COMPONENT DIAGNOSIS >

Wiring Diagram - Sedan

INFOID:00000003220094

DATA LINE

CHARGING SYSTEM

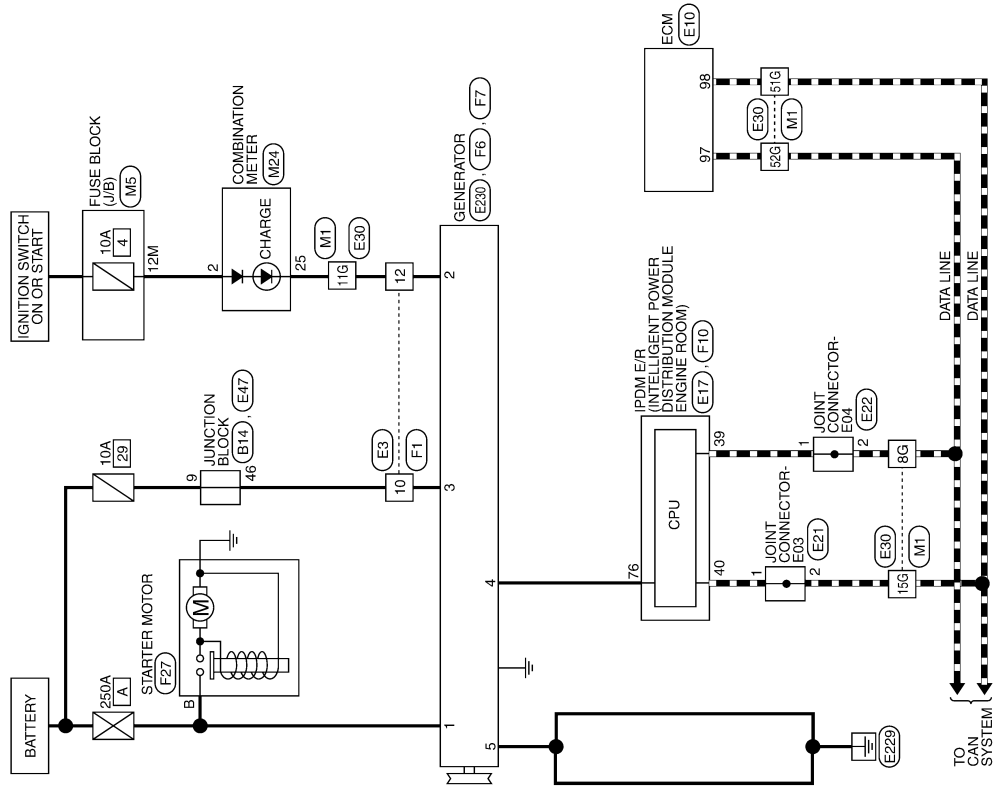

AWMWA0154G

CHARGING SYSTEM CONNECTORS

Connector No.	M1
Connector Name	WIRE TO WIRE
Connector Color	WHITE

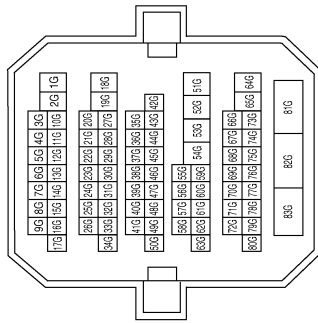

Terminal No.	Color of Wire	Signal Name
8G	P	—
11G	BR	—
15G	L	—
51G	L	—
52G	P	—

Connector No.	M5
Connector Name	FUSE BLOCK (J/B)
Connector Color	WHITE

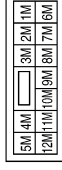

Terminal No.	12M	Color of Wire	O	Signal Name	—
--------------	-----	---------------	---	-------------	---

Connector No.	M24
Connector Name	COMBINATION METER
Connector Color	WHITE

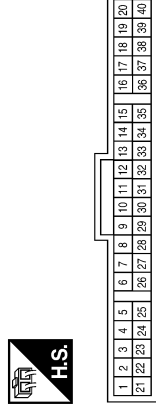

Terminal No.	2	Color of Wire	O	Signal Name	IGN
Terminal No.	25	Color of Wire	BR	Signal Name	CHG

Connector No.	E3
Connector Name	WIRE TO WIRE
Connector Color	WHITE

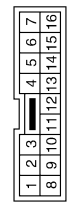

Terminal No.	10	Color of Wire	Y/B	Signal Name	—
Terminal No.	12	Color of Wire	BR	Signal Name	—

A
B
C
D
E
F
G
H
I
J
K
L
N
O
P

CHG

CHARGING SYSTEM

< COMPONENT DIAGNOSIS >

Connector No.	E10
Connector Name	ECM
Connector Color	BLACK

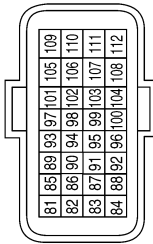

Terminal No.	Color of Wire	Signal Name
97	P	CAN-L
98	L	CAN-H

Connector No.	E17
Connector Name	IPDM E/R (INTELLIGENT POWER DISTRIBUTION MODULE ENGINE ROOM)
Connector Color	WHITE



Terminal No.	Color of Wire	Signal Name
39	P	CAN-L
40	L	CAN-H

Connector No.	E21
Connector Name	JOINT CONNECTOR-E03
Connector Color	WHITE



Terminal No.	Color of Wire	Signal Name
1	L	—
2	L	—

Connector No.	E22
Connector Name	JOINT CONNECTOR-E04
Connector Color	WHITE



Terminal No.	Color of Wire	Signal Name
1	P	—
2	P	—

Connector No.	E30
Connector Name	WIRE TO WIRE
Connector Color	WHITE

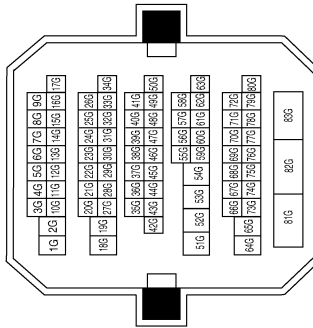

Terminal No.	Color of Wire	Signal Name
8G	P	—
11G	BR	—
15G	L	—
51G	L	—
52G	P	—

ALMIA0064GB

CHARGING SYSTEM

< COMPONENT DIAGNOSIS >

Connector No.	E230
Connector Name	GENERATOR
Connector Color	—



Terminal No.	Color of Wire	Signal Name
5	B	GND

Connector No.	E47
Connector Name	JUNCTION BLOCK
Connector Color	WHITE

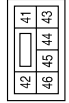

Terminal No.	Color of Wire	Signal Name
46	Y/B	—

Connector No.	E44
Connector Name	JUNCTION BLOCK
Connector Color	BROWN

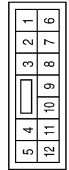

Terminal No.	Color of Wire	Signal Name
9	Y/B	—

Connector No.	F7
Connector Name	GENERATOR
Connector Color	BLACK



Terminal No.	Color of Wire	Signal Name
2	BR	CHG
3	Y/B	BATT
4	GR	—

Connector No.	F6
Connector Name	GENERATOR
Connector Color	—



Terminal No.	Color of Wire	Signal Name
1	B/R	BATT

Connector No.	F1
Connector Name	WIRE TO WIRE
Connector Color	WHITE

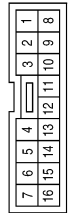

Terminal No.	Color of Wire	Signal Name
10	Y/B	—
12	BR	—

ALMIA0065GB

A
B
C
D
E
F
G
H
I
J
K
L
N
O
P

CHG

CHARGING SYSTEM

< COMPONENT DIAGNOSIS >

Connector No.	F10
Connector Name	IPDM E/R (INTELLIGENT POWER DISTRIBUTION MODULE ENGINE ROOM)
Connector Color	WHITE

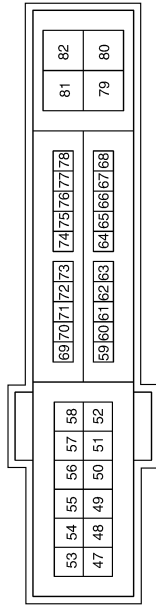

Terminal No.	Color of Wire	Signal Name
76	GR	ALT_C

Connector No.	F27
Connector Name	STARTER MOTOR
Connector Color	—



Terminal No.	Color of Wire	Signal Name
B	B/R	BATT

CHARGING SYSTEM

< SYMPTOM DIAGNOSIS >

SYMPTOM DIAGNOSIS

CHARGING SYSTEM

Symptom Table

INFOID:000000001345230

Symptom	Reference
Battery discharged	Refer to CHG-2, "Work Flow" .
The charge warning lamp does not illuminate when the ignition switch is set to ON.	
The charge warning lamp does not turn OFF after the engine starts.	
The charging warning lamp turns ON when increasing the engine speed.	

A

B

C

D

E

F

G

H

I

J

K

L

CHG

N

O

P

PRECAUTIONS

< PRECAUTION >

PRECAUTION

PRECAUTIONS

Supplemental Restraint System (SRS) "AIR BAG" and "SEAT BELT PRE-TENSIONER"

INFOID:000000001345231

The Supplemental Restraint System such as "AIR BAG" and "SEAT BELT PRE-TENSIONER", used along with a front seat belt, helps to reduce the risk or severity of injury to the driver and front passenger for certain types of collision. This system includes seat belt switch inputs and dual stage front air bag modules. The SRS system uses the seat belt switches to determine the front air bag deployment, and may only deploy one front air bag, depending on the severity of a collision and whether the front occupants are belted or unbelted. Information necessary to service the system safely is included in the SR and SB section of this Service Manual.

WARNING:

- To avoid rendering the SRS inoperative, which could increase the risk of personal injury or death in the event of a collision which would result in air bag inflation, all maintenance must be performed by an authorized NISSAN/INFINITI dealer.
- Improper maintenance, including incorrect removal and installation of the SRS, can lead to personal injury caused by unintentional activation of the system. For removal of Spiral Cable and Air Bag Module, see the SR section.
- Do not use electrical test equipment on any circuit related to the SRS unless instructed to in this Service Manual. SRS wiring harnesses can be identified by yellow and/or orange harnesses or harness connectors.

Precaution for Power Generation Voltage Variable Control System

INFOID:000000001345232

CAUTION:

For this model, the battery current sensor that is installed to the battery cable at the negative terminal measures the charging/discharging current of the battery, and performs various controls. If the electrical component or the ground wire is connected directly to the battery terminal, the current other than that being measured with the battery current sensor is charging to or discharging from the battery. This condition causes the malfunction of the control, and then the battery discharge may occur. Do not connect the electrical component or the ground wire directly to the battery terminal.

PREPARATION

< PREPARATION >

PREPARATION

PREPARATION

Special Service Tool

INFOID:000000001806228

The actual shapes of Kent-Moore tools may differ from those of special service tools illustrated here.

Tool number (Kent-Moore No.) Tool name	Description
— (J-48087) Battery Service Center	Tests battery. For operating instructions, refer to Technical Service Bulletin and Battery Service Center User Guide.
— (J-44373) Model 620 Starting/Charging system tester	Tests starting and charging systems. For operating instructions, refer to Technical Service Bulletin.



WKIA5280E

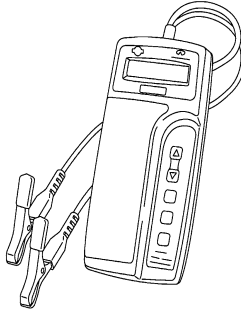

SEL403X

Commercial Service Tool

INFOID:000000001806229

Tool name	Description
Power tool	Loosening bolts and nuts

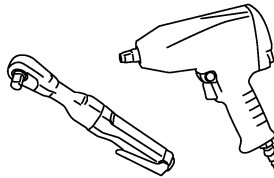

PBIC0190E

A
B
C
D
E
F
G
H
I
J
K
L
N
O
P

CHG

GENERATOR

< ON-VEHICLE REPAIR >

ON-VEHICLE REPAIR

GENERATOR

Removal and Installation

INFOID:000000001345235

QR25DE

Removal

1. Disconnect the battery cable from the negative terminal.
2. Remove engine side undercover, using power tools.
3. Remove drive belt. Refer to [EM-16, "Removal and Installation"](#).
4. Remove engine room cover.
5. Remove "B" terminal nut.
6. Disconnect generator connector.
7. Remove generator ground harness bolt.
8. Remove generator bolts, using power tools.
9. Remove generator assembly upward.

Installation

Installation is in the reverse order of removal.

CAUTION:

Be sure to tighten "B" terminal nut carefully.

- Install generator and check tension of belt. Refer to [MA-14, "DRIVE BELTS : Checking Drive Belts"](#).
- For this model, the power generation voltage variable control system that controls the power generation voltage of the generator has been adopted. Therefore, the power generation voltage variable control system operation inspection should be performed after replacing the generator, and then make sure that the system operates normally. Refer to [CHG-6, "System Description"](#).

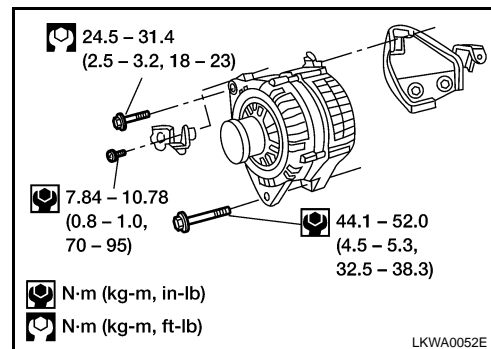

VQ35DE

Removal

1. Disconnect the negative battery terminal.
2. Drain engine coolant. Refer to [CO-33, "Changing Engine Coolant"](#).
3. Remove engine room cover.
4. Remove RH front wheel and tire assembly.
5. Remove front/right-side engine undercover.
6. Remove air cleaner and duct assembly. Refer to [CO-33, "Changing Engine Coolant"](#).
7. Remove battery tray.
8. Remove cooling fan assembly. Refer to [CO-39, "Removal and Installation"](#).
9. Evacuate A/C system. Refer to [HA-33, "HFC-134a \(R-134a\) Service Procedure"](#).
10. Remove the drive belt. Refer to [EM-121, "Removal and Installation"](#).
11. Remove the A/C compressor. Refer to [HA-37, "Removal and Installation for Compressor - VQ35DE Models"](#).
12. Remove idler pulley.
13. Remove A/C idler pulley.
14. Disconnect the oil pressure switch.
15. Disconnect the generator harness connectors.
16. Remove the generator bolt and nuts, using power tools.
17. Slide the generator out and remove.

Installation

GENERATOR

< ON-VEHICLE REPAIR >

Installation is in the reverse order of removal.

CAUTION:

Be sure to tighten "B" terminal nut carefully.

- Install generator and check tension of belt. Refer to [MA-22, "DRIVE BELTS : Checking Drive Belts"](#).
- For this model, the power generation voltage variable control system that controls the power generation voltage of the generator has been adopted. Therefore, the power generation voltage variable control system operation inspection should be performed after replacing the generator, and then make sure that the system operates normally. Refer to [CHG-6, "System Description"](#).

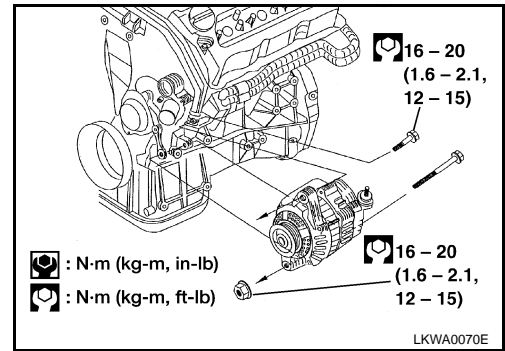

Inspection

GENERATOR PULLEY INSPECTION

Perform the following.

- Make sure that generator pulley does not rattle.
- Make sure that generator pulley nut is tight.

Generator pulley nut : 118 N-m (12.0 kg-m, 87 ft-lb)

INFOID:000000001345236

A
B
C
D
E
F
G
H
I
J
K
L
N
O
P

CHG

SERVICE DATA AND SPECIFICATIONS (SDS)

< SERVICE DATA AND SPECIFICATIONS (SDS)

SERVICE DATA AND SPECIFICATIONS (SDS)

SERVICE DATA AND SPECIFICATIONS (SDS)

Generator

INFOID:000000001345237

Application	QR25DE	VQ35DE
Type	TG12C014	LR1130-701
	Valeo	Hatachi
Nominal rating	12V-110A	12V-130A
Ground polarity	Negative	
Minimum revolution under no-load (When 13.5 volts is applied)	1100 rpm	1,200 rpm
Hot output current (When 13.5 volts is applied)	More than 27A/1,500 rpm More than 90A/2,500 rpm More than 112A/5,000 rpm	More than 78A/1800rpm More than 108A/2,500rpm More than 130A/5,000rpm
Regulated output voltage	14.2 - 14.6V	14.1 - 14.7V @ 20°C
Minimum length of brush	4.4 mm (0.173 in)	6 mm (0.24 in)
Brush spring pressure	1.8 - 3.1 N (0.184 - 0.320 kg, 0.40 - 0.70 lbs)	1.0 - 3.432 N (0.102 - 0.3501 kg, 0.22 - 0.7715 lbs)
Slip ring minimum outer diameter	12.0 mm (.47 in)	26 mm (1.02 in)
Rotor (Field coil) resistance	2.3 ohms	2.1 ohms