

A  
B  
C

# EXL

## SECTION EXL

### EXTERIOR LIGHTING SYSTEM

D  
E

## CONTENTS

<b>BASIC INSPECTION</b> .....	4	Component Parts Location .....	19		
		Component Description .....	20		
<b>DIAGNOSIS AND REPAIR WORKFLOW</b> .....	4	<b>COMBINATION SWITCH</b> .....	21		F
Work Flow .....	4	System Diagram .....	21		G
<b>FUNCTION DIAGNOSIS</b> .....	7	System Description .....	21		
<b>HEADLAMP (HALOGEN TYPE)</b> .....	7	<b>DIAGNOSIS SYSTEM (BCM)</b> .....	25		H
System Diagram .....	7	<b>COMMON ITEM</b> .....	25		
System Description .....	7	COMMON ITEM : Diagnosis Description .....	25		I
Component Parts Location .....	7	COMMON ITEM : CONSULT-III Function (BCM -			
Component Description .....	8	COMMON ITEM) .....	25		
<b>DAYTIME RUNNING LIGHT SYSTEM</b> .....	9	<b>HEADLAMP</b> .....	26		J
System Diagram .....	9	HEADLAMP : CONSULT-III Function (BCM -			
System Description .....	9	HEAD LAMP) .....	26		
Component Parts Location .....	10	<b>FLASHER</b> .....	28		K
Component Description .....	10	FLASHER : CONSULT-III Function (BCM -			
<b>AUTO LIGHT SYSTEM</b> .....	12	FLASHER) .....	28		
System Diagram .....	12	<b>COMB SW</b> .....	28		EXL
System Description .....	12	COMB SW : CONSULT-III Function (BCM -			
Component Parts Location .....	13	COMB SW) .....	29		
Component Description .....	13	<b>BATTERY SAVER</b> .....	30		M
<b>FRONT FOG LAMP</b> .....	15	BATTERY SAVER : CONSULT-III Function (BCM			
System Diagram .....	15	- BATTERY SAVER) .....	30		N
System Description .....	15	<b>DIAGNOSIS SYSTEM (IPDM E/R)</b> .....	32		
Component Parts Location .....	15	Diagnosis Description .....	32		O
Component Description .....	16	CONSULT - III Function (IPDM E/R) .....	35		
<b>TURN SIGNAL AND HAZARD WARNING</b>		<b>COMPONENT DIAGNOSIS</b> .....	37		
<b>LAMPS</b> .....	17	<b>POWER SUPPLY AND GROUND CIRCUIT</b> ....	37		P
System Diagram .....	17	<b>BCM (BODY CONTROL MODULE)</b> .....	37		
System Description .....	17	BCM (BODY CONTROL MODULE) : Diagnosis			
Component Parts Location .....	17	Procedure .....	37		
Component Description .....	18	BCM (BODY CONTROL MODULE) : Special Re-			
<b>PARKING, LICENSE PLATE AND TAIL</b>		pair Requirement .....	37		
<b>LAMPS</b> .....	19				
System Diagram .....	19				
System Description .....	19				

<b>IPDM E/R (INTELLIGENT POWER DISTRIBUTION MODULE ENGINE ROOM)</b> .....	<b>37</b>	Wiring Diagram .....	93
IPDM E/R (INTELLIGENT POWER DISTRIBUTION MODULE ENGINE ROOM) : Diagnosis Procedure .....	38	<b>ECU DIAGNOSIS</b> .....	<b>98</b>
<b>HEADLAMP (HI) CIRCUIT</b> .....	<b>39</b>	<b>BCM (BODY CONTROL MODULE)</b> .....	<b>98</b>
Description .....	39	Reference Value .....	98
Component Function Check .....	39	Terminal Layout .....	102
Diagnosis Procedure .....	39	Physical Values .....	103
<b>HEADLAMP (LO) CIRCUIT</b> .....	<b>41</b>	Wiring Diagram .....	121
Description .....	41	Fail Safe .....	129
Component Function Check .....	41	DTC Inspection Priority Chart .....	131
Diagnosis Procedure .....	41	DTC Index .....	132
<b>FRONT FOG LAMP CIRCUIT</b> .....	<b>43</b>	<b>IPDM E/R (INTELLIGENT POWER DISTRIBUTION MODULE ENGINE ROOM)</b> .....	<b>135</b>
Description .....	43	Reference Value .....	135
Component Function Check .....	43	Terminal Layout .....	136
Diagnosis Procedure .....	43	Physical Values .....	136
<b>PARKING LAMP CIRCUIT</b> .....	<b>45</b>	Wiring Diagram .....	141
Description .....	45	Fail Safe .....	146
Component Function Check .....	45	DTC Index .....	148
Diagnosis Procedure .....	45	<b>SYMPTOM DIAGNOSIS</b> .....	<b>149</b>
<b>TURN SIGNAL LAMP CIRCUIT</b> .....	<b>48</b>	<b>EXTERIOR LIGHTING SYSTEM SYMPTOMS</b> .....	<b>149</b>
Description .....	48	Symptom Table .....	149
Component Function Check .....	48	<b>NORMAL OPERATING CONDITION</b> .....	<b>151</b>
Diagnosis Procedure .....	48	Description .....	151
<b>OPTICAL SENSOR</b> .....	<b>51</b>	<b>BOTH SIDE HEADLAMPS DO NOT SWITCH TO HIGH BEAM</b> .....	<b>152</b>
Description .....	51	Description .....	152
Component Function Check .....	51	Diagnosis Procedure .....	152
Diagnosis Procedure .....	51	<b>BOTH SIDE HEADLAMPS (LO) ARE NOT TURNED ON</b> .....	<b>153</b>
<b>HEADLAMP</b> .....	<b>54</b>	Description .....	153
Wiring Diagram .....	54	Diagnosis Procedure .....	153
<b>DAYTIME RUNNING LIGHT SYSTEM</b> .....	<b>59</b>	<b>PARKING, LICENSE PLATE AND TAIL LAMPS ARE NOT TURNED ON</b> .....	<b>154</b>
<b>HEADLAMP</b> .....	<b>59</b>	Description .....	154
HEADLAMP : Wiring Diagram .....	59	Diagnosis Procedure .....	154
<b>AUTO LIGHT SYSTEM</b> .....	<b>66</b>	<b>BOTH SIDE FRONT FOG LAMPS ARE NOT TURNED ON</b> .....	<b>155</b>
Wiring Diagram .....	66	Description .....	155
<b>FRONT FOG LAMP SYSTEM</b> .....	<b>72</b>	Diagnosis Procedure .....	155
Wiring Diagram .....	72	<b>PRECAUTION</b> .....	<b>156</b>
<b>TURN SIGNAL AND HAZARD WARNING LAMP SYSTEM</b> .....	<b>76</b>	<b>PRECAUTIONS</b> .....	<b>156</b>
Wiring Diagram .....	76	Precaution for Supplemental Restraint System (SRS) "AIR BAG" and "SEAT BELT PRE-TENSIONER" .....	156
<b>PARKING, LICENSE PLATE AND TAIL LAMPS SYSTEM</b> .....	<b>83</b>	Precautions For High-Voltage System .....	156
Wiring Diagram .....	83	General precautions for service operations .....	156
<b>STOP LAMP</b> .....	<b>89</b>	<b>ON-VEHICLE MAINTENANCE</b> .....	<b>157</b>
Wiring Diagram .....	89		
<b>BACK-UP LAMP</b> .....	<b>93</b>		

<b>HEADLAMP</b> .....	<b>157</b>	<b>LICENSE PLATE LAMP</b> .....	<b>165</b>	
Aiming Adjustment .....	157	Bulb Replacement .....	165	A
<b>FRONT FOG LAMP</b> .....	<b>159</b>	Removal and Installation .....	165	
Aiming Adjustment .....	159	<b>REAR COMBINATION LAMP</b> .....	<b>166</b>	B
<b>ON-VEHICLE REPAIR</b> .....	<b>160</b>	Bulb Replacement .....	166	
<b>HEADLAMP</b> .....	<b>160</b>	Removal and Installation .....	166	
Bulb Replacement .....	160	<b>LIGHTING AND TURN SIGNAL SWITCH</b> .....	<b>168</b>	C
Removal and Installation .....	160	Removal and Installation .....	168	
Disassembly and Assembly .....	161	<b>HAZARD SWITCH</b> .....	<b>169</b>	D
<b>FRONT FOG LAMP</b> .....	<b>162</b>	Removal and Installation .....	169	
Bulb Replacement .....	162	<b>SERVICE DATA AND SPECIFICATIONS</b>		
Removal and Installation .....	162	<b>(SDS)</b> .....	<b>170</b>	E
<b>DAYTIME RUNNING LIGHT SYSTEM</b> .....	<b>163</b>	<b>SERVICE DATA AND SPECIFICATIONS</b>		
Removal and Installation .....	163	<b>(SDS)</b> .....	<b>170</b>	F
<b>STOP LAMP</b> .....	<b>164</b>	Headlamp .....	170	
Bulb Replacement .....	164	Exterior Lamp .....	170	G
Removal and Installation .....	164			
				H
				I
				J
				K
				<b>EXL</b>
				M
				N
				O
				P

# DIAGNOSIS AND REPAIR WORKFLOW

< BASIC INSPECTION >

## BASIC INSPECTION

### DIAGNOSIS AND REPAIR WORKFLOW

Work Flow

INFOID:000000004216353

#### OVERALL SEQUENCE

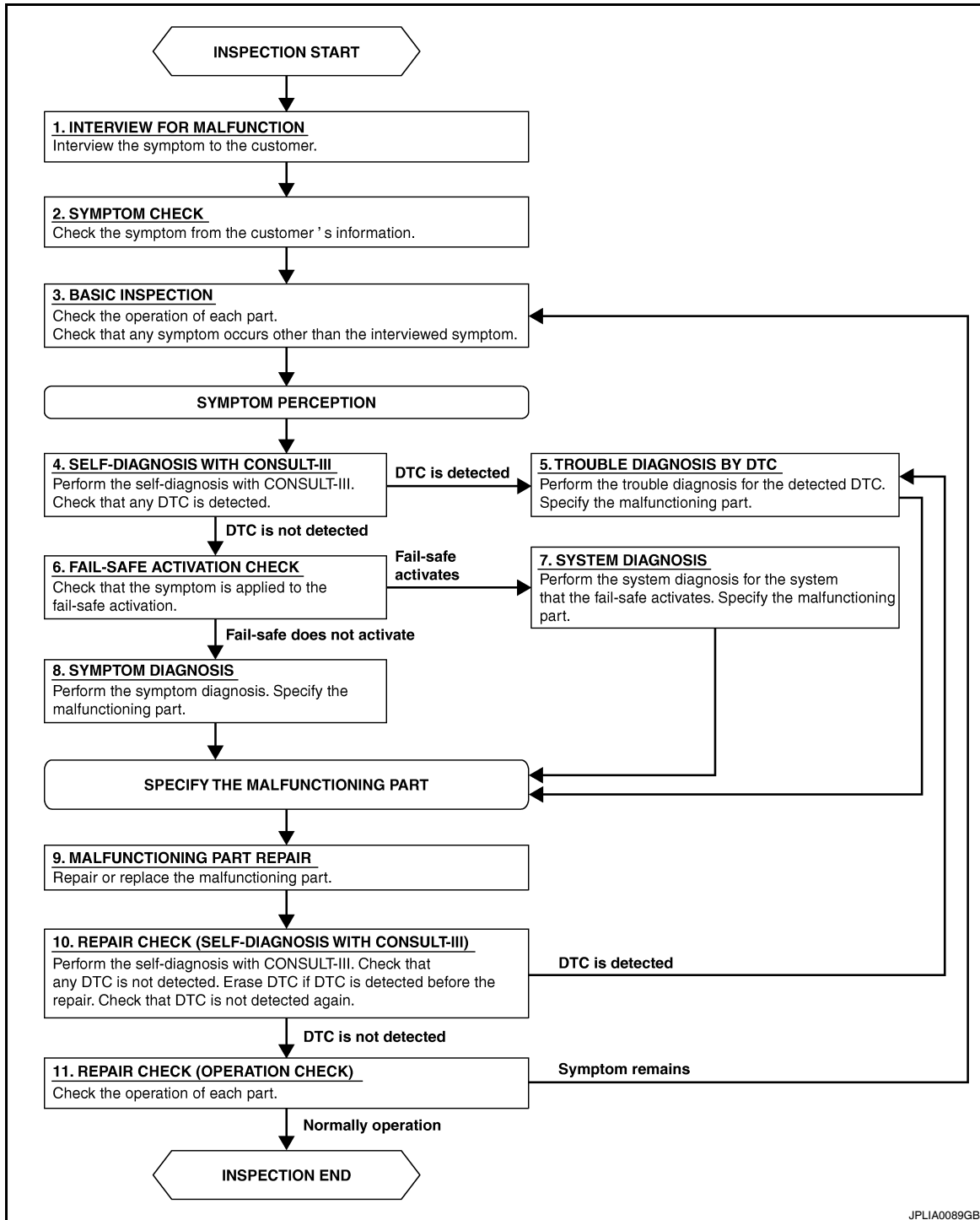

JPLIA0089GB

# DIAGNOSIS AND REPAIR WORKFLOW

< BASIC INSPECTION >

---

DETAILED FLOW

## 1. INTERVIEW FOR MALFUNCTION

---

Find out what the customer's concerns are.

>> GO TO 2

## 2. SYMPTOM CHECK

---

Verify the symptom from the customer's information.

>> GO TO 3

## 3. BASIC INSPECTION

---

Check the operation of each part. Check that any concerns occur other than those mentioned in the customer interview.

>> GO TO 4

## 4. SELF-DIAGNOSIS WITH CONSULT-III

---

Perform the self diagnosis with CONSULT-III. Check that any DTC is detected.

Is any DTC detected?

YES >> GO TO 5

NO >> GO TO 6

## 5. TROUBLE DIAGNOSIS BY DTC

---

Perform the trouble diagnosis for the detected DTC. Specify the malfunctioning part.

>> GO TO 9

## 6. FAIL-SAFE ACTIVATION CHECK

---

Determine if the customer's concern is related to fail-safe activation.

Does the fail-safe activate?

YES >> GO TO 7

NO >> GO TO 8

## 7. SYSTEM DIAGNOSIS

---

Perform the system diagnosis for the system in which the fail-safe activates. Specify the malfunctioning part.

>> GO TO 9

## 8. SYMPTOM DIAGNOSIS

---

Perform the symptom diagnosis. Specify the malfunctioning part.

>> GO TO 9

## 9. MALFUNCTION PART REPAIR

---

Repair or replace the malfunctioning part.

>> GO TO 10

## 10. REPAIR CHECK (SELF-DIAGNOSIS WITH CONSULT-III)

---

Perform the self diagnosis with CONSULT-III. Verified that no DTCs are detected. Erase all DTCs detected prior to the repair. Verify that DTC is not detected again.

Is any DTC detected?

A

B

C

D

E

F

G

H

I

J

K

EXL

M

N

O

P

## DIAGNOSIS AND REPAIR WORKFLOW

< BASIC INSPECTION >

---

YES >> GO TO 5

NO >> GO TO 11

### 11. REPAIR CHECK (OPERATION CHECK)

---

Check the operation of each part.

Does it operate normally?

YES >> Inspection End.

NO >> GO TO 3

# HEADLAMP (HALOGEN TYPE)

< FUNCTION DIAGNOSIS >

## FUNCTION DIAGNOSIS

### HEADLAMP (HALOGEN TYPE)

#### System Diagram

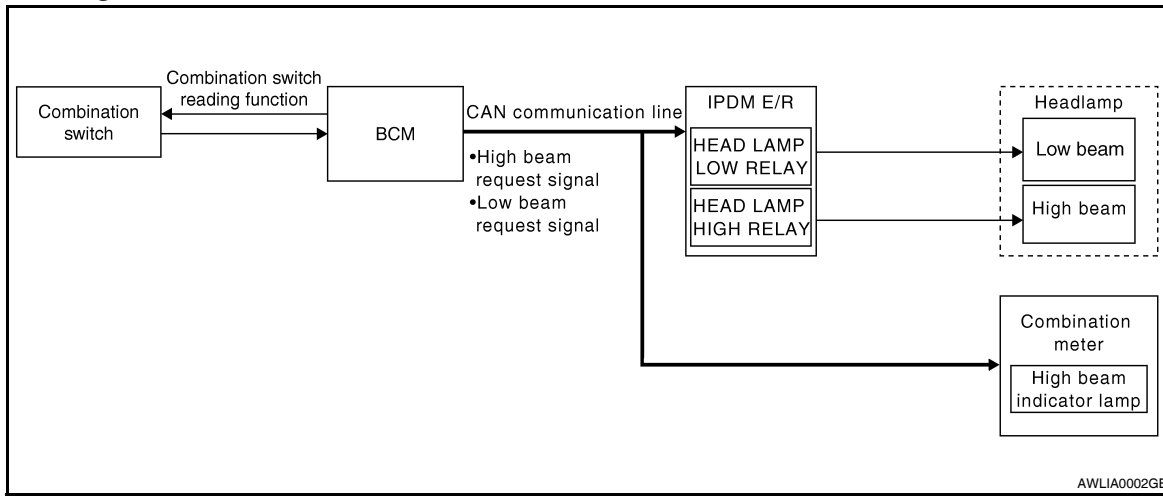

#### System Description

INFOID:000000004216355

Control of the headlamp system operation is dependent upon the position of the lighting switch (combination switch). When the lighting switch is placed in the 2nd position, the BCM (body control module) receives input requesting the headlamps and park lamps to illuminate. This input is communicated to the IPDM E/R (intelligent power distribution module engine room) across the CAN communication lines. The CPU (central processing unit) of the IPDM E/R controls the headlamp high and headlamp low relay coils. When energized, these relays direct power to the respective headlamps, which then illuminate.

#### Component Parts Location

INFOID:000000004216356

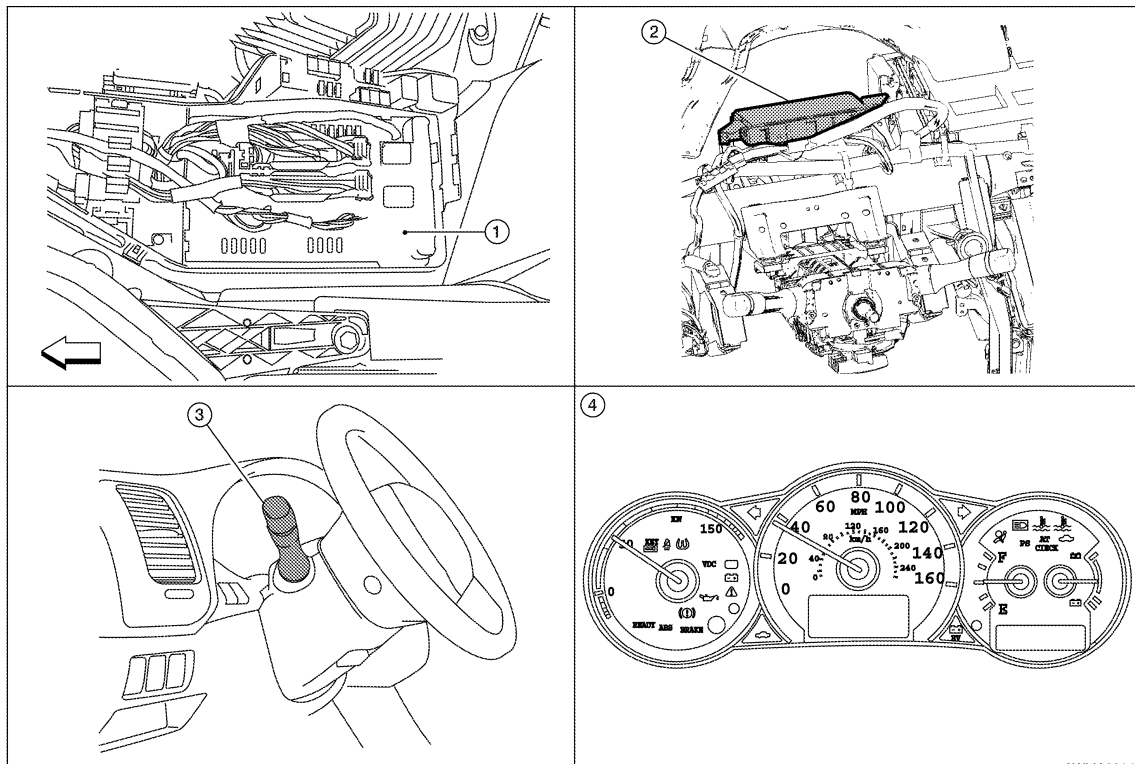

# HEADLAMP (HALOGEN TYPE)

## < FUNCTION DIAGNOSIS >

---

1. IPDM E/R E17, E18, E200
2. BCM M16, M17, M18, M19 (view with instrument panel removed)
3. Combination switch M28
4. Combination meter M24

## Component Description

INFOID:000000004216357

### LOW BEAM OPERATION

When the lighting switch is in 2ND position, the BCM receives input requesting the headlamps to illuminate. This input is communicated to the IPDM E/R across the CAN communication lines. The CPU of the IPDM E/R controls the headlamp low relay coil which supplies power to the low beam headlamps.

### HIGH BEAM OPERATION/FLASH-TO-PASS OPERATION

With the lighting switch in the 2ND position and placed in HIGH position, the BCM receives input requesting the headlamp high beams to illuminate. The flash to pass feature can be used any time and also sends a signal to the BCM. This input is communicated to the IPDM E/R across the CAN communication lines. The CPU of the combination meter controls the ON/OFF status of the HIGH BEAM indicator. The CPU of the IPDM E/R controls the headlamp high relay coil which supplies power to the high beam headlamps.

The combination meter receives a high beam request signal (ON) through the CAN communication lines and turns the high beam indicator lamp ON.

### COMBINATION SWITCH READING FUNCTION

Refer to [BCS-10. "System Description"](#).

### AUTO LIGHT OPERATION

Refer to [EXL-12. "System Description"](#).



# DAYTIME RUNNING LIGHT SYSTEM

< FUNCTION DIAGNOSIS >

## DAYTIME RUNNING LIGHT SYSTEM

### System Diagram

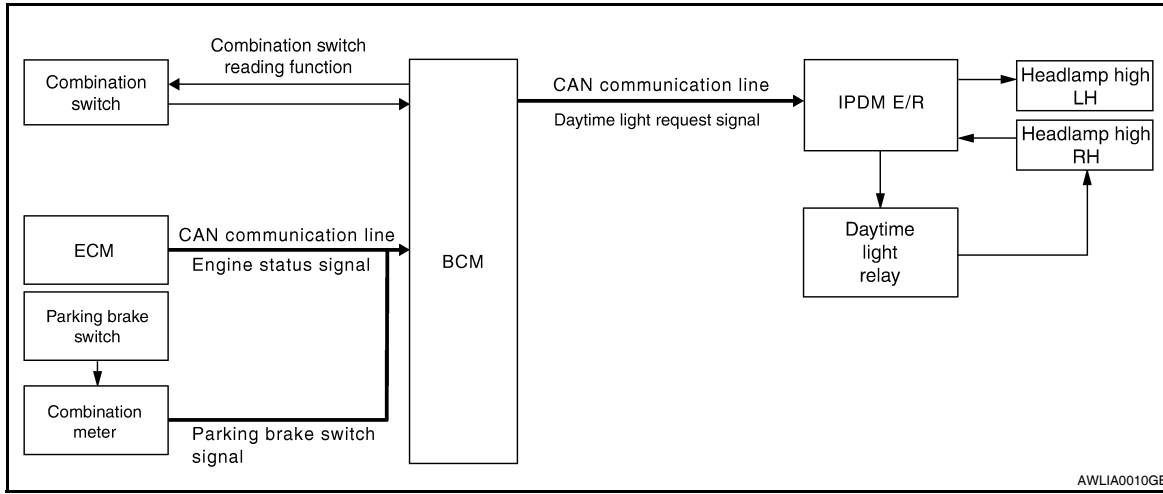

### System Description

INFOID:000000004216359

The headlamp system for Canada vehicles is equipped with a daytime light control unit that activates the high beam headlamps at approximately half illumination whenever the hybrid system is operating. If the parking brake is applied before the hybrid system is started the daytime lights will not be illuminated. The daytime lights will illuminate once the parking brake is released. Thereafter, the daytime lights will continue to operate when the parking brake is applied.

A  
B  
C  
D  
E  
F  
G  
H  
I  
J  
K  
L  
M  
N  
O  
P

EXL

# DAYTIME RUNNING LIGHT SYSTEM

< FUNCTION DIAGNOSIS >

## Component Parts Location

INFOID:000000004216360

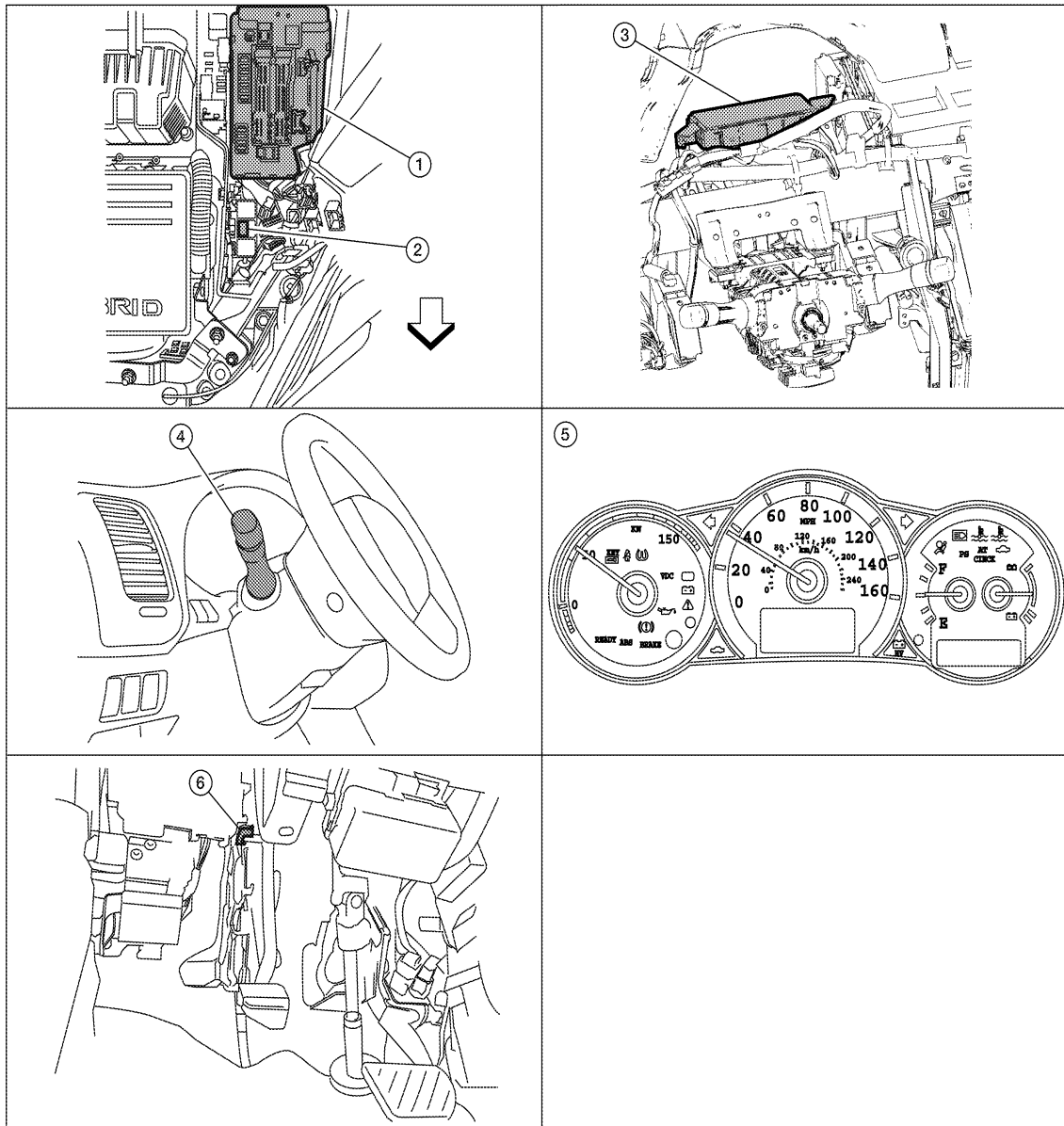

⇐: Front

AWNIA0931ZZ

- |                                  |  |  |
|----------------------------------|--|--|
| 1. IPDM E/R E17, E18, E200, E201 | 2. Daytime running light relay E3 (view with engine room in-line connectors disconnected and positioned aside) | 3. BCM M16, M17, M18, M19 (view with instrument panel removed) |
| 4. Combination switch M28        | 5. Combination meter M24   | 6. Parking brake switch E35                                    |

## Component Description

INFOID:000000004216361

After starting the hybrid system with the parking brake released and the lighting switch in the OFF or 1ST position, the headlamp high beam automatically turns on. With the lighting switch in the 2nd position or with auto-lamps ON, the headlamps function the same as conventional light systems.

# DAYTIME RUNNING LIGHT SYSTEM

## < FUNCTION DIAGNOSIS >

### OPERATION

The BCM monitors inputs from the parking brake switch and the combination switch to determine when to activate the daytime light system. The BCM sends a daytime light request to the IPDM E/R via the CAN communication lines. The IPDM E/R grounds the daytime light relay which in turn, provides power to the ground side of the RH high beam lamp. Power flows backward through the RH high beam lamp to the IPDM E/R, through the high beam fuses, through the LH high beam lamp circuit to the LH high beam lamp and on to ground. The high beam lamps are wired in series which causes them to illuminate at a reduced intensity.

Engine		With engine stopped									With engine running								
		OFF			1ST			2ND			OFF			1ST			2ND		
		Hi	Lo	P	Hi	Lo	P	Hi	Lo	P	Hi	Lo	P	Hi	Lo	P	Hi	Lo	P
Lighting switch	High beam	-	-	-	-	-	×	×	-	×	●*	●*	×	●*	●*	×	×	-	×
	Low beam	-	-	-	-	-	×	×	×	×	-	-	×	-	-	×	×	×	×
Tail lamp		-	-	-	×	×	×	×	×	×	-	-	-	×	×	×	×	×	×
License and instrument illumination lamp		-	-	-	×	×	×	×	×	×	-	-	-	×	×	×	×	×	×

- Hi: "HIGH BEAM" position
- Lo: "LOW BEAM" position
- P: "FLASH TO PASS" position
- ×: Lamp "ON"
- -: Lamp "OFF"
- ●: Lamp dims. (Added functions)
- \*: When starting the engine with the parking brake released, the daytime lights will operate.  
When starting the engine with the parking brake pulled, the daytime lights will not operate.

A  
B  
C  
D  
E  
F  
G  
H  
I  
J  
K  
L  
M  
N  
O  
P

EXL

# AUTO LIGHT SYSTEM

< FUNCTION DIAGNOSIS >

## AUTO LIGHT SYSTEM

### System Diagram

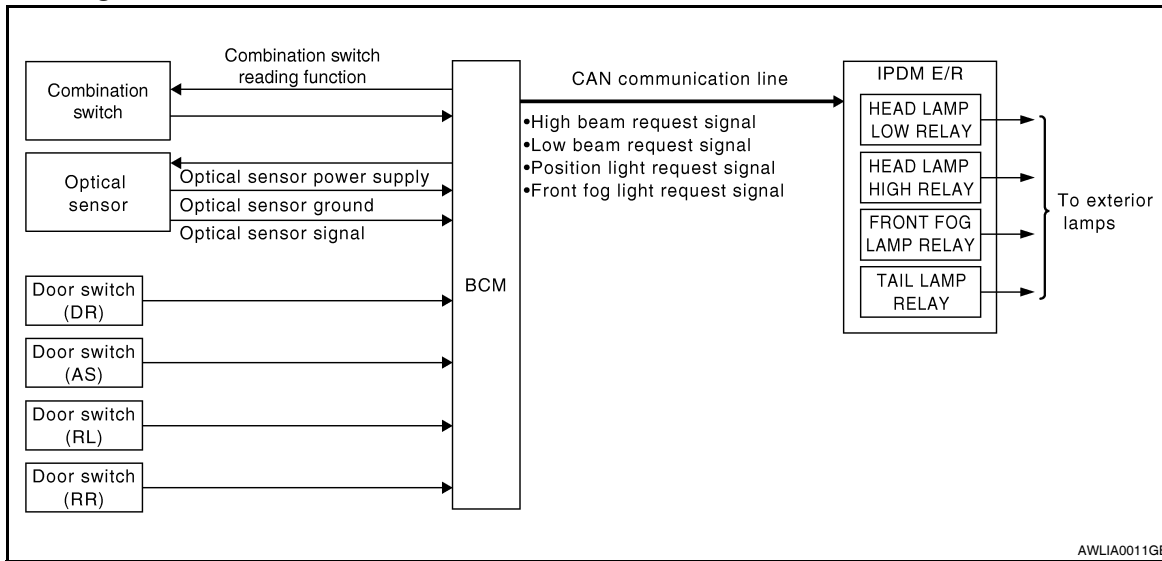

### System Description

INFOID:000000004216363

- BCM (Body Control Module) controls auto light operation according to signals from optical sensor, lighting switch and ignition switch.
- IPDM E/R (Intelligent Power Distribution Module Engine Room) operates parking, license plate, tail, front fog lamps and headlamps according to CAN communication signals from BCM.
- Optical sensor detects ambient brightness of 800 to 2,500 lux. And optical sensor converts light (lux) to voltage, then sends the optical sensor signal to BCM.

### OUTLINE

The auto light control system has an optical sensor that detects outside brightness.

When the lighting switch is in AUTO position, it automatically turns ON/OFF the parking, license plate, tail, front fog lamps and headlamps in accordance with the ambient light. Sensitivity can be adjusted in four steps. For the details of the setting, Refer to [BCS-22, "HEADLAMP : CONSULT-III Function \(BCM - HEAD LAMP\)"](#).

# AUTO LIGHT SYSTEM

< FUNCTION DIAGNOSIS >

## Component Parts Location

INFOID:000000004216364

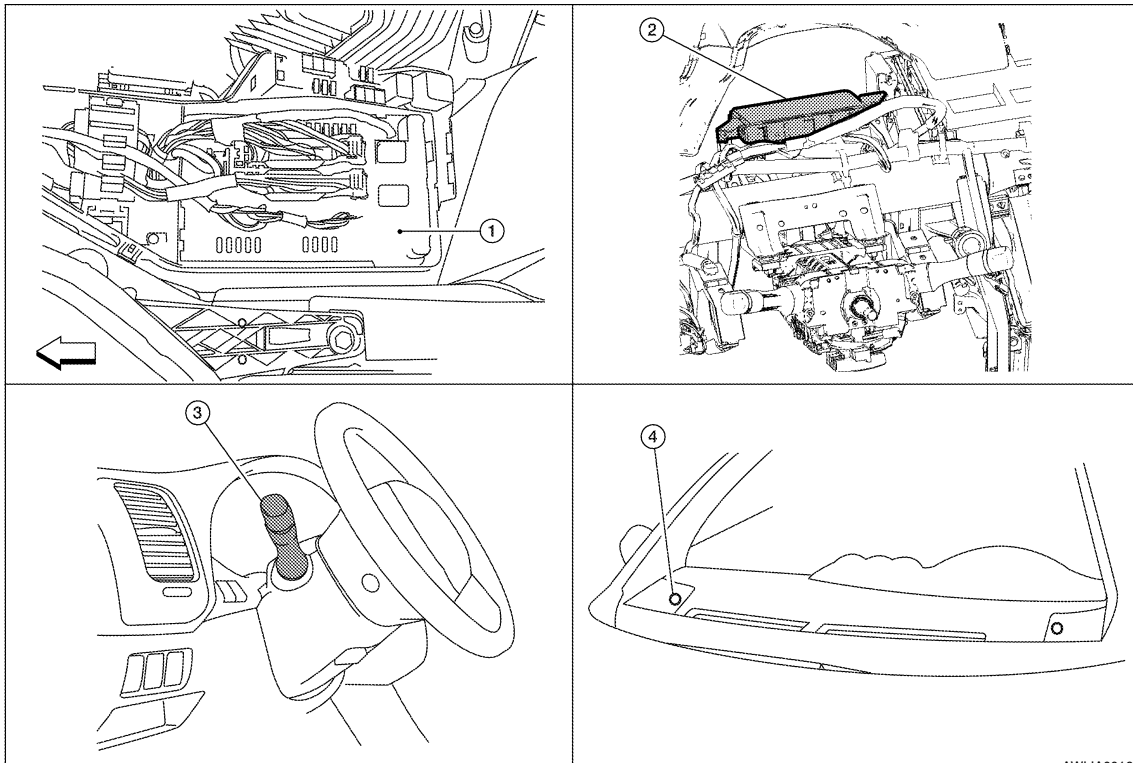

1. IPDM E/R E17, E18, E200
2. BCM M16, M17, M18, M19, M21 (view with instrument panel removed)
3. Combination switch M28
4. Optical sensor M66

## Component Description

INFOID:000000004216365

### AUTO LIGHT OPERATION

Applicable lamps

- Low beam headlamp
- Parking, license plate and tail lamps
- High beam headlamp (with the lighting switch in HIGH BEAM position)
- Front fog lamp (with the lighting switch in front fog lamp ON position)

When the lighting switch is in AUTO position with the ignition switch in ON position, BCM detects the AUTO LIGHT (ON) by BCM combination switch reading function. BCM turns automatically ON/OFF the applicable lamps according to ambient brightness depending on the following condition.

- It turns ON applicable lamps in 3 seconds when ambient brightness is less than 1250 lux.
- The lighted lamps are turned OFF in 5 seconds when ambient brightness becomes 2500 lux or higher.

Releasing Function:

- Turn ignition switch to the OFF position, or
- Change lighting switch to the OFF, 1ST, 2ND position.

#### NOTE:

Timing for when lamps turn ON/OFF can be changed by the function setting of CONSULT-III. Refer to [BCS-22, "HEADLAMP : CONSULT-III Function \(BCM - HEAD LAMP\)".](#)

### COMBINATION SWITCH READING FUNCTION

Refer to [BCS-10, "System Description".](#)

### HEADLAMP LOW AND HIGH OPERATION

Refer to [EXL-7, "System Description".](#)

### FRONT FOG LAMP OPERATION

A

B

C

D

E

F

G

H

I

J

K

EXL

M

N

O

P

## AUTO LIGHT SYSTEM

< FUNCTION DIAGNOSIS >

---

Refer to [EXL-15, "System Description"](#).

PARKING, LICENSE PLATE AND TAIL LAMPS OPERATION

Refer to [EXL-19, "System Description"](#).

# FRONT FOG LAMP

< FUNCTION DIAGNOSIS >

## FRONT FOG LAMP

### System Diagram

INFOID:000000004216366

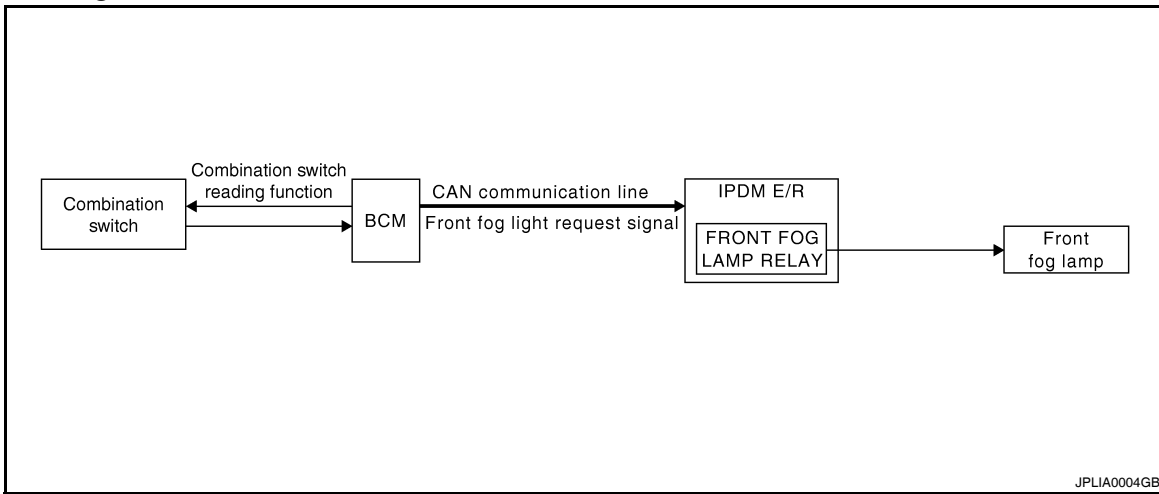

JPLIA0004GB

### System Description

INFOID:000000004216367

- BCM (Body Control Module) controls front fog lamp operation.
- IPDM E/R (Intelligent Power Distribution Module Engine Room) operates front fog lamp according to CAN communication signals from BCM.
- Combination meter operates front fog lamp indicator according to inputs via the CAN communication lines.

### Component Parts Location

INFOID:000000004216368

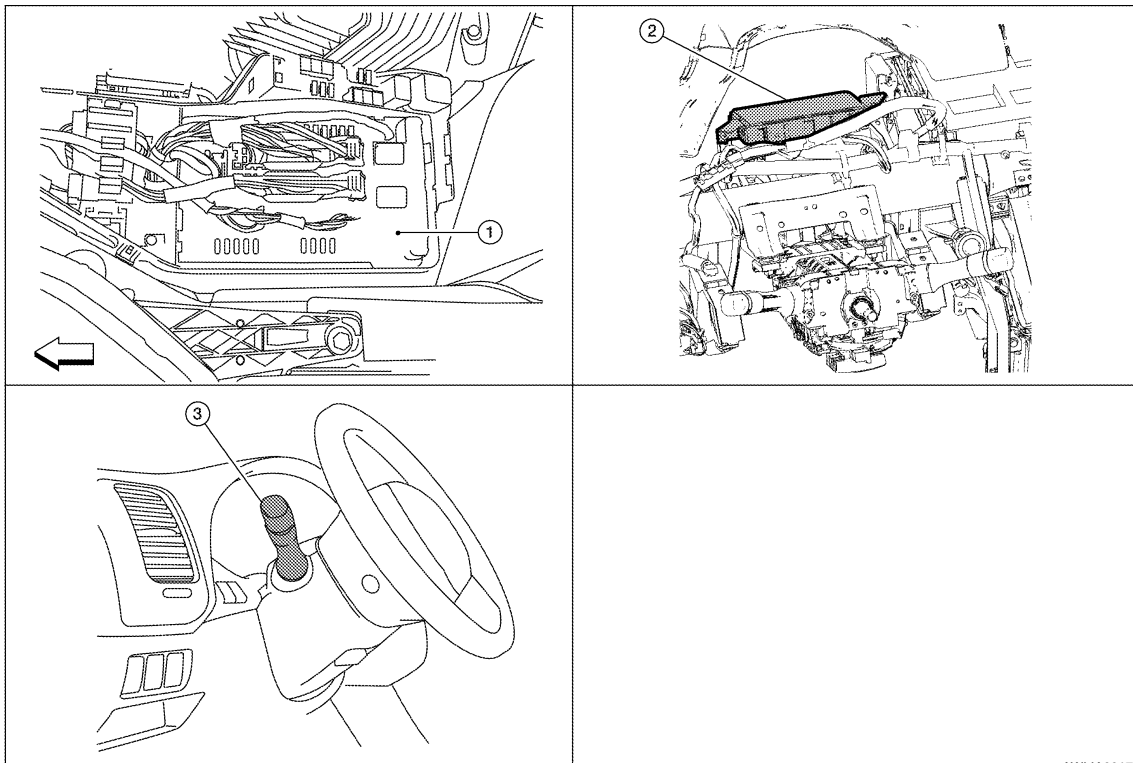

AWLIA0017ZZ

1. IPDM E/R E17, E18, E20
2. BCM M16, M17, M18, M19 (view with instrument panel removed)
3. Combination switch M28

# FRONT FOG LAMP

< FUNCTION DIAGNOSIS >

## Component Description

---

INFOID:000000004216369

### FRONT FOG LAMP OPERATION

When the lighting switch is in front fog lamp ON position and also in 1ST or 2ND position or AUTO position (headlamp is ON), the BCM detects FR FOG ON and the HEAD LAMP1, 2 ON or the AUTO LIGHT ON. The BCM sends a front fog lamp request ON signal through the CAN communication lines to the IPDM E/R. The IPDM E/R then turns ON the front fog lamp relay sending power to the front fog lamps.

The combination meter also receives a front fog lamp request ON signal through the CAN communication lines at which time it turns the front fog indicator ON.



# TURN SIGNAL AND HAZARD WARNING LAMPS

< FUNCTION DIAGNOSIS >

## TURN SIGNAL AND HAZARD WARNING LAMPS

### System Diagram

INFOID:000000004216370

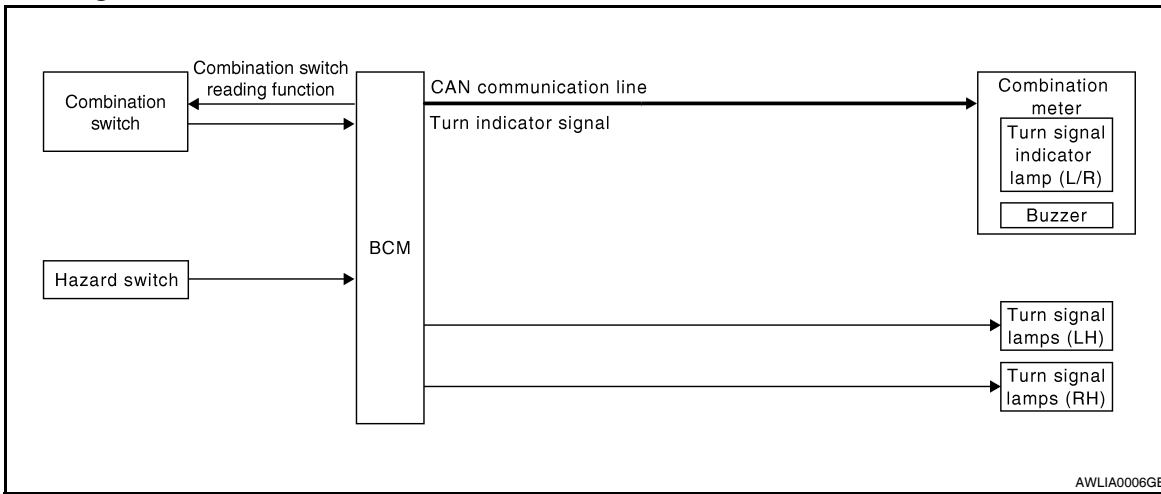

AWLIA0006GE

### System Description

INFOID:000000004216371

- BCM (Body Control Module) controls turn signal lamp (RH and LH) and hazard warning lamp operation.
- Combination meter operates turn (RH and LH) indicator according to CAN communication signals from BCM.

### Component Parts Location

INFOID:000000004216372

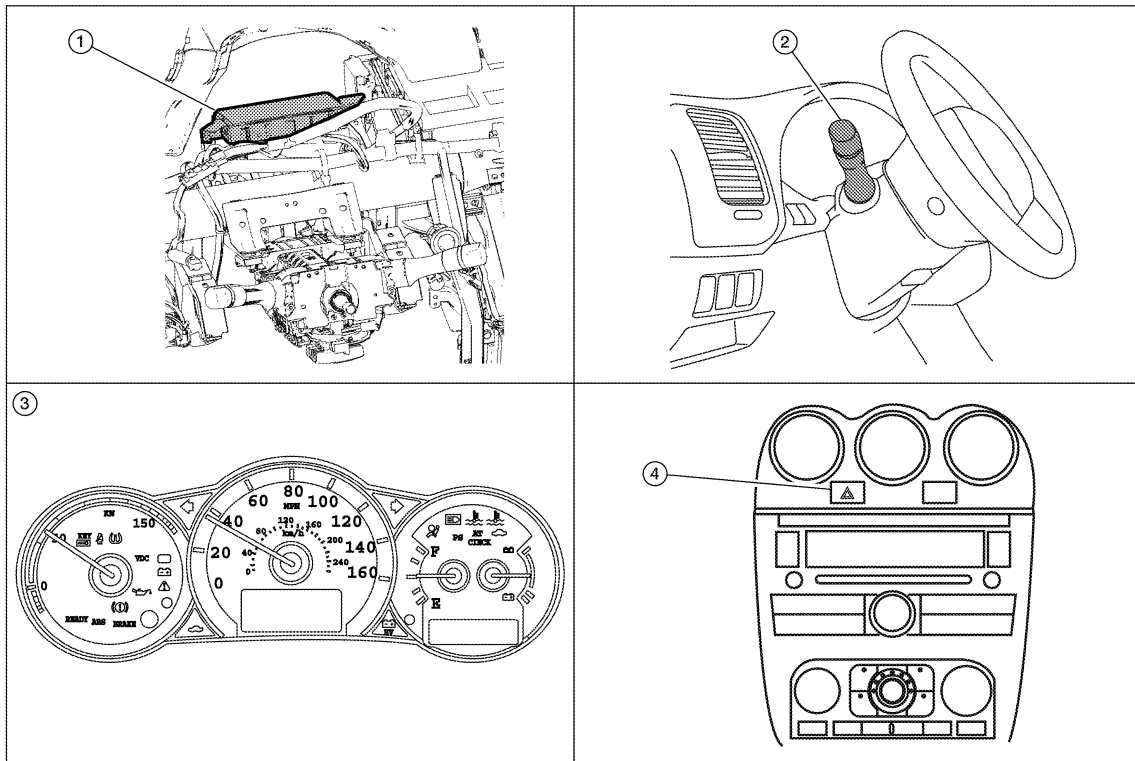

AWLIA0018ZZ

1. BCM M16, M17, M18, M19 (view with instrument panel removed)
2. Combination switch M28
3. Combination meter M24
4. Hazard switch M54

# TURN SIGNAL AND HAZARD WARNING LAMPS

< FUNCTION DIAGNOSIS >

## Component Description

---

INFOID:000000004216373

### TURN SIGNAL OPERATION

When the turn signal switch is in LH or RH position with the ignition switch in ON position, the BCM detects the TURN RH or TURN LH ON request. The BCM outputs the flasher output signal to the respective turn signal lamp. The BCM sends a turn indicator signal ON request through the CAN communication lines to the combination meter. The combination meter then activates the appropriate turn signal indicator and audible buzzer.

### HAZARD LAMP OPERATION

When the hazard switch is in ON position, the BCM detects the hazard switch signal ON. The BCM outputs the flasher output signal (right and left). The BCM sends a hazard indicator signal ON request through the CAN communication lines to the combination meter. The combination meter then activates the hazard indicator and audible buzzer.

### REMOTE KEYLESS ENTRY OPERATION

The remote keyless entry receiver transmits Intelligent Key signal to BCM, then BCM controls hazard lamps. Refer to [BCS-8, "System Description"](#).

# PARKING, LICENSE PLATE AND TAIL LAMPS

< FUNCTION DIAGNOSIS >

## PARKING, LICENSE PLATE AND TAIL LAMPS

### System Diagram

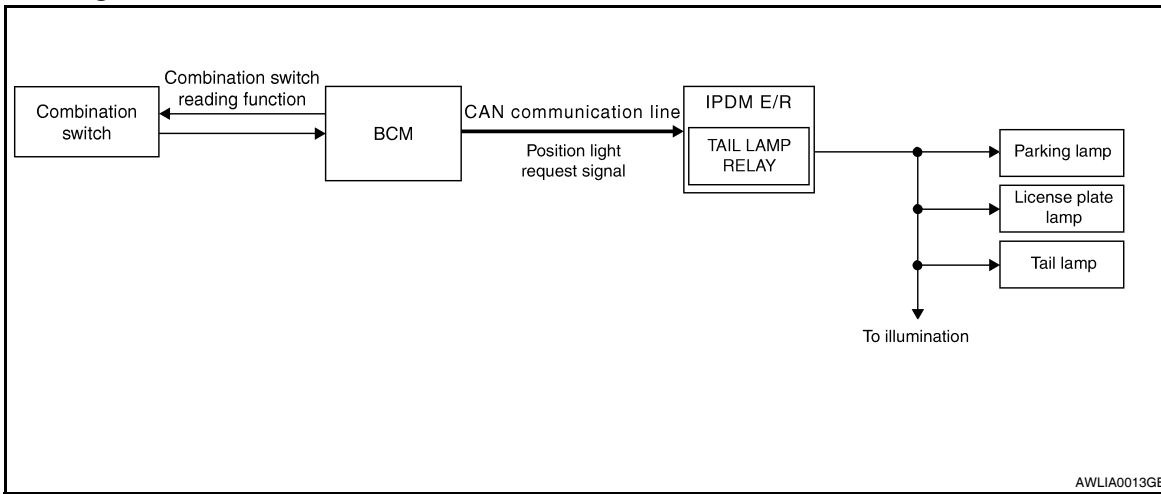

### System Description

INFOID:000000004216375

- BCM (Body Control Module) controls parking, license plate and tail lamps operation.
- IPDM E/R (Intelligent Power Distribution Module Engine Room) operates parking, license plate and tail lamps according to CAN communication signals from BCM.

### Component Parts Location

INFOID:000000004216376

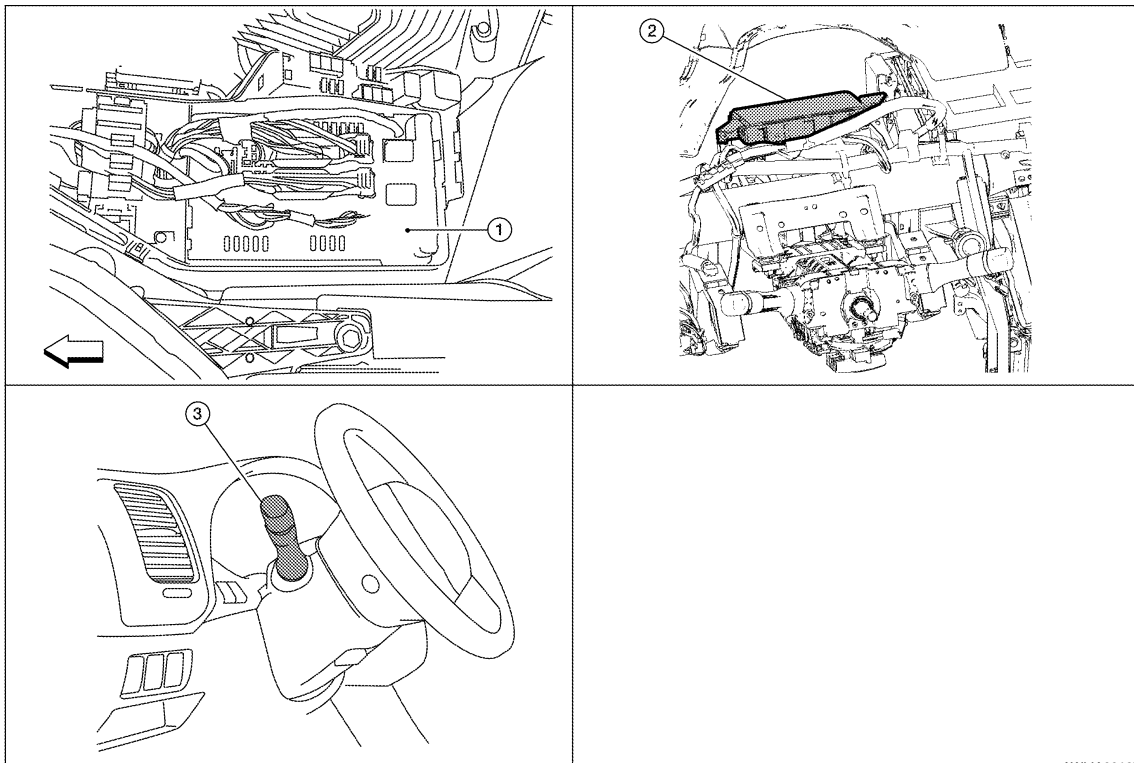

1. IPDM E/R E17, E18, E201

2. BCM M16, M17, M18, M19 (view with instrument panel removed)

3. Combination switch M28

# PARKING, LICENSE PLATE AND TAIL LAMPS

< FUNCTION DIAGNOSIS >

---

## Component Description

INFOID:000000004216377

### PARKING, LICENCE PLATE AND TAIL LAMPS OPERATION

When the lighting switch is in 1ST position, BCM detects the LIGHTING SWITCH 1ST POSITION ON. The BCM sends a parking light ON request through the CAN communication lines to the IPDM E/R. The IPDM E/R then activates the tail lamp relay which sends power to the parking and instrument illumination circuits.

### EXTERIOR LAMP BATTERY SAVER CONTROL

With the lighting switch (combination switch) in the 2nd position and the ignition switch is turned from ON or ACC to OFF, the battery saver feature is activated.

Under this condition, the headlamps remain illuminated for 5 minutes unless the lighting switch position is changed. If the lighting switch position is changed, then the headlamps are turned off.

This setting can be changed by CONSULT-III. Refer to [EXL-30, "BATTERY SAVER : CONSULT-III Function \(BCM - BATTERY SAVER\)"](#).

# COMBINATION SWITCH

< FUNCTION DIAGNOSIS >

## COMBINATION SWITCH

### System Diagram

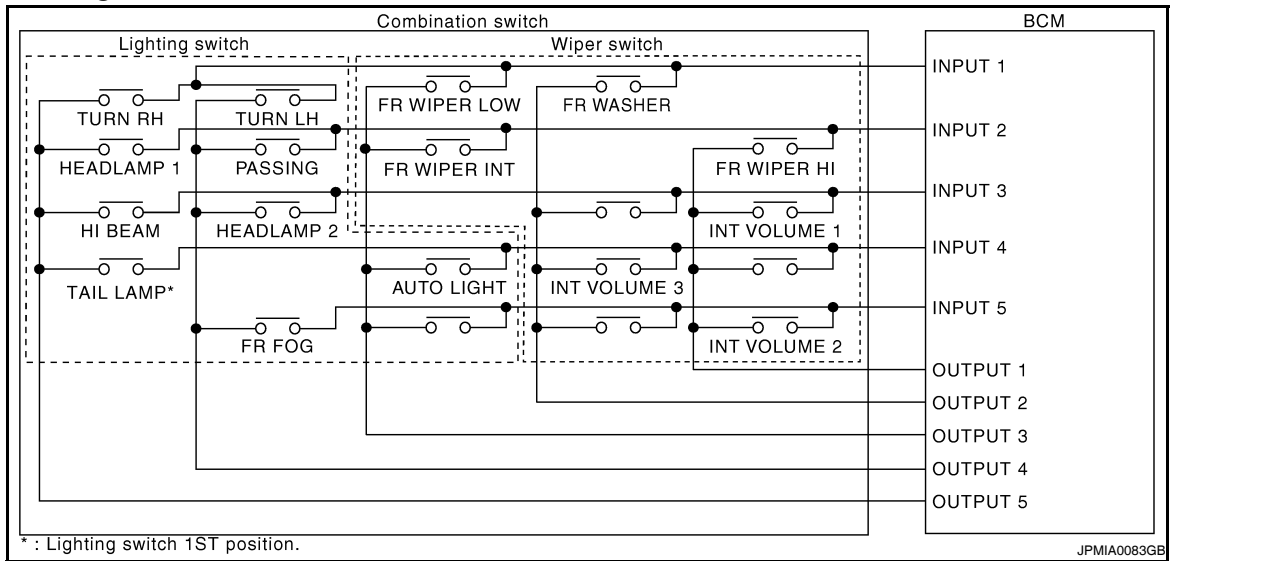

### System Description

INFOID:000000004216379

#### OUTLINE

- BCM reads the status of the combination switch (light, turn signal, wiper and washer) and recognizes the status of each switch.
- BCM is a combination of 5 output terminals (OUTPUT 1 - 5) and 5 input terminals (INPUT 1 - 5). It reads a maximum of 20 switch status.

#### COMBINATION SWITCH MATRIX

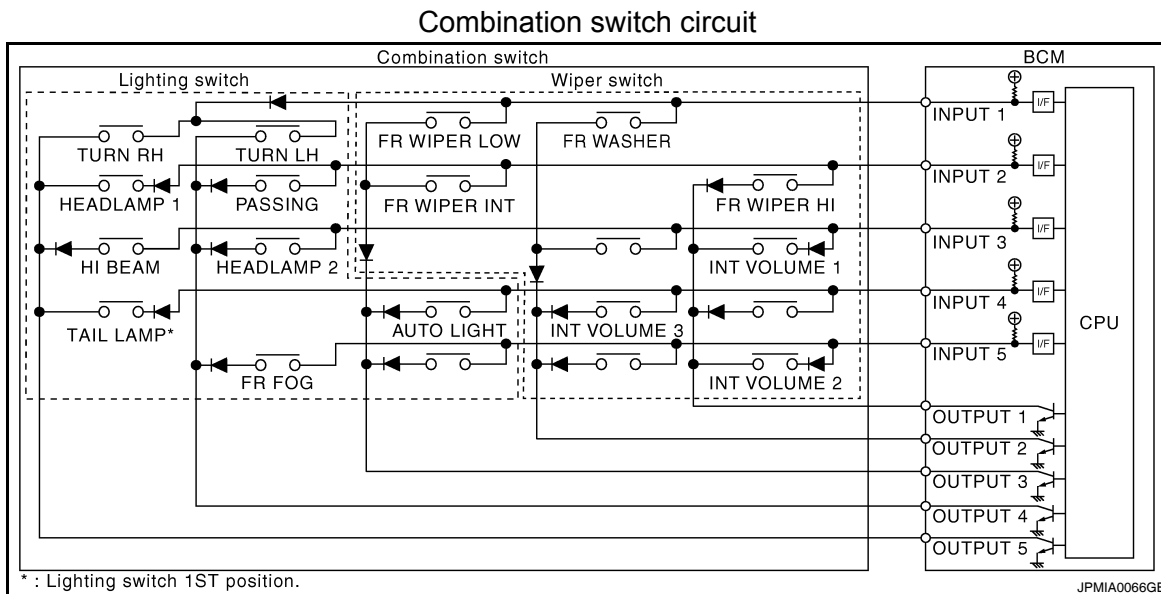

Combination switch INPUT-OUTPUT system list

System	OUTPUT 1	OUTPUT 2	OUTPUT 3	OUTPUT 4	OUTPUT 5
INPUT 1	—	FR WASHER	FR WIPER LOW	TURN LH	TURN RH
INPUT 2	FR WIPER HI	—	FR WIPER INT	PASSING	HEADLAMP 1
INPUT 3	INT VOLUME 1	—	—	HEADLAMP 2	HI BEAM

# COMBINATION SWITCH

## < FUNCTION DIAGNOSIS >

System	OUTPUT 1	OUTPUT 2	OUTPUT 3	OUTPUT 4	OUTPUT 5
INPUT 4	—	INT VOLUME 3	AUTO LIGHT	—	TAIL LAMP
INPUT 5	INT VOLUME 2	—	—	FR FOG	—

**NOTE:**

Headlamp has a dual system switch.

### COMBINATION SWITCH READING FUNCTION

Description

- BCM reads the status of the combination switch at 10ms interval normally.

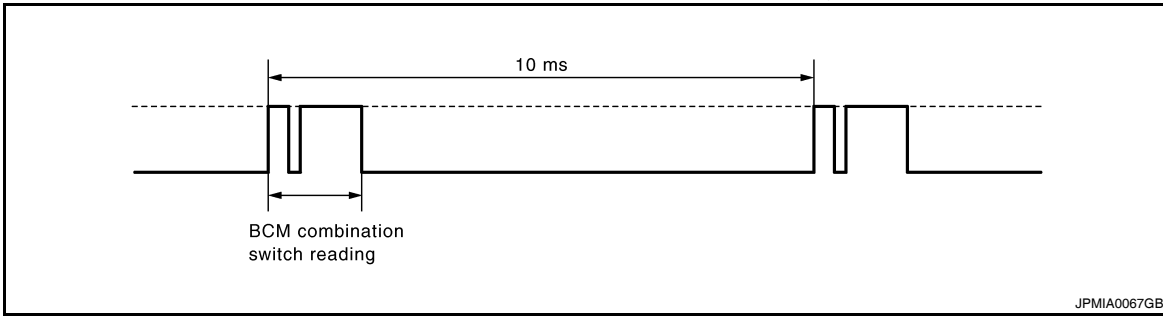

**NOTE:**

BCM reads the status of the combination switch at 60ms interval when BCM is controlled at low power consumption mode.

- BCM operates as follows and judges the status of the combination switch.
- INPUT 1 - 5 outputs the voltage waveforms of 5 systems simultaneously.
- It operates the transistor on OUTPUT side in the following order: OUTPUT 5→4→3→2→1.
- The voltage waveform of INPUT corresponding to the formed circuit changes according to the operation of the transistor on OUTPUT side if any (1 or more) switches are ON.
- It reads this change of the voltage as the status signal of the combination switch.

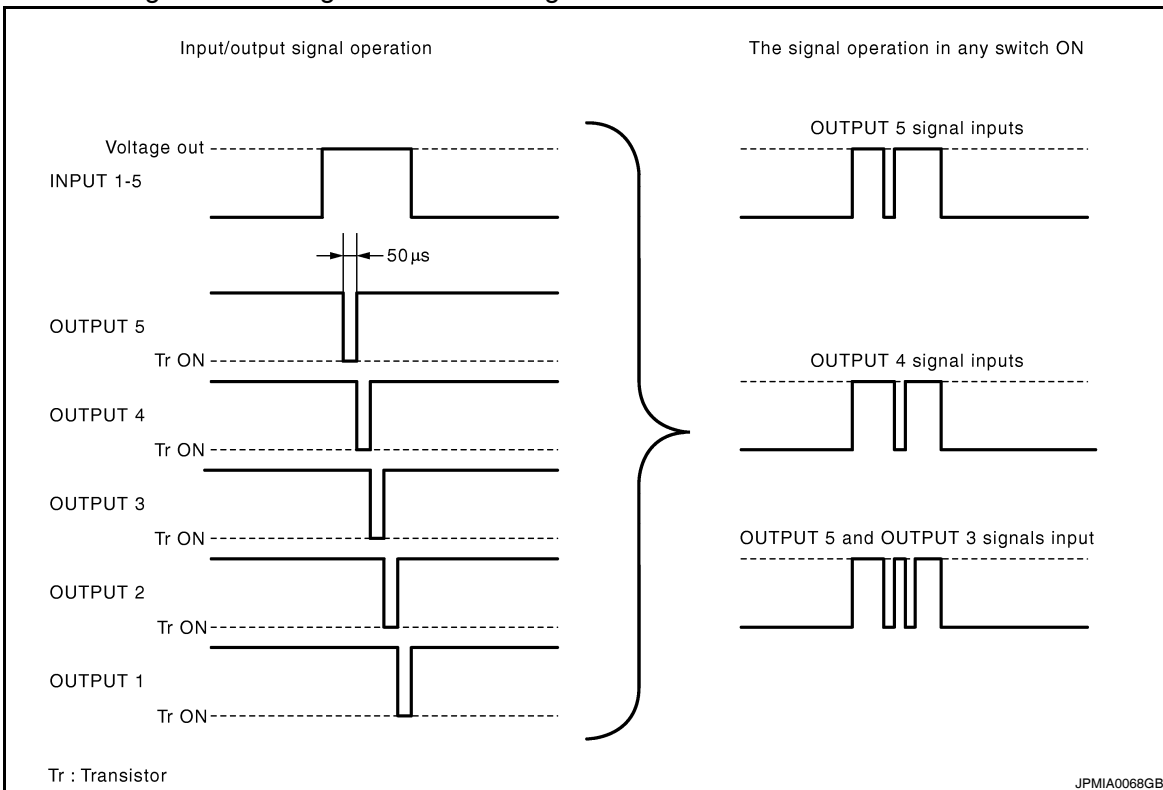

Operation Example

In the following operation example, the combination of the status signals of the combination switch is replaced as follows: INPUT 1 - 5 to "1 - 5" and OUTPUT 1 - 5 to "A - E".

Example 1: When a switch (TURN RH switch) is turned ON

# COMBINATION SWITCH

## < FUNCTION DIAGNOSIS >

- The circuit between INPUT 1 and OUTPUT 5 is formed when the TURN RH switch is turned ON.

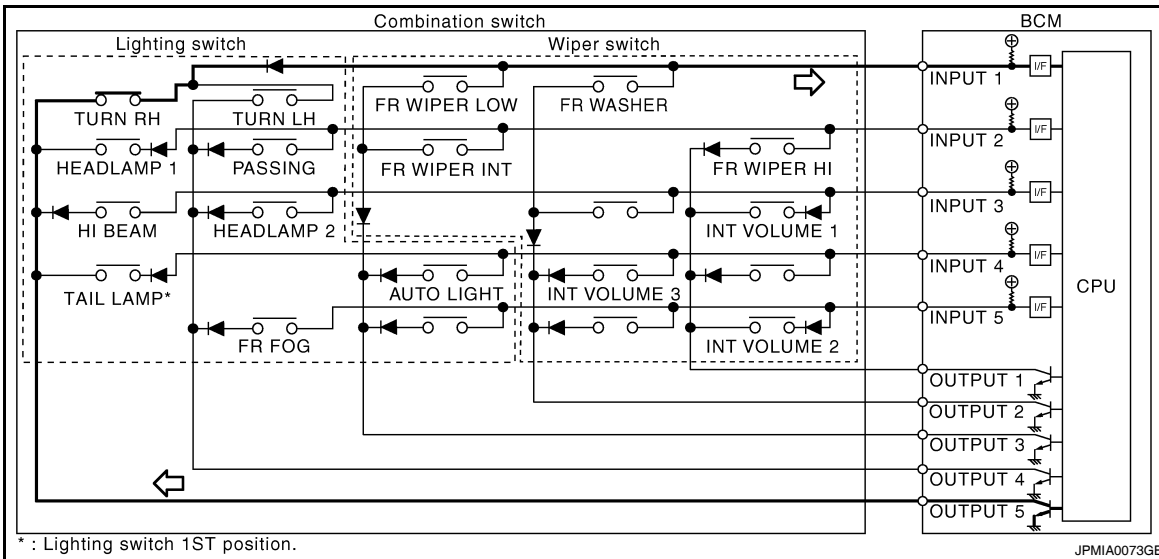

- BCM detects the combination switch status signal "1E" when the signal of OUTPUT 5 is input to INPUT 1.
- BCM judges that the TURN RH switch is ON when the signal "1E" is detected.

Example 2: When some switches (TURN RH switch, FR WIPER LOW switch) are turned ON

- The circuits between INPUT 1 and OUTPUT 5 and between INPUT 1 and OUTPUT 3 are formed when the TURN RH switch and FR WIPER LOW switch are turned ON.

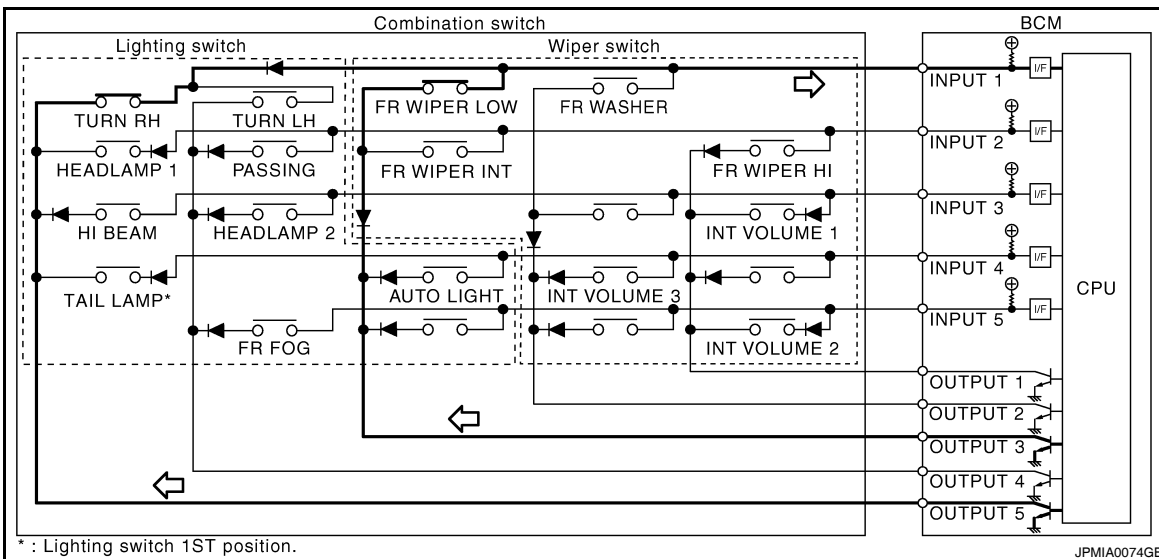

- BCM detects the combination switch status signal "1CE" when the signals of OUTPUT 3 and OUTPUT 5 are input to INPUT 1.
- BCM judges that the TURN RH switch and FR WIPER LOW switch are ON when the signal "1CE" is detected.

## WIPER INTERMITTENT DIAL POSITION SETTING (FRONT WIPER INTERMITTENT OPERATION)

BCM judges the wiper intermittent dial 1 - 7 by the status of INT VOLUME 1, 2, and 3 switches.

# COMBINATION SWITCH

## < FUNCTION DIAGNOSIS >

Wiper intermittent dial position	Intermittent operation delay interval	INT VOLUME switch ON/OFF status		
		INT VOLUME 1 switch	INT VOLUME 2 switch	INT VOLUME 3 switch
1	Short	ON	ON	ON
2		ON	ON	OFF
3		ON	OFF	OFF
4	↑ ↓ Long	OFF	OFF	OFF
5		OFF	OFF	ON
6		OFF	ON	ON
7		OFF	ON	OFF



# DIAGNOSIS SYSTEM (BCM)

< FUNCTION DIAGNOSIS >

## DIAGNOSIS SYSTEM (BCM)

### COMMON ITEM

#### COMMON ITEM : Diagnosis Description

INFOID:000000004501352

#### BCM CONSULT-III FUNCTION

CONSULT-III performs the following functions via CAN communication with BCM.

Diagnosis mode	Function Description
WORK SUPPORT	Changes the setting for each system function.
SELF-DIAG RESULTS	Displays the diagnosis results judged by BCM.
CAN DIAG SUPPORT MNTR	Monitors the reception status of CAN communication viewed from BCM.
DATA MONITOR	The BCM input/output signals are displayed.
ACTIVE TEST	The signals used to activate each device are forcibly supplied from BCM.
ECU IDENTIFICATION	The BCM part number is displayed.
CONFIGURATION	<ul style="list-style-type: none"> <li>Read and save the vehicle specification.</li> <li>Write the vehicle specification when replacing BCM.</li> </ul>

#### SYSTEM APPLICATION

BCM can perform the following functions for each system.

#### NOTE:

It can perform the diagnosis modes except the following for all sub system selection items.

System	Sub system selection item	Diagnosis mode		
		WORK SUPPORT	DATA MONITOR	ACTIVE TEST
Door lock	DOOR LOCK	×	×	×
Rear window defogger	REAR DEFOGGER		×	×
Warning chime	BUZZER		×	×
Interior room lamp timer	INT LAMP	×	×	×
Exterior lamp	HEAD LAMP	×	×	×
Wiper and washer	WIPER	×	×	×
Turn signal and hazard warning lamps	FLASHER	×	×	×
Air conditioner	AIR CONDITONER		×	
Intelligent Key system	INTELLIGENT KEY	×	×	×
Combination switch	COMB SW		×	
BCM	BCM	×		
Immobilizer	IMMU		×	×
Interior room lamp battery saver	BATTERY SAVER	×	×	×
Trunk open	TRUNK		×	
Vehicle security system	THEFT ALM	×	×	×
RAP system	RETAINED PWR		×	
Signal buffer system	SIGNAL BUFFER		×	×
TPMS	AIR PRESSURE MONITOR	×	×	×

#### COMMON ITEM : CONSULT-III Function (BCM - COMMON ITEM)

INFOID:000000004501353

#### ECU IDENTIFICATION

Displays the BCM part No.

#### SELF-DIAG RESULT

Refer to [BCS-81, "DTC Index"](#).

# DIAGNOSIS SYSTEM (BCM)

< FUNCTION DIAGNOSIS >

## HEADLAMP

HEADLAMP : CONSULT-III Function (BCM - HEAD LAMP)

INFOID:000000004501355

### WORK SUPPORT

Work item	Setting item	Setting	
BATTERY SAVER SET	ON <sup>1</sup>	With the exterior lamp battery saver function	
	OFF	Without the exterior lamp battery saver function	
ILL DELAY SET <sup>2</sup>	MODE 1 <sup>1</sup>	45 sec.	Sets delay timer function timer operation time (All doors closed)
	MODE 2	Without the function	
	MODE 3	30 sec.	
	MODE 4	60 sec.	
	MODE 5	90 sec.	
	MODE 6	120 sec.	
	MODE 7	150 sec.	
	MODE 8	180 sec.	
CUSTOM A/LIGHT SETTING <sup>2</sup>	MODE 1 <sup>1</sup>	Normal	
	MODE 2	More sensitive setting than normal setting (Turns ON earlier than normal operation.)	
	MODE 3	More sensitive setting than MODE 2 (Turns ON earlier than MODE 2.)	
	MODE 4	Less sensitive setting than normal setting (Turns ON later than normal operation.)	

1 : Initial setting

2 : With auto light system

### DATA MONITOR

Monitor item [Unit]	Description
PUSH SW [ON/OFF]	The switch status input from push-button ignition switch
ENGINE STATE [STOP/STALL/CRANK/RUN]	The engine status received from ECM with CAN communication
VEH SPEED 1 [km/h]	The value of the vehicle speed received from combination meter with CAN communication
KEY SW-SLOT [ON/OFF]	Key switch status input from key slot

# DIAGNOSIS SYSTEM (BCM)

## < FUNCTION DIAGNOSIS >

Monitor item [Unit]	Description	A
TURN SIGNAL R [ON/OFF]	Each switch status that BCM judges from the combination switch reading function	B
TURN SIGNAL L [ON/OFF]		C
TAIL LAMP SW [ON/OFF]		D
HI BEAM SW [ON/OFF]		E
HEAD LAMP SW1 [ON/OFF]		F
HEAD LAMP SW2 [ON/OFF]		G
PASSING SW [ON/OFF]		H
AUTO LIGHT SW [ON/OFF]		I
FR FOG SW [ON/OFF]		J
DOOR SW-DR [ON/OFF]	The switch status input from front door switch LH	K
DOOR SW-AS [ON/OFF]	The switch status input from front door switch RH	K
DOOR SW-RR [ON/OFF]	The switch status input from rear door switch RH	K
DOOR SW- RL [ON/OFF]	The switch status input from rear door switch LH	K
DOOR SW-BK <sup>1</sup> [ON/OFF]	—	K
OPTICAL (LIGHT) SENSOR [V] <sup>2</sup>	The value of exterior brightness voltage input from the optical sensor	K

1: The item is indicated, not monitored

2: With auto light system

## ACTIVE TEST

Test item	Operation	Description	M
TAIL LAMP	ON	Transmits the position light request signal to IPDM E/R with CAN communication to turn the tail lamp ON.	N
	OFF	Stops the tail lamp request signal transmission.	O
HEAD LAMP	HI	Transmits the high beam request signal with CAN communication to turn the headlamp (HI)	P
	LO	Transmits the low beam request signal with CAN communication to turn the headlamp (LO).	P
	OFF	Stops the high & low beam request signal transmission.	P
FR FOG LAMP	ON	Transmits the front fog lamp light request signal to IPDM E/R with CAN communication to turn the front fog lamp ON.	P
	OFF	Stops the front fog lamp request signal transmission.	P
DAYTIME RUNNING LIGHT <sup>1</sup>	ON	Transmits the daytime running light system request signal to IPDM E/R	P
	OFF	Stops the daytime running light request signal transmission	P

EXL

# DIAGNOSIS SYSTEM (BCM)

## < FUNCTION DIAGNOSIS >

Test item	Operation	Description
CORNERING LAMP <sup>2</sup>	RH	—
	LH	
	OFF	
ILL DIM SIGNAL <sup>2</sup>	ON	—
	OFF	
RR FOG LAMP <sup>2</sup>	ON	—
	OFF	

1: With daytime running light system.

2: The item is indicated, not monitored.

## FLASHER

### FLASHER : CONSULT-III Function (BCM - FLASHER)

INFOID:000000004501354

## WORK SUPPORT

Service item	Setting item	Setting	
HAZARD ANSWER BACK	LOCK ONLY*	Activated when locking.	Sets the hazard warning lamp answer back activation when the door is lock/unlock with the request switch or the key fob.
	UNLK ONLY	Activated when unlocking.	
	LOCK/UNLK	Activated when locking/unlocking	
	OFF	Not activated	

\* : Initial setting

## DATA MONITOR

Monitor item [Unit]	Description
TURN SIGNAL R [ON/OFF]	Each switch condition that BCM judges from the combination switch reading function
TURN SIGNAL L [ON/OFF]	
HAZARD SW [ON/OFF]	The switch status input from the hazard warning switch
RKE LOCK [ON/OFF]	The lock signal status received from the keyless receiver
RKE UNLOCK [ON/OFF]	The unlock signal status received from the keyless receiver
RKE PANIC [ON/OFF]	The panic alarm signal status received from the keyless receiver

## ACTIVE TEST

Test item	Operation	Description
FLASHER	RH	Blinks right turn signal lamp.
	LH	Blinks left turn signal lamp.
	OFF	Turns turn signal lamps (right and left) OFF.

## COMB SW

# DIAGNOSIS SYSTEM (BCM)

< FUNCTION DIAGNOSIS >

COMB SW : CONSULT-III Function (BCM - COMB SW)

INFOID:000000004501356

## DATA MONITOR

Monitor item [UNIT]	Description
FR WIPER HI [OFF/ON]	Displays the status of the FR WIPER HI switch in combination switch judged by BCM with the combination switch reading function.
FR WIPER LOW [OFF/ON]	Displays the status of the FR WIPER LOW switch in combination switch judged by BCM with the combination switch reading function.
FR WASHER SW [OFF/ON]	Displays the status of the FR WASHER switch in combination switch judged by BCM with the combination switch reading function.
FR WIPER INT [OFF/ON]	Displays the status of the FR WIPER INT switch in combination switch judged by BCM with the combination switch reading function.
FR WIPER STOP [OFF/ON]	Displays the status of the front wiper stop position signal received from IPDM E/R via CAN communication.
INT VOLUME [1 - 7]	Displays the status of wiper intermittent dial position judged by BCM with the combination switch reading function
TURN SIGNAL R [OFF/ON]	Displays the status of theTURN RH switch in combination switch judged by BCM with the combination switch reading function.
TURN SIGNAL L [OFF/ON]	Displays the status of theTURN LH switch in combination switch judged by BCM with the combination switch reading function.
TAIL LAMP SW [OFF/ON]	Displays the status of the TAIL LAMP switch in combination switch judged by BCM with the combination switch reading function.
HI BEAM SW [OFF/ON]	Displays the status of the HI BEAM switch in combination switch judged by BCM with the combination switch reading function.
HEAD LAMP SW 1 [OFF/ON]	Displays the status of the HEADLAMP 1 switch in combination switch judged by BCM with the combination switch reading function.
HEAD LAMP SW 2 [OFF/ON]	Displays the status of the HEADLAMP 2 switch in combination switch judged by BCM with the combination switch reading function.
PASSING SW [OFF/ON]	Displays the status of the PASSING switch in combination switch judged by BCM with the combination switch reading function.
AUTO LIGHT SW [OFF/ON]	Displays the status of the AUTO LIGHT switch in combination switch judged by BCM with the combination switch reading function.
FR FOG SW [OFF/ON]	Displays the status of the FR FOG switch in combination switch judged by BCM with the combination switch reading function.

## ACTIVE TEST

Test item	Operation	Description
TAIL LAMP	ON	Transmits the position light request signal to IPDM E/R with CAN communication to turn the tail lamp ON.
	OFF	Stops the tail lamp request signal transmission.
HEAD LAMP	HI	Transmits the high beam request signal with CAN communication to turn the headlamp (HI)
	LO	Transmits the low beam request signal with CAN communication to turn the headlamp (LO).
	OFF	Stops the high & low beam request signal transmission.
FR FOG LAMP	ON	Transmits the front fog lamp light request signal to IPDM E/R with CAN communication to turn the front fog lamp ON.
	OFF	Stops the front fog lamp request signal transmission.
FLASHER	RH	Blinks right turn signal lamp.
	LH	Blinks left turn signal lamp.
	OFF	Turns turn signal lamps (right and left) OFF.

# DIAGNOSIS SYSTEM (BCM)

## < FUNCTION DIAGNOSIS >

Test item	Operation	Description
FRONT WIPER	HI	Transmits the front wiper request signal (HI) to IPDM E/R with CAN communication to operate the front wiper HI operation.
	LO	Transmits the front wiper request signal (LO) to IPDM E/R with CAN communication to operate the front wiper LO operation.
	INT	Transmits the front wiper request signal (INT) to IPDM E/R with CAN communication to operate the front wiper INT operation.
	OFF	Stops transmitting the front wiper request signal to stop the front wiper operation.

## BATTERY SAVER

### BATTERY SAVER : CONSULT-III Function (BCM - BATTERY SAVER)

INFOID:000000004501357

## WORK SUPPORT

Work item	Setting item	Setting
BATTERY SAVER SET	ON*	With the exterior lamp battery saver function
	OFF	Without the exterior lamp battery saver function
ROOM LAMP BAT SAV SET	ON*	With the interior room lamp battery saver function
	OFF	Without the interior room lamp battery saver function
ROOM LAMP TIMER SET	MODE 1*	30 min.
	MODE 2	60 min.
Sets the interior room lamp battery saver timer operating time.		

\* : Initial setting

## DATA MONITOR

Monitor item [Unit]	Description
REQ SW-DR [ON/OFF]	The switch status input from request switch (front LH)
REQ SW-AS [ON/OFF]	The switch status input from front request switch (front RH)
PUSH SW [ON/OFF]	The switch status input from push-button ignition switch
UNLK SEN-DR [ON/OFF]	Status of front door lock assembly LH (door unlock sensor)
KEY SW-SLOT [ON/OFF]	Key switch status input from key slot
DOOR SW-DR [ON/OFF]	The switch status input from front door switch LH
DOOR SW-AS [ON/OFF]	The switch status input from front door switch RH
DOOR SW-RR [ON/OFF]	The switch status input from rear door switch RH
DOOR SW-RL [ON/OFF]	The switch status input from rear door switch LH
DOOR SW-BK [ON/OFF]	<b>NOTE:</b> The item is indicated, not monitored.
CDL LOCK SW [ON/OFF]	Lock switch status received from door lock/unlock switch by power window serial link
CDL UNLOCK SW [ON/OFF]	Unlock switch status received from door lock/unlock switch by power window serial link

# DIAGNOSIS SYSTEM (BCM)

## < FUNCTION DIAGNOSIS >

Monitor item [Unit]	Description
KEY CYL LK-SW [ON/OFF]	Lock switch status received from key cylinder switch by power window serial link
KEY CYL UN-SW [ON/OFF]	Unlock switch status received from key cylinder switch by power window serial link
TRNK/HAT MNTR [ON/OFF]	The switch status input from trunk room lamp switch
RKE-LOCK [ON/OFF]	Lock signal status received from remote keyless entry receiver
RKE-UNLOCK [ON/OFF]	Unlock signal status received from remote keyless entry receiver

## ACTIVE TEST

Test item	Operation	Description
BATTERY SAVER	OFF	Cuts the interior room lamp power supply to turn interior room lamp OFF.
	ON	Outputs the interior room lamp power supply to turn interior room lamp ON.*

\* : Each lamp switch is in ON position.

A  
B  
C  
D  
E  
F  
G  
H  
I  
J  
K  
L  
M  
N  
O  
P

EXL

# DIAGNOSIS SYSTEM (IPDM E/R)

< FUNCTION DIAGNOSIS >

---

## DIAGNOSIS SYSTEM (IPDM E/R)

### Diagnosis Description

INFOID:000000004501358

#### AUTO ACTIVE TEST

##### Description

In auto active test mode, the IPDM E/R sends a drive signal to the following systems to check their operation.

- Oil pressure warning lamp
- Front wiper (LO, HI)
- Parking lamps
- License plate lamps
- Tail lamps
- Front fog lamps (if equipped)
- Headlamps (LO, HI)
- Heater pump
- Cooling fans

##### Operation Procedure

1. Close the hood and lift the wiper arms from the windshield. (Prevent windshield damage due to wiper operation)

##### **NOTE:**

When auto active test is performed with hood opened, sprinkle water on windshield before hand.

2. Turn ignition switch OFF.
3. Turn the ignition switch ON, and within 20 seconds, press the front door switch LH 10 times. Then turn the ignition switch OFF.

##### **CAUTION:**

**Close front door RH.**

4. Turn the ignition switch ON within 10 seconds. After that the horn sounds once and the auto active test starts.
5. The oil pressure warning lamp starts blinking when the auto active test starts.
6. After a series of the following operations is repeated 3 times, auto active test is completed.

##### **NOTE:**

When auto active test mode has to be cancelled halfway through test, turn ignition switch OFF.

##### **CAUTION:**

- If auto active test mode cannot be actuated, check door switch system. Refer to [DLK-69](#), "[Component Function Check](#)".
- Do not start the engine.

Inspection in Auto Active Test Mode



## DIAGNOSIS SYSTEM (IPDM E/R)

### < FUNCTION DIAGNOSIS >

When auto active test mode is actuated, the following 6 steps are repeated 3 times.

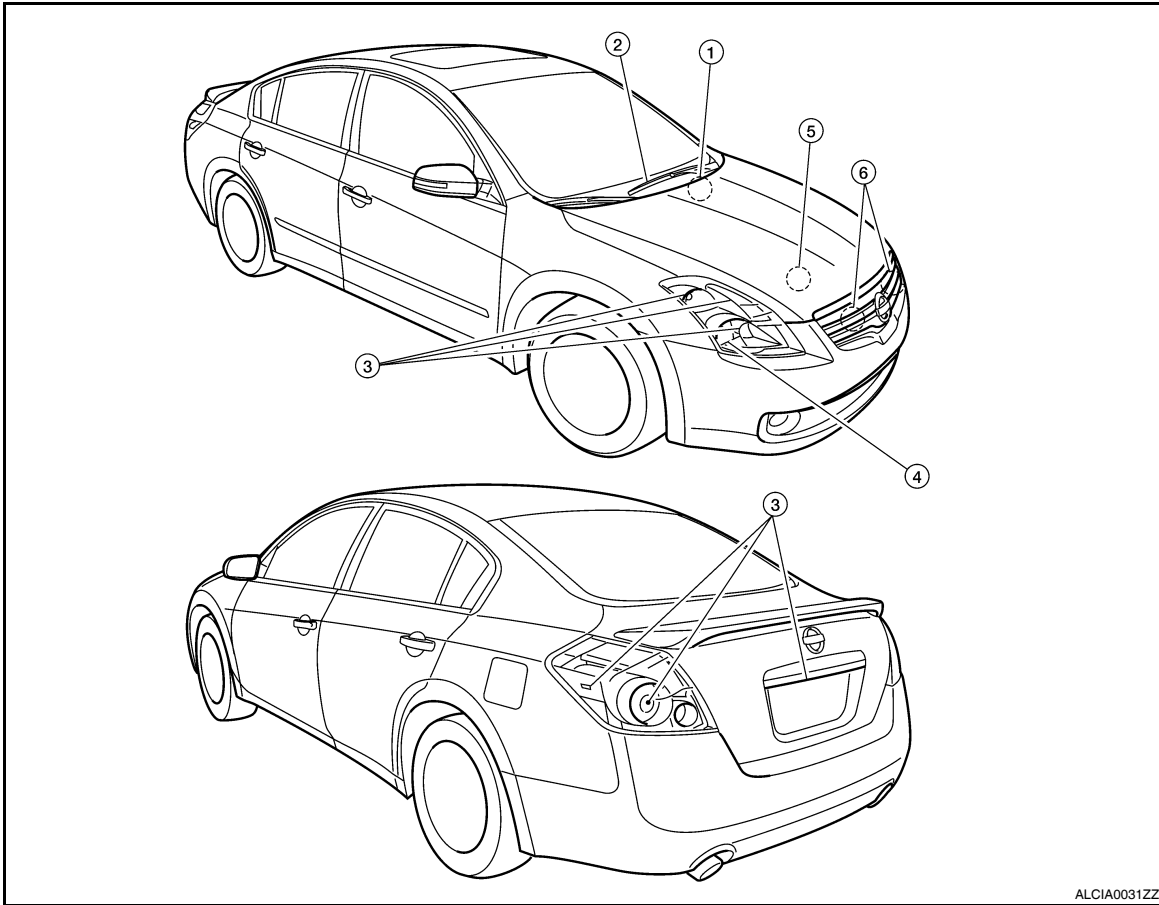

Operation sequence	Inspection Location	Operation
1	Oil pressure warning lamp	Blinks continuously during operation of auto active test
2	Front wiper	LO for 5 seconds → HI for 5 seconds
3	<ul style="list-style-type: none"> <li>• Parking lamps</li> <li>• License plate lamps</li> <li>• Tail lamps</li> <li>• Front fog lamps (if equipped)</li> </ul>	10 seconds
4	Headlamps	LO ↔ HI 5 times
5	Heater pump	ON ↔ OFF 5 times
6*	Cooling fans	MID for 5 seconds → HI for 5 seconds

\*: Outputs duty ratio of 50% for 5 seconds → duty ratio of 100% for 5 seconds on the cooling fan control module.

A  
B  
C  
D  
E  
F  
G  
H  
I  
J  
K  
EXL  
M  
N  
O  
P

# DIAGNOSIS SYSTEM (IPDM E/R)

## < FUNCTION DIAGNOSIS >

### Concept of auto active test

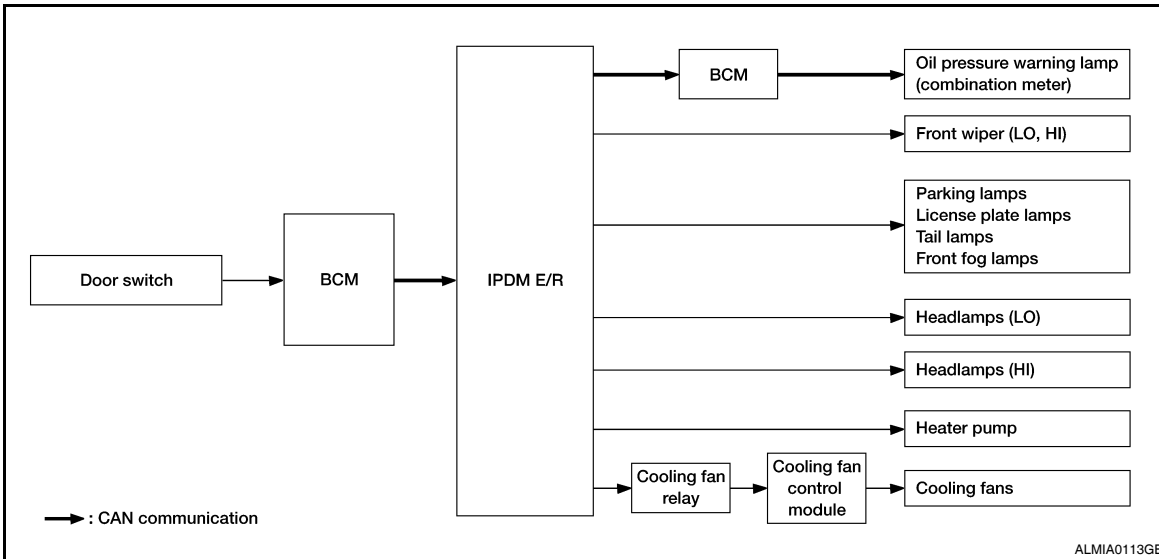

- IPDM E/R starts the auto active test with the door switch signals transmitted by BCM via CAN communication. Therefore, the CAN communication line between IPDM E/R and BCM is considered normal if the auto active test starts successfully.
- The auto active test facilitates troubleshooting if any systems controlled by IPDM E/R cannot be operated.

### Diagnosis chart in auto active test mode

Symptom	Inspection contents	Possible cause
Any of the following components do not operate <ul style="list-style-type: none"> <li>• Parking lamps</li> <li>• License plate lamps</li> <li>• Tail lamps</li> <li>• Front fog lamps (if equipped)</li> <li>• Headlamp (HI, LO)</li> <li>• Front wiper</li> </ul>	Perform auto active test. Does the applicable system operate?	YES BCM signal input circuit
		NO <ul style="list-style-type: none"> <li>• Lamp or motor</li> <li>• Lamp or motor ground circuit</li> <li>• Harness or connector between IPDM E/R and applicable system</li> <li>• IPDM E/R</li> </ul>
Heater pump does not operate	Perform auto active test. Does the heater pump operate?	YES <ul style="list-style-type: none"> <li>• Combination meter signal input circuit</li> <li>• CAN communication signal between combination meter and ECM</li> <li>• CAN communication signal between ECM and IPDM E/R</li> </ul>
		NO <ul style="list-style-type: none"> <li>• Heater pump</li> <li>• Harness or connector between IPDM E/R and magnet clutch</li> <li>• IPDM E/R</li> </ul>
Oil pressure warning lamp does not operate	Perform auto active test. Does the oil pressure warning lamp blink?	YES <ul style="list-style-type: none"> <li>• Harness or connector between IPDM E/R and oil pressure switch</li> <li>• Oil pressure switch</li> <li>• IPDM E/R</li> </ul>
		NO <ul style="list-style-type: none"> <li>• CAN communication signal between IPDM E/R and BCM</li> <li>• CAN communication signal between BCM and combination meter</li> <li>• Combination meter</li> </ul>

# DIAGNOSIS SYSTEM (IPDM E/R)

## < FUNCTION DIAGNOSIS >

Symptom	Inspection contents		Possible cause
Cooling fan does not operate	Perform auto active test. Does the cooling fan operate?	YES	<ul style="list-style-type: none"> <li>• ECM signal input circuit</li> <li>• CAN communication signal between ECM and IPDM E/R</li> </ul>
		NO	<ul style="list-style-type: none"> <li>• Cooling fan</li> <li>• Harness or connector between cooling fan and cooling fan relays</li> <li>• Cooling fan relays</li> <li>• Harness or connector between IPDM E/R and cooling fan relays</li> <li>• IPDM E/R</li> </ul>

## CONSULT - III Function (IPDM E/R)

INFOID:000000004501359

### APPLICATION ITEM

CONSULT-III performs the following functions via CAN communication with IPDM E/R.

Diagnosis mode	Description
ECU Identification	Allows confirmation of IPDM E/R part number.
Self Diagnostic Result	Displays the diagnosis results judged by IPDM E/R.
Data Monitor	Displays the real-time input/output data from IPDM E/R input/output data.
Active Test	IPDM E/R can provide a drive signal to electronic components to check their operations.
CAN Diag Support Monitor	The results of transmit/receive diagnosis of CAN communication can be read.

### SELF DIAGNOSTIC

Refer to [PCS-36, "DTC Index"](#).

### DATA MONITOR

Monitor item

Monitor Item [Unit]	MAIN SIG- NALS	Description
RADFAN REQ [%]	×	Displays the value of the cooling fan speed signal received from ECM via CAN communication.
TAIL&CLR REQ [OFF/ON]	×	Displays the status of the position light request signal received from BCM via CAN communication.
HL LO REQ [OFF/ON]	×	Displays the status of the low beam request signal received from BCM via CAN communication.
HL HI REQ [OFF/ON]	×	Displays the status of the high beam request signal received from BCM via CAN communication.
FR FOG REQ [OFF/ON]	×	Displays the status of the front fog lamp request signal received from BCM via CAN communication.
FR WIP REQ [STOP/1LOW/LOW/HI]	×	Displays the status of the front wiper request signal received from BCM via CAN communication.
WIP AUTO STOP [STOP P/ACT P]	×	Displays the status of the front wiper auto stop signal judged by IPDM E/R.
WIP PROT [OFF/BLOCK]	×	Displays the status of the front wiper fail-safe operation judged by IPDM E/R.
IGN RLY1 -REQ [OFF/ON]		Displays the status of the ignition switch ON signal received from BCM via CAN communication.
IGN RLY [OFF/ON]	×	Displays the status of the ignition relay judged by IPDM E/R.

## DIAGNOSIS SYSTEM (IPDM E/R)

### < FUNCTION DIAGNOSIS >

Monitor Item [Unit]	MAIN SIG- NALS	Description
PUSH SW [OFF/ON]		Displays the status of the push-button ignition switch judged by IPDM E/R.
DETENT SW [OFF/ON]		Displays the status of the CVT device (detention switch) judged by IPDM E/R.
S/L RLY -REQ [OFF/ON]		Displays the status of the electronic steering column lock relay request received from BCM via CAN communication.
S/L STATE [LOCK/UNLK/UNKWN]		Displays the status of the electronic steering column lock judged by IPDM E/R.
DTRL REQ [OFF]		<b>NOTE:</b> This item is displayed, but cannot be monitored.
OIL P SW [OPEN/CLOSE]		Displays the status of the oil pressure switch judged by IPDM E/R.
THFT HRN REQ [OFF/ON]		Displays the status of the theft warning horn request signal received from BCM via CAN communication.
HORN CHIRP [OFF/ON]		Displays the status of the horn reminder signal received from BCM via CAN communication.
CRNRNG LMP REQ [OFF]		<b>NOTE:</b> This item is displayed, but cannot be monitored.

### ACTIVE TEST

#### Test item

Test item	Operation	Description
CORNERING LAMP	OFF	<b>NOTE:</b> This item is displayed, but cannot be monitored.
	LH	
	RH	
HORN	ON	Operates horn relay for 20 ms.
FRONT WIPER	OFF	OFF
	LO	Operates the front wiper relay.
	HI	Operates the front wiper relay and front wiper high relay.
MOTOR FAN	1	OFF
	2	Outputs 50% pulse duty signal (PWM signal) to the cooling fan control module.
	3	Outputs 80% pulse duty signal (PWM signal) to the cooling fan control module.
	4	Outputs 100% pulse duty signal (PWM signal) to the cooling fan control module.
EXTERNAL LAMPS	OFF	OFF
	TAIL	Operates the tail lamp relay.
	LO	Operates the headlamp low relay.
	HI	Operates the headlamp low relay and ON/OFF the headlamp high relay at 1 second intervals.
	FOG	Operates the front fog lamp relay

# POWER SUPPLY AND GROUND CIRCUIT

< COMPONENT DIAGNOSIS >

## COMPONENT DIAGNOSIS

### POWER SUPPLY AND GROUND CIRCUIT

#### BCM (BODY CONTROL MODULE)

#### BCM (BODY CONTROL MODULE) : Diagnosis Procedure

INFOID:000000004501366

### 1. CHECK FUSE AND FUSIBLE LINK

Check if the following BCM fuse or fusible link are blown.

Terminal No.	Signal name	Fuse and fusible link No.
1	Battery power supply	J
11		10

Is the fuse or fusible link blown?

- YES >> Replace the blown fuse or fusible link after repairing the affected circuit.  
 NO >> GO TO 2

### 2. CHECK POWER SUPPLY CIRCUIT

- Turn ignition switch OFF.
- Disconnect BCM.
- Check voltage between BCM harness connector and ground.

Terminals		Voltage (Approx.)
(+)	(-)	
BCM		Ground Battery voltage
Connector	Terminal	
M16	1	
M17	11	

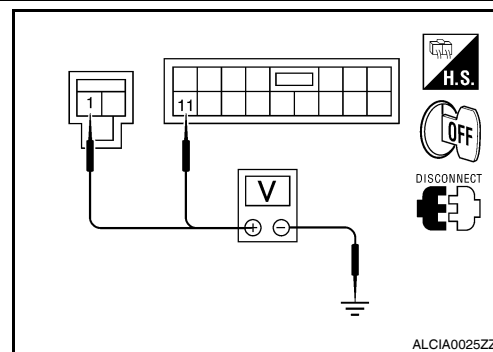

Is the measurement normal?

- YES >> GO TO 3  
 NO >> Repair or replace harness.

### 3. CHECK GROUND CIRCUIT

Check continuity between BCM harness connector and ground.

BCM		Ground	Continuity
Connector	Terminal		Yes
M17	13		Yes

Does continuity exist?

- YES >> Inspection End.  
 NO >> Repair or replace harness.

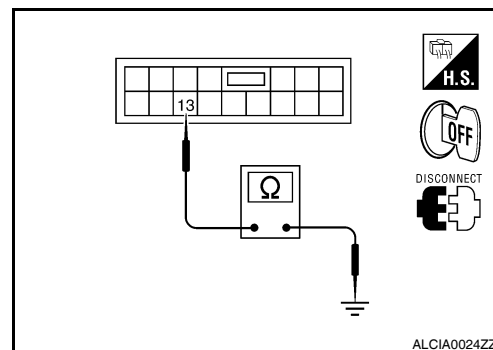

#### BCM (BODY CONTROL MODULE) : Special Repair Requirement

INFOID:000000004501367

### 1. REQUIRED WORK WHEN REPLACING BCM

Initialize control unit. Refer to CONSULT-III operation manual.

>> Work End.

#### IPDM E/R (INTELLIGENT POWER DISTRIBUTION MODULE ENGINE ROOM)

# POWER SUPPLY AND GROUND CIRCUIT

< COMPONENT DIAGNOSIS >

## IPDM E/R (INTELLIGENT POWER DISTRIBUTION MODULE ENGINE ROOM) : Diagnosis Procedure

INFOID:000000004501370

### 1. CHECK FUSES AND FUSIBLE LINK

Check that the following IPDM E/R fuses or fusible link are not blown.

Terminal No.	Signal name	Fuses and fusible link No.
1, 2	Battery power supply	B, E, F
—		42
—		43

Is the fuse blown?

YES >> Replace the blown fuse or fusible link after repairing the affected circuit.

NO >> GO TO 2

### 2. CHECK POWER SUPPLY CIRCUIT

1. Turn ignition switch OFF.
2. Disconnect IPDM E/R.
3. Check voltage between IPDM E/R harness connector and ground.

Terminals		Voltage (V) (Approx.)
(+)	(-)	
IPDM E/R		Battery voltage
Connector	Terminal	
E16	1 2	

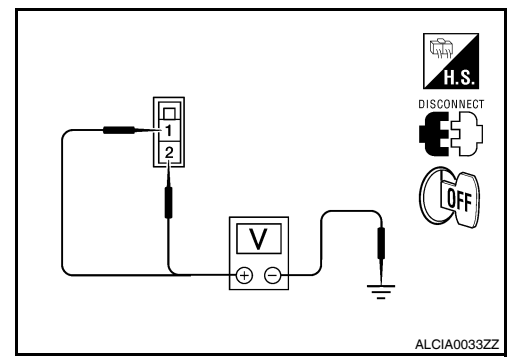

Is the measurement value normal?

YES >> GO TO 3

NO >> Repair or replace harness.

### 3. CHECK GROUND CIRCUIT

Check continuity between IPDM E/R harness connectors and ground.

IPDM E/R		Ground	Continuity
Connector	Terminal		
E18 (A)	12	Ground	Yes
E17 (B)	41		

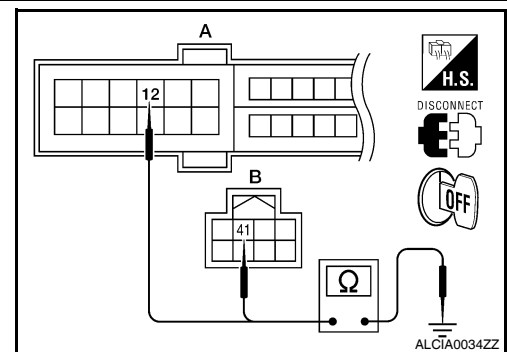

Does continuity exist?

YES >> Inspection End.

NO >> Repair or replace harness.

# HEADLAMP (HI) CIRCUIT

< COMPONENT DIAGNOSIS >

## HEADLAMP (HI) CIRCUIT

### Description

INFOID:000000004216388

The IPDM E/R (intelligent power distribution module engine room) controls the headlamp high relay based on inputs from the BCM over the CAN communication lines. When the headlamp high relay is energized, power flows through fuses 48 and 49, located in the IPDM E/R. Power then flows to the front combination lamps to the headlamp high beam.

### Component Function Check

INFOID:000000004216389

#### 1. CHECK HEADLAMP (HI) OPERATION

##### ⊗ WITHOUT CONSULT-III

1. Start IPDM E/R auto active test. Refer to [PCS-14, "Diagnosis Description"](#).
2. Check that the headlamp switches to the high beam.

##### NOTE:

HI/LO is repeated 1 second each when using the IPDM E/R auto active test.

##### Ⓜ CONSULT-III

1. Select "EXTERNAL LAMP" of IPDM E/R active test item.
2. With operating the test items, check that the headlamp switches to the high beam.

**HI** : Headlamp switches to the high beam.

**OFF** : Headlamp OFF

Does the headlamp switch to the high beam?

YES >> Headlamp (HI) circuit is normal.

NO >> Refer to [EXL-39, "Diagnosis Procedure"](#).

### Diagnosis Procedure

INFOID:000000004216390

#### 1. CHECK HEADLAMP (HI) FUSES

1. Turn the ignition switch OFF.
2. Check that the following fuses are not open.

Unit	Location	Fuse	Capacity
Headlamp HI (LH)	IPDM E/R	48	10A
Headlamp HI (RH)	IPDM E/R	49	10A

Is the fuse open?

YES >> Repair the harness and replace the fuse.

NO >> GO TO 2

#### 2. CHECK HEADLAMP (HI) OUTPUT VOLTAGE

##### Ⓜ CONSULT-III ACTIVE TEST

1. Turn the ignition switch OFF.
2. Disconnect the front combination lamp connector.
3. Turn the ignition switch ON.
4. Select "EXTERNAL LAMP" of IPDM E/R active test item.

# HEADLAMP (HI) CIRCUIT

## < COMPONENT DIAGNOSIS >

- With EXTERNAL LAMP ON, check the voltage between the combination lamp connector and ground.

Terminals			Condition	Voltage
(+)		(-)		
Combination lamp			External lamp	Battery voltage
Connector	Terminal			
RH	E222	3	HI	0V
LH	E213	3	OFF	

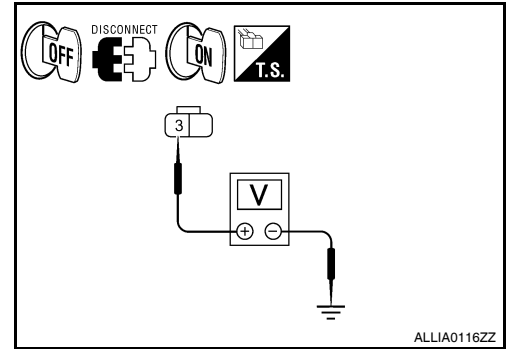

Is the measurement value normal?

- YES >> GO TO 4  
 NO >> GO TO 3

### 3. CHECK HEADLAMP (HI) CIRCUIT FOR OPEN

- Turn the ignition switch OFF.
- Disconnect IPDM E/R connector.
- Check continuity between the IPDM E/R harness connector and the front combination lamp harness connector.

A			B		Continuity
Connector	Terminal		Connector	Terminal	
RH	E200	89	E222	3	Yes
LH		90	E213	3	

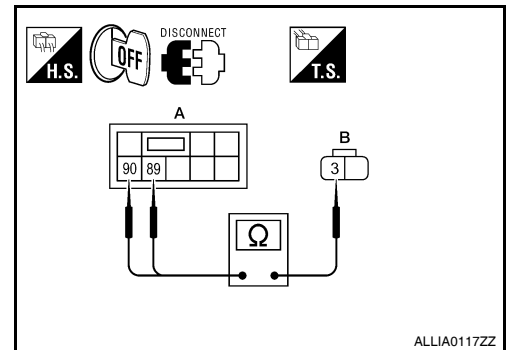

Does continuity exist?

- YES >> GO TO 4  
 NO >> Repair the harnesses or connectors.

### 4. CHECK FRONT COMBINATION LAMP (HI) GROUND CIRCUIT

- Disconnect the front combination lamp connector.
- Check continuity between the front combination lamp harness connector terminal and ground.

Front combination lamp			Ground	Continuity
Connector	Terminal			
RH	E222	4	Yes	
LH	E213	4		

Does continuity exist?

- YES >> Inspect the headlamp bulb.  
 NO >> Repair the harness.

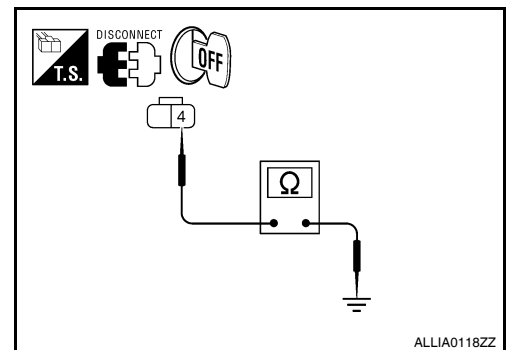



# HEADLAMP (LO) CIRCUIT

< COMPONENT DIAGNOSIS >

## HEADLAMP (LO) CIRCUIT

### Description

INFOID:000000004216391

The IPDM E/R (intelligent power distribution module engine room) controls the headlamp low relay based on inputs from the BCM over the CAN communication lines. When the headlamp low relay is energized, power flows through fuses 51 and 52, located in the IPDM E/R. Power then flows to the front combination lamps to the headlamp low beam.

### Component Function Check

INFOID:000000004216392

#### 1. CHECK HEADLAMP (LO) OPERATION

##### WITHOUT CONSULT-III

1. Start IPDM E/R auto active test. Refer to [PCS-14, "Diagnosis Description"](#).
2. Check that the headlamp is turned ON.

##### **NOTE:**

HI/LO is repeated 1 second each when using the IPDM E/R auto active test.

##### CONSULT-III

1. Select "EXTERNAL LAMP" of IPDM E/R active test item.
2. With operating the test items, check that the headlamp is turned ON.

**LO** : Headlamp ON

**OFF** : Headlamp OFF

##### Is the headlamp turned ON?

YES >> Headlamp (LO) is normal.

NO >> Refer to [EXL-41, "Diagnosis Procedure"](#).

### Diagnosis Procedure

INFOID:000000004216393

#### 1. CHECK HEADLAMP (LO) FUSES

1. Turn the ignition switch OFF.
2. Check that the following fuses are not open.

Unit	Location	Fuse	Capacity
Headlamp LO (LH)	IPDM E/R	51	15A
Headlamp LO (RH)	IPDM E/R	52	15A

##### Is the fuse open?

YES >> Repair the harness and replace the fuse.

NO >> GO TO 2

#### 2. CHECK HEADLAMP (LO) OUTPUT VOLTAGE

##### CONSULT-III

1. Turn the ignition switch OFF.
2. Disconnect the front combination lamp connector.
3. Turn the ignition switch ON.
4. Select "EXTERNAL LAMP" of IPDM E/R active test item.

# HEADLAMP (LO) CIRCUIT

## < COMPONENT DIAGNOSIS >

- With EXTERNAL LAMP ON, check the voltage between the combination lamp connector and ground.

Terminals			Condition	Voltage
(+)		(-)		
Combination lamp			External lamp	Battery voltage
Connector	Terminal			
RH	E223	1	LO	Battery voltage
LH	E212	1	OFF	0V

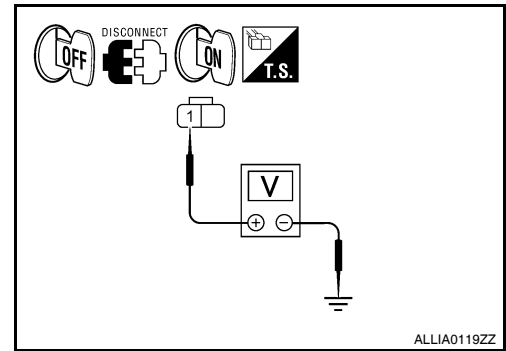

Is the measurement value normal?

- YES >> GO TO 4  
 NO >> GO TO 3

### 3. CHECK HEADLAMP (LO) CIRCUIT FOR OPEN

- Turn the ignition switch OFF.
- Disconnect IPDM E/R connector.
- Check continuity between the IPDM E/R harness connector and the front combination lamp harness connector.

A			B		Continuity
Connector	Terminal		Connector	Terminal	
RH	E200	83	E223	1	Yes
LH		84	E212	1	

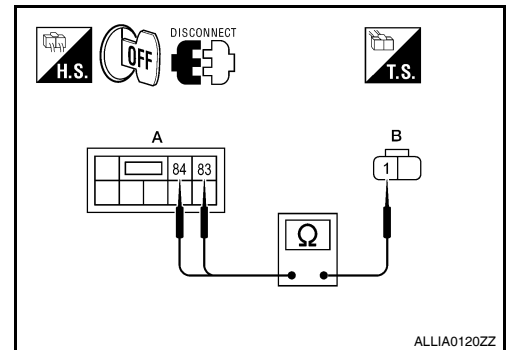

Does continuity exist?

- YES >> GO TO 4  
 NO >> Repair the harnesses or connectors.

### 4. CHECK FRONT COMBINATION LAMP (LO) GROUND CIRCUIT

- Disconnect the front combination lamp connector.
- Check continuity between the front combination lamp harness connector terminal and ground.

Front combination lamp			Ground	Continuity
Connector	Terminal			
RH	E223	2	Ground	Yes
LH	E212	2		

Does continuity exist?

- YES >> Inspect the headlamp bulb.  
 NO >> Repair the harness.

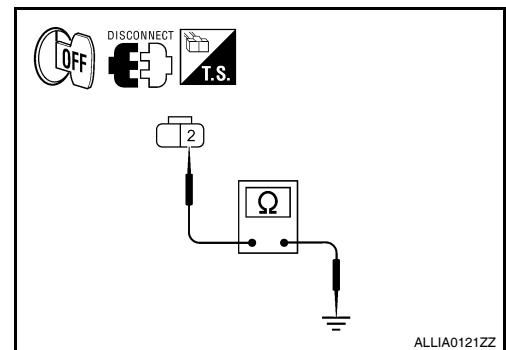

# FRONT FOG LAMP CIRCUIT

< COMPONENT DIAGNOSIS >

## FRONT FOG LAMP CIRCUIT

### Description

INFOID:000000004216394

The IPDM E/R (intelligent power distribution module engine room) controls the front fog lamp relay based on inputs from the BCM over the CAN communication lines. When the front fog lamp relay is energized, power flows from the front fog lamp relay in the IPDM E/R to the front fog lamps.

### Component Function Check

INFOID:000000004216395

#### 1. CHECK FRONT FOG LAMP OPERATION

##### ⊗ WITHOUT CONSULT-III

1. Activate IPDM E/R auto active test. Refer to [PCS-14, "Diagnosis Description"](#).
2. Check that the front fog lamp is turned ON.

##### Ⓜ CONSULT-III

1. Select "EXTERNAL LAMP" of IPDM E/R active test item.
2. With operating the test items, Check that the front fog lamp is turned ON.

**FOG** : Front fog lamp ON  
**OFF** : Front fog lamp OFF

#### Is the front fog lamp turned ON?

- YES >> Front fog lamp circuit is normal.  
 NO >> Refer to [EXL-43, "Diagnosis Procedure"](#).

### Diagnosis Procedure

INFOID:000000004216396

#### 1. CHECK FRONT FOG LAMP FUSE

1. Turn the ignition switch OFF.
2. Check that the following fuses are not open.

Unit	Location	Fuse No.	Capacity
Front fog lamp	IPDM E/R	53	15A

#### Is the fuse open?

- YES >> Repair the harness and replace the fuse.  
 NO >> GO TO 2

#### 2. CHECK FRONT FOG LAMP OUTPUT VOLTAGE

##### Ⓜ CONSULT-III

1. Turn the ignition switch OFF.
2. Disconnect the front fog lamp connector.
3. Turn the ignition switch ON.
4. Select "EXTERNAL LAMP" of IPDM E/R active test item.
5. With EXTERNAL LAMP ON, check the voltage between the fog lamp connector and ground.

Terminals			Condition	Voltage
(+)		(-)		
Front fog lamp			Front fog lamp	Battery voltage
Connector	Terminal			
LH	E214	1	FOG	Battery voltage
RH	E227	1	OFF	0V

#### Is the measurement value normal?

- YES >> GO TO 4

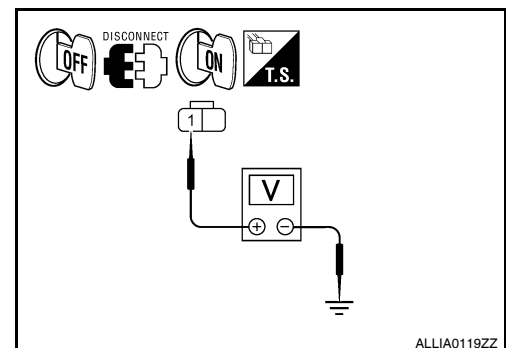

ALLIA0119ZZ

# FRONT FOG LAMP CIRCUIT

## < COMPONENT DIAGNOSIS >

NO >> GO TO 3

### 3. CHECK FRONT FOG LAMP OPEN CIRCUIT

1. Turn the ignition switch OFF.
2. Disconnect IPDM E/R connector.
3. Check continuity between the IPDM E/R harness connector and the front fog lamp harness connector.

A		B		Continuity
Connector	Terminal	Connector	Terminal	
RH	E200	86	E227	Yes
LH		87	E214	

Does continuity exist?

YES >> GO TO 4

NO >> Repair the harnesses or connectors.

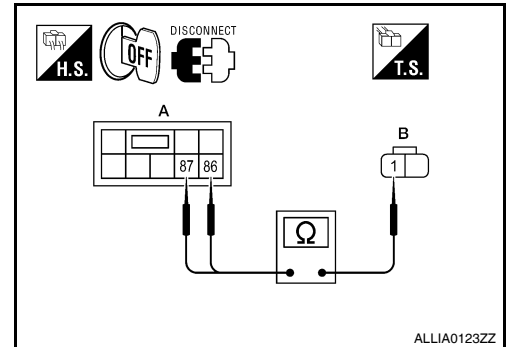

ALLIA0123ZZ

### 4. CHECK FRONT FOG LAMP GROUND CIRCUIT

1. Disconnect the front fog lamp connector.
2. Check continuity between the front fog lamp harness connector terminal and ground.

Front fog lamp			Ground	Continuity
Connector	Terminal			
RH	E227	2	Yes	
LH	E214	2		

Does continuity exist?

YES >> Inspect the fog lamp bulb.

NO >> Repair the harness.

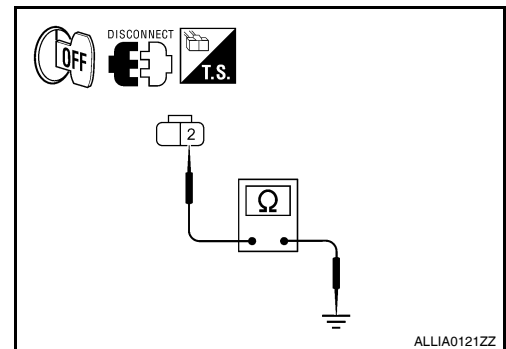

ALLIA0121ZZ

# PARKING LAMP CIRCUIT

< COMPONENT DIAGNOSIS >

## PARKING LAMP CIRCUIT

### Description

INFOID:000000004216397

The IPDM E/R (intelligent power distribution module engine room) controls the tail lamp relay based on inputs from the BCM over the CAN communication lines. When the tail lamp relay is energized, power flows through fuses 46 and 47, located in the IPDM E/R. Power then flows to the front and rear combination lamps.

### Component Function Check

INFOID:000000004216398

#### 1. CHECK PARKING LAMP OPERATION

##### WITHOUT CONSULT-III

1. Activate IPDM E/R auto active test. Refer to [PCS-14, "Diagnosis Description"](#).
2. Check that the parking lamp is turned ON.

##### CONSULT-III

1. Select "EXTERNAL LAMP" of IPDM E/R active test item.
2. With operating the test items, check that the parking lamp is turned ON.

**TAIL : Parking lamp ON**  
**OFF : Parking lamp OFF**

##### Is the parking lamp turned ON?

- YES >> Parking lamp circuit is normal.  
NO >> Refer to [EXL-45, "Diagnosis Procedure"](#).

### Diagnosis Procedure

INFOID:000000004216399

#### 1. CHECK PARKING LAMP FUSES

1. Turn the ignition switch OFF.
2. Check that the following fuses are not open.

Unit	Location	Fuse	Capacity
Parking lamps (front)	IPDM E/R	46	10A
Parking lamps (rear)	IPDM E/R	47	10A

##### Is the fuse open?

- YES >> Repair the harness and replace the fuse.  
NO >> GO TO 2

#### 2. CHECK TAIL LAMP RELAY OUTPUT (VOLTAGE)

##### CONSULT-III

# PARKING LAMP CIRCUIT

## < COMPONENT DIAGNOSIS >

1. Turn the ignition switch OFF.
2. Disconnect the front combination lamp connector.
3. Turn the ignition switch ON.
4. Select "EXTERNAL LAMP" of IPDM E/R active test item.
5. With EXTERNAL LAMP ON, check the voltage between the combination lamp connector and ground.

Terminals			Condition	Voltage
(+)		(-)		
Combination lamp			External lamp	Battery voltage
Connector	Terminal			
Front	A: E218, E225	8	LO	0V
Rear	B: B30, B45	2	OFF	

Is the measurement value normal?

- YES >> GO TO 4  
 NO >> GO TO 3

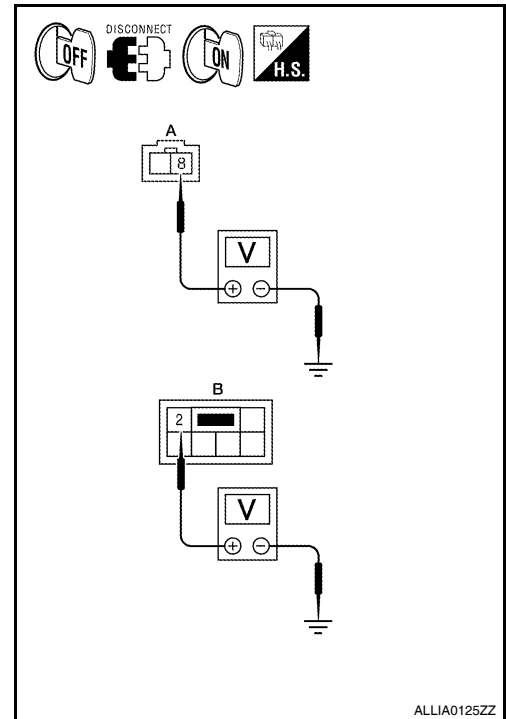

ALLIA0125ZZ

## 3. CHECK PARKING LAMP CIRCUIT (OPEN)

1. Turn the ignition switch OFF.
2. Disconnect IPDM E/R connector.
3. Check continuity between the IPDM E/R harness connector and the combination lamp harness connector.

IPDM E/R		Combination lamp		Continuity
Connector	Terminal	Connector	Terminal	
Front	A: E201	91, 92	B: E218, E225	Yes
Rear	C: E18	7	D: B30, B45	

Does continuity exist?

- YES >> GO TO 4  
 NO >> Repair the harnesses or connectors.

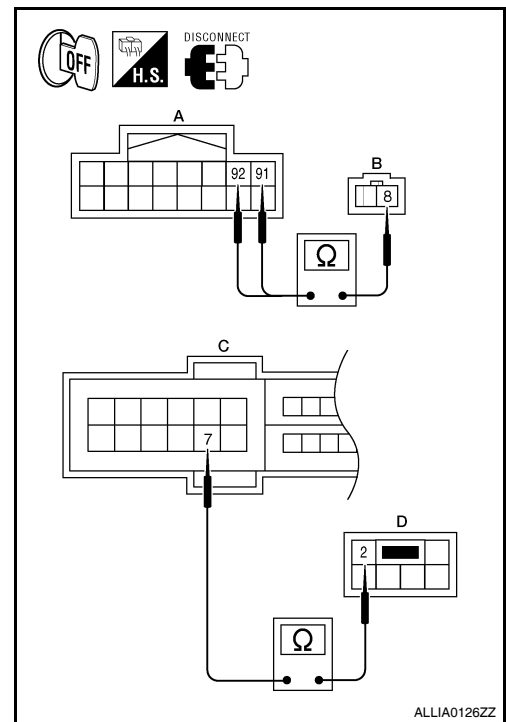

ALLIA0126ZZ

## 4. CHECK PARKING LAMP GROUND CIRCUIT

# PARKING LAMP CIRCUIT

## < COMPONENT DIAGNOSIS >

1. Disconnect the combination lamp connector.
2. Check continuity between the combination lamp harness connector terminal and ground.

Combination lamp			Ground	Continuity
Connector	Terminal	Yes		
Front	A: E218, E225	9	Yes	
Rear	B: B30, B45	5		

### Does continuity exist?

- YES >> Inspect the parking lamp bulb.  
 NO >> Repair the harness.

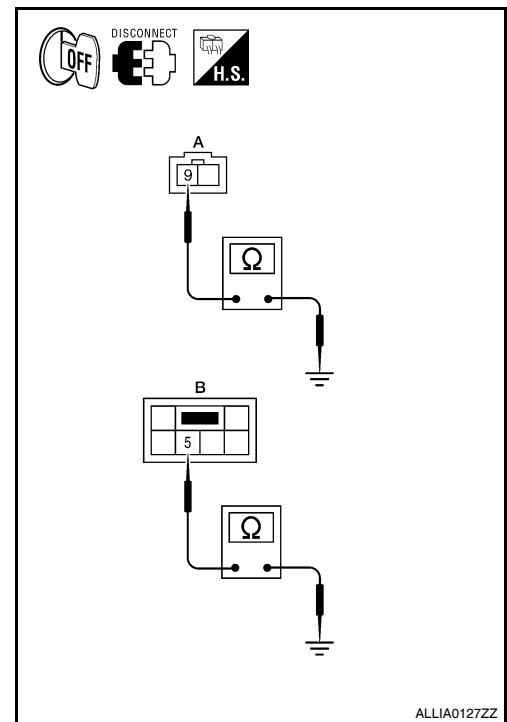

ALLIA0127ZZ

A  
B  
C  
D  
E  
F  
G  
H  
I  
J  
K  
L  
M  
N  
O  
P

EXL

# TURN SIGNAL LAMP CIRCUIT

< COMPONENT DIAGNOSIS >

## TURN SIGNAL LAMP CIRCUIT

### Description

INFOID:000000004216400

The BCM monitors inputs from the combination switch to determine when to activate the turn signals. The BCM outputs voltage direction to the left and right turn signals during turn signal operation or both during hazard warning operation. The BCM sends a turn signal indicator request to the combination meter via the CAN communication lines.

The BCM performs the fast flasher operation (fail-safe) if any bulb or harness of the turn signal lamp circuit is open.

**NOTE:**

Turn signal lamp blinks at normal speed when using the hazard warning lamp.

### Component Function Check

INFOID:000000004216401

#### 1. CHECK TURN SIGNAL LAMP

CONSULT-III

1. Select "FLASHER" of BCM (FLASHER) active test item.
2. With operating the test items, check that the turn signal lamp blinks.

- LH** : Turn signal lamp LH blinking
- RH** : Turn signal lamp RH blinking
- OFF** : The turn signal lamp OFF

Does the turn signal lamp blink?

- YES >> Turn signal lamp circuit is normal.
- NO >> Refer to [EXL-48. "Diagnosis Procedure"](#).

### Diagnosis Procedure

INFOID:000000004216402

#### 1. CHECK TURN SIGNAL LAMP BULB

Check the applicable lamp bulb to be sure the proper bulb standard is in use and the bulb is not open.

Is the bulb OK?

- YES >> GO TO 2
- NO >> Replace the bulb.

#### 2. CHECK TURN SIGNAL LAMP OUTPUT VOLTAGE

1. Turn the ignition switch OFF.
2. Disconnect the front combination lamp connector or the rear combination lamp connector.
3. Turn the ignition switch ON.
4. With operating the turn signal switch, check the voltage between the BCM harness connector and the ground.

Terminals			Test item	Voltage
(+)	(-)			
BCM			FLASHER	
Connector	Terminal			
RH	M17	17	LH or RH	
Ground				
LH	M17	18	OFF	0V

PKID0926E

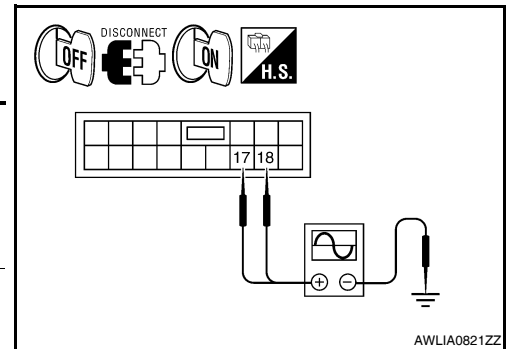



# TURN SIGNAL LAMP CIRCUIT

## < COMPONENT DIAGNOSIS >

Is the measurement value normal?

- YES >> GO TO 3
- NO >> Replace BCM.

### 3. CHECK TURN SIGNAL LAMP CIRCUIT FOR OPEN

1. Turn the ignition switch OFF.
2. Disconnect BCM connector.
3. Check the continuity between the BCM harness connector and the front combination lamp, the rear combination lamp harness connector or the door mirror connector (if equipped with turn signals in mirrors).

BCM		Terminal	Front combination lamp Rear combination lamp Door mirror		Continuity
Connector	Terminal		Connector	Terminal	
Rear LH	M17	18	B30	3	Yes
Front LH			E217	5	
Door mirror LH			D4	7	
Rear RH	M17	17	B45	3	
Front RH			E224	5	
Door mirror RH			D107	7	

Does continuity exist?

- YES >> GO TO 4
- NO >> Repair the harnesses or connectors.

### 4. CHECK TURN SIGNAL LAMP SHORT CIRCUIT

Check continuity between the BCM harness connector and the ground.

BCM		Terminal	Ground	Continuity
Connector	Terminal			
LH	M17	18		No
RH		17		

Does continuity exist?

- YES >> Repair the harnesses or connectors.
- NO >> GO TO 5

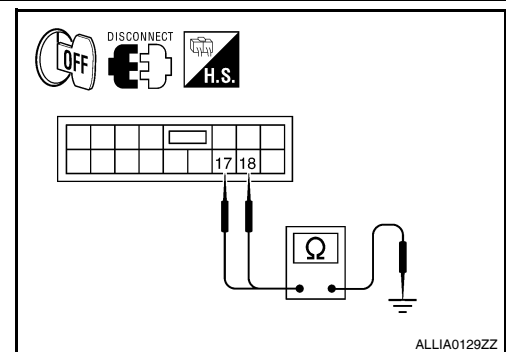

### 5. CHECK TURN SIGNAL LAMP GROUND CIRCUIT

Check continuity between the front combination lamp, the rear combination lamp or the door mirror and ground (if equipped with turn signals in mirrors).

Front combination lamp Rear combination lamp Door mirror		Terminal	Ground	Continuity
Connector	Terminal			
Front RH	E224	7	Ground	Yes
Front LH	E217	7		
Rear RH	B45	5		
Rear LH	B30	5		
Door mirror RH	D107	8		
Door mirror LH	D4	8		

Does continuity exist?

- YES >> Replace the front combination lamp or the rear combination lamp.

## TURN SIGNAL LAMP CIRCUIT

< COMPONENT DIAGNOSIS >

---

NO >> Repair the harnesses or connectors.

# OPTICAL SENSOR

< COMPONENT DIAGNOSIS >

## OPTICAL SENSOR

### Description

INFOID:000000004216403

The optical sensor converts the outside brightness (lux) to voltage and transmits the optical sensor signal to the BCM.

### Component Function Check

INFOID:000000004216404

#### 1. CHECK OPTICAL SENSOR SIGNAL BY CONSULT-III

##### CONSULT-III

1. Turn the ignition switch ON.
2. Select "OPTICAL SENSOR" of BCM (HEAD LAMP) DATA MONITOR item.
3. Turn the lighting switch to AUTO.
4. With the optical sensor illuminating, check the monitor status.

Monitor item	Condition	Voltage
OPTICAL SENSOR	When illuminating	3.1 V or more *
	When shutting off light	0.6 V or less

\*: Illuminates the optical sensor. The value may be less than the standard value if brightness is weak.

##### Is the item status normal?

- YES >> Optical sensor is normal.  
 NO >> Refer to [EXL-51, "Diagnosis Procedure"](#).

### Diagnosis Procedure

INFOID:000000004216405

#### 1. CHECK OPTICAL SENSOR POWER SUPPLY INPUT

1. Turn the ignition switch ON.
2. Turn the lighting switch to AUTO.
3. Check the voltage between the optical sensor harness connector and ground.

Terminals		Voltage
(+)	(-)	
Optical sensor		Ground
Connector	Terminal	
M66	1	

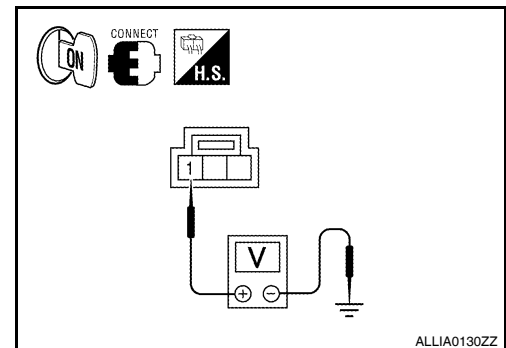

##### Is the measurement value normal?

- YES >> GO TO 2  
 NO >> GO TO 4

#### 2. CHECK OPTICAL SENSOR GROUND INPUT

Check the voltage between the optical sensor harness connector and ground.

Terminals		Voltage
(+)	(-)	
Optical sensor		Ground
Connector	Terminal	
M66	3	

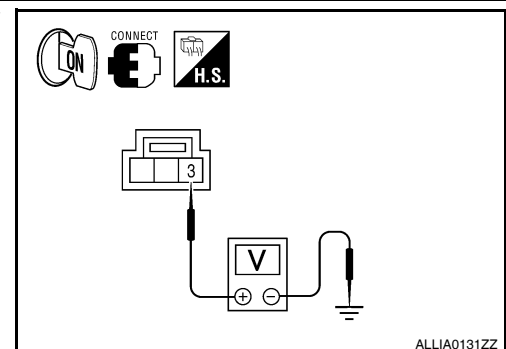

##### Is the measurement value normal?

- YES >> GO TO 3  
 NO >> GO TO 6

# OPTICAL SENSOR

## < COMPONENT DIAGNOSIS >

### 3. CHECK OPTICAL SENSOR SIGNAL OUTPUT

With the optical sensor illuminating, check voltage between the optical sensor harness connector and ground.

Terminals		Condition	Voltage
(+)	(-)		
Optical sensor		Optical sensor	
Connector	Terminal		
M66	2	When illuminating	
		When shutting off light	0.6V or less

\*: Illuminate the optical sensor. The value may be less than the standard if brightness is weak.

Is the measurement value normal?

YES >> GO TO 7

NO >> Replace the optical sensor.

### 4. CHECK OPTICAL SENSOR POWER SUPPLY FOR OPEN CIRCUIT

1. Turn the ignition switch OFF.
2. Disconnect the optical sensor connector and BCM connector.
3. Check continuity between the optical sensor harness connector and the BCM harness connector.

A		B		Continuity
Connector	Terminal	Connector	Terminal	
M66	1	M18	46	Yes

Does continuity exist?

YES >> GO TO 5

NO >> Repair the harnesses or connectors.

### 5. CHECK OPTICAL SENSOR POWER SUPPLY FOR SHORT CIRCUIT

Check the continuity between the optical sensor harness connector and the ground.

Optical sensor		Ground	Continuity
Connector	Terminal		
M66	1		No

Does continuity exist?

YES >> Repair the harnesses or connectors.

NO >> Replace BCM. Refer to [BCS-87, "Removal and Installation"](#).

### 6. CHECK OPTICAL SENSOR GROUND FOR OPEN CIRCUIT

1. Turn the ignition switch OFF.
2. Disconnect the optical sensor connector and BCM connector.

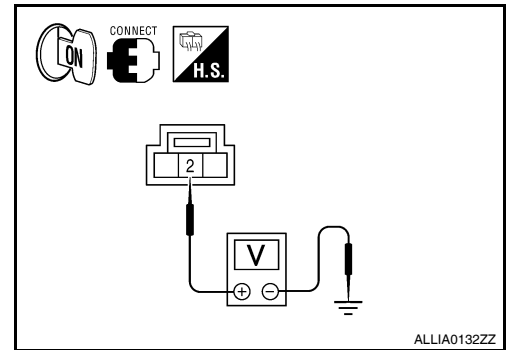

ALLIA0132ZZ

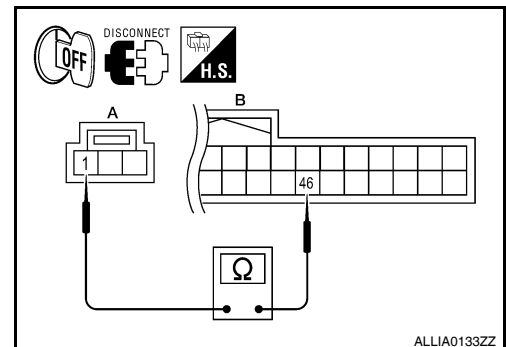

ALLIA0133ZZ

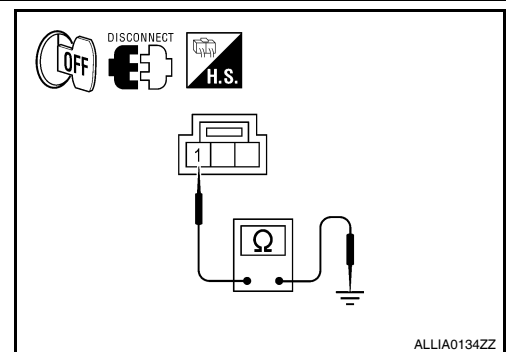

ALLIA0134ZZ

# OPTICAL SENSOR

## < COMPONENT DIAGNOSIS >

3. Check continuity between the optical sensor harness connector and the BCM harness connector.

A		B		Continuity
Connector	Terminal	Connector	Terminal	
M66	3	M18	45	Yes

### Does continuity exist?

YES >> Replace BCM. Refer to [BCS-87. "Removal and Installation"](#).

NO >> Repair the harnesses or connectors.

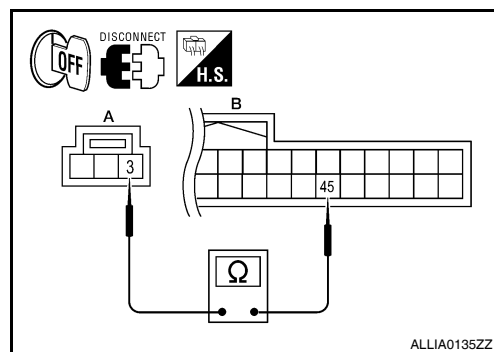

## 7. CHECK OPTICAL SENSOR SIGNAL FOR OPEN CIRCUIT

1. Turn the ignition switch OFF.
2. Disconnect the optical sensor connector and BCM connector.
3. Check continuity between the optical sensor harness connector and the BCM harness connector.

Optical sensor		BCM		Continuity
Connector	Terminal	Connector	Terminal	
M66	2	M18	21	Yes

### Does continuity exist?

YES >> GO TO 8

NO >> Repair the harnesses or connectors.

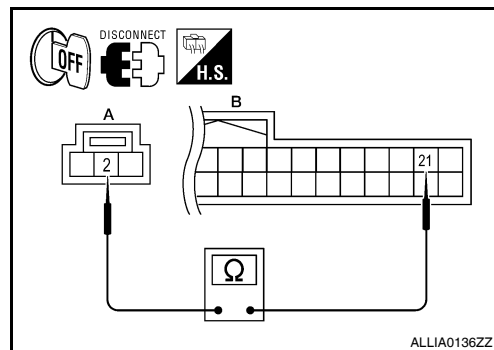

## 8. CHECK OPTICAL SENSOR SIGNAL FOR SHORT CIRCUIT

Check the continuity between the optical sensor harness connector and the ground.

Optical sensor		Ground	Continuity
Connector	Terminal		
M66	2	No	

### Does continuity exist?

YES >> Repair the harnesses or connectors.

NO >> Replace BCM. Refer to [BCS-87. "Removal and Installation"](#).

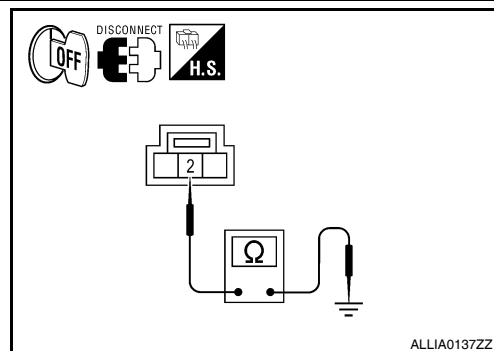

A  
B  
C  
D  
E  
F  
G  
H  
I  
J  
K  
EXL  
M  
N  
O  
P

# HEADLAMP

< COMPONENT DIAGNOSIS >

## HEADLAMP

### Wiring Diagram

INFOID:000000004216406

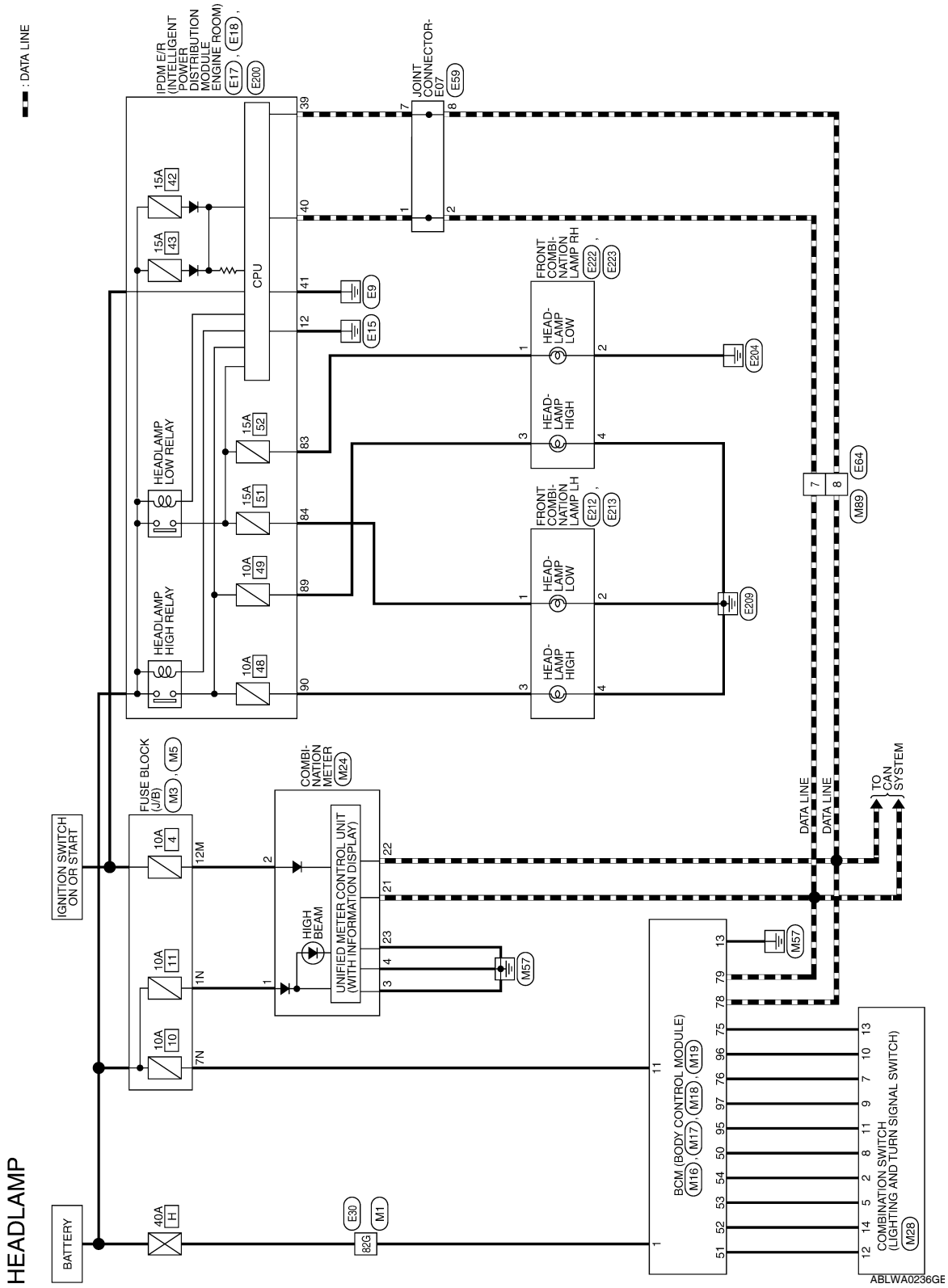

ABLWA0236GE

# HEADLAMP

## < COMPONENT DIAGNOSIS >

### HEADLAMP CONNECTORS

Connector No.	M1
Connector Name	WIRE TO WIRE
Connector Color	WHITE

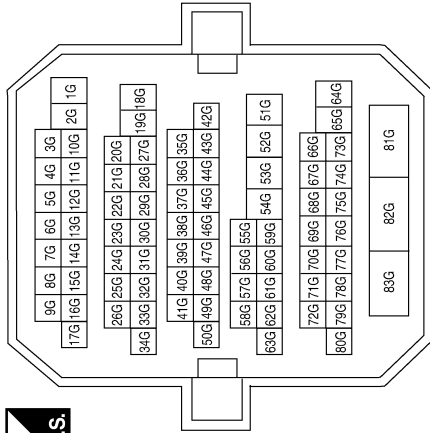

Terminal No.	Color of Wire	Signal Name
82G	W/B	-

Connector No.	M3
Connector Name	FUSE BLOCK (J/B)
Connector Color	WHITE

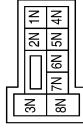

Terminal No.	Color of Wire	Signal Name
1N	W/L	-
7N	Y/R	-

Connector No.	M5
Connector Name	FUSE BLOCK (J/B)
Connector Color	WHITE

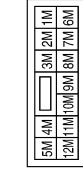

Terminal No.	Color of Wire	Signal Name
12M	O	-

Connector No.	M16
Connector Name	BCM (BODY CONTROL MODULE)
Connector Color	BLACK



Terminal No.	Color of Wire	Signal Name
1	W/B	BAT_POWER_F/L

Connector No.	M17
Connector Name	BCM (BODY CONTROL MODULE)
Connector Color	WHITE

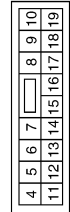

Terminal No.	Color of Wire	Signal Name
11	Y/R	BAT_BCM_FUSE
13	B	GND1

Connector No.	M18
Connector Name	BCM (BODY CONTROL MODULE)
Connector Color	GREEN

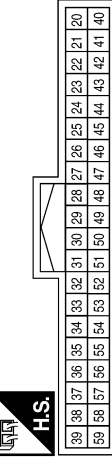

Terminal No.	Color of Wire	Signal Name
50	LG/B	INPUT_5
51	L/W	INPUT_1
52	G/B	INPUT_2
53	LG/R	INPUT_3
54	G/Y	INPUT_4

ABLIA0835GB

A B C D E F G H I J K M N O P

EXL

# HEADLAMP

## < COMPONENT DIAGNOSIS >

Connector No.	M19
Connector Name	BCM (BODY CONTROL MODULE)
Connector Color	BLACK



79	78	77	76	75	74	73	72	71	70	69	68	67	66	65	64	63	62	61	60
99	98	97	96	95	94	93	92	91	90	89	88	87	86	85	84	83	82	81	80



Terminal No.	Color of Wire	Signal Name
75	R/Y	OUTPUT_5
76	R/G	OUTPUT_3
78	P	CAN-L
79	L	CAN-H
95	R/W	OUTPUT_1
96	P/B	OUTPUT_4
97	R/B	OUTPUT_2



5	4	3	2	1		
12	11	10	9	8	7	6

Terminal No.	Color of Wire	Signal Name
7	L	-
8	P	-

Connector No.	M24
Connector Name	COMBINATION METER
Connector Color	WHITE



1	2	3	4	5	6	7	8	9	10	11	12	13	14	15	16	17	18	19	20
21	22	23	24	25	26	27	28	29	30	31	32	33	34	35	36	37	38	39	40

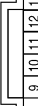

Terminal No.	Color of Wire	Signal Name
1	W/L	BATT
2	O	IGN
3	B	GND
4	B	GND
21	L	CAN-H
22	P	CAN-L
23	B	GND

Connector No.	M28
Connector Name	COMBINATION SWITCH
Connector Color	WHITE



1	2	3	4	5	6		
7	8	9	10	11	12	13	14



Terminal No.	Color of Wire	Signal Name
2	G/Y	OUTPUT_4
5	LG/R	OUTPUT_3
7	R/G	INPUT_3
8	LG/B	OUTPUT_5
9	R/B	INPUT_2
10	P/B	INPUT_4
11	R/W	INPUT_1
12	L/W	OUTPUT_1
13	R/Y	INPUT_5
14	G/B	OUTPUT_2

Connector No.	M89
Connector Name	WIRE TO WIRE
Connector Color	WHITE



Terminal No.	Color of Wire	Signal Name
7	L	-
8	P	-

Connector No.	E17
Connector Name	IPDM E/R (INTELLIGENT POWER DISTRIBUTION MODULE ENGINE ROOM)
Connector Color	WHITE



42	41	40	39
46	45	44	43

Terminal No.	Color of Wire	Signal Name
39	P	CAN-L
40	L	CAN-H
41	B	GND (SIGNAL)

Connector No.	E18
Connector Name	IPDM E/R (INTELLIGENT POWER DISTRIBUTION MODULE ENGINE ROOM)
Connector Color	WHITE



9	10	11	12	13	14				
3	4	5	6	7	8				
25	26	27	28	29	30	31	32	33	34
15	16	17	18	19	20	21	22	23	24
37	38								
35	36								

Terminal No.	Color of Wire	Signal Name
12	B	GND (POWER)



# HEADLAMP

## < COMPONENT DIAGNOSIS >

Connector No.	E64
Connector Name	WIRE TO WIRE
Connector Color	WHITE

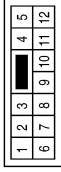

Terminal No.	Color of Wire	Signal Name
7	L	-
8	P	-

Connector No.	E59
Connector Name	JOINT CONNECTOR-E07
Connector Color	BLUE

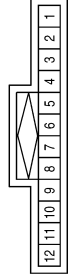

Terminal No.	Color of Wire	Signal Name
1	L	-
2	L	-
7	P	-
8	P	-

Connector No.	E30
Connector Name	WIRE TO WIRE
Connector Color	WHITE

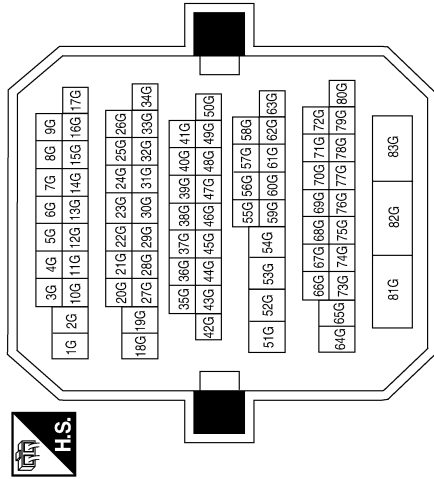

Terminal No.	Color of Wire	Signal Name
82G	W/B	-

Connector No.	E213
Connector Name	FRONT COMBINATION LAMP LH
Connector Color	BLACK



Terminal No.	Color of Wire	Signal Name
3	G	H/L_LH_HI
4	B	GND

Connector No.	E212
Connector Name	FRONT COMBINATION LAMP LH
Connector Color	BLACK



Terminal No.	Color of Wire	Signal Name
1	L	H/L_LH_LO
2	B	GND

Connector No.	E200
Connector Name	IPDM E/R (INTELLIGENT POWER DISTRIBUTION MODULE ENGINE ROOM)
Connector Color	WHITE

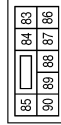

Terminal No.	Color of Wire	Signal Name
83	R/Y	HEADLAMP_LO_RH
84	L	HEADLAMP_LO_LH
89	L/W	HEADLAMP_HI_RH
90	G	HEADLAMP_HI_LH

ABLIA0837GB

# HEADLAMP

## < COMPONENT DIAGNOSIS >

Connector No.	E223
Connector Name	FRONT COMBINATION LAMP RH
Connector Color	BLACK



Terminal No.	Color of Wire	Signal Name
1	R/Y	H/L RH LO
2	B	GND

Connector No.	E222
Connector Name	FRONT COMBINATION LAMP RH
Connector Color	BLACK



Terminal No.	Color of Wire	Signal Name
3	L/W	H/L RH HI
4	B	GND

ALLIA0143GB

# DAYTIME RUNNING LIGHT SYSTEM

< COMPONENT DIAGNOSIS >

## DAYTIME RUNNING LIGHT SYSTEM HEADLAMP

### HEADLAMP : Wiring Diagram

INFOID:000000004216407

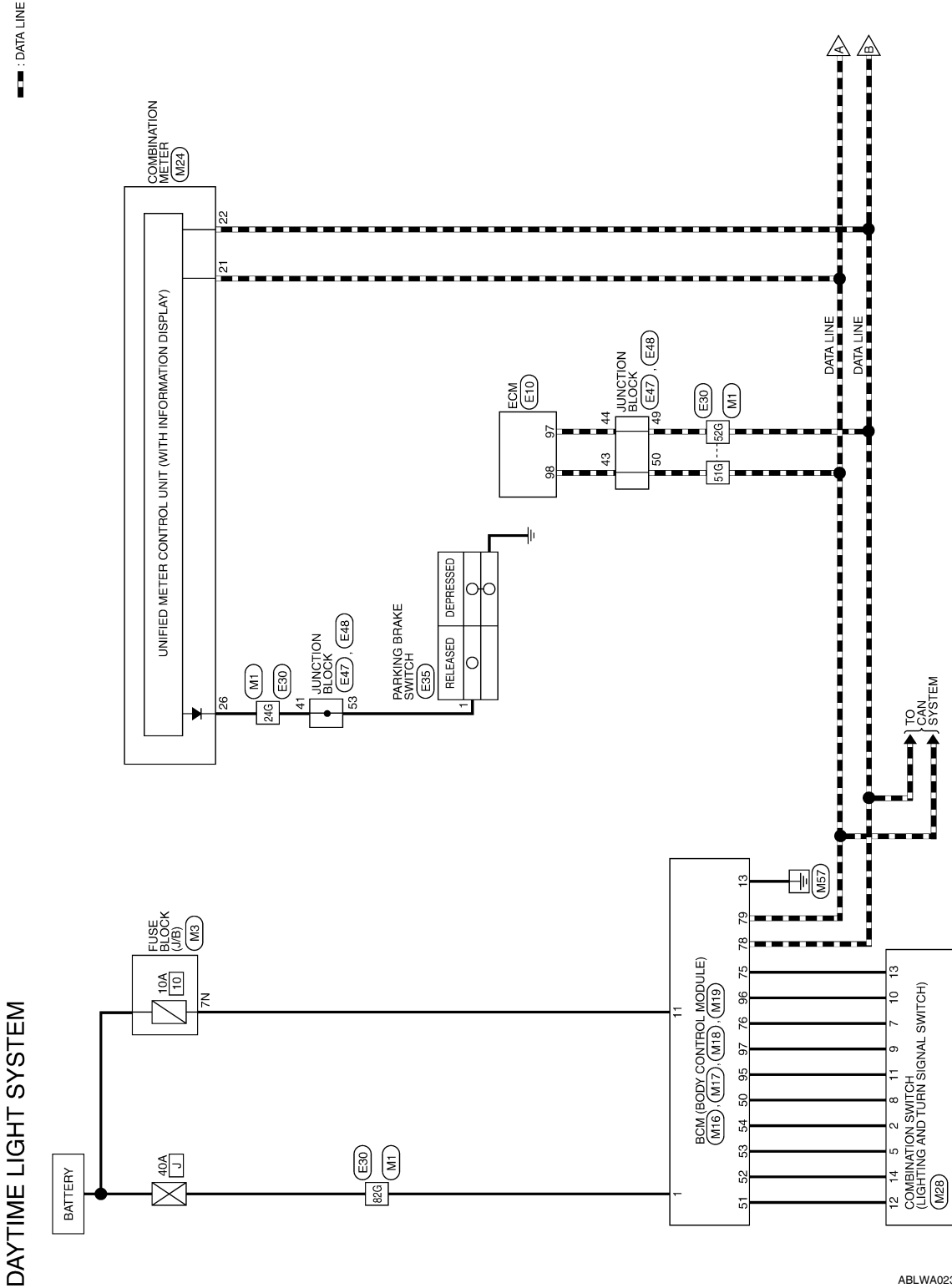

ABLWA0237GE

A  
B  
C  
D  
E  
F  
G  
H  
I  
J  
K  
EXL  
M  
N  
O  
P

# DAYTIME RUNNING LIGHT SYSTEM

## < COMPONENT DIAGNOSIS >

--- : DATA LINE

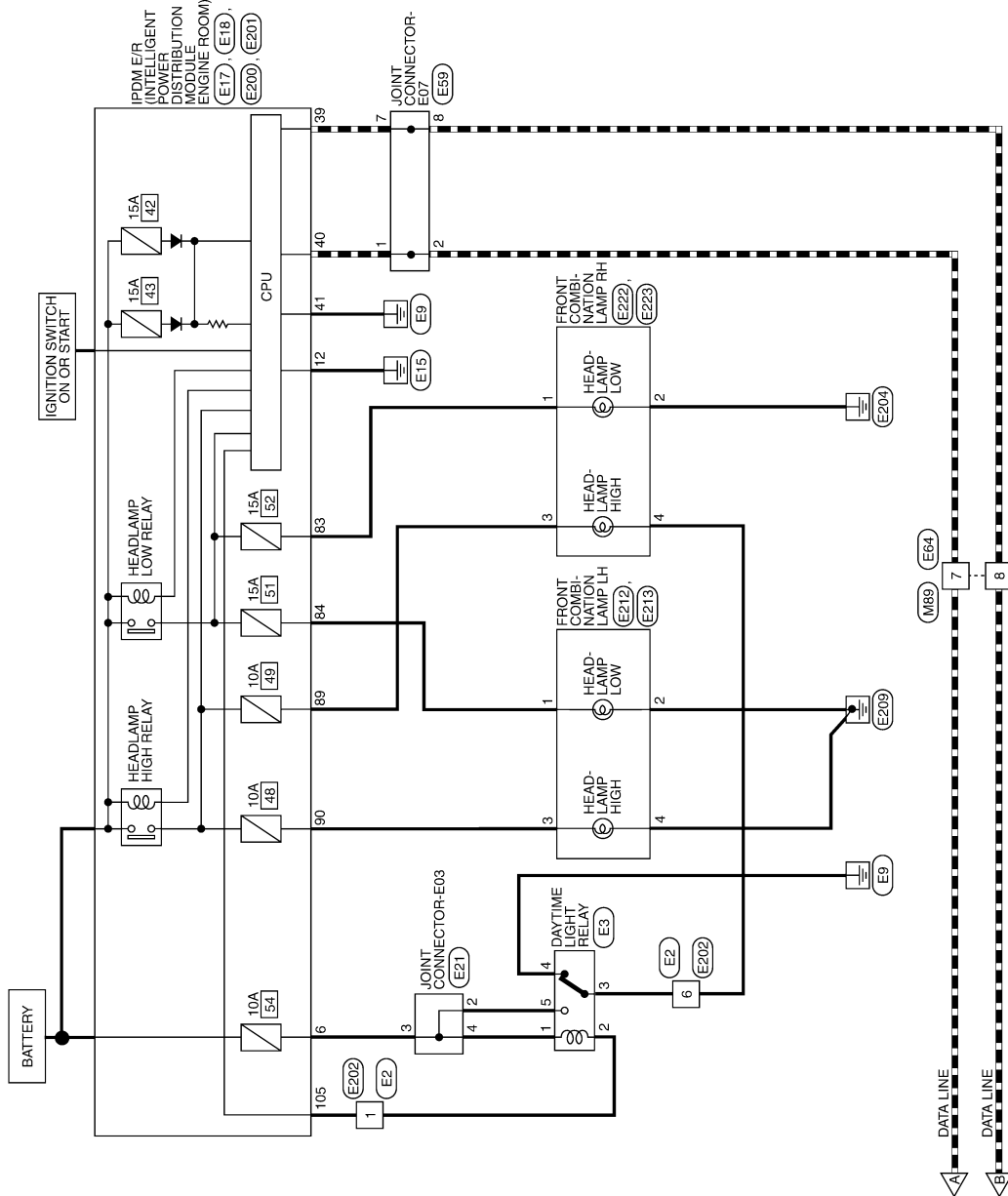

ALLWA0023GB

# DAYTIME RUNNING LIGHT SYSTEM

< COMPONENT DIAGNOSIS >

## DAYTIME LIGHT SYSTEM CONNECTORS

Connector No.	M1
Connector Name	WIRE TO WIRE
Connector Color	WHITE

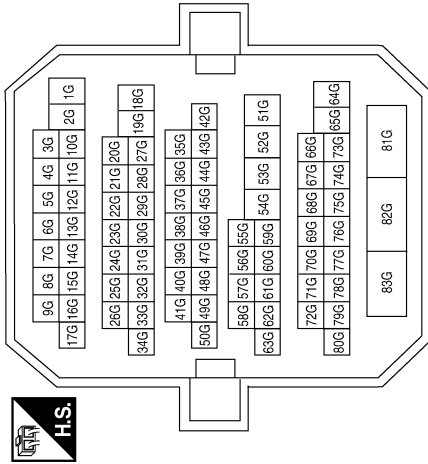

Terminal No.	Color of Wire	Signal Name
24G	G/R	-
51G	L	-
52G	P	-
82G	W/B	-

Connector No.	M3
Connector Name	FUSE BLOCK (J/B)
Connector Color	WHITE

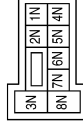

Terminal No.	Color of Wire	Signal Name
7N	Y/R	-

Connector No.	M16
Connector Name	BCM (BODY CONTROL MODULE)
Connector Color	BLACK



Terminal No.	Color of Wire	Signal Name
1	W/B	BAT_POWER_FL

Connector No.	M17
Connector Name	BCM (BODY CONTROL MODULE)
Connector Color	WHITE

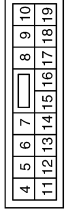

Terminal No.	Color of Wire	Signal Name
11	Y/R	BAT_BCM_FUSE
13	B	GND1

Connector No.	M18
Connector Name	BCM (BODY CONTROL MODULE)
Connector Color	GREEN

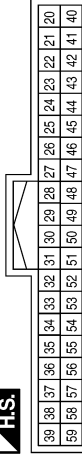

Terminal No.	Color of Wire	Signal Name
50	LG/B	INPUT_5
51	L/W	INPUT_1
52	G/B	INPUT_2
53	LG/R	INPUT_3
54	G/Y	INPUT_4

ABLIA0838GB

A  
B  
C  
D  
E  
F  
G  
H  
I  
J  
K  
L  
M  
N  
O  
P

EXL

# DAYTIME RUNNING LIGHT SYSTEM

## < COMPONENT DIAGNOSIS >

Connector No.	M28
Connector Name	COMBINATION SWITCH
Connector Color	WHITE

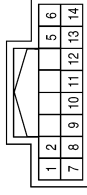

Terminal No.	Color of Wire	Signal Name
2	G/Y	OUTPUT_4
5	LG/R	OUTPUT_3
7	R/G	INPUT_3
8	LG/B	OUTPUT_5
9	R/B	INPUT_2
10	P/B	INPUT_4
11	R/W	INPUT_1
12	L/W	OUTPUT_1
13	R/Y	INPUT_5
14	G/B	OUTPUT_2

Connector No.	M24
Connector Name	COMBINATION METER
Connector Color	WHITE

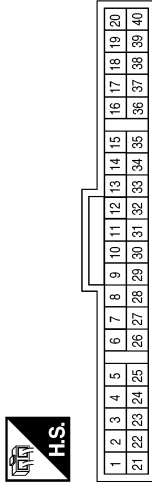

Terminal No.	Color of Wire	Signal Name
21	L	CAN-H
22	P	CAN-L
26	G/R	PKB

Connector No.	M19
Connector Name	BCM (BODY CONTROL MODULE)
Connector Color	BLACK

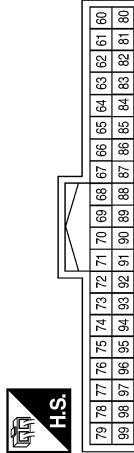

Terminal No.	Color of Wire	Signal Name
75	R/Y	OUTPUT_5
76	R/G	OUTPUT_3
78	P	CAN-L
79	L	CAN-H
95	R/W	OUTPUT_1
96	P/B	OUTPUT_4
97	R/B	OUTPUT_2

Connector No.	E3
Connector Name	DAYTIME LIGHT RELAY
Connector Color	BLACK



Terminal No.	Color of Wire	Signal Name
1	SB	-
2	V	-
3	GR/R	-
4	B	-
5	SB	-

Connector No.	E2
Connector Name	WIRE TO WIRE
Connector Color	WHITE



Terminal No.	Color of Wire	Signal Name
1	V	-
6	GR/R	-

Connector No.	M89
Connector Name	WIRE TO WIRE
Connector Color	WHITE

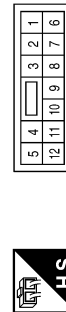

Terminal No.	Color of Wire	Signal Name
7	L	-
8	P	-

ABLIA0953GB

# DAYTIME RUNNING LIGHT SYSTEM

## < COMPONENT DIAGNOSIS >

Connector No.	E10
Connector Name	ECM
Connector Color	BLACK

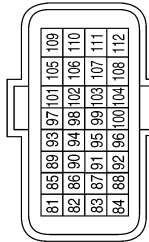

Terminal No.	Color of Wire	Signal Name
97	P	CAN-L
98	L	CAN-H

Connector No.	E17
Connector Name	IPDM E/R (INTELLIGENT POWER DISTRIBUTION MODULE ENGINE ROOM)
Connector Color	WHITE



Terminal No.	Color of Wire	Signal Name
39	P	CAN-L
40	L	CAN-H
41	B	GND (SIGNAL)

Connector No.	E18
Connector Name	IPDM E/R (INTELLIGENT POWER DISTRIBUTION MODULE ENGINE ROOM)
Connector Color	WHITE

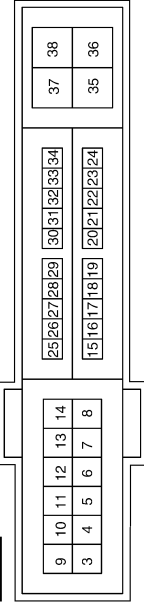

Terminal No.	Color of Wire	Signal Name
6	SB	DTRL
12	B	GND (POWER)

Connector No.	E21
Connector Name	JOINT CONNECTOR-E03
Connector Color	BLACK



Terminal No.	Color of Wire	Signal Name
2	SB	-
3	SB	-
4	SB	-

Connector No.	E30
Connector Name	WIRE TO WIRE
Connector Color	WHITE

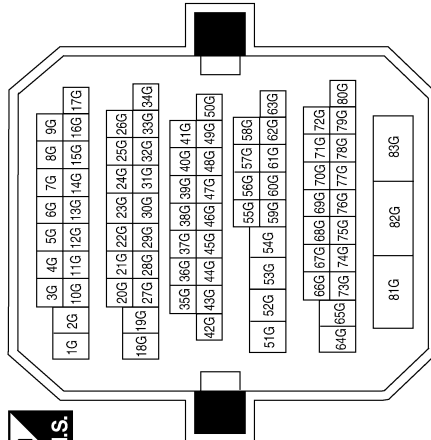

A  
B  
C  
D  
E  
F  
G  
H  
I  
J  
K  
L  
M  
N  
O  
P

EXL

# DAYTIME RUNNING LIGHT SYSTEM

## < COMPONENT DIAGNOSIS >

Connector No.	E48
Connector Name	JUNCTION BLOCK
Connector Color	WHITE

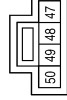

Terminal No.	Color of Wire	Signal Name
49	P	—
50	L	—
53	G/R	—

Connector No.	E47
Connector Name	JUNCTION BLOCK
Connector Color	WHITE



Terminal No.	Color of Wire	Signal Name
41	G/R	—
43	L	—
44	P	—

Connector No.	E35
Connector Name	PARKING BRAKE SWITCH
Connector Color	BLACK



Terminal No.	Color of Wire	Signal Name
1	G/R	—

Connector No.	E200
Connector Name	IPDM E/R (INTELLIGENT POWER DISTRIBUTION MODULE ENGINE ROOM)
Connector Color	WHITE

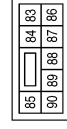

Terminal No.	Color of Wire	Signal Name
83	R/Y	HEADLAMP_LO_RH
84	L	HEADLAMP_LO_LH
89	L/W	HEADLAMP_HI_RH
90	G	HEADLAMP_HI_LH

Connector No.	E64
Connector Name	WIRE TO WIRE
Connector Color	WHITE

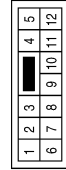

Terminal No.	Color of Wire	Signal Name
7	L	—
8	P	—

Connector No.	E59
Connector Name	JOINT CONNECTOR-E07
Connector Color	BLUE

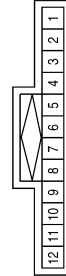

Terminal No.	Color of Wire	Signal Name
1	L	—
2	L	—
7	P	—
8	P	—

ALLIA0147GB



# DAYTIME RUNNING LIGHT SYSTEM

## < COMPONENT DIAGNOSIS >

Connector No.	E212
Connector Name	FRONT COMBINATION LAMP LH
Connector Color	GRAY



Terminal No.	Color of Wire	Signal Name
1	L	H/L LH LO
2	B	GND

Connector No.	E202
Connector Name	WIRE TO WIRE
Connector Color	WHITE

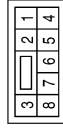

Terminal No.	Color of Wire	Signal Name
1	V	—
6	GR/R	—

Connector No.	E201
Connector Name	IPDM E/R (INTELLIGENT POWER DISTRIBUTION MODULE ENGINE ROOM)
Connector Color	WHITE

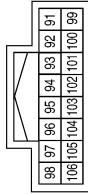

Terminal No.	Color of Wire	Signal Name
105	V	DTRL RLY

Connector No.	E223
Connector Name	FRONT COMBINATION LAMP RH
Connector Color	GRAY



Terminal No.	Color of Wire	Signal Name
1	R/Y	H/L RH LO
2	B	GND

Connector No.	E222
Connector Name	FRONT COMBINATION LAMP RH
Connector Color	BLACK



Terminal No.	Color of Wire	Signal Name
3	L/W	H/L RH HI
4	GR/R	GND

Connector No.	E213
Connector Name	FRONT COMBINATION LAMP LH
Connector Color	BLACK



Terminal No.	Color of Wire	Signal Name
3	G	H/L LH HI
4	B	GND

AWLIA0701GB

A  
B  
C  
D  
E  
F  
G  
H  
I  
J  
K  
EXL  
M  
N  
O  
P

# AUTO LIGHT SYSTEM

< COMPONENT DIAGNOSIS >

## AUTO LIGHT SYSTEM

### Wiring Diagram

INFOID:000000004216408

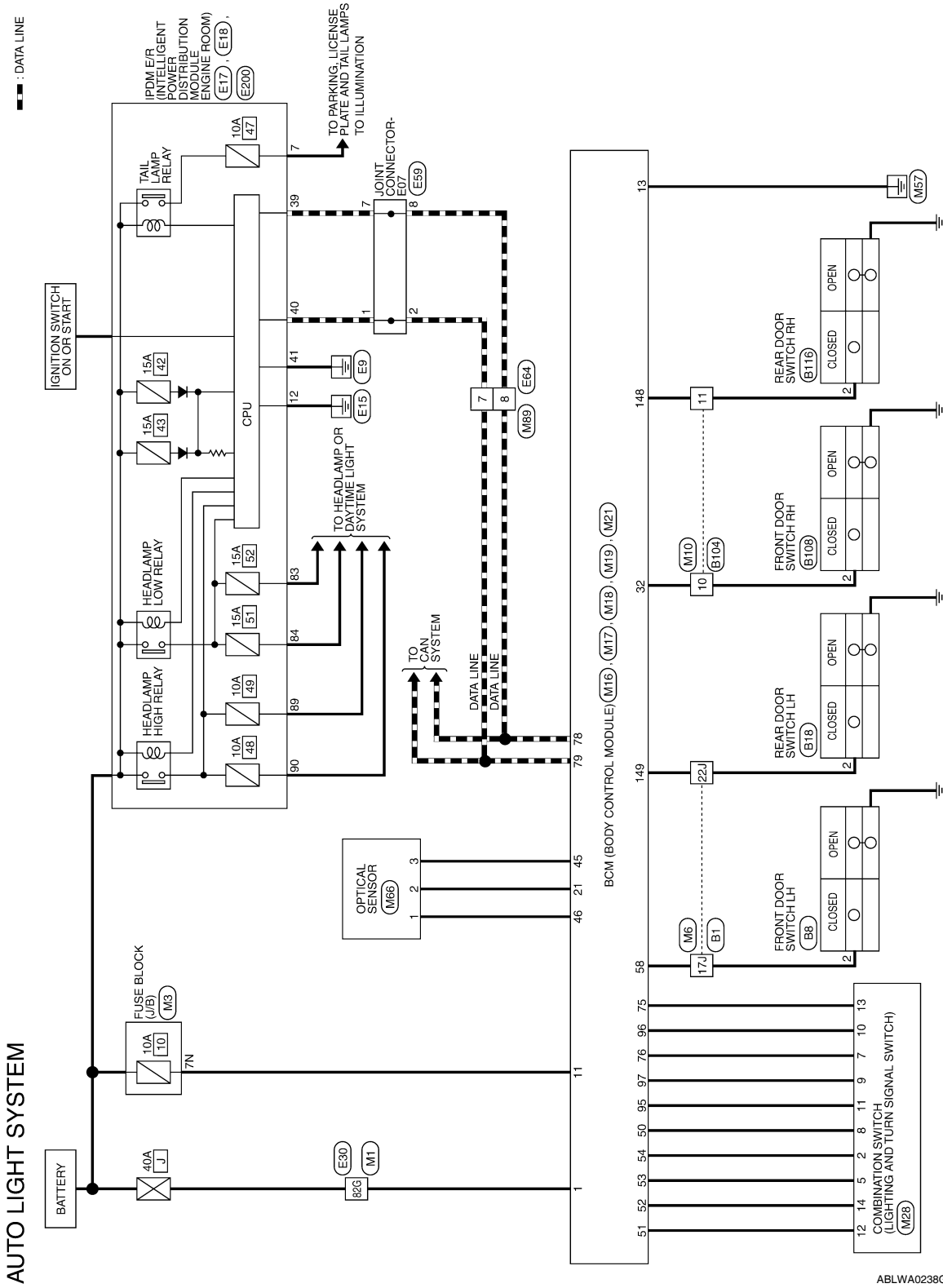

ABLWA0238GE

# AUTO LIGHT SYSTEM

< COMPONENT DIAGNOSIS >

## AUTO LIGHT SYSTEM CONNECTORS

Connector No.	M1
Connector Name	WIRE TO WIRE
Connector Color	WHITE

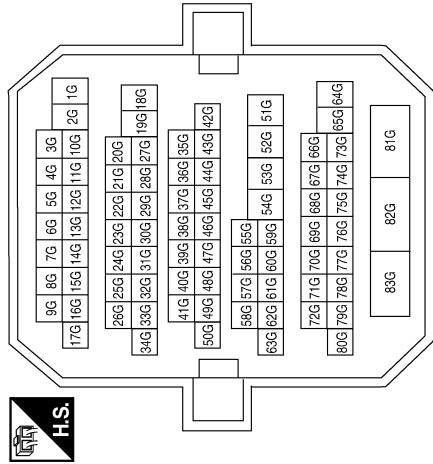

Terminal No.	Color of Wire	Signal Name
82G	W/B	-

Connector No.	M3
Connector Name	FUSE BLOCK (J/B)
Connector Color	WHITE

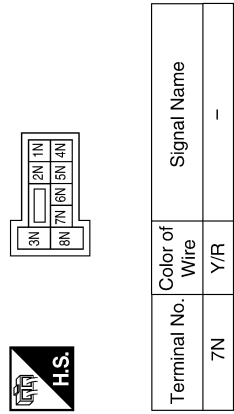

Terminal No.	Color of Wire	Signal Name
7N	Y/R	-

Connector No.	M6
Connector Name	WIRE TO WIRE
Connector Color	WHITE

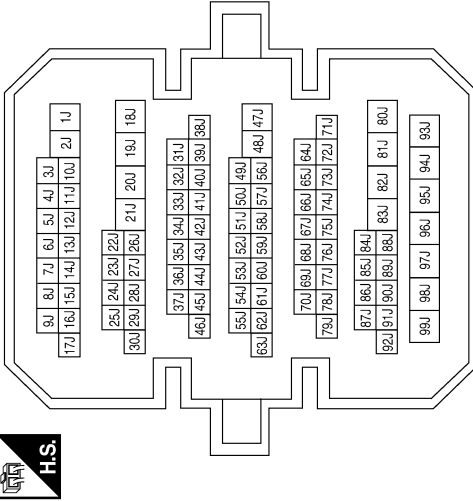

Terminal No.	Color of Wire	Signal Name
17J	SB	-
22J	R/B	-

Connector No.	M10
Connector Name	WIRE TO WIRE
Connector Color	BROWN

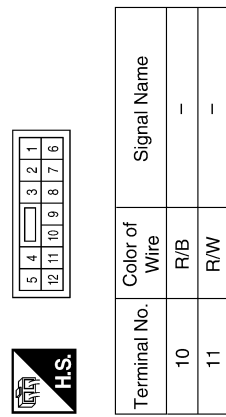

Terminal No.	Color of Wire	Signal Name
10	R/B	-
11	R/W	-

Connector No.	M16
Connector Name	BCM (BODY CONTROL MODULE)
Connector Color	BLACK

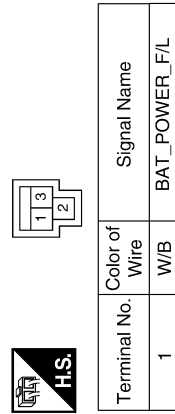

Terminal No.	Color of Wire	Signal Name
1	W/B	BAT_POWER_F/L

Connector No.	M17
Connector Name	BCM (BODY CONTROL MODULE)
Connector Color	WHITE

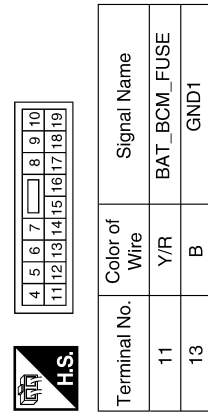

Terminal No.	Color of Wire	Signal Name
11	Y/R	BAT_BCM_FUSE
13	B	GND1

ABLIA0840GB

A B C D E F G H I J K EXL M N O P

# AUTO LIGHT SYSTEM

## < COMPONENT DIAGNOSIS >

Connector No.	M18
Connector Name	BCM (BODY CONTROL MODULE)
Connector Color	GREEN



39	38	37	36	35	34	33	32	31	30	29	28	27	26	25	24	23	22	21	20
59	58	57	56	55	54	53	52	51	50	49	48	47	46	45	44	43	42	41	40

Terminal No.	Color of Wire	Signal Name
21	P/B	ATUO_LIGHT_SENSEN_R_INPUT1
32	R/B	AS_DOOR_SW
45	P	GND_RF2_A/L
46	V/W	A/L_SENS_KEYLESS_TUNER_POWER_SUPPLY
50	LG/B	INPUT_5
51	L/W	INPUT_1
52	G/B	INPUT_2
53	LG/R	INPUT_3
54	G/Y	INPUT_4
58	SB	DR_DOOR_SW

Connector No.	M28
Connector Name	COMBINATION SWITCH
Connector Color	WHITE



1	2	3	4	5	6		
7	8	9	10	11	12	13	14

Connector No.	M19
Connector Name	BCM (BODY CONTROL MODULE)
Connector Color	BLACK



79	78	77	76	75	74	73	72	71	70	69	68	67	66	65	64	63	62	61	60
99	98	97	96	95	94	93	92	91	90	89	88	87	86	85	84	83	82	81	80

Terminal No.	Color of Wire	Signal Name
75	R/Y	OUTPUT_5
76	R/G	OUTPUT_3
78	P	CAN-L
79	L	CAN-H
95	R/W	OUTPUT_1
96	P/B	OUTPUT_4
97	R/B	OUTPUT_2

Terminal No.	Color of Wire	Signal Name
2	G/Y	OUTPUT_4
5	LG/R	OUTPUT_3
7	R/G	INPUT_3
8	LG/B	OUTPUT_5
9	R/B	INPUT_2
10	P/B	INPUT_4
11	R/W	INPUT_1
12	L/W	OUTPUT_1
13	R/Y	INPUT_5
14	G/B	OUTPUT_2

Connector No.	M21
Connector Name	BCM (BODY CONTROL MODULE)
Connector Color	GRAY



131	130	128	127	126	125	124	123	122	121	120	119	118	117	116	115	114	113	112	
151	150	149	148	147	146	145	144	143	142	141	140	139	138	137	136	135	134	133	132

Terminal No.	Color of Wire	Signal Name
148	R/W	RR_DOOR_SW
149	R/B	RL_DOOR_SW

Connector No.	M66
Connector Name	OPTICAL SENSOR
Connector Color	WHITE



1	2	3
---	---	---

Terminal No.	Color of Wire	Signal Name
1	V/W	POWER
2	P/B	OUTPUT
3	P	GND

ABLIA0841GB

# AUTO LIGHT SYSTEM

< COMPONENT DIAGNOSIS >

Connector No.	M89
Connector Name	WIRE TO WIRE
Connector Color	WHITE

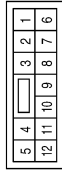

Terminal No.	Color of Wire	Signal Name
7	L	-
8	P	-

Connector No.	E17
Connector Name	IPDM E/R (INTELLIGENT POWER DISTRIBUTION MODULE ENGINE ROOM)
Connector Color	WHITE

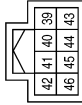

Terminal No.	Color of Wire	Signal Name
39	P	CAN-L
40	L	CAN-H
41	B	GND (SIGNAL)

Connector No.	E18
Connector Name	IPDM E/R (INTELLIGENT POWER DISTRIBUTION MODULE ENGINE ROOM)
Connector Color	WHITE

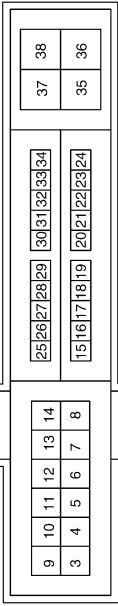

Terminal No.	Color of Wire	Signal Name
7	R/L	TAIL/ILLUMI
12	B	GND (POWER)

Connector No.	E30
Connector Name	WIRE TO WIRE
Connector Color	WHITE

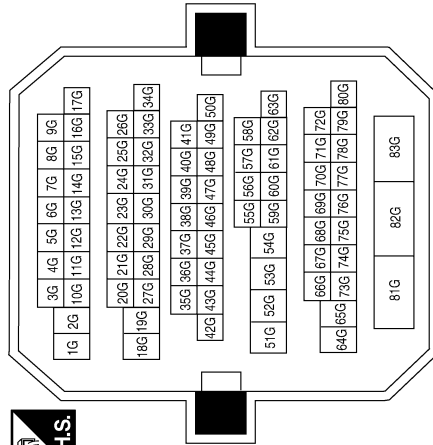

Connector No.	E59
Connector Name	JOINT CONNECTOR-E07
Connector Color	BLUE

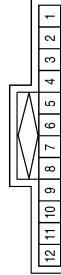

Terminal No.	Color of Wire	Signal Name
1	L	-
2	L	-
7	P	-
8	P	-

ABLIA0842GB

A  
B  
C  
D  
E  
F  
G  
H  
I  
J  
K  
EXL  
M  
N  
O  
P

# AUTO LIGHT SYSTEM

## < COMPONENT DIAGNOSIS >

Connector No.	E64
Connector Name	WIRE TO WIRE
Connector Color	WHITE

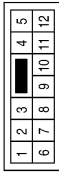

Terminal No.	Color of Wire	Signal Name
7	L	-
8	P	-

Connector No.	E200
Connector Name	IPDM E/R (INTELLIGENT POWER DISTRIBUTION MODULE ENGINE ROOM)
Connector Color	WHITE

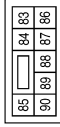

Terminal No.	Color of Wire	Signal Name
83	R/Y	HEADLAMP_LO_RH
84	L	HEADLAMP_LO_LH
89	L/W	HEADLAMP_HI_RH
90	G	HEADLAMP_HI_LH

Connector No.	B1
Connector Name	WIRE TO WIRE
Connector Color	WHITE

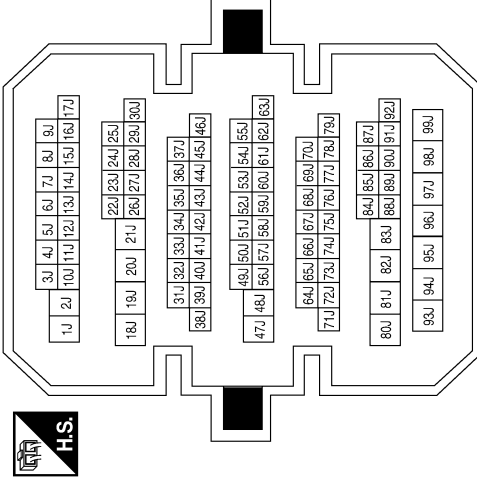

Terminal No.	Color of Wire	Signal Name
17J	SB	-
22J	R/B	-

Connector No.	B8
Connector Name	FRONT DOOR SWITCH LH
Connector Color	WHITE

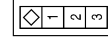

Terminal No.	Color of Wire	Signal Name
2	SB	DOOR SW (DR)

Connector No.	B18
Connector Name	REAR DOOR SWITCH LH
Connector Color	WHITE

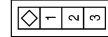

Terminal No.	Color of Wire	Signal Name
2	R/B	DOOR SW (RL)

Connector No.	B104
Connector Name	WIRE TO WIRE
Connector Color	BROWN

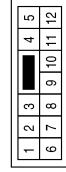

Terminal No.	Color of Wire	Signal Name
10	R/B	-
11	R/W	-

ABLIA0843GB

# AUTO LIGHT SYSTEM

## < COMPONENT DIAGNOSIS >

A  
B  
C  
D  
E  
F  
G  
H  
I  
J  
K  
EXL  
M  
N  
O  
P

Connector No.	B116
Connector Name	REAR DOOR SWITCH RH
Connector Color	WHITE

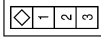

Terminal No.	2	Color of Wire	R/W	Signal Name	DOOR SW (RR)
--------------	---	---------------	-----	-------------	--------------

Connector No.	B108
Connector Name	FRONT DOOR SWITCH RH
Connector Color	WHITE

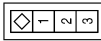

Terminal No.	2	Color of Wire	R/G	Signal Name	DOOR SW (AS)
--------------	---	---------------	-----	-------------	--------------

ABLIA0844GB

# FRONT FOG LAMP SYSTEM

< COMPONENT DIAGNOSIS >

## FRONT FOG LAMP SYSTEM

### Wiring Diagram

INFOID:000000004216409

--- : DATA LINE

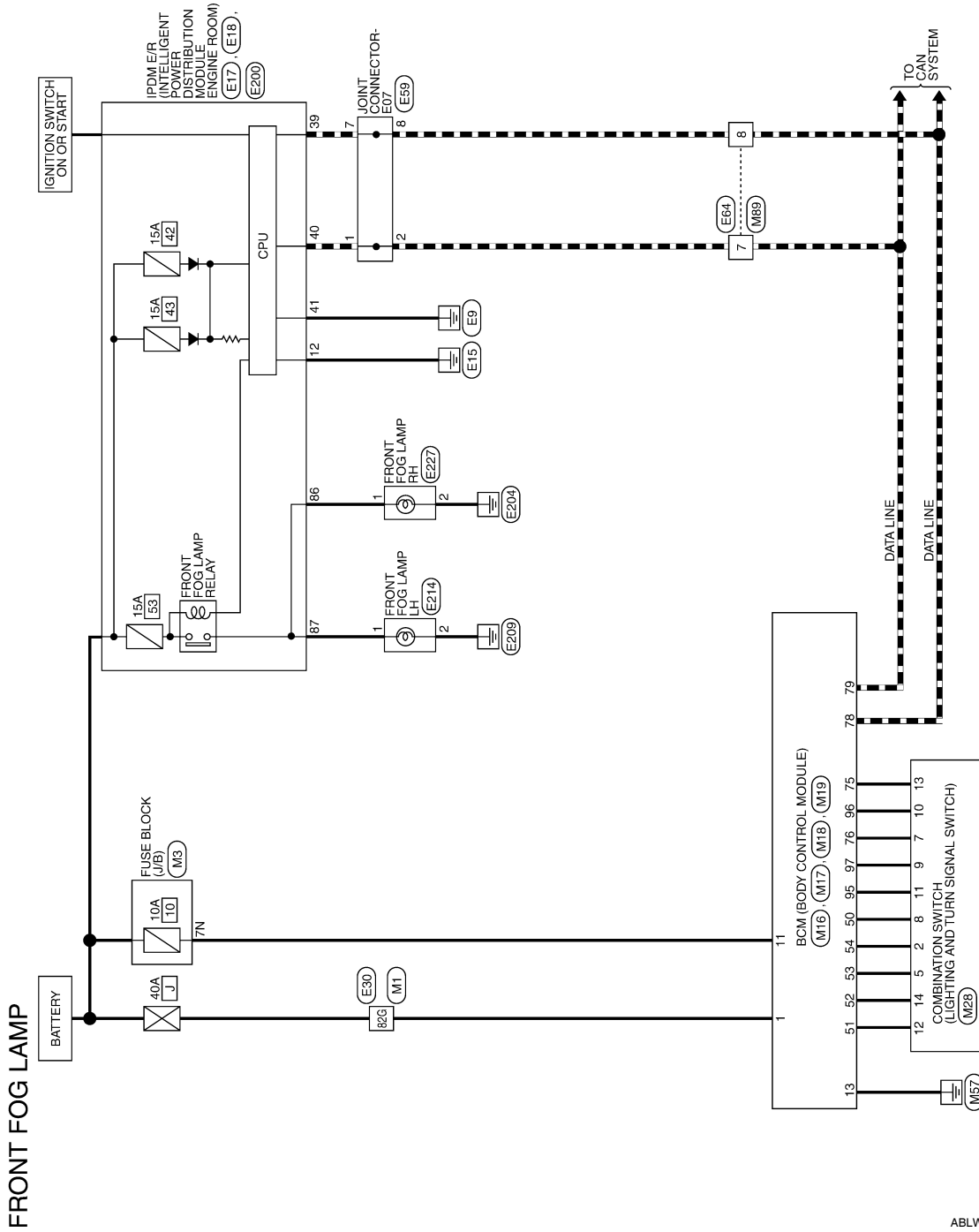

ABLWA0239GE



# FRONT FOG LAMP SYSTEM

< COMPONENT DIAGNOSIS >

## FRONT FOG LAMP CONNECTORS

Connector No.	M1
Connector Name	WIRE TO WIRE
Connector Color	WHITE

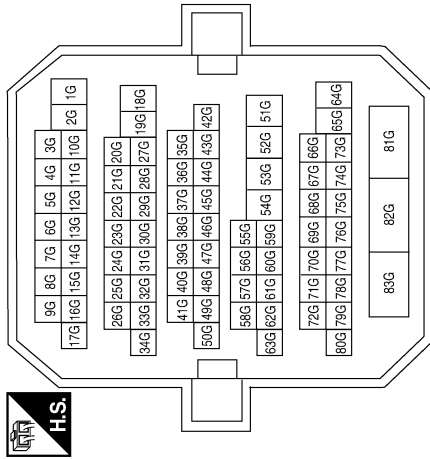

Terminal No.	Color of Wire	Signal Name
82G	W/B	-

Connector No.	M3
Connector Name	FUSE BLOCK (J/B)
Connector Color	WHITE

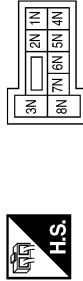

Terminal No.	Color of Wire	Signal Name
7N	Y/R	-

Connector No.	M16
Connector Name	BCM (BODY CONTROL MODULE)
Connector Color	BLACK



Terminal No.	Color of Wire	Signal Name
1	W/B	BAT_POWER_F/L

Connector No.	M17
Connector Name	BCM (BODY CONTROL MODULE)
Connector Color	WHITE

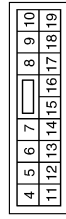

Terminal No.	Color of Wire	Signal Name
11	Y/R	BAT_BCM_FUSE
13	B	GND1

Connector No.	M18
Connector Name	BCM (BODY CONTROL MODULE)
Connector Color	GREEN

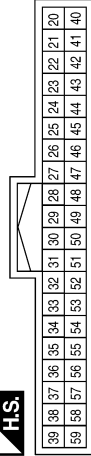

Terminal No.	Color of Wire	Signal Name
50	LG/B	INPUT_5
51	L/W	INPUT_1
52	G/B	INPUT_2
53	LG/R	INPUT_3
54	G/Y	INPUT_4

ABLIA0846GB

A  
B  
C  
D  
E  
F  
G  
H  
I  
J  
K  
L  
M  
N  
O  
P

EXL

# FRONT FOG LAMP SYSTEM

## < COMPONENT DIAGNOSIS >

Connector No.	M19
Connector Name	BCM (BODY CONTROL MODULE)
Connector Color	BLACK

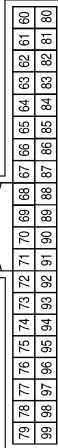

Terminal No.	Color of Wire	Signal Name
75	R/Y	OUTPUT_5
76	R/G	OUTPUT_3
78	P	CAN-L
79	L	CAN-H
95	R/W	OUTPUT_1
96	P/B	OUTPUT_4
97	R/B	OUTPUT_2

Connector No.	M28
Connector Name	COMBINATION SWITCH
Connector Color	WHITE

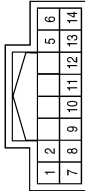

Terminal No.	Color of Wire	Signal Name
2	G/Y	OUTPUT_4
5	LG/R	OUTPUT_3
7	R/G	INPUT_3
8	LG/B	OUTPUT_5
9	R/B	INPUT_2
10	P/B	INPUT_4
11	R/W	INPUT_1
12	L/W	OUTPUT_1
13	R/Y	INPUT_5
14	G/B	OUTPUT_2

Connector No.	M89
Connector Name	WIRE TO WIRE
Connector Color	WHITE

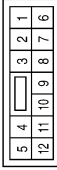

Terminal No.	Color of Wire	Signal Name
7	L	-
8	P	-

Connector No.	E17
Connector Name	IPDM E/R (INTELLIGENT POWER DISTRIBUTION MODULE ENGINE ROOM)
Connector Color	WHITE

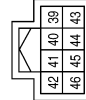

Terminal No.	Color of Wire	Signal Name
39	P	CAN-L
40	L	CAN-H
41	B	GND (SIGNAL)

Connector No.	E18
Connector Name	IPDM E/R (INTELLIGENT POWER DISTRIBUTION MODULE ENGINE ROOM)
Connector Color	WHITE

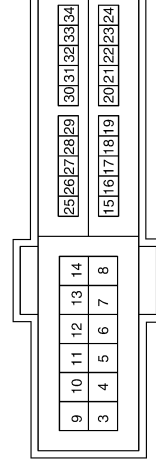

Terminal No.	Color of Wire	Signal Name
12	B	GND (POWER)

# FRONT FOG LAMP SYSTEM

< COMPONENT DIAGNOSIS >

Connector No.	E64
Connector Name	WIRE TO WIRE
Connector Color	WHITE

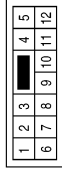

Terminal No.	Color of Wire	Signal Name
7	L	-
8	P	-

Connector No.	E59
Connector Name	JOINT CONNECTOR-E07
Connector Color	BLUE

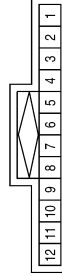

Terminal No.	Color of Wire	Signal Name
1	L	-
2	L	-
7	P	-
8	P	-

Connector No.	E30
Connector Name	WIRE TO WIRE
Connector Color	WHITE

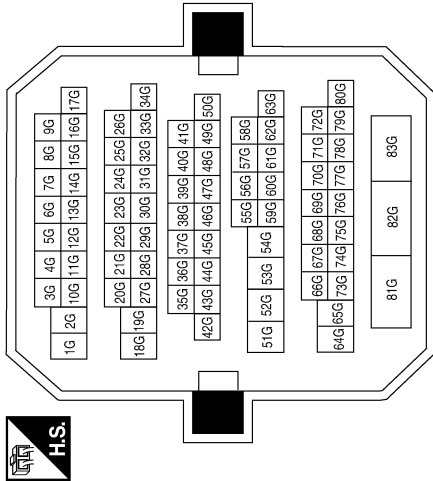

Terminal No.	Color of Wire	Signal Name
82G	W/B	-

Connector No.	E227
Connector Name	FRONT FOG LAMP RH
Connector Color	BLACK



Terminal No.	Color of Wire	Signal Name
1	W/R	FR_FOG_RLY
2	B	GND

Connector No.	E214
Connector Name	FRONT FOG LAMP LH
Connector Color	BLACK



Terminal No.	Color of Wire	Signal Name
1	L/Y	FR_FOG_RLY
2	B	GND

Connector No.	E200
Connector Name	IPDM E/R (INTELLIGENT POWER DISTRIBUTION MODULE ENGINE ROOM)
Connector Color	WHITE



Terminal No.	Color of Wire	Signal Name
86	W/R	FR_FOG_LAMP_RH
87	L/Y	FR_FOG_LAMP_LH

ABLIA0848GB

A  
B  
C  
D  
E  
F  
G  
H  
I  
J  
K  
L  
M  
N  
O  
P

EXL

# TURN SIGNAL AND HAZARD WARNING LAMP SYSTEM

< COMPONENT DIAGNOSIS >

## TURN SIGNAL AND HAZARD WARNING LAMP SYSTEM

### Wiring Diagram

INFOID:000000004216410

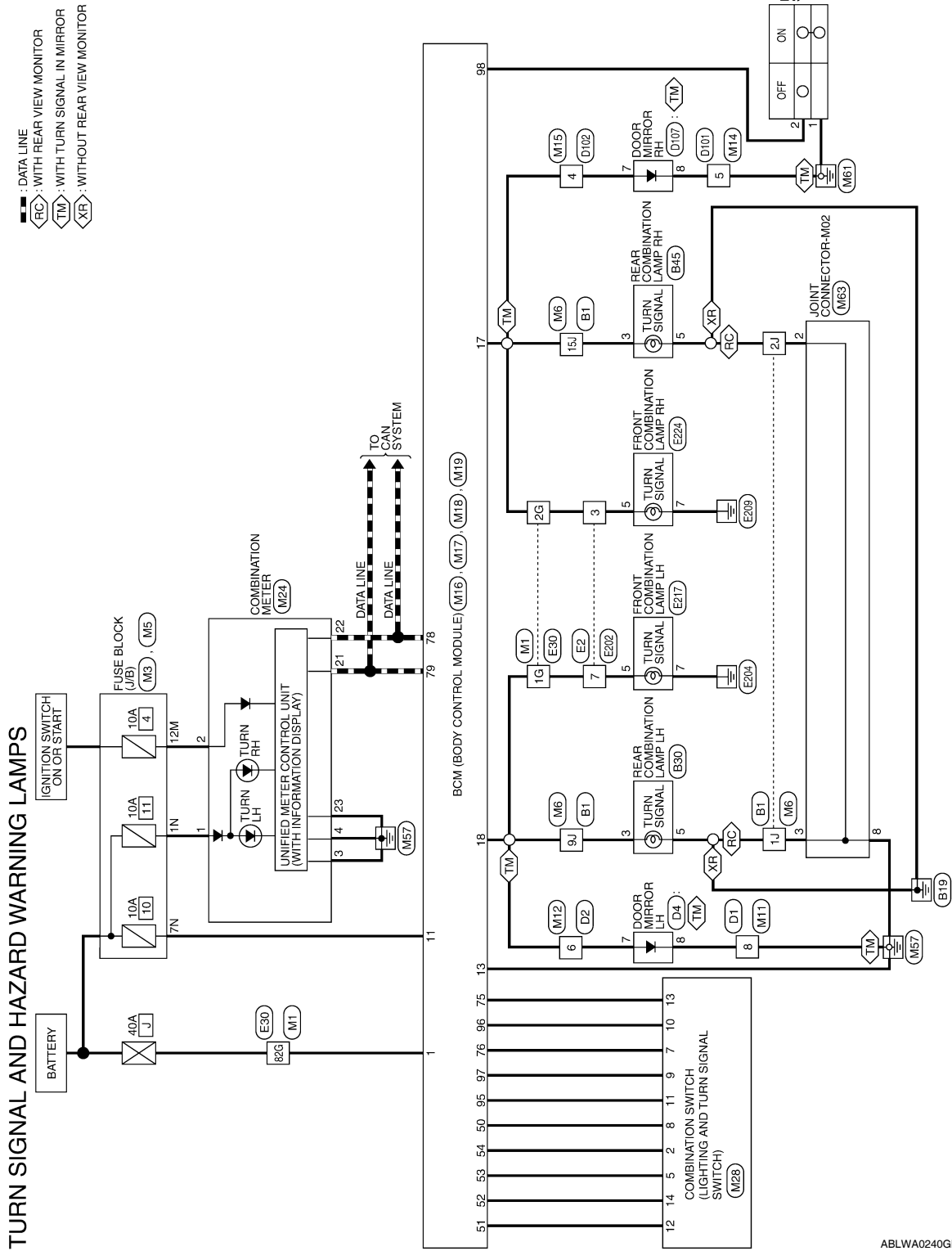

ABLWA0240GE

# TURN SIGNAL AND HAZARD WARNING LAMP SYSTEM

## < COMPONENT DIAGNOSIS >

### TURN SIGNAL AND HAZARD WARNING LAMPS CONNECTORS

Connector No.	M1
Connector Name	WIRE TO WIRE
Connector Color	WHITE

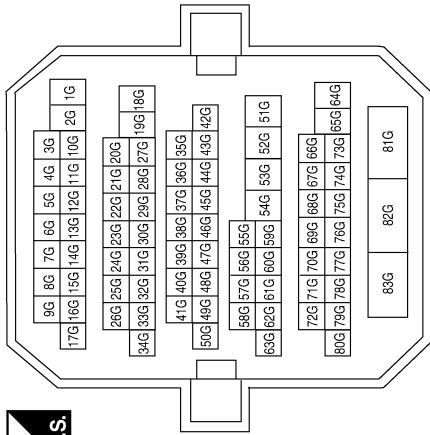

Terminal No.	Color of Wire	Signal Name
1G	G/Y	-
2G	G/B	-
82G	W/B	-

Connector No.	M3
Connector Name	FUSE BLOCK (J/B)
Connector Color	WHITE

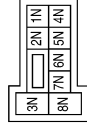

Terminal No.	Color of Wire	Signal Name
1N	W/L	-
7N	Y/R	-

Connector No.	M5
Connector Name	FUSE BLOCK (J/B)
Connector Color	WHITE



Terminal No.	Color of Wire	Signal Name
12M	P	-

A  
B  
C  
D  
E  
F  
G  
H  
I  
J  
K  
L  
M  
N  
O  
P

EXL

# TURN SIGNAL AND HAZARD WARNING LAMP SYSTEM

## < COMPONENT DIAGNOSIS >

Connector No.	M6
Connector Name	WIRE TO WIRE
Connector Color	WHITE

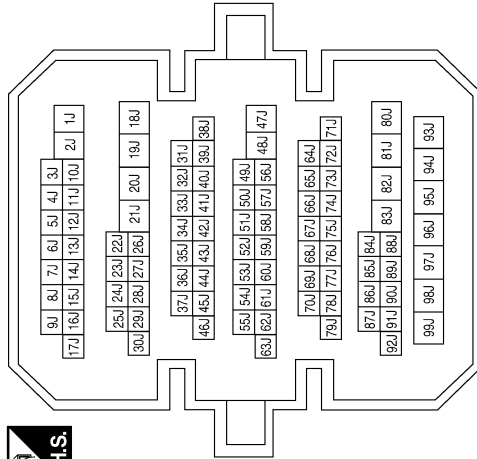

Terminal No.	Color of Wire	Signal Name
1J	B	-
2J	B	-
9J	G/Y	-
15J	G/B	-

Connector No.	M11
Connector Name	WIRE TO WIRE
Connector Color	WHITE

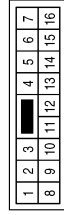

Terminal No.	Color of Wire	Signal Name
8	B	-

Connector No.	M12
Connector Name	WIRE TO WIRE
Connector Color	WHITE

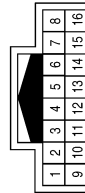

Terminal No.	Color of Wire	Signal Name
6	G/Y	-

Connector No.	M14
Connector Name	WIRE TO WIRE
Connector Color	WHITE

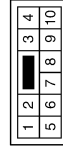

Terminal No.	Color of Wire	Signal Name
5	B	-

Connector No.	M15
Connector Name	WIRE TO WIRE
Connector Color	WHITE

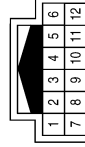

Terminal No.	Color of Wire	Signal Name
4	G/B	-

# TURN SIGNAL AND HAZARD WARNING LAMP SYSTEM

## < COMPONENT DIAGNOSIS >

Connector No.	M16
Connector Name	BCM (BODY CONTROL MODULE)
Connector Color	BLACK



Terminal No.	Color of Wire	Signal Name
1	W/B	BAT_POWER_F/L

Connector No.	M17
Connector Name	BCM (BODY CONTROL MODULE)
Connector Color	WHITE

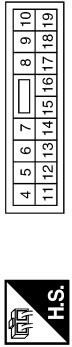

Terminal No.	Color of Wire	Signal Name
11	Y/R	BAT_BCM_FUSE
13	B	GND1
17	G/B	FR_FLASHER
18	G/Y	FL_FLASHER

Connector No.	M18
Connector Name	BCM (BODY CONTROL MODULE)
Connector Color	GREEN

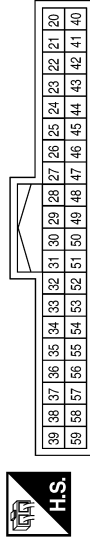

Terminal No.	Color of Wire	Signal Name
50	LG/B	INPUT_5
51	L/W	INPUT_1
52	G/B	INPUT_2
53	LG/R	INPUT_3
54	G/Y	INPUT_4

Connector No.	M19
Connector Name	BCM (BODY CONTROL MODULE)
Connector Color	BLACK

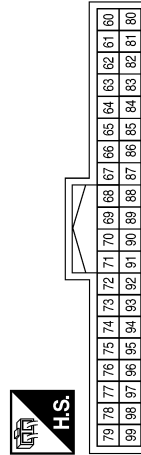

Terminal No.	Color of Wire	Signal Name
75	R/Y	OUTPUT_5
76	R/G	OUTPUT_3
78	P	CAN-L
79	L	CAN-H
95	R/W	OUTPUT_1
96	P/B	OUTPUT_4
97	R/B	OUTPUT_2
98	G/O	HAZARD_SW

Connector No.	M24
Connector Name	COMBINATION METER
Connector Color	WHITE

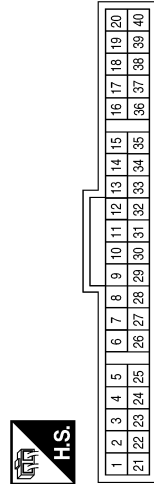

Terminal No.	Color of Wire	Signal Name
1	W/L	BATT
2	O	IGN
3	B	GND
4	B	GND
21	L	CAN-H
22	P	CAN-L
23	B	GND

Connector No.	M28
Connector Name	COMBINATION SWITCH
Connector Color	WHITE

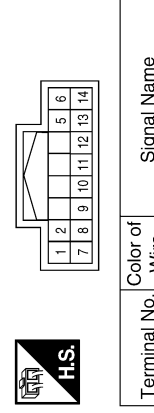

Terminal No.	Color of Wire	Signal Name
2	G/Y	OUTPUT_4
5	LG/R	OUTPUT_3
7	R/G	INPUT_3
8	LG/B	OUTPUT_5
9	R/B	INPUT_2
10	P/B	INPUT_4
11	R/W	INPUT_1
12	L/W	OUTPUT_1
13	R/Y	INPUT_5
14	G/B	OUTPUT_2

ABLIA0851GB

# TURN SIGNAL AND HAZARD WARNING LAMP SYSTEM

## < COMPONENT DIAGNOSIS >

Connector No.	M54
Connector Name	HAZARD SWITCH
Connector Color	WHITE



Terminal No.	Color of Wire	Signal Name
1	B	GND
2	G/O	HAZARD_SW

Connector No.	M63
Connector Name	JOINT CONNECTOR-M02
Connector Color	BLUE

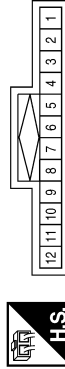

Terminal No.	Color of Wire	Signal Name
2	B	-
3	B	-
8	B	-

Connector No.	E2
Connector Name	WIRE TO WIRE
Connector Color	WHITE

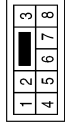

Terminal No.	Color of Wire	Signal Name
3	G/B	-
7	G/Y	-

Connector No.	E30
Connector Name	WIRE TO WIRE
Connector Color	WHITE

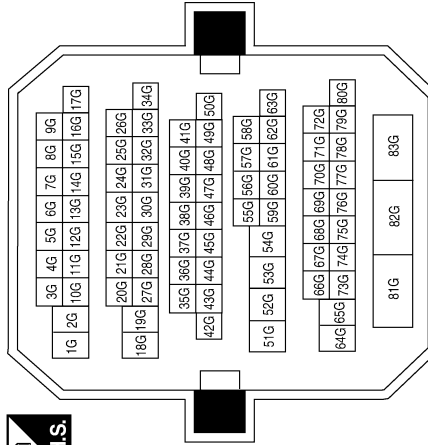

Terminal No.	Color of Wire	Signal Name
1G	G/Y	-
2G	G/B	-
82G	W/B	-

Connector No.	E217
Connector Name	FRONT COMBINATION LAMP LH
Connector Color	GRAY



Terminal No.	Color of Wire	Signal Name
5	G/Y	FLASHER_OUT_PUT (LEFT)
7	B	GND



# TURN SIGNAL AND HAZARD WARNING LAMP SYSTEM

## < COMPONENT DIAGNOSIS >

Connector No.	E224
Connector Name	FRONT COMBINATION LAMP RH
Connector Color	GRAY



Terminal No.	Color of Wire	Signal Name
5	G/B	FLASHER_OUT_PUT (RIGHT)
7	B	GND

Connector No.	B1
Connector Name	WIRE TO WIRE
Connector Color	WHITE

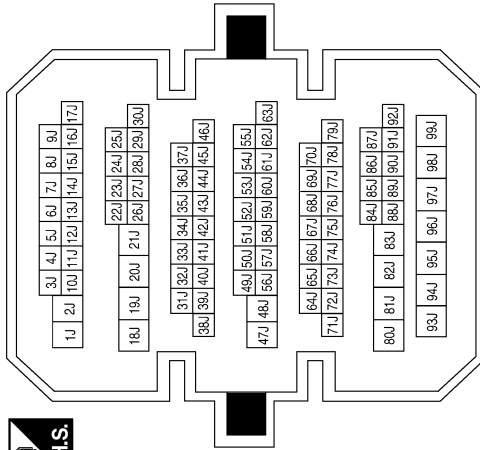

Terminal No.	Color of Wire	Signal Name
1J	B	-
2J	B/R	-
9J	G/Y	-
15J	G/B	-

Connector No.	B30
Connector Name	REAR COMBINATION LAMP LH
Connector Color	WHITE

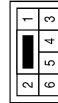

Terminal No.	Color of Wire	Signal Name
3	G/Y	FLASHER_OUT_PUT (LEFT)
5	B	GND

Connector No.	B45
Connector Name	REAR COMBINATION LAMP RH
Connector Color	WHITE



Terminal No.	Color of Wire	Signal Name
3	G/B	FLASHER_OUT_PUT (RIGHT)
5	B/R	GND (WITH REAR VIEW MONITOR)
5	B	GND (WITHOUT REAR VIEW MONITOR)

Connector No.	D1
Connector Name	WIRE TO WIRE
Connector Color	WHITE

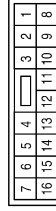

Terminal No.	Color of Wire	Signal Name
8	B	-

ABLIA0853GB

A  
B  
C  
D  
E  
F  
G  
H  
I  
J  
K  
L  
M  
N  
O  
P

EXL

# TURN SIGNAL AND HAZARD WARNING LAMP SYSTEM

## < COMPONENT DIAGNOSIS >

Connector No.	D101
Connector Name	WIRE TO WIRE
Connector Color	WHITE

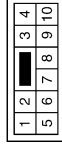

Terminal No.	Color of Wire	Signal Name
5	B	-

Connector No.	D4
Connector Name	DOOR MIRROR LH
Connector Color	WHITE

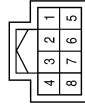

Terminal No.	Color of Wire	Signal Name
7	G/Y	TURN(+)
8	B	TURN(-)

Connector No.	D2
Connector Name	WIRE TO WIRE
Connector Color	WHITE

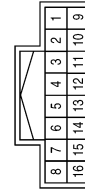

Terminal No.	Color of Wire	Signal Name
6	G/Y	-

Connector No.	D107
Connector Name	DOOR MIRROR RH
Connector Color	WHITE

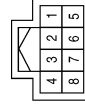

Terminal No.	Color of Wire	Signal Name
7	G/B	TURN(+)
8	B	TURN(-)

Connector No.	D102
Connector Name	WIRE TO WIRE
Connector Color	WHITE

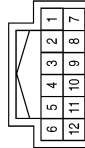

Terminal No.	Color of Wire	Signal Name
4	G/B	-

ABLIA0854GB

# PARKING, LICENSE PLATE AND TAIL LAMPS SYSTEM

< COMPONENT DIAGNOSIS >

## PARKING, LICENSE PLATE AND TAIL LAMPS SYSTEM

### Wiring Diagram

INFOID:000000004216411

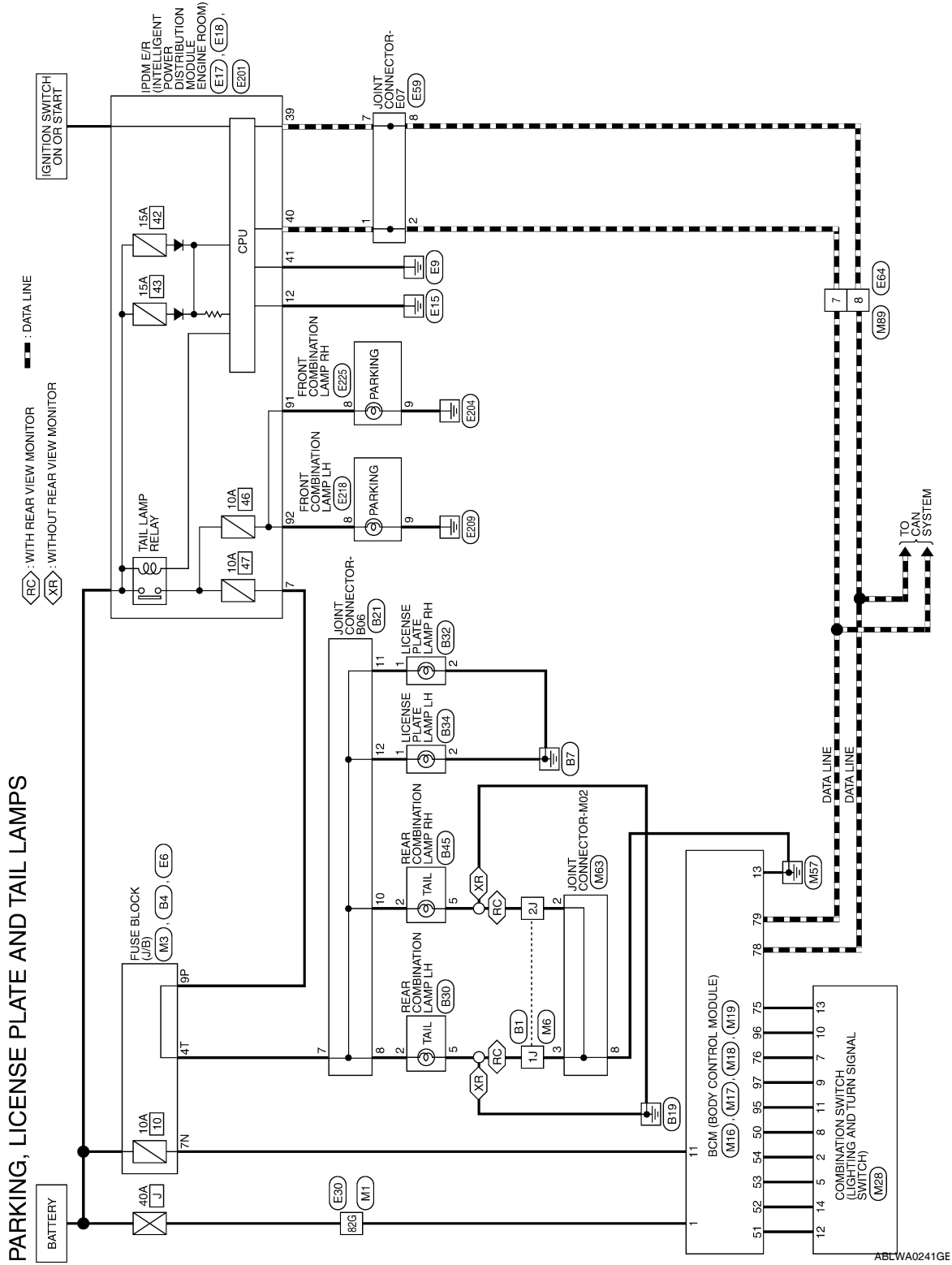

A  
B  
C  
D  
E  
F  
G  
H  
I  
J  
K  
L  
M  
N  
O  
P

EXL

# PARKING, LICENSE PLATE AND TAIL LAMPS SYSTEM

< COMPONENT DIAGNOSIS >

## PARKING, LICENSE PLATE AND TAIL LAMPS CONNECTORS

Connector No.	M1
Connector Name	WIRE TO WIRE
Connector Color	WHITE

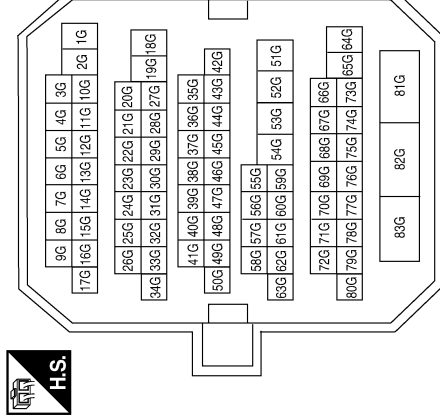

Connector No.	M3
Connector Name	FUSE BLOCK (J/B)
Connector Color	WHITE

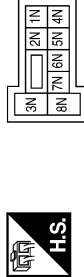

Connector No.	M6
Connector Name	WIRE TO WIRE
Connector Color	WHITE

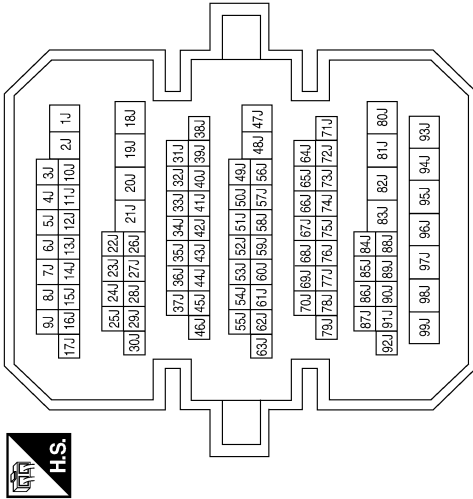

Terminal No.	Color of Wire	Signal Name
82G	W/B	-

Terminal No.	Color of Wire	Signal Name
7N	Y/R	-

Terminal No.	Color of Wire	Signal Name
1J	B	-
2J	B	-

Connector No.	M16
Connector Name	BCM (BODY CONTROL MODULE)
Connector Color	BLACK



Connector No.	M17
Connector Name	BCM (BODY CONTROL MODULE)
Connector Color	WHITE



Terminal No.	Color of Wire	Signal Name
1	W/B	BAT_POWER_F/L

Terminal No.	Color of Wire	Signal Name
11	Y/R	BAT_BCM_FUSE
13	B	GND1

ABLIA0855GB

# PARKING, LICENSE PLATE AND TAIL LAMPS SYSTEM

< COMPONENT DIAGNOSIS >

Connector No.	M28
Connector Name	COMBINATION SWITCH
Connector Color	WHITE

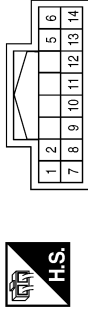

Terminal No.	Color of Wire	Signal Name
2	G/Y	OUTPUT 4
5	LG/R	OUTPUT 3
7	R/G	INPUT 3
8	LG/B	OUTPUT 5
9	R/B	INPUT 2
10	P/B	INPUT 4
11	R/W	INPUT 1
12	L/W	OUTPUT 1
13	R/Y	INPUT 5
14	G/B	OUTPUT 2

Connector No.	M19
Connector Name	BCM (BODY CONTROL MODULE)
Connector Color	BLACK

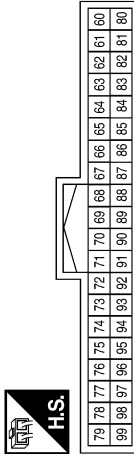

Terminal No.	Color of Wire	Signal Name
75	R/Y	OUTPUT 5
76	R/G	OUTPUT 3
78	P	CAN-L
79	L	CAN-H
95	R/W	OUTPUT 1
96	P/B	OUTPUT 4
97	R/B	OUTPUT 2

Connector No.	M18
Connector Name	BCM (BODY CONTROL MODULE)
Connector Color	GREEN

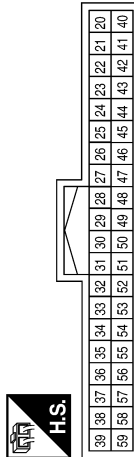

Terminal No.	Color of Wire	Signal Name
50	LG/B	INPUT 5
51	L/W	INPUT 1
52	G/B	INPUT 2
53	LG/R	INPUT 3
54	G/Y	INPUT 4

Connector No.	E6
Connector Name	FUSE BLOCK (J/B)
Connector Color	WHITE

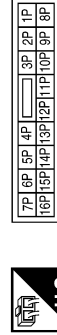

Terminal No.	Color of Wire	Signal Name
9P	R/L	—

Connector No.	M89
Connector Name	WIRE TO WIRE
Connector Color	WHITE

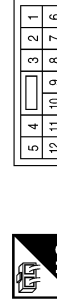

Terminal No.	Color of Wire	Signal Name
7	L	—
8	P	—

Connector No.	M63
Connector Name	JOINT CONNECTOR-M02
Connector Color	BLUE



Terminal No.	Color of Wire	Signal Name
2	B	—
3	B	—
8	B	—

ALLIA0164GB

A  
B  
C  
D  
E  
F  
G  
H  
I  
J  
K  
EXL  
M  
N  
O  
P

# PARKING, LICENSE PLATE AND TAIL LAMPS SYSTEM

## < COMPONENT DIAGNOSIS >

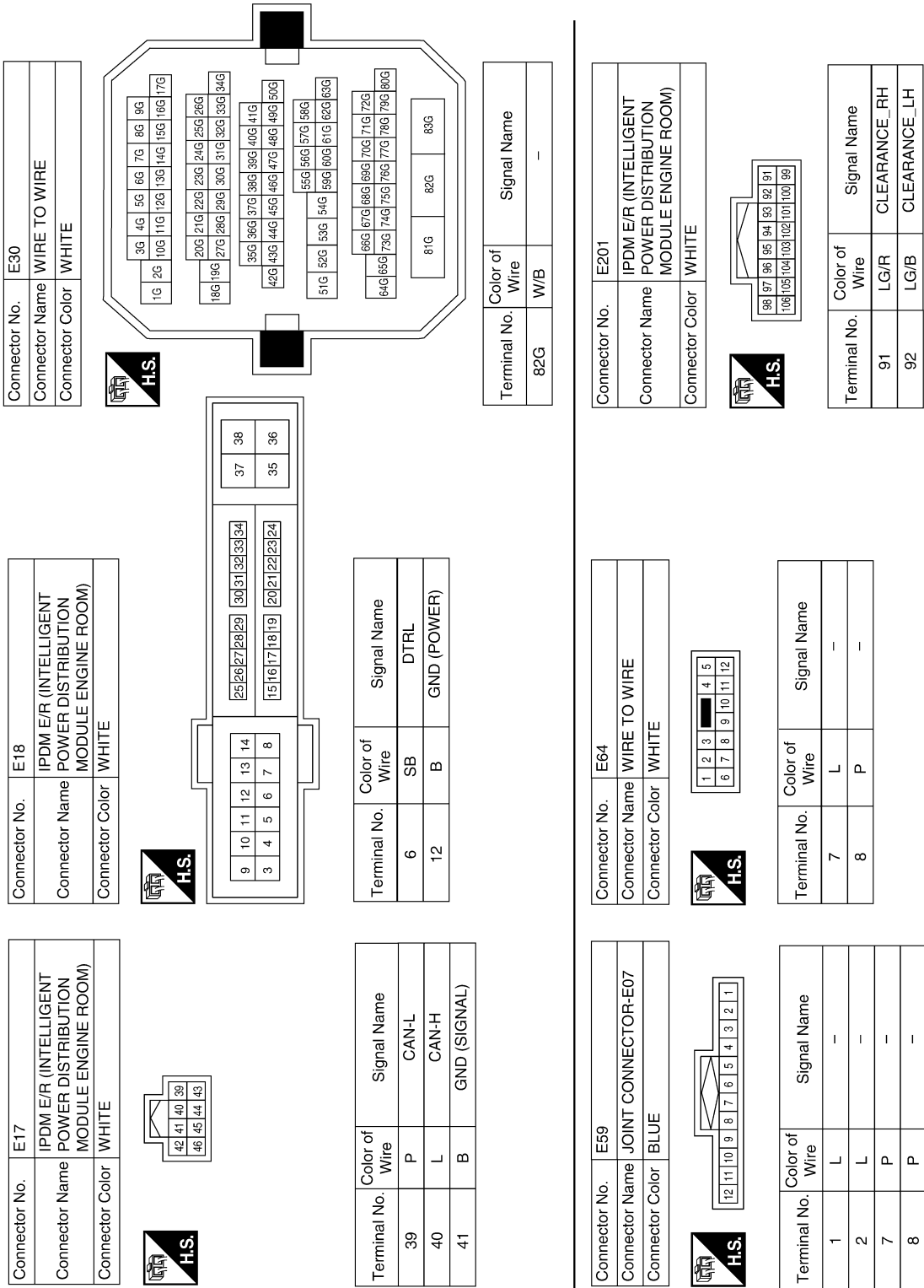

ABLIA00856GB

# PARKING, LICENSE PLATE AND TAIL LAMPS SYSTEM

## < COMPONENT DIAGNOSIS >

Connector No.	E218
Connector Name	FRONT COMBINATION LAMP LH
Connector Color	BLACK



Terminal No.	Color of Wire	Signal Name
8	LG/B	CLEARANCE
9	B	GND

Connector No.	E225
Connector Name	FRONT COMBINATION LAMP RH
Connector Color	BLACK



Terminal No.	Color of Wire	Signal Name
8	LG/R	CLEARANCE
9	B	GND

Connector No.	B1
Connector Name	WIRE TO WIRE
Connector Color	WHITE

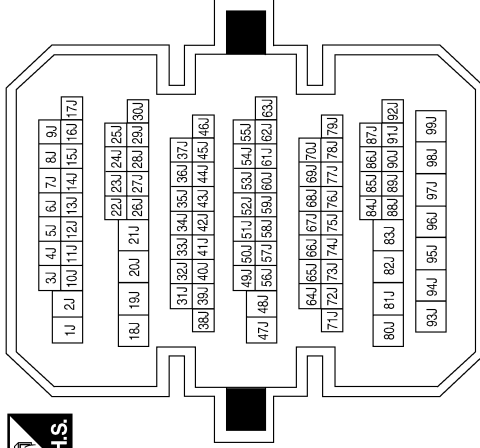

Terminal No.	Color of Wire	Signal Name
1J	B	-
2J	B/R	-

Connector No.	B4
Connector Name	FUSE BLOCK (J/B)
Connector Color	BROWN



Terminal No.	Color of Wire	Signal Name
4T	L/R	-

Connector No.	B21
Connector Name	JOINT CONNECTOR-B06
Connector Color	BLUE

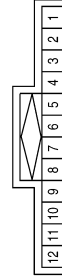

Terminal No.	Color of Wire	Signal Name
7	L/R	-
8	L/R	-
10	L/R	-
11	L/R	-
12	L/R	-

ABLIA0857GB

A  
B  
C  
D  
E  
F  
G  
H  
I  
J  
K  
EXL  
M  
N  
O  
P

# PARKING, LICENSE PLATE AND TAIL LAMPS SYSTEM

## < COMPONENT DIAGNOSIS >

Connector No.	B34
Connector Name	LICENSE PLATE LAMP LH
Connector Color	BROWN



Terminal No.	Color of Wire	Signal Name
1	L/R	TAIL_LAMP
2	B	GND

Connector No.	B32
Connector Name	LICENSE PLATE LAMP RH
Connector Color	BROWN



Terminal No.	Color of Wire	Signal Name
1	L/R	TRIL_LAMP
2	B	GND

Connector No.	B30
Connector Name	REAR COMBINATION LAMP LH
Connector Color	WHITE

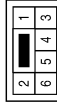

Terminal No.	Color of Wire	Signal Name
2	L/R	TAIL_LAMP
5	BR	GND

Connector No.	B45
Connector Name	REAR COMBINATION LAMP RH
Connector Color	WHITE



Terminal No.	Color of Wire	Signal Name
2	L/R	TAIL_LAMP
5	B/R	GND (WITH REAR VIEW MONITOR)
5	B	GND (WITHOUT REAR VIEW MONITOR)

ABLIA0858GB



# STOP LAMP

< COMPONENT DIAGNOSIS >

## STOP LAMP

### Wiring Diagram

INFOID:000000004216412

- OS : WITHOUT REAR SPOILER
- RC : WITH REAR VIEW MONITOR
- SP : WITH REAR SPOILER
- XR : WITHOUT REAR VIEW MONITOR

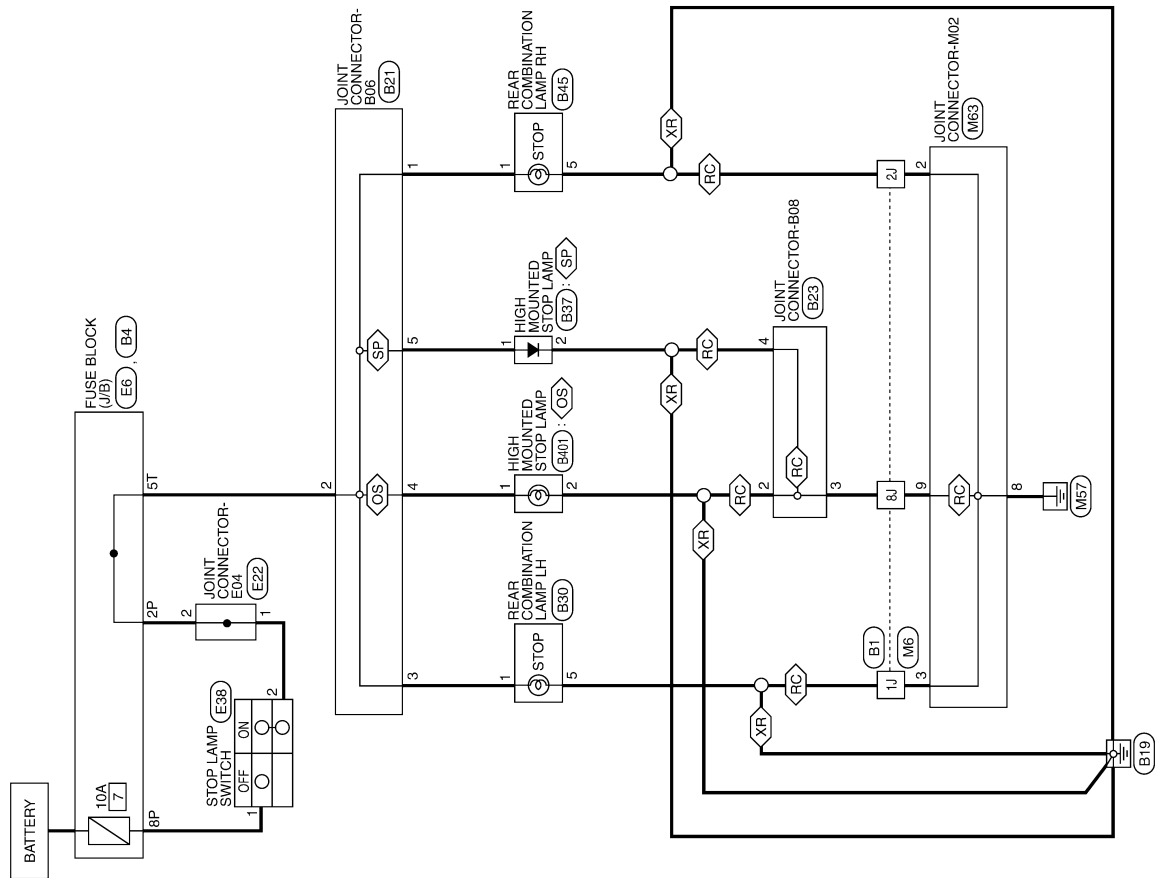

STOP LAMP

AWLWA0205GI

A  
B  
C  
D  
E  
F  
G  
H  
I  
J  
K  
L  
M  
N  
O  
P

EXL

# STOP LAMP

< COMPONENT DIAGNOSIS >

## STOP LAMP CONNECTORS

Connector No.	M6
Connector Name	WIRE TO WIRE
Connector Color	WHITE

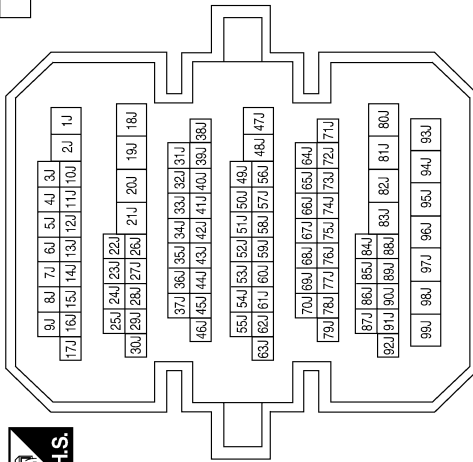

Terminal No.	Color of Wire	Signal Name
1J	B	-
2J	B	-
8J	B	-

Connector No.	M63
Connector Name	JOINT CONNECTOR-M02
Connector Color	BLUE

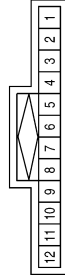

Terminal No.	Color of Wire	Signal Name
2	B	-
3	B	-
8	B	-
9	B	-

Connector No.	E6
Connector Name	FUSE BLOCK (J/B)
Connector Color	WHITE



Terminal No.	Color of Wire	Signal Name
2P	R/G	-
8P	Y/R	-

Connector No.	E22
Connector Name	JOINT CONNECTOR-E04
Connector Color	BLACK

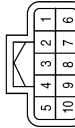

Terminal No.	Color of Wire	Signal Name
1	R/G	-
2	R/G	-

Connector No.	E38
Connector Name	STOP LAMP SWITCH
Connector Color	WHITE



Terminal No.	Color of Wire	Signal Name
1	Y/R	-
2	R/G	-

# STOP LAMP

< COMPONENT DIAGNOSIS >

Connector No.	B4
Connector Name	FUSE BLOCK (J/B)
Connector Color	BROWN

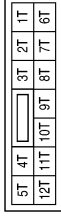

Terminal No.	Color of Wire	Signal Name
5T	O	-

Terminal No.	Color of Wire	Signal Name
1J	B	-
2J	B/R	-
8J	B	-

Connector No.	B1
Connector Name	WIRE TO WIRE
Connector Color	WHITE

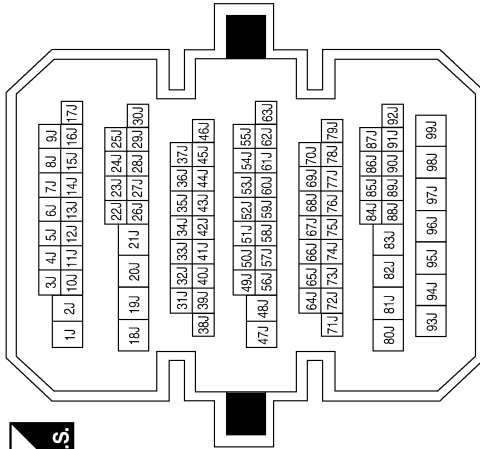

Connector No.	B30
Connector Name	REAR COMBINATION LAMP
Connector Color	WHITE

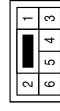

Terminal No.	Color of Wire	Signal Name
1	O	STOP_LAMP
5	BR	GND

Connector No.	B23
Connector Name	JOINT CONNECTOR-B08
Connector Color	WHITE



Terminal No.	Color of Wire	Signal Name
2	B	-
3	B	-
4	B	-

Connector No.	B21
Connector Name	JOINT CONNECTOR-B06
Connector Color	BLUE

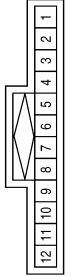

Terminal No.	Color of Wire	Signal Name
1	O	-
2	O	-
3	O	-
4	O	-
5	O	-

ABLIA0860GB

A  
B  
C  
D  
E  
F  
G  
H  
I  
J  
K  
L  
M  
N  
O  
P

EXL

# STOP LAMP

## < COMPONENT DIAGNOSIS >

Connector No.	B45
Connector Name	REAR COMBINATION LAMP RH
Connector Color	WHITE

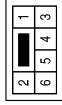

Terminal No.	Color of Wire	Signal Name
1	O	STOP_LAMP
5	B/R	GND (WITH REAR VIEW MONITOR)
5	B	GND (WITHOUT REAR VIEW MONITOR)

Connector No.	B37
Connector Name	HIGH MOUNTED STOP LAMP (WITHOUT REAR SPOILER)
Connector Color	WHITE



Terminal No.	Color of Wire	Signal Name
1	O	STOP_LAMP
2	B	GND

Connector No.	B37
Connector Name	HIGH MOUNTED STOP LAMP (WITH REAR SPOILER)
Connector Color	BROWN



Terminal No.	Color of Wire	Signal Name
1	O	STOP-LAMP
2	B	GND

ABLIA0861GB

# BACK-UP LAMP

< COMPONENT DIAGNOSIS >

## BACK-UP LAMP

### Wiring Diagram

INFOID:000000004216413

RC : WITH REAR VIEW MONITOR  
 XR : WITHOUT REAR VIEW MONITOR

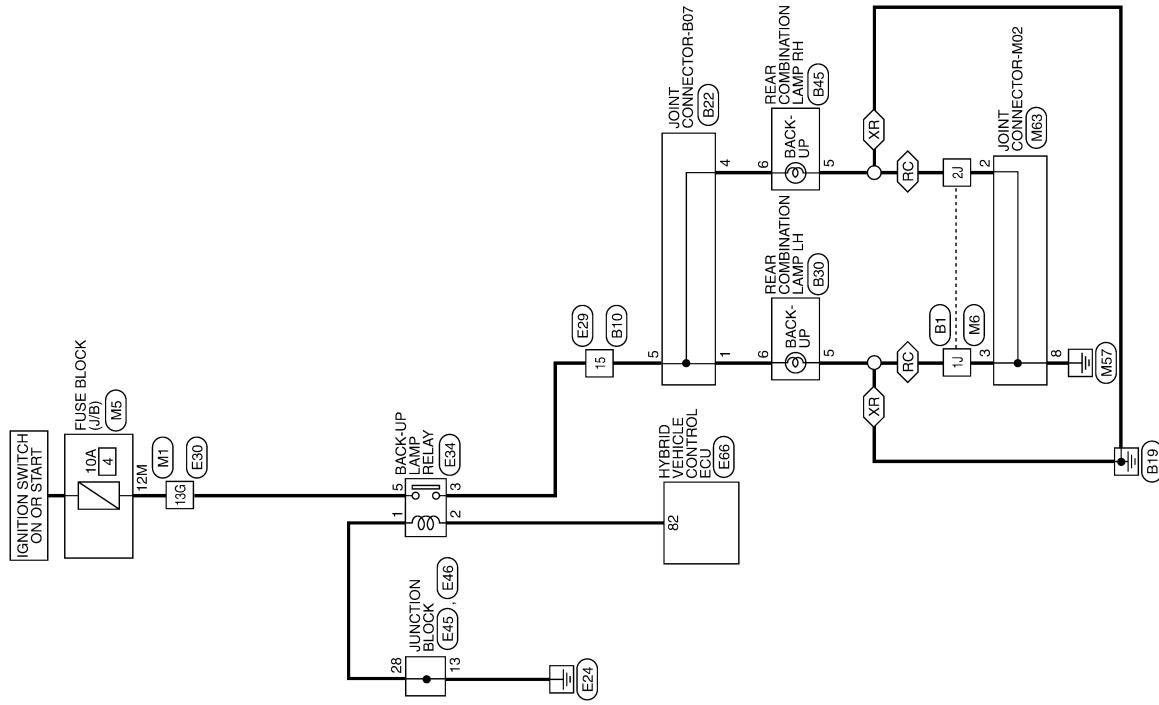

BACK-UP LAMP

A  
 B  
 C  
 D  
 E  
 F  
 G  
 H  
 I  
 J  
 K  
 L  
 M  
 N  
 O  
 P

EXL

AWLWA0155GI

# BACK-UP LAMP

< COMPONENT DIAGNOSIS >

## BACK-UP LAMP CONNECTORS

Connector No.	M1
Connector Name	WIRE TO WIRE
Connector Color	WHITE

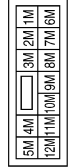
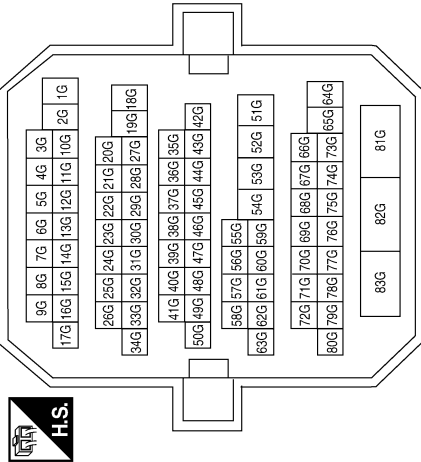

Connector No.	M5
Connector Name	FUSE BLOCK (J/B)
Connector Color	WHITE

Connector No.	M6
Connector Name	WIRE TO WIRE
Connector Color	WHITE

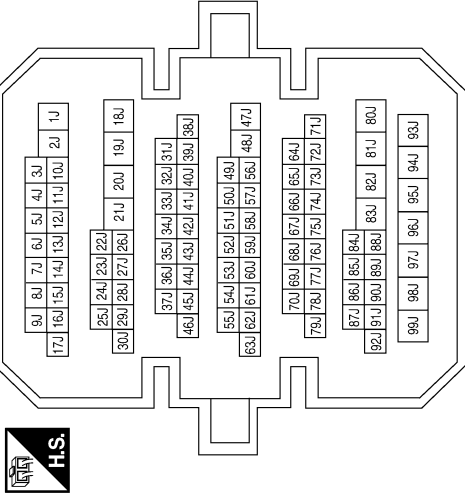

Terminal No.	Color of Wire	Signal Name
13G	O	-

Terminal No.	Color of Wire	Signal Name
12M	P	-

Terminal No.	Color of Wire	Signal Name
1J	B	-
2J	B	-

Connector No.	M63
Connector Name	JOINT CONNECTOR-M02
Connector Color	BLUE

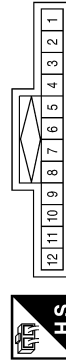

Terminal No.	Color of Wire	Signal Name
2	B	-
3	B	-
8	B	-

Connector No.	E29
Connector Name	WIRE TO WIRE
Connector Color	WHITE

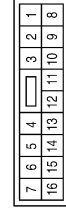

Terminal No.	Color of Wire	Signal Name
15	P/B	-

ABLIA0862GB

# BACK-UP LAMP

## < COMPONENT DIAGNOSIS >

Connector No.	E45
Connector Name	JUNCTION BLOCK
Connector Color	WHITE

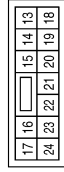

Terminal No.	Color of Wire	Signal Name
13	GR	-

Connector No.	E34
Connector Name	BACK-UP LAMP RELAY
Connector Color	BLUE



Terminal No.	Color of Wire	Signal Name
1	O/B	-
2	Y	-
3	P/B	-
5	O	-

Connector No.	E30
Connector Name	WIRE TO WIRE
Connector Color	WHITE

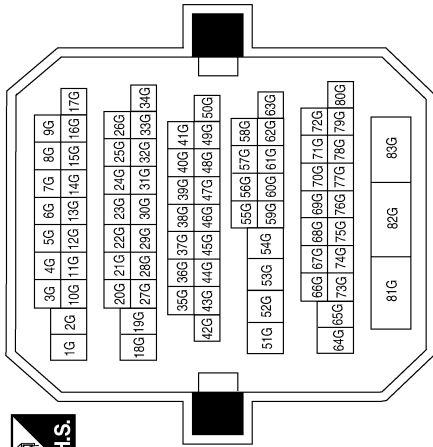

Terminal No.	Color of Wire	Signal Name
13G	O	-

Connector No.	E46
Connector Name	JUNCTION BLOCK
Connector Color	WHITE



Terminal No.	Color of Wire	Signal Name
28	O/B	-

ABLIA0863GB

A  
B  
C  
D  
E  
F  
G  
H  
I  
J  
K  
L  
M  
N  
O  
P

EXL

# BACK-UP LAMP

## < COMPONENT DIAGNOSIS >

Connector No.	B1
Connector Name	WIRE TO WIRE
Connector Color	WHITE

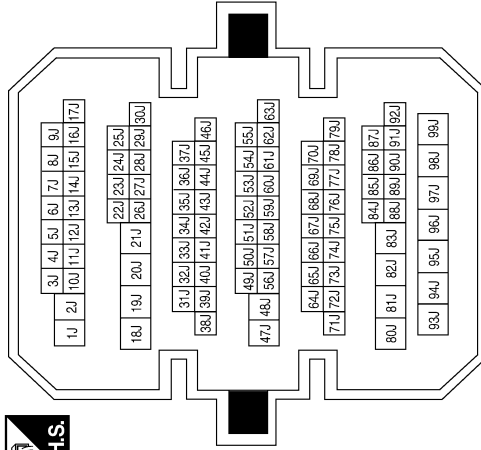

Terminal No.	Color of Wire	Signal Name
1J	B	-
2J	B/R	-

Terminal No.	Color of Wire	Signal Name
82	G/B	BL

Connector No.	E66
Connector Name	HYBRID VEHICLE CONTROL ECU
Connector Color	BLACK

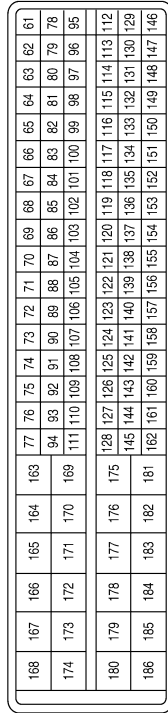

Terminal No.	Color of Wire	Signal Name
15	P/B	-

Connector No.	B10
Connector Name	WIRE TO WIRE
Connector Color	WHITE



ABLIA0864GB



# BACK-UP LAMP

## < COMPONENT DIAGNOSIS >

Connector No.	B45
Connector Name	REAR COMBINATION LAMP RH
Connector Color	WHITE

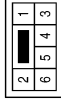

Terminal No.	Color of Wire	Signal Name
5	B/R	GND (WITH REAR VIEW MONITOR)
5	B	GND (WITHOUT REAR VIEW MONITOR)
6	P/B	REV_LAMP

Connector No.	B30
Connector Name	REAR COMBINATION LAMP LH
Connector Color	WHITE

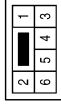

Terminal No.	Color of Wire	Signal Name
5	B	GND
6	P/B	REV_LAMP

Connector No.	B22
Connector Name	JOINT CONNECTOR - B07
Connector Color	GRAY

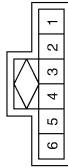

Terminal No.	Color of Wire	Signal Name
1	P/B	-
4	P/B	-
5	P/B	-

A  
B  
C  
D  
E  
F  
G  
H  
I  
J  
K  
EXL  
M  
N  
O  
P

ABLIA0865GB

# BCM (BODY CONTROL MODULE)

< ECU DIAGNOSIS >

## ECU DIAGNOSIS

### BCM (BODY CONTROL MODULE)

Reference Value

INFOID:000000004501334

#### VALUES ON THE DIAGNOSIS TOOL

Monitor Item	Condition	Value/Status
FR WIPER HI	Other than front wiper switch HI	OFF
	Front wiper switch HI	ON
FR WIPER LOW	Other than front wiper switch LO	OFF
	Front wiper switch LO	ON
FR WASHER SW	Front washer switch OFF	OFF
	Front washer switch ON	ON
FR WIPER INT	Other than front wiper switch INT	OFF
	Front wiper switch INT	ON
FR WIPER STOP	Front wiper is not in STOP position	OFF
	Front wiper is in STOP position	ON
INT VOLUME	Wiper intermittent dial is in a dial position 1 - 7	Wiper intermittent dial position
TURN SIGNAL R	Other than turn signal switch RH	OFF
	Turn signal switch RH	ON
TURN SIGNAL L	Other than turn signal switch LH	OFF
	Turn signal switch LH	ON
TAIL LAMP SW	Other than lighting switch 1ST and 2ND	OFF
	Lighting switch 1ST or 2ND	ON
HI BEAM SW	Other than lighting switch HI	OFF
	Lighting switch HI	ON
HEAD LAMP SW 1	Other than lighting switch 2ND	OFF
	Lighting switch 2ND	ON
HEAD LAMP SW 2	Other than lighting switch 2ND	OFF
	Lighting switch 2ND	ON
PASSING SW	Other than lighting switch PASS	OFF
	Lighting switch PASS	ON
AUTO LIGHT SW	Other than lighting switch AUTO	OFF
	Lighting switch AUTO	ON
FR FOG SW	Front fog lamp switch OFF	OFF
	Front fog lamp switch ON	ON
DOOR SW-DR	Front door LH closed	OFF
	Front door LH opened	ON
DOOR SW-AS	Front door RH closed	OFF
	Front door RH opened	ON
DOOR SW-RR	Rear door RH closed	OFF
	Rear door RH opened	ON
DOOR SW-RL	Rear door LH closed	OFF
	Rear door LH opened	ON

## BCM (BODY CONTROL MODULE)

### < ECU DIAGNOSIS >

Monitor Item	Condition	Value/Status	
DOOR SW-BK	<b>NOTE:</b> This item is displayed, but cannot be monitored.	OFF	A
CDL LOCK SW	Other than power door lock switch LOCK	OFF	B
	Door lock/unlock switch LOCK	ON	
CDL UNLOCK SW	Other than door lock/unlock switch UNLOCK	OFF	C
	Door lock/unlock switch UNLOCK	ON	
KEY CYL LK-SW	Other than front door LH key cylinder LOCK position	OFF	D
	Front door LH key cylinder LOCK position	ON	
KEY CYL UN-SW	Other than front door LH key cylinder UNLOCK position	OFF	D
	Front door LH key cylinder UNLOCK position	ON	
KEY CYL SW-TR	<b>NOTE:</b> This item is displayed, but cannot be monitored.	OFF	E
HAZARD SW	When hazard switch is not pressed	OFF	F
	When hazard switch is pressed	ON	
REAR DEF SW	When rear window defogger switch is pressed	ON	
FAN ON SIG	When AUTO switch or fan switch is pressed	ON	
AIR COND SW	When A/C switch is pressed	ON	G
TR CANCEL SW	Trunk lid opener cancel switch OFF	OFF	H
	Trunk lid opener cancel switch ON	ON	
TR/BD OPEN SW	Trunk lid opener switch OFF	OFF	I
	While the trunk lid opener switch is turned ON	ON	
TRNK/HAT MNTR	Trunk lid closed	OFF	I
	Trunk lid opened	ON	
RKE-LOCK	When LOCK button of Intelligent Key is not pressed	OFF	J
	When LOCK button of Intelligent Key is pressed	ON	
RKE-UNLOCK	When UNLOCK button of Intelligent Key is not pressed	OFF	K
	When UNLOCK button of Intelligent Key is pressed	ON	
RKE-TR/BD	When TRUNK OPEN button of Intelligent Key is not pressed	OFF	EXL
	When TRUNK OPEN button of Intelligent Key is pressed	ON	
RKE-PANIC	When PANIC button of Intelligent Key is not pressed	OFF	EXL
	When PANIC button of Intelligent Key is pressed	ON	
RKE-P/W OPEN	When UNLOCK button of Intelligent Key is not pressed and held	OFF	M
	When UNLOCK button of Intelligent Key is pressed and held	ON	
RKE-MODE CHG	When LOCK/UNLOCK button of Intelligent Key is not pressed and held simultaneously	OFF	N
	When LOCK/UNLOCK button of Intelligent Key is pressed and held simultaneously	ON	
OPTICAL SENSOR	When outside of the vehicle is bright	Close to 5 V	O
	When outside of the vehicle is dark	Close to 0 V	
REQ SW-DR	When front door LH request switch is not pressed	OFF	P
	When front door LH request switch is pressed	ON	
REQ SW-AS	When front door RH request switch is not pressed	OFF	P
	When front door RH request switch is pressed	ON	
REQ SW-BD/TR	When trunk request switch is not pressed	OFF	P
	When trunk request switch is pressed	ON	

## BCM (BODY CONTROL MODULE)

### < ECU DIAGNOSIS >

Monitor Item	Condition	Value/Status
PUSH SW	When push-button ignition switch is not pressed	OFF
	When push-button ignition switch is pressed	ON
IGN RLY -F/B	Ignition switch OFF or ACC	OFF
	Ignition switch ON	ON
ACC RLY -F/B	Ignition switch OFF	OFF
	Ignition switch ACC or ON	ON
BRAKE SW 1	When the brake pedal is not depressed	ON
	When the brake pedal is depressed	OFF
DETE/CANCL SW	When selector lever is in P position	OFF
	When selector lever is in any position other than P	ON
SFT PN/N SW	When selector lever is in any position other than P or N	OFF
	When selector lever is in P or N position	ON
S/L -LOCK	Electronic steering column lock LOCK status	OFF
	Electronic steering column lock UNLOCK status	ON
S/L -UNLOCK	Electronic steering column lock UNLOCK status	OFF
	Electronic steering column lock LOCK status	ON
S/L RELAY-F/B	Ignition switch OFF or ACC	OFF
	Ignition switch ON	ON
UNLK SEN-DR	Front door LH UNLOCK status	OFF
	Front door LH LOCK status	ON
PUSH SW -IPDM	When push-button ignition switch is not pressed (IPDM E/R sends via CAN)	OFF
	When push-button ignition switch is pressed (IPDM E/R sends via CAN)	ON
IGN RLY1 F/B	Ignition switch OFF or ACC	OFF
	Ignition switch ON	ON
DETE SW -IPDM	When selector lever is in P position (IPDM E/R sends via CAN)	OFF
	When selector lever is in any position other than P (IPDM E/R sends via CAN)	ON
SFT PN -IPDM	When selector lever is in any position other than P or N (IPDM E/R sends via CAN)	OFF
	When selector lever is in P or N position (IPDM E/R sends via CAN)	ON
SFT P -MET	When selector lever is in any position other than P (combination meter sends via CAN)	OFF
	When selector lever is in P position (combination meter sends via CAN)	ON
SFT N -MET	When selector lever is in any position other than N (combination meter sends via CAN)	OFF
	When selector lever is in N position (combination meter sends via CAN)	ON
ENGINE STATE	Engine stopped	STOP
	While the engine stalls	STALL
	At engine cranking	CRANK
	Engine running	RUN
S/L LOCK-IPDM	Electronic steering column lock LOCK status (IPDM E/R sends via CAN)	OFF
	Electronic steering column lock UNLOCK status (IPDM E/R sends via CAN)	ON

## BCM (BODY CONTROL MODULE)

### < ECU DIAGNOSIS >

Monitor Item	Condition	Value/Status	
S/L UNLCK-IPDM	Electronic steering column lock UNLOCK status (IPDM E/R sends via CAN)	OFF	A
	Electronic steering column lock LOCK status (IPDM E/R sends via CAN)	ON	B
S/L RELAY-REQ	Ignition switch OFF or ACC	OFF	C
	Ignition switch ON	ON	
VEH SPEED 1	While driving	Equivalent to speedometer reading	D
VEH SPEED 2	While driving	Equivalent to speedometer reading	
DR DOOR STATE	Front door LH LOCK status	LOCK	E
	Wait with selective UNLOCK operation (5 seconds)	READY	
	Front door LH UNLOCK status	UNLK	
AS DOOR STATE	Front door RH LOCK status	LOCK	F
	Wait with selective UNLOCK operation (5 seconds)	READY	
	Front door RH UNLOCK status	UNLK	
ID OK FLAG	Ignition switch ACC or ON	RESET	G
	Ignition switch OFF	SET	
PRMT ENG STAT	When the hybrid system start is prohibited	RESET	H
	When the hybrid system start is permitted	SET	
PRMT RKE STAT	<b>NOTE:</b> This item is displayed, but cannot be monitored.	RESET	I
KEY SW -SLOT	When Intelligent Key is not inserted into key slot	OFF	J
	When Intelligent Key is inserted into key slot	ON	
RKE OPE COUN1	During the operation of Intelligent Key	Operation frequency of Intelligent Key	K
RKE OPE COUN2	<b>NOTE:</b> This item is displayed, but cannot be monitored.	Operation frequency of Intelligent Key	
AIR PRESS FL	Ignition switch ON (only when the signal from the transmitter is received)	Air pressure of front LH tire	EXL
AIR PRESS FR	Ignition switch ON (only when the signal from the transmitter is received)	Air pressure of front RH tire	
AIR PRESS RR	Ignition switch ON (only when the signal from the transmitter is received)	Air pressure of rear RH tire	
AIR PRESS RL	Ignition switch ON (only when the signal from the transmitter is received)	Air pressure of rear LH tire	
ID REGST FL1	When ID of front LH tire transmitter is registered (refer to <a href="#">WT-6, "ID Registration Procedure"</a> )	DONE	M
	When ID of front LH tire transmitter is not registered (refer to <a href="#">WT-6, "ID Registration Procedure"</a> )	YET	N
ID REGST FR1	When ID of front RH tire transmitter is registered (refer to <a href="#">WT-6, "ID Registration Procedure"</a> )	DONE	O
	When ID of front RH tire transmitter is not registered (refer to <a href="#">WT-6, "ID Registration Procedure"</a> )	YET	
ID REGST RR1	When ID of rear RH tire transmitter is registered (refer to <a href="#">WT-6, "ID Registration Procedure"</a> )	DONE	P
	When ID of rear RH tire transmitter is not registered (refer to <a href="#">WT-6, "ID Registration Procedure"</a> )	YET	
ID REGST RL1	When ID of rear LH tire transmitter is registered (refer to <a href="#">WT-6, "ID Registration Procedure"</a> )	DONE	
	When ID of rear LH tire transmitter is not registered (refer to <a href="#">WT-6, "ID Registration Procedure"</a> )	YET	

# BCM (BODY CONTROL MODULE)

## < ECU DIAGNOSIS >

Monitor Item	Condition	Value/Status
WARNING LAMP	Tire pressure indicator OFF	OFF
	Tire pressure indicator ON	ON

## Terminal Layout

INFOID:000000004501335

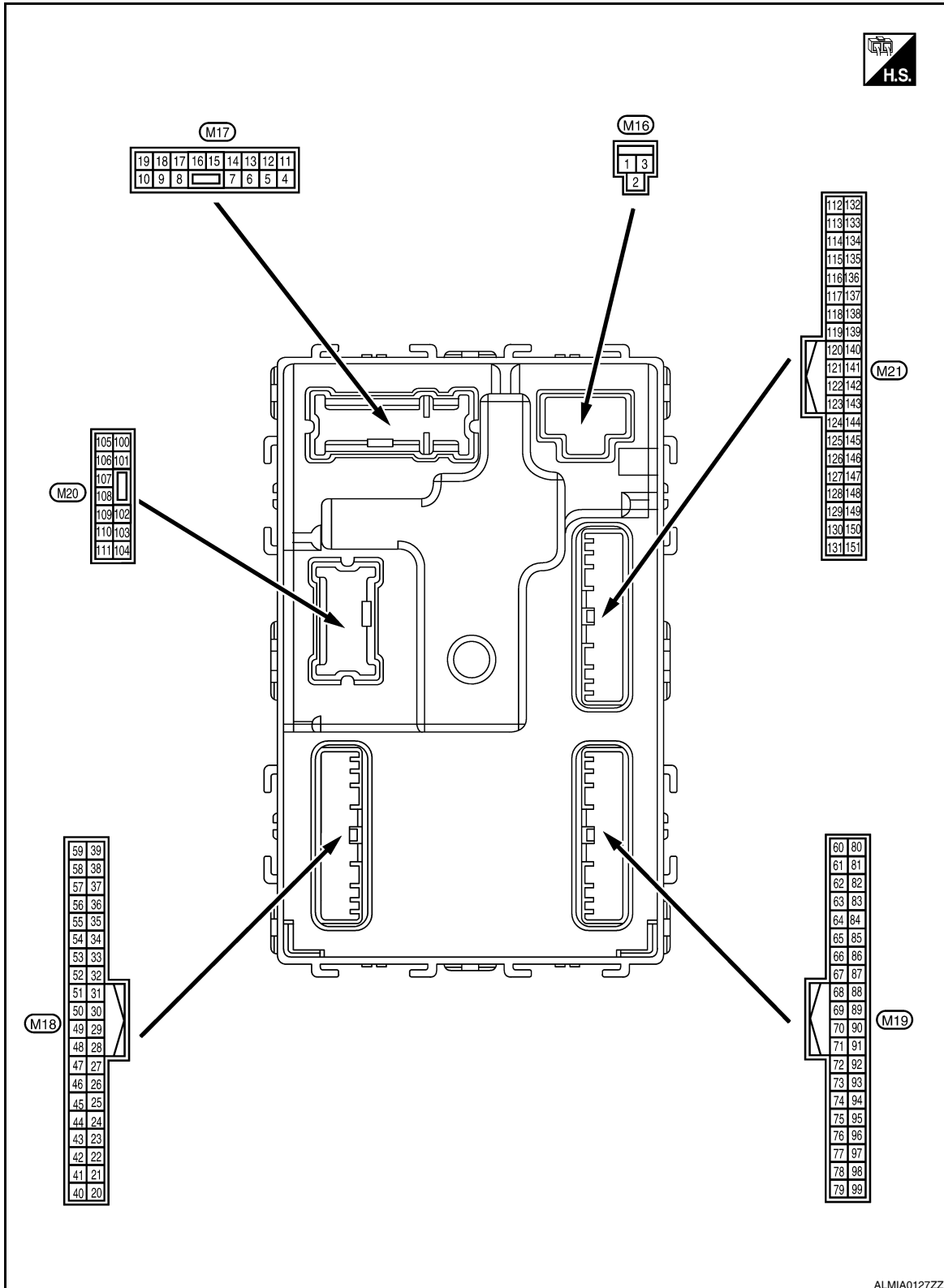

ALMIA0127ZZ

# BCM (BODY CONTROL MODULE)

< ECU DIAGNOSIS >

## Physical Values

INFOID:00000004501336

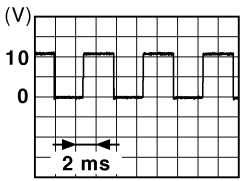
Terminal No. (Wire color)		Description		Condition		Value (Approx.)
		Signal name	Input/ Output			
(+)	(-)					
1 (W/B)	Ground	Battery power supply	Input	Ignition switch OFF		Battery voltage
2 (R/Y)	Ground	Battery power supply output	Output	Ignition switch OFF		Battery voltage
3 (L/W)	Ground	Ignition power supply output	Output	Ignition switch ON		Battery voltage
4 (P/W)	Ground	Interior room lamp power supply	Output	After passing the interior room lamp battery saver operation time		0V
				Any other time after passing the interior room lamp battery saver operation time		Battery voltage
5 (G/Y)	Ground	Front door RH UNLOCK	Output	Front door RH	UNLOCK (actuator is activated)	Battery voltage
					Other than UNLOCK (actuator is not activated)	0V
7 (R/W)	Ground	Step lamp	Output	Room lamp timer	ON	Battery voltage
					OFF	0V
8 (V)	Ground	All doors LOCK	Output	All doors	LOCK (actuator is activated)	Battery voltage
					Other than LOCK (actuator is not activated)	0V
9 (G)	Ground	Front door LH UNLOCK	Output	Front door LH	UNLOCK (actuator is activated)	Battery voltage
					Other than UNLOCK (actuator is not activated)	0V
10 (G/Y)	Ground	Rear door RH and rear door LH UNLOCK	Output	Rear door RH and rear door LH	UNLOCK (actuator is activated)	Battery voltage
					Other than UNLOCK (actuator is not activated)	0V
11 (Y/R)	Ground	Battery power supply	Input	Ignition switch OFF		Battery voltage
13 (B)	Ground	Ground	—	Ignition switch ON		0V
14 (R/Y)	Ground	Push-button ignition switch illumination ground	Input	Tail lamp	OFF	0V
					ON	<p><b>NOTE:</b> When the illumination brightening/dimming level is in the neutral position</p>  <p style="text-align: right;">JSNIA0010GB</p>
15 (Y/L)	Ground	ACC indicator lamp	Output	Ignition switch	OFF	Battery voltage
					ACC	0V

A  
B  
C  
D  
E  
F  
G  
H  
I  
J  
K  
EXL  
M  
N  
O  
P

# BCM (BODY CONTROL MODULE)

## < ECU DIAGNOSIS >

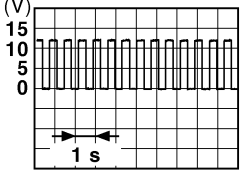
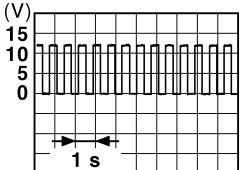
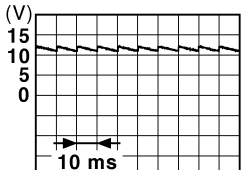
Terminal No. (Wire color)		Description		Condition	Value (Approx.)	
(+)	(-)	Signal name	Input/ Output			
17 (G/B)	Ground	Turn signal (RH)	Output	Ignition switch ON	Turn signal switch OFF	0V
				Turn signal switch RH	 <p style="text-align: right; margin-right: 50px;">PKID0926E</p> <p style="text-align: center;">6.5V</p>	
18 (G/O)	Ground	Turn signal (LH)	Output	Ignition switch ON	Turn signal switch OFF	0V
				Turn signal switch LH	 <p style="text-align: right; margin-right: 50px;">PKID0926E</p> <p style="text-align: center;">6.5V</p>	
19 (Y)	Ground	Room lamp timer control	Output	Interior room lamp	Lamps fully OFF	Battery voltage
					Lamps fully ON	0V
21 (P/B)	Ground	Optical sensor signal	Input	Ignition switch ON	When outside of the vehicle is bright	Close to 5V
					When outside of the vehicle is dark	Close to 0V
24 (R/W)	Ground	Stop lamp switch 1	Input	—	Battery voltage	
26 (O/L)	Ground	Stop lamp switch 2	Input	Stop lamp switch	OFF (brake pedal is not depressed)	0V
					ON (brake pedal is depressed)	Battery voltage
27 (G/W)	Ground	Front door lock assembly LH (unlock sensor)	Input	Front door LH	LOCK status	 <p style="text-align: right; margin-right: 50px;">JPMIA0011GB</p> <p style="text-align: center;">11.8V</p>
					UNLOCK status	0V
29 (Y)	Ground	Key slot switch	Input	When Intelligent Key is inserted into key slot	Battery voltage	
				When Intelligent Key is not inserted into key slot	0V	
30 (V/Y)	Ground	ACC feedback signal	Input	Ignition switch	OFF	0
				ACC or ON	Battery voltage	
31 (G)	Ground	Ignition relay-2 feedback signal	Input	Ignition switch	OFF	0V
				ON	Battery voltage	



# BCM (BODY CONTROL MODULE)

## < ECU DIAGNOSIS >

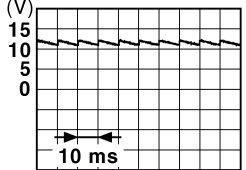
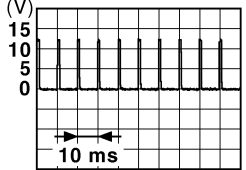
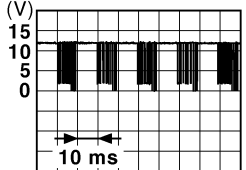
Terminal No. (Wire color)		Description		Condition		Value (Approx.)
(+)	(-)	Signal name	Input/ Output			
32 (R/B)	Ground	Front door RH switch	Input	Front door RH switch	OFF (when front door RH closes)	 <p style="text-align: right; margin-right: 50px;">JPMIA0011GB</p> <p style="text-align: center;">11.8V</p>
					ON (when front door RH opens)	0V
33 (SB)	Ground	Compressor ON signal	Input	A/C switch	OFF	Battery voltage
					ON	0V
34* (L/R)	Ground	Front door lock assembly LH (key cylinder switch) (unlock)	Input	Front door lock assembly LH (key cylinder switch)	OFF (neutral)	Battery voltage
					ON (unlock)	0V
36* (GR)	Ground	Lock switch signal	Input	Door lock/unlock switch	Lock	Battery Voltage
					Unlock	0V
37 (O)	Ground	Trunk lid opener cancel switch	Input	Trunk lid opener cancel switch	CANCEL	 <p style="text-align: right; margin-right: 50px;">JPMIA0012GB</p> <p style="text-align: center;">1.1V</p>
					ON	0V
38 (GR/W)	Ground	Rear window defogger ON signal	Input	Rear window defogger switch	OFF	Battery Voltage V
					ON	0V
39* (GR/R)	Ground	Unlock switch signal	Input	Door lock/unlock switch	Unlock	Battery Voltage
					Lock	0V
40* (Y/G)	Ground	Power window serial link	Input/ Output	Ignition switch ON	 <p style="text-align: right; margin-right: 50px;">JPMIA0013GB</p> <p style="text-align: center;">10.2V</p>	
				Ignition switch OFF or ACC	0V	
41 (W)	Ground	Push-button ignition switch illumination	Output	Engine switch (push switch) illumination	ON	5.5V
					OFF	0V
42 (R)	Ground	LOCK indicator lamp	Output	LOCK indicator lamp	ON	0V
					OFF	Battery voltage
45 (P)	Ground	Receiver & sensor ground	Input	Ignition switch ON	0V	

A  
B  
C  
D  
E  
F  
G  
H  
I  
J  
K  
EXL  
M  
N  
O  
P

# BCM (BODY CONTROL MODULE)

## < ECU DIAGNOSIS >

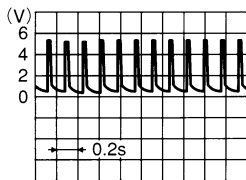
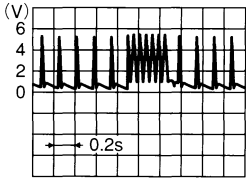
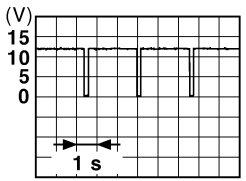
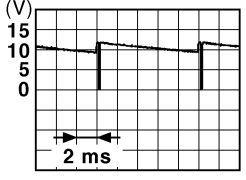
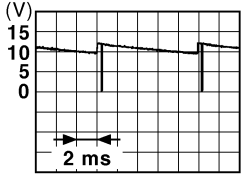
Terminal No. (Wire color)		Description		Condition	Value (Approx.)	
(+)	(-)	Signal name	Input/ Output			
46 (V/W)	Ground	Receiver & sensor power supply output	Output	Ignition switch	OFF	0V
				ACC or ON	5.0V	
47 (G/O)	Ground	Tire pressure receiver signal	Input/ Output	Ignition switch ON	Standby state	 OCC3881D
					When receiving the signal from the transmitter	 OCC3880D
48 (R/B)	Ground	Selector lever P/N position signal	Input	Selector lever	P or N position	12.0V
					Except P and N positions	0V
49 (L/O)	Ground	Security indicator signal	Output	Security indicator	Blinking	 JPMIA0014GB 11.3V
					OFF	Battery voltage
50 (LG/ B)	Ground	Combination switch OUTPUT 5	Output	Combination switch (Wiper intermittent dial 4)	All switch OFF	 JPMIA0031GB 10.7V
					Lighting switch 1ST	
					Lighting switch high-beam	
					Lighting switch 2ND	
				Turn signal switch RH		
51 (L/W)	Ground	Combination switch OUTPUT 1	Output	Combination switch	All switch OFF (Wiper intermittent dial 4)	 JPMIA0032GB 10.7V
					Front wiper switch HI (Wiper intermittent dial 4)	
				Any of the conditions below with all switch OFF		
				• Wiper intermittent dial 1		
				• Wiper intermittent dial 2		
				• Wiper intermittent dial 3		
				• Wiper intermittent dial 6		
				• Wiper intermittent dial 7		

# BCM (BODY CONTROL MODULE)

## < ECU DIAGNOSIS >

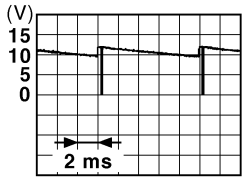
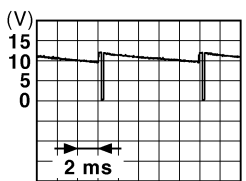
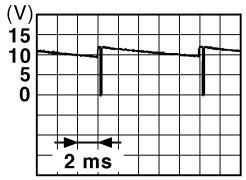
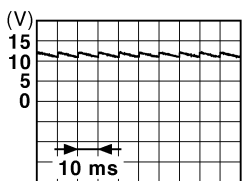
Terminal No. (Wire color)		Description		Condition	Value (Approx.)	
(+)	(-)	Signal name	Input/ Output			
52 (G/B)	Ground	Combination switch OUTPUT 2	Output	Combination switch	All switch OFF (Wiper intermittent dial 4)	0V
					Front washer switch ON (Wiper intermittent dial 4)	 <p style="text-align: right; font-size: small;">JPMIA0033GB</p>
					Any of the conditions below with all switch OFF <ul style="list-style-type: none"> <li>• Wiper intermittent dial 1</li> <li>• Wiper intermittent dial 5</li> <li>• Wiper intermittent dial 6</li> </ul>	
53 (LG/ R)	Ground	Combination switch OUTPUT 3	Output	Combination switch (Wiper intermit- tent dial 4)	All switch OFF	0V
					Front wiper switch INT	 <p style="text-align: right; font-size: small;">JPMIA0034GB</p>
					Front wiper switch LO	
					Lighting switch AUTO	
54 (G/Y)	Ground	Combination switch OUTPUT 4	Output	Combination switch (Wiper intermit- tent dial 4)	All switch OFF	0V
					Front fog lamp switch ON	 <p style="text-align: right; font-size: small;">JPMIA0035GB</p>
					Lighting switch 2ND	
					Lighting switch flash-to- pass	
					Turn signal switch LH	
55 (BR/ W)	Ground	Front blower monitor	Input	Front blower mo- tor switch	ON	Battery voltage
56 (L/B)	Ground	Front door lock as- sembly LH (key cylin- der switch) (lock)	Input	Front door lock assembly LH (key cylinder switch)	OFF (neutral)	Battery voltage
					ON (lock)	0V
57 (W)	Ground	Tire pressure warn- ing check switch	Input	—	—	Battery voltage
58 (SB)	Ground	Front door LH switch	Input	Front door LH switch	OFF (front door LH CLOSE)	 <p style="text-align: right; font-size: small;">JPMIA0011GB</p>
					ON (front door LH OPEN)	
59 (G/R)	Ground	Rear window defog- ger relay	Output	Rear window de- fogger	Active	Battery voltage
					Not activated	0V

A  
B  
C  
D  
E  
F  
G  
H  
I  
J  
K  
M  
N  
O  
P

EXL

# BCM (BODY CONTROL MODULE)

## < ECU DIAGNOSIS >

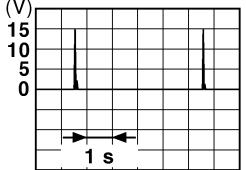
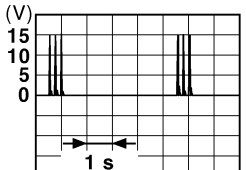
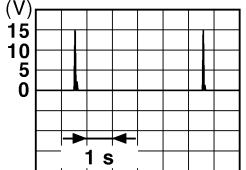
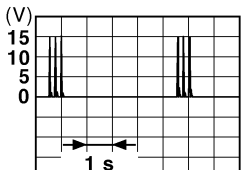
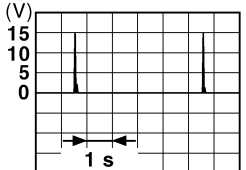
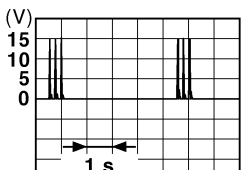
Terminal No. (Wire color)		Description		Condition	Value (Approx.)
(+)	(-)	Signal name	Input/ Output		
60 (B/R)	Ground	Front console antenna 2 (-)	Output	Ignition switch OFF	 <p style="text-align: right; font-size: small;">JMKIA0062GB</p>
				When Intelligent Key is not in the passenger compartment	 <p style="text-align: right; font-size: small;">JMKIA0063GB</p>
61 (W/R)	Ground	Center console antenna 2 (+)	Output	Ignition switch OFF	 <p style="text-align: right; font-size: small;">JMKIA0062GB</p>
				When Intelligent Key is not in the passenger compartment	 <p style="text-align: right; font-size: small;">JMKIA0063GB</p>
62 (B/Y)	Ground	Front outside handle RH antenna (-)	Output	When the front door RH request switch is operated with ignition switch OFF	 <p style="text-align: right; font-size: small;">JMKIA0062GB</p>
				When Intelligent Key is not in the antenna detection area	 <p style="text-align: right; font-size: small;">JMKIA0063GB</p>

# BCM (BODY CONTROL MODULE)

## < ECU DIAGNOSIS >

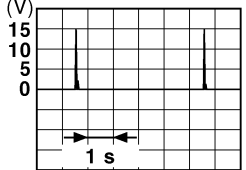
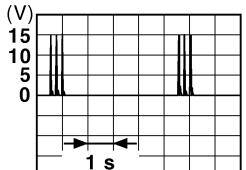
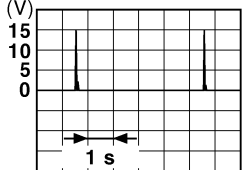
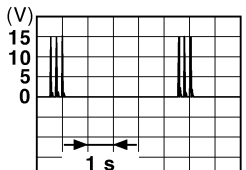
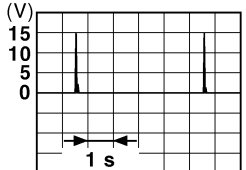
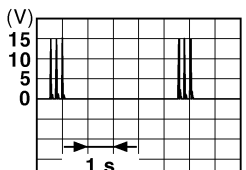
Terminal No. (Wire color)		Description		Condition	Value (Approx.)
(+)	(-)	Signal name	Input/ Output		
63 (LG)	Ground	Front outside handle RH antenna (+)	Output	When the front door RH request switch is operat- ed with ignition switch OFF	When Intelligent Key is in the antenna detection area  <small>JMKIA0062GB</small>
				When Intelligent Key is not in the antenna detection area	 <small>JMKIA0063GB</small>
64 (V)	Ground	Front outside handle LH antenna (-)	Output	When the front door LH request switch is operat- ed with ignition switch OFF	When Intelligent Key is in the antenna detection area  <small>JMKIA0062GB</small>
				When Intelligent Key is not in the antenna detection area	 <small>JMKIA0063GB</small>
65 (P)	Ground	Front outside handle LH antenna (+)	Output	When the front door LH request switch is operat- ed with ignition switch OFF	When Intelligent Key is in the antenna detection area  <small>JMKIA0062GB</small>
				When Intelligent Key is not in the antenna detection area	 <small>JMKIA0063GB</small>

A  
B  
C  
D  
E  
F  
G  
H  
I  
J  
K  
M  
N  
O  
P

EXL

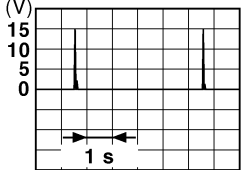
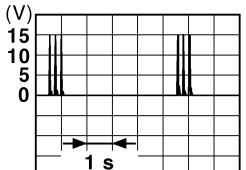
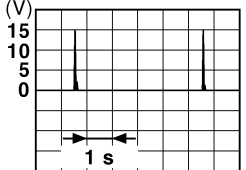
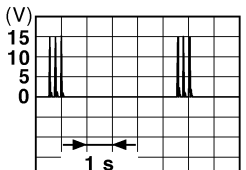

# BCM (BODY CONTROL MODULE)

## < ECU DIAGNOSIS >

Terminal No. (Wire color)		Description		Condition	Value (Approx.)	
(+)	(-)	Signal name	Input/ Output			
66 (R)	Ground	Instrument panel antenna (-)	Output	Ignition switch OFF	 <p style="text-align: right; font-size: small;">JMKIA0062GB</p>	
				When Intelligent Key is not in the passenger compartment	 <p style="text-align: right; font-size: small;">JMKIA0063GB</p>	
67 (G)	Ground	Instrument panel antenna (+)	Output	Ignition switch OFF	 <p style="text-align: right; font-size: small;">JMKIA0062GB</p>	
				When Intelligent Key is not in the passenger compartment	 <p style="text-align: right; font-size: small;">JMKIA0063GB</p>	
68 (G/O)	Ground	NATS antenna amp (built in key slot)	Input/ Output	During waiting	Ignition switch is pressed while inserting the Intelligent Key into the key slot. Just after pressing ignition switch. Pointer of tester should move.	
69 (O)	Ground	NATS antenna amp (built in key slot)	Input/ Output	During waiting	Ignition switch is pressed while inserting the Intelligent Key into the key slot. Just after pressing ignition switch. Pointer of tester should move.	
70 (R/B)	Ground	Ignition relay-2 control	Output	Ignition switch	OFF or ACC	0V
				ON	Battery voltage	

# BCM (BODY CONTROL MODULE)

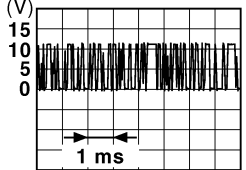
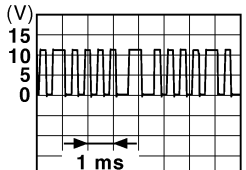
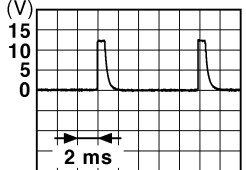
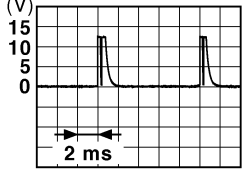

## < ECU DIAGNOSIS >

Terminal No. (Wire color)		Description		Condition	Value (Approx.)
(+)	(-)	Signal name	Input/ Output		
71 (L/O)	Ground	Remote keyless entry receiver signal	Input/ Output	During waiting	 <p style="text-align: right; font-size: small;">JMKIA0064GB</p>
				When operating either button on Intelligent Key	 <p style="text-align: right; font-size: small;">JMKIA0065GB</p>
75 (R/Y)	Ground	Combination switch INPUT 5	Input	All switch OFF (Wiper intermittent dial 4)	 <p style="text-align: right; font-size: small;">JPMIA0041GB</p> <p style="text-align: center;">1.4V</p>
				Combination switch Front fog lamp switch ON (Wiper intermittent dial 4)	 <p style="text-align: right; font-size: small;">JPMIA0037GB</p> <p style="text-align: center;">1.3V</p>
				Any of the conditions below with all switch OFF	<ul style="list-style-type: none"> <li>• Wiper intermittent dial 1</li> <li>• Wiper intermittent dial 2</li> <li>• Wiper intermittent dial 6</li> <li>• Wiper intermittent dial 7</li> </ul>  <p style="text-align: right; font-size: small;">JPMIA0040GB</p> <p style="text-align: center;">1.3V</p>

A  
B  
C  
D  
E  
F  
G  
H  
I  
J  
K  
EXL  
M  
N  
O  
P

# BCM (BODY CONTROL MODULE)

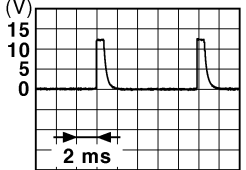
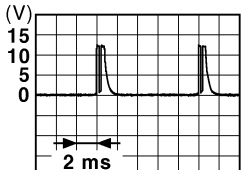
## < ECU DIAGNOSIS >

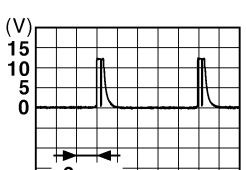
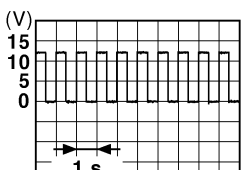
Terminal No. (Wire color)		Description		Condition	Value (Approx.)	
(+)	(-)	Signal name	Input/ Output			
76 (R/G)	Ground	Combination switch INPUT 3	Input	Combination switch	All switch OFF (Wiper intermittent dial 4)	 <p style="text-align: right; font-size: small;">JPMIA0041GB</p> <p style="text-align: center;">1.4V</p>
					Lighting switch high-beam (Wiper intermittent dial 4)	 <p style="text-align: right; font-size: small;">JPMIA0036GB</p> <p style="text-align: center;">1.3V</p>
					Lighting switch 2ND (Wiper intermittent dial 4)	 <p style="text-align: right; font-size: small;">JPMIA0037GB</p> <p style="text-align: center;">1.3V</p>
					Any of the conditions below with all switch OFF	<ul style="list-style-type: none"> <li>• Wiper intermittent dial 1</li> <li>• Wiper intermittent dial 2</li> <li>• Wiper intermittent dial 3</li> </ul>  <p style="text-align: right; font-size: small;">JPMIA0040GB</p> <p style="text-align: center;">1.3V</p>
77 (BR)	Ground	Push-button ignition switch	Input	Engine switch (push switch)	Pressed	0V
				Not pressed	Battery voltage	
78 (P)	Ground	CAN-L	Input/ Output	—	—	
79 (L)	Ground	CAN-H	Input/ Output	—	—	
80 (R/L)	Ground	Key slot illumination	Output	Key slot illumina- tion	OFF	0V
					Blinking	 <p style="text-align: right; font-size: small;">JPMIA0015GB</p> <p style="text-align: center;">6.5V</p>
					ON	Battery voltage



# BCM (BODY CONTROL MODULE)

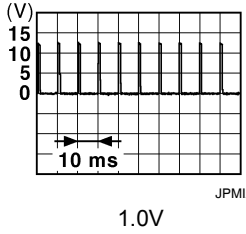
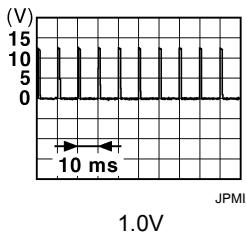

## < ECU DIAGNOSIS >

Terminal No. (Wire color)		Description		Condition		Value (Approx.)
(+)	(-)	Signal name	Input/ Output			
81 (LG)	Ground	ON indicator lamp	Output	Ignition switch	OFF or ACC	Battery voltage
					ON	0V
83 (L)	Ground	ACC relay control	Output	Ignition switch	OFF	0V
					ACC or ON	Battery voltage
84 (Y/R)	Ground	ECTV device (detent switch)	Output	—		Battery voltage
85 (L/O)	Ground	Electronic steering column lock condition No. 1	Input	Electronic steering column lock	Lock status	0V
					Unlock status	Battery voltage
86 (G/R)	Ground	Electronic steering column lock condition No. 2	Input	Electronic steering column lock	Lock status	Battery voltage
					Unlock status	0V
87 (G/B)	Ground	ECTV device (detent switch)	Input	Selector lever	P position	0V
					Any position other than P	Battery voltage
88 (P/L)	Ground	Front door RH request switch	Input	Front door RH request switch	ON (pressed)	0V
					OFF (not pressed)	
89 (B/W)	Ground	Front door LH request switch	Input	Front door LH request switch	ON (pressed)	0V
					OFF (not pressed)	
90 (Y)	Ground	Front blower motor relay control	Output	Ignition switch	OFF or ACC	0V
					ON	Battery voltage
91 (L/R)	Ground	Remote keyless entry receiver power supply	Output	Ignition switch OFF		Battery voltage
94 (G/Y)	Ground	Electronic steering column lock CPU power supply	Output	Ignition switch	OFF or ACC	Battery voltage
					ON	0V

A  
B  
C  
D  
E  
F  
G  
H  
I  
J  
K  
EXL  
M  
N  
O  
P

# BCM (BODY CONTROL MODULE)

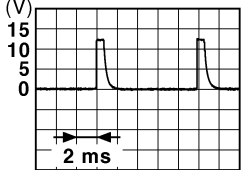
## < ECU DIAGNOSIS >

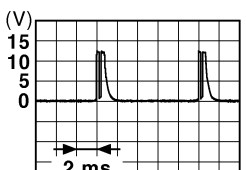
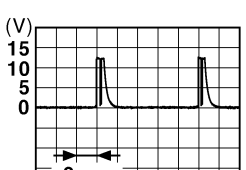
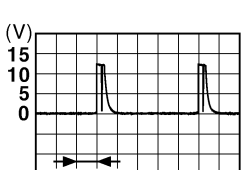
Terminal No. (Wire color)		Description		Condition	Value (Approx.)
(+)	(-)	Signal name	Input/ Output		
95 (R/W)	Ground	Combination switch INPUT 1	Input	Combination switch (Wiper intermittent dial 4)	All switch OFF <div style="text-align: right;">  <p>1.4V</p> </div>
					Turn signal switch LH <div style="text-align: right;">  <p>1.3V</p> </div>
					Turn signal switch RH <div style="text-align: right;">  <p>1.3V</p> </div>
					Front wiper switch LO <div style="text-align: right;">  <p>1.3V</p> </div>
					Front washer switch ON <div style="text-align: right;">  <p>1.3V</p> </div>

# BCM (BODY CONTROL MODULE)

## < ECU DIAGNOSIS >

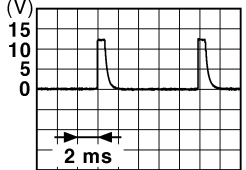
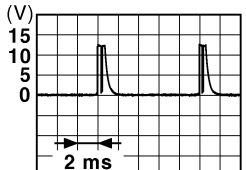
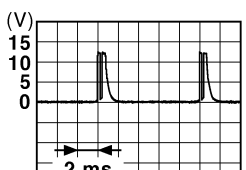
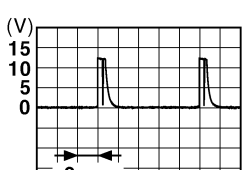

Terminal No. (Wire color)		Description		Condition	Value (Approx.)	
(+)	(-)	Signal name	Input/ Output			
96 (P/B)	Ground	Combination switch INPUT 4	Input	Combination switch	All switch OFF (Wiper intermittent dial 4)	 1.4V
					Lighting switch AUTO (Wiper intermittent dial 4)	 1.3V
					Lighting switch 1ST (Wiper intermittent dial 4)	 1.3V
					Any of the conditions below with all switch OFF • Wiper intermittent dial 1 • Wiper intermittent dial 5 • Wiper intermittent dial 6	 1.3V

A  
B  
C  
D  
E  
F  
G  
H  
I  
J  
K  
L  
M  
N  
O  
P

EXL

# BCM (BODY CONTROL MODULE)

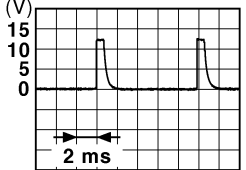
## < ECU DIAGNOSIS >

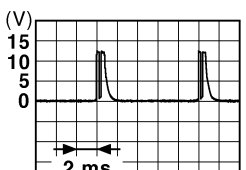
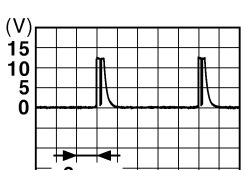
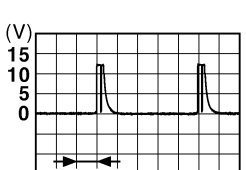
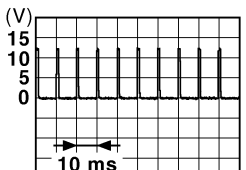
Terminal No. (Wire color)		Description		Condition	Value (Approx.)	
(+)	(-)	Signal name	Input/ Output			
97 (R/B)	Ground	Combination switch INPUT 2	Input	Combination switch (Wiper intermittent dial 4)	All switch OFF	 <p style="text-align: right;">JPMIA0041GB</p> <p style="text-align: center;">1.4V</p>
					Lighting switch flash-to-pass	 <p style="text-align: right;">JPMIA0037GB</p> <p style="text-align: center;">1.3V</p>
					Lighting switch 2ND	 <p style="text-align: right;">JPMIA0036GB</p> <p style="text-align: center;">1.3V</p>
					Front wiper switch INT	 <p style="text-align: right;">JPMIA0038GB</p> <p style="text-align: center;">1.3V</p>
					Front wiper switch HI	 <p style="text-align: right;">JPMIA0040GB</p> <p style="text-align: center;">1.3V</p>
					Pressed	0 V
98 (G/R)	Ground	Hazard switch	Input	Hazard switch	Not pressed	 <p style="text-align: right;">JPMIA0012GB</p> <p style="text-align: center;">1.1V</p>

# BCM (BODY CONTROL MODULE)

## < ECU DIAGNOSIS >

Terminal No. (Wire color)		Description		Condition	Value (Approx.)	
(+)	(-)	Signal name	Input/ Output			
99 (L/Y)	Ground	Electronic steering column lock CPU communication	Input/ Output	Electronic steering column lock	LOCK status	Battery voltage
					LOCK or UNLOCK	<p style="text-align: right; font-size: small;">JMKIA0066GB</p>
					For 15 seconds after UN- LOCK	Battery voltage
					15 seconds or later after UNLOCK	0V
103 (V)	Ground	Trunk lid opening	Output	Trunk lid	Open (trunk lid opener ac- tuator is activated)	Battery voltage
					Close (trunk lid opener ac- tuator is not activated)	0V
110 (V/W)	Ground	Trunk room lamp	Output	Trunk room lamp	ON	0V
					OFF	Battery voltage
114 (B)	Ground	Trunk room antenna 1 (-)	Output	Ignition switch OFF	When Intelligent Key is in the passenger compart- ment	<p style="text-align: right; font-size: small;">JMKIA0062GB</p>
					When Intelligent Key is not in the passenger compart- ment	<p style="text-align: right; font-size: small;">JMKIA0063GB</p>

A  
B  
C  
D  
E  
F  
G  
H  
I  
J  
K  
M  
N  
O  
P

EXL

# BCM (BODY CONTROL MODULE)

## < ECU DIAGNOSIS >

Terminal No. (Wire color)		Description		Condition	Value (Approx.)
(+)	(-)	Signal name	Input/ Output		
115 (W)	Ground	Trunk room antenna 1 (+)	Output	Ignition switch OFF	<p style="text-align: right; font-size: small;">JMKIA0062GB</p>
				When Intelligent Key is not in the passenger compart- ment	<p style="text-align: right; font-size: small;">JMKIA0063GB</p>
118 (L/O)	Ground	Rear bumper anten- na (-)	Output	When the trunk lid request switch is operated with ignition switch OFF	<p style="text-align: right; font-size: small;">JMKIA0062GB</p>
				When Intelligent Key is not in the antenna detection area	<p style="text-align: right; font-size: small;">JMKIA0063GB</p>
119 (BR/ W)	Ground	Rear bumper anten- na (+)	Output	When the trunk lid request switch is operated with ignition switch OFF	<p style="text-align: right; font-size: small;">JMKIA0062GB</p>
				When Intelligent Key is not in the antenna detection area	<p style="text-align: right; font-size: small;">JMKIA0063GB</p>

# BCM (BODY CONTROL MODULE)

## < ECU DIAGNOSIS >

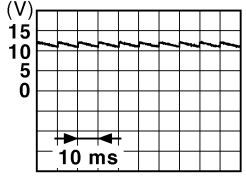
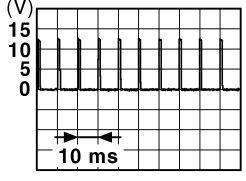
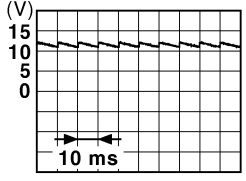
Terminal No. (Wire color)		Description		Condition	Value (Approx.)	
(+)	(-)	Signal name	Input/ Output			
127 (BR/ W)	Ground	Ignition relay (IPDM E/R) control	Output	Ignition switch	OFF or ACC	Battery voltage
					ON	0V
130 (Y/G)	Ground	Trunk room lamp switch	Input	Trunk room lamp switch	OFF (trunk is closed)	 <p style="text-align: right; margin-right: 50px;">JPMIA0011GB</p> <p style="text-align: center;">11.8V</p>
					ON (trunk is open)	0V
132 (R)	Ground	Start signal	Output	Ignition switch ON	When selector lever is in P or N position and the brake peddle is not depressed	0V
					When selector lever is in P or N position and the brake peddle is depressed	Battery voltage
141 (G/R)	Ground	Trunk request switch	Input	Trunk request switch	ON (pressed)	0V
					OFF (not pressed)	 <p style="text-align: right; margin-right: 50px;">JPMIA0016GB</p> <p style="text-align: center;">1.0V</p>
144 (GR)	Ground	Request switch buzz- er	Output	Request switch buzzer	Sounding	0V
					Not sounding	Battery voltage
147 (L/R)	Ground	Trunk lid opener switch	Input	Trunk lid opener switch	Pressed	0V
					Not pressed	Battery voltage
148 (R/W)	Ground	Rear door RH switch	Input	Rear door RH switch	OFF (when rear door RH closes)	 <p style="text-align: right; margin-right: 50px;">JPMIA0011GB</p> <p style="text-align: center;">11.8V</p>
					ON (when rear door RH opens)	0V

A  
B  
C  
D  
E  
F  
G  
H  
I  
J  
K  
EXL  
M  
N  
O  
P

# BCM (BODY CONTROL MODULE)

## < ECU DIAGNOSIS >

Terminal No. (Wire color)		Description		Condition	Value (Approx.)
(+)	(-)	Signal name	Input/ Output		
149 (R/B)	Ground	Rear door LH switch	Input	Rear door LH switch	OFF (when rear door LH closes)
				ON (when rear door LH opens)	0V

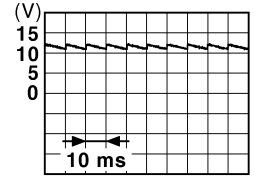

JPMIA0011GB

11.8V

\*: With LH and RH front window anti-pinch system



# BCM (BODY CONTROL MODULE)

< ECU DIAGNOSIS >

## Wiring Diagram

INFOID:000000004501337

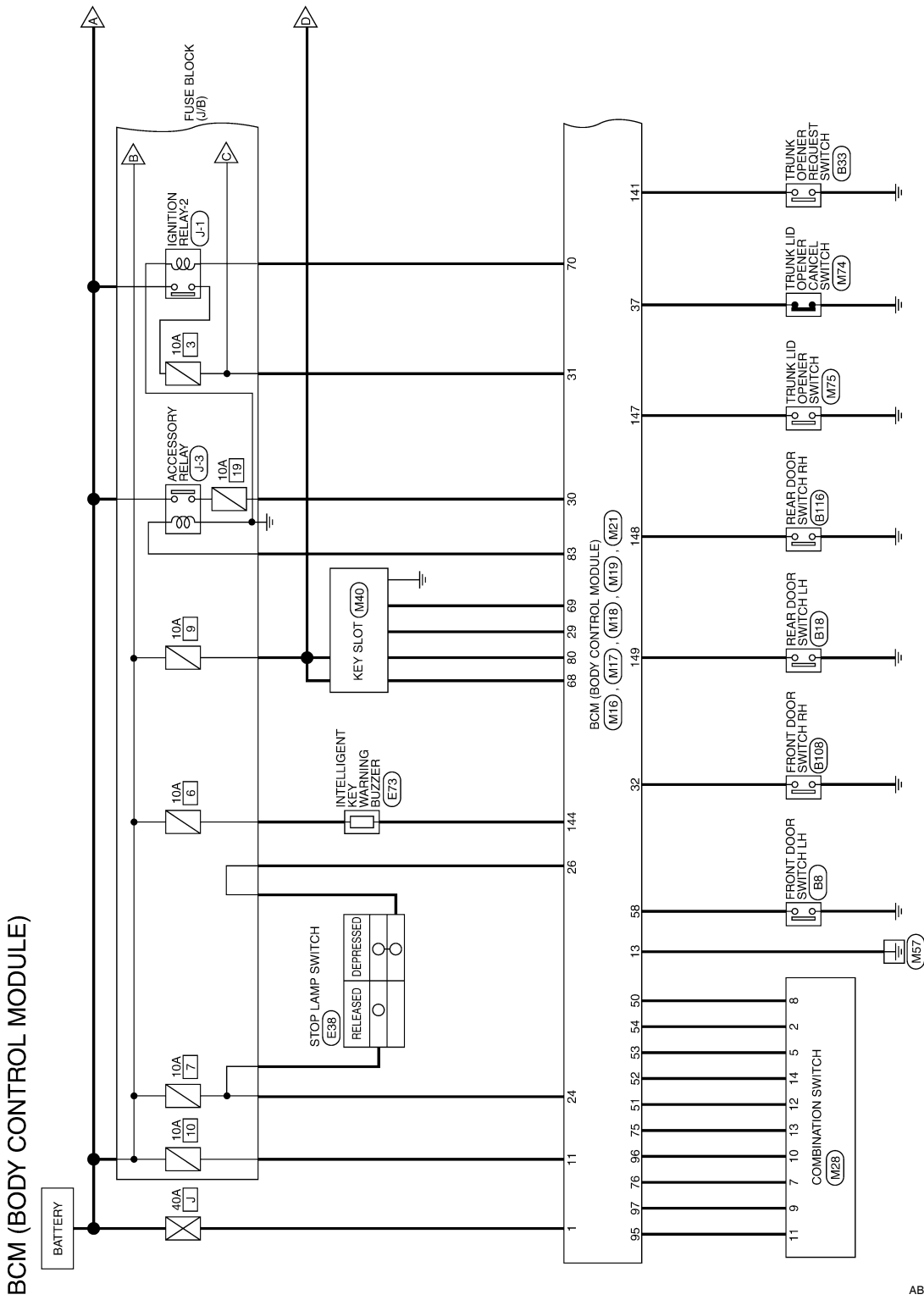

ABMWA0182GI

A  
B  
C  
D  
E  
F  
G  
H  
I  
J  
K  
EXL  
M  
N  
O  
P

# BCM (BODY CONTROL MODULE)

< ECU DIAGNOSIS >

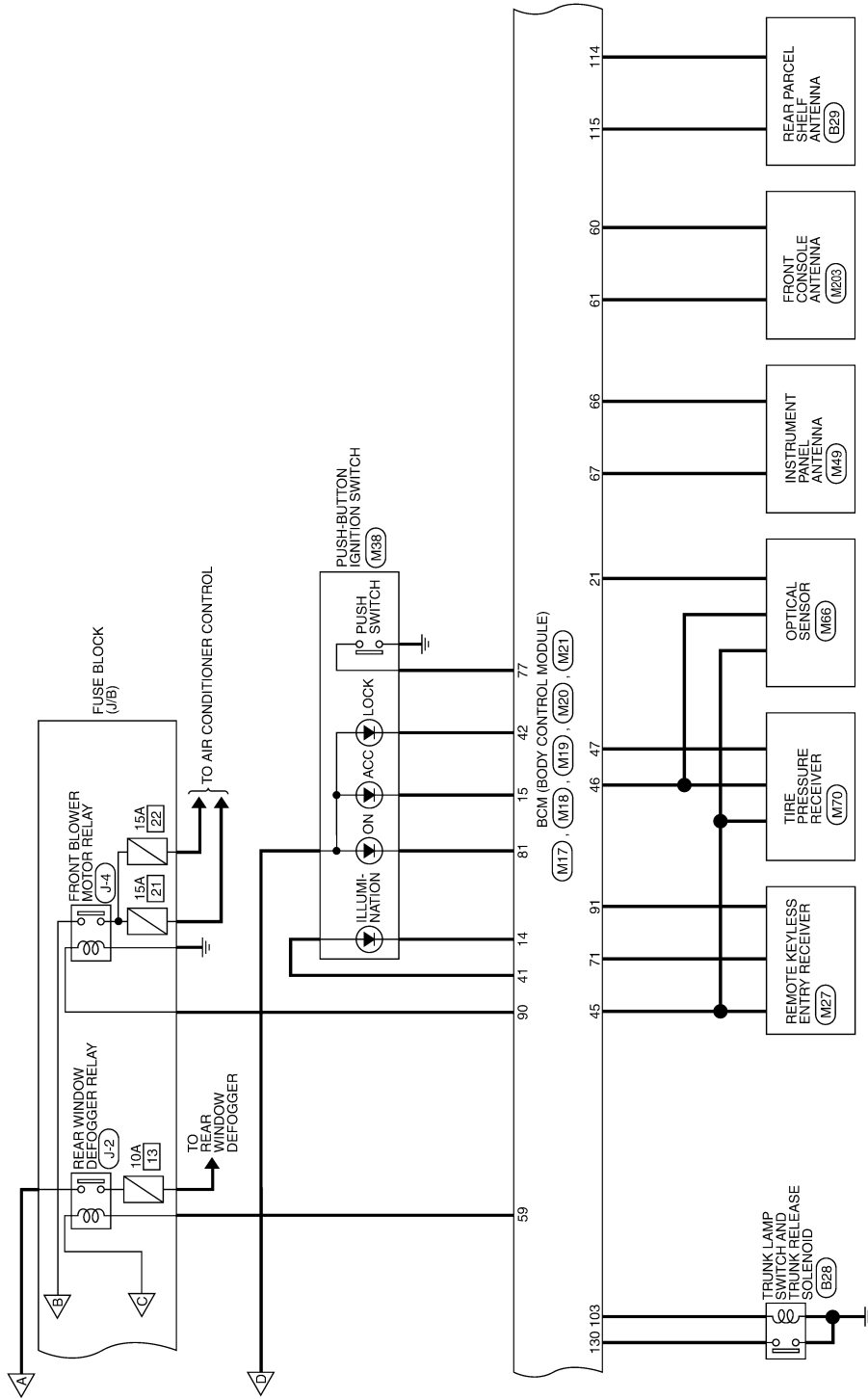

ABMWA0183GI

# BCM (BODY CONTROL MODULE)

< ECU DIAGNOSIS >

▬ : DATA LINE

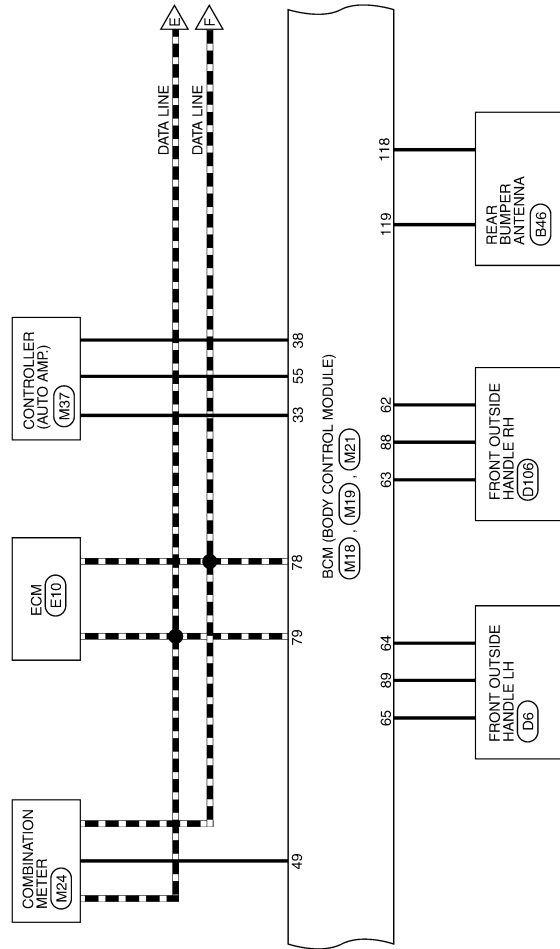

A  
B  
C  
D  
E  
F  
G  
H  
I  
J  
K  
EXL  
M  
N  
O  
P

ALMWA0039Gf

# BCM (BODY CONTROL MODULE)

< ECU DIAGNOSIS >

▬ : DATA LINE

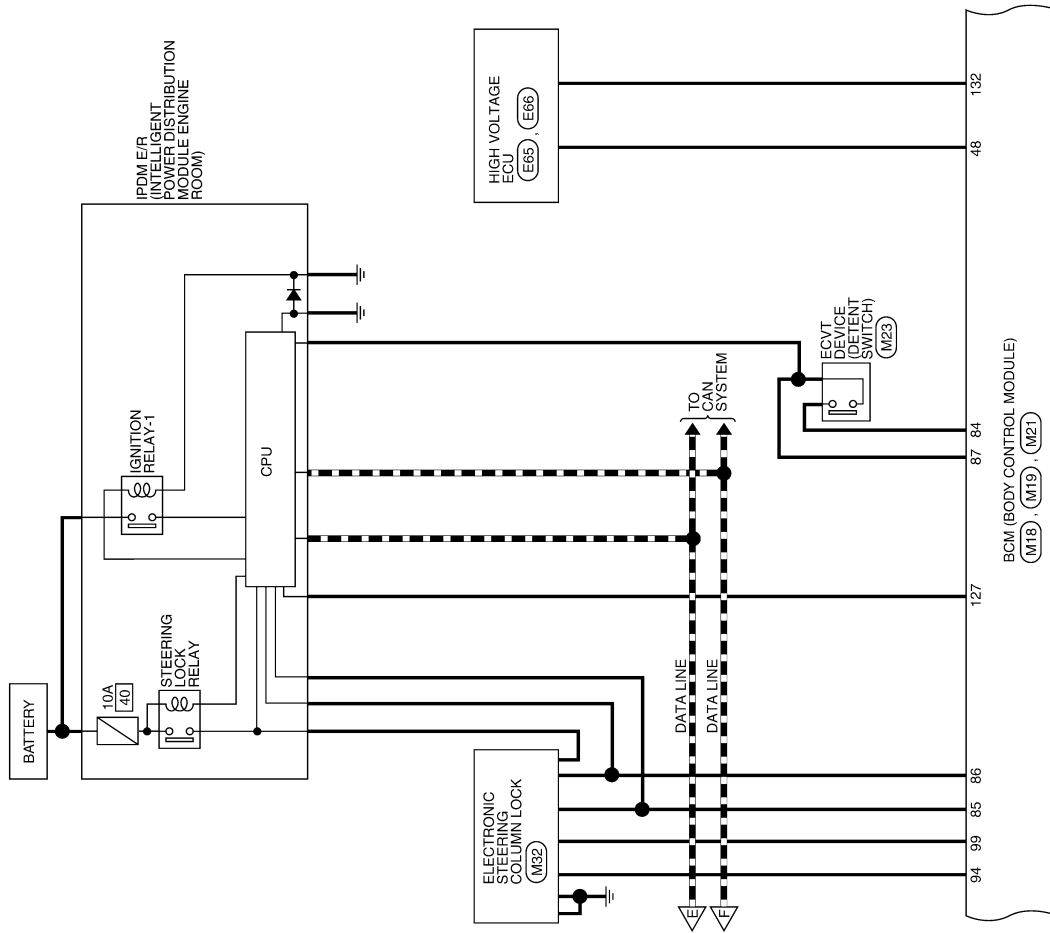

ALMWA0040Gf

# BCM (BODY CONTROL MODULE)

< ECU DIAGNOSIS >

<A1> : WITH LEFT FRONT ONLY POWER WINDOW ANTI-PINCH SYSTEM  
 <A2> : WITH LEFT AND RIGHT FRONT POWER WINDOW ANTI-PINCH SYSTEM

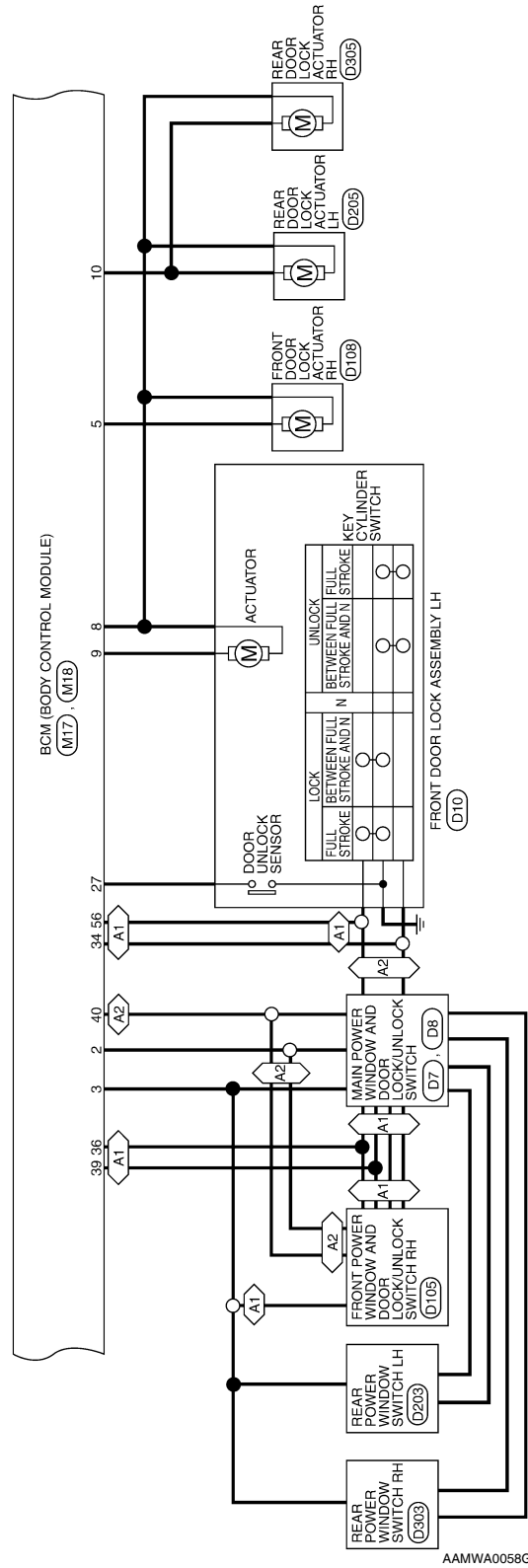

AAMWA0058GI

A  
B  
C  
D  
E  
F  
G  
H  
I  
J  
K  
EXL  
M  
N  
O  
P

# BCM (BODY CONTROL MODULE)

< ECU DIAGNOSIS >

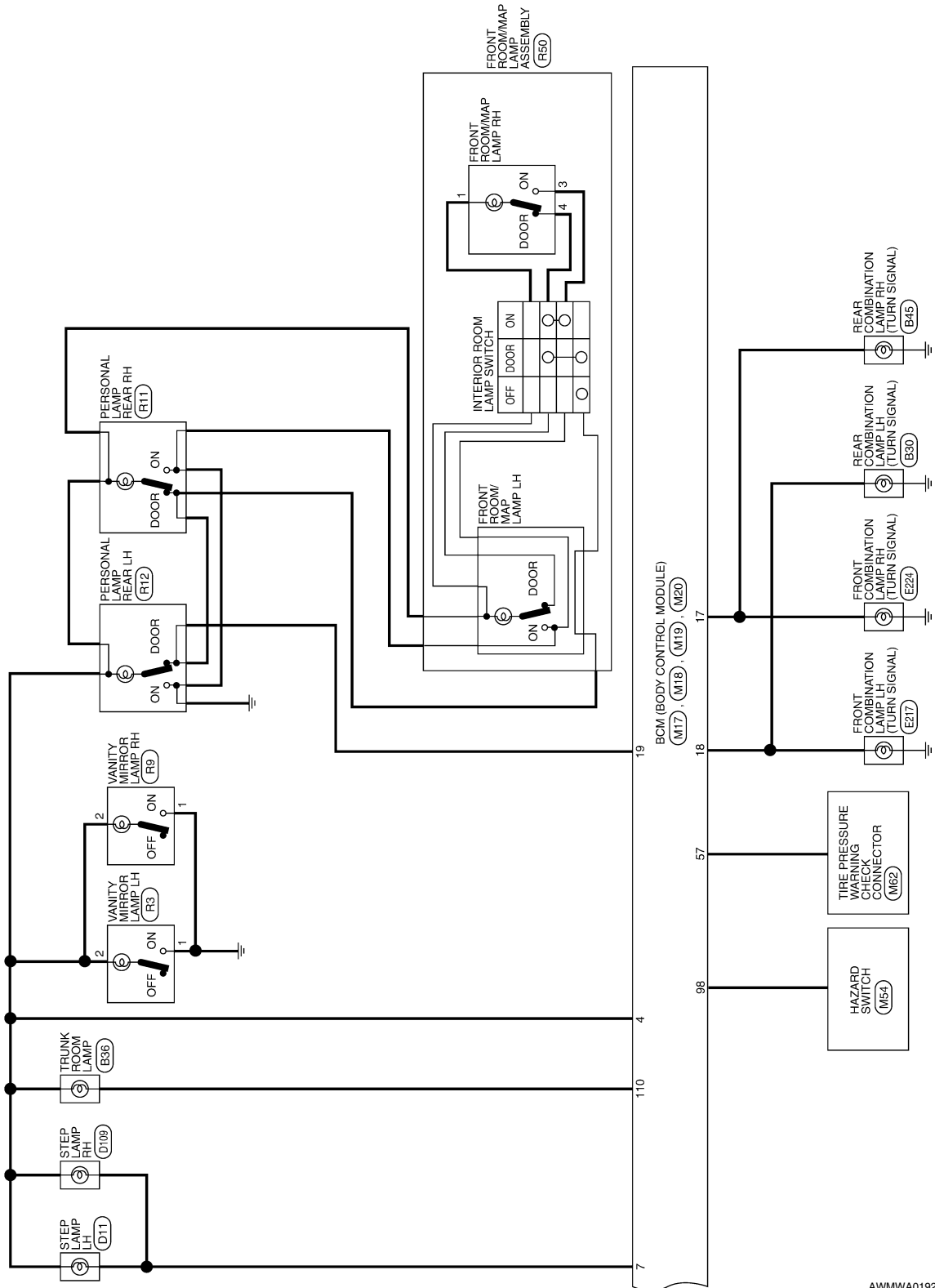

AWMWA0192G

# BCM (BODY CONTROL MODULE)

< ECU DIAGNOSIS >

## BCM (BODY CONTROL MODULE) CONNECTORS

Connector No.	M16
Connector Name	BCM (BODY CONTROL MODULE)
Connector Color	BLACK



Terminal No.	Color of Wire	Signal Name
1	W/B	BAT_POWER_F/L
2	R/Y	PW_POWER_SUPPL Y_PERM
3	L/W	POWER_WINDOW_ POWER_SUPPLY (RAP)

Connector No.	M17
Connector Name	BCM (BODY CONTROL MODULE)
Connector Color	WHITE



Terminal No.	Color of Wire	Signal Name
4	P/W	ROOM_LAMP_BAT_ SAVER
5	G/Y	CDL_AS
6	-	-
7	R/W	STEP_LAMP_OUTPUT
8	V	CDL_COMMON

Terminal No.	Color of Wire	Signal Name
9	G	CDL_DR/FL
10	G/Y	CDL_FR_RL_BACK
11	Y/R	BAT_BCM_FUSE
12	-	-
13	B	GND1
14	R/Y	LOW_SIDE_PUSH_LE D_OUTPUT
15	Y/L	ACC_LED
16	-	-
17	G/B	FR_FLASHER
18	G/O	FL_FLASHER
19	Y	ROOM_LAMP_OUTPUT

Connector No.	M18
Connector Name	BCM (BODY CONTROL MODULE)
Connector Color	GREEN



Terminal No.	Color of Wire	Signal Name
20	-	-
21	P/B	AUTO_LIGHT_SEN SO R_INPUT1
22	-	-
23	-	-
24	R/W	STOP_LAMP_LOW_SW
25	-	-
26	O/L	STOP_LAMP_HIGH_SW

Terminal No.	Color of Wire	Signal Name
27	G/W	DOOR_LOCK_STATUS
28	-	-
29	Y	FOB_IN_SW_1
30	V/Y	ACC_F/B
31	G	IGN_F/B
32	R/B	AS_DOOR_SW
33	SB	AIRCON_SW
34	L/R	DOOR_KEY/C_ UNLOCK_SW
35	-	-
36	GR	CENTRAL_LOCK_SW
37	O	TRUNK_CANCEL_SW
38	GR/W	REAR_DEFOGGER_SW
39	GR/R	CENTRAL_UNLOCK_SW
40	Y/G	PW_K-LINE
41	W	PUSH_LED
42	R	S/L_LOCK_LED
43	-	-
44	-	-
45	P	GND_RF2_AVL
46	V/W	A/L_SENS_KEYLESS_ TUNER_POWER_SUP PLY

Terminal No.	Color of Wire	Signal Name
47	G/O	KEYLESS_TUNER_SI
48	R/B	SHIFT_N/P
49	L/O	IMMO_LED
50	LG/B	INPUT_5
51	L/W	INPUT_1
52	G/B	INPUT_2
53	LG/R	INPUT_3
54	G/Y	INPUT_4
55	BR/W	BLOWER_FAN_SW
56	L/B	DOOR_KEY/C_ LOCK_SW
57	W	TPMS_MODE_TRIGG ER_SW
58	SB	DR_DOOR_SW
59	G/R	REAR_DEFOGGER_ RLY

AWMIA0392GB

A B C D E F G H I J K L M N O P

EXL

# BCM (BODY CONTROL MODULE)

< ECU DIAGNOSIS >

Connector No.	M19
Connector Name	BCM (BODY CONTROL MODULE)
Connector Color	BLACK



79	78	77	76	75	74	73	72	71	70	69	68	67	66	65	64	63	62	61	60
99	98	97	96	95	94	93	92	91	90	89	88	87	86	85	84	83	82	81	80

Terminal No.	Color of Wire	Signal Name
60	B/R	ROOM_ANT_2_B
61	W/R	ROOM_ANT_2_A

Terminal No.	Color of Wire	Signal Name
82	-	-
83	L	ACC_CONT
84	Y/R	AT_DEVICE_OUT
85	L/O	S/L_CONDITION_1
86	G/R	S/L_CONDITION_2
87	G/B	SHIFT_P
88	P/L	AS_REQUEST_SWITCH
89	B/W	DR_REQUEST_SWITCH
90	Y	IGN2_CONT
91	L/R	RF1_POWER_SUPPLY
92	-	-
93	-	-
94	G/Y	S/L_POWER_SUPPLY_12V
95	R/W	OUTPUT_1
96	P/B	OUTPUT_4
97	R/B	OUTPUT_2
98	G/R	HAZARD_SW
99	L/Y	S/L_K-LINE

Terminal No.	Color of Wire	Signal Name
62	B/Y	AS_DOOR_ANT_B
63	LG	AS_DOOR_ANT_A
64	V	DR_DOOR_ANT_B
65	P	DR_DOOR_ANT_A
66	R	ROOM_ANT_1_B
67	G	ROOM_ANT_1_A
68	G/O	FOB_READER_CLOCK
69	O	FOB_READER_DATA
70	R/B	IGN_ELEC_CONT
71	L/O	RF1_TUNER_SIGNAL
72	-	-
73	-	-
75	R/Y	OUTPUT_5
76	R/G	OUTPUT_3
77	BR	ENG_START_SW
78	P	CAN-L
79	L	CAN-H
80	R/L	FOB_SLOT_ILLUMINATION
81	LG	IGN_ON_LED

Connector No.	M20
Connector Name	BCM (BODY CONTROL MODULE)
Connector Color	WHITE



100	101	102	103	104		
105	106	107	108	109	110	111

Terminal No.	Color of Wire	Signal Name
100	-	-
101	-	-
102	-	-
103	V	CDL_BACK_TRUNK
104	-	-
105	-	-
106	-	-
107	-	-
108	-	-
109	-	-
110	V/W	TRUNK_LAMP_OUTPUT
111	-	-

ALMIA0084GB



# BCM (BODY CONTROL MODULE)

< ECU DIAGNOSIS >

Terminal No.	Color of Wire	Signal Name
138	-	-
139	-	-
140	-	-
141	G/R	TRUNK_REQUEST_SW
142	-	-
143	-	-
144	GR	BUZZER
145	-	-
146	-	-
147	L/R	BACK_TRUNK_OPENER
148	R/W	RR_DOOR_SW
149	R/B	RL_DOOR_SW
150	-	-
151	-	-

Terminal No.	Color of Wire	Signal Name
119	BR/W	BACK_DOOR_ANT_A
120	-	-
121	-	-
122	-	-
123	-	-
124	-	-
125	-	-
126	-	-
127	BR/W	IGN_USM_CONT1
128	-	-
129	-	-
130	Y/G	TRUNK_SW
131	-	-
132	R	ST_CONT_USM
133	-	-
134	-	-
135	-	-
136	-	-
137	-	-

Connector No.	M21
Connector Name	BCM (BODY CONTROL MODULE)
Connector Color	GRAY

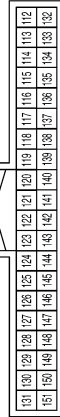

Terminal No.	Color of Wire	Signal Name
112	-	-
113	-	-
114	B	TRUNK_ANT_1_B
115	W	TRUNK_ANT_1_A
116	-	-
117	-	-
118	L/O	BACK_DOOR_ANT_B

Terminal No.	Color of Wire	Signal Name
8	LG/B	OUTPUT_5
9	R/B	INPUT_2
10	P/B	INPUT_4
11	R/W	INPUT_1
12	L/W	OUTPUT_1
13	R/Y	INPUT_5
14	G/B	OUTPUT_2
15	-	-
16	-	-

Connector No.	M28
Connector Name	COMBINATION SWITCH
Connector Color	WHITE

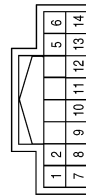

Terminal No.	Color of Wire	Signal Name
1	R/L	WASH_MTR
2	G/Y	OUTPUT_4
3	-	-
4	-	-
5	LG/R	OUTPUT_3
6	B	GND
7	R/G	INPUT_3

AWMIA0393GB

INFOID:000000004501338

## Fail Safe

Display contents of CONSULT	Fail-safe	Cancellation
B2013: ID DISCORD BCM-S/L	Inhibit hybrid system cranking	Erase DTC
B2014: CHAIN OF S/L-BCM	Inhibit hybrid system cranking	Erase DTC

A  
B  
C  
D  
E  
F  
G  
H  
I  
J  
K  
EXL  
M  
N  
O  
P

## BCM (BODY CONTROL MODULE)

### < ECU DIAGNOSIS >

Display contents of CONSULT	Fail-safe	Cancellation
B2190: NATS ANTENNA AMP	Inhibit hybrid system cranking	Erase DTC
B2191: DIFFERENCE OF KEY	Inhibit hybrid system cranking	Erase DTC
B2192: ID DISCORD BCM-ECM	Inhibit hybrid system cranking	Erase DTC
B2193: CHAIN OF BCM-ECM	Inhibit hybrid system cranking	Erase DTC
B2195: ANTI-SCANNING	Inhibit hybrid system cranking	Erase DTC
B2557: VEHICLE SPEED	Inhibit electronic steering column lock	When normal vehicle speed signals have been received from brake ECU actuator and electric unit (control unit) for 500 ms
B2562: LOW VOLTAGE	<ul style="list-style-type: none"> <li>• Inhibit hybrid system cranking</li> <li>• Inhibit electronic steering column lock</li> </ul>	100 ms after the power supply voltage increases to more than 8.8 V
B2563: HI VOLTAGE	<ul style="list-style-type: none"> <li>• Inhibit hybrid system cranking</li> <li>• Inhibit electronic steering column lock</li> </ul>	500 ms after the power supply voltage decreases to less than 18 V
B2601: SHIFT POSITION	Inhibit electronic steering column lock	500 ms after the following signal reception status becomes consistent <ul style="list-style-type: none"> <li>• Selector lever P position switch signal</li> <li>• P range signal (CAN)</li> </ul>
B2602: SHIFT POSITION	Inhibit electronic steering column lock	5 seconds after the following BCM recognition conditions are fulfilled <ul style="list-style-type: none"> <li>• Ignition switch is in the ON position</li> <li>• Selector lever P position switch signal: Except P position (battery voltage)</li> <li>• Vehicle speed: 4 /h or more</li> </ul>
B2603: SHIFT POSI STATUS	Inhibit electronic steering column lock	500 ms after the following BCM recognition conditions are fulfilled <ul style="list-style-type: none"> <li>• Ignition switch is in the ON position</li> <li>• Selector lever P position switch signal: Except P position (battery voltage)</li> <li>• Selector lever P/N position signal: Except P and N positions (0 V)</li> </ul>
B2604: PNP SW	Inhibit electronic steering column lock	500 ms after any of the following BCM recognition conditions is fulfilled <ul style="list-style-type: none"> <li>• Status 1               <ul style="list-style-type: none"> <li>- Ignition switch is in the ON position</li> <li>- Selector lever P/N position signal: P and N position (battery voltage)</li> <li>- P range signal or N range signal (CAN): ON</li> </ul> </li> <li>• Status 2               <ul style="list-style-type: none"> <li>- Ignition switch is in the ON position</li> <li>- Selector lever P/N position signal: Except P and N positions (0 V)</li> <li>- P range signal and N range signal (CAN): OFF</li> </ul> </li> </ul>
B2605: PNP SW	Inhibit electronic steering column lock	500 ms after any of the following BCM recognition conditions is fulfilled <ul style="list-style-type: none"> <li>• Ignition switch is in the ON position               <ul style="list-style-type: none"> <li>- Power position: IGN</li> <li>- Selector lever P/N position signal: Except P and N positions (0 V)</li> <li>- Interlock/PNP switch signal (CAN): OFF</li> </ul> </li> <li>• Status 2               <ul style="list-style-type: none"> <li>- Ignition switch is in the ON position</li> <li>- Selector lever P/N position signal: P or N position (battery voltage)</li> <li>- PNP switch signal (CAN): ON</li> </ul> </li> </ul>

# BCM (BODY CONTROL MODULE)

## < ECU DIAGNOSIS >

Display contents of CONSULT	Fail-safe	Cancellation
B2606: S/L RELAY	Inhibit hybrid system cranking	500 ms after the following CAN signal communication status has become consistent • Electronic steering column lock relay signal (Request signal) • Electronic steering column lock relay signal (Condition signal)
B2607: S/L RELAY	Inhibit hybrid system cranking	500 ms after the following CAN signal communication status has become consistent • Electronic steering column lock relay signal (Request signal) • Electronic steering column lock relay signal (Condition signal)
B2609: S/L STATUS	• Inhibit hybrid system cranking • Inhibit electronic steering column lock	When the following electronic steering column lock conditions agree • BCM electronic steering column lock control status • Electronic steering column lock condition No. 1 signal status • Electronic steering column lock condition No. 2 signal status
B260A: IGNITION RELAY	Inhibit hybrid system cranking	500 ms after the following conditions are fulfilled • IGN relay (IPDM E/R) control signal: OFF (Battery voltage) • Ignition ON signal (CAN to IPDM E/R): OFF (Request signal) • Ignition ON signal (CAN from IPDM E/R): OFF (Condition signal)
B260F: ENG STATE SIG LOST	Maintains the power supply position attained at the time of DTC detection	When any of the following conditions is fulfilled • Power position changes to ACC • Receives hybrid system status signal (CAN)
B2612: S/L STATUS	• Inhibit hybrid system cranking • Inhibit electronic steering column lock	When any of the following conditions is fulfilled • Electronic steering column lock unit status signal (CAN) is received normally • The BCM electronic steering column lock control status matches the electronic steering column lock status recognized by the electronic steering column lock unit status signal (CAN from IPDM E/R)
B2617: STARTER RELAY CIRC	Inhibit hybrid system cranking	1 second after the starter motor relay control inside BCM becomes normal
B2618: BCM	Inhibit hybrid system cranking	1 second after the ignition relay (IPDM E/R) control inside BCM becomes normal
B2619: BCM	Inhibit hybrid system cranking	1 second after the electronic steering column lock unit power supply output control inside BCM becomes normal
B261E: VEHICLE TYPE	Inhibit hybrid system cranking	BCM initialization
B26E1: ENG STATE NO RECIV	Inhibit hybrid system cranking	When any of the following conditions is fulfilled • Power position changes to ACC • Receives hybrid system status signal (CAN)

## DTC Inspection Priority Chart

INFOID:000000004501339

If some DTCs are displayed at the same time, perform inspections one by one based on the following priority chart.

Priority	DTC
1	• B2562: LOW VOLTAGE • B2563: HI VOLTAGE • B261E: VEHICLE TYPE
2	• U1000: CAN COMM CIRCUIT • U1010: CONTROL UNIT (CAN)
3	• B2190: NATS ANTENNA AMP • B2191: DIFFERENCE OF KEY • B2192: ID DISCORD BCM-ECM • B2193: CHAIN OF BCM-ECM

# BCM (BODY CONTROL MODULE)

## < ECU DIAGNOSIS >

Priority	DTC
4	<ul style="list-style-type: none"> <li>• B2013: ID DISCORD BCM-S/L</li> <li>• B2014: CHAIN OF S/L-BCM</li> <li>• B2553: IGNITION RELAY</li> <li>• B2555: STOP LAMP</li> <li>• B2556: PUSH-BTN IGN SW</li> <li>• B2557: VEHICLE SPEED</li> <li>• B2601: SHIFT POSITION</li> <li>• B2602: SHIFT POSITION</li> <li>• B2603: SHIFT POSI STATUS</li> <li>• B2604: PNP SW</li> <li>• B2605: PNP SW</li> <li>• B2606: S/L RELAY</li> <li>• B2607: S/L RELAY</li> <li>• B2609: S/L STATUS</li> <li>• B260A: IGNITION RELAY</li> <li>• B260B: STEERING LOCK UNIT</li> <li>• B260C: STEERING LOCK UNIT</li> <li>• B260D: STEERING LOCK UNIT</li> <li>• B260F: ENG STATE SIG LOST</li> <li>• B2611: ACC RELAY</li> <li>• B2612: S/L STATUS</li> <li>• B2614: ACC RELAY CIRC</li> <li>• B2615: BLOWER RELAY CIRC</li> <li>• B2616: IGN RELAY CIRC</li> <li>• B2617: STARTER RELAY CIRC</li> <li>• B2618: BCM</li> <li>• B2619: BCM</li> <li>• B261A: PUSH-BTN IGN SW</li> <li>• B26E1: ENG STATE NO RECIV</li> <li>• C1729: VHCL SPEED SIG ERR</li> <li>• U0415: VEHICLE SPEED SIG</li> </ul>
5	<ul style="list-style-type: none"> <li>• C1704: LOW PRESSURE FL</li> <li>• C1705: LOW PRESSURE FR</li> <li>• C1706: LOW PRESSURE RR</li> <li>• C1707: LOW PRESSURE RL</li> <li>• C1708: [NO DATA] FL</li> <li>• C1709: [NO DATA] FR</li> <li>• C1710: [NO DATA] RR</li> <li>• C1711: [NO DATA] RL</li> <li>• C1712: [CHECKSUM ERR] FL</li> <li>• C1713: [CHECKSUM ERR] FR</li> <li>• C1714: [CHECKSUM ERR] RR</li> <li>• C1715: [CHECKSUM ERR] RL</li> <li>• C1716: [PRESSDATA ERR] FL</li> <li>• C1717: [PRESSDATA ERR] FR</li> <li>• C1718: [PRESSDATA ERR] RR</li> <li>• C1719: [PRESSDATA ERR] RL</li> <li>• C1720: [CODE ERR] FL</li> <li>• C1721: [CODE ERR] FR</li> <li>• C1722: [CODE ERR] RR</li> <li>• C1723: [CODE ERR] RL</li> <li>• C1724: [BATT VOLT LOW] FL</li> <li>• C1725: [BATT VOLT LOW] FR</li> <li>• C1726: [BATT VOLT LOW] RR</li> <li>• C1727: [BATT VOLT LOW] RL</li> <li>• C1734: CONTROL UNIT</li> </ul>
6	<ul style="list-style-type: none"> <li>• B2621: INSIDE ANTENNA</li> <li>• B2622: INSIDE ANTENNA</li> <li>• B2623: INSIDE ANTENNA</li> </ul>

### DTC Index

INFOID:000000004501340

#### NOTE:

Details of time display

## BCM (BODY CONTROL MODULE)

### < ECU DIAGNOSIS >

- CRNT: Displays when there is a malfunction now or after returning to the normal condition until turning ignition switch OFF → ON again.
- 1 - 39: Displayed if any previous malfunction is present when current condition is normal. It increases like 1 → 2 → 3...38 → 39 after returning to the normal condition whenever ignition switch OFF → ON. The counter remains at 39 even if the number of cycles exceeds it. It is counted from 1 again when turning ignition switch OFF → ON after returning to the normal condition if the malfunction is detected again.

CONSULT display	Fail-safe	Intelligent Key warning lamp ON	Tire pressure monitor warning lamp ON	Reference page
No DTC is detected. further testing may be required.	—	—	—	—
U1000: CAN COMM CIRCUIT	—	—	—	<a href="#">BCS-37</a>
U1010: CONTROL UNIT (CAN)	—	—	—	<a href="#">BCS-38</a>
U0415: VEHICLE SPEED SIG	—	—	—	<a href="#">BCS-39</a>
B2013: ID DISCORD BCM-S/L	×	—	—	<a href="#">SEC-30</a>
B2014: CHAIN OF S/L-BCM	×	—	—	<a href="#">SEC-31</a>
B2190: NATS ANTENNA AMP	×	—	—	<a href="#">SEC-40</a>
B2191: DIFFERENCE OF KEY	×	—	—	<a href="#">SEC-43</a>
B2192: ID DISCORD BCM-ECM	×	—	—	<a href="#">SEC-44</a>
B2193: CHAIN OF BCM-ECM	×	—	—	<a href="#">SEC-45</a>
B2553: IGNITION RELAY	—	—	—	<a href="#">PCS-53</a>
B2555: STOP LAMP	—	—	—	<a href="#">SEC-46</a>
B2556: PUSH-BTN IGN SW	—	×	—	<a href="#">SEC-49</a>
B2557: VEHICLE SPEED	×	×	—	<a href="#">SEC-51</a>
B2562: LOW VOLTAGE	—	—	—	<a href="#">BCS-40</a>
B2563: HI VOLTAGE	×	×	—	<a href="#">BCS-41</a>
B2601: SHIFT POSITION	×	×	—	<a href="#">SEC-52</a>
B2602: SHIFT POSITION	×	×	—	<a href="#">SEC-55</a>
B2603: SHIFT POSI STATUS	×	×	—	<a href="#">SEC-57</a>
B2604: PNP SW	×	×	—	<a href="#">SEC-60</a>
B2607: S/L RELAY	×	×	—	<a href="#">SEC-62</a>
B2609: S/L STATUS	×	×	—	<a href="#">SEC-64</a>
B260A: IGNITION RELAY	×	×	—	<a href="#">PCS-55</a>
B260B: STEERING LOCK UNIT	—	×	—	<a href="#">SEC-68</a>
B260C: STEERING LOCK UNIT	—	×	—	<a href="#">SEC-69</a>
B260D: STEERING LOCK UNIT	—	×	—	<a href="#">SEC-70</a>
B260F: ENG STATE SIG LOST	×	×	—	<a href="#">SEC-71</a>
B2611: ACC RELAY	—	—	—	<a href="#">PCS-56</a>
B2612: S/L STATUS	×	×	—	<a href="#">SEC-72</a>
B2614: ACC RELAY CIRC	—	×	—	<a href="#">PCS-58</a>
B2615: BLOWER RELAY CIRC	—	×	—	<a href="#">PCS-61</a>
B2616: IGN RELAY CIRC	—	×	—	<a href="#">PCS-64</a>
B2617: STARTER RELAY CIRC	×	×	—	<a href="#">SEC-76</a>
B2618: BCM	×	×	—	<a href="#">PCS-67</a>
B2619: BCM	×	×	—	<a href="#">SEC-78</a>
B261A: PUSH-BTN IGN SW	—	×	—	<a href="#">SEC-79</a>

## BCM (BODY CONTROL MODULE)

### < ECU DIAGNOSIS >

CONSULT display	Fail-safe	Intelligent Key warning lamp ON	Tire pressure monitor warning lamp ON	Reference page
B261E: VEHICLE TYPE	×	× (Turn ON for 15 seconds)	—	<a href="#">SEC-81</a>
B2621: INSIDE ANTENNA	—	—	—	<a href="#">DLK-59</a>
B2622: INSIDE ANTENNA	—	—	—	<a href="#">DLK-62</a>
B2623: INSIDE ANTENNA	—	—	—	<a href="#">DLK-65</a>
C1704: LOW PRESSURE FL	—	—	×	<a href="#">WT-8</a>
C1705: LOW PRESSURE FR	—	—	×	<a href="#">WT-8</a>
C1706: LOW PRESSURE RR	—	—	×	<a href="#">WT-8</a>
C1707: LOW PRESSURE RL	—	—	×	<a href="#">WT-8</a>
C1708: [NO DATA] FL	—	—	×	<a href="#">WT-14</a>
C1709: [NO DATA] FR	—	—	×	<a href="#">WT-14</a>
C1710: [NO DATA] RR	—	—	×	<a href="#">WT-14</a>
C1711: [NO DATA] RL	—	—	×	<a href="#">WT-14</a>
C1712: [CHECKSUM ERR] FL	—	—	×	<a href="#">WT-16</a>
C1713: [CHECKSUM ERR] FR	—	—	×	<a href="#">WT-16</a>
C1714: [CHECKSUM ERR] RR	—	—	×	<a href="#">WT-16</a>
C1715: [CHECKSUM ERR] RL	—	—	×	<a href="#">WT-16</a>
C1716: [PRESSDATA ERR] FL	—	—	×	<a href="#">WT-18</a>
C1717: [PRESSDATA ERR] FR	—	—	×	<a href="#">WT-18</a>
C1718: [PRESSDATA ERR] RR	—	—	×	<a href="#">WT-18</a>
C1719: [PRESSDATA ERR] RL	—	—	×	<a href="#">WT-18</a>
C1720: [CODE ERR] FL	—	—	×	<a href="#">WT-16</a>
C1721: [CODE ERR] FR	—	—	×	<a href="#">WT-16</a>
C1722: [CODE ERR] RR	—	—	×	<a href="#">WT-16</a>
C1723: [CODE ERR] RL	—	—	×	<a href="#">WT-16</a>
C1724: [BATT VOLT LOW] FL	—	—	×	<a href="#">WT-16</a>
C1725: [BATT VOLT LOW] FR	—	—	×	<a href="#">WT-16</a>
C1726: [BATT VOLT LOW] RR	—	—	×	<a href="#">WT-16</a>
C1727: [BATT VOLT LOW] RL	—	—	×	<a href="#">WT-16</a>
C1729: VHCL SPEED SIG ERR	—	—	×	<a href="#">WT-19</a>
C1734: CONTROL UNIT	—	—	×	<a href="#">WT-20</a>

# IPDM E/R (INTELLIGENT POWER DISTRIBUTION MODULE ENGINE ROOM)

< ECU DIAGNOSIS >

## IPDM E/R (INTELLIGENT POWER DISTRIBUTION MODULE ENGINE ROOM)

Reference Value

INFOID:000000004501341

VALUES ON THE DIAGNOSIS TOOL

Monitor Item	Condition		Value/Status
RADFAN REQ	Engine idle speed	Changes depending on engine coolant temperature, air conditioner operation status, vehicle speed, etc.	0 - 100 %
TAIL&CLR REQ	Lighting switch OFF		OFF
	Lighting switch 1ST, 2ND, HI or AUTO (Light is illuminated)		ON
HL LO REQ	Lighting switch OFF		OFF
	Lighting switch 2ND HI or AUTO (Light is illuminated)		ON
HL HI REQ	Lighting switch OFF		OFF
	Lighting switch HI		ON
FR FOG REQ	Lighting switch 2ND or AUTO (Light is illuminated)	Front fog lamp switch OFF	OFF
		<ul style="list-style-type: none"> <li>• Front fog lamp switch ON</li> <li>• Daytime light activated (Canada only)</li> </ul>	ON
FR WIP REQ	Ignition switch ON	Front wiper switch OFF	STOP
		Front wiper switch INT	1LOW
		Front wiper switch LO	LOW
		Front wiper switch HI	HI
WIP AUTO STOP	Ignition switch ON	Front wiper stop position	STOP P
		Any position other than front wiper stop position	ACT P
WIP PROT	Ignition switch ON	Front wiper operates normally	OFF
		Front wiper stops at fail-safe operation	BLOCK
IGN RLY1 -REQ	Ignition switch OFF or ACC		OFF
	Ignition switch ON		ON
IGN RLY	Ignition switch OFF or ACC		OFF
	Ignition switch ON		ON
PUSH SW	Release the push-button ignition switch		OFF
	Press the push-button ignition switch		ON
DETENT SW	Ignition switch ON	<ul style="list-style-type: none"> <li>• Press the selector button with CVT selector lever in P position</li> <li>• CVT selector lever in any position other than P</li> </ul>	OFF
		Release the CVT selector button with CVT selector lever in P position	
S/L RLY -REQ	None of the conditions below are present		OFF
	<ul style="list-style-type: none"> <li>• Open the front door LH after the ignition switch is turned OFF (for a few seconds)</li> <li>• Press the push-button ignition switch when the steering lock is activated</li> </ul>		ON

# IPDM E/R (INTELLIGENT POWER DISTRIBUTION MODULE ENGINE ROOM)

## < ECU DIAGNOSIS >

Monitor Item	Condition	Value/Status
S/L STATE	Steering lock is activated	LOCK
	Steering lock is deactivated	UNLK
	[DTC B210A] is detected	UNKWN
DTRL REQ	<b>NOTE:</b> This item is displayed, but cannot be monitored.	OFF
OIL P SW	Ignition switch OFF, ACC or engine running	OPEN
	Ignition switch ON	CLOSE
THFT HRN REQ	Not operated	OFF
	<ul style="list-style-type: none"> <li>Panic alarm is activated</li> <li>Horn is activated with VEHICLE SECURITY (THEFT WARNING) SYSTEM</li> </ul>	ON
HORN CHIRP	Not operated	OFF
	Door locking with Intelligent Key (horn chirp mode)	ON
CRNRNG LMP REQ	<b>NOTE:</b> This item is displayed, but cannot be monitored.	OFF

## Terminal Layout

INFOID:000000004501342

## TERMINAL LAYOUT

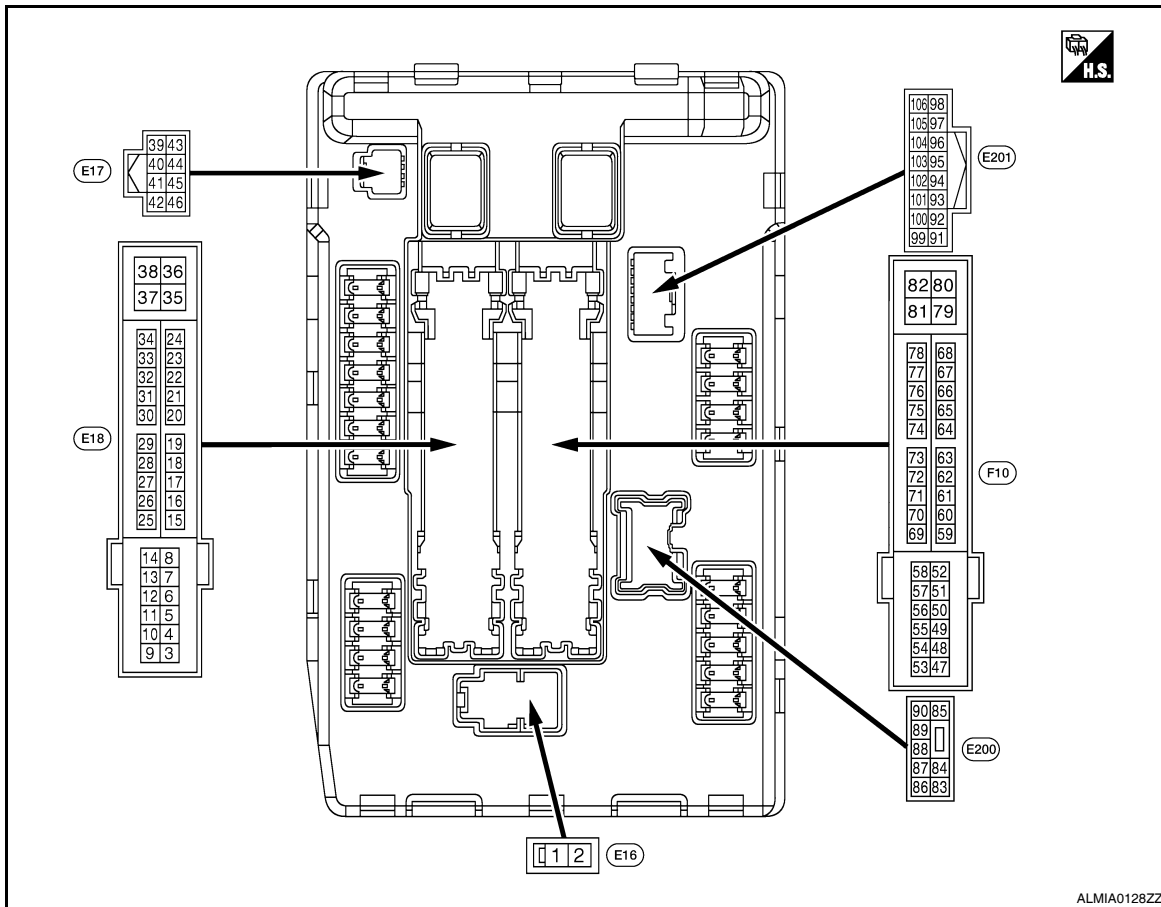

## Physical Values

INFOID:000000004501343

## PHYSICAL VALUES



# IPDM E/R (INTELLIGENT POWER DISTRIBUTION MODULE ENGINE ROOM)

## < ECU DIAGNOSIS >

Terminal No. (Wire color)		Description		Condition		Value (Approx.)
+	-	Signal name	Input/ Output			
1 (R)	Ground	Battery power supply	Input	Ignition switch OFF		Battery voltage
2 (B/Y)	Ground	Battery power supply	Input	Ignition switch OFF		Battery voltage
4 (L/R)	Ground	Front wiper LO	Output	Ignition switch ON	Front wiper switch OFF	0V
					Front wiper switch LO	Battery voltage
5 (L/B)	Ground	Front wiper HI	Output	Ignition switch ON	Front wiper switch OFF	0V
						Front wiper switch HI
6 (SB)	Ground	Daytime light relay power supply (Canada models only)	Output	Ignition switch OFF		Battery voltage
7 (R/L)	Ground	Tail, license plate lamps & interior lamps	Output	Ignition switch ON	Lighting switch OFF	0V
						Lighting switch 1ST
10 (R/B)	Ground	ECM relay power supply	Output	Ignition switch OFF (For a few seconds after turning ignition switch OFF)		0V
				• Ignition switch ON • Ignition switch OFF (More than a few seconds after turning ignition switch OFF)		Battery voltage
11 (P/L)	Ground	Steering lock unit power supply	Output	Ignition switch OFF	A few seconds after opening the driver door	Battery voltage
				Ignition switch LOCK	Press the push-button ignition switch	Battery voltage
				Ignition switch ACC or ON		0V
12 (B)	Ground	Ground	—	Ignition switch ON		0V
13 (W)	Ground	Fuel pump power supply	Output	Approximately 1 second or more after turning the ignition switch ON		0V
				• Approximately 1 second after turning the ignition switch ON • Engine running		Battery voltage
15 (BR)	Ground	Ignition relay-1 power supply	Output	Ignition switch OFF		0V
				Ignition switch ON		Battery voltage
16 (L/Y)	Ground	Front wiper auto stop	Input	Ignition switch ON	Front wiper stop position	0V
						Any position other than front wiper stop position
19 (L/Y)	Ground	Ignition relay-1 power supply	Output	Ignition switch OFF		0V
				Ignition switch ON		Battery voltage
20 (B/Y)	Ground	Ambient sensor ground	—	Ignition switch ON		0V
21 (O/B)	Ground	Ambient sensor	—	Ignition switch ON		5V
22 (W/R)	Ground	Refrigerent pressure sensor ground	—	Ignition switch ON		0V

# IPDM E/R (INTELLIGENT POWER DISTRIBUTION MODULE ENGINE ROOM)

## < ECU DIAGNOSIS >

Terminal No. (Wire color)		Description		Condition	Value (Approx.)
+	-	Signal name	Input/ Output		
23 (B/R)	Ground	Refrigerent pressure sensor	—	<ul style="list-style-type: none"> <li>Ignition switch ON (READY)</li> <li>Both A/C switch and blower motor switch ON (electric compressor operates)</li> </ul>	1.0 - 4.0V
24 (BR/W)	Ground	Refrigerent pressure sensor power supply	—	Ignition switch ON	5V
25 (G/R)	Ground	Ignition relay-1 power supply	Output	Ignition switch OFF	0V
				Ignition switch ON	Battery voltage
27 (BR/W)	Ground	Ignition relay monitor	Input	Ignition switch OFF or ACC	Battery voltage
				Ignition switch ON	0V
28 (BR)	Ground	Push-button ignition switch	Input	Press the push-button ignition switch	0V
				Release the push-button ignition switch	Battery voltage
31 (G/W)	Ground	Ignition relay power supply	Output	Ignition switch OFF	0V
				Ignition switch ON	Battery voltage
32 (LG)	Ground	Electronic steering column lock unit condition-1	Input	Electronic steering column lock is activated	0V
				Electronic steering column lock is deactivated	Battery voltage
33 (W)	Ground	Electronic steering column lock unit condition-2	Input	Electronic steering column lock is activated	Battery voltage
				Electronic steering column lock is deactivated	0V
39 (P)	—	CAN-L	Input/ Output	—	—
40 (L)	—	CAN-H	Input/ Output	—	—
41 (B)	Ground	Ground	—	Ignition switch ON	0V
42 (SB)	Ground	Cooling fan relay-1 control	Input	Ignition switch OFF or ACC	0V
				Ignition switch ON	0.7V
43 (G/B)	Ground	ECVT device (Detention switch)	Input	Press the ECVT selector button (ECVT selector lever P)	Battery voltage
				<ul style="list-style-type: none"> <li>ECVT selector lever in any position other than P</li> <li>Release the ECVT selector button (ECVT selector lever P)</li> </ul>	0V
44 (G/W)	Ground	Horn relay control	Input	The horn is deactivated	Battery voltage
				The horn is activated	0V
45 (L/O)	Ground	Anti theft horn relay control	Input	The horn is deactivated	Battery voltage
				The horn is activated	0V
48 (R)	Ground	Heater pump relay power supply	Output	Engine running	0V
				Heater pump ON (Heater pump is operating)	Battery voltage

# IPDM E/R (INTELLIGENT POWER DISTRIBUTION MODULE ENGINE ROOM)

## < ECU DIAGNOSIS >

Terminal No. (Wire color)		Description		Condition	Value (Approx.)	
+	-	Signal name	Input/ Output			
49 (B/R)	Ground	ECM relay power supply	Output	Ignition switch OFF (For a few seconds after turning ignition switch OFF)	0V	A
				<ul style="list-style-type: none"> <li>Ignition switch ON</li> <li>Ignition switch OFF (More than a few seconds after turning ignition switch OFF)</li> </ul>	Battery voltage	B
51 (LG)	Ground	Ignition relay power supply	Output	Ignition switch OFF	0V	C
				Ignition switch ON	Battery voltage	D
53 (R/W)	Ground	ECM relay power supply	Output	Ignition switch OFF (For a few seconds after turning ignition switch OFF)	0V	E
				<ul style="list-style-type: none"> <li>Ignition switch ON</li> <li>Ignition switch OFF (More than a few seconds after turning ignition switch OFF)</li> </ul>	Battery voltage	F
54 (G/W)	Ground	Throttle control motor relay power supply	Output	Ignition switch OFF (For a few seconds after turning ignition switch OFF)	0V	G
				<ul style="list-style-type: none"> <li>Ignition switch ON</li> <li>Ignition switch OFF (More than a few seconds after turning ignition switch OFF)</li> </ul>	Battery voltage	H
55 (W/L)	Ground	ECM power supply	Output	Ignition switch OFF	Battery voltage	I
56 (R/Y)	Ground	Ignition relay power supply	Output	Ignition switch OFF	0V	J
				Ignition switch ON	Battery voltage	K
57 (O)	Ground	Ignition relay power supply	Output	Ignition switch OFF	0V	L
				Ignition switch ON	Battery voltage	M
69 (W/B)	Ground	ECM relay control	Output	Ignition switch OFF (For a few seconds after turning ignition switch OFF)	Battery voltage	N
				<ul style="list-style-type: none"> <li>Ignition switch ON</li> <li>Ignition switch OFF (More than a few seconds after turning ignition switch OFF)</li> </ul>	0 - 1.5V	O
70 (O)	Ground	Throttle control motor relay control	Output	Ignition switch ON → OFF	0 - 1.0V ↓ Battery voltage ↓ 0V	P
				Ignition switch ON	0 - 1.0V	Q
75 (P/L)	Ground	Oil pressure switch	Input	Ignition switch ON	Engine stopped	0V
				Engine running	Battery voltage	R
77 (B/R)	Ground	Fuel pump relay control	Output	<ul style="list-style-type: none"> <li>Approximately 1 second after turning the ignition switch ON</li> <li>Engine running</li> </ul>	0 - 1.0V	S
				Approximately 1 second or more after turning the ignition switch ON	Battery voltage	T
83 (R/Y)	Ground	Headlamp LO (RH)	Output	Ignition switch ON	Lighting switch OFF	0V
				Lighting switch 2ND	Battery voltage	U

# IPDM E/R (INTELLIGENT POWER DISTRIBUTION MODULE ENGINE ROOM)

## < ECU DIAGNOSIS >

Terminal No. (Wire color)		Description		Condition		Value (Approx.)
+	-	Signal name	Input/ Output			
84 (L)	Ground	Headlamp LO (LH)	Output	Ignition switch ON	Lighting switch OFF	0V
					Lighting switch 2ND	Battery voltage
86 (W/R)	Ground	Front fog lamp (RH)	Output	Lighting switch 2ND	• Front fog lamp switch ON • Daytime light activated (Canada only)	Battery voltage
					Front fog lamp switch OFF	0V
87 (L/Y)	Ground	Front fog lamp (LH)	Output	Lighting switch 2ND	• Front fog lamp switch ON • Daytime light activated (Canada only)	Battery voltage
					Front fog lamp switch OFF	0V
88 (R/W)	Ground	Washer pump power supply	Output	Ignition switch ON		Battery voltage
89 (L/W)	Ground	Headlamp HI (RH)	Output	Ignition switch ON	• Lighting switch HI • Lighting switch PASS	Battery voltage
					Lighting switch OFF	0V
90 (G)	Ground	Headlamp HI (LH)	Output	Ignition switch ON	• Lighting switch HI • Lighting switch PASS	Battery voltage
					Lighting switch OFF	0V
91 (LG/R)	Ground	Parking lamp (RH)	Output	Ignition switch ON	Lighting switch 1ST	Battery voltage
					Lighting switch OFF	0V
92 (LG/B)	Ground	Parking lamp (LH)	Output	Ignition switch ON	Lighting switch 1ST	Battery voltage
					Lighting switch OFF	0V
97 (V)	Ground	Cooling fan control	Output	Engine idling		0-5V
99 (BR/W)	Ground	Ambient sensor ground	—	Ignition switch ON		0V
100 (SB)	Ground	Ambient sensor	—	Ignition switch ON		5V
101 (W)	Ground	Refrigerent pressure sensor ground	—	Ignition switch ON		0V
102 (R)	Ground	Refrigerent pressure sensor	—	• Ignition switch ON (READY) • Both A/C switch and blower motor switch ON (electric compressor operates)		1.0 - 4.0V
103 (P)	Ground	Refrigerent pressure sensor power supply	—	Ignition switch ON		5V
105 (V)	Ground	Daytime light relay control (Canada only)	Output	Ignition switch ON	Daytime light system active	Battery voltage
				Ignition switch ON	Daytime light system inactive	0V

# IPDM E/R (INTELLIGENT POWER DISTRIBUTION MODULE ENGINE ROOM)

< ECU DIAGNOSIS >

## Wiring Diagram

INFOID:000000004501344

### IPDM E/R (INTELLIGENT POWER DISTRIBUTION MODULE ENGINE ROOM)

◊ FL : WITH FRONT FOG LAMPS  
◊ N : FOR CANADA

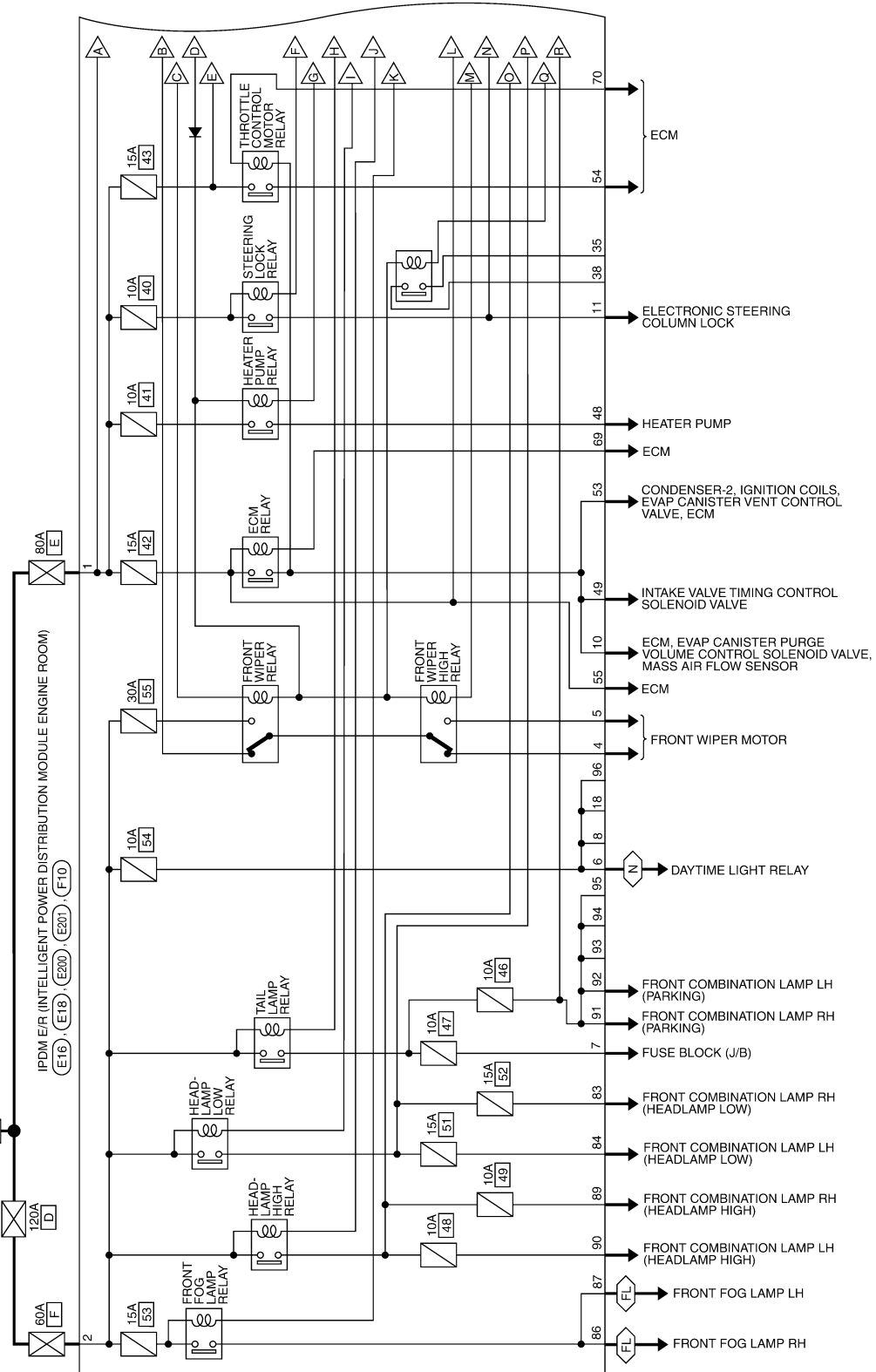

ABMWA0191GI

A  
B  
C  
D  
E  
F  
G  
H  
I  
J  
K  
L  
M  
N  
O  
P

EXL

# IPDM E/R (INTELLIGENT POWER DISTRIBUTION MODULE ENGINE ROOM)

< ECU DIAGNOSIS >

 : DATA LINE  
 : FOR CANADA

IPDM E/R (INTELLIGENT POWER DISTRIBUTION MODULE ENGINE ROOM)

(E17) (E18) (E200) (E201) (E10)

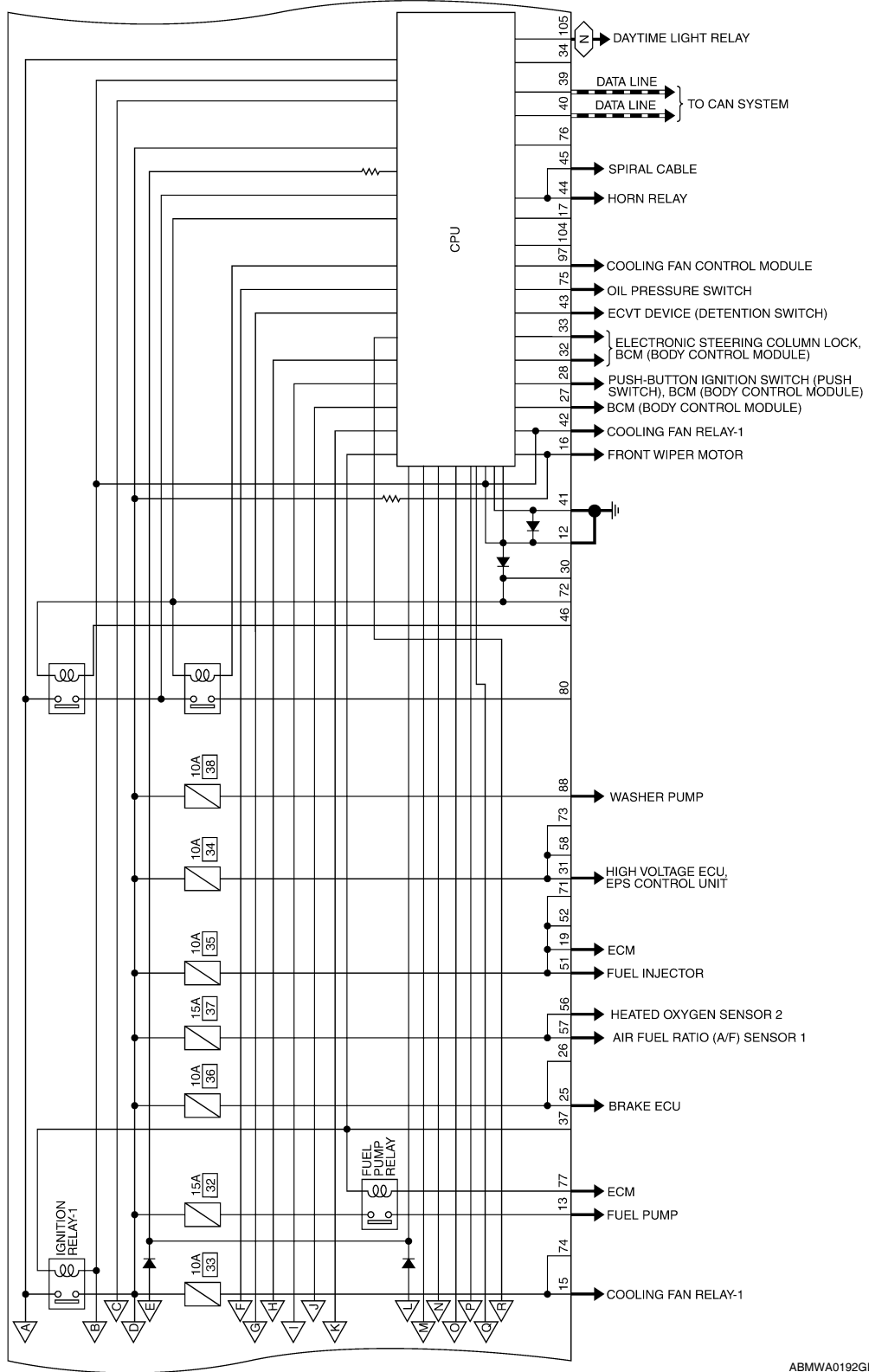

ABMWA0192GI

# IPDM E/R (INTELLIGENT POWER DISTRIBUTION MODULE ENGINE ROOM)

< ECU DIAGNOSIS >

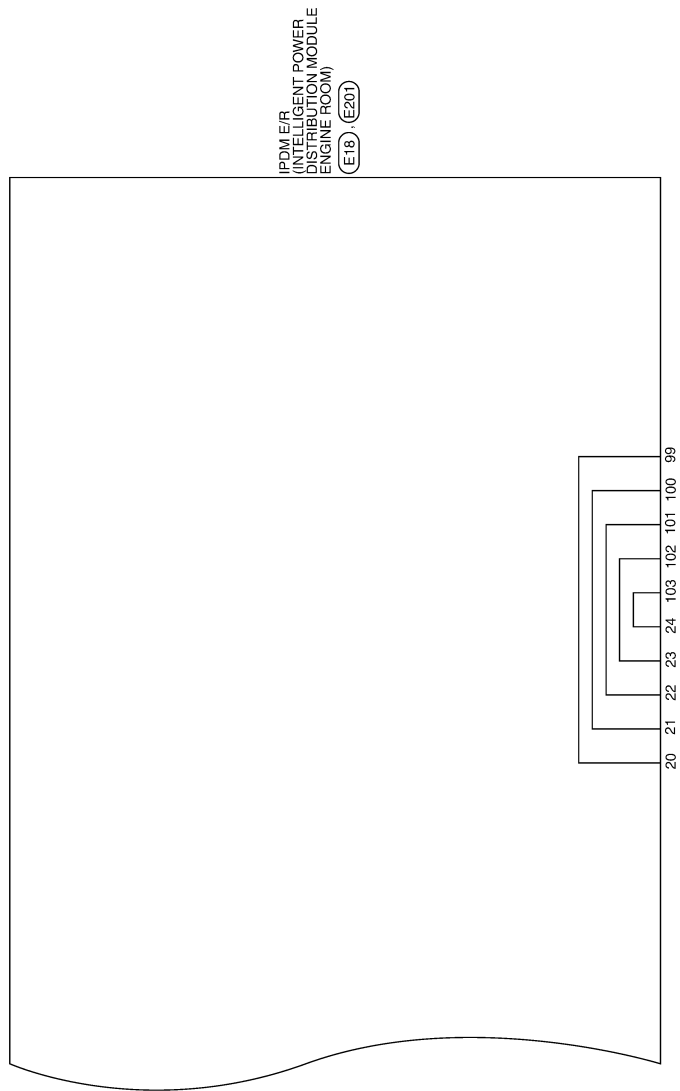

A  
B  
C  
D  
E  
F  
G  
H  
I  
J  
K  
EXL  
M  
N  
O  
P

ALMWA0033Gf

# IPDM E/R (INTELLIGENT POWER DISTRIBUTION MODULE ENGINE ROOM)

< ECU DIAGNOSIS >

## IPDM E/R (INTELLIGENT POWER DISTRIBUTION MODULE ENGINE ROOM) CONNECTORS

Connector No.	E16
Connector Name	IPDM E/R (INTELLIGENT POWER DISTRIBUTION MODULE ENGINE ROOM)
Connector Color	BLACK



Terminal No.	Color of Wire	Signal Name
1	R	F/L_MAIN
2	B/Y	F/L_USM

Connector No.	E17
Connector Name	IPDM E/R (INTELLIGENT POWER DISTRIBUTION MODULE ENGINE ROOM)
Connector Color	WHITE

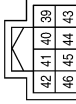

Terminal No.	Color of Wire	Signal Name
39	P	CAN-L
40	L	CAN-H
41	B	GND (SIGNAL)
42	SB	MOTOR_FAN_RLY_MID
43	G/B	DETENT_SW
44	G/W	HORN_RLY
45	L/O	HORN_SW
46	-	-

Connector No.	E18
Connector Name	IPDM E/R (INTELLIGENT POWER DISTRIBUTION MODULE ENGINE ROOM)
Connector Color	WHITE

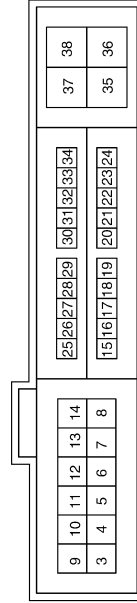

Terminal No.	Color of Wire	Signal Name
8	-	-
9	-	-
10	R/B	ECM_VB
11	P/L	ESCL
12	B	GND (POWER)
13	W	FUEL_PUMP
14	-	-
15	BR	START_IG-E/R
16	L/Y	WIPER_AUTOSTOP
17	-	-
18	-	-
19	L/Y	BCM_IGNSW
20	B/Y	AMB_SENS_GND-E/R
21	O/B	AMB_SENS_SIG-E/R
22	W/R	PD_SENS_GND-E/R

Terminal No.	Color of Wire	Signal Name
3	-	-
4	L/R	FR_WIPER_LO
5	L/B	FR_WIPER_HI
6	SB	DTRL
7	R/L	TAIL/ILLUMI

Terminal No.	Color of Wire	Signal Name
23	B/R	PD_SENS_SIG-E/R
24	BR/W	PD_SENS_PWR-E/R
25	G/R	ABS_ECU
26	-	-
27	BR/W	IGN_SIGNAL
28	BR	PUSH_START_SW
29	-	-
30	-	-
31	G/W	REV_RLY
32	LG	SL_CONDITION_1
33	W	SL_CONDITION_2
34	-	-
35	-	-
36	-	-
37	-	-
38	-	-

ABMIA0566GB



# IPDM E/R (INTELLIGENT POWER DISTRIBUTION MODULE ENGINE ROOM)

< ECU DIAGNOSIS >

Connector No.	E201
Connector Name	IPDM E/R (INTELLIGENT POWER DISTRIBUTION MODULE ENGINE ROOM)
Connector Color	WHITE

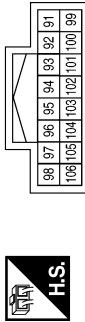

Terminal No.	Color of Wire	Signal Name
91	LG/R	CLEARANCE_RH
92	LG/B	CLEARANCE_LH
93	-	-
94	-	-
95	-	-
96	-	-
97	V	MOTOR_FAN_PWM
98	-	-
99	BR/W	AMB_SENS_GND-FEM
100	SB	AMB_SENS_SIG-FEM
101	W	PD_SENS_GND-FEM
102	R	PD_SENS_SIG-FEM
103	P	PD_SENS_PWR-FEM
104	-	-
105	V	DTRL_RLY
106	-	-

Connector No.	E200
Connector Name	IPDM E/R (INTELLIGENT POWER DISTRIBUTION MODULE ENGINE ROOM)
Connector Color	WHITE



Terminal No.	Color of Wire	Signal Name
83	R/Y	HEADLAMP_LO_RH
84	L	HEADLAMP_LO_LH
85	-	-
86	W/R	FR_FOG_LAMP_RH
87	L/Y	FR_FOG_LAMP_LH
88	R/W	WASHER_MTR
89	L/W	HEADLAMP_HI_RH
90	G	HEADLAMP_HI_LH

ALMIA0077GB

A  
B  
C  
D  
E  
F  
G  
H  
I  
J  
K  
L  
M  
N  
O  
P

EXL

# IPDM E/R (INTELLIGENT POWER DISTRIBUTION MODULE ENGINE ROOM)

< ECU DIAGNOSIS >

Terminal No.	Color of Wire	Signal Name
64	-	-
65	-	-
66	-	-
67	-	-
68	-	-
69	W/B	SSOF
70	O	MOTRLY
71	-	-
72	-	-
73	-	-
74	-	-
75	P/L	OIL_PRESSURE_SW
76	-	-
77	B/R	FPR
78	-	-
79	-	-
80	-	-
81	-	-
82	-	-

Terminal No.	Color of Wire	Signal Name
47	-	-
48	R	ENG_SOL
49	B/R	ENG_SOL
50	-	-
51	LG	INJECTOR_#1
52	-	-
53	R/W	IGN_COIL
54	G/W	ETC
55	W/L	ECM_BAT
56	R/Y	O2_SENS_#1
57	O	O2_SENS_#2
58	-	-
59	-	-
60	-	-
61	-	-
62	-	-
63	-	-

Connector No.	F10
Connector Name	IPDM E/R (INTELLIGENT POWER DISTRIBUTION MODULE ENGINE ROOM)
Connector Color	WHITE

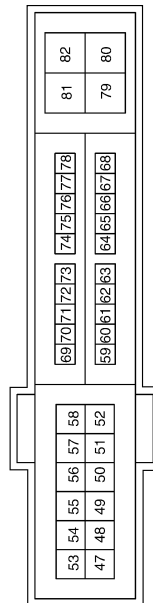

ALMIA0078GB

INFOID:000000004501345

## Fail Safe

### CAN COMMUNICATION CONTROL

When CAN communication with ECM and BCM is impossible, IPDM E/R performs fail-safe control. After CAN communication recovers normally, it also returns to normal control.

If No CAN Communication Is Available With ECM

# IPDM E/R (INTELLIGENT POWER DISTRIBUTION MODULE ENGINE ROOM)

## < ECU DIAGNOSIS >

Control part	Fail-safe in operation
Cooling fan	<ul style="list-style-type: none"> <li>• Signals cooling fans ON when the ignition switch is turned ON</li> <li>• Signals cooling fans OFF when the ignition switch is turned OFF</li> </ul>
Heater pump	Heater pump relay OFF

### If No CAN Communication Is Available With BCM

Control part	Fail-safe in operation
Headlamp	<ul style="list-style-type: none"> <li>• Turns ON the headlamp low relay when the ignition switch is turned ON</li> <li>• Turns OFF the headlamp low relay when the ignition switch is turned OFF</li> <li>• Headlamp high relay OFF</li> </ul>
<ul style="list-style-type: none"> <li>• Parking lamps</li> <li>• License plate lamps</li> <li>• Illuminations</li> <li>• Tail lamps</li> </ul>	<ul style="list-style-type: none"> <li>• Turns ON the tail lamp relay when the ignition switch is turned ON</li> <li>• Turns OFF the tail lamp relay when the ignition switch is turned OFF</li> </ul>
Front wiper	<ul style="list-style-type: none"> <li>• The status just before activation of fail-safe control is maintained until the ignition switch is turned OFF while the front wiper is operating at LO or HI speed.</li> <li>• The wiper is operated at LO speed until the ignition switch is turned OFF if the fail-safe control is activated while the front wiper is set in the INT mode and the front wiper motor is operating.</li> </ul>
Front fog lamps (if equipped)	Front fog lamp relay OFF
Horn	Horn OFF
Ignition relay	The status just before activation of fail-safe is maintained.
Electronic steering column lock unit	Electronic steering column lock relay OFF

### IGNITION RELAY MALFUNCTION DETECTION FUNCTION

- IPDM E/R monitors the voltage at the contact circuit and excitation coil circuit of the ignition relay inside it.
- IPDM E/R judges the ignition relay error if the voltage differs between the contact circuit and the excitation coil circuit.
- If the ignition relay cannot turn OFF due to contact seizure, it activates the tail lamp relay for 10 minutes to alert the user to the ignition relay malfunction when the ignition switch is turned OFF.

DTC	Ignition switch	Ignition relay	Tail lamp relay
—	ON	ON	—
—	OFF	OFF	—
B2098: IGN RELAY ON	OFF	ON	ON (10 minutes)
B2099: IGN RELAY OFF	ON	OFF	—

#### NOTE:

The tail lamp turns OFF when the ignition switch is turned ON.

### FRONT WIPER CONTROL

IPDM E/R detects front wiper stop position by a front wiper auto stop signal.

When a front wiper auto stop signal is in the conditions listed below, IPDM E/R stops power supply to wiper after repeating a front wiper 10 second activation and 20 second stop five times.

Ignition switch	Front wiper switch	Auto stop signal
ON	OFF	Front wiper stop position signal cannot be input 10 seconds.
	ON	The signal does not change for 10 seconds.

#### NOTE:

This operation status can be confirmed on the IPDM E/R “Data Monitor” that displays “BLOCK” for the item “WIP PROT” while the wiper is stopped.

### STARTER MOTOR PROTECTION FUNCTION

IPDM E/R turns OFF the starter control relay to protect the starter motor when the starter control relay remains active for 90 seconds.

# IPDM E/R (INTELLIGENT POWER DISTRIBUTION MODULE ENGINE ROOM)

< ECU DIAGNOSIS >

## DTC Index

INFOID:000000004501346

CONSULT-III display	Fail-safe	TIME <sup>NOTE</sup>		Refer to
No DTC is detected. further testing may be required.	—	—	—	—
U1000: CAN COMM CIRCUIT	×	CRNT	1 – 39	<a href="#">PCS-19</a>
B2098: IGN RELAY ON	×	CRNT	1 – 39	<a href="#">PCS-20</a>
B2099: IGN RELAY OFF	—	CRNT	1 – 39	<a href="#">PCS-21</a>
B2108: STRG LCK RELAY ON	—	CRNT	1 – 39	<a href="#">SEC-34</a>
B2109: STRG LCK RELAY OFF	—	CRNT	1 – 39	<a href="#">SEC-35</a>
B210A: STRG LCK STATE SW	—	CRNT	1 – 39	<a href="#">SEC-36</a>

### NOTE:

The details of TIME display are as follows.

- CRNT: The malfunctions that are detected now
- 1 - 39: The number is indicated when it is normal at present and a malfunction was detected in the past. It increases like 0 → 1 → 2 ... 38 → 39 after returning to the normal condition whenever IGN OFF → ON. It is fixed to 39 until the self-diagnosis results are erased if it is over 39. It returns to 0 when a malfunction is detected again in the process.

# EXTERIOR LIGHTING SYSTEM SYMPTOMS

< SYMPTOM DIAGNOSIS >

## SYMPTOM DIAGNOSIS

### EXTERIOR LIGHTING SYSTEM SYMPTOMS

#### Symptom Table

INFOID:000000004216427

**CAUTION:**

Perform the self-diagnosis with CONSULT-III before the symptom diagnosis. Perform the trouble diagnosis if any DTC is detected.

Symptom		Possible cause	Inspection item
Headlamp does not switch to the high beam.	One side	<ul style="list-style-type: none"> <li>• Fuse</li> <li>• Harness between IPDM E/R and the front combination lamp</li> <li>• Front combination lamp (High beam relay)</li> <li>• IPDM E/R</li> </ul>	Headlamp (HI) circuit Refer to <a href="#">EXL-39</a> .
	Both sides	<b>Symptom diagnosis</b> "BOTH SIDE HEADLAMPS DO NOT SWITCH TO HIGH BEAM" Refer to <a href="#">EXL-152</a> .	
High beam indicator lamp is not turned ON. (Headlamp switches to the high beam.)		<ul style="list-style-type: none"> <li>• Combination meter</li> <li>• BCM</li> </ul>	<ul style="list-style-type: none"> <li>• Combination meter. Data monitor "HI-BEAM IND"</li> <li>• BCM (HEAD LAMP) Active test "HEADLAMP"</li> </ul>
Headlamp does not switch to the low beam.	One side	Front combination lamp (Low beam relay)	—
	Both sides	<ul style="list-style-type: none"> <li>• Combination switch</li> <li>• Harness between the combination switch and BCM</li> <li>• BCM</li> </ul>	Combination switch Refer to <a href="#">BCS-45</a> .
		High beam request signal <ul style="list-style-type: none"> <li>• BCM</li> <li>• IPDM E/R</li> </ul>	IPDM E/R Data monitor "HL HI REQ"
		IPDM E/R	—
Headlamp does not turn ON.	One side	<ul style="list-style-type: none"> <li>• Fuse</li> <li>• Bulb</li> <li>• Harness between IPDM E/R and the front combination lamp</li> <li>• Front combination lamp</li> <li>• IPDM E/R</li> </ul>	Headlamp (LO) circuit Refer to <a href="#">EXL-41</a> .
	Both sides	<b>Symptom diagnosis</b> "BOTH SIDE HEADLAMPS (LO) ARE NOT TURNED ON" Refer to <a href="#">EXL-153, "Description"</a> .	
Headlamp does not turn OFF.	When the ignition switch is turned ON	<ul style="list-style-type: none"> <li>• BCM</li> <li>• Combination switch</li> </ul>	Combination switch Refer to <a href="#">BCS-45, "Diagnosis Procedure"</a> .
	The ignition switch is turned OFF (After activating the battery saver).	IPDM E/R	—
Headlamp is not turned ON/OFF with the lighting switch AUTO.	<ul style="list-style-type: none"> <li>• Combination switch</li> <li>• Harness between the combination switch and BCM</li> <li>• BCM</li> </ul>		Combination switch Refer to <a href="#">BCS-45</a> .
	<ul style="list-style-type: none"> <li>• Optical sensor</li> <li>• Harness between the optical sensor and BCM</li> <li>• BCM</li> </ul>		Optical sensor Refer to <a href="#">EXL-51</a> .

A  
B  
C  
D  
E  
F  
G  
H  
I  
J  
K  
L  
M  
N  
O  
P

EXL

## EXTERIOR LIGHTING SYSTEM SYMPTOMS

### < SYMPTOM DIAGNOSIS >

Symptom	Possible cause	Inspection item	
Daytime light system does not activate.	<ul style="list-style-type: none"> <li>• Either high beam bulb</li> <li>• Parking brake switch</li> <li>• Combination switch</li> <li>• BCM</li> <li>• IPDM E/R</li> <li>• Daytime light relay</li> <li>• Harness between IPDM E/R and daytime light relay.</li> </ul>	Daytime light system description. Refer to <a href="#">EXL-9, "System Description"</a> .	
Front fog lamp is not turned ON.	One side	<ul style="list-style-type: none"> <li>• Front fog lamp bulb</li> <li>• Harness between IPDM E/R and the front combination lamp</li> <li>• Front combination lamp</li> <li>• IPDM E/R</li> </ul> Front fog lamp circuit Refer to <a href="#">EXL-43</a> .	
	Both side	<b>Symptom diagnosis</b> "BOTH SIDE FRONT FOG LAMPS ARE NOT TURNED ON" Refer to <a href="#">EXL-155</a> .	
Parking lamp is not turned ON.	One side	<ul style="list-style-type: none"> <li>• Fuse</li> <li>• Parking lamp bulb</li> <li>• Harness between IPDM E/R and the front/rear combination lamp</li> <li>• Front/rear combination lamp</li> <li>• IPDM E/R</li> </ul> Parking lamp circuit Refer to <a href="#">EXL-45</a> .	
	Both sides	<b>Symptom diagnosis</b> "PARKING, LICENSE PLATE AND TAIL LAMPS ARE NOT TURNED ON" Refer to <a href="#">EXL-154</a> .	
Turn signal lamp does not blink.	Indicator lamp is normal. (The applicable side performs the high flasher activation).	<ul style="list-style-type: none"> <li>• Harness between BCM and each turn signal lamp</li> <li>• Turn signal lamp bulb</li> <li>• Door mirror (if equipped with turn signals in the door mirrors)</li> </ul> Turn signal lamp circuit Refer to <a href="#">EXL-48</a> .	
Turn signal indicator lamp does not blink.	One side	Combination meter	
	Both sides (Always)	<ul style="list-style-type: none"> <li>• Turn signal indicator lamp signal</li> <li>• Combination meter</li> <li>• BCM</li> </ul>	<ul style="list-style-type: none"> <li>• Combination meter.</li> <li>• Data monitor "TURN IND"</li> <li>• BCM (FLASHER)</li> <li>• Active test "FLASHER"</li> </ul>
	Both sides (Does blink when activating the hazard warning lamp with the ignition switch OFF)	<ul style="list-style-type: none"> <li>• The combination meter power supply and the ground circuit</li> <li>• Combination meter</li> </ul>	Combination meter Power supply and the ground circuit Refer to <a href="#">MWI-40, "COMBINATION METER : Diagnosis Procedure"</a> .

# NORMAL OPERATING CONDITION

< SYMPTOM DIAGNOSIS >

## NORMAL OPERATING CONDITION

---

### Description

INFOID:000000004216428

#### AUTO LIGHT SYSTEM

The auto light system may not turn the headlamp ON/OFF immediately after passing a dark area or a bright area (short tunnel, sky bridge, shadowed area etc.). This is normal.

A

B

C

D

E

F

G

H

I

J

K

EXL

M

N

O

P

# BOTH SIDE HEADLAMPS DO NOT SWITCH TO HIGH BEAM

< SYMPTOM DIAGNOSIS >

## BOTH SIDE HEADLAMPS DO NOT SWITCH TO HIGH BEAM

### Description

INFOID:000000004216429

The headlamps (both sides) do not switch to high beam when the lighting switch is in the HI or PASS setting.

### Diagnosis Procedure

INFOID:000000004216430

#### 1.COMBINATION SWITCH INSPECTION

Check the combination switch. Refer to [EXL-152, "Diagnosis Procedure"](#).

Is the combination switch normal?

- YES >> GO TO 2
- NO >> Repair or replace the malfunctioning part.

#### 2.CHECK HEADLAMP (HI) REQUEST SIGNAL INPUT

##### ⓑCONSULT-III DATA MONITOR

1. Select "HL HI REQ" of IPDM E/R DATA MONITOR item.
2. With operating the lighting switch, check the monitor status.

Monitor item	Condition		Monitor status
HL HI REQ	Lighting switch (2ND)	HI or PASS	ON
		Except for HI or PASS	OFF

Is the item status normal?

- YES >> GO TO 3
- NO >> Replace BCM. Refer to [BCS-87, "Removal and Installation"](#).

#### 3.HEADLAMP (HI) CIRCUIT INSPECTION

Check the headlamp (HI) circuit. Refer to [EXL-39, "Description"](#).

Is the headlamp (HI) circuit normal?

- YES >> Replace IPDM E/R. Refer to [PCS-39, "Removal and Installation"](#).
- NO >> Repair or replace the malfunctioning part.



# BOTH SIDE HEADLAMPS (LO) ARE NOT TURNED ON

< SYMPTOM DIAGNOSIS >

## BOTH SIDE HEADLAMPS (LO) ARE NOT TURNED ON

### Description

INFOID:000000004216431

The headlamps (both sides) do not turn ON in any lighting switch setting.

### Diagnosis Procedure

INFOID:000000004216432

#### 1. CHECK COMBINATION SWITCH

Check the combination switch. Refer to [BCS-10. "System Description"](#).

Is the combination switch normal?

- YES >> GO TO 2
- NO >> Repair or replace the malfunctioning part.

#### 2. CHECK HEADLAMP (LO) REQUEST SIGNAL INPUT

Ⓜ CONSULT-III DATA MONITOR

1. Select "HL LO REQ" of IPDM E/R DATA MONITOR item.
2. With operating the lighting switch, check the monitor status.

Monitor item	Condition		Monitor status
HL LO REQ	Lighting switch	2ND	ON
		OFF	OFF

Is the item status normal?

- YES >> GO TO 3
- NO >> Replace BCM. Refer to [BCS-87. "Removal and Installation"](#).

#### 3. HEADLAMP (LO) CIRCUIT INSPECTION

Check the headlamp (LO) circuit. Refer to [EXL-41. "Description"](#).

Is the headlamp (LO) circuit normal?

- YES >> Replace IPDM E/R. Refer to [PCS-39. "Removal and Installation"](#).
- NO >> Repair or replace the malfunctioning part.

A  
B  
C  
D  
E  
F  
G  
H  
I  
J  
K  
M  
N  
O  
P

EXL

# PARKING, LICENSE PLATE AND TAIL LAMPS ARE NOT TURNED ON

< SYMPTOM DIAGNOSIS >

## PARKING, LICENSE PLATE AND TAIL LAMPS ARE NOT TURNED ON

### Description

INFOID:000000004216433

The parking, license plate and tail lamps do not turn ON in with any lighting switch setting.

### Diagnosis Procedure

INFOID:000000004216434

#### 1.COMBINATION SWITCH INSPECTION

Check the combination switch. Refer to [BCS-10, "System Description"](#).

Is the combination switch normal?

YES >> GO TO 2

NO >> Repair or replace the malfunctioning part.

#### 2.CHECK TAIL LAMP RELAY REQUEST SIGNAL INPUT

##### ⓅCONSULT-III DATA MONITOR

1. Select "TAIL & CLR REQ" of IPDM E/R DATA MONITOR item.
2. With operating the lighting switch, check the monitor status.

Monitor item	Condition	Monitor status	
TAIL & CLR REQ	Lighting switch	1ST	ON
		OFF	OFF

Is the item status normal?

YES >> GO TO 3

NO >> Replace BCM. Refer to [BCS-87, "Removal and Installation"](#).

#### 3.PARK LAMP CIRCUIT INSPECTION

Check the parking lamp circuit. Refer to [EXL-45, "Description"](#).

Is the tail lamp circuit normal?

YES >> Replace IPDM E/R. Refer to [PCS-39, "Removal and Installation"](#).

NO >> Repair or replace the malfunctioning part.

# BOTH SIDE FRONT FOG LAMPS ARE NOT TURNED ON

< SYMPTOM DIAGNOSIS >

## BOTH SIDE FRONT FOG LAMPS ARE NOT TURNED ON

### Description

INFOID:000000004216435

The front fog lamps do not turn ON in any setting.

### Diagnosis Procedure

INFOID:000000004216436

#### 1.COMBINATION SWITCH INSPECTION

Check the combination switch. Refer to [BCS-10, "System Description"](#).

Is the combination switch normal?

YES >> GO TO 2

NO >> Repair or replace the malfunctioning part.

#### 2.CHECK FRONT FOG LAMP REQUEST SIGNAL INPUT

ⓂCONSULT-III DATA MONITOR

1. Select "FR FOG REQ" of IPDM E/R DATA MONITOR item.

2. With operating the front fog lamp switch, check the monitor status.

Monitor item	Condition	Monitor status	
FR FOG REQ	Front fog lamp switch (Lighting switch 2ND)	ON	ON
		OFF	OFF

Is the item status normal?

YES >> GO TO 3

NO >> Replace BCM. Refer to [BCS-87, "Removal and Installation"](#).

#### 3.FRONT FOG LAMP CIRCUIT INSPECTION

Check the front fog lamp circuit. Refer to [EXL-43, "Description"](#).

Is the front fog lamp circuit normal?

YES >> Replace IPDM E/R. Refer to [PCS-39, "Removal and Installation"](#).

NO >> Repair or replace the malfunctioning part.

A  
B  
C  
D  
E  
F  
G  
H  
I  
J  
K  
M  
N  
O  
P

EXL

# PRECAUTIONS

< PRECAUTION >

## PRECAUTION

### PRECAUTIONS

#### Precaution for Supplemental Restraint System (SRS) "AIR BAG" and "SEAT BELT PRE-TENSIONER"

INFOID:000000004216437

The Supplemental Restraint System such as "AIR BAG" and "SEAT BELT PRE-TENSIONER", used along with a front seat belt, helps to reduce the risk or severity of injury to the driver and front passenger for certain types of collision. This system includes seat belt switch inputs and dual stage front air bag modules. The SRS system uses the seat belt switches to determine the front air bag deployment, and may only deploy one front air bag, depending on the severity of a collision and whether the front occupants are belted or unbelted. Information necessary to service the system safely is included in the SR and SB section of this Service Manual.

#### **WARNING:**

- **To avoid rendering the SRS inoperative, which could increase the risk of personal injury or death in the event of a collision which would result in air bag inflation, all maintenance must be performed by an authorized NISSAN/INFINITI dealer.**
- **Improper maintenance, including incorrect removal and installation of the SRS, can lead to personal injury caused by unintentional activation of the system. For removal of Spiral Cable and Air Bag Module, see the SR section.**
- **Do not use electrical test equipment on any circuit related to the SRS unless instructed to in this Service Manual. SRS wiring harnesses can be identified by yellow and/or orange harnesses or harness connectors.**

#### Precautions For High-Voltage System

INFOID:000000004216438

Refer to [HBB-92. "Precautions For High-Voltage System"](#).

#### General precautions for service operations

INFOID:000000004216439

- Never work with wet hands.
- Turn the lighting switch OFF before disconnecting and connecting the connector.
- When checking the headlamp on/off operation, check it on vehicle and with the power connected to the vehicle-side connector.
- Do not touch the headlamp bulb glass surface with bare hands or allow oil or grease to get on it. Do not touch the headlamp bulb just after the headlamp is turned off, because it is very hot.
- When the bulb has burned out, wrap it in a thick vinyl bag and discard. Do not break the bulb.
- Leaving the bulb removed from the headlamp housing for a long period of time can deteriorate the performance of the lens and reflector (dirt, clouding). Always prepare a new bulb and have it on hand when replacing the bulb.
- When adjusting the headlamp aiming, turn the aiming adjustment screw only in the tightening direction. (If it is necessary to loosen the screw, first fully loosen the screw, and then turn it in the tightening direction.)
- Do not use organic solvent (paint thinner or gasoline) to clean lamps and to remove old sealant.

# HEADLAMP

< ON-VEHICLE MAINTENANCE >

## ON-VEHICLE MAINTENANCE

### HEADLAMP

#### Aiming Adjustment

INFOID:000000004216440

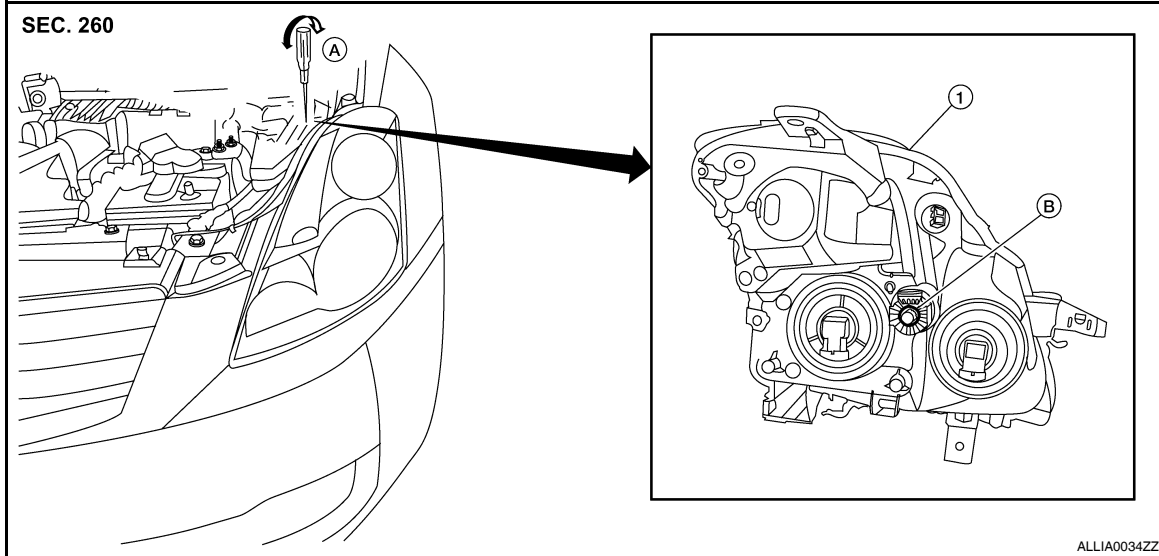

1. Headlamp assembly

A. Suitable tool (for aiming adjustment) B. Adjusting screw

#### NOTE:

For details, refer to the regulations in your area.

#### Headlamp Aiming

#### NOTE:

- If the vehicle front body has been repaired and/or the headlamp assembly has been replaced, check headlamp aiming.
- Before performing headlamp aiming adjustment, check the following:
  - Confirm which type of headlamp is in vehicle.
  - Ensure all tires are inflated to correct pressure.
  - Place vehicle and screen on level surface.
  - Ensure there is no load in vehicle other than the driver (or equivalent weight placed in driver's position).
  - Ensure engine coolant and engine oil are filled to correct level and fuel tank is full.
  - Confirm spare tire, jack and tools are properly stowed.

#### AIMING ADJUSTMENT

# HEADLAMP

< ON-VEHICLE MAINTENANCE >

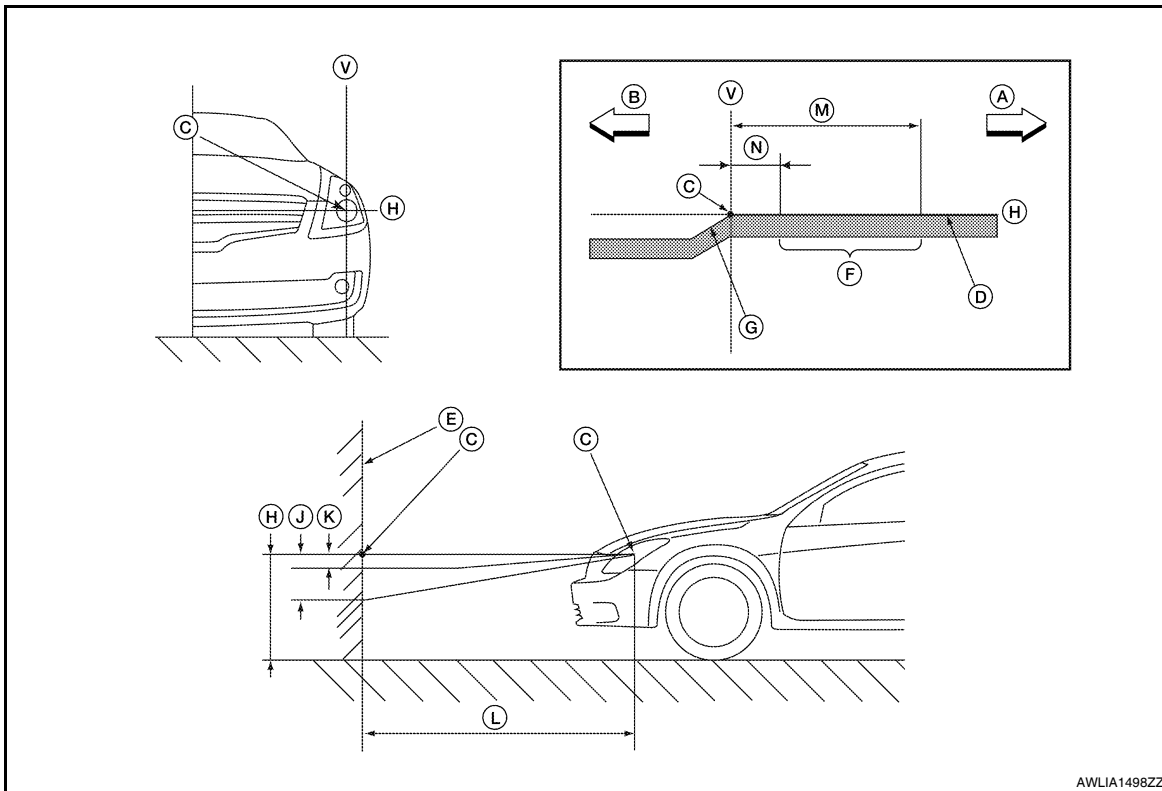

AWLIA1498ZZ

- |                        |                                       |  |
|------------------------|---------------------------------------|--|
| A. Right               | B. Left                               | C. Center of headlamp bulb (H-V point) |
| D. Cutoff line         | E. Screen                             | F. Aim evaluation segment              |
| G. Step                | H. Horizontal center line of headlamp | J. 53.2 mm (2.09 in)                   |
| K. -13.3 mm (-0.52 in) | L. 7.62 m (25 ft)                     | M. 399 mm (15.71 in)                   |
| N. 133 mm (5.24 in)    | V. Vertical center line of headlamp   |  |

- **Basic illuminating area for adjustment should be within the range shown on the aiming chart. Adjust headlamps accordingly.**
- **First loosen the adjusting screw all the way and then make adjustment by tightening the screw.**
  1. Turn headlamp low beam on.
  2. Use adjusting screws to perform aiming adjustment.

# FRONT FOG LAMP

< ON-VEHICLE MAINTENANCE >

## FRONT FOG LAMP

### Aiming Adjustment

INFOID:000000004216441

The fog lamp is a semi-sealed beam type which uses a replaceable halogen bulb. Before performing aiming adjustment, make sure of the following.

- Keep all tires inflated to correct pressure.
- Place vehicle on level ground.
- See that vehicle is unloaded (except for full levels of coolant, engine oil and fuel, and spare tire, jack, and tools). Have the driver or equivalent weight placed in driver seat.

1. Set the distance between the screen and the center of the fog lamp lens as shown.
2. Turn front fog lamps ON.

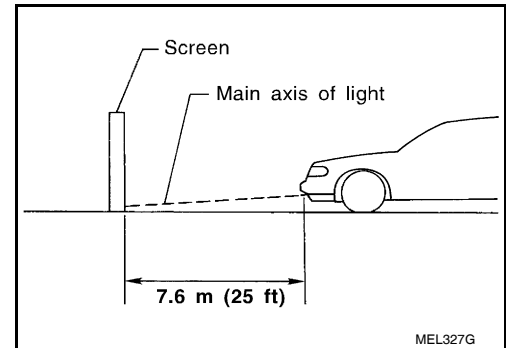

3. Adjust front fog lamps using adjusting screw so that the top edge of the high intensity zone is 100 mm (4 in) below the height of the fog lamp centers as shown.
  - When performing adjustment, if necessary, cover the headlamps and opposite fog lamp.

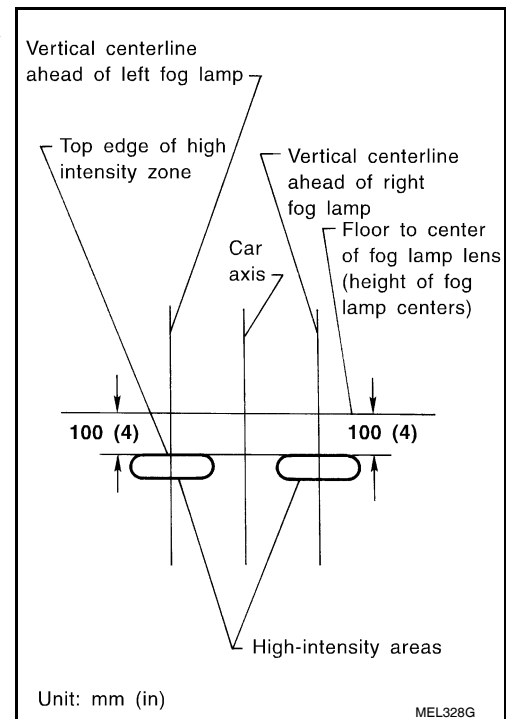

- Adjust aiming in the vertical direction by turning the adjusting screw (A).

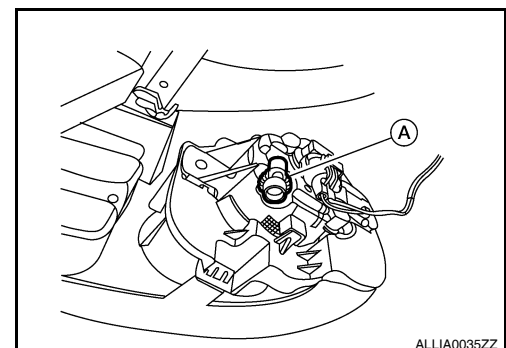

# HEADLAMP

< ON-VEHICLE REPAIR >

## ON-VEHICLE REPAIR

### HEADLAMP

#### Bulb Replacement

INFOID:000000004216442

#### HEADLAMP

**CAUTION:**

Do not touch the glass of bulb directly by hand. Keep grease and other oily substances away from bulb. Do not touch bulb by hand while it is lit or right after being turned off, burning may result.

#### Removal

1. Disconnect 12-volt battery negative terminal. Refer to [PG-69, "Removal and Installation"](#).
2. Position the fender protector aside. Refer to [EXT-18, "Removal and Installation"](#).
3. Turn the headlamp bulb sockets counterclockwise to unlock and remove them.
4. Turn the high beam lamp bulb socket counterclockwise to unlock and remove it.

#### Installation

Installation is in the reverse order of removal.

**CAUTION:**

After installing a headlamp bulb, be sure to install the bulb socket securely to ensure watertightness.

### FRONT TURN SIGNAL LAMP

#### Removal

1. Turn the bulb socket counterclockwise to unlock it.
2. Pull the bulb to remove it.

#### Installation

Installation is in the reverse order of removal.

**CAUTION:**

After installing a headlamp bulb, be sure to install the bulb socket securely to ensure watertightness.

### Removal and Installation

INFOID:000000004216443

### COMBINATION LAMP

#### Removal

1. Disconnect 12-volt battery negative terminal. Refer to [PG-69, "Removal and Installation"](#).
2. Remove the front bumper fascia. Refer to [EXT-12, "Removal and Installation"](#).
3. Ensure lighting switch is OFF.
4. Remove the headlamp bolts (A).
5. Pull the headlamp assembly (1) toward the front of the vehicle, detach the headlamp harness (2) from the headlamp assembly (1), disconnect the bulb connectors and remove.

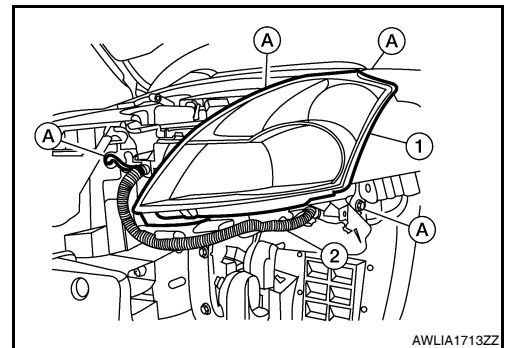

AWLIA1713ZZ

#### Installation

Installation is in the reverse order of removal.

**NOTE:**

Confirm headlamp aiming adjustment. Refer to [EXL-157, "Aiming Adjustment"](#).



# HEADLAMP

< ON-VEHICLE REPAIR >

## Disassembly and Assembly

INFOID:000000004216444

### Combination Lamp

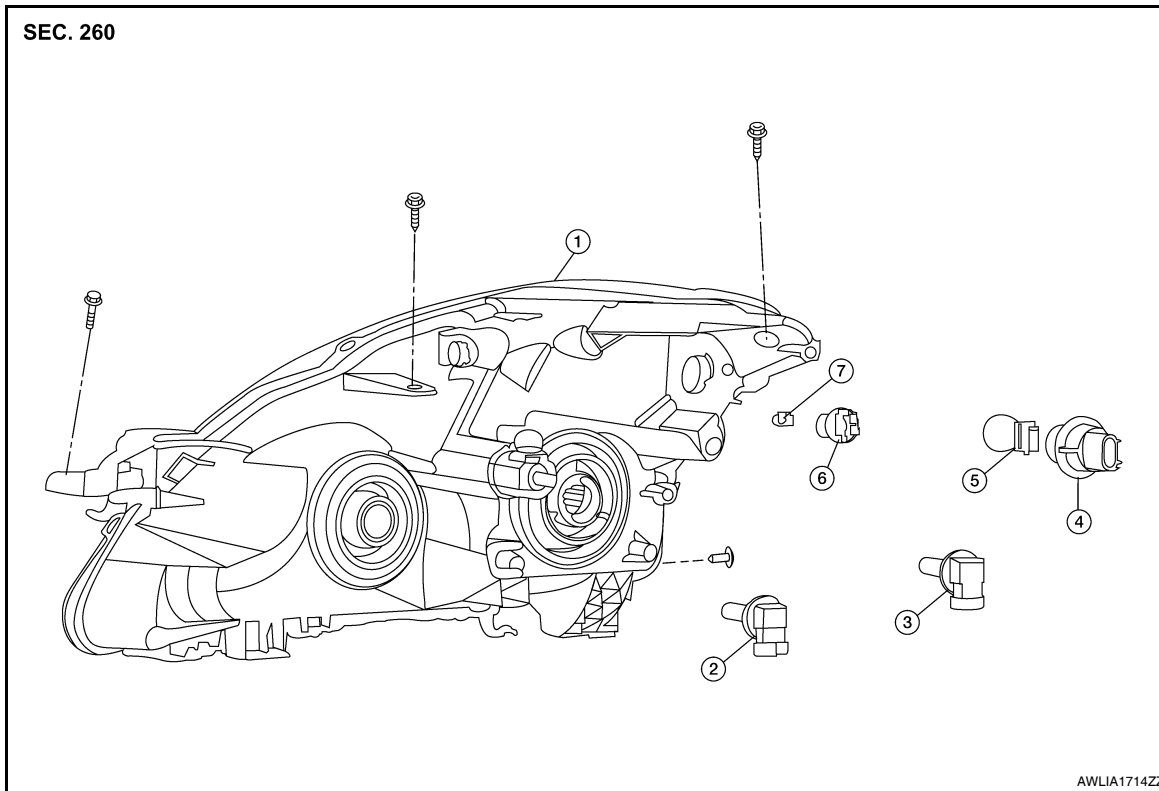

- |                                       |                                  |                                      |
|---------------------------------------|----------------------------------|--------------------------------------|
| 1. Headlamp assembly                  | 2. Halogen lamp bulb (high beam) | 3. Halogen lamp bulb (low beam)      |
| 4. Front turn signal lamp bulb socket | 5. Front turn signal lamp bulb   | 6. Park/side marker lamp bulb socket |
| 7. Park/side marker lamp bulb         |                                  |                                      |

#### Disassembly

#### **CAUTION:**

• Do not touch the glass of the bulb directly by hand. Keep grease and other oily substances away from bulb. Do not touch bulb while it is lit or right after being turned off, burning may result.

1. Turn the halogen lamp bulb (low beam) counterclockwise to unlock and remove it.
2. Turn the halogen lamp bulb (high beam) socket counterclockwise to unlock and remove it.
3. Turn the front turn signal lamp bulb socket counterclockwise to unlock and remove it.
4. Pull the front turn signal lamp bulb from its socket.
5. Turn the park/side marker lamp bulb socket counterclockwise to unlock and remove it.
6. Pull the park/side marker lamp bulb from its socket.

#### Assembly

Assembly is in the reverse order of disassembly.

# FRONT FOG LAMP

< ON-VEHICLE REPAIR >

## FRONT FOG LAMP

### Bulb Replacement

INFOID:000000004216446

#### REMOVAL

##### CAUTION:

- Do not touch the glass of bulb directly by hand. Keep grease and other oily substances away from it. Do not touch bulb by hand while it is lit or right after being turned off. Burning may result.
- Do not leave bulb out of fog lamp reflector for a long time because dust, moisture smoke, etc. may affect the performance of fog lamp. When replacing bulb, be sure to replace it with new one.

##### NOTE:

The fog lamp is a semi-sealed beam type which uses a replaceable halogen bulb.

1. Position the front fender protector aside. Refer to [EXT-18, "Removal and Installation"](#).
2. Disconnect the fog lamp electrical connector.
3. Turn the fog lamp bulb (B) counterclockwise to remove it.
  - Fog lamp assembly (1)
  - Fog lamp bolt (A)

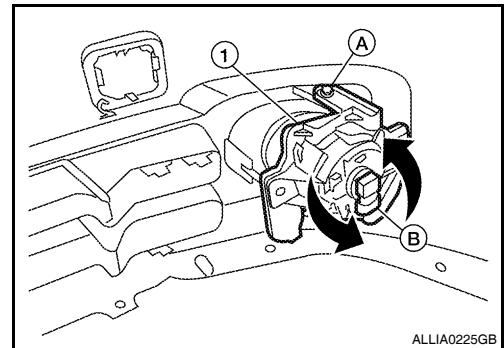

ALLIA0225GB

#### INSTALLATION

Installation is in the reverse order of removal.

### Removal and Installation

INFOID:000000004216446

#### REMOVAL

The fog lamp is a semi-sealed beam type which uses a replaceable halogen bulb.

##### CAUTION:

- Do not leave fog lamp assembly without bulb for a long period of time. Dust, moisture, smoke, etc. entering the fog lamp body may affect the performance. Remove the bulb from the headlamp assembly just before replacement bulb is installed.
- Grasp only the plastic base when handling the bulb. Never touch the glass envelope. Touching the glass could significantly affect the bulb life and/or fog lamp performance.

1. Remove inner splash shield.
2. Position the fender protector aside. Refer to [EXT-18, "Removal and Installation"](#).
3. Disconnect the fog lamp electrical connector.
4. Remove bolt (A) from top of the fog lamp (1).
5. Remove the fog lamp (1).
  - Fog lamp bulb (B)

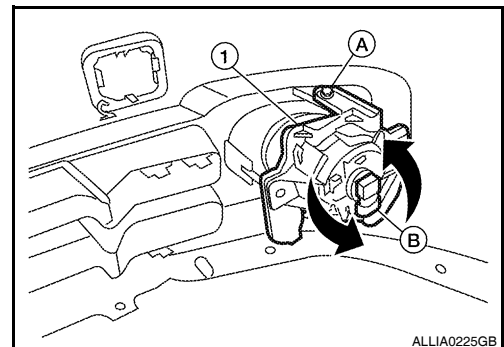

ALLIA0225GB

#### INSTALLATION

Installation is in the reverse order of removal.

- Check fog lamp aiming adjustment. Refer to [EXL-159, "Aiming Adjustment"](#).

# DAYTIME RUNNING LIGHT SYSTEM

< ON-VEHICLE REPAIR >

## DAYTIME RUNNING LIGHT SYSTEM

### Removal and Installation

INFOID:000000004216447

#### REMOVAL

1. Disconnect the IPDM E/R. Refer to [PCS-39. "Removal and Installation"](#).
2. Disconnect the harness junction block to position it aside.
3. Remove the DTRL relay (1).
  -  Front

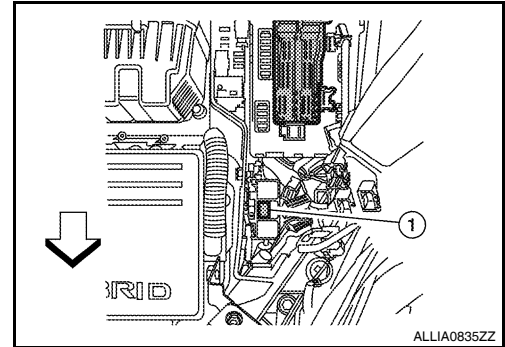

#### INSTALLATION

Installation is in the reverse order of removal.

A  
B  
C  
D  
E  
F  
G  
H  
I  
J  
K  
EXL  
M  
N  
O  
P

# STOP LAMP

< ON-VEHICLE REPAIR >

## STOP LAMP

### Bulb Replacement

INFOID:000000004216448

#### STOP LAMP

##### Removal

1. Remove rear combination lamp. Refer to [EXL-164, "Removal and Installation"](#).
2. Turn bulb socket counterclockwise to unlock and remove from combination lamp assembly.
3. Turn bulb counterclockwise to remove from bulb socket.

##### Installation

Installation is in the reverse order of removal.

### Removal and Installation

INFOID:000000004216449

#### HIGH-MOUNTED STOP LAMP - WITH REAR SPOILER

##### Removal

1. Remove the rear air spoiler. Refer to [EXL-164, "Removal and Installation"](#).
2. Remove the two screws and remove high mounted stop lamp from the rear air spoiler.

##### Installation

Installation is in the reverse order of removal.

#### HIGH-MOUNTED STOP LAMP - WITHOUT REAR AIR SPOILER

##### Removal

1. Slide high-mounted stop lamp assembly rearward on parcel shelf to give clearance to front tabs.
2. Lift front of lamp assembly up and bring forward to give clearance to rear tabs.
3. Disconnect the high-mounted connector and remove.

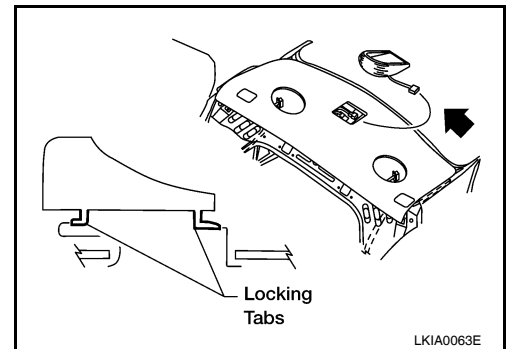

##### Installation

Installation is in the reverse order of removal.

#### REAR COMBINATION LAMP

##### Removal

1. Remove the trunk side finisher. Refer to [INT-27, "Removal and Installation"](#).
2. From trunk, remove the rear combination lamp assembly nuts.
3. Disconnect connectors and remove rear combination lamp assembly.

##### Installation

Installation is in the reverse order of removal.

# LICENSE PLATE LAMP

< ON-VEHICLE REPAIR >

## LICENSE PLATE LAMP

### Bulb Replacement

INFOID:000000004216450

#### LICENSE PLATE LAMP

##### Removal

1. Position trunk lid finisher aside.
2. Turn license plate lamp bulb socket counterclockwise to unlock and remove.
3. Pull license plate lamp bulb to remove from socket.

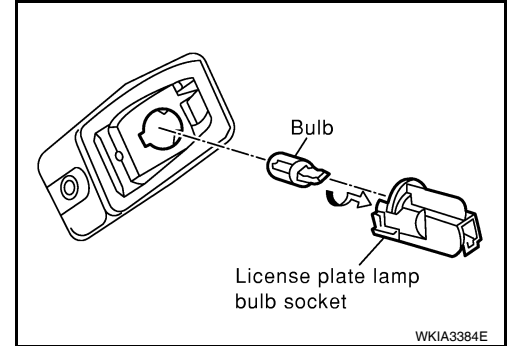

##### Installation

Installation is in the reverse order of removal.

### Removal and Installation

INFOID:000000004216451

#### LICENSE PLATE LAMP

##### Removal

1. Remove the license plate finisher. Refer to [EXL-165, "Removal and Installation"](#).
2. Disconnect the license plate lamp connector.
3. Remove the license plate lamp screw and remove the license plate lamp.

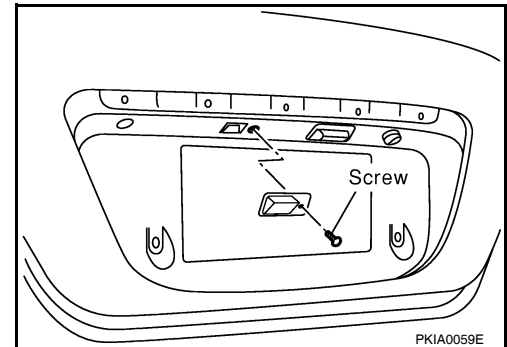

##### Installation

Installation is in the reverse order of removal.

A  
B  
C  
D  
E  
F  
G  
H  
I  
J  
K  
EXL  
M  
N  
O  
P

# REAR COMBINATION LAMP

< ON-VEHICLE REPAIR >

---

## REAR COMBINATION LAMP

### Bulb Replacement

INFOID:000000004216452

#### REAR TURN SIGNAL LAMP

1. Remove the rear combination lamp. Refer to [EXL-166, "Removal and Installation"](#).
2. Turn the rear turn signal lamp bulb socket counterclockwise and remove it.
3. Remove the rear turn signal lamp bulb.
4. Installation is in the reverse order of removal.

#### STOP/TAIL LAMP

1. Remove the rear combination lamp. Refer to [EXL-166, "Removal and Installation"](#).
2. Turn the stop/tail lamp bulb socket counterclockwise and remove it.
3. Remove the stop/tail lamp bulb.
4. Installation is in the reverse order of removal.

#### BACK-UP LAMP

1. Remove the rear combination lamp. Refer to [EXL-166, "Removal and Installation"](#).
2. Turn the back-up lamp bulb socket counterclockwise and remove it.
3. Remove the back-up lamp bulb.
4. Installation is in the reverse order of removal.

#### SIDE MARKER LAMP

1. Remove the rear combination lamp. Refer to [EXL-166, "Removal and Installation"](#).
2. Turn the side marker lamp bulb socket counterclockwise and remove it.
3. Remove the side marker lamp bulb.
4. Installation is in the reverse order of removal.

### Removal and Installation

INFOID:000000004216453

#### COMPONENTS

# REAR COMBINATION LAMP

< ON-VEHICLE REPAIR >

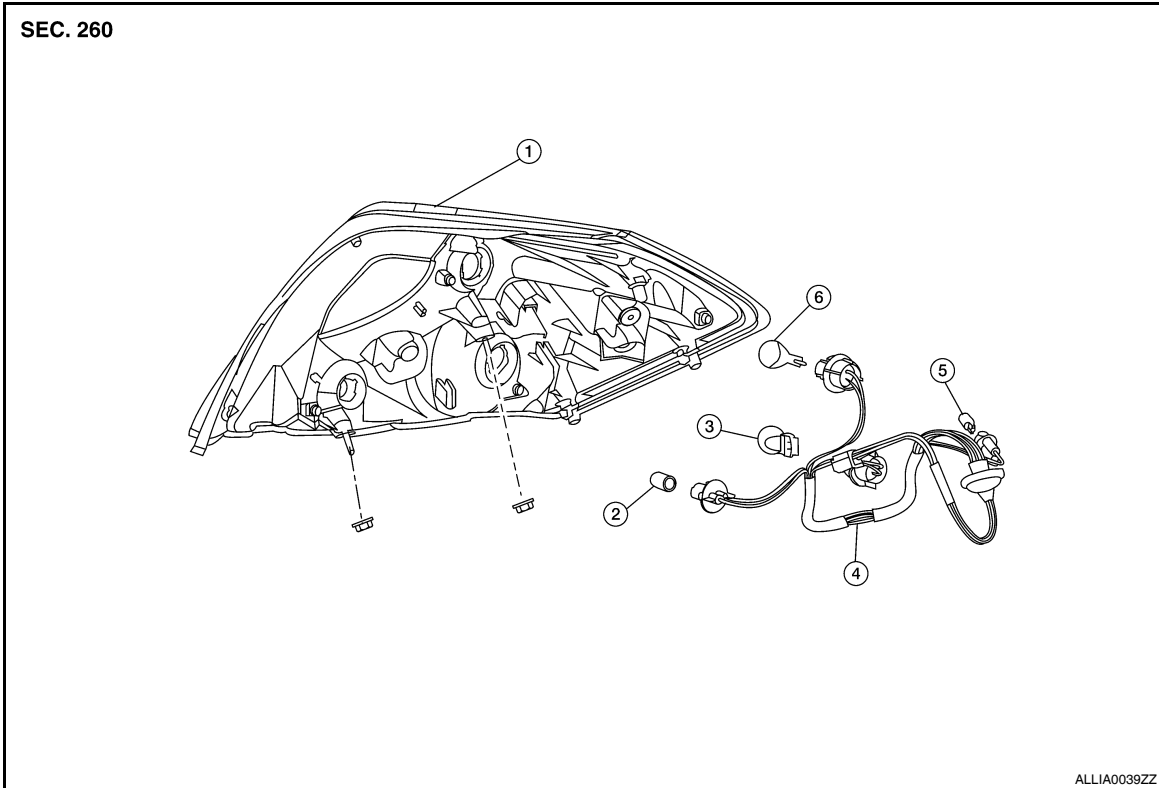

- |                                   |                          |                               |
|-----------------------------------|--------------------------|-------------------------------|
| 1. Rear combination lamp assembly | 2. Back-up lamp bulb     | 3. Stop/Tail lamp bulb        |
| 4. Rear combination lamp harness  | 5. Side marker lamp bulb | 6. Rear turn signal lamp bulb |

## REMOVAL

1. Remove trunk side finisher. Refer to [INT-27, "Removal and Installation"](#).
2. Remove the rear combination lamp nuts.
3. Pull the rear combination lamp assembly toward rear of the vehicle and remove.

## INSTALLATION

Installation is the reverse order of removal.

A  
B  
C  
D  
E  
F  
G  
H  
I  
J  
K  
EXL  
M  
N  
O  
P

## LIGHTING AND TURN SIGNAL SWITCH

< ON-VEHICLE REPAIR >

---

### LIGHTING AND TURN SIGNAL SWITCH

#### Removal and Installation

INFOID:000000004216454

#### Removal

1. Remove the spiral cable. Refer to [SRS-8. "Removal and Installation"](#).
2. Disconnect the lighting and turn signal switch connector and remove the lighting and turn signal switch.

#### Installation

Installation is in the reverse order of removal.



# HAZARD SWITCH

< ON-VEHICLE REPAIR >

## HAZARD SWITCH

### Removal and Installation

INFOID:000000004216455

#### Removal

1. Remove the center ventilator grilles. Refer to [VTL-24, "CENTER VENTILATOR GRILLES : Removal and Installation"](#).
2. Remove the hazard switch screws (A) and remove the hazard switch (1).

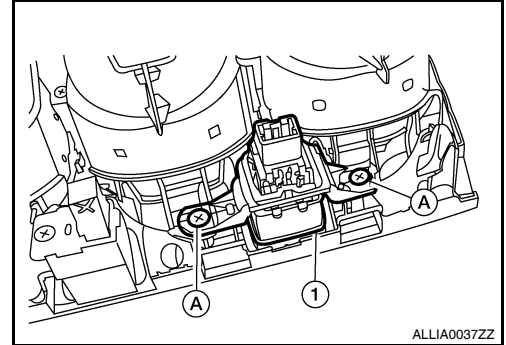

#### Installation

Installation is in the reverse order of removal.

A  
B  
C  
D  
E  
F  
G  
H  
I  
J  
K  
EXL  
M  
N  
O  
P

## SERVICE DATA AND SPECIFICATIONS (SDS)

< SERVICE DATA AND SPECIFICATIONS (SDS)

## SERVICE DATA AND SPECIFICATIONS (SDS)

### SERVICE DATA AND SPECIFICATIONS (SDS)

#### Headlamp

INFOID:000000004216456

Item	Wattage (W)*
Low	55 (H1)
High	60 (HB3)

\*: Always check with the Parts Department for the latest parts information.

#### Exterior Lamp

INFOID:000000004216457

Item	Wattage (W)*	
Front combination lamp	Turn signal lamp	27 (amber)
	Park/side marker lamp	8
Rear combination lamp	Stop/Tail lamp	27/8
	Turn signal lamp	27
	Back-up lamp	13
	Side marker lamp	5
Fog lamp	55 (H11)	
License plate lamp	5	
High-mounted stop lamp (parcel shelf mount)	18	
High-mounted stop lamp (rear air spoiler mount)	LED	

\*: Always check with the Parts Department for the latest parts information.