

SECTION GW

GLASSES, WINDOW SYSTEM & MIRRORS

CONTENTS

PRECAUTIONS	3	AUTO OPERATION	18	F
Precautions for Supplemental Restraint System (SRS) "AIR BAG" and "SEAT BELT PRE-TENSIONER"	3	POWER WINDOW SERIAL LINK	18	B
Handling for Adhesive and Primer	3	POWER WINDOW LOCK	19	C
Trouble Diagnosis Precaution	3	RETAINED POWER OPERATION	19	D
PREPARATION	4	ANTI-PINCH SYSTEM	19	E
Special Service Tool	4	POWER WINDOW CONTROL BY THE FRONT DOOR LOCK ASSEMBLY LH (KEY CYLINDER SWITCH)	19	H
Commercial Service Tool	4	CAN Communication System Description	19	G
SQUEAK AND RATTLE TROUBLE DIAGNOSES	5	Schematic	20	H
Work Flow	5	Wiring Diagram – WINDOW	22	GW
CUSTOMER INTERVIEW	5	Terminal and Reference Value for Main Power Window and Door Lock/Unlock Switch	30	J
DUPLICATE THE NOISE AND TEST DRIVE	6	Terminal and Reference Value for Power Window and Door Lock/Unlock Switch RH	31	K
CHECK RELATED SERVICE BULLETINS	6	Terminal and Reference Value for BCM	32	L
LOCATE THE NOISE AND IDENTIFY THE ROOT CAUSE	6	Work Flow	33	M
REPAIR THE CAUSE	6	CONSULT-II Function (BCM)	33	
CONFIRM THE REPAIR	7	CONSULT-II INSPECTION PROCEDURE	33	
Generic Squeak and Rattle Troubleshooting	7	ACTIVE TEST	34	
INSTRUMENT PANEL	7	WORK SUPPORT	34	
CENTER CONSOLE	7	DATA MONITOR	34	
DOORS	7	Trouble Diagnoses Symptom Chart	36	
TRUNK	8	BCM Power Supply and Ground Circuit Check	37	
SUNROOF/HEADLINING	8	Main Power Window and Door Lock/Unlock Switch Power Supply and Ground Circuit Check	38	
OVERHEAD CONSOLE (FRONT AND REAR)	8	Power Window and Door Lock/Unlock Switch RH Power Supply and Ground Circuit Check	39	
SEATS	8	Front Power Window Motor LH Circuit Check	40	
UNDERHOOD	8	Front Power Window Motor RH Circuit Check	41	
Diagnostic Worksheet	9	Limit Switch Circuit Check Front LH	42	
WINDSHIELD GLASS	11	Limit Switch Circuit Check Front RH	43	
Removal and Installation	11	Encoder Circuit Check Front LH	45	
REMOVAL	11	Encoder Circuit Check Front RH	47	
INSTALLATION	11	Door Switch Check	49	
REAR WINDOW GLASS AND MOLDING	13	Front Door Lock Assembly (Key Cylinder Switch) Check	51	
Removal and Installation	13	Power Window Serial Link Check Front LH and RH ..	53	
REMOVAL	13	Rear Power Window Motor LH Circuit Check	55	
INSTALLATION	14	Rear Power Window Motor RH Circuit Check	57	
POWER WINDOW SYSTEM	15			
Component Parts and Harness Connector Location ..	15			
System Description	15			
MANUAL OPERATION	15			

Rear Power Vent Window Switch Circuit Check	58	CONSULT-II Function (BCM)	80
Rear Power Vent Window Motor LH Circuit Check..	59	CONSULT-II BASIC OPERATION PROCEDURE	
Rear Power Vent Window Motor RH Circuit Check..	59		...80
Rear Power Vent Window Relay (OPEN) Check ...	59	DATA MONITOR	81
Rear Power Vent Window Relay (CLOSE) Check..	61	ACTIVE TEST	81
FRONT DOOR GLASS AND REGULATOR	63	Trouble Diagnoses Symptom Chart	81
Removal and Installation	63	BCM Power Supply and Ground Circuit Check	83
FRONT DOOR GLASS	63	Rear Window Defogger Switch Circuit Check	84
FRONT DOOR GLASS REGULATOR	64	Rear Window Defogger Power Supply Circuit	
SETTING AFTER INSTALLATION	64	Check	85
REAR DOOR GLASS AND REGULATOR	66	Rear Window Defogger Circuit Check	86
Removal and Installation	66	Door Mirror Defogger Power Supply Circuit Check	
REAR DOOR GLASS	66	/ Without Automatic Drive Positioner	86
REAR DOOR GLASS REGULATOR	67	Door Mirror Defogger Power Supply Circuit Check	
SIDE WINDOW GLASS	69	/ With Automatic Drive Positioner	88
Removal and Installation (without Rear Power Vent		Door Mirror LH Defogger Circuit Check / Without	
Windows)	69	Automatic Drive Positioner	90
REMOVAL	69	Door Mirror LH Defogger Circuit Check / With Auto-	
INSTALLATION	69	matic Drive Positioner	91
Removal and Installation (with Rear Power Vent		Door Mirror RH Defogger Circuit Check / Without	
Windows)	70	Automatic Drive Positioner	92
REMOVAL	70	Door Mirror RH Defogger Circuit Check / With Auto-	
INSTALLATION	70	matic Drive Positioner	93
INSIDE MIRROR	71	Rear Window Defogger Signal Check	94
Wiring Diagram –I/MIRR–	71	Filament Check	94
Removal and Installation	72	Filament Repair	95
INSIDE MIRROR	72	REPAIR EQUIPMENT	95
REAR WINDOW DEFOGGER	73	REPAIRING PROCEDURE	95
Component Parts and Harness Connector Location..	73	DOOR MIRROR	97
System Description	73	Wiring Diagram –MIRROR–	97
CAN Communication System Description	74	Door Mirror Assembly	98
Schematic	75	REMOVAL	98
Wiring Diagram — DEF —	76	INSTALLATION	98
Terminal and Reference Value for BCM	79	Door Mirror Glass	98
Terminal and Reference Value for IPDM E/R	79	REMOVAL	98
Work Flow	79	INSTALLATION	99

PRECAUTIONS

PRECAUTIONS

PFP:00001

Precautions for Supplemental Restraint System (SRS) “AIR BAG” and “SEAT BELT PRE-TENSIONER”

EIS0022N

The Supplemental Restraint System such as “AIR BAG” and “SEAT BELT PRE-TENSIONER”, used along with a front seat belt, helps to reduce the risk or severity of injury to the driver and front passenger for certain types of collision. This system includes seat belt switch inputs and dual stage front air bag modules. The SRS system uses the seat belt switches to determine the front air bag deployment, and may only deploy one front air bag, depending on the severity of a collision and whether the front occupants are belted or unbelted. Information necessary to service the system safely is included in the SRS and SB section of this Service Manual.

WARNING:

- To avoid rendering the SRS inoperative, which could increase the risk of personal injury or death in the event of a collision which would result in air bag inflation, all maintenance must be performed by an authorized NISSAN/INFINITI dealer.
- Improper maintenance, including incorrect removal and installation of the SRS, can lead to personal injury caused by unintentional activation of the system. For removal of Spiral Cable and Air Bag Module, see the SRS section.
- Do not use electrical test equipment on any circuit related to the SRS unless instructed to in this Service Manual. SRS wiring harnesses can be identified by yellow and/or orange harnesses or harness connectors.

Handling for Adhesive and Primer

EIS0022O

- Do not use an adhesive which is past its usable date. Shelf life of this product is limited to six months after the date of manufacture. Carefully adhere to the expiration or manufacture date printed on the box.
- Keep primers and adhesive in a cool, dry place. Ideally, they should be stored in a refrigerator.
- Open the seal of the primer and adhesive just before application. Discard the remainder.
- Before application, be sure to shake the primer container to stir the contents. If any floating material is found, do not use it.
- If any primer or adhesive contacts the skin, wipe it off with gasoline or equivalent and wash the skin with soap.
- When using primer and adhesive, always observe the precautions in the instruction manual.

Trouble Diagnosis Precaution

EIS0022P

When you read wiring diagrams, refer to the following:

- [GI-15, "How to Read Wiring Diagrams"](#)
- [PG-4, "POWER SUPPLY ROUTING CIRCUIT"](#)

When you perform trouble diagnosis, refer to the following:

- [GI-11, "HOW TO FOLLOW TEST GROUPS IN TROUBLE DIAGNOSES"](#)
- [GI-27, "How to Perform Efficient Diagnosis for an Electrical Incident"](#)

Check for any service bulletins before servicing the vehicle.

A
B
C
D
E
F
G
H
J
K
L
M

GW

PREPARATION

PREPARATION

PFP:00002

Special Service Tool

EIS0022Q

The actual shapes of Kent-Moore tools may differ from those of special service tools illustrated here.

Tool number (Kent-Moore No.) Tool name	Description
— (J-39570) Chassis ear	Locating the noise
(J-43980) NISSAN Squeak and Rattle Kit	Repairing the cause of noise

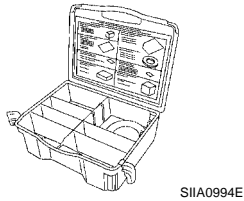
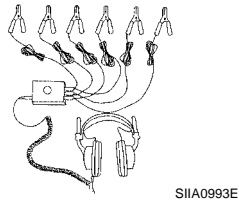

Commercial Service Tool

EIS0022R

Tool name (Kent-Moore No.)	Description
Engine ear (J-39565)	Locating the noise
Suction Lifter (—)	Holding door glass

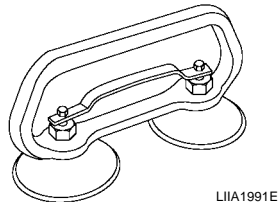
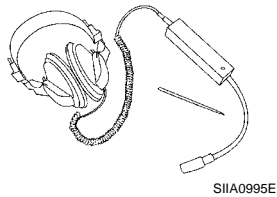

SQUEAK AND RATTLE TROUBLE DIAGNOSES

SQUEAK AND RATTLE TROUBLE DIAGNOSES

PF0:0000

Work Flow

EIS0022S

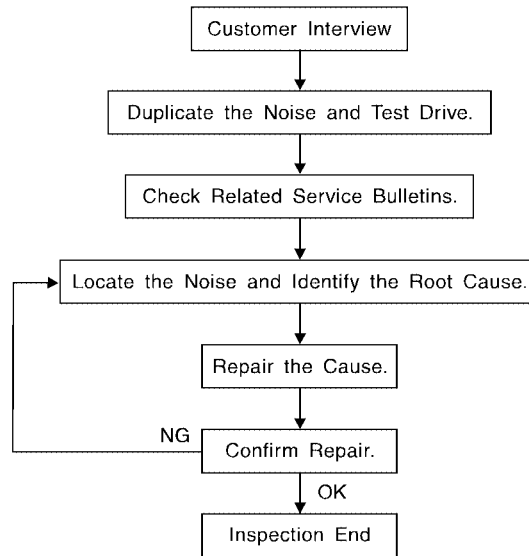

SBT842

CUSTOMER INTERVIEW

Interview the customer if possible, to determine the conditions that exist when the noise occurs. Use the Diagnostic Worksheet during the interview to document the facts and conditions when the noise occurs and any customer's comments; refer to [GW-9, "Diagnostic Worksheet"](#). This information is necessary to duplicate the conditions that exist when the noise occurs.

- The customer may not be able to provide a detailed description or the location of the noise. Attempt to obtain all the facts and conditions that exist when the noise occurs (or does not occur).
- If there is more than one noise in the vehicle, be sure to diagnose and repair the noise that the customer is concerned about. This can be accomplished by test driving the vehicle with the customer.
- After identifying the type of noise, isolate the noise in terms of its characteristics. The noise characteristics are provided so the customer, service adviser and technician are all speaking the same language when defining the noise.
- Squeak —(Like tennis shoes on a clean floor)
Squeak characteristics include the light contact/fast movement/brought on by road conditions/hard surfaces = higher pitch noise/softer surfaces = lower pitch noises/edge to surface = chirping.
- Creak—(Like walking on an old wooden floor)
Creak characteristics include firm contact/slow movement/twisting with a rotational movement/pitch dependent on materials/often brought on by activity.
- Rattle—(Like shaking a baby rattle)
Rattle characteristics include the fast repeated contact/vibration or similar movement/loose parts/missing clip or fastener/incorrect clearance.
- Knock —(Like a knock on a door)
Knock characteristics include hollow sounding/sometimes repeating/often brought on by driver action.
- Tick—(Like a clock second hand)
Tick characteristics include gentle contacting of light materials/loose components/can be caused by driver action or road conditions.
- Thump—(Heavy, muffled knock noise)
Thump characteristics include softer knock/dead sound often brought on by activity.
- Buzz—(Like a bumble bee)
Buzz characteristics include high frequency rattle/firm contact.
- Often the degree of acceptable noise level will vary depending upon the person. A noise that you may judge as acceptable may be very irritating to the customer.
- Weather conditions, especially humidity and temperature, may have a great effect on noise level.

SQUEAK AND RATTLE TROUBLE DIAGNOSES

DUPLICATE THE NOISE AND TEST DRIVE

If possible, drive the vehicle with the customer until the noise is duplicated. Note any additional information on the Diagnostic Worksheet regarding the conditions or location of the noise. This information can be used to duplicate the same conditions when you confirm the repair.

If the noise can be duplicated easily during the test drive, to help identify the source of the noise, try to duplicate the noise with the vehicle stopped by doing one or all of the following:

- 1) Close a door.
 - 2) Tap or push/pull around the area where the noise appears to be coming from.
 - 3) Rev the engine.
 - 4) Use a floor jack to recreate vehicle "twist".
 - 5) At idle, apply engine load (electrical load, half-clutch on M/T model, drive position on A/T model).
 - 6) Raise the vehicle on a hoist and hit a tire with a rubber hammer.
- Drive the vehicle and attempt to duplicate the conditions the customer states exist when the noise occurs.
 - If it is difficult to duplicate the noise, drive the vehicle slowly on an undulating or rough road to stress the vehicle body.

CHECK RELATED SERVICE BULLETINS

After verifying the customer concern or symptom, check ASIST for Technical Service Bulletins (TSBs) related to that concern or symptom.

If a TSB relates to the symptom, follow the procedure to repair the noise.

LOCATE THE NOISE AND IDENTIFY THE ROOT CAUSE

1. Narrow down the noise to a general area. To help pinpoint the source of the noise, use a listening tool (Chassis Ear: J-39570, Engine Ear: J-39565 and mechanic's stethoscope).
2. Narrow down the noise to a more specific area and identify the cause of the noise by:
 - removing the components in the area that you suspect the noise is coming from. Do not use too much force when removing clips and fasteners, otherwise clips and fasteners can be broken or lost during the repair, resulting in the creation of new noise.
 - tapping or pushing/pulling the component that you suspect is causing the noise. Do not tap or push/pull the component with excessive force, otherwise the noise will be eliminated only temporarily.
 - feeling for a vibration with your hand by touching the component(s) that you suspect is (are) causing the noise.
 - placing a piece of paper between components that you suspect are causing the noise.
 - looking for loose components and contact marks.
Refer to [GW-7, "Generic Squeak and Rattle Troubleshooting"](#) .

REPAIR THE CAUSE

- If the cause is a loose component, tighten the component securely.
- If the cause is insufficient clearance between components:
 - separate components by repositioning or loosening and retightening the component, if possible.
 - insulate components with a suitable insulator such as urethane pads, foam blocks, felt cloth tape or urethane tape. A NISSAN Squeak and Rattle Kit (J-43980) is available through your authorized NISSAN Parts Department.

CAUTION:

Do not use excessive force as many components are constructed of plastic and may be damaged.

Always check with the Parts Department for the latest parts information.

The following materials are contained in the NISSAN Squeak and Rattle Kit (J-43980). Each item can be ordered separately as needed.

URETHANE PADS [1.5 mm (0.059 in) thick]

Insulates connectors, harness, etc.

76268-9E005: 100×135 mm (3.94×5.31 in)/76884-71L01: 60×85 mm (2.36×3.35 in)/76884-71L02: 15×25 mm (0.59×0.98 in)

INSULATOR (Foam blocks)

Insulates components from contact. Can be used to fill space behind a panel.

73982-9E000: 45 mm (1.77 in) thick, 50×50 mm (1.97×1.97 in)/73982-50Y00: 10 mm (0.39 in) thick, 50×50 mm (1.97×1.97 in)

INSULATOR (Light foam block)

SQUEAK AND RATTLE TROUBLE DIAGNOSES

80845-71L00: 30 mm (1.18 in) thick, 30×50 mm (1.18×1.97 in)

FELT CLOTH TAPE

Used to insulate where movement does not occur. Ideal for instrument panel applications.

68370-4B000: 15×25 mm (0.59×0.98 in) pad/68239-13E00: 5 mm (0.20 in) wide tape roll. The following materials not found in the kit can also be used to repair squeaks and rattles.

UHMW (TEFLON) TAPE

Insulates where slight movement is present. Ideal for instrument panel applications.

SILICONE GREASE

Used instead of UHMW tape that will be visible or not fit.

Note: Will only last a few months.

SILICONE SPRAY

Use when grease cannot be applied.

DUCT TAPE

Use to eliminate movement.

CONFIRM THE REPAIR

Confirm that the cause of a noise is repaired by test driving the vehicle. Operate the vehicle under the same conditions as when the noise originally occurred. Refer to the notes on the Diagnostic Worksheet.

Generic Squeak and Rattle Troubleshooting

EIS0022T

Refer to Table of Contents for specific component removal and installation information.

INSTRUMENT PANEL

Most incidents are caused by contact and movement between:

1. The cluster lid A and instrument panel
2. Acrylic lens and combination meter housing
3. Instrument panel to front pillar garnish
4. Instrument panel to windshield
5. Instrument panel mounting pins
6. Wiring harnesses behind the combination meter
7. A/C defroster duct and duct joint

These incidents can usually be located by tapping or moving the components to duplicate the noise or by pressing on the components while driving to stop the noise. Most of these incidents can be repaired by applying felt cloth tape or silicone spray (in hard to reach areas). Urethane pads can be used to insulate wiring harness.

CAUTION:

Do not use silicone spray to isolate a squeak or rattle. If you saturate the area with silicone, you will not be able to recheck the repair.

CENTER CONSOLE

Components to pay attention to include:

1. Shifter assembly cover to finisher
2. A/C control unit and cluster lid C
3. Wiring harnesses behind audio and A/C control unit

The instrument panel repair and isolation procedures also apply to the center console.

DOORS

Pay attention to the:

1. Finisher and inner panel making a slapping noise
2. Inside handle escutcheon to door finisher
3. Wiring harnesses tapping
4. Door striker out of alignment causing a popping noise on starts and stops

Tapping or moving the components or pressing on them while driving to duplicate the conditions can isolate many of these incidents. You can usually insulate the areas with felt cloth tape or insulator foam blocks from the NISSAN Squeak and Rattle Kit (J-43980) to repair the noise.

A
B
C
D
E
F
G
H
J
K
L
M

GW

SQUEAK AND RATTLE TROUBLE DIAGNOSES

TRUNK

Trunk noises are often caused by a loose jack or loose items put into the trunk by the owner. In addition look for:

1. Trunk lid bumpers out of adjustment
2. Trunk lid striker out of adjustment
3. The trunk lid torsion bars knocking together
4. A loose license plate or bracket

Most of these incidents can be repaired by adjusting, securing or insulating the item(s) or component(s) causing the noise.

SUNROOF/HEADLINING

Noises in the sunroof/headlining area can often be traced to one of the following:

1. Sunroof lid, rail, linkage or seals making a rattle or light knocking noise
2. Sun visor shaft shaking in the holder
3. Front or rear windshield touching headliner and squeaking

Again, pressing on the components to stop the noise while duplicating the conditions can isolate most of these incidents. Repairs usually consist of insulating with felt cloth tape.

OVERHEAD CONSOLE (FRONT AND REAR)

Overhead console noises are often caused by the console panel clips not being engaged correctly. Most of these incidents are repaired by pushing up on the console at the clip locations until the clips engage.

In addition look for:

1. Loose harness or harness connectors.
2. Front console map/reading lamp lense loose.
3. Loose screws at console attachment points.

SEATS

When isolating seat noise it's important to note the position the seat is in and the load placed on the seat when the noise is present. These conditions should be duplicated when verifying and isolating the cause of the noise.

Cause of seat noise include:

1. Headrest rods and holder
2. A squeak between the seat pad cushion and frame
3. The rear seatback lock and bracket

These noises can be isolated by moving or pressing on the suspected components while duplicating the conditions under which the noise occurs. Most of these incidents can be repaired by repositioning the component or applying urethane tape to the contact area.

UNDERHOOD

Some interior noise may be caused by components under the hood or on the engine wall. The noise is then transmitted into the passenger compartment.

Causes of transmitted underhood noise include:

1. Any component mounted to the engine wall
2. Components that pass through the engine wall
3. Engine wall mounts and connectors
4. Loose radiator mounting pins
5. Hood bumpers out of adjustment
6. Hood striker out of adjustment

These noises can be difficult to isolate since they cannot be reached from the interior of the vehicle. The best method is to secure, move or insulate one component at a time and test drive the vehicle. Also, engine RPM or load can be changed to isolate the noise. Repairs can usually be made by moving, adjusting, securing, or insulating the component causing the noise.

SQUEAK AND RATTLE TROUBLE DIAGNOSES

Diagnostic Worksheet

EIS0022U



SQUEAK & RATTLE DIAGNOSTIC WORKSHEET

Dear Nissan Customer:

We are concerned about your satisfaction with your Nissan vehicle. Repairing a squeak or rattle sometimes can be very difficult. To help us fix your Nissan right the first time, please take a moment to note the area of the vehicle where the squeak or rattle occurs and under what conditions. You may be asked to take a test drive with a service advisor or technician to ensure we confirm the noise you are hearing.

I. WHERE DOES THE NOISE COME FROM? (circle the area of the vehicle)

The illustrations are for reference only, and may not reflect the actual configuration of your vehicle.

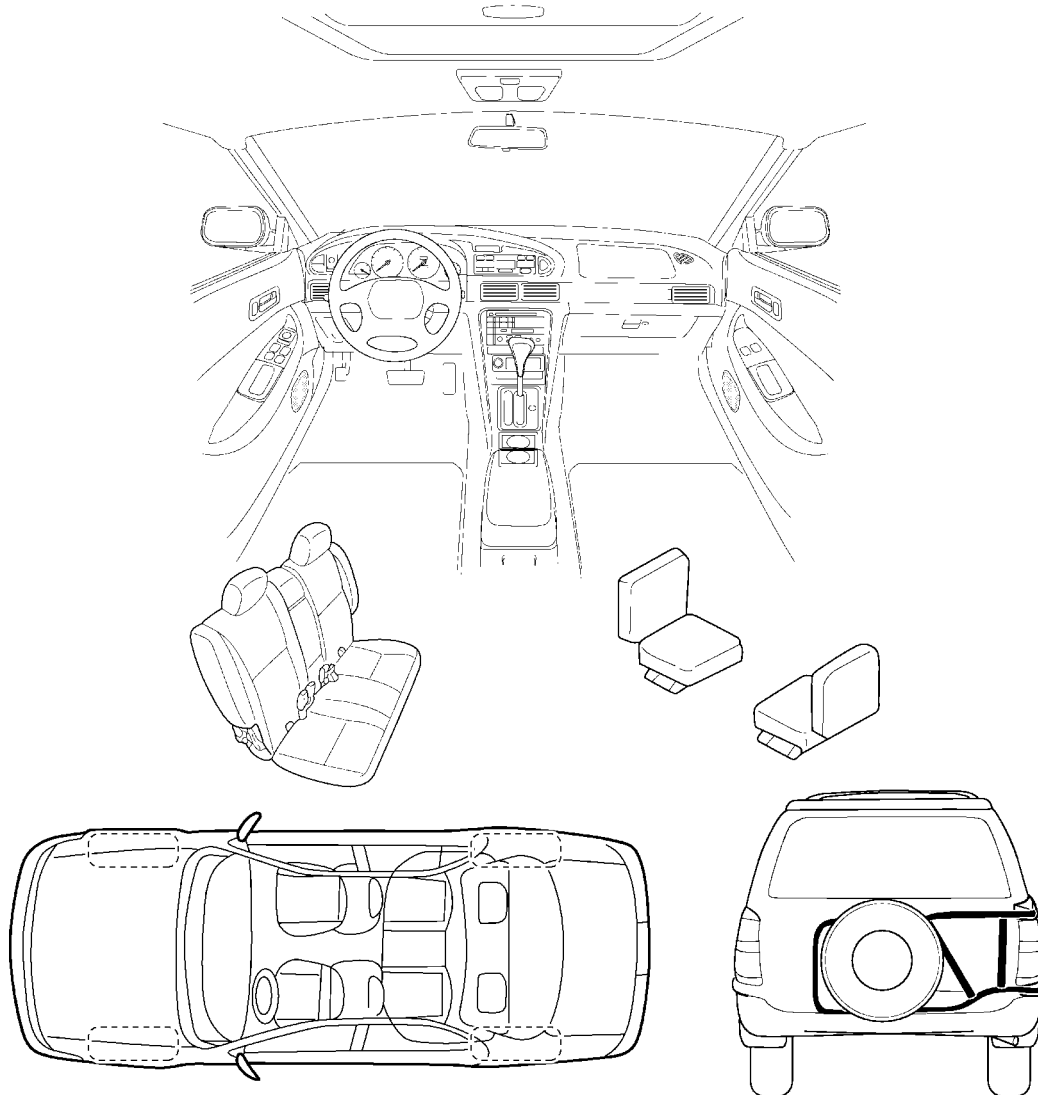

Continue to the back of the worksheet and briefly describe the location of the noise or rattle. In addition, please indicate the conditions which are present when the noise occurs.

LIWA0276E

A
B
C
D
E
F
G
H
GW
J
K
L
M

SQUEAK AND RATTLE TROUBLE DIAGNOSES

SQUEAK & RATTLE DIAGNOSTIC WORKSHEET- page 2

Briefly describe the location where the noise occurs:

II. WHEN DOES IT OCCUR? (check the boxes that apply)

- | | |
|--|---|
| <input type="checkbox"/> anytime | <input type="checkbox"/> after sitting out in the sun |
| <input type="checkbox"/> 1 st time in the morning | <input type="checkbox"/> when it is raining or wet |
| <input type="checkbox"/> only when it is cold outside | <input type="checkbox"/> dry or dusty conditions |
| <input type="checkbox"/> only when it is hot outside | <input type="checkbox"/> other: _____ |

III. WHEN DRIVING:

- through driveways
- over rough roads
- over speed bumps
- only at about ____ mph
- on acceleration
- coming to a stop
- on turns : left, right or either (circle)
- with passengers or cargo
- other: _____
- after driving ____ miles or ____ minutes

IV. WHAT TYPE OF NOISE?

- squeak (like tennis shoes on a clean floor)
- creak (like walking on an old wooden floor)
- rattle (like shaking a baby rattle)
- knock (like a knock on a door)
- tick (like a clock second hand)
- thump (heavy, muffled knock noise)
- buzz (like a bumble bee)

TO BE COMPLETED BY DEALERSHIP PERSONNEL

Test Drive Notes:

	YES	NO	Initials of person performing
Vehicle test driven with customer	<input type="checkbox"/>	<input type="checkbox"/>	_____
- Noise verified on test drive	<input type="checkbox"/>	<input type="checkbox"/>	_____
- Noise source located and repaired	<input type="checkbox"/>	<input type="checkbox"/>	_____
- Follow up test drive performed to confirm repair	<input type="checkbox"/>	<input type="checkbox"/>	_____

VIN: _____ Customer Name: _____

W.O. #: _____ Date: _____

SBT844

This form must be attached to Work Order

WINDSHIELD GLASS

PFP:72712

WINDSHIELD GLASS

Removal and Installation

EIS0022V

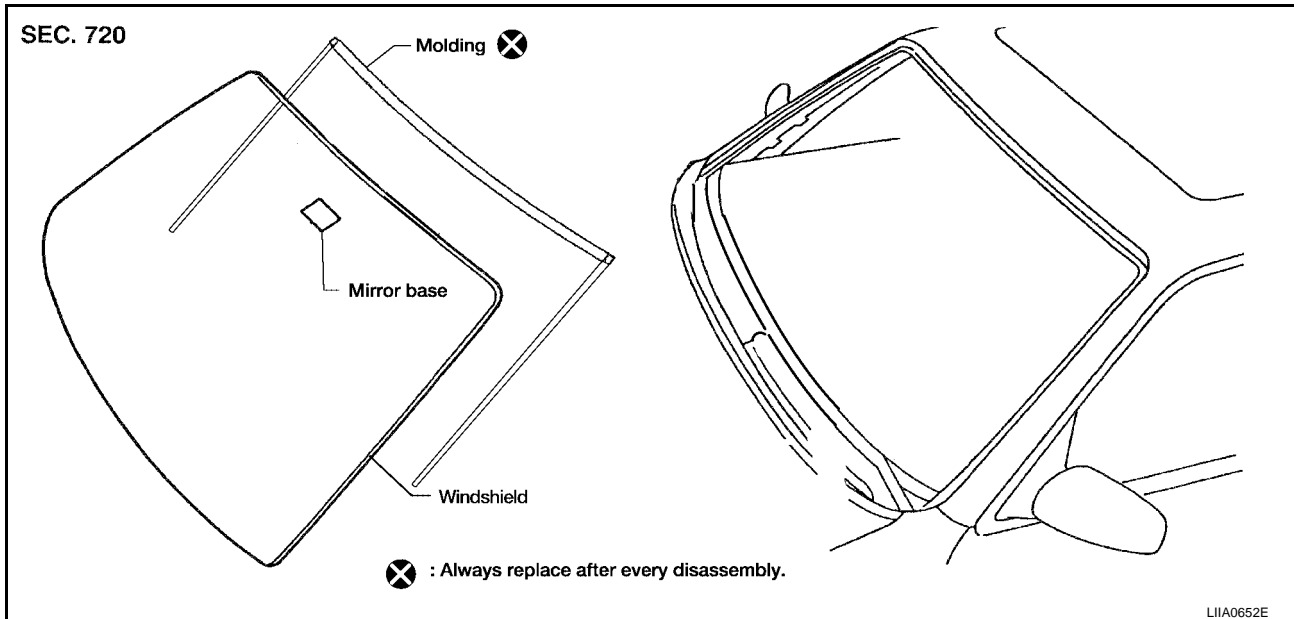

REMOVAL

1. Remove the front pillar garnish. Refer to [EI-30, "BODY SIDE TRIM"](#) .
2. Remove inside mirror. Refer to [GW-72, "Removal and Installation"](#) .
3. Partially remove the headlining (front edge). Refer to [EI-33, "Removal and Installation"](#) .
4. Remove cowl top cover. Refer to [EI-18, "Removal and Installation"](#) .
5. Apply a protective tape around the windshield glass to protect the painted surface from damage.
 - Remove glass using piano wire or power cutting tool and an inflatable pump bag.
 - If a windshield glass is to be reused, mark the body and the glass with mating marks.

WARNING:

When cutting the glass from the vehicle, always wear safety glasses and heavy gloves to help prevent glass splinters from entering your eyes or cutting your hands.

CAUTION:

- When a windshield glass is to be reused, do not use a cutting knife or power cutting tool.
- Be careful not to scratch the glass when removing.
- Do not set or stand glass on its edge. Small chips may develop into cracks.

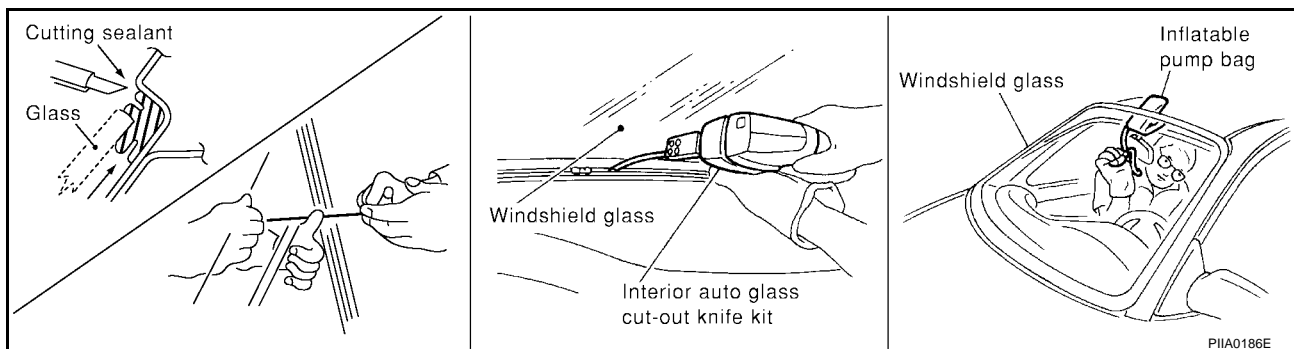

INSTALLATION

- Use a genuine NISSAN Urethane Adhesive Kit (if available) or equivalent and follow the instructions furnished with it.
- While the urethane adhesive is curing, open a door window. This will prevent the glass from being forced out by passenger compartment air pressure when a door is closed.

A
B
C
D
E
F
G
H
J
K
L
M

GW

WINDSHIELD GLASS

- The molding must be installed securely so that it is in position and leaves no gap.
- Inform the customer that the vehicle should remain stationary until the urethane adhesive has completely cured (preferably 24 hours). Curing time varies with temperature and humidity.
- Install parts removed.

WARNING:

- **Keep heat and open flames away as primers and adhesive are flammable.**
- **The materials contained in the kit are harmful if swallowed, and may irritate skin and eyes. Avoid contact with the skin and eyes.**
- **Use in an open, well ventilated location. Avoid breathing the vapors. They can be harmful if inhaled. If affected by vapor inhalation, immediately move to an area with fresh air.**
- **Driving the vehicle before the urethane adhesive has completely cured may affect the performance of the windshield in case of an accident.**

CAUTION:

- **Do not use an adhesive which is past its usable term. Shelf life of this product is limited to six months after the date of manufacture. Carefully adhere to the expiration or manufacture date printed on the box.**
- **Keep primers and adhesive in a cool, dry place. Ideally, they should be stored in a refrigerator.**
- **Do not leave primers or adhesive cartridge unattended with their caps open or off.**
- **The vehicle should not be driven for at least 24 hours or until the urethane adhesive has completely cured. Curing time varies depending on temperature and humidities. The curing time will increase under lower temperatures and lower humidities.**

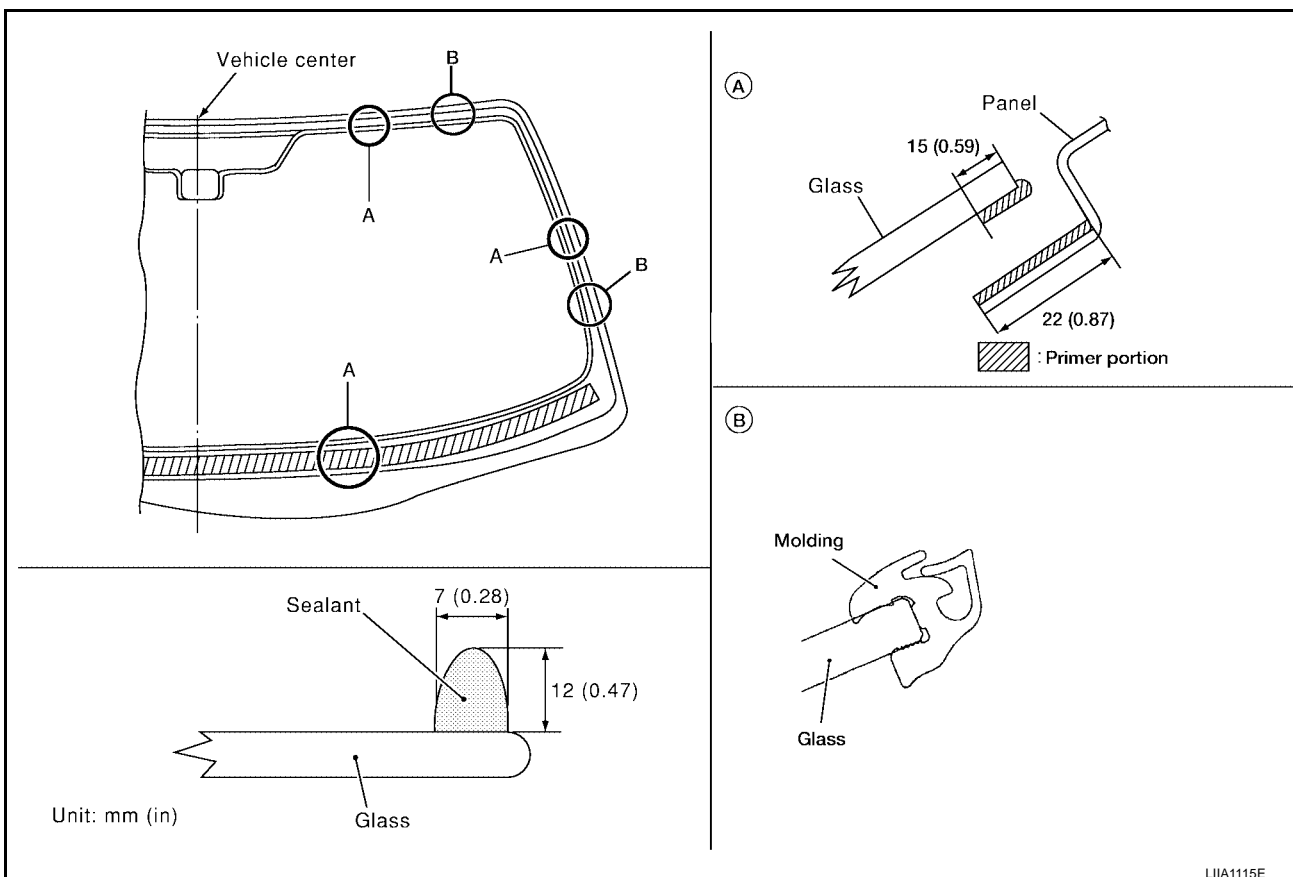

Repairing Water Leaks for Windshield

Leaks can be repaired without removing and reinstalling glass.

If water is leaking between the urethane adhesive material and body or glass, determine the extent of leakage.

This can be done by applying water to the windshield area while pushing glass outward.

To stop the leak, apply primer (if necessary) and then urethane adhesive to the leak point.

REAR WINDOW GLASS AND MOLDING

PF:79712

REAR WINDOW GLASS AND MOLDING

Removal and Installation

EIS00719

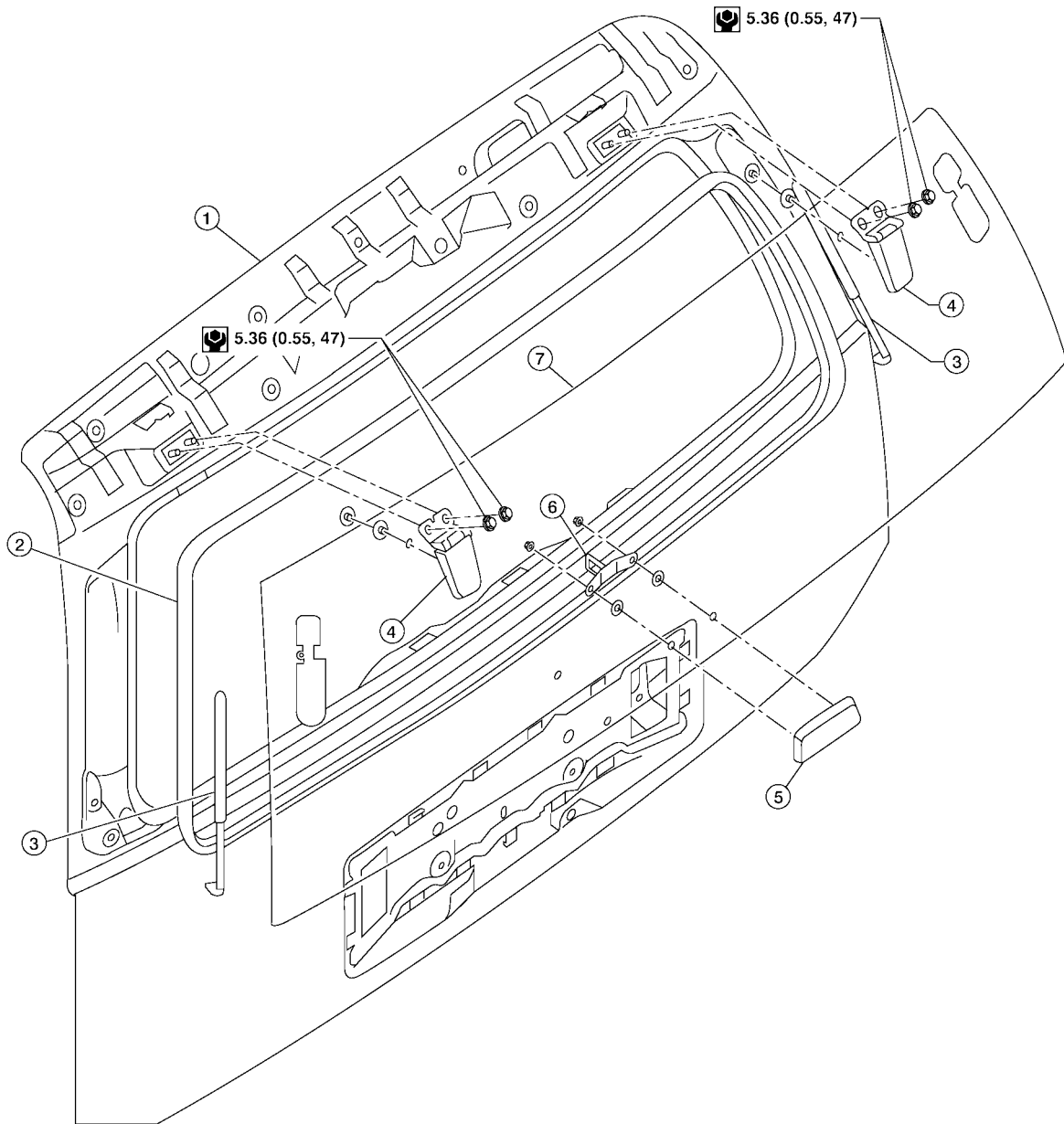

 N-m (kg-m, in-lb)

LIA1892E

- | | | |
|--------------------------------------|-----------------------------|------------------------------------|
| 1. Back door assembly | 2. Weatherstrip | 3. Rear glass stay RH, LH |
| 4. Rear window hinge assembly RH, LH | 5. Rear window glass handle | 6. Rear window glass latch striker |
| 7. Rear glass assembly | | |

REMOVAL

1. Remove the rear spoiler. Refer to [EI-23, "REAR SPOILER"](#).
2. Disconnect the rear window defogger electrical connectors.
3. Remove the rear glass stays.
4. Remove the hinge nuts and the rear glass assembly.
5. Remove the striker and handle.

REAR WINDOW GLASS AND MOLDING

6. Remove the rear glass hinges.

INSTALLATION

Installation is in the reverse order of removal.

POWER WINDOW SYSTEM

Component Parts and Harness Connector Location

EIS0022X

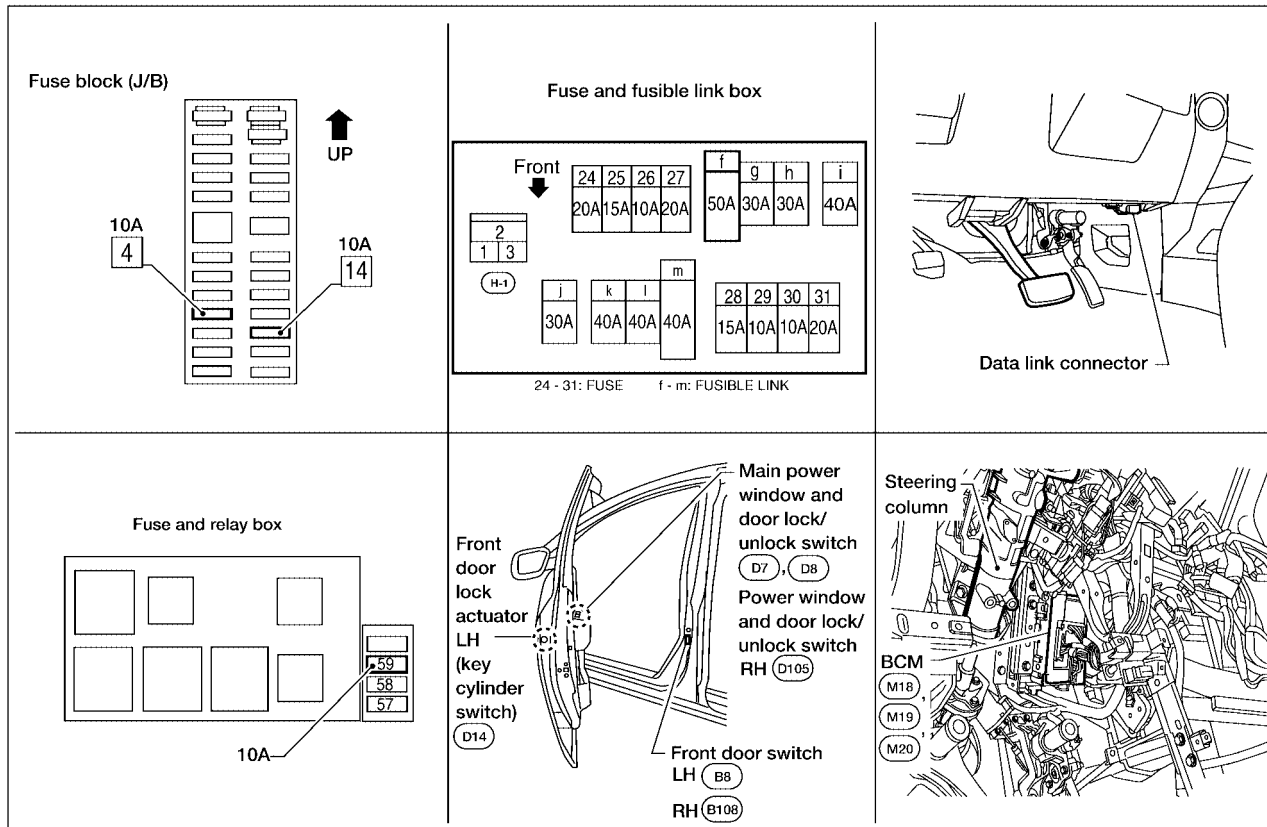

LIA1982E

System Description

EIS0022Y

Power is supplied at all time

- from 50A fusible link (letter f , located in the fuse and fusible link box)
- to BCM terminal 70
- through BCM terminal 69
- to main power window and door lock/unlock switch terminal 19
- to front power window and door lock/unlock switch RH terminal 10.

With ignition switch in ON or START position,

Power is supplied

- through 10A fuse (No. 59, located in the fuse and relay box)
- to BCM terminal 38
- through BCM terminal 68
- to main power window and door lock/unlock switch terminal 10.

With ignition switch in ON or START position,

Ground is supplied

- to BCM terminal 67
- to main power window and door lock/unlock switch terminal 17
- to front power window and door lock/unlock switch RH terminal 11
- through body grounds M57, M61 and M79.

MANUAL OPERATION

Front Driver Side Door

WINDOW UP

When the front LH switch in the main power window and door lock/unlock switch is pressed in the up position,

A
B
C
D
E
F
G
H
GW

POWER WINDOW SYSTEM

Power is supplied

- through main power window and door lock/unlock switch terminal 8
- to front power window motor LH terminal 2.

Ground is supplied

- through main power window and door lock/unlock switch terminal 11
- to front power window motor LH terminal 1.

Then, the motor raises the window until the switch is released.

WINDOW DOWN

When the front LH switch in the main power window and door lock/unlock switch is pressed in the down position

Power is supplied

- through main power window and door lock/unlock switch terminal 11
- to front power window motor LH terminal 1.

Ground is supplied

- through main power window and door lock/unlock switch terminal 8
- to front power window motor LH terminal 2.

Then, the motor lowers the window until the switch is released.

Front Passenger Side Door

POWER WINDOW AND DOOR LOCK/UNLOCK SWITCH RH OPERATION

WINDOW UP

When the power window and door lock/unlock switch RH is pressed in the up position

Power is supplied

- through power window and door lock/unlock switch RH terminal 8
- to front power window motor RH terminal 2.

Ground is supplied

- through power window and door lock/unlock switch RH terminal 9
- to front power window motor RH terminal 1.

Then, the motor raises the window until the switch is released.

WINDOW DOWN

When the power window and door lock/unlock switch RH is pressed in the down position

Power is supplied

- through power window and door lock/unlock switch RH terminal 9
- to front power window motor RH terminal 1.

Ground is supplied

- through power window and door lock/unlock switch RH terminal 8
- to front power window motor RH terminal 2.

Then, the motor lowers the window until the switch is released.

MAIN POWER WINDOW AND DOOR LOCK/UNLOCK SWITCH OPERATION

Signal is sent

- through main power window and door lock/unlock switch terminal 14
- to power window and door lock/unlock switch RH terminal 16.

The operation of power window after receiving the signal is the same as operating the power window with power window and door lock/unlock switch RH.

Rear Door (LH or RH)

REAR POWER WINDOW SWITCH LH OR RH OPERATION

WINDOW UP

When the rear power window switch LH or RH is pressed in the up position

Power is supplied

- through rear power window switch LH or RH terminal 4
- to rear power window motor LH or RH terminal 2.

Ground is supplied

POWER WINDOW SYSTEM

- through rear power window switch LH or RH terminal 5
- to rear power window motor LH or RH terminal 1.

Then, the motor raises the window until the switch is released.

WINDOW DOWN

When the rear power window switch LH or RH is pressed in the down position

Power is supplied

- through rear power window switch LH or RH terminal 5
- to rear power window motor LH or RH terminal 1.

Ground is supplied

- through rear power window switch LH or RH terminal 4
- to rear power window motor LH or RH terminal 2.

Then, the motor lowers the window until the switch is released.

MAIN POWER WINDOW AND DOOR LOCK/UNLOCK SWITCH OPERATION

WINDOW UP

When the main power window and door lock/unlock switch (rear LH) is pressed in the up position

Power is supplied

- through main power window and door lock/unlock switch terminal 3
- to rear power window switch LH terminal 3
- through rear power window switch LH terminal 4
- to rear power window motor LH terminal 2.

Ground is supplied

- through main power window and door lock/unlock switch terminal 1
- to rear power window switch LH terminal 2
- through rear power window switch LH terminal 5
- to rear power window motor LH terminal 1.

Then, the motor raises the window until the switch is released.

When the main power window and door lock/unlock switch (rear RH) is pressed in the up position

Power is supplied

- through main power window and door lock/unlock switch terminal 5
- to rear power window switch RH terminal 3
- through rear power window switch RH terminal 4
- to rear power window motor RH terminal 2.

Ground is supplied

- through main power window and door lock/unlock switch terminal 7
- to rear power window motor RH terminal 2
- through rear power window switch RH terminal 5
- to rear power window switch RH terminal 1.

Then, the motor raises the window until the switch is released.

WINDOW DOWN

When the main power window and door lock/unlock switch (rear LH) is pressed in the down position

Power is supplied

- through main power window and door lock/unlock switch terminal 1
- to rear power window switch LH terminal 2
- through rear power window switch LH terminal 5
- to rear power window motor LH terminal 1.

Ground is supplied

- to main power window and door lock/unlock switch terminal 3
- through rear power window switch LH terminal 4
- through rear power window switch LH terminal 3
- to rear power window motor LH terminal 1.

Then, the motor raises the window until the switch is released.

A

B

C

D

E

F

G

H

GW

J

K

L

M

POWER WINDOW SYSTEM

When the main power window and door lock/unlock switch (rear RH) is pressed in the down position
Power is supplied

- through main power window and door lock/unlock switch terminal 7
- to rear power window switch RH terminal 2
- through rear power window switch RH terminal 5
- to rear power window motor RH terminal 1.

Ground is supplied

- through main power window and door lock/unlock switch terminal 5
- to rear power window switch RH terminal 3
- through rear power window switch RH terminal 4
- to rear power window motor RH terminal 2.

Then, the motor raises the window until the switch is released.

VENT WINDOW CLOSE

When the rear power vent window switch is pressed in the close position
Power is supplied

- to rear power vent window relay (CLOSE) terminal 5
- through rear power vent window relay (CLOSE) terminal 3
- to rear power vent window motors terminal 2.

Ground is supplied

- to rear power vent window relay (OPEN) terminal 4
- through rear power vent window relay (OPEN) terminal 3
- to rear power vent window motors terminal 1.

Then, the motors close the windows until the switch is released.

VENT WINDOW OPEN

When the main power window and door lock/unlock switch (rear LH) is pressed in the open position
Power is supplied

- to rear power vent window relay (OPEN) terminal 5
- through rear power vent window relay (OPEN) terminal 3
- to rear power vent window motors terminal 1.

Ground is supplied

- to rear power vent window relay (CLOSE) terminal 4
- through rear power vent window relay (CLOSE) terminal 3
- to rear power vent window motors terminal 2.

Then, the motors open the windows until the switch is released.

AUTO OPERATION

The power window AUTO feature enables the driver to open or close the window without holding the window switch in the down or up position.

POWER WINDOW SERIAL LINK

Main power window and door lock/unlock switch, power window and door lock/unlock switch RH, and BCM transmit and receive the signal by power window serial link.

The signal is transmitted from BCM to main power window and door lock/unlock switch and power window and door lock/unlock switch RH

- Keyless power window down signal.

The signal is transmitted from main power window and door lock/unlock switch to power window and door lock/unlock switch RH

- Front door window RH operation signal.
- Power window control by front door lock assembly LH (key cylinder switch) signal.
- Power window lock signal.
- Retained power operation signal.

POWER WINDOW SYSTEM

POWER WINDOW LOCK

The power window lock is designed to lock operation of all windows except for front door window LH. When in the lock position, the power window lock signal is transmitted to power window and door lock/unlock switch RH by power window serial link. This prevents the power window motor from operating.

RETAINED POWER OPERATION

When the ignition switch is turned to the OFF position from ON or START position. Power is supplied for 45 seconds

- to main power window and door lock/unlock switch terminal 10
- from BCM terminal 68.

When power and ground are supplied, the BCM continues to be energized, and the power window can be operated.

The retained power operation is canceled when the front LH or front RH door is opened.

RAP signal period can be changed by CONSULT-II. Refer to [GW-33, "CONSULT-II Function \(BCM\)"](#).

ANTI-PINCH SYSTEM

Main power window and door lock/unlock switch and power window and door lock/unlock switch RH monitor the power window motor operation and the power window position (full closed or other) for front LH and front RH power window by the signals from encoder and limit switch in front power window motor LH and RH.

When main power window and door lock/unlock switch or power window and door lock/unlock switch RH detects interruption during the following close operation,

- automatic close operation when ignition switch is in the ON position
- automatic close operation during retained power operation

Main power window and door lock/unlock switch or power window and door lock/unlock switch RH controls each front power window motor for open and the power window will be lowered about 150 mm (5.91 in).

POWER WINDOW CONTROL BY THE FRONT DOOR LOCK ASSEMBLY LH (KEY CYLINDER SWITCH)

When ignition key switch is OFF, front power window LH and RH can be opened or closed by turning the front door lock assembly LH (key cylinder switch) to the UNLOCK / LOCK position for more than 3 seconds.

- Front power windows can be opened as the front door lock assembly LH (key cylinder switch) is kept fully turning to the UNLOCK position.
- Front power windows can be closed as the front door lock assembly LH (key cylinder switch) is kept fully turning to the LOCK position.
- While performing open/close operation for the windows, power window is stopped when the front door lock assembly LH (key cylinder switch) is placed in the NEUTRAL position.
- When the ignition switch is turned ON while the power window opening operation is performed, the power window opening stops.

CAN Communication System Description

Refer to [LAN-5, "CAN COMMUNICATION"](#).

EIS0022Z

POWER WINDOW SYSTEM

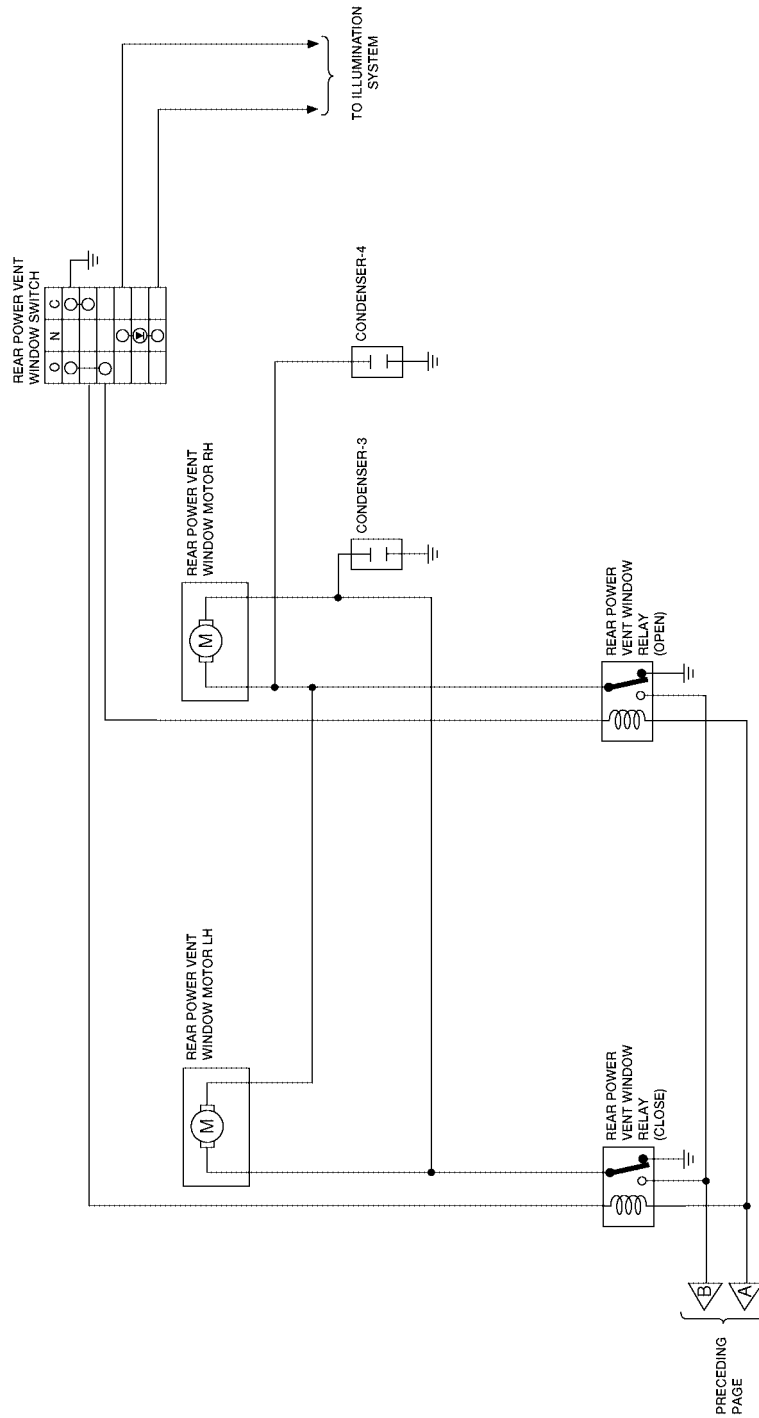

A

B

C

D

E

F

G

H

GW

J

K

L

M

LIWA0370E

POWER WINDOW SYSTEM

EIS00236

Wiring Diagram – WINDOW

GW-WINDOW-01

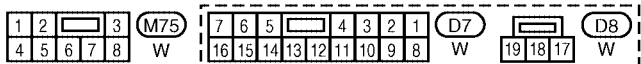
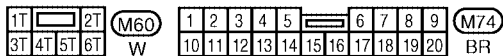
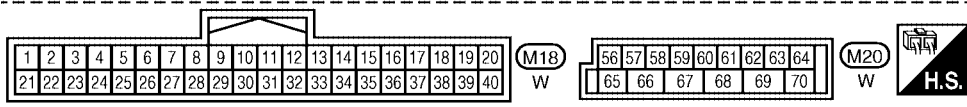
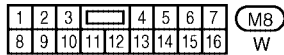
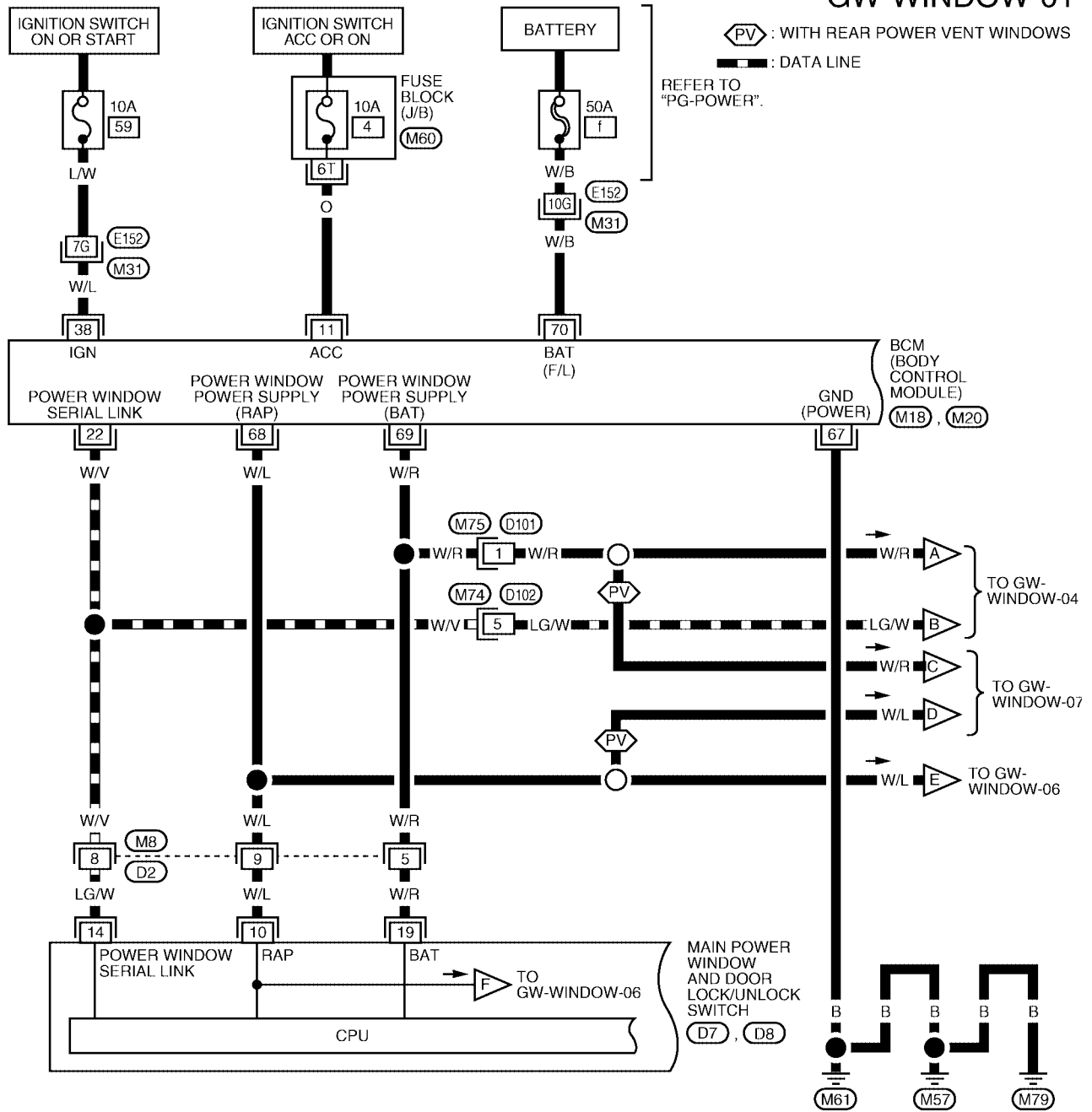

REFER TO THE FOLLOWING.
M31 - SUPER MULTIPLE JUNCTION (SMJ)

WIWA0205E

POWER WINDOW SYSTEM

GW-WINDOW-02

A
B
C
D
E
F
G
H
GW
J
K
L
M

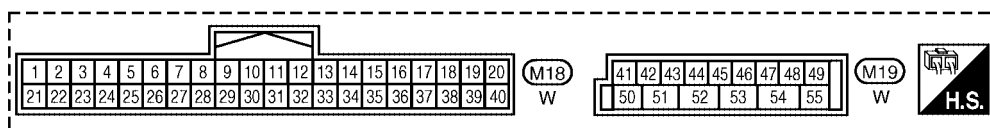
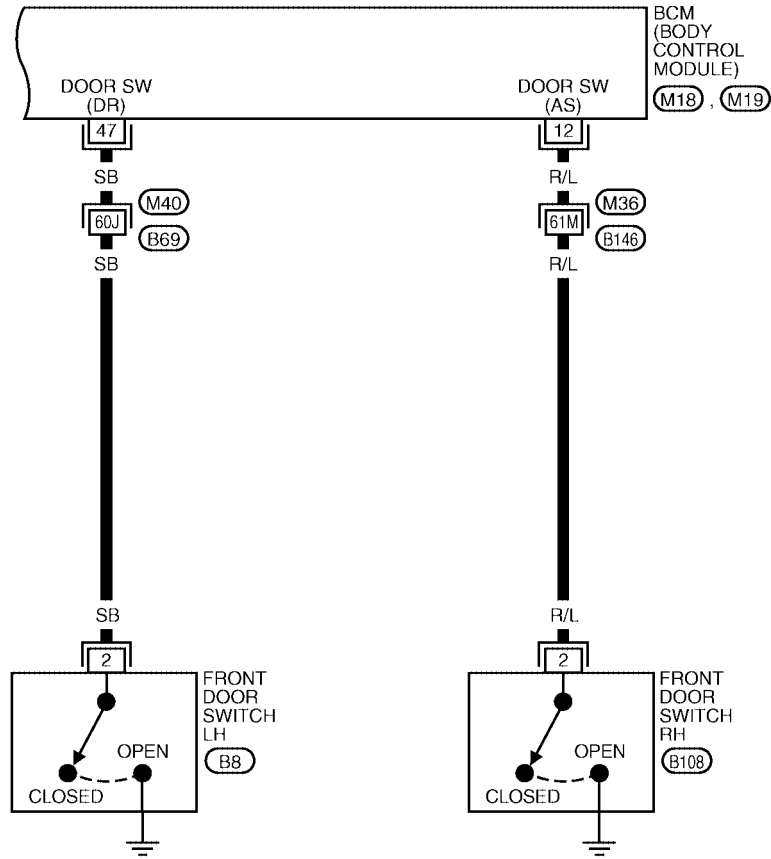

REFER TO THE FOLLOWING.
 (M36), (M40) - SUPER
 MULTIPLE JUNCTION (SMJ)

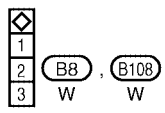

LIWA0372E

POWER WINDOW SYSTEM

GW-WINDOW-03

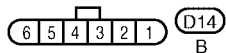
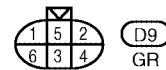
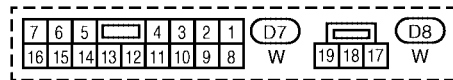
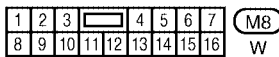
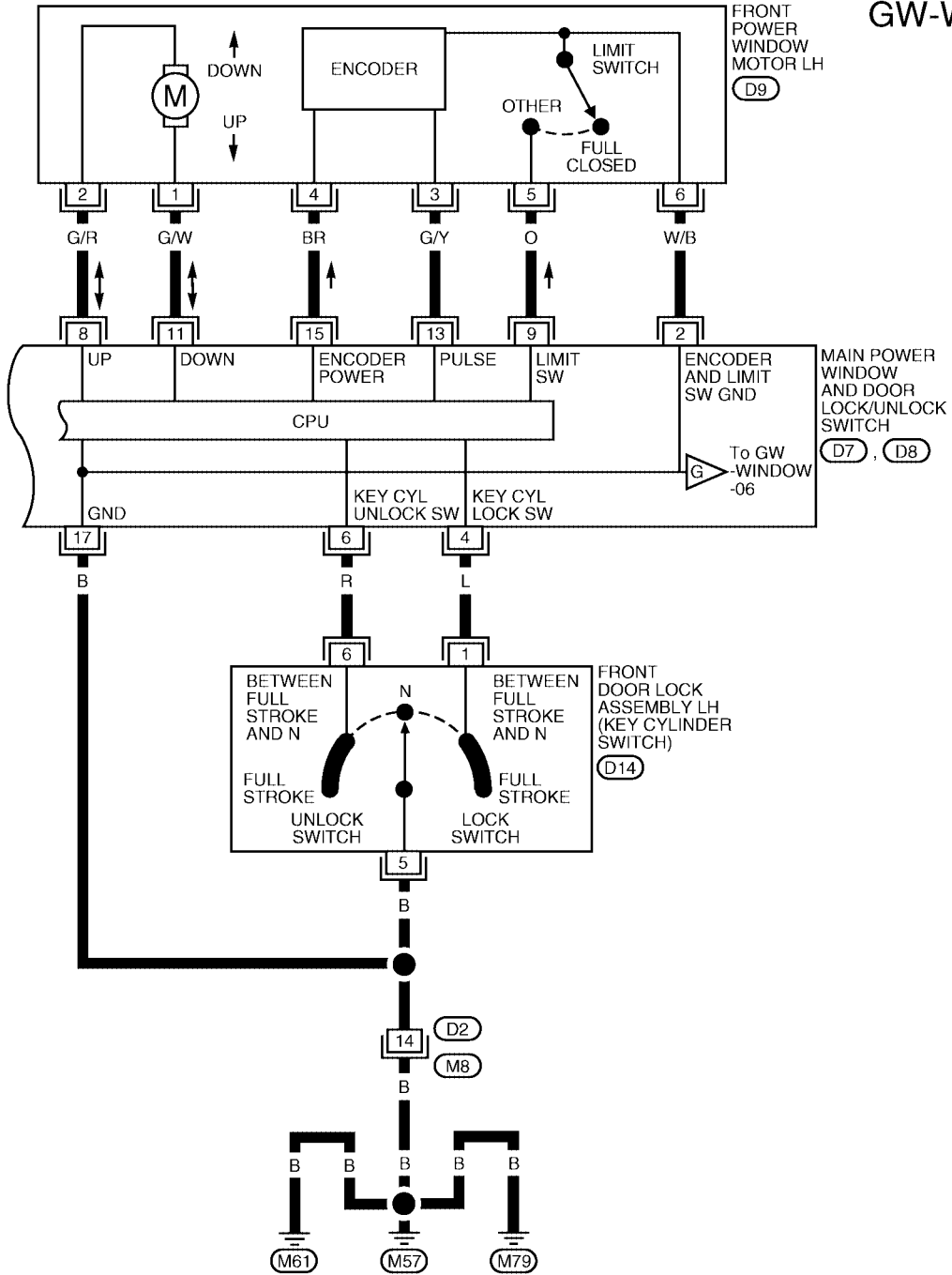

W1WA0216E

POWER WINDOW SYSTEM

GW-WINDOW-04

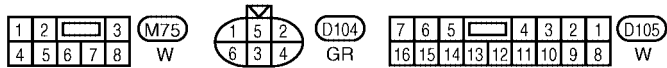
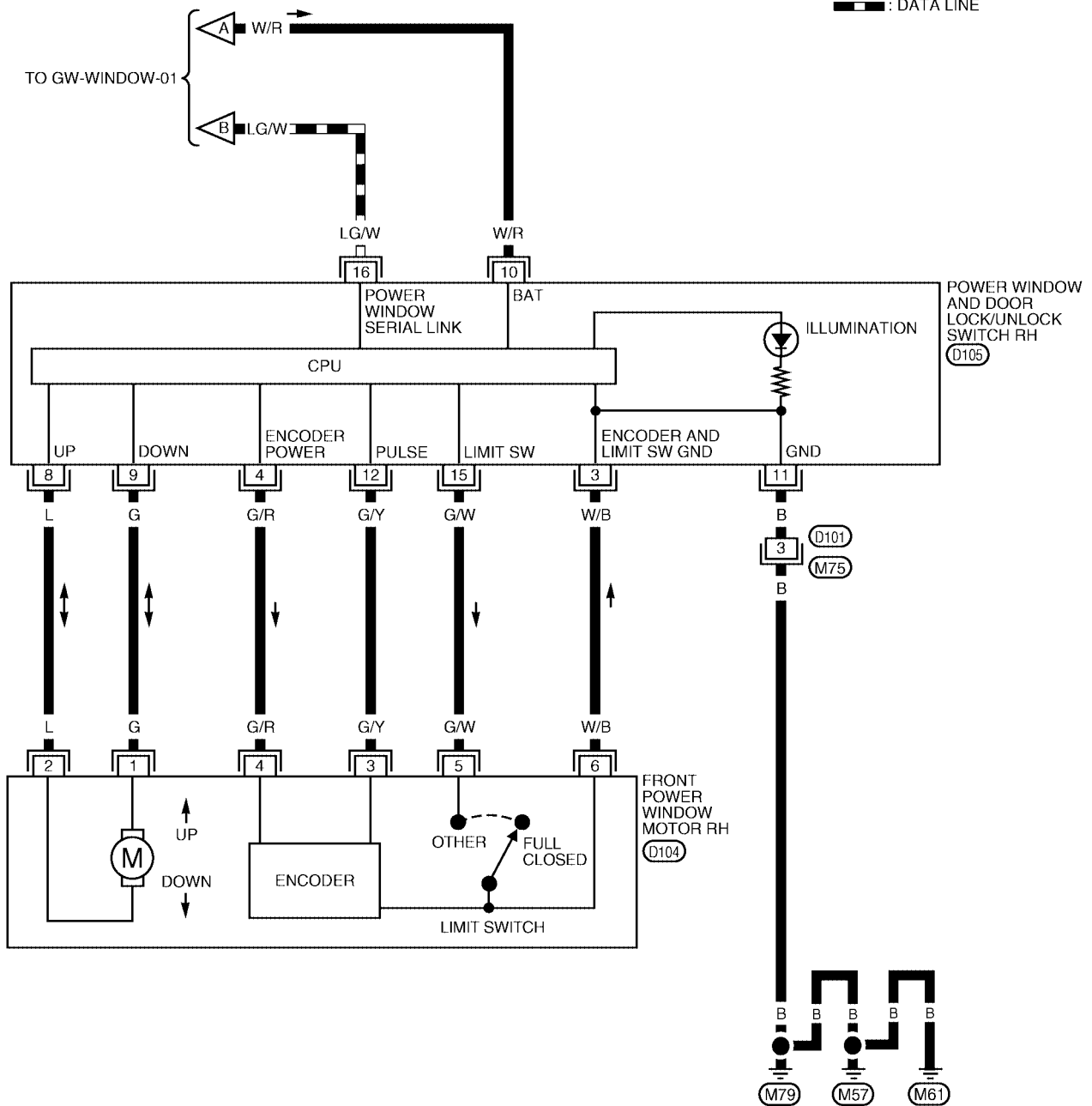

W1WA0206E

POWER WINDOW SYSTEM

GW-WINDOW-05

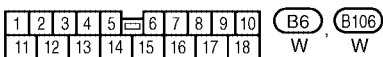
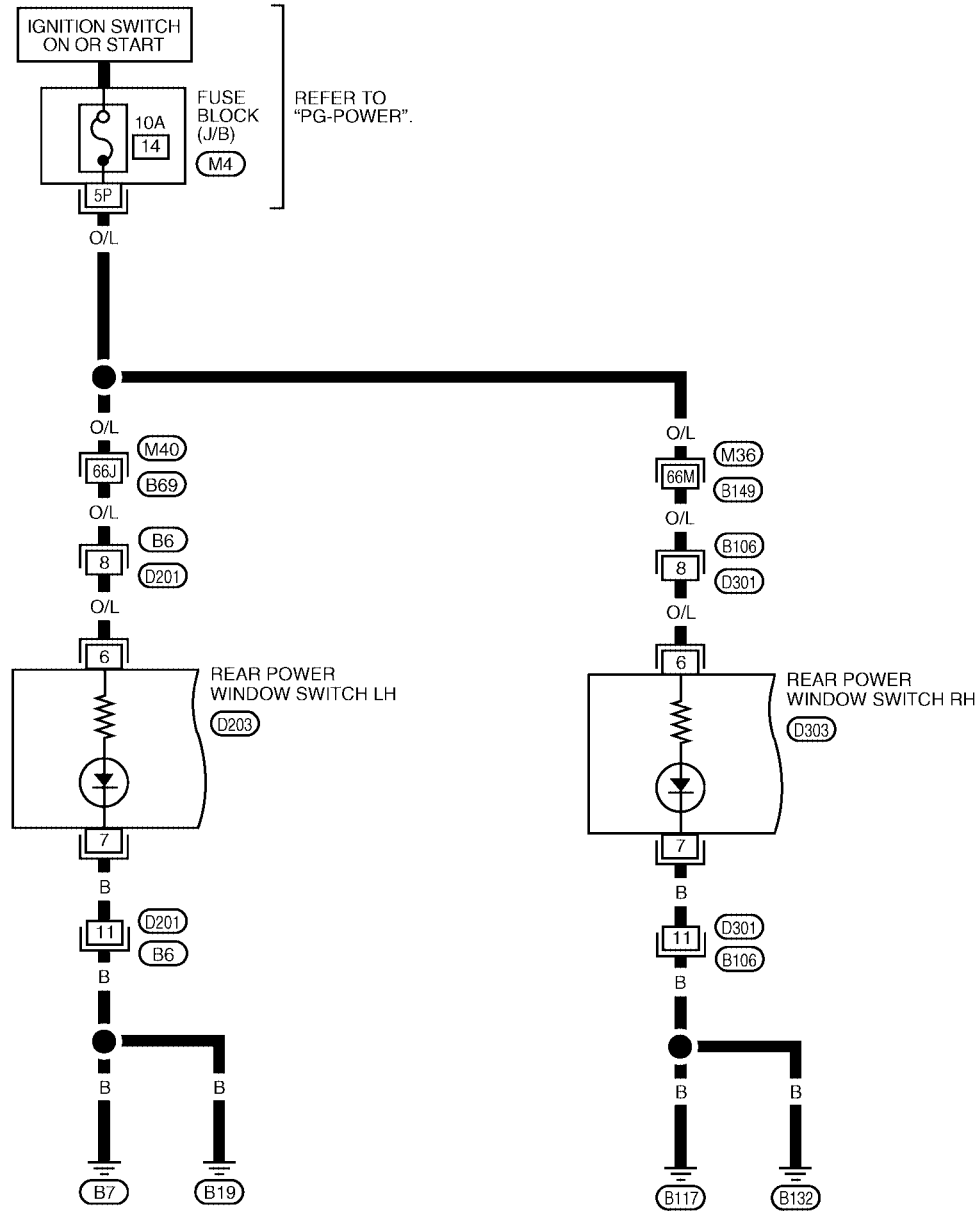

REFER TO THE FOLLOWING.
 (M36), (M40) - SUPER
 MULTIPLE JUNCTION (SMJ)

W1WA0207E

POWER WINDOW SYSTEM

GW-WINDOW-06

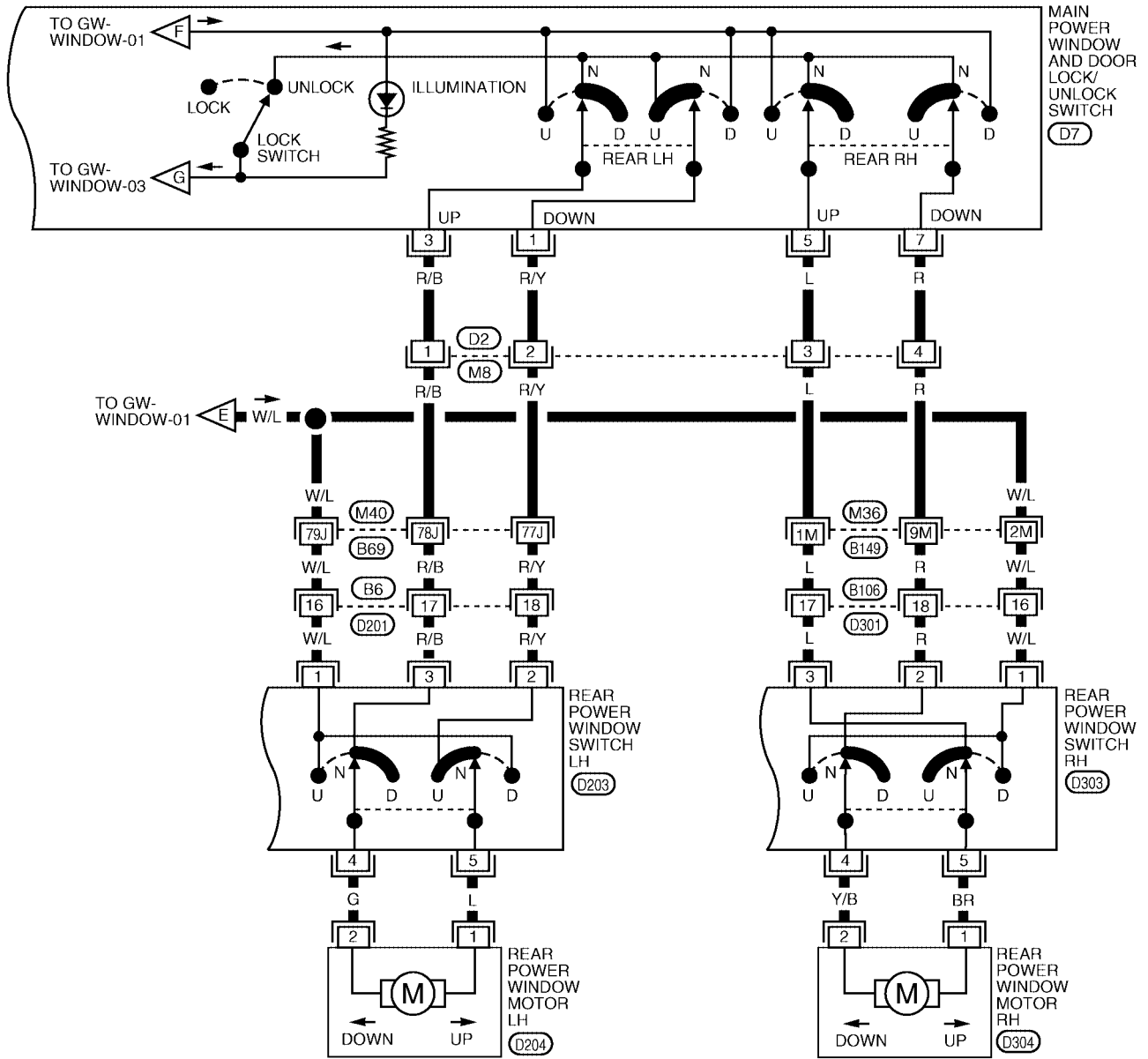

A
B
C
D
E
F
G
H
GW
J
K
L
M

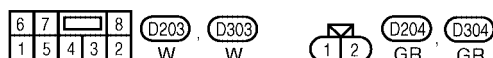
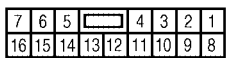
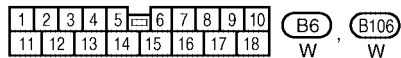
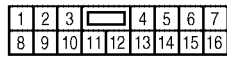

REFER TO THE FOLLOWING.
 (M36), (M40) - SUPER MULTIPLE JUNCTION (SMJ)

W1WA0208E

POWER WINDOW SYSTEM

GW-WINDOW-07

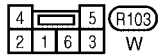
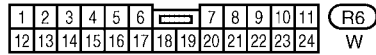
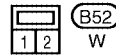
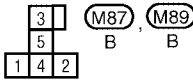
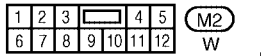
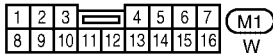
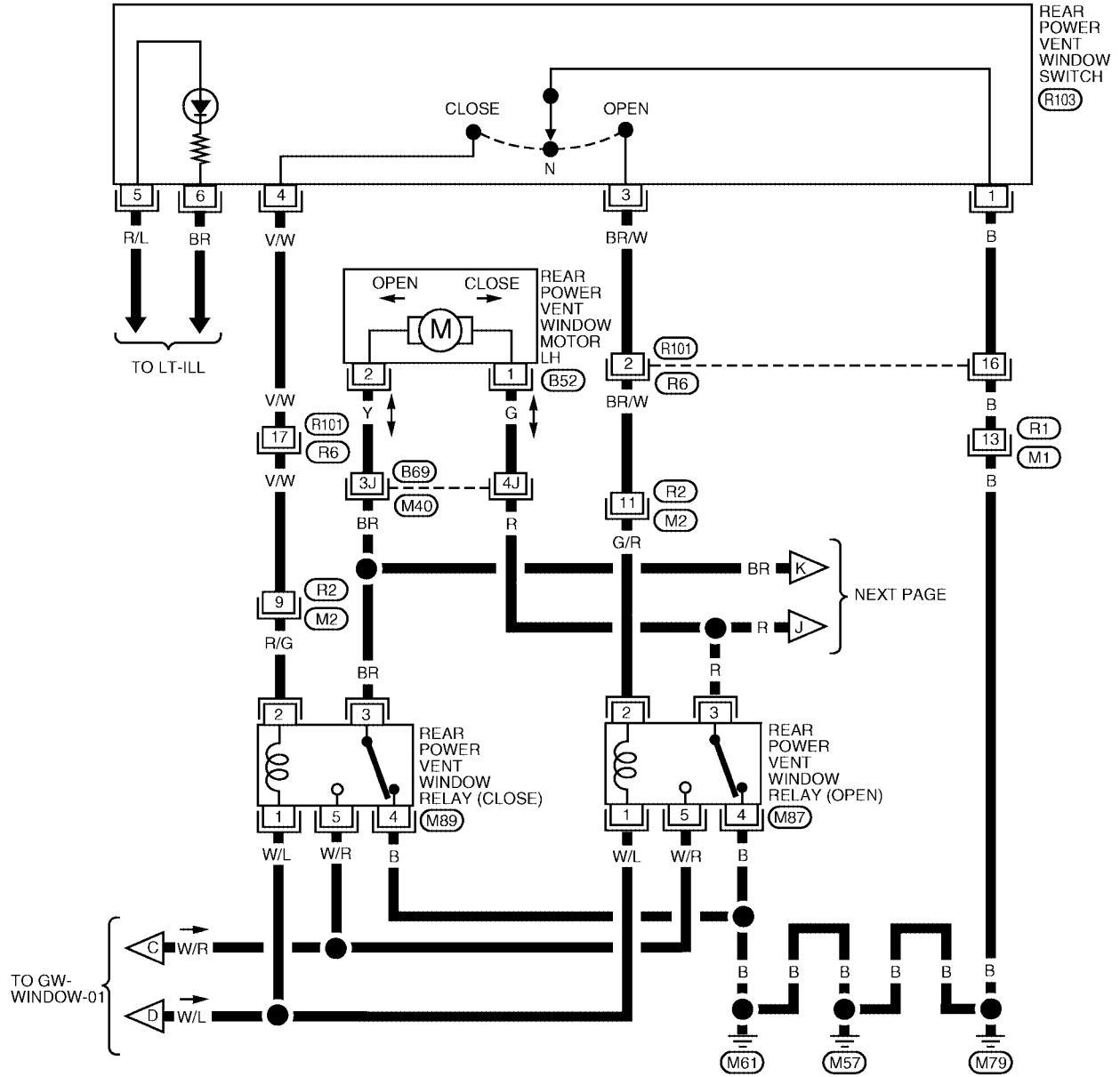

REFER TO THE FOLLOWING.
 (M36), (M40) - SUPER MULTIPLE
 JUNCTION (SMJ)

WIWA0217E

POWER WINDOW SYSTEM

GW-WINDOW-08

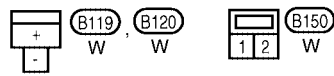
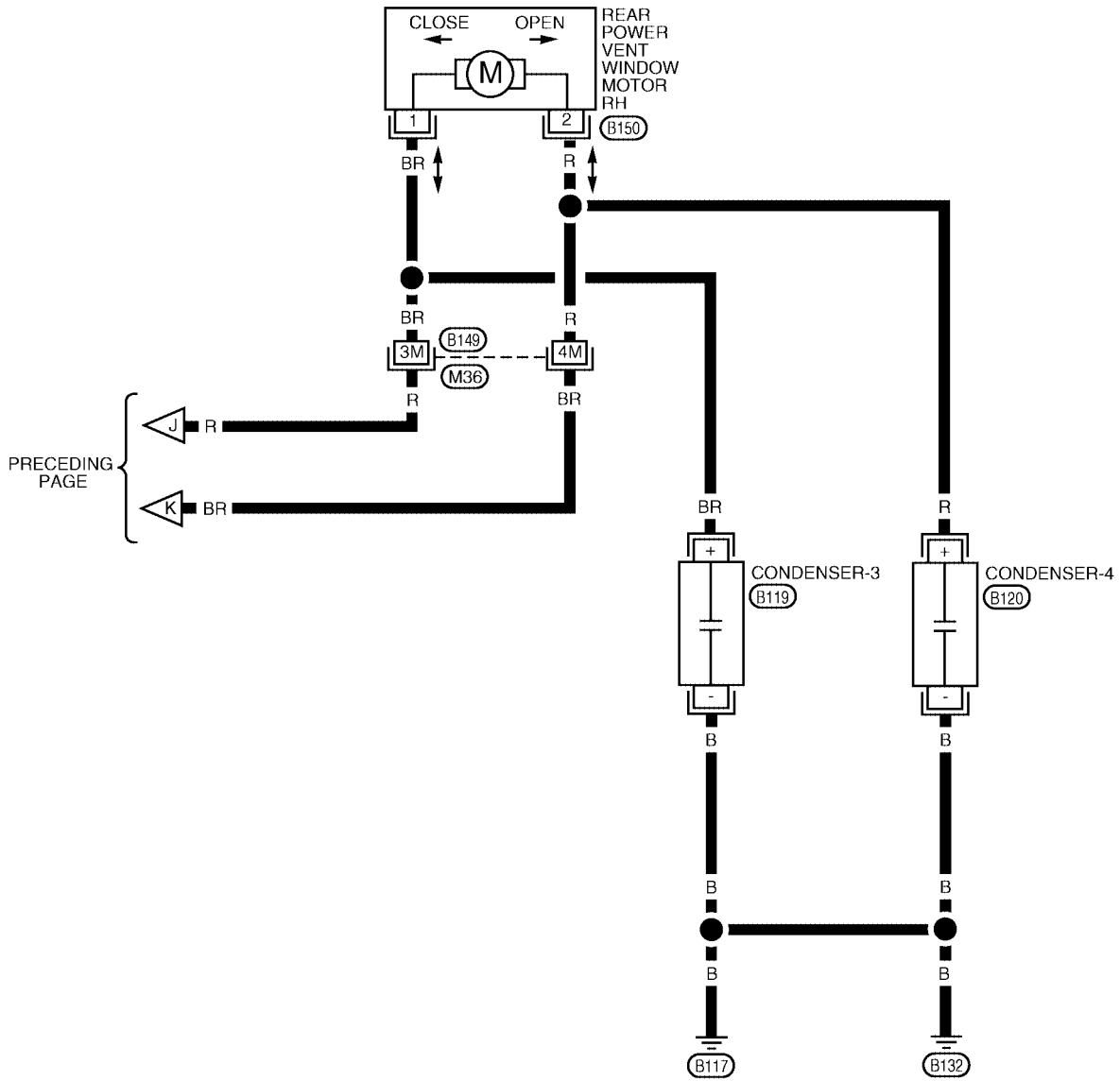

REFER TO THE FOLLOWING.
(M36) - SUPER MULTIPLE JUNCTION (SMJ)

W1WA0218E

POWER WINDOW SYSTEM

Terminal and Reference Value for Main Power Window and Door Lock/Unlock Switch

EIS00237

Terminal	Wire Color	Item	Condition	Voltage (V) (Approx.)
1	R/Y	Rear power window LH DOWN signal	When rear LH switch in main power window and door lock/unlock switch is operated DOWN	Battery voltage
2	W/B	Limit switch and encoder ground	—	0
3	R/B	Rear power window LH UP signal	When rear LH switch in main power window and door lock/unlock switch is operated UP	Battery voltage
4	L	Front door lock assembly LH (key cylinder switch) unlock signal	Key position (Neutral → Unlocked)	5 → 0
5	O/L	Rear power window RH UP signal	When rear RH switch in main power window and door lock/unlock switch is operated UP	Battery voltage
6	R	Front door lock assembly LH (key cylinder switch) lock signal	Key position (Neutral → Locked)	5 → 0
7	R	Rear power window RH DOWN signal	When rear RH switch in main power window and door lock/unlock switch is operated DOWN	Battery voltage
8	G/R	Front power window motor LH UP signal	When power window motor is operated UP	Battery voltage
9	O	Limit switch signal	Driver side door window is between fully-open and just before fully-closed position (ON)	0
			Driver side door window is between just before fully-closed position and fully-closed position (OFF)	5
10	W/L	RAP signal	When ignition switch ON	Battery voltage
			Within 45 seconds after ignition switch is turned to OFF	Battery voltage
			More than 45 seconds after ignition switch is turned to OFF	0
			When front door LH or RH open or power window timer operates	0
11	G/W	Front power window motor LH DOWN signal	When power window motor is operated DOWN	Battery voltage
13	G/Y	Encoder pulse signal	When power window motor operates	 <p style="text-align: right; font-size: small;">OCC3383D</p>

POWER WINDOW SYSTEM

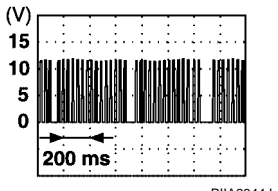
Terminal	Wire Color	Item	Condition	Voltage (V) (Approx.)
14	W/V	Power window serial link	When ignition switch ON or power window timer operates	
15	BR	Encoder power supply	When ignition switch ON or power window timer operates	10
17	B	Ground	—	0
19	W/R	Battery power supply	—	Battery voltage

Terminal and Reference Value for Power Window and Door Lock/Unlock Switch RH

E/IS00238

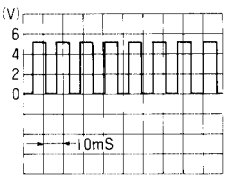
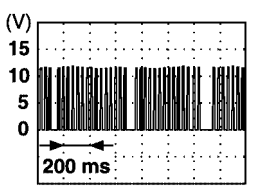
Terminal	Wire Color	Item	Condition	Voltage (V) (Approx.)
3	W/B	Limit switch and encoder ground	—	0
4	G/R	Encoder power supply	When ignition switch ON or power window timer operates	10
8	L	Front power window motor RH UP signal	When power window motor is operated UP	Battery voltage
9	G	Front power window motor RH DOWN signal	When power window motor is operated DOWN	Battery voltage
10	W/R	Battery power supply	—	Battery voltage
11	B	Ground	—	0
12	G/Y	Encoder pulse signal	When power window motor operates	
15	G/W	Limit switch signal	Passenger side door window is between fully-open and just before fully-closed position (ON)	0
			Passenger side door window is between just before fully-closed position and fully-closed position (OFF)	5
16	LG/W	Power window serial link	When ignition switch is ON or power window timer operating	

POWER WINDOW SYSTEM

Terminal and Reference Value for BCM

EIS00239

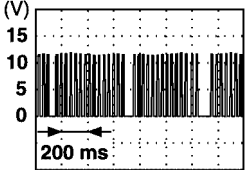
Terminal	Wire Color	Item	Condition	Voltage (V) (Approx.)
11	O	Ignition switch (ACC or ON)	Ignition switch (ACC or ON position)	Battery voltage
12	R/L	Front door switch RH signal	ON (Open)	Battery voltage
			OFF (Close)	0
22	W/V	Power window link signal	When ignition switch ON or power window timer operates	 <p style="text-align: right; font-size: small;">PIIA2344J</p>
38	W/L	Ignition switch (ON or START)	Ignition switch (ON or START position)	Battery voltage
47	SB	Front door switch LH signal	ON (Open)	Battery voltage
			OFF (Close)	0
67	B	Ground	—	0
68	W/L	RAP signal	When ignition switch ON	Battery voltage
			Within 45 seconds after ignition switch is turned to OFF	Battery voltage
			More than 45 seconds after igni- tion switch is turned to OFF	0
			When front door LH or RH is open or power window timer operates	0
69	W/R	Power window power supply	—	Battery voltage
70	W/B	Battery power supply	—	Battery voltage

POWER WINDOW SYSTEM

Work Flow

EIS0023A

1. Check the symptom and customer's requests.
2. Understand the outline of system. Refer to [GW-15, "System Description"](#) .
3. According to the trouble diagnosis chart, repair or replace the cause of the malfunction. Refer to [GW-36, "Trouble Diagnoses Symptom Chart"](#) .
4. Does power window system operate normally? Yes, GO TO 5, If No, GO TO 3.
5. INSPECTION END.

CONSULT-II Function (BCM)

EIS0023B

CONSULT-II can display each diagnostic item using the diagnostic test modes shown following.

BCM diagnostic test item	Diagnostic mode	Content
Inspection by part	WORK SUPPORT	Changes setting of each function.
	DATA MONITOR	Displays BCM input/output data in real time.
	ACTIVE TEST	Operation of electrical loads can be checked by sending drive signal to them.
	SELF-DIAG RESULTS	Displays BCM self-diagnosis results.
	CAN DIAG SUPPORT MNTR	The results of transmit/receive diagnosis of CAN communication can be read.
	ECU PART NUMBER	BCM part number can be read.
	CONFIGURATION	Performs BCM configuration read/write functions.

CONSULT-II INSPECTION PROCEDURE

CAUTION:

If CONSULT-II is used with no connection of CONSULT-II CONVERTER, malfunctions might be detected in self-diagnosis depending on control unit which carries out CAN communication.

1. Connect "CONSULT-II and CONSULT-II CONVERTER" to the data link connector.

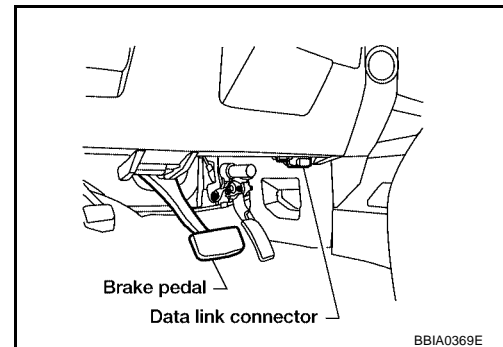

2. Turn ignition switch ON.
3. Touch "START (NISSAN BASED VHCL)".

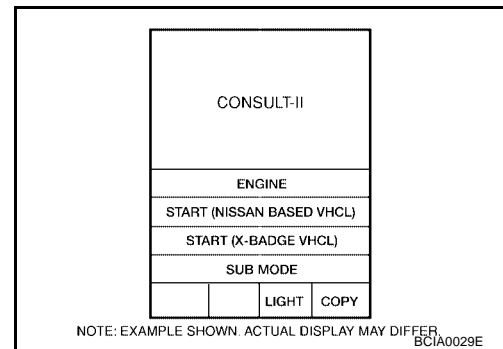

POWER WINDOW SYSTEM

4. Touch "BCM".
If "BCM" is not indicated, refer to [GI-38, "CONSULT-II Data Link Connector \(DLC\) Circuit"](#).

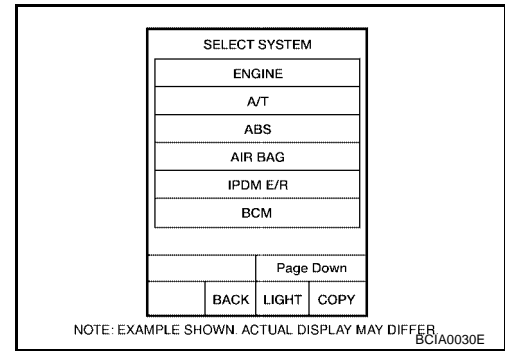

5. Touch "RETAINED PWR".

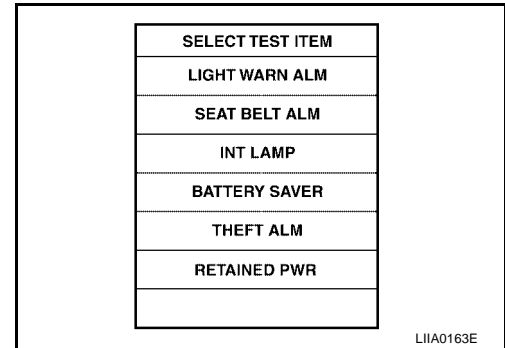

6. Select diagnosis mode.
"ACTIVE TEST" and "WORK SUPPORT" are available.

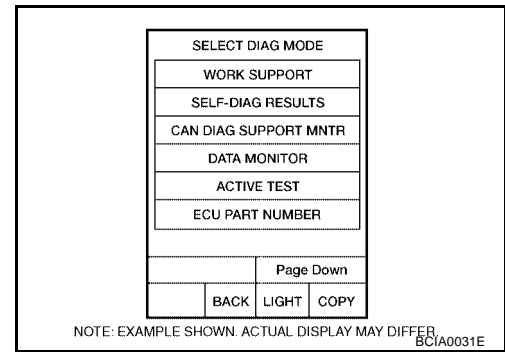

ACTIVE TEST

Test Item	Description
RETAINED PWR	<p>This test is able to supply RAP signal (power) from BCM (body control module) to power window system and power sunroof system (if equipped). Those systems can be operated when turning on "RETAINED PWR" on CONSULT-II screen even if the ignition switch is turned OFF.</p> <p>NOTE: During this test, CONSULT-II can be operated with ignition switch in OFF position. "RETAINED PWR" should be turned "ON" or "OFF" on CONSULT-II screen when ignition switch is ON. Then turn ignition switch OFF to check retained power operation. CONSULT-II might be stuck if "RETAINED PWR" is turned "ON" or "OFF" on CONSULT-II screen when ignition switch is OFF.</p>

WORK SUPPORT

Work item	Description
RETAINED PWR	<p>RAP signal's power supply period can be changed by mode setting. Selects RAP signal's power supply period between three steps</p> <ul style="list-style-type: none"> ● MODE1 (45 sec.) / MODE2 (OFF) / MODE 3 (2 min.).

DATA MONITOR

Work item	Description
IGN ON SW	Indicates (ON / OFF) condition of ignition switch

POWER WINDOW SYSTEM

DOOR SW-DR	Indicates (ON / OFF) condition of front door switch driver side
DOOR SW-AS	Indicates (ON / OFF) condition of front door switch passenger side

A

B

C

D

E

F

G

H

GW

J

K

L

M

POWER WINDOW SYSTEM

EIS0023D

Trouble Diagnoses Symptom Chart

- Check that other systems using the signal of the following systems operate normally.

Symptom	Repair order	Refer to page
None of the power windows can be operated using any switch	1. BCM power supply and ground circuit check	GW-37
	2. Main power window and door lock/unlock power supply and ground circuit check	GW-38
	3. Power window serial link check	GW-53
Front power window LH alone does not operate	1. Front power window motor LH circuit check	GW-40
	2. Replace main power window and door lock/unlock switch	EI-27
Front power window RH alone does not operate	1. Front power window and door lock/unlock switch RH power supply and ground circuit check	GW-39
	2. Power window serial link check	GW-53
	3. Front power window motor RH circuit check	GW-41
	4. Replace BCM	BCS-21
Rear power window LH alone does not operate	1. Rear power window motor LH circuit check	GW-59
Rear power window RH alone does not operate	1. Rear power window motor RH circuit check	GW-59
Rear power vent windows do not operate	1. Rear power vent window switch circuit check	GW-59
Rear power vent window LH alone does not operate	1. Rear power vent window motor LH circuit check	GW-59
Rear power vent window RH alone does not operate	1. Rear power vent window motor RH circuit check	GW-59
Rear power vent windows do not open	1. Rear power vent window relay (OPEN) check	GW-59
Rear power vent windows do not close	1. Rear power vent window relay (CLOSE) check	GW-59
Anti-pinch system does not operate normally (Front LH)	1. Door window sliding part malfunction ● A foreign material adheres to window glass or glass run rubber. ● Glass run rubber wear or deformation. ● Sash is tilted too much, or not enough.	—
	2. Limit switch adjusting	GW-64
	3. Limit switch circuit check LH	GW-42
	4. Encoder circuit check LH	GW-45
Anti-pinch system does not operate normally (Front RH)	1. Door window sliding part malfunction ● A foreign material adheres to window glass or glass run rubber. ● Glass run rubber wear or deformation. ● Sash is tilted too much, or not enough.	—
	2. Limit switch adjusting	GW-64
	3. Limit switch circuit check RH	GW-43
	4. Encoder circuit check RH	GW-47
Power window retained power operation does not operate properly	1. Check the retained power operation mode setting.	GW-34
	2. Door switch check	GW-49
	3. Replace BCM.	BCS-21

POWER WINDOW SYSTEM

Symptom	Repair order	Refer to page
Does not operate by front door lock assembly LH (key cylinder switch)	1. Front door lock assembly LH (key cylinder switch check)	GW-51
	2. Replace main power window and door lock/unlock switch	EI-27
Power window lock switch does not function	1. Power window lock switch circuit check	GW-53

BCM Power Supply and Ground Circuit Check

EIS0023E

1. CHECK FUSE

Check 50A fusible link (letter **f** located in the fuse and fusible link box).
Check 10A fuse (No.59, located in the fuse and relay box).

NOTE:

Refer to [GW-15, "Component Parts and Harness Connector Location"](#).

OK or NG

OK >> GO TO 2.

NG >> If fuse is blown, be sure to eliminate cause of malfunction before installing new fuse. Refer to [PG-3, "PRECAUTIONS"](#)

2. CHECK POWER SUPPLY CIRCUIT

- Turn ignition switch ON.
- Check voltage between BCM connector M18, M20 terminal 38, 70 and ground.

38 (W/L) – Ground : Battery voltage

70 (W/B) – Ground : Battery voltage

OK or NG

OK >> GO TO 3.

NG >> Repair or replace harness.

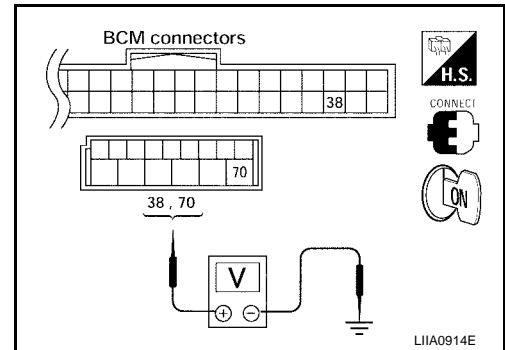

3. CHECK GROUND CIRCUIT

- Turn ignition switch OFF.
- Disconnect BCM.
- Check continuity between BCM connector M20 terminal 67 and ground.

67 (B) – Ground : Continuity should exist.

OK or NG

OK >> Power supply and ground circuit is OK.

NG >> Repair or replace harness.

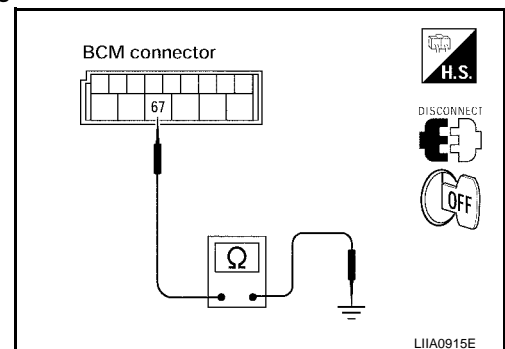

POWER WINDOW SYSTEM

Main Power Window and Door Lock/Unlock Switch Power Supply and Ground Circuit Check

EIS0023G

1. CHECK POWER SUPPLY CIRCUIT

1. Turn ignition switch ON.
2. Check voltage between main power window and door lock/unlock switch connector D7 terminal 10, D8 terminal 19 and ground.

10 (W/L) – Ground : Battery voltage

19 (W/R) – Ground : Battery voltage

OK or NG

OK >> GO TO 2.

NG >> GO TO 3.

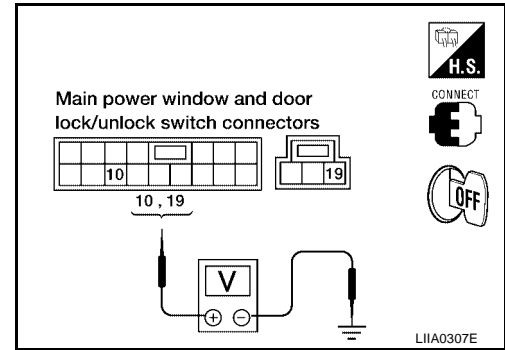

2. CHECK GROUND CIRCUIT

1. Turn ignition switch OFF.
2. Disconnect main power window and door lock/unlock switch.
3. Check continuity between main power window and door lock/unlock switch connector D8 terminal 17 and ground.

17 (B) – Ground : Continuity should exist.

OK or NG

OK >> Power supply and ground circuit are OK.

NG >> Repair or replace harness.

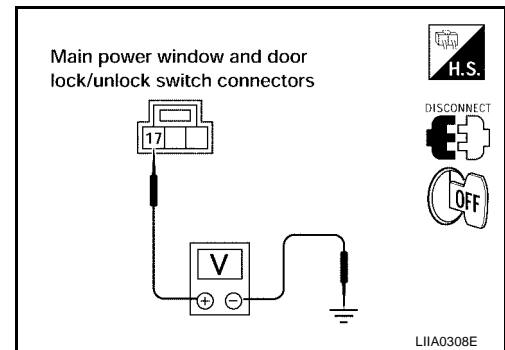

3. CHECK MAIN POWER WINDOW AND DOOR LOCK/UNLOCK SWITCH POWER SUPPLY CIRCUIT

1. Disconnect BCM.
2. Check continuity between BCM connector M20 terminal 68, 69 and main power window and door lock/unlock switch connector D7 terminal 10 and D8 terminal 19.

68 (W/L) – 10 (W/L) : Continuity should exist.

69 (W/R) – 19 (W/R) : Continuity should exist.

OK or NG

OK >> GO TO 4.

NG >> Repair or replace harness.

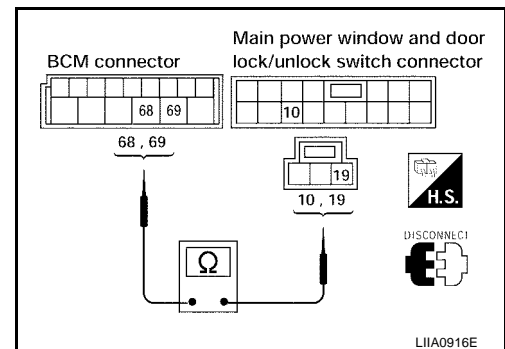

POWER WINDOW SYSTEM

4. CHECK BCM OUTPUT SIGNAL

1. Connect BCM.
2. Turn ignition switch ON.
3. Check voltage between BCM connector M20 terminal 68, 69 and ground.

68 (W/L) – Ground : Battery voltage

69 (W/R) – Ground : Battery voltage

OK or NG

OK >> Check the condition of the harness and the connector.

NG >> Replace BCM.

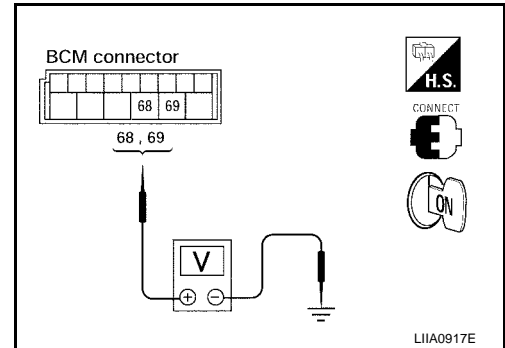

Power Window and Door Lock/Unlock Switch RH Power Supply and Ground Circuit Check

EIS0023H

1. CHECK POWER SUPPLY CIRCUIT

1. Turn ignition switch ON.
2. Check voltage between power window and door lock/unlock switch RH connector D105 terminal 10 and ground.

10 (W/R) – Ground : Battery voltage

OK or NG

OK >> GO TO 2.

NG >> GO TO 3.

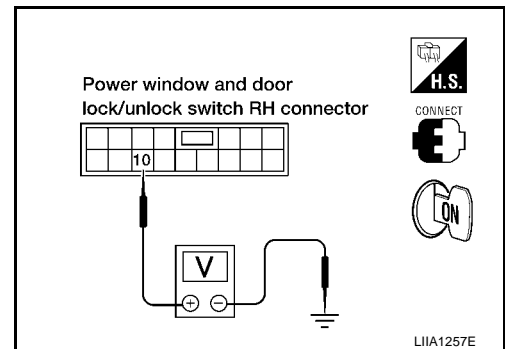

2. CHECK GROUND CIRCUIT

1. Turn ignition switch OFF.
2. Disconnect front power window and door lock/unlock switch RH.
3. Check continuity between power window and door lock/unlock switch RH connector D105 terminal 11 and ground.

11 (B) – Ground : Continuity should exist.

OK or NG

OK >> Power supply and ground circuit are OK.

NG >> Repair or replace harness.

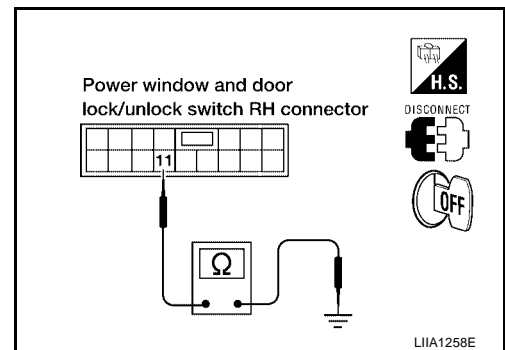

POWER WINDOW SYSTEM

3. CHECK POWER WINDOW AND DOOR LOCK/UNLOCK SWITCH RH POWER SUPPLY CIRCUIT

1. Disconnect BCM.
2. Check continuity between BCM connector M20 terminal 69 and power window and door lock/unlock switch RH connector D105 terminal 10.

69 (W/R) – 10 (W/R) : Continuity should exist.

OK or NG

- OK >> GO TO 4.
 NG >> Repair or replace harness.

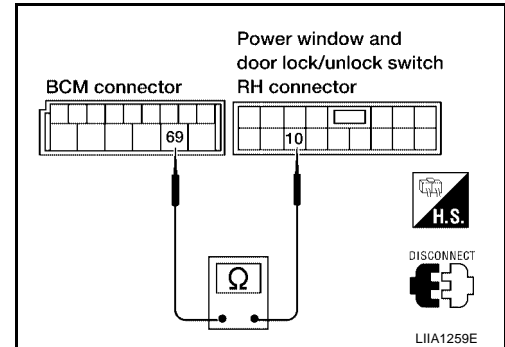

4. CHECK BCM OUTPUT SIGNAL

1. Connect BCM.
2. Turn ignition switch ON.
3. Check voltage between BCM connector M20 terminal 69 and ground.

69 (W/R) – Ground : Battery voltage

OK or NG

- OK >> Check the condition of the harness and the connector
 NG >> Replace BCM.

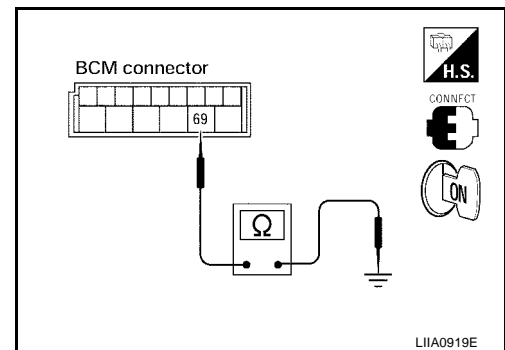

Front Power Window Motor LH Circuit Check

EIS0023I

1. CHECK MAIN POWER WINDOW AND DOOR LOCK/UNLOCK SWITCH OUTPUT SIGNAL

1. Turn ignition switch ON.
2. Check voltage between main power window and door lock/unlock switch connector D7 terminal 8, 11 and ground.

Connector	Terminals (Wire color)		Condition	Voltage (V) (Approx.)
	(+)	(-)		
D7	8 (G/R)	Ground	UP	Battery voltage
			DOWN	0
	11 (G/W)		UP	0
			DOWN	Battery voltage

OK or NG

- OK >> GO TO 2.
 NG >> Replace main power window and door lock/unlock switch.

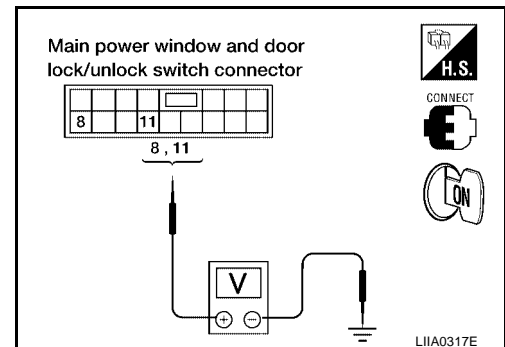

POWER WINDOW SYSTEM

2. CHECK POWER WINDOW MOTOR CIRCUIT

1. Turn ignition switch OFF.
2. Disconnect main power window and door lock/unlock switch and front power window motor LH.
3. Check continuity between main power window and door lock/unlock switch connector D7 terminal 8, 11 and front power window motor LH connector D9 terminal 1, 2.

8 (G/R) – 2 (G/R) : Continuity should exist.

11 (G/W) – 1 (G/W) : Continuity should exist.

OK or NG

- OK >> Replace front power window motor LH.
 NG >> Repair or replace harness.

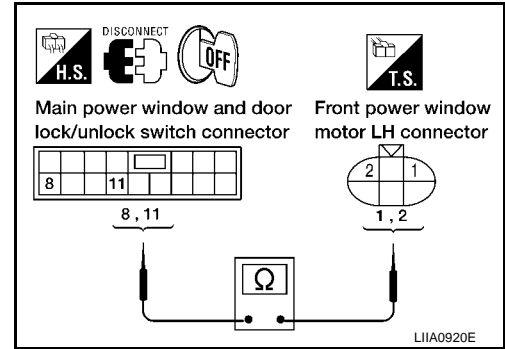

EIS0023J

Front Power Window Motor RH Circuit Check

1. CHECK POWER WINDOW AND DOOR LOCK/UNLOCK SWITCH RH OUTPUT SIGNAL

1. Turn ignition switch ON.
2. Check voltage between power window and door lock/unlock switch RH connector D105 terminal 8, 9 and ground.

Connector	Terminals (Wire color)		Condition	Voltage (V) (Approx.)
	(+)	(-)		
D105	9 (G)	Ground	UP	0
			DOWN	Battery voltage
	8 (L)		UP	Battery voltage
			DOWN	0

OK or NG

- OK >> GO TO 2.
 NG >> Replace power window and door lock/unlock switch RH.

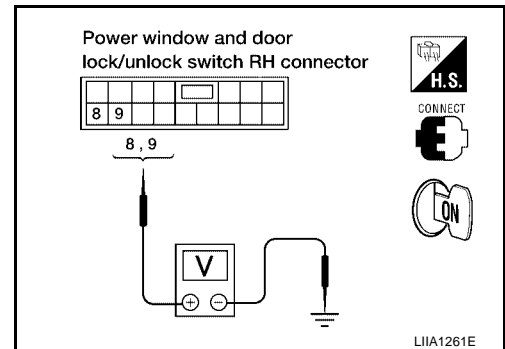

LIA1261E

2. CHECK FRONT POWER WINDOW MOTOR RH CIRCUIT

1. Turn ignition switch OFF.
2. Disconnect front power window motor RH and power window and door lock/unlock switch RH.
3. Check continuity between power window and door lock/unlock switch RH connector D105 terminals 8, 9 and front power window motor RH connector D104 terminals 1, 2.

8 (L) – 2 (L) : Continuity should exist.

9 (G) – 1 (G) : Continuity should exist.

OK or NG

- OK >> Replace front power window motor RH.
 NG >> Repair or replace harness.

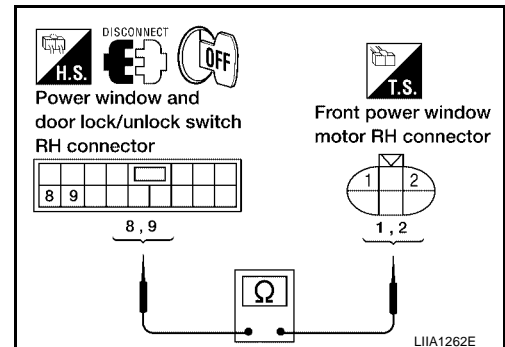

LIA1262E

POWER WINDOW SYSTEM

EIS0023L

Limit Switch Circuit Check Front LH

1. CHECK MAIN POWER WINDOW AND DOOR LOCK/UNLOCK SWITCH LIMIT SIGNAL

1. Turn ignition switch ON.
2. Check voltage between main power window and door lock/unlock switch connector D7 terminal 9 and ground.

Connector	Terminal (Wire color)		Condition	Voltage (V) (Approx.)
	(+)	(-)		
D7	9 (O)	Ground	Driver side door window is between fully-open and just before fully-closed position (ON)	0
			Driver side door window is between just before fully-closed position and fully-closed position (OFF)	5

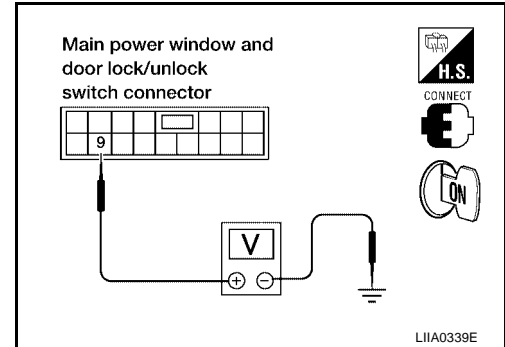

OK or NG

- OK >> Limit switch circuit is OK.
 NG >> GO TO 2.

2. CHECK FRONT POWER WINDOW MOTOR LH LIMIT SIGNAL

1. Turn ignition switch OFF.
2. Disconnect front power window motor LH.
3. Check continuity between front power window motor LH connector D9 terminal 5 and ground.

5 (O) – Ground : Approx. 5V

OK or NG

- OK >> GO TO 3.
 NG >> GO TO 5.

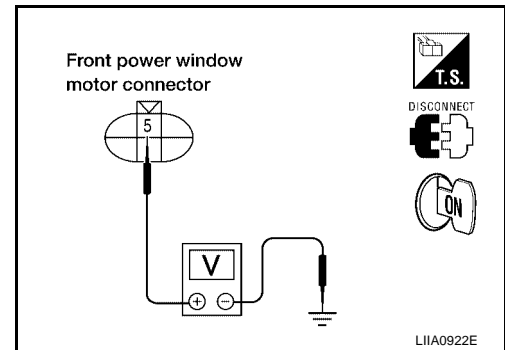

3. CHECK LIMIT SWITCH GROUND CIRCUIT

1. Turn ignition switch OFF.
2. Check continuity between front power window motor LH connector D9 terminal 6 and ground.

6 (W/B) – Ground : Continuity should exist.

OK or NG

- OK >> Replace front power window motor LH.
 NG >> GO TO 4.

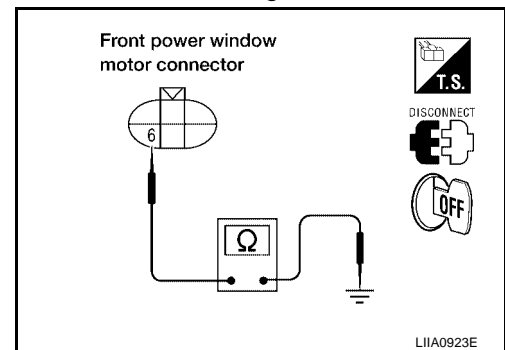

POWER WINDOW SYSTEM

4. CHECK HARNESS CONTINUITY

1. Disconnect main power window and door lock/unlock switch.
2. Check continuity between front power window motor LH connector D9 terminal 6 and main power window and door lock/unlock switch connector D7 terminal 2.

6 (W/B) – 2 (W/B) : Continuity should exist.

OK or NG

- OK >> Replace main power window and door lock/unlock switch.
 NG >> Repair or replace harness.

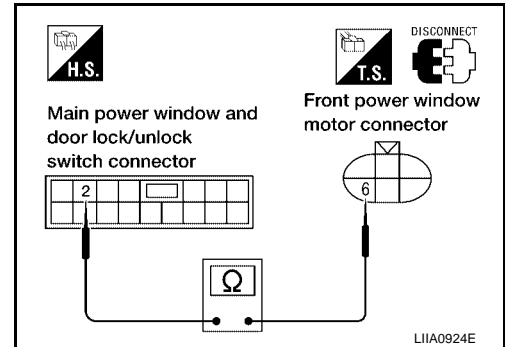

5. CHECK HARNESS CONTINUITY

1. Turn ignition switch OFF.
2. Disconnect main power window and door lock/unlock switch.
3. Check continuity between front power window motor LH connector D9 terminal 5 and main power window and door lock/unlock switch connector D7 terminal 9.

5 (O) – 9 (O) : Continuity should exist.

OK or NG

- OK >> Replace main power window and door lock/unlock switch.
 NG >> Repair or replace harness.

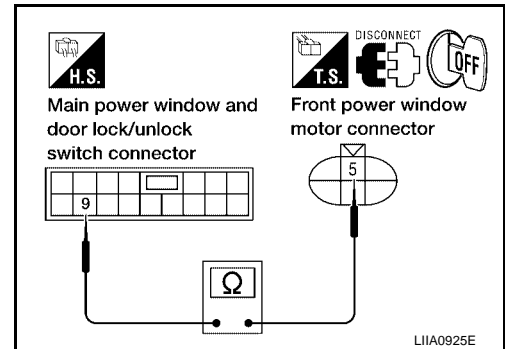

Limit Switch Circuit Check Front RH

1. CHECK POWER WINDOW AND DOOR LOCK/UNLOCK SWITCH RH LIMIT SIGNAL

1. Turn ignition switch ON.
2. Check voltage between power window and door lock/unlock switch RH connector D105 terminal 15 and ground.

Connector	Terminals (Wire color)		Condition	Voltage (V) (Approx.)
	(+)	(-)		
D105	15 (G/W)	Ground	Passenger side door window is between fully-open and just before fully-closed position (ON)	0
			Passenger side door window is between just before fully-closed position and fully-closed position (OFF)	5

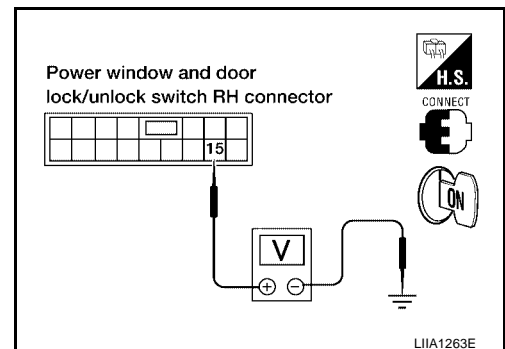

OK or NG

- OK >> Limit switch circuit is OK.
 NG >> GO TO 2.

POWER WINDOW SYSTEM

2. CHECK LIMIT SWITCH GROUND CIRCUIT

1. Turn ignition switch OFF.
2. Disconnect front power window motor RH.
3. Check continuity between front power window motor RH connector D104 terminal 6 and ground.

5 (G/W) – Ground : Approx. 5V

OK or NG

- OK >> GO TO 3.
NG >> GO TO 5.

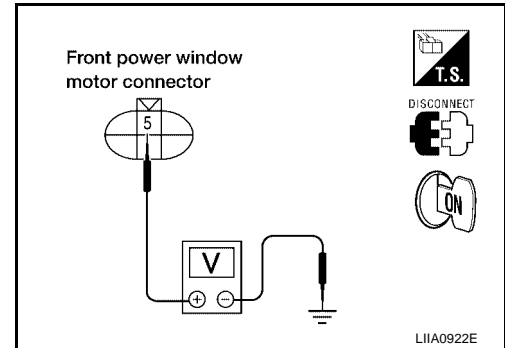

3. CHECK LIMIT SWITCH GROUND CIRCUIT

1. Turn ignition switch OFF.
2. Check continuity between front power window motor RH connector D104 terminal 6 and ground.

6 (W/B) – Ground : Continuity should exist.

OK or NG

- OK >> Replace front power window motor RH.
NG >> GO TO 4.

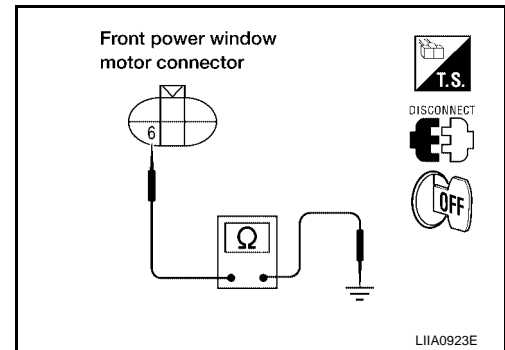

4. CHECK HARNESS CONTINUITY

1. Disconnect front power window and door lock/unlock switch RH.
2. Check continuity between front power window motor RH connector D104 terminal 6 and power window and door lock/unlock switch RH connector D105 terminal 3.

6 (W/B) – 3 (W/B) : Continuity should exist.

OK or NG

- OK >> Replace power window and door lock/unlock switch RH.
NG >> Repair or replace harness.

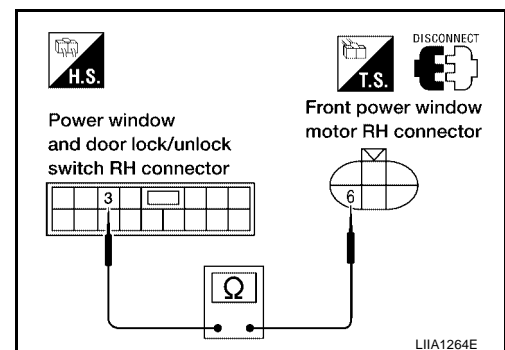

POWER WINDOW SYSTEM

5. CHECK HARNESS CONTINUITY

1. Turn ignition switch OFF.
2. Disconnect power window and door lock/unlock switch RH.
3. Check continuity between power window and door lock/unlock switch RH connector D105 terminal 15 and front power window motor RH connector D104 terminal 5.

15 (G/W) – 5 (G/W) : Continuity should exist.

OK or NG

- OK >> Replace power window and door lock/unlock switch RH.
NG >> Repair or replace harness.

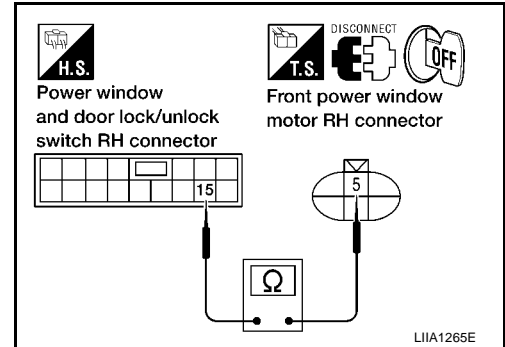

Encoder Circuit Check Front LH

1. CHECK FRONT POWER WINDOW MOTOR LH POWER SUPPLY

1. Turn ignition switch ON.
2. Check voltage between front power window motor LH connector D9 terminal 4 and ground.

4 (BR) – Ground : Approx. 10V

OK or NG

- OK >> GO TO 3.
NG >> GO TO 2.

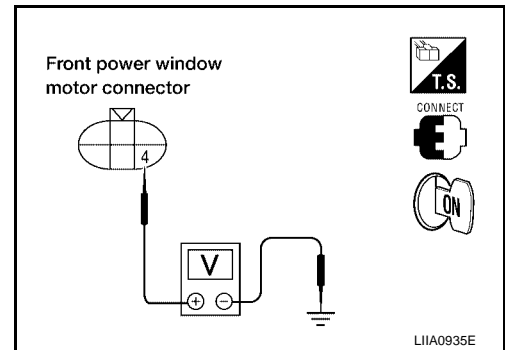

2. CHECK HARNESS CONTINUITY

1. Turn ignition switch OFF.
2. Disconnect front power window motor LH and main power window and door lock/unlock switch.
3. Check continuity between front power window motor LH connector D9 terminal 4 and main power window and door lock/unlock switch connector D7 terminal 15.

4 (BR) – 15 (BR) : Continuity should exist.

OK or NG

- OK >> Replace main power window and door lock/unlock switch.
NG >> Repair or replace harness.

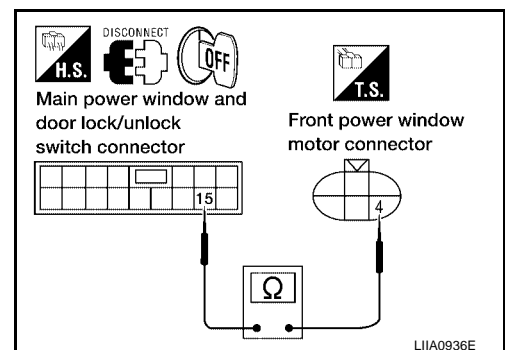

POWER WINDOW SYSTEM

3. CHECK ENCODER GROUND

1. Turn ignition switch OFF.
2. Disconnect front power window motor LH.
3. Check continuity between front power window motor LH connector D9 terminal 6 and ground.

6 (W/B) – Ground : Continuity should exist.

OK or NG

- OK >> GO TO 5.
 NG >> GO TO 4.

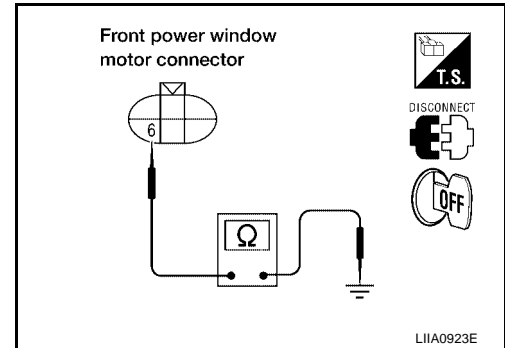

4. CHECK ENCODER GROUND CIRCUIT

1. Disconnect main power window and door lock/unlock switch.
2. Check continuity between front power window motor LH connector D9 terminal 6 and main power window and door lock/unlock switch connector D7 terminal 2.

6 (W/B) – 2 (W/B) : Continuity should exist.

OK or NG

- OK >> Replace main power window and door lock/unlock switch.
 NG >> Repair or replace harness.

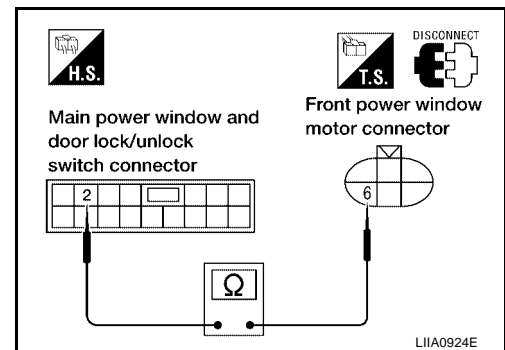

5. CHECK ENCODER SIGNAL

1. Connect front power window motor LH.
2. Turn ignition switch ON.
3. Check the signal between main power window and door lock/unlock switch connector and ground with oscilloscope.

Connector	Terminals (Wire color)		Condition	Signal
	(+)	(-)		
D7	13 (G/Y)	Ground	Opening	<p>OCC3383D</p>

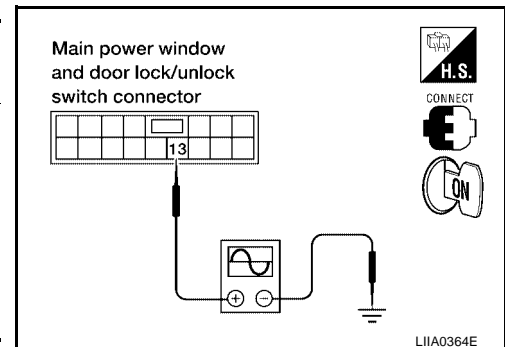

OK or NG

- OK >> Replace main power window and door lock/unlock switch.
 NG >> GO TO 6.

POWER WINDOW SYSTEM

6. CHECK ENCODER CIRCUIT

1. Turn ignition switch OFF.
2. Disconnect front power window motor LH and main power window and door lock/unlock switch.
3. Check continuity between front power window motor LH connector D9 terminal 3 and main power window and door lock/unlock switch connector D7 terminal 13.

3 (G/Y) – 13 (G/Y) : Continuity should exist.

OK or NG

- OK >> Replace front power window motor LH.
NG >> Repair or replace harness.

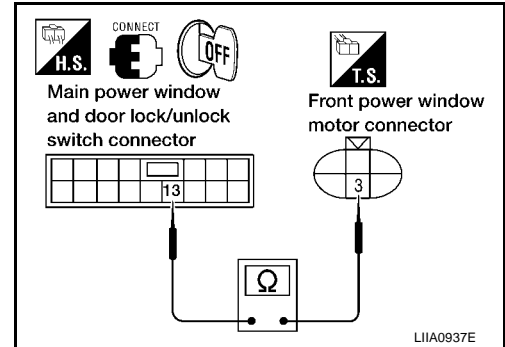

LIIA0937E

EIS0023P

Encoder Circuit Check Front RH

1. CHECK FRONT POWER WINDOW MOTOR RH POWER SUPPLY

1. Turn ignition switch ON.
2. Check voltage between front power window motor RH connector D104 terminal 4 and ground.

4 (G/R) – Ground : Approx. 10V

OK or NG

- OK >> GO TO 3.
NG >> GO TO 2.

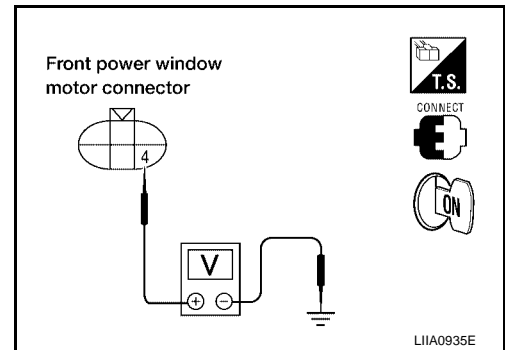

LIIA0935E

2. CHECK HARNESS CONTINUITY

1. Turn ignition switch OFF.
2. Disconnect front power window motor RH and power window and door lock/unlock switch RH.
3. Check continuity between front power window motor RH connector D104 terminal 4 and power window and door lock/unlock switch RH connector D105 terminal 4.

4 (G/R) – 4 (G/R) : Continuity should exist.

OK or NG

- OK >> Replace power window and door lock/unlock switch RH.
NG >> Repair or replace harness.

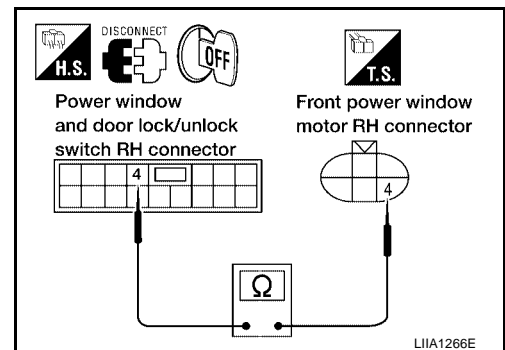

LIIA1266E

POWER WINDOW SYSTEM

3. CHECK ENCODER GROUND

1. Turn ignition switch OFF.
2. Disconnect front power window motor RH.
3. Check continuity between front power window motor RH connector D104 terminal 6 and ground.

6 (W/B) – Ground : Continuity should exist.

OK or NG

- OK >> GO TO 5.
 NG >> GO TO 4.

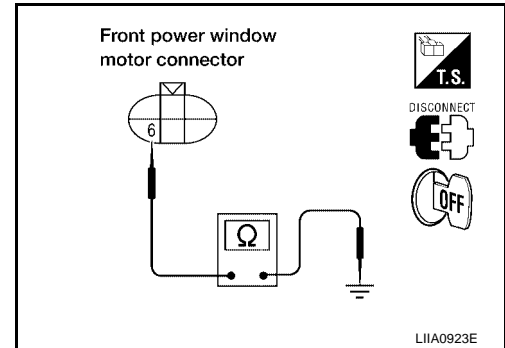

4. CHECK ENCODER GROUND CIRCUIT

1. Disconnect power window and door lock/unlock switch RH.
2. Check continuity between front power window motor RH connector D104 terminal 6 and power window and door lock/unlock switch RH connector D105 terminal 3.

6 (W/B) – 3 (W/B) : Continuity should exist.

OK or NG

- OK >> Replace power window and door lock/unlock switch RH.
 NG >> Repair or replace harness.

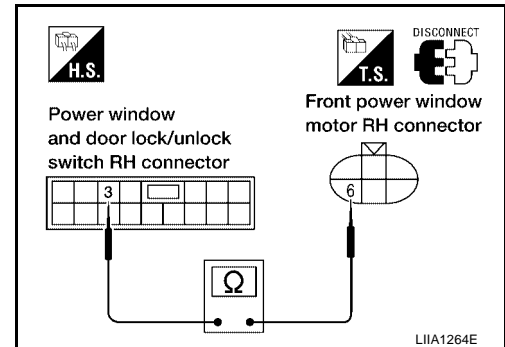

5. CHECK ENCODER SIGNAL

1. Connect front power window motor RH.
2. Turn ignition switch ON.
3. Check the signal between power window and door lock/unlock switch RH connector and ground with oscilloscope.

Connector	Terminals (Wire color)		Condition	Signal
	(+)	(-)		
D105	12 (G/Y)	Ground	Opening	<p>OCC3383D</p>

OK or NG

- OK >> Replace power window and door lock/unlock switch RH.
 NG >> GO TO 6.

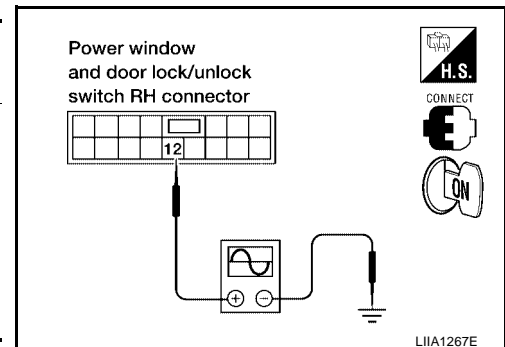

POWER WINDOW SYSTEM

6. CHECK ENCODER CIRCUIT

1. Turn ignition switch OFF.
2. Disconnect front power window motor RH and power window and door lock/unlock switch RH.
3. Check continuity between front power window motor RH connector D104 terminal 3 and power window and door lock/unlock switch RH connector D105 terminal 12.

3 (G/Y) – 12 (G/Y) : Continuity should exist.

OK or NG

- OK >> Replace front power window motor RH.
 NG >> Repair or replace harness.

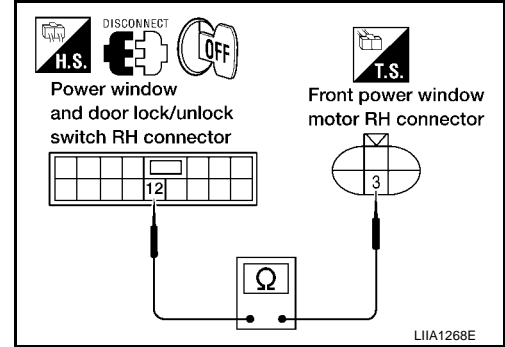

EIS0023Q

Door Switch Check

1. CHECK FRONT DOOR SWITCH INPUT SIGNAL

With CONSULT-II

Check front door switches (“DOOR SW-DR” and “DOOR SW-AS”) in “DATA MONITOR” mode with CONSULT-II.

Monitor item	Condition
DOOR SW-DR	OPEN : ON
	CLOSE : OFF
DOOR SW-AS	OPEN : ON
	CLOSE : OFF

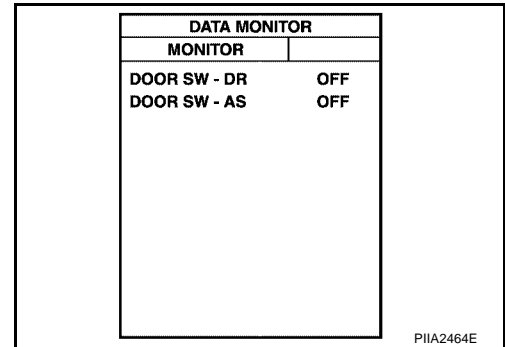

Without CONSULT-II

Check voltage between BCM connector and ground.

Item	Connector	Terminals (Wire color)		Condition	Voltage (V) (Approx.)
		(+)	(-)		
Front RH	M18	12 (R/L)	Ground	OPEN	0
				CLOSE	Battery voltage
Front LH	M19	47 (SB)	Ground	OPEN	0
				CLOSE	Battery voltage

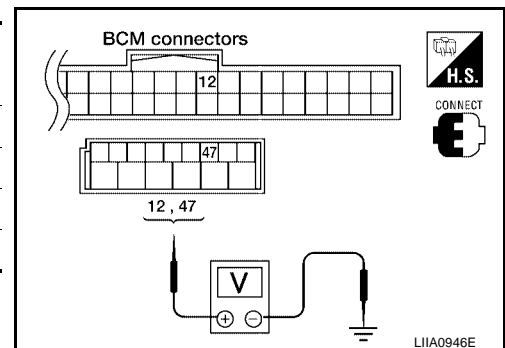

OK or NG

- OK >> Front door switch is OK.
 NG >> GO TO 2.

POWER WINDOW SYSTEM

2. CHECK FRONT DOOR SWITCH CIRCUIT

1. Turn ignition switch OFF.
2. Disconnect front door switch LH or RH and BCM.
3. Check continuity between front door switch connector B8 (LH) or B108 (RH) terminal 2 and BCM connector M19 terminal 47 (LH) or connector M18 terminal 12 (LH).

Front LH

2 (SB) – 47 (SB) : Continuity should exist.

Front RH

2 (R/L) – 12 (R/L) : Continuity should exist.

4. Check continuity between front door switch connector B8 (LH) or B108 (RH) terminal 2 and ground.

2 (SB or R/L) – Ground : Continuity should not exist.

OK or NG

OK >> GO TO 3.

NG >> Repair or replace harness.

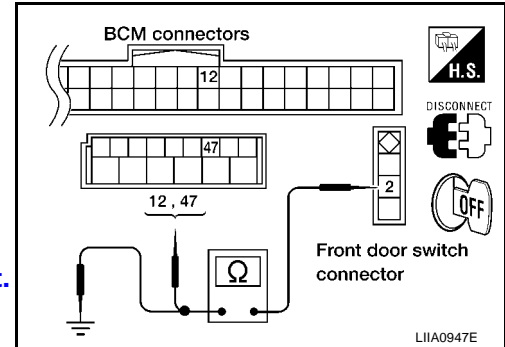

3. CHECK DOOR SWITCH

1. Disconnect front door switch LH or RH.
2. Check continuity between each front door switch terminal 2 and body ground part of front door switch.

Terminal	Door switch	Continuity	
2	Body ground part of front door switch	Pushed	No
	Released	Released	Yes

OK or NG

OK >> Replace BCM.

NG >> Replace malfunctioning front door switch.

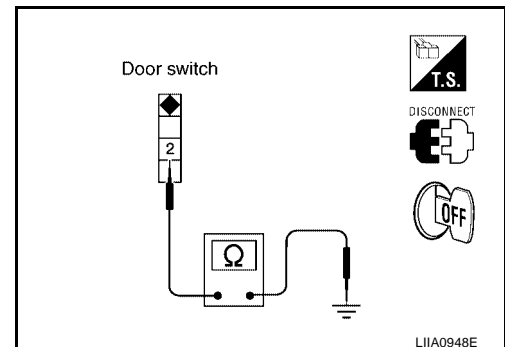

POWER WINDOW SYSTEM

EIS0023S

Front Door Lock Assembly (Key Cylinder Switch) Check

1. CHECK FRONT DOOR LOCK ASSEMBLY LH (KEY CYLINDER SWITCH) INPUT SIGNAL

① With CONSULT-II

- Check front door lock assembly LH (key cylinder switch) ("KEY CYL LK SW") in "DATA MONITOR" mode for "POWER DOOR LOCK SYSTEM" with CONSULT-II. Refer to [GW-34, "DATA MONITOR"](#).

"KEY CYL LK-SW" should be "ON" when key inserted in door key cylinder is turned to lock.

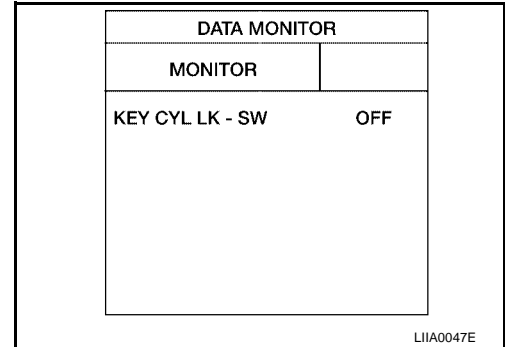

- Check front door lock assembly LH (key cylinder switch) ("KEY CYL UN-SW") in "DATA MONITOR" mode for "POWER DOOR LOCK SYSTEM" with CONSULT-II. Refer to [GW-34, "DATA MONITOR"](#).

"KEY CYL UN-SW" should be "ON" when key inserted in door key cylinder was turned to unlock.

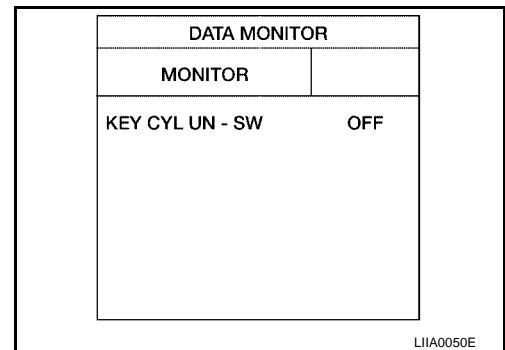

② Without CONSULT-II

Check voltage between main power window and door lock/unlock switch connector and ground.

Connector	Terminals (Wire color)		Key position	Voltage (V) (Approx.)
	(+)	(-)		
D7	6 (R)	Ground	Neutral / Lock	5
			Lock	0
	4 (L)		Neutral / Unlock	5
			Unlock	0

OK or NG

- OK >> Front door lock assembly LH (key cylinder switch) is OK.
- NG >> GO TO 2.

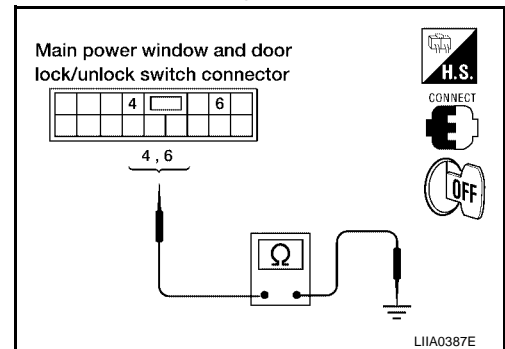

2. CHECK FRONT DOOR LOCK ASSEMBLY LH (KEY CYLINDER SWITCH) CIRCUIT

- Turn ignition switch OFF.
- Disconnect main power window and door lock/unlock switch and front door lock assembly LH (key cylinder switch).
- Check continuity between main power window and door lock/unlock switch connector D7 terminals 4, 6 and front door lock assembly LH (key cylinder switch) connector D14 terminals 1, 6.

6 (R) – 6 (R) : Continuity should exist.

4 (L) – 1 (L) : Continuity should exist.

OK or NG

- OK >> GO TO 3.
- NG >> Repair or replace harness.

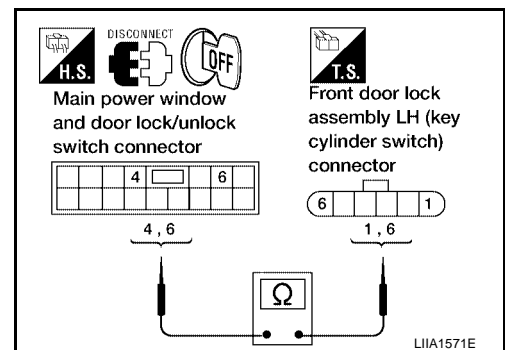

POWER WINDOW SYSTEM

3. CHECK FRONT DOOR LOCK ASSEMBLY LH (KEY CYLINDER SWITCH) GROUND

Check continuity between front door lock assembly LH (key cylinder switch) connector D14 terminal 5 and ground.

5 (B) – Ground : Continuity should exist.

OK or NG

- OK >> GO TO 4.
- NG >> Repair or replace harness.

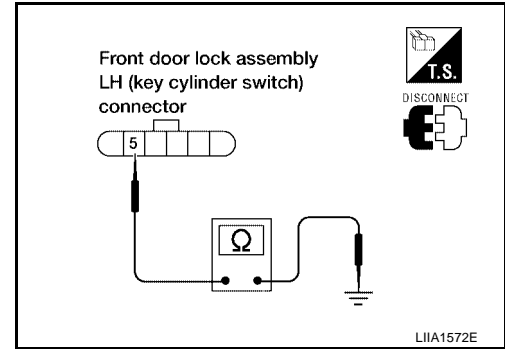

4. CHECK FRONT DOOR LOCK ASSEMBLY LH (KEY CYLINDER SWITCH)

Check continuity between door key cylinder switch LH connector D14 terminal 1, 6 and 5.

Terminals	Key position	Continuity
6	Neutral / Lock	No
	Unlock	Yes
1	Neutral / Unlock	No
	Lock	Yes

OK or NG

- OK >> Replace main power window and door lock/unlock switch.
- NG >> Replace front door lock assembly LH (key cylinder switch).

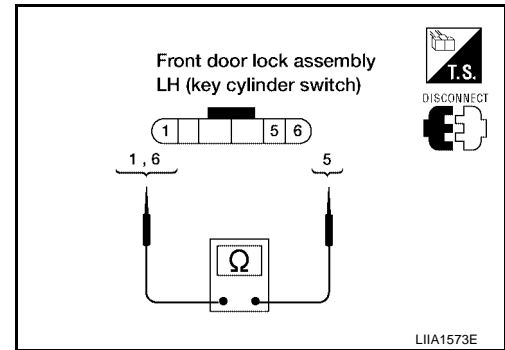

POWER WINDOW SYSTEM

EIS0023U

Power Window Serial Link Check Front LH and RH

1. CHECK SERIAL LINK OUTPUT SIGNAL

With CONSULT-II

Check door lock and unlock switch ("LOCK SW DR/AS", "UNLK SW DR/AS") in DATA MONITOR mode for "REMOTE KEYLESS ENTRY SYSTEM" with CONSULT-II. Refer to [GW-34, "DATA MONITOR"](#).

- When door lock and unlock switch is turned to LOCK
LOCK SW DR/AS : ON
- When door lock and unlock switch is turned to UNLOCK
UNLK SW DR/AS : ON

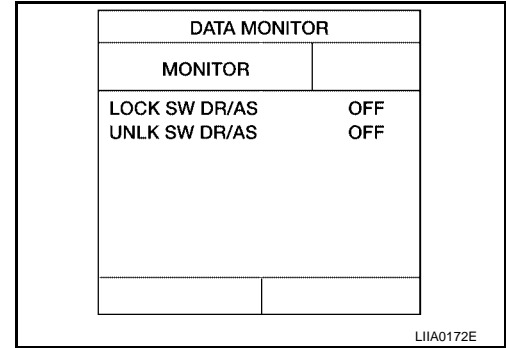

Without CONSULT-II

- Remove key from ignition switch, and the door of driver side and passenger side is closed.
- Check the signal between BCM connector and ground with oscilloscope when door lock and unlock switch (front LH and front RH) is turned "LOCK" or "UNLOCK".
- Make sure signals which are shown in the figure below can be detected during 10 second just after door lock and unlock switch (front LH and front RH) is turned "LOCK" or "UNLOCK".

Connector	Terminals (Wire color)		Signal
	(+)	(-)	
M18	22 (W/V)	Ground	<p>PIIA1297E</p>

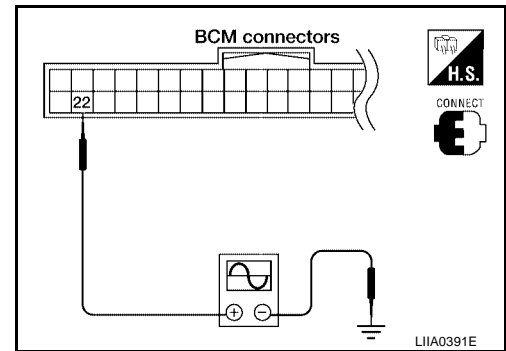

OK or NG

- OK >> GO TO 2.
- NG >> GO TO 3.

POWER WINDOW SYSTEM

2. CHECK BCM OUTPUT SIGNAL

Check power window serial link ("POWER WINDOW DOWN") in "ACTIVE TEST" mode with CONSULT-II. Refer to [GW-34, "ACTIVE TEST"](#).

When "ACTIVE TEST" is executed, is the window of driver side and passenger side lowered.

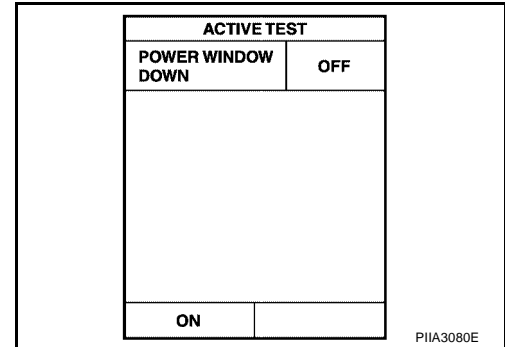

OK or NG

- OK >> Further inspection is necessary. Refer to symptom chart.
- NG >> Replace BCM.

3. CHECK POWER WINDOW SWITCH GROUND

1. Turn ignition switch OFF.
2. Disconnect main power window and door lock/unlock switch and power window and door lock/unlock switch RH.
3. Check continuity between main power window and door lock/unlock switch connector D8 terminal 17 and ground.

17 (B) – Ground : Continuity should exist.

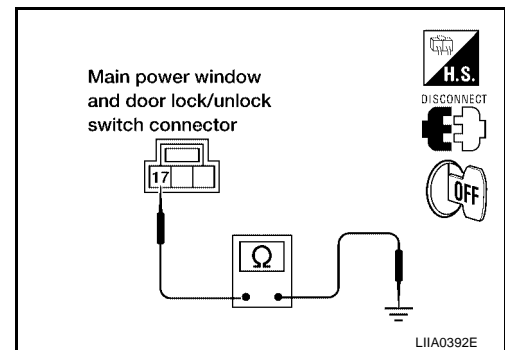

4. Check continuity between power window and door lock/unlock switch RH connector D105 terminal 11 and ground.

11 (B) – Ground : Continuity should exist.

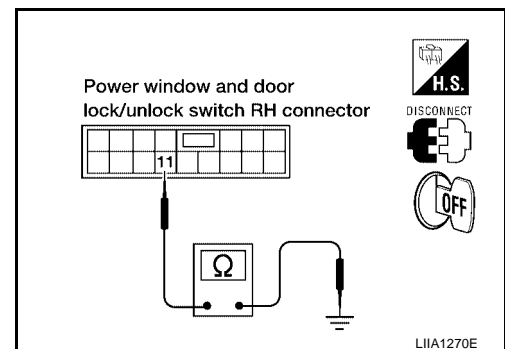

OK or NG

- OK >> GO TO 4.
- NG >> Repair or replace harness.

POWER WINDOW SYSTEM

4. CHECK POWER WINDOW SERIAL LINK CIRCUIT

1. Disconnect BCM.
2. Check continuity between BCM connector M18 terminal 22 and main power window and door lock/unlock switch connector D7 terminal 14.

22 (W/V) – 14 (W/V) : Continuity should exist.

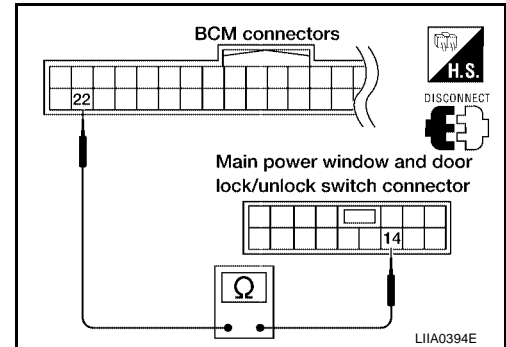

3. Check continuity between BCM connector M18 terminal 22 and power window and door lock/unlock switch RH connector D105 terminal 16.

22 (W/V) – 16 (W/V) : Continuity should exist.

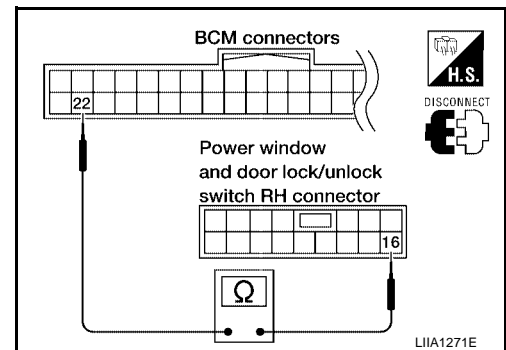

OK or NG

- OK >> Replace main power window and door lock/unlock switch or front power window and door lock/unlock switch RH.
- NG >> Repair or replace harness.

Rear Power Window Motor LH Circuit Check

EIS0027K

1. CHECK REAR POWER WINDOW SWITCH LH OUTPUT SIGNAL

1. Turn ignition switch OFF.
2. Disconnect rear power window motor LH.
3. Turn ignition switch ON.
4. Check voltage between rear power window motor LH connector D204 terminal 1, 2 and ground.

Connector	Terminals (Wire color)		Condition	Voltage (V) (Approx.)
	(+)	(-)		
D204	2 (G)	Ground	UP	Battery voltage
			DOWN	0
	1 (L)		UP	0
			DOWN	Battery voltage

OK or NG

- OK >> Replace rear power window motor LH.
- NG >> GO TO 2

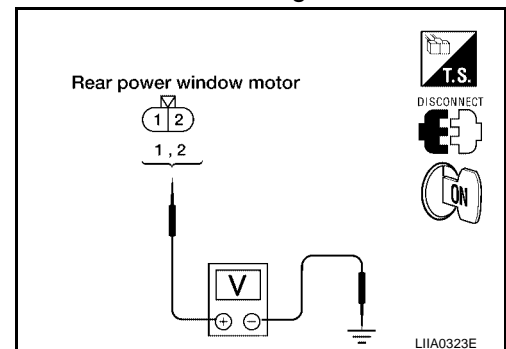

POWER WINDOW SYSTEM

2. CHECK REAR POWER WINDOW MOTOR LH CIRCUIT

1. Turn ignition switch OFF.
2. Disconnect rear power window switch LH.
3. Check continuity between rear power window switch LH connector D203 terminal 4, 5 and rear power window motor LH connector D204 terminal 1, 2.

4 (G) – 2 (G) : Continuity should exist.

5 (L) – 1 (L) : Continuity should exist.

OK or NG

OK >> GO TO 3

NG >> Repair or replace harness.

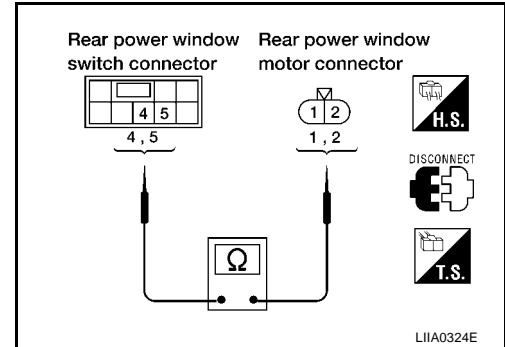

3. CHECK POWER SUPPLY

1. Connect rear power window switch LH.
2. Turn ignition switch ON.
3. Check voltage between rear power window switch LH connector D203 terminal 1 and ground.

1 (W/L) – Ground : Battery voltage

OK or NG

OK >> GO TO 4.

NG >> Repair or replace harness.

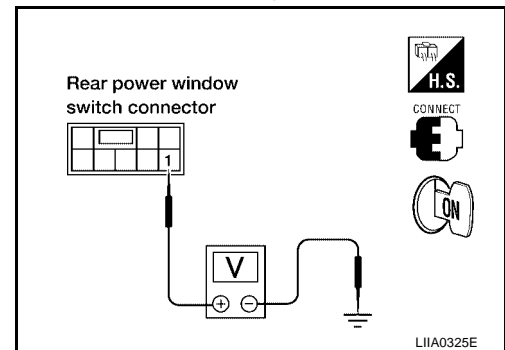

4. CHECK MAIN POWER WINDOW AND DOOR LOCK/UNLOCK SWITCH OUTPUT SIGNAL

1. Turn ignition switch OFF.
2. Confirm that power window lock switch is in unlocked position.
3. Check continuity between main power window and door lock/unlock switch connector D7 terminal 1, 3 and connector D8 terminal 17.

1 (R/Y) – 17 (B) : Continuity should exist.

3 (R/B) – 17 (B) : Continuity should exist.

OK or NG

OK >> Repair or replace harness.

NG >> Replace main power window and door lock/unlock switch.

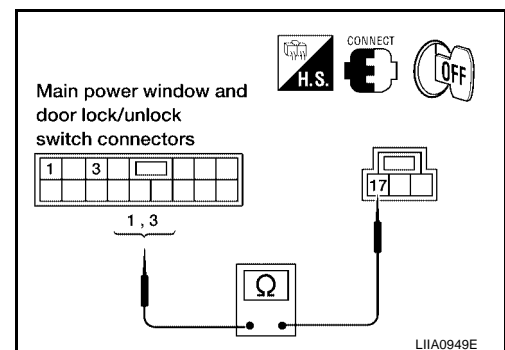

POWER WINDOW SYSTEM

EIS0027L

Rear Power Window Motor RH Circuit Check

1. CHECK REAR POWER WINDOW SWITCH RH OUTPUT SIGNAL

1. Turn ignition switch OFF.
2. Disconnect rear power window motor RH.
3. Turn ignition switch ON.
4. Check voltage between rear power window motor RH connector D304 terminal 1, 2 and ground.

Connector	Terminals (Wire color)		Condition	Voltage (V) (Approx.)
	(+)	(-)		
D304	2 (Y/B)	Ground	UP	Battery voltage
			DOWN	0
	1 (BR)		UP	0
			DOWN	Battery voltage

OK or NG

- OK >> Replace rear power window motor RH.
 NG >> GO TO 2.

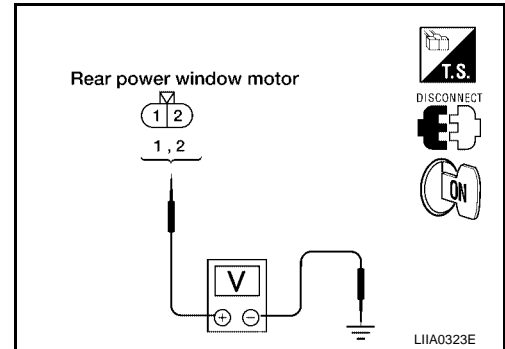

2. CHECK REAR POWER WINDOW MOTOR RH CIRCUIT

1. Turn ignition switch OFF.
2. Disconnect rear power window switch RH.
3. Check continuity between rear power window switch RH connector D303 terminal 4, 5 and rear power window motor RH connector D304 terminal 1, 2.

4 (Y/B) – 2 (Y/B) : Continuity should exist.
5 (BR) – 1 (BR) : Continuity should exist.

OK or NG

- OK >> GO TO 3.
 NG >> Repair or replace harness.

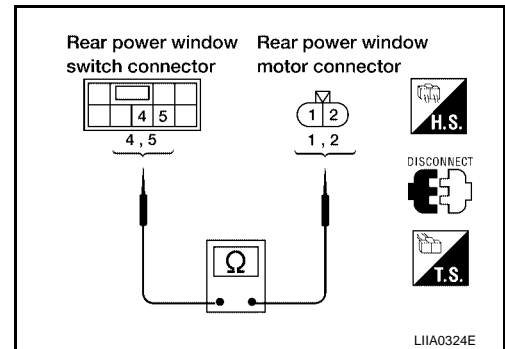

3. CHECK POWER SUPPLY

1. Connect rear power window switch RH.
2. Turn ignition switch ON.
3. Check voltage between rear power window switch RH connector D303 terminal 1 and ground.

1 (W/L) – Ground : Battery voltage

OK or NG

- OK >> GO TO 4.
 NG >> Repair or replace harness.

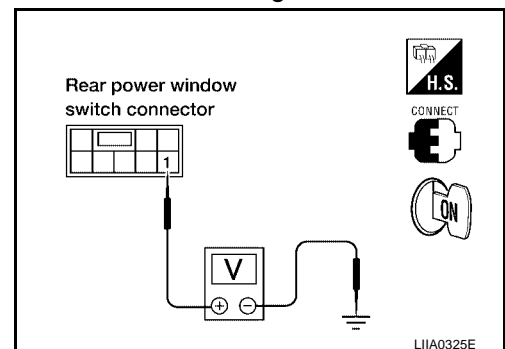

POWER WINDOW SYSTEM

4. CHECK MAIN POWER WINDOW AND DOOR LOCK/UNLOCK SWITCH OUTPUT SIGNAL

1. Confirm that power window lock switch is in unlocked position.
2. Check continuity between main power window and door lock/unlock switch connector D7 terminal 5, 7 and connector D8 terminal 17.

5 (O/L) – 17 (B) : Continuity should exist.
7 (R) – 17 (B) : Continuity should exist.

OK or NG

- OK >> Repair or replace harness.
 NG >> Replace main power window and door lock/unlock switch.

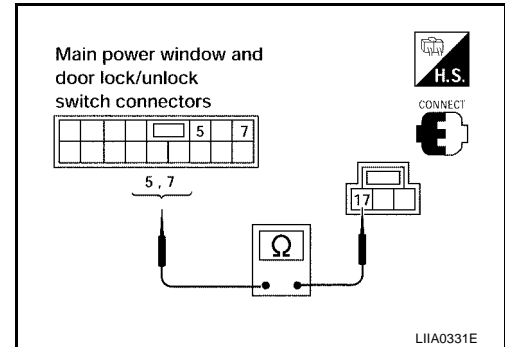

Rear Power Vent Window Switch Circuit Check

EIS002BI

1. CHECK REAR POWER VENT WINDOW SWITCH OPERATION

1. Turn ignition switch OFF.
2. Disconnect rear power vent window switch.
3. Check continuity between rear power vent window switch terminals 1, 3 and 4.

Connector	Terminal		Condition	Continuity
	(+)	(-)		
R103	3	1	Rear power vent window switch is pressed OPEN.	Yes
	4	1	Rear power vent window switch is pressed CLOSE.	Yes

OK or NG

- OK >> GO TO 2.
 NG >> Replace rear power vent window switch.

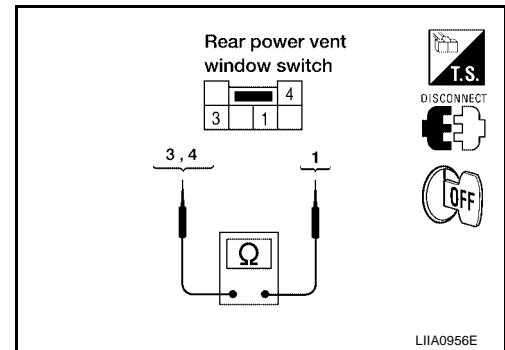

2. CHECK REAR POWER VENT WINDOW SWITCH CIRCUIT HARNESS CONTINUITY

Check continuity between rear power vent window switch connector R103 terminal 1 and ground.

1 (B) – Ground : Continuity should exist.

OK or NG

- OK >> Rear power vent window switch circuit harness OK.
 NG >> Repair or replace harness.

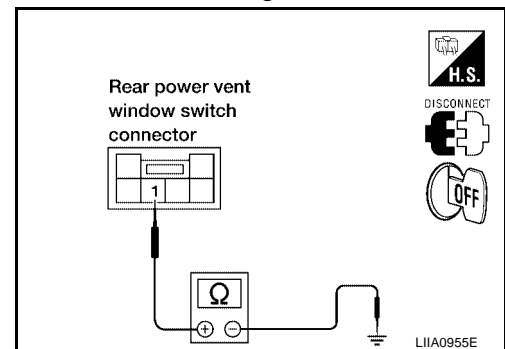

POWER WINDOW SYSTEM

Rear Power Vent Window Motor LH Circuit Check

EIS0023V

1. CHECK REAR POWER VENT WINDOW LH SIGNAL

1. Turn ignition switch OFF.
2. Disconnect rear power vent window motor LH.
3. Turn ignition switch ON.
4. Check voltage between rear power vent window motor LH connector B52 terminal 1, 2 and ground.

Connector	Terminals (Wire color)		Condition	Voltage (V) (Approx.)
	(+)	(-)		
B52	1 (G)	Ground	Opening	Battery voltage
			Closing	0
	2 (Y)		Opening	0
			Closing	Battery voltage

OK or NG

- OK >> Replace rear power vent window motor LH.
 NG >> Repair or replace harness.

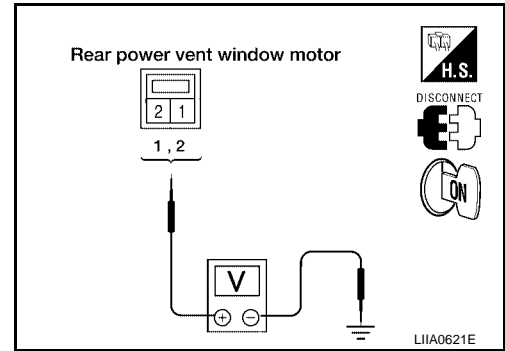

Rear Power Vent Window Motor RH Circuit Check

EIS0023W

1. CHECK REAR POWER VENT WINDOW SWITCH RH SIGNAL

1. Turn ignition switch OFF.
2. Disconnect rear power vent window motor RH.
3. Turn ignition switch ON.
4. Check voltage between rear power vent window motor LH connector B150 terminal 1, 2 and ground.

Connector	Terminals (Wire color)		Condition	Voltage (V) (Approx.)
	(+)	(-)		
B150	1 (BR)	Ground	Opening	Battery voltage
			Closing	0
	2 (R)		Opening	0
			Closing	Battery voltage

OK or NG

- OK >> Replace rear power vent window motor RH.
 NG >> Repair or replace harness.

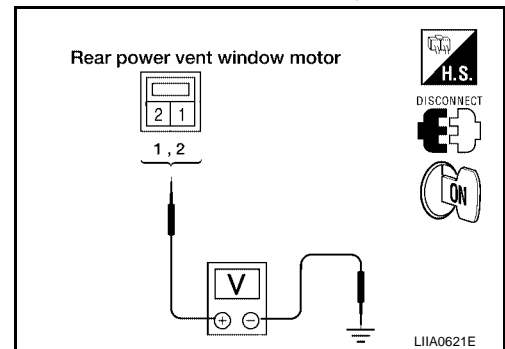

Rear Power Vent Window Relay (OPEN) Check

EIS002BJ

1. CHECK REAR POWER VENT WINDOW RELAY (OPEN) POWER SUPPLY CIRCUIT

1. Turn ignition switch OFF.
2. Disconnect rear power vent window relay (OPEN).
3. Turn ignition switch ON.
4. Check voltage between rear power vent window relay (OPEN) connector and ground.

Connector	Terminals (Wire color)		Voltage (V) (Approx.)
	(+)	(-)	
M87	1 (W/L)	Ground	Battery voltage
	5 (W/R)		

OK or NG

- OK >> GO TO 2.
 NG >> Repair or replace harness.

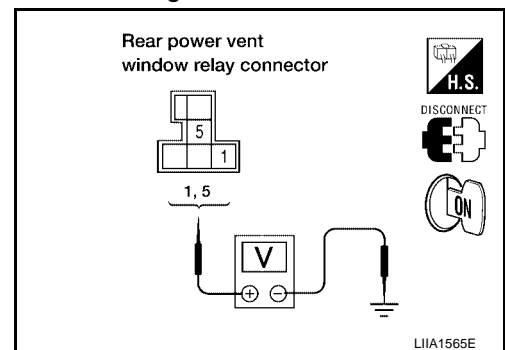

POWER WINDOW SYSTEM

2. CHECK REAR POWER VENT WINDOW RELAY (OPEN)

Check continuity between rear power vent window relay (OPEN) terminals 3 and 4, 3 and 5.

Terminal	Condition	Continuity	
3	4	12V direct current supply between terminals 1 and 2	No
		No current supply	Yes
3	5	12V direct current supply between terminals 1 and 2	Yes
		No current supply	No

OK or NG

OK >> GO TO 3.

NG >> Replace rear power vent window relay (OPEN).

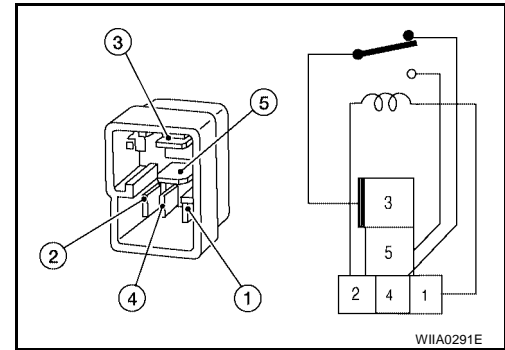

3. CHECK REAR POWER VENT WINDOW RELAY (OPEN) GROUND CIRCUIT

Check continuity between rear power vent window relay (OPEN) connector M87 terminal 4 and ground.

4 (B) – Ground : Continuity should exist.

OK or NG

OK >> GO TO 4.

NG >> Repair or replace harness.

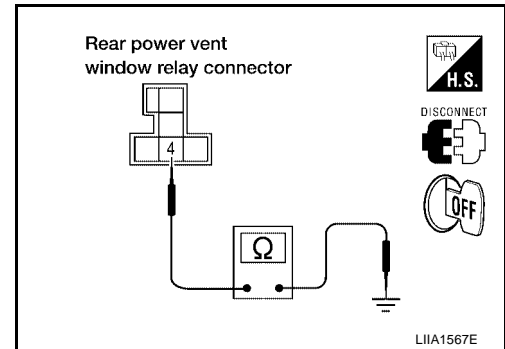

4. CHECK REAR POWER VENT WINDOW RELAY (OPEN) CIRCUIT

1. Disconnect rear power vent window switch.
2. Check voltage between rear power vent window relay (OPEN) connector M87 terminal 2 and rear power vent window switch connector R103 terminal 3.

2 (G/R) – 3 (BR/W) : Continuity should exist.

OK or NG

OK >> Replace rear power vent window switch.

NG >> Repair or replace harness.

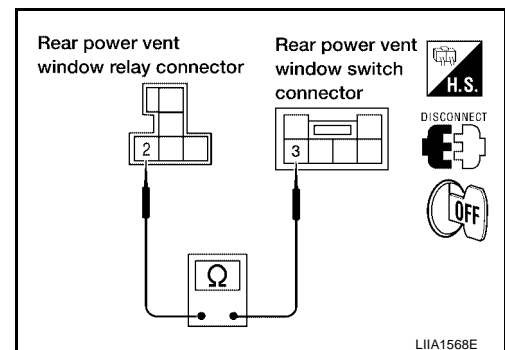

POWER WINDOW SYSTEM

EIS002BL

Rear Power Vent Window Relay (CLOSE) Check

1. CHECK REAR POWER VENT WINDOW RELAY (CLOSE) POWER SUPPLY CIRCUIT

1. Turn ignition switch OFF.
2. Disconnect rear power vent window relay (CLOSE).
3. Turn ignition switch ON.
4. Check voltage between rear power vent window relay (CLOSE) connector and ground.

Connector	Terminals (Wire color)		Voltage (V) (Approx.)
	(+)	(-)	
M89	1 (W/L)	Ground	Battery voltage
	5 (W/R)		

OK or NG

- OK >> GO TO 2.
 NG >> Repair or replace harness.

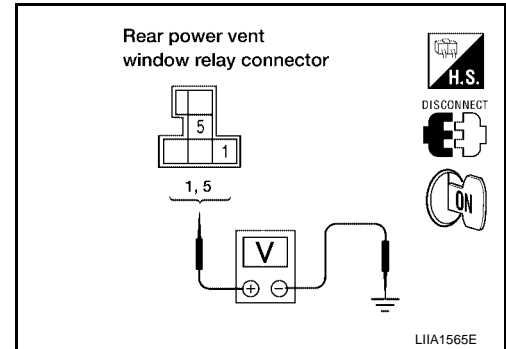

2. CHECK REAR POWER VENT WINDOW RELAY (CLOSE)

Check continuity between rear power vent window relay (CLOSE) terminals 3 and 4, 3 and 5.

Terminal	Condition	Continuity
3	12V direct current supply between terminals 1 and 2	No
	No current supply	Yes
3	12V direct current supply between terminals 1 and 2	Yes
	No current supply	No

OK or NG

- OK >> GO TO 3.
 NG >> Replace rear power vent window relay (CLOSE).

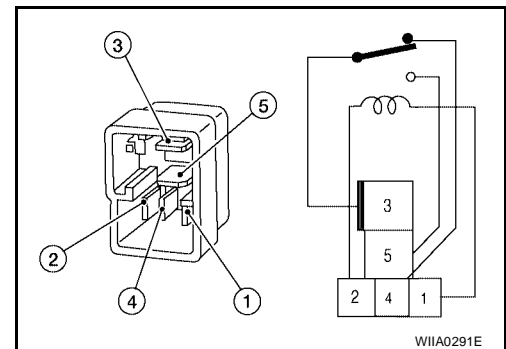

3. CHECK REAR POWER VENT WINDOW RELAY (CLOSE) GROUND CIRCUIT

Check continuity between rear power vent window relay (CLOSE) connector M89 terminal 4 and ground.

4 (B) – Ground : Continuity should exist.

OK or NG

- OK >> GO TO 4.
 NG >> Repair or replace harness.

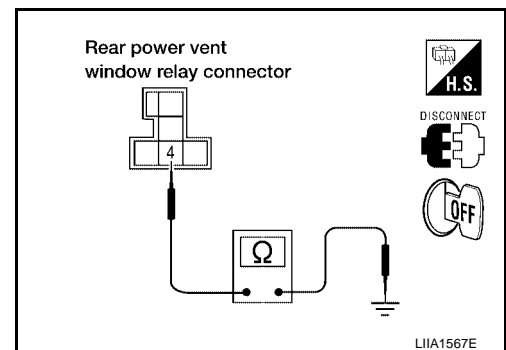

POWER WINDOW SYSTEM

4. CHECK REAR POWER VENT WINDOW RELAY (CLOSE) CIRCUIT

1. Disconnect rear power vent window switch.
2. Check voltage between rear power vent window relay (CLOSE) connector M89 terminal 2 and rear power vent window switch R103 terminal 4.

2 (R/G) – 4 (V/W) : Continuity should exist.

OK or NG

- OK >> Replace rear power vent window switch.
- NG >> Repair or replace harness.

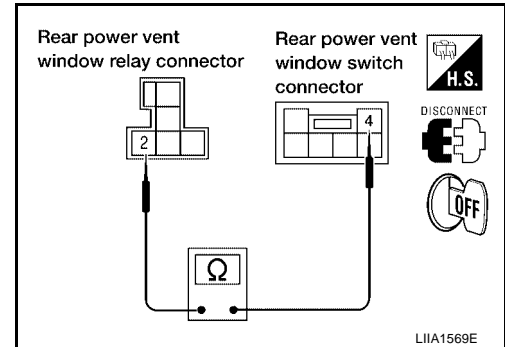

FRONT DOOR GLASS AND REGULATOR

FRONT DOOR GLASS AND REGULATOR

PF0:80300

Removal and Installation

EIS00625

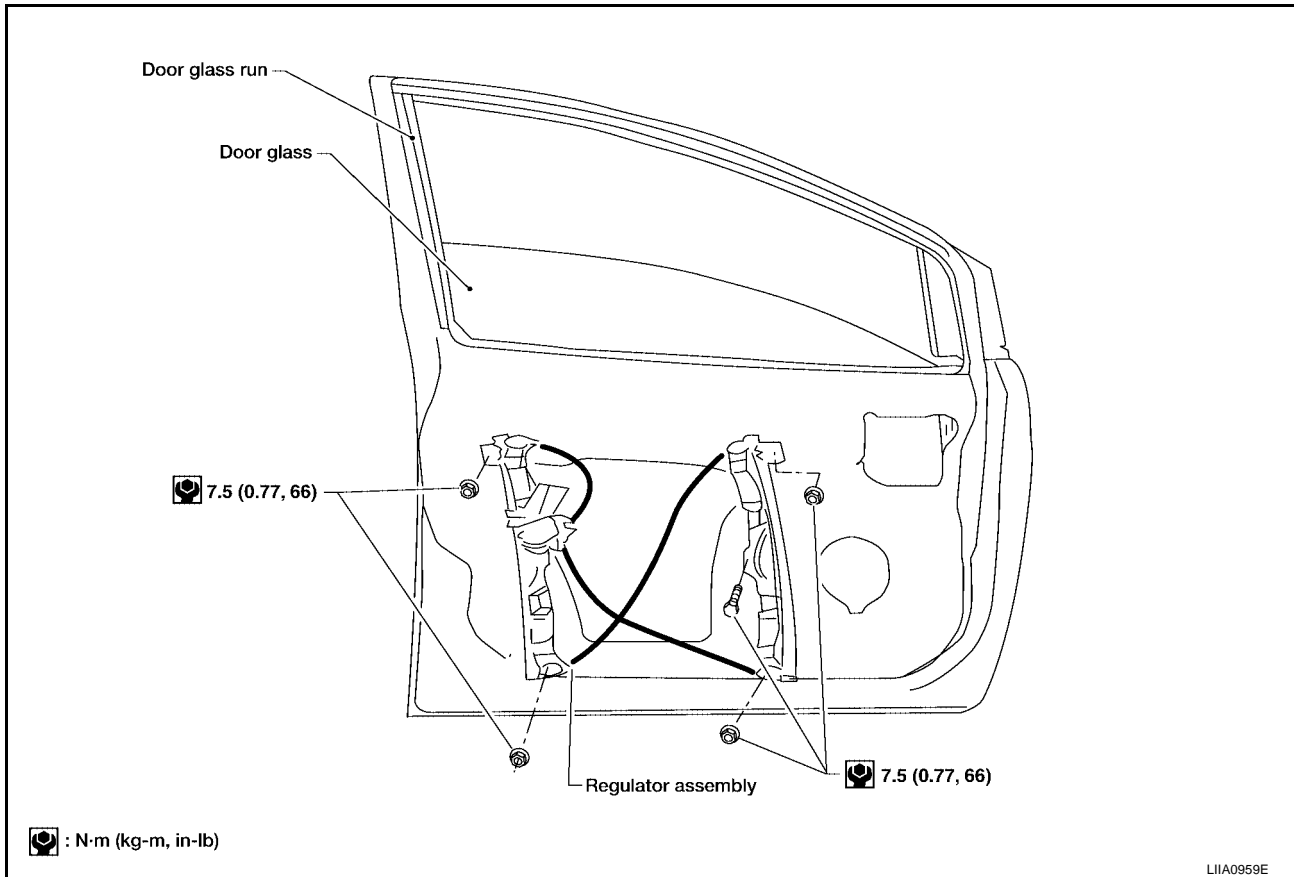

FRONT DOOR GLASS

Removal

1. Remove the front door speaker. Refer to [AV-62, "Removal and Installation of Front Door Speaker"](#).
2. Remove the hole cover over rear glass bolt.
3. Operate the power window main switch to raise/lower the door window until the glass bolts can be seen.
4. Remove the inside seal.
5. Remove the glass bolts.
6. While holding the front door glass, raise it at the rear end and pull the glass out of the sash toward the outside of the door.

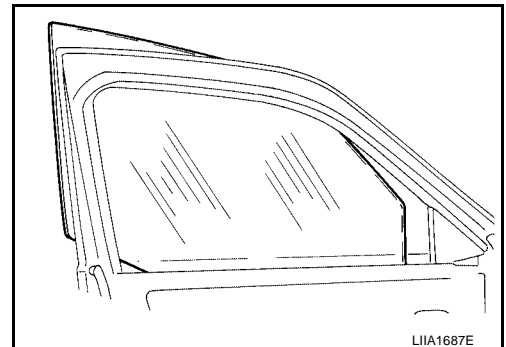

Installation

Installation is in the reverse order of removal.

Glass bolts : 6.1 N·m (0.62 kg-m, 54 in-lb)

A
B
C
D
E
F
G
H
GW
J
K
L
M

FRONT DOOR GLASS AND REGULATOR

Fitting Inspection

- Check that the glass is securely fit into the glass run groove.
- Lower the glass slightly [approximately 10 to 20 mm (0.39 to 0.79 in)] and check that the clearance to the sash is parallel. If the clearance between the glass and sash is not parallel, loosen the regulator bolts, guide rail bolts, and glass and guide rail bolts to correct the glass position.

FRONT DOOR GLASS REGULATOR

Removal

1. Remove the front door speaker. Refer to [AV-62, "Removal and Installation of Front Door Speaker"](#) .
2. Remove the hole cover over rear glass bolt.
3. Operate the power window main switch to raise/lower the door window until the glass bolts can be seen.
4. Remove the inside seal.
5. Remove the glass bolts.
6. Raise the front door glass and hold it in place with suitable tool.
7. Disconnect the harness connector from the regulator assembly.
8. Remove the bolts and the regulator assembly.

Disassembly And Assembly

Remove the regulator motor from the regulator assembly.

Inspection After Removal

Check the regulator assembly for the following items. If a malfunction is detected, replace or grease it.

- Wire wear
- Regulator deformation
- Grease condition for each sliding part

The arrows in the figure show the application points of the body grease.

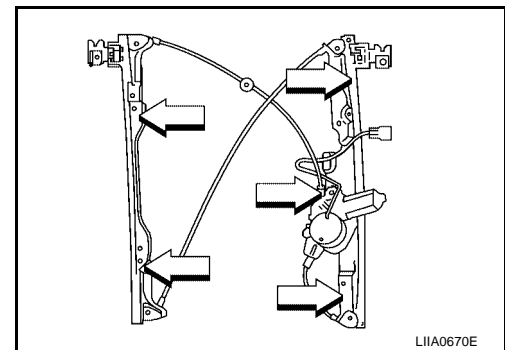

Installation

1. Install the regulator assembly. Refer to [GW-64, "FRONT DOOR GLASS REGULATOR"](#) .
2. Connect the harness connector to the regulator assembly.
3. Align the glass and install the glass bolts.

Glass bolts : 6.1 N-m (0.62 kg-m, 54 in-lb)

4. Reset the limit switch. Refer to [GW-64, "Setting of Limit Switch"](#) .
5. Install front door speaker. Refer to [AV-62, "Removal and Installation of Front Door Speaker"](#) .

SETTING AFTER INSTALLATION

Setting of Limit Switch

If any of the following work has been done, set the limit switch (integrated in the motor).

- Removal and installation of the regulator.
- Removal and installation of the motor from the regulator.
- Removal and installation of the glass.
- Removal and installation of the glass run.

Resetting

After installing each component, perform the following procedure to reset the limit switch.

FRONT DOOR GLASS AND REGULATOR

1. Raise the glass to the top position.
2. While pressing and holding the reset switch, lower the glass to the bottom position.
3. Release the reset switch. Verify that the reset switch returns to the original position, if not, pull the switch using suitable tool.
4. Raise the glass to the top position.

CAUTION:

Do not operate the glass automatically to raise the glass to the top position.

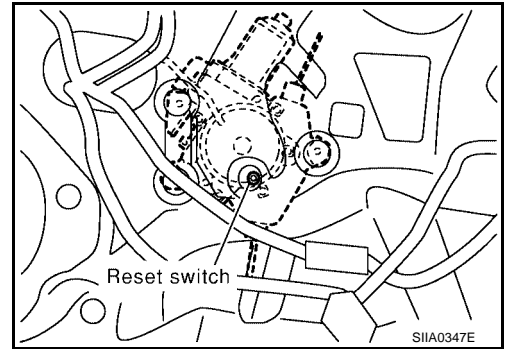

A

B

C

D

E

F

G

H

GW

J

K

L

M

REAR DOOR GLASS AND REGULATOR

REAR DOOR GLASS AND REGULATOR

PFP:82300

Removal and Installation

EIS0062P

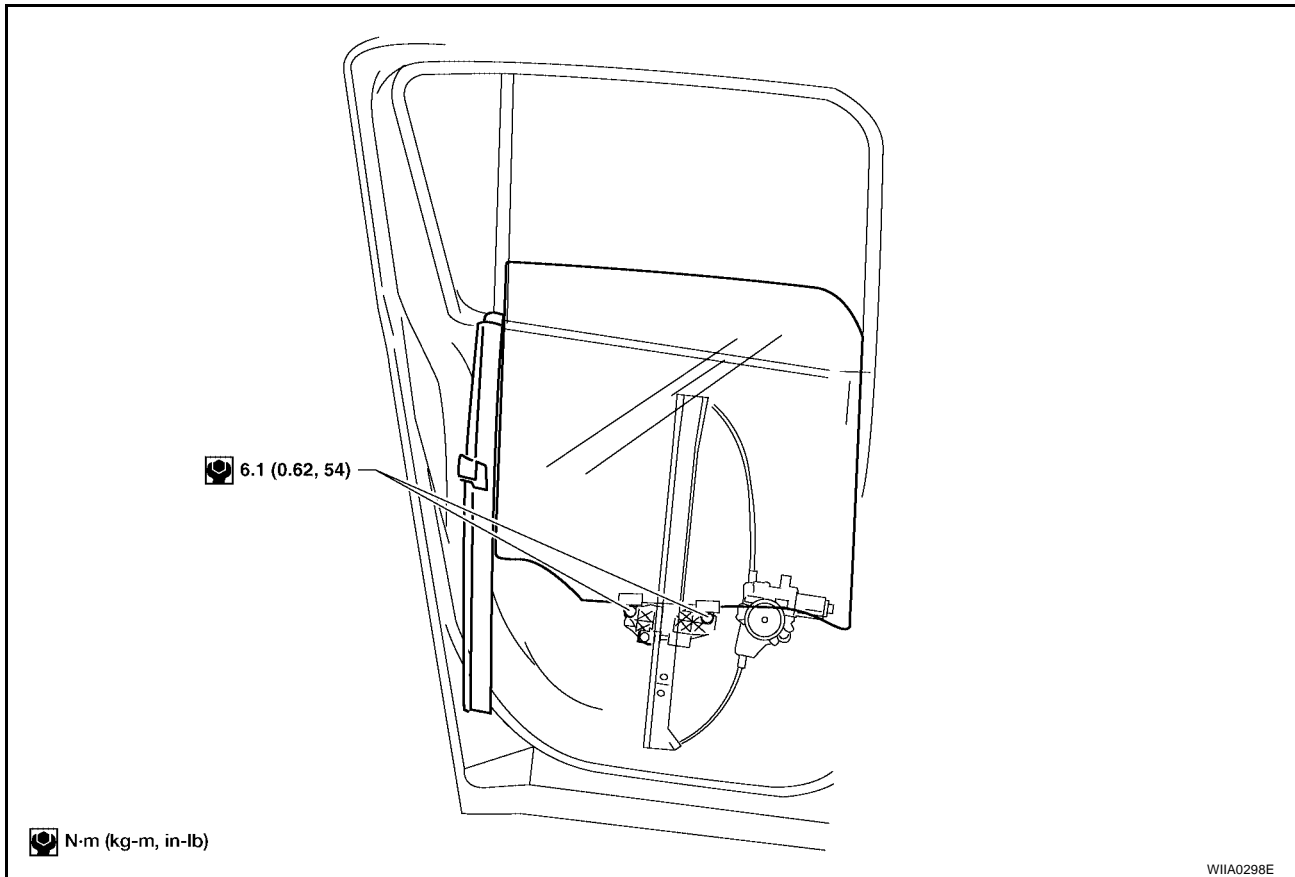

WIIA0298E

REAR DOOR GLASS

Removal

1. Remove the rear door finisher. Refer to [EI-27, "DOOR FINISHER"](#).
2. Operate the power window switch to raise/lower the door window until the glass bolts can be seen.
3. Remove the inside seal.
4. Remove the glass run from the partition glass.
5. Remove the partition sash bolt (lower) and screw (upper) to remove the sash.
6. Remove the glass bolts and glass.

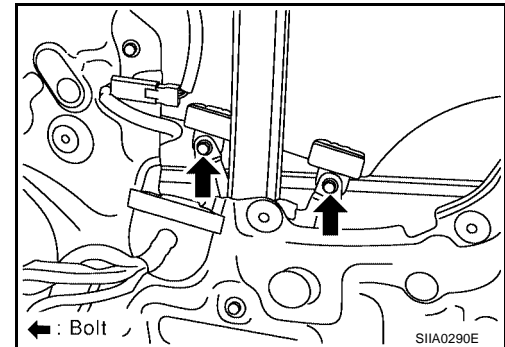

SIIA0290E

Installation

Installation is in the reverse order of removal.

Glass bolts : 6.1 N·m (0.62 Kg·m, 54 in·lb)

Fitting Inspection

- Check that the glass is securely fit into the glass run groove.
- Lower the glass slightly [approximately 10 to 20 mm (0.39 to 0.79 in)], and check that the clearance to the sash is parallel. If the clearance between the glass and sash is not parallel, loosen the regulator bolts, guide rail bolts, and glass and carrier plate bolts to correct the glass position.

REAR DOOR GLASS AND REGULATOR

REAR DOOR GLASS REGULATOR

Removal

1. Remove the rear door finisher. Refer to [EI-27, "DOOR FINISHER"](#).
2. Operate the power window switch to raise/lower the door window until the glass bolts can be seen.
3. Remove the inside seal.
4. Remove the glass bolts.
5. Raise the glass and hold in place with suitable tool.

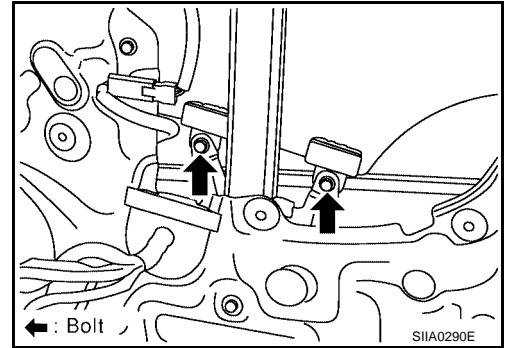

6. Remove the bolts, and the regulator and guide channel.
7. Disconnect the connector from the regulator assembly.

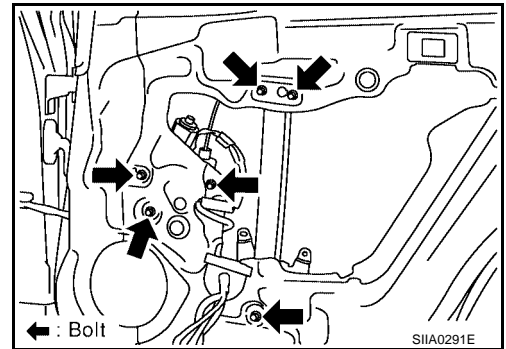

Inspection after removal

Check the regulator assembly for the following items. If a malfunction is detected, replace or grease it.

- Gear wear
- Regulator deformation
- Spring damage
- Grease condition for each sliding part

Installation

1. Connect the harness connector to the regulator assembly and install the regulator and guide channel.

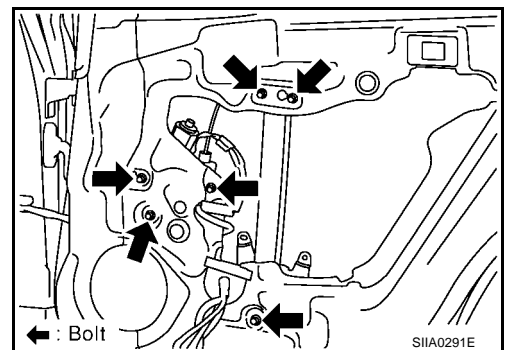

A
B
C
D
E
F
G
H
J
K
L
M

GW

REAR DOOR GLASS AND REGULATOR

2. Install the glass from outside to ensure that it is in both the front and rear glass channels. Tighten glass bolts to the specified torque.

Glass bolts : 6.1 N·m (0.62 kg·m, 54 in-lb)

3. Install the inside seal.
4. Install the rear door finisher. Refer to [EI-27, "DOOR FINISHER"](#)

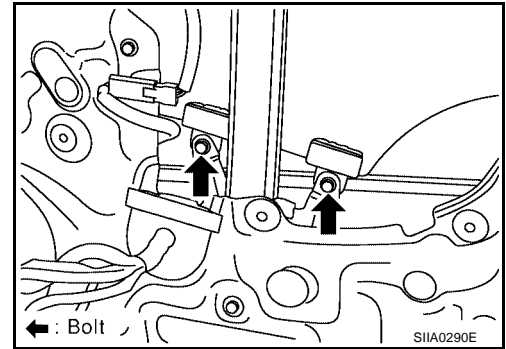

SIDE WINDOW GLASS

PFP:83300

SIDE WINDOW GLASS

Removal and Installation (without Rear Power Vent Windows)

EIS0023Z

SEC. 833

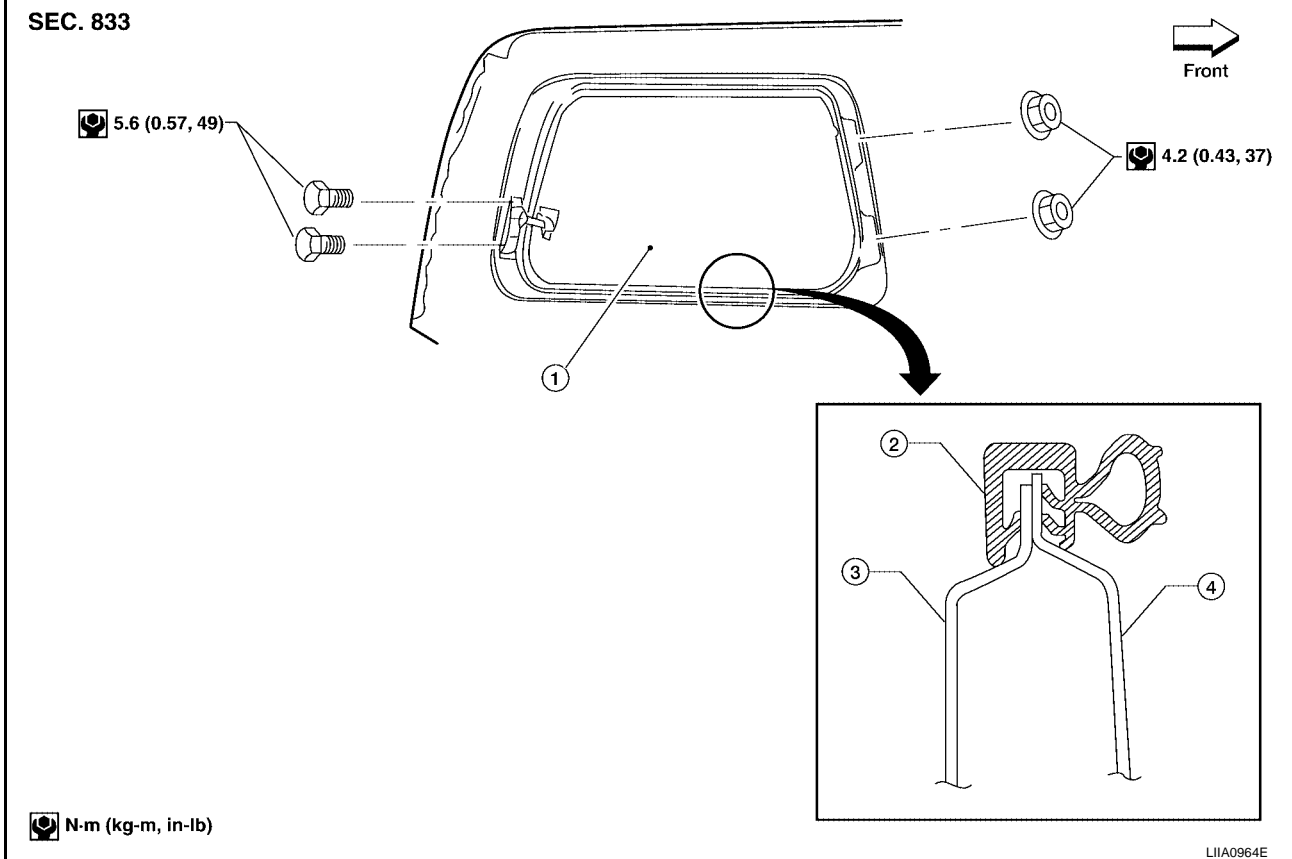

1. Rear side window glass
2. Weatherstrip
3. Inner panel
4. Outer panel

REMOVAL

1. Remove the luggage side upper finisher. Refer to [EI-35, "LUGGAGE FLOOR TRIM"](#).
2. Remove the rear side window latch bolts.
3. Remove the rear side window nuts.

INSTALLATION

Installation should be performed in the reverse procedure of removal.

- Install the glass from outside to insure that it is even with the top and bottom of the opening.

A
B
C
D
E
F
G
H
J
K
L
M

GW

SIDE WINDOW GLASS

Removal and Installation (with Rear Power Vent Windows)

EIS00240

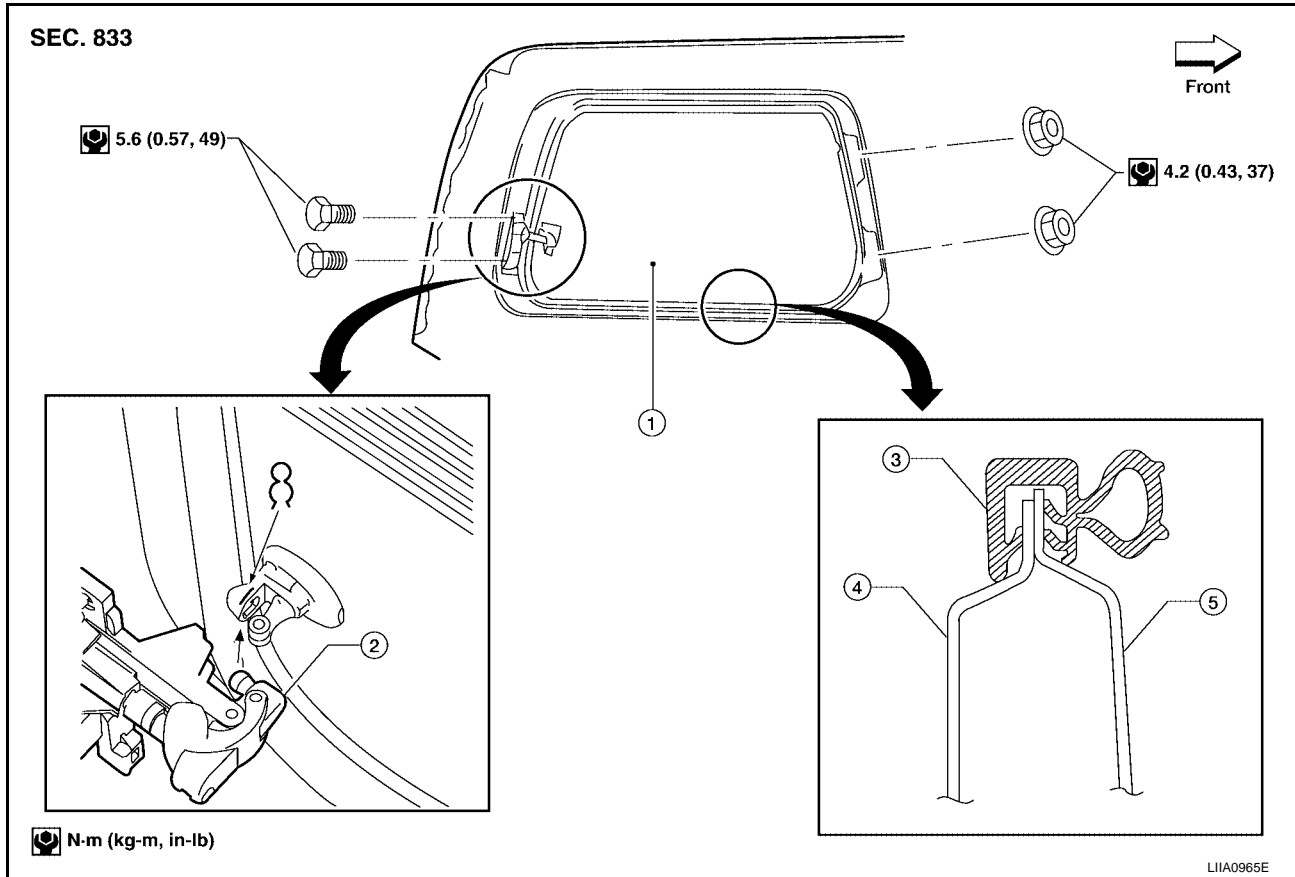

1. Rear side window glass
2. Rear side window motor
3. Weatherstrip
4. Inner Panel
5. Outer panel

REMOVAL

1. Remove the luggage side upper finisher. Refer to [EI-35, "LUGGAGE FLOOR TRIM"](#).
2. Disconnect the rear side window motor harness.
3. Remove the rear side window motor bolts.
4. Remove the rear side window nuts.

INSTALLATION

Installation should be performed in the reverse procedure of removal.

- Install the glass from outside to insure that it is even with the top and bottom of the opening.

INSIDE MIRROR

PF9:96321

INSIDE MIRROR

Wiring Diagram -I/MIRR-

EIS00241

GW-I/MIRR-01

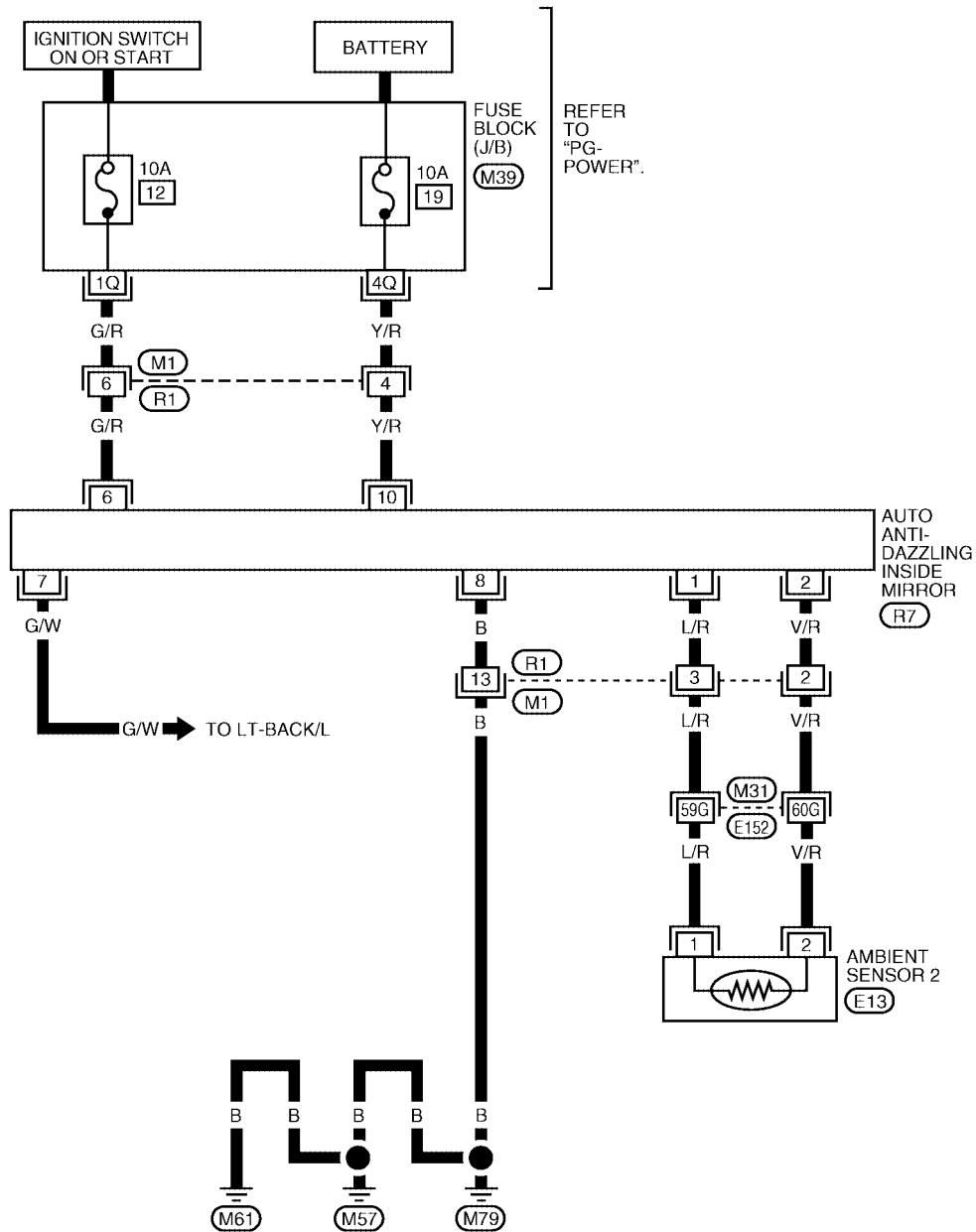

A
B
C
D
E
F
G
H
GW
J
K
L
M

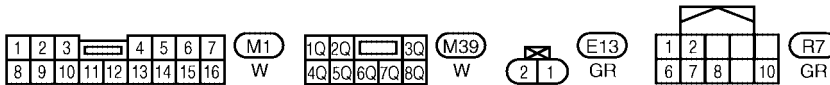

REFER TO THE FOLLOWING.

(M31) - SUPER MULTIPLE JUNCTION (SMJ)

W1WA0211E

INSIDE MIRROR

EIS00242

Removal and Installation INSIDE MIRROR

1. Remove the inside mirror finisher.
2. Slide the mirror upward to remove.
3. Disconnect the connector.

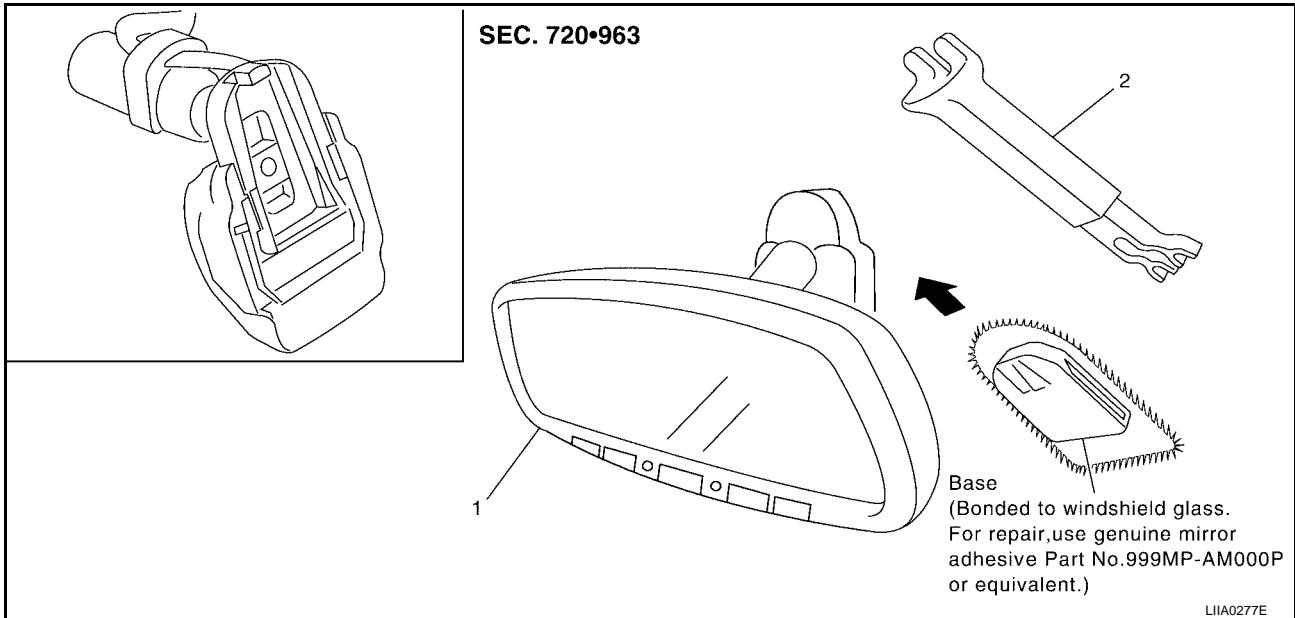

1. Inside mirror

2. Inside mirror finisher

REAR WINDOW DEFOGGER

PFP:25350

EIS00243

REAR WINDOW DEFOGGER

Component Parts and Harness Connector Location

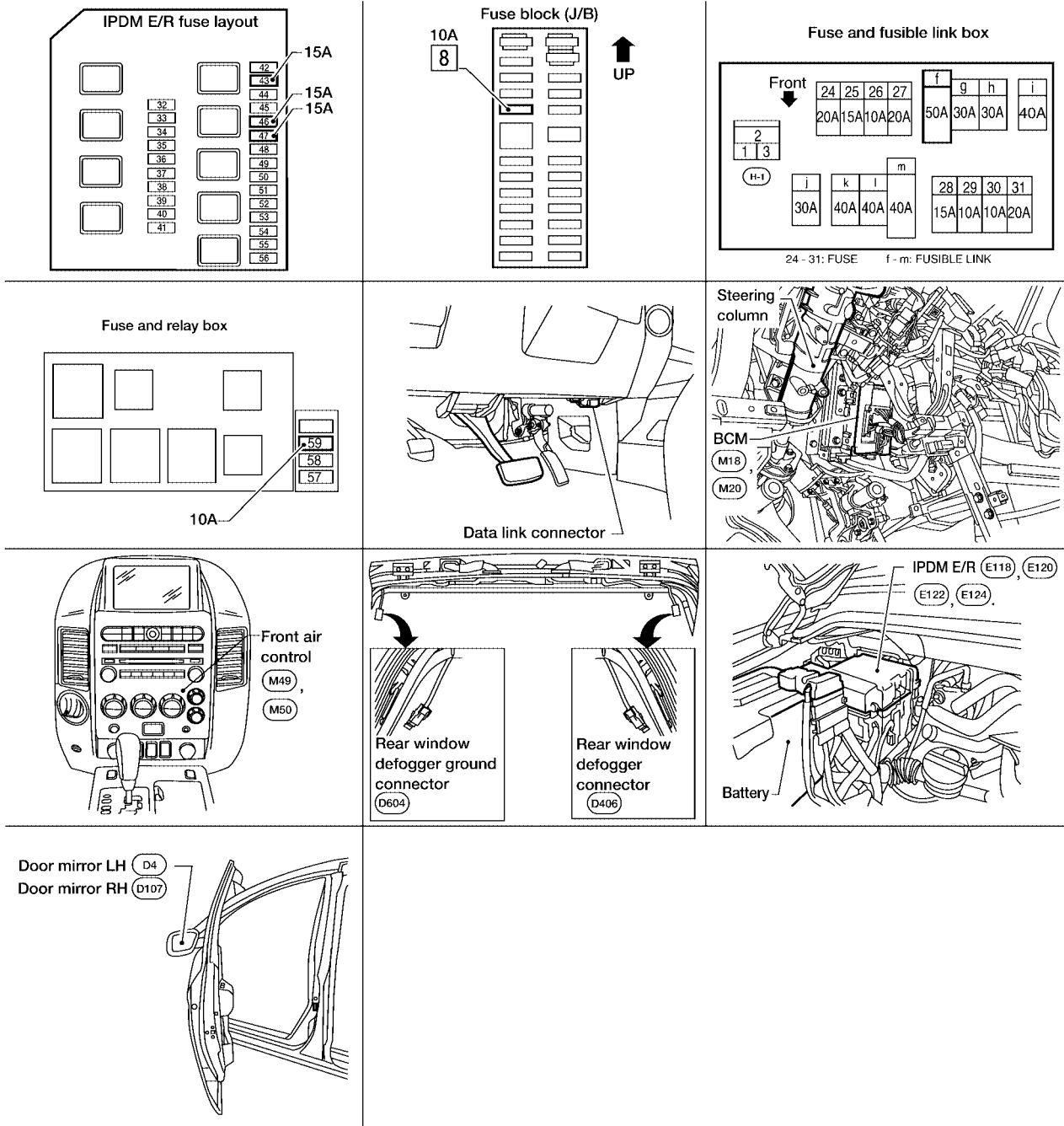

LIA1983E

System Description

EIS00244

The rear window defogger system is controlled by BCM (body control module) and IPDM E/R (intelligent power distribution module engine room).

The rear window defogger operates only for approximately 15 minutes.

Power is supplied at all times

- through 15A fuse (No. 46, and 47, located in the IPDM E/R)
- to rear window defogger relay (located in the IPDM E/R)
- through 50A fusible link [letter f, located in the fuse block (J/B)]
- to BCM terminal 70
- through 15A fuse [No. 43 (with heated mirrors), located in the IPDM E/R]

A
B
C
D
E
F
G
H
J
K
L
M

GW

REAR WINDOW DEFOGGER

- to heated mirror relay (located in the IPDM E/R).

With the ignition switch turned to ON or START position,
Power is supplied

- through ignition switch
- to rear window defogger relay (located in the IPDM E/R)
- through 10A fuse (No. 59, located in the fuse and relay box)
- to BCM terminal 38
- through 10A fuse [No. 8, located in the fuse block (J/B)]
- to front air control terminal 14.

Ground is supplied

- to BCM terminal 67
- to front air control terminal 1
- through body grounds M57, M61 and M79
- to IPDM E/R terminals 38 and 60
- through body grounds E15 and E24.

When front air control (rear window defogger switch) is turned to ON,
Ground is supplied

- to BCM terminal 9
- through front air control terminal 11
- through front air control terminal 1
- through body grounds M57, M61 and M79.

Then rear window defogger switch is illuminated.

Then BCM recognizes that rear window defogger switch is turned to ON.

Then it sends rear window defogger switch signals to IPDM E/R and display control unit (with navigation) or display unit (without navigation) via DATA LINE (CAN H, CAN L).

When display control unit (with navigation) or display unit (without navigation) receives rear window defogger switch signals, and display on the screen.

When IPDM E/R receives rear window defogger switch signals,
Ground is supplied

- to rear window defogger relay (located in the IPDM E/R)
- through IPDM E/R terminal 38
- through IPDM E/R terminal 59
- through body grounds E15 and E24

and then rear window defogger relay is energized.

With power and ground supplied, rear window defogger filaments heat and defog the rear window.

When rear window defogger relay is turned to ON, (with door mirror defogger)

Power is supplied

- through heated mirror relay (located in the IPDM E/R)
- through IPDM E/R terminal 23
- to door mirror defogger (LH and RH) terminal 10.

Door mirror defogger (LH and RH) is grounded through body grounds M57, M61 and M79.

With power and ground supplied, rear window defogger filaments heat and defog the rear window and door mirror defogger filaments heat and defog the mirror.

CAN Communication System Description

EIS00245

Refer to [LAN-5, "CAN COMMUNICATION"](#)

REAR WINDOW DEFOGGER

Schematic

EIS00246

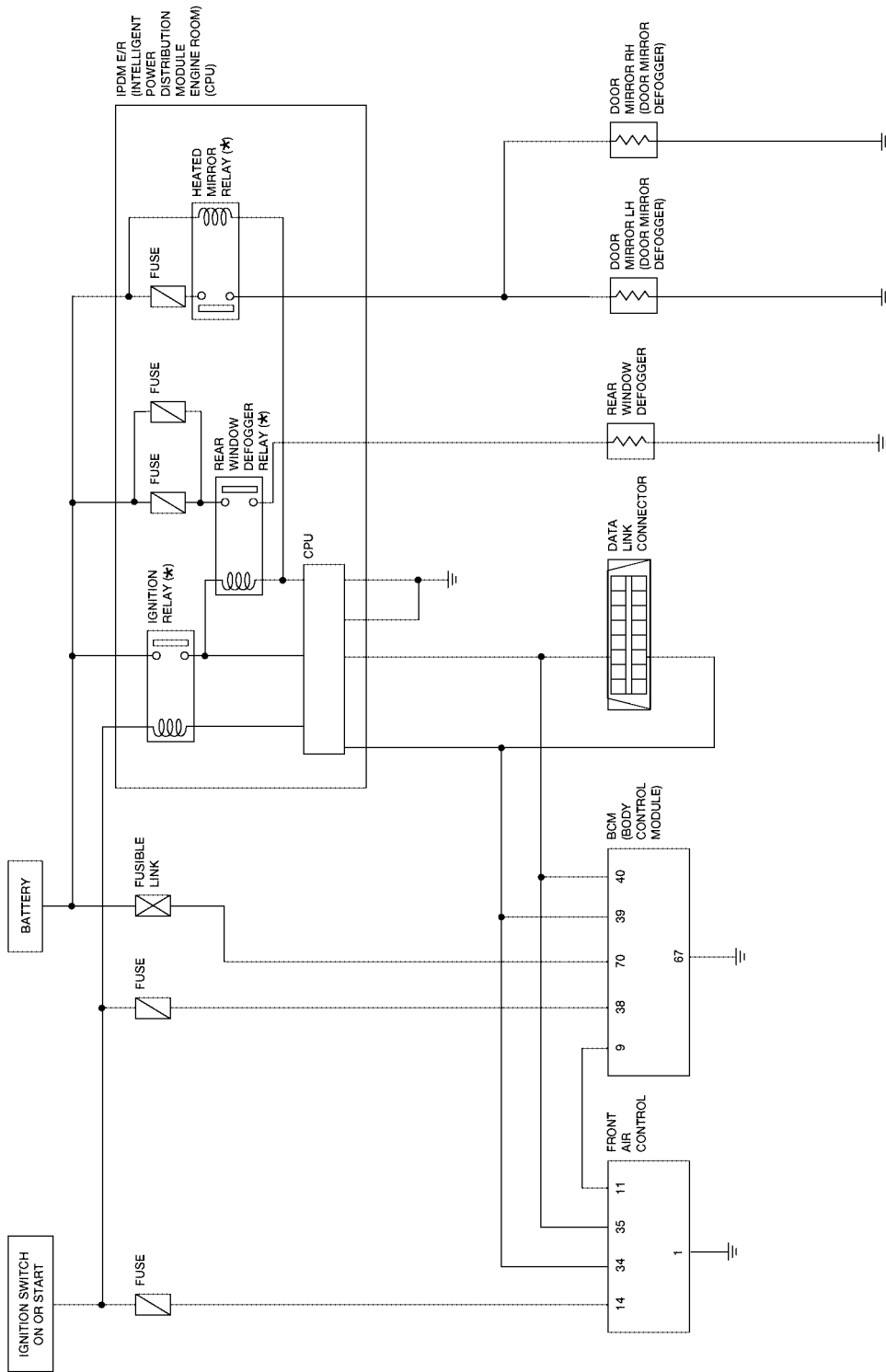

* : This relay is built into the IPDM E/R (Intelligent Power Distribution Module Engine Room)

A
B
C
D
E
F
G
H
GW
J
K
L
M

REAR WINDOW DEFOGGER

Wiring Diagram — DEF —

EIS00247

GW-DEF-01

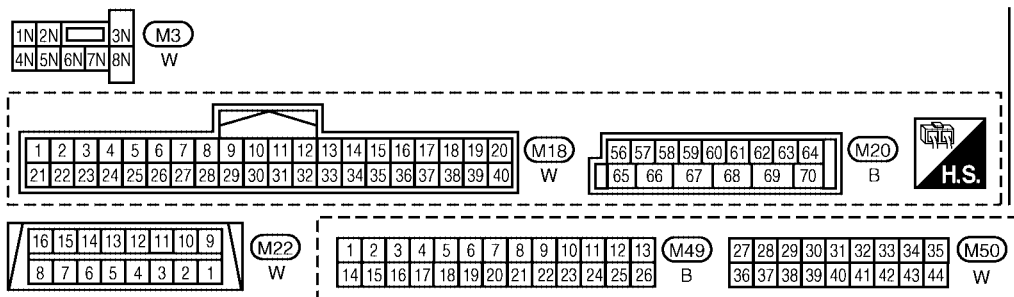
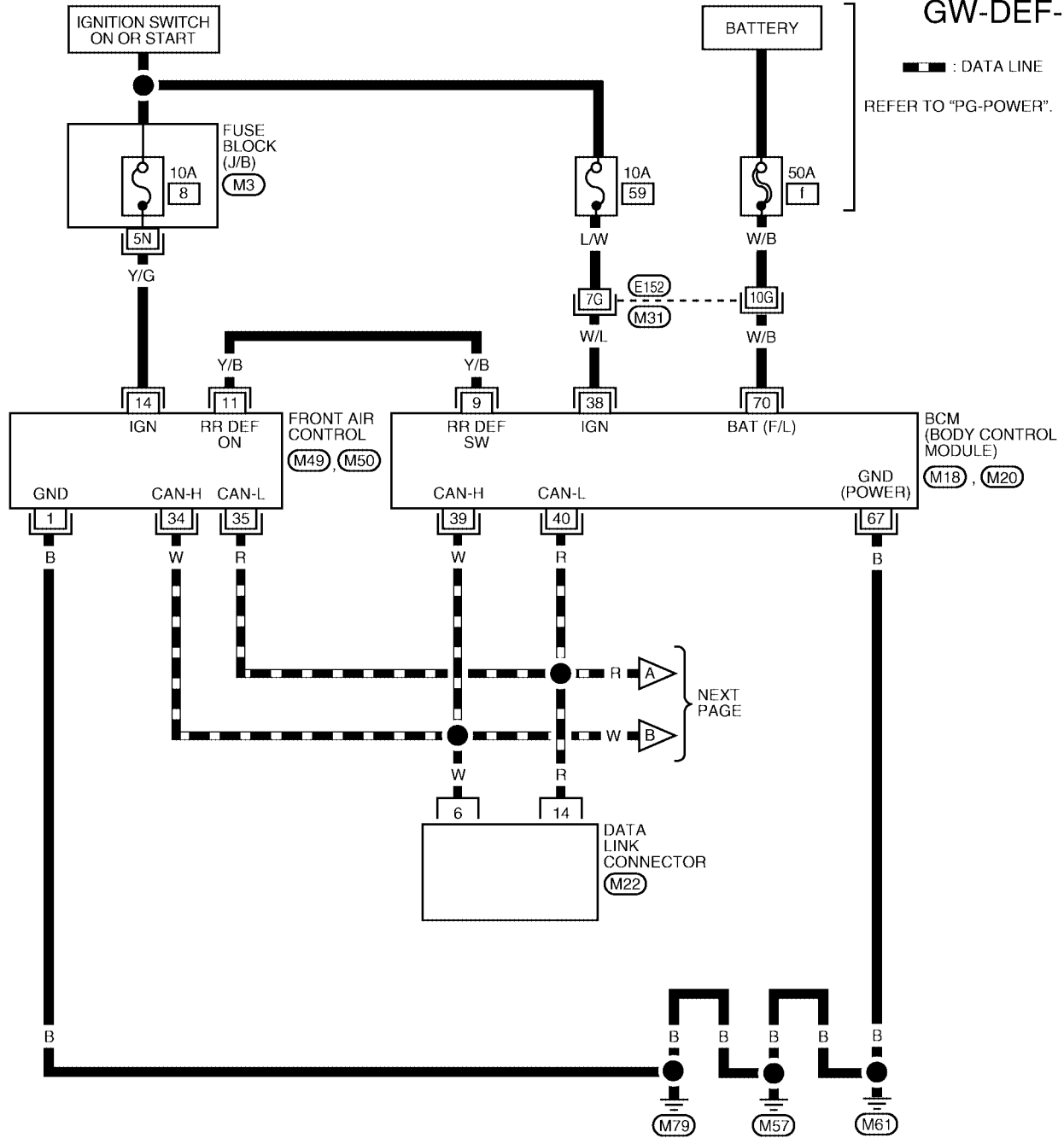

REFER TO THE FOLLOWING.
 (M31) - SUPER MULTIPLE JUNCTION (SMJ)

REAR WINDOW DEFOGGER

GW-DEF-02

A
B
C
D
E
F
G
H
I
J
K
L
M

DATA LINE

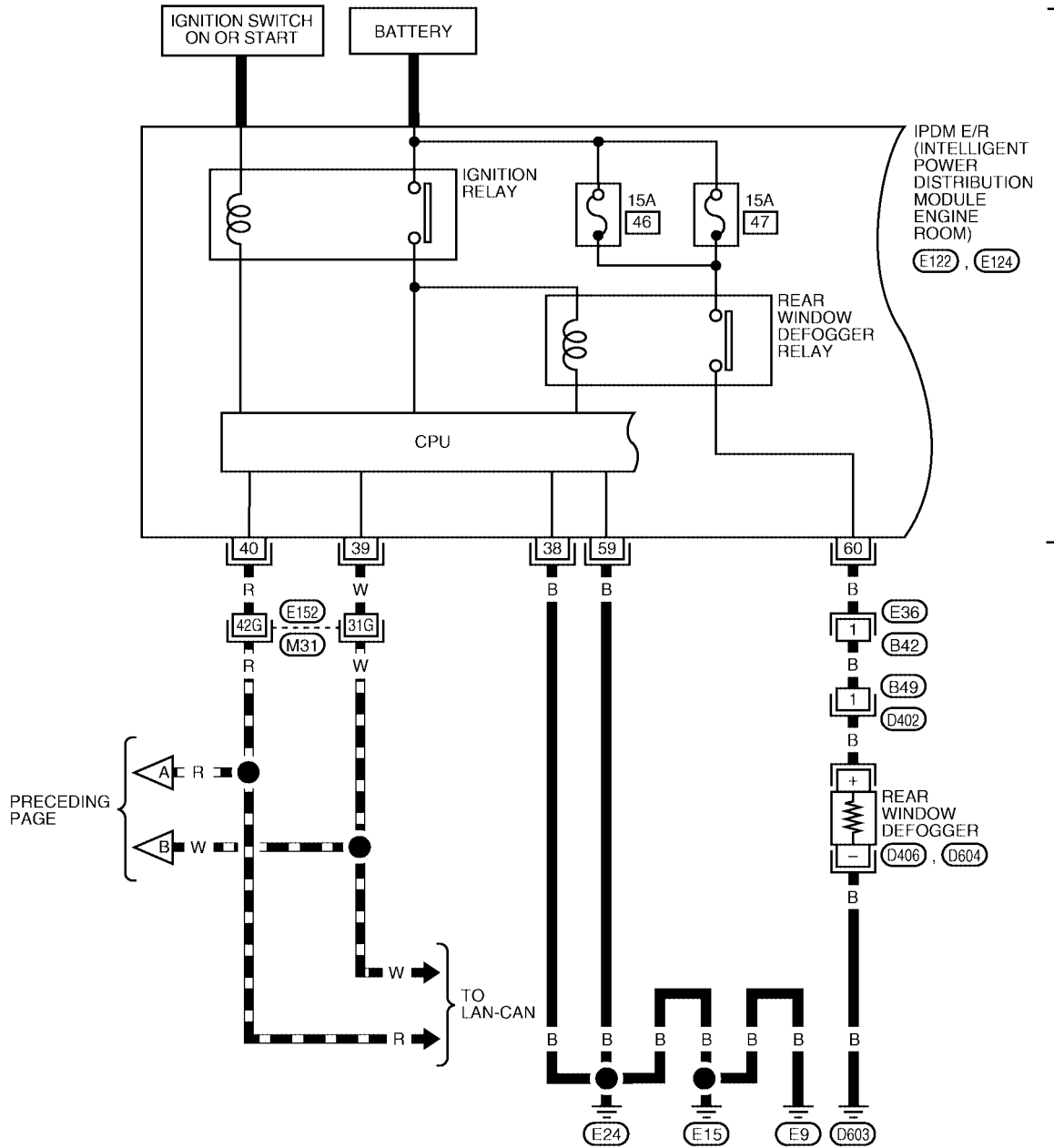

GW

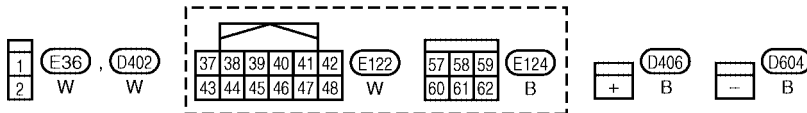

REFER TO THE FOLLOWING.

(M31) - SUPER MULTIPLE JUNCTION (SMJ)

LIWA0381E

REAR WINDOW DEFOGGER

GW-DEF-03

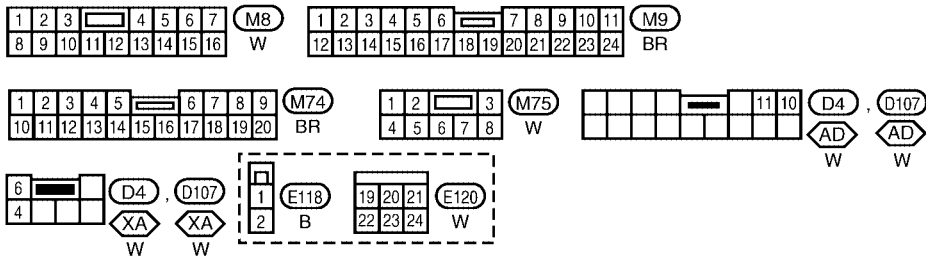
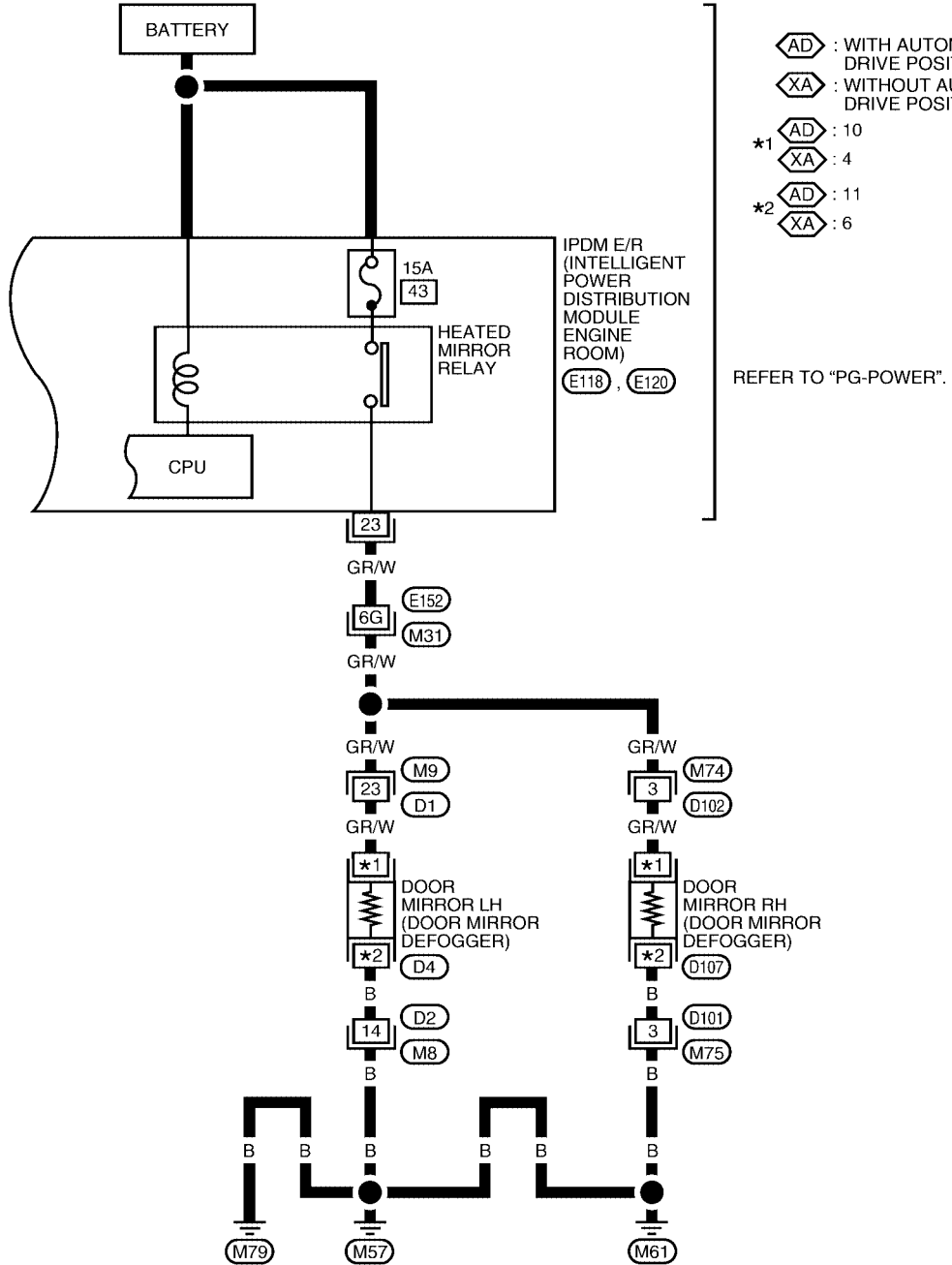

REFER TO THE FOLLOWING.
 (M31) - SUPER MULTIPLE JUNCTION (SMJ)

WIWA0834E

REAR WINDOW DEFOGGER

Terminal and Reference Value for BCM

EIS00248

Terminal	Wire color	Item	Condition	Voltage (V) (Approx.)
9	Y/B	Rear window defogger switch signal	When rear window defogger switch is pressed.	0
			When rear window defogger switch is OFF.	5
38	W/L	Ignition switch ON or START	Ignition switch (ON or START position)	Battery voltage
39	W	CAN H	—	—
40	R	CAN L	—	—
67	B	Ground	—	0
70	W/B	Battery power supply	—	Battery voltage

Terminal and Reference Value for IPDM E/R

EIS00249

Terminal	Wire color	Item	Condition	Voltage (V) (Approx.)
1	B/Y	Battery power supply	—	Battery voltage
22	G	Battery power supply	—	Battery voltage
38	B	Ground (Power)	—	0
39	W	CAN H	—	—
40	R	CAN L	—	—
59	B	Ground (Signal)	—	0
60	B	Rear window defogger output signal	When rear window defogger switch is ON.	Battery voltage
			When rear window defogger switch is OFF.	0

Work Flow

EIS0024A

1. Check the symptom and customer's requests.
2. Understand the outline of system. Refer to [GW-73, "System Description"](#) .
3. According to the trouble diagnosis chart, repair or replace the cause of the malfunction. Refer to [GW-81, "Trouble Diagnoses Symptom Chart"](#) .
4. Does rear window defogger operate normally? YES: GO TO 5, NO: GO TO 3.
5. Inspection End.

REAR WINDOW DEFOGGER

EIS0024B

CONSULT-II Function (BCM)

CONSULT-II can display each diagnostic item using the diagnostic test modes shown following.

BCM diagnostic test item	Diagnostic mode	Content
Inspection by part	WORK SUPPORT	Changes setting of each function.
	DATA MONITOR	Displays BCM input/output data in real time.
	ACTIVE TEST	Operation of electrical loads can be checked by sending drive signal to them.
	SELF-DIAG RESULTS	Displays BCM self-diagnosis results.
	CAN DIAG SUPPORT MNTR	The results of transmit/receive diagnosis of CAN communication can be read.
	ECU PART NUMBER	BCM part number can be read.
	CONFIGURATION	Performs BCM configuration read/write functions.

CONSULT-II BASIC OPERATION PROCEDURE

CAUTION:

If CONSULT-II is used with no connection of CONSULT-II CONVERTER, malfunctions might be detected in self-diagnosis depending on control unit which carries out CAN communication.

1. Turn ignition switch OFF.
2. Connect "CONSULT-II" and CONSULT-II CONVERTER to data link connector.

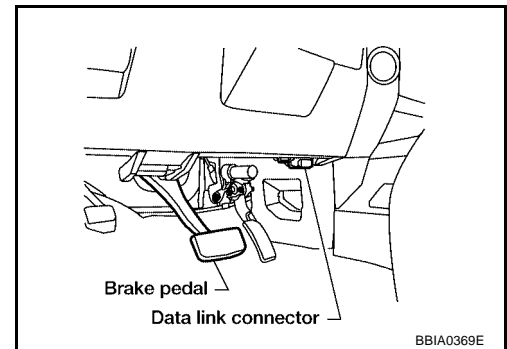

3. Turn ignition switch ON.
4. Touch "START (NISSAN BASED VHCL)".

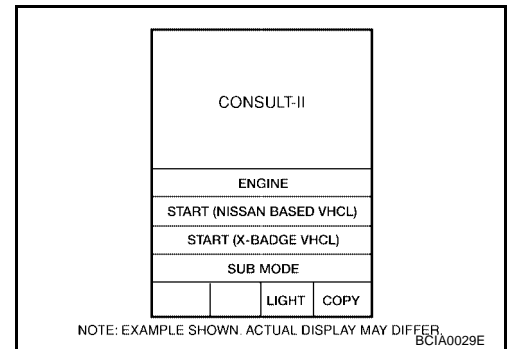

5. Touch "BCM".
If "BCM" is not indicated, go to [GI-38, "CONSULT-II Data Link Connector \(DLC\) Circuit"](#), "CONSULT-II Date Link Connector (DLC) Circuit"

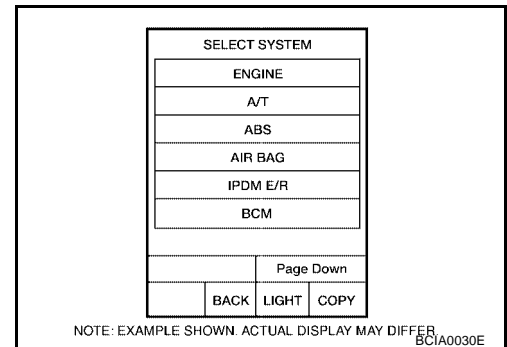

REAR WINDOW DEFOGGER

6. Touch "REAR DEFOGGER".

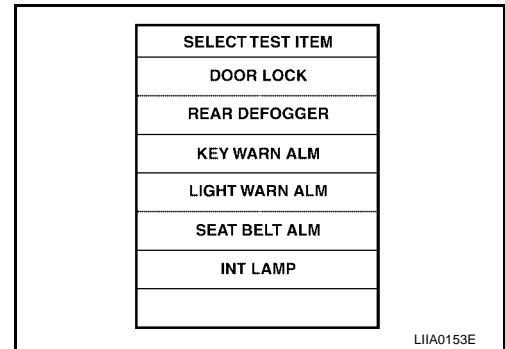

7. Select diagnosis mode, "DATA MONITOR" and "ACTIVE TEST".

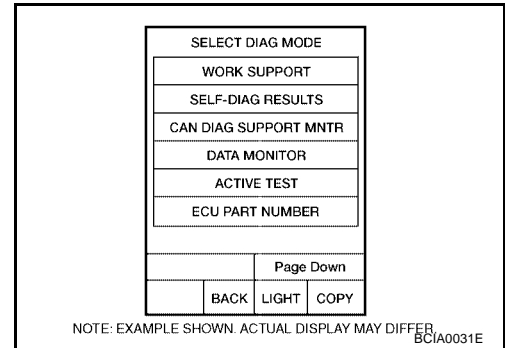

DATA MONITOR Display Item List

Monitor item "Operation"		Content
REAR DEF SW	"ON/OFF"	Displays "Press (ON)/others (OFF)" status determined with the rear window defogger switch.
IGN ON SW	"ON/OFF"	Displays "IGN (ON)/OFF" status determined with the ignition switch signal.

ACTIVE TEST Display Item List

Test item	Content
REAR WINDOW DEFOGGER	Gives a drive signal to the rear window defogger to activate it.

Trouble Diagnoses Symptom Chart

EIS0024C

- Make sure other systems using the signal of the following systems operate normally.

Symptom	Diagnoses / Service procedure	Refer to page
Rear window defogger and door mirror defoggers do not operate. (With door mirror defogger)	1. BCM power supply and ground circuit check	GW-83
	2. IPDM E/R auto active test check	PG-22
	3. Rear window defogger switch circuit check	GW-84
	4. Rear window defogger power supply circuit check	GW-85
	5. Replace IPDM E/ R	PG-28
Rear window defogger does not operate. (Without door mirror defogger)	1. BCM power supply and ground circuit check	GW-83
	2. IPDM E/R auto active test check	PG-22
	3. Rear window defogger switch circuit check	GW-84
	4. Rear window defogger power supply circuit check	GW-85
	5. Rear window defogger circuit check	GW-86
	6. Filament check	GW-94
	7. Replace IPDM E/ R	PG-28

REAR WINDOW DEFOGGER

Symptom	Diagnoses / Service procedure	Refer to page
Rear window defogger does not operate but both of door mirror defoggers operate. (With door mirror defogger)	1. Rear window defogger power supply circuit check	GW-85
	2. Rear window defogger circuit check	GW-86
	3. Filament check	GW-94
	4. Replace IPDM E/R	PG-28
Both door mirror defoggers do not operate but rear window defogger operates. (With door mirror defogger)	1. Door mirror defogger power supply circuit check	GW-86
	2. Replace IPDM E/R	PG-28
Driver side door mirror defogger does not operate.	1. Driver side door mirror defogger circuit check	GW-90
Passenger side door mirror defogger does not operate.	1. Passenger side door mirror defogger circuit check	GW-92
Rear window defogger switch does not light, and rear window defogger is not displayed on the display. But rear window defogger operates.	1. Rear window defogger signal check	GW-94

REAR WINDOW DEFOGGER

EIS0024D

BCM Power Supply and Ground Circuit Check

1. CHECK FUSE

- Check 10A fuse (No.59, located in the fuse and relay box)
- Check 50A fusible link (letter f , located in the fuse and fusible link box)

NOTE:

Refer to [GW-73, "Component Parts and Harness Connector Location"](#) .

OK or NG

OK >> GO TO 2.

NG >> If fuse is blown, be sure to eliminate cause of malfunction before installing new fuse. Refer to [PG-4, "POWER SUPPLY ROUTING CIRCUIT"](#) .

2. CHECK POWER SUPPLY CIRCUIT

1. Turn ignition switch ON.
2. Check voltage between BCM connector M18, M20 terminal 38, 70 and ground.

70 (W/B) – Ground : Battery voltage

38 (W/L) – Ground : Battery voltage

OK or NG

OK >> GO TO 3.

NG >> Repair or replace harness.

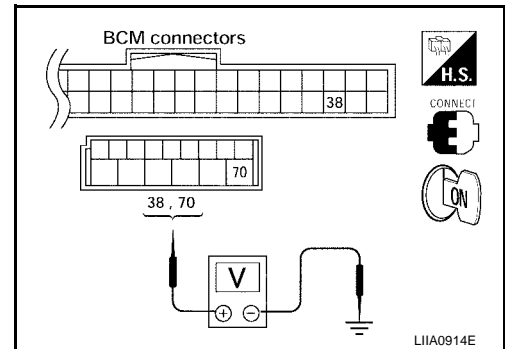

3. CHECK GROUND CIRCUIT

1. Turn ignition switch OFF.
2. Disconnect BCM.
3. Check continuity between BCM connector M20 terminal 67 and ground.

67 (B) – Ground : Continuity should exist.

OK or NG

OK >> BCM power supply and ground circuit is OK.

NG >> Repair or replace harness.

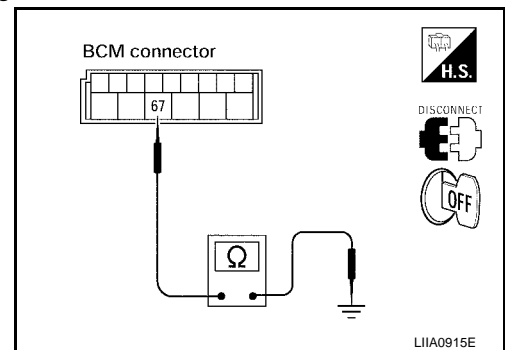

REAR WINDOW DEFOGGER

EIS0024E

Rear Window Defogger Switch Circuit Check

1. CHECK REAR WINDOW DEFOGGER SWITCH OPERATION

With CONSULT-II

Check ("REAR DEF SW", "IGN ON SW") in DATA MONITOR mode with CONSULT-II.

When rear window defogger switch is turned to ON

REAR DEF SW : ON

When ignition switch is turned to ON

IGN ON SW : ON

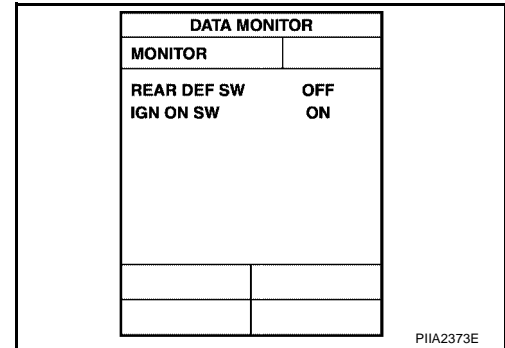

Without CONSULT-II

- Turn ignition switch ON.
- Check voltage between BCM connector and ground.

Connector	Terminal (Wire color)		Condition	Voltage (V) (Approx.)
	(+)	(-)		
M18	9 (Y/B)	Ground	Rear window defogger switch is pressed.	0
			Rear window defogger switch is OFF.	5

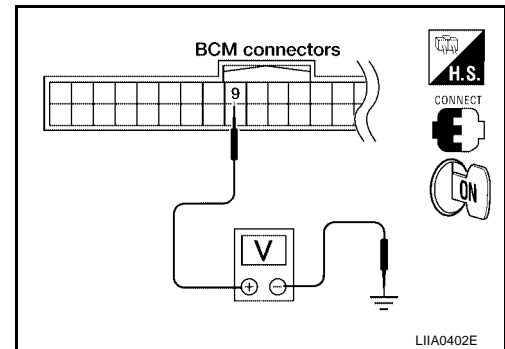

OK or NG

- OK >> Rear window defogger switch check is OK.
 NG >> GO TO 2.

2. CHECK REAR WINDOW DEFOGGER SWITCH CIRCUIT HARNESS CONTINUITY

- Turn ignition switch OFF.
- Disconnect BCM and front air control.
- Check continuity between BCM connector M18 terminal 9 and front air control connector M49 terminal 11.

9 (Y/B) – 11 (Y/B) : Continuity should exist.

- Check continuity between BCM connector M18 terminal 9 and ground

9 (Y/B) – Ground : Continuity should not exist.

OK or NG

- OK >> GO TO 3.
 NG >> Repair or replace harness.

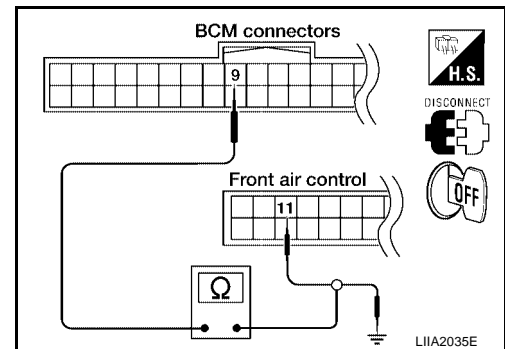

REAR WINDOW DEFOGGER

3. CHECK BCM OUTPUT SIGNAL

1. Connect BCM.
2. Turn ignition switch ON.
3. Check voltage between BCM connector M18 terminal 9 and ground.

9 (Y/B) – Ground : Approx. 5

OK or NG

- OK >> Replace front air control.
 NG >> Replace BCM.

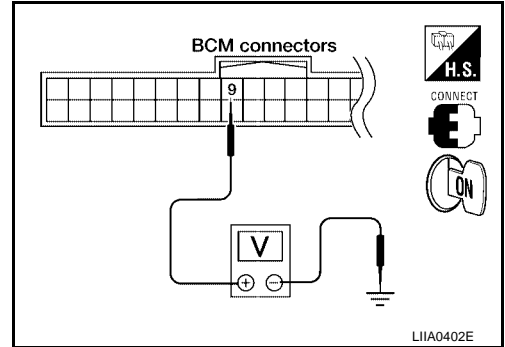

Rear Window Defogger Power Supply Circuit Check

EIS0024F

1. CHECK FUSE

Check if any of the following fuses for IPDM E/R are blown.

COMPONENT PARTS	AMPERE	FUSE NO.
IPDM E/R	15A	46
IPDM E/R	15A	47

NOTE:

Refer to [GW-73, "Component Parts and Harness Connector Location"](#) .

OK or NG

- OK >> GO TO 2.
 NG >> If fuse is blown, be sure to eliminate cause of malfunction before installing new fuse, refer to [GW-73, "Component Parts and Harness Connector Location"](#) .

2. CHECK REAR WINDOW DEFOGGER RELAY OUTPUT SIGNAL

Check voltage between IPDM E/R connector E124 terminal 60 and ground.

60 (G) – Ground : Battery voltage

OK or NG

- OK >> Replace IPDM E/R.
 NG >> Repair or replace harness.

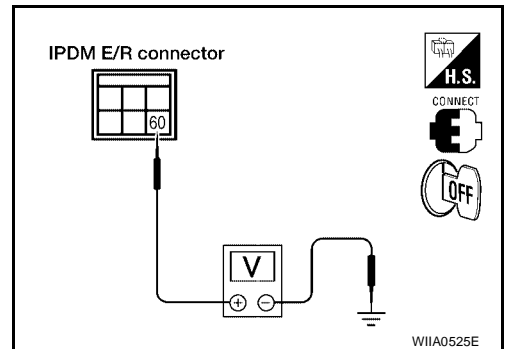

REAR WINDOW DEFOGGER

EIS0024G

Rear Window Defogger Circuit Check

1. CHECK REAR WINDOW DEFOGGER POWER SUPPLY CIRCUIT

1. Turn ignition switch OFF.
2. Disconnect rear window defogger.
3. Turn ignition switch ON.
4. Check voltage between rear window defogger connector D406 terminal + and ground.

Connector	Terminal (Wire color)		Condition	Voltage (V) (Approx.)
	(+)	(-)		
D406	+ (G)	Ground	Rear window defogger switch ON.	Battery voltage
			Rear window defogger switch OFF.	0

OK or NG

- OK >> GO TO 2.
 NG >> Repair or replace harness.

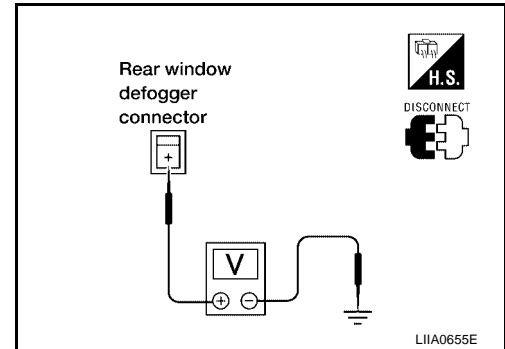

2. CHECK REAR WINDOW DEFOGGER GROUND CIRCUIT

1. Turn ignition switch OFF.
2. Check continuity between rear window defogger connector D604 terminal - and ground.

- (B) – Ground : Continuity should exist.

OK or NG

- OK >> Check filament. Refer to [GW-94, "Filament Check"](#) .
- If filament is OK.
Check the condition of the harness and the connector.
 - If filament is NG.
Repair filament.
- NG >> Repair or replace harness.

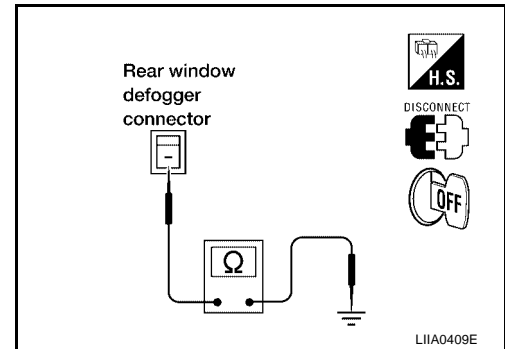

Door Mirror Defogger Power Supply Circuit Check / Without Automatic Drive Positioner

EIS0024H

1. CHECK FUSE

Check if the following fuse for IPDM E/R is blown.

COMPONENT PARTS	AMPERE	FUSE NO.
IPDM E/R	15A	43

NOTE:

Refer to [GW-73, "Component Parts and Harness Connector Location"](#) .

OK or NG

- OK >> GO TO 2.
 NG >> If fuse is blown, be sure to eliminate cause of malfunction before installing new fuse. Refer to [GW-73, "Component Parts and Harness Connector Location"](#) .

REAR WINDOW DEFOGGER

2. CHECK DOOR MIRROR DEFOGGER POWER SUPPLY CIRCUIT 2

Check voltage between IPDM E/R connector and ground.

Connector	Terminal (Wire color)		Condition	Voltage (V) (Approx.)
	(+)	(-)		
E120	23 (L/B)	Ground	Rear window defogger switch ON	Battery voltage
			Rear window defogger switch OFF	0

OK or NG

OK >> GO TO 3.

NG >> Replace IPDM E/R.

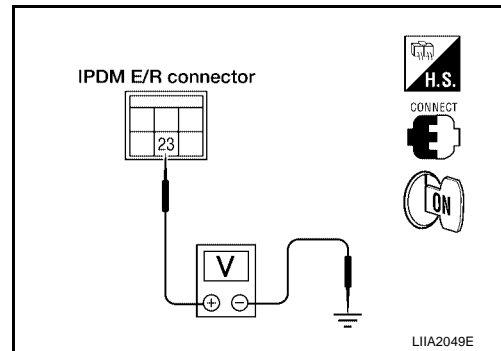

3. CHECK DOOR MIRROR DEFOGGER CIRCUIT

1. Turn ignition switch OFF.
2. Disconnect IPDM E/R and door mirror LH or RH.
3. Check continuity between IPDM E/R connector E120 terminal 23 and door mirror connector D4 (LH) or D107 (RH) terminal 4.

23 (L/B) – 4 (GR/W) : Continuity should exist.

OK or NG

OK >> GO TO 4.

NG >> Repair or replace harness.

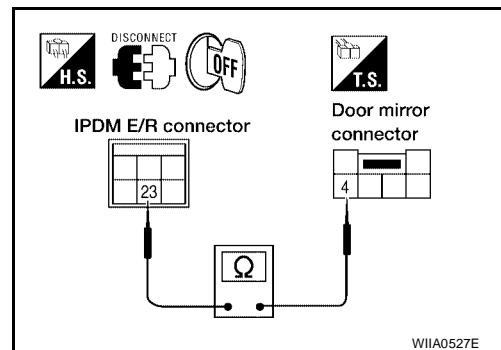

4. CHECK DOOR MIRROR DEFOGGER GROUND CIRCUIT

Check continuity between each door mirror connector D4 (LH) or D107 (RH) terminal 6 and ground.

6 (B) – Ground : Continuity should exist.

OK or NG

OK >> GO TO 5.

NG >> Repair or replace harness.

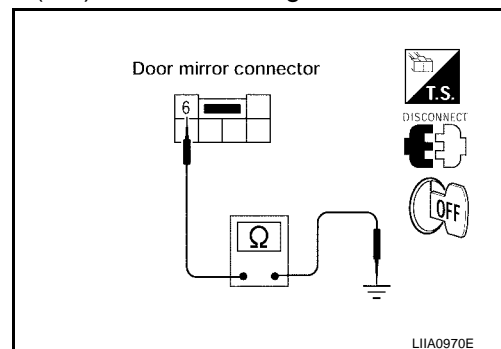

REAR WINDOW DEFOGGER

5. CHECK DOOR MIRROR DEFOGGER

Check continuity between door mirror terminals 4 and 6.

4 (GR/W) –6 (B) : Continuity should exist.

OK or NG

- OK >> Check the condition of the harness and the connector.
- NG >> Replace malfunctioning door mirror LH or RH.

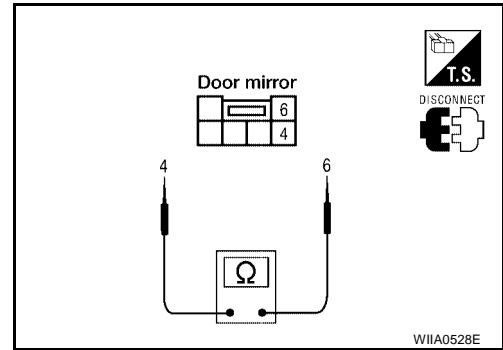

Door Mirror Defogger Power Supply Circuit Check / With Automatic Drive Positioner

EIS002BM

1. CHECK FUSE

Check if the following fuse for IPDM E/R is blown.

COMPONENT PARTS	AMPERE	FUSE NO.
IPDM E/R	15A	43

NOTE:

Refer to [GW-73, "Component Parts and Harness Connector Location"](#) .

OK or NG

- OK >> GO TO 2.
- NG >> If fuse is blown, be sure to eliminate cause of malfunction before installing new fuse. Refer to [GW-73, "Component Parts and Harness Connector Location"](#) .

2. CHECK DOOR MIRROR DEFOGGER POWER SUPPLY CIRCUIT 2

Check voltage between IPDM E/R connector and ground.

Connector	Terminal (Wire color)		Condition	Voltage (V) (Approx.)
	(+)	(-)		
E120	23 (L/B)	Ground	Rear window defogger switch ON	Battery voltage
			Rear window defogger switch OFF	0

OK or NG

- OK >> GO TO 3.
- NG >> Replace IPDM E/R.

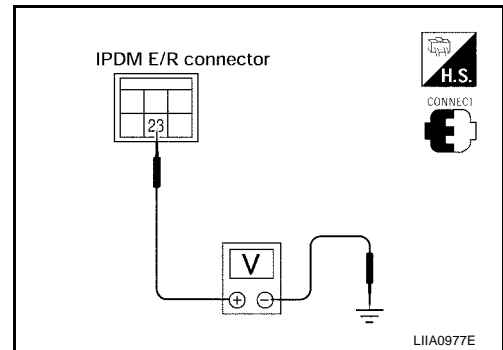

REAR WINDOW DEFOGGER

3. CHECK DOOR MIRROR DEFOGGER CIRCUIT

1. Turn ignition switch OFF.
2. Disconnect IPDM E/R and door mirror LH or RH.
3. Check continuity between IPDM E/R connector E120 terminal 23 and door mirror connector D4 (LH) or D107 (RH) terminal 10.

23 (L/B) – 10 (GR/W) : Continuity should exist.

OK or NG

- OK >> GO TO 4.
- NG >> Repair or replace harness.

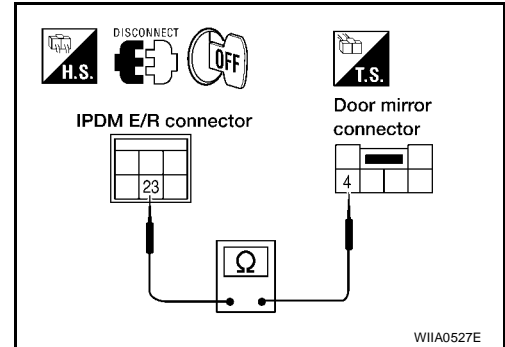

4. CHECK DOOR MIRROR DEFOGGER GROUND CIRCUIT

Check continuity between each door mirror connector D4 (LH) or D107 (RH) terminal 11 and ground.

11 (B) – Ground : Continuity should exist.

OK or NG

- OK >> GO TO 5.
- NG >> Repair or replace harness.

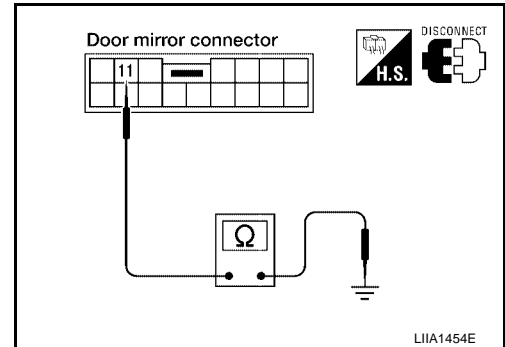

5. CHECK DOOR MIRROR DEFOGGER

Check continuity between door mirror terminals 10 and 11.

10 (GR/W) – 11 (B) : Continuity should exist.

OK or NG

- OK >> Check the condition of the harness and the connector.
- NG >> Replace malfunctioning door mirror LH or RH.

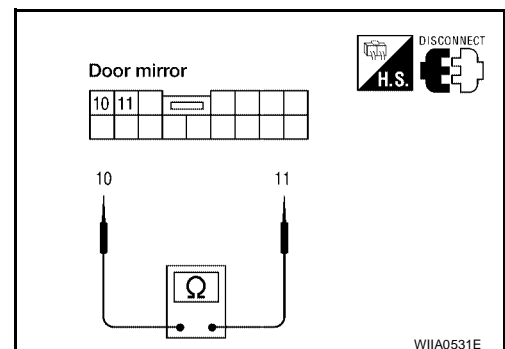

REAR WINDOW DEFOGGER

Door Mirror LH Defogger Circuit Check / Without Automatic Drive Positioner EIS0024I

1. CHECK DOOR MIRROR DEFOGGER POWER SUPPLY CIRCUIT

1. Turn ignition switch OFF.
2. Disconnect door mirror LH.
3. Turn ignition switch ON.
4. Check voltage between door mirror LH connector and ground.

Connector	Terminal (Wire color)		Condition	Voltage (V) (Approx.)
	(+)	(-)		
D4	4 (GR/W)	Ground	Rear window defogger switch ON	Battery voltage
			Rear window defogger switch OFF	0

OK or NG

- OK >> GO TO 2.
 NG >> Repair or replace harness.

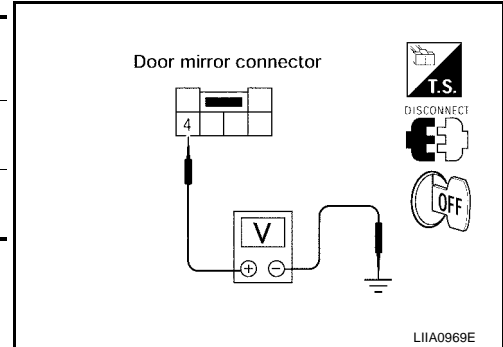

2. CHECK DOOR MIRROR DEFOGGER GROUND CIRCUIT

1. Turn ignition switch OFF.
2. Check continuity between door mirror LH connector D4 terminal 6 and ground.

6 (B) – Ground : Continuity should exist.

OK or NG

- OK >> GO TO 3.
 NG >> Repair or replace harness.

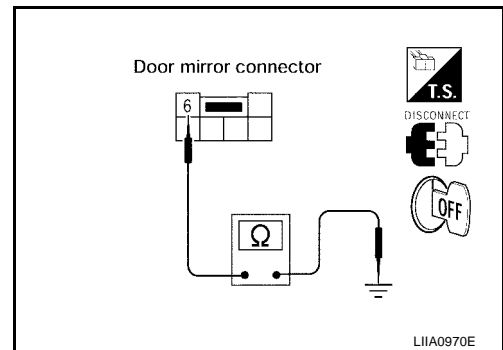

3. CHECK DOOR MIRROR DEFOGGER

Check continuity between door mirror LH terminals 4 and 6.

4 (GR/W) – 6 (B) : Continuity should exist.

OK or NG

- OK >> Repair or replace harness.
 NG >> Replace door mirror LH.

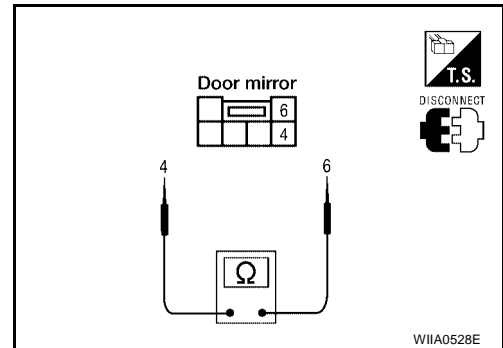

REAR WINDOW DEFOGGER

Door Mirror LH Defogger Circuit Check / With Automatic Drive Positioner

EIS002BN

1. CHECK DOOR MIRROR DEFOGGER POWER SUPPLY CIRCUIT

1. Turn ignition switch OFF.
2. Disconnect door mirror LH.
3. Turn ignition switch ON.
4. Check voltage between door mirror LH connector and ground.

Connector	Terminal (Wire color)		Condition	Voltage (V) (Approx.)
	(+)	(-)		
D4	10 (GR/W)	Ground	Rear window defogger switch ON	Battery voltage
			Rear window defogger switch OFF	0

OK or NG

- OK >> GO TO 2.
 NG >> Repair or replace harness.

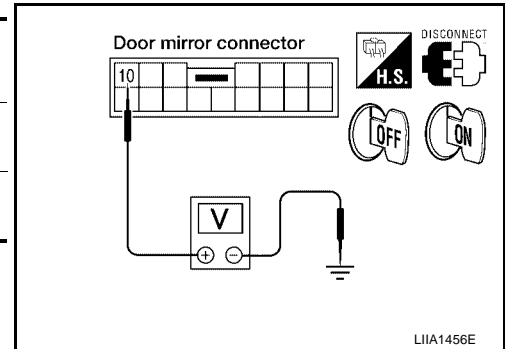

2. CHECK DOOR MIRROR DEFOGGER GROUND CIRCUIT

1. Turn ignition switch OFF.
2. Check continuity between door mirror LH connector D4 terminal 11 and ground.

11 (B) – Ground : Continuity should exist.

OK or NG

- OK >> GO TO 3.
 NG >> Repair or replace harness.

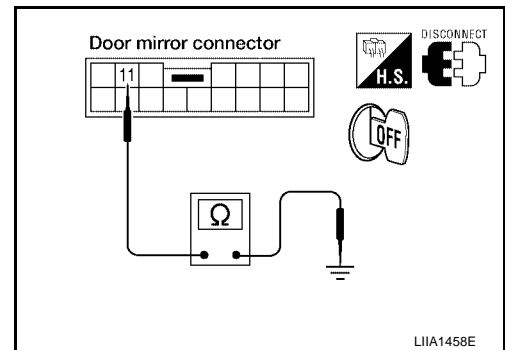

3. CHECK DOOR MIRROR DEFOGGER

Check continuity between door mirror LH terminals 10 and 11.

10 (GR/W) – 11 (B) : Continuity should exist.

OK or NG

- OK >> Repair or replace harness.
 NG >> Replace door mirror LH.

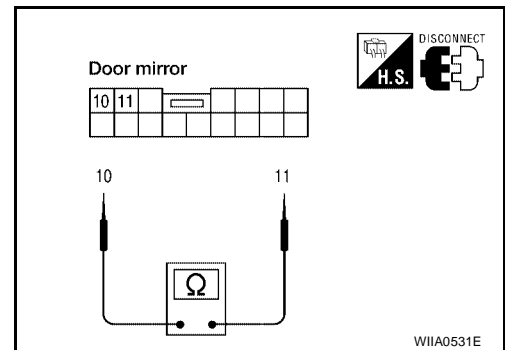

REAR WINDOW DEFOGGER

Door Mirror RH Defogger Circuit Check / Without Automatic Drive Positioner

EIS0024J

1. CHECK DOOR MIRROR DEFOGGER POWER SUPPLY CIRCUIT

1. Turn ignition switch OFF.
2. Disconnect door mirror RH.
3. Turn ignition switch ON.
4. Check voltage between door mirror RH connector and ground.

Connector	Terminal (Wire color)		Condition	Voltage (V) (Approx.)
	(+)	(-)		
D107	4 (GR/W)	Ground	Rear window defogger switch ON	Battery voltage
			Rear window defogger switch OFF	0

OK or NG

- OK >> GO TO 2.
 NG >> Repair or replace harness.

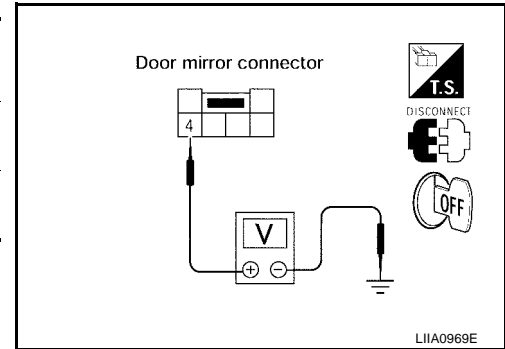

2. CHECK DOOR MIRROR DEFOGGER GROUND CIRCUIT

1. Turn ignition switch OFF.
2. Check continuity between door mirror RH connector D107 terminal 6 and ground.

6 (B) – Ground : Continuity should exist.

OK or NG

- OK >> GO TO 3.
 NG >> Repair or replace harness.

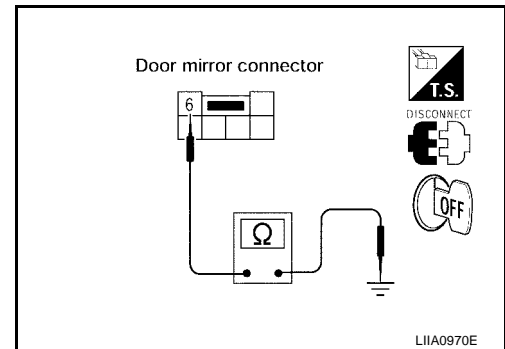

3. CHECK DOOR MIRROR DEFOGGER

Check continuity between door mirror RH terminals 4 and 6.

4 (GR/W) – 6 (B) : Continuity should exist.

OK or NG

- OK >> Repair or replace harness.
 NG >> Replace door mirror RH.

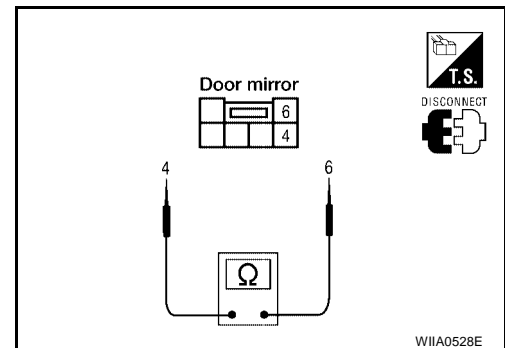

REAR WINDOW DEFOGGER

Door Mirror RH Defogger Circuit Check / With Automatic Drive Positioner

EIS002B0

1. CHECK DOOR MIRROR DEFOGGER POWER SUPPLY CIRCUIT

1. Turn ignition switch OFF.
2. Disconnect door mirror RH.
3. Turn ignition switch ON.
4. Check voltage between door mirror RH connector and ground.

Connector	Terminal (Wire color)		Condition	Voltage (V) (Approx.)
	(+)	(-)		
D107	10 (GR/W)	Ground	Rear window defogger switch ON	Battery voltage
			Rear window defogger switch OFF	0

OK or NG

- OK >> GO TO 2.
 NG >> Repair or replace harness.

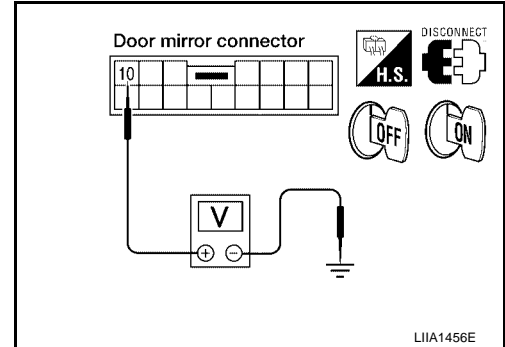

2. CHECK DOOR MIRROR DEFOGGER GROUND CIRCUIT

1. Turn ignition switch OFF.
2. Check continuity between door mirror RH connector D107 terminal 11 and ground.

11 (B) – Ground : Continuity should exist.

OK or NG

- OK >> GO TO 3.
 NG >> Repair or replace harness.

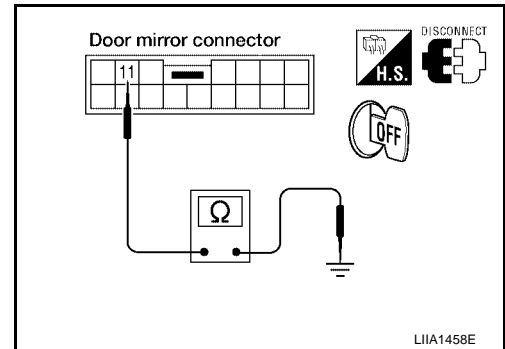

3. CHECK DOOR MIRROR DEFOGGER

Check continuity between door mirror RH terminals 10 and 11.

10 (GR/W) – 11 (B) : Continuity should exist.

OK or NG

- OK >> Repair or replace harness.
 NG >> Replace door mirror RH.

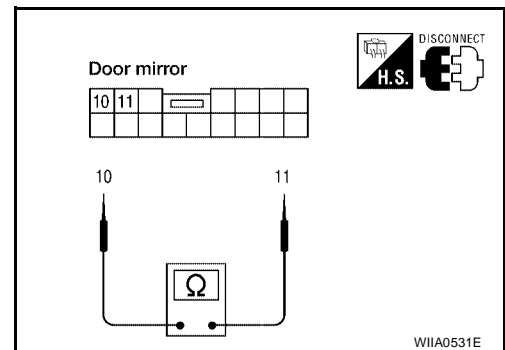

REAR WINDOW DEFOGGER

EIS0024K

Rear Window Defogger Signal Check

1. CHECK AV COMMUNICATION LINE

AV communication line check is executed. Refer to [ATC-32, "CAN Communication System Description"](#).

Is rear window defogger displayed on the display?

OK or NG

OK >> GO TO 2.

NG >> Replace display control unit.

2. CHECK CAN COMMUNICATION LINE

CAN communication line check is executed. Refer to [LAN-5, "CAN COMMUNICATION"](#)

OK or NG

OK >> Check the condition of the harness and the connector.

NG >> In addition, it is necessary to check CAN communication line. Refer to [LAN-5, "CAN COMMUNICATION"](#)

Filament Check

EIS0024L

1. When measuring voltage, wrap tin foil around the top of the negative probe. Then press the foil against the wire with your finger.

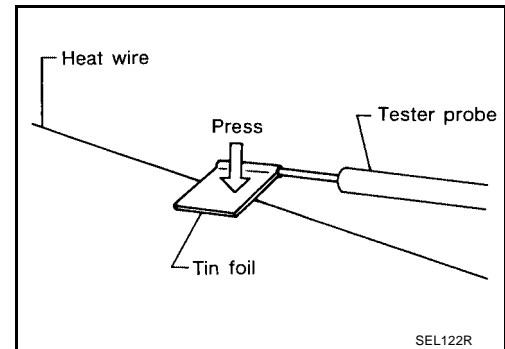

2. Attach probe circuit tester (in Volt range) to middle portion of each filament.

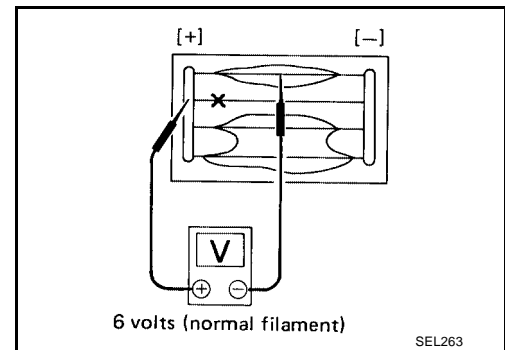

REAR WINDOW DEFOGGER

- If a filament is burned out, circuit tester registers 0 or battery voltage.
- To locate burned out point, move probe to left and right along filament. Test needle will swing abruptly when probe passes the point.

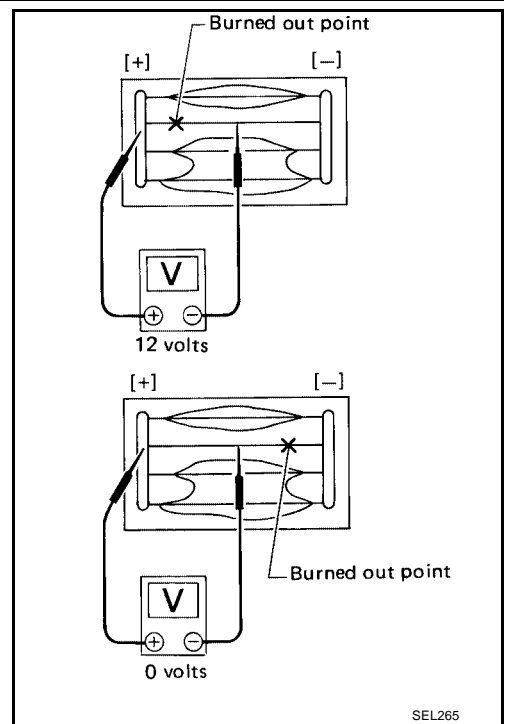

Filament Repair REPAIR EQUIPMENT

- Conductive silver composition (DuPont No. 4817 or equivalent)
- Ruler 30 cm (11.8 in) long
- Drawing pen
- Heat gun
- Alcohol
- Cloth

REPAIRING PROCEDURE

- Wipe broken heat wire and its surrounding area clean with a cloth dampened in alcohol.
- Apply a small amount of conductive silver composition to tip of drawing pen. Shake silver composition container before use.
- Place ruler on glass along broken line. Deposit conductive silver composition on break with drawing pen. Slightly overlap existing heat wire on both sides [preferably 5 mm (0.20 in)] of the break.

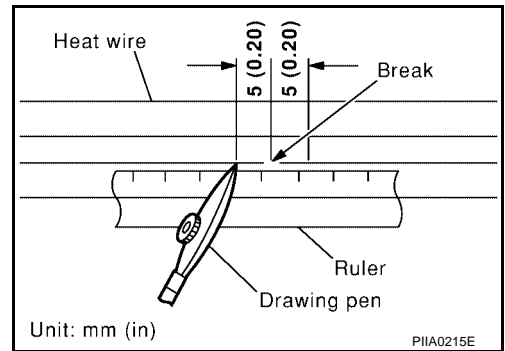

- After repair has been completed, check repaired wire for continuity. This check should be conducted 10 minutes after silver composition is deposited. Do not touch repaired area while test is being conducted.

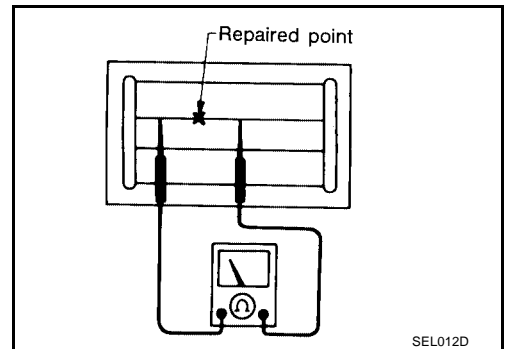

REAR WINDOW DEFOGGER

5. Apply a constant stream of hot air directly to the repaired area for approximately 20 minutes with a heat gun. A minimum distance of 3 cm (1.2 in) should be kept between repaired area and hot air outlet.
If a heat gun is not available, let the repaired area dry for 24 hours.

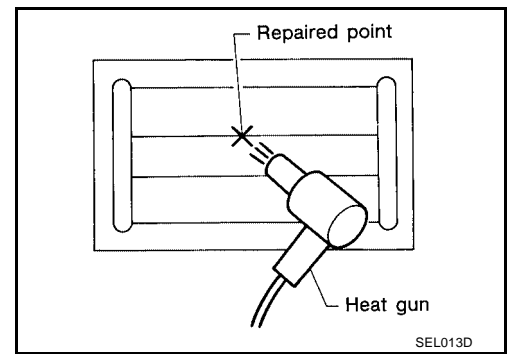

DOOR MIRROR

DOOR MIRROR

Wiring Diagram –MIRROR–

PF9:96301

EIS0024N

GW-MIRROR-01

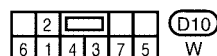
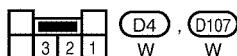
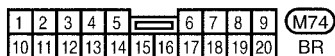
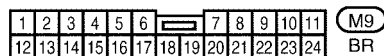
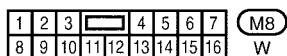
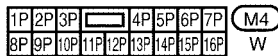
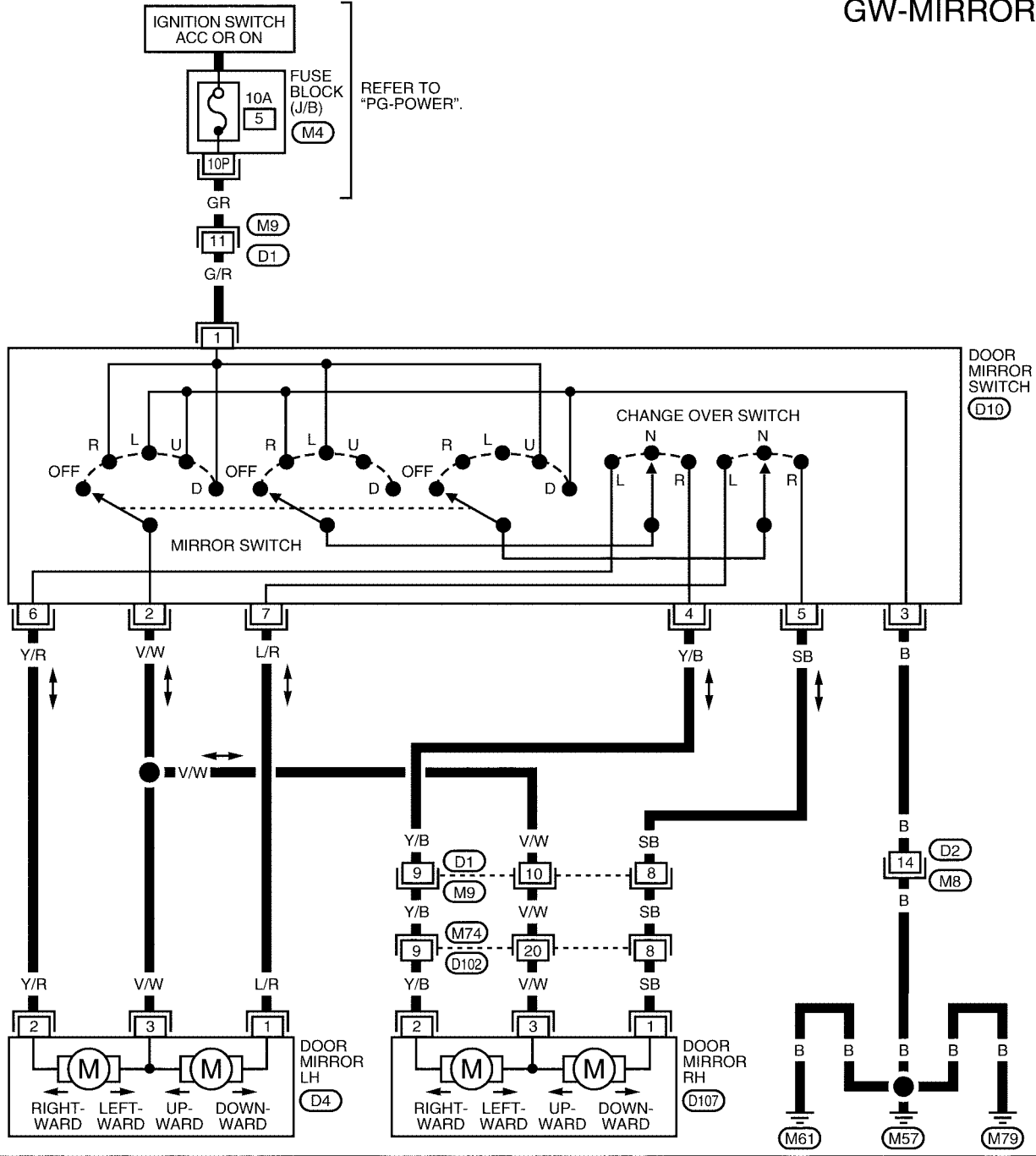

LIWA0209E

DOOR MIRROR

Door Mirror Assembly

EIS003NP

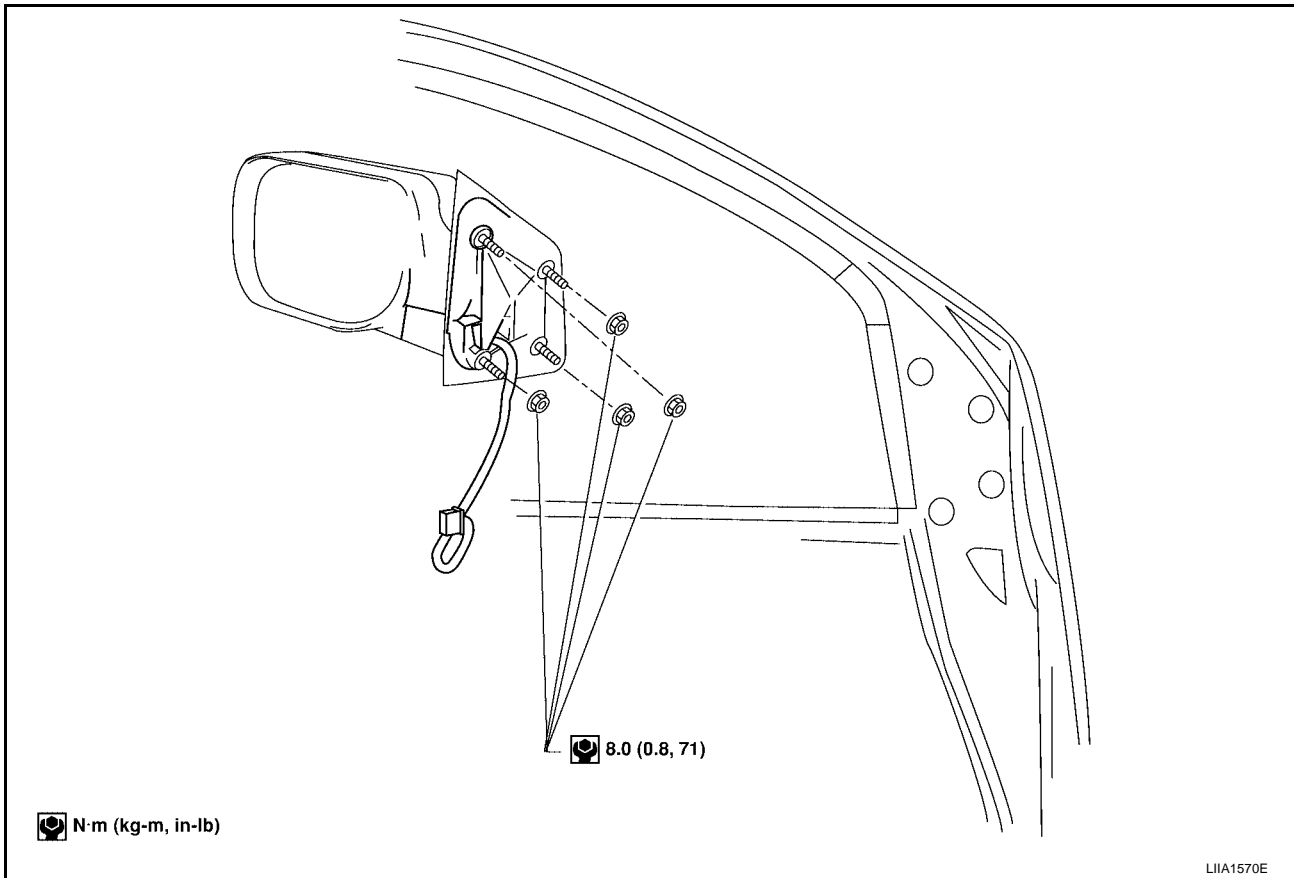

REMOVAL

NOTE:

Be careful not to damage the mirror bodies.

1. Remove the front door finisher. Refer to [EI-27, "FRONT DOOR"](#).
2. Remove the adhesive front door sash cover.
3. Disconnect the door mirror harness connector.
4. Remove the door mirror nuts, and remove the door mirror assembly.

INSTALLATION

Installation is in the reverse order of removal.

Door Mirror Glass

REMOVAL

1. Set mirror assembly mirror glass upward.
2. Apply protective tape to mirror housing.
3. Insert a screwdriver at notch and gently pry mirror glass and holder from mirror holder bracket.
4. Disconnect two electrical connectors from mirror glass and holder.

EIS003NQ

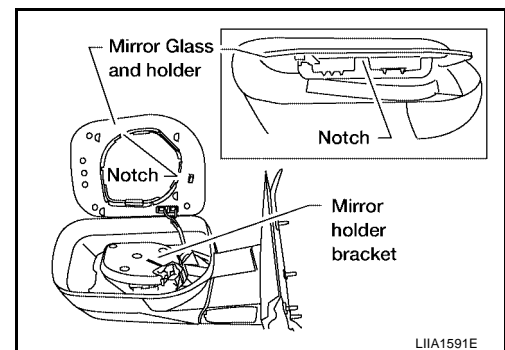

DOOR MIRROR

INSTALLATION

1. Set mirror holder bracket and mirror glass and holder in the horizontal position.
2. Connect two electrical connectors to the back of the mirror holder.
3. Align mirror glass and holder with mirror holder bracket and push mirror glass and holder onto mirror holder bracket.
4. Rotate mirror to ensure proper installation.

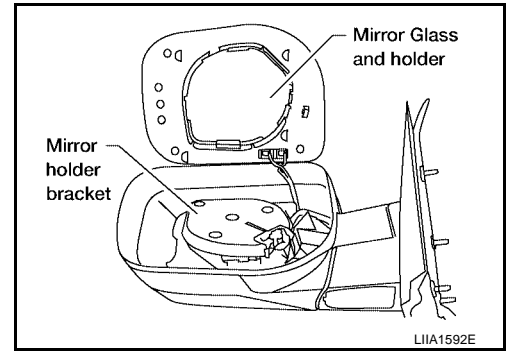

A
B
C
D
E
F
G
H
GW
J
K
L
M

DOOR MIRROR
