

# SECTION **BRC**

## BRAKE CONTROL SYSTEM

A  
B  
C  
D  
E

### CONTENTS

#### VDC/TCS/ABS

<b>PRECAUTIONS</b> .....	<b>3</b>
Precautions for Supplemental Restraint System (SRS) "AIR BAG" and "SEAT BELT PRE-TENSIONER" .....	3
Precautions for Brake System .....	3
Precautions When Using CONSULT-II .....	3
CHECK POINTS FOR USING CONSULT-II .....	3
Precautions for Brake Control .....	4
Precautions for CAN System .....	4
Wiring Diagrams and Trouble Diagnosis .....	5
<b>PREPARATION</b> .....	<b>6</b>
Special Service Tool .....	6
Commercial Service Tools .....	6
<b>SYSTEM DESCRIPTION</b> .....	<b>7</b>
System Components .....	7
ABS Function .....	8
EBD Function .....	8
TCS Function .....	8
VDC Function .....	8
Fail-Safe Function .....	8
ABS/EBD SYSTEM .....	9
VDC/TCS SYSTEM .....	9
ACTIVE BOOSTER .....	9
Hydraulic Circuit Diagram .....	9
<b>CAN COMMUNICATION</b> .....	<b>10</b>
System Description .....	10
<b>TROUBLE DIAGNOSIS</b> .....	<b>11</b>
How to Perform Trouble Diagnoses for Quick and Accurate Repair .....	11
INTRODUCTION .....	11
WORK FLOW .....	12
CLARIFY CONCERN .....	13
EXAMPLE OF DIAGNOSIS SHEET .....	13
Component Parts and Harness Connector Location .....	14
Schematic .....	15
Wiring Diagram — VDC — .....	16
Basic Inspection .....	23
BRAKE FLUID LEVEL, FLUID LEAK, AND BRAKE PAD INSPECTION .....	23

POWER SYSTEM TERMINAL LOOSENESS AND BATTERY INSPECTION .....	23
ABS WARNING LAMP, SLIP INDICATOR LAMP AND VDC OFF INDICATOR LAMP INSPECTION .....	23
Warning Lamp and Indicator Timing .....	24
Control Unit Input/Output Signal Standard .....	24
REFERENCE VALUE FROM CONSULT-II .....	24
CONSULT-II Function (ABS) .....	28
CONSULT-II BASIC OPERATION PROCEDURE .....	28
SELF-DIAGNOSIS .....	29
DATA MONITOR .....	32
ACTIVE TEST .....	35
<b>TROUBLE DIAGNOSIS FOR SELF-DIAGNOSTIC ITEMS</b> .....	<b>38</b>
Wheel Sensor System Inspection .....	38
Engine System Inspection .....	39
ABS/TCS/VDC Control Unit Inspection .....	40
Steering Angle Sensor System .....	40
Yaw Rate/Side/Decel G Sensor System Inspection .....	41
Solenoid and VDC Change-Over Valve System Inspection .....	43
Actuator Motor, Motor Relay, and Circuit Inspection .....	44
Stop Lamp Switch System Inspection .....	45
ABS/TCS/VDC Control Unit Power and Ground Systems Inspection .....	46
Brake Fluid Level Sensor System Inspection .....	47
Active Booster System Inspection .....	48
Delta Stroke Sensor System Inspection .....	49
Pressure Sensor System Inspection .....	51
Steering Angle Sensor Safe Mode Inspection .....	53
CAN Communication System Inspection .....	54
Inspection For Self-diagnosis Result "ST ANGLE SEN SIGNAL" .....	54
Inspection For Self-diagnosis Result "DECEL G SEN SET" .....	54
VDC OFF Indicator lamp Does Not Illuminate .....	55
Component Inspection .....	55
VDC OFF SWITCH .....	55

BRC

G  
H  
I  
J  
K  
L  
M

<b>TROUBLE DIAGNOSES FOR SYMPTOMS</b> .....	<b>56</b>	<b>WHEEL SENSORS</b> .....	<b>63</b>
ABS Works Frequently .....	56	Removal and Installation .....	63
Unexpected Pedal Action .....	57	REMOVAL .....	63
Long Stopping Distance .....	58	INSTALLATION .....	63
ABS Does Not Work .....	58	<b>SENSOR ROTOR</b> .....	<b>64</b>
Pedal Vibration or ABS Operation Noise .....	58	Removal and Installation .....	64
ABS Warning Lamp Does Not Come On When Igni- tion Switch Is Turned On .....	59	<b>ACTUATOR AND ELECTRIC UNIT (ASSEMBLY)</b> ...	<b>65</b>
ABS Warning Lamp Stays On When Ignition Switch Is Turned On .....	59	Removal and Installation .....	65
Vehicle Jerks During TCS/VDC Activation .....	60	REMOVAL .....	65
<b>ON-VEHICLE SERVICE</b> .....	<b>61</b>	INSTALLATION .....	66
Adjustment of Steering Angle Sensor Neutral Posi- tion .....	61	<b>STEERING ANGLE SENSOR</b> .....	<b>67</b>
Calibration of Decel G Sensor .....	61	Removal and Installation .....	67
		<b>G SENSOR</b> .....	<b>68</b>
		Removal and Installation .....	68
		REMOVAL .....	68
		INSTALLATION .....	68

**PRECAUTIONS**

PFP:00001

**Precautions for Supplemental Restraint System (SRS) “AIR BAG” and “SEAT BELT PRE-TENSIONER”**

EFS004UB

The Supplemental Restraint System such as “AIR BAG” and “SEAT BELT PRE-TENSIONER”, used along with a front seat belt, helps to reduce the risk or severity of injury to the driver and front passenger for certain types of collision. Information necessary to service the system safely is included in the SRS and SB section of this Service Manual.

**WARNING:**

- To avoid rendering the SRS inoperative, which could increase the risk of personal injury or death in the event of a collision which would result in air bag inflation, all maintenance must be performed by an authorized NISSAN/INFINITI dealer.
- Improper maintenance, including incorrect removal and installation of the SRS, can lead to personal injury caused by unintentional activation of the system. For removal of Spiral Cable and Air Bag Module, see the SRS section.
- Do not use electrical test equipment on any circuit related to the SRS unless instructed to in this Service Manual. SRS wiring harnesses can be identified by yellow and/or orange harnesses or harness connectors.

**Precautions for Brake System**

EFS004UC

**CAUTION:**

- Always use recommended brake fluid. Refer to [MA-11, "RECOMMENDED FLUIDS AND LUBRICANTS"](#).
- Never reuse drained brake fluid.
- Be careful not to splash brake fluid on painted areas; it may cause paint damage. If brake fluid is splashed on painted areas, wash it away with water immediately.
- To clean or wash all parts of master cylinder and disc brake caliper, use clean brake fluid.
- Never use mineral oils such as gasoline or kerosene. They will ruin rubber parts of the hydraulic system.
- Use flare nut wrench when removing and installing brake tube.
- If a brake fluid leak is found, the part must be disassembled without fail. Then it has to be replaced with a new one if a defect exists.
- Turn the ignition switch OFF and remove the connector of the ABS actuator and electric unit (control unit) or the battery terminal before performing the work.
- Always torque brake lines when installing.
- Burnish the brake contact surfaces after refinishing or replacing rotors, after replacing pads, or if a soft pedal occurs at very low mileage.

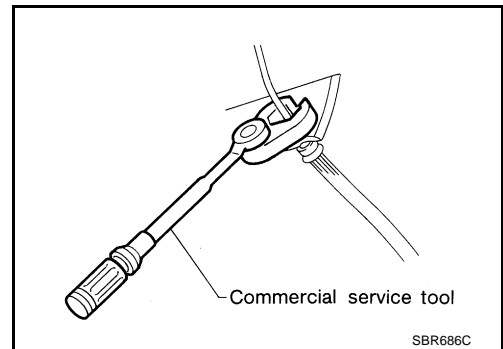

Refer to [BR-24, "BRAKE BURNISHING PROCEDURE"](#) (front disc brake) or [BR-30, "BRAKE BURNISHING PROCEDURE"](#) (rear disc brake).

**WARNING:**

- Clean brake pads and shoes with a waste cloth, then wipe with a dust collector.

**Precautions When Using CONSULT-II**

EFS004UD

When connecting CONSULT-II to data link connector, connect them through CONSULT-II CONVERTER.

**CAUTION:**

If CONSULT-II is used with no connection of CONSULT-II CONVERTER, malfunctions might be detected in self-diagnosis depending on control unit which carries out CAN communication.

**CHECK POINTS FOR USING CONSULT-II**

1. Has CONSULT-II been used without connecting CONSULT-II CONVERTER on this vehicle?
  - If YES, GO TO 2.
  - If NO, GO TO 5.

A  
B  
C  
D  
E  
BRC  
G  
H  
I  
J  
K  
L  
M

# PRECAUTIONS

[VDC/TCS/ABS]

2. Is there any indication other than indications relating to CAN communication system in the self-diagnosis results?
  - If YES, GO TO 3.
  - If NO, GO TO 4.
3. Based on self-diagnosis results unrelated to CAN communication, carry out the inspection.
4. Malfunctions may be detected in self-diagnosis depending on control units carrying out CAN communication. Therefore, erase the self-diagnosis results.
5. Diagnose CAN communication system. Refer to [LAN-5, "CAN COMMUNICATION"](#) .

## Precautions for Brake Control

EFS004UE

- During ABS operation, the brake pedal may vibrate lightly and a mechanical noise may be heard. This is normal.
- Just after starting vehicle, the brake pedal may vibrate or a motor operating noise may be heard from engine compartment. This is a normal status of operation check.
- Stopping distance may be longer than that of vehicles without ABS when vehicle drives on rough, gravel, or snow-covered (fresh, deep snow) roads.
- When an error is indicated by ABS or another warning lamp, collect all necessary information from customer (what symptoms are present under what conditions) and check for simple causes before starting diagnosis. Besides electrical system inspection, check booster operation, brake fluid level, and fluid leaks.
- If incorrect tire sizes or types are installed on the vehicle or brake pads are not Genuine NISSAN parts, stopping distance or steering stability may deteriorate.
- If there is a radio, antenna or related wiring near control module, ABS function may have a malfunction or error.
- If aftermarket parts (car stereo, CD player, etc.) have been installed, check for incidents such as harness pinches, open circuits or improper wiring.
- If the following components are replaced with non-genuine components or modified, the VDC OFF indicator lamp and SLIP indicator lamp may turn on or the VDC system may not operate properly. Components related to suspension (shock absorbers, struts, springs, bushings, etc.), tires, wheels (exclude specified size), components related to brake system (pads, rotors, calipers, etc.), components related to engine (muffler, ECM, etc.), components related to body reinforcement (roll bar, tower bar, etc.).
- Driving with broken or excessively worn suspension components, tires or brake system components may cause the VDC OFF indicator lamp and the SLIP indicator lamp to turn on, and the VDC system may not operate properly.
- When the TCS or VDC is activated by sudden acceleration or sudden turn, some noise may occur. The noise is a result of the normal operation of the TCS and VDC.
- When driving on roads which have extreme slopes (such as mountainous roads) or high banks (such as sharp curves on a freeway), the VDC may not operate normally, or the VDC warning lamp and the SLIP indicator lamp may turn on. This is not a problem if normal operation can be resumed after restarting the engine.
- Sudden turns (such as spin turns, acceleration turns), drifting, etc. with VDC turned off may cause the yaw rate/side G sensor to indicate a problem. This is not a problem if normal operation can be resumed after restarting the engine.

## Precautions for CAN System

EFS004UF

- Do not apply voltage of 7.0V or higher to terminal to be measured.
- Maximum open terminal voltage of tester in use must be less than 7.0V.
- Before checking harnesses, turn ignition switch OFF and disconnect battery negative cable.

# PRECAUTIONS

[VDC/TCS/ABS]

- Area to be repaired must be soldered and wrapped with tape. Make sure that fraying of twisted wire is within 110 mm (4.33 in).

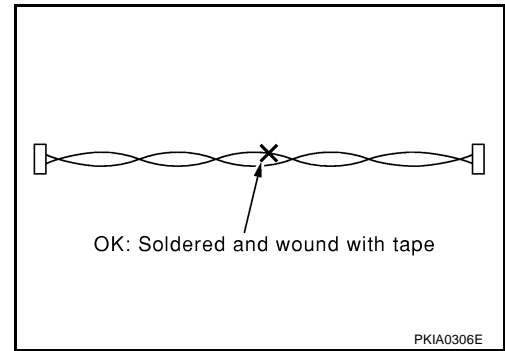

- Do not make a bypass connection to repaired area. (If the circuit is bypassed, characteristics of twisted wire will be lost.)

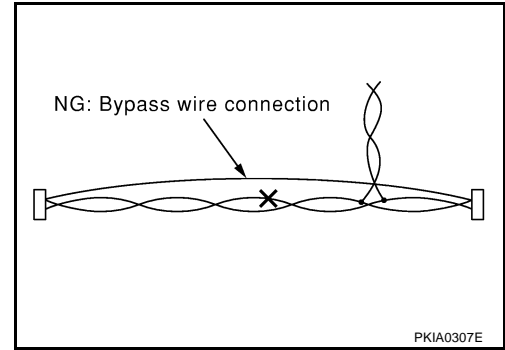

## Wiring Diagrams and Trouble Diagnosis

When you read wiring diagrams, refer to the following:

- [GI-15, "How to Read Wiring Diagrams"](#).
- [PG-4, "POWER SUPPLY ROUTING CIRCUIT"](#).

When you perform trouble diagnosis, refer to the following:

- [GI-11, "HOW TO FOLLOW TEST GROUPS IN TROUBLE DIAGNOSES"](#).
- [GI-27, "How to Perform Efficient Diagnosis for an Electrical Incident"](#).

A  
B  
C  
D  
E  
BRC  
G  
H  
I  
J  
K  
L  
M

# PREPARATION

[VDC/TCS/ABS]

## PREPARATION

PFP:00002

### Special Service Tool

EFS004UH

The actual shapes of Kent-Moore tools may differ from those of special service tools illustrated here.

Tool number (Kent-Moore No.) Tool name	Description
(J-45741) ABS active wheel sensor tester	Checking operation of ABS active wheel sensors

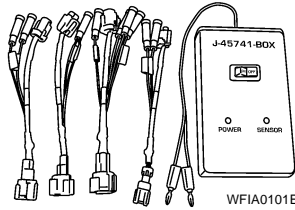

### Commercial Service Tools

EFS004UI

Tool name	Description
1. Flare nut crowfoot 2. Torque wrench	Removing and installing brake piping <b>a: 10mm (0.39 in)/12mm (0.47 in)</b>

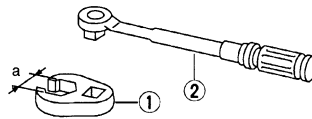

S-NT360

SYSTEM DESCRIPTION

System Components

PFP:00000

EFS004UJ

A

B

C

D

E

**BRC**

G

H

I

J

K

L

M

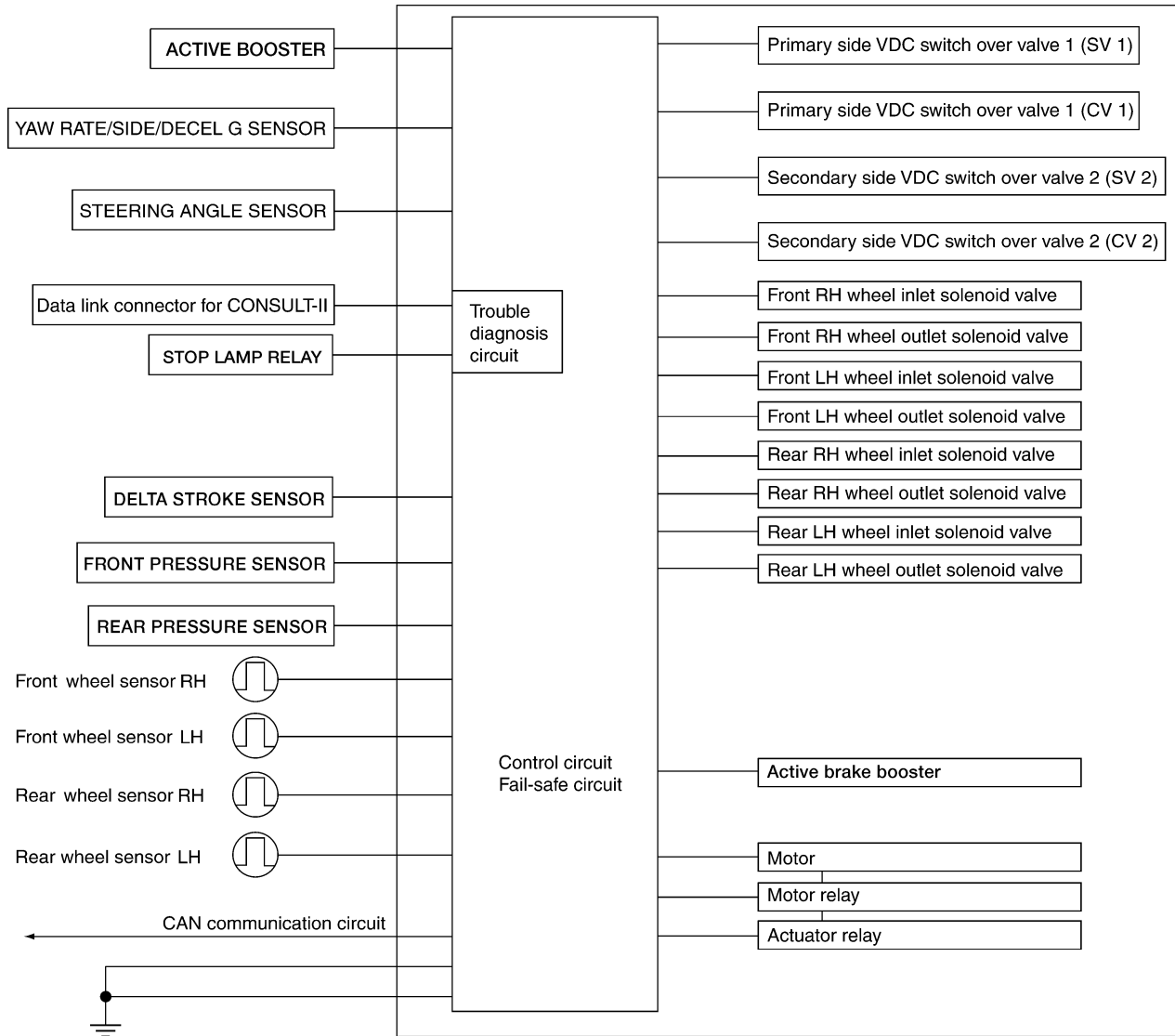

ABS actuator and electric unit (control unit)

## ABS Function

EFS004UK

- The Anti-Lock Brake System detects wheel revolution while braking and improves handling stability during sudden braking by electrically preventing wheel lockup. Maneuverability is also improved for avoiding obstacles.
- If the electrical system malfunctions, the Fail-Safe function is activated, the ABS becomes inoperative and the ABS warning lamp turns on.
- The electrical system can be diagnosed using CONSULT-II.
- During ABS operation, the brake pedal may vibrate lightly and a mechanical noise may be heard. This is normal.
- Just after starting the vehicle, the brake pedal may vibrate or a motor operating noise may be heard from engine compartment. This is a normal status of operation check.
- Stopping distance may be longer than that of vehicles without ABS when vehicle drives on rough, gravel, or snow-covered (fresh, deep snow) roads.

## EBD Function

EFS004UL

- Electronic Brake Distribution is a function that detects subtle slippages between the front and rear wheels during braking, and it improves handling stability by electronically controlling the brake fluid pressure which results in reduced rear wheel slippage.
- If the electrical system malfunctions, the Fail-Safe function is activated, the EBD and ABS become inoperative, and the ABS warning lamp and BRAKE warning lamp are turned on.
- The electrical system can be diagnosed using CONSULT-II.
- During EBD operation, the brake pedal may vibrate lightly and a mechanical noise may be heard. This is normal.
- Just after starting the vehicle, the brake pedal may vibrate or a motor operating noise may be heard from engine compartment. This is a normal status of operation check.

## TCS Function

EFS004UM

- Spinning of the drive wheels is detected by the ABS actuator and electric unit (control unit) using inputs from the wheel speed sensors. If wheel spin occurs, the drive wheel right and left brake fluid pressure control and engine fuel cut are activated while the throttle value is restricted to reduce the engine torque and decrease the amount of wheel spin. In addition, the throttle opening is controlled to achieve the optimum engine torque.
- Depending on road condition, the vehicle may have a sluggish feel. This is normal, because optimum traction has the highest priority during TCS operation.
- TCS may be activated during sudden vehicle acceleration, wide open throttle acceleration, sudden transmission shifts or when the vehicle is driven on a road with a varying surface friction coefficient.
- The SLIP indicator lamp flashes to inform the driver of TCS operation.

## VDC Function

EFS004UN

- In addition to the ABS/TCS function, the driver steering amount and brake operation amount are detected from the steering angle sensor and pressure sensors, and the vehicle's driving status (amount of under steering/over steering) is determined using inputs from the yaw rate sensor/side G sensor, wheel speed sensors, etc. and this information is used to improve vehicle stability by controlling the braking and engine torque application to the wheels.
- The SLIP indicator lamp flashes to inform the driver of VDC operation.
- During VDC operation, the vehicle body and brake pedal may vibrate lightly and a mechanical noise may be heard. This is normal.
- The ABS warning lamp, VDC OFF indicator lamp and SLIP indicator lamp may turn on when the vehicle is subject to strong shaking or large vibration, such as when the vehicle is on a turn table or a ship while the engine is running or on a steep slope. In this case, restart the engine on a normal road and if the ABS warning lamp, VDC OFF indicator lamp and SLIP indicator lamp turn off, there is no problem.

## Fail-Safe Function

EFS004UO

### CAUTION:

If the Fail-Safe function is activated, perform the Self Diagnosis for ABS/TCS/VDC system.



**ABS/EBD SYSTEM**

In case of an electrical malfunction with the ABS, the ABS warning lamp, VDC OFF indicator lamp and SLIP indicator lamp will turn on. In case of an electrical malfunction with the EBD system, the BRAKE warning lamp, ABS warning lamp, VDC OFF indicator lamp and SLIP indicator lamp will turn on. The system will revert to one of the following conditions of the Fail-Safe function.

1. For ABS malfunction, only the EBD is operative and the condition of the vehicle is the same condition of vehicles without ABS/TCS/VDC system.
2. For EBD malfunction, the EBD and ABS become inoperative, and the condition of the vehicle is the same as the condition of vehicles without ABS/TCS/VDC or EBD system.

**VDC/TCS SYSTEM**

In case of TCS/VDC system malfunction, the VDC OFF indicator lamp and SLIP indicator lamp are turned on and the condition of the vehicle is the same as the condition of vehicles without TCS/VDC system. In case of an electrical malfunction with the TCS/VDC system, the ABS control continues to operate normally without TCS/VDC control.

**ACTIVE BOOSTER**

The active brake booster consists of vacuum booster, an active booster control group and a delta stroke sensor. In case of brake booster system malfunction due to loss of vacuum the delta stroke sensor will signal the ABS actuator and electric unit (control unit) that a booster failure has occurred. The active booster then applies supplemental force to the master cylinder relative to the amount of force exerted on the brake pedal.

**Hydraulic Circuit Diagram**

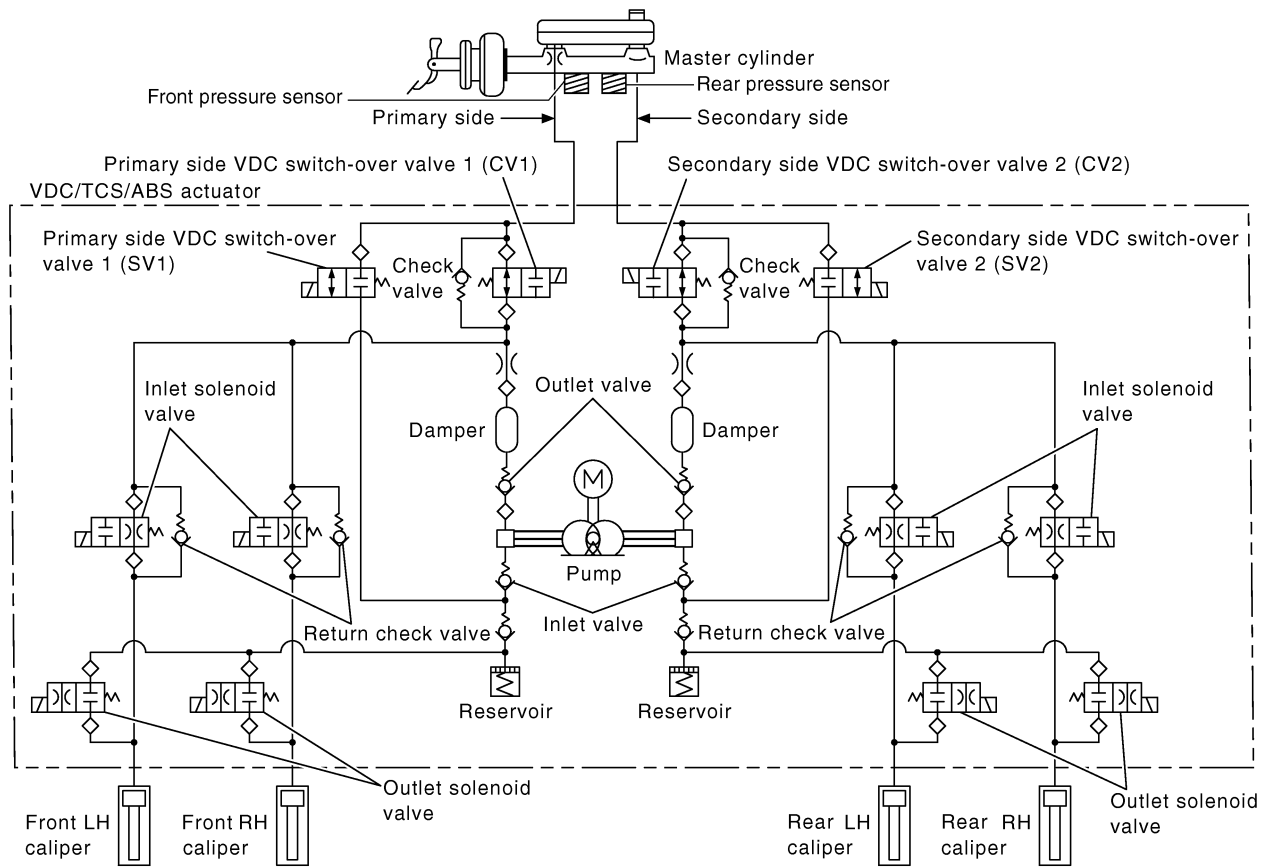

EF5004UP

WFIA0187E

---

**CAN COMMUNICATION**

PF2:23710

**System Description**

EF004UQ

Refer to [LAN-5, "CAN COMMUNICATION"](#) .

**TROUBLE DIAGNOSIS**

**How to Perform Trouble Diagnoses for Quick and Accurate Repair**

**INTRODUCTION**

The ABS/TCS/VDC system has an electronic control unit to control major functions. The control unit accepts input signals from sensors and controls actuator operation. It is also important to check for conventional problems such as air leaks in the booster or lines, lack of brake fluid, or other problems with the brake system.

It is much more difficult to diagnose a problem that occurs intermittently rather than continuously. Most intermittent problems are caused by poor electrical connections or faulty wiring. In this case, careful checking of suspicious circuits may help prevent the replacement of good parts.

A visual check only may not find the cause of the problem, so a road test should be performed.

Before undertaking actual checks, take just a few minutes to talk with a customer who approaches with an ABS/TCS/VDC complaint. The customer is a very good source of information on such problems, especially intermittent ones. Through the talks with the customer, find out what symptoms are present and under what conditions they occur.

Start your diagnosis by looking for “conventional” problems first. This is one of the best ways to troubleshoot brake problems on an ABS/TCS/VDC equipped vehicle. Also check related Service Bulletins for information.

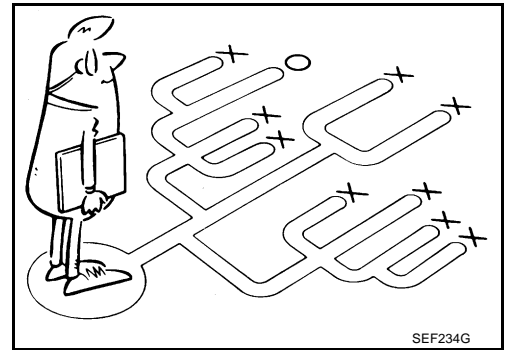
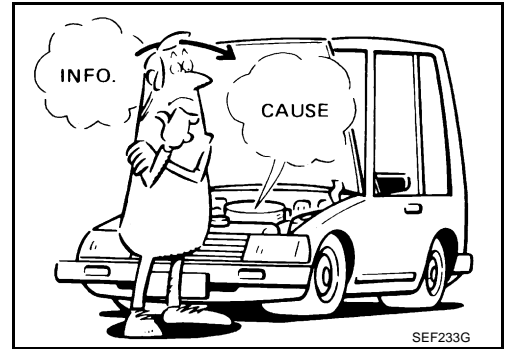

A  
B  
C  
D  
E  
BRC  
G  
H  
I  
J  
K  
L  
M

## WORK FLOW

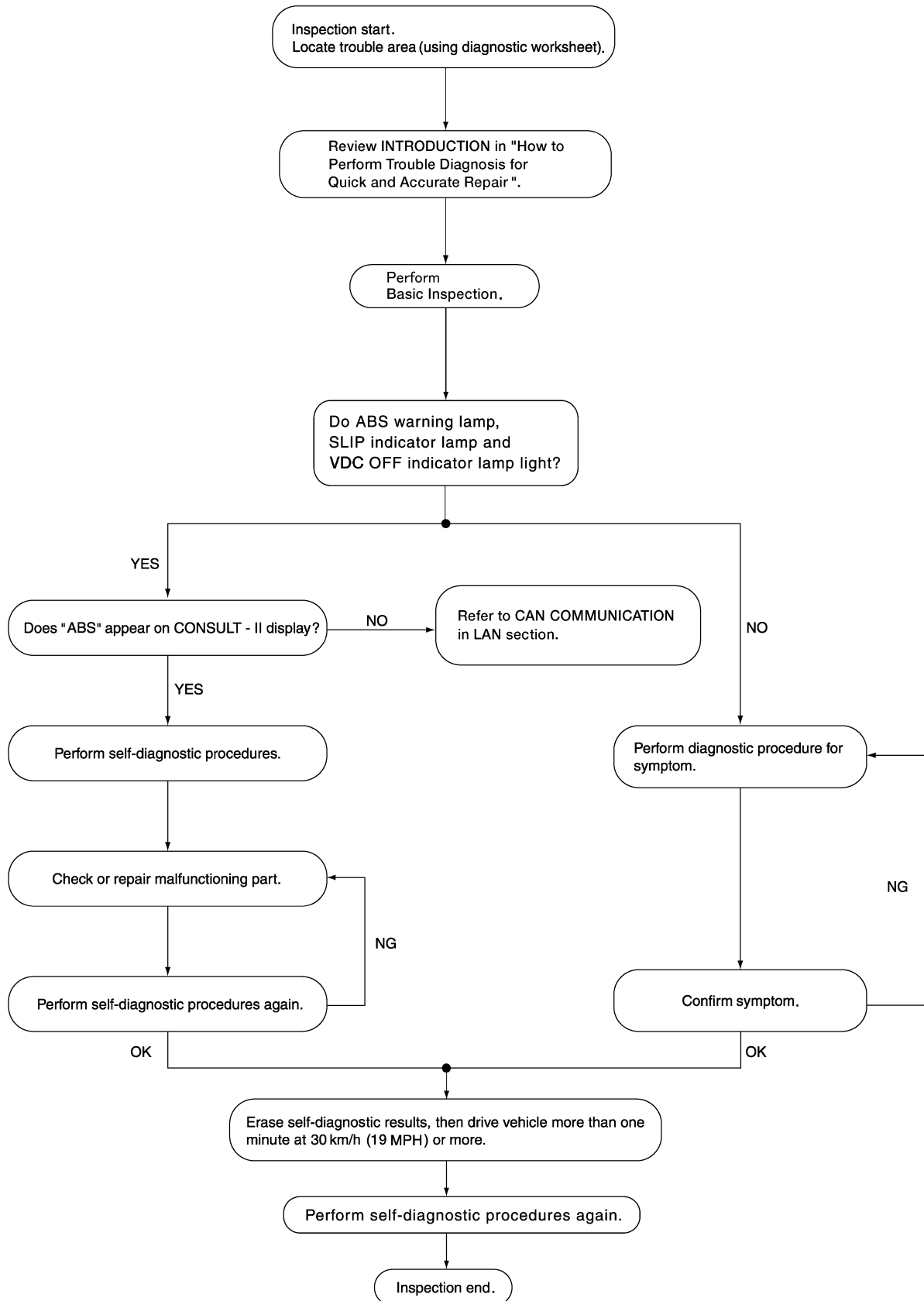

WFIA0358E

# TROUBLE DIAGNOSIS

[VDC/TCS/ABS]

## CLARIFY CONCERN

- A customer's description of a vehicle concern may vary depending on the individual. It is important to clarify the customer's concern.
- Ask the customer about what symptoms are present under what conditions. Use this information to reproduce the symptom while driving.
- It is also important to use the diagnosis sheet to understand what type of trouble the customer is having.

KEY POINTS	
<b>WHAT</b>	..... Vehicle model
<b>WHEN</b>	..... Date, Frequencies
<b>WHERE</b>	..... Road conditions
<b>HOW</b>	..... Operating conditions, Weather conditions, Symptoms

SBR339B

## EXAMPLE OF DIAGNOSIS SHEET

Customer name	Model & Year	VIN	
Engine #	Trans.	Mileage	
Incident Date	Manuf. Date	In Service Date	
Symptoms	<input type="checkbox"/> Noise and vibration (from engine compartment)	<input type="checkbox"/> ABS warning lamp activates	<input type="checkbox"/> Pedal operation
	<input type="checkbox"/> Noise and vibration (from axle)	<input type="checkbox"/> SLIP warning lamp activates	<input type="checkbox"/> Large stroke pedal operation
	<input type="checkbox"/> TCS does not work (drive wheels slip when accelerating)	<input type="checkbox"/> ABS does not work (wheels slip when braking)	<input type="checkbox"/> Firm pedal
	<input type="checkbox"/> Lack of sense of acceleration		
Engine conditions	<input type="checkbox"/> When starting <input type="checkbox"/> After starting		
Road conditions	<input type="checkbox"/> Low friction road ( <input type="checkbox"/> Snow <input type="checkbox"/> Gravel <input type="checkbox"/> Other ) <input type="checkbox"/> Bumps/potholes		
Driving conditions	<input type="checkbox"/> Full-acceleration <input type="checkbox"/> High speed cornering <input type="checkbox"/> Vehicle speed: Greater than 10 km/h (6 MPH) <input type="checkbox"/> Vehicle speed: 10 km/h (6 MPH) or less <input type="checkbox"/> Vehicle is stopped		
Applying brake conditions	<input type="checkbox"/> Suddenly <input type="checkbox"/> Gradually		
Other conditions	<input type="checkbox"/> Operation of electrical equipment <input type="checkbox"/> Shift change <input type="checkbox"/> Other descriptions		

WFIA0097E

A  
B  
C  
D  
E  
G  
H  
I  
J  
K  
L  
M

BRC

# TROUBLE DIAGNOSIS

[VDC/TCS/ABS]

## Component Parts and Harness Connector Location

EFS004US

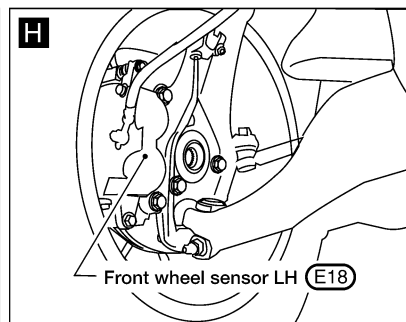
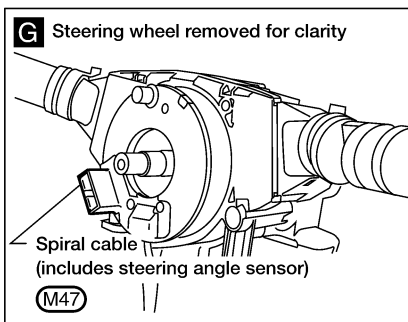
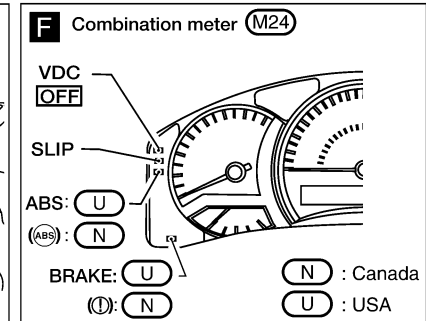
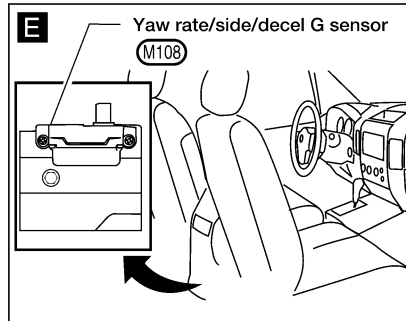
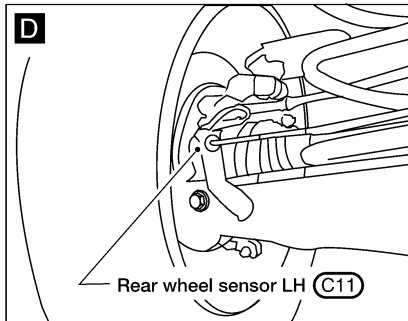
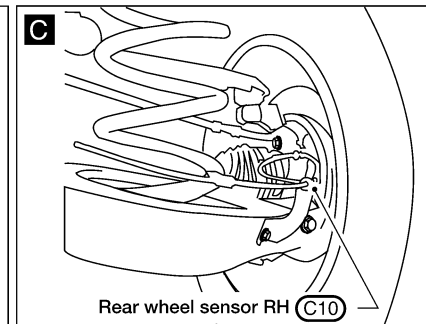
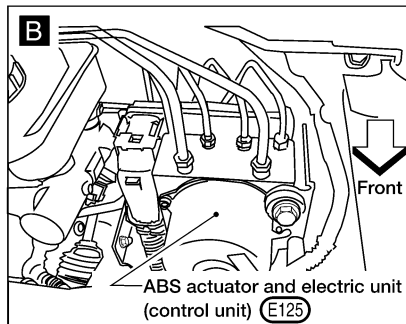
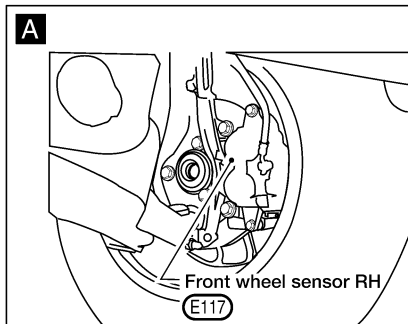
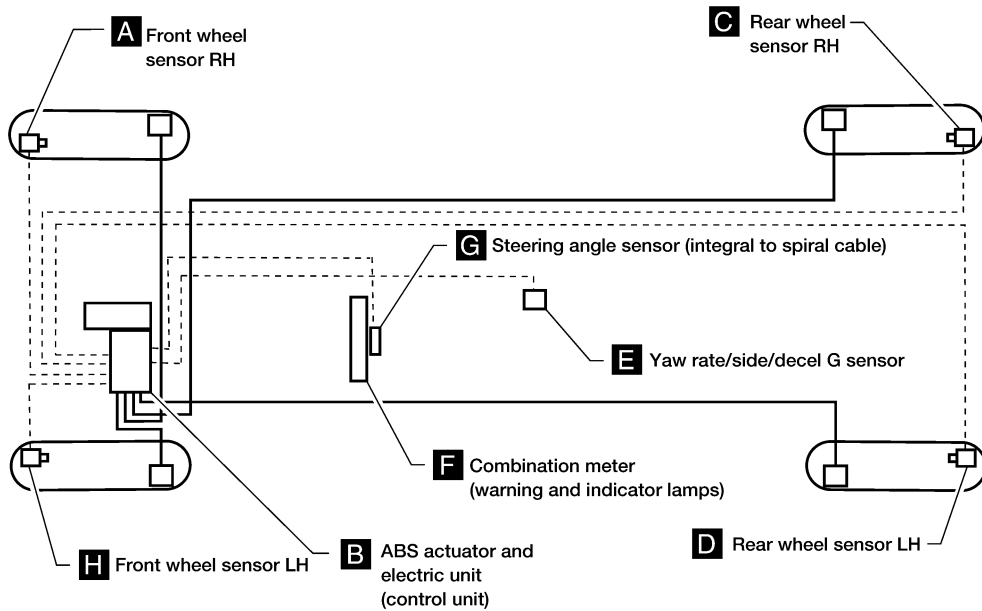

WFIA0342E

### Schematic

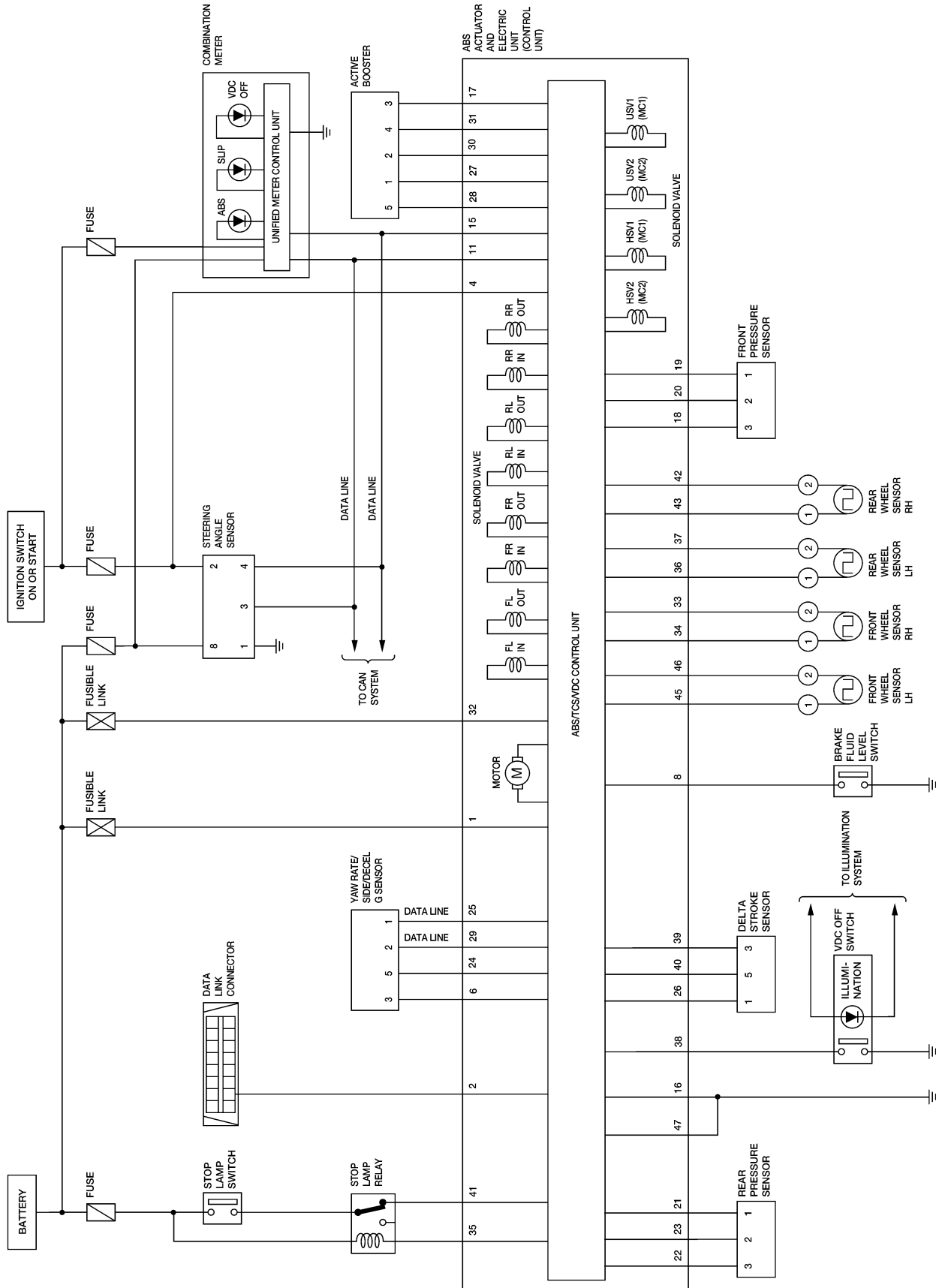

WFWA0190E

A  
B  
C  
D  
E  
**BRC**  
G  
H  
I  
J  
K  
L  
M

# TROUBLE DIAGNOSIS

[VDC/TCS/ABS]

## Wiring Diagram — VDC —

EFS004UU

BRC-VDC-01

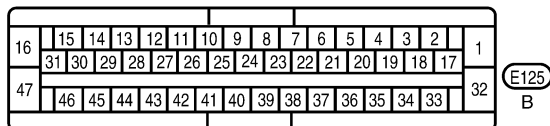
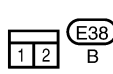
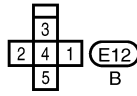
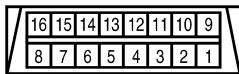
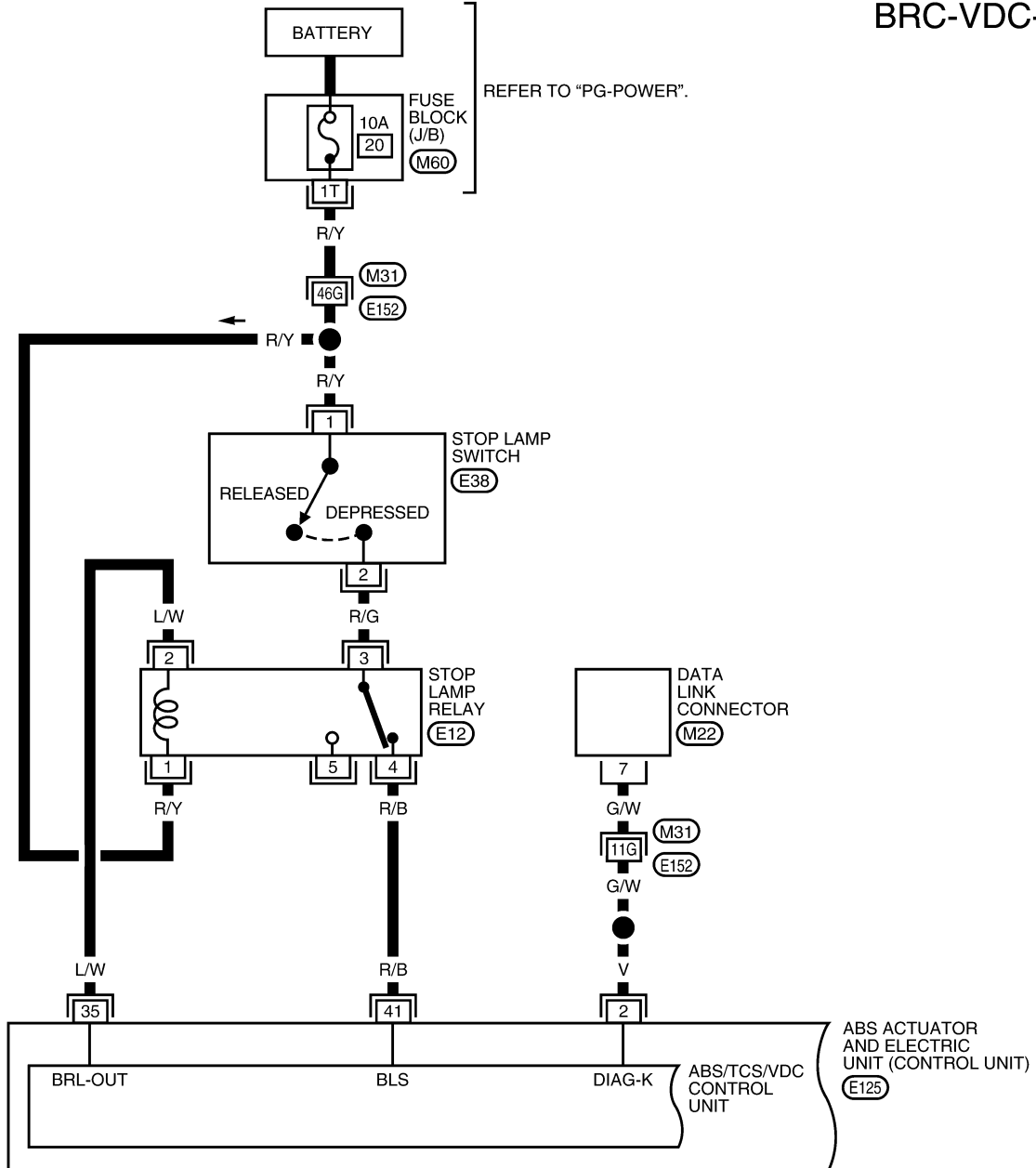

REFER TO THE FOLLOWING.  
(M31) - SUPER MULTIPLE JUNCTION (SMJ)

WFWA0191E



# TROUBLE DIAGNOSIS

[VDC/TCS/ABS]

BRC-VDC-02

A  
B  
C  
D  
E  
**BRC**  
G  
H  
I  
J  
K  
L  
M

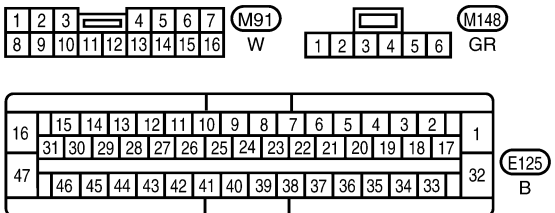
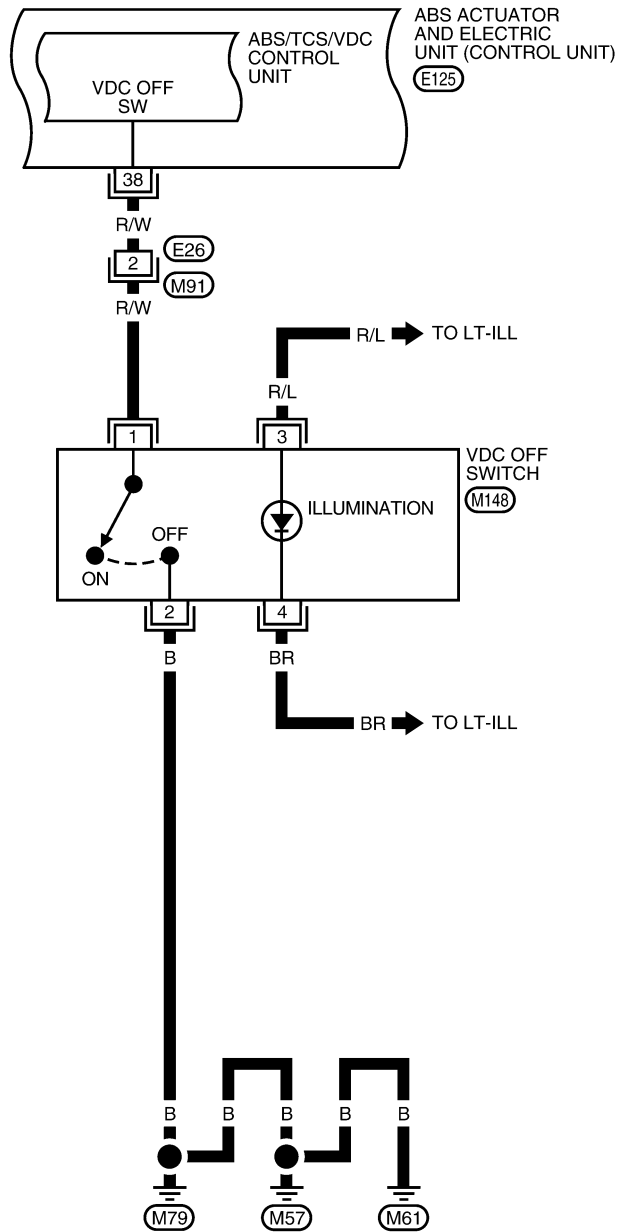

WFWA0192E

# TROUBLE DIAGNOSIS

[VDC/TCS/ABS]

BRC-VDC-03

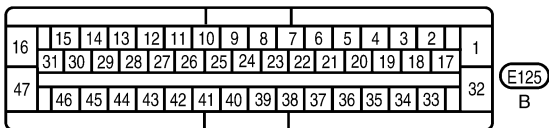
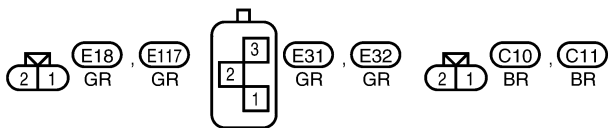
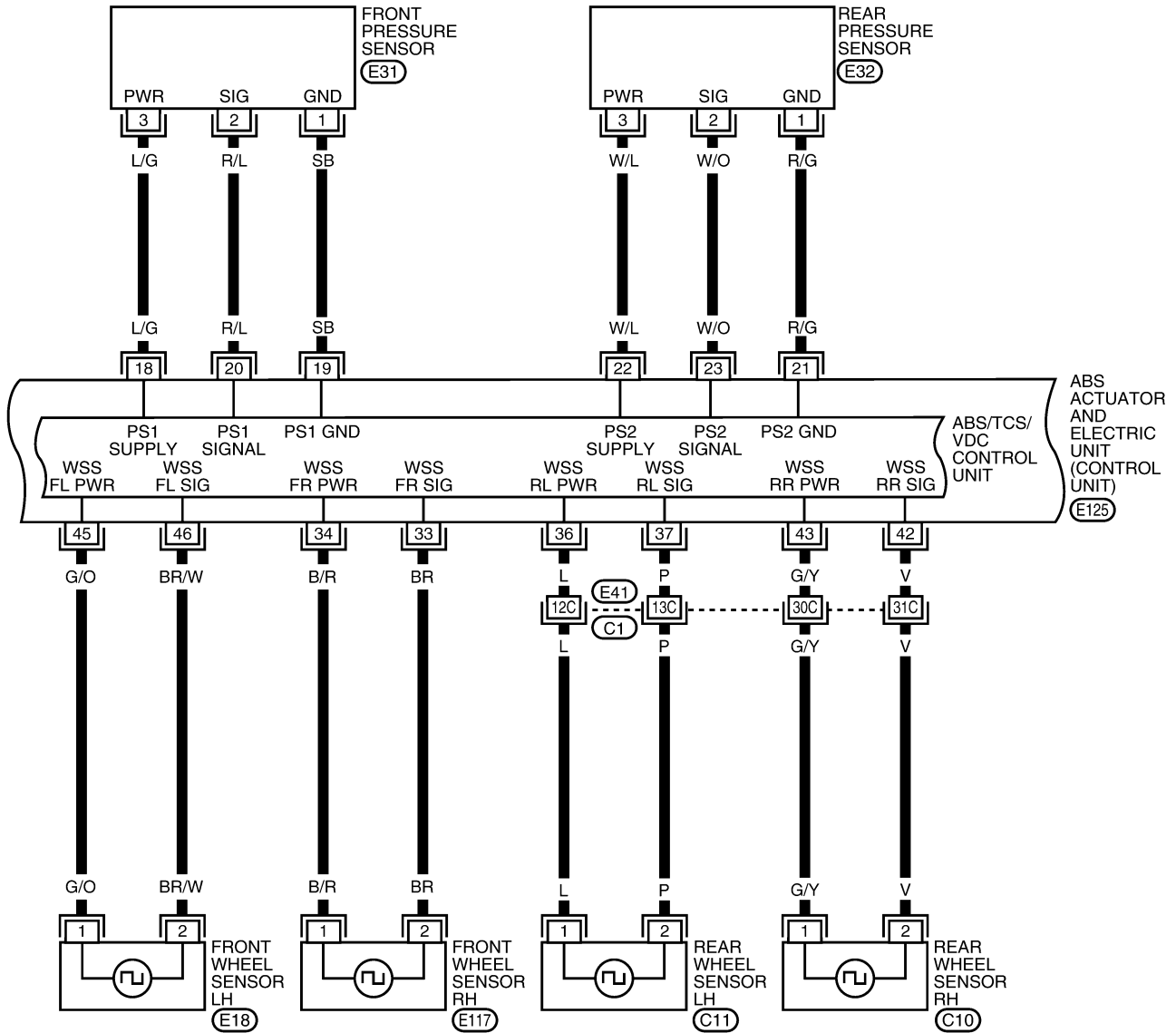

REFER TO THE FOLLOWING.  
 (C1) - SUPER MULTIPLE JUNCTION (SMJ)

WFWA0193E

# TROUBLE DIAGNOSIS

[VDC/TCS/ABS]

## BRC-VDC-04

▬ : DATA LINE

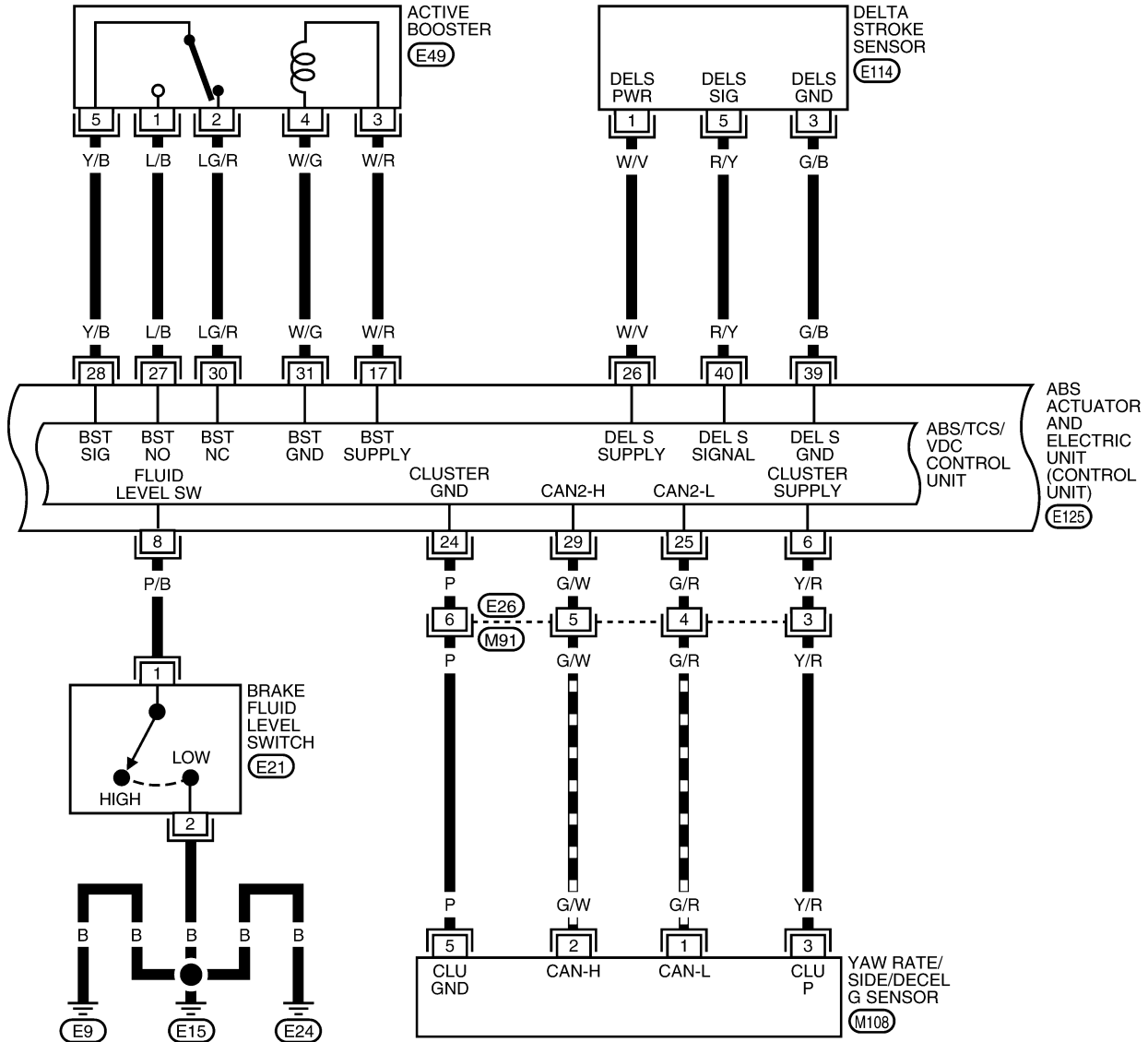

A  
B  
C  
D  
E  
BRC  
G  
H  
I  
J  
K  
L  
M

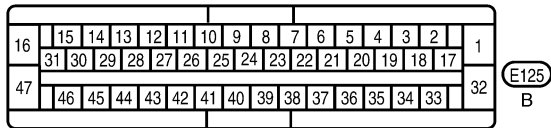
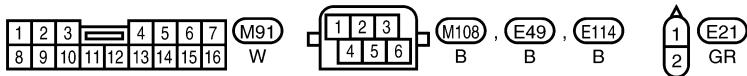

WFWA0194E

# TROUBLE DIAGNOSIS

[VDC/TCS/ABS]

BRC-VDC-05

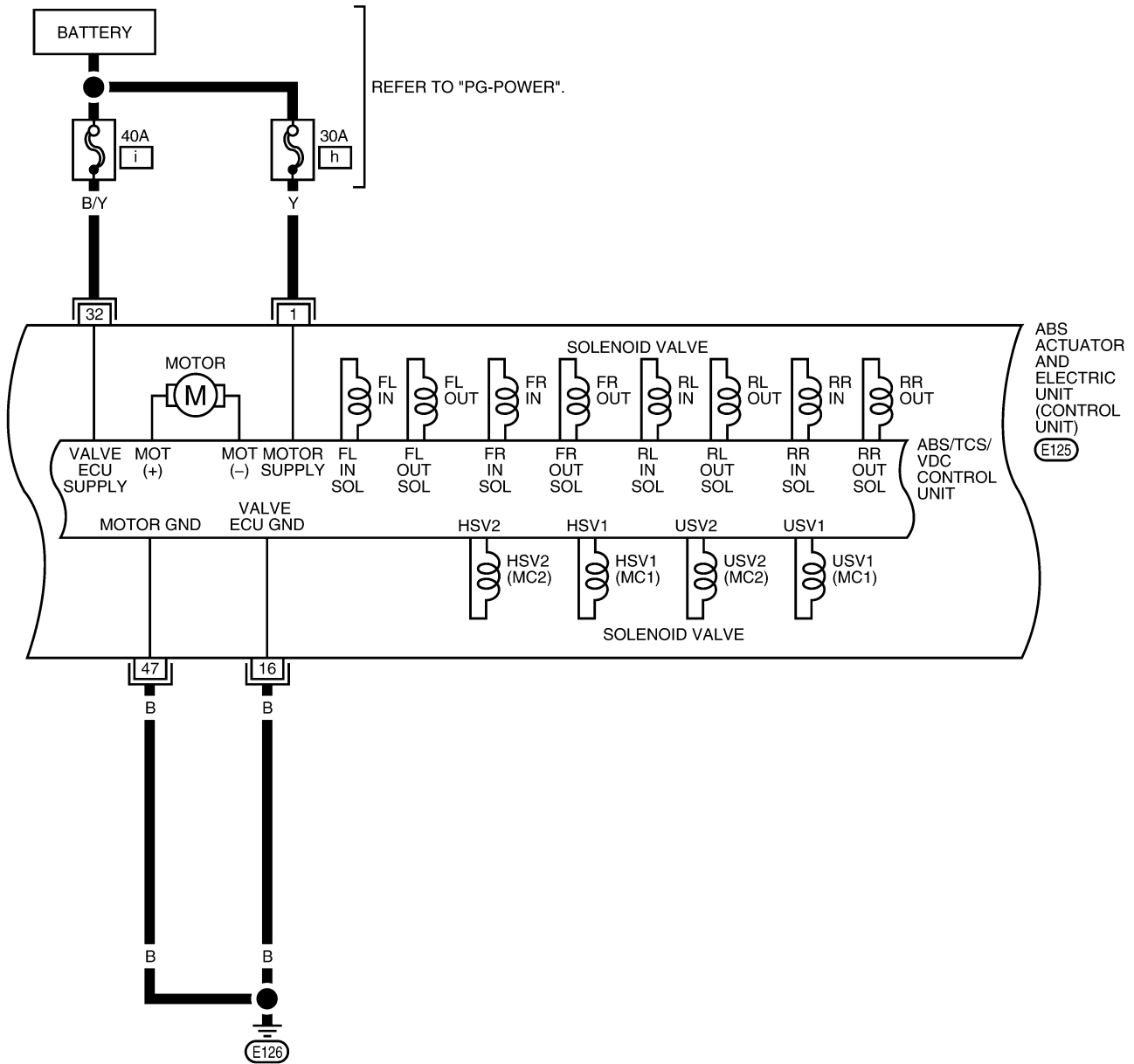

16	15	14	13	12	11	10	9	8	7	6	5	4	3	2	1
	31	30	29	28	27	26	25	24	23	22	21	20	19	18	17
47	46	45	44	43	42	41	40	39	38	37	36	35	34	33	32

E125  
B

WFWA0195E

# TROUBLE DIAGNOSIS

[VDC/TCS/ABS]

## BRC-VDC-06

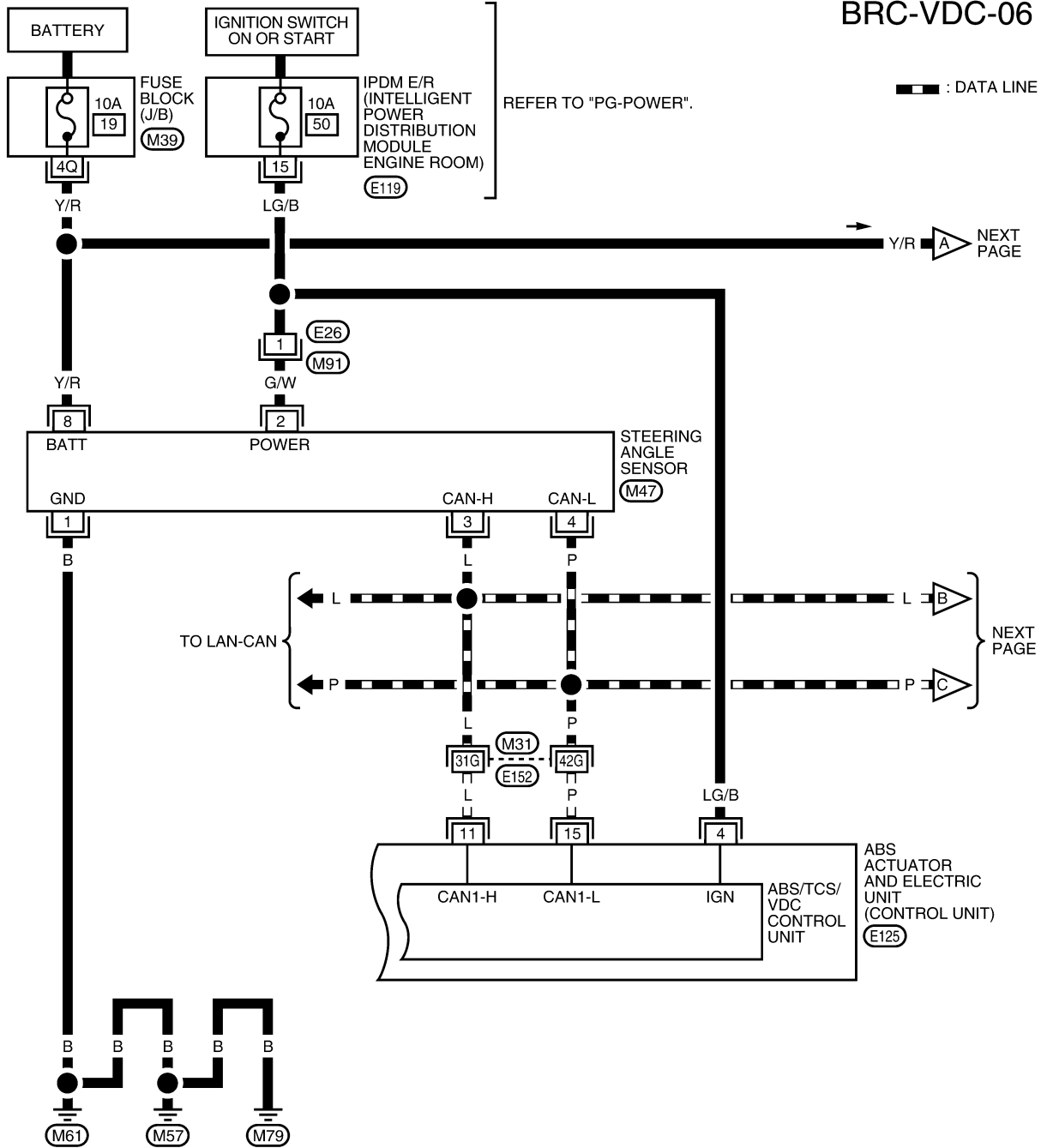

A  
B  
C  
D  
E  
**BRC**  
G  
H  
I  
J  
K  
L  
M

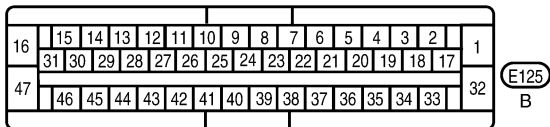
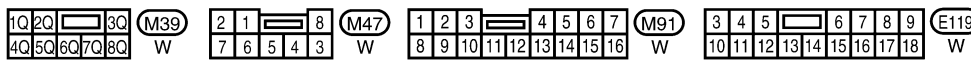

REFER TO THE FOLLOWING.  
**(M31)** - SUPER MULTIPLE JUNCTION (SMJ)

WFWA0196E

# TROUBLE DIAGNOSIS

[VDC/TCS/ABS]

BRC-VDC-07

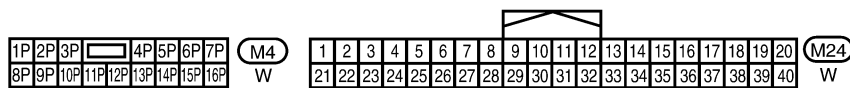
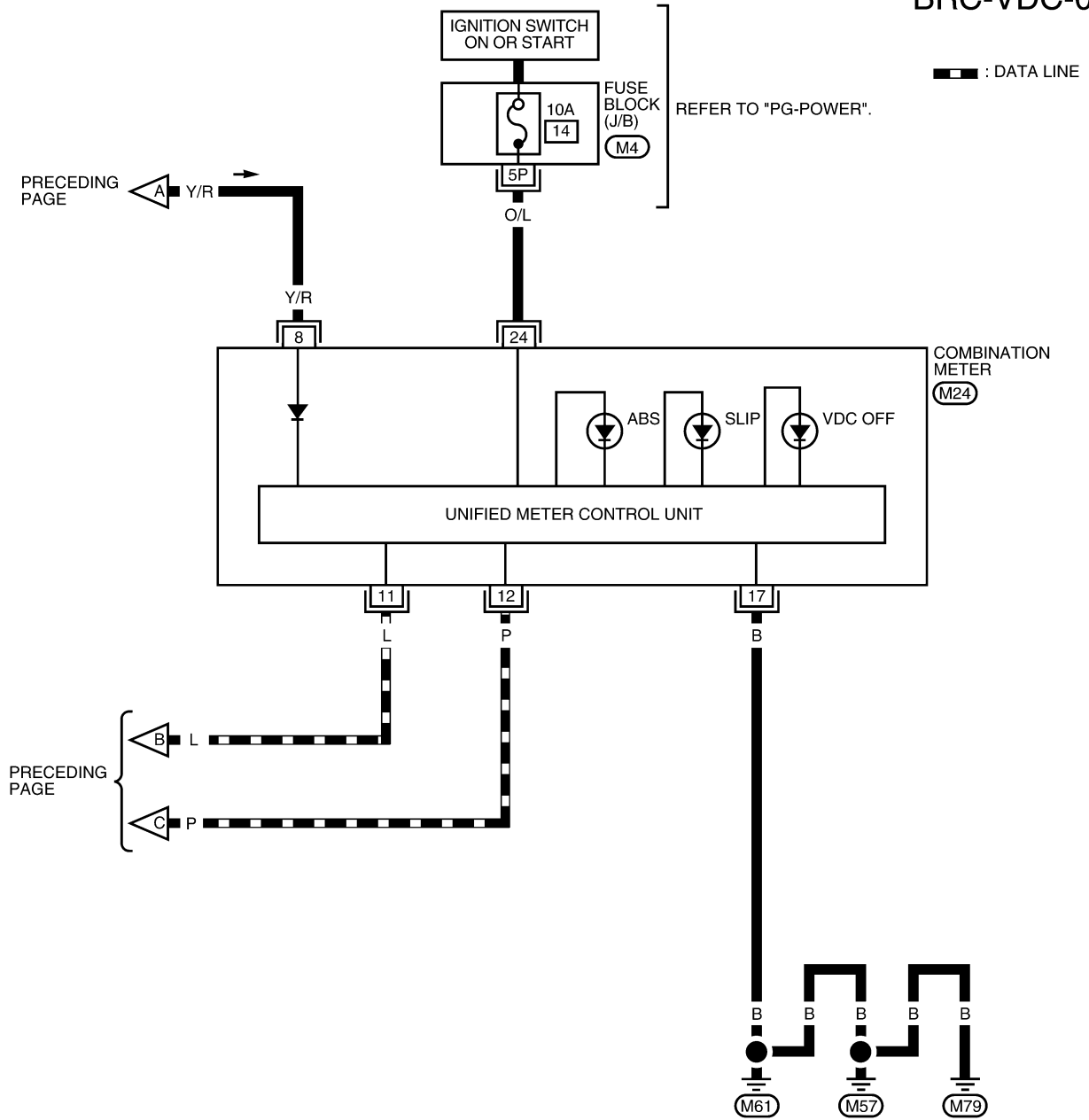

WFWA0197E

**Basic Inspection****BRAKE FLUID LEVEL, FLUID LEAK, AND BRAKE PAD INSPECTION**

1. Check fluid level in the brake fluid reservoir. If fluid level is low, add fluid.
2. Check the brake piping and around the ABS actuator and electric unit (control unit) for leaks. If there is leaking or seeping fluid, check the following items.
  - If ABS actuator and electric unit (control unit) connection is loose, tighten the piping to the specified torque and recheck for leaks.
  - If there is damage to the connection flare nut or ABS actuator and electric unit (control unit) threads, replace the damaged part and recheck for leaks.
  - When there is fluid leaking or seeping from a fluid connection, use a clean cloth to wipe off the fluid and recheck for leaks. If fluid is still seeping out, replace the damaged part. If the fluid is leaking at the ABS actuator and electric unit (control unit), replace the ABS actuator and electric unit (control unit) assembly.

**CAUTION:**

**The ABS actuator and electric unit (control unit) cannot be disassembled and must be replaced as an assembly.**

3. Check the brake pads for excessive wear.

**POWER SYSTEM TERMINAL LOOSENESS AND BATTERY INSPECTION**

Make sure the battery positive cable, negative cable and ground connection are not loose. In addition, make sure the battery is sufficiently charged.

**ABS WARNING LAMP, SLIP INDICATOR LAMP AND VDC OFF INDICATOR LAMP INSPECTION**

1. Make sure ABS warning lamp, SLIP indicator lamp and VDC OFF indicator lamp (when VDC OFF switch is off), turn on for approximately 1 second when the ignition switch is turned ON. If they do not, check the VDC OFF indicator lamp and the VDC OFF switch. Refer to [BRC-55, "VDC OFF SWITCH"](#) . Check CAN communications. If there are no errors with the VDC OFF switch or CAN communication system, check combination meter. Refer to [DI-5, "COMBINATION METERS"](#) .
2. Make sure the lamps turn off approximately 1 second after the ignition switch is turned ON. If the lamp does not turn off, conduct self-diagnosis.
3. With the engine running, make sure the VDC OFF indicator lamp turns on and off when the VDC OFF switch is turned on and off. If the indicator lamp status does not correspond to switch operation, check the VDC OFF switch. Refer to [BRC-55, "VDC OFF SWITCH"](#) .
4. Make sure ABS warning lamp, SLIP indicator lamp and VDC OFF indicator lamp turn off approximately 2 seconds after the engine is started. If ABS warning lamp, SLIP indicator lamp or VDC OFF indicator lamp have not turned off 10 seconds after the engine has been started, conduct self-diagnosis of the ABS actuator and electric unit (control unit).
5. After conducting the self-diagnosis, be sure to erase the error memory. Refer to [BRC-28, "CONSULT-II Function \(ABS\)"](#) .

A

B

C

D

E

BRC

G

H

I

J

K

L

M

# TROUBLE DIAGNOSIS

[VDC/TCS/ABS]

## Warning Lamp and Indicator Timing

EFS004UW

Condition	ABS warning lamp	VDC OFF indicator lamp	SLIP indicator lamp	Remarks
When the ignition switch is OFF	—	—	—	—
After the ignition switch is turned ON for approx. 1 second	×	×	×	—
After the ignition switch is turned ON for approx. 2 seconds	—	—	—	Lamp goes off approx. 2 seconds after the engine is started.
When the VDC OFF switch is pressed (VDC function OFF)	—	×	—	—
ABS/TCS/VDC malfunction	×	×	×	When the ABS actuator and electric unit (control unit) is malfunctioning (power supply or ground malfunction).
	×	×	—	
When the VDC is malfunctioning	—	×	×	—

X: ON  
—: OFF

## Control Unit Input/Output Signal Standard REFERENCE VALUE FROM CONSULT-II

EFS004UX

### CAUTION:

The display shows the control unit calculation data, so a normal value might be displayed even in the event the output circuit (harness) is open or short circuited.

Monitor item	Display content	Data monitor		Note: Error inspection checklist
		Condition	Reference value in normal operation	
N POSI SIG	PNP switch signal ON/OFF condition	A/T shift position = N position	ON	<a href="#">BRC-54, "CAN Communication System Inspection"</a>
		A/T shift position = other than N positions	OFF	
P POSI SIG	PNP switch signal ON/OFF condition	A/T shift position P position	ON	<a href="#">BRC-54, "CAN Communication System Inspection"</a>
		A/T shift position = other than P positions	OFF	
GEAR	A/T gear position	1st gear	1	—
		2nd gear	2	
		3rd gear	3	
		4th gear	4	
		5th gear	5	
FR RH SENSOR FR LH SENSOR RR RH SENSOR RR LH SENSOR	Wheel speed	Vehicle stopped	0 [km/h (MPH)]	<a href="#">BRC-38, "Wheel Sensor System Inspection"</a>
		Vehicle running (Note 1)	Almost in accordance with speedometer display (within ±10%)	
ACCEL POS SIG	Open/close condition of throttle valve (linked with accelerator pedal).	Accelerator pedal not depressed (ignition switch is ON)	0%	<a href="#">BRC-54, "CAN Communication System Inspection"</a>
		Depress accelerator pedal (ignition switch is ON)	0 to 100%	
ENGINE SPEED	With engine running	With engine stopped	0 rpm	<a href="#">BRC-39, "Engine System Inspection"</a>
		Engine running	Almost in accordance with tachometer display	



# TROUBLE DIAGNOSIS

[VDC/TCS/ABS]

Monitor item	Display content	Data monitor		Note: Error inspection checklist
		Condition	Reference value in normal operation	
STR ANGLE SIG	Steering angle detected by steering angle sensor	Straight-ahead	Approx. 0 deg	<a href="#">BRC-40. "Steering Angle Sensor System"</a>
		Steering wheel turned	-756 to 756 deg	
YAW RATE SEN	Yaw rate detected by yaw rate sensor	Vehicle stopped	Approx. 0 d/s	<a href="#">BRC-41. "Yaw Rate/Side/Decel G Sensor System Inspection"</a>
		Vehicle running	-100 to 100 d/s	
SIDE G SENSOR	Transverse G detected by side G-sensor	Vehicle stopped	Approx. 0 m/s <sup>2</sup>	<a href="#">BRC-41. "Yaw Rate/Side/Decel G Sensor System Inspection"</a>
		Vehicle running	-16.7 to 16.7 m/s <sup>2</sup>	
BATTERY VOLT	Battery voltage supplied to ABS actuator and electric unit (control unit)	Ignition switch ON	10 to 16V	<a href="#">BRC-46. "ABS/TCS/VDC Control Unit Power and Ground Systems Inspection"</a>
STOP LAMP SW	Stop lamp switch operation	Brake pedal depressed	ON	<a href="#">BRC-45. "Stop Lamp Switch System Inspection"</a>
		Brake pedal not depressed	OFF	
OFF SW	VDC OFF switch ON/OFF status	VDC OFF switch ON (When VDC OFF indicator lamp is ON)	ON	<a href="#">BRC-55. "VDC OFF SWITCH"</a>
		VDC OFF switch OFF (When VDC OFF indicator lamp is OFF)	OFF	
ABS WARN LAMP	ABS warning lamp ON condition (Note 2)	ABS warning lamp ON	ON	—
		ABS warning lamp OFF	OFF	
MOTOR RELAY	Operation status of motor and motor relay	Ignition switch ON or running (ABS not activated)	OFF	<a href="#">BRC-44. "Actuator Motor, Motor Relay, and Circuit Inspection"</a>
		Ignition switch ON or engine running (ABS activated)	ON	
ACTUATOR RLY	Actuator relay operation status	Vehicle stopped (Ignition switch ON)	OFF	<a href="#">BRC-44. "Actuator Motor, Motor Relay, and Circuit Inspection"</a>
		Vehicle stopped (Engine running)	ON	
OFF LAMP	VDC OFF indicator lamp status (Note 3)	When VDC OFF indicator lamp is ON	ON	<a href="#">BRC-54. "CAN Communication System Inspection"</a>
		When VDC OFF indicator lamp is OFF	OFF	
SLIP LAMP	SLIP indicator lamp status (Note 4)	When SLIP indicator lamp is ON	ON	<a href="#">BRC-54. "CAN Communication System Inspection"</a>
		When SLIP indicator lamp is OFF	OFF	

A  
B  
C  
D  
E  
BRC  
G  
H  
I  
J  
K  
L  
M

# TROUBLE DIAGNOSIS

[VDC/TCS/ABS]

Monitor item	Display content	Data monitor		Note: Error inspection checklist
		Condition	Reference value in normal operation	
FR LH IN SOL FR LH OUT SOL FR RH IN SOL FR RH OUT SOL RR RH IN SOL RR RH OUT SOL RR LH IN SOL RR LH OUT SOL	Solenoid valve operation	Actuator (solenoid) is active ("ACTIVE TEST" with CONSULT-II) or actuator relay is inactive (in fail-safe mode).	ON	<a href="#">BRC-43. "Solenoid and VDC Change-Over Valve System Inspection"</a>
		When actuator (solenoid) is not active and actuator relay is active (ignition switch ON).	OFF	
CV1 CV2 SV1 SV2	VDC switch-over valve status	When actuator (switch-over valve) is active ("ACTIVE TEST" with CONSULT-II) or actuator relay is inactive (when in fail-safe mode).	ON	<a href="#">BRC-41. "Yaw Rate/Side/Decel G Sensor System Inspection"</a>
		When actuator (switch-over valve) is not active and actuator relay is active (ignition switch ON).	OFF	
DECEL G-SEN	Longitudinal acceleration detected by Decel G-Sensor	Vehicle stopped	Approx. 0 G	<a href="#">BRC-41. "Yaw Rate/Side/Decel G Sensor System Inspection"</a>
		Vehicle running	-1.7 to 1.7 G	
PRESS SENSOR	Brake fluid pressure detected by pressure sensor	Do not step on the Brake pedal (When ignition switch is ON)	Approx. 0 bar	—
		Step on the Brake pedal (When ignition switch is ON)	-40 to 300 bar	
FLUID LEV SW	ON/OFF status of brake fluid level switch	When brake fluid level switch ON	ON	<a href="#">DI-30. "WARNING LAMPS"</a>
		When brake fluid level switch OFF	OFF	
VDC SIGNAL TCS SIGNAL ABS SIGNAL EBD SIGNAL	Signal status	VDC active TCS active ABS active EBD active	ON	VDC system TCS system ABS system EBD system
		VDC not active TCS not active ABS not active EBD not active	OFF	
VDC FAIL SIG TCS FAIL SIG ABS FAIL SIG EBD FAIL SIG	Fail signal status	VDC fail TCS fail ABS fail EBD fail	ON	VDC system TCS system ABS system EBD system
		VDC normal TCS normal ABS normal EBD normal	OFF	

Note 1: Confirm tire pressure is normal.

Note 2: ON/OFF timing of ABS warning lamp

ON: For approximately 1 second after ignition switch is turned ON, or when a malfunction is detected.

OFF: Approximately 1 second after ignition switch is turned ON (when system is in normal operation) and TCS/VDC function is not activated.

Note 3: ON/OFF timing of VDC OFF indicator lamp

ON: For approximately 1 second after ignition switch is turned ON, or when a malfunction is detected and VDC OFF switch is ON.

OFF: Approximately 1 second after ignition switch is turned ON (when system is in normal operation.) And when VDC OFF switch is OFF.

Note 4: SLIP indicator lamp ON/OFF timing

ON: For approximately 1 second after ignition switch is turned ON, or when a malfunction is detected and TCS/VDC function is activated while driving.

# TROUBLE DIAGNOSIS

[VDC/TCS/ABS]

OFF: Approximately 1 second after ignition switch is turned ON (when system is in normal operation) and TCS/VDC function is not activated.

Flashing: TCS/VDC function is active during driving

A

B

C

D

E

**BRC**

G

H

I

J

K

L

M

## CONSULT-II Function (ABS)

CONSULT-II can display each diagnostic item using the diagnostic test modes shown following.

ABS diagnostic mode	Description
WORK SUPPORT	Supports inspection and adjustments. Commands are transmitted to the ABS actuator and electric unit (control unit) for setting the status suitable for required operation, input/output signals are received from the ABS actuator and electric unit (control unit) and received data is displayed.
SELF-DIAG RESULTS	Displays ABS actuator and electric unit (control unit) self-diagnosis results.
DATA MONITOR	Displays ABS actuator and electric unit (control unit) input/output data in real time.
CAN DIAG SUPPORT MNTR	The result of transmit/receive diagnosis of CAN communication can be read.
ACTIVE TEST	Operation of electrical loads can be checked by sending drive signal to them.
FUNCTION TEST	Conducted by CONSULT-II instead of a technician to determine whether each system is "OK" or "NG".
ECU PART NUMBER	ABS actuator and electric unit (control unit) part number can be read.

### CONSULT-II BASIC OPERATION PROCEDURE

1. Turn ignition switch OFF.
2. Connect CONSULT-II and CONSULT-II CONVERTER to the data link connector.

**CAUTION:**

If CONSULT-II is used with no connection of CONSULT-II CONVERTER, malfunctions might be detected in self-diagnosis depending on control unit which carries out CAN communication.

3. Turn ignition switch ON.

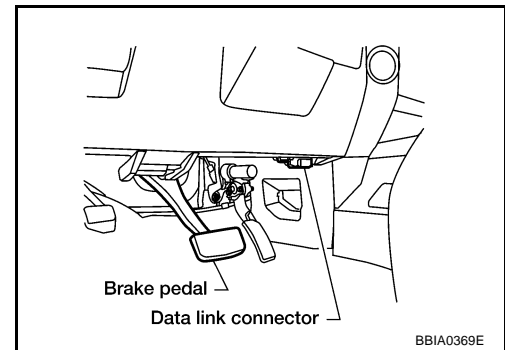

4. Touch "START (NISSAN BASED VHCL)".

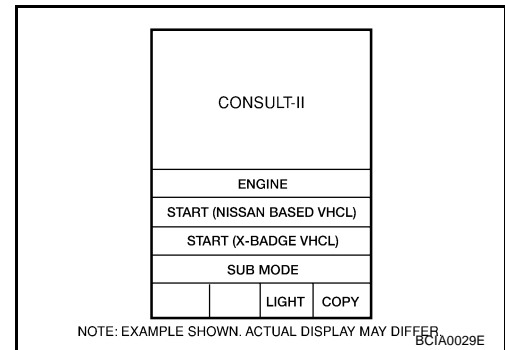

5. Touch "ABS" in the "SELECT SYSTEM" screen.  
If "ABS" is not indicated, go to [GI-39, "CONSULT-II Data Link Connector \(DLC\) Circuit"](#).

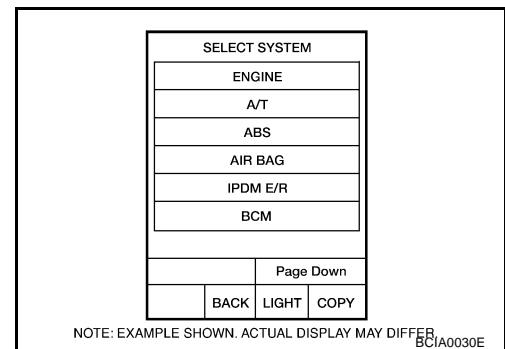

6. Select the required diagnostic location from the "SELECT DIAG MODE" screen.  
For further information, see the CONSULT-II Operation Manual.

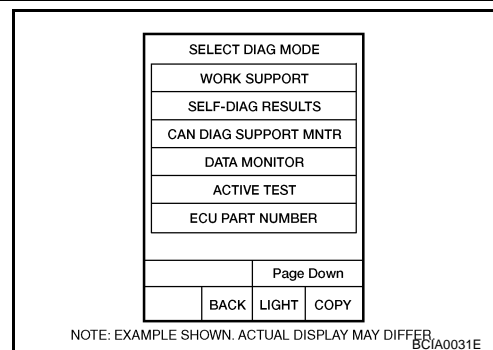

## SELF-DIAGNOSIS

### Description

If an error is detected in the system, the ABS warning lamp will turn on. In this case, perform self-diagnosis as follows:

### Operation Procedure

1. Turn ignition switch OFF.
2. Connect CONSULT-II and CONSULT-II CONVERTER to the data link connector.

#### CAUTION:

If CONSULT-II is used with no connection of CONSULT-II CONVERTER, malfunctions might be detected in self-diagnosis depending on control unit which carries out CAN communication.

3. Turn ignition switch ON.
4. Start engine and drive at approximately 30 km/h (19 MPH) or more for approximately 1 minute.
5. After stopping the vehicle, with the engine running, touch "START (NISSAN BASED VHCL)", "ABS", "SELF-DIAG RESULTS" in order on the CONSULT-II screen.

#### CAUTION:

If "START (NISSAN BASED VHCL)" is touched immediately after starting the engine or turning on the ignition switch, "ABS" might not be displayed in the SELECT SYSTEM screen. In this case, repeat the operation from step 1.

6. The self-diagnostic results are displayed. (If necessary, the self-diagnostic results can be printed out by touching "PRINT".)
  - When "NO DTC IS DETECTED" is displayed, check the ABS warning lamp, SLIP indicator lamp and VDC OFF indicator lamp.
7. Conduct the appropriate inspection from the display item list, and repair or replace the malfunctioning component.
8. Start engine and drive at approximately 30 km/h (19 MPH) or more for approximately 1 minute.

#### CAUTION:

● When a wheel sensor "short-circuit" is detected, if the vehicle is not driven at 30 km/h (19 MPH) for at least 1 minute, the ABS warning lamp will not turn off even if the malfunction is repaired.

9. Turn ignition switch OFF to prepare for erasing the memory.
10. Start the engine and touch "START (NISSAN BASED VHCL)", "ABS", "SELF-DIAG RESULTS", "ERASE" in order on the CONSULT-II screen to erase the error memory.  
If "ABS" is not indicated, go to [GI-39, "CONSULT-II Data Link Connector \(DLC\) Circuit"](#).

#### CAUTION:

If the error memory is not erased, re-conduct the operation from step 5.

11. For the final inspection, drive at approximately 30 km/h (19 MPH) or more for approximately 1 minute and confirm that the ABS warning lamp, SLIP indicator lamp, and VDC OFF indicator lamp are off.

# TROUBLE DIAGNOSIS

[VDC/TCS/ABS]

## Display Item List

Self-diagnostic item	Malfunction detecting condition	Check system
FR LH SENSOR 1 [C1104]	Circuit of front LH wheel sensor is open, shorted or sensor power voltage is unusual.	<a href="#">BRC-38. "Wheel Sensor System Inspection"</a> (Note 1)
RR RH SENSOR 1 [C1101]	Circuit of rear RH wheel sensor is open, shorted or sensor power voltage is unusual.	
FR RH SENSOR 1 [C1103]	Circuit of front RH wheel sensor is open, shorted or sensor power voltage is unusual.	
RR LH SENSOR 1 [C1102]	Circuit of rear LH wheel sensor is open, shorted or sensor power voltage is unusual.	
FR LH SENSOR 2 [C1108]	ABS actuator and electric unit (control unit) cannot identify sensor pulses, because of large gap between wheel sensor and sensor rotor.	
RR RH SENSOR 2 [C1105]	ABS actuator and electric unit (control unit) cannot identify sensor pulses, because of large gap between wheel sensor and sensor rotor.	
FR RH SENSOR 2 [C1107]	ABS actuator and electric unit (control unit) cannot identify sensor pulses, because of large gap between wheel sensor and sensor rotor.	
RR LH SENSOR 2 [C1106]	ABS actuator and electric unit (control unit) cannot identify sensor pulses, because of large gap between wheel sensor and sensor rotor.	
ABS SENSOR [C1115]	Wheel sensor input is abnormal.	
STOP LAMP SW [C1116]	Stop lamp switch or circuit malfunction.	
DECEL G SEN SET [C1160]	ABS decel sensor adjustment is incomplete.	<a href="#">BRC-54. "Inspection For Self-diagnosis Result "DECEL G SEN SET"</a>
ST ANGL SEN SAFE [C1163]	When steering angle sensor is in safe mode.	<a href="#">BRC-53. "Steering Angle Sensor Safe Mode Inspection"</a>
ST ANGLE SEN CIRCUIT [C1143]	Neutral position of steering angle sensor is dislocated, or steering angle sensor is malfunctioning.	<a href="#">BRC-40. "Steering Angle Sensor System"</a>
YAW RATE SENSOR [C1145]	Yaw rate sensor has generated an error, or yaw rate sensor signal line is open or shorted.	<a href="#">BRC-41. "Yaw Rate/Side/Decel G Sensor System Inspection"</a>

# TROUBLE DIAGNOSIS

[VDC/TCS/ABS]

Self-diagnostic item	Malfunction detecting condition	Check system	
FR LH IN ABS SOL [C1120]	Circuit of front LH IN ABS solenoid is open or shorted, or control line is open or shorted to power supply or ground.	BRC-43. "Solenoid and VDC Change-Over Valve System Inspection"	
FR LH OUT ABS SOL [C1121]	Circuit of front LH OUT ABS solenoid is open or shorted, or control line is open or shorted to power supply or ground.		
RR RH IN ABS SOL [C1126]	Circuit of rear RH IN ABS solenoid is open or shorted, or control line is open or shorted to power supply or ground.		
RR RH OUT ABS SOL [C1127]	Circuit of rear RH OUT ABS solenoid is open or shorted, or control line is open or shorted to power supply or ground.		
FR RH IN ABS SOL [C1122]	Circuit of front RH IN ABS solenoid is open or shorted, or control line is open or shorted to power supply or ground.		
FR RH OUT ABS SOL [C1123]	Circuit of front RH OUT ABS solenoid is open or shorted, or control line is open or shorted to power supply or ground.		
RR LH IN ABS SOL [C1124]	Circuit of rear LH IN ABS solenoid is open or shorted, or control line is open or shorted to power supply or ground.		
RR LH OUT ABS SOL [C1125]	Circuit of rear LH OUT ABS solenoid is open or shorted, or control line is open or shorted to power supply or ground.		
CV1 [C1164]	Front side VDC switch-over solenoid valve (cut valve) is open or shorted, or control line is open or shorted to power supply or ground.		
CV2 [C1165]	Rear side VDC switch-over solenoid valve (cut valve) is open or shorted, or control line is open or shorted to power supply or ground.		
SV1 [C1166]	Front side VDC switch-over solenoid valve (suction valve) is open or shorted, or control line is open or shorted to power supply or ground.		
SV2 [C1167]	Rear side VDC switch-over solenoid valve (suction valve) is open or shorted, or control line is open or shorted to power supply or ground.		
PUMP MOTOR (Note 3) [C1111]	During actuator motor operation with ON, when actuator motor turns OFF or when control line for actuator motor relay is open. During actuator motor operation with OFF, when actuator motor turns ON or when control line for relay is shorted to ground.		BRC-44. "Actuator Motor, Motor Relay, and Circuit Inspection"
BATTERY VOLTAGE [ABNORMAL] [C1109]	ABS actuator and electric unit (control unit) power voltage is too low.		BRC-46. "ABS/TCS/VDC Control Unit Power and Ground Systems Inspection"
ST ANGLE SEN SIGNAL [C1144]	Neutral position correction of steering angle sensor is not finished.	BRC-54. "Inspection For Self-diagnosis Result "ST ANGLE SEN SIGNAL""	
ST ANG SEN COM CIR [C1156]	CAN communication line or steering angle sensor has generated an error.	BRC-40. "Steering Angle Sensor System"	
LONGITUDINAL G-SENSOR [C1113]	Longitudinal G-sensor is malfunctioning, or signal line of longitudinal G-sensor is open or shorted.	BRC-41. "Yaw Rate/Side/Decel G Sensor System Inspection"	
CONTROLLER FAILURE [C1110]	Internal malfunction of ABS actuator and electric unit (control unit)	BRC-40. "ABS/TCS/VDC Control Unit Inspection"	
CAN COMM CIRCUIT [U1000]	<ul style="list-style-type: none"> <li>● CAN communication line is open or shorted.</li> <li>● ABS actuator and electric unit (control unit) internal malfunction</li> <li>● Battery voltage for ECM is suddenly interrupted for approximately 0.5 second or more.</li> </ul>	BRC-54. "CAN Communication System Inspection" (Note 2)	

A  
B  
C  
D  
E  
BRC  
G  
H  
I  
J  
K  
L  
M

# TROUBLE DIAGNOSIS

[VDC/TCS/ABS]

Self-diagnostic item	Malfunction detecting condition	Check system
LATERAL G-SENSOR [C1146]	Lateral G-sensor is malfunctioning, or signal line of lateral G-sensor is open or shorted.	<a href="#">BRC-41. "Yaw Rate/Side/Decel G Sensor System Inspection"</a>
BR FLUID LEVEL LOW [C1155]	Brake fluid level drops or circuit between ABS actuator and electric unit (control unit) and brake fluid level switch is open or shorted.	<a href="#">BRC-47. "Brake Fluid Level Sensor System Inspection"</a>
ENGIN SIGNAL 1 [C1130]	Based on the signal from ECM, ABS actuator and electric unit (control unit) judges that engine fuel cut system is malfunctioning.	<a href="#">BRC-39. "Engine System Inspection"</a>
ENGIN SIGNAL 2 [C1131]	Based on the signal from ECM, ABS actuator and electric unit (control unit) judges that engine fuel cut system is malfunctioning.	
ENGIN SIGNAL 3 [C1132]	Based on the signal from ECM, ABS actuator and electric unit (control unit) judges that engine fuel cut system is malfunctioning.	
ENGIN SIGNAL 4 [C1133]	Based on the signal from ECM, ABS actuator and electric unit (control unit) judges that engine fuel cut system is malfunctioning.	
ENGIN SIGNAL 6 [C1136]	Based on the signal from ECM, ABS actuator and electric unit (control unit) judges that engine fuel cut system is malfunctioning.	
ACTR RELAY CIRCUIT [C1140]	ABS actuator relay or circuit malfunction.	
PRESS SENSE CIRCUIT [C1142]	ABS pressure sensor circuit malfunction.	<a href="#">BRC-51. "Pressure Sensor System Inspection"</a>
ABS VARIANT CODING [C1170]	V coding is not malfunctioning.	ABS actuator and electric unit (control unit) and circuit
ACTIVE BOOSTER SOLENOID NG [C1178]	Active booster solenoid is malfunctioning, or signal line of active booster servo is open or shorted.	<a href="#">BRC-48. "Active Booster System Inspection"</a>
DELTA S SEN NG [C1179]	Delta stroke sensor malfunctioning, or signal line of delta stroke sensor is open or shorted.	<a href="#">BRC-49. "Delta Stroke Sensor System Inspection"</a>
ACTIVE BOOSTER RESPONSE NG [C1181]	Active booster response is malfunctioning, or signal line of active booster response is open or shorted.	<a href="#">BRC-48. "Active Booster System Inspection"</a>
BRAKE RELEASE SW NG [C1184]	Brake release switch is malfunctioning, or signal line of brake release switch is open or shorted.	
BRAKE BOOSTER DEFECT [C1189]	Brake booster is defective or malfunctioning.	

Note 1. If wheel sensor 2 for each wheel is indicated, check ABS actuator and electric unit (control unit) power supply voltage in addition to wheel sensor circuit check.

Note 2. If multiple malfunctions are detected including CAN communication line [U1000], perform diagnosis for CAN communication line first.

Note 3: "ACTUATOR RLY" on the CONSULT-II self-diagnosis results indicates the malfunction of the actuator motor relay or circuit.

## DATA MONITOR

### Operation Procedure

1. After turning OFF the ignition switch, connect CONSULT-II and the CONSULT-II CONVERTER to the data link connector.

#### CAUTION:

If CONSULT-II is used with no connection of CONSULT-II CONVERTER, malfunctions might be detected in self-diagnosis depending on control unit which carries out CAN communication.



# TROUBLE DIAGNOSIS

[VDC/TCS/ABS]

2. Touch "START (NISSAN BASED VHCL)", "ABS", "DATA MONITOR" in order on the CONSULT-II screen. If "ABS" is not indicated, go to [GI-39, "CONSULT-II Data Link Connector \(DLC\) Circuit"](#).
- CAUTION:**  
When "START (NISSAN BASED VHCL)" is touched immediately after starting the engine or turning on the ignition switch, "ABS" might not be displayed in the system selection screen. In this case, repeat the operation from step 2.
3. Return to the Monitor Item Selection screen, and touch "ECU INPUT SIGNALS", "MAIN SIGNALS", or "SELECTION FROM MENU". Refer to the following information.
  4. When "START" is touched, the data monitor screen is displayed.

## Display Item List

Item (Unit)	Data monitor item selection			Remarks
	ECU INPUT SIGNALS	MAIN SIGNALS	SELECTION FROM MENU	
GEAR	×	×	×	Gear position judged by PNP switch signal is displayed.
FR RH SENSOR (km/h, MPH)	×	×	×	Wheel speed calculated by front RH wheel sensor signal is displayed.
FR LH SENSOR (km/h, MPH)	×	×	×	Wheel speed calculated by front LH wheel sensor signal is displayed.
RR RH SENSOR (km/h, MPH)	×	×	×	Wheel speed calculated by rear RH wheel sensor signal is displayed.
RR LH SENSOR (km/h, MPH)	×	×	×	Wheel speed calculated by rear LH wheel sensor signal is displayed.
BATTERY VOLT (V)	×	×	×	Voltage supplied to ABS actuator and electric unit (control unit) is displayed.
N POSI SIG	–	–	×	Shift position judged by PNP switch signal.
P POSI SIG	–	–	×	Shift position judged by PNP switch signal.
ACCEL POS SIG (%)	×	–	×	Throttle valve open/close status judged by CAN communication signal is displayed.
ENGINE SPEED (rpm)	×	×	×	Engine speed judged by CAN communication signal is displayed.
STR ANGLE SIG (deg)	×	–	×	Steering angle detected by steering angle sensor is displayed.
YAW RATE SEN (d/s)	×	×	×	Yaw rate detected by yaw rate sensor is displayed.
DECEL G SEN (d/s)	×	×	×	Longitudinal acceleration detected by decel G-sensor is displayed.
SIDE G-SENSOR (m/s <sup>2</sup> )	×	–	×	Transverse acceleration detected by side G-sensor is displayed.
STOP LAMP SW (ON/OFF)	×	×	×	Stop lamp switch (ON/OFF) status is displayed.
OFF SW (ON/OFF)	×	×	×	VDC OFF switch (ON/OFF) status is displayed.
ABS WARN LAMP (ON/OFF)	–	×	×	ABS warning lamp (ON/OFF) status is displayed.
SLIP LAMP (ON/OFF)	–	×	×	SLIP indicator lamp (ON/OFF) status is displayed.
FR LH IN SOL (ON/OFF)	–	×	×	Front LH IN ABS solenoid (ON/OFF) status is displayed.

# TROUBLE DIAGNOSIS

[VDC/TCS/ABS]

Item (Unit)	Data monitor item selection			Remarks
	ECU INPUT SIGNALS	MAIN SIGNALS	SELECTION FROM MENU	
FR LH OUT SOL (ON/OFF)	-	×	×	Front LH OUT ABS solenoid (ON/OFF) status is displayed.
RR RH IN SOL (ON/OFF)	-	×	×	Rear RH IN ABS solenoid (ON/OFF) status is displayed.
RR RH OUT SOL (ON/OFF)	-	×	×	Rear RH OUT ABS solenoid (ON/OFF) status is displayed.
FR RH IN SOL (ON/OFF)	-	×	×	Front RH IN ABS solenoid (ON/OFF) status is displayed.
FR RH OUT SOL (ON/OFF)	-	×	×	Front RH OUT ABS solenoid (ON/OFF) status is displayed.
RR LH IN SOL (ON/OFF)	-	×	×	Rear LH IN ABS solenoid (ON/OFF) status is displayed.
RR LH OUT SOL (ON/OFF)	-	×	×	Rear LH OUT ABS solenoid (ON/OFF) status is displayed.
OFF LAMP (ON/OFF)	-	×	×	OFF Lamp (ON/OFF) status is displayed.
MOTOR RELAY (ON/OFF)	-	×	×	ABS motor relay signal (ON/OFF) status is displayed.
ACTUATOR RLY (ON/OFF)	-	×	×	ABS actuator relay signal (ON/OFF) status is displayed.
CV1 (ON/OFF)	-	-	×	Front side switch-over solenoid valve (cut valve) (ON/OFF) status is displayed.
CV2 (ON/OFF)	-	-	×	Rear side switch-over solenoid valve (cut-valve) (ON/OFF) status is displayed.
SV1 (ON/OFF)	-	-	×	Front side switch-over solenoid valve (suction valve) (ON/OFF) status is displayed.
SV2 (ON/OFF)	-	-	×	Rear side switch-over solenoid valve (suction valve) (ON/OFF) status is displayed.
VDC FAIL SIG (ON/OFF)	-	-	×	VDC fail signal (ON/OFF) status is displayed.
TCS FAIL SIG (ON/OFF)	-	-	×	TCS fail signal (ON/OFF) status is displayed.
ABS FAIL SIG (ON/OFF)	-	-	×	ABS fail signal (ON/OFF) status is displayed.
EBD FAIL SIG (ON/OFF)	-	-	×	EBD fail signal (ON/OFF) status is displayed.
FLUID LEV SW (ON/OFF)	×	-	×	Brake fluid level switch (ON/OFF) status is displayed.
EBD SIGNAL (ON/OFF)	-	-	×	EBD operation (ON/OFF) status is displayed.
ABS SIGNAL (ON/OFF)	-	-	×	ABS operation (ON/OFF) status is displayed.
TCS SIGNAL (ON/OFF)	-	-	×	TCS operation (ON/OFF) status is displayed.
VDC SIGNAL (ON/OFF)	-	-	×	VDC operation (ON/OFF) status is displayed.
EBD WARN LAMP	-	-	×	Brake warning lamp (ON/OFF) status is displayed.

# TROUBLE DIAGNOSIS

[VDC/TCS/ABS]

Item (Unit)	Data monitor item selection			Remarks
	ECU INPUT SIGNALS	MAIN SIGNALS	SELECTION FROM MENU	
SLCT LVR POSI	×	×	×	Shift position judged by PNP switch signal.
R POSI SIG	–	–	×	Shift position judged by PNP switch signal.
4WD FAIL REQ	–	–	×	The state of 4WD controller is displayed by CAN communication signal.
2WD/4WD	–	–	×	It recognizes on software whether it is 2WD and whether it is in 4WD state.
BST OPER SIG	–	–	×	Active booster operation (ON/OFF) status is displayed.
PRESS SENSOR	×	–	×	Brake pressure detected by pressure sensor is displayed.
CRANKING SIG	–	–	×	The input state of the key SW START position signal is displayed.
PRESS SEN 2	–	–	×	Brake pressure detected by pressure sensor is displayed.
DELTA S SEN	–	–	×	The amount of stroke sensor movements in the active booster detected by DELTA S SEN is displayed.
RELEASE SW NO	–	–	×	Release switch signal (ON/OFF) status is displayed. "ON" indicates that the brake pedal is depressed. "OFF" is that the brake pedal is released.
RELEASE SW NC	–	–	×	Release switch signal (ON/OFF) status is displayed. "OFF" indicates that the brake pedal is depressed on. "ON" is that the brake pedal is released.
OHB FAIL	–	–	×	OHB fail status is displayed.
HBA FAIL	–	–	×	HBA fail status is displayed.
OHB SIG	–	–	×	OHB operation (ON/OFF) status is displayed.
HBA SIG	–	–	×	HBA operation (ON/OFF) status is displayed.
PRES CTRL ACC	–	–	×	Pressure control state (ON/OFF) is displayed. It is applied only to an ICC vehicle.
PRES FAIL ACC	–	–	×	Pressure control fail state (ON/OFF) is displayed. It is applied only to an ICC vehicle.
STP OFF RLY	–	–	×	Stop lamp relay signal (ON/OFF) status is displayed.

×: Applicable

–: Not applicable

## ACTIVE TEST

### CAUTION:

- Do not perform active test while driving.
- Make sure to completely bleed air from the brake system.

# TROUBLE DIAGNOSIS

[VDC/TCS/ABS]

- The ABS and brake (EBD) warning lamps turn on during the active test.

## Operation Procedure

1. Connect the CONSULT-II and CONSULT-II CONVERTER to the data link connector and start the engine.

**CAUTION:**

If CONSULT-II is used with no connection of CONSULT-II CONVERTER, malfunctions might be detected in self-diagnosis depending on control unit which carries out CAN communication.

2. Touch "START (NISSAN BASED VHCL)" on the display screen.
3. Touch "ABS".  
If "ABS" is not indicated, go to [GI-39. "CONSULT-II Data Link Connector \(DLC\) Circuit"](#).
4. Touch "ACTIVE TEST".
5. The test item selection screen is displayed.
6. Touch necessary test item.

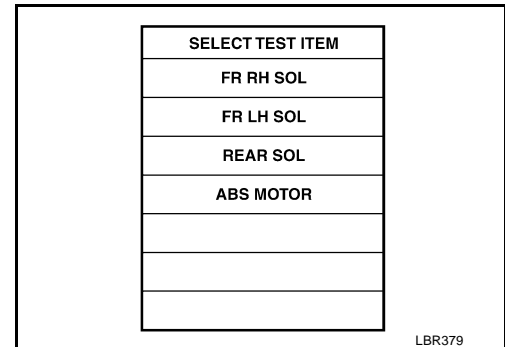

LBR379

7. With the "MAIN SIGNALS" display selected, touch "START".
8. The Active Test screen will be displayed, so conduct the following test.

## Solenoid Valve Operation Chart

Operation		ABS solenoid valve			ABS solenoid valve (ACT)		
		UP	KEEP	DOWN	UP	ACTUA-TOR UP	ACTUA-TOR KEEP
FR RH SOL FR RH ABS SOLE- NOID (ACT)	FR RH IN SOL	OFF	ON	ON	OFF	OFF	OFF
	FR RH OUT SOL	OFF	OFF	ON*	OFF	OFF	OFF
FR LH SOL FR LH ABS SOLE- NOID (ACT)	FR LH IN SOL	OFF	ON	ON	OFF	OFF	OFF
	FR LH OUT SOL	OFF	OFF	ON*	OFF	OFF	OFF
RR RH SOL RR RH ABS SOLE- NOID (ACT)	RR RH IN SOL	OFF	ON	ON	OFF	OFF	OFF
	RR RH OUT SOL	OFF	OFF	ON*	OFF	OFF	OFF
RR LH SOL RR LH ABS SOLE- NOID (ACT)	RR LH IN SOL	OFF	ON	ON	OFF	OFF	OFF
	RR LH OUT SOL	OFF	OFF	ON*	OFF	OFF	OFF
REAR SOL	RR RH IN SOL	OFF	ON	ON	OFF	OFF	OFF
	RR RH OUT SOL	OFF	OFF	ON*	OFF	OFF	OFF
	RR LH IN SOL	OFF	ON	ON	OFF	OFF	OFF
	RR LH OUT SOL	OFF	OFF	ON*	OFF	OFF	OFF

\*: ON for 1 to 2 seconds after the touch, and then OFF

**NOTE:**

- If active test is performed with brake pedal depressed, pedal stroke may change. This is normal.
- "TEST IS STOPPED" is displayed approximately 10 seconds after operation starts.
- After "TEST IS STOPPED" is displayed, to perform test again, repeat Step 6.

# TROUBLE DIAGNOSIS

[VDC/TCS/ABS]

## ABS Motor

Touch "ON" and "OFF" on the screen. Check that ABS motor relay operates as shown in table below.

Operation	ON	OFF
ABS actuator relay	ON	ON
ABS motor relay	ON	OFF

### NOTE:

- If active test is performed with brake pedal depressed, pedal stroke may change. This is normal.
- "TEST IS STOPPED" is displayed approximately 10 seconds after operation starts.

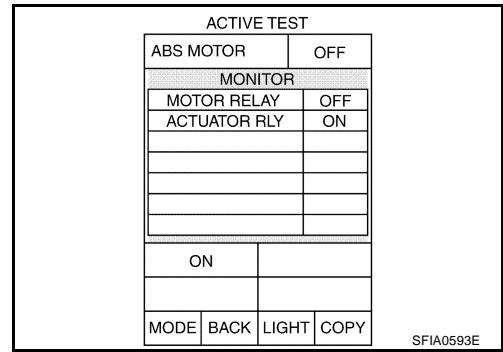

A  
B  
C  
D  
E  
G  
H  
I  
J  
K  
L  
M

**BRC**

**TROUBLE DIAGNOSIS FOR SELF-DIAGNOSTIC ITEMS**

PFP:00000

EFS004UZ

**Wheel Sensor System Inspection**

## INSPECTION PROCEDURE

**1. CONNECTOR INSPECTION**

Disconnect the ABS actuator and electric unit (control unit) connector E125 and wheel sensor of malfunctioning code.

Check the terminals for deformation, disconnection, looseness or damage.

OK or NG

OK >> GO TO 2.

NG >> Repair or replace as necessary.

**2. CHECK WHEEL SENSOR OUTPUT SIGNAL**

1. Connect ABS active wheel sensor tester (J-45741) to wheel sensor using appropriate adapter.

2. Turn on the ABS active wheel sensor tester power switch.

**NOTE:**

The green POWER indicator should illuminate. If the POWER indicator does not illuminate, replace the battery in the ABS active wheel sensor tester before proceeding.

3. Spin the wheel of the vehicle by hand and observe the red SENSOR indicator on the ABS active wheel sensor tester. The red SENSOR indicator should flash on and off to indicate an output signal.

**NOTE:**

If the red SENSOR indicator illuminates but does not flash, reverse the polarity of the tester leads and retest.

Does the ABS active wheel sensor tester detect a signal?

YES >> GO TO 3.

NO >> Replace the wheel sensor. Refer to [BRC-63, "Removal and Installation"](#).

**3. CHECK TIRES**

Check for inflation pressure, wear and size of each tire.

Are tire pressure and size correct and is tire wear within specifications?

YES >> GO TO 4.

NO >> Adjust tire pressure or replace tire(s).

**4. CHECK WHEEL BEARINGS**

Check wheel bearing axial end play. Refer to [FAX-5, "WHEEL BEARING INSPECTION"](#) or [RAX-5, "WHEEL BEARING INSPECTION"](#).

OK or NG

OK >> GO TO 5.

NG >> Repair or replace as necessary. Refer to [FAX-5, "WHEEL BEARING INSPECTION"](#) or [RAX-5, "WHEEL BEARING INSPECTION"](#).

**5. CHECK WIRING HARNESS FOR SHORT CIRCUIT**

1. Disconnect ABS actuator and electric unit (control unit) connector and wheel sensor connector of malfunction code No.

2. Check resistance between wheel sensor harness connector terminals and ground.

**Continuity should not exist.**

OK or NG

OK >> GO TO 6.

NG >> Repair the circuit.

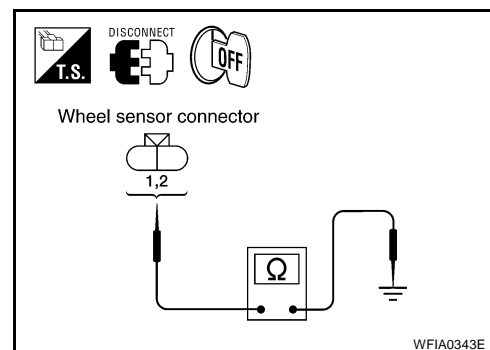

WFIA0343E

# TROUBLE DIAGNOSIS FOR SELF-DIAGNOSTIC ITEMS

[VDC/TCS/ABS]

## 6. CHECK WIRING HARNESS FOR OPEN CIRCUIT

1. Check continuity between ABS actuator and electric unit (control unit) harness connector E125 and the malfunctioning wheel sensor harness connector E18, E117, C10, or C11.

Wheel sensor	ABS actuator and electric unit (control unit)		Wheel sensor		Continuity
	Connector - terminal	Wire color	Connector - terminal	Wire color	
Front LH	E125 - 45	G/O	E18 - 1	G/O	Yes
	E125 - 46	BR/W	E18 - 2	BR/W	
Front RH	E125 - 34	B/R	E117 - 1	B/R	
	E125 - 33	BR	E117 - 2	BR	
Rear LH	E125 - 37	P	C11 - 2	P	
	E125 - 36	L	C11 - 1	L	
Rear RH	E125 - 42	V	C10 - 2	V	
	E125 - 43	G/Y	C10 - 1	G/Y	

**Continuity should exist.**

OK or NG

OK >> Replace the ABS actuator and electric unit (control unit). Refer to [BRC-65, "Removal and Installation"](#).

NG >> Repair the circuit.

## Engine System Inspection

EFS004V0

### INSPECTION PROCEDURE

#### 1. SELF-DIAGNOSIS RESULT CHECK

Check self-diagnosis results.

Self-diagnosis results
ENGINE SIGNAL 1
ENGINE SIGNAL 2
ENGINE SIGNAL 3
ENGINE SIGNAL 4
ENGINE SIGNAL 6

Is the above displayed in the self-diagnosis display items?

YES >> GO TO 2.

NO >> Inspection End.

#### 2. ENGINE SYSTEM INSPECTION

1. Perform ECM self-diagnosis and repair as necessary. Refer to [EC-127, "SELF-DIAG RESULTS MODE"](#).
2. Perform ABS actuator and electric unit (control unit) self-diagnosis again.

OK or NG

OK >> Inspection End.

NG >> Repair or replace as necessary.

**ABS/TCS/VDC Control Unit Inspection**

INSPECTION PROCEDURE

**1. SELF-DIAGNOSIS RESULT CHECK**

Check self-diagnosis results.

Self-diagnosis results
CONTROLLER FAILURE

Is the above displayed in the self-diagnosis display items?

YES >> Replace ABS actuator and electric unit (control unit). Refer to [BRC-65, "Removal and Installation"](#)

NO >> Inspection End.

**Steering Angle Sensor System**

INSPECTION PROCEDURE

**1. CHECK SELF-DIAGNOSIS RESULT**

Check self-diagnosis results.

Self-diagnosis results
ST ANGLE SEN COM CIR

Is above displayed in self-diagnosis item?

YES >> GO TO 2.

NO >> Inspection End.

**2. CHECK CONNECTOR**

1. Disconnect steering angle sensor connector M47 and ABS actuator and electric unit (control unit) connector E125 and check terminals for deformation, disconnection, looseness, or damage. Repair or replace as necessary.

2. Reconnect connectors and repeat ABS actuator and electric unit (control unit) self-diagnosis.

IS "ST ANGLE SEN COM CIR" DISPLAYED?

YES >> GO TO 3.

NO >> Inspection End.

**3. CHECK STEERING ANGLE SENSOR HARNESS**

1. Check CAN communication system. Refer to [LAN-5, "CAN COMMUNICATION"](#).

2. Turn ignition switch OFF and disconnect steering angle sensor connector M47 and ABS actuator and electric unit (control unit) connector E125.

3. Check continuity between ABS actuator and electric unit (control unit) connector E125 and steering angle sensor connector M47.

ABS actuator and electric unit (control unit) harness connector E125	Steering angle sensor harness connector M47	Continuity
11 (L)	3 (L)	Yes
15 (P)	4 (P)	Yes

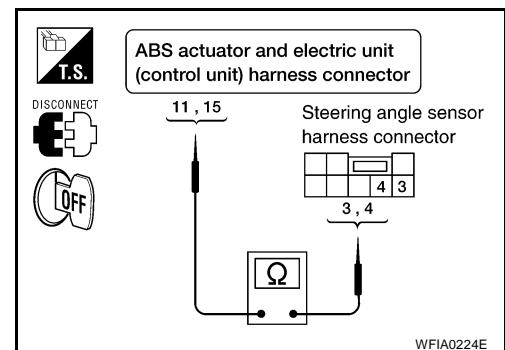

OK or NG

OK >> GO TO 4.

NG >> Repair or replace harness.



**4. CHECK DATA MONITOR**

1. Connect steering angle sensor and ABS actuator and electric unit (control unit) connectors.
2. Use "DATA MONITOR" to check if the status of "STR ANGLE SIG" is normal.

Steering condition	Data monitor
Straight-ahead	-3.5 deg to +3.5 deg
Turn wheel to the right by 90°	Approx. - 90deg
Turn wheel to the left by 90°	Approx. + 90deg

**OK or NG**

- OK >> Perform ABS actuator and electric unit (control unit) self-diagnosis again.  
 NG >> Replace spiral cable (steering angle sensor) and adjust neutral position of steering angle sensor.  
 Refer to [BRC-61, "Adjustment of Steering Angle Sensor Neutral Position"](#).

**Yaw Rate/Side/Decel G Sensor System Inspection**

EFS004V3

**CAUTION:**

Sudden turns (such as spin turns, acceleration turns), drifting, etc. when VDC function is OFF may cause the yaw rate/side/decel G sensor system to indicate a problem. This is not a problem if normal operation can be resumed after restarting the engine.

**INSPECTION PROCEDURE****1. SELF-DIAGNOSIS RESULT CHECK**

Check self-diagnosis results.

Self-diagnosis results
YAW RATE SENSOR
LONGITUDINAL G-SENSOR
LATERAL G-SENSOR

**CAUTION:**

If vehicle is on turn table at entrance to parking garage, or on other moving surface, VDC OFF indicator lamp may illuminate and CONSULT-II self-diagnosis may indicate yaw rate sensor system malfunction. However, in this case there is no malfunction in yaw rate sensor system. Take vehicle off of turn table or other moving surface, and start engine. Results will return to normal.

Is the above displayed in the self-diagnosis display items?

- YES >> GO TO 2.  
 NO >> Inspection End.

**2. CONNECTOR INSPECTION**

Disconnect the ABS actuator and electric unit (control unit) connector E125 and yaw rate/side/decel G sensor connector M108.

Check the terminals for deformation, disconnection, looseness or damage.

**OK or NG**

- OK >> GO TO 3.  
 NG >> Repair or replace as necessary.

## TROUBLE DIAGNOSIS FOR SELF-DIAGNOSTIC ITEMS

[VDC/TCS/ABS]

### 3. YAW RATE/SIDE/DECEL G SENSOR HARNESS INSPECTION

1. Turn off the ignition switch and disconnect yaw rate/side/decel G sensor connector M108 and ABS actuator and electric unit (control unit) connector E125.
2. Check continuity between the ABS actuator and electric unit (control unit) connector E125 and the yaw rate/side/decel G sensor connector M108.

ABS actuator and electric unit (control unit) harness connector E125	Yaw rate/side/decel G sensor harness connector M108	Continuity
6 (Y/R)	3 (Y/R)	Yes
24 (P)	5 (P)	
25 (G/R)	1 (G/R)	
29 (G/W)	2 (G/W)	

OK or NG

OK >> GO TO 4.

NG >> Repair or replace as necessary.

### 4. YAW RATE/SIDE/DECEL G SENSOR INSPECTION

1. Connect the yaw rate/side/decel G sensor connector M108 and ABS actuator and electric unit (control unit) connector E125.
2. Use "DATA MONITOR" to check if the yaw rate/side/decel G sensor signals are normal.

Vehicle status	Yaw rate sensor (Data monitor standard)	Side G sensor (Data monitor standard)	Decel G Sensor (Data monitor standard)
When stopped	-4 to +4 deg/s	-1.1 to +1.1 m/s	-0.11 G to +0.11 G
Right turn	Negative value	Negative value	-
Left turn	Positive value	Positive value	-
Speed up	-	-	Negative value
Speed down	-	-	Positive value

OK or NG

OK >> Inspection End.

NG >> Replace the yaw rate/side/decel G sensor. Refer to [BRC-68, "Removal and Installation"](#) .

**Solenoid and VDC Change-Over Valve System Inspection**

INSPECTION PROCEDURE

**1. SELF-DIAGNOSIS RESULT CHECK**

Check self-diagnosis results.

Self-diagnosis results
FR LH IN ABS SOL
FR LH OUT ABS SOL
RR RH IN ABS SOL
RR RH OUT ABS SOL
FR RH IN ABS SOL
FR RH OUT ABS SOL
RR LH IN ABS SOL
RR LH OUT ABS SOL
CV 1
CV 2
SV 1
SV 2

Is the above displayed in the self-diagnosis display items?

YES >> GO TO 2.

NO >> Inspection End.

**2. CONNECTOR INSPECTION**

1. Disconnect ABS actuator and electric unit (control unit) connector E125.
2. Check the terminals for deformation, disconnection, looseness or damage.

OK or NG

OK >> GO TO 3.

NG >> Repair or replace as necessary.

A  
B  
C  
D  
E  
BRC  
G  
H  
I  
J  
K  
L  
M

### 3. CHECKING SOLENOID POWER AND GROUND

1. Check voltage between ABS actuator and electric unit (control unit) harness connector E125 and body ground.

ABS actuator and electric unit (control unit) connector E125	Body ground	Measured value (Approx.)
32 (B/Y)	—	12V

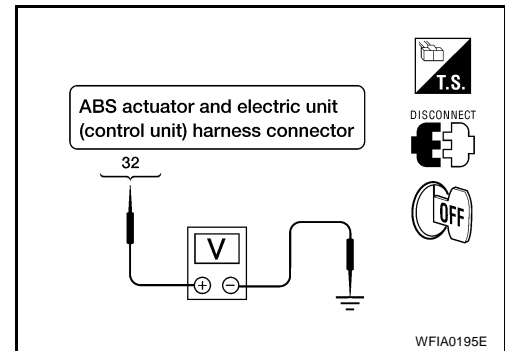

2. Check resistance between ABS actuator and electric unit (control unit) harness connector E125 and body ground.

ABS actuator and electric unit (control unit) connector E125	Body ground	Measured value $\Omega$ (Approx.)
16 (B)	—	0 $\Omega$
47 (B)	—	0 $\Omega$

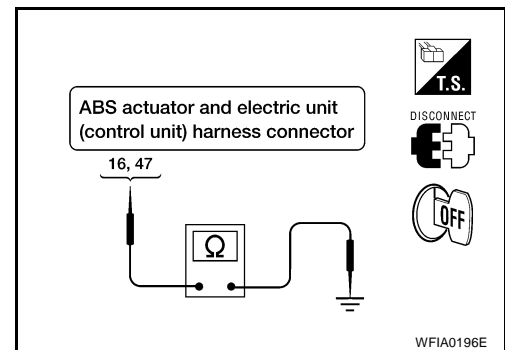

OK or NG

- OK >> Perform self-diagnosis again. If the same results appear, replace ABS actuator and electric unit (control unit). Refer to [BRC-65, "Removal and Installation"](#).
- NG >> Repair the circuit.

### Actuator Motor, Motor Relay, and Circuit Inspection

EFS004V5

#### INSPECTION PROCEDURE

#### 1. CHECKING SELF-DIAGNOSIS RESULTS

Check self-diagnosis results.

Self-diagnosis results
CONSULT-II display items
PUMP MOTOR
ACTR RELAY CIRCUIT

Is the above displayed in the self-diagnosis display items?

- YES >> GO TO 2.  
 NO >> Inspection End.

#### 2. CONNECTOR INSPECTION

1. Disconnect ABS actuator and electric unit (control unit) connector E125.
2. Check the terminals for deformation, disconnection, looseness or damage.

OK or NG

- OK >> GO TO 3.  
 NG >> Repair or replace as necessary.

# TROUBLE DIAGNOSIS FOR SELF-DIAGNOSTIC ITEMS

[VDC/TCS/ABS]

## 3. CHECKING ABS MOTOR AND MOTOR RELAY POWER SYSTEM

1. Check voltage between ABS actuator and electric unit (control unit) harness connector E125 and body ground.

ABS actuator and electric unit (control unit) connector E125	Body ground	Measured value (Approx.)
1 (Y)	—	12V

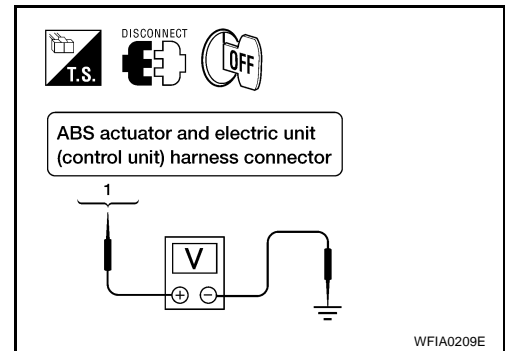

2. Check resistance between ABS actuator and electric unit (control unit) connector E125 and body ground.

ABS actuator and electric unit (control unit) harness connector E125	Body ground	Measured value $\Omega$ (Approx.)
16 (B)	—	0 $\Omega$
47 (B)	—	0 $\Omega$

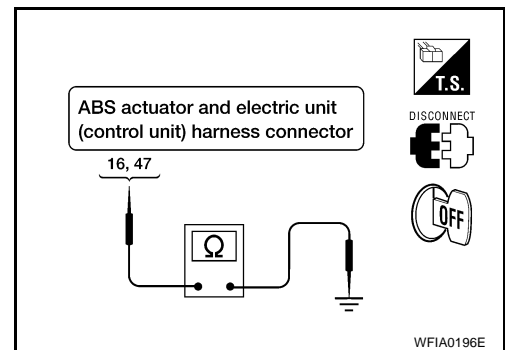

OK or NG

OK >> Perform self-diagnosis again. If the same results appear, replace ABS actuator and electric unit (control unit). Refer to [BRC-65, "Removal and Installation"](#).

NG >> Repair the circuit.

## Stop Lamp Switch System Inspection

EFS004V6

### INSPECTION PROCEDURE

#### 1. SELF-DIAGNOSIS RESULT CHECK

Check self-diagnosis results.

Self-diagnosis results
STOP LAMP SW

Is the above displayed in the self-diagnosis display items?

YES >> GO TO 2.

NO >> Inspection End.

#### 2. CONNECTOR INSPECTION

1. Disconnect the ABS actuator and electric unit (control unit) connector E125 and stop lamp switch connector E38.
2. Check the terminals for deformation, disconnection, looseness or damage.

OK or NG

OK >> GO TO 3.

NG >> Repair or replace as necessary.

### 3. STOP LAMP SWITCH INSPECTION

Check the voltage between the ABS actuator and electric unit (control unit) harness connector E125 terminal 41 (R/B) and body ground.

**Brake pedal depressed : Battery voltage (approx. 12V)**

**Brake pedal not depressed : Approx. 0V**

OK or NG

OK >> Perform self-diagnosis again. If the same results appear, replace ABS actuator and electric unit (control unit). Refer to [BRC-65, "Removal and Installation"](#).

NG >> GO TO 4.

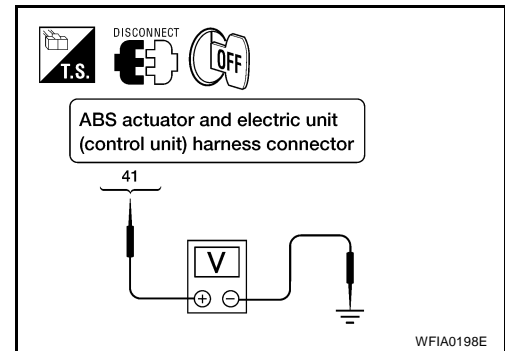

### 4. STOP LAMP RELAY CIRCUIT INSPECTION

1. Disconnect the stop lamp relay harness connector E12.
2. Check the continuity between the ABS actuator and electric unit (control unit) harness connector E125 terminal 41 (R/B) and stop lamp relay harness connector E12 terminal 4 (R/B).

**Continuity should exist**

OK or NG

OK >> Perform self-diagnosis again. If the same results appear, replace ABS actuator and electric unit (control unit). Refer to [BRC-65, "Removal and Installation"](#).

NG >> Refer to [LT-97, "STOP LAMP"](#).

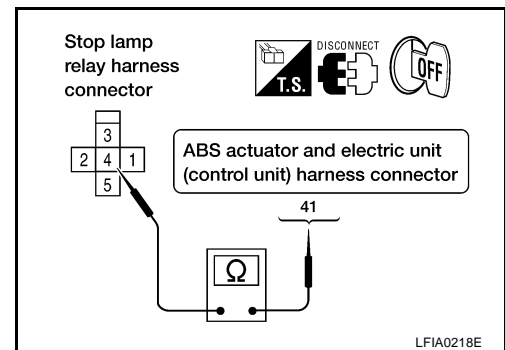

## ABS/TCS/VDC Control Unit Power and Ground Systems Inspection

EFS004V7

### INSPECTION PROCEDURE

#### 1. SELF-DIAGNOSIS RESULT CHECK

Check self-diagnosis results.

Self-diagnosis results
BATTERY VOLTAGE

Is the above displayed in the self-diagnosis display items?

YES >> GO TO 2.

NO >> Inspection End.

#### 2. CONNECTOR INSPECTION

1. Disconnect the ABS actuator and electric unit (control unit) connector E125.
2. Check the terminals for deformation, disconnection, looseness or damage.

OK or NG

OK >> GO TO 3.

NG >> Repair or replace as necessary.

# TROUBLE DIAGNOSIS FOR SELF-DIAGNOSTIC ITEMS

[VDC/TCS/ABS]

## 3. ABS/TCS/VDC CONTROL UNIT POWER AND GROUND CIRCUIT INSPECTION

Measure the voltage and continuity between the ABS actuator and electric unit (control unit) harness connector E125 and body ground.

Signal name	ABS actuator and electric unit (control unit) harness connector E125	Body ground	Measured value
Power supply	1 (Y)	—	Battery voltage (Approx. 12V)
	32 (B/Y)		
Ground	16 (B)	—	Continuity should exist.
	47 (B)		

OK or NG

- OK >> Check the battery for loose terminals, low voltage, etc. Repair as necessary.
- NG >> Repair the circuit.

## Brake Fluid Level Sensor System Inspection

EFS004V8

BRC

### INSPECTION PROCEDURE

#### 1. SELF-DIAGNOSIS RESULT CHECK

1. Check the brake reservoir tank fluid level. If the level is low, add brake fluid.
2. Erase the self-diagnosis results and check the self-diagnosis results.

Self-diagnosis results

BR FLUID LEVEL LOW

Is the above displayed in the self-diagnosis display items?

- YES >> GO TO 2.
- NO >> Inspection End.

#### 2. CONNECTOR INSPECTION

1. Disconnect the ABS actuator and electric unit (control unit) connector E125 and brake fluid level switch connector E21.
2. Check the terminals for deformation, disconnection, looseness or damage.

OK or NG

- OK >> GO TO 3.
- NG >> Repair or replace as necessary.

# TROUBLE DIAGNOSIS FOR SELF-DIAGNOSTIC ITEMS

[VDC/TCS/ABS]

## 3. CHECK THE HARNESS BETWEEN THE BRAKE FLUID LEVEL SENSOR AND THE ABS ACTUATOR AND ELECTRIC UNIT (CONTROL UNIT)

Check the continuity between the brake fluid level switch harness connector E21 and the ABS actuator and electric unit (control unit) harness connector E125.

ABS actuator and electric unit (control unit) harness connector E125	Brake fluid level switch harness connector E21	Continuity
8 (P/B)	1 (P/B)	Yes
8 (P/B)	Ground	No
Ground	2 (B)	Yes

OK or NG

OK >> Perform self-diagnosis again. If the same results appear, replace ABS actuator and electric unit (control unit). Refer to [BRC-65, "Removal and Installation"](#).

NG >> Repair the circuit.

## Active Booster System Inspection

EFS004V9

### INSPECTION PROCEDURE

#### 1. DISPLAY SELF DIAGNOSIS RESULTS

Check self-diagnosis results.

Self-diagnosis results

ACTIVE BOOSTER SOLENOID NG

ACTIVE BOOSTER RESPONSE NG

BRAKE RELEASE SW NG

BRAKE BOOSTER DEFECT

Is the above displayed in the self-diagnosis display items?

YES >> GO TO 2.

NO >> Inspection End.

#### 2. CONNECTOR INSPECTION

1. Turn the ignition switch OFF.
2. Disconnect the active booster connector E49 and ABS actuator and electric unit (control unit) connector E125 and inspect the terminals for deformation, disconnection, looseness, or damage.

OK or NG

OK >> GO TO 3.

NG >> Repair connector.



# TROUBLE DIAGNOSIS FOR SELF-DIAGNOSTIC ITEMS

[VDC/TCS/ABS]

## 3. ACTIVE BOOSTER CIRCUIT INSPECTION

1. Measure the continuity between the ABS actuator and electric unit (control unit) connector E125 and active booster connector E49.

ABS actuator and electric unit (control unit) connector E125	Active booster connector E49	Continuity
17 (W/R)	3 (W/R)	Yes
27 (L/B)	1 (L/B)	
28 (Y/B)	5 (Y/B)	
30 (LG/R)	2 (LG/R)	
31 (W/G)	4 (W/G)	

2. Measure the continuity between the ABS actuator and electric unit (control unit) connector E125 and body ground.

ABS actuator and electric unit (control unit) connector E125	Body ground	Continuity
17 (W/R)	—	No
27 (L/B)		
28 (Y/B)		
30 (LG/R)		
31 (W/G)		

OK or NG

- OK >> GO TO 4.  
NG >> Repair or replace harness or connector.

## 4. ACTIVE BOOSTER SENSOR INSPECTION

1. Reconnect the active booster and ABS actuator and electric unit (control unit) connectors.  
2. Use "DATA MONITOR" to check if the status of "RELEASE SW NO" and "RELEASE SW NC" is normal.

Condition	Data monitor display	
	RELEASE SW NO	RELEASE SW NC
When brake pedal is depressed	ON	OFF
When brake pedal is released	OFF	ON

OK or NG

- OK >> Inspection End.  
NG >> Replace active booster.

## Delta Stroke Sensor System Inspection

EFS004VA

### INSPECTION PROCEDURE

#### 1. DISPLAY SELF DIAGNOSIS RESULTS

Check self-diagnosis results.

Self-diagnosis results
DELTA S SEN NG

Is the above displayed in the self-diagnosis display items?

- YES >> GO TO 2.  
NO >> Inspection End.

# TROUBLE DIAGNOSIS FOR SELF-DIAGNOSTIC ITEMS

[VDC/TCS/ABS]

## 2. CONNECTOR INSPECTION

1. Turn the ignition switch OFF.
2. Disconnect the delta stroke sensor connector E114 and ABS actuator and electric unit (control unit) connector E125 and inspect the terminals for deformation, disconnection, looseness, or damage.

OK or NG

- OK >> GO TO 3.  
NG >> Repair connector.

## 3. DELTA STROKE SENSOR CIRCUIT INSPECTION

1. Measure the continuity between the ABS actuator and electric unit (control unit) connector E125 and delta stroke sensor connector E114.

ABS actuator and electric unit (control unit) connector E125	Delta stroke sensor connector E114	Continuity
26 (W/V)	1 (W/V)	Yes
39 (G/B)	3 (G/B)	
40 (R/Y)	5 (R/Y)	

2. Measure the continuity between the ABS actuator and electric unit (control unit) connector E125 and body ground.

ABS actuator and electric unit (control unit) connector E125	Body ground	Continuity
26 (W/V)	—	No
39 (G/B)		
40 (R/Y)		

OK or NG

- OK >> GO TO 4.  
NG >> Repair or replace harness or connector.

## 4. DELTA STROKE SENSOR INSPECTION

1. Reconnect the delta stroke sensor and ABS actuator and electric unit (control unit) connectors.
2. Use "DATA MONITOR" to check if the status of "DELTA S SEN" is normal.

Condition	Data monitor display (Approx.)
	DELTA S SEN
When brake pedal is released	0.00 mm (+0.6/-0.4)
When brake pedal is depressed	1.05–1.80 mm

OK or NG

- OK >> Inspection End.  
NG >> Replace delta stroke sensor.

# TROUBLE DIAGNOSIS FOR SELF-DIAGNOSTIC ITEMS

[VDC/TCS/ABS]

EFS004VB

## Pressure Sensor System Inspection

### FRONT PRESSURE INSPECTION PROCEDURE

#### 1. DISPLAY SELF DIAGNOSIS RESULTS

Check self-diagnosis results.

Self-diagnosis results

PRESS SENSE CIRCUIT

Is the above displayed in the self-diagnosis display items?

YES >> GO TO 2.

NO >> Inspection End.

#### 2. CONNECTOR INSPECTION

1. Turn the ignition switch OFF.
2. Disconnect the front pressure sensor connector E31 and ABS actuator and electric unit (control unit) connector E125 and inspect the terminals for deformation, disconnection, looseness, or damage.

OK or NG

OK >> GO TO 3.

NG >> Repair connector.

#### 3. FRONT PRESSURE SENSOR CIRCUIT INSPECTION

1. Measure the continuity between the ABS actuator and electric unit (control unit) harness connector E125 and front pressure sensor harness connector E31.

ABS actuator and electric unit (control unit) harness connector E125	Front pressure sensor harness connector E31	Continuity
18 (L/G)	3 (L/G)	Yes
19 (SB)	1 (SB)	
20 (R/L)	2 (R/L)	

2. Measure the continuity between the ABS actuator and electric unit (control unit) harness connector E125 and body ground.

ABS actuator and electric unit (control unit) harness connector E125	Body ground	Continuity
18 (L/G)	—	No
19 (SB)		
20 (R/L)		

OK or NG

OK >> GO TO 4.

NG >> Repair or replace harness or connector.

# TROUBLE DIAGNOSIS FOR SELF-DIAGNOSTIC ITEMS

[VDC/TCS/ABS]

## 4. FRONT PRESSURE SENSOR INSPECTION

1. Reconnect the front pressure sensor and ABS actuator and electric unit (control unit) connectors.
2. Use "DATA MONITOR" to check if the status of "PRESS SENSOR" is normal.

Condition	Data monitor display (Approx.)
	PRESS SENSOR
When brake pedal is depressed	Positive value
When brake pedal is released	0 bar

OK or NG

- OK >> Inspection End.  
NG >> Replace pressure sensor.

## REAR PRESSURE INSPECTION PROCEDURE

### 1. DISPLAY SELF DIAGNOSIS RESULTS

Check self-diagnosis results.

Self-diagnosis results
PRESS SENSE CIRCUIT

Is the above displayed in the self-diagnosis display items?

- YES >> GO TO 2.  
NO >> Inspection End.

### 2. CONNECTOR INSPECTION

1. Turn the ignition switch OFF.
2. Disconnect the rear pressure sensor connector E32 and ABS actuator and electric unit (control unit) connector E125 and inspect the terminals for deformation, disconnection, looseness, or damage.

OK or NG

- OK >> GO TO 3.  
NG >> Repair connector.

### 3. REAR PRESSURE SENSOR CIRCUIT INSPECTION

1. Measure the continuity between the ABS actuator and electric unit (control unit) connector E125 and rear pressure sensor connector E32.

ABS actuator and electric unit (control unit) connector E125	Rear pressure sensor connector E32	Continuity
21 (R/G)	1 (R/G)	Yes
22 (W/L)	3 (W/L)	
23 (W/O)	2 (W/O)	

2. Measure the continuity between the ABS actuator and electric unit (control unit) connector E125 and body ground.

ABS actuator and electric unit (control unit) connector E125	Body ground	Continuity
21 (R/G)	—	No
22 (W/L)		
23 (W/O)		

OK or NG

- OK >> GO TO 4.  
NG >> Repair or replace harness or connector.

**4. REAR PRESSURE SENSOR INSPECTION**

1. Reconnect the rear pressure sensor and ABS actuator and electric unit (control unit) connectors.
2. Use "DATA MONITOR" to check if the status of "PRESS SEN 2" is normal.

Condition	Data monitor display (Approx.)
	PRESS SEN 2
When brake pedal is depressed	Positive value
When brake pedal is released	0 bar

OK or NG

- OK >> Inspection End.
- NG >> Replace rear pressure sensor.

**Steering Angle Sensor Safe Mode Inspection**

EFS00695

INSPECTION PROCEDURE

**1. INDICATOR LAMP CHECK**

Check that VDC OFF indicator lamp is on.

OK or NG

- OK >> GO TO 2.
- NG >> GO TO 3.

**2. ADJUSTMENT OF STEERING ANGLE SENSOR NEUTRAL POSITION**

Adjust steering angle sensor neutral position. Refer to [BRC-61, "Adjustment of Steering Angle Sensor Neutral Position"](#).

OK or NG

- OK >> GO TO 3.
- NG >> Check steering angle sensor. Refer to [BRC-40, "Steering Angle Sensor System"](#).

**3. INDICATOR LAMP CHECK**

Check that VDC OFF indicator lamp is off.

OK or NG

- OK >> GO TO 4.
- NG >> Perform basic inspection. Refer to [BRC-23, "Basic Inspection"](#).

**4. CHECK SELF-DIAGNOSTIC RESULTS**

Perform ABS actuator and electric unit (control unit) self-diagnosis.

Self-diagnosis results
ST ANGL SEN SAFE

**NOTE:**

When self-diagnostic results show items other than those above, perform repair or replacement for the item indicated and repeat self-diagnosis.

Is the above displayed on self-diagnosis display?

- YES >> Erase error memory.
- NO >> Inspection End.

**CAN Communication System Inspection**

## INSPECTION PROCEDURE

**1. CHECK CONNECTOR**

1. Turn ignition switch OFF, disconnect the ABS actuator and electric unit (control unit) connector, and check the terminals for deformation, disconnection, looseness, and so on. If there is a malfunction, repair or replace the terminal.
2. Reconnect connector to perform self-diagnosis.

Is "CAN COMM CIRCUIT" displayed in self-diagnosis display items?

- YES >> Print out the self-diagnostic results, and refer to [LAN-5, "CAN COMMUNICATION"](#) .  
 NO >> Connector terminal is loose, damaged, open, or shorted.

**Inspection For Self-diagnosis Result "ST ANGLE SEN SIGNAL"**

## INSPECTION PROCEDURE

**1. DISPLAY SELF-DIAGNOSIS RESULTS**

Check self-diagnosis results.

Self-diagnosis results
ST ANGLE SEN SIGNAL

Do self-diagnosis results indicate anything other than shown above?

- YES >> Perform repair or replacement for the item indicated.  
 NO >> Perform adjustment of steering angle sensor neutral position. GO TO 2.

**2. PERFORM SELF-DIAGNOSIS AGAIN**

1. Turn the ignition switch to OFF and then to ON and erase self-diagnosis results.
2. Perform ABS actuator and electric unit (control unit) self-diagnosis again.

Are any self-diagnosis results displayed?

- YES >> Replace steering angle sensor. Refer to [BRC-67, "Removal and Installation"](#) .  
 NO >> Inspection End.

**Inspection For Self-diagnosis Result "DECEL G SEN SET"**

## INSPECTION PROCEDURE

**1. PERFORM SELF-DIAGNOSIS**

Check self-diagnosis results.

Self-diagnosis results
DECEL G SEN SET

Do self-diagnosis results indicate anything other than shown above?

- YES >> Perform repair or replacement for the item indicated.  
 NO >> Perform calibration of decel G sensor. Refer to [BRC-61, "Calibration of Decel G Sensor"](#) . GO TO 2.

**2. PERFORM SELF-DIAGNOSIS AGAIN**

1. Turn the ignition switch to OFF and then to ON and erase self-diagnosis results.
2. Perform ABS actuator and electric unit (control unit) self-diagnosis again.

Are any self-diagnosis results displayed?

- YES >> Replace yaw rate/side/decel G sensor. Refer to [BRC-68, "Removal and Installation"](#) .  
 NO >> Inspection End.

# TROUBLE DIAGNOSIS FOR SELF-DIAGNOSTIC ITEMS

[VDC/TCS/ABS]

## VDC OFF Indicator lamp Does Not Illuminate

EFS004VF

### INSPECTION PROCEDURE

#### 1. CHECK VDC OFF INDICATOR LAMP

Disconnect ABS actuator and electric unit (control unit) connector E125.

Do the ABS warning lamp and VDC OFF indicator lamp illuminate?

YES >> Replace ABS actuator and electric unit (control unit). Refer to [BRC-65, "Removal and Installation"](#)

NO >> Replace combination meter. Refer to [IP-12, "COMBINATION METER"](#).

### Component Inspection

EFS004VG

#### VDC OFF SWITCH

Check the continuity between terminals 1 and 2.

- 1 - 2** : Continuity should exist when pushing the switch.  
Continuity should not exist when releasing the switch.

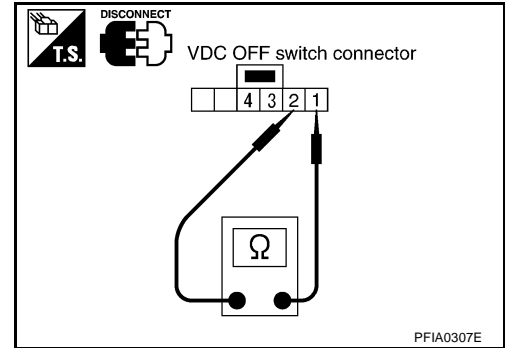

A  
B  
C  
D  
E  
BRC  
G  
H  
I  
J  
K  
L  
M

**TROUBLE DIAGNOSES FOR SYMPTOMS**

PFP:99999

**ABS Works Frequently**

EFS004VH

**1. CHECK WARNING LAMP ACTIVATION**

---

Make sure warning lamp remains off while driving.

OK or NG

OK >> GO TO 2.

NG >> Carry out self-diagnosis. Refer to [BRC-29, "SELF-DIAGNOSIS"](#) .

**2. CHECK WHEEL SENSORS**

---

Check the following.

- Wheel sensor mounting for looseness
- Wheel sensors for physical damage
- Wheel sensor connectors for terminal damage or loose connections

OK or NG

OK >> GO TO 3.

NG >> Repair or replace as necessary.

**3. CHECK FRONT AND REAR AXLES**

---

Check front and rear axles for excessive looseness. Refer to [FAX-5, "WHEEL BEARING INSPECTION"](#) or [RAX-5, "WHEEL BEARING INSPECTION"](#) .

OK or NG

OK >> GO TO 4.

NG >> Repair as necessary.

**4. CHECK BRAKE FLUID PRESSURE**

---

Check brake fluid pressure distribution.

Refer to [BRC-23, "Basic Inspection"](#) .

Is brake fluid pressure distribution normal?

YES >> Inspection End.

NO >> Perform Basic Inspection. Refer to [BRC-23, "Basic Inspection"](#) .



**Unexpected Pedal Action****1. CHECK WARNING LAMP ACTIVATION**

Make sure warning lamp remains off while driving.

OK or NG

OK >> GO TO 2.

NG >> Carry out self-diagnosis. Refer to [BRC-29, "SELF-DIAGNOSIS"](#) .

**2. CHECK BRAKE PEDAL STROKE**

Check brake pedal stroke.

Is pedal stroke excessive?

YES >> Perform Basic Inspection. Refer to [BRC-23, "Basic Inspection"](#) .

NO >> GO TO 3.

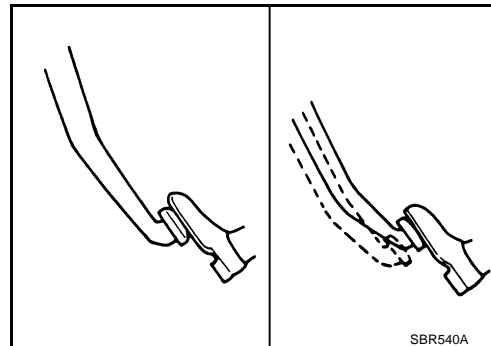
**3. CHECK CONNECTOR AND BRAKING PERFORMANCE**

1. Disable ABS by disconnecting ABS actuator and electric unit (control unit) connector.
2. Drive vehicle and check brake operation.

**NOTE:**

- Stopping distance may be longer than vehicles without ABS when road condition is slippery.
- Driving the vehicle with the ABS actuator and electric unit (control unit) disconnected may induce DTCs in electrical control units using CAN communication. After the inspection, clear all DTCs. Refer to [LAN-5, "CAN COMMUNICATION"](#) .

OK or NG

OK >> GO TO 4.

NG >> Perform Basic Inspection. Refer to [BRC-23, "Basic Inspection"](#) .

**4. CHECK WHEEL SENSORS**

Check the following.

- Wheel sensor mounting for looseness
- Wheel sensors for physical damage
- Wheel sensor connectors for terminal damage or loose connections

OK or NG

OK >> Check ABS actuator and electric unit (control unit) connector terminals for deformation, disconnection, looseness or damage. Reconnect ABS actuator and electric unit (control unit) harness connector. Then retest.

NG >> Repair or replace as necessary.

## Long Stopping Distance

### 1. CHECK BASE BRAKING SYSTEM PERFORMANCE

1. Disable ABS by disconnecting ABS actuator and electric unit (control unit) connector.
2. Drive vehicle and check brake operation.

**NOTE:**

- Stopping distance may be longer than vehicles without ABS when road condition is slippery.
- Driving the vehicle with the ABS actuator and electric unit (control unit) disconnected may induce DTCs in electrical control units using CAN communication. After the inspection, clear all DTCs. Refer to [LAN-5, "CAN COMMUNICATION"](#).

OK or NG

- OK >> Go to [BRC-56, "ABS Works Frequently"](#).
- NG >> Perform Basic Inspection. Refer to [BRC-23, "Basic Inspection"](#).

## ABS Does Not Work

**CAUTION:**

The ABS does not operate when the vehicle speed is 10 km/h (6 MPH) or less.

### 1. CHECK WARNING LAMP ACTIVATION

Turn ignition switch ON and check for warning lamp activation.

- Warning lamp should activate for approximately 1 second after turning the ignition switch ON.

OK or NG

- OK >> Carry out self-diagnosis. Refer to [BRC-29, "SELF-DIAGNOSIS"](#).
- NG >> Go to [BRC-59, "ABS Warning Lamp Stays On When Ignition Switch Is Turned On"](#).

## Pedal Vibration or ABS Operation Noise

**NOTE:**

During ABS activation, pedal vibration may be felt and a noise may be heard. This is normal and does not indicate a malfunction.

### 1. CHECK SYMPTOM

1. Apply brake.
2. Start engine.

Does the symptom occur only when engine is started?

- YES >> Carry out self-diagnosis. Refer to [BRC-29, "SELF-DIAGNOSIS"](#).
- NO >> GO TO 2.

### 2. RECHECK SYMPTOM

Does the symptom occur only when electrical equipment switches (such as headlamps) are turned on?

- YES >> Check for radio, antenna or related wiring that is routed too close to the ABS actuator and electric unit (control unit) and reroute as necessary.
- NO >> Go to [BRC-56, "ABS Works Frequently"](#).

**ABS Warning Lamp Does Not Come On When Ignition Switch Is Turned On** EFS004VM

**1. CHECK ABS ACTUATOR AND ELECTRIC UNIT (CONTROL UNIT) FUSES**

Check 30A fusible link **h** and 40A fusible link **i** for ABS actuator and electric unit (control unit). For fusible link layout, refer to [PG-4, "POWER SUPPLY ROUTING CIRCUIT"](#) .

OK or NG

OK >> GO TO 2.

NG >> If fusible link is blown, be sure to eliminate cause of problem before replacing.

**2. CHECK ABS ACTUATOR AND ELECTRIC UNIT (CONTROL UNIT) POWER SUPPLY CIRCUITS**

1. Disconnect ABS actuator and electric unit (control unit) connector.
2. Check voltage between ABS actuator and electric unit (control unit) connector terminal 1 (Y) and ground and terminal 32 (B/Y) and ground.

Does battery voltage exist?

YES >> GO TO 3.

NO >> Repair harness or connectors between fusible link and ABS actuator and electric unit (control unit).

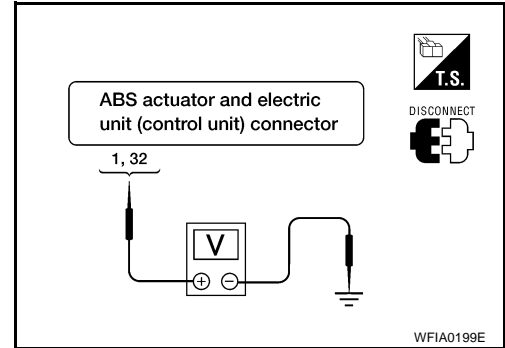

**3. CHECK ABS ACTUATOR AND ELECTRIC UNIT (CONTROL UNIT) GROUND CIRCUIT**

Check continuity between ABS actuator and electric unit (control unit) connector terminal 16 (B) and ground and terminal 47 (B) and ground.

Does continuity exist?

YES >> Replace ABS actuator and electric unit (control unit). Refer to [BRC-65, "Removal and Installation"](#) .

NO >> Repair harness or connectors between ABS actuator and electric unit (control unit) and ground.

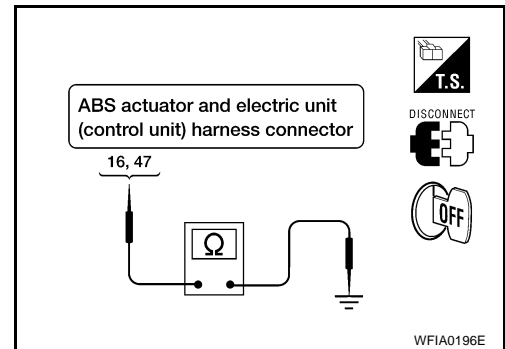

**ABS Warning Lamp Stays On When Ignition Switch Is Turned On** EFS004VN

**1. CARRY OUT SELF-DIAGNOSIS**

Carry out self-diagnosis. Refer to [BRC-29, "SELF-DIAGNOSIS"](#) .

Are malfunctions detected in self-diagnosis?

YES >> Refer to [BRC-30, "Display Item List"](#) .

NO >> Refer to [DI-30, "WARNING LAMPS"](#) .

## Vehicle Jerks During TCS/VDC Activation

---

### 1. ABS ACTUATOR AND ELECTRIC UNIT (CONTROL UNIT) SELF-DIAGNOSIS

---

Perform ABS actuator and electric unit (control unit) self-diagnosis.

Are self-diagnosis result items displayed?

- YES >> After checking and repairing the applicable item, perform the ABS actuator and electric unit (control unit) self-diagnosis again.
- NO >> GO TO 2.

### 2. ENGINE SPEED SIGNAL INSPECTION

---

Perform data monitor with CONSULT-II for the ABS actuator and electric unit (control unit).

Is the engine speed at idle 400 rpm or higher?

- YES >> GO TO 4.
- NO >> GO TO 3.

### 3. ECM SELF-DIAGNOSIS

---

Perform ECM self-diagnosis.

Are self-diagnosis result items displayed?

- YES >> After checking and repairing the applicable item, perform the ECM self-diagnosis again.
- NO >> GO TO 4.

### 4. TCM SELF-DIAGNOSIS

---

Perform TCM self-diagnosis.

Are self-diagnosis result items displayed?

- YES >> After checking and repairing the applicable item, perform the TCM self-diagnosis again.
- NO >> GO TO 5.

### 5. CONNECTOR INSPECTION

---

Disconnect the ABS actuator and electric unit (control unit) connector and the ECM connectors and check the terminals for deformation, disconnection, looseness or damage.

OK or NG

- OK >> GO TO 6.
- NG >> Repair or replace as necessary.

### 6. CAN COMMUNICATION INSPECTION

---

Check the CAN communication system. Refer to [BRC-54, "CAN Communication System Inspection"](#) .

OK or NG

- OK >> Inspection End.
- NG >> Refer to [LAN-5, "CAN COMMUNICATION"](#) .

ON-VEHICLE SERVICE

PFP:00000

Adjustment of Steering Angle Sensor Neutral Position

EFS004VP

After removing/installing or replacing ABS actuator and electric unit (control unit), steering angle sensor, steering and suspension components which affect wheel alignment or after adjusting wheel alignment, be sure to adjust neutral position of steering angle sensor before running vehicle.

NOTE:

Adjustment of steering angle sensor neutral position requires CONSULT-II.

1. Stop vehicle with front wheels in straight-ahead position.
2. Connect CONSULT-II and CONSULT-II CONVERTER to data link connector on vehicle, and turn ignition switch ON (do not start engine).
3. Touch "ABS", "WORK SUPPORT" and "ST ANGLE SENSOR ADJUSTMENT" on CONSULT-II screen in this order.

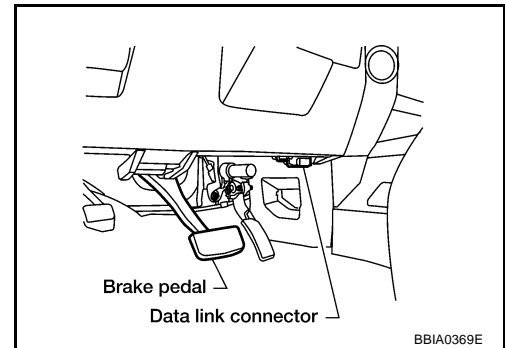

4. Touch "START".

CAUTION:

Do not touch steering wheel while adjusting steering angle sensor.

5. After approximately 10 seconds, touch "END". (After approximately 60 seconds, it ends automatically.)
6. Turn ignition switch OFF, then turn it ON again.
7. Run vehicle with front wheels in straight-ahead position, then stop.
8. Select "DATA MONITOR", "SELECTION FROM MENU", and "STR ANGLE SIG" on CONSULT-II screen. Then check that "STR ANGLE SIG" is within 0±3.5 deg. If value is more than specification, repeat steps 1 to 5.
9. Erase memory of ABS actuator and electric unit (control unit) and ECM.
10. Turn ignition switch to OFF.

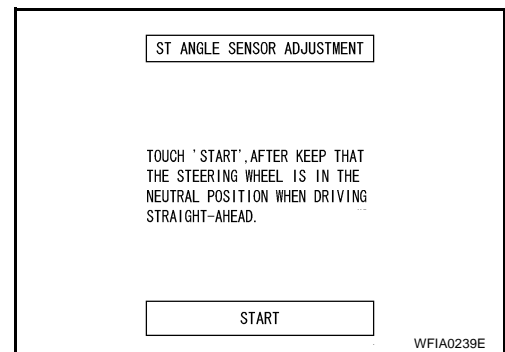

Calibration of Decel G Sensor

EFS004VQ

After removing/installing or replacing ABS actuator and electric unit (control unit), yaw rate/side/decel G sensor, steering and suspension components which affect wheel alignment or after adjusting wheel alignment, be sure to calibrate the decel G sensor before running vehicle.

NOTE:

Calibration of decel G sensor requires CONSULT-II.

1. Stop vehicle with front wheels in straight-ahead position.

CAUTION:

● The work should be done on a level area with an unloaded vehicle.

● Keep all the tires inflated to the correct pressures. Adjust the tire pressure to the specified pressure value.

2. Connect CONSULT-II with CONSULT-II CONVERTER to data link connector on vehicle, and turn ignition switch ON (do not start engine).

CAUTION:

If CONSULT-II is used with no connection of CONSULT-II CONVERTER, malfunctions might be detected in self-diagnosis depending on control unit which carries out CAN communication.

3. Touch "ABS", "WORK SUPPORT" and "DECEL G SEN CALIBRATION" on CONSULT-II screen in this order. Refer to [BRC-28, "CONSULT-II BASIC OPERATION PROCEDURE"](#) .

4. Touch "START".

**CAUTION:**

**Set vehicle as shown in the display.**

5. After approximately 10 seconds, touch "END". (After approximately 60 seconds, it ends automatically.)
6. Turn ignition switch OFF, then turn it ON again.

**CAUTION:**

**Be sure to carry out above operation**

7. Run vehicle with front wheels in straight-ahead position, then stop.
8. Select "DATA MONITOR", "SELECTION FROM MENU", and "DECEL G SEN" on CONSULT-II screen. Then check that "DECEL G SEN" is within  $\pm 0.08G$ . If value is more than specification, repeat steps 3 to 7.
9. Erase memory of ABS actuator and electric unit (control unit) and ECM.
10. Turn ignition switch to OFF.

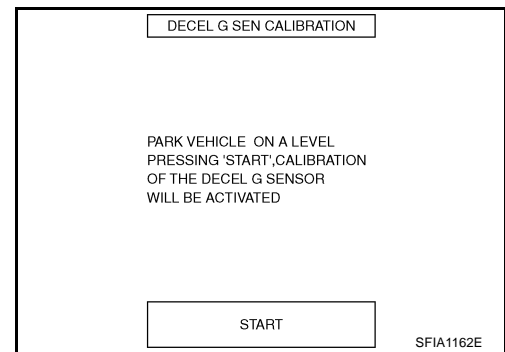

## WHEEL SENSORS

### Removal and Installation

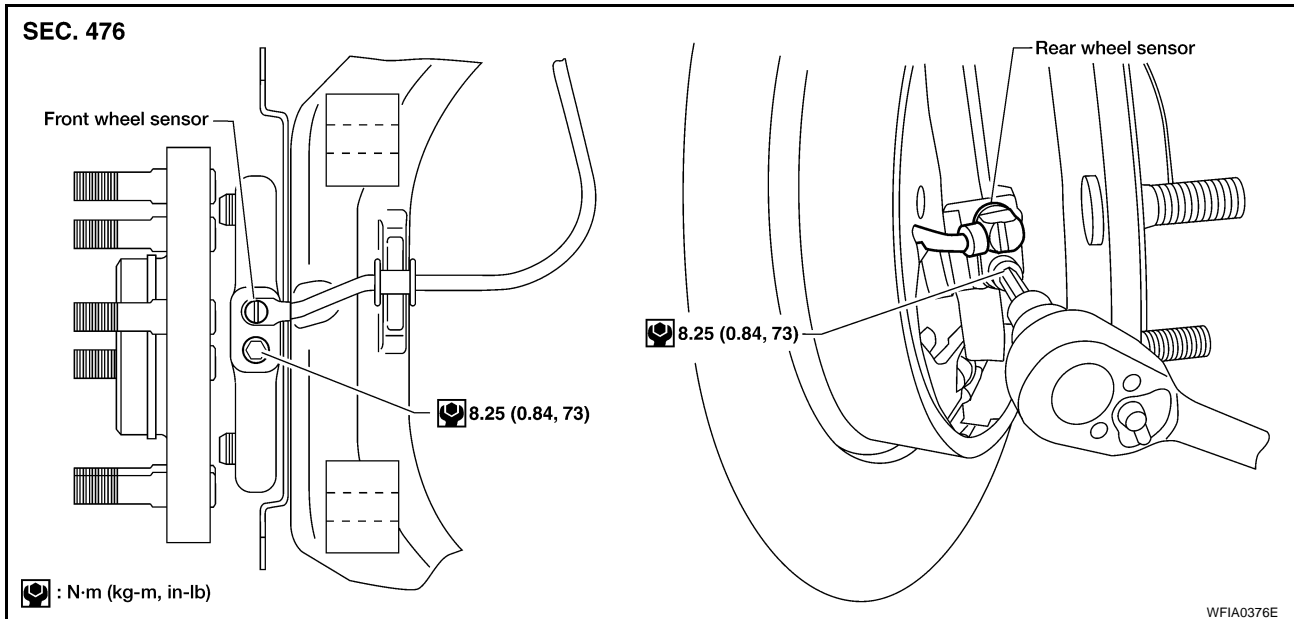

### REMOVAL

1. Remove wheel sensor mounting screw.
  - When removing the front wheel sensor, first remove the disc rotor to gain access to the front wheel sensor mounting bolt. Refer to [BR-21, "Removal and Installation of Brake Caliper and Disc Rotor"](#).
  - When removing the rear wheel sensor, first remove the rear hub and bearing assembly to gain access to the rear wheel sensor mounting bolt. Refer to [RAX-5, "Removal and Installation"](#).
2. Pull out the sensor, being careful to turn it as little as possible.
 

**CAUTION:**

  - **Do not pull on the sensor harness.**
3. Disconnect wheel sensor harness electrical connector, then remove harness from mounts.

### INSTALLATION

Installation is in the reverse order of removal. Tighten wheel sensor bolt to the specified torque.

**CAUTION:**

Installation should be performed while paying attention to the following.

- Inspect wheel sensor O-ring, replace sensor assembly if damaged.
- Before installing wheel sensor, make sure no foreign materials (such as iron fragments) are adhered to the pick-up part of the sensor, to the inside of the sensor mounting hole or on the rotor mounting surface.
- Apply a coat of suitable grease to the wheel sensor O-ring and mounting hole.

A  
B  
C  
D  
E  
BRC

G

H

I

J

K

L

M

---

## SENSOR ROTOR

PF:47970

### Removal and Installation

EFS004VS

**NOTE:**

The wheel sensor rotors are built into the wheel hubs and are not removable. If damaged, replace wheel hub and bearing assembly. Refer to [FAX-5, "Removal and Installation"](#) (front), [RAX-5, "Removal and Installation"](#) (rear).



## ACTUATOR AND ELECTRIC UNIT (ASSEMBLY)

PFP:47660

### Removal and Installation

EFS004VT

SEC. 476

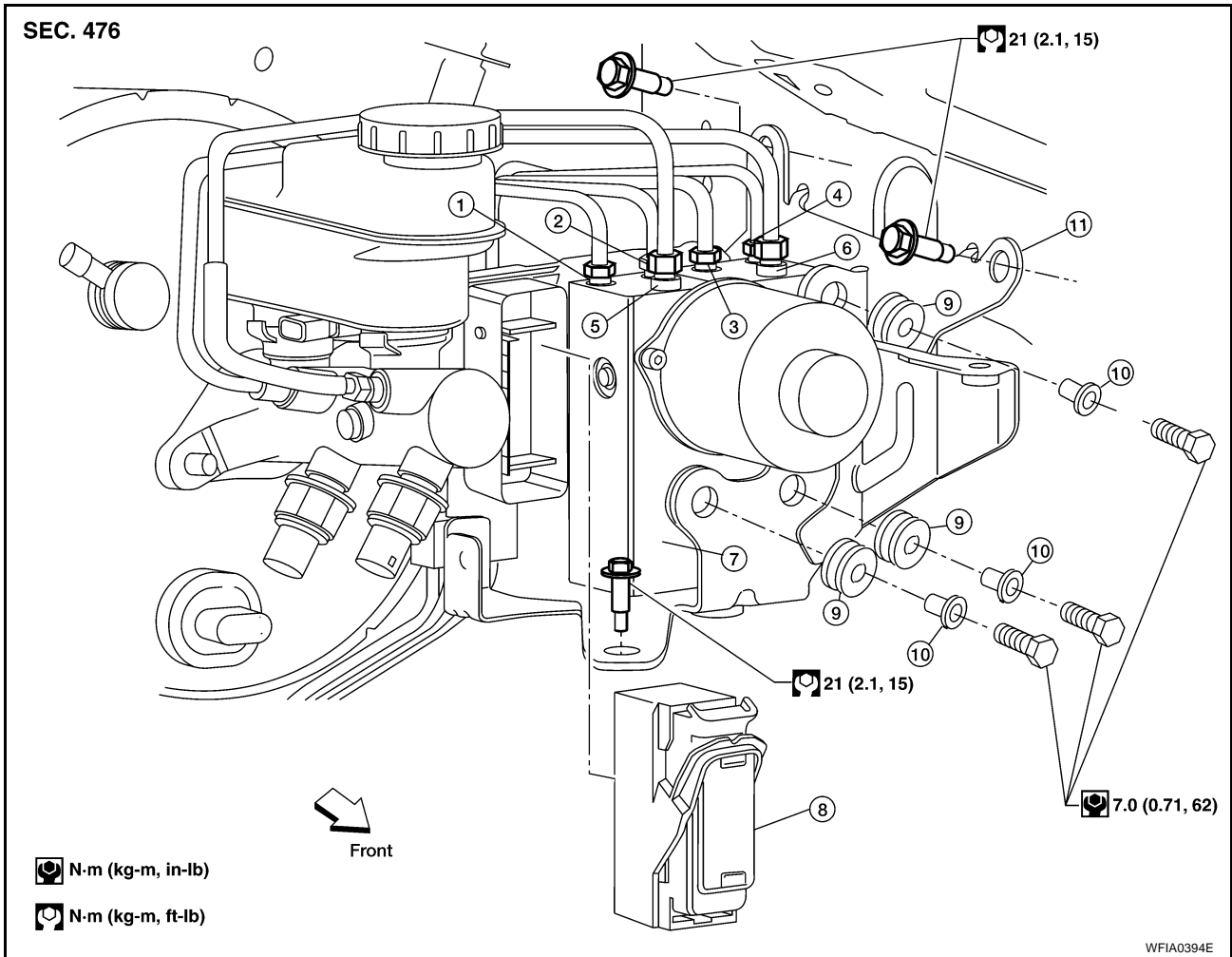

- |  |  |  |
|--|--|--|
| 1. To rear left                                  | 2. To rear right                           | 3. To front left                         |
| 4. To front right                                | 5. From the master cylinder secondary side | 6. From the master cylinder primary side |
| 7. ABS actuator and electric unit (control unit) | 8. Harness connector                       | 9. Grommet                               |
| 10. Collar                                       | 11. Mounting bracket                       |  |

### REMOVAL

1. Disconnect the negative battery terminal.
2. Remove the cowl top extension. Refer to [EI-19, "Removal and Installation"](#).
3. Drain the brake fluid. Refer to [BR-9, "Drain and Refill"](#).
4. Disconnect the actuator harness from the ABS actuator and electric unit (control unit).

**CAUTION:**

- To remove the brake tubes, use a flare nut wrench to prevent the flare nuts and brake tubes from being damaged.
- Be careful not to splash brake fluid on painted areas.

5. Disconnect the brake tubes.
6. Remove the three bolts and remove the ABS actuator and electric unit (control unit).

## INSTALLATION

Installation is in the reverse order of removal.

### **CAUTION:**

To install, use a flare nut wrench (commercial service tool).

- Always tighten brake tubes to specification when installing. Refer to [BR-11, "Hydraulic Circuit"](#) .
- Never reuse drained brake fluid.
- After installation of the ABS actuator and electric unit (control unit), perform the following.
  - Refill brake system with new brake fluid. Then bleed the air from the system. Refer to [BR-10, "Bleeding Brake System"](#) .
  - Adjust the steering angle sensor. Refer to [BRC-61, "Adjustment of Steering Angle Sensor Neutral Position"](#) .
  - Calibrate the decel G sensor. Refer to [BRC-61, "Calibration of Decel G Sensor"](#) .

# STEERING ANGLE SENSOR

[VDC/TCS/ABS]

---

## STEERING ANGLE SENSOR

PF2:25554

### Removal and Installation

EFS004VJ

**NOTE:**

The steering angle sensor is an integral part of the spiral cable. Refer to [SRS-48, "Removal and Installation"](#) .

A

B

C

D

E

**BRC**

G

H

I

J

K

L

M

**G SENSOR****Removal and Installation****REMOVAL**

1. Remove center console. Refer to [IP-14, "CENTER CONSOLE"](#) .
2. Remove yaw rate/side/decel G sensor attaching nuts.

**CAUTION:**

- Do not use power tools to remove or install yaw rate/side/decel G sensor.
  - Do not drop or strike the yaw rate/side/decel G sensor.
3. Disconnect harness connector and remove the yaw rate/side/decel G sensor.

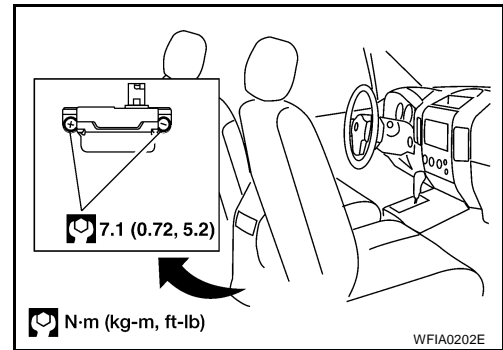
**INSTALLATION**

To install, reverse the removal procedure.

**CAUTION:**

- Do not drop or strike the yaw rate/side/decel G sensor.
- After installation, calibrate the decel G sensor. Refer to [BRC-61, "Calibration of Decel G Sensor"](#) .