

SECTION **FSU**
FRONT SUSPENSION

A
B
C
D

FSU

CONTENTS

PRECAUTIONS	2	STABILIZER BAR	12	F
Precautions	2	Removal and Installation	12	
PREPARATION	3	REMOVAL	12	G
Special Service Tools	3	INSPECTION AFTER REMOVAL	12	
Commercial Service Tools	3	INSTALLATION	12	
NOISE, VIBRATION, AND HARSHNESS (NVH)		UPPER LINK	13	H
TROUBLESHOOTING	4	Removal and Installation	13	
NVH Troubleshooting Chart	4	REMOVAL	13	
FRONT SUSPENSION ASSEMBLY	5	INSPECTION AFTER REMOVAL	13	I
Components	5	INSTALLATION	13	
ON-VEHICLE SERVICE	6	LOWER LINK	14	J
Front Suspension Parts	6	Removal and Installation	14	
Front Wheel Alignment	6	REMOVAL	14	
PRELIMINARY INSPECTION	6	INSPECTION AFTER REMOVAL	14	
GENERAL INFORMATION AND RECOMMEN-		INSTALLATION	14	
DATIONS	6	UPPER BALL JOINT AND LOWER BALL JOINT...	15	K
THE ALIGNMENT PROCESS	7	Removal and Installation	15	
CAMBER AND CASTER	7	Inspection	15	
TOE-IN	7	SWINGING FORCE	15	L
FRONT WHEEL TURNING ANGLE	8	TURNING FORCE	15	
COIL SPRING AND SHOCK ABSORBER	10	VERTICAL END PLAY	15	
Removal and Installation	10	KNUCKLE	16	M
REMOVAL	10	On-Vehicle Inspection and Service	16	
INSTALLATION	10	Removal and Installation	16	
Disassembly and Assembly	10	REMOVAL	16	
DISASSEMBLY	10	INSPECTION AFTER REMOVAL	17	
INSPECTION AFTER DISASSEMBLY	10	INSTALLATION	18	
ASSEMBLY	11	SERVICE DATA AND SPECIFICATIONS (SDS)	19	
		General Specifications (Front)	19	
		Wheel Alignment (Unladen*1)*6	19	
		Ball Joint	20	
		Wheelarch Height (Unladen*1)	20	

PRECAUTIONS

PRECAUTIONS

PFP:00001

Precautions

EES001DW

- When installing the rubber bushings, the final tightening must be done under unladen condition and with the tires on level ground. Oil will shorten the life of the rubber bushings, so wipe off any spilled oil immediately.
- Unladen condition means the fuel tank, engine coolant and lubricants are at the full specification. The spare tire, jack, hand tools, and mats are in their designated positions.
- After installing suspension components, check the wheel alignment.
- Lock nuts are not reusable. Always use new lock nuts for installation. New lock nuts are pre-oiled, do not apply any additional lubrication.

PREPARATION

PREPARATION

PF0:00002

Special Service Tools

EES001DX

The actual shapes of Kent-Moore tools may differ from those of special service tools illustrated here.

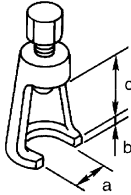
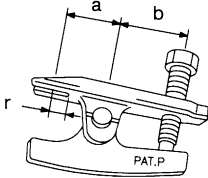
Tool number (Kent-Moore No.) Tool name	Description
ST29020001 (J-24319-01) Gear arm puller	 Removing ball joint for knuckle spindle a: 34 mm (1.34 in) b: 6.5 mm (0.256 in) c: 61.5 mm (2.421 in)
HT72520000 (J-25730-A) Ball joint remover	 Removing tie-rod outer end a: 33 mm (1.30 in) b: 50 mm (1.97 in) r: 11.5 mm (0.453 in)

Commercial Service Tools

EES001DY

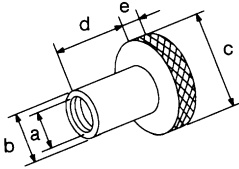
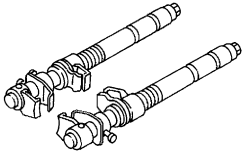
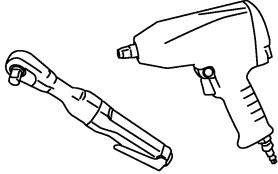
Tool name	Description
Attachment wheel alignment	 Measure wheel alignment a: Screw M24 x 1.5 pitch b: 35 mm (1.38 in) dia. c: 65 mm (2.56 in) dia. d: 56 mm (2.20 in) e: 12 mm (0.47 in)
Spring compressor	 Removing and installing coil spring
Power tool	 Loosening bolts and nuts

NOISE, VIBRATION, AND HARSHNESS (NVH) TROUBLESHOOTING

NOISE, VIBRATION, AND HARSHNESS (NVH) TROUBLESHOOTING

PF0:00003

NVH Troubleshooting Chart

EES001DZ

Use the chart below to help you find the cause of the symptom. Repair or replace parts as necessary.

Symptom		Possible Cause and SUSPECTED PARTS													Reference page			
		Improper installation, looseness	Shock absorber deformation, damage or deflection	Bushing or mounting deterioration	Parts interference	Spring fatigue	Suspension looseness	Incorrect wheel alignment	Stabilizer bar fatigue	PROPELLER SHAFT	FRONT FINAL DRIVE	DRIVE SHAFT	WHEEL HUB	TIRES		ROAD WHEEL	BRAKES	STEERING
Symptom	Noise	x	x	x	x	x	x			x	x	x	x	x	x	x	x	FSU-5
	Shake	x	x	x	x		x			x		x	x	x	x	x	x	FSU-10
	Vibration	x	x	x	x	x				x		x	x	x				FSU-5
	Shimmy	x	x	x	x			x				x	x	x	x	x	x	FSU-5
	Shudder	x	x	x								x	x	x	x	x	x	FSU-20
	Poor quality ride or handling	x	x	x	x	x		x	x			x	x	x	x			FSU-6 FSU-6 FSU-6 FSU-6
																		PR-3, "NVH Troubleshooting Chart" FFD-6, "NVH Troubleshooting Chart" FAX-4, "NVH Troubleshooting Chart" FAX-4, "NVH Troubleshooting Chart" WT-4, "NVH Troubleshooting Chart" WT-4, "NVH Troubleshooting Chart" WT-4, "NVH Troubleshooting Chart" BR-5, "NVH Troubleshooting Chart" PS-5, "NVH Troubleshooting Chart"

x: Applicable

FRONT SUSPENSION ASSEMBLY

FRONT SUSPENSION ASSEMBLY

PF5:54010

Components

EES001E0

SEC. 391 • 400 • 401

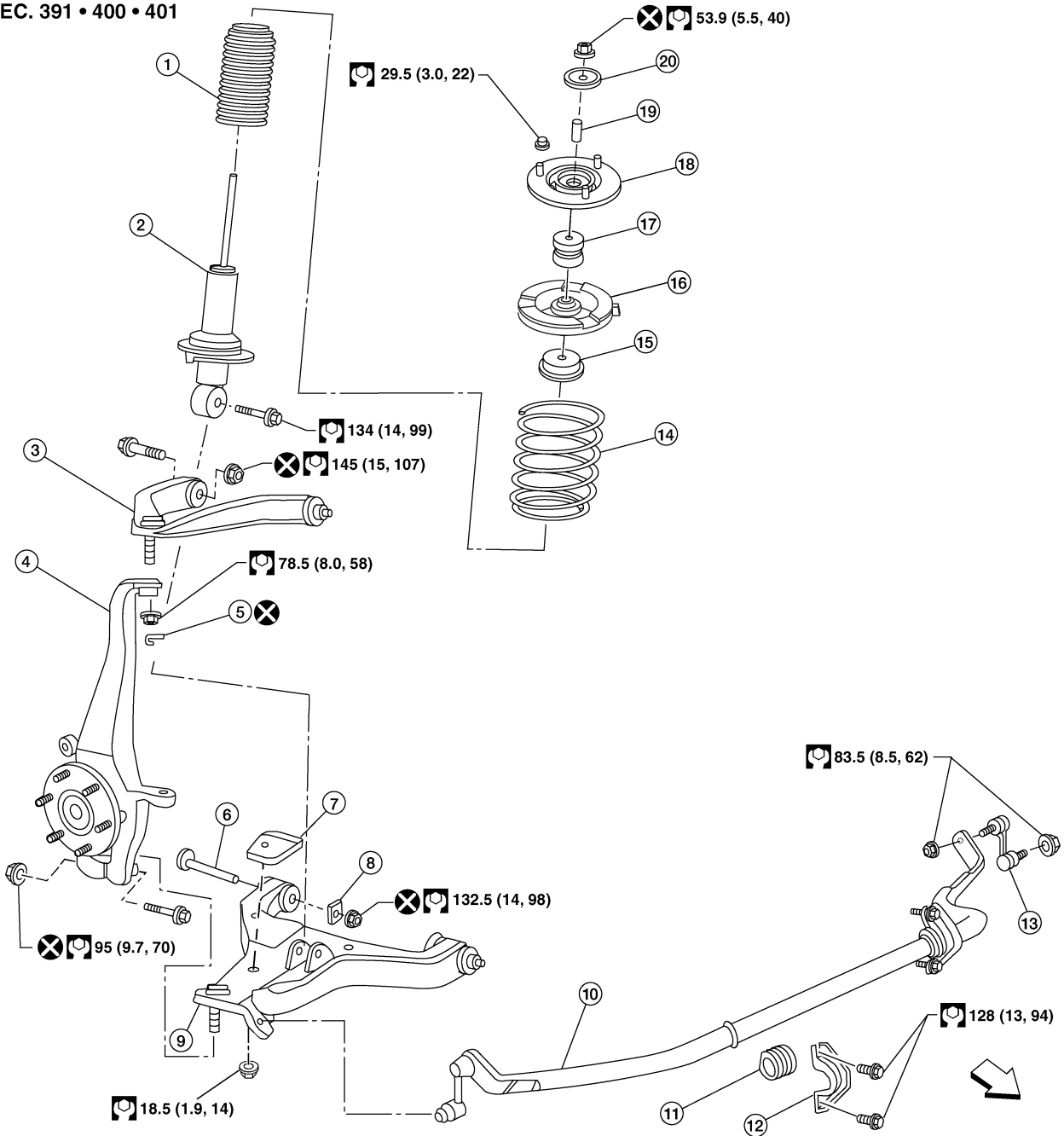

- | | | |
|-----------------------|----------------------------|---------------------------------------|
| 1. Dust cover | 2. Shock absorber | 3. Upper link |
| 4. Steering knuckle | 5. Cotter pin | 6. Bolt |
| 7. Jounce bumper | 8. Washer | 9. Lower link |
| 10. Stabilizer bar | 11. Stabilizer bar bushing | 12. Stabilizer bar mounting bracket |
| 13. Connecting rod | 14. Coil spring | 15. Upper seat |
| 16. Upper spring seat | 17. Shock absorber bushing | 18. Shock absorber mounting insulator |
| 19. Spacer | 20. Washer | ← Front |

WEIA0156E

ON-VEHICLE SERVICE

PF0:0000

Front Suspension Parts

EES001E1

Check front suspension parts for excessive play, cracks, wear and other damage.

- Shake each front wheel to check for excessive play. If looseness is noted, inspect wheel bearing end play, then check ball joint end play. Refer to [FAX-5, "WHEEL BEARING INSPECTION"](#) and [FSU-15, "Inspection"](#).
- Make sure that the cotter pin is inserted (4x4 only).
- Retighten all nuts and bolts to the specified torque.

Suspension component torques : Refer to [FSU-5, "Components"](#).

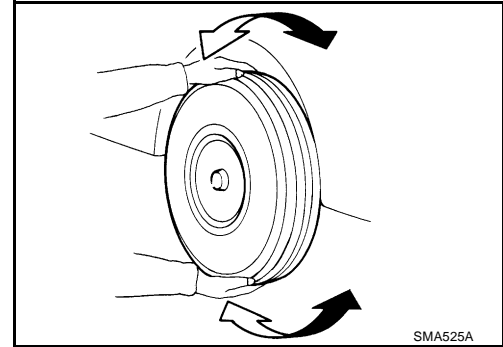

- Check shock absorber for oil leakage and other damage.
- Check suspension ball joint for grease leakage and ball joint dust cover for cracks and other damage.

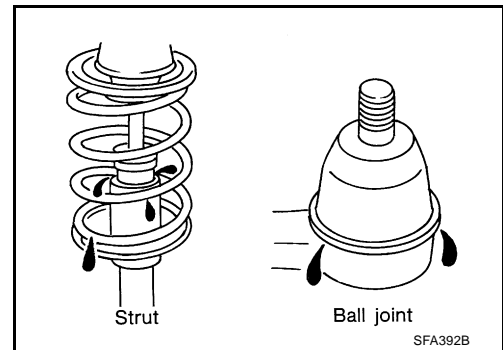

Front Wheel Alignment PRELIMINARY INSPECTION

EES001E2

WARNING:

Always adjust the alignment with the vehicle on a flat surface.

NOTE:

If alignment is out of specification, inspect and replace any damaged or worn suspension parts before making any adjustments.

1. Check and adjust the wheel alignment with the vehicle under unladen conditions. "Unladen conditions" means that the fuel, coolant, and lubricant are full; and that the spare tire, jack, hand tools and mats are in their designated positions.
2. Check the tires for incorrect air pressure and excessive wear.
3. Check the wheels for run out and damage. Refer to [WT-5, "Inspection"](#).
4. Check the wheel bearing axial end play. Refer to [FAX-5, "WHEEL BEARING INSPECTION"](#).
5. Check the shock absorbers for leaks or damage.
6. Check each mounting point of the suspension components for any excessive looseness or damage.
7. Check each link, arm, and the rear suspension member for any damage.
8. Check the vehicle height. Refer to [FSU-20, "Wheelarch Height \(Unladen*1\)"](#).
 - Verify the level using Consult-II memory register 1103 and set to 0 ± 10 mm (0 ± 0.39 in) as necessary.

GENERAL INFORMATION AND RECOMMENDATIONS

1. A Four-Wheel Thrust Alignment should be performed.
 - This type of alignment is recommended for any NISSAN vehicle.
 - The four-wheel "thrust" process helps ensure that the vehicle is properly aligned and the steering wheel is centered.
 - The alignment machine itself should be capable of accepting any NISSAN vehicle.
 - The alignment machine should be checked to ensure that it is level.
2. Make sure the alignment machine is properly calibrated.
 - Your alignment machine should be regularly calibrated in order to give correct information.

ON-VEHICLE SERVICE

- Check with the manufacturer of your specific alignment machine for their recommended Service/Calibration Schedule.

THE ALIGNMENT PROCESS

IMPORTANT: Use only the alignment specifications listed in this Service Manual. Refer to [FSU-19, "Wheel Alignment \(Unladen^{*1}\)*6"](#).

1. When displaying the alignment settings, many alignment machines use "indicators": (Green/red, plus or minus, Go/No Go). **Do NOT use these indicators.**
 - The alignment specifications programmed into your alignment machine that operate these indicators may not be correct.
 - This may result in an ERROR.
2. Some newer alignment machines are equipped with an optional "Rolling Compensation" method to "compensate" the sensors (alignment targets or head units). **Do NOT use this "Rolling Compensation" method.**
 - Use the "Jacking Compensation" method. After installing the alignment targets or head units, raise the vehicle and rotate the wheels 1/2 turn both ways.
 - See Instructions in the alignment machine you are using for more information.

CAMBER AND CASTER

1. Measure camber and caster of both the right and left wheels with a suitable alignment gauge and adjust as necessary to specification.

Camber and Caster : Refer to [FSU-19, "Wheel Alignment \(Unladen^{*1}\)*6"](#).

NOTE:

Some vehicles may be equipped with straight (non-adjustable) lower link bolts and washers. In order to adjust camber and caster on these vehicles, first replace the lower link bolts and washers with adjustable (cam) bolts and washers.

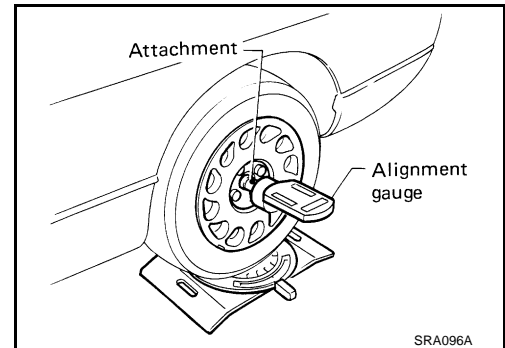

2. If outside of the specified value, adjust camber and caster using the cam bolts (1) in the front lower link (2).

CAUTION:

After adjusting the camber then check the toe-in.

NOTE:

Camber changes about 3' (0.05°) minutes with each graduation of one cam bolt. Refer to table below for examples of lower link cam bolt effect on camber and caster.

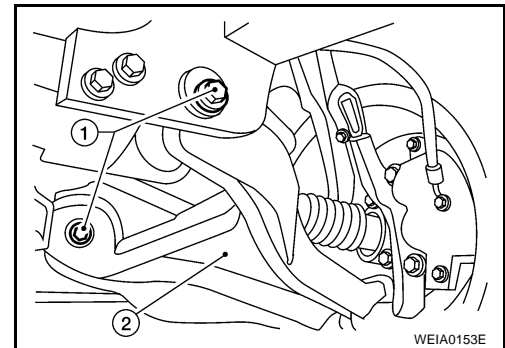

Rear cam bolt	1 In	1 Out	1 In	1 Out	0	0	1 In	1 Out
Front cam bolt	1 Out	1 In	1 In	1 Out	1 In	1 Out	0	0
Camber Degree minute (Decimal degree)	0' (0°)	0' (0°)	7' (0.12°)	- 7' (-0.12°)	3' (0.05°)	- 3' (-0.05°)	3' (0.05°)	- 3' (-0.05°)
Caster Degree minute (Decimal degree)	- 14' (-0.23°)	14' (0.23°)	0' (0°)	0' (0°)	7' (0.12°)	- 7' (-0.12°)	- 7' (-0.12°)	7' (0.12°)

3. Tighten the adjusting bolt nuts to specification. Refer to [FSU-5, "Components"](#).

TOE-IN

WARNING:

- Always perform the following procedure on a flat surface.
- Make sure that no person is in front of the vehicle before pushing it.

ON-VEHICLE SERVICE

1. Bounce the front of vehicle up and down to stabilize the vehicle height (posture).
2. Push the vehicle straight ahead about 5 m (16 ft).
3. Put a mark on base line of the tread (rear side) of both front tires at the same height as hub center as shown. These marks are measuring points.

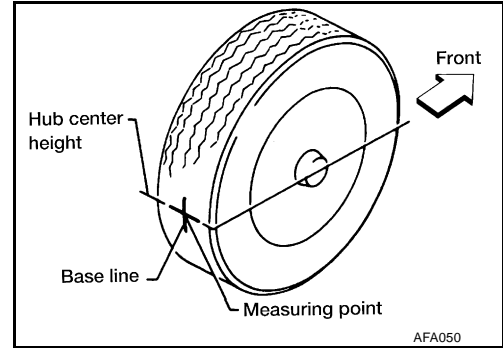

4. Measure the distance "A" on the rear side of the front tires as shown.
5. Push the vehicle slowly ahead to rotate the wheels 180° degrees (1/2 a turn).

CAUTION:

If the wheels have rotated more than 180° degrees (1/2 turn), start this procedure again from the beginning. Never push the vehicle backward.

6. Measure the distance "B" on the front side of the front tires at the same marks as shown. Total toe-in is calculated as "A" – "B".

Total toe-in : Refer to [FSU-19, "Wheel Alignment \(Unladen^{*1}\)^{*6}"](#) .

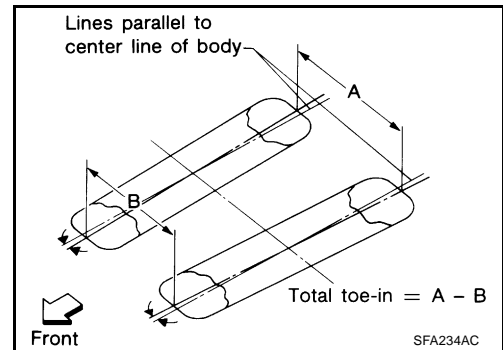

7. Adjust the toe-in by varying the length of the steering outer socket.
 - a. Loosen the outer tie-rod lock nuts.
 - b. Adjust the toe-in by screwing the outer tie-rods in or out.

Standard length "L" : Refer to [PS-32, "Steering Outer Socket and Inner Socket"](#) .

- c. Tighten the outer tie-rod lock nuts to specification.

Lock nut : Refer to [PS-16, "Disassembly and Assembly"](#) .

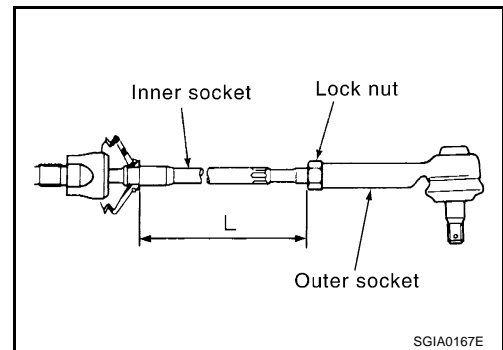

FRONT WHEEL TURNING ANGLE

NOTE:

Check front wheel turning angle after the toe-in inspection.

1. Place front wheels on turning radius gauges in straight ahead position and rear wheels on stands so that vehicle can be level. Check the maximum inner and outer wheel turning angles for LH and RH road wheels.
2. Start engine and run at idle, turn steering wheel all the way right and left, measure the turning angle.

Wheel turning angle (full turn) : Refer to [FSU-19, "Wheel Alignment \(Unladen^{*1}\)^{*6}"](#) .

- Any turning angles are not adjustable. If any of steering angles are out of the specification, check if the following parts are worn or damaged.

- Steering gear
- Steering column
- Front suspension components

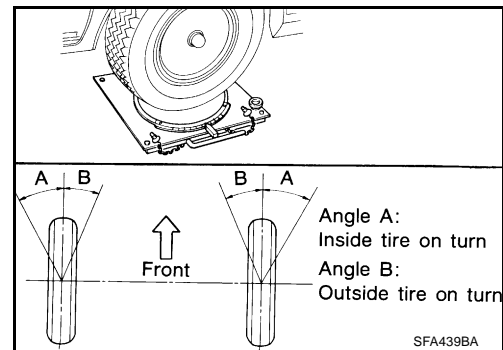

ON-VEHICLE SERVICE

If found that they are worn or damaged, replace them with new ones.

A

B

C

D

FSU

F

G

H

I

J

K

L

M

COIL SPRING AND SHOCK ABSORBER

COIL SPRING AND SHOCK ABSORBER

PFP:56210

Removal and Installation

EES001E3

REMOVAL

1. Remove the wheel and tire using power tool.
2. Remove the shock absorber lower bolt using power tool.
3. Remove the three shock absorber upper mounting nuts using power tool.
4. Remove the coil spring and shock absorber assembly.
 - Turn steering knuckle out to gain enough clearance for removal.

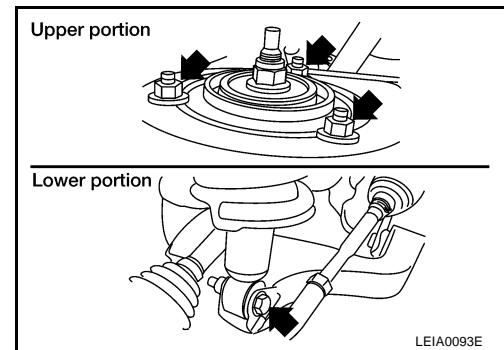

INSTALLATION

Installation is in the reverse order of removal.

- The step in the strut assembly lower seat faces outside of vehicle.
- Tighten all nuts and bolts to specification. Refer to [FSU-5, "Components"](#).
- When installing wheel and tire, refer to [WT-7, "Rotation"](#).

Disassembly and Assembly

EES001E4

1. Set the shock absorber in a vise, then loosen (without removing) the piston rod lock nut as shown.

CAUTION:

Do not remove piston rod lock nut at this time.

2. Compress the spring using commercial service tool until the shock absorber mounting insulator can be turned by hand.

WARNING:

Make sure that the pawls of the two spring compressors are firmly hooked on the spring. The spring compressors must be tightened alternately and evenly so as not to tilt the spring.

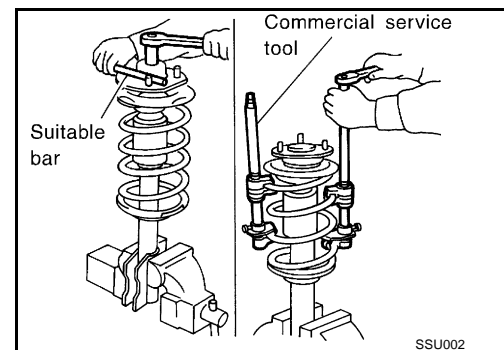

3. Remove the piston rod lock nut.
 - Discard the piston rod lock nut, use a new nut for assembly.

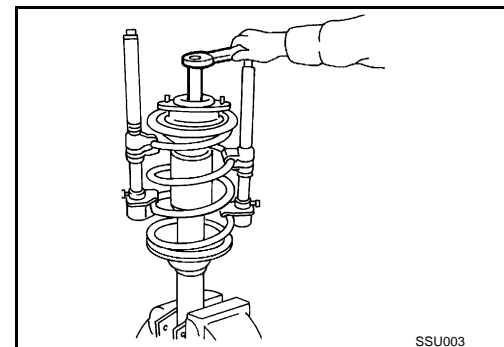

INSPECTION AFTER DISASSEMBLY

Shock Absorber Assembly

- Check for smooth operation through a full stroke, both compression and extension.
- Check for oil leakage on welded or gland packing portions.
- Check piston rod for cracks, deformation or other damage and replace if necessary.

Mounting Insulator and Rubber Parts

Check cemented rubber-to-metal portion for separation or cracks. Check rubber parts for deterioration and replace if necessary.

COIL SPRING AND SHOCK ABSORBER

Coil Spring

- Check for cracks, deformation or other damage and replace if necessary.
- Check the free spring height.

Front spring free height

4x2 : 325.5 ± 3 mm (12.8 ± 0.1 in)

4x4 : 335.0 ± 3 mm (13.2 ± 0.1 in)

ASSEMBLY

1. When installing coil spring on strut, it must be positioned as shown.

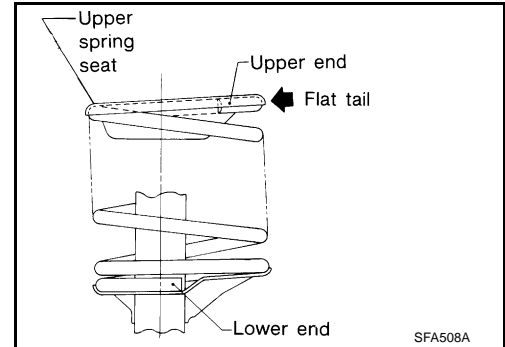

2. Install upper spring seat as shown in line with lower shock mount and step in lower seat.
 - The step in the strut assembly lower seat faces outside of vehicle.
3. Tighten the piston rod lock nut to specification. Refer to [FSU-5. "Components"](#).
 - Use a new piston rod lock nut for assembly.

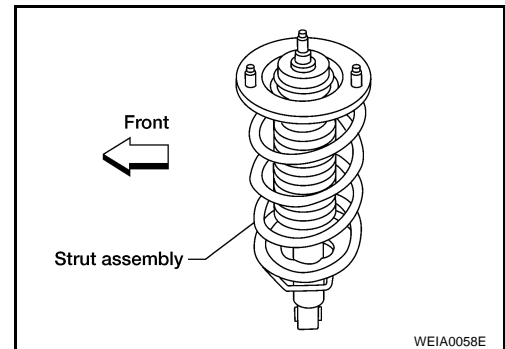

STABILIZER BAR

STABILIZER BAR

PF5:54611

Removal and Installation

EES001E5

REMOVAL

1. Remove engine under cover using power tool.
2. Remove stabilizer bar mounting bracket bolts and connecting rod nuts using power tool, as shown.
3. Remove bushings from stabilizer bar.

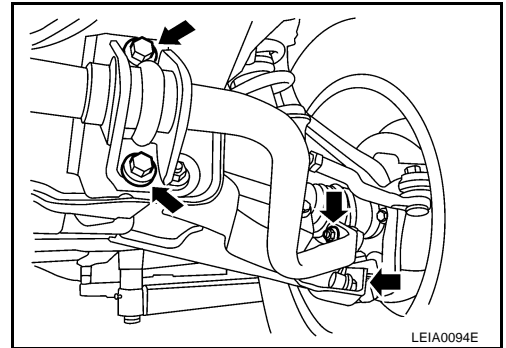

INSPECTION AFTER REMOVAL

- Check stabilizer bar for twist and deformation. Replace if necessary.
- Check rubber bushing for cracks, wear and deterioration. Replace if necessary.

INSTALLATION

Installation is in the reverse order of removal.

- Tighten all nuts and bolts to specification. Refer to [FSU-5, "Components"](#) .

UPPER LINK

PFP:54524

UPPER LINK

Removal and Installation

EES001E6

REMOVAL

1. Remove the wheel and tire using power tool.
2. Remove coil spring and shock absorber assembly using power tool. Refer to [FSU-10, "Removal and Installation"](#).
3. Remove cotter pin and nut from upper link ball joint.
4. Separate upper link ball joint stud from steering knuckle using Tool.
 - Support lower link with jack.

Tool number : ST29020001 (J24319-01)

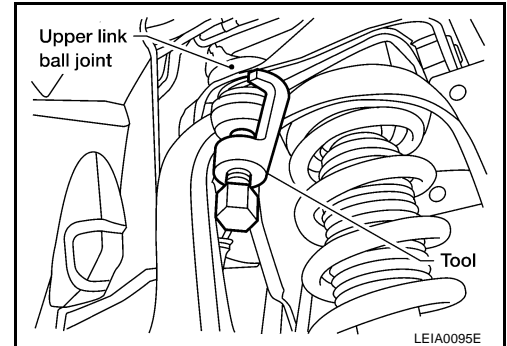

5. Remove upper link mounting bolts and nuts.

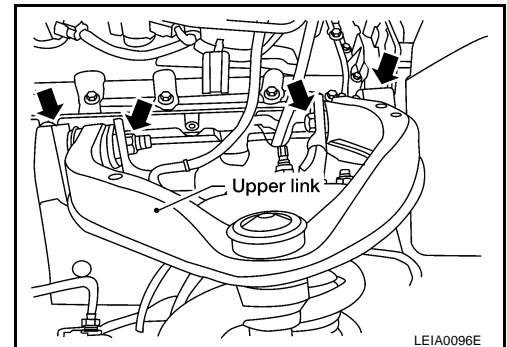

INSPECTION AFTER REMOVAL

Upper Link

Check for deformation and cracks. Replace if necessary.

Upper Link Ball Joint

Check for distortion and damage. Replace if necessary.

INSTALLATION

Installation is in the reverse order of removal.

- Tighten all nuts and bolts to specification. Refer to [FSU-5, "Components"](#).
- When installing wheel and tire, refer to [WT-7, "Rotation"](#).
- After installation, check that the front wheel alignment is within specification. Refer to [FSU-6, "Front Wheel Alignment"](#).

LOWER LINK

PFP:55020

EES001E7

LOWER LINK

Removal and Installation

REMOVAL

1. Remove the wheel and tire using power tool.
2. Remove lower shock absorber bolt.
3. Remove stabilizer bar connecting rod lower nut using power tool, then separate connecting rod from lower link. Refer to [FSU-12, "Removal and Installation"](#) .
4. Remove drive shaft, if equipped. Refer to [FAX-7, "Removal and Installation"](#) .
5. Remove pinch bolt from steering knuckle using power tool, then separate lower link ball joint from steering knuckle.

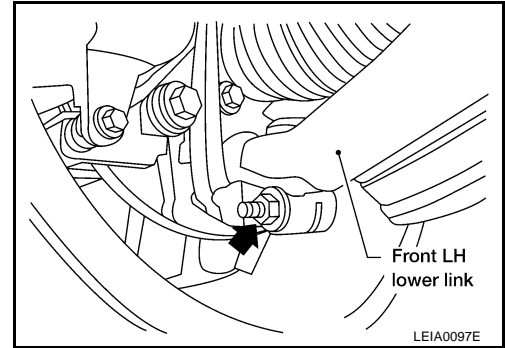

6. Remove lower link adjusting bolts and nuts, then the lower link.

NOTE:

Camber changes about 3' (0.05°) minutes with each graduation of one cam bolt. Refer to table below for examples of lower link cam bolt effect on camber and caster.

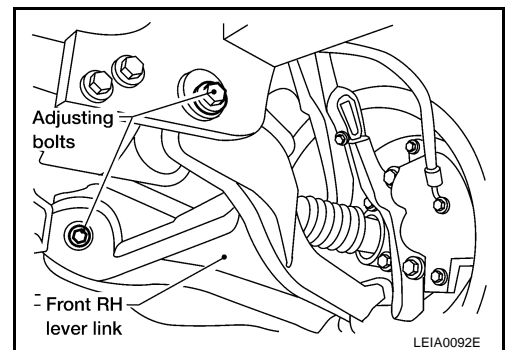

INSPECTION AFTER REMOVAL

Lower Link

Check for deformation and cracks. Replace if necessary.

Lower Link Bushing

Check for distortion and damage. Replace if necessary.

INSTALLATION

Installation is in the reverse order of removal.

- Tighten all nuts and bolts to specification. Refer to [FSU-5, "Components"](#) .
- When installing wheel and tire, refer to [WT-7, "Rotation"](#) .
- After installation, check that the front wheel alignment is within specification. Refer to [FSU-6, "Front Wheel Alignment"](#) .

UPPER BALL JOINT AND LOWER BALL JOINT

UPPER BALL JOINT AND LOWER BALL JOINT

PFPP:40110

Removal and Installation

EES001E8

The ball joints are part of the upper and lower links. Refer to [FSU-13, "Removal and Installation"](#) (upper link), [FSU-14, "Removal and Installation"](#) (lower link).

Inspection

EES001E9

- Check the ball joint for excessive play. Replace the upper or lower link assembly if any of the following exists:
 - Ball joint stud is worn.
 - Ball joint is hard to swing.
 - Ball joint play in axial directions or end play is excessive.

SWINGING FORCE

NOTE:

Before checking the axial forces and end play, turn the lower ball joint at least 10 revolutions so that the ball joint is properly broken in.

Swinging force "A" : 7.8 - 54.9 N (0.8 - 5.6 kg-f,
1.8 - 12.3 lb-f)

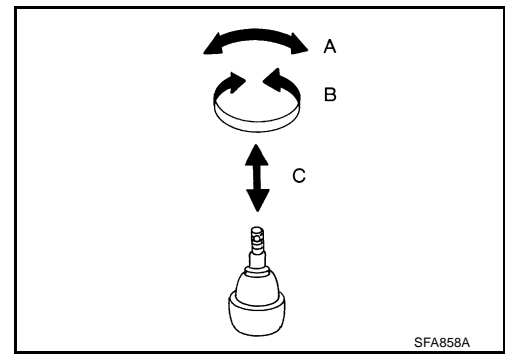

TURNING FORCE

NOTE:

Before checking the axial forces and end play, turn the lower ball joint at least 10 revolutions so that the ball joint is properly broken in.

Turning torque "B" : 0.49 - 3.43 N-m (0.05 - 0.35 kg-m,
4 - 30 in-lb)

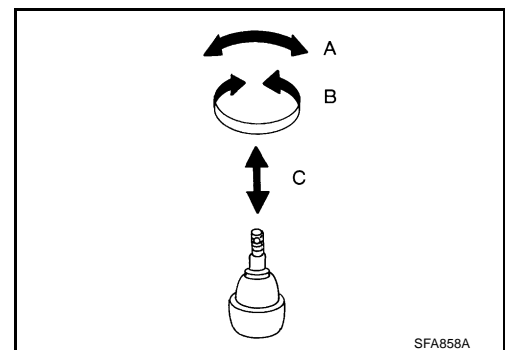

VERTICAL END PLAY

Check dust cover for damage. Replace it and the cover clamp if necessary.

NOTE:

Before checking the axial forces and end play, turn the lower ball joint at least 10 revolutions so that the ball joint is properly broken in.

Vertical end play "C" : 0 mm (0 in)

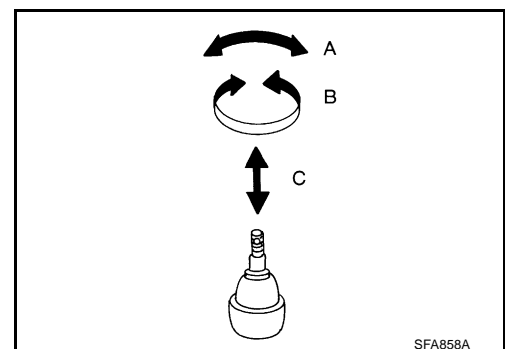

A
B
C
D

FSU

F
G
H
I
J
K
L
M

KNUCKLE

PFP:40014

On-Vehicle Inspection and Service

EES001EA

Make sure the mounting conditions (looseness, backlash) of each component and component status (wear, damage) are within specifications. Refer to [FSU-20, "Ball Joint"](#) .

Removal and Installation

EES001EB

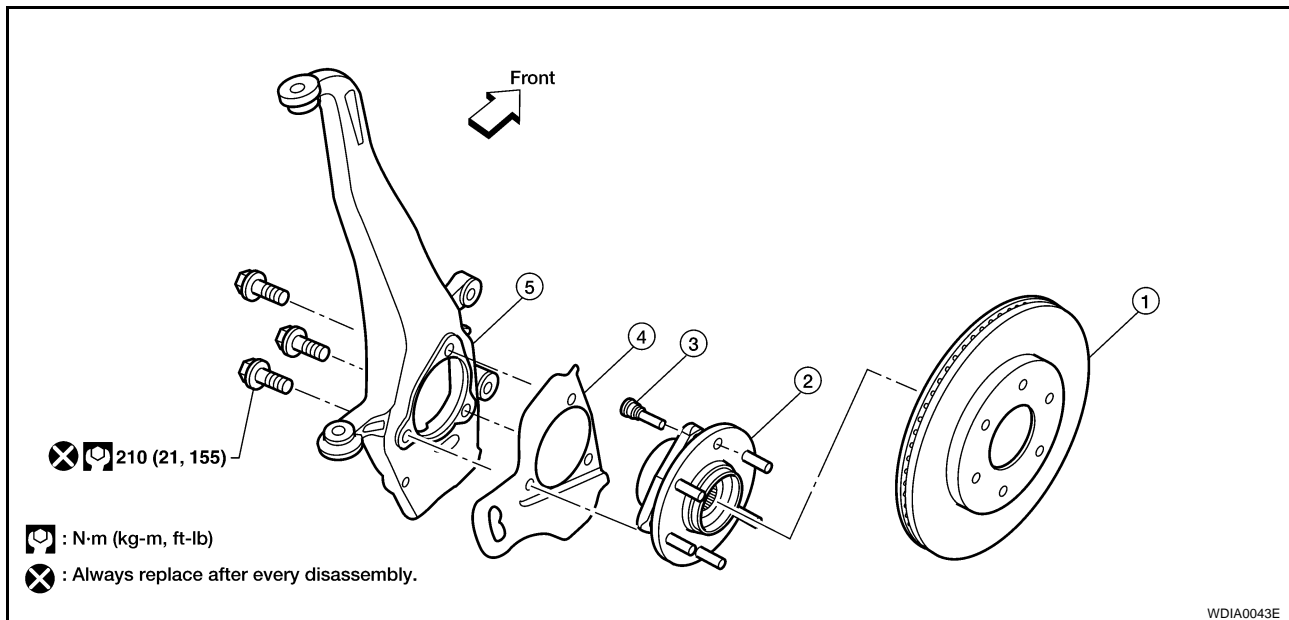

- | | | |
|-----------------|-----------------------------------|---------------|
| 1. Disc rotor | 2. Wheel hub and bearing assembly | 3. Wheel stud |
| 4. Splash guard | 5. Steering knuckle | |

REMOVAL

1. Remove wheel and tire from vehicle using power tool.
2. Without disassembling the hydraulic lines, remove brake caliper using power tool. Reposition it aside with wire. Refer to [BR-21, "Removal and Installation of Brake Caliper and Disc Rotor"](#) .

NOTE:

Avoid depressing brake pedal while brake caliper is removed.

3. Put alignment marks on disc rotor and wheel hub and bearing assembly, then remove disc rotor.

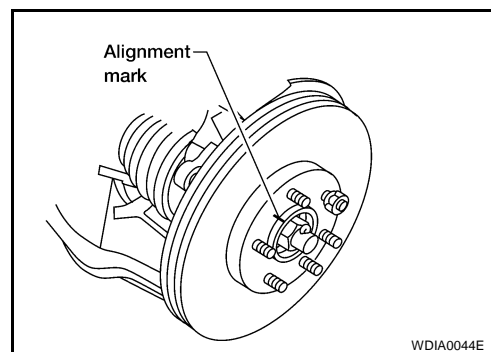

4. Remove ABS sensor from steering knuckle. Refer to [BRC-63, "Removal and Installation"](#) .

CAUTION:

Do not pull on ABS sensor harness.

5. Remove cotter pin, then remove lock nut from drive shaft using power tool.
6. Remove steering outer socket cotter pin at steering knuckle, then loosen mounting nut using power tool.

KNUCKLE

7. Disconnect steering outer socket from steering knuckle using Tool. Be careful not to damage ball joint boot.

CAUTION:

To prevent damage to threads and to prevent Tool from coming off suddenly, temporarily tighten mounting nut.

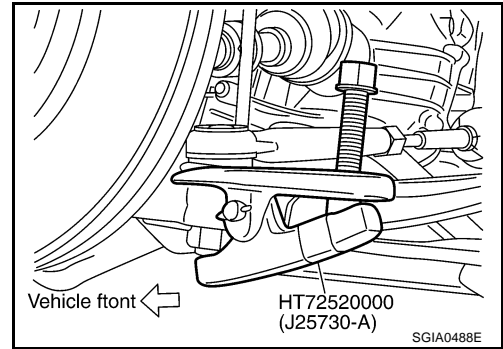

8. Remove the coil spring and shock absorber assembly using power tool. Refer to [FSU-10, "Removal and Installation"](#).
9. Remove drive shaft, if equipped. Refer to [FAX-7, "Removal and Installation"](#).
10. Remove wheel hub and bearing assembly bolts using power tool.
11. Remove splash guard and wheel hub and bearing assembly from steering knuckle.
12. Support lower link using a suitable jack.
13. Remove cotter pin and nut from upper link ball joint.
14. Separate upper link ball joint from steering knuckle using Tool.

Tool number : ST29020001 (J-24319-01)

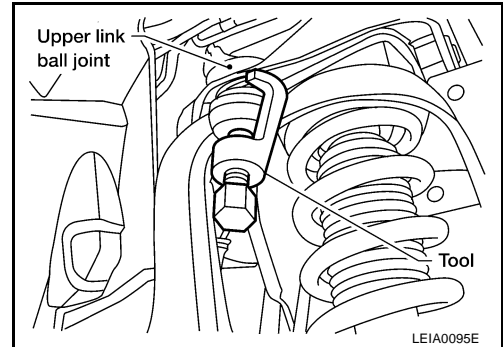

15. Remove pinch bolt from steering knuckle using power tool, then separate lower link ball joint from steering knuckle.

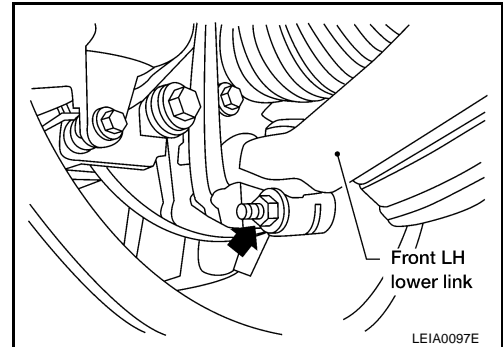

16. Remove steering knuckle from vehicle.

INSPECTION AFTER REMOVAL

Check for deformity, cracks and damage on each part, replace if necessary.

- Perform ball joint inspection. Refer to [FSU-15, "Inspection"](#).

KNUCKLE

INSTALLATION

Installation is in the reverse order of removal.

- Refer to [FSU-5, "Components"](#) for tightening torques.
- When installing disc rotor on wheel hub and bearing assembly, align the marks.

NOTE:

When not using the alignment mark, refer to [BR-31, "Front Disc Brake"](#) .

- When installing wheel and tire, refer to [WT-7, "Rotation"](#) .

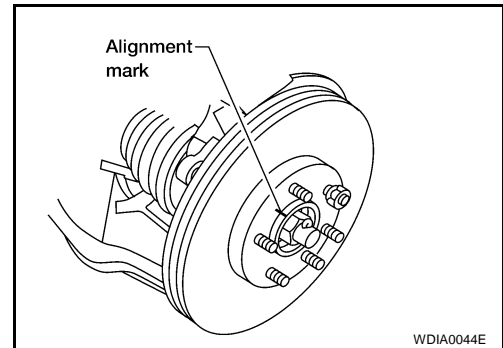

SERVICE DATA AND SPECIFICATIONS (SDS)

SERVICE DATA AND SPECIFICATIONS (SDS)

PF0:00030

General Specifications (Front)

EES001EC

Suspension type	Independent double wishbone coil over shock
Shock absorber type	Double-acting hydraulic
Stabilizer	Standard equipment

Wheel Alignment (Unladen ^{*1})*⁶

EES001ED

Drive type		4x2	4x4	
Camber Degree minute (decimal degree)	Minimum	-0° 51' (-0.85°)	-0° 33' (-0.55°)	
	Nominal	-0° 6' (-0.10°)	0° 12' (0.20°)	
	Maximum	0° 39' (0.65°)	0° 57' (0.95°)	
	Cross camber	0° 45' (0.75°) or less	0° 45' (0.75°) or less	
Caster Degree minute (decimal degree)	Minimum	Standard	2° 21' (2.35°)	2° 15' (2.25°)
		Air leveling	3° 15' (3.25°)	2° 45' (2.75°)
	Nominal	Standard	3° 24' (3.40°)	3° 0' (3.00°)
		Air leveling	4° 0' (4.00°)	3° 30' (3.50°)
	Maximum	Standard	4° 09' (4.15°)	3° 45' (3.75°)
		Air leveling	4° 45' (4.75°)	4° 15' (4.25°)
Cross caster		0° 45' (0.75°) or less	0° 45' (0.75°) or less	
Kingpin inclination Degree minute (decimal degree)		13° 32' (13.53°)	13° 13' (13.22°)	

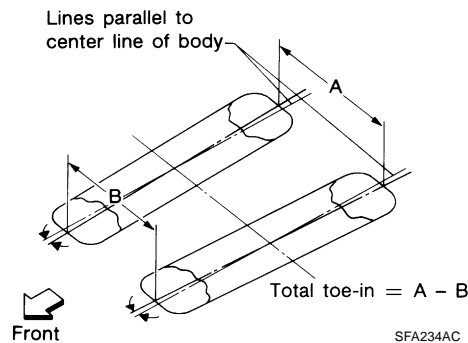

Total toe-in	Distance (A - B)	Minimum	1.8 mm (0.07 in)	1.8 mm (0.07 in)
		Nominal	2.8 mm (0.11 in)	2.8 mm (0.11 in)
		Maximum	3.8 mm (0.15 in)	3.8 mm (0.15 in)
	Angle (left side and right side) Degree minute (Decimal degree)	Minimum	0° 3' (0.05°)	0° 3' (0.05°)
		Nominal	0° 5' (0.08°)	0° 5' (0.08°)
		Maximum	0° 7' (0.12°)	0° 7' (0.12°)
Wheel turning angle (full turn)	Inside Degree minute (Decimal degree)	34° 30' - 38° 30' ^{*2} (34.50° - 38.50°)	34° 56' - 38° 56' ^{*4} (34.93° - 38.93°)	
	Outside Degree minute (Decimal degree)	30° 58' - 34° 58' ^{*3} (30.97° - 34.97°)	31° 01' - 35° 01' ^{*5} (31.02° - 35.02°)	

*1: Fuel, radiator coolant and engine oil full. Spare tire, jack, hand tools and mats in designated positions.

*2: Target value 37° 30' (37.50°)

*3: Target value 33° 58' (33.97°)

*4: Target value 37° 56' (37.93°)

*5: Target value 34° 01' (34.02°)

*6: Some vehicles may be equipped with straight (non-adjustable) lower link bolts and washers. In order to adjust camber and caster on these vehicles, first replace the lower link bolts and washers with adjustable (cam) bolts and washers.

SERVICE DATA AND SPECIFICATIONS (SDS)

Ball Joint

EES001EE

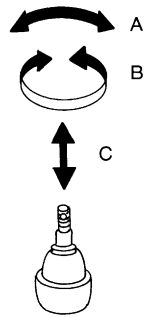

SFA858A

Swinging force "A"	7.8 - 54.9 N (0.8 - 5.6 kg-f, 1.8 - 12.3 lb-f)
Turning torque "B"	0.49 - 3.43 N·m (0.05 - 0.35 kg-m, 4 - 30 in-lb)
Vertical end play "C"	0 mm (0 in)

Wheelarch Height (Unladen*¹)

EES001EF

Unit: mm (in)

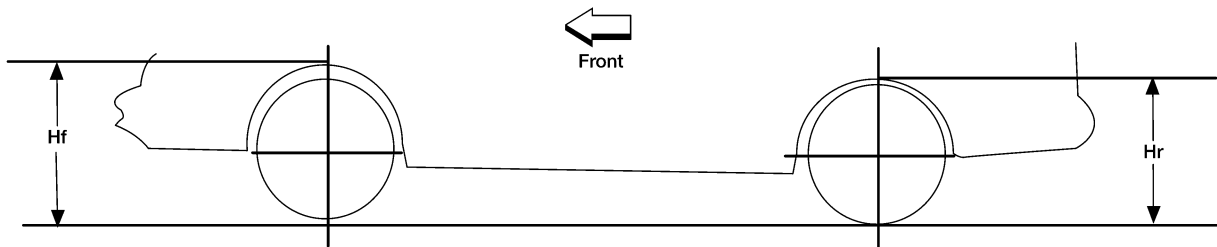

LEIA0085E

Suspension type	With air leveling* ²				Without air leveling			
	4x2		4x4		4x2		4x4	
Applied model								
Tire size	265/70R18	285/70R17	265/70R18	285/70R17	265/70R18	285/70R17	265/70R18	285/70R17
Front wheelarch height (Hf)	917 (36.10)	918 (36.14)	935 (36.81)	936 (36.85)	916 (36.06)	917 (36.10)	935 (36.81)	936 (36.85)
Rear wheelarch height (Hr)	916 (36.06)	917 (36.10)	936 (36.85)	937 (36.89)	937 (36.89)	938 (36.93)	957 (36.68)	958 (37.72)

*1: Fuel, radiator coolant and engine oil full. Spare tire, jack, hand tools and mats in designated positions.

*2: Verify the vehicle height. If vehicle height is not within ± 10 mm (0.39 in) of the specification, perform the control unit initialization procedure. Refer to [RSU-46, "Initialization Procedure"](#).