

SECTION **PB**
PARKING BRAKE SYSTEM

A
B
C
D
E
PB
G
H
I
J
K
L
M

CONTENTS

PREPARATION	2	PARKING BRAKE SHOE	6
Commercial Service Tools	2	Removal and Installation	6
PARKING BRAKE SYSTEM	3	COMPONENTS	6
On-Vehicle Service	3	REMOVAL	6
PEDAL STROKE	3	INSPECTION AFTER REMOVAL	7
INSPECTION	3	INSTALLATION	7
ADJUSTMENT	3	SERVICE DATA AND SPECIFICATIONS (SDS)	9
PARKING BRAKE CONTROL	4	Parking Drum Brake	9
Components	4	Parking Brake Control	9
Removal and Installation	4		
REMOVAL	4		
INSTALLATION	5		

PREPARATION

PREPARATION

PF0:00002

Commercial Service Tools

EFS004U4

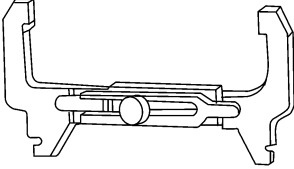
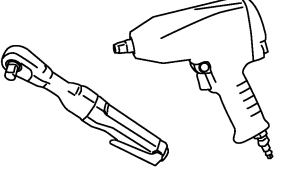
Tool number (Kent-Moore No.) Tool name		Description
— (J-21177-A) Brake drum clearance gauge	 WFIA0167E	Measuring rear rotor drum to parking brake shoe clearance
Power tool	 PBIC0190E	Loosening bolts and nuts

PARKING BRAKE SYSTEM

PARKING BRAKE SYSTEM

PFP:36010

On-Vehicle Service PEDAL STROKE

EF5004U5

- When parking brake pedal is operated with the specified force, make sure the stroke is within the specified number of notches. Check by listening and counting the ratchet clicks.

Pedal stroke : 3 – 4 notches [under force of 196 N (20.0 kg, 44.1 lb)]

INSPECTION

- Make sure the components are attached properly, checking for looseness or backlash.
- Check parking brake pedal assembly for bends, damage and cracks, and replace if necessary.
- Check cable for wear and damage, and replace if necessary.
- Check parking brake warning lamp switch for malfunction, and replace if necessary. Refer to [DI-31, "Wiring Diagram — WARN —"](#).

ADJUSTMENT

- Remove lower instrument panel LH. Refer to [IP-12, "LOWER INSTRUMENT PANEL LH"](#).
- Partially engage parking brake pedal to access adjusting nut.
- Insert a deep socket wrench to rotate adjusting nut and loosen cable sufficiently. Then, disengage the parking brake pedal.

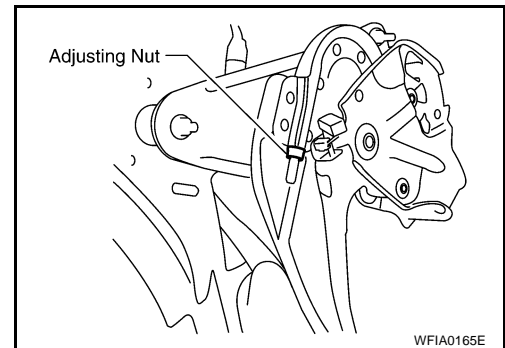

- Remove the wheel and tire using power tool.
- Remove the rotor and measure inner diameter at widest point using Tool.

Tool number : — (J-21177A)

- Transfer measurement less 0.6 mm to the parking brake shoes and adjust accordingly.
- Using wheel nuts, secure the disc to the hub to prevent it from tilting.
- Rotate disc rotor to make sure there is no drag.
- Adjust cable as follows:
 - Operate pedal 10 or more times with a force of 490 N (50 kg, 110 lb).
 - Rotate adjusting nut with deep socket to adjust pedal stroke to specification.

Pedal stroke : 3 – 4 notches [under force of 196 N (20.0 kg, 44.1 lb)]

- With parking brake pedal completely disengaged, make sure there is no drag on the parking brake.

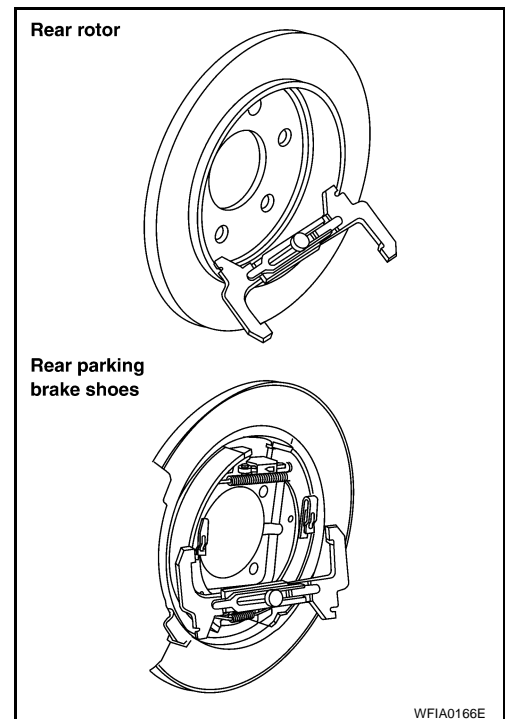

PARKING BRAKE CONTROL

PFP:36010

EFS004U6

PARKING BRAKE CONTROL

Components

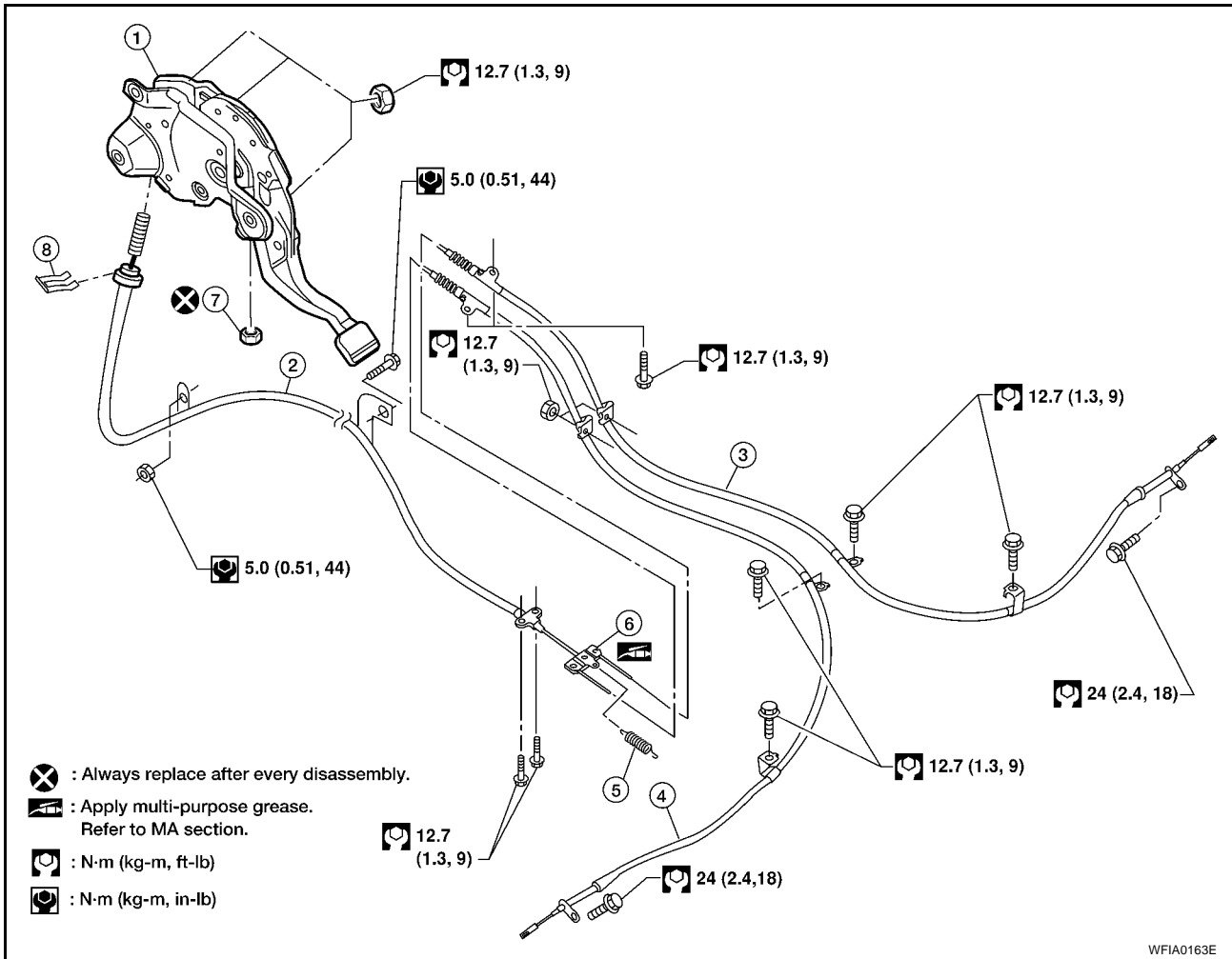

- | | | |
|--------------------|------------------|---------------------|
| 1. Pedal assembly | 2. Front cable | 3. Right rear cable |
| 4. Left rear cable | 5. Return spring | 6. Equalizer |
| 7. Adjusting nut | 8. Lock plate | |

Removal and Installation

REMOVAL

EFS004U7

1. Remove the lower instrument panel LH and center console. Refer to [IP-13, "LOWER INSTRUMENT PANEL RH AND GLOVE BOX"](#) and [IP-14, "CENTER CONSOLE"](#).
2. Remove the floor trim. Refer to [EI-34, "Removal and Installation"](#).
3. Remove the parking brake control adjusting nut.
CAUTION:
Do not reuse adjusting nut after removing it.
4. Remove the lock plate from the front cable.
5. Remove front parking brake cable bolts and nut.
6. Disconnect return spring from equalizer.
7. Disconnect the front parking brake cable from the equalizer and remove front cable.
8. Remove the rear disc rotors. Refer to [BR-27, "Removal and Installation of Brake Caliper and Disc Rotor"](#).
9. Remove parking brake shoes, and remove rear cable from toggle lever. Refer to [PB-6, "Removal and Installation"](#).
10. Remove equalizer from right and left rear cables.
11. Remove right and left rear cable bolts and nuts, then remove right and left rear cables.

PARKING BRAKE CONTROL

INSTALLATION

- Installation is in the reverse order of removal.

CAUTION:

Do not reuse adjusting nut after removing it.

- Adjust parking brake. Refer to [PB-3, "ADJUSTMENT"](#) .

A

B

C

D

E

PB

G

H

I

J

K

L

M

PARKING BRAKE SHOE

PF0:44060

EFS004U8

PARKING BRAKE SHOE

Removal and Installation COMPONENTS

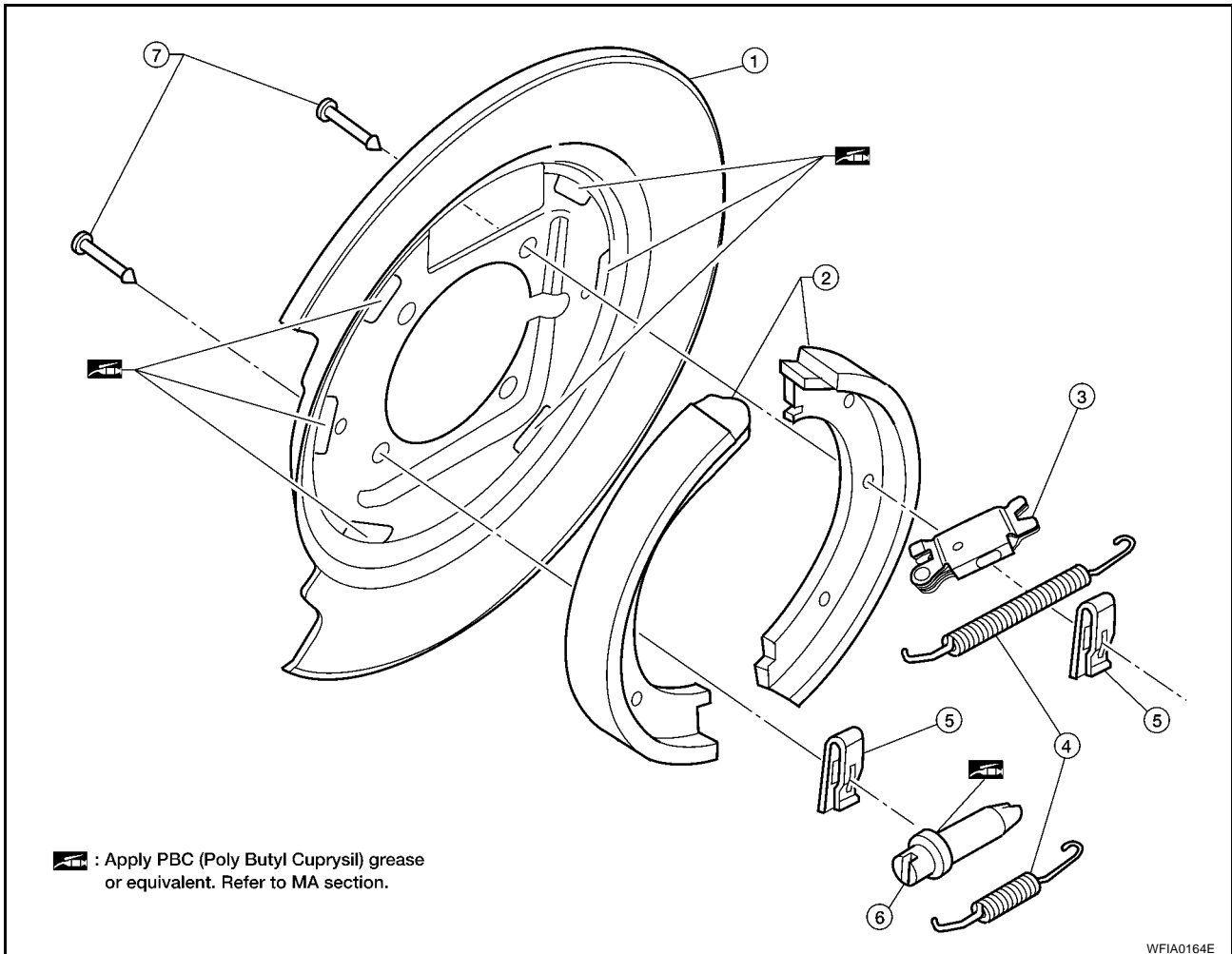

- | | | |
|---------------------|--------------|-----------------|
| 1. Back plate | 2. Shoes | 3. Toggle lever |
| 4. Return springs | 5. Retainers | 6. Adjuster |
| 7. Anti-rattle pins | | |

REMOVAL

WARNING:

Clean the brakes with a vacuum dust collector to minimize the hazard of airborne particles or other materials.

NOTE:

Remove the disc rotor only with the parking brake pedal completely disengaged.

1. Remove the rear disc rotor. Refer to [BR-27, "Removal and Installation of Brake Caliper and Disc Rotor"](#).
2. Remove the rear drive shaft. Refer to [RAX-7, "Removal and Installation"](#).
3. Disconnect ABS sensor at harness connector. Then remove ABS sensor wire from grommet mounts.
4. Remove wheel hub and bearing assembly. Refer to [RAX-5, "Removal and Installation"](#).
 - Withdraw ABS sensor harness through back plate when removing wheel hub and bearing assembly.
5. Remove the return springs.
6. Remove the adjuster.
7. Remove the retainers, anti-rattle pins and shoes.
8. Disconnect the parking brake cable from the toggle lever.
9. Remove back plate.

PARKING BRAKE SHOE

INSPECTION AFTER REMOVAL

Lining Thickness Inspection

- Check thickness of lining.
 - Standard thickness "A"** : 5.15 ± 0.25 mm
(0.203 ± 0.010 in)
 - Repair limit thickness "A"** : 0.5 mm (0.020 in)

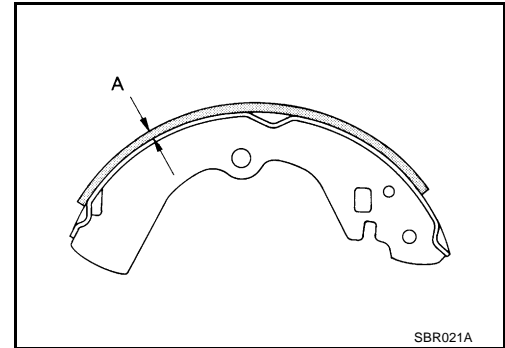

Drum Inner Diameter Inspection

- Check drum inner diameter.
 - Standard inner diameter** : 205 ± 0.13 mm
(8.07 ± 0.01 in)
 - Maximum inner diameter** : 205.7 mm (8.10 in)

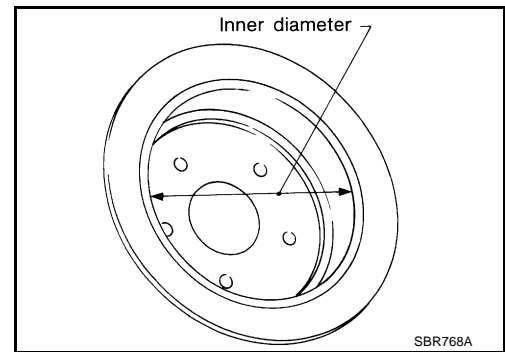

Other Inspections

- Check shoe sliding surface for excessive wear and damage.
- Check anti-rattle pin for excessive wear and corrosion.
- Check return spring for sagging.
- Check adjuster for rough operation.
- When disassembling adjuster, apply PBC (Poly Butyl Cuprysil) grease or equivalent to the adjuster threads. Refer to [MA-11, "RECOMMENDED FLUIDS AND LUBRICANTS"](#).
- Check either visually or with a vernier caliper to see if there is any excessive wear, cracks, or damage inside drum.

INSTALLATION

Installation is in the reverse order of removal.

- Apply brake grease to the specified points during assembly. Refer to [PB-4, "Components"](#).
- Install adjuster so that threaded part expands when rotating it in the direction shown by the arrow.
- Shorten adjuster by rotating it in the opposite direction as shown by the arrow.

NOTE:

After replacing brake shoes or disc rotors, or if parking brake does not function well, perform break-in operation as follows.

1. Adjust parking brake pedal stroke. Refer to [PB-3, "ADJUSTMENT"](#).
2. Perform parking brake burnishing operation by driving the vehicle forward under the following conditions:
 - **Vehicle speed 40 km/h (25 MPH) set (forward)**
 - **Parking brake operating force 196 N (20.0 kg, 44.1 lb) set**
 - **Apply time 30 sec.**

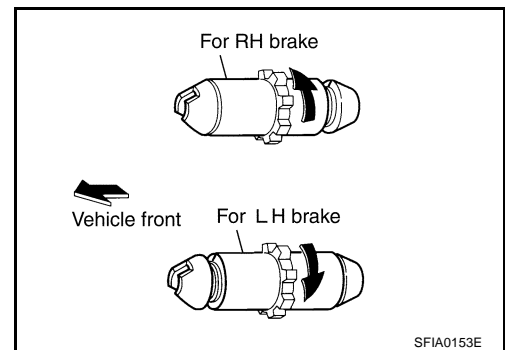

PARKING BRAKE SHOE

CAUTION:

- To prevent lining from getting too hot, allow a cool off period of approximately 5 minutes after every break-in operation.
 - Do not perform excessive break-in operations, because it may cause uneven or early wear of lining.
3. After burnishing operation, check parking brake pedal stroke. Readjust if it is now longer than the specified stroke. Refer to [PB-3, "ADJUSTMENT"](#) .

SERVICE DATA AND SPECIFICATIONS (SDS)

SERVICE DATA AND SPECIFICATIONS (SDS)

PFP:00030

Parking Drum Brake

EFS004U9

Unit: mm (in)

Type	Drum	
Brake lining	Standard thickness (new)	5.15 ± 0.25 (0.203 ± 0.010)
	Wear limit thickness	0.5 (0.020)
Drum inner diameter (disc)	Standard inner diameter (new)	205 ± 0.13 (8.07 ± 0.01)
	Wear limit of inner diameter	205.7 (8.10)

Parking Brake Control

EFS004UA

Control type	Foot pedal
Number of notches [under force of 196 N (20.0 kg, 44.1 lb)]	3 – 4 notches
Number of notches when warning lamp switch comes on	1 notch

A
B
C
D
E
G
H
I
J
K
L
M

PB

SERVICE DATA AND SPECIFICATIONS (SDS)
