

SECTION **RFD**
REAR FINAL DRIVE

A
B
C
RFD

CONTENTS

PREPARATION	2	BLY	14	F
Special Service Tools	2	REMOVAL OF DRIVE PINION ASSEMBLY	15	
Commercial Service Tools	4	DISASSEMBLY OF DIFFERENTIAL CASE		
NOISE, VIBRATION, AND HARSHNESS (NVH)		ASSEMBLY	17	G
TROUBLESHOOTING	5	INSPECTION	18	
NVH Troubleshooting Chart	5	ADJUSTMENT OF DIFFERENTIAL CASE	18	H
FRONT OIL SEAL	6	SIDE BEARING PRELOAD	19	
Removal and Installation	6	TOOTH CONTACT	20	H
REMOVAL	6	ASSEMBLY OF DIFFERENTIAL CASE ASSEM-		
INSTALLATION	7	BLY	21	
SIDE OIL SEAL	8	INSTALLATION OF DRIVE PINION ASSEMBLY..	22	I
Removal and Installation	8	INSTALLATION OF DIFFERENTIAL CASE		
REMOVAL	8	ASSEMBLY	24	
INSTALLATION	8	SERVICE DATA AND SPECIFICATIONS (SDS)	27	J
REAR FINAL DRIVE ASSEMBLY	10	General Specifications	27	
Removal and Installation	10	Drive Gear Runout	27	
REMOVAL	10	Side Gear Adjustment	27	K
INSTALLATION	11	AVAILABLE SIDE GEAR THRUST WASHERS...	27	
Components	12	Drive Pinion Height Adjustment	27	
Pre-Inspection	13	AVAILABLE PINION HEIGHT ADJUSTING		
TOTAL PRELOAD	13	WASHERS	27	L
DRIVE GEAR TO DRIVE PINION BACKLASH...	13	Drive Pinion Preload Adjustment	27	
DRIVE GEAR RUNOUT	13	Side Bearing Preload Adjustment	28	
COMPANION FLANGE RUNOUT	14	SIDE BEARING ADJUSTING WASHERS	28	M
TOOTH CONTACT	14	Total Preload Adjustment	28	
Disassembly and Assembly	14			
REMOVAL OF DIFFERENTIAL CASE ASSEM-				

PREPARATION

PREPARATION

PFP:00002

Special Service Tools

EDS003PQ

The actual shapes of the tools may differ from those of the special service tools illustrated here.

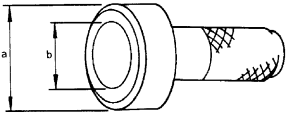
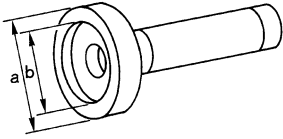
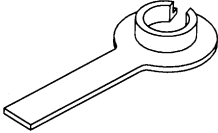
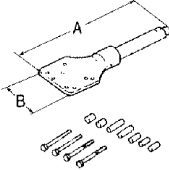
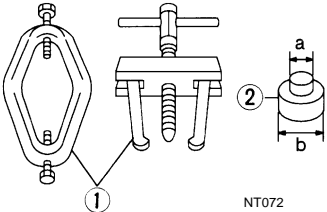
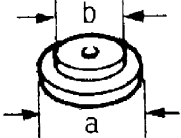
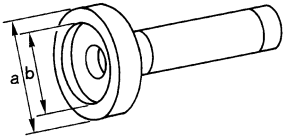
Tool name Tool number	Description
Drift ST15310000  <p style="text-align: right; margin-right: 50px;">ZZA0811D</p>	<ul style="list-style-type: none"> ● Installing front oil seal ● Installing drive pinion rear bearing outer race. <p>a: 96 mm (3.77 in) dia. b: 84 mm (3.30 in) dia.</p>
Drift ST35271000  <p style="text-align: right; margin-right: 50px;">ZZA1143D</p>	Installing side oil seal a: 72 mm (2.83 in) dia. b: 63 mm (2.48 in) dia.
Protector KV38107900  <p style="text-align: right; margin-right: 50px;">S-NT129</p>	Installing side flange
Attachment KV38100800  <p style="text-align: right; margin-right: 50px;">SDIA0267E</p>	Fixing unit assembly a: 541 mm (21.30 in) dia. b: 200 mm (7.87 in) dia.
Differential side bearing puller set ST3306S001 1.ST33051001 2.ST33061000  <p style="text-align: right; margin-right: 50px;">NT072</p>	Removing side bearing inner race a: 28.5 mm (1.122 in) dia. b: 38 mm (1.50 in) dia.
Drift ST30621000  <p style="text-align: right; margin-right: 50px;">ZZA0810D</p>	Installing drive pinion front bearing outer race a: 79 mm (3.11 in) dia. b: 59 mm (2.32 in) dia.
Drift KV38100200  <p style="text-align: right; margin-right: 50px;">ZZA1143D</p>	Installing side bearing inner race a: 65 mm (2.55 in) dia. b: 49 mm (1.92 in) dia.

PREPARATION

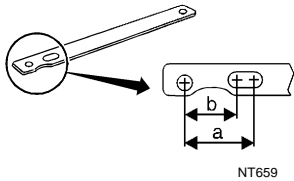
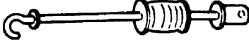
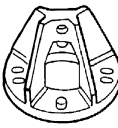
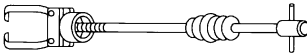
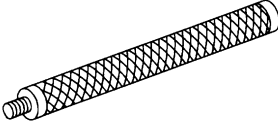
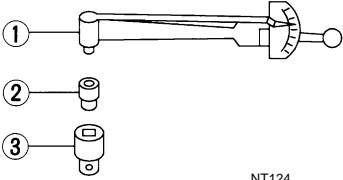
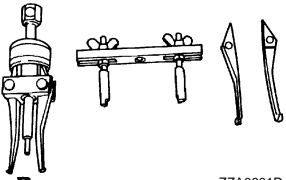
Tool name Tool number	Description	
Drive pinion flange wrench KV40104000 	Removing and installing drive pinion nut a: 85 mm (3.35 in) dia. b: 65 mm (2.56 in) dia.	A B C
Slide hammer ST36230000 	Removing side flange	RFD E
Axle stand KV40104100 	Removing side flange	F G
Slide hammer HT72400000 	Removing differential case assembly	H I J
Drift ST35325000 	Installing drive pinion rear bearing outer race (use with ST30621000)	K L
Preload gauge ST3127S000 1. Torque wrench GG91030000 2. Socket adapter (1/2 in) HT62940000 3. Socket adapter (3/8 in) HT62900000 	Measuring pinion bearing preload and total preload	M
Side bearing outer race puller ST33290001 	Removing front oil seal	

PREPARATION

Tool name Tool number	Description
Drift ST33081000	Installing side bearing a: 43 mm (1.69 in) dia. b: 33.5 mm (1.31 in) dia.
Bearing puller ST30021000	Removing drive pinion rear bearing inner race
Drift ST30022000	Installing drive pinion rear bearing inner race a: 110 mm (4.33 in) dia. b: 46 mm (1.81 in) dia.

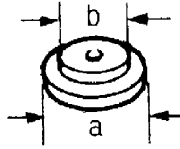

ZZA0810D

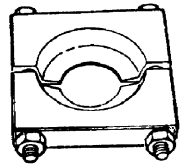

ZZA0700D

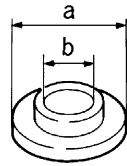

ZZA0920D

Commercial Service Tools

EDS003PR

Tool name	Description
Power tool	Removing bolts and nuts

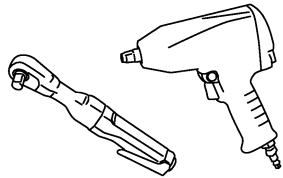

PBIC0190E

NOISE, VIBRATION, AND HARSHNESS (NVH) TROUBLESHOOTING

NOISE, VIBRATION, AND HARSHNESS (NVH) TROUBLESHOOTING

PF0:0003

NVH Troubleshooting Chart

EDS003PS

Use the chart below to help you find the cause of the symptom. If necessary, repair or replace these parts.

Symptom			Possible cause and SUSPECTED PARTS													Reference page						
FINAL DRIVE	Noise	x	Rough gear tooth																RFD-18			
			Improper gear contact																		RFD-14	
			Tooth surfaces worn																		RFD-14	
			Incorrect backlash																		RFD-13	
			Companion flange excessive runout																		—	
			Improper gear oil																		MA-11, "Fluids and Lubricants"	
			PROPELLER SHAFT																		PR-3, "NVH Troubleshooting Chart"	
			AXLE																		FAX-4 (FAX), RAX-4 (RAX)	
			SUSPENSION																			FSU-4 (FSU), RSU-5 (RSU)
			TIRES																			WT-4, "NVH Troubleshooting Chart"
			ROAD WHEEL																			WT-4, "NVH Troubleshooting Chart"
			DRIVE SHAFT																			FAX-4, "NVH Troubleshooting Chart" RAX-4, "NVH Troubleshooting Chart"
			BRAKES																			BR-5, "NVH Troubleshooting Chart"
STEERING																			PS-5, "NVH Troubleshooting Chart"			

x: Applicable

A
B
C
RFD
E
F
G
H
I
J
K
L
M

FRONT OIL SEAL

Removal and Installation

REMOVAL

1. Remove the drive shaft inside flange bolts to disconnect the rear drive shafts from the rear final drive. Support the rear drive shafts using suitable wire.

NOTE:

Disconnecting the rear drive shafts is necessary to measure the total preload accurately.

2. Remove the rear propeller shaft. Refer to [PR-9, "REMOVAL"](#).

CAUTION:

Do not damage the propeller shaft tube.

3. Check the total preload. Refer to [RFD-13, "TOTAL PRELOAD"](#).
4. Put a mark on the end of the drive pinion corresponding to the position mark "B" on the companion flange as shown.

CAUTION:

- Use paint to make the matching mark "B" on the drive pinion. Never damage the drive pinion.
- The mark "B" on the companion flange indicates the maximum vertical runout position.

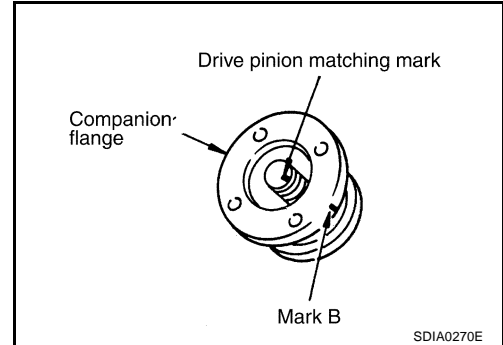

5. Remove drive pinion nut using Tool as shown.

Tool number : KV40104000

- Discard the drive pinion nut and use a new drive pinion nut for installation.

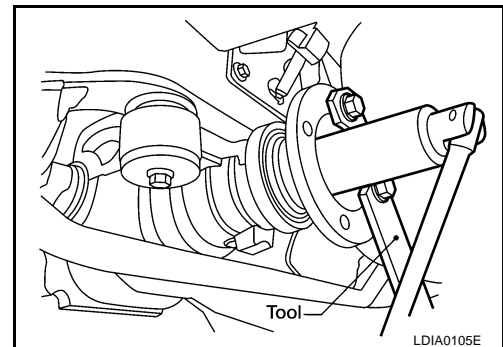

6. Remove the companion flange using suitable tool as shown.

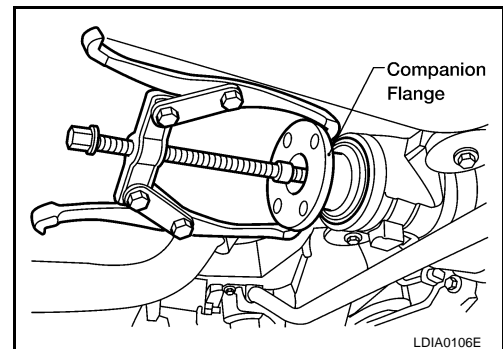

FRONT OIL SEAL

7. Remove the front oil seal using Tool as shown.

Tool number : ST33290001

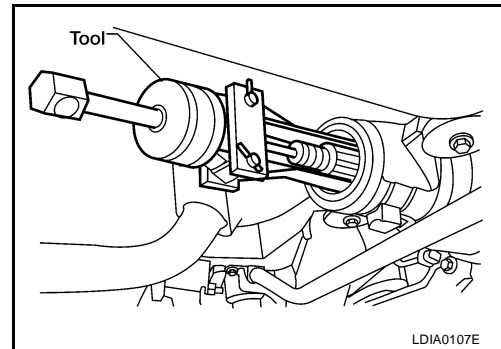

INSTALLATION

1. Apply multi-purpose grease to the sealing lips of the new oil seal, then press the front oil seal into the carrier using Tool as shown.

Tool number : ST15310000

CAUTION:

- Keep the new oil seal even when installing, do not tilt the oil seal when pressing it in.
- Discard the old oil seal, always install a new oil seal.

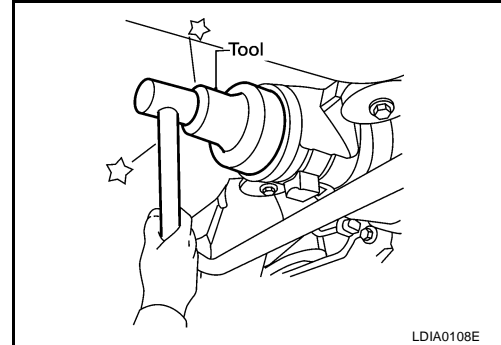

2. Align the matching mark of the drive pinion with the matching mark "B" of the companion flange as shown, then install the companion flange.
3. Apply oil or multi-purpose grease on the drive pinion threads and the seating surface of drive pinion nut.

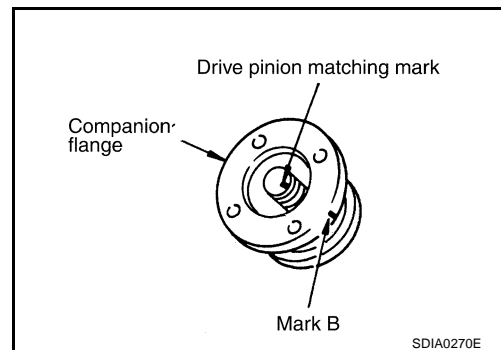

4. Install new drive pinion nut using Tool.
- Tighten the drive pinion nut to the minimum specified torque. Final drive pinion nut torque will be determined when adjusting the total preload. Refer to [RFD-13, "TOTAL PRELOAD"](#).

Tool number : KV40104000

Drive pinion nut : 167 - 372 N-m (17 - 38 kg-m,
124 - 274 ft-lb)

CAUTION:

The drive pinion nut is not reusable. Use a new drive pinion nut for installation.

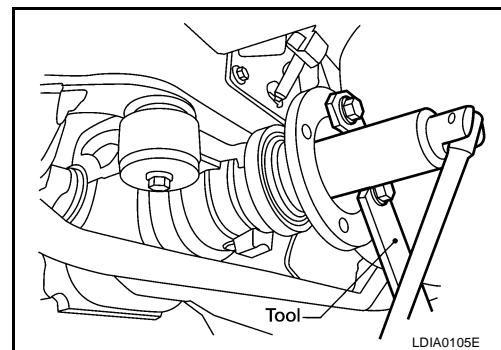

5. Install the rear propeller shaft. Refer to [PR-9, "INSTALLATION"](#).
6. Connect the rear drive shafts to the rear final drive. Tighten the drive shaft inside flange bolts to specification.

Drive shaft inside flange bolt : 118 N-m (12 kg-m, 87 ft-lb)

7. Check the rear final drive fluid and add fluid as necessary. Refer to [MA-25, "Checking Final Drive Oil"](#).

SIDE OIL SEAL

PFP:33142

EDS003PU

SIDE OIL SEAL

Removal and Installation

REMOVAL

1. Remove the drive shaft inside flange bolts to disconnect the rear drive shafts from the rear final drive. Support the rear drive shaft using a suitable wire.
2. Remove the side flange using Tools as shown.
 - a. Install Tool "A" on the side flange.

Tool number **A: KV40104100**

- b. Pull the side flange out using Tool "B" as shown.

Tool number **B: ST36230000**

Circlip installed position : **Final drive side**

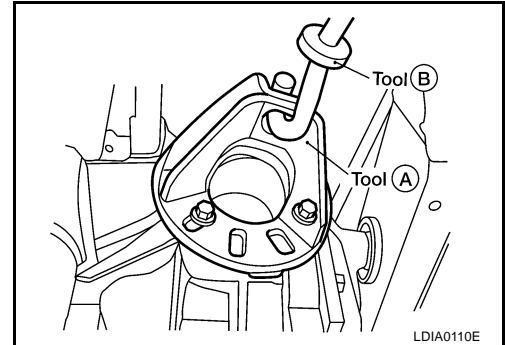

3. Remove the side oil seal using a suitable tool as shown.

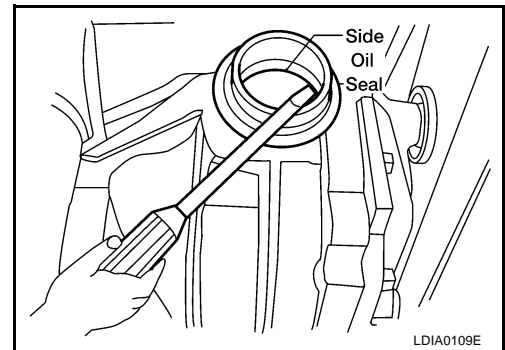

INSTALLATION

1. Apply multi-purpose grease to the sealing lips of the new side oil seal.
2. Install the new side oil seal until the front surface of the side oil seal is level with the end surface of the housing using tool.

Tool number : **ST35271000**

CAUTION:

- Keep the side oil seal even when installing, do not tilt the side oil seal when pressing it in.
- Discard the old side oil seal, always install a new side oil seal.

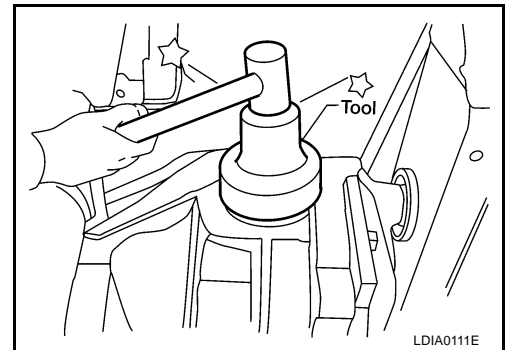

3. Install the side flange using Tool.
 - a. Attach Tool to the side oil seal as shown.

Tool number : **KV38107900**

- b. After the side flange is inserted and the serrated part of the side gear has engaged the serrated part of the flange, remove Tool.
- c. Position a suitable drift on the center of the side flange, then drive it in until the sound changes.

NOTE:

When the installation is complete, the driving sound of the side flange turns into a sound which seems to affect the whole final drive.

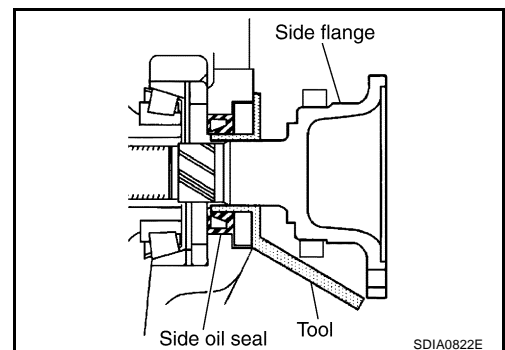

SIDE OIL SEAL

4. Check measurement "A" after the side flange installation is complete as shown.

Measurement "A" : approx. 339.5 mm (13.37 in)

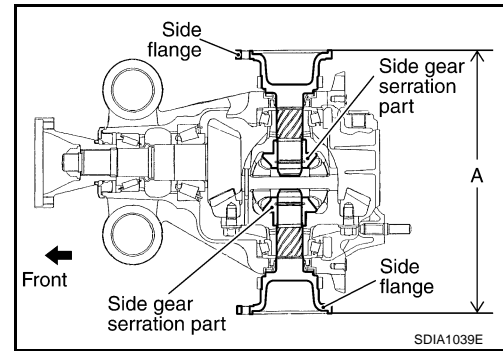

5. Connect the rear drive shafts to the rear final drive. Tighten the drive shaft inside flange bolts to specification.

Drive shaft inside flange bolts : 118 N·m (12 kg·m, 87 lb-ft)

A
B
C

RFD

E
F
G
H
I
J
K
L
M

REAR FINAL DRIVE ASSEMBLY

PF3:38300

REAR FINAL DRIVE ASSEMBLY

Removal and Installation

EDS003PV

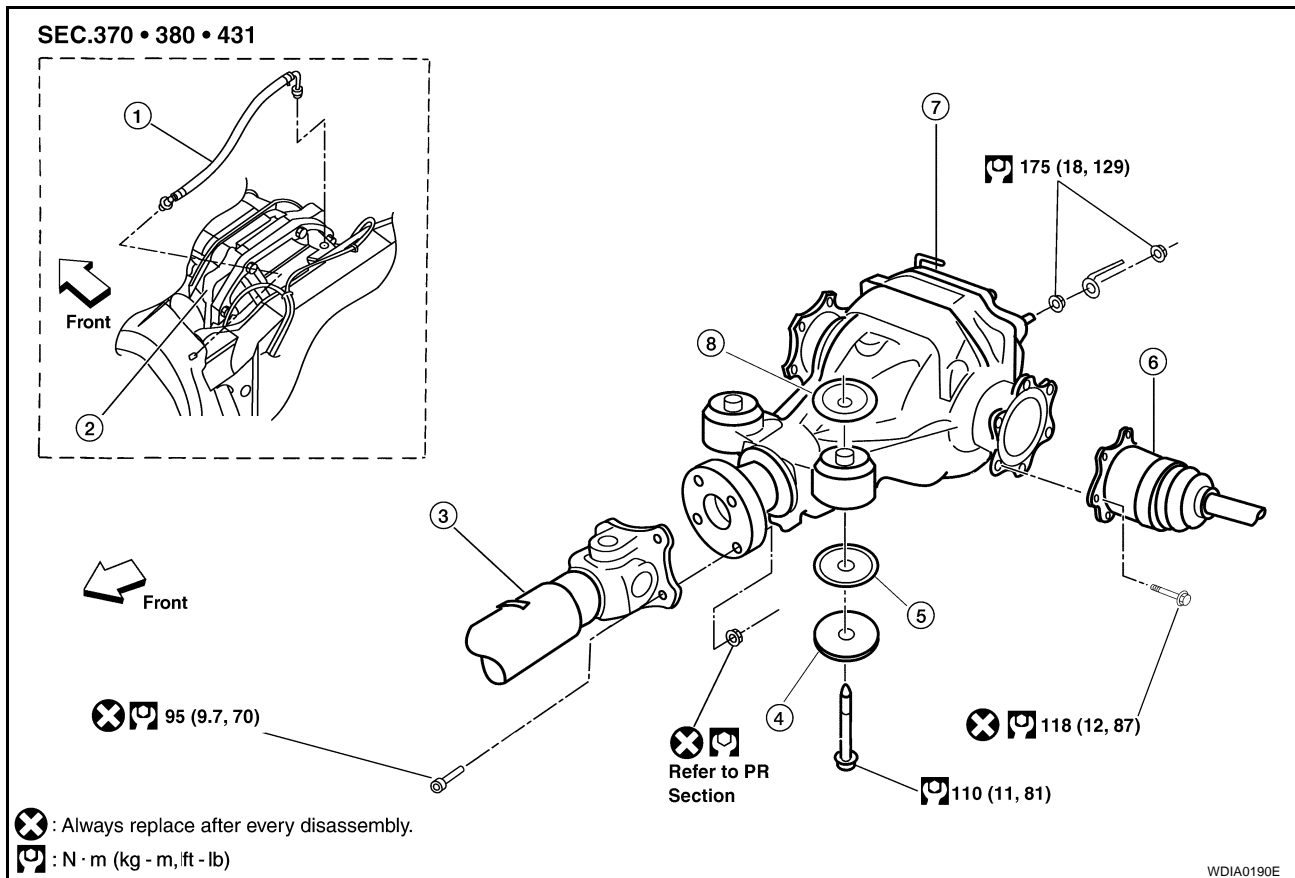

- | | | |
|------------------------------|------------------------------|-------------------------|
| 1. Breather hose | 2. Rear final drive assembly | 3. Rear propeller shaft |
| 4. Washer | 5. Lower stopper | 6. Rear drive shaft |
| 7. Rear final drive assembly | 8. Upper stopper | |

NOTE:

- Insert the plastic end of the breather hose into the hole in the suspension member.
- Insert the metallic end of the breather hose into the rear final drive cover with the blue paint mark facing forward.

REMOVAL

1. Remove the rear propeller shaft from the rear final drive. Refer to [PR-9, "REMOVAL"](#).

CAUTION:

Do not impact or damage the rear propeller shaft.

2. Remove the rear stabilizer bar using power tool. Refer to [RSU-41, "REMOVAL"](#).
3. Remove the spare tire.
4. Disconnect the rear drive shaft from the rear final drive and position it out of the way using a suitable wire. Refer to [RAX-7, "REMOVAL"](#).
5. Disconnect the breather hose from the rear final drive cover.
6. Position a suitable jack under the rear final drive case.

CAUTION:

Do not position the jack under the rear final drive cover (aluminum cover).

7. Remove the rear final drive bolts and nuts, and remove the rear final drive using the suitable jack.

REAR FINAL DRIVE ASSEMBLY

INSTALLATION

Installation is in the reverse order of removal.

CAUTION:

After installation, check the final drive oil level. Refer to [MA-25, "Checking Final Drive Oil"](#) .

A

B

C

RFD

E

F

G

H

I

J

K

L

M

REAR FINAL DRIVE ASSEMBLY

EDS003PW

Components

R230 2-PINION

SEC.380

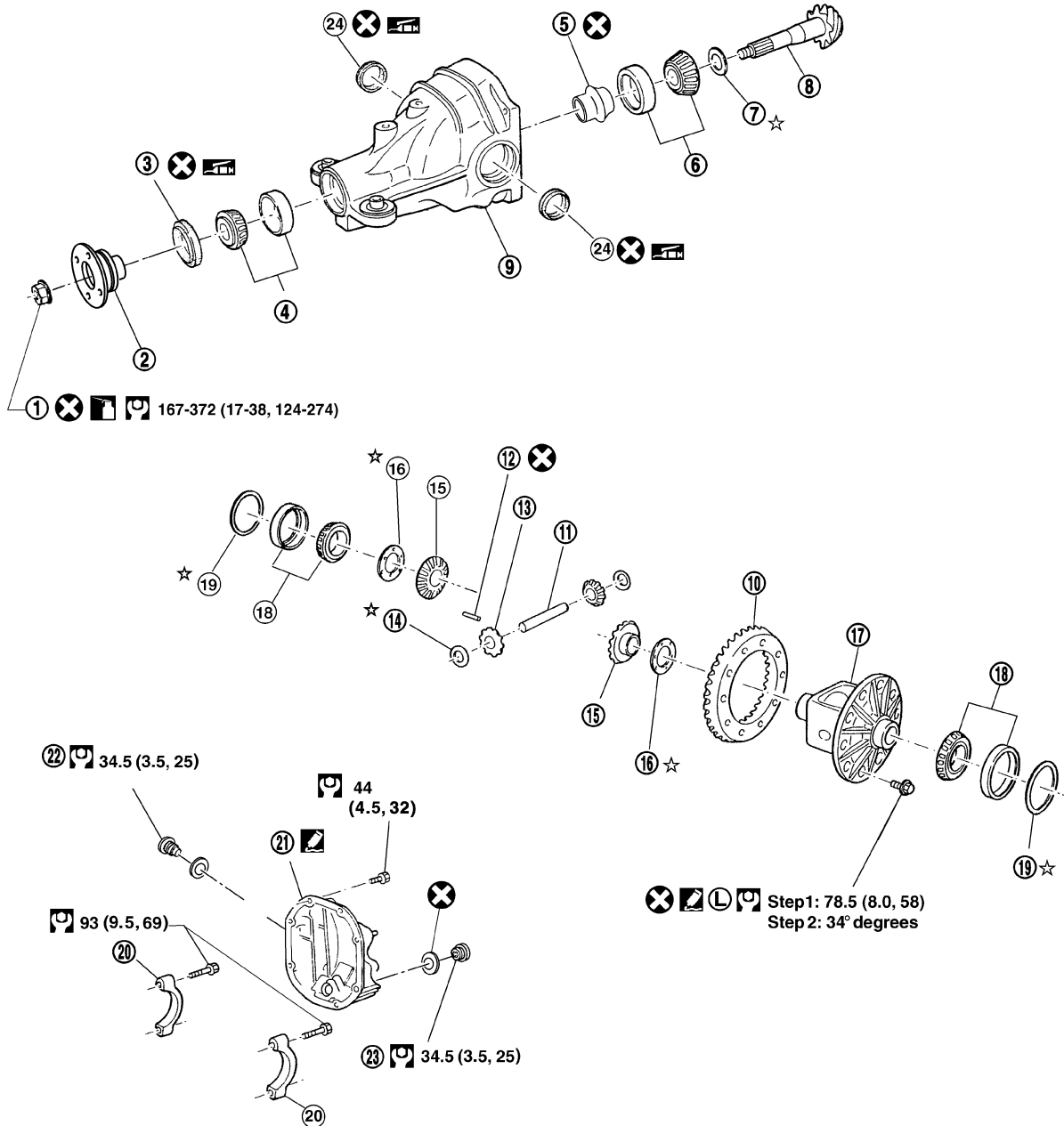

- : Lubricate with new gear oil
- : Apply genuine medium strength locking sealant or equivalent. Refer to GI section.
- : N•m (kg-m, ft-lb)
- : Apply genuine thread sealant or equivalent. Refer to GI section.
- ☆ : Adjustment is required.
- : Always replace after every disassembly.
- : Lubricate with grease.

WDIA0191E

REAR FINAL DRIVE ASSEMBLY

- | | | |
|-----------------------------------|---|------------------------|
| 1. Drive pinion nut | 2. Companion flange | 3. Front oil seal |
| 4. Pinion front bearing | 5. Pinion bearing adjusting spacer (collapsible spacer) | 6. Pinion rear bearing |
| 7. Pinion height adjusting washer | 8. Drive pinion | 9. Gear carrier |
| 10. Drive gear | 11. Pinion mate shaft | 12. Lock pin |
| 13. Pinion mate gear | 14. Pinion mate thrust washer | 15. Side gear |
| 16. Side gear thrust washer | 17. Differential case | 18. Side bearing |
| 19. Side bearing adjusting washer | 20. Bearing cap | 21. Rear cover |
| 22. Filler plug | 23. Drain plug | 24. Side oil seal |

CAUTION:

Final drive pinion nut torque will be determined when adjusting the total preload. Refer to [RFD-13](#), "[TOTAL PRELOAD](#)".

Pre-Inspection

EDS003PX

Before disassembling the rear final drive, perform the following inspections.

TOTAL PRELOAD

- Turn the drive pinion in both directions several times to set the bearing rollers.
- Check the total preload using Tool.

Tool number : ST3127S000
Total preload : 2.05 - 4.11 N·m (0.21 - 0.42 kg·m, 19 - 36 in·lb)

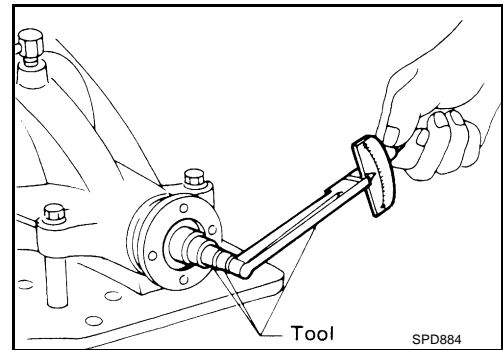

DRIVE GEAR TO DRIVE PINION BACKLASH

Check the drive gear to drive pinion backlash using a dial gauge at several points as shown.

Drive gear to drive pinion backlash : 0.13 - 0.18 mm (0.0051 - 0.0070 in)

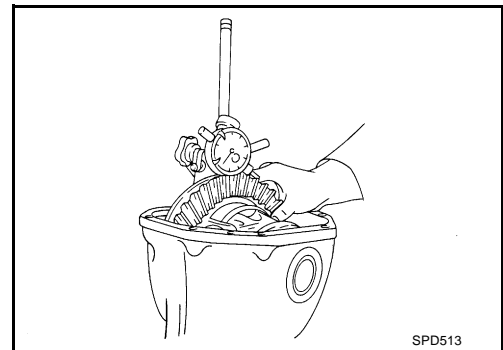

DRIVE GEAR RUNOUT

Check the runout of the drive gear using a dial gauge as shown.

Runout limit : 0.05 mm (0.0020 in) or less

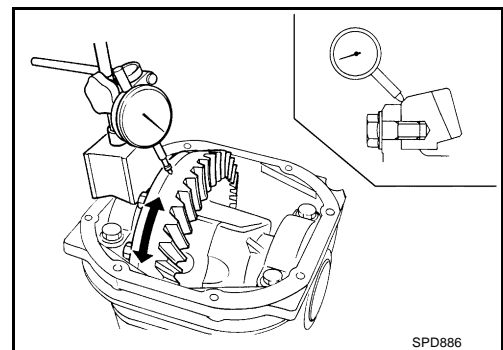

REAR FINAL DRIVE ASSEMBLY

COMPANION FLANGE RUNOUT

Mount the dial gauge indicator so the dial gauge needle is positioned on the propeller shaft mounting surface. Rotate the companion flange and measure the runout as shown.

Companion flange runout : 0.08 mm (0.003 in) or less

- If runout is not within specification, remove the companion flange, rotate 90° in relation to the drive pinion, and install the companion flange using a new drive pinion nut. Tighten the drive pinion nut to the minimum specified torque. Final drive pinion nut torque will be determined when adjusting the total preload. Refer to [RFD-13, "TOTAL PRELOAD"](#).

Tool number : KV40104000

**Drive pinion nut : 167 - 372 N·m (17 - 38 kg·m,
124 - 274 ft·lb)**

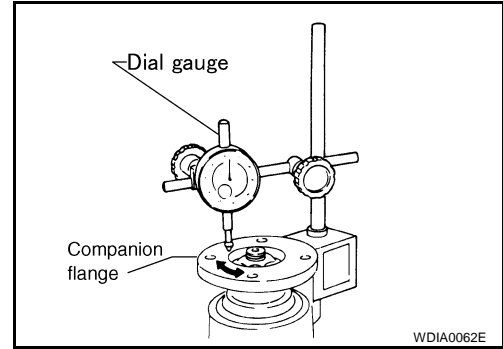

CAUTION:

The drive pinion nut is not reusable. Use a new drive pinion nut for installation.

- If runout is not within specification after rotating the companion flange 90° on the drive pinion, replace the companion flange. Recheck the companion flange runout.
- If the new companion flange runout is not within specification, inspect the drive pinion bearing and the drive pinion. Repair as necessary.

CAUTION:

Clean all of the rust and dirt off of the companion flange surface before measuring the companion flange runout.

TOOTH CONTACT

Check the tooth contact. Refer to [RFD-14, "TOOTH CONTACT"](#).

Disassembly and Assembly

REMOVAL OF DIFFERENTIAL CASE ASSEMBLY

1. Use two 45 mm (1.77 in) spacers to mount the gear carrier on Tool.

Tool number : KV38100800

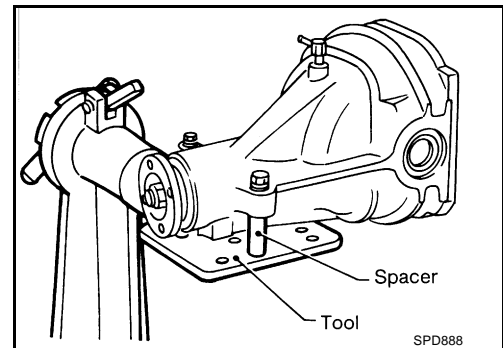

2. For installation, paint match marks on one side of the bearing caps as shown.

NOTE:

Bearing caps are line-bored for initial assembly. Replace the bearing caps in their original positions.

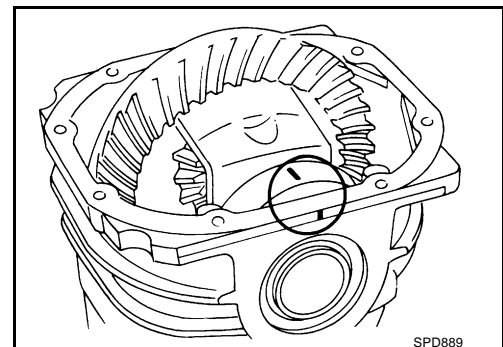

REAR FINAL DRIVE ASSEMBLY

3. Remove the bearing caps.

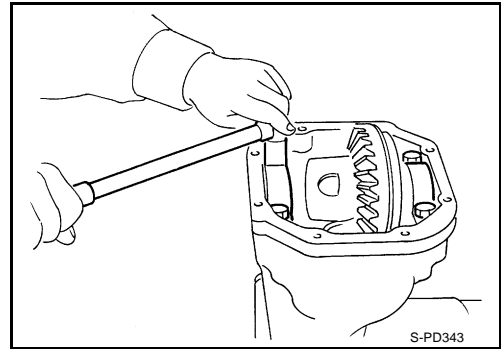

4. Lift the differential case assembly out of the gear carrier using Tool.

Tool number : HT72400000

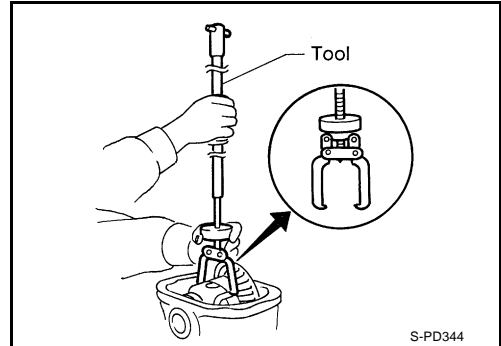

- Keep the side bearing outer races together with the inner races. Do not mix them up.
- Keep the adjusting washers together with the bearings.

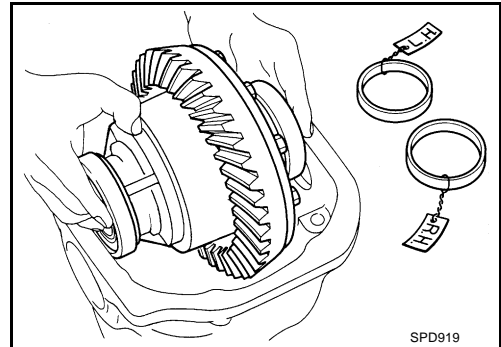

REMOVAL OF DRIVE PINION ASSEMBLY

1. Apply match marks on the companion flange and drive pinion using paint.
2. Loosen the drive pinion nut using Tool as shown.

Tool number : KV40104000

- Discard the drive pinion nut and use a new drive pinion nut for installation.

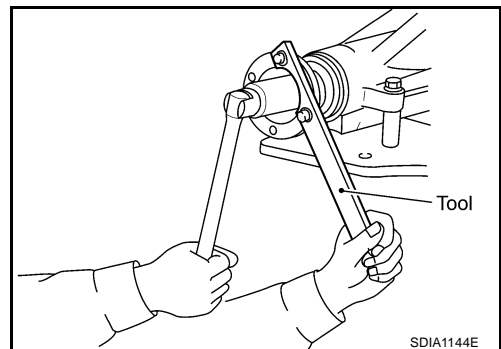

A
B
C
RFD

E
F
G
H
I
J
K

L
M

REAR FINAL DRIVE ASSEMBLY

3. Remove the drive pinion together with the rear bearing inner race and the bearing adjusting spacer.
4. Remove the front oil seal. Refer to [RFD-6, "Removal and Installation"](#) .
5. Remove the pinion front bearing inner race.
6. Remove the side oil seal. Refer to [RFD-8, "Removal and Installation"](#) .

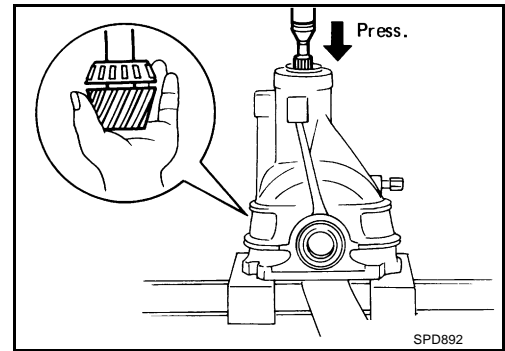

7. Remove the pinion bearing outer races using a suitable brass drift.

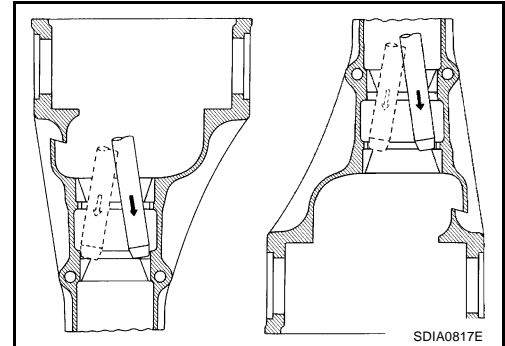

8. Remove the pinion rear bearing inner race and the drive pinion height adjusting washer using Tool.

Tool number: : ST30021000

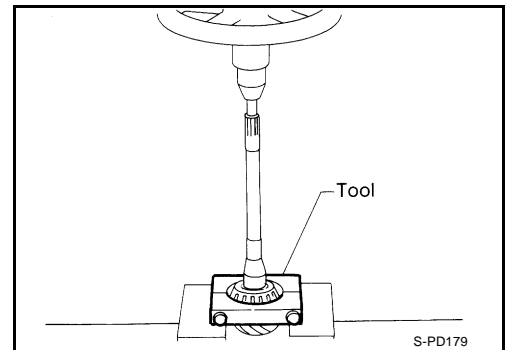

REAR FINAL DRIVE ASSEMBLY

DISASSEMBLY OF DIFFERENTIAL CASE ASSEMBLY

1. Remove the side bearing inner races using Tools.

CAUTION:

To prevent damage to the bearing, engage the puller jaws in the groove.

Tool number A: ST3306S001
 B: ST33061000

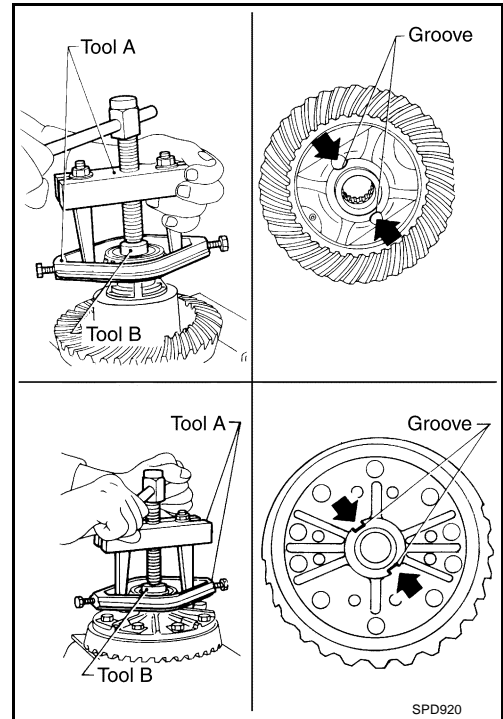

- Do not to mix the left and right side parts, clearly label the parts during disassembly.

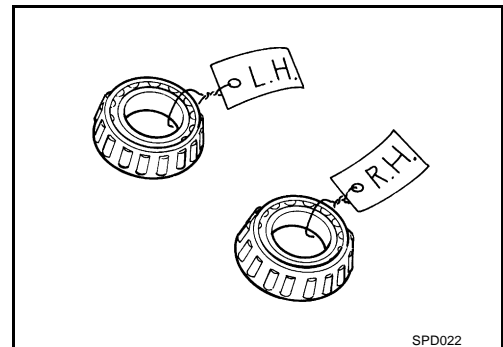

2. Loosen the drive gear bolts in a criss-cross pattern and remove the bolts.
3. Tap the drive gear off the differential case using a soft hammer.
 - Tap evenly all around the drive gear to keep the drive gear from binding.

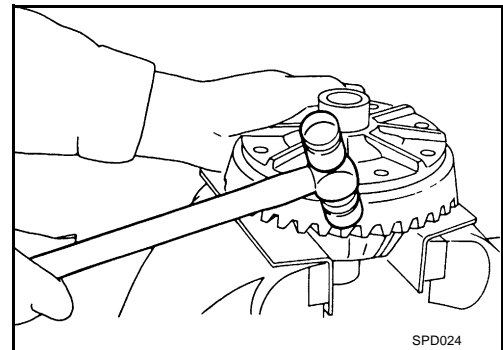

REAR FINAL DRIVE ASSEMBLY

4. Drive the pinion mate shaft lock pin out from the drive gear side using a suitable punch.

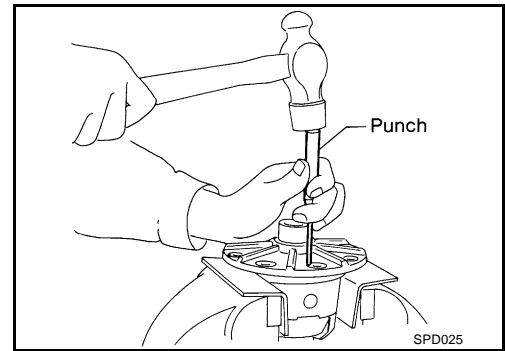

INSPECTION

Contact Surfaces

1. Clean the disassembled parts in a suitable solvent and blow dry using compressed air.
2. If the following surfaces are burred or scratched, smooth them using an oil stone.
 - Differential case
 - Side gear
 - Pinion mate gear
 - Pinion mate shaft

Bearing

1. Thoroughly clean the bearing.
2. Check the bearing for wear, scratches, pitting, or flaking.
3. Check the tapered roller bearing for smooth rotation. If damaged, replace the outer race and inner race as a set.

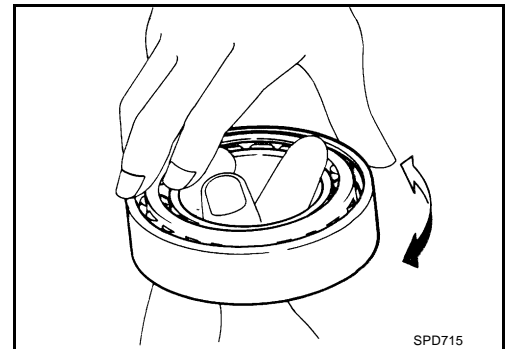

ADJUSTMENT OF DIFFERENTIAL CASE

Thrust Washer Selection

1. Install the side gears, pinion mate gears, and thrust washers into the differential case.

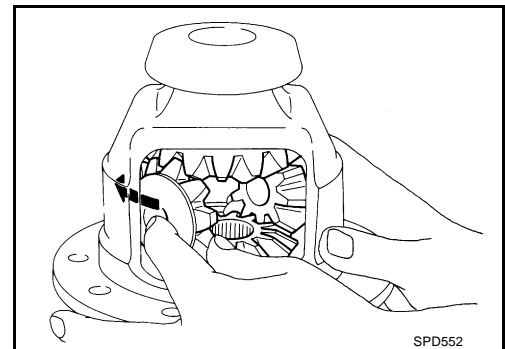

REAR FINAL DRIVE ASSEMBLY

2. Install the pinion mate shaft into the differential case so that it meets the lock pin holes.

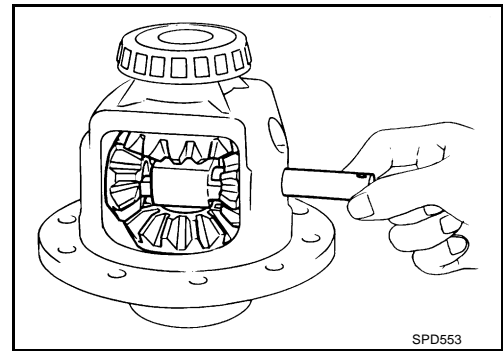

3. Adjust the clearance between rear face of side gear and thrust washer by selecting the correct thickness side gear thrust washer. Refer to [RFD-27, "AVAILABLE SIDE GEAR THRUST WASHERS"](#). Use two feeler gauges as shown to prevent the side gear from leaning.

Side gear thrust washer and differential case clearance : 0.20 mm (0.0079 in) or less

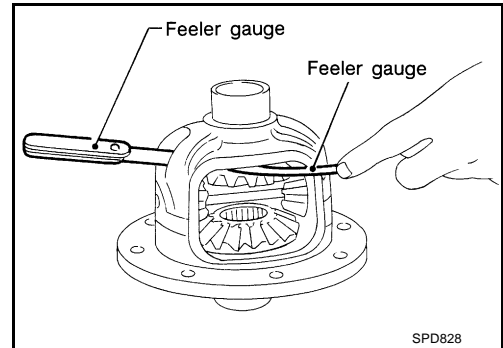

SIDE BEARING PRELOAD

NOTE:

A selection of carrier side bearing adjusting washers is required for completion of this procedure.

1. All parts must be clean. The bearings must be well lubricated with light oil or DEXRON™ type automatic transmission fluid.
2. Place the differential case assembly, with the side bearing outer races installed, into the gear carrier.

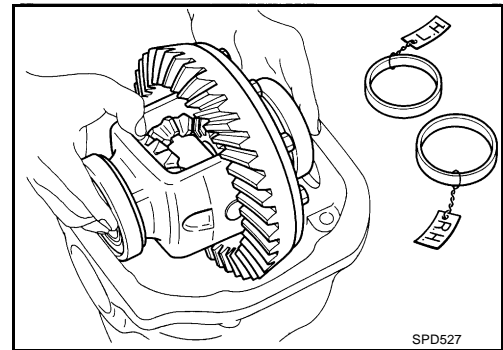

3. Insert the left and right side bearing adjusting washers in position between the side bearings and the gear carrier as shown.

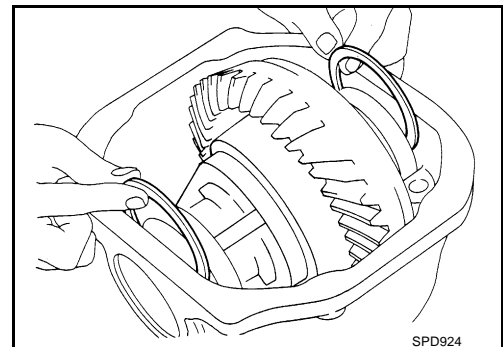

REAR FINAL DRIVE ASSEMBLY

4. Install the side bearing caps in their original locations marked during disassembly, and tighten the bearing cap bolts to specification.

Bearing cap bolts : 93 N·m (9.5 kg-m, 69 ft.-lb)

5. Turn the carrier several times to seat the bearings.

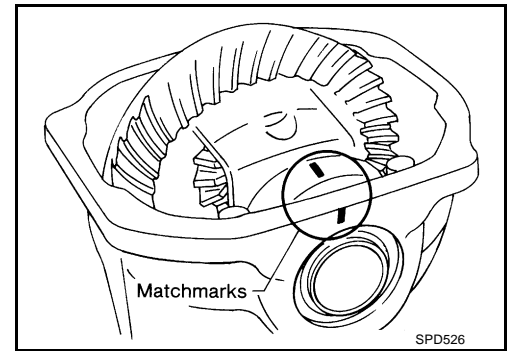

6. Measure the turning force of the carrier at the drive gear retaining bolts using a suitable spring gauge.

Drive gear bolt pulling force : 29.4 - 147 N (3 - 15 kg-f, 22 - 108 lb-f)

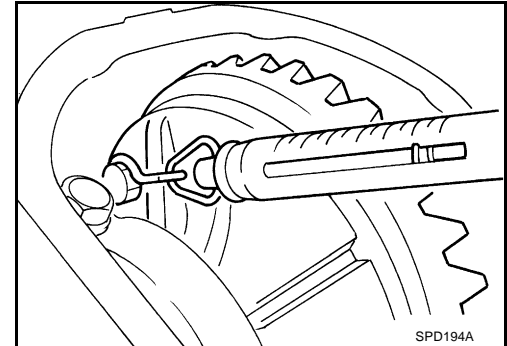

7. If the turning force is not within the specification, adjust the turning force.

- If the turning force is less than specification, install thicker washers.
- If the turning force is greater than specification, install thinner washers.
- Select the correct washer size to adjust the turning force. Refer to [RFD-28, "SIDE BEARING ADJUSTING WASHERS"](#)

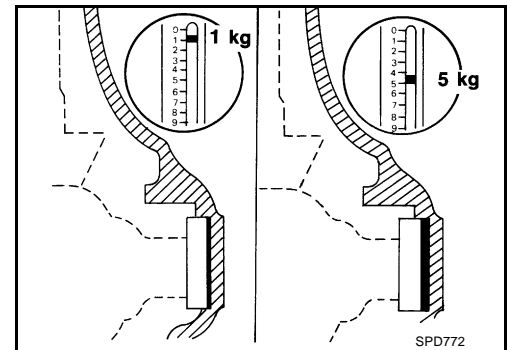

8. Record the selected washer thickness required for the correct carrier side bearing preload.

9. Remove the differential case assembly from the gear carrier using Tool. Save the selected side bearing adjusting washers for assembly.

Tool number : HT72400000

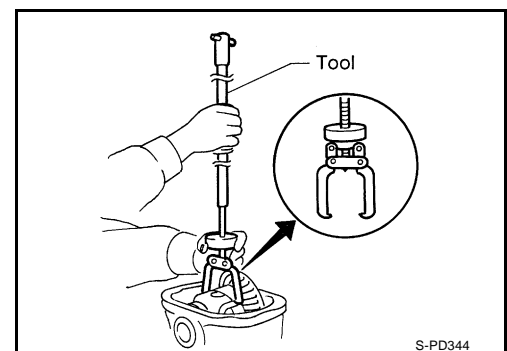

TOOTH CONTACT

NOTE:

Checking the gear tooth contact pattern is necessary to verify that there is the correct tooth contact between the drive gear and the drive pinion.

Hypoid gears which are not positioned properly may be noisy or have a short service life. Check the gear tooth contact pattern to obtain the best contact for low noise and long service life.

REAR FINAL DRIVE ASSEMBLY

1. Thoroughly clean the drive gear and drive pinion teeth.
2. Lightly apply a mixture of powdered ferric oxide and oil or the equivalent. Apply it to 3 or 4 teeth of the drive gear drive side.

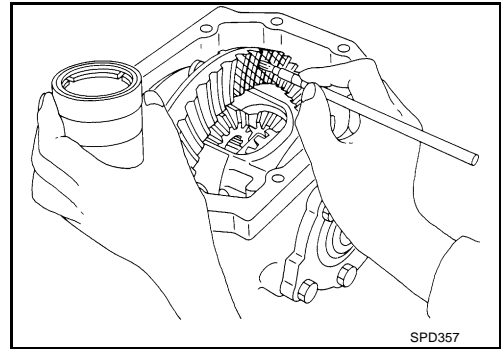

3. Use your hand to hold the companion flange steady and rotate the drive gear in both directions.

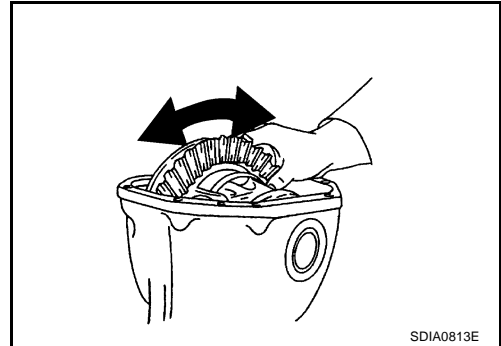

4. Check the tooth contact as shown.

Usually the pattern will be correct if shims are correctly calculated and the backlash is correct. However, in rare cases, trial and error processes may be employed to obtain a correct pattern. The tooth pattern is the best indication of how well a differential has been set up.

<p>Heel contact</p>	<p>Face contact</p>	<p>Toe contact</p>	<p>Flank contact</p>
<p>To correct, increase thickness of pinion height adjusting washer in order to bring drive pinion close to Drive gear.</p>		<p>To correct, reduce thickness of pinion height adjusting washer in order to make drive pinion go away from Drive gear.</p>	
<p>Correct tooth contact</p>			

When adjustment is completed, be sure to wipe off completely the ferric oxide and oil or their equivalent.

SDIA1910E

ASSEMBLY OF DIFFERENTIAL CASE ASSEMBLY

1. Install the pinion mate shaft lock pin using a suitable punch as shown. The lock pin must be flush with the case.
2. Place the differential case on the drive gear.

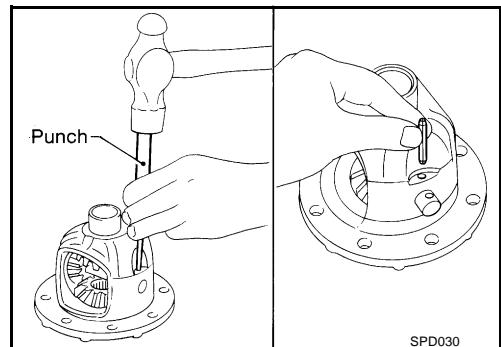

A
B
C
RFD
E
F
G
H
I
J
K
L
M

REAR FINAL DRIVE ASSEMBLY

3. Apply genuine medium strength locking sealant or equivalent as shown. Refer to [GI-45, "Recommended Chemical Products and Sealants"](#).
 - Tighten the drive gear bolts in a criss-cross pattern to specification.

Drive gear bolts

Step 1 : 78.5 N-m (8.0 kg-m, 58 ft-lb)

Step 2 : 34° degrees

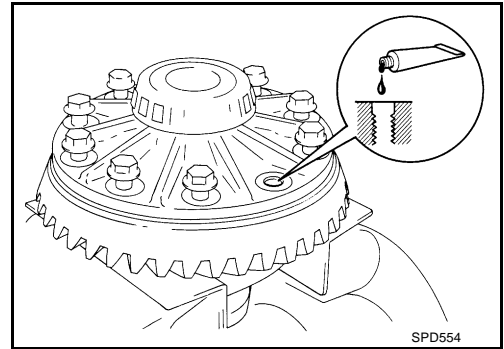

4. Press-fit the side bearing inner races on the differential case using Tools.

Tool number A: KV38100200

B: ST33081000

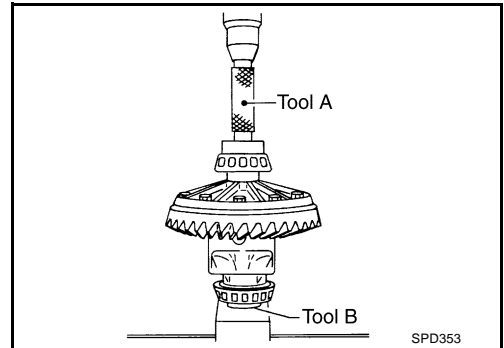

INSTALLATION OF DRIVE PINION ASSEMBLY

1. Press-fit the pinion front and rear bearing outer races using Tools.

Tool number A: ST15310000

B: ST35325000

C: ST30621000

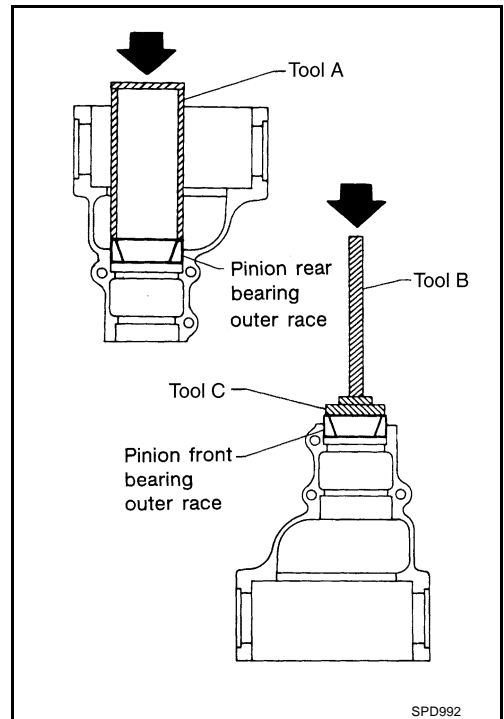

2. Select pinion height adjusting washer. Refer to [RFD-27, "Drive Pinion Height Adjustment"](#).

REAR FINAL DRIVE ASSEMBLY

3. Install the selected pinion height adjusting washer in the drive pinion. Using a suitable press and Tool, press-fit pinion rear bearing inner race into the drive pinion.

Tool number : ST30022000

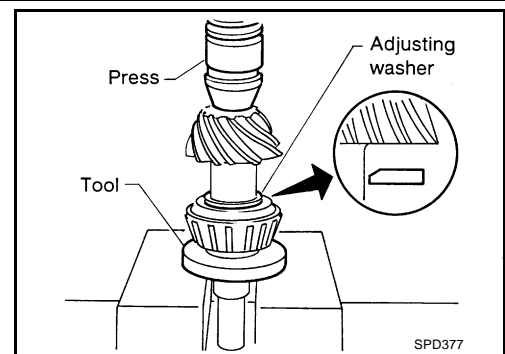

4. Apply multi-purpose grease to the pinion rear bearing inner race and pinion front bearing inner race.

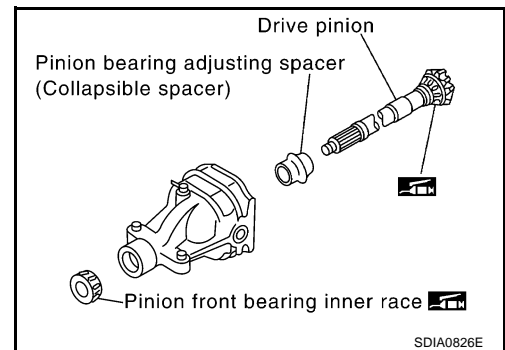

5. Set the drive pinion assembly in the differential carrier as shown, and install drive pinion using a suitable press and suitable tool. Stop when drive pinion touches the bearing.

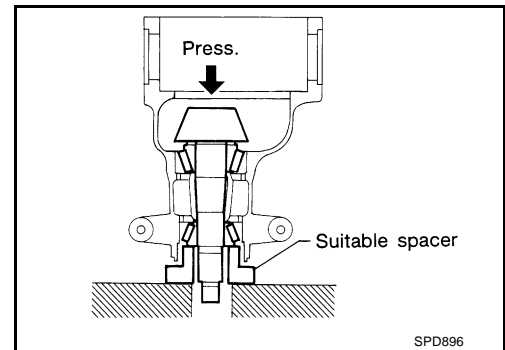

6. Install the front oil seal using Tool. Refer to [RFD-6, "Removal and Installation"](#).
7. Install the companion flange, and tighten the pinion nut to a minimum using Tool. Check that the threaded portion of the drive pinion and drive pinion nut are free of oil or grease.

Tool number : KV40104000

CAUTION:

The drive pinion nut is not reusable. Use a new drive pinion nut for installation.

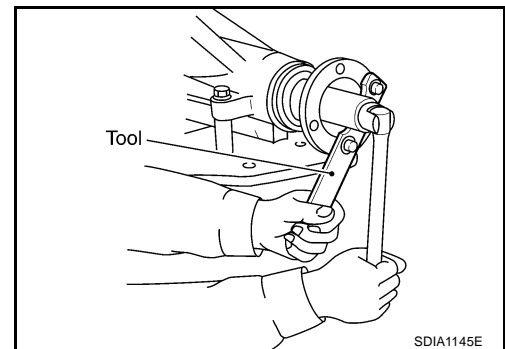

REAR FINAL DRIVE ASSEMBLY

8. Tighten the drive pinion nut by very small increments until the specified preload is achieved, when checking the preload, turn drive pinion in both directions several times.

Tool number : **ST3127S000**

Pinion bearing preload : **1.77 - 2.64 N·m (0.18 - 0.26 kg·m, 16 - 23 in·lb)**

- If the pinion bearing preload is less than specification, tighten the drive pinion nut.
- If pinion bearing preload is greater than specification, replace the pinion bearing adjusting spacer.

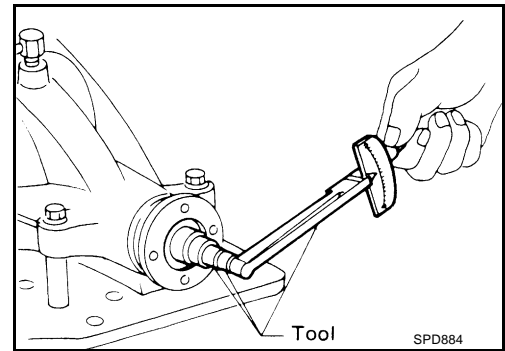

INSTALLATION OF DIFFERENTIAL CASE ASSEMBLY

1. Select the side bearing adjusting washer. Refer to [RFD-19, "SIDE BEARING PRELOAD"](#).
2. Install the differential case assembly with side bearing outer races into the gear carrier.

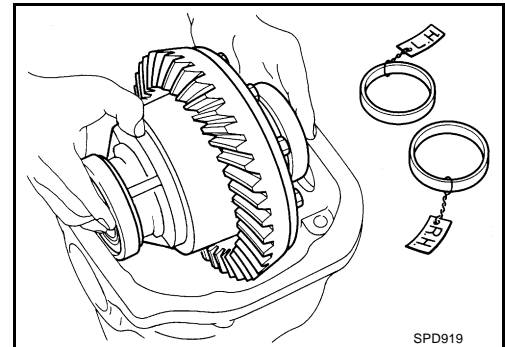

3. Insert the left and right side bearing adjusting washers into place between the side bearings and the gear carrier.

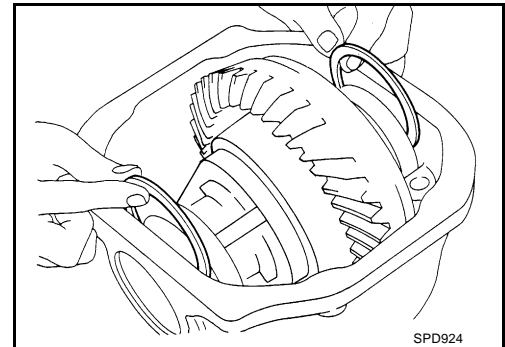

4. Install the side bearing caps. Align the matching mark on the bearing cap with the matching mark on the gear carrier, and tighten the bearing cap bolts to specification.

Bearing cap bolts : **93 N·m (9.5 kg·m, 69 ft·lb)**

5. Install the side oil seals. Refer to [RFD-8, "Removal and Installation"](#).

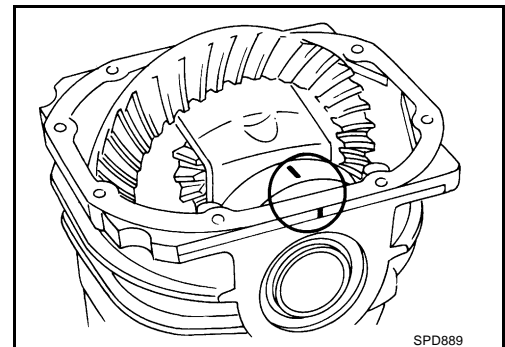

REAR FINAL DRIVE ASSEMBLY

6. Measure the drive gear-to-drive pinion backlash with a dial indicator at several points.

**Drive gear to drive pinion backlash : 0.13 - 0.18 mm
(0.0051 - 0.0070 in)**

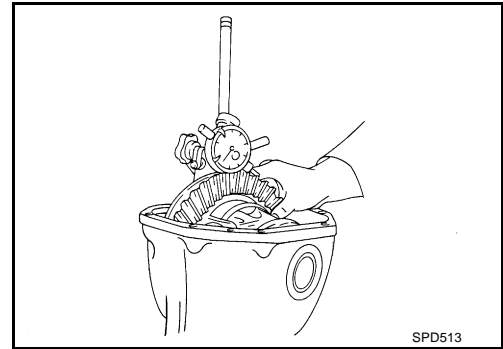

- If the backlash is less than specification, adjust the washer thickness. Decrease the thickness of the left washer and increase the thickness of the right washer by the same amount.
- If the backlash is greater than specification, adjust the washer thickness. Increase the thickness of the left washer and decrease the thickness of the right washer by the same amount.
- Never change the total amount of the washers as it will change the bearing preload.

7. Check the total preload using Tool.

Tool number : ST3127S000

When checking the preload, turn the drive pinion in both directions several times to seat the bearing rollers correctly.

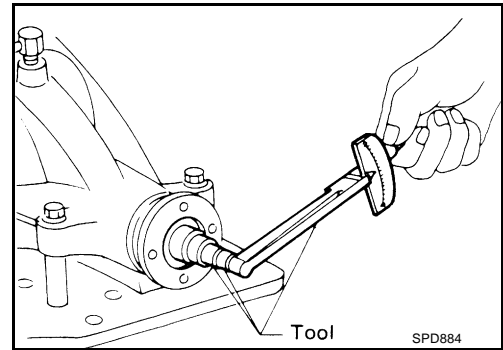

Total preload : 2.05 - 4.11 N·m (0.21 - 0.42 kg·m, 19 - 36 in·lb)

- If the preload is greater than specification, remove the same amount of washer thickness from each side.
 - If the preload is less than specification, add the same amount of washer thickness to each side.
 - Never add or remove a different amount of washer thickness from each side. A difference in the amount of washer thickness will change the drive gear-to-drive pinion backlash.
8. Recheck the drive gear-to-drive pinion backlash. Increase or decrease in thickness of the washers will change the drive gear-to-drive pinion backlash.
- Check whether the backlash varies excessively in different places. Foreign matter may be caught between the drive gear and the differential case causing the variation in backlash.
 - The backlash can vary greatly even when the drive gear runout is within specification. To correct this variation, replace the hypoid gear set or differential case.
9. Check runout of drive gear using a dial indicator.

Runout limit : 0.05 mm (0.0020 in) or less

10. Check the tooth contact.
Refer to [RFD-14, "TOOTH CONTACT"](#) .

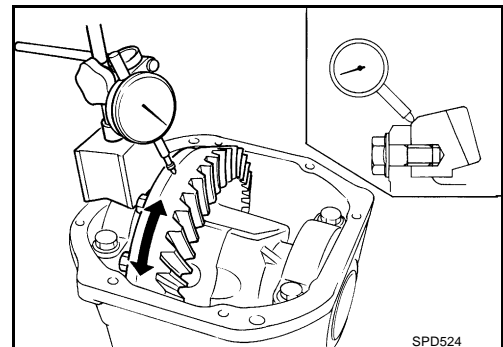

REAR FINAL DRIVE ASSEMBLY

11. Install the rear cover on the gear carrier. Apply Genuine NISSAN RTV Sealant or equivalent, to the rear cover as shown. Refer to [GI-45, "Recommended Chemical Products and Sealants"](#).

Rear cover bolts : 44 N·m (4.5 kg·m, 32 ft·lb)

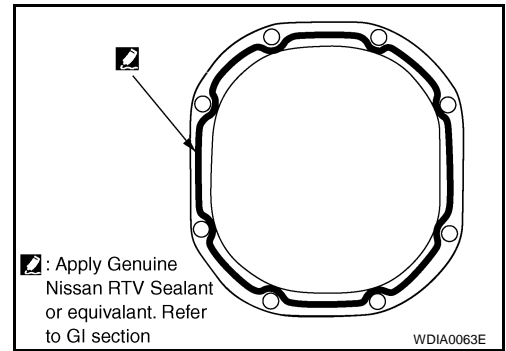

SERVICE DATA AND SPECIFICATIONS (SDS)

SERVICE DATA AND SPECIFICATIONS (SDS)

PF0:00030

General Specifications

EDS003PZ

Grade	SE		LE
	Standard	Optional	Standard
Final drive model	R230 (2 - pinion)		
Gear ratio	2.937 : 1	3.357 : 1	
Number of teeth (drive gear / drive pinion)	47 / 16	47 / 14	
Oil capacity (approx.)	1.75 ℓ (3 3/4 US pt, 3 1/8 Imp pt)		

Drive Gear Runout

EDS003Q0

Unit: mm (in)

Final drive model	R230 (2 - pinion)
Drive gear runout limit	0.05 (0.0020) or less

Side Gear Adjustment

EDS003Q1

Unit: mm (in)

Final drive model	R230 (2 - pinion)
Clearance limit between side gear and differential case	0.20 (0.0079) or less

AVAILABLE SIDE GEAR THRUST WASHERS

Unit: mm (in)

Final drive model	R230 (2 - pinion)	
	Thickness	Part number
Thrust washer	1.75 (0.0688)	38424 7S000
	1.80 (0.0708)	38424 7S001
	1.85 (0.0728)	38424 7S002

Drive Pinion Height Adjustment

EDS003Q2

AVAILABLE PINION HEIGHT ADJUSTING WASHERS

Unit: mm (in)

Final drive model	R230 (2 - pinion)			
	Thickness	Part number	Thickness	Part number
Adjusting washer	2.59 (0.1020)	38154 40P00	2.79 (0.1098)	38154 40P10
	2.61 (0.1028)	38154 40P01	2.81 (0.1106)	38154 40P11
	2.63 (0.1035)	38154 40P02	2.83 (0.1114)	38154 40P12
	2.65 (0.1043)	38154 40P03	2.85 (0.1122)	38154 40P13
	2.67 (0.1051)	38154 40P04	2.87 (0.1130)	38154 40P14
	2.69 (0.1059)	38154 40P05	2.89 (0.1138)	38154 40P15
	2.71 (0.1067)	38154 40P06	2.91 (0.1146)	38154 40P16
	2.73 (0.1075)	38154 40P07	2.93 (0.1154)	38154 40P17
	2.75 (0.1083)	38154 40P08	2.95 (0.1161)	38154 40P18
	2.77 (0.1091)	38154 40P09	2.97 (0.1169)	38154 40P19

Drive Pinion Preload Adjustment

EDS003Q3

Final drive model	R230 (2 - pinion)
Drive pinion preload	1.77 – 2.64 N·m (0.18 – 0.26 kg–m, 16 – 23 in-lb)

SERVICE DATA AND SPECIFICATIONS (SDS)

Side Bearing Preload Adjustment

EDS003Q4

Final drive model	R230 (2 - pinion)
Side bearing preload (reference value)	0.20 – 0.52 N·m (0.02 – 0.05 kg-m, 2 – 4 in-lb)
Drive gear bolt pulling force (by spring gauge)	29.4 – 147 N (3 – 15 kg-f, 22 – 108 lb-f)

SIDE BEARING ADJUSTING WASHERS

Unit: mm (in)

Final drive model	R230 (2 - pinion)			
	Thickness	Part number	Thickness	Part number
Adjusting washer	2.00 (0.0787)	38453 40P00	2.35 (0.0925)	38453 40P07
	2.05 (0.0807)	38453 40P01	2.40 (0.0945)	38453 40P08
	2.10 (0.0827)	38453 40P02	2.45 (0.0965)	38453 40P09
	2.15 (0.0846)	38453 40P03	2.50 (0.0984)	38453 40P10
	2.20 (0.0866)	38453 40P04	2.55 (0.1004)	38453 40P11
	2.25 (0.0886)	38453 40P05	2.60 (0.1024)	38453 40P12
	2.30 (0.0906)	38453 40P06		

Total Preload Adjustment

EDS003Q5

Final drive model	R230 (2 - pinion)
Total preload with oil seal	2.05 – 4.11 N·m (0.21 – 0.42 kg-m, 19 – 36 in-lb)
Drive gear to drive pinion backlash	0.13 – 0.18 mm (0.0051 – 0.0070 in)