

SECTION **RSU**  
 REAR SUSPENSION

A  
B  
C  
D

RSU

CONTENTS

<b>PRECAUTIONS</b> .....	<b>3</b>	<b>TROUBLE DIAGNOSES FOR SYMPTOMS</b> .....	<b>23</b>	F
Precautions for Supplemental Restraint System (SRS) "AIR BAG" and "SEAT BELT PRE-TENSIONER" .....	3	Load Leveling Rear Air Suspension System Does Not Operate .....	23	G
Precautions for Rear Suspension .....	3	CK SUSP Indicator Lamp Stays On When Ignition Switch Is Turned On .....	24	H
<b>PREPARATION</b> .....	<b>4</b>	<b>REAR SUSPENSION ASSEMBLY</b> .....	<b>25</b>	I
Commercial Service Tools .....	4	Components .....	25	J
<b>NOISE, VIBRATION, AND HARSHNESS (NVH)</b>		On-Vehicle Inspection and Service .....	26	K
<b>TROUBLESHOOTING</b> .....	<b>5</b>	SHOCK ABSORBER INSPECTION (WITH AND WITHOUT THE AIR LEVELING SYSTEM) .....	26	L
NVH Troubleshooting Chart .....	5	Wheel Alignment Inspection .....	27	M
<b>CAN COMMUNICATION</b> .....	<b>6</b>	PRELIMINARY INSPECTION .....	27	
System Description .....	6	GENERAL INFORMATION AND RECOMMENDATIONS .....	27	
<b>TROUBLE DIAGNOSIS</b> .....	<b>7</b>	THE ALIGNMENT PROCESS .....	28	
How to Perform Trouble Diagnoses for Quick and Accurate Repair .....	7	CAMBER .....	28	
INTRODUCTION .....	7	TOE-IN .....	28	
CLARIFY CONCERN .....	7	<b>REAR SUSPENSION MEMBER</b> .....	<b>30</b>	
WORK FLOW .....	8	Removal and Installation .....	30	
Component Parts and Harness Connector Location .....	9	REMOVAL .....	31	
Wiring Diagram — A/SUSP — .....	10	INSPECTION AFTER REMOVAL .....	32	
Basic Inspection .....	12	INSTALLATION .....	33	
AIR HOSES .....	12	<b>SHOCK ABSORBER</b> .....	<b>34</b>	
POWER SYSTEM TERMINAL LOOSENESS AND BATTERY INSPECTION .....	12	Removal and Installation .....	34	
CK SUSP INDICATOR LAMP INSPECTION .....	12	REMOVAL .....	34	
CK SUSP Indicator Lamp Timing .....	12	INSTALLATION .....	34	
Control Unit Input/Output Signal Standard .....	12	Inspection .....	34	
CONSULT-II Function (AIR LEVELIZER) .....	13	<b>SUSPENSION ARM</b> .....	<b>35</b>	
CONSULT-IIBASICOPERATIONPROCEDURE .....	13	Removal and Installation .....	35	
WORK SUPPORT .....	14	REMOVAL .....	35	
SELF-DIAGNOSIS .....	14	INSTALLATION .....	35	
DATA MONITOR .....	15	Inspection .....	36	
ACTIVE TEST .....	16	<b>FRONT LOWER LINK</b> .....	<b>37</b>	
<b>TROUBLE DIAGNOSIS FOR SELF-DIAGNOSTIC ITEMS</b> .....	<b>17</b>	Removal and Installation .....	37	
Height Sensor System Inspection .....	17	REMOVAL .....	37	
Exhaust Valve Solenoid System Inspection .....	19	INSPECTION AFTER REMOVAL .....	37	
Compressor Motor, Compressor Motor Relay and Circuit Inspection .....	20	INSTALLATION .....	37	
		Inspection .....	38	
		<b>REAR LOWER LINK &amp; COIL SPRING</b> .....	<b>39</b>	
		Removal and Installation .....	39	

REMOVAL .....	39	<b>HEIGHT SENSOR .....</b>	<b>44</b>
INSTALLATION .....	40	Removal and Installation .....	44
Inspection .....	40	REMOVAL .....	44
<b>STABILIZER BAR .....</b>	<b>41</b>	INSTALLATION .....	45
Removal and Installation .....	41	<b>CONTROL UNIT .....</b>	<b>46</b>
REMOVAL .....	41	Removal and Installation .....	46
INSTALLATION .....	41	REMOVAL .....	46
Inspection .....	41	INSTALLATION .....	46
<b>REAR LOAD LEVELING AIR SUSPENSION COM-</b>		Initialization Procedure .....	46
<b>PRESSOR ASSEMBLY .....</b>	<b>42</b>	<b>SERVICE DATA AND SPECIFICATIONS (SDS) .....</b>	<b>47</b>
Removal and Installation .....	42	Wheel Alignment (Unladen* <sup>1</sup> ) .....	47
REMOVAL .....	42	Ball Joint .....	47
INSTALLATION .....	43	Wheelarch Height (Unladen* <sup>1</sup> ) .....	48

# PRECAUTIONS

## PRECAUTIONS

PFP:00001

### Precautions for Supplemental Restraint System (SRS) “AIR BAG” and “SEAT BELT PRE-TENSIONER”

EES001EG

The Supplemental Restraint System such as “AIR BAG” and “SEAT BELT PRE-TENSIONER”, used along with a front seat belt, helps to reduce the risk or severity of injury to the driver and front passenger for certain types of collision. This system includes seat belt switch inputs and dual stage front air bag modules. The SRS system uses the seat belt switches to determine the front air bag deployment, and may only deploy one front air bag, depending on the severity of a collision and whether the front occupants are belted or unbelted. Information necessary to service the system safely is included in the SRS and SB section of this Service Manual.

#### **WARNING:**

- To avoid rendering the SRS inoperative, which could increase the risk of personal injury or death in the event of a collision which would result in air bag inflation, all maintenance must be performed by an authorized NISSAN/INFINITI dealer.
- Improper maintenance, including incorrect removal and installation of the SRS, can lead to personal injury caused by unintentional activation of the system. For removal of Spiral Cable and Air Bag Module, see the SRS section.
- Do not use electrical test equipment on any circuit related to the SRS unless instructed to in this Service Manual. SRS wiring harnesses can be identified by yellow and/or orange harnesses or harness connectors.

### Precautions for Rear Suspension

EES001EH

- When installing the rubber bushings, the final tightening must be done under unladen condition and with the tires on level ground. Oil will shorten the life of the rubber bushings, so wipe off any spilled oil immediately.
- Unladen condition means the fuel tank, engine coolant and lubricants are at the full specification. The spare tire, jack, hand tools, and mats are in their designated positions.
- After installing suspension components, check the wheel alignment.
- Caulking nuts are not reusable. Always use new caulking nuts for installation. New caulking nuts are pre-oiled, do not apply any additional lubrication.

A  
B  
C  
D  
RSU  
F  
G  
H  
I  
J  
K  
L  
M

# PREPARATION

## PREPARATION

PFP:00002

### Commercial Service Tools

EES001EJ

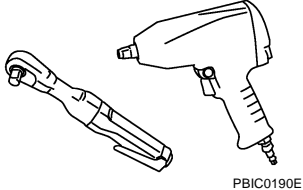
Tool name	Description
Power tool  PBIC0190E	<ul style="list-style-type: none"><li>● Removing wheel nuts</li><li>● Removing brake caliper assembly</li><li>● Removing rear suspension component parts</li></ul>

# NOISE, VIBRATION, AND HARSHNESS (NVH) TROUBLESHOOTING

## NOISE, VIBRATION, AND HARSHNESS (NVH) TROUBLESHOOTING

PF0:0003

### NVH Troubleshooting Chart

EES001EK

Use chart below to help you find the cause of the symptom. If necessary, repair or replace these parts.

Symptom		Possible cause and SUSPECTED PARTS													Reference page				
		Improper installation, looseness	Shock absorber deformation, damage or deflection	Bushing or mounting deterioration	Parts interference	Spring fatigue	Suspension looseness	Incorrect wheel alignment	Stabilizer bar fatigue	PROPELLER SHAFT	DIFFERENTIAL	FRONT SUSPENSION	FRONT AXLE	TIRES		ROAD WHEEL	DRIVE SHAFT	BRAKES	STEERING
Symptom	Noise	x	x	x	x	x	x			x	x	x		x	x	x	x	x	RSU-25
	Shake	x	x	x	x		x			x		x		x	x	x	x	x	RSU-26
	Vibration	x	x	x	x	x				x		x		x		x		x	—
	Shimmy	x	x	x	x			x				x		x	x		x	x	—
	Shudder	x	x	x								x		x	x		x	x	RSU-25
	Poor quality ride or handling	x	x	x	x	x		x	x			x		x	x				RSU-27
																		RSU-26	
																		PR-3, "NVH Troubleshooting Chart"	
																		RAX-4, "NVH Troubleshooting Chart"	
																		FSU-4, "NVH Troubleshooting Chart"	
																		FAX-4, "NVH Troubleshooting Chart"	
																		WT-4, "NVH Troubleshooting Chart"	
																		WT-4, "NVH Troubleshooting Chart"	
																		RAX-4, "NVH Troubleshooting Chart"	
																		BR-5, "NVH Troubleshooting Chart"	
																		PS-5, "NVH Troubleshooting Chart"	

x: Applicable

A  
B  
C  
D  
RSU  
F  
G  
H  
I  
J  
K  
L  
M

# CAN COMMUNICATION

---

## CAN COMMUNICATION

PF2:23710

### System Description

EES001EL

Refer to [LAN-5, "CAN COMMUNICATION"](#) .

## TROUBLE DIAGNOSIS

### How to Perform Trouble Diagnoses for Quick and Accurate Repair

EES001EM

#### INTRODUCTION

The rear load leveling air suspension system uses an electronic control unit to control major functions. The control unit accepts input signals from the height sensor and controls compressor and exhaust valve operation.

It is much more difficult to diagnose a rear load leveling air suspension system problem that occurs intermittently rather than continuously. Most intermittent problems are caused by poor electrical connections or faulty wiring. In this case, careful checking of suspicious circuits may help prevent the replacement of good parts.

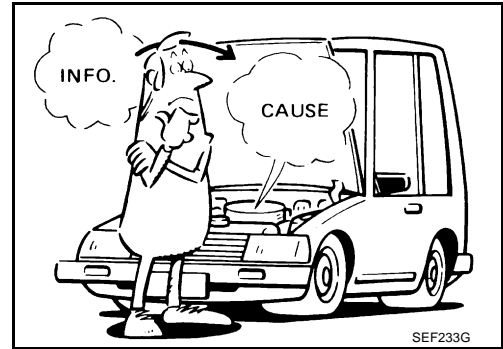

Before undertaking actual checks, take just a few minutes to talk with a customer who approaches with an air suspension system complaint. The customer is a very good source of information on such problems, especially intermittent ones. Through discussion with the customer, find out what symptoms are present and under what conditions they occur.

Start your diagnosis by looking for basic mechanical problems first. This is one of the best ways to troubleshoot concerns on an air suspension system equipped vehicle. Also check related Service Bulletins for information.

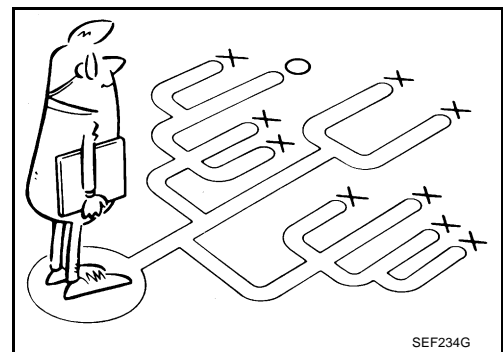

#### CLARIFY CONCERN

- A customer's description of a vehicle concern may vary depending on the individual. It is important to clarify the customer's concern.
- Ask the customer about what symptoms are present under what conditions. Use this information to reproduce the symptom.

#### KEY POINTS

- |              |       |  |
|--------------|-------|--|
| <b>WHAT</b>  | ..... | Vehicle model  |
| <b>WHEN</b>  | ..... | Date, Frequencies  |
| <b>WHERE</b> | ..... | Road conditions  |
| <b>HOW</b>   | ..... | Operating conditions,<br>Weather conditions,<br>Symptoms |

SBR339B

A  
B  
C  
D  
RSU  
F  
G  
H  
I  
J  
K  
L  
M

# TROUBLE DIAGNOSIS

## WORK FLOW

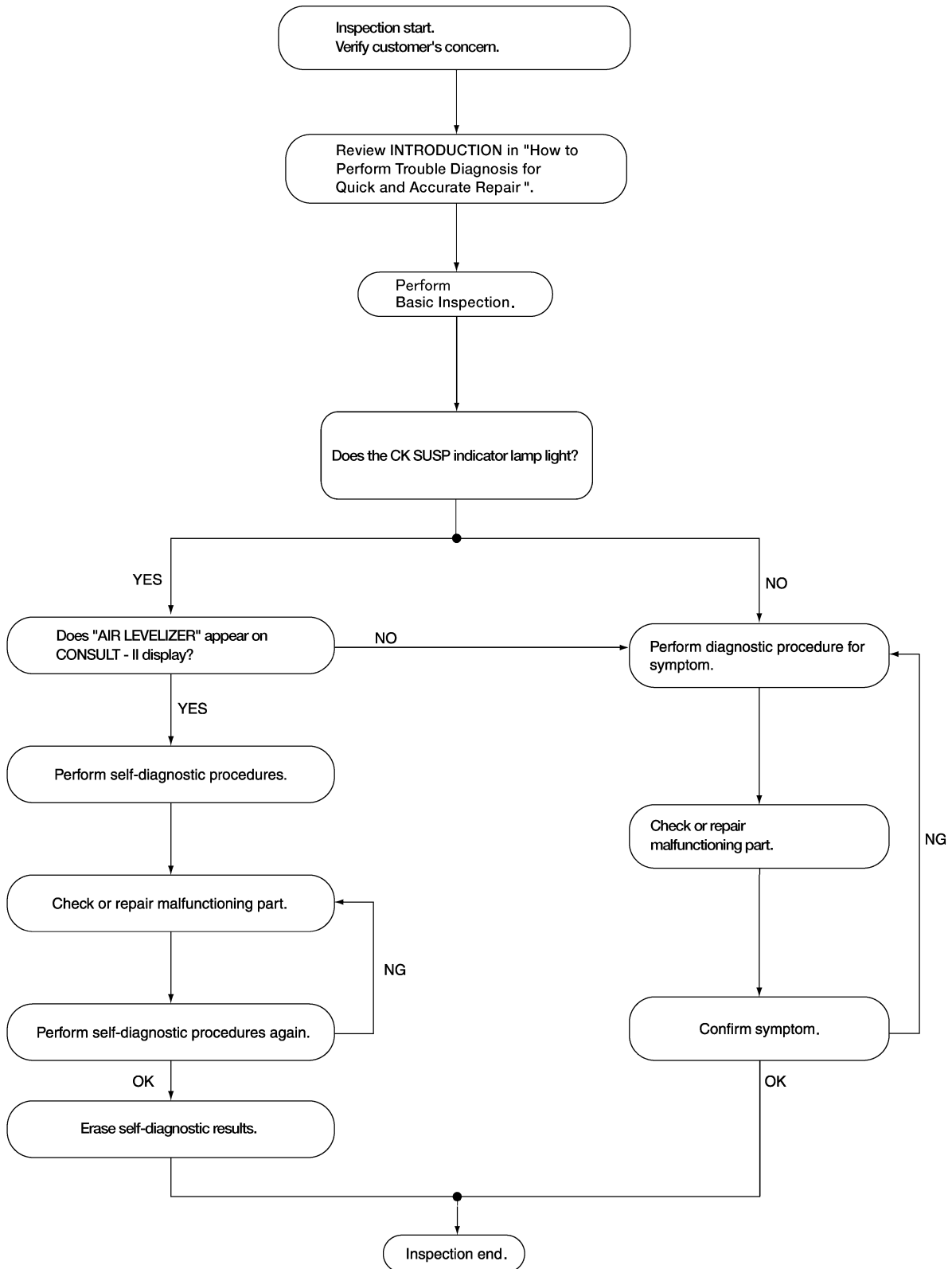

WEIA0077E



# TROUBLE DIAGNOSIS

## Component Parts and Harness Connector Location

EES002C6

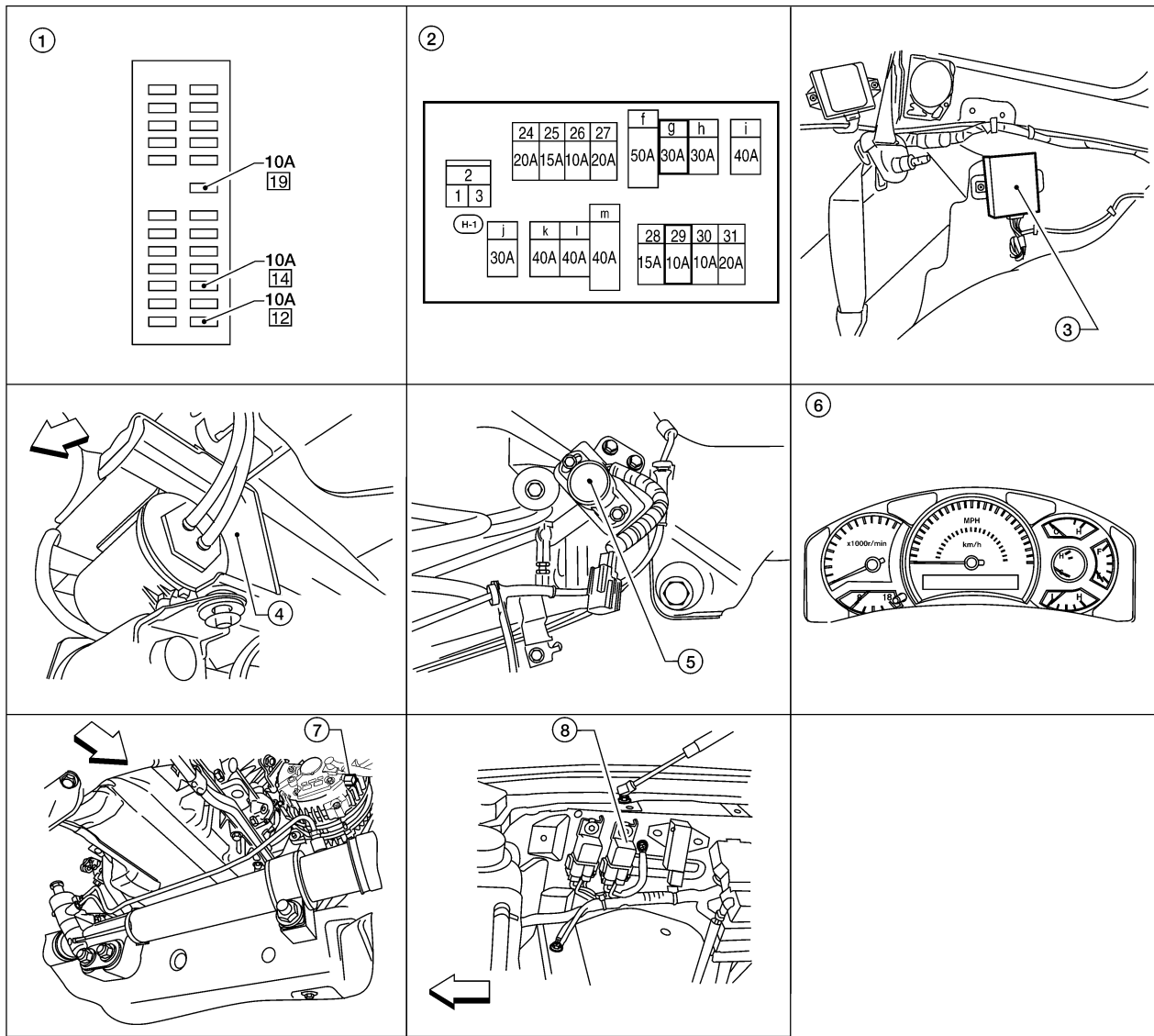

↔ Front

- |  |  |   |
|--|--|---|
| 1. Fuse Block (J/B)                            | 2. Fuse and fusible link box   | 3. Suspension control unit B3<br>(View with upper and lower luggage side finishers removed) |
| 4. Suspension air compressor C9                | 5. Heights sensor C8 (View from under vehicle)                                     | 6. Combination meter M24  |
| 7. Generator E205<br>(View from under vehicle) | 8. Suspension air compressor motor relay E130, E131<br>(View with battery removed) |   |

LEIA0127E

A  
B  
C  
D  
RSU  
F  
G  
H  
I  
J  
K  
L  
M

# TROUBLE DIAGNOSIS

## Wiring Diagram — A/SUSP —

EES001EO

### RSU-A/SUSP-01

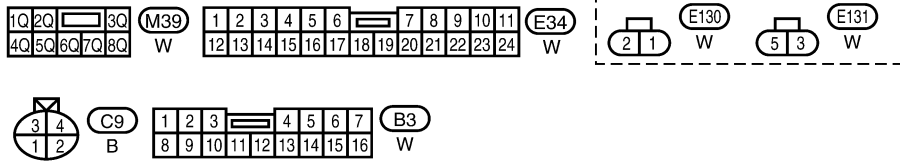
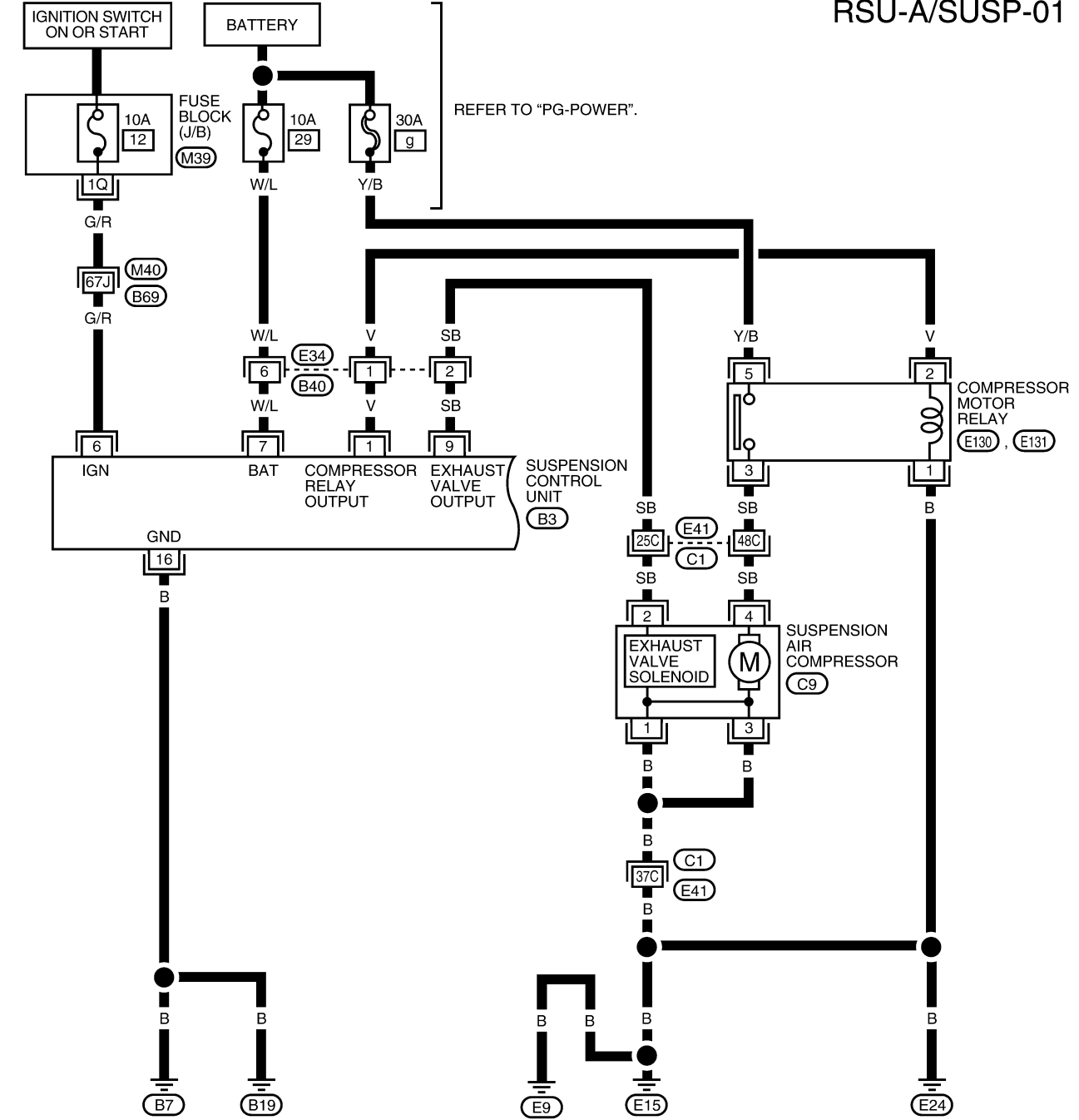

REFER TO THE FOLLOWING.  
 (M40), (C1) - SUPER MULTIPLE JUNCTION (SMJ)

WEWA0026E

# TROUBLE DIAGNOSIS

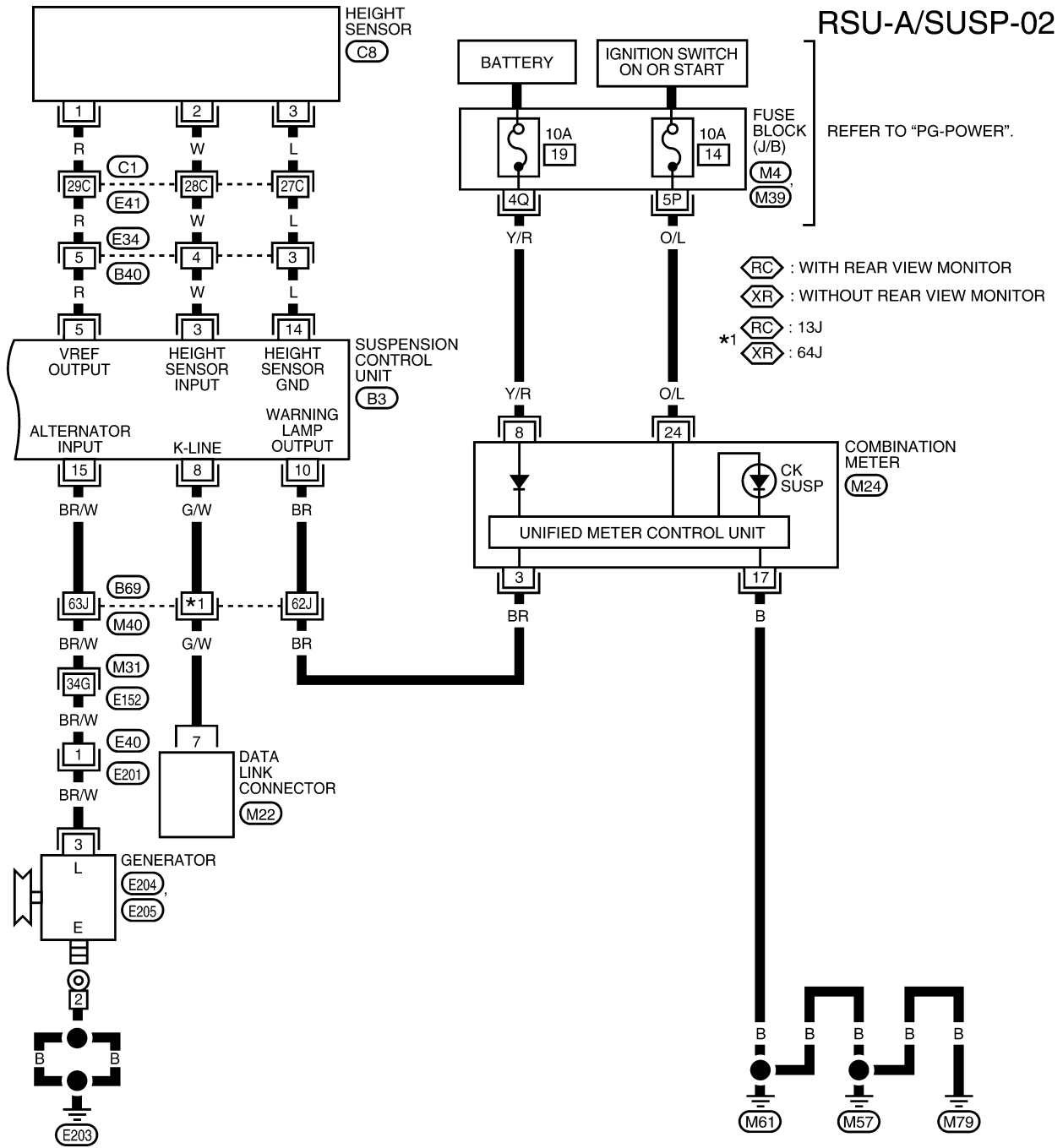

A  
B  
C  
D  
RSU  
F  
G  
H  
I  
J  
K  
L  
M

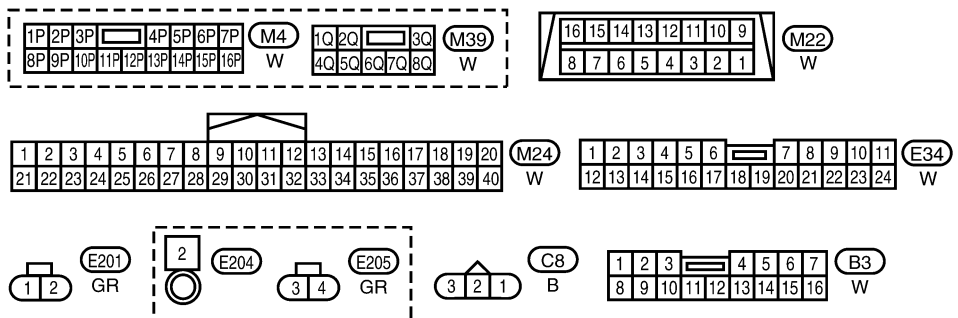

REFER TO THE FOLLOWING.  
 (M31), (M40), (C1) - SUPER  
 MULTIPLE JUNCTION (SMJ)

WEWA0027E

# TROUBLE DIAGNOSIS

## Basic Inspection

EES001EP

### AIR HOSES

1. Check for pinched or damaged air hoses between the suspension air reservoir and each load leveling rear air suspension shock absorber. Reposition, repair or replace hoses as necessary.
2. Check the air hose connections at the suspension air reservoir and at the shock absorbers for leaks. If connections are leaking, repair or replace hoses as necessary.

### POWER SYSTEM TERMINAL LOOSENESS AND BATTERY INSPECTION

Make sure the battery positive cable, negative cable and ground connection are not loose. In addition, make sure the battery is sufficiently charged.

### CK SUSP INDICATOR LAMP INSPECTION

1. Make sure the CK SUSP indicator lamp turns on for approximately 2 seconds when the ignition switch is turned ON. If it does not, check the combination meter. Refer to [DI-5, "COMBINATION METERS"](#).
2. Make sure the lamp turns off approximately 2 seconds after the ignition switch is turned ON. If the lamp does not turn off, conduct self-diagnosis of the suspension control unit. Refer to [RSU-14, "SELF-DIAGNOSIS"](#).
3. After conducting the self-diagnosis, be sure to erase the error memory. Refer to [RSU-13, "CONSULT-II Function \(AIR LEVELIZER\)"](#).

### CK SUSP Indicator Lamp Timing

EES001EQ

Condition	CK SUSP indicator lamp	Remarks
Ignition switch OFF	—	—
Ignition switch ON	X	Turns off after approximately 2 seconds.

X: ON

—: OFF

### Control Unit Input/Output Signal Standard

EES001ER

Terminal		Item	Condition	Voltage (V) (Approx.)
+	—			
1 (V)	Ground	Compressor relay output	Ignition switch ON or START	Battery voltage
3 (W)		Height sensor signal input		0.2V - 4.8V
5 (R)		Reference voltage		5V
6 (G/R)		Ignition power	—	Battery voltage
7 (W/L)		Battery power		
8 (G/W)		Diagnostic K-line	—	—
9 (SB)		Exhaust valve output	Ignition switch ON or START	Battery voltage
10 (BR)		Warning lamp	—	—
14 (L)		Height sensor ground	—	—
15 (BR/W)		Alternator L signal input	Engine running	—
16 (B)		Suspension control unit ground	—	0V

( ): Wire color

# TROUBLE DIAGNOSIS

## CONSULT-II Function (AIR LEVELIZER)

EES001ES

CONSULT-II can display each diagnostic item using the diagnostic test modes shown following.

AIR LEVELIZER diagnostic mode	Description
WORK SUPPORT	Supports inspections and adjustments. Commands are transmitted to the suspension control unit for setting the status suitable for required operation, input/output signals are received from the suspension control unit and received data is displayed.
SELF-DIAG RESULTS	Displays suspension control unit self-diagnosis results.
DATA MONITOR	Displays suspension control unit input/output data in real time.
ACTIVE TEST	Operation of electrical loads can be checked by sending drive signal to them.
ECU PART NUMBER	Suspension control unit part number can be read.

### CONSULT-II BASIC OPERATION PROCEDURE

#### CAUTION:

If CONSULT-II is used with no connection of CONSULT-II CONVERTER, malfunctions might be detected in self-diagnosis depending on control unit which carries out CAN communication.

1. Turn ignition switch OFF.
2. Connect CONSULT-II and CONSULT-II CONVERTER to the data link connector.
3. Turn ignition switch ON.

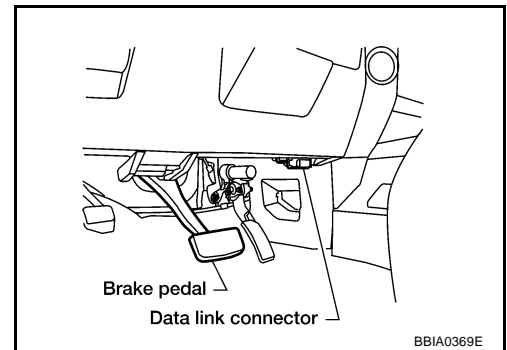

4. Touch "START (NISSAN BASED VHCL)".

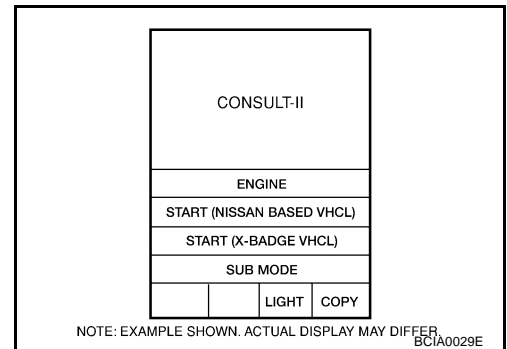

5. Touch "AIR LEVELIZER" in the "SELECT SYSTEM" screen. If "AIR LEVELIZER" is not indicated, go to [GI-39, "CONSULT-II Data Link Connector \(DLC\) Circuit"](#).

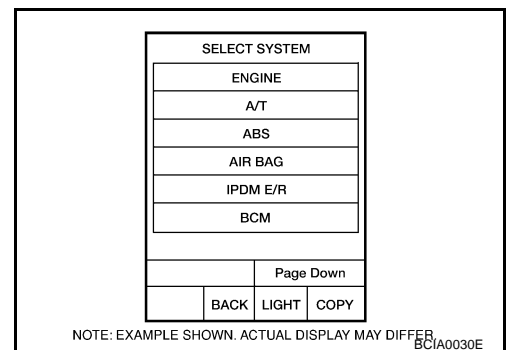

# TROUBLE DIAGNOSIS

6. Select the required operation from the "SELECT DIAG MODE" screen.  
For further information, see the CONSULT-II Operation Manual.

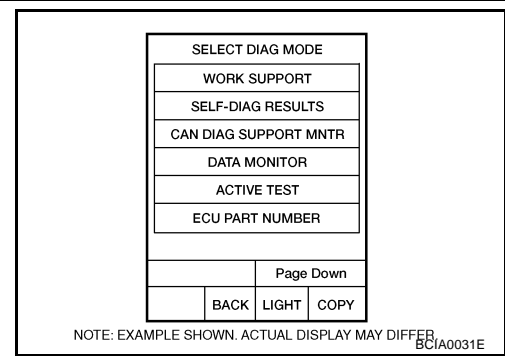

## WORK SUPPORT

### Operation Procedure

1. Touch "AIR LEVELIZER" on "SELECT SYSTEM" screen.
2. Touch "WORK SUPPORT" on "SELECT DIAG MODE" screen.
3. Touch item on "SELECT WORK ITEM" screen.
4. Touch "START".
5. The setting will be changed and "ADJUSTMENT COMPLETE" will be displayed.
6. Touch "END".

### Display Item List

Item	Description
STANDARD HEIGHT LEVEL	This mode allows the vehicle height to be set to vehicle height specification within tolerance.
ADJUST HEIGHT INI	The initialization value and flag can be set in the suspension control unit in this mode.
CLEAR HEIGHT INI	This mode clears the initialization flag and value in the suspension control unit.

## SELF-DIAGNOSIS

### Description

If an error is detected in the system, perform self-diagnosis as follows:

### Operation Procedure

1. Turn ignition switch OFF.
2. Connect CONSULT-II and CONSULT-II CONVERTER to the data link connector.
 

**CAUTION:**  
If CONSULT-II is used with no connection of CONSULT-II CONVERTER, malfunctions might be detected in self-diagnosis depending on control unit which carries out CAN communication.
3. Turn ignition switch ON.
4. After stopping the vehicle, with the engine running, touch "START (NISSAN BASED VHCL)", "AIR LEVELIZER", "SELF-DIAG RESULTS" in order on the CONSULT-II screen.
 

**CAUTION:**  
If "START (NISSAN BASED VHCL)" is touched immediately after starting the engine or turning on the ignition switch, "AIR LEVELIZER" might not be displayed in the "SELECT SYSTEM" screen. In this case, repeat the operation from step 1.
5. The self-diagnostic results are displayed. (If necessary, the self-diagnostic results can be printed out by touching "COPY".)
  - When "NO DTC IS DETECTED" is displayed, check the CK SUSP indicator lamp.
6. Conduct the appropriate inspection from the display item list, and repair or replace the malfunctioning component.
7. Start and run the vehicle for approximately 1 minute.
8. Turn ignition switch OFF to prepare for erasing the memory.
9. Start the engine and touch "START (NISSAN BASED VHCL)", "AIR LEVELIZER", "SELF-DIAG RESULTS", "ERASE MEMORY" in order on the CONSULT-II screen to erase the error memory.  
If "AIR LEVELIZER" is not indicated, go to [GI-39, "CONSULT-II Data Link Connector \(DLC\) Circuit"](#).

# TROUBLE DIAGNOSIS

## CAUTION:

If the error memory is not erased, re-conduct the operation from step 7.

- For the final inspection, start and run the vehicle for approximately 1 minute and confirm that the CK SUSP indicator lamp is off.

## Display Item List

Self-diagnostic item	Malfunction detecting condition	Check system
Vehicle height sensor [C1801]	Vehicle height sensor voltage is less than 0.2V or greater than 4.8V for more than 60 seconds.	Refer to <a href="#">RSU-17, "Height Sensor System Inspection"</a> .
Compressor relay [C1802]	<ol style="list-style-type: none"> <li>Driving transistor for compressor relay is off and monitor voltage continues high level for more than 10 seconds.</li> <li>Driving transistor for compressor relay is on and monitor voltage continues low level for more than 5 seconds.</li> </ol>	Refer to <a href="#">RSU-20, "Compressor Motor, Compressor Motor Relay and Circuit Inspection"</a> .
Exhaust solenoid [C1803]	<ol style="list-style-type: none"> <li>Driving transistor for exhaust solenoid is off and monitor voltage continues high level for more than 10 seconds.</li> <li>Driving transistor for exhaust solenoid is on and monitor voltage continues low level for more than 5 seconds.</li> </ol>	Refer to <a href="#">RSU-19, "Exhaust Valve Solenoid System Inspection"</a> .
Vehicle height adjusting trouble (compressor) [C1804]	Continuous compressor relay ON time is more than 120 seconds.	Refer to <a href="#">RSU-20, "Compressor Motor, Compressor Motor Relay and Circuit Inspection"</a> .
Vehicle height adjusting trouble (exhaust solenoid) [C1805]	Continuous exhaust solenoid ON time is more than 120 seconds.	Refer to <a href="#">RSU-19, "Exhaust Valve Solenoid System Inspection"</a> .
Vehicle height sensor locking trouble [C1806]	Output sensor voltage variation $\pm 0.02V$ is more than 100 hour when vehicle height range is normal.	Refer to <a href="#">RSU-17, "Height Sensor System Inspection"</a> .
Sensor 5V trouble [C1807]	Sensor reference voltage is less than 0.8V or more than 6V for 20 seconds.	Refer to <a href="#">RSU-17, "Height Sensor System Inspection"</a> .
Integral time trouble by supplying air [C1808]	Integral discontinuous time on the compressor is more than 180 seconds.	Refer to <a href="#">RSU-20, "Compressor Motor, Compressor Motor Relay and Circuit Inspection"</a> .

## DATA MONITOR

### Operation Procedure

- After turning OFF the ignition switch, connect CONSULT-II and the CONSULT-II CONVERTER to the data link connector.

## CAUTION:

If CONSULT-II is used with no connection of CONSULT-II CONVERTER, malfunctions might be detected in self-diagnosis depending on control unit which carries out CAN communication.

- Touch "START (NISSAN BASED VHCL)", "AIR LEVELIZER", "DATA MONITOR" in order on the CONSULT-II screen.  
If "AIR LEVELIZER" is not indicated, go to [GI-39, "CONSULT-II Data Link Connector \(DLC\) Circuit"](#).

## CAUTION:

When "START (NISSAN BASED VHCL)" is touched immediately after starting the engine or turning on the ignition switch, "AIR LEVELIZER" might not be displayed in the "SELECT SYSTEM" screen. In this case, repeat the operation from step 2.

- Return to the "SELECT MONITOR ITEM" screen, and touch "ALL ITEMS" or "SELECTION FROM MENU". Refer to the following information.
- When "START" is touched, the data monitor screen is displayed.

# TROUBLE DIAGNOSIS

## Display Item List

Test Item	Data monitor item selection	
	ALL SIGNALS	SELECTION FROM MENU
HEIGT SEN	X	X
HEIGT CALC	X	X
SEN FIX TIME	X	X
HEIGT INI VAL	X	X
COMPRESSOR	X	X
EXH SOLENOID	X	X
ACG L	X	X

X: Applicable

–: Not applicable

## ACTIVE TEST

### CAUTION:

- Do not perform active test while driving.

## Operation Procedure

1. Connect the CONSULT-II and CONSULT-II CONVERTER to the data link connector and start the engine.

### CAUTION:

If CONSULT-II is used with no connection of CONSULT-II CONVERTER, malfunctions might be detected in self-diagnosis depending on control unit which carries out CAN communication.

2. Touch "START (NISSAN BASED VHCL)" on the display screen.
3. Touch "AIR LEVELIZER".  
If "AIR LEVELIZER" is not indicated, go to [GI-39, "CONSULT-II Data Link Connector \(DLC\) Circuit"](#) .
4. Touch "ACTIVE TEST".
5. The "SELECT TEST ITEM" screen is displayed.
6. Touch necessary test item.
7. With the "MAIN SIGNALS" display highlighted, touch "START".
8. The active test screen will be displayed.

## Display Item List

Test Item	Description
COMPRESSOR	OFF/ON
EXHAUST SOLENOID	OFF/ON
WARNING LAMP	OFF/ON

### CAUTION:

The "COMPRESSOR" active test will remain ON until it is turned off using CONSULT-II. Allowing the compressor to run for an extended period of time may cause damage to air suspension system components due to excessive pressure in the air suspension system.

### NOTE:

- "TEST IS STOPPED" is displayed approximately 10 seconds after operation starts for all active test items except "COMPRESSOR".
- After "TEST IS STOPPED" is displayed, to perform test again, repeat Step 6.



# TROUBLE DIAGNOSIS FOR SELF-DIAGNOSTIC ITEMS

## TROUBLE DIAGNOSIS FOR SELF-DIAGNOSTIC ITEMS

PDF:00000

### Height Sensor System Inspection

EES001ET

#### INSPECTION PROCEDURE

#### 1. SELF-DIAGNOSIS RESULT CHECK

Check self-diagnosis results.

Self-diagnosis results
C1801
C1806
C1807

Is the above displayed in the self-diagnosis display items?

YES >> GO TO 3.

NO >> GO TO 2.

#### 2. DATA MONITOR CHECK

Conduct data monitor of "HEIGT SEN" to check if the status is normal.

HEIGT SEN	0.2V - 4.8V
-----------	-------------

OK or NG

OK >> Inspection End.

NG >> GO TO 3.

#### 3. CONNECTOR INSPECTION

1. Turn ignition switch OFF.
2. Disconnect suspension control unit connector B3 and height sensor C8.
3. Check the terminals for deformation, disconnection, looseness or damage.

OK or NG

OK >> GO TO 4.

NG >> Repair or replace as necessary.

A

B

C

D

RSU

F

G

H

I

J

K

L

M

# TROUBLE DIAGNOSIS FOR SELF-DIAGNOSTIC ITEMS

## 4. CHECK HEIGHT SENSOR POWER AND GROUND

1. Reconnect the suspension control unit connector.
2. Turn the ignition switch ON.
3. Check voltage between height sensor connector C8 terminal 1 (R) and ground.

**Voltage** : **Approx. 5V**

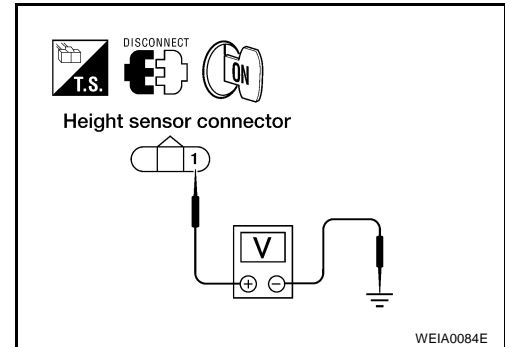

4. Turn ignition switch OFF.
5. Check resistance between height sensor connector C8 terminal 3 (L) and ground.

**Continuity should exist.**

OK or NG

OK >> GO TO 5.

NG >> Repair the circuit.

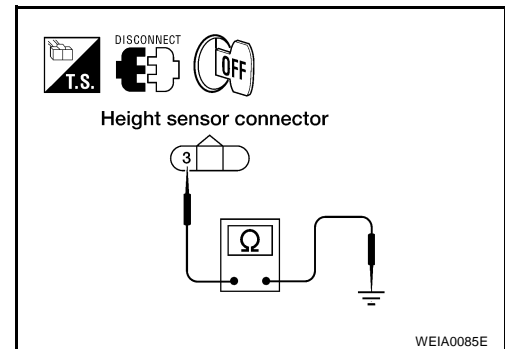

## 5. CHECK HEIGHT SENSOR SIGNAL CIRCUIT

1. Disconnect the suspension control unit connector.
2. Check resistance between height sensor connector C8 terminal 2 (W) and suspension control unit connector B3 terminal 3 (W).

**Continuity should exist.**

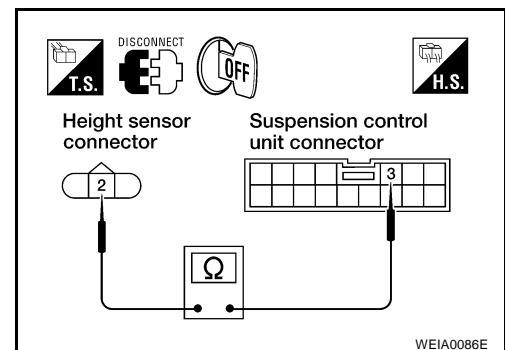

3. Check resistance between height sensor connector C8 terminal 2 (W) and ground.

**Continuity should not exist.**

OK or NG

OK >> Replace the height sensor. Refer to [RSU-44, "HEIGHT SENSOR"](#).

NG >> Repair the circuit.

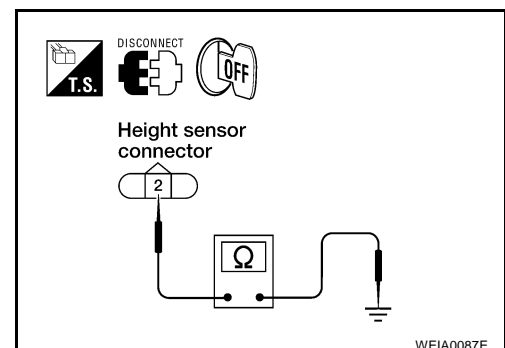

# TROUBLE DIAGNOSIS FOR SELF-DIAGNOSTIC ITEMS

EES001EU

## Exhaust Valve Solenoid System Inspection

### INSPECTION PROCEDURE

#### 1. SELF-DIAGNOSIS RESULT CHECK

Check self-diagnosis results.

Self-diagnosis results
C1803
C1805

Is the above displayed in the self-diagnosis display items?

- YES >> If code C1803 was retrieved during self-diagnosis, GO TO 3. If code C1805 was retrieved during self-diagnosis, GO TO 2.
- NO >> Inspection End.

#### 2. CHECK SYSTEM OPERATION

1. Load vehicle to standard laden condition (with driver, front passenger, 2 passengers in second row seats and no cargo).
2. Conduct active test of "COMPRESSOR" to raise vehicle ride height to +20mm.

**CAUTION:**

The "COMPRESSOR" active test will remain ON until it is turned off using CONSULT-II. Allowing the compressor to run for an extended period of time may cause damage to air suspension system components due to excessive pressure in the air suspension system.

3. Return the rear load leveling air suspension system to normal operating mode.
4. Check self-diagnostic results.

Is code C1805 displayed again?

- YES >> GO TO 3.
- NO >> Inspection End.

#### 3. CONNECTOR INSPECTION

1. Disconnect suspension control unit connector B3 and suspension air compressor C9.
2. Check the terminals for deformation, disconnection, looseness or damage.

OK or NG

- OK >> If code C1805 was retrieved during self-diagnosis, GO TO 4. If code C1803 was retrieved during self-diagnosis, GO TO 6.
- NG >> Repair or replace as necessary.

#### 4. AIR HOSE INSPECTION

Inspect for pinched or damaged air hoses between the suspension air reservoir and each load leveling rear air suspension shock absorber.

OK or NG

- OK >> GO TO 5.
- NG >> Repair or replace as necessary.

A  
B  
C  
D  
RSU  
F  
G  
H  
I  
J  
K  
L  
M

# TROUBLE DIAGNOSIS FOR SELF-DIAGNOSTIC ITEMS

## 5. EXHAUST VALVE SOLENOID INSPECTION

Apply 12V to suspension air compressor C9 terminal 2 and body ground to suspension air compressor C9 terminal 1.

**System air pressure should vent.**

OK or NG

OK >> GO TO 6.

NG >> Replace the suspension air compressor. Refer to [RSU-42. "REAR LOAD LEVELING AIR SUSPENSION COMPRESSOR ASSEMBLY"](#).

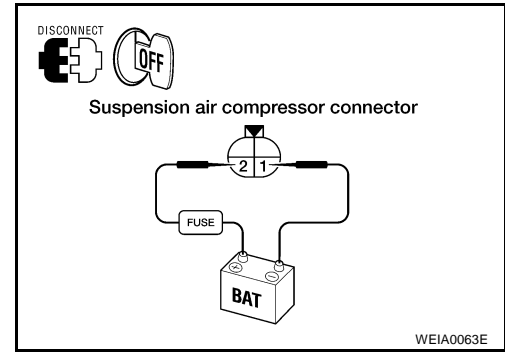

## 6. CHECK EXHAUST VALVE SOLENOID POWER AND GROUND

1. Reconnect the suspension control unit connector.
2. Turn the ignition switch ON.
3. Check voltage between suspension air compressor connector C9 terminal 2 (SB) and ground.

**Voltage : Approx. 12V**

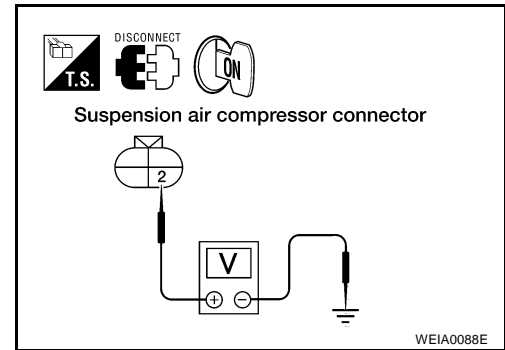

4. Check resistance between suspension air compressor connector C9 terminal 1 (B) and ground.

**Continuity should exist.**

OK or NG

OK >> Replace the suspension control unit. Refer to [RSU-46. "CONTROL UNIT"](#).

NG >> Repair the circuit.

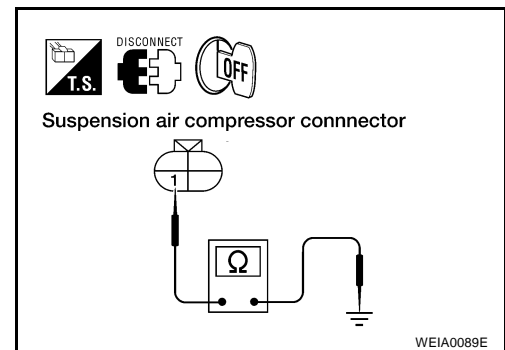

## Compressor Motor, Compressor Motor Relay and Circuit Inspection

EES001EV

### INSPECTION PROCEDURE

#### 1. SELF-DIAGNOSIS RESULT CHECK

Check self-diagnosis results.

Self-diagnosis results
C1802
C1804
C1808

Is the above displayed in the self-diagnosis display items?

YES >> If code C1802 was retrieved during self-diagnosis, GO TO 3. If code C1804 or C1808 was retrieved during self-diagnosis, GO TO 2.

NO >> Inspection End.

# TROUBLE DIAGNOSIS FOR SELF-DIAGNOSTIC ITEMS

## 2. CHECK SYSTEM OPERATION

1. Load vehicle to standard laden condition (with driver, front passenger, 2 passengers in second row seats and no cargo).
2. Conduct active test of "EXHAUST SOLENOID" to lower vehicle ride height to -20mm.
3. Return the rear load leveling air suspension system to normal operating mode.
4. Check self-diagnostic results.

Is code C1804 or C1808 displayed again?

YES >> GO TO 3.

NO >> Inspection End.

## 3. CONNECTOR INSPECTION

1. Disconnect suspension control unit connector B3 and suspension air compressor C9.
2. Check the terminals for deformation, disconnection, looseness or damage.

OK or NG

OK >> If code C1804 or C1808 was retrieved during self-diagnosis, GO TO 4. If code C1802 was retrieved during self-diagnosis, GO TO 6.

NG >> Repair or replace as necessary.

## 4. AIR HOSE INSPECTION

Inspect for pinched or damaged air hoses between the suspension air reservoir and each load leveling rear air suspension shock absorber.

OK or NG

OK >> GO TO 5.

NG >> Repair or replace as necessary.

## 5. SUSPENSION AIR COMPRESSOR INSPECTION

Apply 12V to suspension air compressor C9 terminal 2 and body ground to suspension air compressor C9 terminal 1.

**System air pressure should vent.**

OK or NG

OK >> GO TO 6.

NG >> Replace the suspension air compressor. Refer to [RSU-42. "REAR LOAD LEVELING AIR SUSPENSION COMPRESSOR ASSEMBLY"](#).

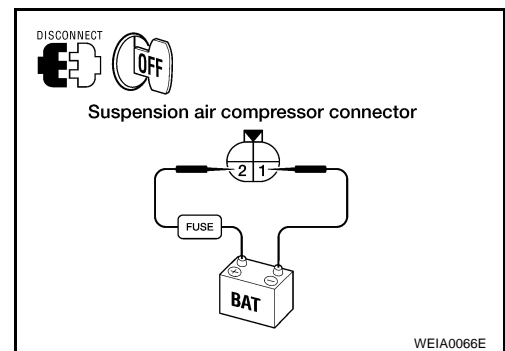

# TROUBLE DIAGNOSIS FOR SELF-DIAGNOSTIC ITEMS

## 6. CHECK SUSPENSION AIR COMPRESSOR POWER AND GROUND

1. Connect suspension control unit connector B3.
2. Turn the ignition switch ON.
3. Check voltage between suspension air compressor connector C9 terminal 2 (SB) and ground.

**Voltage** : **Approx. 12V**

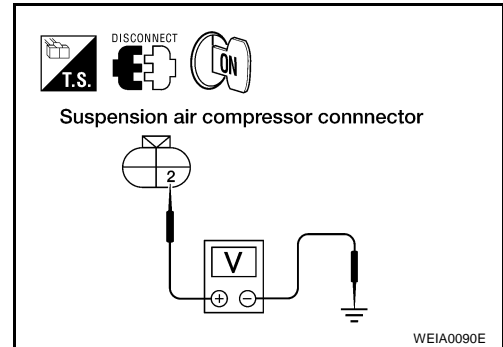

4. Check resistance between suspension air compressor connector C9 terminal 1 (B) and ground.

**Continuity should exist.**

### OK or NG

- OK >> Replace the suspension control unit. Refer to [RSU-46](#).  
**"CONTROL UNIT"**.
- NG >> Repair the circuit.

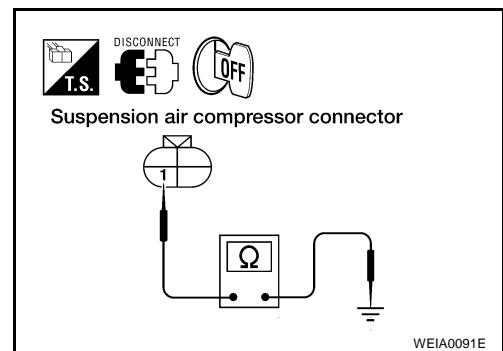

# TROUBLE DIAGNOSES FOR SYMPTOMS

PF9:99999

## TROUBLE DIAGNOSES FOR SYMPTOMS

### Load Leveling Rear Air Suspension System Does Not Operate

EES001EW

#### 1. CHECK WARNING LAMP ACTIVATION

Make sure warning lamp remains off while driving.

OK or NG

OK >> GO TO 2.

NG >> Carry out self-diagnosis. Refer to [RSU-14, "SELF-DIAGNOSIS"](#) .

#### 2. CHECK FUSES

Check that the following fuses are not blown.

Unit	Terminals	Signal name	Fuse or Fusible Link
Suspension control unit	6	Ignition switch ON or START	12 (10A)
	7	Battery power	29 (10A)
Compressor motor relay	5		g (30A)
Combination meter	24	Ignition switch ON or START	14 (10A)
	8	Battery power	19 (10A)

OK or NG

OK >> GO TO 3.

NG >> If fuse is blown, be sure to eliminate cause of blown fuse before installing new fuse. Refer to [PG-4, "POWER SUPPLY ROUTING CIRCUIT"](#) .

#### 3. CHECK SUSPENSION CONTROL UNIT POWER AND GROUND

- Turn the ignition switch ON.
- Check voltage between suspension control unit connector B3 terminal 6 (G/R) and ground and between suspension control unit connector B3 terminal 7 (W/L) and ground.

**Voltage : Approx. 12V**

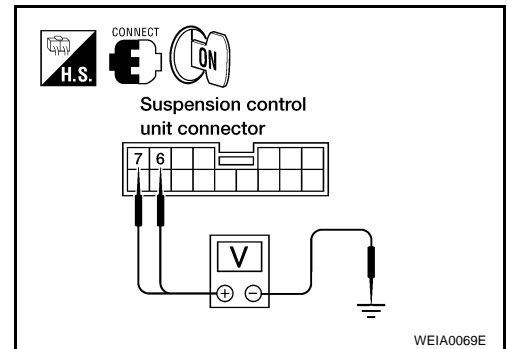

- Check resistance between suspension control unit connector B3 terminal 16 (B) and ground.

**Continuity should exist.**

OK or NG

OK >> GO TO 4.

NG >> Repair the circuit.

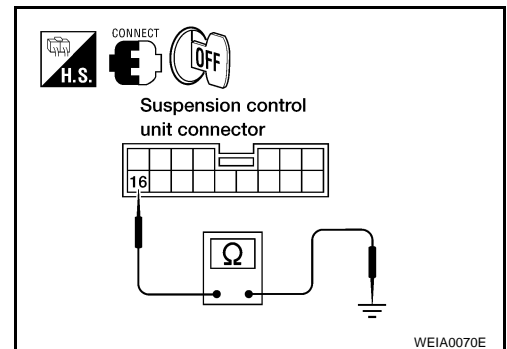

# TROUBLE DIAGNOSES FOR SYMPTOMS

## 4. CHECK GENERATOR SIGNAL INPUT

1. Start the engine.
2. Check voltage between suspension control unit connector B3 terminal 15 (BR/W) and ground.

**Voltage** : **Approx. 12V**

OK or NG

- OK >> Replace the suspension control unit. Refer to [RSU-46, "CONTROL UNIT"](#).
- NG >> Repair the circuit.

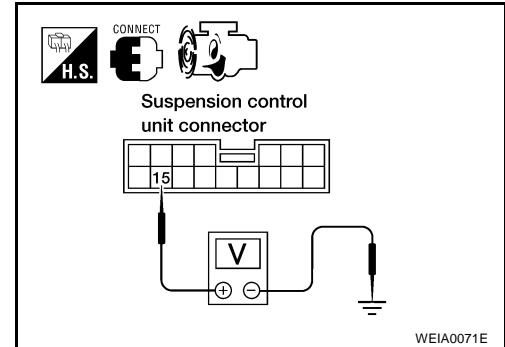

## CK SUSP Indicator Lamp Stays On When Ignition Switch Is Turned On

EES001EX

### 1. CARRY OUT SELF-DIAGNOSIS

Carry out self-diagnosis. Refer to [RSU-14, "SELF-DIAGNOSIS"](#).

Are malfunctions detected in self-diagnosis?

- YES >> Refer to [RSU-15, "Display Item List"](#).
- NO >> Refer to [DI-30, "WARNING LAMPS"](#).



# REAR SUSPENSION ASSEMBLY

## REAR SUSPENSION ASSEMBLY

### Components

PFP:55020

EES001EY

### Rear Suspension Without Rear Load Leveling Air Suspension System

SEC. 431 • 432

A  
B  
C  
D  
RSU  
F  
G  
H  
I  
J  
K  
L  
M

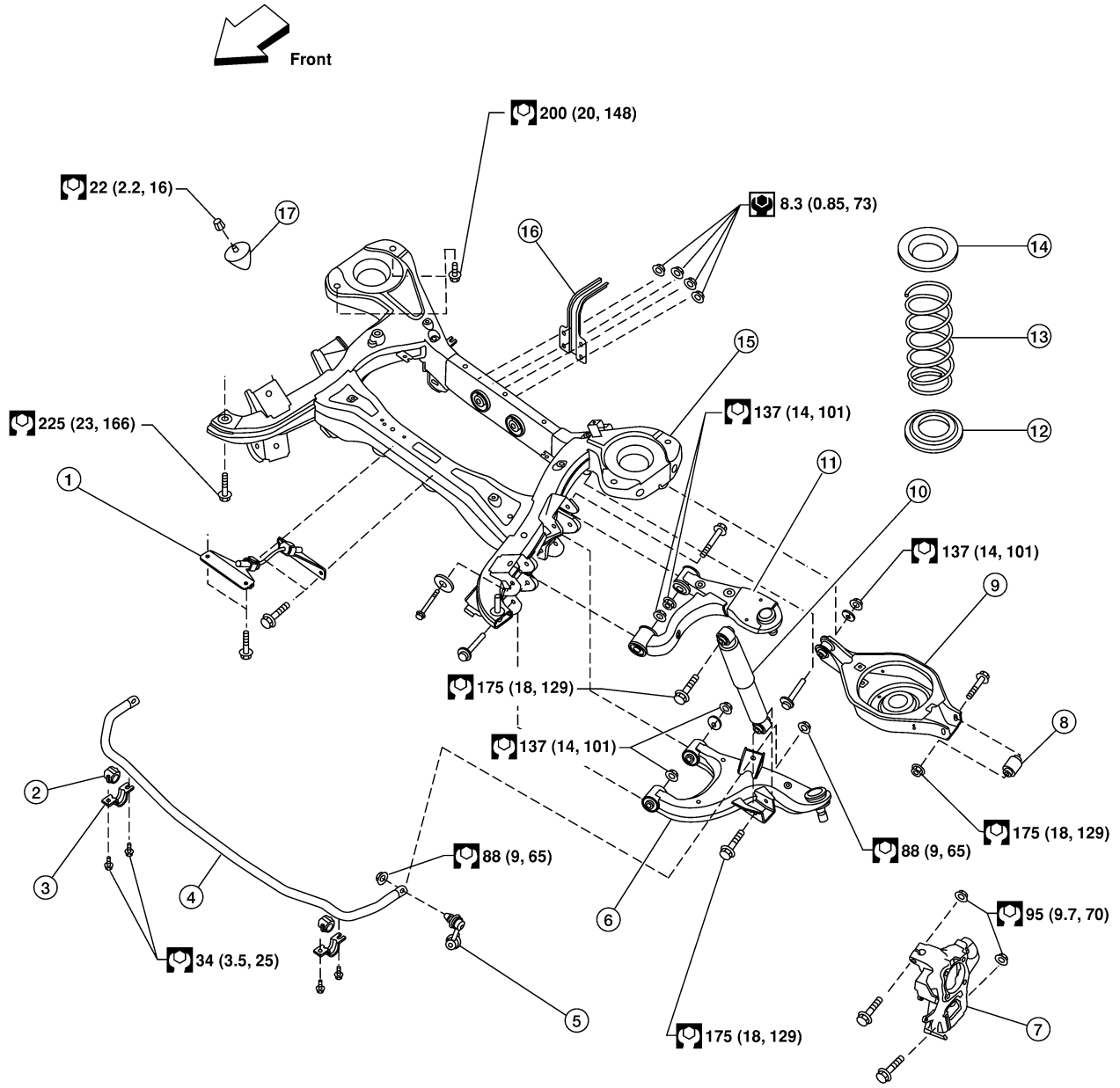

N·m (kg-m, in-lb)

N·m (kg-m, ft-lb)

WEIA0092E

# REAR SUSPENSION ASSEMBLY

- |                           |                           |                            |
|---------------------------|---------------------------|----------------------------|
| 1. Seat belt latch anchor | 2. Stabilizer bar bushing | 3. Stabilizer bar clamp    |
| 4. Stabilizer bar         | 5. Connecting rod         | 6. Front lower link        |
| 7. Knuckle                | 8. Bushing                | 9. Rear lower link         |
| 10. Shock absorber        | 11. Suspension arm        | 12. Lower rubber seat      |
| 13. Coil spring           | 14. Upper rubber seat     | 15. Rear suspension member |
| 16. Spare tire bracket    | 17. Bound bumper          |                            |

## Rear Load Leveling Air Suspension System

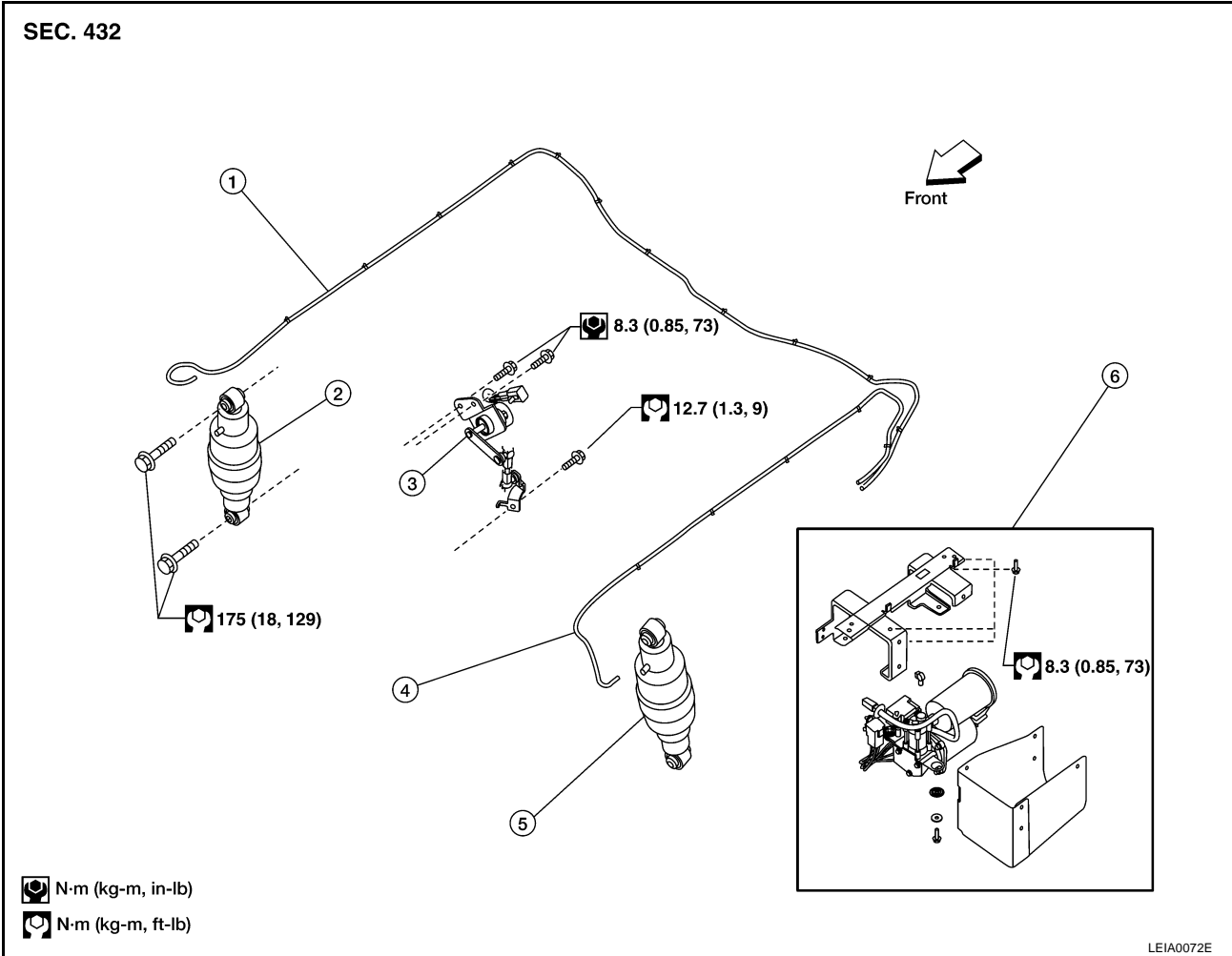

- |   |                       |  |
|---|-----------------------|--|
| 1. Rear load leveling air suspension hose, RH | 2. Shock absorber, RH | 3. Height sensor   |
| 4. Rear load leveling air suspension hose, LH | 5. Shock absorber, LH | 6. Rear load leveling air suspension compressor assembly |

## On-Vehicle Inspection and Service

EES001EZ

Check all of the component mountings for any excessive looseness, or back lash. Check the components for any excessive wear, damage, or abnormal conditions. Repair or replace the components as necessary.

### SHOCK ABSORBER INSPECTION (WITH AND WITHOUT THE AIR LEVELING SYSTEM)

- For vehicles without the rear load leveling air suspension system, check the shock absorbers for any oil leaks or damage, and replace as necessary.
- For vehicles with the rear load leveling air suspension system, check the shock absorbers for any air leaks or damage, and replace as necessary.
- For vehicles with the rear load leveling air suspension system, check the hoses for any air leaks or damage, and replace as necessary.

# REAR SUSPENSION ASSEMBLY

EES001F0

## Wheel Alignment Inspection

### Rear Wheel Alignment Adjusting Bolts

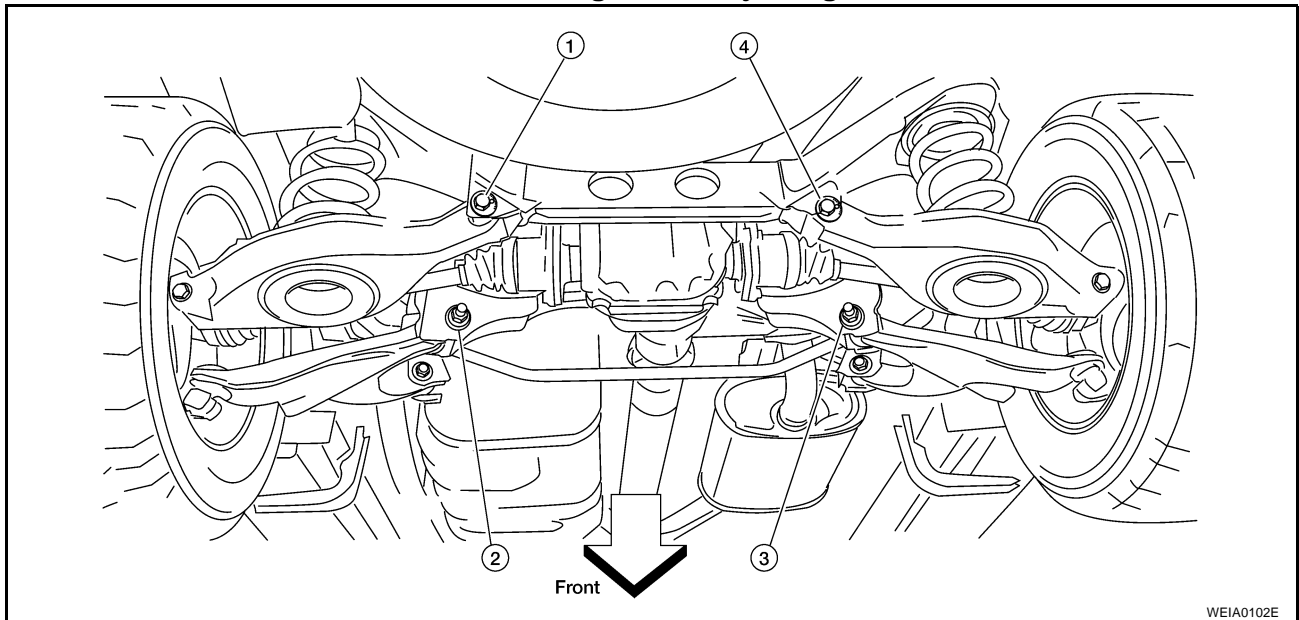

WEIA0102E

1. Rear lower link adjusting bolt, LH
2. Front lower link adjusting bolt, LH
3. Front lower link adjusting bolt, RH
4. Rear lower link adjusting bolt, RH

### PRELIMINARY INSPECTION

#### **WARNING:**

Always adjust the alignment with the vehicle on a flat surface. Use CONSULT-II "EXHAUST SOLENOID" active test to release the air pressure from the rear load leveling air suspension system.

#### **NOTE:**

If alignment is out of specification, inspect and replace any damaged or worn rear suspension parts before making any adjustments.

1. Check and adjust the wheel alignment with the vehicle under unladen conditions. "Unladen conditions" means that the fuel, coolant, and lubricant are full; and that the spare tire, jack, hand tools and mats are in their designated positions.
2. Check the tires for incorrect air pressure and excessive wear.
3. Check the wheels for runout and damage.
4. Check the wheel bearing axial end play.

**Axial end play : 0 mm (0 in)**

5. Check the shock absorbers. Refer to [RSU-26, "SHOCK ABSORBER INSPECTION \(WITH AND WITHOUT THE AIR LEVELING SYSTEM\)"](#).
6. Check each mounting point of the suspension components for any excessive looseness or damage.
7. Check each link, arm, and the rear suspension member for any damage.
8. Check the vehicle height. Refer to [RSU-48, "Wheelarch Height \(Unladen\\*1\)"](#).
  - If vehicle height is not within  $\pm 10$  mm (0.39 in) of the specification, perform the control unit initialization procedure. Refer to [RSU-46, "Initialization Procedure"](#).

### GENERAL INFORMATION AND RECOMMENDATIONS

1. A Four-Wheel Thrust Alignment should be performed.
  - This type of alignment is recommended for any NISSAN vehicle.
  - The four-wheel "thrust" process helps ensure that the vehicle is properly aligned and the steering wheel is centered.
  - The alignment machine itself should be capable of accepting any NISSAN vehicle.
  - The alignment machine should be checked to ensure that it is level.
2. Make sure the alignment machine is properly calibrated.

# REAR SUSPENSION ASSEMBLY

- Your alignment machine should be regularly calibrated in order to give correct information.
- Check with the manufacturer of your specific alignment machine for their recommended Service/Calibration Schedule.

## THE ALIGNMENT PROCESS

**IMPORTANT:** Use only the alignment specifications listed in this Service Manual. Refer to [RSU-47, "Wheel Alignment \(Unladen\\*<sup>1</sup>\)"](#)

1. When displaying the alignment settings, many alignment machines use "indicators": (Green/red, plus or minus, Go/No Go). **Do NOT use these indicators.**
  - The alignment specifications programmed into your alignment machine that operate these indicators may not be correct.
  - This may result in an ERROR.
2. Some newer alignment machines are equipped with an optional "Rolling Compensation" method to "compensate" the sensors (alignment targets or head units). **Do NOT use this "Rolling Compensation" method.**
  - Use the "Jacking Compensation" method. After installing the alignment targets or head units, raise the vehicle and rotate the wheels 1/2 turn both ways.
  - See Instructions in the alignment machine you are using for more information.

## CAMBER

1. Measure camber of both the right and left wheels with a suitable alignment gauge and adjust as necessary to specification.

**Camber** : Refer to [RSU-47, "Wheel Alignment \(Unladen\\*<sup>1</sup>\)"](#) .

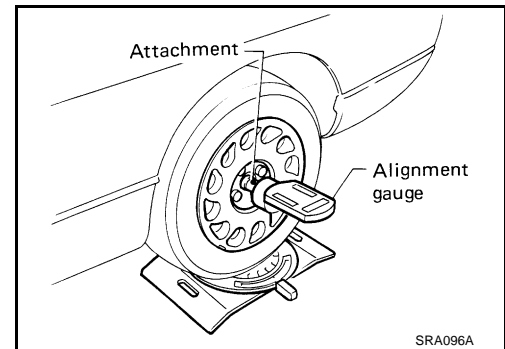

2. If outside of the specified value, adjust the camber using the adjusting bolt in the front lower link.

### CAUTION:

**After adjusting the camber then check the toe-in.**

### NOTE:

Camber changes about 0° 5' with each graduation of the adjusting bolt.

3. Tighten the adjusting bolt nuts to specification.

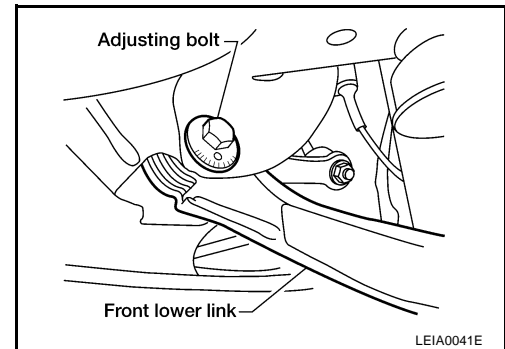

## TOE-IN

1. Bounce the rear of the vehicle up and down two to three times to stabilize the vehicle height. Refer to [RSU-48, "Wheelarch Height \(Unladen\\*<sup>1</sup>\)"](#) .
2. Push the vehicle straight ahead about 5 m (16 ft).

## REAR SUSPENSION ASSEMBLY

3. Put a mark on the base line of the tread (rear side) of both of the tires at the same height as the center of the hub. This will be the measuring points.
4. Measure the distance "A" (rear side) across from tire to tire.

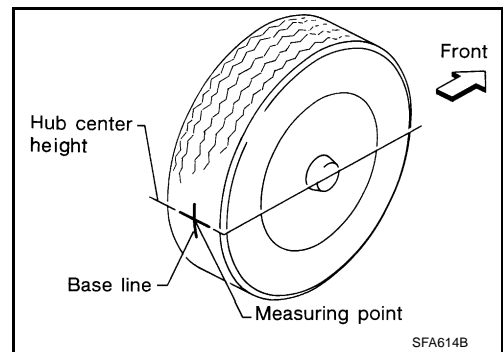

5. Push the vehicle slowly ahead to rotate the wheels 180° (a half turn).  
If the wheels are rotated more than 180° (a half turn), then repeat the above steps. Never push the vehicle backward.
6. Measure the distance "B" (front side) across from tire to tire.

**Total toe-in** : Refer to [RSU-47, "Wheel Alignment \(Unladen\\*1\)"](#) .

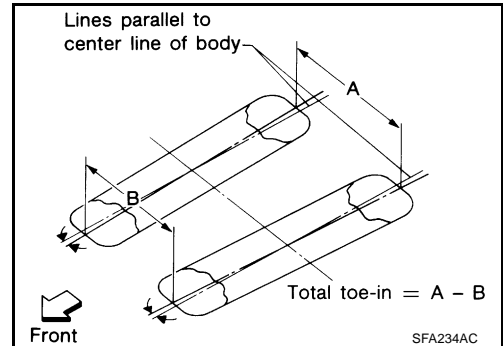

7. If the toe-in is outside the specified value, adjust the toe-in using the adjusting bolt in the rear lower link.

**CAUTION:**

**Be sure to adjust equally on RH and LH sides using the adjusting bolt.**

**NOTE:**

Toe changes about 1.5 mm (0.059 in) [one side] with each graduation of the adjusting bolt.

8. Tighten the adjusting bolt nuts to specification.

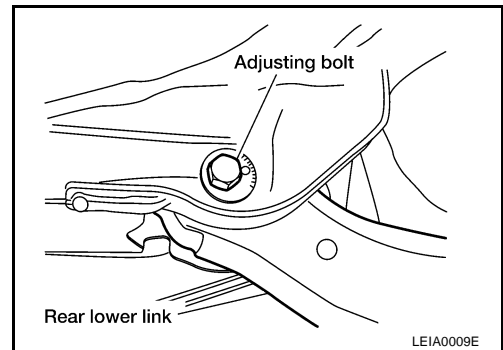

# REAR SUSPENSION MEMBER

## REAR SUSPENSION MEMBER

PFP:55501

### Removal and Installation

EES001F1

#### Rear Suspension Without Rear Load Leveling Air Suspension System

SEC. 431 • 432

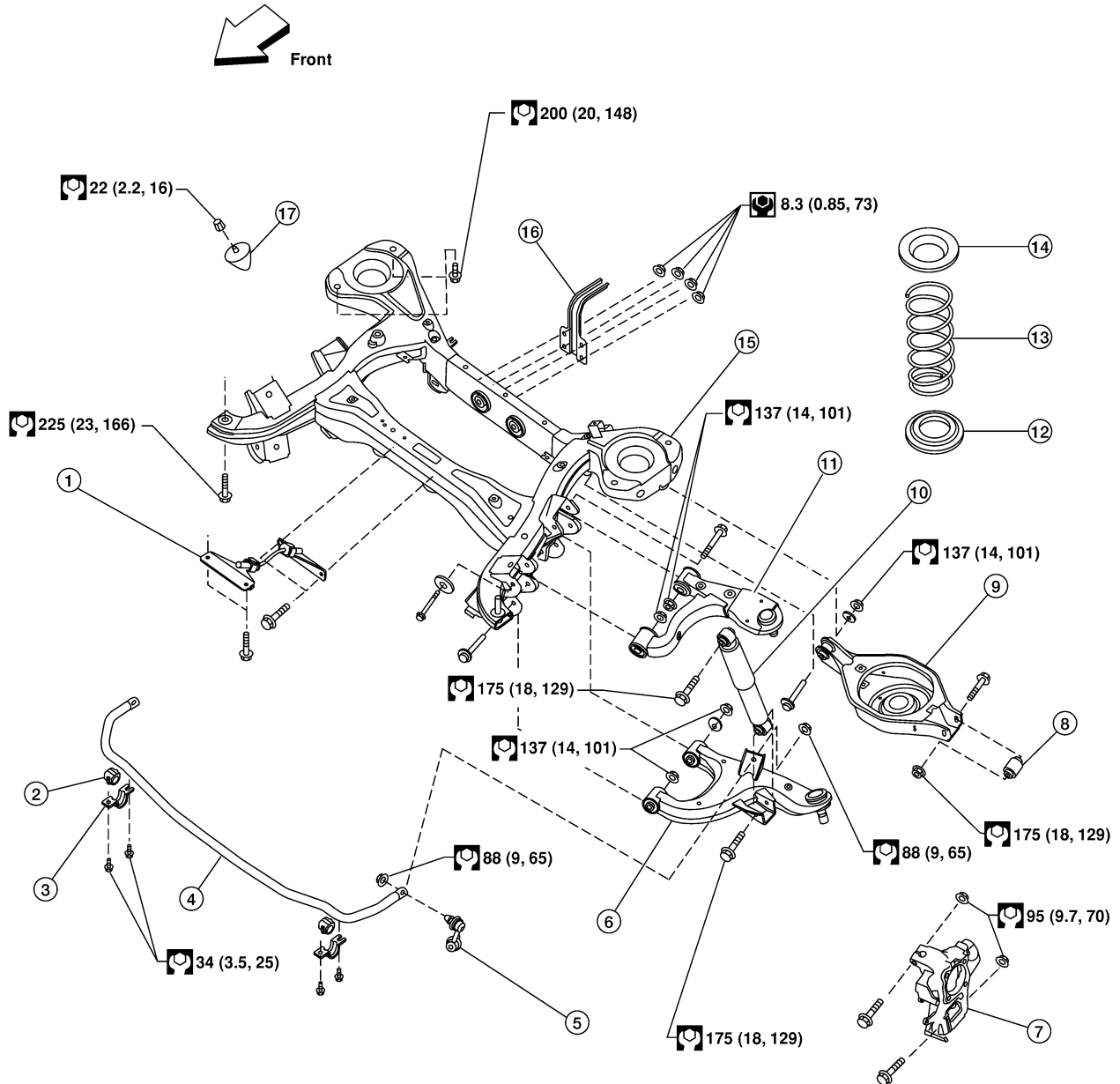

N·m (kg-m, in-lb)

N·m (kg-m, ft-lb)

WEIA0092E

# REAR SUSPENSION MEMBER

- |                           |                           |                            |
|---------------------------|---------------------------|----------------------------|
| 1. Seat belt latch anchor | 2. Stabilizer bar bushing | 3. Stabilizer bar clamp    |
| 4. Stabilizer bar         | 5. Connecting rod         | 6. Front lower link        |
| 7. Knuckle                | 8. Bushing                | 9. Rear lower link         |
| 10. Shock absorber        | 11. Suspension arm        | 12. Lower rubber seat      |
| 13. Coil spring           | 14. Upper rubber seat     | 15. Rear suspension member |
| 16. Spare tire bracket    | 17. Bound bumper          |                            |

## Rear Load Leveling Air Suspension System

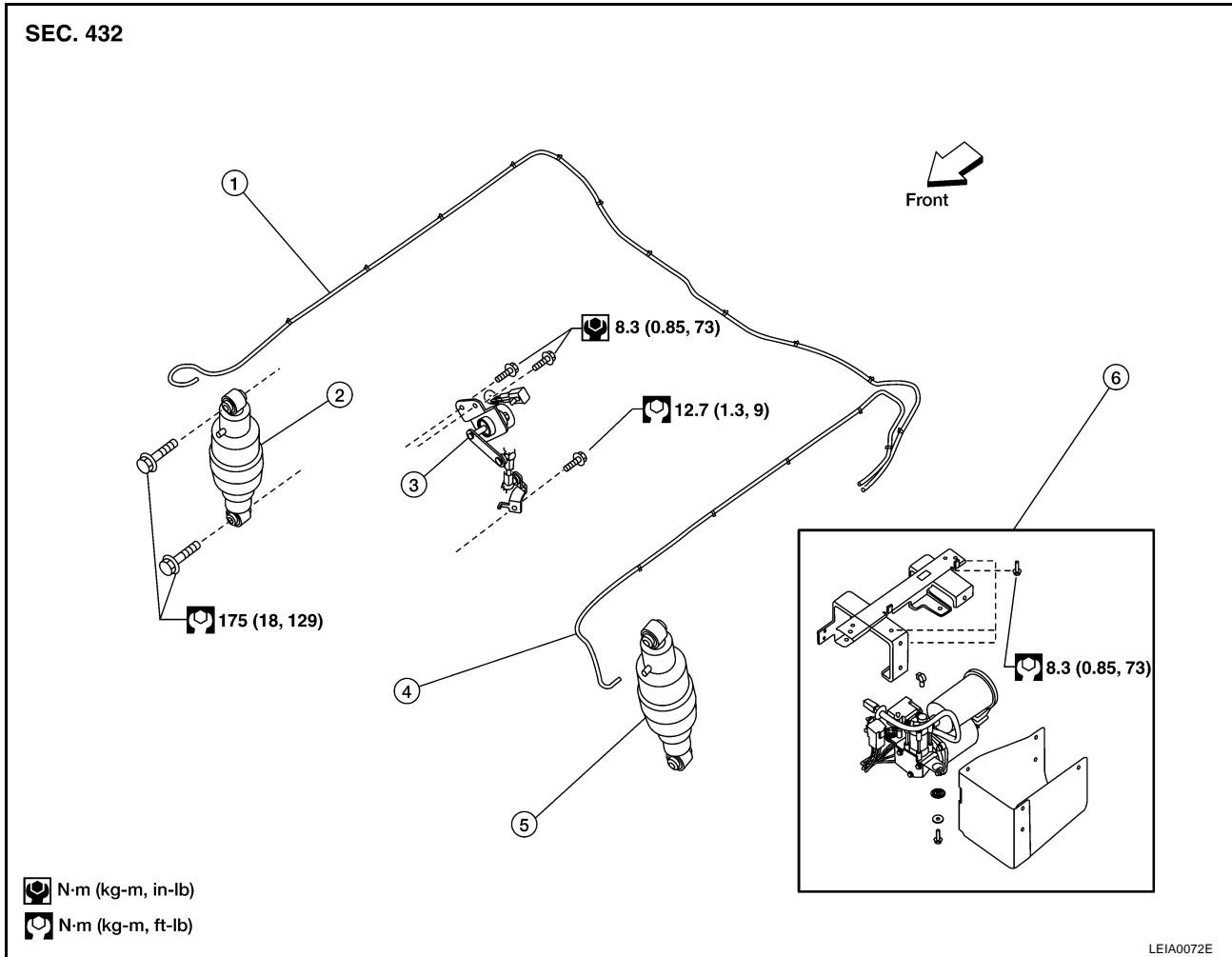

- |   |                       |  |
|---|-----------------------|--|
| 1. Rear load leveling air suspension hose, RH | 2. Shock absorber, RH | 3. Height sensor   |
| 4. Rear load leveling air suspension hose, LH | 5. Shock absorber, LH | 6. Rear load leveling air suspension compressor assembly (includes the bracket and rubber cover) |

### REMOVAL

1. If equipped with rear load leveling air suspension system, use CONSULT-II "EXHAUST SOLENOID" active test to release the air pressure from the rear load leveling air suspension system.
2. If equipped with the rear load leveling air suspension system, disconnect the electrical connectors for the height sensor and the rear load leveling air suspension compressor assembly.
3. If equipped with the rear load leveling air suspension system, unclip the rubber cover to access the rear load leveling air suspension compressor assembly.

## REAR SUSPENSION MEMBER

- If equipped with the rear load leveling air suspension system, disconnect the rear load leveling air suspension hoses at the rear load leveling air suspension compressor assembly.

- To disconnect the hoses, push in on the lock ring using a suitable tool and pull the hose out.

- Remove both of the rear wheel and tire assemblies using power tool.

- Remove the brake caliper without disconnecting the brake hoses, using power tool. Reposition the brake caliper out of the way using a suitable wire. Refer to [BR-27, "Removal and Installation of Brake Caliper and Disc Rotor"](#).

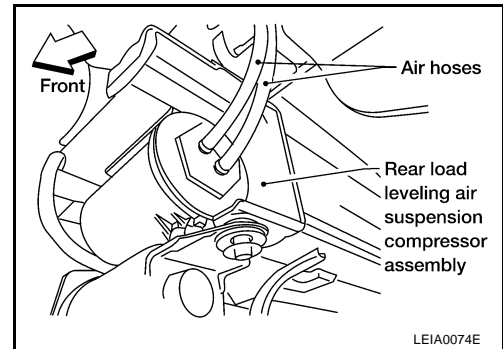

### CAUTION:

- Do not crimp or stretch the brake hose when repositioning the brake caliper out of the way.
- Do not press brake pedal while the brake caliper is removed.

- Remove the spare tire.

- Disconnect the two rear ABS sensor electrical connectors.

- Remove the two rear drive shafts. Refer to [RAX-7, "REAR DRIVE SHAFT"](#).

- Remove the rear final drive. Refer to [RFD-10, "REAR FINAL DRIVE ASSEMBLY"](#).

- Remove the EVAP canister bolt from the top of the rear suspension member.

- Disconnect the parking brake cables from the brackets on the rear suspension member.

- Set a suitable jack to support each of the rear lower links and the coil spring tension.

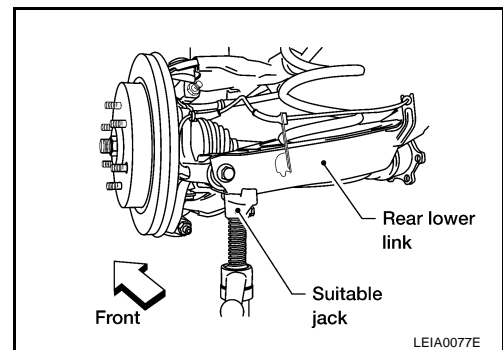

- Remove both of the rear lower link outer bolts and lower the jack to remove the rear coil springs.

- Remove the two bolts to disconnect the seat belt latch anchor from the rear suspension member.

- Disconnect both of the connecting rods from the rear stabilizer bar.

- Set a suitable jack under the rear suspension member.

- Remove the six rear suspension member bolts.

- Slowly lower the jack to remove the rear suspension member, suspension arm, front and rear lower links and stabilizer bar as an assembly.

- If necessary, remove the suspension arm, spare tire bracket, height sensor, rear load leveling air suspension hoses, stabilizer bar, and front and rear lower links from the rear suspension member.

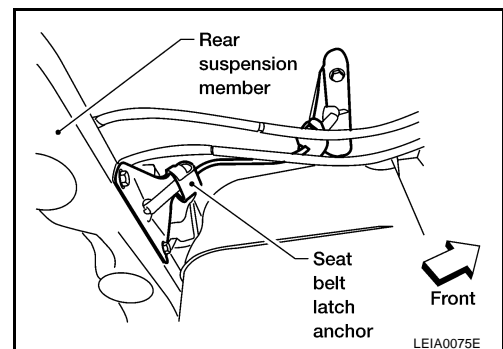

### INSPECTION AFTER REMOVAL

Check rear suspension member for deformation, cracks, and other damage and replace if necessary.



# REAR SUSPENSION MEMBER

## INSTALLATION

Installation is in the reverse order of removal.

- When raising the rear suspension member assembly, use the locating pins to align the rear suspension member to the vehicle body.

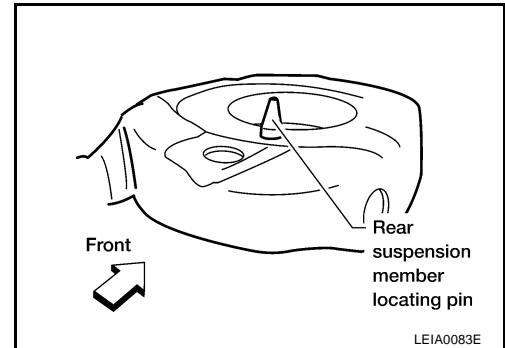

- When installing the upper and lower rubber seats for the rear coil springs, the arrow embossed on the rubber seats must point out toward the wheel and tire assembly.

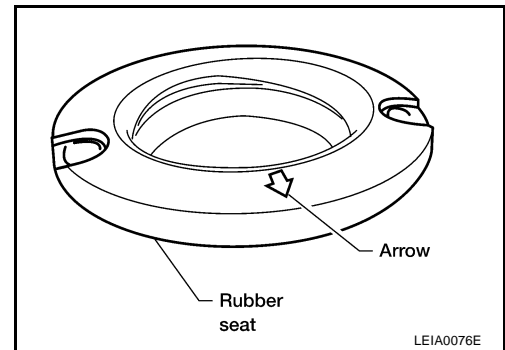

- To connect the rear load leveling air suspension hoses, the lock ring must be fully seated in the fitting. Insert the hose "B" into the lock ring "A" until the lock ring "A" is touching the hose "B" as shown. Pull on the hose to check that it is securely inserted.

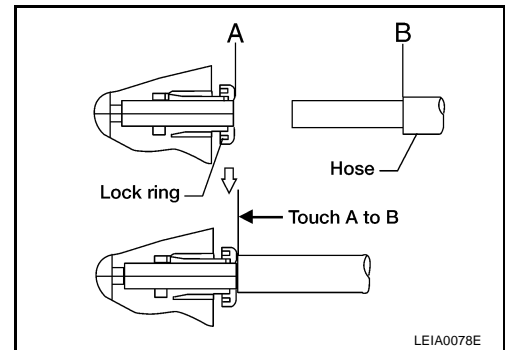

- Perform final tightening of nuts and bolts for the links (rubber bushing) under unladen condition (unladen condition means that the fuel tank, engine coolant and lubricants are at the full specification, and the spare tire, jack, hand tools, and mats are in their designated positions) with the tires on level ground.
- Check the wheel alignment. Refer to [RSU-27, "Wheel Alignment Inspection"](#).

# SHOCK ABSORBER

PFP:56210

## SHOCK ABSORBER

EES001F2

### Removal and Installation

#### REMOVAL

1. Remove the wheel and tire assembly using power tool. Refer to [WT-7, "Rotation"](#) .
2. If equipped with the rear load leveling air suspension system, use CONSULT-II "EXHAUST SOLENOID" active test to release the air pressure from the rear load leveling air suspension system.
3. If equipped with the rear load leveling air suspension system, disconnect the rear load leveling air suspension hose from the shock absorber.
  - To disconnect the hose, push in on the lock ring using a suitable tool and pull the air hose out.

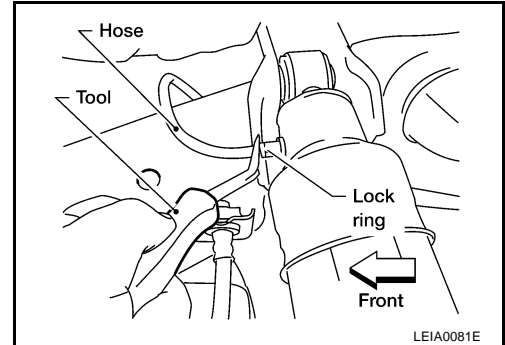

4. Remove the shock absorber upper and lower end bolts using power tool.
5. Remove the shock absorber.

#### **CAUTION:**

**If equipped with the rear load leveling air suspension system, do not damage the rubber boot on the shock absorber.**

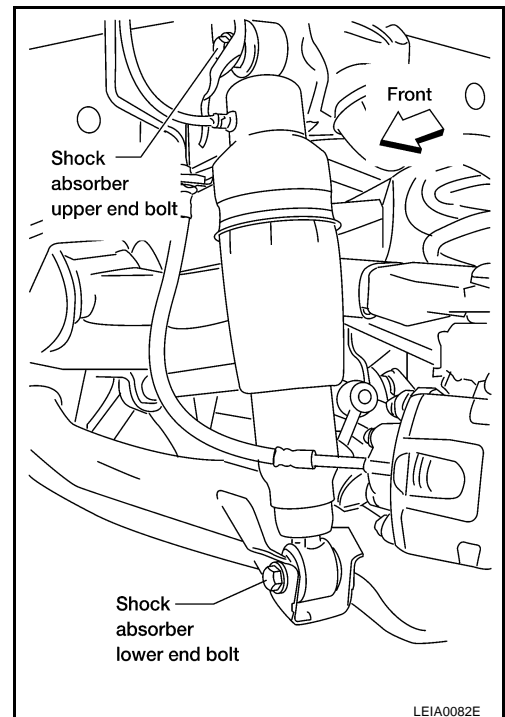

#### INSTALLATION

Installation is in the reverse order of removal.

- Tighten the shock absorber bolts to specification. Refer to [RSU-25, "Components"](#) .

#### Inspection

EES001F3

- Check for oil leakage on welded or gland packing portions.
- If equipped with the rear load leveling air suspension system, check the shock absorber for any air leaks or damage to the rubber boot.
- Check the shock absorber for smooth operation through a full stroke, both compression and extension.
- Check piston rod for cracks, deformation or other damage and replace if necessary.

# SUSPENSION ARM

PFP:55501

## SUSPENSION ARM

### Removal and Installation

EES001F4

1. Remove the rear suspension member assembly using power tool. Refer to [RSU-30, "REAR SUSPENSION MEMBER"](#).

#### NOTE:

It is necessary to remove the rear suspension member to remove the front upper bolt from the suspension arm.

2. Remove the shock absorber upper end bolt.
3. Remove the suspension arm upper nuts and bolts on the suspension member side using power tool.

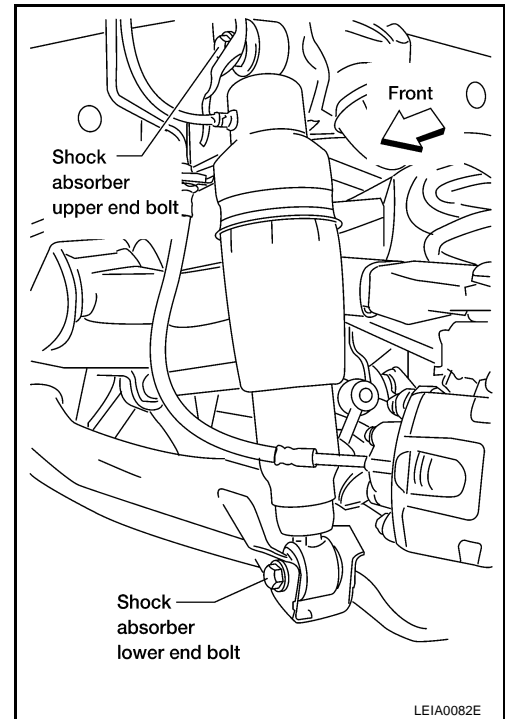

4. Remove the suspension arm pinch bolt and nut on the knuckle side using power tool.
5. Disconnect the suspension arm from the knuckle using a soft hammer.

#### CAUTION:

**Do not damage the ball joint with the soft hammer.**

6. Remove the suspension arm.

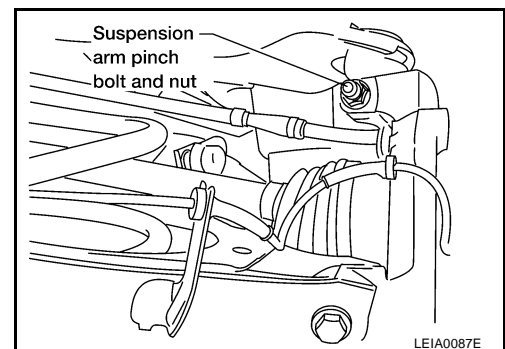

## INSTALLATION

Installation is in the reverse order of removal.

- Tighten the nuts and bolts to specification. Refer to [RSU-25, "Components"](#).
- Perform final tightening of nuts and bolts for the links (rubber bushing) under unladen condition (unladen condition means that the fuel tank, engine coolant and lubricants are at the full specification, and the spare tire, jack, hand tools, and mats are in their designated positions) with the tires on level ground.
- Check the wheel alignment. Refer to [RSU-27, "Wheel Alignment Inspection"](#).

# SUSPENSION ARM

EES001F5

## Inspection

- Check suspension arm for damage, cracks, deformation and replace if necessary.
- Check rubber bushing for damage, cracks and deformation. Replace suspension arm assembly if necessary.
- Check ball joint. Replace suspension arm assembly if any of the following exists:
  - Ball stud is worn.
  - Joint is hard to swing.
  - Play in axial direction is excessive.
- Before checking, turn ball joint at least 10 revolutions so that ball joint is properly broken in.

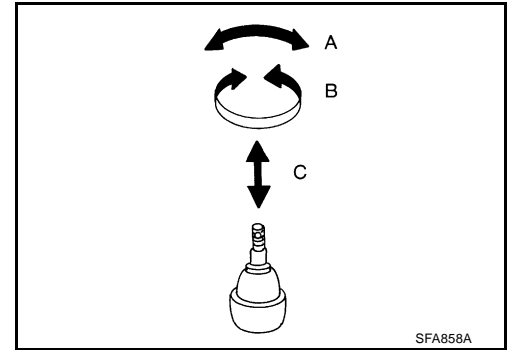

**Swinging force "A"** : Refer to [RSU-47, "Ball Joint"](#) .

**Turning force "B"** : Refer to [RSU-47, "Ball Joint"](#) .

**Vertical end play "C"** : Refer to [RSU-47, "Ball Joint"](#) .

# FRONT LOWER LINK

PF5:55110

EES001F6

## FRONT LOWER LINK

### Removal and Installation

#### REMOVAL

1. Remove the wheel and tire assembly using power tool.
2. If equipped with rear load leveling air suspension system, use CONSULT-II "EXHAUST SOLENOID" active test to release the air pressure from the rear load leveling air suspension system.
3. Remove the shock absorber lower end bolt.
4. Remove the adjusting bolt and nut, and the bolt and nut, from the front lower link and rear suspension member using power tool.

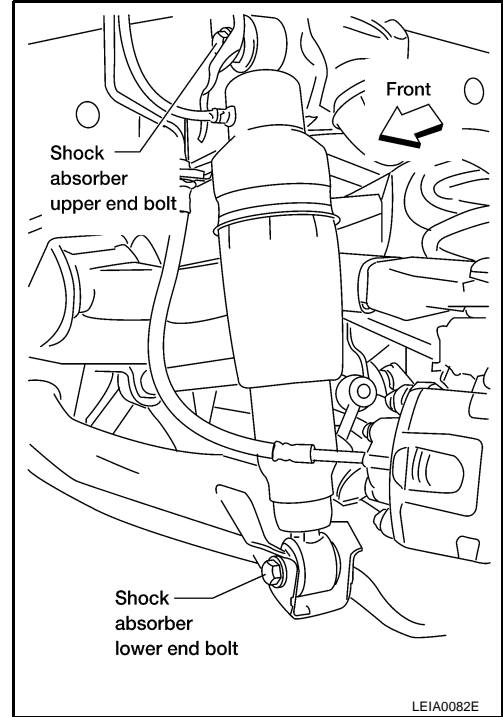

5. Remove the front lower link pinch bolt and nut on the knuckle side using power tool.
6. Disconnect the front lower link from the knuckle using a soft hammer.

#### **CAUTION:**

**Do not damage the ball joint with the soft hammer.**

7. Remove the front lower link.

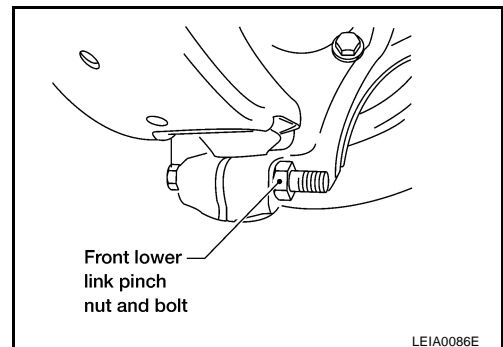

#### INSPECTION AFTER REMOVAL

- Check front lower link and bushing for any deformation, crack, or damage. Replace if necessary.

#### INSTALLATION

Installation is in the reverse order of removal.

- Tighten the nuts and bolts to specification. Refer to [RSU-25, "Components"](#).
- Perform final tightening of nuts and bolts for the links (rubber bushing) under unladen condition (unladen condition means that the fuel tank, engine coolant and lubricants are at the full specification, and the spare tire, jack, hand tools, and mats are in their designated positions) with the tires on level ground.
- Check the wheel alignment. Refer to [RSU-27, "Wheel Alignment Inspection"](#).

A  
B  
C  
D  
RSU  
F  
G  
H  
I  
J  
K  
L  
M

# FRONT LOWER LINK

EES001F7

## Inspection

- Check suspension arm for damage, cracks, deformation and replace if necessary.
- Check rubber bushing for damage, cracks and deformation. Replace suspension arm assembly if necessary.
- Check ball joint. Replace suspension arm assembly if any of the following exists:
  - Ball stud is worn.
  - Joint is hard to swing.
  - Play in axial direction is excessive.
- Before checking, turn ball joint at least 10 revolutions so that ball joint is properly broken in.

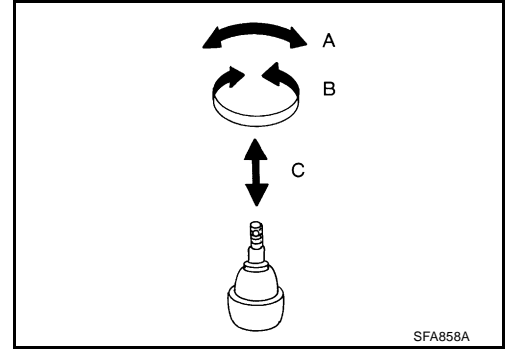

SFA858A

**Swinging force "A"** : Refer to [RSU-47, "Ball Joint"](#) .

**Turning force "B"** : Refer to [RSU-47, "Ball Joint"](#) .

**Vertical end play "C"** : Refer to [RSU-47, "Ball Joint"](#) .

# REAR LOWER LINK & COIL SPRING

## REAR LOWER LINK & COIL SPRING

PFP:551B0

### Removal and Installation REMOVAL

EES001F8

1. Remove the wheel and tire assembly using power tool. Refer to [WT-7, "Rotation"](#) .
2. If equipped with rear load leveling air suspension system, use CONSULT-II "EXHAUST SOLENOID" active test to release the air pressure from the rear load leveling air suspension system.
3. If equipped with the rear load leveling air suspension system, for removing the LH rear lower link and coil spring, remove the height sensor arm bracket bolt from the rear lower link.

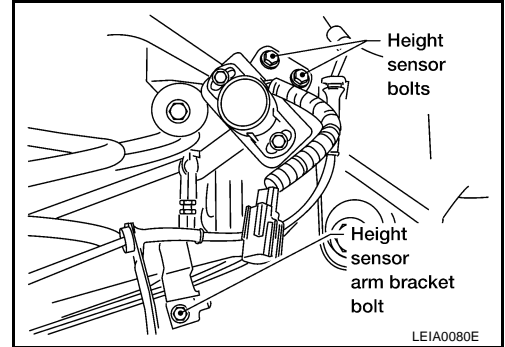

4. Set a suitable jack to relieve the coil spring tension and support the rear lower link.

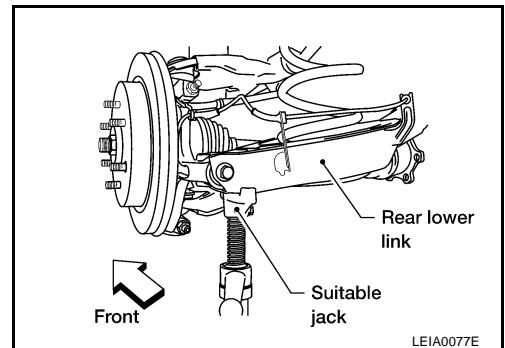

5. Loosen the rear lower link adjusting bolt and nut connected to the rear suspension member, using power tool.

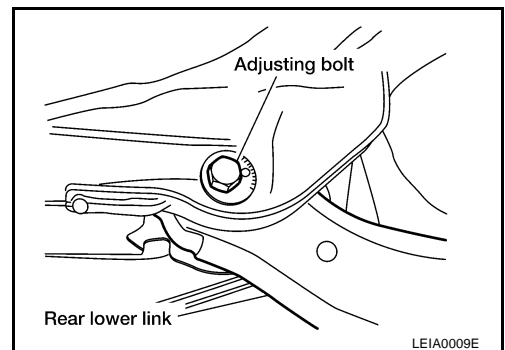

6. Remove the rear lower link bolt and nut from the knuckle using power tool.

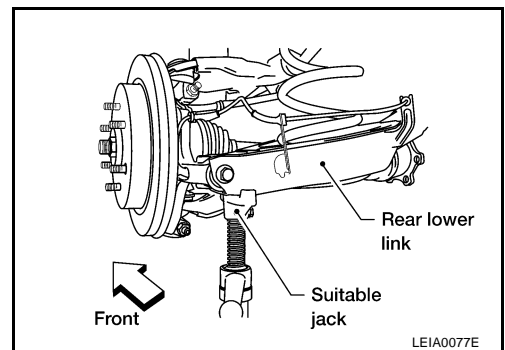

7. Slowly lower the suitable jack to release the coil spring tension. Then remove the upper rubber seat, coil spring and lower rubber seat from the rear lower link.

A  
B  
C  
D  
RSU  
F  
G  
H  
I  
J  
K  
L  
M

## REAR LOWER LINK & COIL SPRING

8. Remove the rear lower link adjusting bolt and nut from the rear suspension member using power tool, then remove the rear lower link.

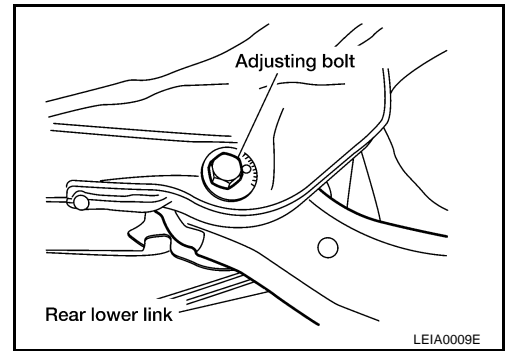

### INSTALLATION

Installation is in the reverse order of removal.

- Tighten the nuts and bolts to specification. Refer to [RSU-25, "Components"](#).
- When installing the upper and lower rubber seats for the rear coil springs, the arrow embossed on the rubber seats must point out toward the wheel and tire assembly.
- After installing the rear lower link and coil spring, check the wheel alignment and adjust if necessary. Refer to [RSU-27, "Wheel Alignment Inspection"](#).

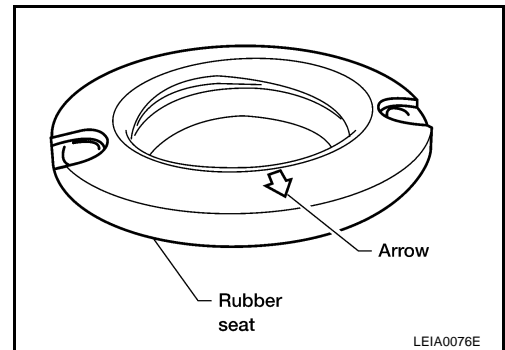

### Inspection

Check for deformation, cracks, or other damage and replace if necessary.

EES001F9



# STABILIZER BAR

PFP:56230

## STABILIZER BAR

### Removal and Installation

EES001FA

1. Disconnect the stabilizer bar ends from the connecting rods using power tool.

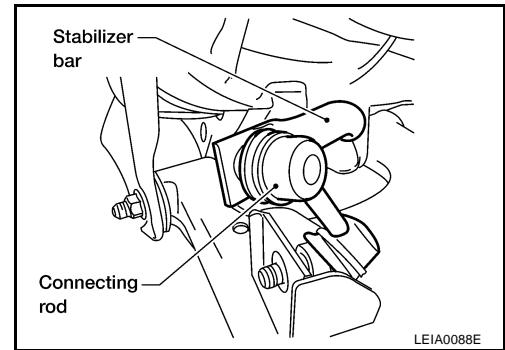

2. Remove the stabilizer bar clamps using power tool, and remove the stabilizer bar bushings.
3. Remove the stabilizer bar.

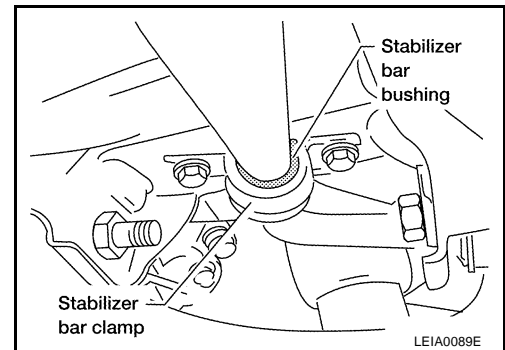

### INSTALLATION

Installation is in the reverse order of removal.

- Tighten the nuts and bolts to specification. Refer to [RSU-25, "Components"](#).
- Install the stabilizer bar with the ball joint sockets properly aligned.
- Install the stabilizer bar bushing and clamp so they are positioned inside of the sideslip prevention clamp on the stabilizer bar.

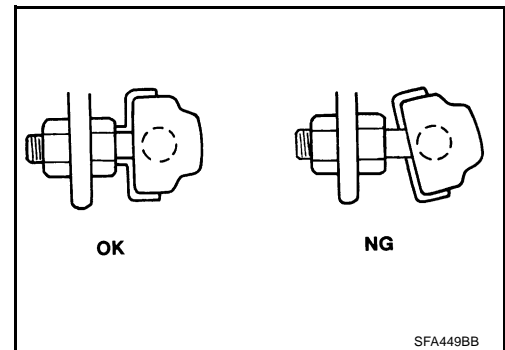

### Inspection

EES001FB

- Check stabilizer bar for any deformation, cracks, or damage and replace if necessary.
- Check rubber bushings for deterioration, or cracks and replace if necessary.

# REAR LOAD LEVELING AIR SUSPENSION COMPRESSOR ASSEMBLY

## REAR LOAD LEVELING AIR SUSPENSION COMPRESSOR ASSEMBLY

PF-P:53400

### Removal and Installation

EES001FC

#### Rear Load Leveling Air Suspension System

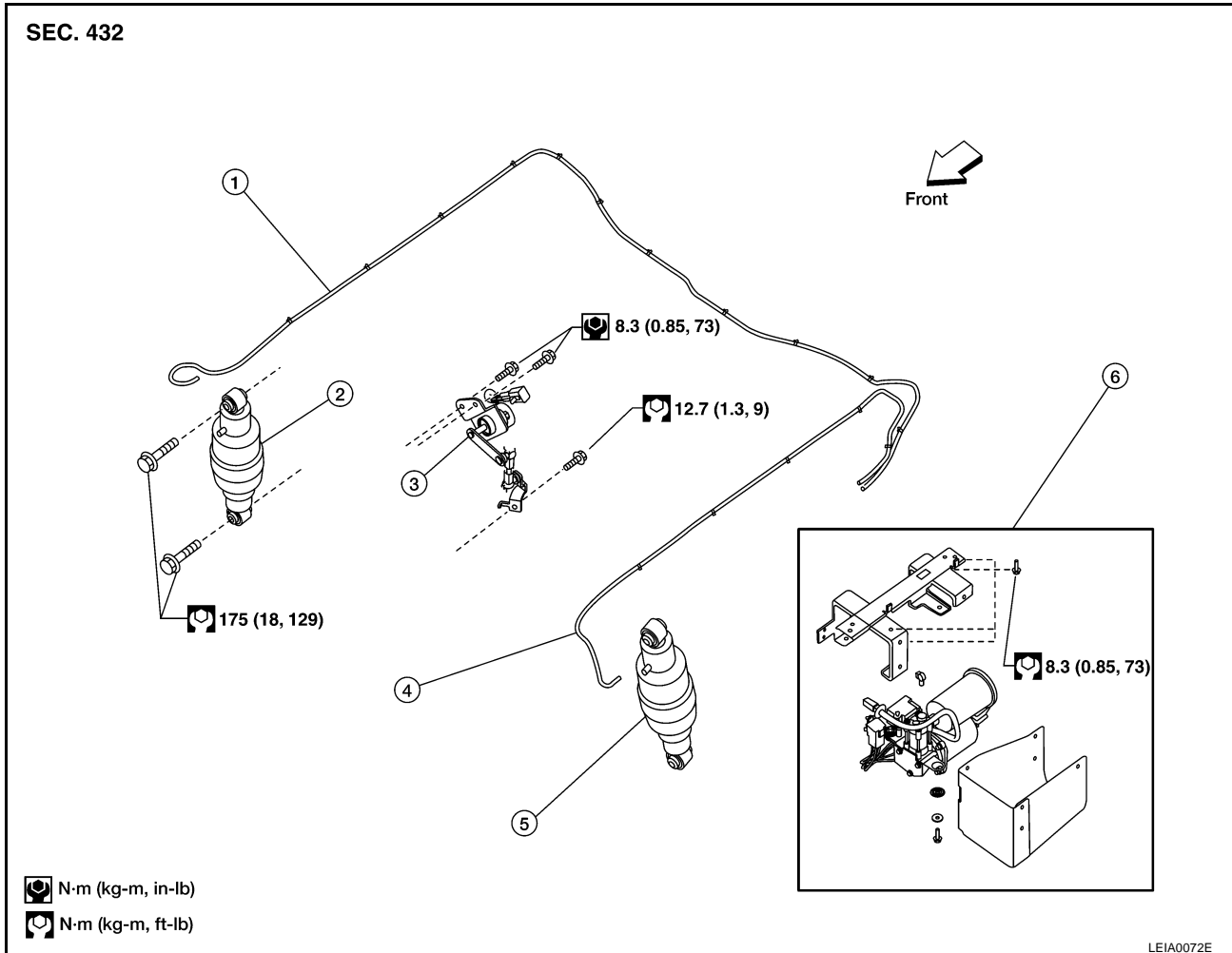

- |   |                       |  |
|---|-----------------------|--|
| 1. Rear load leveling air suspension hose, RH | 2. Shock absorber, RH | 3. Height sensor   |
| 4. Rear load leveling air suspension hose, LH | 5. Shock absorber, LH | 6. Rear load leveling air suspension compressor assembly |

### REMOVAL

- Use CONSULT-II "EXHAUST SOLENOID" active test to release the air pressure from the rear load leveling air suspension system.
- Disconnect the electrical connectors for the rear load leveling air suspension compressor assembly.
- Unclip the rubber cover to access the rear load leveling air suspension compressor assembly.
- Disconnect the rear load leveling air suspension hoses at the rear load leveling air suspension compressor assembly.
  - To disconnect the hoses, push in on the lock ring using a suitable tool and pull the hose out.

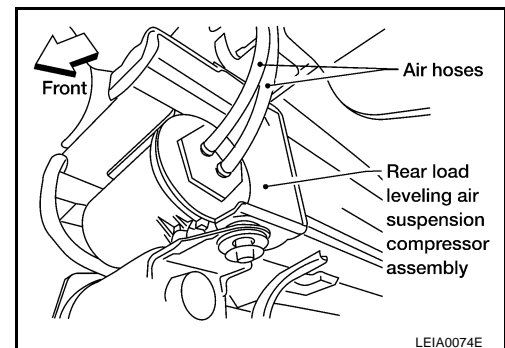

# REAR LOAD LEVELING AIR SUSPENSION COMPRESSOR ASSEMBLY

- Remove the four bolts that mount the rear load leveling air suspension compressor assembly to the underbody.

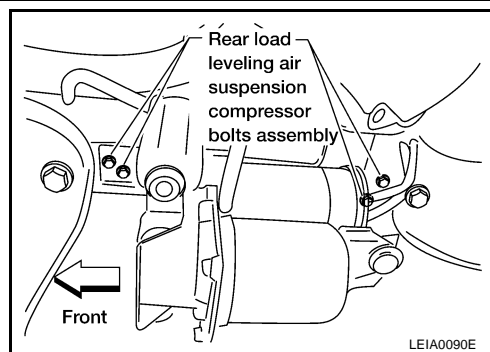

## INSTALLATION

Installation is in the reverse order of removal.

- To connect the rear load leveling air suspension hoses, the lock ring must be fully seated in the fitting. Insert the hose "B" into the lock ring "A" until the lock ring "A" is touching the hose "B" as shown. Pull on the hose to check that it is securely inserted.

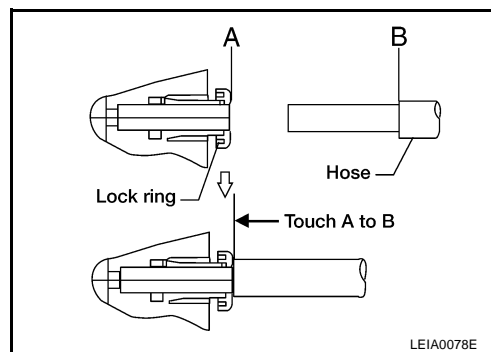

A  
B  
C  
D

RSU

F  
G  
H

I  
J  
K  
L  
M

# HEIGHT SENSOR

PFP:53820

EES001FD

## HEIGHT SENSOR

### Removal and Installation

#### Rear Load Leveling Air Suspension System

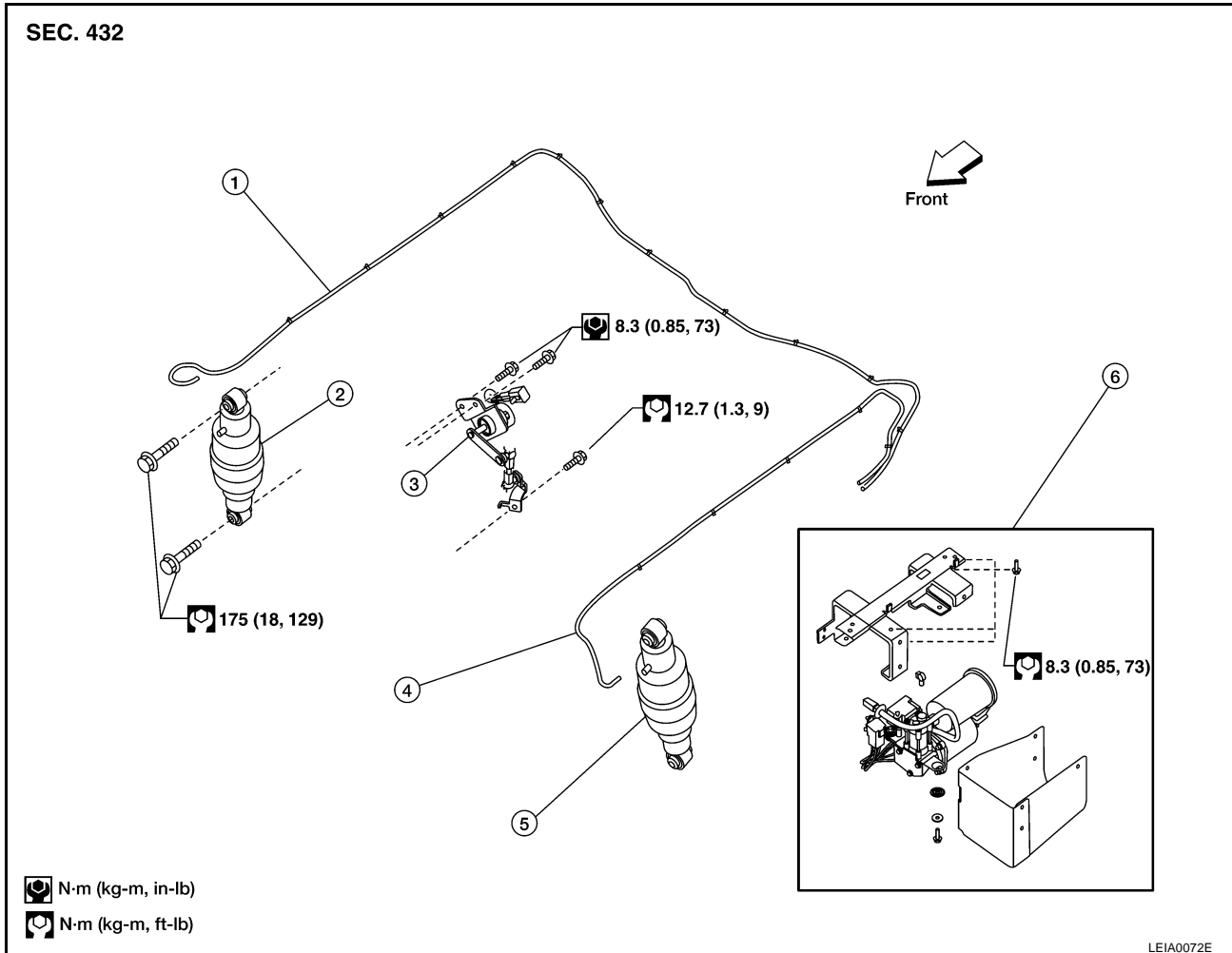

- |   |                       |  |
|---|-----------------------|--|
| 1. Rear load leveling air suspension hose, RH | 2. Shock absorber, RH | 3. Height sensor   |
| 4. Rear load leveling air suspension hose, LH | 5. Shock absorber, LH | 6. Rear load leveling air suspension compressor assembly |

### REMOVAL

1. Use CONSULT-II "EXHAUST SOLENOID" active test to release the air pressure from the rear load leveling air suspension system.
2. Disconnect the electrical connector for the height sensor.
3. Remove the two height sensor bolts and height sensor arm bracket bolt.
4. Remove the height sensor.

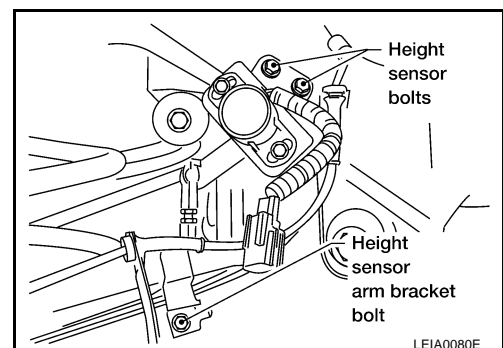

# HEIGHT SENSOR

## INSTALLATION

Installation is in the reverse order of removal.

1. Start the engine.
2. Use CONSULT-II to perform "STANDARD HEIGHT LEVEL" work support function.
3. Using data monitor of CONSULT-II, verify "HEIGT CALC" is at 0 mm.
4. Check the vehicle height. Refer to [RSU-48, "Wheelarch Height \(Unladen\\*1\)"](#) . If vehicle height is not within  $\pm 10$  mm (0.39 in) of the specification, perform the initialization procedure. Refer to [RSU-46, "Initialization Procedure"](#) .

A

B

C

D

RSU

F

G

H

I

J

K

L

M

# CONTROL UNIT

## CONTROL UNIT

PFP:47850

### Removal and Installation

EES001FE

#### REMOVAL

1. Remove the rear LH interior trim panel. Refer to [EI-32, "BODY SIDE TRIM"](#) .
2. Disconnect the battery negative terminal.
3. Disconnect the suspension control unit electrical connector.
4. Remove the two bolts and remove the suspension control unit.

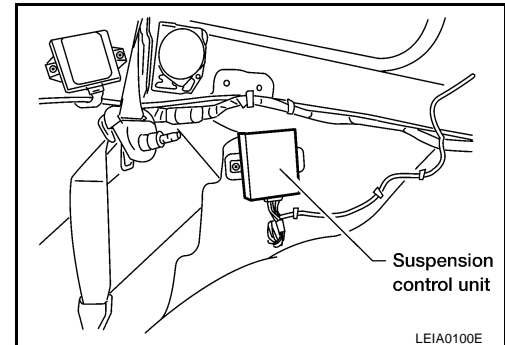

#### INSTALLATION

Installation is in the reverse order of removal.

**Suspension control unit bolts : 6 N·m (0.6 kg·m, 53 in·lb)**

#### Initialization Procedure

EES001FF

1. If control unit has been replaced, proceed to step 2. If control unit has not been replaced, use CONSULT-II "CLEAR HEIGHT INI" work support function to clear initialization flag and value. The CK SUSP warning lamp should illuminate. Using CONSULT-II "EXHAUST SOLENOID" active test, release the air pressure from the rear load leveling air suspension system.
2. Roll vehicle forward and backward.
3. Use CONSULT-II "ADJUST HEIGHT INI" work support function to set initialization condition.
4. Confirm that CK SUSP warning lamp is OFF.

# SERVICE DATA AND SPECIFICATIONS (SDS)

## SERVICE DATA AND SPECIFICATIONS (SDS)

PF0:00030

### Wheel Alignment (Unladen\*1)

EES001FG

Applied model		Without air leveling	With air leveling
Camber Degree minute (decimal degree)	Minimum	- 0° 25' (- 0.4°)	- 1° 0' (- 1°)
	Nominal	0° 5' (0.1°)	- 0° 30' (- 0.5°)
	Maximum	0° 35' (0.6°)	0° 0' (0°)
	Cross camber	0° 45' (0.75°) or less	

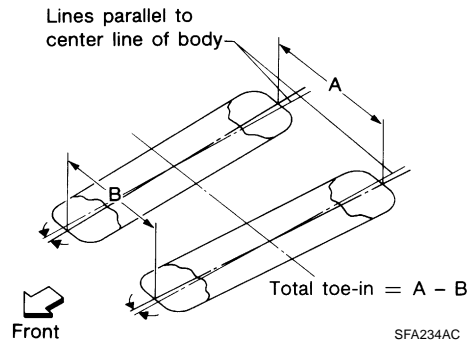

Total toe-in	Distance (A - B)	Minimum	- 2.4 mm (- 0.094 in)	0 mm (0 in)
		Nominal	0.9 mm (0.035 in)	3.3 mm (0.130 in)
		Maximum	4.2 mm (0.165 in)	6.6 mm (0.260 in)
		Cross toe	2 mm (0.079 in) or less	
	Angle (left side and right side) Degree minute (decimal degree)	Minimum	- 0° 5' (- 0.8°)	0° 0' (0°)
		Nominal	0° 2' (0.03°)	0° 7' (0.11°)
		Maximum	0° 9' (0.14°)	0° 14' (0.22°)
		Cross toe	0° 8' (0.14°) or less	

\*1: Fuel tank, engine coolant and engine oil full. Spare tire, jack, hand tools and mats in designated positions.

### Ball Joint

EES001FH

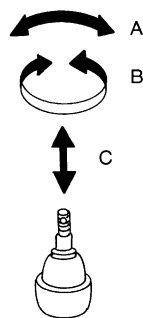

Swinging force (measurement point at cotter pin hole of ball stud) "A"	11.4 - 145.5 N (1.16 - 14.8 kg, 2.56 - 32.7 lb)
Turning torque "B"	0.5 - 6.4 N·m (0.06 - 0.65 kg·m, 5 - 56 in·lb)
Vertical end play "C"	0 mm (0 in)

# SERVICE DATA AND SPECIFICATIONS (SDS)

## Wheelarch Height (Unladen\*<sup>1</sup>)

EES001FI

Unit: mm (in)

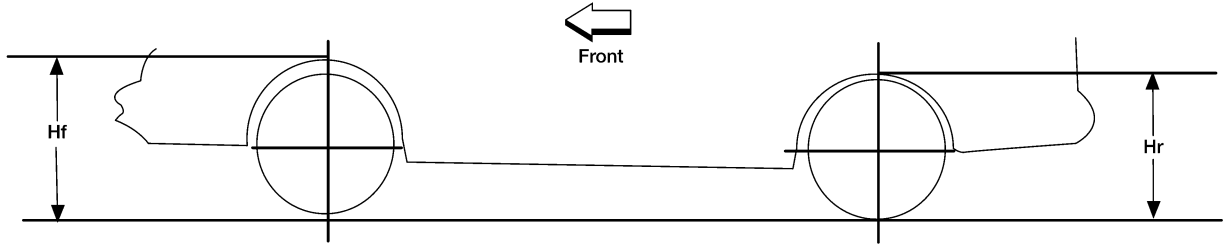

LEIA0085E

Suspension type	With air leveling* <sup>2</sup>				Without air leveling			
	4x2		4x4		4x2		4x4	
Applied model								
Tire size	265/70R18	285/70R17	265/70R18	285/70R17	265/70R18	285/70R17	265/70R18	285/70R17
Front wheelarch height (Hf)	917 (36.10)	918 (36.14)	935 (36.81)	936 (36.85)	916 (36.06)	917 (36.10)	935 (36.81)	936 (36.85)
Rear wheelarch height (Hr)	916 (36.06)	917 (36.10)	936 (36.85)	937 (36.89)	937 (36.89)	938 (36.93)	957 (36.68)	958 (37.72)

\*1: Fuel, radiator coolant and engine oil full. Spare tire, jack, hand tools and mats in designated positions.

\*2: Verify the vehicle height. If vehicle height is not within  $\pm 10$  mm (0.39 in) of the specification, perform the control unit initialization procedure. Refer to [RSU-46, "Initialization Procedure"](#).