

SECTION LAN
LAN SYSTEM

A
B
C
D
E
F
G
H
I
J
L
M

CONTENTS

CAN

PRECAUTIONS	3	DESCRIPTION OF "CAN DIAG SUPPORT MNTR" SCREEN FOR ABS ACTUATOR AND ELECTRIC UNIT (CONTROL UNIT)	22
Precautions for Supplemental Restraint System (SRS) "AIR BAG" and "SEAT BELT PRE-TENSIONER"	3	DESCRIPTION OF "CAN DIAG SUPPORT MNTR" SCREEN FOR IPDM E/R	23
Precautions When Using CONSULT-II	3	DESCRIPTION OF "CAN DIAG SUPPORT MNTR" SCREEN FOR DISPLAY CONTROL UNIT	24
CHECK POINTS FOR USING CONSULT-II	3	CAN COMMUNICATION	25
Precautions For Trouble Diagnosis	3	System Description	25
CAN SYSTEM	3	Component Parts and Harness Connector Location..	25
Precautions For Harness Repair	4	Schematic	26
CAN SYSTEM	4	Wiring Diagram — CAN —	27
TROUBLE DIAGNOSES WORK FLOW	5	CAN Communication Unit	30
When Displaying CAN Communication System Errors	5	TYPE 1/ TYPE 2/TYPER3	31
WHEN A MALFUNCTION IS DETECTED BY CAN COMMUNICATION SYSTEM	5	TYPE 4/ TYPE 5/TYPER6	34
WHEN A MALFUNCTION IS DETECTED EXCEPT CAN COMMUNICATION SYSTEM	5	CAN SYSTEM (TYPE 1)	38
TROUBLE DIAGNOSIS FLOW CHART	6	Component Parts and Harness Connector Location..	38
Diagnosis Procedure	7	Schematic	38
SELECTING CAN SYSTEM TYPE (HOW TO USE SPECIFICATION TABLE)	7	Wiring Diagram — CAN —	38
ACQUISITION OF DATA BY CONSULT-II	8	Check Sheet	39
HOW TO USE CHECK SHEET TABLE	9	CHECK SHEET RESULTS (EXAMPLE)	41
CAN Diagnostic Support Monitor	16	CAN SYSTEM (TYPE 2)	53
DESCRIPTION OF "CAN DIAG SUPPORT MNTR" SCREEN FOR ECM	16	Component Parts and Harness Connector Location..	53
DESCRIPTION OF "CAN DIAG SUPPORT MNTR" SCREEN FOR TCM	17	Schematic	53
DESCRIPTION OF "CAN DIAG SUPPORT MNTR" SCREEN FOR DRIVER SEAT CONTROL UNIT	18	Wiring Diagram — CAN —	53
DESCRIPTION OF "CAN DIAG SUPPORT MNTR" SCREEN FOR BCM	19	Check Sheet	54
DESCRIPTION OF "CAN DIAG SUPPORT MNTR" SCREEN FOR FRONT AIR CONTROL..	20	CHECK SHEET RESULTS (EXAMPLE)	56
DESCRIPTION OF "CAN DIAG SUPPORT MNTR" SCREEN FOR TRANSFER CONTROL UNIT	21	CAN SYSTEM (TYPE 3)	70
DESCRIPTION OF "CAN DIAG SUPPORT MNTR" SCREEN FOR ABS ACTUATOR AND ELECTRIC UNIT (CONTROL UNIT)	22	Component Parts and Harness Connector Location..	70
DESCRIPTION OF "CAN DIAG SUPPORT MNTR" SCREEN FOR IPDM E/R	23	Schematic	70
DESCRIPTION OF "CAN DIAG SUPPORT MNTR" SCREEN FOR DISPLAY CONTROL UNIT	24	Wiring Diagram — CAN —	70
CAN COMMUNICATION	25	Check Sheet	71
System Description	25	CHECK SHEET RESULTS (EXAMPLE)	73
Component Parts and Harness Connector Location..	25	CAN SYSTEM (TYPE 4)	88
Schematic	26	Component Parts and Harness Connector Location..	88
Wiring Diagram — CAN —	27	Schematic	88
CAN Communication Unit	30	Wiring Diagram — CAN —	88
TYPE 1/ TYPE 2/TYPER3	31	Check Sheet	89
TYPE 4/ TYPE 5/TYPER6	34	CHECK SHEET RESULTS (EXAMPLE)	91
CAN SYSTEM (TYPE 1)	38		
Component Parts and Harness Connector Location..	38		
Schematic	38		
Wiring Diagram — CAN —	38		
Check Sheet	39		
CHECK SHEET RESULTS (EXAMPLE)	41		
CAN SYSTEM (TYPE 2)	53		
Component Parts and Harness Connector Location..	53		
Schematic	53		
Wiring Diagram — CAN —	53		
Check Sheet	54		
CHECK SHEET RESULTS (EXAMPLE)	56		
CAN SYSTEM (TYPE 3)	70		
Component Parts and Harness Connector Location..	70		
Schematic	70		
Wiring Diagram — CAN —	70		
Check Sheet	71		
CHECK SHEET RESULTS (EXAMPLE)	73		
CAN SYSTEM (TYPE 4)	88		
Component Parts and Harness Connector Location..	88		
Schematic	88		
Wiring Diagram — CAN —	88		
Check Sheet	89		
CHECK SHEET RESULTS (EXAMPLE)	91		

LAN

CAN SYSTEM (TYPE 5)	104	Data Link Connector Circuit	143
Component Parts and Harness Connector Location	104	Inspection Between Data Link Connector and ABS	
Schematic	104	Actuator and Electric Unit (Control Unit) Circuit ...	144
Wiring Diagram — CAN —	104	ECM Circuit Inspection	145
Check Sheet	105	TCM Circuit Inspection	146
CHECK SHEET RESULTS (EXAMPLE)	107	Driver Seat Control Unit Circuit Inspection	146
CAN SYSTEM (TYPE 6)	122	Combination Meter Circuit Inspection	147
Component Parts and Harness Connector Location	122	Display Control Unit Circuit Inspection	147
Schematic	122	BCM Circuit Inspection	148
Wiring Diagram — CAN —	122	Data Link Connector Circuit Inspection	148
Check Sheet	123	Steering Angle Sensor Circuit Inspection	149
CHECK SHEET RESULTS (EXAMPLE)	125	Front Air Control Circuit Inspection	149
TROUBLE DIAGNOSIS FOR SYSTEM	141	Transfer Control Unit Circuit Inspection	150
Inspection Between TCM and Driver Seat Control		ABS Actuator and Electric Unit (Control Unit) Circuit	
Unit Circuit	141	Inspection	151
Inspection Between TCM and Data Link Connector		IPDM E/R Circuit Inspection	151
Circuit	142	CAN Communication Circuit Inspection	152
Inspection Between Driver Seat Control Unit and		IPDM E/R Ignition Relay Circuit Inspection	153

PRECAUTIONS

Precautions for Supplemental Restraint System (SRS) “AIR BAG” and “SEAT BELT PRE-TENSIONER”

UKS0017I

The Supplemental Restraint System such as “AIR BAG” and “SEAT BELT PRE-TENSIONER”, used along with a front seat belt, helps to reduce the risk or severity of injury to the driver and front passenger for certain types of collision. This system includes seat belt switch inputs and dual stage front air bag modules. The SRS system uses the seat belt switches to determine the front air bag deployment, and may only deploy one front air bag, depending on the severity of a collision and whether the front occupants are belted or unbelted. Information necessary to service the system safely is included in the SRS and SB section of this Service Manual.

WARNING:

- To avoid rendering the SRS inoperative, which could increase the risk of personal injury or death in the event of a collision which would result in air bag inflation, all maintenance must be performed by an authorized NISSAN/INFINITI dealer.
- Improper maintenance, including incorrect removal and installation of the SRS, can lead to personal injury caused by unintentional activation of the system. For removal of Spiral Cable and Air Bag Module, see the SRS section.
- Do not use electrical test equipment on any circuit related to the SRS unless instructed to in this Service Manual. SRS wiring harnesses can be identified by yellow and/or orange harnesses or harness connectors.

Precautions When Using CONSULT-II

UKS0017J

When connecting CONSULT-II to data link connector, connect them through CONSULT-II CONVERTER.

CAUTION:

If CONSULT-II is used with no connection of CONSULT-II CONVERTER, malfunctions might be detected in self-diagnosis depending on control unit which carry out CAN communication.

CHECK POINTS FOR USING CONSULT-II

1. Has CONSULT-II been used without connecting CONSULT-II CONVERTER on this vehicle?
 - If YES, GO TO 2.
 - If NO, GO TO 5.
2. Is there any indication other than indications relating to CAN communication system in the self-diagnosis results?
 - If YES, GO TO 3.
 - If NO, GO TO 4.
3. Based on self-diagnosis results unrelated to CAN communication, carry out the inspection.
4. Malfunctions may be detected in self-diagnosis depending on control units carrying out CAN communication. Therefore, erase the self-diagnosis results.
5. Diagnose CAN communication system. Refer to [LAN-5, "TROUBLE DIAGNOSES WORK FLOW"](#) .

Precautions For Trouble Diagnosis CAN SYSTEM

UKS0017K

- Do not apply voltage of 7.0 V or higher to the measurement terminals.
- Use the tester with its open terminal voltage being 7.0 V or less.
- Be sure to turn ignition switch OFF and disconnect the battery cable from the negative terminal before checking the circuit.

A
B
C
D
E
F
G
H
I
J
L
M

LAN

Precautions For Harness Repair CAN SYSTEM

- Solder the repaired parts, and wrap with tape. [Frays of twisted line must be within 110 mm (4.33 in).]

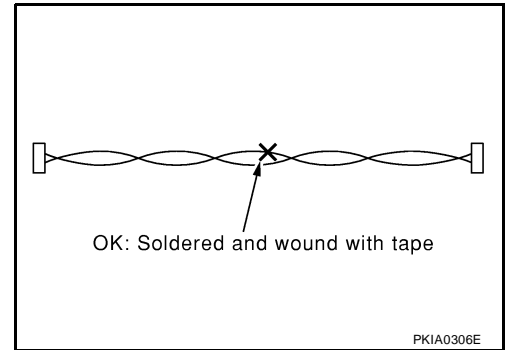

- Do not perform bypass wire connections for the repair parts. (The spliced wire will become separated and the characteristics of twisted line will be lost.)

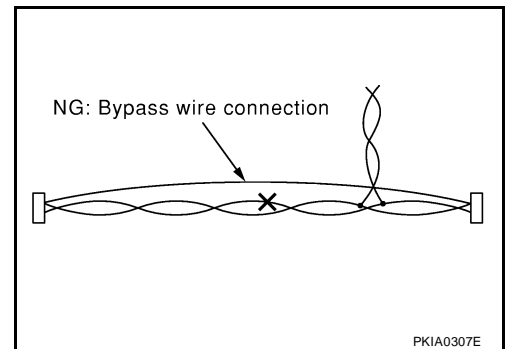

TROUBLE DIAGNOSES WORK FLOW

PFP:00004

When Displaying CAN Communication System Errors

UKS004SP

WHEN A MALFUNCTION IS DETECTED BY CAN COMMUNICATION SYSTEM

- CAN communication line is open. (CAN H, CAN L, or both)
- CAN communication line is shorted. (Ground, between CAN lines, or other harnesses)
- The areas related to CAN communication of unit is malfunctioning.

WHEN A MALFUNCTION IS DETECTED EXCEPT CAN COMMUNICATION SYSTEM

- Removal and installation of parts: When the units that perform CAN communication or the sensors related to CAN communication are removed and installed, malfunction may be detected (or DTC other than CAN communication may be detected).
- Fuse blown out (removed): CAN communication of the unit may be stopped at such time.
- Low voltage: If the voltage decreases because of battery discharge when IGN is ON, malfunction may be detected by self-diagnosis according to the units.

A
B
C
D
E
F
G
H
I
J
L
M

LAN

TROUBLE DIAGNOSIS FLOW CHART

Depending on the control unit which performs CAN communication, "U1010" may be indicated as the result of self-diagnosis. Replace the control unit if "U1010" is indicated.

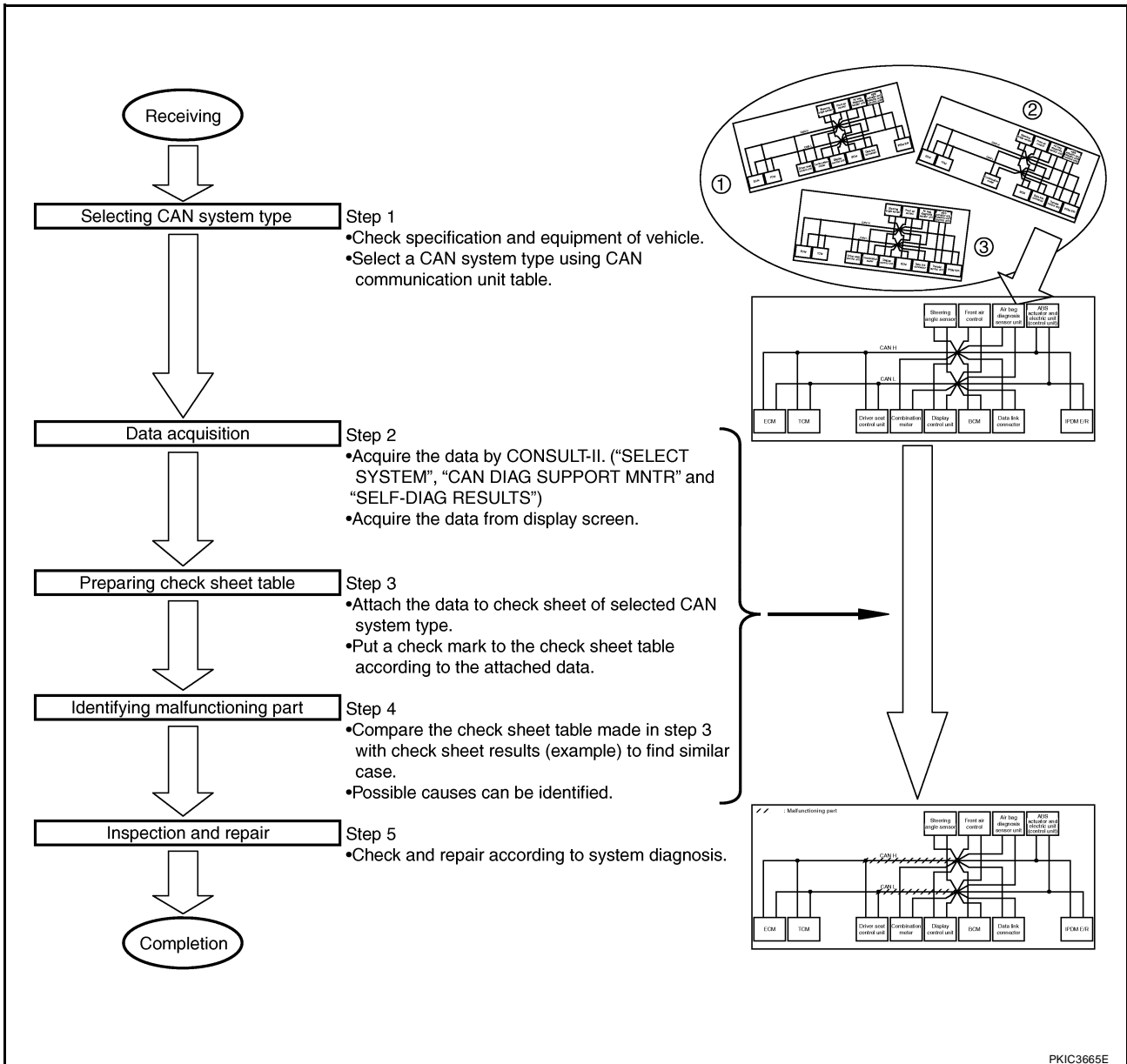

- Step 1: Refer to [LAN-7, "SELECTING CAN SYSTEM TYPE \(HOW TO USE SPECIFICATION TABLE\)"](#) .
- Step 2: Refer to [LAN-8, "ACQUISITION OF DATA BY CONSULT-II"](#) .
- Step 3: Refer to [LAN-9, "HOW TO USE CHECK SHEET TABLE"](#) .
- Step 4: Refer to [LAN-10, "Example of Filling in Check Sheet When Initial Conditions Are Reproduced"](#) .
- Step 5: Refer to [LAN-141, "TROUBLE DIAGNOSIS FOR SYSTEM"](#) .

TROUBLE DIAGNOSES WORK FLOW

[CAN]

UKS004SQ

Diagnosis Procedure

SELECTING CAN SYSTEM TYPE (HOW TO USE SPECIFICATION TABLE)

Determine CAN system type from the equipment of the vehicle to select applicable check sheet.

(Example) Wagon/2WD/VK56DE/AT/VDC/With automatic drive positioner/With navigation system

CAN Communication Unit

Go to CAN system, when selecting your CAN system type from the following table.

Body type	Wagon					
Axle	2WD			4WD		
Engine	VK56DE					
Transmission	A/T					
Brake control	VDC					
Automatic drive positioner		x	x		x	x
Navigation system			x			x
CAN system type	1	2	3	4	5	6
CAN system trouble diagnosis	XXXX	XXXX	XXXX	XXXX	XXXX	XXXX

Check basic specification of the vehicle.

Select "x" if it is model with automatic drive positioner.

Select "x" if it is model with navigation system.

Which number is selected when sequentially selecting from the top of the specification table?

The number is "CAN system type" of the applicable vehicle.

In the case of this example:
It corresponds to type 3.

x: Applicable

PKIC3666E

A
B
C
D
E
F
G
H
I
J

LAN

L
M

TROUBLE DIAGNOSES WORK FLOW

[CAN]

HOW TO USE CHECK SHEET TABLE

Use when the initial conditions are reproduced													Use when the initial conditions are not reproduced	
Check sheet table														
SELECT SYSTEM screen	Initial diagnosis	Transmit diagnosis	CAN DIAG SUPPORT MNTR										SELF-DIAG RESULTS	
			Receive diagnosis											
			ECM	TCM	METER /M&A	DISPLAY	BCM/SEC	STRG	HVAC	VDC/TCS /ABS	IPDM E/R			
ENGINE	-	-	UNKWN	-	UNKWN	UNKWN	-	UNKWN	-	-	UNKWN	UNKWN	CAN COMM CIRCUIT (U1000)	CAN COMM CIRCUIT (U1001)
A/T	-	NG	UNKWN	UNKWN	-	UNKWN	-	-	-	-	UNKWN	-	CAN COMM CIRCUIT (U1000)	-
AUTO DRIVE POS.	No indication	-	-	-	UNKWN	UNKWN	-	UNKWN	-	-	-	-	CAN COMM CIRCUIT (U1000)	-
Display control unit	-	NG	UNKWN	UNKWN	-	UNKWN	-	UNKWN	-	UNKWN	-	UNKWN	-	-
BCM	No indication	NG	UNKWN	UNKWN	-	UNKWN	-	-	-	-	-	UNKWN	CAN COMM CIRCUIT (U1000)	-
HVAC	No indication	-	UNKWN	UNKWN	-	-	UNKWN	UNKWN	-	-	UNKWN	-	-	-
ABS	-	NG	UNKWN	UNKWN	UNKWN	-	-	-	UNKWN	-	-	-	CAN COMM CIRCUIT (U1000)	-
IPDM E/R	No indication	-	UNKWN	UNKWN	-	-	-	UNKWN	-	-	-	-	CAN COMM CIRCUIT (U1000)	-

① Unit that performs CAN communication diagnosis

② SELECT SYSTEM screen

③ Initial diagnosis

④ Transmit diagnosis

⑤ Receive diagnosis

PKIC3656E

- Unit names displayed on CONSULT-II
- “No indication”: Put a check mark to it if the unit name described in step 1 is not displayed on “SELECT SYSTEM” screen of CONSULT-II. (Unit communicating with CONSULT-II via CAN communication line)
“-”: Column not used (Unit communicating with CONSULT-II excluding CAN communication line)
- “NG”: Display “NG” when malfunction is detected in the initial diagnosis of the diagnosed unit. Replace the unit if “NG” is displayed.
“-”: Column not used (Initial diagnosis is not performed.)
- “UNKWN”: Display “UNKWN” when the diagnosed unit does not transmit the data normally. Put a check mark to it if “UNKWN” is displayed on CONSULT-II.
“-”: Column not used (Transmit diagnosis is not performed.)
- “UNKWN”: Display “UNKWN” when the diagnosed unit does not receive the data normally. Put a check mark to it if “UNKWN” is displayed on CONSULT-II.
“-”: Column not used (It is not necessary for CAN communication trouble diagnosis.)

NOTE:

CAN communication diagnosis checks if CAN communication works normally. (Contents of data are not diagnosed.)

- When the initial conditions are reproduced, refer to [LAN-10, "Example of Filling in Check Sheet When Initial Conditions Are Reproduced"](#).
- When the initial conditions are not reproduced, refer to [LAN-14, "Example of Filling in Check Sheet When Initial Conditions Are Not Reproduced"](#).

TROUBLE DIAGNOSES WORK FLOW

[CAN]

Example of Filling in Check Sheet When Initial Conditions Are Reproduced

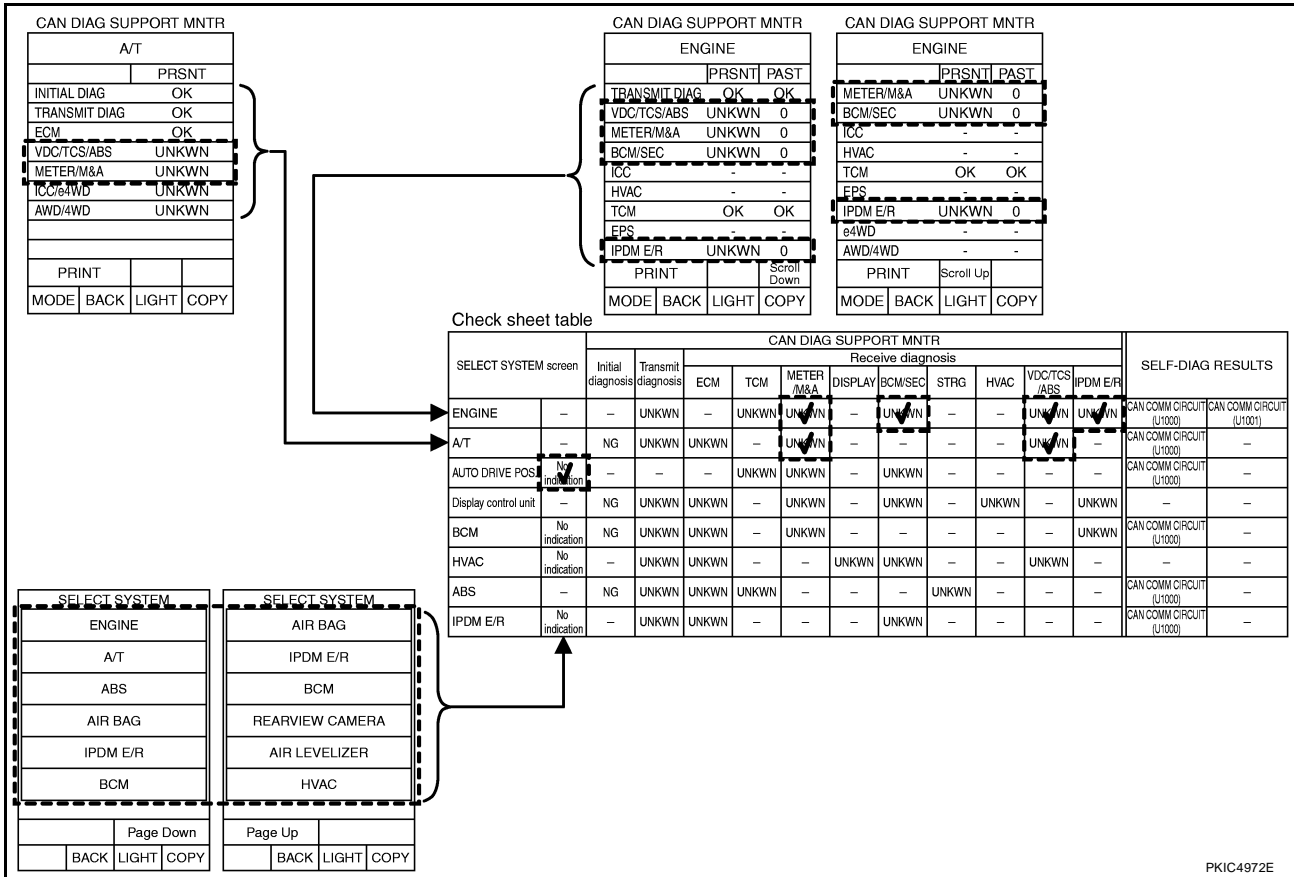

- Put a check mark to "No indication" if some of unit names listed on the column of diagnosis system selection screen of a check sheet table are not displayed on "SELECT SYSTEM" screen attached to the check sheet.

NOTE:

Put a check mark to "No indication" of AUTO DRIVE POS. because AUTO DRIVE POS. is not displayed on "SELECT SYSTEM" screen.

- Confirm the unit name that "UNKWN" is displayed from the copy of "CAN DIAG SUPPORT MNTR" screen of "ENGINE" attached to the check sheet, and then put a check mark to the check sheet table.

NOTE:

In "CAN DIAG SUPPORT MNTR" screen, "UNKWN" is displayed on "VDC/TCS/ABS", "METER/M&A", "BCM/SEC" and "IPDM E/R". Put a check mark to it.

- Confirm the unit name that "UNKWN" is displayed on the copy of "CAN DIAG SUPPORT MNTR" screen of "A/T" as well as "ENGINE". And then, put a check mark to the check sheet table.

NOTE:

- For "A/T", "UNKWN" is displayed on "VDC/TCS/ABS", "METER/M&A", "ICC/e4WD" and "AWD/4WD". But put a check mark to "VDC/TCS/ABS" and "METER/M&A" because "UNKWN" is listed on the column of reception diagnosis of the check sheet table.

TROUBLE DIAGNOSES WORK FLOW

[CAN]

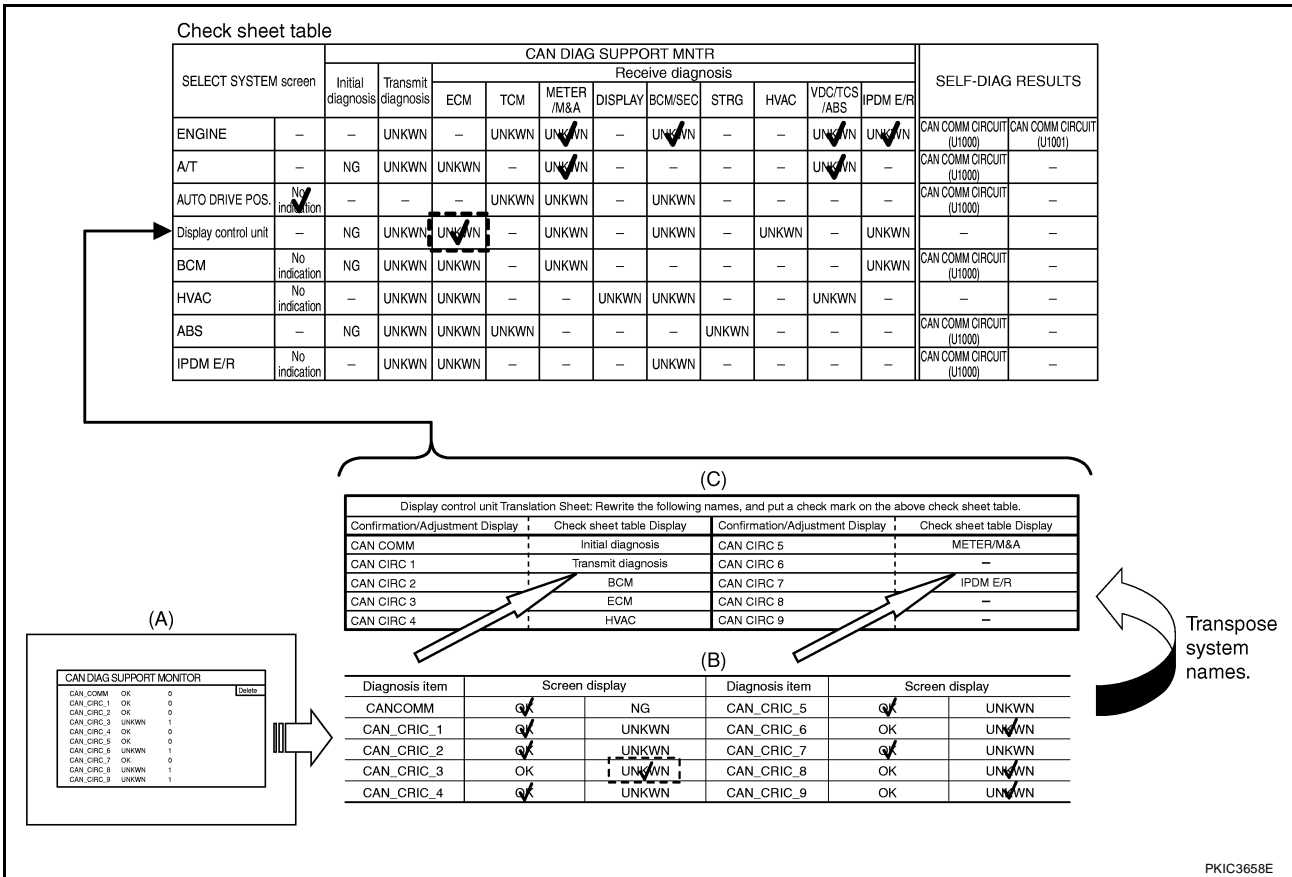

4. Display control unit reads the CAN diagnosis support monitor check sheet (B) [AV-144, "CAN Communication Line Check"](#) transferred from the display screen (A). The transferred CAN diagnosis support monitor check sheet is copied to the Check sheet, and conversed according to the Display control unit Translation Sheet (C). And then put a check mark to the check sheet table.

NOTE:

In the CAN diagnosis support monitor check sheet (B), check marks are put to "CAN CIRC 3", "CAN CIRC 6", "CAN CIRC 8" and "CAN CIRC 9". But, in the column of the check sheet table indication in Display control unit Translation Sheet (C), "ECM" is listed only for "CAN CIRC 3". Therefore, put a check mark to "ECM" because "UNKWN" is listed on the column of reception diagnosis of the check sheet table.

TROUBLE DIAGNOSES WORK FLOW

[CAN]

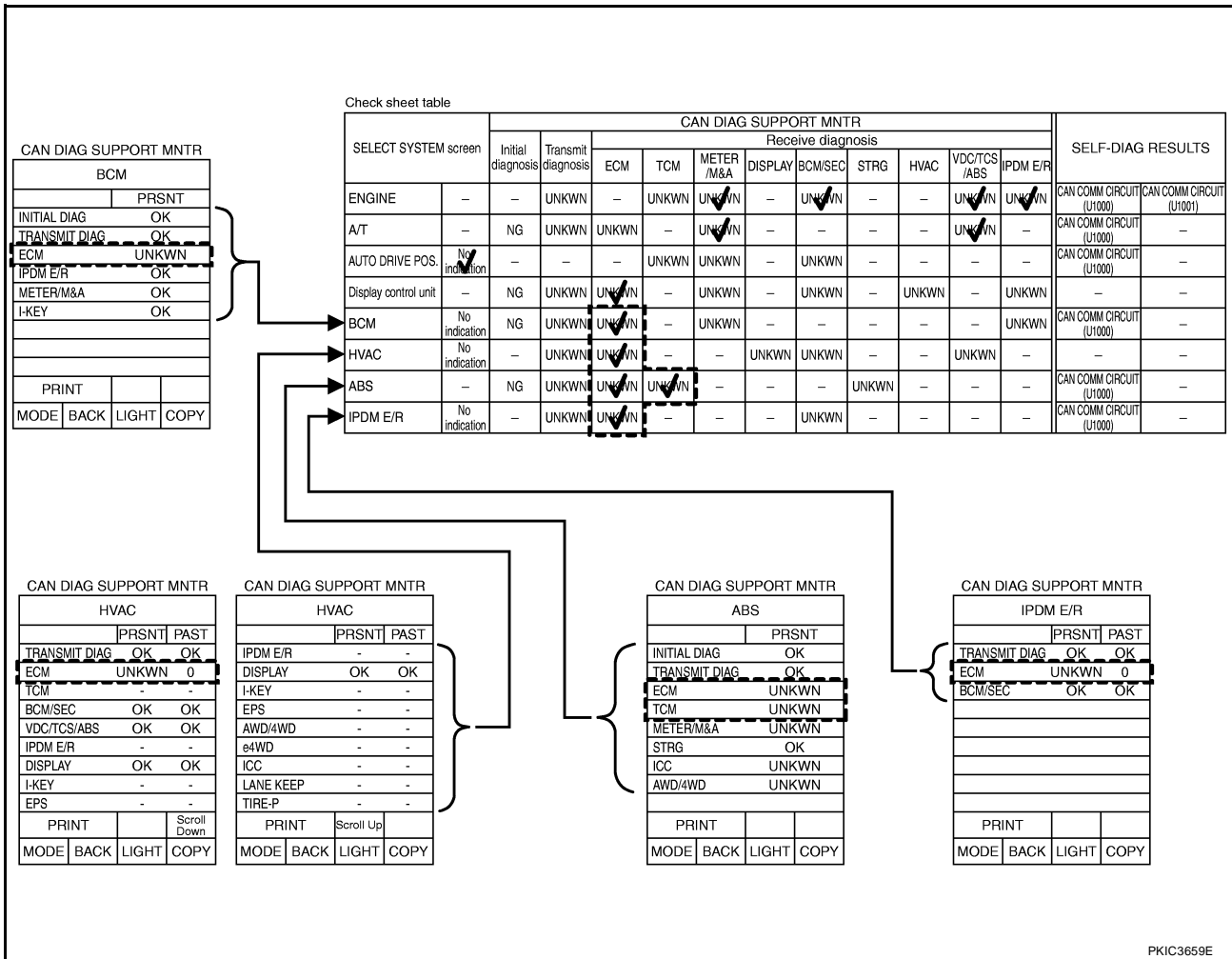

5. Confirm the unit name that “UNKW” is displayed on the copy of “CAN DIAG SUPPORT MNTR” screen of “BCM”, “HVAC”, “ABS” and “IPDM E/R” as well as “ENGINE”. And then, put a check mark to the check sheet table.

NOTE:

- For “BCM”, “UNKW” is displayed on “ECM”. Put a check mark to it.
- For “HVAC”, “UNKW” is displayed on “ECM”. Put a check mark to it.
- For “ABS”, “UNKW” is displayed on “ECM”, “TCM”, “METER/M&A”, “ICC” and “AWD/4WD”. But put a check mark to “ECM” and “TCM” because “UNKW” is listed on the column of reception diagnosis of the check sheet table.
- For “IPDM E/R”, “UNKW” is displayed on “ECM”. Put a check mark to it.

CAUTION:

“ALL MODE AWD/4WD” puts a check mark on the check sheet when “Present” is “UNKW” and “Past” is “0”.

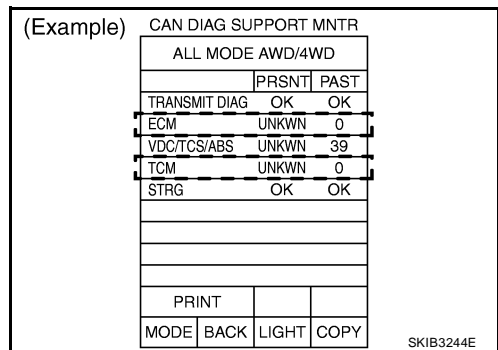

TROUBLE DIAGNOSES WORK FLOW

[CAN]

The arranged results of CAN diagnosis support monitor

Check sheet table

SELECT SYSTEM screen	CAN DIAG SUPPORT MNTR											SELF-DIAG RESULTS		
	Initial diagnosis	Transmit diagnosis	Receive diagnosis											
			ECM	TCM	METER /M&A	DISPLAY	BCM/SEC	STRG	HVAC	VDC/TCS /ABS	IPDM E/R			
ENGINE	-	-	UNKW	-	UNKW	UNKW	-	UNKW	-	-	UNKW	UNKW	CAN COMM CIRCUIT [U1000]	CAN COMM CIRCUIT [U1001]
A/T	-	NG	UNKW	UNKW	-	UNKW	-	-	-	-	UNKW	-	CAN COMM CIRCUIT [U1000]	-
AUTO DRIVE POS.	No indication	-	-	-	UNKW	UNKW	-	UNKW	-	-	-	-	CAN COMM CIRCUIT [U1000]	-
Display control unit	-	NG	UNKW	UNKW	-	UNKW	-	UNKW	-	UNKW	-	UNKW	-	-
BCM	No indication	NG	UNKW	UNKW	-	UNKW	-	-	-	-	-	UNKW	CAN COMM CIRCUIT [U1000]	-
HVAC	No indication	-	UNKW	UNKW	-	-	UNKW	UNKW	-	-	-	UNKW	-	-
ABS	-	NG	UNKW	UNKW	UNKW	-	-	-	UNKW	-	-	-	CAN COMM CIRCUIT [U1000]	-
IPDM E/R	No indication	-	UNKW	UNKW	-	-	-	UNKW	-	-	-	-	CAN COMM CIRCUIT [U1000]	-

Choose similar indications between the results of CAN diagnosis support monitor and the results of the check sheet. Malfunctioning parts are found.

Case 2
Check harness between driver seat control unit and data link connector.

Check sheet results (example)

SELECT SYSTEM screen	CAN DIAG SUPPORT MNTR											SELF-DIAG RESULTS		
	Initial diagnosis	Transmit diagnosis	Receive diagnosis											
			ECM	TCM	METER /M&A	DISPLAY	BCM/SEC	STRG	HVAC	VDC/TCS /ABS	IPDM E/R			
ENGINE	-	-	UNKW	-	UNKW	UNKW	-	UNKW	-	-	UNKW	UNKW	CAN COMM CIRCUIT [U1000]	CAN COMM CIRCUIT [U1001]
A/T	-	NG	UNKW	UNKW	-	UNKW	-	-	-	-	UNKW	-	CAN COMM CIRCUIT [U1000]	-
AUTO DRIVE POS.	No indication	-	-	-	UNKW	UNKW	-	UNKW	-	-	-	-	CAN COMM CIRCUIT [U1000]	-
Display control unit	-	NG	UNKW	UNKW	-	UNKW	-	UNKW	-	UNKW	-	UNKW	-	-
BCM	No indication	NG	UNKW	UNKW	-	UNKW	-	-	-	-	-	UNKW	CAN COMM CIRCUIT [U1000]	-
HVAC	No indication	-	UNKW	UNKW	-	-	UNKW	UNKW	-	-	-	UNKW	-	-
ABS	-	NG	UNKW	UNKW	UNKW	-	-	-	UNKW	-	-	-	CAN COMM CIRCUIT [U1000]	-
IPDM E/R	No indication	-	UNKW	UNKW	-	-	-	UNKW	-	-	-	-	CAN COMM CIRCUIT [U1000]	-

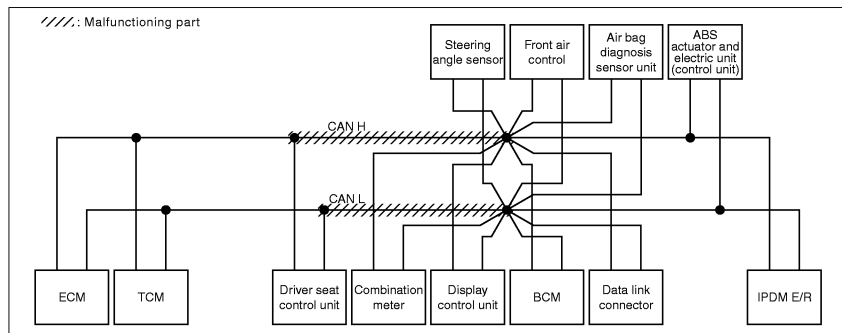

PK1C3660E

NOTE:

There is a case that some of "CAN DIAG SUPPORT MNTR" and "SELF-DIAG RESULTS" are not needed for diagnosis. In the case, "UNKW" and "CAN COMM CIRCUIT [U1000]" in "Check sheet results (example)" change to "-". Then, ignore check marks on the check sheet table.

6. Perform system diagnosis for possible causes identified.
7. Perform diagnosis again after inspection and repair. Make sure that repair is completely performed, and then end the procedure.

Start CAN system trouble diagnosis if this procedure can be confirmed. Refer to [LAN-30, "CAN Communication Unit"](#).

TROUBLE DIAGNOSES WORK FLOW

[CAN]

Example of Filling in Check Sheet When Initial Conditions Are Not Reproduced

Check sheet table

SELECT SYSTEM screen	CAN DIAG SUPPORT MNTR											SELF-DIAG RESULTS		
	Initial diagnosis	Transmit diagnosis	Receive diagnosis											
			ECM	TCM	METER /M&A	DISPLAY	BCM/SEC	STRG	HVAC	VDC/TCS /ABS	IPDM E/R	CAN COMM CIRCUIT (U1001)	CAN COMM CIRCUIT (U1000)	
ENGINE	-	-	UNKWN	-	UNKWN	UNKWN	-	UNKWN	-	-	UNKWN	UNKWN	CAN COMM CIRCUIT (U1001)	✓
A/T	-	NG	UNKWN	UNKWN	-	UNKWN	-	-	-	-	UNKWN	-	CAN COMM CIRCUIT (U1000)	✓
AUTO DRIVE POS.	No indication	-	-	-	UNKWN	UNKWN	-	UNKWN	-	-	-	-	CAN COMM CIRCUIT (U1000)	✓
Display control unit	-	NG	UNKWN	UNKWN	-	UNKWN	-	UNKWN	-	UNKWN	-	UNKWN	-	-
BCM	No indication	NG	UNKWN	UNKWN	-	UNKWN	-	-	-	-	-	UNKWN	CAN COMM CIRCUIT (U1000)	-
HVAC	No indication	-	UNKWN	UNKWN	-	-	UNKWN	UNKWN	-	-	UNKWN	-	-	-
ABS	-	NG	UNKWN	UNKWN	UNKWN	-	-	-	UNKWN	-	-	-	CAN COMM CIRCUIT (U1000)	✓
IPDM E/R	No indication	-	UNKWN	UNKWN	-	-	-	UNKWN	-	-	-	-	CAN COMM CIRCUIT (U1000)	✓

SYSTEM ENGINE SYSTEM A/T SYSTEM AUTO DRIVE POS. SYSTEM BCM

SELF-DIAG RESULTS SELF-DIAG RESULTS SELF-DIAG RESULTS SELF-DIAG RESULTS

DTC RESULTS TIME DTC RESULTS DTC RESULTS TIME DTC RESULTS TIME

CAN COMM CIRCUIT [U1001] 11 CAN COMM CIRCUIT [U1000] CAN COMM CIRCUIT [U1000] 1 NO DTC IS DETECTED. FURTHER TESTING MAY BE REQUIRED.

SYSTEM HVAC SYSTEM ABS SYSTEM IPDM E/R

SELF-DIAG RESULTS SELF-DIAG RESULTS SELF-DIAG RESULTS

DTC RESULTS TIME DTC RESULTS TIME DTC RESULTS TIME

NO DTC IS DETECTED. FURTHER TESTING MAY BE REQUIRED. CAN COMM CIRCUIT [U1000] 1 CAN COMM CIRCUIT [U1000] PAST

PKIC3661E

- See "SELF-DIAG RESULTS" of all units attached to the check sheet. If "CAN COMM CIRCUIT" or "CAN COMM CIRCUIT [U1000]" is displayed, put a check mark to the applicable column of self-diagnostic results of the check sheet table.

NOTE:

- For "ENGINE", "CAN COMM CIRCUIT [U1001]" is displayed. Put a check mark to it.
- For "A/T", "CAN COMM CIRCUIT [U1000]" is displayed. Put a check mark to it.
- For "AUTO DRIVE POS.", "CAN COMM CIRCUIT [U1000]" is displayed. Put a check mark to it.
- For "BCM", "NO DTC IS DETECTED" is displayed. Do not put a check mark to it.
- For "HVAC", "NO DTC IS DETECTED" is displayed. Do not put a check mark to it.
- For "ABS", "CAN COMM CIRCUIT [U1000]" is displayed. Put a check mark to it.
- For "IPDM E/R", "CAN COMM CIRCUIT [U1000]" is displayed. Put a check mark to it.

TROUBLE DIAGNOSES WORK FLOW

[CAN]

The arranged results of self-diagnosis

SELECT SYSTEM screen	CAN DIAG SUPPORT MNTR											SELF-DIAG RESULTS				
	Initial diagnosis	Transmit diagnosis	Receive diagnosis											IPDM E/R		
			ECM	TCM	METER /M/A	DISPLAY	BCM/SEC	STRG	HVAC	VDC/TC/ABS	IPDM E/R					
ENGINE	-	-	UNKWN	-	UNKWN	UNKWN	-	UNKWN	UNKWN	-	UNKWN	-	UNKWN	-	CAN COMM CIRCUIT [U1000]	CAN COMM CIRCUIT [U1000]
A/T	-	NG	UNKWN	UNKWN	-	UNKWN	-	UNKWN	-	-	-	-	UNKWN	-	CAN COMM CIRCUIT [U1000]	CAN COMM CIRCUIT [U1000]
AUTO DRIVE POS.	No indicator	-	-	-	UNKWN	UNKWN	-	UNKWN	-	-	-	-	-	-	CAN COMM CIRCUIT [U1000]	-
Display control unit	-	NG	UNKWN	UNKWN	-	UNKWN	-	UNKWN	-	UNKWN	-	-	UNKWN	-	CAN COMM CIRCUIT [U1000]	-
BCM	No indicator	-	UNKWN	UNKWN	-	UNKWN	-	UNKWN	-	-	-	-	-	-	CAN COMM CIRCUIT [U1000]	-
HVAC	No indicator	-	UNKWN	UNKWN	-	UNKWN	UNKWN	-	-	UNKWN	-	-	UNKWN	-	CAN COMM CIRCUIT [U1000]	-
ABS	-	NG	UNKWN	UNKWN	UNKWN	-	-	-	-	UNKWN	-	-	-	-	CAN COMM CIRCUIT [U1000]	-
IPDM E/R	No indicator	-	UNKWN	UNKWN	-	-	-	-	-	UNKWN	-	-	-	-	CAN COMM CIRCUIT [U1000]	-

When the arranged results of self-diagnosis and check sheet results (example) are corresponding, possible causes can be selected.

Case 1

Check harness between TCM and driver seat control unit.

SELECT SYSTEM screen	CAN DIAG SUPPORT MNTR											SELF-DIAG RESULTS				
	Initial diagnosis	Transmit diagnosis	Receive diagnosis											IPDM E/R		
			ECM	TCM	METER /M/A	DISPLAY	BCM/SEC	STRG	HVAC	VDC/TC/ABS	IPDM E/R					
ENGINE	-	-	UNKWN	-	UNKWN	UNKWN	-	UNKWN	UNKWN	-	UNKWN	-	UNKWN	-	CAN COMM CIRCUIT [U1000]	CAN COMM CIRCUIT [U1000]
A/T	-	NG	UNKWN	UNKWN	-	UNKWN	-	UNKWN	-	-	-	-	UNKWN	-	CAN COMM CIRCUIT [U1000]	CAN COMM CIRCUIT [U1000]
AUTO DRIVE POS.	No indicator	-	-	-	UNKWN	UNKWN	-	UNKWN	-	-	-	-	-	-	CAN COMM CIRCUIT [U1000]	-
Display control unit	-	NG	UNKWN	UNKWN	-	UNKWN	-	UNKWN	-	UNKWN	-	-	UNKWN	-	CAN COMM CIRCUIT [U1000]	-
BCM	No indicator	-	UNKWN	UNKWN	-	UNKWN	-	UNKWN	-	-	-	-	-	-	CAN COMM CIRCUIT [U1000]	-
HVAC	No indicator	-	UNKWN	UNKWN	-	UNKWN	UNKWN	-	-	UNKWN	-	-	UNKWN	-	CAN COMM CIRCUIT [U1000]	-
ABS	-	NG	UNKWN	UNKWN	UNKWN	-	-	-	-	UNKWN	-	-	-	-	CAN COMM CIRCUIT [U1000]	-
IPDM E/R	No indicator	-	UNKWN	UNKWN	-	-	-	-	-	UNKWN	-	-	-	-	CAN COMM CIRCUIT [U1000]	-

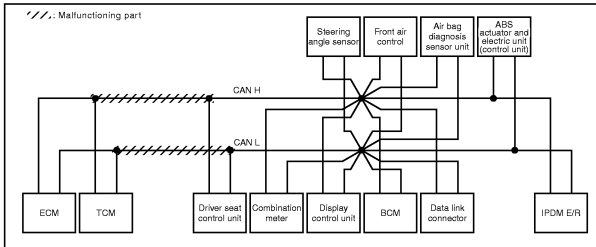

Case 2

Check harness between driver seat control unit and data link connector.

SELECT SYSTEM screen	CAN DIAG SUPPORT MNTR											SELF-DIAG RESULTS				
	Initial diagnosis	Transmit diagnosis	Receive diagnosis											IPDM E/R		
			ECM	TCM	METER /M/A	DISPLAY	BCM/SEC	STRG	HVAC	VDC/TC/ABS	IPDM E/R					
ENGINE	-	-	UNKWN	-	UNKWN	UNKWN	-	UNKWN	UNKWN	-	UNKWN	-	UNKWN	-	CAN COMM CIRCUIT [U1000]	CAN COMM CIRCUIT [U1000]
A/T	-	NG	UNKWN	UNKWN	-	UNKWN	-	UNKWN	-	-	-	-	UNKWN	-	CAN COMM CIRCUIT [U1000]	CAN COMM CIRCUIT [U1000]
AUTO DRIVE POS.	No indicator	-	-	-	UNKWN	UNKWN	-	UNKWN	-	-	-	-	-	-	CAN COMM CIRCUIT [U1000]	-
Display control unit	-	NG	UNKWN	UNKWN	-	UNKWN	-	UNKWN	-	UNKWN	-	-	UNKWN	-	CAN COMM CIRCUIT [U1000]	-
BCM	No indicator	-	UNKWN	UNKWN	-	UNKWN	-	UNKWN	-	-	-	-	-	-	CAN COMM CIRCUIT [U1000]	-
HVAC	No indicator	-	UNKWN	UNKWN	-	UNKWN	UNKWN	-	-	UNKWN	-	-	UNKWN	-	CAN COMM CIRCUIT [U1000]	-
ABS	-	NG	UNKWN	UNKWN	UNKWN	-	-	-	-	UNKWN	-	-	-	-	CAN COMM CIRCUIT [U1000]	-
IPDM E/R	No indicator	-	UNKWN	UNKWN	-	-	-	-	-	UNKWN	-	-	-	-	CAN COMM CIRCUIT [U1000]	-

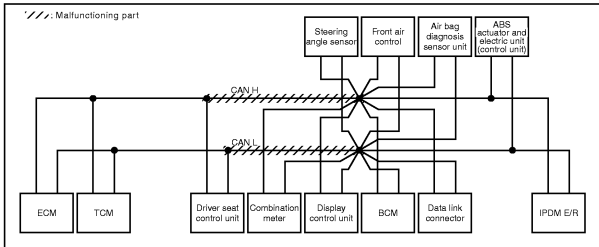

PKIC3662E

NOTE:

There is a case that some of "CAN DIAG SUPPORT MNTR" and "SELF-DIAG RESULTS" are not needed for diagnosis. In the case, "UNKWN" and "CAN COMM CIRCUIT [U1000]" in "Check sheet results (example)" change to "-". Then, ignore check marks on the check sheet table.

2. For the selected possible causes, it is expected that malfunctions have been found in the past.

TROUBLE DIAGNOSES WORK FLOW

[CAN]

UKS004SR

CAN Diagnostic Support Monitor DESCRIPTION OF “CAN DIAG SUPPORT MNTR” SCREEN FOR ECM

(Example)	CAN DIAG SUPPORT MNTR	CAN DIAG SUPPORT MNTR																																																																													
	<table border="1" style="width: 100%; border-collapse: collapse;"> <tr><th colspan="3">ENGINE</th></tr> <tr><td></td><th>PRSNT</th><th>PAST</th></tr> <tr><td>TRANSMIT DIAG</td><td>OK</td><td>OK</td></tr> <tr><td>VDC/TCS/ABS</td><td>OK</td><td>OK</td></tr> <tr><td>METER/M&A</td><td>OK</td><td>OK</td></tr> <tr><td>BCM/SEC</td><td>OK</td><td>OK</td></tr> <tr><td>ICC</td><td>-</td><td>-</td></tr> <tr><td>HVAC</td><td>-</td><td>-</td></tr> <tr><td>TCM</td><td>OK</td><td>OK</td></tr> <tr><td>EPS</td><td>-</td><td>-</td></tr> <tr><td>IPDM E/R</td><td>OK</td><td>OK</td></tr> <tr><td>PRINT</td><td></td><td>Scroll Down</td></tr> <tr><td>MODE</td><td>BACK</td><td>LIGHT COPY</td></tr> </table>	ENGINE				PRSNT	PAST	TRANSMIT DIAG	OK	OK	VDC/TCS/ABS	OK	OK	METER/M&A	OK	OK	BCM/SEC	OK	OK	ICC	-	-	HVAC	-	-	TCM	OK	OK	EPS	-	-	IPDM E/R	OK	OK	PRINT		Scroll Down	MODE	BACK	LIGHT COPY	<table border="1" style="width: 100%; border-collapse: collapse;"> <tr><th colspan="3">ENGINE</th></tr> <tr><td></td><th>PRSNT</th><th>PAST</th></tr> <tr><td>METER/M&A</td><td>OK</td><td>OK</td></tr> <tr><td>BCM/SEC</td><td>OK</td><td>OK</td></tr> <tr><td>ICC</td><td>-</td><td>-</td></tr> <tr><td>HVAC</td><td>-</td><td>-</td></tr> <tr><td>TCM</td><td>OK</td><td>OK</td></tr> <tr><td>EPS</td><td>-</td><td>-</td></tr> <tr><td>IPDM E/R</td><td>OK</td><td>OK</td></tr> <tr><td>e4WD</td><td>-</td><td>-</td></tr> <tr><td>AWD/4WD</td><td>OK</td><td>OK</td></tr> <tr><td>PRINT</td><td></td><td>Scroll Up</td></tr> <tr><td>MODE</td><td>BACK</td><td>LIGHT COPY</td></tr> </table>	ENGINE				PRSNT	PAST	METER/M&A	OK	OK	BCM/SEC	OK	OK	ICC	-	-	HVAC	-	-	TCM	OK	OK	EPS	-	-	IPDM E/R	OK	OK	e4WD	-	-	AWD/4WD	OK	OK	PRINT		Scroll Up	MODE	BACK
ENGINE																																																																															
	PRSNT	PAST																																																																													
TRANSMIT DIAG	OK	OK																																																																													
VDC/TCS/ABS	OK	OK																																																																													
METER/M&A	OK	OK																																																																													
BCM/SEC	OK	OK																																																																													
ICC	-	-																																																																													
HVAC	-	-																																																																													
TCM	OK	OK																																																																													
EPS	-	-																																																																													
IPDM E/R	OK	OK																																																																													
PRINT		Scroll Down																																																																													
MODE	BACK	LIGHT COPY																																																																													
ENGINE																																																																															
	PRSNT	PAST																																																																													
METER/M&A	OK	OK																																																																													
BCM/SEC	OK	OK																																																																													
ICC	-	-																																																																													
HVAC	-	-																																																																													
TCM	OK	OK																																																																													
EPS	-	-																																																																													
IPDM E/R	OK	OK																																																																													
e4WD	-	-																																																																													
AWD/4WD	OK	OK																																																																													
PRINT		Scroll Up																																																																													
MODE	BACK	LIGHT COPY																																																																													

PKIC3562E

“SELECT SYSTEM” screen	“CAN DIAG SUPPORT MNTR” screen	Description	Present	Past
ENGINE	TRANSMIT DIAG	Make sure of normal transmission.	OK/UNKWN/-	OK/0/1~39/-
	VDC/TCS/ABS	Make sure of normal reception from ABS actuator and electric unit (control unit).	OK/UNKWN/-	
	METER/M&A	Make sure of normal reception from combination meter.	OK/UNKWN/-	
	BCM/SEC	Make sure of normal reception from BCM.	OK/UNKWN/-	
	ICC	ICC is not diagnosed.	-	
	HVAC	HVAC is not diagnosed.	-	
	TCM	Make sure of normal reception from TCM.	OK/UNKWN/-	
	EPS	EPS is not diagnosed.	-	
	IPDM E/R	Make sure of normal reception from IPDM E/R.	OK/UNKWN/-	
	e4WD	e4WD is not diagnosed.	-	
AWD/4WD	Make sure of normal reception from transfer control unit.	OK/UNKWN/-		

Display Results (Present)

- OK: Normal
- UNKWN: The diagnosed unit does not transmit or receive the applicable data normally.
- -: There is no received unit or the unit is not in the condition that reception diagnosis is performed.

Display Results (Past)

- OK: Normal
- 0: There is malfunction now.
- 1 ~ 39: Displays when it is normal at present and finds malfunction in the past. It increases like 0→1→2...38→39 after returning to the normal condition whenever IGN OFF→ON. If it is over 39, it is fixed to 39 until the self-diagnostic results are erased. It returns to 0 when malfunction is detected again in the process.
- -: Undiagnosed

TROUBLE DIAGNOSES WORK FLOW

[CAN]

DESCRIPTION OF “CAN DIAG SUPPORT MNTR” SCREEN FOR TCM

(Example)

CAN DIAG SUPPORT MNTR			
A/T			
		PRSNT	
INITIAL DIAG		OK	
TRANSMIT DIAG		OK	
ECM		OK	
VDC/TCS/ABS		OK	
METER/M&A		OK	
ICC/e4WD		UNKWN	
AWD/4WD		OK	
PRINT			
MODE	BACK	LIGHT	COPY

SKIB2335E

“SELECT SYSTEM” screen	“CAN DIAG SUPPORT MNTR” screen	Description	Present
A/T	INITIAL DIAG	Make sure that microcomputer in ECU works normally.	OK/NG
	TRANSMIT DIAG	Make sure of normal transmission.	OK/UNKWN
	ECM	Make sure of normal reception from ECM.	OK/UNKWN
	VDC/TCS/ABS	Make sure of normal reception from ABS actuator and electric unit (control unit).	OK/UNKWN
	METER/M&A	Make sure of normal reception from combination meter.	OK/UNKWN
	ICC/e4WD	ICC/e4WD is not diagnosed.	UNKWN
	AWD/4WD	Make sure of normal reception from transfer control unit.	OK/UNKWN

Display Results (Present)

- OK: Normal
- NG: Malfunction
- UNKWN: The diagnosed unit does not transmit or receive the applicable data normally.

A
B
C
D
E
F
G
H
I
J
L
M

LAN

TROUBLE DIAGNOSES WORK FLOW

[CAN]

DESCRIPTION OF “CAN DIAG SUPPORT MNTR” SCREEN FOR BCM

(Example)

CAN DIAG SUPPORT MNTR			
BCM			
		PRSNT	
INITIAL DIAG		OK	
TRANSMIT DIAG		OK	
ECM		OK	
IPDM E/R		OK	
METER/M&A		OK	
I-KEY		OK	
PRINT			
MODE	BACK	LIGHT	COPY

SKIB1625E

“SELECT SYSTEM” screen	“CAN DIAG SUPPORT MNTR” screen	Description	Present
BCM	INITIAL DIAG	Make sure that microcomputer in ECU works normally.	OK/NG
	TRANSMIT DIAG	Make sure of normal transmission.	OK/UNKWN
	ECM	Make sure of normal reception from ECM.	OK/UNKWN
	IPDM E/R	Make sure of normal reception from IPDM E/R.	OK/UNKWN
	METER/M&A	Make sure of normal reception from combination meter.	OK/UNKWN
	I-KEY	I-KEY is not diagnosed.	OK

Display Results (Present)

- OK: Normal
- NG: Malfunction
- UNKWN: The diagnosed unit does not transmit or receive the applicable data normally.

A
B
C
D
E
F
G
H
I
J
L
M

LAN

TROUBLE DIAGNOSES WORK FLOW

[CAN]

DESCRIPTION OF "CAN DIAG SUPPORT MNTR" SCREEN FOR FRONT AIR CONTROL

(Example)	CAN DIAG SUPPORT MNTR	CAN DIAG SUPPORT MNTR																																																																													
	<table border="1" style="width: 100%; border-collapse: collapse;"> <tr><td colspan="3" style="text-align: center;">HVAC</td></tr> <tr><td></td><td style="text-align: center;">PRSNT</td><td style="text-align: center;">PAST</td></tr> <tr><td>TRANSMIT DIAG</td><td style="text-align: center;">OK</td><td style="text-align: center;">OK</td></tr> <tr><td>ECM</td><td style="text-align: center;">OK</td><td style="text-align: center;">OK</td></tr> <tr><td>TCM</td><td style="text-align: center;">-</td><td style="text-align: center;">-</td></tr> <tr><td>BCM/SEC</td><td style="text-align: center;">OK</td><td style="text-align: center;">OK</td></tr> <tr><td>VDC/TCS/ABS</td><td style="text-align: center;">OK</td><td style="text-align: center;">OK</td></tr> <tr><td>IPDM E/R</td><td style="text-align: center;">-</td><td style="text-align: center;">-</td></tr> <tr><td>DISPLAY</td><td style="text-align: center;">OK</td><td style="text-align: center;">OK</td></tr> <tr><td>I-KEY</td><td style="text-align: center;">-</td><td style="text-align: center;">-</td></tr> <tr><td>EPS</td><td style="text-align: center;">-</td><td style="text-align: center;">-</td></tr> <tr><td colspan="2" style="text-align: center;">PRINT</td><td style="text-align: center;">Scroll Down</td></tr> <tr><td>MODE</td><td>BACK</td><td>LIGHT COPY</td></tr> </table>	HVAC				PRSNT	PAST	TRANSMIT DIAG	OK	OK	ECM	OK	OK	TCM	-	-	BCM/SEC	OK	OK	VDC/TCS/ABS	OK	OK	IPDM E/R	-	-	DISPLAY	OK	OK	I-KEY	-	-	EPS	-	-	PRINT		Scroll Down	MODE	BACK	LIGHT COPY	<table border="1" style="width: 100%; border-collapse: collapse;"> <tr><td colspan="3" style="text-align: center;">HVAC</td></tr> <tr><td></td><td style="text-align: center;">PRSNT</td><td style="text-align: center;">PAST</td></tr> <tr><td>IPDM E/R</td><td style="text-align: center;">-</td><td style="text-align: center;">-</td></tr> <tr><td>DISPLAY</td><td style="text-align: center;">OK</td><td style="text-align: center;">OK</td></tr> <tr><td>I-KEY</td><td style="text-align: center;">-</td><td style="text-align: center;">-</td></tr> <tr><td>EPS</td><td style="text-align: center;">-</td><td style="text-align: center;">-</td></tr> <tr><td>AWD/4WD</td><td style="text-align: center;">-</td><td style="text-align: center;">-</td></tr> <tr><td>e4WD</td><td style="text-align: center;">-</td><td style="text-align: center;">-</td></tr> <tr><td>ICC</td><td style="text-align: center;">-</td><td style="text-align: center;">-</td></tr> <tr><td>LANE KEEP</td><td style="text-align: center;">-</td><td style="text-align: center;">-</td></tr> <tr><td>TIRE-P</td><td style="text-align: center;">-</td><td style="text-align: center;">-</td></tr> <tr><td colspan="2" style="text-align: center;">PRINT</td><td style="text-align: center;">Scroll Up</td></tr> <tr><td>MODE</td><td>BACK</td><td>LIGHT COPY</td></tr> </table>	HVAC				PRSNT	PAST	IPDM E/R	-	-	DISPLAY	OK	OK	I-KEY	-	-	EPS	-	-	AWD/4WD	-	-	e4WD	-	-	ICC	-	-	LANE KEEP	-	-	TIRE-P	-	-	PRINT		Scroll Up	MODE	BACK
HVAC																																																																															
	PRSNT	PAST																																																																													
TRANSMIT DIAG	OK	OK																																																																													
ECM	OK	OK																																																																													
TCM	-	-																																																																													
BCM/SEC	OK	OK																																																																													
VDC/TCS/ABS	OK	OK																																																																													
IPDM E/R	-	-																																																																													
DISPLAY	OK	OK																																																																													
I-KEY	-	-																																																																													
EPS	-	-																																																																													
PRINT		Scroll Down																																																																													
MODE	BACK	LIGHT COPY																																																																													
HVAC																																																																															
	PRSNT	PAST																																																																													
IPDM E/R	-	-																																																																													
DISPLAY	OK	OK																																																																													
I-KEY	-	-																																																																													
EPS	-	-																																																																													
AWD/4WD	-	-																																																																													
e4WD	-	-																																																																													
ICC	-	-																																																																													
LANE KEEP	-	-																																																																													
TIRE-P	-	-																																																																													
PRINT		Scroll Up																																																																													
MODE	BACK	LIGHT COPY																																																																													

PKIC4721E

"SELECT SYSTEM" screen	"CAN DIAG SUPPORT MNTR" screen	Description	Present	Past
HVAC	TRANSMIT DIAG	Make sure of normal transmission.	OK/UNKWN/-	OK/0/1~39/-
	ECM	Make sure of normal reception from ECM.	OK/UNKWN/-	
	TCM	TCM is not diagnosed.	-	
	BCM/SEC	Make sure of normal reception from BCM.	OK/UNKWN/-	
	VDC/TCS/ABS	Make sure of normal reception from ABS actuator and electric unit (control unit).	OK/UNKWN/-	
	IPDM E/R	IPDM E/R is not diagnosed.	-	
	DISPLAY	Make sure of normal reception from display control unit.	OK/UNKWN/-	
	I-KEY	I-KEY is not diagnosed.	-	
	EPS	EPS is not diagnosed.	-	
	AWD/4WD	AWD/4WD is not diagnosed.	-	
	e4WD	e4WD is not diagnosed.	-	
	ICC	ICC is not diagnosed.	-	
	LANE KEEP	LANE KEEP is not diagnosed.	-	
TIRE-P	TIRE-P is not diagnosed.	-		

Display Results (Present)

- OK: Normal
- UNKWN: The diagnosed unit does not transmit or receive the applicable data normally.
- -: There is no received unit or the unit is not in the condition that reception diagnosis is performed.

Display Results (Past)

- OK: Normal
- 0: There is malfunction now.
- 1 ~ 39: Displays when it is normal at present and finds malfunction in the past. It increases like 0→1→2...38→39 after returning to the normal condition whenever IGN OFF→ON. If it is over 39, it is fixed to 39 until the self-diagnostic results are erased. It returns to 0 when malfunction is detected again in the process.
- -: Undiagnosed

TROUBLE DIAGNOSES WORK FLOW

[CAN]

DESCRIPTION OF “CAN DIAG SUPPORT MNTR” SCREEN FOR TRANSFER CONTROL UNIT

(Example)

CAN DIAG SUPPORT MNTR			
ALL MODE AWD/4WD			
	PRSNT	PAST	
TRANSMIT DIAG	OK	OK	
ECM	OK	OK	
VDC/TCS/ABS	OK	OK	
TCM	OK	OK	
STRG	OK	OK	
PRINT			
MODE	BACK	LIGHT	COPY

PKIC3565E

“SELECT SYSTEM” screen	“CAN DIAG SUPPORT MNTR” screen	Description	Present	Past
ALL MODE AWD/ 4WD	TRANSMIT DIAG	Make sure of normal transmission.	OK/UNKWN/-	OK/0/1~39/-
	ECM	Make sure of normal reception from ECM.	OK/UNKWN/-	
	VDC/TCS/ABS	Make sure of normal reception from ABS actuator and electric unit (control unit).	OK/UNKWN/-	
	TCM	Make sure of normal reception from TCM.	OK/UNKWN/-	
	STRG	Make sure of normal reception from steering angle sensor.	OK/UNKWN/-	

Display Results (Present)

- OK: Normal
- UNKWN: The diagnosed unit does not transmit or receive the applicable data normally.

CAUTION:

“UNKWN” is indicated by erasing the self-diagnosis result when any malfunction was detected in past.

- -: There is no received unit or the unit is not in the condition that reception diagnosis is performed.

Display Results (Past)

- OK: Normal
- 0: There is malfunction now.
- 1 ~ 39: Displays when it is normal at present and finds malfunction in the past. It increases like 0→1→2...38→39 after returning to the normal condition whenever IGN OFF→ON. If it is over 39, it is fixed to 39 until the self-diagnostic results are erased. It returns to 0 when malfunction is detected again in the process.
- -: Undiagnosed

CAUTION:

- “UNKWN” is indicated in “Present” and “0” is indicated in “Past” when any malfunction is detected at present.
- “UNKWN” is indicated in “Present” and “1~39” is indicated in “Past” when any malfunction was detected in past.

(Example)

CAN DIAG SUPPORT MNTR			
ALL MODE AWD/4WD			
	PRSNT	PAST	
TRANSMIT DIAG	OK	OK	
ECM	UNKWN	0	
VDC/TCS/ABS	UNKWN	39	
TCM	UNKWN	0	
STRG	OK	OK	
PRINT			
MODE	BACK	LIGHT	COPY

SKIB3246E

TROUBLE DIAGNOSES WORK FLOW

[CAN]

DESCRIPTION OF “CAN DIAG SUPPORT MNTR” SCREEN FOR ABS ACTUATOR AND ELECTRIC UNIT (CONTROL UNIT)

(Example)

CAN DIAG SUPPORT MNTR			
ABS			
		PRSNT	
INITIAL DIAG		OK	
TRANSMIT DIAG		OK	
ECM		OK	
TCM		OK	
METER/M&A		UNKWN	
STRG		OK	
ICC		UNKWN	
AWD/4WD		OK	
PRINT			
MODE	BACK	LIGHT	COPY

PKIB6078E

“SELECT SYSTEM” screen	“CAN DIAG SUPPORT MNTR” screen	Description	Present
ABS	INITIAL DIAG	Make sure that microcomputer in ECU works normally.	OK/NG
	TRANSMIT DIAG	Make sure of normal transmission.	OK/UNKWN
	ECM	Make sure of normal reception from ECM.	OK/UNKWN
	TCM	Make sure of normal reception from TCM.	OK/UNKWN
	METER/M&A	METER/M&A is not diagnosed.	UNKWN
	STRG	Make sure of normal reception from steering angle sensor.	OK/UNKWN
	ICC	ICC is not diagnosed.	UNKWN
	AWD/4WD	Make sure of normal reception from transfer control unit.	OK/UNKWN

Display Results (Present)

- OK: Normal
- NG: Malfunction
- UNKWN: The diagnosed unit does not transmit or receive the applicable data normally.

TROUBLE DIAGNOSES WORK FLOW

[CAN]

DESCRIPTION OF “CAN DIAG SUPPORT MNTR” SCREEN FOR DISPLAY CONTROL UNIT

(Example)

CAN DIAG SUPPORT MONITOR			
CAN_COMM	OK	0	<input type="button" value="Delete"/>
CAN_CIRC_1	OK	0	
CAN_CIRC_2	OK	0	
CAN_CIRC_3	OK	0	
CAN_CIRC_4	UNKWN	1	
CAN_CIRC_5	UNKWN	1	
CAN_CIRC_6	UNKWN	1	
CAN_CIRC_7	OK	0	
CAN_CIRC_8	OK	0	
CAN_CIRC_9	OK	0	

SKIB0645E

Unit name	Diagnosis item	Description	“CAN DIAG SUPPORT MONITOR” screen	Error counter (Reference)
Display control unit	CAN COMM	Make sure that microcomputer in ECU works normally.	OK/NG	0/1~50
	CAN CIRC 1	Make sure of normal transmission.	OK/UNKWN	
	CAN CIRC 2	Make sure of normal reception from BCM.	OK/UNKWN	
	CAN CIRC 3	Make sure of normal reception from ECM.	OK/UNKWN	
	CAN CIRC 4	Make sure of normal reception from front air control.	OK/UNKWN	
	CAN CIRC 5	Make sure of normal reception from combination meter.	OK/UNKWN	
	CAN CIRC 6	CAN CIRC 6 is not diagnosed.	UNKWN	
	CAN CIRC 7	Make sure of normal reception from IPDM E/R.	OK/UNKWN	
	CAN CIRC 8	CAN CIRC 8 is not diagnosed.	UNKWN	
	CAN CIRC 9	CAN CIRC 9 is not diagnosed.	UNKWN	

Display Results (Present)

- OK : Normal
- NG : Malfunction
- UNKWN : The diagnosed unit does not transmit or receive the applicable data normally.

Display Results : Error Counter (Reference)

- 0 : It is normal now.
- 1 ~ 50 : Displays when it finds malfunction in the past even if it is normal or there is a malfunction at present. Also, displays when diagnosis is not performed. It increase like 0→1→2...49→50 after returning to the normal condition whenever IGN OFF→ON. If it is over 50, it is fixed to 50 until the self-diagnostic results are erased. Keep this condition until resetting it.

CAN COMMUNICATION

PFP:23710

System Description

UKS000NU

CAN (Controller Area Network) is a serial communication line for real time application. It is an on-vehicle multiplex communication line with high data communication speed and excellent error detection ability. Many electronic control units are equipped onto a vehicle, and each control unit shares information and links with other control units during operation (not independent). In CAN communication, control units are connected with 2 communication lines (CAN H line, CAN L line) allowing a high rate of information transmission with less wiring. Each control unit transmits/receives data but selectively reads required data only.

Component Parts and Harness Connector Location

UKS004R3

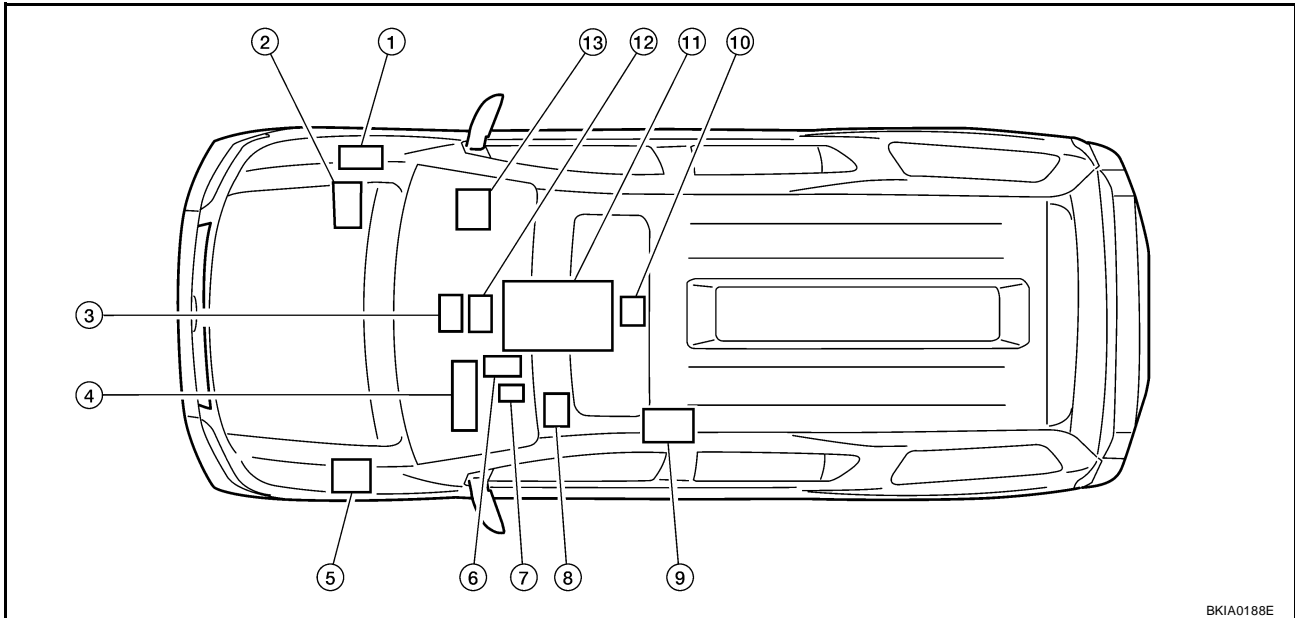

- | | | |
|---|---|--|
| 1. ECM E16 | 2. IPDM E/R E122 | 3. Display control unit M95 (with NAVI) |
| 4. Combination meter M24 | 5. ABS actuator and electric unit (control unit) E125 | 6. BCM M18 |
| 7. Data link connector M22 | 8. Steering angle sensor M47 | 9. Driver seat control unit P2 (with automatic drive positioner) |
| 10. Air bag diagnosis sensor unit M35 | 11. A/T assembly F9 | 12. Front air control M50 |
| 13. Transfer control unit E142 (with 4-wheel drive) | | |

BKIA0188E

A
B
C
D
E
F
G
H
I
J
LAN
L
M

CAN COMMUNICATION

[CAN]

Schematic

UKS004R4

- (4W) : WITH 4-WHEEL DRIVE
- (AD) : WITH AUTOMATIC DRIVE POSITIONER
- (FA) : FRONT AIR CONTROL WITH DISPLAY
- (NV) : WITH NAVI
- (XC) : FRONT AIR CONTROL WITHOUT DISPLAY

- *1 (FA) : 41
- (XC) : 34
- *2 (FA) : 42
- (XC) : 35

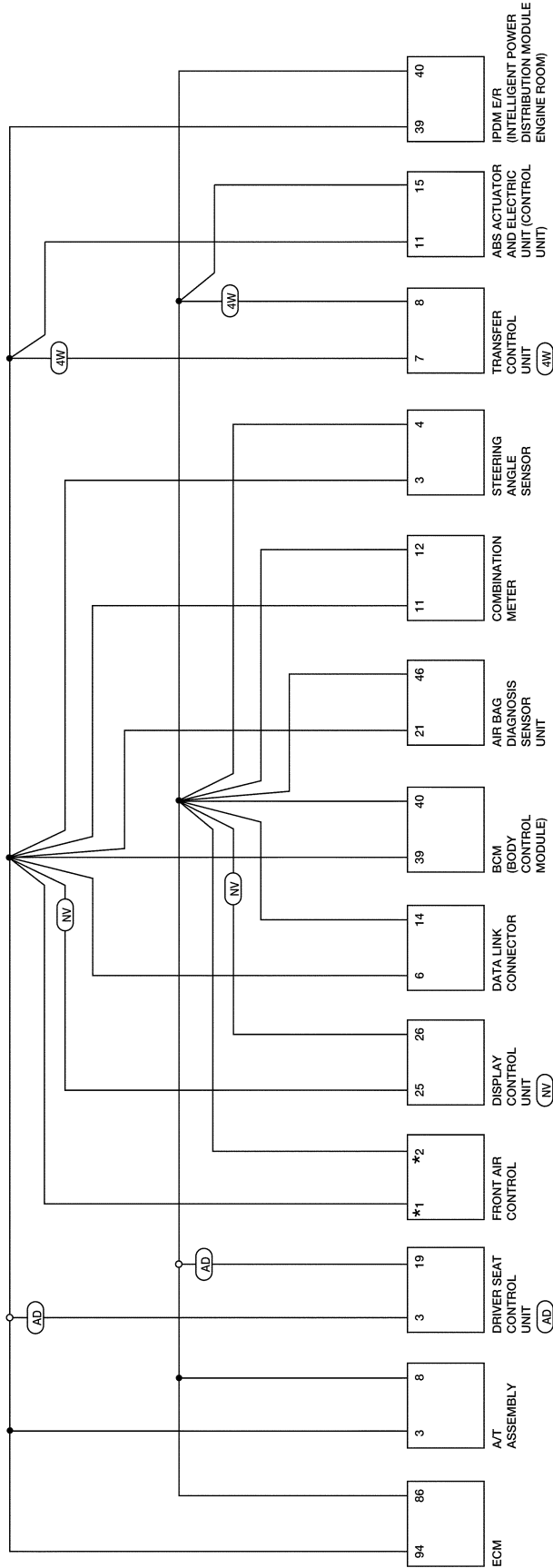

BKWA0642E

CAN COMMUNICATION

[CAN]

Wiring Diagram — CAN —

UKS004R5

LAN-CAN-01

— : DATA LINE

(AD) : WITH AUTOMATIC DRIVE POSITIONER

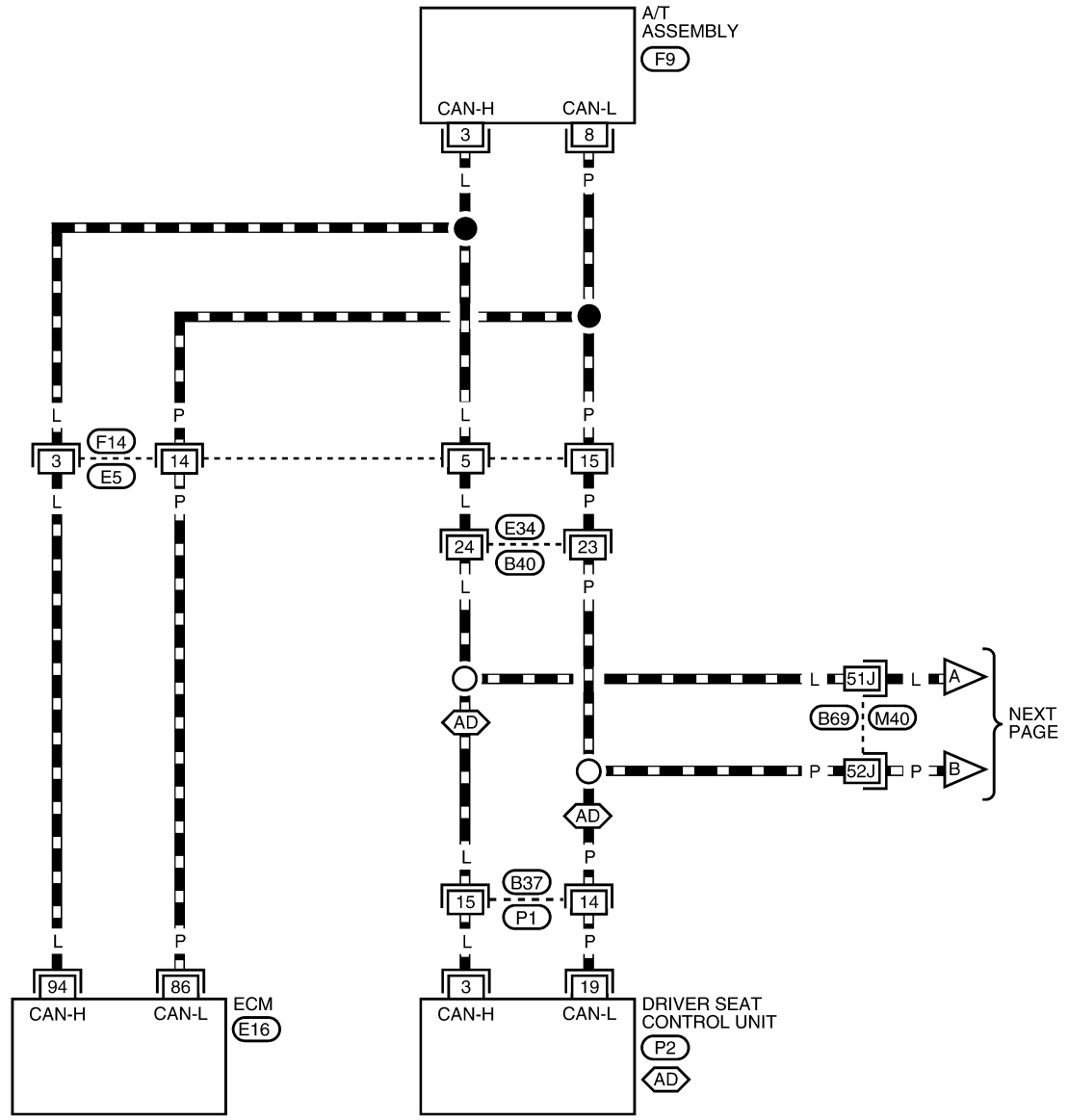

NEXT PAGE

A
B
C
D
E
F
G
H
I
J
LAN
L
M

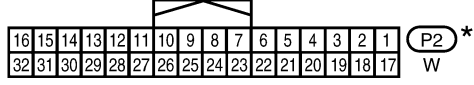
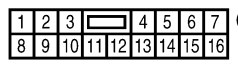
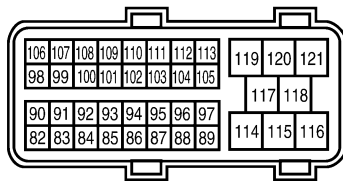

REFER TO THE FOLLOWING.

(M40) - SUPER MULTIPLE JUNCTION (SMJ)

*: THIS CONNECTOR IS NOT SHOWN IN "HARNESS LAYOUT" OF PG SECTION.

BKWA0643E

CAN COMMUNICATION

[CAN]

LAN-CAN-02

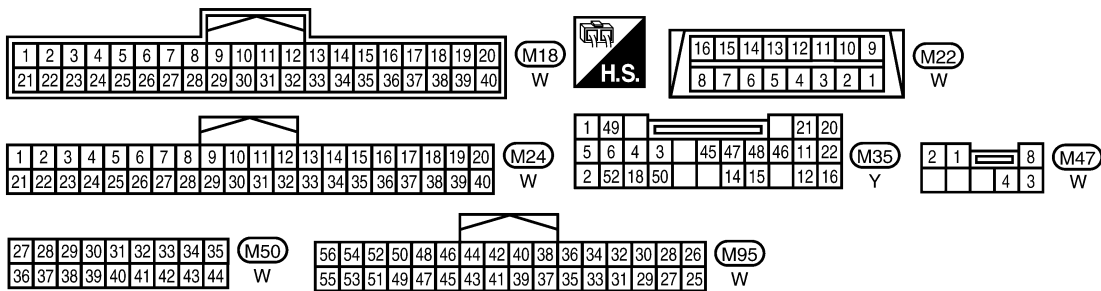
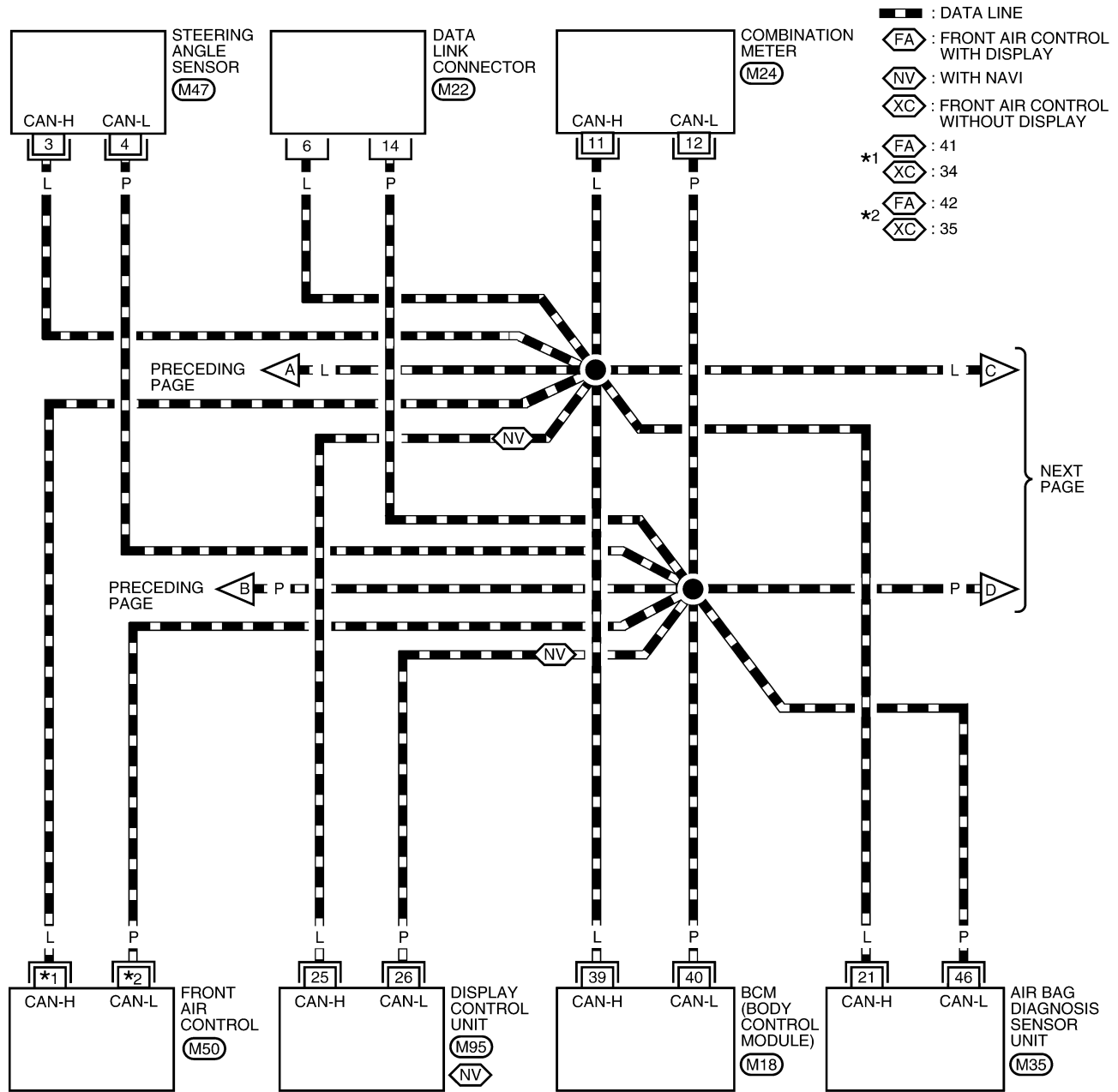

BKWA0644E

LAN-CAN-03

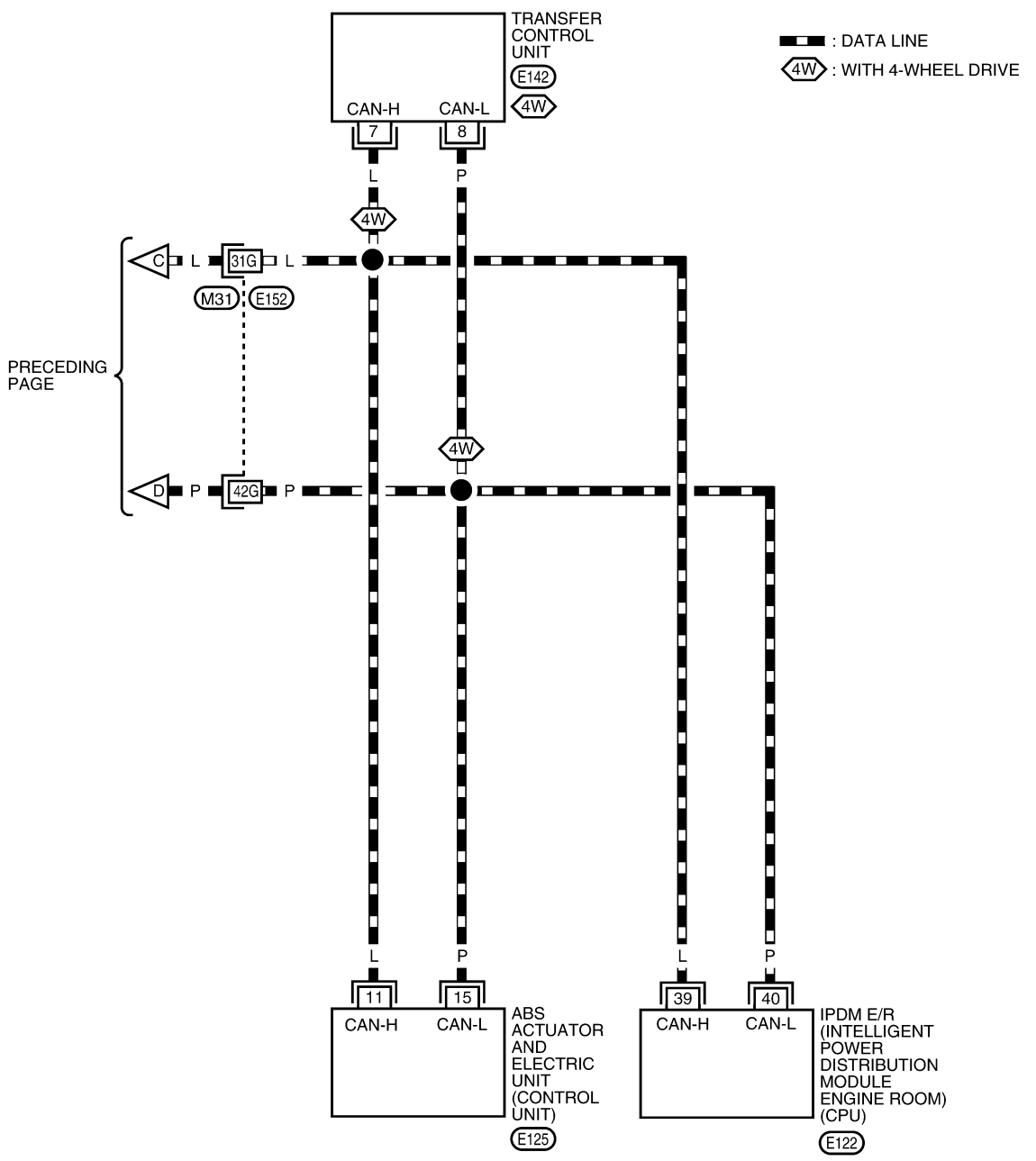

A
B
C
D
E
F
G
H
I
J
LAN
L
M

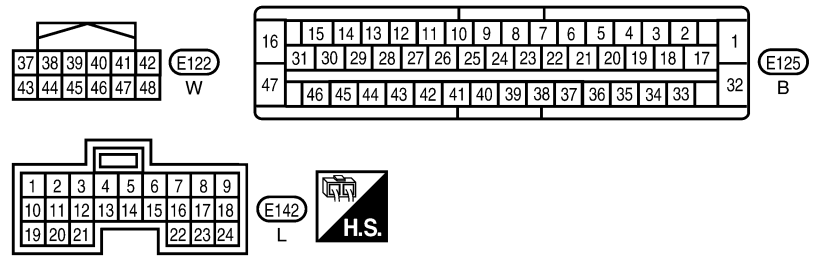

REFER TO THE FOLLOWING.
 (M31) - SUPER MULTIPLE JUNCTION (SMJ)

BKWA0645E

CAN Communication Unit

Go to CAN system, when selecting your CAN system type from the following table.

Body type	Wagon					
Axle	2WD			4WD		
Engine	VK56DE					
Transmission	A/T					
Brake control	VDC					
Automatic drive positioner		×	×		×	×
Navigation system			×			×
CAN system type	1	2	3	4	5	6
CAN system trouble diagnosis	LAN-38	LAN-53	LAN-70	LAN-88	LAN-104	LAN-122

×: Applicable

NOTE:

Confirming the presence of the following items helps to identify CAN system type.

- Models with automatic drive positioner

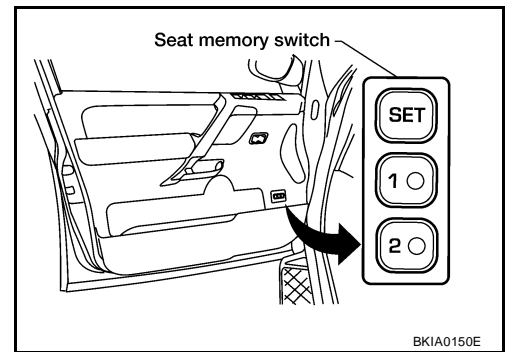

- Models with 4WD

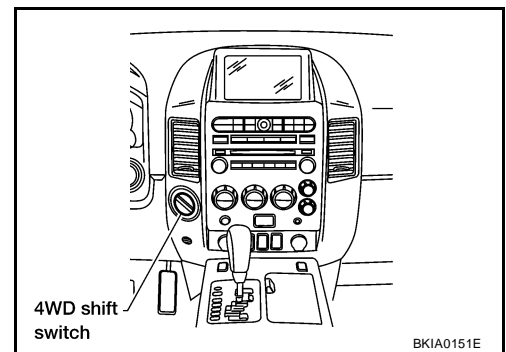

- Models with navigation system

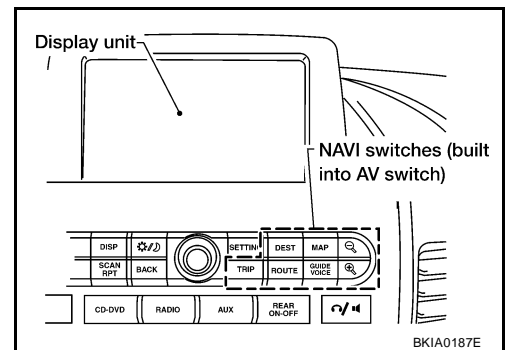

CAN COMMUNICATION

[CAN]

TYPE 1/ TYPE 2/TYPE3

System diagram

- Type 1

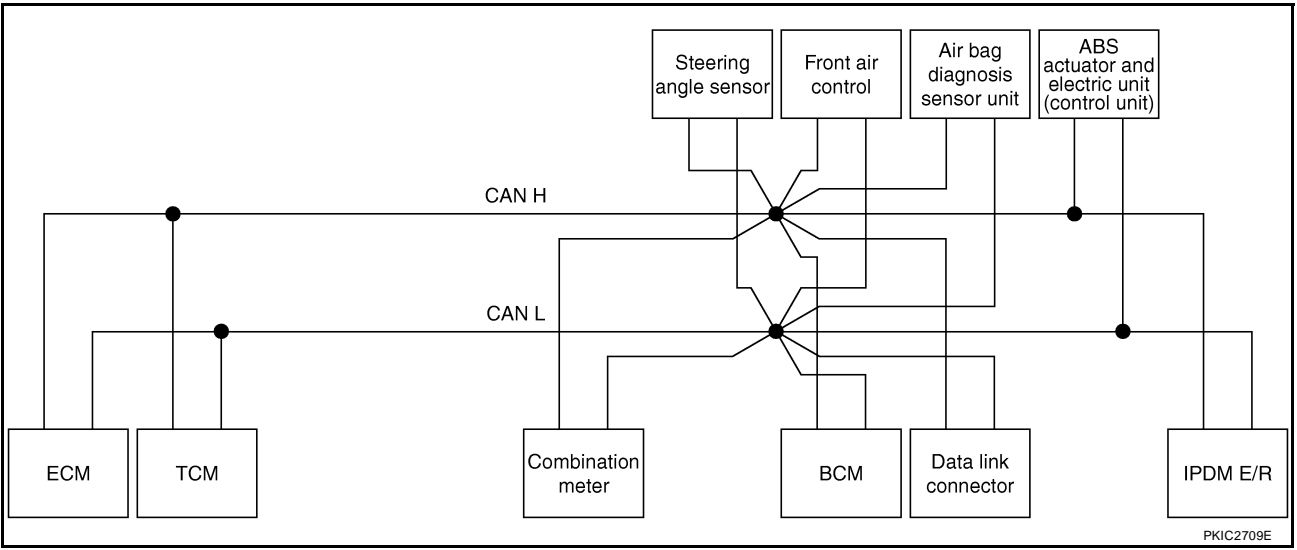

- Type 2

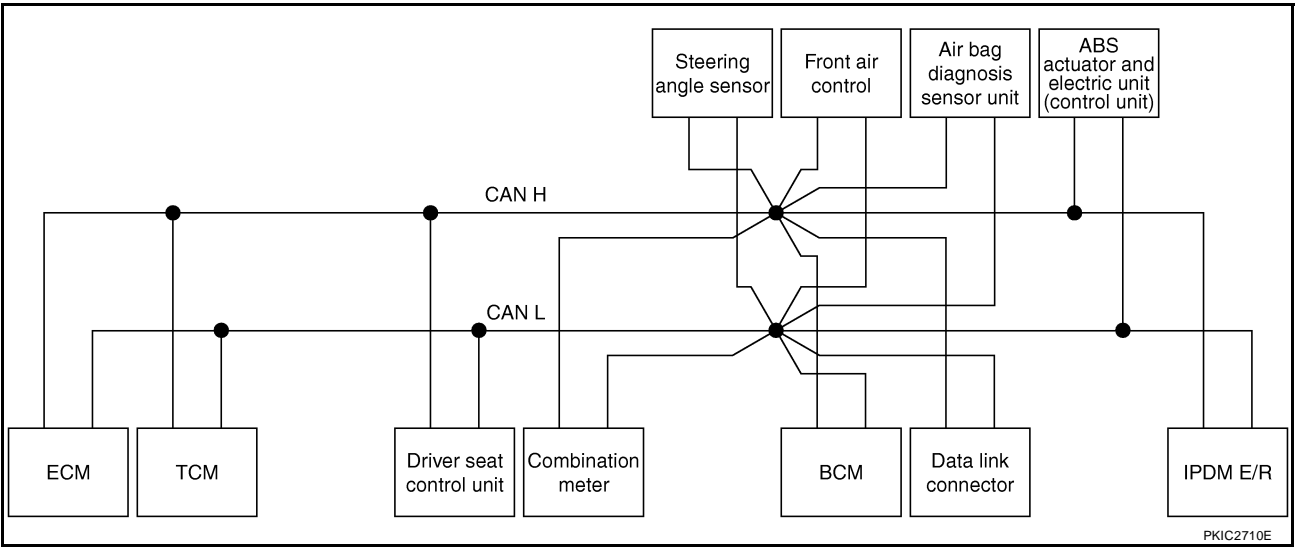

- Type 3

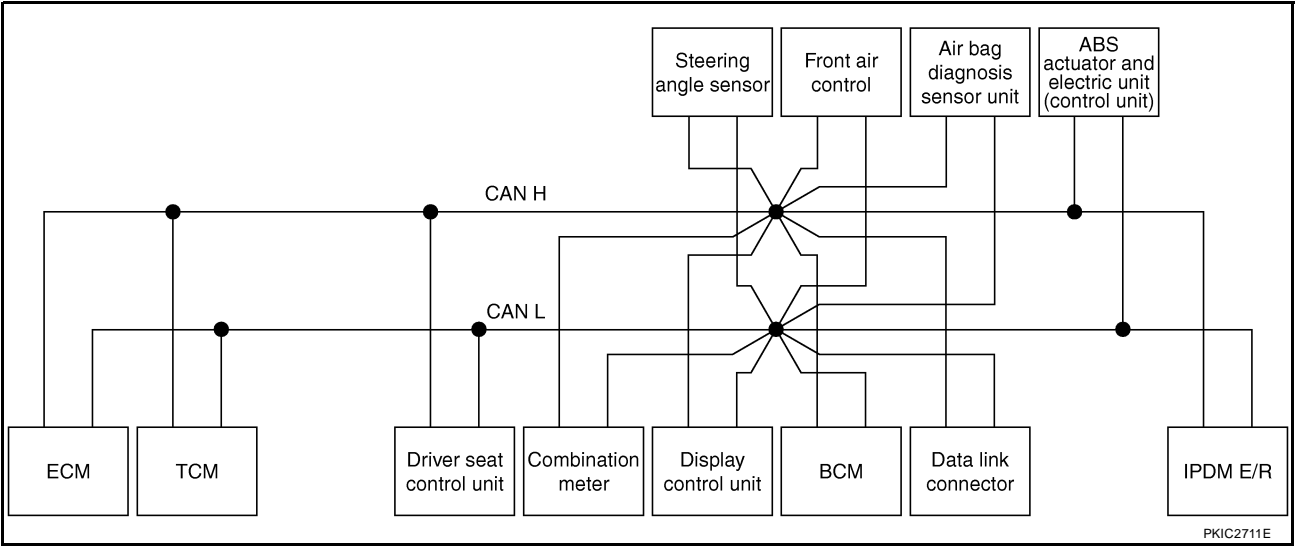

A
B
C
D
E
F
G
H
I
J
K
L
M

LAN

CAN COMMUNICATION

[CAN]

Input/output signal chart

T: Transmit R: Receive

Signals	ECM	TCM	Driver seat control unit	Combination meter	Display control unit ^{*1}	BCM	Steering angle sensor	Front air control	ABS actuator and electric unit (control unit)	IPDM E/R
A/C compressor request signal	T									R
Accelerator pedal position signal	T	R							R	
ASCD CRUISE lamp signal	T			R						
ASCD OD cancel request signal	T	R								
ASCD operation signal	T	R								
ASCD SET lamp signal	T			R						
Battery voltage signal	T	R								
Closed throttle position signal	T	R								
Cooling fan speed request signal	T									R
Engine coolant temperature signal	T			R				R		
Engine speed signal	T	R		R	R			R	R	
Engine status signal	T					R				
Fuel consumption monitor signal	T			R						
				T	R					
Malfunction indicator lamp signal	T			R						
Wide open throttle position signal	T	R								
A/T CHECK indicator lamp signal		T		R						
A/T fluid temperature sensor signal		T		R						
A/T position indicator lamp signal		T		R						
A/T self-diagnosis signal	R	T								
Output shaft revolution signal	R	T								
P range signal		T	R	R					R	
Turbine revolution signal	R	T								
System setting signal			T		R					
			R		T					
Door switch signal			R	R	R	T				R
Ignition switch signal			R			T				
Key fob door unlock signal			R			T				
Key fob ID signal			R			T				
Key switch signal			R			T				
Sleep wake up signal			R	R		T				R
1st position switch signal		R		T						
4th position switch signal		R		T						

CAN COMMUNICATION

[CAN]

Signals	ECM	TCM	Driver seat control unit	Combination meter	Display control unit*1	BCM	Steering angle sensor	Front air control	ABS actuator and electric unit (control unit)	IPDM E/R
Distance to empty signal				T	R					
Fuel level low warning signal				T	R					
Fuel level sensor signal	R			T						
Stop lamp switch signal		R		T		R				
Tow mode switch signal		R		T						
Vehicle speed signal				R				R	T	
	R	R	R	T	R	R				
A/C switch/indicator signal					T			R		
					R			T		
A/C switch signal	R					T		R		
Blower fan motor switch signal	R					T				
Buzzer output signal				R		T				
Day time running light request signal				R		T				
Front fog light request signal						T				R
Front wiper request signal						T				R
High beam request signal				R		T				R
High beam status signal	R									T
Horn chirp signal						T				R
Low beam request signal						T				R
Low beam status signal	R									T
Position light request signal				R		T				R
Rear window defogger switch signal						T		R		R
Theft warning horn request signal						T				R
Tire pressure data signal					R	T				
Tire pressure signal					R	T				
Turn indicator signal				R		T				
Steering angle sensor signal							T		R	
ABS warning lamp signal				R					T	
Brake warning lamp signal				R					T	
SLIP indicator lamp signal				R					T	
VDC OFF indicator lamp signal				R					T	
Front wiper stop position signal						R				T
Rear window defogger control signal	R				R					T

● *1: with navigation system model only

A
B
C
D
E
F
G
H
I
J
K
L
M

LAN

CAN COMMUNICATION

[CAN]

TYPE 4/ TYPE 5/TYPE6

System diagram

- Type 4

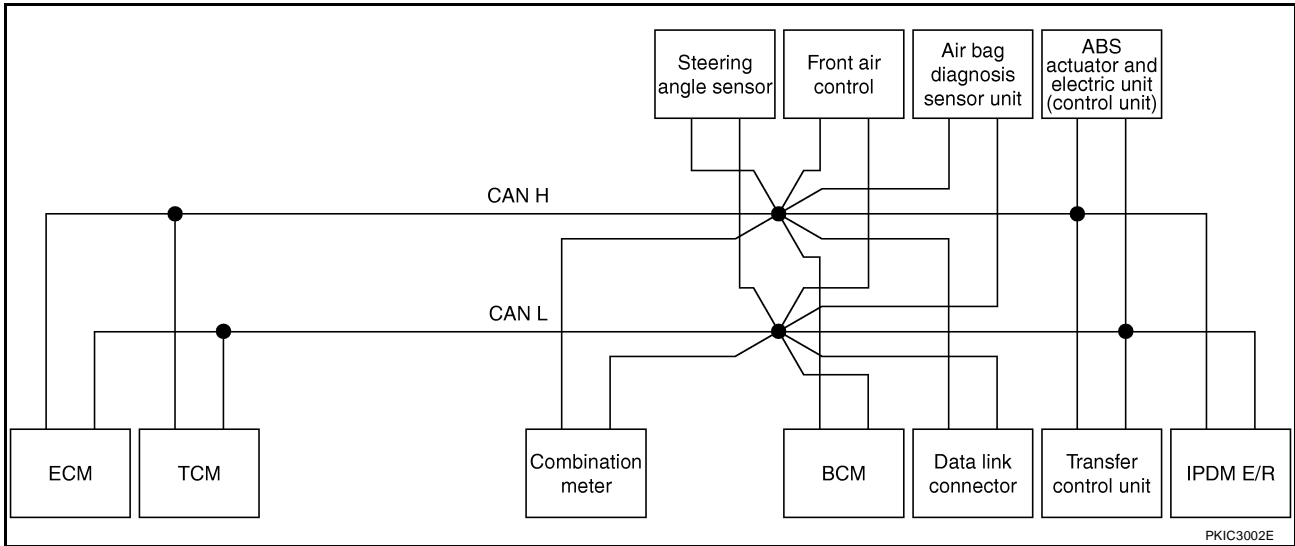

- Type 5

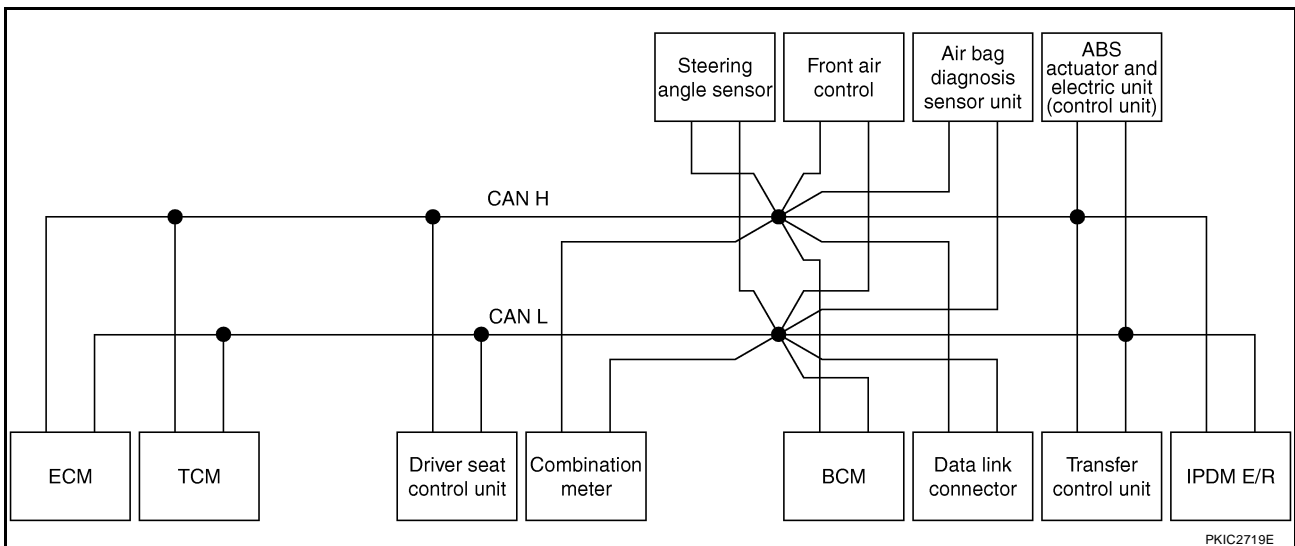

- Type 6

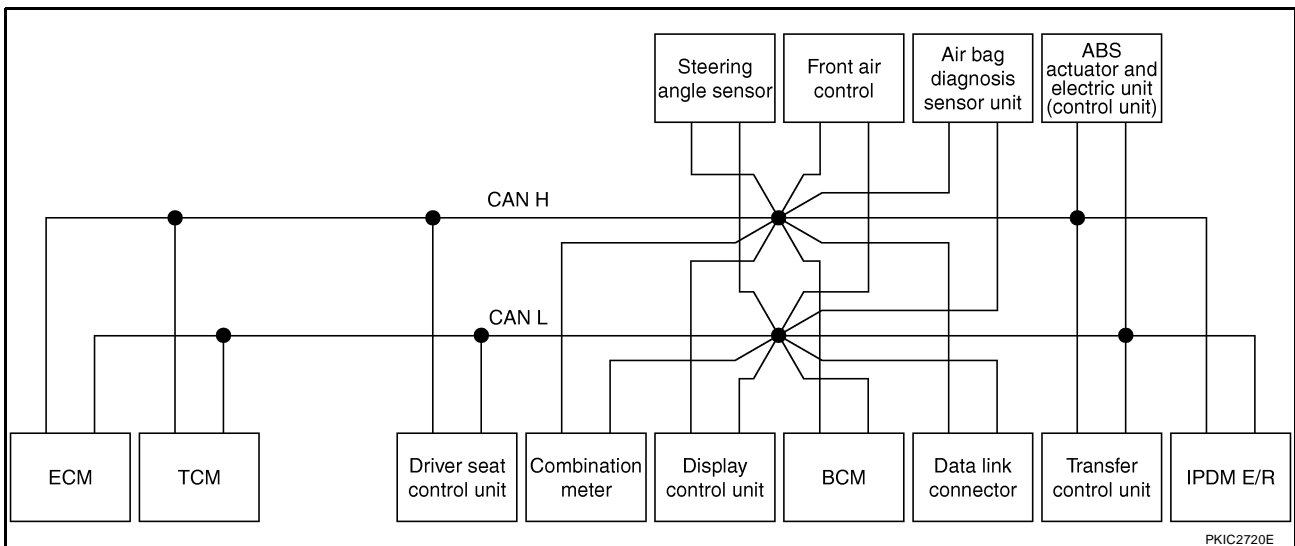

CAN COMMUNICATION

[CAN]

Input/output signal chart

T: Transmit R: Receive

Signals	ECM	TCM	Driver seat control unit	Combination meter	Display control unit*1	BCM	Steering angle sensor	Front air control	Transfer control unit	ABS actuator and electric unit (control unit)	IPDM E/R
A/C compressor request signal	T										R
Accelerator pedal position signal	T	R							R	R	
ASCD CRUISE lamp signal	T			R							
ASCD OD cancel request signal	T	R									
ASCD operation signal	T	R									
ASCD SET lamp signal	T			R							
Battery voltage signal	T	R									
Closed throttle position signal	T	R									
Cooling fan speed request signal	T										R
Engine coolant temperature signal	T			R				R			
Engine speed signal	T	R		R	R			R	R	R	
Engine status signal	T					R					
Fuel consumption monitor signal	T			R							
				T	R						
Malfunction indicator lamp signal	T			R							
Wide open throttle position signal	T	R									
A/T CHECK indicator lamp signal		T		R							
A/T fluid temperature sensor signal		T		R							
A/T position indicator lamp signal		T		R					R		
A/T self-diagnosis signal	R	T									
Output shaft revolution signal	R	T							R		
P range signal		T	R	R						R	
Turbine revolution signal	R	T									
System setting signal			T		R	T					
			R		T	R					
1st position switch signal		R		T							
4th position switch signal		R		T							
Distance to empty signal				T	R						
Fuel level low warning signal				T	R						
Fuel level sensor signal	R			T							
Stop lamp switch signal		R		T		R					
Tow mode switch signal		R		T							

A
B
C
D
E
F
G
H
I
J

LAN

L
M

CAN COMMUNICATION

[CAN]

Signals	ECM	TCM	Driver seat control unit	Combination meter	Display control unit*1	BCM	Steering angle sensor	Front air control	Transfer control unit	ABS actuator and electric unit (control unit)	IPDM E/R
Vehicle speed signal				R				R	R	T	
	R	R	R	T	R	R					
A/C switch/indicator signal					T			R			
					R			T			
A/C switch signal	R					T		R			
Blower fan motor switch signal	R					T					
Buzzer output signal				R		T					
Day time running light request signal				R		T					
Door switch signal			R	R	R	T					R
Front fog light request signal						T					R
Front wiper request signal						T					R
High beam request signal				R		T					R
High beam status signal	R										T
Horn chirp signal						T					R
Ignition switch signal			R			T					
Key fob door unlock signal			R			T					
Key fob ID signal			R			T					
Key switch signal			R			T					
Low beam request signal						T					R
Low beam status signal	R										T
Position light request signal				R		T					R
Rear window defogger switch signal						T		R			R
Sleep wake up signal			R	R		T					R
Theft warning horn request signal						T					R
Turn indicator signal				R		T					
Tire pressure data signal					R	T					
Tire pressure signal					R	T					
Steering angle sensor signal							T			R	
ABS warning lamp signal				R						T	
Brake warning lamp signal				R						T	
SLIP indicator lamp signal				R						T	
VDC OFF indicator lamp signal				R						T	
Front wiper stop position signal						R					T
Rear window defogger control signal	R				R						T

- *1: with navigation system model only

A

B

C

D

E

F

G

H

I

J

LAN

L

M

CAN SYSTEM (TYPE 1)

PF2:23710

Component Parts and Harness Connector Location

UKS004S1

Refer to [LAN-25, "Component Parts and Harness Connector Location"](#) .

Schematic

UKS004S2

Refer to [LAN-26, "Schematic"](#) .

Wiring Diagram — CAN —

UKS004S3

Refer to [LAN-27, "Wiring Diagram — CAN —"](#) .

CAN SYSTEM (TYPE 1)

[CAN]

UKS004S4

Check Sheet

NOTE:

If a check mark is put on "NG" on "INITIAL DIAG (Initial diagnosis)", replace the control unit.

Check sheet table													
SELECT SYSTEM screen		CAN DIAG SUPPORT MNTR									SELF-DIAG RESULTS		
		Initial diagnosis	Transmit diagnosis	Receive diagnosis									IPDM E/R
				ECM	TCM	METER /M&A	BCM/SEC	STRG	VDC/TCS /ABS				
ENGINE	-	-	UNKWN	-	UNKWN	UNKWN	UNKWN	-	UNKWN	UNKWN	CAN COMM CIRCUIT (U1000)	CAN COMM CIRCUIT (U1001)	
A/T	-	NG	UNKWN	UNKWN	-	UNKWN	-	-	UNKWN	-	CAN COMM CIRCUIT (U1000)	-	
BCM	No indication	NG	UNKWN	UNKWN	-	UNKWN	-	-	-	UNKWN	CAN COMM CIRCUIT (U1000)	-	
HVAC	No indication	-	UNKWN	UNKWN	-	-	-	UNKWN	-	UNKWN	-	-	
ABS	-	NG	UNKWN	UNKWN	UNKWN	-	-	UNKWN	-	-	CAN COMM CIRCUIT (U1000)	-	
IPDM E/R	No indication	-	UNKWN	UNKWN	-	-	-	UNKWN	-	-	CAN COMM CIRCUIT (U1000)	-	
Symptoms :													
<div style="display: flex; justify-content: space-around; width: 100%;"> <div style="border: 1px solid black; padding: 20px; width: 40%; text-align: center;"> Attach copy of SELECT SYSTEM </div> <div style="border: 1px solid black; padding: 20px; width: 40%; text-align: center;"> Attach copy of SELECT SYSTEM </div> </div>													

PKIC4706E

A
B
C
D
E
F
G
H
I
J
L
M

LAN

CAN SYSTEM (TYPE 1)

[CAN]

Attach copy of
ENGINE
SELF-DIAG RESULTS

Attach copy of
A/T
SELF-DIAG RESULTS

Attach copy of
BCM
SELF-DIAG RESULTS

Attach copy of
HVAC
SELF-DIAG RESULTS

Attach copy of
ABS
SELF-DIAG RESULTS

Attach copy of
IPDM E/R
SELF-DIAG RESULTS

Attach copy of
ENGINE
CAN DIAG SUPPORT
MNTR

Attach copy of
A/T
CAN DIAG SUPPORT
MNTR

Attach copy of
BCM
CAN DIAG SUPPORT
MNTR

Attach copy of
HVAC
CAN DIAG SUPPORT
MNTR

Attach copy of
ABS
CAN DIAG SUPPORT
MNTR

Attach copy of
IPDM E/R
CAN DIAG SUPPORT
MNTR

PKIB6628E

CAN SYSTEM (TYPE 1)

[CAN]

CHECK SHEET RESULTS (EXAMPLE)

NOTE:

If a check mark is put on "NG" on "INITIAL DIAG (Initial diagnosis)", replace the control unit.

Case 1

Check harness between TCM and data link connector. Refer to [LAN-142, "Inspection Between TCM and Data Link Connector Circuit"](#).

SELECT SYSTEM screen		CAN DIAG SUPPORT MNTR									SELF-DIAG RESULTS	
		Initial diagnosis	Transmit diagnosis	Receive diagnosis						IPDM E/R		
				ECM	TCM	METER /M&A	BCM/SEC	STRG	VDC/TCS /ABS			
ENGINE	-	-	UNKWN	-	UNKWN	UN KN WN	UN KN WN	-	UN KN WN	UN KN WN	CAN COMM CIRCUIT (U1000)	CAN COMM CIRCUIT (U1001)
A/T	-	NG	UNKWN	UNKWN	-	UN KN WN	-	-	UN KN WN	-	CAN COMM CIRCUIT (U1000)	-
BCM	No indication	NG	UNKWN	UN KN WN	-	UNKWN	-	-	-	UNKWN	CAN COMM CIRCUIT (U1000)	-
HVAC	No indication	-	UNKWN	UN KN WN	-	-	UNKWN	-	UNKWN	-	-	-
ABS	-	NG	UNKWN	UN KN WN	UN KN WN	-	-	UNKWN	-	-	CAN COMM CIRCUIT (U1000)	-
IPDM E/R	No indication	-	UNKWN	UN KN WN	-	-	UNKWN	-	-	-	CAN COMM CIRCUIT (U1000)	-

PKIC4707E

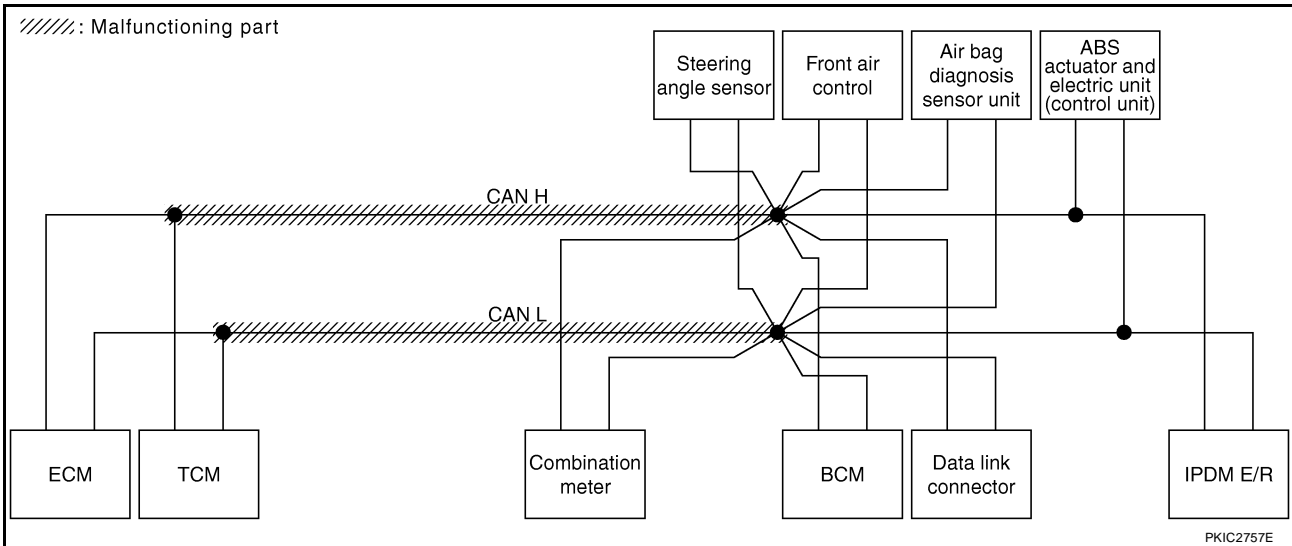

PKIC2757E

CAN SYSTEM (TYPE 1)

[CAN]

Case 2

Check harness between data link connector and ABS actuator and electric unit (control unit). Refer to [LAN-144, "Inspection Between Data Link Connector and ABS Actuator and Electric Unit \(Control Unit\) Circuit"](#) .

SELECT SYSTEM screen		CAN DIAG SUPPORT MNTR									SELF-DIAG RESULTS		
		Initial diagnosis	Transmit diagnosis	Receive diagnosis						VDC/TCS /ABS			IPDM E/R
				ECM	TCM	METER /M&A	BCM/SEC	STRG					
ENGINE	-	-	UNKWN	-	UNKWN	UNKWN	UNKWN	-	UNKWN	UNKWN	CAN COMM CIRCUIT (U1000)	CAN COMM CIRCUIT (U001)	
A/T	-	NG	UNKWN	UNKWN	-	UNKWN	-	-	UNKWN	-	CAN COMM CIRCUIT (U000)	-	
BCM	No indication	NG	UNKWN	UNKWN	-	UNKWN	-	-	-	UNKWN	CAN COMM CIRCUIT (U1000)	-	
HVAC	No indication	-	UNKWN	UNKWN	-	-	UNKWN	-	UNKWN	-	-	-	
ABS	-	NG	UNKWN	UNKWN	UNKWN	-	-	UNKWN	-	-	CAN COMM CIRCUIT (U000)	-	
IPDM E/R	No indication	-	UNKWN	UNKWN	-	-	UNKWN	-	-	-	CAN COMM CIRCUIT (U000)	-	

PKIC4708E

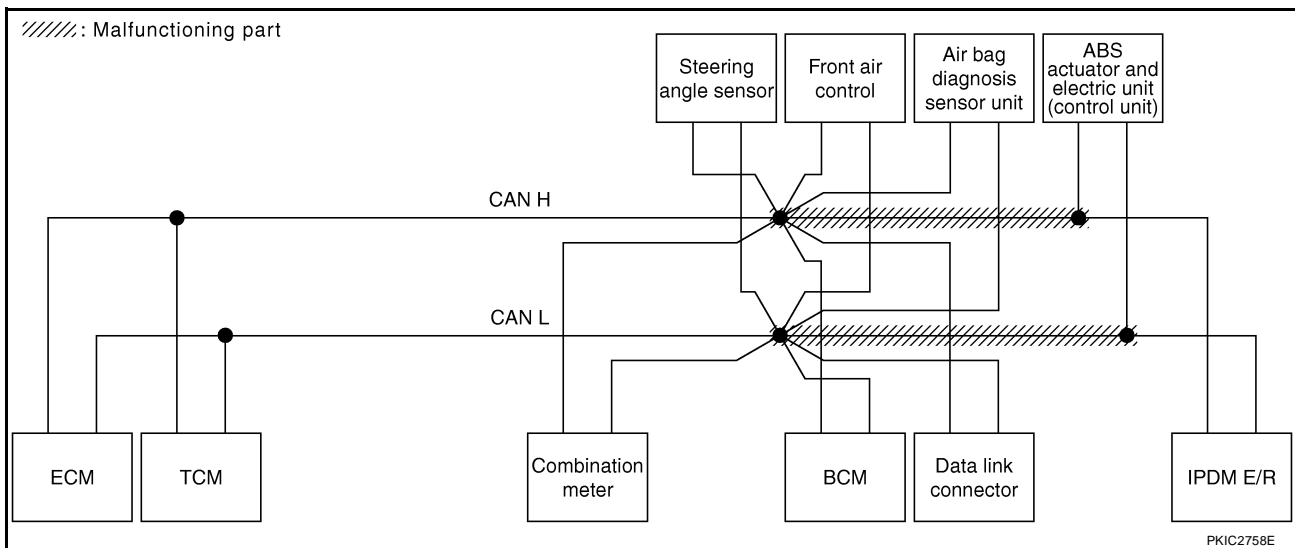

CAN SYSTEM (TYPE 1)

[CAN]

Case 3

Check ECM circuit. Refer to [LAN-145, "ECM Circuit Inspection"](#) .

SELECT SYSTEM screen		CAN DIAG SUPPORT MNTR									SELF-DIAG RESULTS	
		Initial diagnosis	Transmit diagnosis	Receive diagnosis						IPDM E/R		
				ECM	TCM	METER /M&A	BCM/SEC	STRG	VDC/TCS /ABS			
ENGINE	-	-	UNKWN ✓	-	UNKWN ✓	UNKWN ✓	UNKWN ✓	-	UNKWN ✓	UNKWN ✓	CAN COMM CIRCUIT (U000) ✓	CAN COMM CIRCUIT (U001) ✓
A/T	-	NG	UNKWN	UNKWN ✓	-	UNKWN	-	-	UNKWN	-	CAN COMM CIRCUIT (U000) ✓	-
BCM	No indication	NG	UNKWN	UNKWN ✓	-	UNKWN	-	-	-	UNKWN	CAN COMM CIRCUIT (U1000)	-
HVAC	No indication	-	UNKWN	UNKWN ✓	-	-	UNKWN	-	UNKWN	-	-	-
ABS	-	NG	UNKWN	UNKWN ✓	UNKWN	-	-	UNKWN	-	-	CAN COMM CIRCUIT (U000) ✓	-
IPDM E/R	No indication	-	UNKWN	UNKWN ✓	-	-	UNKWN	-	-	-	CAN COMM CIRCUIT (U000) ✓	-

PKIC4709E

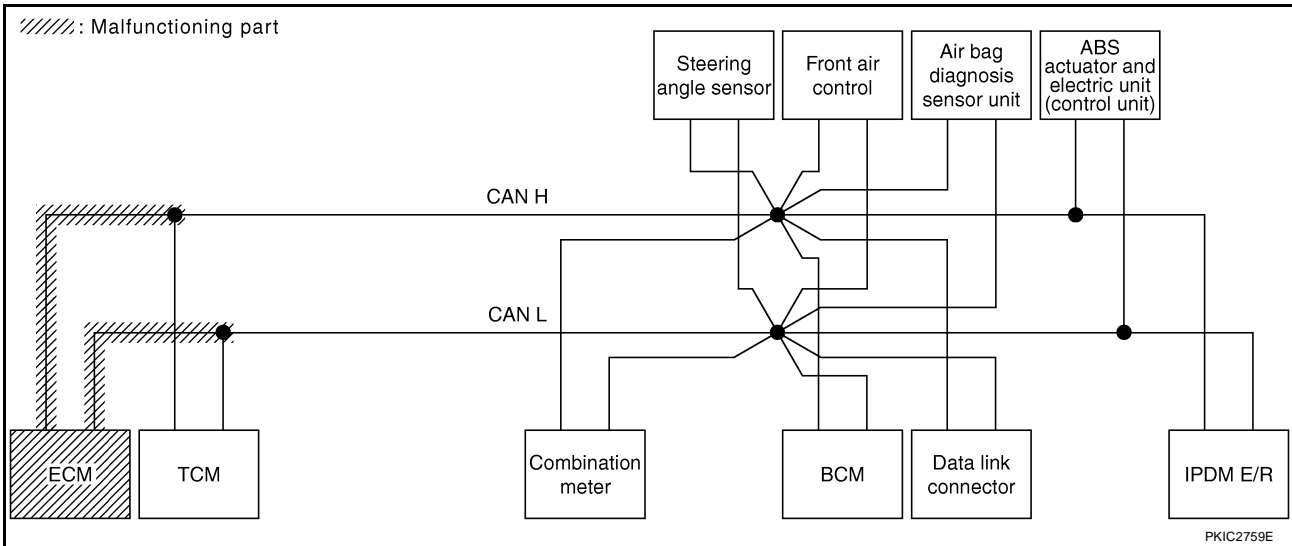

CAN SYSTEM (TYPE 1)

[CAN]

Case 4

Check TCM circuit. Refer to [LAN-146, "TCM Circuit Inspection"](#) .

SELECT SYSTEM screen		CAN DIAG SUPPORT MNTR									SELF-DIAG RESULTS	
		Initial diagnosis	Transmit diagnosis	Receive diagnosis								
				ECM	TCM	METER /M&A	BCM/SEC	STRG	VDC/TCS /ABS	IPDM E/R		
ENGINE	-	-	UNKWN	-	UNKWN	UNKWN	UNKWN	-	UNKWN	UNKWN	CAN COMM CIRCUIT (U1000)	CAN COMM CIRCUIT (U1001)
A/T	-	NG	UNKWN	UNKWN	-	UNKWN	-	-	UNKWN	-	CAN COMM CIRCUIT (U1000)	-
BCM	No indication	NG	UNKWN	UNKWN	-	UNKWN	-	-	-	UNKWN	CAN COMM CIRCUIT (U1000)	-
HVAC	No indication	-	UNKWN	UNKWN	-	-	UNKWN	-	UNKWN	-	-	-
ABS	-	NG	UNKWN	UNKWN	UNKWN	-	-	UNKWN	-	-	CAN COMM CIRCUIT (U1000)	-
IPDM E/R	No indication	-	UNKWN	UNKWN	-	-	UNKWN	-	-	-	CAN COMM CIRCUIT (U1000)	-

PKIC4710E

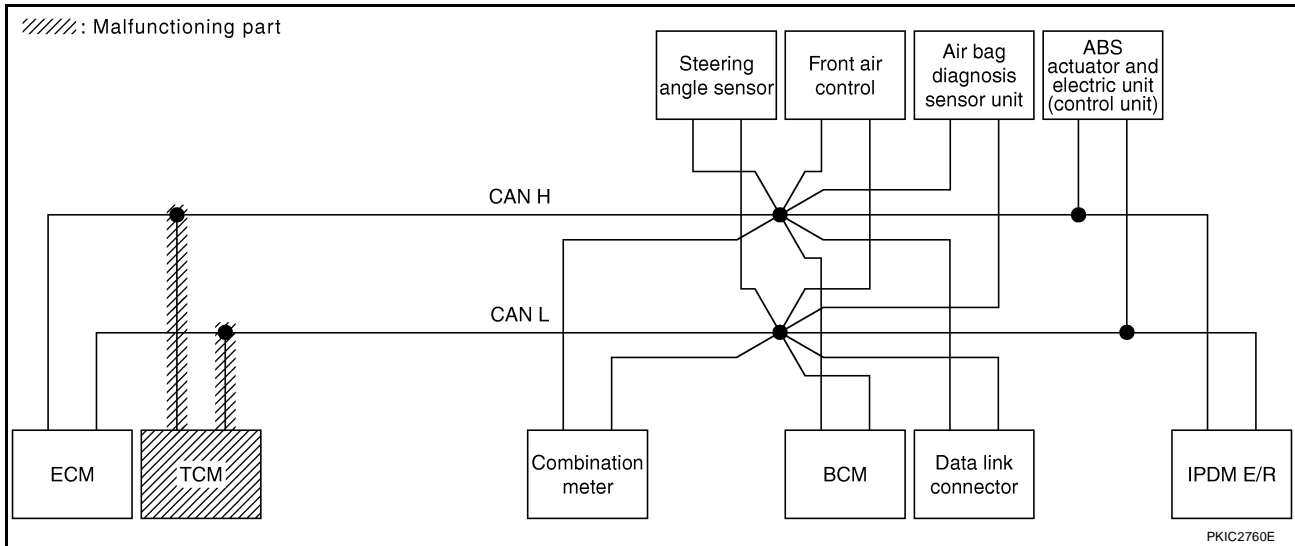

PKIC2760E

CAN SYSTEM (TYPE 1)

[CAN]

Case 5

Check combination meter circuit. Refer to [LAN-147, "Combination Meter Circuit Inspection"](#) .

SELECT SYSTEM screen		CAN DIAG SUPPORT MNTR									SELF-DIAG RESULTS	
		Initial diagnosis	Transmit diagnosis	Receive diagnosis						IPDM E/R		
				ECM	TCM	METER /M&A	BCM/SEC	STRG	VDC/TCS /ABS			
ENGINE	-	-	UNKWN	-	UNKWN	UNKWN	UNKWN	-	UNKWN	UNKWN	CAN COMM CIRCUIT (U1000)	CAN COMM CIRCUIT (U001)
A/T	-	NG	UNKWN	UNKWN	-	UNKWN	-	-	UNKWN	-	CAN COMM CIRCUIT (U1000)	-
BCM	No indication	NG	UNKWN	UNKWN	-	UNKWN	-	-	-	UNKWN	CAN COMM CIRCUIT (U1000)	-
HVAC	No indication	-	UNKWN	UNKWN	-	-	UNKWN	-	UNKWN	-	-	-
ABS	-	NG	UNKWN	UNKWN	UNKWN	-	-	UNKWN	-	-	CAN COMM CIRCUIT (U1000)	-
IPDM E/R	No indication	-	UNKWN	UNKWN	-	-	UNKWN	-	-	-	CAN COMM CIRCUIT (U1000)	-

PKIC4711E

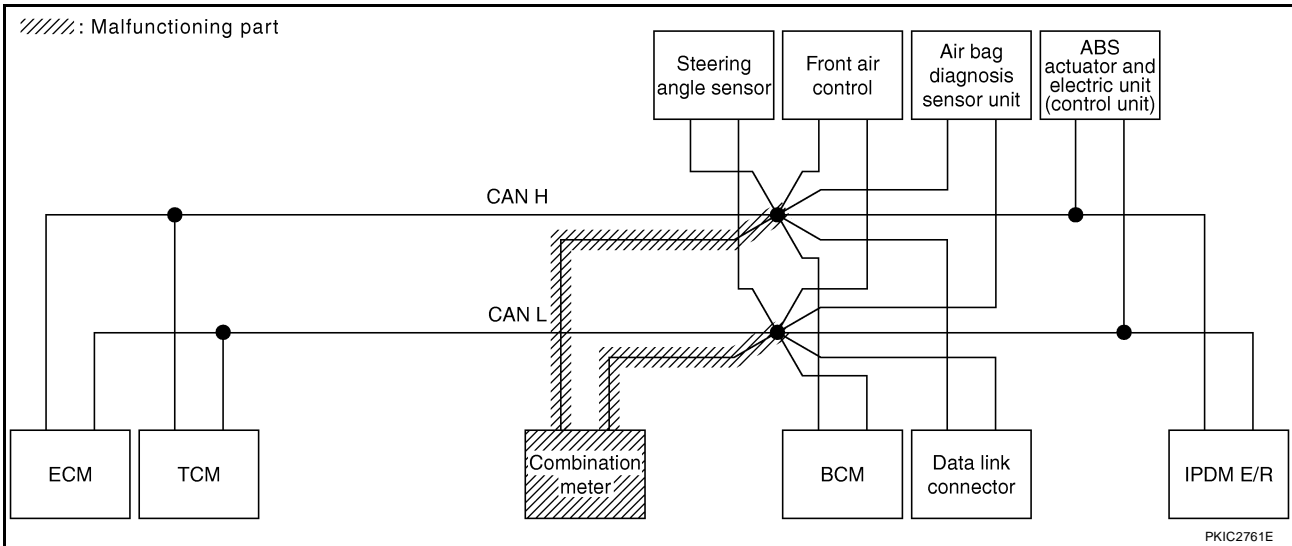

A

B

C

D

E

F

G

H

I

J

LAN

L

M

CAN SYSTEM (TYPE 1)

[CAN]

Case 6

Check BCM circuit. Refer to [LAN-148, "BCM Circuit Inspection"](#) .

SELECT SYSTEM screen		CAN DIAG SUPPORT MNTR									SELF-DIAG RESULTS	
		Initial diagnosis	Transmit diagnosis	Receive diagnosis								
				ECM	TCM	METER /M&A	BCM/SEC	STRG	VDC/TCS /ABS	IPDM E/R		
ENGINE	-	-	UNKWN	-	UNKWN	UNKWN	UNKWN	-	UNKWN	UNKWN	CAN COMM CIRCUIT (U1000)	CAN COMM CIRCUIT (U001)
A/T	-	NG	UNKWN	UNKWN	-	UNKWN	-	-	UNKWN	-	CAN COMM CIRCUIT (U1000)	-
BCM	No indication	NG	UNKWN	UNKWN	-	UNKWN	-	-	-	UNKWN	CAN COMM CIRCUIT (U1000)	-
HVAC	No indication	-	UNKWN	UNKWN	-	-	UNKWN	-	UNKWN	-	-	-
ABS	-	NG	UNKWN	UNKWN	UNKWN	-	-	UNKWN	-	-	CAN COMM CIRCUIT (U1000)	-
IPDM E/R	No indication	-	UNKWN	UNKWN	-	-	UNKWN	-	-	-	CAN COMM CIRCUIT (U1000)	-

PKIC4712E

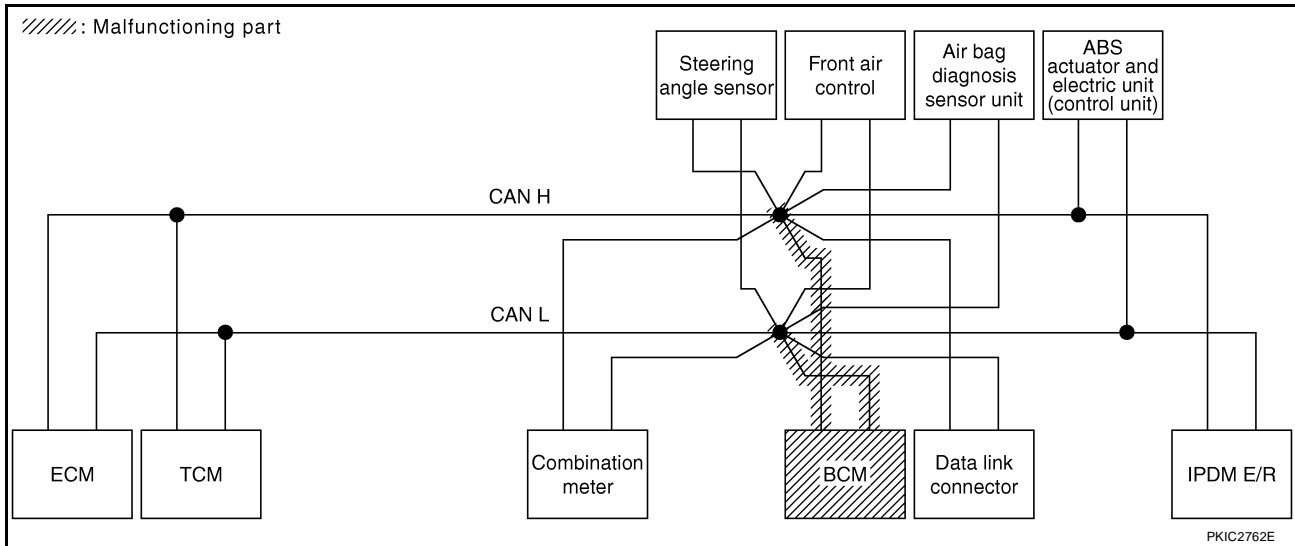

PKIC2762E

CAN SYSTEM (TYPE 1)

[CAN]

Case 7

Check data link connector circuit. Refer to [LAN-148, "Data Link Connector Circuit Inspection"](#) .

SELECT SYSTEM screen		CAN DIAG SUPPORT MNTR									SELF-DIAG RESULTS	
		Initial diagnosis	Transmit diagnosis	Receive diagnosis						IPDM E/R		
				ECM	TCM	METER /M&A	BCM/SEC	STRG	VDC/TCS /ABS			
ENGINE	-	-	UNKWN	-	UNKWN	UNKWN	UNKWN	-	UNKWN	UNKWN	CAN COMM CIRCUIT (U1000)	CAN COMM CIRCUIT (U1001)
A/T	-	NG	UNKWN	UNKWN	-	UNKWN	-	-	UNKWN	-	CAN COMM CIRCUIT (U1000)	-
BCM	No indication	NG	UNKWN	UNKWN	-	UNKWN	-	-	-	UNKWN	CAN COMM CIRCUIT (U1000)	-
HVAC	No indication	-	UNKWN	UNKWN	-	-	UNKWN	-	UNKWN	-	-	-
ABS	-	NG	UNKWN	UNKWN	UNKWN	-	-	UNKWN	-	-	CAN COMM CIRCUIT (U1000)	-
IPDM E/R	No indication	-	UNKWN	UNKWN	-	-	UNKWN	-	-	-	CAN COMM CIRCUIT (U1000)	-

PKIC4713E

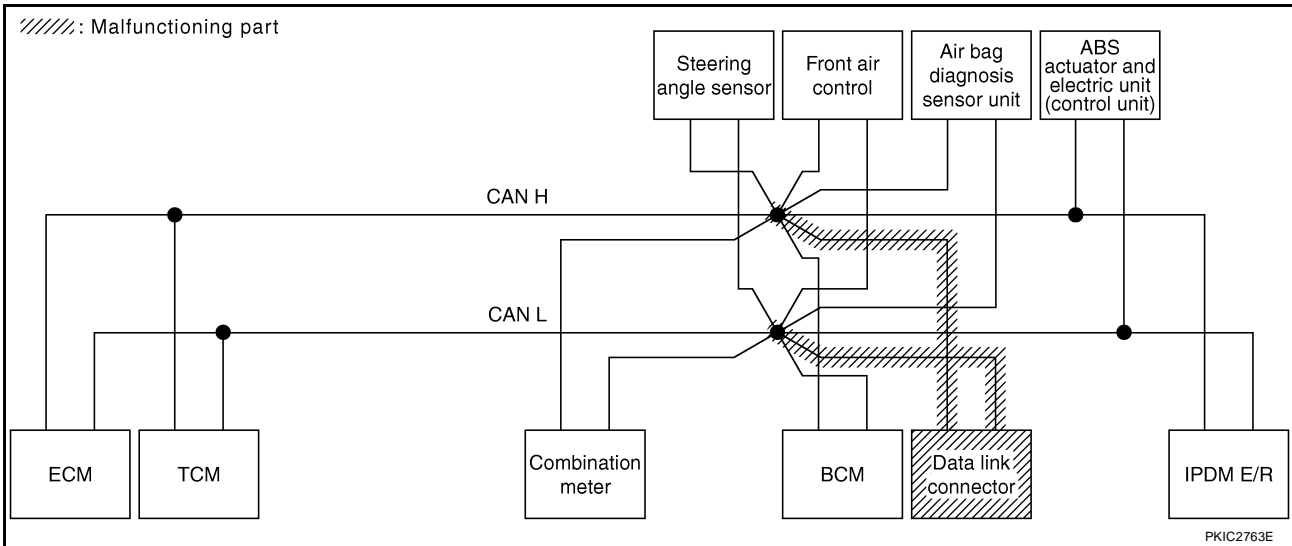

CAN SYSTEM (TYPE 1)

[CAN]

Case 8

Check steering angle sensor circuit. Refer to [LAN-149, "Steering Angle Sensor Circuit Inspection"](#) .

SELECT SYSTEM screen		CAN DIAG SUPPORT MNTR									SELF-DIAG RESULTS	
		Initial diagnosis	Transmit diagnosis	Receive diagnosis								
				ECM	TCM	METER /M&A	BCM/SEC	STRG	VDC/TCS /ABS	IPDM E/R		
ENGINE	-	-	UNKWN	-	UNKWN	UNKWN	UNKWN	-	UNKWN	UNKWN	CAN COMM CIRCUIT (U1000)	CAN COMM CIRCUIT (U1001)
A/T	-	NG	UNKWN	UNKWN	-	UNKWN	-	-	UNKWN	-	CAN COMM CIRCUIT (U1000)	-
BCM	No indication	NG	UNKWN	UNKWN	-	UNKWN	-	-	-	UNKWN	CAN COMM CIRCUIT (U1000)	-
HVAC	No indication	-	UNKWN	UNKWN	-	-	UNKWN	-	UNKWN	-	-	-
ABS	-	NG	UNKWN	UNKWN	UNKWN	-	-	UNKWN	-	-	CAN COMM CIRCUIT (U1000)	-
IPDM E/R	No indication	-	UNKWN	UNKWN	-	-	UNKWN	-	-	-	CAN COMM CIRCUIT (U1000)	-

PKIC4714E

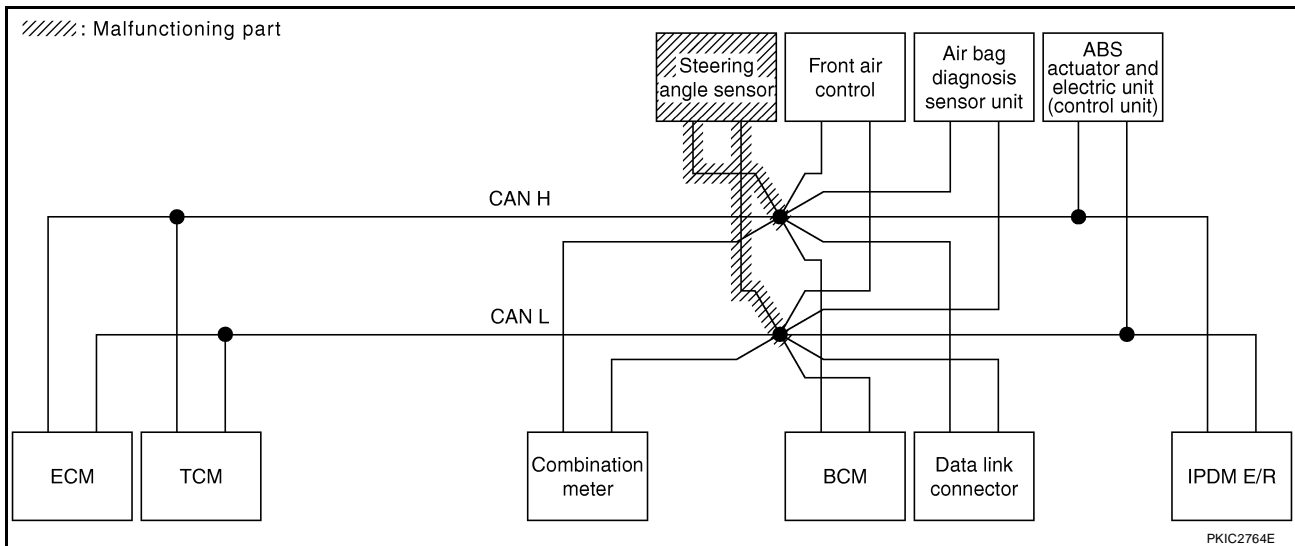

PKIC2764E

CAN SYSTEM (TYPE 1)

[CAN]

Case 9

Check front air control circuit. Refer to [LAN-149, "Front Air Control Circuit Inspection"](#) .

SELECT SYSTEM screen		CAN DIAG SUPPORT MNTR									SELF-DIAG RESULTS	
		Initial diagnosis	Transmit diagnosis	Receive diagnosis						IPDM E/R		
				ECM	TCM	METER /M&A	BCM/SEC	STRG	VDC/TCS /ABS			
ENGINE	—	—	UNKWN	—	UNKWN	UNKWN	UNKWN	—	UNKWN	UNKWN	CAN COMM CIRCUIT (U1000)	CAN COMM CIRCUIT (U1001)
A/T	—	NG	UNKWN	UNKWN	—	UNKWN	—	—	UNKWN	—	CAN COMM CIRCUIT (U1000)	—
BCM	No indication	NG	UNKWN	UNKWN	—	UNKWN	—	—	—	UNKWN	CAN COMM CIRCUIT (U1000)	—
HVAC	No indication	—	UNKWN	UNKWN	—	—	UNKWN	—	UNKWN	—	—	—
ABS	—	NG	UNKWN	UNKWN	UNKWN	—	—	UNKWN	—	—	CAN COMM CIRCUIT (U1000)	—
IPDM E/R	No indication	—	UNKWN	UNKWN	—	—	UNKWN	—	—	—	CAN COMM CIRCUIT (U1000)	—

PKIC4715E

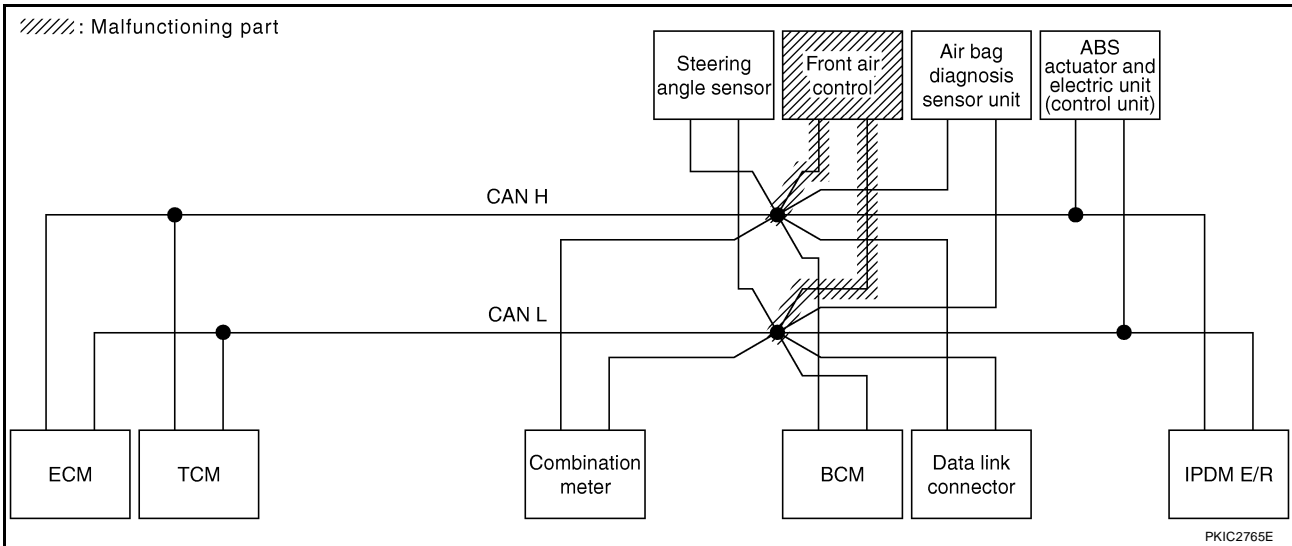

CAN SYSTEM (TYPE 1)

[CAN]

Case 10

Check ABS actuator and electric unit (control unit) circuit. Refer to [LAN-151, "ABS Actuator and Electric Unit \(Control Unit\) Circuit Inspection"](#) .

SELECT SYSTEM screen		CAN DIAG SUPPORT MNTR									SELF-DIAG RESULTS	
		Initial diagnosis	Transmit diagnosis	Receive diagnosis								
				ECM	TCM	METER /M&A	BCM/SEC	STRG	VDC/TCS /ABS	IPDM E/R		
ENGINE	-	-	UNKWN	-	UNKWN	UNKWN	UNKWN	-	UNKWN	UNKWN	CAN COMM CIRCUIT (U1000)	CAN COMM CIRCUIT (U001)
A/T	-	NG	UNKWN	UNKWN	-	UNKWN	-	-	UNKWN	-	CAN COMM CIRCUIT (U000)	-
BCM	No indication	NG	UNKWN	UNKWN	-	UNKWN	-	-	-	UNKWN	CAN COMM CIRCUIT (U1000)	-
HVAC	No indication	-	UNKWN	UNKWN	-	-	UNKWN	-	UNKWN	-	-	-
ABS	-	NG	UNKWN	UNKWN	UNKWN	-	-	UNKWN	-	-	CAN COMM CIRCUIT (U000)	-
IPDM E/R	No indication	-	UNKWN	UNKWN	-	-	UNKWN	-	-	-	CAN COMM CIRCUIT (U1000)	-

PKIC4716E

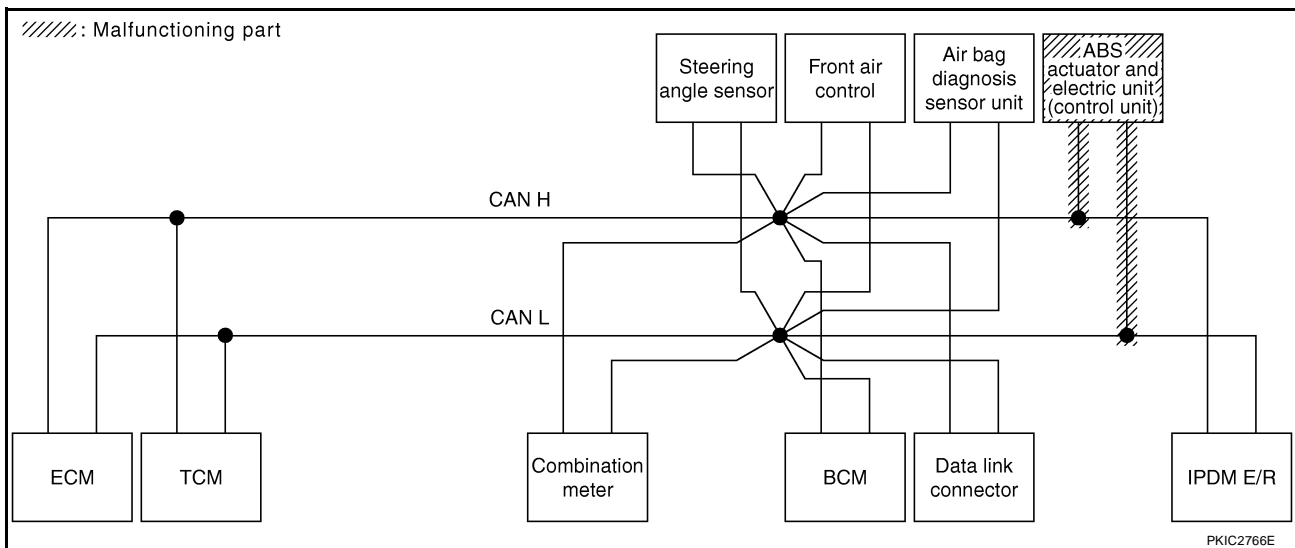

CAN SYSTEM (TYPE 1)

[CAN]

Case 11

Check IPDM E/R circuit. Refer to [LAN-151, "IPDM E/R Circuit Inspection"](#) .

SELECT SYSTEM screen		CAN DIAG SUPPORT MNTR									SELF-DIAG RESULTS	
		Initial diagnosis	Transmit diagnosis	Receive diagnosis						IPDM E/R		
				ECM	TCM	METER /M&A	BCM/SEC	STRG	VDC/TCS /ABS			
ENGINE	-	-	UNKWN	-	UNKWN	UNKWN	UNKWN	-	UNKWN	UNKWN	CAN COMM CIRCUIT (U1000)	CAN COMM CIRCUIT (U001)
A/T	-	NG	UNKWN	UNKWN	-	UNKWN	-	-	UNKWN	-	CAN COMM CIRCUIT (U1000)	-
BCM	No indication	NG	UNKWN	UNKWN	-	UNKWN	-	-	-	UNKWN	CAN COMM CIRCUIT (U1000)	-
HVAC	No indication	-	UNKWN	UNKWN	-	-	UNKWN	-	UNKWN	-	-	-
ABS	-	NG	UNKWN	UNKWN	UNKWN	-	-	UNKWN	-	-	CAN COMM CIRCUIT (U1000)	-
IPDM E/R	No indication	-	UNKWN	UNKWN	-	-	UNKWN	-	-	-	CAN COMM CIRCUIT (U000)	-

PKIC4717E

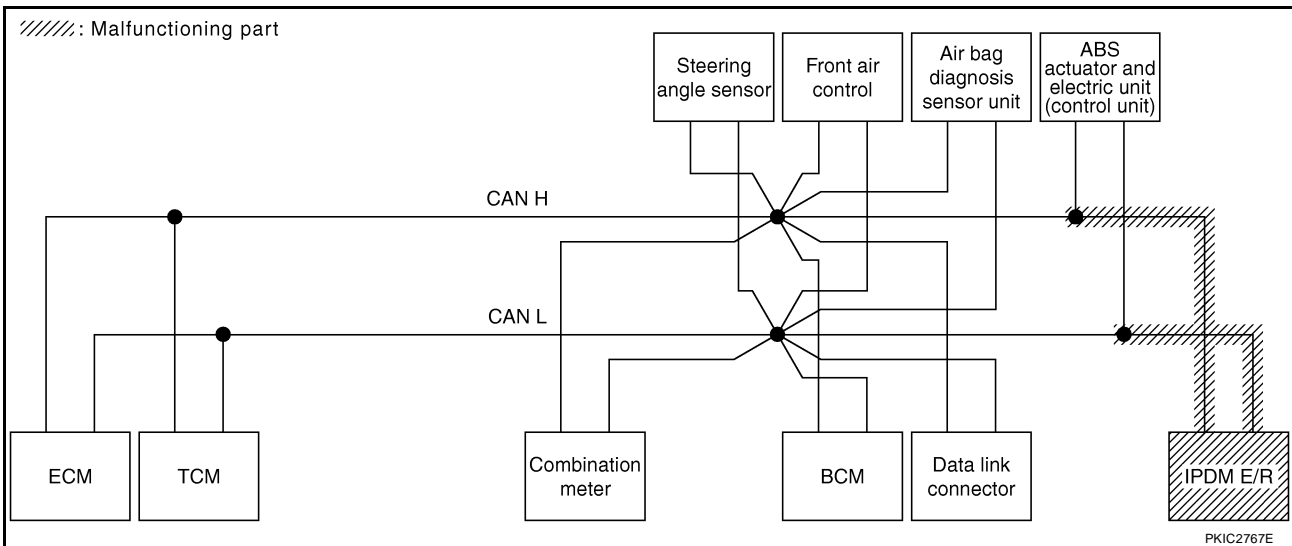

Case 12

Check CAN communication circuit. Refer to [LAN-152, "CAN Communication Circuit Inspection"](#) .

SELECT SYSTEM screen		CAN DIAG SUPPORT MNTR									SELF-DIAG RESULTS	
		Initial diagnosis	Transmit diagnosis	Receive diagnosis						IPDM E/R		
				ECM	TCM	METER /M&A	BCM/SEC	STRG	VDC/TCS /ABS			
ENGINE	-	-	UNKWN	-	UNKWN	UNKWN	UNKWN	-	UNKWN	UNKWN	CAN COMM CIRCUIT (U000)	CAN COMM CIRCUIT (U001)
A/T	-	NG	UNKWN	UNKWN	-	UNKWN	-	-	UNKWN	-	CAN COMM CIRCUIT (U000)	-
BCM	No indication	NG	UNKWN	UNKWN	-	UNKWN	-	-	-	UNKWN	CAN COMM CIRCUIT (U1000)	-
HVAC	No indication	-	UNKWN	UNKWN	-	-	UNKWN	-	UNKWN	-	-	-
ABS	-	NG	UNKWN	UNKWN	UNKWN	-	-	UNKWN	-	-	CAN COMM CIRCUIT (U000)	-
IPDM E/R	No indication	-	UNKWN	UNKWN	-	-	UNKWN	-	-	-	CAN COMM CIRCUIT (U000)	-

PKIC4718E

CAN SYSTEM (TYPE 1)

[CAN]

Case 13

Check IPDM E/R ignition relay circuit continuously sticks "OFF". Refer to [LAN-153, "IPDM E/R Ignition Relay Circuit Inspection"](#) .

SELECT SYSTEM screen		CAN DIAG SUPPORT MNTR									SELF-DIAG RESULTS	
		Initial diagnosis	Transmit diagnosis	Receive diagnosis								
				ECM	TCM	METER /M&A	BCM/SEC	STRG	VDC/TCS /ABS	IPDM E/R		
ENGINE	-	-	UNKWN	-	✓	UNKWN	UNKWN	-	✓	UNKWN	CAN COMM CIRCUIT (U1000) ✓	CAN COMM CIRCUIT (U1001) ✓
A/T	-	NG	UNKWN	UNKWN	-	UNKWN	-	-	UNKWN	-	CAN COMM CIRCUIT (U1000)	-
BCM	No indication	NG	UNKWN	UNKWN	-	UNKWN	-	-	-	UNKWN	CAN COMM CIRCUIT (U1000)	-
HVAC	No indication	-	UNKWN	UNKWN	-	-	UNKWN	-	✓	-	-	-
ABS	-	NG	UNKWN	UNKWN	UNKWN	-	-	UNKWN	-	-	CAN COMM CIRCUIT (U1000)	-
IPDM E/R	No indication	-	UNKWN	UNKWN	-	-	UNKWN	-	-	-	CAN COMM CIRCUIT (U1000)	-

PKIC4719E

Case 14

Check IPDM E/R ignition relay circuit continuously sticks "ON". Refer to [LAN-153, "IPDM E/R Ignition Relay Circuit Inspection"](#) .

SELECT SYSTEM screen		CAN DIAG SUPPORT MNTR									SELF-DIAG RESULTS	
		Initial diagnosis	Transmit diagnosis	Receive diagnosis								
				ECM	TCM	METER /M&A	BCM/SEC	STRG	VDC/TCS /ABS	IPDM E/R		
ENGINE	-	-	UNKWN	-	UNKWN	UNKWN	UNKWN	-	UNKWN	UNKWN	CAN COMM CIRCUIT (U1000)	CAN COMM CIRCUIT (U1001)
A/T	-	NG	UNKWN	-	-	-	-	-	UNKWN	-	CAN COMM CIRCUIT (U1000) ✓	-
BCM	No indication	NG	UNKWN	UNKWN	-	UNKWN	-	-	-	UNKWN	CAN COMM CIRCUIT (U1000)	-
HVAC	No indication	-	UNKWN	UNKWN	-	-	UNKWN	-	UNKWN	-	-	-
ABS	-	NG	UNKWN	-	UNKWN	-	-	-	-	-	CAN COMM CIRCUIT (U1000) ✓	-
IPDM E/R	No indication	-	UNKWN	UNKWN	-	-	UNKWN	-	-	-	CAN COMM CIRCUIT (U1000)	-

PKIC4720E

CAN SYSTEM (TYPE 2)

[CAN]

CAN SYSTEM (TYPE 2)

PF2:23710

Component Parts and Harness Connector Location

UKS004S5

Refer to [LAN-25, "Component Parts and Harness Connector Location"](#) .

Schematic

UKS004S6

Refer to [LAN-26, "Schematic"](#) .

Wiring Diagram — CAN —

UKS004S7

Refer to [LAN-27, "Wiring Diagram — CAN —"](#) .

A

B

C

D

E

F

G

H

I

J

LAN

L

M

CAN SYSTEM (TYPE 2)

[CAN]

UKS004S8

Check Sheet

NOTE:

If a check mark is put on "NG" on "INITIAL DIAG (Initial diagnosis)", replace the control unit.

Check sheet table												
SELECT SYSTEM screen		CAN DIAG SUPPORT MNTR									SELF-DIAG RESULTS	
		Initial diagnosis	Transmit diagnosis	Receive diagnosis								
				ECM	TCM	METER /M&A	BCM/SEC	STRG	VDC/TCS /ABS	IPDM E/R		
ENGINE	-	-	UNKWN	-	UNKWN	UNKWN	UNKWN	-	UNKWN	UNKWN	CAN COMM CIRCUIT (U1000)	CAN COMM CIRCUIT (U1001)
A/T	-	NG	UNKWN	UNKWN	-	UNKWN	-	-	UNKWN	-	CAN COMM CIRCUIT (U1000)	-
AUTO DRIVE POS.	No indication	-	-	-	UNKWN	UNKWN	UNKWN	-	-	-	CAN COMM CIRCUIT (U1000)	-
BCM	No indication	NG	UNKWN	UNKWN	-	UNKWN	-	-	-	UNKWN	CAN COMM CIRCUIT (U1000)	-
HVAC	No indication	-	UNKWN	UNKWN	-	-	UNKWN	-	UNKWN	-	-	-
ABS	-	NG	UNKWN	UNKWN	UNKWN	-	-	UNKWN	-	-	CAN COMM CIRCUIT (U1000)	-
IPDM E/R	No indication	-	UNKWN	UNKWN	-	-	UNKWN	-	-	-	CAN COMM CIRCUIT (U1000)	-
Symptoms :												
<div style="display: flex; justify-content: space-around; width: 100%;"> <div style="border: 1px solid black; width: 200px; height: 150px; display: flex; align-items: center; justify-content: center;"> <p>Attach copy of SELECT SYSTEM</p> </div> <div style="border: 1px solid black; width: 200px; height: 150px; display: flex; align-items: center; justify-content: center;"> <p>Attach copy of SELECT SYSTEM</p> </div> </div>												

PKIC2942E

CAN SYSTEM (TYPE 2)

[CAN]

A
B
C
D
E
F
G
H
I
J
L
M

Attach copy of
ENGINE
SELF-DIAG RESULTS

Attach copy of
A/T
SELF-DIAG RESULTS

Attach copy of
AUTO DRIVE POS.
SELF-DIAG RESULTS

Attach copy of
BCM
SELF-DIAG RESULTS

Attach copy of
HVAC
SELF-DIAG RESULTS

Attach copy of
ABS
SELF-DIAG RESULTS

Attach copy of
IPDM E/R
SELF-DIAG RESULTS

Attach copy of
ENGINE
CAN DIAG SUPPORT
MNTR

Attach copy of
A/T
CAN DIAG SUPPORT
MNTR

Attach copy of
AUTO DRIVE POS.
CAN DIAG SUPPORT
MNTR

Attach copy of
BCM
CAN DIAG SUPPORT
MNTR

Attach copy of
HVAC
CAN DIAG SUPPORT
MNTR

Attach copy of
ABS
CAN DIAG SUPPORT
MNTR

Attach copy of
IPDM E/R
CAN DIAG SUPPORT
MNTR

LAN

PKIB6658E

CAN SYSTEM (TYPE 2)

[CAN]

CHECK SHEET RESULTS (EXAMPLE)

NOTE:

If a check mark is put on "NG" on "INITIAL DIAG (Initial diagnosis)", replace the control unit.

Case 1

Check harness between TCM and driver seat control unit. Refer to [LAN-141, "Inspection Between TCM and Driver Seat Control Unit Circuit"](#).

SELECT SYSTEM screen		CAN DIAG SUPPORT MNTR									SELF-DIAG RESULTS	
		Initial diagnosis	Transmit diagnosis	Receive diagnosis								
				ECM	TCM	METER /M&A	BCM/SEC	STRG	VDC/TCS /ABS	IPDM E/R		
ENGINE	-	-	UNKWN	-	UNKWN	✓	✓	-	✓	✓	CAN COMM CIRCUIT (U1000)	CAN COMM CIRCUIT (U001) ✓
A/T	-	NG	UNKWN	UNKWN	-	✓	-	-	✓	-	CAN COMM CIRCUIT (U000) ✓	-
AUTO DRIVE POS.	No indication	-	-	-	✓	UNKWN	UNKWN	-	-	-	CAN COMM CIRCUIT (U000) ✓	-
BCM	No indication	NG	UNKWN	✓	-	UNKWN	-	-	-	UNKWN	CAN COMM CIRCUIT (U1000)	-
HVAC	No indication	-	UNKWN	✓	-	-	UNKWN	-	UNKWN	-	-	-
ABS	-	NG	UNKWN	✓	✓	-	-	UNKWN	-	-	CAN COMM CIRCUIT (U000) ✓	-
IPDM E/R	No indication	-	UNKWN	✓	-	-	UNKWN	-	-	-	CAN COMM CIRCUIT (U000) ✓	-

PKIC3258E

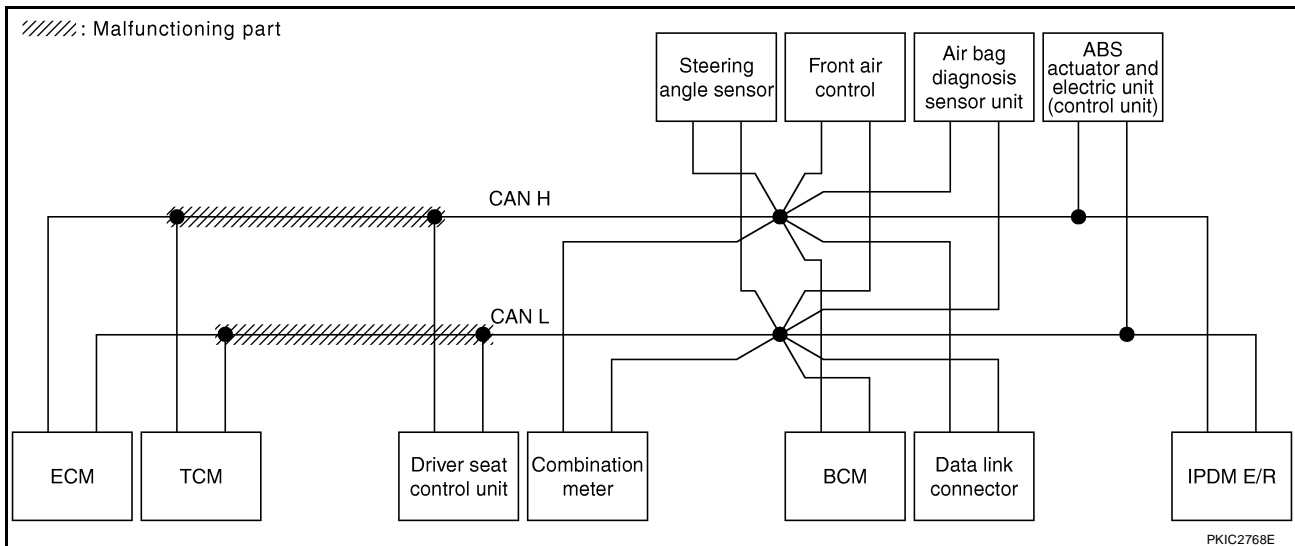

PKIC2768E

CAN SYSTEM (TYPE 2)

[CAN]

Case 2

Check harness between driver seat control unit and data link connector. Refer to [LAN-143, "Inspection Between Driver Seat Control Unit and Data Link Connector Circuit"](#) .

SELECT SYSTEM screen		CAN DIAG SUPPORT MNTR									SELF-DIAG RESULTS	
		Initial diagnosis	Transmit diagnosis	Receive diagnosis								
				ECM	TCM	METER /M&A	BCM/SEC	STRG	VDC/TCS /ABS	IPDM E/R		
ENGINE	-	-	UNKWN	-	UNKWN	✓	✓	-	UNKWN	✓	CAN COMM CIRCUIT (U1000)	CAN COMM CIRCUIT (U1001)
A/T	-	NG	UNKWN	UNKWN	-	✓	-	-	UNKWN	-	CAN COMM CIRCUIT (U1000)	-
AUTO DRIVE POS.	No indication	-	-	-	UNKWN	UNKWN	UNKWN	-	-	-	CAN COMM CIRCUIT (U1000)	-
BCM	No indication	NG	UNKWN	✓	-	UNKWN	-	-	-	UNKWN	CAN COMM CIRCUIT (U1000)	-
HVAC	No indication	-	UNKWN	✓	-	-	UNKWN	-	UNKWN	-	-	-
ABS	-	NG	UNKWN	✓	✓	-	-	UNKWN	-	-	CAN COMM CIRCUIT (U1000)	-
IPDM E/R	No indication	-	UNKWN	✓	-	-	UNKWN	-	-	-	CAN COMM CIRCUIT (U1000)	-

PKIC3259E

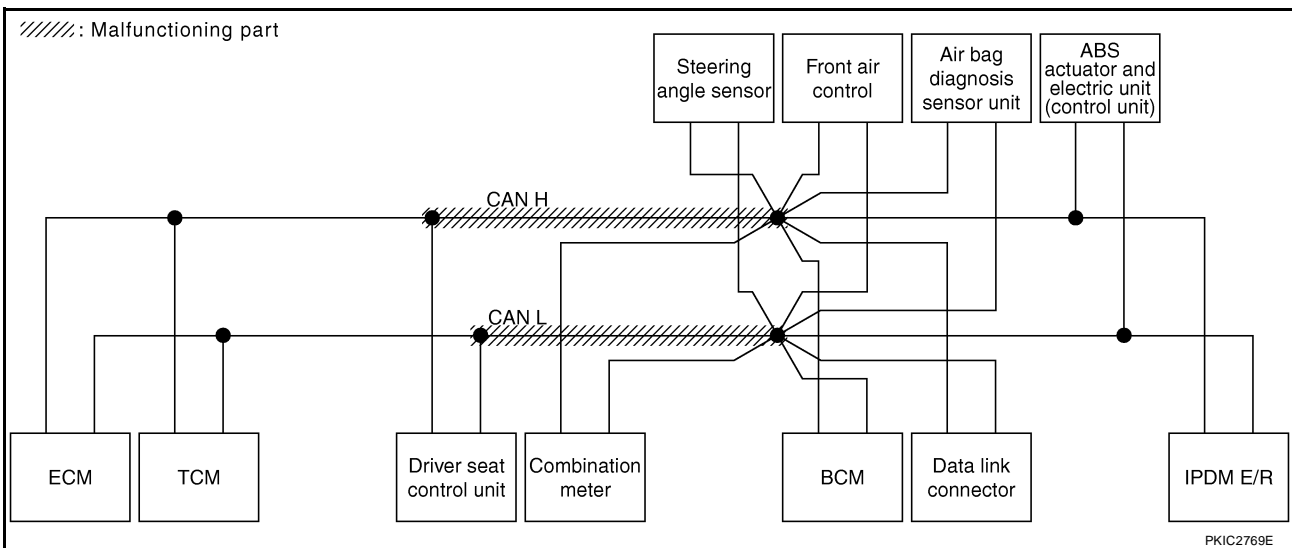

CAN SYSTEM (TYPE 2)

[CAN]

Case 3

Check harness between data link connector and ABS actuator and electric unit (control unit). Refer to LAN-144, "Inspection Between Data Link Connector and ABS Actuator and Electric Unit (Control Unit) Circuit" .

SELECT SYSTEM screen		CAN DIAG SUPPORT MNTR									SELF-DIAG RESULTS	
		Initial diagnosis	Transmit diagnosis	Receive diagnosis								
				ECM	TCM	METER /M&A	BCM/SEC	STRG	VDC/TCS /ABS	IPDM E/R		
ENGINE	-	-	UNKWN	-	UNKWN	UNKWN	UNKWN	-	UNKWN	UNKWN	CAN COMM CIRCUIT (U1000)	CAN COMM CIRCUIT (U001)
A/T	-	NG	UNKWN	UNKWN	-	UNKWN	-	-	UNKWN	-	CAN COMM CIRCUIT (U000)	-
AUTO DRIVE POS.	No indication	-	-	-	UNKWN	UNKWN	UNKWN	-	-	-	CAN COMM CIRCUIT (U1000)	-
BCM	No indication	NG	UNKWN	UNKWN	-	UNKWN	-	-	-	UNKWN	CAN COMM CIRCUIT (U1000)	-
HVAC	No indication	-	UNKWN	UNKWN	-	-	UNKWN	-	UNKWN	-	-	-
ABS	-	NG	UNKWN	UNKWN	UNKWN	-	-	UNKWN	-	-	CAN COMM CIRCUIT (U000)	-
IPDM E/R	No indication	-	UNKWN	UNKWN	-	-	UNKWN	-	-	-	CAN COMM CIRCUIT (U000)	-

PKIC3260E

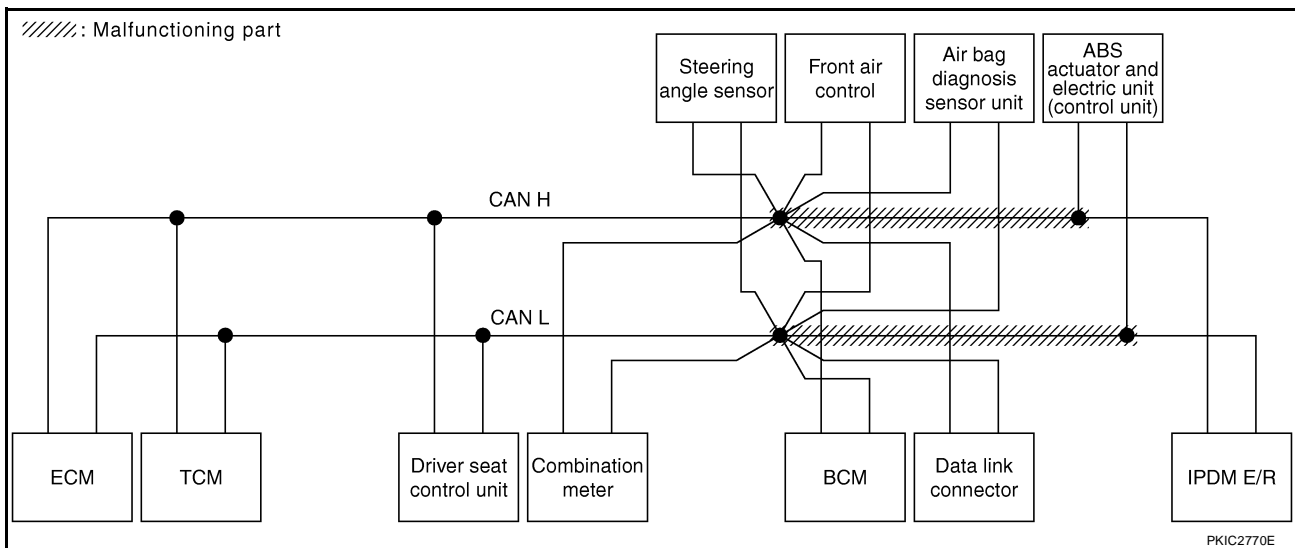

CAN SYSTEM (TYPE 2)

[CAN]

Case 4

Check ECM circuit. Refer to [LAN-145, "ECM Circuit Inspection"](#) .

SELECT SYSTEM screen		CAN DIAG SUPPORT MNTR									SELF-DIAG RESULTS	
		Initial diagnosis	Transmit diagnosis	Receive diagnosis								
				ECM	TCM	METER /M&A	BCM/SEC	STRG	VDC/TCS /ABS	IPDM E/R		
ENGINE	-	-	UNKWN ✓	-	UNKWN ✓	UNKWN ✓	UNKWN ✓	-	UNKWN ✓	UNKWN ✓	CAN COMM CIRCUIT (U1000) ✓	CAN COMM CIRCUIT (U1001) ✓
A/T	-	NG	UNKWN	UNKWN ✓	-	UNKWN	-	-	UNKWN	-	CAN COMM CIRCUIT (U1000) ✓	-
AUTO DRIVE POS.	No indication	-	-	-	UNKWN	UNKWN	UNKWN	-	-	-	CAN COMM CIRCUIT (U1000)	-
BCM	No indication	NG	UNKWN	UNKWN ✓	-	UNKWN	-	-	-	UNKWN	CAN COMM CIRCUIT (U1000)	-
HVAC	No indication	-	UNKWN	UNKWN ✓	-	-	UNKWN	-	UNKWN	-	-	-
ABS	-	NG	UNKWN	UNKWN ✓	UNKWN	-	-	UNKWN	-	-	CAN COMM CIRCUIT (U1000) ✓	-
IPDM E/R	No indication	-	UNKWN	UNKWN ✓	-	-	UNKWN	-	-	-	CAN COMM CIRCUIT (U1000) ✓	-

PKIC3261E

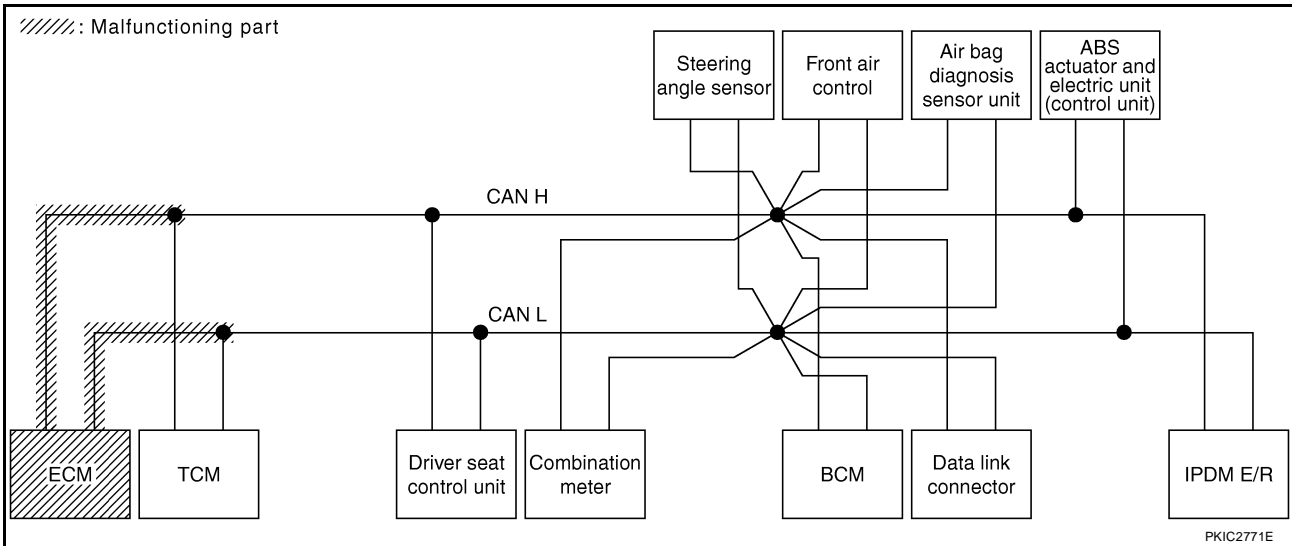

CAN SYSTEM (TYPE 2)

[CAN]

Case 5

Check TCM circuit. Refer to [LAN-146, "TCM Circuit Inspection"](#) .

SELECT SYSTEM screen		CAN DIAG SUPPORT MNTR									SELF-DIAG RESULTS	
		Initial diagnosis	Transmit diagnosis	Receive diagnosis								
				ECM	TCM	METER /M&A	BCM/SEC	STRG	VDC/TCS /ABS	IPDM E/R		
ENGINE	-	-	UNKWN	-	UNKWN	UNKWN	UNKWN	-	UNKWN	UNKWN	CAN COMM CIRCUIT (U1000)	CAN COMM CIRCUIT (U1001)
A/T	-	NG	UNKWN	UNKWN	-	UNKWN	-	-	UNKWN	-	CAN COMM CIRCUIT (U1000)	-
AUTO DRIVE POS.	No indication	-	-	-	UNKWN	UNKWN	UNKWN	-	-	-	CAN COMM CIRCUIT (U1000)	-
BCM	No indication	NG	UNKWN	UNKWN	-	UNKWN	-	-	-	UNKWN	CAN COMM CIRCUIT (U1000)	-
HVAC	No indication	-	UNKWN	UNKWN	-	-	UNKWN	-	UNKWN	-	-	-
ABS	-	NG	UNKWN	UNKWN	UNKWN	-	-	UNKWN	-	-	CAN COMM CIRCUIT (U1000)	-
IPDM E/R	No indication	-	UNKWN	UNKWN	-	-	UNKWN	-	-	-	CAN COMM CIRCUIT (U1000)	-

PKIC3262E

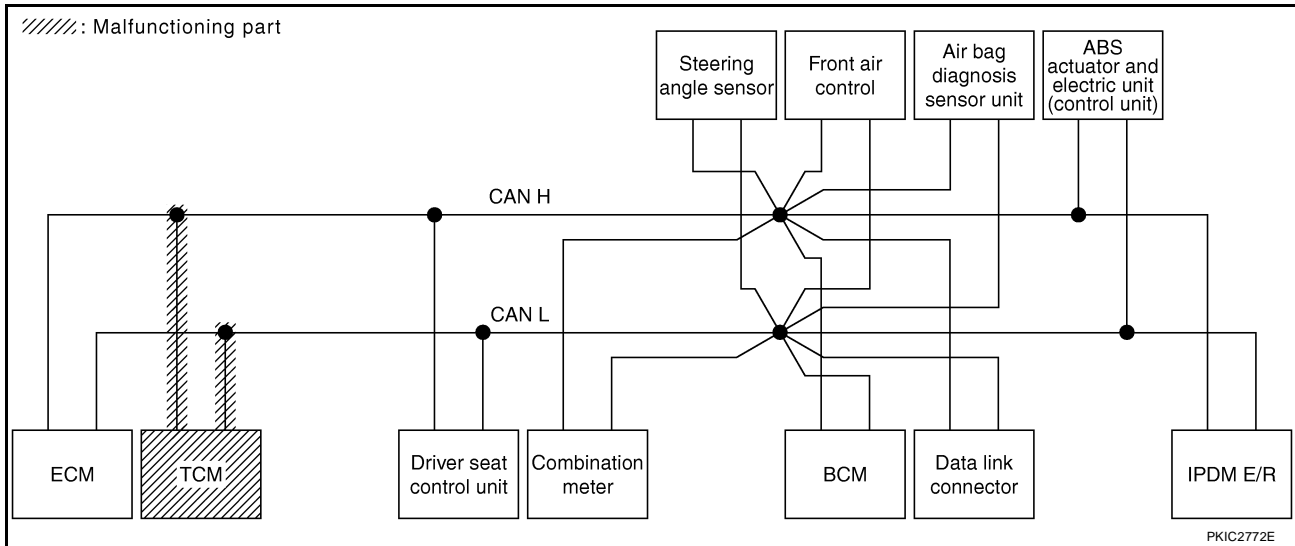

PKIC2772E

CAN SYSTEM (TYPE 2)

[CAN]

Case 6

Check driver seat control unit circuit. Refer to [LAN-146, "Driver Seat Control Unit Circuit Inspection"](#) .

SELECT SYSTEM screen		CAN DIAG SUPPORT MNTR									SELF-DIAG RESULTS	
		Initial diagnosis	Transmit diagnosis	Receive diagnosis								
				ECM	TCM	METER /M&A	BCM/SEC	STRG	VDC/TCS /ABS	IPDM E/R		
ENGINE	-	-	UNKWN	-	UNKWN	UNKWN	UNKWN	-	UNKWN	UNKWN	CAN COMM CIRCUIT (U1000)	CAN COMM CIRCUIT (U1001)
A/T	-	NG	UNKWN	UNKWN	-	UNKWN	-	-	UNKWN	-	CAN COMM CIRCUIT (U1000)	-
AUTO DRIVE POS.	No indication	-	-	-	UNKWN	UNKWN	UNKWN	-	-	-	CAN COMM CIRCUIT (U1000)	-
BCM	No indication	NG	UNKWN	UNKWN	-	UNKWN	-	-	-	UNKWN	CAN COMM CIRCUIT (U1000)	-
HVAC	No indication	-	UNKWN	UNKWN	-	-	UNKWN	-	UNKWN	-	-	-
ABS	-	NG	UNKWN	UNKWN	UNKWN	-	-	UNKWN	-	-	CAN COMM CIRCUIT (U1000)	-
IPDM E/R	No indication	-	UNKWN	UNKWN	-	-	UNKWN	-	-	-	CAN COMM CIRCUIT (U1000)	-

PKIC3263E

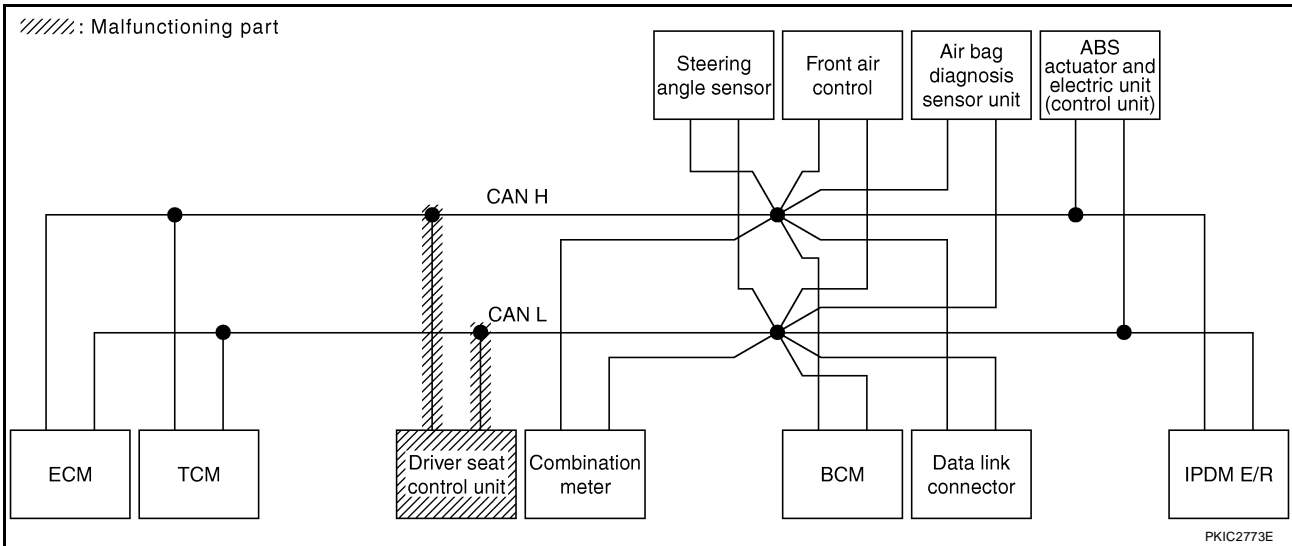

CAN SYSTEM (TYPE 2)

[CAN]

Case 7

Check combination meter circuit. Refer to [LAN-147, "Combination Meter Circuit Inspection"](#) .

SELECT SYSTEM screen		CAN DIAG SUPPORT MNTR									SELF-DIAG RESULTS	
		Initial diagnosis	Transmit diagnosis	Receive diagnosis								
				ECM	TCM	METER /M&A	BCM/SEC	STRG	VDC/TCS /ABS	IPDM E/R		
ENGINE	–	–	UNKWN	–	UNKWN	UN ✓ KN	UNKWN	–	UNKWN	UNKWN	CAN COMM CIRCUIT (U1000)	CAN COMM CIRCUIT (U1001)
A/T	–	NG	UNKWN	UNKWN	–	UN ✓ KN	–	–	UNKWN	–	CAN COMM CIRCUIT (U1000)	–
AUTO DRIVE POS.	No indication	–	–	–	UNKWN	UN ✓ KN	UNKWN	–	–	–	CAN COMM CIRCUIT (U1000)	–
BCM	No indication	NG	UNKWN	UNKWN	–	UN ✓ KN	–	–	–	UNKWN	CAN COMM CIRCUIT (U1000)	–
HVAC	No indication	–	UNKWN	UNKWN	–	–	UNKWN	–	UNKWN	–	–	–
ABS	–	NG	UNKWN	UNKWN	UNKWN	–	–	UNKWN	–	–	CAN COMM CIRCUIT (U1000)	–
IPDM E/R	No indication	–	UNKWN	UNKWN	–	–	UNKWN	–	–	–	CAN COMM CIRCUIT (U1000)	–

PKIC3264E

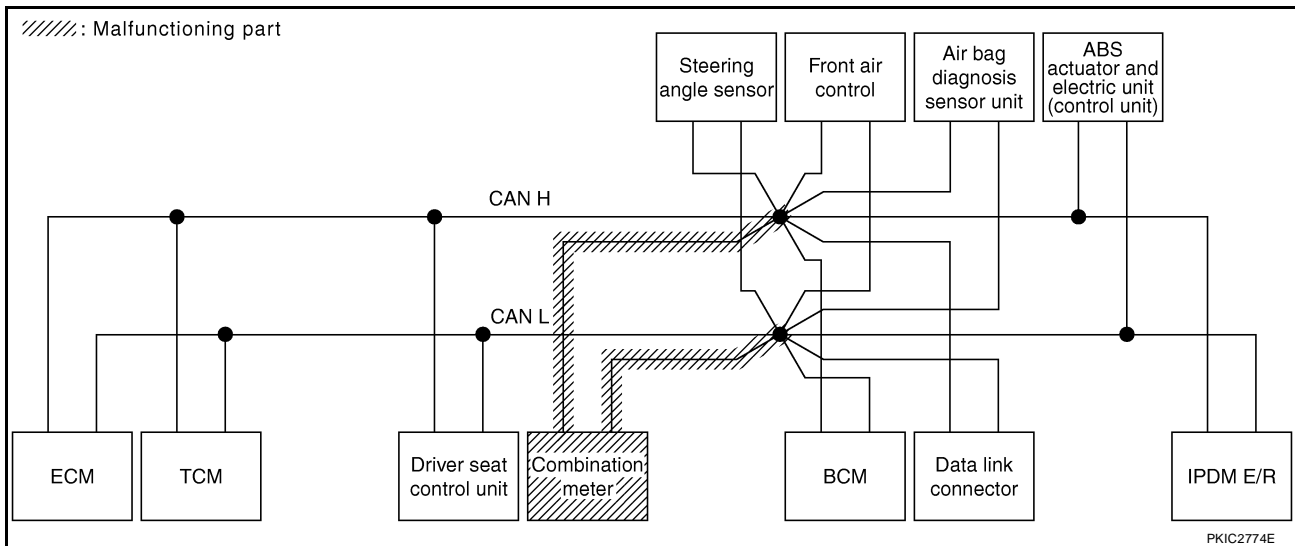

CAN SYSTEM (TYPE 2)

[CAN]

Case 8

Check BCM circuit. Refer to [LAN-148, "BCM Circuit Inspection"](#) .

SELECT SYSTEM screen		CAN DIAG SUPPORT MNTR									SELF-DIAG RESULTS	
		Initial diagnosis	Transmit diagnosis	Receive diagnosis						IPDM E/R		
				ECM	TCM	METER /M&A	BCM/SEC	STRG	VDC/TCS /ABS			
ENGINE	—	—	UNKWN	—	UNKWN	UNKWN	UN ✓ KN	—	UNKWN	UNKWN	CAN COMM CIRCUIT (U1000)	CAN COMM CIRCUIT (U1001)
A/T	—	NG	UNKWN	UNKWN	—	UNKWN	—	—	UNKWN	—	CAN COMM CIRCUIT (U1000)	—
AUTO DRIVE POS.	No indication	—	—	—	UNKWN	UNKWN	UN ✓ KN	—	—	—	CAN COMM CIRCUIT (U1000)	—
BCM	No indication	NG	UNKWN	UNKWN	—	UNKWN	—	—	—	UNKWN	CAN COMM CIRCUIT (U1000)	—
HVAC	No indication	—	UNKWN	UNKWN	—	—	UN ✓ KN	—	UNKWN	—	—	—
ABS	—	NG	UNKWN	UNKWN	UNKWN	—	—	UNKWN	—	—	CAN COMM CIRCUIT (U1000)	—
IPDM E/R	No indication	—	UNKWN	UNKWN	—	—	UN ✓ KN	—	—	—	CAN COMM CIRCUIT (U1000)	—

PKIC3265E

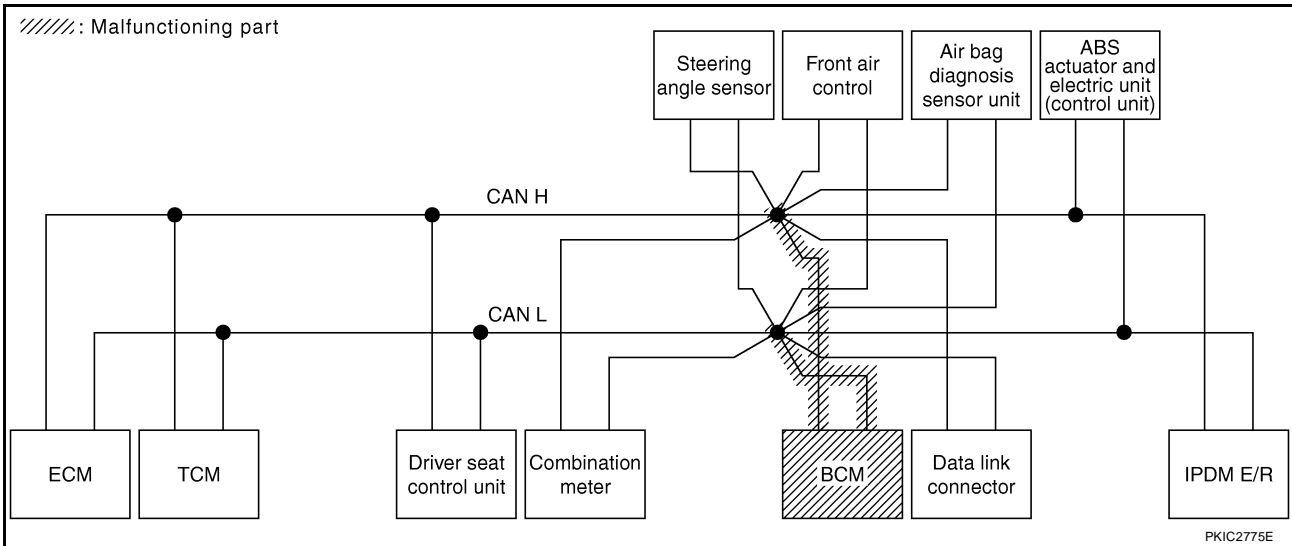

CAN SYSTEM (TYPE 2)

[CAN]

Case 9

Check data link connector circuit. Refer to [LAN-148, "Data Link Connector Circuit Inspection"](#) .

SELECT SYSTEM screen		CAN DIAG SUPPORT MNTR									SELF-DIAG RESULTS	
		Initial diagnosis	Transmit diagnosis	Receive diagnosis								
				ECM	TCM	METER /M&A	BCM/SEC	STRG	VDC/TCS /ABS	IPDM E/R		
ENGINE	-	-	UNKWN	-	UNKWN	UNKWN	UNKWN	-	UNKWN	UNKWN	CAN COMM CIRCUIT (U1000)	CAN COMM CIRCUIT (U1001)
A/T	-	NG	UNKWN	UNKWN	-	UNKWN	-	-	UNKWN	-	CAN COMM CIRCUIT (U1000)	-
AUTO DRIVE POS.	No indication	-	-	-	UNKWN	UNKWN	UNKWN	-	-	-	CAN COMM CIRCUIT (U1000)	-
BCM	No indication	NG	UNKWN	UNKWN	-	UNKWN	-	-	-	UNKWN	CAN COMM CIRCUIT (U1000)	-
HVAC	No indication	-	UNKWN	UNKWN	-	-	UNKWN	-	UNKWN	-	-	-
ABS	-	NG	UNKWN	UNKWN	UNKWN	-	-	UNKWN	-	-	CAN COMM CIRCUIT (U1000)	-
IPDM E/R	No indication	-	UNKWN	UNKWN	-	-	UNKWN	-	-	-	CAN COMM CIRCUIT (U1000)	-

PKIC3266E

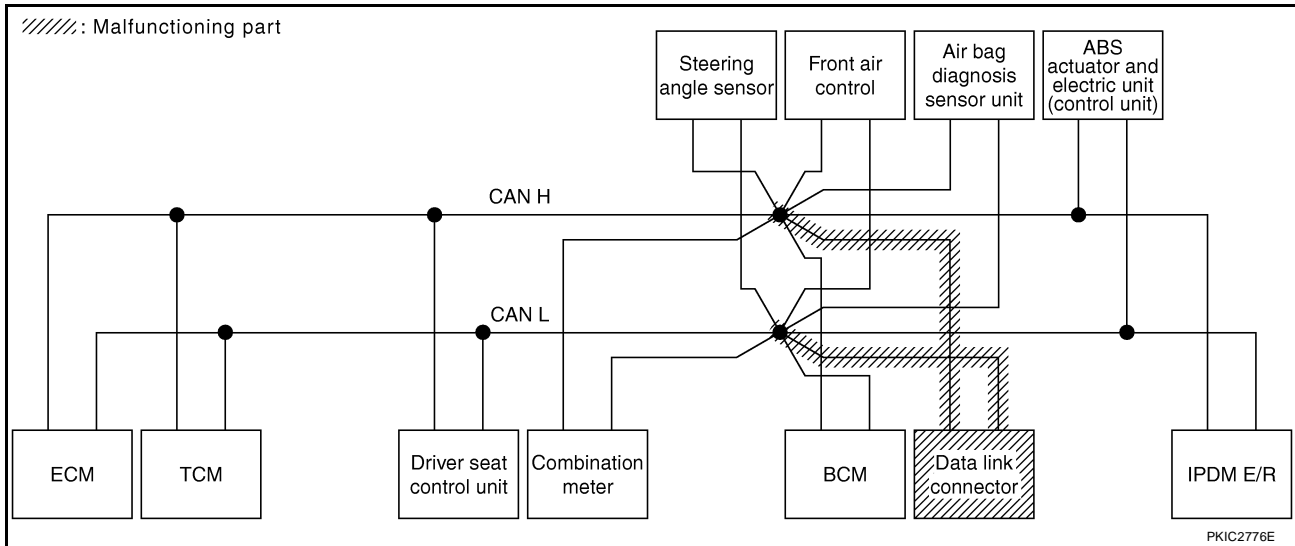

CAN SYSTEM (TYPE 2)

[CAN]

Case 10

Check steering angle sensor circuit. Refer to [LAN-149, "Steering Angle Sensor Circuit Inspection"](#).

SELECT SYSTEM screen		CAN DIAG SUPPORT MNTR									SELF-DIAG RESULTS	
		Initial diagnosis	Transmit diagnosis	Receive diagnosis								
				ECM	TCM	METER /M&A	BCM/SEC	STRG	VDC/TCS /ABS	IPDM E/R		
ENGINE	-	-	UNKWN	-	UNKWN	UNKWN	UNKWN	-	UNKWN	UNKWN	CAN COMM CIRCUIT (U1000)	CAN COMM CIRCUIT (U1001)
A/T	-	NG	UNKWN	UNKWN	-	UNKWN	-	-	UNKWN	-	CAN COMM CIRCUIT (U1000)	-
AUTO DRIVE POS.	No indication	-	-	-	UNKWN	UNKWN	UNKWN	-	-	-	CAN COMM CIRCUIT (U1000)	-
BCM	No indication	NG	UNKWN	UNKWN	-	UNKWN	-	-	-	UNKWN	CAN COMM CIRCUIT (U1000)	-
HVAC	No indication	-	UNKWN	UNKWN	-	-	UNKWN	-	UNKWN	-	-	-
ABS	-	NG	UNKWN	UNKWN	UNKWN	-	-	UNKWN	-	-	CAN COMM CIRCUIT (U1000)	-
IPDM E/R	No indication	-	UNKWN	UNKWN	-	-	UNKWN	-	-	-	CAN COMM CIRCUIT (U1000)	-

PKIC3267E

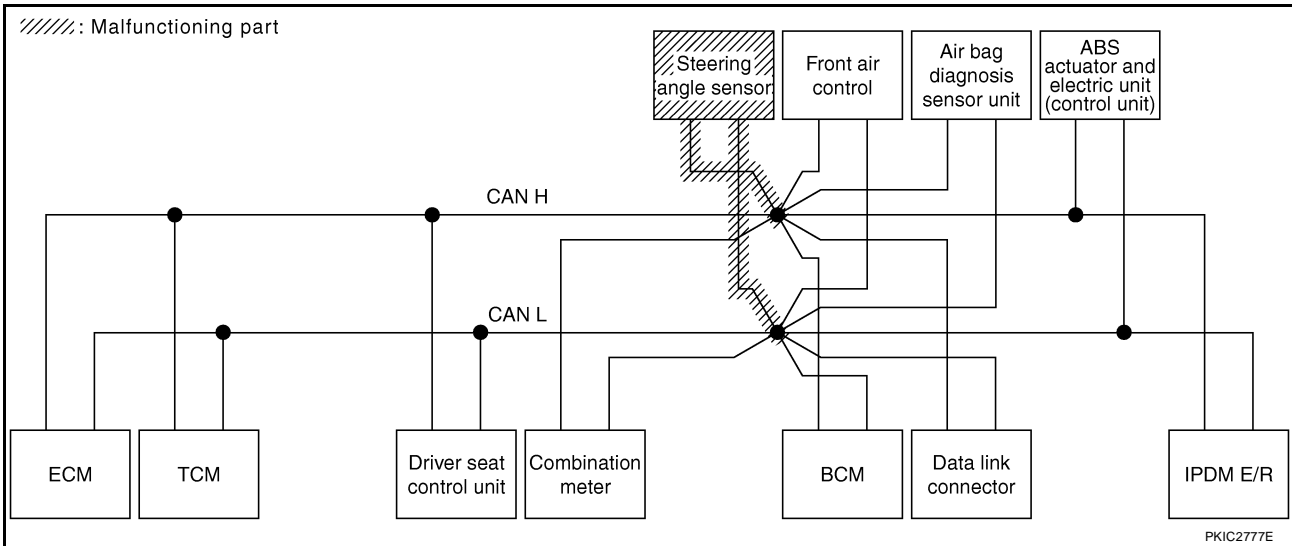

PKIC2777E

CAN SYSTEM (TYPE 2)

[CAN]

Case 11

Check front air control circuit. Refer to [LAN-149, "Front Air Control Circuit Inspection"](#) .

SELECT SYSTEM screen		CAN DIAG SUPPORT MNTR									SELF-DIAG RESULTS	
		Initial diagnosis	Transmit diagnosis	Receive diagnosis								
				ECM	TCM	METER /M&A	BCM/SEC	STRG	VDC/TCS /ABS	IPDM E/R		
ENGINE	–	–	UNKWN	–	UNKWN	UNKWN	UNKWN	–	UNKWN	UNKWN	CAN COMM CIRCUIT (U1000)	CAN COMM CIRCUIT (U1001)
A/T	–	NG	UNKWN	UNKWN	–	UNKWN	–	–	UNKWN	–	CAN COMM CIRCUIT (U1000)	–
AUTO DRIVE POS.	No indication	–	–	–	UNKWN	UNKWN	UNKWN	–	–	–	CAN COMM CIRCUIT (U1000)	–
BCM	No indication	NG	UNKWN	UNKWN	–	UNKWN	–	–	–	UNKWN	CAN COMM CIRCUIT (U1000)	–
HVAC	No indication	–	UNKWN	UNKWN	–	–	UNKWN	–	UNKWN	–	–	–
ABS	–	NG	UNKWN	UNKWN	UNKWN	–	–	UNKWN	–	–	CAN COMM CIRCUIT (U1000)	–
IPDM E/R	No indication	–	UNKWN	UNKWN	–	–	UNKWN	–	–	–	CAN COMM CIRCUIT (U1000)	–

PKIC3268E

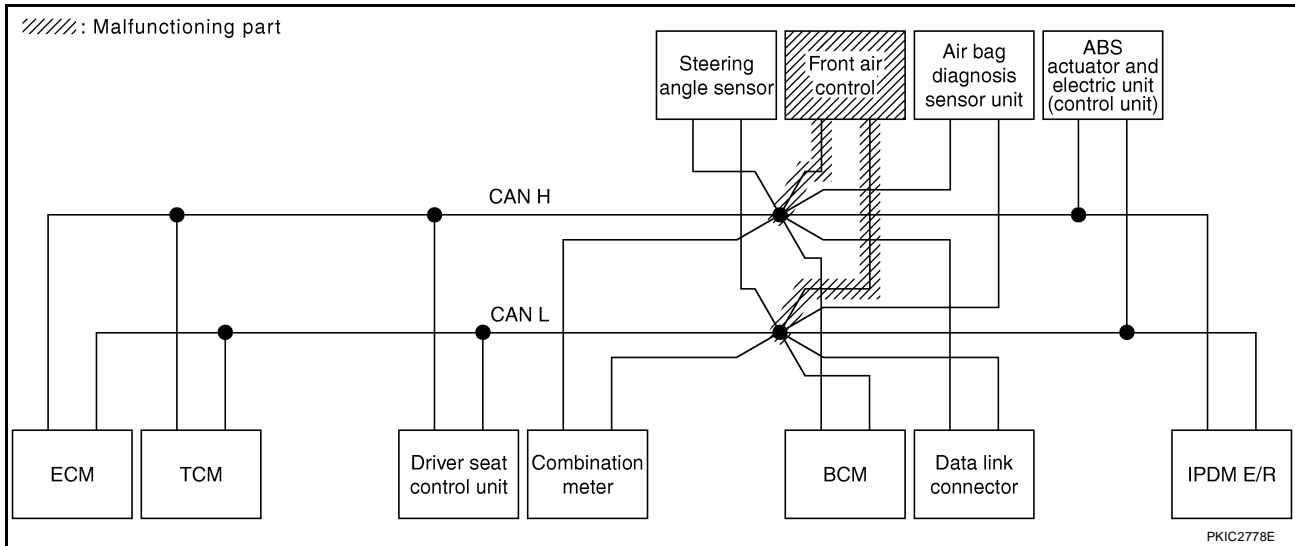

CAN SYSTEM (TYPE 2)

[CAN]

Case 12

Check ABS actuator and electric unit (control unit) circuit. Refer to [LAN-151, "ABS Actuator and Electric Unit \(Control Unit\) Circuit Inspection"](#).

SELECT SYSTEM screen		CAN DIAG SUPPORT MNTR									SELF-DIAG RESULTS	
		Initial diagnosis	Transmit diagnosis	Receive diagnosis								
				ECM	TCM	METER /M&A	BCM/SEC	STRG	VDC/TCS /ABS	IPDM E/R		
ENGINE	-	-	UNKWN	-	UNKWN	UNKWN	UNKWN	-	UNKWN	UNKWN	CAN COMM CIRCUIT (U1000)	CAN COMM CIRCUIT (U1001)
A/T	-	NG	UNKWN	UNKWN	-	UNKWN	-	-	UNKWN	-	CAN COMM CIRCUIT (U1000)	-
AUTO DRIVE POS.	No indication	-	-	-	UNKWN	UNKWN	UNKWN	-	-	-	CAN COMM CIRCUIT (U1000)	-
BCM	No indication	NG	UNKWN	UNKWN	-	UNKWN	-	-	-	UNKWN	CAN COMM CIRCUIT (U1000)	-
HVAC	No indication	-	UNKWN	UNKWN	-	-	UNKWN	-	UNKWN	-	-	-
ABS	-	NG	UNKWN	UNKWN	UNKWN	-	-	UNKWN	-	-	CAN COMM CIRCUIT (U1000)	-
IPDM E/R	No indication	-	UNKWN	UNKWN	-	-	UNKWN	-	-	-	CAN COMM CIRCUIT (U1000)	-

PKIC3269E

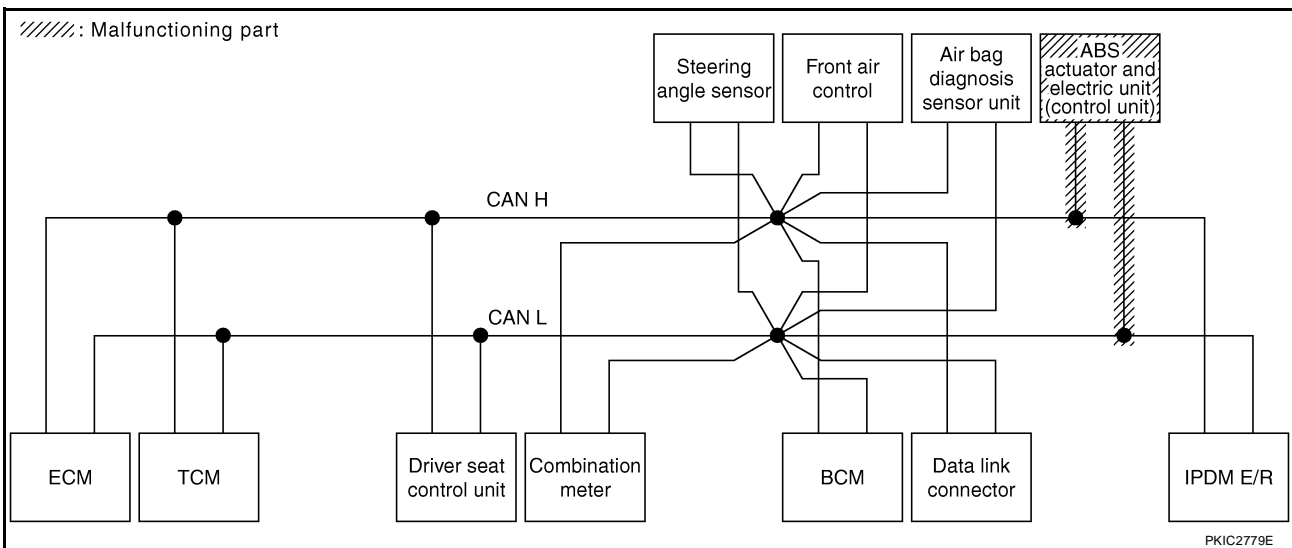

PKIC2779E

CAN SYSTEM (TYPE 2)

[CAN]

Case 13

Check IPDM E/R circuit. Refer to [LAN-151, "IPDM E/R Circuit Inspection"](#) .

SELECT SYSTEM screen		CAN DIAG SUPPORT MNTR									SELF-DIAG RESULTS		
		Initial diagnosis	Transmit diagnosis	Receive diagnosis									
				ECM	TCM	METER /M&A	BCM/SEC	STRG	VDC/TCS /ABS	IPDM E/R			
ENGINE	-	-	UNKWN	-	UNKWN	UNKWN	UNKWN	-	UNKWN	UNKWN	✓	CAN COMM CIRCUIT (U1000)	CAN COMM CIRCUIT (U1001)
A/T	-	NG	UNKWN	UNKWN	-	UNKWN	-	-	UNKWN	-	-	CAN COMM CIRCUIT (U1000)	-
AUTO DRIVE POS.	No indication	-	-	-	UNKWN	UNKWN	UNKWN	-	-	-	-	CAN COMM CIRCUIT (U1000)	-
BCM	No indication	NG	UNKWN	UNKWN	-	UNKWN	-	-	-	UNKWN	✓	CAN COMM CIRCUIT (U1000)	-
HVAC	No indication	-	UNKWN	UNKWN	-	-	UNKWN	-	UNKWN	-	-	-	-
ABS	-	NG	UNKWN	UNKWN	UNKWN	-	-	UNKWN	-	-	-	CAN COMM CIRCUIT (U1000)	-
IPDM E/R	No indication	-	UNKWN	UNKWN	-	-	UNKWN	-	-	-	-	CAN COMM CIRCUIT (U1000)	-

PKIC3270E

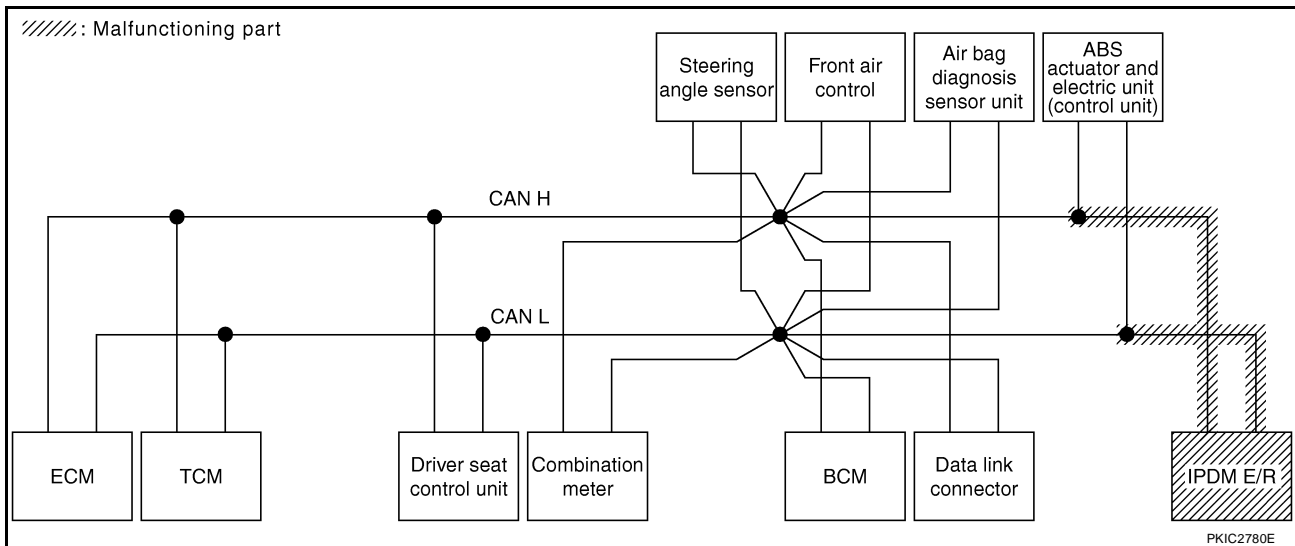

Case 14

Check CAN communication circuit. Refer to [LAN-152, "CAN Communication Circuit Inspection"](#) .

SELECT SYSTEM screen		CAN DIAG SUPPORT MNTR									SELF-DIAG RESULTS		
		Initial diagnosis	Transmit diagnosis	Receive diagnosis									
				ECM	TCM	METER /M&A	BCM/SEC	STRG	VDC/TCS /ABS	IPDM E/R			
ENGINE	-	-	UNKWN	-	UNKWN	UNKWN	UNKWN	-	UNKWN	UNKWN	✓	CAN COMM CIRCUIT (U1000)	CAN COMM CIRCUIT (U1001)
A/T	-	NG	UNKWN	UNKWN	-	UNKWN	-	-	UNKWN	-	-	CAN COMM CIRCUIT (U1000)	-
AUTO DRIVE POS.	No indication	-	-	-	UNKWN	UNKWN	UNKWN	-	-	-	-	CAN COMM CIRCUIT (U1000)	-
BCM	No indication	NG	UNKWN	UNKWN	-	UNKWN	-	-	-	UNKWN	-	CAN COMM CIRCUIT (U1000)	-
HVAC	No indication	-	UNKWN	UNKWN	-	-	UNKWN	-	UNKWN	-	-	-	-
ABS	-	NG	UNKWN	UNKWN	UNKWN	-	-	UNKWN	-	-	-	CAN COMM CIRCUIT (U1000)	-
IPDM E/R	No indication	-	UNKWN	UNKWN	-	-	UNKWN	-	-	-	-	CAN COMM CIRCUIT (U1000)	-

PKIC3271E

CAN SYSTEM (TYPE 2)

[CAN]

Case 15

Check IPDM E/R ignition relay circuit continuously sticks "OFF". Refer to [LAN-153, "IPDM E/R Ignition Relay Circuit Inspection"](#).

SELECT SYSTEM screen		CAN DIAG SUPPORT MNTR									SELF-DIAG RESULTS	
		Initial diagnosis	Transmit diagnosis	Receive diagnosis								
				ECM	TCM	METER /M&A	BCM/SEC	STRG	VDC/TCS /ABS	IPDM E/R		
ENGINE	–	–	UNKWN	–	UNKWN	UNKWN	UNKWN	–	UNKWN	UNKWN	CAN COMM CIRCUIT (U1000)	CAN COMM CIRCUIT (U1001)
A/T	–	NG	UNKWN	UNKWN	–	UNKWN	–	–	UNKWN	–	CAN COMM CIRCUIT (U1000)	–
AUTO DRIVE POS.	No indication	–	–	–	UNKWN	UNKWN	UNKWN	–	–	–	CAN COMM CIRCUIT (U1000)	–
BCM	No indication	NG	UNKWN	UNKWN	–	UNKWN	–	–	–	UNKWN	CAN COMM CIRCUIT (U1000)	–
HVAC	No indication	–	UNKWN	UNKWN	–	–	UNKWN	–	UNKWN	–	–	–
ABS	–	NG	UNKWN	UNKWN	UNKWN	–	–	UNKWN	–	–	CAN COMM CIRCUIT (U1000)	–
IPDM E/R	No indication	–	UNKWN	UNKWN	–	–	UNKWN	–	–	–	CAN COMM CIRCUIT (U1000)	–

PKIC3272E

Case 16

Check IPDM E/R ignition relay circuit continuously sticks "ON". Refer to [LAN-153, "IPDM E/R Ignition Relay Circuit Inspection"](#).

SELECT SYSTEM screen		CAN DIAG SUPPORT MNTR									SELF-DIAG RESULTS	
		Initial diagnosis	Transmit diagnosis	Receive diagnosis								
				ECM	TCM	METER /M&A	BCM/SEC	STRG	VDC/TCS /ABS	IPDM E/R		
ENGINE	–	–	UNKWN	–	UNKWN	UNKWN	UNKWN	–	UNKWN	UNKWN	CAN COMM CIRCUIT (U1000)	CAN COMM CIRCUIT (U1001)
A/T	–	NG	UNKWN	–	–	–	–	–	UNKWN	–	CAN COMM CIRCUIT (U1000)	–
AUTO DRIVE POS.	No indication	–	–	–	UNKWN	UNKWN	UNKWN	–	–	–	CAN COMM CIRCUIT (U1000)	–
BCM	No indication	NG	UNKWN	UNKWN	–	UNKWN	–	–	–	UNKWN	CAN COMM CIRCUIT (U1000)	–
HVAC	No indication	–	UNKWN	UNKWN	–	–	UNKWN	–	UNKWN	–	–	–
ABS	–	NG	UNKWN	–	UNKWN	–	–	–	–	–	CAN COMM CIRCUIT (U1000)	–
IPDM E/R	No indication	–	UNKWN	UNKWN	–	–	UNKWN	–	–	–	CAN COMM CIRCUIT (U1000)	–

PKIC3273E

CAN SYSTEM (TYPE 3)

PF2:23710

Component Parts and Harness Connector Location

UKS004S9

Refer to [LAN-25, "Component Parts and Harness Connector Location"](#) .

Schematic

UKS004SA

Refer to [LAN-26, "Schematic"](#) .

Wiring Diagram — CAN —

UKS004SB

Refer to [LAN-27, "Wiring Diagram — CAN —"](#) .

CAN SYSTEM (TYPE 3)

[CAN]

UKS004SC

Check Sheet

NOTE:

If a check mark is put on "NG" on "INITIAL DIAG (Initial diagnosis)", replace the control unit.

Check sheet table															
SELECT SYSTEM screen		CAN DIAG SUPPORT MNTR											SELF-DIAG RESULTS		
		Initial diagnosis	Transmit diagnosis	Receive diagnosis											IPDM E/R
				ECM	TCM	METER /M&A	DISPLAY	BCM/SEC	STRG	HVAC	VDC/TCS /ABS				
ENGINE	-	-	UNKWN	-	UNKWN	UNKWN	-	UNKWN	-	-	UNKWN	UNKWN	CAN COMM CIRCUIT (U1000)	CAN COMM CIRCUIT (U1001)	
A/T	-	NG	UNKWN	UNKWN	-	UNKWN	-	-	-	-	UNKWN	-	CAN COMM CIRCUIT (U1000)	-	
AUTO DRIVE POS.	No indication	-	-	-	UNKWN	UNKWN	-	UNKWN	-	-	-	-	CAN COMM CIRCUIT (U1000)	-	
Display control unit	-	NG	UNKWN	UNKWN	-	UNKWN	-	UNKWN	-	UNKWN	-	UNKWN	-	-	
BCM	No indication	NG	UNKWN	UNKWN	-	UNKWN	-	-	-	-	-	UNKWN	CAN COMM CIRCUIT (U1000)	-	
HVAC	No indication	-	UNKWN	UNKWN	-	-	UNKWN	UNKWN	-	-	UNKWN	-	-	-	
ABS	-	NG	UNKWN	UNKWN	UNKWN	-	-	-	UNKWN	-	-	-	CAN COMM CIRCUIT (U1000)	-	
IPDM E/R	No indication	-	UNKWN	UNKWN	-	-	-	UNKWN	-	-	-	-	CAN COMM CIRCUIT (U1000)	-	

Symptoms :

Attach copy of
SELECT SYSTEM

Attach copy of
SELECT SYSTEM

Display control unit Translation Sheet: Rewrite the following names, and put a check mark on the above check sheet table.			
Confirmation/Adjustment Display	Check sheet table Display	Confirmation/Adjustment Display	Check sheet table Display
CAN COMM	Initial diagnosis	CAN CIRC 5	METER/M&A
CAN CIRC 1	Transmit diagnosis	CAN CIRC 6	-
CAN CIRC 2	BCM	CAN CIRC 7	IPDM E/R
CAN CIRC 3	ECM	CAN CIRC 8	-
CAN CIRC 4	HVAC	CAN CIRC 9	-

Attach copy of
display control unit
CAN DIAG SUPPORT MONITOR check sheet

PKIC2943E

A
B
C
D
E
F
G
H
I
J
L
M

LAN

CAN SYSTEM (TYPE 3)

[CAN]

Attach copy of
ENGINE
SELF-DIAG RESULTS

Attach copy of
A/T
SELF-DIAG RESULTS

Attach copy of
AUTO DRIVE POS.
SELF-DIAG RESULTS

Attach copy of
BCM
SELF-DIAG RESULTS

Attach copy of
HVAC
SELF-DIAG RESULTS

Attach copy of
ABS
SELF-DIAG RESULTS

Attach copy of
IPDM E/R
SELF-DIAG RESULTS

Attach copy of
ENGINE
CAN DIAG SUPPORT
MNTR

Attach copy of
A/T
CAN DIAG SUPPORT
MNTR

Attach copy of
AUTO DRIVE POS.
CAN DIAG SUPPORT
MNTR

Attach copy of
BCM
CAN DIAG SUPPORT
MNTR

Attach copy of
HVAC
CAN DIAG SUPPORT
MNTR

Attach copy of
ABS
CAN DIAG SUPPORT
MNTR

Attach copy of
IPDM E/R
CAN DIAG SUPPORT
MNTR

PKIB6658E

CAN SYSTEM (TYPE 3)

[CAN]

CHECK SHEET RESULTS (EXAMPLE)

NOTE:

If a check mark is put on "NG" on "INITIAL DIAG (Initial diagnosis)", replace the control unit.

Case 1

Check harness between TCM and driver seat control unit. Refer to [LAN-141, "Inspection Between TCM and Driver Seat Control Unit Circuit"](#).

SELECT SYSTEM screen		CAN DIAG SUPPORT MNTR											SELF-DIAG RESULTS			
		Initial diagnosis	Transmit diagnosis	Receive diagnosis											CAN COMM CIRCUIT (U1000)	CAN COMM CIRCUIT (U1001)
				ECM	TCM	METER /M&A	DISPLAY	BCM/SEC	STRG	HVAC	VDC/TCS /ABS	IPDM E/R				
ENGINE	-	-	UNKWN	-	UNKWN	✓	-	UNKWN	-	-	-	UNKWN	UNKWN	CAN COMM CIRCUIT (U1000)	CAN COMM CIRCUIT (U1001)	
A/T	-	NG	UNKWN	UNKWN	-	UNKWN	-	-	-	-	-	UNKWN	-	CAN COMM CIRCUIT (U1000)	-	
AUTO DRIVE POS.	No indication	-	-	-	UNKWN	UNKWN	-	UNKWN	-	-	-	-	-	CAN COMM CIRCUIT (U1000)	-	
Display control unit	-	NG	UNKWN	UNKWN	-	UNKWN	-	UNKWN	-	UNKWN	-	UNKWN	-	-	-	
BCM	No indication	NG	UNKWN	UNKWN	-	UNKWN	-	-	-	-	-	UNKWN	-	CAN COMM CIRCUIT (U1000)	-	
HVAC	No indication	-	UNKWN	UNKWN	-	-	UNKWN	UNKWN	-	-	-	UNKWN	-	-	-	
ABS	-	NG	UNKWN	UNKWN	UNKWN	-	-	-	UNKWN	-	-	-	-	CAN COMM CIRCUIT (U1000)	-	
IPDM E/R	No indication	-	UNKWN	UNKWN	-	-	-	UNKWN	-	-	-	-	-	CAN COMM CIRCUIT (U1000)	-	

PKIC3274E

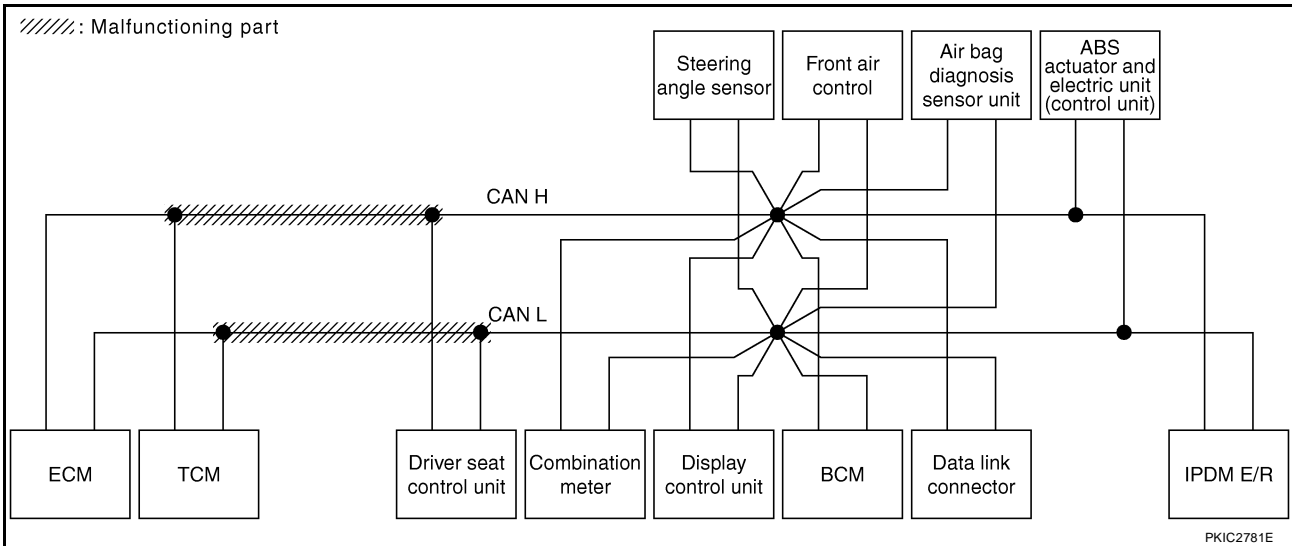

PKIC2781E

CAN SYSTEM (TYPE 3)

[CAN]

Case 2

Check harness between driver seat control unit and data link connector. Refer to [LAN-143, "Inspection Between Driver Seat Control Unit and Data Link Connector Circuit"](#) .

SELECT SYSTEM screen		CAN DIAG SUPPORT MNTR											SELF-DIAG RESULTS		
		Initial diagnosis	Transmit diagnosis	Receive diagnosis											IPDM E/R
				ECM	TCM	METER /M&A	DISPLAY	BCM/SEC	STRG	HVAC	VDC/TCS /ABS				
ENGINE	-	-	UNKWN	-	UNKWN	✓	-	✓	-	-	✓	✓	CAN COMM CIRCUIT (U1000)	CAN COMM CIRCUIT (U1001)	
A/T	-	NG	UNKWN	UNKWN	-	✓	-	-	-	-	✓	-	CAN COMM CIRCUIT (U1000)	-	
AUTO DRIVE POS.	No indication ✓	-	-	-	UNKWN	UNKWN	-	UNKWN	-	-	-	-	CAN COMM CIRCUIT (U1000)	-	
Display control unit	-	NG	UNKWN	✓	-	UNKWN	-	UNKWN	-	UNKWN	-	UNKWN	-	-	
BCM	No indication	NG	UNKWN	✓	-	UNKWN	-	-	-	-	-	UNKWN	CAN COMM CIRCUIT (U1000)	-	
HVAC	No indication	-	UNKWN	✓	-	-	UNKWN	UNKWN	-	-	UNKWN	-	-	-	
ABS	-	NG	UNKWN	✓	✓	-	-	-	UNKWN	-	-	-	CAN COMM CIRCUIT (U1000)	-	
IPDM E/R	No indication	-	UNKWN	✓	-	-	-	UNKWN	-	-	-	-	CAN COMM CIRCUIT (U1000)	-	

PKIC3275E

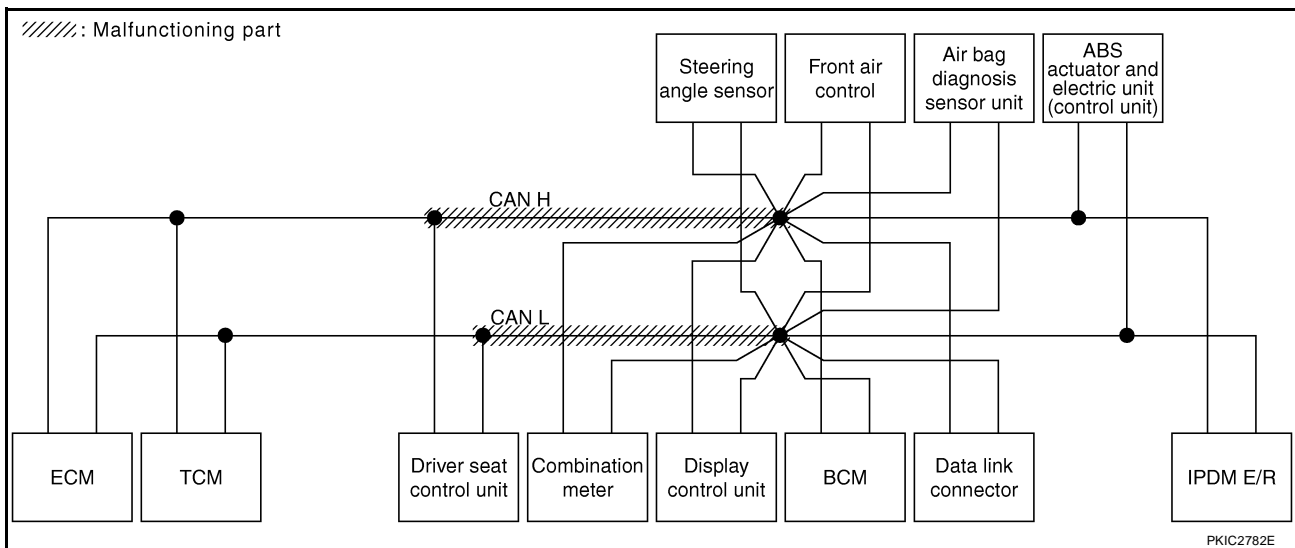

PKIC2782E

CAN SYSTEM (TYPE 3)

[CAN]

Case 3

Check harness between data link connector and ABS actuator and electric unit (control unit). Refer to LAN-144, "Inspection Between Data Link Connector and ABS Actuator and Electric Unit (Control Unit) Circuit" .

SELECT SYSTEM screen		CAN DIAG SUPPORT MNTR											SELF-DIAG RESULTS		
		Initial diagnosis	Transmit diagnosis	Receive diagnosis											IPDM E/R
				ECM	TCM	METER /M&A	DISPLAY	BCM/SEC	STRG	HVAC	VDC/TCS /ABS				
ENGINE	-	-	UNKWN	-	UNKWN	UNKWN	-	UNKWN	-	-	UNKWN	UNKWN	CAN COMM CIRCUIT (U1000)	CAN COMM CIRCUIT (U1001)	
A/T	-	NG	UNKWN	UNKWN	-	UNKWN	-	-	-	-	UNKWN	-	CAN COMM CIRCUIT (U1000)	-	
AUTO DRIVE POS.	No indication	-	-	-	UNKWN	UNKWN	-	UNKWN	-	-	-	-	CAN COMM CIRCUIT (U1000)	-	
Display control unit	-	NG	UNKWN	UNKWN	-	UNKWN	-	UNKWN	-	UNKWN	-	UNKWN	-	-	
BCM	No indication	NG	UNKWN	UNKWN	-	UNKWN	-	-	-	-	-	UNKWN	CAN COMM CIRCUIT (U1000)	-	
HVAC	No indication	-	UNKWN	UNKWN	-	-	UNKWN	UNKWN	-	-	UNKWN	-	-	-	
ABS	-	NG	UNKWN	UNKWN	UNKWN	UNKWN	-	-	UNKWN	-	-	-	CAN COMM CIRCUIT (U1000)	-	
IPDM E/R	No indication	-	UNKWN	UNKWN	-	-	-	UNKWN	-	-	-	-	CAN COMM CIRCUIT (U1000)	-	

PKIC3276E

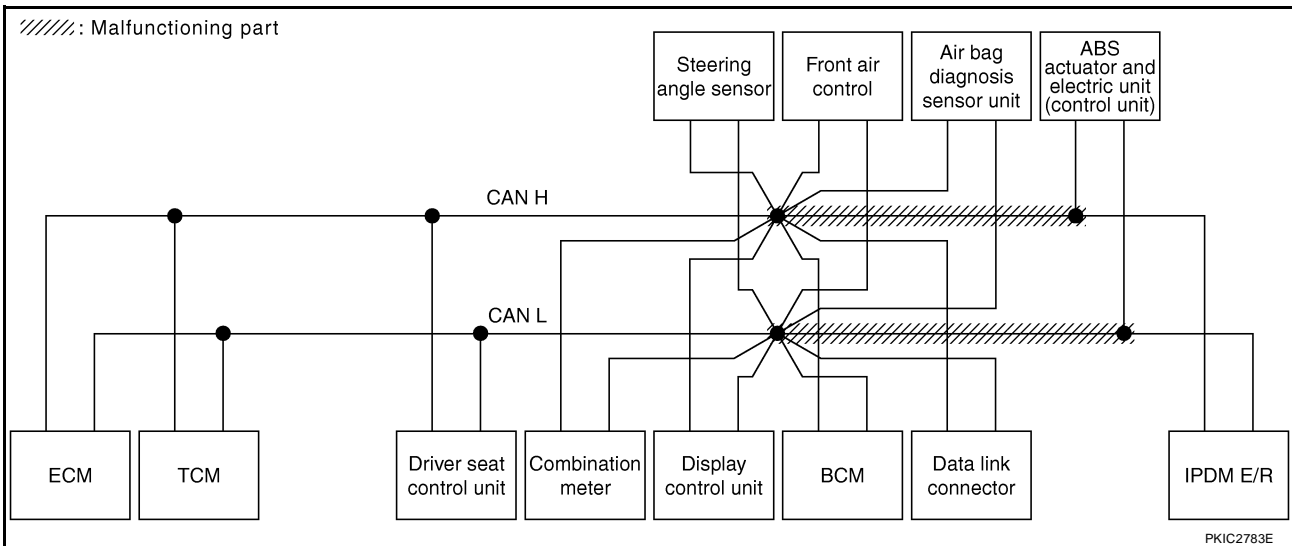

PKIC2783E

CAN SYSTEM (TYPE 3)

[CAN]

Case 4

Check ECM circuit. Refer to [LAN-145, "ECM Circuit Inspection"](#) .

SELECT SYSTEM screen		CAN DIAG SUPPORT MNTR											SELF-DIAG RESULTS		
		Initial diagnosis	Transmit diagnosis	Receive diagnosis											IPDM E/R
				ECM	TCM	METER /M&A	DISPLAY	BCM/SEC	STRG	HVAC	VDC/TCS /ABS				
ENGINE	-	-	UNKWN	-	UNKWN	UNKWN	-	UNKWN	-	-	UNKWN	UNKWN	CAN COMM CIRCUIT (U600)	CAN COMM CIRCUIT (U601)	
A/T	-	NG	UNKWN	UNKWN	-	UNKWN	-	-	-	-	UNKWN	-	CAN COMM CIRCUIT (U600)	-	
AUTO DRIVE POS.	No indication	-	-	-	UNKWN	UNKWN	-	UNKWN	-	-	-	-	CAN COMM CIRCUIT (U1000)	-	
Display control unit	-	NG	UNKWN	UNKWN	-	UNKWN	-	UNKWN	-	UNKWN	-	UNKWN	-	-	
BCM	No indication	NG	UNKWN	UNKWN	-	UNKWN	-	-	-	-	-	UNKWN	CAN COMM CIRCUIT (U1000)	-	
HVAC	No indication	-	UNKWN	UNKWN	-	-	UNKWN	UNKWN	-	-	UNKWN	-	-	-	
ABS	-	NG	UNKWN	UNKWN	-	-	-	-	UNKWN	-	-	-	CAN COMM CIRCUIT (U600)	-	
IPDM E/R	No indication	-	UNKWN	UNKWN	-	-	-	UNKWN	-	-	-	-	CAN COMM CIRCUIT (U600)	-	

PKIC3277E

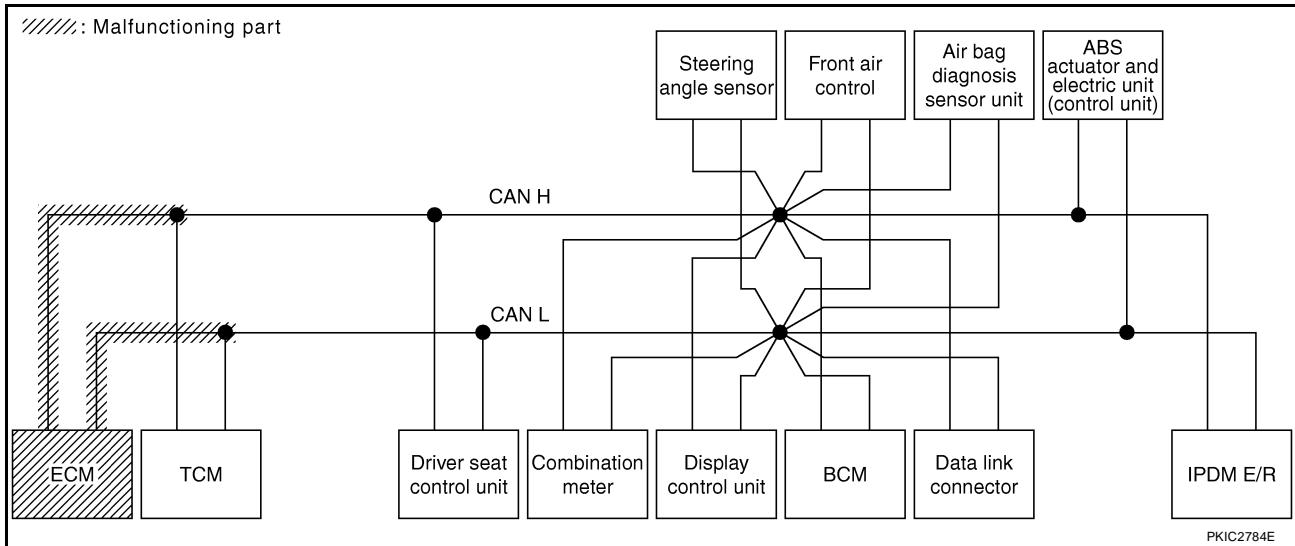

PKIC2784E

CAN SYSTEM (TYPE 3)

[CAN]

Case 5

Check TCM circuit. Refer to [LAN-146, "TCM Circuit Inspection"](#) .

SELECT SYSTEM screen		CAN DIAG SUPPORT MNTR											SELF-DIAG RESULTS		
		Initial diagnosis	Transmit diagnosis	Receive diagnosis											IPDM E/R
				ECM	TCM	METER /M&A	DISPLAY	BCM/SEC	STRG	HVAC	VDC/TCS /ABS				
ENGINE	-	-	UNKWN	-	UN KN WN	UNKWN	-	UNKWN	-	-	UNKWN	UNKWN	CAN COMM CIRCUIT (U100)	CAN COMM CIRCUIT (U101)	
A/T	-	NG	UNKWN	UN KN WN	-	UN KN WN	-	-	-	-	UNKWN	-	CAN COMM CIRCUIT (U100)	-	
AUTO DRIVE POS.	No indication	-	-	-	UN KN WN	UNKWN	-	UNKWN	-	-	-	-	CAN COMM CIRCUIT (U100)	-	
Display control unit	-	NG	UNKWN	UNKWN	-	UNKWN	-	UNKWN	-	UNKWN	-	UNKWN	-	-	
BCM	No indication	NG	UNKWN	UNKWN	-	UNKWN	-	-	-	-	-	UNKWN	CAN COMM CIRCUIT (U1000)	-	
HVAC	No indication	-	UNKWN	UNKWN	-	-	UNKWN	UNKWN	-	-	UNKWN	-	-	-	
ABS	-	NG	UNKWN	UNKWN	UN KN WN	-	-	-	UNKWN	-	-	-	CAN COMM CIRCUIT (U100)	-	
IPDM E/R	No indication	-	UNKWN	UNKWN	-	-	-	UNKWN	-	-	-	-	CAN COMM CIRCUIT (U1000)	-	

PKIC3278E

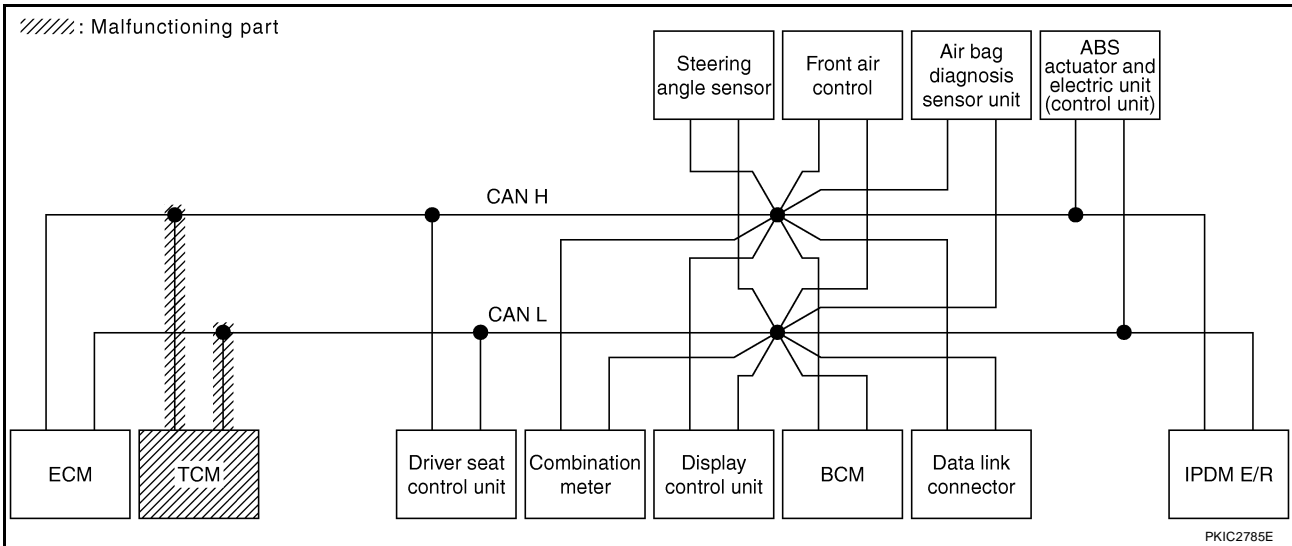

CAN SYSTEM (TYPE 3)

[CAN]

Case 6

Check driver seat control unit circuit. Refer to [LAN-146, "Driver Seat Control Unit Circuit Inspection"](#) .

SELECT SYSTEM screen		CAN DIAG SUPPORT MNTR											SELF-DIAG RESULTS		
		Initial diagnosis	Transmit diagnosis	Receive diagnosis											IPDM E/R
				ECM	TCM	METER /M&A	DISPLAY	BCM/SEC	STRG	HVAC	VDC/TCS /ABS				
ENGINE	-	-	UNKWN	-	UNKWN	UNKWN	-	UNKWN	-	-	UNKWN	UNKWN	CAN COMM CIRCUIT (U1000)	CAN COMM CIRCUIT (U1001)	
A/T	-	NG	UNKWN	UNKWN	-	UNKWN	-	-	-	-	UNKWN	-	CAN COMM CIRCUIT (U1000)	-	
AUTO DRIVE POS.	No indication ✓	-	-	-	UNKWN	UNKWN	-	UNKWN	-	-	-	-	CAN COMM CIRCUIT (U1000) ✓	-	
Display control unit	-	NG	UNKWN	UNKWN	-	UNKWN	-	UNKWN	-	UNKWN	-	UNKWN	-	-	
BCM	No indication	NG	UNKWN	UNKWN	-	UNKWN	-	-	-	-	-	UNKWN	CAN COMM CIRCUIT (U1000)	-	
HVAC	No indication	-	UNKWN	UNKWN	-	-	UNKWN	UNKWN	-	-	UNKWN	-	-	-	
ABS	-	NG	UNKWN	UNKWN	UNKWN	-	-	-	UNKWN	-	-	-	CAN COMM CIRCUIT (U1000)	-	
IPDM E/R	No indication	-	UNKWN	UNKWN	-	-	-	UNKWN	-	-	-	-	CAN COMM CIRCUIT (U1000)	-	

PKIC3279E

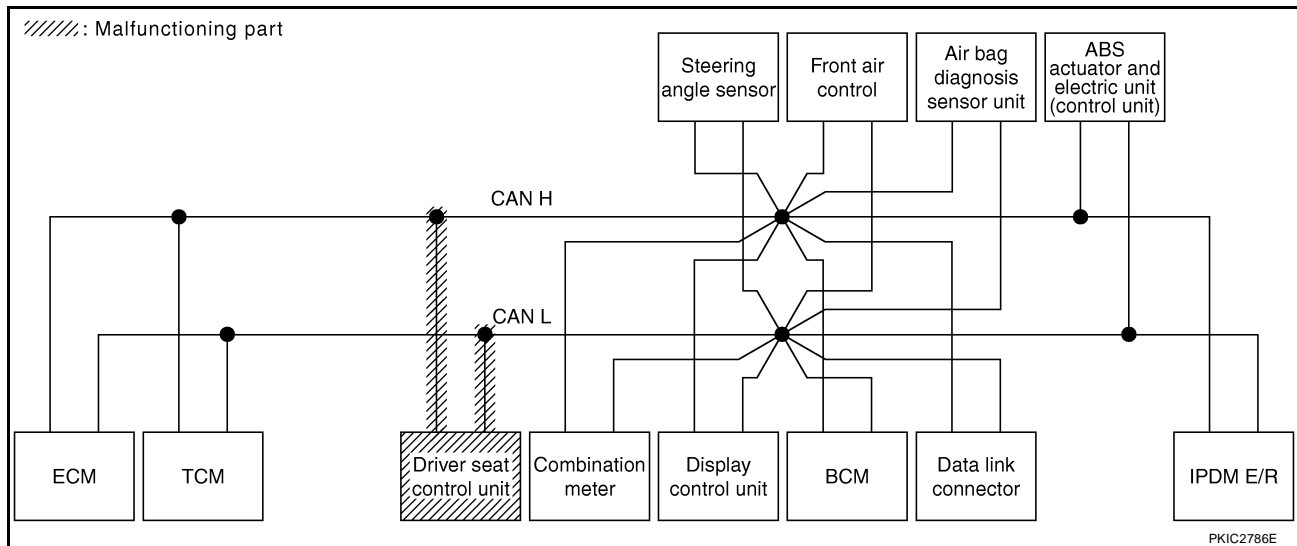

PKIC2786E

CAN SYSTEM (TYPE 3)

[CAN]

Case 7

Check combination meter circuit. Refer to [LAN-147, "Combination Meter Circuit Inspection"](#).

SELECT SYSTEM screen		CAN DIAG SUPPORT MNTR											SELF-DIAG RESULTS	
		Initial diagnosis	Transmit diagnosis	Receive diagnosis										
				ECM	TCM	METER /M&A	DISPLAY	BCM/SEC	STRG	HVAC	VDC/TCS /ABS	IPDM E/R		
ENGINE	-	-	UNKWN	-	UNKWN	UN ✓ WN	-	UNKWN	-	-	UNKWN	UNKWN	CAN COMM CIRCUIT (U1000)	CAN COMM CIRCUIT (U1001)
A/T	-	NG	UNKWN	UNKWN	-	UN ✓ WN	-	-	-	-	UNKWN	-	CAN COMM CIRCUIT (U1000)	-
AUTO DRIVE POS.	No indication	-	-	-	UNKWN	UN ✓ WN	-	UNKWN	-	-	-	-	CAN COMM CIRCUIT (U1000)	-
Display control unit	-	NG	UNKWN	UNKWN	-	UN ✓ WN	-	UNKWN	-	UNKWN	-	UNKWN	-	-
BCM	No indication	NG	UNKWN	UNKWN	-	UN ✓ WN	-	-	-	-	-	UNKWN	CAN COMM CIRCUIT (U1000)	-
HVAC	No indication	-	UNKWN	UNKWN	-	-	UNKWN	UNKWN	-	-	UNKWN	-	-	-
ABS	-	NG	UNKWN	UNKWN	UNKWN	-	-	-	UNKWN	-	-	-	CAN COMM CIRCUIT (U1000)	-
IPDM E/R	No indication	-	UNKWN	UNKWN	-	-	-	UNKWN	-	-	-	-	CAN COMM CIRCUIT (U1000)	-

PKIC3280E

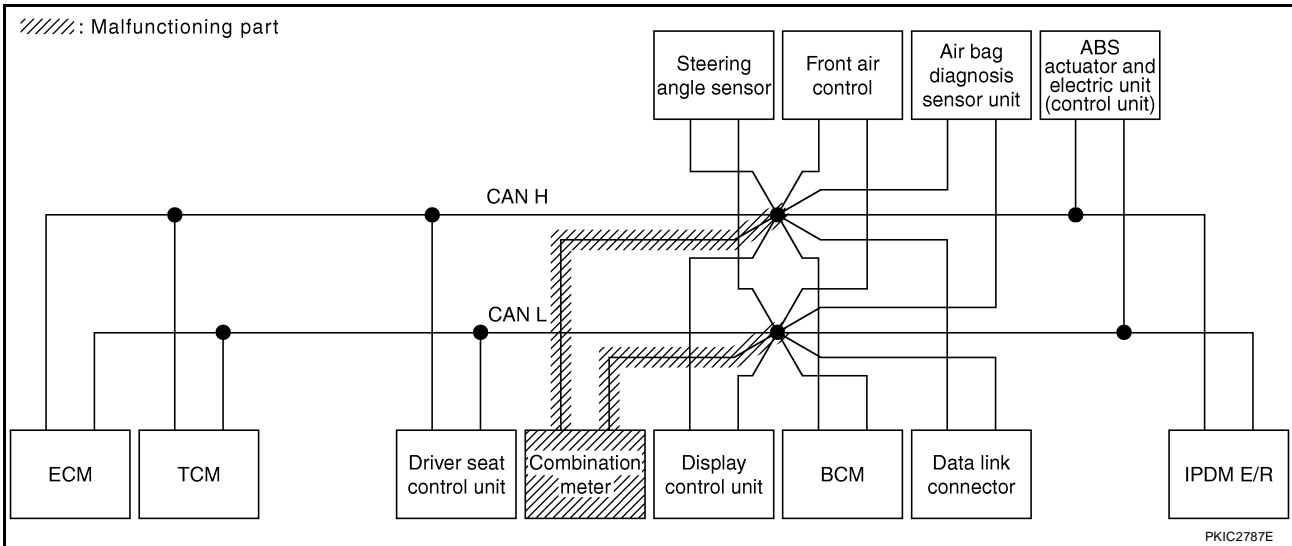

CAN SYSTEM (TYPE 3)

[CAN]

Case 8

Check display control unit circuit. Refer to [LAN-147, "Display Control Unit Circuit Inspection"](#) .

SELECT SYSTEM screen		CAN DIAG SUPPORT MNTR											SELF-DIAG RESULTS		
		Initial diagnosis	Transmit diagnosis	Receive diagnosis											IPDM E/R
				ECM	TCM	METER /M&A	DISPLAY	BCM/SEC	STRG	HVAC	VDC/TCS /ABS				
ENGINE	-	-	UNKWN	-	UNKWN	UNKWN	-	UNKWN	-	-	UNKWN	UNKWN	CAN COMM CIRCUIT (U1000)	CAN COMM CIRCUIT (U1001)	
A/T	-	NG	UNKWN	UNKWN	-	UNKWN	-	-	-	-	UNKWN	-	CAN COMM CIRCUIT (U1000)	-	
AUTO DRIVE POS.	No indication	-	-	-	UNKWN	UNKWN	-	UNKWN	-	-	-	-	CAN COMM CIRCUIT (U1000)	-	
Display control unit	-	NG	UNKWN ✓	UNKWN ✓	-	UNKWN ✓	-	UNKWN ✓	-	UNKWN ✓	-	UNKWN ✓	-	-	
BCM	No indication	NG	UNKWN	UNKWN	-	UNKWN	-	-	-	-	-	UNKWN	CAN COMM CIRCUIT (U1000)	-	
HVAC	No indication	-	UNKWN	UNKWN	-	-	UNKWN ✓	UNKWN	-	-	UNKWN	-	-	-	
ABS	-	NG	UNKWN	UNKWN	UNKWN	-	-	-	UNKWN	-	-	-	CAN COMM CIRCUIT (U1000)	-	
IPDM E/R	No indication	-	UNKWN	UNKWN	-	-	-	UNKWN	-	-	-	-	CAN COMM CIRCUIT (U1000)	-	

PKIC3281E

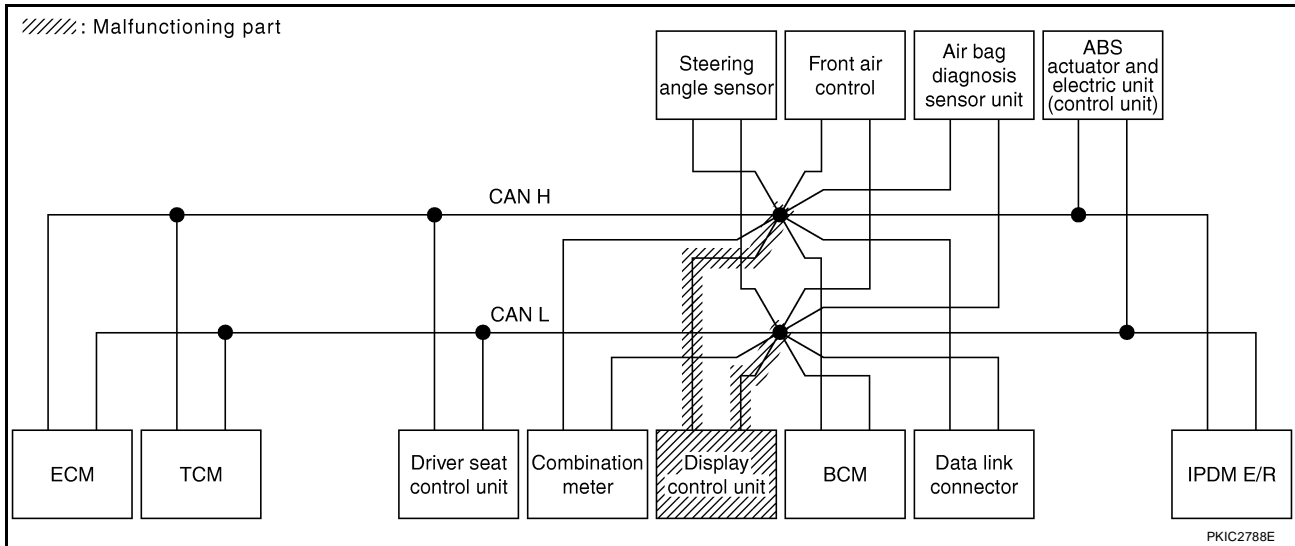

PKIC2788E

CAN SYSTEM (TYPE 3)

[CAN]

Case 9

Check BCM circuit. Refer to [LAN-148, "BCM Circuit Inspection"](#) .

SELECT SYSTEM screen		CAN DIAG SUPPORT MNTR											SELF-DIAG RESULTS		
		Initial diagnosis	Transmit diagnosis	Receive diagnosis											IPDM E/R
				ECM	TCM	METER /M&A	DISPLAY	BCM/SEC	STRG	HVAC	VDC/TCS /ABS				
ENGINE	-	-	UNKWN	-	UNKWN	UNKWN	-	UNKWN	-	-	UNKWN	UNKWN	CAN COMM CIRCUIT (U1000)	CAN COMM CIRCUIT (U1001)	
A/T	-	NG	UNKWN	UNKWN	-	UNKWN	-	-	-	-	UNKWN	-	CAN COMM CIRCUIT (U1000)	-	
AUTO DRIVE POS.	No indication	-	-	-	UNKWN	UNKWN	-	UNKWN	-	-	-	-	CAN COMM CIRCUIT (U1000)	-	
Display control unit	-	NG	UNKWN	UNKWN	-	UNKWN	-	UNKWN	-	UNKWN	-	UNKWN	-	-	
BCM	No indication	NG	UNKWN	UNKWN	-	UNKWN	-	-	-	-	-	UNKWN	CAN COMM CIRCUIT (U1000)	-	
HVAC	No indication	-	UNKWN	UNKWN	-	-	UNKWN	UNKWN	-	-	UNKWN	-	-	-	
ABS	-	NG	UNKWN	UNKWN	UNKWN	-	-	-	UNKWN	-	-	-	CAN COMM CIRCUIT (U1000)	-	
IPDM E/R	No indication	-	UNKWN	UNKWN	-	-	-	UNKWN	-	-	-	-	CAN COMM CIRCUIT (U1000)	-	

PKIC3282E

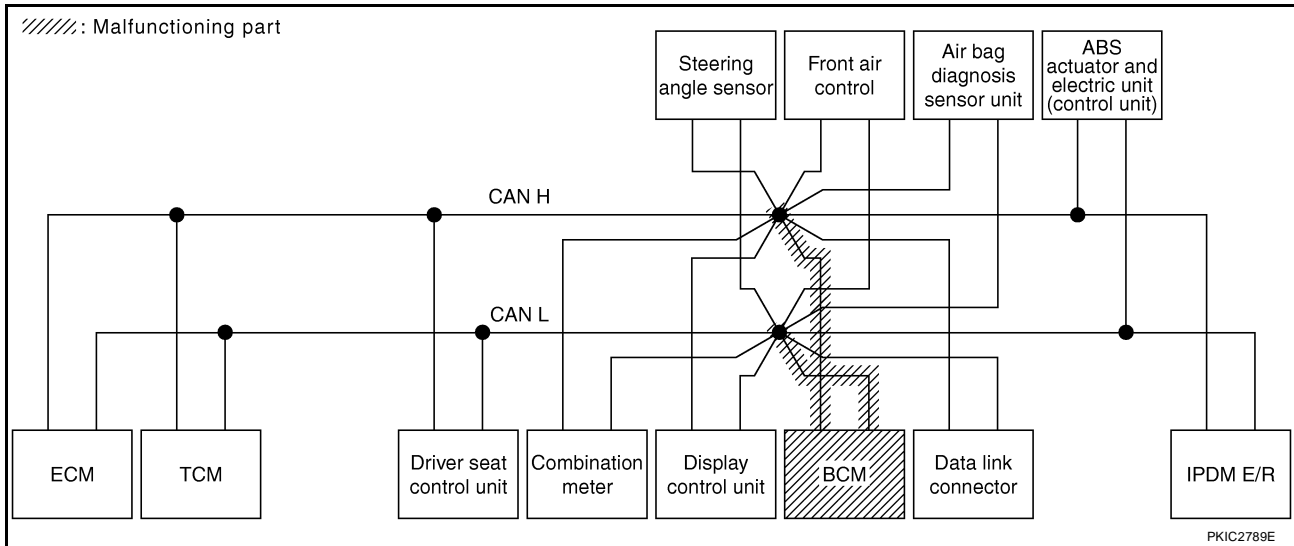

CAN SYSTEM (TYPE 3)

[CAN]

Case 10

Check data link connector circuit. Refer to [LAN-148, "Data Link Connector Circuit Inspection"](#) .

SELECT SYSTEM screen		CAN DIAG SUPPORT MNTR											SELF-DIAG RESULTS		
		Initial diagnosis	Transmit diagnosis	Receive diagnosis											IPDM E/R
				ECM	TCM	METER /M&A	DISPLAY	BCM/SEC	STRG	HVAC	VDC/TCS /ABS				
ENGINE	-	-	UNKWN	-	UNKWN	UNKWN	-	UNKWN	-	-	UNKWN	UNKWN	CAN COMM CIRCUIT (U1000)	CAN COMM CIRCUIT (U1001)	
A/T	-	NG	UNKWN	UNKWN	-	UNKWN	-	-	-	-	UNKWN	-	CAN COMM CIRCUIT (U1000)	-	
AUTO DRIVE POS.	No indication	-	-	-	UNKWN	UNKWN	-	UNKWN	-	-	-	-	CAN COMM CIRCUIT (U1000)	-	
Display control unit	-	NG	UNKWN	UNKWN	-	UNKWN	-	UNKWN	-	UNKWN	-	UNKWN	-	-	
BCM	No indication	NG	UNKWN	UNKWN	-	UNKWN	-	-	-	-	-	UNKWN	CAN COMM CIRCUIT (U1000)	-	
HVAC	No indication	-	UNKWN	UNKWN	-	-	UNKWN	UNKWN	-	-	UNKWN	-	-	-	
ABS	-	NG	UNKWN	UNKWN	UNKWN	-	-	-	UNKWN	-	-	-	CAN COMM CIRCUIT (U1000)	-	
IPDM E/R	No indication	-	UNKWN	UNKWN	-	-	-	UNKWN	-	-	-	-	CAN COMM CIRCUIT (U1000)	-	

PKIC3283E

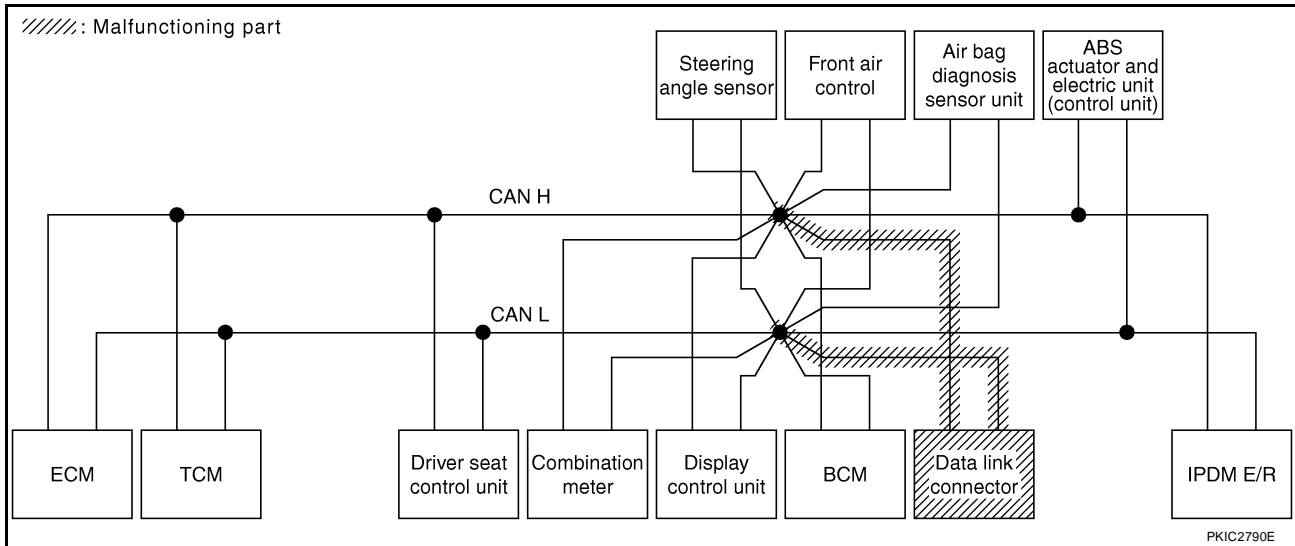

CAN SYSTEM (TYPE 3)

[CAN]

Case 11

Check steering angle sensor circuit. Refer to [LAN-149, "Steering Angle Sensor Circuit Inspection"](#).

SELECT SYSTEM screen		CAN DIAG SUPPORT MNTR											SELF-DIAG RESULTS		
		Initial diagnosis	Transmit diagnosis	Receive diagnosis											IPDM E/R
				ECM	TCM	METER /M&A	DISPLAY	BCM/SEC	STRG	HVAC	VDC/TCS /ABS				
ENGINE	-	-	UNKWN	-	UNKWN	UNKWN	-	UNKWN	-	-	UNKWN	UNKWN	CAN COMM CIRCUIT (U1000)	CAN COMM CIRCUIT (U1001)	
A/T	-	NG	UNKWN	UNKWN	-	UNKWN	-	-	-	-	UNKWN	-	CAN COMM CIRCUIT (U1000)	-	
AUTO DRIVE POS.	No indication	-	-	-	UNKWN	UNKWN	-	UNKWN	-	-	-	-	CAN COMM CIRCUIT (U1000)	-	
Display control unit	-	NG	UNKWN	UNKWN	-	UNKWN	-	UNKWN	-	UNKWN	-	UNKWN	-	-	
BCM	No indication	NG	UNKWN	UNKWN	-	UNKWN	-	-	-	-	-	UNKWN	CAN COMM CIRCUIT (U1000)	-	
HVAC	No indication	-	UNKWN	UNKWN	-	-	UNKWN	UNKWN	-	-	UNKWN	-	-	-	
ABS	-	NG	UNKWN	UNKWN	UNKWN	-	-	-	UNKWN	-	-	-	CAN COMM CIRCUIT (U1000)	-	
IPDM E/R	No indication	-	UNKWN	UNKWN	-	-	-	UNKWN	-	-	-	-	CAN COMM CIRCUIT (U1000)	-	

PKIC3284E

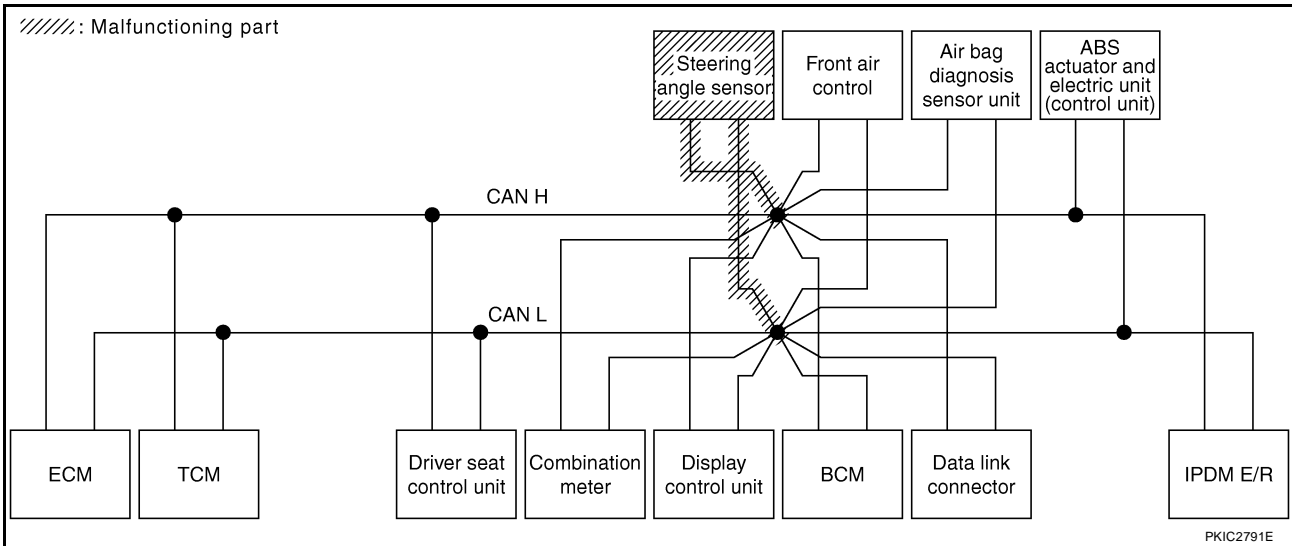

PKIC2791E

CAN SYSTEM (TYPE 3)

[CAN]

Case 12

Check front air control circuit. Refer to [LAN-149, "Front Air Control Circuit Inspection"](#) .

SELECT SYSTEM screen		CAN DIAG SUPPORT MNTR											SELF-DIAG RESULTS		
		Initial diagnosis	Transmit diagnosis	Receive diagnosis											IPDM E/R
				ECM	TCM	METER /M&A	DISPLAY	BCM/SEC	STRG	HVAC	VDC/TCS /ABS				
ENGINE	-	-	UNKWN	-	UNKWN	UNKWN	-	UNKWN	-	-	UNKWN	UNKWN	CAN COMM CIRCUIT (U1000)	CAN COMM CIRCUIT (U1001)	
A/T	-	NG	UNKWN	UNKWN	-	UNKWN	-	-	-	-	UNKWN	-	CAN COMM CIRCUIT (U1000)	-	
AUTO DRIVE POS.	No indication	-	-	-	UNKWN	UNKWN	-	UNKWN	-	-	-	-	CAN COMM CIRCUIT (U1000)	-	
Display control unit	-	NG	UNKWN	UNKWN	-	UNKWN	-	UNKWN	-	UNKWN	-	UNKWN	-	-	
BCM	No indication	NG	UNKWN	UNKWN	-	UNKWN	-	-	-	-	-	UNKWN	CAN COMM CIRCUIT (U1000)	-	
HVAC	No indication	-	UNKWN	UNKWN	-	-	UNKWN	UNKWN	-	-	UNKWN	-	-	-	
ABS	-	NG	UNKWN	UNKWN	UNKWN	-	-	-	UNKWN	-	-	-	CAN COMM CIRCUIT (U1000)	-	
IPDM E/R	No indication	-	UNKWN	UNKWN	-	-	-	UNKWN	-	-	-	-	CAN COMM CIRCUIT (U1000)	-	

PKIC3285E

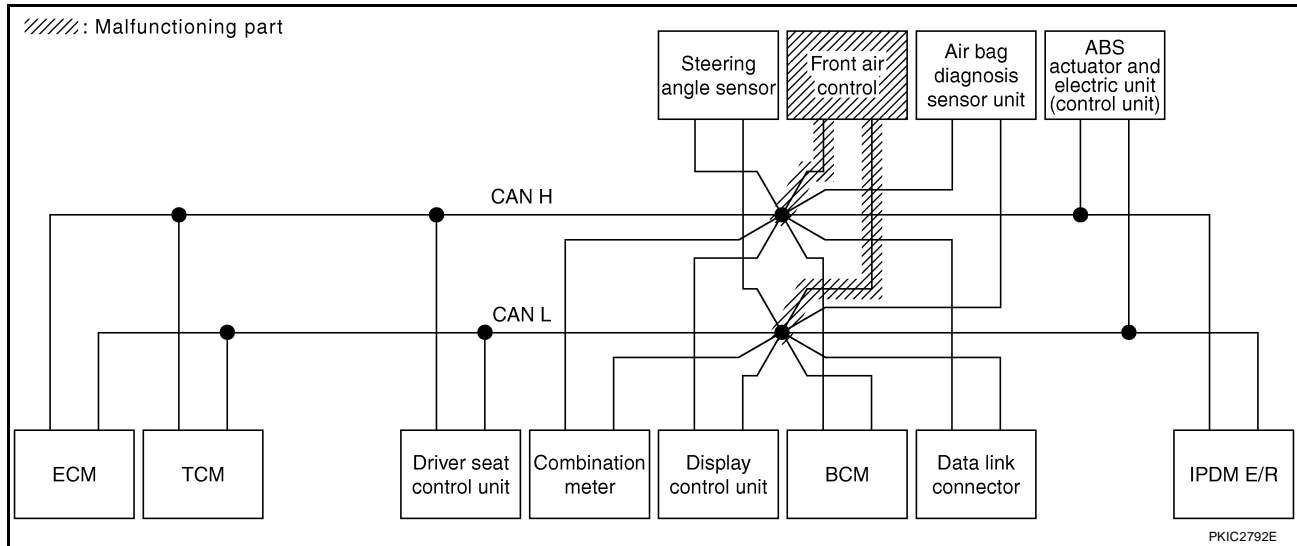

CAN SYSTEM (TYPE 3)

[CAN]

Case 13

Check ABS actuator and electric unit (control unit) circuit. Refer to [LAN-151, "ABS Actuator and Electric Unit \(Control Unit\) Circuit Inspection"](#).

SELECT SYSTEM screen		CAN DIAG SUPPORT MNTR											SELF-DIAG RESULTS		
		Initial diagnosis	Transmit diagnosis	Receive diagnosis											IPDM E/R
				ECM	TCM	METER /M&A	DISPLAY	BCM/SEC	STRG	HVAC	VDC/TCS /ABS				
ENGINE	-	-	UNKWN	-	UNKWN	UNKWN	-	UNKWN	-	-	UNKWN	UNKWN	CAN COMM CIRCUIT (U1000)	CAN COMM CIRCUIT (U1001)	
A/T	-	NG	UNKWN	UNKWN	-	UNKWN	-	-	-	-	UNKWN	-	CAN COMM CIRCUIT (U1000)	-	
AUTO DRIVE POS.	No indication	-	-	-	UNKWN	UNKWN	-	UNKWN	-	-	-	-	CAN COMM CIRCUIT (U1000)	-	
Display control unit	-	NG	UNKWN	UNKWN	-	UNKWN	-	UNKWN	-	UNKWN	-	UNKWN	-	-	
BCM	No indication	NG	UNKWN	UNKWN	-	UNKWN	-	-	-	-	-	UNKWN	CAN COMM CIRCUIT (U1000)	-	
HVAC	No indication	-	UNKWN	UNKWN	-	-	UNKWN	UNKWN	-	-	UNKWN	-	-	-	
ABS	-	NG	UNKWN	UNKWN	UNKWN	-	-	-	UNKWN	-	-	-	CAN COMM CIRCUIT (U1000)	-	
IPDM E/R	No indication	-	UNKWN	UNKWN	-	-	-	UNKWN	-	-	-	-	CAN COMM CIRCUIT (U1000)	-	

PKIC3286E

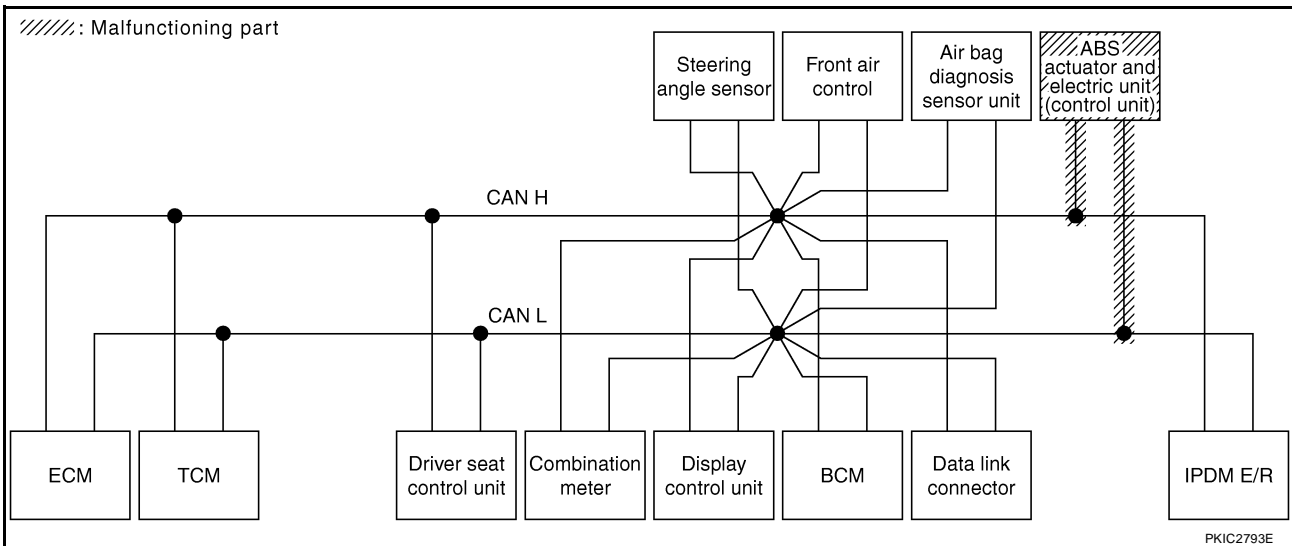

CAN SYSTEM (TYPE 3)

[CAN]

Case 14

Check IPDM E/R circuit. Refer to [LAN-151, "IPDM E/R Circuit Inspection"](#).

SELECT SYSTEM screen		CAN DIAG SUPPORT MNTR											SELF-DIAG RESULTS		
		Initial diagnosis	Transmit diagnosis	Receive diagnosis											IPDM E/R
				ECM	TCM	METER /M&A	DISPLAY	BCM/SEC	STRG	HVAC	VDC/TCS /ABS				
ENGINE	-	-	UNKWN	-	UNKWN	UNKWN	-	UNKWN	-	-	UNKWN	UNKWN	CAN COMM CIRCUIT (U1000)	CAN COMM CIRCUIT (U1001)	
A/T	-	NG	UNKWN	UNKWN	-	UNKWN	-	-	-	-	UNKWN	-	CAN COMM CIRCUIT (U1000)	-	
AUTO DRIVE POS.	No indication	-	-	-	UNKWN	UNKWN	-	UNKWN	-	-	-	-	CAN COMM CIRCUIT (U1000)	-	
Display control unit	-	NG	UNKWN	UNKWN	-	UNKWN	-	UNKWN	-	UNKWN	-	UNKWN	-	-	
BCM	No indication	NG	UNKWN	UNKWN	-	UNKWN	-	-	-	-	-	UNKWN	CAN COMM CIRCUIT (U1000)	-	
HVAC	No indication	-	UNKWN	UNKWN	-	-	UNKWN	UNKWN	-	-	UNKWN	-	-	-	
ABS	-	NG	UNKWN	UNKWN	UNKWN	-	-	-	UNKWN	-	-	-	CAN COMM CIRCUIT (U1000)	-	
IPDM E/R	No indication	-	UNKWN	UNKWN	-	-	-	UNKWN	-	-	-	-	CAN COMM CIRCUIT (U1000)	-	

PKIC3287E

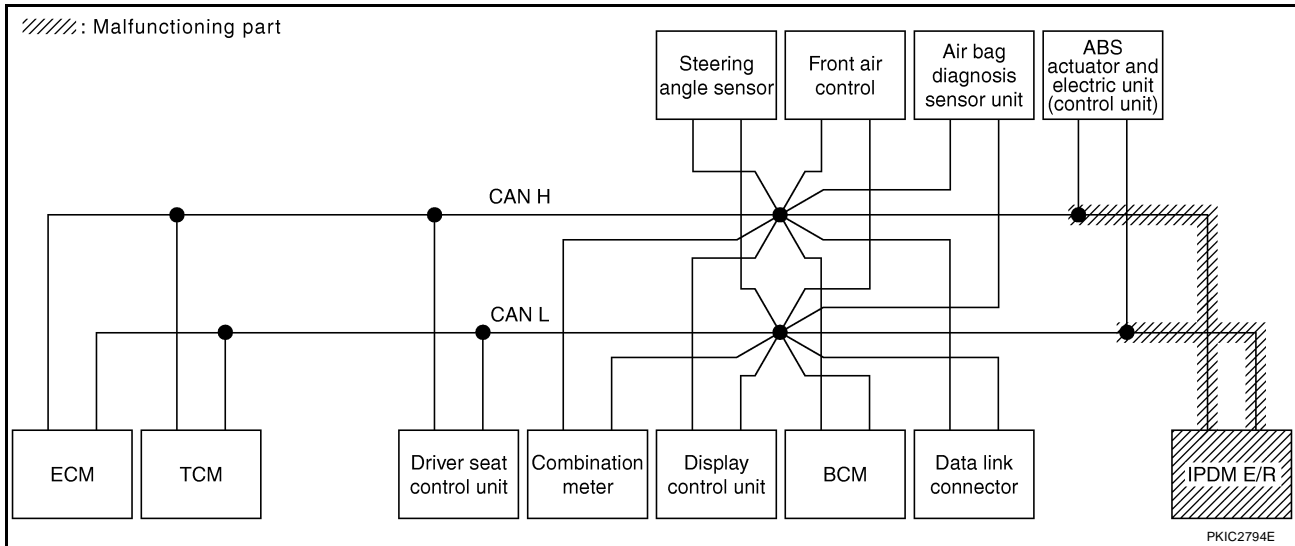

Case 15

Check CAN communication circuit. Refer to [LAN-152, "CAN Communication Circuit Inspection"](#).

SELECT SYSTEM screen		CAN DIAG SUPPORT MNTR											SELF-DIAG RESULTS		
		Initial diagnosis	Transmit diagnosis	Receive diagnosis											IPDM E/R
				ECM	TCM	METER /M&A	DISPLAY	BCM/SEC	STRG	HVAC	VDC/TCS /ABS				
ENGINE	-	-	UNKWN	-	UNKWN	UNKWN	-	UNKWN	-	-	UNKWN	UNKWN	CAN COMM CIRCUIT (U1000)	CAN COMM CIRCUIT (U1001)	
A/T	-	NG	UNKWN	UNKWN	-	UNKWN	-	-	-	-	UNKWN	-	CAN COMM CIRCUIT (U1000)	-	
AUTO DRIVE POS.	No indication	-	-	-	UNKWN	UNKWN	-	UNKWN	-	-	-	-	CAN COMM CIRCUIT (U1000)	-	
Display control unit	-	NG	UNKWN	UNKWN	-	UNKWN	-	UNKWN	-	UNKWN	-	UNKWN	-	-	
BCM	No indication	NG	UNKWN	UNKWN	-	UNKWN	-	-	-	-	-	UNKWN	CAN COMM CIRCUIT (U1000)	-	
HVAC	No indication	-	UNKWN	UNKWN	-	-	UNKWN	UNKWN	-	-	UNKWN	-	-	-	
ABS	-	NG	UNKWN	UNKWN	UNKWN	-	-	-	UNKWN	-	-	-	CAN COMM CIRCUIT (U1000)	-	
IPDM E/R	No indication	-	UNKWN	UNKWN	-	-	-	UNKWN	-	-	-	-	CAN COMM CIRCUIT (U1000)	-	

PKIC3288E

CAN SYSTEM (TYPE 3)

[CAN]

Case 16

Check IPDM E/R ignition relay circuit continuously sticks "OFF". Refer to [LAN-153, "IPDM E/R Ignition Relay Circuit Inspection"](#) .

SELECT SYSTEM screen		CAN DIAG SUPPORT MNTR											SELF-DIAG RESULTS		
		Initial diagnosis	Transmit diagnosis	Receive diagnosis											IPDM E/R
				ECM	TCM	METER /M&A	DISPLAY	BCM/SEC	STRG	HVAC	VDC/TCS /ABS				
ENGINE	-	-	UNKWN	-	UNKWN	UNKWN	-	UNKWN	-	-	UNKWN	UNKWN	CAN COMM CIRCUIT (U1000)	CAN COMM CIRCUIT (U1001)	
A/T	-	NG	UNKWN	UNKWN	-	UNKWN	-	-	-	-	UNKWN	-	CAN COMM CIRCUIT (U1000)	-	
AUTO DRIVE POS.	No indication	-	-	-	UNKWN	UNKWN	-	UNKWN	-	-	-	-	CAN COMM CIRCUIT (U1000)	-	
Display control unit	-	NG	UNKWN	UNKWN	-	UNKWN	-	UNKWN	-	UNKWN	-	UNKWN	-	-	
BCM	No indication	NG	UNKWN	UNKWN	-	UNKWN	-	-	-	-	-	UNKWN	CAN COMM CIRCUIT (U1000)	-	
HVAC	No indication	-	UNKWN	UNKWN	-	-	UNKWN	UNKWN	-	-	UNKWN	-	-	-	
ABS	-	NG	UNKWN	UNKWN	UNKWN	-	-	-	UNKWN	-	-	-	CAN COMM CIRCUIT (U1000)	-	
IPDM E/R	No indication	-	UNKWN	UNKWN	-	-	-	UNKWN	-	-	-	-	CAN COMM CIRCUIT (U1000)	-	

PKIC3289E

Case 17

Check IPDM E/R ignition relay circuit continuously sticks "ON". Refer to [LAN-153, "IPDM E/R Ignition Relay Circuit Inspection"](#) .

SELECT SYSTEM screen		CAN DIAG SUPPORT MNTR											SELF-DIAG RESULTS		
		Initial diagnosis	Transmit diagnosis	Receive diagnosis											IPDM E/R
				ECM	TCM	METER /M&A	DISPLAY	BCM/SEC	STRG	HVAC	VDC/TCS /ABS				
ENGINE	-	-	UNKWN	-	UNKWN	UNKWN	-	UNKWN	-	-	UNKWN	UNKWN	CAN COMM CIRCUIT (U1000)	CAN COMM CIRCUIT (U1001)	
A/T	-	NG	UNKWN	-	-	-	-	-	-	-	UNKWN	-	CAN COMM CIRCUIT (U1000)	-	
AUTO DRIVE POS.	No indication	-	-	-	UNKWN	UNKWN	-	UNKWN	-	-	-	-	CAN COMM CIRCUIT (U1000)	-	
Display control unit	-	NG	UNKWN	UNKWN	-	UNKWN	-	UNKWN	-	UNKWN	-	UNKWN	-	-	
BCM	No indication	NG	UNKWN	UNKWN	-	UNKWN	-	-	-	-	-	UNKWN	CAN COMM CIRCUIT (U1000)	-	
HVAC	No indication	-	UNKWN	UNKWN	-	-	UNKWN	UNKWN	-	-	UNKWN	-	-	-	
ABS	-	NG	UNKWN	-	UNKWN	-	-	-	-	-	-	-	CAN COMM CIRCUIT (U1000)	-	
IPDM E/R	No indication	-	UNKWN	UNKWN	-	-	-	UNKWN	-	-	-	-	CAN COMM CIRCUIT (U1000)	-	

PKIC3290E

A
B
C
D
E
F
G
H
I
J
L
M

LAN

CAN SYSTEM (TYPE 4)

[CAN]

CAN SYSTEM (TYPE 4)

PF2:23710

Component Parts and Harness Connector Location

UKS004SD

Refer to [LAN-25, "Component Parts and Harness Connector Location"](#) .

Schematic

UKS004SE

Refer to [LAN-26, "Schematic"](#) .

Wiring Diagram — CAN —

UKS004SF

Refer to [LAN-27, "Wiring Diagram — CAN —"](#) .

CAN SYSTEM (TYPE 4)

[CAN]

UKS004SG

Check Sheet

NOTE:

If a check mark is put on "NG" on "INITIAL DIAG (Initial diagnosis)", replace the control unit.

Check sheet table														
SELECT SYSTEM screen		CAN DIAG SUPPORT MNTR										SELF-DIAG RESULTS		
		Initial diagnosis	Transmit diagnosis	Receive diagnosis										
				ECM	TCM	METER /M&A	BCM/SEC	STRG	AWD/4WD	VDC/TCS /ABS	IPDM E/R			
ENGINE	-	-	UNKWN	-	UNKWN	UNKWN	UNKWN	-	UNKWN	UNKWN	UNKWN	CAN COMM CIRCUIT (U1000)	CAN COMM CIRCUIT (U1001)	
A/T	-	NG	UNKWN	UNKWN	-	UNKWN	-	-	UNKWN	UNKWN	-	CAN COMM CIRCUIT (U1000)	-	
BCM	No indication	NG	UNKWN	UNKWN	-	UNKWN	-	-	-	-	UNKWN	CAN COMM CIRCUIT (U1000)	-	
HVAC	No indication	-	UNKWN	UNKWN	-	-	UNKWN	-	-	-	UNKWN	-	-	
ALL MODE AWD/4WD	No indication	-	UNKWN	UNKWN	UNKWN	-	-	UNKWN	-	-	UNKWN	CAN COMM CIRCUIT (U1000)	-	
ABS	-	NG	UNKWN	UNKWN	UNKWN	-	-	UNKWN	UNKWN	-	-	CAN COMM CIRCUIT (U1000)	-	
IPDM E/R	No indication	-	UNKWN	UNKWN	-	-	UNKWN	-	-	-	-	CAN COMM CIRCUIT (U1000)	-	

Symptoms :

Attach copy of
SELECT SYSTEM

Attach copy of
SELECT SYSTEM

PKIC3464E

A
B
C
D
E
F
G
H
I
J
L
M

LAN

CAN SYSTEM (TYPE 4)

[CAN]

Attach copy of ENGINE SELF-DIAG RESULTS	Attach copy of A/T SELF-DIAG RESULTS	Attach copy of BCM SELF-DIAG RESULTS	Attach copy of HVAC SELF-DIAG RESULTS
Attach copy of ALL MODE AWD/4WD SELF-DIAG RESULTS	Attach copy of ABS SELF-DIAG RESULTS	Attach copy of IPDM E/R SELF-DIAG RESULTS	
Attach copy of ENGINE CAN DIAG SUPPORT MNTR	Attach copy of A/T CAN DIAG SUPPORT MNTR	Attach copy of BCM CAN DIAG SUPPORT MNTR	Attach copy of HVAC CAN DIAG SUPPORT MNTR
Attach copy of ALL MODE AWD/4WD CAN DIAG SUPPORT MNTR	Attach copy of ABS CAN DIAG SUPPORT MNTR	Attach copy of IPDM E/R CAN DIAG SUPPORT MNTR	

PKIB6772E

CAN SYSTEM (TYPE 4)

[CAN]

CHECK SHEET RESULTS (EXAMPLE)

NOTE:

If a check mark is put on "NG" on "INITIAL DIAG (Initial diagnosis)", replace the control unit.

Case 1

Check harness between TCM and data link connector. Refer to [LAN-142, "Inspection Between TCM and Data Link Connector Circuit"](#).

SELECT SYSTEM screen		CAN DIAG SUPPORT MNTR										SELF-DIAG RESULTS		
		Initial diagnosis	Transmit diagnosis	Receive diagnosis										
				ECM	TCM	METER /M&A	BCM/SEC	STRG	AWD/4WD	VDC/TCS /ABS	IPDM E/R			
ENGINE	-	-	UNKWN	-	UNKWN	✓	✓	-	✓	✓	✓	✓	CAN COMM CIRCUIT (U1000)	CAN COMM CIRCUIT (U1001)
A/T	-	NG	UNKWN	UNKWN	-	✓	-	-	✓	✓	-	-	CAN COMM CIRCUIT (U1000)	-
BCM	No indication	NG	UNKWN	✓	-	UNKWN	-	-	-	-	UNKWN	-	CAN COMM CIRCUIT (U1000)	-
HVAC	No indication	-	UNKWN	✓	-	-	UNKWN	-	-	UNKWN	-	-	-	-
ALL MODE AWD/4WD	No indication	-	UNKWN	✓	✓	-	-	UNKWN	-	UNKWN	-	-	CAN COMM CIRCUIT (U1000)	-
ABS	-	NG	UNKWN	✓	✓	-	-	UNKWN	UNKWN	-	-	-	CAN COMM CIRCUIT (U1000)	-
IPDM E/R	No indication	-	UNKWN	✓	-	-	UNKWN	-	-	-	-	-	CAN COMM CIRCUIT (U1000)	-

PKIC3467E

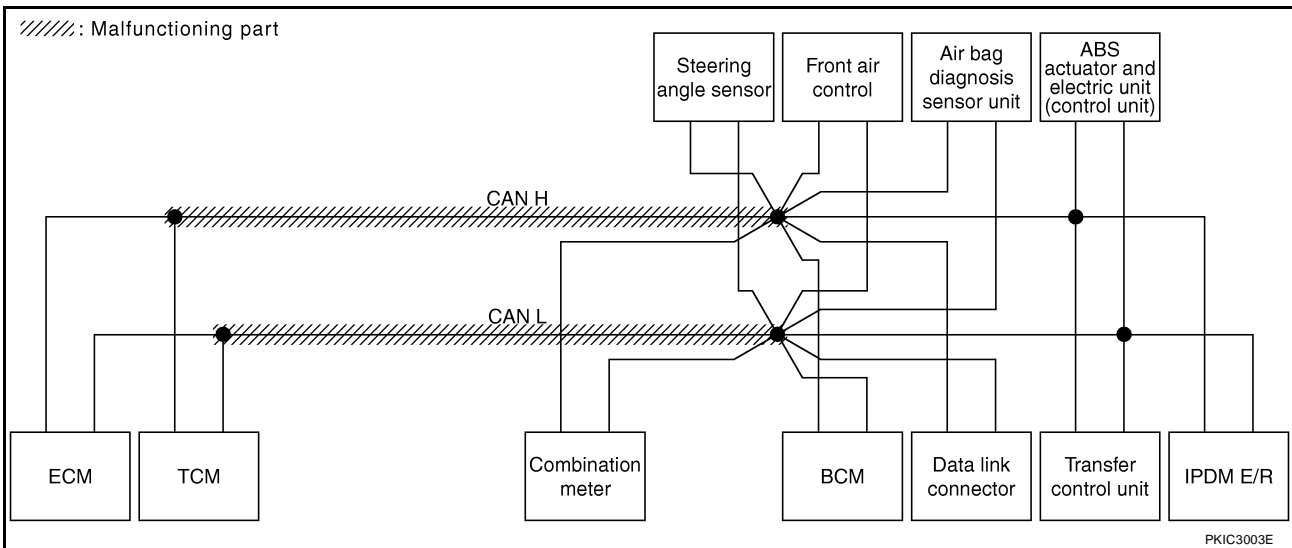

PKIC3003E

CAN SYSTEM (TYPE 4)

[CAN]

Case 2

Check harness between data link connector and ABS actuator and electric unit (control unit). Refer to [LAN-144, "Inspection Between Data Link Connector and ABS Actuator and Electric Unit \(Control Unit\) Circuit"](#) .

SELECT SYSTEM screen		CAN DIAG SUPPORT MNTR										SELF-DIAG RESULTS			
		Initial diagnosis	Transmit diagnosis	Receive diagnosis											
				ECM	TCM	METER /M&A	BCM/SEC	STRG	AWD/4WD	VDC/TCS /ABS	IPDM E/R				
ENGINE	-	-	UNKWN	-	UNKWN	UNKWN	UNKWN	-	UNKWN	UNKWN	UNKWN	UNKWN	UNKWN	CAN COMM CIRCUIT (U1000)	CAN COMM CIRCUIT (U001)
A/T	-	NG	UNKWN	UNKWN	-	UNKWN	-	-	UNKWN	UNKWN	-	-	-	CAN COMM CIRCUIT (U000)	-
BCM	No indication	NG	UNKWN	UNKWN	-	UNKWN	-	-	-	-	-	UNKWN	UNKWN	CAN COMM CIRCUIT (U1000)	-
HVAC	No indication	-	UNKWN	UNKWN	-	-	UNKWN	-	-	-	UNKWN	-	-	-	-
ALL MODE AWD/4WD	No indication	-	UNKWN	UNKWN	UNKWN	-	-	UNKWN	-	UNKWN	-	-	-	CAN COMM CIRCUIT (U000)	-
ABS	-	NG	UNKWN	UNKWN	UNKWN	-	-	UNKWN	UNKWN	-	-	-	-	CAN COMM CIRCUIT (U000)	-
IPDM E/R	No indication	-	UNKWN	UNKWN	-	-	UNKWN	-	-	-	-	-	-	CAN COMM CIRCUIT (U000)	-

PKIC3468E

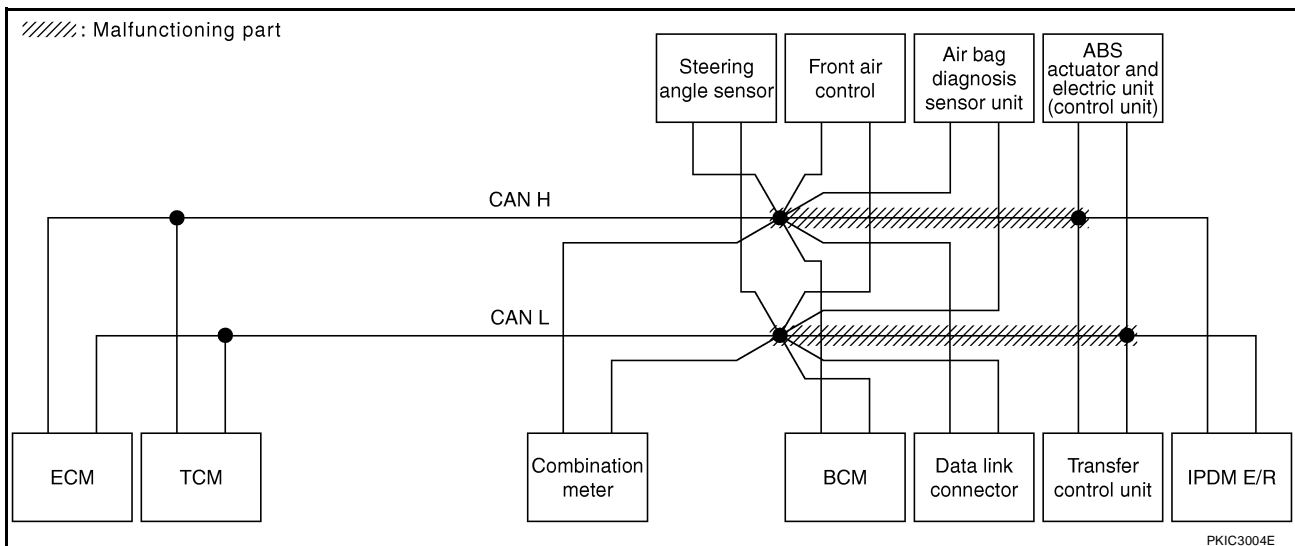

PKIC3004E

CAN SYSTEM (TYPE 4)

[CAN]

Case 3

Check ECM circuit. Refer to [LAN-145, "ECM Circuit Inspection"](#) .

SELECT SYSTEM screen		CAN DIAG SUPPORT MNTR										SELF-DIAG RESULTS		
		Initial diagnosis	Transmit diagnosis	Receive diagnosis										
				ECM	TCM	METER /M&A	BCM/SEC	STRG	AWD/4WD	VDC/TCS /ABS	IPDM E/R			
ENGINE	-	-	UNKWN	-	UNKWN	UNKWN	UNKWN	-	UNKWN	UNKWN	UNKWN	CAN COMM CIRCUIT (U100)	CAN COMM CIRCUIT (U101)	
A/T	-	NG	UNKWN	UNKWN	-	UNKWN	-	-	UNKWN	UNKWN	-	CAN COMM CIRCUIT (U100)	-	
BCM	No indication	NG	UNKWN	UNKWN	-	UNKWN	-	-	-	-	UNKWN	CAN COMM CIRCUIT (U100)	-	
HVAC	No indication	-	UNKWN	UNKWN	-	-	UNKWN	-	-	UNKWN	-	-	-	
ALL MODE AWD/4WD	No indication	-	UNKWN	UNKWN	UNKWN	-	-	UNKWN	-	UNKWN	-	CAN COMM CIRCUIT (U100)	-	
ABS	-	NG	UNKWN	UNKWN	UNKWN	-	-	UNKWN	UNKWN	-	-	CAN COMM CIRCUIT (U100)	-	
IPDM E/R	No indication	-	UNKWN	UNKWN	-	-	UNKWN	-	-	-	-	CAN COMM CIRCUIT (U100)	-	

PKIC3469E

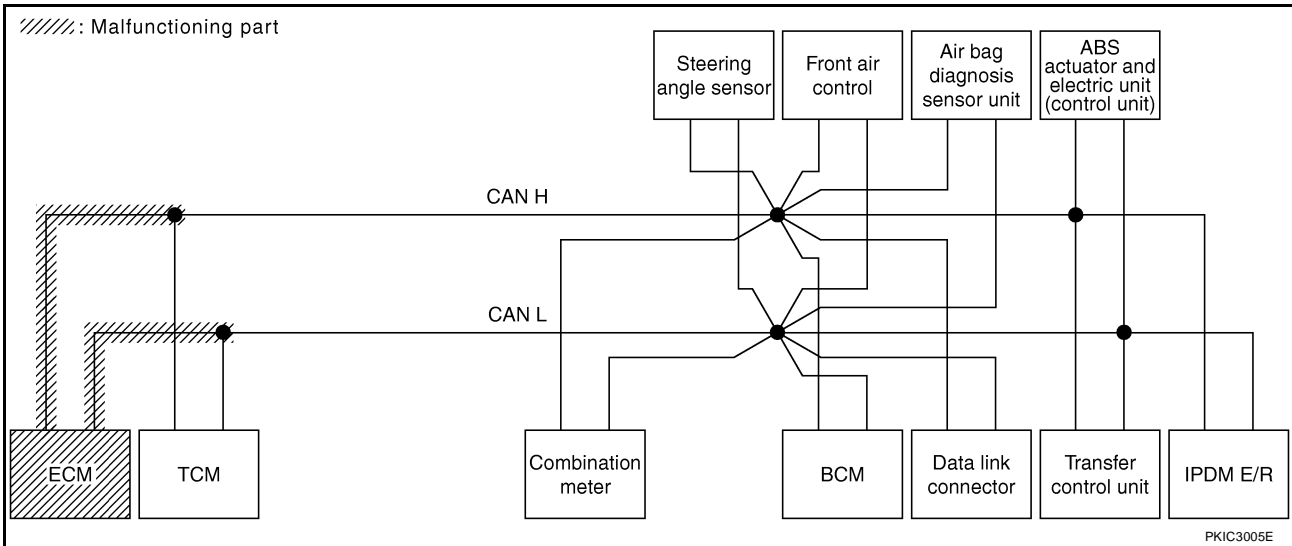

PKIC3005E

CAN SYSTEM (TYPE 4)

[CAN]

Case 4

Check TCM circuit. Refer to [LAN-146, "TCM Circuit Inspection"](#) .

SELECT SYSTEM screen		CAN DIAG SUPPORT MNTR										SELF-DIAG RESULTS		
		Initial diagnosis	Transmit diagnosis	Receive diagnosis										
				ECM	TCM	METER /M&A	BCM/SEC	STRG	AWD/4WD	VDC/TCS /ABS	IPDM E/R			
ENGINE	-	-	UNKWN	-	UNKWN	UNKWN	UNKWN	-	UNKWN	UNKWN	UNKWN	CAN COMM CIRCUIT (U1000)	CAN COMM CIRCUIT (U1001)	
A/T	-	NG	UNKWN	UNKWN	-	UNKWN	-	-	UNKWN	UNKWN	-	CAN COMM CIRCUIT (U1000)	-	
BCM	No indication	NG	UNKWN	UNKWN	-	UNKWN	-	-	-	-	UNKWN	CAN COMM CIRCUIT (U1000)	-	
HVAC	No indication	-	UNKWN	UNKWN	-	-	UNKWN	-	-	UNKWN	-	-	-	
ALL MODE AWD/4WD	No indication	-	UNKWN	UNKWN	UNKWN	-	-	UNKWN	-	UNKWN	-	CAN COMM CIRCUIT (U1000)	-	
ABS	-	NG	UNKWN	UNKWN	UNKWN	-	-	UNKWN	UNKWN	-	-	CAN COMM CIRCUIT (U1000)	-	
IPDM E/R	No indication	-	UNKWN	UNKWN	-	-	UNKWN	-	-	-	-	CAN COMM CIRCUIT (U1000)	-	

PKIC3470E

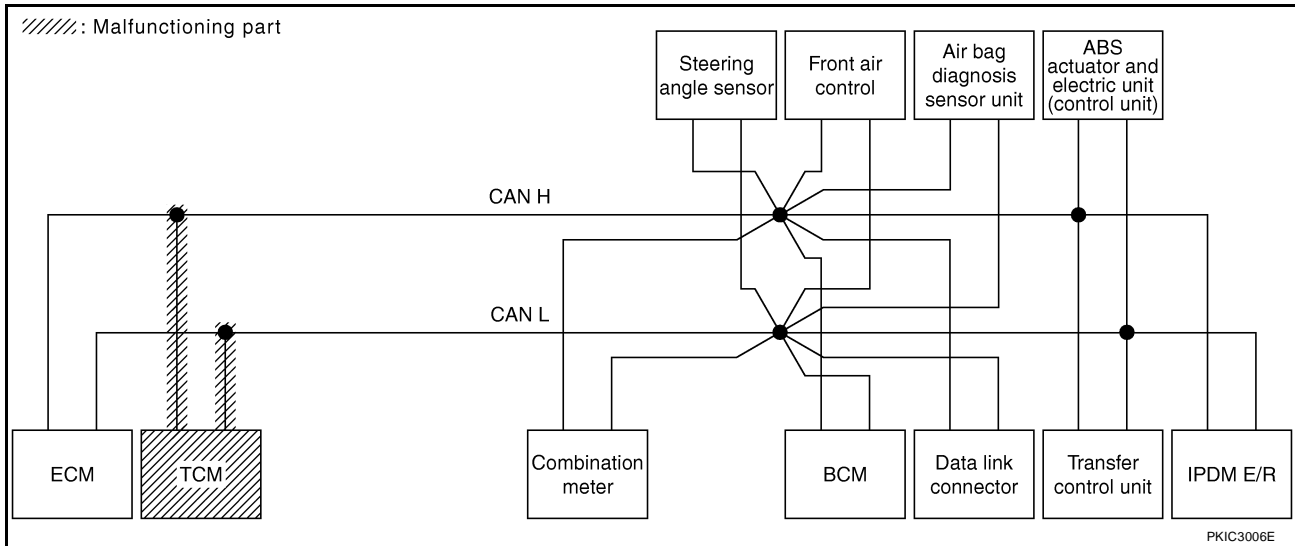

CAN SYSTEM (TYPE 4)

[CAN]

Case 5

Check combination meter circuit. Refer to [LAN-147, "Combination Meter Circuit Inspection"](#).

SELECT SYSTEM screen		CAN DIAG SUPPORT MNTR										SELF-DIAG RESULTS		
		Initial diagnosis	Transmit diagnosis	Receive diagnosis										
				ECM	TCM	METER /M&A	BCM/SEC	STRG	AWD/4WD	VDC/TCS /ABS	IPDM E/R			
ENGINE	-	-	UNKWN	-	UNKWN	UNKWN	UNKWN	-	UNKWN	UNKWN	UNKWN	CAN COMM CIRCUIT (U1000)	CAN COMM CIRCUIT (U1001)	
A/T	-	NG	UNKWN	UNKWN	-	UNKWN	-	-	UNKWN	UNKWN	-	CAN COMM CIRCUIT (U1000)	-	
BCM	No indication	NG	UNKWN	UNKWN	-	UNKWN	-	-	-	-	UNKWN	CAN COMM CIRCUIT (U1000)	-	
HVAC	No indication	-	UNKWN	UNKWN	-	-	UNKWN	-	-	UNKWN	-	-	-	
ALL MODE AWD/4WD	No indication	-	UNKWN	UNKWN	UNKWN	-	-	UNKWN	-	UNKWN	-	CAN COMM CIRCUIT (U1000)	-	
ABS	-	NG	UNKWN	UNKWN	UNKWN	-	-	UNKWN	UNKWN	-	-	CAN COMM CIRCUIT (U1000)	-	
IPDM E/R	No indication	-	UNKWN	UNKWN	-	-	UNKWN	-	-	-	-	CAN COMM CIRCUIT (U1000)	-	

PKIC3471E

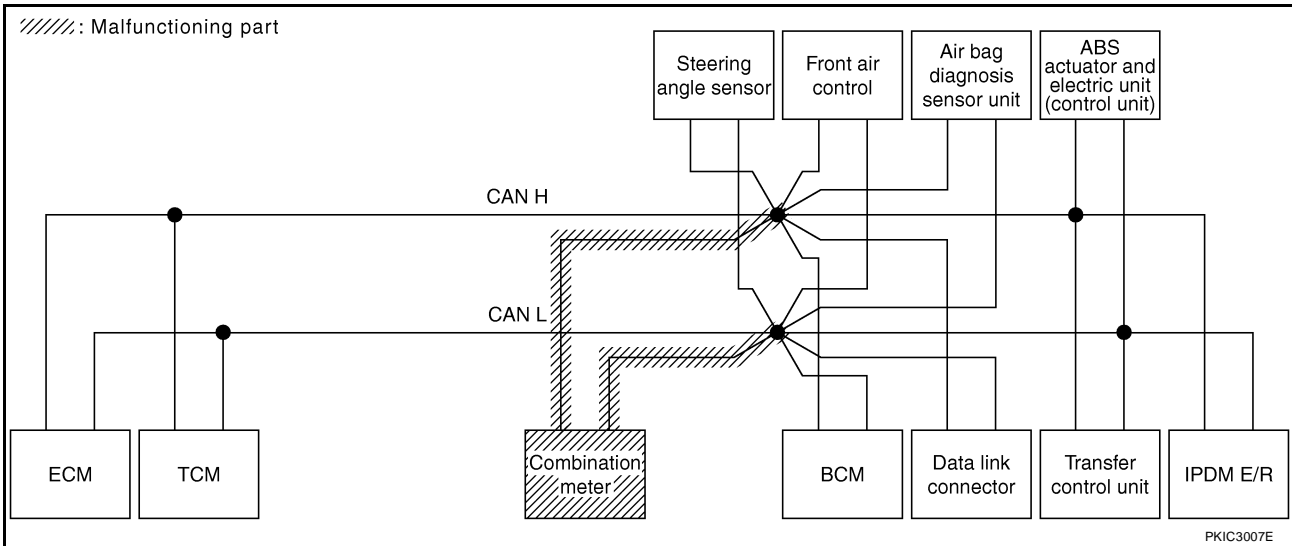

PKIC3007E

CAN SYSTEM (TYPE 4)

[CAN]

Case 6

Check BCM circuit. Refer to [LAN-148, "BCM Circuit Inspection"](#) .

SELECT SYSTEM screen		CAN DIAG SUPPORT MNTR										SELF-DIAG RESULTS		
		Initial diagnosis	Transmit diagnosis	Receive diagnosis										
				ECM	TCM	METER /M&A	BCM/SEC	STRG	AWD/4WD	VDC/TCS /ABS	IPDM E/R			
ENGINE	-	-	UNKWN	-	UNKWN	UNKWN	UNKWN	-	UNKWN	UNKWN	UNKWN	CAN COMM CIRCUIT (U1000)	CAN COMM CIRCUIT (U1001)	
A/T	-	NG	UNKWN	UNKWN	-	UNKWN	-	-	UNKWN	UNKWN	-	CAN COMM CIRCUIT (U1000)	-	
BCM	No indication	NG	UNKWN	UNKWN	-	UNKWN	-	-	-	-	UNKWN	CAN COMM CIRCUIT (U1000)	-	
HVAC	No indication	-	UNKWN	UNKWN	-	-	UNKWN	-	-	UNKWN	-	-	-	
ALL MODE AWD/4WD	No indication	-	UNKWN	UNKWN	UNKWN	-	-	UNKWN	-	UNKWN	-	CAN COMM CIRCUIT (U1000)	-	
ABS	-	NG	UNKWN	UNKWN	UNKWN	-	-	UNKWN	UNKWN	-	-	CAN COMM CIRCUIT (U1000)	-	
IPDM E/R	No indication	-	UNKWN	UNKWN	-	-	UNKWN	-	-	-	-	CAN COMM CIRCUIT (U1000)	-	

PKIC3472E

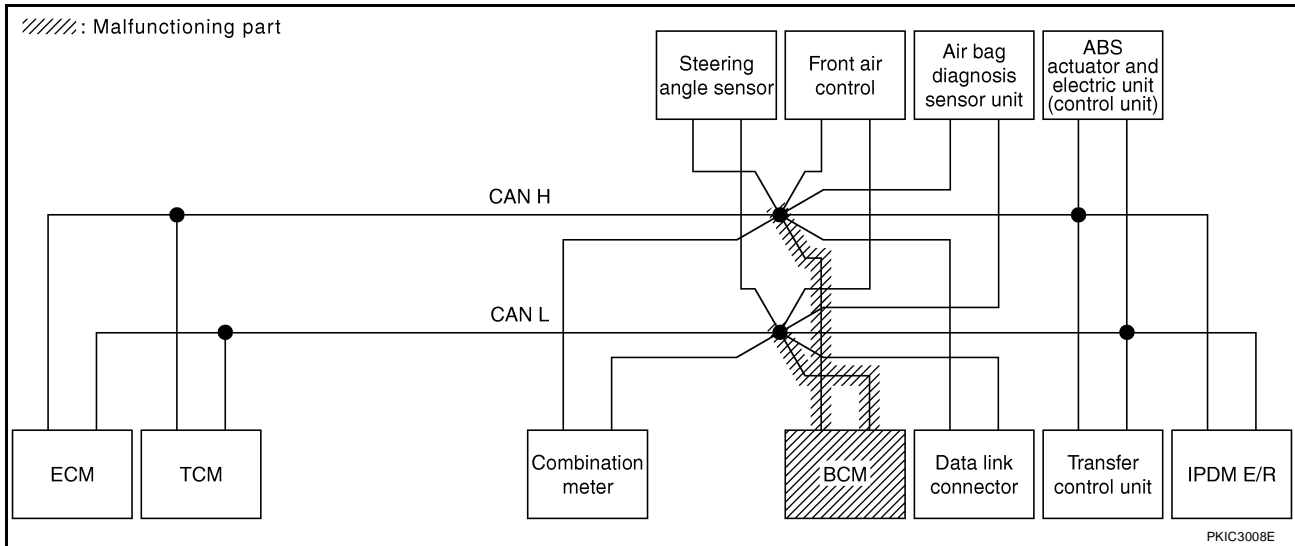

PKIC3008E

CAN SYSTEM (TYPE 4)

[CAN]

Case 7

Check data link connector circuit. Refer to [LAN-148, "Data Link Connector Circuit Inspection"](#) .

SELECT SYSTEM screen		CAN DIAG SUPPORT MNTR										SELF-DIAG RESULTS		
		Initial diagnosis	Transmit diagnosis	Receive diagnosis										
				ECM	TCM	METER /M&A	BCM/SEC	STRG	AWD/4WD	VDC/TCS /ABS	IPDM E/R			
ENGINE	-	-	UNKWN	-	UNKWN	UNKWN	UNKWN	-	UNKWN	UNKWN	UNKWN	CAN COMM CIRCUIT (U1000)	CAN COMM CIRCUIT (U1001)	
A/T	-	NG	UNKWN	UNKWN	-	UNKWN	-	-	UNKWN	UNKWN	-	CAN COMM CIRCUIT (U1000)	-	
BCM	No indication	NG	UNKWN	UNKWN	-	UNKWN	-	-	-	-	UNKWN	CAN COMM CIRCUIT (U1000)	-	
HVAC	No indication	-	UNKWN	UNKWN	-	-	UNKWN	-	-	UNKWN	-	-	-	
ALL MODE AWD/4WD	No indication	-	UNKWN	UNKWN	UNKWN	-	-	UNKWN	-	UNKWN	-	CAN COMM CIRCUIT (U1000)	-	
ABS	-	NG	UNKWN	UNKWN	UNKWN	-	-	UNKWN	UNKWN	-	-	CAN COMM CIRCUIT (U1000)	-	
IPDM E/R	No indication	-	UNKWN	UNKWN	-	-	UNKWN	-	-	-	-	CAN COMM CIRCUIT (U1000)	-	

PKIC3473E

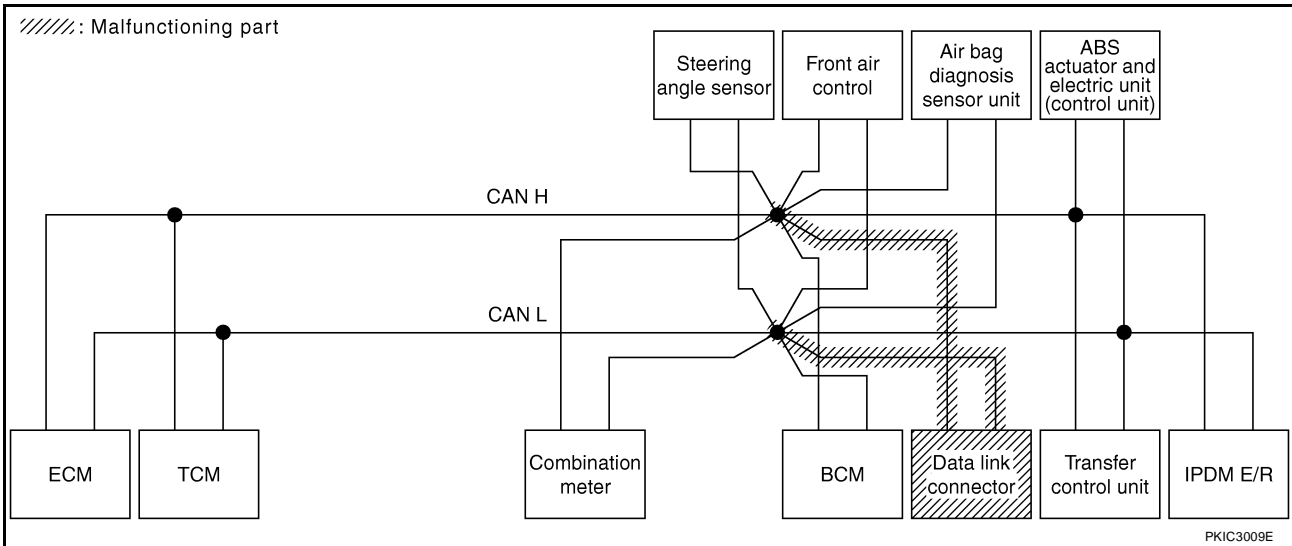

PKIC3009E

CAN SYSTEM (TYPE 4)

[CAN]

Case 8

Check steering angle sensor circuit. Refer to [LAN-149, "Steering Angle Sensor Circuit Inspection"](#) .

SELECT SYSTEM screen		CAN DIAG SUPPORT MNTR										SELF-DIAG RESULTS		
		Initial diagnosis	Transmit diagnosis	Receive diagnosis										
				ECM	TCM	METER /M&A	BCM/SEC	STRG	AWD/4WD	VDC/TCS /ABS	IPDM E/R			
ENGINE	-	-	UNKWN	-	UNKWN	UNKWN	UNKWN	-	UNKWN	UNKWN	UNKWN	CAN COMM CIRCUIT (U1000)	CAN COMM CIRCUIT (U1001)	
A/T	-	NG	UNKWN	UNKWN	-	UNKWN	-	-	UNKWN	UNKWN	-	CAN COMM CIRCUIT (U1000)	-	
BCM	No indication	NG	UNKWN	UNKWN	-	UNKWN	-	-	-	-	UNKWN	CAN COMM CIRCUIT (U1000)	-	
HVAC	No indication	-	UNKWN	UNKWN	-	-	UNKWN	-	-	UNKWN	-	-	-	
ALL MODE AWD/4WD	No indication	-	UNKWN	UNKWN	UNKWN	-	-	UNKWN	-	UNKWN	-	CAN COMM CIRCUIT (U1000)	-	
ABS	-	NG	UNKWN	UNKWN	UNKWN	-	-	UNKWN	-	UNKWN	-	CAN COMM CIRCUIT (U1000)	-	
IPDM E/R	No indication	-	UNKWN	UNKWN	-	-	UNKWN	-	-	-	-	CAN COMM CIRCUIT (U1000)	-	

PKIC3474E

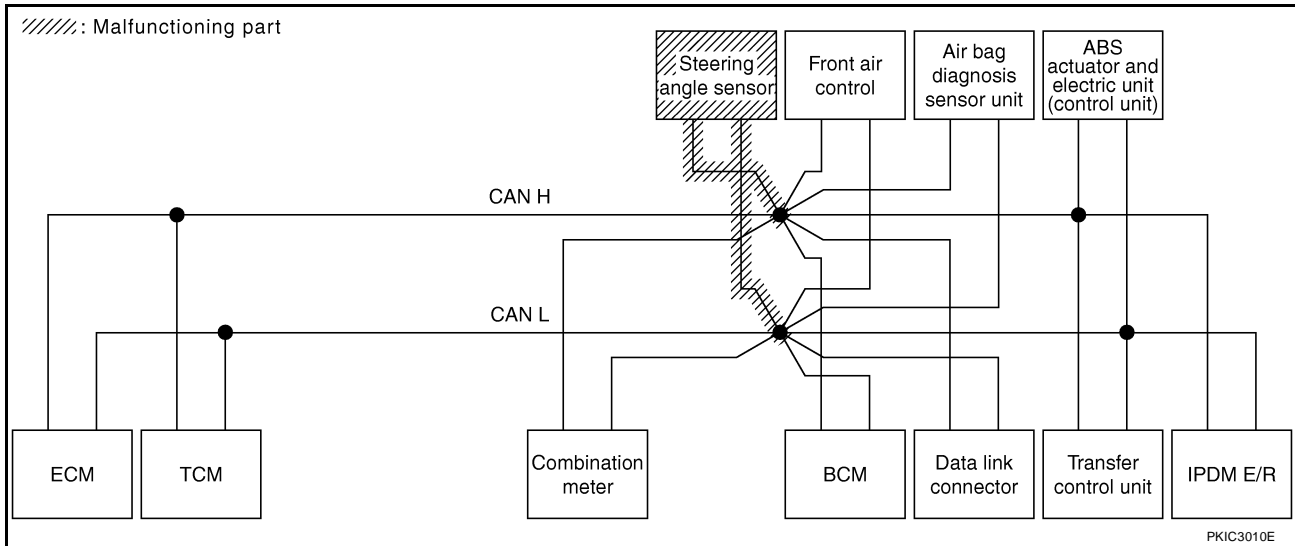

PKIC3010E

CAN SYSTEM (TYPE 4)

[CAN]

Case 9

Check front air control circuit. Refer to [LAN-149, "Front Air Control Circuit Inspection"](#) .

SELECT SYSTEM screen		CAN DIAG SUPPORT MNTR										SELF-DIAG RESULTS		
		Initial diagnosis	Transmit diagnosis	Receive diagnosis										
				ECM	TCM	METER /M&A	BCM/SEC	STRG	AWD/4WD	VDC/TCS /ABS	IPDM E/R			
ENGINE	-	-	UNKWN	-	UNKWN	UNKWN	UNKWN	-	UNKWN	UNKWN	UNKWN	CAN COMM CIRCUIT (U1000)	CAN COMM CIRCUIT (U1001)	
A/T	-	NG	UNKWN	UNKWN	-	UNKWN	-	-	UNKWN	UNKWN	-	CAN COMM CIRCUIT (U1000)	-	
BCM	No indication	NG	UNKWN	UNKWN	-	UNKWN	-	-	-	-	UNKWN	CAN COMM CIRCUIT (U1000)	-	
HVAC	No indication	-	UNKWN	UNKWN	-	-	UNKWN	-	-	UNKWN	-	-	-	
ALL MODE AWD/4WD	No indication	-	UNKWN	UNKWN	UNKWN	-	-	UNKWN	-	UNKWN	-	CAN COMM CIRCUIT (U1000)	-	
ABS	-	NG	UNKWN	UNKWN	UNKWN	-	-	UNKWN	UNKWN	-	-	CAN COMM CIRCUIT (U1000)	-	
IPDM E/R	No indication	-	UNKWN	UNKWN	-	-	UNKWN	-	-	-	-	CAN COMM CIRCUIT (U1000)	-	

PKIC3475E

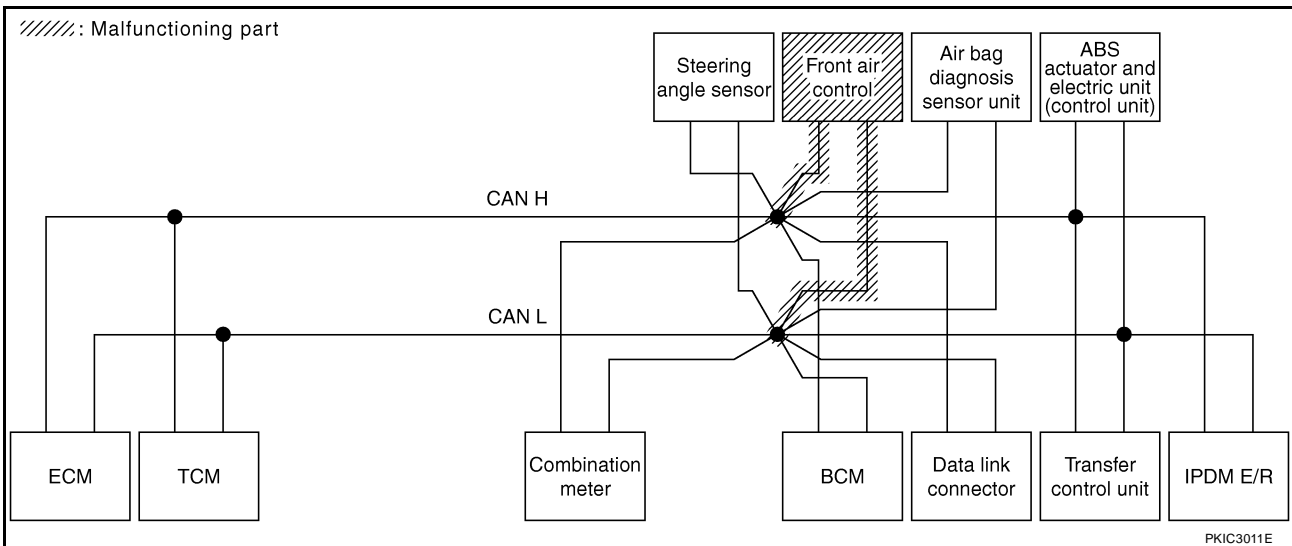

PKIC3011E

CAN SYSTEM (TYPE 4)

[CAN]

Case 10

Check transfer control unit circuit. Refer to [LAN-150, "Transfer Control Unit Circuit Inspection"](#) .

SELECT SYSTEM screen		CAN DIAG SUPPORT MNTR										SELF-DIAG RESULTS		
		Initial diagnosis	Transmit diagnosis	Receive diagnosis										
				ECM	TCM	METER /M&A	BCM/SEC	STRG	AWD/4WD	VDC/TCS /ABS	IPDM E/R			
ENGINE	-	-	UNKWN	-	UNKWN	UNKWN	UNKWN	-	UNKWN	UNKWN	UNKWN	CAN COMM CIRCUIT (U1000)	CAN COMM CIRCUIT (U001)	
A/T	-	NG	UNKWN	UNKWN	-	UNKWN	-	-	UNKWN	UNKWN	-	CAN COMM CIRCUIT (U1000)	-	
BCM	No indication	NG	UNKWN	UNKWN	-	UNKWN	-	-	-	-	UNKWN	CAN COMM CIRCUIT (U1000)	-	
HVAC	No indication	-	UNKWN	UNKWN	-	-	UNKWN	-	-	UNKWN	-	-	-	
ALL MODE AWD/4WD	No indication	-	UNKWN	UNKWN	UNKWN	-	-	UNKWN	-	UNKWN	-	CAN COMM CIRCUIT (U1000)	-	
ABS	-	NG	UNKWN	UNKWN	UNKWN	-	-	UNKWN	UNKWN	-	-	CAN COMM CIRCUIT (U1000)	-	
IPDM E/R	No indication	-	UNKWN	UNKWN	-	-	UNKWN	-	-	-	-	CAN COMM CIRCUIT (U1000)	-	

PKIC3476E

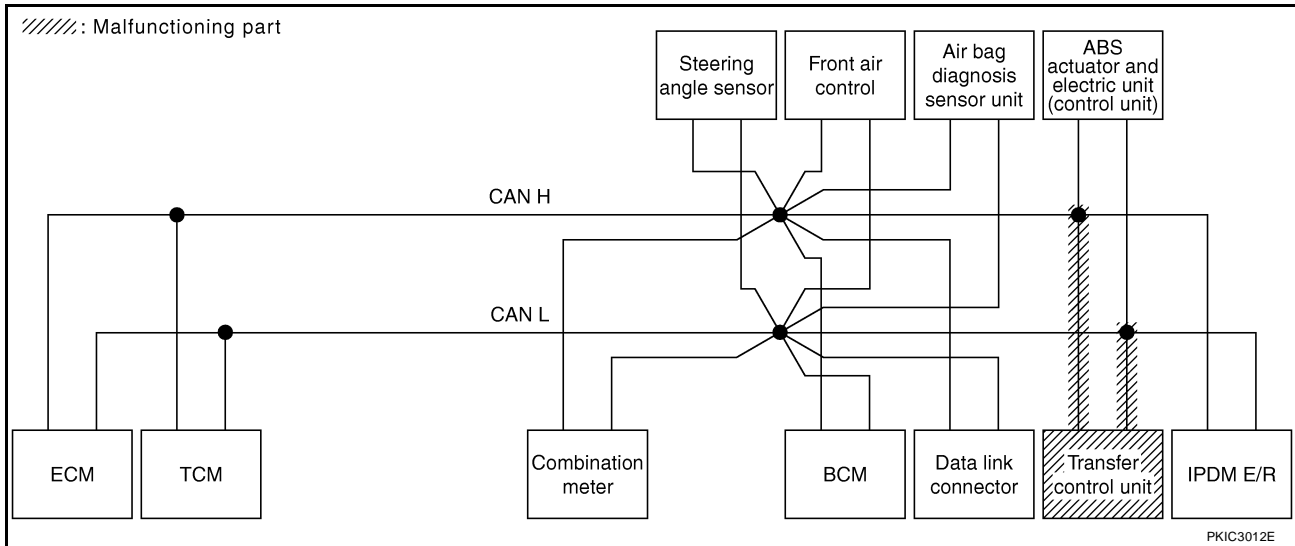

PKIC3012E

CAN SYSTEM (TYPE 4)

[CAN]

Case 11

Check ABS actuator and electric unit (control unit) circuit. Refer to [LAN-151, "ABS Actuator and Electric Unit \(Control Unit\) Circuit Inspection"](#).

SELECT SYSTEM screen		CAN DIAG SUPPORT MNTR										SELF-DIAG RESULTS		
		Initial diagnosis	Transmit diagnosis	Receive diagnosis										
				ECM	TCM	METER /M&A	BCM/SEC	STRG	AWD/4WD	VDC/TCS /ABS	IPDM E/R			
ENGINE	—	—	UNKWN	—	UNKWN	UNKWN	UNKWN	—	UNKWN	UNKWN	UNKWN	UNKWN	CAN COMM CIRCUIT (U1000)	CAN COMM CIRCUIT (U1001)
A/T	—	NG	UNKWN	UNKWN	—	UNKWN	—	—	UNKWN	UNKWN	—	—	CAN COMM CIRCUIT (U1000)	—
BCM	No indication	NG	UNKWN	UNKWN	—	UNKWN	—	—	—	—	—	UNKWN	CAN COMM CIRCUIT (U1000)	—
HVAC	No indication	—	UNKWN	UNKWN	—	—	UNKWN	—	—	—	UNKWN	—	—	—
ALL MODE AWD/4WD	No indication	—	UNKWN	UNKWN	UNKWN	—	—	UNKWN	—	UNKWN	—	—	CAN COMM CIRCUIT (U1000)	—
ABS	—	NG	UNKWN	UNKWN	UNKWN	—	—	UNKWN	UNKWN	—	—	—	CAN COMM CIRCUIT (U1000)	—
IPDM E/R	No indication	—	UNKWN	UNKWN	—	—	UNKWN	—	—	—	—	—	CAN COMM CIRCUIT (U1000)	—

PKIC3477E

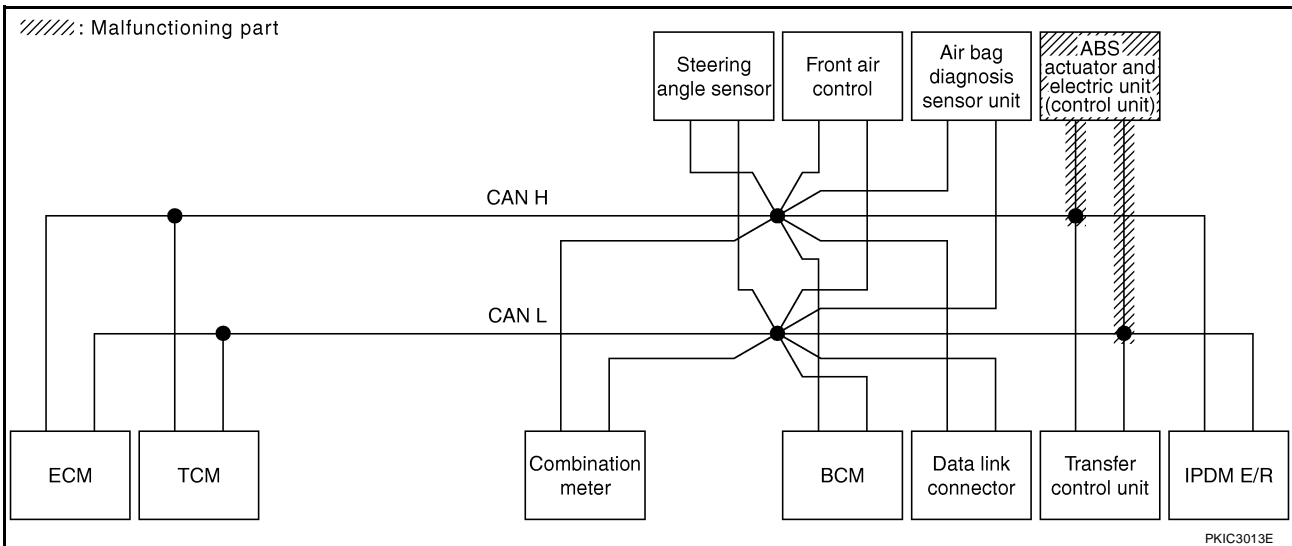

CAN SYSTEM (TYPE 4)

[CAN]

Case 12

Check IPDM E/R circuit. Refer to [LAN-151, "IPDM E/R Circuit Inspection"](#) .

SELECT SYSTEM screen		CAN DIAG SUPPORT MNTR										SELF-DIAG RESULTS		
		Initial diagnosis	Transmit diagnosis	Receive diagnosis										
				ECM	TCM	METER /M&A	BCM/SEC	STRG	AWD/4WD	VDC/TCS /ABS	IPDM E/R			
ENGINE	-	-	UNKWN	-	UNKWN	UNKWN	UNKWN	-	UNKWN	UNKWN	UNKWN	UNKWN	CAN COMM CIRCUIT (U1000)	CAN COMM CIRCUIT (U001)
A/T	-	NG	UNKWN	UNKWN	-	UNKWN	-	-	UNKWN	UNKWN	-	-	CAN COMM CIRCUIT (U1000)	-
BCM	No indication	NG	UNKWN	UNKWN	-	UNKWN	-	-	-	-	UNKWN	UNKWN	CAN COMM CIRCUIT (U1000)	-
HVAC	No indication	-	UNKWN	UNKWN	-	-	UNKWN	-	-	UNKWN	-	-	-	-
ALL MODE AWD/4WD	No indication	-	UNKWN	UNKWN	UNKWN	-	-	UNKWN	-	UNKWN	-	-	CAN COMM CIRCUIT (U1000)	-
ABS	-	NG	UNKWN	UNKWN	UNKWN	-	-	UNKWN	UNKWN	-	-	-	CAN COMM CIRCUIT (U1000)	-
IPDM E/R	No indication	-	UNKWN	UNKWN	-	-	UNKWN	-	-	-	-	-	CAN COMM CIRCUIT (U000)	-

PKIC3478E

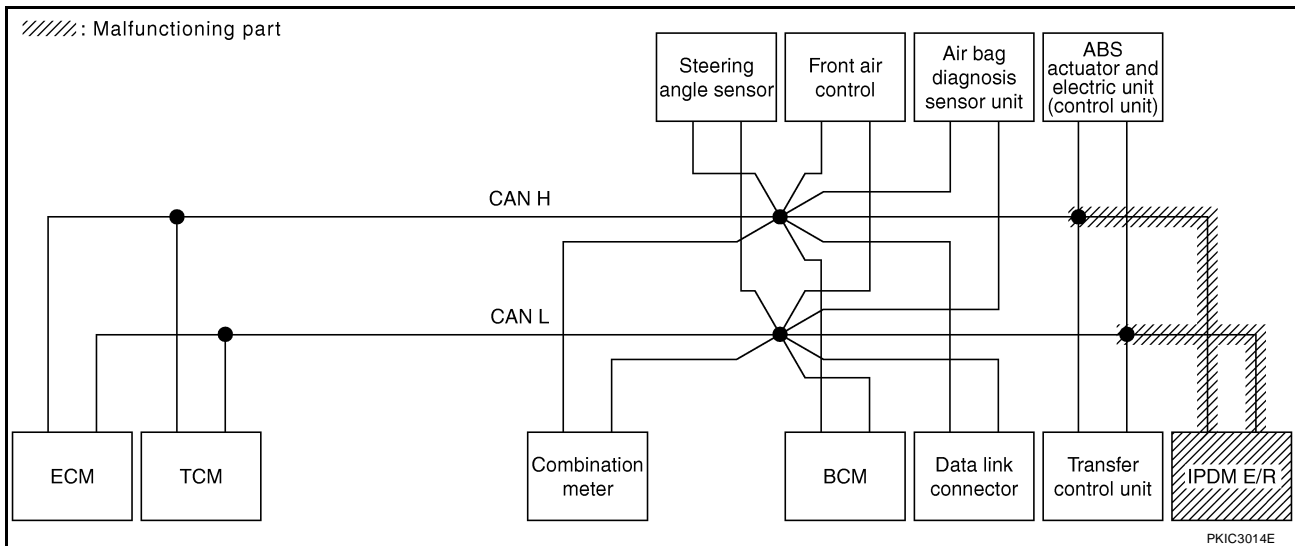

Case 13

Check CAN communication circuit. Refer to [LAN-152, "CAN Communication Circuit Inspection"](#) .

SELECT SYSTEM screen		CAN DIAG SUPPORT MNTR										SELF-DIAG RESULTS		
		Initial diagnosis	Transmit diagnosis	Receive diagnosis										
				ECM	TCM	METER /M&A	BCM/SEC	STRG	AWD/4WD	VDC/TCS /ABS	IPDM E/R			
ENGINE	-	-	UNKWN	-	UNKWN	UNKWN	UNKWN	-	UNKWN	UNKWN	UNKWN	UNKWN	CAN COMM CIRCUIT (U000)	CAN COMM CIRCUIT (U001)
A/T	-	NG	UNKWN	UNKWN	-	UNKWN	-	-	UNKWN	UNKWN	-	-	CAN COMM CIRCUIT (U000)	-
BCM	No indication	NG	UNKWN	UNKWN	-	UNKWN	-	-	-	-	UNKWN	UNKWN	CAN COMM CIRCUIT (U1000)	-
HVAC	No indication	-	UNKWN	UNKWN	-	-	UNKWN	-	-	UNKWN	-	-	-	-
ALL MODE AWD/4WD	No indication	-	UNKWN	UNKWN	UNKWN	-	-	UNKWN	-	UNKWN	-	-	CAN COMM CIRCUIT (U000)	-
ABS	-	NG	UNKWN	UNKWN	UNKWN	-	-	UNKWN	UNKWN	-	-	-	CAN COMM CIRCUIT (U000)	-
IPDM E/R	No indication	-	UNKWN	UNKWN	-	-	UNKWN	-	-	-	-	-	CAN COMM CIRCUIT (U000)	-

PKIC3479E

CAN SYSTEM (TYPE 4)

[CAN]

Case 14

Check IPDM E/R ignition relay circuit continuously sticks "OFF". Refer to [LAN-153, "IPDM E/R Ignition Relay Circuit Inspection"](#) .

SELECT SYSTEM screen		CAN DIAG SUPPORT MNTR										SELF-DIAG RESULTS		
		Initial diagnosis	Transmit diagnosis	Receive diagnosis										IPDM E/R
				ECM	TCM	METER /M&A	BCM/SEC	STRG	AWD/4WD	VDC/TCS /ABS				
ENGINE	–	–	UNKWN	–	UNKWN	UNKWN	UNKWN	–	UNKWN	UNKWN	UNKWN	CAN COMM CIRCUIT (U100)	CAN COMM CIRCUIT (U101)	
A/T	–	NG	UNKWN	UNKWN	–	UNKWN	–	–	UNKWN	UNKWN	–	CAN COMM CIRCUIT (U100)	–	
BCM	No indication	NG	UNKWN	UNKWN	–	UNKWN	–	–	–	–	UNKWN	CAN COMM CIRCUIT (U100)	–	
HVAC	No indication	–	UNKWN	UNKWN	–	–	UNKWN	–	–	UNKWN	–	–	–	
ALL MODE AWD/4WD	No indication	–	UNKWN	UNKWN	UNKWN	–	–	UNKWN	–	UNKWN	–	CAN COMM CIRCUIT (U100)	–	
ABS	–	NG	UNKWN	UNKWN	UNKWN	–	–	UNKWN	UNKWN	–	–	CAN COMM CIRCUIT (U100)	–	
IPDM E/R	No indication	–	UNKWN	UNKWN	–	–	UNKWN	–	–	–	–	CAN COMM CIRCUIT (U100)	–	

PKIC3480E

Case 15

Check IPDM E/R ignition relay circuit continuously sticks "ON". Refer to [LAN-153, "IPDM E/R Ignition Relay Circuit Inspection"](#) .

SELECT SYSTEM screen		CAN DIAG SUPPORT MNTR										SELF-DIAG RESULTS		
		Initial diagnosis	Transmit diagnosis	Receive diagnosis										IPDM E/R
				ECM	TCM	METER /M&A	BCM/SEC	STRG	AWD/4WD	VDC/TCS /ABS				
ENGINE	–	–	UNKWN	–	UNKWN	UNKWN	UNKWN	–	UNKWN	UNKWN	UNKWN	CAN COMM CIRCUIT (U100)	CAN COMM CIRCUIT (U101)	
A/T	–	NG	UNKWN	–	–	–	–	–	–	UNKWN	–	CAN COMM CIRCUIT (U100)	–	
BCM	No indication	NG	UNKWN	UNKWN	–	UNKWN	–	–	–	–	UNKWN	CAN COMM CIRCUIT (U100)	–	
HVAC	No indication	–	UNKWN	UNKWN	–	–	UNKWN	–	–	UNKWN	–	–	–	
ALL MODE AWD/4WD	No indication	–	UNKWN	UNKWN	UNKWN	–	–	UNKWN	–	UNKWN	–	CAN COMM CIRCUIT (U100)	–	
ABS	–	NG	UNKWN	–	UNKWN	–	–	–	–	–	–	CAN COMM CIRCUIT (U100)	–	
IPDM E/R	No indication	–	UNKWN	UNKWN	–	–	UNKWN	–	–	–	–	CAN COMM CIRCUIT (U100)	–	

PKIC3481E

CAN SYSTEM (TYPE 5)

PF2P:23710

Component Parts and Harness Connector Location

UKS004SH

Refer to [LAN-25, "Component Parts and Harness Connector Location"](#) .

Schematic

UKS004SI

Refer to [LAN-26, "Schematic"](#) .

Wiring Diagram — CAN —

UKS004SJ

Refer to [LAN-27, "Wiring Diagram — CAN —"](#) .

CAN SYSTEM (TYPE 5)

[CAN]

UKS004SK

Check Sheet

NOTE:

If a check mark is put on "NG" on "INITIAL DIAG (Initial diagnosis)", replace the control unit.

Check sheet table												SELF-DIAG RESULTS	
SELECT SYSTEM screen		CAN DIAG SUPPORT MNTR											
		Initial diagnosis	Transmit diagnosis	Receive diagnosis									
ECM	TCM			METER /M&A	BCM/SEC	STRG	AWD/4WD	VDC/TCS /ABS	IPDM E/R	CAN COMM CIRCUIT (U1000)	CAN COMM CIRCUIT (U1001)		
ENGINE	-	-	UNKWN	-	UNKWN	UNKWN	UNKWN	-	UNKWN	UNKWN	UNKWN	-	-
A/T	-	NG	UNKWN	UNKWN	-	UNKWN	-	-	UNKWN	UNKWN	-	-	-
AUTO DRIVE POS.	No indication	-	-	-	UNKWN	UNKWN	UNKWN	-	-	-	-	-	-
BCM	No indication	NG	UNKWN	UNKWN	-	UNKWN	-	-	-	-	UNKWN	-	-
HVAC	No indication	-	UNKWN	UNKWN	-	-	UNKWN	-	-	UNKWN	-	-	-
ALL MODE AWD/4WD	No indication	-	UNKWN	UNKWN	UNKWN	-	-	UNKWN	-	UNKWN	-	-	-
ABS	-	NG	UNKWN	UNKWN	UNKWN	-	-	UNKWN	UNKWN	-	-	-	-
IPDM E/R	No indication	-	UNKWN	UNKWN	-	-	UNKWN	-	-	-	-	-	-

Symptoms :

Attach copy of
SELECT SYSTEM

Attach copy of
SELECT SYSTEM

PKIC3465E

A
B
C
D
E
F
G
H
I
J
L
M

LAN

CAN SYSTEM (TYPE 5)

[CAN]

Attach copy of
ENGINE
SELF-DIAG RESULTS

Attach copy of
A/T
SELF-DIAG RESULTS

Attach copy of
AUTO DRIVE POS.
SELF-DIAG RESULTS

Attach copy of
BCM
SELF-DIAG RESULTS

Attach copy of
HVAC
SELF-DIAG RESULTS

Attach copy of
ALL MODE AWD/4WD
SELF-DIAG RESULTS

Attach copy of
ABS
SELF-DIAG RESULTS

Attach copy of
IPDM E/R
SELF-DIAG RESULTS

Attach copy of
ENGINE
CAN DIAG SUPPORT
MNTR

Attach copy of
A/T
CAN DIAG SUPPORT
MNTR

Attach copy of
AUTO DRIVE POS.
CAN DIAG SUPPORT
MNTR

Attach copy of
BCM
CAN DIAG SUPPORT
MNTR

Attach copy of
HVAC
CAN DIAG SUPPORT
MNTR

Attach copy of
ALL MODE AWD/4WD
CAN DIAG SUPPORT
MNTR

Attach copy of
ABS
CAN DIAG SUPPORT
MNTR

Attach copy of
IPDM E/R
CAN DIAG SUPPORT
MNTR

PKIB6773E

CAN SYSTEM (TYPE 5)

[CAN]

CHECK SHEET RESULTS (EXAMPLE)

NOTE:

If a check mark is put on "NG" on "INITIAL DIAG (Initial diagnosis)", replace the control unit.

Case 1

Check harness between TCM and driver seat control unit. Refer to [LAN-141, "Inspection Between TCM and Driver Seat Control Unit Circuit"](#).

SELECT SYSTEM screen		CAN DIAG SUPPORT MNTR										SELF-DIAG RESULTS		
		Initial diagnosis	Transmit diagnosis	Receive diagnosis										
				ECM	TCM	METER /M&A	BCM/SEC	STRG	AWD/4WD	VDC/TCS /ABS	IPDM E/R			
ENGINE	-	-	UNKWN	-	UNKWN	✓/UNKWN	✓/UNKWN	-	UNKWN	UNKWN	UNKWN	CAN COMM CIRCUIT (U1000)	CAN COMM CIRCUIT (U001)	
A/T	-	NG	UNKWN	UNKWN	-	✓/UNKWN	-	-	UNKWN	UNKWN	-	CAN COMM CIRCUIT (U000)	-	
AUTO DRIVE POS.	No indication	-	-	-	UNKWN	UNKWN	UNKWN	-	-	-	-	CAN COMM CIRCUIT (U000)	-	
BCM	No indication	NG	UNKWN	✓/UNKWN	-	UNKWN	-	-	-	-	UNKWN	CAN COMM CIRCUIT (U1000)	-	
HVAC	No indication	-	UNKWN	✓/UNKWN	-	-	UNKWN	-	-	UNKWN	-	-	-	
ALL MODE AWD/4WD	No indication	-	UNKWN	✓/UNKWN	UNKWN	-	-	UNKWN	-	UNKWN	-	CAN COMM CIRCUIT (U000)	-	
ABS	-	NG	UNKWN	✓/UNKWN	UNKWN	-	-	UNKWN	UNKWN	-	-	CAN COMM CIRCUIT (U000)	-	
IPDM E/R	No indication	-	UNKWN	✓/UNKWN	-	-	UNKWN	-	-	-	-	CAN COMM CIRCUIT (U000)	-	

PKIC3482E

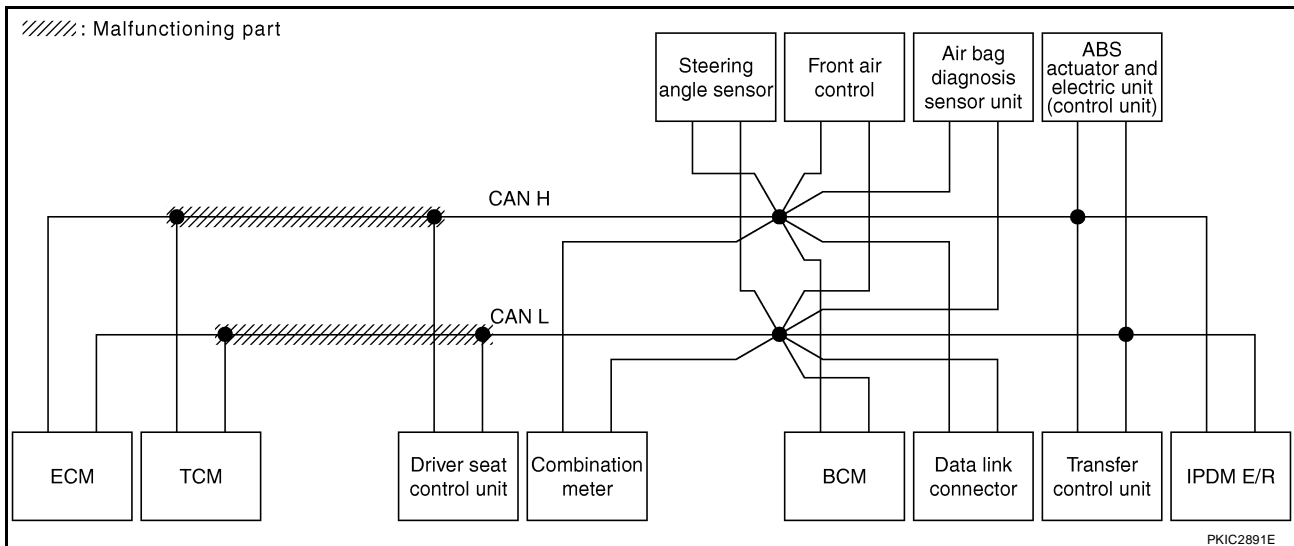

PKIC2891E

CAN SYSTEM (TYPE 5)

[CAN]

Case 2

Check harness between driver seat control unit and data link connector. Refer to [LAN-143, "Inspection Between Driver Seat Control Unit and Data Link Connector Circuit"](#) .

SELECT SYSTEM screen		CAN DIAG SUPPORT MNTR										SELF-DIAG RESULTS	
		Initial diagnosis	Transmit diagnosis	Receive diagnosis									
				ECM	TCM	METER /M&A	BCM/SEC	STRG	AWD/4WD	VDC/TCS /ABS	IPDM E/R		
ENGINE	-	-	UNKWN	-	UNKWN	UN KN WN	UN KN WN	-	UN KN WN	UN KN WN	UN KN WN	CAN COMM CIRCUIT (U1000)	CAN COMM CIRCUIT (U1001)
A/T	-	NG	UNKWN	UNKWN	-	UN KN WN	-	-	UN KN WN	UN KN WN	-	CAN COMM CIRCUIT (U1000)	-
AUTO DRIVE POS.	No indication	-	-	-	UNKWN	UNKWN	UNKWN	-	-	-	-	CAN COMM CIRCUIT (U1000)	-
BCM	No indication	NG	UNKWN	UN KN WN	-	UNKWN	-	-	-	-	UNKWN	CAN COMM CIRCUIT (U1000)	-
HVAC	No indication	-	UNKWN	UN KN WN	-	-	UNKWN	-	-	UNKWN	-	-	-
ALL MODE AWD/4WD	No indication	-	UNKWN	UN KN WN	UN KN WN	-	-	UNKWN	-	UNKWN	-	CAN COMM CIRCUIT (U1000)	-
ABS	-	NG	UNKWN	UN KN WN	UN KN WN	-	-	UNKWN	UNKWN	-	-	CAN COMM CIRCUIT (U1000)	-
IPDM E/R	No indication	-	UNKWN	UN KN WN	-	-	UNKWN	-	-	-	-	CAN COMM CIRCUIT (U1000)	-

PKIC3483E

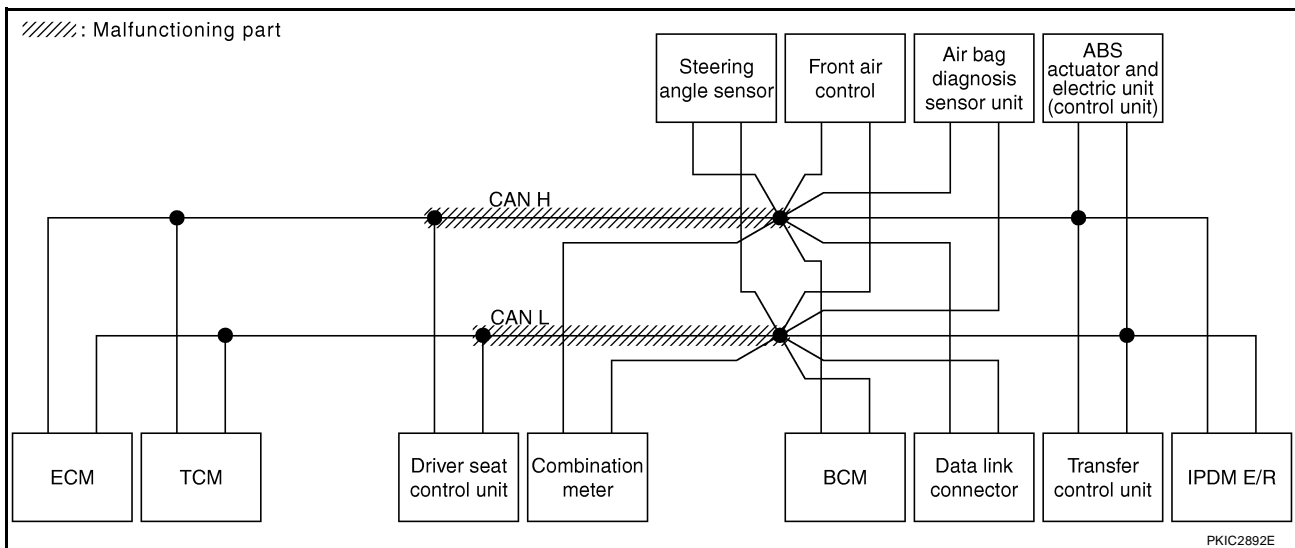

CAN SYSTEM (TYPE 5)

[CAN]

Case 3

Check harness between data link connector and ABS actuator and electric unit (control unit). Refer to [LAN-144, "Inspection Between Data Link Connector and ABS Actuator and Electric Unit \(Control Unit\) Circuit"](#).

SELECT SYSTEM screen		CAN DIAG SUPPORT MNTR										SELF-DIAG RESULTS		
		Initial diagnosis	Transmit diagnosis	Receive diagnosis										
				ECM	TCM	METER /M&A	BCM/SEC	STRG	AWD/4WD	VDC/TCS /ABS	IPDM E/R			
ENGINE	-	-	UNKWN	-	UNKWN	UNKWN	UNKWN	-	UNKWN	UNKWN	UNKWN	CAN COMM CIRCUIT (U1000)	CAN COMM CIRCUIT (U1001)	
A/T	-	NG	UNKWN	UNKWN	-	UNKWN	-	-	UNKWN	UNKWN	-	CAN COMM CIRCUIT (U1000)	-	
AUTO DRIVE POS.	No indication	-	-	-	UNKWN	UNKWN	UNKWN	-	-	-	-	CAN COMM CIRCUIT (U1000)	-	
BCM	No indication	NG	UNKWN	UNKWN	-	UNKWN	-	-	-	-	UNKWN	CAN COMM CIRCUIT (U1000)	-	
HVAC	No indication	-	UNKWN	UNKWN	-	-	UNKWN	-	-	UNKWN	-	-	-	
ALL MODE AWD/4WD	No indication	-	UNKWN	UNKWN	UNKWN	-	-	UNKWN	-	UNKWN	-	CAN COMM CIRCUIT (U1000)	-	
ABS	-	NG	UNKWN	UNKWN	UNKWN	-	-	UNKWN	UNKWN	-	-	CAN COMM CIRCUIT (U1000)	-	
IPDM E/R	No indication	-	UNKWN	UNKWN	-	-	UNKWN	-	-	-	-	CAN COMM CIRCUIT (U1000)	-	

PKIC3484E

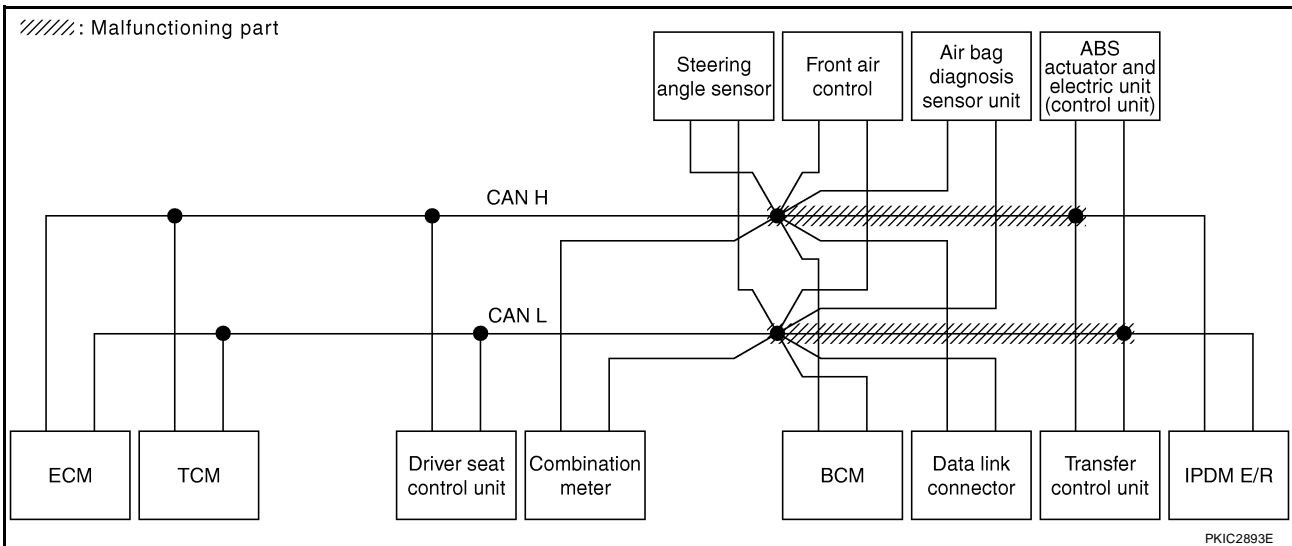

CAN SYSTEM (TYPE 5)

[CAN]

Case 4

Check ECM circuit. Refer to [LAN-145, "ECM Circuit Inspection"](#) .

SELECT SYSTEM screen		CAN DIAG SUPPORT MNTR										SELF-DIAG RESULTS		
		Initial diagnosis	Transmit diagnosis	Receive diagnosis										
				ECM	TCM	METER /M&A	BCM/SEC	STRG	AWD/4WD	VDC/TCS /ABS	IPDM E/R			
ENGINE	-	-	UNKWN	-	UNKWN	UNKWN	UNKWN	-	UNKWN	UNKWN	UNKWN	CAN COMM CIRCUIT (U1000)	CAN COMM CIRCUIT (U1001)	
A/T	-	NG	UNKWN	UNKWN	-	UNKWN	-	-	UNKWN	UNKWN	-	CAN COMM CIRCUIT (U1000)	-	
AUTO DRIVE POS.	No indication	-	-	-	UNKWN	UNKWN	UNKWN	-	-	-	-	CAN COMM CIRCUIT (U1000)	-	
BCM	No indication	NG	UNKWN	UNKWN	-	UNKWN	-	-	-	-	UNKWN	CAN COMM CIRCUIT (U1000)	-	
HVAC	No indication	-	UNKWN	UNKWN	-	-	UNKWN	-	-	UNKWN	-	-	-	
ALL MODE AWD/4WD	No indication	-	UNKWN	UNKWN	UNKWN	-	-	UNKWN	-	UNKWN	-	CAN COMM CIRCUIT (U1000)	-	
ABS	-	NG	UNKWN	UNKWN	UNKWN	-	-	UNKWN	UNKWN	-	-	CAN COMM CIRCUIT (U1000)	-	
IPDM E/R	No indication	-	UNKWN	UNKWN	-	-	UNKWN	-	-	-	-	CAN COMM CIRCUIT (U1000)	-	

PKIC3485E

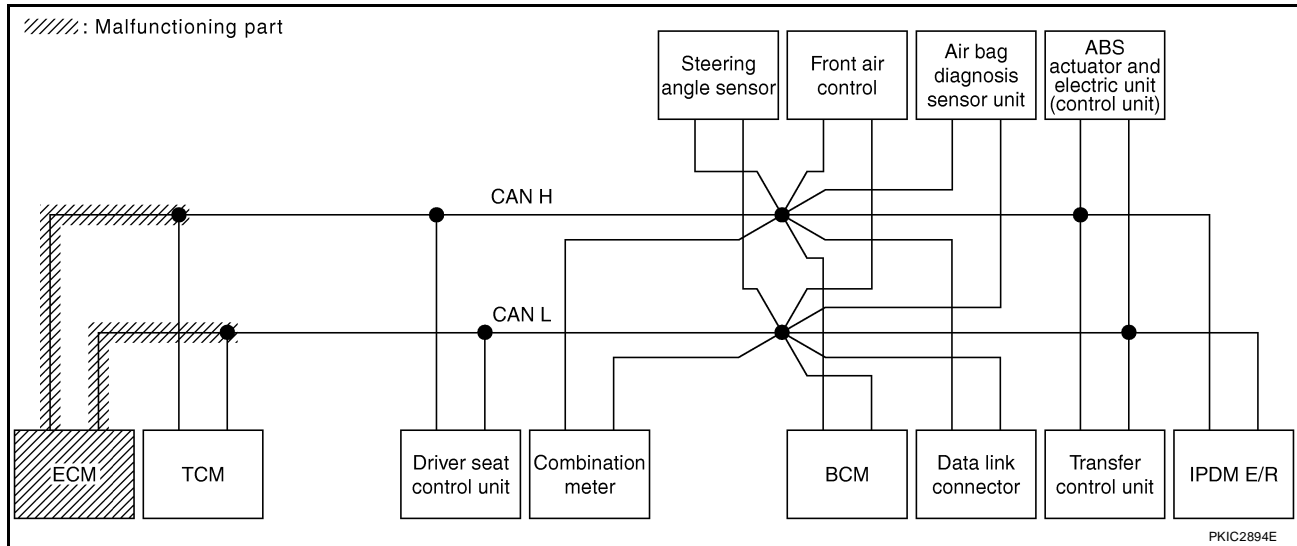

CAN SYSTEM (TYPE 5)

[CAN]

Case 5

Check TCM circuit. Refer to [LAN-146, "TCM Circuit Inspection"](#) .

SELECT SYSTEM screen		CAN DIAG SUPPORT MNTR										SELF-DIAG RESULTS	
		Initial diagnosis	Transmit diagnosis	Receive diagnosis									
				ECM	TCM	METER /M&A	BCM/SEC	STRG	AWD/4WD	VDC/TCS /ABS	IPDM E/R		
ENGINE	-	-	UNKWN	-	UNKWN	UNKWN	UNKWN	-	UNKWN	UNKWN	UNKWN	CAN COMM CIRCUIT (U1000)	CAN COMM CIRCUIT (U1001)
A/T	-	NG	UNKWN	UNKWN	-	UNKWN	-	-	UNKWN	UNKWN	-	CAN COMM CIRCUIT (U1000)	-
AUTO DRIVE POS.	No indication	-	-	-	UNKWN	UNKWN	UNKWN	-	-	-	-	CAN COMM CIRCUIT (U1000)	-
BCM	No indication	NG	UNKWN	UNKWN	-	UNKWN	-	-	-	-	UNKWN	CAN COMM CIRCUIT (U1000)	-
HVAC	No indication	-	UNKWN	UNKWN	-	-	UNKWN	-	-	UNKWN	-	-	-
ALL MODE AWD/4WD	No indication	-	UNKWN	UNKWN	UNKWN	-	-	UNKWN	-	UNKWN	-	CAN COMM CIRCUIT (U1000)	-
ABS	-	NG	UNKWN	UNKWN	UNKWN	-	-	UNKWN	UNKWN	-	-	CAN COMM CIRCUIT (U1000)	-
IPDM E/R	No indication	-	UNKWN	UNKWN	-	-	UNKWN	-	-	-	-	CAN COMM CIRCUIT (U1000)	-

PKIC3486E

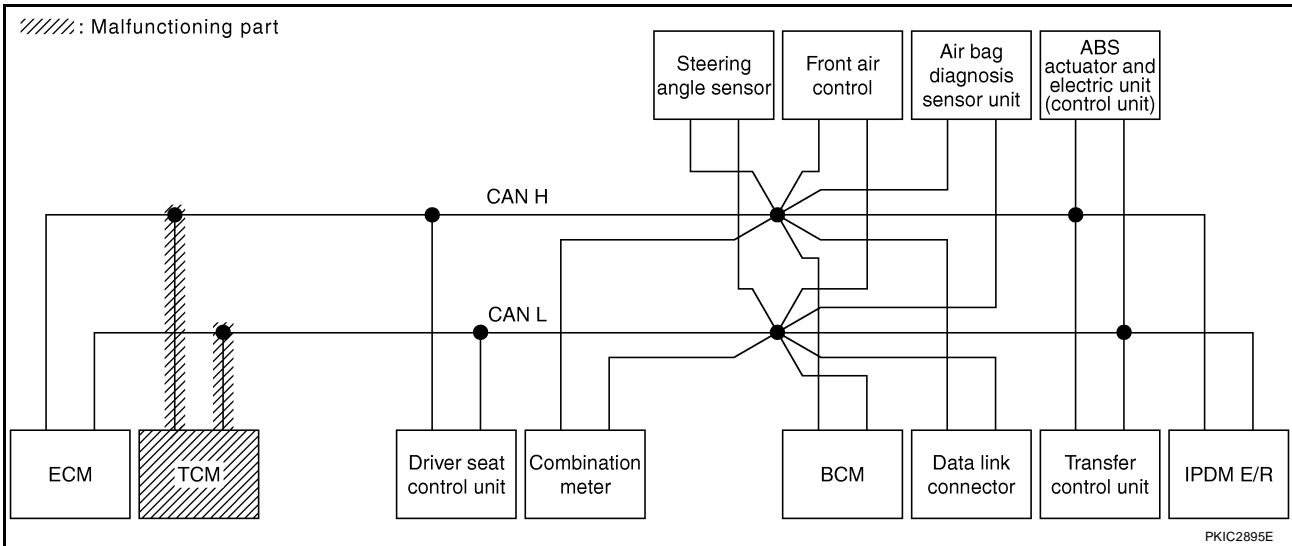

A

B

C

D

E

F

G

H

I

J

LAN

L

M

CAN SYSTEM (TYPE 5)

[CAN]

Case 6

Check driver seat control unit circuit. Refer to [LAN-146, "Driver Seat Control Unit Circuit Inspection"](#) .

SELECT SYSTEM screen		CAN DIAG SUPPORT MNTR										SELF-DIAG RESULTS		
		Initial diagnosis	Transmit diagnosis	Receive diagnosis										
				ECM	TCM	METER /M&A	BCM/SEC	STRG	AWD/4WD	VDC/TCS /ABS	IPDM E/R			
ENGINE	-	-	UNKWN	-	UNKWN	UNKWN	UNKWN	-	UNKWN	UNKWN	UNKWN	CAN COMM CIRCUIT (U1000)	CAN COMM CIRCUIT (U1001)	
A/T	-	NG	UNKWN	UNKWN	-	UNKWN	-	-	UNKWN	UNKWN	-	CAN COMM CIRCUIT (U1000)	-	
AUTO DRIVE POS.	No indication	-	-	-	UNKWN	UNKWN	UNKWN	-	-	-	-	CAN COMM CIRCUIT (U1000)	-	
BCM	No indication	NG	UNKWN	UNKWN	-	UNKWN	-	-	-	-	UNKWN	CAN COMM CIRCUIT (U1000)	-	
HVAC	No indication	-	UNKWN	UNKWN	-	-	UNKWN	-	-	UNKWN	-	-	-	
ALL MODE AWD/4WD	No indication	-	UNKWN	UNKWN	UNKWN	-	-	UNKWN	-	UNKWN	-	CAN COMM CIRCUIT (U1000)	-	
ABS	-	NG	UNKWN	UNKWN	UNKWN	-	-	UNKWN	UNKWN	-	-	CAN COMM CIRCUIT (U1000)	-	
IPDM E/R	No indication	-	UNKWN	UNKWN	-	-	UNKWN	-	-	-	-	CAN COMM CIRCUIT (U1000)	-	

PKIC3487E

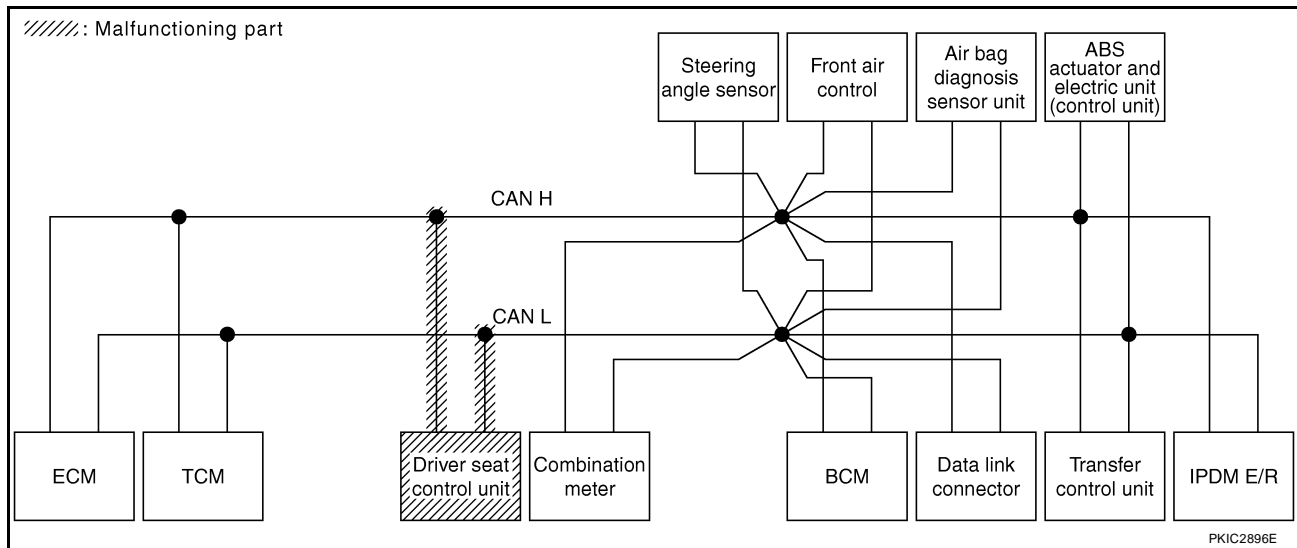

CAN SYSTEM (TYPE 5)

[CAN]

Case 7

Check combination meter circuit. Refer to [LAN-147, "Combination Meter Circuit Inspection"](#).

SELECT SYSTEM screen		CAN DIAG SUPPORT MNTR										SELF-DIAG RESULTS	
		Initial diagnosis	Transmit diagnosis	Receive diagnosis									
				ECM	TCM	METER /M&A	BCM/SEC	STRG	AWD/4WD	VDC/TCS /ABS	IPDM E/R		
ENGINE	-	-	UNKWN	-	UNKWN	UNKWN	UNKWN	-	UNKWN	UNKWN	UNKWN	CAN COMM CIRCUIT (U1000)	CAN COMM CIRCUIT (U1001)
A/T	-	NG	UNKWN	UNKWN	-	UNKWN	-	-	UNKWN	UNKWN	-	CAN COMM CIRCUIT (U1000)	-
AUTO DRIVE POS.	No indication	-	-	-	UNKWN	UNKWN	UNKWN	-	-	-	-	CAN COMM CIRCUIT (U1000)	-
BCM	No indication	NG	UNKWN	UNKWN	-	UNKWN	-	-	-	-	UNKWN	CAN COMM CIRCUIT (U1000)	-
HVAC	No indication	-	UNKWN	UNKWN	-	-	UNKWN	-	-	UNKWN	-	-	-
ALL MODE AWD/4WD	No indication	-	UNKWN	UNKWN	UNKWN	-	-	UNKWN	-	UNKWN	-	CAN COMM CIRCUIT (U1000)	-
ABS	-	NG	UNKWN	UNKWN	UNKWN	-	-	UNKWN	UNKWN	-	-	CAN COMM CIRCUIT (U1000)	-
IPDM E/R	No indication	-	UNKWN	UNKWN	-	-	UNKWN	-	-	-	-	CAN COMM CIRCUIT (U1000)	-

PKIC3488E

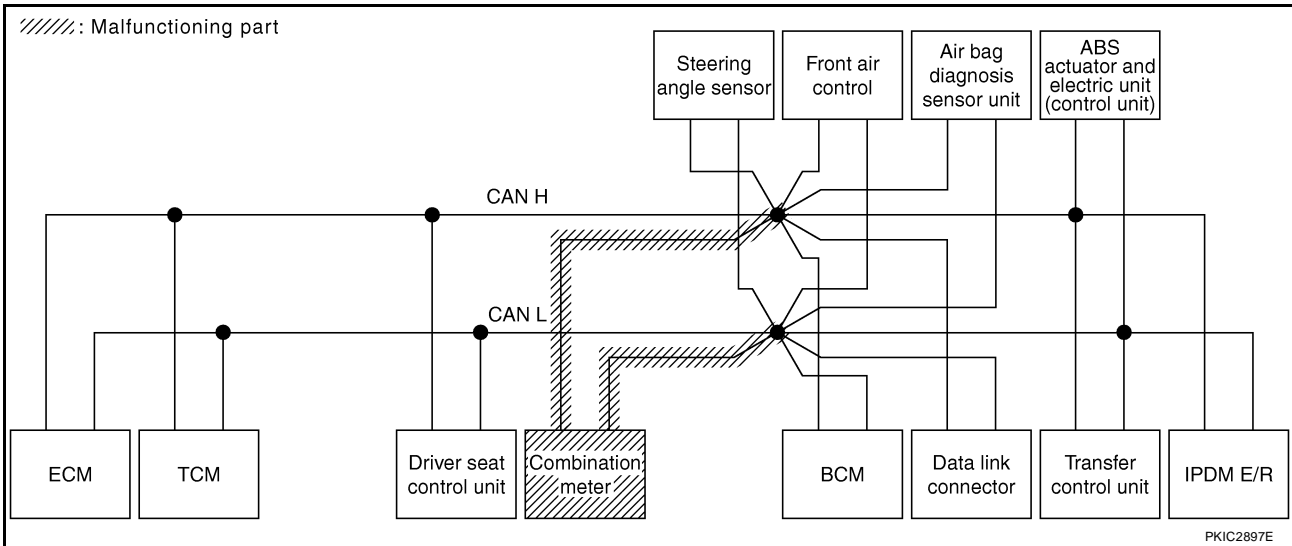

CAN SYSTEM (TYPE 5)

[CAN]

Case 8

Check BCM circuit. Refer to [LAN-148, "BCM Circuit Inspection"](#) .

SELECT SYSTEM screen		CAN DIAG SUPPORT MNTR										SELF-DIAG RESULTS		
		Initial diagnosis	Transmit diagnosis	Receive diagnosis										
				ECM	TCM	METER /M&A	BCM/SEC	STRG	AWD/4WD	VDC/TCS /ABS	IPDM E/R			
ENGINE	-	-	UNKWN	-	UNKWN	UNKWN	UNKWN	-	UNKWN	UNKWN	UNKWN	CAN COMM CIRCUIT (U1000)	CAN COMM CIRCUIT (U1001)	
A/T	-	NG	UNKWN	UNKWN	-	UNKWN	-	-	UNKWN	UNKWN	-	CAN COMM CIRCUIT (U1000)	-	
AUTO DRIVE POS.	No indication	-	-	-	UNKWN	UNKWN	UNKWN	-	-	-	-	CAN COMM CIRCUIT (U1000)	-	
BCM	No indication	NG	UNKWN	UNKWN	-	UNKWN	-	-	-	-	UNKWN	CAN COMM CIRCUIT (U1000)	-	
HVAC	No indication	-	UNKWN	UNKWN	-	-	UNKWN	-	-	UNKWN	-	-	-	
ALL MODE AWD/4WD	No indication	-	UNKWN	UNKWN	UNKWN	-	-	UNKWN	-	UNKWN	-	CAN COMM CIRCUIT (U1000)	-	
ABS	-	NG	UNKWN	UNKWN	UNKWN	-	-	UNKWN	UNKWN	-	-	CAN COMM CIRCUIT (U1000)	-	
IPDM E/R	No indication	-	UNKWN	UNKWN	-	-	UNKWN	-	-	-	-	CAN COMM CIRCUIT (U1000)	-	

PKIC3489E

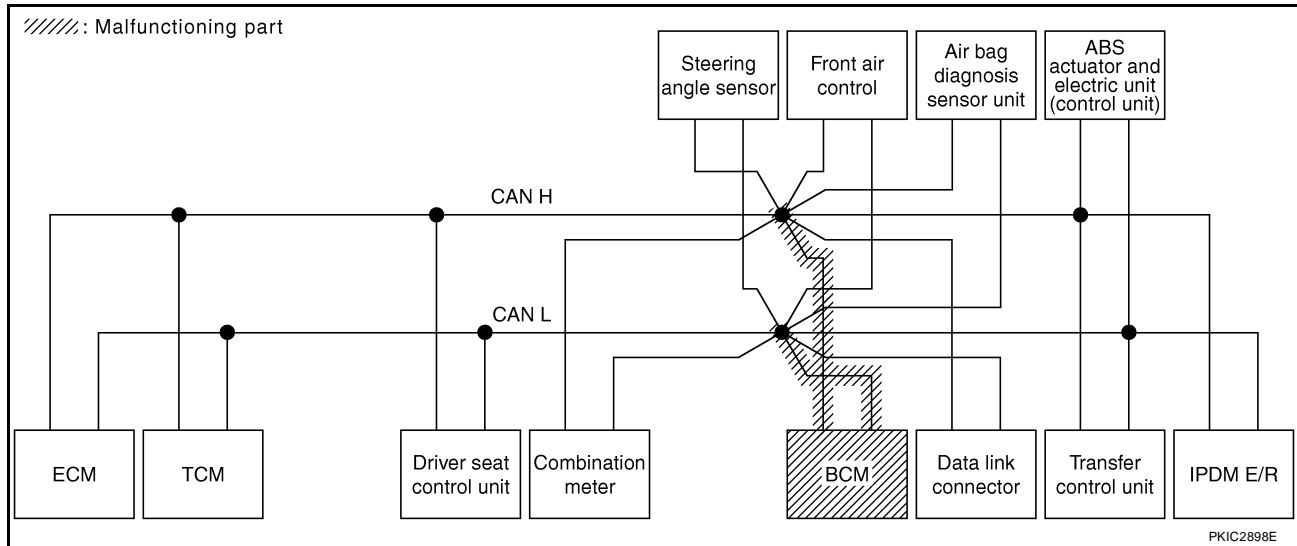

PKIC2898E

CAN SYSTEM (TYPE 5)

[CAN]

Case 9

Check data link connector circuit. Refer to [LAN-148, "Data Link Connector Circuit Inspection"](#) .

SELECT SYSTEM screen		CAN DIAG SUPPORT MNTR										SELF-DIAG RESULTS	
		Initial diagnosis	Transmit diagnosis	Receive diagnosis									
				ECM	TCM	METER /M&A	BCM/SEC	STRG	AWD/4WD	VDC/TCS /ABS	IPDM E/R		
ENGINE	-	-	UNKWN	-	UNKWN	UNKWN	UNKWN	-	UNKWN	UNKWN	UNKWN	CAN COMM CIRCUIT (U1000)	CAN COMM CIRCUIT (U1001)
A/T	-	NG	UNKWN	UNKWN	-	UNKWN	-	-	UNKWN	UNKWN	-	CAN COMM CIRCUIT (U1000)	-
AUTO DRIVE POS.	No indication	-	-	-	UNKWN	UNKWN	UNKWN	-	-	-	-	CAN COMM CIRCUIT (U1000)	-
BCM	No indication	NG	UNKWN	UNKWN	-	UNKWN	-	-	-	-	UNKWN	CAN COMM CIRCUIT (U1000)	-
HVAC	No indication	-	UNKWN	UNKWN	-	-	UNKWN	-	-	UNKWN	-	-	-
ALL MODE AWD/4WD	No indication	-	UNKWN	UNKWN	UNKWN	-	-	UNKWN	-	UNKWN	-	CAN COMM CIRCUIT (U1000)	-
ABS	-	NG	UNKWN	UNKWN	UNKWN	-	-	UNKWN	UNKWN	-	-	CAN COMM CIRCUIT (U1000)	-
IPDM E/R	No indication	-	UNKWN	UNKWN	-	-	UNKWN	-	-	-	-	CAN COMM CIRCUIT (U1000)	-

PKIC3490E

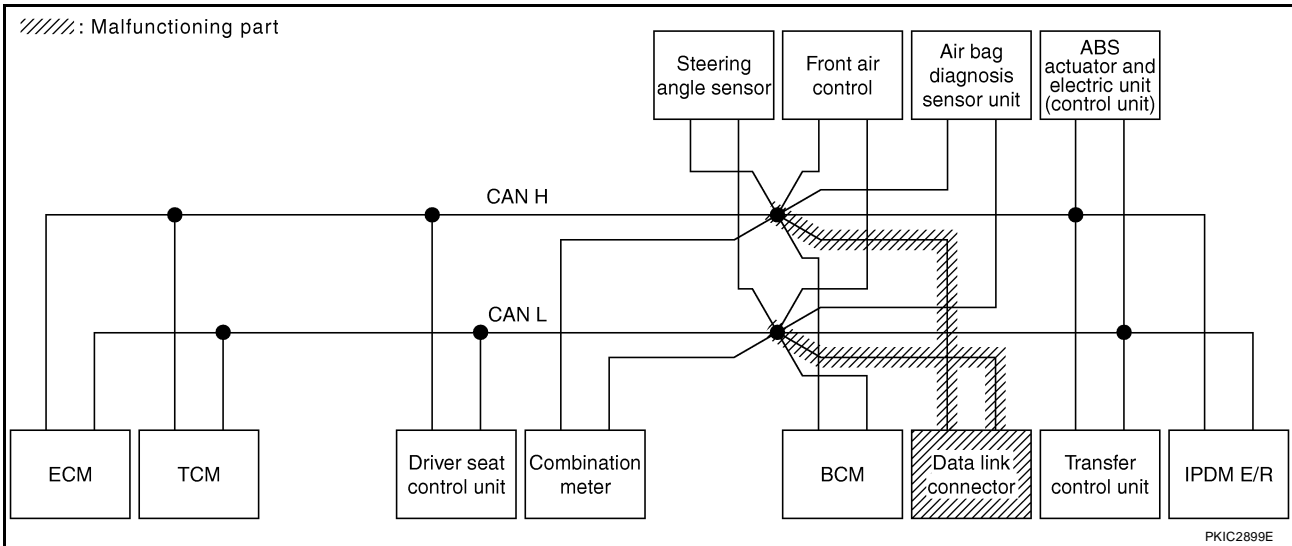

A

B

C

D

E

F

G

H

I

J

LAN

L

M

CAN SYSTEM (TYPE 5)

[CAN]

Case 10

Check steering angle sensor circuit. Refer to [LAN-149, "Steering Angle Sensor Circuit Inspection"](#) .

SELECT SYSTEM screen		CAN DIAG SUPPORT MNTR										SELF-DIAG RESULTS		
		Initial diagnosis	Transmit diagnosis	Receive diagnosis										
				ECM	TCM	METER /M&A	BCM/SEC	STRG	AWD/4WD	VDC/TCS /ABS	IPDM E/R			
ENGINE	-	-	UNKWN	-	UNKWN	UNKWN	UNKWN	-	UNKWN	UNKWN	UNKWN	CAN COMM CIRCUIT (U1000)	CAN COMM CIRCUIT (U1001)	
A/T	-	NG	UNKWN	UNKWN	-	UNKWN	-	-	UNKWN	UNKWN	-	CAN COMM CIRCUIT (U1000)	-	
AUTO DRIVE POS.	No indication	-	-	-	UNKWN	UNKWN	UNKWN	-	-	-	-	CAN COMM CIRCUIT (U1000)	-	
BCM	No indication	NG	UNKWN	UNKWN	-	UNKWN	-	-	-	-	UNKWN	CAN COMM CIRCUIT (U1000)	-	
HVAC	No indication	-	UNKWN	UNKWN	-	-	UNKWN	-	-	UNKWN	-	-	-	
ALL MODE AWD/4WD	No indication	-	UNKWN	UNKWN	UNKWN	-	-	UNKWN	-	UNKWN	-	CAN COMM CIRCUIT (U1000)	-	
ABS	-	NG	UNKWN	UNKWN	UNKWN	-	-	UNKWN	UNKWN	-	-	CAN COMM CIRCUIT (U1000)	-	
IPDM E/R	No indication	-	UNKWN	UNKWN	-	-	UNKWN	-	-	-	-	CAN COMM CIRCUIT (U1000)	-	

PKIC3491E

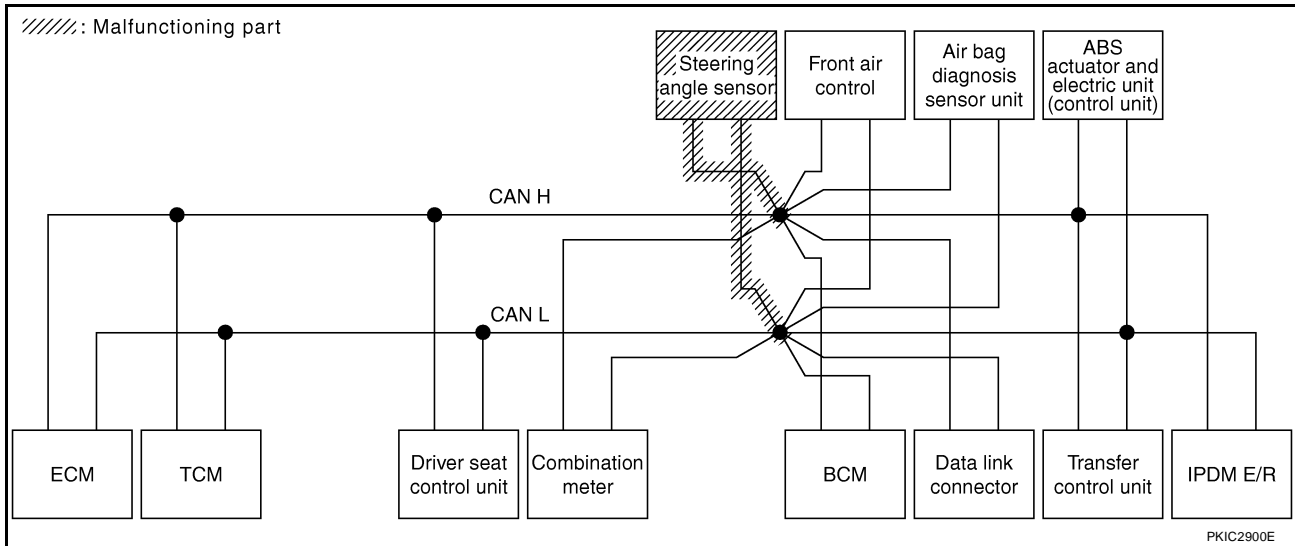

PKIC2900E

CAN SYSTEM (TYPE 5)

[CAN]

Case 11

Check front air control circuit. Refer to [LAN-149, "Front Air Control Circuit Inspection"](#) .

SELECT SYSTEM screen		CAN DIAG SUPPORT MNTR										SELF-DIAG RESULTS		
		Initial diagnosis	Transmit diagnosis	Receive diagnosis										
				ECM	TCM	METER /M&A	BCM/SEC	STRG	AWD/4WD	VDC/TCS /ABS	IPDM E/R			
ENGINE	-	-	UNKWN	-	UNKWN	UNKWN	UNKWN	-	UNKWN	UNKWN	UNKWN	CAN COMM CIRCUIT (U1000)	CAN COMM CIRCUIT (U1001)	
A/T	-	NG	UNKWN	UNKWN	-	UNKWN	-	-	UNKWN	UNKWN	-	CAN COMM CIRCUIT (U1000)	-	
AUTO DRIVE POS.	No indication	-	-	-	UNKWN	UNKWN	UNKWN	-	-	-	-	CAN COMM CIRCUIT (U1000)	-	
BCM	No indication	NG	UNKWN	UNKWN	-	UNKWN	-	-	-	-	UNKWN	CAN COMM CIRCUIT (U1000)	-	
HVAC	No indication	-	UNKWN	UNKWN	-	-	UNKWN	-	-	UNKWN	-	-	-	
ALL MODE AWD/4WD	No indication	-	UNKWN	UNKWN	UNKWN	-	-	UNKWN	-	UNKWN	-	CAN COMM CIRCUIT (U1000)	-	
ABS	-	NG	UNKWN	UNKWN	UNKWN	-	-	UNKWN	UNKWN	-	-	CAN COMM CIRCUIT (U1000)	-	
IPDM E/R	No indication	-	UNKWN	UNKWN	-	-	UNKWN	-	-	-	-	CAN COMM CIRCUIT (U1000)	-	

PKIC3492E

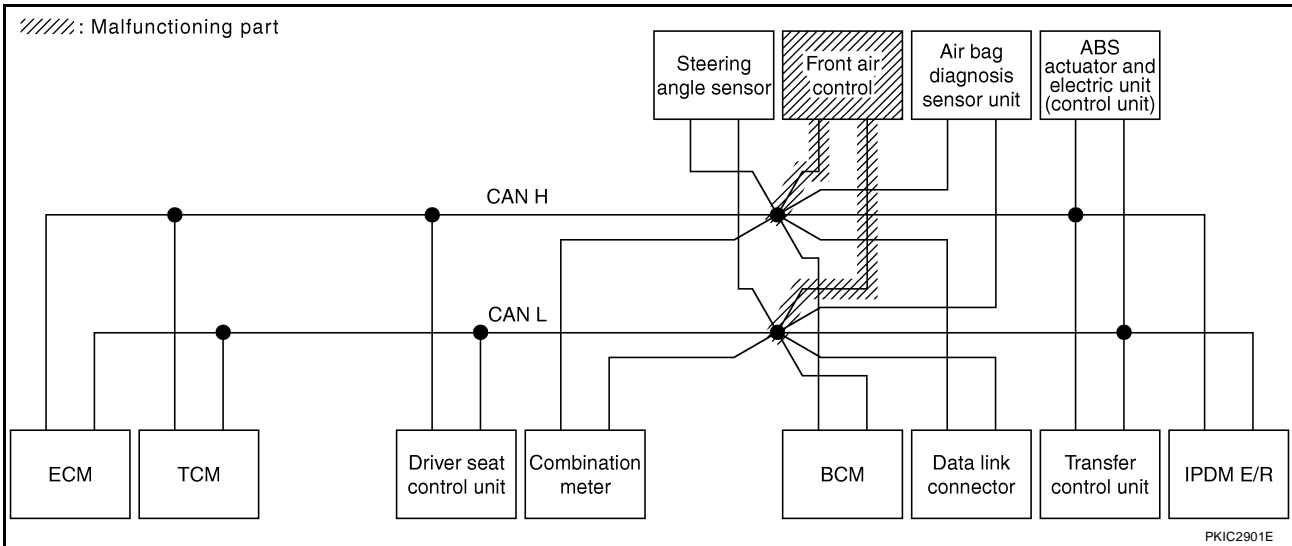

CAN SYSTEM (TYPE 5)

[CAN]

Case 12

Check transfer control unit circuit. Refer to [LAN-150, "Transfer Control Unit Circuit Inspection"](#) .

SELECT SYSTEM screen		CAN DIAG SUPPORT MNTR										SELF-DIAG RESULTS		
		Initial diagnosis	Transmit diagnosis	Receive diagnosis										
				ECM	TCM	METER /M&A	BCM/SEC	STRG	AWD/4WD	VDC/TCS /ABS	IPDM E/R			
ENGINE	-	-	UNKWN	-	UNKWN	UNKWN	UNKWN	-	UNKWN	UNKWN	UNKWN	CAN COMM CIRCUIT (U1000)	CAN COMM CIRCUIT (U1001)	
A/T	-	NG	UNKWN	UNKWN	-	UNKWN	-	-	UNKWN	UNKWN	-	CAN COMM CIRCUIT (U1000)	-	
AUTO DRIVE POS.	No indication	-	-	-	UNKWN	UNKWN	UNKWN	-	-	-	-	CAN COMM CIRCUIT (U1000)	-	
BCM	No indication	NG	UNKWN	UNKWN	-	UNKWN	-	-	-	-	UNKWN	CAN COMM CIRCUIT (U1000)	-	
HVAC	No indication	-	UNKWN	UNKWN	-	-	UNKWN	-	-	UNKWN	-	-	-	
ALL MODE AWD/4WD	No indication	-	UNKWN	UNKWN	UNKWN	-	-	UNKWN	-	UNKWN	-	CAN COMM CIRCUIT (U1000)	-	
ABS	-	NG	UNKWN	UNKWN	UNKWN	-	-	UNKWN	UNKWN	-	-	CAN COMM CIRCUIT (U1000)	-	
IPDM E/R	No indication	-	UNKWN	UNKWN	-	-	UNKWN	-	-	-	-	CAN COMM CIRCUIT (U1000)	-	

PKIC3493E

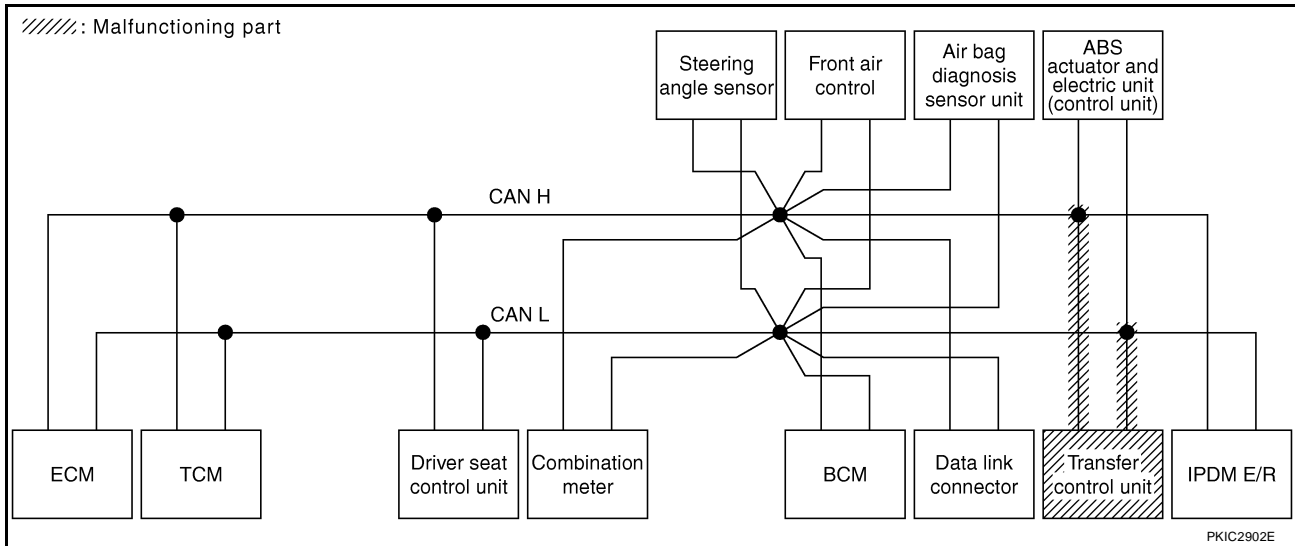

CAN SYSTEM (TYPE 5)

[CAN]

Case 13

Check ABS actuator and electric unit (control unit) circuit. Refer to [LAN-151, "ABS Actuator and Electric Unit \(Control Unit\) Circuit Inspection"](#).

SELECT SYSTEM screen		CAN DIAG SUPPORT MNTR										SELF-DIAG RESULTS	
		Initial diagnosis	Transmit diagnosis	Receive diagnosis									
				ECM	TCM	METER /M&A	BCM/SEC	STRG	AWD/4WD	VDC/TCS /ABS	IPDM E/R		
ENGINE	-	-	UNKWN	-	UNKWN	UNKWN	UNKWN	-	UNKWN	UNKWN	UNKWN	CAN COMM CIRCUIT (U1000)	CAN COMM CIRCUIT (U1001)
A/T	-	NG	UNKWN	UNKWN	-	UNKWN	-	-	UNKWN	UNKWN	-	CAN COMM CIRCUIT (U1000)	-
AUTO DRIVE POS.	No indication	-	-	-	UNKWN	UNKWN	UNKWN	-	-	-	-	CAN COMM CIRCUIT (U1000)	-
BCM	No indication	NG	UNKWN	UNKWN	-	UNKWN	-	-	-	-	UNKWN	CAN COMM CIRCUIT (U1000)	-
HVAC	No indication	-	UNKWN	UNKWN	-	-	UNKWN	-	-	UNKWN	-	-	-
ALL MODE AWD/4WD	No indication	-	UNKWN	UNKWN	UNKWN	-	-	UNKWN	-	UNKWN	-	CAN COMM CIRCUIT (U1000)	-
ABS	-	NG	UNKWN	UNKWN	UNKWN	-	-	UNKWN	UNKWN	-	-	CAN COMM CIRCUIT (U1000)	-
IPDM E/R	No indication	-	UNKWN	UNKWN	-	-	UNKWN	-	-	-	-	CAN COMM CIRCUIT (U1000)	-

PKIC3494E

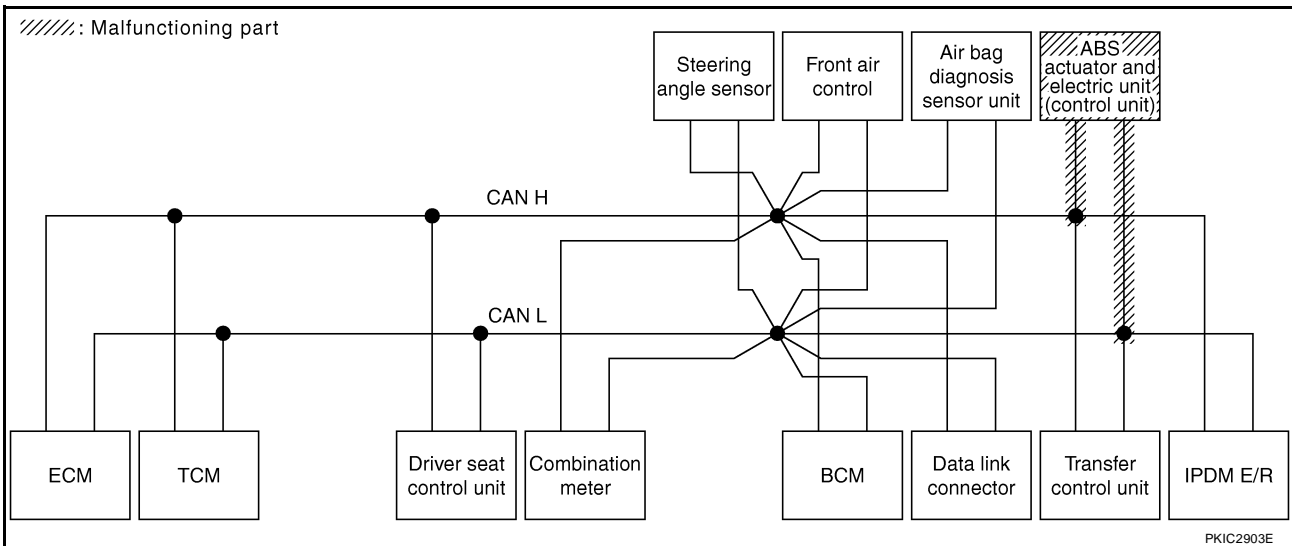

CAN SYSTEM (TYPE 5)

[CAN]

Case 14

Check IPDM E/R circuit. Refer to [LAN-151, "IPDM E/R Circuit Inspection"](#) .

SELECT SYSTEM screen		CAN DIAG SUPPORT MNTR										SELF-DIAG RESULTS		
		Initial diagnosis	Transmit diagnosis	Receive diagnosis										
				ECM	TCM	METER /M&A	BCM/SEC	STRG	AWD/4WD	VDC/TCS /ABS	IPDM E/R			
ENGINE	-	-	UNKWN	-	UNKWN	UNKWN	UNKWN	-	UNKWN	UNKWN	UNKWN	UNKWN	CAN COMM CIRCUIT (U1000)	CAN COMM CIRCUIT (U1001)
A/T	-	NG	UNKWN	UNKWN	-	UNKWN	-	-	UNKWN	UNKWN	-	-	CAN COMM CIRCUIT (U1000)	-
AUTO DRIVE POS.	No indication	-	-	-	UNKWN	UNKWN	UNKWN	-	-	-	-	-	CAN COMM CIRCUIT (U1000)	-
BCM	No indication	NG	UNKWN	UNKWN	-	UNKWN	-	-	-	-	UNKWN	UNKWN	CAN COMM CIRCUIT (U1000)	-
HVAC	No indication	-	UNKWN	UNKWN	-	-	UNKWN	-	-	-	UNKWN	-	-	-
ALL MODE AWD/4WD	No indication	-	UNKWN	UNKWN	UNKWN	-	-	UNKWN	-	-	UNKWN	-	CAN COMM CIRCUIT (U1000)	-
ABS	-	NG	UNKWN	UNKWN	UNKWN	-	-	UNKWN	UNKWN	-	-	-	CAN COMM CIRCUIT (U1000)	-
IPDM E/R	No indication	-	UNKWN	UNKWN	-	-	UNKWN	-	-	-	-	-	CAN COMM CIRCUIT (U1000)	-

PKIC3495E

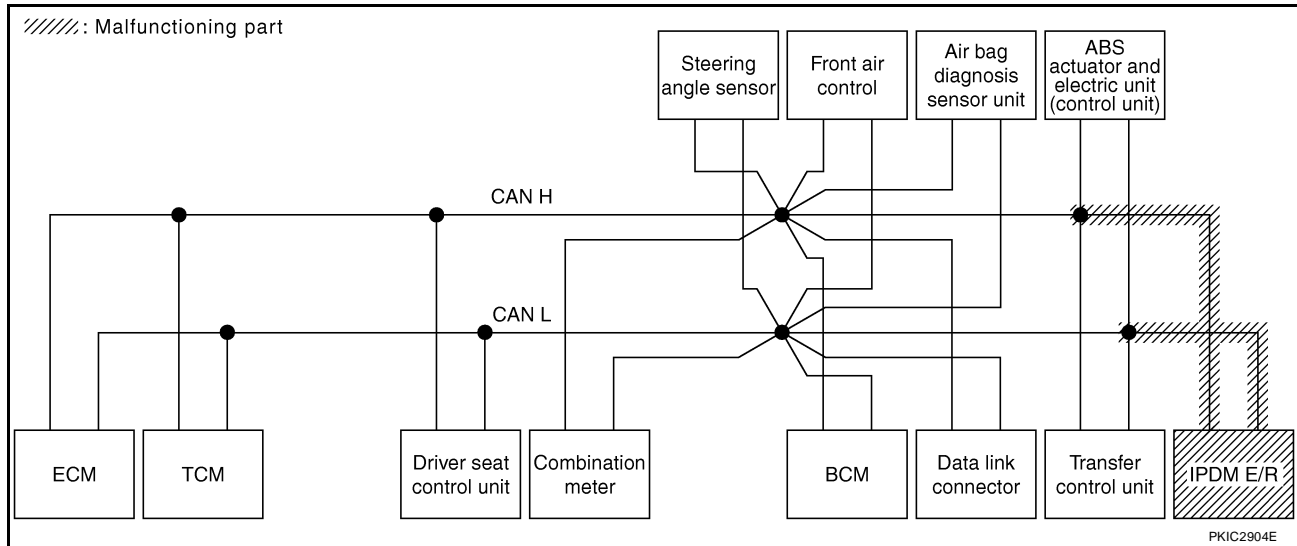

Case 15

Check CAN communication circuit. Refer to [LAN-152, "CAN Communication Circuit Inspection"](#) .

SELECT SYSTEM screen		CAN DIAG SUPPORT MNTR										SELF-DIAG RESULTS		
		Initial diagnosis	Transmit diagnosis	Receive diagnosis										
				ECM	TCM	METER /M&A	BCM/SEC	STRG	AWD/4WD	VDC/TCS /ABS	IPDM E/R			
ENGINE	-	-	UNKWN	-	UNKWN	UNKWN	UNKWN	-	UNKWN	UNKWN	UNKWN	UNKWN	CAN COMM CIRCUIT (U1000)	CAN COMM CIRCUIT (U1001)
A/T	-	NG	UNKWN	UNKWN	-	UNKWN	-	-	UNKWN	UNKWN	-	-	CAN COMM CIRCUIT (U1000)	-
AUTO DRIVE POS.	No indication	-	-	-	UNKWN	UNKWN	UNKWN	-	-	-	-	-	CAN COMM CIRCUIT (U1000)	-
BCM	No indication	NG	UNKWN	UNKWN	-	UNKWN	-	-	-	-	UNKWN	UNKWN	CAN COMM CIRCUIT (U1000)	-
HVAC	No indication	-	UNKWN	UNKWN	-	-	UNKWN	-	-	-	UNKWN	-	-	-
ALL MODE AWD/4WD	No indication	-	UNKWN	UNKWN	UNKWN	-	-	UNKWN	-	-	UNKWN	-	CAN COMM CIRCUIT (U1000)	-
ABS	-	NG	UNKWN	UNKWN	UNKWN	-	-	UNKWN	UNKWN	-	-	-	CAN COMM CIRCUIT (U1000)	-
IPDM E/R	No indication	-	UNKWN	UNKWN	-	-	UNKWN	-	-	-	-	-	CAN COMM CIRCUIT (U1000)	-

PKIC3496E

CAN SYSTEM (TYPE 5)

[CAN]

Case 16

Check IPDM E/R ignition relay circuit continuously sticks "OFF". Refer to [LAN-153, "IPDM E/R Ignition Relay Circuit Inspection"](#) .

SELECT SYSTEM screen		CAN DIAG SUPPORT MNTR										SELF-DIAG RESULTS		
		Initial diagnosis	Transmit diagnosis	Receive diagnosis										
				ECM	TCM	METER /M&A	BCM/SEC	STRG	AWD/4WD	VDC/TCS /ABS	IPDM E/R			
ENGINE	–	–	UNKWN	–	UNKWN	UNKWN	UNKWN	–	UNKWN	UNKWN	UNKWN	CAN COMM CIRCUIT (U1000)	CAN COMM CIRCUIT (U1001)	
A/T	–	NG	UNKWN	UNKWN	–	UNKWN	–	–	UNKWN	UNKWN	–	CAN COMM CIRCUIT (U1000)	–	
AUTO DRIVE POS.	No indication	–	–	–	UNKWN	UNKWN	UNKWN	–	–	–	–	CAN COMM CIRCUIT (U1000)	–	
BCM	No indication	NG	UNKWN	UNKWN	–	UNKWN	–	–	–	–	UNKWN	CAN COMM CIRCUIT (U1000)	–	
HVAC	No indication	–	UNKWN	UNKWN	–	–	UNKWN	–	–	UNKWN	–	–	–	
ALL MODE AWD/4WD	No indication	–	UNKWN	UNKWN	UNKWN	–	–	UNKWN	–	UNKWN	–	CAN COMM CIRCUIT (U1000)	–	
ABS	–	NG	UNKWN	UNKWN	UNKWN	–	–	UNKWN	UNKWN	–	–	CAN COMM CIRCUIT (U1000)	–	
IPDM E/R	No indication	–	UNKWN	UNKWN	–	–	UNKWN	–	–	–	–	CAN COMM CIRCUIT (U1000)	–	

PKIC3497E

Case 17

Check IPDM E/R ignition relay circuit continuously sticks "ON". Refer to [LAN-153, "IPDM E/R Ignition Relay Circuit Inspection"](#) .

SELECT SYSTEM screen		CAN DIAG SUPPORT MNTR										SELF-DIAG RESULTS		
		Initial diagnosis	Transmit diagnosis	Receive diagnosis										
				ECM	TCM	METER /M&A	BCM/SEC	STRG	AWD/4WD	VDC/TCS /ABS	IPDM E/R			
ENGINE	–	–	UNKWN	–	UNKWN	UNKWN	UNKWN	–	UNKWN	UNKWN	UNKWN	CAN COMM CIRCUIT (U1000)	CAN COMM CIRCUIT (U1001)	
A/T	–	NG	UNKWN	–	–	–	–	–	–	UNKWN	–	CAN COMM CIRCUIT (U1000)	–	
AUTO DRIVE POS.	No indication	–	–	–	UNKWN	UNKWN	UNKWN	–	–	–	–	CAN COMM CIRCUIT (U1000)	–	
BCM	No indication	NG	UNKWN	UNKWN	–	UNKWN	–	–	–	–	UNKWN	CAN COMM CIRCUIT (U1000)	–	
HVAC	No indication	–	UNKWN	UNKWN	–	–	UNKWN	–	–	UNKWN	–	–	–	
ALL MODE AWD/4WD	No indication	–	UNKWN	UNKWN	UNKWN	–	–	UNKWN	–	UNKWN	–	CAN COMM CIRCUIT (U1000)	–	
ABS	–	NG	UNKWN	–	UNKWN	–	–	–	–	–	–	CAN COMM CIRCUIT (U1000)	–	
IPDM E/R	No indication	–	UNKWN	UNKWN	–	–	UNKWN	–	–	–	–	CAN COMM CIRCUIT (U1000)	–	

PKIC3498E

CAN SYSTEM (TYPE 6)

PF2:23710

Component Parts and Harness Connector Location

UKS004SL

Refer to [LAN-25, "Component Parts and Harness Connector Location"](#) .

Schematic

UKS004SM

Refer to [LAN-26, "Schematic"](#) .

Wiring Diagram — CAN —

UKS004SN

Refer to [LAN-27, "Wiring Diagram — CAN —"](#) .

CAN SYSTEM (TYPE 6)

[CAN]

UKS004SO

Check Sheet

NOTE:

If a check mark is put on "NG" on "INITIAL DIAG (Initial diagnosis)", replace the control unit.

Check sheet table														SELF-DIAG RESULTS	
SELECT SYSTEM screen		Initial diagnosis	Transmit diagnosis	CAN DIAG SUPPORT MNTR											
				Receive diagnosis											
				ECM	TCM	METER /M&A	DISPLAY	BCM/SEC	STRG	HVAC	AWD/4WD	VDC/TCS /ABS	IPDM E/R	CAN COMM CIRCUIT (U1000)	CAN COMM CIRCUIT (U1001)
ENGINE	-	-	UNKWN	-	UNKWN	UNKWN	-	UNKWN	-	-	UNKWN	UNKWN	UNKWN	CAN COMM CIRCUIT (U1000)	CAN COMM CIRCUIT (U1001)
A/T	-	NG	UNKWN	UNKWN	-	UNKWN	-	-	-	-	UNKWN	UNKWN	-	CAN COMM CIRCUIT (U1000)	-
AUTO DRIVE POS.	No indication	-	-	-	UNKWN	UNKWN	-	UNKWN	-	-	-	-	-	CAN COMM CIRCUIT (U1000)	-
Display control unit	-	NG	UNKWN	UNKWN	-	UNKWN	-	UNKWN	-	UNKWN	-	-	UNKWN	-	-
BCM	No indication	NG	UNKWN	UNKWN	-	UNKWN	-	-	-	-	-	-	UNKWN	CAN COMM CIRCUIT (U1000)	-
HVAC	No indication	-	UNKWN	UNKWN	-	-	UNKWN	UNKWN	-	-	-	UNKWN	-	-	-
ALL MODE AWD/4WD	No indication	-	UNKWN	UNKWN	UNKWN	-	-	-	UNKWN	-	-	UNKWN	-	CAN COMM CIRCUIT (U1000)	-
ABS	-	NG	UNKWN	UNKWN	UNKWN	-	-	-	UNKWN	-	UNKWN	-	-	CAN COMM CIRCUIT (U1000)	-
IPDM E/R	No indication	-	UNKWN	UNKWN	-	-	-	UNKWN	-	-	-	-	-	CAN COMM CIRCUIT (U1000)	-

Symptoms :

Attach copy of
SELECT SYSTEM

Attach copy of
SELECT SYSTEM

Display control unit Translation Sheet: Rewrite the following names, and put a check mark on the above check sheet table.			
Confirmation/Adjustment Display	Check sheet table Display	Confirmation/Adjustment Display	Check sheet table Display
CAN COMM	Initial diagnosis	CAN CIRC 5	METER/M&A
CAN CIRC 1	Transmit diagnosis	CAN CIRC 6	-
CAN CIRC 2	BCM	CAN CIRC 7	IPDM E/R
CAN CIRC 3	ECM	CAN CIRC 8	-
CAN CIRC 4	HVAC	CAN CIRC 9	-

Attach copy of
display control unit
CAN DIAG SUPPORT MONITOR check sheet

PKIC3466E

A
B
C
D
E
F
G
H
I
J
L
M

LAN

CAN SYSTEM (TYPE 6)

[CAN]

Attach copy of
ENGINE
SELF-DIAG RESULTS

Attach copy of
A/T
SELF-DIAG RESULTS

Attach copy of
AUTO DRIVE POS.
SELF-DIAG RESULTS

Attach copy of
BCM
SELF-DIAG RESULTS

Attach copy of
HVAC
SELF-DIAG RESULTS

Attach copy of
ALL MODE AWD/4WD
SELF-DIAG RESULTS

Attach copy of
ABS
SELF-DIAG RESULTS

Attach copy of
IPDM E/R
SELF-DIAG RESULTS

Attach copy of
ENGINE
CAN DIAG SUPPORT
MNTR

Attach copy of
A/T
CAN DIAG SUPPORT
MNTR

Attach copy of
AUTO DRIVE POS.
CAN DIAG SUPPORT
MNTR

Attach copy of
BCM
CAN DIAG SUPPORT
MNTR

Attach copy of
HVAC
CAN DIAG SUPPORT
MNTR

Attach copy of
ALL MODE AWD/4WD
CAN DIAG SUPPORT
MNTR

Attach copy of
ABS
CAN DIAG SUPPORT
MNTR

Attach copy of
IPDM E/R
CAN DIAG SUPPORT
MNTR

PKIB6773E

CAN SYSTEM (TYPE 6)

[CAN]

CHECK SHEET RESULTS (EXAMPLE)

NOTE:

If a check mark is put on "NG" on "INITIAL DIAG (Initial diagnosis)", replace the control unit.

Case 1

Check harness between TCM and driver seat control unit. Refer to [LAN-141, "Inspection Between TCM and Driver Seat Control Unit Circuit"](#).

SELECT SYSTEM screen		CAN DIAG SUPPORT MNTR											SELF-DIAG RESULTS		
		Initial diagnosis	Transmit diagnosis	Receive diagnosis											
				ECM	TCM	METER /M&A	DISPLAY	BCM/SEC	STRG	HVAC	AWD/4WD	VDC/TCS /ABS			IPDM E/R
ENGINE	-	-	UNKWN	-	UNKWN	✓	-	UNKWN	-	-	UNKWN	UNKWN	UNKWN	CAN COMM CIRCUIT (U1000)	CAN COMM CIRCUIT (U1001)
A/T	-	NG	UNKWN	UNKWN	-	UNKWN	-	-	-	-	UNKWN	UNKWN	-	CAN COMM CIRCUIT (U1000)	-
AUTO DRIVE POS.	No indication	-	-	-	UNKWN	UNKWN	-	UNKWN	-	-	-	-	-	CAN COMM CIRCUIT (U1000)	-
Display control unit	-	NG	UNKWN	UNKWN	-	UNKWN	-	UNKWN	-	UNKWN	-	-	UNKWN	-	-
BCM	No indication	NG	UNKWN	UNKWN	-	UNKWN	-	-	-	-	-	-	UNKWN	CAN COMM CIRCUIT (U1000)	-
HVAC	No indication	-	UNKWN	UNKWN	-	-	UNKWN	UNKWN	-	-	-	UNKWN	-	-	-
ALL MODE AWD/4WD	No indication	-	UNKWN	UNKWN	UNKWN	-	-	-	UNKWN	-	-	UNKWN	-	CAN COMM CIRCUIT (U1000)	-
ABS	-	NG	UNKWN	UNKWN	UNKWN	-	-	-	UNKWN	-	UNKWN	-	-	CAN COMM CIRCUIT (U1000)	-
IPDM E/R	No indication	-	UNKWN	UNKWN	-	-	-	UNKWN	-	-	-	-	-	CAN COMM CIRCUIT (U1000)	-

PKIC3499E

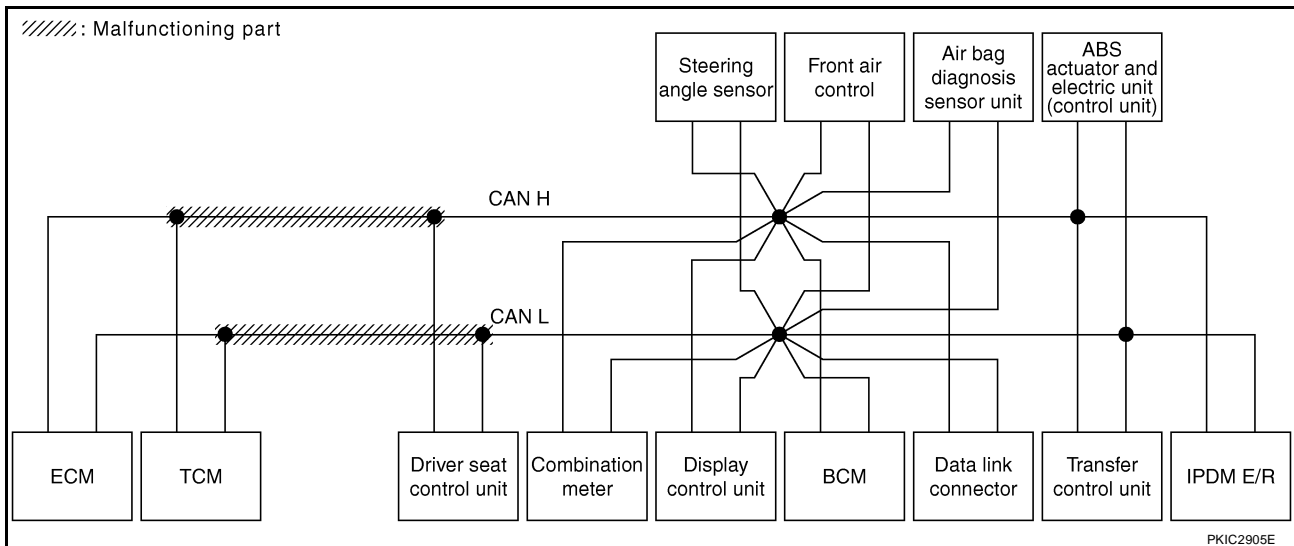

PKIC2905E

CAN SYSTEM (TYPE 6)

[CAN]

Case 2

Check harness between driver seat control unit and data link connector. Refer to [LAN-143, "Inspection Between Driver Seat Control Unit and Data Link Connector Circuit"](#) .

SELECT SYSTEM screen		CAN DIAG SUPPORT MNTR											SELF-DIAG RESULTS		
		Initial diagnosis	Transmit diagnosis	Receive diagnosis											IPDM E/R
				ECM	TCM	METER /M&A	DISPLAY	BCM/SEC	STRG	HVAC	AWD/4WD	VDC/TCS /ABS			
ENGINE	-	-	UNKWN	-	UNKWN	UN ✓ KN	-	UN ✓ KN	-	-	UN ✓ KN	UN ✓ KN	UN ✓ KN	CAN COMM CIRCUIT (U1000)	CAN COMM CIRCUIT (U001)
A/T	-	NG	UNKWN	UNKWN	-	UN ✓ KN	-	-	-	-	UN ✓ KN	UN ✓ KN	-	CAN COMM CIRCUIT (U000)	-
AUTO DRIVE POS.	No indication	-	-	-	UNKWN	UNKWN	-	UNKWN	-	-	-	-	-	CAN COMM CIRCUIT (U000)	-
Display control unit	-	NG	UNKWN	UN ✓ KN	-	UNKWN	-	UNKWN	-	UNKWN	-	-	UNKWN	-	-
BCM	No indication	NG	UNKWN	UN ✓ KN	-	UNKWN	-	-	-	-	-	-	UNKWN	CAN COMM CIRCUIT (U1000)	-
HVAC	No indication	-	UNKWN	UN ✓ KN	-	-	UNKWN	UNKWN	-	-	-	UNKWN	-	-	-
ALL MODE AWD/4WD	No indication	-	UNKWN	UN ✓ KN	UN ✓ KN	-	-	-	UNKWN	-	-	UNKWN	-	CAN COMM CIRCUIT (U000)	-
ABS	-	NG	UNKWN	UN ✓ KN	UN ✓ KN	-	-	-	UNKWN	-	UNKWN	-	-	CAN COMM CIRCUIT (U000)	-
IPDM E/R	No indication	-	UNKWN	UN ✓ KN	-	-	-	UNKWN	-	-	-	-	-	CAN COMM CIRCUIT (U000)	-

PKIC3500E

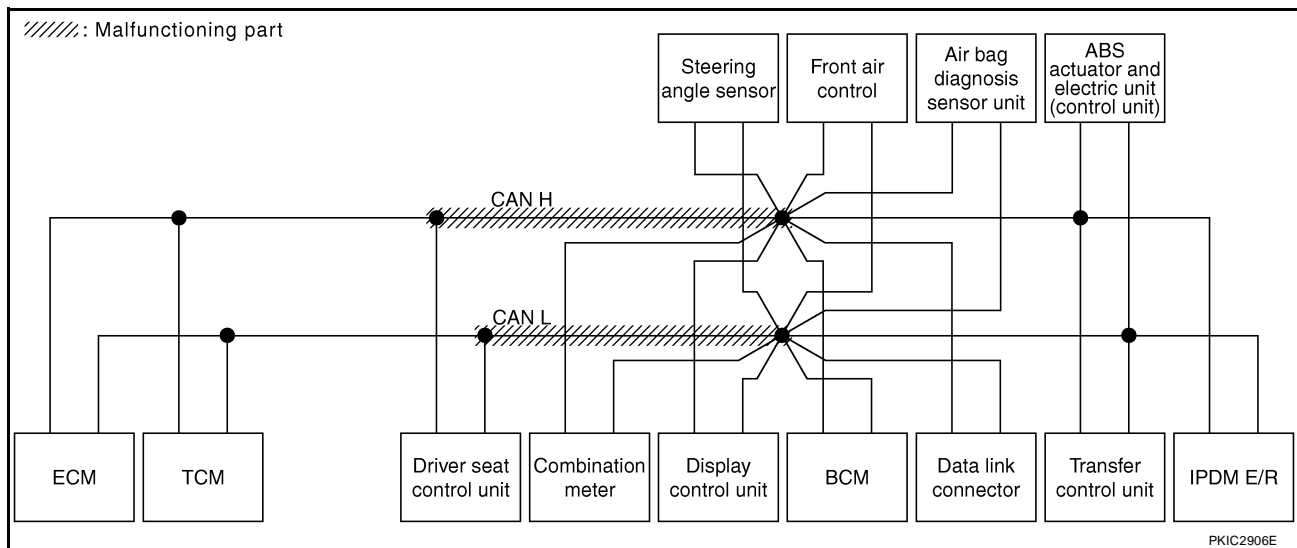

PKIC2906E

CAN SYSTEM (TYPE 6)

[CAN]

Case 4

Check ECM circuit. Refer to [LAN-145, "ECM Circuit Inspection"](#) .

SELECT SYSTEM screen		CAN DIAG SUPPORT MNTR											SELF-DIAG RESULTS		
		Initial diagnosis	Transmit diagnosis	Receive diagnosis											IPDM E/R
				ECM	TCM	METER /M&A	DISPLAY	BCM/SEC	STRG	HVAC	AWD/4WD	VDC/TCS /ABS			
ENGINE	-	-	UNKWN	-	UNKWN	UNKWN	-	UNKWN	-	-	UNKWN	UNKWN	UNKWN	CAN COMM CIRCUIT (U000)	CAN COMM CIRCUIT (U001)
A/T	-	NG	UNKWN	UNKWN	-	UNKWN	-	-	-	-	UNKWN	UNKWN	-	CAN COMM CIRCUIT (U000)	-
AUTO DRIVE POS.	No indication	-	-	-	UNKWN	UNKWN	-	UNKWN	-	-	-	-	-	CAN COMM CIRCUIT (U1000)	-
Display control unit	-	NG	UNKWN	UNKWN	-	UNKWN	-	UNKWN	-	UNKWN	-	-	UNKWN	-	-
BCM	No indication	NG	UNKWN	UNKWN	-	UNKWN	-	-	-	-	-	-	UNKWN	CAN COMM CIRCUIT (U1000)	-
HVAC	No indication	-	UNKWN	UNKWN	-	-	UNKWN	UNKWN	-	-	-	UNKWN	-	-	-
ALL MODE AWD/4WD	No indication	-	UNKWN	UNKWN	UNKWN	-	-	-	UNKWN	-	-	UNKWN	-	CAN COMM CIRCUIT (U000)	-
ABS	-	NG	UNKWN	UNKWN	UNKWN	-	-	-	UNKWN	-	UNKWN	-	-	CAN COMM CIRCUIT (U000)	-
IPDM E/R	No indication	-	UNKWN	UNKWN	-	-	-	UNKWN	-	-	-	-	-	CAN COMM CIRCUIT (U000)	-

PKIC3502E

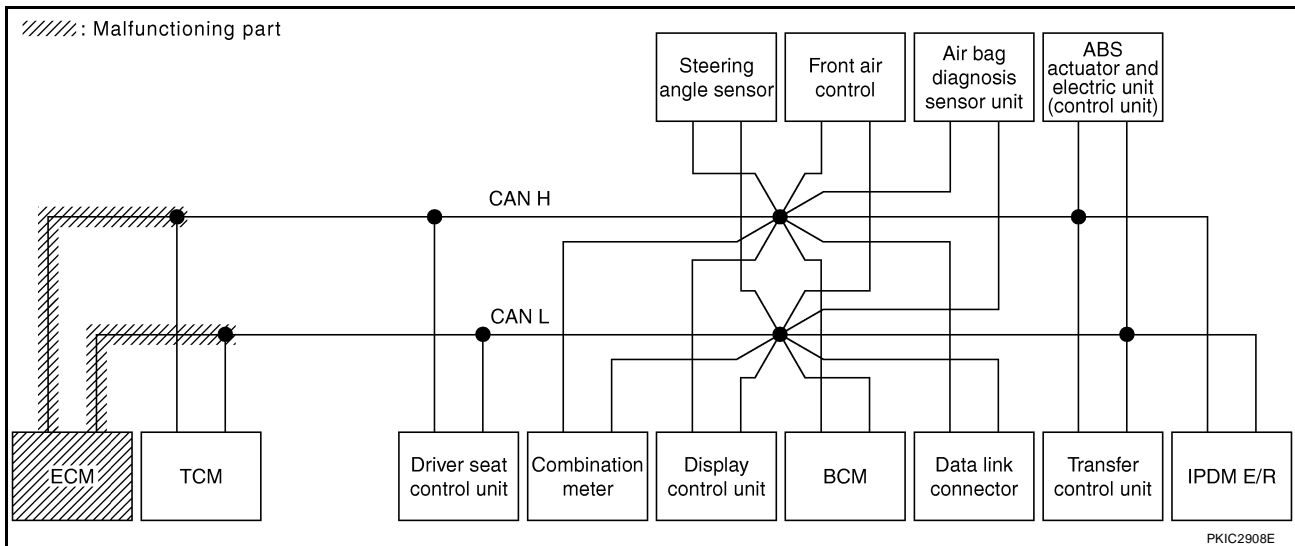

PKIC2908E

CAN SYSTEM (TYPE 6)

[CAN]

Case 5

Check TCM circuit. Refer to [LAN-146, "TCM Circuit Inspection"](#) .

SELECT SYSTEM screen		CAN DIAG SUPPORT MNTR											SELF-DIAG RESULTS		
		Initial diagnosis	Transmit diagnosis	Receive diagnosis											IPDM E/R
				ECM	TCM	METER /M&A	DISPLAY	BCM/SEC	STRG	HVAC	AWD/4WD	VDC/TCS /ABS			
ENGINE	-	-	UNKWN	-	UN KN W N	UNKWN	-	UNKWN	-	-	UNKWN	UNKWN	UNKWN	CAN COMM CIRCUIT (U1000)	CAN COMM CIRCUIT (U1001)
A/T	-	NG	UNKWN	UN KN W N	-	UN KN W N	-	-	-	-	UNKWN	UN KN W N	-	CAN COMM CIRCUIT (U1000)	-
AUTO DRIVE POS.	No indication	-	-	-	UN KN W N	UNKWN	-	UNKWN	-	-	-	-	-	CAN COMM CIRCUIT (U1000)	-
Display control unit	-	NG	UNKWN	UNKWN	-	UNKWN	-	UNKWN	-	UNKWN	-	-	UNKWN	-	-
BCM	No indication	NG	UNKWN	UNKWN	-	UNKWN	-	-	-	-	-	-	UNKWN	CAN COMM CIRCUIT (U1000)	-
HVAC	No indication	-	UNKWN	UNKWN	-	-	UNKWN	UNKWN	-	-	-	UNKWN	-	-	-
ALL MODE AWD/4WD	No indication	-	UNKWN	UNKWN	UN KN W N	-	-	-	UNKWN	-	-	UNKWN	-	CAN COMM CIRCUIT (U1000)	-
ABS	-	NG	UNKWN	UNKWN	UN KN W N	-	-	-	UNKWN	-	UNKWN	-	-	CAN COMM CIRCUIT (U1000)	-
IPDM E/R	No indication	-	UNKWN	UNKWN	-	-	-	UNKWN	-	-	-	-	-	CAN COMM CIRCUIT (U1000)	-

PKIC3503E

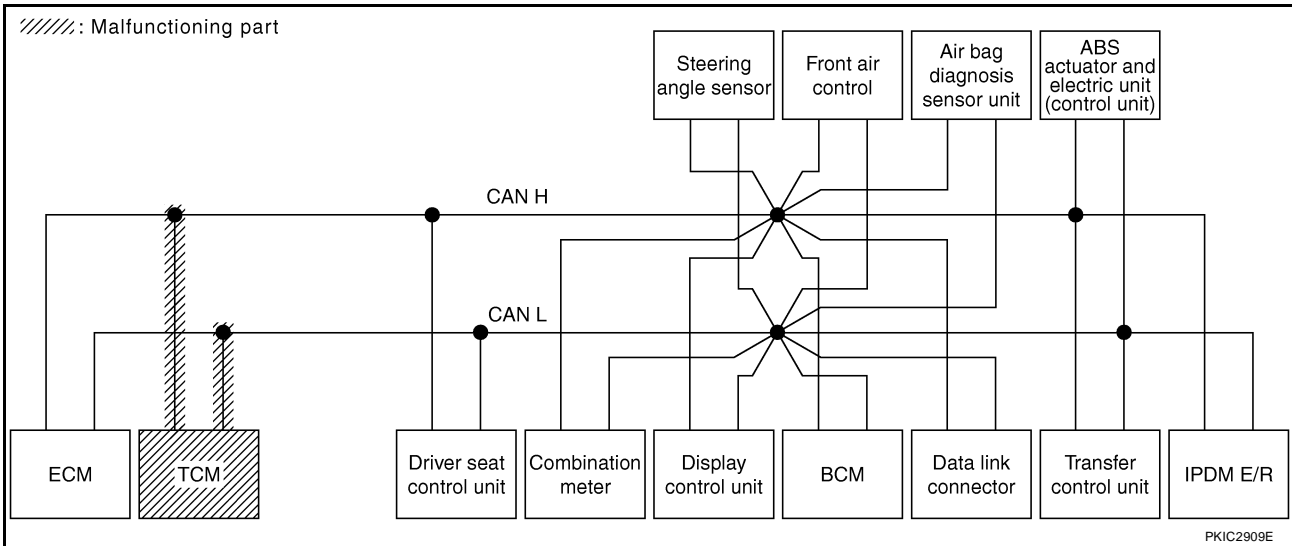

PKIC2909E

CAN SYSTEM (TYPE 6)

[CAN]

Case 6

Check driver seat control unit circuit. Refer to [LAN-146, "Driver Seat Control Unit Circuit Inspection"](#) .

SELECT SYSTEM screen		CAN DIAG SUPPORT MNTR											SELF-DIAG RESULTS		
		Initial diagnosis	Transmit diagnosis	Receive diagnosis											IPDM E/R
				ECM	TCM	METER /M&A	DISPLAY	BCM/SEC	STRG	HVAC	AWD/4WD	VDC/TCS /ABS			
ENGINE	-	-	UNKWN	-	UNKWN	UNKWN	-	UNKWN	-	-	UNKWN	UNKWN	UNKWN	CAN COMM CIRCUIT (U1000)	CAN COMM CIRCUIT (U1001)
A/T	-	NG	UNKWN	UNKWN	-	UNKWN	-	-	-	-	UNKWN	UNKWN	-	CAN COMM CIRCUIT (U1000)	-
AUTO DRIVE POS.	No indication	-	-	-	UNKWN	UNKWN	-	UNKWN	-	-	-	-	-	CAN COMM CIRCUIT (U1000)	-
Display control unit	-	NG	UNKWN	UNKWN	-	UNKWN	-	UNKWN	-	UNKWN	-	-	UNKWN	-	-
BCM	No indication	NG	UNKWN	UNKWN	-	UNKWN	-	-	-	-	-	-	UNKWN	CAN COMM CIRCUIT (U1000)	-
HVAC	No indication	-	UNKWN	UNKWN	-	-	UNKWN	UNKWN	-	-	-	UNKWN	-	-	-
ALL MODE AWD/4WD	No indication	-	UNKWN	UNKWN	UNKWN	-	-	-	UNKWN	-	-	UNKWN	-	CAN COMM CIRCUIT (U1000)	-
ABS	-	NG	UNKWN	UNKWN	UNKWN	-	-	-	UNKWN	-	UNKWN	-	-	CAN COMM CIRCUIT (U1000)	-
IPDM E/R	No indication	-	UNKWN	UNKWN	-	-	-	UNKWN	-	-	-	-	-	CAN COMM CIRCUIT (U1000)	-

PKIC3504E

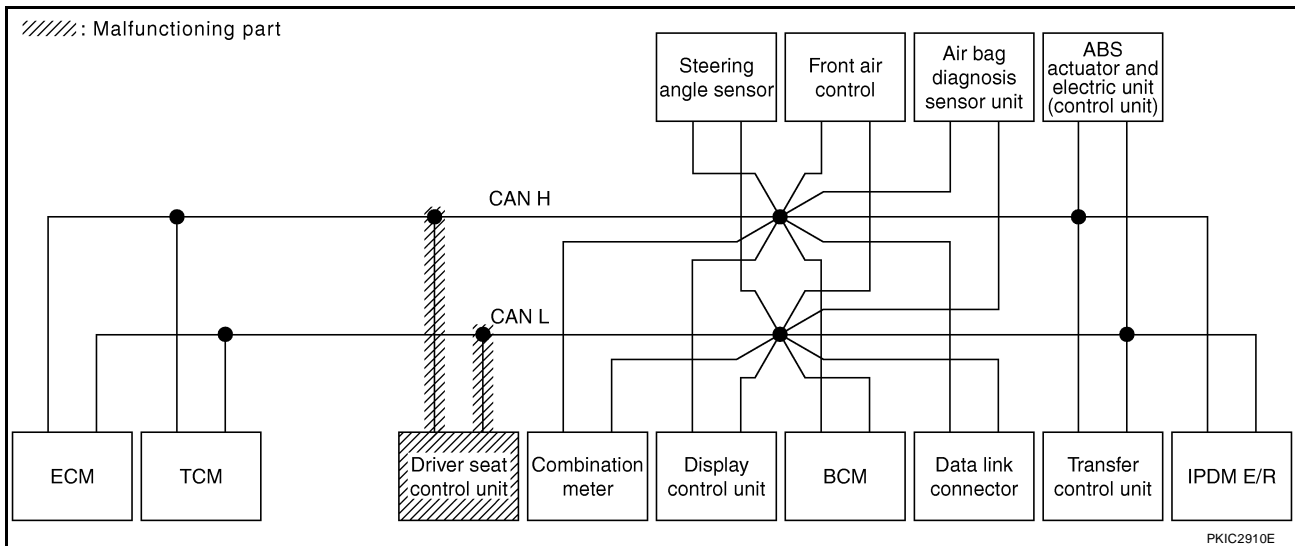

PKIC2910E

CAN SYSTEM (TYPE 6)

[CAN]

Case 7

Check combination meter circuit. Refer to [LAN-147, "Combination Meter Circuit Inspection"](#) .

SELECT SYSTEM screen		CAN DIAG SUPPORT MNTR											SELF-DIAG RESULTS											
		Initial diagnosis	Transmit diagnosis	Receive diagnosis											ECM	TCM	METER /M&A	DISPLAY	BCM/SEC	STRG	HVAC	AWD/4WD	VDC/TCS /ABS	IPDM E/R
				ECM	TCM	METER /M&A	DISPLAY	BCM/SEC	STRG	HVAC	AWD/4WD	VDC/TCS /ABS												
ENGINE	-	-	UNKWN	-	UNKWN	✓	-	UNKWN	-	-	UNKWN	UNKWN	UNKWN	CAN COMM CIRCUIT (U1000)	CAN COMM CIRCUIT (U1001)									
A/T	-	NG	UNKWN	UNKWN	-	✓	-	-	-	-	UNKWN	UNKWN	-	CAN COMM CIRCUIT (U1000)	-									
AUTO DRIVE POS.	No indication	-	-	-	UNKWN	✓	-	UNKWN	-	-	-	-	-	CAN COMM CIRCUIT (U1000)	-									
Display control unit	-	NG	UNKWN	UNKWN	-	✓	-	UNKWN	-	UNKWN	-	-	UNKWN	-	-									
BCM	No indication	NG	UNKWN	UNKWN	-	✓	-	-	-	-	-	-	UNKWN	CAN COMM CIRCUIT (U1000)	-									
HVAC	No indication	-	UNKWN	UNKWN	-	-	-	UNKWN	UNKWN	-	-	UNKWN	-	-	-									
ALL MODE AWD/4WD	No indication	-	UNKWN	UNKWN	UNKWN	-	-	-	UNKWN	-	-	UNKWN	-	CAN COMM CIRCUIT (U1000)	-									
ABS	-	NG	UNKWN	UNKWN	UNKWN	-	-	-	UNKWN	-	UNKWN	-	-	CAN COMM CIRCUIT (U1000)	-									
IPDM E/R	No indication	-	UNKWN	UNKWN	-	-	-	UNKWN	-	-	-	-	-	CAN COMM CIRCUIT (U1000)	-									

PKIC3505E

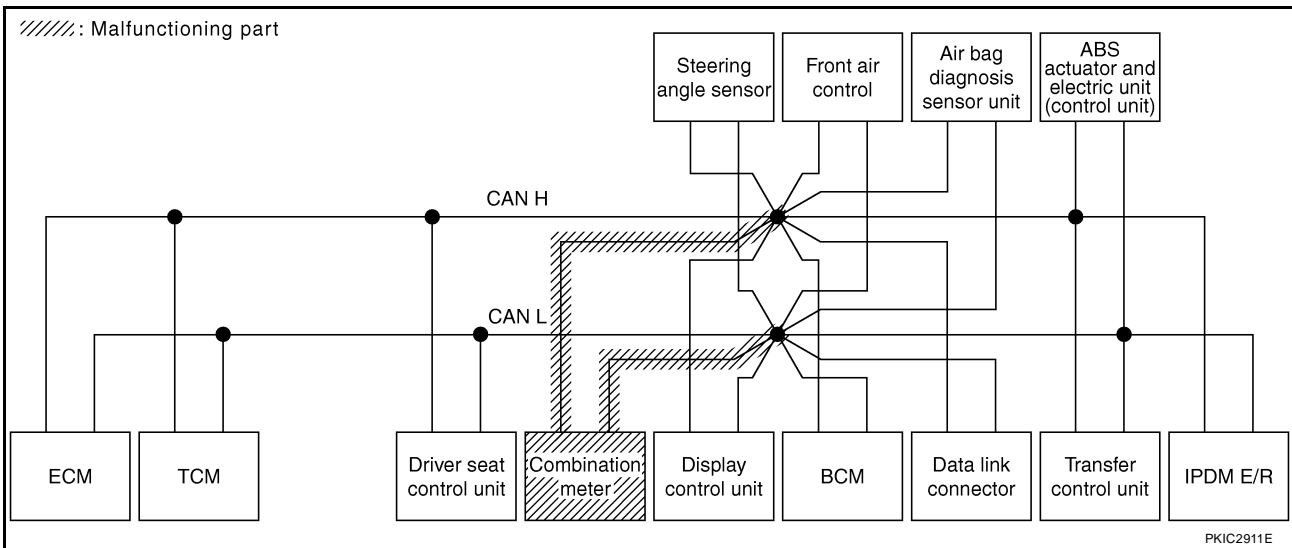

CAN SYSTEM (TYPE 6)

[CAN]

Case 8

Check display control unit circuit. Refer to [LAN-147, "Display Control Unit Circuit Inspection"](#) .

SELECT SYSTEM screen		CAN DIAG SUPPORT MNTR											SELF-DIAG RESULTS		
		Initial diagnosis	Transmit diagnosis	Receive diagnosis											
				ECM	TCM	METER /M&A	DISPLAY	BCM/SEC	STRG	HVAC	AWD/4WD	VDC/TCS /ABS			IPDM E/R
ENGINE	-	-	UNKWN	-	UNKWN	UNKWN	-	UNKWN	-	-	UNKWN	UNKWN	UNKWN	CAN COMM CIRCUIT (U1000)	CAN COMM CIRCUIT (U1001)
A/T	-	NG	UNKWN	UNKWN	-	UNKWN	-	-	-	-	UNKWN	UNKWN	-	CAN COMM CIRCUIT (U1000)	-
AUTO DRIVE POS.	No indication	-	-	-	UNKWN	UNKWN	-	UNKWN	-	-	-	-	-	CAN COMM CIRCUIT (U1000)	-
Display control unit	-	NG	✓	✓	-	✓	-	✓	-	✓	-	-	✓	-	-
BCM	No indication	NG	UNKWN	UNKWN	-	UNKWN	-	-	-	-	-	-	UNKWN	CAN COMM CIRCUIT (U1000)	-
HVAC	No indication	-	UNKWN	UNKWN	-	-	✓	UNKWN	-	-	-	UNKWN	-	-	-
ALL MODE AWD/4WD	No indication	-	UNKWN	UNKWN	UNKWN	-	-	-	UNKWN	-	-	UNKWN	-	CAN COMM CIRCUIT (U1000)	-
ABS	-	NG	UNKWN	UNKWN	UNKWN	-	-	-	UNKWN	-	UNKWN	-	-	CAN COMM CIRCUIT (U1000)	-
IPDM E/R	No indication	-	UNKWN	UNKWN	-	-	-	UNKWN	-	-	-	-	-	CAN COMM CIRCUIT (U1000)	-

PKIC3506E

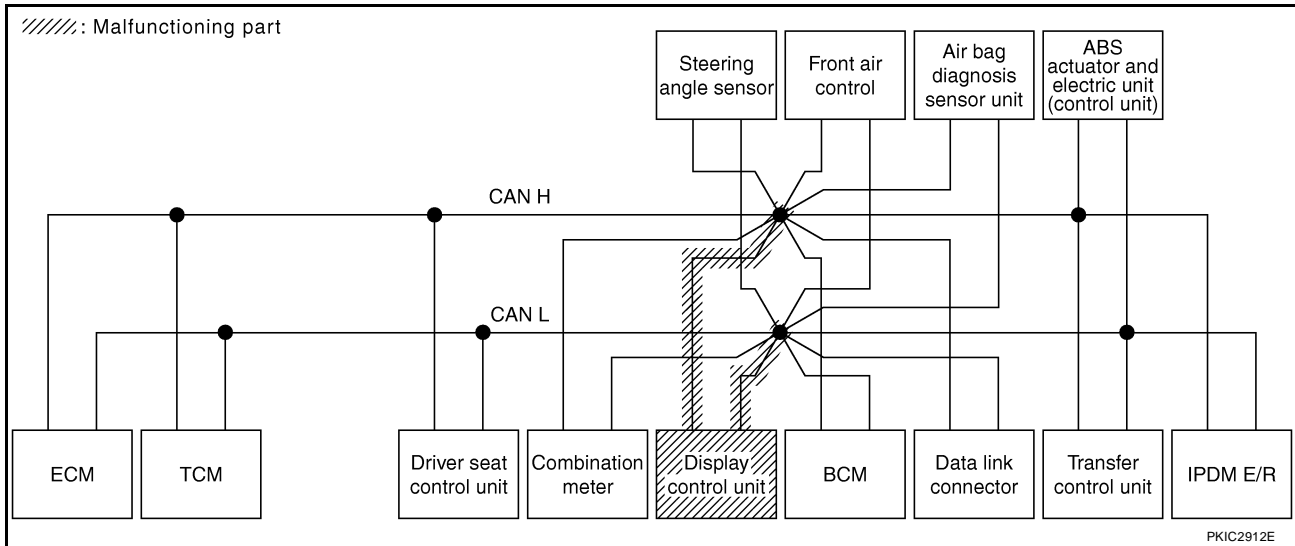

PKIC2912E

CAN SYSTEM (TYPE 6)

[CAN]

Case 9

Check BCM circuit. Refer to [LAN-148, "BCM Circuit Inspection"](#).

SELECT SYSTEM screen		CAN DIAG SUPPORT MNTR											SELF-DIAG RESULTS		
		Initial diagnosis	Transmit diagnosis	Receive diagnosis											IPDM E/R
				ECM	TCM	METER /M&A	DISPLAY	BCM/SEC	STRG	HVAC	AWD/4WD	VDC/TCS /ABS			
ENGINE	-	-	UNKWN	-	UNKWN	UNKWN	-	UN ✓ WN	-	-	UNKWN	UNKWN	UNKWN	CAN COMM CIRCUIT (U1000)	CAN COMM CIRCUIT (U1001)
A/T	-	NG	UNKWN	UNKWN	-	UNKWN	-	-	-	-	UNKWN	UNKWN	-	CAN COMM CIRCUIT (U1000)	-
AUTO DRIVE POS.	No indication	-	-	-	UNKWN	UNKWN	-	UN ✓ WN	-	-	-	-	-	CAN COMM CIRCUIT (U1000)	-
Display control unit	-	NG	UNKWN	UNKWN	-	UNKWN	-	UN ✓ WN	-	UNKWN	-	-	UNKWN	-	-
BCM	No indication	NG	UNKWN	UNKWN	-	UNKWN	-	-	-	-	-	-	UNKWN	CAN COMM CIRCUIT (U1000)	-
HVAC	No indication	-	UNKWN	UNKWN	-	-	UNKWN	UN ✓ WN	-	-	-	UNKWN	-	-	-
ALL MODE AWD/4WD	No indication	-	UNKWN	UNKWN	UNKWN	-	-	-	UNKWN	-	-	UNKWN	-	CAN COMM CIRCUIT (U1000)	-
ABS	-	NG	UNKWN	UNKWN	UNKWN	-	-	-	UNKWN	-	UNKWN	-	-	CAN COMM CIRCUIT (U1000)	-
IPDM E/R	No indication	-	UNKWN	UNKWN	-	-	-	UN ✓ WN	-	-	-	-	-	CAN COMM CIRCUIT (U1000)	-

PKIC3507E

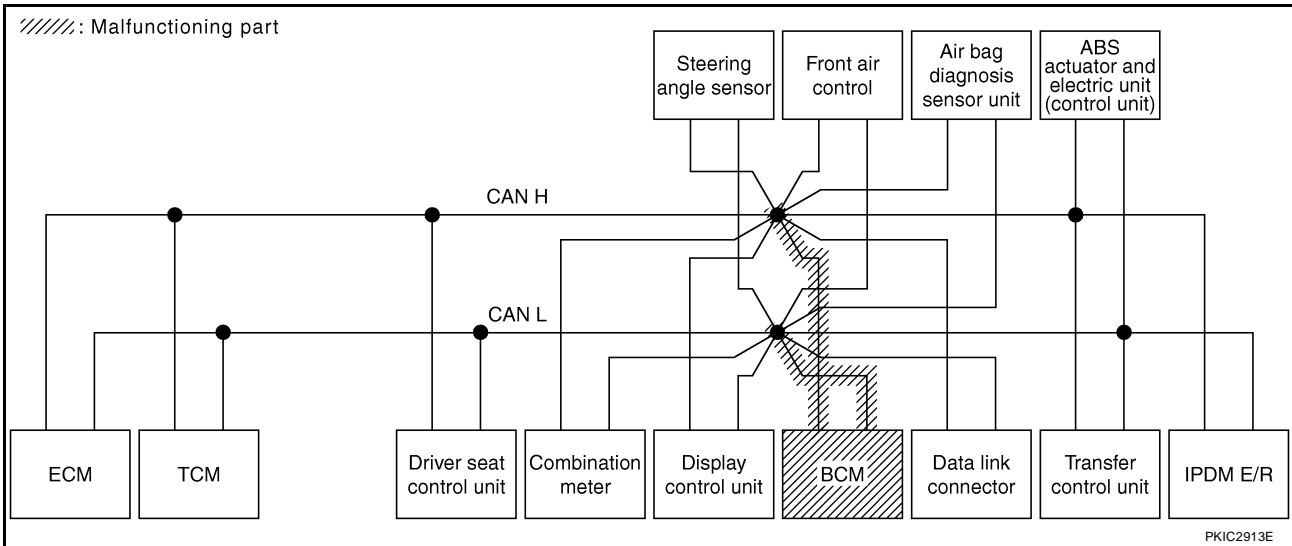

CAN SYSTEM (TYPE 6)

[CAN]

Case 10

Check data link connector circuit. Refer to [LAN-148, "Data Link Connector Circuit Inspection"](#) .

SELECT SYSTEM screen		CAN DIAG SUPPORT MNTR											SELF-DIAG RESULTS		
		Initial diagnosis	Transmit diagnosis	Receive diagnosis											IPDM E/R
				ECM	TCM	METER /M&A	DISPLAY	BCM/SEC	STRG	HVAC	AWD/4WD	VDC/TCS /ABS			
ENGINE	-	-	UNKWN	-	UNKWN	UNKWN	-	UNKWN	-	-	UNKWN	UNKWN	UNKWN	CAN COMM CIRCUIT (U1000)	CAN COMM CIRCUIT (U1001)
A/T	-	NG	UNKWN	UNKWN	-	UNKWN	-	-	-	-	UNKWN	UNKWN	-	CAN COMM CIRCUIT (U1000)	-
AUTO DRIVE POS.	No indication	-	-	-	UNKWN	UNKWN	-	UNKWN	-	-	-	-	-	CAN COMM CIRCUIT (U1000)	-
Display control unit	-	NG	UNKWN	UNKWN	-	UNKWN	-	UNKWN	-	UNKWN	-	-	UNKWN	-	-
BCM	No indication	NG	UNKWN	UNKWN	-	UNKWN	-	-	-	-	-	-	UNKWN	CAN COMM CIRCUIT (U1000)	-
HVAC	No indication	-	UNKWN	UNKWN	-	-	UNKWN	UNKWN	-	-	-	UNKWN	-	-	-
ALL MODE AWD/4WD	No indication	-	UNKWN	UNKWN	UNKWN	-	-	-	UNKWN	-	-	UNKWN	-	CAN COMM CIRCUIT (U1000)	-
ABS	-	NG	UNKWN	UNKWN	UNKWN	-	-	-	UNKWN	-	UNKWN	-	-	CAN COMM CIRCUIT (U1000)	-
IPDM E/R	No indication	-	UNKWN	UNKWN	-	-	-	UNKWN	-	-	-	-	-	CAN COMM CIRCUIT (U1000)	-

PKIC3508E

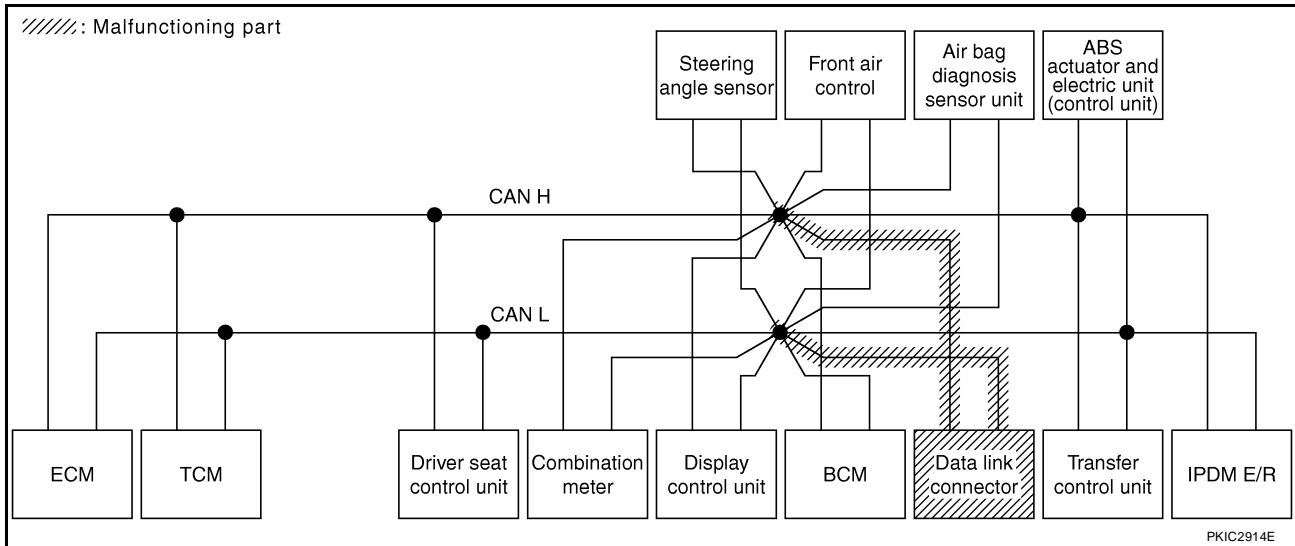

PKIC2914E

CAN SYSTEM (TYPE 6)

[CAN]

Case 11

Check steering angle sensor circuit. Refer to [LAN-149, "Steering Angle Sensor Circuit Inspection"](#).

SELECT SYSTEM screen		CAN DIAG SUPPORT MNTR											SELF-DIAG RESULTS		
		Initial diagnosis	Transmit diagnosis	Receive diagnosis											IPDM E/R
				ECM	TCM	METER /M&A	DISPLAY	BCM/SEC	STRG	HVAC	AWD/4WD	VDC/TCS /ABS			
ENGINE	-	-	UNKWN	-	UNKWN	UNKWN	-	UNKWN	-	-	UNKWN	UNKWN	UNKWN	CAN COMM CIRCUIT (U1000)	CAN COMM CIRCUIT (U1001)
A/T	-	NG	UNKWN	UNKWN	-	UNKWN	-	-	-	-	UNKWN	UNKWN	-	CAN COMM CIRCUIT (U1000)	-
AUTO DRIVE POS.	No indication	-	-	-	UNKWN	UNKWN	-	UNKWN	-	-	-	-	-	CAN COMM CIRCUIT (U1000)	-
Display control unit	-	NG	UNKWN	UNKWN	-	UNKWN	-	UNKWN	-	UNKWN	-	-	UNKWN	-	-
BCM	No indication	NG	UNKWN	UNKWN	-	UNKWN	-	-	-	-	-	-	UNKWN	CAN COMM CIRCUIT (U1000)	-
HVAC	No indication	-	UNKWN	UNKWN	-	-	UNKWN	UNKWN	-	-	-	UNKWN	-	-	-
ALL MODE AWD/4WD	No indication	-	UNKWN	UNKWN	UNKWN	-	-	-	UNKWN	-	-	UNKWN	-	CAN COMM CIRCUIT (U1000)	-
ABS	-	NG	UNKWN	UNKWN	UNKWN	-	-	-	UNKWN	-	UNKWN	-	-	CAN COMM CIRCUIT (U1000)	-
IPDM E/R	No indication	-	UNKWN	UNKWN	-	-	-	UNKWN	-	-	-	-	-	CAN COMM CIRCUIT (U1000)	-

PKIC3509E

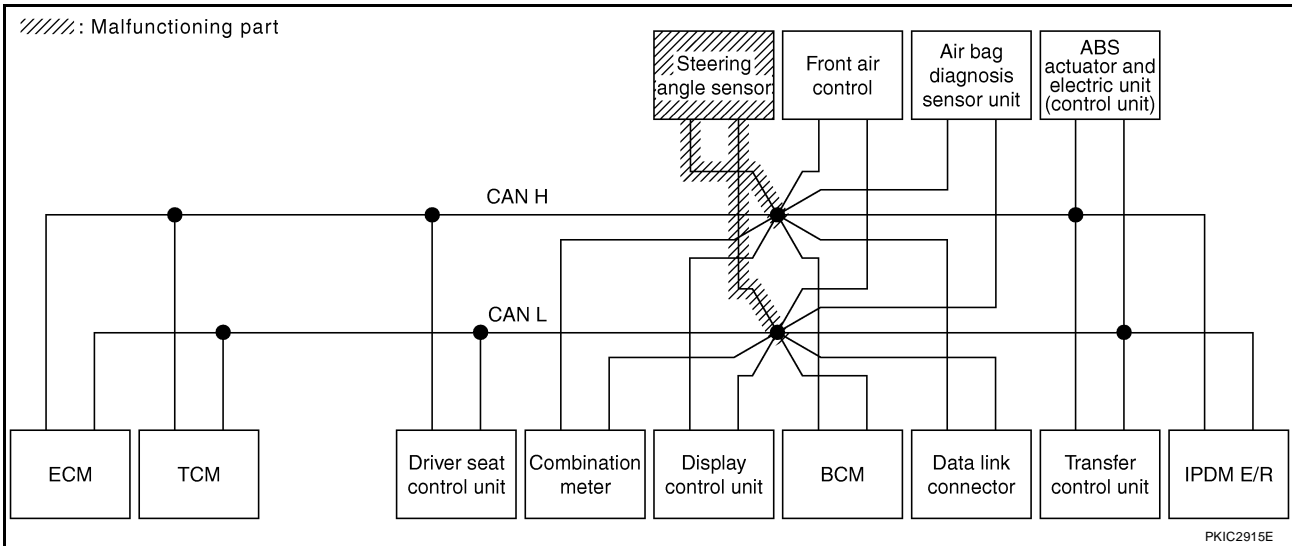

PKIC2915E

CAN SYSTEM (TYPE 6)

[CAN]

Case 12

Check front air control circuit. Refer to [LAN-149, "Front Air Control Circuit Inspection"](#) .

SELECT SYSTEM screen		CAN DIAG SUPPORT MNTR											SELF-DIAG RESULTS		
		Initial diagnosis	Transmit diagnosis	Receive diagnosis											
				ECM	TCM	METER /M&A	DISPLAY	BCM/SEC	STRG	HVAC	AWD/4WD	VDC/TCS /ABS			IPDM E/R
ENGINE	-	-	UNKWN	-	UNKWN	UNKWN	-	UNKWN	-	-	UNKWN	UNKWN	UNKWN	CAN COMM CIRCUIT (U1000)	CAN COMM CIRCUIT (U1001)
A/T	-	NG	UNKWN	UNKWN	-	UNKWN	-	-	-	-	UNKWN	UNKWN	-	CAN COMM CIRCUIT (U1000)	-
AUTO DRIVE POS.	No indication	-	-	-	UNKWN	UNKWN	-	UNKWN	-	-	-	-	-	CAN COMM CIRCUIT (U1000)	-
Display control unit	-	NG	UNKWN	UNKWN	-	UNKWN	-	UNKWN	-	UNKWN	-	UNKWN	-	-	-
BCM	No indication	NG	UNKWN	UNKWN	-	UNKWN	-	-	-	-	-	-	UNKWN	CAN COMM CIRCUIT (U1000)	-
HVAC	No indication	-	UNKWN	UNKWN	-	-	UNKWN	UNKWN	-	-	-	UNKWN	-	-	-
ALL MODE AWD/4WD	No indication	-	UNKWN	UNKWN	UNKWN	-	-	-	UNKWN	-	-	UNKWN	-	CAN COMM CIRCUIT (U1000)	-
ABS	-	NG	UNKWN	UNKWN	UNKWN	-	-	-	UNKWN	-	UNKWN	-	-	CAN COMM CIRCUIT (U1000)	-
IPDM E/R	No indication	-	UNKWN	UNKWN	-	-	-	UNKWN	-	-	-	-	-	CAN COMM CIRCUIT (U1000)	-

PKIC3510E

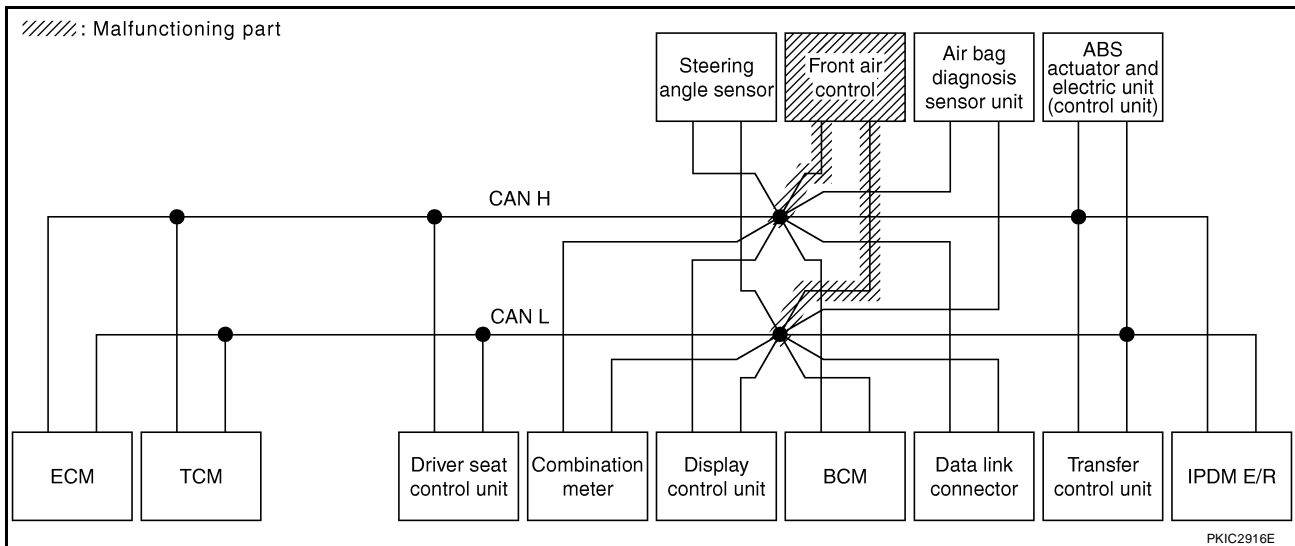

PKIC2916E

CAN SYSTEM (TYPE 6)

[CAN]

Case 13

Check transfer control unit circuit. Refer to [LAN-150, "Transfer Control Unit Circuit Inspection"](#).

SELECT SYSTEM screen		CAN DIAG SUPPORT MNTR												SELF-DIAG RESULTS	
		Initial diagnosis	Transmit diagnosis	Receive diagnosis											
				ECM	TCM	METER /M&A	DISPLAY	BCM/SEC	STRG	HVAC	AWD/4WD	VDC/TCS /ABS	IPDM E/R		
ENGINE	-	-	UNKWN	-	UNKWN	UNKWN	-	UNKWN	-	-	UNKWN	UNKWN	UNKWN	CAN COMM CIRCUIT (U1000)	CAN COMM CIRCUIT (U1001)
A/T	-	NG	UNKWN	UNKWN	-	UNKWN	-	-	-	-	UNKWN	UNKWN	-	CAN COMM CIRCUIT (U1000)	-
AUTO DRIVE POS.	No indication	-	-	-	UNKWN	UNKWN	-	UNKWN	-	-	-	-	-	CAN COMM CIRCUIT (U1000)	-
Display control unit	-	NG	UNKWN	UNKWN	-	UNKWN	-	UNKWN	-	UNKWN	-	-	UNKWN	-	-
BCM	No indication	NG	UNKWN	UNKWN	-	UNKWN	-	-	-	-	-	-	UNKWN	CAN COMM CIRCUIT (U1000)	-
HVAC	No indication	-	UNKWN	UNKWN	-	-	UNKWN	UNKWN	-	-	-	UNKWN	-	-	-
ALL MODE AWD/4WD	No indication	-	UNKWN	UNKWN	UNKWN	-	-	-	UNKWN	-	-	UNKWN	-	CAN COMM CIRCUIT (U1000)	-
ABS	-	NG	UNKWN	UNKWN	UNKWN	-	-	-	UNKWN	-	UNKWN	-	-	CAN COMM CIRCUIT (U1000)	-
IPDM E/R	No indication	-	UNKWN	UNKWN	-	-	-	UNKWN	-	-	-	-	-	CAN COMM CIRCUIT (U1000)	-

PKIC3511E

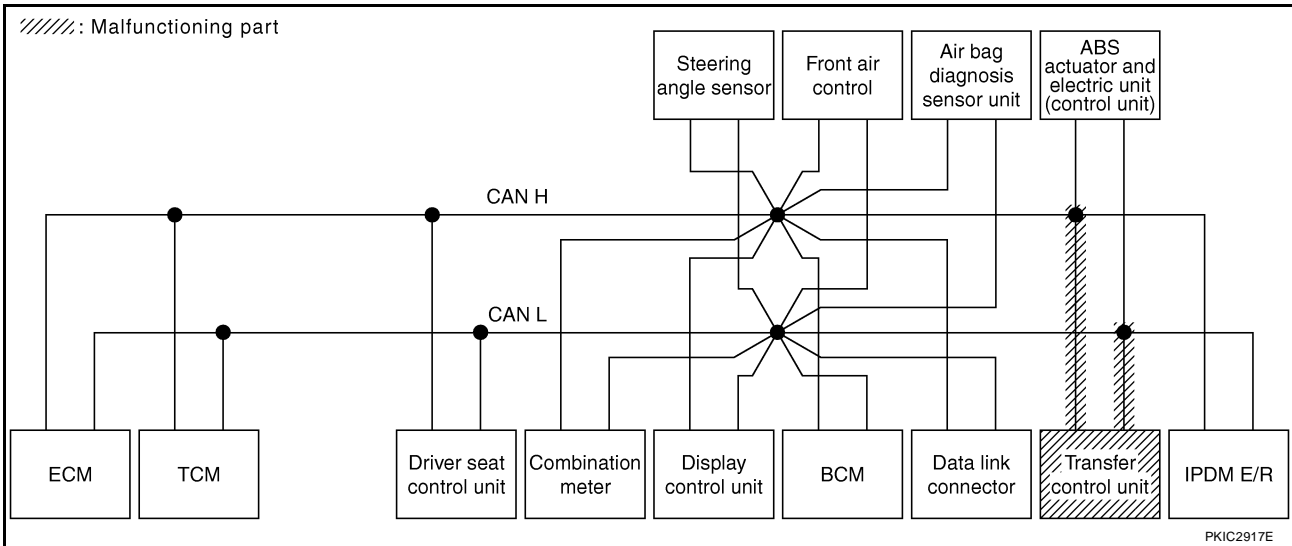

CAN SYSTEM (TYPE 6)

[CAN]

Case 14

Check ABS actuator and electric unit (control unit) circuit. Refer to [LAN-151, "ABS Actuator and Electric Unit \(Control Unit\) Circuit Inspection"](#) .

SELECT SYSTEM screen		CAN DIAG SUPPORT MNTR											SELF-DIAG RESULTS				
		Initial diagnosis	Transmit diagnosis	Receive diagnosis													
				ECM	TCM	METER /M&A	DISPLAY	BCM/SEC	STRG	HVAC	AWD/4WD	VDC/TCS /ABS			IPDM E/R		
ENGINE	-	-	UNKWN	-	UNKWN	UNKWN	-	UNKWN	-	-	UNKWN	UNKWN	UNKWN	UNKWN	UNKWN	CAN COMM CIRCUIT (U1000)	CAN COMM CIRCUIT (U1001)
A/T	-	NG	UNKWN	UNKWN	-	UNKWN	-	-	-	-	UNKWN	UNKWN	-	-	CAN COMM CIRCUIT (U1000)	-	
AUTO DRIVE POS.	No indication	-	-	-	UNKWN	UNKWN	-	UNKWN	-	-	-	-	-	-	CAN COMM CIRCUIT (U1000)	-	
Display control unit	-	NG	UNKWN	UNKWN	-	UNKWN	-	UNKWN	-	UNKWN	-	-	UNKWN	-	-	-	
BCM	No indication	NG	UNKWN	UNKWN	-	UNKWN	-	-	-	-	-	-	UNKWN	-	CAN COMM CIRCUIT (U1000)	-	
HVAC	No indication	-	UNKWN	UNKWN	-	-	UNKWN	UNKWN	-	-	-	UNKWN	-	-	-	-	
ALL MODE AWD/4WD	No indication	-	UNKWN	UNKWN	UNKWN	-	-	-	UNKWN	-	-	UNKWN	-	-	CAN COMM CIRCUIT (U1000)	-	
ABS	-	NG	UNKWN	UNKWN	UNKWN	-	-	-	UNKWN	-	UNKWN	-	-	-	CAN COMM CIRCUIT (U1000)	-	
IPDM E/R	No indication	-	UNKWN	UNKWN	-	-	-	UNKWN	-	-	-	-	-	-	CAN COMM CIRCUIT (U1000)	-	

PKIC3512E

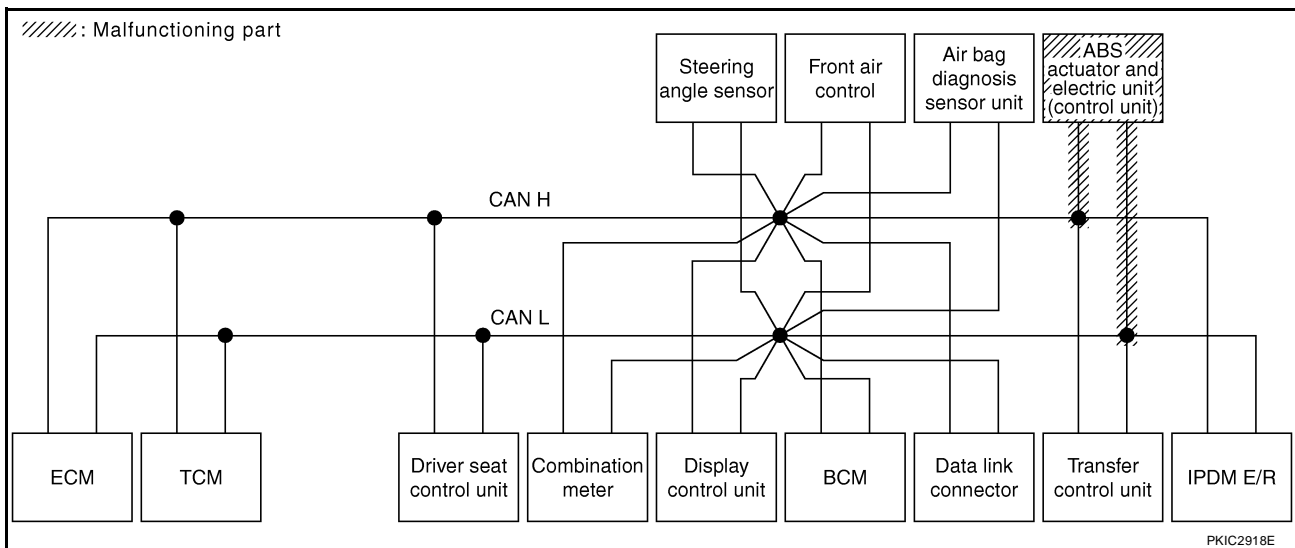

PKIC2918E

CAN SYSTEM (TYPE 6)

[CAN]

Case 15

Check IPDM E/R circuit. Refer to [LAN-151, "IPDM E/R Circuit Inspection"](#) .

SELECT SYSTEM screen		CAN DIAG SUPPORT MNTR											SELF-DIAG RESULTS		
		Initial diagnosis	Transmit diagnosis	Receive diagnosis											IPDM E/R
				ECM	TCM	METER /M&A	DISPLAY	BCM/SEC	STRG	HVAC	AWD/4WD	VDC/TCS /ABS			
ENGINE	-	-	UNKWN	-	UNKWN	UNKWN	-	UNKWN	-	-	UNKWN	UNKWN	UNKWN	CAN COMM CIRCUIT (U1000)	CAN COMM CIRCUIT (U1001)
A/T	-	NG	UNKWN	UNKWN	-	UNKWN	-	-	-	-	UNKWN	UNKWN	-	CAN COMM CIRCUIT (U1000)	-
AUTO DRIVE POS.	No indication	-	-	-	UNKWN	UNKWN	-	UNKWN	-	-	-	-	-	CAN COMM CIRCUIT (U1000)	-
Display control unit	-	NG	UNKWN	UNKWN	-	UNKWN	-	UNKWN	-	UNKWN	-	-	UNKWN	-	-
BCM	No indication	NG	UNKWN	UNKWN	-	UNKWN	-	-	-	-	-	-	UNKWN	CAN COMM CIRCUIT (U1000)	-
HVAC	No indication	-	UNKWN	UNKWN	-	-	UNKWN	UNKWN	-	-	-	UNKWN	-	-	-
ALL MODE AWD/4WD	No indication	-	UNKWN	UNKWN	UNKWN	-	-	-	UNKWN	-	-	UNKWN	-	CAN COMM CIRCUIT (U1000)	-
ABS	-	NG	UNKWN	UNKWN	UNKWN	-	-	-	UNKWN	-	UNKWN	-	-	CAN COMM CIRCUIT (U1000)	-
IPDM E/R	No indication	-	UNKWN	UNKWN	-	-	-	UNKWN	-	-	-	-	-	CAN COMM CIRCUIT (U1000)	-

PKIC3513E

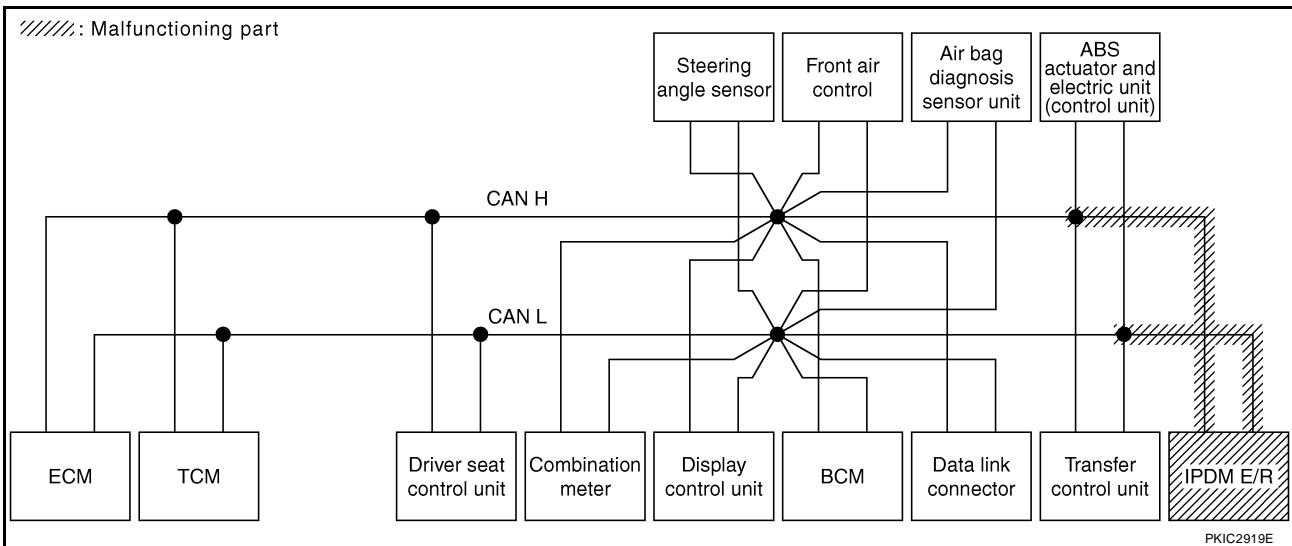

Case 16

Check CAN communication circuit. Refer to [LAN-152, "CAN Communication Circuit Inspection"](#) .

SELECT SYSTEM screen		CAN DIAG SUPPORT MNTR											SELF-DIAG RESULTS		
		Initial diagnosis	Transmit diagnosis	Receive diagnosis											IPDM E/R
				ECM	TCM	METER /M&A	DISPLAY	BCM/SEC	STRG	HVAC	AWD/4WD	VDC/TCS /ABS			
ENGINE	-	-	UNKWN	-	UNKWN	UNKWN	-	UNKWN	-	-	UNKWN	UNKWN	UNKWN	CAN COMM CIRCUIT (U1000)	CAN COMM CIRCUIT (U1001)
A/T	-	NG	UNKWN	UNKWN	-	UNKWN	-	-	-	-	UNKWN	UNKWN	-	CAN COMM CIRCUIT (U1000)	-
AUTO DRIVE POS.	No indication	-	-	-	UNKWN	UNKWN	-	UNKWN	-	-	-	-	-	CAN COMM CIRCUIT (U1000)	-
Display control unit	-	NG	UNKWN	UNKWN	-	UNKWN	-	UNKWN	-	UNKWN	-	-	UNKWN	-	-
BCM	No indication	NG	UNKWN	UNKWN	-	UNKWN	-	-	-	-	-	-	UNKWN	CAN COMM CIRCUIT (U1000)	-
HVAC	No indication	-	UNKWN	UNKWN	-	-	UNKWN	UNKWN	-	-	-	UNKWN	-	-	-
ALL MODE AWD/4WD	No indication	-	UNKWN	UNKWN	UNKWN	-	-	-	UNKWN	-	-	UNKWN	-	CAN COMM CIRCUIT (U1000)	-
ABS	-	NG	UNKWN	UNKWN	UNKWN	-	-	-	UNKWN	-	UNKWN	-	-	CAN COMM CIRCUIT (U1000)	-
IPDM E/R	No indication	-	UNKWN	UNKWN	-	-	-	UNKWN	-	-	-	-	-	CAN COMM CIRCUIT (U1000)	-

PKIC3514E

CAN SYSTEM (TYPE 6)

[CAN]

Case 17

Check IPDM E/R ignition relay circuit continuously sticks "OFF". Refer to [LAN-153, "IPDM E/R Ignition Relay Circuit Inspection"](#) .

SELECT SYSTEM screen		CAN DIAG SUPPORT MNTR											SELF-DIAG RESULTS				
		Initial diagnosis	Transmit diagnosis	Receive diagnosis											IPDM E/R		
				ECM	TCM	METER /M&A	DISPLAY	BCM/SEC	STRG	HVAC	AWD/4WD	VDC/TCS /ABS					
ENGINE	-	-	UNKWN	-	UNKWN	UNKWN	-	UNKWN	-	-	UNKWN	UNKWN	UNKWN	UNKWN	UNKWN	CAN COMM CIRCUIT (U1000)	CAN COMM CIRCUIT (U1001)
A/T	-	NG	UNKWN	UNKWN	-	UNKWN	-	-	-	-	UNKWN	UNKWN	-	-	-	CAN COMM CIRCUIT (U1000)	-
AUTO DRIVE POS.	No indication	-	-	-	UNKWN	UNKWN	-	UNKWN	-	-	-	-	-	-	-	CAN COMM CIRCUIT (U1000)	-
Display control unit	-	NG	UNKWN	UNKWN	-	UNKWN	-	UNKWN	-	UNKWN	-	-	UNKWN	-	-	-	-
BCM	No indication	NG	UNKWN	UNKWN	-	UNKWN	-	-	-	-	-	-	UNKWN	-	-	CAN COMM CIRCUIT (U1000)	-
HVAC	No indication	-	UNKWN	UNKWN	-	-	UNKWN	UNKWN	-	-	-	UNKWN	-	-	-	-	-
ALL MODE AWD/4WD	No indication	-	UNKWN	UNKWN	UNKWN	-	-	-	UNKWN	-	-	UNKWN	-	-	-	CAN COMM CIRCUIT (U1000)	-
ABS	-	NG	UNKWN	UNKWN	UNKWN	-	-	-	UNKWN	-	UNKWN	-	-	-	-	CAN COMM CIRCUIT (U1000)	-
IPDM E/R	No indication	-	UNKWN	UNKWN	-	-	-	UNKWN	-	-	-	-	-	-	-	CAN COMM CIRCUIT (U1000)	-

PKIC3515E

Case 18

Check IPDM E/R ignition relay circuit continuously sticks "ON". Refer to [LAN-153, "IPDM E/R Ignition Relay Circuit Inspection"](#) .

SELECT SYSTEM screen		CAN DIAG SUPPORT MNTR											SELF-DIAG RESULTS				
		Initial diagnosis	Transmit diagnosis	Receive diagnosis											IPDM E/R		
				ECM	TCM	METER /M&A	DISPLAY	BCM/SEC	STRG	HVAC	AWD/4WD	VDC/TCS /ABS					
ENGINE	-	-	UNKWN	-	UNKWN	UNKWN	-	UNKWN	-	-	UNKWN	UNKWN	UNKWN	UNKWN	UNKWN	CAN COMM CIRCUIT (U1000)	CAN COMM CIRCUIT (U1001)
A/T	-	NG	UNKWN	-	-	-	-	-	-	-	-	UNKWN	-	-	-	CAN COMM CIRCUIT (U1000)	-
AUTO DRIVE POS.	No indication	-	-	-	UNKWN	UNKWN	-	UNKWN	-	-	-	-	-	-	-	CAN COMM CIRCUIT (U1000)	-
Display control unit	-	NG	UNKWN	UNKWN	-	UNKWN	-	UNKWN	-	UNKWN	-	-	UNKWN	-	-	-	-
BCM	No indication	NG	UNKWN	UNKWN	-	UNKWN	-	-	-	-	-	-	UNKWN	-	-	CAN COMM CIRCUIT (U1000)	-
HVAC	No indication	-	UNKWN	UNKWN	-	-	UNKWN	UNKWN	-	-	-	UNKWN	-	-	-	-	-
ALL MODE AWD/4WD	No indication	-	UNKWN	UNKWN	UNKWN	-	-	-	UNKWN	-	-	UNKWN	-	-	-	CAN COMM CIRCUIT (U1000)	-
ABS	-	NG	UNKWN	-	UNKWN	-	-	-	-	-	-	-	-	-	-	CAN COMM CIRCUIT (U1000)	-
IPDM E/R	No indication	-	UNKWN	UNKWN	-	-	-	UNKWN	-	-	-	-	-	-	-	CAN COMM CIRCUIT (U1000)	-

PKIC3516E

TROUBLE DIAGNOSIS FOR SYSTEM

PF0:00000

Inspection Between TCM and Driver Seat Control Unit Circuit

UKS004RG

1. CHECK CONNECTOR

1. Turn ignition switch OFF.
2. Disconnect the battery cable from the negative terminal.
3. Check following terminals and connectors for damage, bend and loose connection (connector side and harness side).
 - Harness connector F14
 - Harness connector E5
 - Harness connector E34
 - Harness connector B40

OK or NG

- OK >> GO TO 2.
- NG >> Repair terminal or connector.

2. CHECK HARNESS FOR OPEN CIRCUIT

1. Disconnect A/T assembly connector and harness connector F14.
2. Check continuity between A/T assembly harness connector (A) and harness connector (B).

A		B		Continuity
Connector	Terminal	Connector	Terminal	
F9	3	F14	5	Yes
	8		15	Yes

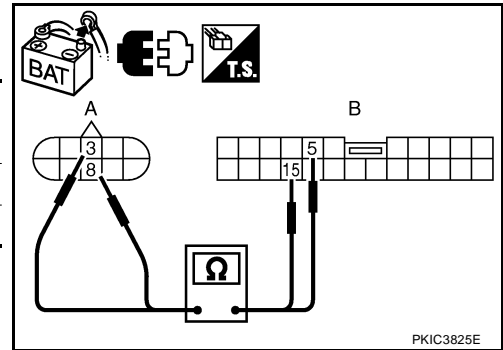

OK or NG

- OK >> GO TO 3.
- NG >> Repair harness.

3. CHECK HARNESS FOR OPEN CIRCUIT

1. Disconnect harness connector E34.
2. Check continuity between harness connector (A) and harness connector (B).

A		B		Continuity
Connector	Terminal	Connector	Terminal	
E5	5	E34	24	Yes
	15		23	Yes

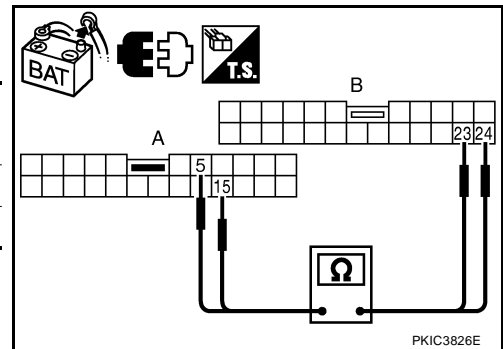

OK or NG

- OK >> GO TO 4.
- NG >> Repair harness.

A
B
C
D
E
F
G
H
I
J
LAN
L
M

4. CHECK HARNESS FOR OPEN CIRCUIT

1. Disconnect harness connector B37.
2. Check continuity between harness connector (A) and harness connector (B).

A		B		Continuity
Connector	Terminal	Connector	Terminal	
B40	24	B37	15	Yes
	23		14	Yes

OK or NG

- OK >> Connect all the connectors and diagnose again. Refer to [LAN-5, "TROUBLE DIAGNOSES WORK FLOW"](#).
- NG >> Repair harness.

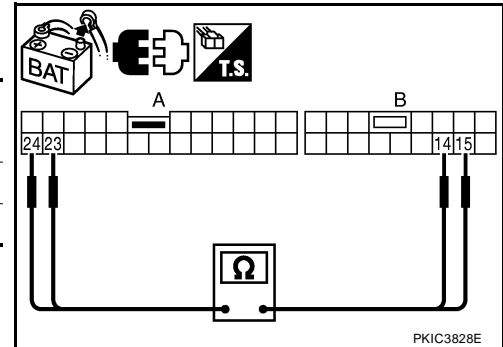

Inspection Between TCM and Data Link Connector Circuit

UKS004RH

1. CHECK CONNECTOR

1. Turn ignition switch OFF.
2. Disconnect the battery cable from the negative terminal.
3. Check following terminals and connectors for damage, bend and loose connection (connector side and harness side).
 - Harness connector F14
 - Harness connector E5
 - Harness connector E34
 - Harness connector B40
 - Harness connector B69
 - Harness connector M40

OK or NG

- OK >> GO TO 2.
- NG >> Repair terminal or connector.

2. CHECK HARNESS FOR OPEN CIRCUIT

1. Disconnect A/T assembly connector and harness connector F14.
2. Check continuity between A/T assembly harness connector (A) and harness connector (B).

A		B		Continuity
Connector	Terminal	Connector	Terminal	
F9	3	F14	5	Yes
	8		15	Yes

OK or NG

- OK >> GO TO 3.
- NG >> Repair harness.

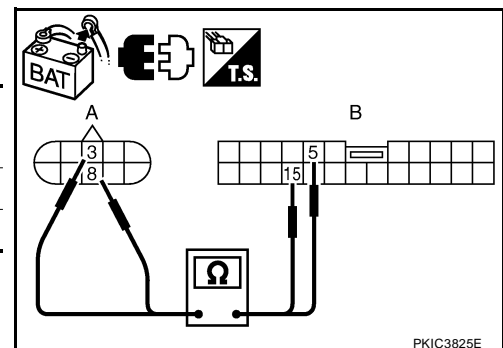

3. CHECK HARNESS FOR OPEN CIRCUIT

1. Disconnect harness connector E34.
2. Check continuity between harness connector (A) and harness connector (B).

A		B		Continuity
Connector	Terminal	Connector	Terminal	
E5	5	E34	24	Yes
	15		23	Yes

OK or NG

- OK >> GO TO 4.
- NG >> Repair harness.

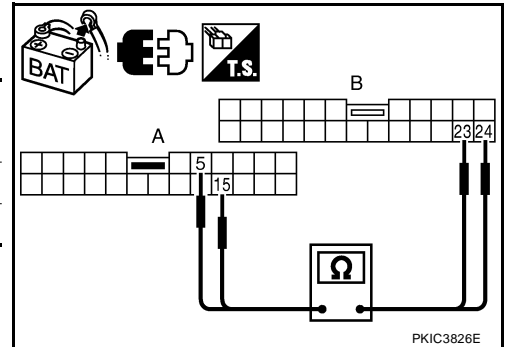

4. CHECK HARNESS FOR OPEN CIRCUIT

1. Disconnect harness connector B69.
2. Check continuity between harness connector (A) and harness connector (B).

A		B		Continuity
Connector	Terminal	Connector	Terminal	
B40	24	B69	51J	Yes
	23		52J	Yes

OK or NG

- OK >> GO TO 5.
- NG >> Repair harness.

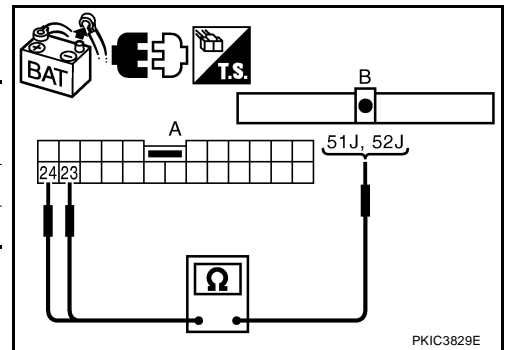

5. CHECK HARNESS FOR OPEN CIRCUIT

Check continuity between harness connector (A) and data link connector (B).

A		B		Continuity
Connector	Terminal	Connector	Terminal	
M40	51J	M22	6	Yes
	52J		14	Yes

OK or NG

- OK >> Connect all the connectors and diagnose again. Refer to [LAN-5, "TROUBLE DIAGNOSES WORK FLOW"](#).
- NG >> Repair harness.

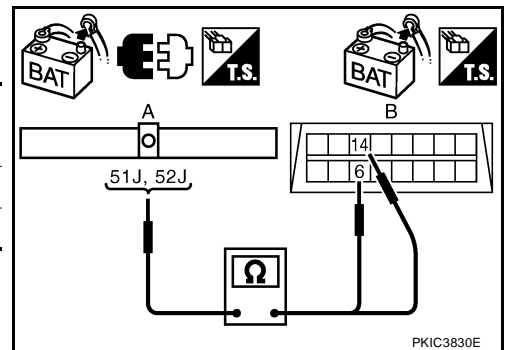

Inspection Between Driver Seat Control Unit and Data Link Connector Circuit

UKS004RK

1. CHECK CONNECTOR

1. Turn ignition switch OFF.
2. Disconnect the battery cable from the negative terminal.
3. Check following terminals and connectors for damage, bend and loose connection (connector side and harness side).
 - Harness connector B69
 - Harness connector M40

OK or NG

- OK >> GO TO 2.
- NG >> Repair terminal or connector.

A
B
C
D
E
F
G
H
I
J
L
M

LAN

2. CHECK HARNESS FOR OPEN CIRCUIT

1. Disconnect harness connector B37 and harness connector B69.
2. Check continuity between harness connector (A) and harness connector (B).

A		B		Continuity
Connector	Terminal	Connector	Terminal	
B37	15	B69	51J	Yes
	14		52J	Yes

OK or NG

- OK >> GO TO 3.
- NG >> Repair harness.

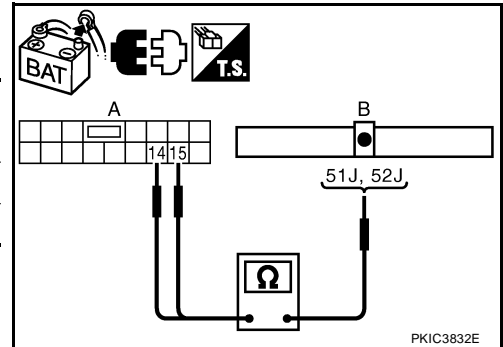

3. CHECK HARNESS FOR OPEN CIRCUIT

Check continuity between harness connector (A) and data link connector (B).

A		B		Continuity
Connector	Terminal	Connector	Terminal	
M40	51J	M22	6	Yes
	52J		14	Yes

OK or NG

- OK >> Connect all the connectors and diagnose again. Refer to [LAN-5, "TROUBLE DIAGNOSES WORK FLOW"](#).
- NG >> Repair harness.

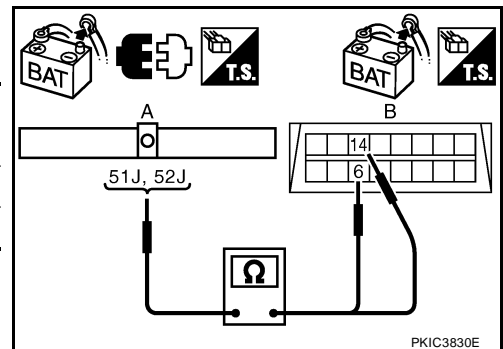

Inspection Between Data Link Connector and ABS Actuator and Electric Unit (Control Unit) Circuit

UKS004RL

1. CHECK CONNECTOR

1. Turn ignition switch OFF.
2. Disconnect the battery cable from the negative terminal.
3. Check following terminals and connectors for damage, bend and loose connection (connector side and harness side).
 - Harness connector M31
 - Harness connector E152

OK or NG

- OK >> GO TO 2.
- NG >> Repair terminal or connector.

2. CHECK HARNESS FOR OPEN CIRCUIT

1. Disconnect harness connector M31.
2. Check continuity between data link connector (A) and harness connector (B).

A		B		Continuity
Connector	Terminal	Connector	Terminal	
M22	6	M31	31G	Yes
	14		42G	Yes

OK or NG

- OK >> GO TO 3.
- NG >> Repair harness.

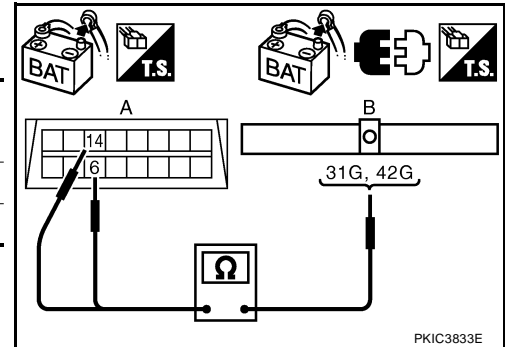

3. CHECK HARNESS FOR OPEN CIRCUIT

1. Disconnect ABS actuator and electric unit (control unit) connector.
2. Check continuity between harness connector (A) and ABS actuator and electric unit (control unit) connector (B).

A		B		Continuity
Connector	Terminal	Connector	Terminal	
E152	31G	E125	11	Yes
	42G		15	Yes

OK or NG

- OK >> Connect all the connectors and diagnose again. Refer to [LAN-5, "TROUBLE DIAGNOSES WORK FLOW"](#).
- NG >> Repair harness.

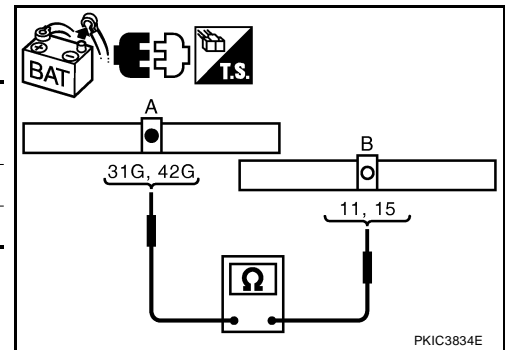

ECM Circuit Inspection

1. CHECK CONNECTOR

1. Turn ignition switch OFF.
2. Disconnect the battery cable from the negative terminal.
3. Check following terminals and connectors for damage, bend and loose connection (control module side and harness side).
 - ECM connector
 - Harness connector E5
 - Harness connector F14

OK or NG

- OK >> GO TO 2.
- NG >> Repair terminal or connector.

A
B
C
D
E
F
G
H
I
J

LAN

L
M

2. CHECK HARNESS FOR OPEN CIRCUIT

1. Disconnect ECM connector.
2. Check resistance between ECM harness connector terminals.

ECM connector	Terminal		Resistance (Approx.)
E16	94	86	108 – 132 Ω

OK or NG

- OK >> Replace ECM.
- NG >> Repair harness between ECM and A/T assembly.

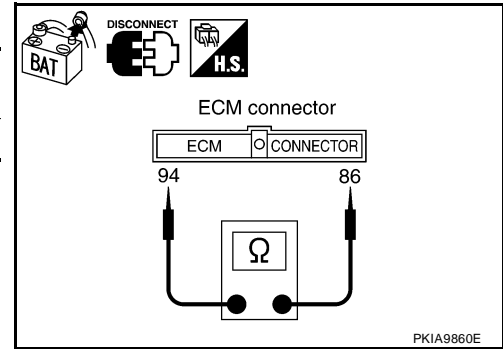

UKS004RN

TCM Circuit Inspection

1. CHECK CONNECTOR

1. Turn ignition switch OFF.
2. Disconnect the battery cable from the negative terminal.
3. Check terminals and connector of A/T assembly for damage, bend and loose connection (control module side and harness side).

OK or NG

- OK >> GO TO 2.
- NG >> Repair terminal or connector.

2. CHECK HARNESS FOR OPEN CIRCUIT

1. Disconnect A/T assembly connector.
2. Check resistance between A/T assembly harness connector terminals.

A/T assembly connector	Terminal		Resistance (Approx.)
F9	3	8	54 – 66 Ω

OK or NG

- OK >> Replace control valve with TCM.
- NG >> Repair harness between A/T assembly and harness connector F14.

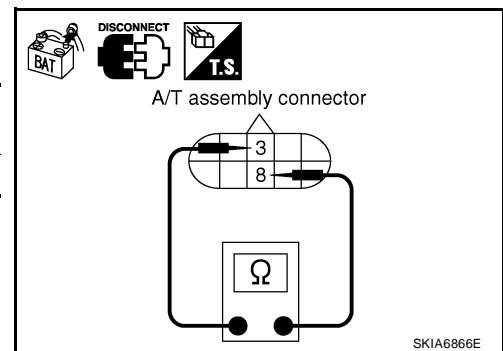

UKS004RP

Driver Seat Control Unit Circuit Inspection

1. CHECK CONNECTOR

1. Turn ignition switch OFF.
2. Disconnect the battery cable from the negative terminal.
3. Check following terminals and connectors for damage, bend and loose connection (control unit side and harness side).
 - Driver seat control unit connector
 - Harness connector P1
 - Harness connector B37

OK or NG

- OK >> GO TO 2.
- NG >> Repair terminal or connector.

2. CHECK HARNESS FOR OPEN CIRCUIT

1. Disconnect driver seat control unit connector.
2. Check resistance between driver seat control unit harness connector terminals.

Driver seat control unit connector	Terminal		Resistance (Approx.)
P2	3	19	54 – 66 Ω

OK or NG

- OK >> Replace driver seat control unit.
- NG >> Repair harness between driver seat control unit and harness connector B69.

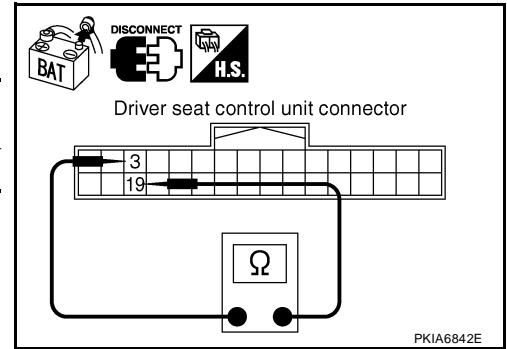

UKS004RQ

Combination Meter Circuit Inspection

1. CHECK CONNECTOR

1. Turn ignition switch OFF.
2. Disconnect the battery cable from the negative terminal.
3. Check terminals and connector of combination meter for damage, bend and loose connection (meter side and harness side).

OK or NG

- OK >> GO TO 2.
- NG >> Repair terminal or connector.

2. CHECK HARNESS FOR OPEN CIRCUIT

1. Disconnect combination meter connector.
2. Check resistance between combination meter harness connector terminals.

Combination meter connector	Terminal		Resistance (Approx.)
M24	11	12	54 – 66 Ω

OK or NG

- OK >> Replace combination meter.
- NG >> Repair harness between combination meter and data link connector.

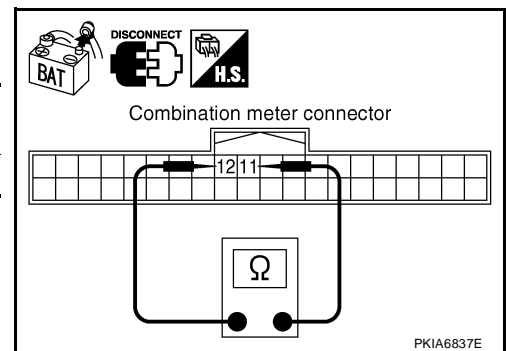

UKS004RR

Display Control Unit Circuit Inspection

1. CHECK CONNECTOR

1. Turn ignition switch OFF.
2. Disconnect the battery cable from the negative terminal.
3. Check terminals and connector of display control unit for damage, bend and loose connection (control unit side and harness side).

OK or NG

- OK >> GO TO 2.
- NG >> Repair terminal or connector.

A
B
C
D
E
F
G
H
I
J
LAN
L
M

2. CHECK HARNESS FOR OPEN CIRCUIT

1. Disconnect display control unit connector.
2. Check resistance between display control unit harness connector terminals.

Display control unit connector	Terminal		Resistance (Approx.)
	25	26	
M95	25	26	54 – 66 Ω

OK or NG

- OK >> Replace display control unit.
- NG >> Repair harness between display control unit and data link connector.

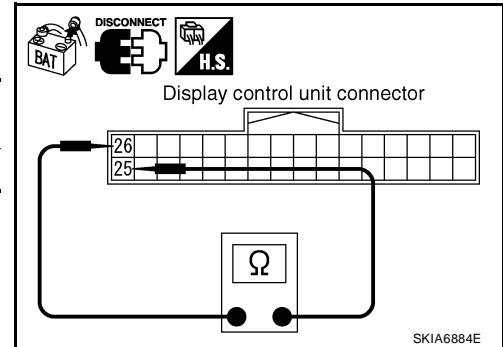

UKS004RS

BCM Circuit Inspection

1. CHECK CONNECTOR

1. Turn ignition switch OFF.
2. Disconnect the battery cable from the negative terminal.
3. Check terminals and connector of BCM for damage, bend and loose connection (control module side and harness side).

OK or NG

- OK >> GO TO 2.
- NG >> Repair terminal or connector.

2. CHECK HARNESS FOR OPEN CIRCUIT

1. Disconnect BCM connector.
2. Check resistance between BCM harness connector terminals.

BCM connector	Terminal		Resistance (Approx.)
	39	40	
M18	39	40	54 – 66 Ω

OK or NG

- OK >> Replace BCM. Refer to [BCS-20, "Removal and Installation"](#).
- NG >> Repair harness between BCM and data link connector.

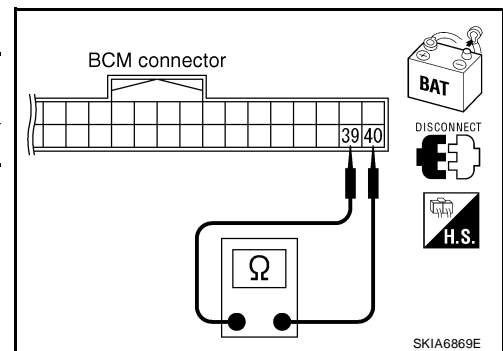

UKS004RT

Data Link Connector Circuit Inspection

1. CHECK CONNECTOR

1. Turn ignition switch OFF.
2. Disconnect the battery cable from the negative terminal.
3. Check the terminals and connector of data link connector for damage, bend and loose connection (connector side and harness side).

OK or NG

- OK >> GO TO 2.
- NG >> Repair terminal or connector.

2. CHECK HARNESS FOR OPEN CIRCUIT

Check resistance between data link connector terminals.

Data link connector	Terminal		Resistance (Approx.)
M22	6	14	54 – 66 Ω

OK or NG

- OK >> Diagnose again. Refer to [LAN-5, "TROUBLE DIAGNOSES WORK FLOW"](#).
- NG >> Repair harness between data link connector and combination meter.

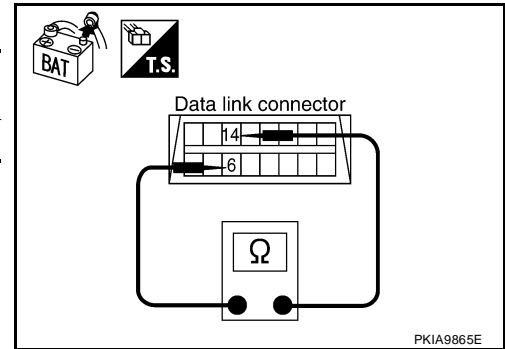

UKS004RU

Steering Angle Sensor Circuit Inspection

1. CHECK CONNECTOR

1. Turn ignition switch OFF.
2. Disconnect the battery cable from the negative terminal.
3. Check terminals and connector of steering angle sensor for damage, bend and loose connection (sensor side and harness side).

OK or NG

- OK >> GO TO 2.
- NG >> Repair terminal or connector.

2. CHECK HARNESS FOR OPEN CIRCUIT

1. Disconnect steering angle sensor connector.
2. Check resistance between steering angle sensor harness connector terminals.

Steering angle sensor connector	Terminal		Resistance (Approx.)
M47	3	4	54 – 66 Ω

OK or NG

- OK >> Replace steering angle sensor.
- NG >> Repair harness between steering angle sensor and data link connector.

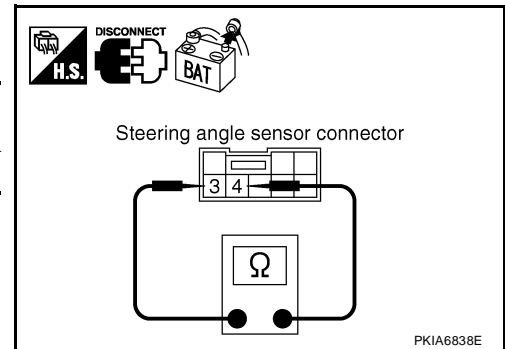

UKS004RV

Front Air Control Circuit Inspection

1. CHECK CONNECTOR

1. Turn ignition switch OFF.
2. Disconnect the battery cable from the negative terminal.
3. Check terminals and connector of front air control for damage, bend and loose connection (unit side and harness side).

OK or NG

- OK >> GO TO 2.
- NG >> Repair terminal or connector.

A
B
C
D
E
F
G
H
I
J
LAN
L
M

2. CHECK HARNESS FOR OPEN CIRCUIT

Front air control with display

1. Disconnect front air control connector.
2. Check resistance between front air control harness connector terminals.

Front air control connector	Terminal		Resistance (Approx.)
M50	41	42	54 – 66 Ω

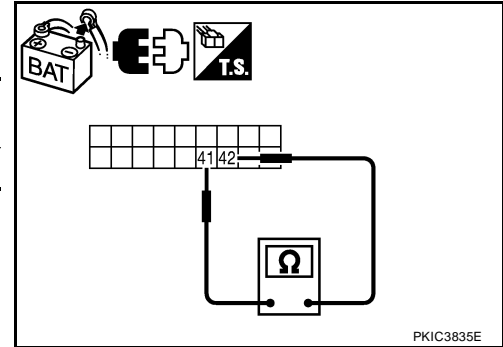

Front air control without display

1. Disconnect front air control connector.
2. Check resistance between front air control harness connector terminals.

Front air control connector	Terminal		Resistance (Approx.)
M50	34	35	54 – 66 Ω

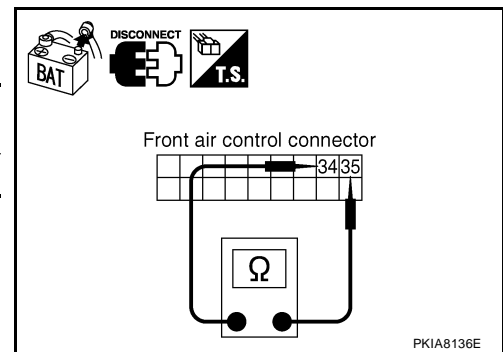

OK or NG

- OK >> Replace front air control.
- NG >> Repair harness between front air control and data link connector.

Transfer Control Unit Circuit Inspection

1. CHECK CONNECTOR

1. Turn ignition switch OFF.
2. Disconnect the battery cable from the negative terminal.
3. Check terminals and connector of transfer control unit for damage, bend and loose connection (control unit side and harness side).

OK or NG

- OK >> GO TO 2.
- NG >> Repair terminal or connector.

2. CHECK HARNESS FOR OPEN CIRCUIT

1. Disconnect transfer control unit connector.
2. Check resistance between transfer control unit harness connector terminals.

Transfer control unit connector	Terminal		Resistance (Approx.)
E142	7	8	54 – 66 Ω

OK or NG

- OK >> Replace transfer control unit.
- NG >> Repair harness between transfer control unit and harness connector E152.

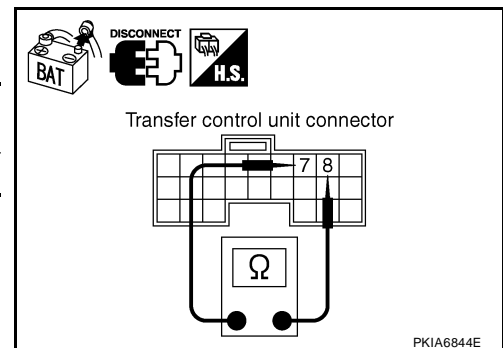

ABS Actuator and Electric Unit (Control Unit) Circuit Inspection

1. CHECK CONNECTOR

1. Turn ignition switch OFF.
2. Disconnect the battery cable from the negative terminal.
3. Check terminals and connector of ABS actuator and electric unit (control unit) for damage, bend and loose connection (control unit side and harness side).

OK or NG

- OK >> GO TO 2.
- NG >> Repair terminal or connector.

2. CHECK HARNESS FOR OPEN CIRCUIT

1. Disconnect ABS actuator and electric unit (control unit) connector.
2. Check resistance between ABS actuator and electric unit (control unit) harness connector terminals.

ABS actuator and electric unit (control unit) connector	Terminal		Resistance (Approx.)
E125	11	15	54 – 66 Ω

OK or NG

- OK >> Replace ABS actuator and electric unit (control unit).
- NG >> Repair harness between ABS actuator and electric unit (control unit) and harness connector E125.

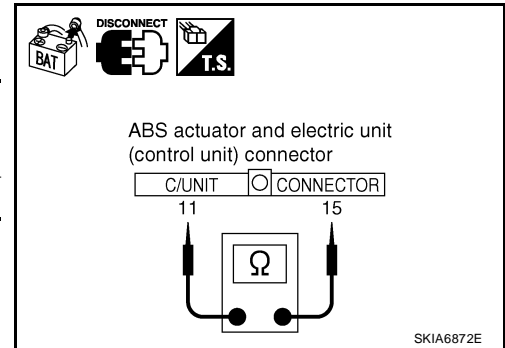

IPDM E/R Circuit Inspection

1. CHECK CONNECTOR

1. Turn ignition switch OFF.
2. Disconnect the battery cable from the negative terminal.
3. Check terminals and connector of IPDM E/R for damage, bend and loose connection (control module side and harness side).

OK or NG

- OK >> GO TO 2.
- NG >> Repair terminal or connector.

2. CHECK HARNESS FOR OPEN CIRCUIT

1. Disconnect IPDM E/R connector.
2. Check resistance between IPDM E/R harness connector terminals.

IPDM E/R connector	Terminal		Resistance (Approx.)
E122	39	40	108 – 132 Ω

OK or NG

- OK >> Replace IPDM E/R.
- NG >> Repair harness between IPDM E/R and harness connector E122.

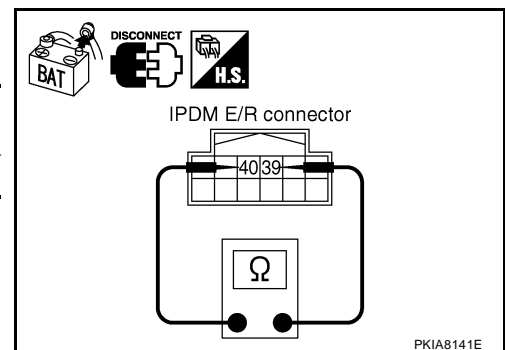

CAN Communication Circuit Inspection

1. CHECK CONNECTOR

1. Turn ignition switch OFF.
2. Disconnect the battery cable from the negative terminal.
3. Disconnect the harness connector for each unit on the CAN network and check terminals for deformation, disconnection, looseness or damage.

OK or NG

- OK >> GO TO 2.
- NG >> Repair terminal or connector as necessary.

2. CHECK HARNESS FOR SHORT CIRCUIT

With all module and control unit connectors disconnected, check continuity between data link connector terminals.

Data link connector	Terminal		Continuity
M22	6	14	No

OK or NG

- OK >> GO TO 3.
- NG >> ● Repair harness.
 - Change harness if shielded lines are used for the harness.

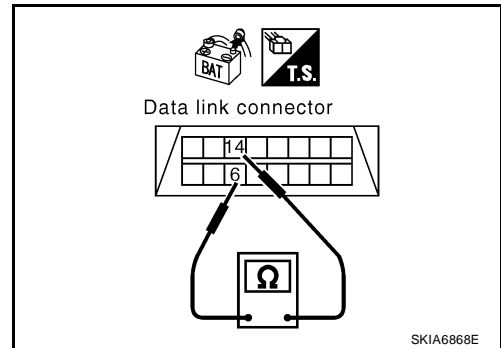

SKIA6868E

3. CHECK HARNESS FOR SHORT CIRCUIT

Check continuity between data link connector terminals and ground.

Data link connector	Terminal		Continuity
M22	6	Ground	No
	14	Ground	No

OK or NG

- OK >> GO TO 4.
- NG >> ● Repair harness.
 - Change harness if shielded lines are used for the harness.

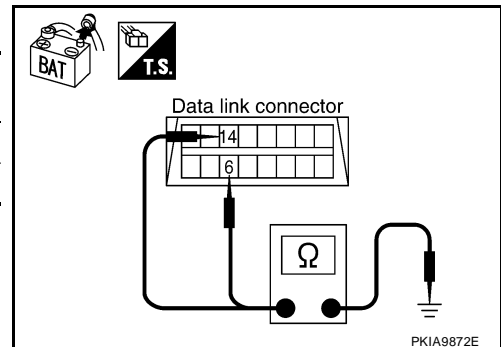

PKIA9872E

4. ECM AND IPDM E/R INTERNAL CIRCUIT INSPECTION

1. Remove ECM and IPDM E/R from vehicle.
2. Check resistance between ECM terminals.

Terminal		Resistance (Approx.)
94	86	108 – 132 Ω

3. Check resistance between IPDM E/R terminals.

Terminal		Resistance (Approx.)
39	40	108 – 132 Ω

OK or NG

- OK >> GO TO 5.
- NG >> Replace ECM and/or IPDM E/R.

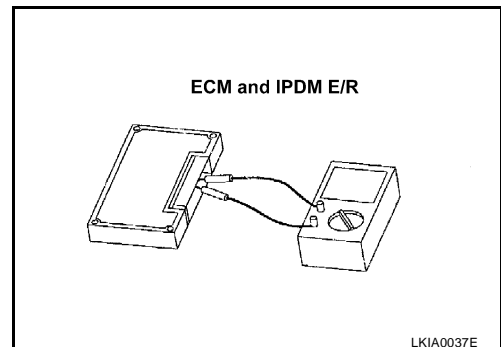

LKIA0037E

5. CHECK SYMPTOM

1. Fill in described symptoms on the column "Symptom" in the check sheet.
2. Connect all connectors, and then make sure that the symptom is reproduced.

OK or NG

OK >> GO TO 6.

NG >> Refer to [LAN-14, "Example of Filling in Check Sheet When Initial Conditions Are Not Reproduced"](#)

6. UNIT REPRODUCIBILITY INSPECTION

Perform the following procedure for each unit on the CAN network, and then perform reproducibility test.

1. Turn ignition switch OFF.
2. Disconnect the battery cable from the negative terminal.
3. Disconnect the unit connector.
4. Connect the battery cable to the negative terminal.
5. Make sure that the symptom filled in the "Symptom" of the check sheet is reproduced. (Do not confuse it with the symptom related to removed unit.)
6. Make sure that the same symptom is reproduced.

Inspection results

Reproduced>>Install removed unit, and then check the other unit.

Not reproduced>>Replace removed unit.

IPDM E/R Ignition Relay Circuit Inspection

UKS004S0

Check the following. If no malfunction is found, replace the IPDM E/R.

- IPDM E/R power supply circuit. Refer to [PG-28, "IPDM E/R Power/Ground Circuit Inspection"](#).
- Ignition power supply circuit. Refer to [PG-13, "IGNITION POWER SUPPLY — IGNITION SW. IN ON AND/OR START"](#).

LAN

