

A
LU

SECTION LU

ENGINE LUBRICATION SYSTEM

C

CONTENTS

D
E

<p>PRECAUTIONS 2</p> <p style="padding-left: 20px;">Precautions for Supplemental Restraint System (SRS) "AIR BAG" and "SEAT BELT PRE-TENSIONER" 2</p> <p style="padding-left: 20px;">Precautions for Liquid Gasket 2</p> <p style="padding-left: 40px;">REMOVAL OF LIQUID GASKET SEALING 2</p> <p style="padding-left: 40px;">LIQUID GASKET APPLICATION PROCEDURE..... 2</p> <p>PREPARATION 4</p> <p style="padding-left: 20px;">Special Service Tools 4</p> <p style="padding-left: 20px;">Commercial Service Tool 5</p> <p>LUBRICATION SYSTEM 6</p> <p style="padding-left: 20px;">Lubrication Circuit 6</p> <p style="padding-left: 20px;">System Drawing 7</p> <p>ENGINE OIL 8</p> <p style="padding-left: 20px;">Inspection 8</p> <p style="padding-left: 40px;">OIL LEVEL 8</p> <p style="padding-left: 40px;">OIL APPEARANCE 8</p> <p style="padding-left: 40px;">OIL LEAKAGE 8</p> <p style="padding-left: 40px;">OIL PRESSURE CHECK 8</p> <p style="padding-left: 20px;">CHANGING ENGINE OIL 9</p> <p>OIL FILTER 11</p> <p style="padding-left: 20px;">Removal and Installation 11</p> <p style="padding-left: 40px;">REMOVAL 11</p> <p style="padding-left: 40px;">INSTALLATION 11</p> <p style="padding-left: 40px;">INSPECTION AFTER INSTALLATION 11</p>	<p>OIL COOLER 12</p> <p style="padding-left: 20px;">Removal and Installation 12</p> <p style="padding-left: 40px;">REMOVAL 12</p> <p style="padding-left: 40px;">INSPECTION AFTER REMOVAL 12</p> <p style="padding-left: 40px;">INSTALLATION 13</p> <p style="padding-left: 40px;">INSPECTION AFTER INSTALLATION 13</p> <p>OIL PUMP 14</p> <p style="padding-left: 20px;">Removal and Installation 14</p> <p style="padding-left: 40px;">REMOVAL 14</p> <p style="padding-left: 40px;">INSTALLATION 14</p> <p style="padding-left: 40px;">INSPECTION AFTER INSTALLATION 15</p> <p style="padding-left: 20px;">Disassembly and Assembly 15</p> <p style="padding-left: 40px;">DISASSEMBLY 15</p> <p style="padding-left: 40px;">INSPECTION AFTER DISASSEMBLY 15</p> <p style="padding-left: 40px;">ASSEMBLY 16</p> <p>SERVICE DATA AND SPECIFICATIONS (SDS) 17</p> <p style="padding-left: 20px;">Standard and Limit 17</p> <p style="padding-left: 40px;">OIL PRESSURE 17</p> <p style="padding-left: 40px;">OIL PUMP 17</p> <p style="padding-left: 40px;">REGULATOR VALVE 17</p> <p style="padding-left: 40px;">ENGINE OIL CAPACITY (APPROXIMATE) 17</p>	<p>F</p> <p>G</p> <p>H</p> <p>I</p> <p>J</p> <p>K</p> <p>L</p> <p>M</p>
---	---	---

PRECAUTIONS

PRECAUTIONS

PFP:00001

Precautions for Supplemental Restraint System (SRS) “AIR BAG” and “SEAT BELT PRE-TENSIONER”

EBS00RJM

The Supplemental Restraint System such as “AIR BAG” and “SEAT BELT PRE-TENSIONER”, used along with a front seat belt, helps to reduce the risk or severity of injury to the driver and front passenger for certain types of collision. This system includes seat belt switch inputs and dual stage front air bag modules. The SRS system uses the seat belt switches to determine the front air bag deployment, and may only deploy one front air bag, depending on the severity of a collision and whether the front occupants are belted or unbelted. Information necessary to service the system safely is included in the SRS and SB section of this Service Manual.

WARNING:

- To avoid rendering the SRS inoperative, which could increase the risk of personal injury or death in the event of a collision which would result in air bag inflation, all maintenance must be performed by an authorized NISSAN/INFINITI dealer.
- Improper maintenance, including incorrect removal and installation of the SRS, can lead to personal injury caused by unintentional activation of the system. For removal of Spiral Cable and Air Bag Module, see the SRS section.
- Do not use electrical test equipment on any circuit related to the SRS unless instructed to in this Service Manual. SRS wiring harnesses can be identified by yellow and/or orange harnesses or harness connectors.

Precautions for Liquid Gasket REMOVAL OF LIQUID GASKET SEALING

EBS00NIO

- After removing the bolts and nuts, separate the mating surface and remove the old liquid gasket sealing using Tool.

Tool number : KV10111100 (J-37228)

CAUTION:

Do not damage the mating surfaces.

- Tap the seal cutter to insert it.
- In areas where the Tool is difficult to use, lightly tap to slide it.

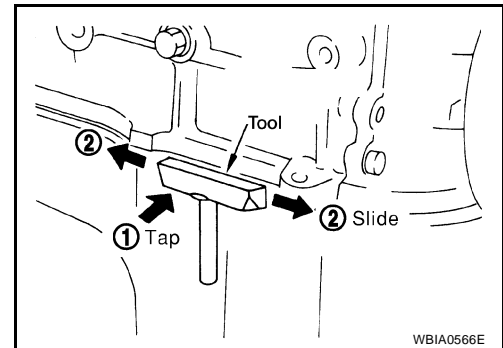

LIQUID GASKET APPLICATION PROCEDURE

1. Remove the old liquid gasket adhering to the gasket application surface and the mating surface using suitable tool.
 - Remove the liquid gasket completely from the groove of the liquid gasket application surface, bolts, and bolt holes.
2. Thoroughly clean the mating surfaces and remove adhering moisture, grease and foreign material.

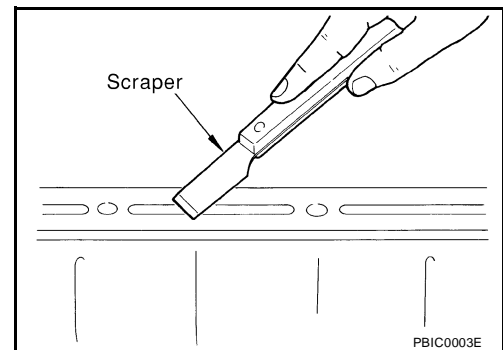

PRECAUTIONS

3. Attach the liquid gasket tube to the Tool.

Tool number : WS39930000 (—)

Use Genuine RTV Silicone Sealant or equivalent. Refer to GI-45, "Recommended Chemical Products and Sealants" .

4. Apply the liquid gasket without breaks to the specified location with the specified dimensions.

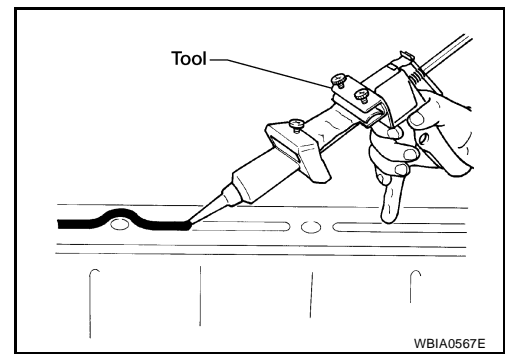

- If there is a groove for the liquid gasket application, apply the liquid gasket to the groove.
- As for the bolt holes, normally apply the liquid gasket inside the holes. If specified in the procedure, it should also be applied outside the holes.
- Within five minutes of liquid gasket application, install the mating component.
- If the liquid gasket protrudes, wipe it off immediately.
- Do not retighten after the installation.
- Wait 30 minutes or more after installation before refilling the engine with engine oil and engine coolant.

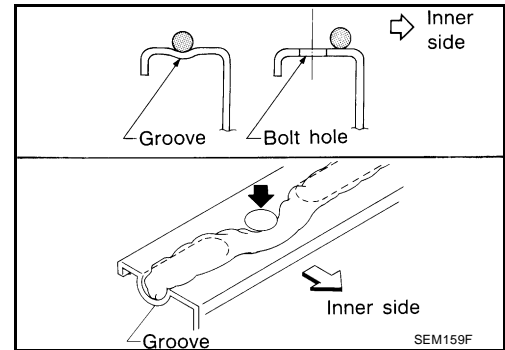

CAUTION:

If there are specific instructions in this manual, observe them.

A
LU
C
D
E
F
G
H
I
J
K
L
M

PREPARATION

PFP:00002

PREPARATION

Special Service Tools

EBS00L4V

The actual shapes of Kent-Moore tools may differ from those of special service tools illustrated here.

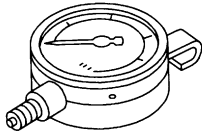
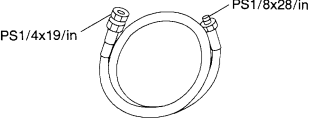
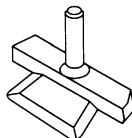
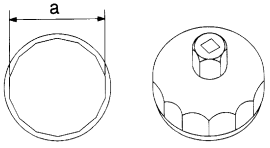
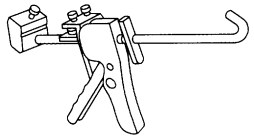
Tool number (Kent-Moore No.) Tool name	Description
ST25051001 (J-25695-1) Oil pressure gauge	Measuring oil pressure Maximum measuring range: 2,452 kPa (25 kg/cm², 356 psi)
 <p style="text-align: center;">S-NT050</p>	
ST25052000 (J-25695-2) Hose	Adapting oil pressure gauge to cylinder block
 <p style="text-align: center;">S-NT559</p>	
KV10111100 (J-37228) Seal cutter	Removing steel oil pan and rear timing chain case
 <p style="text-align: center;">NT046</p>	
KV10115801 (J-38956) Oil filter wrench	Removing and installing oil filter a: 64.3 mm (2.531 in)
 <p style="text-align: center;">S-NT375</p>	
WS39930000 (—) Tube presser	Pressing the tube of liquid gasket
 <p style="text-align: center;">S-NT052</p>	

PREPARATION

Commercial Service Tool

EBS00L4W

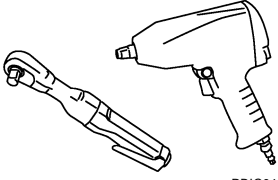
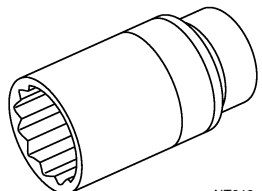
Tool name	Description
Power tool  <p>PBIC0190E</p>	Loosening bolts and nuts
Deep socket  <p>NT818</p>	Removing and installing oil pressure switch Deep socket 26 mm

A
LU
 C
 D
 E
 F
 G
 H
 I
 J
 K
 L
 M

LUBRICATION SYSTEM

LUBRICATION SYSTEM

PF15010

Lubrication Circuit

EBS00L4X

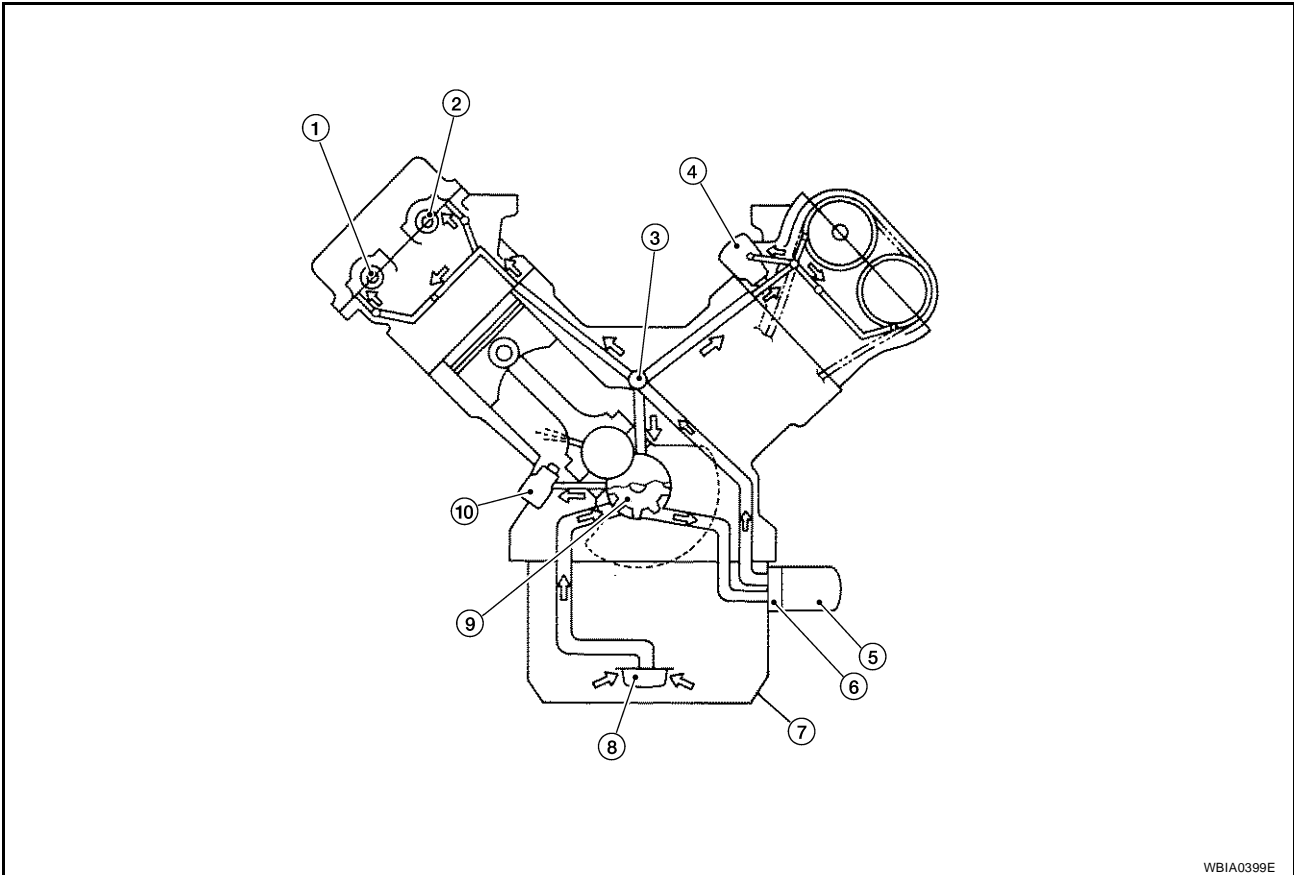

WBIA0399E

- | | | |
|----------------------------------|--------------------|--------------------|
| 1. Exhaust camshaft | 2. Intake camshaft | 3. Main oil galley |
| 4. Chain tensioner (Left bank) | 5. Oil filter | 6. Oil cooler |
| 7. Oil pan | 8. Oil strainer | 9. Oil pump |
| 10. Chain tensioner (Right bank) | | |

LUBRICATION SYSTEM

System Drawing

EBS00L4Y

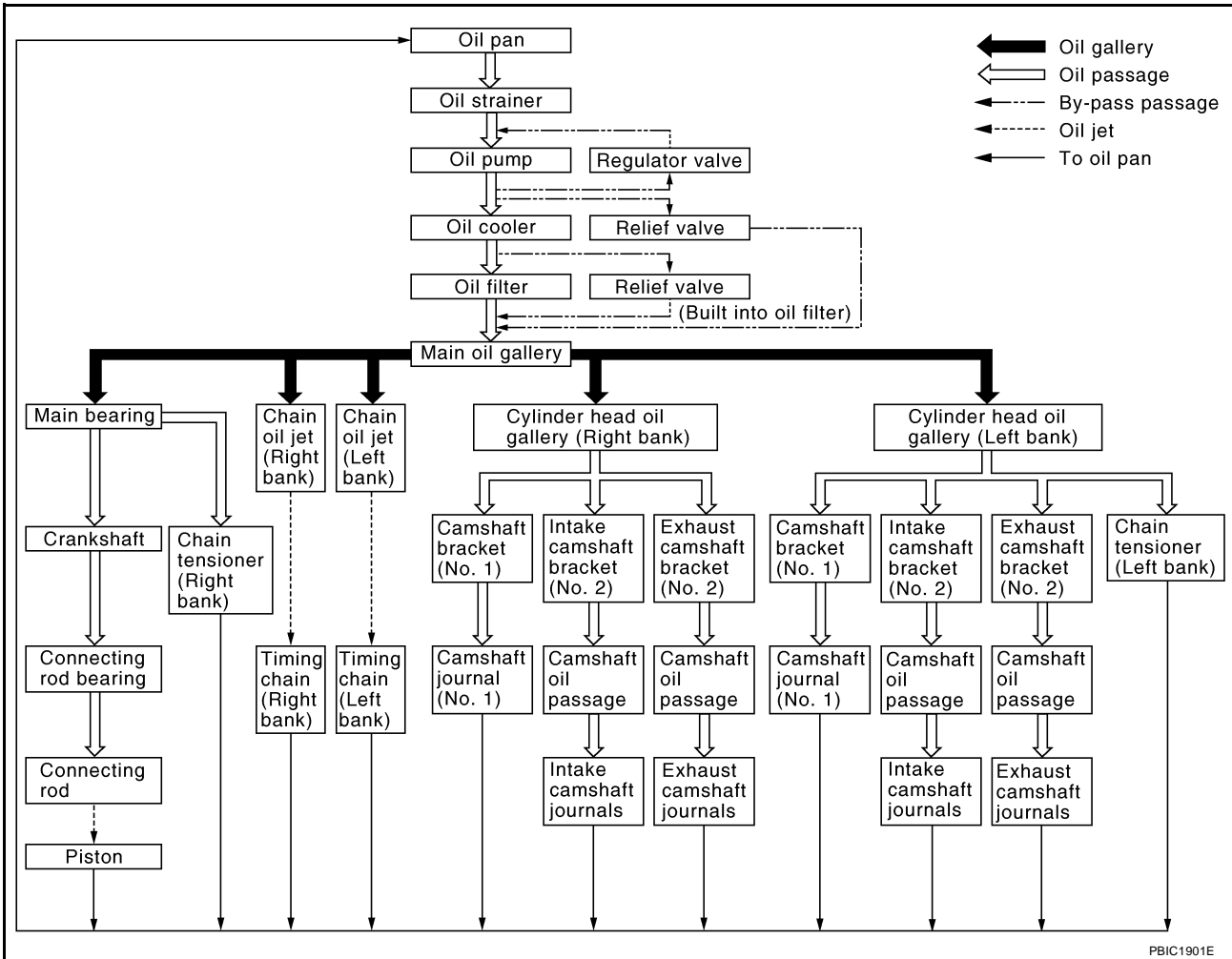

PBIC1901E

A
LU
C
D
E
F
G
H
I
J
K
L
M

ENGINE OIL

ENGINE OIL

PFP:KLA92

Inspection OIL LEVEL

EBS00L4Z

- Before starting the engine make sure the vehicle is parked on a flat and level surface, then check the oil level. If the engine is already running, turn it off and allow 10 minutes before checking.
- Check that the oil level is within the low (L) and high (H) range as indicated on the dipstick.
- If the engine oil level is out of range, add oil as necessary. Refer to [MA-11, "Fluids and Lubricants"](#).

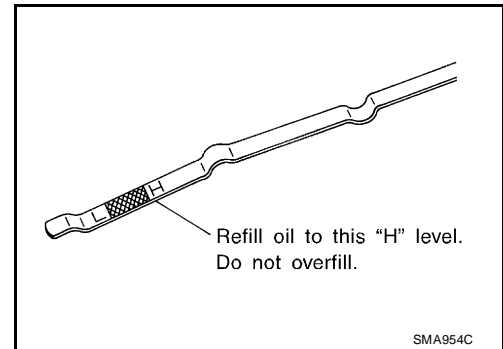

OIL APPEARANCE

- Check the engine oil for a white milky appearance or excessive contamination.
- If the engine oil is milky, it is highly probable that it is contaminated with engine coolant. Repair the broken parts.

OIL LEAKAGE

Check for oil leakage around the following areas:

- Oil pan
- Oil pan drain plug
- Oil pressure sensor
- Oil filter
- Oil cooler
- Intake valve timing control cover
- Intake valve timing control solenoid valve
- Front cover
- Mating surface between cylinder block and cylinder head
- Mating surface between cylinder head and rocker cover
- Crankshaft oil seal (front and rear)

OIL PRESSURE CHECK

WARNING:

- **Be careful not to burn yourself, as engine oil may be hot.**
 - **Put the selector lever in the Park "P" position.**
1. Check the engine oil level. Refer to [LU-8, "OIL LEVEL"](#).
 2. Remove engine front undercover using power tool.
 3. Disconnect the oil pressure sensor harness connector.
 4. Remove the oil pressure sensor.

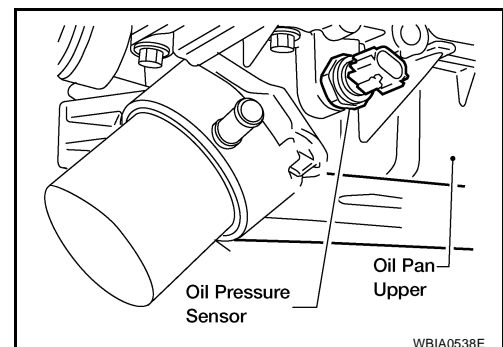

ENGINE OIL

5. Install Tools.

Tool number : ST25051001 (J-25695-1)
 : ST25052000 (J-25695-2)

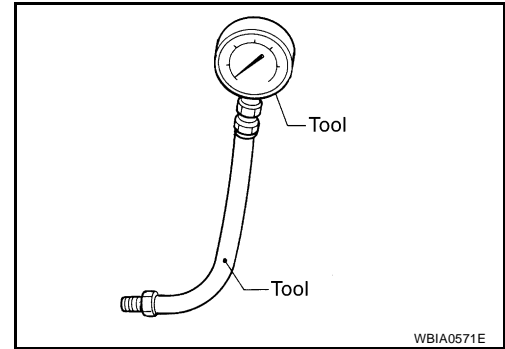

6. Start the engine and warm it up to normal operating temperature.
7. Check the engine oil pressure with engine running under no-load.

Engine oil pressure [Engine oil temperature at 80°C (175°F)]

Unit: kPa (kg/cm², psi)

Engine Speed	Approximate Discharge Pressure
Idle speed	More than 98 (1.0, 14)
2,000 rpm	More than 294 (3.0, 43)

CAUTION:

If the difference is extreme, check the oil passages and oil pump for leaks and blockages.

8. After the inspections, install oil pressure sensor as follows:
 - a. Remove old liquid gasket adhering to oil pressure sensor and engine.
 - b. Apply liquid gasket and tighten oil pressure sensor to the specification.
Use Genuine RTV Silicone Sealant or equivalent. Refer to [GI-45. "Recommended Chemical Products and Sealants"](#) .

Oil pressure sensor torque : 14.7 N-m (1.5 kg-m, 11 ft-lb)

- c. After warming up engine, make sure there is no leakage of engine oil with engine running.

CHANGING ENGINE OIL

EBS00RJN

WARNING:

- **Be careful not to burn yourself, as the engine and engine oil are hot.**
 - **Prolonged and repeated contact with used engine oil may cause skin cancer; try to avoid direct skin contact with used oil. If skin contact is made, wash thoroughly with soap or hand cleaner as soon as possible.**
1. Warm up the engine, and check for any oil leaks.
 2. Stop the engine and wait for at least 10 minutes.
 3. Remove the oil drain plug and oil filler cap to drain the old oil.
 4. Install a new washer on the oil drain plug, then install the oil drain plug in the oil pan.

Oil drain plug : Refer to [EM-77. "CYLINDER BLOCK"](#) .

CAUTION:

Clean the drain plug and install with a new washer.

5. Refill the engine with new specified engine oil.

Oil grade and viscosity : Refer to [MA-11. "Fluids and Lubricants"](#) .

Oil capacity : Refer to [MA-11. "Fluids and Lubricants"](#) .

CAUTION:

The refill capacity depends on the oil temperature and drain time. Use the "Refill oil capacity" values as a reference and check the oil level using the dipstick when filling the engine with oil.

6. Warm up the engine and check the area around the drain plug and oil filter for any oil leaks.
7. Stop the engine and wait for more than 10 minutes.

ENGINE OIL

8. Check the oil level using the dipstick as shown. Add oil as necessary and install the oil filler cap.

CAUTION:

Do not overfill the engine with oil.

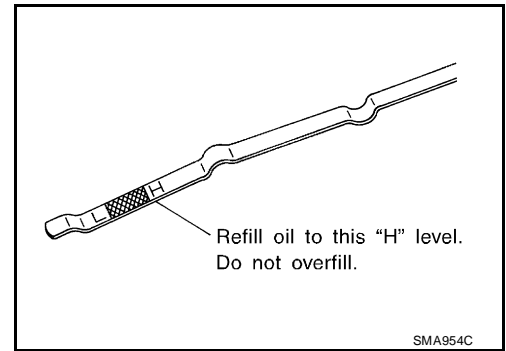

OIL FILTER

PFP:15208

EBS00L51

OIL FILTER

Removal and Installation

REMOVAL

1. Remove the engine front undercover using power tool.
2. Remove the oil filter using Tool as shown.

Tool number : KV10115801 (J-38956)

CAUTION:

- The oil filter is equipped with a pressure relief valve.
- Use Genuine NISSAN oil filter or equivalent.
- Be careful not to get burned when the engine and engine oil are hot.
- When removing, prepare a shop cloth to absorb any engine oil leaks or spills.
- Do not allow engine oil to adhere to the drive belts.
- Completely wipe off any engine oil that adheres to the engine and the vehicle.

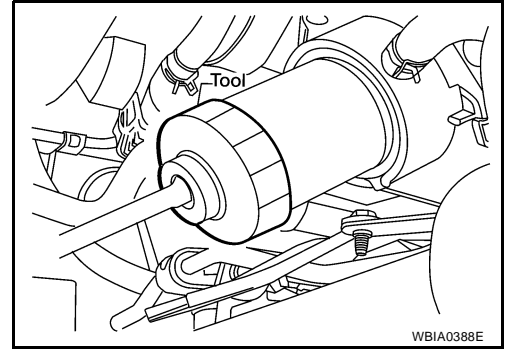

INSTALLATION

1. Remove foreign materials adhering to the oil filter seal mating surface.
2. Apply clean engine oil to the oil filter seal circumference of the new oil filter.

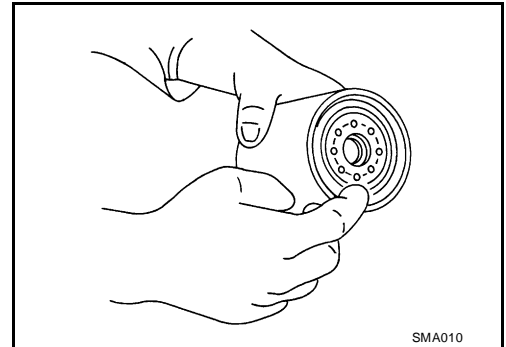

3. Screw the oil filter manually until it touches the installation surface, then tighten it by 2/3 turn. Or tighten to specification.

Oil filter : 17.7 N·m (1.8 kg-m, 13 ft-lb)

4. Inspect the engine for oil leaks. Refer to [LU-11, "INSPECTION AFTER INSTALLATION"](#).
5. Install the engine front undercover using power tool.

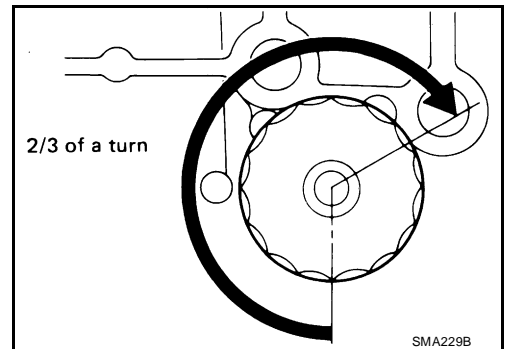

INSPECTION AFTER INSTALLATION

1. Check the engine oil level. Refer to [LU-8, "OIL LEVEL"](#).
2. Start the engine and check for engine oil leaks.
3. Stop the engine and wait for 10 minutes.
4. Check the engine oil level and add engine oil as required.

OIL COOLER

OIL COOLER

PF2:21305

Removal and Installation

EBS00L52

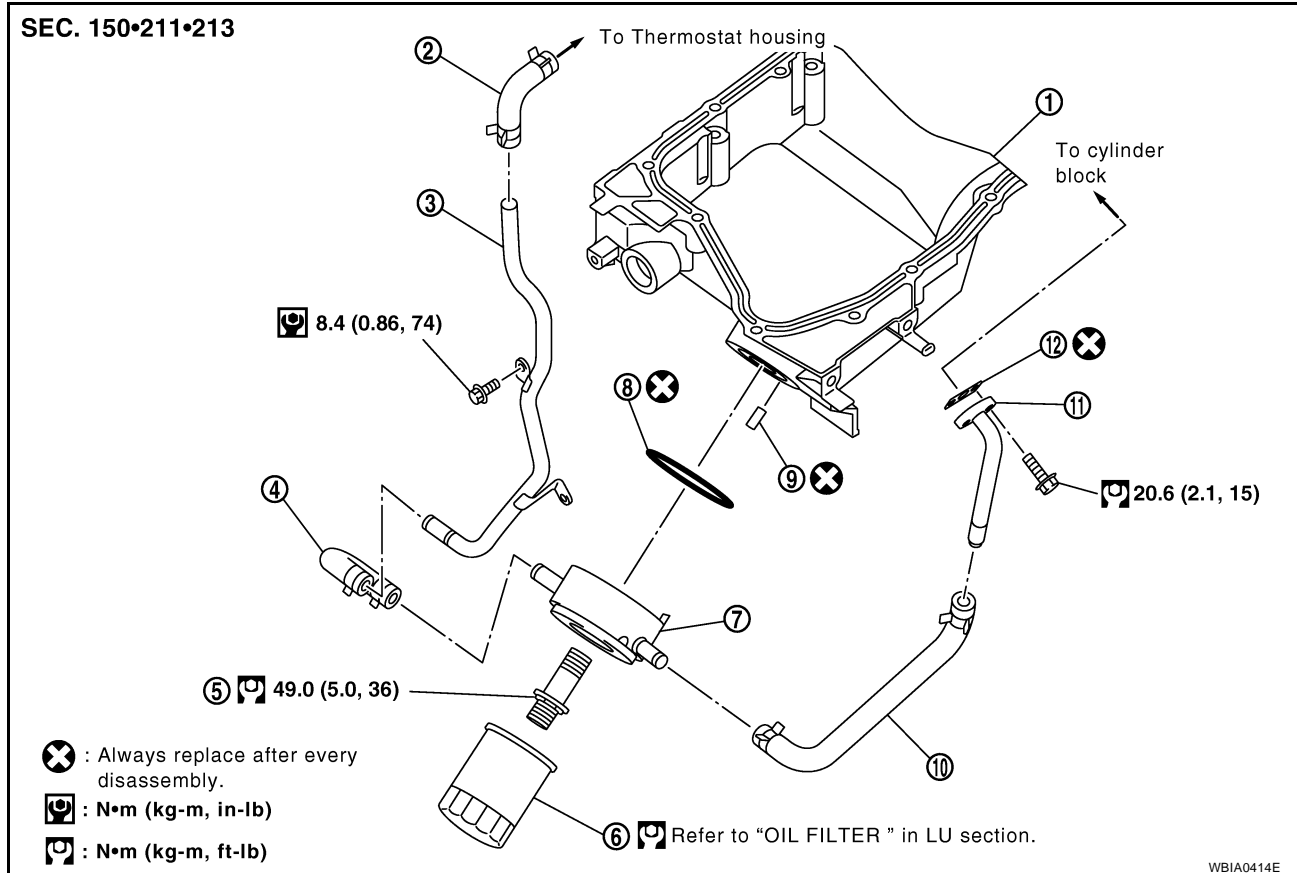

- | | | |
|----------------|--------------------|-----------------|
| 1. Oil pan | 2. Water hose | 3. Water pipe |
| 4. Water hose | 5. Connector bolt | 6. Oil filter |
| 7. Oil cooler | 8. O-ring | 9. Relief valve |
| 10. Water hose | 11. Connector pipe | 12. Gasket |

WARNING:

Be careful not to burn yourself, as the engine oil and engine coolant are hot.

REMOVAL

1. Remove engine front undercover using power tool.
2. Disconnect water hoses, pinching hoses near oil cooler to prevent engine coolant from spilling.

CAUTION:

Do not spill engine coolant on the drive belt.

3. Remove oil filter. Refer to [LU-11, "Removal and Installation"](#).

CAUTION:

Do not spill engine oil on the drive belts.

4. Remove connector bolt, and remove oil cooler.

INSPECTION AFTER REMOVAL

Oil Cooler

Check oil cooler for cracks. Check oil cooler for clogging by blowing compressed air through engine coolant inlet. If necessary, replace oil cooler assembly.

Relief Valve

Inspect relief valve for movement, cracks and breaks by pushing the ball. If replacement is necessary, remove the valve by prying it out using a suitable tool. Install a new valve in place by tapping it.

OIL COOLER

INSTALLATION

Installation is in the reverse order of removal, paying attention to the following:

- Confirm that no foreign objects are adhering to the sealing surfaces of the oil cooler or oil pan.
- Tighten the connecting bolt after aligning the stopper on the oil pan side with protrusion of the oil cooler.

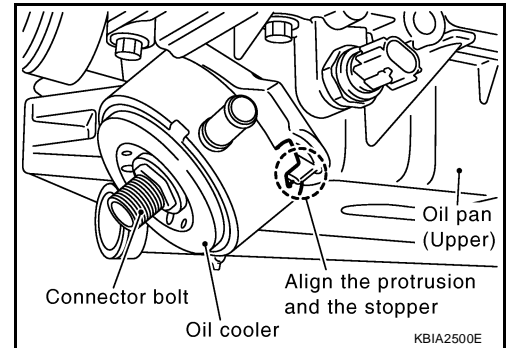

INSPECTION AFTER INSTALLATION

1. Check levels and add engine oil and engine coolant. Refer to [LU-8, "OIL LEVEL"](#) and [CO-10, "LEVEL CHECK"](#).
2. Start the engine, and check for leaks of engine oil and engine coolant.
3. Stop the engine and wait for 10 minutes.
4. Check engine oil level and engine coolant level again.

OIL PUMP

OIL PUMP

PFP:15010

Removal and Installation

EBS00L53

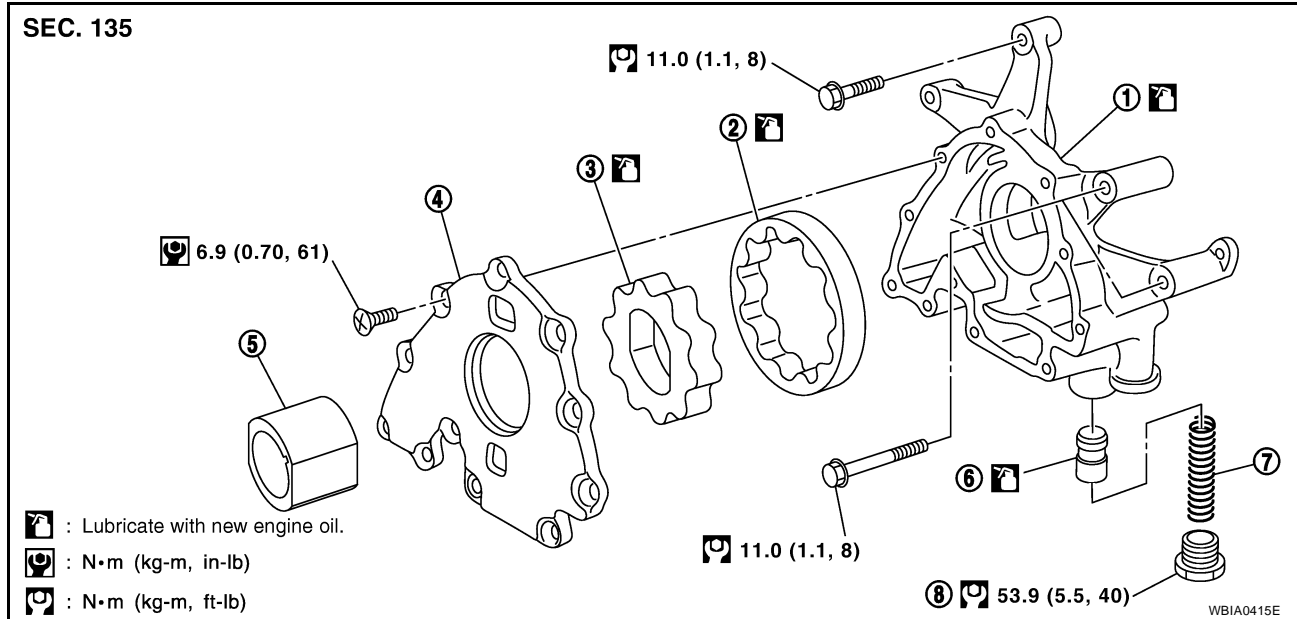

- | | | |
|---------------------|--------------------------|--------------------|
| 1. Oil pump body | 2. Outer rotor | 3. Inner rotor |
| 4. Oil pump cover | 5. Oil pump drive spacer | 6. Regulator valve |
| 7. Regulator spring | 8. Regulator plug | |

REMOVAL

1. Remove front cover. Refer to [EM-37, "Removal and Installation"](#).
2. Remove the oil pump drive spacer.
3. Remove the oil pump.

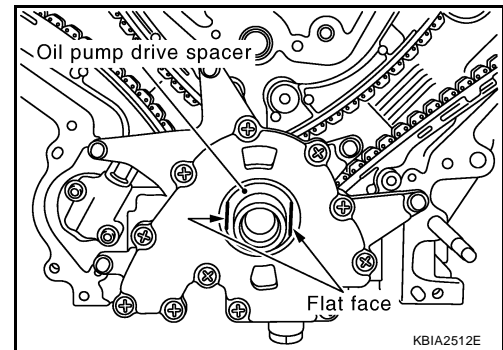

INSTALLATION

Installation is in the reverse order of removal, paying attention of the following:

- When inserting the oil pump drive spacer, align the crankshaft key and the flat face of the inner rotor.
- If they are not aligned, rotate the oil pump inner rotor by hand.
- Make sure that the each part is aligned and tap lightly until it reaches the end.

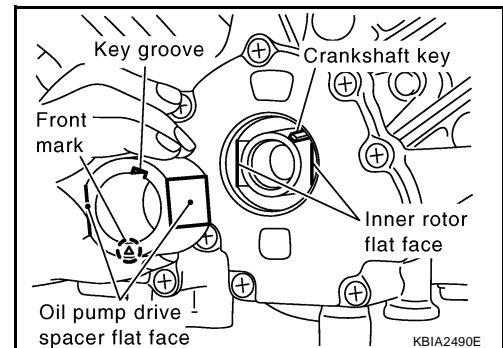

OIL PUMP

INSPECTION AFTER INSTALLATION

- Start the engine, and check for leaks of engine oil.
- Stop engine and wait 10 minutes.
- Check level and add engine oil as required. Refer to [LU-8, "ENGINE OIL"](#).

Disassembly and Assembly DISASSEMBLY

EBS00L54

1. Remove oil pump cover.
2. Remove inner rotor and outer rotor from oil pump body.
3. Remove the regulator plug, regulator spring and regulator valve.

INSPECTION AFTER DISASSEMBLY

Clearance of Oil Pump Parts

- Measure radial clearance using a suitable tool.

Body to outer rotor (position 1)
: 0.114 - 0.200 mm (0.0045 - 0.0079 in)

Inner rotor to outer rotor tip (position 2)
: Below 0.180 mm (0.0071 in)

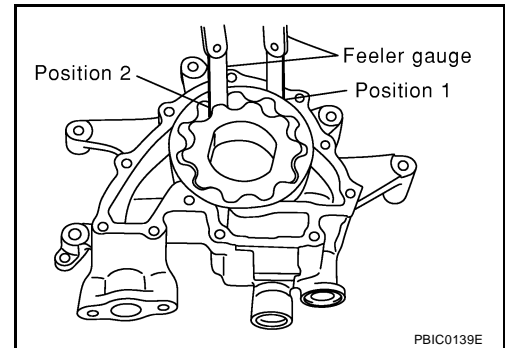

- Measure side clearance using suitable tools.

Body to inner rotor (position 3)
: 0.030 - 0.070 mm (0.0012 - 0.0028 in)

Body to outer rotor (position 4)
: 0.030 - 0.090 mm (0.0012 - 0.0035 in)

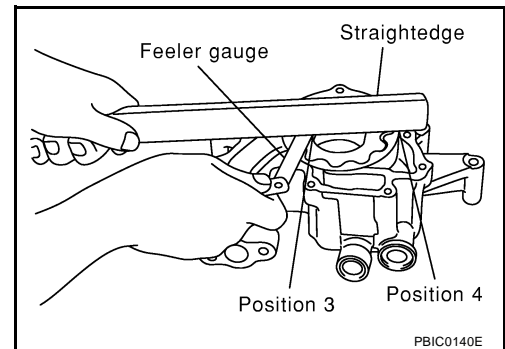

- Calculate the clearance between inner rotor and oil pump body as follows.

1. Measure the outer diameter of protruded portion of inner rotor (position 5) using suitable tool.

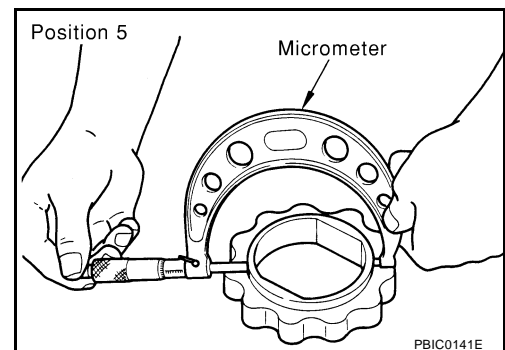

OIL PUMP

2. Measure the inner diameter of oil pump body to brazed portion (position 6) using suitable tool.

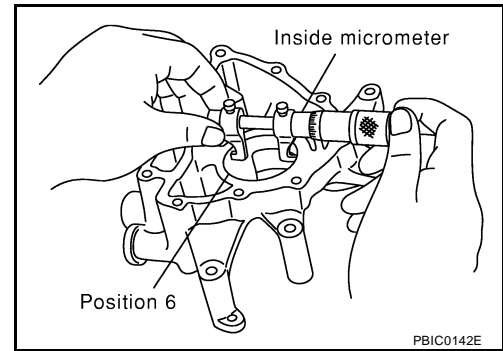

3. Calculate the clearance using the following formula.
 - (Clearance) = (Inner diameter of oil pump body) - (Outer diameter of inner rotor)

Inner rotor to brazed portion of housing clearance
: 0.045 - 0.091 mm (0.0018 - 0.0036 in)

Regulator Valve Clearance

Check regulator valve to oil pump cover clearance using the following formula.

- (Clearance) = D1 (Valve hole diameter) - D2 (Outer Diameter of valve)

Regulator valve to oil pump cover
: 0.040 - 0.097 mm (0.0016 - 0.0038 in)

CAUTION:

- Coat regulator valve with engine oil.
- Check that it falls smoothly into the regulator valve hole by its own weight.

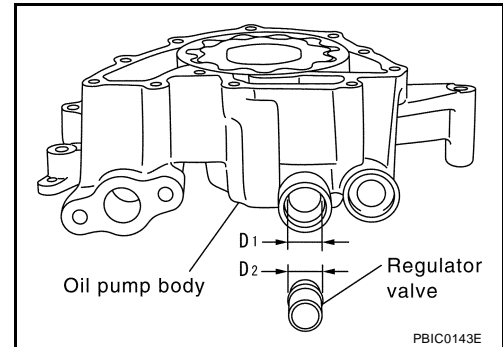

ASSEMBLY

Installation is in the reverse order of removal.

NOTE:

Install the inner rotor and outer rotor with the punched marks on the oil pump cover side.

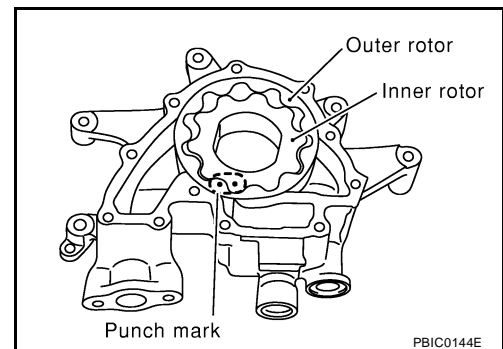

SERVICE DATA AND SPECIFICATIONS (SDS)

SERVICE DATA AND SPECIFICATIONS (SDS)

PFP:00030

Standard and Limit OIL PRESSURE

EBS00L55

Unit: kPa (kg/cm², psi)

Engine speed rpm	Approximate discharge oil pressure
Idle speed 2,000	More than 98 (1.0, 14) More than 294 (3.0, 43)

OIL PUMP

Unit: mm (in)

Body to outer rotor radial clearance	0.114 - 0.200 (0.0045 - 0.0079)
Inner rotor to outer rotor tip clearance	Below 0.180 (0.0071)
Body to inner rotor side clearance	0.030 - 0.070 (0.0012 - 0.0028)
Body to outer rotor side clearance	0.030 - 0.090 (0.0012 - 0.0035)
Inner rotor to brazed portion of housing clearance	0.045 - 0.091 (0.0018 - 0.0036)

REGULATOR VALVE

Unit: mm (in)

Regulator valve to oil pump cover clearance	0.040 - 0.097 (0.0016 - 0.0038)
---	---------------------------------

ENGINE OIL CAPACITY (APPROXIMATE)

Unit: ℓ (US qt, Imp qt)

Drain and refill	With oil filter change	6.2 (6 1/2, 5-1/2)
	Without oil filter change	5.9 (6-1/4, 5-1/4)
Dry engine (engine overhaul)		7.6 (8, 6-3/4)

SERVICE DATA AND SPECIFICATIONS (SDS)
