

A  
B  
C

# SECTION PS

## POWER STEERING SYSTEM

### CONTENTS

<p><b>PRECAUTIONS</b> ..... 2</p> <p style="padding-left: 20px;">Precautions for Supplemental Restraint System (SRS) "AIR BAG" and "SEAT BELT PRE-TENSIONER" ..... 2</p> <p style="padding-left: 20px;">Precautions for Steering System ..... 2</p> <p><b>PREPARATION</b> ..... 3</p> <p style="padding-left: 20px;">Special Service Tools (SST) ..... 3</p> <p style="padding-left: 20px;">Commercial Service Tools ..... 4</p> <p><b>NOISE, VIBRATION, AND HARSHNESS (NVH)</b></p> <p><b>TROUBLESHOOTING</b> ..... 5</p> <p style="padding-left: 20px;">NVH Troubleshooting Chart ..... 5</p> <p><b>POWER STEERING FLUID</b> ..... 6</p> <p style="padding-left: 20px;">Checking Fluid Level ..... 6</p> <p style="padding-left: 20px;">Checking Fluid Leakage ..... 6</p> <p style="padding-left: 20px;">Air Bleeding Hydraulic System ..... 6</p> <p><b>STEERING WHEEL</b> ..... 8</p> <p style="padding-left: 20px;">On-Vehicle Inspection and Service ..... 8</p> <p style="padding-left: 40px;">CHECKING CONDITION OF INSTALLATION ..... 8</p> <p style="padding-left: 40px;">CHECKING STEERING WHEEL PLAY ..... 8</p> <p style="padding-left: 40px;">CHECKING NEUTRAL POSITION ON STEERING WHEEL ..... 8</p> <p style="padding-left: 40px;">CHECKING STEERING WHEEL TURNING FORCE ..... 8</p> <p style="padding-left: 40px;">CHECKING FRONT WHEEL TURNING ANGLE... 9</p> <p style="padding-left: 20px;">Removal and Installation ..... 9</p> <p style="padding-left: 40px;">REMOVAL ..... 9</p> <p style="padding-left: 40px;">INSTALLATION ..... 9</p> <p><b>STEERING COLUMN</b> ..... 10</p> <p style="padding-left: 20px;">Removal and Installation ..... 10</p> <p style="padding-left: 40px;">REMOVAL ..... 10</p> <p style="padding-left: 40px;">INSPECTION AFTER REMOVAL ..... 12</p> <p style="padding-left: 40px;">INSTALLATION ..... 12</p>	<p style="padding-left: 20px;">INSPECTION AFTER INSTALLATION ..... 13</p> <p style="padding-left: 20px;">Disassembly and Assembly ..... 13</p> <p style="padding-left: 40px;">DISASSEMBLY ..... 13</p> <p style="padding-left: 40px;">ASSEMBLY ..... 14</p> <p style="padding-left: 20px;">INSPECTION AFTER ASSEMBLY ..... 14</p> <p><b>POWER STEERING GEAR AND LINKAGE</b> ..... 15</p> <p style="padding-left: 20px;">Removal and Installation ..... 15</p> <p style="padding-left: 40px;">REMOVAL ..... 15</p> <p style="padding-left: 40px;">INSTALLATION ..... 16</p> <p style="padding-left: 20px;">INSPECTION AFTER INSTALLATION ..... 17</p> <p style="padding-left: 20px;">Disassembly and Assembly ..... 17</p> <p style="padding-left: 40px;">DISASSEMBLY ..... 17</p> <p style="padding-left: 40px;">INSPECTION AFTER DISASSEMBLY ..... 18</p> <p style="padding-left: 40px;">ASSEMBLY ..... 19</p> <p><b>POWER STEERING OIL PUMP</b> ..... 21</p> <p style="padding-left: 20px;">On-Vehicle Inspection and Service ..... 21</p> <p style="padding-left: 40px;">CHECKING RELIEF OIL PRESSURE ..... 21</p> <p style="padding-left: 20px;">Removal and Installation ..... 21</p> <p style="padding-left: 40px;">REMOVAL ..... 21</p> <p style="padding-left: 40px;">INSTALLATION ..... 21</p> <p style="padding-left: 20px;">Disassembly and Assembly ..... 22</p> <p style="padding-left: 40px;">INSPECTION BEFORE DISASSEMBLY ..... 22</p> <p style="padding-left: 40px;">DISASSEMBLY ..... 22</p> <p style="padding-left: 40px;">INSPECTION AFTER DISASSEMBLY ..... 22</p> <p style="padding-left: 40px;">ASSEMBLY ..... 22</p> <p><b>HYDRAULIC LINE</b> ..... 23</p> <p style="padding-left: 20px;">Removal and Installation ..... 23</p> <p><b>SERVICE DATA AND SPECIFICATIONS (SDS)</b> ..... 25</p> <p style="padding-left: 20px;">Steering Wheel ..... 25</p> <p style="padding-left: 20px;">Steering Column ..... 25</p> <p style="padding-left: 20px;">Steering Outer Socket and Inner Socket ..... 26</p> <p style="padding-left: 20px;">Tie-rod ..... 26</p> <p style="padding-left: 20px;">Steering Gear ..... 26</p> <p style="padding-left: 20px;">Oil Pump ..... 27</p> <p style="padding-left: 20px;">Steering Fluid ..... 27</p>
---	--

A  
B  
C  
D  
E  
F  
PS  
H  
I  
J  
K  
L  
M

# PRECAUTIONS

## PRECAUTIONS

PF0:00001

### Precautions for Supplemental Restraint System (SRS) “AIR BAG” and “SEAT BELT PRE-TENSIONER”

EGS0007G

The Supplemental Restraint System such as “AIR BAG” and “SEAT BELT PRE-TENSIONER”, used along with a front seat belt, helps to reduce the risk or severity of injury to the driver and front passenger for certain types of collision. This system includes seat belt switch inputs and dual stage front air bag modules. The SRS system uses the seat belt switches to determine the front air bag deployment, and may only deploy one front air bag, depending on the severity of a collision and whether the front occupants are belted or unbelted. Information necessary to service the system safely is included in the SRS and SB section of this Service Manual.

#### **WARNING:**

- To avoid rendering the SRS inoperative, which could increase the risk of personal injury or death in the event of a collision which would result in air bag inflation, all maintenance must be performed by an authorized NISSAN/INFINITI dealer.
- Improper maintenance, including incorrect removal and installation of the SRS, can lead to personal injury caused by unintentional activation of the system. For removal of Spiral Cable and Air Bag Module, see the SRS section.
- Do not use electrical test equipment on any circuit related to the SRS unless instructed to in this Service Manual. SRS wiring harnesses can be identified by yellow and/or orange harnesses or harness connectors.

### Precautions for Steering System

EGS0007H

- Before disassembly, thoroughly clean the outside of the unit.
- Disassembly should be done in a clean work area. It is important to prevent the internal parts from becoming contaminated by dirt or other foreign matter.
- For easier and proper assembly, place disassembled parts in order on a parts rack.
- Use nylon cloth or paper towels to clean the parts; common shop rags can leave lint that might interfere with their operation.
- Before inspection or reassembly, carefully clean all parts with a general purpose, non-flammable solvent.
- Before assembly, apply a coat of recommended Genuine NISSAN PSF or equivalent to hydraulic parts. Petroleum jelly may be applied to O-rings and seals. Do not use any grease.
- Replace all gaskets, seals and O-rings. Avoid damaging O-rings, seals and gaskets during installation. Perform functional tests whenever designated.

# PREPARATION

PFP:00002

## PREPARATION

### Special Service Tools (SST)

EGS00127

The actual shapes of Kent-Moore tools may differ from those of special service tools illustrated here.

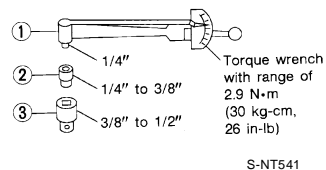
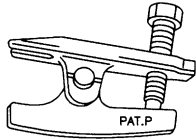
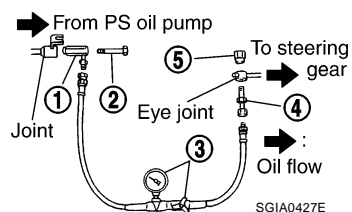
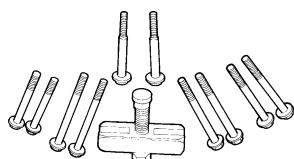
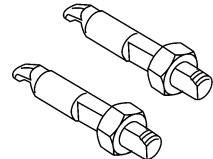
Tool number (Kent-Moore No.) Tool name	Description
ST3127 S000 (See J-25765-A) Preload gauge 1. GG9103000 (J-25765-A) Torque wrench 2. HT62940000 ( — ) Socket adapter 3. HT62900000 ( — ) Socket adapter	Inspecting of pinion rotating torque and rotational torque for ball joint 
HT72520000 (J-25730-A) Ball joint remover	Removing steering outer socket 
1. KV48105300-4 and 5295262U10 ( — ) Connector A and O-ring 2. KV48105300-3 and 5295262U00 ( — ) Eye-bolt and O-ring 3. KV48103500 (J-26357 and J-26357-10) Pressure gauge and shut-off valve 4. KV48105300-1 and 5295262U00 ( — ) Connector B and O-ring 5. KV48105300-2 ( — ) Nut	Measuring oil pump relief pressure 
KV481J0010 (J-1859-A) Steering wheel puller	Removing steering wheel 
KV481J0020 (J-42578) Steering wheel puller legs	Removing steering wheel 

A  
B  
C  
D  
E  
F  
PS  
H  
I  
J  
K  
L  
M

# PREPARATION

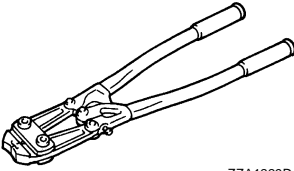
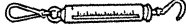
Tool number (Kent-Moore No.) Tool name	Description
KV40107300 ( — )	Crimping boot bands
 <p style="text-align: right; margin-top: 10px;">ZZA1229D</p>	
— (J-44372) Spring gauge	Measuring steering wheel turning force
 <p style="text-align: right; margin-top: 10px;">LST024</p>	

## Commercial Service Tools

EGS00128

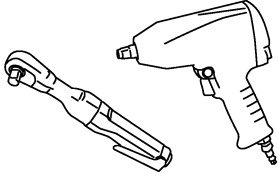
Tool name	Description
Power tool	Removing nuts and bolts
 <p style="text-align: right; margin-top: 10px;">PBIC0190E</p>	

# NOISE, VIBRATION, AND HARSHNESS (NVH) TROUBLESHOOTING

## NOISE, VIBRATION, AND HARSHNESS (NVH) TROUBLESHOOTING

PF0:0003

### NVH Troubleshooting Chart

EGS000TK

Use chart below to help you find the cause of the symptom. If necessary, repair or replace these parts.

Symptom	Possible cause and suspected parts													Reference page																	
	Noise	Shake	Vibration	Shimmy	Shudder	Fluid level	Air in hydraulic system	Outer socket ball joint swinging force	Outer socket ball joint rotating torque	Outer socket ball joint end play	Steering fluid leakage	Steering wheel play	Steering gear rack sliding force		Drive belt looseness	Improper steering wheel	Improper installation or looseness of tilt lock lever	Mounting rubber deterioration	Steering column deformation or damage	Improper installation or looseness of steering column	Steering linkage looseness	PROPELLER SHAFT	FRONT FINAL DRIVE	WHEEL HUB	SUSPENSION	TIRES	ROAD WHEEL	DRIVE SHAFT	BRAKES		
	x					x		x	x	x	x	x	x	x																	PS-6
	x																													PS-6	
	x																													PS-26, "Steering Outer Socket and Inner Socket"	
	x																													PS-26, "Steering Outer Socket and Inner Socket"	
	x																													PS-26, "Steering Outer Socket and Inner Socket"	
	x																													PS-6	
	x																													PS-8	
	x																													PS-8	
	x																													EM-13, "Checking Drive Belts"	
		x																												PS-8	
		x																												PS-13	
			x																											PS-18, "INSPECTION AFTER DISASSEMBLY"	
				x																										PS-10	
					x																									PS-10	
						x																								PS-15	
							x																							PR-3, "NVH Troubleshooting Chart"	
								x																						FFD-6, "NVH Troubleshooting Chart"	
									x																					FAX-4, "NVH Troubleshooting Chart"	
										x																				FSU-4, "NVH Troubleshooting Chart"	
											x																			WT-4, "NVH Troubleshooting Chart"	
												x																		WT-4, "NVH Troubleshooting Chart"	
													x																	FAX-4, "NVH Troubleshooting Chart"	
														x																BR-5, "NVH Troubleshooting Chart"	

x: Applicable

A  
B  
C  
D  
E  
F  
PS  
H  
I  
J  
K  
L  
M

# POWER STEERING FLUID

PPF:KLF20

## POWER STEERING FLUID

EGS0007L

### Checking Fluid Level

Check the power steering fluid level with the engine off.  
Check fluid level, referring to the scale on reservoir tank.  
Use HOT range for fluid temperatures of 50° – 80°C (122° – 176°F).  
Use COLD range for fluid temperatures of 0° – 30°C (32° – 86°F).

#### CAUTION:

- Do not overfill.
- Do not reuse any power steering fluid.
- Use the recommended power steering fluid or equivalent. Refer to [MA-11, "RECOMMENDED FLUIDS AND LUBRICANTS"](#).

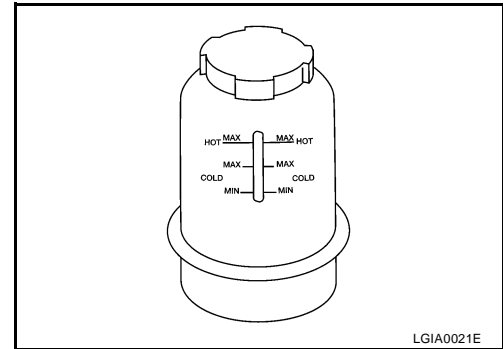

### Checking Fluid Leakage

EGS0007M

Check the hydraulic piping lines for improper attachment and for leaks, cracks, damage, loose connections, chafing or deterioration.

1. Run engine until fluid temperature reaches 50° – 80°C (122° – 176°F) in reservoir tank. Keep engine speed idle.
2. Turn steering wheel right-to-left several times.
3. Hold steering wheel at each "lock" position for five seconds to check fluid leakage.

#### CAUTION:

**Do not hold steering wheel in a locked position for more than 10 seconds. (There is the possibility that oil pump may be damaged.)**

4. If fluid leakage at connections is noticed, then loosen flare nut and then retighten. Do not over tighten connector as this can damage O-ring, washer and connector.
5. If fluid leakage from oil pump is noticed, check oil pump. Refer to [PS-21, "POWER STEERING OIL PUMP"](#).
6. Check steering gear boots for accumulation of fluid indicating a leak from the steering gear.

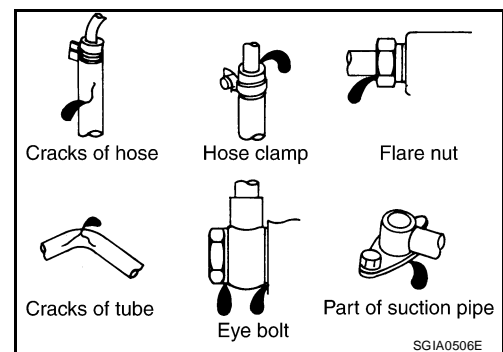

### Air Bleeding Hydraulic System

EGS0007N

Incomplete air bleeding causes the following. When this happens, bleed air again.

- Air bubbles in reservoir tank.
- Clicking noise in oil pump.
- Excessive buzzing in oil pump.

#### NOTE:

When vehicle is stationary or while steering wheel is being turned slowly, some noise may be heard from oil pump or gear. This noise is normal and does not affect any system.

1. Stop engine, and then turn steering wheel fully to right and left several times.

#### CAUTION:

**Do not allow steering fluid reservoir tank to go below the MIN level line. Check tank frequently and add fluid as needed.**

2. Run engine at idle speed. Turn steering wheel fully right and then fully left, hold for about three seconds. Then check for fluid leakage.
3. Repeat step 2 several times at about three second intervals.

#### CAUTION:

**Do not hold steering wheel in the locked position for more than 10 seconds. (There is the possibility that oil pump may be damaged.)**

4. Check for air bubbles or cloudy fluid.
5. If air bubbles or cloudiness still exists, stop engine, perform steps 2 and 3 again until air bubbles or cloudiness does not exist.

# POWER STEERING FLUID

---

6. Stop engine, check fluid level.

A

B

C

D

E

F

**PS**

H

I

J

K

L

M

# STEERING WHEEL

## STEERING WHEEL

PFP:48430

### On-Vehicle Inspection and Service CHECKING CONDITION OF INSTALLATION

EGS00070

- Check installation condition of steering gear assembly, front suspension, axle and steering column.
- Check if movement exists when steering wheel is moved up and down, to the left and right and to the axial direction.

**End play of the axle direction : 0 mm (0 in)  
for steering wheel**

- Check if the nuts for steering gear assembly are loose. Refer to [PS-15, "POWER STEERING GEAR AND LINKAGE"](#).

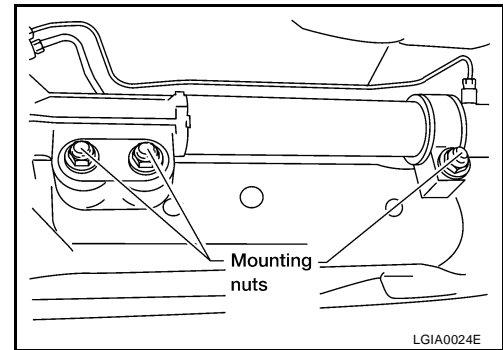

### CHECKING STEERING WHEEL PLAY

1. Turn tires straight ahead, start engine, then turn steering wheel to the left and right lightly, and measure steering wheel movement on the outer circumference when steering wheel is turned up to the point where tires start moving.

**Steering wheel play on the outer circumference : 0 – 35 mm (0 – 1.38 in)**

### CHECKING NEUTRAL POSITION ON STEERING WHEEL

- Check neutral position on steering wheel after confirming that front wheel alignment is correct. Refer to [FSU-6, "Front Wheel Alignment"](#).
1. Turn tires straight ahead, check if steering wheel is in the neutral position.
  2. If it is not in the neutral position, remove steering wheel and reinstall it correctly.
  3. If the neutral position cannot be attained by repositioning the steering wheel two teeth or less on steering stem, loosen tie-rod lock nuts of steering outer sockets, then adjust tie-rods by the same amount in the opposite direction.

### CHECKING STEERING WHEEL TURNING FORCE

1. Park vehicle on a level, dry surface and set parking brake.
2. Start engine.
3. Bring power steering fluid up to an operating temperature of approximately 60° – 80°C (140° – 176°F). Make sure the tires are inflated to specified pressure. Refer to [WT-34, "Tire"](#).
4. Check steering wheel turning force using Tool when steering wheel has been turned 360° from the neutral position.

**Tool number : J-44372**

**Steering wheel : 39 N (4 kg-f, 9 lb-f) or less  
turning force**

5. If steering wheel turning force is out of specification, inspect the following:
  - Steering column. Refer to [PS-12, "INSPECTION AFTER REMOVAL"](#).
  - Power steering oil pump. Refer to [PS-21, "CHECKING RELIEF OIL PRESSURE"](#).
6. If steering column and power steering oil pump meet specifications, replace steering gear. Refer to [PS-15, "Removal and Installation"](#).

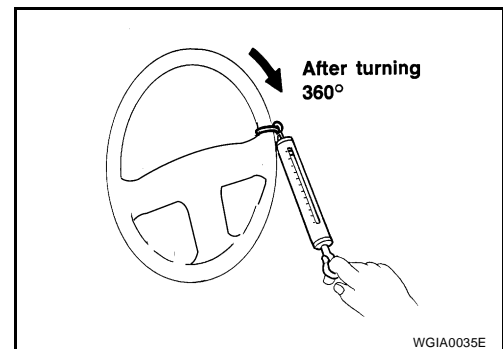



# STEERING WHEEL

## CHECKING FRONT WHEEL TURNING ANGLE

When checking front wheel turning angle, refer to [FSU-8, "FRONT WHEEL TURNING ANGLE"](#) .

## Removal and Installation

### REMOVAL

1. Set the front wheels in the straight-ahead position.
2. Remove the driver air bag module. Refer to [SRS-45, "Removal and Installation"](#) .
3. Disconnect steering wheel switches.
4. Remove the steering wheel center nut.
5. Remove the steering wheel using Tools.

**Tool number**    **A: KV481J0010 (J-1859-A)**  
                          **B: KV481J0020 (J-42578)**

### CAUTION:

**Place a piece of tape across the spiral cable so it will not be rotated out of position.**

6. Inspect the steering wheel near the puller holes for damage. If damaged, replace the steering wheel.
  - Remove steering wheel rear cover and steering wheel switches, if required.

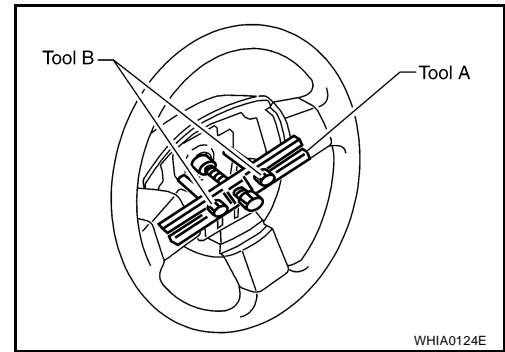

### INSTALLATION

Installation is in the reverse order of removal.

- Align spiral cable correctly when installing steering wheel. Make sure that the spiral cable is in the neutral position. The neutral position is detected by turning left 2.6 revolutions from the right end position and ending with the knob at the top.
- If equipped with VDC, refer to [BRC-62, "Adjustment of Steering Angle Sensor Neutral Position"](#) for steering angle sensor adjustment.
- After the work is completed, perform self-diagnosis to make sure no malfunction is detected. Refer to [SRS-20, "SRS Operation Check"](#) .
- Tighten steering wheel center nut to specification. Refer to [PS-9, "Removal and Installation"](#) .

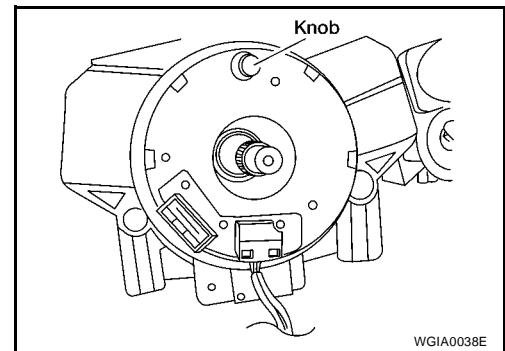

### CAUTION:

- The spiral cable may snap due to steering operation if the cable is not installed in the correct position.
- With the steering linkage disconnected, the cable may snap by turning the steering wheel beyond the limited number of turns. The spiral cable can be turned counterclockwise about 2.5 turns from the neutral position.

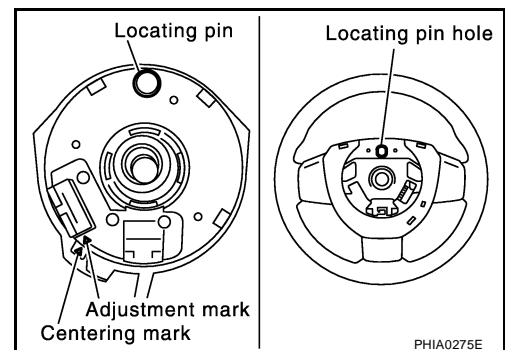

A  
B  
C  
D  
E  
F  
PS  
H  
I  
J  
K  
L  
M

# STEERING COLUMN

PFP:48810

## STEERING COLUMN

### Removal and Installation

EGS00070

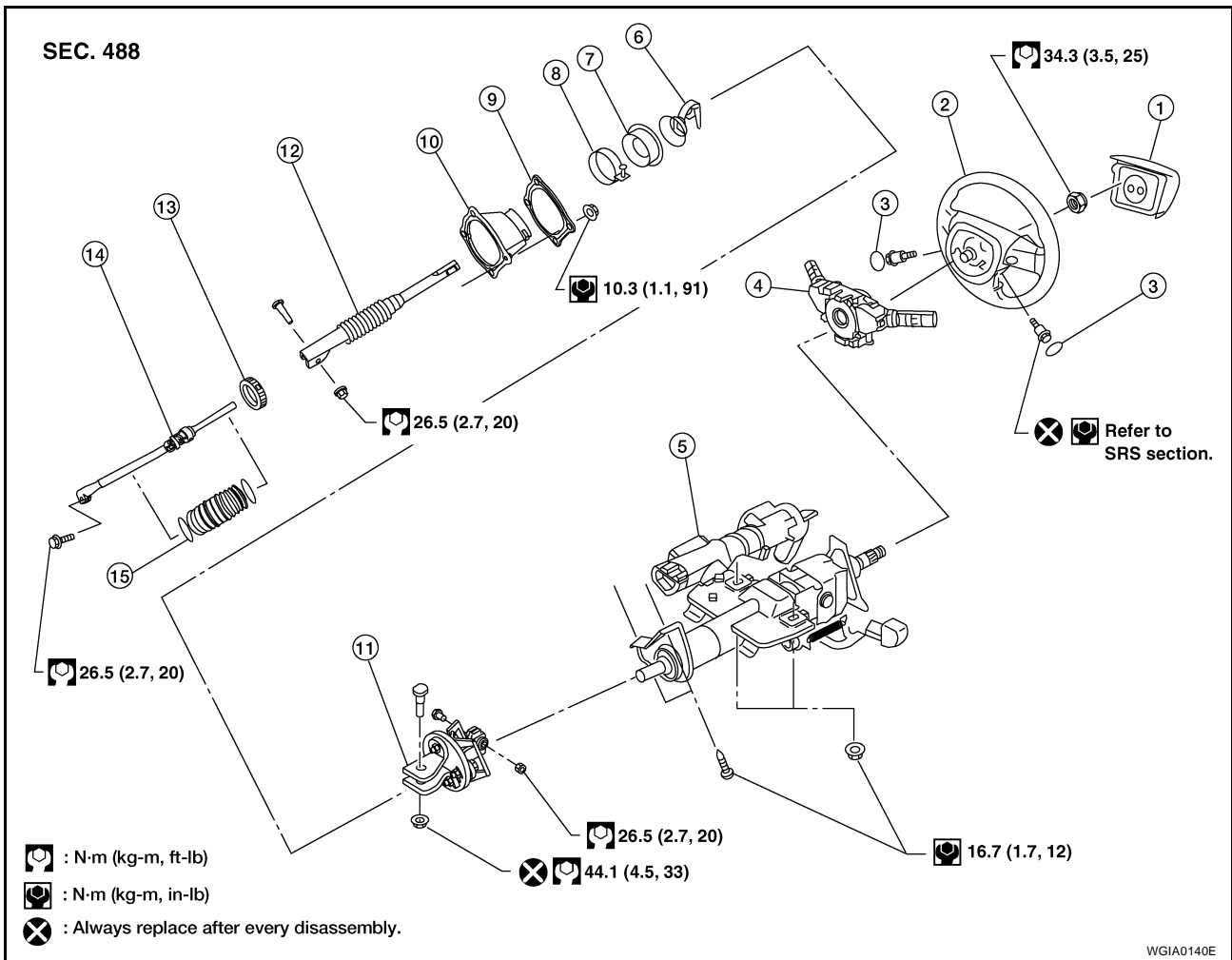

- |  |                             |                              |
|--|-----------------------------|------------------------------|
| 1. Driver air bag module               | 2. Steering wheel           | 3. Steering wheel side cover |
| 4. Combination switch and spiral cable | 5. Steering column assembly | 6. Collar                    |
| 7. Hole cover seal                     | 8. Clamp                    | 9. Hole cover mounting plate |
| 10. Hole cover                         | 11. Upper joint             | 12. Upper shaft              |
| 13. Boot clamp                         | 14. Lower joint shaft       | 15. Boot and clips (plastic) |

### CAUTION:

- Care must be taken not to give axial impact to steering column assembly during removal and installation.
- Care must be taken not to move steering gear during removal of steering column assembly.

### REMOVAL

1. Remove the combination switch and spiral cable from steering column assembly with combination switches attached. Refer to [SRS-47, "Removal and Installation"](#).

## STEERING COLUMN

2. Remove tilt lever knob from tilt lever by inserting a suitable tool into slot of tilt lever knob, then depress tab and withdraw tilt lever knob.

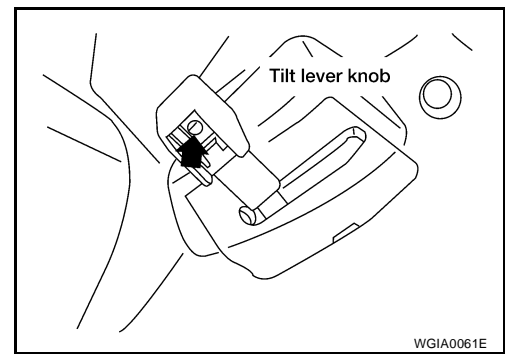

3. Remove lower instrument panel LH. Refer to [IP-12, "LOWER INSTRUMENT PANEL LH"](#).
4. Remove steering column cover and ignition key finisher. Refer to [IP-10, "Removal and Installation"](#).
5. Remove knee protector screws, then knee protector.

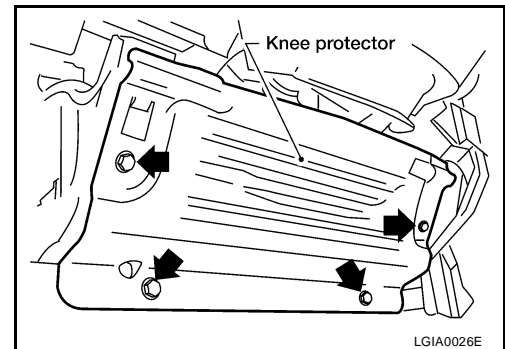

6. Remove lock nut and bolt, then separate upper joint from upper shaft.

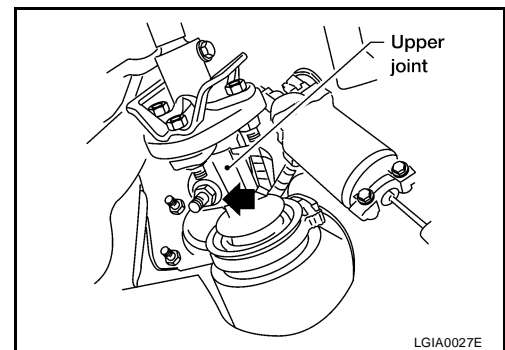

7. Remove the steering column assembly nuts and bolts, then remove steering column assembly from steering member.

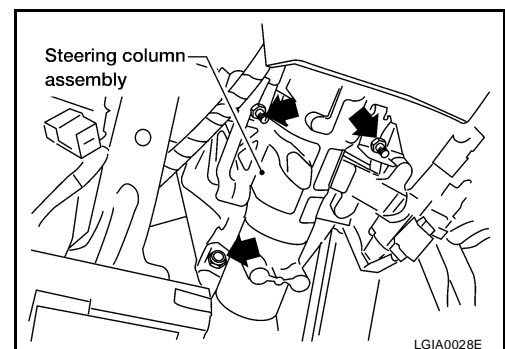

8. Remove hole cover seal and clamp.
9. Remove nuts and hole cover mounting plate and hole cover from dash panel.

# STEERING COLUMN

10. Raise vehicle, then remove lower joint shaft bolt and remove lower joint shaft and upper shaft from vehicle.
  - During lower joint detachment, insert a tool into the yoke groove to prevent gouging damage.

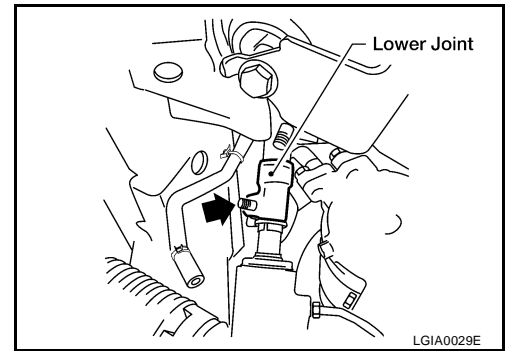

## INSPECTION AFTER REMOVAL

- Check for damage to steering column assembly jacket tube. If damage is found, replace steering column assembly with new one.
- If vehicle has been in a collision, check column length "L1" or "L2" as shown. If out of specification, replace steering column assembly with a new one.

### Column length

L1 : 158 mm (6.22 in)

L2 : 262 mm (10.31 in)

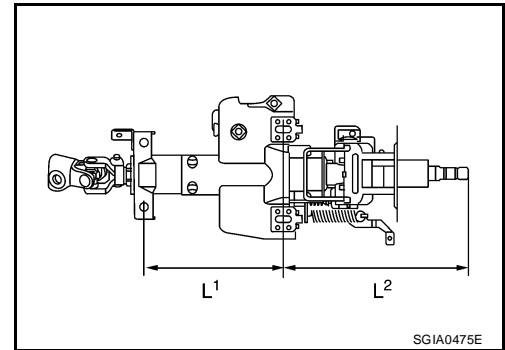

- Check for proper lubrication, apply multi-purpose grease as necessary to external joints and levers. Refer to [MA-11, "RECOMMENDED FLUIDS AND LUBRICANTS"](#).

## INSTALLATION

Installation is in the reverse order of removal.

### CAUTION:

**When installing the steering column, finger-tighten all of the lower bracket and joint bolts; then tighten them to specification. Do not apply undue stress to the steering column.**

### NOTE:

Align slit of the coupling joint with projection on dust cover. Insert the joint until surface "A" contacts surface "B".

- After installation, turn steering wheel to make sure it moves smoothly. Make sure the number of turns are the same from the straight-forward position to left and right locks. Make sure that the steering wheel is in a neutral position when driving straight ahead.
- When installing steering column to steering member, install nut from front side of vehicle.
- The lower nut on the upper joint may not be reused.

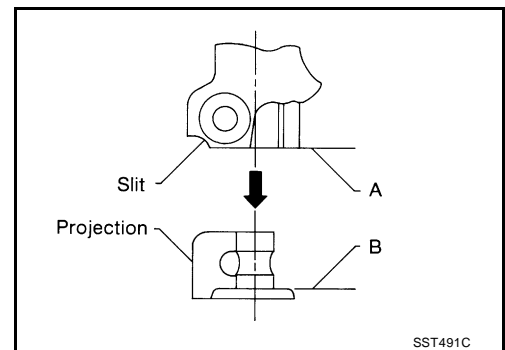

# STEERING COLUMN

## INSPECTION AFTER INSTALLATION

- After installing steering column to vehicle, check tilt device operation range is within specification.

**Range "A" : 61.3 mm (2.41 in)**

- Check if steering wheel operation can turn to the end of the left and right stops smoothly.

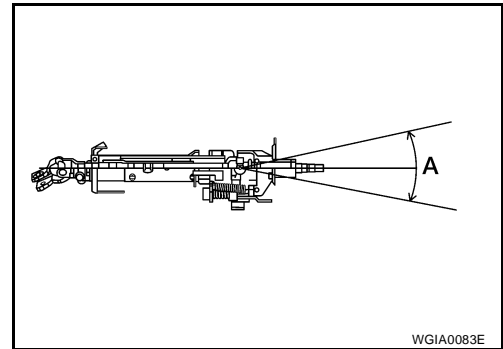

## Disassembly and Assembly

EGS000TR

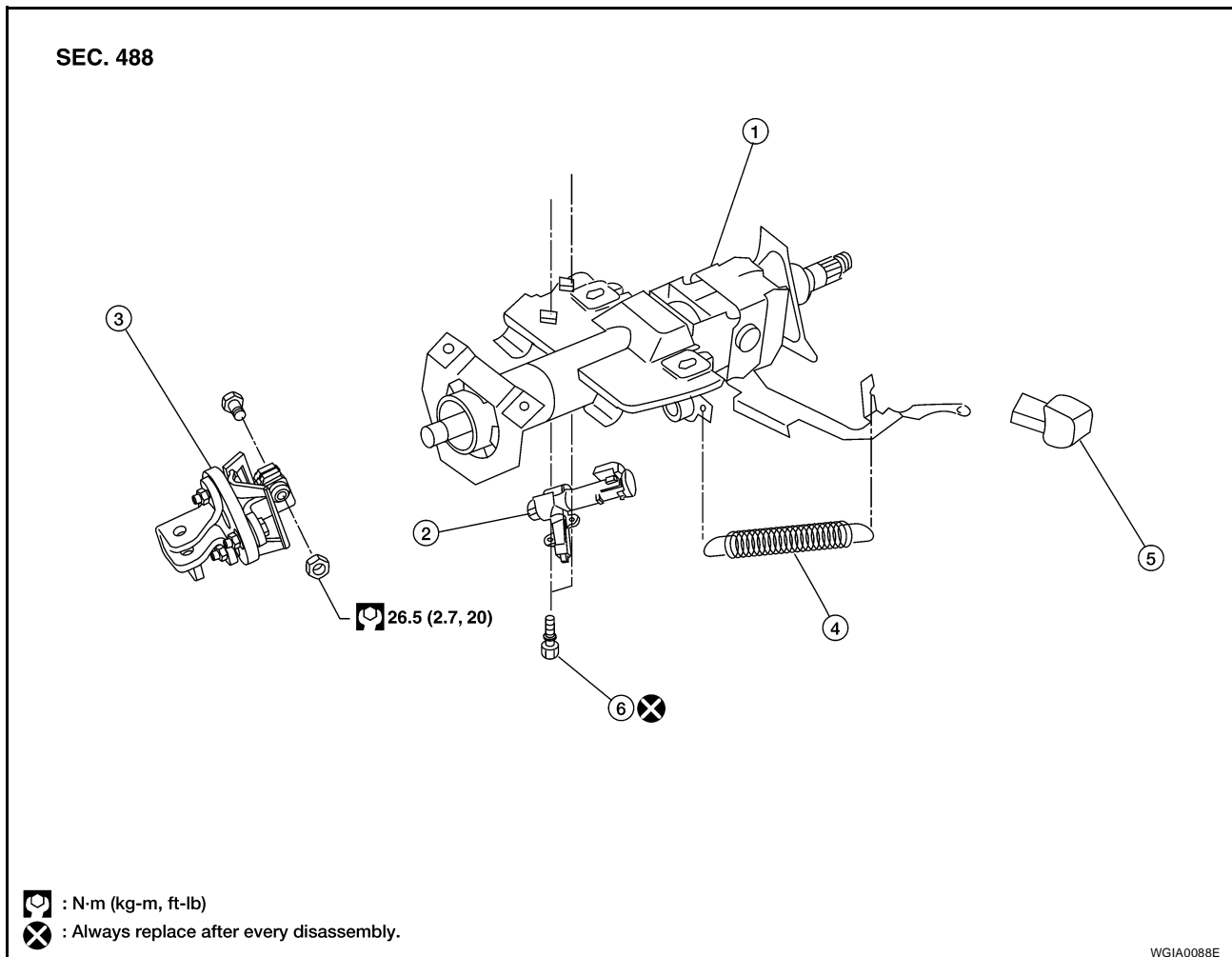

- |                             |                    |                     |
|-----------------------------|--------------------|---------------------|
| 1. Steering column assembly | 2. Ignition switch | 3. Upper joint      |
| 4. Spring                   | 5. Tilt lever knob | 6. Self-shear screw |

## DISASSEMBLY

- Remove spring from steering column assembly and tilt lever.
- Remove bolt from upper joint, then remove upper joint from steering column assembly.
- Remove ignition switch tamper resistant self-shear type screws with a drill or other appropriate tool.

# STEERING COLUMN

## ASSEMBLY

Assembly is in the reverse order of disassembly.

- Install new tamper resistant self-shear type screws.

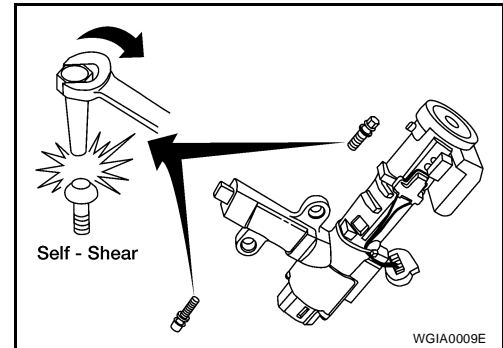

## INSPECTION AFTER ASSEMBLY

When the steering wheel does not turn smoothly, check the steering column as follows:

1. Check the column bearings for damage or unevenness. Replace the steering column as an assembly, if necessary.
2. Check the column tube for deformation or breakage. Replace the steering column as an assembly, if necessary.
3. If the vehicle has been involved in a collision, or if noise and rattles are heard during a turn, check the length (L) of the column. If out of specification, replace the steering column as an assembly.

**Steering column length (L) : 610 mm (24.02 in)**

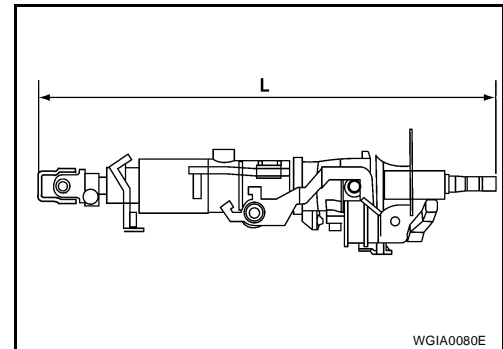

4. Check for proper lubrication of joints and levers, apply multi-purpose grease as necessary. Refer to [MA-11, "RECOMMENDED FLUIDS AND LUBRICANTS"](#).
5. Check for wear around the seal edges, replace steering column assembly as necessary.
6. Check for corrosion or pitting around the seal sliding area.
7. After installing the steering column, check the tilt mechanism for proper operation.

**Tilt mechanism range : 3° per notch at 5 steps**

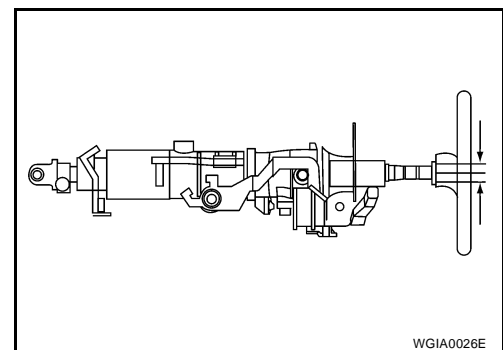

## CAUTION:

- Do not exert any load or impact in the axial direction immediately before or after column removal.
- After installation, check for smooth steering wheel rotation, without any catches or noise.
- Replace the column if it is depleted of grease, worn, damaged, or if any scratches or coating separation is present on the shaft seal area causing grease to leak out of sealed steering column assembly.

# POWER STEERING GEAR AND LINKAGE

## POWER STEERING GEAR AND LINKAGE

PF:49001

### Removal and Installation

EGS000TS

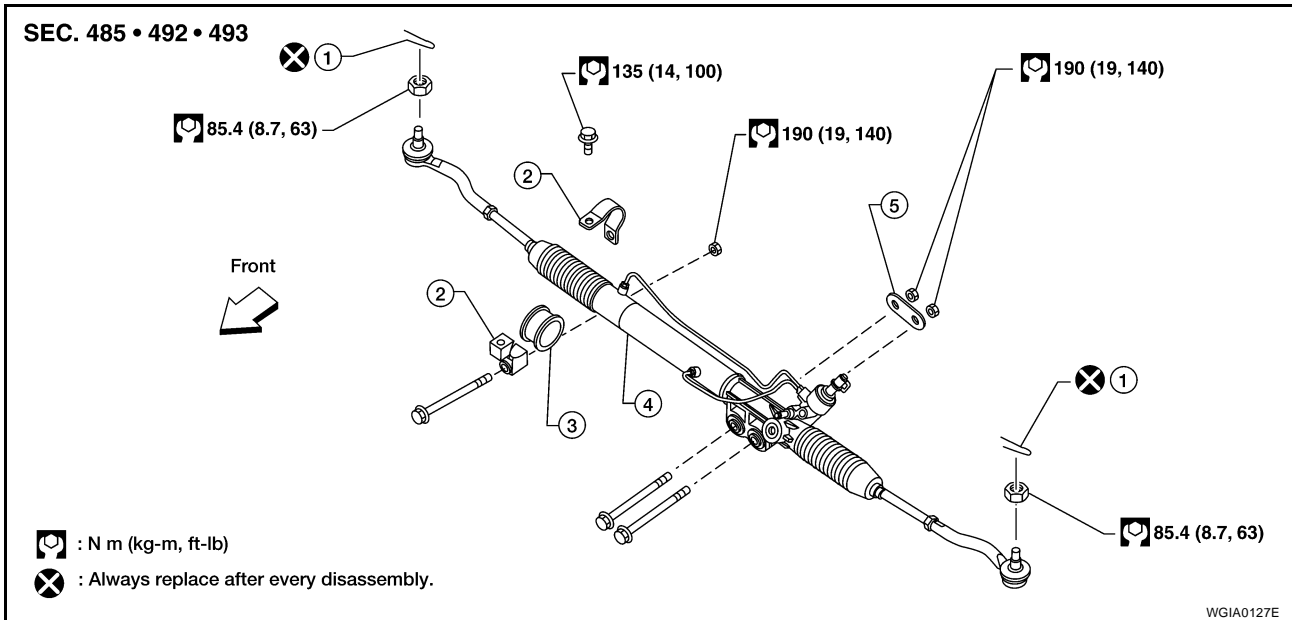

- |                           |                     |                       |
|---------------------------|---------------------|-----------------------|
| 1. Cotter pin             | 2. Mounting bracket | 3. Mounting insulator |
| 4. Steering gear assembly | 5. Washer           |                       |

#### CAUTION:

Spiral cable may snap due to steering operation if steering column is separated from steering gear assembly. Therefore secure steering wheel to avoid turning.

#### REMOVAL

1. Turn wheels to the straight-ahead position.
2. Remove tires from vehicle using power tool.
3. Remove undercover using power tool.
4. On 4WD model, remove front final drive, then support drive shafts with wire. Refer to [FFD-12, "Removal and Installation"](#).
5. Remove cotter pin at steering outer socket and discard, then loosen nut.
6. Remove steering outer socket from steering knuckle using Tool. Be careful not to damage ball joint boot.

#### CAUTION:

Temporarily tighten mounting nut to prevent damage to threads and to prevent Tool from coming off.

**Tool number** : HT72520000 (J-25730-A)

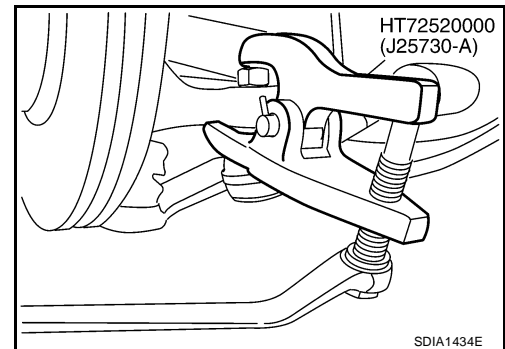

7. On 2WD model, remove stabilizer bar bracket bolts and reposition stabilizer bar. Refer to [FSU-12, "Removal and Installation"](#).

## POWER STEERING GEAR AND LINKAGE

8. Disconnect oil piping (high pressure side and low pressure side) from steering gear assembly, then drain fluid from piping.

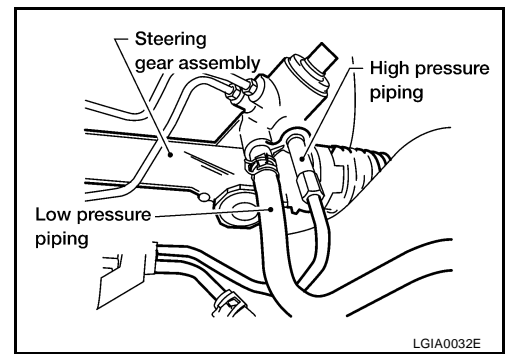

9. Remove lower joint bolt of lower joint shaft.

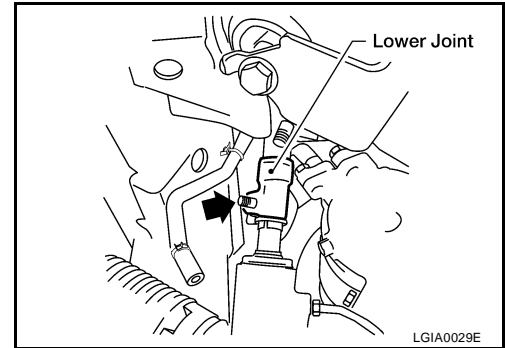

10. Remove nuts of steering gear assembly using power tool, then remove bolts and steering gear assembly.

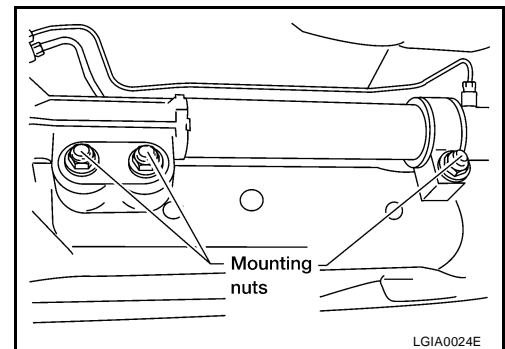

### INSTALLATION

Installation is in the reverse order of removal.

- After removing/installing or replacing steering components, check wheel alignment. Refer to [FSU-6, "Front Wheel Alignment"](#).
- After adjusting wheel alignment, adjust neutral position of steering angle sensor. Refer to [BRC-62, "Adjustment of Steering Angle Sensor Neutral Position"](#).
- With steering wheel in straight ahead position, make sure slit of lower joint fits with the projection on rear cover cap, while checking that mark on steering gear assembly aligns with mark on rear cover cap. Insert the joint until surface "A" contacts surface "B".

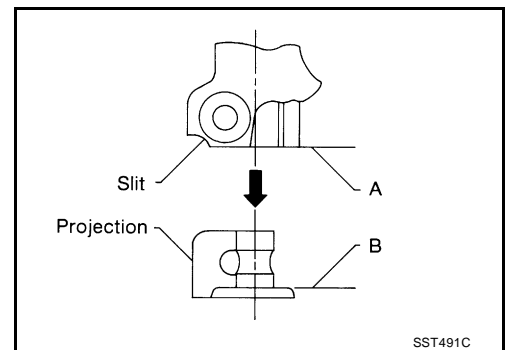

- After installation, bleed the air from the steering hydraulic system. Refer to [PS-6, "Air Bleeding Hydraulic System"](#).



# POWER STEERING GEAR AND LINKAGE

## INSPECTION AFTER INSTALLATION

Check if steering wheel turns smoothly when it is turned several times fully to the left and right lock positions.

## Disassembly and Assembly

EGS00129

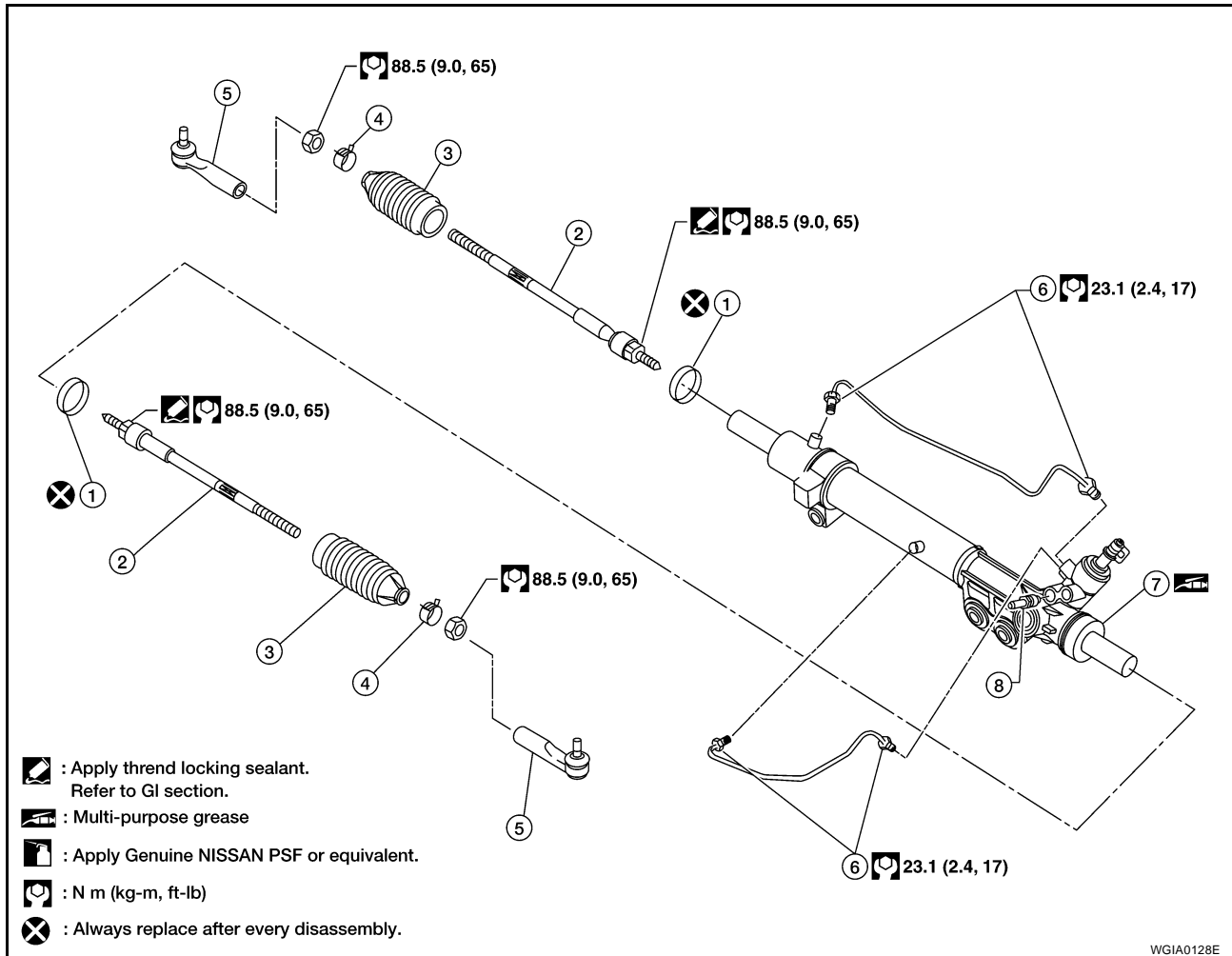

- |                          |                 |                   |
|--------------------------|-----------------|-------------------|
| 1. Boot clamp            | 2. Inner socket | 3. Boot           |
| 4. Boot clamp            | 5. Outer socket | 6. Cylinder tubes |
| 7. Gear housing assembly | 8. Connector    |                   |

### CAUTION:

- Secure steering gear assembly with a vise, using copper plates or something similar to prevent it from being damaged. Do not grip cylinder with a vise.
- Before performing disassembly, clean steering gear assembly with kerosene. Be careful not to bring any kerosene into contact with the discharge and return port connectors.

### DISASSEMBLY

- Remove cylinder tubes from gear housing assembly.
- Loosen lock nuts of outer sockets, and remove outer sockets.
- Remove boot clamps of the small diameter side and the large diameter side, then remove boot.

### CAUTION:

When removing boots, be careful not to damage inner socket and gear housing assembly. If they are damaged, change them to avoid oil leaks.

- Remove inner sockets.

# POWER STEERING GEAR AND LINKAGE

## INSPECTION AFTER DISASSEMBLY

### Boot

Check boot for tears, cracks and deformation. Replace if necessary.

### Gear Housing Assembly

Check gear housing assembly for dents, cracks or damage. Replace as an assembly if necessary.

### Outer Socket and Inner Socket

#### SWING TORQUE

- Measure the swing torque, using Tool. When ball stud and inner socket start moving the measured value must be within the specification. If the reading is outside the specification, replace the socket.

**Tool number : — (J-44372)**

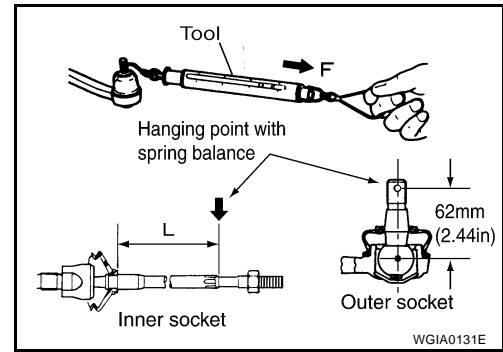

Item	Outer socket	Inner socket
Measuring point	Cotter pin hole of stud	Shown as L: 83.2 mm (3.276 in)
Swing torque	0.3 – 2.9 N·m (0.03 – 0.29 kg·m, 3 – 25 in·lb)	1.0 – 7.8 N·m (0.11 – 0.79 kg·m, 9 – 69 in·lb)
Measuring value (F)	4.84 – 46.7 N (0.50 – 4.7 kg·f, 4 - 34 lb·f)	12.1 – 93.7 N (1.3 – 9.5 kg, 9 – 69 lb)

#### ROTATING TORQUE

- Measure the rotating torque, using Tool. If the value is outside the specification, replace the outer sockets.

**Tool number : ST3127S000 (J-25765-A)**

**Rotating torque : 0.3 – 2.9 N·m (0.03 – 0.29 kg·m, 3 – 25 in·lb)**

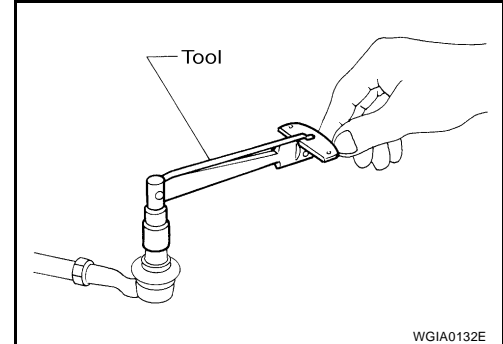

#### AXIAL END PLAY

- Apply a load of 490 N (50 kg·f, 110 lb·f) to the ball stud axially. Use a dial gauge to measure the amount of the movement that the stud makes. If the value is outside the specification, replace the sockets.

**Outer socket : 0.5 mm (0.020 in) or less**

**Inner socket : 0.2 mm (0.008 in) or less**

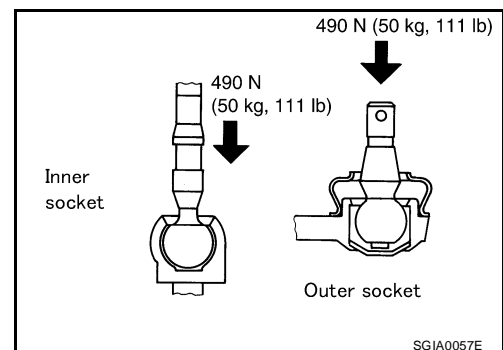

# POWER STEERING GEAR AND LINKAGE

## ASSEMBLY

1. Install the inner sockets.
2. Install the large-diameter side of the boots to the gear housing assembly.
3. Install the small-diameter side of the boots to the groove of the inner sockets.

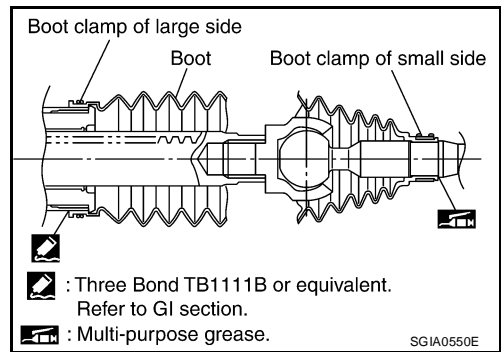

4. Install the boot clamps to the boots, as shown.

### CAUTION:

Do not reuse the large-diameter boot clamps.

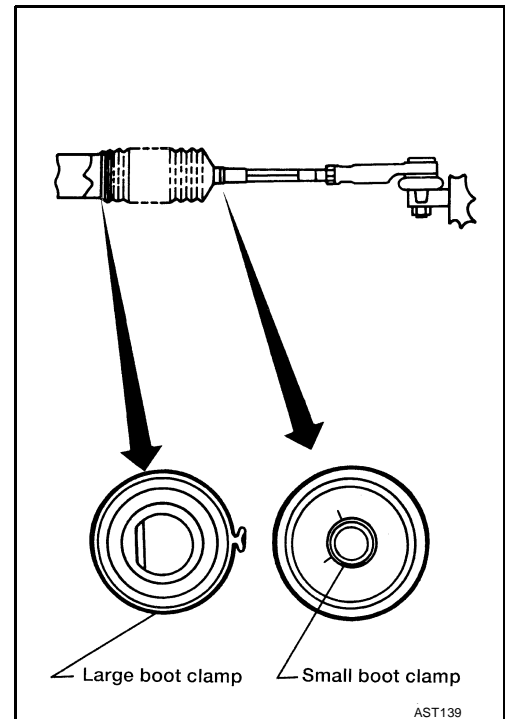

5. Crimp the large-diameter boot clamps, using Tool.  
**Tool number** : KV40107300 ( — )
6. Install the cylinder tubes to the gear housing assembly.
7. Install the lock nuts and outer sockets to the inner sockets.

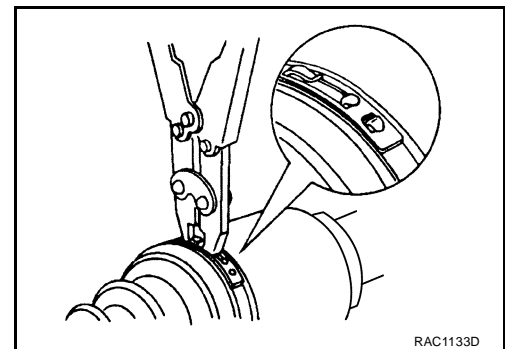

A  
B  
C  
D  
E  
F  
PS  
H  
I  
J  
K  
L  
M

## POWER STEERING GEAR AND LINKAGE

8. Thread the outer sockets onto the inner sockets to the specified length "L", then tighten the lock nuts to the specification. Refer to [PS-17, "Disassembly and Assembly"](#) . Reconfirm that the tie-rod length "L" is within specification.

**Maximum inner socket : 115.2 mm (4.54 in)  
length "L"**

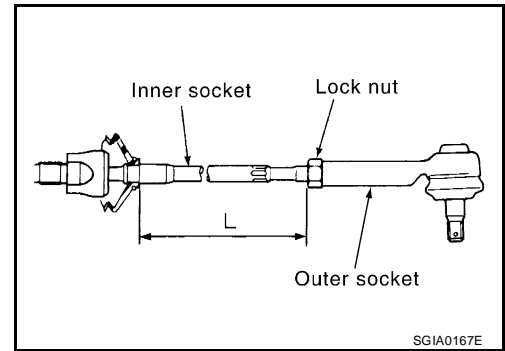

# POWER STEERING OIL PUMP

PF:49110

EGS000TU

## POWER STEERING OIL PUMP

### On-Vehicle Inspection and Service CHECKING RELIEF OIL PRESSURE

#### CAUTION:

Before starting work, confirm belt tension is correct. Refer to [EM-13, "Checking Drive Belts"](#).

1. Connect Tool between oil pump discharge connector and high pressure hose and then bleed air from the hydraulic circuit.

Tool number:		
Pressure gauge and shut-off valve		KV48103500 (J26357 and J26357-10)
Oil pump side	Connector A and O-ring	KV48105300-4 and 5295262U10 ( — )
	Eye-bolt and O-ring	KV48105300-3 and 5295262U00 ( — )
High pressure piping side	Connector B and O-ring	KV48105300-1 and 5295262U00 ( — )
	Nut	KV48105300-2 ( — )

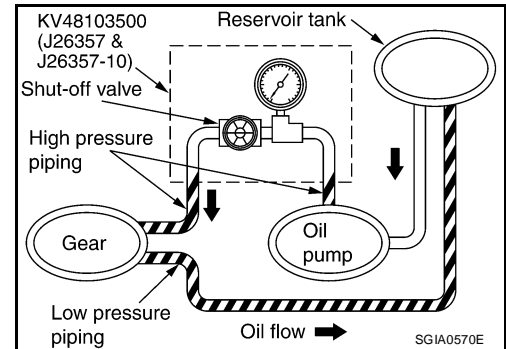

2. Start engine. Allow engine to run until tank temperature reaches 50 – 80°C (122 – 176°F).

#### CAUTION:

- Warm up engine with shut-off valve fully opened. If engine is started with shut-off valve closed, fluid pressure in power steering pump increases to maximum. This will raise fluid temperature excessively.
- Be careful not to contact hose with belt when engine is started.

3. With engine at idle, close shut-off valve and read the relief oil pressure.

**Relief oil pressure : 9.0 – 9.8 mPa (91.77 – 99.93 kg/cm<sup>2</sup> , 1305.34 – 1421.37 psi)**

#### CAUTION:

**Do not close shut-off valve of pressure gauge for more than 10 seconds.**

4. After measurement, open shut-off valve slowly.
  - If relief oil pressure is outside the specification, disassemble and repair oil pump. Refer to [LU-14, "OIL PUMP"](#).
5. After inspection, disconnect oil pressure gauge and oil pressure gauge adapter from hydraulic circuit, connect oil pump discharge connector and high pressure hose. Add fluid and bleed air from hydraulic circuit thoroughly. Refer to [PS-6, "Air Bleeding Hydraulic System"](#).

## Removal and Installation

### REMOVAL

EGS000TV

1. Drain power steering fluid from reservoir tank.
2. Remove engine room cover. Refer to [EM-12, "Removal and Installation"](#).
3. Remove air duct assembly. Refer to [EM-15, "Removal and Installation"](#).
4. Remove power steering reservoir tank.
5. Remove serpentine drive belt from auto tensioner and power steering pump. Refer to [EM-13, "Removal and Installation"](#).
6. Disconnect pressure sensor electrical connector.
7. Remove high pressure and low pressure piping from power steering oil pump. Refer to [PS-23, "HYDRAULIC LINE"](#).
8. Remove mounting bolts, then remove power steering pump.

### INSTALLATION

Installation is in the reverse order of removal. Refer to [PS-23, "HYDRAULIC LINE"](#) for tightening torque.

- After installation, bleed air. Refer to [PS-6, "Air Bleeding Hydraulic System"](#).

#### NOTE:

Belt tension is automatic and requires no adjustment.

# POWER STEERING OIL PUMP

## Disassembly and Assembly

EGS0012A

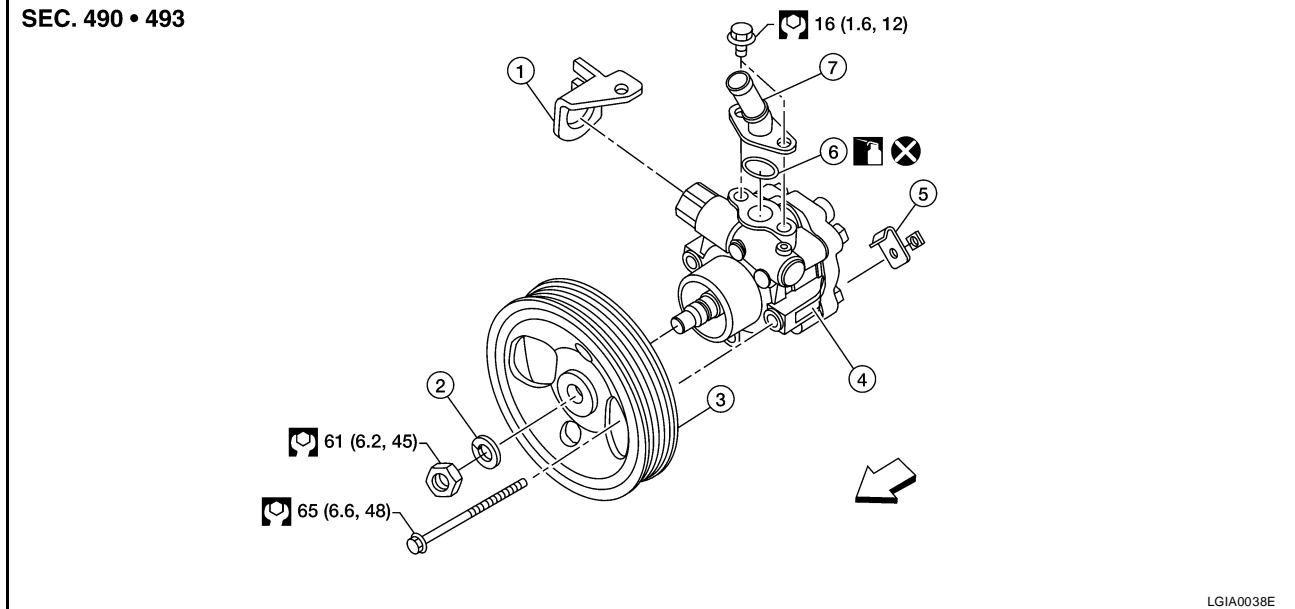

- |                        |                               |           |
|------------------------|-------------------------------|-----------|
| 1. Bracket             | 2. Spring washer              | 3. Pulley |
| 4. Power steering pump | 5. High pressure hose bracket | 6. O-ring |
| 7. Suction pipe        | ← Front                       |           |

### INSPECTION BEFORE DISASSEMBLY

Disassemble the power steering oil pump only if the following items are found.

- Deformed or damaged pulley, bracket, connector or suction pipe.
- Oil leakage from the suction pipe or connector.

### DISASSEMBLY

#### NOTE:

Mount the power steering oil pump in a vise as needed.

1. Remove the connector bolt, connector and copper washers.

#### CAUTION:

**Do not reuse the copper washers.**

2. Remove the suction pipe and O-ring.

#### CAUTION:

**Do not reuse the O-ring.**

3. Remove the pulley nut and pulley.
4. Remove the bracket bolts and bracket.

### INSPECTION AFTER DISASSEMBLY

#### Body Assembly Inspection

Check the power steering oil pump body assembly for damage. If any damage is found, replace with a new power steering oil pump assembly.

### ASSEMBLY

Assembly is in the reverse order of disassembly.

#### CAUTION:

- **Do not reuse the copper gaskets**
- **Do not reuse the O-ring. Apply a coat of Genuine Nissan PSF or equivalent to the O-ring.**

# HYDRAULIC LINE

PFP:49721

## HYDRAULIC LINE

### Removal and Installation

EGS000TX

Refer to the following illustration for hydraulic line removal.

SEC. 490 • 492 • 497

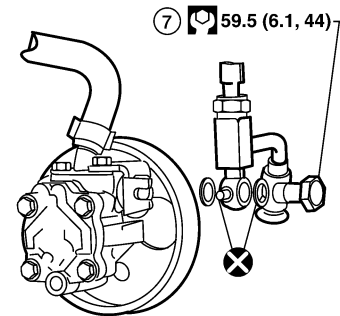
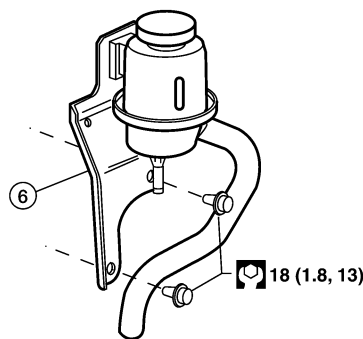
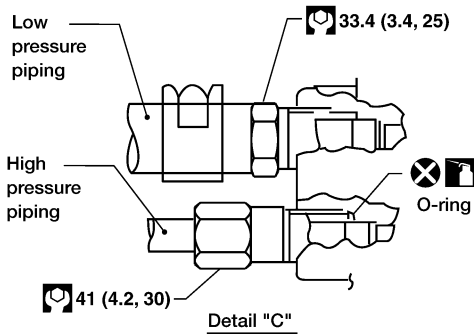
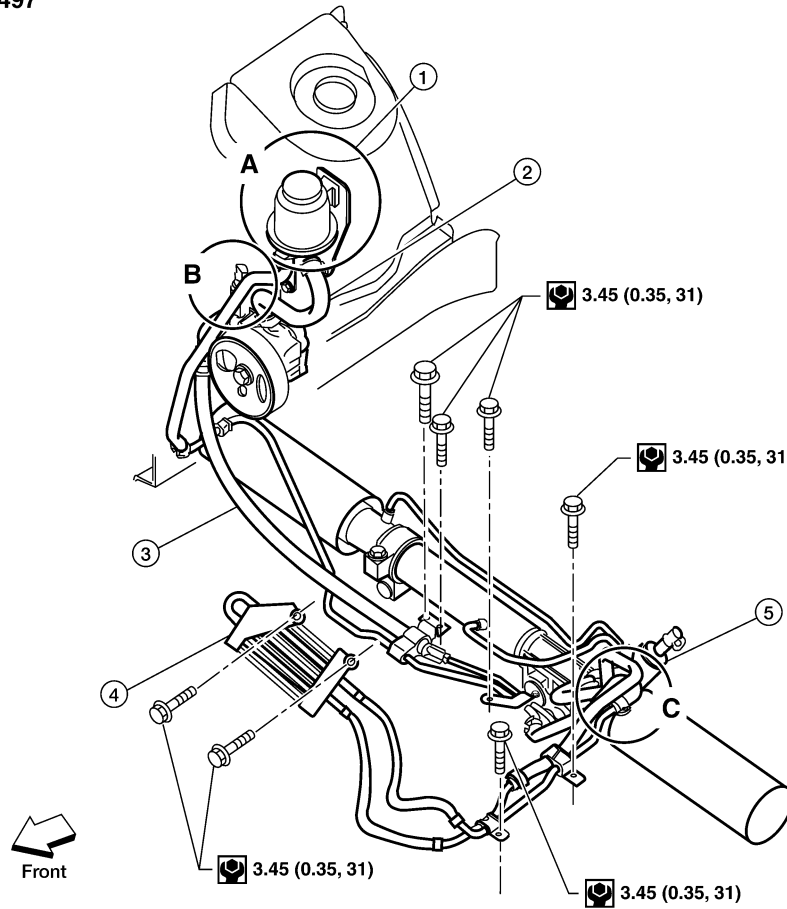

- : Lubricate with engine oil
- : N m (kg-m, ft-lb)
- : N m (kg-m, in-lb)
- : Always replace after every disassembly.

- |                   |                           |                           |
|-------------------|---------------------------|---------------------------|
| 1. Reservoir tank | 2. Suction hose           | 3. High pressure hose     |
| 4. Oil cooler     | 5. Steering gear assembly | 6. Reservoir tank bracket |
| 7. Eye bolt       |                           |                           |

WGIA0096E

# HYDRAULIC LINE

Installation is in the reverse order of removal.

- Confirm mating marks are aligned with hose and clamp, then correct if needed.

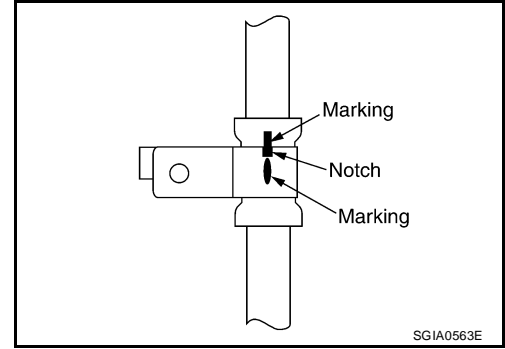

- To install eye joint, align projection of eye joint with notch of power steering pump, and attach eye joint to power steering pump properly. Tighten eye bolt by hand fully, then torque to specification.

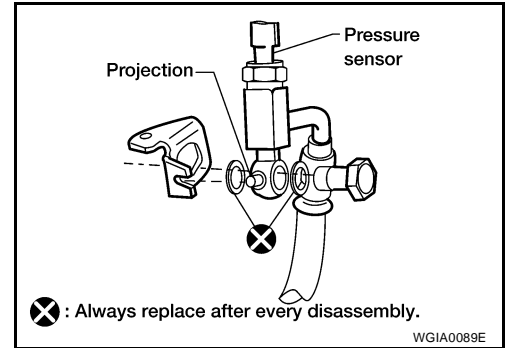



# SERVICE DATA AND SPECIFICATIONS (SDS)

## SERVICE DATA AND SPECIFICATIONS (SDS)

PF0:00030

### Steering Wheel

EGS000TY

End play of the axle direction for steering wheel	0 mm (0 in)
Steering wheel play on the outer circumference	0 – 35 mm (0 – 1.38 in)

### Steering Column

EGS000TZ

Unit: mm (in)

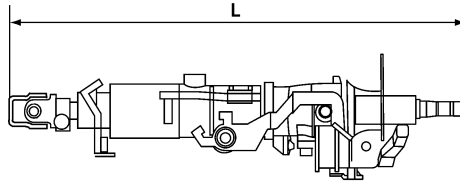

WGIA0080E

Steering column assembly length "L"	610 (24.02)
-------------------------------------	-------------

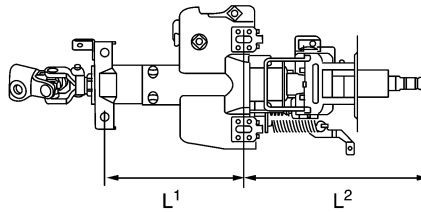

SGIA0475E

Steering column length "L1"	158 (6.22)
Steering column length "L2"	262 (10.31)

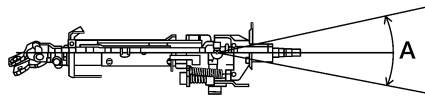

WGIA0083E

Tilt range "A"	61.3 (2.41)
Tilt mechanism range	3° per notch at 5 steps

# SERVICE DATA AND SPECIFICATIONS (SDS)

## Steering Outer Socket and Inner Socket

EGS000U0

Steering gear type	PR26AM
--------------------	--------

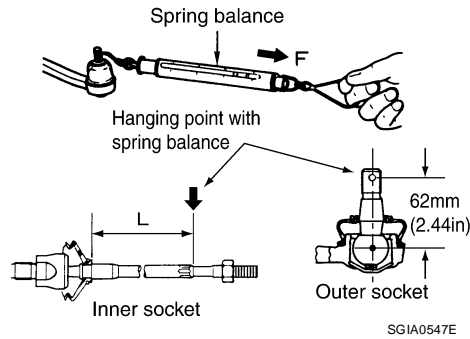

Tie-rod ball joint outer socket	Swinging torque	0.3 – 2.9 N·m (0.03 – 0.29 kg-m, 3 – 25 in-lb)
	Measurement on spring balance ● Measuring point: cotter pin hole of stud	4.84 – 46.7 N (0.50 – 4.7 kg-f, 4 – 34 lb-f)
	Rotating torque	0.3 – 2.9 N·m (0.03 – 0.29 kg-m, 3 – 25 in-lb)
	Axial end play	0.5 mm (0.020 in) or less
Tie-rod ball joint inner socket	Swinging torque	1.0 – 7.8 N·m (0.11 – 0.79 kg-m, 9 – 69 in-lb)
	Measurement on spring balance ● Measuring point: L mark see above, L=83.2 mm (3.276 in).	12.1 – 93.7 N (1.3 – 9.5 kg-f, 9 – 69 lb-f)
	Axial end play	0.2 mm (0.008 in) or less

## Tie-rod

EGS0012B

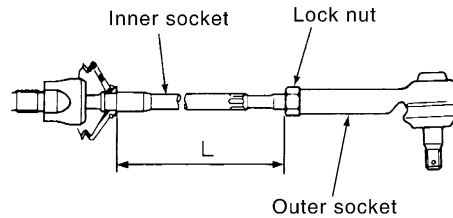

Tie-rod maximum length "L"	115.2 mm (4.54 in)
----------------------------	--------------------

## Steering Gear

EGS000U1

Steering gear model	PR26AM
---------------------	--------

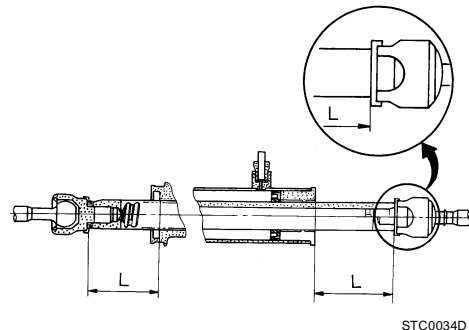

Rack neutral position, dimension "L" (rack stroke)	85.5 mm (3.36 in)
--	-------------------

## SERVICE DATA AND SPECIFICATIONS (SDS)

Steering gear model		PR26AM	
Rack sliding force	At the neutral point: Range within $\pm 11.5$ mm ( $\pm 0.453$ in) from the neutral position (in power ON)	Area average value	250.1 – 308.9 N (25.5 – 31.5 kg, 56.2 – 69.5 lb)
		Area minimum value	200 N (20.4 kg, 45 lb)
		Allowable variation	98 N (10 kg, 22 lb) or less

### Oil Pump

EGS000U2

Oil pump relief hydraulic pressure	9.0 – 9.8 mPa (91.77 – 99.93 kg/cm <sup>2</sup> , 1305.34 – 1421.37 psi)
------------------------------------	--

### Steering Fluid

EGS000U3

Fluid capacity	Approx. 1.0 ℓ (2 1/8 US pt, 1 3/4 Imp pt)
----------------	---

A  
B  
C  
D  
E  
F  
PS  
H  
I  
J  
K  
L  
M

# SERVICE DATA AND SPECIFICATIONS (SDS)

---