

SECTION **RAX**  
REAR AXLE

A  
B  
C

RAX

CONTENTS

E

<b>PRECAUTIONS</b> .....	2	<b>REAR DRIVE SHAFT</b> .....	7	F
Caution .....	2	Removal and Installation .....	7	
<b>PREPARATION</b> .....	3	REMOVAL .....	7	
Special Service Tools (SST) .....	3	INSPECTION AFTER REMOVAL .....	7	G
Commercial Service Tools .....	3	INSTALLATION .....	7	
<b>NOISE, VIBRATION, AND HARSHNESS (NVH)</b>		Disassembly and Assembly .....	8	
<b>TROUBLESHOOTING</b> .....	4	DISASSEMBLY .....	8	H
NVH Troubleshooting Chart .....	4	INSPECTION AFTER DISASSEMBLY .....	9	
<b>WHEEL HUB</b> .....	5	ASSEMBLY .....	10	
On-Vehicle Inspection and Service .....	5	<b>SERVICE DATA AND SPECIFICATIONS (SDS)</b> .....	13	I
WHEEL BEARING INSPECTION .....	5	Wheel Bearing .....	13	
Removal and Installation .....	5	Drive Shaft .....	13	
REMOVAL .....	5			J
INSTALLATION .....	6			

J

K

L

M

# PRECAUTIONS

---

## PRECAUTIONS

PF0:00001

### Caution

EDS001TZ

Observe the following precautions when disassembling and servicing drive shaft.

- Perform work in a location which is as dust-free as possible.
- Before disassembling and servicing, clean the outside of parts.
- Prevention of the entry of foreign objects must be taken into account during disassembly of the service location.
- Disassembled parts must be carefully reassembled in the correct order. If work is interrupted, a clean cover must be placed over parts.
- Paper shop cloths must be used. Fabric shop cloths must not be used because of the danger of lint adhering to parts.
- Disassembled parts (except for rubber parts) should be cleaned with kerosene which shall be removed by blowing with air or wiping with paper shop cloths.

# PREPARATION

## PREPARATION

PF0:00002

### Special Service Tools (SST)

EDS001U0

The actual shapes of the Kent-Moore tools may differ from those of the special service tools illustrated here.

Tool number (Kent-Moore No.) Tool name	Description
KV38100500 ( — ) Drift	Installing drive shaft plug <b>a: 80 mm (3.15 in) dia.</b> <b>b: 60 mm (2.36 in) dia.</b>
KV38102200 ( — ) Drift	Installing drive shaft plug <b>a: 90 mm (3.54 in) dia.</b> <b>b: 31 mm (1.22 in) dia.</b>

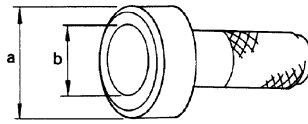

ZZA0701D

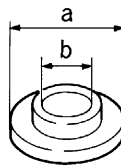

ZZA0920D

### Commercial Service Tools

EDS001U1

Tool name	Description
Power tools	Removing bolts and nuts

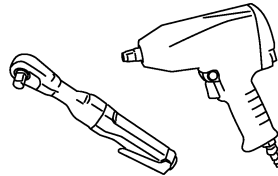

PBIC0190E

A  
B  
C  
RAX  
E  
F  
G  
H  
I  
J  
K  
L  
M

# NOISE, VIBRATION, AND HARSHNESS (NVH) TROUBLESHOOTING

## NOISE, VIBRATION, AND HARSHNESS (NVH) TROUBLESHOOTING

PF0:00003

### NVH Troubleshooting Chart

EDS001U2

Use chart below to help you find the cause of the symptom. If necessary, repair or replace these parts.

Reference page		Possible cause and SUSPECTED PARTS													
		Excessive joint angle	Joint sliding resistance	Imbalance	Improper installation, looseness	Parts interference	REAR FINAL DRIVE	FRONT AXLE	FRONT SUSPENSION	REAR SUSPENSION	TIRES	ROAD WHEEL	PROPELLER SHAFT	BRAKES	STEERING
Symptom	Noise	x	x		x	x	x	x	x		x	x	x	x	x
	Shake	x		x	x	x		x	x		x	x	x	x	x
	Vibration				x	x		x	x	x	x	x			x
	Shimmy				x	x		x	x		x	x		x	x
	Shudder				x			x	x		x	x		x	x
	Poor quality ride or handling				x	x		x	x	x	x	x			x

x: Applicable

# WHEEL HUB

## WHEEL HUB

PFP:43202

### On-Vehicle Inspection and Service

EDS001U3

Inspect the components for any looseness or back lash. Inspect each component for any excessive wear or damage. Replace any components as necessary.

### WHEEL BEARING INSPECTION

- Move the wheel hub and bearing assembly in the axial direction by hand to check the axial end play. Check that the axial end play is with specification. Replace the wheel hub and bearing assembly as necessary.

**Axial end play : 0 mm (0 in)**

- Rotate the wheel hub and bearing assembly to check that there are no unusual noises or other abnormal conditions. Replace the wheel hub and bearing assembly as necessary.

### Removal and Installation

EDS001U4

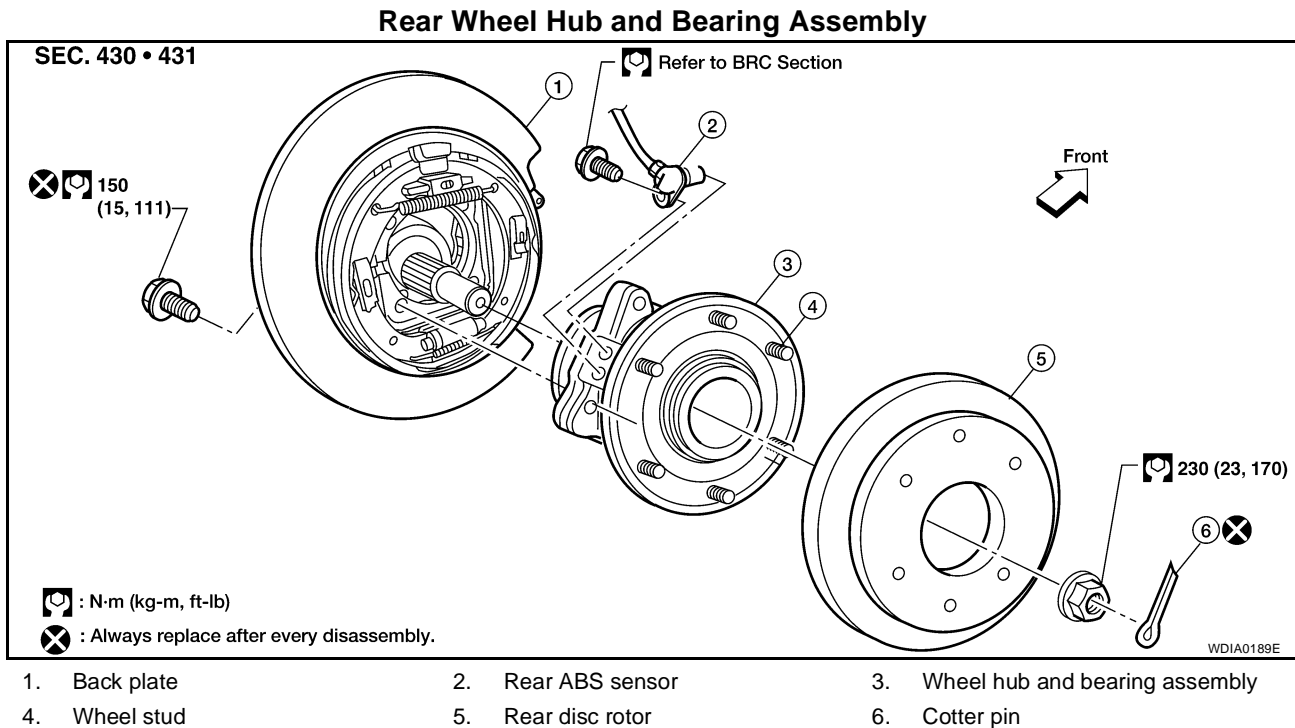

#### NOTE:

The rear ABS sensor is routed through the back of the rear backing plate and into the side of the wheel hub and bearing assembly. It is necessary to remove the wheel hub and bearing assembly to remove the rear ABS sensor.

#### REMOVAL

1. Remove the wheel and tire using power tool.
2. Remove the rear brake caliper, without disconnecting the hydraulic hose, using power tool. Reposition the rear brake caliper aside using suitable wire. Refer to [BR-28, "Removal and Installation of Brake Caliper and Disc Rotor"](#).

#### NOTE:

- Do not depress the brake pedal while the brake caliper is removed.
3. Remove the rear disc rotor.

# WHEEL HUB

4. Remove the cotter pin, then remove the nut from the drive shaft using power tool.
  - Discard the cotter pin, use a new one for installation.
5. Remove the drive shaft. Refer to [RAX-7, "REAR DRIVE SHAFT"](#)

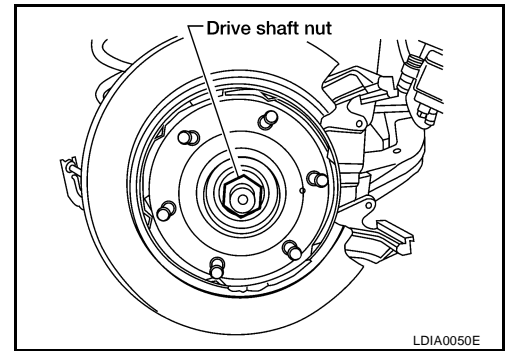

6. Remove the four wheel hub and bearing assembly bolts using power tool.
  - Discard the four wheel hub and bearing assembly bolts, use new ones for installation.
7. Pull out the wheel hub and bearing assembly for access to remove the rear ABS sensor from the wheel hub and bearing assembly as shown.
  - Inspect the ABS sensor O-ring, replace the ABS sensor assembly if damaged.
  - Clean the ABS sensor hole and mounting surface with a suitable brake cleaner and a clean lint-free shop rag. Be careful that dirt and debris do not enter the axle bearing area.
  - Apply a coat of suitable grease to the ABS sensor O-ring and mounting hole.

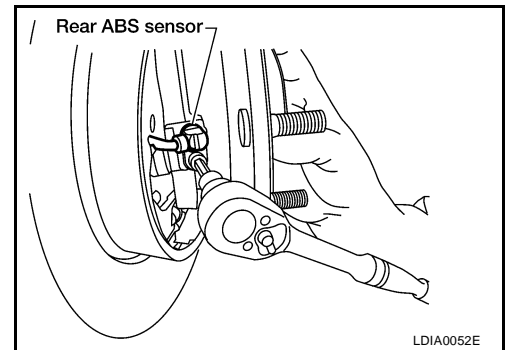

**CAUTION:**

**Do not pull on the ABS harness.**

8. Remove the wheel hub and bearing assembly.

## INSTALLATION

Installation is in the reverse order of removal.

- Inspect the ABS sensor O-ring, replace the ABS sensor assembly if damaged.
- Clean the ABS sensor hole and mounting surface with a suitable brake cleaner and a clean lint-free shop rag. Be careful that dirt and debris do not enter the axle bearing area.
- Apply a coat of suitable grease to the ABS sensor O-ring and mounting hole.
- Use a new cotter pin for installation.
- Use new wheel hub and bearing assembly bolts for installation.

# REAR DRIVE SHAFT

PDF:39600

EDS001U5

## REAR DRIVE SHAFT

### Removal and Installation REMOVAL

1. Remove the wheel and tire using power tool.
2. Remove the stabilizer bar clamp. Refer to [RSU-26, "Components"](#).
3. Remove the cotter pin and discard, then remove the lock nut from the drive shaft.
  - Do not reuse the cotter pin, discard after removal and use a new cotter pin for installation.

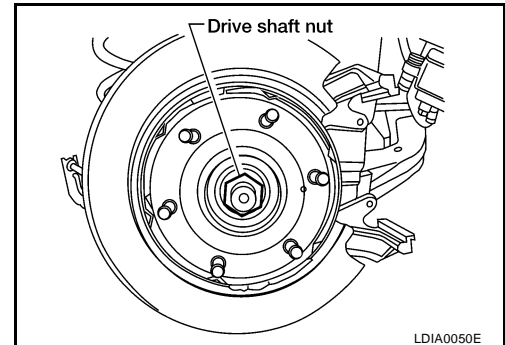

4. Remove the six bolts from the inside flange of the drive shaft using power tool.
  - Do not reuse the drive shaft inside flange bolts and washers, discard after removal and use new bolts and washers for installation.
5. Separate the drive shaft from the wheel hub and bearing assembly by lightly tapping the end with a suitable hammer and wood block. If it is difficult to separate, use a suitable puller.
6. Remove the drive shaft.

#### **CAUTION:**

**When removing the drive shaft, do not bend at an excessive angle to the drive shaft joint. Do not excessively extend the slide joint.**

### INSPECTION AFTER REMOVAL

- Move the joint up and down, left and right, and in the axial direction. Check for any rough movement or significant looseness.
- Check the boot for cracks or other damage, and for any grease leakage.
- If necessary, disassemble the drive shaft, and repair as necessary.

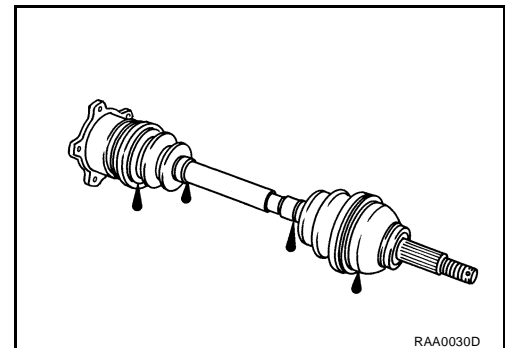

### INSTALLATION

Installation is in the reverse order of removal.

- Do not reuse the drive shaft inside flange bolts and washers, discard after removal and use new bolts and washers for installation.
- Do not reuse the cotter pin, discard after removal and use a new cotter pin for installation.

**Drive shaft lock nut** : Refer to [RAX-5, "Removal and Installation"](#).

**Drive shaft inside flange bolts** : Refer to [RAX-7, "REAR DRIVE SHAFT"](#).

# REAR DRIVE SHAFT

EDS001U6

## Disassembly and Assembly

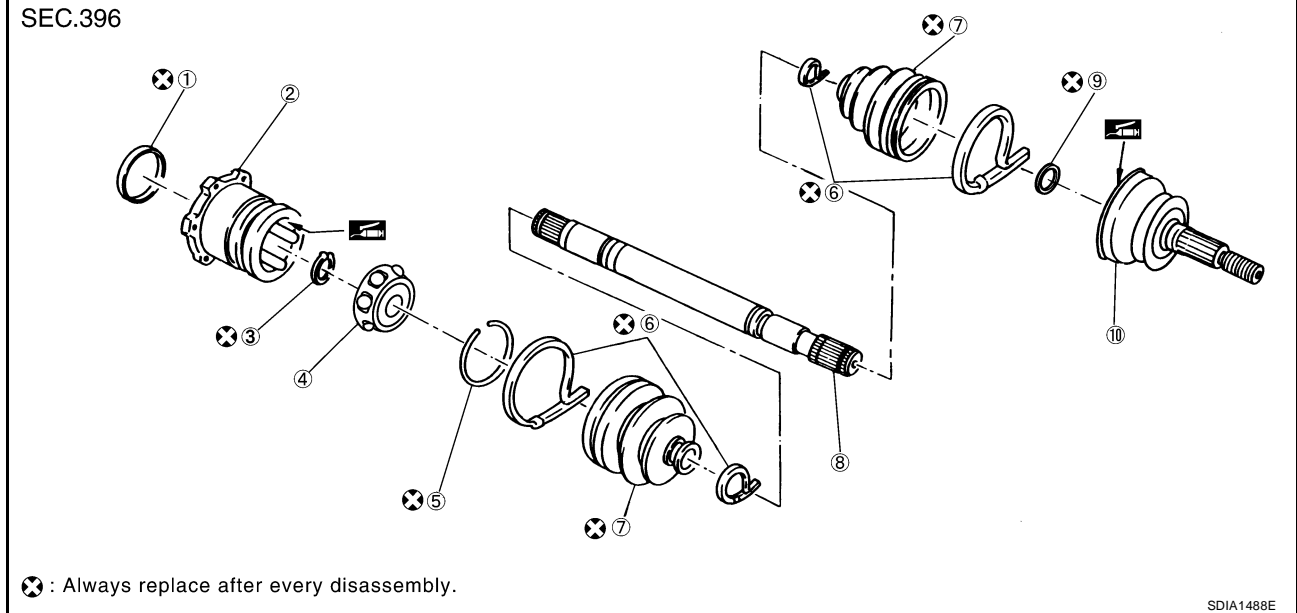

- |   |                 |              |
|---|-----------------|--------------|
| 1. Plug                                       | 2. Housing      | 3. Snap ring |
| 4. Ball cage, steel ball, liner race assembly | 5. Stopper ring | 6. Boot band |
| 7. Boot                                       | 8. Shaft        | 9. Circlip   |
| 10. Joint sub-assembly                        |                 |              |

### DISASSEMBLY

#### Final Drive Side

1. Secure the drive shaft in a vise.

**CAUTION:**

**When securing the drive shaft in a vise, use copper or aluminum plates between the vise and the drive shaft.**

2. Remove the boot bands.
3. If the plug needs to be removed, move the boot to the wheel side, then drive the plug out using a suitable tool.
4. Remove the stopper ring using a suitable tool as shown, and pull the housing out.

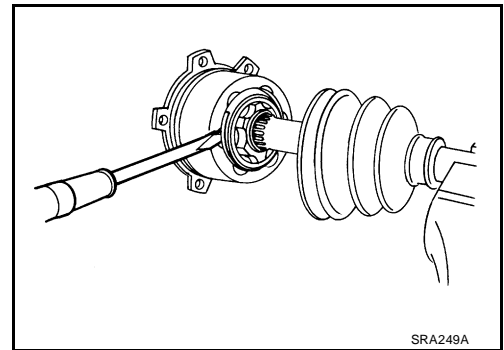

5. Remove the snap ring using a suitable tool, then remove the ball cage, steel ball, inner race assembly from the drive shaft.

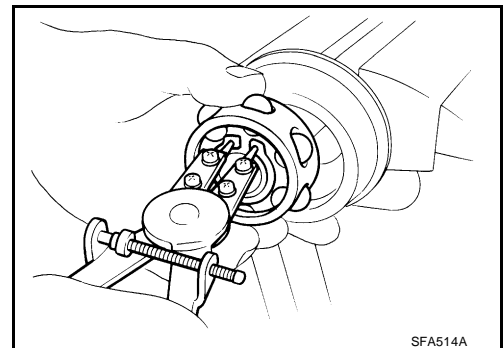



# REAR DRIVE SHAFT

6. Remove the boot from the drive shaft.
7. Remove any old grease on the housing using paper towels.

## Wheel Side

1. Secure the drive shaft in a vise.

### CAUTION:

**When securing the drive shaft in a vise, use copper or aluminum plates between the vise and the drive shaft.**

2. Remove the boot bands, then remove the boot from the joint sub-assembly.
3. Screw a suitable drive shaft puller 30 mm (1.18 in) or more into the threaded part of the joint sub-assembly. Pull the joint sub-assembly out of the drive shaft as shown.

### CAUTION:

- If the joint sub-assembly cannot be removed after five or more attempts, replace the drive shaft and joint sub-assembly as a set.
- Align the sliding hammer and drive shaft and remove the joint sub-assembly by pulling directly.

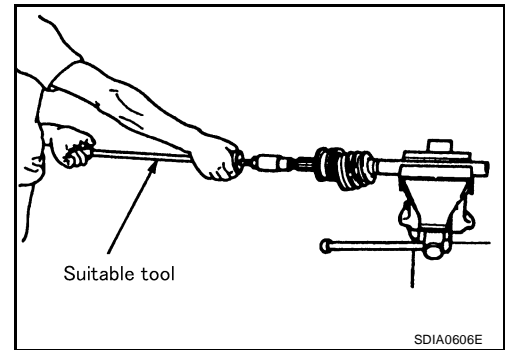

4. Remove the boot from the drive shaft.
5. Remove the circlip from the drive shaft.
6. While rotating the ball cage, remove any old grease on the joint sub-assembly using paper towels.

## INSPECTION AFTER DISASSEMBLY

### Drive Shaft

- Replace the drive shaft if there is any runout, cracking, or other damage.

### Joint Sub-assembly

- Check for any rough rotation or unusual axial looseness.
- Clean any foreign material from inside the joint sub-assembly.
- Check for any compression scars, cracks, or fractures.

### CAUTION:

**If any defective conditions are found in the joint sub-assembly components, replace the entire joint sub-assembly.**

### Sliding Joint Side (Housing)

- Check for any compression scars, cracks, fractures, or unusual wear on the ball rolling surface.
- Check for any damage to the drive shaft screws.
- Check for any deformation of the boot installation components.

### Ball Cage

- Check the sliding surface for any compression scars, cracks, or fractures.

### Steel Ball

- Check for any compression scars, cracks, fractures, or unusual wear.

### Inner Race

- Check the ball sliding surface for any compression scars, cracks, or fractures.
- Check for any damage to the serrated part.

### CAUTION:

**If any defective conditions are found, install a new housing, ball cage, steel ball, and inner race as a set.**

# REAR DRIVE SHAFT

## ASSEMBLY

### Final Drive Side

1. If the plug has been removed, use Tool to press in a new one.

**Tool number** : KV38100500 ( — )

: KV38102200 ( — )

**NOTE:**

Discard the old plug and use a new one for assembly.

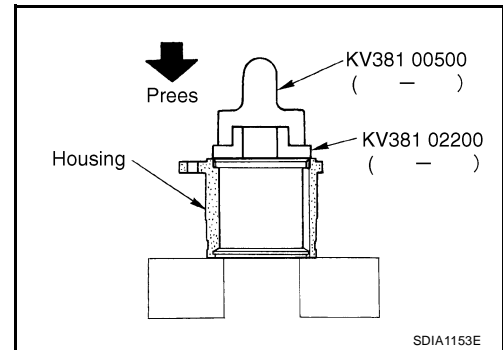

2. Wrap the serrated part of the shaft with tape. Install the boot band and boot to shaft.

**NOTE:**

Discard the old boot band and boot and use a new one for assembly.

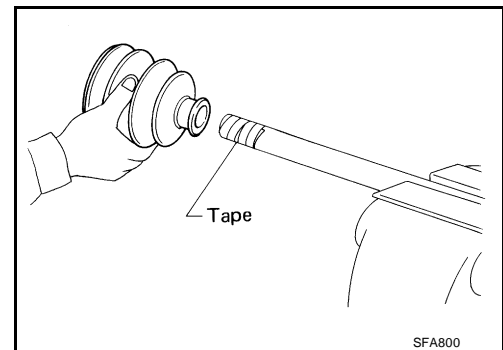

3. Remove the tape wound around the serrated part of the shaft.
4. Install the ball cage, steel ball, and inner race assembly on the shaft, and secure them tightly using the snap ring.

**NOTE:**

Discard the old snap ring and use a new one for assembly.

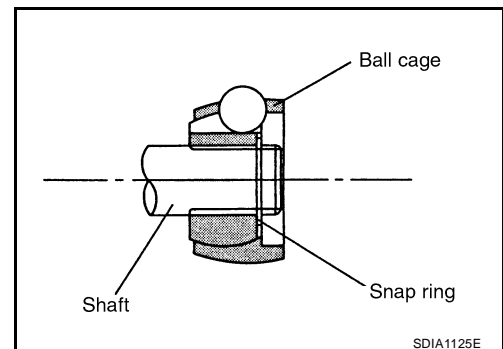

5. Insert the specified quantity of Genuine NISSAN Grease or equivalent, onto the housing (indicated by \* marks), and install it onto shaft. Refer to [MA-11, "Fluids and Lubricants"](#).

**Grease capacity** : 175 – 195 g (6.17 – 6.88 oz)

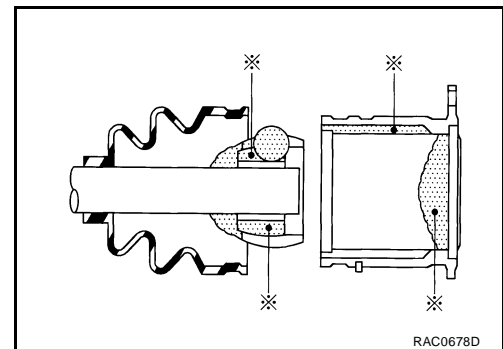

6. Install the stopper ring onto the housing.
7. After installation, pull on the shaft to check engagement between the joint sub-assembly and the stopper ring.

## REAR DRIVE SHAFT

8. Install the boot securely into the grooves (indicated by \* marks) as shown.

**CAUTION:**

If there is grease on boot mating surfaces (indicated by \* marks) of shaft and housing, boot may come off. Remove all grease from surfaces.

9. Check that the boot installation length "L" is the length indicated below. Insert a suitable tool into large side of the boot. Bleed the air from the boot to prevent any boot deformation.

**Boot installation length "L" : 147.9 mm (5.82 in)**

**CAUTION:**

- The boot may break if the boot installation length is less than the specified value.
- Do not touch the tip of the tool to the inside of the boot.

10. Secure the large and small ends of the boot with the new boot bands as shown.

**NOTE:**

Discard the old boot bands and use new ones for assembly.

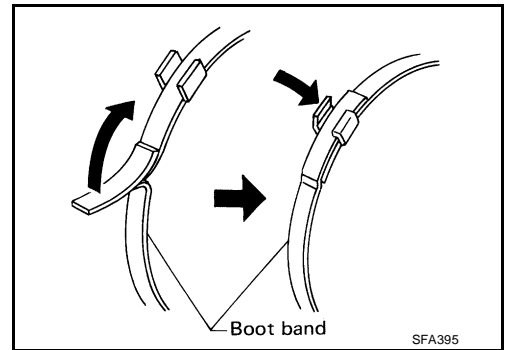
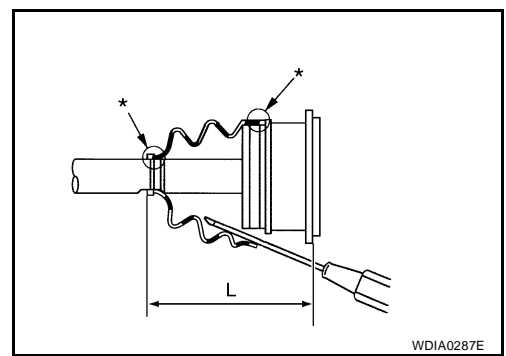

11. After installing the housing and shaft, rotate the boot to check that the boot is positioned correctly. If the boot is not positioned correctly, reposition the boot and secure the boot using a new boot band.

### Wheel Side

1. Insert the Genuine NISSAN Grease or equivalent, into the joint sub-assembly serration hole until the grease begins to ooze from the ball groove and serration hole. Refer to [MA-11, "Fluids and Lubricants"](#) . After inserting the grease, use a shop cloth to wipe off the grease that has oozed out.

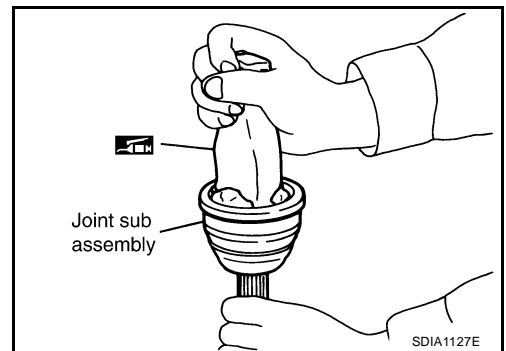

2. Wind the serrated part of the shaft with tape. Install the boot band and boot onto the shaft. Do not damage the boot.

**NOTE:**

Discard the old boot band and boot and use a new one for assembly.

3. Remove the protective tape wound around the serrated part of the shaft.

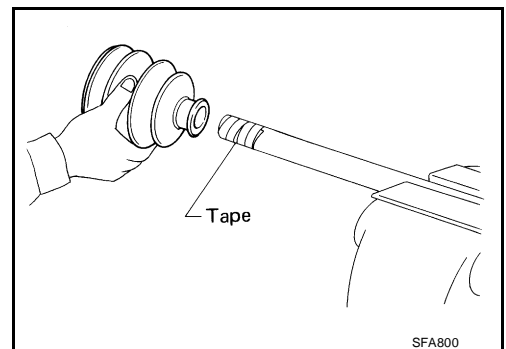

A  
B  
C  
RAX

E  
F  
G  
H

I  
J  
K  
L  
M

## REAR DRIVE SHAFT

- Attach the circlip to the shaft. The circlip must fit securely into the shaft groove. Attach the nut to the joint sub-assembly. Use a suitable tool to press-fit the circlip.

**NOTE:**

Discard the old circlip and use a new one for assembly.

- Insert the specified quantity of Genuine NISSAN Grease or equivalent, into the housing from the large end of the boot. Refer to [MA-11, "Fluids and Lubricants"](#).

**Grease capacity : 140 – 160 g (4.93 – 5.64 oz)**

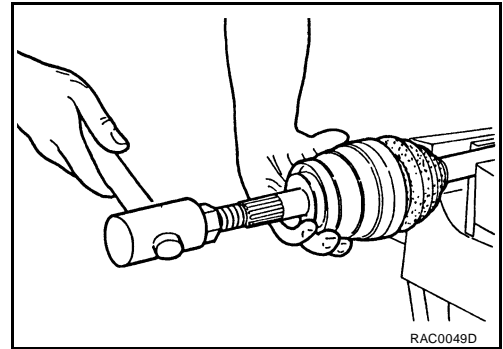

- Install the boot securely into the grooves (indicated by the \* marks) as shown.

**CAUTION:**

If there is grease on the boot mating surfaces (indicated by the \* marks) of the shaft and housing, the boot may come off. Remove all grease from the shaft surfaces.

- Check that the boot installation length "L" is the specified length. Insert a suitable tool into the large side of the boot. Bleed the air from the boot to prevent boot deformation.

**Boot installation length "L" : 134.5 mm (5.30 in)**

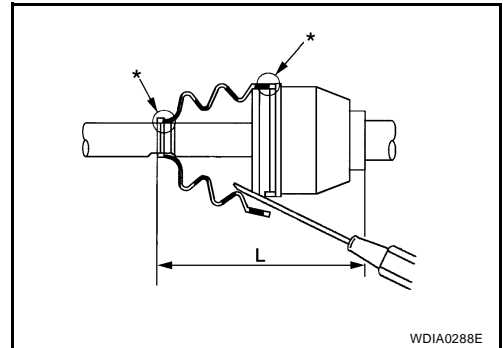

**CAUTION:**

- The boot may break if the boot installation length is less than the specified length.
- Do not touch the tip of the tool to the inside of the boot.

- Secure the large and small ends of the boot using new boot bands as shown.

**NOTE:**

Discard the old boot bands and use new ones for assembly.

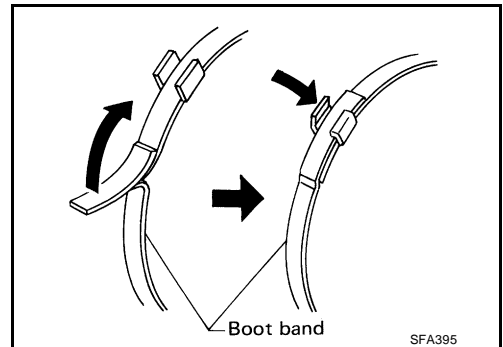

- After installing the joint sub-assembly and shaft, rotate the boot to check that it is positioned correctly. If the boot is not positioned correctly, reposition the boot and secure the boot using a new boot band.

# SERVICE DATA AND SPECIFICATIONS (SDS)

## SERVICE DATA AND SPECIFICATIONS (SDS)

PDF:00030

### Wheel Bearing

EDS001U7

Measurement of spring scale	Less than 26.6 N (2.7 kg, 5.95 lb)
Axial end play	0 mm (0 in)

### Drive Shaft

EDS001U8

Joint	Wheel side	Final drive side
Grease capacity	140 – 160 g (4.93 – 5.64 oz)	175 – 195 g (6.17 – 6.88 oz)
Boot installed length	134.5 mm (5.30 in)	147.9 mm (5.82 in)

A  
B  
C  
RAX  
E  
F  
G  
H  
I  
J  
K  
L  
M

# SERVICE DATA AND SPECIFICATIONS (SDS)

---