

SECTION **SE**
SEAT

A
B
C
D
E
F
G
H
SE
J
K
L
M

CONTENTS

PRECAUTIONS	3	Drive Positioner Control Unit	27
Precautions for Supplemental Restraint System (SRS) "AIR BAG" and "SEAT BELT PRE-TENSIONER"	3	Work Flow	29
Precautions for Work	3	Preliminary Check	30
PREPARATION	4	SETTING CHANGE FUNCTION	30
Special Service Tool	4	POWER SUPPLY AND GROUND CIRCUIT INSPECTION	30
Commercial Service Tool	4	CONSULT-II Function (AUTO DRIVE POS.)	33
SQUEAK AND RATTLE TROUBLE DIAGNOSES	5	CONSULT-II INSPECTION PROCEDURE	33
Work Flow	5	SELF-DIAGNOSIS RESULTS	35
CUSTOMER INTERVIEW	5	DATA MONITOR	36
DUPLICATE THE NOISE AND TEST DRIVE	6	ACTIVE TEST	36
CHECK RELATED SERVICE BULLETINS	6	CAN Communication Inspection Using CONSULT-II (Self-Diagnosis)	37
LOCATE THE NOISE AND IDENTIFY THE ROOT CAUSE	6	Symptom Chart	37
REPAIR THE CAUSE	6	Sliding Motor Circuit Inspection	39
CONFIRM THE REPAIR	7	Reclining Motor LH Circuit Inspection	40
Generic Squeak and Rattle Troubleshooting	7	Lifting Motor (Front) Circuit Inspection	41
INSTRUMENT PANEL	7	Lifting Motor (Rear) Circuit Inspection	43
CENTER CONSOLE	7	Pedal Adjusting Motor Circuit Inspection	44
DOORS	7	Mirror Motor LH Circuit Check	45
TRUNK	8	Mirror Motor RH Circuit Check	47
SUNROOF/HEADLINING	8	Sliding Sensor Circuit Inspection	49
OVERHEAD CONSOLE (FRONT AND REAR).....	8	Reclining Sensor Circuit Inspection	50
SEATS	8	Lifting Sensor (Front) Circuit Inspection	51
UNDERHOOD	8	Lifting Sensor (Rear) Circuit Inspection	52
Diagnostic Worksheet	9	Pedal Adjusting Sensor Circuit Inspection	53
AUTOMATIC DRIVE POSITIONER	11	Mirror Sensor LH Circuit Check	54
Component Parts And Harness Connector Location	11	Mirror Sensor RH Circuit Check	55
System Description	12	Sliding Switch Circuit Inspection	57
FAIL-SAFE MODE	12	Reclining Switch Inspection	59
CANCEL OF FAIL-SAFE MODE	13	Lifting Switch (Front) Circuit Inspection	60
CAN Communication System Description	13	Lifting Switch (Rear) Circuit Inspection	62
Schematic	14	Power Seat Switch Ground Inspection	63
Wiring Diagram — AUT/DP —	16	Pedal Adjusting Switch Circuit Inspection	64
Terminals and Reference Values for BCM	25	Door Mirror Remote Control Switch (Changeover Switch) Circuit Check	66
Terminals and Reference Values for Driver Seat Control Unit	25	Door Mirror Remote Control Switch (Mirror Switch) Circuit Check	67
Terminals and Reference Values for Automatic		Door Mirror Remote Control Switch Ground Circuit Inspection	69

Seat Memory Switch Circuit Inspection	69	SEAT CUSHION ASSEMBLY (PASSENGER)	90
Seat Memory Indicator Lamp Circuit Inspection	71	SECOND SEAT	92
Door Mirror Sensor Power Supply and Ground Circuit inspection	72	Second Row Outboard	92
A/T Device (Park Position Switch) Circuit Inspection..	73	REMOVAL	92
Front Door Switch LH Circuit Inspection	74	INSTALLATION	92
UART Communication Line Circuit Inspection	75	DISASSEMBLY AND ASSEMBLY	93
Removal and Installation	77	Second Row Center	96
POWER SEAT	78	REMOVAL	96
Schematic	78	INSTALLATION	96
Wiring Diagram – SEAT –	79	DISASSEMBLY AND ASSEMBLY	97
HEATED SEAT	82	THIRD SEAT	99
Description	82	LH Side Seat	99
Wiring Diagram – HSEAT –	83	REMOVAL	99
FRONT SEAT	85	INSTALLATION	99
Removal and Installation	85	DISASSEMBLY AND ASSEMBLY	100
REMOVAL	88	RH Side Seat	101
INSTALLATION	88	REMOVAL	101
Disassembly and Assembly	88	INSTALLATION	102
SEATBACK TRIM AND PAD	88	DISASSEMBLY AND ASSEMBLY	103
REMOVAL OF SEATBACK ASSEMBLY	89		
INSTALLATION OF SEATBACK ASSEMBLY ...	90		
SEAT CUSHION TRIM AND PAD (DRIVER) OR			

PRECAUTIONS

PRECAUTIONS

PFP:00001

Precautions for Supplemental Restraint System (SRS) “AIR BAG” and “SEAT BELT PRE-TENSIONER”

EIS00404

The Supplemental Restraint System such as “AIR BAG” and “SEAT BELT PRE-TENSIONER”, used along with a front seat belt, helps to reduce the risk or severity of injury to the driver and front passenger for certain types of collision. This system includes seat belt switch inputs and dual stage front air bag modules. The SRS system uses the seat belt switches to determine the front air bag deployment, and may only deploy one front air bag, depending on the severity of a collision and whether the front occupants are belted or unbelted. Information necessary to service the system safely is included in the SRS and SB section of this Service Manual.

WARNING:

- To avoid rendering the SRS inoperative, which could increase the risk of personal injury or death in the event of a collision which would result in air bag inflation, all maintenance must be performed by an authorized NISSAN/INFINITI dealer.
- Improper maintenance, including incorrect removal and installation of the SRS, can lead to personal injury caused by unintentional activation of the system. For removal of Spiral Cable and Air Bag Module, see the SRS section.
- Do not use electrical test equipment on any circuit related to the SRS unless instructed to in this Service Manual. SRS wiring harnesses can be identified by yellow and/or orange harnesses or harness connectors.

Precautions for Work

EIS00405

- When removing or disassembling each component, be careful not to damage or deform it. If a component may be subject to interference, be sure to protect it with a shop cloth.
- When removing (disengaging) components with a screwdriver or similar tool, be sure to wrap the component with a shop cloth or vinyl tape to protect it.
- Protect the removed parts with a shop cloth and keep them.
- Replace a deformed or damaged clip.
- If a part is specified as a non-reusable part, always replace it with new one.
- Be sure to tighten bolts and nuts securely to the specified torque.
- After re-installation is completed, be sure to check that each part works normally.
- Follow the steps below to clean components.
 - Water soluble foul: Dip a soft cloth into lukewarm water, and wring the water out of the cloth to wipe the fouled area.
Then rub with a soft and dry cloth.
 - Oily foul: Dip a soft cloth into lukewarm water with mild detergent (concentration: within 2 to 3%), and wipe the fouled area.
Then dip a cloth into fresh water, and wring the water out of the cloth to wipe the detergent off. Then rub with a soft and dry cloth.
- Do not use organic solvent such as thinner, benzene, alcohol, or gasoline.
- For genuine leather seats, use a genuine leather seat cleaner.

PREPARATION

PREPARATION

PFP:00002

Special Service Tool

EIS00406

The actual shapes of Kent-Moore tools may differ from those of special service tools illustrated here.

Tool number (Kent-Moore No.) Tool name	Description
— (J-39570) Chassis ear	Locating the noise
— (J-43980) NISSAN Squeak and Rattle Kit	Repairing the cause of noise

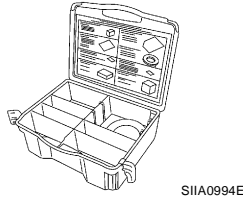
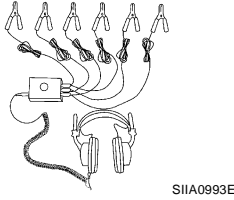

Commercial Service Tool

EIS00407

(Kent-Moore No.) Tool name	Description
(J-39565) Engine ear	Locating the noise

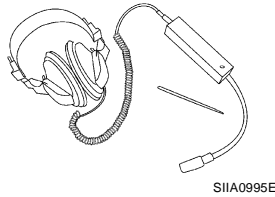

SQUEAK AND RATTLE TROUBLE DIAGNOSES

SQUEAK AND RATTLE TROUBLE DIAGNOSES

PF0:0000

Work Flow

EIS00408

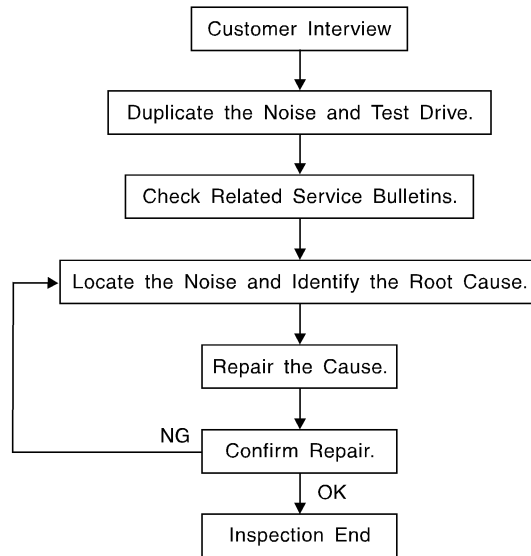

SBT842

CUSTOMER INTERVIEW

Interview the customer if possible, to determine the conditions that exist when the noise occurs. Use the Diagnostic Worksheet during the interview to document the facts and conditions when the noise occurs and any customer's comments; refer to [SE-9, "Diagnostic Worksheet"](#). This information is necessary to duplicate the conditions that exist when the noise occurs.

- The customer may not be able to provide a detailed description or the location of the noise. Attempt to obtain all the facts and conditions that exist when the noise occurs (or does not occur).
- If there is more than one noise in the vehicle, be sure to diagnose and repair the noise that the customer is concerned about. This can be accomplished by test driving the vehicle with the customer.
- After identifying the type of noise, isolate the noise in terms of its characteristics. The noise characteristics are provided so the customer, service adviser and technician are all speaking the same language when defining the noise.
- Squeak —(Like tennis shoes on a clean floor)
Squeak characteristics include the light contact/fast movement/brought on by road conditions/hard surfaces = higher pitch noise/softer surfaces = lower pitch noises/edge to surface = chirping.
- Creak—(Like walking on an old wooden floor)
Creak characteristics include firm contact/slow movement/twisting with a rotational movement/pitch dependent on materials/often brought on by activity.
- Rattle—(Like shaking a baby rattle)
Rattle characteristics include the fast repeated contact/vibration or similar movement/loose parts/missing clip or fastener/incorrect clearance.
- Knock —(Like a knock on a door)
Knock characteristics include hollow sounding/sometimes repeating/often brought on by driver action.
- Tick—(Like a clock second hand)
Tick characteristics include gentle contacting of light materials/loose components/can be caused by driver action or road conditions.
- Thump—(Heavy, muffled knock noise)
Thump characteristics include softer knock/dead sound often brought on by activity.
- Buzz—(Like a bumble bee)
Buzz characteristics include high frequency rattle/firm contact.
- Often the degree of acceptable noise level will vary depending upon the person. A noise that you may judge as acceptable may be very irritating to the customer.
- Weather conditions, especially humidity and temperature, may have a great effect on noise level.

SQUEAK AND RATTLE TROUBLE DIAGNOSES

DUPLICATE THE NOISE AND TEST DRIVE

If possible, drive the vehicle with the customer until the noise is duplicated. Note any additional information on the Diagnostic Worksheet regarding the conditions or location of the noise. This information can be used to duplicate the same conditions when you confirm the repair.

If the noise can be duplicated easily during the test drive, to help identify the source of the noise, try to duplicate the noise with the vehicle stopped by doing one or all of the following:

- 1) Close a door.
 - 2) Tap or push/pull around the area where the noise appears to be coming from.
 - 3) Rev the engine.
 - 4) Use a floor jack to recreate vehicle "twist".
 - 5) At idle, apply engine load (electrical load, half-clutch on M/T model, drive position on A/T model).
 - 6) Raise the vehicle on a hoist and hit a tire with a rubber hammer.
- Drive the vehicle and attempt to duplicate the conditions the customer states exist when the noise occurs.
 - If it is difficult to duplicate the noise, drive the vehicle slowly on an undulating or rough road to stress the vehicle body.

CHECK RELATED SERVICE BULLETINS

After verifying the customer concern or symptom, check ASIST for Technical Service Bulletins (TSBs) related to that concern or symptom.

If a TSB relates to the symptom, follow the procedure to repair the noise.

LOCATE THE NOISE AND IDENTIFY THE ROOT CAUSE

1. Narrow down the noise to a general area. To help pinpoint the source of the noise, use a listening tool (Chassis Ear: J-39570, Engine Ear: J-39565 and mechanic's stethoscope).
2. Narrow down the noise to a more specific area and identify the cause of the noise by:
 - removing the components in the area that you suspect the noise is coming from. Do not use too much force when removing clips and fasteners, otherwise clips and fasteners can be broken or lost during the repair, resulting in the creation of new noise.
 - tapping or pushing/pulling the component that you suspect is causing the noise. Do not tap or push/pull the component with excessive force, otherwise the noise will be eliminated only temporarily.
 - feeling for a vibration with your hand by touching the component(s) that you suspect is (are) causing the noise.
 - placing a piece of paper between components that you suspect are causing the noise.
 - looking for loose components and contact marks.
Refer to [SE-7, "Generic Squeak and Rattle Troubleshooting"](#).

REPAIR THE CAUSE

- If the cause is a loose component, tighten the component securely.
- If the cause is insufficient clearance between components:
 - separate components by repositioning or loosening and retightening the component, if possible.
 - insulate components with a suitable insulator such as urethane pads, foam blocks, felt cloth tape or urethane tape. A NISSAN Squeak and Rattle Kit (J-43980) is available through your authorized NISSAN Parts Department.

CAUTION:

Do not use excessive force as many components are constructed of plastic and may be damaged.

Always check with the Parts Department for the latest parts information.

The following materials are contained in the NISSAN Squeak and Rattle Kit (J-43980). Each item can be ordered separately as needed.

URETHANE PADS [1.5 mm (0.059 in) thick]

Insulates connectors, harness, etc.

76268-9E005: 100×135 mm (3.94×5.31 in)/76884-71L01: 60×85 mm (2.36×3.35 in)/76884-71L02: 15×25 mm (0.59×0.98 in)

INSULATOR (Foam blocks)

Insulates components from contact. Can be used to fill space behind a panel.

73982-9E000: 45 mm (1.77 in) thick, 50×50 mm (1.97×1.97 in)/73982-50Y00: 10 mm (0.39 in) thick, 50×50 mm (1.97×1.97 in)

INSULATOR (Light foam block)

SQUEAK AND RATTLE TROUBLE DIAGNOSES

80845-71L00: 30 mm (1.18 in) thick, 30×50 mm (1.18×1.97 in)

FELT CLOTH TAPE

Used to insulate where movement does not occur. Ideal for instrument panel applications.

68370-4B000: 15×25 mm (0.59×0.98 in) pad/68239-13E00: 5 mm (0.20 in) wide tape roll. The following materials not found in the kit can also be used to repair squeaks and rattles.

UHMW (TEFLON) TAPE

Insulates where slight movement is present. Ideal for instrument panel applications.

SILICONE GREASE

Used instead of UHMW tape that will be visible or not fit.

Note: Will only last a few months.

SILICONE SPRAY

Use when grease cannot be applied.

DUCT TAPE

Use to eliminate movement.

CONFIRM THE REPAIR

Confirm that the cause of a noise is repaired by test driving the vehicle. Operate the vehicle under the same conditions as when the noise originally occurred. Refer to the notes on the Diagnostic Worksheet.

Generic Squeak and Rattle Troubleshooting

EIS00409

Refer to Table of Contents for specific component removal and installation information.

INSTRUMENT PANEL

Most incidents are caused by contact and movement between:

1. The cluster lid A and instrument panel
2. Acrylic lens and combination meter housing
3. Instrument panel to front pillar garnish
4. Instrument panel to windshield
5. Instrument panel mounting pins
6. Wiring harnesses behind the combination meter
7. A/C defroster duct and duct joint

These incidents can usually be located by tapping or moving the components to duplicate the noise or by pressing on the components while driving to stop the noise. Most of these incidents can be repaired by applying felt cloth tape or silicone spray (in hard to reach areas). Urethane pads can be used to insulate wiring harness.

CAUTION:

Do not use silicone spray to isolate a squeak or rattle. If you saturate the area with silicone, you will not be able to recheck the repair.

CENTER CONSOLE

Components to pay attention to include:

1. Shifter assembly cover to finisher
2. A/C control unit and cluster lid C
3. Wiring harnesses behind audio and A/C control unit

The instrument panel repair and isolation procedures also apply to the center console.

DOORS

Pay attention to the:

1. Finisher and inner panel making a slapping noise
2. Inside handle escutcheon to door finisher
3. Wiring harnesses tapping
4. Door striker out of alignment causing a popping noise on starts and stops

Tapping or moving the components or pressing on them while driving to duplicate the conditions can isolate many of these incidents. You can usually insulate the areas with felt cloth tape or insulator foam blocks from the NISSAN Squeak and Rattle Kit (J-43980) to repair the noise.

SQUEAK AND RATTLE TROUBLE DIAGNOSES

TRUNK

Trunk noises are often caused by a loose jack or loose items put into the trunk by the owner. In addition look for:

1. Trunk lid bumpers out of adjustment
2. Trunk lid striker out of adjustment
3. The trunk lid torsion bars knocking together
4. A loose license plate or bracket

Most of these incidents can be repaired by adjusting, securing or insulating the item(s) or component(s) causing the noise.

SUNROOF/HEADLINING

Noises in the sunroof/headlining area can often be traced to one of the following:

1. Sunroof lid, rail, linkage or seals making a rattle or light knocking noise
2. Sun visor shaft shaking in the holder
3. Front or rear windshield touching headliner and squeaking

Again, pressing on the components to stop the noise while duplicating the conditions can isolate most of these incidents. Repairs usually consist of insulating with felt cloth tape.

OVERHEAD CONSOLE (FRONT AND REAR)

Overhead console noises are often caused by the console panel clips not being engaged correctly. Most of these incidents are repaired by pushing up on the console at the clip locations until the clips engage.

In addition look for:

1. Loose harness or harness connectors.
2. Front console map/reading lamp lense loose.
3. Loose screws at console attachment points.

SEATS

When isolating seat noise it's important to note the position the seat is in and the load placed on the seat when the noise is present. These conditions should be duplicated when verifying and isolating the cause of the noise.

Cause of seat noise include:

1. Headrest rods and holder
2. A squeak between the seat pad cushion and frame
3. The rear seatback lock and bracket

These noises can be isolated by moving or pressing on the suspected components while duplicating the conditions under which the noise occurs. Most of these incidents can be repaired by repositioning the component or applying urethane tape to the contact area.

UNDERHOOD

Some interior noise may be caused by components under the hood or on the engine wall. The noise is then transmitted into the passenger compartment.

Causes of transmitted underhood noise include:

1. Any component mounted to the engine wall
2. Components that pass through the engine wall
3. Engine wall mounts and connectors
4. Loose radiator mounting pins
5. Hood bumpers out of adjustment
6. Hood striker out of adjustment

These noises can be difficult to isolate since they cannot be reached from the interior of the vehicle. The best method is to secure, move or insulate one component at a time and test drive the vehicle. Also, engine RPM or load can be changed to isolate the noise. Repairs can usually be made by moving, adjusting, securing, or insulating the component causing the noise.

SQUEAK AND RATTLE TROUBLE DIAGNOSES

Diagnostic Worksheet

EIS0040A

Dear Customer:

We are concerned about your satisfaction with your vehicle. Repairing a squeak or rattle sometimes can be very difficult. To help us fix your vehicle right the first time, please take a moment to note the area of the vehicle where the squeak or rattle occurs and under what conditions. You may be asked to take a test drive with a service advisor or technician to ensure we confirm the noise you are hearing.

SQUEAK & RATTLE DIAGNOSTIC WORKSHEET

I. WHERE DOES THE NOISE COME FROM? (circle the area of the vehicle)

The illustrations are for reference only, and may not reflect the actual configuration of your vehicle.

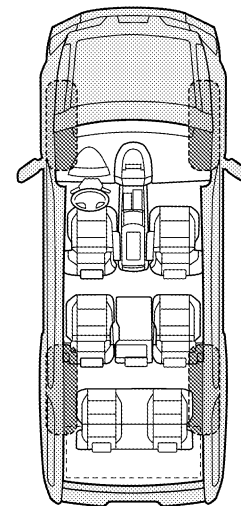
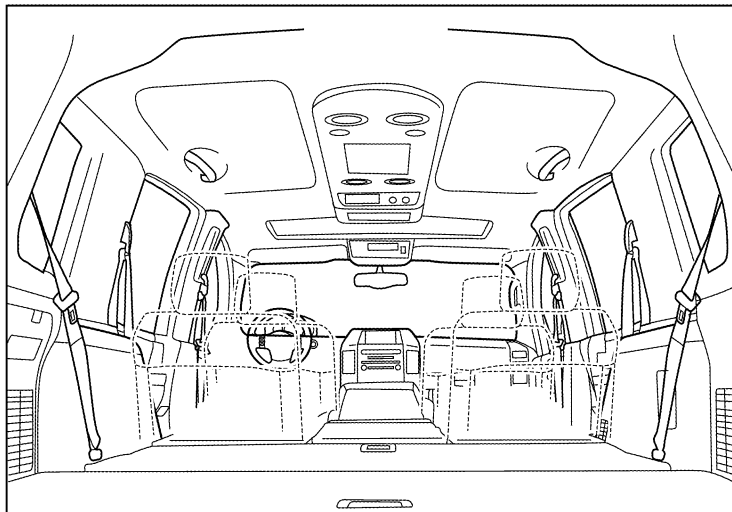
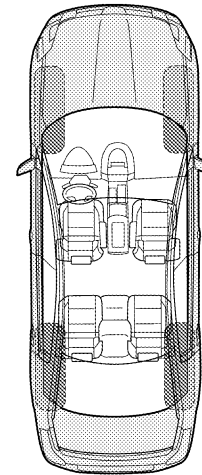
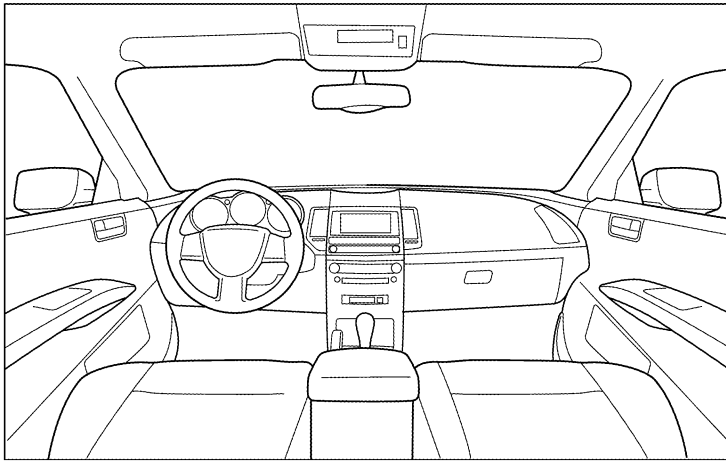

Continue to page 2 of the worksheet and briefly describe the location of the noise or rattle. In addition, please indicate the conditions which are present when the noise occurs.

A
B
C
D
E
F
G
H
SE
J
K
L
M

SQUEAK AND RATTLE TROUBLE DIAGNOSES

SQUEAK & RATTLE DIAGNOSTIC WORKSHEET - page 2

Briefly describe the location where the noise occurs:

II. WHEN DOES IT OCCUR? (please check the boxes that apply)

- | | |
|---|--|
| <input type="checkbox"/> Anytime | <input type="checkbox"/> After sitting out in the rain |
| <input type="checkbox"/> 1st time in the morning | <input type="checkbox"/> When it is raining or wet |
| <input type="checkbox"/> Only when it is cold outside | <input type="checkbox"/> Dry or dusty conditions |
| <input type="checkbox"/> Only when it is hot outside | <input type="checkbox"/> Other: |

III. WHEN DRIVING:

- Through driveways
- Over rough roads
- Over speed bumps
- Only about ____ mph
- On acceleration
- Coming to a stop
- On turns: left, right or either (circle)
- With passengers or cargo
- Other: _____
- After driving ____ miles or ____ minutes

IV. WHAT TYPE OF NOISE

- Squeak (like tennis shoes on a clean floor)
- Creak (like walking on an old wooden floor)
- Rattle (like shaking a baby rattle)
- Knock (like a knock at the door)
- Tick (like a clock second hand)
- Thump (heavy muffled knock noise)
- Buzz (like a bumble bee)

TO BE COMPLETED BY DEALERSHIP PERSONNEL

Test Drive Notes:

	YES	NO	Initials of person performing
Vehicle test driven with customer	<input type="checkbox"/>	<input type="checkbox"/>	_____
- Noise verified on test drive	<input type="checkbox"/>	<input type="checkbox"/>	_____
- Noise source located and repaired	<input type="checkbox"/>	<input type="checkbox"/>	_____
- Follow up test drive performed to confirm repair	<input type="checkbox"/>	<input type="checkbox"/>	_____

LAI0071E

AUTOMATIC DRIVE POSITIONER

PFP:28491

EIS0040B

AUTOMATIC DRIVE POSITIONER

Component Parts And Harness Connector Location

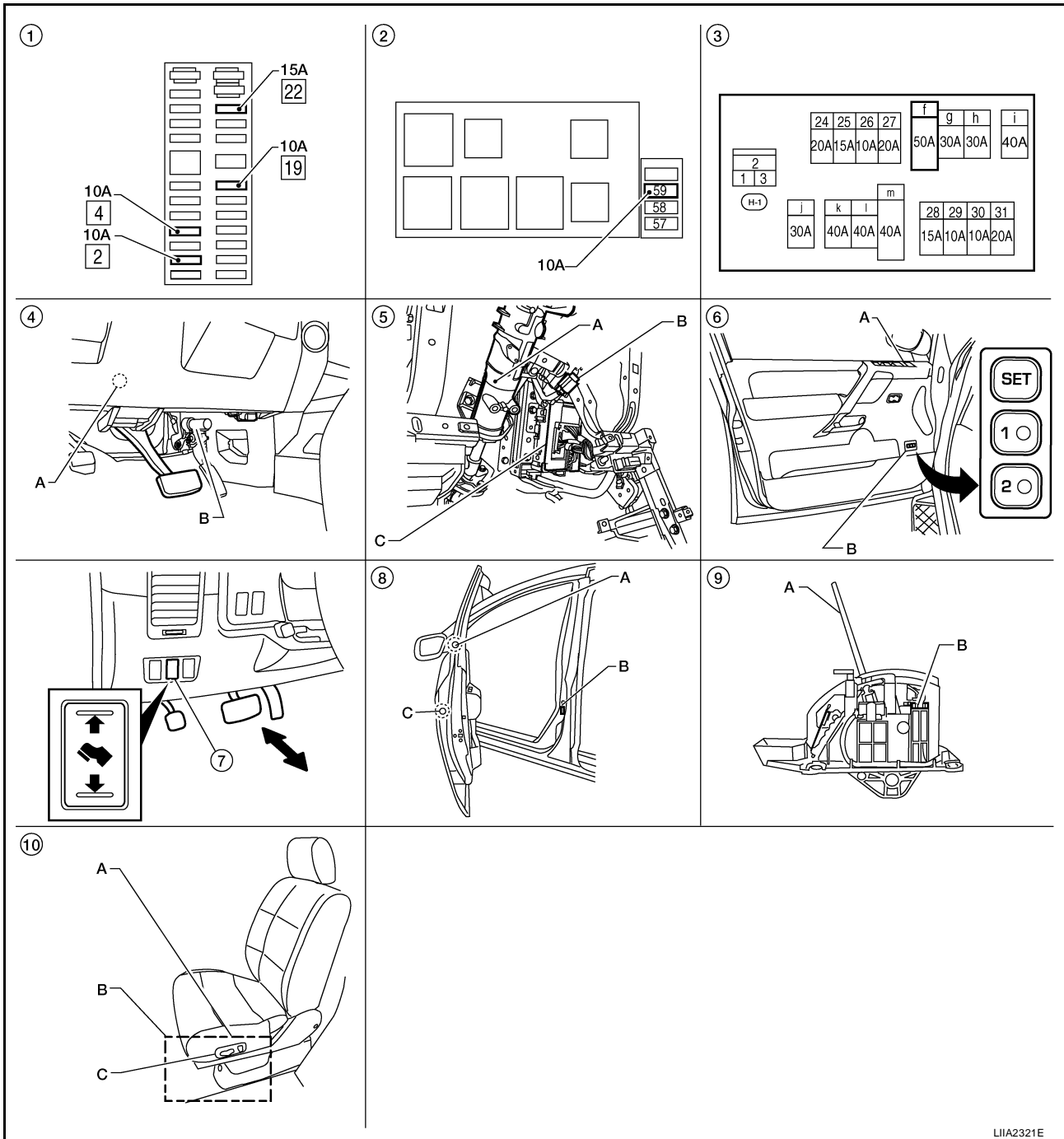

- | | | |
|---|--|---|
| 1. Fuse block (J/B) | 2. Fuse and relay box | 3. Fuse and fusible link box |
| 4. A. Automatic drive positioner control unit M33, M34
B. Pedal adjusting motor E109, E110 | 5. A. Steering column
B. Key switch and key lock solenoid M27
C. BCM M18, M19, M20
(View with instrument panel removed) | 6. A. Door mirror remote control switch D10
B. Seat memory switch D5 |

LIIA2321E

AUTOMATIC DRIVE POSITIONER

- | | | |
|--|---|--|
| <p>7. Pedal adjusting switch M96</p> | <p>8. A. Door mirror LH D4, door mirror RH D107
 B. Front door switch LH B8
 C. Front door lock assembly LH (key cylinder switch) D14</p> | <p>9. A. A/T selector lever
 B. A/T device (park position switch) M203</p> |
| <p>10. A. Sliding motor LH P4 (driver seat view), reclining motor LH P5, lifting motor (front) P6, lifting motor (rear) P7
 B. Driver seat control unit P2, P3
 C. Power seat switch LH P8</p> | | |

System Description

EIS0040E

- Refer to Owner's Manual for Automatic Drive Positioner system operating instructions.
- The settings (ON/OFF) of the automatic sliding seat (Entry/Exiting operation) at entry/exit can be changed as desired, using the display unit in the center of the instrument panel. The set content is transmitted by CAN communication, from display unit (without NAVI) or display control unit (with NAVI) to driver seat control unit.
- Using CONSULT-II, the seat slide amount at entry/exit setting can be changed.

Function	Description	
Memory operation	The front seat LH, pedal (accelerator, brake) and door mirror move to the stored driving position by pushing seat memory switch (1 or 2).	
Entry/Exiting function	Exiting operation	At exit, the seat moves backward. (Exiting position)
	Entry operation	At entry, the seat returns from Exiting position to the previous driving position before the Exiting operation.
Keyfob interlock operation	Perform memory operation, turnout operation and return operation by pressing keyfob unlock button.	

NOTE:

- Disconnecting the battery erases the stored memory.
- After connecting the battery, insert the key into the ignition cylinder and turn the front door switch LH ON (open)→OFF (close)→ON (open), the Entry/Exiting function becomes possible.
- After Exiting operation is carried out, return operation can be operated.

Auto operation temporary stop conditions.	When ignition switch is turned to START during seat memory switch operation and return operation, seat memory switch operation and return operation is stopped.
Auto operation stop conditions.	<ul style="list-style-type: none"> ● When the vehicle speed becomes 7 km/h (4 MPH) or higher (memory switch operation and entry operation). ● When the setting switch, seat memory switch 1, or 2 are pressed. ● When A/T selector lever is in any position other than P. ● When the door mirror remote control switch is operated (when ignition switch turned to ON). ● When power seat switch turned ON. ● When pedal adjusting switch turned ON. ● When front seat LH sliding Entry/Exiting setting is OFF (entry/exiting operation).

NOTE:

During automatic operation, if the ignition switch is turned ON→START, the automatic operation is suspended. When the ignition switch returns to ON, it resumes.

FAIL-SAFE MODE

When any manual and automatic operations are not performed, if any motor operations of front seat LH or pedals are detected for T2 or more, status is judged "Output error".

OPERATED PORTION	T2
Seat sliding	Approx. 0.1 sec.
Seat reclining	Same as above
Seat lifting (Front)	Same as above

AUTOMATIC DRIVE POSITIONER

OPERATED PORTION	T2
Seat lifting (Rear)	Same as above
Pedal adjust	Same as above

CANCEL OF FAIL-SAFE MODE

The mode is cancelled when the A/T selector lever is shifted to P position from any other position.

NOTE:

The front seat LH position and pedal adjustment functions (see the following table) operate simultaneously in the order of priority.

Priority	Function	Priority	Function
1	Seat sliding, (door mirror LH/RH)*	4	Seat lifter-FR
2	Pedal	5	Seat lifter-RR
3	Seat reclining		

*: In conjunction with sliding the seat, the door mirrors are positioned.

CAN Communication System Description

EIS0040F

Refer to [LAN-25, "CAN COMMUNICATION"](#) .

A
B
C
D
E
F
G
H
J
K
L
M

SE

AUTOMATIC DRIVE POSITIONER

Schematic

EIS0040G

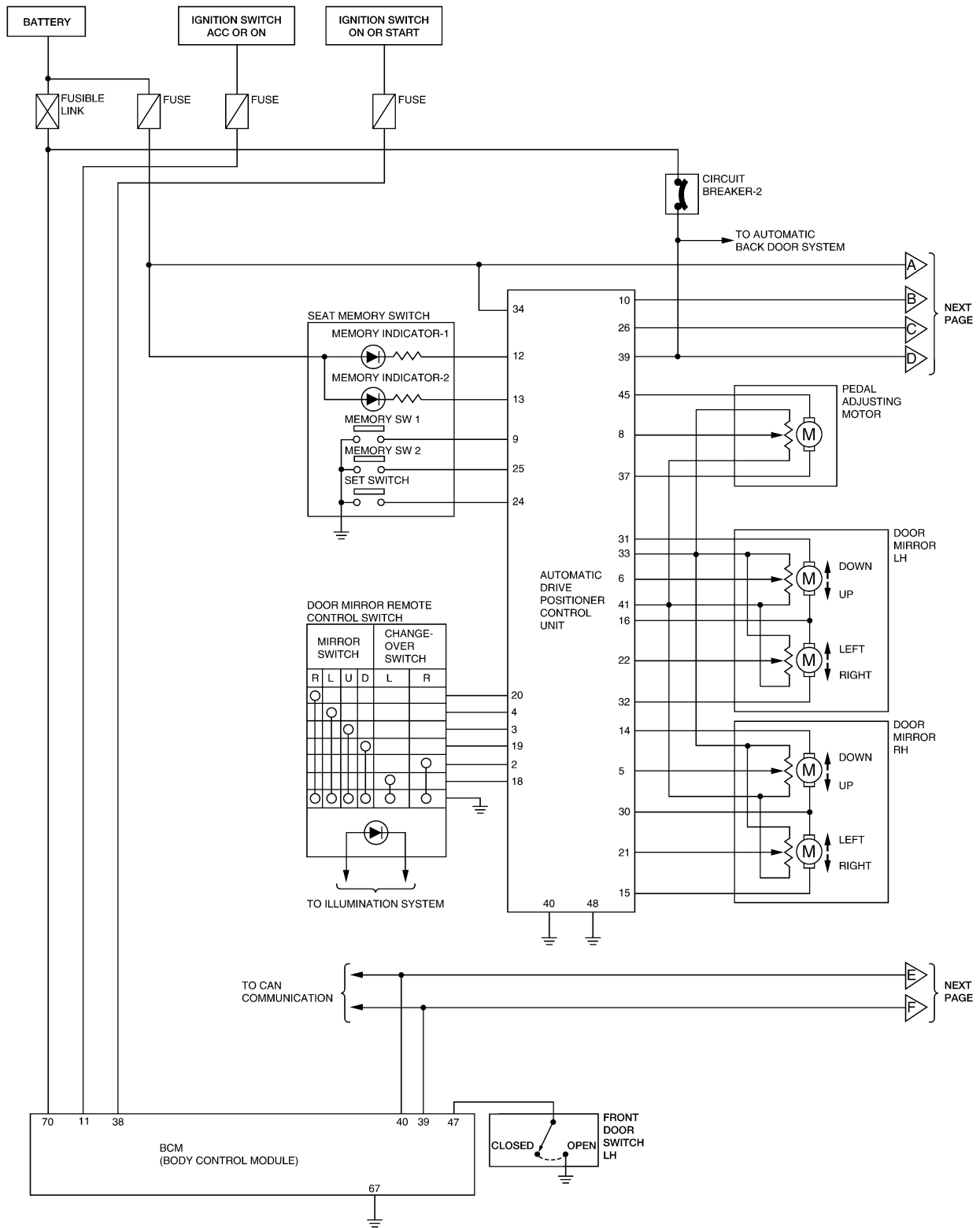

WIWA1192E

AUTOMATIC DRIVE POSITIONER

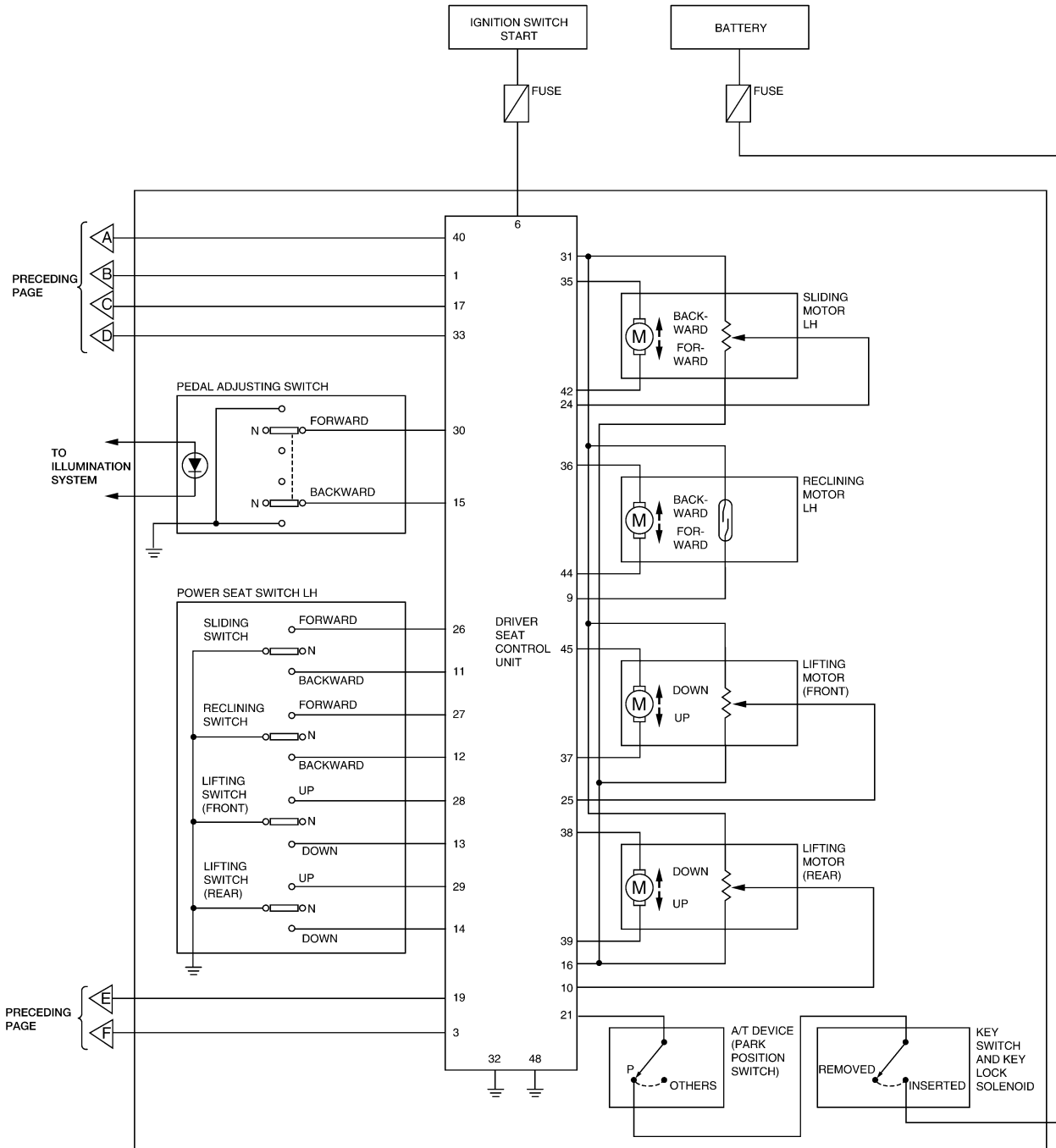

A
 B
 C
 D
 E
 F
 G
 H
SE
 J
 K
 L
 M

WIWA1193E

AUTOMATIC DRIVE POSITIONER

EIS0040H

Wiring Diagram — AUT/DP —

SE-AUT/DP-01

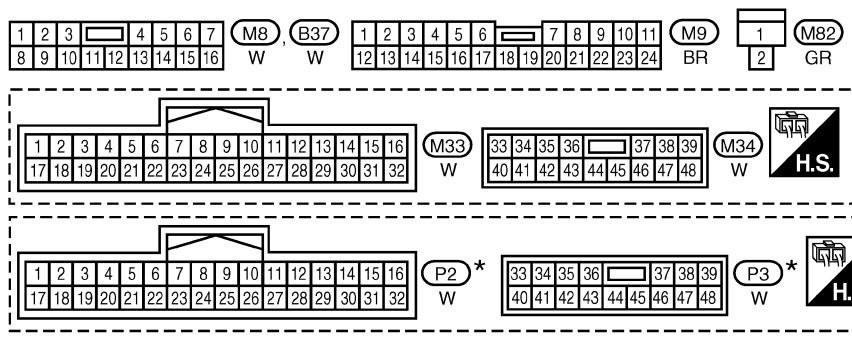
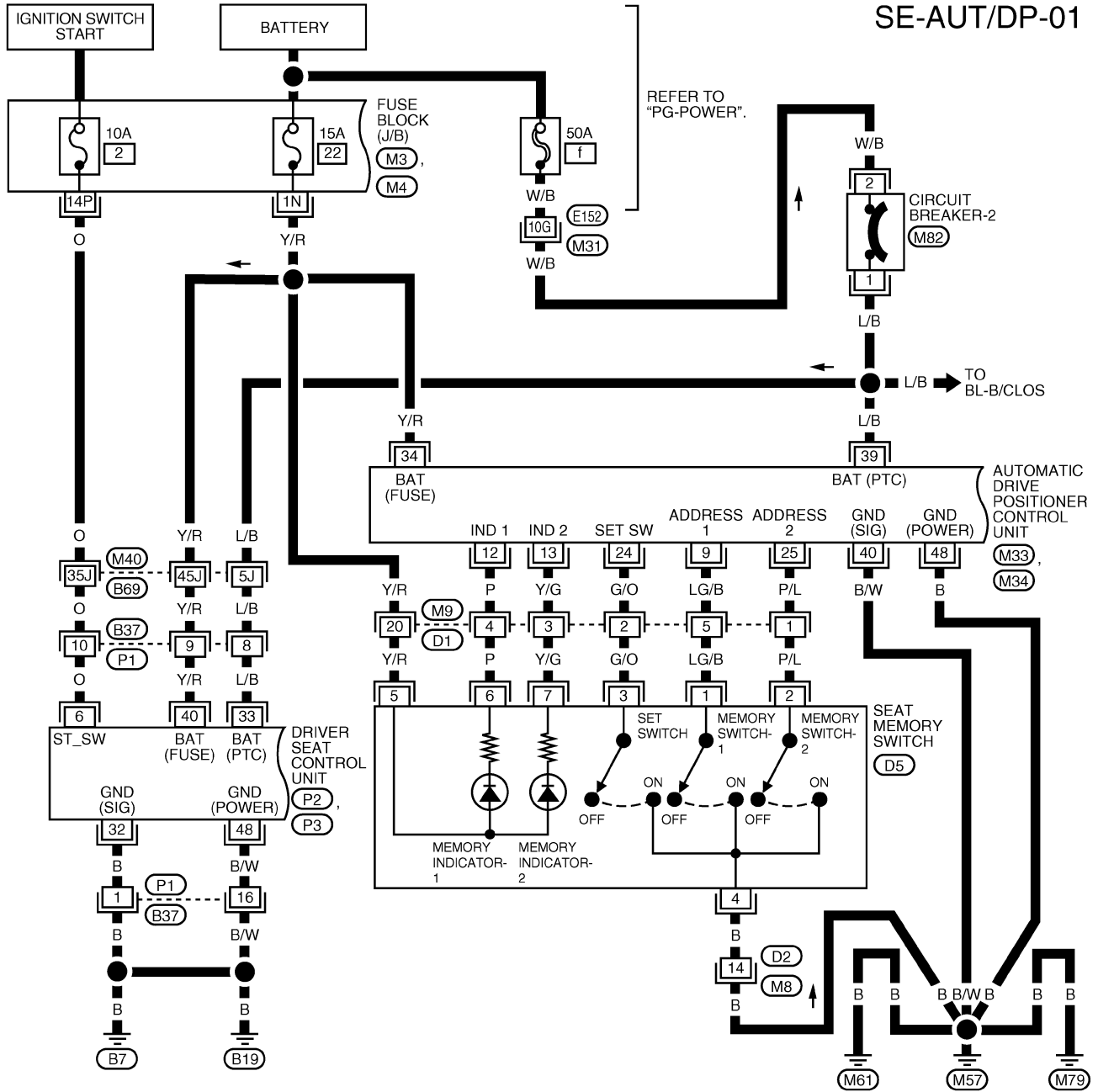

REFER TO THE FOLLOWING.
 (M3), (M4) - FUSE BLOCK J/B
 (M31), (M40) - SUPER MULTIPLE JUNCTION (SMJ)

* : THIS CONNECTOR IS NOT SHOWN IN "HARNESS LAYOUT" OF PG SECTION.

WIWA1194E

AUTOMATIC DRIVE POSITIONER

SE-AUT/DP-02

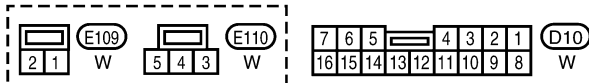
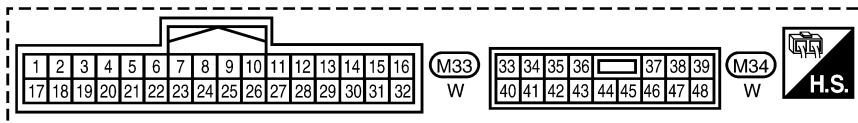
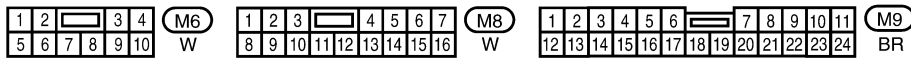
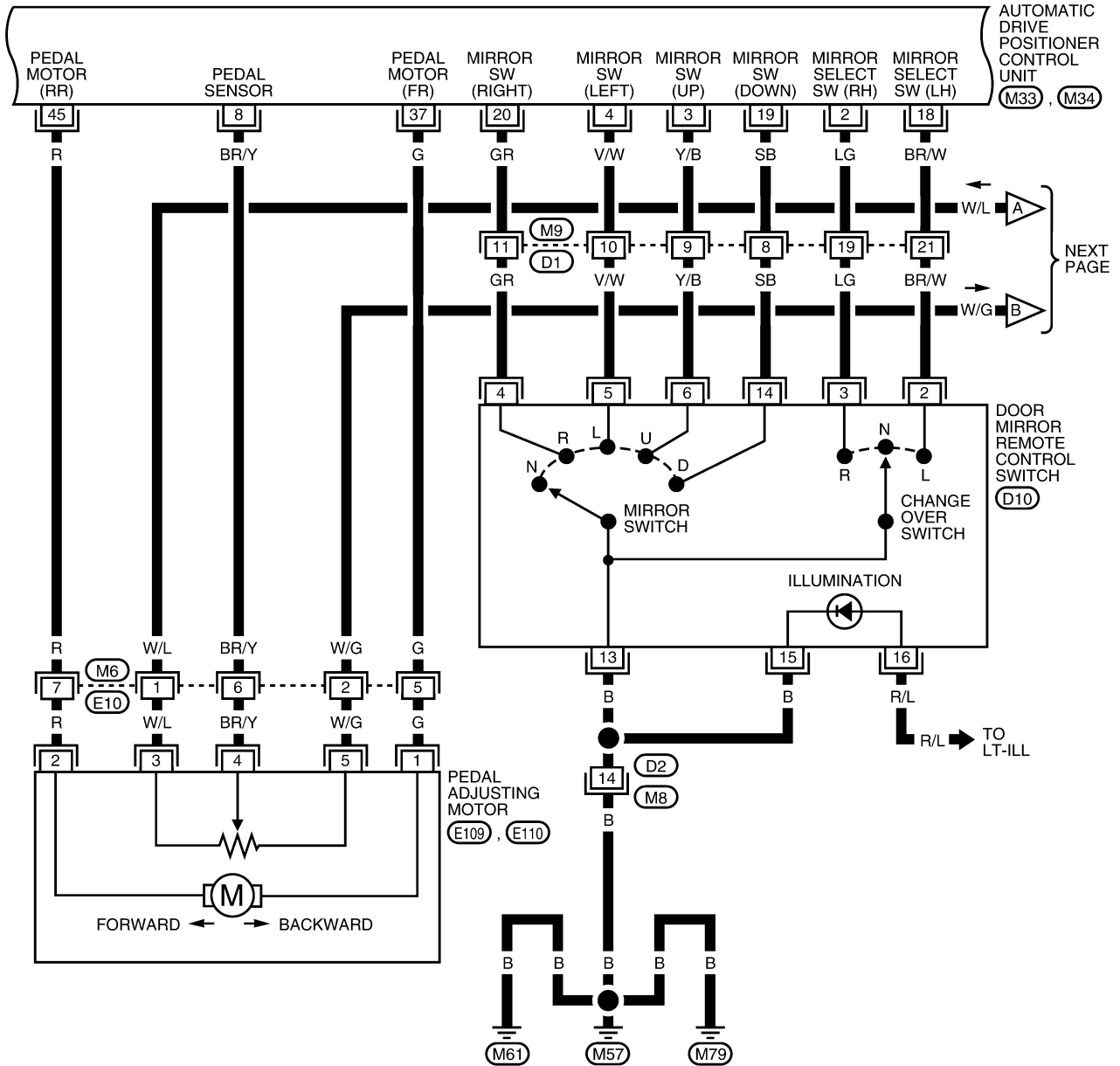

WIWA1408E

AUTOMATIC DRIVE POSITIONER

SE-AUT/DP-03

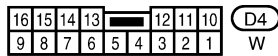
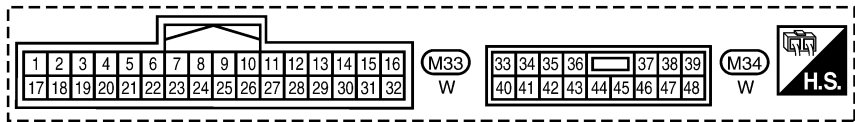
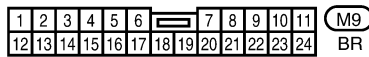
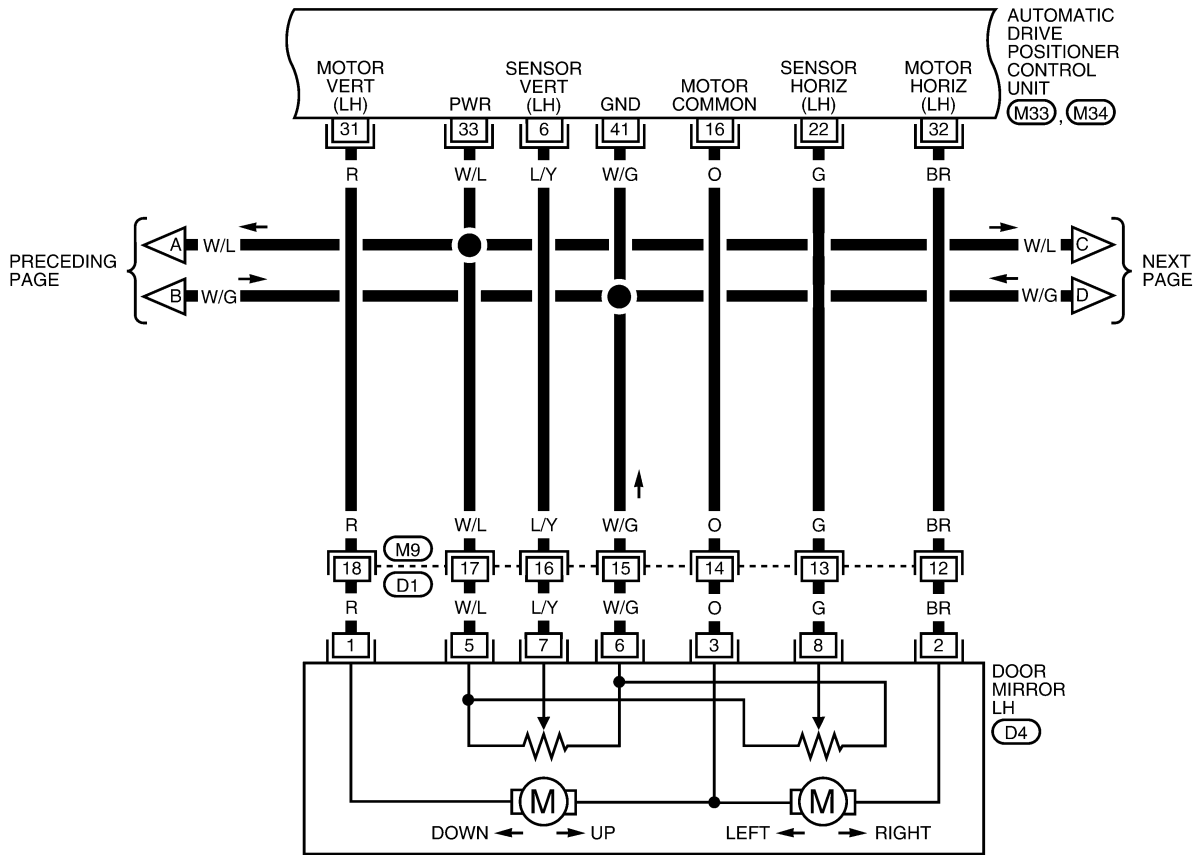

WIWA0579E

AUTOMATIC DRIVE POSITIONER

SE-AUT/DP-04

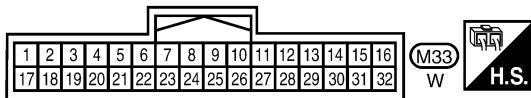
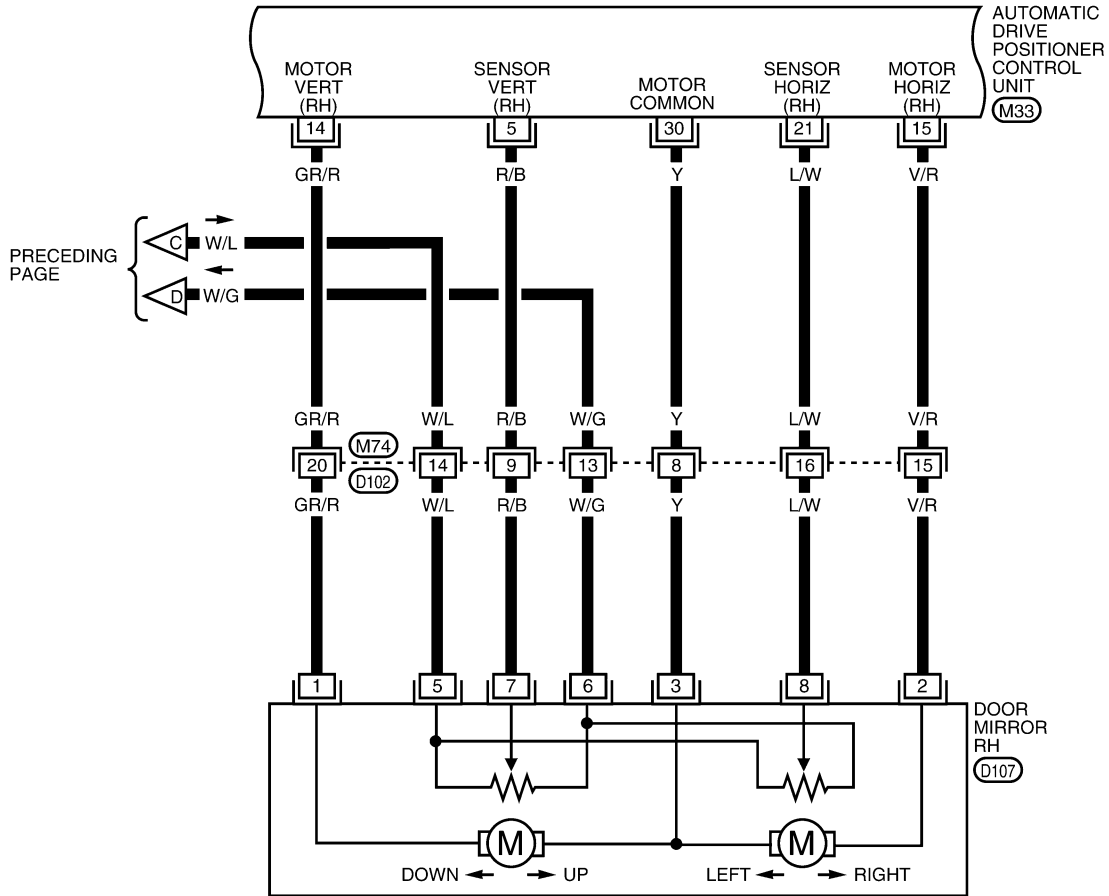

W1WA0220E

AUTOMATIC DRIVE POSITIONER

SE-AUT/DP-05

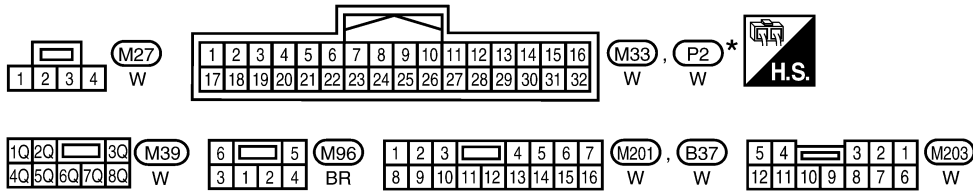
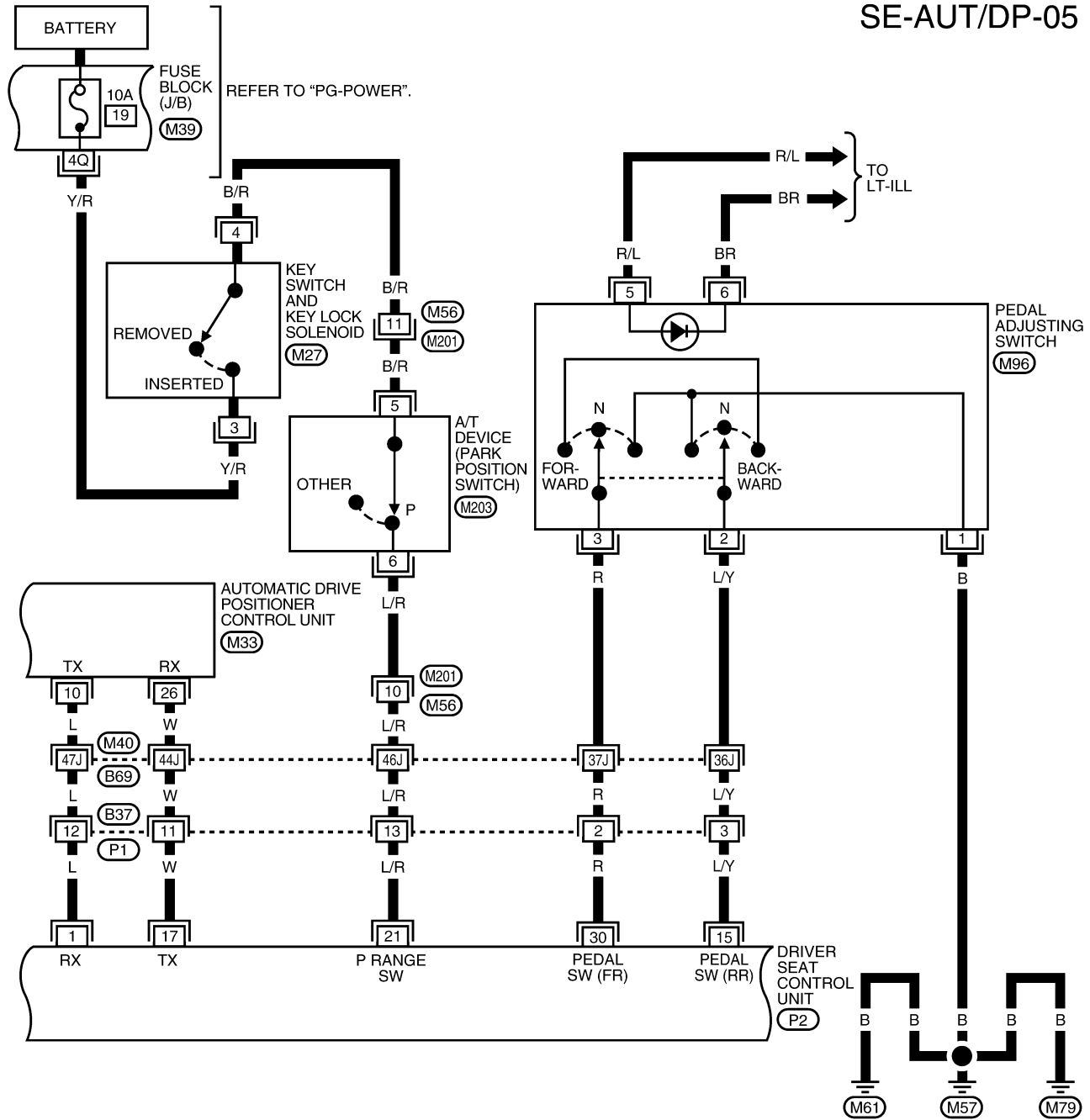

REFER TO THE FOLLOWING.
 (M40) - SUPER MULTIPLE JUNCTION (SMJ)

*: THIS CONNECTOR IS NOT SHOWN IN "HARNESS LAYOUT" OF PG SECTION.

WIWA1198E

AUTOMATIC DRIVE POSITIONER

SE-AUT/DP-06

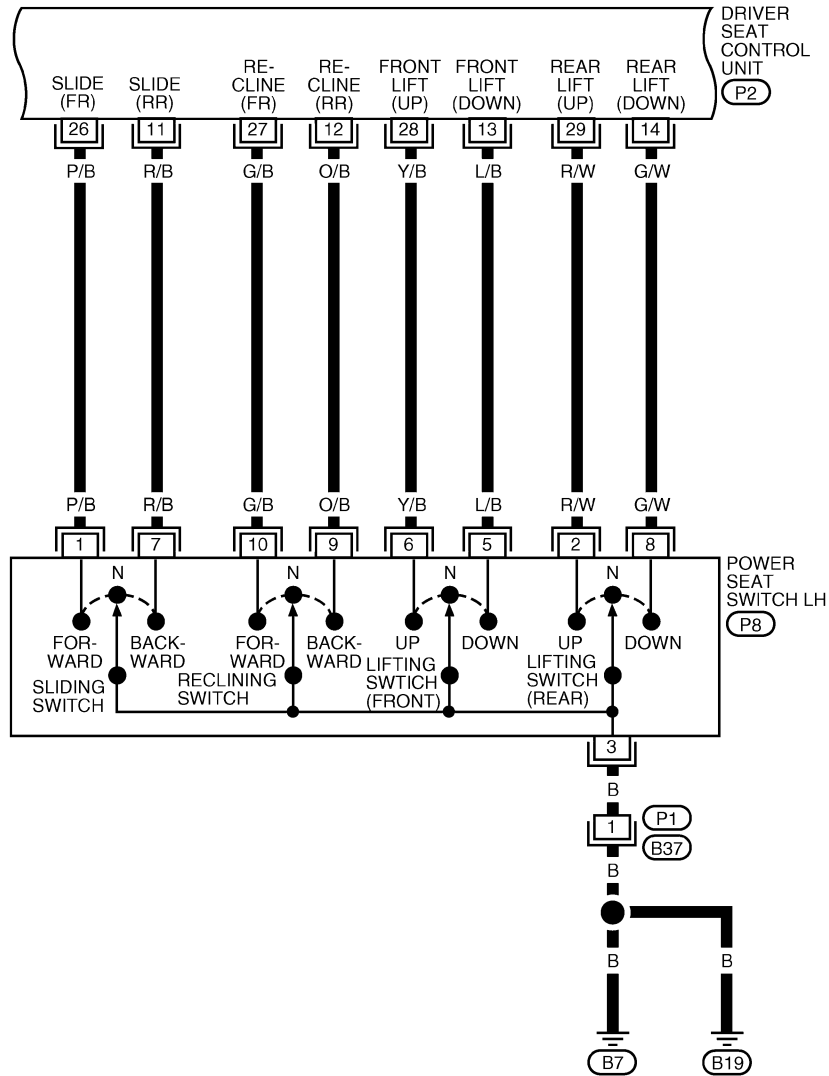

A
B
C
D
E
F
G
H
SE
J
K
L
M

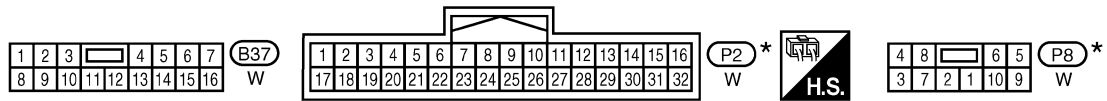

*: THIS CONNECTOR IS NOT SHOWN IN "HARNESS LAYOUT" OF PG SECTION.

W1WA0222E

AUTOMATIC DRIVE POSITIONER

SE-AUT/DP-07

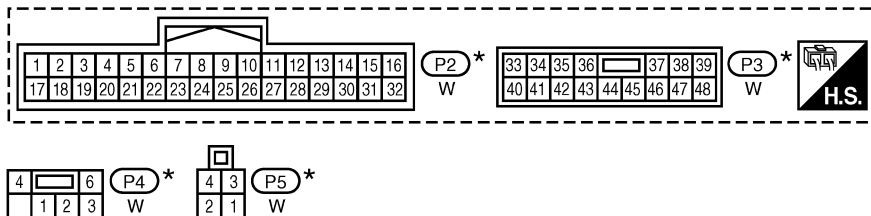
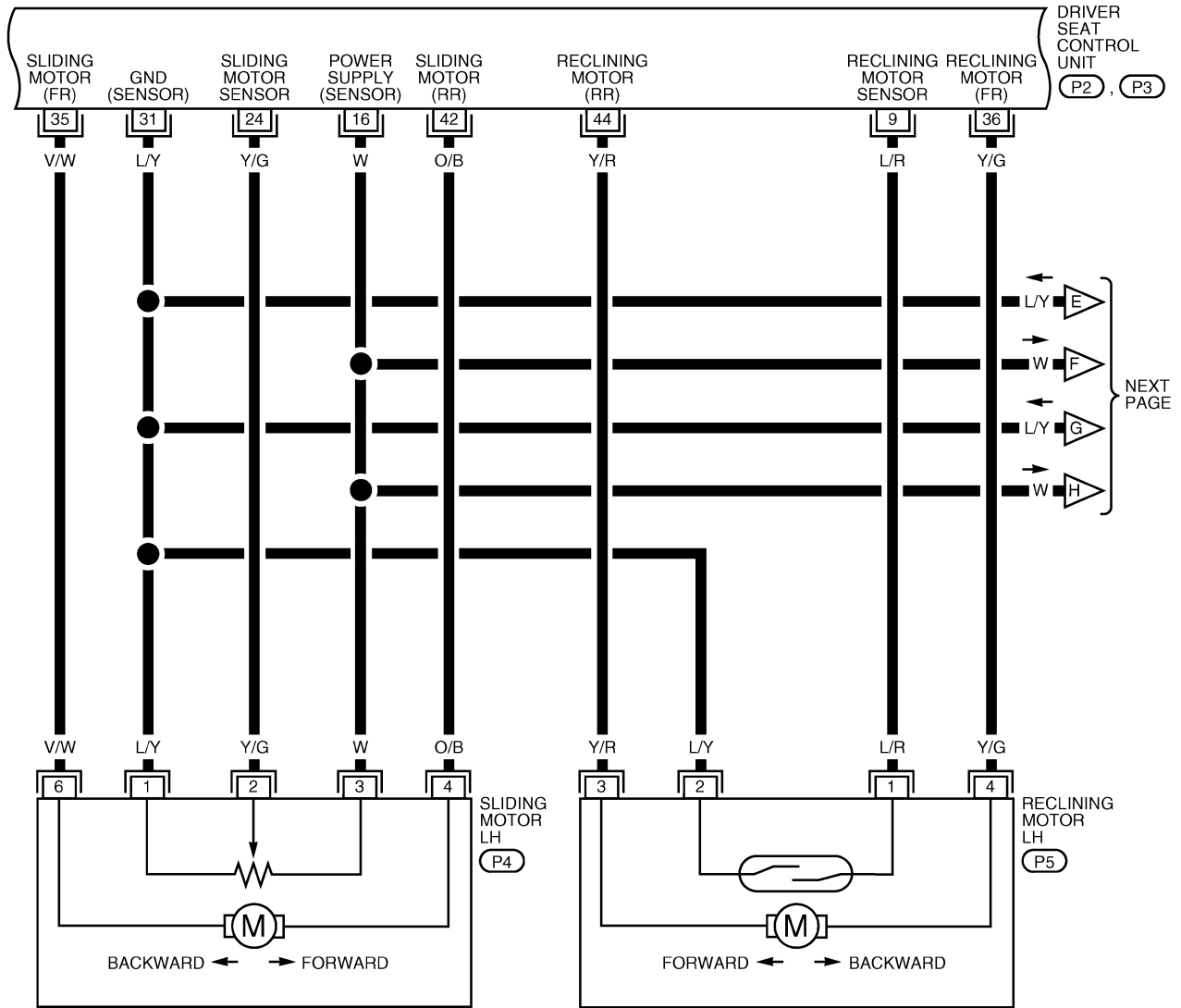

* : THIS CONNECTOR IS NOT SHOWN IN "HARNESS LAYOUT" OF PG SECTION.

WIWA0223E

AUTOMATIC DRIVE POSITIONER

SE-AUT/DP-08

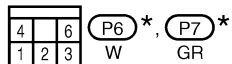
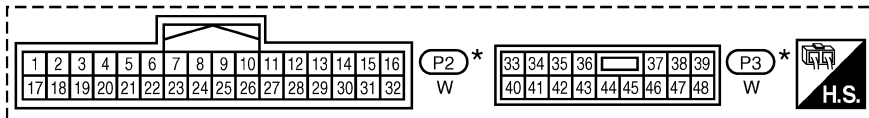
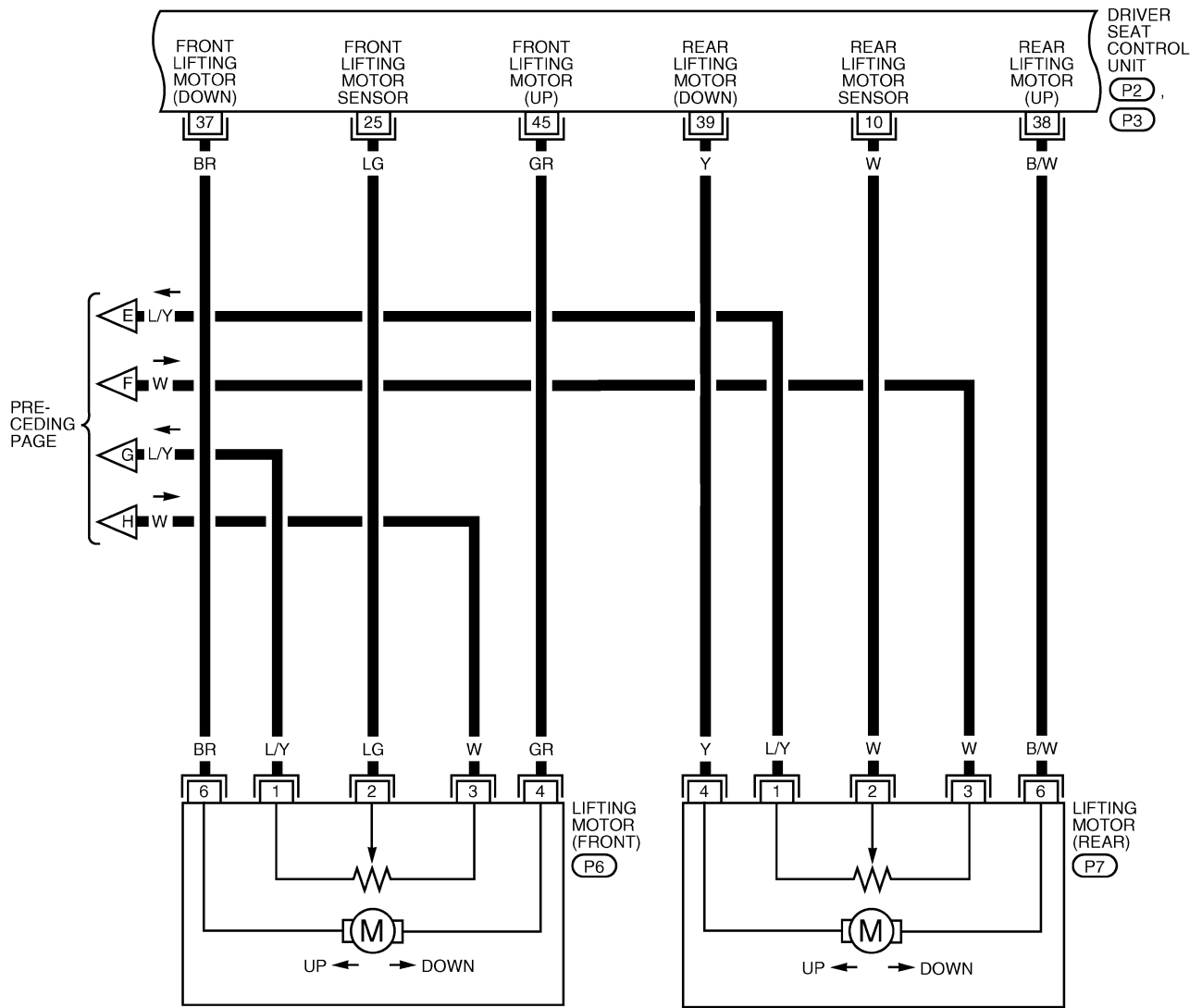

* : THIS CONNECTOR IS NOT SHOWN IN "HARNESS LAYOUT" OF PG SECTION.

WIWA0224E

AUTOMATIC DRIVE POSITIONER

SE-AUT/DP-09

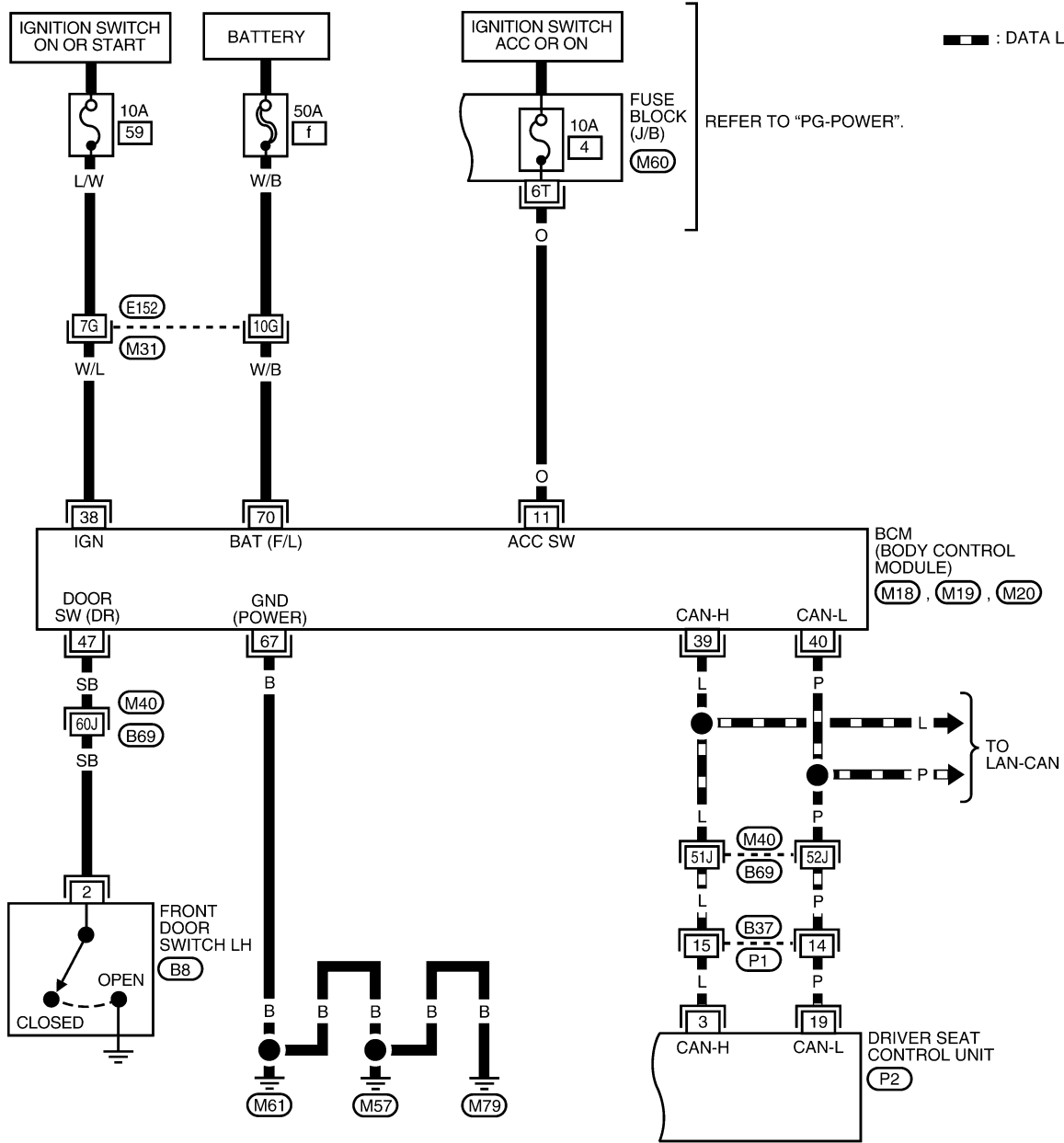

REFER TO THE FOLLOWING.
 (M31), (M40) - SUPER MULTIPLE JUNCTION (SMJ)

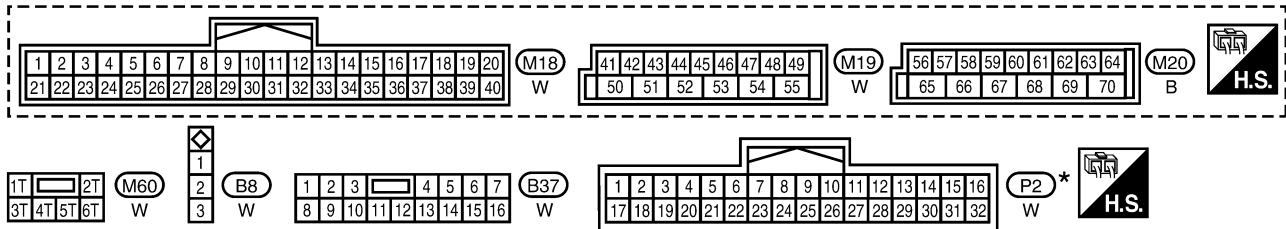

*: THIS CONNECTOR IS NOT SHOWN IN "HARNESS LAYOUT" OF PG SECTION.

WIWA1409E

AUTOMATIC DRIVE POSITIONER

Terminals and Reference Values for BCM

EIS0040I

Terminal	Wire Color	Item	Condition	Voltage (V) (Approx.)
11	O	Ignition switch (ACC or ON)	Ignition switch (ACC or ON position)	Battery voltage
38	W/L	Ignition switch (ON or START)	Ignition switch (ON or START position)	Battery voltage
39	L	CAN-H	—	—
40	P	CAN-L	—	—
47	SB	Front door switch LH	ON (Open) → OFF (Closed)	0 → Battery voltage
67	B	Ground	—	0
70	W/B	Battery power supply	—	Battery voltage

Terminals and Reference Values for Driver Seat Control Unit

EIS0040J

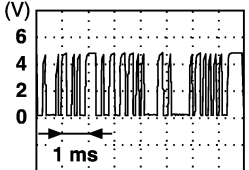
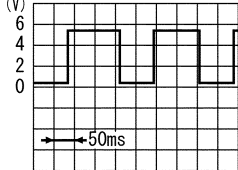
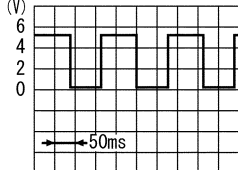
Terminal	Wire Color	Item	Condition	Voltage (V) (Approx.)
1	L	UART LINE (RX)	Pedal adjusting switch ON (FORWARD or BACKWARD operation)	 <p style="text-align: right; font-size: small;">PIIA4813E</p>
3	L	CAN-H	—	—
6	O	Ignition switch (START)	Ignition switch (START position)	Battery voltage
9	L/R	Reclining motor sensor signal	ON (seat reclining motor operation)	 <p style="text-align: right; font-size: small;">SIIA0692J</p>
			Other than above	0 or 5
10	W	Rear lifting motor sensor signal	ON (rear lifting motor operation)	 <p style="text-align: right; font-size: small;">SIIA0693J</p>
			Other than above	0 or 5
11	R/B	Sliding switch BACKWARD signal	ON (seat sliding switch BACKWARD operation)	0
			Other than above	Battery voltage
12	O/B	Reclining switch BACKWARD signal	ON (seat reclining switch BACKWARD operation)	0
			Other than above	Battery voltage
13	L/B	Front lifting switch DOWN signal	ON (front lifting switch DOWN operation)	0
			Other than above	Battery voltage

AUTOMATIC DRIVE POSITIONER

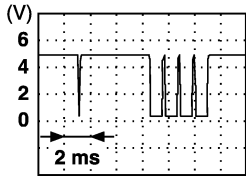
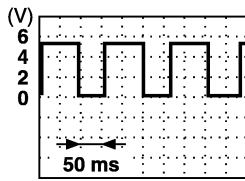
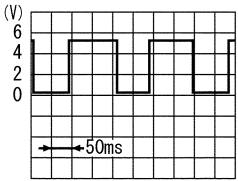
Terminal	Wire Color	Item	Condition	Voltage (V) (Approx.)
14	G/W	Rear lifting switch DOWN signal	ON (rear lifting switch DOWN operation)	0
			Other than above	Battery voltage
15	L/Y	Pedal adjusting switch BACKWARD signal	ON (pedal adjusting switch BACKWARD operation)	0
			Other than above	Battery voltage
16	W	Seat sensor power	Ignition switch ON	5
17	W	UART LINE (TX)	Pedal adjusting switch ON (FORWARD or BACKWARD operation)	 PIIA4814E
19	P	CAN-L	—	—
21	L/R	A/T device (park position switch) signal	A/T selector lever in P position	0
			A/T selector lever other than P position with ignition key in ignition cylinder	Battery voltage
24	Y/G	Seat sliding motor sensor signal	ON (seat sliding motor operation)	 PIIA3277E
			Other than above	0 or 5
25	LG	Front lifting motor sensor signal	ON (front lifting motor operation)	 SIIA0691J
			Other than above.	0 or 5
26	P/B	Seat sliding switch FORWARD signal	ON (seat sliding switch FORWARD operation)	0
			Other than above	Battery voltage
27	G/B	Seat reclining switch FORWARD signal	ON (seat reclining switch FORWARD operation)	0
			Other than above	Battery voltage
28	Y/B	Front lifting switch UP signal	ON (front lifting switch UP operation)	0
			Other than above	Battery voltage
29	R/W	Rear lifting switch UP signal	ON (rear lifting switch UP operation)	0
			Other than above	Battery voltage
30	R	Pedal adjusting switch FORWARD signal	ON (pedal adjusting switch FORWARD operation)	0
			Other than above	Battery voltage

AUTOMATIC DRIVE POSITIONER

Terminal	Wire Color	Item	Condition	Voltage (V) (Approx.)
31	L/Y	Sensor ground	—	0
32	B	Ground	—	0
33	L/B	Battery power supply	—	Battery voltage
35	V/W	Sliding motor FORWARD output signal	Sliding switch FORWARD operation (Motor operated)	Battery voltage
			Other than above	0
36	Y/G	Reclining motor FORWARD output signal	Reclining switch FORWARD operation (Motor operated)	Battery voltage
			Other than above	0
37	BR	Front lifting motor DOWN output signal	Front lifting switch DOWN operation (Motor operated)	Battery voltage
			Other than above	0
38	B/W	Rear lifting motor UP output signal	Rear end lifting switch UP operation (Motor operated)	Battery voltage
			Other than above	0
39	Y	Rear lifting motor DOWN output signal	Rear end lifting switch DOWN operation (Motor operated)	Battery voltage
			Other than above	0
40	Y/R	Battery power supply	—	Battery voltage
42	O/B	Sliding motor BACKWARD output signal	Sliding switch BACKWARD operation (Motor operated)	Battery voltage
			Other than above	0
44	Y/R	Reclining motor BACKWARD output signal	Reclining switch BACKWARD operation (Motor operated)	Battery voltage
			Other than above	0
45	GR	Front lifting motor UP output signal	Front lifting switch UP operation (Motor operated)	Battery voltage
			Other than above	0
48	B/W	Ground	—	0

Terminals and Reference Values for Automatic Drive Positioner Control Unit

EIS0040K

Terminal	Wire Color	Item	Condition	Voltage (V) (Approx.)
2	LG	Changeover switch RH signal	Changeover switch in RH position	0
			Other than above	5
3	Y/B	Mirror switch UP signal	Mirror switch in UP position	0
			Other than above	5
4	V/W	Mirror switch LEFT signal	Mirror switch in LEFT position	0
			Other than above	5
5	R/B	Mirror sensor (RH vertical) signal	Mirror motor RH is operated UP or DOWN	Changes between 3.4 (close to peak) 0.6 (close to valley)
6	L/Y	Mirror sensor (LH vertical) signal	Mirror motor LH is operated UP or DOWN	Changes between 3.4 (close to peak) 0.6 (close to valley)
8	BR/Y	Pedal sensor input signal	Pedal position front end	0.5
			Pedal position rear end	4.5
9	LG/B	Seat memory switch 1 signal	Memory switch 1 ON	0
			Memory switch 1 OFF	5

AUTOMATIC DRIVE POSITIONER

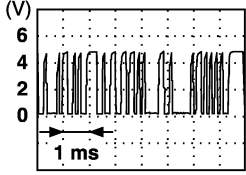
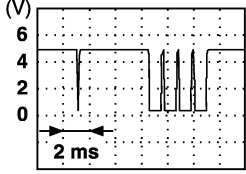
Terminal	Wire Color	Item	Condition	Voltage (V) (Approx.)
10	L	UART LINE (TX)	Pedal adjusting switch ON (FORWARD or BACKWARD operation)	 PIIA4813E
12	P	Seat memory switch indicator 1 signal	Memory switch 1 ON	0
			Memory switch 1 OFF	Battery voltage
13	Y/G	Seat memory switch indicator 2 signal	Memory switch 2 ON	0
			Memory switch 2 OFF	Battery voltage
14	GR/R	Mirror motor RH UP signal	Mirror motor RH is operated UP	1.5 - Battery voltage
			Other than above	0
15	V/R	Mirror motor RH LEFT signal	Mirror motor RH is operated LEFT	1.5 - Battery voltage
			Other than above	0
16	O	Mirror motor LH DOWN signal	Mirror motor LH is operated DOWN	1.5 - Battery voltage
			Other than above	0
		Mirror motor LH RIGHT signal	Mirror motor LH is operated RIGHT	1.5 - Battery voltage
			Other than above	0
18	BR/W	Changeover switch LH signal	Changeover switch in LH position	0
			Other than above	5
19	SB	Mirror switch DOWN signal	Mirror switch in DOWN position	0
			Other than above	5
20	GR	Mirror switch RIGHT signal	Mirror switch in RIGHT position	0
			Other than above	5
21	L/W	Mirror sensor (RH horizontal) signal	Mirror motor RH is operated LEFT or RIGHT	Changes between 3.4 (close to left edge) 0.6 (close to right edge)
22	G	Mirror sensor (LH horizontal) signal	Mirror motor LH is operated LEFT or RIGHT	Changes between 3.4 (close to right edge) 0.6 (close to left edge)
24	G/O	Seat memory set switch signal	Set switch 1 ON	0
			Set switch 1 OFF	5
25	P/L	Seat memory switch 2 signal	Memory switch 2 ON	0
			Memory switch 2 OFF	5
26	W	UART LINE (RX)	Pedal adjusting switch ON (FORWARD or BACKWARD operation)	 PIIA4814E
30	Y	Mirror motor RH DOWN signal	Mirror motor RH is operated DOWN	1.5 - Battery voltage
			Other than above	0
		Mirror motor RH RIGHT signal	Mirror motor RH is operated RIGHT	1.5 - Battery voltage
			Other than above	0
31	R	Mirror motor LH UP signal	Mirror motor LH is operated UP	1.5 - Battery voltage
			Other than above	0

AUTOMATIC DRIVE POSITIONER

Terminal	Wire Color	Item	Condition	Voltage (V) (Approx.)	
32	BR	Mirror motor LH LEFT signal	Mirror motor LH is operated LEFT	1.5 - Battery voltage	A
			Other than above	0	B
33	W/L	Sensor power supply	—	5	B
34	Y/R	Battery power supply	—	Battery voltage	
37	G	Pedal adjust motor FORWARD signal	Pedal adjust motor FORWARD operation (Motor operated)	Battery voltage	C
			Other than above	0	D
39	L/B	Battery power supply	—	Battery voltage	D
40	B/W	Ground	—	0	
41	W/G	Sensor ground	—	0	E
45	R	Pedal adjust motor BACKWARD signal	Pedal adjust motor BACKWARD operation (Motor operated)	Battery voltage	E
			Other than above	0	F
48	B	Ground	—	0	

Work Flow

EIS0040L

1. Check the symptom and customer's requests.
2. Understand the system description. Refer to [SE-12, "System Description"](#).
3. Perform the preliminary check. Refer to [SE-30, "Preliminary Check"](#).
4. Check the self-diagnosis, results using CONSULT-II. Refer to [SE-33, "CONSULT-II Function \(AUTO DRIVE POS.\)"](#).
5. Repair or replace depending on the self-diagnostic results.
6. Based on the trouble diagnosis chart, repair or replace the cause of the malfunction. Refer to [SE-37, "Symptom Chart"](#).
7. Does the automatic drive positioner system operate normally?
If it is normal, GO TO 8.
If it is not normal, GO TO 3.
8. Inspection End.

SE

J

K

L

M

AUTOMATIC DRIVE POSITIONER

EIS0040M

Preliminary Check SETTING CHANGE FUNCTION

The settings of the automatic driving positioner system can be changed, using CONSULT-II and the display unit (without NAVI) or display control unit (with NAVI).

×: Applicable –: Not applicable

Setting item	Content	CONSULT-II (WORK SUPPORT)	Display unit	Default setting	Factory setting
SEAT SLIDE VOLUME SET	The distance at exiting operation can be selected from the following 3 modes.	40mm	—	×	×
		80mm		—	—
		150mm		—	—
Sliding Front Seat When Entry/ Exiting Vehicle	The seat sliding turnout and return at entry/exit can be selected: ON (operated)–OFF (not operated)	ON	ON: Indicator lamp ON	—	×
		OFF	OFF: Indicator lamp OFF	×	—
Reset custom settings*	All settings to default.	—	Default: Setting button ON	—	—

It is possible to set sliding front seat for entry/exit of vehicle by pressing set switch.

Content	Setting change operation	Indicator LEDs
The seat sliding turnout and return at entry/exit can be operated.	Press the set switch for more than 10 seconds	Blinking twice
The seat sliding turnout and return at entry/exit can be not operated.		Blinking once

*: Setting of sliding front seat for entry/exit of vehicle is ON at factory-shipment. But if custom settings are reset, setting turns OFF.

NOTE:

After the setting is registered, the new setting is effective, even if the battery is disconnected.

POWER SUPPLY AND GROUND CIRCUIT INSPECTION

1. CHECK BCM FUSES AND FUSIBLE LINK

Check if any of the following fuses for the BCM are blown.

Unit	Power source	Fuse No.
BCM	Battery power supply	f (50A)
	ON or START power supply	59 (10A)
	ACC or ON power supply	4 (10A)

NOTE:

Refer to [SE-11, "Component Parts And Harness Connector Location"](#) .

OK or NG

OK >> GO TO 2.

NG >> If fuse or fusible link is blown, be sure to eliminate cause of malfunction before installing new fuse.
Refer to [PG-65, "ELECTRICAL UNITS LOCATION"](#) .

AUTOMATIC DRIVE POSITIONER

2. CHECK BCM POWER SUPPLY CIRCUIT

1. Turn ignition switch OFF.
2. Disconnect BCM.
3. Check voltage between BCM connector and ground as follows.

Connector	Terminals		Power source	Condition	Voltage (V) (Approx)
	(+)	(-)			
M20	70	Ground	Battery power supply	Ignition switch OFF	Battery voltage
M18	38	Ground	Ignition power supply	Ignition switch ON or START	Battery voltage
	11	Ground	ACC power supply	Ignition switch ACC or ON	Battery voltage

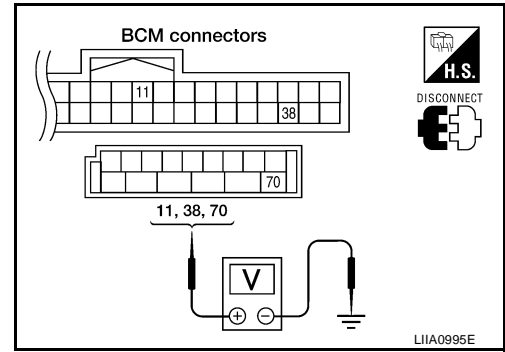

OK or NG

- OK >> GO TO 3.
- NG >> Repair or replace the harness.

3. CHECK BCM GROUND CIRCUIT

Check continuity between BCM connector M20 terminal 67 and ground.

67 - Ground : Continuity should exist.

OK or NG

- OK >> BCM circuit is OK. Check the driver seat control unit. GO TO 4.
- NG >> Repair or replace the harness.

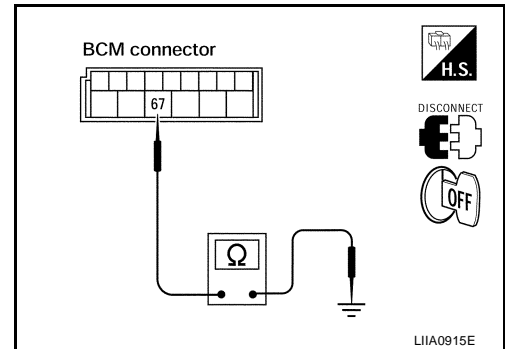

4. CHECK DRIVER SEAT CONTROL UNIT FUSE

Make sure any of the following fuses for the driver seat control unit and automatic drive positioner control unit are not blown.

Unit	Power source	Fuse No.
Driver seat control unit	START power supply	2 (10A)
Driver seat control unit and automatic drive positioner control unit	Battery power supply	22 (15A)
	Battery power supply	f (50A)

NOTE:

Refer to [SE-11, "Component Parts And Harness Connector Location"](#).

OK or NG

- OK >> GO TO 5.
- NG >> If fuse is blown, be sure to eliminate cause of malfunction before installing new fuse. Refer to [PG-65, "ELECTRICAL UNITS LOCATION"](#).

AUTOMATIC DRIVE POSITIONER

5. CHECK DRIVER SEAT CONTROL UNIT POWER SUPPLY CIRCUIT

1. Disconnect driver seat control unit.
2. Check voltage between driver seat control unit connector and ground.

Connector	Terminals		Power source	Condition	Voltage (V) (Approx)
	(+)	(-)			
P3	33	Ground	Battery power supply	Ignition switch OFF	Battery voltage
	40	Ground	Battery power supply	Ignition switch OFF	Battery voltage
P2	6	Ground	START power supply	Ignition switch START	Battery voltage

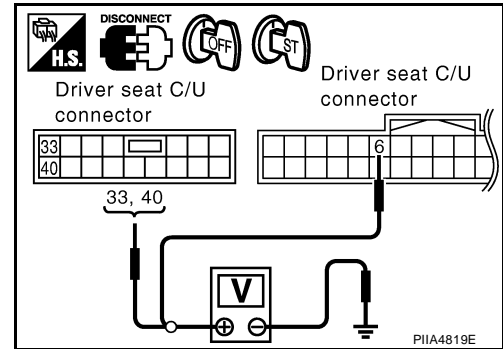

OK or NG

- OK >> GO TO 6.
 NG >> Repair or replace harness.

6. CHECK DRIVER SEAT CONTROL UNIT GROUND CIRCUIT

1. Turn ignition switch OFF.
2. Check continuity between the driver seat control unit connector P2 terminal 32, P3 terminal 48 and ground.

32 - Ground : Continuity should exist.
48 - Ground : Continuity should exist.

OK or NG

- OK >> Driver seat control unit circuit check is OK. Check the automatic drive positioner control unit. GO TO 7.
 NG >> Repair or replace harness.

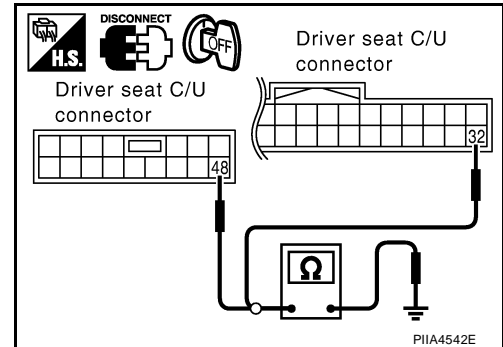

7. CHECK AUTOMATIC DRIVE POSITIONER CONTROL UNIT POWER SUPPLY CIRCUIT

1. Disconnect automatic drive positioner control unit.
2. Check voltage between automatic drive positioner control unit connector M34 terminal 34, 39 and ground.

Connector	Terminals		Condition	Voltage (V) (Approx)
	(+)	(-)		
M34	34	Ground	Ignition switch OFF	Battery voltage
	39	Ground	Ignition switch OFF	Battery voltage

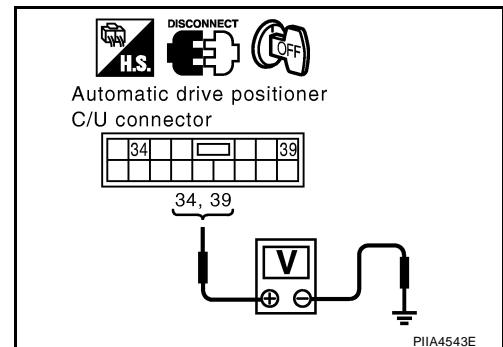

OK or NG

- OK >> GO TO 8.
 NG >> Repair or replace harness.

AUTOMATIC DRIVE POSITIONER

8. CHECK AUTOMATIC DRIVE POSITIONER CONTROL UNIT GROUND CIRCUIT

Check continuity between the automatic drive positioner control unit connector M34 terminal 40, 48 and ground.

- 40 - Ground : Continuity should exist.**
- 48 - Ground : Continuity should exist.**

OK or NG

- OK >> Automatic drive positioner control unit circuit is OK.
- NG >> Repair or replace harness.

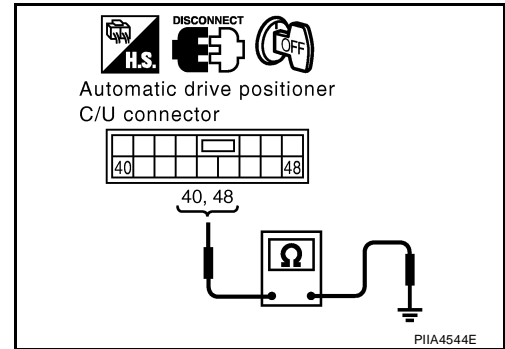

CONSULT-II Function (AUTO DRIVE POS.)

EIS0040N

CONSULT-II can display each diagnostic item using the diagnostic test modes shown following.

AUTO DRIVE POS. diagnostic mode	Description
WORK SUPPORT	Supports inspections and adjustments. Commands are transmitted to the driver seat control unit for setting the status suitable for required operation, input/output signals are received from the driver seat control unit and received data is displayed.
SELF-DIAG RESULTS	Displays driver seat control unit self-diagnosis results.
DATA MONITOR	Displays driver seat control unit input/output data in real time.
CAN DIAG SUPPORT MNTR	The result of transmit/receive diagnosis of CAN communication can be read.
ACTIVE TEST	Operation of electrical loads can be checked by sending drive signal to them.
ECU PART NUMBER	Driver seat control unit part number can be read.

CONSULT-II INSPECTION PROCEDURE

CAUTION:

If CONSULT-II is used with no connection of CONSULT-II CONVERTER, malfunctions might be detected in self-diagnosis depending on control unit which carries out CAN communication.

1. Turn ignition switch OFF.
2. Connect CONSULT-II and CONSULT-II CONVERTER to the data link connector.
3. Turn ignition switch ON.

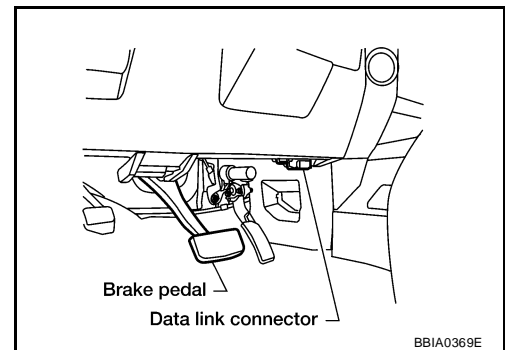

4. Touch "START (NISSAN BASED VHCL)".

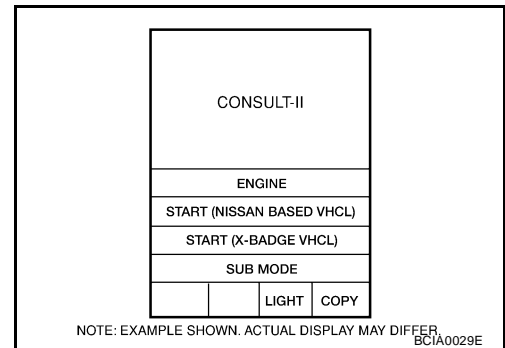

AUTOMATIC DRIVE POSITIONER

5. Touch "AUTO DRIVE POS".
If "AUTO DRIVE POS." is not indicated, refer to [GI-39, "CONSULT-II Data Link Connector \(DLC\) Circuit"](#) .

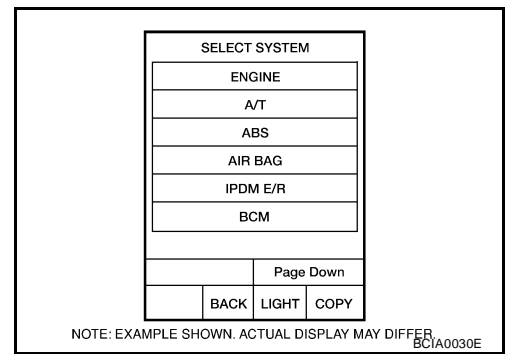

6. Select diagnosis mode.
"DATA MONITOR", "ACTIVE TEST", "SELF-DIAG RESULTS",
"ECU PART NUMBER" and "WORK SUPPORT" are available.

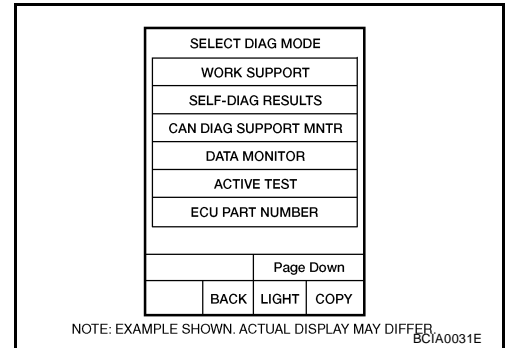

AUTOMATIC DRIVE POSITIONER

SELF-DIAGNOSIS RESULTS

DISPLAY ITEM LIST

CONSULT-II display	Item	Malfunction is detected when...	Reference page
CAN COMM CIRC [U1000]	CAN communication	Malfunction is detected in CAN communication.	SE-37
SEAT SLIDE [B2112]	Seat slide motor	When any manual and automatic operations are not performed, if any motor operations of seat slide is detected for 0.1 second or more, status is judged "Output error".	SE-39 , SE-49
SEAT RECLINING [B2113]	Seat reclining motor	When any manual and automatic operations are not performed, if any motor operations of seat reclining is detected for 0.1 second or more, status is judged "Output error".	SE-40 , SE-50
SEAT LIFTER FR [B2114]	Seat lifting FORWARD motor	When any manual and automatic operations are not performed, if any motor operations of seat lifting FORWARD is detected for 0.1 second or more, status is judged "Output error".	SE-41 , SE-51
SEAT LIFTER RR [B2115]	Seat lifting BACKWARD motor	When any manual and automatic operations are not performed, if any motor operations of seat lifting BACKWARD is detected for 0.1 second or more, status is judged "Output error".	SE-43 , SE-51
ADJ PEDAL MOTOR [B2117]	Pedal adjust motor	When any manual and automatic operations are not performed, if motor operation of pedal is detected for 0.1 second or more, status is judged "Output error".	SE-44
ADJ PEDAL SENSOR [B2120]	Pedal adjust sensor	When pedal adjust sensor detects 0.5V or lower, or 4.5V or higher, for 0.5 seconds or more.	SE-53
DETENT SW [B2126]	Park position switch	With the A/T selector lever in P position (park position switch OFF), if the vehicle speed of 7 km/h (4 MPH) or higher was input the park position switch input system is judged malfunctioning.	SE-73
UART COMM [B2128]	UART communication	Malfunction is detected in UART communication.	SE-75

NOTE:

- If park switch error is detected, manual adjustable pedal operation cannot be performed when ignition switch turns ON.
- The displays of CAN communication and detection switch display error detecting condition from memory erase to the present on "TIME".
 - If error is detected in the past and present error is detected, "CRNT" is displayed.
 - If error is detected in the past and present error is not detected, "PAST" is displayed.
 - If error has never been detected, nothing is displayed on "TIME".
- Any items other than CAN communication and park switch count error detection frequency occurred after erase history to "1-127".
 - If error was detected in the past, error detection frequency from memory erase to the present is displayed on "TIME".
 - If error has never been detected, nothing is displayed on "TIME".
 - Can clear the detected memory.
 - Normal: Clear memory in normal condition, history is erased and nothing is displayed on "TIME".
 - Error: Clear memory in error condition, error is detected again and "1" is displayed on "TIME".

AUTOMATIC DRIVE POSITIONER

DATA MONITOR SELECTION FROM MENU

Monitor item [OPERATION or UNIT]	Contents
SLIDE SW-FR	"ON/OFF" ON/OFF status judged from the sliding switch (FR) signal is displayed.
SLIDE SW-RR	"ON/OFF" ON/OFF status judged from the sliding switch (RR) signal is displayed.
RECLN SW-FR	"ON/OFF" ON/OFF status judged from the reclining switch (FR) signal is displayed.
RECLN SW-RR	"ON/OFF" ON/OFF status judged from the reclining switch (RR) signal is displayed.
LIFT FR SW-UP	"ON/OFF" ON/OFF status judged from the FR lifter switch (UP) signal is displayed.
LIFT FR SW-DN	"ON/OFF" ON/OFF status judged from the FR lifter switch (DOWN) signal is displayed.
LIFT RR SW-UP	"ON/OFF" ON/OFF status judged from the RR lifter switch (UP) signal is displayed.
LIFT RR SW-DN	"ON/OFF" ON/OFF status judged from the RR lifter switch (DOWN) signal is displayed.
MIR CON SW-UP	"ON/OFF" ON/OFF status judged from the door mirror remote control switch (UP) signal is displayed.
MIR CON SW-DN	"ON/OFF" ON/OFF status judged from the door mirror remote control switch (DOWN) signal is displayed.
MIR CON SW-RH	"ON/OFF" ON/OFF status judged from the door mirror remote control switch (RIGHT) signal is displayed.
MIR CON SW-LH	"ON/OFF" ON/OFF status judged from the door mirror remote control switch (LEFT) signal is displayed.
MIR CHNG SW-R	"ON/OFF" ON/OFF status judged from the door mirror remote control switch (switching to RIGHT) signal is displayed.
MIR CHNG SW-L	"ON/OFF" ON/OFF status judged from the door mirror remote control switch (switching to LEFT) signal is displayed.
SET SW	"ON/OFF" ON/OFF status judged from the setting switch signal is displayed.
PEDAL SW-FR	"ON/OFF" ON/OFF status judged from the pedal adjusting switch (FR) signal is displayed.
PEDAL SW-RR	"ON/OFF" ON/OFF status judged from the pedal adjusting switch (RR) signal is displayed.
MEMORY SW1	"ON/OFF" ON/OFF status judged from the seat memory switch 1 signal is displayed.
MEMORY SW2	"ON/OFF" ON/OFF status judged from the seat memory switch 2 signal is displayed.
DETENT SW	"ON/OFF" The A/T selector lever position "OFF (P position) / ON (other than P position)" judged from the park position switch signal is displayed.
STARTER SW	"ON/OFF" Ignition key switch ON (START, ON) /OFF (ignition switch IGN, ACC, or OFF) status judged from the ignition switch signal is displayed.
SLIDE PULSE	— Value (32768) when battery connects is as standard. If it moves backward, the value increases. If it moves forward, the value decreases.
RECLN PULSE	— Value (32768) when battery connects is as standard. If it moves backward, the value increases. If it moves forward, the value decreases.
LIFT FR PULSE	— Value (32768) when battery connects is as standard. If it moves DOWN, the value increases. If it moves UP, the value decreases.
LIFT RR PULSE	— Value (32768) when battery connects is as standard. If it moves DOWN, the value increases. If it moves UP, the value decreases.
MIR/SEN RH R-L	"V" Voltage output from RH door mirror sensor (LH/RH) is displayed.
MIR/SEN RH U-D	"V" Voltage output from RH door mirror sensor (UP/DOWN) is displayed.
MIR/SEN LH R-L	"V" Voltage output from LH door mirror sensor (LH/RH) is displayed.
MIR/SEN LH U-D	"V" Voltage output from LH door mirror sensor (UP/DOWN) is displayed.
PEDAL SEN	"V" The pedal position (voltage) judged from the pedal adjust sensor signal is displayed.

ACTIVE TEST

CAUTION:

During vehicle driving, do not perform active test.

AUTOMATIC DRIVE POSITIONER

NOTE:

If active test is performed, reset automatic drive positioner seat memory after performing work.

DISPLAY ITEM LIST

Test item	Description
SEAT SLIDE	The sliding motor is activated by receiving the drive signal.
SEAT RECLINING	The reclining motor is activated by receiving the drive signal.
SEAT LIFTER FR	The lifting motor (front) is activated by receiving the drive signal.
SEAT LIFTER RR	The lifting motor (rear) is activated by receiving the drive signal.
ADJ PEDAL MOTOR	The pedal adjust motor is activated by receiving the drive signal.
MEMORY SW INDCTR	The memory switch indicator is lit by receiving the drive signal.
MIRROR MOTOR RH	The RH mirror motor moves the mirror UP/DOWN and LEFT/RIGHT by receiving the drive signal.
MIRROR MOTOR LH	The LH mirror motor moves the mirror UP/DOWN and LEFT/RIGHT by receiving the drive signal.

CAN Communication Inspection Using CONSULT-II (Self-Diagnosis)

EIS00400

1. SELF-DIAGNOSTIC RESULT CHECK

CAUTION:

If CONSULT-II is used with no connection of CONSULT-II CONVERTER, malfunctions might be detected in self-diagnosis depending on control unit which carries out CAN communication.

1. Connect to CONSULT-II, and select "AUTO DRIVE POS." on the "SELECT DIAG SYSTEM" screen.
2. Select "SELF-DIAG RESULTS" on "SELECT DIAG MODE" screen.
3. Check display content in self-diagnostic results.

CONSULT-II display code	Diagnosis item
U1000	INITIAL DIAG
	TRANSMIT DIAG
	BCM/SEC
	IPDM E/R
	METER/M&A
	TCM

Contents displayed

No malfunction>>Inspection End.

Malfunction in CAN communication system>>After printing the monitor items, go to "CAN System". Refer to [LAN-3, "Precautions When Using CONSULT-II"](#).

Symptom Chart

EIS0040P

Symptom	Diagnoses/service procedure	Refer to page	
Only setting change function cannot be set with display.	1. Preliminary check	SE-30	
	2. CAN communication inspection using CONSULT-II (self-diagnosis)	SE-37	
	3. If the above systems are normal, check display system.	Display system (without NAVI)	DI-5
		Navigation system (with NAVI)	AV-88

AUTOMATIC DRIVE POSITIONER

Symptom	Diagnoses/service procedure	Refer to page
A part of seat system does not operate (both automatically and manually).	1. Sliding motor circuit inspection	SE-39
	2. Reclining motor circuit inspection	SE-40
	3. Lifting motor (front) circuit inspection	SE-41
	4. Lifting motor (rear) circuit inspection	SE-43
	5. If the above systems are normal, replace the driver seat control unit.	SE-11
A part of pedal adjust and door mirror does not operate (both automatically and manually).	1. Pedal adjusting motor circuit inspection	SE-44
	2. Mirror motor LH circuit check	SE-45
	3. Mirror motor RH circuit check	SE-47
	4. If the above systems are normal, replace the automatic drive positioner control unit.	SE-11
A part of seat system does not operate (only automatic operation).	1. Sliding sensor circuit inspection	SE-49
	2. Reclining sensor circuit inspection	SE-50
	3. Lifting sensor (front) circuit inspection	SE-51
	4. Lifting sensor (rear) circuit inspection	SE-52
	5. If the above systems are normal, replace the driver seat control unit.	SE-11
A part of door mirror system does not operate (only automatic operation).	1. Mirror sensor LH circuit check	SE-54
	2. Mirror sensor RH circuit check	SE-55
	3. If the above systems are normal, replace the automatic drive positioner control unit.	SE-11
All of the automatic operations do not operate.	1. A/T device (park position switch) circuit inspection	SE-73
	2. UART communication line circuit inspection	SE-75
	3. Pedal adjusting sensor circuit inspection	SE-53
	4. If all the above systems are normal, replace the automatic drive positioner control unit.	SE-11
A part of seat system does not operate (only manual operation).	1. Sliding switch circuit inspection	SE-57
	2. Reclining switch circuit inspection	SE-59
	3. Lifting switch (front) circuit inspection	SE-60
	4. Lifting switch (rear) circuit inspection	SE-62
	5. If the above systems are normal, replace the driver seat control unit.	SE-11
A part of pedal adjust and door mirror does not operate (only manual operation).	1. Pedal adjusting switch circuit inspection	SE-64
	2. Door mirror remote control switch (change over switch) circuit inspection	SE-66
	3. Door mirror remote control switch (mirror switch) switching circuit inspection	SE-67
	4. If the above systems are normal, replace the automatic drive positioner control unit.	SE-11
Automatic drive positioner system does not operate (only memory switch operation).	1. Seat memory switch circuit inspection	SE-69
	2. If the above systems are normal, replace the driver seat control unit.	SE-11
Seat memory indicator lamps 1 and 2 do not illuminate.	1. Seat memory indicator lamp circuit inspection	SE-71
	2. If all the above systems are normal, replace the driver seat control unit.	SE-11
The Entry/Exiting does not operate when door is opened and closed. (The Entry/Exiting operates with key switch)	1. Front door switch circuit inspection	SE-74
	2. If all the above systems are normal, replace the BCM.	BCS-20

AUTOMATIC DRIVE POSITIONER

Symptom	Diagnoses/service procedure	Refer to page
Door mirror system does not operate (only manual operation).	1. Door mirror remote control switch ground circuit inspection	SE-69
Door mirror system does not operate (only automatic operation).	1. Door mirror sensor power supply and ground circuit inspection	SE-72
Seat system does not operate (only manual operation).	1. Power seat switch ground circuit inspection	SE-63

Sliding Motor Circuit Inspection

EIS00400

1. CHECK SEAT SLIDING MECHANISM

Check the following.

- Operation malfunction caused by sliding rail deformation, pinched harness or other foreign materials
- Operation malfunction caused by foreign materials adhered to the sliding motor LH or sliding rail connector rod
- Operation malfunction and interference with other parts by poor installation

OK or NG

OK >> GO TO 2.

NG >> Repair or replace the malfunctioning part and check again.

2. CHECK FUNCTION

With CONSULT-II

Check operation with "SEAT SLIDE" in ACTIVE TEST.

Test item	Description
SEAT SLIDE	The sliding motor is activated by receiving the drive signal.

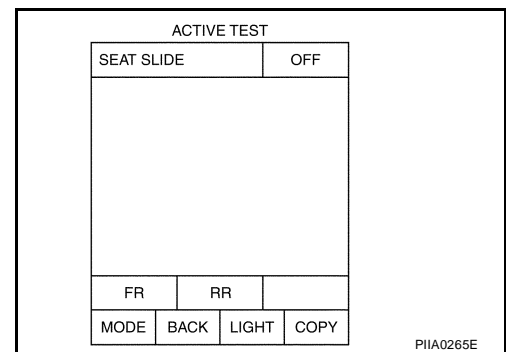

Without CONSULT-II

GO TO 3.

OK or NG

OK >> Sliding motor circuit is OK.

NG >> GO TO 3.

3. CHECK SLIDING MOTOR CIRCUIT HARNESS CONTINUITY

1. Turn ignition switch OFF.
2. Disconnect driver seat control unit and sliding motor LH.
3. Check continuity between driver seat control unit connector P3 terminals 35, 42 and sliding motor connector P4 terminals 4, 6.

35 - 6 : Continuity should exist.

42 - 4 : Continuity should exist.

4. Check continuity between driver seat control unit connector P3 terminals 35, 42 and ground.

35 - Ground : Continuity should not exist.

42 - Ground : Continuity should not exist.

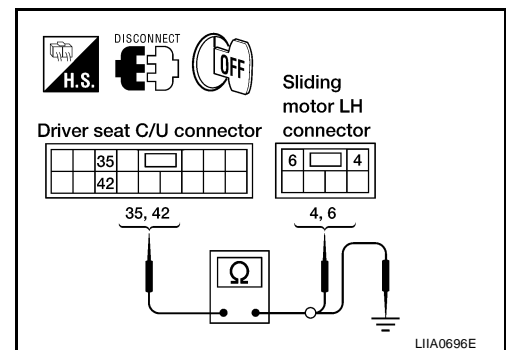

OK or NG

OK >> GO TO 4.

NG >> Repair or replace harness.

AUTOMATIC DRIVE POSITIONER

4. CHECK DRIVER SEAT CONTROL UNIT OUTPUT SIGNAL

1. Connect the driver seat control unit and sliding motor LH.
2. Check voltage between driver seat control unit connector and ground.

Connector	Terminals		Condition	Voltage (V) (Approx.)
	(+)	(-)		
P3	35	Ground	Sliding switch ON (FORWARD operation)	Battery voltage
			Other than above	0
	42		Sliding switch ON (BACKWARD operation)	Battery voltage
			Other than above	0

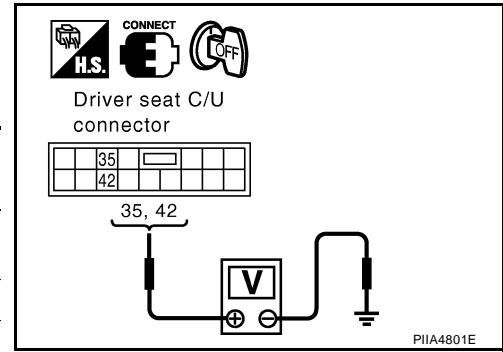

OK or NG

- OK >> Replace sliding motor. Refer to [SE-85, "FRONT SEAT"](#).
- NG >> Replace driver seat control unit. Refer to [SE-85, "FRONT SEAT"](#).

Reclining Motor LH Circuit Inspection

EIS0040R

1. CHECK SEAT RECLINING MECHANISM

Check the following.

- Operation malfunction caused by an interference with the center pillar or center console
- Operation malfunction and interference with other parts by poor installation

OK or NG

- OK >> GO TO 2.
- NG >> Repair or replace the malfunctioning part and check again.

2. CHECK FUNCTION

With CONSULT-II

Check operation with "SEAT RECLINING" in ACTIVE TEST.

Test item	Description
SEAT RECLINING	The reclining motor LH is activated by receiving the drive signal.

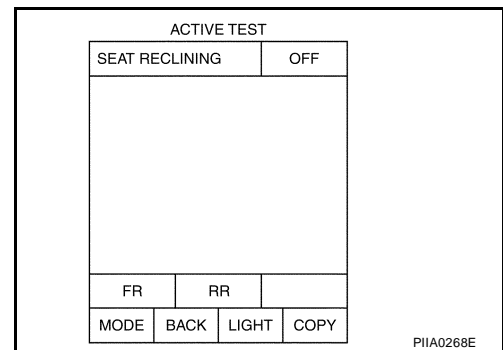

Without CONSULT-II

GO TO 3.

OK or NG

- OK >> Reclining motor LH circuit is OK.
- NG >> GO TO 3.

AUTOMATIC DRIVE POSITIONER

3. CHECK RECLINING MOTOR CIRCUIT HARNESS CONTINUITY

1. Turn ignition switch OFF.
2. Disconnect driver seat control unit and reclining motor LH.
3. Check continuity between driver seat control unit connector P3 terminals 36, 44 and reclining motor LH connector P5 terminals 3, 4.

36 - 4 : Continuity should exist.

44 - 3 : Continuity should exist.

4. Check continuity between driver seat control unit connector P3 terminals 36, 44 and ground.

36 - Ground : Continuity should not exist.

44 - Ground : Continuity should not exist.

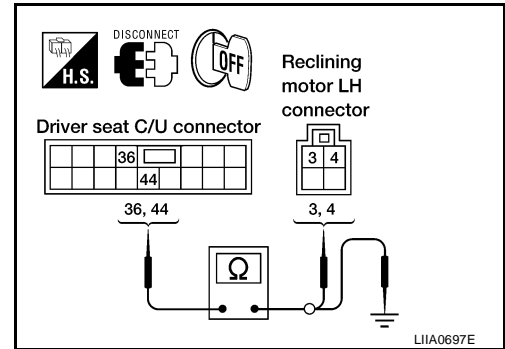

OK or NG

OK >> GO TO 4.

NG >> Repair or replace harness.

4. CHECK DRIVER SEAT CONTROL UNIT OUTPUT SIGNAL

1. Connect the driver seat control unit and reclining motor LH.
2. Check voltage between driver seat control unit connector and ground.

Connector	Terminals		Condition	Voltage (V) (Approx.)
	(+)	(-)		
P3	36	Ground	Reclining switch ON (FORWARD operation)	Battery voltage
			Other than above	0
	44		Reclining switch ON (BACKWARD operation)	Battery voltage
			Other than above	0

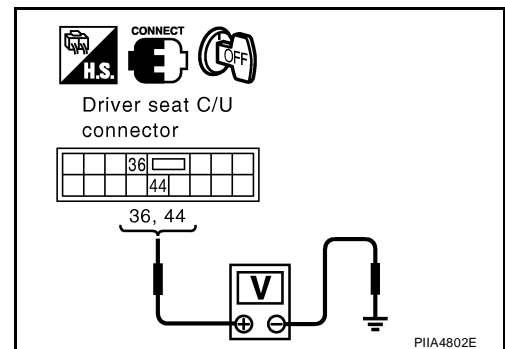

OK or NG

OK >> Replace reclining motor LH. Refer to [SE-85, "FRONT SEAT"](#).

NG >> Replace driver seat control unit. Refer to [SE-85, "FRONT SEAT"](#).

Lifting Motor (Front) Circuit Inspection

EIS0040S

1. CHECK FRONT END SEAT LIFTING MECHANISM

Check the following.

- Operation malfunction caused by lifter mechanism deformation, pinched harness or other foreign materials
- Operation malfunction caused by foreign materials adhered to the lifting motor (front) or lead screws
- Operation malfunction and interference with other parts by installation

OK or NG

OK >> GO TO 2.

NG >> Repair or replace the malfunctioning part and check again.

AUTOMATIC DRIVE POSITIONER

2. CHECK FUNCTION

With CONSULT-II

Check operation with "SEAT LIFTER FR" in ACTIVE TEST.

Test item	Description
SEAT LIFTER FR	The lifting motor (front) is activated by receiving the drive signal.

Without CONSULT-II

GO TO 3.

OK or NG

- OK >> Lifting motor (front) circuit is OK.
 NG >> GO TO 3.

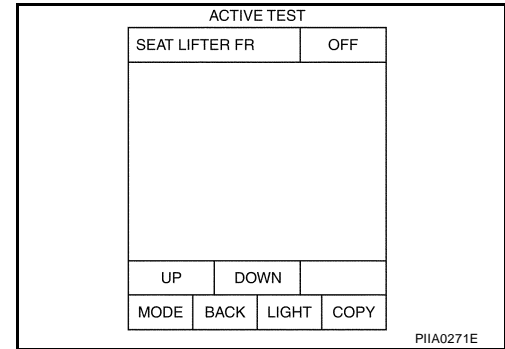

3. CHECK LIFTING MOTOR (FRONT) CIRCUIT HARNESS CONTINUITY

- Turn ignition switch OFF.
- Disconnect driver seat control unit and lifting motor (front).
- Check continuity between driver seat control unit connector P3 terminals 37, 45 and lifting motor (front) connector P6 terminals 4, 6.

- 37 - 6 : Continuity should exist.**
45 - 4 : Continuity should exist.

- Check continuity between driver seat control unit connector P3 terminals 37, 45 and ground.

- 37 - Ground : Continuity should not exist.**
45 - Ground : Continuity should not exist.

OK or NG

- OK >> GO TO 4.
 NG >> Repair or replace harness.

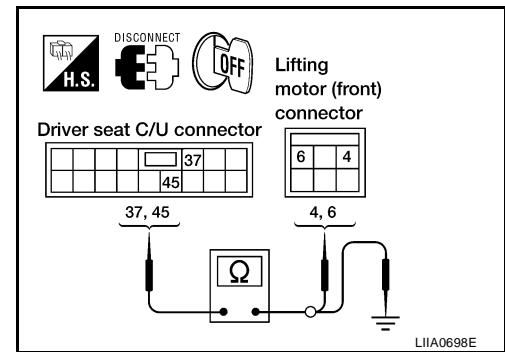

4. CHECK DRIVER SEAT CONTROL UNIT OUTPUT SIGNAL

- Connect the driver seat control unit and lifting motor (front).
- Check voltage between driver seat control unit connector and ground.

Connector	Terminals		Condition	Voltage (V) (Approx)
	(+)	(-)		
P3	37	Ground	Lifting switch (front) ON (DOWN operation)	Battery voltage
			Other than above	0
	45		Lifting switch (front) ON (UP operation)	Battery voltage
			Other than above	0

OK or NG

- OK >> Replace lifting motor (front). Refer to [SE-85, "FRONT SEAT"](#) .
 NG >> Replace driver seat control unit. Refer to [SE-85, "FRONT SEAT"](#) .

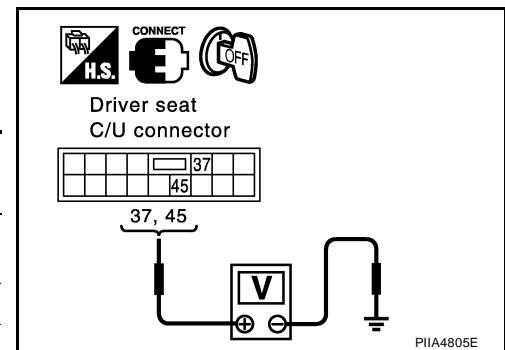

AUTOMATIC DRIVE POSITIONER

EIS0040T

Lifting Motor (Rear) Circuit Inspection

1. CHECK REAR SEAT LIFTING MECHANISM

Check the following.

- Operation malfunction caused by lifter mechanism deformation or pinched harness or other foreign materials
- Operation malfunction caused by foreign materials adhered to the lifting motor (rear) or lead screws
- Operation malfunction and interference with other parts by poor installation

OK or NG

OK >> GO TO 2.

NG >> Repair the malfunctioning part and check again.

2. CHECK FUNCTION

Ⓜ With CONSULT-II

Check operation with "SEAT LIFTER RR" in ACTIVE TEST.

Test item	Description
SEAT LIFTER RR	The lifting motor (rear) is activated by receiving the drive signal.

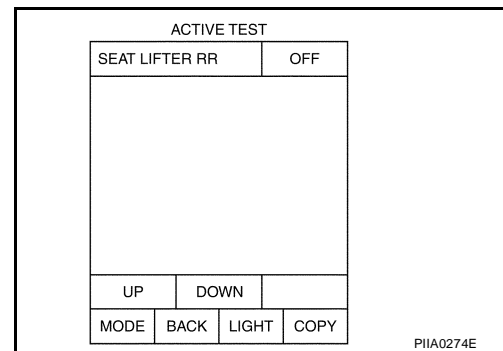

ⓧ Without CONSULT-II

GO TO 3.

OK or NG

OK >> Lifting motor (rear) circuit is OK.

NG >> GO TO 3.

3. CHECK LIFTING MOTOR (REAR) CIRCUIT HARNESS CONTINUITY

1. Turn ignition switch OFF.
2. Disconnect driver seat control unit and lifting motor (rear).
3. Check continuity between driver seat control unit connector P3 terminals 38, 39 and lifting motor (rear) connector P7 terminals 4, 6.

38 - 6 : Continuity should exist.

39 - 4 : Continuity should exist.

4. Check continuity between driver seat control unit P3 terminals 38, 39 and ground.

38 - Ground : Continuity should not exist.

39 - Ground : Continuity should not exist.

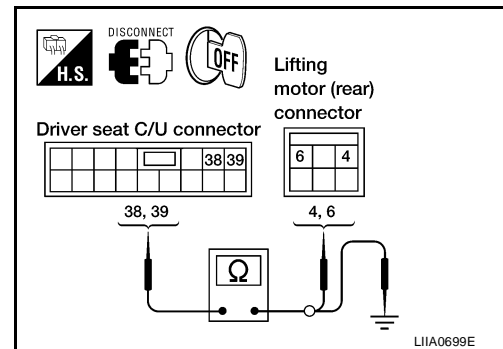

OK or NG

OK >> GO TO 4.

NG >> Repair or replace harness.

AUTOMATIC DRIVE POSITIONER

4. CHECK DRIVER SEAT CONTROL UNIT OUTPUT SIGNAL

1. Connect the driver seat control unit and lifting motor (rear).
2. Check voltage between driver seat control unit connector and ground.

Connector	Terminals		Condition	Voltage (V) (Approx.)
	(+)	(-)		
P3	38	Ground	Lifting switch (rear) ON (UP operation)	Battery voltage
			Other than above	0
	39		Lifting switch (rear) ON (DOWN operation)	Battery voltage
			Other than above	0

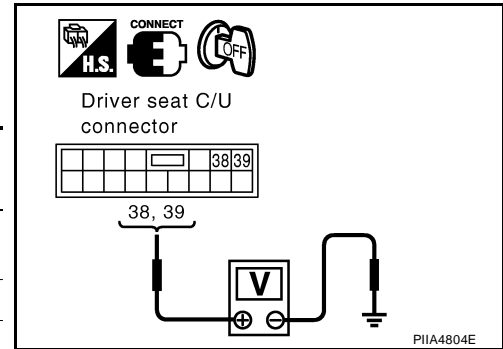

OK or NG

- OK >> Replace lifting motor (rear). Refer to [SE-85, "FRONT SEAT"](#) .
 NG >> Replace driver seat control unit. Refer to [SE-85, "FRONT SEAT"](#) .

Pedal Adjusting Motor Circuit Inspection

EIS0040U

1. CHECK PEDAL ADJUSTING MECHANISM

Check the following.

- Operation malfunction caused by pedal adjusting mechanism deformation or pinched harness or other foreign materials
- Operation malfunction and interference with other parts by poor installation

OK or NG

- OK >> GO TO 2.
 NG >> Repair or replace the malfunctioning part and check again.

2. CHECK FUNCTION

With CONSULT-II

Check operation with "ADJ PEDAL MOTOR" in ACTIVE TEST.

Test item	Description
ADJ PEDAL MOTOR	The pedal adjusting motor is activated by receiving the drive signal.

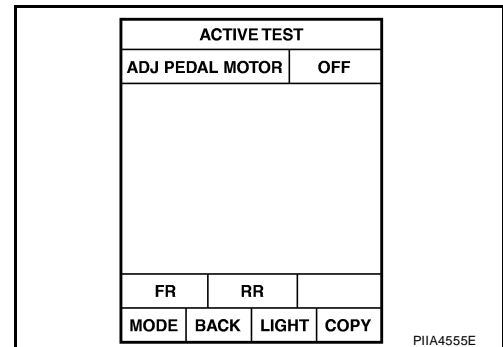

Without CONSULT-II

GO TO 3.

OK or NG

- OK >> Pedal adjusting motor circuit is OK.
 NG >> GO TO 3.

AUTOMATIC DRIVE POSITIONER

3. CHECK PEDAL ADJUSTING MOTOR CIRCUIT HARNESS CONTINUITY

1. Turn ignition switch OFF.
2. Disconnect automatic drive positioner control unit and pedal adjusting motor.
3. Check continuity between automatic drive positioner control unit connector M34 terminals 37, 45 and pedal adjusting motor connector E109 terminals 1, 2.

37 - 1 : Continuity should exist.

45 - 2 : Continuity should exist.

4. Check continuity between automatic drive positioner control unit connector M34 terminals 37, 45 and ground.

37 - Ground : Continuity should not exist.

45 - Ground : Continuity should not exist.

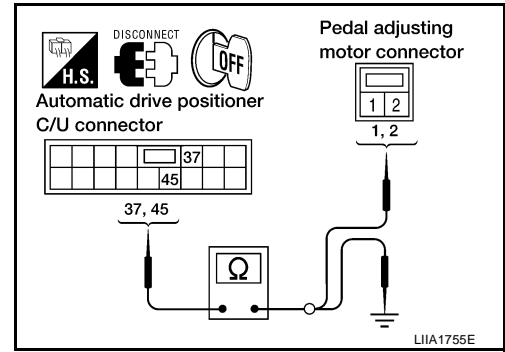

OK or NG

OK >> GO TO 4.

NG >> Repair or replace harness.

4. CHECK AUTOMATIC DRIVE POSITIONER CONTROL UNIT OUTPUT SIGNAL

1. Connect the automatic drive positioner control unit and pedal adjusting motor.
2. Check voltage between automatic drive positioner control unit connector and ground.

Connector	Terminals		Condition	Voltage (V) (Approx.)
	(+)	(-)		
M34	37	Ground	Pedal adjusting switch ON (FORWARD operation)	Battery voltage
			Other than above	0
	45		Pedal adjusting switch ON (BACKWARD operation)	Battery voltage
			Other than above	0

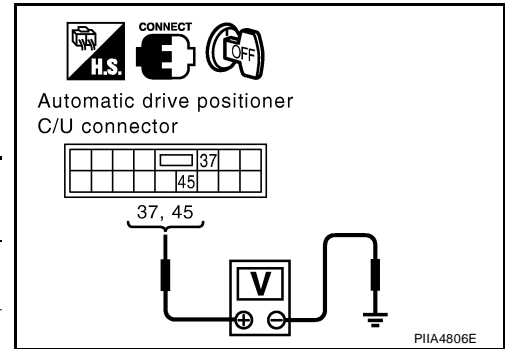

OK or NG

OK >> Replace pedal adjusting motor.

NG >> Replace automatic drive positioner control unit.

Mirror Motor LH Circuit Check

EIS0040V

1. CHECK DOOR MIRROR LH MECHANISM

Check the following items.

Operation malfunction caused by a foreign object caught in door mirror face edge.

OK or NG

OK >> GO TO 2.

NG >> Repair or replace the malfunctioning parts, and check the symptom again.

AUTOMATIC DRIVE POSITIONER

2. CHECK FUNCTION

With CONSULT-II

Check the operation with "MIRROR MOTOR LH" in the ACTIVE TEST.

Test item	Description
MIRROR MOTOR LH	The mirror motor LH moves the mirror UP/DOWN and LEFT/RIGHT by receiving the drive signal.

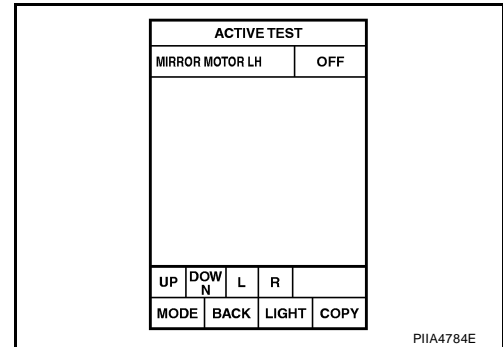

Without CONSULT-II

GO TO 3.

OK or NG

OK >> Mirror motor LH circuit is OK.

NG >> GO TO 3.

3. CHECK DOOR MIRROR MOTOR LH CIRCUIT HARNESS CONTINUITY

- Turn ignition switch OFF.
- Disconnect automatic drive positioner control unit and door mirror LH.
- Check continuity between automatic drive positioner control unit connector M33 terminals 16, 31, 32 and door mirror LH connector D4 terminals 1, 2, 3.

16 - 3 : Continuity should exist.

31 - 1 : Continuity should exist.

32 - 2 : Continuity should exist.

- Check continuity between automatic drive positioner control unit connector M41 terminals 16, 31, 32 and ground.

16 - Ground : Continuity should not exist.

31 - Ground : Continuity should not exist.

32 - Ground : Continuity should not exist.

OK or NG

OK >> GO TO 4.

NG >> Repair or replace harness.

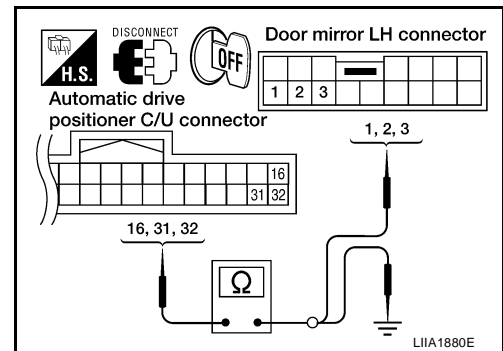

AUTOMATIC DRIVE POSITIONER

4. CHECK MIRROR MOTOR SIGNAL

1. Connect automatic drive positioner control unit and door mirror LH.
2. Turn ignition switch to ACC.
3. Check voltage between door mirror LH connector and ground.

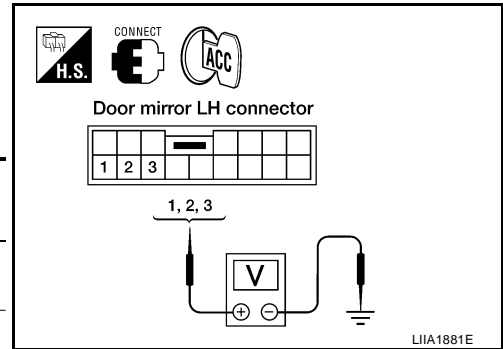

Connector	Terminals		Condition	Voltage (V) (Approx.)
	(+)	(-)		
D4	1	Ground	When motor is operated UP	1.5 - Battery voltage
			Other than above	0
	2		When motor is operated LEFT	1.5 - Battery voltage
			Other than above	0
	3		When motor is operated DOWN or RIGHT	1.5 - Battery voltage
			Other than above	0

OK or NG

- OK >> Replace door mirror LH. Refer to [GW-98, "Door Mirror Assembly"](#).
- NG >> Repair or replace harness.

Mirror Motor RH Circuit Check

EIS0040W

1. CHECK DOOR MIRROR RH MECHANISM

Check the following items.

Operation malfunction caused by a foreign object caught in door mirror face edge.

OK or NG

- OK >> GO TO 2.
- NG >> Repair or replace the malfunctioning parts, and check the symptom again.

2. CHECK FUNCTION

With CONSULT-II

Check the operation with "MIRROR MOTOR RH" in the ACTIVE TEST.

Test item	Description
MIRROR MOTOR RH	The mirror motor RH moves the mirror UP/DOWN and LEFT/RIGHT by receiving the drive signal.

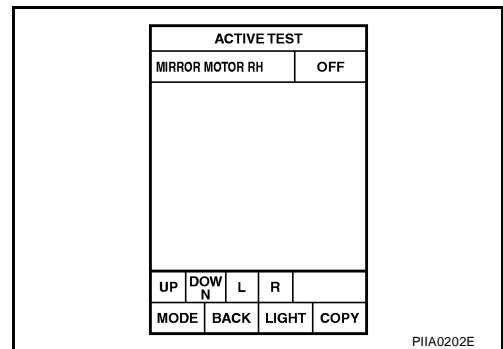

Without CONSULT-II

GO TO 3.

OK or NG

- OK >> Mirror motor RH circuit is OK.
- NG >> GO TO 3.

AUTOMATIC DRIVE POSITIONER

3. CHECK DOOR MIRROR RH CIRCUIT HARNESS CONTINUITY

1. Turn ignition switch OFF.
2. Disconnect automatic drive positioner control unit and door mirror RH connector.
3. Check continuity between automatic drive positioner control unit connector M33 terminals 14, 15, 30 and door mirror RH connector D107 terminals 1, 2, 3.

14 - 1 : Continuity should exist.
15 - 2 : Continuity should exist.
30 - 3 : Continuity should exist.

4. Check continuity between automatic drive positioner control unit connector M33 terminals 14, 15, 30 and ground.

14 - Ground : Continuity should not exist.
15 - Ground : Continuity should not exist.
30 - Ground : Continuity should not exist.

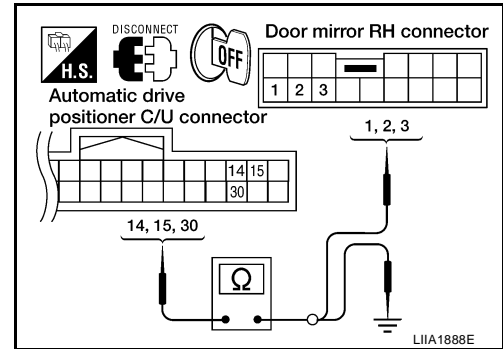

OK or NG

- OK >> GO TO 4.
 NG >> Repair or replace harness.

4. CHECK MIRROR MOTOR SIGNAL

1. Connect automatic drive positioner control unit and door mirror RH connector.
2. Turn ignition switch to ACC.
3. Check voltage between door mirror RH connector and ground.

Connector	Terminals		Condition	Voltage (V) (Approx.)
	(+)	(-)		
D107	1	Ground	Mirror motor is operated UP	1.5 - Battery voltage
			Other than above	0
	2		Mirror motor is operated LEFT	1.5 - Battery voltage
			Other than above	0
	3		Mirror motor is operated DOWN or RIGHT	1.5 - Battery voltage
			Other than above	0

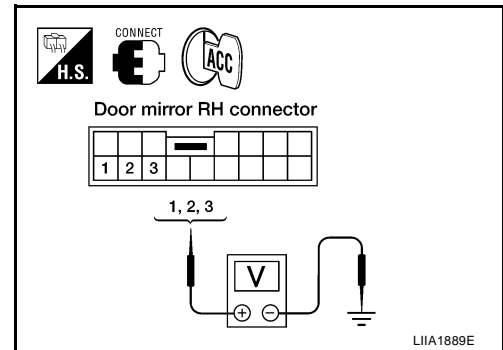

OK or NG

- OK >> Replace door mirror motor RH. Refer to [GW-98, "Door Mirror Assembly"](#).
 NG >> Repair or replace harness.

AUTOMATIC DRIVE POSITIONER

EIS0040X

Sliding Sensor Circuit Inspection

1. CHECK FUNCTION

With CONSULT-II

Check operation with "SLIDE PULSE" on the DATA MONITOR to make sure the pulse changes.

Monitor item [OPERATION or UNIT]	Contents
SLIDE PULSE	The seat sliding position (pulse) judged from the sliding sensor signal is displayed

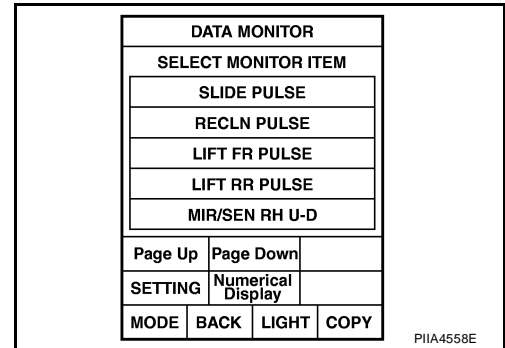

Without CONSULT-II

- Turn ignition switch OFF.
- Check signal between driver seat control unit connector and ground, with oscilloscope.

Connector	Terminals		Condition	Signal
	(+)	(-)		
P2	24	Ground	Sliding motor operation	

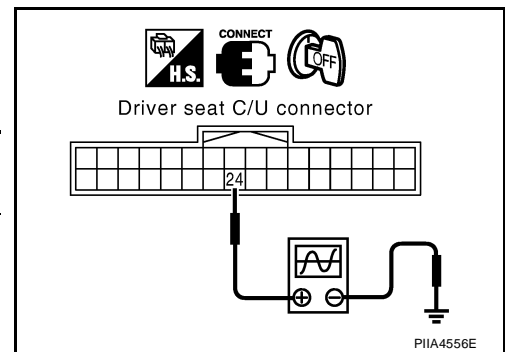

OK or NG

- OK >> Sliding sensor circuit is OK.
 NG >> GO TO 2.

2. CHECK SLIDING MOTOR SENSOR CIRCUIT HARNESS CONTINUITY

- Disconnect driver seat control unit connector and sliding motor LH connector.
- Check continuity between driver seat control unit connector P2 terminals 16, 24, 31 and sliding motor P4 terminals 1, 2, 3.

- 16 - 3** : Continuity should exist.
24 - 2 : Continuity should exist.
31 - 1 : Continuity should exist.

- Check continuity between driver seat control unit P2 terminals 16, 24, 31 and ground.

- 16 - Ground** : Continuity should not exist.
24 - Ground : Continuity should not exist.
31 - Ground : Continuity should not exist

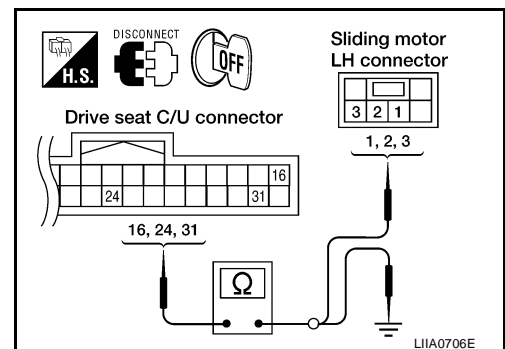

OK or NG

- OK >> Replace sliding motor. Refer to [SE-85, "FRONT SEAT"](#).
 NG >> Repair or replace harness.

AUTOMATIC DRIVE POSITIONER

EIS0040Y

Reclining Sensor Circuit Inspection

1. CHECK FUNCTION

With CONSULT-II

Check operation with "RECLN PULSE" on the DATA MONITOR to make sure the pulse changes.

Monitor item [OPERATION or UNIT]	Contents
RECLN PULSE	The seat reclining position (pulse) judged from the reclining sensor is displayed

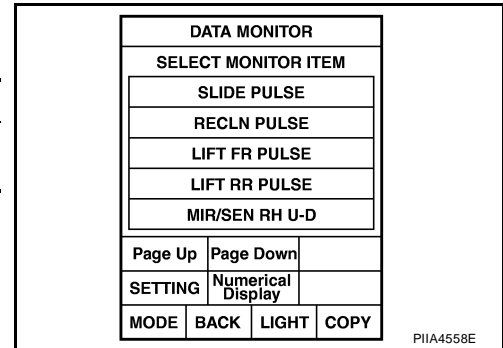

Without CONSULT-II

1. Turn ignition switch OFF.
2. Check signal between driver seat control unit connector and ground, with oscilloscope.

Connector	Terminals		Condition	Signal
	(+)	(-)		
P2	9	Ground	Reclining motor operation	

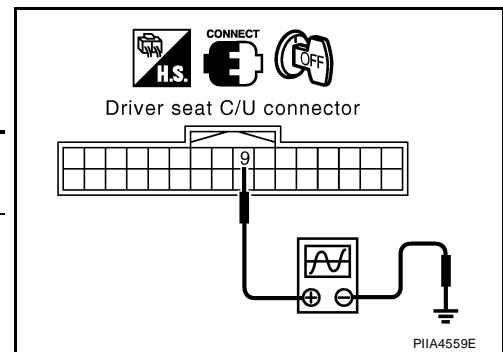

OK or NG

- OK >> Reclining sensor circuit is OK.
 NG >> GO TO 2.

2. CHECK RECLINING MOTOR SENSOR CIRCUIT HARNESS CONTINUITY

1. Disconnect driver seat control unit and reclining motor LH.
2. Check continuity between driver seat control unit connector P2 terminals 9, 31 and reclining motor LH connector P5 terminals 1, 2.

9 - 2 : Continuity should exist.
31 - 1 : Continuity should exist.

3. Check continuity between driver seat control unit connector P2 terminals 9, 31 and ground.

9 - Ground : Continuity should not exist.
31 - Ground : Continuity should not exist.

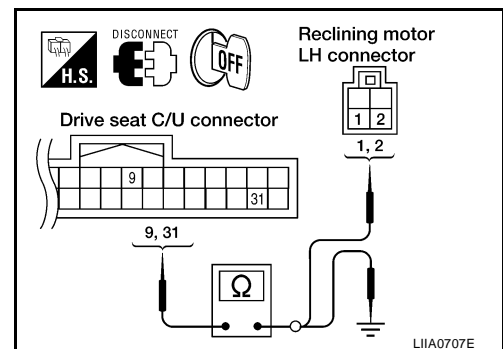

OK or NG

- OK >> Replace reclining motor. Refer to [SE-85, "FRONT SEAT"](#).
 NG >> Repair or replace harness.

AUTOMATIC DRIVE POSITIONER

EIS0040Z

Lifting Sensor (Front) Circuit Inspection

1. CHECK FUNCTION

With CONSULT-II

Check operation with "LIFT FR PULSE" on the DATA MONITOR to make sure the pulse changes.

Monitor item [OPERATION or UNIT]	Contents
LIFT FR PULSE	The front lifting position (pulse) judged from the lifting sensor (front) is displayed

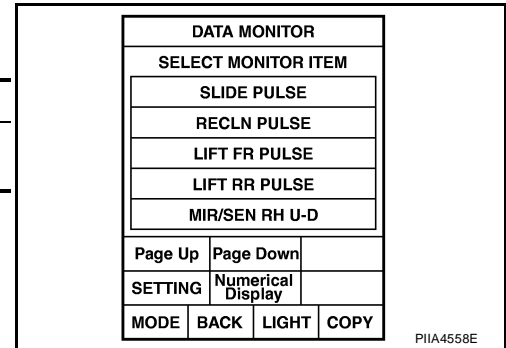

Without CONSULT-II

- Turn ignition switch OFF.
- Check signal between driver seat control unit connector and ground, with oscilloscope.

Connector	Terminals		Condition	Signal
	(+)	(-)		
P2	25	Ground	Lifting motor (front) operation	

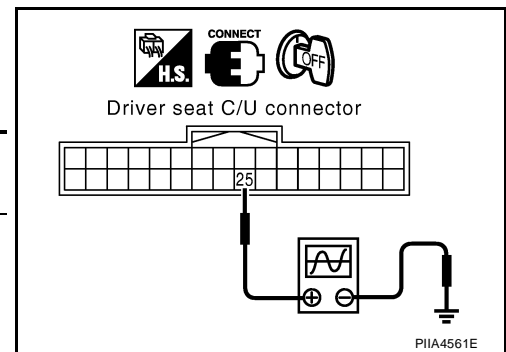

OK or NG

- OK >> Front lifting sensor is OK.
 NG >> GO TO 2.

2. CHECK FRONT LIFTING MOTOR SENSOR CIRCUIT HARNESS CONTINUITY

- Disconnect driver seat control unit and lifting motor (front).
- Check continuity between driver seat control unit connector P2 terminals 16, 25, 31 and lifting motor (front) connector P6 terminals 1, 2, 3.

- 16 - 3** : Continuity should exist.
25 - 2 : Continuity should exist.
31 - 1 : Continuity should exist.

- Check continuity between driver seat control unit connector P2 terminals 16, 25, 31 and ground.

- 16 - Ground** : Continuity should not exist.
25 - Ground : Continuity should not exist.
31 - Ground : Continuity should not exist.

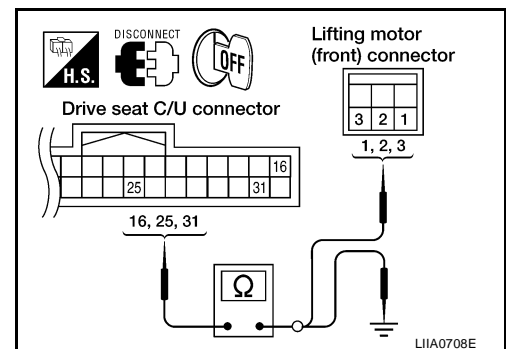

OK or NG

- OK >> Replace lifting motor (front). Refer to [SE-85, "FRONT SEAT"](#).
 NG >> Repair or replace harness.

AUTOMATIC DRIVE POSITIONER

EIS004P0

Lifting Sensor (Rear) Circuit Inspection

1. CHECK FUNCTION

☑ With CONSULT-II

Check operation with "LIFT RR PULSE" on the DATA MONITOR to make sure pulse changes.

Monitor item [OPERATION or UNIT]		
LIFT RR PULSE	—	The rear lifting position (pulse) judged from the lifting sensor (rear) is displayed.

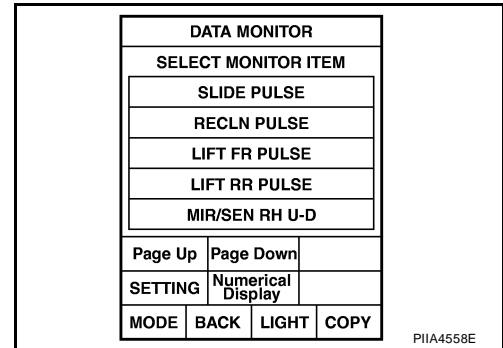

☒ Without CONSULT-II

- Turn ignition switch OFF.
- Check signal between driver seat control unit connector and ground, with oscilloscope.

Connector	Terminals		Condition	Signal
	(+)	(-)		
P2	10	Ground	Lifting motor (rear) operation	

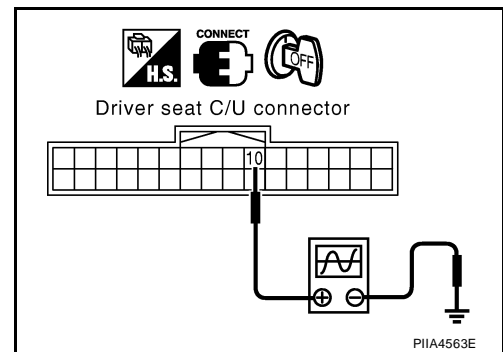

OK or NG

- OK >> Rear lifting sensor circuit is OK.
- NG >> GO TO 2.

2. CHECK REAR LIFTING MOTOR SENSOR CIRCUIT HARNESS CONTINUITY

- Disconnect driver seat control unit and lifting motor (rear).
- Check continuity between driver seat control unit connector P2 terminals 10, 16, 31 and lifting motor (rear) connector P7 terminals 1, 2, 3.

- 10 - 2** : Continuity should exist.
- 16 - 3** : Continuity should exist.
- 31 - 1** : Continuity should exist.

- Check continuity between driver seat control unit connector P2 terminals 10, 16, 31 and ground.

- 10 - Ground** : Continuity should not exist.
- 16 - Ground** : Continuity should not exist.
- 31 - Ground** : Continuity should not exist.

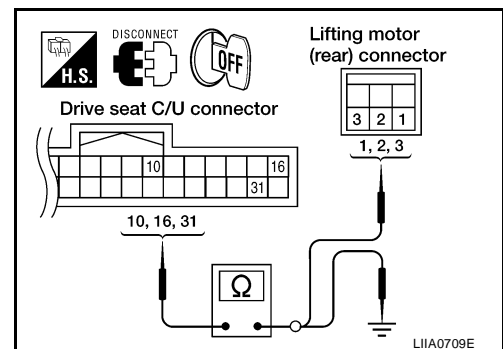

OK or NG

- OK >> Replace lifting motor (rear). Refer to [SE-85, "FRONT SEAT"](#).
- NG >> Repair or replace harness.

AUTOMATIC DRIVE POSITIONER

EIS004P1

Pedal Adjusting Sensor Circuit Inspection

1. CHECK FUNCTION

With CONSULT-II

Operate the pedal adjusting switch with "PEDAL SEN" on the DATA MONITOR to make sure the voltage changes.

Monitor item [OPERATION or UNIT]	Contents
PEDAL SEN	"V" The pedal adjusting position (voltage) judged from the pedal adjust sensor signal is displayed.

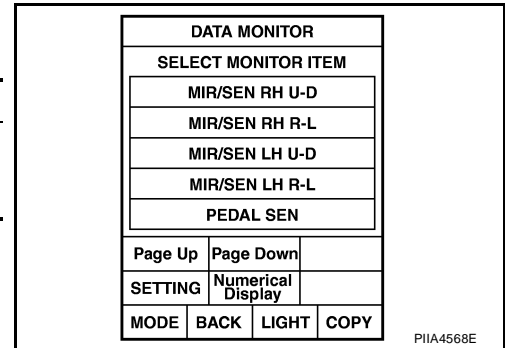

Without CONSULT-II

- Turn ignition switch OFF.
- Check voltage between automatic drive positioner control unit connector and ground.

Connector	Terminals		Condition	Voltage (V) (Approx.)
	(+)	(-)		
M33	8	Ground	Pedal front end position	0.5
			Pedal back end position	4.5

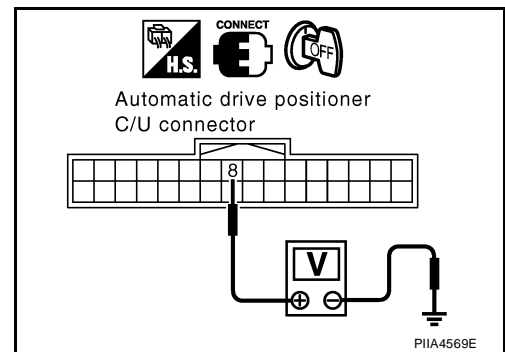

OK or NG

- OK >> Pedal adjusting sensor circuit is OK.
 NG >> GO TO 2.

2. CHECK PEDAL ADJUSTING SENSOR CIRCUIT HARNESS CONTINUITY

- Disconnect automatic drive positioner control unit and pedal adjusting sensor.
- Check continuity between automatic drive positioner connector M33, M34 terminals 8, 33, 41 and pedal adjusting sensor connector E110 terminals 3, 4, 5.

- 8 - 4 : Continuity should exist.**
33 - 3 : Continuity should exist.
41 - 5 : Continuity should exist.

- Check continuity between automatic drive positioner control unit connector M33, M34 terminals 8, 33, 41 and ground.

- 8 - Ground : Continuity should not exist.**
33 - Ground : Continuity should not exist.
41 - Ground : Continuity should not exist.

OK or NG

- OK >> Replace pedal adjusting motor. Refer to [BR-8. "Removal and Installation"](#) .
 NG >> Repair or replace harness.

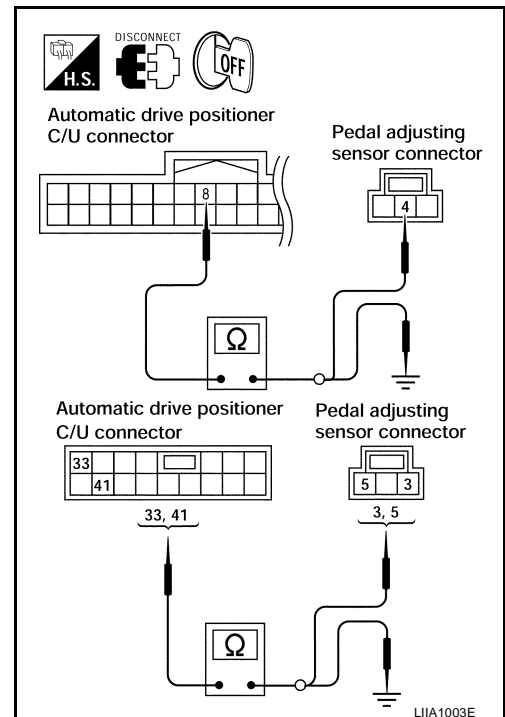

AUTOMATIC DRIVE POSITIONER

EIS004P2

Mirror Sensor LH Circuit Check

1. CHECK DOOR MIRROR FUNCTION

Check the following items.
Operation malfunction in memory control

NOTE:

If a door mirror face position is set to an implausible angle, the set position may not be reproduced.

OK or NG

OK >> GO TO 2.

NG >> Repair or replace the malfunctioning parts, and check the symptom again.

2. CHECK MIRROR SENSOR INSPECTION

Ⓜ With CONSULT-II

Check that "ON" is displayed on "MIR/SEN LH R-L, MIR/SEN LH U-D" in the DATA MONITOR.

Monitor item [OPERATION or UNIT]		Contents
MIR/SEN LH R-L	"V"	Voltage output from door mirror LH sensor (LH/RH) is displayed.
MIR/SEN LH U-D	"V"	Voltage output from door mirror LH sensor (UP/DOWN) is displayed.

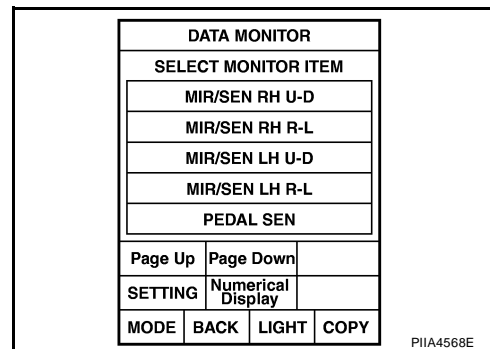

⊗ Without CONSULT-II

1. Turn ignition switch to ACC.
2. Check voltage between door mirror LH connector and ground.

Connector	Terminals		Condition	Voltage (V) (Approx.)
	(+)	(-)		
D4	7	Ground	Mirror motor is operated UP or DOWN	Changes between 3.4 (close to peak) – 0.6 (close to valley)
	8		Mirror motor is operated LEFT or RIGHT	Changes between 3.4 (close to right edge) – 0.6 (close to left edge)

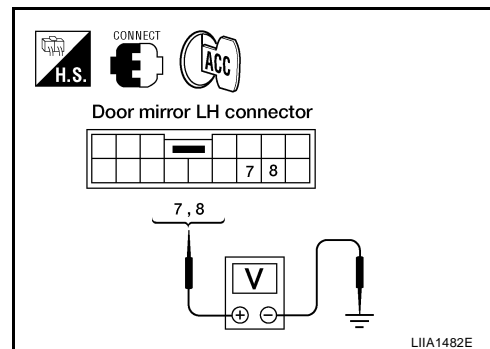

OK or NG

OK >> Mirror sensor LH is OK.

NG >> GO TO 3.

AUTOMATIC DRIVE POSITIONER

3. CHECK HARNESS CONTINUITY 1

1. Disconnect automatic drive positioner control unit and door mirror LH.
2. Check continuity between automatic drive positioner control unit connector M34 terminals 33, 41 and door mirror LH connector D4 terminals 5, 6.

33 - 5 : Continuity should exist.

41 - 6 : Continuity should exist.

3. Check continuity between automatic drive positioner control unit connector M34 terminals 33, 41 and ground.

33 - Ground : Continuity should not exist.

41 - Ground : Continuity should not exist.

OK or NG

OK >> GO TO 4.

NG >> Repair or replace harness.

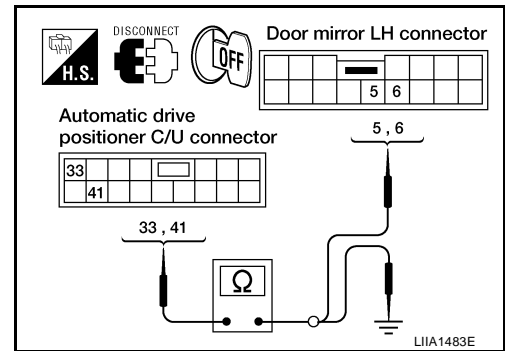

4. CHECK HARNESS CONTINUITY 2

1. Disconnect automatic drive positioner control unit and door mirror LH.
2. Check continuity between automatic drive positioner control unit connector M33 terminals 6, 22 and door mirror LH connector D4 terminals 7, 8.

6 - 7 : Continuity should exist.

22 - 8 : Continuity should exist.

3. Check continuity between automatic drive positioner control unit connector M33 terminals 6, 22 and ground.

6 - Ground : Continuity should not exist.

22 - Ground : Continuity should not exist.

OK or NG

OK >> Replace door mirror LH. Refer to [GW-98, "Door Mirror Assembly"](#).

NG >> Repair or replace harness.

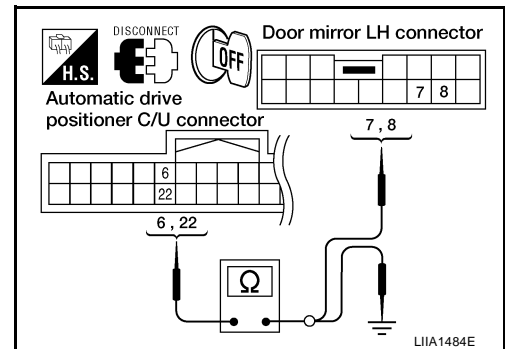

Mirror Sensor RH Circuit Check

EIS004P3

1. CHECK DOOR MIRROR FUNCTION

Check the following items.

Operation malfunction in memory control

NOTE:

If a door mirror face position is set to an implausible angle, the set position may not be reproduced.

OK or NG

OK >> GO TO 2.

NG >> Repair or replace the malfunctioning parts, and check the symptom again.

AUTOMATIC DRIVE POSITIONER

2. CHECK MIRROR SENSOR INSPECTION

With CONSULT-II

Check that "ON" is displayed on "MIR/SEN RH R-L, MIR/SEN RH U-D" in the DATA MONITOR.

Monitor item [OPERATION or UNIT]		Contents
MIR/SEN RH R-L	"V"	Voltage output from door mirror RH sensor (LH/RH) is displayed.
MIR/SEN RH U-D	"V"	Voltage output from door mirror RH sensor (UP/DOWN) is displayed.

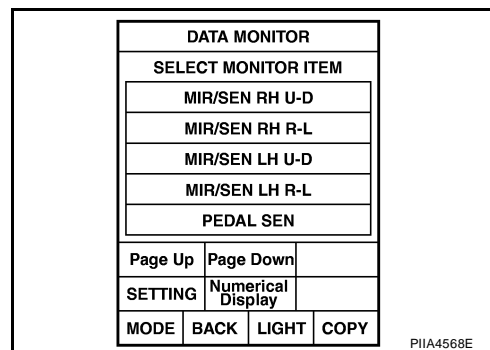

Without CONSULT-II

1. Turn ignition switch to ACC.
2. Check voltage between door mirror RH connector and ground.

Connector	Terminals		Condition	Voltage(V) (Approx.)
	(+)	(-)		
D107	7	Ground	Mirror motor is operated UP or DOWN	Changes between 3.4 (close to peak) – 0.6 (close to valley)
	8		Mirror motor is operated LEFT or RIGHT	Changes between 3.4 (close to left edge) – 0.6 (close to right edge)

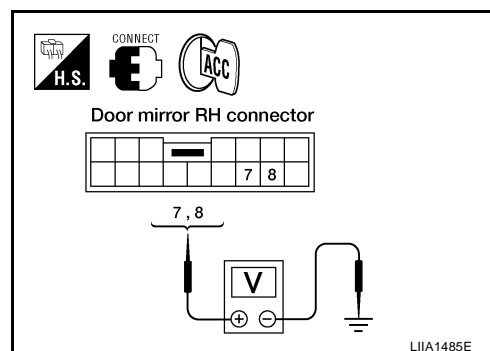

OK or NG

- OK >> Mirror sensor RH is OK.
 NG >> GO TO 3.

3. CHECK HARNESS CONTINUITY 1

1. Disconnect automatic drive positioner control unit and door mirror RH.
2. Check continuity between automatic drive positioner control unit connector M34 terminals 33, 41 and door mirror RH connector D107 terminals 5, 6.

33 - 5 : Continuity should exist.

41 - 6 : Continuity should exist.

3. Check continuity between automatic drive positioner control unit connector M34 terminals 33, 41 and ground.

33 - Ground : Continuity should not exist.

41 - Ground : Continuity should not exist.

OK or NG

- OK >> GO TO 4.
 NG >> Repair or replace harness.

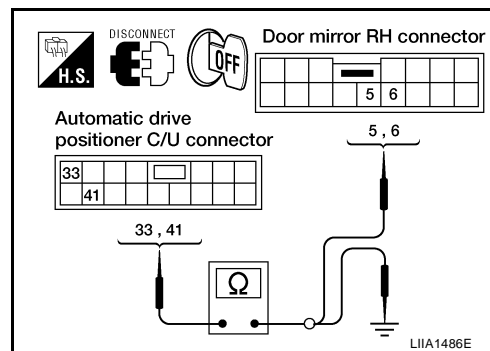

AUTOMATIC DRIVE POSITIONER

4. CHECK HARNESS CONTINUITY 2

1. Disconnect automatic drive positioner control unit and door mirror RH.
2. Check continuity between automatic drive positioner control unit connector M33 terminals 5, 21 and door mirror RH connector D107 terminals 7, 8.

5 - 7 : Continuity should exist.

21 - 8 : Continuity should exist.

3. Check continuity between automatic drive positioner control unit connector M33 terminals 5, 21 and ground.

5 - Ground : Continuity should not exist.

21 - Ground : Continuity should not exist.

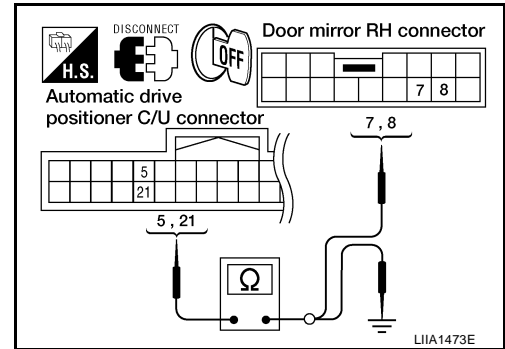

OK or NG

OK >> Replace door mirror RH. Refer to [GW-98, "Door Mirror Assembly"](#).

NG >> Repair or replace harness.

Sliding Switch Circuit Inspection

EIS004P4

1. CHECK FUNCTION

With CONSULT-II

With "SLIDE SW-FR, SLIDE SW-RR" on the DATA MONITOR, operate the sliding switch to check ON/OFF operation.

Monitor item [OPERATION or UNIT]		Contents
SLIDE SW-FR	"ON/OFF"	ON/OFF status judged from the sliding switch (FR) signal is displayed.
SLIDE SW-RR	"ON/OFF"	ON/OFF status judged from the sliding switch (RR) signal is displayed.

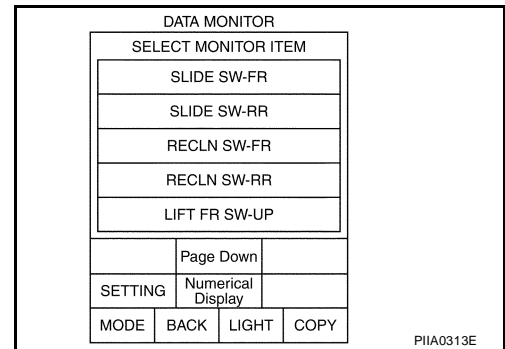

Without CONSULT-II

1. Turn ignition switch OFF.
2. Check voltage between driver seat control unit connector and ground.

Connector	Terminal		Condition	Voltage (V) (Approx.)
	(+)	(-)		
P2	11	Ground	Sliding switch ON (BACKWARD operation)	0
			Other than above	Battery voltage
	26		Sliding switch ON (FORWARD operation)	0
			Other than above	Battery voltage

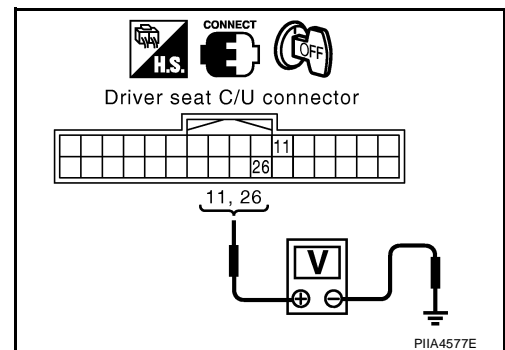

OK or NG

OK >> Sliding switch circuit is OK.

NG >> GO TO 2.

AUTOMATIC DRIVE POSITIONER

2. CHECK SLIDING SWITCH CIRCUIT HARNESS CONTINUITY

1. Disconnect driver seat control unit connector and power seat switch LH connector.
2. Check continuity between driver seat control unit connector P2 terminals 11, 26 and power seat switch LH connector P8 terminals 1, 7.

11 - 7 : Continuity should exist.
26 - 1 : Continuity should exist.

3. Check continuity between driver seat control unit connector P2 terminals 11, 26 and ground.

11 - Ground : Continuity should not exist.
26 - Ground : Continuity should not exist.

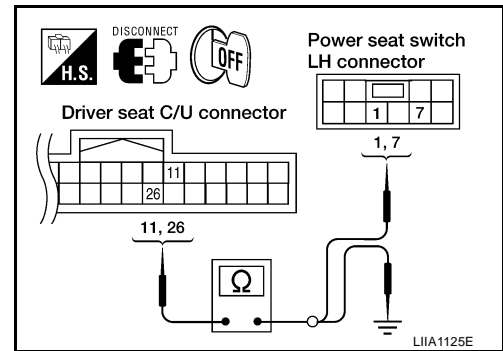

OK or NG

- OK >> GO TO 3.
 NG >> Repair or replace harness.

3. CHECK SLIDING SWITCH

Check continuity between power seat switch LH terminals as follows.

Terminals		Condition	Continuity
(+)	(-)		
7	3	Sliding switch ON (BACKWARD operation)	Yes
		Other than above	No
1		Sliding switch ON (FORWARD operation)	Yes
		Other than above	No

OK or NG

- OK >> Check the condition of the harness and connector.
 NG >> Replace power seat switch LH. Refer to [SE-85, "FRONT SEAT"](#) .

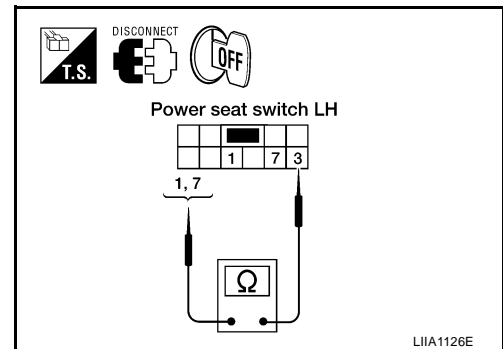

AUTOMATIC DRIVE POSITIONER

EIS004P5

Reclining Switch Inspection

1. CHECK FUNCTION

With CONSULT-II

With "RECLN SW-FR, RECLN SW-RR" on the DATA MONITOR, operate the reclining switch to check ON/OFF operation.

Monitor item [OPERATION or UNIT]		Contents
RECLN SW-FR	"ON/OFF"	ON/OFF status judged from the reclining switch (FR) signal is displayed.
RECLN SW-RR	"ON/OFF"	ON/OFF status judged from the reclining switch (RR) signal is displayed.

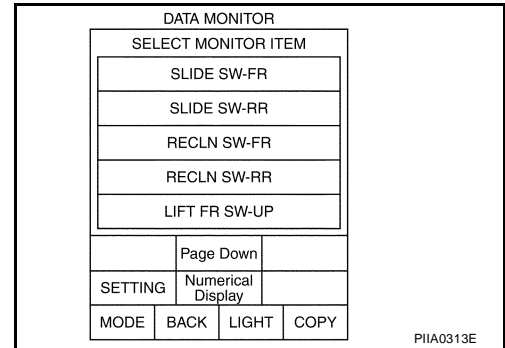

Without CONSULT-II

- Turn ignition switch OFF.
- Check voltage between driver seat control unit connector and ground.

Connector	Terminals		Condition	Voltage (V) (Approx.)
	(+)	(-)		
P2	12	Ground	Reclining switch ON (BACKWARD operation)	0
			Other than above	Battery voltage
	27		Reclining switch ON (FORWARD operation)	0
			Other than above	Battery voltage

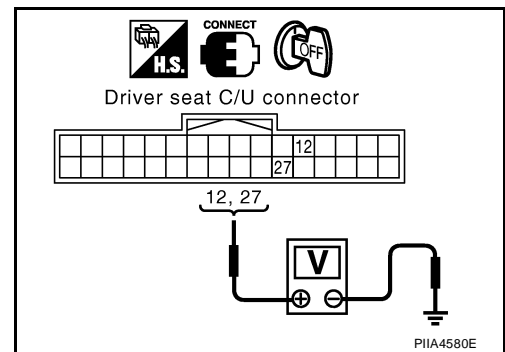

OK or NG

- OK >> Reclining switch circuit is OK.
 NG >> GO TO 2.

2. CHECK RECLINING SWITCH CIRCUIT HARNESS CONTINUITY

- Disconnect driver seat control unit and power seat switch LH.
- Check continuity between driver seat control unit connector P2 terminals 12, 27 and power seat switch LH connector P8 terminals 9, 10.

- 12 - 9** : Continuity should exist.
27 - 10 : Continuity should exist.

- Check continuity between driver seat control unit connector P2 terminals 12, 27 and ground.

- 12 - Ground** : Continuity should not exist.
27 - Ground : Continuity should not exist.

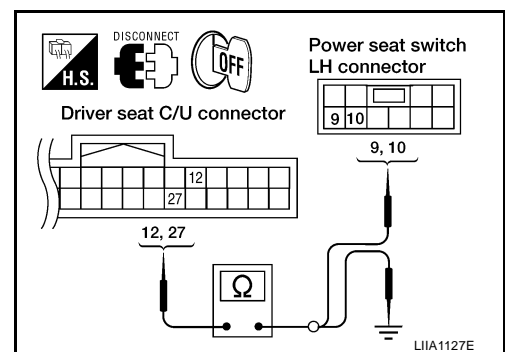

OK or NG

- OK >> GO TO 3.
 NG >> Repair or replace harness.

AUTOMATIC DRIVE POSITIONER

3. RECLINING SWITCH INSPECTION

Check continuity between power seat switch LH terminals as follows.

Terminals	Condition	Continuity
9	Reclining switch ON (BACKWARD operation)	Yes
	Other than above	No
10	Reclining switch ON (FORWARD operation)	Yes
	Other than above	No

OK or NG

- OK >> Check the condition of the harness and connector.
- NG >> Replace power seat switch LH. Refer to [SE-85, "FRONT SEAT"](#) .

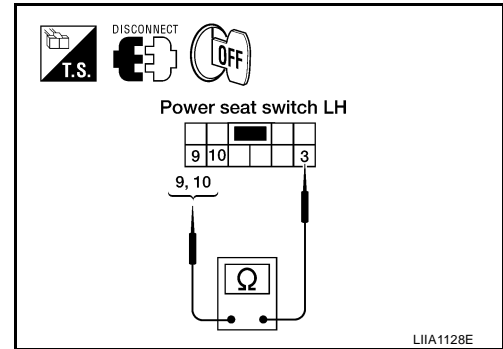

Lifting Switch (Front) Circuit Inspection

EIS004P6

1. CHECK FUNCTION

With CONSULT-II

With "LIFT FR SW-UP, LIFT FR SW-DN" on the DATA MONITOR, operate the lifting switch (front) to check ON/OFF operation.

Monitor item [OPERATION or UNIT]	Contents
LIFT FR SW-DN	"ON/OFF" ON/OFF status judged from the FR lifter switch (DOWN) signal is displayed.
LIFT FR SW-UP	"ON/OFF" ON/OFF status judged from the FR lifter switch (UP) signal is displayed.

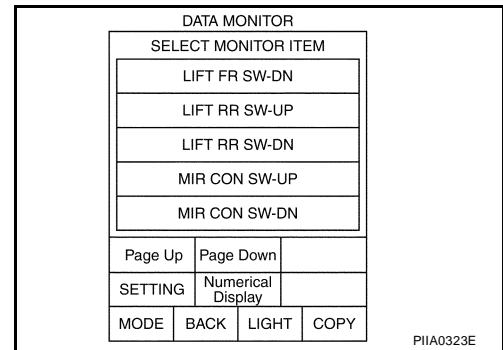

Without CONSULT-II

1. Turn ignition switch OFF.
2. Check voltage between driver seat control unit connector and ground.

Connector	Terminals		Condition	Voltage (V) (Approx.)
	(+)	(-)		
P2	13	Ground	Lifting switch (front) ON (DOWN operation)	0
			Other than above	Battery voltage
	28		Lifting switch (front) ON (UP operation)	0
			Other than above	Battery voltage

OK or NG

- OK >> Lifting switch (front) circuit is OK.
- NG >> GO TO 2.

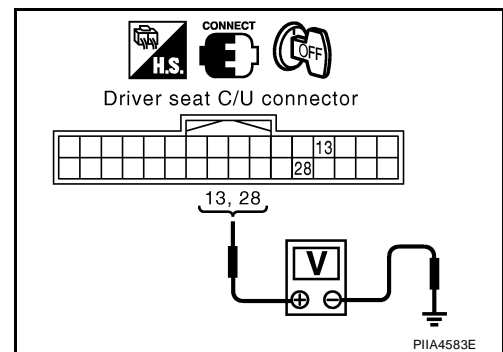

AUTOMATIC DRIVE POSITIONER

2. CHECK LIFTING SWITCH (FRONT) CIRCUIT HARNESS CONTINUITY

1. Disconnect driver seat control unit and power seat switch LH.
2. Check continuity between driver seat control unit connector P2 terminals 13, 28 and power seat switch LH connector P2 terminals 5, 6.

13 - 5 : Continuity should exist.

28 - 6 : Continuity should exist.

3. Check continuity between driver seat control unit connector P2 terminals 13, 28 and ground

13 - Ground : Continuity should not exist.

28 - Ground : Continuity should not exist.

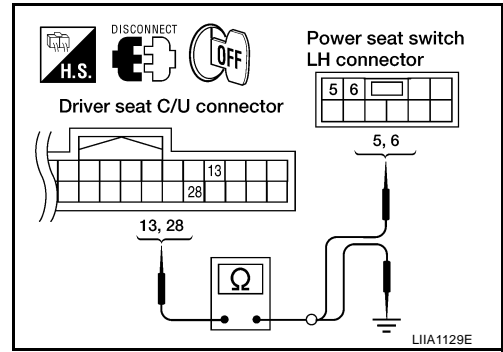

OK or NG

OK >> GO TO 3.

NG >> Repair or replace harness.

3. CHECK LIFTING SWITCH (FRONT)

Check continuity between power seat switch LH terminals as follows.

Terminals	Condition	Continuity
5	Lifting switch (front) ON (DOWN operation)	Yes
	Other than above	No
6	Lifting switch (front) ON (UP operation)	Yes
	Other than above	No

OK or NG

OK >> Check the condition of the harness and connector.

NG >> Replace power seat switch LH. Refer to [SE-85, "FRONT SEAT"](#) .

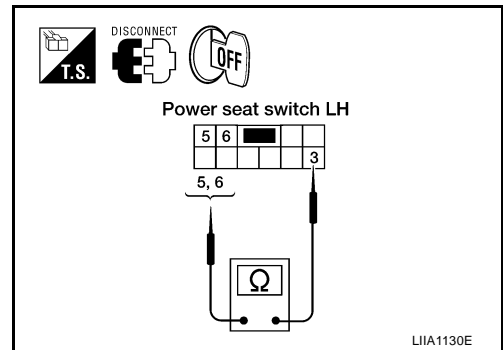

AUTOMATIC DRIVE POSITIONER

EIS004P7

Lifting Switch (Rear) Circuit Inspection

1. CHECK FUNCTION

With CONSULT-II

With "LIFT RR SW-UP, LIFT RR SW-DN" on the DATA MONITOR, operate the rear lifting switch to check ON/OFF operation.

Monitor item [OPERATION or UNIT]	Contents	
LIFT RR SW-UP	"ON/OFF"	Operation (ON)/open (OFF) status judged from the RR lifter switch (UP) signal is displayed.
LIFT RR SW-DN	"ON/OFF"	Operation (ON)/open (OFF) status judged from the RR lifter switch (DOWN) signal is displayed.

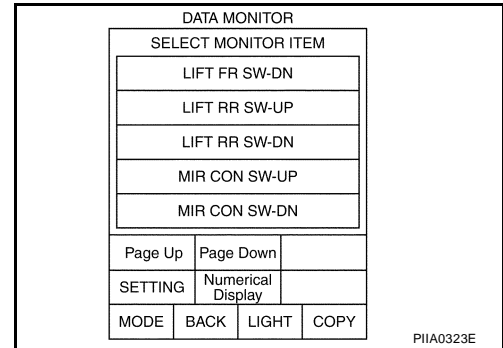

Without CONSULT-II

- Turn ignition switch OFF.
- Check voltage between driver seat control unit connector and ground.

Connector	Terminals		Condition	Voltage (V) (Approx.)
	(+)	(-)		
P2	14	Ground	Rear lifting switch ON (DOWN operation)	0
			Other than above	Battery voltage
	29		Rear lifting switch ON (UP operation)	0
			Other than above	Battery voltage

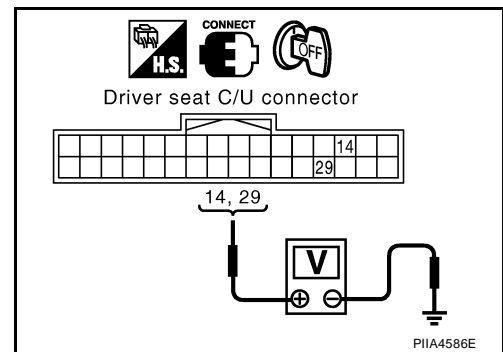

OK or NG

- OK >> Rear lifting switch circuit is OK.
- NG >> GO TO 2.

2. CHECK LIFTING SWITCH (REAR) CIRCUIT HARNESS CONTINUITY

- Disconnect driver seat control unit and power seat switch LH.
- Check continuity between driver seat control unit connector P2 terminals 14, 29 and power seat switch connector P8 terminals 2, 8.

14 - 8 : Continuity should exist.
29 - 2 : Continuity should exist.

- Check continuity between driver seat control unit connector P2 terminals 14, 29 and ground.

14 - Ground : Continuity should not exist.
29 - Ground : Continuity should not exist.

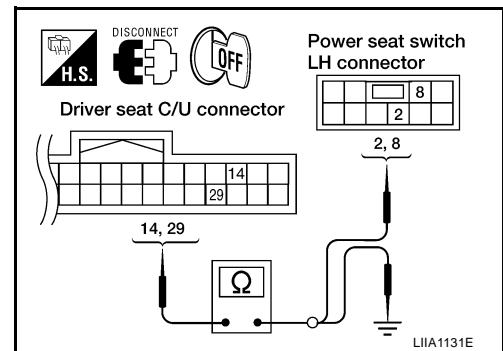

OK or NG

- OK >> GO TO 3.
- NG >> Repair or replace harness.

AUTOMATIC DRIVE POSITIONER

3. CHECK LIFTING SWITCH (REAR)

Check continuity between power seat switch LH terminals as follows.

Terminals	Condition	Continuity
8	Lifting switch (rear) ON (DOWN operation)	Yes
	Other than above	No
2	Lifting switch (rear) ON (UP operation)	Yes
	Other than above	No

OK or NG

OK >> Check the condition of the harness and connector.

NG >> Replace power seat switch LH. Refer to [SE-85, "FRONT SEAT"](#).

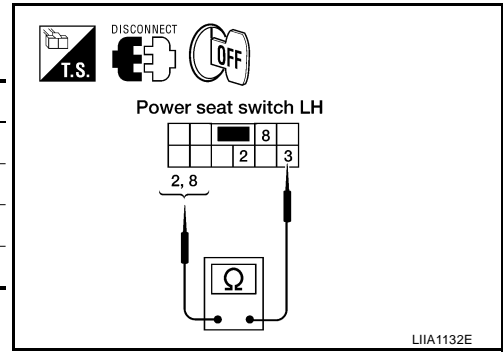

Power Seat Switch Ground Inspection

EIS004P8

1. CHECK POWER SEAT SWITCH GROUND CIRCUIT

Check continuity between power seat switch LH connector P8 terminal 3 and ground.

3 - Ground : Continuity should exist.

OK or NG

OK >> Check the condition of the harness and connector.

NG >> Repair or replace harness.

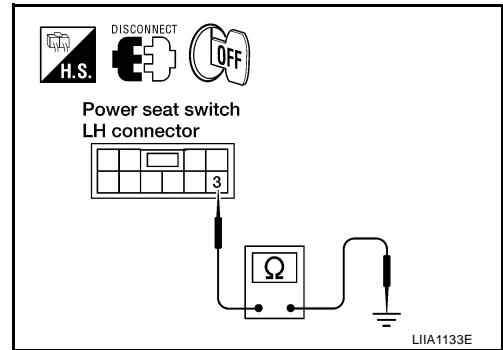

A
B
C
D
E
F
G
H
SE
J
K
L
M

AUTOMATIC DRIVE POSITIONER

EIS004P9

Pedal Adjusting Switch Circuit Inspection

1. CHECK FUNCTION

With CONSULT-II

With "PEDAL SW-FR, PEDAL SW-RR" on the DATA MONITOR, operate the pedal adjusting switch to check ON/OFF operation.

Monitor item [OPERATION or UNIT]		Contents
PEDAL SW-FR	"ON/OFF"	Operation (ON)/open (OFF) status judged from the pedal adjusting switch (FR) signal is displayed.
PEDAL SW-RR	"ON/OFF"	Operation (ON)/open (OFF) status judged from the pedal adjusting switch (RR) signal is displayed.

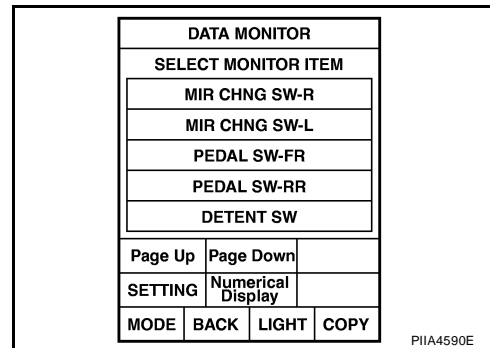

Without CONSULT-II

- Turn ignition switch OFF.
- Check voltage between driver seat control unit connector and ground.

Connector	Terminals		Condition	Voltage (V) (Approx.)
	(+)	(-)		
P2	15	Ground	Pedal adjusting switch ON (BACKWARD operation)	0
			Other than above	Battery voltage
	30		Pedal adjusting switch ON (FORWARD operation)	0
			Other than above	Battery voltage

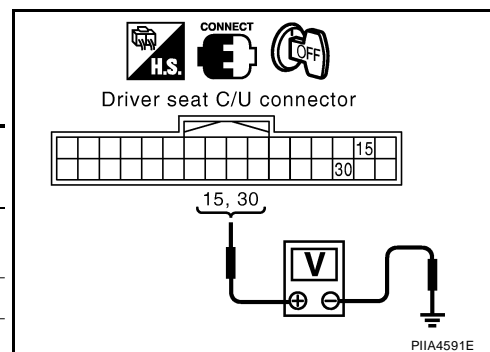

OK or NG

- OK >> Pedal adjusting switch circuit is OK.
NG >> GO TO 2.

2. CHECK PEDAL ADJUSTING SWITCH CIRCUIT HARNESS CONTINUITY

- Disconnect driver seat control unit and pedal adjusting switch.
- Check continuity between driver seat control unit connector P2 terminals 15, 30 and pedal adjusting switch connector M96 terminals 2, 3.

15 - 2 : Continuity should exist.

30 - 3 : Continuity should exist.

- Check continuity between driver seat control unit connector P2 terminals 15, 30 and ground.

15 - Ground : Continuity should not exist.

30 - Ground : Continuity should not exist.

OK or NG

- OK >> GO TO 3.
NG >> Repair or replace harness.

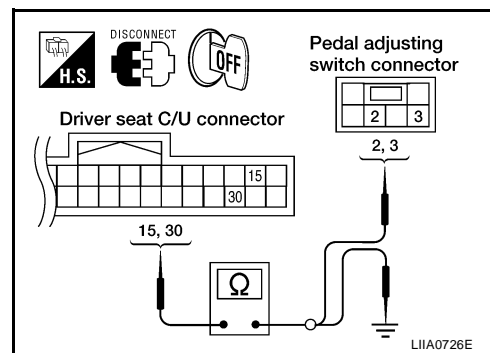

AUTOMATIC DRIVE POSITIONER

3. CHECK PEDAL ADJUSTING SWITCH

Check continuity between pedal adjusting switch terminals as follows.

Terminals	Condition	Continuity
2	Pedal adjusting switch ON (BACKWARD operation)	Yes
	Other than above	No
3	Pedal adjusting switch ON (FORWARD operation)	Yes
	Other than above	No

OK or NG

OK >> GO TO 4.

NG >> Replace pedal adjusting switch.

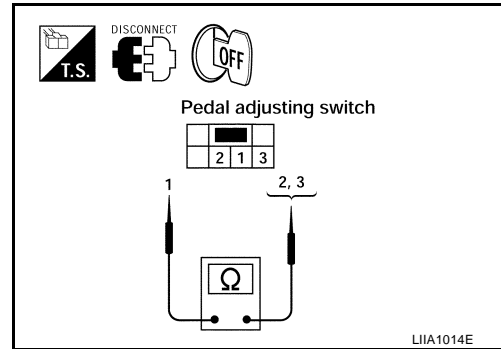

4. CHECK PEDAL ADJUSTING SWITCH GROUND CIRCUIT

Check continuity between pedal adjusting switch connector M96 terminal 4 and ground.

1 - Ground : Continuity should exist.

OK or NG

OK >> Check the condition of the harness and connector.

NG >> Replace or replace harness.

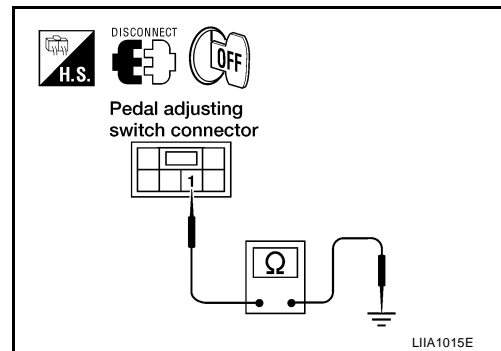

A
B
C
D
E
F
G
H
SE
J
K
L
M

AUTOMATIC DRIVE POSITIONER

Door Mirror Remote Control Switch (Changeover Switch) Circuit Check

EIS004PA

1. CHECK DOOR MIRROR REMOTE CONTROL SWITCH (CHANGEOVER SWITCH) SIGNAL

With CONSULT-II

Check the operation on "MIR CHNG SW-R" or "MIR CHNG SW-L" in the DATA MONITOR.

Monitor item [OPERATION or UNIT]		Contents
MIR CHNG SW-R	"ON/OFF"	ON/OFF status judged from the changeover switch (switching to RIGHT) signal is displayed.
MIR CHNG SW-L	"ON/OFF"	ON/OFF status judged from the changeover switch (switching to LEFT) signal is displayed.

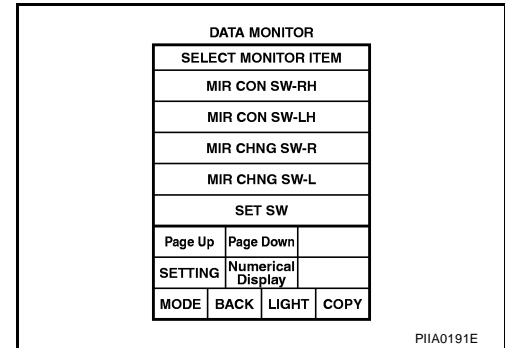

Without CONSULT-II

- Turn ignition switch to ACC.
- Check voltage between automatic drive positioner control unit connector and ground.

Connector	Terminals		Condition	Voltage (V) (Approx.)
	(+)	(-)		
M33	2	Ground	Changeover switch RIGHT position	0
			Other than above	5
	18		Changeover switch LEFT position	0
			Other than above	5

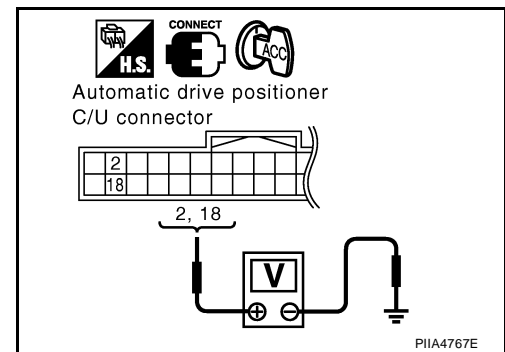

OK or NG

- OK >> Door mirror remote control switch (changeover switch) is OK.
- NG >> GO TO 2.

2. CHECK DOOR MIRROR SWITCH CIRCUIT HARNESS CONTINUITY

- Turn ignition switch OFF.
- Disconnect automatic drive positioner control unit and door mirror remote control switch.
- Check continuity between automatic drive positioner control unit connector M33 terminals 2, 18 and door mirror remote control switch connector D10 terminals 2, 3.

2 - 3 : Continuity should exist.
18 - 2 : Continuity should exist.

- Check continuity between automatic drive positioner control unit connector M33 terminals 2, 18 and ground.

2 - Ground : Continuity should not exist.
18 - Ground : Continuity should not exist.

OK or NG

- OK >> GO TO 3.
- NG >> Repair or replace harness.

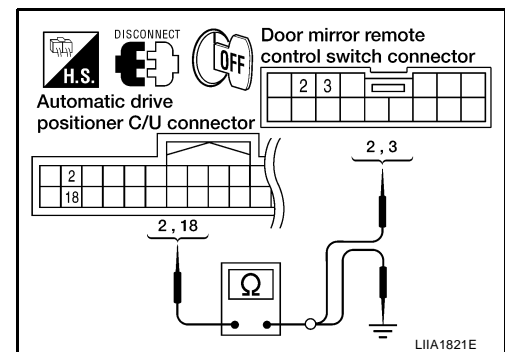

AUTOMATIC DRIVE POSITIONER

3. CHECK DOOR MIRROR REMOTE CONTROL SWITCH (CHANGEOVER SWITCH)

Check continuity between door mirror remote control switch terminals as follows.

Terminals		Condition	Continuity
3	13	Changeover switch RIGHT position	Yes
		Other than above	No
2		Changeover switch LEFT position	Yes
		Other than above	No

OK or NG

OK >> Check the condition of the harness and the connector.

NG >> Replace door mirror remote control switch. Refer to [EI-29, "FRONT DOOR"](#).

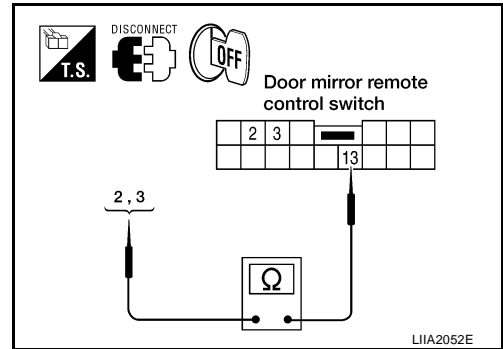

Door Mirror Remote Control Switch (Mirror Switch) Circuit Check

EIS004PB

1. CHECK DOOR MIRROR REMOTE CONTROL SWITCH (MIRROR SWITCH) SIGNAL

With CONSULT-II

Check the operation on "MIR CON SW-UP/DN" and "MIR CON SW-RH/LH" in the DATA MONITOR.

Monitor item [OPERATION or UNIT]		Contents
MIR CON SW-UP	"ON/OFF"	ON/OFF status judged from the mirror switch (UP) signal is displayed.
MIR CON SW-DN	"ON/OFF"	ON/OFF status judged from the mirror switch (DOWN) signal is displayed.
MIR CON SW-RH	"ON/OFF"	ON/OFF status judged from the mirror switch (RIGHT) signal is displayed.
MIR CON SW-LH	"ON/OFF"	ON/OFF status judged from the mirror switch (LEFT) signal is displayed.

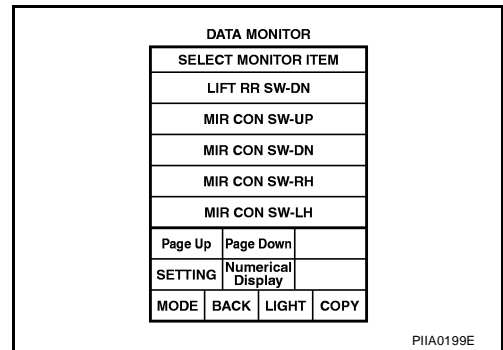

Without CONSULT-II

- Turn ignition switch to ACC.
- Check voltage between automatic drive positioner control unit connector and ground.

Connector	Terminals		Condition	Voltage (V) (Approx.)
	(+)	(-)		
M33	3	Ground	Mirror switch UP operation	0
			Other than above	5
	4		Mirror switch LEFT operation	0
			Other than above	5
	19		Mirror switch DOWN operation	0
			Other than above	5
	20		Mirror switch RIGHT operation	0
			Other than above	5

OK or NG

OK >> Door mirror remote control switch (mirror switch) circuit is OK.

NG >> GO TO 2.

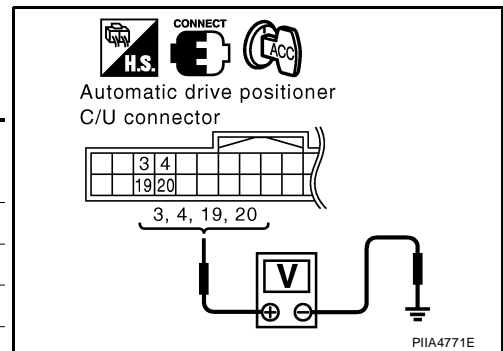

AUTOMATIC DRIVE POSITIONER

2. CHECK HARNESS CONTINUITY

1. Turn ignition switch OFF.
2. Disconnect automatic drive positioner control unit and door mirror remote control switch.
3. Check continuity between automatic drive positioner control unit connector M33 terminals 3, 4, 19, 20 and door mirror remote control switch connector D10 terminals 4, 5, 6, 14.

- 3 - 6 : Continuity should exist.**
- 4 - 5 : Continuity should exist.**
- 19 - 14 : Continuity should exist.**
- 20 - 4 : Continuity should exist.**

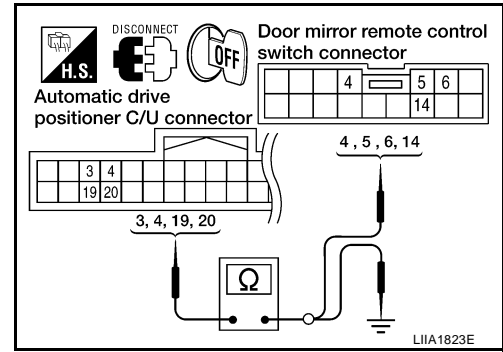

4. Check continuity between automatic drive positioner control unit connector M33 terminals 3, 4, 19, 20 and ground.

- 3 - Ground : Continuity should not exist.**
- 4 - Ground : Continuity should not exist.**
- 19 - Ground : Continuity should not exist.**
- 20 - Ground : Continuity should not exist.**

OK or NG

- OK >> GO TO 3.
- NG >> Repair or replace harness.

3. CHECK DOOR MIRROR REMOTE CONTROL SWITCH (MIRROR SWITCH)

Check continuity between door mirror remote control switch terminals as follows.

Terminals	Switch condition	Continuity
4	Mirror switch RIGHT operation	Yes
	Other than above	No
5	Mirror switch LEFT operation	Yes
	Other than above	No
6	Mirror switch UP operation	Yes
	Other than above	No
14	Mirror switch DOWN operation	Yes
	Other than above	No

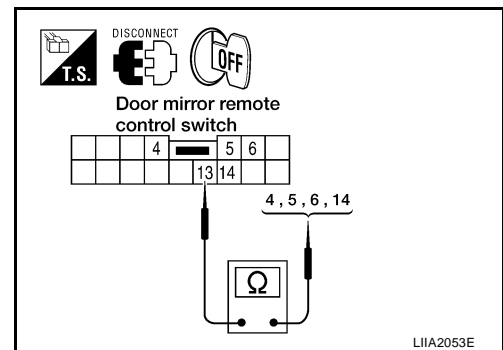

OK or NG

- OK >> Check the condition of the harness and connector.
- NG >> Replace door mirror remote control switch. Refer to [EI-29, "FRONT DOOR"](#).

AUTOMATIC DRIVE POSITIONER

Door Mirror Remote Control Switch Ground Circuit Inspection

EIS004PC

1. CHECK DOOR MIRROR REMOTE CONTROL SWITCH GROUND CIRCUIT

Check continuity between door mirror remote control switch connector D10 terminal 13 and ground.

13 - Ground : Continuity should exist.

OK or NG

- OK >> GO TO 2.
- NG >> Repair or replace harness.

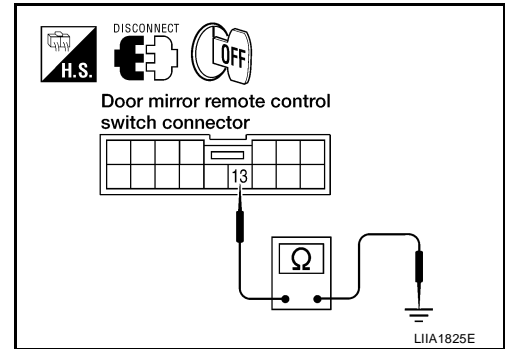

2. CHECK DOOR MIRROR REMOTE CONTROL SWITCH (CHANGEOVER SWITCH)

Check continuity between door mirror remote control switch terminals as follows.

Terminals	Condition	Continuity
3	Changeover switch RIGHT position	Yes
	Other than above	No
2	Changeover switch LEFT position	Yes
	Other than above	No

OK or NG

- OK >> Check the condition of the harness and the connector.
- NG >> Replace door mirror remote control switch. Refer to [EI-29, "FRONT DOOR"](#).

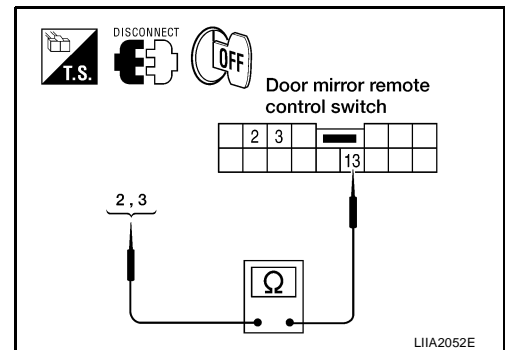

Seat Memory Switch Circuit Inspection

EIS004PD

1. CHECK FUNCTION

With CONSULT-II

With "SET SW, MEMORY SW1, MEMORY SW2" on the DATA MONITOR, operate the switch to check ON/OFF operation.

Monitor item [OPERATION or UNIT]	Contents
MEMORY SW1	"ON/OFF" ON/OFF status judged from the seat memory switch 1 signal is displayed.
MEMORY SW2	"ON/OFF" ON/OFF status judged from the seat memory switch 2 signal is displayed.
SET SW	"ON/OFF" ON/OFF status judged from the setting switch signal is displayed.

Without CONSULT-II

GO TO 2.

OK or NG

- OK >> Seat memory switch circuit is OK.
- NG >> GO TO 2.

DATA MONITOR

MONITOR		
SLIDE SW-FR	OFF	
SLIDE SW-RR	OFF	
RECLN SW-FR	OFF	
RECLN SW-RR	OFF	
LIFT FR SW-UP	OFF	
LIFT FR SW-DN	OFF	
LIFT RR SW-UP	OFF	
LIFT RR SW-DN	OFF	
SET SW	OFF	

Page Down

RECORD

MODE	BACK	LIGHT	COPY
------	------	-------	------

DATA MONITOR

MONITOR		
TELESCO SW-FR	OFF	
TELESCO SW-RR	OFF	
TILT SW-UP	OFF	
TILT SW-DOWN	OFF	
MEMORY SW 1	OFF	
MEMORY SW 2	OFF	
CANCEL SW	OFF	
DOOR SW-DR	OFF	
VHCL SPEED SE	<7km/	

Page Up Page Down

RECORD

MODE	BACK	LIGHT	COPY
------	------	-------	------

PIIA0309E

AUTOMATIC DRIVE POSITIONER

2. CHECK SEAT MEMORY SWITCH

1. Turn ignition switch OFF.
2. Disconnect seat memory switch.
3. Operate the setting switch and seat memory switch.
4. Check continuity between seat memory switch terminals as follows.

Terminal	Condition	Continuity
1	Memory switch 1: ON	Yes
	Memory switch 1: OFF	No
2	Memory switch 2: ON	Yes
	Memory switch 2: OFF	No
3	Set switch: ON	Yes
	Set switch: OFF	No

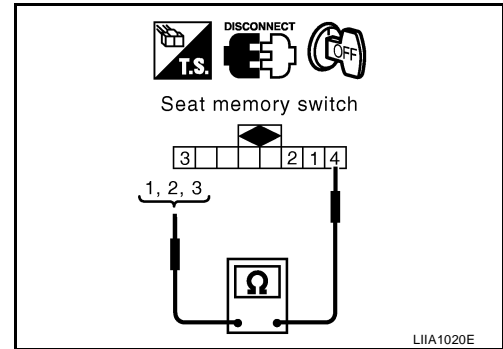

OK or NG

- OK >> GO TO 3.
 NG >> Replace seat memory switch. Refer to [EI-29, "FRONT DOOR"](#) .

3. CHECK HARNESS CONTINUITY

1. Disconnect automatic drive positioner control unit.
2. Check continuity between automatic drive positioner control unit connector M33 terminals 9, 24, 25 and seat memory switch connector D5 terminals 1, 2, 3.

- 9 - 1 : Continuity should exist.**
24 - 3 : Continuity should exist.
25 - 2 : Continuity should exist.

3. Check continuity between automatic drive positioner control unit connector M41 terminals 9, 24, 25 and ground.

- 9 - Ground : Continuity should not exist.**
24 - Ground : Continuity should not exist.
25 - Ground : Continuity should not exist.

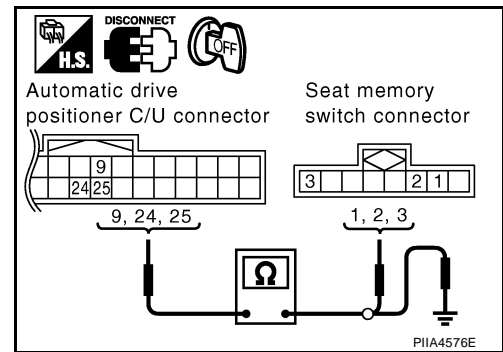

OK or NG

- OK >> GO TO 4.
 NG >> Repair or replace harness.

4. CHECK SEAT MEMORY SWITCH GROUND CIRCUIT

Check continuity between seat memory switch D5 terminal 4 and ground.

- 4 - Ground : Continuity should exist.**

OK or NG

- OK >> Replace automatic drive positioner control unit.
 NG >> Repair or replace harness.

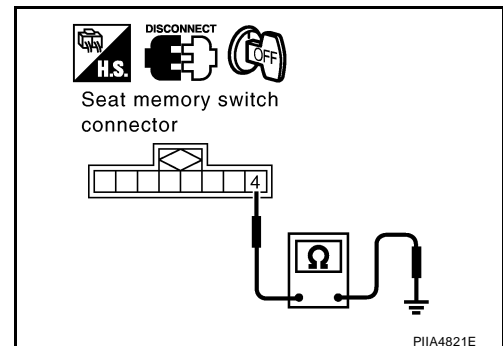

AUTOMATIC DRIVE POSITIONER

EIS004PE

Seat Memory Indicator Lamp Circuit Inspection

1. CHECK FUNCTION

With CONSULT-II

With "MEMORY SW INDCTR" in ACTIVE TEST, check operation.

Test item	Description
MEMORY SW INDCTR	The memory switch indicator is lit by receiving the drive signal.

Without CONSULT-II

GO TO 2.

OK or NG

- OK >> Seat memory switch indicator lamp circuit is OK.
 NG >> GO TO 2.

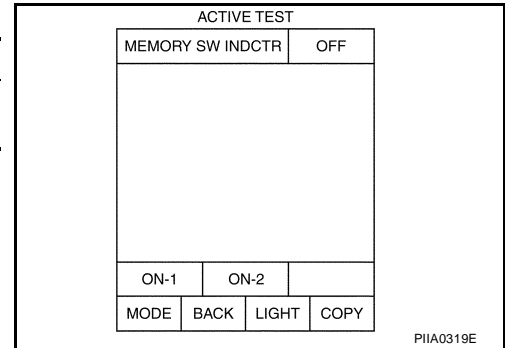

2. CHECK SEAT MEMORY SWITCH POWER SUPPLY CIRCUIT

- Turn ignition switch OFF.
- Disconnect seat memory switch.
- Check voltage between seat memory switch connector D5 terminal 5 and ground.

5 - Ground : Battery voltage

OK or NG

- OK >> GO TO 3.
 NG >> Repair or replace harness.

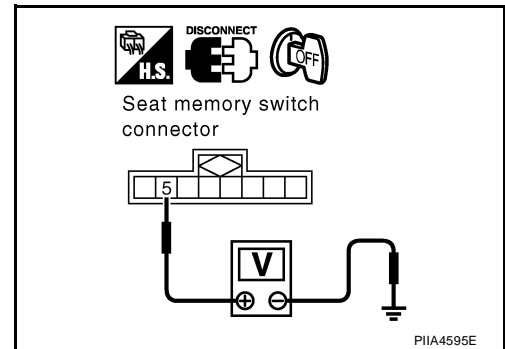

3. CHECK SEAT MEMORY INDICATOR CIRCUIT HARNESS CONTINUITY

- Disconnect automatic drive positioner control unit.
- Check continuity between automatic drive positioner control unit connector M33 terminals 12, 13 and seat memory switch connector D5 terminals 6, 7.

12 - 6 : Continuity should exist.
13 - 7 : Continuity should exist.

- Check continuity between automatic drive positioner control unit connector M33 terminals 12, 13 and ground.

12 - Ground : Continuity should not exist.
13 - Ground : Continuity should not exist.

OK or NG

- OK >> GO TO 4.
 NG >> Repair or replace harness.

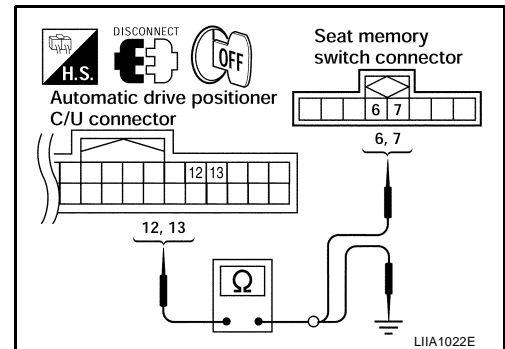

AUTOMATIC DRIVE POSITIONER

4. CHECK SEAT MEMORY SWITCH INDICATOR SIGNAL

1. Connect seat memory switch.
2. Turn ignition switch ON.
3. Check voltage between automatic drive positioner control unit connector M33 terminals 12, 13 and ground.

12 - Ground : Battery voltage

13 - Ground : Battery voltage

OK or NG

OK >> Replace automatic drive positioner control unit.

NG >> Replace seat memory switch. Refer to [EI-29, "FRONT DOOR"](#).

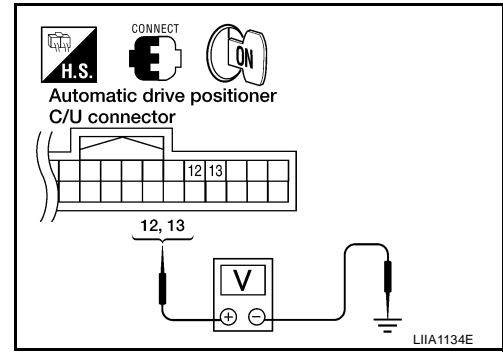

Door Mirror Sensor Power Supply and Ground Circuit inspection

EIS004PF

1. CHECK DOOR MIRROR SENSOR CIRCUIT HARNESS CONTINUITY

1. Disconnect automatic drive positioner control unit and door mirror (LH and RH).
2. Check continuity between automatic drive positioner control unit connector M34 terminal 33, 41 and door mirror connector D4 (LH), D107 (RH) terminal 5, 6.

33 - 5 : Continuity should exist.

41 - 6 : Continuity should exist.

3. Check continuity between automatic drive positioner control unit connector M34 terminal 33, 41 and ground.

33 - Ground : Continuity should not exist.

41 - Ground : Continuity should not exist.

OK or NG

OK >> GO TO 2.

NG >> Repair or replace harness.

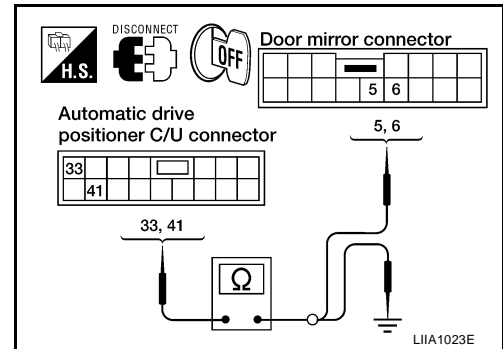

2. CHECK MIRROR SENSOR POWER SUPPLY

1. Connect automatic drive positioner control unit and door mirror LH.
2. Turn ignition switch to ACC.
3. Check voltage between automatic drive positioner control unit connector M34 terminal 33 and ground.

33 - Ground : Approx. 5V

OK or NG

OK >> GO TO 3.

NG >> Replace automatic drive positioner control unit.

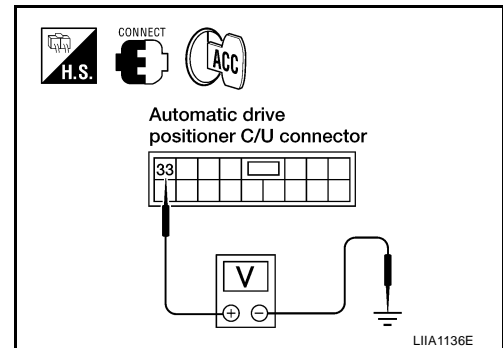

AUTOMATIC DRIVE POSITIONER

3. CHECK MIRROR SENSOR GROUND CIRCUIT

1. Turn ignition switch OFF.
2. Check continuity between automatic drive positioner control unit connector M34 terminal 41 and ground.

41 - Ground : Continuity should exist.

OK or NG

- OK >> Check the condition of the harness and connector.
 NG >> Replace automatic drive positioner control unit.

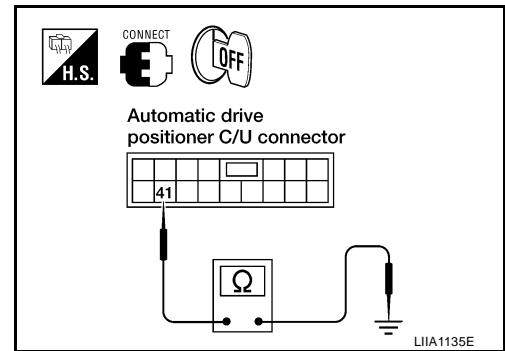

A/T Device (Park Position Switch) Circuit Inspection

EIS004PG

1. CHECK FUNCTION

Ⓜ With CONSULT-II

Check that when the A/T shift lever is in P position, "DETENT SW" on the DATA MONITOR becomes OFF.

Monitor item [OPERATION or UNIT]	Contents	
DETENT SW	"ON/OFF"	The A/T selector lever position "P position (OFF)/other than P position (ON)" judged from the park position switch signal is displayed.

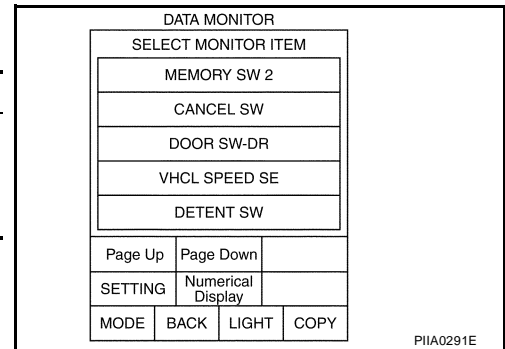

⊗ Without CONSULT-II

GO TO 2.

OK or NG

- OK >> A/T device (park position switch) circuit is OK.
 NG >> GO TO 2.

2. CHECK A/T DEVICE (PARK POSITION SWITCH) HARNESS

1. Turn ignition switch OFF.
2. Disconnect A/T device and driver seat control unit.
3. Check continuity between A/T device connector M203 terminal 6 and driver seat control unit connector P2 terminal 21.

6 - 21 : Continuity should exist.

4. Check continuity between A/T device connector M203 terminal 6 and ground.

6 - Ground : Continuity should not exist.

OK or NG

- OK >> GO TO 3.
 NG >> Repair or replace harness.

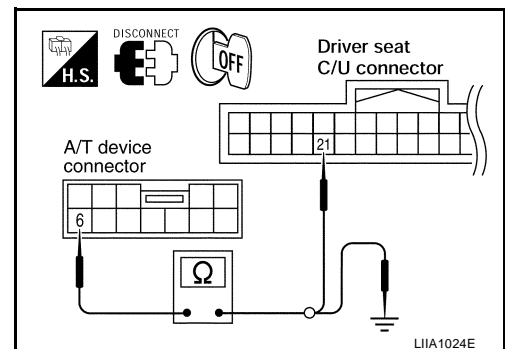

AUTOMATIC DRIVE POSITIONER

3. CHECK PARK POSITION SWITCH

Check continuity between A/T device (park position switch) terminals as follows.

Terminals		Condition	Continuity
5	6	P position	No
		Other than P position	Yes

OK or NG

- OK >> A/T device is OK.
- NG >> Replace A/T device.

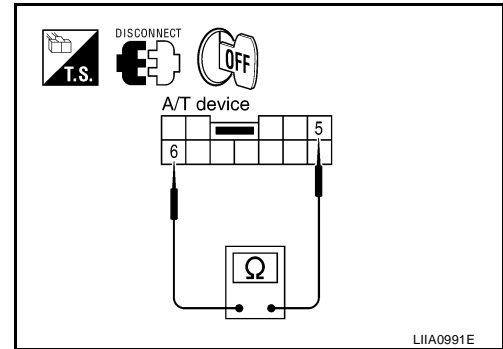

LIA0991E

EIS004PH

Front Door Switch LH Circuit Inspection

1. CHECK FUNCTION

With CONSULT-II

Touch "DOOR SW DR" on the DATA MONITOR, check ON/OFF operation when the front door is open and closed.

Monitor item [OPERATION or UNIT]	Contents	
DOOR SW DR	"ON/OFF"	Door open (ON)/door closed (OFF) status judged from the front door switch is displayed.

Without CONSULT-II

GO TO 2.

OK or NG

- OK >> Front door switch LH circuit is OK.
- NG >> GO TO 2.

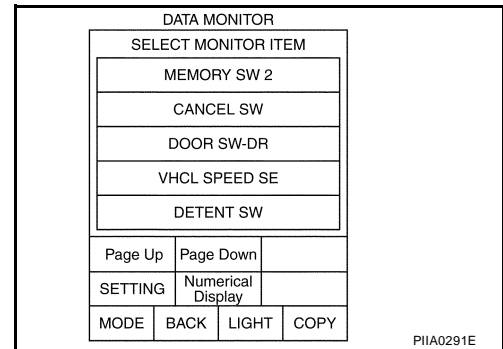

PIIA0291E

2. CHECK FRONT DOOR SWITCH LH

1. Turn ignition switch OFF.
2. Disconnect front door switch.
3. Check continuity between front door switch LH terminal and ground part of door switch as follows.

Terminals		Condition	Continuity
2	Ground	With the front door switch LH pressed	No
		With the front door switch LH released	Yes

OK or NG

- OK >> GO TO 3.
- NG >> Replace front door switch LH.

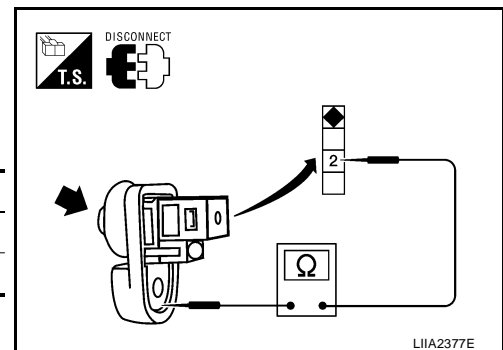

LIA2377E

AUTOMATIC DRIVE POSITIONER

3. CHECK HARNESS CONTINUITY

1. Disconnect BCM.
2. Check continuity between BCM connector M19 terminal 47 and front door switch LH connector B8 terminal 2.

47 - 2 : Continuity should exist.

3. Check continuity between BCM connector M19 terminal 47 and ground.

47 - Ground : Continuity should not exist.

OK or NG

- OK >> Front door switch LH circuit is OK.
 NG >> Repair or replace harness.

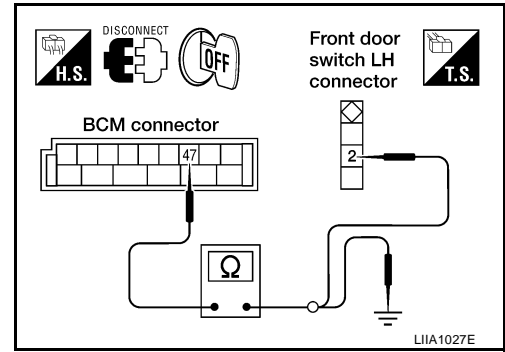

UART Communication Line Circuit Inspection

EIS004PI

1. CHECK UART LINE INPUT/OUTPUT SIGNAL 1

1. Turn ignition switch OFF.
2. Check signal between driver seat control unit connector and ground, with oscilloscope.

Connector	Terminals		Condition	Signal
	(+)	(-)		
P2	17	Ground	Pedal adjusting switch ON (FORWARD or BACKWARD operation)	

PIIA4814E

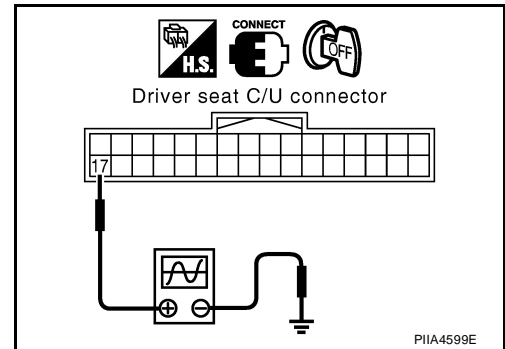

PIIA4599E

OK or NG

- OK >> GO TO 2.
 NG >> Check the following.
- When voltage wave form does not appear with a constant voltage (approx. 5V), replace driver seat control unit. Refer to [SE-85, "FRONT SEAT"](#) .
 - When voltage wave form does not appear with a constant voltage (approx. 0V), replace automatic driver seat control unit.

AUTOMATIC DRIVE POSITIONER

2. CHECK UART LINE INPUT/OUTPUT SIGNAL 2

Check signal between automatic drive positioner control unit connector ground, with oscilloscope.

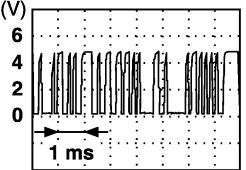
Connector	Terminals		Condition	Signal
	(+)	(-)		
M33	10	Ground	Pedal adjusting switch ON (FORWARD or BACKWARD operation)	 PIIA4813E

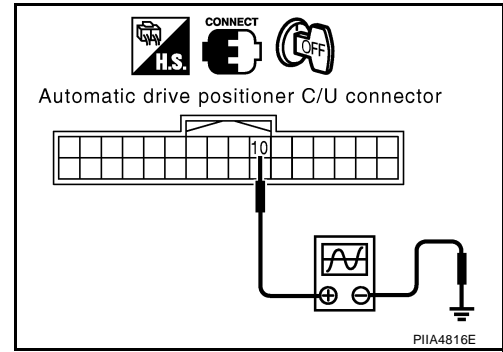

OK or NG

OK >> GO TO 3.

NG >> Check the following.

- When voltage wave form does not appear with a constant voltage (approx. 5V), replace automatic drive positioner control unit.
- When voltage wave form does not appear with a constant voltage (approx. 0V), replace driver seat control unit. Refer to [SE-85, "FRONT SEAT"](#).

3. CHECK UART LINE HARNESS

1. Disconnect driver seat control unit and automatic drive positioner control unit.
2. Check continuity between driver seat control unit connector P2 terminals 1, 17, and automatic drive positioner connector M33 terminals 10, 26.

1 - 10 : Continuity should exist.

17 - 26 : Continuity should exist.

3. Check continuity between driver seat control unit connector P2 terminals 1, 17 and ground.

1 - Ground : Continuity should not exist.

17 - Ground : Continuity should not exist.

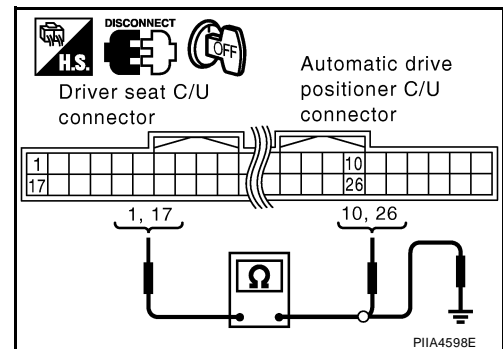

OK or NG

OK >> GO TO 4.

NG >> Repair or replace harness.

4. CHECK DRIVER SEAT CONTROL UNIT

Does the automatic drive positioner operate when the driver seat control unit is exchanged?

OK or NG

OK >> Replace driver seat control unit. Refer to [SE-85, "FRONT SEAT"](#).

NG >> Replace automatic drive positioner control unit.

AUTOMATIC DRIVE POSITIONER

Removal and Installation

EIS004PJ

Refer to [ACC-3, "ACCELERATOR CONTROL SYSTEM"](#) and [BR-6, "BRAKE PEDAL"](#) .

A

B

C

D

E

F

G

H

SE

J

K

L

M

POWER SEAT

POWER SEAT Schematic

PFP:87016

EIS004PK

(PP) : WITH FRONT PASSENGER POWER SEAT

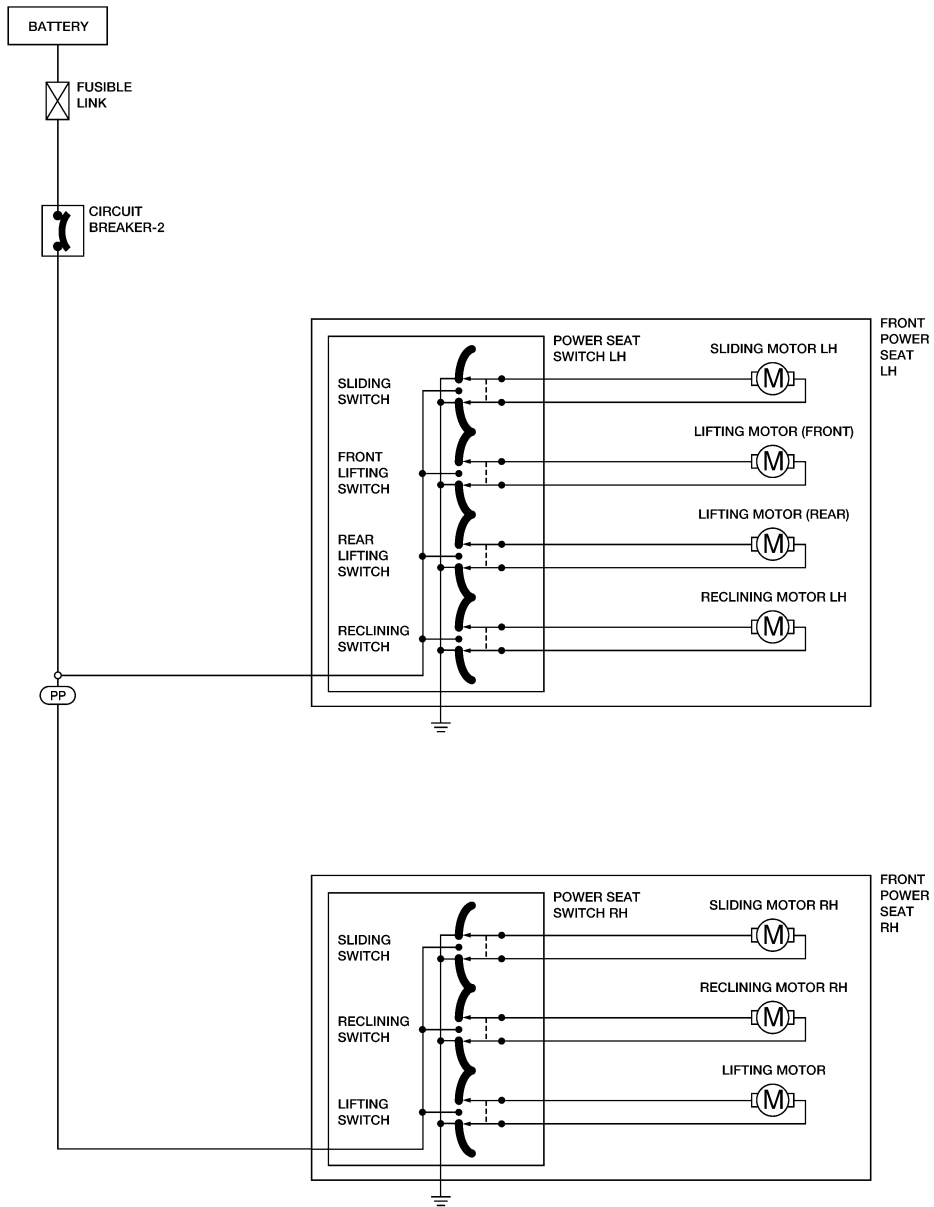

WIWA1410E

POWER SEAT

Wiring Diagram – SEAT –

EIS004PL

SE-SEAT-01

⬡ : WITH FRONT PASSENGER POWER SEAT

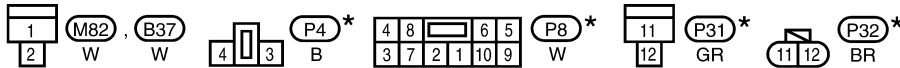
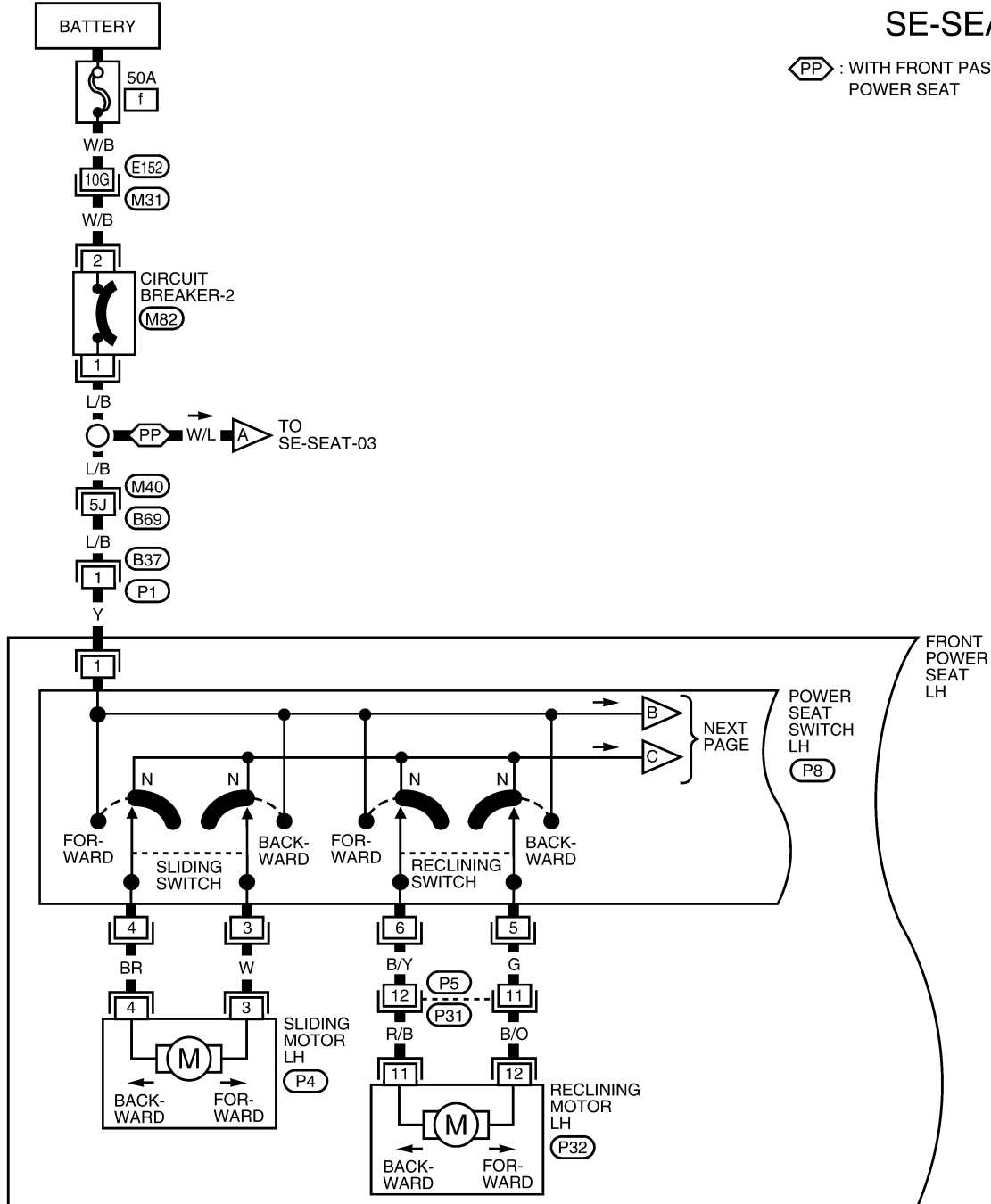

REFER TO THE FOLLOWING.
 (M31), (M40) - SUPER
 MULTIPLE JUNCTION (SMJ)

* : THIS CONNECTOR IS NOT SHOWN IN "HARNESS LAYOUT" OF PG SECTION.

WIWA1411E

POWER SEAT

SE-SEAT-02

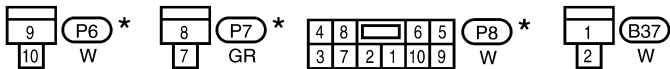
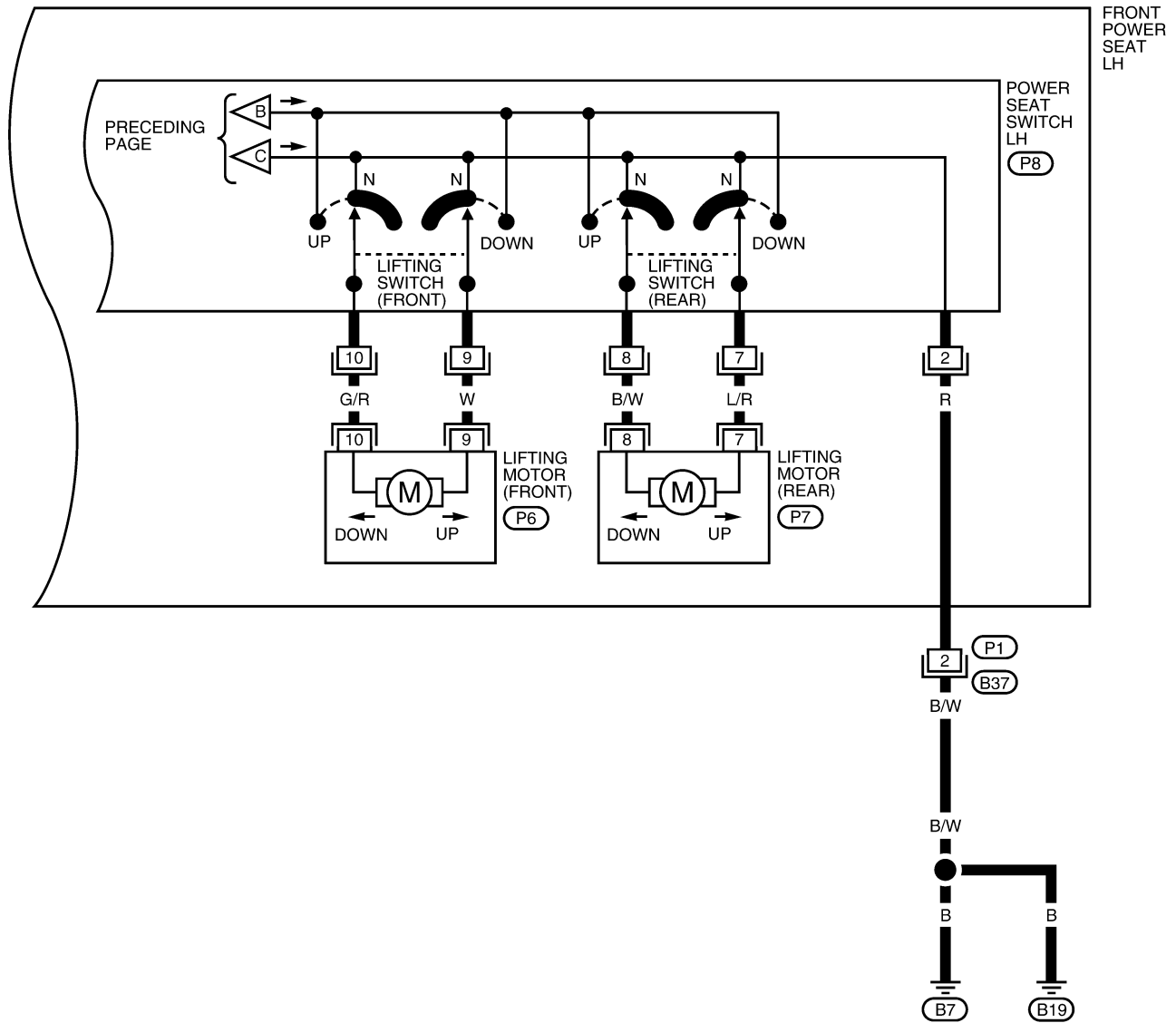

*: THIS CONNECTOR IS NOT SHOWN IN "HARNES LAYOUT" OF PG SECTION.

WIWA1412E

POWER SEAT

SE-SEAT-03

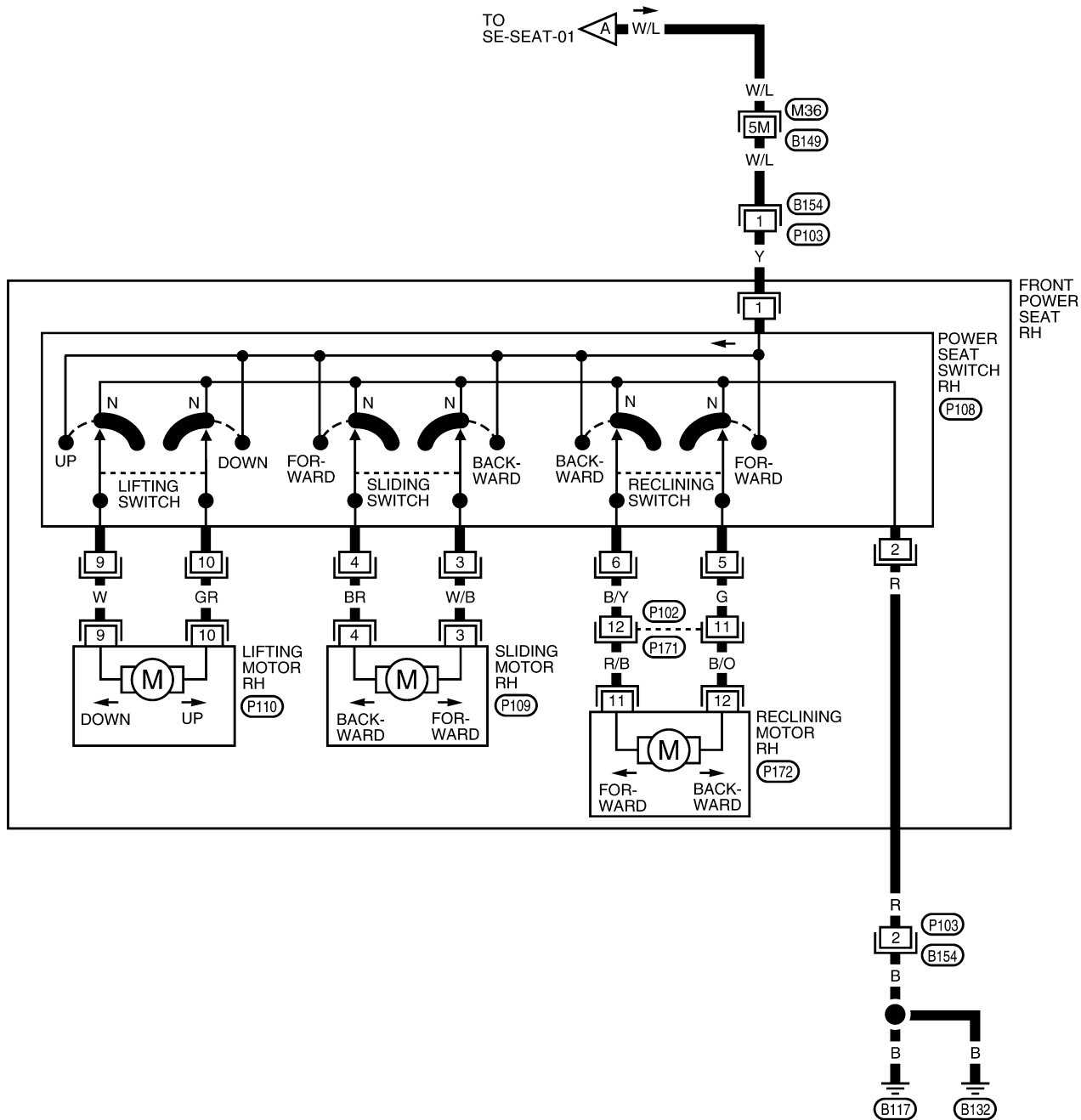

A
B
C
D
E
F
G
H
I
J
K
L
M

SE

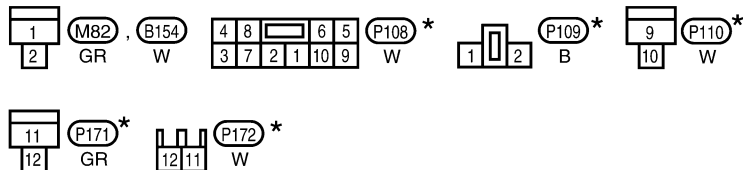

REFER TO THE FOLLOWING.
 (M31), (M36) - SUPER
 MULTIPLE JUNCTION (SMJ)

* : THIS CONNECTOR IS NOT SHOWN IN "HARNESS LAYOUT" OF PG SECTION.

W1WA1413E

HEATED SEAT

HEATED SEAT

PFP:87335

Description

EIS004PM

- When handling seat, be extremely careful not to scratch heating unit.
- Front passenger seat cushion and seatbacks equipped with airbags cannot be disassembled. They are replaced as assemblies only.
- Do not use any organic solvent, such as thinner, benzene, alcohol, etc. to clean trim.

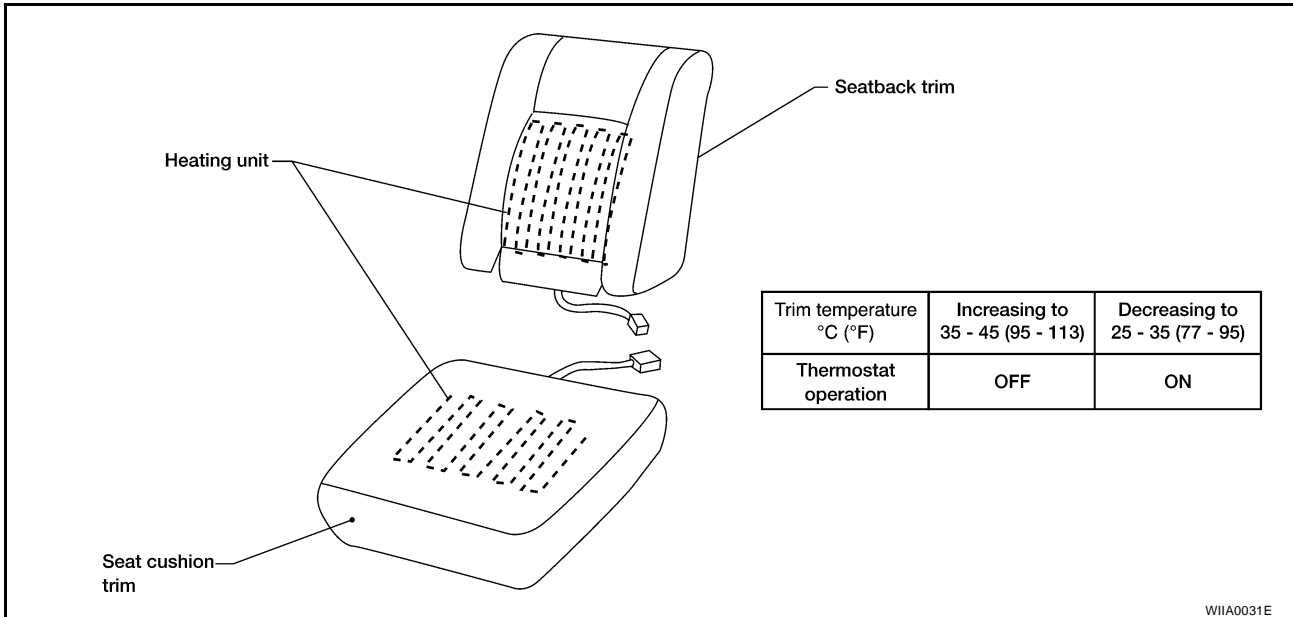

W1IA0031E

HEATED SEAT

Wiring Diagram – HSEAT –

EIS004PO

SE-HSEAT-01

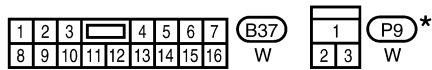
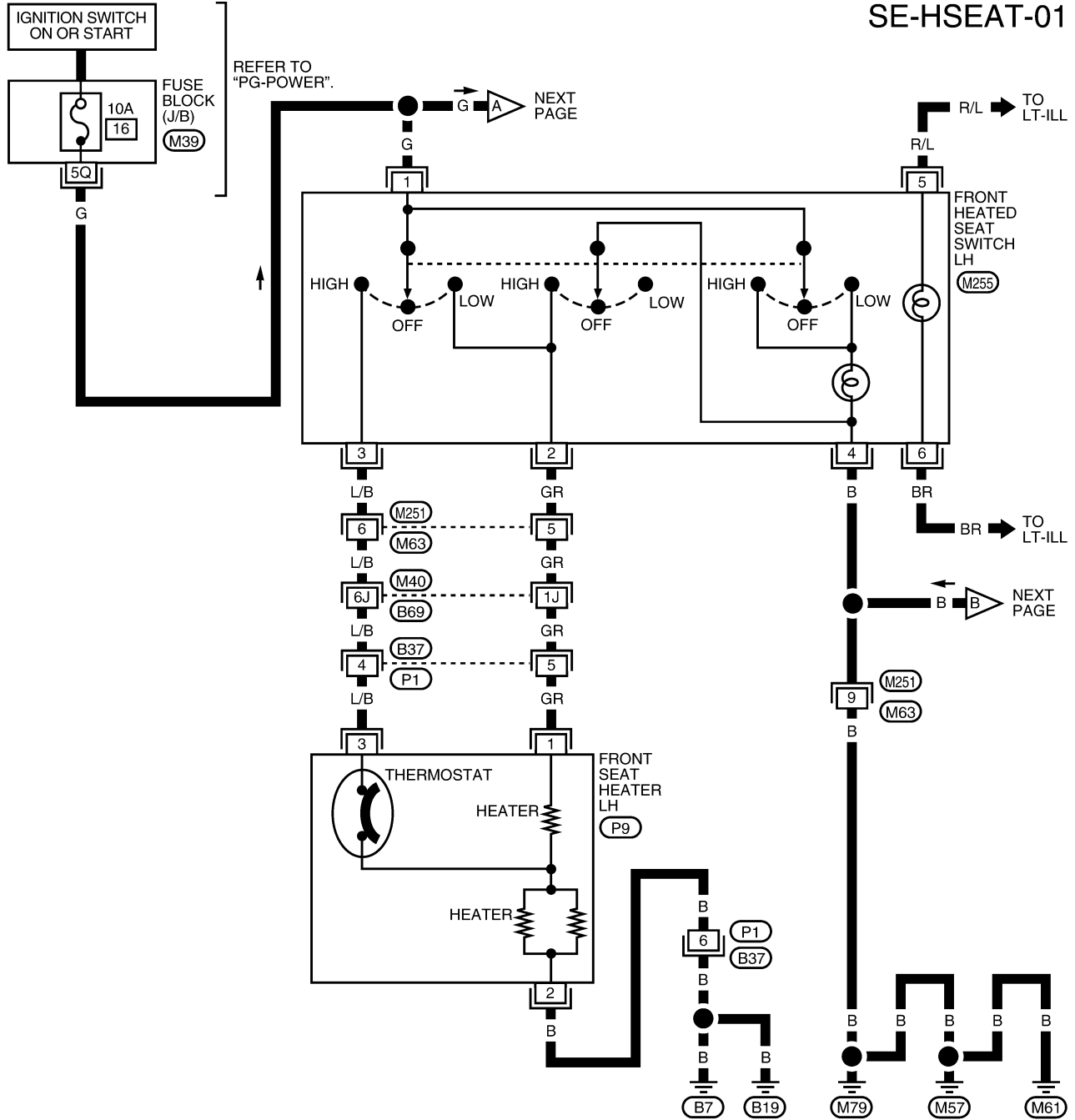

REFER TO THE FOLLOWING.
 (M40) - SUPER MULTIPLE JUNCTION (SMJ)

* : THIS CONNECTOR IS NOT SHOWN IN "HARNESS LAYOUT" OF PG SECTION.

WIWA0600E

HEATED SEAT

SE-HSEAT-02

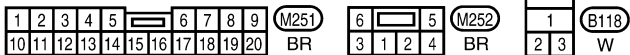
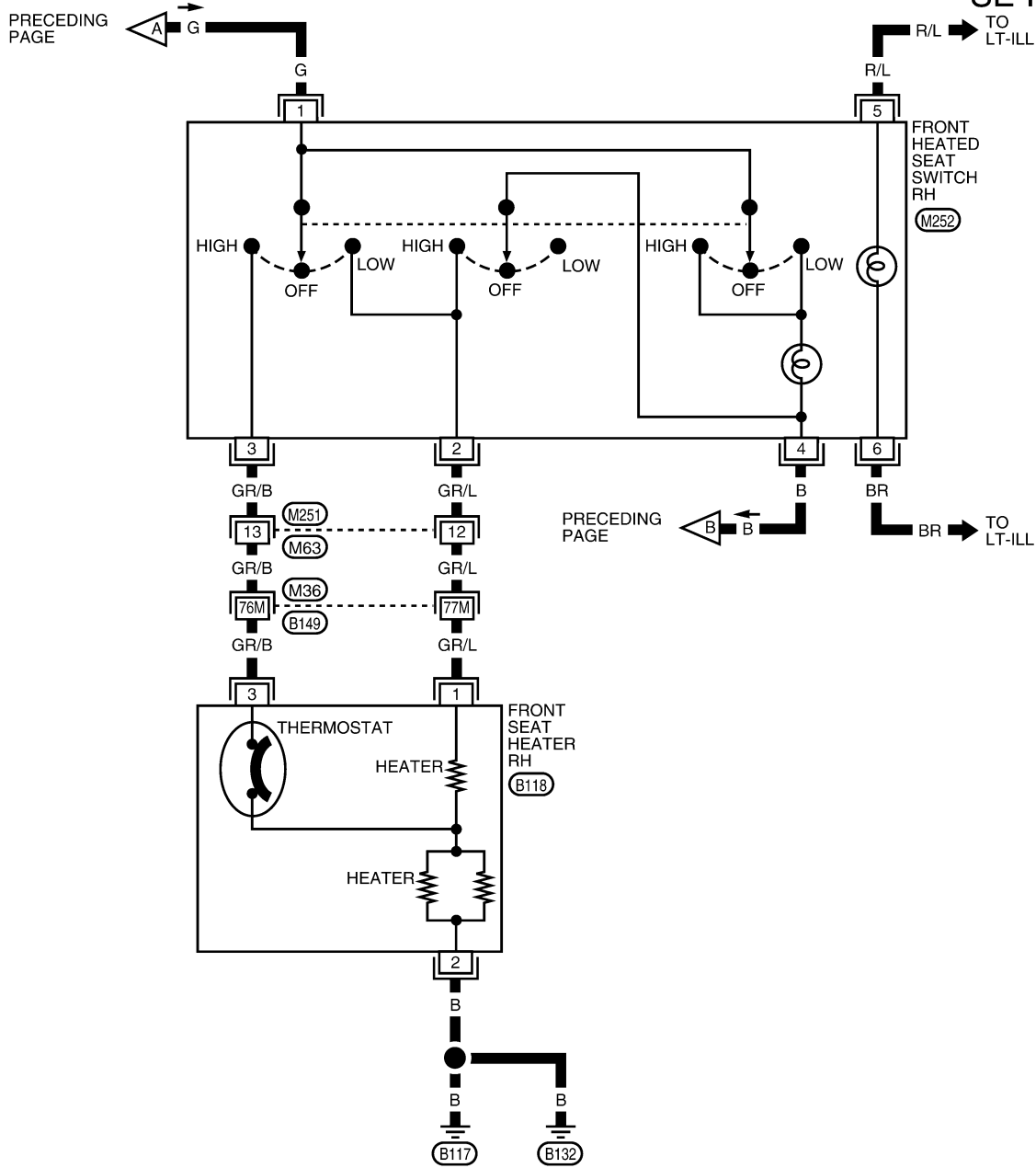

REFER TO THE FOLLOWING.
 (M36) - SUPER MULTIPLE
 JUNCTION (SMJ)

WIWA0601E

FRONT SEAT

PFP:87000

EIS004PP

FRONT SEAT

Removal and Installation

Driver Seat

SEC. 870

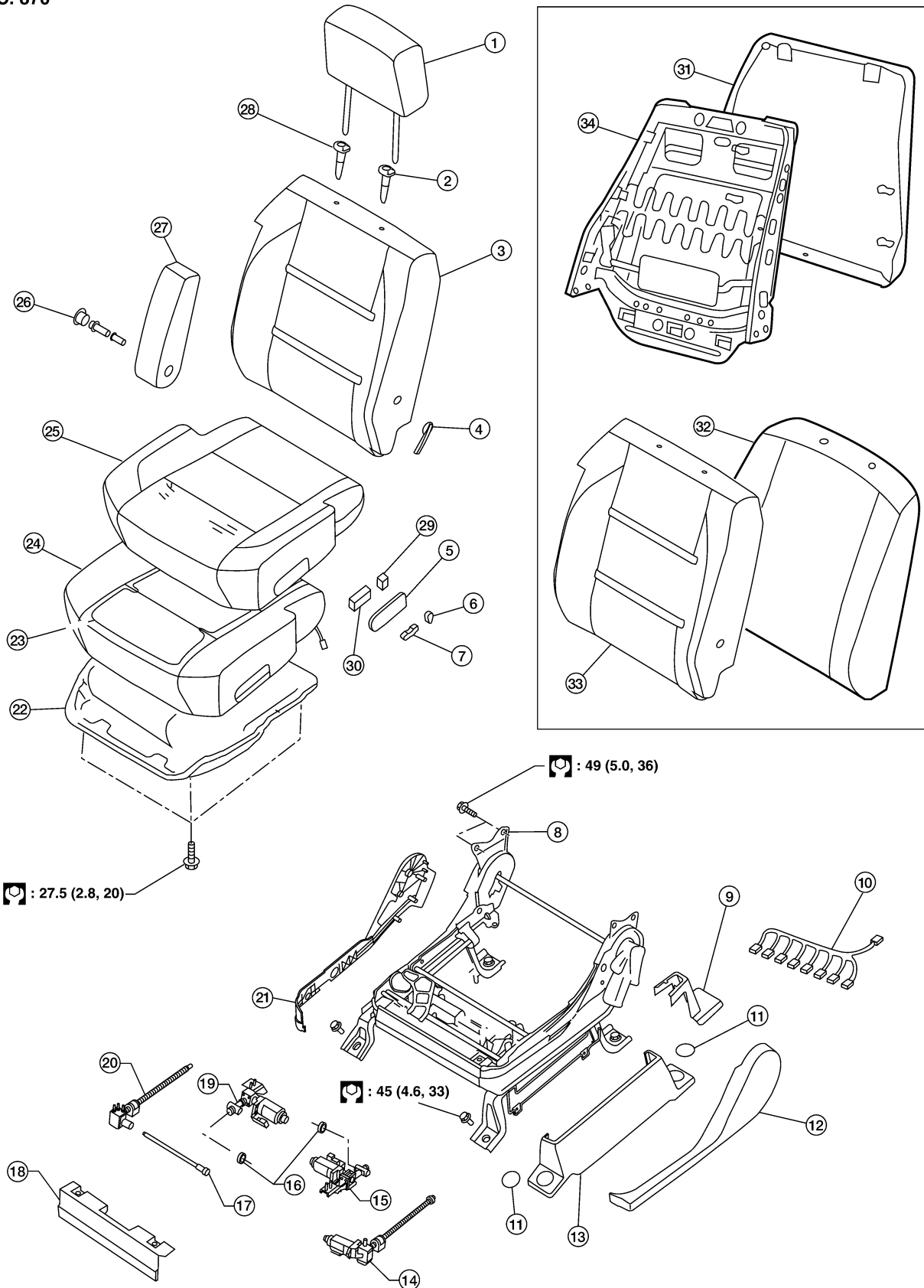

A
B
C
D
E
F
G
H
SE
J
K
L
M

FRONT SEAT

- | | | |
|---|---|--|
| 1. Headrest | 2. Headrest holder with multi position lock | 3. Seatback assembly (with side air bag) |
| 4. Lumbar support lever | 5. Power seat switch escutcheon | 6. Recliner switch knob |
| 7. Slide switch knob | 8. Driver power seat frame assembly | 9. LH outer leg cover |
| 10. Driver seat wiring harness | 11. Bolt cover | 12. Seat cushion outer finisher |
| 13. Outer pedestal finisher | 14. Slide motor | 15. Rear lifter motor |
| 16. Bushing | 17. Drive cable | 18. Seat cushion front finisher |
| 19. Front lifter motor | 20. Slide gear | 21. Seat cushion inner finisher |
| 22. Seat cushion frame | 23. Seat cushion heating element | 24. Seat cushion pad |
| 25. Seat cushion trim cover | 26. Armrest bolt cover | 27. Armrest assembly |
| 28. Headrest holder | 29. Recliner switch | 30. Seat slide switch |
| 31. Seatback board (without side air bag) | 32. Seatback pad (without side air bag) | 33. Seatback trim cover (without side air bag) |
| 34. Seatback frame (without side air bag) | | |

FRONT SEAT

Passenger Seat

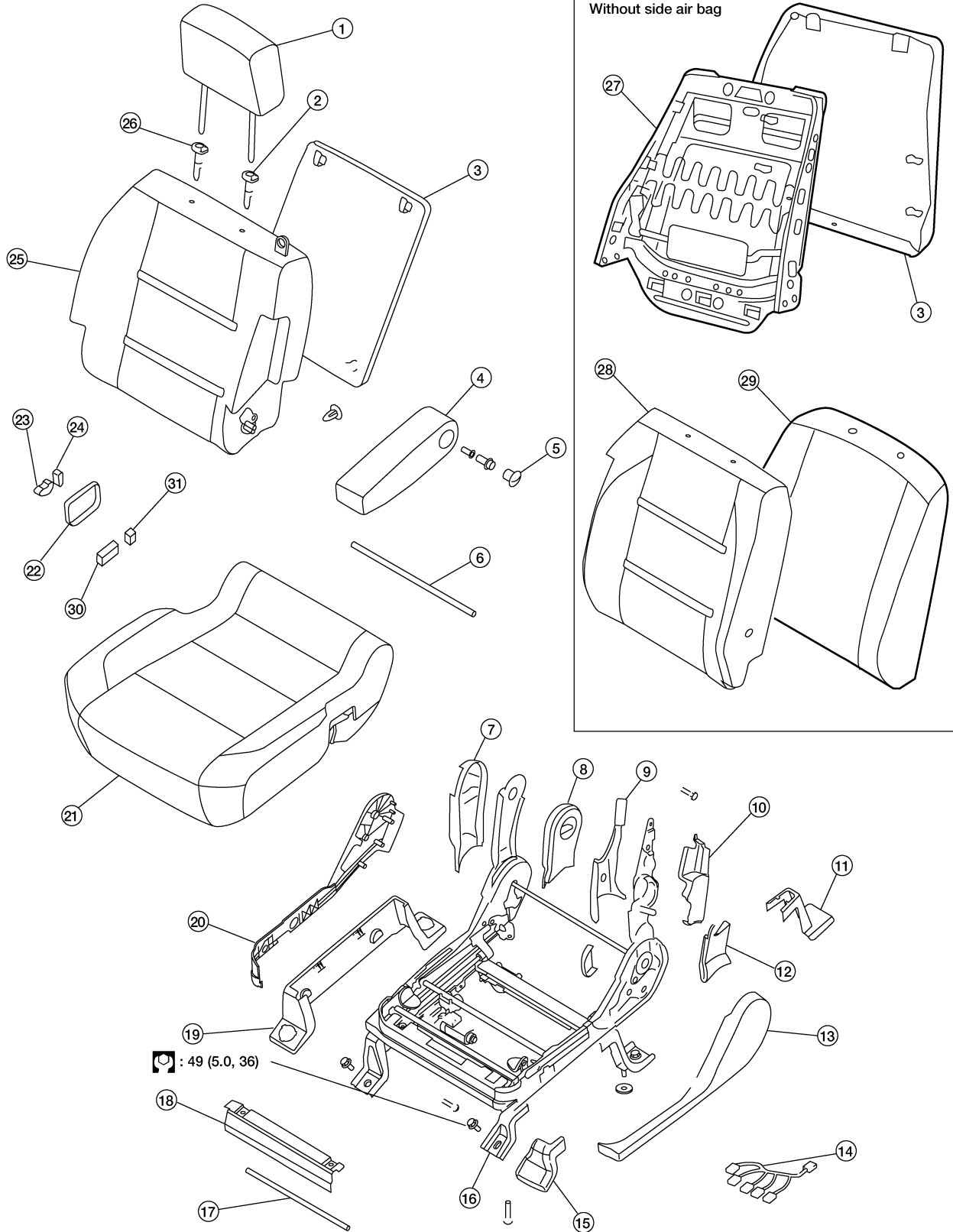

A
B
C
D
E
F
G
H
SE
J
K
L
M

1. Headrest

2. Headrest holder with multi position lock

3. Seatback board

4. Armrest assembly

5. Armrest bolt cover

6. Fold flat link bar

 : 49 (5.0, 36)

W1IA0475E

FRONT SEAT

-
- | | | |
|---------------------------------------|---------------------------------------|--|
| 7. Outboard reclining arm outer cover | 8. Outboard reclining arm inner cover | 9. Inboard reclining arm inner cove |
| 10. Latch cover | 11. LH outer leg cover | 12. Outboard reclining arm inner cover |
| 13. Seat cushion inner cover | 14. Passenger seat wiring harness | 15. Inner front leg cover |
| 16. Power seat frame assembly | 17. NVH assembly | 18. Seat cushion front finisher |
| 19. Outer pedestal finisher | 20. Seat cushion outer finisher | 21. Seat cushion assembly |
| 22. Power seat switch escutcheon | 23. Slide switch knob | 24. Recliner switch knob |
| 25. Seatback assembly | 26. Headrest holder | 27. Seatback frame |
| 28. Seatback trim cover | 29. Seatback pad | 30. Recliner switch |
| 31. Seat slide switch | | |

REMOVAL

When removing or installing the seat trim, handle it carefully to keep dirt out and avoid damage.

CAUTION:

- Before removing the front seat, turn the ignition switch off, disconnect both battery cables and wait at least 3 minutes.
- When checking the power seat circuit for continuity using a circuit tester, do not confuse its connector with the side air bag module connector. Such an error may cause the air bag to deploy.
- Do not drop, tilt, or bump the side air bag module while installing the seat. Always handle it with care.
- After front side air bag module inflates, front seatback assembly must be replaced.
- Front passenger seat is equipped with an Occupant Classification System sensor and control module. Do not disassemble front passenger seat cushion assembly or remove the trim as this will affect the Occupant Classification System calibration.
- Always replace passenger seat cushion as an assembly.

1. Slide the seat until the four body mounting bolts are visible and a tool can be inserted.

NOTE:

- If disassembling the seat after removal, set the front/rear cushion lifters to the top position.
2. Disconnect both battery cables and wait at least 3 minutes.
 3. Disconnect the side air bag module harness connector.
 4. Remove the four body mounting bolts.
 5. Disconnect the power seat harness connectors and remove the seat from the vehicle.

NOTE:

When removing and installing the seat, use shop cloths to protect the vehicle from damage.

INSTALLATION

- Installation is in the reverse order of removal.

Disassembly and Assembly SEATBACK TRIM AND PAD

EIS004PQ

WARNING:

Removal of front side air bag module should only be done to allow deployment of front side air bag module prior to disposal of seatback assembly.

NOTE:

Only complete seatback assemblies can be replaced on vehicles equipped with side air bags.

NOTE:

Be sure to set the front/rear cushion lifter to the top position.

FRONT SEAT

1. Remove the seatback board from the back of the seatback.

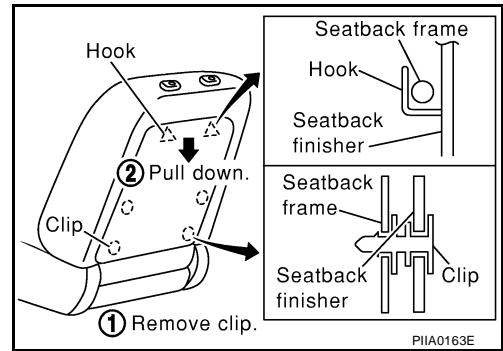

2. Remove the retainer.

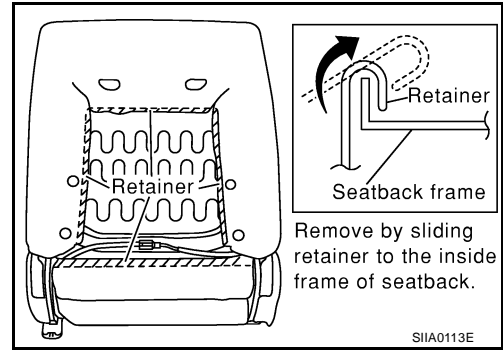

3. Remove the headrest.

4. From inside of the seatback, squeeze the headrest holder tabs at the base of the stay pipe and pull the up to remove.

NOTE:

Before installing the headrest holder, check its orientation (front/rear and right/left).

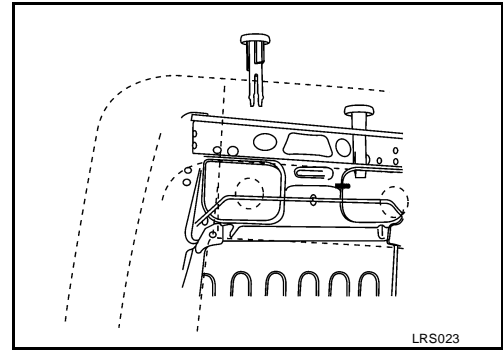

5. Remove the snap ring and the lumbar support lever knob.

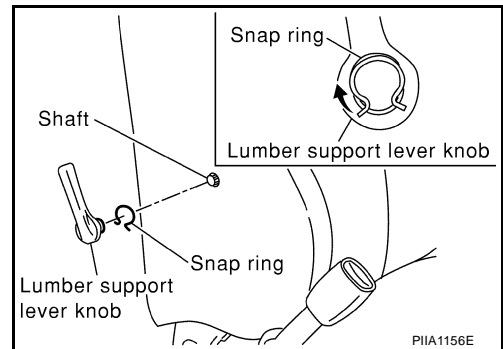

6. Disconnect the seatback heater harness. Remove the seatback trim and pad assembly. Remove the hog ring to separate the seatback trim from the pad and the heater unit.

REMOVAL OF SEATBACK ASSEMBLY

1. After completing the steps 1 and 2 of "Seatback Trim and Pad", remove the side air bag harness connector from the seat cushion.
2. Remove the mounting bolts (2 for each side) and seatback assembly.

A
B
C
D
E
F
G
H
SE
J
K
L
M

FRONT SEAT

INSTALLATION OF SEATBACK ASSEMBLY

- Installation is in the reverse order of removal.

SEAT CUSHION TRIM AND PAD (DRIVER) OR SEAT CUSHION ASSEMBLY (PASSENGER)

CAUTION:

- Front passenger seat is equipped with an Occupant Classification System sensor and control module. Do not disassemble front passenger seat cushion assembly or remove the trim as this will affect the Occupant Classification System calibration.
- Always replace passenger seat cushion as an assembly.
- when removed, the passenger seat cushion must always be placed pan side UP to prevent damage.
- During installation, the wire harness clips must be reinstalled in the holes they were originally in. Do not add clips.
- The Occupant Classification System control module can only be replaced as part of the seat cushion assembly.

NOTE:

If the vehicle has been involved in a collision the seat must be inspected for damage. Refer to [SRS-59, "COLLISION DIAGNOSIS"](#).

1. Remove the power seat switch knobs and power seat switch escutcheon (or recline knobs on manual seat).

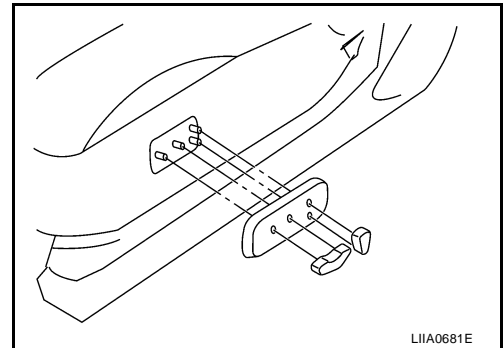

2. Remove the front seat cushion finisher (inner).

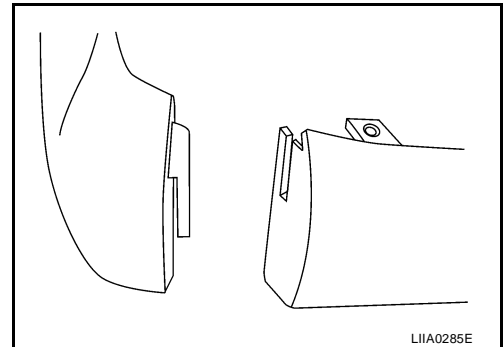

3. Remove the power seat switch screws (or lift knobs on manual seats).
4. Remove four bolts and the seat cushion assembly.

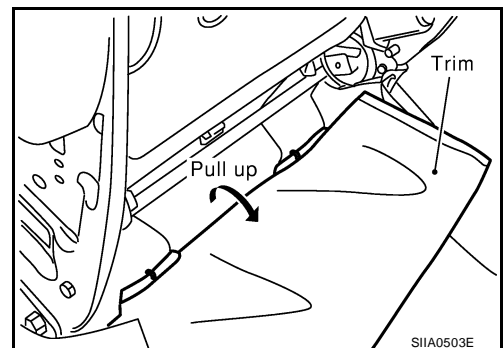

5. Remove the retainer on the seat cushion frame, then remove the harness connector for the seat heater.

FRONT SEAT

-
6. On the drivers seat only, after removing the seat cushion trim and pad, remove the hog rings to separate the trim cover from the pad and seat cushion heater unit.

A

B

C

D

E

F

G

H

SE

J

K

L

M

SECOND SEAT

SECOND SEAT

PFP:88000

Second Row Outboard REMOVAL

EIS007WX

1. Remove seat base trim cover.
2. Lift handle and tilt seat forward.
3. Remove seat anchor nuts, bolts and seat assembly.

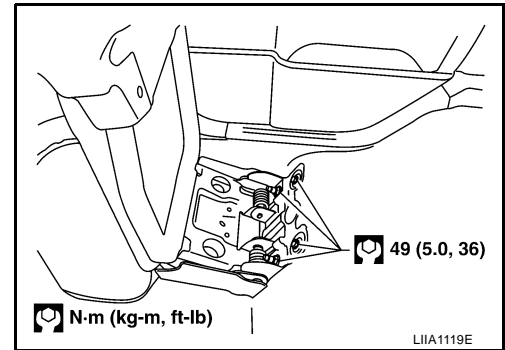

INSTALLATION

Installation is in the reverse order of removal.

SECOND SEAT

DISASSEMBLY AND ASSEMBLY

Second Row RH

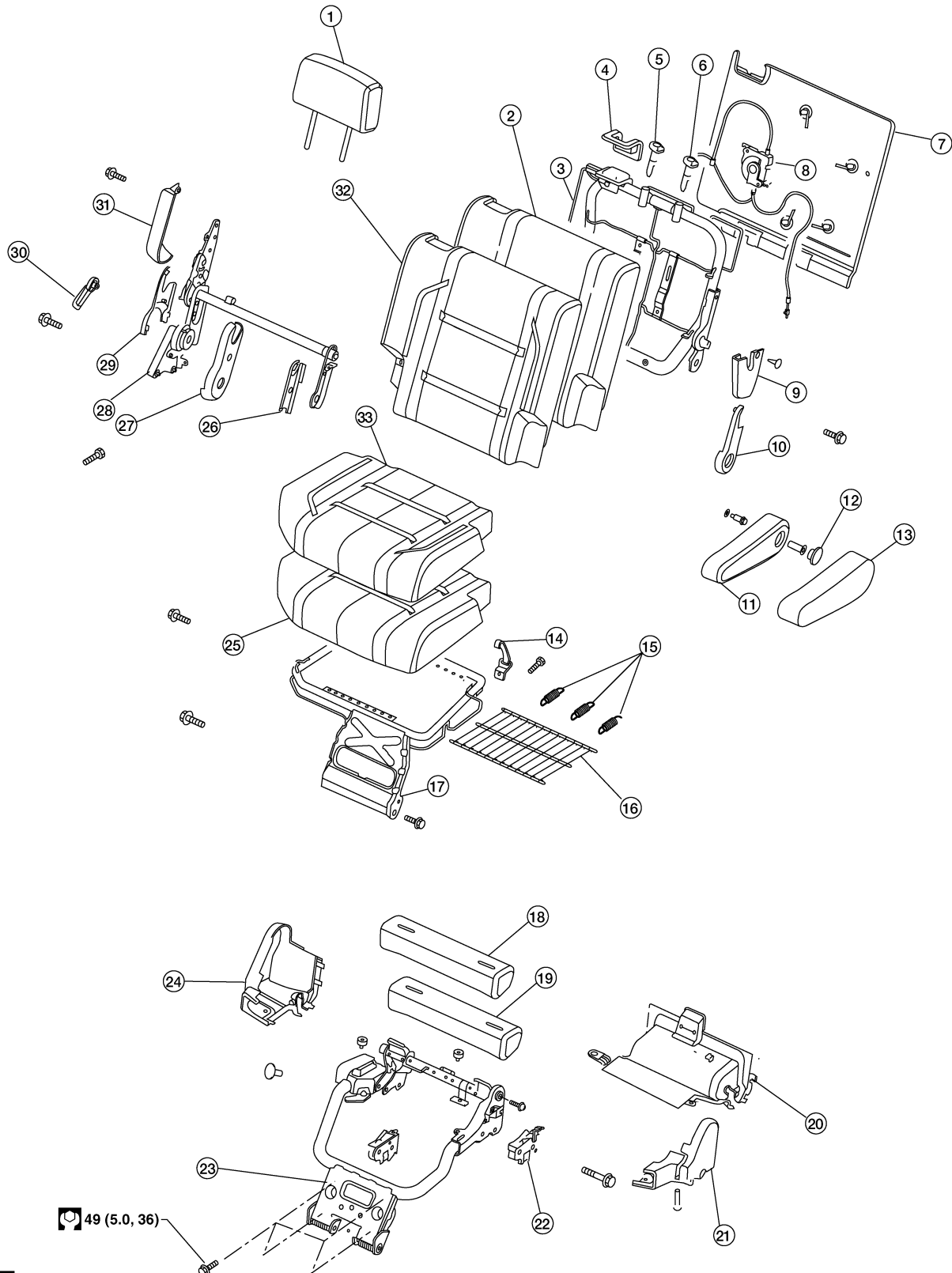

A
B
C
D
E
F
G
H
SE
J
K
L
M

SECOND SEAT

- | | | |
|--------------------------------------|--|--|
| 1. Headrest | 2. Seatback pad | 3. Seatback frame |
| 4. Rear seat bezel | 5. RH Headrest guide | 6. LH Headrest guide |
| 7. Seat back panel | 8. Seat actuator assembly | 9. Reclining device inner cover |
| 10. Reclining device inner mid cover | 11. Armrest assembly | 12. Armrest bolt cover |
| 13. Armrest trim cover | 14. Latch assembly | 15. Seat cushion mat springs |
| 16. Seat cushion mat | 17. Seat cushion frame assembly | 18. Seat support trim cover |
| 19. Seat support pad assembly | 20. Lower rear seat cover | 21. Lower rear seat cover inner |
| 22. Outboard cushion floor latch | 23. Seat cushion support frame assembly | 24. Lower rear seat cover outer |
| 25. Seat cushion pad | 26. Inner inboard reclining device cover | 27. Outer inboard reclining device cover |
| 28. Seat latch and recliner release | 29. Reclining device outer mid cover | 30. Reclining device lever |
| 31. Reclining device outer cover | 32. Seatback trim cover | 33. Seat cushion trim cover |

SECOND SEAT

- | | | |
|--|--------------------------------------|--|
| 7. Headrest | 8. Seat latch and recliner release | 9. Reclining device outer cover |
| 10. Reclining device lever | 11. Reclining device outer mid cover | 12. Outer inboard reclining device cover |
| 13. Inner inboard reclining device cover | 14. Seat cushion trim cover | 15. Seat cushion pad |
| 16. Seat cushion frame assembly | 17. Lower rear seat cover outer | 18. Outboard cushion floor latch |
| 19. Seat cushion support frame assembly | 20. Inboard cushion floor latch | 21. Lower rear seat cover inner |
| 22. Lower rear seat cover | 23. Seat support pad assembly | 24. Seat support trim cover |
| 25. Seat cushion mat | 26. Seat cushion mat springs | 27. Latch assembly |
| 28. Armrest assembly | 29. Armrest trim cover | 30. Reclining device outer cover |
| 31. Reclining device inner mid cover | 32. Seatback frame | 33. Seat actuator assembly |

Second Row Center REMOVAL

EIS007WY

1. Tilt the seat cushion forward.
2. Remove the seat anchor bolts.
3. Tilt the seat cushion back and remove the seat.

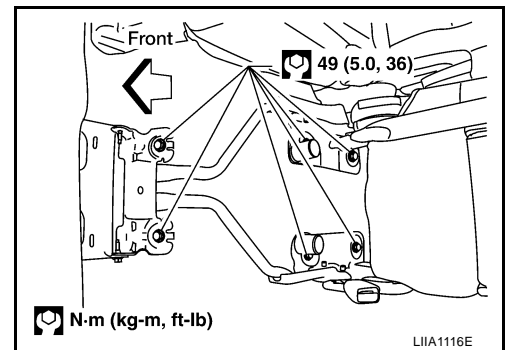

INSTALLATION

Installation is in the reverse order of removal.

SECOND SEAT

DISASSEMBLY AND ASSEMBLY

Second Row Center

SEC. 881

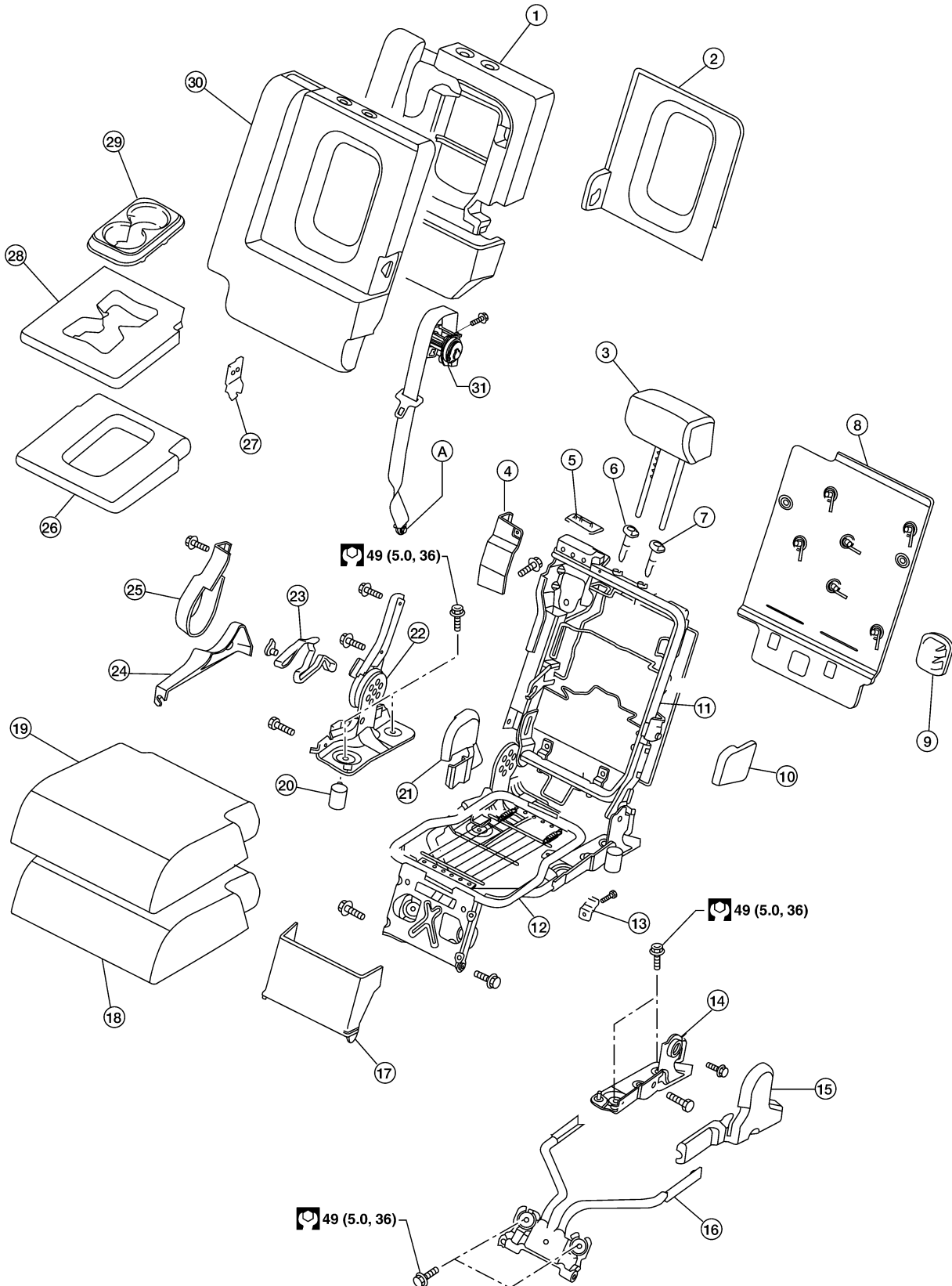

A
B
C
D
E
F
G
H
SE
J
K
L
M

WI1A1366E

SECOND SEAT

- | | | |
|---|--|------------------------------|
| 1. Seatback pad | 2. Armrest finisher | 3. Headrest |
| 4. Seat belt retractor cover | 5. Seat belt bezel | 6. RH headrest guide locking |
| 7. LH headrest guide free | 8. Seatback board | 9. Seat bracket cover |
| 10. Armrest pivot bracket cover | 11. Seatback frame | 12. Seat cushion frame |
| 13. Latch assembly | 14. Lower rear pivot bracket support | 15. Outer hinge cover |
| 16. Center seat base assembly | 17. Link and pivot bracket apron | 18. Seat cushion pad |
| 19. Seat cushion trim cover | 20. Cushion stop bumper | 21. Inner lever cover |
| 22. Seat hinge assembly | 23. Seat lever assembly | 24. Outer lever cover |
| 25. Seat lock cover | 26. Armrest cover | 27. Armrest bracket |
| 28. Armrest pad | 29. Cup holder | 30. Seatback trim cover |
| 31. Seat belt retractor and belt assembly | A. Refer to SB-6, "Removal and Installation of Second Row Seat Belt" | |

THIRD SEAT

PFP:88300

EIS004PR

THIRD SEAT

LH Side Seat REMOVAL

1. Remove the storage bin. Refer to [EI-37, "LUGGAGE FLOOR TRIM"](#) .
2. Remove the lower base trim covers.
3. Remove front link nuts and the LH hinge front bolt.

Front link nuts : 45 N·m (4.6 Kg-m, 33 ft-lb)

LH hinge front bolt : 45 N·m (4.6 Kg-m, 33 ft-lb)

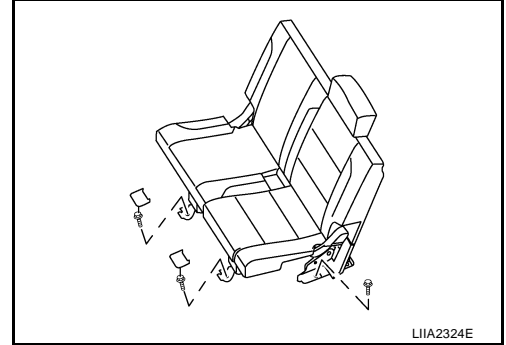

4. Remove push pin (2) and release elastic band (3) from seat frame (1).

- ←: Vehicle front

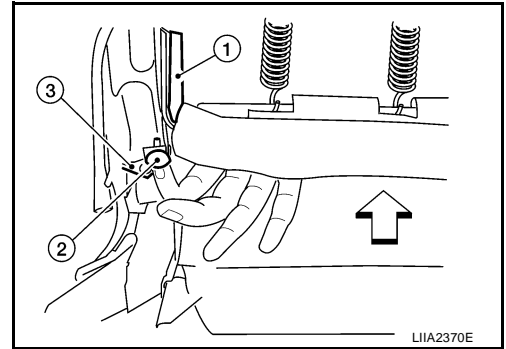

5. Partially lift seatback upright, then remove seat belt buckle (2) from between hinge cover (1) and seat cushion side facing (3).

- ←: Vehicle front

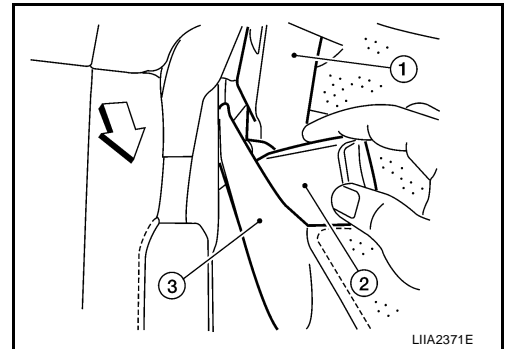

6. Retract the seat into the cargo floor position.
7. Remove the seat hinge rear bolt (A) and seat belt buckle bolt (B) from the seat assembly.

Seat hinge rear bolt : 45 N·m (4.6 Kg-m, 33 ft-lb)

Seat belt buckle bolt : 50 N·m (5.1 Kg-m, 37 ft-lb)

CAUTION:

Discard the seat belt buckle bolt and use a new bolt for installation.

8. Remove the seat assembly.

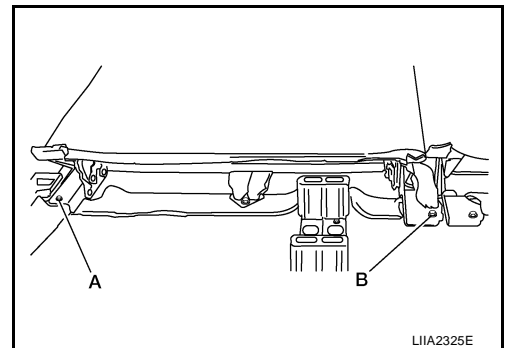

INSTALLATION

Installation is in the reverse order of removal.

A
B
C
D
E
F
G
H
SE
J
K
L
M

THIRD SEAT

DISASSEMBLY AND ASSEMBLY

Third seat LH

SEC. 882

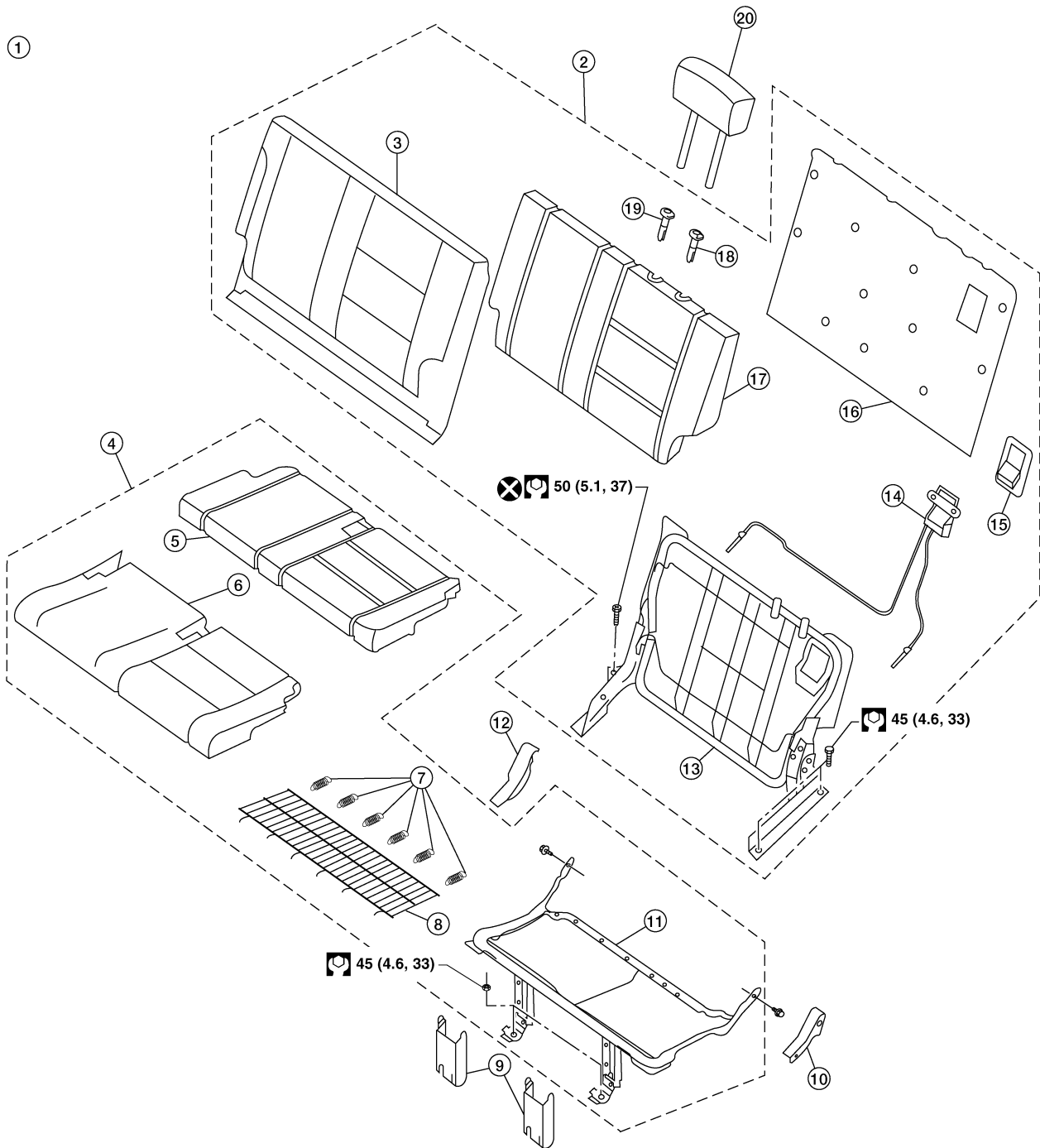

LIA2322E

THIRD SEAT

- | | | |
|-----------------------------|-----------------------------|------------------------------|
| 1. LH third seat assembly | 2. Seatback assembly | 3. Seatback trim cover |
| 4. Seat cushion assembly | 5. Seat cushion pad | 6. Seat cushion trim cover |
| 7. Flex mat springs | 8. Flex mat | 9. Front link covers |
| 10. RH hinge cover | 11. Seat cushion frame | 12. LH hinge cover |
| 13. Seatback frame assembly | 14. Seatback cable assembly | 15. Release handle bezel |
| 16. Seatback board | 17. Seatback pad | 18. Headrest holder, locking |
| 19. Headrest holder, free | 20. Headrest | |

CAUTION:

Discard the seat belt buckle bolt and use a new bolt for installation.

RH Side Seat REMOVAL

EIS004PS

1. Remove the storage bin. Refer to [EI-37, "LUGGAGE FLOOR TRIM"](#).
2. Remove the lower base trim covers.
3. Remove front link nuts (A) and RH hinge front bolt (B).

Front link nuts : 45 N·m (4.6 Kg-m, 33 ft-lb)

RH hinge front bolt : 45 N·m (4.6 Kg-m, 33 ft-lb)

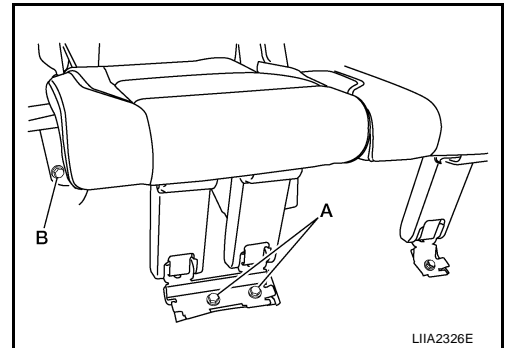

4. Remove push pin (2) and release elastic band (3) from seat frame (1).

● ←: Vehicle front

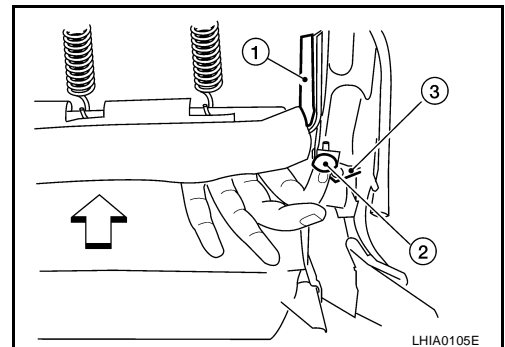

5. Partially lift seatback upright, then remove seat belt buckle (2) from between hinge cover (1) and seat cushion side facing (3).

● ←: Vehicle front

6. Retract the seat into the cargo floor position.

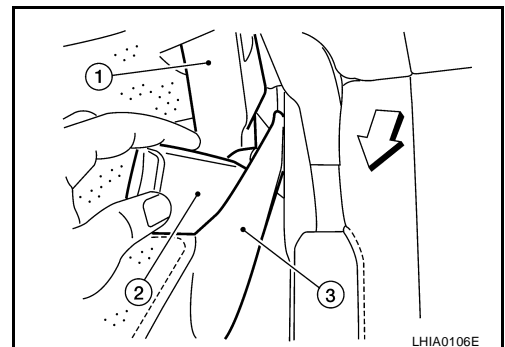

THIRD SEAT

7. Remove the rear bolts from the seat assembly.

Seat hinge rear bolt : 45 N·m (4.6 Kg-m, 33 ft-lb)

8. Remove the seat assembly.

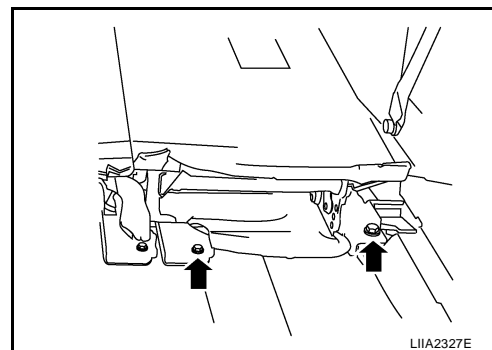

INSTALLATION

Installation is in the reverse order of removal.

THIRD SEAT

DISASSEMBLY AND ASSEMBLY

Third seat RH

SEC. 882

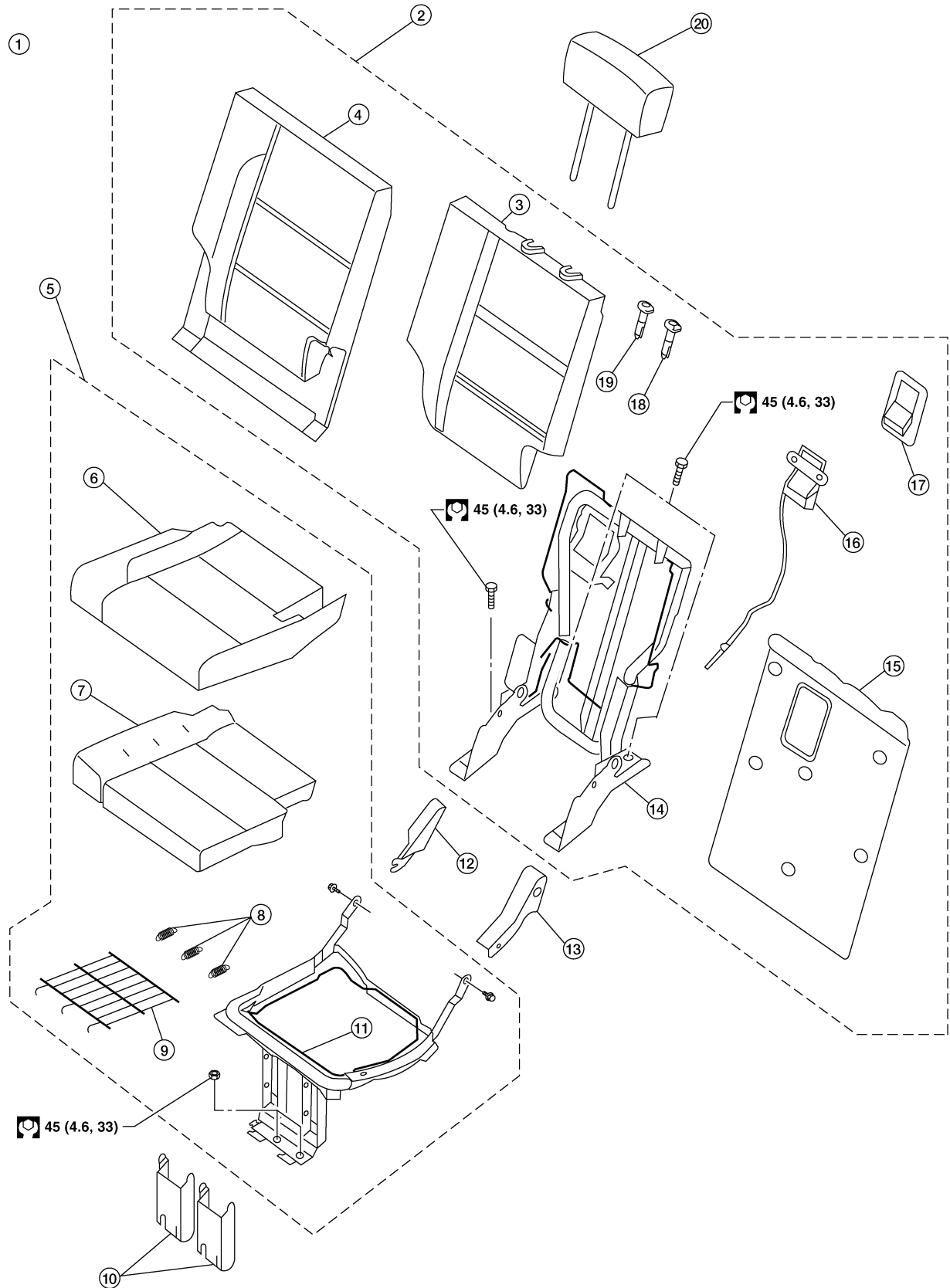

A
B
C
D
E
F
G
H
SE
J
K
L
M

LIA2323E

THIRD SEAT

- | | | |
|-----------------------------|-----------------------------|------------------------------|
| 1. RH third seat assembly | 2. Seatback assembly | 3. Seatback pad |
| 4. Seatback trim cover | 5. Seat cushion assembly | 6. Seat cushion trim cover |
| 7. Seat cushion pad | 8. Flex mat springs | 9. Flex mat |
| 10. Front link covers | 11. Seat cushion frame | 12. RH hinge cover |
| 13. LH hinge cover | 14. Seatback frame assembly | 15. Seatback board |
| 16. Seatback cable assembly | 17. Release handle bezel | 18. Headrest holder, locking |
| 19. Headrest holder, free | 20. Headrest | |