

A
B
AT
D
E
F
G
H
I
J
K
L
M

SECTION **AT**

AUTOMATIC TRANSMISSION

CONTENTS

<p>INDEX FOR DTC 5</p> <p> Alphabetical Index 5</p> <p> DTC No. Index 6</p> <p>PRECAUTIONS 7</p> <p> Precautions for Supplemental Restraint System (SRS) "AIR BAG" and "SEAT BELT PRE-TENSIONER" 7</p> <p> Precautions for On Board Diagnostic (OBD) System of A/T and Engine 7</p> <p> Precautions 8</p> <p> Service Notice or Precautions 9</p> <p>PREPARATION 10</p> <p> Special Service Tools 10</p> <p> Commercial Service Tools 11</p> <p>A/T FLUID 12</p> <p> Changing Automatic Transmission Fluid (ATF) 12</p> <p> Checking Automatic Transmission Fluid (ATF) 12</p> <p> A/T Fluid Cooler Cleaning 14</p> <p>A/T CONTROL SYSTEM 17</p> <p> Cross-Sectional View (2WD models) 17</p> <p> Cross-Sectional View (4WD models) 18</p> <p> Shift Mechanism 19</p> <p> TCM Function 30</p> <p> CAN Communication 31</p> <p> Input/Output Signal of TCM 31</p> <p> Line Pressure Control 32</p> <p> Shift Control 33</p> <p> Lock-up Control 34</p> <p> Engine Brake Control 36</p> <p> Control Valve 36</p> <p>ON BOARD DIAGNOSTIC (OBD) SYSTEM 38</p> <p> Introduction 38</p> <p> OBD-II Function for A/T System 38</p> <p> One or Two Trip Detection Logic of OBD-II 38</p> <p> OBD-II Diagnostic Trouble Code (DTC) 38</p> <p> Malfunction Indicator Lamp (MIL) 41</p> <p>TROUBLE DIAGNOSIS 42</p> <p> DTC Inspection Priority Chart 42</p> <p> Fail-Safe 42</p> <p> How To Perform Trouble Diagnosis For Quick and</p>	<p>Accurate Repair 44</p> <p>A/T Electrical Parts Location 49</p> <p>Schematic 50</p> <p>Inspections Before Trouble Diagnosis 51</p> <p> Check Before Engine is Started 55</p> <p> Check at Idle 55</p> <p> Cruise Test - Part 1 56</p> <p> Cruise Test - Part 2 58</p> <p> Cruise Test - Part 3 59</p> <p> Vehicle Speed When Shifting Gears 60</p> <p> Vehicle Speed When Performing and Releasing Complete Lock-up 60</p> <p> Symptom Chart 61</p> <p> TCM Input/Output Signal Reference Values 83</p> <p> CONSULT-II Function (A/T) 84</p> <p>DTC U1000 CAN COMMUNICATION LINE 93</p> <p> Description 93</p> <p> On Board Diagnosis Logic 93</p> <p> Possible Cause 93</p> <p> DTC Confirmation Procedure 93</p> <p> Wiring Diagram — AT — CAN 94</p> <p> Diagnostic Procedure 95</p> <p>DTC P0615 START SIGNAL CIRCUIT 96</p> <p> Description 96</p> <p> CONSULT-II Reference Value 96</p> <p> On Board Diagnosis Logic 96</p> <p> Possible Cause 96</p> <p> DTC Confirmation Procedure 96</p> <p> Wiring Diagram — AT — STSIG 97</p> <p> Diagnostic Procedure 98</p> <p>DTC P0700 TCM 100</p> <p> Description 100</p> <p> On Board Diagnosis Logic 100</p> <p> Possible Cause 100</p> <p> DTC Confirmation Procedure 100</p> <p> Diagnostic Procedure 100</p> <p>DTC P0705 PARK/NEUTRAL POSITION SWITCH 101</p> <p> Description 101</p> <p> CONSULT-II Reference Value 101</p> <p> On Board Diagnosis Logic 101</p>
--	--

Possible Cause	101	CONSULT-II Reference Value	123
DTC Confirmation Procedure	101	On Board Diagnosis Logic	123
Wiring Diagram — AT — PNP/SW	102	Possible Cause	123
Diagnostic Procedure	103	DTC Confirmation Procedure	123
DTC P0717 TURBINE REVOLUTION SENSOR ... 105		Wiring Diagram — AT — FTS	124
Description	105	Diagnostic Procedure	125
CONSULT-II Reference Value	105	Component Inspection	126
On Board Diagnosis Logic	105	DTC P1721 VEHICLE SPEED SENSOR MTR 128	
Possible Cause	105	Description	128
DTC Confirmation Procedure	105	CONSULT-II Reference Value	128
Diagnostic Procedure	106	On Board Diagnosis Logic	128
DTC P0720 VEHICLE SPEED SENSOR A/T (REV- OLUTION SENSOR) 107		Possible Cause	128
Description	107	DTC Confirmation Procedure	128
CONSULT-II Reference Value	107	Diagnostic Procedure	129
On Board Diagnosis Logic	107	DTC P1730 A/T INTERLOCK 130	
Possible Cause	107	Description	130
DTC Confirmation Procedure	107	On Board Diagnosis Logic	130
Wiring Diagram — AT — VSSA/T	109	Possible Cause	130
Diagnostic Procedure	110	DTC Confirmation Procedure	130
DTC P0725 ENGINE SPEED SIGNAL 112		Judgement of A/T Interlock	131
Description	112	Diagnostic Procedure	131
CONSULT-II Reference Value	112	DTC P1731 A/T 1ST ENGINE BRAKING 133	
On Board Diagnosis Logic	112	Description	133
Possible Cause	112	CONSULT-II Reference Value	133
DTC Confirmation Procedure	112	On Board Diagnosis Logic	133
Diagnostic Procedure	112	Possible Cause	133
DTC P0740 TORQUE CONVERTER CLUTCH SOLENOID VALVE 114		DTC Confirmation Procedure	133
Description	114	Diagnostic Procedure	134
CONSULT-II Reference Value	114	DTC P1752 INPUT CLUTCH SOLENOID VALVE . 135	
On Board Diagnosis Logic	114	Description	135
Possible Cause	114	CONSULT-II Reference Value	135
DTC Confirmation Procedure	114	On Board Diagnosis Logic	135
Diagnostic Procedure	115	Possible Cause	135
DTC P0744 A/T TCC S/V FUNCTION (LOCK-UP). 116		DTC Confirmation Procedure	135
Description	116	Diagnostic Procedure	136
CONSULT-II Reference Value	116	DTC P1754 INPUT CLUTCH SOLENOID VALVE FUNCTION 137	
On Board Diagnosis Logic	116	Description	137
Possible Cause	116	CONSULT-II Reference Value	137
DTC Confirmation Procedure	116	On Board Diagnosis Logic	137
Diagnostic Procedure	117	Possible Cause	137
DTC P0745 LINE PRESSURE SOLENOID VALVE 118		DTC Confirmation Procedure	137
Description	118	Diagnostic Procedure	138
CONSULT-II Reference Value	118	DTC P1757 FRONT BRAKE SOLENOID VALVE .. 139	
On Board Diagnosis Logic	118	Description	139
Possible Cause	118	CONSULT-II Reference Value	139
DTC Confirmation Procedure	118	On Board Diagnosis Logic	139
Diagnostic Procedure	119	Possible Cause	139
DTC P1705 THROTTLE POSITION SENSOR 120		DTC Confirmation Procedure	139
Description	120	Diagnostic Procedure	140
CONSULT-II Reference Value	120	DTC P1759 FRONT BRAKE SOLENOID VALVE FUNCTION 141	
On Board Diagnosis Logic	120	Description	141
Possible Cause	120	CONSULT-II Reference Value	141
DTC Confirmation Procedure	120	On Board Diagnosis Logic	141
Diagnostic Procedure	120	Possible Cause	141
DTC P1710 A/T FLUID TEMPERATURE SENSOR CIRCUIT 123		DTC Confirmation Procedure	141
Description	123	Diagnostic Procedure	142
		DTC P1762 DIRECT CLUTCH SOLENOID VALVE. 143	

Description	143	DTC Confirmation Procedure	157	
CONSULT-II Reference Value	143	Diagnostic Procedure	158	A
On Board Diagnosis Logic	143	DTC P1845 ATF PRESSURE SWITCH 5	159	
Possible Cause	143	Description	159	B
DTC Confirmation Procedure	143	CONSULT-II Reference Value	159	
Diagnostic Procedure	144	On Board Diagnosis Logic	159	
DTC P1764 DIRECT CLUTCH SOLENOID VALVE		Possible Cause	159	
FUNCTION	145	DTC Confirmation Procedure	159	AT
Description	145	Diagnostic Procedure	160	
CONSULT-II Reference Value	145	DTC P1846 ATF PRESSURE SWITCH 6	161	
On Board Diagnosis Logic	145	Description	161	D
Possible Cause	145	CONSULT-II Reference Value	161	
DTC Confirmation Procedure	145	On Board Diagnosis Logic	161	
Diagnostic Procedure	146	Possible Cause	161	E
DTC P1767 HIGH AND LOW REVERSE CLUTCH		DTC Confirmation Procedure	161	
SOLENOID VALVE	147	Diagnostic Procedure	162	
Description	147	MAIN POWER SUPPLY AND GROUND CIRCUIT. 163		
CONSULT-II Reference Value	147	Wiring Diagram — AT — MAIN	163	F
On Board Diagnosis Logic	147	Diagnostic Procedure	164	
Possible Cause	147	CLOSED THROTTLE POSITION AND WIDE OPEN		
DTC Confirmation Procedure	147	THROTTLE POSITION CIRCUIT	167	G
Diagnostic Procedure	148	CONSULT-II Reference Value	167	
DTC P1769 HIGH AND LOW REVERSE CLUTCH		Diagnostic Procedure	167	
SOLENOID VALVE FUNCTION	149	BRAKE SIGNAL CIRCUIT	168	H
Description	149	CONSULT-II Reference Value	168	
CONSULT-II Reference Value	149	Diagnostic Procedure	168	
On Board Diagnosis Logic	149	TOW MODE SWITCH	169	I
Possible Cause	149	Description	169	
DTC Confirmation Procedure	149	Wiring Diagram — AT — TMSW	170	
Diagnostic Procedure	150	Diagnostic Procedure	171	
DTC P1772 LOW COAST BRAKE SOLENOID		TROUBLE DIAGNOSIS FOR SYMPTOMS	172	J
VALVE	151	Wiring Diagram — AT — NONDTC	172	
Description	151	A/T CHECK Indicator Lamp Does Not Come On .	175	
CONSULT-II Reference Value	151	Engine Cannot Be Started In “P” or “N” Position .	175	
On Board Diagnosis Logic	151	In “P” Position, Vehicle Moves When Pushed	176	K
Possible Cause	151	In “N” Position, Vehicle Moves	177	
DTC Confirmation Procedure	151	Large Shock(“N” to “D” Position)	178	
Diagnostic Procedure	152	Vehicle Does Not Creep Backward In “R” Position	181	L
DTC P1774 LOW COAST BRAKE SOLENOID		Vehicle Does Not Creep Forward In “D” Position .	184	
VALVE FUNCTION	153	Vehicle Cannot Be Started From D1	186	
Description	153	A/T Does Not Shift: D1 → D2	189	M
CONSULT-II Reference Value	153	A/T Does Not Shift: D2 → D3	191	
On Board Diagnosis Logic	153	A/T Does Not Shift: D3 → D4	193	
Possible Cause	153	A/T Does Not Shift: D4 → D5	196	
DTC Confirmation Procedure	153	A/T Does Not Perform Lock-up	198	
Diagnostic Procedure	154	A/T Does Not Hold Lock-up Condition	200	
DTC P1841 ATF PRESSURE SWITCH 1	155	Lock-up Is Not Released	202	
Description	155	Engine Speed Does Not Return to Idle	203	
CONSULT-II Reference Value	155	A/T Does Not Shift: 5th gear → 4th gear	204	
On Board Diagnosis Logic	155	A/T Does Not Shift: 4th gear → 3rd gear	207	
Possible Cause	155	A/T Does Not Shift: 3rd gear → 2nd gear	208	
DTC Confirmation Procedure	155	A/T Does Not Shift: 2nd gear → 1st gear	210	
Diagnostic Procedure	156	Vehicle Does Not Decelerate By Engine Brake ...	213	
DTC P1843 ATF PRESSURE SWITCH 3	157	A/T SHIFT LOCK SYSTEM	216	
Description	157	Description	216	
CONSULT-II Reference Value	157	Shift Lock System Electrical Parts Location	216	
On Board Diagnosis Logic	157	Wiring Diagram — AT — SHIFT	217	
Possible Cause	157	Shift Lock Control Unit Reference Values	218	
		Component Inspection	219	

SHIFT CONTROL SYSTEM	221	Front Sun Gear, 3rd One-Way Clutch	279
Control Device Removal and Installation	221	Front Carrier, Input Clutch, Rear Internal Gear	281
Adjustment of A/T Position	222	Mid Sun Gear, Rear Sun Gear, High and Low	
Checking of A/T Position	222	Reverse Clutch Hub	286
ON-VEHICLE SERVICE	223	High and Low Reverse Clutch	291
Oil Pan	223	Direct Clutch	293
Control Valve With TCM and A/T Fluid Temperature		ASSEMBLY	295
Sensor 2	225	Assembly (1)	295
Rear Oil Seal	235	Adjustment	308
AIR BREATHER HOSE	236	Assembly (2)	310
Removal and Installation	236	SERVICE DATA AND SPECIFICATIONS (SDS) ...	317
TRANSMISSION ASSEMBLY	238	General Specifications	317
Removal and Installation (2WD)	238	Vehicle Speed When Shifting Gears	317
Removal and Installation (4WD)	241	Vehicle Speed When Performing and Releasing	
OVERHAUL	245	Complete Lock-up	318
Components	245	Stall Speed	318
Oil Channel	253	Line Pressure	318
Locations of Adjusting Shims, Needle Bearings,		A/T Fluid Temperature Sensor	318
Thrust Washers and Snap Rings	255	Turbine Revolution Sensor	318
DISASSEMBLY	259	Vehicle Speed Sensor A/T (Revolution Sensor) ..	318
Disassembly	259	Reverse brake	319
REPAIR FOR COMPONENT PARTS	277	Total End Play	319
Oil Pump	277		

INDEX FOR DTC

INDEX FOR DTC

PFP:00024

Alphabetical Index

ECS00GVY

NOTE:

If DTC U1000 is displayed with other DTC, first perform the trouble diagnosis for DTC U1000. Refer to [AT-93, "DTC U1000 CAN COMMUNICATION LINE"](#).

Items (CONSULT- II screen terms)	DTC		Reference page
	OBD- II	Except OBD- II	
	CONSULT- II GST (*1)	CONSULT- II only "A/T"	
A/T 1ST E/BRAKING	—	P1731	AT-133
ATF PRES SW 1/CIRC	—	P1841	AT-155
ATF PRES SW 3/CIRC	—	P1843	AT-157
ATF PRES SW 5/CIRC	—	P1845	AT-159
ATF PRES SW 6/CIRC	—	P1846	AT-161
A/T INTERLOCK	P1730	P1730	AT-130
A/T TCC S/V FNCTN	P0744	P0744	AT-116
ATF TEMP SEN/CIRC	P0710	P1710	AT-120
CAN COMM CIRCUIT	U1000	U1000	AT-93
D/C SOLENOID/CIRC	P1762	P1762	AT-143
D/C SOLENOID FNCTN	P1764 (*2)	P1764	AT-145
ENGINE SPEED SIG	—	P0725	AT-112
FR/B SOLENOID/CIRC	P1757	P1757	AT-139
FR/B SOLENOID FNCT	P1759	P1759	AT-141
HLR/C SOL/CIRC	P1767	P1767	AT-147
HLR/C SOL FNCTN	P1769 (*2)	P1769	AT-149
I/C SOLENOID/CIRC	P1752	P1752	AT-135
I/C SOLENOID FNCTN	P1754 (*2)	P1754	AT-137
L/PRESS SOL/CIRC	P0745	P0745	AT-118
LC/B SOLENOID/CIRC	P1772	P1772	AT-151
LC/B SOLENOID FNCT	P1774	P1774	AT-153
PNP SW/CIRC	P0705	P0705	AT-101
STARTER RELAY/CIRC	—	P0615	AT-96
TCC SOLENOID/CIRC	P0740	P0740	AT-112
TCM	P0700	P0700	AT-100
TP SEN/CIRC A/T	—	P1705	AT-120
TURBINE REV S/CIRC	P0717	P0717	AT-105
VEH SPD SE/CIR·MTR	—	P1721	AT-128
VEH SPD SEN/CIR AT	P0720	P0720	AT-107

*1: These numbers are prescribed by SAE J2012.

*2: These malfunctions cannot be displayed MIL if another malfunction is assigned to MIL.

INDEX FOR DTC

ECS00GVZ

DTC No. Index

NOTE:

If DTC U1000 is displayed with other DTC, first perform the trouble diagnosis for DTC U1000. Refer to [AT-93, "DTC U1000 CAN COMMUNICATION LINE"](#) .

DTC		Items (CONSULT- II screen terms)	Reference page
OBD- II CONSULT- II GST (*1)	Except OBD- II CONSULT- II only "A/T"		
—	P0615	STARTER RELAY/CIRC	AT-96
P0700	P0700	TCM	AT-100
P0705	P0705	PNP SW/CIRC	AT-101
P0710	P1710	ATF TEMP SEN/CIRC	AT-120
P0717	P0717	TURBINE REV S/CIRC	AT-105
P0720	P0720	VEH SPD SEN/CIR AT	AT-107
—	P0725	ENGINE SPEED SIG	AT-112
P0740	P0740	TCC SOLENOID/CIRC	AT-112
P0744	P0744	A/T TCC S/V FNCTN	AT-116
P0745	P0745	L/PRESS SOL/CIRC	AT-118
—	P1705	TP SEN/CIRC A/T	AT-120
—	P1721	VEH SPD SE/CIR-MTR	AT-128
P1730	P1730	A/T INTERLOCK	AT-130
—	P1731	A/T 1ST E/BRAKING	AT-133
P1752	P1752	I/C SOLENOID/CIRC	AT-135
P1754 (*2)	P1754	I/C SOLENOID FNCTN	AT-137
P1757	P1757	FR/B SOLENOID/CIRC	AT-139
P1759 (*2)	P1759	FR/B SOLENOID FNCT	AT-141
P1762	P1762	D/C SOLENOID/CIRC	AT-143
P1764 (*2)	P1764	D/C SOLENOID FNCTN	AT-145
P1767	P1767	HLR/C SOL/CIRC	AT-147
P1769	P1769	HLR/C SOL FNCTN	AT-149
P1772	P1772	LC/B SOLENOID/CIRC	AT-151
P1774	P1774	LC/B SOLENOID FNCT	AT-153
—	P1841	ATF PRES SW 1/CIRC	AT-155
—	P1843	ATF PRES SW 3/CIRC	AT-157
—	P1845	ATF PRES SW 5/CIRC	AT-159
—	P1846	ATF PRES SW 6/CIRC	AT-161
U1000	U1000	CAN COMM CIRCUIT	AT-93

*1: These numbers are prescribed by SAE J2012.

*2: These malfunctions cannot be displayed MIL if another malfunction is assigned to MIL.

PRECAUTIONS

PRECAUTIONS

PF0:00001

Precautions for Supplemental Restraint System (SRS) “AIR BAG” and “SEAT BELT PRE-TENSIONER”

ECS00GW0

The Supplemental Restraint System such as “AIR BAG” and “SEAT BELT PRE-TENSIONER”, used along with a front seat belt, helps to reduce the risk or severity of injury to the driver and front passenger for certain types of collision. This system includes seat belt switch inputs and dual stage front air bag modules. The SRS system uses the seat belt switches to determine the front air bag deployment, and may only deploy one front air bag, depending on the severity of a collision and whether the front occupants are belted or unbelted. Information necessary to service the system safely is included in the SRS and SB section of this Service Manual.

WARNING:

- To avoid rendering the SRS inoperative, which could increase the risk of personal injury or death in the event of a collision which would result in air bag inflation, all maintenance must be performed by an authorized NISSAN/INFINITI dealer.
- Improper maintenance, including incorrect removal and installation of the SRS, can lead to personal injury caused by unintentional activation of the system. For removal of Spiral Cable and Air Bag Module, see the SRS section.
- Do not use electrical test equipment on any circuit related to the SRS unless instructed to in this Service Manual. SRS wiring harnesses can be identified by yellow and/or orange harnesses or harness connectors.

Precautions for On Board Diagnostic (OBD) System of A/T and Engine

ECS00GW1

The ECM has an on board diagnostic system. It will light up the malfunction indicator lamp (MIL) to warn the driver of a malfunction causing emission deterioration.

CAUTION:

- Be sure to turn the ignition switch “OFF” and disconnect the negative battery cable before any repair or inspection work. The open/short circuit of related switches, sensors, solenoid valves, etc. Will cause the MIL to light up.
- Be sure to connect and lock the connectors securely after work. A loose (unlocked) connector will cause the MIL to light up due to an open circuit. (Be sure the connector is free from water, grease, dirt, bent terminals, etc.)
- Be sure to route and secure the harnesses properly after work. Interference of the harness with a bracket, etc. May cause the MIL to light up due to a short circuit.
- Be sure to connect rubber tubes properly after work. A misconnected or disconnected rubber tube may cause the MIL to light up due to a malfunction of the EGR system or fuel injection system, etc.
- Be sure to erase the unnecessary malfunction information (repairs completed) from the TCM and ECM before returning the vehicle to the customer.

PRECAUTIONS

ECS00GW2

Precautions

- Before connecting or disconnecting the A/T assembly harness connector, turn ignition switch "OFF" and disconnect negative battery cable. Because battery voltage is applied to TCM even if ignition switch is turned "OFF".

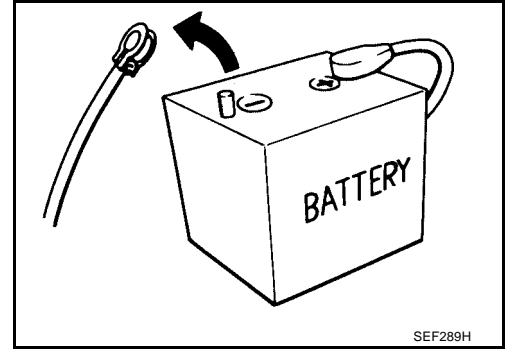

- After performing each TROUBLE DIAGNOSIS, perform "DTC (Diagnostic Trouble Code) CONFIRMATION PROCEDURE".
If the repair is completed the DTC should not be displayed in the "DTC CONFIRMATION PROCEDURE".

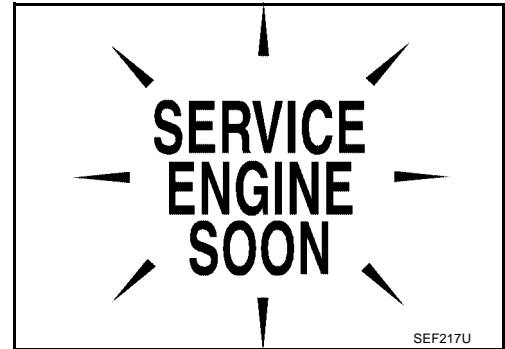

- Always use the specified brand of ATF. Refer to [MA-11, "RECOMMENDED FLUIDS AND LUBRICANTS"](#) .
- Use paper rags not cloth rags during work.
- After replacing the ATF, dispose of the waste oil using the methods prescribed by law, ordinance, etc.
- Before proceeding with disassembly, thoroughly clean the outside of the transmission. It is important to prevent the internal parts from becoming contaminated by dirt or other foreign matter.
- Disassembly should be done in a clean work area.
- Use lint-free cloth or towels for wiping parts clean. Common shop rags can leave fibers that could interfere with the operation of the transmission.
- Place disassembled parts in order for easier and proper assembly.
- All parts should be carefully cleaned with a general purpose, non-flammable solvent before inspection or reassembly.
- Gaskets, seals and O-rings should be replaced any time the transmission is disassembled.
- It is very important to perform functional tests whenever they are indicated.
- The valve body contains precision parts and requires extreme care when parts are removed and serviced. Place disassembled valve body parts in order for easier and proper assembly. Care will also prevent springs and small parts from becoming scattered or lost.
- Properly installed valves, sleeves, plugs, etc. will slide along bores in valve body under their own weight.
- Before assembly, apply a coat of recommended ATF to all parts. Apply petroleum jelly to protect O-rings and seals, or hold bearings and washers in place during assembly. Do not use grease.
- Extreme care should be taken to avoid damage to O-rings, seals and gaskets when assembling.
- Clean or replace ATF cooler if excessive foreign material is found in oil pan or clogging strainer. Refer to [AT-14, "A/T Fluid Cooler Cleaning"](#) .
- After overhaul, refill the transmission with new ATF.
- When the A/T drain plug is removed, only some of the fluid is drained. Old A/T fluid will remain in torque converter and ATF cooling system.
Always follow the procedures under "Changing A/T Fluid" in the AT section when changing A/T fluid. Refer to [AT-12, "Changing Automatic Transmission Fluid \(ATF\)"](#) , [AT-12, "Checking Automatic Transmission Fluid \(ATF\)"](#) .

PRECAUTIONS

ECS00GW3

Service Notice or Precautions

ATF COOLER SERVICE

If A/T fluid contains frictional material (clutches, bands, etc.), or if an A/T is repaired, overhauled, or replaced, inspect and clean the A/T fluid cooler mounted in the radiator or replace the radiator. Flush cooler lines using cleaning solvent and compressed air after repair. For A/T fluid cooler cleaning procedure, refer to [AT-14, "A/T Fluid Cooler Cleaning"](#) . For radiator replacement, refer to [CO-14, "Removal and Installation"](#) .

CHECKING AND CHANGING A/T FLUID SERVICE

Increase ATF temperature by 80°C (176°F) once, and then check ATF level in 65°C (149°F) when adjusting ATF level.

NOTE:

JA60 uses both systems of a water-cooling and of an air-cooling. Air-cooling system has a by-pass valve. When ATF temperature is not over 50°C (122°F) with water-cooling system OFF, it does not flow to air-cooling system. If ATF level is set without the flow of ATF, the level will be 10mm lower than the standard. Therefore, piping should be filled with ATF when adjusting level.

OBD-II SELF-DIAGNOSIS

- A/T self-diagnosis is performed by the TCM in combination with the ECM. Refer to the table on [AT-86, "SELF-DIAGNOSTIC RESULT MODE"](#) for the indicator used to display each self-diagnostic result.
- The self-diagnostic results indicated by the MIL are automatically stored in both the ECM and TCM memories.

Always perform the procedure on [AT-39, "HOW TO ERASE DTC"](#) to complete the repair and avoid unnecessary blinking of the MIL.

For details of OBD-II, refer to [EC-48, "ON BOARD DIAGNOSTIC \(OBD\) SYSTEM"](#) .

- **Certain systems and components, especially those related to OBD, may use the new style slide-locking type harness connector. For description and how to disconnect, refer to [PG-68, "HARNESS CONNECTOR"](#) .**

PREPARATION

PFP:00002

ECS00GW4

PREPARATION

Special Service Tools

The actual shapes of Kent-Moore tools may differ from those of special service tools illustrated here.

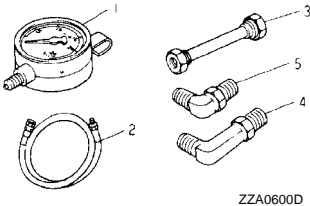
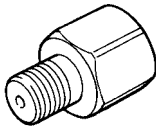
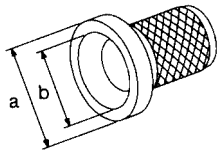
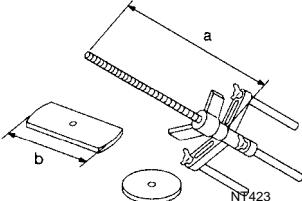
Tool number (Kent-Moore No.) Tool name	Description
<p>ST2505S001 (J-34301-C) Oil pressure gauge set 1. ST25051001 (—) Oil pressure gauge 2. ST25052000 (—) Hose 3. ST25053000 (—) Joint pipe 4. ST25054000 (—) Adapter 5. ST25055000 (—) Adapter</p> 	<p>Measuring line pressure</p>
<p>KV31103600 (J-45674) Joint pipe adapter (With ST25054000)</p> 	<p>Measuring line pressure</p>
<p>ST33400001 (J-26082) Drift</p> 	<ul style="list-style-type: none"> ● Installing rear oil seal (2WD models) ● Installing oil pump housing oil seal <p>a: 60 mm (2.36 in) dia. b: 47 mm (1.85 in) dia.</p>
<p>KV31102400 (J-34285 and J-34285-87) Clutch spring compressor</p> 	<p>Installing reverse brake return spring retainer a: 320 mm (12.60 in) b: 174 mm (6.85 in)</p>

PREPARATION

Tool number (Kent-Moore No.) Tool name	Description
ST25850000 (J-25721-A) Sliding hammer <div data-bbox="609 273 933 472" style="text-align: center;"> <p>NT422</p> </div>	Remove oil pump assembly a: 179 mm (7.05 in) b: 70 mm (2.76 in) c: 40 mm (1.57 in) d: M12X1.75P
— (J-47002) Transmission jack adapter kit 1. — (J-47002-2) Center bracket 2. — (J-47002-3) Adapter plate 3. — (J-47002-4) Adapter block <div data-bbox="609 546 933 766" style="text-align: center;"> <p>WCIA0499E</p> </div>	Assist in removal of transmission and transfer case as one assembly using only one transmission jack.

A
B
AT
D
E
F
G
H
I
J
K
L
M

Commercial Service Tools

ECS00GW5

Tool name	Description
Power tool <div data-bbox="625 966 917 1155" style="text-align: center;"> <p>PBIC0190E</p> </div>	Loosening bolts and nuts
Drift <div data-bbox="657 1228 885 1386" style="text-align: center;"> <p>NT083</p> </div>	Installing manual shaft seals a: 22 mm (0.87 in) dia.
Drift <div data-bbox="649 1449 893 1617" style="text-align: center;"> <p>SCIA5338E</p> </div>	Installing rear oil seal (4WD models) a: 64 mm (2.52 in) dia.

A/T FLUID

PFM:KLE40

Changing Automatic Transmission Fluid (ATF)

ECS00GW6

1. Drive the vehicle to warm up the ATF to approximately 80° C (176° F).
2. Stop the engine.
3. Remove the ATF level gauge.
4. Drain the ATF from the drain plug hole and then install the drain plug with a new gasket. Refill the transmission with new ATF. Always refill with the same volume as the drained ATF. Use the ATF level gauge to check the ATF level as shown. Add ATF as necessary.

Drain plug : Refer to [AT-245, "Components"](#) .

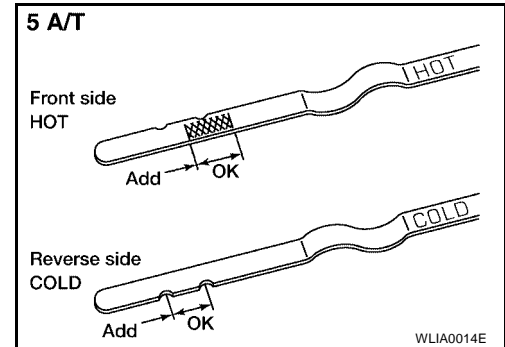

- To flush out the old ATF from the transmission oil coolers, pour new ATF into the charging pipe with the engine idling and at the same time drain the old ATF from the auxiliary transmission oil cooler hose return line.
- When the color of the ATF coming out of the auxiliary transmission oil cooler hose return line is about the same as the color of the new ATF, flushing out the old ATF is complete. The amount of new ATF used for flushing should be 30% to 50% of the specified capacity.

ATF type and capacity : Refer to [MA-11, "Fluids and Lubricants"](#) .

CAUTION:

- Use only the specified ATF and do not mix with other fluids.
 - Using an ATF other than the specified ATF will cause deterioration in driveability and automatic transmission durability, and may damage the automatic transmission, which is not covered by the warranty.
 - When filling the transmission with ATF, do not spill the ATF on any heat generating parts such as the exhaust manifold.
 - Do not reuse the drain plug gasket.
5. Install the ATF level gauge in the ATF charging pipe and tighten the level gauge bolt to specification.

Level gauge bolt : Refer to [AT-238, "Removal and Installation \(2WD\)"](#) .

6. Drive the vehicle to warm up the ATF to approximately 80° C (176° F).
7. Check the ATF level and condition. Refer to [AT-12, "Checking Automatic Transmission Fluid \(ATF\)"](#) . If the ATF is still dirty, repeat steps 2 through 5.

Checking Automatic Transmission Fluid (ATF)

ECS00GW7

1. Before driving, the ATF level can be checked at ATF temperatures of 30° to 50°C (86° to 122°F) using the "COLD" range on the ATF level gauge as follows:
 - a. Park the vehicle on a level surface and set the parking brake.
 - b. Start the engine and move the selector lever through each gear position. Shift the selector lever into the "P" position.
 - c. Check the ATF level with the engine idling.
 - d. Remove the ATF level gauge and wipe it clean with a lint-free paper.

CAUTION:

When wiping the ATF from the ATF level gauge, always use a lint-free paper, not a cloth.

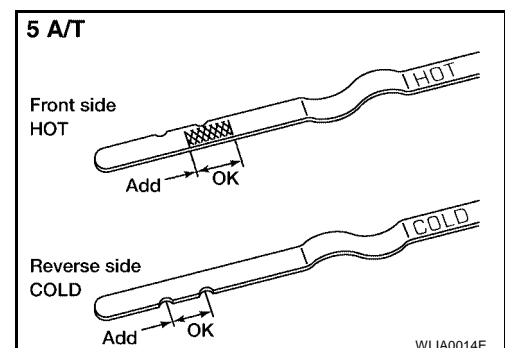

A/T FLUID

- e. Re-insert the ATF level gauge into the charging pipe until the cap contacts the top of the charging pipe as shown.

CAUTION:

To check ATF level, insert the ATF level gauge until the cap contacts the top of the charging pipe, with the gauge reversed from the normal inserted position.

- f. Remove the ATF level gauge and note the ATF level. If the ATF level is at low side of range, add ATF to the transmission through the charging pipe.

CAUTION:

Do not overfill the transmission with ATF.

- g. Install the ATF level gauge and the ATF level gauge bolt.

ATF level gauge bolt : Refer to [AT-238, "Removal and Installation \(2WD\)"](#) .

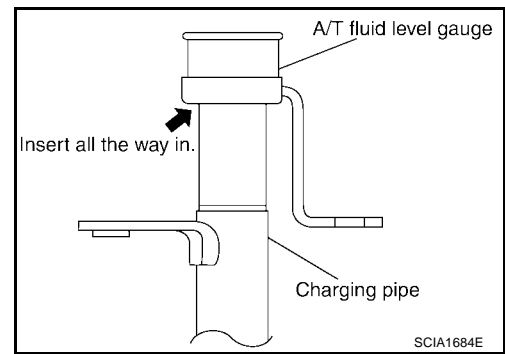

2. Warm up the engine and transmission.
3. Check for any ATF leaks.
4. Drive the vehicle to increase the ATF temperature to 80° C (176° F).
5. Allow the ATF temperature to fall to approximately 65° C (149° F). Use the CONSULT-II to monitor the ATF temperature as follows:

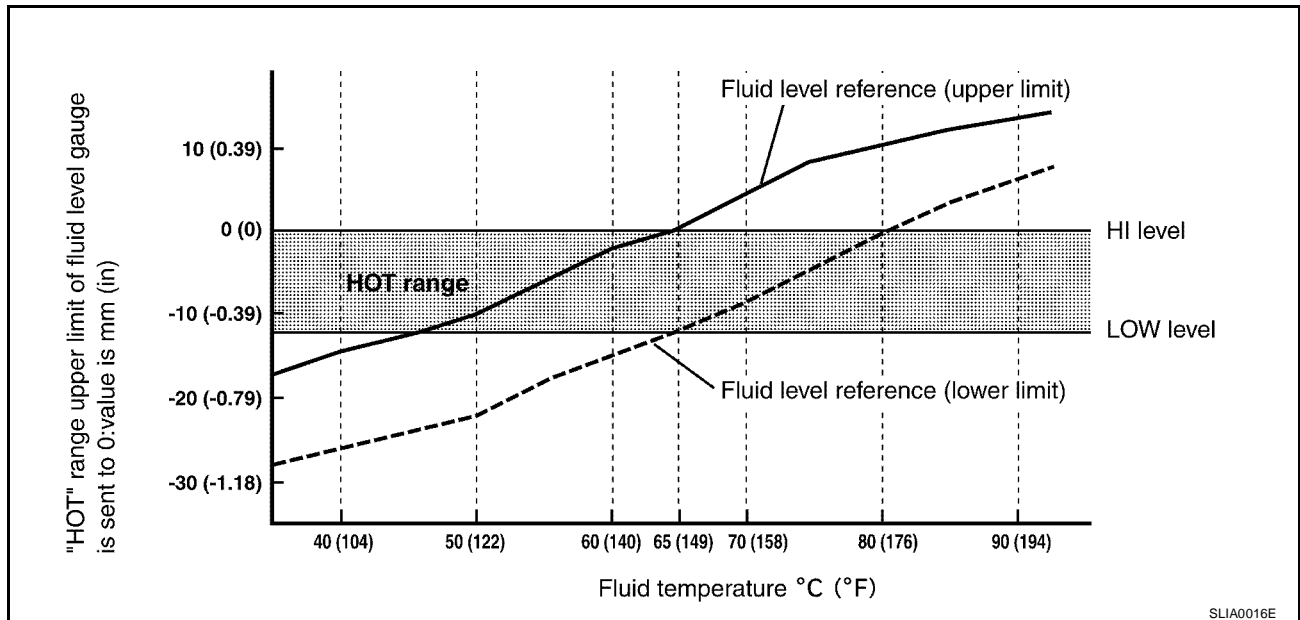

NOTE:

The ATF level will be significantly affected by the ATF temperature as shown. Therefore monitor the ATF temperature data using the CONSULT-II.

- a. Connect CONSULT-II to data link connector.
- b. Select "MAIN SIGNALS" in "DATA MONITOR" mode for "A/T" with CONSULT-II.
- c. Read out the value of "ATF TEMP 1".

A/T FLUID

6. Re-check the ATF level at ATF temperatures of approximately 65°C (149°F) using the "HOT" range on the ATF level gauge as shown. The "HOT" range is between 50° - 80° C (122° - 176° F).

CAUTION:

- When wiping the ATF from the ATF level gauge, always use lint-free paper, not a cloth.

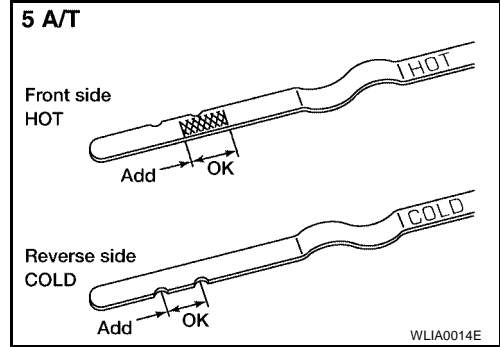

- To check the ATF level, insert the ATF level gauge until the cap contacts the top of the charging pipe, with the gauge reversed from the normal inserted position as shown.

7. Check the ATF condition.

- If the ATF is very dark or has some burned smell, there may be an internal problem with the transmission. Refer to [AT-172, "TROUBLE DIAGNOSIS FOR SYMPTOMS"](#). Flush the transmission cooling system after repairing the transmission.
- If the ATF contains frictional material (clutches, bands, etc.), replace the radiator and flush the transmission cooler lines using cleaning solvent and compressed air after repairing the transmission.

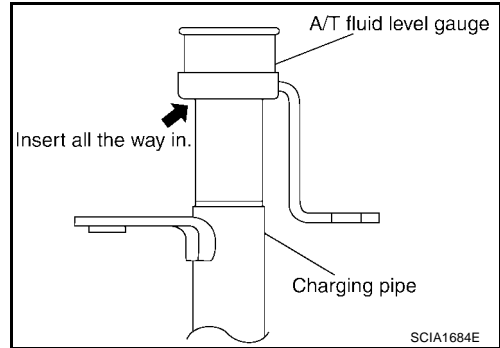

8. Install the ATF level gauge in the charging pipe.
9. Tighten the ATF level gauge bolt to specification.

ATF level gauge bolt : Refer to [AT-238, "Removal and Installation \(2WD\)"](#) .

A/T Fluid Cooler Cleaning

ECS00GW8

Whenever an automatic transmission is repaired, overhauled, or replaced, the A/T fluid cooler mounted in the radiator must be inspected and cleaned.

Metal debris and friction material, if present, can become trapped in the A/T fluid cooler. This debris can contaminate the newly serviced A/T or, in severe cases, can block or restrict the flow of A/T fluid. In either case, malfunction of the newly serviced A/T may result.

Debris, if present, may build up as A/T fluid enters the cooler inlet. It will be necessary to back flush the cooler through the cooler outlet in order to flush out any built up debris.

A/T FLUID COOLER CLEANING PROCEDURE

1. Position an oil pan under the automatic transmission's inlet and outlet cooler hoses.
2. Identify the inlet and outlet fluid cooler hoses.
3. Disconnect the fluid cooler inlet and outlet rubber hoses from the steel cooler tubes or bypass valve.

NOTE:

Replace the cooler hoses if rubber material from the hose remains on the tube fitting.

4. Allow any A/T fluid that remains in the cooler hoses to drain into the oil pan.

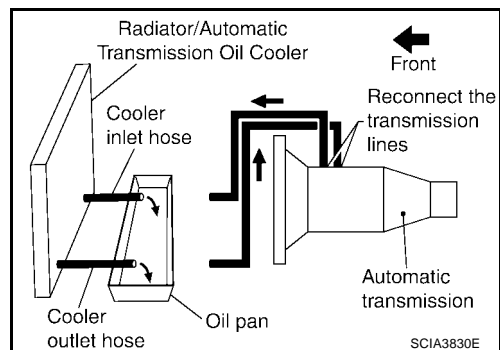

A/T FLUID

5. Insert the extension adapter hose of a can of Transmission Cooler Cleaner (Nissan P/N 999MP-AM006) into the cooler outlet hose.

CAUTION:

- Wear safety glasses and rubber gloves when spraying the Transmission Cooler Cleaner.
- Spray cooler cleaner only with adequate ventilation.
- Avoid contact with eyes and skin.
- Do not breath vapors or spray mist.

6. Hold the hose and can as high as possible and spray Transmission Cooler Cleaner in a continuous stream into the cooler outlet hose until fluid flows out of the cooler inlet hose for 5 seconds.
7. Insert the tip of an air gun into the end of the cooler outlet hose.
8. Wrap a shop rag around the air gun tip and of the cooler outlet hose.

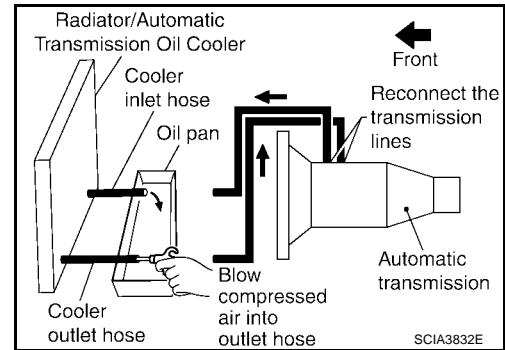
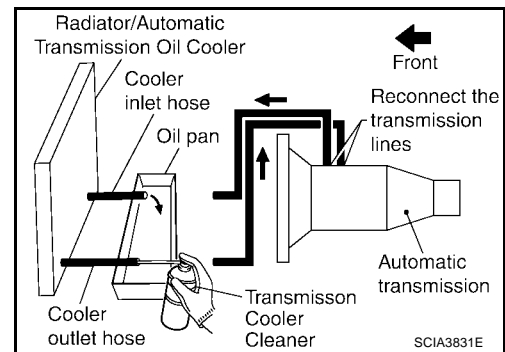

9. Blow compressed air regulated to 5 - 9 kg/cm² (70 - 130 psi) through the cooler outlet hose for 10 seconds to force out any remaining fluid.
10. Repeat steps 5 through 9 three additional times.
11. Position an oil pan under the banjo bolts that connect the fluid cooler steel lines to the transmission.
12. Remove the banjo bolts.
13. Flush each steel line from the cooler side back toward the transmission by spraying Transmission Cooler Cleaner in a continuous stream for 5 seconds.
14. Blow compressed air regulated to 5 - 9 kg/cm² (70 - 130 psi) through each steel line from the cooler side back toward the transmission for 10 seconds to force out any remaining fluid.
15. Ensure all debris is removed from the steel cooler lines.
16. Ensure all debris is removed from the banjo bolts and fittings.
17. Perform [AT-15, "A/T FLUID COOLER DIAGNOSIS PROCEDURE"](#).

A/T FLUID COOLER DIAGNOSIS PROCEDURE

NOTE:

Insufficient cleaning of the cooler inlet hose exterior may lead to inaccurate debris identification.

1. Position an oil pan under the automatic transmission's inlet and outlet cooler hoses.
2. Clean the exterior and tip of the cooler inlet hose.
3. Insert the extension adapter hose of a can of Transmission Cooler Cleaner (Nissan P/N 999MP-AM006) into the cooler outlet hose.

CAUTION:

- Wear safety glasses and rubber gloves when spraying the Transmission Cooler Cleaner.
- Spray cooler cleaner only with adequate ventilation.
- Avoid contact with eyes and skin.
- Do not breath vapors or spray mist.

4. Hold the hose and can as high as possible and spray Transmission Cooler Cleaner in a continuous stream into the cooler outlet hose until fluid flows out of the cooler inlet hose for 5 seconds.

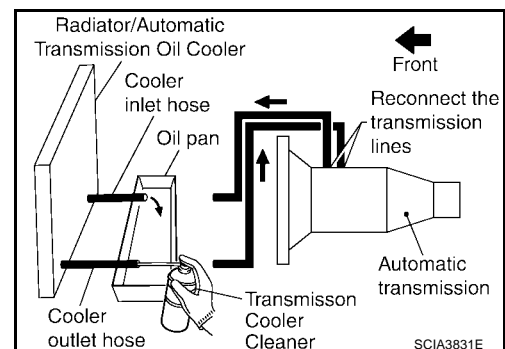

A/T FLUID

5. Tie a common white, basket-type coffee filter to the end of the cooler inlet hose.

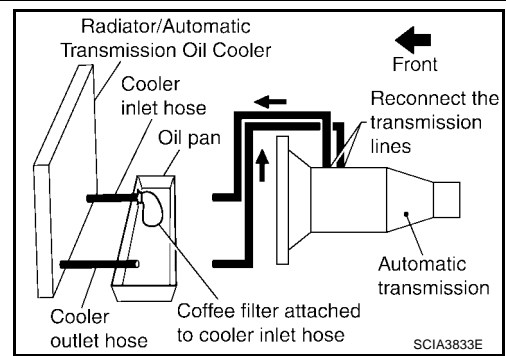

6. Insert the tip of an air gun into the end of the cooler outlet hose.
7. Wrap a shop rag around the air gun tip and end of cooler outlet hose.
8. Blow compressed air regulated to 5 - 9 kg/cm² (70 - 130 psi) through the cooler outlet hose to force any remaining A/T fluid into the coffee filter.
9. Remove the coffee filter from the end of the cooler inlet hose.
10. Perform [AT-16, "A/T FLUID COOLER INSPECTION PROCEDURE"](#) .

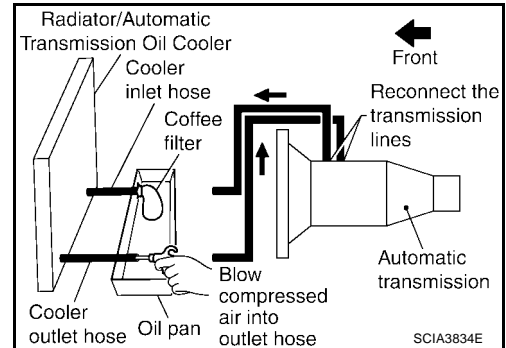

A/T FLUID COOLER INSPECTION PROCEDURE

1. Inspect the coffee filter for debris.
 - a. If small metal debris less than 1mm (0.040 in) in size or metal powder is found in the coffee filter, this is normal. If normal debris is found, the A/T fluid cooler/radiator can be re-used and the procedure is ended.
 - b. If one or more pieces of debris are found that are over 1mm (0.040 in) in size and/or peeled clutch facing material is found in the coffee filter, the fluid cooler is not serviceable. The A/T fluid cooler/radiator must be replaced and the inspection procedure is ended. Refer to [CO-14, "RADIATOR"](#) .

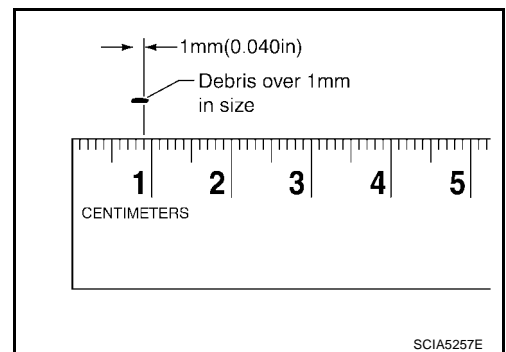
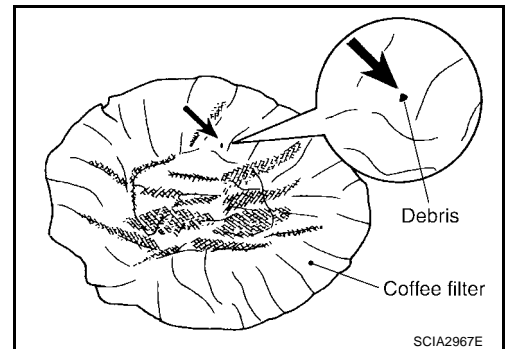

A/T FLUID COOLER FINAL INSPECTION

After performing all procedures, ensure that all remaining oil is cleaned from all components.

A/T CONTROL SYSTEM

A/T CONTROL SYSTEM

PFP:31036

Cross-Sectional View (2WD models)

ECS00GW9

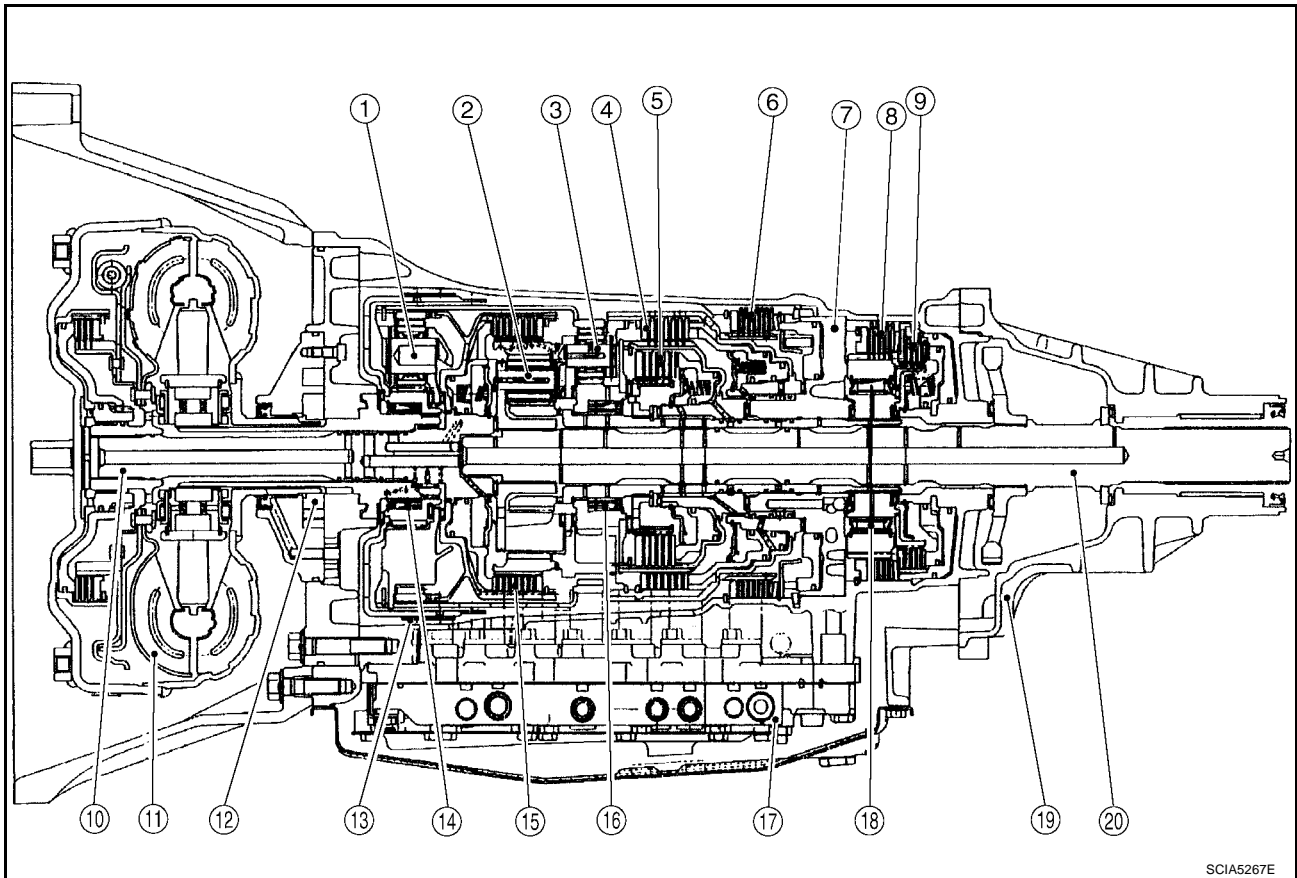

- | | | |
|-------------------------|--------------------------------|----------------------------|
| 1. Front planetary gear | 2. Mid planetary gear | 3. Rear planetary gear |
| 4. Direct clutch | 5. High and low reverse clutch | 6. Reverse brake |
| 7. Drum support | 8. Forward brake | 9. Low coast brake |
| 10. Input shaft | 11. Torque converter | 12. Oil pump |
| 13. Front brake | 14. 3rd one-way clutch | 15. Input clutch |
| 16. 1st one-way clutch | 17. Control valve with TCM | 18. Forward one-way clutch |
| 19. Rear extension | 20. Output shaft | |

SCIA5267E

A/T CONTROL SYSTEM

Cross-Sectional View (4WD models)

ECS00GWA

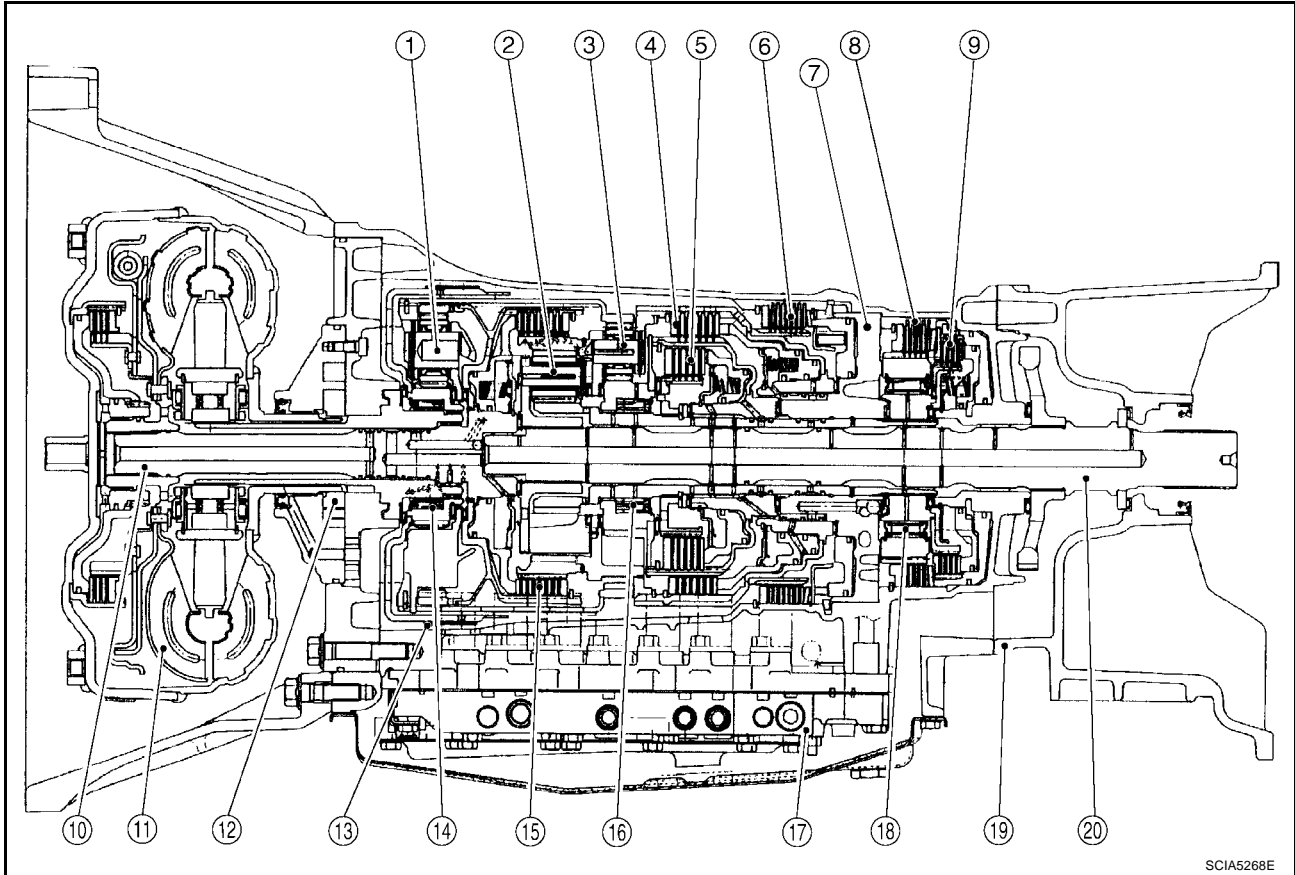

SCIA5268E

- | | | |
|-------------------------|--------------------------------|----------------------------|
| 1. Front planetary gear | 2. Mid planetary gear | 3. Rear planetary gear |
| 4. Direct clutch | 5. High and low reverse clutch | 6. Reverse brake |
| 7. Drum support | 8. Forward brake | 9. Low coast brake |
| 10. Input shaft | 11. Torque converter | 12. Oil pump |
| 13. Front brake | 14. 3rd one-way clutch | 15. Input clutch |
| 16. 1st one-way clutch | 17. Control valve with TCM | 18. Forward one-way clutch |
| 19. Adapter case | 20. Output shaft | |

A/T CONTROL SYSTEM

ECS00GWB

Shift Mechanism

The automatic transmission uses compact triple planetary gear systems to improve power-transmission efficiency, simplify construction and reduce weight.

It also employs an optimum shift control and super wide gear ratios. They improve starting performance and acceleration during medium and high-speed operation.

CONSTRUCTION

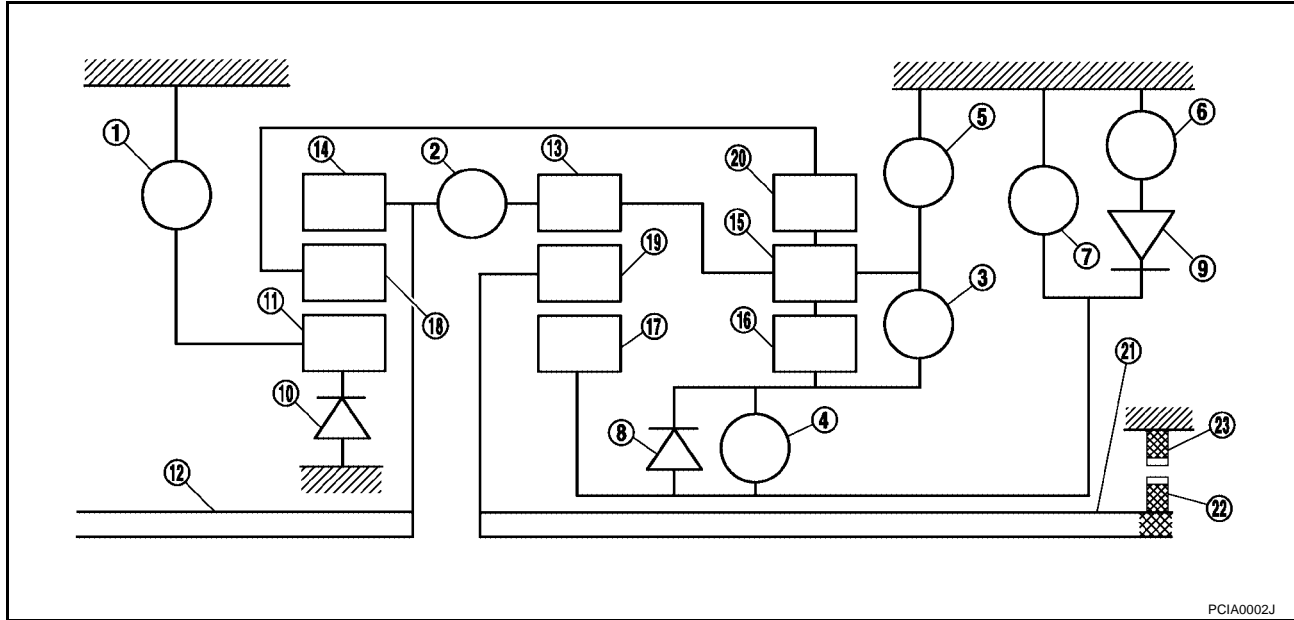

- | | | |
|--------------------------------|-------------------------|---------------------------|
| 1. Front brake | 2. Input clutch | 3. Direct clutch |
| 4. High and low reverse clutch | 5. Reverse brake | 6. Forward brake |
| 7. Low coast brake | 8. 1st one-way clutch | 9. Forward one-way clutch |
| 10. 3rd one-way clutch | 11. Front sun gear | 12. Input shaft |
| 13. Mid internal gear | 14. Front internal gear | 15. Rear carrier |
| 16. Rear sun gear | 17. Mid sun gear | 18. Front carrier |
| 19. Mid carrier | 20. Rear internal gear | 21. Output shaft |
| 22. Parking gear | 23. Parking pawl | |

FUNCTION OF CLUTCH AND BRAKE

Name of the Part	Abbreviation	Function
Front brake (1)	FR/B	Fastens the front sun gear (11).
Input clutch (2)	I/C	Connects the input shaft (12), the front internal gear (14) and the mid internal gear (13).
Direct clutch (3)	D/C	Connects the rear carrier (15) and the rear sun gear (16).
High and low reverse clutch (4)	HLR/C	Connects the mid sun gear (17) and the rear sun gear (16).
Reverse brake (5)	R/B	Fastens the rear carrier (15).
Forward brake (6)	Fwd/B	Fastens the mid sun gear (17).
Low coast brake (7)	LC/B	Fastens the mid sun gear (17).
1st one-way clutch (8)	1st OWC	Allows the rear sun gear (16) to turn freely forward relative to the mid sun gear (17) but fastens it for reverse rotation.
Forward one-way clutch (9)	Fwd OWC	Allows the mid sun gear (17) to turn freely in the forward direction but fastens it for reverse rotation.
3rd one-way clutch (10)	3rd OWC	Allows the front sun gear (11) to turn freely in the forward direction but fastens it for reverse rotation.

A/T CONTROL SYSTEM

CLUTCH AND BAND CHART

Shift position		I/C	HLR/C	D/C	R/B	FR/B	LC/B	Fwd/B	1st OWC	Fwd OWC	3rd OWC	Remarks
P			△			△						PARK POSITION
R			○		○	○			☆		☆	REVERSE POSITION
N			△			△						NEUTRAL POSITION
D	1st		△*			△	△**	○	☆	☆	☆	Automatic shift 1⇔2⇔3⇔4⇔5
	2nd			○		△		○		☆	☆	
	3rd		○	○		○		△	★		☆	
	4th	○	○	○				△	★			
	5th	○	○			○		△	★		★	
4	1st		△*			△	△**	○	☆	☆	☆	Automatic shift 1⇔2⇔3⇔4
	2nd			○		△		○		☆	☆	
	3rd		○	○		○		△	★		☆	
	4th	○	○	○				△	★			
3	1st		△*			△	△**	○	☆	☆	☆	Automatic shift 1⇔2⇔3⇔4
	2nd			○		△		○		☆	☆	
	3rd		○	○		○		△	★		☆	
	4th	○	○	○				△	★			
2	1st		△*			△	△**	○	☆	☆	☆	Automatic shift 1⇔2⇔3⇔4
	2nd			○		○	○	○		☆	☆	
	3rd		○	○		○		△	★		☆	
	4th	○	○	○				△	★			
1	1st		○			○	○	○	☆	☆	☆	Locks (held stationary in 1st gear) 1⇔2⇔3⇔4
	2nd			○		○	○	○		☆	☆	
	3rd		○	○		○		△	★		☆	
	4th	○	○	○				△	★			

- ○—Operates
- ☆—Operates during “progressive” acceleration.
- ★—Operates and effects power transmission while coasting.
- △—Line pressure is applied but does not affect power transmission.
- △*—Operates under conditions shown in HLR/C Operating Condition
- △**—Operates under conditions shown in LC/B Operating Condition. Delay control is applied during D (4,3,2,1) ⇒N shift.

A/T CONTROL SYSTEM

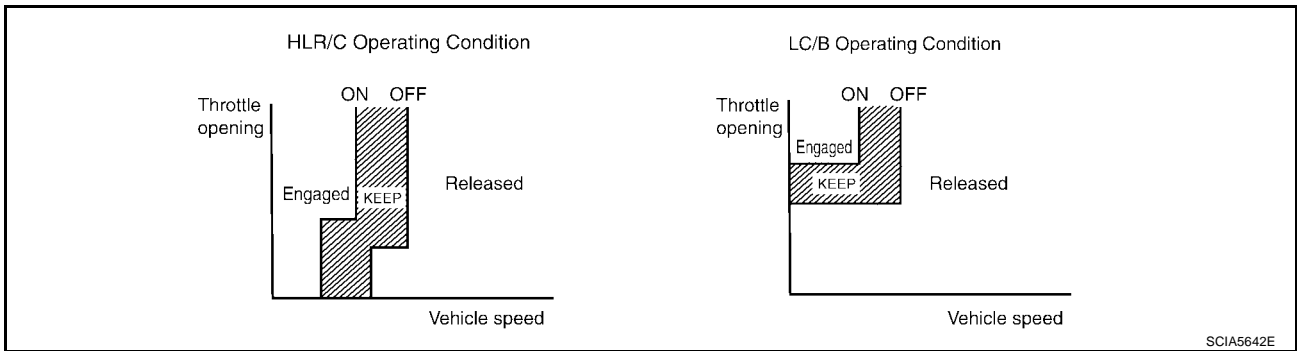

POWER TRANSMISSION

“N” Position

Since both the forward brake and the reverse brake are released, torque from the input shaft drive is not transmitted to the output shaft.

“P” Position

- The same as for the “N” position, both the forward brake and the reverse brake are released, so torque from the input shaft drive is not transmitted to the output shaft.
- The parking pawl linked with the select lever meshes with the parking gear and fastens the output shaft mechanically.

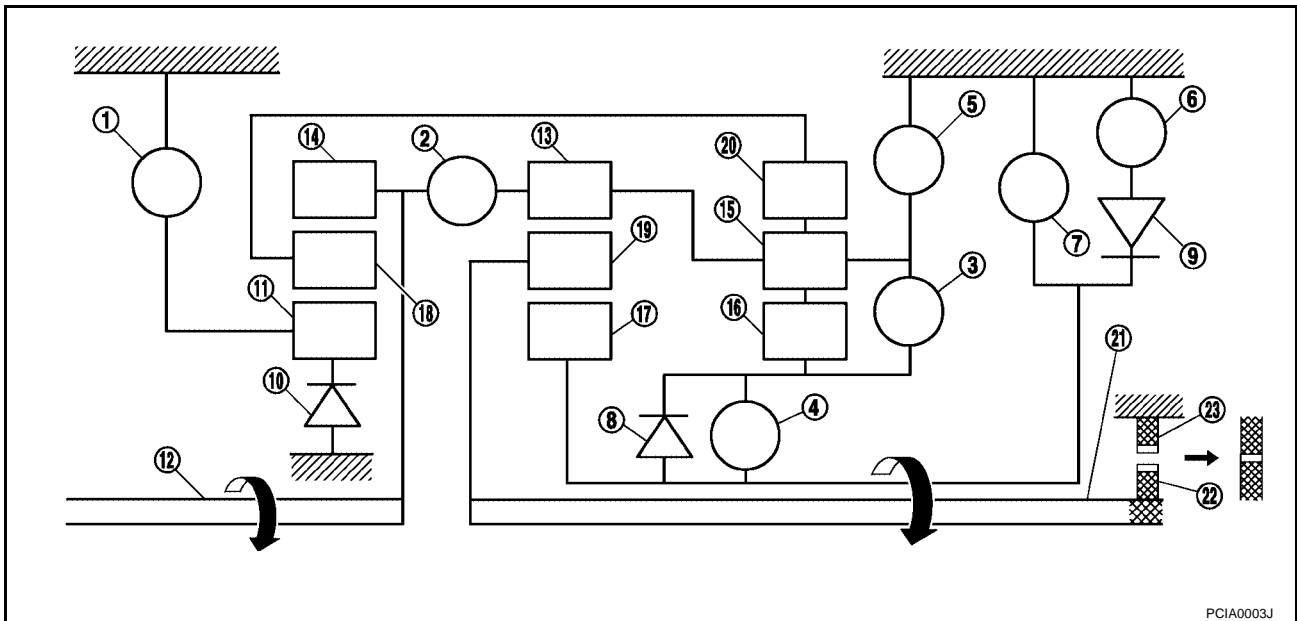

- | | | |
|--------------------------------|-------------------------|---------------------------|
| 1. Front brake | 2. Input clutch | 3. Direct clutch |
| 4. High and low reverse clutch | 5. Reverse brake | 6. Forward brake |
| 7. Low coast brake | 8. 1st one-way clutch | 9. Forward one-way clutch |
| 10. 3rd one-way clutch | 11. Front sun gear | 12. Input shaft |
| 13. Mid internal gear | 14. Front internal gear | 15. Rear carrier |
| 16. Rear sun gear | 17. Mid sun gear | 18. Front carrier |
| 19. Mid carrier | 20. Rear internal gear | 21. Output shaft |
| 22. Parking gear | 23. Parking pawl | |

A/T CONTROL SYSTEM

“D”, “4”, “3”, “2” Positions 1st Gear

- The forward brake and the forward one-way clutch regulate reverse rotation of the mid sun gear.
- The 1st one-way clutch regulates reverse rotation of the rear sun gear.
- The 3rd one-way clutch regulates reverse rotation of the front sun gear.
- During deceleration, the mid sun gear turns forward, so the forward one-way clutch idles and the engine brake is not activated.

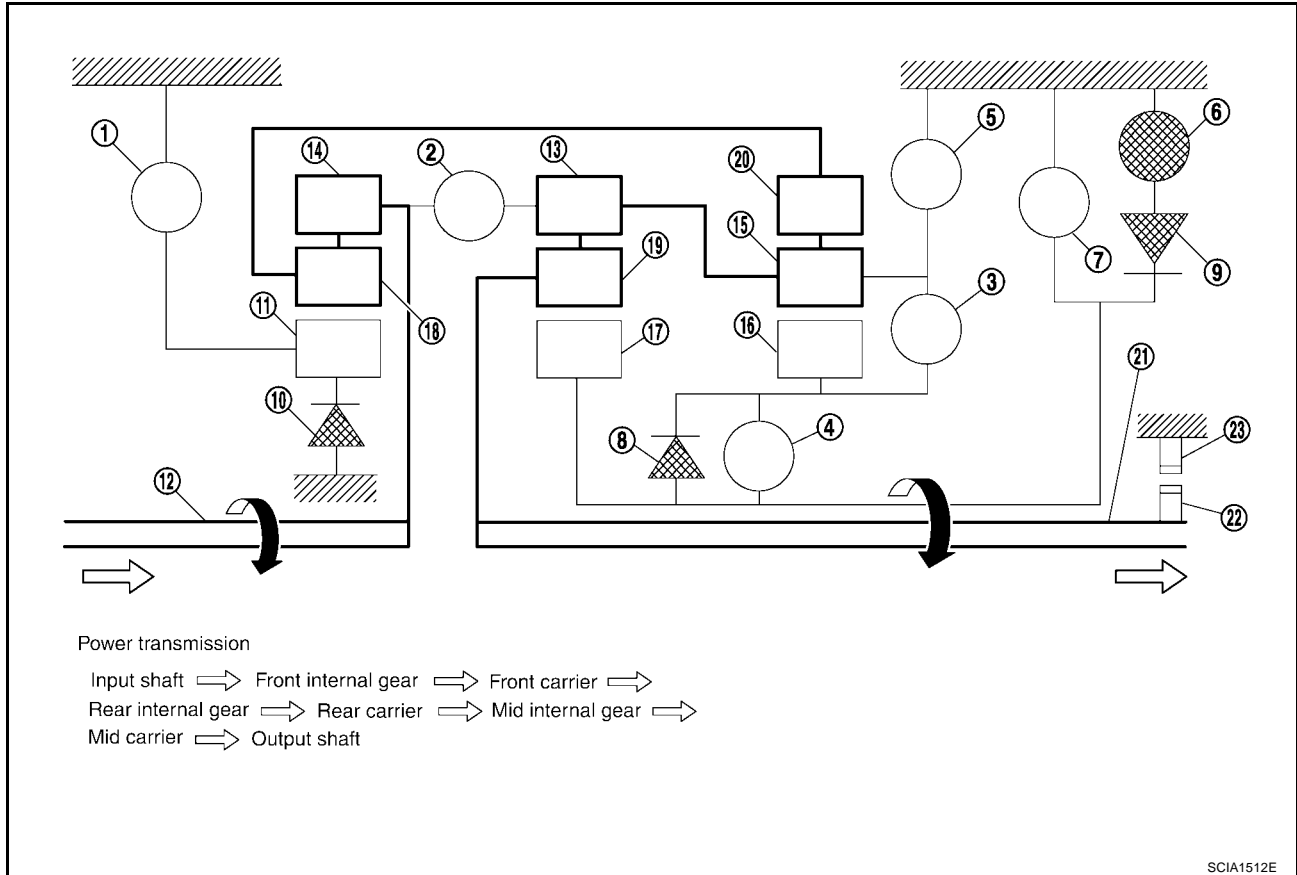

- | | | |
|--------------------------------|-------------------------|---------------------------|
| 1. Front brake | 2. Input clutch | 3. Direct clutch |
| 4. High and low reverse clutch | 5. Reverse brake | 6. Forward brake |
| 7. Low coast brake | 8. 1st one-way clutch | 9. Forward one-way clutch |
| 10. 3rd one-way clutch | 11. Front sun gear | 12. Input shaft |
| 13. Mid internal gear | 14. Front internal gear | 15. Rear carrier |
| 16. Rear sun gear | 17. Mid sun gear | 18. Front carrier |
| 19. Mid carrier | 20. Rear internal gear | 21. Output shaft |
| 22. Parking gear | 23. Parking pawl | |

A/T CONTROL SYSTEM

"1 " Position 1st Gear

- The front brake fastens the front sun gear.
- The forward brake and the forward one-way clutch regulate reverse rotation of the mid sun gear.
- High and low reverse clutch connects the rear sun gear and the mid sun gear.
- The low coast brake fastens the mid sun gear.
- During deceleration, the low coast brake regulates forward rotation of the mid sun gear and the engine brake functions.

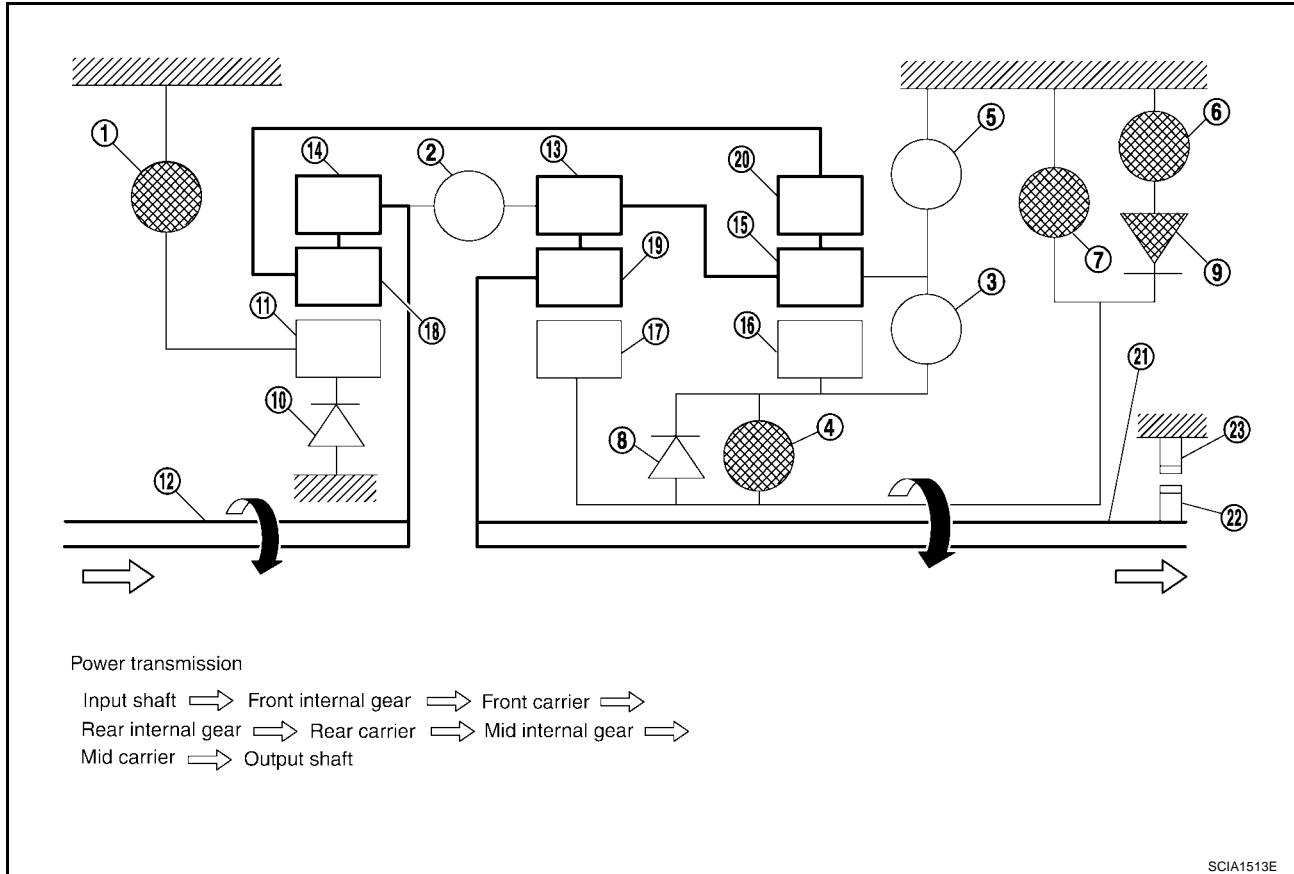

- | | | |
|--------------------------------|-------------------------|---------------------------|
| 1. Front brake | 2. Input clutch | 3. Direct clutch |
| 4. High and low reverse clutch | 5. Reverse brake | 6. Forward brake |
| 7. Low coast brake | 8. 1st one-way clutch | 9. Forward one-way clutch |
| 10. 3rd one-way clutch | 11. Front sun gear | 12. Input shaft |
| 13. Mid internal gear | 14. Front internal gear | 15. Rear carrier |
| 16. Rear sun gear | 17. Mid sun gear | 18. Front carrier |
| 19. Mid carrier | 20. Rear internal gear | 21. Output shaft |
| 22. Parking gear | 23. Parking pawl | |

A/T CONTROL SYSTEM

“D”, “4”, “3” Positions 2nd Gear

- The forward brake and the forward one-way clutch regulate reverse rotation of the mid sun gear.
- The 3rd one-way clutch regulates reverse rotation of the front sun gear.
- The direct clutch is coupled and the rear carrier and rear sun gear are connected.
- During deceleration, the mid sun gear turns forward, so the forward one-way clutch idles and engine brake is not activated.

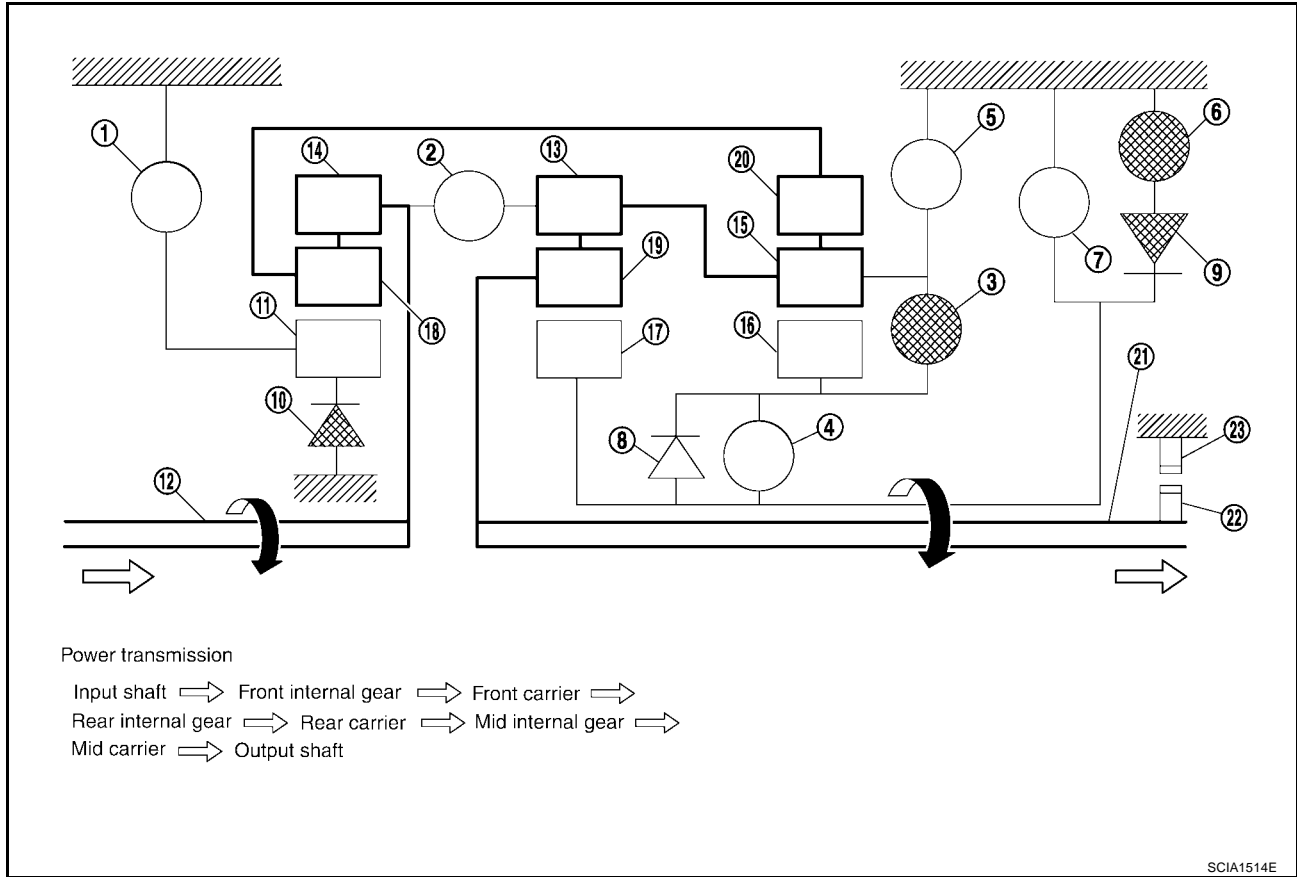

- | | | |
|--------------------------------|-------------------------|---------------------------|
| 1. Front brake | 2. Input clutch | 3. Direct clutch |
| 4. High and low reverse clutch | 5. Reverse brake | 6. Forward brake |
| 7. Low coast brake | 8. 1st one-way clutch | 9. Forward one-way clutch |
| 10. 3rd one-way clutch | 11. Front sun gear | 12. Input shaft |
| 13. Mid internal gear | 14. Front internal gear | 15. Rear carrier |
| 16. Rear sun gear | 17. Mid sun gear | 18. Front carrier |
| 19. Mid carrier | 20. Rear internal gear | 21. Output shaft |
| 22. Parking gear | 23. Parking pawl | |

A/T CONTROL SYSTEM

"2", "1" Positions 2nd Gear

- The front brake fastens the front sun gear.
- The forward brake and the forward one-way clutch regulate reverse rotation of the mid sun gear.
- The direct clutch is coupled, and the rear carrier and rear sun gear are connected.
- The low coast brake fastens the mid sun gear.
- During deceleration, the low coast brake regulates forward rotation of the mid sun gear and the engine brake functions.

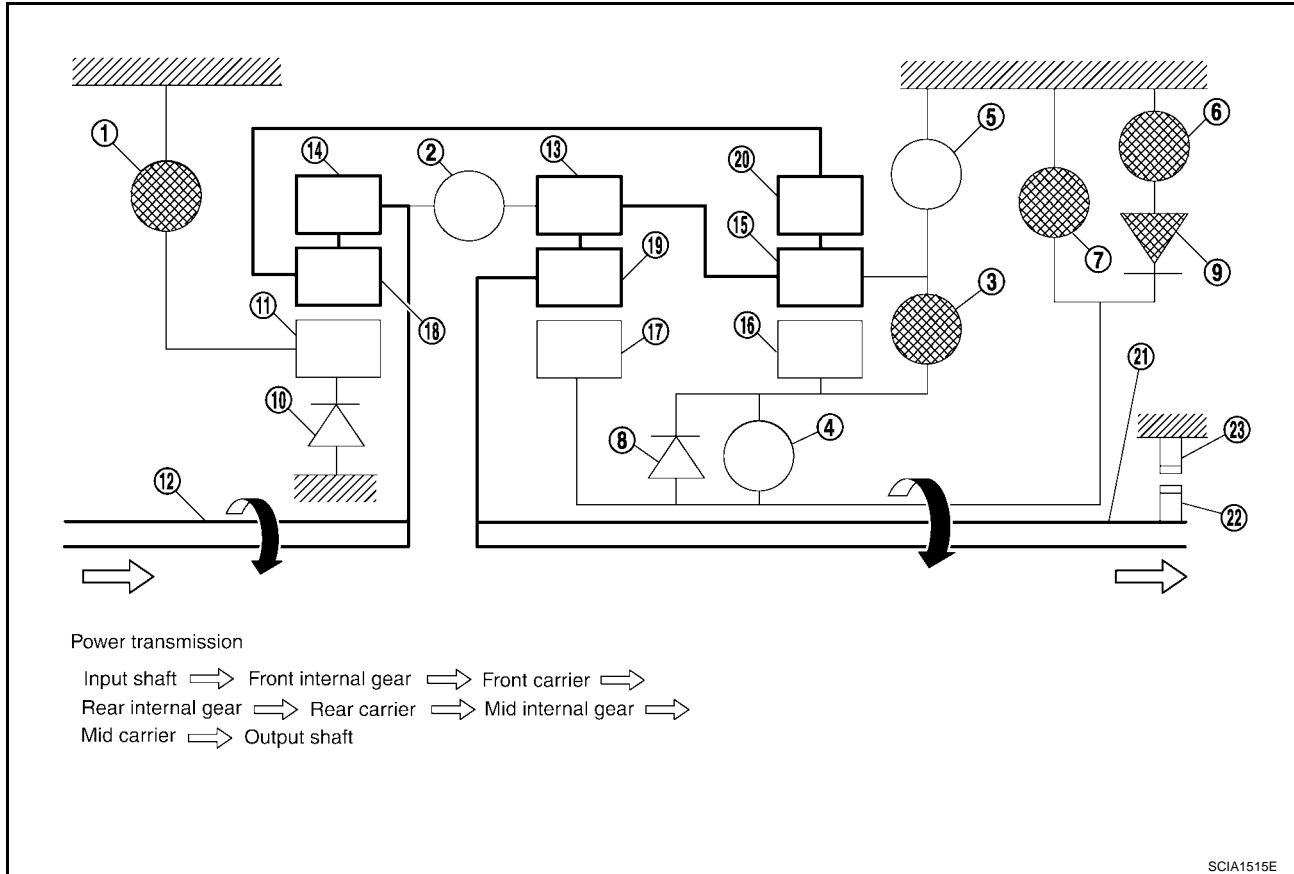

- | | | |
|--------------------------------|-------------------------|---------------------------|
| 1. Front brake | 2. Input clutch | 3. Direct clutch |
| 4. High and low reverse clutch | 5. Reverse brake | 6. Forward brake |
| 7. Low coast brake | 8. 1st one-way clutch | 9. Forward one-way clutch |
| 10. 3rd one-way clutch | 11. Front sun gear | 12. Input shaft |
| 13. Mid internal gear | 14. Front internal gear | 15. Rear carrier |
| 16. Rear sun gear | 17. Mid sun gear | 18. Front carrier |
| 19. Mid carrier | 20. Rear internal gear | 21. Output shaft |
| 22. Parking gear | 23. Parking pawl | |

A/T CONTROL SYSTEM

“D”, “4”, “3” Positions 3rd Gear

- The front brake fastens the front sun gear.
- The direct clutch is coupled, and the rear carrier and rear sun gear are connected.
- The high and low reverse clutch is coupled and the mid sun gear and rear sun gear are connected.

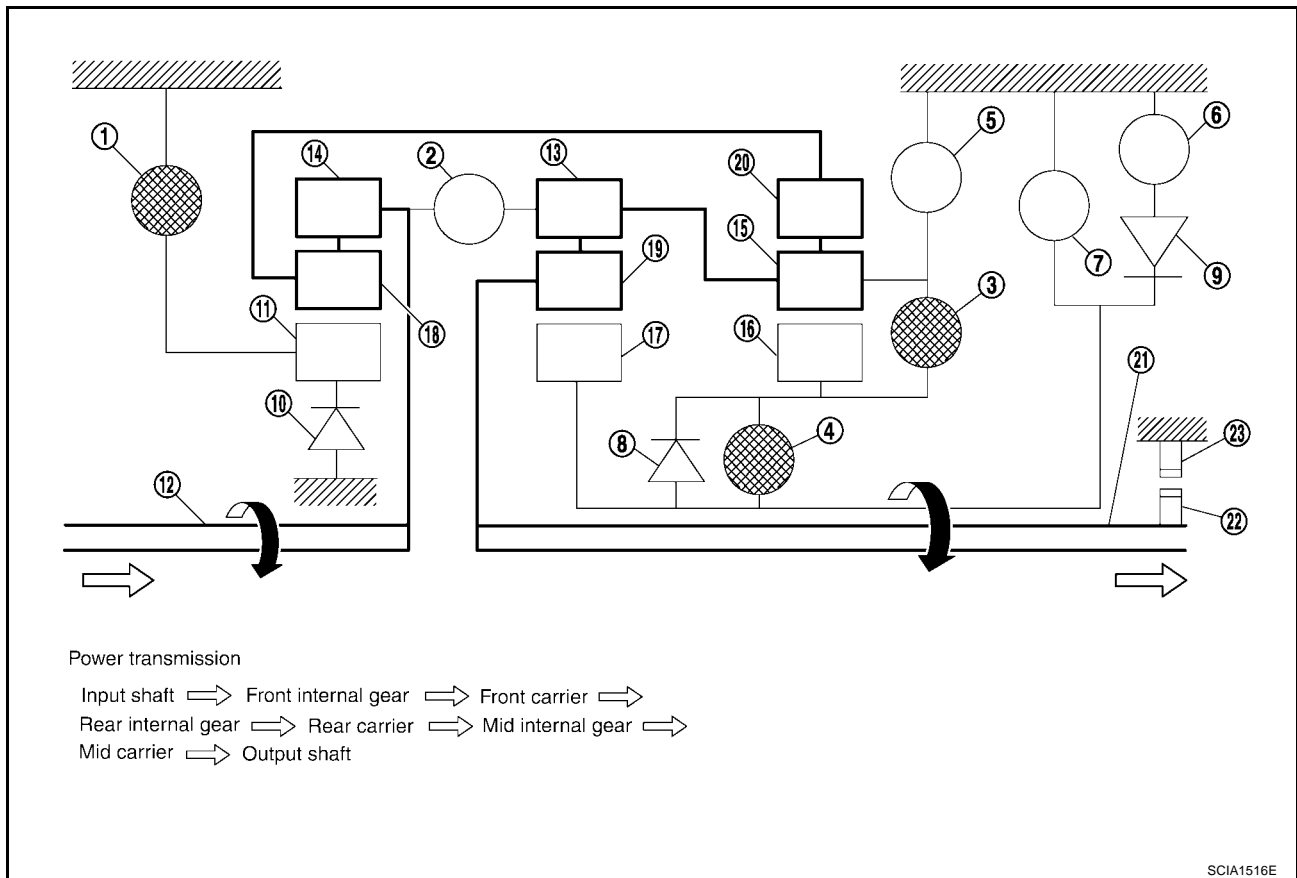

- | | | |
|--------------------------------|-------------------------|---------------------------|
| 1. Front brake | 2. Input clutch | 3. Direct clutch |
| 4. High and low reverse clutch | 5. Reverse brake | 6. Forward brake |
| 7. Low coast brake | 8. 1st one-way clutch | 9. Forward one-way clutch |
| 10. 3rd one-way clutch | 11. Front sun gear | 12. Input shaft |
| 13. Mid internal gear | 14. Front internal gear | 15. Rear carrier |
| 16. Rear sun gear | 17. Mid sun gear | 18. Front carrier |
| 19. Mid carrier | 20. Rear internal gear | 21. Output shaft |
| 22. Parking gear | 23. Parking pawl | |

A/T CONTROL SYSTEM

“D”, “4” Positions 4th Gear

- The direct clutch is coupled, and the rear carrier and rear sun gear are connected.
- The high and low reverse clutch is coupled and the mid sun gear and rear sun gear are connected.
- The input clutch is coupled and the front internal gear and mid internal gear are connected.
- The drive power is conveyed to the front internal gear, mid internal gear, and rear carrier and the three planetary gears rotate forward as one unit.

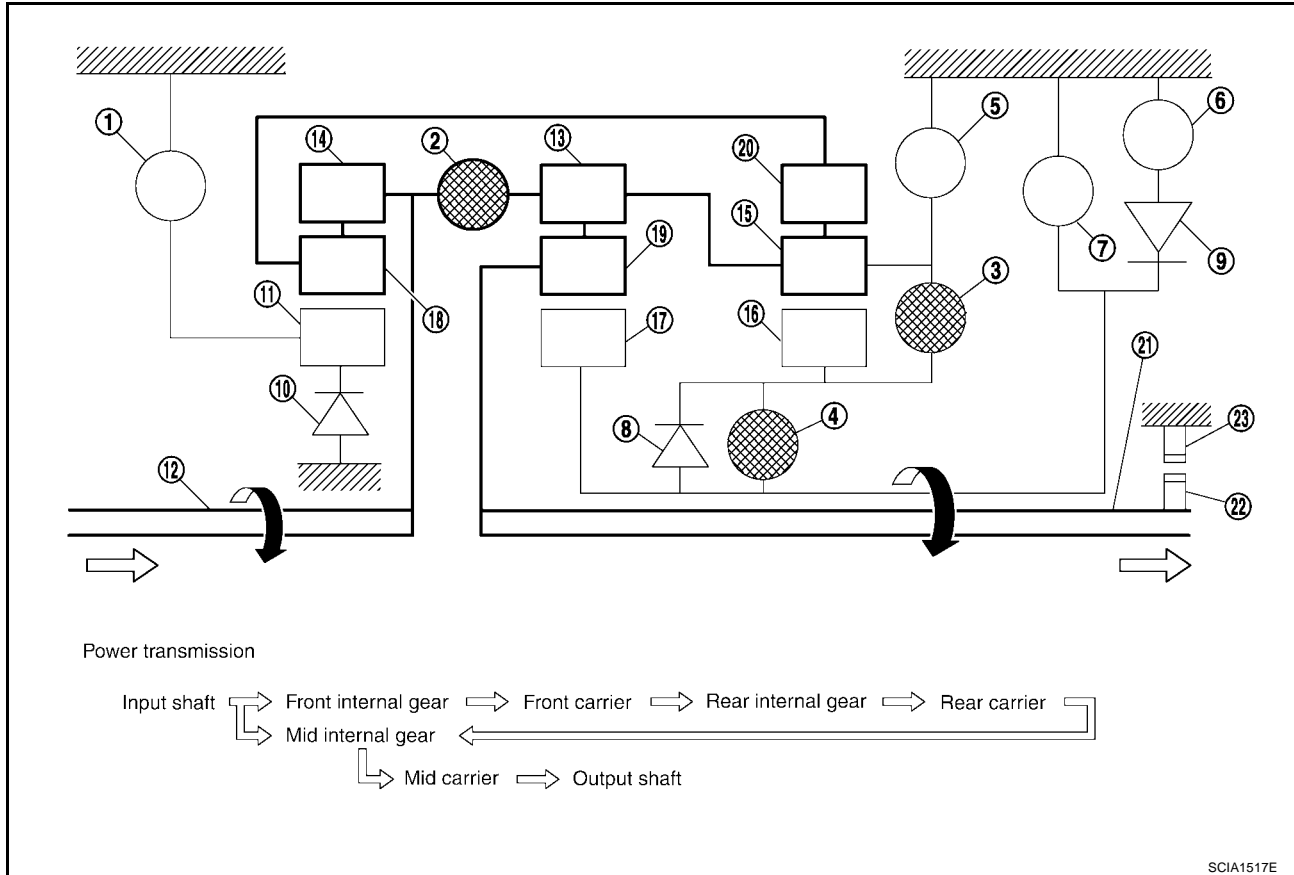

- | | | |
|--------------------------------|-------------------------|---------------------------|
| 1. Front brake | 2. Input clutch | 3. Direct clutch |
| 4. High and low reverse clutch | 5. Reverse brake | 6. Forward brake |
| 7. Low coast brake | 8. 1st one-way clutch | 9. Forward one-way clutch |
| 10. 3rd one-way clutch | 11. Front sun gear | 12. Input shaft |
| 13. Mid internal gear | 14. Front internal gear | 15. Rear carrier |
| 16. Rear sun gear | 17. Mid sun gear | 18. Front carrier |
| 19. Mid carrier | 20. Rear internal gear | 21. Output shaft |
| 22. Parking gear | 23. Parking pawl | |

SCIA1517E

A/T CONTROL SYSTEM

“D” Position 5th Gear

- The front brake fastens the front sun gear.
- The input clutch is coupled and the front internal gear and mid internal gear are connected.
- The high and low reverse clutch is coupled and the mid sun gear and rear sun gear are connected.

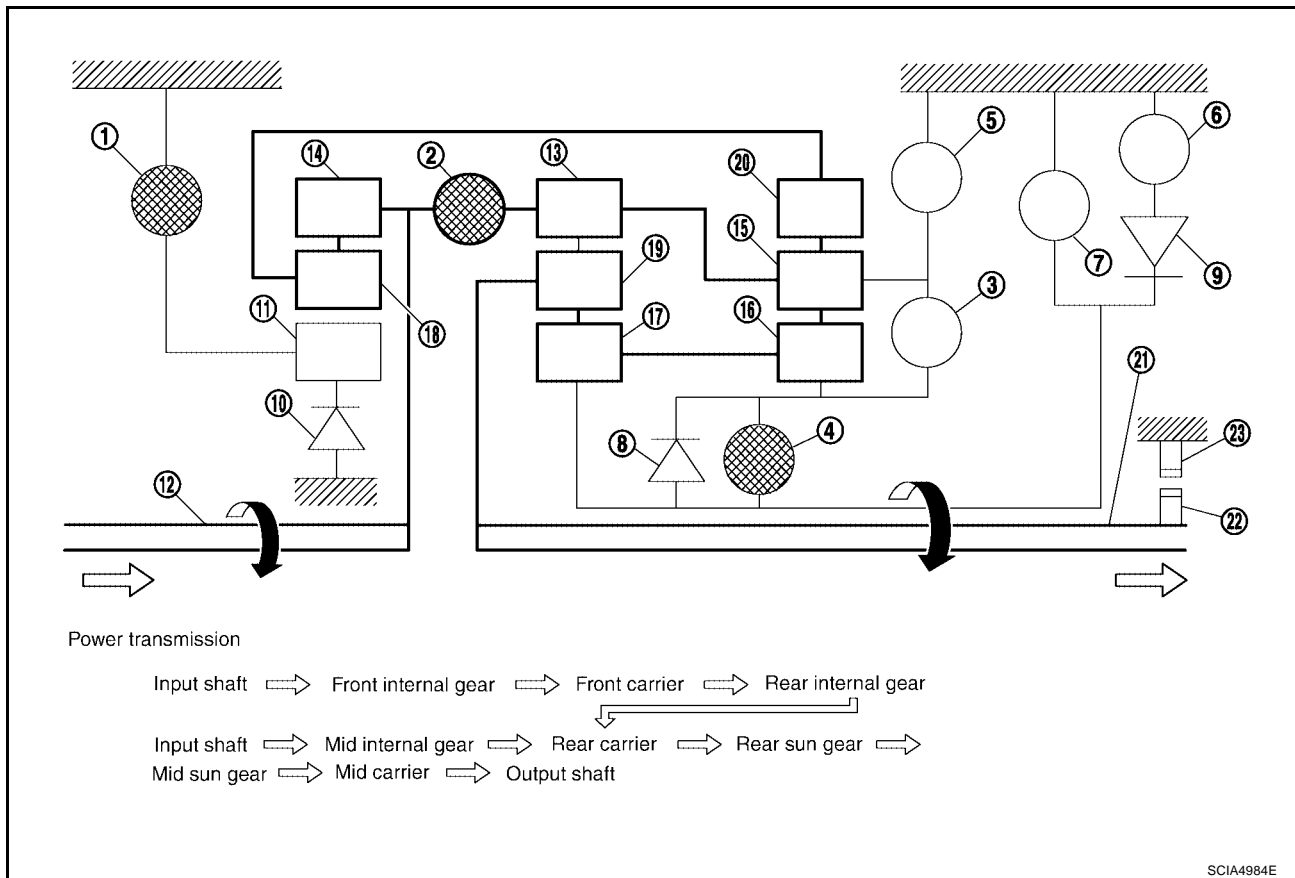

- | | | |
|--------------------------------|-------------------------|---------------------------|
| 1. Front brake | 2. Input clutch | 3. Direct clutch |
| 4. High and low reverse clutch | 5. Reverse brake | 6. Forward brake |
| 7. Low coast brake | 8. 1st one-way clutch | 9. Forward one-way clutch |
| 10. 3rd one-way clutch | 11. Front sun gear | 12. Input shaft |
| 13. Mid internal gear | 14. Front internal gear | 15. Rear carrier |
| 16. Rear sun gear | 17. Mid sun gear | 18. Front carrier |
| 19. Mid carrier | 20. Rear internal gear | 21. Output shaft |
| 22. Parking gear | 23. Parking pawl | |

A/T CONTROL SYSTEM

"R" Position

- The front brake fastens the front sun gear.
- The high and low reverse clutch is coupled, and the mid sun gear and rear sun gear are connected.
- The reverse brake fastens the rear carrier.

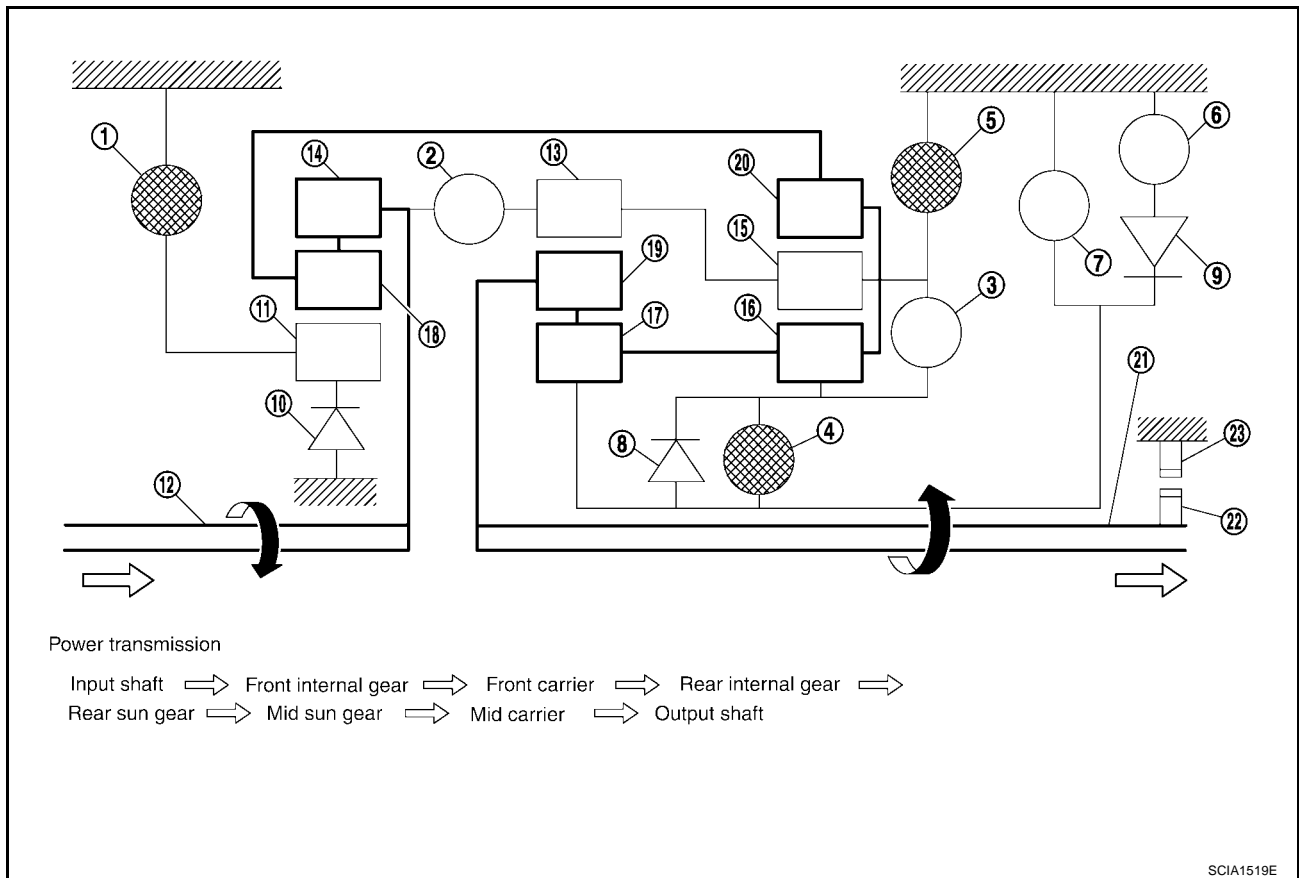

- | | | |
|--------------------------------|-------------------------|---------------------------|
| 1. Front brake | 2. Input clutch | 3. Direct clutch |
| 4. High and low reverse clutch | 5. Reverse brake | 6. Forward brake |
| 7. Low coast brake | 8. 1st one-way clutch | 9. Forward one-way clutch |
| 10. 3rd one-way clutch | 11. Front sun gear | 12. Input shaft |
| 13. Mid internal gear | 14. Front internal gear | 15. Rear carrier |
| 16. Rear sun gear | 17. Mid sun gear | 18. Front carrier |
| 19. Mid carrier | 20. Rear internal gear | 21. Output shaft |
| 22. Parking gear | 23. Parking pawl | |

A/T CONTROL SYSTEM

ECS00GWC

TCM Function

The function of the TCM is to:

- Receive input signals sent from various switches and sensors.
- Determine required line pressure, shifting point, lock-up operation, and engine brake operation.
- Send required output signals to the respective solenoids.

CONTROL SYSTEM OUTLINE

The automatic transmission senses vehicle operating conditions through various sensors or signals. It always controls the optimum shift position and reduces shifting and lock-up shocks.

SENSORS (or SIGNALS)		TCM		ACTUATORS
PNP switch Accelerator pedal position sensor Closed throttle position signal Wide open throttle position signal Engine speed signal A/T fluid temperature sensor Revolution sensor Vehicle speed signal Stop lamp switch signal Turbine revolution sensor 1st position switch signal 4th position switch signal ATF pressure switch signal Tow mode switch signal	⇒	Shift control Line pressure control Lock-up control Engine brake control Timing control Fail-safe control Self-diagnosis CONSULT-II communication line Duet-EA control CAN system	⇒	Input clutch solenoid valve Direct clutch solenoid valve Front brake solenoid valve High and low reverse clutch solenoid valve Low coast brake solenoid valve Torque converter clutch solenoid valve Line pressure solenoid valve A/T CHECK indicator lamp Starter relay Back-up lamp relay

CONTROL SYSTEM DIAGRAM

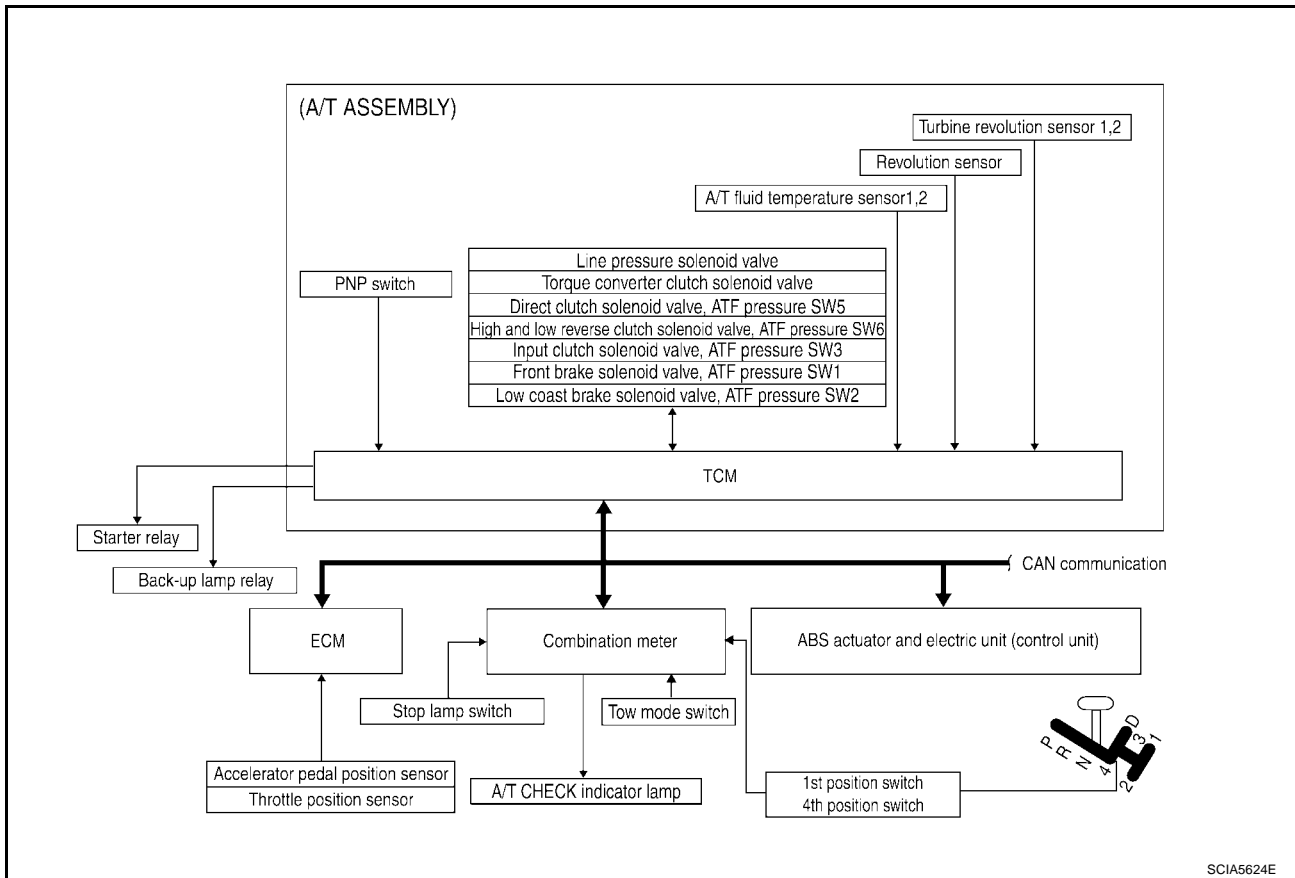

SCIA5624E

A/T CONTROL SYSTEM

ECS00GWD

CAN Communication SYSTEM DESCRIPTION

CAN (Controller Area Network) is a serial communication line for real time application. It is an on-vehicle multiplex communication line with high data communication speed and excellent error detection ability. Many electronic control units are equipped onto a vehicle, and each control unit shares information and links with other control units during operation (not independent). In CAN communication, control units are connected with 2 communication lines (CAN H line, CAN L line) allowing a high rate of information transmission with less wiring. Each control unit transmits/receives data but selectively reads required data only. For details, refer to [EC-31. "CAN COMMUNICATION"](#).

Input/Output Signal of TCM

ECS00GWE

Control item		Line pressure control	Vehicle speed control	Shift control	Lock-up control	Engine brake control	Fail-safe function (*3)	Self-diagnostics function	
Input	Accelerator pedal position signal (*4)	X	X	X	X	X	X	X	
	Vehicle speed sensor A/T (revolution sensor)	X	X	X	X		X	X	
	Vehicle speed sensor MTR(*1) (*4)	X	X	X	X			X	
	Closed throttle position signal(*4)	(*2) X	(*2) X		X	(*2) X		X	
	Wide open throttle position signal(*4)	(*2) X	(*2) X			(*2) X		X	
	Turbine revolution sensor 1	X	X		X		X	X	
	Turbine revolution sensor 2 (for 4th speed only)	X	X		X		X	X	
	Engine speed signals(*4)				X			X	
	PNP switch	X	X	X	X	X	X	X	
	A/T fluid temperature sensors 1, 2	X	X	X	X	X	X	X	
	ASCD	Operation signal(*4)		X	X	X	X		
		Overdrive cancel signal(*4)		X		X	X		
	TCM power supply voltage signal		X	X	X	X	X		X
Output	Direct clutch solenoid (ATF pressure switch 5)		X	X			X	X	
	Input clutch solenoid (ATF pressure switch 3)		X	X			X	X	
	High and low reverse clutch solenoid (ATF pressure switch 6)		X	X			X	X	
	Front brake solenoid (ATF pressure switch 1)		X	X			X	X	
	Low coast brake solenoid (ATF pressure switch 2)		X	X		X	X	X	
	Line pressure solenoid	X	X	X	X	X	X	X	
	TCC solenoid				X		X	X	
	Starter relay						X	X	

*1: Spare for vehicle speed sensor-A/T (revolution sensor)

*2: Spare for accelerator pedal position signal

*3: If these input and output signals are different, the TCM triggers the fail-safe function.

*4: CAN communications

A/T CONTROL SYSTEM

ECS00GWF

Line Pressure Control

- When an input torque signal equivalent to the engine drive force is sent from the ECM to the TCM, the TCM controls the line pressure solenoid.
- This line pressure solenoid controls the pressure regulator valve as the signal pressure and adjusts the pressure of the operating oil discharged from the oil pump to the line pressure most appropriate to the driving state.

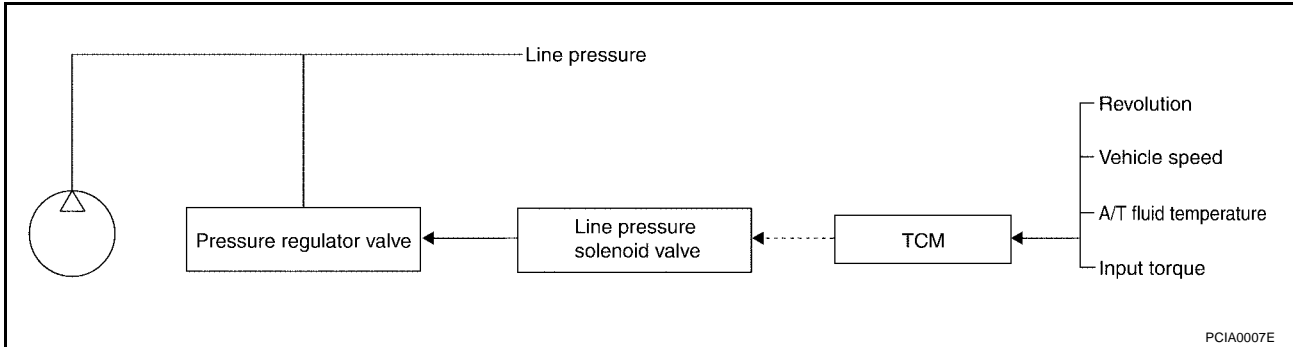

LINE PRESSURE CONTROL IS BASED ON THE TCM LINE PRESSURE CHARACTERISTIC PATTERN

- The TCM has stored in memory a number of patterns for the optimum line pressure characteristic for the driving state.
- In order to obtain the most appropriate line pressure characteristic to meet the current driving state, the TCM controls the line pressure solenoid current value and thus controls the line pressure.

Normal Control

Each clutch is adjusted to the necessary pressure to match the engine drive force.

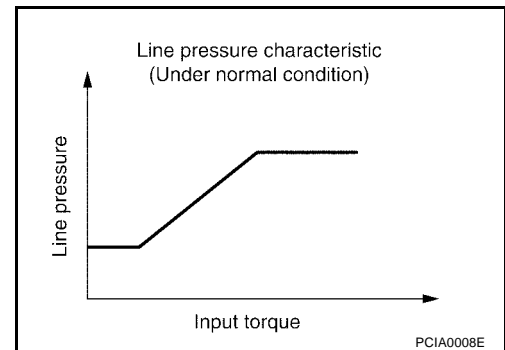

Back-up Control (Engine Brake)

When the select operation is performed during driving and the transmission is shifted down, the line pressure is set according to the vehicle speed.

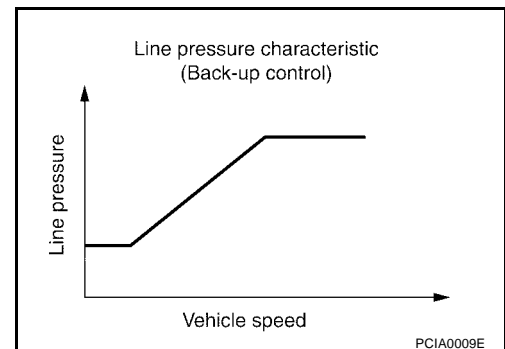

A/T CONTROL SYSTEM

During Shift Change

The necessary and adequate line pressure for shift change is set. For this reason, line pressure pattern setting corresponds to input torque and gearshift selection. Also, line pressure characteristic is set according to engine speed, during engine brake operation.

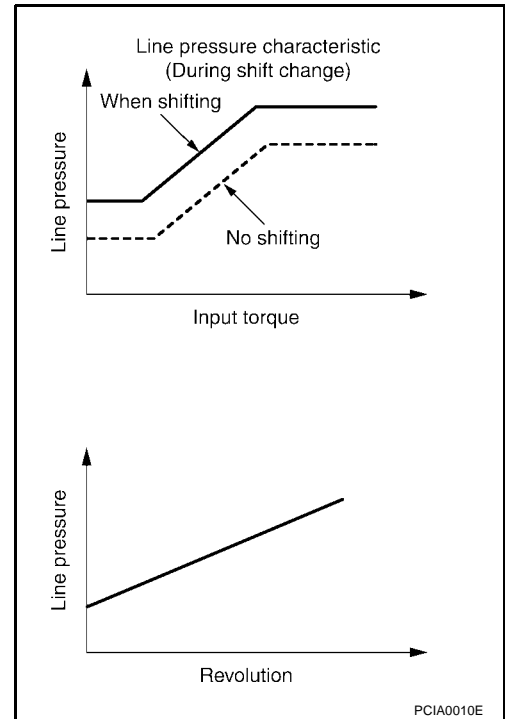

At Low Fluid Temperature

When the A/T fluid temperature drops below the prescribed temperature, in order to speed up the action of each friction element, the line pressure is set higher than the normal line pressure characteristic.

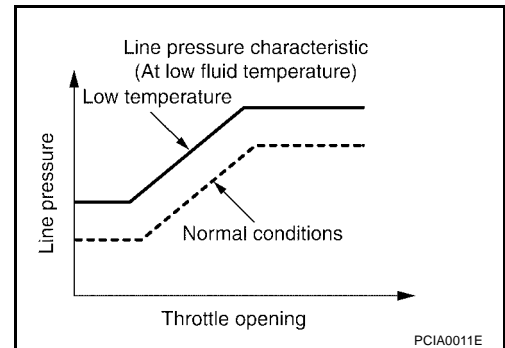

Shift Control

The clutch pressure control solenoid is controlled by the signals from the switches and sensors. Thus, the clutch pressure is adjusted to be appropriate to the engine load state and vehicle driving state. It becomes possible to finely control the clutch hydraulic pressure with high precision and a smoother shift change characteristic is attained.

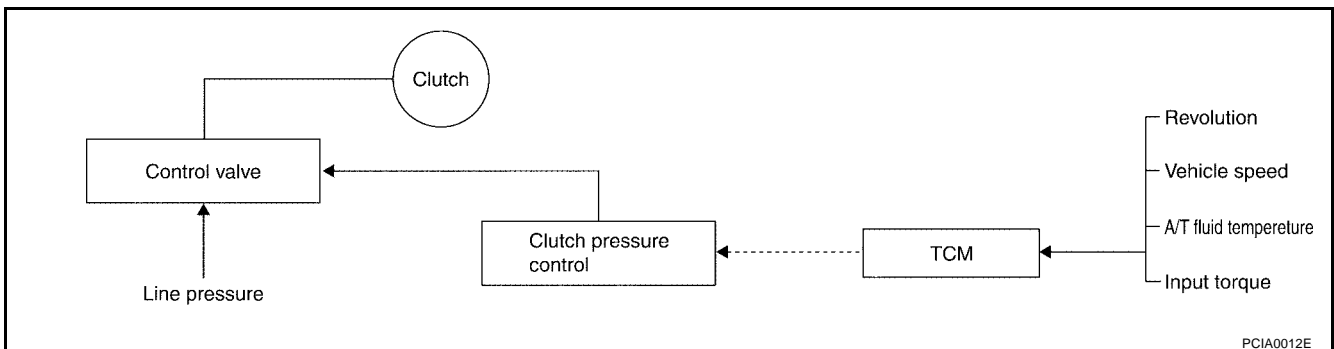

SHIFT CHANGE

The clutch is controlled with the optimum timing and oil pressure by the engine speed, engine torque information, etc.

A/T CONTROL SYSTEM

Shift Change System Diagram

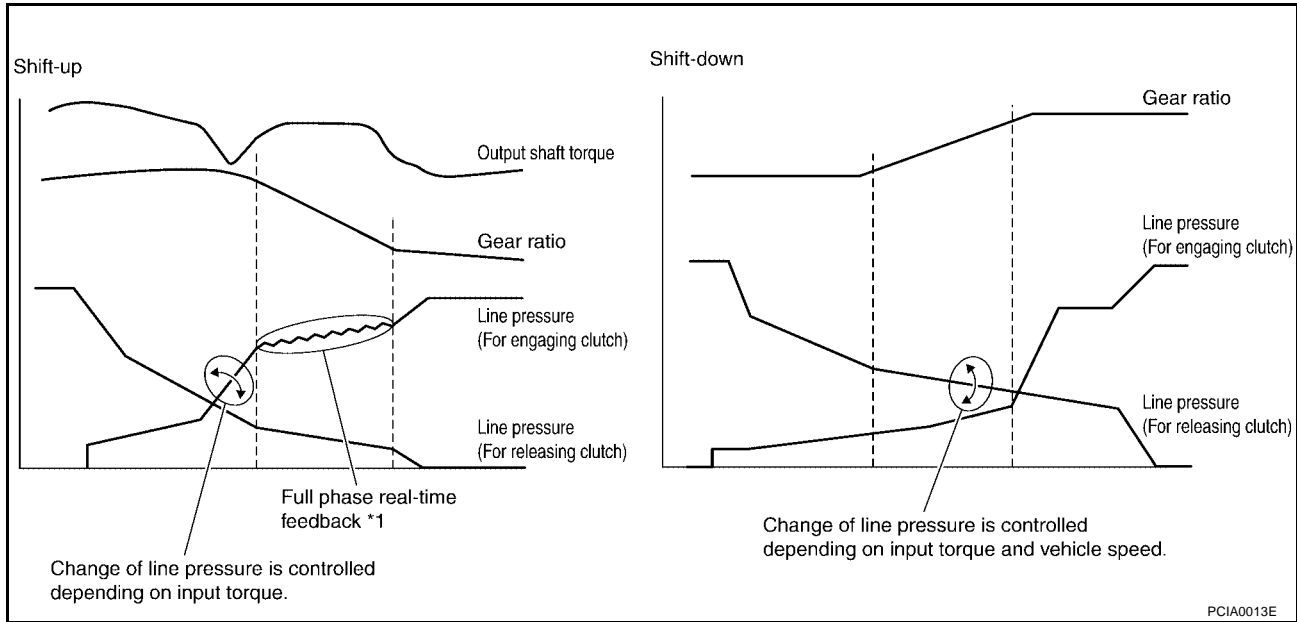

*1: Full phase real-time feedback control monitors movement of gear ratio at gear change, and controls oil pressure at real-time to achieve the best gear ratio.

Lock-up Control

ECS00GWH

The torque converter clutch piston in the torque converter is engaged to eliminate torque converter slip to increase power transmission efficiency.

The torque converter clutch control valve operation is controlled by the torque converter clutch solenoid valve, which is controlled by a signal from TCM, and the torque converter clutch control valve engages or releases the torque converter clutch piston.

Lock-up Operation Condition Table

Select lever	D position		4 position	3 position	2 position
Gear position	5	4	4	3	2
Lock-up	×	—	×	×	×
Slip lock-up	×	×	—	—	—

TORQUE CONVERTER CLUTCH CONTROL VALVE CONTROL

Lock-up Control System Diagram

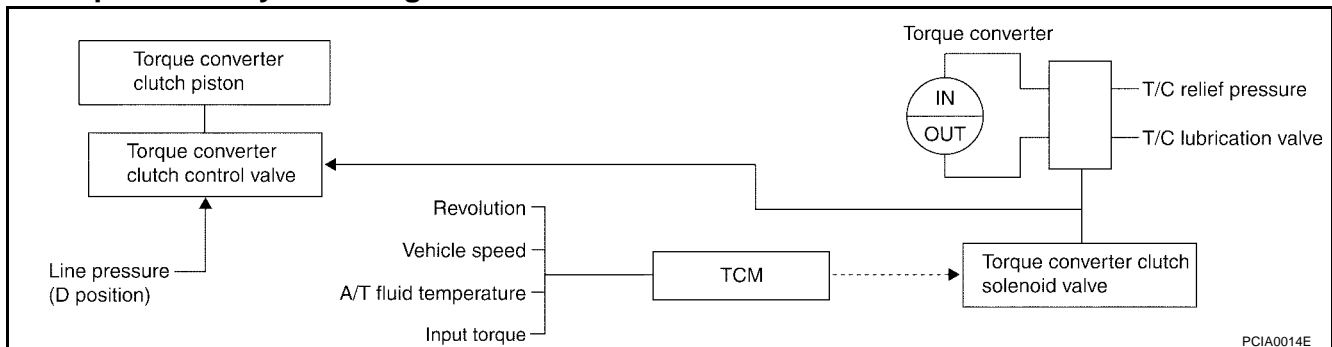

Lock-up Released

- In the lock-up released state, the torque converter clutch control valve is set into the unlocked state by the torque converter clutch solenoid and the lock-up apply pressure is drained. In this way, the torque converter clutch piston is not coupled.

A/T CONTROL SYSTEM

Lock-up Applied

- In the lock-up applied state, the torque converter clutch control valve is set into the locked state by the torque converter clutch solenoid and lock-up apply pressure is generated. In this way, the torque converter clutch piston is pressed and coupled.

SMOOTH LOCK-UP CONTROL

When shifting from the lock-up released state to the lock-up applied state, the current output to the torque converter clutch solenoid is controlled with the TCM. In this way, when shifting to the lock-up applied state, the torque converter clutch is temporarily set to the half-clutched state to reduce the shock.

Half-clutched State

- The current output from the TCM to the torque converter clutch solenoid is varied to gradually increase the torque converter clutch solenoid pressure. In this way, the lock-up apply pressure gradually rises and while the torque converter clutch piston is put into half-clutched status, the torque converter clutch piston operating pressure is increased and the coupling is completed smoothly.

Slip Lock-up Control

- In the slip region, the torque converter clutch solenoid current is controlled with the TCM to put it into the half-clutched state. This absorbs the engine torque fluctuation and lock-up operates from low speed. This raises the fuel efficiency for 4th and 5th gears at both low speed and when the accelerator has a low degree of opening.

A

B

AT

D

E

F

G

H

I

J

K

L

M

A/T CONTROL SYSTEM

Engine Brake Control

ECS00GWJ

- The forward one-way clutch transmits the drive force from the engine to the rear wheels. But the reverse drive from the rear wheels is not transmitted to the engine because the one-way clutch is idling. Therefore, the low coast brake solenoid is operated to prevent the forward one-way clutch from idling and the engine brake is operated in the same manner as conventionally.

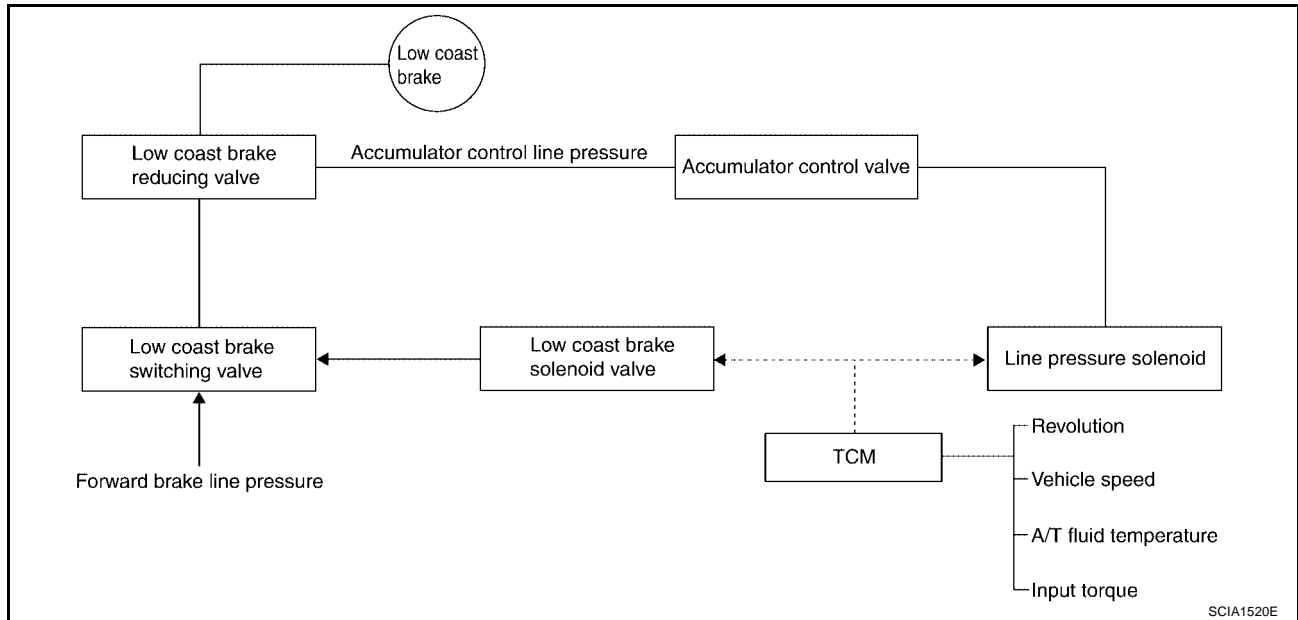

SCIA1520E

- The operation of the low coast brake solenoid switches the low coast brake switching valve and controls the coupling and releasing of the low coast brake. The low coast brake reducing valve controls the low coast brake coupling force.

Control Valve FUNCTION OF CONTROL VALVE

ECS00GWJ

Name	Function
Torque converter regulator valve	In order to prevent the pressure supplied to the torque converter from being excessive, the line pressure is adjusted to the optimum pressure (torque converter operating pressure).
Pressure regulator valve Pressure regulator plug Pressure regulator sleeve	Adjusts the oil discharged from the oil pump to the optimum pressure (line pressure) for the driving state.
Front brake control valve	When the front brake is coupled, adjusts the line pressure to the optimum pressure (front brake pressure) and supplies it to the front brake. (In 1st, 2nd, 3rd, and 5th gears, adjusts the clutch pressure.)
Accumulator control valve	Adjusts the pressure (accumulator control pressure) acting on the accumulator piston and low coast reducing valve to the pressure appropriate to the driving state.
Pilot valve A	Adjusts the line pressure and produces the constant pressure (pilot pressure) required for line pressure control, shift change control, and lock-up control.
Pilot valve B	Adjusts the line pressure and produces the constant pressure (pilot pressure) required for shift change control.
Low coast brake switching valve	During engine braking, supplies the line pressure to the low coast brake reducing valve.
Low coast brake reducing valve	When the low coast brake is coupled, adjusts the line pressure to the optimum pressure (low coast brake pressure) and supplies it to the low coast brake.
N-R accumulator	Produces the stabilizing pressure for when N-R is selected.
Direct clutch piston switching valve	Operates in 4th gear and switches the direct clutch coupling capacity.
High and low reverse clutch control valve	When the high and low reverse clutch is coupled, adjusts the line pressure to the optimum pressure (high and low reverse clutch pressure) and supplies it to the high and low reverse clutch. (In 1st, 3rd, 4th and 5th gears, adjusts the clutch pressure.)

A/T CONTROL SYSTEM

Name	Function
Input clutch control valve	When the input clutch is coupled, adjusts the line pressure to the optimum pressure (input clutch pressure) and supplies it to the input clutch. (In 4th and 5th gears, adjusts the clutch pressure.)
Direct clutch control valve	When the direct clutch is coupled, adjusts the line pressure to the optimum pressure (direct clutch pressure) and supplies it to the direct clutch. (In 2nd, 3rd, and 4th gears, adjusts the clutch pressure.)
TCC control valve TCC control plug TCC control sleeve	Switches the lock-up to operating or released. Also, by performing the lock-up operation transiently, lock-up smoothly.
Torque converter lubrication valve	Operates during lock-up to switch the torque converter, cooling, and lubrication system oil path.
Cool bypass valve	Allows excess oil to bypass cooler circuit without being fed into it.
Line pressure relief valve	Discharges excess oil from line pressure circuit.
N-D accumulator	Produces the stabilizing pressure for when N-D is selected.
Manual valve	Sends line pressure to each circuit according to the select position. The circuits to which the line pressure is not sent drain.

FUNCTION OF PRESSURE SWITCH

Name	Function
Pressure switch 1 (FR/B)	Detects any malfunction in the front brake hydraulic pressure. When it detects any malfunction, it puts the system into fail-safe mode.
Pressure switch 2 (LC/B)	Detects any malfunction in the low coast brake hydraulic pressure. When it detects any malfunction, it puts the system into fail-safe mode.
Pressure switch 3 (I/C)	Detects any malfunction in the input clutch hydraulic pressure. When it detects any malfunction, it puts the system into fail-safe mode.
Pressure switch 5 (D/C)	Detects any malfunction in the direct clutch hydraulic pressure. When it detects any malfunction, it puts the system into fail-safe mode.
Pressure switch 6 (HLR/C)	Detects any malfunction in the high and low reverse clutch hydraulic pressure. When it detects any malfunction, it puts the system into fail-safe mode.

ON BOARD DIAGNOSTIC (OBD) SYSTEM

PFP:00028

Introduction

ECS00GWK

The A/T system has two self-diagnostic systems.

The first is the emission-related on board diagnostic system (OBD-II) performed by the TCM in combination with the ECM. The malfunction is indicated by the MIL (malfunction indicator lamp) and is stored as a DTC in the ECM memory but not the TCM memory.

The second is the TCM original self-diagnosis indicated by the A/T CHECK indicator lamp. The malfunction is stored in the TCM memory. The detected items are overlapped with OBD-II self-diagnostic items. For detail, refer to [AT-86, "SELF-DIAGNOSTIC RESULT MODE"](#).

OBD-II Function for A/T System

ECS00GWL

The ECM provides emission-related on board diagnostic (OBD-II) functions for the A/T system. One function is to receive a signal from the TCM used with OBD-related parts of the A/T system. The signal is sent to the ECM when a malfunction occurs in the corresponding OBD-related part. The other function is to indicate a diagnostic result by means of the MIL (malfunction indicator lamp) on the instrument panel. Sensors, switches and solenoid valves are used as sensing elements.

The MIL automatically illuminates in One or Two Trip Detection Logic when a malfunction is sensed in relation to A/T system parts.

One or Two Trip Detection Logic of OBD-II ONE TRIP DETECTION LOGIC

ECS00GWM

If a malfunction is sensed during the first test drive, the MIL will illuminate and the malfunction will be stored in the ECM memory as a DTC. The TCM is not provided with such a memory function.

TWO TRIP DETECTION LOGIC

When a malfunction is sensed during the first test drive, it is stored in the ECM memory as a 1st trip DTC (diagnostic trouble code) or 1st trip freeze frame data. At this point, the MIL will not illuminate. — 1st Trip



If the same malfunction as that experienced during the first test drive is sensed during the second test drive, the MIL will illuminate. — 2nd Trip

The "Trip" in the "One or Two Trip Detection Logic" means a driving mode in which self-diagnosis is performed during vehicle operation.

OBD-II Diagnostic Trouble Code (DTC) HOW TO READ DTC AND 1ST TRIP DTC

ECS00GWN

DTC and 1st trip DTC can be read by the following methods.

( with **CONSULT-II** or ( **GST**) CONSULT-II or GST (Generic Scan Tool) Examples: P0705, P0720 etc. These DTC are prescribed by SAE J2012.

(CONSULT-II also displays the malfunctioning component or system.)

- **1st trip DTC No. is the same as DTC No.**
- **Output of the diagnostic trouble code indicates that the indicated circuit has a malfunction. However, in case of the Mode II and GST, they do not indicate whether the malfunction is still occurring or occurred in the past and returned to normal. CONSULT-II can identify them as shown below, therefore, CONSULT-II (if available) is recommended.**

A sample of CONSULT-II display for DTC and 1st trip DTC is shown on the next page. DTC or 1st trip DTC of a malfunction is displayed in SELF-DIAGNOSTIC RESULTS mode for "ENGINE" with CONSULT-II. Time data indicates how many times the vehicle was driven after the last detection of a DTC.

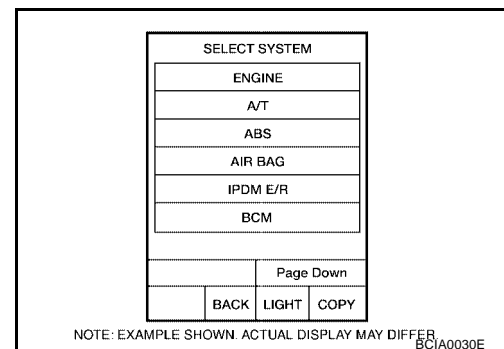

ON BOARD DIAGNOSTIC (OBD) SYSTEM

If the DTC is being detected currently, the time data will be "0".

SELF-DIAG RESULTS	
DTC RESULTS	TIME
PNP SW/CIRC [P0705]	0

SAT015K

If a 1st trip DTC is stored in the ECM, the time data will be "1t".

SELF-DIAG RESULTS	
DTC RESULTS	TIME
PNP SW/CIRC [P0705]	1 t

SAT016K

Freeze Frame Data and 1st Trip Freeze Frame Data

The ECM has a memory function, which stores the driving condition such as fuel system status, calculated load value, engine coolant temperature, short term fuel trim, long term fuel trim, engine speed and vehicle speed at the moment the ECM detects a malfunction.

Data which are stored in the ECM memory, along with the 1st trip DTC, are called 1st trip freeze frame data, and the data, stored together with the DTC data, are called freeze frame data and displayed on CONSULT-II or GST. The 1st trip freeze frame data can only be displayed on the CONSULT-II screen, not on the GST. For detail, refer to [AT-38. "ON BOARD DIAGNOSTIC \(OBD\) SYSTEM"](#).

Only one set of freeze frame data (either 1st trip freeze frame data or freeze frame data) can be stored in the ECM. 1st trip freeze frame data is stored in the ECM memory along with the 1st trip DTC. There is no priority for 1st trip freeze frame data and it is updated each time a different 1st trip DTC is detected. However, once freeze frame data (2nd trip detection/MIL on) is stored in the ECM memory, 1st trip freeze frame data is no longer stored. Remember, only one set of freeze frame data can be stored in the ECM. The ECM has the following priorities to update the data.

Priority	Items
1	Freeze frame data Misfire — DTC: P0300 - P0306 Fuel Injection System Function — DTC: P0171, P0172, P0174, P0175
2	Except the above items (Includes A/T related items)
3	1st trip freeze frame data

Both 1st trip freeze frame data and freeze frame data (along with the DTC) are cleared when the ECM memory is erased.

HOW TO ERASE DTC

The diagnostic trouble code can be erased by CONSULT-II, GST or ECM DIAGNOSTIC TEST MODE as described following.

- If the battery cable is disconnected, the diagnostic trouble code will be lost within 24 hours.
- When you erase the DTC, using CONSULT-II or GST is easier and quicker than switching the mode selector on the ECM.

The following emission-related diagnostic information is cleared from the ECM memory when erasing DTC related to OBD-II. For details, refer to [EC-49. "EMISSION-RELATED DIAGNOSTIC INFORMATION ITEMS"](#).

- Diagnostic trouble codes (DTC)
- 1st trip diagnostic trouble codes (1st trip DTC)
- Freeze frame data

A
B
AT
D
E
F
G
H
I
J
K
L
M

ON BOARD DIAGNOSTIC (OBD) SYSTEM

- 1st trip freeze frame data
- System readiness test (SRT) codes
- Test values

HOW TO ERASE DTC (WITH CONSULT-II)

- If a DTC is displayed for both ECM and TCM, it is necessary to be erased for both ECM and TCM.
1. If the ignition switch stays "ON" after repair work, be sure to turn ignition switch "OFF" once. Wait at least 10 seconds and then turn it "ON" (engine stopped) again.
 2. Turn CONSULT-II "ON" and touch "A/T".
 3. Touch "SELF-DIAG RESULTS".
 4. Touch "ERASE". (The DTC in the TCM will be erased.) Then touch "BACK" twice.
 5. Touch "ENGINE".
 6. Touch "SELF-DIAG RESULTS".
 7. Touch "ERASE". (The DTC in the ECM will be erased.)

How to erase DTC (With CONSULT-II)

1. If the ignition switch stays "ON" after repair work, be sure to turn ignition switch "OFF" once. Wait at least 10 seconds and then turn it "ON" (engine stopped) again.

SELECT SYSTEM
A/T
ENGINE

2. Turn CONSULT-II "ON", and touch "A/T".

SELECT DIAG MODE
SELF-DIAG RESULTS
DATA MONITOR
CAN DIAG SUPPORT MNTR
FUNCTION TEST
DTC WORK SUPPORT
ECU PART NUMBER

3. Touch "SELF-DIAG RESULTS".

SELF-DIAG RESULTS
DTC RESULTS
TCC SOLENOID/CIRC [P0740]

4. Touch "ERASE". (The DTC in the TCM will be erased.)

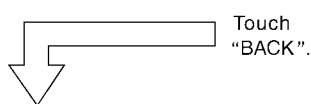

SELECT SYSTEM
A/T
ENGINE

5. Touch "ENGINE".

SELECT DIAG MODE
WORK SUPPORT
SELF-DIAG RESULTS
DATA MONITOR
DATA MONITOR(SPEC)
CAN DIAG SUPPORT MNTR
ACTIVE TEST

6. Touch "SELF-DIAG RESULTS".

SELF-DIAG RESULTS	
DTC RESULTS	TIME
TCC SOLENOID/CIRC [P0740]	0

7. Touch "ERASE". (The DTC in the TCM will be erased.)

SCIA5671E

HOW TO ERASE DTC (WITH GST)

1. If the ignition switch stays "ON" after repair work, be sure to turn ignition switch "OFF" once. Wait at least 10 seconds and then turn it "ON" (engine stopped) again.
2. Select Mode 4 with the Generic Scan Tool (GST). For details refer to [EC-136, "Generic Scan Tool \(GST\) Function"](#).

HOW TO ERASE DTC (NO TOOLS)

1. Disconnect battery for 24 hours.
2. Reconnect battery.

ON BOARD DIAGNOSTIC (OBD) SYSTEM

Malfunction Indicator Lamp (MIL)

ECS00GWO

DESCRIPTION

The MIL is located on the instrument panel.

1. The MIL will light up when the ignition switch is turned "ON" without the engine running. This is a bulb check.
 - If the MIL does not light up, refer to [DI-27, "WARNING LAMPS"](#).
2. When the engine is started, the MIL should go off. If the MIL remains on, the on board diagnostic system has detected an engine system malfunction.

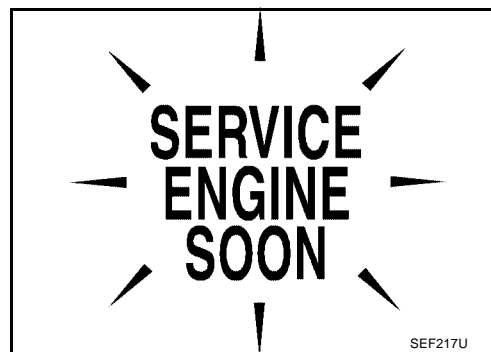

A

B

AT

D

E

F

G

H

I

J

K

L

M

TROUBLE DIAGNOSIS

TROUBLE DIAGNOSIS

PFP:00004

DTC Inspection Priority Chart

ECS00GWP

If some DTCs are displayed at the same time, perform inspections one by one based on the following priority chart.

NOTE:

If DTC U1000 is displayed with other DTCs, first perform the trouble diagnosis for DTC U1000. Refer to [AT-93](#).

Priority	Detected items (DTC)
1	U1000 CAN communication line
2	Except above

Fail-Safe

ECS00GWQ

The TCM has an electrical fail-safe mode. This mode makes it possible to operate even if there is an error in a main electronic control input/output signal circuit. In fail-safe mode the transmission is fixed in 2nd, 4th or 5th (depending on the breakdown position), so the customer should feel "slipping" or "poor acceleration".

Even when the electronic circuits are normal, under special conditions (for example, when slamming on the brake with the wheels spinning drastically and stopping the tire rotation), the transmission can go into fail-safe mode. If this happens, switch "OFF" the ignition switch for 10 seconds, then switch it "ON" again to return to the normal shift pattern. Therefore, the customer's vehicle has returned to normal, so handle according to the "diagnostics flow" (Refer to [AT-45, "WORK FLOW"](#)).

FAIL-SAFE FUNCTION

If any malfunction occurs in a sensor or solenoid, this function controls the A/T to mark driving possible.

Vehicle Speed Sensor

- Signals are input from two systems - from vehicle speed sensor A/T (revolution sensor) installed on the transmission and from combination meter so normal driving is possible even if there is a malfunction in one of the systems. And if vehicle speed sensor A/T (revolution sensor) has unusual cases, 5th gear is prohibited.

Accelerator Pedal Position Sensor

- If there is a malfunction in one of the systems, the accelerator opening angle is controlled by ECM according to a pre-determined accelerator angle to make driving possible. And if there are malfunctions in tow systems, the engine speed is fixed by ECM to a pre-determined engine speed to make driving possible.

Throttle Position Sensor

- If there is a malfunction in one of the systems, the accelerator opening angle is controlled by ECM according to a pre-determined accelerator angle to make driving possible. And if there are malfunctions in tow systems, the accelerator opening angle is controlled by the idle signal sent from the ECM which is based on input indicating either idle condition or off-idle condition (pre-determined accelerator opening) in order to make driving possible.

PNP Switch

- In the unlikely event that a malfunction signal enters the TCM, the position indicator is switched "OFF", the starter relay is switched "OFF" (starter starting is disabled), the back-up lamp relay switched "OFF" (back-up lamp is OFF) and the position is fixed to the "D" range to make driving possible.

Starter Relay

- The starter relay is switched "OFF". (Starter starting is disabled.)

TROUBLE DIAGNOSIS

A/T Interlock

- If there is an A/T interlock judgment malfunction, the transmission is fixed in 2nd gear to make driving possible.

NOTE:

When the vehicle is driven fixed in 2nd gear, a turbine revolution sensor malfunction is displayed, but this is not a turbine revolution sensor malfunction.

- When the coupling pattern below is detected, the fail-safe action corresponding to the pattern is performed.

A/T INTERLOCK COUPLING PATTERN TABLE

●: NG X: OK

Gear position		ATF pressure switch output					Fail-safe function	Clutch pressure output pattern after fail-safe function					
		SW3 (I/C)	SW6 (HLR/C)	SW5 (D/C)	SW1 (FR/B)	SW2 (LC/B)		I/C	HLR/C	D/C	FR/B	LC/B	L/U
A/T interlock coupling pattern	3rd	–	X	X	–	●	Held in 2nd gear	OFF	OFF	ON	OFF	OFF	OFF
	4th	–	X	X	–	●	Held in 2nd gear	OFF	OFF	ON	OFF	OFF	OFF
	5th	X	X	–	X	●	Held in 2nd gear	OFF	OFF	ON	OFF	OFF	OFF

A/T 1st Engine Braking

- When there is an A/T first gear engine brake judgment malfunction, the low coast brake solenoid is switched “OFF” to avoid the engine brake operation.

Line Pressure Solenoid

- The solenoid is switched “OFF” and the line pressure is set to the maximum hydraulic pressure to make driving possible.

Torque Converter Clutch Solenoid

- The solenoid is switched “OFF” to release the lock-up.

Low Coast Brake Solenoid

- When a (electrical or functional) malfunction occurs, in order to make driving possible, the engine brake is not applied in 1st and 2nd gear.

Input Clutch Solenoid

- If a (electrical or functional) malfunction occurs with the solenoid either “ON” or “OFF”, the transmission is held in 4th gear to make driving possible.

Direct Clutch Solenoid

- If a (electrical or functional) malfunction occurs with the solenoid either “ON” or “OFF”, the transmission is held in 4th gear to make driving possible.

Front Brake Solenoid

- If a (electrical or functional) malfunction occurs with the solenoid “ON”, in order to make driving possible, the A/T is held in 5th gear; if the solenoid is OFF, 4th gear.

High and Low Reverse Clutch Solenoid

- If a (electrical or functional) malfunction occurs with the solenoid either “ON” or “OFF”, the transmission is held in 4th gear to make driving possible.

Turbine Revolution Sensor 1 or 2

- The control is the same as if there were no turbine revolution sensors, 5th gear is prohibited.

TROUBLE DIAGNOSIS

How To Perform Trouble Diagnosis For Quick and Accurate Repair INTRODUCTION

ECS00GWR

The TCM receives a signal from the vehicle speed sensor, accelerator pedal position sensor (throttle position sensor) or PNP switch and provides shift control or lock-up control via A/T solenoid valves.

The TCM also communicates with the ECM by means of a signal sent from sensing elements used with the OBD-related parts of the A/T system for malfunction-diagnostic purposes. The TCM is capable of diagnosing malfunctioning parts while the ECM can store malfunctions in its memory.

Input and output signals must always be correct and stable in the operation of the A/T system. The A/T system must be in good operating condition and be free of valve seizure, solenoid valve malfunction, etc.

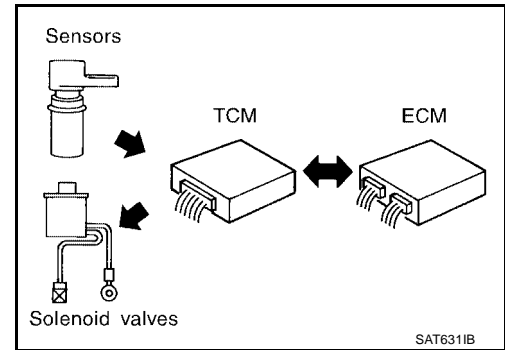

It is much more difficult to diagnose a error that occurs intermittently rather than continuously. Most intermittent errors are caused by poor electric connections or improper wiring. In this case, careful checking of suspected circuits may help prevent the replacement of good parts.

A visual check only may not find the cause of the errors. A road test with CONSULT-II (or GST) or a circuit tester connected should be performed. Follow the [AT-45. "WORK FLOW"](#) .

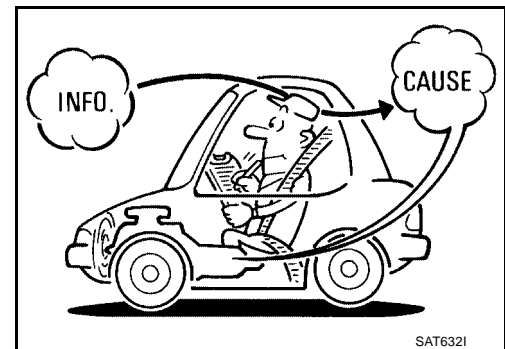

Before undertaking actual checks, take a few minutes to talk with a customer who approaches with a driveability complaint. The customer can supply good information about such errors, especially intermittent ones. Find out what symptoms are present and under what conditions they occur. A "Diagnostic Worksheet" as shown on the example (Refer to [AT-46](#)) should be used.

Start your diagnosis by looking for "conventional" errors first. This will help troubleshoot driveability errors on an electronically controlled engine vehicle.

Also check related Service bulletins.

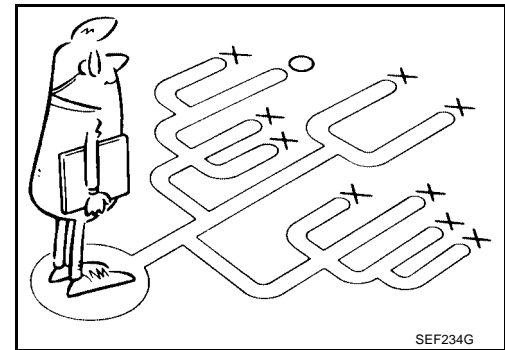

TROUBLE DIAGNOSIS

WORK FLOW

A good understanding of the malfunction conditions can make troubleshooting faster and more accurate. In general, each customer feels differently about a malfunction. It is important to fully understand the symptoms or conditions for a customer complaint. Make good use of the two sheets provided, "Information From Customer" (Refer to [AT-46](#)) and "Diagnostic Worksheet" (Refer to [AT-46](#)), to perform the best troubleshooting possible.

Work Flow Chart

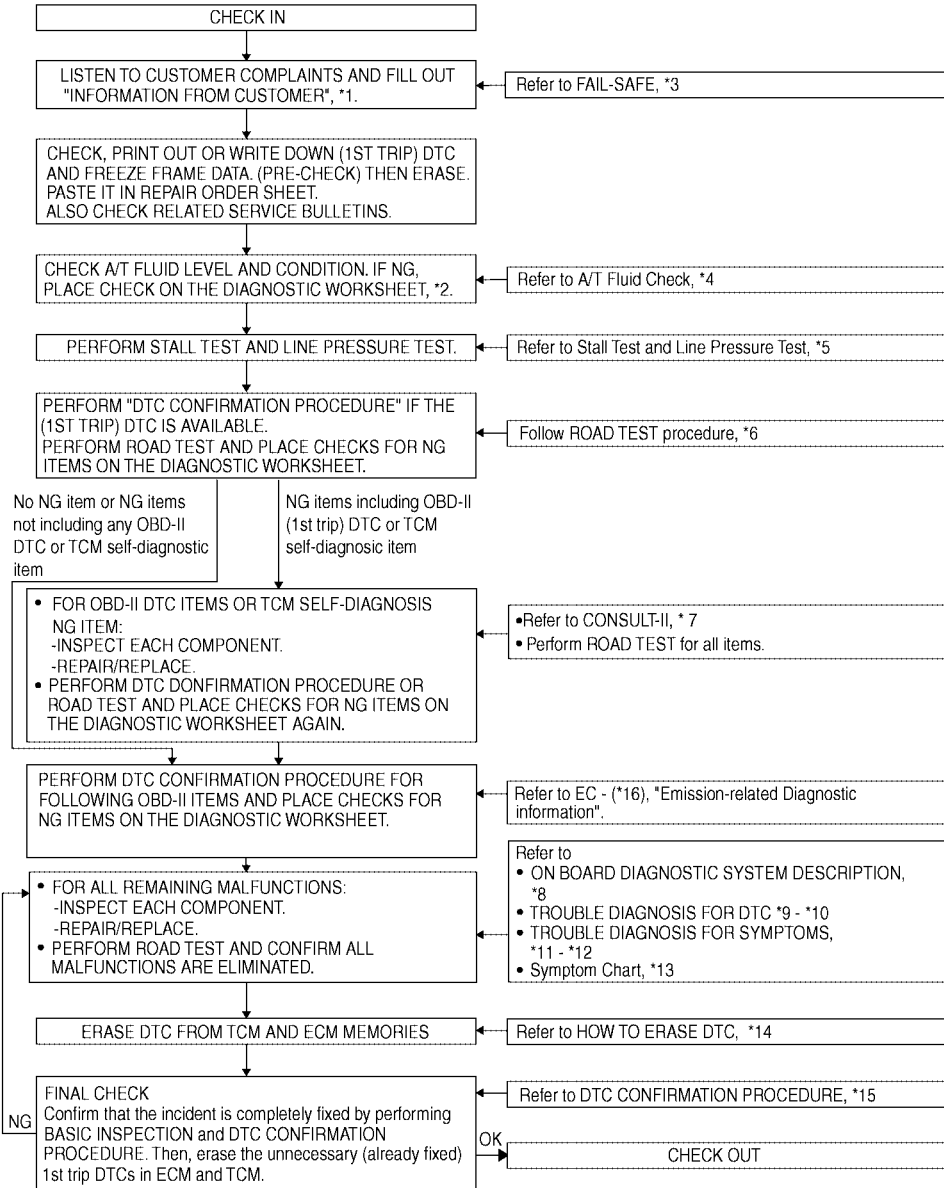

- | | | |
|-----------------------------|---|-----------------------------|
| *1. AT-46 | *2. AT-46 | *3. AT-42 |
| *4. AT-51 | *5. AT-51 , AT-52 | *6. AT-54 |
| *7. AT-84 | *8. AT-38 | *9. AT-93 |
| *10. AT-169 | *11. AT-172 | *12. AT-213 |
| *13. AT-61 | *14. AT-39 | *15. AT-161 |
| *16. EC-49 | | |

WCIA0251E

TROUBLE DIAGNOSIS

DIAGNOSTIC WORKSHEET

Information From Customer

KEY POINTS

- **WHAT.....** Vehicle & A/T model
- **WHEN.....** Date, Frequencies
- **WHERE.....** Road conditions
- **HOW.....** Operating conditions, Symptoms

Customer name MR/MS	Model & Year	VIN
Trans. Model	Engine	Mileage
Malfunction Date	Manuf. Date	In Service Date
Frequency	<input type="checkbox"/> Continuous <input type="checkbox"/> Intermittent (times a day)	
Symptoms	<input type="checkbox"/> Vehicle does not move. (<input type="checkbox"/> Any position <input type="checkbox"/> Particular position)	
	<input type="checkbox"/> No up-shift (<input type="checkbox"/> 1st → 2nd <input type="checkbox"/> 2nd → 3rd <input type="checkbox"/> 3rd → 4th <input type="checkbox"/> 4th → 5th)	
	<input type="checkbox"/> No down-shift (<input type="checkbox"/> 5th → 4th <input type="checkbox"/> 4th → 3rd <input type="checkbox"/> 3rd → 2nd <input type="checkbox"/> 2nd → 1st)	
	<input type="checkbox"/> Lock-up malfunction	
	<input type="checkbox"/> Shift point too high or too low.	
	<input type="checkbox"/> Shift shock or slip (<input type="checkbox"/> N → D <input type="checkbox"/> Lock-up <input type="checkbox"/> Any drive position)	
	<input type="checkbox"/> Noise or vibration	
	<input type="checkbox"/> No kick down	
Malfunction indicator lamp (MIL)	<input type="checkbox"/> No pattern select	
	<input type="checkbox"/> Others ()	
	<input type="checkbox"/> Continuously lit	<input type="checkbox"/> Not lit

Diagnostic Worksheet Chart

1	<input type="checkbox"/> Read the item on cautions concerning fail-safe and understand the customer's complaint.	AT-42
2	<input type="checkbox"/> ATF inspection	AT-51
	<input type="checkbox"/> Leak (Repair leak location.) <input type="checkbox"/> State <input type="checkbox"/> Amount	
3	<input type="checkbox"/> Stall test and line pressure test	
	<input type="checkbox"/> Stall test	
	<input type="checkbox"/> Torque converter one-way clutch <input type="checkbox"/> Front brake <input type="checkbox"/> High and low reverse clutch <input type="checkbox"/> Low coast brake <input type="checkbox"/> Forward brake <input type="checkbox"/> Reverse brake <input type="checkbox"/> Forward one-way clutch	<input type="checkbox"/> 1st one-way clutch <input type="checkbox"/> 3rd one-way clutch <input type="checkbox"/> Engine <input type="checkbox"/> Line pressure low <input type="checkbox"/> Except for input clutch and direct clutch, clutches and brakes OK
<input type="checkbox"/> Line pressure inspection - Suspected part:		AT-51, AT-52

TROUBLE DIAGNOSIS

		<input type="checkbox"/> Perform all road tests and enter checks in required inspection items.	AT-54	A
		Check before engine is started		
		<input type="checkbox"/> AT-175. "A/T CHECK Indicator Lamp Does Not Come On" . <input type="checkbox"/> Perform self-diagnostics Enter checks for detected items. AT-86	AT-55	B
	4-1.	<input type="checkbox"/> AT-93. "DTC U1000 CAN COMMUNICATION LINE" <input type="checkbox"/> AT-96. "DTC P0615 START SIGNAL CIRCUIT" <input type="checkbox"/> AT-100. "DTC P0700 TCM" <input type="checkbox"/> AT-101. "DTC P0705 PARK/NEUTRAL POSITION SWITCH" <input type="checkbox"/> AT-105. "DTC P0717 TURBINE REVOLUTION SENSOR" <input type="checkbox"/> AT-107. "DTC P0720 VEHICLE SPEED SENSOR A/T (REVOLUTION SENSOR)" <input type="checkbox"/> AT-112. "DTC P0725 ENGINE SPEED SIGNAL" <input type="checkbox"/> AT-114. "DTC P0740 TORQUE CONVERTER CLUTCH SOLENOID VALVE" <input type="checkbox"/> AT-116. "DTC P0744 A/T TCC S/V FUNCTION (LOCK-UP)" <input type="checkbox"/> AT-118. "DTC P0745 LINE PRESSURE SOLENOID VALVE" <input type="checkbox"/> AT-120. "DTC P1705 THROTTLE POSITION SENSOR" <input type="checkbox"/> AT-123. "DTC P1710 A/T FLUID TEMPERATURE SENSOR CIRCUIT" <input type="checkbox"/> AT-128. "DTC P1721 VEHICLE SPEED SENSOR MTR" <input type="checkbox"/> AT-130. "DTC P1730 A/T INTERLOCK" <input type="checkbox"/> AT-133. "DTC P1731 A/T 1ST ENGINE BRAKING" <input type="checkbox"/> AT-135. "DTC P1752 INPUT CLUTCH SOLENOID VALVE" <input type="checkbox"/> AT-137. "DTC P1754 INPUT CLUTCH SOLENOID VALVE FUNCTION" <input type="checkbox"/> AT-139. "DTC P1757 FRONT BRAKE SOLENOID VALVE" <input type="checkbox"/> AT-141. "DTC P1759 FRONT BRAKE SOLENOID VALVE FUNCTION" <input type="checkbox"/> AT-143. "DTC P1762 DIRECT CLUTCH SOLENOID VALVE" <input type="checkbox"/> AT-145. "DTC P1764 DIRECT CLUTCH SOLENOID VALVE FUNCTION" <input type="checkbox"/> AT-147. "DTC P1767 HIGH AND LOW REVERSE CLUTCH SOLENOID VALVE" <input type="checkbox"/> AT-149. "DTC P1769 HIGH AND LOW REVERSE CLUTCH SOLENOID VALVE FUNCTION" <input type="checkbox"/> AT-151. "DTC P1772 LOW COAST BRAKE SOLENOID VALVE" <input type="checkbox"/> AT-153. "DTC P1774 LOW COAST BRAKE SOLENOID VALVE FUNCTION" <input type="checkbox"/> AT-155. "DTC P1841 ATF PRESSURE SWITCH 1" <input type="checkbox"/> AT-157. "DTC P1843 ATF PRESSURE SWITCH 3" <input type="checkbox"/> AT-159. "DTC P1845 ATF PRESSURE SWITCH 5" <input type="checkbox"/> AT-161. "DTC P1846 ATF PRESSURE SWITCH 6"		AT
4				D
				E
				F
				G
				H
				I
				J
	4-2.	Idle inspection		
		<input type="checkbox"/> AT-175. "Engine Cannot Be Started In "P" or "N" Position" <input type="checkbox"/> AT-176. "In "P" Position, Vehicle Moves When Pushed" <input type="checkbox"/> AT-177. "In "N" Position, Vehicle Moves" <input type="checkbox"/> AT-178. "Large Shock("N" to "D" Position)" <input type="checkbox"/> AT-181. "Vehicle Does Not Creep Backward In "R" Position" <input type="checkbox"/> AT-184. "Vehicle Does Not Creep Forward In "D" Position"	AT-55	K
				L
	4-3.	Part 1		
		<input type="checkbox"/> AT-186. "Vehicle Cannot Be Started From D1" <input type="checkbox"/> AT-189. "A/T Does Not Shift: D1 → D2" <input type="checkbox"/> AT-191. "A/T Does Not Shift: D2 → D3" <input type="checkbox"/> AT-193. "A/T Does Not Shift: D3 → D4" <input type="checkbox"/> AT-196. "A/T Does Not Shift: D4 → D5" <input type="checkbox"/> AT-198. "A/T Does Not Perform Lock-up" <input type="checkbox"/> AT-200. "A/T Does Not Hold Lock-up Condition" <input type="checkbox"/> AT-202. "Lock-up Is Not Released" <input type="checkbox"/> AT-203. "Engine Speed Does Not Return to Idle"	AT-56	M

TROUBLE DIAGNOSIS

4	4-3	Part 2 <input type="checkbox"/> AT-186, "Vehicle Cannot Be Started From D1" <input type="checkbox"/> AT-189, "A/T Does Not Shift: D1 → D2" <input type="checkbox"/> AT-191, "A/T Does Not Shift: D2 → D3" <input type="checkbox"/> AT-193, "A/T Does Not Shift: D3 → D4"	AT-58
		Part 3 <input type="checkbox"/> AT-204, "A/T Does Not Shift: 5th gear → 4th gear" <input type="checkbox"/> AT-207, "A/T Does Not Shift: 4th gear → 3rd gear" <input type="checkbox"/> AT-208, "A/T Does Not Shift: 3rd gear → 2nd gear" <input type="checkbox"/> AT-210, "A/T Does Not Shift: 2nd gear → 1st gear" <input type="checkbox"/> AT-213, "Vehicle Does Not Decelerate By Engine Brake" <input type="checkbox"/> Perform self-diagnostics Enter checks for detected items. AT-86	AT-59
		<input type="checkbox"/> AT-93, "DTC U1000 CAN COMMUNICATION LINE" <input type="checkbox"/> AT-96, "DTC P0615 START SIGNAL CIRCUIT" <input type="checkbox"/> AT-100, "DTC P0700 TCM" <input type="checkbox"/> AT-101, "DTC P0705 PARK/NEUTRAL POSITION SWITCH" <input type="checkbox"/> AT-105, "DTC P0717 TURBINE REVOLUTION SENSOR" <input type="checkbox"/> AT-107, "DTC P0720 VEHICLE SPEED SENSOR A/T (REVOLUTION SENSOR)" <input type="checkbox"/> AT-112, "DTC P0725 ENGINE SPEED SIGNAL" <input type="checkbox"/> AT-114, "DTC P0740 TORQUE CONVERTER CLUTCH SOLENOID VALVE" <input type="checkbox"/> AT-116, "DTC P0744 A/T TCC S/V FUNCTION (LOCK-UP)" <input type="checkbox"/> AT-118, "DTC P0745 LINE PRESSURE SOLENOID VALVE" <input type="checkbox"/> AT-120, "DTC P1705 THROTTLE POSITION SENSOR" <input type="checkbox"/> AT-123, "DTC P1710 A/T FLUID TEMPERATURE SENSOR CIRCUIT" <input type="checkbox"/> AT-128, "DTC P1721 VEHICLE SPEED SENSOR MTR" <input type="checkbox"/> AT-130, "DTC P1730 A/T INTERLOCK" <input type="checkbox"/> AT-133, "DTC P1731 A/T 1ST ENGINE BRAKING" <input type="checkbox"/> AT-135, "DTC P1752 INPUT CLUTCH SOLENOID VALVE" <input type="checkbox"/> AT-137, "DTC P1754 INPUT CLUTCH SOLENOID VALVE FUNCTION" <input type="checkbox"/> AT-139, "DTC P1757 FRONT BRAKE SOLENOID VALVE" <input type="checkbox"/> AT-141, "DTC P1759 FRONT BRAKE SOLENOID VALVE FUNCTION" <input type="checkbox"/> AT-143, "DTC P1762 DIRECT CLUTCH SOLENOID VALVE" <input type="checkbox"/> AT-145, "DTC P1764 DIRECT CLUTCH SOLENOID VALVE FUNCTION" <input type="checkbox"/> AT-147, "DTC P1767 HIGH AND LOW REVERSE CLUTCH SOLENOID VALVE" <input type="checkbox"/> AT-149, "DTC P1769 HIGH AND LOW REVERSE CLUTCH SOLENOID VALVE FUNCTION" <input type="checkbox"/> AT-151, "DTC P1772 LOW COAST BRAKE SOLENOID VALVE" <input type="checkbox"/> AT-153, "DTC P1774 LOW COAST BRAKE SOLENOID VALVE FUNCTION" <input type="checkbox"/> AT-155, "DTC P1841 ATF PRESSURE SWITCH 1" <input type="checkbox"/> AT-157, "DTC P1843 ATF PRESSURE SWITCH 3" <input type="checkbox"/> AT-159, "DTC P1845 ATF PRESSURE SWITCH 5" <input type="checkbox"/> AT-161, "DTC P1846 ATF PRESSURE SWITCH 6"	
<input type="checkbox"/> Inspect each system for items found to be NG in the self-diagnostics and repair or replace the malfunction parts.			
6	<input type="checkbox"/> Perform all road tests and enter the checks again for the required items.	AT-54	
7	<input type="checkbox"/> For any remaining NG items, perform the "diagnostics procedure" and repair or replace the malfunction parts. See the chart for diagnostics by symptoms. (This chart also contains other symptoms and inspection procedures.)	AT-61	
8	<input type="checkbox"/> Erase the results of the self-diagnostics from the TCM.	AT-39	

TROUBLE DIAGNOSIS

A/T Electrical Parts Location

ECS00GWS

A
B
AT
D
E
F
G
H
I
J
K
L
M

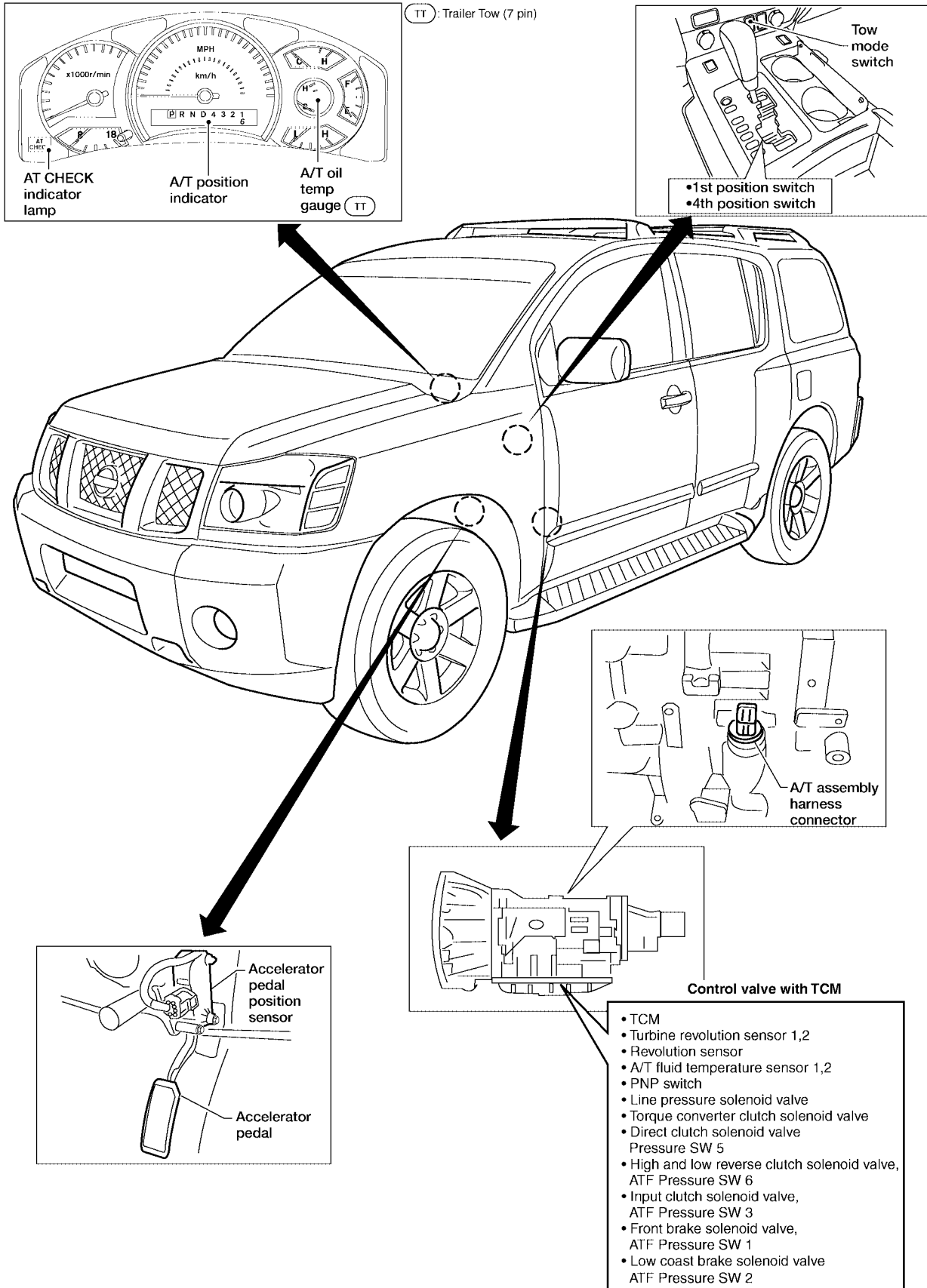

WCIA0551E

TROUBLE DIAGNOSIS

Schematic

ECS00GWT

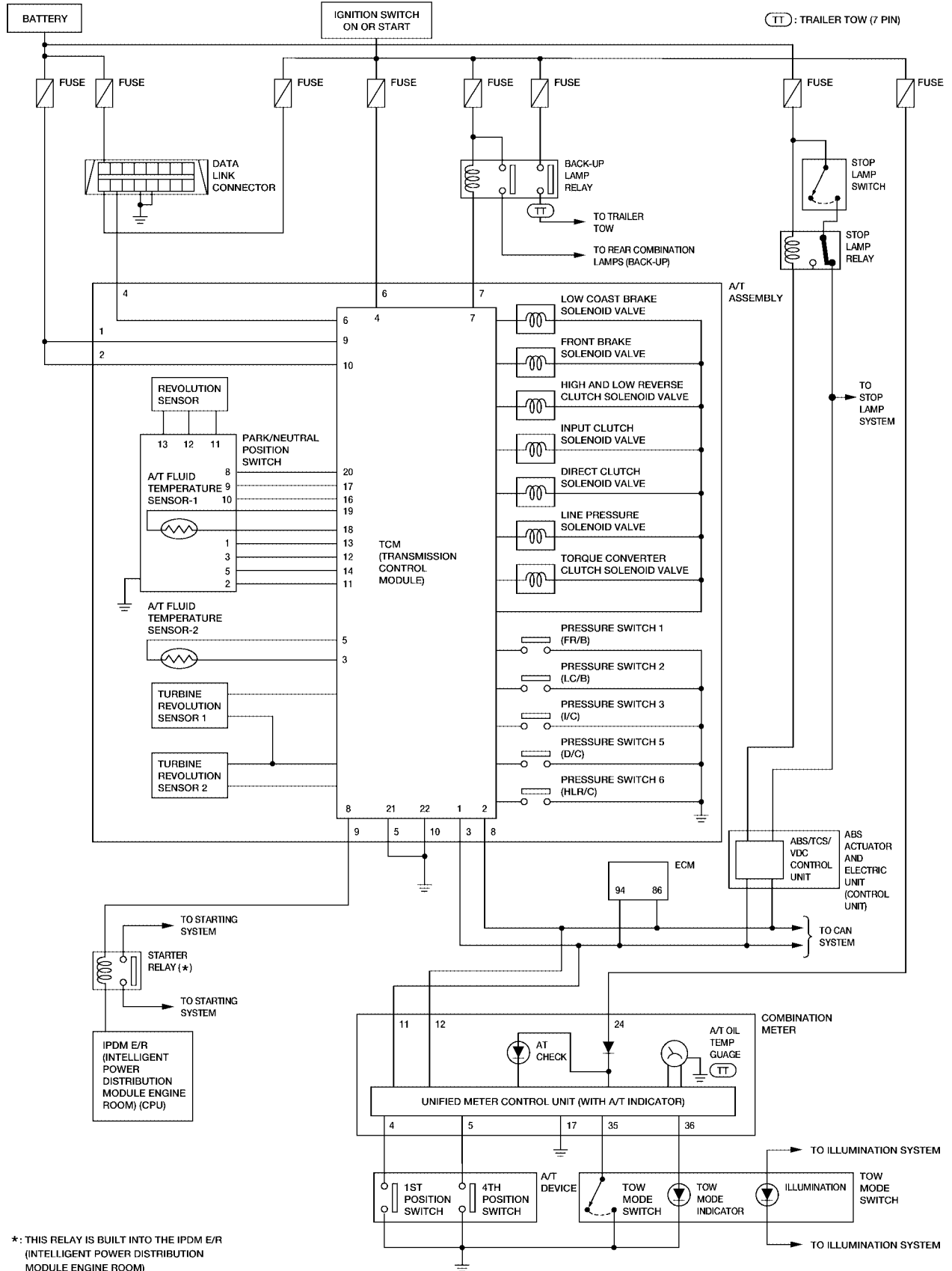

BCWA0503E

TROUBLE DIAGNOSIS

ECS00GWU

Inspections Before Trouble Diagnosis

A/T FLUID CHECK

Fluid Leakage and Fluid Level Check

- Inspect for fluid leakage and check the fluid level. Refer to [AT-12, "Checking Automatic Transmission Fluid \(ATF\)"](#).

Fluid Condition Check

Inspect the fluid condition.

Fluid condition	Conceivable Cause	Required Operation
Varnished (viscous varnish state)	Clutch, brake scorched	Replace the ATF and check the A/T main unit and the vehicle for malfunctions (wire harnesses, cooler pipes, etc.)
Milky white or cloudy	Water in the fluid	Replace the ATF and check for places where water is getting in.
Large amount of metal powder mixed in	Unusual wear of sliding parts within A/T	Replace the ATF and check for improper operation of the A/T.

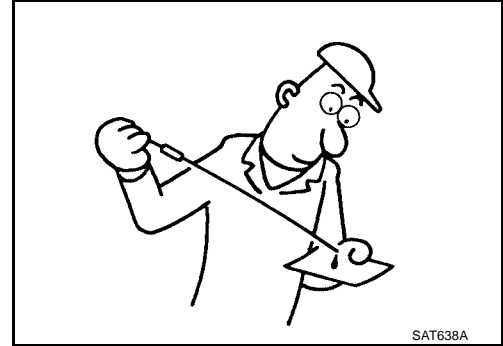

STALL TEST

Stall Test Procedure

- Inspect the amount of engine oil. Replenish the engine oil if necessary.
- Drive for about 10 minutes to warm up the vehicle so that the A/T fluid temperature is 50 to 80°C (122 to 176°F). Inspect the amount of ATF. Replenish if necessary.

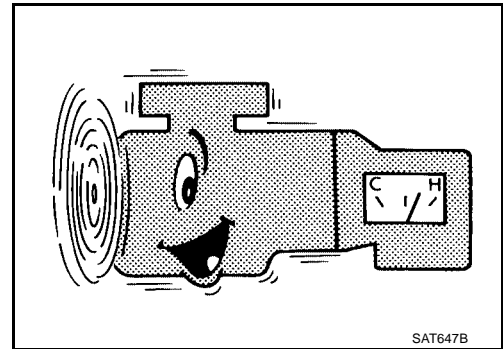

- Securely engage the parking brake so that the tires do not turn.

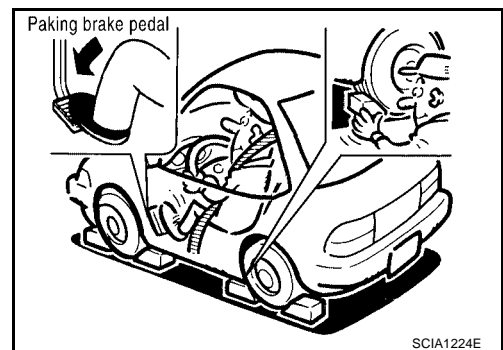

- Engine start, apply foot brake, and place selector lever in "D" position.
- While holding down the foot brake, gradually press down the accelerator pedal.
- Quickly read off the stall speed, then quickly remove your foot from the accelerator pedal.

CAUTION:

Do not hold down the accelerator pedal for more than 5 seconds during this test.

- Move the selector lever to the "N" position.

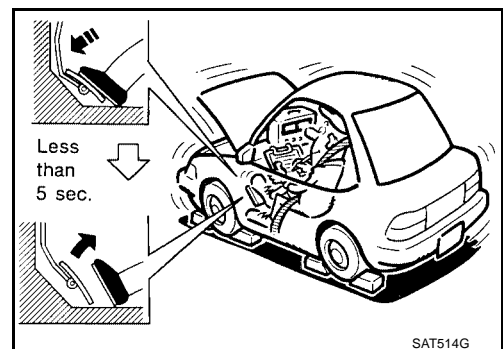

A
B
AT
D
E
F
G
H
I
J
K
L
M

TROUBLE DIAGNOSIS

8. Cool down the ATF.

CAUTION:

Run the engine at idle for at least one minute.

Stall speed: 2,350 - 2,650 rpm

Judgement of Stall Test

	Selector lever position		Expected problem location
	D	R	
Stall rotation	H	O	<ul style="list-style-type: none"> ● Forward brake ● Forward one-way clutch ● 1st one-way clutch ● 3rd one-way clutch
	O	H	<ul style="list-style-type: none"> ● Reverse brake
	L	L	<ul style="list-style-type: none"> ● Engine and torque converter one-way clutch
	H	H	<ul style="list-style-type: none"> ● Line pressure low

O: Stall speed within standard value position

H: Stall speed higher than standard value

L: Stall speed lower than standard value

Stall test standard value position

Does not shift-up D position 1 → 2	Slipping in 2nd, 3rd, 4th gears	Direct clutch slippage
Does not shift-up D position 2 → 3	Slipping in 3rd, 4th, 5th gears	High and low reverse clutch slippage
Does not shift-up D position 3 → 4	Slipping in 4th, 5th gears	Input clutch slippage
Does not shift-up D position 4 → 5	Slipping in 5th gear	Front brake slippage

LINE PRESSURE TEST

Line Pressure Test Port

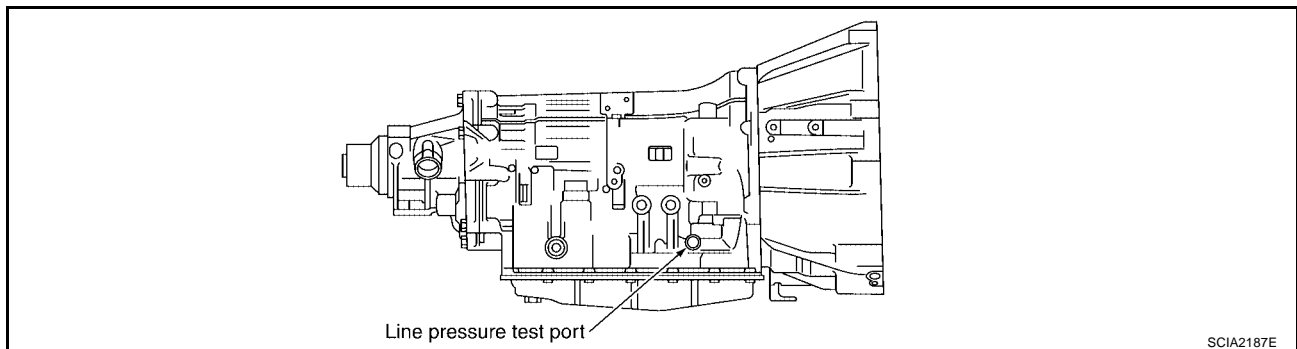

Line Pressure Test Procedure

1. Inspect the amount of engine oil and replenish if necessary.
2. Drive the car for about 10 minutes to warm it up so that the ATF reaches in range of 50 to 80°C (122 to 176°F), then inspect the amount of ATF and replenish if necessary.

NOTE:

The automatic fluid temperature rises in range of 50 to 80°C (122 to 176°F) during 10 minutes of driving.

TROUBLE DIAGNOSIS

3. After warming up remove the oil pressure detection plug and install the Tool.

CAUTION:

When using the oil pressure gauge, be sure to use the O-ring attached to the oil pressure detection plug.

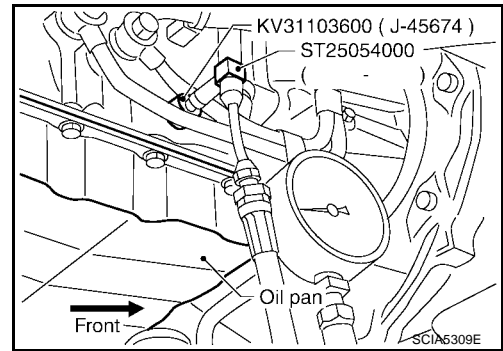

4. Securely engage the parking brake so that the tires do not turn.

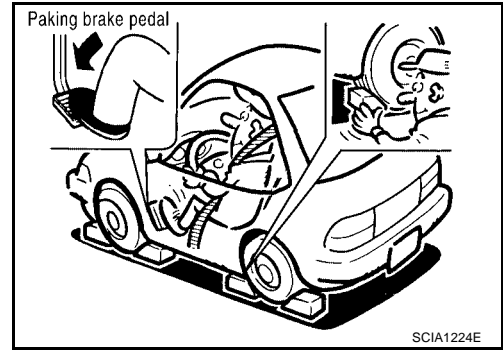

5. Start the engine, then measure the line pressure at both idle and the stall speed.

CAUTION:

- Keep the brake pedal pressed all the way down during measurement.
- When measuring the line pressure at the stall speed, refer to [AT-51, "STALL TEST"](#).

6. After the measurements are complete, install the oil pressure detection plug and tighten to the regulation torque below.

Oil pressure detection plug :7.3 N·m (0.74 kg·m, 65 in·lb)

CAUTION:

Do not reuse the O-ring.

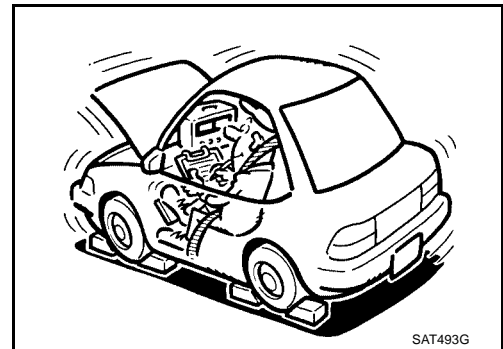

Line Pressure

Engine speed	Line pressure [kPa (kg/cm ² , psi)]	
	R position	D position
At idle speed	425 - 465 (4.3 - 4.7, 62 - 67)	379 - 428 (3.9 - 4.4, 55 - 62)
At stall speed	1,605 - 1,950 (16.4 - 19.9, 233 - 283)	1,310 - 1,500 (13.4 - 15.3, 190 - 218)

A
B
AT
D
E
F
G
H
I
J
K
L
M

TROUBLE DIAGNOSIS

Judgement of Line Pressure Test

Judgement		Possible cause
Idle speed	Low for all positions (P, R, N, D)	<p>Possible causes include malfunctions in the pressure supply system and low oil pump output.</p> <p>For example</p> <ul style="list-style-type: none"> ● Oil pump wear ● Pressure regulator valve or plug sticking or spring fatigue ● Oil strainer ⇒ oil pump ⇒ pressure regulator valve passage oil leak ● Engine idle speed too low
	Only low for a specific position	<p>Possible causes include an oil pressure leak in a passage or device related to the position after the pressure is distributed by the manual valve.</p>
	High	<p>Possible causes include a sensor malfunction or malfunction in the line pressure adjustment function.</p> <p>For example</p> <ul style="list-style-type: none"> ● Accelerator pedal position signal malfunction ● ATF temperature sensor malfunction ● Line pressure solenoid malfunction (sticking in "OFF" state, filter clog, cut line) ● Pressure regulator valve or plug sticking
Stall speed	Oil pressure does not rise higher than the oil pressure for idle.	<p>Possible causes include a sensor malfunction or malfunction in the pressure adjustment function.</p> <p>For example</p> <ul style="list-style-type: none"> ● Accelerator pedal position signal malfunction ● TCM breakdown ● Line pressure solenoid malfunction (shorting, sticking in "ON" state) ● Pressure regulator valve or plug sticking ● Pilot valve sticking or pilot filter clogged
	The pressure rises, but does not enter the standard position.	<p>Possible causes include malfunctions in the pressure supply system and malfunction in the pressure adjustment function.</p> <p>For example</p> <ul style="list-style-type: none"> ● Accelerator pedal position signal malfunction ● Line pressure solenoid malfunction (sticking, filter clog) ● Pressure regulator valve or plug sticking ● Pilot valve sticking or pilot filter clogged
	Only low for a specific position	<p>Possible causes include an oil pressure leak in a passage or device related to the position after the pressure is distributed by the manual valve.</p>

ROAD TEST

Description

- The road test inspects overall performance of the A/T and analyzes possible malfunction causes.
- The road test is carried out in the following three stages.
 1. Check before engine is started. Refer to [AT-55](#) .
 2. Check at idle. Refer to [AT-55](#) .
 3. Cruise test
 - Inspect all the items from Part 1 to Part 3. Refer to [AT-56](#) , [AT-58](#) , [AT-59](#) .
- Before beginning the road test, check the test procedure and inspection items.
- Test all inspection items until the symptom is uncovered. Diagnose NG items when all road tests are complete.

TROUBLE DIAGNOSIS

Check Before Engine is Started

ECS00GWV

1. CHECK AT CHECK INDICATOR LAMP

1. Park vehicle on level surface.
2. Move selector lever to "P" position.
3. Turn ignition switch to "OFF" position and wait at least 10 seconds.
4. Turn ignition switch to "ON" position. (Do not start engine.)

Does AT CHECK indicator lamp light up for about 2 seconds?

YES >> 1. Turn ignition switch to "OFF" position.

2. Carry out the self-diagnostics and record all NG items on the diagnostics worksheet. Refer to [AT-86](#).

3. Go to [AT-55, "Check at Idle"](#).

NO >> Stop the road test and go to [AT-175, "A/T CHECK Indicator Lamp Does Not Come On"](#).

Check at Idle

ECS00GWV

1. CHECK STARTING THE ENGINE

1. Park vehicle on level surface.
2. Move selector lever to "P" or "N" position.
3. Turn ignition switch to "OFF" position.
4. Turn ignition switch to "START" position.

Does the engine start?

YES >> GO TO 2.

NO >> Stop the road test and go to [AT-175, "Engine Cannot Be Started In "P" or "N" Position"](#).

2. CHECK STARTING THE ENGINE

1. Turn ignition switch to "ON" position.
2. Move selector lever in "D", "4", "3", "2", "1" or "R" position.
3. Turn ignition switch to "START" position.

Does the engine start in either position?

YES >> Stop the road test and go to [AT-175, "Engine Cannot Be Started In "P" or "N" Position"](#).

NO >> GO TO 3.

3. CHECK "P" POSITION FUNCTIONS

1. Move selector lever to "P" position.
2. Turn ignition switch to "OFF" position.
3. Release the parking brake.
4. Push the vehicle forward or backward.
5. Engage the parking brake.

When you push the vehicle with disengaging the parking brake, does it move?

YES >> Enter a check mark at "In "P" Position Vehicle Moves When Pushed" on the diagnostics worksheet, then continue the road test.

NO >> GO TO 4.

TROUBLE DIAGNOSIS

4. CHECK "N" POSITION FUNCTIONS

1. Start the engine.
2. Move selector lever to "N" position.
3. Release the parking brake.

Does vehicle move forward or backward?

- YES >> Enter a check mark at "In "N" Position Vehicle Moves" on the diagnostics worksheet, then continue the road test.
- NO >> GO TO 5.

5. CHECK SHIFT SHOCK

1. Engage the brake.
2. Move selector lever to "D" position.

When the transmission is shifted from "N" to "D", is there an excessive shock?

- YES >> Enter a check mark at "Large Shock ("N" to "D" Position) on the diagnostics worksheet, then continue the road test.
- NO >> GO TO 6.

6. CHECK "R" POSITION FUNCTIONS

1. Engage the brake.
2. Move selector lever to "R" position.
3. Release the brake for 4 to 5 seconds.

Does the vehicle creep backward?

- YES >> GO TO 7.
- NO >> Enter a check mark at "Vehicle Does Not Creep Backward In "R" Position" on the diagnostics worksheet, then continue the road test.

7. CHECK "D" POSITION FUNCTIONS

Inspect whether the vehicle creeps forward when the transmission is put into the "D" position.

Does the vehicle creep forward in the "D" positions?

- YES >> Go to [AT-56, "Cruise Test - Part 1"](#) , [AT-58, "Cruise Test - Part 2"](#) , and [AT-59, "Cruise Test - Part 3"](#) .
- NO >> Enter a check mark at "Vehicle Does Not Creep Forward in "D" Position" on the diagnostics worksheet, then continue the road test.

Cruise Test - Part 1

ECS00GWX

1. CHECK STARTING OUT FROM D1

1. Drive the vehicle for about 10 minutes to warm up the engine oil and ATF.
Appropriate temperature for the ATF: 50 - 80°C (122 - 176°F)
2. Park the vehicle on a level surface.
3. Move selector lever to "P" position.
4. Start the engine.
5. Move selector lever to "D" position.
6. Press the accelerator pedal about half way down to accelerate the vehicle.

Ⓟ **With CONSULT-II**

Read off the gear positions.

Starts from D1?

- YES >> GO TO 2.
- NO >> Enter a check mark at "Vehicle Cannot be Started From D1" on the diagnostics worksheet, then continue the road test.

TROUBLE DIAGNOSIS

2. CHECK SHIFT-UP D1 → D2

Press down the accelerator pedal about half way and inspect if the vehicle shifts up (D1 → D2) at the appropriate speed.

- Refer to [AT-60, "Vehicle Speed When Shifting Gears"](#) .

With CONSULT-II

Read the gear position, throttle degree of opening, and vehicle speed.

Does the A/T shift-up D1 → D2 at the correct speed?

YES >> GO TO 3.

NO >> Enter a check mark at "A/T Does Not Shift: D1 → D2" on the diagnostics worksheet, then continue the road test.

3. CHECK SHIFT-UP D2 → D3

Press down the accelerator pedal about half way and inspect if the vehicle shifts up (D2 → D3) at the appropriate speed.

- Refer to [AT-60, "Vehicle Speed When Shifting Gears"](#) .

With CONSULT-II

Read the gear position, throttle degree of opening, and vehicle speed.

Does the A/T shift-up D2 → D3 at the correct speed?

YES >> GO TO 4.

NO >> Enter a check mark at "A/T Does Not Shift: D2 → D3" on the diagnostics worksheet, then continue the road test.

4. CHECK SHIFT-UP D3 → D4

Press down the accelerator pedal about half way and inspect if the vehicle shifts up (D3 → D4) at the appropriate speed.

- Refer to [AT-60, "Vehicle Speed When Shifting Gears"](#) .

With CONSULT-II

Read the gear position, throttle degree of opening, and vehicle speed.

Does the A/T shift-up D3 → D4 at the correct speed?

YES >> GO TO 5.

NO >> Enter a check mark at "A/T Does Not Shift: D3 → D4" on the diagnostics worksheet, then continue the road test.

5. CHECK SHIFT-UP D4 → D5

Press down the accelerator pedal about half way and inspect if the vehicle shifts up (D4 → D5) at the appropriate speed.

- Refer to [AT-60, "Vehicle Speed When Shifting Gears"](#) .

With CONSULT-II

Read the gear position, throttle degree of opening, and vehicle speed.

Does the A/T shift-up D4 → D5 at the correct speed?

YES >> GO TO 6.

NO >> Enter a check mark at "A/T Does Not Shift: D4 → D5" on the diagnostics worksheet, then continue the road test.

TROUBLE DIAGNOSIS

6. CHECK LOCK-UP

When releasing accelerator pedal from D5, check lock-up from D5 to L/U.

- Refer to [AT-60, "Vehicle Speed When Shifting Gears"](#) .

Ⓜ With CONSULT-II

Select "TCC SOLENOID 0.00A" with the "MAIN SIGNAL" mode for A/T.

Does it lock-up?

YES >> GO TO 7.

NO >> Enter a check mark at "A/T Does Not Perform Lock-up" on the diagnostics worksheet, then continue the road test.

7. CHECK LOCK-UP HOLD

Does it maintain lock-up status?

YES >> GO TO 8.

NO >> Enter a check mark at "A/T Does Not Hold Lock-up Condition" on the diagnostics worksheet, then continue the road test.

8. CHECK LOCK-UP RELEASE

Check lock-up cancellation by depressing brake pedal lightly to decelerate.

Ⓜ With CONSULT-II

Select "TCC SOLENOID 0.00A" with the "MAIN SIGNAL" mode for A/T.

Does lock-up cancel?

YES >> GO TO 9.

NO >> Enter a check mark at "Lock-up Is Not Released" on the diagnostics worksheet, then continue the road test.

9. CHECK SHIFT-DOWN D5 → D4

Decelerate by pressing lightly on the brake pedal.

Ⓜ With CONSULT-II

Read the gear position and engine speed.

When the A/T shift-down D5 → D4, does the engine speed drop smoothly back to idle?

YES >> 1. Stop the vehicle.

2. Go to Cruise test - Part 2 (Refer to [AT-58](#)).

NO >> Enter a check mark at "Engine Speed Does Not Return to Idle" on the diagnostics worksheet, then continue the road test. Go to Cruise test - Part 2 (Refer to [AT-58](#)).

Cruise Test - Part 2

ECS00GWY

1. CHECK STARTING FROM D1

1. Move selector lever the "D" position.
2. Accelerate at half throttle.

Ⓜ With CONSULT-II

Read the gear position.

Does it start from D1?

YES >> GO TO 2.

NO >> Enter a check mark at "Vehicle Cannot Be Started From D1" on the diagnostics worksheet, then continue the road test.

TROUBLE DIAGNOSIS

2. CHECK SHIFT-UP D1 → D2

Press the accelerator pedal down all the way and inspect whether or not the transmission shifts up (D1 → D2) at the correct speed.

- Refer to [AT-60, "Vehicle Speed When Shifting Gears"](#) .

With CONSULT-II

Read the gear position, throttle position and vehicle speed.

Does the A/T shift-up D1 → D2 at the correct speed?

YES >> GO TO 3.

NO >> Enter a check mark at "Vehicle Does Not Shift: D1 → D2" on the diagnostics worksheet, then continue the road test.

3. CHECK SHIFT-UP D2 → D3

Press the accelerator pedal down all the way and inspect whether or not the transmission shifts up (D2 → D3) at the correct speed.

- Refer to [AT-60, "Vehicle Speed When Shifting Gears"](#) .

With CONSULT-II

Read the gear position, throttle position and vehicle speed.

Does the A/T shift-up D2 → D3 at the correct speed?

YES >> GO TO 4.

NO >> Enter a check mark at "Vehicle Does Not Shift: D2 → D3" on the diagnostics worksheet, then continue the road test.

4. CHECK SHIFT-UP D3 → D4 AND ENGINE BRAKE

When the transmission changes speed D3 → D4, return the accelerator pedal.

Does the A/T shift-up D3 → D4 and apply the engine brake?

YES >> 1. Stop the vehicle.

2. See [AT-59, "Cruise Test - Part 3"](#) .

NO >> Enter a check mark at "Vehicle Does Not Shift: D3 → D4" on the diagnostics worksheet, then continue the road test.

Cruise Test - Part 3

ECS00GWZ

1. CHECK SHIFT-DOWN

During D5 driving, move gear selector from D → 4 → 3 → 2 → 1.

With CONSULT-II

Read the gear position.

Is downshifting correctly performed?

YES >> GO TO 2.

NO >> Enter a check mark at "Vehicle does not shift" at the corresponding position (5th → 4th, 4th → 3rd, 3rd → 2nd, 2nd → 1st) on the diagnostics worksheet, then continue the road test.

2. CHECK ENGINE BRAKE

Does engine braking effectively reduce speed in 11 position?

YES >> 1. Stop the vehicle.

2. Carry out the self-diagnostics. Refer to [AT-86, "SELF-DIAGNOSTIC RESULT MODE"](#) .

NO >> Enter a check mark at "Vehicle Does Not Decelerate By Engine Brake" on the diagnostics worksheet, then continue trouble diagnosis.

TROUBLE DIAGNOSIS

Vehicle Speed When Shifting Gears NORMAL MODE

ECS00GX0

Final gear ratio	Throttle position	Vehicle speed km/h (MPH)							
		D1 →D2	D2 →D3	D3 →D4	D4 →D5	D5 →D4	D4 →D3	D3 →D2	D2 →D1
2.937	Full throttle	70 - 74 (44 - 46)	112 - 120 (70 - 75)	176 - 186 (110 - 116)	249 - 259 (155 - 161)	245 - 255 (152 - 159)	166 - 176 (103 - 110)	100 - 108 (62 - 67)	43 - 47 (27 - 30)
	Half throttle	46 - 50 (28 - 31)	75 - 81 (47 - 50)	104 - 112 (65 - 70)	136 - 144 (85 - 89)	111 - 119 (69 - 74)	76 - 84 (47 - 52)	44 - 50 (27 - 31)	11 - 15 (7 - 10)
3.357	Full throttle	61 - 65 (38 - 41)	97 - 105 (61 - 66)	153 - 163 (95 - 102)	236 - 246 (147 - 153)	232 - 242 (144 - 151)	143 - 153 (89 - 95)	87 - 95 (54 - 59)	43 - 47 (27 - 29)
	Half throttle	41 - 45 (26 - 28)	67 - 73 (42 - 45)	90 - 98 (56 - 61)	119 - 127 (74 - 79)	97 - 105 (60 - 65)	65 - 73 (40 - 45)	39 - 45 (24 - 28)	11 - 15 (7 - 10)

- At half throttle, the accelerator opening is 4/8 of the full opening.

TOW MODE

Final gear ratio	Throttle position	Vehicle speed km/h (MPH)							
		D1 →D2	D2 →D3	D3 →D4	D4 →D5	D5 →D4	D4 →D3	D3 →D2	D2 →D1
2.937	Full throttle	70 - 74 (44 - 46)	112 - 120 (70 - 75)	176 - 186 (110 - 116)	249 - 259 (155 - 161)	245 - 255 (152 - 159)	166 - 176 (103 - 110)	100 - 108 (62 - 67)	43 - 47 (27 - 30)
	Half throttle	50 - 54 (31 - 34)	82 - 88 (51 - 55)	114 - 122 (71 - 76)	136 - 144 (85 - 89)	111 - 119 (69 - 74)	76 - 84 (47 - 52)	44 - 50 (27 - 31)	11 - 15 (7 - 10)
3.357	Full throttle	61 - 65 (38 - 41)	97 - 105 (61 - 66)	153 - 163 (95 - 102)	236 - 246 (147 - 153)	232 - 242 (144 - 151)	143 - 153 (89 - 95)	87 - 95 (54 - 59)	43 - 47 (27 - 29)
	Half throttle	46 - 50 (29 - 31)	73 - 79 (45 - 49)	99 - 107 (62 - 66)	119 - 127 (74 - 79)	97 - 105 (60 - 65)	65 - 73 (40 - 45)	39 - 45 (24 - 28)	11 - 15 (7 - 10)

- At half throttle, the accelerator opening is 4/8 of the full opening.

Vehicle Speed When Performing and Releasing Complete Lock-up

ECS00GX1

Final gear ratio	Throttle position	Vehicle speed km/h (MPH)	
		Lock-up "ON"	Lock-up "OFF"
2.937	Closed throttle	74 - 82 (46 - 51)	71 - 79 (45 - 49)
	Half throttle	178 - 186 (111 - 116)	136 - 144 (85 - 90)
3.357	Closed throttle	65 - 73 (41 - 46)	62 - 70 (39 - 44)
	Half throttle	161 - 169 (100 - 105)	118 - 126 (74 - 79)

- At closed throttle, the accelerator opening is less than 1/8 condition.
- At half throttle, the accelerator opening is 4/8 of the full opening.

TROUBLE DIAGNOSIS

ECS00GX3

Symptom Chart

- The diagnostics item numbers show the sequence for inspection. Inspect in order from item 1.
- Overhaul and inspect inside the A/T only if A/T fluid condition is NG. Refer to [AT-51, "A/T FLUID CHECK"](#).

No.	Items	Symptom	Condition	Diagnostic Item	Reference page
1		Large shock. ("N" → "D" position) Refer to AT-178, "Large Shock("N" to "D" Position)" .	ON vehicle	1. Engine idle speed	EC-81
				2. Engine speed signal	AT-112
				3. Accelerator pedal position sensor	AT-120
				4. Control cable adjustment	AT-222
				5. ATF temperature sensor	AT-123
				6. ATF pressure switch 1 and front brake solenoid valve	AT-155, AT-139
				7. CAN communication line	AT-93
				8. Fluid level and state	AT-51
				9. Line pressure test	AT-52
				10. Control valve with TCM	AT-225
			OFF vehicle	11. Forward brake (Parts behind drum support is impossible to perform inspection by disassembly. Refer to AT-17 , AT-18 .	AT-259
2	Shift Shock	Shock is too large when changing D1 → D2 .	ON vehicle	1. Accelerator pedal position sensor	AT-120
				2. Control cable adjustment	AT-222
				3. ATF pressure switch 5 and direct clutch solenoid valve	AT-159, AT-143
				4. CAN communication line	AT-93
				5. Engine speed signal	AT-112
				6. Turbine revolution sensor	AT-105
				7. Vehicle speed sensor A/T and vehicle speed sensor MTR	AT-107, AT-128
				8. Fluid level and state	AT-51
				9. Control valve with TCM	AT-225
			OFF vehicle	10. Direct clutch	AT-293
3		Shock is too large when changing D2 → D3 .	ON vehicle	1. Accelerator pedal position sensor	AT-120
				2. Control cable adjustment	AT-222
				3. ATF pressure switch 6, high and low reverse clutch solenoid valve	AT-161, AT-147
				4. CAN communication line	AT-93
				5. Engine speed signal	AT-112
				6. Turbine revolution sensor	AT-105
				7. Vehicle speed sensor A/T and vehicle speed sensor MTR	AT-107, AT-128
				8. Fluid level and state	AT-51
				9. Control valve with TCM	AT-225
			OFF vehicle	10. High and low reverse clutch	AT-291

TROUBLE DIAGNOSIS

No.	Items	Symptom	Condition	Diagnostic Item	Reference page
4		Shock is too large when changing D3 → D4 .	ON vehicle	1. Accelerator pedal position sensor	AT-120
				2. Control cable adjustment	AT-222
				3. ATF pressure switch 3 and input clutch solenoid valve	AT-157, AT-135
				4. CAN communication line	AT-93
				5. Engine speed signal	AT-112
				6. Turbine revolution sensor	AT-105
				7. Vehicle speed sensor A/T and vehicle speed sensor MTR	AT-107, AT-128
				8. Fluid level and state	AT-51
				9. Control valve with TCM	AT-225
			OFF vehicle	10. Input clutch	AT-281
5	Shift Shock	Shock is too large when changing D4 → D5 .	ON vehicle	1. Accelerator pedal position sensor	AT-120
				2. Control cable adjustment	AT-222
				3. ATF pressure switch 1 and front brake solenoid valve	AT-155, AT-139
				4. CAN communication line	AT-93
				5. Engine speed signal	AT-112
				6. Turbine revolution sensor	AT-105
				7. Vehicle speed sensor A/T and vehicle speed sensor MTR	AT-107, AT-128
				8. Fluid level and state	AT-51
				9. Control valve with TCM	AT-225
			OFF vehicle	10. Front brake (brake band)	AT-245
				11. Input clutch	AT-281
6		Shock is too large for downshift when accelerator pedal is pressed.	ON vehicle	1. Accelerator pedal position sensor	AT-120
				2. Control cable adjustment	AT-222
				3. CAN communication line	AT-93
				4. Engine speed signal	AT-112
				5. Turbine revolution sensor	AT-105
				6. Vehicle speed sensor A/T and vehicle speed sensor MTR	AT-107, AT-128
				7. Fluid level and state	AT-51
				8. Control valve with TCM	AT-225
			OFF vehicle	9. Front brake (brake band)	AT-245
				10. Input clutch	AT-281
				11. High and low reverse clutch	AT-291
				12. Direct clutch	AT-293

TROUBLE DIAGNOSIS

No.	Items	Symptom	Condition	Diagnostic Item	Reference page	
7		Shock is too large for upshift when accelerator pedal is released.	ON vehicle	1. Accelerator pedal position sensor	AT-120	A
				2. Control cable adjustment	AT-222	B
				3. Engine speed signal	AT-112	
				4. CAN communication line	AT-93	
				5. Turbine revolution sensor	AT-105	AT
				6. Vehicle speed sensor A/T and vehicle speed sensor MTR	AT-107, AT-128	
				7. Fluid level and state	AT-51	D
				8. Control valve with TCM	AT-225	
			OFF vehicle	9. Front brake (brake band)	AT-245	
				10. Input clutch	AT-281	E
				11. High and low reverse clutch	AT-291	
				12. Direct clutch	AT-293	F
8	Shift Shock	Shock is too large for lock-up.	ON vehicle	1. Accelerator pedal position sensor	AT-120	
				2. Control cable adjustment	AT-222	G
				3. Engine speed signal	AT-112	
				4. CAN communication line	AT-93	
				5. Turbine revolution sensor	AT-105	H
				6. Vehicle speed sensor A/T and vehicle speed sensor MTR	AT-107, AT-128	
				7. Torque converter clutch solenoid valve	AT-114	I
				8. Fluid level and state	AT-51	
				9. Control valve with TCM	AT-225	J
			OFF vehicle	10. Torque converter	AT-259	
9		Shock is too large during engine brake.	ON vehicle	1. Accelerator pedal position sensor	AT-120	
				2. Control cable adjustment	AT-222	K
				3. CAN communication line	AT-93	
				4. Fluid level and state	AT-51	L
				5. Control valve with TCM	AT-225	
			OFF vehicle	6. Front brake (brake band)	AT-245	
				7. Input clutch	AT-281	M
				8. High and low reverse clutch	AT-291	
				9. Direct clutch	AT-293	

TROUBLE DIAGNOSIS

No.	Items	Symptom	Condition	Diagnostic Item	Reference page
10		Gear does not change from D → D2 . Refer to AT-189, "A/T Does Not Shift: D1 → D2" .	ON vehicle	1. Fluid level and state	AT-51
				2. Vehicle speed sensor A/T and vehicle speed sensor MTR	AT-107, AT-128
				3. ATF pressure switch 5 and direct clutch solenoid valve	AT-159, AT-143
				4. Line pressure test	AT-52
				5. CAN communication line	AT-93
				6. Control valve with TCM	AT-225
			OFF vehicle	7. Direct clutch	AT-293
11		Gear does not change from D → D3 . Refer to AT-191, "A/T Does Not Shift: D2 → D3" .	ON vehicle	1. Fluid level and state	AT-51
				2. Vehicle speed sensor A/T and vehicle speed sensor MTR	AT-107, AT-128
				3. ATF pressure switch 6, high and low reverse clutch solenoid valve	AT-161, AT-147
				4. Line pressure test	AT-52
				5. CAN communication line	AT-93
				6. Control valve with TCM	AT-225
			OFF vehicle	7. High and low reverse clutch	AT-291
12	No Up Shift	Gear does not change from D → D4 . Refer to AT-193, "A/T Does Not Shift: D3 → D4" .	ON vehicle	1. Fluid level and state	AT-51
				2. Vehicle speed sensor A/T and vehicle speed sensor MTR	AT-107, AT-128
				3. ATF pressure switch 3 and input clutch solenoid valve	AT-157, AT-135
				4. ATF pressure switch 1 and front brake solenoid valve	AT-155, AT-139
				5. Line pressure test	AT-52
				6. CAN communication line	AT-93
				7. Control valve with TCM	AT-225
OFF vehicle	8. Input clutch	AT-281			
13		Gear does not change from D → D5 . Refer to AT-196, "A/T Does Not Shift: D4 → D5" .	ON vehicle	1. Fluid level and state	AT-51
				2. Vehicle speed sensor A/T and vehicle speed sensor MTR	AT-107, AT-128
				3. ATF pressure switch 1 and front brake solenoid valve	AT-155, AT-139
				4. ATF pressure switch 5 and direct clutch solenoid valve	AT-159, AT-143
				5. Turbine revolution sensor	AT-105
				6. Line pressure test	AT-52
				7. CAN communication line	AT-93
				8. Control valve with TCM	AT-225
			OFF vehicle	9. Front brake (brake band)	AT-259
			10. Input clutch	AT-281	

TROUBLE DIAGNOSIS

No.	Items	Symptom	Condition	Diagnostic Item	Reference page			
14		In "D" or "4" range, does not downshift to 4th gear. Refer to AT-204, "A/T Does Not Shift: 5th gear → 4th gear" .	ON vehicle	1. Fluid level and state	AT-51			
				2. Vehicle speed sensor A/T and vehicle speed sensor MTR	AT-107, AT-128			
				3. ATF pressure switch 1 and front brake solenoid valve	AT-155, AT-139			
				4. ATF pressure switch 5 and direct clutch solenoid valve	AT-159, AT-143			
				5. CAN communication line	AT-93			
				6. Line pressure test	AT-52			
				7. Control valve with TCM	AT-225			
			OFF vehicle	8. Front brake (brake band)	AT-259			
			9. Input clutch	AT-281				
15	No Down Shift	In "D" or "3" range, does not downshift to 3rd gear. Refer to AT-207, "A/T Does Not Shift: 4th gear → 3rd gear" .	ON vehicle	1. Fluid level and state	AT-51			
				2. Vehicle speed sensor A/T and vehicle speed sensor MTR	AT-107, AT-128			
				3. ATF pressure switch 3 and input clutch solenoid valve	AT-157, AT-135			
				4. ATF pressure switch 1 and front brake solenoid valve	AT-155, AT-139			
				5. CAN communication line	AT-93			
				6. Line pressure test	AT-52			
				7. Control valve with TCM	AT-225			
			OFF vehicle	8. Input clutch	AT-281			
			16		In "D" or "2" range, does not downshift to 2nd gear. Refer to AT-208, "A/T Does Not Shift: 3rd gear → 2nd gear" .	ON vehicle	1. Fluid level and state	AT-51
2. Vehicle speed sensor A/T and vehicle speed sensor MTR	AT-107, AT-128							
3. ATF pressure switch 6, high and low reverse clutch solenoid valve	AT-161, AT-147							
4. CAN communication line	AT-93							
5. Line pressure test	AT-52							
6. Control valve with TCM	AT-225							
OFF vehicle	7. High and low reverse clutch	AT-291						
17		In "D" or "1" range, does not downshift to 1st gear. Refer to AT-210, "A/T Does Not Shift: 2nd gear → 1st gear" .				ON vehicle	1. Fluid level and state	AT-51
							2. Vehicle speed sensor A/T and vehicle speed sensor MTR	AT-107, AT-128
			3. ATF pressure switch 5 and direct clutch solenoid valve	AT-159, AT-143				
			4. CAN communication line	AT-93				
			5. Line pressure test	AT-52				
			6. Control valve with TCM	AT-225				
			OFF vehicle	7. Direct clutch	AT-293			

A

B

AT

D

E

F

G

H

I

J

K

L

M

TROUBLE DIAGNOSIS

No.	Items	Symptom	Condition	Diagnostic Item	Reference page
18	Slips/Will Not engage	When "D" position, remains in 1st gear.	ON vehicle	1. Fluid level and state	AT-51
				2. Vehicle speed sensor A/T and vehicle speed sensor MTR	AT-107, AT-128
				3. Direct clutch solenoid valve	AT-143
				4. Line pressure test	AT-52
				5. CAN communication line	AT-93
				6. Control valve with TCM	AT-225
			OFF vehicle	7. 3rd one-way clutch	AT-279
				8. 1st one-way clutch	AT-286
				9. Gear system	AT-245
				10. Reverse brake	AT-259
				11. Forward one-way clutch (Parts behind drum support is impossible to perform inspection by disassembly. Refer to AT-17 , AT-18)	AT-259
				12. Forward brake (Parts behind drum support is impossible to perform inspection by disassembly. Refer to AT-17 , AT-18)	AT-259
19		When "D" position, remains in 2nd gear.	ON vehicle	1. Fluid level and state	AT-51
				2. Vehicle speed sensor A/T and vehicle speed sensor MTR	AT-107, AT-128
				3. Low coast brake solenoid valve	AT-151
				4. Line pressure test	AT-52
				5. CAN communication line	AT-93
				6. Control valve with TCM	AT-225
			OFF vehicle	7. 3rd one-way clutch	AT-279
				8. Gear system	AT-245
				9. Direct clutch	AT-293
				10. Forward brake (Parts behind drum support is impossible to perform inspection by disassembly. Refer to AT-17 , AT-18)	AT-259

TROUBLE DIAGNOSIS

No.	Items	Symptom	Condition	Diagnostic Item	Reference page
20		When "D" position, remains in 3rd gear.	ON vehicle	1. Fluid level and state	AT-51
				2. Vehicle speed sensor A/T and vehicle speed sensor MTR	AT-107, AT-128
				3. Line pressure test	AT-52
				4. CAN communication line	AT-93
				5. Control valve with TCM	AT-225
			OFF vehicle	6. 3rd one-way clutch	AT-279
				7. Gear system	AT-245
				8. High and low reverse clutch	AT-291
				9. Forward one-way clutch (Parts behind drum support is impossible to perform inspection by disassembly. Refer to AT-17 , AT-18)	AT-259
				10. Forward brake (Parts behind drum support is impossible to perform inspection by disassembly. Refer to AT-17 , AT-18)	AT-259
21	Slips/Will Not engage	When "D" position, remains in 4th gear.	ON vehicle	1. Fluid level and state	AT-51
				2. Vehicle speed sensor A/T and vehicle speed sensor MTR	AT-107, AT-128
				3. ATF pressure switch 3 and input clutch solenoid valve	AT-157, AT-135
				4. ATF pressure switch 5 and direct clutch solenoid valve	AT-159, AT-143
				5. ATF pressure switch 6, high and low reverse clutch solenoid valve	AT-161, AT-147
				6. Low coast brake solenoid valve	AT-151
				7. Front brake solenoid valve	AT-139
				8. Line pressure test	AT-52
				9. CAN communication line	AT-93
				10. Control valve with TCM	AT-225
			OFF vehicle	11. Input clutch	AT-281
				12. Gear system	AT-245
				13. High and low reverse clutch	AT-291
				14. Direct clutch	AT-293

A
B
AT
D
E
F
G
H
I
J
K
L
M

TROUBLE DIAGNOSIS

No.	Items	Symptom	Condition	Diagnostic Item	Reference page
22		When "D" position, remains in 5th gear.	ON vehicle	1. Fluid level and state	AT-51
				2. Vehicle speed sensor A/T and vehicle speed sensor MTR	AT-107 , AT-128
				3. ATF pressure switch 1 and front brake solenoid valve	AT-155 , AT-139
				4. Line pressure test	AT-52
				5. CAN communication line	AT-93
				6. Control valve with TCM	AT-225
			OFF vehicle	7. Front brake (brake band)	AT-259
				8. Input clutch	AT-281
				9. Gear system	AT-245
				10. High and low reverse clutch	AT-291
23	Slips/Will Not Engage	Vehicle cannot be started from D1 . Refer to AT-186 , " Vehicle Cannot Be Started From D1 ".	ON vehicle	1. Fluid level and state	AT-51
				2. Accelerator pedal position sensor	AT-120
				3. Line pressure test	AT-52
				4. CAN communication line	AT-93
				5. Control valve with TCM	AT-225
			OFF vehicle	6. Torque converter	AT-259
				7. Oil pump assembly	AT-277
				8. 3rd one-way clutch	AT-279
				9. 1st one-way clutch	AT-286
				10. Gear system	AT-245
				11. Reverse brake	AT-259
				12. Forward one-way clutch (Parts behind drum support is impossible to perform inspection by disassembly. Refer to AT-17 , AT-18)	AT-259
				13. Forward brake (Parts behind drum support is impossible to perform inspection by disassembly. Refer to AT-17 , AT-18)	AT-259
24		Does not lock-up. Refer to AT-198 , " A/T Does Not Perform Lock-up ".	ON vehicle	1. Fluid level and state	AT-51
				2. Line pressure test	AT-52
				3. Engine speed signal	AT-112
				4. Turbine revolution sensor	AT-105
				5. Torque converter clutch solenoid valve	AT-114
				6. CAN communication line	AT-93
				7. Control valve with TCM	AT-225
			OFF vehicle	8. Torque converter	AT-259
				9. Oil pump assembly	AT-277

TROUBLE DIAGNOSIS

No.	Items	Symptom	Condition	Diagnostic Item	Reference page		
25	Slips/Will Not engage	Does not hold lock-up condition. Refer to AT-200, "A/T Does Not Hold Lock-up Condition" .	ON vehicle	1. Fluid level and state	AT-51	A	
				2. Line pressure test	AT-52	B	
				3. Engine speed signal	AT-112		
				4. Turbine revolution sensor	AT-105		
				5. Torque converter clutch solenoid valve	AT-114	AT	
				6. CAN communication line	AT-93		
				7. Control valve with TCM	AT-225		
			OFF vehicle	8. Torque converter	AT-259	D	
				9. Oil pump assembly	AT-277		
26		Slips/Will Not engage	Lock-up is not released. Refer to AT-202, "Lock-up Is Not Released" .	ON vehicle	1. Fluid level and state	AT-51	E
					2. Line pressure test	AT-52	
					3. Engine speed signal	AT-112	
					4. Turbine revolution sensor	AT-105	F
					5. Torque converter clutch solenoid valve	AT-114	
					6. CAN communication line	AT-93	G
					7. Control valve with TCM	AT-225	
				OFF vehicle	8. Torque converter	AT-259	H
					9. Oil pump assembly	AT-277	
27	Slips/Will Not engage		No shock at all or the clutch slips when vehicle changes speed D1 → D2 .	ON vehicle	1. Fluid level and state	AT-51	I
					2. Vehicle speed sensor A/T and vehicle speed sensor MTR	AT-107, AT-128	
					3. ATF pressure switch 5 and direct clutch solenoid valve	AT-159, AT-143	J
					4. CAN communication line	AT-93	
					5. Line pressure test	AT-52	
					6. Control valve with TCM	AT-225	K
				OFF vehicle	7. Torque converter	AT-259	
					8. Oil pump assembly	AT-277	L
					9. 3rd one-way clutch	AT-279	
		10. Gear system			AT-245		
		11. Direct clutch			AT-293	M	
		12. Forward brake (Parts behind drum support is impossible to perform inspection by disassembly. Refer to AT-17 , AT-18)			AT-259		

TROUBLE DIAGNOSIS

No.	Items	Symptom	Condition	Diagnostic Item	Reference page
28	Slips/Will Not engage	No shock at all or the clutch slips when vehicle changes speed D2 → D3 .	ON vehicle	1. Fluid level and state	AT-51
				2. Vehicle speed sensor A/T and vehicle speed sensor MTR	AT-107 , AT-128
				3. ATF pressure switch 6, high and low reverse clutch solenoid valve	AT-161 , AT-147
				4. CAN communication line	AT-93
				5. Line pressure test	AT-52
				6. Control valve with TCM	AT-225
			OFF vehicle	7. Torque converter	AT-259
				8. Oil pump assembly	AT-277
				9. 3rd one-way clutch	AT-279
				10. Gear system	AT-245
				11. High and low reverse clutch	AT-291
				12. Forward one- way clutch (Parts behind drum support is impossible to perform inspection by disassembly. Refer to AT-17 , AT-18)	AT-259
				13. Forward brake (Parts behind drum support is impossible to perform inspection by disassembly. Refer to AT-17 , AT-18)	AT-259
29	Slips/Will Not engage	No shock at all or the clutch slips when vehicle changes speed D3 → D4 .	ON vehicle	1. Fluid level and state	AT-51
				2. Vehicle speed sensor A/T and vehicle speed sensor MTR	AT-107 , AT-128
				3. ATF pressure switch 3 and input clutch solenoid valve	AT-157 , AT-135
				4. ATF pressure switch 1 and front brake solenoid valve	AT-155 , AT-139
				5. CAN communication line	AT-93
				6. Line pressure test	AT-52
				7. Control valve with TCM	AT-225
			OFF vehicle	8. Torque converter	AT-259
				9. Oil pump assembly	AT-277
				10. Input clutch	AT-281
				11. Gear system	AT-245
				12. High and low reverse clutch	AT-291
				13. Direct clutch	AT-293

TROUBLE DIAGNOSIS

No.	Items	Symptom	Condition	Diagnostic Item	Reference page	
30	Slips/Will Not engage	No shock at all or the clutch slips when vehicle changes speed D4 → D5 .	ON vehicle	1. Fluid level and state	AT-51	A
				2. Vehicle speed sensor A/T and vehicle speed sensor MTR	AT-107, AT-128	B
				3. ATF pressure switch 1 and front brake solenoid valve	AT-155, AT-139	AT
				4. ATF pressure switch 5 and direct clutch solenoid valve	AT-159, AT-143	
				5. CAN communication line	AT-93	D
				6. Line pressure test	AT-52	
				7. Control valve with TCM	AT-225	
			OFF vehicle	8. Torque converter	AT-259	E
				9. Oil pump assembly	AT-277	
				10. Front brake (brake band)	AT-259	F
				11. Input clutch	AT-281	
				12. Gear system	AT-245	G
				13. High and low reverse clutch	AT-291	
31	Slips/Will Not engage	When you press the accelerator pedal and shift speed D5 → D4 the engine idles or the transmission slips.	ON vehicle	1. Fluid level and state	AT-51	H
				2. Vehicle speed sensor A/T and vehicle speed sensor MTR	AT-107, AT-128	I
				3. ATF pressure switch 1 and front brake solenoid valve	AT-155, AT-139	J
				4. ATF pressure switch 5 and direct clutch solenoid valve	AT-159, AT-143	
				5. CAN communication line	AT-93	K
				6. Line pressure test	AT-52	L
				7. Control valve with TCM	AT-225	
			OFF vehicle	8. Torque converter	AT-259	M
				9. Oil pump assembly	AT-277	
				10. Input clutch	AT-281	
				11. Gear system	AT-245	
				12. High and low reverse clutch	AT-291	
				13. Direct clutch	AT-293	

TROUBLE DIAGNOSIS

No.	Items	Symptom	Condition	Diagnostic Item	Reference page
32	Slips/Will Not engage	When you press the accelerator pedal and shift speed D4 → D3 the engine idles or the transmission slips.	ON vehicle	1. Fluid level and state	AT-51
				2. Vehicle speed sensor A/T and vehicle speed sensor MTR	AT-107 , AT-128
				3. ATF pressure switch 3 and input clutch solenoid valve	AT-157 , AT-135
				4. ATF pressure switch 1 and front brake solenoid valve	AT-155 , AT-139
				5. CAN communication line	AT-93
				6. Line pressure test	AT-52
				7. Control valve with TCM	AT-225
			OFF vehicle	8. Torque converter	AT-259
				9. Oil pump assembly	AT-277
				10. 3rd one-way clutch	AT-279
				11. Gear system	AT-245
				12. High and low reverse clutch	AT-291
				13. Forward one- way clutch (Parts behind drum support is impossible to perform inspection by disassembly. Refer to AT-17 , AT-18)	AT-259
				14. Forward brake (Parts behind drum support is impossible to perform inspection by disassembly. Refer to AT-17 , AT-18)	AT-259
33	Slips/Will Not engage	When you press the accelerator pedal and shift speed D3 → D2 the engine idles or the transmission slips.	ON vehicle	1. Fluid level and state	AT-51
				2. Vehicle speed sensor A/T and vehicle speed sensor MTR	AT-107 , AT-128
				3. ATF pressure switch 6, high and low reverse clutch solenoid valve	AT-161 , AT-147
				4. ATF pressure switch 5 and direct clutch solenoid valve	AT-159 , AT-143
				5. CAN communication line	AT-93
				6. Line pressure test	AT-52
				7. Control valve with TCM	AT-225
			OFF vehicle	8. Torque converter	AT-259
				9. Oil pump assembly	AT-277
				10. 3rd one-way clutch	AT-279
				11. Gear system	AT-245
				12. Direct clutch	AT-293
				13. Forward brake (Parts behind drum support is impossible to perform inspection by disassembly. Refer to AT-17 , AT-18)	AT-259

TROUBLE DIAGNOSIS

No.	Items	Symptom	Condition	Diagnostic Item	Reference page
34	Slips/Will Not Engage	When you press the accelerator pedal and shift speed D2 → D1 the engine idles or the transmission slips.	ON vehicle	1. Fluid level and state	AT-51
				2. Vehicle speed sensor A/T and vehicle speed sensor MTR	AT-107, AT-128
				3. ATF pressure switch 5 and direct clutch solenoid valve	AT-159, AT-143
				4. CAN communication line	AT-93
				5. Line pressure test	AT-52
				6. Control valve with TCM	AT-225
			OFF vehicle	7. Torque converter	AT-259
				8. Oil pump assembly	AT-277
				9. 3rd one-way clutch	AT-279
				10. 1st one-way clutch	AT-286
				11. Gear system	AT-245
				12. Reverse brake	AT-259
				13. Forward one- way clutch (Parts behind drum support is impossible to perform inspection by disassembly. Refer to AT-17 , AT-18	AT-259
				14. Forward brake (Parts behind drum support is impossible to perform inspection by disassembly. Refer to AT-17 , AT-18	AT-259
35	With selector lever in "D" position, acceleration is extremely poor.		ON vehicle	1. Fluid level and state	AT-51
				2. Line pressure test	AT-52
				3. Accelerator pedal position sensor	AT-120
				4. CAN communication line	AT-93
				5. PNP switch	AT-101
				6. Control cable adjustment	AT-222
				7. Control valve with TCM	AT-225
			OFF vehicle	8. Torque converter	AT-259
				9. Oil pump assembly	AT-277
				10. 1st one-way clutch	AT-286
				11. Gear system	AT-245
				12. Reverse brake	AT-259
				13. Forward one- way clutch (Parts behind drum support is impossible to perform inspection by disassembly. Refer to AT-17 , AT-18	AT-259
				14. Forward brake (Parts behind drum support is impossible to perform inspection by disassembly. Refer to AT-17 , AT-18	AT-259

A
B
AT
D
E
F
G
H
I
J
K
L
M

TROUBLE DIAGNOSIS

No.	Items	Symptom	Condition	Diagnostic Item	Reference page
36		With selector lever in "R" position, acceleration is extremely poor.	ON vehicle	1. Fluid level and state	AT-51
				2. Line pressure test	AT-52
				3. Accelerator pedal position sensor	AT-120
				4. ATF pressure switch 6, high and low reverse clutch solenoid valve	AT-161 , AT-147
				5. CAN communication line	AT-93
				6. PNP switch	AT-101
				7. Control cable adjustment	AT-222
				8. Control valve with TCM	AT-225
			OFF vehicle	9. Gear system	AT-245
				10. Output shaft	AT-259
				11. Reverse brake	AT-259
37	Slips/Will Not Engage	While starting off by accelerating in 1st, engine races or slippage occurs.	ON vehicle	1. Fluid level and state	AT-51
				2. Line pressure test	AT-52
				3. Accelerator pedal position sensor	AT-120
				4. CAN communication line	AT-93
				5. Control valve with TCM	AT-225
			OFF vehicle	6. Torque converter	AT-259
				7. Oil pump assembly	AT-277
				8. 3rd one-way clutch	AT-279
				9. 1st one-way clutch	AT-286
				10. Gear system	AT-245
				11. Reverse brake	AT-259
				12. Forward one-way clutch (Parts behind drum support is impossible to perform inspection by disassembly. Refer to AT-17 , AT-18	AT-259
				13. Forward brake (Parts behind drum support is impossible to perform inspection by disassembly. Refer to AT-17 , AT-18	AT-259
38		While accelerating in 2nd, engine races or slippage occurs.	ON vehicle	1. Fluid level and state	AT-51
				2. Line pressure test	AT-52
				3. Accelerator pedal position sensor	AT-120
				4. CAN communication line	AT-93
				5. ATF pressure switch 5 and direct clutch solenoid valve	AT-159 , AT-143
				6. Control valve with TCM	AT-225
			OFF vehicle	7. Torque converter	AT-259
				8. Oil pump assembly	AT-277
				9. 3rd one-way clutch	AT-279
				10. Gear system	AT-245
				11. Direct clutch	AT-293
				12. Forward brake (Parts behind drum support is impossible to perform inspection by disassembly. Refer to AT-17 , AT-18	AT-259

TROUBLE DIAGNOSIS

No.	Items	Symptom	Condition	Diagnostic Item	Reference page
39	Slips/Will Not Engage	While accelerating in 3rd, engine races or slippage occurs.	ON vehicle	1. Fluid level and state	AT-51
				2. Line pressure test	AT-52
				3. Accelerator pedal position sensor	AT-120
				4. CAN communication line	AT-93
				5. ATF pressure switch 6, high and low reverse clutch solenoid valve	AT-161 , AT-147
				6. Control valve with TCM	AT-225
			OFF vehicle	7. Torque converter	AT-259
				8. Oil pump assembly	AT-277
				9. 3rd one-way clutch	AT-279
				10. Gear system	AT-245
				11. High and low reverse clutch	AT-291
				12. Forward one- way clutch (Parts behind drum support is impossible to perform inspection by disassembly. Refer to AT-17 , AT-18)	AT-259
				13. Forward brake (Parts behind drum support is impossible to perform inspection by disassembly. Refer to AT-17 , AT-18)	AT-259
40		While accelerating in 4th, engine races or slippage occurs.	ON vehicle	1. Fluid level and state	AT-51
				2. Line pressure test	AT-52
				3. Accelerator pedal position sensor	AT-120
				4. CAN communication line	AT-93
				5. ATF pressure switch 3 and input clutch solenoid valve	AT-157 , AT-135
				6. Control valve with TCM	AT-225
			OFF vehicle	7. Torque converter	AT-259
				8. Oil pump assembly	AT-277
				9. Input clutch	AT-281
				10. Gear system	AT-245
				11. High and low reverse clutch	AT-291
				12. Direct clutch	AT-293

A
B
AT
D
E
F
G
H
I
J
K
L
M

TROUBLE DIAGNOSIS

No.	Items	Symptom	Condition	Diagnostic Item	Reference page				
41		While accelerating in 5th, engine races or slippage occurs.	ON vehicle	1. Fluid level and state	AT-51				
				2. Line pressure test	AT-52				
				3. Accelerator pedal position sensor	AT-120				
				4. CAN communication line	AT-93				
				5. ATF pressure switch 1 and front brake solenoid valve	AT-155, AT-139				
				6. Control valve with TCM	AT-225				
			OFF vehicle	7. Torque converter	AT-259				
				8. Oil pump assembly	AT-277				
				9. Front brake (brake band)	AT-259				
				10. Input clutch	AT-281				
				11. Gear system	AT-245				
				12. High and low reverse clutch	AT-291				
42	Slips/Will Not Engage	Slips at lock-up.	ON vehicle	1. Fluid level and state	AT-51				
				2. Line pressure test	AT-52				
				3. Engine speed signal	AT-112				
				4. Turbine revolution sensor	AT-105				
				5. Torque converter clutch solenoid valve	AT-114				
				6. CAN communication line	AT-93				
				7. Control valve with TCM	AT-225				
			OFF vehicle	8. Torque converter	AT-259				
				9. Oil pump assembly	AT-277				
				43		No creep at all. Refer to AT-181 , " Vehicle Does Not Creep Backward In "R" Position " ,) AT-184 , " Vehicle Does Not Creep Forward In "D" Position "	ON vehicle	1. Fluid level and state	AT-51
								2. Line pressure test	AT-52
								3. Accelerator pedal position sensor	AT-120
4. ATF pressure switch 5 and direct clutch solenoid valve	AT-159, AT-143								
5. PNP switch	AT-101								
6. CAN communication line	AT-93								
7. Control cable adjustment	AT-222								
8. Control valve with TCM	AT-225								
OFF vehicle	9. Torque converter	AT-259							
	10. Oil pump assembly	AT-277							
	11. 1st one-way clutch	AT-286							
	12. Gear system	AT-245							
	13. Reverse brake	AT-259							
	14. Direct clutch	AT-293							
	15. Forward one- way clutch (Parts behind drum support is impossible to perform inspection by disassembly. Refer to AT-17 , AT-18	AT-259							
	16. Forward brake (Parts behind drum support is impossible to perform inspection by disassembly. Refer to AT-17 , AT-18	AT-259							

TROUBLE DIAGNOSIS

No.	Items	Symptom	Condition	Diagnostic Item	Reference page
44		Vehicle cannot run in all positions.	ON vehicle	1. Fluid level and state	AT-51
				2. Line pressure test	AT-52
				3. PNP switch	AT-101
				4. Control cable adjustment	AT-222
				5. Control valve with TCM	AT-225
			OFF vehicle	6. Oil pump assembly	AT-277
				7. Gear system	AT-245
				8. Output shaft	AT-259
45	Slips/Will Not Engage	With selector lever in "D" position, driving is not possible.	ON vehicle	1. Fluid level and state	AT-51
				2. Line pressure test	AT-52
				3. PNP switch	AT-101
				4. Control cable adjustment	AT-222
				5. Control valve with TCM	AT-225
			OFF vehicle	6. Torque converter	AT-259
				7. Oil pump assembly	AT-277
				8. 1st one-way clutch	AT-286
				9. Gear system	AT-245
				10. Reverse brake	AT-259
				11. Forward one- way clutch (Parts behind drum support is impossible to perform inspection by disassembly. Refer to AT-17 , AT-18	AT-259
				12. Forward brake (Parts behind drum support is impossible to perform inspection by disassembly. Refer to AT-17 , AT-18	AT-259
46		With selector lever in "R" position, driving is not possible.	ON vehicle	1. Fluid level and state	AT-51
				2. Line pressure test	AT-52
				3. PNP switch	AT-101
				4. Control cable adjustment	AT-222
				5. Control valve with TCM	AT-225
			OFF vehicle	6. Gear system	AT-245
				7. Output shaft	AT-259
				8. Reverse brake	AT-259
47	Others	Shift point is high in "D" position.	ON vehicle	1. Vehicle speed sensor A/T and vehicle speed sensor MTR	AT-107 , AT-128
				2. Accelerator pedal position sensor	AT-120
				3. CAN communication line	AT-93
				4. ATF temperature sensor	AT-123
				5. Control valve with TCM	AT-225

A
B
AT
D
E
F
G
H
I
J
K
L
M

TROUBLE DIAGNOSIS

No.	Items	Symptom	Condition	Diagnostic Item	Reference page
48		Shift point is low in "D" position.	ON vehicle	1. Vehicle speed sensor A/T and vehicle speed sensor MTR	AT-107 , AT-128
				2. Accelerator pedal position sensor	AT-120
				3. CAN communication line	AT-93
				4. Control valve with TCM	AT-225
49		Judder occurs during lock-up.	ON vehicle	1. Fluid level and state	AT-51
				2. Engine speed signal	AT-112
				3. Turbine revolution sensor	AT-105
				4. Vehicle speed sensor A/T and vehicle speed sensor MTR	AT-107 , AT-128
			OFF vehicle	5. Accelerator pedal position sensor	AT-120
				6. CAN communication line	AT-93
				7. Torque converter clutch solenoid valve	AT-114
				8. Control valve with TCM	AT-225
			9. Torque converter	AT-259	
50	Others	Strange noise in "R" position.	ON vehicle	1. Fluid level and state	AT-51
				2. Engine speed signal	AT-112
				3. CAN communication line	AT-93
				4. Control valve with TCM	AT-225
			OFF vehicle	5. Torque converter	AT-259
				6. Oil pump assembly	AT-277
				7. Gear system	AT-245
				8. High and low reverse clutch	AT-291
				9. Reverse brake	AT-259
51		Strange noise in "N" position.	ON vehicle	1. Fluid level and state	AT-51
				2. Engine speed signal	AT-112
				3. CAN communication line	AT-93
				4. Control valve with TCM	AT-225
			OFF vehicle	5. Torque converter	AT-259
				6. Oil pump assembly	AT-277
				7. Gear system	AT-245
52		Strange noise in "D" position.	ON vehicle	1. Fluid level and state	AT-51
				2. Engine speed signal	AT-112
				3. CAN communication line	AT-93
				4. Control valve with TCM	AT-225
			OFF vehicle	5. Torque converter	AT-259
				6. Oil pump assembly	AT-277
				7. Gear system	AT-245
				8. Forward brake (Parts behind drum support is impossible to perform inspection by disassembly. Refer to AT-17 , AT-18)	AT-259

TROUBLE DIAGNOSIS

No.	Items	Symptom	Condition	Diagnostic Item	Reference page
53		Vehicle dose not decelerate by engine brake. Refer to AT-213 . "Vehicle Does Not Decelerate By Engine Brake" .	ON vehicle	1. PNP switch	AT-101
				2. Fluid level and state	AT-51
				3. Control cable adjustment	AT-222
				4. 1st position switch	AT-213
				5. ATF pressure switch 5	AT-159
				6. CAN communication line	AT-93
				7. Control valve with TCM	AT-225
			OFF vehicle	8. Input clutch	AT-281
				9. High and low reverse clutch	AT-291
				10. Direct clutch	AT-293
54	Others	Engine brake does not operate in "2" position.	ON vehicle	1. PNP switch	AT-101
				2. Fluid level and state	AT-51
				3. Control cable adjustment	AT-222
				5. ATF pressure switch 6	AT-161
				6. CAN communication line	AT-93
				7. Control valve with TCM	AT-225
				OFF vehicle	8. Front brake (brake band)
			9. Input clutch		AT-281
			10. High and low reverse clutch		AT-291
			55		Engine brake does not operate in "1" position.
2. Fluid level and state	AT-51				
3. Control cable adjustment	AT-222				
4. 1st position switch	AT-213				
5. ATF pressure switch 5	AT-159				
6. CAN communication line	AT-93				
7. Control valve with TCM	AT-225				
OFF vehicle	8. Input clutch	AT-281			
	9. High and low reverse clutch	AT-291			
	10. Direct clutch	AT-293			

A
B
AT
D
E
F
G
H
I
J
K
L
M

TROUBLE DIAGNOSIS

No.	Items	Symptom	Condition	Diagnostic Item	Reference page
56		Maximum speed low.	ON vehicle	1. Fluid level and state	AT-51
				2. Line pressure test	AT-52
				3. Accelerator pedal position sensor	AT-120
				4. CAN communication line	AT-93
				5. Direct clutch solenoid valve	AT-143
				6. Control valve with TCM	AT-225
			OFF vehicle	7. Torque converter	AT-259
				8. Oil pump assembly	AT-277
				9. Input clutch	AT-281
				10. Gear system	AT-245
				11. High and low reverse clutch	AT-291
				12. Direct clutch	AT-293
				13. Forward one- way clutch (Parts behind drum support is impossible to perform inspection by disassembly. Refer to AT-17 , AT-18	AT-259
				14 Forward brake (Parts behind drum support is impossible to perform inspection by disassembly. Refer to AT-17 , AT-18	AT-259
57	Others	Extremely large creep.	ON vehicle	1. Engine idle speed	EC-81
				2. CAN communication line	AT-93
				3. ATF pressure switch 5	AT-159
			OFF vehicle	4. Torque converter	AT-259
58		With selector lever in "P" position, vehicle does not enter parking condition or, with selector lever in another position, parking condition is not cancelled. Refer to AT-176 , " In "P" Position, Vehicle Moves When Pushed "	ON vehicle	1. PNP switch	AT-101
				2. Control cable adjustment	AT-222
			OFF vehicle	3. Parking pawl components	AT-245
59		Vehicle runs with transmission in "P" position.	ON vehicle	1. PNP switch	AT-101
				2. Fluid level and state	AT-51
				3. Control cable adjustment	AT-222
				4. Control valve with TCM	AT-225
				5. Parking pawl components	AT-245
			OFF vehicle	6. Gear system	AT-245

TROUBLE DIAGNOSIS

No.	Items	Symptom	Condition	Diagnostic Item	Reference page
60		Vehicle runs with transmission in "N" position. Refer to AT-177, "In "N" Position, Vehicle Moves" .	ON vehicle	1. PNP switch	AT-101
				2. Fluid level and state	AT-51
				3. Control cable adjustment	AT-222
				4. Control valve with TCM	AT-225
			OFF vehicle	5. Input clutch	AT-281
				6. Gear system	AT-245
				7. Direct clutch	AT-293
				8. Reverse brake	AT-259
				9. Forward one- way clutch (Parts behind drum support is impossible to perform inspection by disassembly. Refer to AT-17 , AT-18	AT-259
				10. Forward brake (Parts behind drum support is impossible to perform inspection by disassembly. Refer to AT-17 , AT-18	AT-259
61	Others	Engine does not start in "N" or "P" position. Refer to AT-175, "Engine Cannot Be Started In "P" or "N" Position" .	ON vehicle	1. Ignition switch and starter	PG-4, SC-10
				2. Control cable adjustment	AT-222
				3. PNP switch	AT-101
62	Others	Engine starts in positions other than "N" or "P".	ON vehicle	1. Ignition switch and starter	PG-4, SC-10
				2. Control cable adjustment	AT-222
				3. PNP switch	AT-101
63		Engine stall.	ON vehicle	1. Fluid level and state	AT-51
				2. Engine speed signal	AT-112
				3. Turbine revolution sensor	AT-105
				4. Torque converter clutch solenoid valve	AT-114
				5. CAN communication line	AT-93
				6. Control valve with TCM	AT-225
			OFF vehicle	7. Torque converter	AT-259
64		Engine stalls when select lever shifted "N" → "D", "R".	ON vehicle	1. Fluid level and state	AT-51
				2. Engine speed signal	AT-112
				3. Turbine revolution sensor	AT-105
				4. Torque converter clutch solenoid valve	AT-114
				5. CAN communication line	AT-93
				6. Control valve with TCM	AT-225
			OFF vehicle	7. Torque converter	AT-259

A
B
AT
D
E
F
G
H
I
J
K
L
M

TROUBLE DIAGNOSIS

No.	Items	Symptom	Condition	Diagnostic Item	Reference page
65	Others	Engine speed does not return to idle. Refer to AT-203 , " Engine Speed Does Not Return to Idle ".	ON vehicle	1. Fluid level and state	AT-51
				2. ATF pressure switch 5 and direct clutch solenoid valve	AT-159 , AT-143
				3. ATF pressure switch 1 and front brake solenoid valve	AT-155 , AT-139
				4. Accelerator pedal position sensor	AT-120
				5. Vehicle speed sensor A/T and vehicle speed sensor MTR	AT-107 , AT-128
				6. CAN communication line	AT-93
				7. Control valve with TCM	AT-225
			OFF vehicle	8. Front brake (brake band)	AT-259
			9. Direct clutch	AT-293	

TROUBLE DIAGNOSIS

TCM Input/Output Signal Reference Values A/T ASSEMBLY HARNESS CONNECTOR TERMINAL LAYOUT



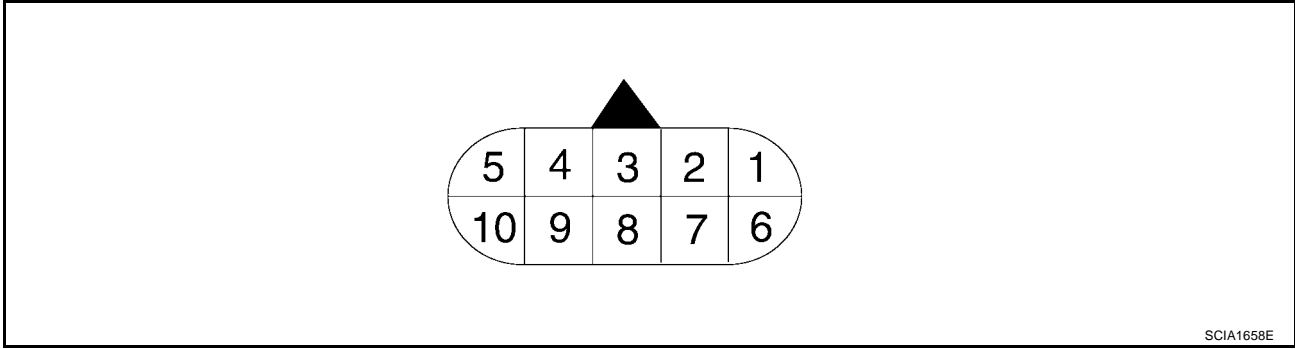



ECS00GX4



SCIA1658E

TERMINALS AND REFERENCE VALUES FOR TCM

Data are reference value and are measured between each terminal and ground.

Terminal No.	Wire color	Item	Condition	Data (Pyrex.)	
1	P	Power supply (Memory back-up)	Always	Battery voltage	
2	P	Power supply (Memory back-up)	Always	Battery voltage	
3	L	CAN-H	-	-	
4	V	K-line (CONSULT-II signal)	The terminal is connected to the data link connector for CONSULT-II.	-	
5	B	Ground	Always	0V	
6	Y/R	Power supply		-	Battery voltage
				-	0V
7	R	Back-up lamp relay		Selector lever in "R" position.	0V
				Selector lever in other positions.	Battery voltage
8	P	CAN-L	-	-	
9	B/R	Starter relay		Selector lever in "N", "P" positions.	Battery voltage
				Selector lever in other positions.	0V
10	B	Ground	Always	0V	

TROUBLE DIAGNOSIS

CONSULT-II Function (A/T)

ECS00GX5

CONSULT-II can display each diagnostic item using the diagnostic test modes shown following.

TCM diagnostic mode	Description
WORK SUPPORT	Supports inspections and adjustments. Commands are transmitted to the TCM for setting the status suitable for required operation, input/output signals are received from the TCM and received data is displayed.
SELF-DIAG RESULTS	Displays TCM self-diagnosis results.
DATA MONITOR	Displays TCM input/output data in real time.
CAN DIAG SUPPORT MNTR	The result of transmit/receive diagnosis of CAN communication can be read.
ACTIVE TEST	Operation of electrical loads can be checked by sending drive signal to them.
FUNCTION TEST	Conducted by CONSULT-II instead of a technician to determine whether each system is "OK" or "NG".
ECU PART NUMBER	TCM part number can be read.

CONSULT-II REFERENCE VALUE

NOTICE:

- The CONSULT-II electrically displays shift timing and lock-up timing (that is, operation timing of each solenoid).
Check for time difference between actual shift timing and the CONSULT-II display. If the difference is noticeable, mechanical parts (except solenoids, sensors, etc.) may be malfunctioning. Check mechanical parts using applicable diagnostic procedures.
- Shift schedule (which implies gear position) displayed on CONSULT-II and that indicated in Service Manual may differ slightly. This occurs because of the following reasons:
 - Actual shift schedule has more or less tolerance or allowance,
 - Shift schedule indicated in Service Manual refers to the point where shifts start, and
 - Gear position displayed on CONSULT-II indicates the point where shifts are completed.
- Display of solenoid valves on CONSULT-II changes at the start of shifting, while gear position is displayed upon completion of shifting (which is computed by TCM).

Item name	Condition	Display value (Approx.)
ATF TEMP SE 1	0°C (32° F) - 20°C (68°F) - 80°C (176°F)	3.3 - 2.7 - 0.9 V
ATF TEMP SE 2		3.3 - 2.5 - 0.7 V
TCC SOLENOID	When perform slip lock-up	0.2 - 0.4 A
	When perform lock-up	0.4 - 0.6 A
SLCT LVR POSI	Selector lever in "N", "P" position.	N/P
	Selector lever in "R" position.	R
	Selector lever in "D" position.	D
	Selector lever in "4" position.	4
	Selector lever in "3" position.	3
	Selector lever in "2" position.	2
VHCL/S SE-A/T	During driving	Approximately matches the speedometer reading.
		Approximately matches the speedometer reading.
ENGINE SPEED	Engine running	Closely matches the tachometer reading.
LINE PRES SOL	During driving	0.2 - 0.6 A
TURBINE REV	During driving (lock-up ON)	Approximately matches the engine speed.
VHCL/S SE-MTR	During driving	Approximately matches the speedometer reading.

TROUBLE DIAGNOSIS

Item name	Condition	Display value (Approx.)	
ATF PRES SW 1	Front brake engaged. Refer to AT-20	ON	A
	Front brake disengaged. Refer to AT-20	OFF	
ATF PRES SW 2	Low coast brake engaged. Refer to AT-20	ON	B
	Low coast brake disengaged. Refer to AT-20	OFF	
ATF PRES SW 3	Input clutch engaged. Refer to AT-20	ON	AT
	Input clutch disengaged. Refer to AT-20	OFF	
ATF PRES SW 5	Direct clutch engaged. Refer to AT-20AT-20	ON	D
	Direct clutch disengaged. Refer to AT-20	OFF	
ATF PRES SW 6	High and low reverse clutch engaged. Refer to AT-20	ON	E
	High and low reverse clutch disengaged. Refer to AT-20	OFF	
I/C SOLENOID	Input clutch disengaged. Refer to AT-20	0.6 - 0.8 A	F
	Input clutch engaged. Refer to AT-20	0 - 0.05 A	
FR/B SOLENOID	Front brake engaged. Refer to AT-20	0.6 - 0.8 A	G
	Front brake disengaged. Refer to AT-20	0 - 0.05 A	
D/C SOLENOID	Direct clutch disengaged. Refer to AT-20	0.6 - 0.8 A	H
	Direct clutch engaged. Refer to AT-20	0 - 0.05 A	
HLR/C SOL	High and low reverse clutch disengaged. Refer to AT-20	0.6 - 0.8 A	I
	High and low reverse clutch engaged. Refer to AT-20	0 - 0.05 A	
ON OFF SOL	Low coast brake engaged. Refer to AT-20	ON	J
	Low coast brake disengaged. Refer to AT-20	OFF	
STARTER RELAY	Selector lever in "N", "P" position.	ON	K
	Selector lever in other position.	OFF	
ACCELE POSI	Released accelerator pedal.	0.0/8	L
	Fully depressed accelerator pedal.	8/8	
CLSD THL POS	Released accelerator pedal.	ON	M
	Fully depressed accelerator pedal.	OFF	
W/O THL POS	Fully depressed accelerator pedal.	ON	
	Released accelerator pedal.	OFF	
BRAKE SW	Depressed brake pedal.	ON	
	Released brake pedal.	OFF	

TROUBLE DIAGNOSIS

CONSULT-II START PROCEDURE

Refer to [GI-38, "CONSULT-II Start Procedure"](#) .

SELF-DIAGNOSTIC RESULT MODE

Operation Procedure

After performing SELF-DIAGNOSTIC RESULT MODE, place check marks for results on the [AT-46, "DIAGNOSTIC WORKSHEET"](#) . Reference pages are provided following the items.

Display Items List

X: Applicable, —: Not applicable

Items (CONSULT-II screen terms)	Malfunction is detected when...	TCM self-diagnosis	OBD-II (DTC)
		"A/T" with CONSULT-II	MIL indicator lamp*1, "ENGINE" with CONSULT-II or GST
CAN COMM CIRCUIT	<ul style="list-style-type: none"> When a malfunction is detected in CAN communications 	U1000	U1000
STARTER RELAY/ CIRC	<ul style="list-style-type: none"> If this signal is ON other than in P or N position, this is judged to be a malfunction. (And if it is OFF in P or N position, this too is judged to be a malfunction.) 	P0615	—
TCM	<ul style="list-style-type: none"> TCM is malfunctioning. 	P0700	P0700
PNP SW/CIRC	<ul style="list-style-type: none"> PNP switch 1-4 signals input with impossible pattern "P" position is detected from N position without any other position being detected in between. 	P0705	P0705
TURBINE REV S/CIRC	<ul style="list-style-type: none"> TCM does not receive the proper voltage signal from the sensor. TCM detects an irregularity only at position of 4th gear for turbine revolution sensor 2. 	P0717	P0717
VEH SPD SEN/CIR AT (Revolution sensor)	<ul style="list-style-type: none"> Signal from vehicle speed sensor A/T (Revolution sensor) not input due to cut line or the like Unexpected signal input during running After ignition switch is turned ON, unexpected signal input from vehicle speed sensor MTR before the vehicle starts moving 	P0720	P0720
ENGINE SPEED SIG	<ul style="list-style-type: none"> TCM does not receive the CAN communication signal from the ECM. 	P0725	—
TCC SOLENOID/CIRC	<ul style="list-style-type: none"> Normal voltage not applied to solenoid due to cut line, short, or the like 	P0740	P0740
A/T TCC S/V FNCTN	<ul style="list-style-type: none"> A/T cannot perform lock-up even if electrical circuit is good. TCM detects as irregular by comparing difference value with slip rotation. 	P0744	P0744*2
L/PRESS SOL/CIRC	<ul style="list-style-type: none"> Normal voltage not applied to solenoid due to cut line, short, or the like TCM detects as irregular by comparing target value with monitor value. 	P0745	P0745
TP SEN/CIRC A/T	<ul style="list-style-type: none"> TCM does not receive the proper accelerator pedal position signals (input by CAN communication) from ECM. 	P1705	P1705
ATF TEMP SEN/CIRC	<ul style="list-style-type: none"> During running, the ATF temperature sensor signal voltage is excessively high or low 	P1710	P0710
VEH SPD SE/CIR·MTR	<ul style="list-style-type: none"> Signal (CAN communication) from vehicle speed sensor MTR not input due to cut line or the like Unexpected signal input during running 	P1721	—
A/T INTERLOCK	<ul style="list-style-type: none"> Except during shift change, the gear position and ATF pressure switch states are monitored and comparative judgement made. 	P1730	P1730
A/T 1ST E/BRAKING	<ul style="list-style-type: none"> Each ATF pressure switch and solenoid current is monitored and if a pattern is detected having engine braking 1st gear other than in the "1" position, a malfunction is detected. 	P1731	—

TROUBLE DIAGNOSIS

Items (CONSULT-II screen terms)	Malfunction is detected when...	TCM self-diagnosis	OBD-II (DTC)	A
		"A/T" with CONSULT-II	MIL indicator lamp*1, "ENGINE" with CONSULT-II or GST	B
I/C SOLENOID/CIRC	<ul style="list-style-type: none"> Normal voltage not applied to solenoid due to functional malfunction, cut line, short, or the like TCM detects as irregular by comparing target value with monitor value. 	P1752	P1752	AT
I/C SOLENOID FNCTN	<ul style="list-style-type: none"> TCM detects that actual gear ratio is irregular, and relation between gear position and condition of ATF pressure switch 3 is irregular during depressing accelerator pedal. (Other than during shift change) TCM detects that relation between gear position and condition of ATF pressure switch 3 is irregular during releasing accelerator pedal. (Other than during shift change) 	P1754	P1754*2	D E
FR/B SOLENOID/CIRC	<ul style="list-style-type: none"> Normal voltage not applied to solenoid due to functional malfunction, cut line, short, or the like TCM detects as irregular by comparing target value with monitor value. 	P1757	P1757	F
FR/B SOLENOID FNCT	<ul style="list-style-type: none"> TCM detects that actual gear ratio is irregular, and relation between gear position and condition of ATF pressure switch 1 is irregular during depressing accelerator pedal. (Other than during shift change) TCM detects that relation between gear position and condition of ATF pressure switch 1 is irregular during releasing accelerator pedal. (Other than during shift change) 	P1759	P1759*2	G H
D/C SOLENOID/CIRC	<ul style="list-style-type: none"> Normal voltage not applied to solenoid due to cut line, short, or the like TCM detects as irregular by comparing target value with monitor value. 	P1762	P1762	I
D/C SOLENOID FNCTN	<ul style="list-style-type: none"> TCM detects that actual gear ratio is irregular, and relation between gear position and condition of ATF pressure switch 5 is irregular during depressing accelerator pedal. (Other than during shift change) TCM detects that relation between gear position and condition of ATF pressure switch 5 is irregular during releasing accelerator pedal. (Other than during shift change) 	P1764	P1764*2	J
HLR/C SOL/CIRC	<ul style="list-style-type: none"> Normal voltage not applied to solenoid due to functional malfunction, cut line, short, or the like TCM detects as irregular by comparing target value with monitor value. 	P1767	P1767	K
HLR/C SOL FNCTN	<ul style="list-style-type: none"> TCM detects that actual gear ratio is irregular, and relation between gear position and condition of ATF pressure switch 6 is irregular during depressing accelerator pedal. (Other than during shift change) TCM detects that relation between gear position and condition of ATF pressure switch 6 is irregular during releasing accelerator pedal. (Other than during shift change) 	P1769	P1769*2	L M
LC/B SOLENOID/CIRC	<ul style="list-style-type: none"> Normal voltage not applied to solenoid due to functional malfunction, cut line, short, or the like 	P1772	P1772	
LC/B SOLENOID FNCT	<ul style="list-style-type: none"> TCM detects an improper voltage drop when it tries to operate the solenoid valve. Condition of ATF pressure switch 2 is different from monitor value, and relation between gear position and actual gear ratio is irregular. 	P1774	P1774*2	
ATF PRES SW 1/CIRC	<ul style="list-style-type: none"> TCM detects that actual gear ratio is normal, and relation between gear position and condition of ATF pressure switch 1 is irregular during depressing accelerator pedal. (Other than during shift change) 	P1841	—	
ATF PRES SW 3/CIRC	<ul style="list-style-type: none"> TCM detects that actual gear ratio is normal, and relation between gear position and condition of ATF pressure switch 3 is irregular during depressing accelerator pedal. (Other than during shift change) 	P1843	—	
ATF PRES SW 5/CIRC	<ul style="list-style-type: none"> TCM detects that actual gear ratio is normal, and relation between gear position and condition of ATF pressure switch 5 is irregular during depressing accelerator pedal. (Other than during shift change) 	P1845	—	

TROUBLE DIAGNOSIS

Items (CONSULT-II screen terms)	Malfunction is detected when...	TCM self-diagnosis	OBD-II (DTC)
		"A/T" with CONSULT-II	MIL indicator lamp*1, "ENGINE" with CONSULT-II or GST
ATF PRES SW 6/CIRC	<ul style="list-style-type: none"> ● TCM detects that actual gear ratio is normal, and relation between gear position and condition of ATF pressure switch 6 is irregular during depressing accelerator pedal. (Other than during shift change) 	P1846	—
NO DTC IS DETECTED FURTHER TESTING MAY BE REQUIRED	<ul style="list-style-type: none"> ● No NG item has been detected. 	X	X

*1: Refer to [EC-63, "Malfunction Indicator Lamp \(MIL\)"](#).

*2: These malfunctions cannot be displayed MIL if another malfunction is assigned to MIL.

TROUBLE DIAGNOSIS

DATA MONITOR MODE

Display Items List

X: Standard, —: Not applicable

Monitored item (Unit)	Monitor Item Selection			Remarks
	ECU INPUT SIGNALS	MAIN SIGNALS	SELECTION FROM MENU	
VHCL/S SE-A/T (km/h)	X	X	X	Revolution sensor
VHCL/S SE-MTR (km/h)	X	—	X	
ACCELE POSI (0.0/8)	X	—	X	Accelerator pedal position signal
THROTTLE POSI (0.0/8)	X	X	X	Degree of opening for accelerator recognized by the TCM For fail-safe operation, the specific value used for control is displayed.
CLSD THL POS (ON-OFF display)	X	—	X	Signal input with CAN communications
W/O THL POS (ON-OFF display)	X	—	X	
BRAKE SW (ON-OFF display)	X	—	X	Stop lamp switch
GEAR	—	X	X	Gear position recognized by the TCM updated after gear-shifting
ENGINE SPEED (rpm)	X	X	X	
TURBINE REV (rpm)	X	X	X	
OUTPUT REV (rpm)	X	X	X	
GEAR RATIO	—	X	X	
TC SLIP SPEED (rpm)	—	X	X	Difference between engine speed and torque converter input shaft speed
F SUN GR REV (rpm)	—	—	X	
F CARR GR REV (rpm)	—	—	X	
ATF TEMP SE 1 (V)	X	—	X	
ATF TEMP SE 2 (V)	X	—	X	
ATF TEMP 1 (°C)	—	X	X	
ATF TEMP 2 (°C)	—	X	X	
BATTERY VOLT (V)	X	—	X	
ATF PRES SW 1 (ON-OFF display)	X	X	X	(for FR/B solenoid)
ATF PRES SW 2 (ON-OFF display)	X	X	X	(for LC/B solenoid)
ATF PRES SW 3 (ON-OFF display)	X	X	X	(for I/C solenoid)
ATF PRES SW 5 (ON-OFF display)	X	X	X	(for D/C solenoid)
ATF PRES SW 6 (ON-OFF display)	X	X	X	(for HLR/C solenoid)
PNP SW 1 (ON-OFF display)	X	—	X	
PNP SW 2 (ON-OFF display)	X	—	X	
PNP SW 3 (ON-OFF display)	X	—	X	
PNP SW 4 (ON-OFF display)	X	—	X	
SLCT LVR POSI	—	X	X	Selector lever position is recognized by the TCM. For fail-safe operation, the specific value used for control is displayed.
1 POSITION SW (ON-OFF display)	X	—	X	1st position switch
OD CONT SW (ON-OFF display)	X	—	X	4th position switch

TROUBLE DIAGNOSIS

Monitored item (Unit)	Monitor Item Selection			Remarks
	ECU INPUT SIGNALS	MAIN SIGNALS	SELECTION FROM MENU	
POWERSHIFT SW (ON-OFF display)	X	—	X	Not mounted but displayed.
HOLD SW (ON-OFF display)	X	—	X	
MANU MODE SW (ON-OFF display)	X	—	X	
NON M-MODE SW (ON-OFF display)	X	—	X	
UP SW LEVER (ON-OFF display)	X	—	X	
DOWN SW LEVER (ON-OFF display)	X	—	X	
SFT UP ST SW (ON-OFF display)	—	—	X	
SFT DWN ST SW (ON-OFF display)	—	—	X	
ASCD-OD CUT (ON-OFF display)	—	—	X	ICC (Intelligent cruise control)
ASCD-CRUISE (ON-OFF display)	—	—	X	
ABS SIGNAL (ON-OFF display)	—	—	X	ICC (Intelligent cruise control)
ACC OD CUT (ON-OFF display)	—	—	X	
ACC SIGNAL (ON-OFF display)	—	—	X	ICC (Intelligent cruise control)
TCS GR/P KEEP (ON-OFF display)	—	—	X	
TCS SIGNAL 2 (ON-OFF display)	—	—	X	ICC (Intelligent cruise control)
TCS SIGNAL 1 (ON-OFF display)	—	—	X	
TCC SOLENOID (A)	—	X	X	LC/B solenoid
LINE PRES SOL (A)	—	X	X	
I/C SOLENOID (A)	—	X	X	LC/B solenoid
FR/B SOLENOID (A)	—	X	X	
D/C SOLENOID (A)	—	X	X	LC/B solenoid
HLR/C SOL (A)	—	X	X	
ON OFF SOL (ON-OFF display)	—	—	X	LC/B solenoid
TCC SOL MON (A)	—	—	X	
L/P SOL MON (A)	—	—	X	LC/B solenoid
I/C SOL MON (A)	—	—	X	
FR/B SOL MON (A)	—	—	X	LC/B solenoid
D/C SOL MON (A)	—	—	X	
HLR/C SOL MON (A)	—	—	X	LC/B solenoid
ONOFF SOL MON (ON-OFF display)	—	—	X	
P POSI IND (ON-OFF display)	—	—	X	LC/B solenoid
R POSI IND (ON-OFF display)	—	—	X	
N POSI IND (ON-OFF display)	—	—	X	LC/B solenoid
D POSI IND (ON-OFF display)	—	—	X	
4TH POSI IND (ON-OFF display)	—	—	X	LC/B solenoid
3RD POSI IND (ON-OFF display)	—	—	X	
2ND POSI IND (ON-OFF display)	—	—	X	LC/B solenoid
1ST POSI IND (ON-OFF display)	—	—	X	
MANU MODE IND (ON-OFF display)	—	—	X	Not mounted but displayed.
POWER M LAMP (ON-OFF display)	—	—	X	
F-SAFE IND/L (ON-OFF display)	—	—	X	

TROUBLE DIAGNOSIS

Monitored item (Unit)	Monitor Item Selection			Remarks	A
	ECU INPUT SIGNALS	MAIN SIG- NALS	SELEC- TION FROM MENU		B
ATF WARN LAMP (ON-OFF display)	—	—	X		AT
BACK-UP LAMP (ON-OFF display)	—	—	X		D
STARTER RELAY (ON-OFF display)	—	—	X		E
PNP SW3 MON (ON-OFF display)	—	—	X		F
C/V CLB ID1	—	—	X		G
C/V CLB ID2	—	—	X		H
C/V CLB ID3	—	—	X		I
UNIT CLB ID1	—	—	X		J
UNIT CLB ID2	—	—	X		K
UNIT CLB ID3	—	—	X		L
TRGT GR RATIO	—	—	X		M
TRGT PRES TCC (kPa)	—	—	X		
TRGT PRES L/P (kPa)	—	—	X		
TRGT PRES I/C (kPa)	—	—	X		
TRGT PRE FR/B (kPa)	—	—	X		
TRGT PRES D/C (kPa)	—	—	X		
TRG PRE HLR/C (kPa)	—	—	X		
SHIFT PATTERN	—	—	X		
DRV CST JUDGE	—	—	X		
START RLY MON	—	—	X		
NEXT GR POSI	—	—	X		
SHIFT MODE	—	—	X		
MANU GR POSI	—	—	X		
VEHICLE SPEED (km/h)	—	X	X	Vehicle speed recognized by the TCM.	
Voltage (V)	—	—	X	Displays the value measured by the voltage probe.	
Frequency (Hz)	—	—	X	The value measured by the pulse probe is displayed.	
DUTY-HI (high) (%)	—	—	X		
DUTY-LOW (low) (%)	—	—	X		
PLS WIDTH-HI (ms)	—	—	X		
PLS WIDTH-LOW (ms)	—	—	X		

DTC WORK SUPPORT MODE

Display Items List

DTC work support item	Description	Check item
I/C SOL FUNCTN CHECK*	—	—
FR/B SOL FUNCTN CHECK*	—	—
D/C SOL FUNCTN CHECK*	—	—
HLR/C SOL FUNCTN CHECK*	—	—

TROUBLE DIAGNOSIS

DTC work support item	Description	Check item
LC/B SOL FUNCTN CHECK*	—	—
TCC SOL FUNCTN CHECK	<p>Following items for "TCC solenoid function (lock-up) " can be confirmed.</p> <ul style="list-style-type: none"> ● Self-diagnosis status (whether the diagnosis is being conducted or not) ● Self-diagnosis result (OK or NG) 	<ul style="list-style-type: none"> ● TCC solenoid valve ● Hydraulic control circuit

*: Do not use, but displayed.

DTC U1000 CAN COMMUNICATION LINE

DTC U1000 CAN COMMUNICATION LINE

PFP:23710

Description

ECS00GX6

CAN (Controller Area Network) is a serial communication line for real time application. It is an on-vehicle multiplex communication line with high data communication speed and excellent malfunction detection ability. Many electronic control units are equipped onto a vehicle, and each control unit shares information and links with other control units during operation (not independent). In CAN communication, control units are connected with 2 communication lines (CAN H line, CAN L line) allowing a high rate of information transmission with less wiring. Each control unit transmits/receives data but selectively reads required data only.

On Board Diagnosis Logic

ECS00GX7

- This is an OBD-II self-diagnostic item.
- Diagnostic trouble code "U1000 CAN COMM CIRCUIT" with CONSULT-II is detected when TCM cannot communicate to other control units.

Possible Cause

ECS00GX8

Harness or connectors
(CAN communication line is open or shorted.)

DTC Confirmation Procedure

ECS00GX9

NOTE:

If "DTC Confirmation Procedure" has been previously performed, always turn ignition switch "OFF" and wait at least 10 seconds before performing the next test.

After the repair, perform the following procedure to confirm the malfunction is eliminated.

WITH CONSULT-II

1. Turn ignition switch "ON". (Do not start engine.)
2. Select "DATA MONITOR" mode for "ENGINE" with CONSULT-II.
3. Start engine and wait for at least 6 seconds.
4. If DTC is detected, go to [AT-95, "Diagnostic Procedure"](#).

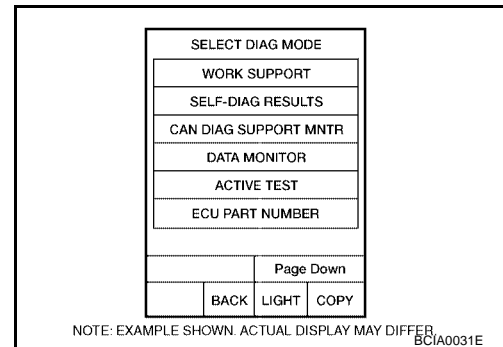

WITH GST



Follow the procedure "WITH CONSULT-II".

DTC U1000 CAN COMMUNICATION LINE

Wiring Diagram — AT — CAN

ECS00GXA

AT-CAN-01

-  : DETECTABLE LINE FOR DTC
-  : NON-DETECTABLE LINE FOR DTC
-  : DATA LINE

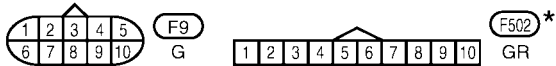
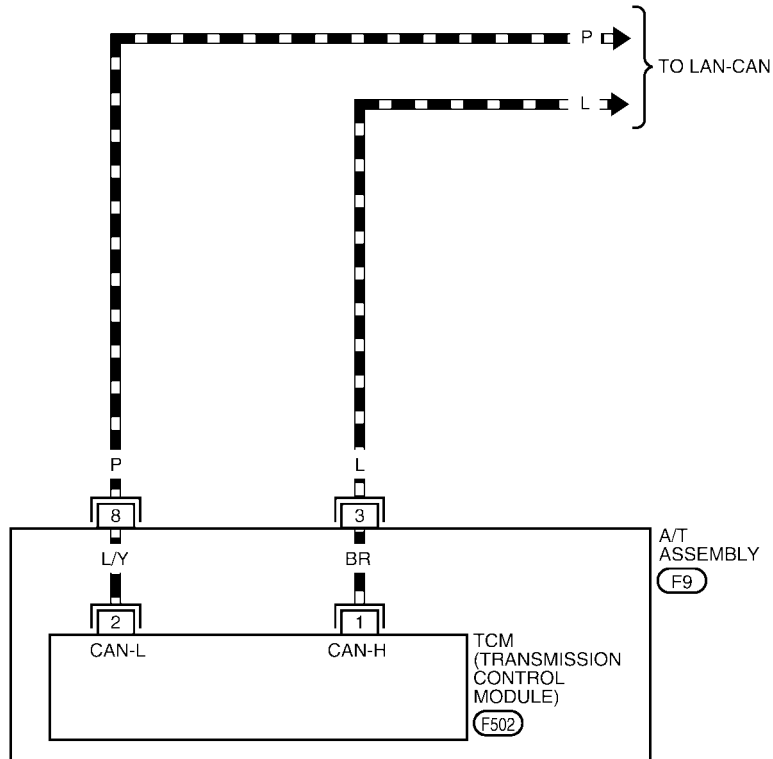

*: THIS CONNECTOR IS NOT SHOWN IN "HARNESS LAYOUT" OF PG SECTION.

BCWA0320E

DTC U1000 CAN COMMUNICATION LINE

TCM INPUT/OUTPUT SIGNAL REFERENCE VALUES

Refer to [AT-83, "TCM Input/Output Signal Reference Values"](#) .

Diagnostic Procedure

ECS00GX8

1. CHECK CAN COMMUNICATION CIRCUIT

Ⓜ With CONSULT-II

1. Turn ignition switch "ON" and start engine.
2. Select "SELF-DIAG RESULTS" mode for "A/T" with CONSULT-II.

Is any malfunction of the "CAN COMM CIRCUIT" indicated?

YES >> Print out CONSULT-II screen, GO TO LAN section.
Refer to [LAN-42, "Precautions When Using CONSULT-II"](#) .

NO >> **INSPECTION END**

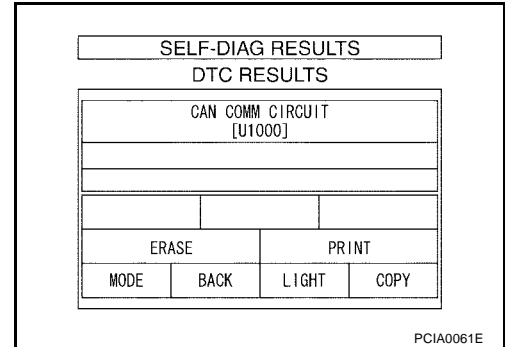

A

B

AT

D

E

F

G

H

I

J

K

L

M

DTC P0615 START SIGNAL CIRCUIT

DTC P0615 START SIGNAL CIRCUIT

PFP:25230

Description

ECS00GXC

- TCM prohibits cranking other than at “P” or “N” position.

CONSULT-II Reference Value

ECS00GXD

Item name	Condition	Display value
STARTER RELAY	Selector lever in “N”, “P” position.	ON
	Selector lever in other position.	OFF

On Board Diagnosis Logic

ECS00GXE

- This is not an OBD-II self-diagnostic item.
- Diagnostic trouble code “P0615 STARTER RELAY/CIRC” with CONSULT-II is detected when park/neutral (PNP) relay (starter relay) is switched “ON” other than at “P” or “N” position. (Or when switched “OFF” at “P” or “N” position).

Possible Cause

ECS00GXF

- Harness or connectors
[The park/neutral position (PNP) relay (starter relay) and TCM circuit is open or shorted.]
- Park/neutral position (PNP) relay (starter relay)

DTC Confirmation Procedure

ECS00GXG

NOTE:

If “DTC Confirmation Procedure” has been previously performed, always turn ignition switch “OFF” and wait at least 10 seconds before performing the next test.

After the repair, perform the following procedure to confirm the malfunction is eliminated.

④ WITH CONSULT-II

1. Turn ignition switch “ON”. (Do not start engine.)
2. Select “DATA MONITOR” mode for “A/T” with CONSULT-II.
3. Start engine.
4. Drive vehicle for at least 2 consecutive seconds.
5. If DTC is detected, go to [AT-98. "Diagnostic Procedure"](#).

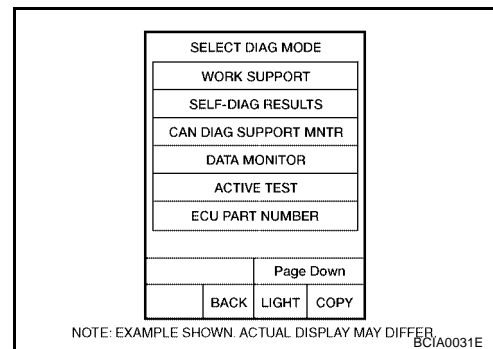

DTC P0615 START SIGNAL CIRCUIT

Wiring Diagram — AT — STSIG

ECS00GXH

AT-STSIG-01

: DETECTABLE LINE FOR DTC
 : NON-DETECTABLE LINE FOR DTC

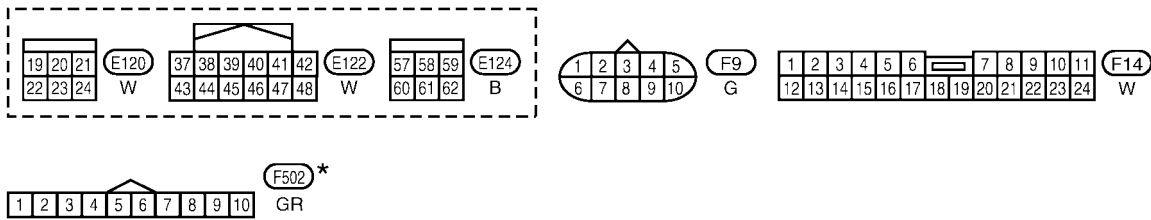
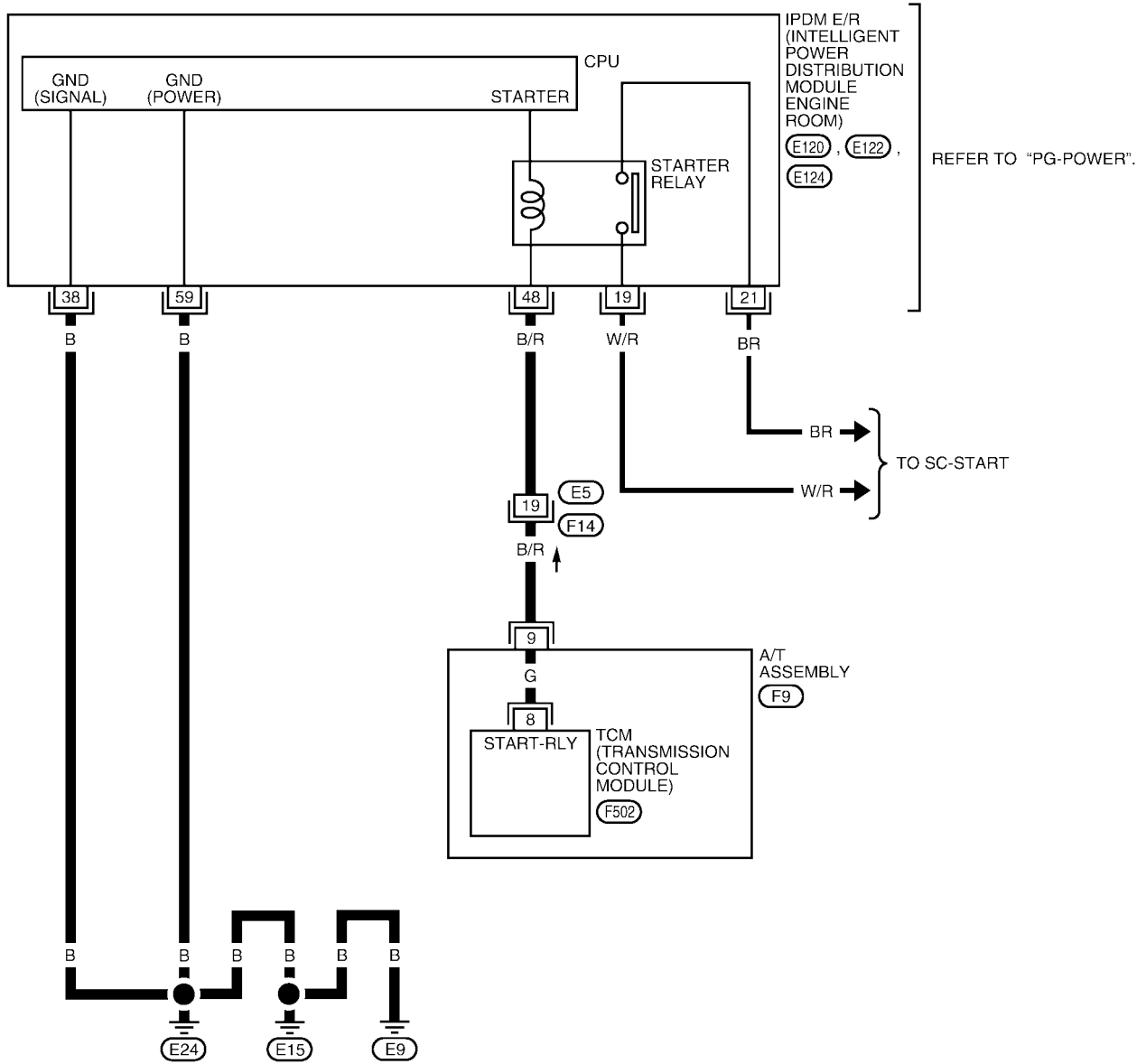

*: THIS CONNECTOR IS NOT SHOWN IN "HARNESS LAYOUT" OF PG SECTION.

BCWA0321E

DTC P0615 START SIGNAL CIRCUIT

TCM INPUT/OUTPUT SIGNAL REFERENCE VALUES

Refer to [AT-83, "TCM Input/Output Signal Reference Values"](#).

Diagnostic Procedure

ECS00GX1

1. CHECK STARTER RELAY

Ⓟ With CONSULT-II

- Turn ignition switch "ON". (Do not start engine.)
- Select "SELECTION FROM MENU" in "DATA MONITOR" mode for "A/T" with CONSULT-II and check monitor "STARTER RELAY" ON/OFF.

Item name	Condition	Display value
STARTER RELAY	Selector lever in "N", "P" positions.	ON
	Selector lever in other positions.	OFF

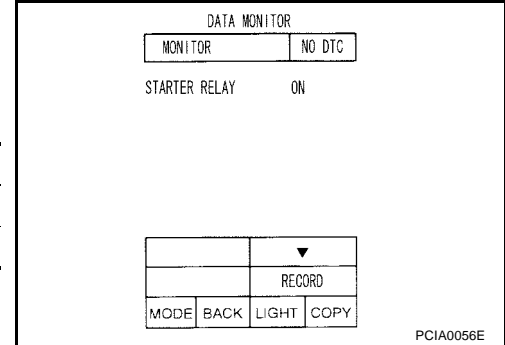

ⓧ Without CONSULT-II

- Turn ignition switch "ON". (Do not start engine.)
- Check voltage between the IPDM E/R connector and ground.

Item	Connector	Terminal	Shift position	Voltage (Approx.)
Starter relay	E122	48	"N" and "P"	Battery voltage
			"R" and "D"	0V

OK or NG

- OK >> GO TO 5.
 NG >> GO TO 2.

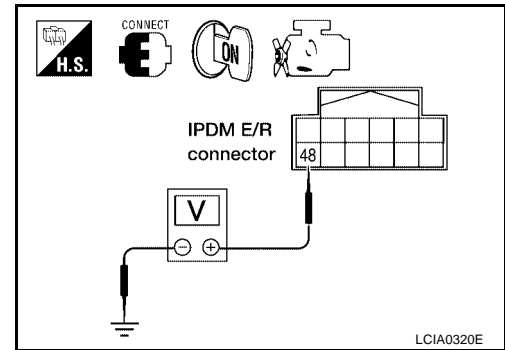

2. CHECK HARNESS BETWEEN A/T ASSEMBLY HARNESS CONNECTOR AND IPDM E/R CONECTOR.

- Turn ignition switch OFF.
- Disconnect A/T assembly harness connector and IPDM E/R connector.

Item	Connector	Terminal	Continuity
A/T assembly harness connector	F9	9	Yes
IPDM E/R connector	E122	48	

- Check continuity between A/T assembly harness connector and IPDM E/R connector.
- If OK, check harness for short to ground and short to power.
- Reinstall any part removed.

OK or NG

- OK >> GO TO 3.
 NG >> Repair open circuit or short to ground or short to power in harness or connectors.

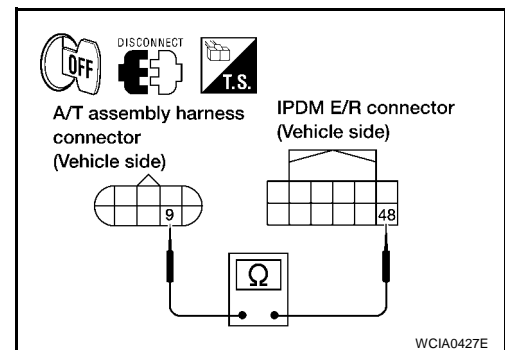

DTC P0615 START SIGNAL CIRCUIT

3. CHECK TERMINAL CORD ASSEMBLY

1. Remove control valve with TCM. Refer to [AT-225, "Control Valve With TCM and A/T Fluid Temperature Sensor 2"](#) .
2. Disconnect A/T assembly harness connector and TCM connector.
3. Check continuity between A/T assembly harness connector terminal and TCM connector terminal.

Item	Connector	Terminal	Continuity
A/T assembly harness connector	F9	9	Yes
TCM connector	F502	8	

4. If OK, check harness for short to ground and short to power.
5. Reinstall any part removed.

OK or NG

- OK >> GO TO 4.
- NG >> Replace open circuit or short to ground and short to power in harness or connectors.

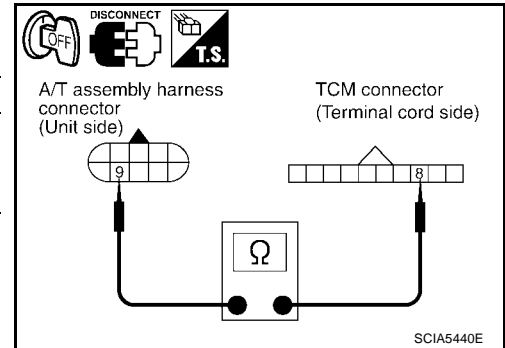

4. DETECT MALFUNCTIONING ITEM

Check the following items:

- Starter relay, Refer to [SC-10, "STARTING SYSTEM"](#) .
- IPDM E/R, Refer to [PG-18, "IPDM E/R \(INTELLIGENT POWER DISTRIBUTION MODULE ENGINE ROOM\)"](#) .

OK or NG

- OK >> Replace the control valve with TCM. Refer to [AT-225, "Control Valve With TCM and A/T Fluid Temperature Sensor 2"](#) .
- NG >> Repair or replace damaged parts.

5. CHECK DTC

Perform "DTC Confirmation Procedure".

- Refer to [AT-96, "DTC Confirmation Procedure"](#) .

OK or NG

- OK >> **INSPECTION END**
- NG >> GO TO 2.

DTC P0700 TCM

PF:31036

DTC P0700 TCM

Description

ECS00GXJ

The TCM consists of a microcomputer and connectors for signal input and output and for power supply. The TCM controls the A/T.

On Board Diagnosis Logic

ECS00GXK

- This is an OBD-II self-diagnostic item.
- Diagnostic trouble code "P0700 TCM" with CONSULT-II is detected when the TCM is malfunctioning.

Possible Cause

ECS00GXL

TCM.

DTC Confirmation Procedure

ECS00GXM

NOTE:

If "DTC Confirmation Procedure" has been previously performed, always turn ignition switch "OFF" and wait at least 10 seconds before performing the next test.

After the repair, perform the following procedure to confirm the malfunction is eliminated.

WITH CONSULT-II

1. Turn ignition switch "ON". (Do not start engine.)
2. Select "DATA MONITOR" mode for "A/T" with CONSULT-II.
3. Start engine.
4. Run engine for at least 2 consecutive seconds at idle speed.
5. If DTC is detected, go to [AT-100, "Diagnostic Procedure"](#).

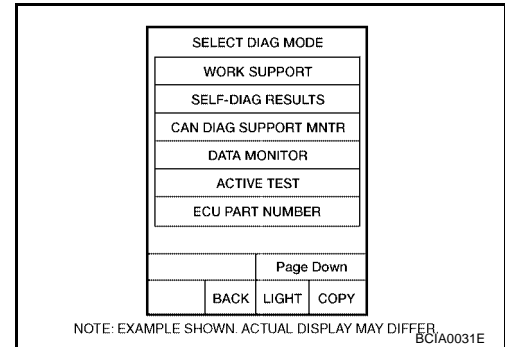

WITH GST

Follow the procedure "With CONSULT-II".

Diagnostic Procedure

ECS00GXN

1. CHECK DTC

With CONSULT-II

1. Turn ignition switch "ON". (Do not start engine.)
2. Select "SELF DIAG RESULTS" mode for "A/T" with CONSULT-II.
3. Touch "ERASE".
4. Turn ignition switch "OFF" and wait at least 10 seconds.
5. Perform DTC Confirmation Procedure, [AT-100, "DTC Confirmation Procedure"](#).

Is the "TCM" displayed again?

YES >> Replace the control valve with TCM. Refer to [AT-225, "Control Valve With TCM and A/T Fluid Temperature Sensor 2"](#).

NO >> **INSPECTION END**

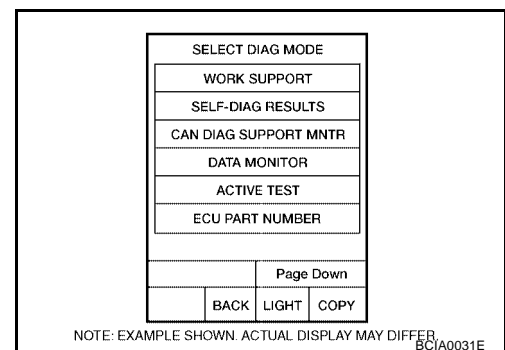

DTC P0705 PARK/NEUTRAL POSITION SWITCH

DTC P0705 PARK/NEUTRAL POSITION SWITCH

PF03:32006

Description

ECS00GX0

- The park/neutral position (PNP) switch includes a transmission position switch.
- The transmission range switch detects the selector lever position and sends a signal to the TCM.

CONSULT-II Reference Value

ECS00GXP

Item name	Condition	Display value
SLCTLVR POSI	Selector lever in "N", "P" positions.	N/P
	Selector lever in "R" position.	R
	Selector lever in "D" position.	D
	Selector lever in "4" position.	4
	Selector lever in "3" position.	3
	Selector lever in "2" position.	2
	Selector lever in "1" position.	1

On Board Diagnosis Logic

ECS00GX0

- This is an OBD-II self-diagnostic item.
- Diagnostic trouble code "P0705 PNP SW/CIRC" with CONSULT-II is detected under the following conditions.
 - When TCM does not receive the correct voltage signal from the PNP switch 1, 2, 3, 4 based on the gear position.
 - When no other position but "P" position is detected from "N" positions.

Possible Cause

ECS00GXR

- Harness or connectors
[The park/neutral position (PNP) switch 1, 2, 3, 4 and TCM circuit is open or shorted.]
- Park/neutral position (PNP) switch 1, 2, 3, 4

DTC Confirmation Procedure

ECS00GXS

CAUTION:

Always drive vehicle at a safe speed.

NOTE:

If "DTC Confirmation Procedure" has been previously performed, always turn ignition switch "OFF" and wait at least 10 seconds before performing the next test.

After the repair, perform the following procedure to confirm the malfunction is eliminated.

WITH CONSULT-II

1. Turn ignition switch "ON". (Do not start engine.)
2. Select "DATA MONITOR" mode for "ENGINE" with CONSULT-II.
3. Start engine.
4. Drive vehicle and maintain the following conditions for at least 2 consecutive seconds.
THRTL POS SEN: More than 1.2V
5. If DTC is detected, go to [AT-103, "Diagnostic Procedure"](#).

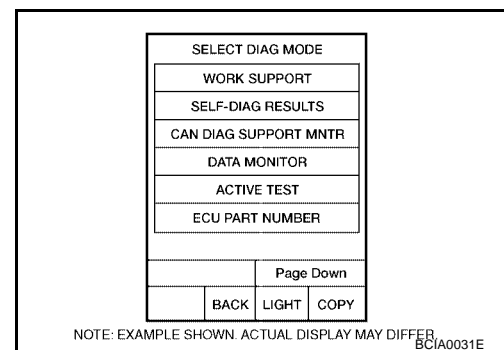

WITH GST

Follow the procedure "With CONSULT-II".

DTC P0705 PARK/NEUTRAL POSITION SWITCH

Wiring Diagram — AT — PNP/SW

ECS00GXT

AT-PNP/SW-01

: DETECTABLE LINE FOR DTC
 : NON-DETECTABLE LINE FOR DTC

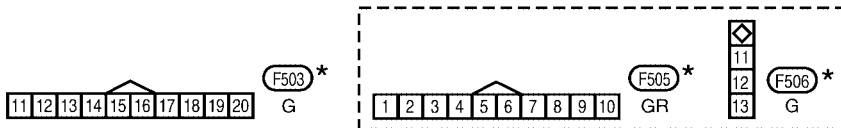
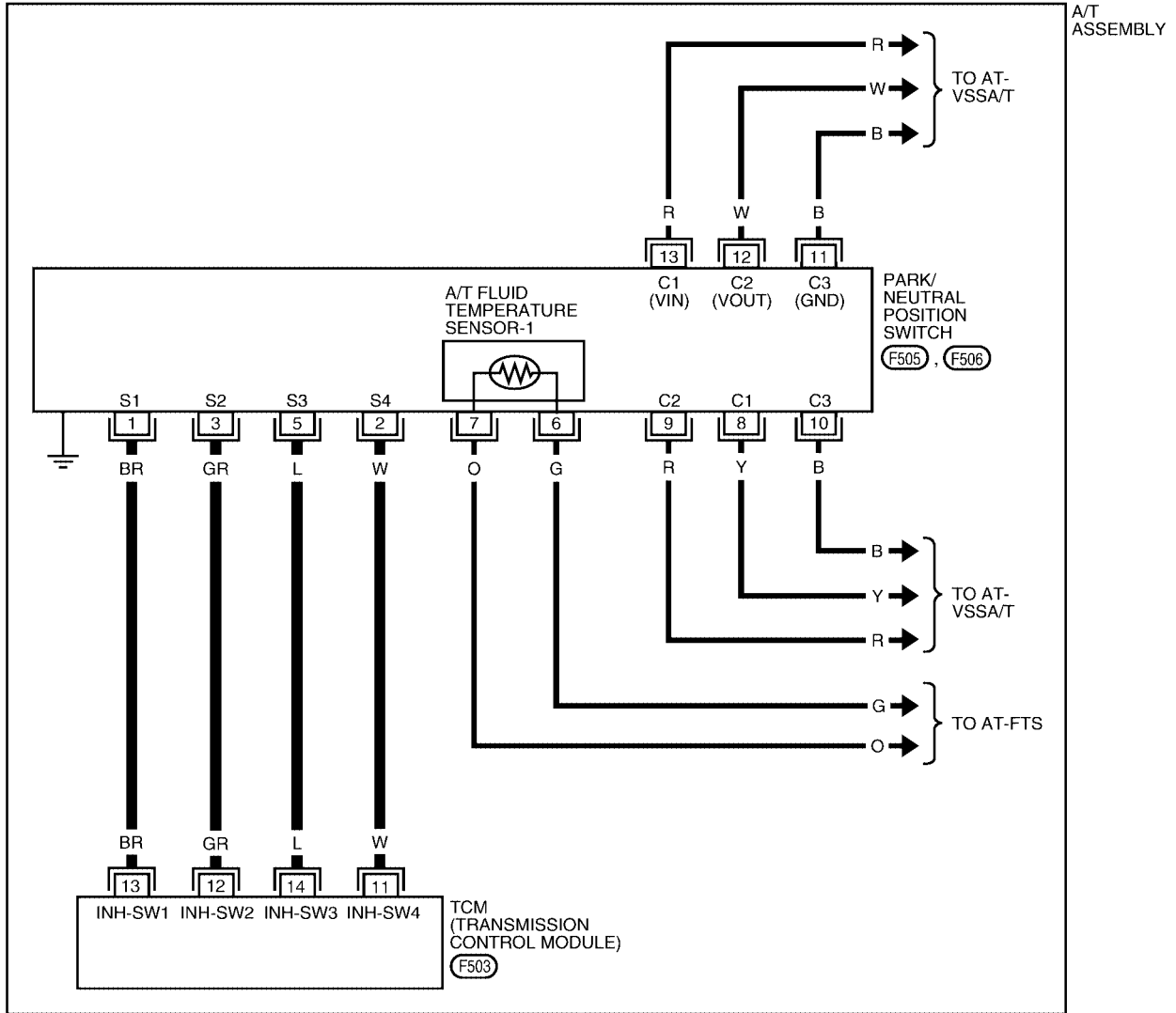

*: THIS CONNECTOR IS NOT SHOWN IN "HARNESS LAYOUT" OF PG SECTION.

BCWA0520E

DTC P0705 PARK/NEUTRAL POSITION SWITCH

ECS00GXU

Diagnostic Procedure

1. CHECK PNP SW CIRCUIT

With CONSULT-II

1. Turn ignition switch "ON". (Do not start engine.)
2. Select "SELECTION FROM MENU" in "DATA MONITOR" mode for "A/T" with CONSULT-II.
3. Check if correct selector lever position (N/P, R or D) is displayed as selector lever is moved into each position.

DATA MONITOR	
MONITOR	NO. DTC
ATF PRES SW 2	OFF
ATF PRES SW 3	OFF
ATF PRES SW 5	OFF
ATF PRES SW 6	OFF
SLCT LVR POSI	N-P

Δ	▽		
RECORD			
MODE	BACK	LIGHT	COPY

PCIA0034E

Item name	Condition	Display value
SLCTLVR POSI	Selector lever in "N", "P" positions.	N/P
	Selector lever in "R" position.	R
	Selector lever in "D" position.	D
	Selector lever in "4" position.	4
	Selector lever in "3" position.	3
	Selector lever in "2" position.	2
	Selector lever in "1" position.	1

OK or NG

- OK >> GO TO 5.
- NG >> GO TO 2.

2. CHECK TCM POWER SUPPLY AND GROUND CIRCUIT

Perform TCM power supply and ground circuit. Refer to [AT-163, "MAIN POWER SUPPLY AND GROUND CIRCUIT"](#).

OK or NG

- OK >> GO TO 3.
- NG >> Repair or replace damaged parts.

3. DETECT MALFUNCTIONING ITEM

Check the following items:

- A/T assembly harness connector pin terminals for damage or loose connection with harness connector.

OK or NG

- OK >> GO TO 4.
- NG >> Repair or replace damaged parts.

DTC P0705 PARK/NEUTRAL POSITION SWITCH

4. CHECK SUB-HARNESS

1. Remove control valve with TCM. Refer to [AT-225, "Control Valve With TCM and A/T Fluid Temperature Sensor 2"](#) .
2. Disconnect park/neutral position switch connector and TCM connector.
3. Check continuity between park/neutral position switch connector terminals and TCM connector terminals.

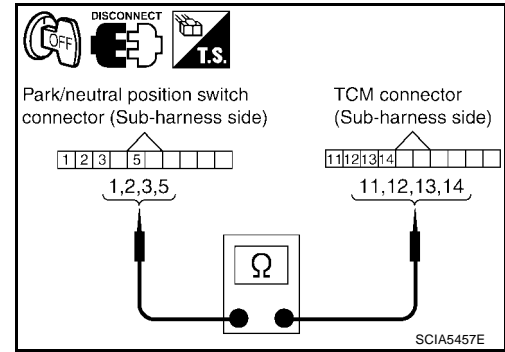

Item	Connector	Terminal	Continuity
Park/neutral position switch connector	F505	1	Yes
TCM connector	F503	13	
Park/neutral position switch connector	F505	2	Yes
TCM connector	F503	11	
Park/neutral position switch connector	F505	3	Yes
TCM connector	F503	12	
Park/neutral position switch connector	F505	5	Yes
TCM connector	F503	14	

4. If OK, check harness for short to ground and short to power.
5. Reinstall any part removed.

OK or NG

- OK >> Replace the control valve with TCM. Refer to [AT-225, "Control Valve With TCM and A/T Fluid Temperature Sensor 2"](#) .
- NG >> Replace open circuit or short to ground and short to power in harness or connectors.

5. CHECK DTC

Perform "DTC Confirmation Procedure".

- Refer to [AT-101, "DTC Confirmation Procedure"](#) .

OK or NG

- OK >> **INSPECTION END**
- NG >> GO TO 2.

DTC P0717 TURBINE REVOLUTION SENSOR

DTC P0717 TURBINE REVOLUTION SENSOR

PDF:31935

Description

ECS00GXV

The turbine revolution sensor detects input shaft rpm (revolutions per minute). It is located on the input side of the automatic transmission. Monitors revolution of sensor 1 and sensor 2 for non-standard conditions.

CONSULT-II Reference Value

ECS00GXW

Item name	Condition	Display value (rpm)
TURBINE REV	During driving (lock-up ON)	Approximately matches the engine speed.

On Board Diagnosis Logic

ECS00GXX

- This is an OBD-II self-diagnostic item.
- Diagnostic trouble code "P0717 TURBINE REV S/CIRC" with CONSULT-II is detected under the following conditions.
 - When TCM does not receive the proper voltage signal from the sensor.
 - When TCM detects an irregularity only at position of 4th gear for turbine revolution sensor 2.

Possible Cause

ECS00GXY

- Harness or connectors
(The sensor circuit is open or shorted.)
- Turbine revolution sensor 1, 2

DTC Confirmation Procedure

ECS00GXZ

CAUTION:

Always drive vehicle at a safe speed.

NOTE:

If "DTC Confirmation Procedure" has been previously performed, always turn ignition switch "OFF" and wait at least 10 seconds before performing the next test.

After the repair, perform the following procedure to confirm the malfunction is eliminated.

WITH CONSULT-II

1. Turn ignition switch "ON". (Do not start engine.)
2. Select "DATA MONITOR" mode for "A/T" with CONSULT-II.
3. Start engine and maintain the following conditions for at least 5 consecutive seconds.

VHCL SPEED SE: 40 km/h (25 MPH) or more

ENGINE SPEED: 1,500 rpm or more

ACCELE POS: 0.5/8 or more

Selector lever: "D" position

Gear position (Turbine revolution sensor 1): 4th or 5th position

Gear position (Turbine revolution sensor 2): All position

Driving location: Driving the vehicle uphill (increased engine load) will help maintain the driving conditions required for this test.

4. If DTC is detected, go to [AT-106, "Diagnostic Procedure"](#).

WITH GST

Follow the procedure "With CONSULT-II".

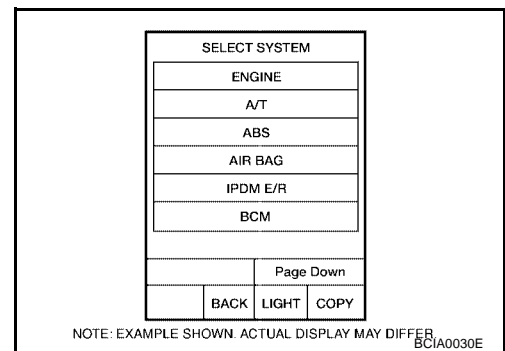

DTC P0717 TURBINE REVOLUTION SENSOR

ECS00GY0

Diagnostic Procedure

1. CHECK INPUT SIGNAL

With CONSULT-II

1. Start engine.
2. Select "ECU INPUT SIGNALS" in "DATA MONITOR" mode for "A/T" with CONSULT-II.
3. Vehicle start and read out the value of "TURBINE REV".

Item name	Condition	Display value (rpm)
TURBINE REV	During driving (lock-up ON)	Approximately matches the engine speed.

OK or NG

- OK >> GO TO 4.
NG >> GO TO 2.

DATA MONITOR	
MONITOR	NO DTC
W/O THL POS	OFF
BRAKE SW	OFF
ENGINE SPEED	0 rpm
TURBINE REV	0 rpm
OUTPUT REV	0 rpm
▼	
RECORD	
MODE	BACK
LIGHT	COPY

PCIA0041E

2. CHECK TCM POWER SUPPLY AND GROUND CIRCUIT

Check TCM power supply and ground circuit. Refer to [AT-163, "MAIN POWER SUPPLY AND GROUND CIRCUIT"](#).

OK or NG

- OK >> GO TO 3.
NG >> Repair or replace damaged parts.

3. DETECT MALFUNCTIONING ITEM

Check the following items:

- The A/T assembly harness connector pin terminals for damage or loose connection with harness connector.

OK or NG

- OK >> Replace the control valve with TCM. Refer to [AT-225, "Control Valve With TCM and A/T Fluid Temperature Sensor 2"](#).
- NG >> Repair or replace damaged parts.

4. CHECK DTC

Perform "DTC Confirmation Procedure".

- Refer to [AT-105, "DTC Confirmation Procedure"](#).

OK or NG

- OK >> **INSPECTION END**
NG >> GO TO 2.

DTC P0720 VEHICLE SPEED SENSOR A/T (REVOLUTION SENSOR)

DTC P0720 VEHICLE SPEED SENSOR A/T (REVOLUTION SENSOR)

PFP:32702

Description

ECS00GY1

The revolution sensor detects the revolution of the idler gear parking pawl lock gear and emits a pulse signal. The pulse signal is sent to the TCM which converts it into vehicle speed.

CONSULT-II Reference Value

ECS00GY2

Item name	Condition	Display value (km/h)
VHCL/S SE·A/T	During driving	Approximately matches the speedometer reading.

On Board Diagnosis Logic

ECS00GY3

- This is an OBD-II self-diagnostic item.
- Diagnostic trouble code “P0720 VEH SPD SEN/CIR AT” with CONSULT-II is detected under the following conditions.
 - When TCM does not receive the proper voltage signal from the sensor.
 - After ignition switch is turned “ON”, irregular signal input from vehicle speed sensor MTR before the vehicle starts moving.

Possible Cause

ECS00GY4

- Harness or connectors
(The sensor circuit is open or shorted.)
- Revolution sensor
- Vehicle speed sensor MTR

DTC Confirmation Procedure

ECS00GY5

CAUTION:

- Always drive vehicle at a safe speed.
- Be careful not to rev engine into the red zone on the tachometer.

NOTE:

If “DTC Confirmation Procedure” has been previously performed, always turn ignition switch “OFF” and wait at least 10 seconds before performing the next test.

After the repair, perform the following procedure to confirm the malfunction is eliminated.

WITH CONSULT-II

1. Turn ignition switch “ON”. (Do not start engine.)
2. Select “DATA MONITOR” mode for “A/T” with CONSULT-II.
3. Drive vehicle and check for an increase of “VHCL/S SE·A/T” value in response to “VHCL/S SE·MTR” value.
If the check result is NG, go to [AT-110, "Diagnostic Procedure"](#) .
If the check result is OK, go to following step.
4. Select “DATA MONITOR” mode for “ENGINE” with CONSULT-II.
5. Start engine and maintain the following conditions for at least 5 consecutive seconds.
VHCL SPEED SE: 30 km/h (19 MPH) or more
THRTL POS SEN: More than 1.0/8
Selector lever: “D” position
Driving location: Driving the vehicle uphill (increased engine load) will help maintain the driving conditions required for this test.
If the check result is NG, go to [AT-110, "Diagnostic Procedure"](#) .
If the check result is OK, go to following step.
6. Maintain the following conditions for at least 5 consecutive seconds.
ENGINE SPEED: 3,500 rpm or more
THRTL POS SEN: More than 1.0/8
Selector lever: “D” position
Driving location: Driving the vehicle uphill (increased engine load) will help maintain the driving conditions required for this test.
If the check result is NG, go to [AT-110, "Diagnostic Procedure"](#) .

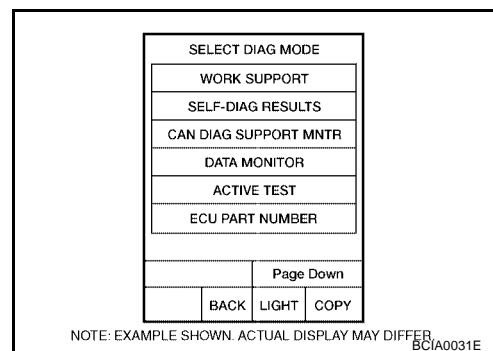

DTC P0720 VEHICLE SPEED SENSOR A/T (REVOLUTION SENSOR)



WITH GST

Follow the procedure "With CONSULT-II".

DTC P0720 VEHICLE SPEED SENSOR A/T (REVOLUTION SENSOR)

Wiring Diagram — AT — VSSA/T

ECS00GY6

AT-VSSA/T-01

: DETECTABLE LINE FOR DTC
 : NON-DETECTABLE LINE FOR DTC

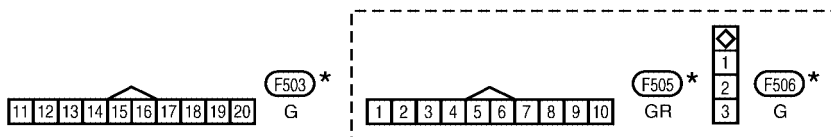
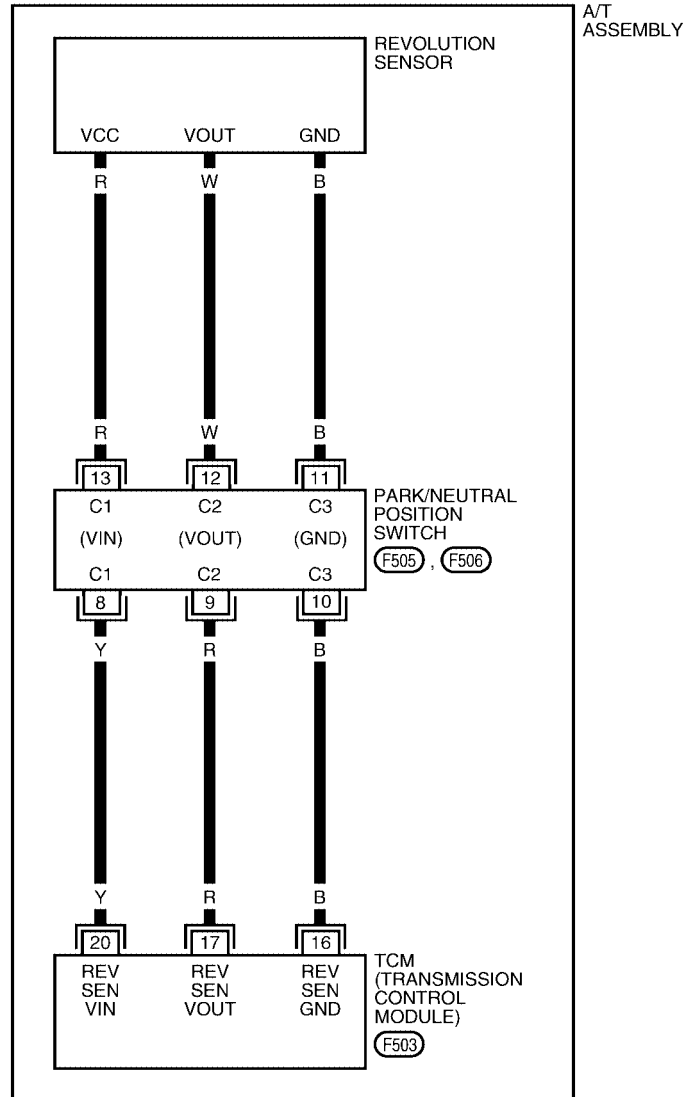

*: THIS CONNECTOR IS NOT SHOWN IN "HARNESS LAYOUT" OF PG SECTION.

BCWA0504E

DTC P0720 VEHICLE SPEED SENSOR A/T (REVOLUTION SENSOR)

ECS00GY7

Diagnostic Procedure

1. CHECK INPUT SIGNAL

With CONSULT-II

1. Turn ignition switch "ON".
2. Select "ECU INPUT SIGNALS" in "DATA MONITOR" mode for "A/T" with CONSULT-II.
3. Start the engine.
4. Read out the value of "VHCL/S SE·A/T" while driving. Check the value changes according to driving speed.

Item name	Condition	Display value (km/h)
VHCL/S SE·A/T	During driving	Approximately matches the speedometer reading.

DATA MONITOR	
MONITOR	NO.DTC
VHCL/S SE·A/T	0km/h
VHCL/S SE·MTR	0km/h
ACCELE POSI	0.0/8
THROTTLE POS	0.0/8
CLSD THL POS	ON
W/O THL POS	OFF
	▽
	RECORD
MODE	BACK
LIGHT	COPY

SCIA2148E

OK or NG

- OK >> GO TO 6.
- NG >> GO TO 2.

2. CHECK TCM POWER SUPPLY AND GROUND CIRCUIT

Check TCM power supply and ground circuit. Refer to [AT-163, "MAIN POWER SUPPLY AND GROUND CIRCUIT"](#).

OK or NG

- OK >> GO TO 3.
- NG >> Repair or replace damaged parts.

3. DETECT MALFUNCTIONING ITEM

Check the following items:

- The A/T assembly harness connector pin terminals for damage or loose connection with harness connector.

OK or NG

- OK >> GO TO 4.
- NG >> Repair or replace damaged parts.

DTC P0720 VEHICLE SPEED SENSOR A/T (REVOLUTION SENSOR)

4. CHECK SUB-HARNESS

1. Remove control valve with TCM. Refer to [AT-225, "Control Valve With TCM and A/T Fluid Temperature Sensor 2"](#) .
2. Disconnect park/neutral position switch connector and TCM connector.
3. Check continuity between park/neutral position switch connector terminals and TCM connector terminals.

Item	Connector	Terminal	Continuity
Park/neutral position switch connector	F505	8	Yes
TCM connector	F503	20	
Park/neutral position switch connector	F505	9	Yes
TCM connector	F503	17	
Park/neutral position switch connector	F505	10	Yes
TCM connector	F503	16	

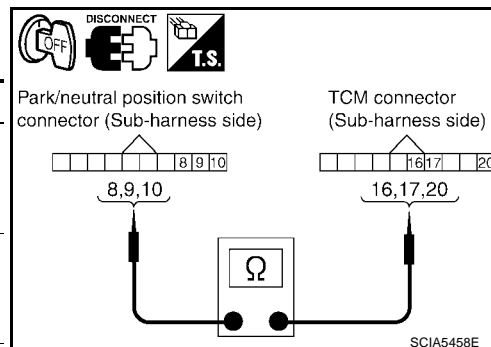

4. If OK, check harness for short to ground and short to power.
5. Reinstall any part removed.

OK or NG

- OK >> GO TO 5.
- NG >> Replace open circuit or short to ground and short to power in harness or connectors.

5. REPLACE THE REVOLUTION SENSOR AND CHECK DTC

1. Replace the revolution sensor. Refer to [AT-259, "Disassembly"](#) .
2. Perform "DTC Confirmation Procedure". Refer to [AT-107, "DTC Confirmation Procedure"](#) .

OK or NG

- OK >> **INSPECTION END**
- NG >> Replace the control valve with TCM. Refer to [AT-225, "Control Valve With TCM and A/T Fluid Temperature Sensor 2"](#) .

6. CHECK DTC

Perform "DTC Confirmation Procedure".

- Refer to [AT-107, "DTC Confirmation Procedure"](#) .

OK or NG

- OK >> **INSPECTION END**
- NG >> GO TO 2.

DTC P0725 ENGINE SPEED SIGNAL

DTC P0725 ENGINE SPEED SIGNAL

PF2:24825

Description

ECS00GY8

The engine speed signal is sent from the ECM to the TCM.

CONSULT-II Reference Value

ECS00GY9

Item name	Condition	Display value (rpm)
ENGINE SPEED	Engine running	Closely matches the tachometer reading.

On Board Diagnosis Logic

ECS00GYA

- This is not an OBD-II self-diagnostic item.
- Diagnostic trouble code "P0725 ENGINE SPEED SIG" with CONSULT-II is detected when TCM does not receive the ignition signal from ECM during engine cranking or running.

Possible Cause

ECS00GYB

Harness or connectors
(The ECM to the TCM circuit is open or shorted.)

DTC Confirmation Procedure

ECS00GYC

CAUTION:

Always drive vehicle at a safe speed.

NOTE:

If "DTC Confirmation Procedure" has been previously performed, always turn ignition switch "OFF" and wait at least 10 seconds before performing the next test.

After the repair, perform the following procedure to confirm the malfunction is eliminated.

WITH CONSULT-II

1. Turn ignition switch "ON" and select "DATA MONITOR" mode for "A/T" with CONSULT-II.
2. Start engine and maintain the following conditions for at least 10 consecutive seconds.
VHCL SPEED SE: 10 km/h (6 MPH) or more
ACCELE POSI: More than 1/8
Selector lever: "D" position
3. If DTC is detected, go to [AT-112, "Diagnostic Procedure"](#).

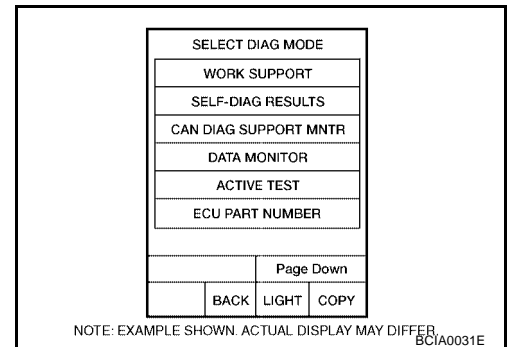

Diagnostic Procedure

ECS00GYD

1. CHECK CAN COMMUNICATION LINE

Perform the self-diagnosis. Refer to [AT-86, "SELF-DIAGNOSTIC RESULT MODE"](#).

Is a malfunction in the CAN communication indicated in the results?

- YES >> Check CAN communication line. Refer to [AT-93, "DTC U1000 CAN COMMUNICATION LINE"](#).
NO >> GO TO 2.

DTC P0725 ENGINE SPEED SIGNAL

2. CHECK DTC WITH TCM

With CONSULT-II

1. Start engine.
2. Select "ECU INPUT SIGNALS" in "DATA MONITOR" mode for "A/T" with CONSULT-II.
3. While monitoring engine speed, check for engine speed change corresponding to wide-open throttle position signal.

Item name	Condition	Display value (rpm)
ENGINE SPEED	Engine running	Closely matches the tachometer reading.

OK or NG

- OK >> GO TO 3.
- NG >> Check the ignition signal circuit.
 - Refer to [EC-672, "IGNITION SIGNAL"](#).

DATA MONITOR			
MONITOR	NO. DTC		
W/O THL POS	OFF		
BRAKE SW	OFF		
ENGINE SPEED	0 rpm		
TURBINE REV	0 rpm		
OUTPUT REV	0 rpm		
▼			
RECORD			
MODE	BACK	LIGHT	COPY

PCIA0041E

3. CHECK DTC

Perform "DTC Confirmation Procedure".

- Refer to [AT-112, "DTC Confirmation Procedure"](#).

OK or NG

- OK >> **INSPECTION END**
- NG >> GO TO 4.

4. CHECK TCM POWER SUPPLY AND GROUND CIRCUIT

Check TCM power supply and ground circuit. Refer to [AT-163, "MAIN POWER SUPPLY AND GROUND CIRCUIT"](#).

OK or NG

- OK >> GO TO 5.
- NG >> Repair or replace damaged parts.

5. DETECT MALFUNCTIONING ITEM

Check the following items:

- The A/T assembly harness connector pin terminals for damage or loose connection with harness connector.

OK or NG

- OK >> Replace the control valve with TCM. Refer to [AT-225, "Control Valve With TCM and A/T Fluid Temperature Sensor 2"](#).
- NG >> Repair or replace damaged parts.

DTC P0740 TORQUE CONVERTER CLUTCH SOLENOID VALVE

DTC P0740 TORQUE CONVERTER CLUTCH SOLENOID VALVE

PF3:31940

Description

ECS00GYE

- The torque converter clutch solenoid valve is activated, with the gear in D4 , D5 by the TCM in response to signals sent from the vehicle speed sensor and accelerator pedal position sensor (throttle position sensor). Torque converter clutch piston operation will then be controlled.
- Lock-up operation, however, is prohibited when A/T fluid temperature is too low.
- When the accelerator pedal is depressed (less than 1/8) in lock-up condition, the engine speed should not change abruptly. If there is a big jump in engine speed, there is no lock-up.

CONSULT-II Reference Value

ECS00GYF

Item name	Condition	Display value (Approx.)
TCC SOLENOID	When performing slip lock-up	0.2 - 0.4 A
	When performing lock-up	0.4 - 0.6 A

On Board Diagnosis Logic

ECS00GYG

- This is an OBD-II self-diagnostic item.
- Diagnostic trouble code "P0740 TCC SOLENOID/CIRC" with CONSULT-II is detected under the following conditions.
 - When TCM detects an improper voltage drop when it tries to operate the solenoid valve.
 - When TCM detects as irregular by comparing target value with monitor value.

Possible Cause

ECS00GYH

- Torque converter clutch solenoid valve
- Harness or connectors
(The solenoid circuit is open or shorted.)

DTC Confirmation Procedure

ECS00GYI

CAUTION:

Always drive vehicle at a safe speed.

NOTE:

If "DTC Confirmation Procedure" has been previously performed, always turn ignition switch "OFF" and wait at least 10 seconds before performing the next test.

After the repair, perform the following procedure to confirm the malfunction is eliminated.

WITH CONSULT-II

1. Turn ignition switch "ON". (Do not start engine.)
2. Select "DATA MONITOR" mode for "ENGINE" with CONSULT-II.
3. Start engine and maintain the following conditions for at least 5 consecutive seconds.

VHCL SPEED SE: 80 km/h (50 MPH) or more

ACCELE POS: 0.5/8 - 1.0/8

SELECTOR LEVER: "D" position

Driving location: Driving the vehicle uphill (increased engine load) will help maintain the driving conditions required for this test.

4. If DTC is detected go to [AT-115, "Diagnostic Procedure"](#).

WITH GST

Follow the procedure "With CONSULT-II".

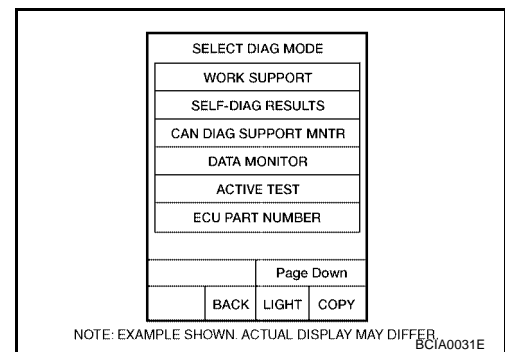

DTC P0740 TORQUE CONVERTER CLUTCH SOLENOID VALVE

ECS00GYJ

Diagnostic Procedure

1. CHECK INPUT SIGNAL

With CONSULT-II

1. Turn ignition switch "ON".
2. Select "MAIN SIGNALS" in "DATA MONITOR" mode for "A/T" with CONSULT-II.
3. Start engine.
4. Read out the value of "TCC SOLENOID" while driving.

DATA MONITOR	
MONITOR	NO DTC
TCC SOLENOID	XXXX
LINE PRES SOL	XXXX
I/C SOLENOID	XXXX
FR/B SOLENOID	XXXX
D/C SOLENOID	XXXX
HLR/C SOL	XXXX
	▽
	RECORD
MODE	BACK
LIGHT	COPY

SCIA4793E

Item name	Condition	Display value (Approx.)
TCC SOLENOID	When performing slip lock-up	0.2 - 0.4 A
	When performing lock-up	0.4 - 0.6 A

OK or NG

- OK >> GO TO 4.
NG >> GO TO 2.

2. CHECK TCM POWER SUPPLY AND GROUND CIRCUIT

Check TCM power supply and ground circuit. Refer to [AT-163, "MAIN POWER SUPPLY AND GROUND CIRCUIT"](#).

OK or NG

- OK >> GO TO 3.
NG >> Repair or replace damaged parts.

3. DETECT MALFUNCTIONING ITEM

Check the following items:

- The A/T assembly harness connector pin terminals for damage or loose connection with harness connector.

OK or NG

- OK >> Replace the control valve with TCM. Refer to [AT-225, "Control Valve With TCM and A/T Fluid Temperature Sensor 2"](#).
NG >> Repair or replace damaged parts.

4. CHECK DTC

Perform "DTC Confirmation Procedure".

- Refer to [AT-114, "DTC Confirmation Procedure"](#).

OK or NG

- OK >> **INSPECTION END**
NG >> GO TO 2.

DTC P0744 A/T TCC S/V FUNCTION (LOCK-UP)

DTC P0744 A/T TCC S/V FUNCTION (LOCK-UP)

PF3:31940

Description

ECS00GYK

This malfunction is detected when the A/T does not shift into 5th gear position or the torque converter clutch does not lock-up as instructed by the TCM. This is not only caused by electrical malfunction (circuits open or shorted) but also by mechanical malfunction such as control valve sticking, improper solenoid valve operation, etc.

CONSULT-II Reference Value

ECS00GYL

Item name	Condition	Display value (Approx.)
TCC SOLENOID	When performing slip lock-up	0.2 - 0.4 A
	When performing lock-up	0.4 - 0.6 A

On Board Diagnosis Logic

ECS00GYM

- This is an OBD-II self-diagnostic item.
- Diagnostic trouble code "P0744 A/T TCC S/V FNCTN" with CONSULT-II is detected under the following conditions.
 - When A/T cannot perform lock-up even if electrical circuit is good.
 - When TCM detects as irregular by comparing difference value with slip rotation.

Possible Cause

ECS00GYN

- Harness or connectors
(The solenoid circuit is open or shorted.)
- Torque converter clutch solenoid valve
- Hydraulic control circuit

DTC Confirmation Procedure

ECS00GYO

CAUTION:

Always drive vehicle at a safe speed.

NOTE:

If "DTC Confirmation Procedure" has been previously performed, always turn ignition switch "OFF" and wait at least 10 seconds before performing the next test.

After the repair, perform the following procedure to confirm the malfunction is eliminated.

WITH CONSULT-II

1. Start engine and Select "TCC S/V FNCTN CHECK" of "DTC WORK SUPPORT" mode for "A/T" with CONSULT-II and touch "START".

2. Accelerate vehicle to more than 80 km/h (50 MPH) and maintain the following condition continuously until "TESTING" has turned to "COMPLETE". (It will take approximately 30 seconds after "TESTING" shows.)

ACCELE POSI: More than 1.0/8 (at all times during step 4)

TCC SOLENOID: 0.4 - 0.6 A

Selector lever: "D" position

[Reference speed: Constant speed of more than 80 km/h (50 MPH)]

- Make sure "GEAR" shows "5".
 - For shift schedule, refer to [AT-318, "Vehicle Speed When Performing and Releasing Complete Lock-up"](#).
 - If "TESTING" does not appear on CONSULT-II for a long time, select "SELF-DIAG RESULTS". In case a 1st trip DTC other than P0744 is shown, refer to applicable "TROUBLE DIAGNOSIS FOR DTC".
3. Make sure that "OK" is displayed. (If "NG" is displayed, refer to "DIAGNOSTIC PROCEDURE".)
Refer to [AT-117, "Diagnostic Procedure"](#).
Refer to shift schedule, [AT-318, "Vehicle Speed When Performing and Releasing Complete Lock-up"](#).

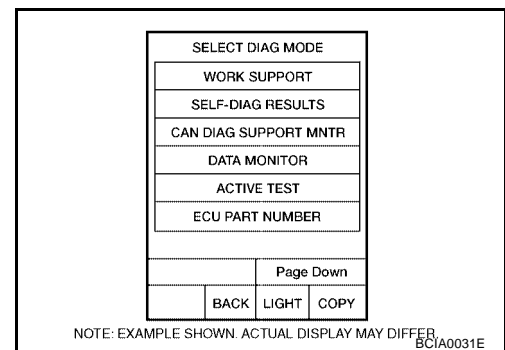

DTC P0744 A/T TCC S/V FUNCTION (LOCK-UP)

WITH GST

Follow the procedure "With CONSULT-II".

Diagnostic Procedure

ECS00GYP

1. CHECK INPUT SIGNAL

With CONSULT-II

1. Turn ignition switch "ON".
2. Select "MAIN SIGNALS" in "DATA MONITOR" mode for "A/T" with CONSULT-II.
3. Start the engine.
4. Read out the value of "TCC SOLENOID" while driving.

DATA MONITOR	
MONITOR	NO DTC
TCC SOLENOID	XXXX
LINE PRES SOL	XXXX
I/C SOLENOID	XXXX
FR/B SOLENOID	XXXX
D/C SOLENOID	XXXX
HLR/C SOL	XXXX
	▽
	RECORD
MODE	BACK
LIGHT	COPY

SCIA4793E

Item name	Condition	Display value (Approx.)
TCC SOLENOID	When performing slip lock-up	0.2 - 0.4 A
	When performing lock-up	0.4 - 0.6 A

OK or NG

- OK >> GO TO 4.
- NG >> GO TO 2.

2. CHECK TCM POWER SUPPLY AND GROUND CIRCUIT

Check TCM power supply and ground circuit. Refer to [AT-163, "MAIN POWER SUPPLY AND GROUND CIRCUIT"](#).

OK or NG

- OK >> GO TO 3.
- NG >> Repair or replace damaged parts.

3. DETECT MALFUNCTIONING ITEM

Check the following items:

- The A/T assembly harness connector pin terminals for damage or loose connection with harness connector.

OK or NG

- OK >> Replace the control valve with TCM. Refer to [AT-225, "Control Valve With TCM and A/T Fluid Temperature Sensor 2"](#).
- NG >> Repair or replace damaged parts.

4. CHECK DTC

Perform "DTC Confirmation Procedure".

- Refer to [AT-116, "DTC Confirmation Procedure"](#).

OK or NG

- OK >> **INSPECTION END**
- NG >> GO TO 2.

DTC P0745 LINE PRESSURE SOLENOID VALVE

DTC P0745 LINE PRESSURE SOLENOID VALVE

PF3:31940

Description

ECS00GYQ

The line pressure solenoid valve regulates the oil pump discharge pressure to suit the driving condition in response to a signal sent from the TCM.

The line pressure duty cycle value is not consistent when the closed throttle position signal is "ON". To confirm the line pressure duty cycle at low pressure, the accelerator (throttle) should be open until the closed throttle position signal is "OFF".

CONSULT-II Reference Value

ECS00GYR

Item name	Condition	Display value (Approx.)
LINE PRES SOL	During driving	0.2 - 0.6 A

On Board Diagnosis Logic

ECS00GYS

- This is an OBD-II self-diagnostic item.
- Diagnostic trouble code "P0745 L/PRESS SOL/CIRC" with CONSULT-II is detected under the following conditions.
 - When TCM detects an improper voltage drop when it tries to operate the solenoid valve.
 - When TCM detects as irregular by comparing target value with monitor value.

Possible Cause

ECS00GYT

- Harness or connectors
(The solenoid circuit is open or shorted.)
- Line pressure solenoid valve

DTC Confirmation Procedure

ECS00GYU

NOTE:

If "DTC Confirmation Procedure" has been previously performed, always turn ignition switch "OFF" and wait at least 10 seconds before performing the next test.

After the repair, perform the following procedure to confirm the malfunction is eliminated.

④ WITH CONSULT-II

1. Turn ignition switch "ON" and select "DATA MONITOR" mode for "ENGINE" with CONSULT-II.
2. Engine start and wait at least 5 second.
3. If DTC is detected, go to [AT-119, "Diagnostic Procedure"](#).

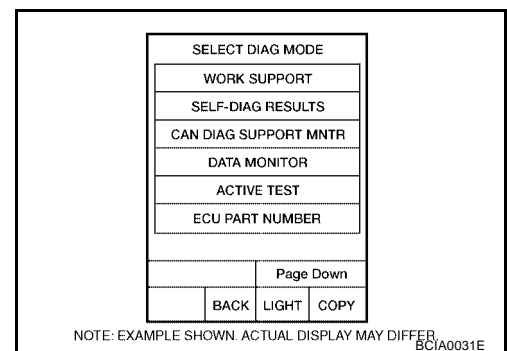

④ WITH GST

Follow the procedure "With CONSULT-II".

DTC P0745 LINE PRESSURE SOLENOID VALVE

ECS00GYV

Diagnostic Procedure

1. CHECK INPUT SIGNAL

With CONSULT-II

1. Turn ignition switch "ON".
2. Select "MAIN SIGNALS" in "DATA MONITOR" mode for "A/T" with CONSULT-II.
3. Start the engine.
4. Read out the value of "LINE PRES SOL" while driving.

Item name	Condition	Display value (Approx.)
LINE PRES SOL	During driving	0.2 - 0.6 A

DATA MONITOR			
MONITOR		NO DTC	
TCC SOLENOID	XXXX		
LINE PRES SOL	XXXX		
I/C SOLENOID	XXXX		
FR/B SOLENOID	XXXX		
D/C SOLENOID	XXXX		
HLR/C SOL	XXXX		
		▽	
		RECORD	
MODE	BACK	LIGHT	COPY

SCIA4793E

OK or NG

- OK >> GO TO 4.
- NG >> GO TO 2.

2. CHECK TCM POWER SUPPLY AND GROUND CIRCUIT

Check TCM power supply and ground circuit. Refer to [AT-163, "MAIN POWER SUPPLY AND GROUND CIRCUIT"](#).

OK or NG

- OK >> GO TO 3.
- NG >> Repair or replace damaged parts.

3. DETECT MALFUNCTIONING ITEM

Check the following items:

- The A/T assembly harness connector pin terminals for damage or loose connection with harness connector.

OK or NG

- OK >> Replace the control valve with TCM. Refer to [AT-225, "Control Valve With TCM and A/T Fluid Temperature Sensor 2"](#).
- NG >> Repair or replace damaged parts.

4. CHECK DTC

Perform "DTC Confirmation Procedure".

- Refer to [AT-118, "DTC Confirmation Procedure"](#).

OK or NG

- OK >> **INSPECTION END**
- NG >> GO TO 2.

DTC P1705 THROTTLE POSITION SENSOR

DTC P1705 THROTTLE POSITION SENSOR

PF2:22620

Description

ECS00GYW

Electric throttle control actuator consists of throttle control motor, accelerator pedal position sensor, throttle position sensor, etc. The actuator sends a signal to the ECM, and ECM sends signals to TCM with CAN communication.

CONSULT-II Reference Value

ECS00GYX

Item name	Condition	Display value (Approx.)
ACCELE POSI	Released accelerator pedal.	0.0/8
	Fully depressed accelerator pedal.	8/8

On Board Diagnosis Logic

ECS00GYY

- This is not an OBD-II self-diagnostic item.
- Diagnostic trouble code "P1705 TP SEN/CIRC A/T" with CONSULT-II is detected when TCM does not receive the proper accelerator pedal position signals (input by CAN communication) from ECM.

Possible Cause

ECS00GYZ

Harness or connectors
(The sensor circuit is open or shorted.)

DTC Confirmation Procedure

ECS00GZ0

NOTE:

If "DTC Confirmation Procedure" has been previously performed, always turn ignition switch "OFF" and wait at least 10 seconds before performing the next test.

After the repair, perform the following procedure to confirm the malfunction is eliminated.

WITH CONSULT-II

1. Turn ignition switch "ON". (Do not start engine.)
2. Select "DATA MONITOR" mode for "A/T" with CONSULT-II.
3. Start engine and let it idle for 1 second.
4. If DTC is detected, go to [AT-120, "Diagnostic Procedure"](#).

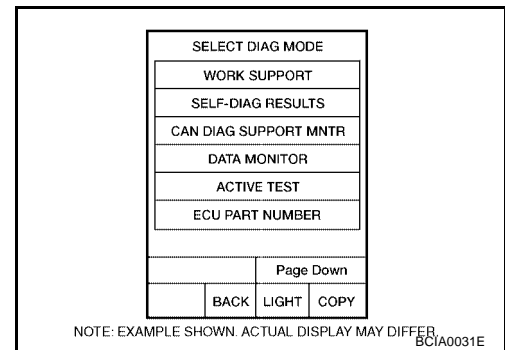

ECS00GZ1

Diagnostic Procedure

1. CHECK CAN COMMUNICATION LINE

Perform the self-diagnosis. Refer to [AT-86, "SELF-DIAGNOSTIC RESULT MODE"](#).

Is a malfunction in the CAN communication indicated in the results?

- YES >> Check CAN communication line. Refer to [AT-93, "DTC U1000 CAN COMMUNICATION LINE"](#).
NO >> GO TO 2.

DTC P1705 THROTTLE POSITION SENSOR

2. CHECK DTC WITH TCM

With CONSULT-II

1. Turn ignition switch "ON". (Do not start engine.)
2. Select "ECU INPUT SIGNALS" in "DATA MONITOR" mode for "A/T" with CONSULT-II.
3. Depress accelerator pedal and read out the value of "ACCELE POSI".

Item name	Condition	Display value (Approx.)
ACCELE POSI	Released accelerator pedal.	0.0/8
	Fully depressed accelerator pedal.	8/8

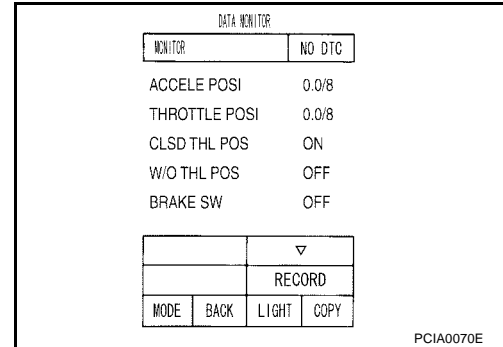

4. Select "SELF-DIAG RESULTS" mode for "A/T" with CONSULT-II. Refer to [AT-86, "SELF-DIAGNOSTIC RESULT MODE"](#).

OK or NG

- OK >> GO TO 4.
- NG >> GO TO 3.

3. CHECK DTC WITH ECM

With CONSULT-II

1. Turn ignition switch "ON". (Do not start engine.)
2. Select "SELF-DIAG RESULTS" mode for "ENGINE" with CONSULT-II. Refer to [AT-84, "CONSULT-II Function \(A/T\)"](#).

OK or NG

- OK >> GO TO 4.
- NG >> Check the DTC detected item. Refer to [AT-84, "CONSULT-II Function \(A/T\)"](#).
 - If CAN communication line is detected, go to [AT-93, "DTC U1000 CAN COMMUNICATION LINE"](#).

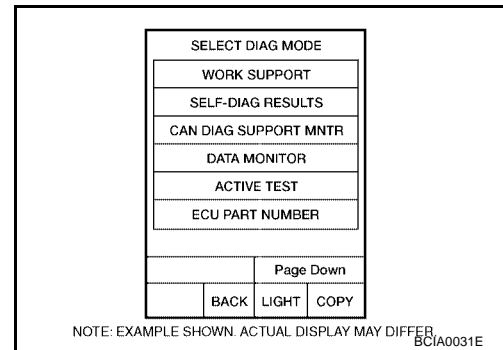

4. CHECK DTC

Perform "DTC Confirmation Procedure".

- Refer to [AT-120, "DTC Confirmation Procedure"](#).

OK or NG

- OK >> **INSPECTION END**
- NG >> GO TO 5.

5. CHECK TCM POWER SUPPLY AND GROUND CIRCUIT

Check TCM power supply and ground circuit. Refer to [AT-163, "MAIN POWER SUPPLY AND GROUND CIRCUIT"](#).

OK or NG

- OK >> GO TO 6.
- NG >> Repair or replace damaged parts.

DTC P1705 THROTTLE POSITION SENSOR

6. DETECT MALFUNCTIONING ITEM

Check the following items:

- The A/T assembly harness connector pin terminals for damage or loose connection with harness connector.

OK or NG

OK >> Replace the control valve with TCM. Refer to [AT-225, "Control Valve With TCM and A/T Fluid Temperature Sensor 2"](#).

NG >> Repair or replace damaged parts.

DTC P1710 A/T FLUID TEMPERATURE SENSOR CIRCUIT

DTC P1710 A/T FLUID TEMPERATURE SENSOR CIRCUIT

PF3:31940

Description

ECS00G22

The A/T fluid temperature sensor detects the A/T fluid temperature and sends a signal to the TCM.

CONSULT-II Reference Value

ECS00G23

Item name	Condition °C (°F)	Display value (Approx.)
ATF TEMP SE 1	0 (32) - 20 (68) - 80 (176)	3.3 - 2.7 - 0.9 V
ATF TEMP SE 2		3.3 - 2.5 - 0.7 V

On Board Diagnosis Logic

ECS00G24

- This is an OBD-II self-diagnostic item.
- Diagnostic trouble code "P1710 (A/T), P0710 (ENGINE) ATF TEMP SEN/CIRC" with CONSULT-II is detected when TCM receives an excessively low or high voltage from the sensor.

Possible Cause

ECS00G25

- Harness or connectors
(The sensor circuit is open or shorted.)
- A/T fluid temperature sensors 1, 2

DTC Confirmation Procedure

ECS00G26

CAUTION:

Always drive vehicle at a safe speed.

NOTE:

If "DTC Confirmation Procedure" has been previously performed, always turn ignition switch "OFF" and wait at least 10 seconds before performing the next test.

After the repair, perform the following procedure to confirm the malfunction is eliminated.

WITH CONSULT-II

1. Turn ignition switch "ON". (Do not start engine.)
2. Select "DATA MONITOR" mode for "ENGINE" with CONSULT-II.
3. Start engine and maintain the following conditions for at least 10 minutes (Total). (It is not necessary to maintain continuously.)
VHCL SPEED SE: 10 km/h (6 MPH) or more
THRTL POS SEN: More than 1.0/8
Selector lever: "D" position
4. If DTC is detected, go to [AT-125, "Diagnostic Procedure"](#).

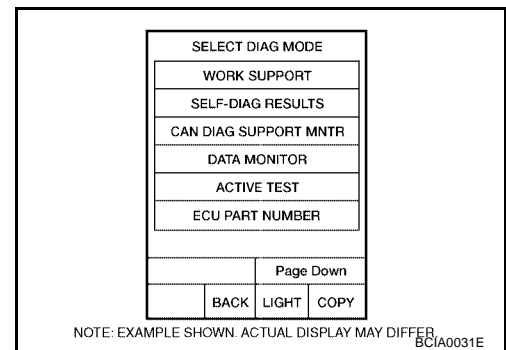

WITH GST

Follow the procedure "With CONSULT-II".

DTC P1710 A/T FLUID TEMPERATURE SENSOR CIRCUIT

Wiring Diagram — AT — FTS

ECS00GZ7

AT-FTS-01

: DETECTABLE LINE FOR DTC
 : NON-DETECTABLE LINE FOR DTC

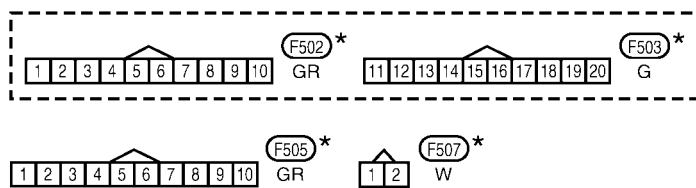
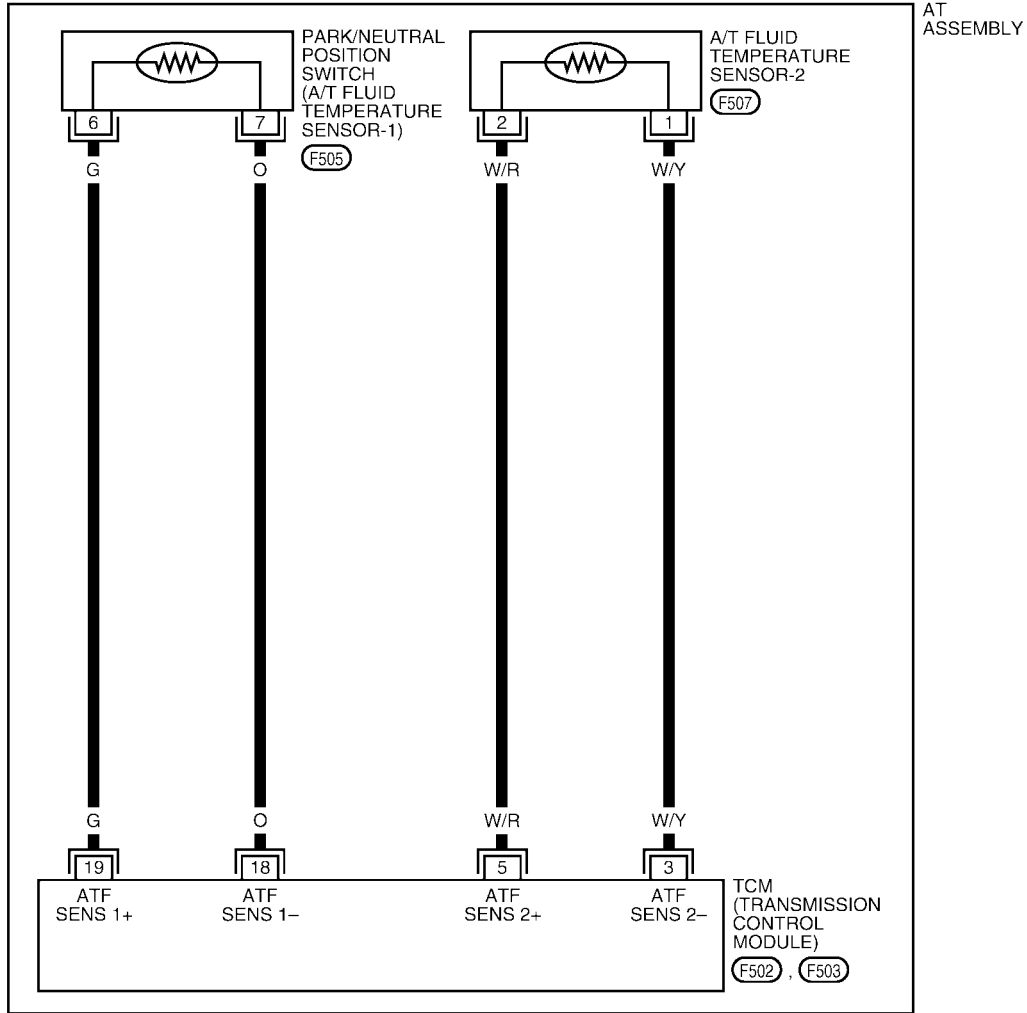

*: THIS CONNECTOR IS NOT SHOWN IN "HARNESS LAYOUT" OF PG SECTION.

BCWA0323E

DTC P1710 A/T FLUID TEMPERATURE SENSOR CIRCUIT

ECS00GZ8

Diagnostic Procedure

1. CHECK A/T FLUID TEMPERATURE SENSOR 1 SIGNAL

With CONSULT-II

1. Start engine.
2. Select "ECU INPUT SIGNALS" in "DATA MONITOR" mode for "A/T" with CONSULT-II.
3. Read out the value of "ATF TEMP SE 1".

Item name	Condition °C (°F)	Display value (Approx.)
ATF TEMP SE 1	0 (32) - 20 (68) - 80 (176)	3.3 - 2.7 - 0.9 V

OK or NG

- OK >> GO TO 2.
NG >> GO TO 3.

DATA MONITOR	
MONITOR	NO DTC
OUTPUT REV	0 rpm
ATF TEMP SE 1	1.84 v
ATF TEMP SE 2	1.72 v
BATTERY BOLT	11.5 v
ATF PRES SW 1	OFF

Δ	▽
RECORD	
MODE	BACK
LIGHT	COPY

PCIA0039E

2. CHECK A/T FLUID TEMPERATURE SENSOR 2 SIGNAL

With CONSULT-II

1. Start engine.
2. Select "ECU INPUT SIGNALS" in "DATA MONITOR" mode for "A/T" with CONSULT-II.
3. Read out the value of "ATF TEMP SE 2".

Item name	Condition °C (°F)	Display value (Approx.)
ATF TEMP SE 2	0 (32) - 20 (68) - 80 (176)	3.3 - 2.5 - 0.7 V

OK or NG

- OK >> GO TO 8.
NG >> GO TO 5.

DATA MONITOR	
MONITOR	NO DTC
OUTPUT REV	0 rpm
ATF TEMP SE 1	1.84 v
ATF TEMP SE 2	1.72 v
BATTERY BOLT	11.5 v
ATF PRES SW 1	OFF

Δ	▽
RECORD	
MODE	BACK
LIGHT	COPY

PCIA0039E

3. CHECK A/T FLUID TEMPERATURE SENSOR 1

Check A/T fluid temperature sensor 1. Refer to [AT-126, "A/T FLUID TEMPERATURE SENSOR 1"](#).

OK or NG

- OK >> GO TO 4.
NG >> Replace the control valve with TCM. Refer to [AT-225, "Control Valve With TCM and A/T Fluid Temperature Sensor 2"](#).

4. CHECK SUB-HARNESS

1. Disconnect park/neutral position switch connector and TCM connector.
2. Check continuity between park/neutral position switch connector terminals and TCM connector terminals.

Item	Connector	Terminal	Continuity
Park/neutral position switch connector	F505	6	Yes
TCM connector	F503	19	
Park/neutral position switch connector	F505	7	Yes
TCM connector	F503	18	

3. If OK, check harness for short to ground and short to power.

OK or NG

- OK >> GO TO 7.
NG >> Replace open circuit or short to ground and short to power in harness or connectors.

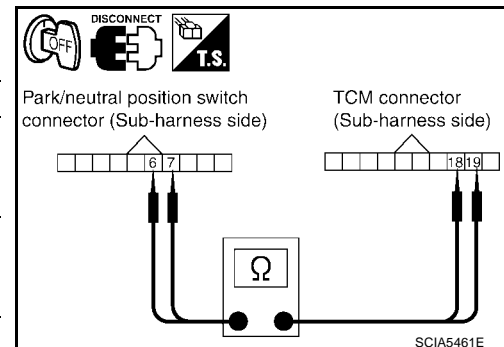

DTC P1710 A/T FLUID TEMPERATURE SENSOR CIRCUIT

5. CHECK A/T FLUID TEMPERATURE SENSOR 2

Check A/T fluid temperature sensor 2. Refer to [AT-127, "A/T FLUID TEMPERATURE SENSOR 2"](#) .

OK or NG

OK >> GO TO 6.

NG >> Replace the A/T fluid temperature sensor 2. Refer to [AT-233, "A/T FLUID TEMPERATURE SENSOR 2 REMOVAL AND INSTALLATION"](#) .

6. CHECK TERMINAL CORD ASSEMBLY

1. Disconnect A/T fluid temperature sensor 2 connector and TCM connector.
2. Check continuity between A/T fluid temperature sensor 2 connector terminals and TCM connector terminals.

Item	Connector	Terminal	Continuity
A/T fluid temperature sensor 2 connector	F507	1	Yes
TCM connector	F502	3	
A/T fluid temperature sensor 2 connector	F507	2	Yes
TCM connector	F502	5	

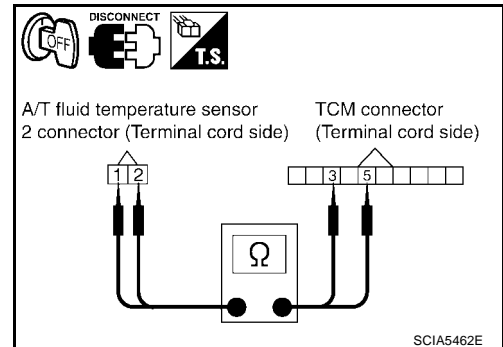

3. If OK, check harness for short to ground and short to power.

OK or NG

OK >> GO TO 7.

NG >> Replace open circuit or short to ground and short to power in harness or connectors.

7. CHECK TCM POWER SUPPLY AND GROUND CIRCUIT

1. Check TCM power supply and ground circuit. Refer to [AT-163, "MAIN POWER SUPPLY AND GROUND CIRCUIT"](#) .
2. Reinstall any part removed.

OK or NG

OK >> Replace the control valve with TCM. Refer to [AT-225, "Control Valve With TCM and A/T Fluid Temperature Sensor 2"](#) .

NG >> Repair or replace damaged parts.

8. CHECK DTC

Perform "DTC Confirmation Procedure".

- Refer to [AT-123, "DTC Confirmation Procedure"](#) .

OK or NG

OK >> **INSPECTION END**

NG >> GO TO 1.

Component Inspection A/T FLUID TEMPERATURE SENSOR 1

ECS00GZ9

1. Remove control valve with TCM. Refer to [AT-225, "Control Valve With TCM and A/T Fluid Temperature Sensor 2"](#) .

DTC P1710 A/T FLUID TEMPERATURE SENSOR CIRCUIT

2. Check resistance between terminals.

Name	Terminal	Temperature °C (°F)	Resistance (Approx.) (kΩ)
A/T fluid temperature sensor 1	6-7	0 (32)	15
		20 (68)	6.5
		80 (176)	0.9

3. If NG, replace the control valve with TCM. Refer to [AT-225, "Control Valve With TCM and A/T Fluid Temperature Sensor 2"](#)

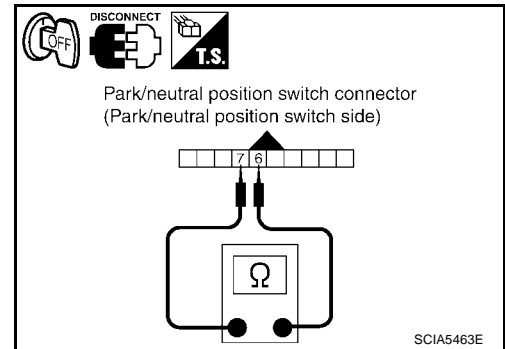

A/T FLUID TEMPERATURE SENSOR 2

1. Remove A/T fluid temperature sensor 2. Refer to [AT-233, "A/T FLUID TEMPERATURE SENSOR 2 REMOVAL AND INSTALLATION"](#).

2. Check resistance between terminals.

Name	Terminal	Temperature °C (°F)	Resistance (Approx.) (kΩ)
A/T fluid temperature sensor 2	1-2	0 (32)	10
		20 (68)	4
		80 (176)	0.5

3. If NG, replace the A/T fluid temperature sensor 2. Refer to [AT-233, "A/T FLUID TEMPERATURE SENSOR 2 REMOVAL AND INSTALLATION"](#).

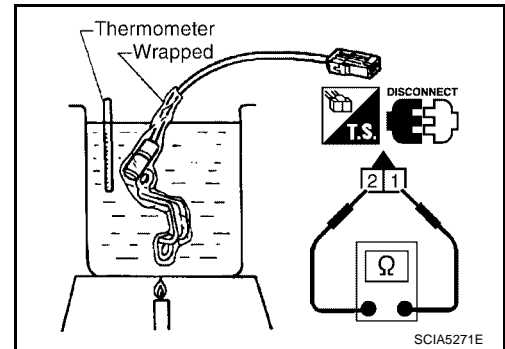

DTC P1721 VEHICLE SPEED SENSOR MTR

DTC P1721 VEHICLE SPEED SENSOR MTR

PF2:24814

Description

ECS00GZA

The vehicle speed sensor-MTR signal is transmitted from combination meter to TCM by CAN communication line. The signal functions as an auxiliary device to the revolution sensor when it is malfunctioning. The TCM will then use the vehicle speed sensor-MTR signal.

CONSULT-II Reference Value

ECS00GZB

Item name	Condition	Display value (km/h)
VHCL/S SE-MTR	During driving	Approximately matches the speedometer reading.

On Board Diagnosis Logic

ECS00GZC

- This is not an OBD-II self-diagnostic item.
- Diagnostic trouble code "P1721 VHE SPD SE-MTR" with CONSULT-II is detected when TCM does not receive the proper vehicle speed sensor MTR signal (input by CAN communication) from combination meter.

Possible Cause

ECS00GZD

Harness or connectors
(The sensor circuit is open or shorted.)

DTC Confirmation Procedure

ECS00GZE

CAUTION:

Always drive vehicle at a safe speed.

NOTE:

If "DTC Confirmation Procedure" has been previously performed, always turn ignition switch "OFF" and wait at least 10 seconds before performing the next test.

After the repair, perform the following procedure to confirm the malfunction is eliminated.

④ WITH CONSULT-II

1. Turn ignition switch "ON". (Do not start engine.)
2. Select "DATA MONITOR" mode for "A/T" with CONSULT-II.
3. Start engine and maintain the following conditions for at least 5 consecutive seconds.
ACCELE POS: 1/8 or less
VHCL SPEED SE: 30 km/h (17 MPH) or more
4. If DTC is detected, go to [AT-129, "Diagnostic Procedure"](#).

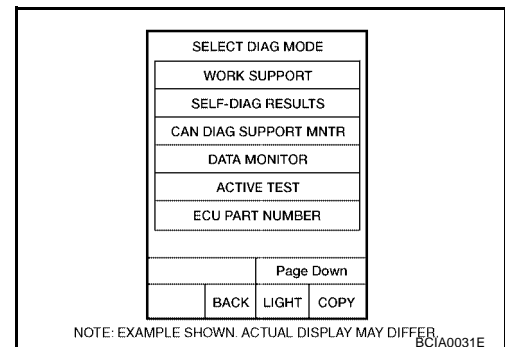

DTC P1721 VEHICLE SPEED SENSOR MTR

ECS00GZF

Diagnostic Procedure

1. CHECK CAN COMMUNICATION LINE

Perform the self-diagnosis. Refer [AT-86, "SELF-DIAGNOSTIC RESULT MODE"](#) .

Is a malfunction in the CAN communication indicated in the results?

- YES >> Check CAN communication line. Refer to [AT-93, "DTC U1000 CAN COMMUNICATION LINE"](#) .
NO >> GO TO 2.

2. CHECK INPUT SIGNAL

With CONSULT-II

1. Start engine.
2. Select "ECU INPUT SIGNALS" in "DATA MONITOR" mode for "A/T" with CONSULT-II.
3. Drive vehicle and read out the value of "VHCL/S SE-MTR".

Item name	Condition	Display value (Approx.)(km/h)
VHCL/S SE-MTR	During driving	Approximately matches the speedometer reading.

OK or NG

- OK >> GO TO 4.
NG >> GO TO 3.

DATA MONITOR	
MONITOR	NO DTC
VHCL/S SE-A/T	0km/h
VHCL/S SE-MTR	0km/h
ACCELE POSI	0.0/8
THROTTLE POS	0.0/8
CLSD THL POS	ON
W/O THL POS	OFF
	▽
	RECORD
MODE	BACK
LIGHT	COPY

SCIA2148E

3. CHECK COMBINATION METERS

Check combination meter. Refer to [DI-16, "How to Proceed With Trouble Diagnosis"](#) .

OK or NG

- OK >> GO TO 4.
NG >> Repair or replace damaged parts.

4. CHECK DTC

Perform "DTC Confirmation Procedure".

- Refer to [AT-128, "DTC Confirmation Procedure"](#) .

OK or NG

- OK >> **INSPECTION END**
NG >> GO TO 5.

5. CHECK TCM POWER SUPPLY AND GROUND CIRCUIT

Check TCM power supply and ground circuit. Refer to [AT-163, "MAIN POWER SUPPLY AND GROUND CIRCUIT"](#) .

OK or NG

- OK >> GO TO 6.
NG >> Repair or replace damaged parts.

6. DETECT MALFUNCTIONING ITEM

Check the following items:

- The A/T assembly harness connector pin terminals for damage or loose connection with harness connector.

OK or NG

- OK >> Replace the control valve with TCM. Refer to [AT-225, "Control Valve With TCM and A/T Fluid Temperature Sensor 2"](#) .
NG >> Repair or replace damaged parts.

DTC P1730 A/T INTERLOCK

DTC P1730 A/T INTERLOCK

PF0:00000

Description

ECS00GZG

- Fail-safe function to detect interlock conditions.

On Board Diagnosis Logic

ECS00GZH

- This is an OBD-II self-diagnostic item.
- Diagnostic trouble code "P1730 A/T INTERLOCK" with CONSULT-II is detected when TCM does not receive the proper voltage signal from the sensor and switch.
- TCM monitors and compares gear position and conditions of each ATF pressure switch when gear is steady.

Possible Cause

ECS00GZI

- Harness or connectors
(The solenoid and switch circuit is open or shorted.)
- Low coast brake solenoid valve
- ATF pressure switch 2

DTC Confirmation Procedure

ECS00GZJ

NOTE:

If "DTC Confirmation Procedure" has been previously performed, always turn ignition switch "OFF" and wait at least 10 seconds before performing the next test.

After the repair, perform the following procedure to confirm the malfunction is eliminated.

WITH CONSULT-II

1. Turn ignition switch "ON". (Do not start engine.)
2. Select "DATA MONITOR" mode for "A/T" with CONSULT-II.
3. Start engine.
4. Drive vehicle and maintain the following conditions for at least 2 consecutive seconds.
Selector lever: "D" position
5. If DTC is detected, go to [AT-131, "Diagnostic Procedure"](#).

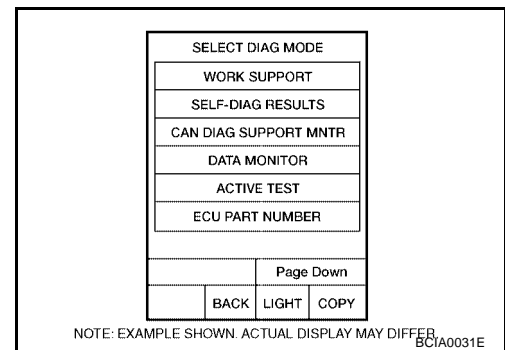

WITH GST

Follow the procedure "With CONSULT-II".

DTC P1730 A/T INTERLOCK

ECS00GZK

Judgement of A/T Interlock

When A/T Interlock is judged to be malfunctioning, the vehicle should be fixed in 2nd gear, and should be set in a condition in which it can travel.

When one of the following fastening patterns is detected, the fail-safe function in correspondence with the individual pattern should be performed.

A/T INTERLOCK COUPLING PATTERN TABLE

●: NG, X: OK

Gear position		ATF pressure switch output					Fail-safe function	Clutch pressure output pattern after fail-safe function					
		SW3 (I/C)	SW6 (HLR/C)	SW5 (D/C)	SW1 (FR/B)	SW2 (LC/B)		I/C	HLR/C	D/C	FR/B	LC/B	LU
A/T interlock coupling pattern	3rd	-	X	X	-	●	Held in 2nd gear	OFF	OFF	ON	OFF	OFF	OFF
	4th	-	X	X	-	●	Held in 2nd gear	OFF	OFF	ON	OFF	OFF	OFF
	5th	X	X	-	X	●	Held in 2nd gear	OFF	OFF	ON	OFF	OFF	OFF

Diagnostic Procedure

ECS00GZL

1. SELF-DIAGNOSIS

Ⓟ With CONSULT-II

1. Drive vehicle.
2. Stop vehicle and turn ignition switch "OFF".
3. Turn ignition switch "ON".
4. Select "SELF-DIAG RESULTS" mode for "A/T" with CONSULT-II.

OK or NG

OK >> GO TO 2.

NG >> Check low coast brake solenoid valve circuit and function. Refer to [AT-151, "DTC P1772 LOW COAST BRAKE SOLENOID VALVE"](#) , [AT-153, "DTC P1774 LOW COAST BRAKE SOLENOID VALVE FUNCTION"](#) .

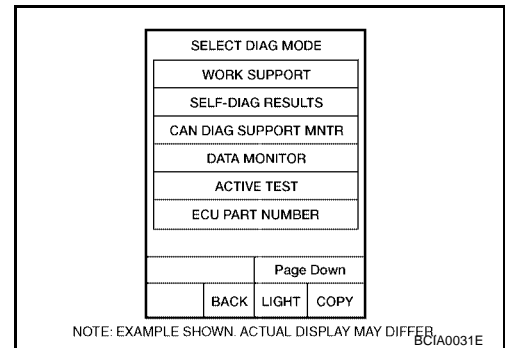

2. CHECK DTC

Perform "DTC Confirmation Procedure".

- Refer to [AT-130, "DTC Confirmation Procedure"](#) .

OK or NG

OK >> **INSPECTION END**

NG >> GO TO 3.

3. CHECK TCM POWER SUPPLY AND GROUND CIRCUIT

Check TCM power supply and ground circuit. Refer to [AT-163, "MAIN POWER SUPPLY AND GROUND CIRCUIT"](#) .

OK or NG

OK >> GO TO 4.

NG >> Repair or replace damaged parts.

DTC P1730 A/T INTERLOCK

4. DETECT MALFUNCTIONING ITEM

Check the following items:

- The A/T assembly harness connector pin terminals for damage or loose connection with harness connector.

OK or NG

OK >> Replace the control valve with TCM. Refer to [AT-225, "Control Valve With TCM and A/T Fluid Temperature Sensor 2"](#).

NG >> Repair or replace damaged parts.

DTC P1731 A/T 1ST ENGINE BRAKING

DTC P1731 A/T 1ST ENGINE BRAKING

PF:00000

Description

ECS00GZM

Fail-safe function to prevent sudden decrease in speed by engine brake other than at "1" position.

CONSULT-II Reference Value

ECS00GZN

Item name	Condition	Display value
ON OFF SOL	Low coast brake engaged. Refer to AT-20 .	ON
	Low coast brake disengaged. Refer to AT-20 .	OFF
ATF PRES SW 2	Low coast brake engaged. Refer to AT-20	ON
	Low coast brake disengaged. Refer to AT-20 .	OFF

On Board Diagnosis Logic

ECS00GZO

- This is not an OBD-II self-diagnostic item.
- Diagnostic trouble code "P1731 A/T 1ST E/BRAKING" with CONSULT-II is detected under the following conditions.
 - When TCM does not receive the proper voltage signal from the sensor.
 - When TCM monitors each ATF pressure switch and solenoid monitor value, and detects as irregular when engine brake of 1st gear acts other than at 1 position.

Possible Cause

ECS00GZP

- Harness or connectors
(The sensor circuit is open or shorted.)
- Low coast brake solenoid valve
- ATF pressure switch 2

DTC Confirmation Procedure

ECS00GZQ

NOTE:

If "DTC Confirmation Procedure" has been previously performed, always turn ignition switch "OFF" and wait at least 10 seconds before performing the next test.

After the repair, perform the following procedure to confirm the malfunction is eliminated.

WITH CONSULT-II

1. Turn ignition switch "ON". (Do not start engine.)
2. Select "DATA MONITOR" mode for "A/T" with CONSULT-II.
3. Start engine.
4. Drive vehicle and maintain the following conditions for at least 2 consecutive seconds.
ENGINE SPEED: 1,200 rpm
Selector lever: "1" position
Gear position: 1st gear
5. If DTC is detected, go to [AT-134, "Diagnostic Procedure"](#) .

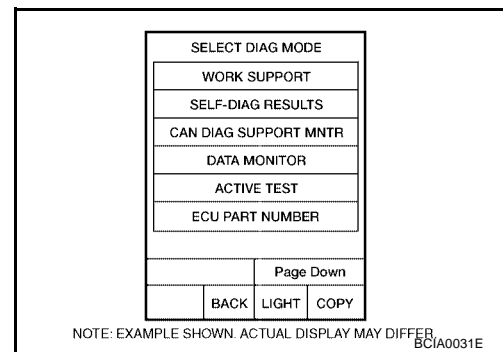

DTC P1731 A/T 1ST ENGINE BRAKING

ECS00GZR

Diagnostic Procedure

1. CHECK INPUT SIGNALS

With CONSULT-II

1. Start the engine.
2. Select "SELECTION FROM MENU" in "DATA MONITOR" for "A/T" with CONSULT-II"
3. Drive vehicle in the "1" position (1st gear), and confirm the ON/OFF actuation of "ATF PRES SW 2" and "ON OFF SOL".

Item name	Condition	Display value
ON OFF SOL	Low coast brake engaged. Refer to AT-20 .	ON
	Low coast brake disengaged. Refer to AT-20 .	OFF
ATF PRES SW 2	Low coast brake engaged. Refer to AT-20 .	ON
	Low coast brake disengaged. Refer to AT-20 .	OFF

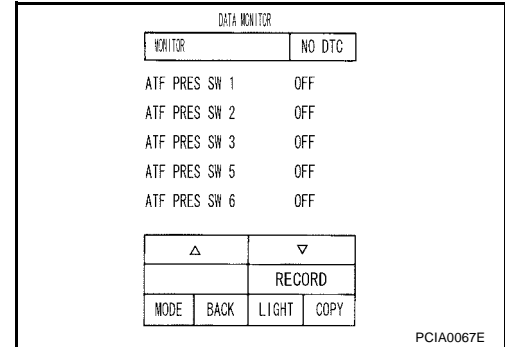

OK or NG

- OK >> GO TO 4.
NG >> GO TO 2.

2. CHECK TCM POWER SUPPLY AND GROUND CIRCUIT

Check TCM power supply and ground circuit. Refer to [AT-163, "MAIN POWER SUPPLY AND GROUND CIRCUIT"](#) .

OK or NG

- OK >> GO TO 3.
NG >> Repair or replace damaged parts.

3. DETECT MALFUNCTIONING ITEM

Check the following items:

- The A/T assembly harness connector pin terminals for damage or loose connection with harness connector.

OK or NG

- OK >> Replace the control valve with TCM. Refer to [AT-225, "Control Valve With TCM and A/T Fluid Temperature Sensor 2"](#) .
NG >> Repair or replace damaged parts.

4. CHECK DTC

Perform "DTC Confirmation Procedure".

- Refer to [AT-133, "DTC Confirmation Procedure"](#) .

OK or NG

- OK >> **INSPECTION END**
NG >> GO TO 2.

DTC P1752 INPUT CLUTCH SOLENOID VALVE

DTC P1752 INPUT CLUTCH SOLENOID VALVE

PF3:31940

Description

ECS00GZS

Input clutch solenoid valve is controlled by the TCM in response to signals sent from the PNP switch, vehicle speed sensor and accelerator pedal position sensor (throttle position sensor). Gears will then be shifted to the optimum position.

CONSULT-II Reference Value

ECS00GZT

Item name	Condition	Display value (Approx.)
I/C SOLENOID	Input clutch disengaged. Refer to AT-20 .	0.6 - 0.8 A
	Input clutch engaged. Refer to AT-20 .	0 - 0.05 A

On Board Diagnosis Logic

ECS00GZU

- This is an OBD-II self-diagnostic item.
- Diagnostic trouble code “P1752 I/C SOLENOID/CIRC” with CONSULT-II is detected under the following conditions.
 - When TCM detects an improper voltage drop when it tries to operate the solenoid valve.
 - When TCM detects as irregular by comparing target value with monitor value.

Possible Cause

ECS00GZV

- Harness or connectors
(The solenoid circuit is open or shorted.)
- Input clutch solenoid valve

DTC Confirmation Procedure

ECS00GZW

CAUTION:

Always drive vehicle at a safe speed.

NOTE:

If “DTC Confirmation Procedure” has been previously performed, always turn ignition switch “OFF” and wait at least 10 seconds before performing the next test.

After the repair, perform the following procedure to confirm the malfunction is eliminated.

WITH CONSULT-II

1. Turn ignition switch “ON”. (Do not start engine.)
2. Select “DATA MONITOR” mode for “A/T” with CONSULT-II.
3. Start engine.
4. Drive vehicle and maintain the following conditions for at least 5 consecutive seconds.

ACCELE POS: 1.5/8 - 2.0/8

Selector lever: “D” position

Gear position: 3rd ⇒ 4th Gear (I/C ON/OFF)

Driving location: Driving the vehicle uphill (increased engine load) will help maintain the driving conditions required for this test.

5. If DTC is detected go to [AT-136, "Diagnostic Procedure"](#) .

WITH GST

Follow the procedure “With CONSULT-II”.

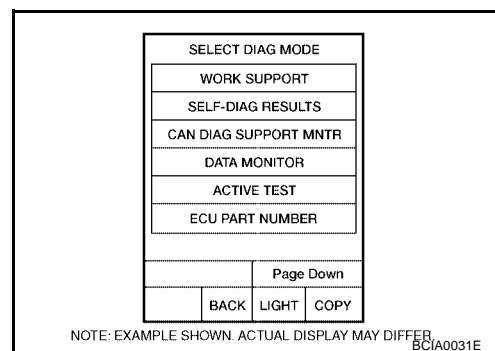

DTC P1752 INPUT CLUTCH SOLENOID VALVE

ECS00GZX

Diagnostic Procedure

1. CHECK INPUT SIGNAL

With CONSULT-II

1. Turn ignition switch "ON".
2. Select "MAIN SIGNALS" in "DATA MONITOR" mode for "A/T" with CONSULT-II.
3. Start the engine.
4. Read out the value of "I/C SOLENOID" while driving.

Item name	Condition	Display value (Approx.)
I/C SOLENOID	Input clutch disengaged. Refer to AT-20 .	0.6 - 0.8 A
	Input clutch engaged. Refer to AT-20 .	0 - 0.05 A

DATA MONITOR			
MONITOR		NO DTC	
TCC SOLENOID	XXXX		
LINE PRES SOL	XXXX		
I/C SOLENOID	XXXX		
FR/B SOLENOID	XXXX		
D/C SOLENOID	XXXX		
HLR/C SOL	XXXX		
		▽	
		RECORD	
MODE	BACK	LIGHT	COPY

SCIA4793E

OK or NG

- OK >> GO TO 4.
NG >> GO TO 2.

2. CHECK TCM POWER SUPPLY AND GROUND CIRCUIT

Check TCM power supply and ground circuit. Refer to [AT-163, "MAIN POWER SUPPLY AND GROUND CIRCUIT"](#) .

OK or NG

- OK >> GO TO 3.
NG >> Repair or replace damaged parts.

3. DETECT MALFUNCTIONING ITEM

Check the following items:

- The A/T assembly harness connector pin terminals for damage or loose connection with harness connector.

OK or NG

- OK >> Replace the control valve with TCM. Refer to [AT-225, "Control Valve With TCM and A/T Fluid Temperature Sensor 2"](#) .
NG >> Repair or replace damaged parts.

4. CHECK DTC

Perform "DTC Confirmation Procedure".

- Refer to [AT-135, "DTC Confirmation Procedure"](#) .

OK or NG

- OK >> **INSPECTION END**
NG >> GO TO 2.

DTC P1754 INPUT CLUTCH SOLENOID VALVE FUNCTION

DTC P1754 INPUT CLUTCH SOLENOID VALVE FUNCTION

PF3:31940

Description

ECS00GZY

- Input clutch solenoid valve is controlled by the TCM in response to signals sent from the PNP switch, vehicle speed sensor and accelerator pedal position sensor (throttle position sensor). Gears will then be shifted to the optimum position.
- This is not only caused by electrical malfunction (circuits open or shorted) but also by mechanical malfunction such as control valve sticking, improper solenoid valve operation.

CONSULT-II Reference Value

ECS00GZZ

Item name	Condition	Display value (Approx.)
I/C SOLENOID	Input clutch disengaged. Refer to AT-163	0.6 - 0.8 A
	Input clutch engaged. Refer to AT-163	0 - 0.05 A
ATF PRES SW 3	Input clutch engaged. Refer to AT-163	ON
	Input clutch disengaged. Refer to AT-163	OFF

On Board Diagnosis Logic

ECS00H00

- This is an OBD-II self-diagnostic item.
- Diagnostic trouble code "P1754 I/C SOLENOID FNCTN" with CONSULT-II is detected under the following conditions.
 - When TCM detects that actual gear ratio is irregular, and relation between gear position and condition of pressure switch 3 is irregular during depressing accelerator pedal. (Other than during shift change)
 - When TCM detects that relation between gear position and condition of ATF pressure switch 3 is irregular during releasing accelerator pedal. (Other than during shift change)

Possible Cause

ECS00H01

- Harness or connectors
(The solenoid and switch circuits are open or shorted.)
- Input clutch solenoid valve
- ATF pressure switch 3

DTC Confirmation Procedure

ECS00H02

CAUTION:

Always drive vehicle at a safe speed.

NOTE:

If "DTC Confirmation Procedure" has been previously performed, always turn ignition switch "OFF" and wait at least 10 seconds before performing the next test.

After the repair, perform the following procedure to confirm the malfunction is eliminated.

WITH CONSULT-II

1. Start engine.
2. Accelerate vehicle to maintain the following conditions.
ACCELE POSI: 1.5/8 - 2.0/8
Selector lever: "D" position
Gear position: 3rd ⇒ 4th Gear (I/C ON/OFF)
Driving location: Driving the vehicle uphill (increased engine load) will help maintain the driving conditions required for this test.
3. Perform step "2" again.
4. Turn ignition switch "OFF", then perform step "1" to "3" again.
5. Check "SELF-DIAG RESULTS" mode for "A/T" with CONSULT-II. If DTC (P1754) is detected, refer to [AT-138, "Diagnostic Procedure"](#).
If DTC (P1752) is detected, go to [AT-136, "Diagnostic Procedure"](#).
If DTC (P1843) is detected, go to [AT-158, "Diagnostic Procedure"](#).

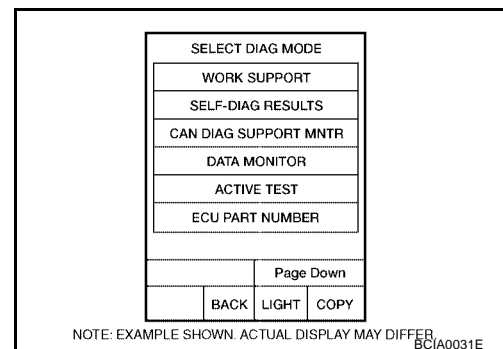

DTC P1754 INPUT CLUTCH SOLENOID VALVE FUNCTION

ECS00H03

Diagnostic Procedure

1. CHECK INPUT SIGNALS

With CONSULT-II

1. Turn ignition switch "ON". (Do not start engine.)
2. Select "SELECTION FROM MENU" in "DATA MONITOR" mode for "A/T" with CONSULT-II.
3. Start the engine.
4. Drive vehicle in the "D" position (3rd ⇒ 4th gear), and confirm the ON/OFF actuation of the "ATF PRES SW 3" and electrical current value of "I/C SOLENOID".

DATA MONITOR			
MONITOR		NO DTC	
I/C SOLENOID		XXX A	
ATF PRES SW 3		OFF	
RECORD			
MODE	BACK	LIGHT	COPY

SCIA4795E

Item name	Condition	Display value (Approx.)
I/C SOLENOID	Input clutch disengaged. Refer to AT-163	0.6 - 0.8 A
	Input clutch engaged. Refer to AT-163	0 - 0.05 A
ATF PRES SW 3	Input clutch engaged. Refer to AT-163	ON
	Input clutch disengaged. Refer to AT-163	OFF

OK or NG

- OK >> GO TO 4.
NG >> GO TO 2.

2. CHECK TCM POWER SUPPLY AND GROUND CIRCUIT

Check TCM power supply and ground circuit. Refer to [AT-163, "MAIN POWER SUPPLY AND GROUND CIRCUIT"](#).

OK or NG

- OK >> GO TO 3.
NG >> Repair or replace damaged parts.

3. DETECT MALFUNCTIONING ITEM

Check the following items:

- The A/T assembly harness connector pin terminals for damage or loose connection with harness connector.

OK or NG

- OK >> Replace the control valve with TCM. Refer to [AT-225, "Control Valve With TCM and A/T Fluid Temperature Sensor 2"](#).
NG >> Repair or replace damaged parts.

4. CHECK DTC

Perform "DTC Confirmation Procedure".

- Refer to [AT-157, "DTC Confirmation Procedure"](#).

OK or NG

- OK >> **INSPECTION END**
NG >> GO TO 2.

DTC P1757 FRONT BRAKE SOLENOID VALVE

DTC P1757 FRONT BRAKE SOLENOID VALVE

PF:31940

Description

ECS00H04

Front brake solenoid valve is controlled by the TCM in response to signals sent from the PNP switch, vehicle speed sensor and accelerator pedal position sensor (throttle position sensor). Gears will then be shifted to the optimum position.

CONSULT-II Reference Value

ECS00H05

Item name	Condition	Display value (Approx.)
FR/B SOLENOID	Front brake engaged. Refer to AT-20	0.6 - 0.8 A
	Front brake disengaged. Refer to AT-20	0 - 0.05 A

On Board Diagnosis Logic

ECS00H06

- This is an OBD-II self-diagnostic item.
- Diagnostic trouble code "P1757 FR/B SOLENOID/CIRC" with CONSULT-II is detected under the following conditions.
 - When TCM detects an improper voltage drop when it tries to operate the solenoid valve.
 - When TCM detects as irregular by comparing target value with monitor value.

Possible Cause

ECS00H07

- Harness or connectors
(The solenoid circuit is open or shorted.)
- Front brake solenoid valve

DTC Confirmation Procedure

ECS00H08

CAUTION:

Always drive vehicle at a safe speed.

NOTE:

If "DTC Confirmation Procedure" has been previously performed, always turn ignition switch "OFF" and wait at least 10 seconds before performing the next test.

After the repair, perform the following procedure to confirm the malfunction is eliminated.

WITH CONSULT-II

1. Turn ignition switch "ON". (Do not start engine.)
2. Select "DATA MONITOR" mode for "A/T" with CONSULT-II.
3. Start engine.
4. Drive vehicle and maintain the following conditions for at least 5 consecutive seconds.

ACCELE POS: 1.5/8 - 2.0/8

Selector lever: "D" position

Gear position: 3rd ⇒ 4th Gear (FR/B ON/OFF)

Driving location: Driving the vehicle uphill (increased engine load) will help maintain the driving conditions required for this test.

5. If DTC is detected go to [AT-140, "Diagnostic Procedure"](#).

WITH GST

Follow the procedure "With CONSULT-II".

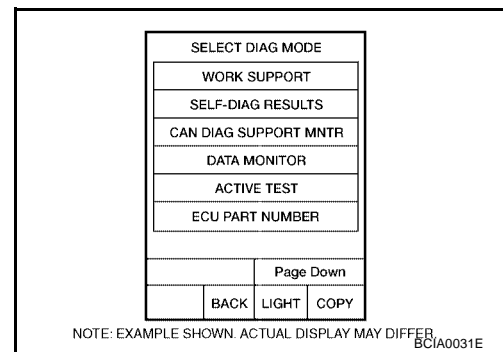

DTC P1757 FRONT BRAKE SOLENOID VALVE

ECS00H09

Diagnostic Procedure

1. CHECK INPUT SIGNAL

With CONSULT-II

1. Turn ignition switch "ON".
2. Select "MAIN SIGNALS" in "DATA MONITOR" mode for "A/T" with CONSULT-II.
3. Start engine.
4. Read out the value of "FR/B SOLENOID" while driving.

Item name	Condition	Display value (Approx.)
FR/B SOLENOID	Front brake engaged. Refer to AT-20	0.6 - 0.8 A
	Front brake disengaged. Refer to AT-20	0 - 0.05 A

DATA MONITOR			
MONITOR		NO DTC	
TCC SOLENOID		XXXX	
LINE PRES SOL		XXXX	
I/C SOLENOID		XXXX	
FR/B SOLENOID		XXXX	
D/C SOLENOID		XXXX	
HLR/C SOL		XXXX	
		▽	
		RECORD	
MODE	BACK	LIGHT	COPY

SCIA4793E

OK or NG

- OK >> GO TO 4.
NG >> GO TO 2.

2. CHECK TCM POWER SUPPLY AND GROUND CIRCUIT

Check TCM power supply and ground circuit. Refer to [AT-163, "MAIN POWER SUPPLY AND GROUND CIRCUIT"](#).

OK or NG

- OK >> GO TO 3.
NG >> Repair or replace damaged parts.

3. DETECT MALFUNCTIONING ITEM

Check the following items:

- The A/T assembly harness connector pin terminals for damage or loose connection with harness connector.

OK or NG

- OK >> Replace the control valve with TCM. Refer to [AT-225, "Control Valve With TCM and A/T Fluid Temperature Sensor 2"](#).
NG >> Repair or replace damaged parts.

4. CHECK DTC

Perform "DTC Confirmation Procedure".

- Refer to [AT-139, "DTC Confirmation Procedure"](#).

OK or NG

- OK >> **INSPECTION END**
NG >> GO TO 2.

DTC P1759 FRONT BRAKE SOLENOID VALVE FUNCTION

DTC P1759 FRONT BRAKE SOLENOID VALVE FUNCTION

PF3:31940

Description

ECS00H0A

- Front brake solenoid valve is controlled by the TCM in response to signals sent from the PNP switch, vehicle speed sensor and accelerator pedal position sensor (throttle position sensor). Gears will then be shifted to the optimum position.
- This is not only caused by electrical malfunction (circuits open or shorted) but also by mechanical malfunction such as control valve sticking, improper solenoid valve operation.

CONSULT-II Reference Value

ECS00H0B

Item name	Condition	Display value (Approx.)
FR/B SOLENOID	Front brake engaged. Refer to AT-20	0.6 - 0.8 A
	Front brake disengaged. Refer to AT-20	0 - 0.05 A
ATF PRES SW 1	Front brake engaged. Refer to AT-20	ON
	Front brake disengaged. Refer to AT-20	OFF

On Board Diagnosis Logic

ECS00H0C

- This is an OBD-II self-diagnostic item.
- Diagnostic trouble code "P1759 FR/B SOLENOID FNCT" with CONSULT-II is detected under the following conditions.
 - When TCM detects that actual gear ratio is irregular, and relation between gear position and condition of ATF pressure switch 1 is irregular during depressing accelerator pedal. (Other than during shift change)
 - When TCM detects that relation between gear position and condition of ATF pressure switch 1 is irregular during releasing accelerator pedal. (Other than during shift change)

Possible Cause

ECS00H0D

- Harness or connectors
(The solenoid and switch circuits are open or shorted.)
- Front brake solenoid valve
- ATF pressure switch 1

DTC Confirmation Procedure

ECS00H0E

CAUTION:

Always drive vehicle at a safe speed.

NOTE:

If "DTC Confirmation Procedure" has been previously performed, always turn ignition switch "OFF" and wait at least 10 seconds before performing the next test.

After the repair, perform the following procedure to confirm the malfunction is eliminated.

WITH CONSULT-II

1. Start engine.
2. Accelerate vehicle to maintain the following conditions.
ACCELE POS: 1.5/8 - 2.0/8
Selector lever: "D" position
Gear position: 3rd ⇒ 4th Gear (FR/B ON/OFF)
Driving location: Driving the vehicle uphill (increased engine load) will help maintain the driving conditions required for this test.
3. Perform step "2" again.
4. Turn ignition switch "OFF", then perform step "1" to "3" again.
5. Check "SELF-DIAG RESULTS" mode for "A/T" with CONSULT-II. If DTC (P1759) is detected, refer to [AT-142, "Diagnostic Procedure"](#) is detected, go to [AT-140, "Diagnostic Procedure"](#).
If DTC (P1841) is detected, go to [AT-156, "Diagnostic Procedure"](#).

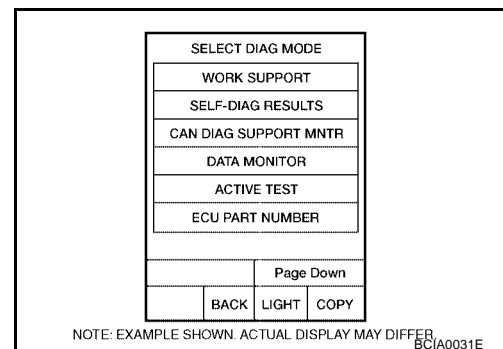

DTC P1759 FRONT BRAKE SOLENOID VALVE FUNCTION

ECS00H0F

Diagnostic Procedure

1. CHECK INPUT SIGNALS

With CONSULT-II

1. Start engine.
2. Select "SELECTION FROM MENU" in "DATA MONITOR" mode for "A/T" with CONSULT-II.
3. Drive vehicle in the "D" position (3rd ⇒ 4th gear), and confirm the ON/OFF actuation of the "ATF PRES SW 1" and electrical current value of "FR/B SOLENOID".

DATA MONITOR			
MONITOR		NO DTC	
ATF PRES SW 1		OFF	
FR/B SOLENOID		XXX A	
RECORD			
MODE	BACK	LIGHT	COPY

SCIA4796E

Item name	Condition	Display value (Approx.)
FR/B SOLENOID	Front brake engaged. Refer to AT-20	0.6 - 0.8 A
	Front brake disengaged. Refer to AT-20	0 - 0.05 A
ATF PRES SW 1	Front brake engaged. Refer to AT-20	ON
	Front brake disengaged. Refer to AT-20	OFF

OK or NG

- OK >> GO TO 4.
NG >> GO TO 2.

2. CHECK TCM POWER SUPPLY AND GROUND CIRCUIT

Check TCM power supply and ground circuit. Refer to [AT-163, "MAIN POWER SUPPLY AND GROUND CIRCUIT"](#).

OK or NG

- OK >> GO TO 3.
NG >> Repair or replace damaged parts.

3. DETECT MALFUNCTIONING ITEM

Check the following items:

- The A/T assembly harness connector pin terminals for damage or loose connection with harness connector.

OK or NG

- OK >> Replace the control valve with TCM. Refer to [AT-225, "Control Valve With TCM and A/T Fluid Temperature Sensor 2"](#).
- NG >> Repair or replace damaged parts.

4. CHECK DTC

Perform "DTC Confirmation Procedure".

- Refer to [AT-141, "DTC Confirmation Procedure"](#).

OK or NG

- OK >> **INSPECTION END**
NG >> GO TO 2.

DTC P1762 DIRECT CLUTCH SOLENOID VALVE

DTC P1762 DIRECT CLUTCH SOLENOID VALVE

PF3:31940

Description

ECS00H0G

Direct clutch solenoid valve is controlled by the TCM in response to signals sent from the PNP switch, vehicle speed sensor and accelerator pedal position sensor (throttle position sensor). Gears will then be shifted to the optimum position.

CONSULT-II Reference Value

ECS00H0H

Item name	Condition	Display value (Approx.)
D/C SOLENOID	Direct clutch disengaged. Refer to AT-20	0.6 - 0.8 A
	Direct clutch engaged. Refer to AT-20	0 - 0.05 A

On Board Diagnosis Logic

ECS00H0I

- This is an OBD-II self-diagnostic item.
- Diagnostic trouble code “P1762 D/C SOLENOID/CIRC” with CONSULT-II is detected under the following conditions.
 - When TCM detects an improper voltage drop when it tries to operate the solenoid valve.
 - When TCM detects as irregular by comparing target value with monitor value.

Possible Cause

ECS00H0J

- Harness or connectors
(The solenoid circuit is open or shorted.)
- Direct clutch solenoid valve

DTC Confirmation Procedure

ECS00H0K

NOTE:

If “DTC Confirmation Procedure” has been previously performed, always turn ignition switch “OFF” and wait at least 10 seconds before performing the next test.

After the repair, perform the following procedure to confirm the malfunction is eliminated.

WITH CONSULT-II

1. Turn ignition switch “ON”. (Do not start engine.)
2. Select “DATA MONITOR” mode for “A/T” with CONSULT-II.
3. Start engine.
4. Drive vehicle and maintain the following conditions for at least 5 consecutive seconds.
ACCELE POS: 1.5/8 - 2.0/8
Selector lever: “D” position
Gear position: 1st ⇒ 2nd Gear (D/C ON/OFF)
Driving location: Driving the vehicle uphill (increased engine load) will help maintain the driving conditions required for this test.
5. If DTC is detected, go to [AT-144, "Diagnostic Procedure"](#) .

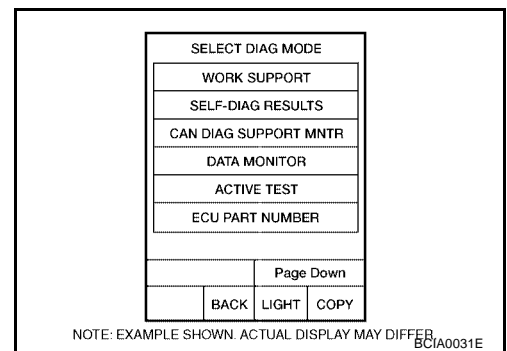

WITH GST

Follow the procedure “With CONSULT-II”.

DTC P1762 DIRECT CLUTCH SOLENOID VALVE

ECS00H0L

Diagnostic Procedure

1. CHECK INPUT SIGNAL

With CONSULT-II

1. Turn ignition switch "ON".
2. Select "MAIN SIGNALS" in "DATA MONITOR" mode for "A/T" with CONSULT-II.
3. Start the engine.
4. Read out the value of "D/C SOLENOID" while driving.

Item name	Condition	Display value (Approx.)
D/C SOLENOID	Direct clutch disengaged. Refer to AT-20	0.6 - 0.8 A
	Direct clutch engaged. Refer to AT-20	0 - 0.05 A

DATA MONITOR			
MONITOR		NO DTC	
TCC SOLENOID	XXXX		
LINE PRES SOL	XXXX		
I/C SOLENOID	XXXX		
FR/B SOLENOID	XXXX		
D/C SOLENOID	XXXX		
HLR/C SOL	XXXX		
		▽	
		RECORD	
MODE	BACK	LIGHT	COPY

SCIA4793E

OK or NG

- OK >> GO TO 4.
NG >> GO TO 2.

2. CHECK TCM POWER SUPPLY AND GROUND CIRCUIT

Check TCM power supply and ground circuit. Refer to [AT-163, "MAIN POWER SUPPLY AND GROUND CIRCUIT"](#).

OK or NG

- OK >> GO TO 3.
NG >> Repair or replace damaged parts.

3. DETECT MALFUNCTIONING ITEM

Check the following items:

- The A/T assembly harness connector pin terminals for damage or loose connection with harness connector.

OK or NG

- OK >> Replace the control valve with TCM. Refer to [AT-225, "Control Valve With TCM and A/T Fluid Temperature Sensor 2"](#).
NG >> Repair or replace damaged parts.

4. CHECK DTC

Perform "DTC Confirmation Procedure".

- Refer to [AT-143, "DTC Confirmation Procedure"](#).

OK or NG

- OK >> **INSPECTION END**
NG >> GO TO 2.

DTC P1764 DIRECT CLUTCH SOLENOID VALVE FUNCTION

DTC P1764 DIRECT CLUTCH SOLENOID VALVE FUNCTION

PF3:31940

Description

ECS00H0M

- Direct clutch solenoid valve is controlled by the TCM in response to signals sent from the PNP switch, vehicle speed sensor and accelerator pedal position sensor (throttle position sensor). Gears will then be shifted to the optimum position.
- This is not only caused by electrical malfunction (circuits open or shorted) but also by mechanical malfunction such as control valve sticking, improper solenoid valve operation.

CONSULT-II Reference Value

ECS00H0N

Item name	Condition	Display value (Approx.)
D/C SOLENOID	Direct clutch disengaged. Refer to AT-20	0.6 - 0.8 A
	Direct clutch engaged. Refer to AT-20	0 - 0.05 A
ATF PRES SW 5	Direct clutch engaged. Refer to AT-20	ON
	Direct clutch disengaged. Refer to AT-20	OFF

On Board Diagnosis Logic

ECS00H0O

- This is an OBD-II self-diagnostic item.
- Diagnostic trouble code "P1764 D/C SOLENOID FNCTN" with CONSULT-II is detected under the following conditions.
 - When TCM detects that actual gear ratio is irregular, and relation between gear position and condition of ATF pressure switch 5 is irregular during depressing accelerator pedal. (Other than during shift change)
 - When TCM detects that relation between gear position and condition of ATF pressure switch 5 is irregular during releasing accelerator pedal. (Other than during shift change)

Possible Cause

ECS00H0P

- Harness or connectors
(The solenoid and switch circuits are open or shorted.)
- Direct clutch solenoid valve
- ATF pressure switch 5

DTC Confirmation Procedure

ECS00H0Q

NOTE:

If "DTC Confirmation Procedure" has been previously performed, always turn ignition switch "OFF" and wait at least 10 seconds before performing the next test.

After the repair, perform the following procedure to confirm the malfunction is eliminated.

WITH CONSULT-II

1. Start engine.
2. Accelerate vehicle to maintain the following conditions.
ACCELE POS: 1.5/8 - 2.0/8
Selector lever: "D" position
Gear position: 1st ⇒ 2nd Gear (D/C ON/OFF)
Driving location: Driving the vehicle uphill (increased engine load) will help maintain the driving conditions required for this test.
3. Perform step "2" again.
4. Turn ignition switch "OFF", then perform step "1" to "3" again.
5. Check "SELF-DIAG RESULTS" mode for "AT" with CONSULT-II. If DTC (P1764) is detected, refer to [AT-146, "Diagnostic Procedure"](#).
If DTC (P1762) is detected, go to [AT-144, "Diagnostic Procedure"](#).
If DTC (P1845) is detected, go to [AT-160, "Diagnostic Procedure"](#).

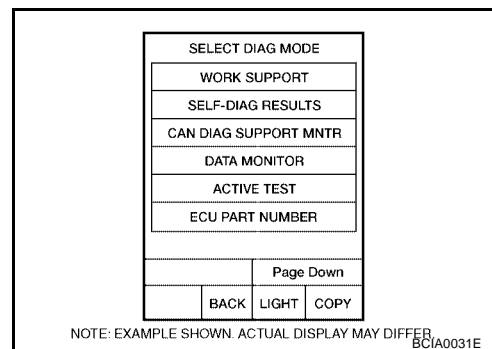

WITH GST

Follow the procedure "With CONSULT-II".

DTC P1764 DIRECT CLUTCH SOLENOID VALVE FUNCTION

ECS00H0R

Diagnostic Procedure

1. CHECK INPUT SIGNALS

With CONSULT-II

1. Start the engine.
2. Select "SELECTION FROM MENU" in "DATA MONITOR" mode for "A/T" with CONSULT-II.
3. Drive vehicle in the "D" position (1st ⇒ 2nd gear), and confirm the display actuation of the "ATF PRES SW 5" and electrical current value of "D/C SOLENOID".

DATA MONITOR			
MONITOR		NO DTC	
D/C SOLENOID		XXXX	
ATF PRES SW 5		OFF	
RECORD			
MODE	BACK	LIGHT	COPY

SCIA4797E

Item name	Condition	Display value (Approx.)
D/C SOLENOID	Direct clutch disengaged. Refer to AT-20	0.6 - 0.8 A
	Direct clutch engaged. Refer to AT-20	0 - 0.05 A
ATF PRES SW 5	Direct clutch engaged. Refer to AT-20	ON
	Direct clutch disengaged. Refer to AT-20	OFF

OK or NG

- OK >> GO TO 4.
NG >> GO TO 2.

2. CHECK TCM POWER SUPPLY AND GROUND CIRCUIT

Check TCM power supply and ground circuit. Refer to [AT-163, "MAIN POWER SUPPLY AND GROUND CIRCUIT"](#).

OK or NG

- OK >> GO TO 3.
NG >> Repair or replace damaged parts.

3. DETECT MALFUNCTIONING ITEM

Check the following items:

- The A/T assembly harness connector pin terminals for damage or loose connection with harness connector.

OK or NG

- OK >> Replace the control valve with TCM. Refer to [AT-225, "Control Valve With TCM and A/T Fluid Temperature Sensor 2"](#).
NG >> Repair or replace damaged parts.

4. CHECK DTC

Perform "DTC Confirmation Procedure".

- Refer to [AT-145, "DTC Confirmation Procedure"](#).

OK or NG

- OK >> **INSPECTION END**
NG >> GO TO 2.

DTC P1767 HIGH AND LOW REVERSE CLUTCH SOLENOID VALVE

DTC P1767 HIGH AND LOW REVERSE CLUTCH SOLENOID VALVE

PF3:31940

Description

ECS00H0S

High and low reverse clutch solenoid valve is controlled by the TCM in response to signals sent from the PNP switch, vehicle speed sensor and accelerator pedal position sensor (throttle position sensor). Gears will then be shifted to the optimum position.

CONSULT-II Reference Value

ECS00H0T

Item name	Condition	Display value (Approx.)
HLR/C SOL	High and low reverse clutch disengaged. Refer to AT-20	0.6 - 0.8 A
	High and low reverse clutch engaged. Refer to AT-20	0 - 0.05 A

On Board Diagnosis Logic

ECS00H0U

- This is an OBD-II self-diagnostic item.
- Diagnostic trouble code "P1767 HLR/C SOL/CIRC" with CONSULT-II or is detected under the following conditions.
 - When TCM detects an improper voltage drop when it tries to operate the solenoid valve.
 - When TCM detects as irregular by comparing target value with monitor value.

Possible Cause

ECS00H0V

- Harness or connectors
(The solenoid circuit is open or shorted.)
- High and low reverse clutch solenoid valve

DTC Confirmation Procedure

ECS00H0W

CAUTION:

Always drive vehicle at a safe speed.

NOTE:

If "DTC Confirmation Procedure" has been previously performed, always turn ignition switch "OFF" and wait at least 10 seconds before performing the next test.

After the repair, perform the following procedure to confirm the malfunction is eliminated.

WITH CONSULT-II

1. Turn ignition switch "ON". (Do not start engine.)
2. Select "DATA MONITOR" mode for "A/T" with CONSULT-II.
3. Start engine.
4. Drive vehicle and maintain the following conditions for at least 5 consecutive seconds.

ACCELE POS: 1.5/8 - 2.0/8

Selector lever: "D" position

Gear position: 2nd ⇒ 3rd Gear (HLR/C ON/OFF)

Driving location: Driving the vehicle uphill (increased engine load) will help maintain the driving conditions required for this test.

5. If DTC is detected, go to [AT-148, "Diagnostic Procedure"](#).

WITH GST

Follow the procedure "With CONSULT-II".

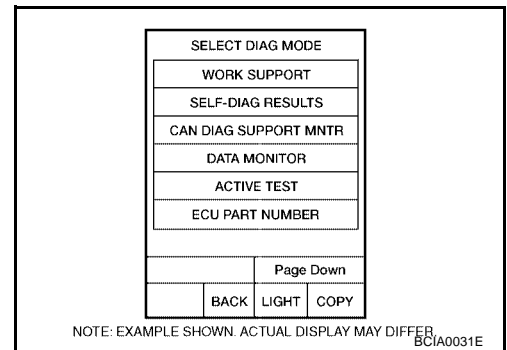

DTC P1767 HIGH AND LOW REVERSE CLUTCH SOLENOID VALVE

ECS00H0X

Diagnostic Procedure

1. CHECK INPUT SIGNAL

With CONSULT-II

1. Turn ignition switch "ON".
2. Select "MAIN SIGNALS" in "DATA MONITOR" mode for "A/T" with CONSULT-II.
3. Start the engine.
4. Read out the value of "HLR/C SOLENOID" while driving.

DATA MONITOR			
MONITOR		NO DTC	
TCC SOLENOID		XXXX	
LINE PRES SOL		XXXX	
I/C SOLENOID		XXXX	
FR/B SOLENOID		XXXX	
D/C SOLENOID		XXXX	
HLR/C SOL		XXXX	
		▽	
		RECORD	
MODE	BACK	LIGHT	COPY

SCIA4793E

Item name	Condition	Display value (Approx.)
HLR/C SOL	High and low reverse clutch disengaged. Refer to AT-20	0.6 - 0.8 A
	High and low reverse clutch engaged. Refer to AT-20	0 - 0.05 A

OK or NG

- OK >> GO TO 4.
NG >> GO TO 2.

2. CHECK TCM POWER SUPPLY AND GROUND CIRCUIT

Check TCM power supply and ground circuit Refer to [AT-163, "MAIN POWER SUPPLY AND GROUND CIRCUIT"](#) .

OK or NG

- OK >> GO TO 3.
NG >> Repair or replace damaged parts.

3. DETECT MALFUNCTIONING ITEM

Check the following items:

- The A/T assembly harness connector pin terminals for damage or loose connection with harness connector.

OK or NG

- OK >> Replace the control valve with TCM. Refer to [AT-225, "Control Valve With TCM and A/T Fluid Temperature Sensor 2"](#) .
NG >> Repair or replace damaged parts.

4. CHECK DTC

Perform "DTC Confirmation Procedure".

- Refer to [AT-147, "DTC Confirmation Procedure"](#) .

OK or NG

- OK >> **INSPECTION END**
NG >> GO TO 2.

DTC P1769 HIGH AND LOW REVERSE CLUTCH SOLENOID VALVE FUNCTION

DTC P1769 HIGH AND LOW REVERSE CLUTCH SOLENOID VALVE FUNCTION

PFP:31940

Description

ECS00H0Y

- High and low reverse clutch solenoid valve is controlled by the TCM in response to signals sent from the PNP switch, vehicle speed sensor and accelerator pedal position sensor (throttle position sensor). Gears will then be shifted to the optimum position.
- This is not only caused by electrical malfunction (circuits open or shorted) but also by mechanical malfunction such as control valve sticking, improper solenoid valve operation.

CONSULT-II Reference Value

ECS00H0Z

Item name	Condition	Display value (Approx.)
HLR/C SOL	High and low reverse clutch disengaged. Refer to AT-20	0.6 - 0.8 A
	High and low reverse clutch engaged. Refer to AT-20	0 - 0.05 A
ATF PRES SW 6	High and low reverse clutch engaged. Refer to AT-20	ON
	High and low reverse clutch disengaged. Refer to AT-20	OFF

On Board Diagnosis Logic

ECS00H10

- This is an OBD-II self-diagnostic item.
- Diagnostic trouble code "P1769 HLR/C SOL FNCTN" with CONSULT-II is detected under the following conditions.
 - When TCM detects that actual gear ratio is irregular, and relation between gear position and condition of ATF pressure switch 6 is irregular during depressing accelerator pedal. (Other than during shift change)
 - When TCM detects that relation between gear position and condition of ATF pressure switch 6 is irregular during releasing accelerator pedal. (Other than during shift change)

Possible Cause

ECS00H11

- Harness or connectors
(The solenoid and switch circuits are open or shorted.)
- High and low reverse clutch solenoid valve
- ATF pressure switch 6

DTC Confirmation Procedure

ECS00H12

CAUTION:

Always drive vehicle at a safe speed.

NOTE:

If "DTC Confirmation Procedure" has been previously performed, always turn ignition switch "OFF" and wait at least 10 seconds before performing the next test.

After the repair, perform the following procedure to confirm the malfunction is eliminated.

WITH CONSULT-II

- Start engine.
- Accelerate vehicle to maintain the following conditions.
ACCELE POS: 1.5/8 - 2.0/8
Selector lever: "D" position
Gear position: 2nd ⇒ 3rd Gear (HLR/C ON/OFF)
Driving location: Driving the vehicle uphill (increased engine load) will help maintain the driving conditions required for this test.
- Perform step "2" again.
- Turn ignition switch "OFF", then perform step "1" to "3" again.
- Check "SELF-DIAG RESULTS" mode for "AT" with CONSULT-II. If DTC (P1769) is detected, refer to [AT-150, "Diagnostic Procedure"](#).
If DTC (P1767) is detected, go to [AT-148, "Diagnostic Procedure"](#).
If DTC (P1846) is detected, go to [AT-162, "Diagnostic Procedure"](#).

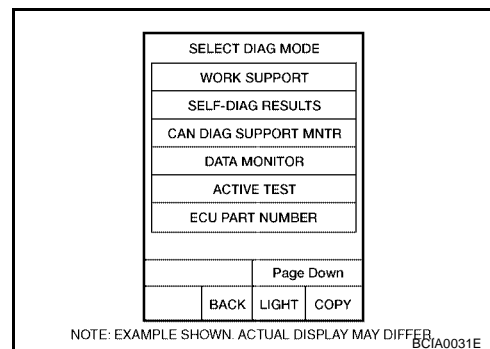

DTC P1769 HIGH AND LOW REVERSE CLUTCH SOLENOID VALVE FUNCTION

ECS00H13

Diagnostic Procedure

1. CHECK INPUT SIGNALS

With CONSULT-II

1. Start the engine.
2. Select "SELECTION FROM MENU" in "DATA MONITOR" mode for "A/T" with CONSULT-II.
3. Drive vehicle in the "D" position (2nd ⇒ 3rd gear), and confirm the ON/OFF actuation of the "ATF PRES SW 6" and electrical current value of "HLR/C SOL".

DATA MONITOR			
MONITOR		NO DTC	
HLR/C SOL		XXX A	
ATF PRES SW 6		OFF	
RECORD			
MODE	BACK	LIGHT	COPY

SCIA4798E

Item name	Condition	Display value (Approx.)
HLR/C SOL	High and low reverse clutch disengaged. Refer to AT-20	0.6 - 0.8 A
	High and low reverse clutch engaged. Refer to AT-20	0 - 0.05 A
ATF PRES SW 6	High and low reverse clutch engaged. Refer to AT-20	ON
	High and low reverse clutch disengaged. Refer to AT-20	OFF

OK or NG

- OK >> GO TO 4.
NG >> GO TO 2.

2. CHECK TCM POWER SUPPLY AND GROUND CIRCUIT

Check TCM power supply and ground circuit. Refer to [AT-163, "MAIN POWER SUPPLY AND GROUND CIRCUIT"](#).

OK or NG

- OK >> GO TO 3.
NG >> Repair or replace damaged parts.

3. DETECT MALFUNCTIONING ITEM

Check the following items:

- The A/T assembly harness connector pin terminals for damage or loose connection with harness connector.

OK or NG

- OK >> Replace the control valve with TCM. Refer to [AT-225, "Control Valve With TCM and A/T Fluid Temperature Sensor 2"](#).
- NG >> Repair or replace damaged parts.

4. CHECK DTC

Perform "DTC Confirmation Procedure".

- Refer to [AT-149, "DTC Confirmation Procedure"](#).

OK or NG

- OK >> **INSPECTION END**
NG >> GO TO 2.

DTC P1772 LOW COAST BRAKE SOLENOID VALVE

DTC P1772 LOW COAST BRAKE SOLENOID VALVE

PF3:31940

Description

ECS00H14

Low coast brake solenoid valve is turned "ON" or "OFF" by the TCM in response to signals sent from the PNP switch, vehicle speed sensor and accelerator pedal position sensor (throttle position sensor). Gears will then be shifted to the optimum position.

CONSULT-II Reference Value

ECS00H15

Item name	Condition	Display value
ON OFF SOL	Low coast brake engaged. Refer to AT-20	ON
	Low coast brake disengaged. Refer to AT-20	OFF

On Board Diagnosis Logic

ECS00H16

- This is an OBD-II self-diagnostic item.
- Diagnostic trouble code "P1772 LC/B SOLENOID/CIRC" with CONSULT-II is detected when TCM detects an improper voltage drop when it tries to operate the solenoid valve.

Possible Cause

ECS00H17

- Harness or connectors
(The solenoid circuit is open or shorted.)
- Low coast brake solenoid valve

DTC Confirmation Procedure

ECS00H18

NOTE:

If "DTC Confirmation Procedure" has been previously performed, always turn ignition switch "OFF" and wait at least 10 seconds before performing the next test.

After the repair, perform the following procedure to confirm the malfunction is eliminated.

WITH CONSULT-II

1. Turn ignition switch "ON". (Do not start engine.)
2. Select "DATA MONITOR" mode for "ENGINE" with CONSULT-II.
3. Start engine.
4. Drive vehicle and maintain the following conditions for at least 5 consecutive seconds.
Selector lever: "1" or "2"
Gear position: "1st" or "2nd" gear (LC/B ON/OFF)
5. If DTC is detected, go to [AT-152, "Diagnostic Procedure"](#).

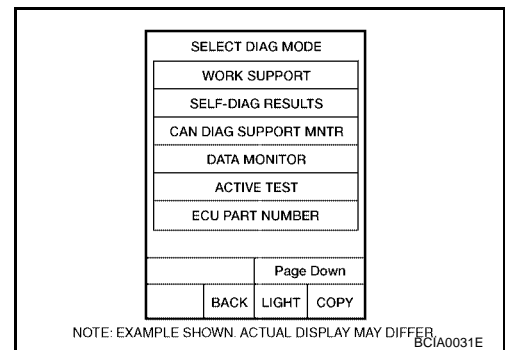

WITH GST

Follow the procedure "With CONSULT-II".

DTC P1772 LOW COAST BRAKE SOLENOID VALVE

ECS00H19

Diagnostic Procedure

1. CHECK INPUT SIGNAL

With CONSULT-II

1. Turn ignition switch "ON".
2. Select "SELECTION FROM MENU" in "DATA MONITOR" mode for "A/T" with CONSULT-II.
3. Start the engine.
4. Read out the value of "ON OFF SOL" while driving.

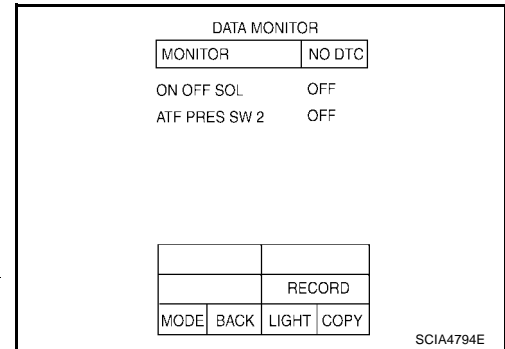

Item name	Condition	Display value
ON OFF SOL	Low coast brake engaged. Refer to AT-20	ON
	Low coast brake disengaged. Refer to AT-20	OFF

OK or NG

- OK >> GO TO 4.
NG >> GO TO 2.

2. CHECK TCM POWER SUPPLY AND GROUND CIRCUIT

Check TCM power supply and ground circuit. Refer to [AT-163, "MAIN POWER SUPPLY AND GROUND CIRCUIT"](#).

OK or NG

- OK >> GO TO 3.
NG >> Repair or replace damaged parts.

3. DETECT MALFUNCTIONING ITEM

Check the following items:

- The A/T assembly harness connector pin terminals for damage or loose connection with harness connector.

OK or NG

- OK >> Replace the control valve with TCM. Refer to [AT-225, "Control Valve With TCM and A/T Fluid Temperature Sensor 2"](#).
- NG >> Repair or replace damaged parts.

4. CHECK DTC

Perform "DTC Confirmation Procedure".

- Refer to [AT-151, "DTC Confirmation Procedure"](#).

OK or NG

- OK >> **INSPECTION END**
NG >> GO TO 2.

DTC P1774 LOW COAST BRAKE SOLENOID VALVE FUNCTION

DTC P1774 LOW COAST BRAKE SOLENOID VALVE FUNCTION

PF3:31940

Description

ECS00H1A

- Low coast brake solenoid valve is turned “ON” or “OFF” by the TCM in response to signals sent from the PNP switch, vehicle speed sensor and accelerator pedal position sensor (throttle position sensor). Gears will then be shifted to the optimum position.
- This is not only caused by electrical malfunction (circuits open or shorted) but also by mechanical malfunction such as control valve sticking, improper solenoid valve operation.

CONSULT-II Reference Value

ECS00H1B

Item name	Condition	Display value
ON OFF SOL	Low coast brake engaged. Refer to AT-20	ON
	Low coast brake disengaged. Refer to AT-20	OFF
ATF PRES SW 2	Low coast brake engaged. Refer to AT-20	ON
	Low coast brake disengaged. Refer to AT-20	OFF

On Board Diagnosis Logic

ECS00H1C

- This is an OBD-II self-diagnostic item.
- Diagnostic trouble code “P1774 LC/B SOLENOID FNCT” with CONSULT-II is detected under the following conditions.
 - When TCM detects that actual gear ratio is irregular, and relation between gear position and condition of ATF pressure switch 2 is irregular during depressing accelerator pedal. (Other than during shift change)
 - When TCM detects that relation between gear position and condition of ATF pressure switch 2 is irregular during releasing accelerator pedal. (Other than during shift change)

Possible Cause

ECS00H1D

- Harness or connectors
(The solenoid and switch circuits are open or shorted.)
- Low coast brake solenoid valve
- ATF pressure switch 2

DTC Confirmation Procedure

ECS00H1E

CAUTION:

Always drive vehicle at a safe speed.

NOTE:

If “DTC Confirmation Procedure” has been previously performed, always turn ignition switch “OFF” and wait at least 10 seconds before performing the next test.

After the repair, perform the following procedure to confirm the malfunction is eliminated.

WITH CONSULT-II

1. Start engine.
2. Accelerate vehicle to maintain the following conditions.
Selector lever: “1” or “2” position
Gear position: “1st” or “2nd” gear (LC/B ON/OFF)
3. Perform step “2” again.
4. Turn ignition switch “OFF”, then perform step “1” to “3” again.
5. Check “SELF-DIAG RESULTS” mode for “A/T” with CONSULT-II. If DTC (P1774) is detected, refer to [AT-154, "Diagnostic Procedure"](#).
If DTC (P1772) is detected, go to [AT-152, "Diagnostic Procedure"](#).

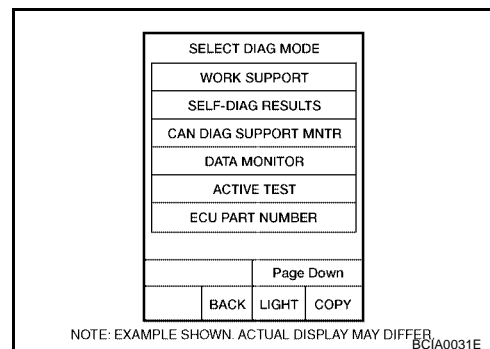

WITH GST

Follow the procedure “With CONSULT-II”.

DTC P1774 LOW COAST BRAKE SOLENOID VALVE FUNCTION

ECS00H1F

Diagnostic Procedure

1. CHECK INPUT SIGNALS

With CONSULT-II

1. Start the engine.
2. Select "SELECTION FROM MENU" in "DATA MONITOR" mode for "A/T" with CONSULT-II.
3. Drive vehicle in the "1" or "2" position ("1" or "2" gear) and confirm the ON/OFF actuation of the "ATF PRES SW 2" and "ON OFF SOL".

DATA MONITOR			
MONITOR		NO DTC	
ON OFF SOL		OFF	
ATF PRES SW 2		OFF	
RECORD			
MODE	BACK	LIGHT	COPY

SCIA4794E

Item name	Condition	Display value
ON OFF SOL	Low coast brake engaged. Refer to AT-20	ON
	Low coast brake disengaged. Refer to AT-20	OFF
ATF PRES SW 2	Low coast brake engaged. Refer to AT-20	ON
	Low coast brake disengaged. Refer to AT-20	OFF

OK or NG

- OK >> GO TO 4.
NG >> GO TO 2.

2. CHECK TCM POWER SUPPLY AND GROUND CIRCUIT

Check TCM power supply and ground circuit. Refer to [AT-163, "MAIN POWER SUPPLY AND GROUND CIRCUIT"](#).

OK or NG

- OK >> GO TO 3.
NG >> Repair or replace damaged parts.

3. DETECT MALFUNCTIONING ITEM

Check the following items:

- The A/T assembly harness connector pin terminals for damage or loose connection with harness connector.

OK or NG

- OK >> Replace the control valve with TCM. Refer to [AT-225, "Control Valve With TCM and A/T Fluid Temperature Sensor 2"](#).
- NG >> Repair or replace damaged parts.

4. CHECK DTC

Perform "DTC Confirmation Procedure".

- Refer to [AT-153, "DTC Confirmation Procedure"](#).

OK or NG

- OK >> **INSPECTION END**
NG >> GO TO 2.

DTC P1841 ATF PRESSURE SWITCH 1

DTC P1841 ATF PRESSURE SWITCH 1

PFP:25240

Description

ECS00H1G

Fail-safe function to detect front brake clutch solenoid valve condition.

CONSULT-II Reference Value

ECS00H1H

Item name	Condition	Display value
ATF PRES SW 1	Front brake engaged. Refer to AT-20	ON
	Front brake disengaged. Refer to AT-20	OFF

On Board Diagnosis Logic

ECS00H1I

- This is not an OBD-II self-diagnostic item.
- Diagnostic trouble code "P1841 ATF PRES SW 1/CIRC" with CONSULT-II is detected when TCM detects that actual gear ratio is normal, and relation between gear position and condition of ATF pressure switch 1 is irregular during depressing accelerator pedal. (Other than during shift change)

Possible Cause

ECS00H1J

- ATF pressure switch 1
- Harness or connectors
(The switch circuit is open or shorted.)

DTC Confirmation Procedure

ECS00H1K

CAUTION:

Always drive vehicle at a safe speed.

NOTE:

If "DTC Confirmation Procedure" has been previously performed, always turn ignition switch "OFF" and wait at least 10 seconds before performing the next test.

After the repair, perform the following procedure to confirm the malfunction is eliminated.

WITH CONSULT-II

1. Start engine.
2. Accelerate vehicle to maintain the following conditions.
ACCELE POS: 1.5/8 - 2.0/8
Selector lever: "D" position
Gear position: 3rd ⇒ 4th Gear (FR/B ON/OFF)
Driving location: Driving the vehicle uphill (increased engine load) will help maintain the driving conditions required for this test.
3. Perform step "2" again.
4. Turn ignition switch "OFF", then perform step "1" to "3" again.
5. Check "SELF-DIAG RESULTS" mode for "AT" with CONSULT-II.

If DTC (P1841) is detected, go to [AT-156, "Diagnostic Procedure"](#).

If DTC (P1757) is detected, go to [AT-140, "Diagnostic Procedure"](#).

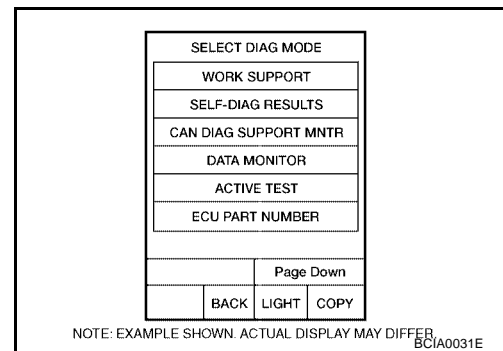

DTC P1841 ATF PRESSURE SWITCH 1

ECS00H1L

Diagnostic Procedure

1. CHECK INPUT SIGNAL

With CONSULT-II

1. Start engine.
2. Select "ECU INPUT SIGNALS" or "MAIN SIGNALS" in "DATA MONITOR" mode for "A/T" with CONSULT-II.
3. Drive vehicle in the "D" position (3rd ⇒ 4th gear), and confirm the ON/OFF actuation of the "ATF PRES SW 1".

Item name	Condition	Display value
ATF PRES SW 1	Front brake engaged. Refer to AT-20	ON
	Front brake disengaged. Refer to AT-20	OFF

OK or NG

- OK >> GO TO 4.
NG >> GO TO 2.

DATA MONITOR	
MONITOR	NO DTC
ATF PRES SW 1	OFF
ATF PRES SW 2	OFF
ATF PRES SW 3	OFF
ATF PRES SW 5	OFF
ATF PRES SW 6	OFF

Δ	▽		
RECORD			
MODE	BACK	LIGHT	COPY

PCIA0067E

2. CHECK TCM POWER SUPPLY AND GROUND CIRCUIT

Check TCM power supply and ground circuit. Refer to [AT-163, "MAIN POWER SUPPLY AND GROUND CIRCUIT"](#).

OK or NG

- OK >> GO TO 3.
NG >> Repair or replace damaged parts.

3. DETECT MALFUNCTIONING ITEM

Check the following items:

- The A/T assembly harness connector pin terminals for damage or loose connection with harness connector.

OK or NG

- OK >> Replace the control valve with TCM. Refer to [AT-225, "Control Valve With TCM and A/T Fluid Temperature Sensor 2"](#).
- NG >> Repair or replace damaged parts.

4. CHECK DTC

Perform "DTC Confirmation Procedure".

- Refer to [AT-155, "DTC Confirmation Procedure"](#).

OK or NG

- OK >> **INSPECTION END**
NG >> GO TO 2.

DTC P1843 ATF PRESSURE SWITCH 3

DTC P1843 ATF PRESSURE SWITCH 3

PFP:25240

Description

ECS00H1M

Fail-safe function to detect input clutch solenoid valve condition.

CONSULT-II Reference Value

ECS00H1N

Item name	Condition	Display value
ATF PRES SW 3	Input clutch engaged. Refer to AT-20	ON
	Input clutch disengaged. Refer to AT-20	OFF

On Board Diagnosis Logic

ECS00H1O

- This is not an OBD-II self-diagnostic item.
- Diagnostic trouble code "P1843 ATF PRES SW 3/CIRC" with CONSULT-II is detected when TCM detects that actual gear ratio is normal, and relation between gear position and condition of ATF pressure switch 3 is irregular during depressing accelerator pedal. (Other than during shift change)

Possible Cause

ECS00H1P

- ATF pressure switch 3
- Harness or connectors
(The switch circuit is open or shorted.)

DTC Confirmation Procedure

ECS00H1Q

CAUTION:

Always drive vehicle at a safe speed.

NOTE:

If "DTC Confirmation Procedure" has been previously performed, always turn ignition switch "OFF" and wait at least 10 seconds before performing the next test.

After the repair, perform the following procedure to confirm the malfunction is eliminated.

WITH CONSULT-II

1. Start engine.
2. Accelerate vehicle to maintain the following conditions.
ACCELE POS: 1.5/8 - 2.0/8
Selector lever: "D" position
Gear position: 3rd ⇒ 4th Gear (I/C ON/OFF)
Driving location: Driving the vehicle uphill (increased engine load) will help maintain the driving conditions required for this test.
3. Perform step "2" again.
4. Turn ignition switch "OFF", then perform step "1" to "3" again.
5. Check "SELF-DIAG RESULTS" mode for "AT" with CONSULT-II.

If DTC (P1843) is detected, go to [AT-158, "Diagnostic Procedure"](#).

If DTC (P1752) is detected, go to [AT-136, "Diagnostic Procedure"](#).

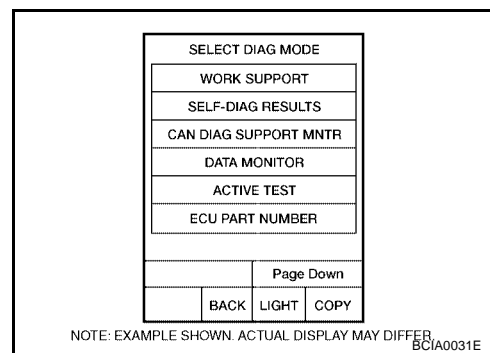

DTC P1843 ATF PRESSURE SWITCH 3

ECS00H1R

Diagnostic Procedure

1. CHECK INPUT SIGNAL

With CONSULT-II

1. Start engine.
2. Select "ECU INPUT SIGNALS" or "MAIN SIGNALS" in "DATA MONITOR" mode for "A/T" with CONSULT-II.
3. Drive vehicle in the "D" position (3rd ⇒ 4th gear), and confirm the ON/OFF actuation of the "ATF PRES SW 3".

Item name	Condition	Display value
ATF PRES SW 3	Input clutch engaged. Refer to AT-20	ON
	Input clutch disengaged. Refer to AT-20	OFF

OK or NG

- OK >> GO TO 4.
NG >> GO TO 2.

DATA MONITOR	
MONITOR	NO DTC
ATF PRES SW 1	OFF
ATF PRES SW 2	OFF
ATF PRES SW 3	OFF
ATF PRES SW 5	OFF
ATF PRES SW 6	OFF

△	▽		
RECORD			
MODE	BACK	LIGHT	COPY

PCIA0067E

2. CHECK TCM POWER SUPPLY AND GROUND CIRCUIT

Check TCM power supply and ground circuit. Refer to [AT-163, "MAIN POWER SUPPLY AND GROUND CIRCUIT"](#).

OK or NG

- OK >> GO TO 3.
NG >> Repair or replace damaged parts.

3. DETECT MALFUNCTIONING ITEM

Check the following items:

- The A/T assembly harness connector pin terminals for damage or loose connection with harness connector.

OK or NG

- OK >> Replace the control valve with TCM. Refer to [AT-225, "Control Valve With TCM and A/T Fluid Temperature Sensor 2"](#).
- NG >> Repair or replace damaged parts.

4. CHECK DTC

Perform "DTC Confirmation Procedure".

- Refer to [AT-157, "DTC Confirmation Procedure"](#).

OK or NG

- OK >> **INSPECTION END**
NG >> GO TO 2.

DTC P1845 ATF PRESSURE SWITCH 5

DTC P1845 ATF PRESSURE SWITCH 5

PF2:25240

Description

ECS00H1S

Fail-safe function to detect direct clutch solenoid valve condition.

CONSULT-II Reference Value

ECS00H1T

Item name	Condition	Display value
ATF PRES SW 5	Direct clutch engaged. Refer to AT-160	ON
	Direct clutch disengaged. Refer to AT-160	OFF

On Board Diagnosis Logic

ECS00H1U

- This is not an OBD-II self-diagnostic item.
- Diagnostic trouble code "P1845 ATF PRES SW 5/CIRC" with CONSULT-II is detected when TCM detects that actual gear ratio is normal, and relation between gear position and condition of ATF pressure switch 5 is irregular during depressing accelerator pedal. (Other than during shift change)

Possible Cause

ECS00H1V

- ATF pressure switch 5
- Harness or connectors
(The switch circuit is open or shorted.)

DTC Confirmation Procedure

ECS00H1W

CAUTION:

Always drive vehicle at a safe speed.

NOTE:

If "DTC Confirmation Procedure" has been previously performed, always turn ignition switch "OFF" and wait at least 10 seconds before performing the next test.

After the repair, perform the following procedure to confirm the malfunction is eliminated.

WITH CONSULT-II

1. Start engine.
2. Accelerate vehicle to maintain the following conditions.
ACCELE POS: 1.5/8 - 2.0/8
Selector lever: "D" position
Gear position: 1st ⇒ 2nd Gear (D/C ON/OFF)
Driving location: Driving the vehicle uphill (increased engine load) will help maintain the driving conditions required for this test.
3. Perform step "2" again.
4. Turn ignition switch "OFF", then perform step "1" to "3" again.
5. Check "SELF-DIAG RESULTS" mode for "AT" with CONSULT-II.

If DTC (P1845) is detected, go to [AT-160, "Diagnostic Procedure"](#).

If DTC (P1762) is detected, go to [AT-144, "Diagnostic Procedure"](#).

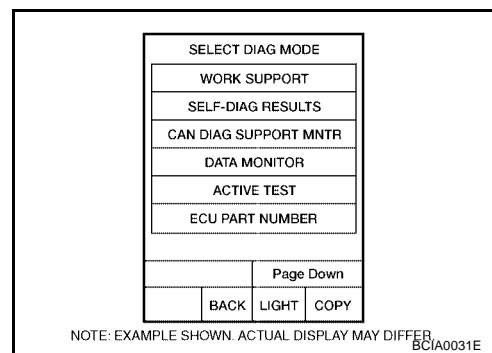

DTC P1845 ATF PRESSURE SWITCH 5

ECS00H1X

Diagnostic Procedure

1. CHECK INPUT SIGNAL

With CONSULT-II

1. Start engine.
2. Select "ECU INPUT SIGNALS" or "MAIN SIGNALS" in "DATA MONITOR" mode for "A/T" with CONSULT-II.
3. Drive vehicle in the "D" position (1st ⇒ 2nd gear), and confirm the ON/OFF actuation of the "ATF PRES SW 5".

Item name	Condition	Display value
ATF PRES SW 5	Direct clutch engaged. Refer to AT-160	ON
	Direct clutch disengaged. Refer to AT-160	OFF

OK or NG

- OK >> GO TO 4.
NG >> GO TO 2.

DATA MONITOR	
MONITOR	NO DTC
ATF PRES SW 1	OFF
ATF PRES SW 2	OFF
ATF PRES SW 3	OFF
ATF PRES SW 5	OFF
ATF PRES SW 6	OFF

Δ	▽		
RECORD			
MODE	BACK	LIGHT	COPY

PCIA0067E

2. CHECK TCM POWER SUPPLY AND GROUND CIRCUIT

Check TCM power supply and ground circuit. Refer to [AT-163, "MAIN POWER SUPPLY AND GROUND CIRCUIT"](#).

OK or NG

- OK >> GO TO 3.
NG >> Repair or replace damaged parts.

3. DETECT MALFUNCTIONING ITEM

Check the following items:

- The A/T assembly harness connector pin terminals for damage or loose connection with harness connector.

OK or NG

- OK >> Replace the control valve with TCM. Refer to [AT-225, "Control Valve With TCM and A/T Fluid Temperature Sensor 2"](#).
- NG >> Repair or replace damaged parts.

4. CHECK DTC

Perform "DTC Confirmation Procedure".

- Refer to [AT-159, "DTC Confirmation Procedure"](#).

OK or NG

- OK >> **INSPECTION END**
NG >> GO TO 2.

DTC P1846 ATF PRESSURE SWITCH 6

DTC P1846 ATF PRESSURE SWITCH 6

PFP:25240

Description

ECS00H1Y

Fail-safe function to detect high and low reverse clutch solenoid valve condition.

CONSULT-II Reference Value

ECS00H1Z

Item name	Condition	Display value
ATF PRES SW 6	High and low reverse clutch engaged. Refer to AT-20	ON
	High and low reverse clutch disengaged. Refer to AT-20	OFF

On Board Diagnosis Logic

ECS00H20

- This is not an OBD-II self-diagnostic item.
- Diagnostic trouble code "P1846 ATF PRES SW 6/CIRC" with CONSULT-II is detected when TCM detects that actual gear ratio is normal, and relation between gear position and condition of ATF pressure switch 6 is irregular during depressing accelerator pedal. (Other than during shift change)

Possible Cause

ECS00H21

- ATF pressure switch 6
- Harness or connectors
(The switch circuit is open or shorted.)

DTC Confirmation Procedure

ECS00H22

CAUTION:

Always drive vehicle at a safe speed.

NOTE:

If "DTC Confirmation Procedure" has been previously performed, always turn ignition switch "OFF" and wait at least 10 seconds before performing the next test.

After the repair, perform the following procedure to confirm the malfunction is eliminated.

WITH CONSULT-II

1. Start engine.
2. Accelerate vehicle to maintain the following conditions.
ACCELE POS: 1.5/8 - 2.0/8
Selector lever: "D" position
Gear position: 2nd ⇒ 3rd Gear (HLR/C ON/OFF)
Driving location: Driving the vehicle uphill (increased engine load) will help maintain the driving conditions required for this test.
3. Perform step "2" again.
4. Turn ignition switch "OFF", then perform step "1" to "3" again.
5. Check "SELF-DIAG RESULTS" mode for "AT" with CONSULT-II.

If DTC (P1846) is detected, go to [AT-162, "Diagnostic Procedure"](#).

If DTC (P1767) is detected, go to [AT-148, "Diagnostic Procedure"](#).

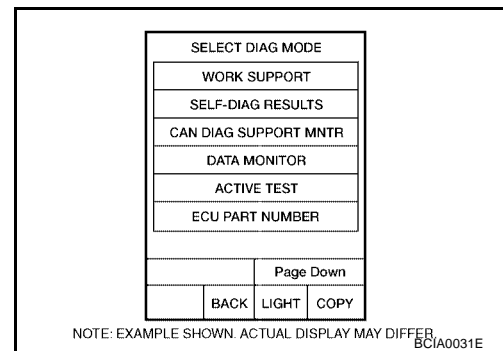

DTC P1846 ATF PRESSURE SWITCH 6

ECS00H23

Diagnostic Procedure

1. CHECK INPUT SIGNAL

With CONSULT-II

1. Start the engine.
2. Select "ECU INPUT SIGNALS" or "MAIN SIGNALS" in "DATA MONITOR" mode for "A/T" with CONSULT-II.
3. Drive vehicle in the "D" position (2nd ⇒ 3rd gear), and confirm the ON/OFF actuation of the "ATF PRES SW 6".

Item name	Condition	Display value
ATF PRES SW 6	High and low reverse clutch engaged. Refer to AT-20	ON
	High and low reverse clutch disengaged. Refer to AT-20	OFF

DATA MONITOR	
MONITOR	NO DTC
ATF PRES SW 1	OFF
ATF PRES SW 2	OFF
ATF PRES SW 3	OFF
ATF PRES SW 5	OFF
ATF PRES SW 6	OFF

Δ	▽		
RECORD			
MODE	BACK	LIGHT	COPY

PCIA0067E

OK or NG

- OK >> GO TO 4.
NG >> GO TO 2.

2. CHECK TCM POWER SUPPLY AND GROUND CIRCUIT

Check TCM power supply and ground circuit. Refer to [AT-163, "MAIN POWER SUPPLY AND GROUND CIRCUIT"](#).

OK or NG

- OK >> GO TO 3.
NG >> Repair or replace damaged parts.

3. DETECT MALFUNCTIONING ITEM

Check the following items:

- The A/T assembly harness connector pin terminals for damage or loose connection with harness connector.

OK or NG

- OK >> Replace the control valve with TCM. Refer to [AT-225, "Control Valve With TCM and A/T Fluid Temperature Sensor 2"](#).
- NG >> Repair or replace damaged parts.

4. CHECK DTC

Perform "DTC Confirmation Procedure".

- Refer to [AT-161, "DTC Confirmation Procedure"](#).

OK or NG

- OK >> **INSPECTION END**
NG >> GO TO 2.

MAIN POWER SUPPLY AND GROUND CIRCUIT

MAIN POWER SUPPLY AND GROUND CIRCUIT

Wiring Diagram — AT — MAIN

PF0:00100

ECS00H24

AT-MAIN-01

: DETECTABLE LINE FOR DTC
 : NON-DETECTABLE LINE FOR DTC

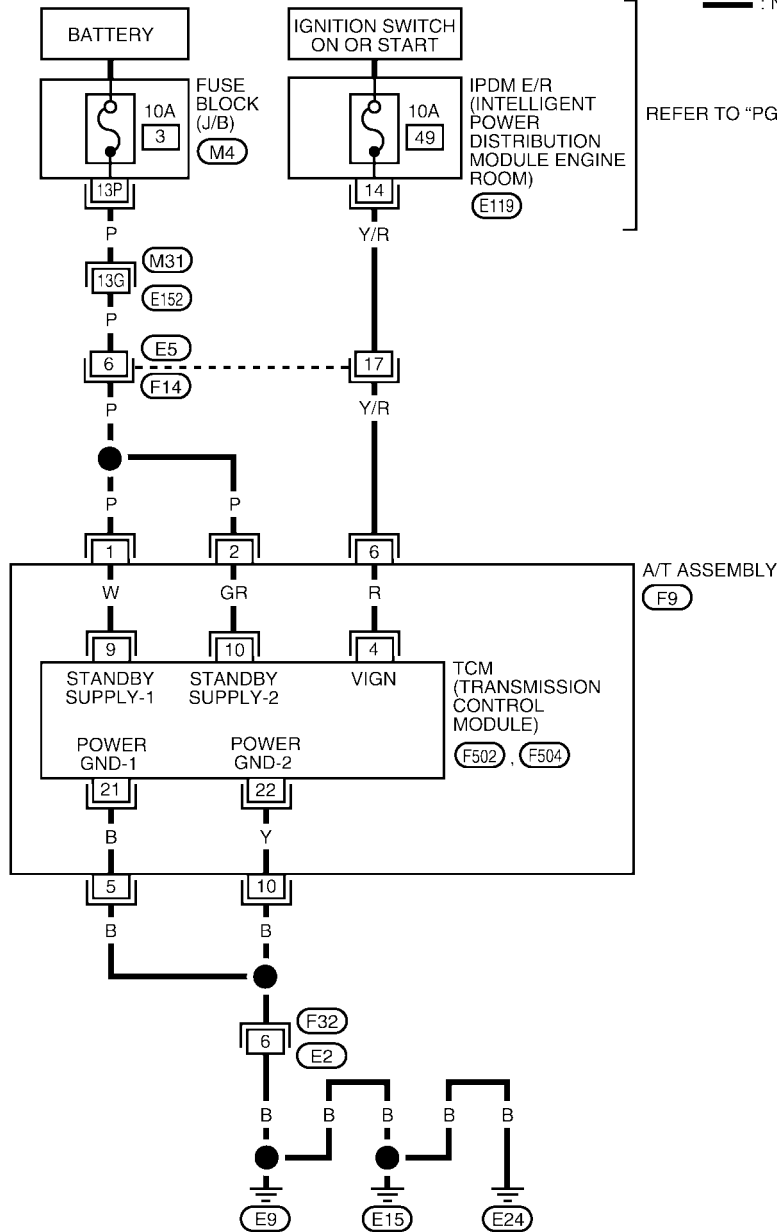

REFER TO "PG-POWER".

A/T ASSEMBLY (F9)

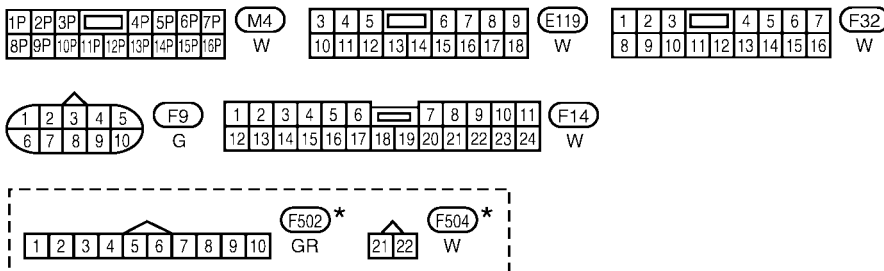

REFER TO THE FOLLOWING.

(M31) - SUPER MULTIPLE JUNCTION (SMJ)

*: THIS CONNECTOR IS NOT SHOWN IN "HARNESS LAYOUT" OF PG SECTION.

BCWA0324E

MAIN POWER SUPPLY AND GROUND CIRCUIT

TCM INPUT/OUTPUT SIGNAL REFERENCE VALUES

Refer to [AT-83, "TCM Input/Output Signal Reference Values"](#) .

Diagnostic Procedure

ECS00H25

1. CHECK TCM POWER SOURCE STEP 1

1. Turn ignition switch OFF.
2. Disconnect A/T assembly harness connector.
3. Check voltage between A/T assembly harness connector terminals and ground.

Item	Connector	Terminal	Voltage
TCM	F9	1 - Ground	Battery voltage
		2 - Ground	
		6 - Ground	0V

OK or NG

- OK >> GO TO 2.
 NG >> GO TO 3.

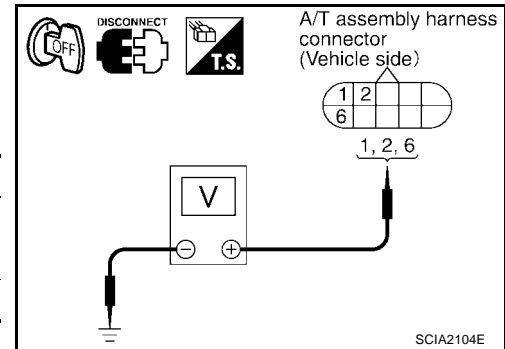

2. CHECK TCM POWER SOURCE STEP 2

1. Disconnect A/T assembly harness connector.
2. Turn ignition switch ON. (Do not start engine.)
3. Check voltage between A/T assembly harness connector terminals and ground.

Item	Connector	Terminal	Voltage
TCM	F9	1 - Ground	Battery voltage
		2 - Ground	
		6 - Ground	

OK or NG

- OK >> GO TO 4.
 NG >> GO TO 3.

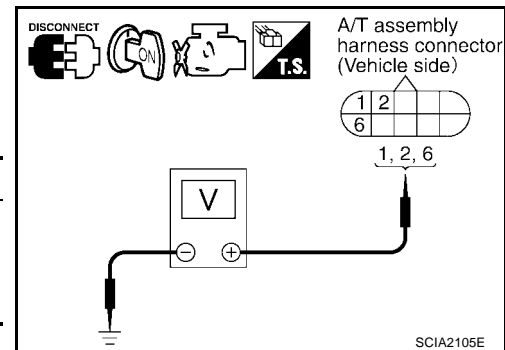

3. DETECT MALFUNCTIONING ITEM

Check the following items:

- Harness for short or open between battery and A/T assembly harness connector terminals 1, 2
- Harness for short or open between ignition switch and A/T assembly harness connector terminal 6
- 10A fuse [No. 3, located in the fuse block (J/B)] and 10A fuse (No. 49, located in the IPDM E/R)
- Ignition switch, Refer to [PG-4, "POWER SUPPLY ROUTING CIRCUIT"](#) .

OK or NG

- OK >> GO TO 4.
 NG >> Repair or replace damaged parts.

MAIN POWER SUPPLY AND GROUND CIRCUIT

4. CHECK TCM GROUND CIRCUIT

1. Turn ignition switch OFF.
2. Disconnect A/T assembly harness connector.
3. Check continuity between A/T assembly harness connector F9 terminals 5, 10 and ground.

Continuity should exist.

If OK, check harness for short to ground and short to power.

OK or NG

OK >> GO TO 5.

NG >> Repair open circuit or short to ground or short to power in harness or connectors.

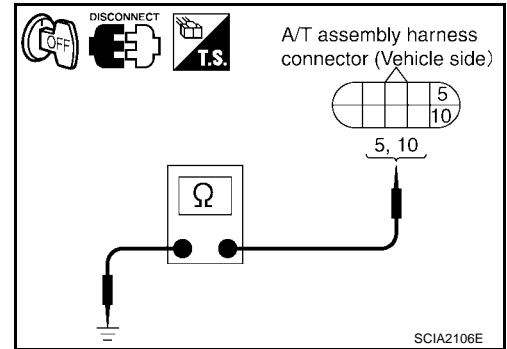

5. DETECT MALFUNCTIONING ITEM

Check the following items:

- The A/T assembly harness connector terminals for damage or loose connection with harness connector.

OK or NG

OK >> GO TO 6.

NG >> Repair or replace damaged parts.

6. PERFORM SELF-DIAGNOSIS

Perform self-diagnosis. Refer to [AT-86, "SELF-DIAGNOSTIC RESULT MODE"](#) .

OK or NG

OK >> **INSPECTION END**

NG-1 >> Self-diagnosis does not activate: GO TO 7.

NG-2 >> DTC is displayed: Check the malfunctioning system. Refer to [AT-86, "SELF-DIAGNOSTIC RESULT MODE"](#) .

MAIN POWER SUPPLY AND GROUND CIRCUIT

7. CHECK TERMINAL CORD ASSEMBLY

1. Remove control valve with TCM. Refer to [AT-225, "Control Valve With TCM and A/T Fluid Temperature Sensor 2"](#) .
2. Disconnect A/T assembly harness connector and TCM connector.
3. Check continuity between A/T assembly harness connector terminals and TCM connector terminals.

Item	Connector	Terminal	Continuity
A/T assembly harness connector	F9	1	Yes
TCM connector	F502	9	
A/T assembly harness connector	F9	2	Yes
TCM connector	F502	10	
A/T assembly harness connector	F9	6	Yes
TCM connector	F502	4	

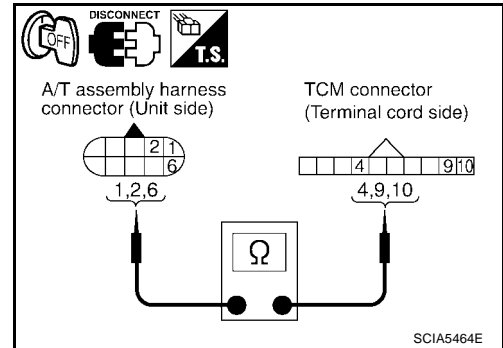

4. Check continuity between A/T assembly harness connector terminals and TCM connector terminals.

Item	Connector	Terminal	Continuity
A/T assembly harness connector	F9	5	Yes
TCM connector	F504	21	
A/T assembly harness connector	F9	10	Yes
TCM connector	F504	22	

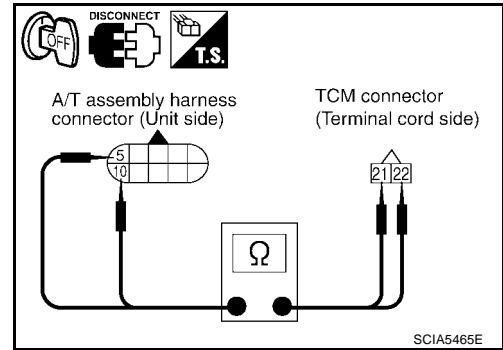

5. If OK, check harness for short to ground and short to power.

OK or NG

- OK >> Replace the control valve with TCM. Refer to [AT-225, "Control Valve With TCM and A/T Fluid Temperature Sensor 2"](#) .
- NG >> Replace open circuit or short to ground and short to power in harness or connectors.

CLOSED THROTTLE POSITION AND WIDE OPEN THROTTLE POSITION CIRCUIT

CLOSED THROTTLE POSITION AND WIDE OPEN THROTTLE POSITION CIRCUIT

PFP:18002

CONSULT-II Reference Value

ECS00H26

Item name	Condition	Display value
CLSD THL POS	Released accelerator pedal.	ON
	Fully depressed accelerator pedal.	OFF
W/O THL POS	Fully depressed accelerator pedal.	ON
	Released accelerator pedal.	OFF

Diagnostic Procedure

ECS00H27

1. CHECK CAN COMMUNICATION LINE

Perform the self-diagnosis. Refer to [AT-86, "SELF-DIAGNOSTIC RESULT MODE"](#) .

Is a malfunction in the CAN communication indicated in the results?

- YES >> Check CAN communication line. Refer to [AT-93, "DTC U1000 CAN COMMUNICATION LINE"](#) .
- NO >> GO TO 2.

2. CHECK THROTTLE POSITION SIGNAL CIRCUIT

With CONSULT-II

- Turn ignition switch "ON". (Do not start engine.)
- Select "ECU INPUT SIGNALS" in "DATA MONITOR" mode for "A/T" with CONSULT-II.
- Depress accelerator pedal and read out the value of "CLSD THL POS" and "W/O THL POS".

DATA MONITOR	
MONITOR	NO DTC
ACCELE POSI	0.0/8
THROTTLE POSI	0.0/8
CLSD THL POS	ON
W/O THL POS	OFF
BRAKE SW	OFF
▼	
RECORD	
MODE	BACK
LIGHT	COPY

PCIA0070E

Accelerator Pedal Operation	Monitor Item	
	CLSD THL POS	W/O THL POS
Released	ON	OFF
Fully depressed	OFF	ON

OK or NG

- OK >> **INSPECTION END**
- NG >> Check the following items. If NG, repair or replace damaged parts.
 - Perform the self-diagnosis for "ENGINE" with CONSULT-II.
 - Open circuit or short to ground or short to power in harness or connectors.
 - Pin terminals for damage or loose connection with harness connector.

BRAKE SIGNAL CIRCUIT

BRAKE SIGNAL CIRCUIT

PFP:25320

CONSULT-II Reference Value

ECS00H28

Item name	Condition	Display value
BRAKE SW	Depressed brake pedal.	ON
	Released brake pedal.	OFF

Diagnostic Procedure

ECS00H29

1. CHECK CAN COMMUNICATION LINE

Perform the self-diagnosis. Refer to [AT-86, "SELF-DIAGNOSTIC RESULT MODE"](#) .

Is a malfunction in the CAN communication indicated in the results?

- YES >> Check CAN communication line. Refer to [EC-161, "DTC U1000, U1001 CAN COMMUNICATION LINE"](#) .
- NO >> GO TO 2.

2. CHECK STOP LAMP SWITCH CIRCUIT

With CONSULT-II

- Turn ignition switch "ON". (Do not start engine.)
- Select "ECU INPUT SIGNALS" in "DATA MONITOR" mode for "A/T" with CONSULT-II.
- Read out ON/OFF switching action of the "BRAKE SW".

OK or NG

- OK >> **INSPECTION END**
- NG >> GO TO 3.

DATA MONITOR	
MONITOR	NO DTC
ACCELE POSI	0.0/8
THROTTLE POSI	0.0/8
CLSD THL POS	ON
W/O THL POS	OFF
BRAKE SW	OFF
▽	
RECORD	
MODE	BACK
LIGHT	COPY

PCIA0070E

3. CHECK STOP LAMP SWITCH

Check continuity between stop lamp switch terminals 1 and 2.

Condition	Continuity
When brake pedal is depressed	Yes
When brake pedal is released	No

Check stop lamp switch after adjusting brake pedal — refer to [BR-6, "BRAKE PEDAL"](#) .

OK or NG

- OK >> Check stop lamp switch circuit.
- NG >> Repair or replace stop lamp switch.

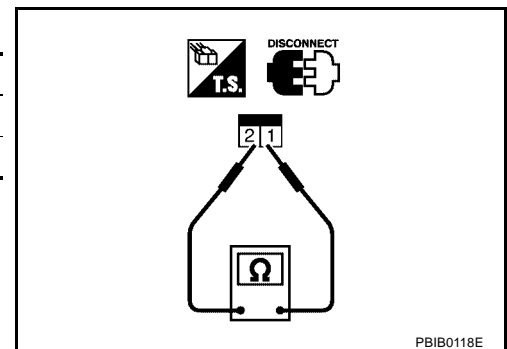

TOW MODE SWITCH

TOW MODE SWITCH

PFP:25129

Description

ECS00H2A

When tow mode switch is "ON", tow mode switch signals are sent to TCM from combination meter by CAN communication line. Then it's a tow mode condition.

A

B

AT

D

E

F

G

H

I

J

K

L

M

TOW MODE SWITCH

Wiring Diagram — AT — TMSW

ECS00H2B

AT-TMSW-01

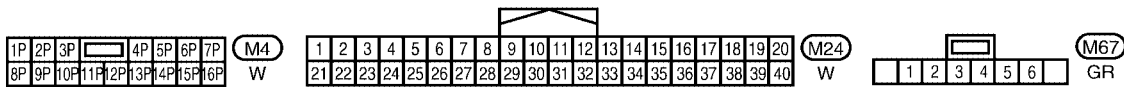
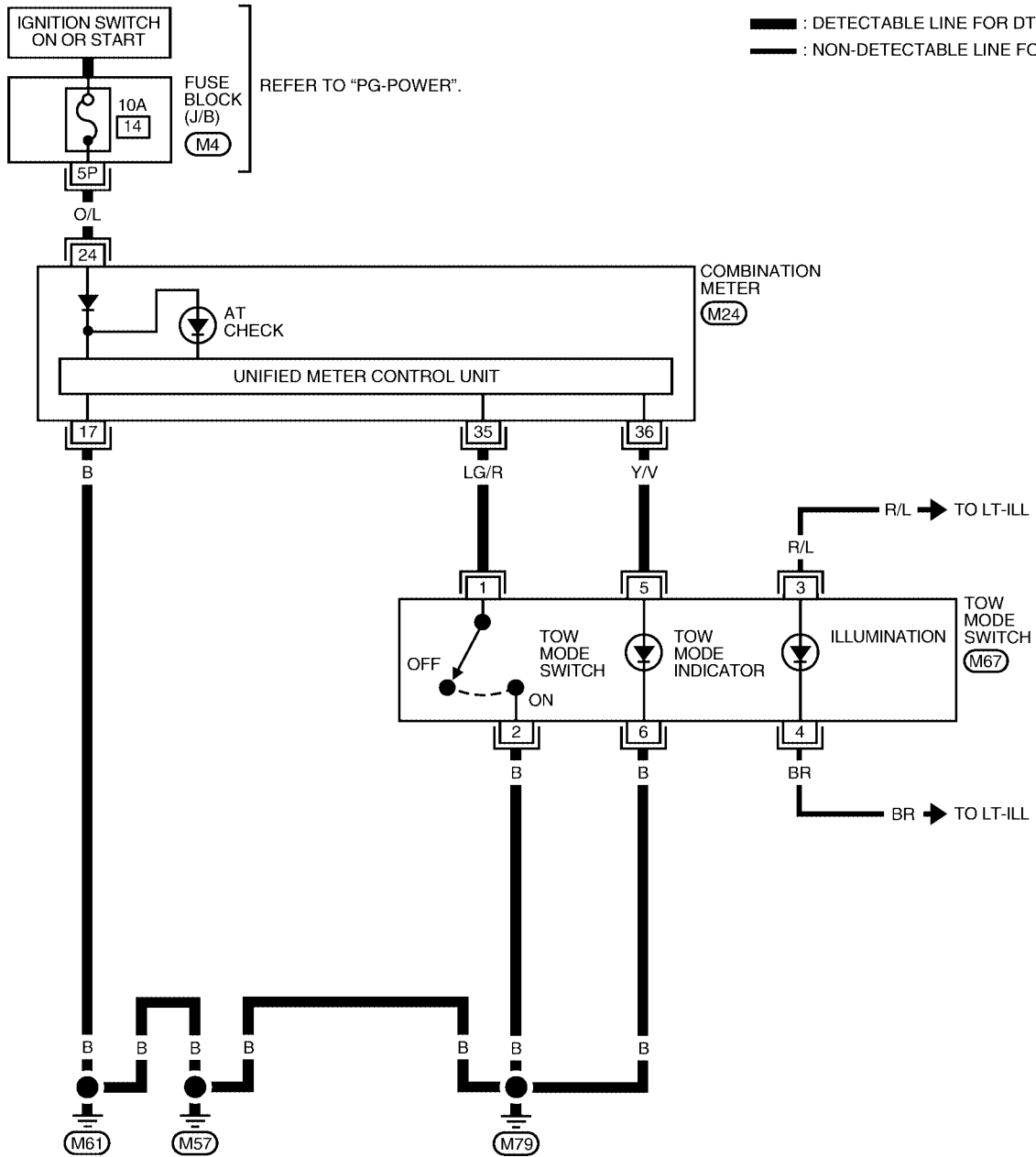

BCWA0505E

TOW MODE SWITCH

ECS00H2C

Diagnostic Procedure

1. CHECK CAN COMMUNICATION LINE

Perform the self-diagnosis. Refer to [AT-86, "SELF-DIAGNOSTIC RESULT MODE"](#) .

Is any malfunction in the CAN communication indicated in the results?

- YES >> Check CAN communication line. Refer to [AT-93, "DTC U1000 CAN COMMUNICATION LINE"](#) .
 NO >> GO TO 2.

2. CHECK POWER SOURCE

- Turn ignition switch "ON". (Do not start engine.)
- Check the voltage between tow mode switch connector M67 terminal 1 and ground.

Condition	Tow mode switch	Data (Approx.)
When ignition switch is turned to "ON"	ON	0V
	OFF	Battery voltage

OK or NG

- OK >> **INSPECTION END**
 NG >> GO TO 3.

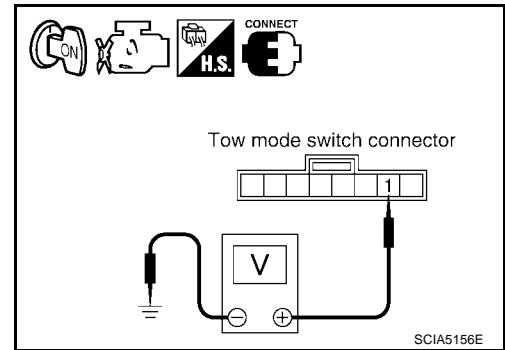

3. CHECK TOW MODE SWITCH

- Turn ignition switch "OFF".
- Disconnect tow mode switch connector.
- Check continuity between tow mode switch connector M67 terminals 1 and 2.

Condition	Continuity
Tow mode switch "ON"	Yes
Tow mode switch "OFF"	No

OK or NG

- OK >> GO TO 4.
 NG >> Repair or replace tow mode switch.

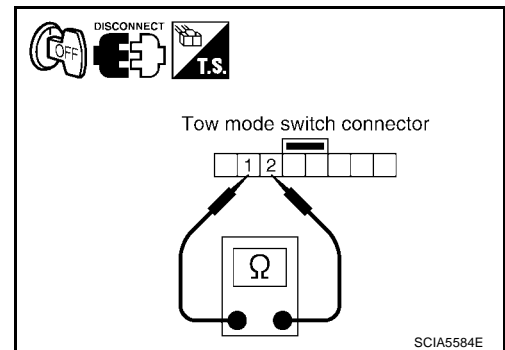

4. DETECT MALFUNCTIONING ITEM

Check the following items. If any items are damaged, repair or replace damaged parts.

- Harness for short or open between combination meter connector terminal 35 and tow mode switch connector terminal 1.
- Harness for short or open between tow mode switch connector terminal 2 and ground.

OK or NG

- OK >> GO TO 5.
 NG >> Repair or replace damaged parts.

5. CHECK COMBINATION METER

Check the combination meter. Refer to [DI-16, "How to Proceed With Trouble Diagnosis"](#) .

OK or NG

- OK >> **INSPECTION END**
 NO >> Repair or replace damaged parts.

TROUBLE DIAGNOSIS FOR SYMPTOMS

PF0:0007

TROUBLE DIAGNOSIS FOR SYMPTOMS

Wiring Diagram — AT — NONDTC

ECS00H2D

AT-NONDTC-01

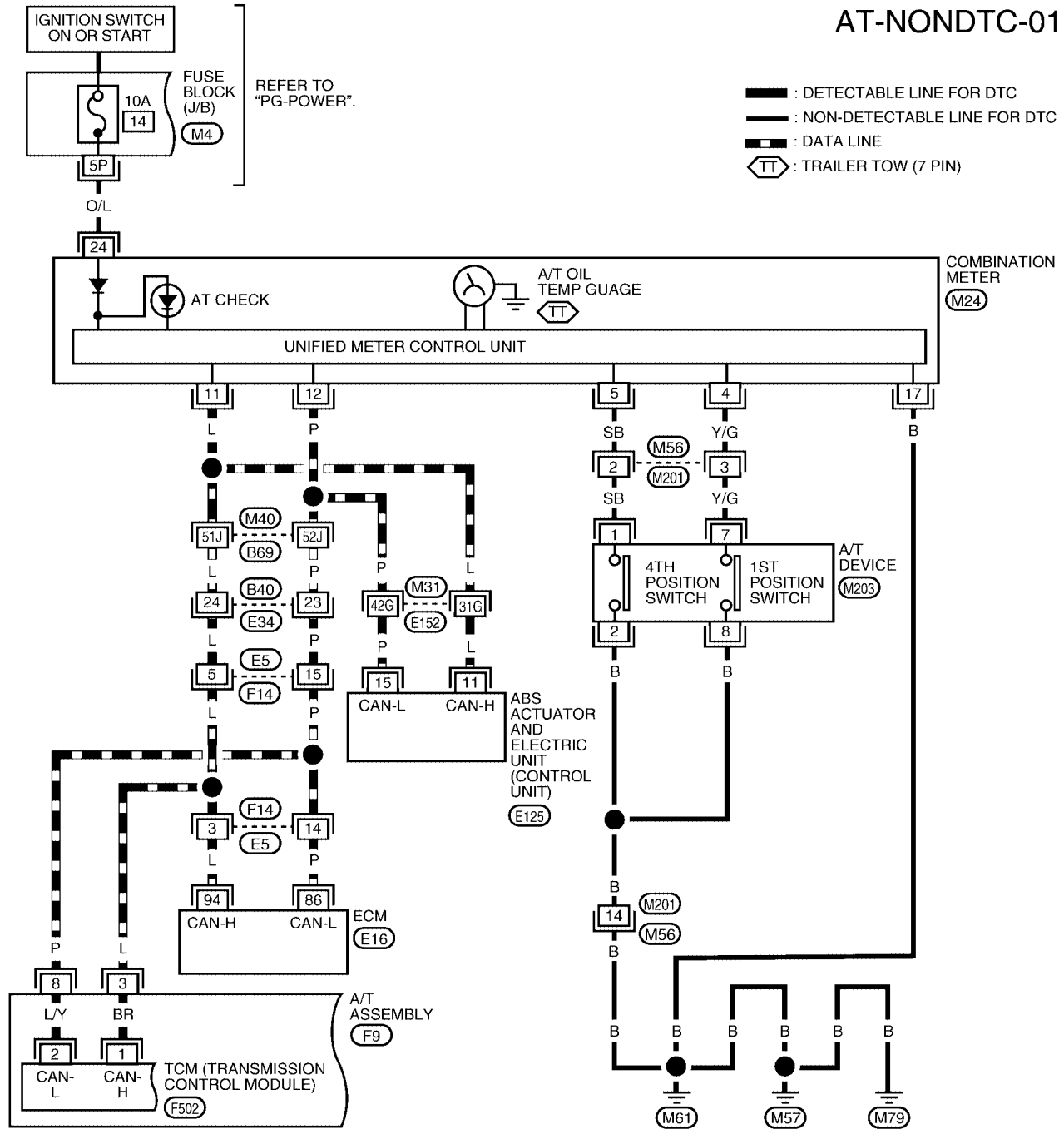

- : DETECTABLE LINE FOR DTC
- : NON-DETECTABLE LINE FOR DTC
- : DATA LINE
- TT : TRAILER TOW (7 PIN)

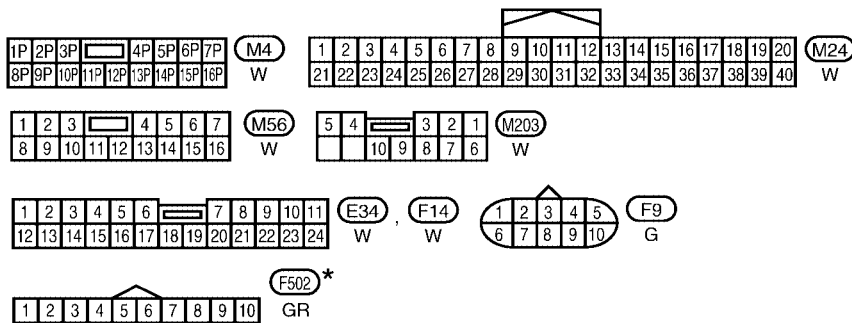

REFER TO THE FOLLOWING.
 (E16), (E125) - ELECTRICAL UNITS
 (M31), (M40) - SUPER MULTIPLE JUNCTION (SMJ)

*: THIS CONNECTOR IS NOT SHOWN IN "HARNESS LAYOUT" OF PG SECTION.

BCWA0506E

TROUBLE DIAGNOSIS FOR SYMPTOMS

AT-NONDTC-02

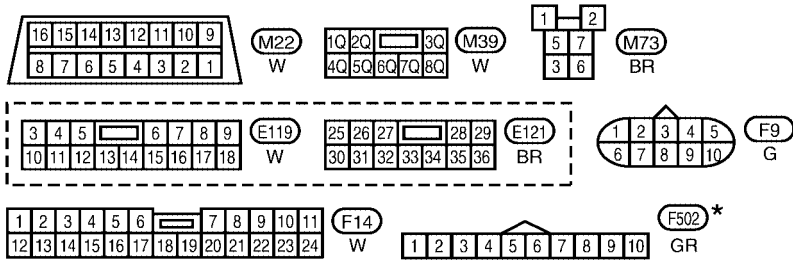
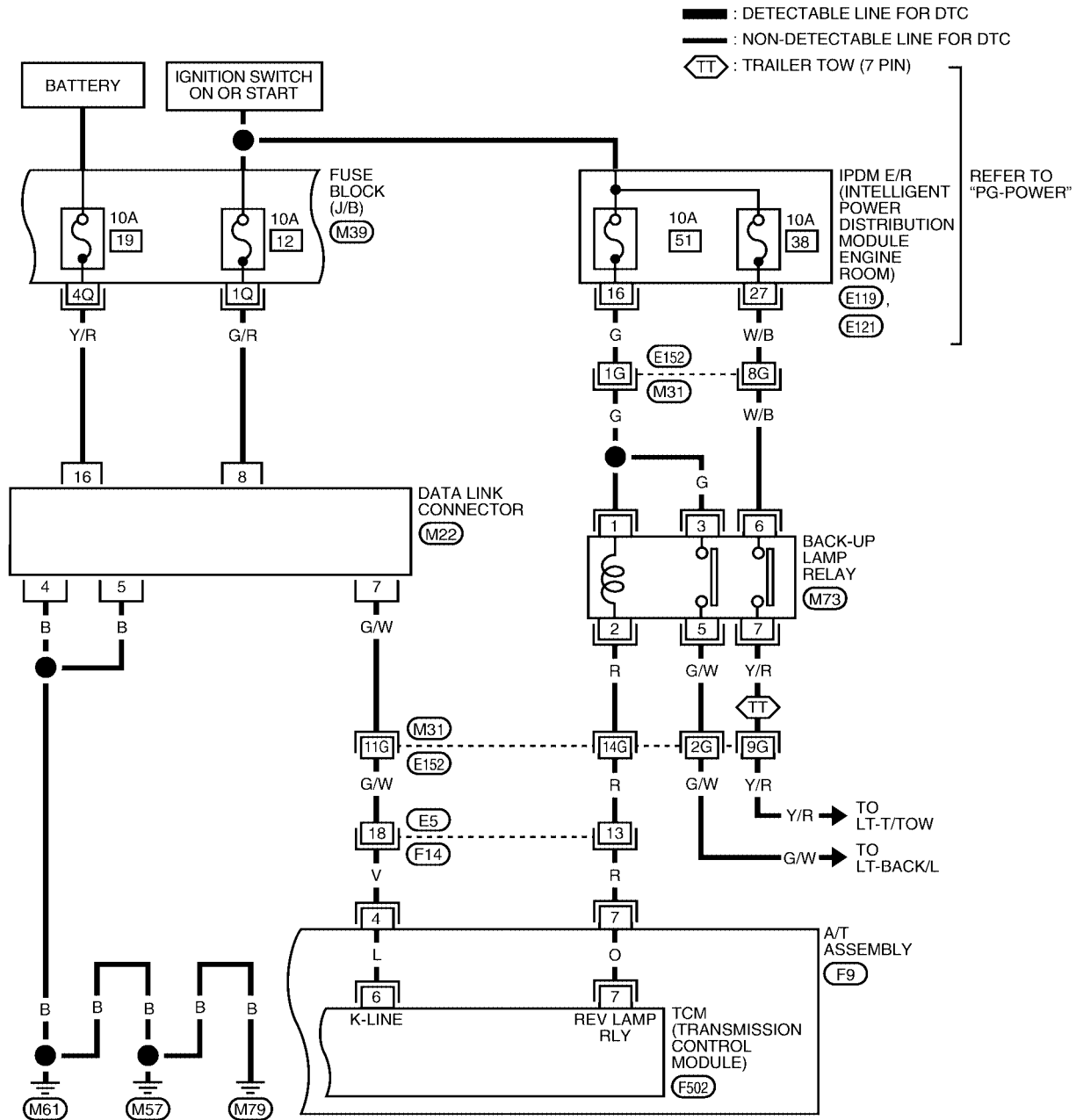

* : THIS CONNECTOR IS NOT SHOWN IN "HARNESS LAYOUT" OF PG SECTION.

BCWA0507E

TROUBLE DIAGNOSIS FOR SYMPTOMS

AT-NONDTC-03

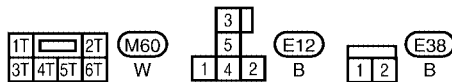
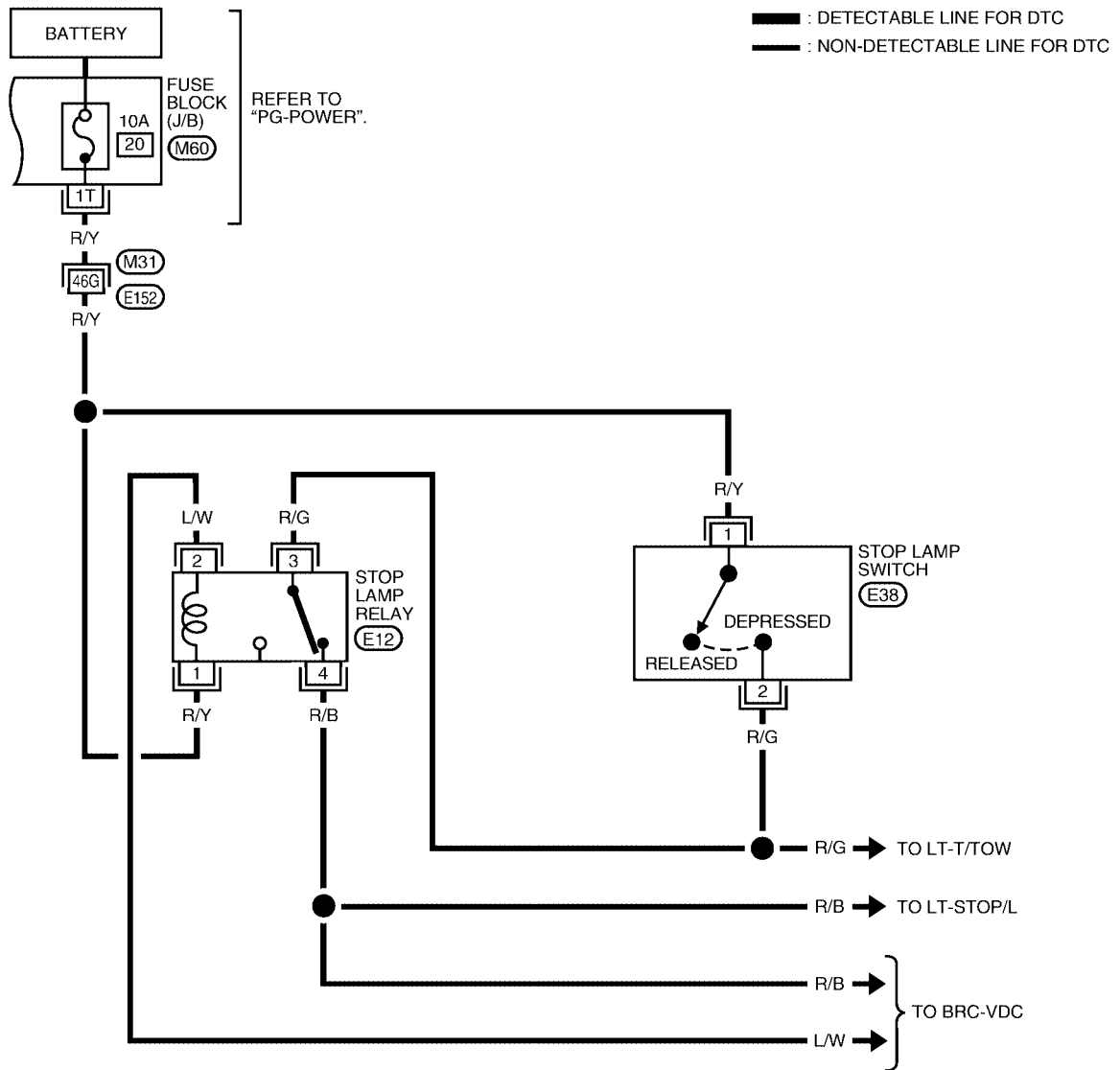

REFER TO THE FOLLOWING.
 M31 - SUPER MULTIPLE JUNCTION (SMJ)

BCWA0508E

TROUBLE DIAGNOSIS FOR SYMPTOMS

TCM INPUT/OUTPUT SIGNAL REFERENCE VALUES

Refer to [AT-83, "TCM Input/Output Signal Reference Values"](#) .

A/T CHECK Indicator Lamp Does Not Come On

ECS00H2E

SYMPTOM:

A/T CHECK indicator lamp does not come on for about 2 seconds when turning ignition switch to "ON".

DIAGNOSTIC PROCEDURE

1. CHECK CAN COMMUNICATION LINE

Perform the self-diagnosis. Refer to [AT-86, "SELF-DIAGNOSTIC RESULT MODE"](#) .

Is a malfunction in the CAN communication indicated in the results?

YES >> Check CAN communication line. Refer to [AT-93, "DTC U1000 CAN COMMUNICATION LINE"](#) .

NO >> GO TO 2.

2. CHECK A/T CHECK INDICATOR LAMP CIRCUIT

Check the combination meter. Refer to [DI-5, "COMBINATION METERS"](#) .

OK or NG

OK >> GO TO 3.

NG >> Repair or replace damaged parts.

3. CHECK TCM POWER SUPPLY AND GROUND CIRCUIT

Check TCM power supply and ground circuit. Refer to [AT-163, "MAIN POWER SUPPLY AND GROUND CIRCUIT"](#) .

OK or NG

OK >> **INSPECTION END**

NG >> Repair or replace damaged parts.

Engine Cannot Be Started In "P" or "N" Position

ECS00H2F

SYMPTOM:

- Engine cannot be started with selector lever in "P" or "N" position.
- Engine can be started with selector lever in "D" or "R" position.

DIAGNOSTIC PROCEDURE

1. CHECK SELF-DIAGNOSIS RESULTS

Perform self-diagnosis. Refer to [AT-86, "SELF-DIAGNOSTIC RESULT MODE"](#) .

Do the self-diagnosis results indicate PNP switch?

YES >> Check the malfunctioning system. Refer to [AT-101, "DTC P0705 PARK/NEUTRAL POSITION SWITCH"](#) .

NO >> GO TO 2.

2. CHECK CONTROL CABLE

Check the control cable.

- Refer to [AT-222, "Checking of A/T Position"](#) .

OK or NG

OK >> GO TO 3.

NG >> Adjust control cable. Refer to [AT-222, "Adjustment of A/T Position"](#) .

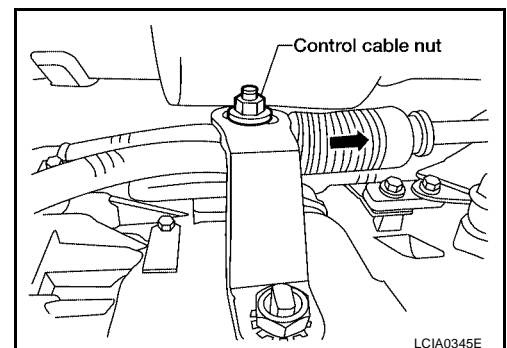

TROUBLE DIAGNOSIS FOR SYMPTOMS

3. CHECK STARTING SYSTEM

Check the starting system. Refer to [SC-10, "STARTING SYSTEM"](#) .

OK or NG

- OK >> **INSPECTION END**
- NG >> Repair or replace damaged parts.

In "P" Position, Vehicle Moves When Pushed SYMPTOM:

ECS00H2G

Even though the selector lever is set in the "P" position, the parking mechanism is not actuated, allowing the vehicle to be moved when it is pushed.

DIAGNOSTIC PROCEDURE

1. CHECK PNP SWITCH CIRCUIT

Perform self-diagnosis. Refer to [AT-86, "SELF-DIAGNOSTIC RESULT MODE"](#) .

Do the self-diagnosis results indicate PNP switch?

- YES >> Check the malfunctioning system. Refer to [AT-101, "DTC P0705 PARK/NEUTRAL POSITION SWITCH"](#) .
- NO >> GO TO 2.

2. CHECK CONTROL CABLE

Check the control cable.

- Refer to [AT-222, "Checking of A/T Position"](#) .

OK or NG

- OK >> GO TO 3.
- NG >> Adjust control cable. Refer to [AT-222, "Adjustment of A/T Position"](#) .

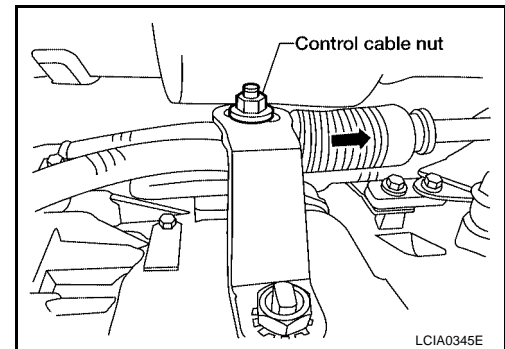

3. CHECK A/T FLUID CONDITION

1. Remove oil pan. Refer to [AT-225, "Control Valve With TCM and A/T Fluid Temperature Sensor 2"](#) .
2. Check A/T fluid condition. Refer to [AT-12, "Checking Automatic Transmission Fluid \(ATF\)"](#) .

OK or NG

- OK >> **INSPECTION END**
- NG >> GO TO 4.

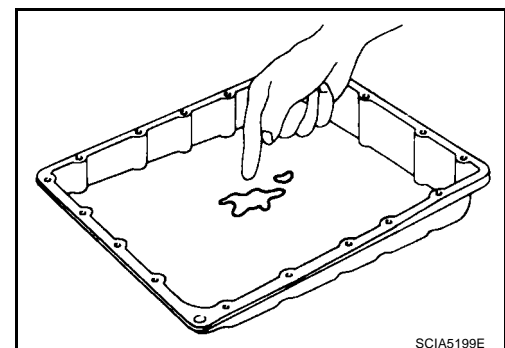

4. DETECT MALFUNCTIONING ITEM

- Check the malfunction items. If any items are damaged, repair or replace damaged parts. Refer to [AT-61, "Symptom Chart"](#) (Symptom No.58).

OK or NG

- OK >> **INSPECTION END**
- NG >> Repair or replace damaged parts.

TROUBLE DIAGNOSIS FOR SYMPTOMS

ECS00H2H

In "N" Position, Vehicle Moves

SYMPTOM:

Vehicle moves forward or backward when selecting "N" position.

DIAGNOSTIC PROCEDURE

1. CHECK PNP SWITCH CIRCUIT

Perform self-diagnosis. Refer to [AT-86, "SELF-DIAGNOSTIC RESULT MODE"](#) .

Do the self-diagnostic results indicate PNP switch?

YES >> Check the malfunctioning system. Refer to [AT-101, "DTC P0705 PARK/NEUTRAL POSITION SWITCH"](#) .

NO >> GO TO 2.

2. CHECK CONTROL CABLE

Check the control cable.

- Refer to [AT-222, "Checking of A/T Position"](#) .

OK or NG

OK >> GO TO 3.

NG >> Adjust control cable. Refer to [AT-222, "Adjustment of A/T Position"](#) .

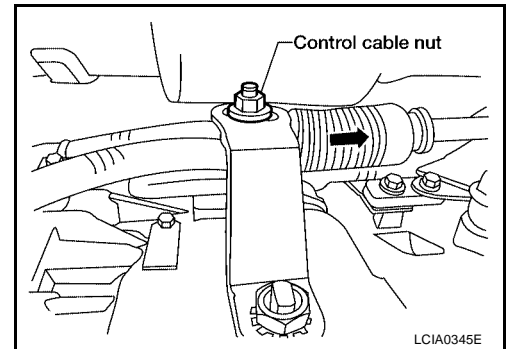

3. CHECK A/T FLUID LEVEL

Check A/T fluid level. Refer to [AT-12, "Checking Automatic Transmission Fluid \(ATF\)"](#) .

OK or NG

OK >> GO TO 4.

NG >> Refill ATF.

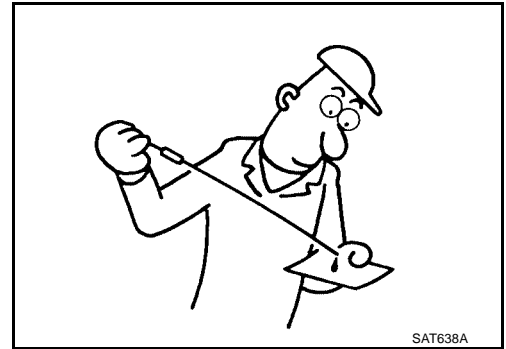

4. CHECK A/T FLUID CONDITION

1. Remove oil pan. Refer to [AT-225, "Control Valve With TCM and A/T Fluid Temperature Sensor 2"](#) .

2. Check A/T fluid condition. Refer to [AT-12, "Checking Automatic Transmission Fluid \(ATF\)"](#) .

OK or NG

OK >> GO TO 5.

NG >> Check the malfunction items. If any items are damaged, repair or replace damaged parts. Refer to [AT-61, "Symptom Chart"](#) (Symptom No.60).

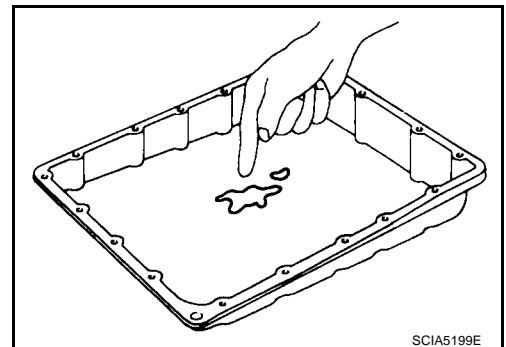

A
B
AT
D
E
F
G
H
I
J
K
L
M

TROUBLE DIAGNOSIS FOR SYMPTOMS

5. CHECK SYMPTOM

Check again. Refer to [AT-55, "Check at Idle"](#) .

OK or NG

- OK >> **INSPECTION END**
- NG >> GO TO 6.

6. PERFORM TCM INSPECTION

1. Perform TCM input/output signals inspection. Refer to [AT-83, "TCM Input/Output Signal Reference Values"](#) .
2. If NG, recheck A/T assembly harness connector terminals for damage or loose connection with harness connector.

OK or NG

- OK >> **INSPECTION END**
- NG >> Repair or replace damaged parts.

Large Shock("N" to "D" Position) SYMPTOM:

ECS00H2I

A noticeable shock occurs when the selector lever is shifted from the "N" to "D" position.

DIAGNOSTIC PROCEDURE

1. CHECK SELF-DIAGNOSTIC RESULTS

Perform self-diagnosis. Refer to [AT-86, "SELF-DIAGNOSTIC RESULT MODE"](#) .

Do the self-diagnostic results indicate A/T fluid temperature sensor, engine speed signal, accelerator pedal position sensor, ATF pressure switch 1, front brake solenoid valve, CAN communication line?

- YES >> Check the malfunctioning system. Refer to [AT-123, "DTC P1710 A/T FLUID TEMPERATURE SENSOR CIRCUIT"](#) , [AT-112, "DTC P0725 ENGINE SPEED SIGNAL"](#) , [AT-120, "DTC P1705 THROTTLE POSITION SENSOR"](#) , [AT-155, "DTC P1841 ATF PRESSURE SWITCH 1"](#) , [AT-139, "DTC P1757 FRONT BRAKE SOLENOID VALVE"](#) , [AT-93, "DTC U1000 CAN COMMUNICATION LINE"](#) .

- NO >> GO TO 2.

2. ENGINE IDLE SPEED

Check the engine idle speed. Refer to [EC-81, "Idle Speed and Ignition Timing Check"](#) .

OK or NG

- OK >> GO TO 3.
- NG >> Repair.

3. CHECK CONTROL CABLE

Check the control cable.

- Refer to [AT-222, "Checking of A/T Position"](#) .

OK or NG

- OK >> GO TO 4.
- NG >> Adjust control cable. Refer to [AT-222, "Adjustment of A/T Position"](#) .

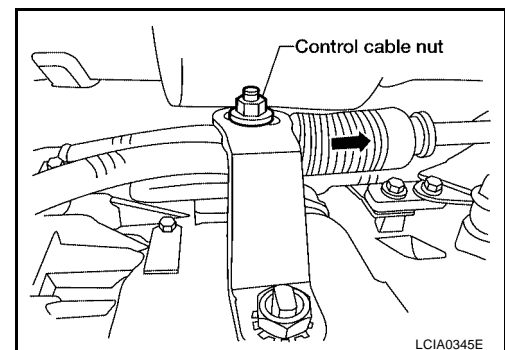

TROUBLE DIAGNOSIS FOR SYMPTOMS

4. CHECK A/T FLUID LEVEL

Check the A/T fluid level. Refer to [AT-12, "Checking Automatic Transmission Fluid \(ATF\)"](#) .

OK or NG

- OK >> GO TO 5.
- NG >> Refill ATF.

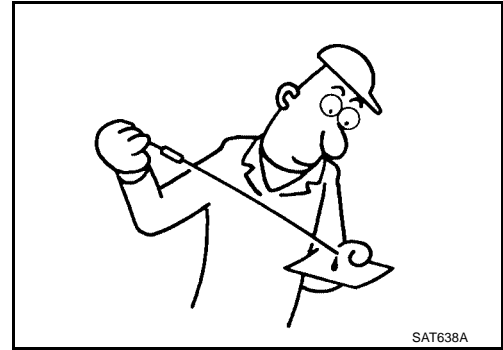

5. CHECK LINE PRESSURE

Check line pressure at idle with selector lever in "D" position. Refer to [AT-52, "LINE PRESSURE TEST"](#) .

OK or NG

- OK >> GO TO 8.
- NG - 1 >> Line pressure high: GO TO 6.
- NG - 2 >> Line pressure low: GO TO 7.

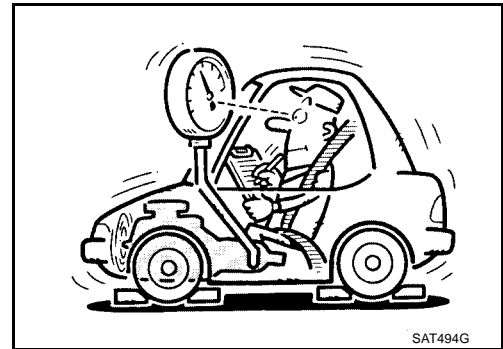

6. DETECT MALFUNCTIONING ITEM

1. Check control valve with TCM. Refer to [AT-225, "Control Valve With TCM and A/T Fluid Temperature Sensor 2"](#) .
2. Disassemble A/T. Refer to [AT-259, "Disassembly"](#) .
3. Check the following items:
 - Oil pump assembly. Refer to [AT-277, "Oil Pump"](#) .

OK or NG

- OK >> GO TO 8.
- NG >> Repair or replace damaged parts.

7. DETECT MALFUNCTIONING ITEM

1. Check control valve with TCM. Refer to [AT-225, "Control Valve With TCM and A/T Fluid Temperature Sensor 2"](#) .
2. Disassemble A/T. Refer to [AT-259, "Disassembly"](#) .
3. Check the following items:
 - Oil pump assembly. Refer to [AT-277, "Oil Pump"](#) .
 - Power train system. Refer to [AT-259, "Disassembly"](#) .
 - Transmission case. Refer to [AT-259, "Disassembly"](#) .

OK or NG

- OK >> GO TO 8.
- NG >> Repair or replace damaged parts.

A
B
AT
D
E
F
G
H
I
J
K
L
M

TROUBLE DIAGNOSIS FOR SYMPTOMS

8. CHECK A/T FLUID CONDITION

1. Remove oil pan. Refer to [AT-225, "Control Valve With TCM and A/T Fluid Temperature Sensor 2"](#) .
2. Check A/T fluid condition. Refer to [AT-12, "Checking Automatic Transmission Fluid \(ATF\)"](#) .

OK or NG

- OK >> GO TO 10.
- NG >> GO TO 9.

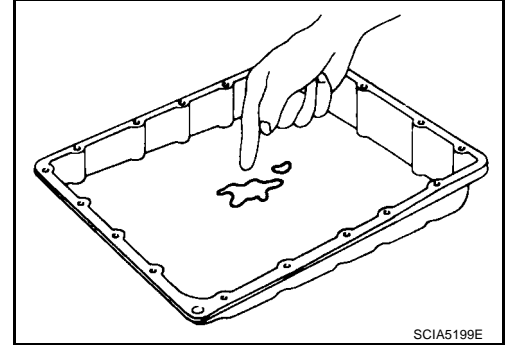

9. DETECT MALFUNCTIONING ITEM

- Check the malfunction items. If any items are damaged, repair or replace damaged parts. Refer to [AT-61, "Symptom Chart"](#) (Symptom No.1).

OK or NG

- OK >> GO TO 10.
- NG >> Repair or replace damaged parts.

10. CHECK SYMPTOM

Check again. Refer to [AT-55, "Check at Idle"](#) .

OK or NG

- OK >> **INSPECTION END**
- NG >> GO TO 11.

11. PERFORM TCM INSPECTION

1. Perform TCM input/output signals inspection. Refer to [AT-83, "TCM Input/Output Signal Reference Values"](#) .
2. If NG, recheck A/T assembly harness connector terminals for damage or loose connection with harness connector.

OK or NG

- OK >> **INSPECTION END**
- NG >> Repair or replace damaged parts.

TROUBLE DIAGNOSIS FOR SYMPTOMS

Vehicle Does Not Creep Backward In "R" Position

ECS00H2J

SYMPTOM:

The vehicle does not creep in the "R" position. Or an extreme lack of acceleration is observed.

DIAGNOSTIC PROCEDURE

1. CHECK SELF-DIAGNOSTIC RESULTS

Perform self-diagnosis. Refer to [AT-86, "SELF-DIAGNOSTIC RESULT MODE"](#) .

Do the self-diagnostic results indicate accelerator pedal position sensor, ATF pressure switch 6, high and low reverse clutch solenoid valve, CAN communication line, PNP switch?

YES >> Check the malfunctioning system. Refer to [AT-120, "DTC P1705 THROTTLE POSITION SENSOR"](#) , [AT-161, "DTC P1846 ATF PRESSURE SWITCH 6"](#) , [AT-147, "DTC P1767 HIGH AND LOW REVERSE CLUTCH SOLENOID VALVE"](#) , [AT-93, "DTC U1000 CAN COMMUNICATION LINE"](#) , [AT-101, "DTC P0705 PARK/NEUTRAL POSITION SWITCH"](#) .

NO >> GO TO 2.

2. CHECK CONTROL CABLE

Check the control cable.

- Refer to [AT-222, "Checking of A/T Position"](#) .

OK or NG

OK >> GO TO 3.

NG >> Adjust control cable. Refer to [AT-222, "Adjustment of A/T Position"](#) .

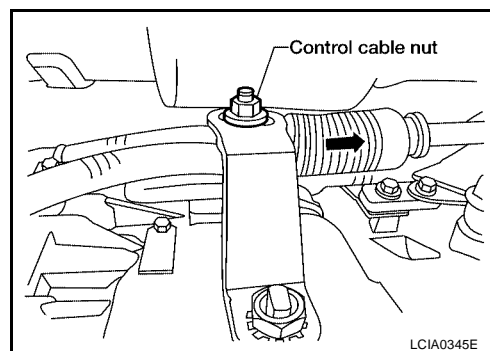

3. CHECK A/T FLUID LEVEL

Check A/T fluid level. Refer to [AT-12, "Checking Automatic Transmission Fluid \(ATF\)"](#) .

OK or NG

OK >> GO TO 4.

NG >> Refill ATF.

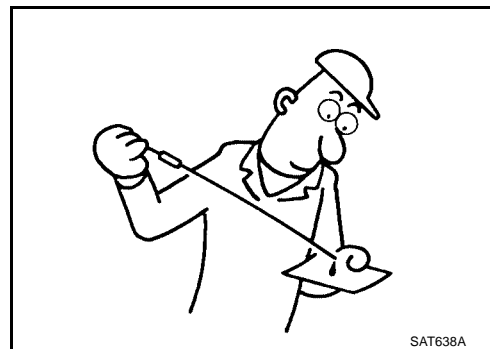

4. CHECK STALL TEST

Check stall revolution with selector lever in "1" and "R" positions. Refer to [AT-51, "STALL TEST"](#) .

OK or NG

OK >> GO TO 6.

OK in "1" position, NG in "R" position>>GO TO 5.

NG in both "1" and "R" positions>>GO TO 8.

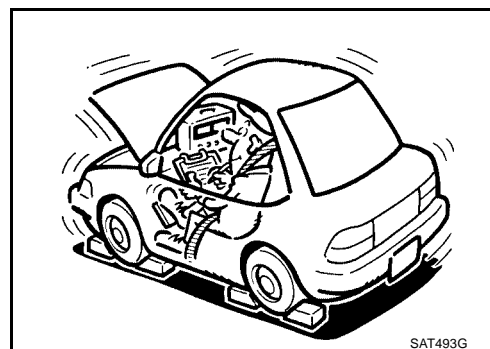

TROUBLE DIAGNOSIS FOR SYMPTOMS

5. DETECT MALFUNCTIONING ITEM

1. Disassemble A/T. Refer to [AT-259, "Disassembly"](#) .
2. Check the following items:
 - Reverse brake. Refer to [AT-259, "Disassembly"](#) .

OK or NG

- OK >> GO TO 9.
- NG >> Repair or replace damaged parts.

6. CHECK LINE PRESSURE

Check the line pressure with the engine idling. Refer to [AT-52, "LINE PRESSURE TEST"](#) .

OK or NG

- OK >> GO TO 9.
- NG - 1 >> Line pressure high. GO TO 7.
- NG - 2 >> Line pressure low. GO TO 8.

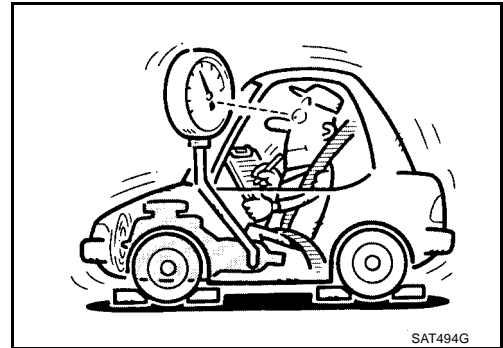

7. DETECT MALFUNCTIONING ITEM

1. Check control valve with TCM. Refer to [AT-225, "Control Valve With TCM and A/T Fluid Temperature Sensor 2"](#) .
2. Disassemble A/T. Refer to [AT-259, "Disassembly"](#) .
3. Check the following items:
 - Oil pump assembly. Refer to [AT-277, "Oil Pump"](#) .

OK or NG

- OK >> GO TO 9.
- NG >> Repair or replace damaged parts.

8. DETECT MALFUNCTIONING ITEM

1. Check control valve with TCM. Refer to [AT-225, "Control Valve With TCM and A/T Fluid Temperature Sensor 2"](#) .
2. Disassemble A/T. Refer to [AT-259, "Disassembly"](#) .
3. Check the following items:
 - Oil pump assembly. Refer to [AT-277, "Oil Pump"](#) .
 - Power train system. Refer to [AT-259, "Disassembly"](#) .
 - Transmission case. Refer to [AT-259, "Disassembly"](#) .

OK or NG

- OK >> GO TO 9.
- NG >> Repair or replace damaged parts.

TROUBLE DIAGNOSIS FOR SYMPTOMS

9. CHECK A/T FLUID CONDITION

1. Remove oil pan. Refer to [AT-225, "Control Valve With TCM and A/T Fluid Temperature Sensor 2"](#) .
2. Check A/T fluid condition. Refer to [AT-51, "Fluid Condition Check"](#) .

OK or NG

- OK >> GO TO 10.
- NG >> GO TO 13.

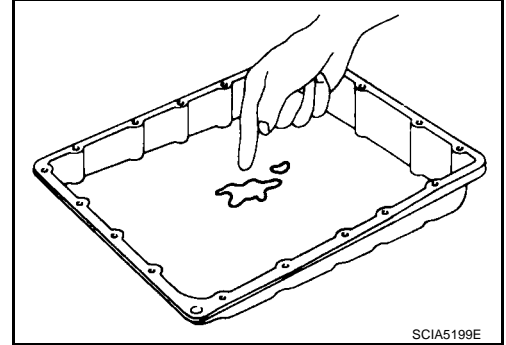

10. DETECT MALFUNCTIONING ITEM

- Check the malfunction items. If any items are damaged, repair or replace damaged parts. Refer to [AT-61, "Symptom Chart"](#) (Symptom No.43).

OK or NG

- OK >> GO TO 11.
- NG >> Repair or replace damaged parts.

11. CHECK SYMPTOM

Check again. Refer to [AT-55, "Check at Idle"](#) .

OK or NG

- OK >> **INSPECTION END**
- NG >> GO TO 12.

12. PERFORM TCM INSPECTION

1. Perform TCM input/output signals inspection. Refer to [AT-83, "TCM Input/Output Signal Reference Values"](#) .
2. If NG, recheck A/T assembly harness connector terminals for damage or loose connection with harness connector.

OK or NG

- OK >> **INSPECTION END**
- NG >> Repair or replace damaged parts.

13. DETECT MALFUNCTIONING ITEM

- Check the malfunction items. If any items are damaged, repair or replace damaged parts. Refer to [AT-61, "Symptom Chart"](#) (Symptom No.43).

OK or NG

- OK >> GO TO 11.
- NG >> Repair or replace damaged parts.

TROUBLE DIAGNOSIS FOR SYMPTOMS

ECS00H2K

Vehicle Does Not Creep Forward In "D" Position

SYMPTOM:

Vehicle does not creep forward when selecting "D" position.

DIAGNOSTIC PROCEDURE

1. CHECK SELF-DIAGNOSTIC RESULTS

Perform self-diagnosis. Refer to [AT-86, "SELF-DIAGNOSTIC RESULT MODE"](#) .

Do the self-diagnostic results indicate accelerator pedal position sensor, CAN communication line, PNP switch?

YES >> Check the malfunctioning system. Refer to [AT-120, "DTC P1705 THROTTLE POSITION SENSOR"](#) , [AT-93, "DTC U1000 CAN COMMUNICATION LINE"](#) , [AT-101, "DTC P0705 PARK/NEUTRAL POSITION SWITCH"](#) .

NO >> GO TO 2.

2. CHECK CONTROL CABLE

Check the control cable.

● Refer to [AT-222, "Checking of A/T Position"](#) .

OK or NG

OK >> GO TO 3.

NG >> Adjust control cable. Refer to [AT-222, "Adjustment of A/T Position"](#) .

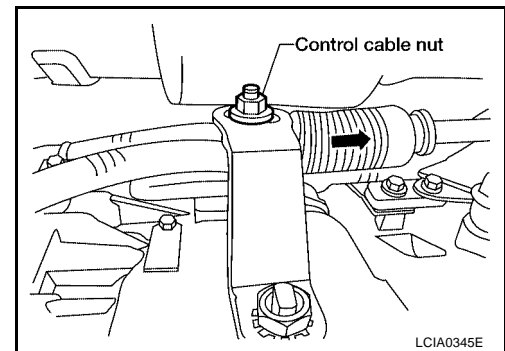

3. CHECK A/T FLUID LEVEL

Check A/T fluid level. Refer to [AT-12, "Checking Automatic Transmission Fluid \(ATF\)"](#) .

OK or NG

OK >> GO TO 4.

NG >> Refill ATF.

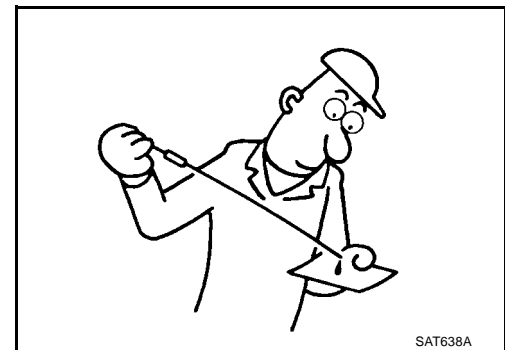

4. CHECK STALL TEST

Check stall revolution with selector lever in "D" position. Refer to [AT-51, "STALL TEST"](#) .

OK or NG

OK >> GO TO 5.

NG >> GO TO 7.

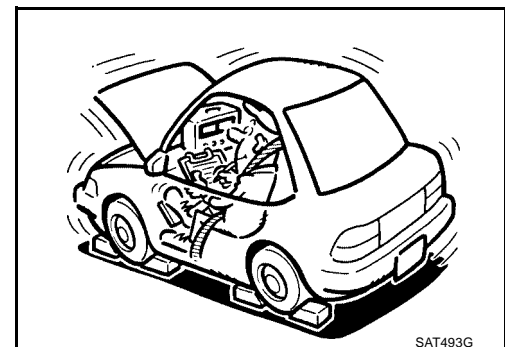

TROUBLE DIAGNOSIS FOR SYMPTOMS

5. CHECK LINE PRESSURE

Check line pressure at idle with selector lever in "D" position. Refer to [AT-52, "LINE PRESSURE TEST"](#) .

OK or NG

- OK >> GO TO 8.
- NG - 1 >> Line pressure high. GO TO 6.
- NG - 2 >> Line pressure low. GO TO 7.

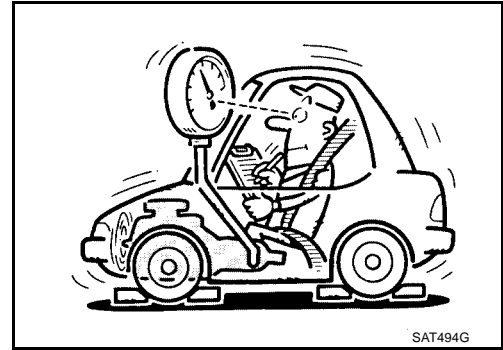

6. DETECT MALFUNCTIONING ITEM

1. Check control valve with TCM. Refer to [AT-225, "Control Valve With TCM and A/T Fluid Temperature Sensor 2"](#) .
2. Disassemble A/T. Refer to [AT-259, "Disassembly"](#) .
3. Check the following items:
 - Oil pump assembly. Refer to [AT-277, "Oil Pump"](#) .

OK or NG

- OK >> GO TO 8.
- NG >> Repair or replace damaged parts.

7. DETECT MALFUNCTIONING ITEM

1. Check control valve with TCM. Refer to [AT-225, "Control Valve With TCM and A/T Fluid Temperature Sensor 2"](#) .
2. Disassemble A/T. Refer to [AT-259, "Disassembly"](#) .
3. Check the following items:
 - Oil pump assembly. Refer to [AT-277, "Oil Pump"](#) .
 - Power train system. Refer to [AT-259, "Disassembly"](#) .
 - Transmission case. Refer to [AT-259, "Disassembly"](#) .

OK or NG

- OK >> GO TO 8.
- NG >> Repair or replace damaged parts.

8. CHECK A/T FLUID CONDITION

1. Remove oil pan. Refer to [AT-225, "Control Valve With TCM and A/T Fluid Temperature Sensor 2"](#) .
2. Check A/T fluid condition. Refer to [AT-51, "Fluid Condition Check"](#) .

OK or NG

- OK >> GO TO 9.
- NG >> GO TO 12.

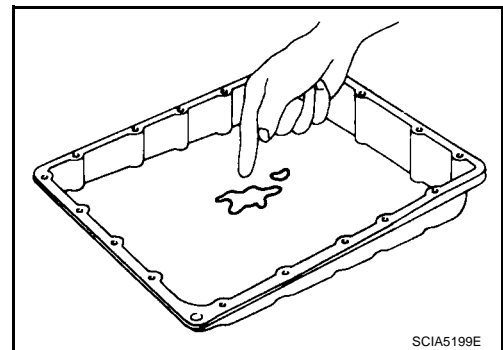

TROUBLE DIAGNOSIS FOR SYMPTOMS

9. DETECT MALFUNCTIONING ITEM

- Check the malfunction items. If any items are damaged, repair or replace damaged parts. Refer to [AT-61, "Symptom Chart"](#) (Symptom No.43).

OK or NG

- OK >> GO TO 10.
NG >> Repair or replace damaged parts.

10. CHECK SYMPTOM

Check again. Refer to [AT-55, "Check at Idle"](#) .

OK or NG

- OK >> **INSPECTION END**
NG >> GO TO 11.

11. PERFORM TCM INSPECTION

1. Perform TCM input/output signals inspection. Refer to [AT-83, "TCM Input/Output Signal Reference Values"](#) .
2. If NG, recheck A/T assembly harness connector terminals for damage or loose connection with harness connector.

OK or NG

- OK >> **INSPECTION END**
NG >> Repair or replace damaged parts.

12. DETECT MALFUNCTIONING ITEM

- Check the malfunction items. If any items are damaged, repair or replace damaged parts. Refer to [AT-61, "Symptom Chart"](#) (Symptom No.43).

OK or NG

- OK >> GO TO 10.
NG >> Repair or replace damaged parts.

Vehicle Cannot Be Started From D1 SYMPTOM:

ECS00H2L

Vehicle cannot be started from D1 on cruise test - Part 1.

DIAGNOSTIC PROCEDURE

1. CONFIRM THE SYMPTOM

Check if vehicle creeps in "R" position.

OK or NG

- OK >> GO TO 2.
NG >> Refer to [AT-181, "Vehicle Does Not Creep Backward In "R" Position"](#) .

2. CHECK SELF-DIAGNOSTIC RESULTS

Perform self-diagnosis. Refer to [AT-86, "SELF-DIAGNOSTIC RESULT MODE"](#) .

Is any malfunction detected by self-diagnostic results?

- YES >> Check the malfunctioning system.
NO >> GO TO 3.

TROUBLE DIAGNOSIS FOR SYMPTOMS

3. CHECK ACCELERATOR PEDAL POSITION(APP) SENSOR

Check accelerator pedal position (APP) sensor. Refer to [AT-120, "DTC P1705 THROTTLE POSITION SENSOR"](#) .

OK or NG

- OK >> GO TO 4.
- NG >> Repair or replace accelerator pedal position (APP) sensor.

4. CHECK A/T FLUID LEVEL

Check A/T fluid level. Refer to [AT-12, "Checking Automatic Transmission Fluid \(ATF\)"](#) .

OK or NG

- OK >> GO TO 5.
- NG >> Refill ATF.

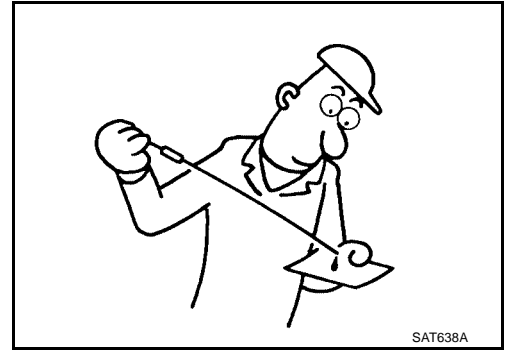

5. CHECK LINE PRESSURE

Check line pressure at the engine stall point. Refer to [AT-52, "LINE PRESSURE TEST"](#) .

OK or NG

- OK >> GO TO 8.
- NG - 1 >> Line pressure high. GO TO 6.
- NG - 2 >> Line pressure low. GO TO 7.

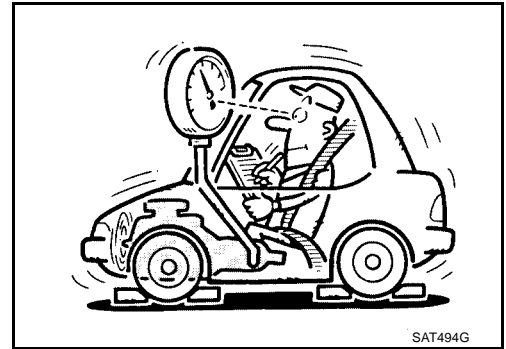

6. DETECT MALFUNCTIONING ITEM

1. Check control valve with TCM. Refer to [AT-225, "Control Valve With TCM and A/T Fluid Temperature Sensor 2"](#) .
2. Disassemble A/T. Refer to [AT-259, "Disassembly"](#) .
3. Check the following items:
 - Oil pump assembly. Refer to [AT-277, "Oil Pump"](#) .

OK or NG

- OK >> GO TO 8.
- NG >> Repair or replace damaged parts.

TROUBLE DIAGNOSIS FOR SYMPTOMS

7. DETECT MALFUNCTIONING ITEM

1. Check control valve with TCM. Refer to [AT-225, "Control Valve With TCM and A/T Fluid Temperature Sensor 2"](#) .
2. Disassemble A/T. Refer to [AT-259, "Disassembly"](#) .
3. Check the following items:
 - Oil pump assembly. Refer to [AT-277, "Oil Pump"](#) .
 - Power train system. Refer to [AT-259, "Disassembly"](#) .
 - Transmission case. Refer to [AT-259, "Disassembly"](#) .

OK or NG

- OK >> GO TO 8.
NG >> Repair or replace damaged parts.

8. CHECK A/T FLUID CONDITION

1. Remove oil pan. Refer to [AT-225, "Control Valve With TCM and A/T Fluid Temperature Sensor 2"](#) .
2. Check A/T fluid condition. Refer to [AT-51, "Fluid Condition Check"](#) .

OK or NG

- OK >> GO TO 9.
NG >> GO TO 12.

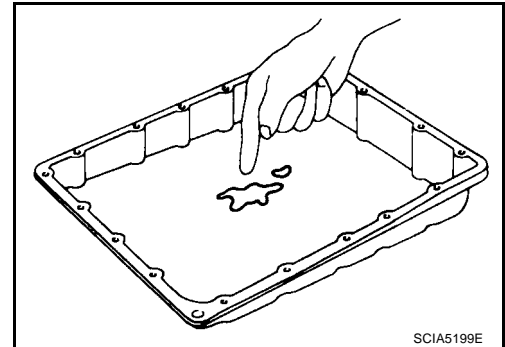

9. DETECT MALFUNCTIONING ITEM

- Check the malfunction items. If any items are damaged, repair or replace damaged parts. Refer to [AT-61, "Symptom Chart"](#) (Symptom No.23).

OK or NG

- OK >> GO TO 10.
NG >> Repair or replace damaged parts.

10. CHECK SYMPTOM

Check again. Refer to [AT-56, "Cruise Test - Part 1"](#) , [AT-58, "Cruise Test - Part 2"](#) .

OK or NG

- OK >> **INSPECTION END**
NG >> GO TO 11.

11. PERFORM TCM INSPECTION

1. Perform TCM input/output signals inspection. Refer to [AT-83, "TCM Input/Output Signal Reference Values"](#) .
2. If NG, recheck A/T assembly harness connector terminals for damage or loose connection with harness connector.

OK or NG

- OK >> **INSPECTION END**
NG >> Repair or replace damaged parts.

TROUBLE DIAGNOSIS FOR SYMPTOMS

12. DETECT MALFUNCTIONING ITEM

- Check the malfunction items. If any items are damaged, repair or replace damaged parts. Refer to [AT-61, "Symptom Chart"](#) (Symptom No.23).

OK or NG

- OK >> GO TO 10.
- NG >> Repair or replace damaged parts.

A/T Does Not Shift: D1 → D2

SYMPTOM:

The vehicle does not shift-up from the D1 to D2 gear at the specified speed.

DIAGNOSTIC PROCEDURE

1. CONFIRM THE SYMPTOM

Check if vehicle creeps forward in "D" position and vehicle can be started from D1.

OK or NG

- OK >> GO TO 2.
- NG >> Refer to [AT-184, "Vehicle Does Not Creep Forward In "D" Position"](#) , [AT-186, "Vehicle Cannot Be Started From D1"](#) .

2. CHECK SELF-DIAGNOSTIC RESULTS

Perform self-diagnosis. Refer to [AT-86, "SELF-DIAGNOSTIC RESULT MODE"](#) .

Do the self-diagnostic results indicate ATF pressure switch 5, direct clutch solenoid valve, accelerator pedal position sensor, vehicle speed sensor A/T (revolution sensor) and vehicle speed sensor MTR?

- YES >> Check the malfunctioning system. Refer to [AT-159, "DTC P1845 ATF PRESSURE SWITCH 5"](#) , [AT-143, "DTC P1762 DIRECT CLUTCH SOLENOID VALVE"](#) , [AT-120, "DTC P1705 THROTTLE POSITION SENSOR"](#) , [AT-107, "DTC P0720 VEHICLE SPEED SENSOR A/T \(REVOLUTION SENSOR\)"](#) , [AT-128, "DTC P1721 VEHICLE SPEED SENSOR MTR"](#) .
- NO >> GO TO 3.

3. CHECK A/T FLUID LEVEL

Check A/T fluid level. Refer to [AT-12, "Checking Automatic Transmission Fluid \(ATF\)"](#) .

OK or NG

- OK >> GO TO 4.
- NG >> Refill ATF.

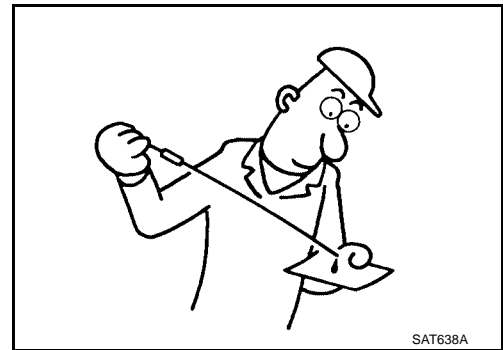

4. CHECK LINE PRESSURE

Check line pressure at the engine stall point. Refer to [AT-52, "LINE PRESSURE TEST"](#) .

OK or NG

- OK >> GO TO 7.
- NG - 1 >> Line pressure high. GO TO 5.
- NG - 2 >> Line pressure low. GO TO 6.

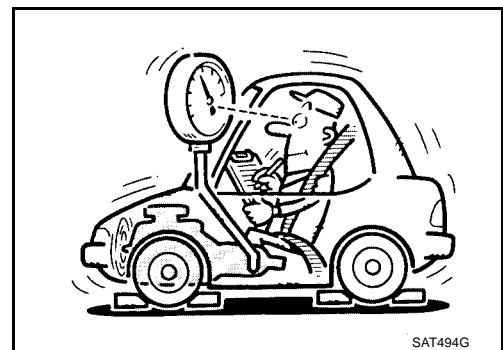

TROUBLE DIAGNOSIS FOR SYMPTOMS

5. DETECT MALFUNCTIONING ITEM

1. Check control valve with TCM. Refer to [AT-225, "Control Valve With TCM and A/T Fluid Temperature Sensor 2"](#) .
2. Disassemble A/T. Refer to [AT-259, "Disassembly"](#) .
3. Check the following items:
 - Oil pump assembly. Refer to [AT-277, "Oil Pump"](#) .

OK or NG

- OK >> GO TO 7.
- NG >> Repair or replace damaged parts.

6. DETECT MALFUNCTIONING ITEM

1. Check control valve with TCM. Refer to [AT-225, "Control Valve With TCM and A/T Fluid Temperature Sensor 2"](#) .
2. Disassemble A/T. Refer to [AT-259, "Disassembly"](#) .
3. Check the following items:
 - Oil pump assembly. Refer to [AT-277, "Oil Pump"](#) .
 - Power train system. Refer to [AT-259, "Disassembly"](#) .
 - Transmission case. Refer to [AT-259, "Disassembly"](#) .

OK or NG

- OK >> GO TO 7.
- NG >> Repair or replace damaged parts.

7. CHECK A/T FLUID CONDITION

1. Remove oil pan. Refer to [AT-225, "Control Valve With TCM and A/T Fluid Temperature Sensor 2"](#) .
2. Check A/T fluid condition. Refer to [AT-51, "Fluid Condition Check"](#) .

OK or NG

- OK >> GO TO 8.
- NG >> GO TO 11.

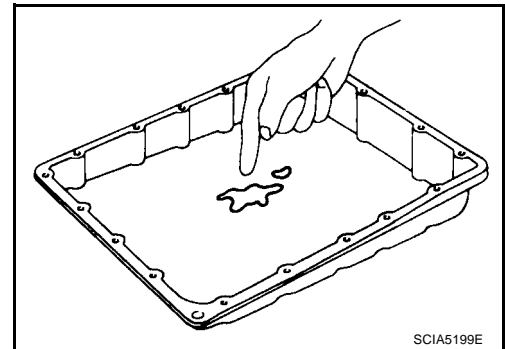

SCIA5199E

8. DETECT MALFUNCTIONING ITEM

- Check the malfunction items. If any items are damaged, repair or replace damaged parts. Refer to [AT-61, "Symptom Chart"](#) (Symptom No.10).

OK or NG

- OK >> GO TO 9.
- NG >> Repair or replace damaged parts.

9. CHECK SYMPTOM

Check again. Refer to [AT-56, "Cruise Test - Part 1"](#) , [AT-58, "Cruise Test - Part 2"](#) .

OK or NG

- OK >> **INSPECTION END**
- NG >> GO TO 10.

TROUBLE DIAGNOSIS FOR SYMPTOMS

10. PERFORM TCM INSPECTION

1. Perform TCM input/output signals inspection. Refer to [AT-83, "TCM Input/Output Signal Reference Values"](#) .
2. If NG, recheck A/T assembly harness connector terminals for damage or loose connection with harness connector.

OK or NG

- OK >> **INSPECTION END**
NG >> Repair or replace damaged parts.

11. DETECT MALFUNCTIONING ITEM

- Check the malfunction items. If any items are damaged, repair or replace damaged parts. Refer to [AT-61, "Symptom Chart"](#) (Symptom No.10).

OK or NG

- OK >> GO TO 9.
NG >> Repair or replace damaged parts.

A/T Does Not Shift: D2 → D3

ECS00H2N

SYMPTOM:

The vehicle does not shift-up from D2 to D3 gear at the specified speed.

DIAGNOSTIC PROCEDURE

1. CONFIRM THE SYMPTOM

Check if vehicle creeps forward in "D" position and vehicle can be started from D1.

OK or NG

- OK >> GO TO 2.
NG >> Refer to [AT-184, "Vehicle Does Not Creep Forward In "D" Position"](#) , [AT-186, "Vehicle Cannot Be Started From D1"](#) .

2. CHECK SELF-DIAGNOSTIC RESULTS

Perform self-diagnosis. Refer to [AT-86, "SELF-DIAGNOSTIC RESULT MODE"](#) .

Do the self-diagnostic results indicate ATF pressure switch 6, high and low reverse clutch solenoid valve, accelerator pedal position sensor, vehicle speed sensor A/T (revolution sensor) and vehicle speed sensor MTR?

- YES >> Check the malfunctioning system. Refer to [AT-161, "DTC P1846 ATF PRESSURE SWITCH 6"](#) , [AT-147, "DTC P1767 HIGH AND LOW REVERSE CLUTCH SOLENOID VALVE"](#) , [AT-120, "DTC P1705 THROTTLE POSITION SENSOR"](#) , [AT-107, "DTC P0720 VEHICLE SPEED SENSOR A/T \(REVOLUTION SENSOR\)"](#) , [AT-128, "DTC P1721 VEHICLE SPEED SENSOR MTR"](#) .
- NO >> GO TO 3.

3. CHECK A/T FLUID LEVEL

Check A/T fluid level. Refer to [AT-12, "Checking Automatic Transmission Fluid \(ATF\)"](#) .

OK or NG

- OK >> GO TO 4.
NG >> Refill ATF.

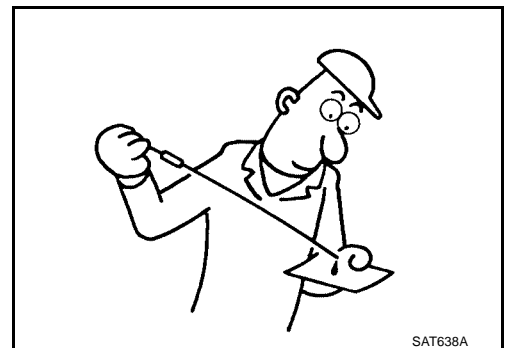

TROUBLE DIAGNOSIS FOR SYMPTOMS

4. CHECK LINE PRESSURE

Check line pressure at the engine stall point. Refer to [AT-52, "LINE PRESSURE TEST"](#) .

OK or NG

- OK >> GO TO 7.
- NG - 1 >> Line pressure high. GO TO 5.
- NG - 2 >> Line pressure low. GO TO 6.

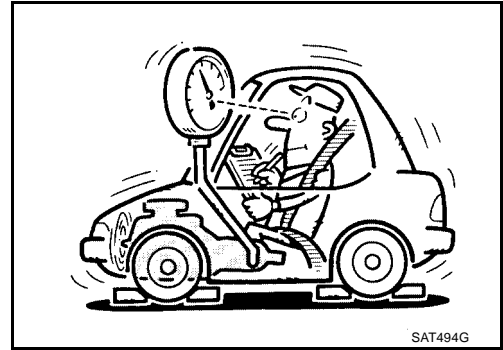

5. DETECT MALFUNCTIONING ITEM

1. Check control valve with TCM. Refer to [AT-225, "Control Valve With TCM and A/T Fluid Temperature Sensor 2"](#) .
2. Disassemble A/T. Refer to [AT-259, "Disassembly"](#) .
3. Check the following items:
 - Oil pump assembly. Refer to [AT-277, "Oil Pump"](#) .

OK or NG

- OK >> GO TO 7.
- NG >> Repair or replace damaged parts.

6. DETECT MALFUNCTIONING ITEM

1. Check control valve with TCM. Refer to [AT-225, "Control Valve With TCM and A/T Fluid Temperature Sensor 2"](#) .
2. Disassemble A/T. Refer to [AT-259, "Disassembly"](#) .
3. Check the following items:
 - Oil pump assembly. Refer to [AT-277, "Oil Pump"](#) .
 - Power train system. Refer to [AT-259, "Disassembly"](#) .
 - Transmission case. Refer to [AT-259, "Disassembly"](#) .

OK or NG

- OK >> GO TO 7.
- NG >> Repair or replace damaged parts.

7. CHECK A/T FLUID CONDITION

1. Remove oil pan. Refer to [AT-225, "Control Valve With TCM and A/T Fluid Temperature Sensor 2"](#) .
2. Check A/T fluid condition. Refer to [AT-51, "Fluid Condition Check"](#) .

OK or NG

- OK >> GO TO 8.
- NG >> GO TO 11.

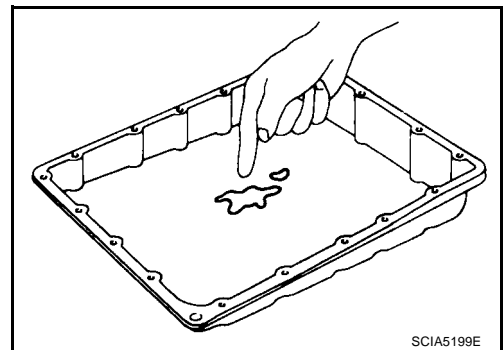

TROUBLE DIAGNOSIS FOR SYMPTOMS

8. DETECT MALFUNCTIONING ITEM

- Check the malfunction items. If any items are damaged, repair or replace damaged parts. Refer to [AT-61, "Symptom Chart"](#) (Symptom No.11).

OK or NG

- OK >> GO TO 9.
- NG >> Repair or replace damaged parts.

9. CHECK SYMPTOM

Check again. Refer to [AT-56, "Cruise Test - Part 1"](#) , [AT-58, "Cruise Test - Part 2"](#) .

OK or NG

- OK >> **INSPECTION END**
- NG >> GO TO 10.

10. PERFORM TCM INSPECTION

1. Perform TCM input/output signals inspection. Refer to [AT-83, "TCM Input/Output Signal Reference Values"](#) .
2. If NG, recheck A/T assembly harness connector terminals for damage or loose connection with harness connector.

OK or NG

- OK >> **INSPECTION END**
- NG >> Repair or replace damaged parts.

11. DETECT MALFUNCTIONING ITEM

- Check the malfunction items. If any items are damaged, repair or replace damaged parts. Refer to [AT-61, "Symptom Chart"](#) (Symptom No.11).

OK or NG

- OK >> GO TO 9.
- NG >> Repair or replace damaged parts.

A/T Does Not Shift: D3 → D4 SYMPTOM:

ECS00H20

- The vehicle does not shift-up from the D3 to D4 gear at the specified speed.
- The vehicle does not shift-up from the D3 to D4 gear unless A/T is warmed up.

DIAGNOSTIC PROCEDURE

1. CONFIRM THE SYMPTOM

Check if vehicle creeps forward in "D" position and vehicle can be started from D1.

OK or NG

- OK >> GO TO 2.
- NG >> Refer to [AT-184, "Vehicle Does Not Creep Forward In "D" Position"](#) , [AT-186, "Vehicle Cannot Be Started From D1"](#) .

2. CHECK SELF-DIAGNOSTIC RESULTS

Perform self-diagnosis. Refer to [AT-86, "SELF-DIAGNOSTIC RESULT MODE"](#) .

Do the self-diagnostic results indicate ATF pressure switch 1, ATF pressure switch 3, front brake solenoid valve, input clutch solenoid valve, accelerator pedal position sensor, vehicle speed sensor A/T (revolution sensor) and vehicle speed sensor MTR?

- YES >> Check the malfunctioning system. Refer to [AT-155, "DTC P1841 ATF PRESSURE SWITCH 1"](#) , [AT-157, "DTC P1843 ATF PRESSURE SWITCH 3"](#) , [AT-135, "DTC P1752 INPUT CLUTCH SOLENOID VALVE"](#) , [AT-139, "DTC P1757 FRONT BRAKE SOLENOID VALVE"](#) , [AT-120, "DTC](#)

TROUBLE DIAGNOSIS FOR SYMPTOMS

[P1705 THROTTLE POSITION SENSOR](#) , [AT-107, "DTC P0720 VEHICLE SPEED SENSOR A/T \(REVOLUTION SENSOR\)"](#) , [AT-128, "DTC P1721 VEHICLE SPEED SENSOR MTR"](#) .

NO >> GO TO 3.

3. CHECK A/T FLUID LEVEL

Check A/T fluid level. Refer to [AT-12, "Checking Automatic Transmission Fluid \(ATF\)"](#) .

OK or NG

OK >> GO TO 4.
NG >> Refill ATF.

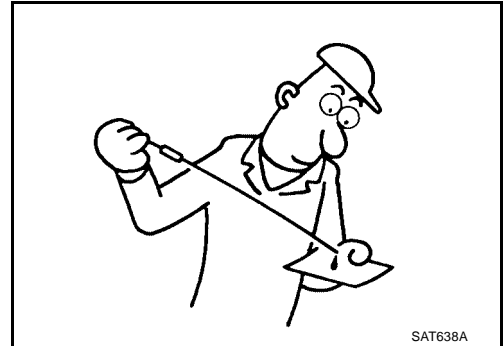

4. CHECK LINE PRESSURE

Check line pressure at the engine stall point. Refer to [AT-52, "LINE PRESSURE TEST"](#) .

OK or NG

OK >> GO TO 7.
NG - 1 >> Line pressure high. GO TO 5.
NG - 2 >> Line pressure low. GO TO 6.

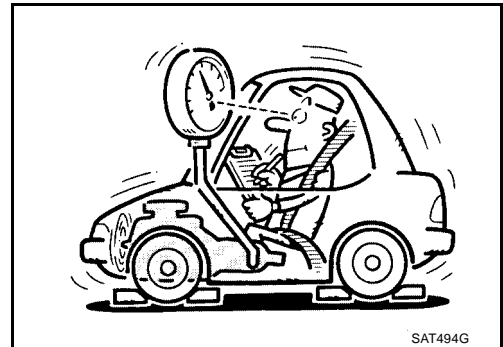

5. DETECT MALFUNCTIONING ITEM

1. Check control valve with TCM. Refer to [AT-225, "Control Valve With TCM and A/T Fluid Temperature Sensor 2"](#) .
2. Disassemble A/T. Refer to [AT-259, "Disassembly"](#) .
3. Check the following items:
 - Oil pump assembly. Refer to [AT-277, "Oil Pump"](#) .

OK or NG

OK >> GO TO 7.
NG >> Repair or replace damaged parts.

6. DETECT MALFUNCTIONING ITEM

1. Check control valve with TCM. Refer to [AT-225, "Control Valve With TCM and A/T Fluid Temperature Sensor 2"](#) .
2. Disassemble A/T. Refer to [AT-259, "Disassembly"](#) .
3. Check the following items:
 - Oil pump assembly. Refer to [AT-277, "Oil Pump"](#) .
 - Power train system. Refer to [AT-259, "Disassembly"](#) .
 - Transmission case. Refer to [AT-259, "Disassembly"](#) .

OK or NG

OK >> GO TO 7.
NG >> Repair or replace damaged parts.

TROUBLE DIAGNOSIS FOR SYMPTOMS

7. CHECK A/T FLUID CONDITION

1. Remove oil pan. Refer to [AT-225, "Control Valve With TCM and A/T Fluid Temperature Sensor 2"](#) .
2. Check A/T fluid condition. Refer to [AT-51, "Fluid Condition Check"](#) .

OK or NG

- OK >> GO TO 8.
- NG >> GO TO 11.

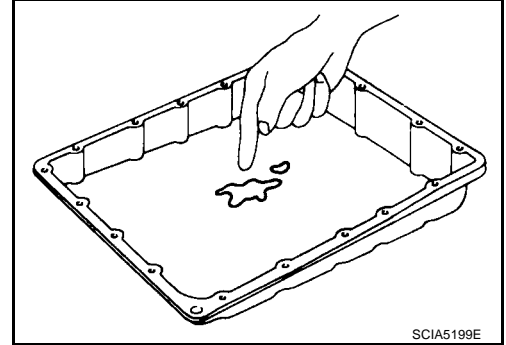

8. DETECT MALFUNCTIONING ITEM

- Check the malfunction items. If any items are damaged, repair or replace damaged parts. Refer to [AT-61, "Symptom Chart"](#) (Symptom No.12).

OK or NG

- OK >> GO TO 9.
- NG >> Repair or replace damaged parts.

9. CHECK SYMPTOM

Check again. Refer to [AT-56, "Cruise Test - Part 1"](#) , [AT-58, "Cruise Test - Part 2"](#) .

OK or NG

- OK >> **INSPECTION END**
- NG >> GO TO 10.

10. PERFORM TCM INSPECTION

1. Perform TCM input/output signals inspection. Refer to [AT-83, "TCM Input/Output Signal Reference Values"](#) .
2. If NG, recheck A/T assembly harness connector terminals for damage or loose connection with harness connector.

OK or NG

- OK >> **INSPECTION END**
- NG >> Repair or replace damaged parts.

11. DETECT MALFUNCTIONING ITEM

- Check the malfunction items. If any items are damaged, repair or replace damaged parts. Refer to [AT-61, "Symptom Chart"](#) (Symptom No.12).

OK or NG

- OK >> GO TO 9.
- NG >> Repair or replace damaged parts.

A
B
AT
D
E
F
G
H
I
J
K
L
M

TROUBLE DIAGNOSIS FOR SYMPTOMS

ECS00H2P

A/T Does Not Shift: D4 → D5

SYMPTOM:

- The vehicle does not shift-up from the D4 to D5 gear at the specified speed.
- The vehicle does not shift-up from the D4 to D5 gear unless A/T is warmed up.

DIAGNOSTIC PROCEDURE

1. CONFIRM THE SYMPTOM

Check if vehicle creeps forward in "D" position and vehicle can be started from D1.

OK or NG

OK >> GO TO 2.

NG >> Refer to [AT-184, "Vehicle Does Not Creep Forward In "D" Position"](#) , [AT-186, "Vehicle Cannot Be Started From D1"](#) .

2. CHECK SELF-DIAGNOSTIC RESULTS

Perform self-diagnosis. Refer to [AT-86, "SELF-DIAGNOSTIC RESULT MODE"](#) .

Do the self-diagnostic results indicate ATF pressure switch 1, ATF pressure switch 5, front brake solenoid valve, direct clutch solenoid valve, accelerator pedal position sensor, turbine revolution sensor, vehicle speed sensor A/T (revolution sensor) and vehicle speed sensor MTR?

YES >> Check the malfunctioning system. Refer to [AT-155, "DTC P1841 ATF PRESSURE SWITCH 1"](#) , [AT-159, "DTC P1845 ATF PRESSURE SWITCH 5"](#) , [AT-139, "DTC P1757 FRONT BRAKE SOLENOID VALVE"](#) , [AT-143, "DTC P1762 DIRECT CLUTCH SOLENOID VALVE"](#) , [AT-120, "DTC P1705 THROTTLE POSITION SENSOR"](#) , [AT-105, "DTC P0717 TURBINE REVOLUTION SENSOR"](#) , [AT-107, "DTC P0720 VEHICLE SPEED SENSOR A/T \(REVOLUTION SENSOR\)"](#) , [AT-128, "DTC P1721 VEHICLE SPEED SENSOR MTR"](#) .

NO >> GO TO 3.

3. CHECK A/T FLUID LEVEL

Check A/T fluid level. Refer to [AT-12, "Checking Automatic Transmission Fluid \(ATF\)"](#) .

OK or NG

OK >> GO TO 4.

NG >> Refill ATF.

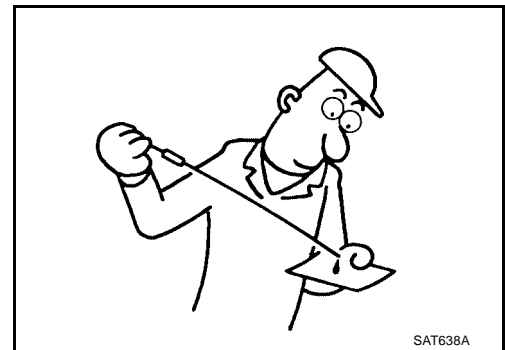

4. CHECK LINE PRESSURE

Check line pressure at the engine stall point. Refer to [AT-52, "LINE PRESSURE TEST"](#) .

OK or NG

OK >> GO TO 7.

NG - 1 >> Line pressure high. GO TO 5.

NG - 2 >> Line pressure low. GO TO 6.

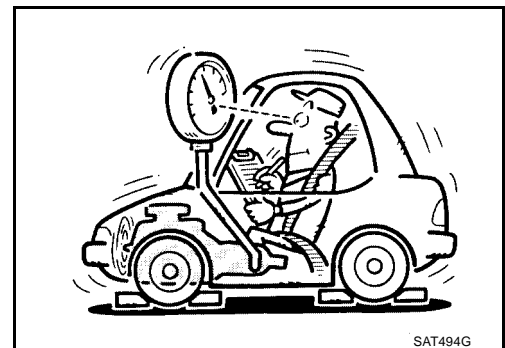

TROUBLE DIAGNOSIS FOR SYMPTOMS

5. DETECT MALFUNCTIONING ITEM

1. Check control valve with TCM. Refer to [AT-225, "Control Valve With TCM and A/T Fluid Temperature Sensor 2"](#) .
2. Disassemble A/T. Refer to [AT-259, "Disassembly"](#) .
3. Check the following items:
 - Oil pump assembly. Refer to [AT-277, "Oil Pump"](#) .

OK or NG

- OK >> GO TO 7.
- NG >> Repair or replace damaged parts.

6. DETECT MALFUNCTIONING ITEM

1. Check control valve with TCM. Refer to [AT-225, "Control Valve With TCM and A/T Fluid Temperature Sensor 2"](#) .
2. Disassemble A/T. Refer to [AT-259, "Disassembly"](#) .
3. Check the following items:
 - Oil pump assembly. Refer to [AT-277, "Oil Pump"](#) .
 - Power train system. Refer to [AT-259, "Disassembly"](#) .
 - Transmission case. Refer to [AT-259, "Disassembly"](#) .

OK or NG

- OK >> GO TO 7.
- NG >> Repair or replace damaged parts.

7. CHECK A/T FLUID CONDITION

1. Remove oil pan. Refer to [AT-225, "Control Valve With TCM and A/T Fluid Temperature Sensor 2"](#) .
2. Check A/T fluid condition. Refer to [AT-51, "Fluid Condition Check"](#) .

OK or NG

- OK >> GO TO 8.
- NG >> GO TO 11.

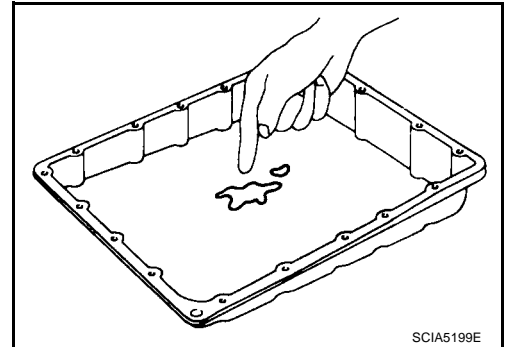

8. DETECT MALFUNCTIONING ITEM

- Check the malfunction items. If any items are damaged, repair or replace damaged parts. Refer to [AT-61, "Symptom Chart"](#) (Symptom No.13).

OK or NG

- OK >> GO TO 9.
- NG >> Repair or replace damaged parts.

9. CHECK SYMPTOM

Check again. Refer to [AT-56, "Cruise Test - Part 1"](#) .

OK or NG

- OK >> **INSPECTION END**
- NG >> GO TO 10.

TROUBLE DIAGNOSIS FOR SYMPTOMS

10. PERFORM TCM INSPECTION

1. Perform TCM input/output signals inspection. Refer to [AT-83, "TCM Input/Output Signal Reference Values"](#) .
2. If NG, recheck A/T assembly harness connector terminals for damage or loose connection with harness connector.

OK or NG

- OK >> **INSPECTION END**
NG >> Repair or replace damaged parts.

11. DETECT MALFUNCTIONING ITEM

- Check the malfunction items. If any items are damaged, repair or replace damaged parts. Refer to [AT-61, "Symptom Chart"](#) (Symptom No.13).

OK or NG

- OK >> GO TO 9.
NG >> Repair or replace damaged parts.

A/T Does Not Perform Lock-up SYMPTOM:

ECS00H2Q

A/T does not perform lock-up at the specified speed.

DIAGNOSTIC PROCEDURE

1. CHECK SELF-DIAGNOSTIC RESULTS

Perform self-diagnosis. Refer to [AT-86, "SELF-DIAGNOSTIC RESULT MODE"](#) .

Do the self-diagnostic results indicate torque converter clutch solenoid valve, engine speed signal, turbine revolution sensor, accelerator pedal position sensor, CAN communication?

- YES >> Check the malfunctioning system. Refer to [AT-114, "DTC P0740 TORQUE CONVERTER CLUTCH SOLENOID VALVE"](#) , [AT-112, "DTC P0725 ENGINE SPEED SIGNAL"](#) , [AT-105, "DTC P0717 TURBINE REVOLUTION SENSOR"](#) , [AT-120, "DTC P1705 THROTTLE POSITION SENSOR"](#) , [AT-93, "DTC U1000 CAN COMMUNICATION LINE"](#) .
- NO >> GO TO 2.

2. CHECK A/T FLUID LEVEL

Check A/T fluid level. Refer to [AT-12, "Checking Automatic Transmission Fluid \(ATF\)"](#) .

OK or NG

- OK >> GO TO 3.
NG >> Refill ATF.

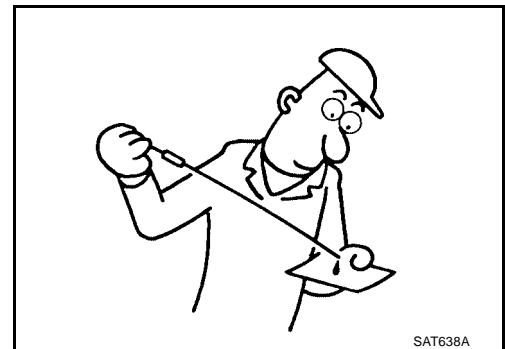

TROUBLE DIAGNOSIS FOR SYMPTOMS

3. CHECK LINE PRESSURE

Check line pressure at the engine stall point. Refer to [AT-52, "LINE PRESSURE TEST"](#) .

OK or NG

- OK >> GO TO 6.
- NG - 1 >> Line pressure high. GO TO 4.
- NG - 2 >> Line pressure low. GO TO 5.

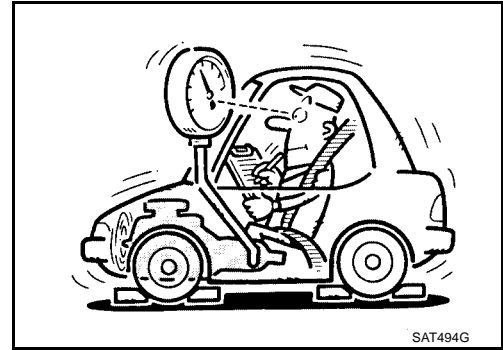

4. DETECT MALFUNCTIONING ITEM

1. Check control valve with TCM. Refer to [AT-225, "Control Valve With TCM and A/T Fluid Temperature Sensor 2"](#) .
2. Disassemble A/T. Refer to [AT-259, "Disassembly"](#) .
3. Check the following items:
 - Oil pump assembly. Refer to [AT-277, "Oil Pump"](#) .

OK or NG

- OK >> GO TO 7.
- NG >> Repair or replace damaged parts.

5. DETECT MALFUNCTIONING ITEM

1. Check control valve with TCM. Refer to [AT-225, "Control Valve With TCM and A/T Fluid Temperature Sensor 2"](#) .
2. Disassemble A/T. Refer to [AT-259, "Disassembly"](#) .
3. Check the following items:
 - Oil pump assembly. Refer to [AT-277, "Oil Pump"](#) .
 - Power train system. Refer to [AT-259, "Disassembly"](#) .
 - Transmission case. Refer to [AT-259, "Disassembly"](#) .

OK or NG

- OK >> GO TO 7.
- NG >> Repair or replace damaged parts.

6. CHECK A/T FLUID CONDITION

1. Remove oil pan. Refer to [AT-225, "Control Valve With TCM and A/T Fluid Temperature Sensor 2"](#) .
2. Check A/T fluid condition. Refer to [AT-51, "Fluid Condition Check"](#) .

OK or NG

- OK >> GO TO 7.
- NG >> GO TO 10.

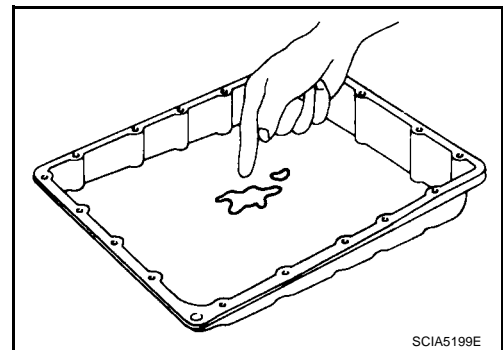

TROUBLE DIAGNOSIS FOR SYMPTOMS

7. DETECT MALFUNCTIONING ITEM

- Check the malfunction items. If any items are damaged, repair or replace damaged parts. Refer to [AT-61, "Symptom Chart"](#) (Symptom No.24).

OK or NG

- OK >> GO TO 8.
NG >> Repair or replace damaged parts.

8. CHECK SYMPTOM

Check again. Refer to [AT-56, "Cruise Test - Part 1"](#) .

OK or NG

- OK >> **INSPECTION END**
NG >> GO TO 9.

9. PERFORM TCM INSPECTION

1. Perform TCM input/output signals inspection. Refer to [AT-83, "TCM Input/Output Signal Reference Values"](#) .
2. If NG, recheck A/T assembly harness connector terminals for damage or loose connection with harness connector.

OK or NG

- OK >> **INSPECTION END**
NG >> Repair or replace damaged parts.

10. DETECT MALFUNCTIONING ITEM

- Check the malfunction items. If any items are damaged, repair or replace damaged parts. Refer to [AT-61, "Symptom Chart"](#) (Symptom No.24).

OK or NG

- OK >> GO TO 8.
NG >> Repair or replace damaged parts.

A/T Does Not Hold Lock-up Condition SYMPTOM:

ECS00H2R

The lock-up condition cannot be maintained for more than 30 seconds.

DIAGNOSTIC PROCEDURE

1. CHECK SELF-DIAGNOSTIC RESULTS

Perform self-diagnosis. Refer to [AT-86, "SELF-DIAGNOSTIC RESULT MODE"](#) .

Do the self-diagnostic results indicate torque converter clutch solenoid valve, engine speed signal, turbine revolution sensor, CAN communication?

- YES >> Check the malfunctioning system. Refer to [AT-114, "DTC P0740 TORQUE CONVERTER CLUTCH SOLENOID VALVE"](#) , [AT-112, "DTC P0725 ENGINE SPEED SIGNAL"](#) , [AT-105, "DTC P0717 TURBINE REVOLUTION SENSOR"](#) , [AT-93, "DTC U1000 CAN COMMUNICATION LINE"](#)

- NO >> GO TO 2.

TROUBLE DIAGNOSIS FOR SYMPTOMS

2. CHECK A/T FLUID LEVEL

Check A/T fluid level. Refer to [AT-12, "Checking Automatic Transmission Fluid \(ATF\)"](#) .

OK or NG

- OK >> GO TO 3.
- NG >> Refill ATF.

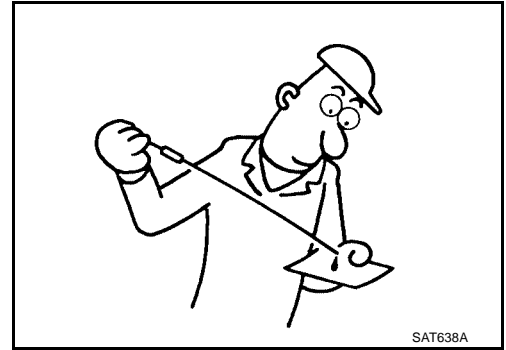

3. CHECK A/T FLUID CONDITION

1. Remove oil pan. Refer to [AT-225, "Control Valve With TCM and A/T Fluid Temperature Sensor 2"](#) .
2. Check A/T fluid condition. Refer to [AT-51, "Fluid Condition Check"](#) .

OK or NG

- OK >> GO TO 4.
- NG >> GO TO 7.

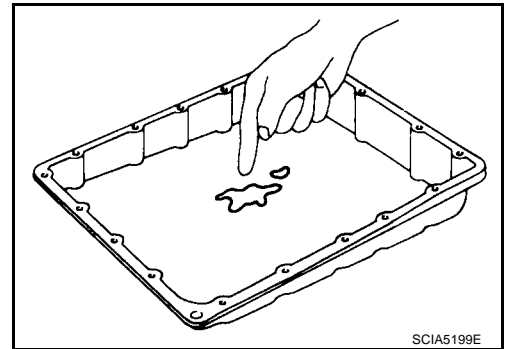

4. DETECT MALFUNCTIONING ITEM

- Check the malfunction items. If any items are damaged, repair or replace damaged parts. Refer to [AT-61, "Symptom Chart"](#) (Symptom No.25).

OK or NG

- OK >> GO TO 5.
- NG >> Repair or replace damaged parts.

5. CHECK SYMPTOM

Check again. Refer to [AT-56, "Cruise Test - Part 1"](#) .

OK or NG

- OK >> **INSPECTION END**
- NG >> GO TO 6.

6. PERFORM TCM INSPECTION

1. Perform TCM input/output signals inspection. Refer to [AT-83, "TCM Input/Output Signal Reference Values"](#) .
2. If NG, recheck A/T assembly harness connector terminals for damage or loose connection with harness connector.

OK or NG

- OK >> **INSPECTION END**
- NG >> Repair or replace damaged parts.

A
B
AT
D
E
F
G
H
I
J
K
L
M

TROUBLE DIAGNOSIS FOR SYMPTOMS

7. DETECT MALFUNCTIONING ITEM

- Check the malfunction items. If any items are damaged, repair or replace damaged parts. Refer to [AT-61, "Symptom Chart"](#) (Symptom No.25).

OK or NG

- OK >> GO TO 5.
NG >> Repair or replace damaged parts.

Lock-up Is Not Released SYMPTOM:

ECS00H2S

The lock-up condition cannot be cancelled even after releasing the accelerator pedal.

DIAGNOSTIC PROCEDURE

1. CHECK SELF-DIAGNOSTIC RESULTS

Perform self-diagnosis. Refer to [AT-86, "SELF-DIAGNOSTIC RESULT MODE"](#) .

Do the self-diagnostic results indicate torque converter clutch solenoid valve, engine speed signal, turbine revolution sensor, CAN communication?

- YES >> Check the malfunctioning system. Refer to [AT-114, "DTC P0740 TORQUE CONVERTER CLUTCH SOLENOID VALVE"](#) , [AT-112, "DTC P0725 ENGINE SPEED SIGNAL"](#) , [AT-105, "DTC P0717 TURBINE REVOLUTION SENSOR"](#) , [AT-93, "DTC U1000 CAN COMMUNICATION LINE"](#)
- NO >> GO TO 2.

2. CHECK SYMPTOM

Check again. Refer to [AT-56, "Cruise Test - Part 1"](#) .

OK or NG

- OK >> **INSPECTION END**
NG >> GO TO 3.

3. PERFORM TCM INSPECTION

1. Perform TCM input/output signals inspection. Refer to [AT-83, "TCM Input/Output Signal Reference Values"](#) .
2. If NG, recheck A/T assembly harness connector terminals for damage or loose connection with harness connector.

OK or NG

- OK >> **INSPECTION END**
NG >> Repair or replace damaged parts.

TROUBLE DIAGNOSIS FOR SYMPTOMS

ECS00H2T

Engine Speed Does Not Return to Idle

SYMPTOM:

When a shift-down is performed, the engine speed does not smoothly return to the idling speed.

DIAGNOSTIC PROCEDURE

1. CHECK A/T FLUID LEVEL

Check A/T fluid level. Refer to [AT-12, "Checking Automatic Transmission Fluid \(ATF\)"](#).

OK or NG

- OK >> GO TO 2.
- NG >> Refill ATF.

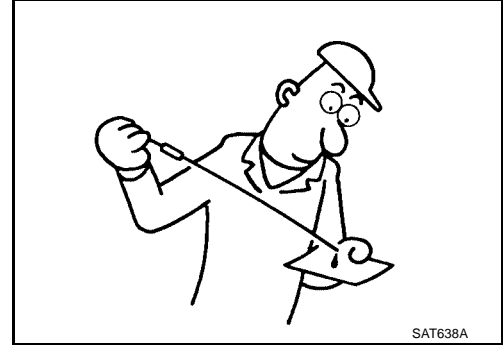

2. CHECK SELF-DIAGNOSTIC RESULTS

Perform self-diagnosis. Refer to [AT-86, "SELF-DIAGNOSTIC RESULT MODE"](#).

Do the self-diagnostic results indicate front brake solenoid valve, direct clutch solenoid valve, ATF pressure switch 1, ATF pressure switch 5, accelerator pedal position sensor, vehicle speed sensor A/T (revolution sensor) and vehicle speed sensor MTR?

- YES >> Check the malfunctioning system. Refer to [AT-139, "DTC P1757 FRONT BRAKE SOLENOID VALVE"](#), [AT-143, "DTC P1762 DIRECT CLUTCH SOLENOID VALVE"](#), [AT-155, "DTC P1841 ATF PRESSURE SWITCH 1"](#), [AT-159, "DTC P1845 ATF PRESSURE SWITCH 5"](#), [AT-120, "DTC P1705 THROTTLE POSITION SENSOR"](#), [AT-107, "DTC P0720 VEHICLE SPEED SENSOR A/T \(REVOLUTION SENSOR\)"](#), [AT-128, "DTC P1721 VEHICLE SPEED SENSOR MTR"](#).
- NO >> GO TO 3.

3. CHECK A/T FLUID CONDITION

1. Remove oil pan. Refer to [AT-225, "Control Valve With TCM and A/T Fluid Temperature Sensor 2"](#).
2. Check A/T fluid condition. Refer to [AT-51, "Fluid Condition Check"](#).

OK or NG

- OK >> GO TO 4.
- NG >> GO TO 7.

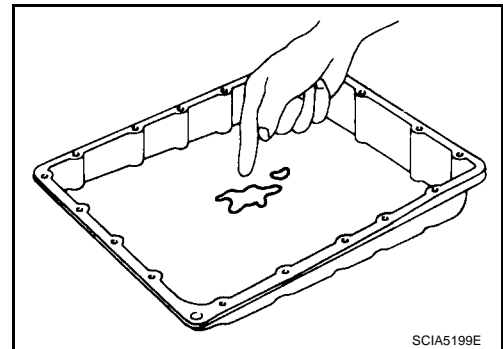

4. DETECT MALFUNCTIONING ITEM

- Check the malfunction items. If any items are damaged, repair or replace damaged parts. Refer to [AT-61, "Symptom Chart"](#) (Symptom No.65).

OK or NG

- OK >> GO TO 5.
- NG >> Repair or replace damaged parts.

A
B
AT
D
E
F
G
H
I
J
K
L
M

TROUBLE DIAGNOSIS FOR SYMPTOMS

5. CHECK SYMPTOM

Check again. Refer to [AT-56, "Cruise Test - Part 1"](#) .

OK or NG

- OK >> **INSPECTION END**
- NG >> GO TO 6.

6. PERFORM TCM INSPECTION

1. Perform TCM input/output signals inspection. Refer to [AT-83, "TCM Input/Output Signal Reference Values"](#) .
2. If NG, recheck A/T assembly harness connector terminals for damage or loose connection with harness connector.

OK or NG

- OK >> **INSPECTION END**
- NG >> Repair or replace damaged parts.

7. DETECT MALFUNCTIONING ITEM

- Check the malfunction items. If any items are damaged, repair or replace damaged parts. Refer to [AT-61, "Symptom Chart"](#) (Symptom No.65).

OK or NG

- OK >> GO TO 5.
- NG >> Repair or replace damaged parts.

A/T Does Not Shift: 5th gear → 4th gear **SYMPTOM:**

ECS00H2U

When shifted from D5 to 44 position, does not downshift from 5th to 4th gears.

DIAGNOSTIC PROCEDURE

1. CHECK SELF-DIAGNOSIS RESULTS

Perform self-diagnosis. Refer to [AT-86, "SELF-DIAGNOSTIC RESULT MODE"](#) .

Do the self-diagnosis results indicate PNP switch, ATF pressure switch 1?

- YES >> Check the malfunctioning system. Refer to [AT-120, "DTC P1705 THROTTLE POSITION SENSOR"](#) , [AT-155, "DTC P1841 ATF PRESSURE SWITCH 1"](#) .
- NO >> GO TO 2.

TROUBLE DIAGNOSIS FOR SYMPTOMS

2. CHECK 4TH POSITION SWITCH CIRCUIT

With CONSULT-II

1. Turn ignition switch "ON".
2. Select "ECU INPUT SIGNALS" in "DATA MONITOR" mode for "A/T" with CONSULT-II.
3. Read out "OD CONT SW" switch moving selector lever to each position.

Monitor item	Condition	Display value
OD CONT SW	When setting the selector lever to "4" and "3" position.	ON
	When setting selector lever to other positions.	OFF

DATA MONITOR	
MONITORING	
1 POSITION SW	OFF
OD CONT SW	ON
POWERSHIFT SW	OFF
HOLD SW	OFF
MANU MODE SW	OFF

LCIA0339E

Without CONSULT-II

1. Turn ignition switch "ON".(Do not start engine)
2. Check voltage between A/T device harness connector terminal and ground.

Item	Connector No.	Terminal No.	Condition	Data (Approx.)
4th position switch	M203	1 - Ground	When setting the selector lever to "4" and "3" position.	0V
			When setting selector lever to other positions.	Battery voltage

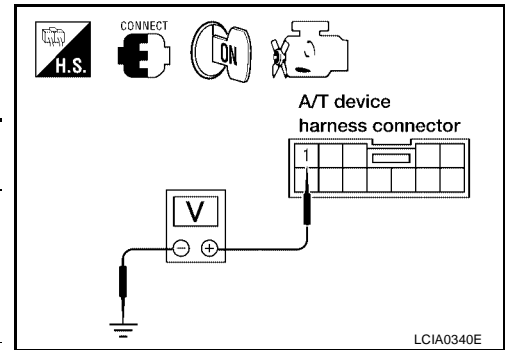

OK or NG

- OK >> GO TO 3.
- NG >> Repair or replace damaged parts.

3. CHECK A/T FLUID LEVEL

Check the A/T fluid level. Refer to [AT-12, "Checking Automatic Transmission Fluid \(ATF\)"](#).

OK or NG

- OK >> GO TO 4.
- NG >> Refill ATF.

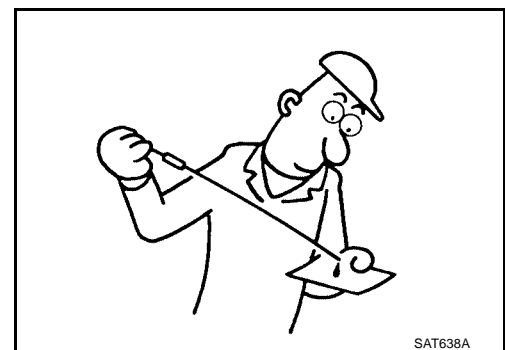

TROUBLE DIAGNOSIS FOR SYMPTOMS

4. CHECK CONTROL CABLE

Check the control cable.

- Refer to [AT-222, "Checking of A/T Position"](#) .

OK or NG

OK >> GO TO 5.

NG >> Adjust control cable. Refer to [AT-222, "Adjustment of A/T Position"](#) .

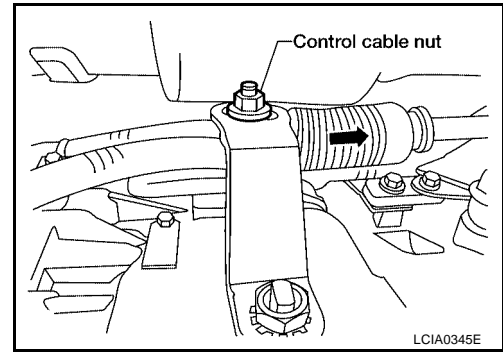

5. CHECK A/T FLUID CONDITION

1. Remove oil pan. Refer to [AT-225, "Control Valve With TCM and A/T Fluid Temperature Sensor 2"](#) .

2. Check A/T fluid condition. Refer to [AT-51, "Fluid Condition Check"](#) .

OK or NG

OK >> GO TO 6.

NG >> GO TO 9.

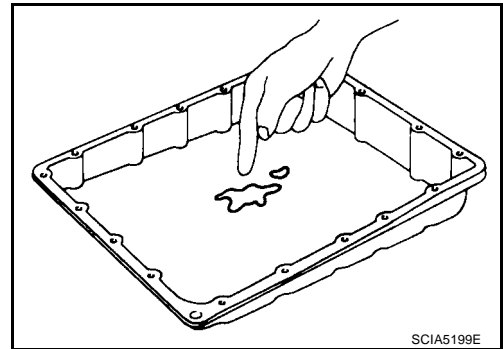

6. DETECT MALFUNCTIONING ITEM

- Check the malfunction items. If any items are damaged, repair or replace damaged parts. Refer to [AT-61, "Symptom Chart"](#) (Symptom No.14).

OK or NG

OK >> GO TO 7.

NG >> Repair or replace damaged parts.

7. CHECK SYMPTOM

Check again. Refer to [AT-59, "Cruise Test - Part 3"](#) .

OK or NG

OK >> **INSPECTION END**

NG >> GO TO 8.

8. PERFORM TCM INSPECTION

1. Perform TCM input/output signals inspection. Refer to [AT-83, "TCM Input/Output Signal Reference Values"](#) .
2. If NG, recheck A/T assembly harness connector terminals for damage or loose connection with harness connector.

OK or NG

OK >> **INSPECTION END**

NG >> Repair or replace damaged parts.

TROUBLE DIAGNOSIS FOR SYMPTOMS

9. DETECT MALFUNCTIONING ITEM

- Check the malfunction items. If any items are damaged, repair or replace damaged parts. Refer to [AT-61, "Symptom Chart"](#) (Symptom No.14).

OK or NG

- OK >> GO TO 7.
- NG >> Repair or replace damaged parts.

A/T Does Not Shift: 4th gear → 3rd gear SYMPTOM:

ECS00H2V

When shifted from 4th to 3rd position, does not downshift from 4th to 3rd gears.

DIAGNOSTIC PROCEDURE

1. CHECK SELF-DIAGNOSIS RESULTS

Perform self-diagnosis. Refer to [AT-86, "SELF-DIAGNOSTIC RESULT MODE"](#) .

Do the self-diagnosis results indicate PNP switch, ATF pressure switch 1, ATF pressure switch 3?

- YES >> Check the malfunctioning system. Refer to [AT-101, "DTC P0705 PARK/NEUTRAL POSITION SWITCH"](#) , [AT-155, "DTC P1841 ATF PRESSURE SWITCH 1"](#) , [AT-157, "DTC P1843 ATF PRES-SURE SWITCH 3"](#) .
- NO >> GO TO 2.

2. CHECK A/T FLUID LEVEL

Check the A/T fluid level. Refer to [AT-12, "Checking Automatic Transmission Fluid \(ATF\)"](#) .

OK or NG

- OK >> GO TO 3.
- NG >> Refill ATF.

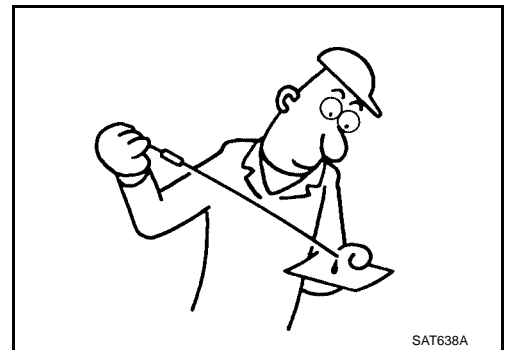

3. CHECK CONTROL CABLE

Check the control cable.

- Refer to [AT-222, "Checking of A/T Position"](#) .

OK or NG

- OK >> GO TO 4.
- NG >> Adjust control cable. Refer to [AT-222, "Adjustment of A/T Position"](#) .

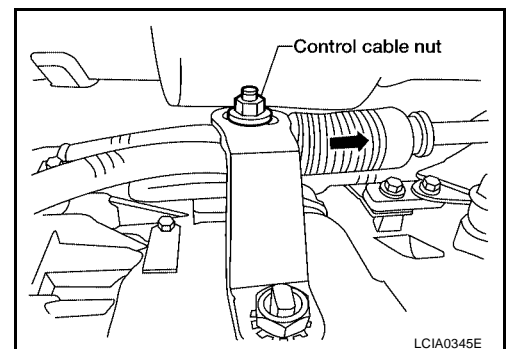

TROUBLE DIAGNOSIS FOR SYMPTOMS

4. CHECK A/T FLUID CONDITION

1. Remove oil pan. Refer to [AT-225, "Control Valve With TCM and A/T Fluid Temperature Sensor 2"](#) .
2. Check A/T fluid condition. Refer to [AT-51, "Fluid Condition Check"](#) .

OK or NG

- OK >> GO TO 5.
- NG >> GO TO 8.

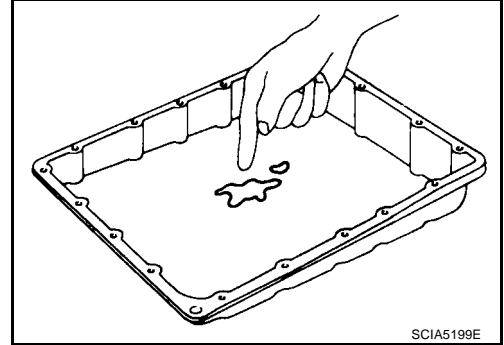

5. DETECT MALFUNCTIONING ITEM

- Check the malfunction items. If any items are damaged, repair or replace damaged parts. Refer to [AT-61, "Symptom Chart"](#) (Symptom No.15).

OK or NG

- OK >> GO TO 6.
- NG >> Repair or replace damaged parts.

6. CHECK SYMPTOM

Check again. Refer to [AT-59, "Cruise Test - Part 3"](#) .

OK or NG

- OK >> **INSPECTION END**
- NG >> GO TO 7.

7. PERFORM TCM INSPECTION

1. Perform TCM input/output signals inspection. Refer to [AT-83, "TCM Input/Output Signal Reference Values"](#) .
2. If NG, recheck A/T assembly harness connector terminals for damage or loose connection with harness connector.

OK or NG

- OK >> **INSPECTION END**
- NG >> Repair or replace damaged parts.

8. DETECT MALFUNCTIONING ITEM

- Check the malfunction items. If any items are damaged, repair or replace damaged parts. Refer to [AT-61, "Symptom Chart"](#) (Symptom No.15).

OK or NG

- OK >> GO TO 6.
- NG >> Repair or replace damaged parts.

A/T Does Not Shift: 3rd gear → 2nd gear

SYMPTOM:

When shifted from 3³ to 2² position, does not downshift from 3rd to 2nd gears.

ECS00H2W

TROUBLE DIAGNOSIS FOR SYMPTOMS

DIAGNOSTIC PROCEDURE

1. CHECK SELF-DIAGNOSIS RESULTS

Perform self-diagnosis. Refer to [AT-86, "SELF-DIAGNOSTIC RESULT MODE"](#) .

Do the self-diagnosis results indicate PNP switch, ATF pressure switch 6?

- YES >> Check the malfunctioning system. Refer to [AT-101, "DTC P0705 PARK/NEUTRAL POSITION SWITCH"](#) , [AT-161, "DTC P1846 ATF PRESSURE SWITCH 6"](#) .
- NO >> GO TO 2.

2. CHECK A/T FLUID LEVEL

Check the A/T fluid level. Refer to [AT-12, "Checking Automatic Transmission Fluid \(ATF\)"](#) .

OK or NG

- OK >> GO TO 3.
- NG >> Refill ATF.

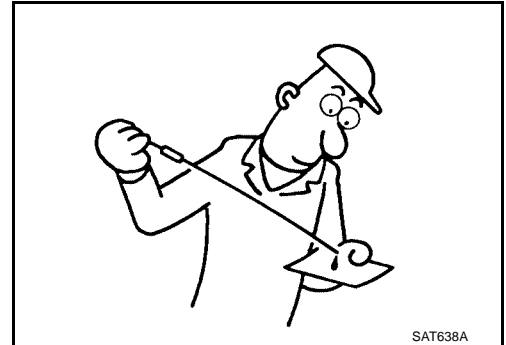

3. CHECK CONTROL CABLE

Check the control cable.

- Refer to [AT-222, "Checking of A/T Position"](#) .

OK or NG

- OK >> GO TO 4.
- NG >> Adjust control cable. Refer to [AT-222, "Adjustment of A/T Position"](#) .

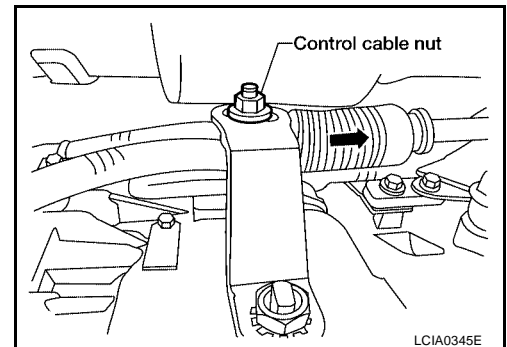

4. CHECK A/T FLUID CONDITION

- Remove oil pan. Refer to [AT-225, "Control Valve With TCM and A/T Fluid Temperature Sensor 2"](#) .
- Check A/T fluid condition. Refer to [AT-51, "Fluid Condition Check"](#) .

OK or NG

- OK >> GO TO 5.
- NG >> GO TO 8.

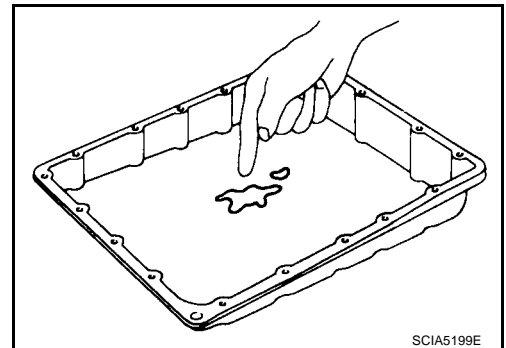

5. DETECT MALFUNCTIONING ITEM

- Check the malfunction items. If any items are damaged, repair or replace damaged parts. Refer to [AT-61, "Symptom Chart"](#) (Symptom No.16).

OK or NG

- OK >> GO TO 6.
- NG >> Repair or replace damaged parts.

TROUBLE DIAGNOSIS FOR SYMPTOMS

6. CHECK SYMPTOM

Check again. Refer to [AT-59, "Cruise Test - Part 3"](#) .

OK or NG

OK >> **INSPECTION END**
NG >> GO TO 7.

7. PERFORM TCM INSPECTION

1. Perform TCM input/output signals inspection. Refer to [AT-83, "TCM Input/Output Signal Reference Values"](#) .
2. If NG, recheck A/T assembly harness connector terminals for damage or loose connection with harness connector.

OK or NG

OK >> **INSPECTION END**
NG >> Repair or replace damaged parts.

8. DETECT MALFUNCTIONING ITEM

- Check the malfunction items. If any items are damaged, repair or replace damaged parts. Refer to [AT-61, "Symptom Chart"](#) (Symptom No.16).

OK or NG

OK >> GO TO 6.
NG >> Repair or replace damaged parts.

A/T Does Not Shift: 2nd gear → 1st gear **SYMPTOM:**

ECS00H2X

When shifted from 2nd to 1st position, does not downshift from 2nd to 1st gears.

DIAGNOSTIC PROCEDURE

1. CHECK SELF-DIAGNOSIS RESULTS

Perform self-diagnosis. Refer to [AT-86, "SELF-DIAGNOSTIC RESULT MODE"](#) .

Do the self-diagnosis results indicate PNP switch, ATF pressure switch 5?

YES >> Check the malfunctioning system. Refer to [AT-101, "DTC P0705 PARK/NEUTRAL POSITION SWITCH"](#) , [AT-159, "DTC P1845 ATF PRESSURE SWITCH 5"](#) .
NO >> GO TO 2.

TROUBLE DIAGNOSIS FOR SYMPTOMS

2. CHECK 1ST POSITION SWITCH CIRCUIT

With CONSULT-II

1. Turn ignition switch "ON".
2. Select "ECU INPUT SIGNALS" in "DATA MONITOR" mode for "A/T" with CONSULT-II.
3. Read out "1 POSITION SW" switch moving selector lever to each position.

Monitor item	Condition	Display value
1 POSITION SW	When setting the selector lever to "1" position.	ON
	When setting selector lever to other positions.	OFF

DATA MONITOR	
MONITORING	
1 POSITION SW	OFF
OD CONT SW	ON
POWERSHIFT SW	OFF
HOLD SW	OFF
MANU MODE SW	OFF

LCIA0339E

Without CONSULT-II

1. Turn ignition switch "ON". (Do not start engine)
2. Check voltage between A/T device harness connector terminal and ground.

Item	Connector No.	Terminal No.	Condition	Data (Approx.)
1st position switch	M203	7 - Ground	When setting the selector lever to "1" position.	0V
			When setting selector lever to other positions.	Battery voltage

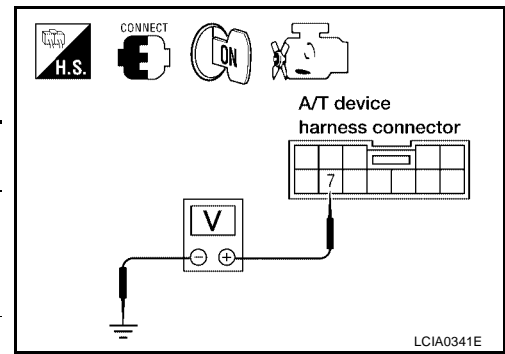

OK or NG

- OK >> GO TO 3.
- NG >> Repair or replace damaged parts.

3. CHECK A/T FLUID LEVEL

Check the A/T fluid level. Refer to [AT-12, "Checking Automatic Transmission Fluid \(ATF\)"](#).

OK or NG

- OK >> GO TO 4.
- NG >> Refill ATF.

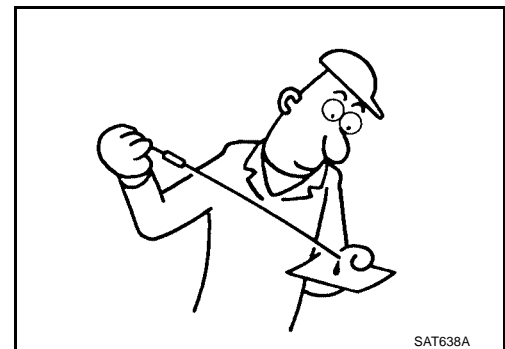

TROUBLE DIAGNOSIS FOR SYMPTOMS

4. CHECK CONTROL CABLE

Check the control cable.

- Refer to [AT-222, "Checking of A/T Position"](#) .

OK or NG

OK >> GO TO 5.

NG >> Adjust control cable. Refer to [AT-222, "Adjustment of A/T Position"](#) .

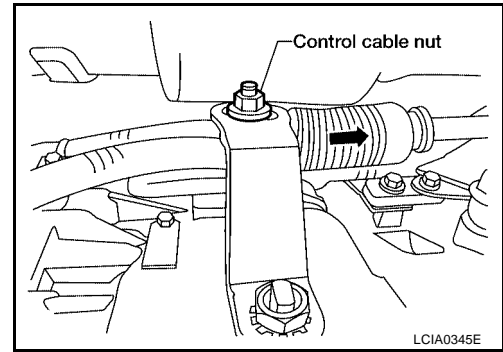

5. CHECK A/T FLUID CONDITION

1. Remove oil pan. Refer to [AT-225, "Control Valve With TCM and A/T Fluid Temperature Sensor 2"](#) .

2. Check A/T fluid condition. Refer to [AT-51, "Fluid Condition Check"](#) .

OK or NG

OK >> GO TO 6.

NG >> GO TO 9.

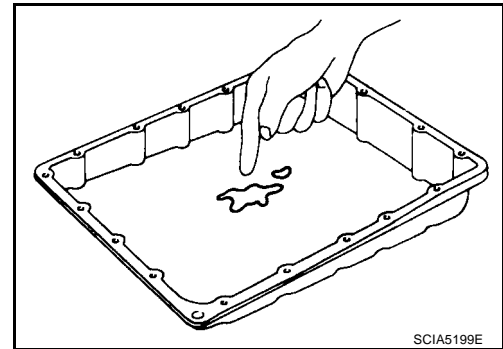

6. DETECT MALFUNCTIONING ITEM

- Check the malfunction items. If any items are damaged, repair or replace damaged parts. Refer to [AT-61, "Symptom Chart"](#) (Symptom No.17).

OK or NG

OK >> GO TO 7.

NG >> Repair or replace damaged parts.

7. CHECK SYMPTOM

Check again. Refer to [AT-58, "Cruise Test - Part 2"](#) .

OK or NG

OK >> **INSPECTION END**

NG >> GO TO 8.

8. PERFORM TCM INSPECTION

1. Perform TCM input/output signals inspection. Refer to [AT-83, "TCM Input/Output Signal Reference Values"](#) .

2. If NG, recheck A/T assembly harness connector terminals for damage or loose connection with harness connector.

OK or NG

OK >> **INSPECTION END**

NG >> Repair or replace damaged parts.

TROUBLE DIAGNOSIS FOR SYMPTOMS

9. DETECT MALFUNCTIONING ITEM

- Check the malfunction items. If any items are damaged, repair or replace damaged parts. Refer to [AT-61, "Symptom Chart"](#) (Symptom No.17).

OK or NG

- OK >> GO TO 7.
- NG >> Repair or replace damaged parts.

Vehicle Does Not Decelerate By Engine Brake SYMPTOM:

ECS00H2Y

No engine brake is applied when the gear is shifted from the 22 to 11 .

DIAGNOSTIC PROCEDURE

1. CHECK SELF-DIAGNOSIS RESULTS

Perform self-diagnosis.

Do the self-diagnosis results indicate PNP switch, ATF pressure switch 5?

- YES >> Check the malfunctioning system. Refer to [AT-101, "DTC P0705 PARK/NEUTRAL POSITION SWITCH"](#) , [AT-159, "DTC P1845 ATF PRESSURE SWITCH 5"](#) .
- NO >> GO TO 2.

2. CHECK 1ST POSITION SWITCH CIRCUIT

With CONSULT-II

- Turn ignition switch "ON".
- Select "ECU INPUT SIGNALS" in "DATA MONITOR" mode for "A/T" with CONSULT-II.
- Read out "1 POSITION SW" moving switch selector lever to each position.

Monitor item	Condition	Display value
1 POSITION SW	When setting the selector lever to "1" position.	ON
	When setting selector lever to other positions.	OFF

DATA MONITOR	
MONITORING	
1 POSITION SW	OFF
OD CONT SW	ON
POWERSHIFT SW	OFF
HOLD SW	OFF
MANU MODE SW	OFF

LCIA0339E

Without CONSULT-II

- Turn ignition switch "ON".(Do not start engine)
- Check voltage between A/T device harness connector terminal and ground.

Item	Connector No.	Terminal No.	Condition	Data (Approx.)
1st position switch	M203	7 - Ground	When setting the selector lever to "1" position.	0V
			When setting selector lever to other positions.	Battery voltage

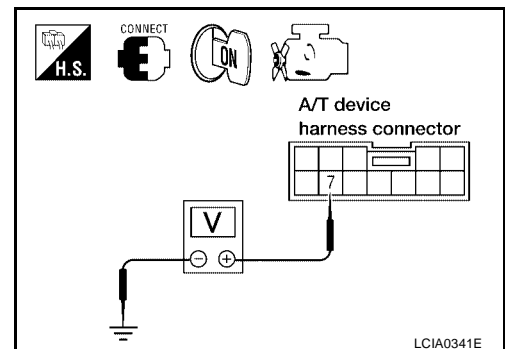

OK or NG

- OK >> GO TO 3.
- NG >> Repair or replace damaged parts.

TROUBLE DIAGNOSIS FOR SYMPTOMS

3. CHECK A/T FLUID LEVEL

Check the A/T fluid level. Refer to [AT-12, "Checking Automatic Transmission Fluid \(ATF\)"](#).

OK or NG

- OK >> GO TO 4.
- NG >> Refill ATF.

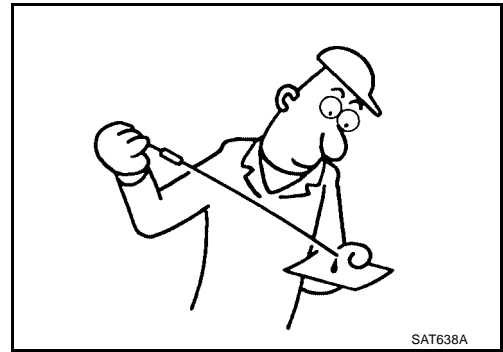

4. CHECK CONTROL CABLE

Check the control cable.

- Refer to [AT-222, "Checking of A/T Position"](#).

OK or NG

- OK >> GO TO 5.
- NG >> Adjust control cable. Refer to [AT-222, "Adjustment of A/T Position"](#).

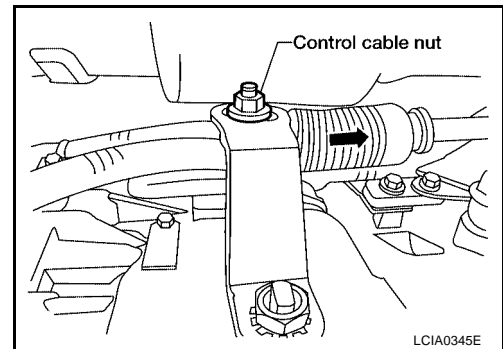

5. CHECK A/T FLUID CONDITION

1. Remove oil pan. Refer to [AT-225, "Control Valve With TCM and A/T Fluid Temperature Sensor 2"](#).
2. Check A/T fluid condition. Refer to [AT-51, "Fluid Condition Check"](#).

OK or NG

- OK >> GO TO 6.
- NG >> GO TO 9.

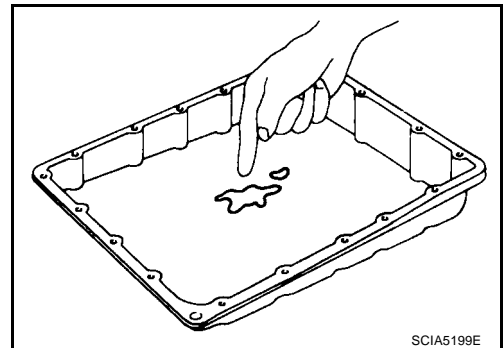

6. DETECT MALFUNCTIONING ITEM

- Check the malfunction items. If any items are damaged, repair or replace damaged parts. Refer to [AT-61, "Symptom Chart"](#) ((Symptom No.53).

OK or NG

- OK >> GO TO 7.
- NG >> Repair or replace damaged parts.

7. CHECK SYMPTOM

Check again. Refer to [AT-59, "Cruise Test - Part 3"](#).

OK or NG

- OK >> **INSPECTION END**
- NG >> GO TO 8.

TROUBLE DIAGNOSIS FOR SYMPTOMS

8. PERFORM TCM INSPECTION

1. Perform TCM input/output signals inspection. Refer to [AT-83, "TCM Input/Output Signal Reference Values"](#) .
2. If NG, recheck A/T assembly harness connector terminals for damage or loose connection with harness connector.

OK or NG

- OK >> **INSPECTION END**
NG >> Repair or replace damaged parts.

9. DETECT MALFUNCTIONING ITEM

- Check the malfunction items. If any items are damaged, repair or replace damaged parts. Refer to [AT-61, "Symptom Chart"](#) (Symptom No.53).

OK or NG

- OK >> GO TO 7.
NG >> Repair or replace damaged parts.

A
B
AT
D
E
F
G
H
I
J
K
L
M

A/T SHIFT LOCK SYSTEM

A/T SHIFT LOCK SYSTEM

PFP:34950

Description

ECS00H2Z

- The electrical key interlock mechanism also operates as a shift lock:
With the ignition switch turned to ON, the selector lever cannot be shifted from "P" (parking) to any other position unless the brake pedal is depressed.
With the key removed, the selector lever cannot be shifted from "P" to any other position.
The key cannot be removed unless the selector lever is placed in "P".
- The shift lock and key interlock mechanisms are controlled by the ON-OFF operation of the shift lock solenoid and by the operation of the rotator and slider located inside the key cylinder, respectively.

Shift Lock System Electrical Parts Location

LCIA0326E

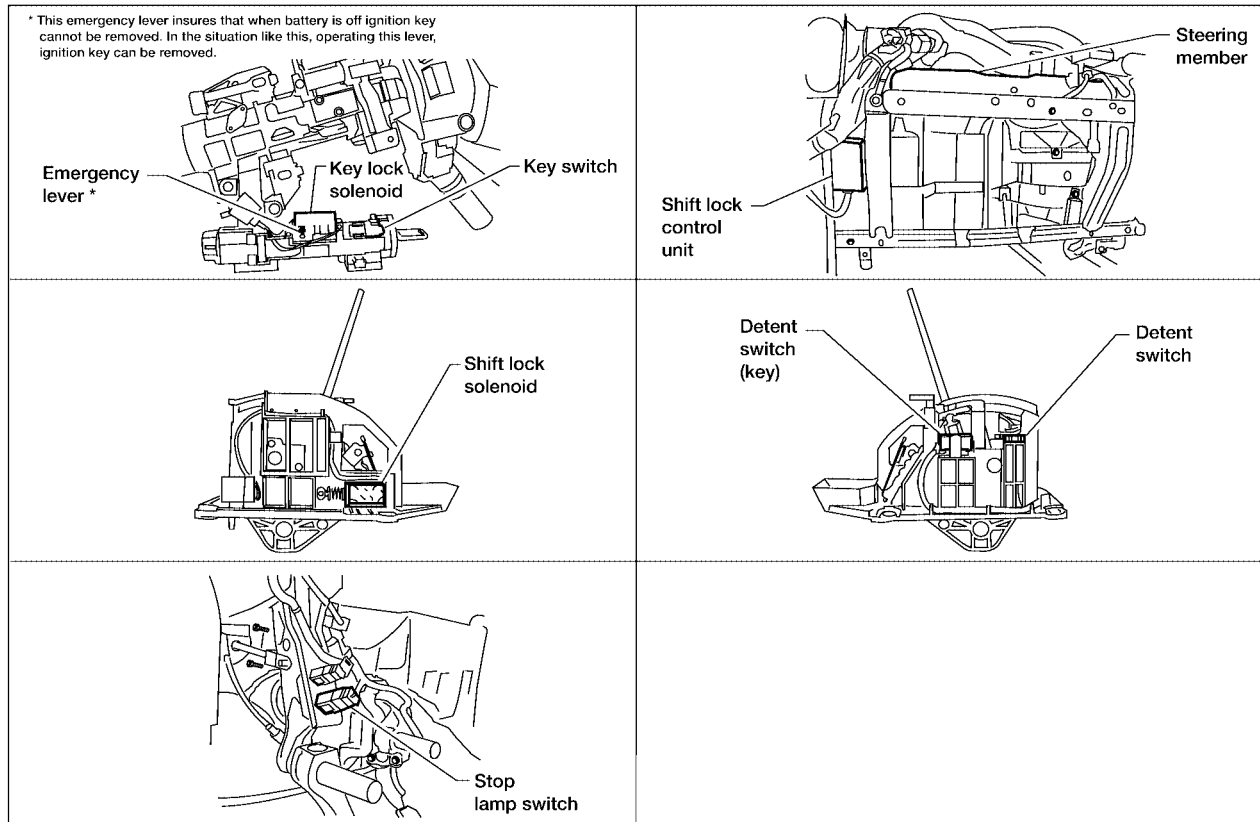

LCIA0326E

A/T SHIFT LOCK SYSTEM

Wiring Diagram — AT — SHIFT

ECS00H31

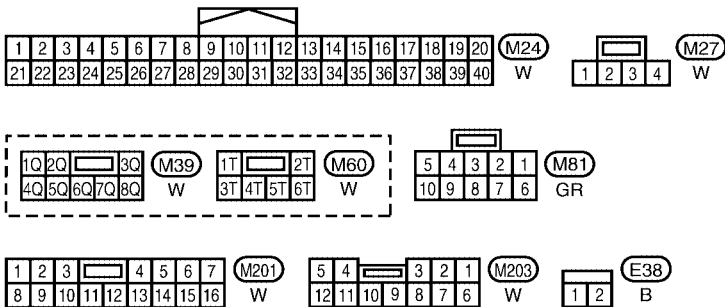
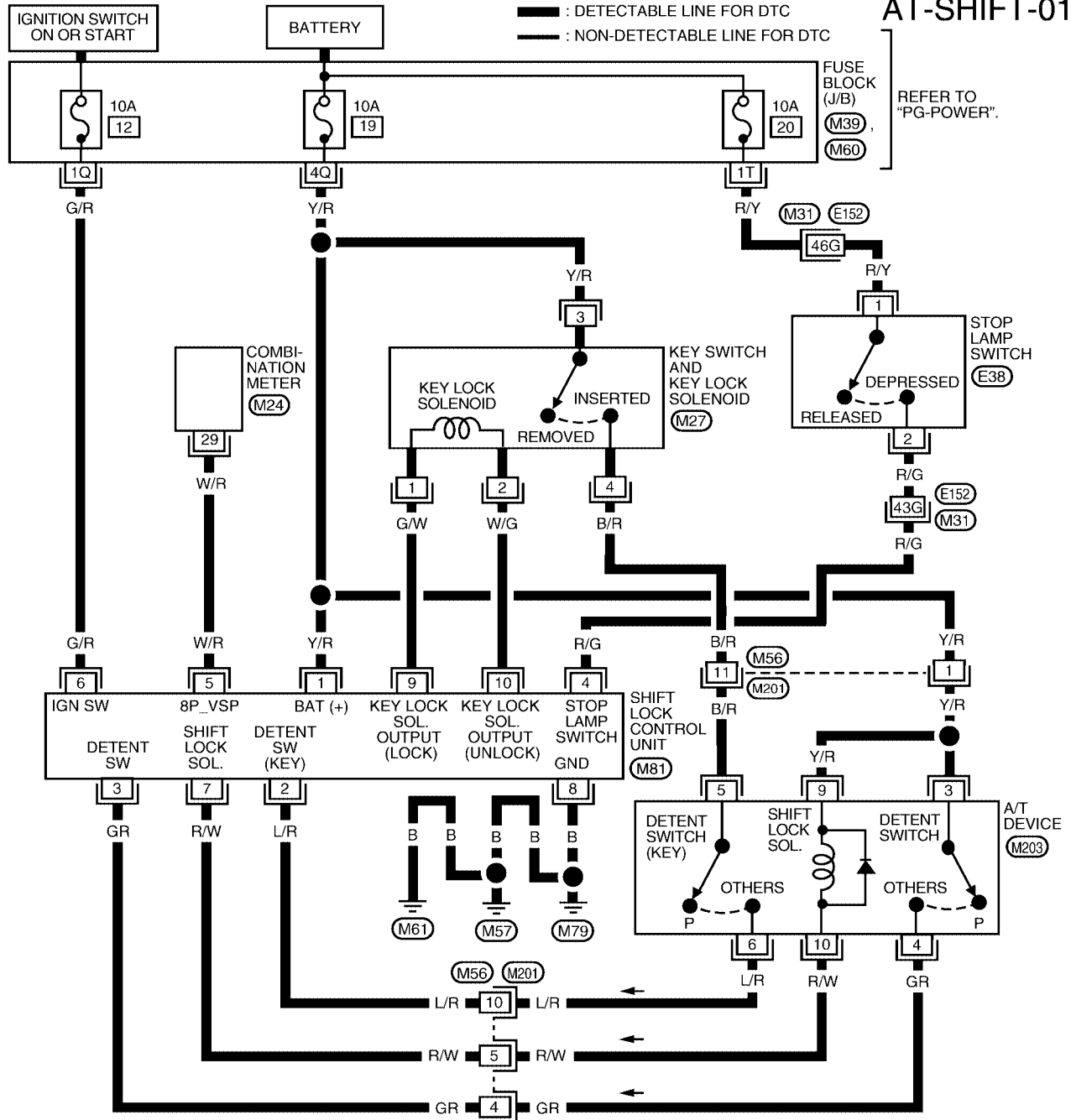

REFER TO THE FOLLOWING.
 (M31) - SUPER MULTIPLE JUNCTION (SMJ)

A/T SHIFT LOCK SYSTEM

Shift Lock Control Unit Reference Values SHIFT LOCK HARNESS CONNECTOR TERMINALS LAYOUT

ECS00H32

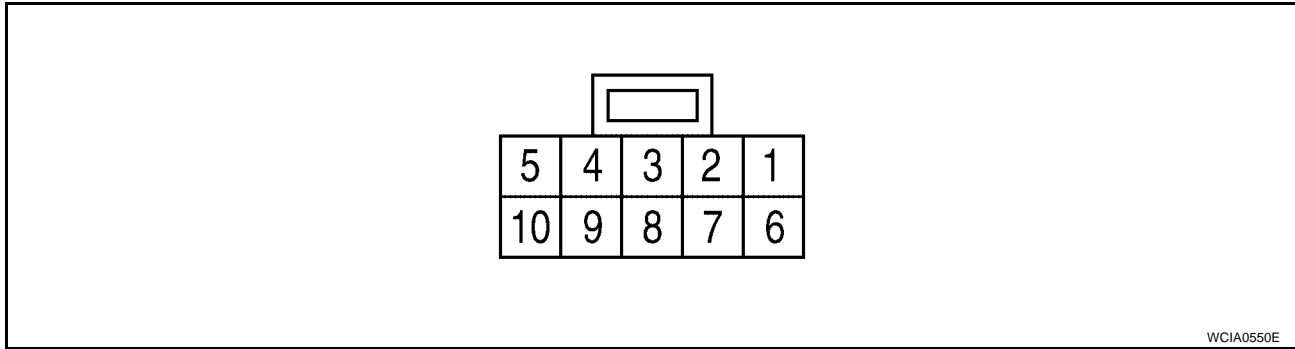

WCIA0550E

SHIFT LOCK CONTROL UNIT INSPECTION TABLE

Data are reference values.

TERMINAL NO.	WIRE COLOR	ITEM	CONDITION	VOLTAGE (Approx.)
1	Y/R	Power source	Ignition switch: "ON"	Battery voltage
			Ignition switch: "OFF"	Battery voltage
2	L/R	Detention switch (for key)	When selector lever is not in "P" position with key inserted.	Battery voltage
			Except the above	0V
3	GR	Detention switch (for shift)	When selector lever is not in "P" position	Battery voltage
			Except the above	0V
4	R/G	Stop lamp switch	When brake pedal is depressed	Battery voltage
			When brake pedal is released	0V
5	W/R	Vehicle speed signal	—	—
6	G/R	Ignition signal	Ignition switch: "OFF"	0V
			Ignition switch: "ON"	Battery voltage
7	R/W	Shift lock solenoid	When brake pedal is depressed with ignition switch "ON".	0V
			When brake pedal is depressed.	Battery voltage
8	B	Ground	Always	0V
9	G/W	Key lock solenoid	When the selector lever is set to a position other than the "P" position, and the key switch is turned from "ON" to "OFF"	Battery voltage for approx. 0.1 sec. (Note)
			Except the above	0V
10	W/G	Key unlock solenoid	When ignition switch is not in "ON" position with key inserted.	Battery voltage for approx. 0.1 sec. (Note)
			Except the above	0V

NOTE:

Confirm that the pointer swings only momentarily because the output time is so short. If the inspection is done with an oscilloscope, it should be observed that the power source voltage lasts for 3.5 to 10 ms.

A/T SHIFT LOCK SYSTEM

ECS00H33

Component Inspection SHIFT LOCK SOLENOID

- Check operation by applying battery voltage to A/T device terminal 9 and ground to terminal 10.

CAUTION:

Be sure to apply the voltage of the correct polarity to the respective terminals. Otherwise, the part may be damaged.

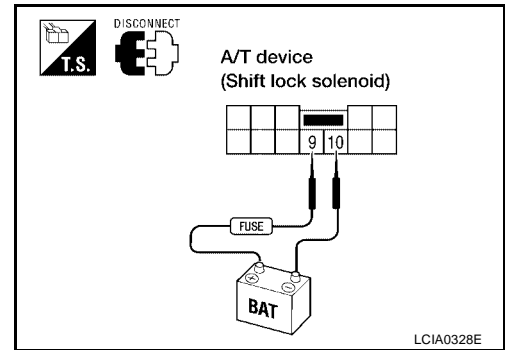

DETENTION SWITCH

For key:

- Check continuity between terminals of the A/T device.

Condition	Terminal No.	Continuity
When selector lever is "P" position.	5 - 6	No
When selector lever is not "P" position.		Yes

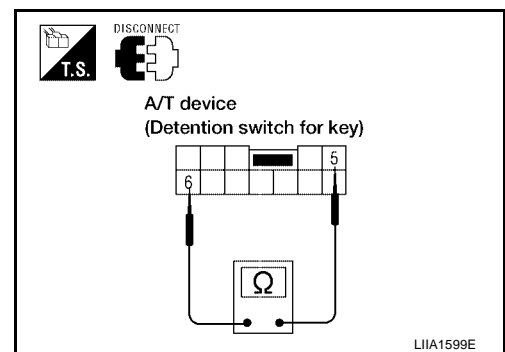

DETENTION SWITCH

For shift:

- Check continuity between terminals of the A/T device.

Condition	Terminal No.	Continuity
When selector lever is "P" position.	3 - 4	No
When selector lever is not "P" position.		Yes

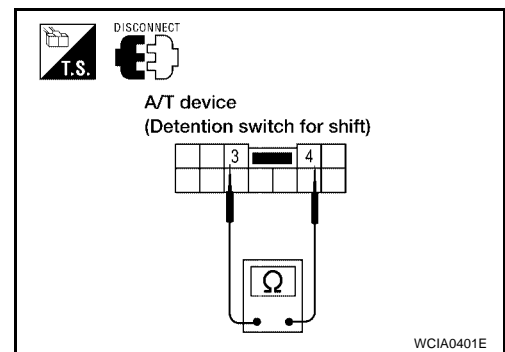

KEY LOCK SOLENOID

Key lock

- Check operation by applying battery voltage to key switch and key lock solenoid terminal 1 and ground to terminal 2.

CAUTION:

Be careful not to cause burnout of the harness.

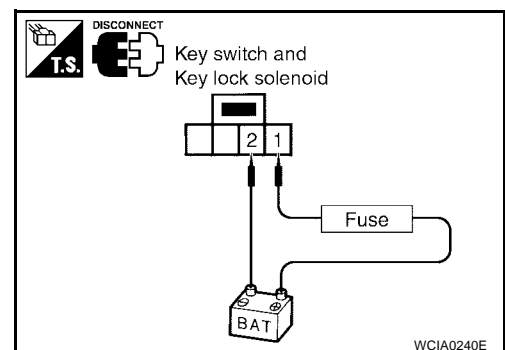

A
B
AT
D
E
F
G
H
I
J
K
L
M

A/T SHIFT LOCK SYSTEM

Key unlock

- Check operation by applying battery voltage to key switch and key lock solenoid terminal 2 and ground to terminal 1.

CAUTION:

Be careful not to cause burnout of the harness.

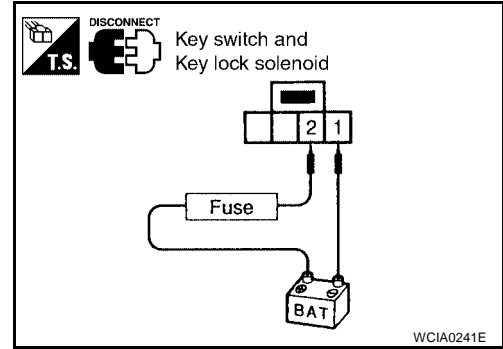

KEY SWITCH

- Check continuity between terminals of the key switch and key lock solenoid.

Condition	Terminal No.	Continuity
Key inserted	3 - 4	Yes
Key withdrawn		No

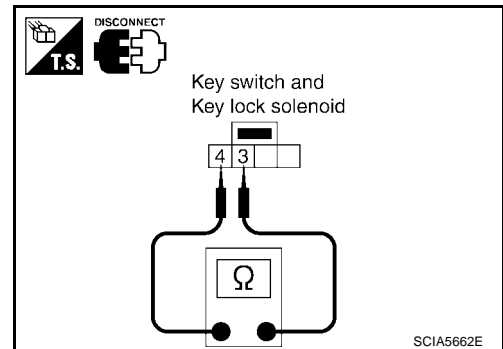

STOP LAMP SWITCH

- Check continuity between terminals of the stop lamp switch harness connector.

Condition	Terminal No.	Continuity
When brake pedal is depressed	1 - 2	Yes
When brake pedal is released		No

Check stop lamp switch after adjusting brake pedal.

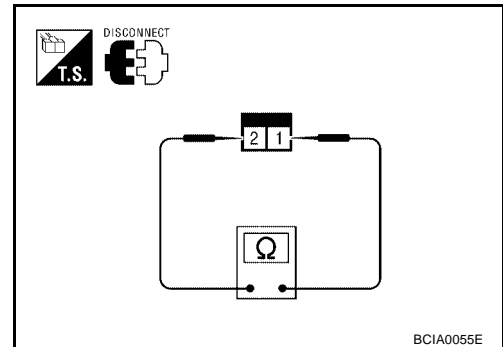

SHIFT CONTROL SYSTEM

SHIFT CONTROL SYSTEM

PFP:34901

Control Device Removal and Installation

ECS00H34

SEC. 349

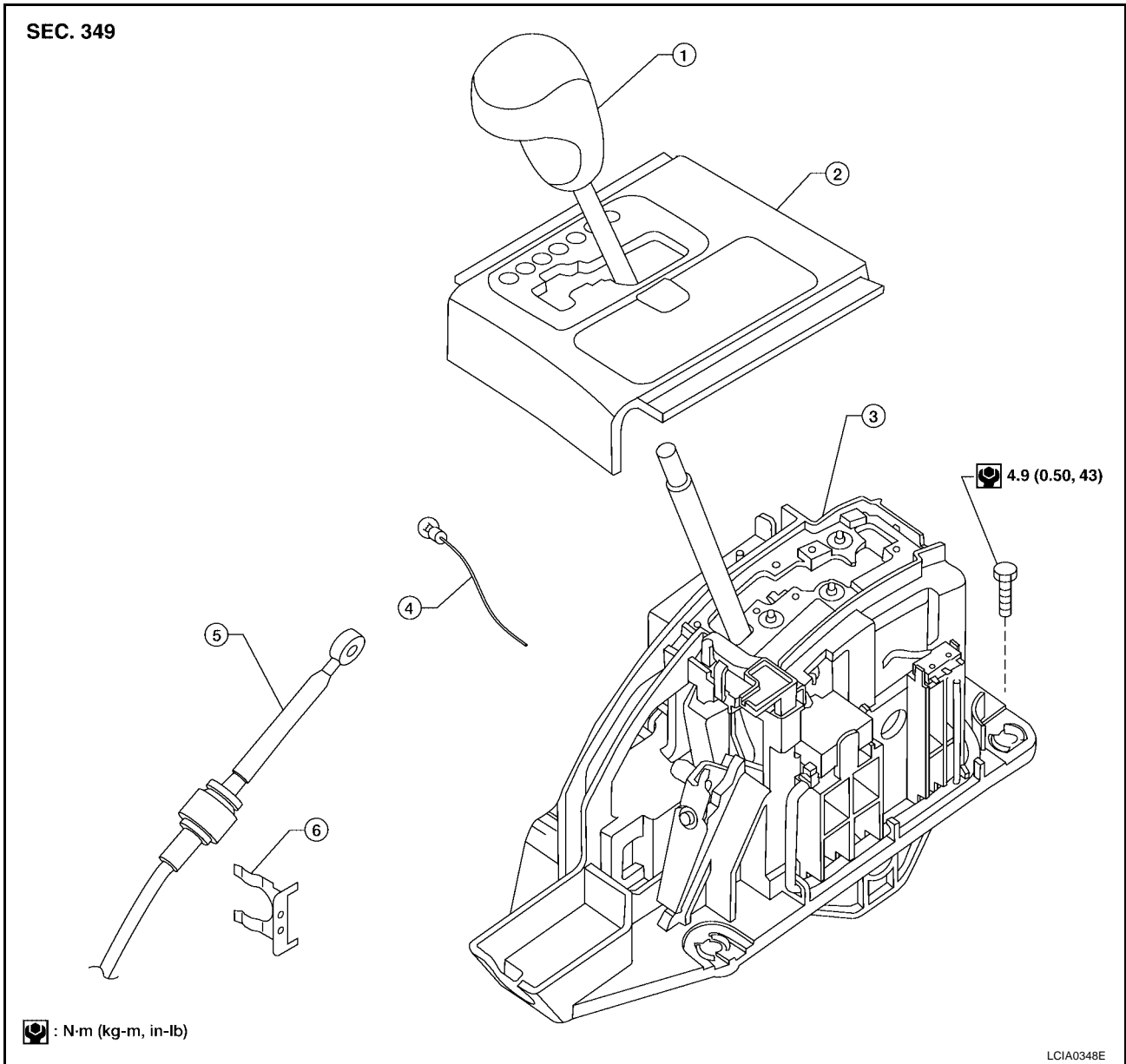

- | | | |
|----------------------|-------------------------------|----------------------------|
| 1. Select lever knob | 2. A/T console finisher | 3. Control device assembly |
| 4. Position lamp | 5. A/T selector control cable | 6. Lock plate |

A
B
AT
D
E
F
G
H
I
J
K
L
M

SHIFT CONTROL SYSTEM

REMOVAL

1. Remove negative battery terminal. Refer to [SC-4, "BATTERY"](#) .
2. Remove A/T finisher. Refer to [IP-13, "A/T FINISHER"](#) .
3. Disconnect selector control cable.
4. Disconnect A/T device harness connector.
5. Remove control device assembly.

INSTALLATION

Installation is in reverse order of removal. Be careful of the following:

- After installation is completed, adjust and check A/T position.

Adjustment of A/T Position

1. Loosen nut of control cable.
2. Place PNP switch and selector lever in "P" position.
3. After pushing the control cable in the direction shown with a force of 9.8 N·m (1kg·m, 2.2 lb-ft), release it. This is in the natural state, tighten control cable nut to specifications.

Control cable nut : 14.5 N·m (1.5 kg·m, 11 ft·lb)

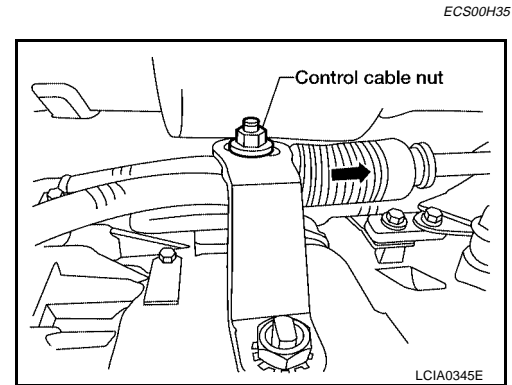

Checking of A/T Position

1. Place selector lever in "P" position, and turn ignition switch ON (engine stop).
2. Make sure selector lever can be shifted to other than "P" position when brake pedal is depressed. Also make sure selector lever can be shifted from "P" position only when brake pedal is depressed.
3. Move the selector lever and check for excessive effort, sticking, noise or rattle.
4. Confirm the selector lever stops at each position with the feel of engagement when it is moved through all the positions. Check whether or not the actual position the selector lever is in matches the position shown by the shift position indicator and the transmission body.
5. The method of operating the lever to individual positions correctly should be as shown.
6. Confirm the back-up lamps illuminate only when lever is placed in the "R" position. Confirm the back-up lamps does not illuminate when selector lever is pushed against "R" position in the "P" or "N" position.
7. Confirm the engine can only be started with the selector lever in the "P" and "N" positions.
8. Make sure transmission is locked completely in "P" position.

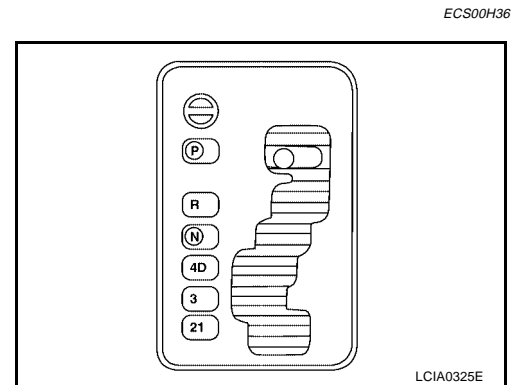

ON-VEHICLE SERVICE

PFP:00000

Oil Pan REMOVAL AND INSTALLATION

ECS00H37

Removal

1. Drain A/T fluid. Refer to [AT-12, "Changing Automatic Transmission Fluid \(ATF\)"](#) .
2. Remove oil pan and gasket.

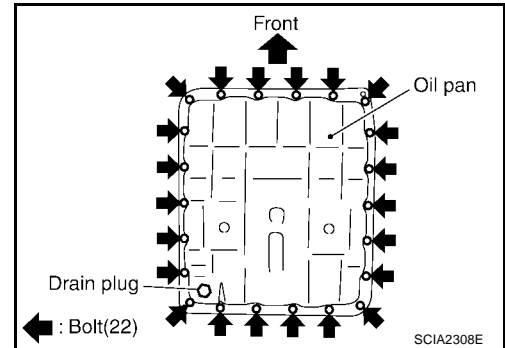

3. Check foreign materials in oil pan to help determine cause of malfunction. If the A/T fluid is very dark, has some burned smell, or contains foreign particles, friction material (clutches, band) may need replacement. A tacky film that will not wipe clean indicates varnish build up. Varnish can cause valves, servo, and clutches to stick and can inhibit pump pressure.

CAUTION:

If friction material is detected, flush the transmission cooler after repair. Refer to [AT-14, "A/T FLUID COOLER CLEANING PROCEDURE"](#) .

4. Remove magnets from oil pan.

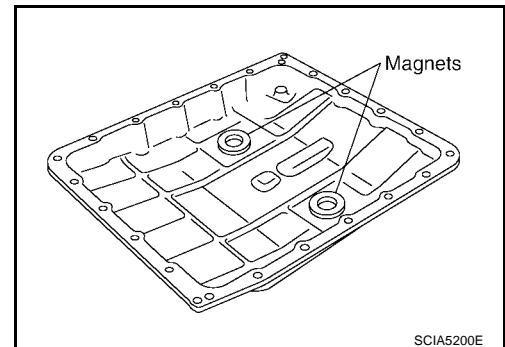

Installation

1. Install the oil pan magnets as shown.

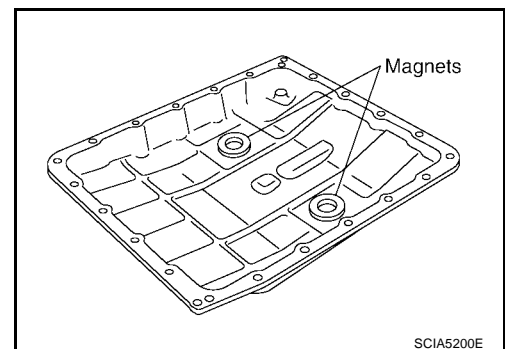

A
B
AT
D
E
F
G
H
I
J
K
L
M

ON-VEHICLE SERVICE

2. Install the oil pan and new oil pan gasket.

CAUTION:

- Do not reuse the oil pan gasket.
- Completely remove all moisture, oil and old gasket from the oil pan gasket mating surfaces and holes.
- Always replace the oil pan bolts as they are self-sealing.
- Be sure the oil pan drain plug hole is located to the rear of the transmission assembly.
- Partially install the oil pan bolts in a criss-cross pattern to prevent dislocation of the gasket.
- Be careful not to pinch harnesses.

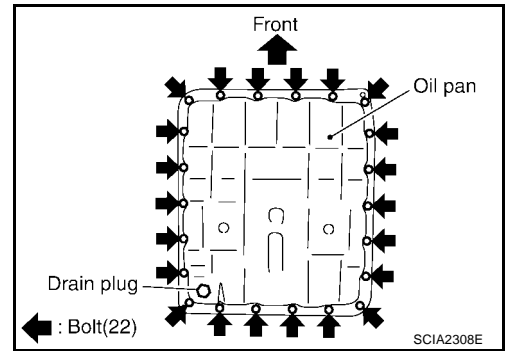

3. Tighten new oil pan bolts in numerical order as shown.

Oil pan bolts : 7.9 N-m (0.81 kg-m, 70 in-lb)

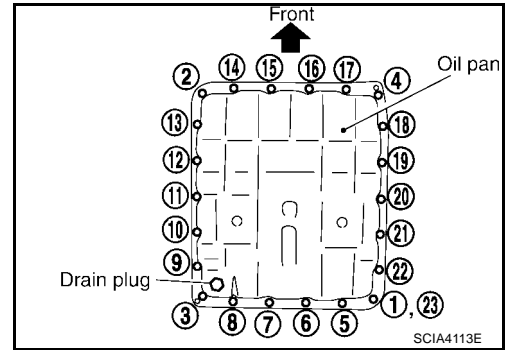

4. Install drain plug in oil pan with new gasket.

CAUTION:

Do not reuse the drain plug gasket.

Drain plug : 34 N-m (3.5 kg-m, 25 ft-lb)

5. Refill the transmission assembly with fluid. Refer to [AT-12. "Changing Automatic Transmission Fluid \(ATF\)"](#).

ON-VEHICLE SERVICE

Control Valve With TCM and A/T Fluid Temperature Sensor 2 COMPONENTS

ECS00H38

A
B
AT
D
E
F
G
H
I
J
K
L
M

SEC.313 · 314 · 315 · 316 · 317 · 319

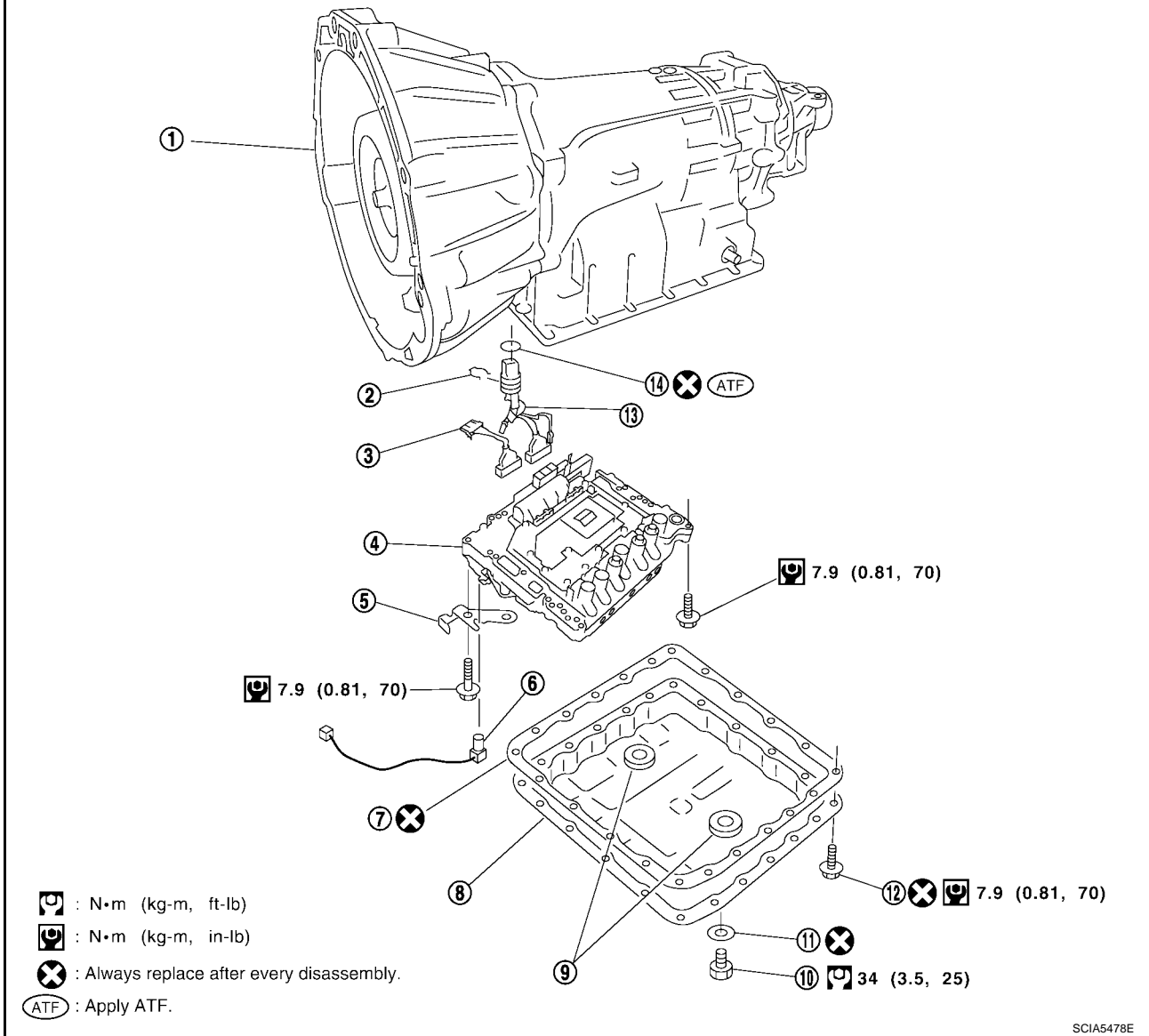

- | | | |
|----------------------------|-----------------------|-----------------------------------|
| 1. Transmission assembly | 2. Snap ring | 3. Sub-harness |
| 4. Control valve with TCM | 5. Bracket | 6. A/T fluid temperature sensor 2 |
| 7. Oil pan gasket | 8. Oil pan | 9. Magnets |
| 10. Drain plug | 11. Drain plug gasket | 12. Oil pan bolt |
| 13. Terminal cord assembly | 14. O-ring | |

ON-VEHICLE SERVICE

CONTROL VALVE WITH TCM REMOVAL AND INSTALLATION

Removal

1. Disconnect negative battery terminal
2. Drain ATF through drain plug.
3. Disconnect A/T assembly harness connector.
4. Remove snap ring from A/T assembly harness connector.

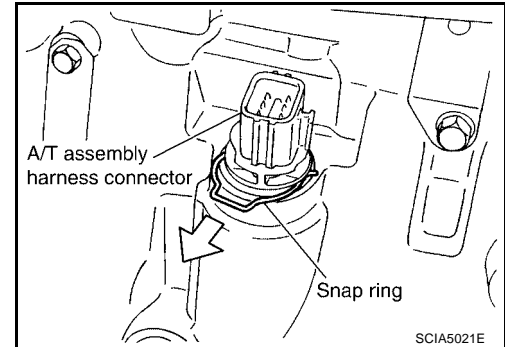

5. Push A/T assembly harness connector.

CAUTION:

Be careful not to damage connector.

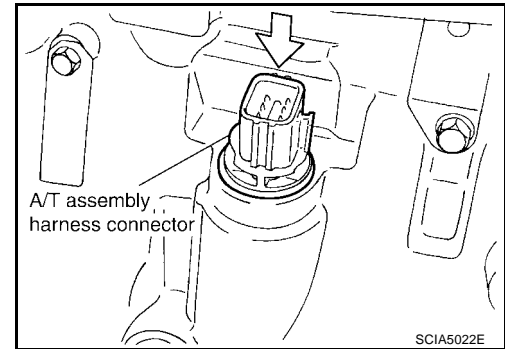

6. Remove oil pan and oil pan gasket. Refer to [AT-223, "Oil Pan"](#).
7. Disconnect A/T fluid temperature sensor 2 connector.

CAUTION:

Be careful not to damage connector.

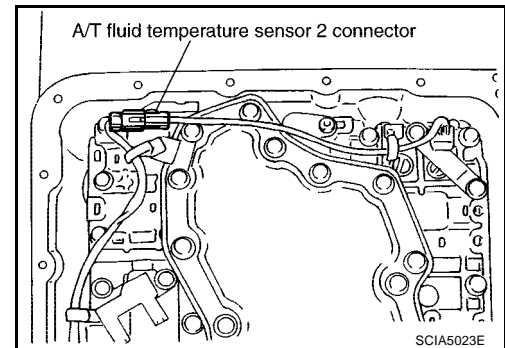

8. Straighten terminal clip to free terminal cord assembly and A/T fluid temperature sensor 2 harness.

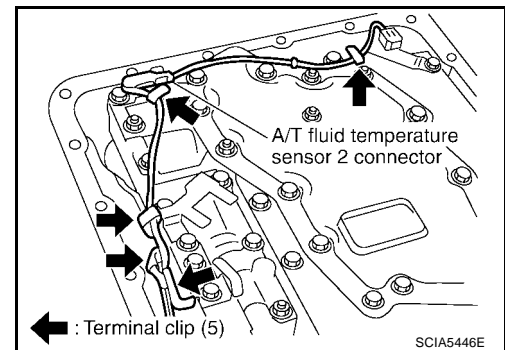

ON-VEHICLE SERVICE

9. Disconnect revolution sensor connector.

CAUTION:
Be careful not to damage connector.

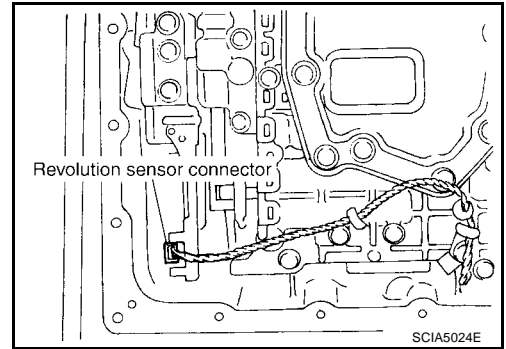

10. Straighten terminal clips to free revolution sensor harness.

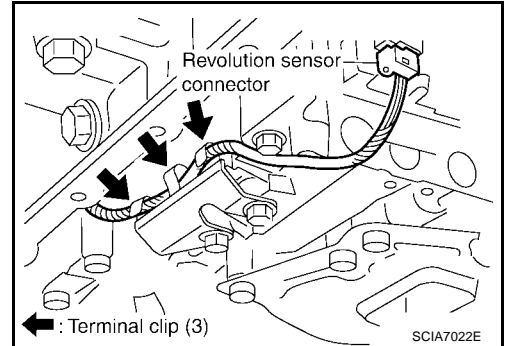

11. Remove bolts A, B and C from control valve with TCM.

Bolt symbol	Length mm (in)	Number of bolts
A	42 (1.65)	5
B	55 (2.17)	6
C	40 (1.57)	1

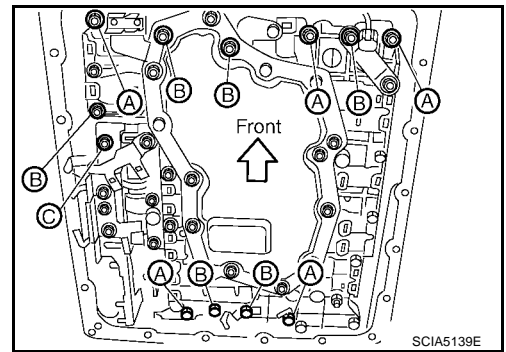

12. Remove control valve with TCM from transmission case.

CAUTION:
Be careful with the manual valve notch and manual plate height. Remove it vertically.

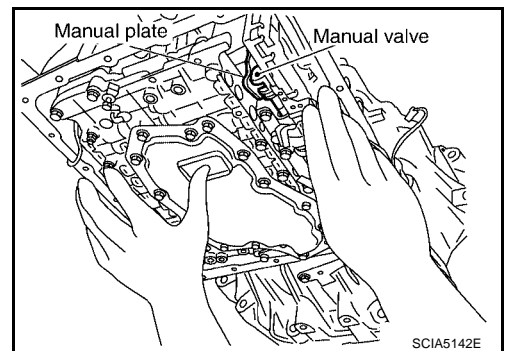

13. Remove A/T fluid temperature sensor 2 with bracket from control valve with TCM.

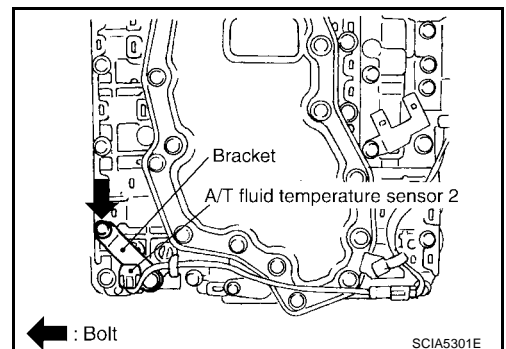

A
B
AT
D
E
F
G
H
I
J
K
L
M

ON-VEHICLE SERVICE

14. Remove bracket from A/T fluid temperature sensor 2.

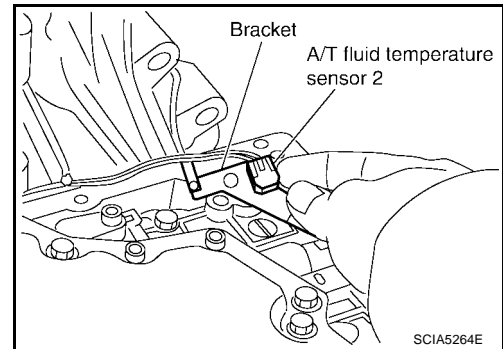

15. Remove O-ring from A/T assembly harness connector.

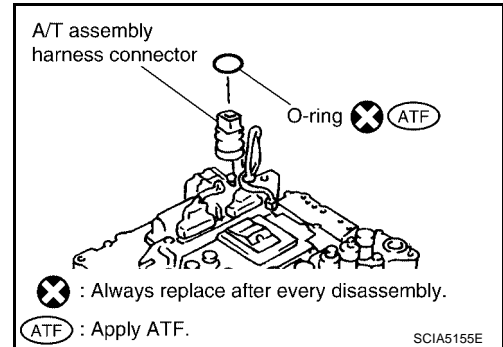

16. Disconnect TCM connectors.

CAUTION:
Be careful not to damage connectors.

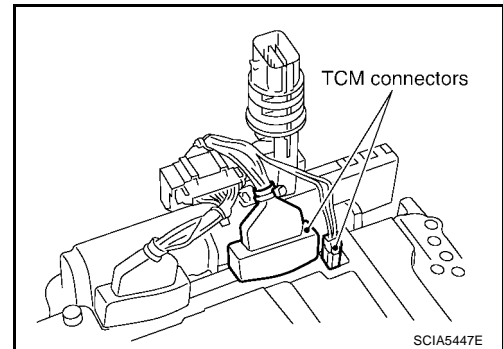

17. Remove A/T assembly harness connector from control valve with TCM using suitable tool.

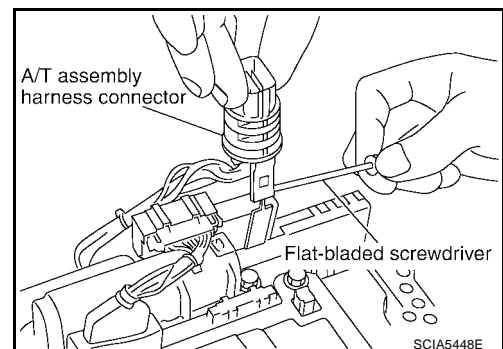

18. Disconnect TCM connector and park/neutral position switch connector

CAUTION:
Be careful not to damage connectors.

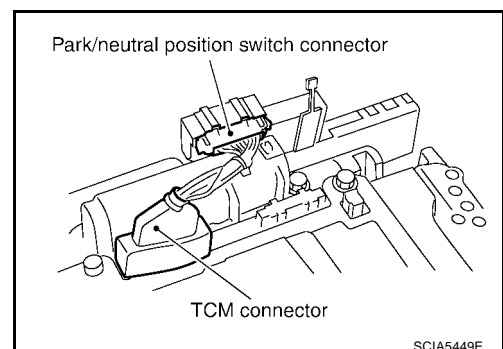

ON-VEHICLE SERVICE

Installation

1. Connect TCM connector and park/neutral position switch connector.

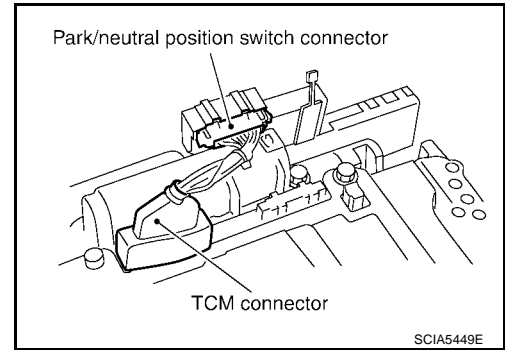

2. Install A/T assembly harness connector to control valve with TCM.

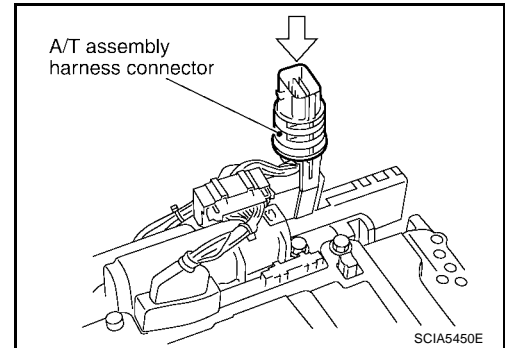

3. Connect TCM connector.

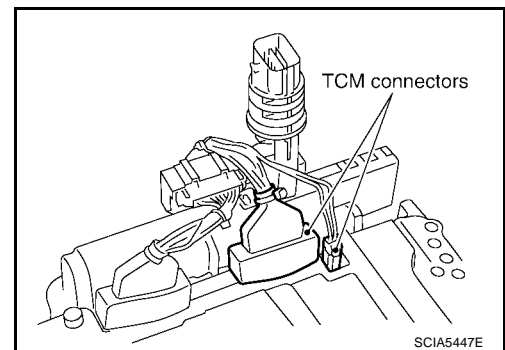

4. Install new O-ring in A/T assembly harness connector.

NOTE:

- Do not reuse O-ring.
- Apply ATF to O-ring.

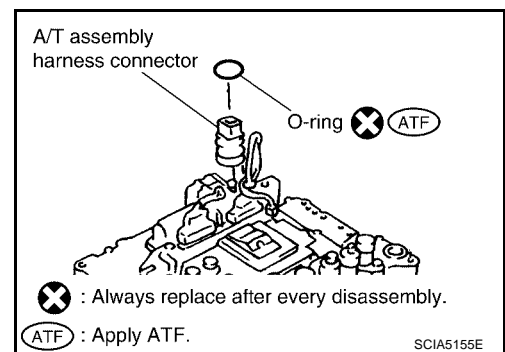

A
B
AT
D
E
F
G
H
I
J
K
L
M

ON-VEHICLE SERVICE

5. Install A/T fluid temperature sensor 2 to bracket.

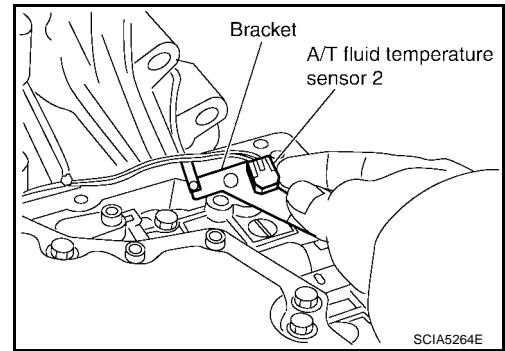

6. Install A/T fluid temperature sensor 2 (with bracket) in control valve with TCM. Tighten A/T fluid temperature sensor 2 bolt to the specified torque. Refer to [AT-245, "Components"](#).

CAUTION:

Adjust bolt hole of bracket to bolt hole of control valve with TCM.

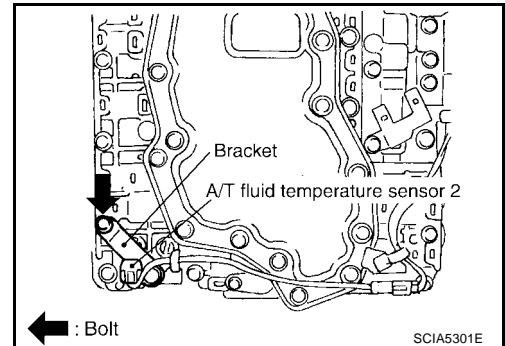

7. Install control valve with TCM in transmission case.

CAUTION:

- Make sure that turbine revolution sensor securely installs turbine revolution sensor hole.
- Hang down revolution sensor harness toward outside so as not to disturb installation of control valve with TCM.
- Adjust A/T assembly harness connector of control valve with TCM to terminal hole of transmission case.

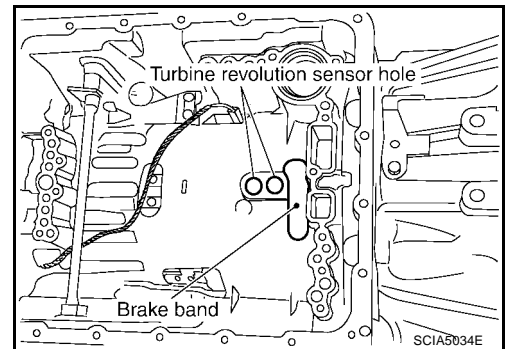

- Assemble it so that manual valve cutout is engaged with manual plate projection.

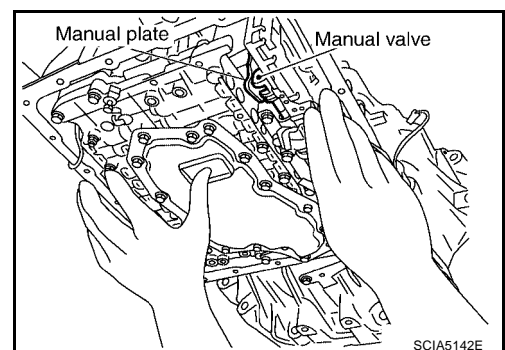

ON-VEHICLE SERVICE

8. Install bolts A, B and C in control valve with TCM.

Bolt symbol	Length mm (in)	Number of bolts
A	42 (1.65)	5
B	55 (2.17)	6
C	40 (1.57)	1

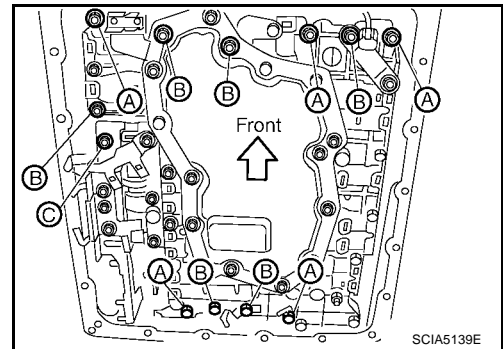

9. Tighten bolt 1, 2 and 3 temporarily to prevent dislocation. Then tighten them in order (1 → 2 → 3), and then tighten other bolts.
10. Tighten control valve with TCM bolts to the specified torque. Refer to [AT-245, "Components"](#).

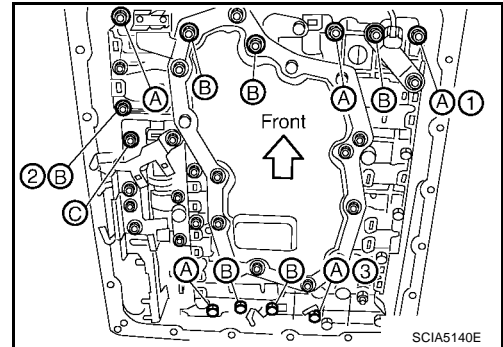

11. Connect A/T fluid temperature sensor 2 connector.

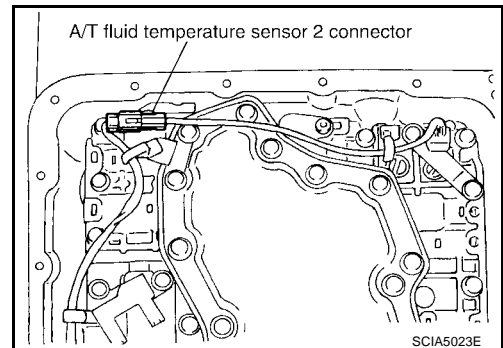

12. Securely fasten terminal cord assembly and A/T fluid temperature sensor 2 harness with terminal clips.

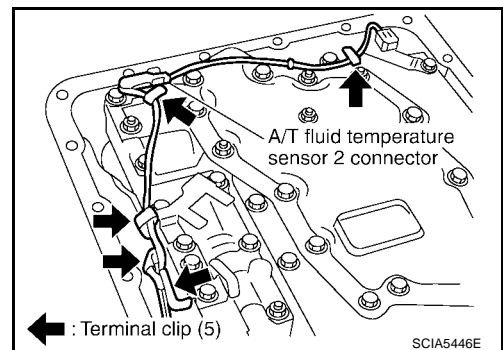

ON-VEHICLE SERVICE

13. Connect revolution sensor connector.

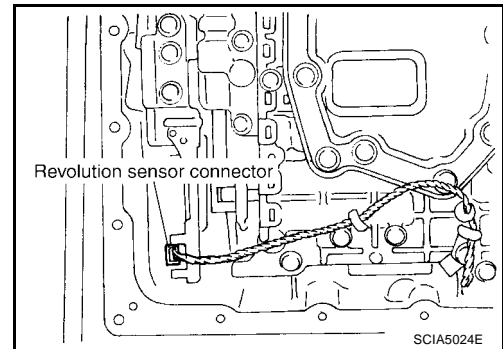

14. Securely fasten revolution sensor harness with terminal clips.

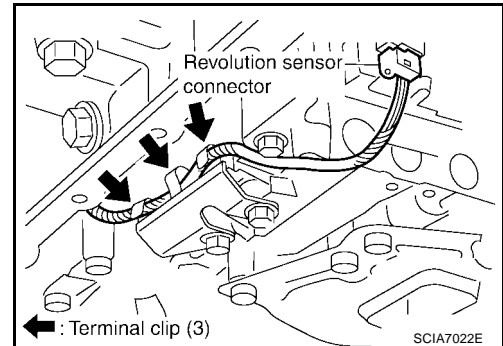

15. Install oil pan to transmission case. Refer to [AT-223, "Oil Pan"](#) .

16. Pull up A/T assembly harness connector.

CAUTION:

Be careful not to damage connector.

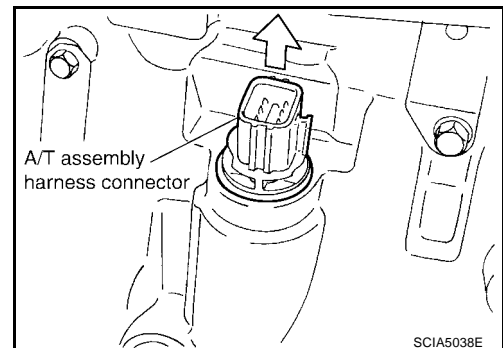

17. Install snap ring to A/T assembly harness connector.

18. Connect A/T assembly harness connector.

19. Pour ATF into transmission assembly. Refer to [AT-12, "Changing Automatic Transmission Fluid \(ATF\)"](#) .

20. Connect the negative battery terminal

CAUTION:

After completing installation, check A/T fluid leakage and fluid level. Refer to [AT-12, "Changing Automatic Transmission Fluid \(ATF\)"](#) , [AT-12, "Checking Automatic Transmission Fluid \(ATF\)"](#)

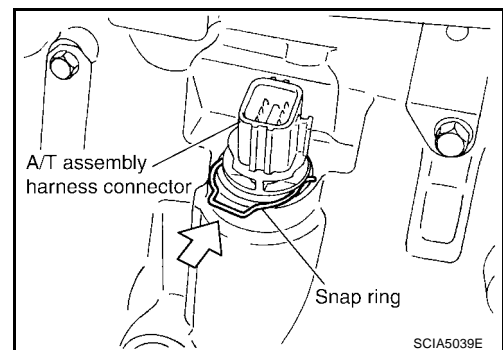

ON-VEHICLE SERVICE

A/T FLUID TEMPERATURE SENSOR 2 REMOVAL AND INSTALLATION

Removal

1. Disconnect negative battery terminal
2. Remove oil pan and oil pan gasket. Refer to [AT-223, "Oil Pan"](#).
3. Disconnect A/T fluid temperature sensor 2 connector.

CAUTION:

Be careful not to damage connector.

4. Straighten terminal clip to free A/T fluid temperature sensor 2 harness.

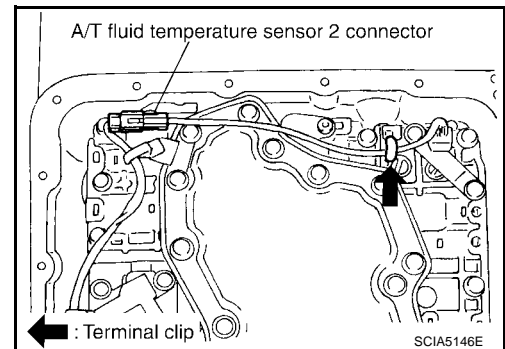
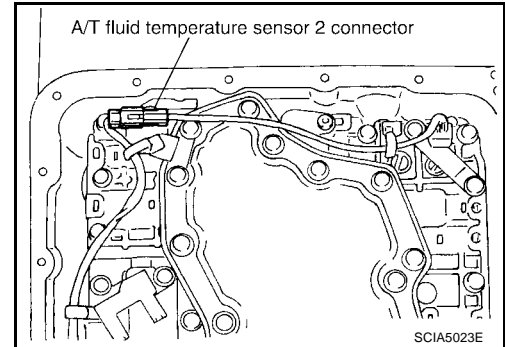

5. Remove A/T fluid temperature sensor 2 with bracket from control valve with TCM.

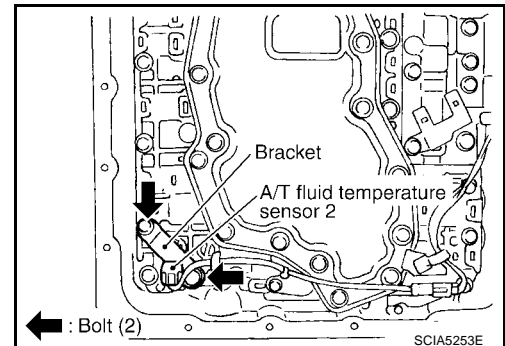

6. Remove bracket from A/T fluid temperature sensor 2.

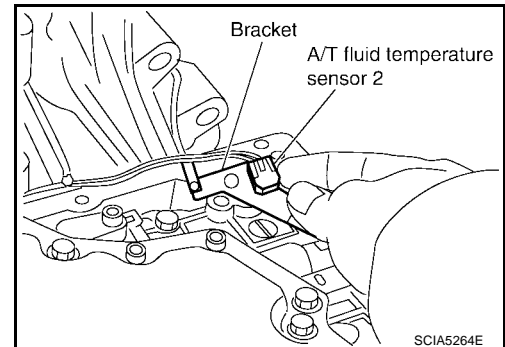

ON-VEHICLE SERVICE

Installation

1. Install A/T fluid temperature sensor 2 to bracket.

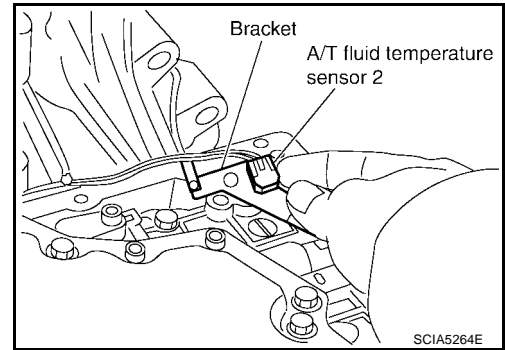

2. Install A/T fluid temperature sensor 2 (with bracket) in control valve with TCM. Tighten A/T fluid temperature sensor 2 bolt to the specified torque. Refer to [AT-245, "Components"](#).

CAUTION:

Adjust bolt hole of bracket to bolt hole of control valve with TCM.

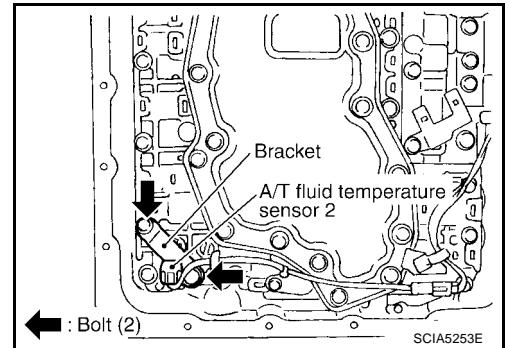

3. Connect A/T fluid temperature sensor 2 connector.

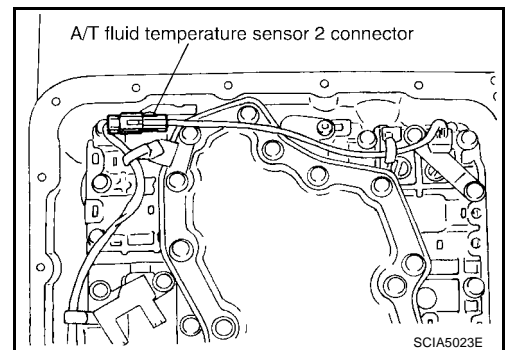

4. Securely fasten A/T temperature sensor 2 harness with terminal clip.

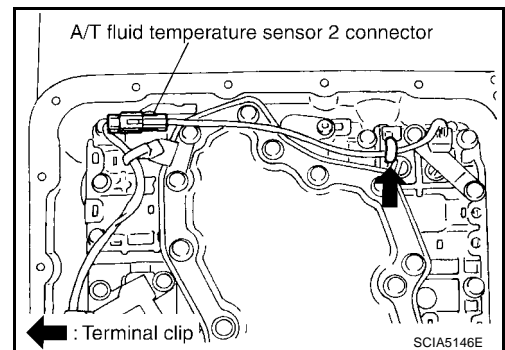

5. Install oil pan to transmission case. Refer to [AT-223, "Oil Pan"](#).
6. Connect the negative battery terminal

CAUTION:

After completing installation, check for A/T fluid leakage and fluid level. Refer to [AT-12, "Changing Automatic Transmission Fluid \(ATF\)"](#), [AT-12, "Checking Automatic Transmission Fluid \(ATF\)"](#).

Rear Oil Seal REMOVAL AND INSTALLATION

Removal

1. Remove rear propeller shaft. Refer to [PR-9, "REMOVAL"](#).
2. Remove transfer from transmission (4WD models). Refer to [TF-144, "REMOVAL"](#).
3. Remove rear oil seal using suitable tool.

CAUTION:

Be careful not to scratch rear extension assembly (2WD models) or adapter case assembly (4WD models).

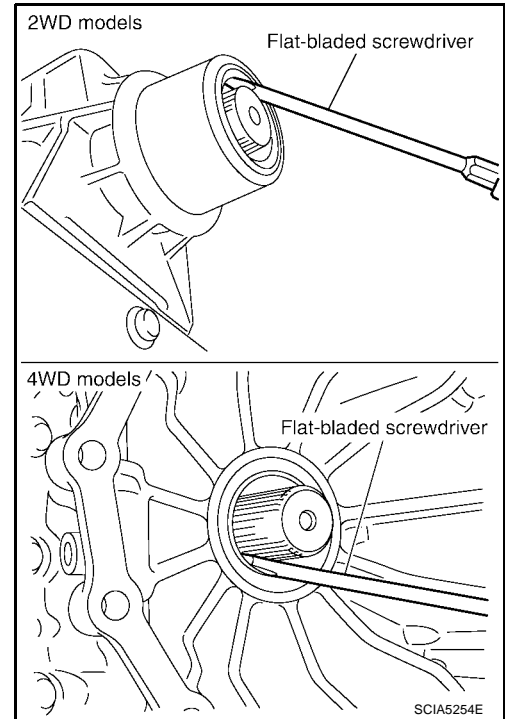

Installation

1. Install new rear oil seal until it is flush with component face into the extension case (2WD models) using Tool, or adapter case (4WD models) using suitable tool.

Tool number : **ST33400001 (J-26082)**

CAUTION:

- Apply ATF to rear oil seal.
- Do not reuse rear oil seal.

2. Install transfer to transmission (4WD models). Refer to [TF-144, "INSTALLATION"](#).
3. Install rear propeller shaft. Refer to [PR-9, "INSTALLATION"](#).

CAUTION:

After completing installation, check for A/T fluid leakage and fluid level. Refer to [AT-12, "Changing Automatic Transmission Fluid \(ATF\)"](#) and [AT-12, "Checking Automatic Transmission Fluid \(ATF\)"](#).

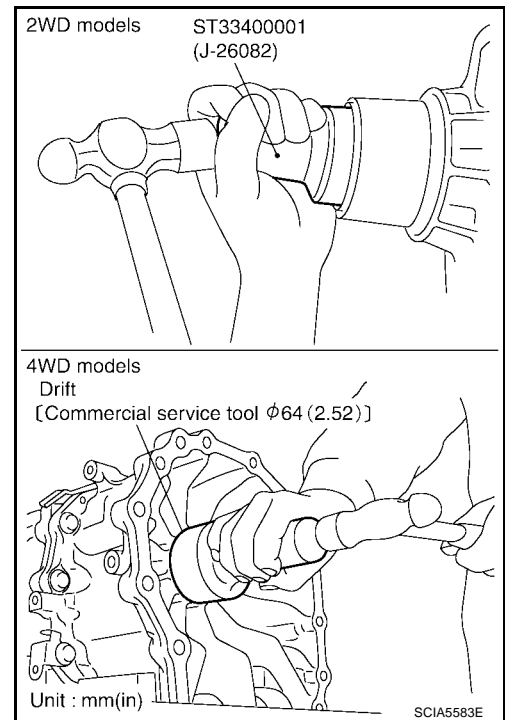

AIR BREATHER HOSE

AIR BREATHER HOSE

PFP:31098

Removal and Installation 2WD

ECS00H3A

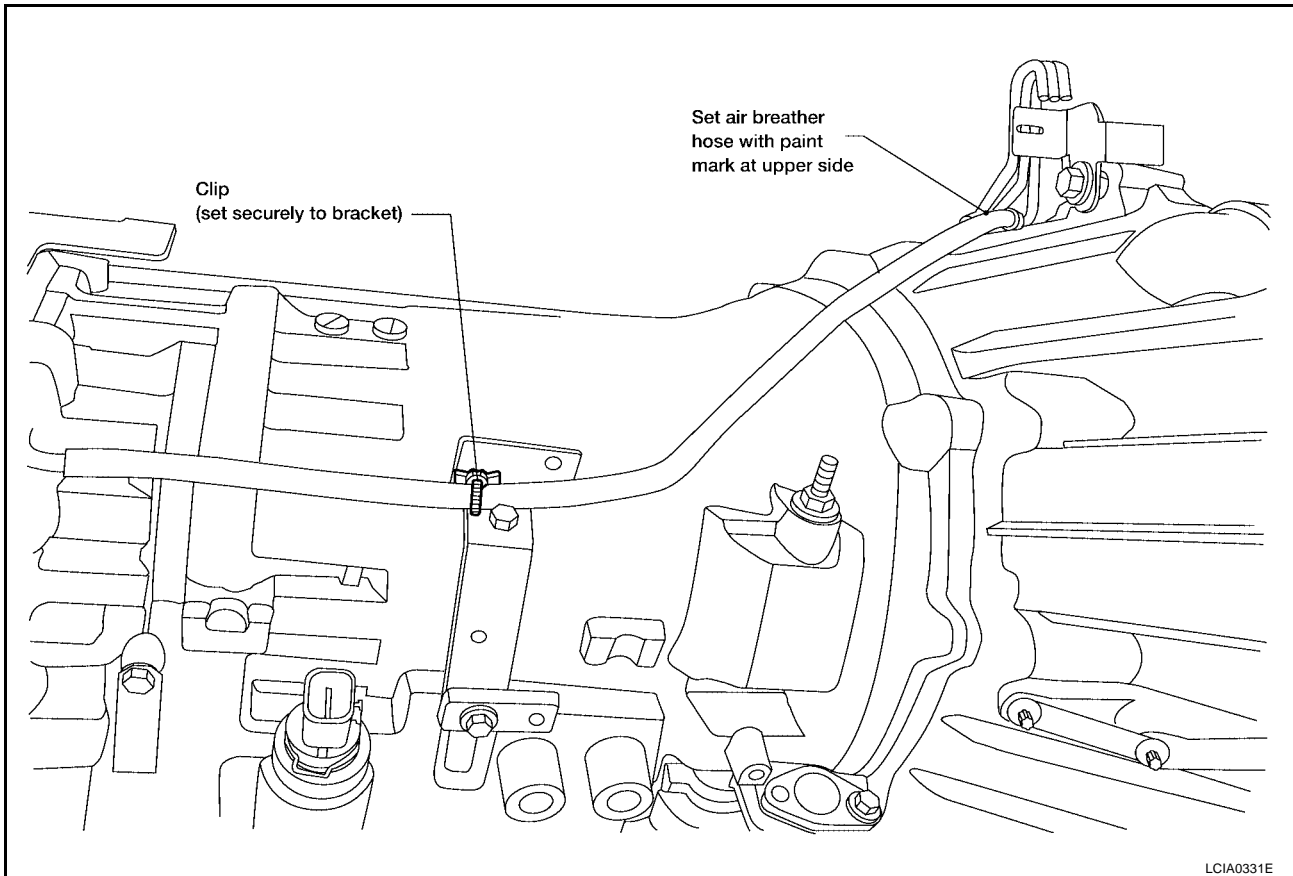

CAUTION:

- When installing an air breather hose, do not crush or block by folding or bending the hose.
- When inserting a hose to the transmission tube, be sure to insert it fully until its end reaches the tube bend portion.

AIR BREATHER HOSE

4WD

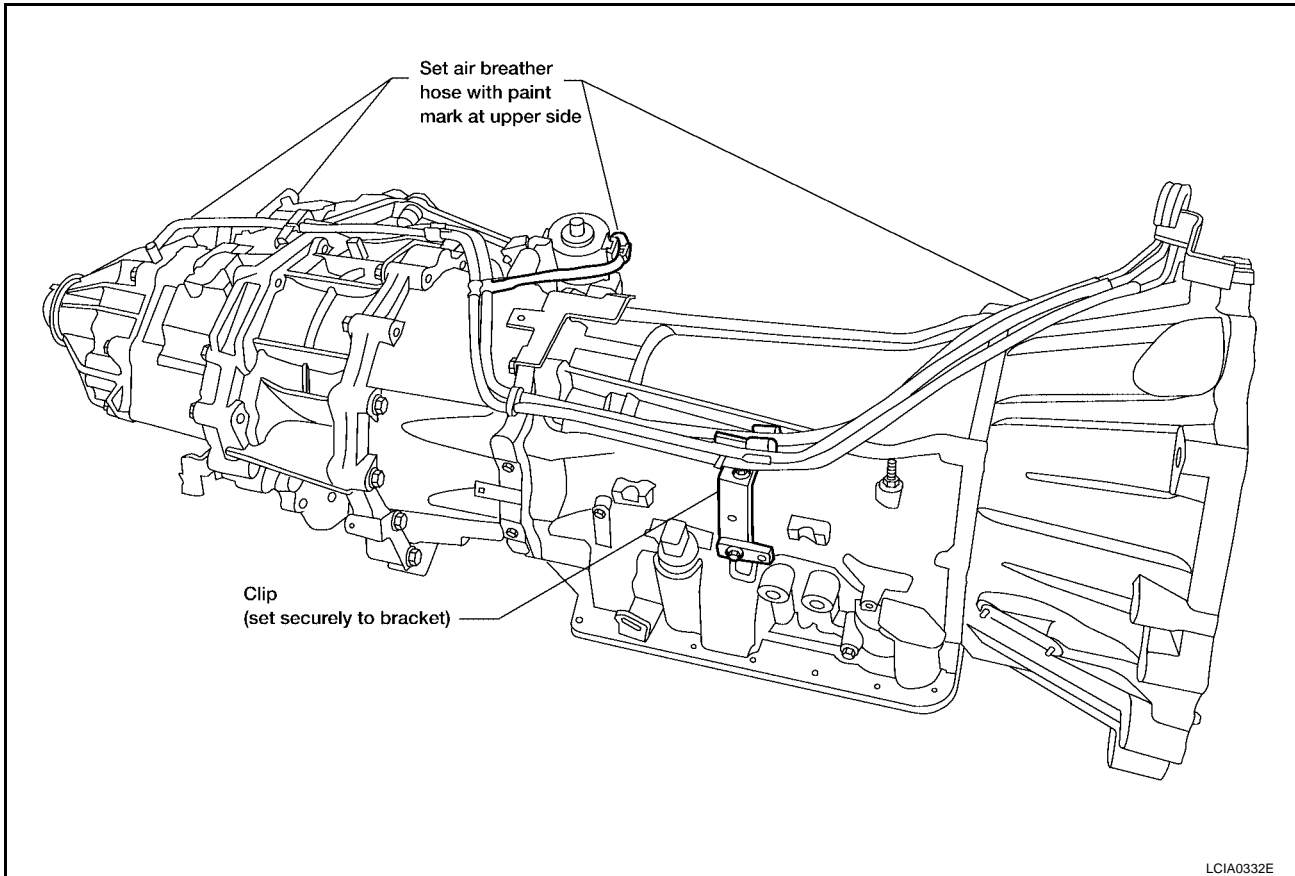

CAUTION:

- When installing an air breather hose, do not crush or block by folding or bending the hose.
- When inserting a hose to the transmission tube, be sure to insert it fully until its end reaches the tube bend portion.

A

B

AT

D

E

F

G

H

I

J

K

L

M

TRANSMISSION ASSEMBLY

PFP:31020

TRANSMISSION ASSEMBLY

Removal and Installation (2WD) COMPONENTS

ECS00H3B

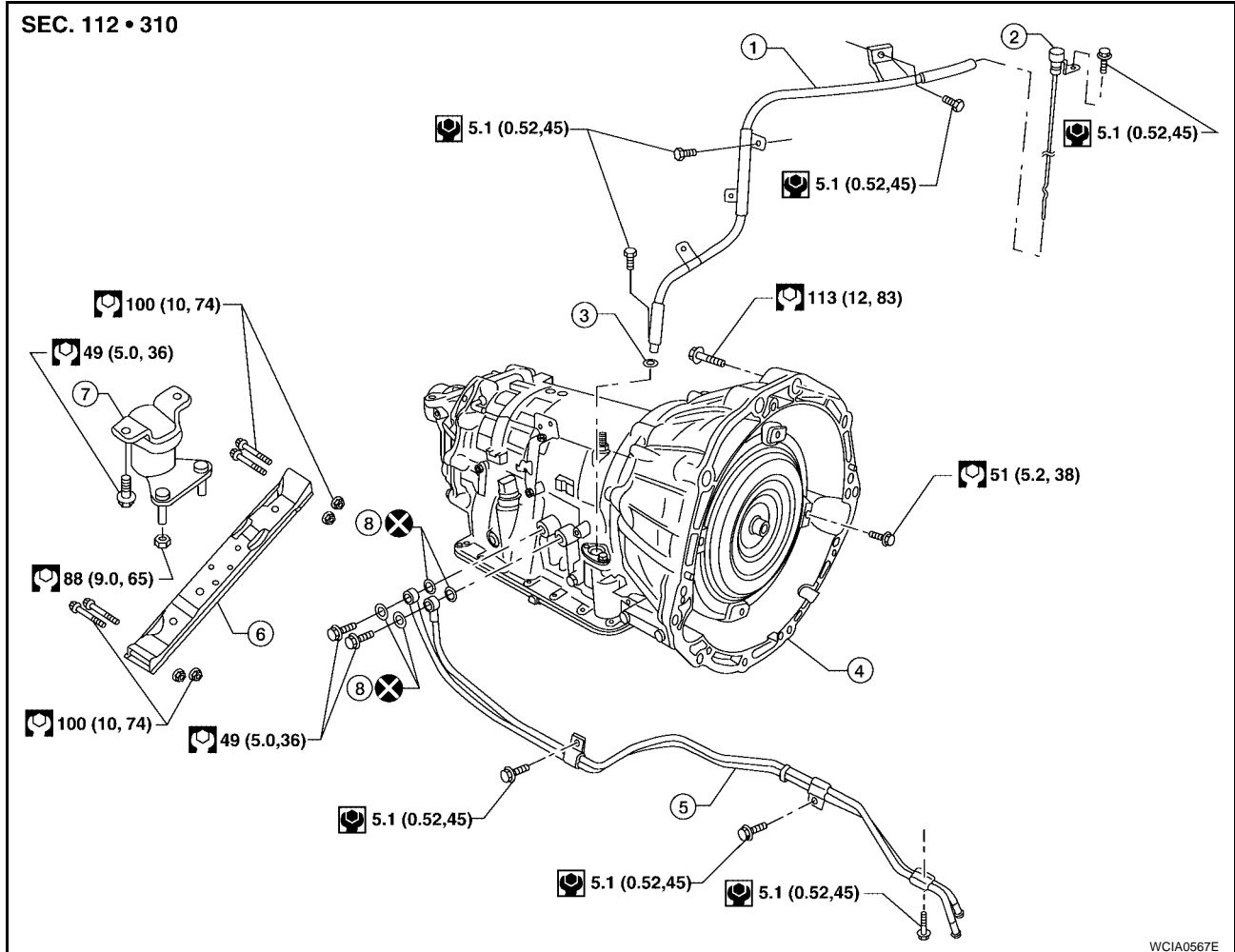

WCIA0567E

- | | | |
|-----------------------------|------------------------|---------------------|
| 1. A/T fluid indicator pipe | 2. A/T fluid indicator | 3. O-ring |
| 4. Transmission assembly | 5. Fluid cooler tube | 6. A/T cross member |
| 7. Insulator | 8. Copper washers | |

REMOVAL

CAUTION:

When removing the A/T assembly from engine, first remove the crankshaft position sensor (POS) from the A/T assembly.

Be careful not to damage sensor edge.

1. Disconnect the negative battery terminal.
2. Remove engine cover.
3. Remove A/T fluid indicator gauge.
4. Remove undercovers using power tool.
5. Remove exhaust front tube and center muffler using power tool. Refer to [EX-4, "REMOVAL"](#).
6. Remove rear propeller shaft. Refer to [PR-9, "REMOVAL"](#).
7. Remove A/T control cable. Refer to [AT-222, "REMOVAL"](#).

TRANSMISSION ASSEMBLY

8. Remove crankshaft position sensor (POS) from A/T assembly.

CAUTION:

- Do not subject it to impact by dropping or hitting it.
- Do not disassemble.
- Do not allow metal filings or foreign material to get on the sensor front edge magnetic area.
- Do not place in an area affected by magnetism.

9. Remove fluid cooler tube.

10. Remove dust cover from converter housing.

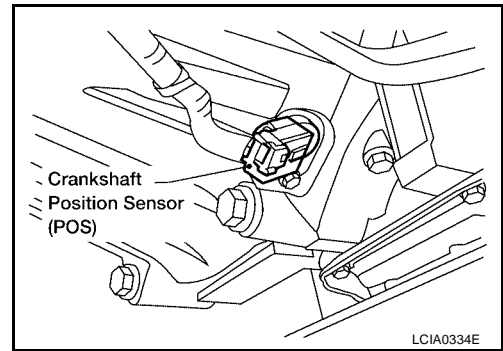

11. Turn crankshaft to access and remove the four bolts for drive plate and torque converter.

CAUTION:

When turning crankshaft, turn it clockwise as viewed from the front of the engine.

12. Support A/T assembly with a transmission jack.

CAUTION:

When setting the transmission jack, be careful not to allow it to collide against the drain plug.

13. Remove cross member using power tool.

14. Remove air breather hose. Refer to [AT-236, "Removal and Installation"](#).

15. Disconnect A/T assembly connector.

16. Remove A/T fluid indicator pipe from A/T assembly.

17. Plug any openings such as the A/T fluid indicator pipe hole.

18. Remove the A/T assembly to engine bolts using power tool.

19. Remove A/T assembly from vehicle using transmission jack.

CAUTION:

- Secure torque converter to prevent it from dropping.
- Secure A/T assembly to a transmission jack.

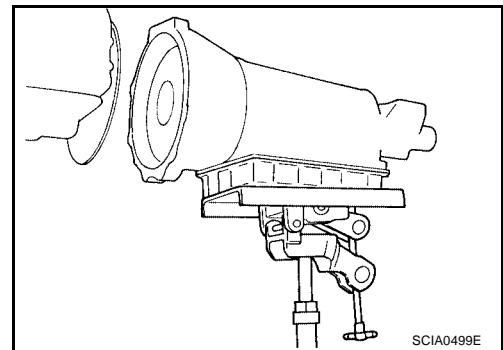
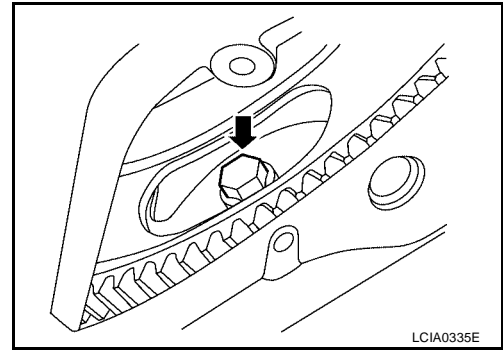

INSPECTION

Installation and Inspection of Torque Converter

- After inserting a torque converter to a transmission, be sure to check dimension A to ensure it is within specifications.

Dimension A : 24.0 mm (0.94 in) or more

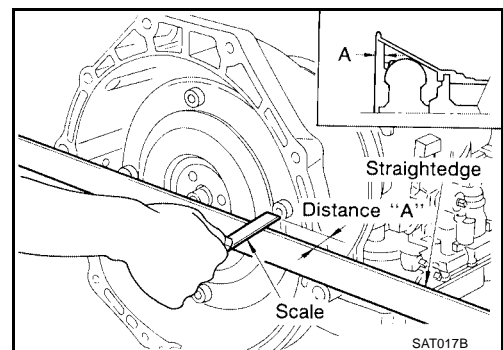

TRANSMISSION ASSEMBLY

INSTALLATION

Installation of the remaining components is in the reverse order of the removal, while paying attention to the following:

- When installing transmission to the engine, attach the bolts as shown.

Transmission to engine bolts : 113 N-m (12 kg-m, 83 ft-lb)

NOTE:

*: No.2 bolt also secures air breather vent.

CAUTION:

- When replacing an engine or transmission you must make sure the dowels are installed correctly during re-assembly.
 - Improper alignment caused by missing dowels may cause vibration, oil leaks or breakage of drivetrain components.
-
- Align the positions of bolts for drive plate with those of the torque converter, and temporarily tighten the bolts. Then tighten the bolts with the specified torque.

CAUTION:

- When turning crankshaft, turn it clockwise as viewed from the front of the engine.
- After converter is installed to drive plate, rotate crankshaft several turns and check to be sure that transmission rotates freely without binding.
- Install crankshaft position sensor (POS).
- After completing installation check fluid leakage, fluid level and the positions of A/T. Refer to [AT-12, "Checking Automatic Transmission Fluid \(ATF\)"](#) , [AT-222, "Checking of A/T Position"](#) and [AT-222, "Adjustment of A/T Position"](#) .

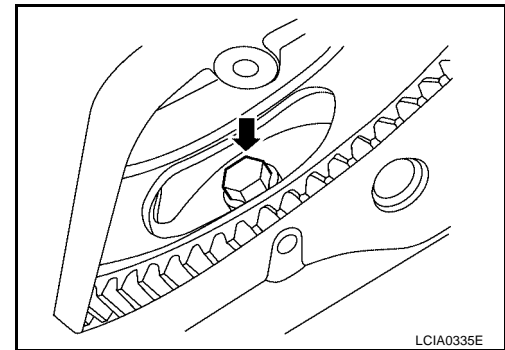
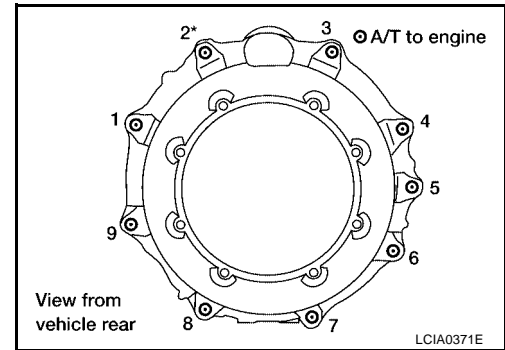

TRANSMISSION ASSEMBLY

ECS00H3C

Removal and Installation (4WD) COMPONENTS

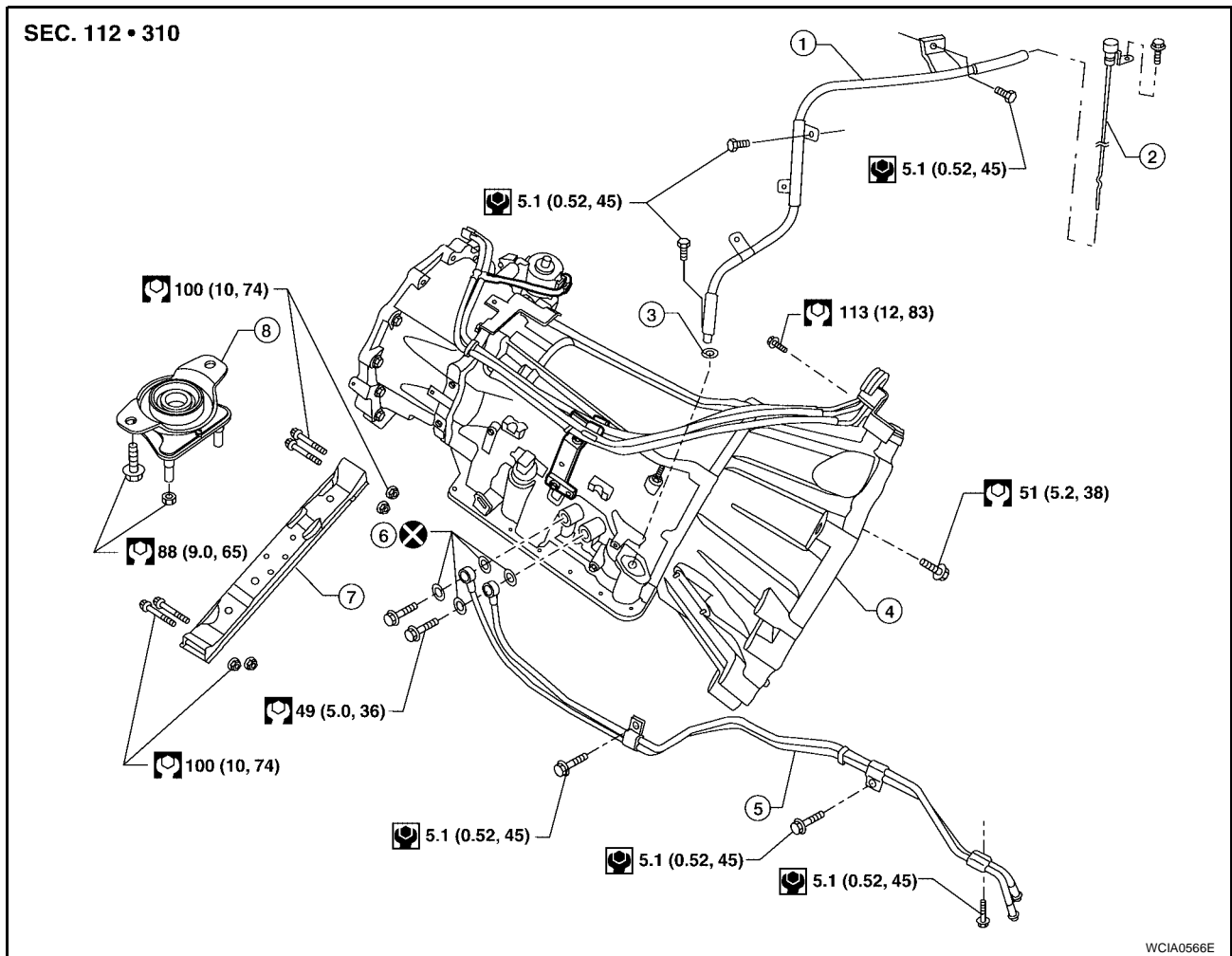

- | | | |
|-----------------------------|------------------------|------------------|
| 1. A/T fluid indicator pipe | 2. A/T fluid indicator | 3. O-ring |
| 4. Transmission assembly | 5. Fluid cooler tube | 6. Copper washer |
| 7. A/T cross member | 8. Insulator | |

REMOVAL

CAUTION:

When removing the A/T assembly from engine, first remove the crankshaft position sensor (POS) from the A/T assembly.

Be careful not to damage sensor edge.

1. Disconnect the negative battery terminal.
2. Remove engine cover using power tool.
3. Remove A/T fluid indicator.
4. Remove undercovers using power tool.
5. Remove exhaust front tube and center muffler using power tool. Refer to [EX-4, "REMOVAL"](#).
6. Remove propeller shafts. Refer to [PR-5, "REMOVAL"](#) and [PR-9, "REMOVAL"](#).
7. Remove A/T control cable. Refer to [AT-222, "REMOVAL"](#).

TRANSMISSION ASSEMBLY

8. Remove crankshaft position sensor (POS) from A/T assembly.

CAUTION:

- Do not subject it to impact by dropping or hitting it.
- Do not disassemble.
- Do not allow metal filings or foreign material to get on the sensor's front edge magnetic area.
- Do not place in an area affected by magnetism.

9. Disconnect A/T fluid cooler tube from A/T assembly.
10. Remove dust cover from converter housing.

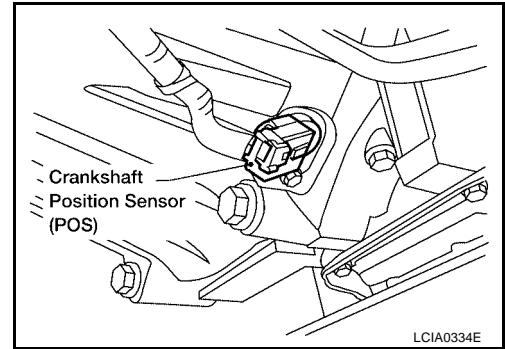

11. Turn crankshaft, and remove the four bolts for drive plate and torque converter.

CAUTION:

When turning crankshaft, turn it clockwise as viewed from the front of the engine.

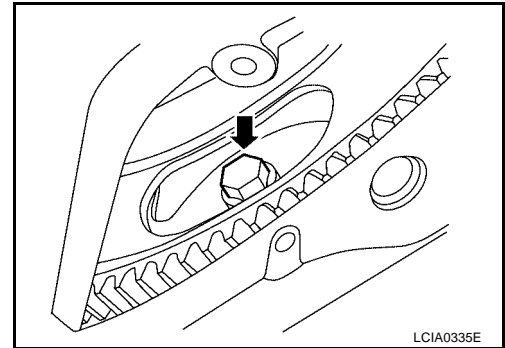

12. Support A/T assembly using transmission jack and Tool.

Tool number : — (J-47002)

CAUTION:

When setting the transmission jack, be careful not to allow it to collide against the drain plug.

NOTE:

The actual special service tool may differ from tool shown.

13. Remove cross member using power tool.
14. Tilt the transmission slightly to keep the clearance between body and transmission, then disconnect air breather hose from A/T fluid indicator pipe. Refer to [AT-241, "REMOVAL"](#).
15. Disconnect A/T assembly connector and transfer unit connector.
16. Remove A/T fluid indicator pipe.
17. Plug any openings such as the fluid charging pipe hole.
18. Remove A/T assembly to engine bolts using power tool.
19. Remove A/T assembly with transfer from vehicle.

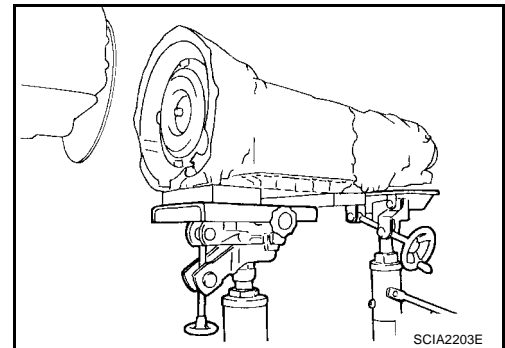

CAUTION:

- Secure torque converter to prevent it from dropping.
- Secure A/T assembly to transmission jack.

20. Remove transfer from A/T assembly. Refer to [TF-144, "REMOVAL"](#).

TRANSMISSION ASSEMBLY

INSPECTION

Installation and Inspection of Torque Converter

- After inserting a torque converter to a transmission, be sure to check dimension A to ensure it is within specifications.

Dimension A : 24.0 mm (0.94 in) or more

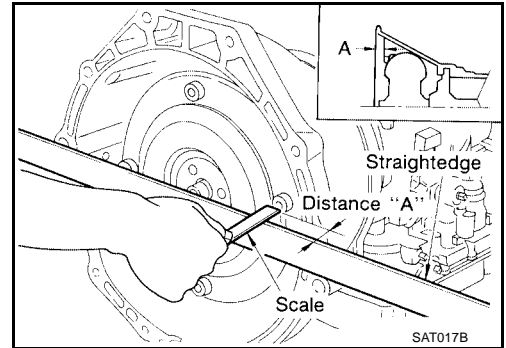

A

B

AT

D

E

F

G

H

I

J

K

L

M

TRANSMISSION ASSEMBLY

INSTALLATION

Installation of the remaining components is in the reverse order of removal, while paying attention to the following:

- When installing transmission to the engine, attach the bolts as shown.

Transmission to engine bolts : 113 N-m (12 kg-m, 83 ft-lb)

NOTE:

*: No.2 bolt also secures air breather vent.

CAUTION:

- When replacing an engine or transmission you must make sure the dowels are installed correctly during re-assembly.
 - Improper alignment caused by missing dowels may cause vibration, oil leaks or breakage of drivetrain components.
-
- Align the positions of bolts for drive plate with those of the torque converter, and temporarily tighten the bolts. Then tighten the bolts with the specified torque.

CAUTION:

- When turning crankshaft, turn it clockwise as viewed from the front of the engine.
- After converter is installed to drive plate, rotate crankshaft several turns and check to be sure that transmission rotates freely without binding.
- Install crankshaft position sensor (POS).
- After completing installation, check fluid leakage, fluid level, and the positions of A/T. Refer to [AT-12, "Checking Automatic Transmission Fluid \(ATF\)"](#) , [AT-222, "Checking of A/T Position"](#) and [AT-222, "Adjustment of A/T Position"](#) .

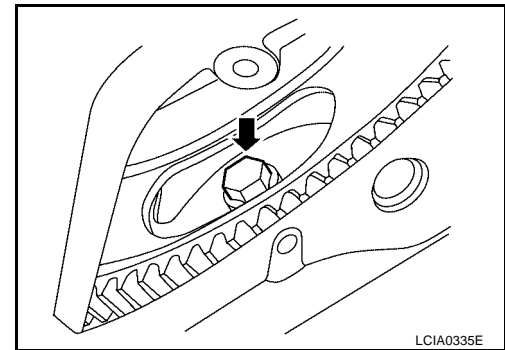
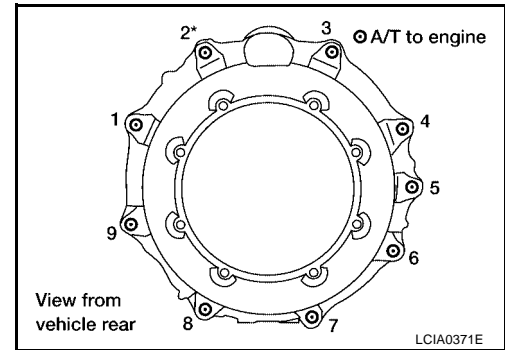

OVERHAUL

OVERHAUL Components

PF0:0000

ECS00H3D

SEC.311·313·314·315

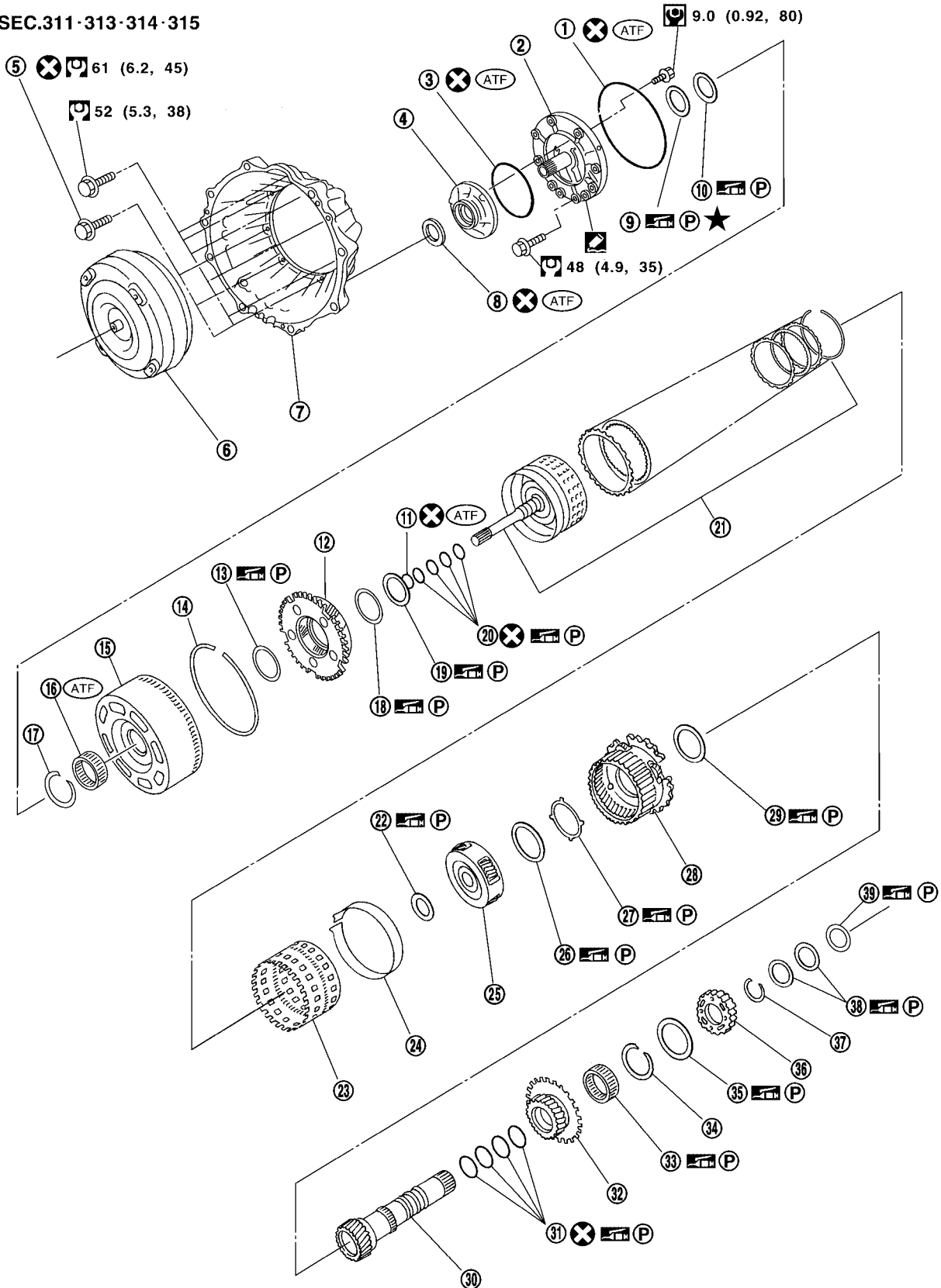

A
B
AT
D
E
F
G
H
I
J
K
L
M

OVERHAUL

- | | | |
|---------------------------|------------------------------|-------------------------------------|
| 1. O-ring | 2. Oil pump cover | 3. O-ring |
| 4. Oil pump housing | 5. Self-sealing bolt | 6. Torque converter |
| 7. Converter housing | 8. Oil pump housing oil seal | 9. Bearing race |
| 10. Needle bearing | 11. O-ring | 12. Front carrier assembly |
| 13. Needle bearing | 14. Snap ring | 15. Front sun gear |
| 16. 3rd one-way clutch | 17. Snap ring | 18. Bearing race |
| 19. Needle bearing | 20. Seal ring | 21. Input clutch assembly |
| 22. Needle bearing | 23. Rear internal gear | 24. Brake band |
| 25. Mid carrier assembly | 26. Needle bearing | 27. Bearing race |
| 28. Rear carrier assembly | 29. Needle bearing | 30. Mid sun gear |
| 31. Seal ring | 32. Rear sun gear | 33. 1st one-way clutch |
| 34. Snap ring | 35. Needle bearing | 36. High and low reverse clutch hub |
| 37. Snap ring | 38. Bearing race | 39. Needle bearing |

 Apply Genuine Silicone RTV or the equivalent. Refer to GI-XX, "Recommended chemical products and sealants"

OVERHAUL

SEC.315· 316

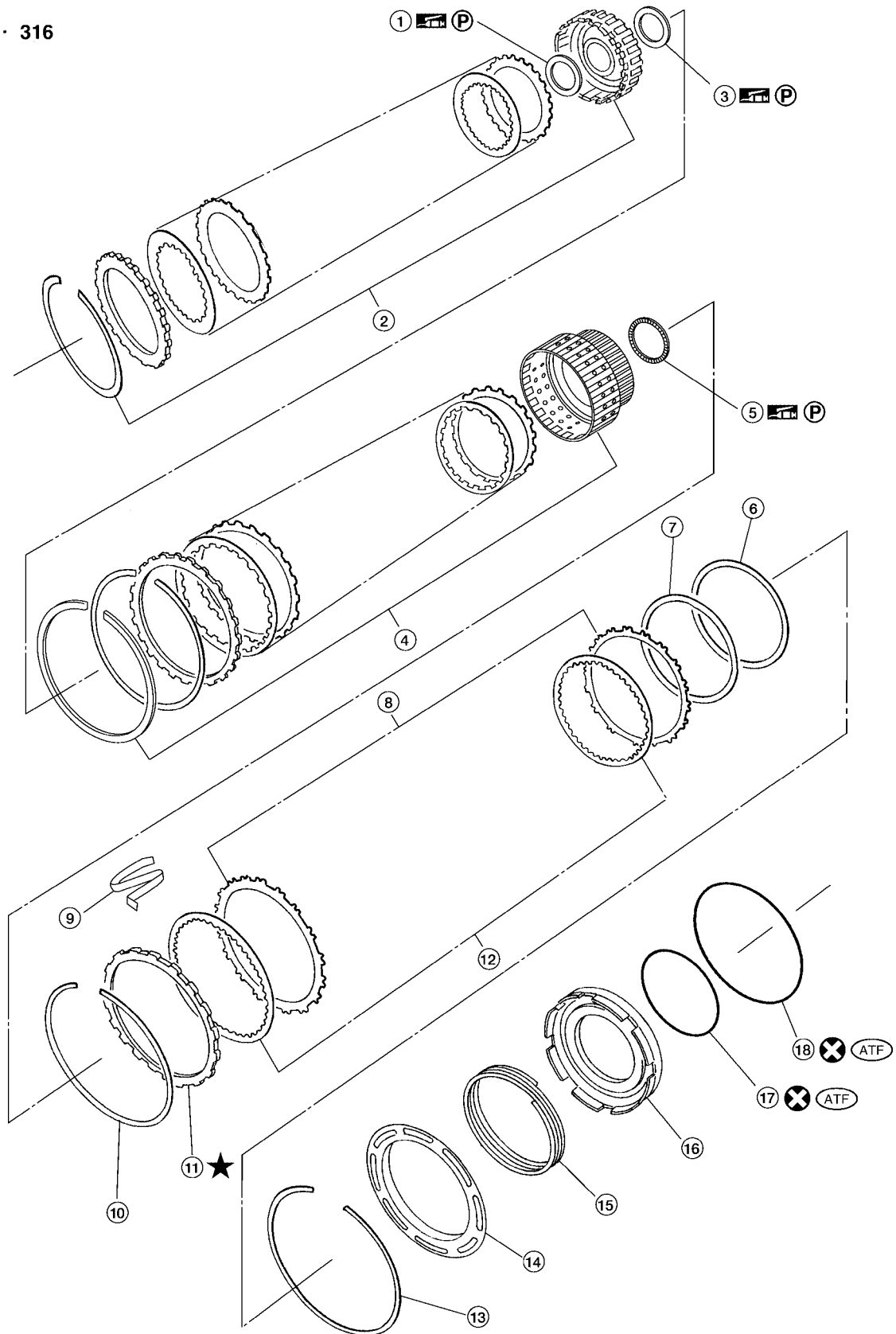

A
B
AT
D
E
F
G
H
I
J
K
L
M

- | | | |
|---------------------------|---|-----------------------------|
| 1. Bearing race | 2. High and low reverse clutch assembly | 3. Needle bearing |
| 4. Direct clutch assembly | 5. Needle bearing | 6. Reverse brake dish plate |

WCIA0623E

OVERHAUL

- | | | |
|-----------------------------|-----------------------------------|-------------------------------|
| 7. Reverse brake dish plate | 8. Reverse brake driven plate | 9. N-spring |
| 10. Snap ring | 11. Reverse brake retaining plate | 12. Reverse brake drive plate |
| 13. Snap ring | 14. Spring retainer | 15. Return spring |
| 16. Reverse brake piston | 17. D-ring | 18. D-ring |

OVERHAUL

2WD models

SEC.313 · 314 · 315 · 316 · 317 · 319

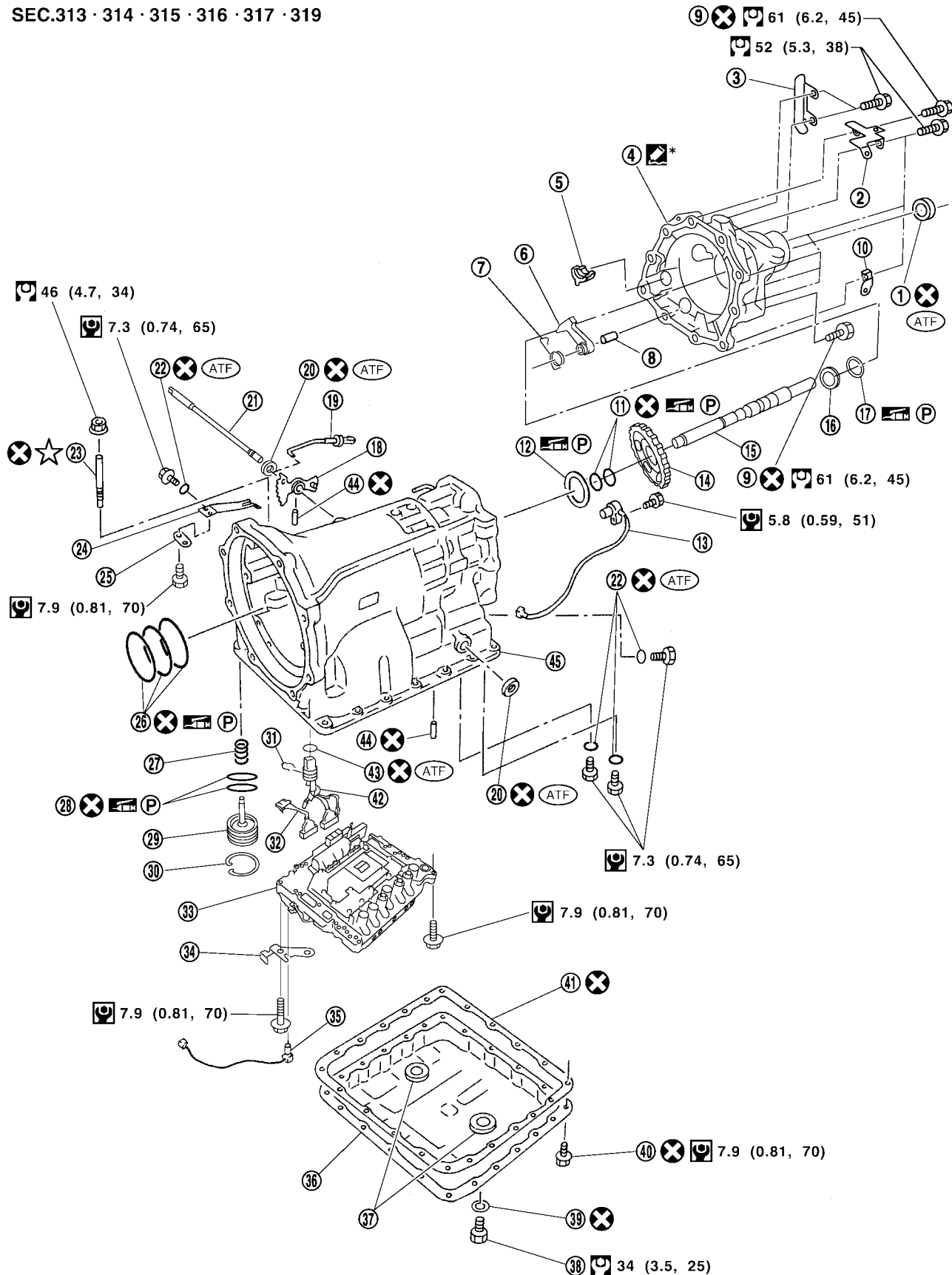

A
B
AT
D
E
F
G
H
I
J
K
L
M

- 1. Rear oil seal
- 4. Rear extension

- 2. Bracket
- 5. Parking actuator support

- 3. Bracket
- 6. Parking pawl

WCIA0564E

OVERHAUL

- | | | |
|-----------------------|------------------------------------|----------------------------|
| 7. Return spring | 8. Pawl shaft | 9. Self-sealing bolt |
| 10. Bracket | 11. Seal ring | 12. Needle bearing |
| 13. Revolution sensor | 14. Parking gear | 15. Output shaft |
| 16. Bearing race | 17. Needle bearing | 18. Manual plate |
| 19. Parking rod | 20. Manual shaft oil seal | 21. Manual shaft |
| 22. O-ring | 23. Band servo anchor end pin | 24. Detent spring |
| 25. Spacer | 26. Seal rings | 27. Return spring |
| 28. O-ring | 29. Servo assembly | 30. Snap ring |
| 31. Snap ring | 32. Sub-harness | 33. Control valve with TCM |
| 34. Bracket | 35. A/T fluid temperature sensor 2 | 36. Oil pan |
| 37. Magnets | 38. Drain plug | 39. Drain plug gasket |
| 40. Oil pan bolt | 41. Oil pan gasket | 42. Terminal cord assembly |
| 43. O-ring | 44. Retaining pin | 45. Transmission case |

OVERHAUL

4WD models

SEC.313 · 314 · 315 · 316 · 317 · 319

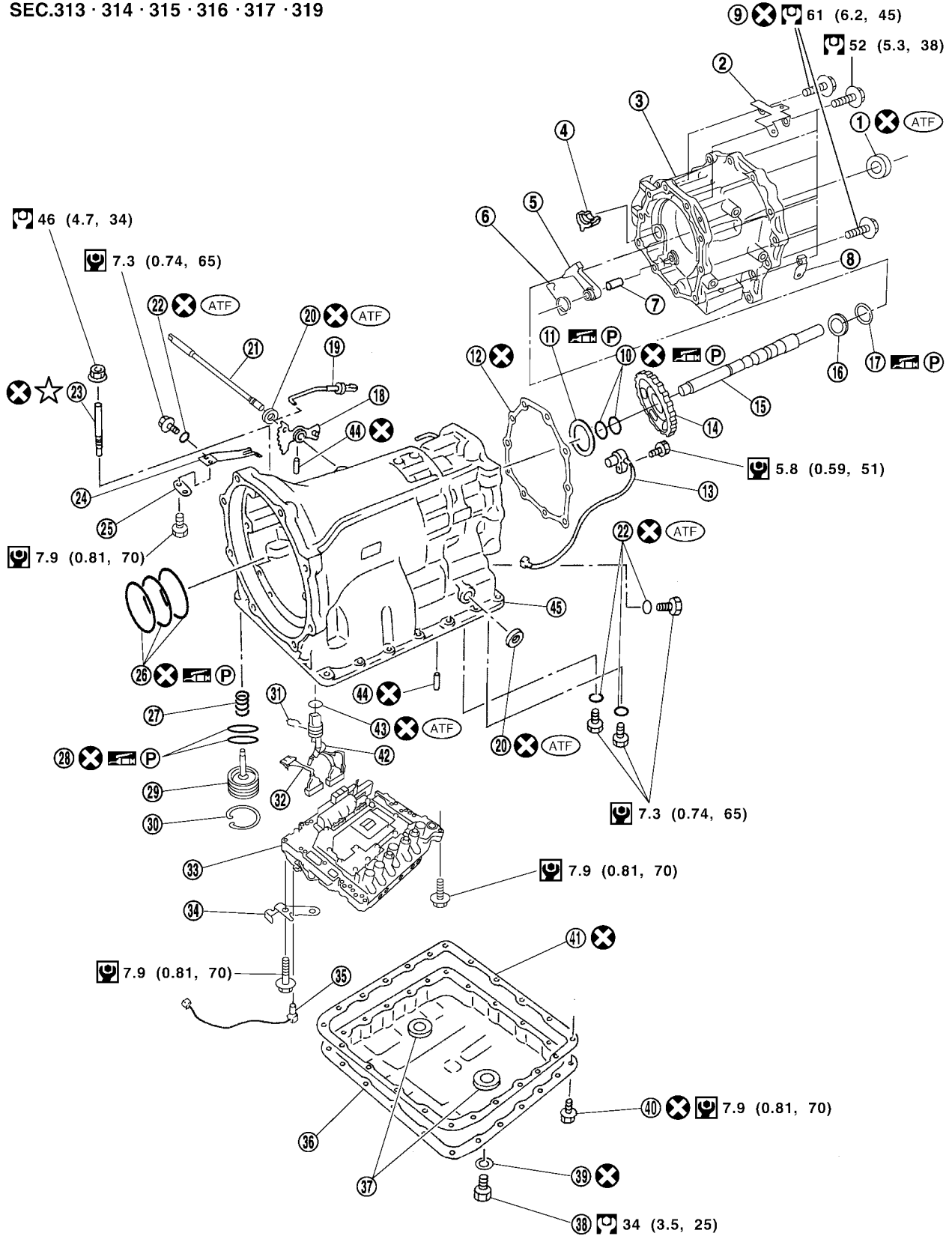

- 1. Rear oil seal
- 4. Parking actuator support

- 2. Bracket
- 5. Parking pawl

- 3. Adapter case
- 6. Return spring

WCIA0565E

OVERHAUL

- | | | |
|-----------------------|------------------------------------|----------------------------|
| 7. Pawl shaft | 8. Bracket | 9. Self-sealing bolt |
| 10. Seal ring | 11. Needle bearing | 12. Gasket |
| 13. Revolution sensor | 14. Parking gear | 15. Output shaft |
| 16. Bearing race | 17. Needle bearing | 18. Manual plate |
| 19. Parking rod | 20. Manual shaft oil seal | 21. Manual shaft |
| 22. O-ring | 23. Band servo anchor end pin | 24. Detent spring |
| 25. Spacer | 26. Seal rings | 27. Return spring |
| 28. O-ring | 29. Servo assembly | 30. Snap ring |
| 31. Snap ring | 32. Sub-harness | 33. Control valve with TCM |
| 34. Bracket | 35. A/T fluid temperature sensor 2 | 36. Oil pan |
| 37. Magnets | 38. Drain plug | 39. Drain plug gasket |
| 40. Oil pan bolt | 41. Oil pan gasket | 42. Terminal cord assembly |
| 43. O-ring | 44. Retaining pin | 45. Transmission case |

OVERHAUL

Oil Channel

ECS00H3E

2WD models

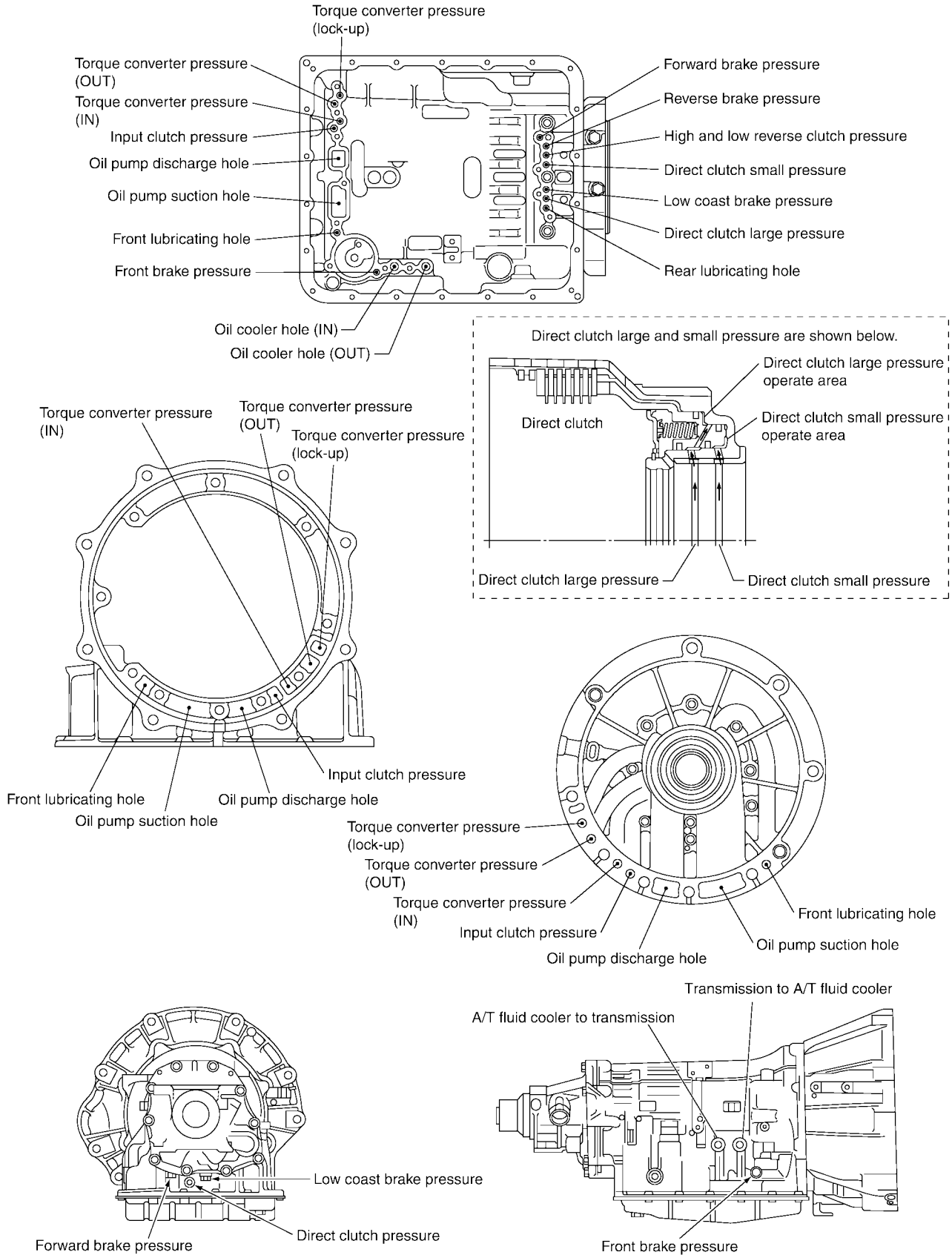

A
B
AT
D
E
F
G
H
I
J
K
L
M

OVERHAUL

4WD models

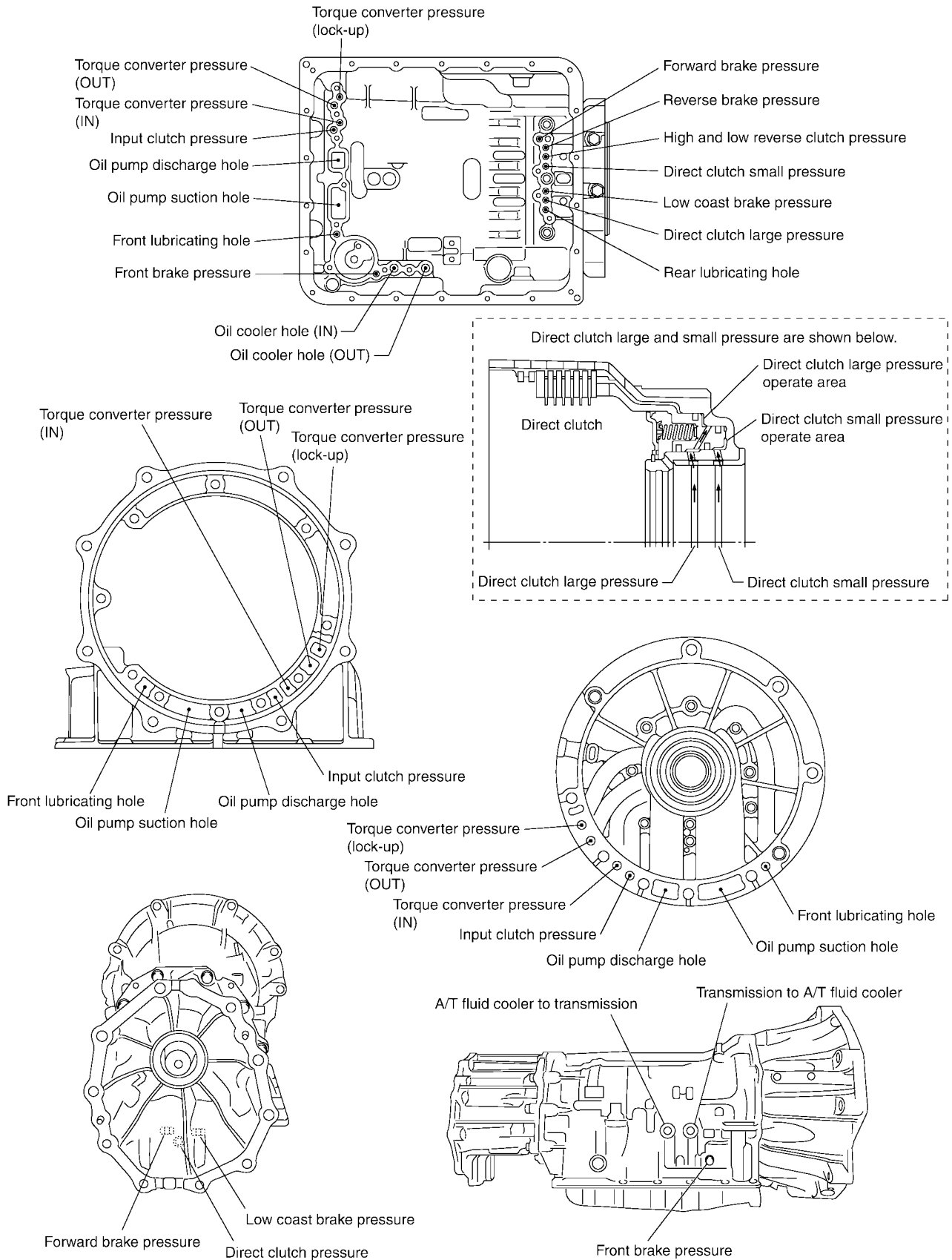

SCIA5189E

OVERHAUL

Locations of Adjusting Shims, Needle Bearings, Thrust Washers and Snap Rings

ECS00H3F

2WD models

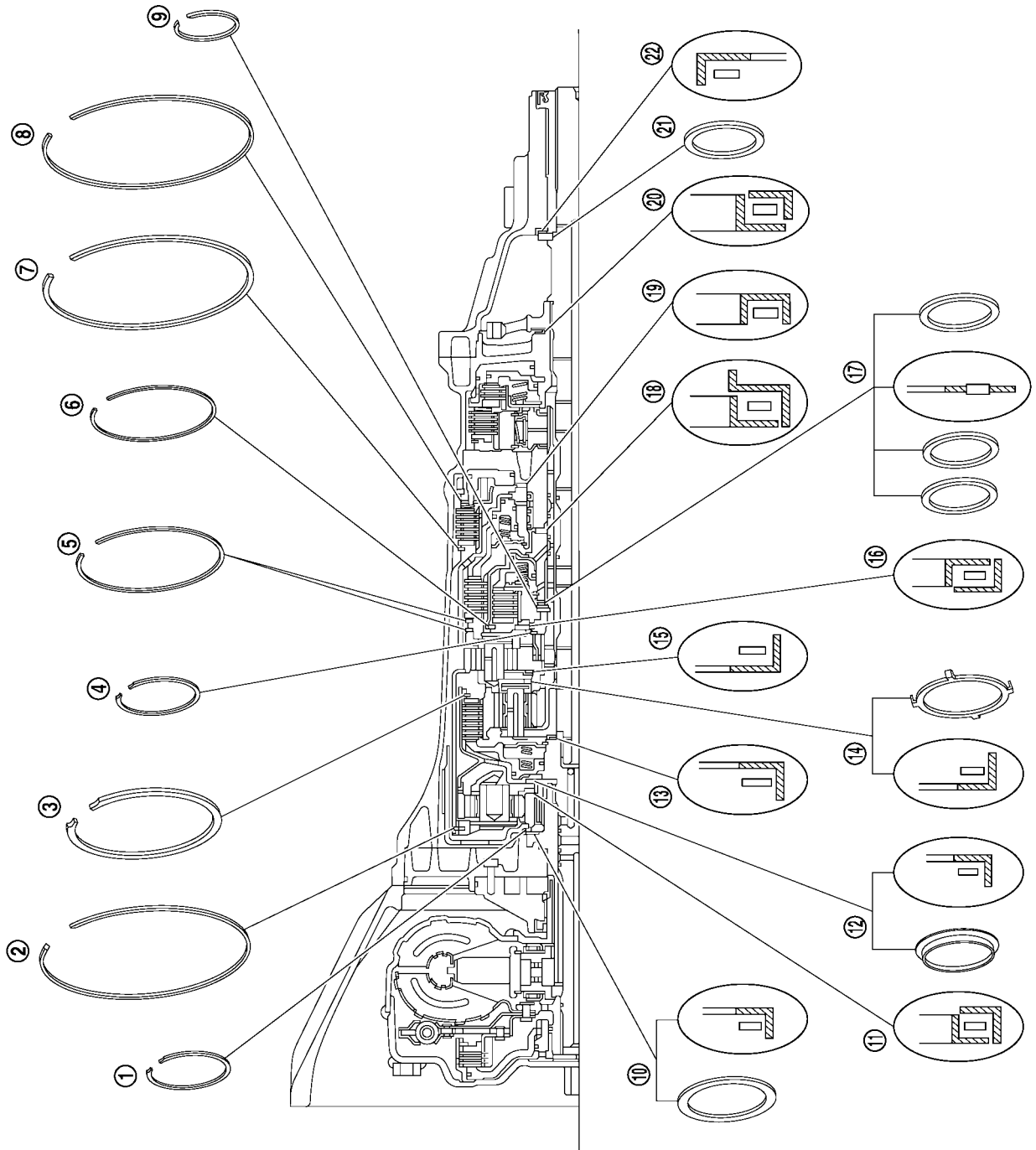

A

B

AT

D

E

F

G

H

I

J

K

L

M

OVERHAUL

1. Outer diameter 68 mm (2.68 in)
2. Outer diameter 182 mm (7.17 in)
3. Outer diameter 172 mm (6.77 in)
4. Outer diameter 71 mm (2.80 in)
5. Outer diameter 169 mm (6.65 in)
6. Outer diameter 134 mm (5.28 in)
7. Outer diameter 181 mm (7.13 in)
8. Outer diameter 181 mm (7.13 in)
9. Outer diameter 48 mm (1.89 in)
10. Outer diameter 80 mm (3.15 in)
11. Outer diameter 77 mm (3.03 in)
12. Outer diameter 77 mm (3.03 in)
13. Outer diameter 47 mm (1.85 in)
14. Outer diameter 84 mm (3.31 in)
15. Outer diameter 84 mm (3.31 in)
16. Outer diameter 92 mm (3.62 in)
17. Outer diameter 60 mm (2.36 in)
18. Outer diameter 63 mm (2.48 in)
19. Outer diameter 92 mm (3.62 in)
20. Outer diameter 65 mm (2.56 in)
21. Bearing race
22. Outer diameter 60 mm (2.36 in)

OVERHAUL

4WD models

A
B
AT
D
E
F
G
H
I
J
K
L
M

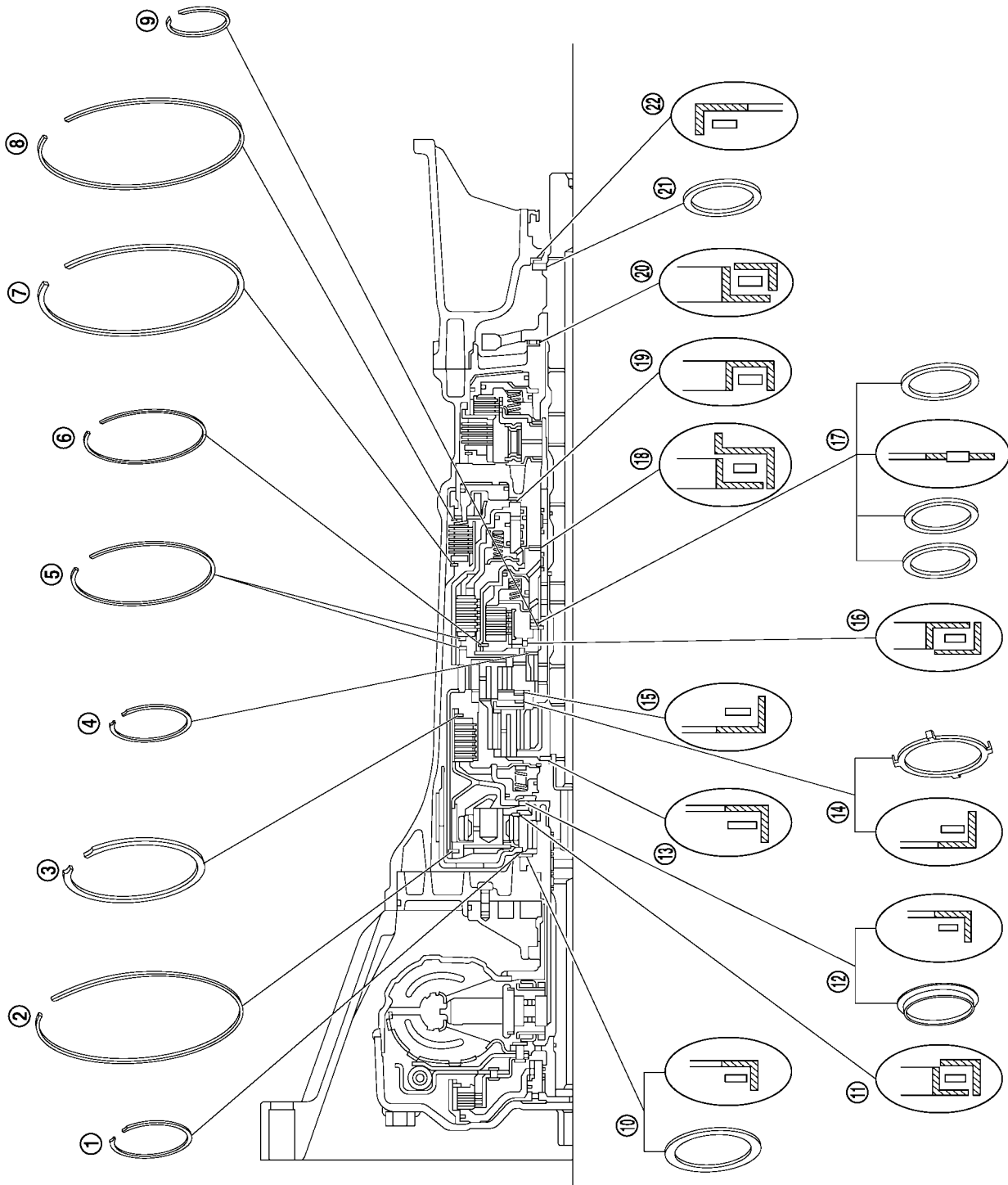

- | | | |
|-----------------------------------|------------------------------------|------------------------------------|
| 1. Outer diameter 68 mm (2.68 in) | 2. Outer diameter 182 mm (7.17 in) | 3. Outer diameter 172 mm (6.77 in) |
| 4. Outer diameter 71 mm (2.80 in) | 5. Outer diameter 169 mm (6.65 in) | 6. Outer diameter 134 mm (5.28 in) |

WCIA0561E

OVERHAUL

- | | | |
|------------------------------------|------------------------------------|------------------------------------|
| 7. Outer diameter 181 mm (7.13 in) | 8. Outer diameter 181 mm (7.13 in) | 9. Outer diameter 48 mm (1.89 in) |
| 10. Outer diameter 80 mm (3.15 in) | 11. Outer diameter 77 mm (3.03 in) | 12. Outer diameter 77 mm (3.03 in) |
| 13. Outer diameter 47 mm (1.85 in) | 14. Outer diameter 84 mm (3.31 in) | 15. Outer diameter 84 mm (3.31 in) |
| 16. Outer diameter 92 mm (3.62 in) | 17. Outer diameter 60 mm (2.36 in) | 18. Outer diameter 63 mm (2.48 in) |
| 19. Outer diameter 92 mm (3.62 in) | 20. Outer diameter 65 mm (2.56 in) | 21. Bearing race |
| 22. Outer diameter 60 mm (2.36 in) | | |

DISASSEMBLY

PFP:31020

Disassembly

ECS00H3G

CAUTION:

Do not disassemble parts behind drum support. Refer to [AT-17, "Cross-Sectional View \(2WD models\)"](#) or [AT-18, "Cross-Sectional View \(4WD models\)"](#) .

1. Drain ATF through drain plug.
2. Remove torque converter by holding it firmly and turing while pulling straight out.

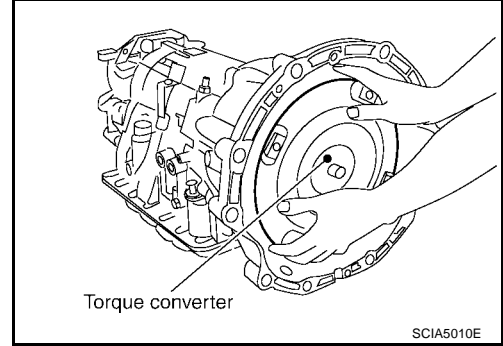

3. Check torque converter one-way clutch using check tool as shown.
 - a. Insert check tool into the groove of bearing support built into one-way clutch outer race.
 - b. While holding bearing support with check tool, rotate one-way clutch spline using suitable tool.
 - c. Check that inner race rotates clockwise only. If not, replace torque converter assembly.

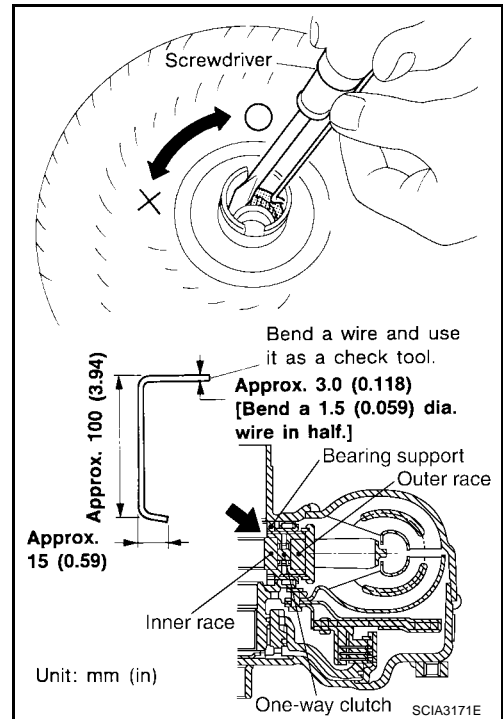

4. Remove converter housing from transmission case.

A : Self-sealing bolt

CAUTION:

Be careful not to scratch converter housing.

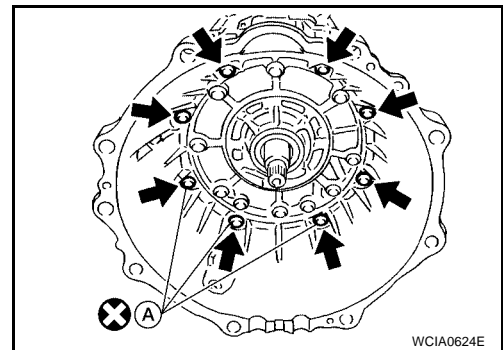

DISASSEMBLY

5. Remove O-ring from input clutch assembly.

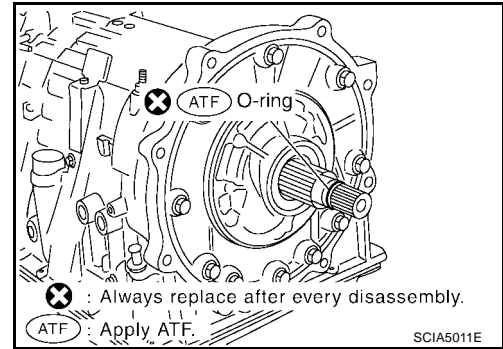

6. Remove bolts for oil pump assembly and transmission case.

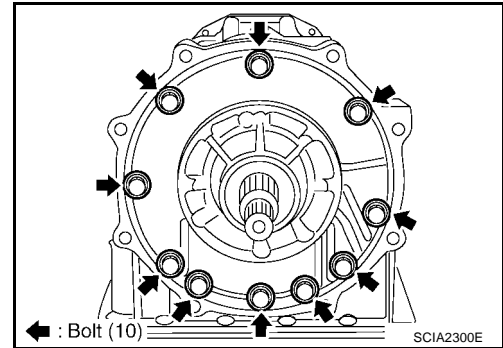

7. Extract oil pump assembly evenly from transmission case using Tool.

Tool number : ST25850000 (J-25721-A)

CAUTION:

- Fully tighten sliding hammer screw.
- Make sure that bearing race is installed to the oil pump assembly edge surface.

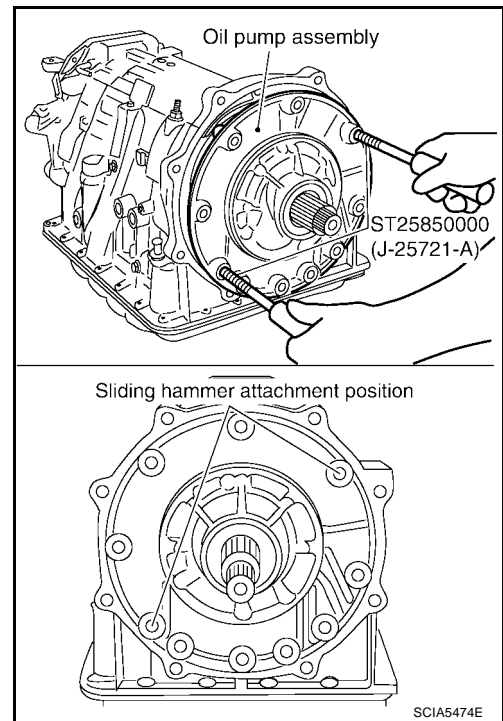

8. Remove O-ring from oil pump assembly.

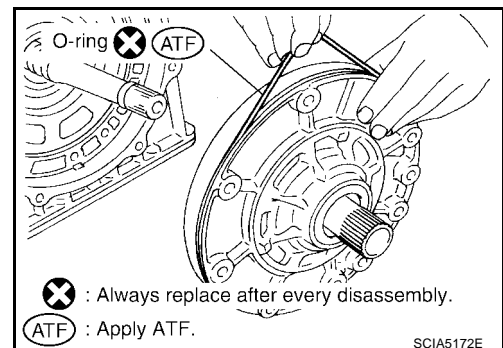

DISASSEMBLY

9. Remove bearing race from oil pump assembly.

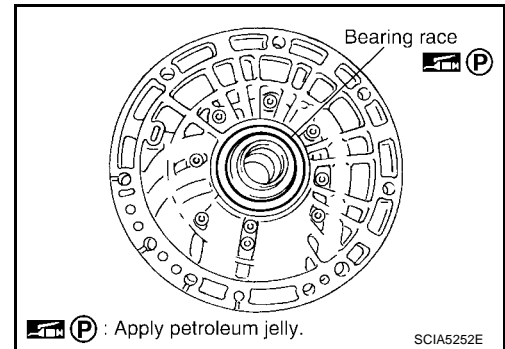

10. Remove needle bearing from front sun gear assembly.

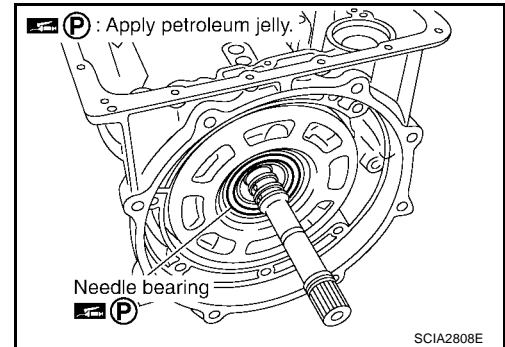

11. Remove front sun gear assembly from front carrier assembly.

NOTE:

Remove front sun gear assembly by rotating left/right.

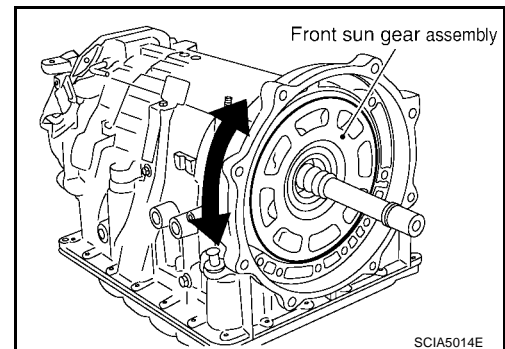

12. Remove seal rings from input clutch assembly.

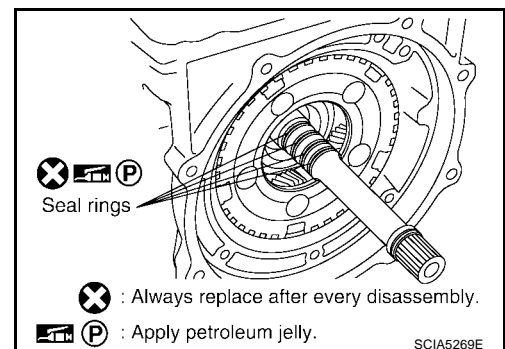

13. Remove front carrier assembly, input clutch assembly and rear internal gear as a unit.

CAUTION:

Be careful to remove it with needle bearing.

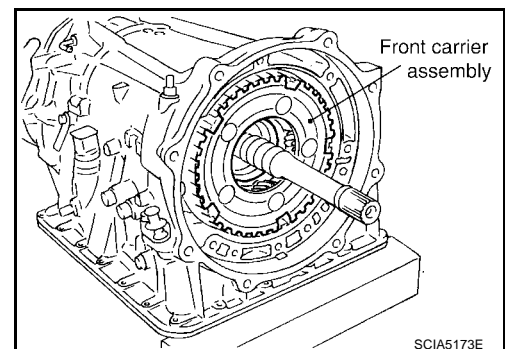

A
B
AT
D
E
F
G
H
I
J
K
L
M

DISASSEMBLY

14. Loosen lock nut and remove band servo anchor end pin from transmission case.

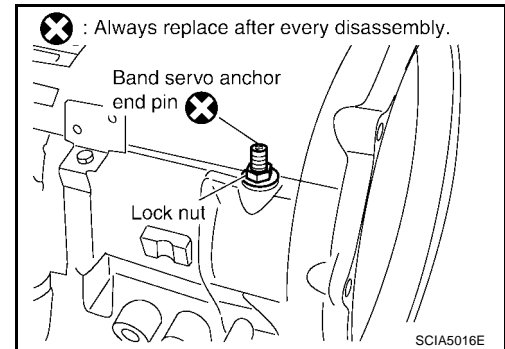

15. Remove brake band from transmission case.

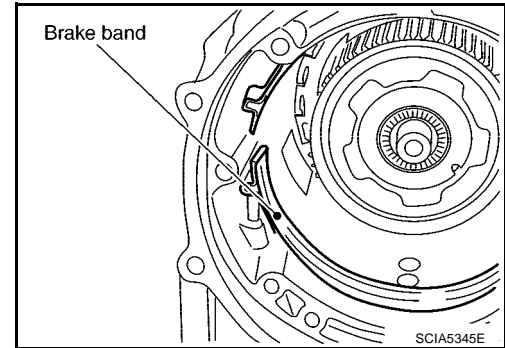

- To prevent brake linings from cracking or peeling, do not stretch the flexible band unnecessarily. When removing the brake band, always secure it with a clip as shown. Leave the clip in position after removing the brake band.
- Check brake band facing for damage, cracks, wear or burns.

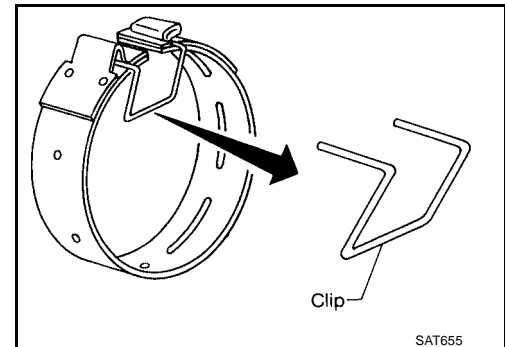

16. Remove mid carrier assembly and rear carrier assembly as a unit.

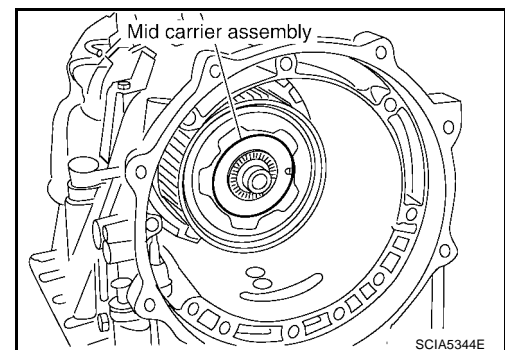

DISASSEMBLY

17. Remove mid carrier assembly from rear carrier assembly.

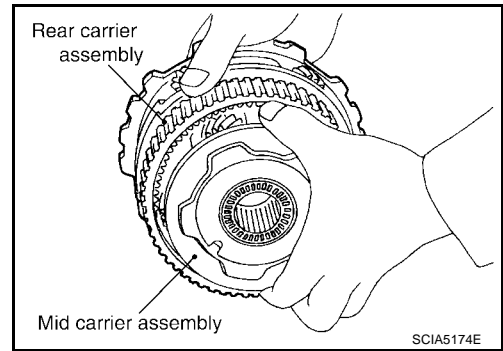

18. Remove needle bearing (front side) from mid carrier assembly.

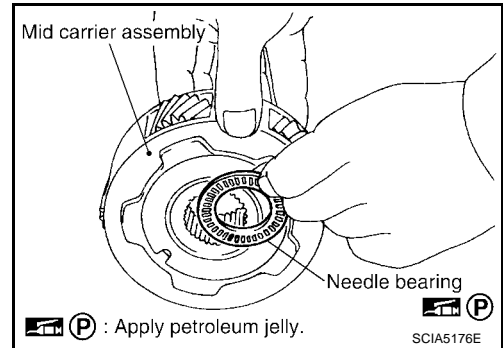

19. Remove needle bearing (rear side) from mid carrier assembly.

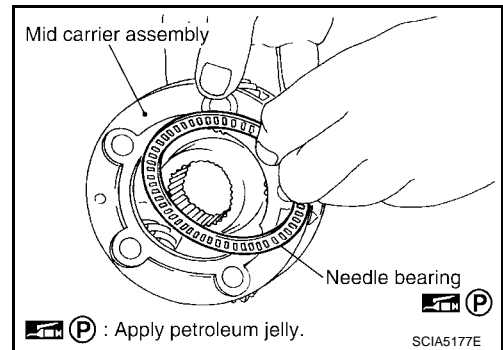

20. Remove bearing race from rear carrier assembly.

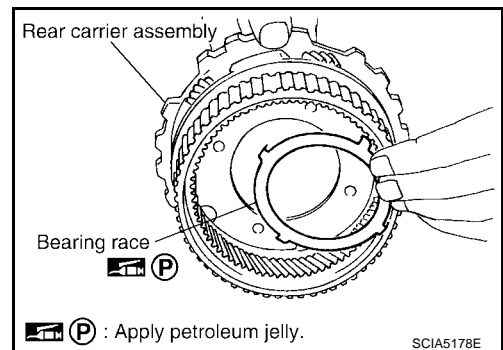

21. Remove needle bearing from rear carrier assembly.

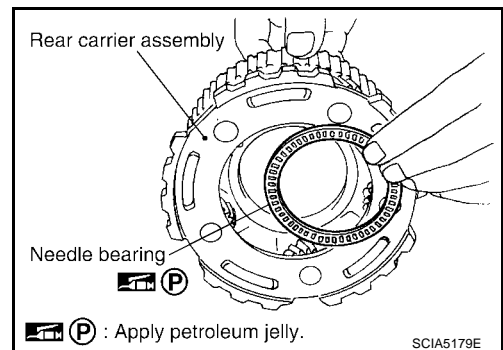

A
B
AT
D
E
F
G
H
I
J
K
L
M

DISASSEMBLY

22. Remove mid sun gear assembly, rear sun gear assembly and high and low reverse clutch hub as a unit.

CAUTION:

Be careful to remove them with bearing races and needle bearing.

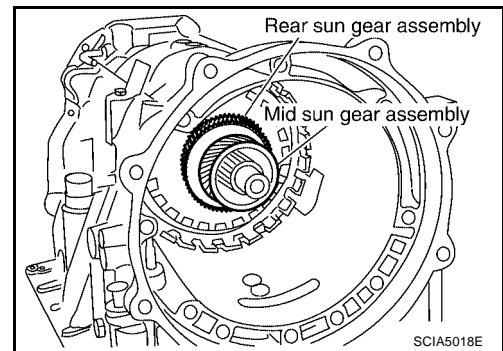

23. Remove high and low reverse clutch assembly from direct clutch assembly.

CAUTION:

Make sure that needle bearing is installed to the high and low reverse clutch assembly edge surface.

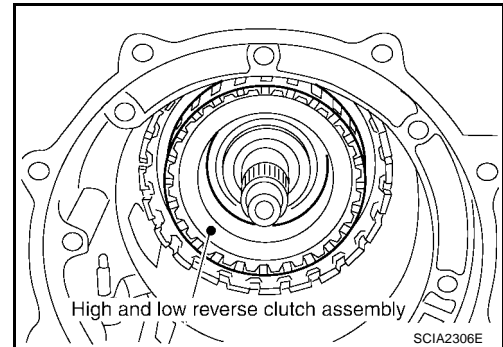

24. Remove direct clutch assembly from reverse brake.

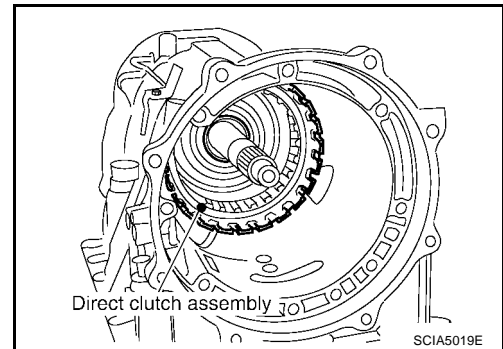

25. Remove needle bearing from drum support edge surface.

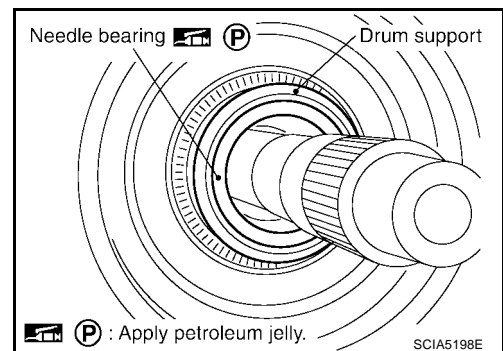

26. Remove snap ring from A/T assembly harness connector.

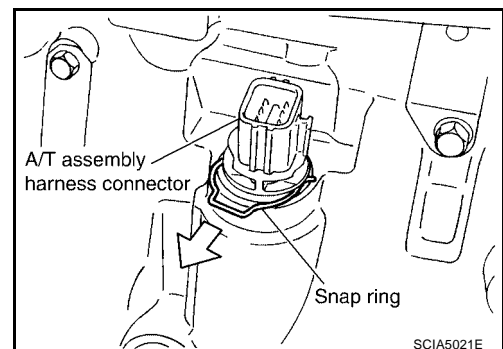

DISASSEMBLY

27. Push A/T assembly harness connector.

CAUTION:
Be careful not to damage connector.

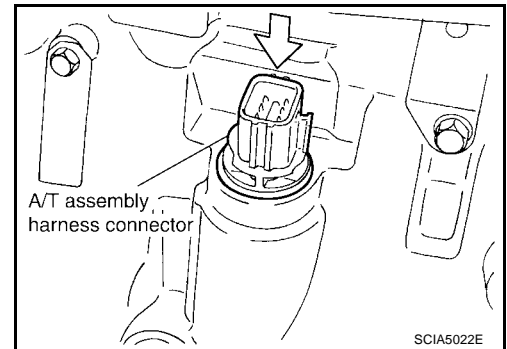

28. Remove oil pan and oil pan gasket. Refer to [AT-223, "Oil Pan"](#) .

29. Disconnect A/T fluid temperature sensor 2 connector.

CAUTION:
Be careful not to damage connector.

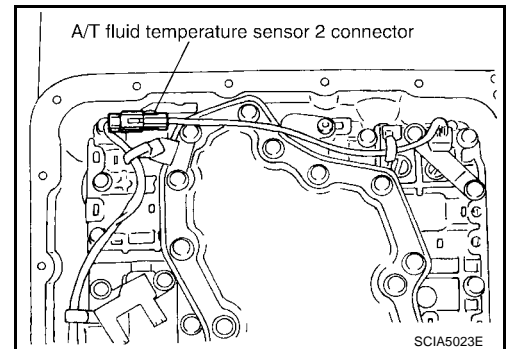

30. Straighten terminal clip to free terminal cord assembly and A/T fluid temperature sensor 2 harness.

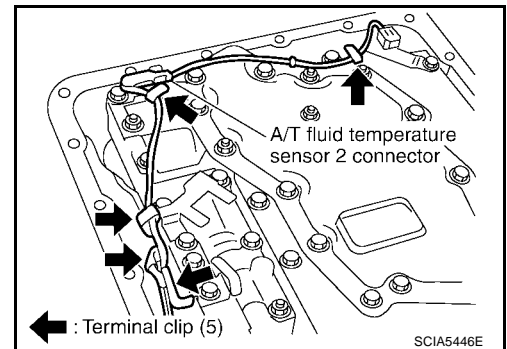

31. Disconnect revolution sensor connector.

CAUTION:
Be careful not to damage connector.

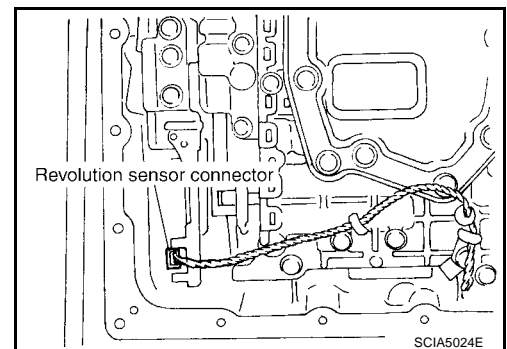

A
B
AT
D
E
F
G
H
I
J
K
L
M

DISASSEMBLY

32. Straighten terminal clips to free revolution sensor harness.

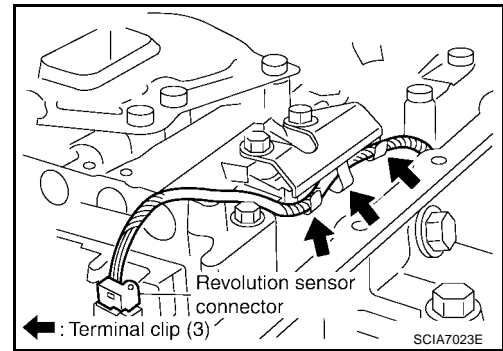

33. Remove bolts A, B and C from control valve with TCM.

Bolt symbol	Length mm (in)	Number of bolts
A	42 (1.65)	5
B	55 (2.17)	6
C	40 (1.57)	1

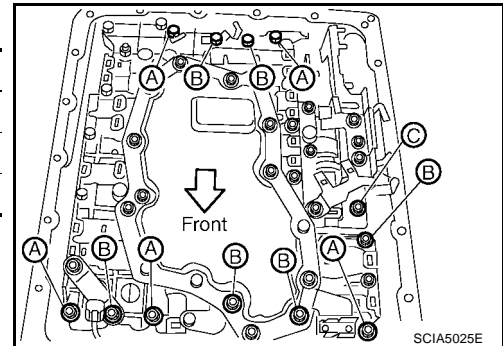

34. Remove control valve with TCM from transmission case.

CAUTION:

When removing, be careful with transmission assembly terminal connector and the manual valve notch and manual plate height. Remove it vertically.

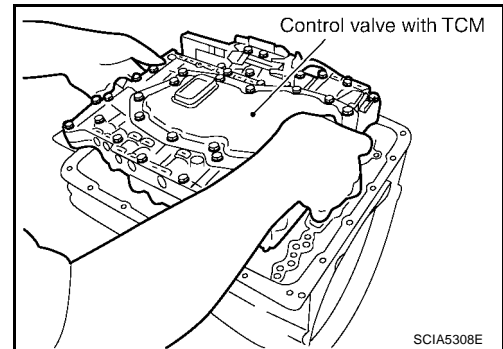

35. Remove A/T fluid temperature sensor 2 with bracket from control valve with TCM.

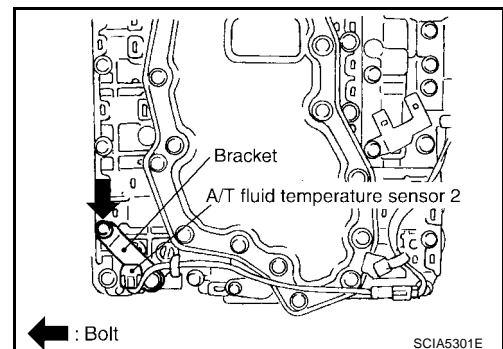

36. Remove bracket from A/T fluid temperature sensor 2.

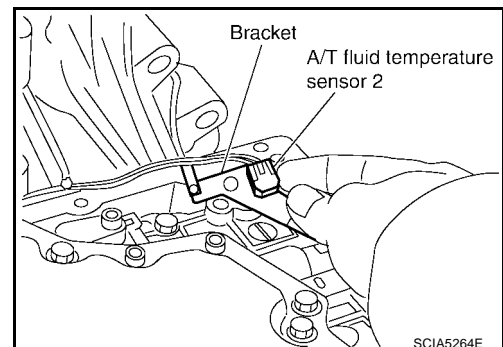

DISASSEMBLY

37. Remove O-ring from A/T assembly harness connector.

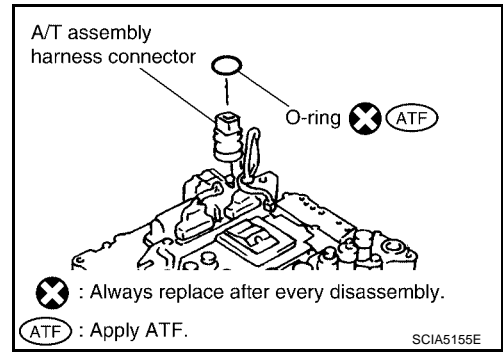

38. Disconnect TCM connectors.

CAUTION:
Be careful not to damage connectors.

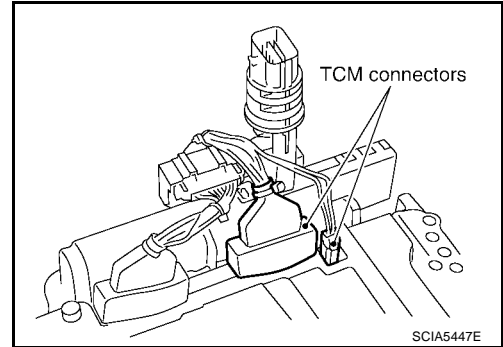

39. Remove A/T assembly harness connector from control valve with TCM using suitable tool.

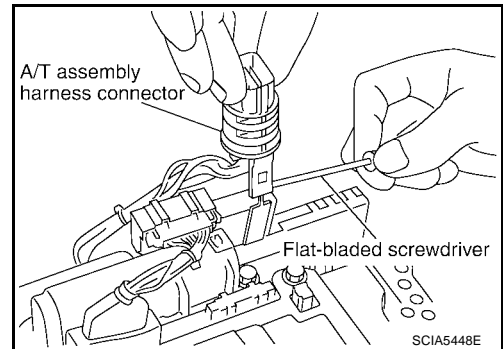

40. Disconnect TCM connector and park/neutral position switch connector.

CAUTION:
Be careful not to damage connectors.

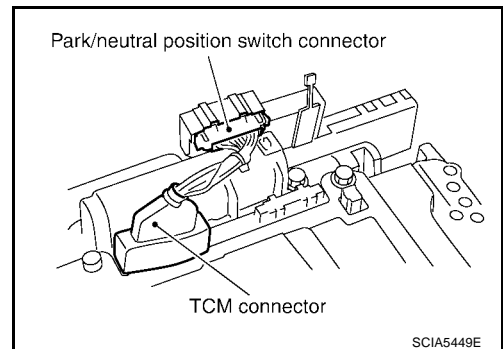

41. Remove rear extension assembly (2WD models) or adapter case assembly (4WD models) according to the following procedures.

DISASSEMBLY

a. 2WD models

- Self-sealing bolts (2)

- Remove bolts for rear extension assembly and transmission case.
- Remove brackets (1).

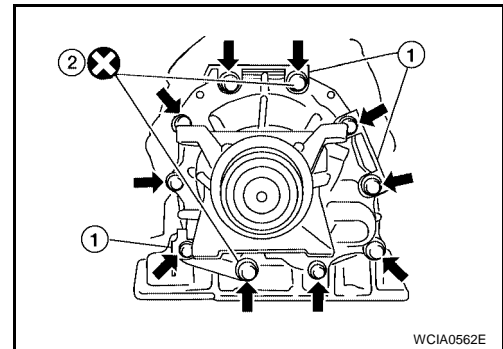

- Tap rear extension assembly using suitable tool.

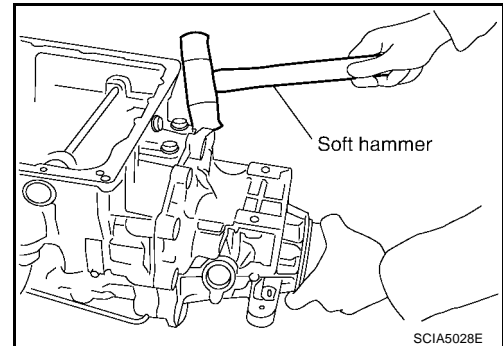

- Remove rear extension assembly with needle bearing from transmission case.

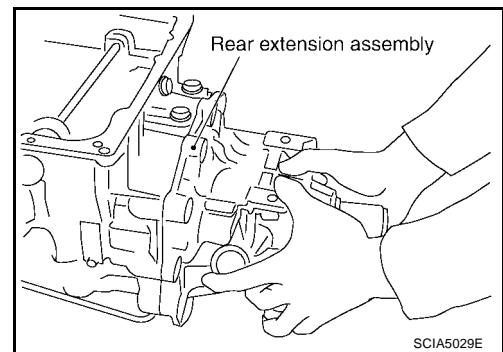

b. 4WD models

- Self-sealing bolts (2)

- Remove bolts for adapter case assembly and transmission case.
- Remove brackets (1).

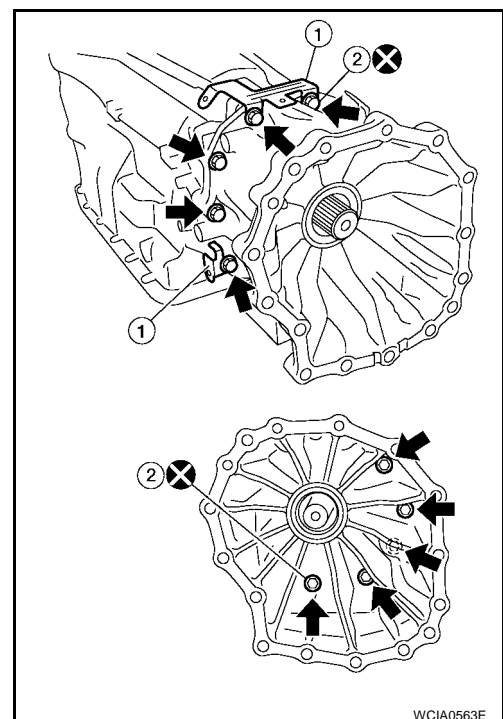

DISASSEMBLY

- iii. Tap adapter case assembly using suitable tool.
- iv. Remove adapter case assembly with needle bearing from transmission case.

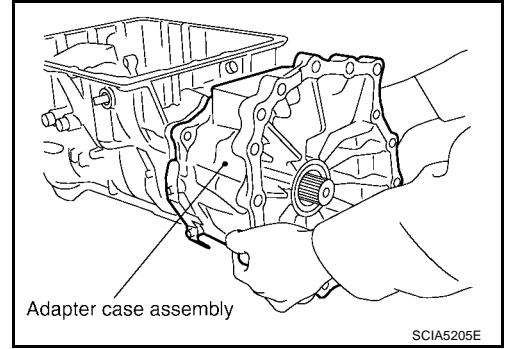

- v. Remove gasket from transmission case.

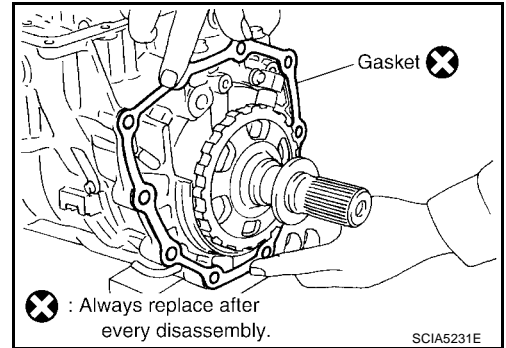

- 42. Remove bearing race from output shaft.

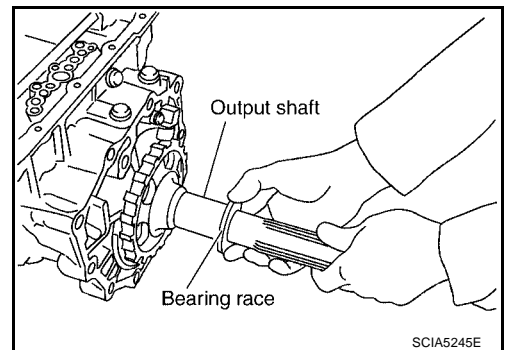

- 43. Remove output shaft from transmission case by rotating left/right.

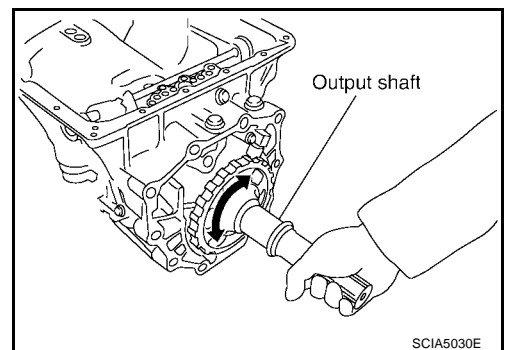

A
B
AT
D
E
F
G
H
I
J
K
L
M

DISASSEMBLY

44. Remove parking gear from output shaft.

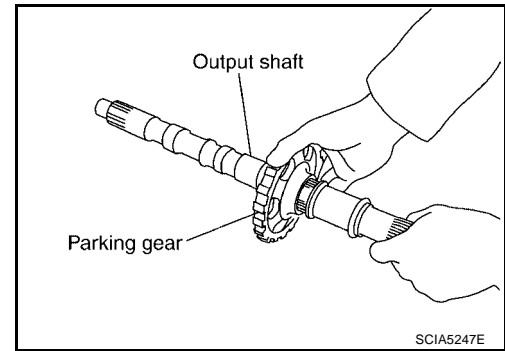

45. Remove seal rings from output shaft.

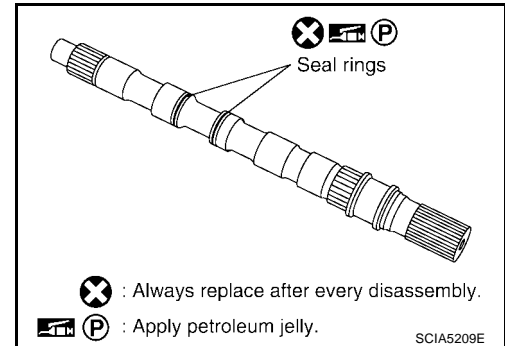

46. Remove needle bearing from transmission case.

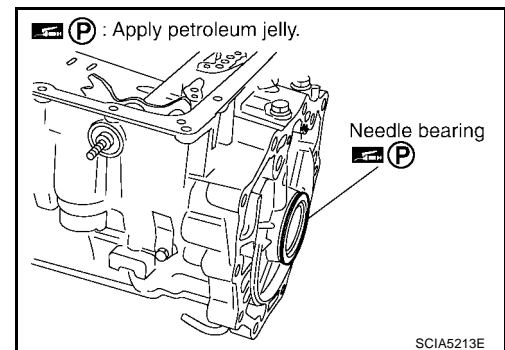

47. Remove revolution sensor from transmission case.

CAUTION:

- Do not subject it to impact by dropping or hitting it.
- Be careful not to damage harness with the edge of case.
- Do not allow metal filings or foreign material to get on the sensor front edge magnetic area.
- Do not place in an area affected by magnetism.

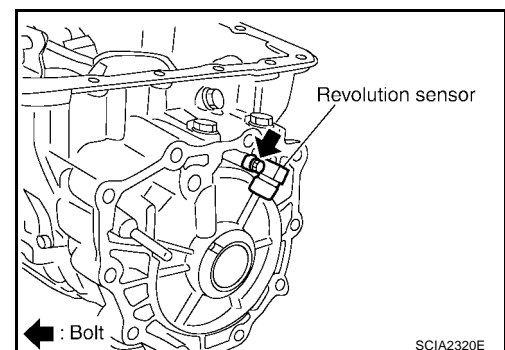

48. Remove reverse brake snap ring using 2 flat-bladed screwdrivers.

NOTE:

Press out snap ring from the transmission case oil pan side gap using a flat-bladed screwdriver, and remove it using another screwdriver.

49. Remove reverse brake retaining plate from transmission case.

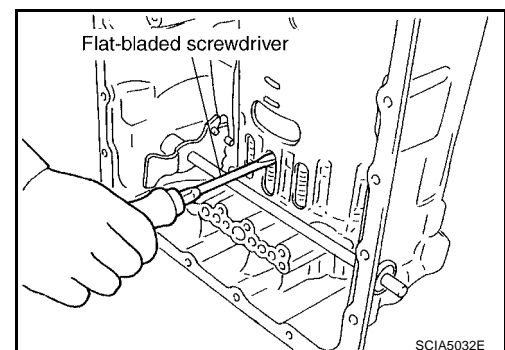

DISASSEMBLY

50. Remove N-spring from transmission case.

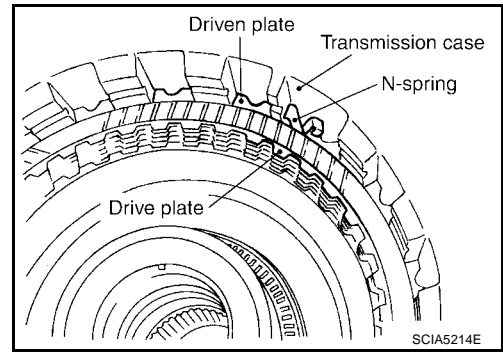

51. Remove reverse brake drive plates, driven plates and dish plate from transmission case.

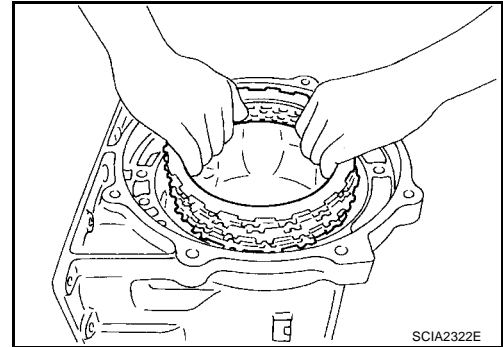

52. Remove snap ring from transmission case while compressing return spring, using Tool.

Tool number : KV31102400 (J-34285 and J- 34285-87)

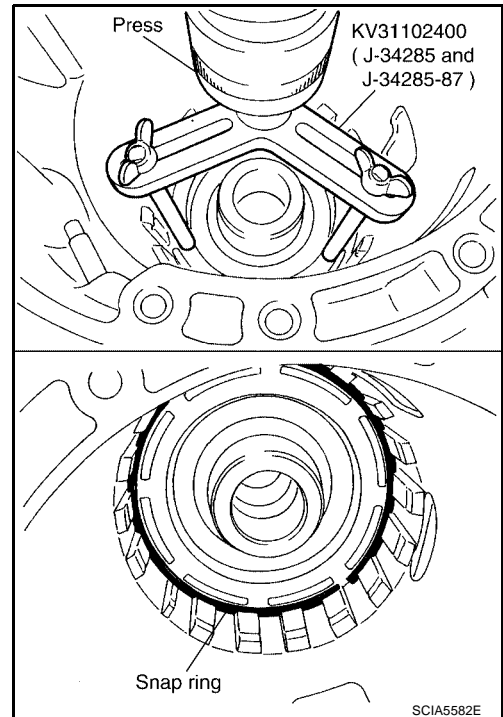

53. Remove spring retainer and return spring from transmission case.

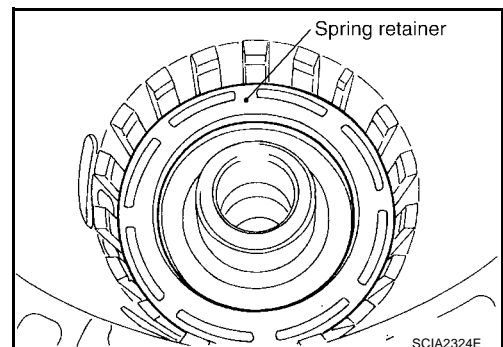

A
B
AT
D
E
F
G
H
I
J
K
L
M

DISASSEMBLY

54. Remove seal rings from drum support.

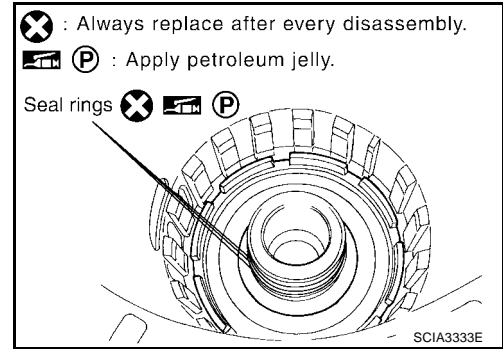

55. Remove needle bearing from drum support edge surface.

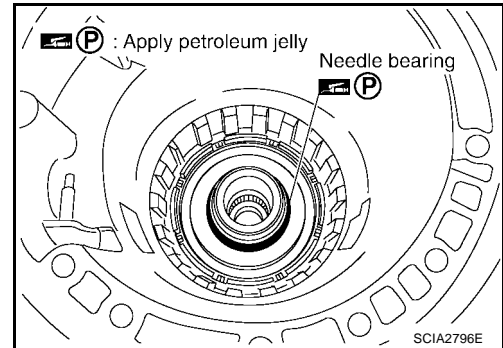

56. Remove reverse brake piston from transmission case with compressed air. Refer to [AT-253, "Oil Channel"](#) .

CAUTION:

Care should be taken not to abruptly blow air. It makes pistons incline, as the result, it becomes hard to disassemble the pistons.

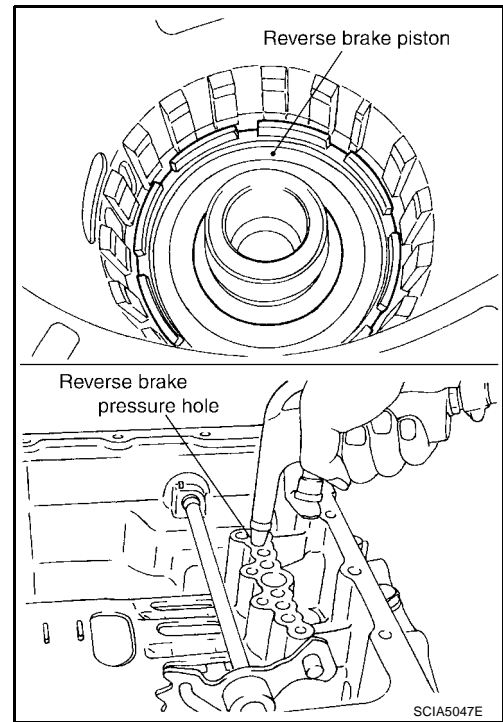

57. Remove D-rings from reverse brake piston.

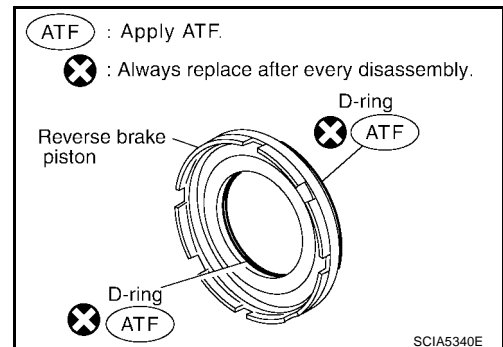

DISASSEMBLY

58. Knock out retaining pin using suitable tool.

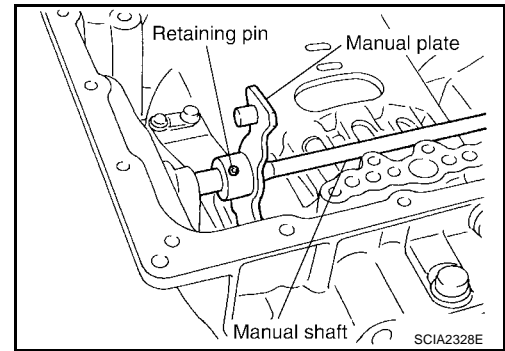

59. Remove manual shaft retaining pin using suitable tool.

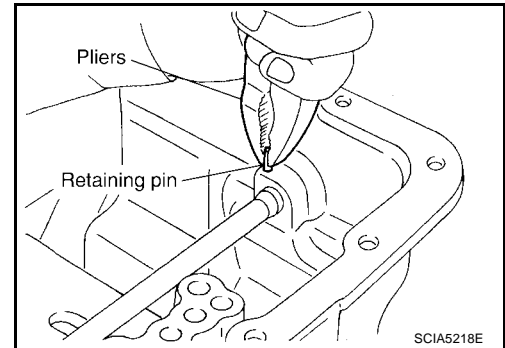

60. Remove manual plate (with parking rod) from manual shaft.

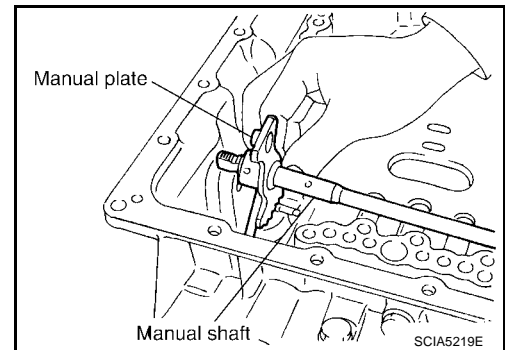

61. Remove parking rod from manual plate.

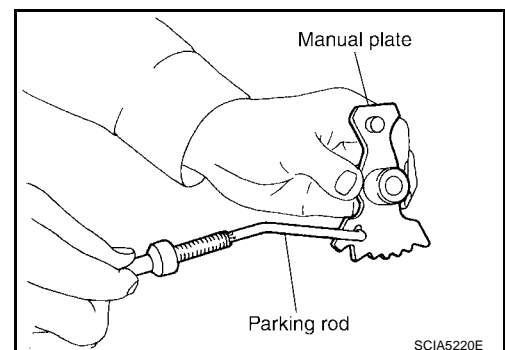

62. Remove manual shaft from transmission case.

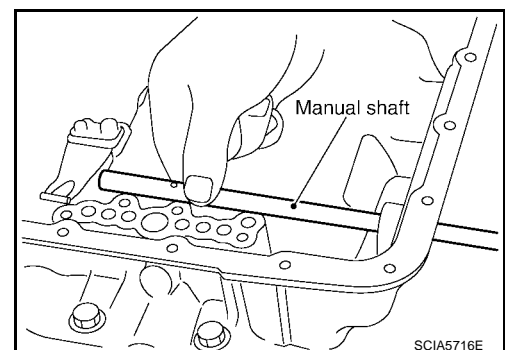

A
B
AT
D
E
F
G
H
I
J
K
L
M

DISASSEMBLY

63. Remove manual shaft oil seals using suitable tool.

CAUTION:

Be careful not to scratch transmission case.

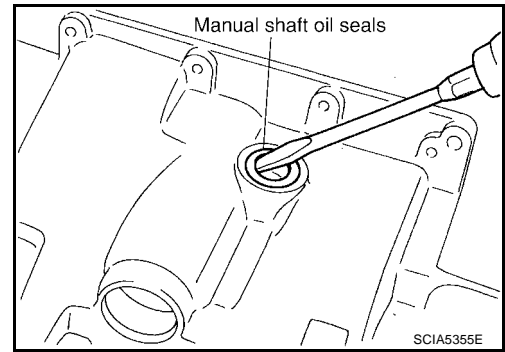

64. Remove detent spring and spacer from transmission case.

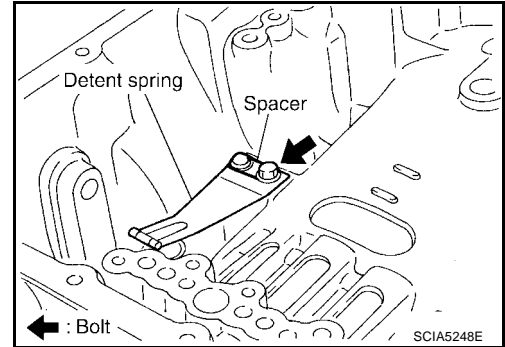

65. Remove snap ring from transmission case using suitable tool.

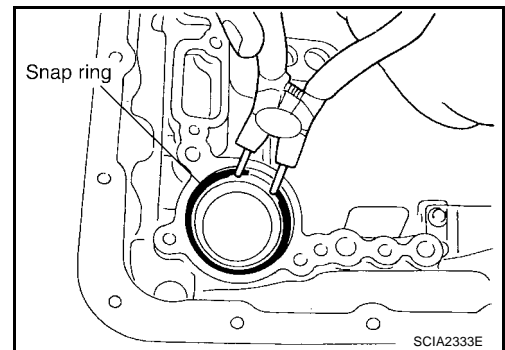

66. Remove servo assembly (with return spring) from transmission case.

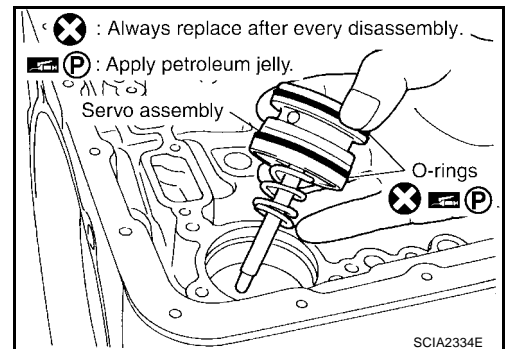

DISASSEMBLY

67. Remove return spring from servo assembly.

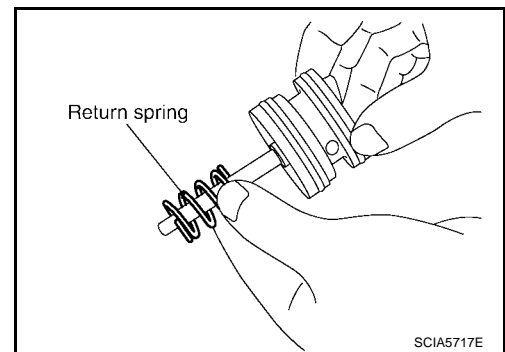

68. Remove O-rings from servo assembly.

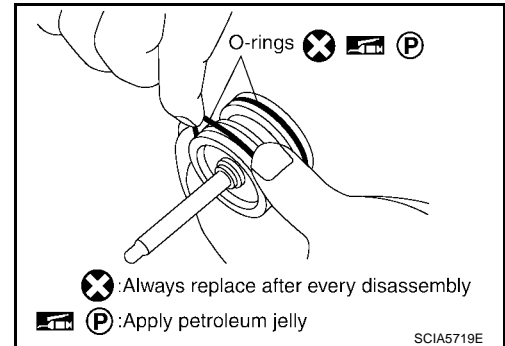

69. Remove parking actuator support from rear extension (2WD models) or adapter case (4WD models).

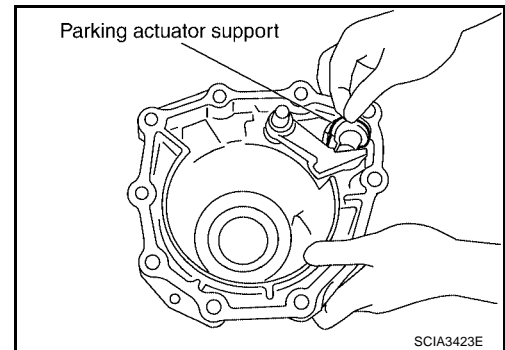

70. Remove parking pawl (with return spring) and pawl shaft from rear extension (2WD models) or adapter case (4WD models).

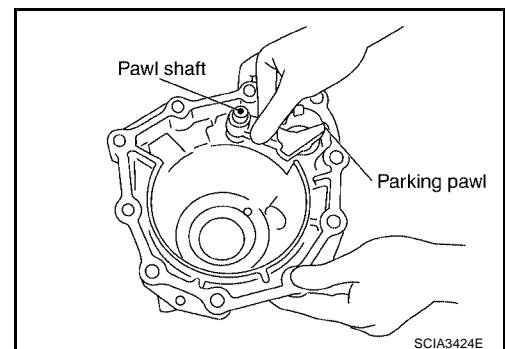

71. Remove return spring (1) from parking pawl (2).

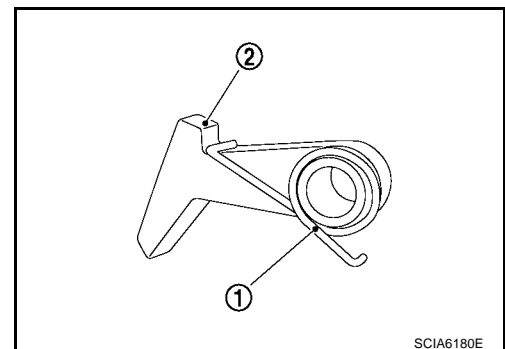

A
B
AT
D
E
F
G
H
I
J
K
L
M

DISASSEMBLY

72. Remove needle bearing from rear extension (2WD models) or adapter case (4WD models).

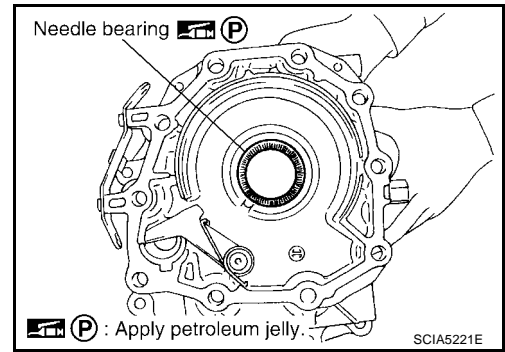

73. Remove rear oil seal from rear extension (2WD models) or adapter case (4WD models) using suitable tool.

CAUTION:

Be careful not to scratch rear extension (2WD models) or adapter case (4WD models).

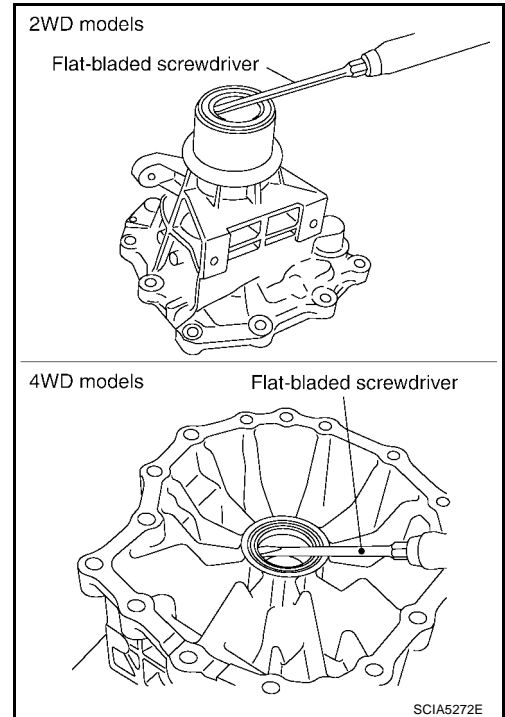

REPAIR FOR COMPONENT PARTS

PFP:00000

EC500185

REPAIR FOR COMPONENT PARTS

Oil Pump COMPONENTS

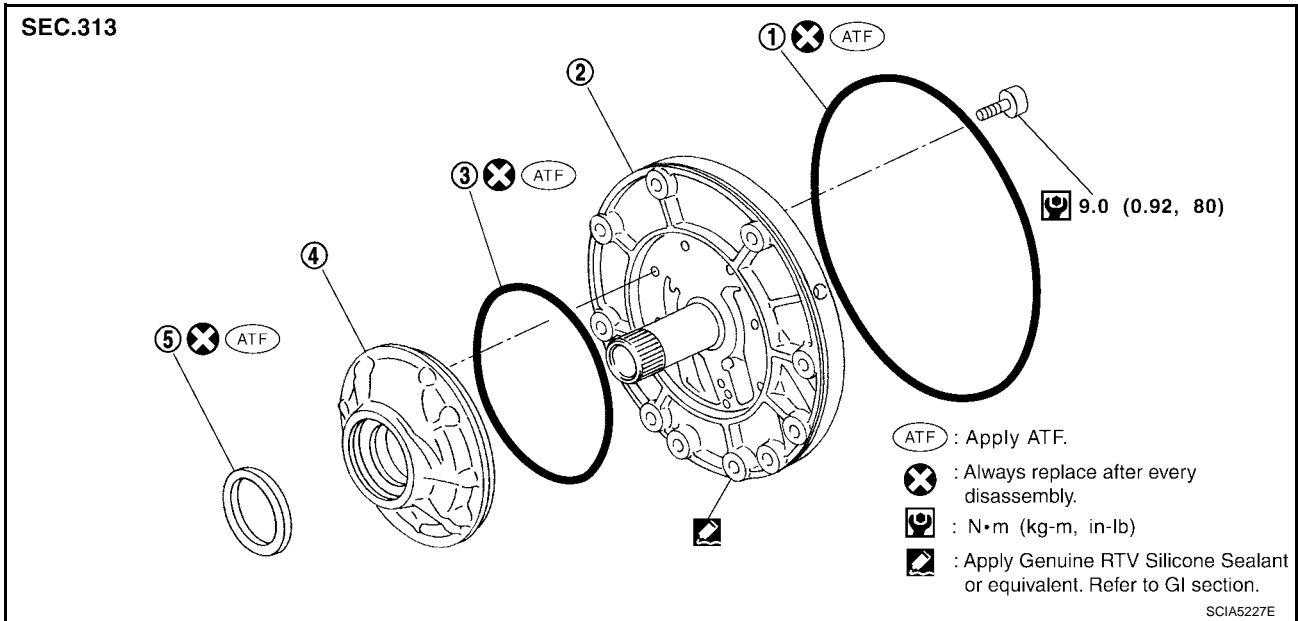

1. O-ring
2. Oil pump cover
3. O-ring
4. Oil pump housing
5. Oil pump housing oil seal

DISASSEMBLY

1. Remove oil pump housing from oil pump cover.

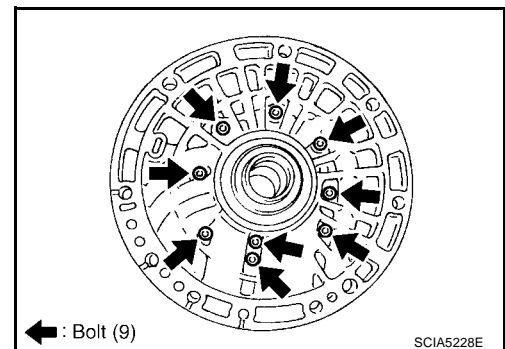

2. Remove oil pump housing oil seal using suitable tool.

CAUTION:

Be careful not to scratch oil pump housing.

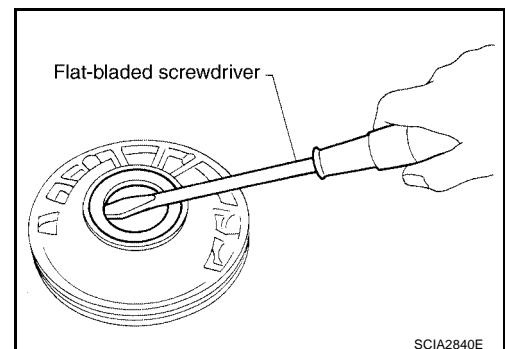

REPAIR FOR COMPONENT PARTS

3. Remove O-ring from oil pump housing.

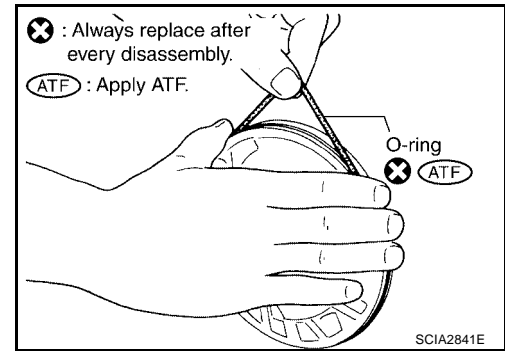

4. Remove O-ring from oil pump cover.

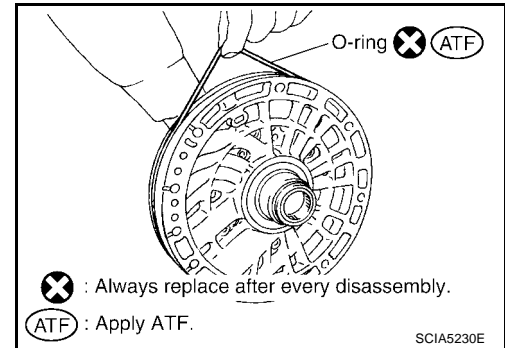

ASSEMBLY

1. Install new O-ring to oil pump cover.

CAUTION:

- Do not reuse O-ring.
- Apply ATF to O-ring.

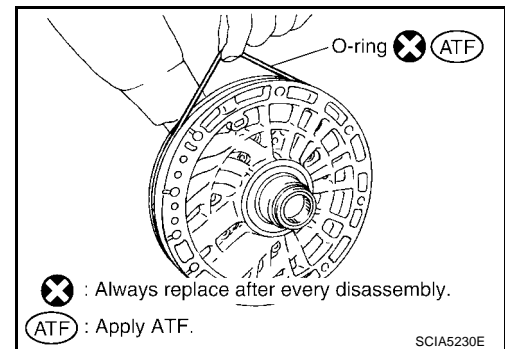

2. Install new O-ring to oil pump housing.

CAUTION:

- Do not reuse O-ring.
- Apply ATF to O-ring.

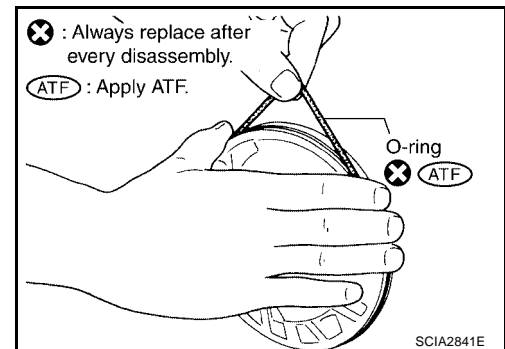

REPAIR FOR COMPONENT PARTS

3. Install new oil pump housing oil seal to the oil pump housing until it is flush with the face of oil pump housing using Tool.

CAUTION:

- Do not reuse oil seal.
- Apply ATF to oil seal.

Tool number : ST33400001 (J-26082)

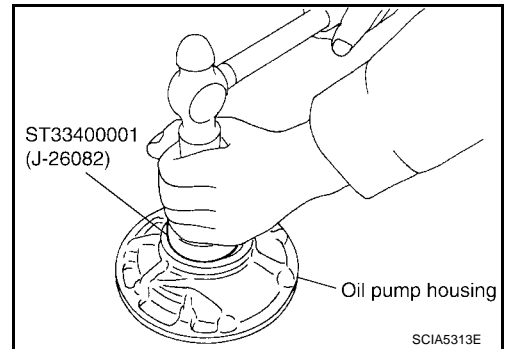

4. Install oil pump housing in oil pump cover. Tighten oil pump housing bolts to the specified torque. Refer to [AT-245, "Components"](#).

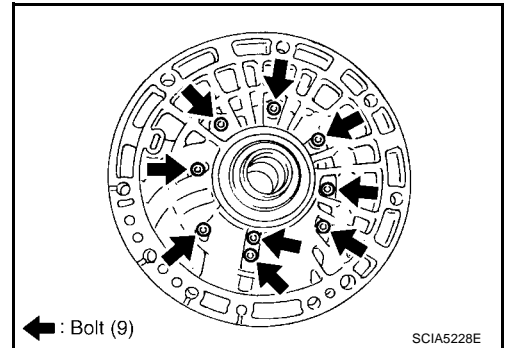

Front Sun Gear, 3rd One-Way Clutch COMPONENTS

EC500186

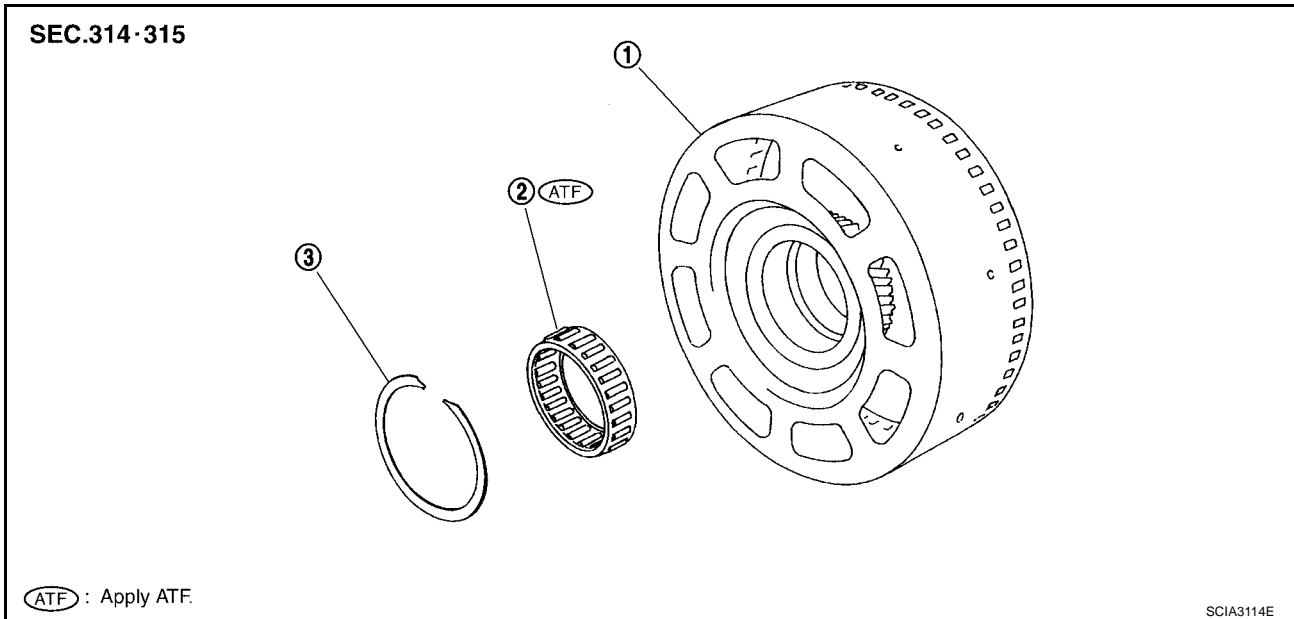

1. Front sun gear

2. 3rd one-way clutch

3. Snap ring

DISASSEMBLY

1. Remove snap ring from front sun gear using suitable tool.

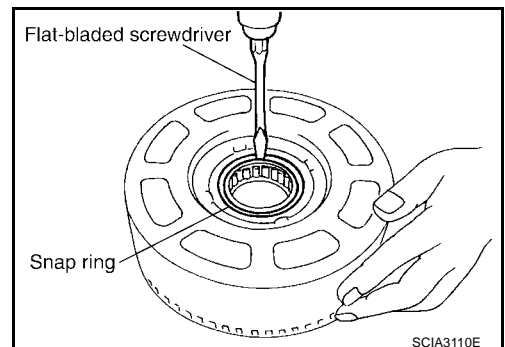

A
B
AT
D
E
F
G
H
I
J
K
L
M

REPAIR FOR COMPONENT PARTS

2. Remove 3rd one-way clutch from front sun gear.

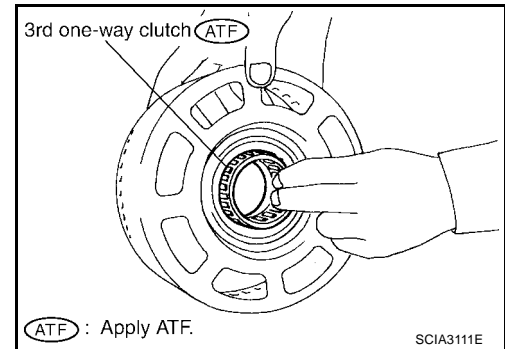

INSPECTION

3rd One-way Clutch

- Check frictional surface for wear or damage.

CAUTION:

If necessary, replace the 3rd one-way clutch.

Front Sun Gear Snap Ring

- Check for deformation, fatigue or damage.

CAUTION:

If necessary, replace the snap ring.

Front Sun Gear

- Check for deformation, fatigue or damage.

CAUTION:

If necessary, replace the front sun gear.

ASSEMBLY

1. Install 3rd one-way clutch in front sun gear.

CAUTION:

Apply ATF to 3rd one-way clutch.

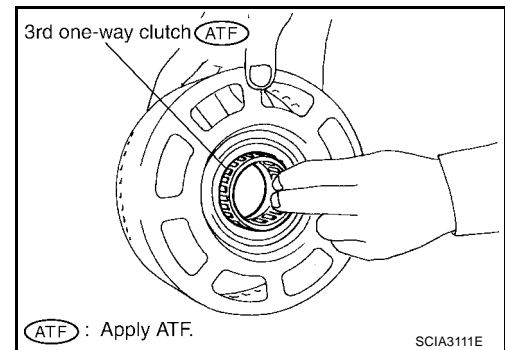

2. Install snap ring in front sun gear using suitable tool.

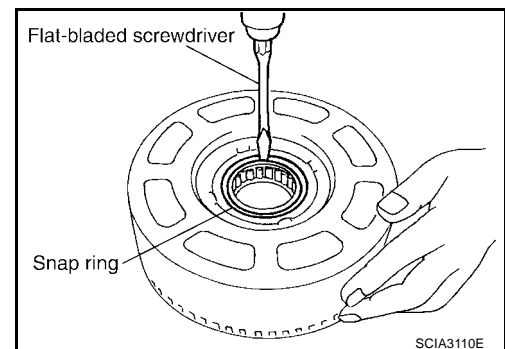

3. Check operation of 3rd one-way clutch.
 - a. Hold oil pump assembly and turn front sun gear.

REPAIR FOR COMPONENT PARTS

- b. Check 3rd one-way clutch for correct locking and unlocking directions.

CAUTION:

If not as shown, check installation direction of 3rd one-way clutch.

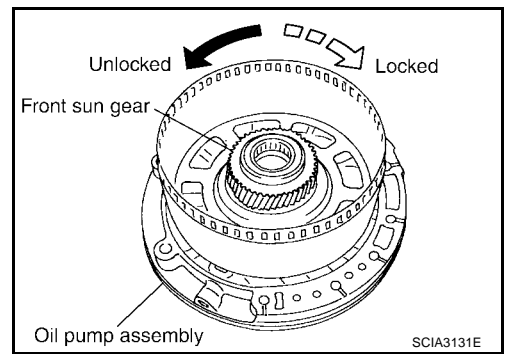

Front Carrier, Input Clutch, Rear Internal Gear COMPONENTS

SEC.314·315

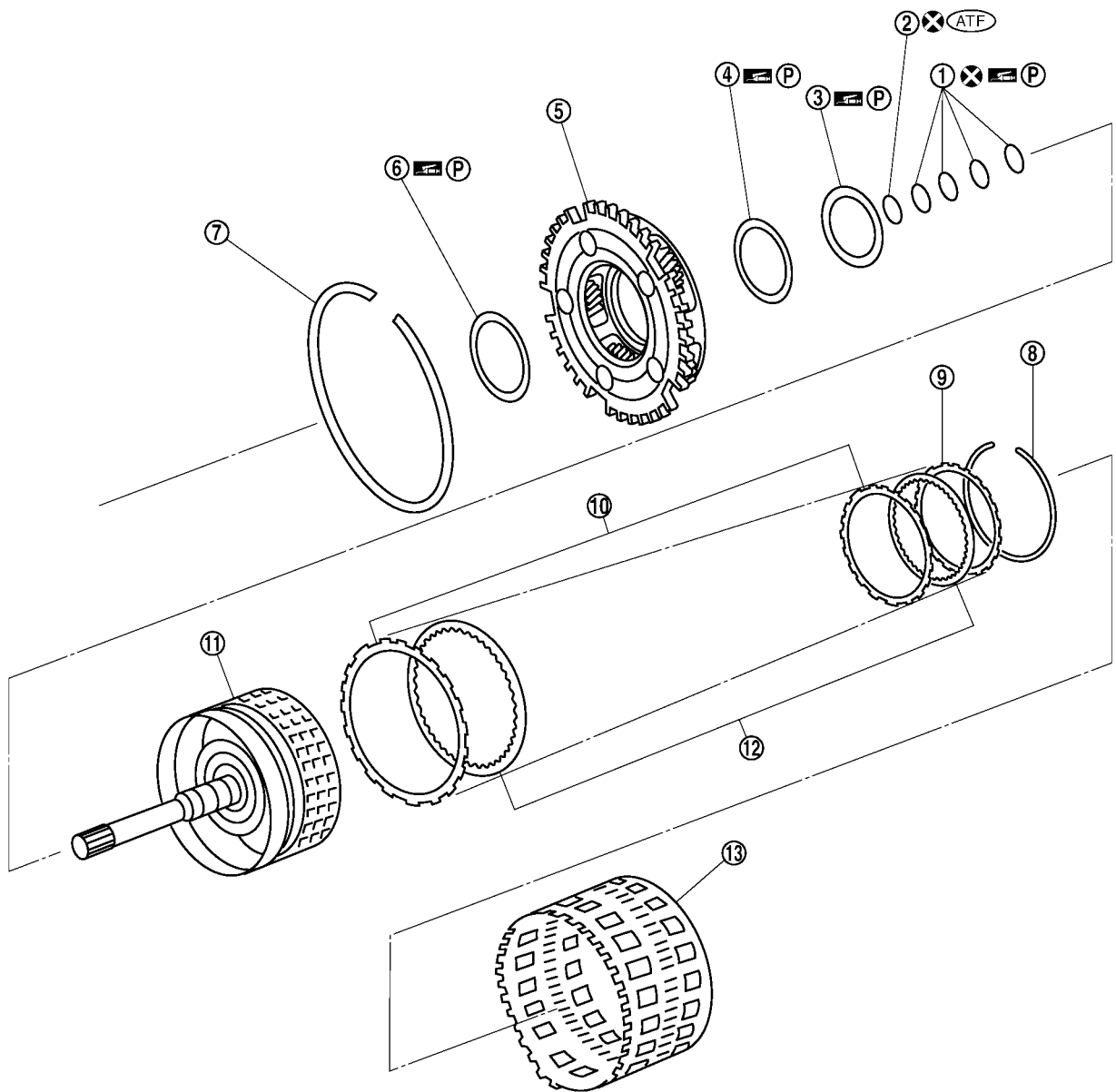

(ATF) : Apply ATF

(P) : Apply petroleum jelly.

(X) : Always replace after every disassembly.

SCIA5244E

A
B
AT
D
E
F
G
H
I
J
K
L
M

REPAIR FOR COMPONENT PARTS

- | | | |
|------------------------|---------------------------|--------------------|
| 1. Seal ring | 2. O-ring | 3. Needle bearing |
| 4. Bearing race | 5. Front carrier assembly | 6. Needle bearing |
| 7. Snap ring | 8. Snap ring | 9. Retaining plate |
| 10. Driven plate | 11. Input clutch drum | 12. Drive plate |
| 13. Rear internal gear | | |

DISASSEMBLY

1. Compress snap ring using suitable tool.
2. Remove front carrier assembly and input clutch assembly from rear internal gear.
3. Remove front carrier assembly from input clutch assembly.

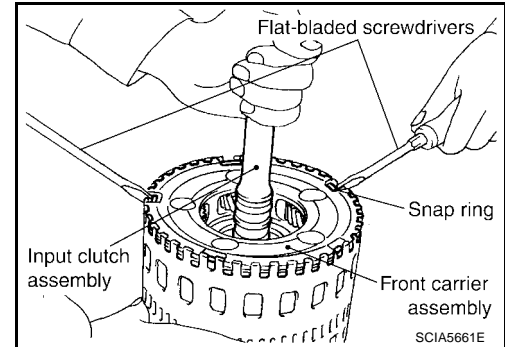

- a. Remove bearing race from front carrier assembly.

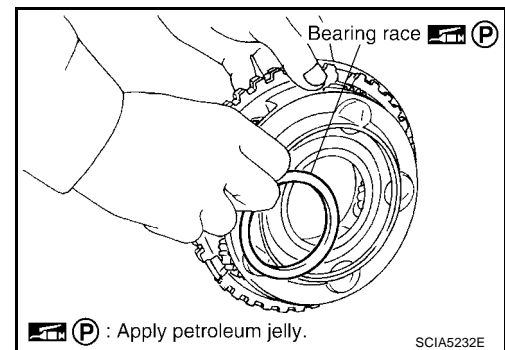

- b. Remove needle bearing from front carrier assembly.

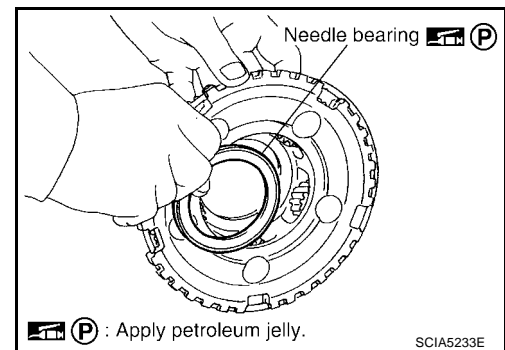

- c. Remove snap ring from front carrier assembly.

CAUTION:
Do not expand snap ring excessively.

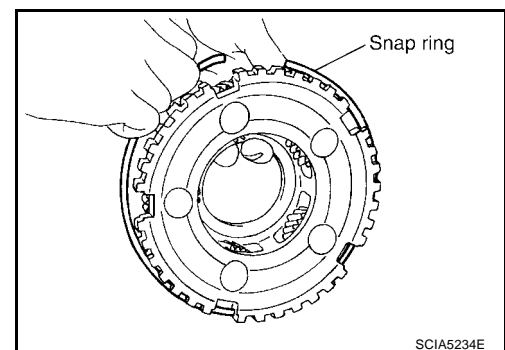

REPAIR FOR COMPONENT PARTS

4. Disassemble input clutch assembly.
 - a. Remove O-ring and seal rings from input clutch assembly.

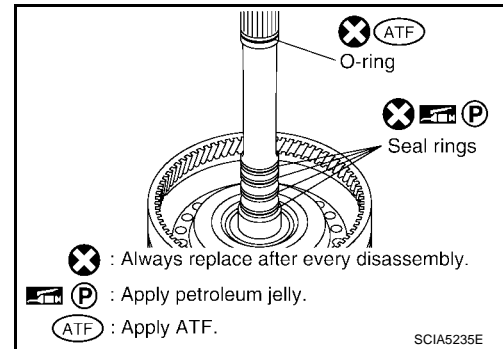

- b. Remove needle bearing from input clutch assembly.

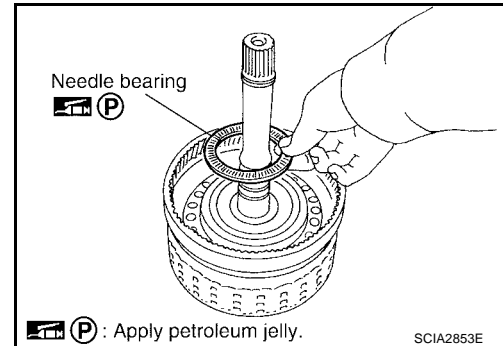

- c. Remove snap ring from input clutch drum using suitable tool.
 - d. Remove drive plates, driven plates and retaining plate from input clutch drum.

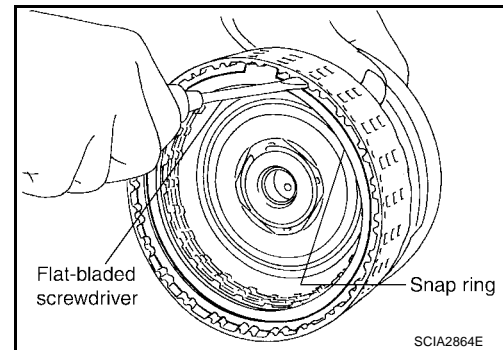

INSPECTION

Front Carrier Snap Ring

- Check for deformation, fatigue or damage.

CAUTION:

If necessary, replace the snap ring.

Input Clutch Snap Ring

- Check for deformation, fatigue or damage.

CAUTION:

If necessary, replace the input clutch assembly.

Input Clutch Drum

- Check for deformation, fatigue or damage or burns.

CAUTION:

If necessary, replace the input clutch assembly.

Input Clutch Drive Plates

- Check facing for burns, cracks or damage.

CAUTION:

If necessary, replace the input clutch assembly.

Input Clutch Retaining Plate and Driven Plates

- Check facing for burns, cracks or damage.

A
B
AT
D
E
F
G
H
I
J
K
L
M

REPAIR FOR COMPONENT PARTS

CAUTION:

If necessary, replace the input clutch assembly.

Front Carrier Assembly

- Check for deformation, fatigue or damage.

CAUTION:

If necessary, replace the front carrier assembly.

Rear Internal Gear

- Check for deformation, fatigue or damage.

CAUTION:

If necessary, replace the rear internal gear.

ASSEMBLY

1. Install input clutch.
 - a. Install drive plates, driven plates and retaining plate in input clutch drum.

CAUTION:

Take care with order of plates.

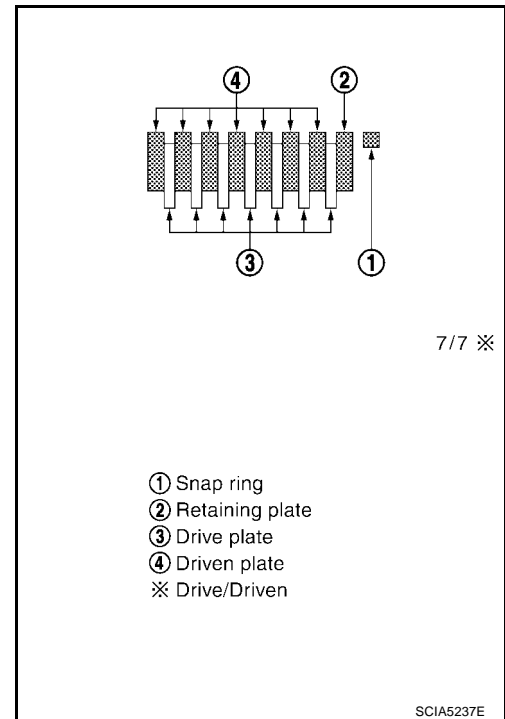

- b. Install snap ring in input clutch drum using suitable tool.

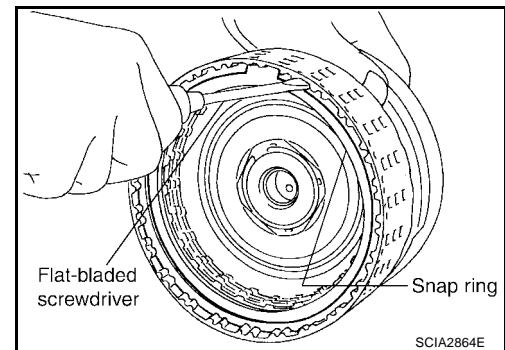

REPAIR FOR COMPONENT PARTS

- c. Install needle bearing in input clutch assembly.

CAUTION:

Apply petroleum jelly to needle bearing.

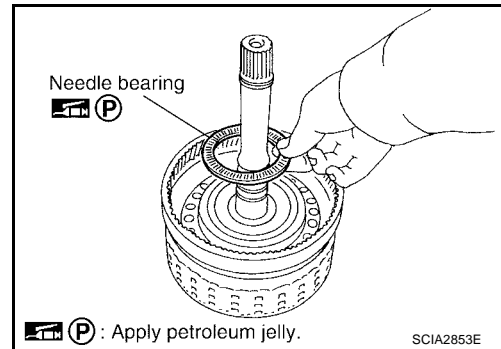

- d. Install new O-ring and new seal rings in input clutch assembly.

CAUTION:

- Do not reuse O-ring and seal rings.
- Apply ATF to O-ring.
- Apply petroleum jelly to seal rings.

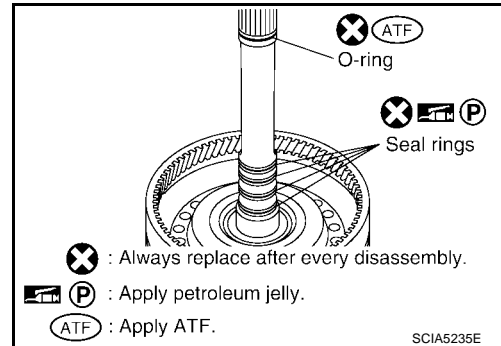

2. Install front carrier assembly.

- a. Install snap ring to front carrier assembly.

CAUTION:

Do not expand snap ring excessively.

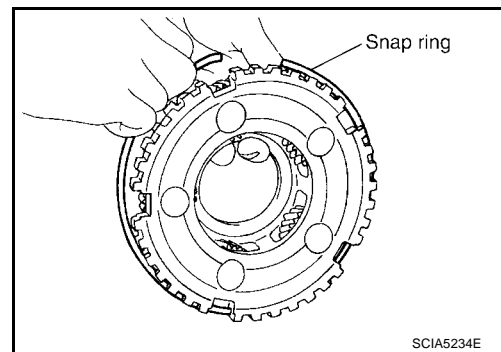

- b. Install needle bearing in front carrier assembly.

CAUTION:

- Take care with the direction of needle bearing. Refer to [AT-255, "Locations of Adjusting Shims, Needle Bearings, Thrust Washers and Snap Rings"](#).
- Apply petroleum jelly to needle bearing.

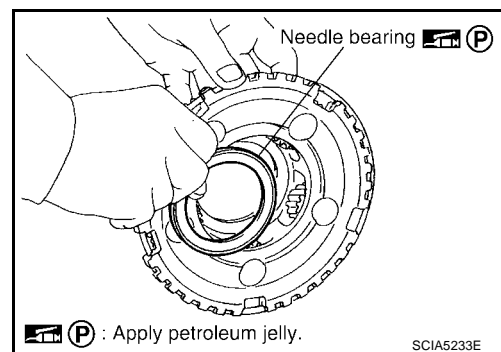

- c. Install bearing race in front carrier assembly.

CAUTION:

Apply petroleum jelly to bearing race.

- d. Install front carrier assembly to input clutch assembly.

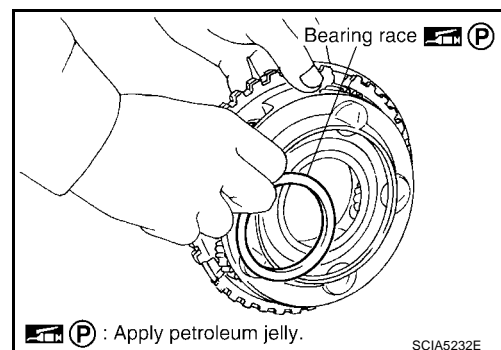

REPAIR FOR COMPONENT PARTS

3. Compress snap ring using suitable tool.
4. Install front carrier assembly and input clutch assembly to rear internal gear.

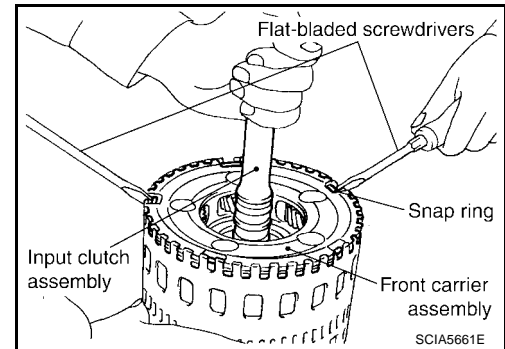

Mid Sun Gear, Rear Sun Gear, High and Low Reverse Clutch Hub COMPONENTS

ECS00188

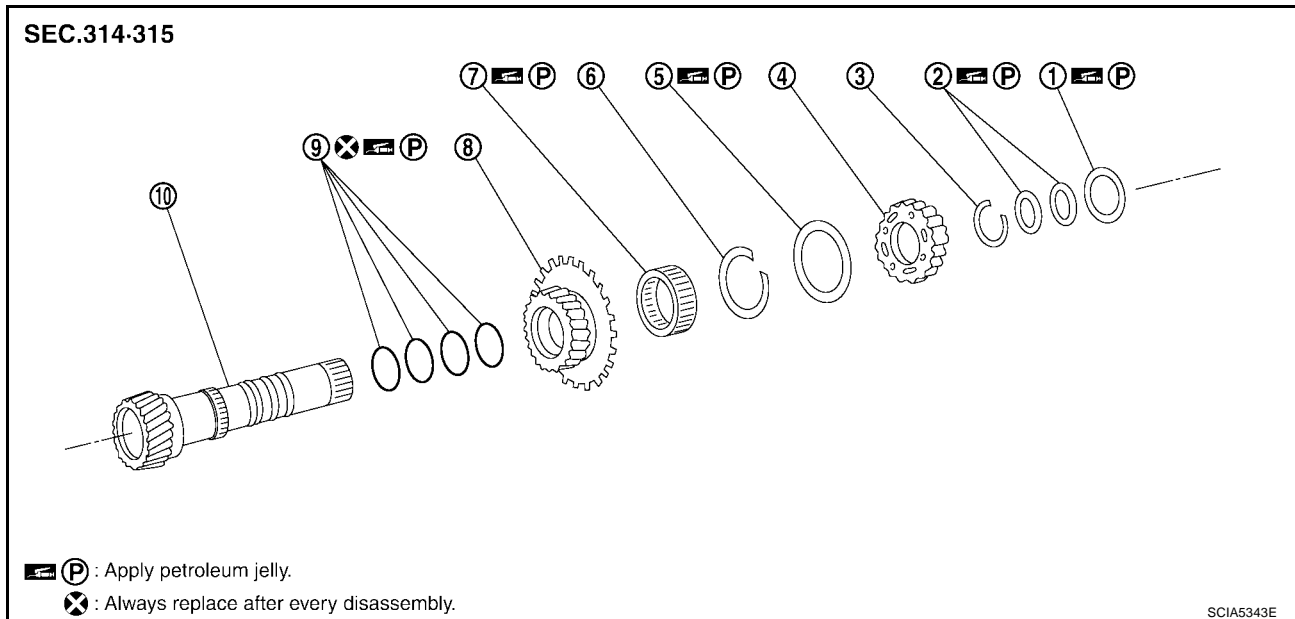

- | | | |
|------------------------------------|-------------------|--------------|
| 1. Needle bearing | 2. Bearing race | 3. Snap ring |
| 4. High and low reverse clutch hub | 5. Needle bearing | 6. Snap ring |
| 7. 1st one-way clutch | 8. Rear sun gear | 9. Seal ring |
| 10. Mid sun gear | | |

DISASSEMBLY

1. Remove needle bearing and bearing races from high and low reverse clutch hub.

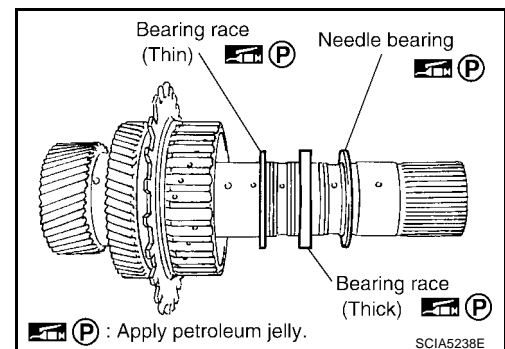

REPAIR FOR COMPONENT PARTS

2. Remove snap ring from mid sun gear assembly using suitable tool.

CAUTION:

Do not expand snap ring excessively.

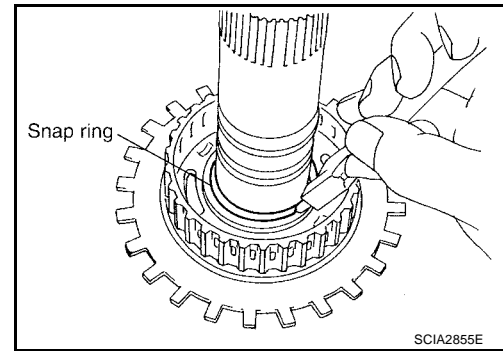

3. Remove high and low reverse clutch hub from mid sun gear assembly.

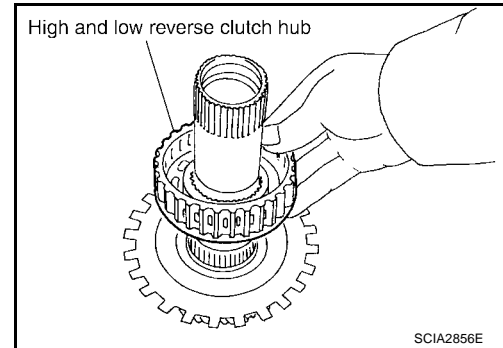

- a. Remove needle bearing from high and low reverse clutch hub.

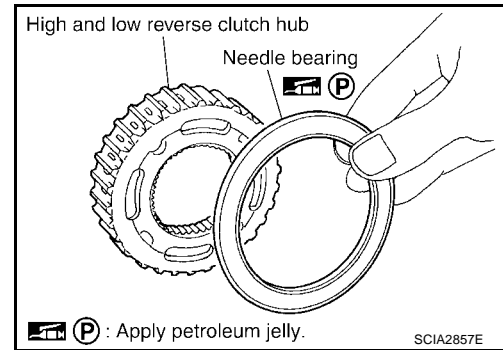

4. Remove rear sun gear assembly from mid sun gear assembly.

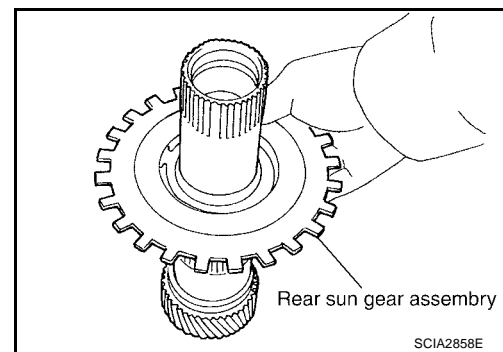

A
B
AT
D
E
F
G
H
I
J
K
L
M

REPAIR FOR COMPONENT PARTS

- a. Remove snap ring from rear sun gear using suitable tool.

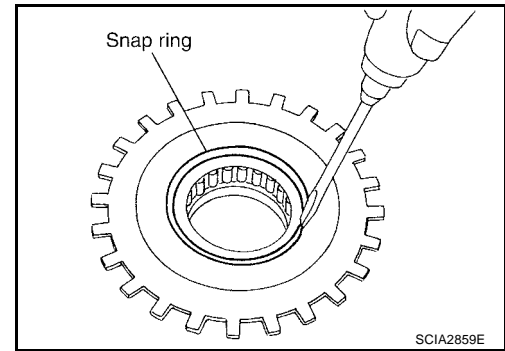

- b. Remove 1st one-way clutch from rear sun gear.

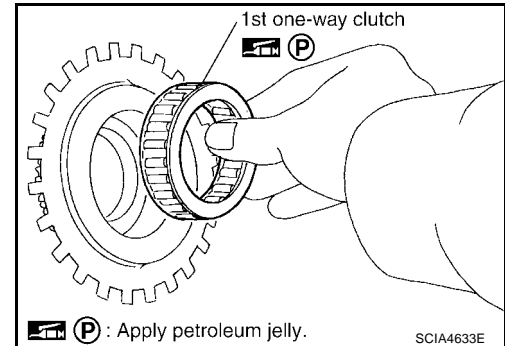

5. Remove seal rings from mid sun gear.

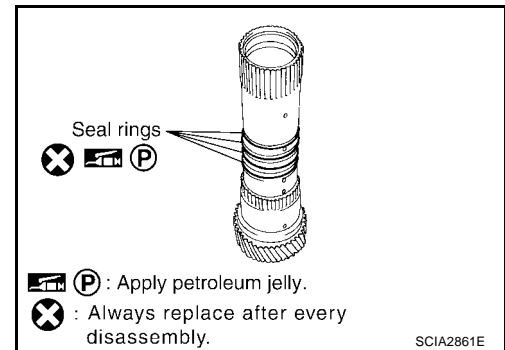

INSPECTION

High and Low Reverse Clutch Hub Snap Ring, Rear Sun Gear Snap Ring

- Check for deformation, fatigue or damage.

CAUTION:

If necessary, replace the snap ring.

1st One-way Clutch

- Check frictional surface for wear or damage.

CAUTION:

If necessary, replace the 1st one-way clutch.

Mid Sun Gear

- Check for deformation, fatigue or damage.

CAUTION:

If necessary, replace the mid sun gear.

Rear Sun Gear

- Check for deformation, fatigue or damage.

CAUTION:

If necessary, replace the rear sun gear.

High and Low Reverse Clutch Hub

- Check for deformation, fatigue or damage.

REPAIR FOR COMPONENT PARTS

CAUTION:

If necessary, replace the high and low reverse clutch hub.

ASSEMBLY

1. Install new seal rings to mid sun gear.

CAUTION:

- Do not reuse seal rings.
- Apply petroleum jelly to seal rings.

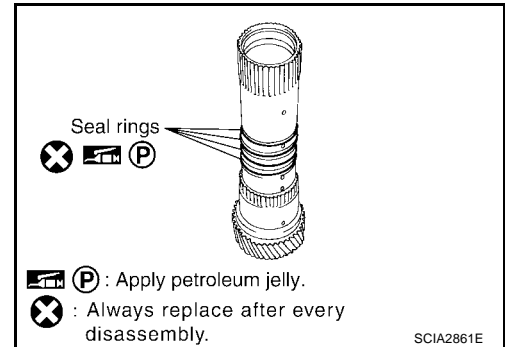

2. Install 1st one-way clutch to rear sun gear.

CAUTION:

Apply petroleum jelly to 1st one-way clutch.

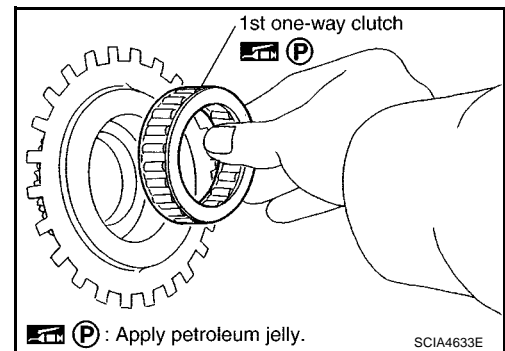

3. Install snap ring to rear sun gear using suitable tool.

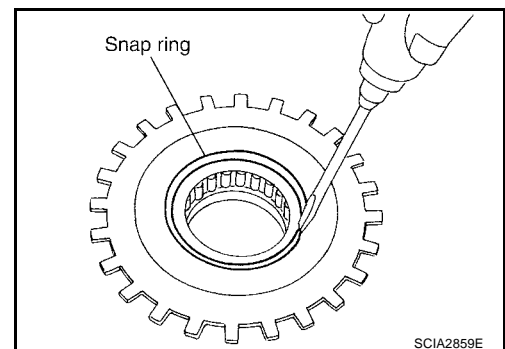

4. Install rear sun gear assembly to mid sun gear assembly.

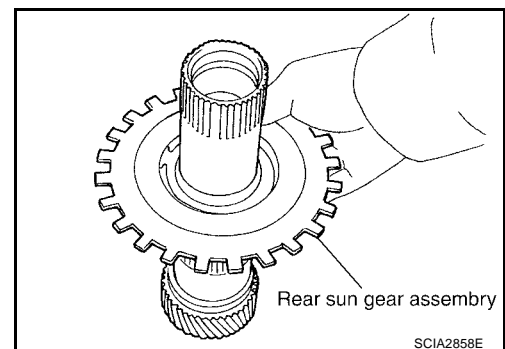

A
B
AT
D
E
F
G
H
I
J
K
L
M

REPAIR FOR COMPONENT PARTS

5. Install needle bearing to high and low reverse clutch hub.

CAUTION:

- Take care with the direction of needle bearing. Refer to [AT-255, "Locations of Adjusting Shims, Needle Bearings, Thrust Washers and Snap Rings"](#).
- Apply petroleum jelly to needle bearing.

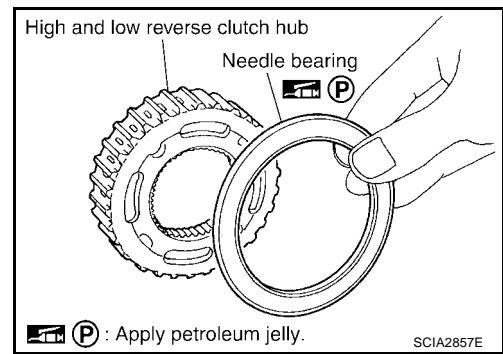

6. Install high and low reverse clutch hub to mid sun gear assembly.

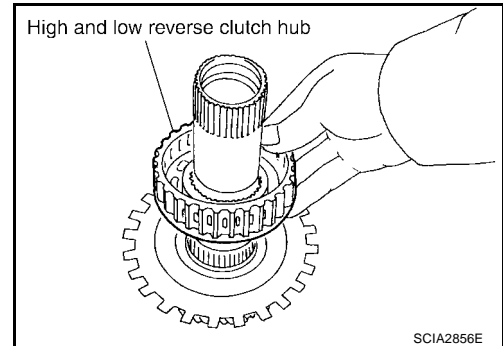

7. Install snap ring to mid sun gear assembly using suitable tool.

CAUTION:

Do not expand snap ring excessively.

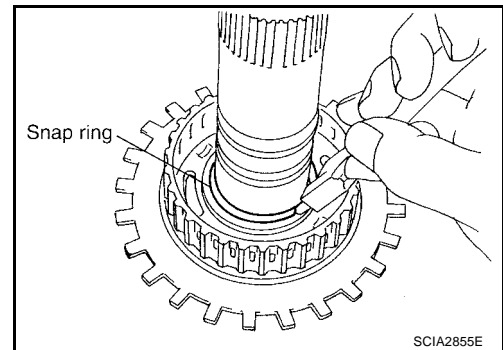

8. Check operation of 1st one-way clutch.

- a. Hold mid sun gear and turn rear sun gear.
b. Check 1st one-way clutch for correct locking and unlocking directions.

CAUTION:

If not as shown, check installation direction of 1st one-way clutch.

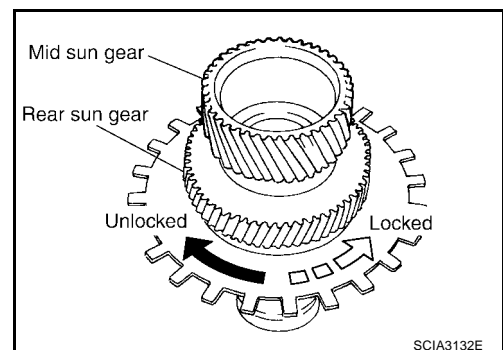

9. Install needle bearing and bearing races to high and low reverse clutch hub.

CAUTION:

- Apply petroleum jelly to needle bearing and bearing races.
- Take care with order of bearing races.

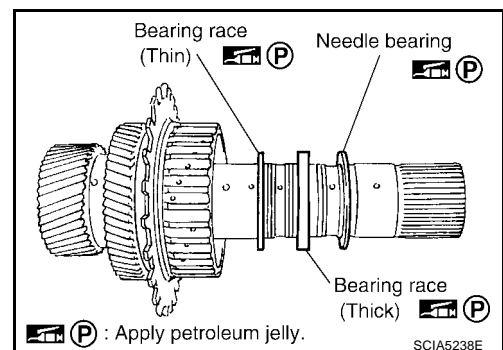

REPAIR FOR COMPONENT PARTS

High and Low Reverse Clutch COMPONENTS

ECS00189

A

B

AT

D

E

F

G

H

I

J

K

L

M

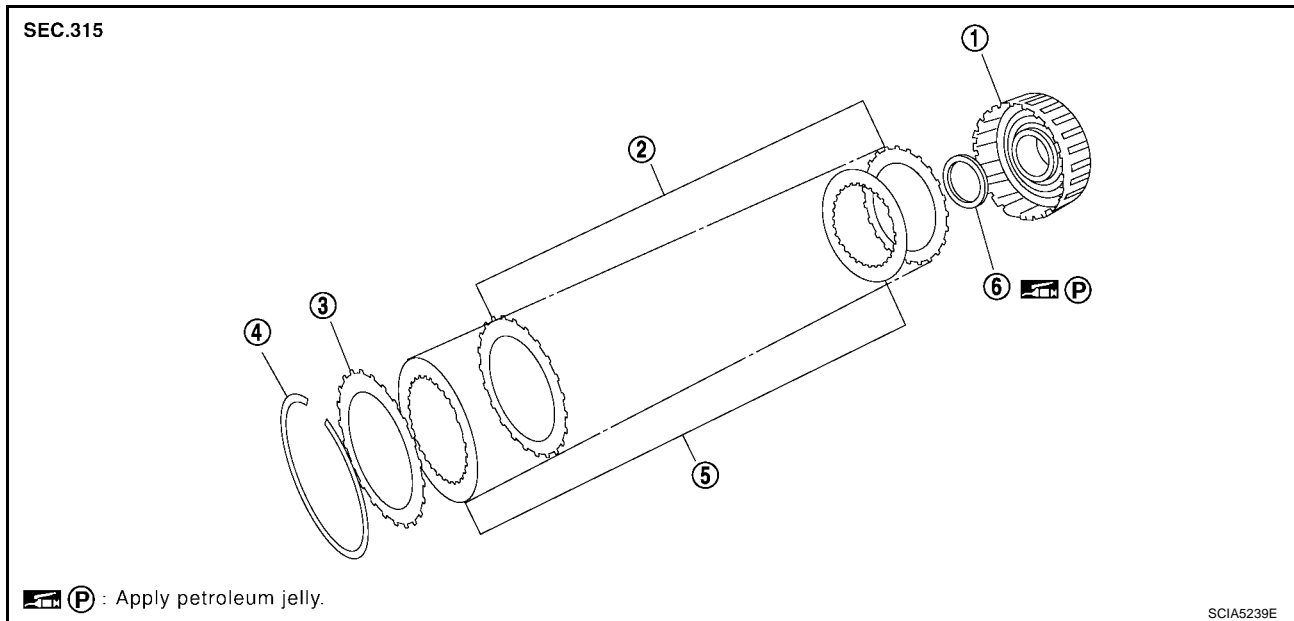

- | | | |
|-------------------------------------|-----------------|--------------------|
| 1. High and low reverse clutch drum | 2. Driven plate | 3. Retaining plate |
| 4. Snap ring | 5. Drive plate | 6. Bearing race |

DISASSEMBLY

1. Remove bearing race from high and low reverse clutch drum.

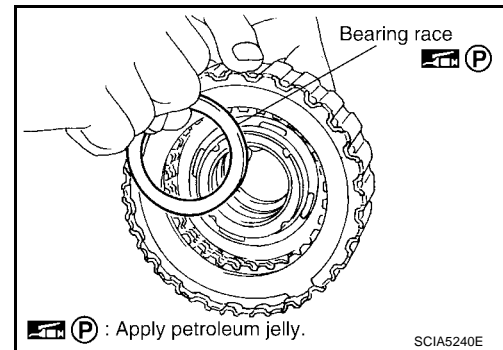

2. Remove snap ring from high and low reverse clutch drum using suitable tool.
3. Remove drive plates, driven plates and retaining plate from high and low reverse clutch drum.

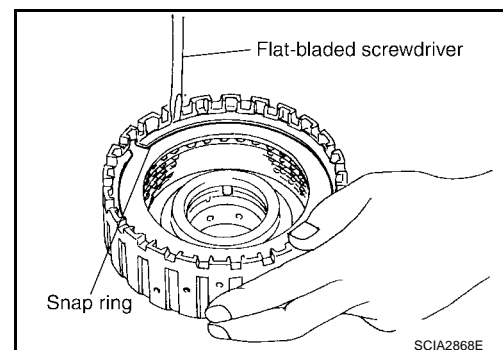

INSPECTION

- Check the following, and replace high and low reverse clutch assembly if necessary.

High and Low Reverse Clutch Snap Ring

- Check for deformation, fatigue or damage.

High and Low Reverse Clutch Drive Plates

- Check facing for burns, cracks or damage.

REPAIR FOR COMPONENT PARTS

High and Low Reverse Clutch Retaining Plate and Driven Plates

- Check facing for burns, cracks or damage.

ASSEMBLY

1. Install drive plates, driven plates and retaining plate in high and low reverse clutch drum.

CAUTION:

Take care with the order of plates.

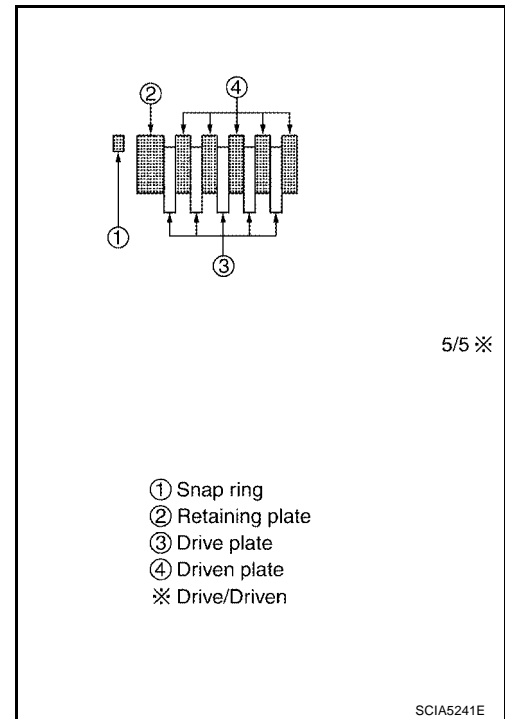

2. Install snap ring in high and low reverse clutch drum using suitable tool.

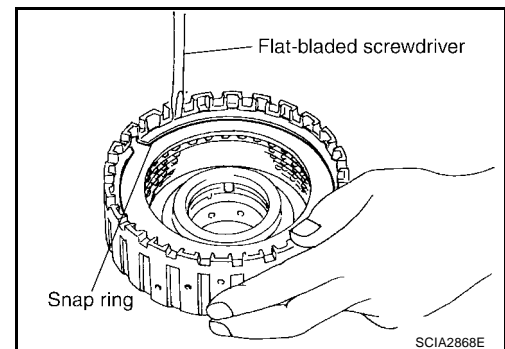

3. Install bearing race to high and low reverse clutch drum.

CAUTION:

Apply petroleum jelly to bearing race.

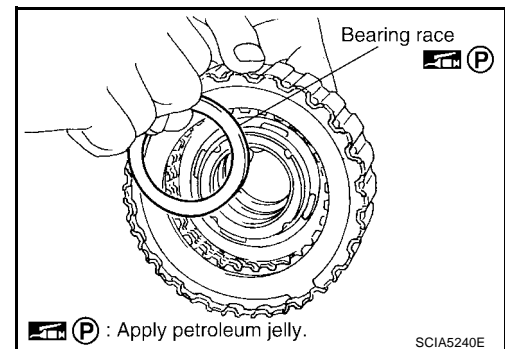

REPAIR FOR COMPONENT PARTS

Direct Clutch COMPONENTS

ECS0018A

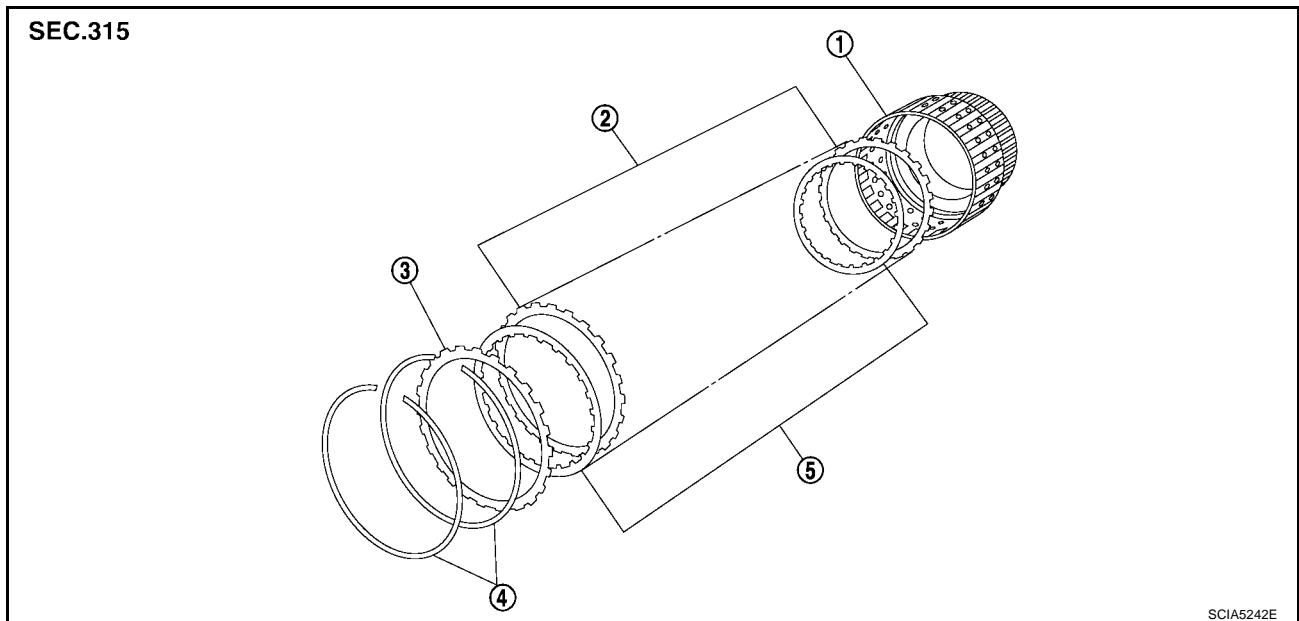

- | | | |
|-----------------------|-----------------|--------------------|
| 1. Direct clutch drum | 2. Driven plate | 3. Retaining plate |
| 4. Snap ring | 5. Drive plate | |

DISASSEMBLY

1. Remove snap rings from direct clutch drum using suitable tool.
2. Remove drive plates, driven plates and retaining plate from direct clutch drum.

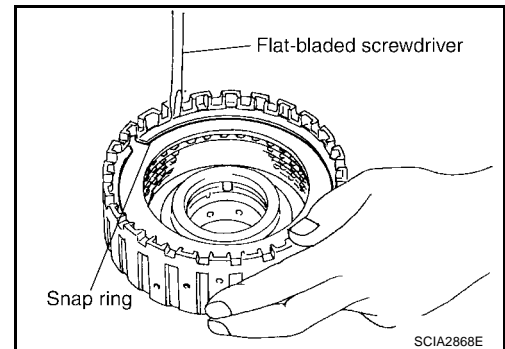

INSPECTION

- Check the following, and replace direct clutch assembly if necessary.

Direct Clutch Snap Rings

- Check for deformation, fatigue or damage.

Direct Clutch Drive Plates

- Check facing for burns, cracks or damage.

Direct Clutch Retaining Plate and Driven Plates

- Check facing for burns, cracks or damage.

A
B
AT
D
E
F
G
H
I
J
K
L
M

REPAIR FOR COMPONENT PARTS

ASSEMBLY

1. Install drive plates, driven plates and retaining plate in direct clutch drum.

CAUTION:

Take care with the order of plates.

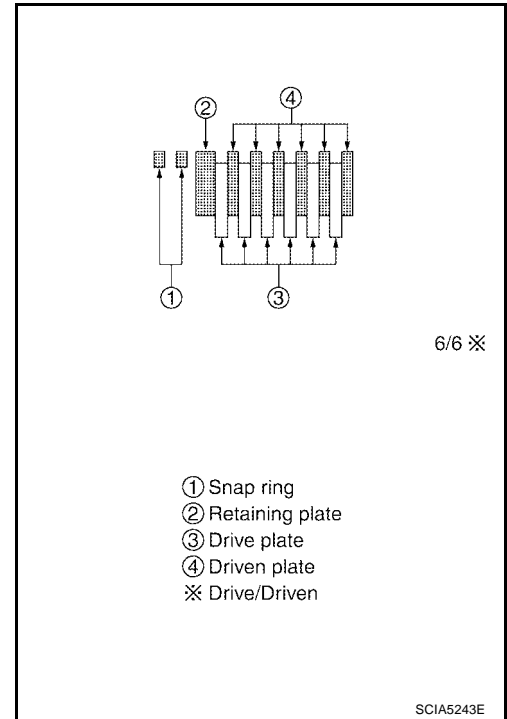

2. Install snap rings in direct clutch drum using suitable tool.

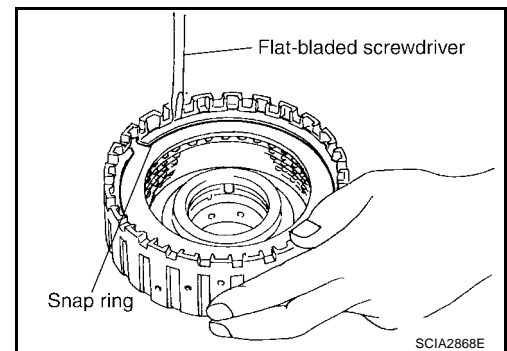

ASSEMBLY

ASSEMBLY

PF0:0000

ECS00H3N

Assembly (1)

1. Drive new manual shaft oil seals into the transmission case until it is flush using suitable tool.

CAUTION:

- Apply ATF to manual shaft oil seals.
- Do not reuse manual shaft oil seals.

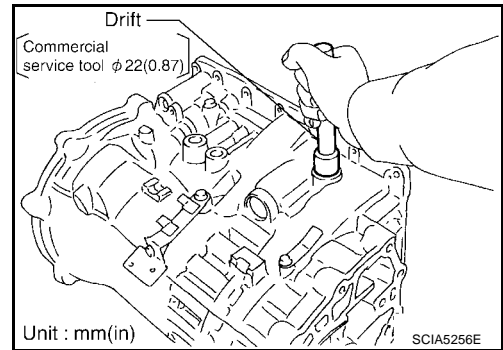

2. Install detent spring and spacer in transmission case. Tighten bolt to the specified torque. Refer to [AT-245, "Components"](#).

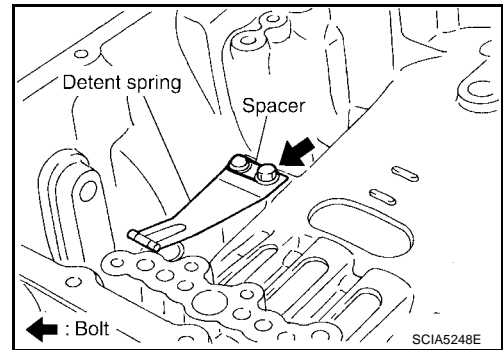

3. Install manual shaft to transmission case.

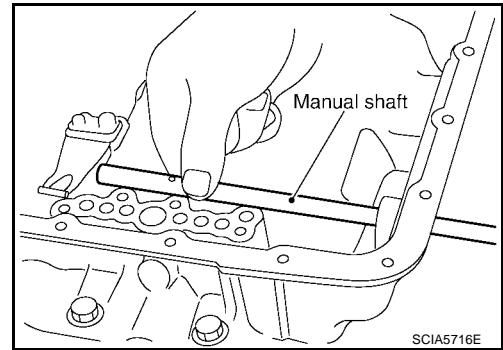

4. Install parking rod to manual plate.

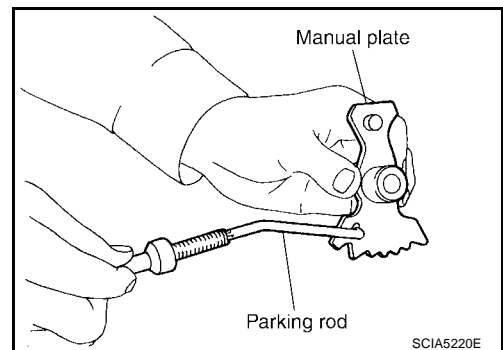

A
B
AT
D
E
F
G
H
I
J
K
L
M

ASSEMBLY

5. Install manual plate (with parking rod) to manual shaft.

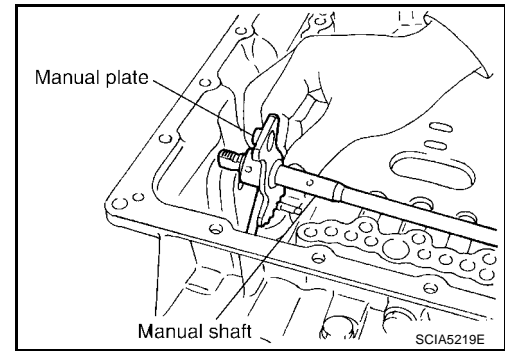

6. Install new retaining pin into the manual plate and manual shaft.
- Fit pinhole of the manual plate to pinhole of the manual shaft using suitable tool.
 - Tap the new retaining pin into the manual plate using suitable tool.

CAUTION:

- Drive retaining pin to 2mm (0.8 in) over the manual plate.
- Do not reuse retaining pin.

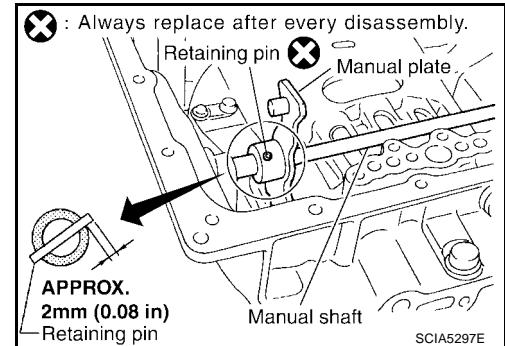

7. Install new retaining pin into the transmission case and manual shaft.

- Fit pinhole of the transmission case to pinhole of the manual shaft using suitable tool.
- Tap the new retaining pin into the transmission case, using suitable tool.

CAUTION:

- Drive retaining pin to 5 mm (0.20 in) over the transmission case.
- Do not reuse retaining pin.

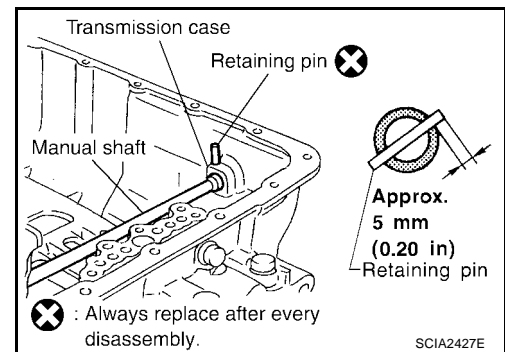

8. Install new O-rings to servo assembly.

CAUTION:

- Do not reuse O-rings.
- Apply petroleum jelly to O-rings.

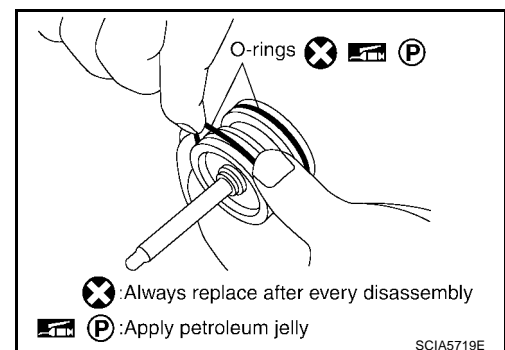

9. Install return spring to servo assembly.

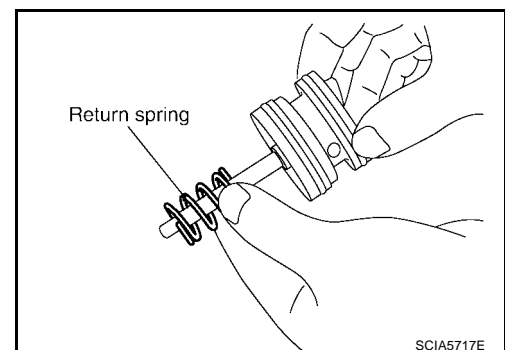

ASSEMBLY

10. Install servo assembly in transmission case.

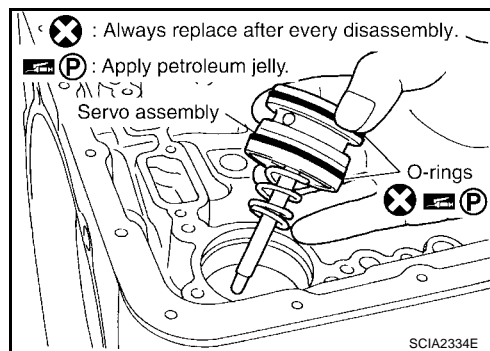

11. Install snap ring to transmission case using suitable tool.

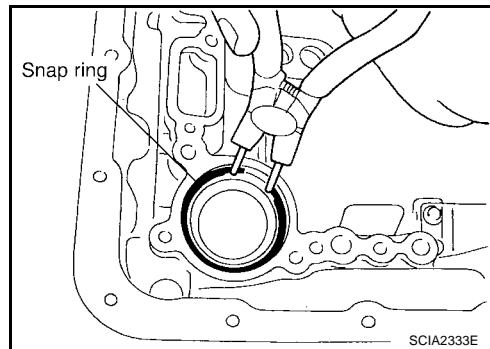

12. Install new D-rings in reverse brake piston.

CAUTION:

- Do not reuse D-rings.
- Apply ATF to D-rings.

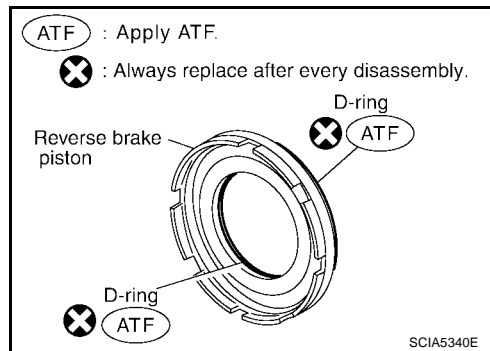

13. Install reverse brake piston in transmission case.

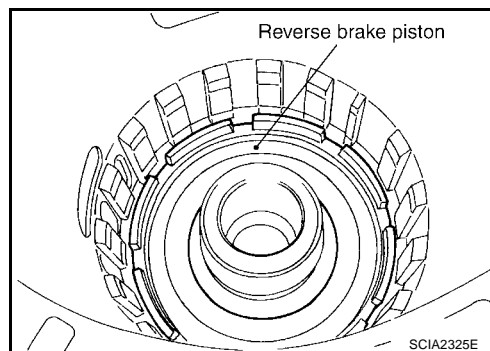

14. Install needle bearing to drum support edge surface.

CAUTION:

Apply petroleum jelly to needle bearing.

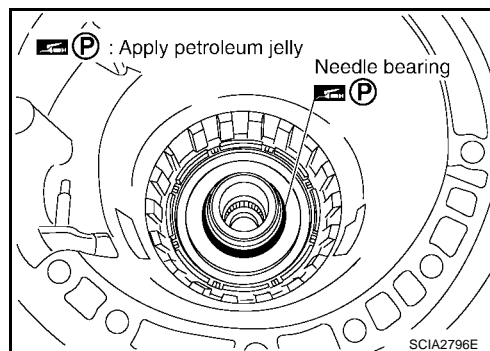

A
B
AT
D
E
F
G
H
I
J
K
L
M

ASSEMBLY

15. Install new seal rings to drum support.

CAUTION:

- Do not reuse seal rings.
- Apply petroleum jelly to seal rings.

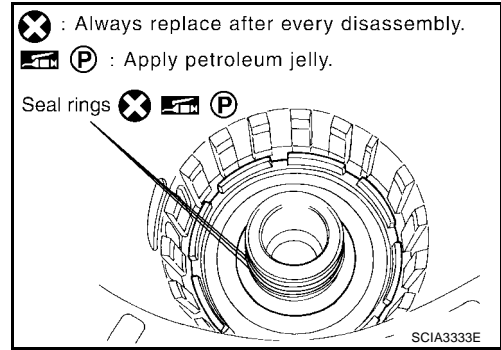

16. Install spring retainer and return spring in transmission case.

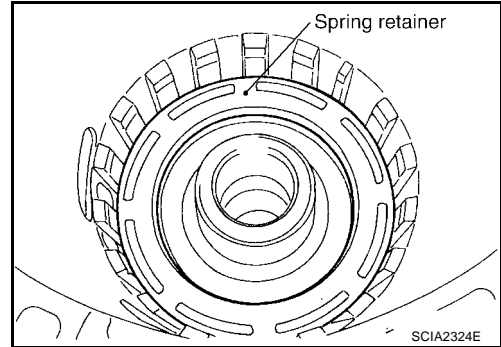

17. Install snap ring in transmission case while compressing return spring using Tool.

Tool number : KV31102400 (J-34285 and J-34285-87)

CAUTION:

Securely assemble them so that snap ring tension is slightly weak.

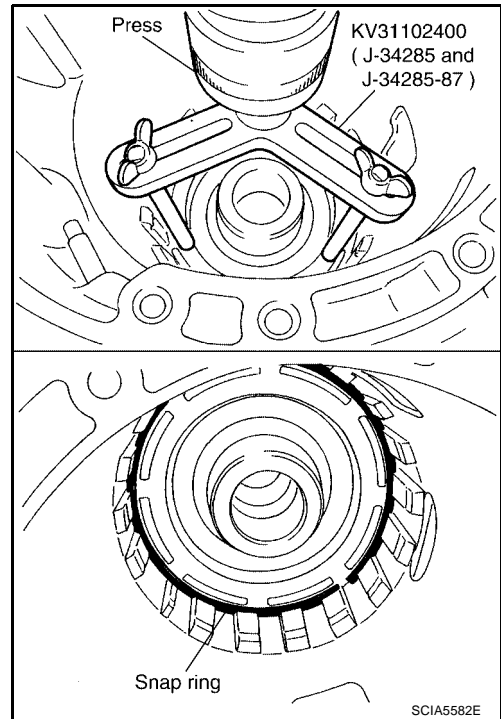

18. Install reverse brake drive plates (3), driven plates (4) and dish plate (4) in transmission case.

- Snap ring (1)
- Retaining plate (2)

CAUTION:

Take care with the order and direction of plates.

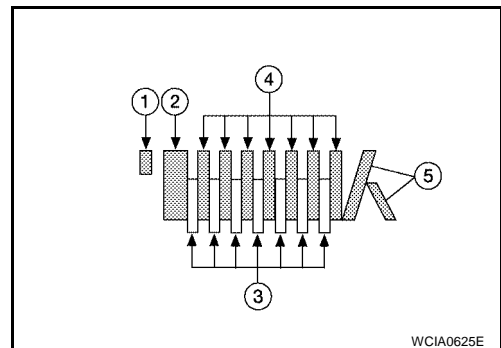

ASSEMBLY

19. Assemble N-spring.
20. Install reverse brake retaining plate in transmission case.

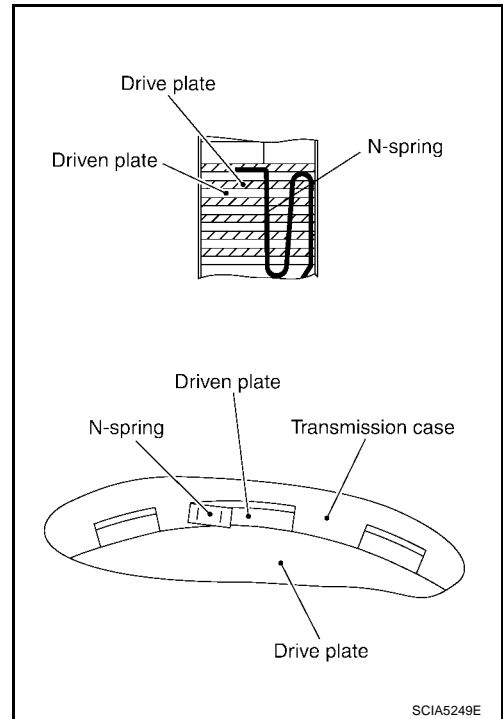

21. Install snap ring in transmission case.

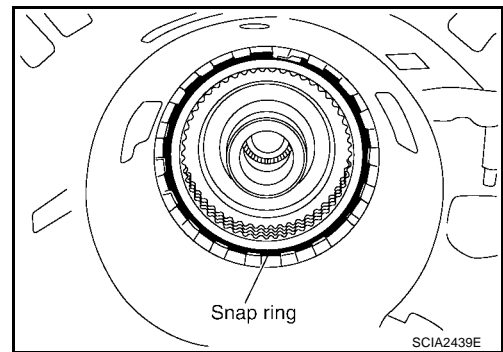

22. Measure clearance between retaining plate and snap ring. If not within specified clearance, select proper retaining plate.

Specified clearance "A" : Standard: 0.7 - 1.1mm
(0.028 - 0.043 in)

Retaining plate : Refer to [AT-319, "Reverse brake"](#) .

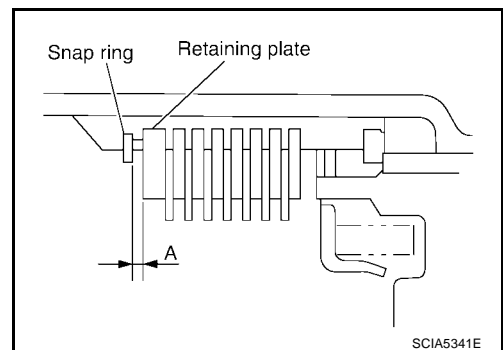

23. Install needle bearing to transmission case.

CAUTION:

- Take care with the direction of needle bearing. Refer to [AT-255, "Locations of Adjusting Shims, Needle Bearings, Thrust Washers and Snap Rings"](#) .
- Apply petroleum jelly to needle bearing.

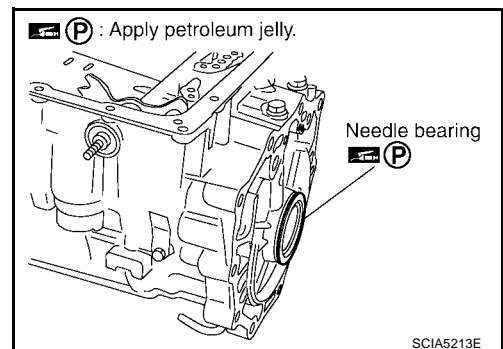

ASSEMBLY

24. Install revolution sensor to transmission case. Tighten revolution sensor bolt to the specified torque. Refer to [AT-245. "Components"](#).

CAUTION:

- Do not subject it to impact by dropping or hitting it.
- Be careful not to damage harness with the edge of case.
- Do not allow metal filings or foreign material to get on the sensor front edge magnetic area.
- Do not place in an area affected by magnetism.

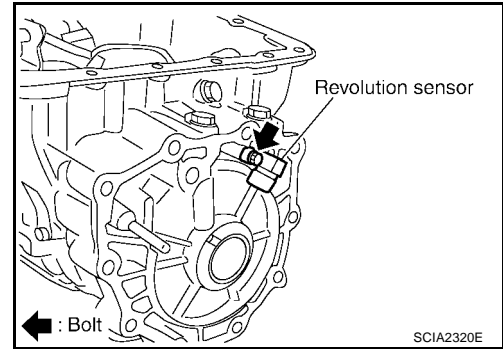

25. Install new rear oil seal until it is flush into the rear extension (2WD models) using Tool or adapter case (4WD models) using suitable tool.

Tool number : ST33400001 (J-26082)

CAUTION:

- Apply ATF to rear oil seal.
- Do not reuse rear oil seal.

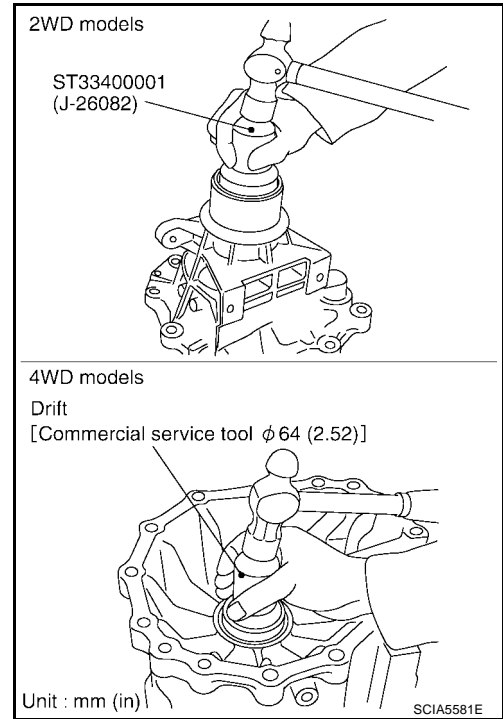

26. Install return spring (1) to parking pawl (2).

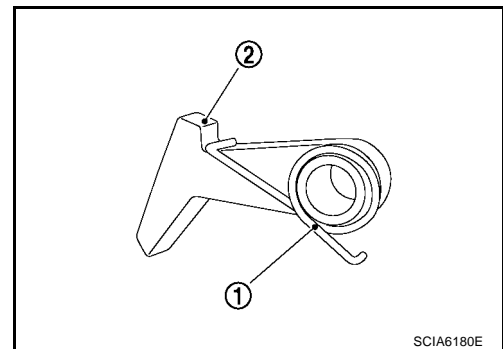

27. Install parking pawl (with return spring) and pawl shaft to rear extension (2WD models) or adapter case (4WD models).

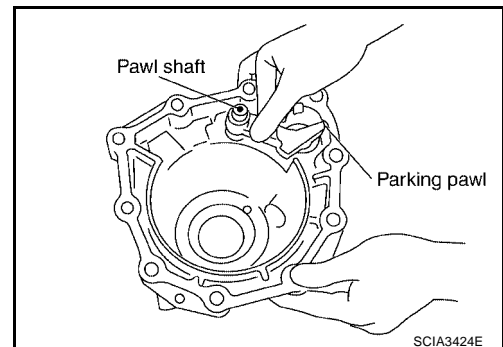

ASSEMBLY

28. Install parking actuator support to rear extension (2WD models) or adapter case (4WD models).

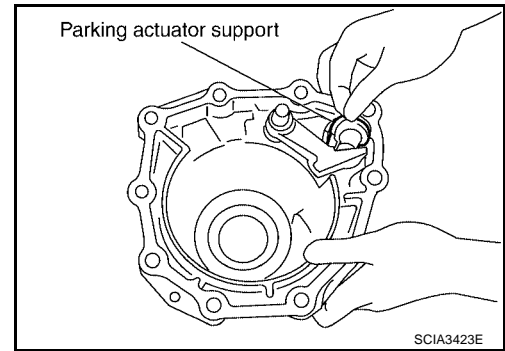

29. Install needle bearing to rear extension (2WD models) or adapter case (4WD models).

CAUTION:

Apply petroleum jelly to needle bearing.

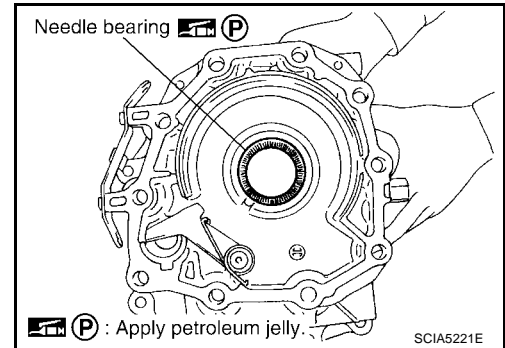

30. Install new seal rings to output shaft.

CAUTION:

- Do not reuse seal rings.
- Apply petroleum jelly to seal rings.

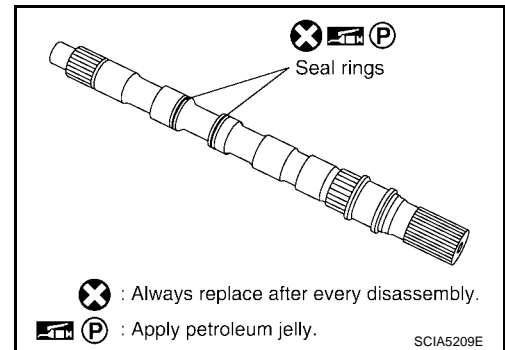

31. Install parking gear to output shaft.

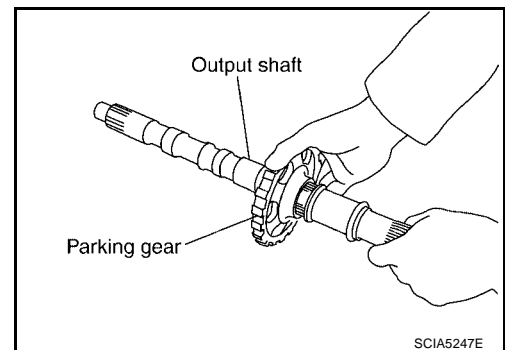

32. Install output shaft in transmission case.

CAUTION:

Be careful not to mistake front for rear because both sides looks similar. (Thinner end is front side.)

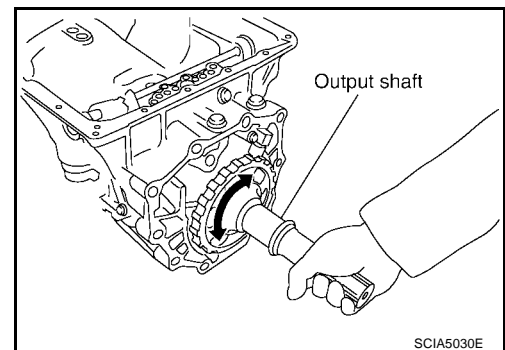

ASSEMBLY

33. Install bearing race in output shaft.

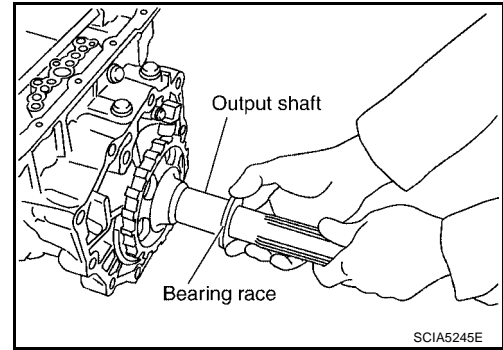

34. Install rear extension assembly (2WD models) or adapter case assembly (4WD models) according to the following procedures.

a. **2WD models**

i. Apply recommended sealant (Genuine Anaerobic Liquid Gasket or equivalent) to rear extension assembly as shown. Refer to [GI-47, "Recommended Chemical Products and Sealants"](#).

CAUTION:

Completely remove all moisture, oil and old sealant from the transmission case and rear extension assembly mating surfaces.

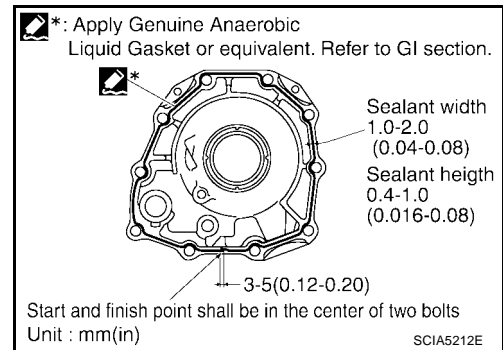

ii. Install rear extension assembly to transmission case.

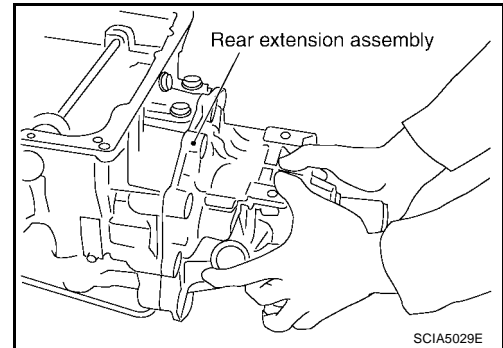

iii. Install brackets (1).

iv. Tighten rear extension assembly bolts to specified torque.

CAUTION:

Do not reuse self-sealing bolts (2).

Rear extension assembly bolts : 52 N·m (5.3 kg·m, 38 ft·lb)

Self-sealing bolts : 61 N·m (6.2 kg·m, 45 ft·lb)

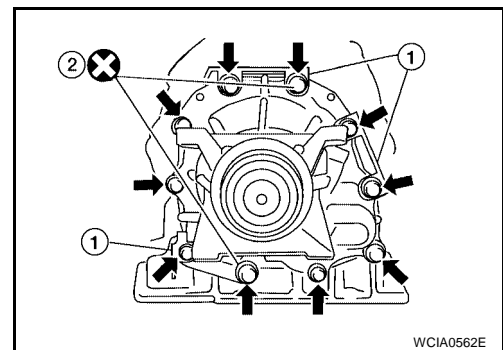

ASSEMBLY

b. 4WD models

i. Install new gasket to transmission case.

CAUTION:

- Do not reuse gasket.
- Completely remove all moisture, oil and old gasket from the transmission case and adapter case assembly mating surfaces.

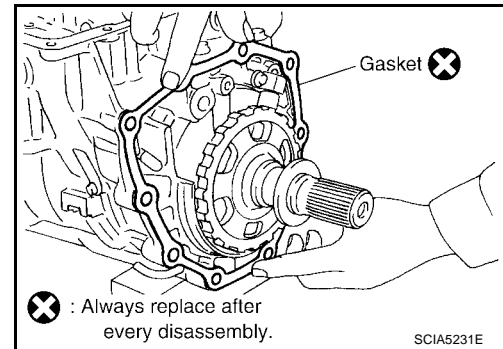

ii. Install adapter case assembly to transmission case.

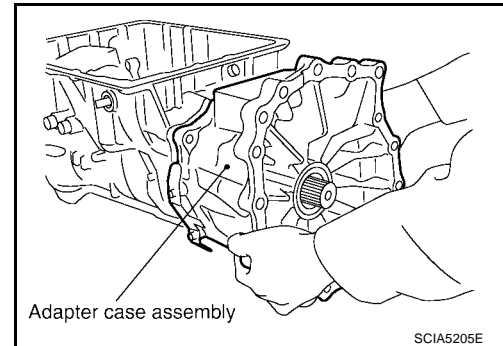

iii. Install brackets (1).

iv. Tighten adapter case assembly bolts to specified torque.

CAUTION:

Do not reuse self-sealing bolts (2).

Adapter case assembly bolts : 52 N-m (5.3 kg-m,
38 ft-lb)

Self-sealing bolt : 61 N-m (6.2 kg-m,
45 ft-lb)

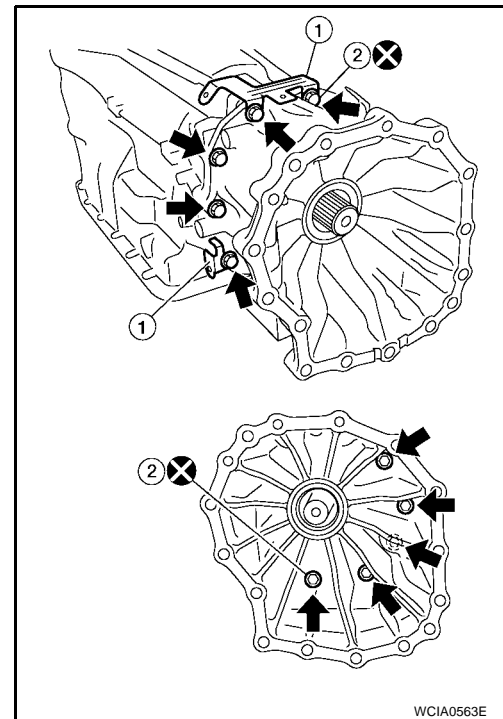

35. Install needle bearing in drum support edge surface.

CAUTION:

Apply petroleum jelly to needle bearing.

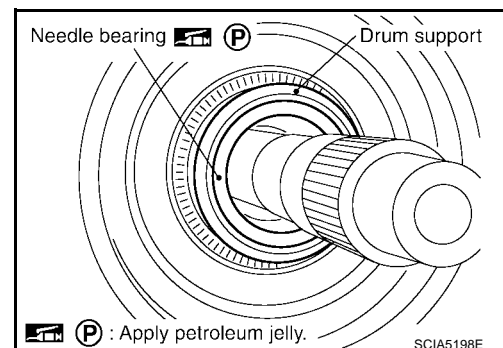

ASSEMBLY

36. Install direct clutch assembly in reverse brake.

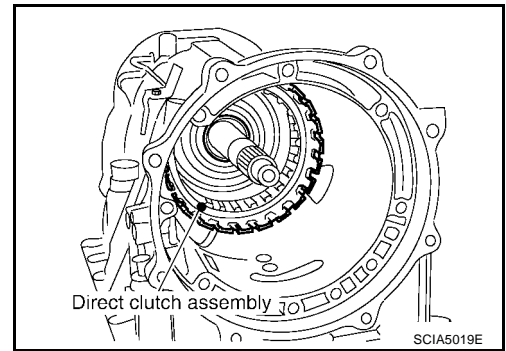

37. Install high and low reverse clutch assembly in direct clutch assembly.

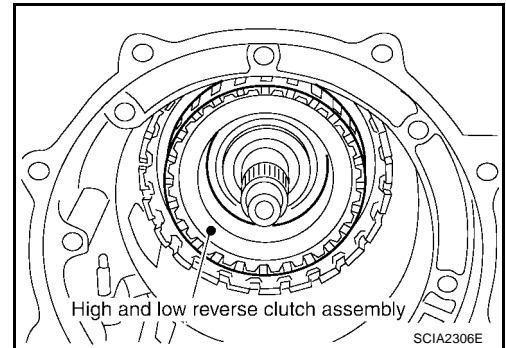

38. Align the drive plate using suitable tool.

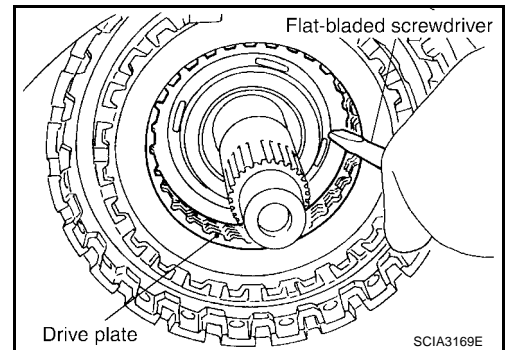

39. Install high and low reverse clutch hub, mid sun gear assembly and rear sun gear assembly as a unit.

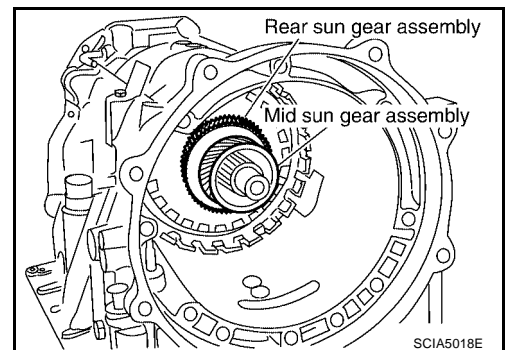

ASSEMBLY

CAUTION:

Check that portion A of high and low reverse clutch drum protrudes approximately 2 mm (0.08 in) beyond portion B of rear sun gear.

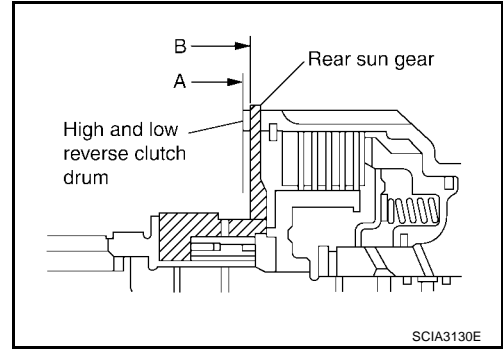

40. Install needle bearing in rear carrier assembly.

CAUTION:

Apply petroleum jelly to needle bearing.

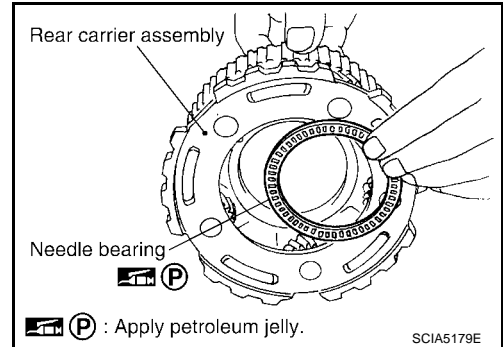

41. Install bearing race in rear carrier assembly.

CAUTION:

Apply petroleum jelly to bearing race.

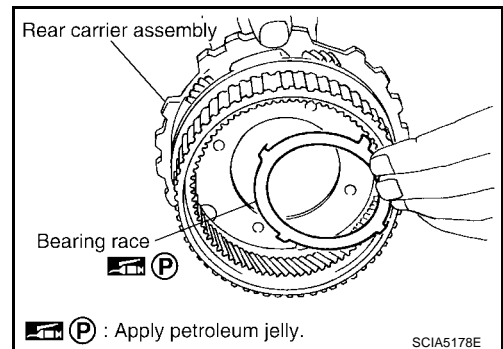

42. Install rear carrier assembly in direct clutch drum.

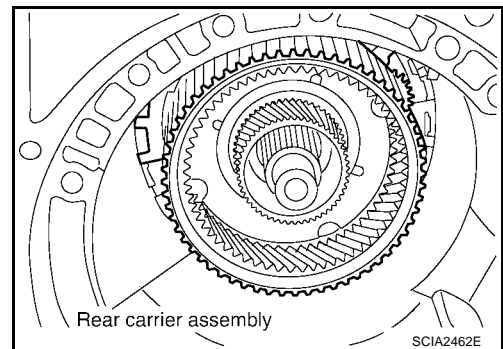

A
B
AT
D
E
F
G
H
I
J
K
L
M

ASSEMBLY

43. Install needle bearing (rear side) in mid carrier assembly.

CAUTION:

Apply petroleum jelly to needle bearing.

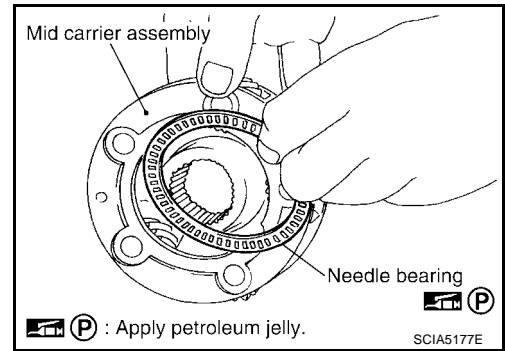

44. Install needle bearing (front side) in mid carrier assembly.

CAUTION:

Apply petroleum jelly to needle bearing.

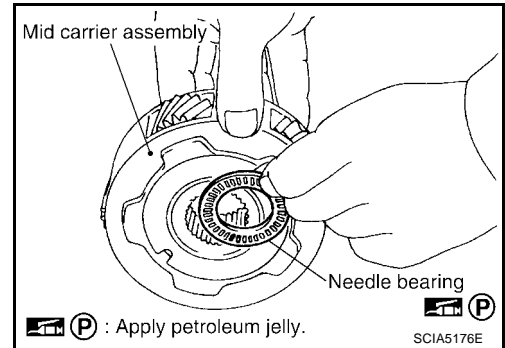

45. Install mid carrier assembly in rear carrier assembly.

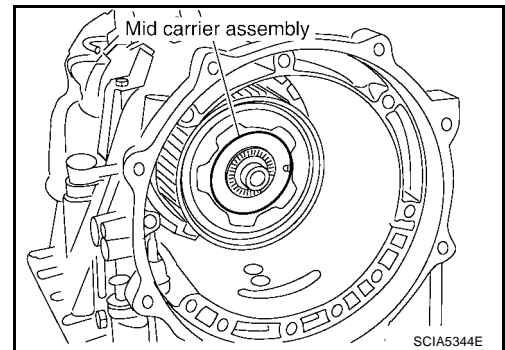

46. Install front carrier assembly, input clutch assembly and rear internal gear as a unit.

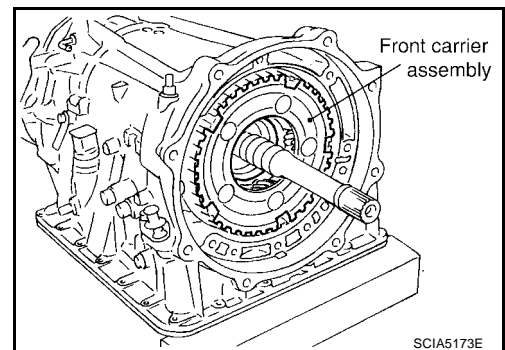

47. Install new seal rings in input clutch assembly.

CAUTION:

- Do not reuse seal rings.
- Apply petroleum jelly to seal rings.

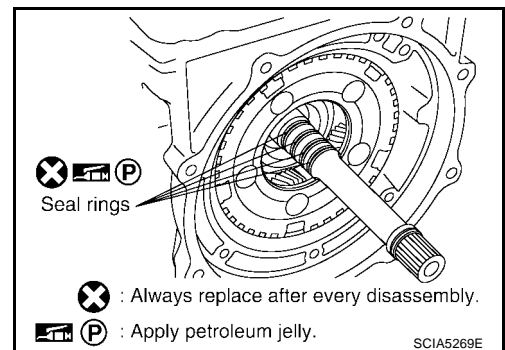

ASSEMBLY

48. Install new band servo anchor end pin and lock nut in transmission case.

CAUTION:

Do not reuse band servo anchor end pin.

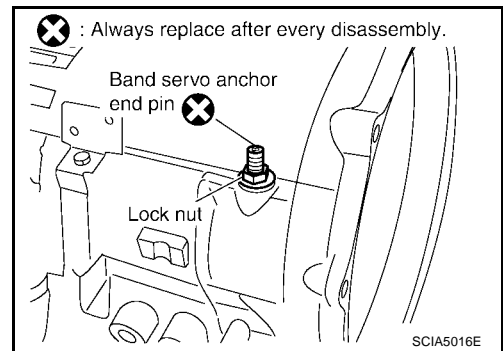

49. Install brake band in transmission case.

CAUTION:

Assemble it so that identification to avoid incorrect installation faces servo side.

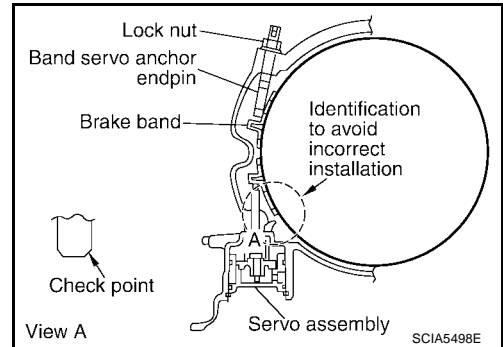

50. Install front sun gear assembly to front carrier assembly.

CAUTION:

Apply ATF to front sun gear radial bearing and 3rd one-way clutch end bearing.

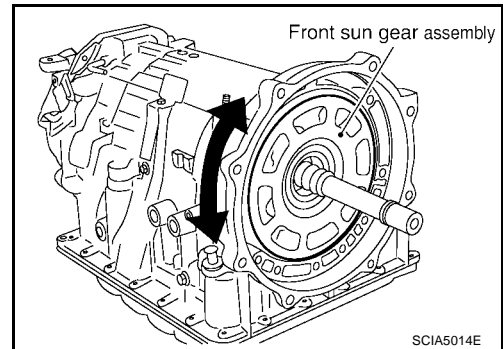

51. Install needle bearing in front sun gear assembly.

CAUTION:

Apply petroleum jelly to needle bearing.

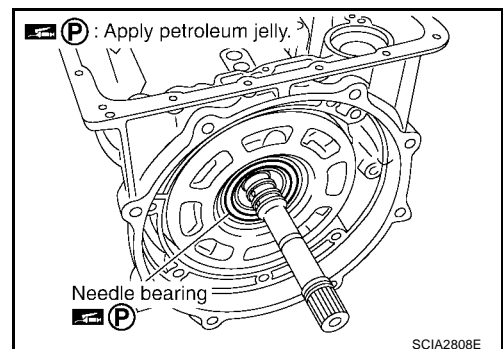

52. Adjust brake band tilting using clips so that brake band contacts front sun gear drum evenly.

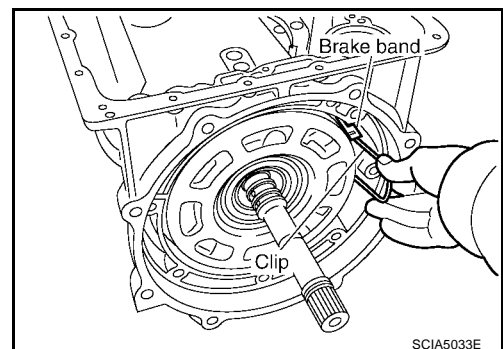

A
B
AT
D
E
F
G
H
I
J
K
L
M

ASSEMBLY

53. Adjust brake band.

- a. Loosen lock nut.
- b. Tighten band servo anchor end pin to specified torque.

**Band servo anchor end pin : 5.0 N-m (0.51 kg-m,
44 in-lb)**

- c. Back off band servo anchor end pin three turns.
- d. Holding band servo anchor end pin, tighten lock nut to specified torque. Refer to [AT-245, "Components"](#).

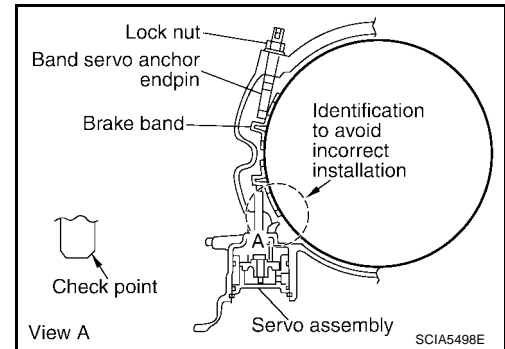

ECS00H30

Adjustment TOTAL END PLAY

- Measure clearance between front sun gear and bearing race for oil pump cover.
- Select proper thickness of bearing race so that end play is within specifications.

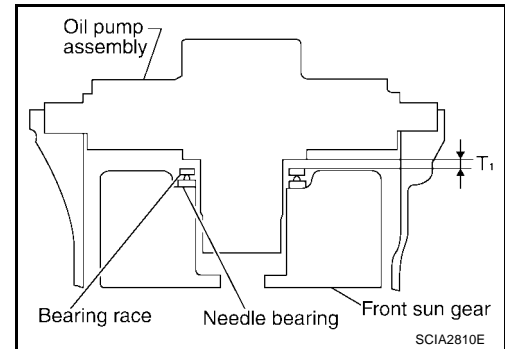

1. Measure dimensions "K" and "L" and then calculate dimension "J".

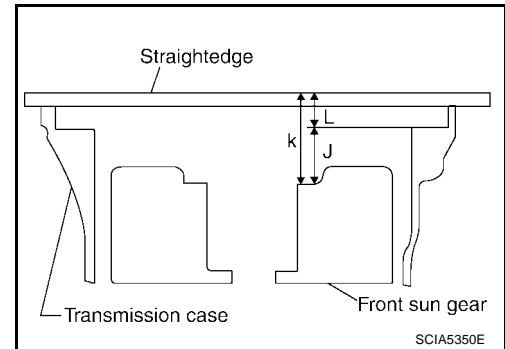

- a. Measure dimension "K".

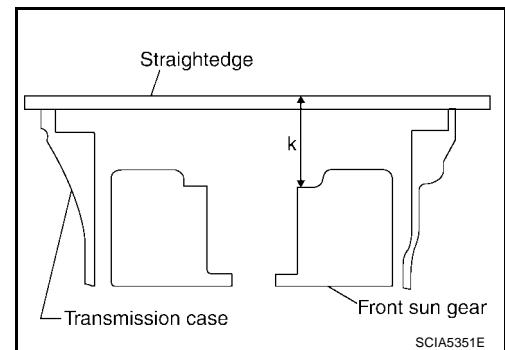

ASSEMBLY

- b. Measure dimension "L".
- c. Calculate dimension "J".

"J": Distance between oil pump fitting surface of transmission case and needle bearing mating surface of front sun gear.

$$J = K - L$$

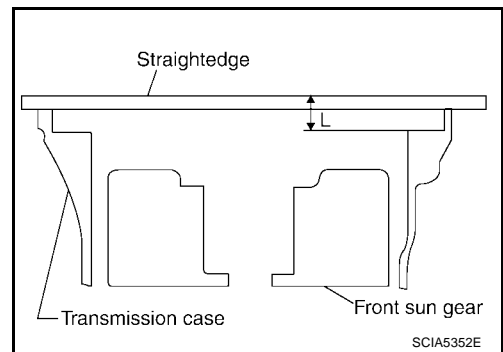

2. Measure dimensions "M1" and "M2" and then calculate dimension "M".

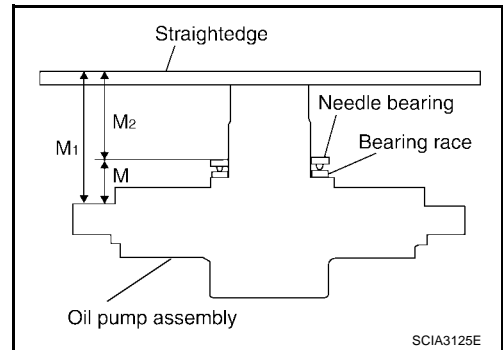

- a. Place bearing race and needle bearing on oil pump assembly.

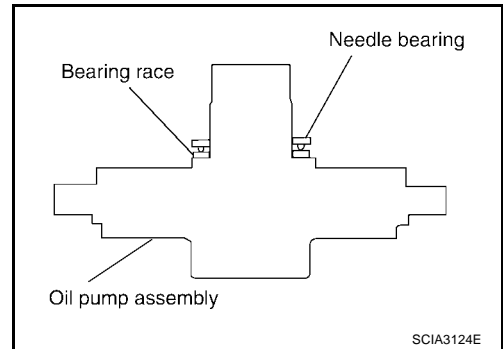

- b. Measure dimension "M1".

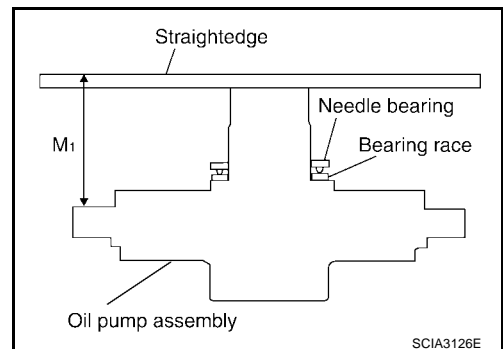

- c. Measure dimension "M2".

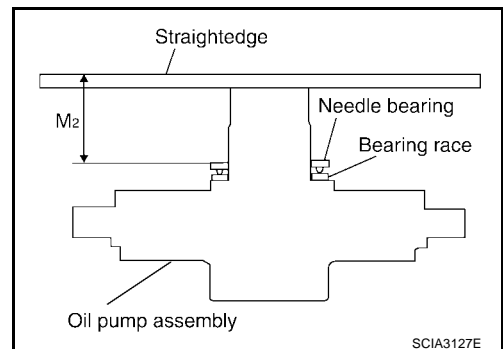

A
B
AT
D
E
F
G
H
I
J
K
L
M

ASSEMBLY

d. Calculate dimension "M".

"M": Distance between transmission case fitting surface of oil pump and needle bearing on oil pump.

$$M = M_1 - M_2$$

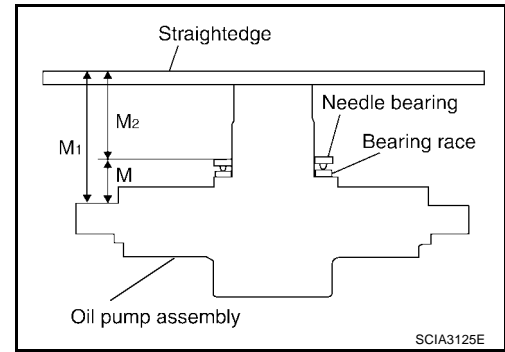

3. Adjust total end play "T1".

$$T_1 = J - M$$

Total end play "T1":

0.25 - 0.55 mm (0.0098 - 0.0217 in)

- Select proper thickness of bearing race so that total end play is within specifications.

Bearing races:

Refer to AT-319, "BEARING RACE FOR ADJUSTING TOTAL END PLAY".

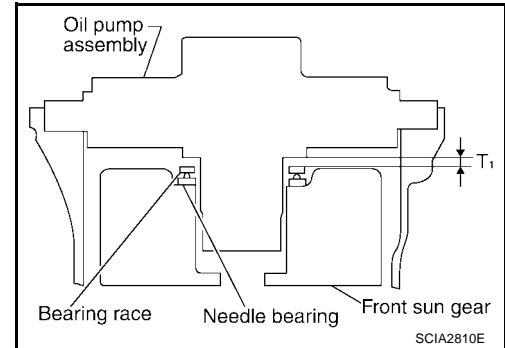

Assembly (2)

1. Install new O-ring to oil pump assembly.

CAUTION:

- Do not reuse O-ring.
- Apply ATF to O-ring.

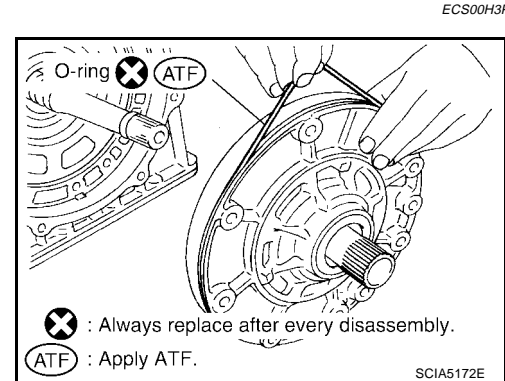

2. Install bearing race to oil pump assembly.

CAUTION:

Apply petroleum jelly to bearing race.

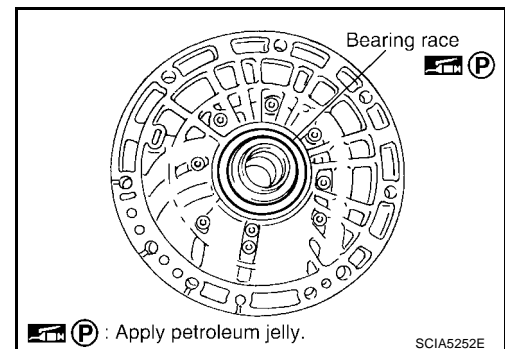

ASSEMBLY

3. Install oil pump assembly in transmission case.

CAUTION:

Apply ATF to oil pump radial bearing.

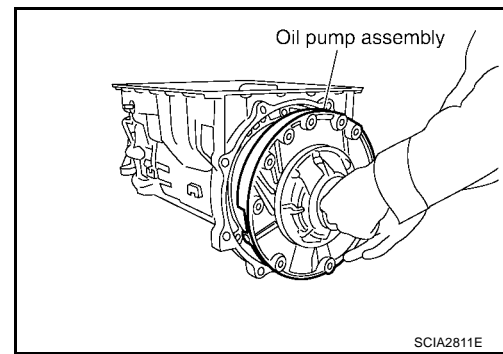

4. Apply recommended sealant (Genuine RTV Silicone Sealant or equivalent) to oil pump assembly as shown. Refer to [GI-47, "Recommended Chemical Products and Sealants"](#).

CAUTION:

Completely remove all moisture, oil and old sealant from the oil pump bolts and oil pump bolt surfaces.

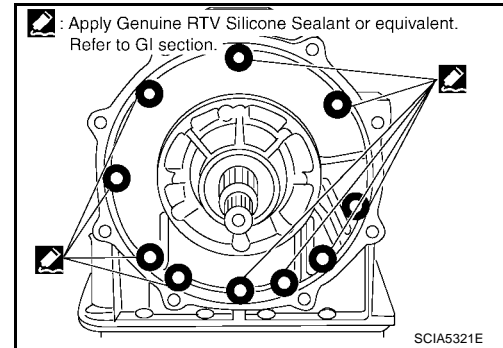

5. Tighten oil pump bolts to specified torque. Refer to [AT-245, "Components"](#).

CAUTION:

Apply ATF to oil pump bushing.

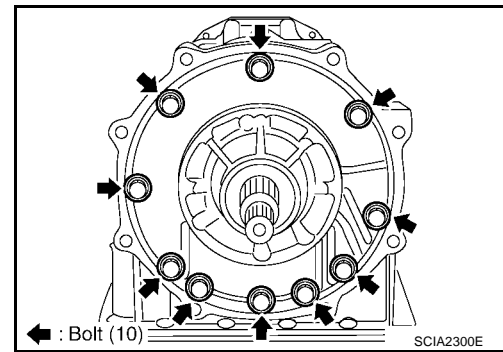

6. Install new O-ring to input clutch assembly.

CAUTION:

- Do not reuse O-ring.
- Apply ATF to O-ring.

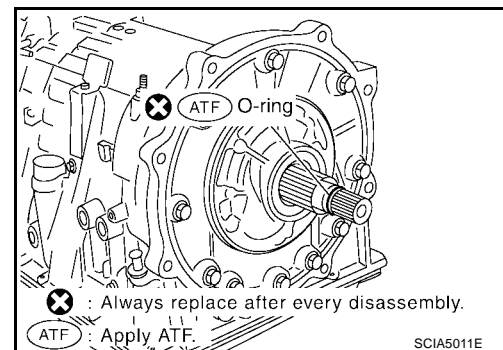

7. Install converter housing to transmission case.

CAUTION:

Do not reuse self-sealing bolts (A).

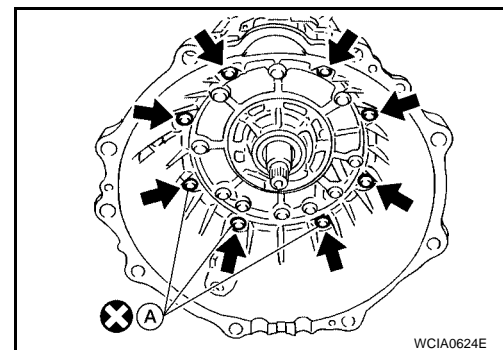

A
B
AT
D
E
F
G
H
I
J
K
L
M

ASSEMBLY

8. Make sure that brake band does not close turbine revolution sensor hole.

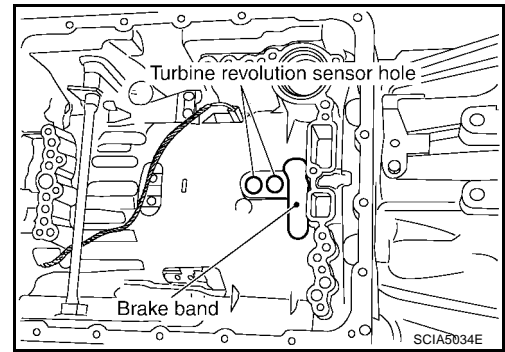

9. Install control valve with TCM.
a. Install A/T fluid temperature sensor 2 to bracket.

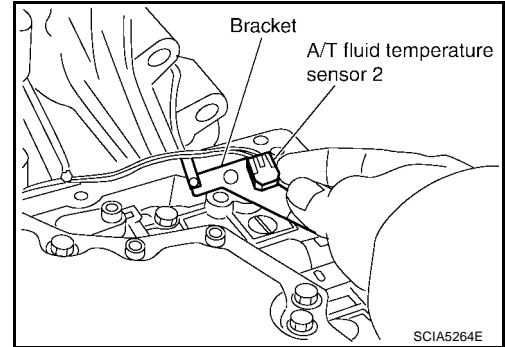

- b. Install A/T fluid temperature sensor 2 (with bracket) in control valve with TCM. Tighten A/T fluid temperature sensor 2 bolt to the specified torque. Refer to [AT-245, "Components"](#).

CAUTION:

Adjust bolt hole of bracket to bolt hole of control valve with TCM.

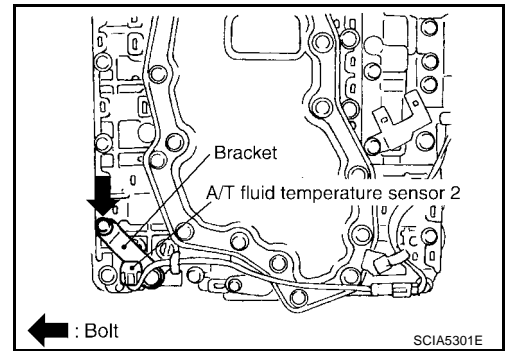

- c. Install new O-ring to A/T assembly harness connector.

CAUTION:

- Do not reuse O-ring.
- Apply ATF to O-ring.

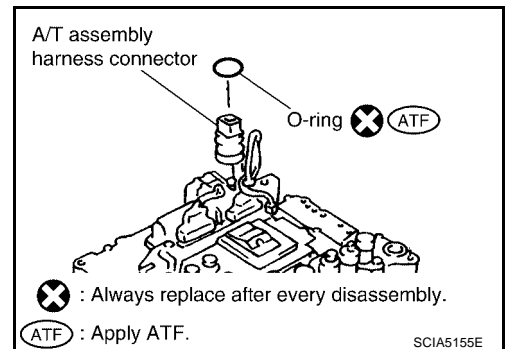

- d. Connect TCM connector and park/neutral position (PNP) switch connector.

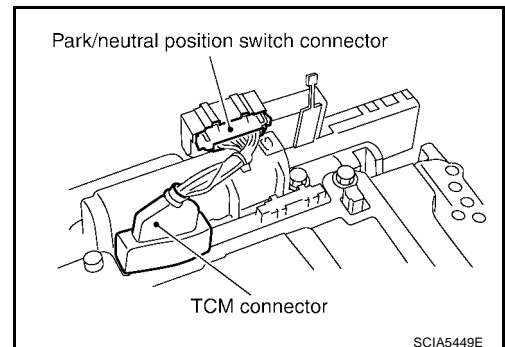

ASSEMBLY

e. Install A/T assembly harness connector to control valve with TCM.

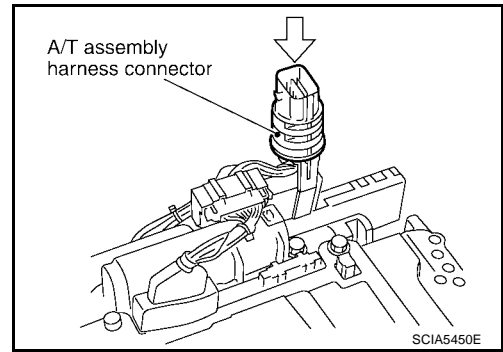

f. Connect TCM connectors.

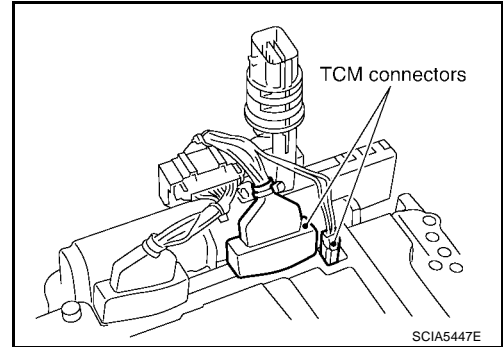

g. Install control valve with TCM in transmission case.

CAUTION:

- Make sure that turbine revolution sensor securely installs into turbine revolution sensor hole.
- Adjust A/T assembly harness connector of control valve with TCM to terminal hole of transmission case.
- Hang down revolution sensor harness toward outside so as not to disturb installation of control valve with TCM.

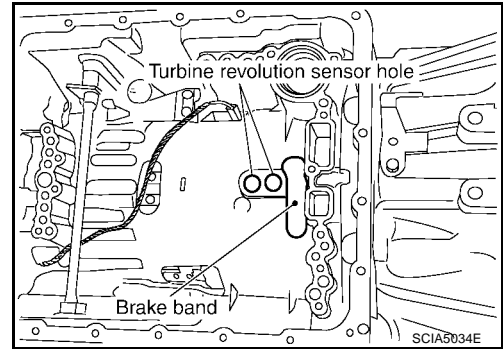

- Assemble it so that manual valve cutout is engaged with manual plate projection.

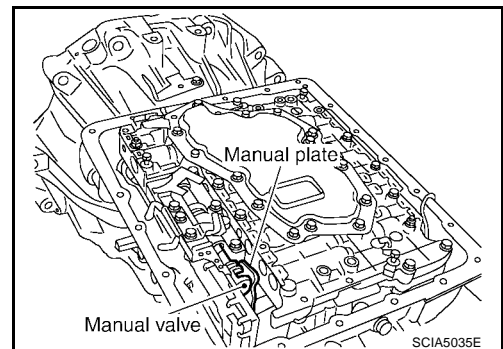

h. Install bolts A, B and C to control valve with TCM.

Bolt symbol	Length: mm (in)	Number of bolts
A	42 (1.65)	5
B	55 (2.17)	6
C	40 (1.57)	1

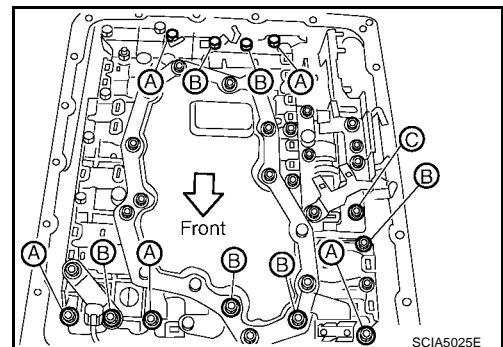

A
B
AT
D
E
F
G
H
I
J
K
L
M

ASSEMBLY

- i. Tighten bolt 1, 2 and 3 temporarily to prevent dislocation. Then tighten them in order (1 → 2 → 3), and then tighten other bolts.
- j. Tighten control valve with TCM bolts to the specified torque. Refer to [AT-245. "Components"](#) .

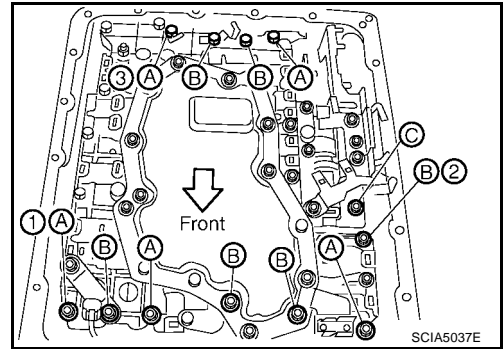

- 10. Connect A/T fluid temperature sensor 2 connector.

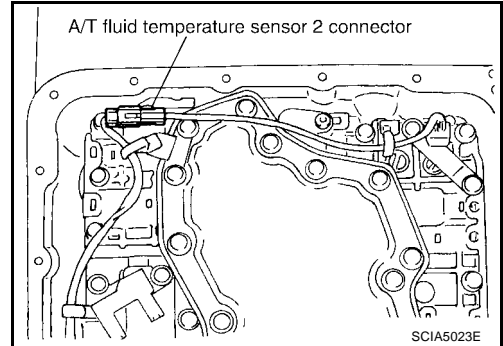

- 11. Securely fasten terminal cord assembly and A/T fluid temperature sensor 2 harness with terminal clips.

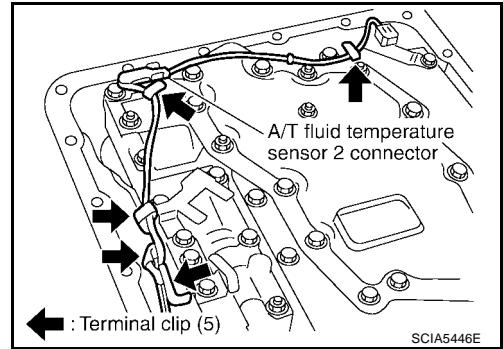

- 12. Connect revolution sensor connector.

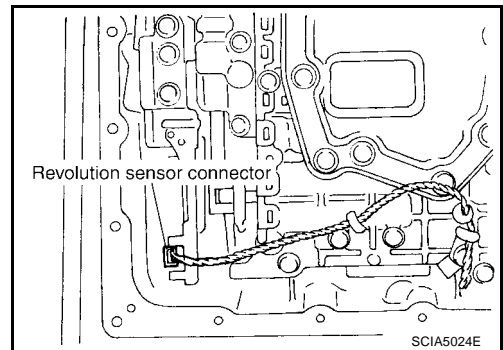

- 13. Securely fasten revolution sensor harness with terminal clips.

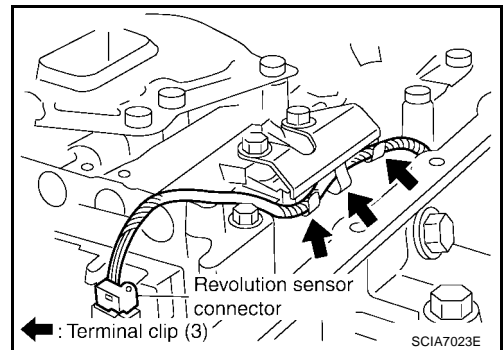

ASSEMBLY

14. Pull down A/T assembly harness connector.

CAUTION:

Be careful not to damage connector.

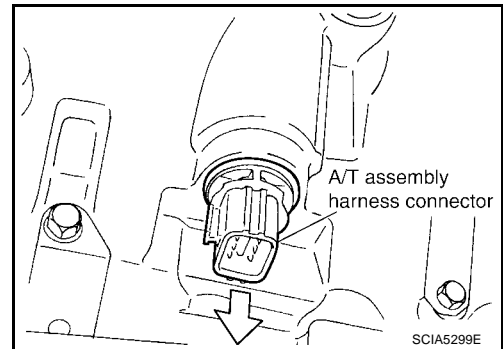

15. Install snap ring to A/T assembly harness connector.

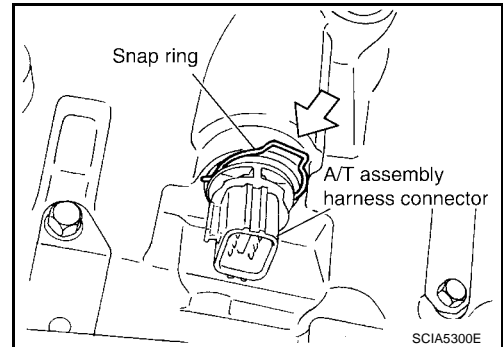

16. Install the oil pan magnets as shown.

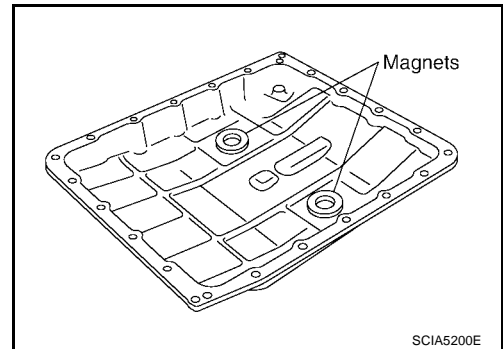

17. Install the oil pan and new oil pan gasket.

CAUTION:

- Do not reuse the oil pan gasket.
- Completely remove all moisture, oil and old gasket from the oil pan gasket mating surfaces and holes.
- Always replace the oil pan bolts as they are self-sealing.
- Be sure the oil pan drain plug hole is located to the rear of the transmission assembly.
- Partially install the oil pan bolts in a criss-cross pattern to prevent dislocation of the gasket.
- Be careful not to pinch harnesses.

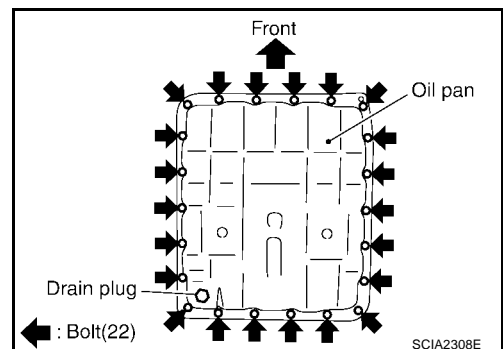

A
B
AT
D
E
F
G
H
I
J
K
L
M

ASSEMBLY

18. Tighten new oil pan bolts in numerical order as shown.

Oil pan bolts : 7.9 N-m (0.81 kg-m, 70 in-lb)

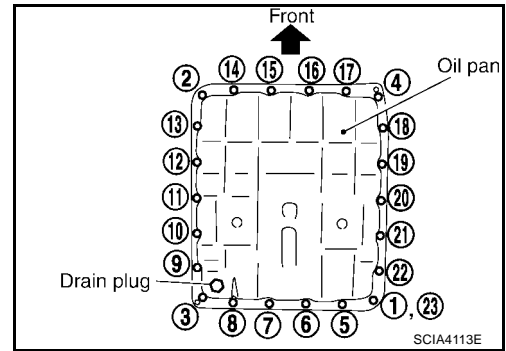

19. Install drain plug in oil pan with new gasket.

CAUTION:

Do not reuse the drain plug gasket.

Drain plug : 34 N-m (3.5 kg-m, 25 ft-lb)

20. Install torque converter.

a. Pour ATF into torque converter.

- Approximately 2 liter (2-1/8 US qt, 1-3/4 Imp qt) of fluid is required for a new torque converter.
- When reusing old torque converter, add the same amount of fluid as was drained.

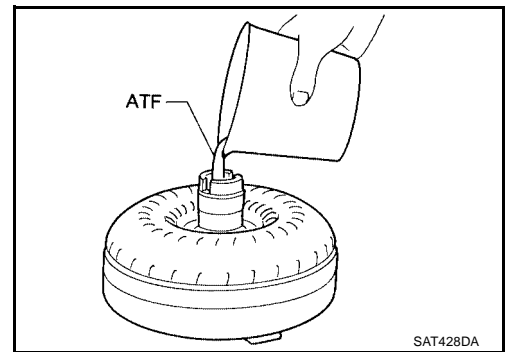

b. Install torque converter while aligning notches of torque converter with notches of oil pump.

CAUTION:

Install torque converter while rotating it.

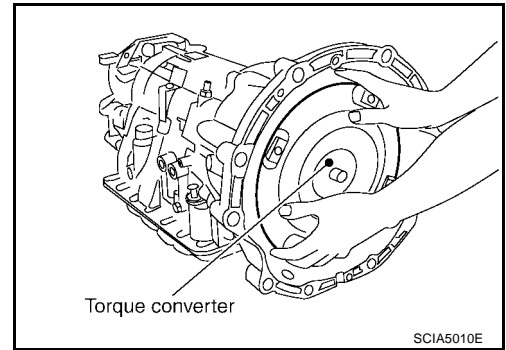

c. Measure distance "A" to check that torque converter is in proper position.

Distance "A" : 24.0 mm (0.94 in) or more

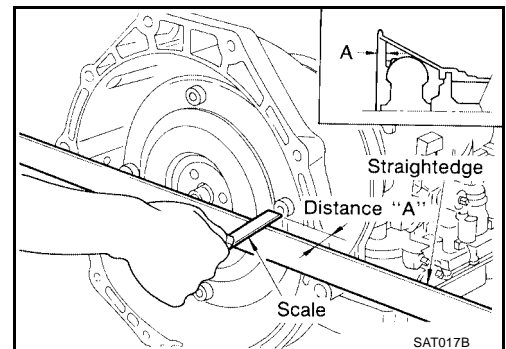

SERVICE DATA AND SPECIFICATIONS (SDS)

SERVICE DATA AND SPECIFICATIONS (SDS)

PF0:00030

General Specifications

ECS00H3Q

Applied model		2WD	4WD
Automatic transmission model		RE5R05A	
Transmission model code number		95X5B	95X5C
Stall torque ratio		2.0: 1	
Transmission gear ratio	1st	3.827	
	2nd	2.368	
	3rd	1.520	
	4th	1.000	
	5th	0.834	
	Reverse	2.613	
Recommended fluid		Genuine NISSAN Matic J ATF *1	
Fluid capacity		10.6 liter (11-1/4 US qt, 9-3/8 Imp qt)	

CAUTION:

- Use only Genuine NISSAN Matic J ATF. Do not mix with other fluid.
- Using automatic transmission fluid other than Genuine NISSAN Matic J ATF will deteriorate in driveability and automatic transmission durability, and may damage the automatic transmission, which is not covered by the warranty.

*1: Refer to [MA-11, "Fluids and Lubricants"](#).

Vehicle Speed When Shifting Gears NORMAL MODE

ECS00H3R

Final gear ratio	Throttle position	Vehicle speed km/h (MPH)							
		D1 →D2	D2 →D3	D3 →D4	D4 →D5	D5 →D4	D4 →D3	D3 →D2	D2 →D1
2.937	Full throttle	70 - 74 (44 - 46)	112 - 120 (70 - 75)	176 - 186 (110 - 116)	249 - 259 (155 - 161)	245 - 255 (152 - 159)	166 - 176 (103 - 110)	100 - 108 (62 - 67)	43 - 47 (27 - 30)
	Half throttle	46 - 50 (28 - 31)	75 - 81 (47 - 50)	104 - 112 (65 - 70)	136 - 144 (85 - 89)	111 - 119 (69 - 74)	76 - 84 (47 - 52)	44 - 50 (27 - 31)	11 - 15 (7 - 10)
3.357	Full throttle	61 - 65 (38 - 41)	97 - 105 (61 - 66)	153 - 163 (95 - 102)	236 - 246 (147 - 153)	232 - 242 (144 - 151)	143 - 153 (89 - 95)	87 - 95 (54 - 59)	43 - 47 (27 - 29)
	Half throttle	41 - 45 (26 - 28)	67 - 73 (42 - 45)	90 - 98 (56 - 61)	119 - 127 (74 - 79)	97 - 105 (60 - 65)	65 - 73 (40 - 45)	39 - 45 (24 - 28)	11 - 15 (7 - 10)

- At half throttle, the accelerator opening is 4/8 of the full opening.

TOW MODE

Final gear ratio	Throttle position	Vehicle speed km/h (MPH)							
		D1 →D2	D2 →D3	D3 →D4	D4 →D5	D5 →D4	D4 →D3	D3 →D2	D2 →D1
2.937	Full throttle	70 - 74 (44 - 46)	112 - 120 (70 - 75)	176 - 186 (110 - 116)	249 - 259 (155 - 161)	245 - 255 (152 - 159)	166 - 176 (103 - 110)	100 - 108 (62 - 67)	43 - 47 (27 - 30)
	Half throttle	50 - 54 (31 - 34)	82 - 88 (51 - 55)	114 - 122 (71 - 76)	136 - 144 (85 - 89)	111 - 119 (69 - 74)	76 - 84 (47 - 52)	44 - 50 (27 - 31)	11 - 15 (7 - 10)
3.357	Full throttle	61 - 65 (38 - 41)	97 - 105 (61 - 66)	153 - 163 (95 - 102)	236 - 246 (147 - 153)	232 - 242 (144 - 151)	143 - 153 (89 - 95)	87 - 95 (54 - 59)	43 - 47 (27 - 29)
	Half throttle	46 - 50 (29 - 31)	73 - 79 (45 - 59)	99 - 107 (62 - 66)	119 - 127 (74 - 79)	97 - 105 (60 - 65)	65 - 73 (40 - 45)	39 - 45 (24 - 28)	11 - 15 (7 - 10)

- At half throttle, the accelerator opening is 4/8 of the full opening.

SERVICE DATA AND SPECIFICATIONS (SDS)

Vehicle Speed When Performing and Releasing Complete Lock-up

ECS00H3S

Final gear ratio	Throttle position	Vehicle speed km/h (MPH)	
		Lock-up "ON"	Lock-up "OFF"
2.937	Closed throttle	74 - 82 (46 - 51)	71 - 79 (45 - 49)
	Half throttle	178 - 186 (111 - 116)	136 - 144 (85 - 90)
3.357	Closed throttle	65 - 73 (41 - 46)	62 - 70 (39 - 44)
	Half throttle	161 - 169 (100 - 105)	118 - 126 (74 - 79)

- At closed throttle, the accelerator opening is less than 1/8 condition.
- At half throttle, the accelerator opening is 4/8 of the full opening.

Stall Speed

ECS00H3T

Stall speed	2,350 - 2,650 rpm
-------------	-------------------

Line Pressure

ECS00H3U

Engine speed	Line pressure [kPa (kg/cm ² , psi)]	
	R position	D position
At idle speed	425 - 465 (4.3 - 4.7, 62 - 67)	379 - 428 (3.9 - 4.4, 55 - 62)
At stall speed	1,605 - 1,950 (16.4 - 19.9, 233 - 283)	1,310 - 1,500 (13.4 - 15.3, 190 - 218)

A/T Fluid Temperature Sensor

ECS00H3V

Name	Condition	CONSULT-II "DATA MONITOR" (Approx.) (V)	Resistance (Approx.) (kΩ)
ATF TEMP SE 1	0°C (32°F)	3.3	15
	20°C (68°F)	2.7	6.5
	80°C (176°F)	0.9	0.9
ATF TEMP SE 2	0°C (32°F)	3.3	10
	20°C (68°F)	2.5	4
	80°C (176°F)	0.7	0.5

Turbine Revolution Sensor

ECS00H3W

Name	Condition	Data (Approx.)
Turbine revolution sensor 1	When running at 50 km/h (31 MPH) in 4th speed with the closed throttle position switch "OFF".	1.3 (kHz)
Turbine revolution sensor 2	When moving at 20 km/h (12 MPH) in 1st speed with the closed throttle position switch "OFF".	

Vehicle Speed Sensor A/T (Revolution Sensor)

ECS00H3X

Name	Condition	Data (Approx.)
Revolution sensor	When moving at 20 km/h (12 MPH).	185 (Hz)

SERVICE DATA AND SPECIFICATIONS (SDS)

Reverse brake

ECS00H3Y

	Thickness mm (in)	Part number*
Thickness of retaining plates	4.2 (0.165)	31667 90X14
	4.4 (0.173)	31667 90X15
	4.6 (0.181)	31667 90X16
	4.8 (0.189)	31667 90X17
	5.0 (0.197)	31667 90X18
	5.2 (0.205)	31667 90X19

*: Always check with the Parts Department for the latest parts information.

Total End Play

ECS00H3Z

Total end play mm (in)	0.25 - 0.55 (0.0098 - 0.0217)
------------------------	-------------------------------

BEARING RACE FOR ADJUSTING TOTAL END PLAY

Thickness mm (in)	Part number*
0.8 (0.031)	31435 95X00
1.0 (0.039)	31435 95X01
1.2 (0.047)	31435 95X02
1.4 (0.055)	31435 95X03
1.6 (0.063)	31435 95X04
1.8 (0.071)	31435 95X05

*: Always check with the Parts Department for the latest parts information.

SERVICE DATA AND SPECIFICATIONS (SDS)
