

A  
EM  
C  
D  
E  
F  
G  
H  
I  
J  
K  
L  
M

# SECTION **EM**

## ENGINE MECHANICAL

### CONTENTS

<p><b>PRECAUTIONS ..... 3</b></p> <p>    Precautions for Supplemental Restraint System (SRS) “AIR BAG” and “SEAT BELT PRE-TENSIONER” ..... 3</p> <p>    Precautions for Drain Engine Coolant ..... 3</p> <p>    Precautions for Disconnecting Fuel Piping ..... 3</p> <p>    Precautions for Removal and Disassembly ..... 3</p> <p>    Precautions for Inspection, Repair and Replacement ..... 3</p> <p>    Precautions for Assembly and Installation ..... 3</p> <p>    Parts Requiring Angular Tightening ..... 4</p> <p>    Precautions for Liquid Gasket ..... 4</p> <p>        REMOVAL OF LIQUID GASKET SEALING ..... 4</p> <p>        LIQUID GASKET APPLICATION PROCEDURE... 4</p> <p><b>PREPARATION ..... 6</b></p> <p>    Special Service Tools ..... 6</p> <p>    Commercial Service Tools ..... 8</p> <p><b>NOISE, VIBRATION, AND HARSHNESS (NVH)</b></p> <p><b>TROUBLESHOOTING ..... 10</b></p> <p>    NVH Troubleshooting —Engine Noise ..... 10</p> <p>    Use the Chart Below to Help You Find the Cause of the Symptom. .... 11</p> <p><b>ENGINE ROOM COVER ..... 12</b></p> <p>    Removal and Installation ..... 12</p> <p>        REMOVAL ..... 12</p> <p>        INSTALLATION ..... 12</p> <p><b>DRIVE BELTS ..... 13</b></p> <p>    Checking Drive Belts ..... 13</p> <p>        DRIVE BELT TENSION ..... 13</p> <p>    Removal and Installation ..... 13</p> <p>        REMOVAL ..... 13</p> <p>        INSTALLATION ..... 14</p> <p>    Drive Belt Auto Tensioner and Idler Pulley ..... 14</p> <p>        REMOVAL ..... 14</p> <p>        INSTALLATION ..... 14</p> <p><b>AIR CLEANER AND AIR DUCT ..... 15</b></p> <p>    Removal and Installation ..... 15</p> <p>        REMOVAL ..... 15</p>	<p>        INSTALLATION ..... 15</p> <p>    Removal and Installation (Viscous paper type) ..... 16</p> <p>        REMOVAL ..... 16</p> <p>        INSTALLATION ..... 16</p> <p><b>INTAKE MANIFOLD ..... 17</b></p> <p>    Removal and Installation ..... 17</p> <p>        REMOVAL ..... 17</p> <p>        INSTALLATION ..... 19</p> <p>    INSPECTION AFTER INSTALLATION ..... 20</p> <p><b>EXHAUST MANIFOLD AND THREE WAY CATALYST ..... 21</b></p> <p>    Removal and Installation ..... 21</p> <p>        REMOVAL ..... 21</p> <p>        INSPECTION AFTER REMOVAL ..... 22</p> <p>        INSTALLATION ..... 22</p> <p><b>OIL PAN AND OIL STRAINER ..... 24</b></p> <p>    Removal and Installation ..... 24</p> <p>        REMOVAL ..... 24</p> <p>        INSPECTION AFTER REMOVAL ..... 25</p> <p>        INSTALLATION ..... 26</p> <p>        INSPECTION AFTER INSTALLATION ..... 27</p> <p><b>IGNITION COIL ..... 28</b></p> <p>    Removal and Installation ..... 28</p> <p>        REMOVAL ..... 28</p> <p>        INSTALLATION ..... 28</p> <p><b>SPARK PLUG (PLATINUM-TIPPED TYPE) ..... 29</b></p> <p>    Removal and Installation ..... 29</p> <p>        REMOVAL ..... 29</p> <p>        INSPECTION AFTER REMOVAL ..... 29</p> <p>        INSTALLATION ..... 30</p> <p><b>FUEL INJECTOR AND FUEL TUBE ..... 31</b></p> <p>    Removal and Installation ..... 31</p> <p>        REMOVAL ..... 31</p> <p>        INSTALLATION ..... 32</p> <p>        INSPECTION AFTER INSTALLATION ..... 34</p> <p><b>ROCKER COVER ..... 35</b></p> <p>    Removal and Installation ..... 35</p> <p>        REMOVAL ..... 35</p> <p>        INSTALLATION ..... 36</p>
---	---

<b>TIMING CHAIN</b> .....	<b>37</b>	<b>CYLINDER BLOCK</b> .....	<b>80</b>
Removal and Installation .....	37	Disassembly and Assembly .....	80
REMOVAL .....	38	DISASSEMBLY .....	81
INSPECTION AFTER REMOVAL .....	40	ASSEMBLY .....	84
INSTALLATION .....	41	How to Select Piston and Bearing .....	89
<b>CAMSHAFT</b> .....	<b>46</b>	DESCRIPTION .....	89
Removal and Installation .....	46	HOW TO SELECT PISTON .....	89
REMOVAL .....	46	HOW TO SELECT CONNECTING ROD BEAR-	
INSPECTION AFTER REMOVAL .....	49	ING .....	90
INSTALLATION .....	51	HOW TO SELECT MAIN BEARING .....	92
Inspection after Installation .....	55	Inspection After Disassembly .....	96
INSPECTION OF CAMSHAFT SPROCKET		CRANKSHAFT END PLAY .....	96
(INT) OIL GROOVE .....	55	CONNECTING ROD SIDE CLEARANCE .....	96
Valve Clearance .....	56	PISTON AND PISTON PIN CLEARANCE .....	96
INSPECTION .....	56	PISTON RING SIDE CLEARANCE .....	97
ADJUSTMENT .....	59	PISTON RING END GAP .....	97
<b>OIL SEAL</b> .....	<b>61</b>	CONNECTING ROD BEND AND TORSION .....	98
Removal and Installation of Valve Oil Seal .....	61	CONNECTING ROD BEARING (BIG END) .....	98
REMOVAL .....	61	CONNECTING ROD BUSHING OIL CLEAR-	
INSTALLATION .....	61	ANCE (SMALL END) .....	98
Removal and Installation of Front Oil Seal .....	62	CYLINDER BLOCK DISTORTION .....	99
REMOVAL .....	62	MAIN BEARING HOUSING INSIDE DIAMETER .....	100
INSTALLATION .....	62	PISTON TO CYLINDER BORE CLEARANCE .....	100
Removal and Installation of Rear Oil Seal .....	63	CRANKSHAFT JOURNAL DIAMETER .....	101
REMOVAL .....	63	CRANKSHAFT PIN DIAMETER .....	102
INSTALLATION .....	63	OUT-OF-ROUND AND TAPER OF CRANK-	
<b>CYLINDER HEAD</b> .....	<b>65</b>	SHAFT .....	102
On-Vehicle Service .....	65	CRANKSHAFT RUNOUT .....	102
CHECKING COMPRESSION PRESSURE .....	65	CONNECTING ROD BEARING OIL CLEAR-	
Removal and Installation .....	66	ANCE .....	102
REMOVAL .....	66	MAIN BEARING OIL CLEARANCE .....	103
INSPECTION AFTER REMOVAL .....	67	CRUSH HEIGHT OF MAIN BEARING .....	104
INSTALLATION .....	67	CRUSH HEIGHT OF CONNECTING ROD	
Disassembly and Assembly .....	68	BEARING .....	104
DISASSEMBLY .....	68	MAIN BEARING CAP BOLT DIAMETER .....	104
ASSEMBLY .....	69	CONNECTING ROD BOLT DIAMETER .....	105
Inspection After Disassembly .....	70	<b>SERVICE DATA AND SPECIFICATIONS (SDS) ...</b>	<b>106</b>
CYLINDER HEAD DISTORTION .....	70	Standard and Limit .....	106
VALVE DIMENSIONS .....	71	GENERAL SPECIFICATIONS .....	106
VALVE GUIDE CLEARANCE .....	71	DRIVE BELTS .....	106
VALVE GUIDE REPLACEMENT .....	72	EXHAUST MANIFOLD .....	106
VALVE SEAT CONTACT .....	73	CAMSHAFT AND CAMSHAFT BEARING .....	107
VALVE SEAT REPLACEMENT .....	73	CYLINDER HEAD .....	109
VALVE SPRING SQUARENESS .....	75	CYLINDER BLOCK .....	111
VALVE SPRING DIMENSIONS AND VALVE		PISTON, PISTON RING AND PISTON PIN .....	112
SPRING PRESSURE LOAD .....	75	CONNECTING ROD .....	112
<b>ENGINE ASSEMBLY</b> .....	<b>76</b>	CRANKSHAFT .....	113
Removal and Installation .....	76	MAIN BEARING .....	114
REMOVAL .....	76		
INSTALLATION .....	78		
INSPECTION AFTER INSTALLATION .....	78		

# PRECAUTIONS

## PRECAUTIONS

PF0:00001

### Precautions for Supplemental Restraint System (SRS) “AIR BAG” and “SEAT BELT PRE-TENSIONER”

EBS00U8E

The Supplemental Restraint System such as “AIR BAG” and “SEAT BELT PRE-TENSIONER”, used along with a front seat belt, helps to reduce the risk or severity of injury to the driver and front passenger for certain types of collision. This system includes seat belt switch inputs and dual stage front air bag modules. The SRS system uses the seat belt switches to determine the front air bag deployment, and may only deploy one front air bag, depending on the severity of a collision and whether the front occupants are belted or unbelted. Information necessary to service the system safely is included in the SRS and SB section of this Service Manual.

#### **WARNING:**

- To avoid rendering the SRS inoperative, which could increase the risk of personal injury or death in the event of a collision which would result in air bag inflation, all maintenance must be performed by an authorized NISSAN/INFINITI dealer.
- Improper maintenance, including incorrect removal and installation of the SRS, can lead to personal injury caused by unintentional activation of the system. For removal of Spiral Cable and Air Bag Module, see the SRS section.
- Do not use electrical test equipment on any circuit related to the SRS unless instructed to in this Service Manual. SRS wiring harnesses can be identified by yellow and/or orange harnesses or harness connectors.

### Precautions for Drain Engine Coolant

EBS00U8F

Drain engine coolant when engine is cooled.

### Precautions for Disconnecting Fuel Piping

EBS00U8G

- Before starting work, make sure no fire or spark producing items are in the work area.
- Release fuel pressure before disconnecting and disassembly.
- After disconnecting pipes, plug openings to stop fuel leakage.

### Precautions for Removal and Disassembly

EBS00U8H

- When instructed to use special service tools, use the specified tools. Always be careful to work safely, avoid forceful or uninstructed operations.
- Exercise maximum care to avoid damage to mating or sliding surfaces.
- Cover openings of engine system with tape or the equivalent, if necessary, to seal out foreign materials.
- Mark and arrange disassembly parts in an organized way for easy troubleshooting and assembly.
- When loosening nuts and bolts, as a basic rule, start with the one furthest outside, then the one diagonally opposite, and so on. If the order of loosening is specified, do exactly as specified. Power tools may be used where noted in the step.

### Precautions for Inspection, Repair and Replacement

EBS00U8I

Before repairing or replacing, thoroughly inspect parts. Inspect new replacement parts in the same way, and replace if necessary.

### Precautions for Assembly and Installation

EBS00U8J

- Use torque wrench to tighten bolts or nuts to specification.
- When tightening nuts and bolts, as a basic rule, equally tighten in several different steps starting with the ones in center, then ones on inside and outside diagonally in this order. If the order of tightening is specified, do exactly as specified.
- Replace with new gasket, packing, oil seal or O-ring.
- Thoroughly wash, clean, and air-blow each part. Carefully check engine oil or engine coolant passages for any restriction and blockage.
- Avoid damaging sliding or mating surfaces. Completely remove foreign materials such as cloth lint or dust. Before assembly, oil sliding surfaces well.
- Release air within route when refilling after draining engine coolant.

# PRECAUTIONS

- Before starting engine, apply fuel pressure to fuel lines with turning ignition switch ON (with engine stopped). Then make sure that there are no leaks at fuel line connections.
- After repairing, start engine and increase engine speed to check engine coolant, fuel, oil, and exhaust systems for leakage.

## Parts Requiring Angular Tightening

EBS00U8K

- For final tightening of the following engine parts use Tool:

**Tool number : KV10112100 (BT-8653-A)**

- Cylinder head bolts
- Main bearing cap bolts
- Connecting rod cap bolts
- Crankshaft pulley bolt (No angle wrench is required as the bolt flange is provided with notches for angle tightening)
- Do not use a torque value for final tightening.
- The torque value for these parts are for a preliminary step.
- Ensure thread and seat surfaces are clean and lightly coated with engine oil.

## Precautions for Liquid Gasket REMOVAL OF LIQUID GASKET SEALING

EBS00U8L

- After removing the bolts and nuts, separate the mating surface and remove the old liquid gasket sealing using Tool.

**Tool number : KV1011100 (J-37228)**

### CAUTION:

**Do not damage the mating surfaces.**

- Tap the seal cutter to insert it.
- In areas where the Tool is difficult to use, lightly tap to slide it.

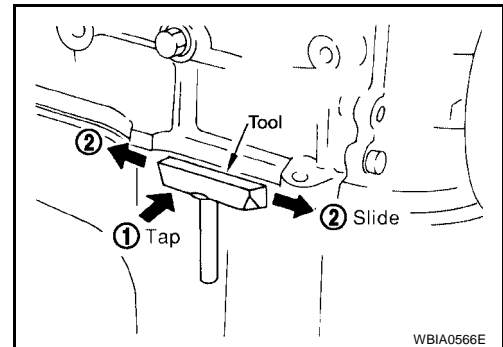

## LIQUID GASKET APPLICATION PROCEDURE

1. Remove the old liquid gasket adhering to the gasket application surface and the mating surface using suitable tool.
  - Remove the liquid gasket completely from the groove of the liquid gasket application surface, bolts, and bolt holes.
2. Thoroughly clean the mating surfaces and remove adhering moisture, grease and foreign material.

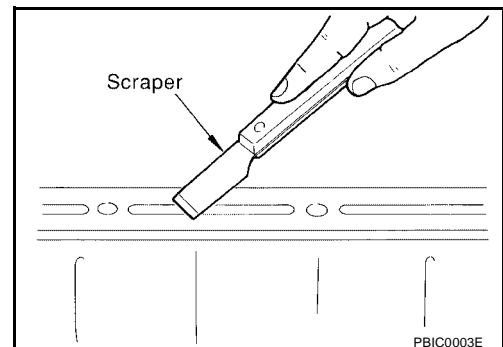

3. Attach the liquid gasket tube to the Tool.

**Tool number : WS39930000 ( — )**

**Use Genuine RTV Silicone Sealant or equivalent. Refer to [GI-47, "Recommended Chemical Products and Sealants"](#).**

4. Apply the liquid gasket without breaks to the specified location with the specified dimensions.

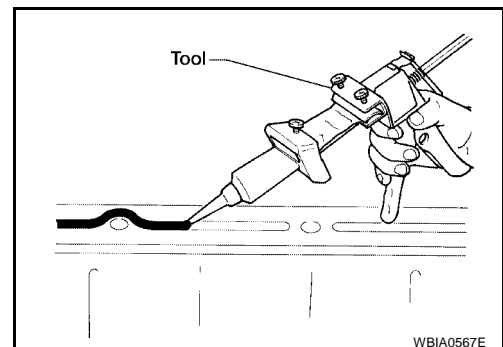

## PRECAUTIONS

- If there is a groove for the liquid gasket application, apply the liquid gasket to the groove.
- As for the bolt holes, normally apply the liquid gasket inside the holes. If specified in the procedure, it should also be applied outside the holes.
- Within five minutes of liquid gasket application, install the mating component.
- If the liquid gasket protrudes, wipe it off immediately.
- Do not retighten after the installation.
- Wait 30 minutes or more after installation before refilling the engine with engine oil and engine coolant.

**CAUTION:**

**If there are specific instructions in this manual, observe them.**

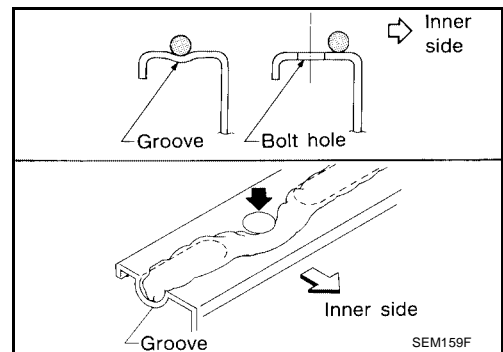

A

EM

C

D

E

F

G

H

I

J

K

L

M

# PREPARATION



PFP:00002

## PREPARATION

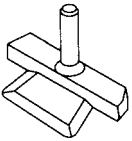
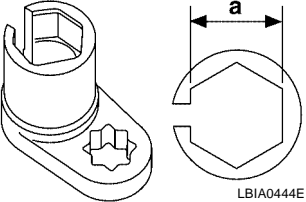

### Special Service Tools

EBS00U8M

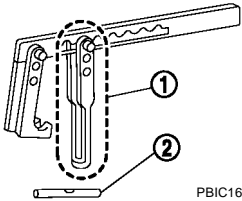
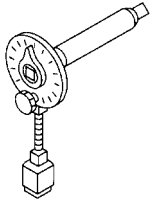
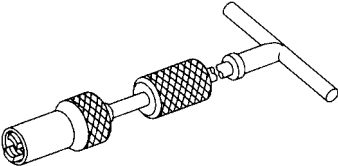
The actual shapes of Kent-Moore tools may differ from those of special service tools illustrated here.

Tool number (Kent-Moore No.) Tool name	Description
KV10111100 (J-37228) Seal cutter <div style="text-align: center;">  <p>S-NT046</p> </div>	Removing steel oil pan and rear timing chain case
— (J-44626) Air fuel sensor Socket <div style="text-align: center;">  <p>LBIA0444E</p> </div>	Loosening or tightening air fuel ratio A/F sensor <b>a: 22 mm (0.87 in)</b>
EG15050500 (J-45402) Compression gauge adapter <div style="text-align: center;">  <p>ZZA1225D</p> </div>	Inspecting compression pressure
KV10116200 (J-26336-A) Valve spring compressor 1. KV10115900 (J-26336-20) Attachment 2. KV10109220 ( — ) Adapter <div style="text-align: center;">  <p>PBIC1650E</p> </div>	Disassembling valve mechanism Part (1) is a component of KV10116200 (J-26336-A), but part (2) is not.
KV10112100 (BT-8653-A) Angle wrench <div style="text-align: center;">  <p>S-NT014</p> </div>	Tightening bolts for cylinder head, main bearing cap and connecting rod cap
KV10107902 (J-38959) Valve oil seal puller <div style="text-align: center;">  <p>S-NT011</p> </div>	Removing valve oil seal

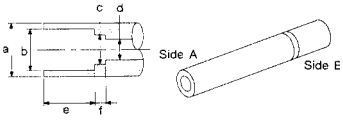
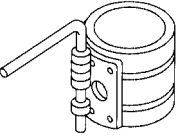
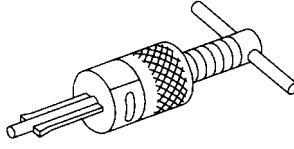
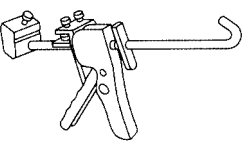
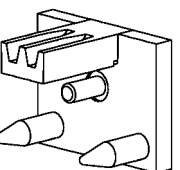
# PREPARATION

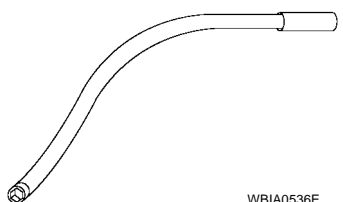
Tool number (Kent-Moore No.) Tool name	Description
KV10115600 (J-38958) Valve oil seal drift <div style="text-align: center;">  <p style="text-align: center;">S-NT603</p> </div>	Installing valve oil seal <b>Use side A.</b> <b>a: 20 (0.79) dia.</b> <b>d: 8 (0.31) dia.</b> <b>b: 13 (0.51) dia.</b> <b>e: 10.7 (0.421) dia.</b> <b>c: 10.3 (0.406) dia.</b> <b>f: 5 (0.20) dia.</b> Unit: mm (in)
EM03470000 (J-8037) Piston ring compressor <div style="text-align: center;">  <p style="text-align: center;">S-NT044</p> </div>	Installing piston assembly into cylinder bore
ST16610001 (J-23907) Pilot bushing puller <div style="text-align: center;">  <p style="text-align: center;">S-NT045</p> </div>	Removing crankshaft pilot bushing
WS39930000 ( — ) Tube presser <div style="text-align: center;">  <p style="text-align: center;">S-NT052</p> </div>	Pressing the tube of liquid gasket
— (J-45476) Ring gear stopper <div style="text-align: center;">  <p style="text-align: center;">PBIC1655E</p> </div>	Removing and installing crankshaft pulley
16441 6N210 (J-45488) Quick connector release <div style="text-align: center;">  <p style="text-align: center;">PBIC0198E</p> </div>	Removing fuel tube quick connectors in engine room (Available in SEC. 164 of PARTS CATALOG: Part No. 16441 6N210)
— (J-46535) Drive belt tension releaser <div style="text-align: center;">  <p style="text-align: center;">WBIA0536E</p> </div>	Releasing drive belt tension

A  
EM  
C  
D  
E  
F  
G  
H  
I  
J  
K  
L  
M

# PREPARATION

## Commercial Service Tools

EBS00U8N

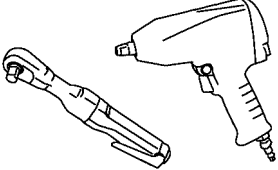
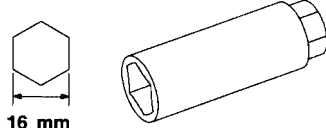
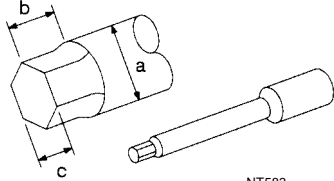
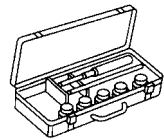
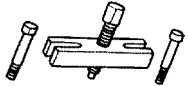
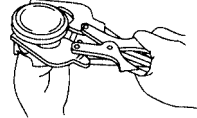
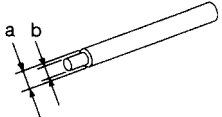
(Kent-Moore No.) Tool name	Description
Power tool   PBIC0190E	Loosening bolts and nuts
Spark plug wrench   16 mm (0.63 in)  S-NT047	Removing and installing spark plug
(J-24239-01) Cylinder head bolt wrench   NT583	Loosening and tightening cylinder head bolt, and use with angle wrench [SST: KV10112100 (BT-8653-A)] <b>a: 13 (0.51) dia.</b> <b>b: 12 (0.47)</b> <b>c: 10 (0.39)</b> Unit: mm (in)
Valve seat cutter set   S-NT048	Finishing valve seat dimensions
Pulley puller   ZZA0010D	Removing crankshaft pulley
Piston ring expander   S-NT030	Removing and installing piston ring
Valve guide drift   S-NT015	Removing and installing valve guide <b>Intake &amp; Exhaust:</b> <b>a: 9.5 mm (0.374 in) dia.</b> <b>b: 5.5 mm (0.217 in) dia.</b>

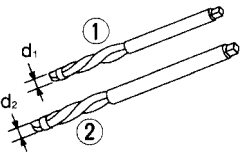
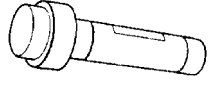
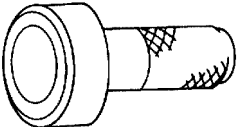
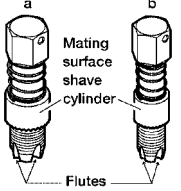
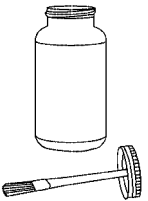

# PREPARATION

(Kent-Moore No.) Tool name	Description
Valve guide reamer   S-NT016	1: Reaming valve guide hole 2: Reaming hole for oversize valve guide <b>Intake &amp; Exhaust:</b> <b>d1 : 6.0 mm (0.236 in) dia.</b> <b>d2 : 10.175 - 10.196 mm (0.4006 - 0.4014 in) dia.</b>
Front oil seal drift   ZZA0012D	Installing front oil seal
Rear oil seal drift   ZZA0025D	Installing rear oil seal
(J-43897-18) (J-43897-12) Oxygen sensor thread cleaner   AEM488	Reconditioning the exhaust system threads before installing a new Air Fuel Ratio sensor and heated oxygen sensor (Use with anti-seize lubricant shown below.) <b>a: J-43897-18 (18 mm dia.) (0.71 in)</b> <b>b: J-43897-12 (12 mm dia.) (0.55 in)</b>
Anti-seize lubricant (Permatex 133AR or equivalent meeting MIL specification MIL-A-907)   AEM489	Lubricating A/F sensors and heated oxygen sensor thread cleaning tool when reconditioning exhaust system threads

A  
EM  
C  
D  
E  
F  
G  
H  
I  
J  
K  
L  
M

# NOISE, VIBRATION, AND HARSHNESS (NVH) TROUBLESHOOTING

## NOISE, VIBRATION, AND HARSHNESS (NVH) TROUBLESHOOTING

PF0:00003

### NVH Troubleshooting —Engine Noise

EBS00U80

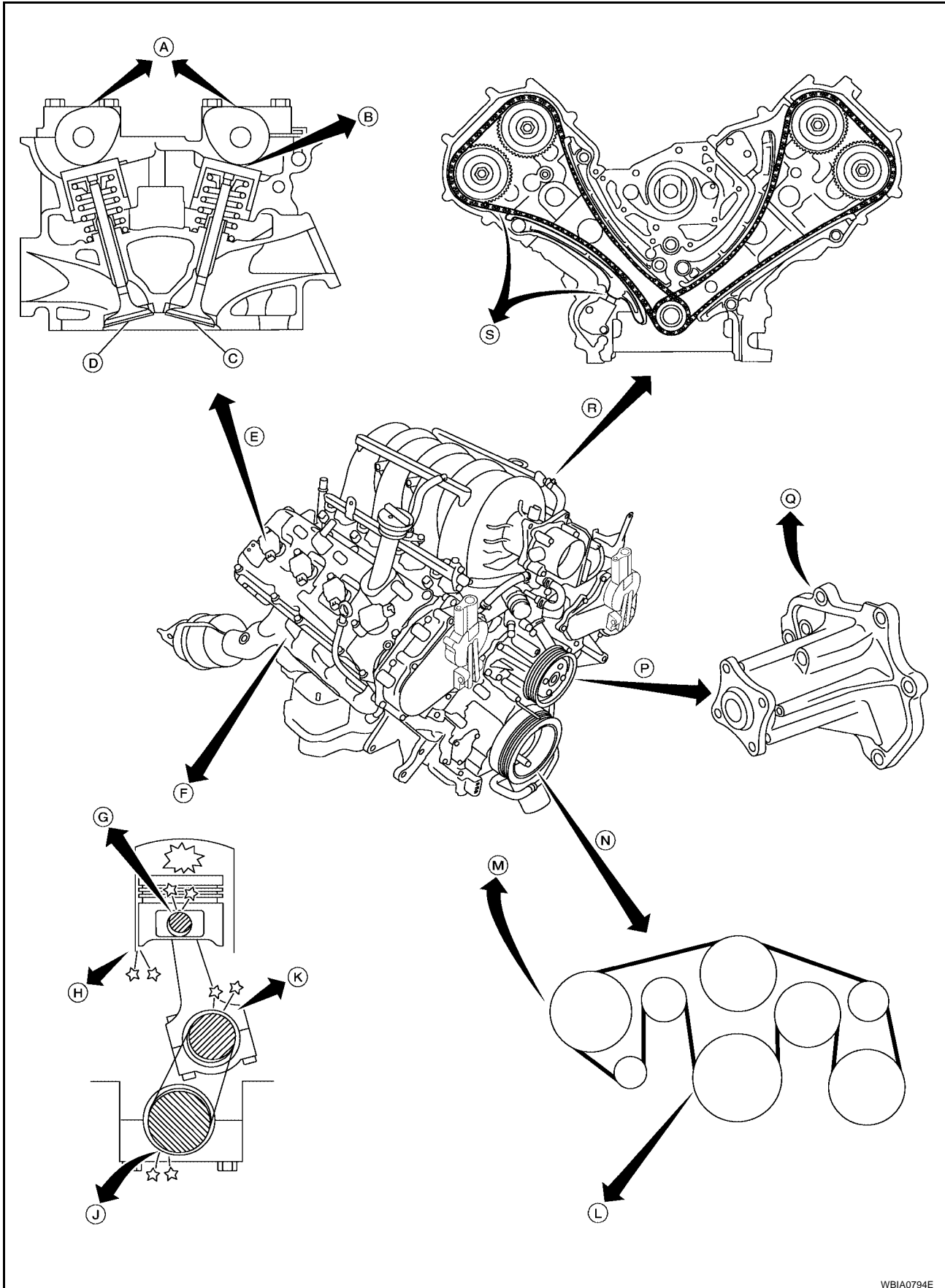

WBIA0794E

# NOISE, VIBRATION, AND HARSHNESS (NVH) TROUBLESHOOTING

EBS00U8P

## Use the Chart Below to Help You Find the Cause of the Symptom.

1. Locate the area where noise occurs.
2. Confirm the type of noise.
3. Specify the operating condition of engine.
4. Check specified noise source.

If necessary, repair or replace these parts.

Location of noise	Type of noise	Operating condition of engine						Source of noise	Check item	Reference page
		Before warm-up	After warm-up	When starting	When idling	When racing	While driving			
Top of engine Rocker cover Cylinder head	Ticking or clicking	C	A	—	A	B	—	Tappet noise	Valve clearance	<a href="#">EM-71</a>
	Rattle	C	A	—	A	B	C	Camshaft bearing noise	Camshaft journal clearance Camshaft runout	<a href="#">EM-50</a> <a href="#">EM-49</a>
Crankshaft pulley Cylinder block (Side of engine) Oil pan	Slap or knock	—	A	—	B	B	—	Piston pin noise	Piston and piston pin clearance Connecting rod bushing clearance	<a href="#">EM-97</a> <a href="#">EM-99</a>
	Slap or rap	A	—	—	B	B	A	Piston slap noise	Piston-to-bore clearance Piston ring side clearance Piston ring end gap Connecting rod bend and torsion	<a href="#">EM-101</a> <a href="#">EM-97</a> <a href="#">EM-97</a> <a href="#">EM-98</a>
	Knock	A	B	C	B	B	B	Connecting rod bearing noise	Connecting rod bushing oil clearance (Small end) Connecting rod bearing clearance (Big end)	<a href="#">EM-99</a> <a href="#">EM-98</a>
	Knock	A	B	—	A	B	C	Main bearing noise	Main bearing oil clearance Crankshaft runout	<a href="#">EM-103</a> <a href="#">EM-102</a>
Front of engine Chain case cover Front cover	Tapping or ticking	A	A	—	B	B	B	Timing chain and chain tensioner noise	Timing chain cracks and wear Timing chain tensioner operation	<a href="#">EM-40</a> <a href="#">EM-37</a>
Front of engine	Squeaking or fizzing	A	B	—	B	—	C	Drive belts (Sticking or slipping)	Drive belts deflection	<a href="#">EM-13</a>
	Creaking	A	B	A	B	A	B	Drive belts (Slipping)	Idler pulley bearing operation	
	Squall Creaking	A	B	—	B	A	B	Water pump noise	Water pump operation	<a href="#">EM-40</a>

A: Closely related B: Related C: Sometimes related —: Not related

# ENGINE ROOM COVER

## ENGINE ROOM COVER

PFP:14049

### Removal and Installation REMOVAL

EBS00U8Q

- Remove the engine cover bolts and cover.

**CAUTION:**

Do not damage or scratch cover when installing or removing.

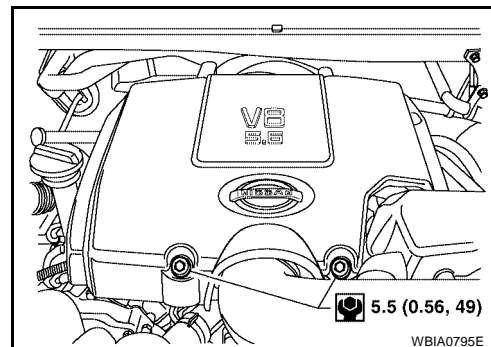

### INSTALLATION

Installation is in the reverse order of removal.

# DRIVE BELTS

PF0:02117

EBS00U8R

## DRIVE BELTS

### Checking Drive Belts

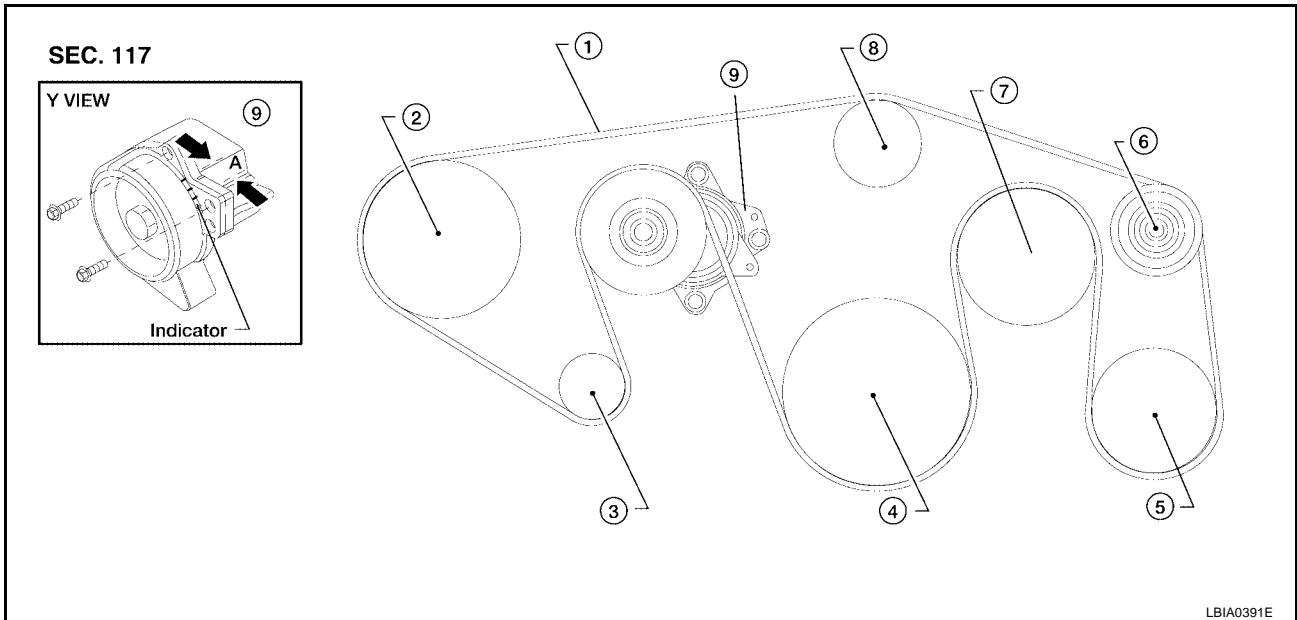

- |                       |                               |                              |
|-----------------------|-------------------------------|------------------------------|
| 1. Drive belt         | 2. Power steering pump pulley | 3. Generator pulley          |
| 4. Crankshaft pulley  | 5. A/C compressor             | 6. Idler pulley              |
| 7. Cooling fan pulley | 8. Water pump pulley          | 9. Drive belt auto tensioner |

#### **WARNING:**

**Be sure to perform when the engine is stopped.**

1. Remove air duct and resonator assembly when inspecting drive belt.
2. Make sure that indicator (single line notch) of each auto tensioner is within the allowable working range "A" (between three line notches) as shown.

#### **NOTE:**

- Check the drive belt auto tensioner indication when the engine is cold.
  - The indicator notch is located on the moving side of the drive belt auto tensioner.
3. Visually check entire belt for wear, damage or cracks.
  4. If the indicator is out of allowable working range or belt is damaged, replace the belt. Refer to [EM-13, "Checking Drive Belts"](#).

### DRIVE BELT TENSION

There is no manual drive belt tension adjustment. The drive belt tension is automatically adjusted by the drive belt auto tensioner.

### Removal and Installation

#### REMOVAL

1. Remove the air duct and resonator assembly. Refer to [EM-15, "REMOVAL"](#).
2. Install Tool on drive belt auto tensioner pulley bolt, move in the direction of arrow (loosening direction of tensioner) as shown.

**Tool number** : — (J-46535)

#### **CAUTION:**

**Avoid placing hand in a location where pinching may occur if the holding tool accidentally comes off.**

3. Remove the drive belt.

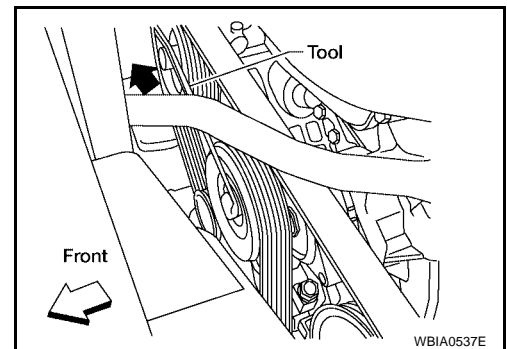

# DRIVE BELTS

## INSTALLATION

Installation is in the reverse order of removal.

### CAUTION:

**Make sure belt is securely installed around all pulleys.**

- Rotate the crankshaft pulley several turns clockwise to equalize belt tension between pulleys.
- Make sure belt tension is within the allowable working range, using the indicator notch on the drive belt auto tensioner. Refer to [EM-13, "Checking Drive Belts"](#) .

## Drive Belt Auto Tensioner and Idler Pulley

EBS00U8T

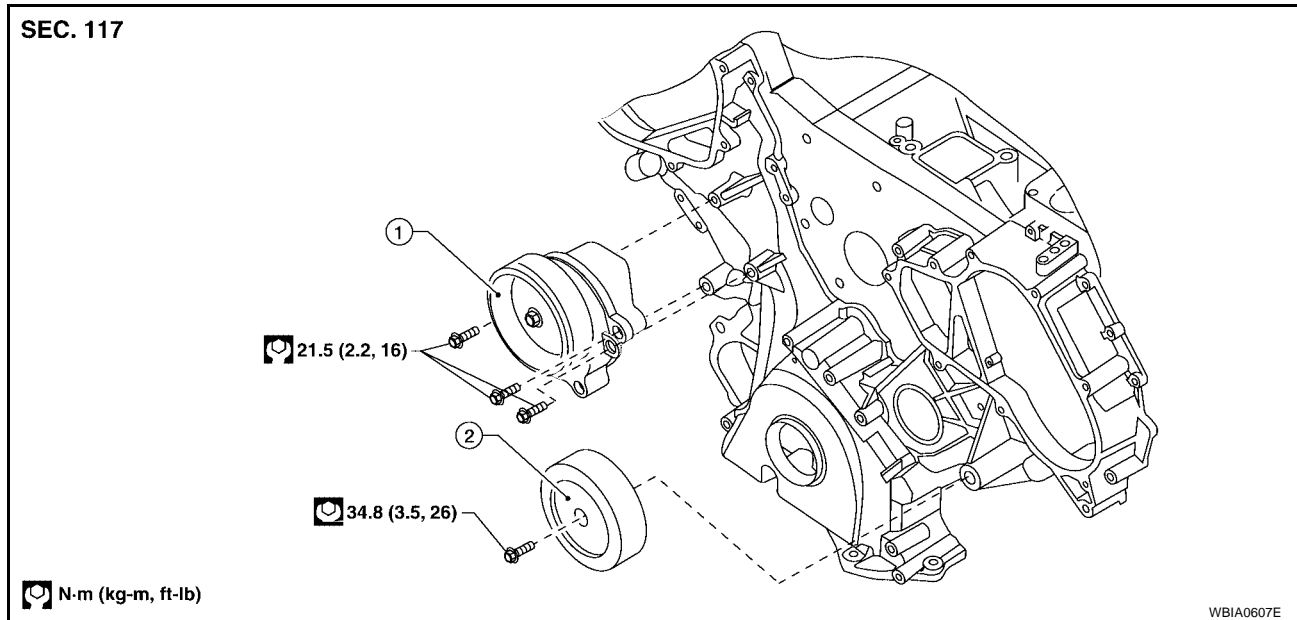

1. Drive belt auto tensioner

2. Idler pulley

## REMOVAL

1. Remove the air duct and resonator assembly. Refer to [EM-15, "REMOVAL"](#) .
2. Remove the drive belt. Refer to [EM-13, "REMOVAL"](#) .
3. Remove the drive belt auto tensioner and idler pulley using power tool.

## INSTALLATION

Installation is in the reverse order of removal.

# AIR CLEANER AND AIR DUCT

PF16500

EBS00U8U

## AIR CLEANER AND AIR DUCT

### Removal and Installation

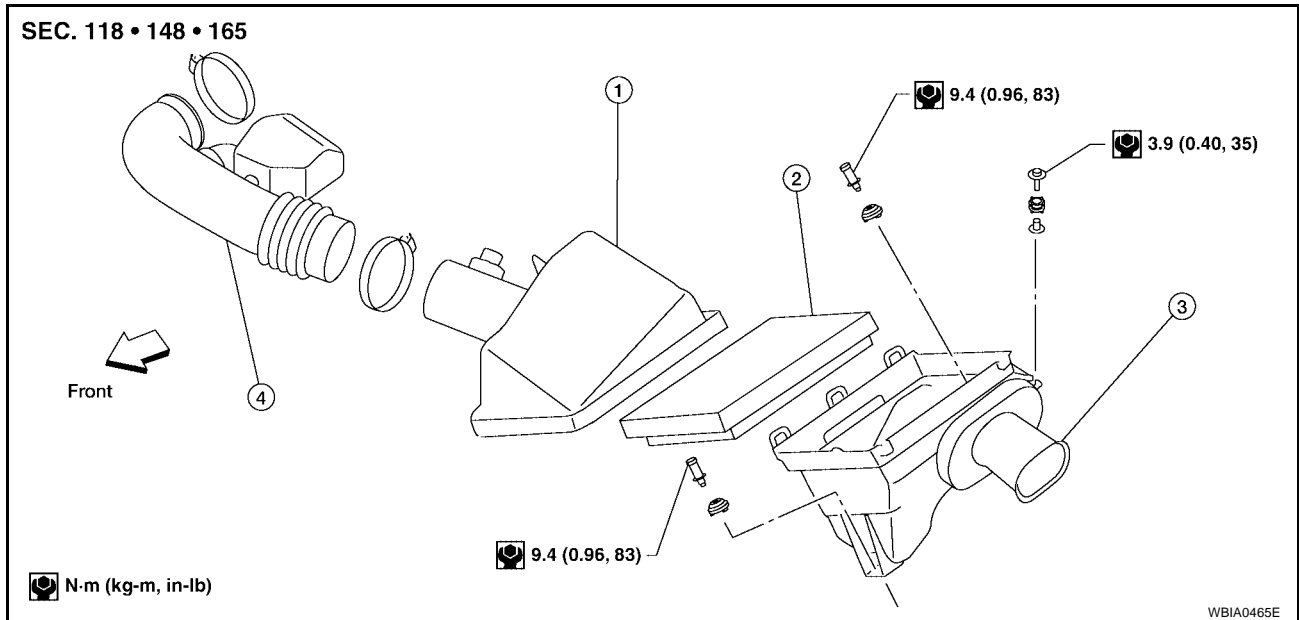

1. Air cleaner case (upper)
2. Air cleaner filter
3. Air cleaner case (lower)
4. Air duct and resonator assembly

### REMOVAL

1. Remove the engine room cover using power tool. Refer to [EM-12, "REMOVAL"](#).
  2. Disconnect the harness connector from air cleaner case (upper).
  3. Remove the air duct and resonator assembly and air cleaner case.
  4. Remove air cleaner filter and air cleaner case (lower)
- Add marks as necessary for easier installation.

### INSTALLATION

Installation is in the reverse order of removal.

# AIR CLEANER AND AIR DUCT

EBS00U8V

## Removal and Installation (Viscous paper type) REMOVAL

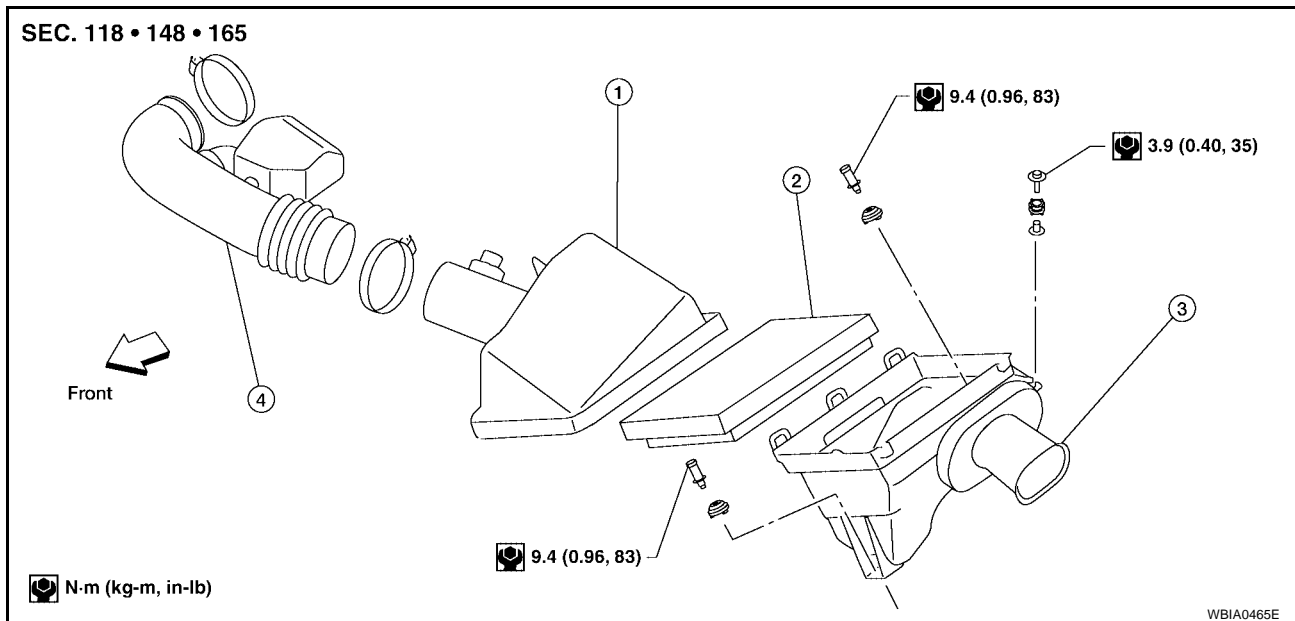

1. Air cleaner case (upper)
2. Air cleaner filter
3. Air cleaner case (lower)
4. Air duct and resonator assembly

### NOTE:

- The viscous paper type filter does not need cleaning between replacement intervals.
  - Replace the air filter as necessary for periodic maintenance. Refer to [MA-7, "PERIODIC MAINTENANCE"](#).
1. Remove the air duct and resonator assembly.
  2. Remove the air cleaner case (upper).
  3. Remove the air cleaner filter from the air cleaner case (lower).

### INSTALLATION

1. Install the new air cleaner filter in the air cleaner case (lower).
2. Install the air cleaner case (upper).
3. Install the air duct and resonator assembly (inlet).



# INTAKE MANIFOLD

PFP:14003

EBS00U8W

## INTAKE MANIFOLD

### Removal and Installation

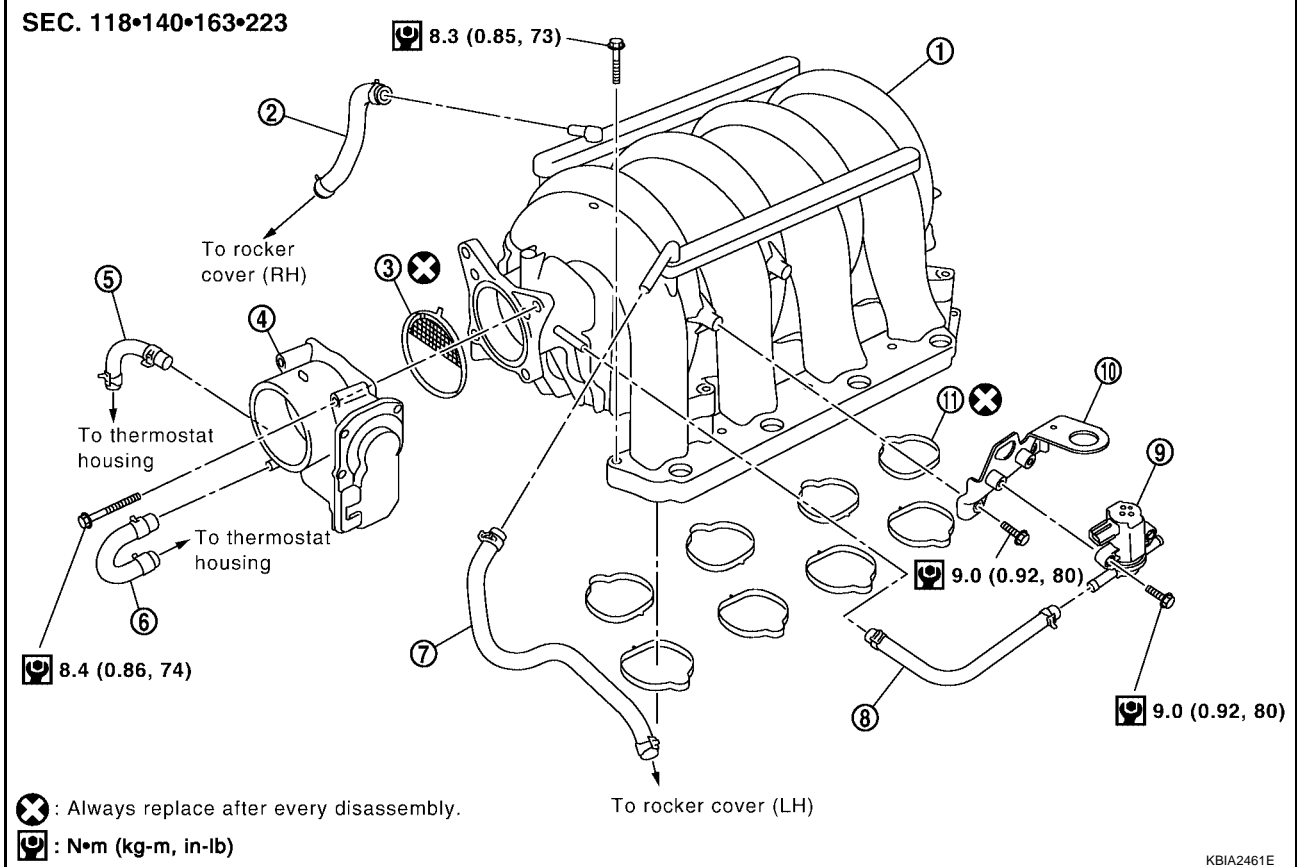

- |                                       |               |   |
|---------------------------------------|---------------|---|
| 1. Intake manifold                    | 2. PCV hose   | 3. Gasket                                     |
| 4. Electric throttle control actuator | 5. Water hose | 6. Water hose                                 |
| 7. PCV hose                           | 8. EVAP hose  | 9. EVAP canister purge control solenoid valve |
| 10. Bracket                           | 11. Gasket    |   |

### REMOVAL

- Partially drain the engine coolant. Refer to [CO-11, "DRAINING ENGINE COOLANT"](#).

#### **WARNING:**

**To avoid the danger of being scalded, never drain the engine coolant when the engine is hot.**

- Remove the engine room cover using power tool. Refer to [EM-12, "REMOVAL"](#).
- Release the fuel pressure. Refer to [EC-87, "FUEL PRESSURE RELEASE"](#).
- Remove the air duct and resonator assembly. Refer to [EM-15, "REMOVAL"](#).
- Disconnect the fuel tube quick connector on the engine side.

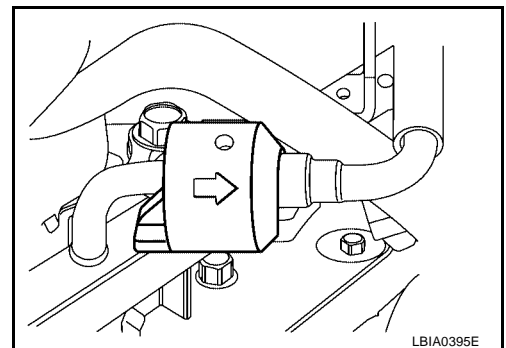

## INTAKE MANIFOLD

- Perform the following steps to disconnect the quick connector using Tool.

**Tool number : 16441 6N210 (J-45488)**

- Remove quick connector cap (engine side only).

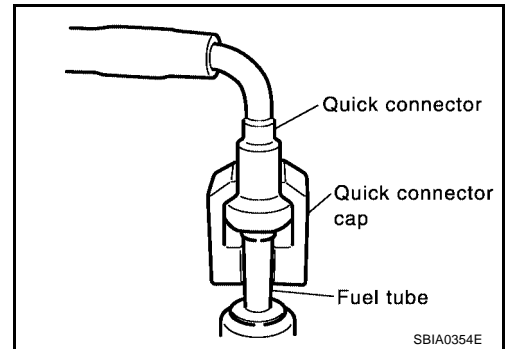

- With the sleeve side of Tool facing quick connector, install Tool onto fuel tube.
- Insert Tool into quick connector until sleeve contacts and goes no further. Hold the Tool in that position.

**CAUTION:**

**Inserting the Tool hard will not disconnect quick connector. Hold Tool where it contacts and goes no further.**

- Draw and pull out quick connector straight from fuel tube.

**CAUTION:**

- Pull quick connector holding "A" position in illustration.
- Do not pull with lateral force applied. O-ring inside quick connector may be damaged.
- Prepare container and cloth beforehand as fuel will leak out.
- Avoid fire and sparks.
- Be sure to cover openings of disconnected pipes with plug or plastic bag to avoid fuel leakage and entry of foreign materials.

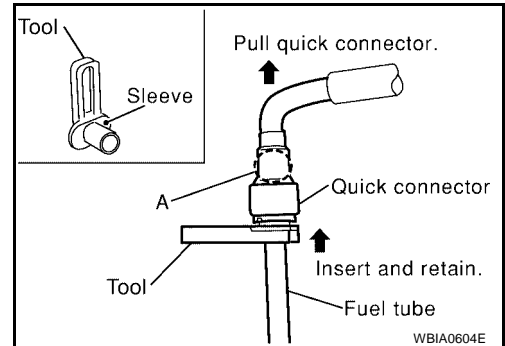

- Remove or disconnect harnesses, brackets, vacuum hose, vacuum gallery and PCV hose and tube from intake manifold.
- Remove electric throttle control actuator by loosening bolts diagonally.

**CAUTION:**

- Handle carefully to avoid any damage to the electric throttle control actuator.
- Do not disassemble.

- Remove the fuel injectors and fuel tube assembly. Refer to [EM-31, "REMOVAL"](#).
- Loosen the bolts in reverse order shown using power tool.
- Remove the intake manifold.

**CAUTION:**

**Cover engine openings to avoid entry of foreign materials.**

- Clean all gasket mating surfaces, do not reuse gaskets.

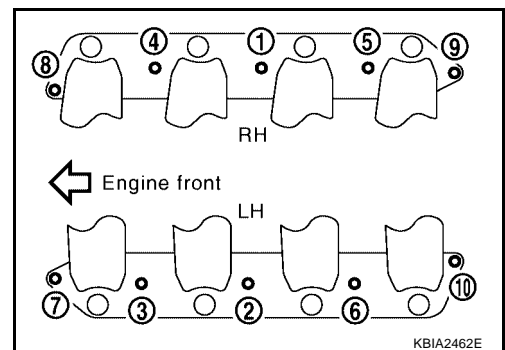

# INTAKE MANIFOLD

## INSTALLATION

Installation is in the reverse order of removal.

- Tighten the intake manifold bolts in numerical order as shown.

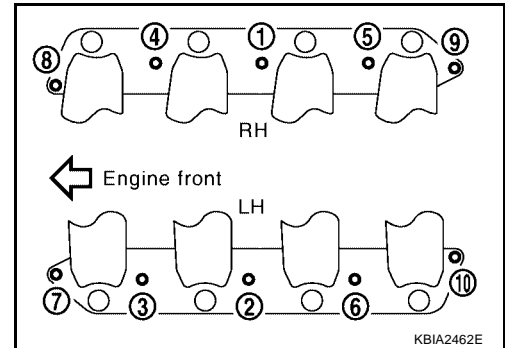

- Install the EVAP canister purge control solenoid valve connector with it facing front of engine.
- Tighten the electronic throttle control actuator bolts of the electric throttle control actuator equally and diagonally in several steps.
- After installation perform procedure in [EM-20, "INSPECTION AFTER INSTALLATION"](#).
- Install the water hose so that its overlap width for connection is between 27 mm (1.06 in) and 32 mm (1.26 in) (target: 27 mm 1.06 in).

## Connecting Quick Connector of Fuel Tube

Install quick connector as follows (the steps are the same for quick connectors on both engine side and vehicle side except for the quick connector cap).

1. Make sure no foreign substances are deposited in and around tube and quick connector, and they are not damaged.
2. Thinly apply new engine oil around the fuel tube from tip end to the spool end.
3. Align center to insert quick connector straight into fuel tube.

- Insert until the paint mark for engagement identification (white) goes completely inside quick connector so that you cannot see it from the straight side of the connected part. Use a mirror to check this where it is not possible to view directly from the straight side, such as quick connector on vehicle side.

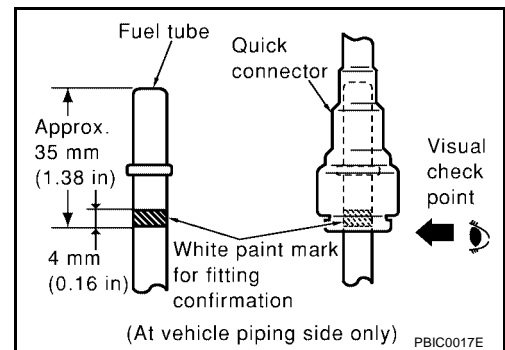

- Insert fuel tube into quick connector until top spool is completely inside quick connector, and 2nd level spool exposes right below quick connector on engine side.

### CAUTION:

- Hold "A" position in illustration when inserting fuel tube into quick connector.
- Carefully align center to avoid inclined insertion to prevent damage to O-ring inside quick connector.
- Insert until you hear a "click" sound and actually feel the engagement.
- To avoid misidentification of engagement with a similar sound, be sure to perform the next step.

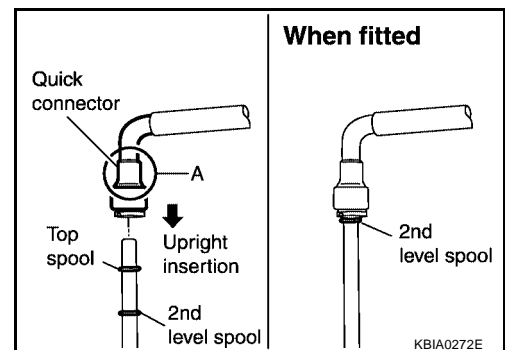

4. Pull quick connector by hand holding "A" position. Make sure it is completely engaged (connected) so that it does not come out from fuel tube.

### NOTE:

Recommended pulling force is 50 N (5.1 kg, 11.2 lb).

## INTAKE MANIFOLD

5. Install the quick connector cap on the quick connector joint (on engine side only).
6. Install the fuel hose and tube to hose clamps.
7. Refill the engine coolant. Refer to [CO-11, "REFILLING ENGINE COOLANT"](#) .

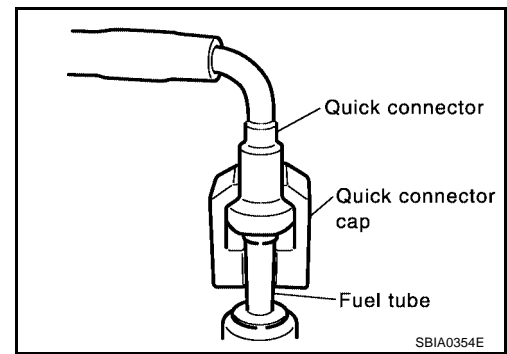

### INSPECTION AFTER INSTALLATION

- After installing fuel tubes, make sure there is no fuel leakage at connections in the following steps.
  - Apply fuel pressure to fuel lines by turning ignition switch ON (with engine stopped). Then check for fuel leaks at connections.
  - Start the engine and rev it up and check for fuel leaks at the connections.
- Perform procedures for "Throttle Valve Closed Position Learning" after finishing repairs. Refer to [EC-84, "Throttle Valve Closed Position Learning"](#) .
- If electric throttle control actuator is replaced, perform procedures for "Idle Air Volume Learning" after finishing repairs. Refer to [EC-85, "Idle Air Volume Learning"](#) .

# EXHAUST MANIFOLD AND THREE WAY CATALYST

PF14004

EBS00U8X

## EXHAUST MANIFOLD AND THREE WAY CATALYST

### Removal and Installation

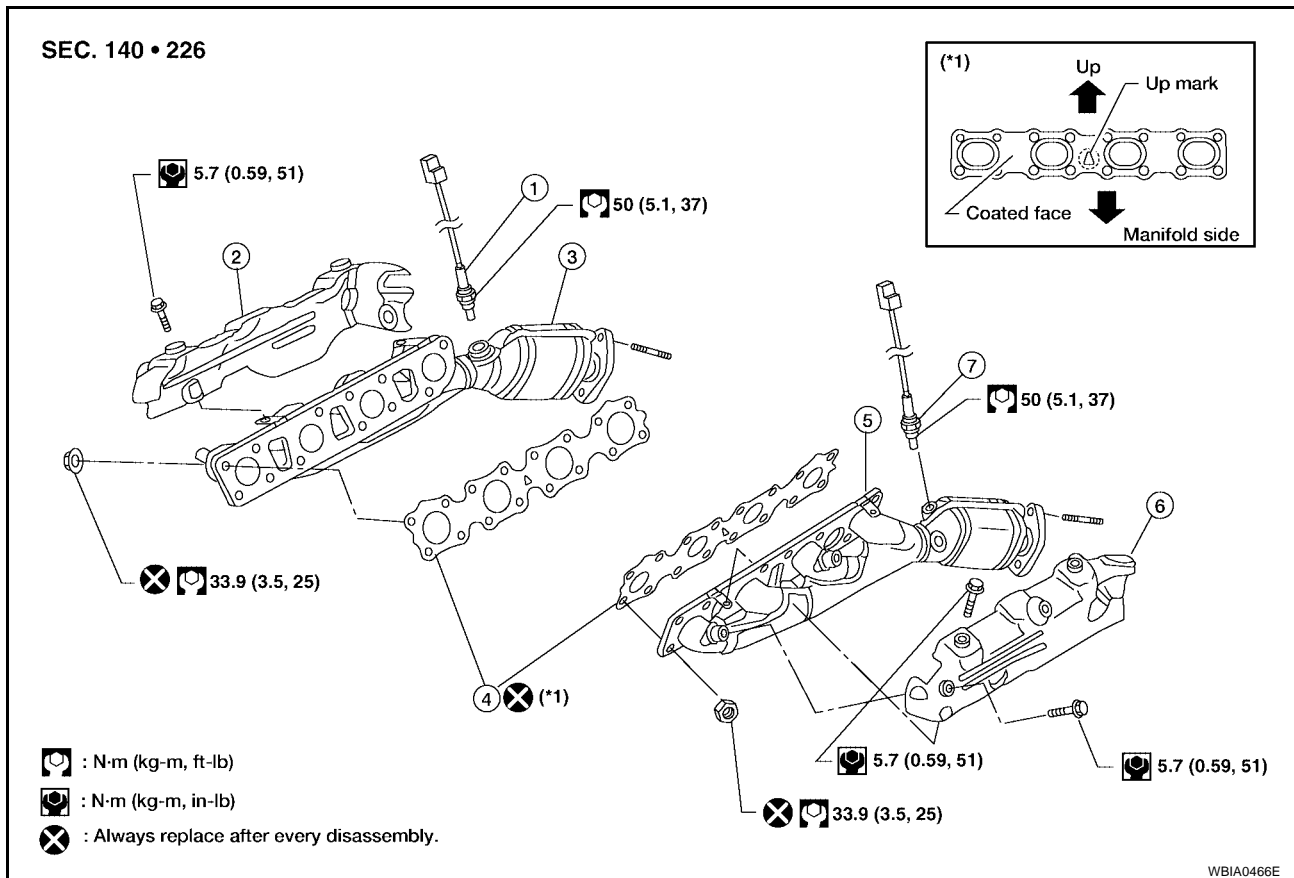

1. Air fuel ratio A/F sensor 1 (bank 2)
2. Exhaust manifold cover (bank 2)
3. Exhaust manifold (bank 2)
4. Gaskets
5. Exhaust manifold (bank 1)
6. Exhaust manifold cover (bank 1)
7. Air fuel ratio A/F sensor 1 (bank 1)

### REMOVAL

#### WARNING:

Perform the work when the exhaust and cooling system have cooled sufficiently.

1. Remove the air duct and resonator assembly. Refer to [EM-15, "Removal and Installation"](#).
2. Drain the engine coolant from the radiator. Refer to [CO-11, "DRAINING ENGINE COOLANT"](#).
3. Remove the engine undercover using power tool.
4. Remove the radiator and radiator hoses. Refer to [CO-14, "REMOVAL"](#).
5. Remove the drive belts. Refer to [EM-13, "REMOVAL"](#).
6. Remove the air fuel ratio A/F sensors (bank 1, bank 2).
  - Follow steps below to remove each air fuel ratio A/F sensor.
- a. Remove the harness connector of each air fuel ratio A/F sensor, and harness from bracket and middle clamp.

# EXHAUST MANIFOLD AND THREE WAY CATALYST

- b. Remove the air fuel ratio A/F sensors from both left and right exhaust manifolds using Tool.

**Tool number** : — (J-44626)

**CAUTION:**

- Do not damage the air fuel ratio A/F sensors
- Discard any air fuel ratio A/F sensor which has been dropped from a height of more than 0.5m (19.7 in) onto a hard surface such as a concrete floor. Replace it with a new one.

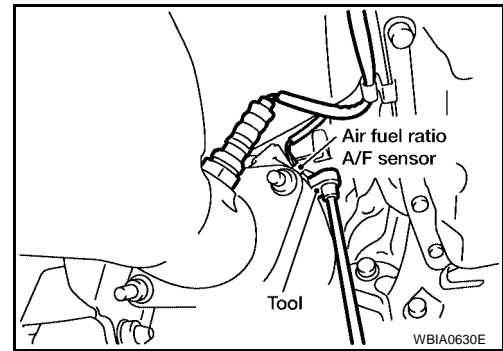

7. Remove the front cross bar.
8. Remove the exhaust manifold (LH) following the steps below.
- Remove the exhaust front tube. Refer to [EM-21, "REMOVAL"](#).
  - Remove the exhaust manifold cover.
  - Loosen the nuts in reverse order of illustration (A) using power tool.
  - Remove the exhaust studs from positions 2, 4, 6, 8 and remove left exhaust manifold
9. Remove the exhaust manifold (RH) following the steps below.
- Remove the exhaust front tube. Refer to [EX-4, "REMOVAL"](#).
  - Remove the oil level gauge guide. Refer to [EM-24, "REMOVAL"](#).

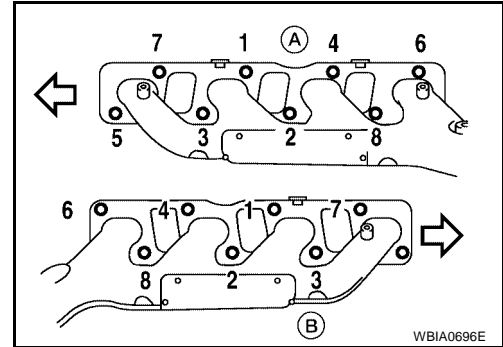

- Remove the exhaust manifold cover.
- Loosen the nuts in reverse order of illustration (B) using power tool A/F.
- Remove the exhaust studs from positions 2, 4, 6, 8 and remove right exhaust manifold.

## INSPECTION AFTER REMOVAL

### Surface Distortion

- Check the flatness of each exhaust manifold flange surface using suitable tools.

**Flatness limit** : 0.3 mm (0.012 in)

- If measurement exceeds the limit, replace the exhaust manifold.

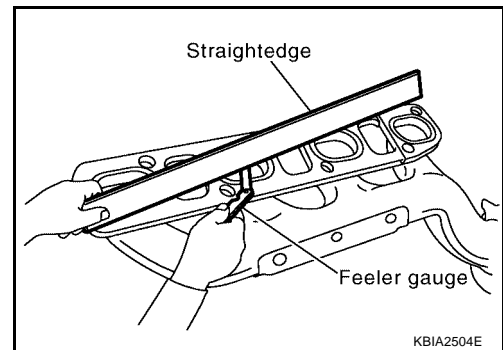

## INSTALLATION

Installation is in the reverse order of removal.

- Install new exhaust manifold gasket with the top of the triangular up mark on it facing up and its coated face (gray side) toward the exhaust manifold side.

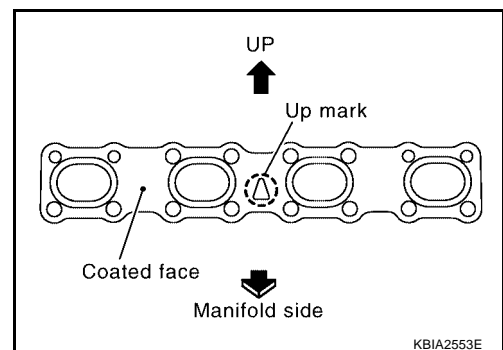

## EXHAUST MANIFOLD AND THREE WAY CATALYST

- Tighten the exhaust manifold nuts in the numerical order shown. Then recheck the torque of the nuts both (A) and (B).

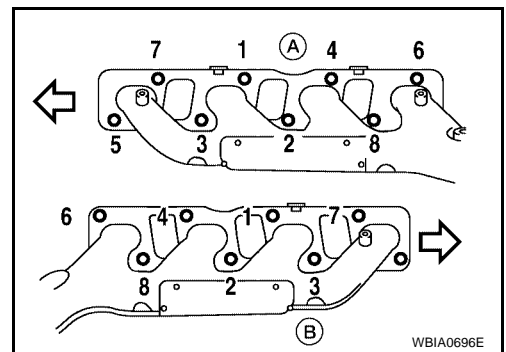

- Before installing new air fuel ratio A/F sensors, clean the exhaust system threads using Tool and apply anti-seize lubricant.

**Tool number** : J-43879-12

: J-43897-18

### CAUTION:

- Do not over tighten the air fuel ratio A/F sensors. Doing so may cause damage to the sensor, resulting in the MIL coming on.

# OIL PAN AND OIL STRAINER

PF:11110

EBS00U8Y

## OIL PAN AND OIL STRAINER

### Removal and Installation

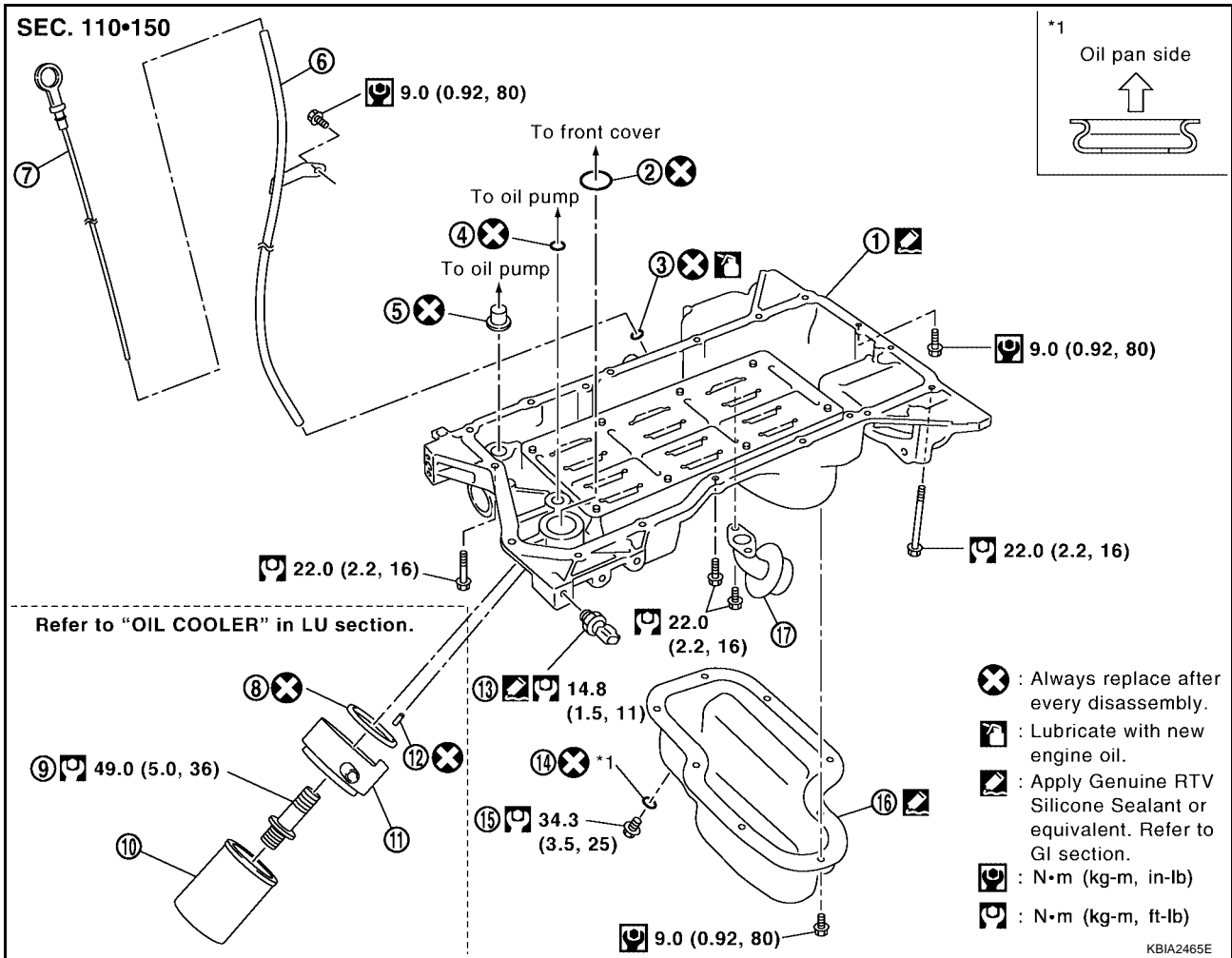

- |                         |                         |                          |
|-------------------------|-------------------------|--------------------------|
| 1. Oil pan (upper)      | 2. O-ring               | 3. O-ring                |
| 4. O-ring               | 5. O-ring (with collar) | 6. Oil level gauge guide |
| 7. Oil level gauge      | 8. O-ring               | 9. Connector bolt        |
| 10. Oil filter          | 11. Oil cooler          | 12. Relief valve         |
| 13. Oil pressure switch | 14. Gasket              | 15. Drain plug           |
| 16. Oil pan (lower)     | 17. Oil strainer        |                          |

### REMOVAL

#### WARNING:

To avoid the danger of being scalded, never drain the engine oil when the engine is hot.

1. Remove the engine. Refer to [EM-76, "REMOVAL"](#).
2. Remove the oil pan (lower) using the following steps.
  - a. Remove the oil pan (lower) bolts using power tool.

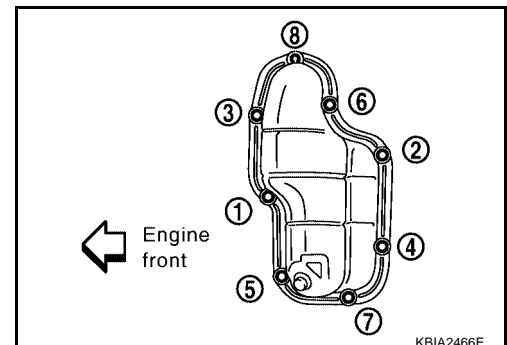



# OIL PAN AND OIL STRAINER

- b. Insert Tool between the lower oil pan and the upper oil pan.

**Tool number** : KV10111100 (J-37228)

**CAUTION:**

- Be careful not to damage the mating surface.
- Do not insert a screwdriver, this will damage the mating surfaces.

- c. Slide (1) the Tool by tapping (2) its side with a hammer to remove the lower oil pan from the upper oil pan.

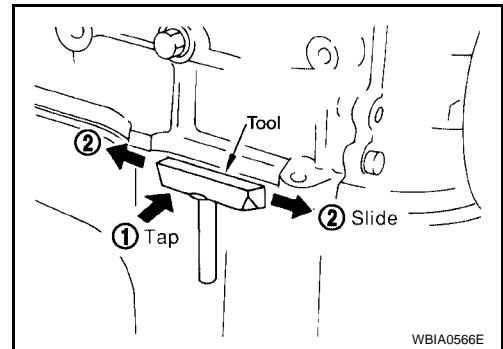

3. Remove the oil strainer from the oil pan (upper).  
 4. Remove the oil pan (upper) using the following steps.  
 a. Remove the oil pan (upper) bolts as shown.

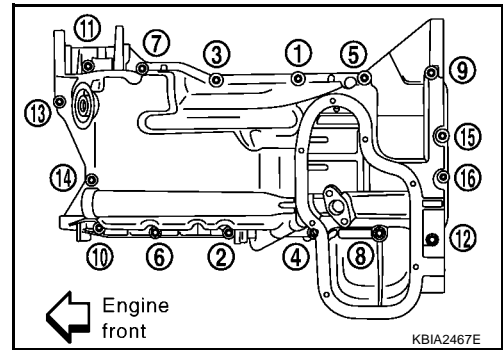

- b. Remove the oil pan (upper) from the cylinder block by prying it at the points shown, using suitable tool.

**CAUTION:**

**Do not damage mating surface.**

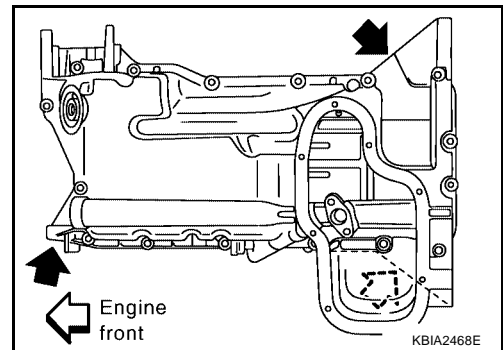

5. Remove the O-rings from the oil pump and front cover.

**NOTE:**

Do not reuse O-rings.

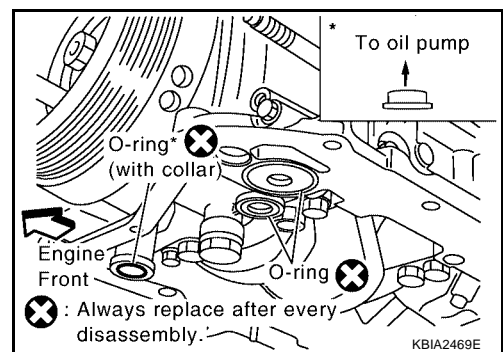

## INSPECTION AFTER REMOVAL

Clean the oil strainer.

A  
EM  
C  
D  
E  
F  
G  
H  
I  
J  
K  
L  
M

# OIL PAN AND OIL STRAINER

## INSTALLATION

1. Install the oil pan (upper) using the following steps.

- a. Apply liquid gasket thoroughly as shown.  
Use Genuine RTV Silicone Sealant or equivalent. Refer to [GI-47, "Recommended Chemical Products and Sealants"](#).

**CAUTION:**

Apply liquid gasket to outside of bolt hole for the hole shown by ★.

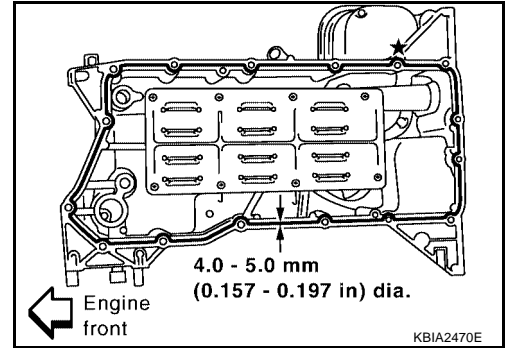

- b. Install new O-rings to the oil pump and front cover side.

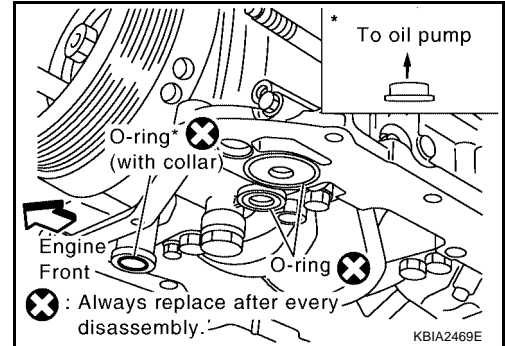

- c. Tighten the bolts in numerical order as shown.

- M6 × 30 mm (1.18 in) : No. 15, 16**  
**M8 × 25 mm (0.98in) : No. 1, 3, 5, 7, 11, 13**  
**M8 × 45 mm (1.77 in) : No. 2, 4, 6, 8, 10, 14**  
**M8 × 123 mm (4.84in) : No. 9, 12**

2. Install the oil strainer to the oil pan (upper).

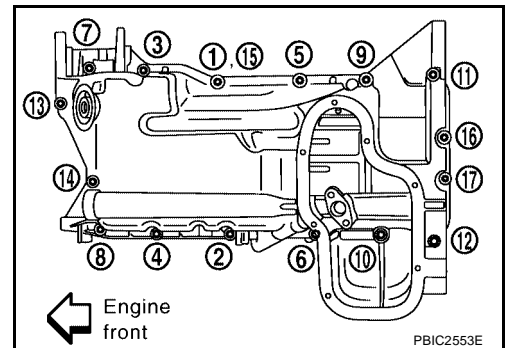

3. Install the oil pan (lower).

- a. Apply liquid gasket thoroughly as shown.  
Use Genuine RTV Silicone Sealant or equivalent. Refer to [GI-47, "Recommended Chemical Products and Sealants"](#)

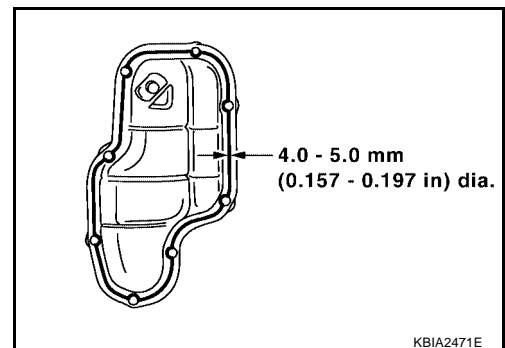

## OIL PAN AND OIL STRAINER

b. Tighten the oil pan (lower) bolts in numerical order as shown.

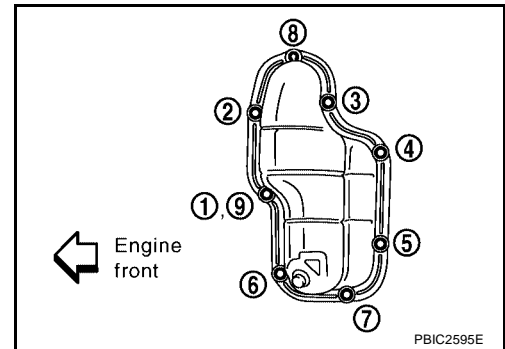

4. Install the oil pan drain plug.
5. Install engine assembly. Refer to [EM-78, "INSTALLATION"](#).
  - Do not fill the engine oil for at least 30 minutes after oil pan is installed.

### INSPECTION AFTER INSTALLATION

1. Check engine oil level and add engine oil if necessary. Refer to [LU-8, "OIL LEVEL"](#).
2. Start the engine, and check for leaks of engine oil.
3. Stop engine and wait for 10 minutes.
4. Check engine oil level again.

# IGNITION COIL

## IGNITION COIL

PF2:22448

### Removal and Installation

EBS00U8Z

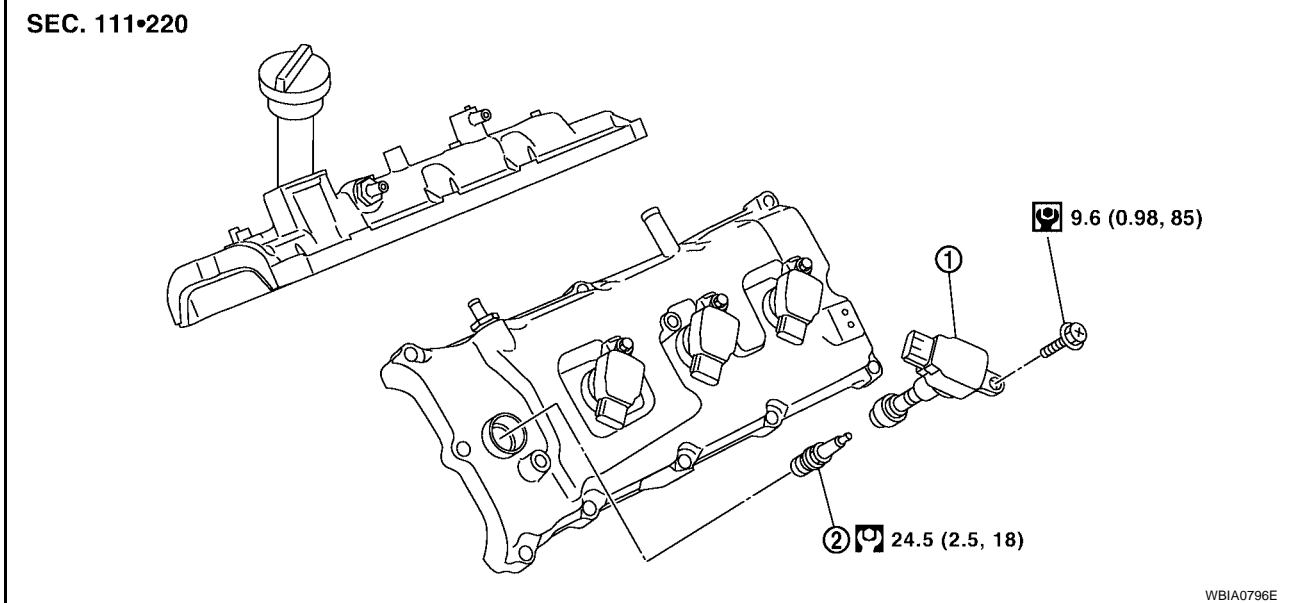

1. Ignition coil

2. Spark plug

### REMOVAL

1. Remove the engine room cover using power tool. Refer to [EM-12, "REMOVAL"](#).
2. Disconnect the harness connector from the ignition coil.
3. Remove the ignition coil.

#### **CAUTION:**

**Do not shock ignition coil.**

### INSTALLATION

Installation is in the reverse order of removal.

# SPARK PLUG (PLATINUM-TIPPED TYPE)

## SPARK PLUG (PLATINUM-TIPPED TYPE)

PF2:22401

### Removal and Installation

EBS00U90

SEC. 111•220

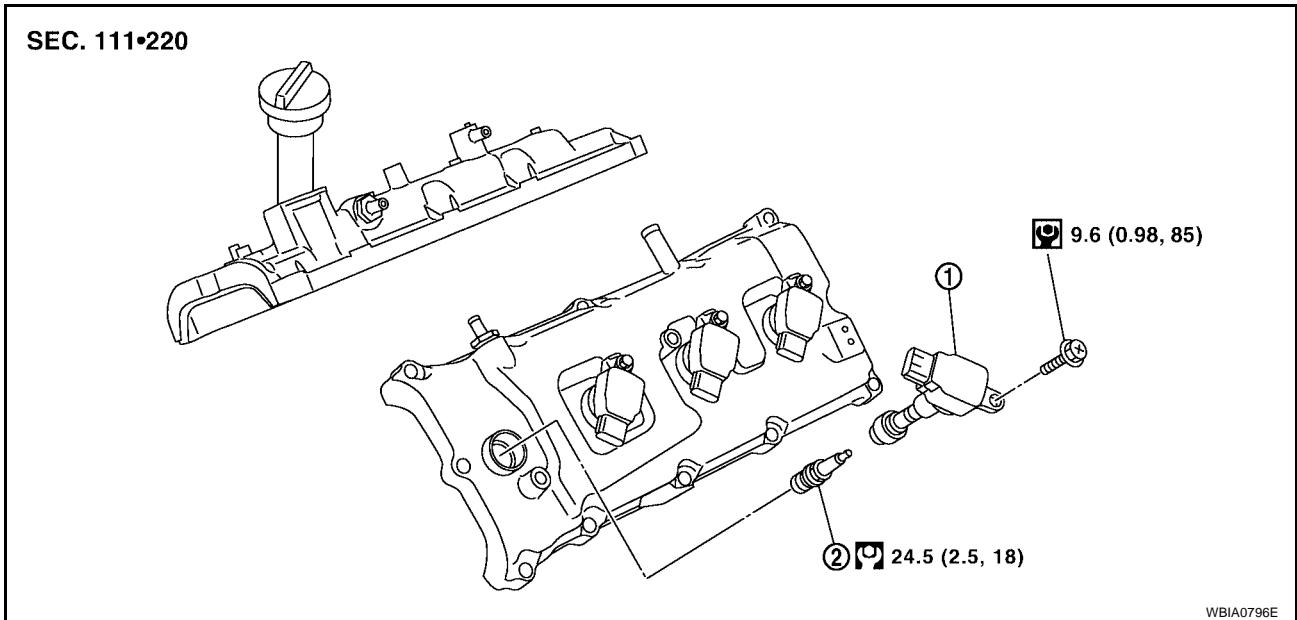

1. Ignition coil

2. Spark plug

### REMOVAL

1. Remove the ignition coil. Refer to [EM-28, "REMOVAL"](#).
2. Remove the spark plug using suitable tool.

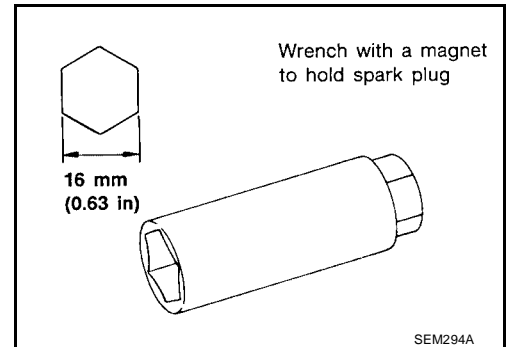

### INSPECTION AFTER REMOVAL

- Do not use a wire brush for cleaning.

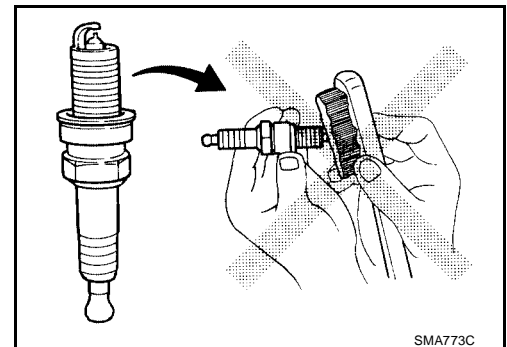

- If the spark plug tip is covered with carbon, a spark plug cleaner may be used.

**Cleaner air pressure** : Less than 588 kPa (5.9 bar, 6 kg/cm<sup>2</sup>, 85 psi)

**Cleaning time** : Less than 20 seconds

## SPARK PLUG (PLATINUM-TIPPED TYPE)

- Checking and adjusting plug gap is not required between change intervals.

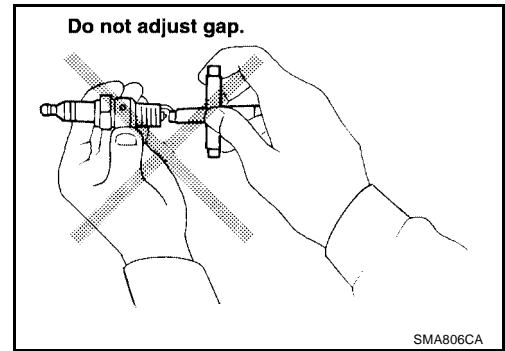

### INSTALLATION

Installation is in the reverse order of removal.

Make	NGK	
Model	Standard	FFV
Standard type	DIFR5A-11	DIFR5A-11D
Gap (Nominal)	1.1 mm (0.043 in)	

**CAUTION:**

**Do not drop or shock spark plug.**

# FUEL INJECTOR AND FUEL TUBE

PFP:16600

EBS00U91

## FUEL INJECTOR AND FUEL TUBE

### Removal and Installation

SEC. 164

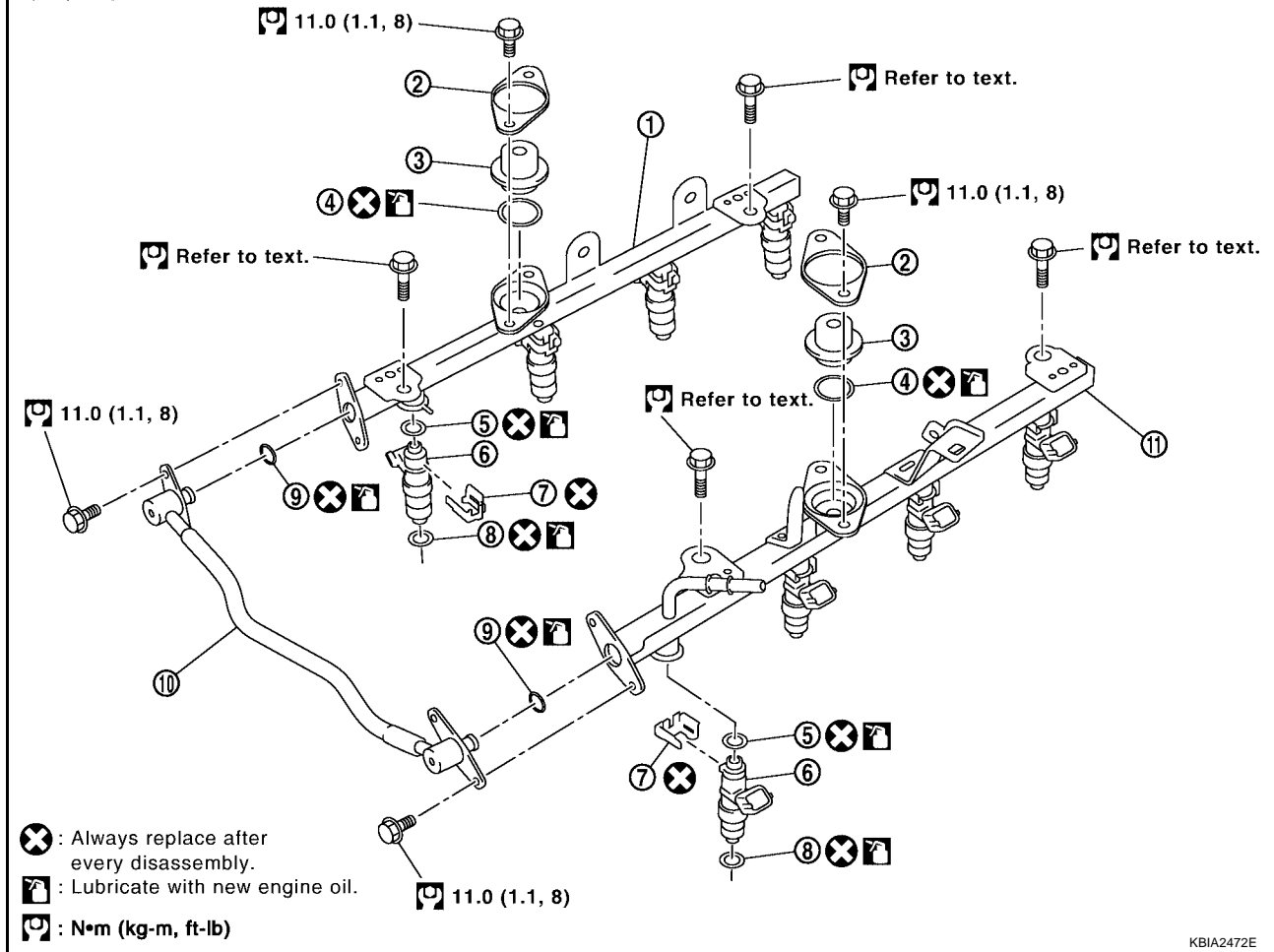

- |                        |                    |                  |
|------------------------|--------------------|------------------|
| 1. Fuel tube (RH)      | 2. Cap             | 3. Fuel damper   |
| 4. O-ring              | 5. O-ring (blue)   | 6. Fuel injector |
| 7. Clip                | 8. O-ring (brown)  | 9. O-ring        |
| 10. Fuel hose assembly | 11. Fuel tube (LH) |                  |

KBIA2472E

#### CAUTION:

Do not remove or disassemble parts unless instructed as shown.

#### REMOVAL

1. Remove the engine room cover using power tool. Refer to [EM-12, "REMOVAL"](#).
2. Release the fuel pressure. Refer to [EC-87, "FUEL PRESSURE RELEASE"](#).
3. Disconnect the negative battery terminal.
4. Disconnect the fuel injector harness connectors.
5. Disconnect the fuel hose assembly from the fuel tubes (RH and LH).

#### CAUTION:

- While hoses are disconnected, plug them to prevent fuel from draining.
- Do not separate the fuel connector and fuel hose.

6. Remove the fuel injectors with the fuel tube assembly.

## FUEL INJECTOR AND FUEL TUBE

7. Remove the fuel injector from the fuel tube using the following steps.
  - a. Spread open and remove the clip.
  - b. Remove the fuel injector from the fuel tube by pulling straight out.

**CAUTION:**

- Be careful with remaining fuel that may leak out from fuel tube.
- Do not damage injector nozzles during removal.
- Do not bump or drop fuel injectors.
- Do not disassemble fuel injectors.

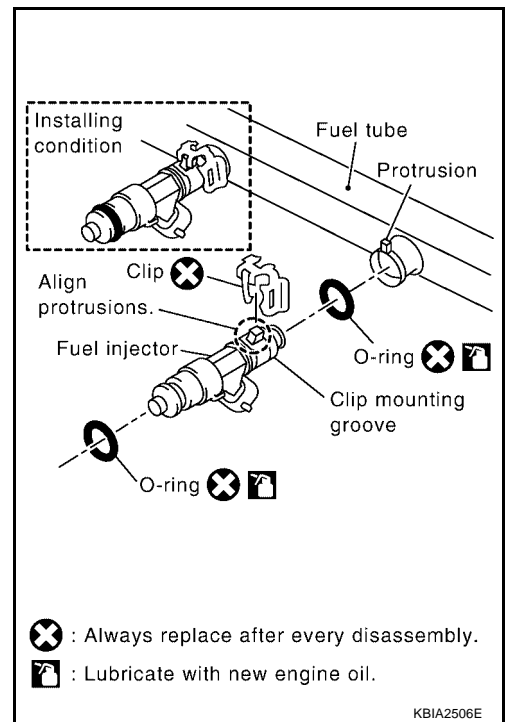

8. Remove the fuel damper from each fuel tube.

### INSTALLATION

1. Install the fuel damper to each fuel tube using the following steps.
  - a. Apply engine oil to the new O-ring and set it into the cup of the fuel tube.

**CAUTION:**

- Handle O-ring with bare hands. Never wear gloves.
- Lubricate new O-ring with new engine oil.
- Do not clean O-ring with solvent.
- Make sure that O-ring and its mating part are free of foreign material.
- When installing O-ring, do not scratch it with tool or fingernails.
- Do not twist or stretch the O-ring.

- b. Make sure that the backup spacer is in the O-ring connecting surface of the fuel damper.

**NOTE:**

The backup spacer is part of the fuel damper assembly.

- c. Insert the fuel damper until it seats on the fuel tube.

**CAUTION:**

- Insert straight, making sure that the axis is lined up.
- Do not pressure-fit with excessive force.

**Reference value** :130 N (13.3 kg, 29.2 lb)

- d. Install the cap, and then tighten the bolts evenly.
    - After tightening the bolts, make sure that there is no gap between the cap and fuel tube.
2. Install new O-rings to the fuel injector paying attention to the items below.

**CAUTION:**

- Upper and lower O-rings are different colors.

**Fuel tube side** : Blue

**Nozzle side** : Brown

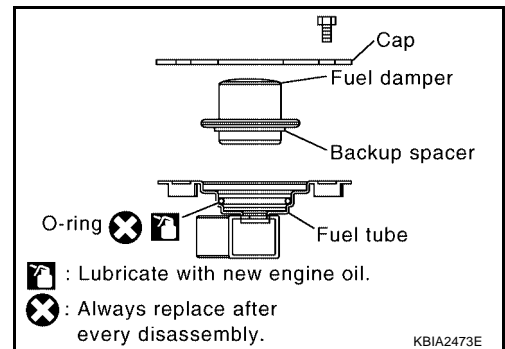



## FUEL INJECTOR AND FUEL TUBE

- Handle O-ring with bare hands. Never wear gloves.
- Lubricate new O-ring with new engine oil.
- Do not clean O-ring with solvent.
- Make sure that O-ring and its mating part are free of foreign material.
- When installing O-ring, be careful not to scratch it with tool or fingernails. Also be careful not to twist or stretch O-ring.
- If O-ring was stretched while it was being attached, do not insert it quickly into fuel tube.
- Insert O-ring straight into fuel tube. Do not angle or twist it.

3. Install the fuel injector to the fuel tube using the following steps.

- a. Insert new clip into clip mounting groove on the fuel injector.
- Insert clip so that lug "A" of fuel injector matches notch "A" of the clip.

**CAUTION:**

- Do not reuse clip. Replace it with a new one.
- Do not allow the clip to interfere with the O-ring. If interference occurs, replace the O-ring.

b. Insert the fuel injector into the fuel tube with the clip attached.

- Insert it while matching it to the axial center.
- Insert fuel injector so that lug "B" of fuel tube matches notch "B" of the clip.
- Make sure that the fuel tube flange is securely seated in the flange fixing groove on the clip.

c. Make sure that installation is complete by checking that the fuel injector does not rotate or come off.

- Make sure that the protrusions of the fuel injectors are aligned with the cutouts of the clips after installation.

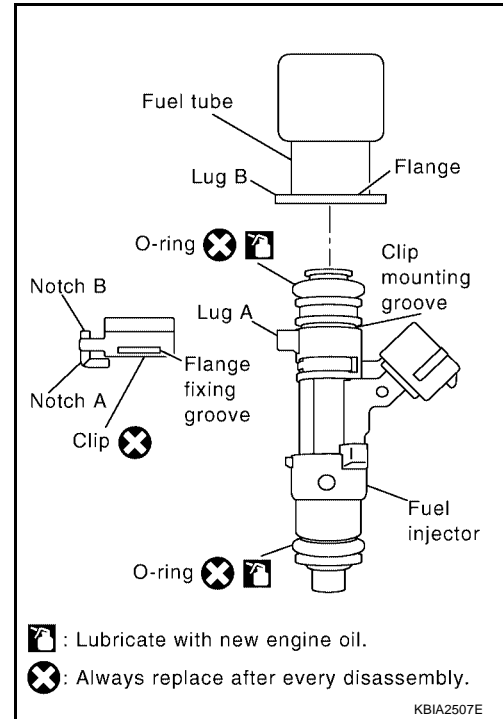

4. Install the fuel tube and fuel injector assembly to the intake manifold.

**CAUTION:**

**Do not let the tip of the injector nozzle come in contact with other parts.**

- Tighten fuel tube assembly bolts "a" to "b" in illustration in two steps.

**1st step : 12.8 N·m (1.3 kg-m, 9 ft-lb)**

**2nd step : 24.5 N·m (2.5 kg-m, 18 ft-lb)**

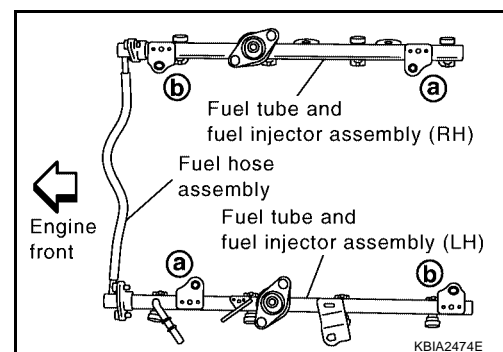

5. Install the fuel hose assembly.

- Insert connectors straight, making sure that the axis is lined up with fuel tube side to prevent O-ring from being damaged.
- Tighten bolts evenly in several steps.
- Make sure that there is no gap between the flange and fuel tube after tightening the bolts.

**CAUTION:**

- Handle O-ring with bare hands. Do not wear gloves.
- Lubricate O-ring with new engine oil.
- Do not clean O-ring with solvent.

## FUEL INJECTOR AND FUEL TUBE

---

- Make sure that O-ring and its mating part are free of foreign material.
- When installing O-ring, be careful not to scratch it with tool or fingernails. Also be careful not to twist or stretch O-ring.
- If O-ring was stretched while it was being attached, do not insert it quickly into fuel tube.
- Insert new O-ring straight into fuel tube. Do not twist it.

6. Installation of the remaining components is in the reverse order of removal.

### INSPECTION AFTER INSTALLATION

After installing the fuel tubes, make sure there are no fuel leaks at the connections using the following steps.

1. Apply fuel pressure to the fuel lines by turning ignition switch ON (with engine stopped). Then check for fuel leaks at the connections.

**NOTE:**

Use mirrors for checking on hidden points.

2. Start the engine and rev it up and check for fuel leaks at the connections.

**CAUTION:**

**Do not touch the engine immediately after stopping, as engine becomes extremely hot.**

# ROCKER COVER

PFP:13264

EBS00U92

## ROCKER COVER

### Removal and Installation

SEC. 111•118

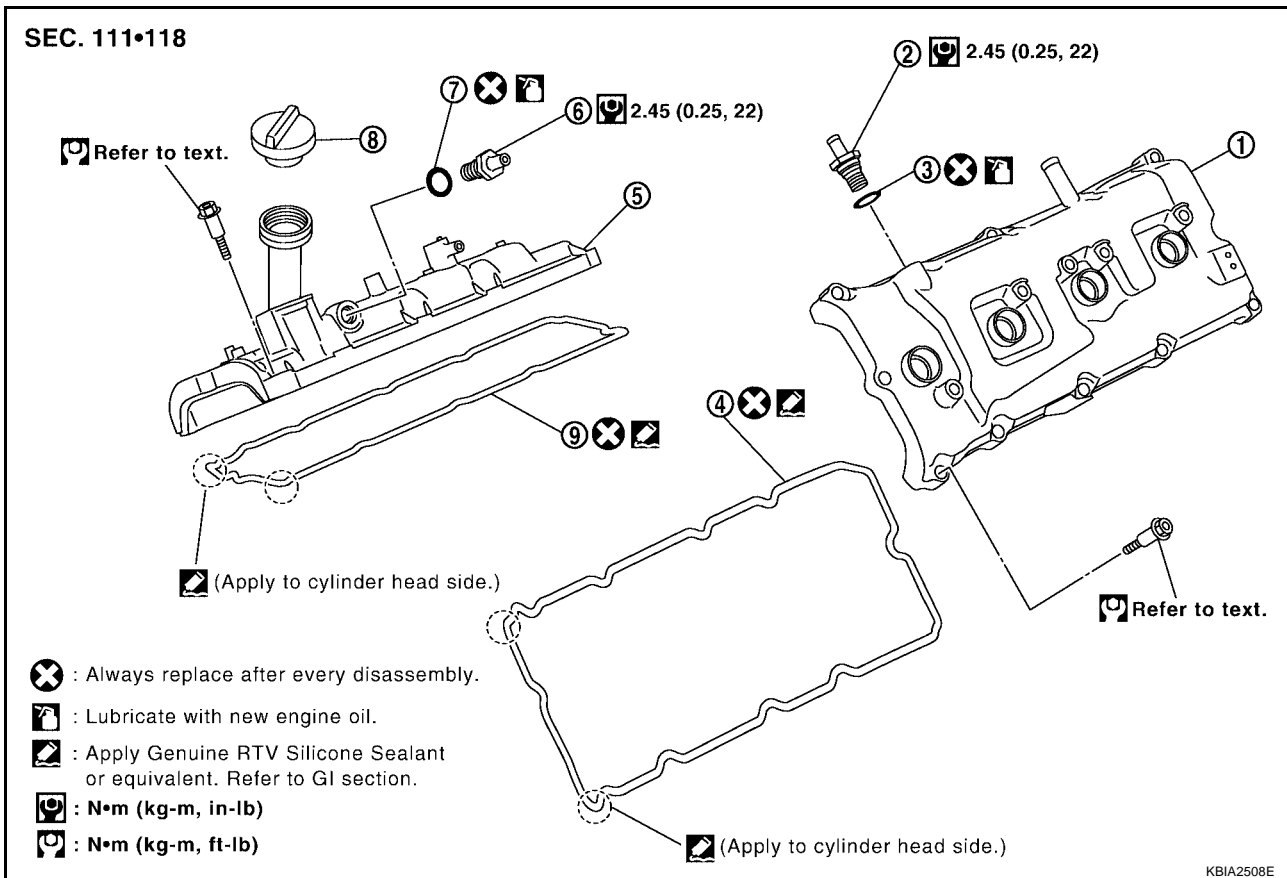

- |                             |                      |                             |
|-----------------------------|----------------------|-----------------------------|
| 1. Rocker cover (LH)        | 2. PCV control valve | 3. O-ring                   |
| 4. Rocker cover gasket (LH) | 5. Rocker cover (RH) | 6. PCV control valve        |
| 7. O-ring                   | 8. Oil filler cap    | 9. Rocker cover gasket (RH) |

### REMOVAL

- Remove the engine room cover using power tool. Refer to [EM-12, "REMOVAL"](#).
- Remove the air duct and resonator assembly. Refer to [EM-15, "REMOVAL"](#) (for LH only).
- Move the harness on the upper rocker cover and its peripheral aside.
- Remove the electric throttle control actuator, loosening the bolts diagonally (for LH only).
- Remove the ignition coils. Refer to [EM-28, "REMOVAL"](#).
- Remove the PCV hose from the PCV control valves.
  - ←: Engine front
- Loosen the bolts in reverse order shown using power tool for rocker cover (A) or (B).

#### CAUTION:

Do not hold the rocker cover (RH) (B) by the oil filler neck.

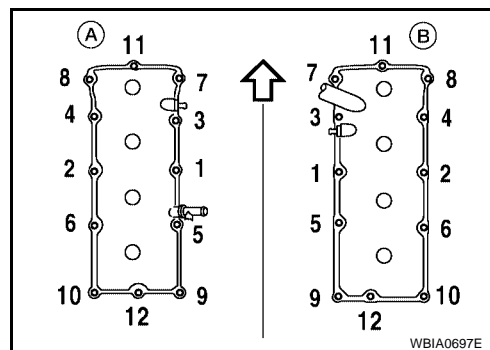

WBIA0697E

# ROCKER COVER

## INSTALLATION

1. Apply liquid gasket to the joint part of the cylinder head and camshaft bracket following the steps below.

### NOTE:

Illustration shows an example of (LH) side (zoomed in shows No.1 camshaft bracket).

- a. Refer to illustration "a" to apply liquid gasket to the joint part of No.1 camshaft bracket and cylinder head.
- b. Refer to illustration "b" to apply liquid gasket 90° to illustration "a".

**Use Genuine RTV Silicone Sealant or equivalent. Refer to [GI-47, "Recommended Chemical Products and Sealants"](#).**

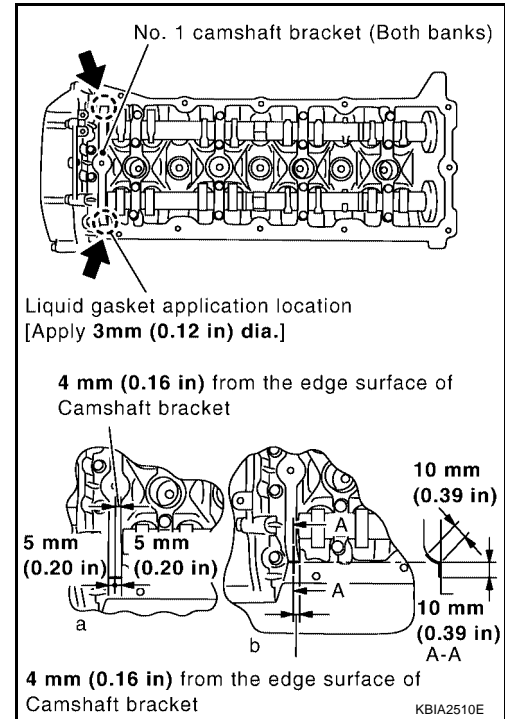

2. Install the rocker cover (A) or (B).
  - Make sure the new rocker cover gasket is installed in the groove of the rocker cover (A) or (B).
  - Tighten the bolts in two steps in the numerical order shown.

- 1st step : 2.0 N·m (0.2 kg-m, 18 in-lb)**  
**2nd step : 8.3 N·m (0.85 kg-m, 73 in-lb)**

### CAUTION:

**Do not hold the rocker cover (RH) (B) by the oil filler neck.**

3. Install the PCV hoses.

### NOTE:

- Remove foreign materials from inside the hose using compressed air.
- The inserted length is within 25 - 30 mm (0.98 - 1.18 in) [Target: 25 mm (0.98 in)].

4. Installation of the remaining components is in the reverse order of removal.

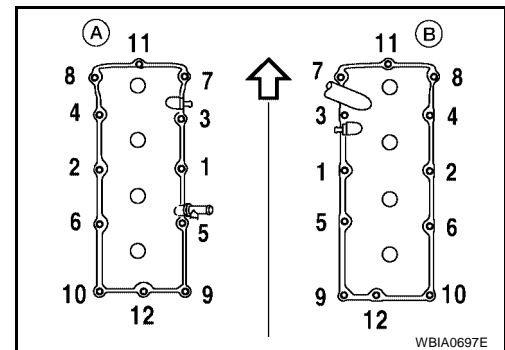



# TIMING CHAIN

- |  |   |   |
|--|---|---|
| 1. Camshaft sprocket LH bank EXH             | 2. Camshaft sprocket LH bank INT (VTC)              | 3. Camshaft sprocket RH bank INT (VTC)              |
| 4. Camshaft sprocket RH bank EXH             | 5. Front cover                                      | 6. Intake valve control solenoid valve (LH)         |
| 7. Intake valve control solenoid cover (LH)  | 8. Intake valve timing control position sensor (LH) | 9. Intake valve timing control position sensor (RH) |
| 10. Intake valve control solenoid cover (RH) | 11. Camshaft position sensor (PHASE)                | 12. Crankshaft pulley bolt                          |
| 13. Crankshaft pulley                        | 14. Chain tensioner cover                           | 15. Front oil sea                                   |
| 16. Intake valve control solenoid valve (RH) | 17. O-ring  | 18. Timing chain tension guide RH bank              |
| 19. Timing chain slack guide (RH)            | 20. Timing chain LH bank                            | 21. Timing chain (RH)                               |
| 22. Chain tensioner (RH)                     | 23. Timing chain slack guide LH bank                | 24. Timing chain tension guide LH bank              |
| 25. Chain tensioner (LH)                     | 26. O-ring  | 27. Bracket   |
| 28. Oil pump drive spacer                    | 29. Oil pump assembly                               | 30. Crankshaft sprocket                             |

## NOTE:

- To remove timing chain and associated parts, start with those on the LH bank. The procedure for removing parts on the RH bank is omitted because it is the same as that for removal on the LH bank.
- To install timing chain and associated parts, start with those on the RH bank. The procedure for installing parts on the LH bank is omitted because it is the same as that for installation on the RH bank.

## REMOVAL

1. Remove the engine assembly from the vehicle. Refer to [EM-76, "REMOVAL"](#).
2. Remove the following components and related parts:
  - Drive belt auto tensioner and idler pulley. Refer to [EM-13, "REMOVAL"](#).
  - Thermostat housing and water hose. Refer to [CO-21, "Removal of Thermostat Housing, Water Outlet and Heater Pipe"](#).
  - Oil pan (lower), (upper) and oil strainer. Refer to [EM-24, "REMOVAL"](#).
  - Ignition coil. Refer to [EM-28, "REMOVAL"](#).
  - Rocker cover. Refer to [EM-35, "REMOVAL"](#).
3. Remove the chain case cover RH bank (A) and chain case cover LH bank (B) as follows:
  - a. Loosen and remove the bolts as shown.
  - b. Cut the liquid gasket and remove the covers using Tool.

**Tool number : KV10111100 (J-37228)**

**CAUTION:**  
Do not damage mating surfaces.

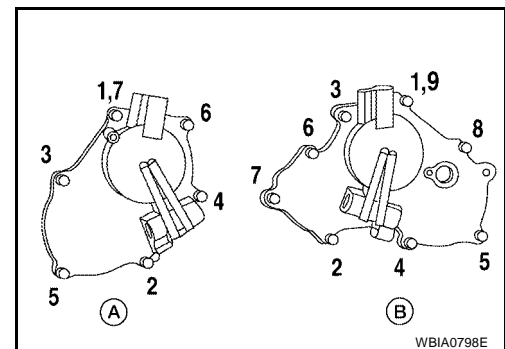

4. Obtain compression TDC of No. 1 cylinder as follows:
  - a. Turn the crankshaft pulley clockwise to align the TDC identification notch (without paint mark) with the timing indicator on the front cover.

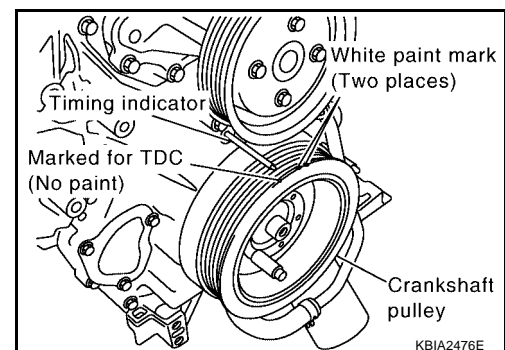

# TIMING CHAIN

- b. At this time, make sure both intake and exhaust cam lobes of No. 1 cylinder (top front on LH bank) point outside.
- If they do not point outside, turn crankshaft pulley once more.

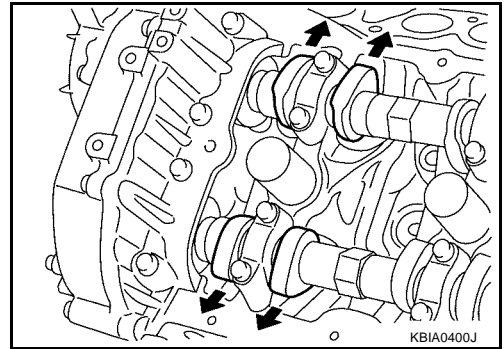

5. Remove the crankshaft pulley.
- a. Loosen the crankshaft pulley bolts using a hammer handle to secure the crankshaft.

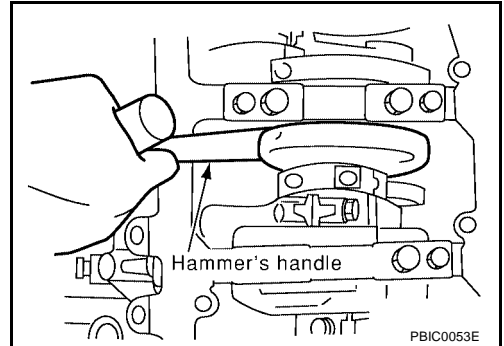

- b. Remove the crankshaft pulley from the crankshaft using tool.
- Remove the crankshaft pulley using suitable tool. Set the bolts in the two bolt holes [M6 x 1.0 mm (0.04 in)] on the front surface.

**NOTE:**

The dimension between the centers of the two bolt holes is 61 mm (2.40 in).

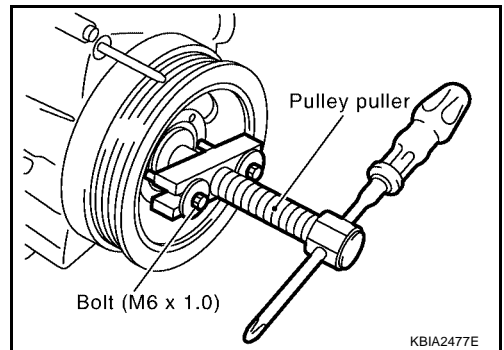

6. Remove the front cover.
- a. Loosen and remove the bolts in the reverse of order shown.
- b. Cut the liquid gasket and remove the covers using Tool.

**Tool number : KV10111100 (J-37228)**

**CAUTION:**

**Do not damage mating surfaces.**

7. Remove the front oil seal using suitable tool.

**CAUTION:**

**Do not damage front cover.**

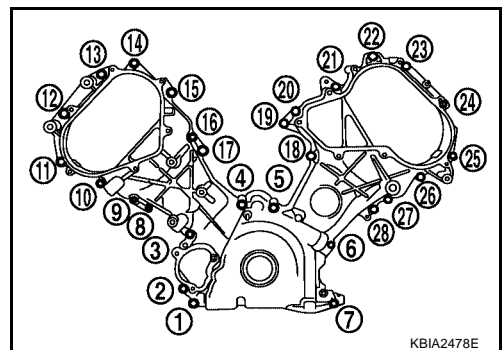

8. Remove the oil pump drive spacer.
- Hold and remove the flat space of the oil pump drive spacer by pulling it forward.

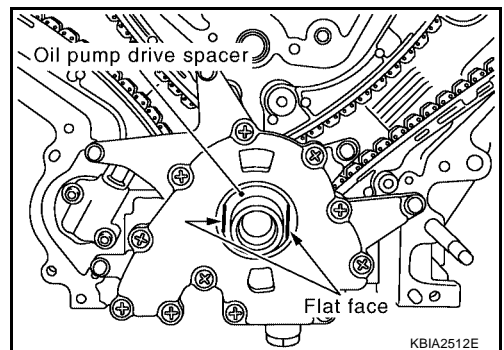

# TIMING CHAIN

9. Remove the oil pump. Refer to [LU-14, "REMOVAL"](#) .
10. Remove the chain tensioner on the LH bank using the following steps.

**NOTE:**

To remove the timing chain and associated parts, start with those on the LH bank. The procedure for removing parts on the RH bank is omitted because it is the same as that for the LH bank.

- a. Squeeze the return-proof clip ends using suitable tool and push the plunger into the tensioner body.
- b. Secure the plunger using stopper pin.
  - Stopper pin is made from hard wire approximately 1 mm (0.04 in) in diameter.
- c. Remove the bolts and chain tensioner.

**WARNING:**

**Plunger, spring, and spring seat pop out when (squeezing) return-proof clip without holding plunger head. It may cause serious injuries. Always hold plunger head when removing.**

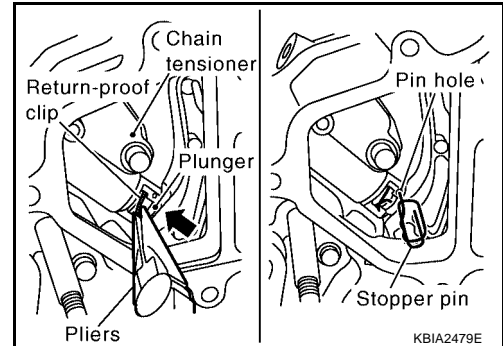

**NOTE:**

- Stop the plunger in the fully extended position by using the return-proof clip 1 if the stopper pin is removed.
- Push the plunger 2 into the tensioner body while squeezing the return-proof clip 1. Secure it using stopper pin 3.

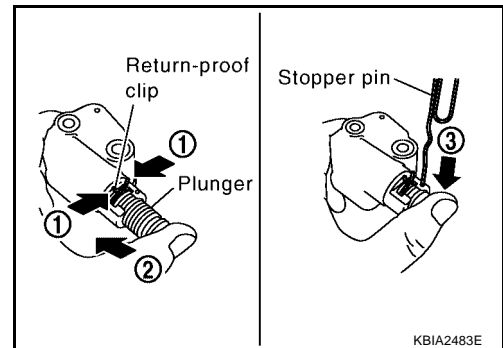

11. Remove the timing chain tension guide and timing chain slack guide.
12. Remove the timing chain and crankshaft sprocket.
13. Loosen the camshaft sprocket bolts as shown and remove the camshaft sprocket.

**CAUTION:**

**To avoid interference between valves and pistons, do not turn crankshaft or camshaft when timing chain is disconnected.**

14. Repeat the same procedure to remove the RH timing chain and associated parts.

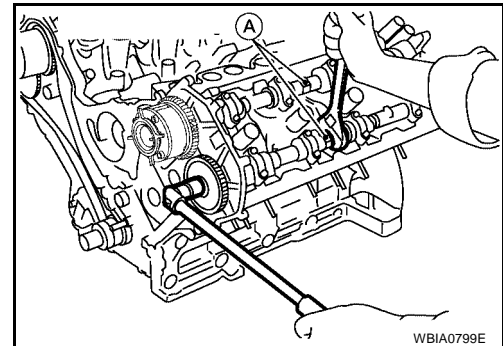

## INSPECTION AFTER REMOVAL

**Check for cracks and any excessive wear at link plates. Replace chain if necessary.**

- In the same way as for the LH bank, inspect the timing chain and associated parts on the RH bank.

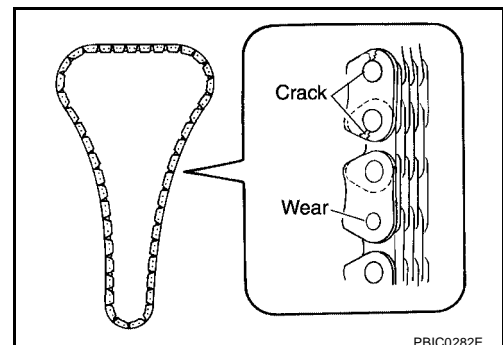



# TIMING CHAIN

## INSTALLATION

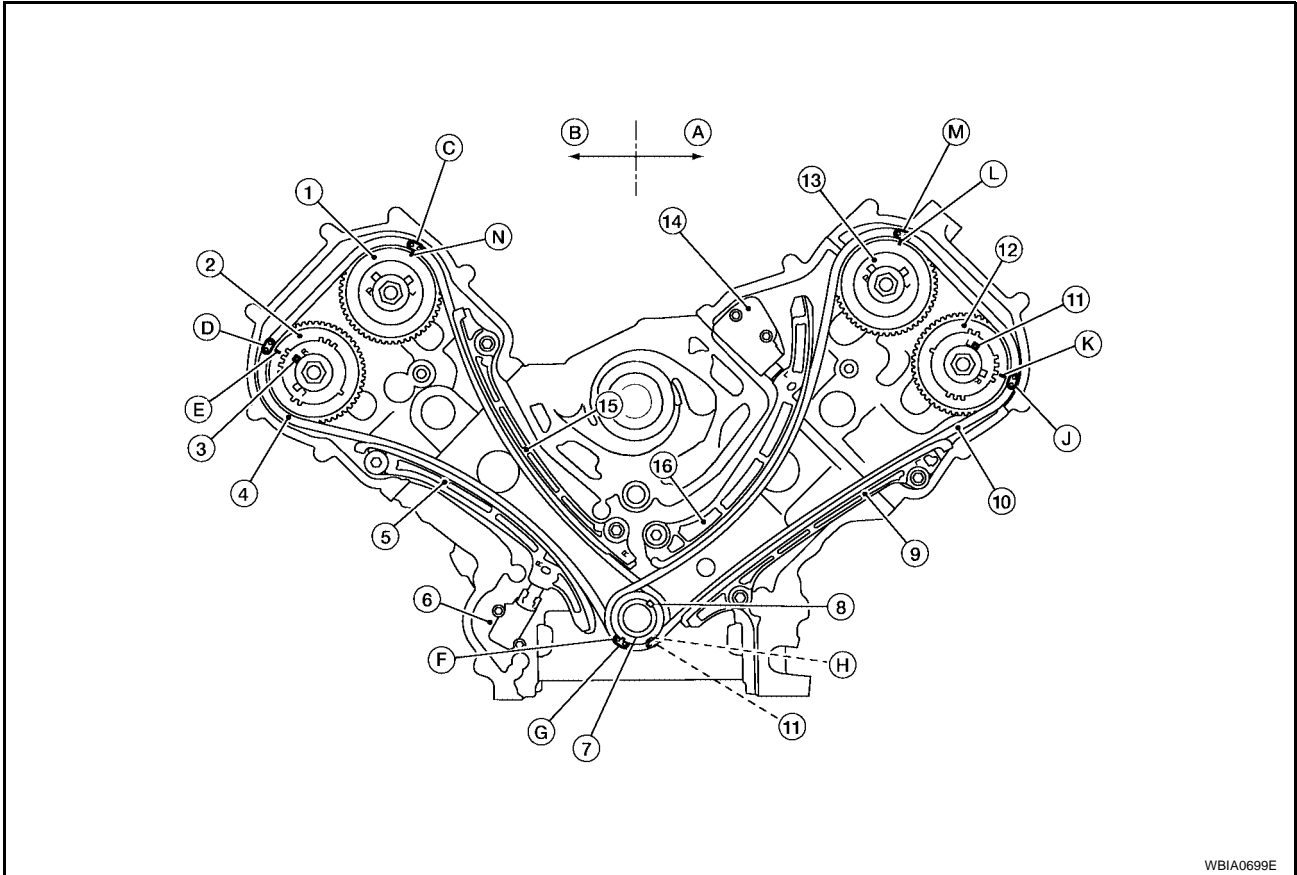

- |   |  |  |
|---|--|--|
| 1. RH bank Camshaft sprocket (INT) (VTC)  | 2. RH bank Camshaft sprocket (EXH)                 | 3. RH bank camshaft dowel pin                      |
| 4. Timing chain                           | 5. RH bank Timing chain slack guide                | 6. Primary timing chain tensioner                  |
| 7. Crankshaft sprocket                    | 8. Crankshaft key                                  | 9. LH Timing chain tension guide                   |
| 10. Timing chain                          | 11. LH Camshaft dowel pin                          | 12. LH bank Camshaft sprocket (EXH)                |
| 13. LH bank Camshaft sprocket (INT) (VTC) | 14. Secondary timing chain tensioner               | 15. RH bank timing chain tension guide             |
| 16. LH timing chain slack guide           | A. LH bank   | B. RH bank   |
| C. Alignment mark (Link color: copper)    | D. Alignment mark (Link color: copper)             | E. Alignment mark (Identification mark)            |
| F. Alignment mark for LH bank (Notch)     | G. Alignment mark for LH bank (Link color: Yellow) | H. Alignment mark for RH bank (Link color: Yellow) |
| J. Alignment mark (Link color: copper)    | K. Alignment mark (Identification mark)            | L. Alignment mark (Identification mark)            |
| M. Alignment mark (Link color: copper)    | N. Alignment mark (Identification mark)            |  |

### NOTE:

- The above figure shows the relationship between the mating mark on each timing chain and that of the corresponding sprocket, with the components installed.
- To install the timing chain and associated parts, start with those on the RH bank. The procedure for installing parts on the LH bank is omitted because it is the same as that for installation on the RH bank.

# TIMING CHAIN

1. Make sure the crankshaft key and RH bank camshaft dowel pin and LH bank camshaft dowel pin are facing in the direction shown.

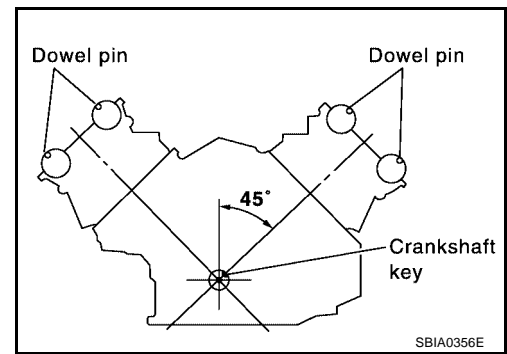

2. Install the camshaft sprockets.

- Install the intake camshaft sprocket and exhaust camshaft sprockets by selectively using the groove of the dowel pin according to the bank. (Common part used for both banks.)
- Lock the hexagonal part of the camshaft in the same way as for removal, and tighten the bolts.
- B = V: Exhaust

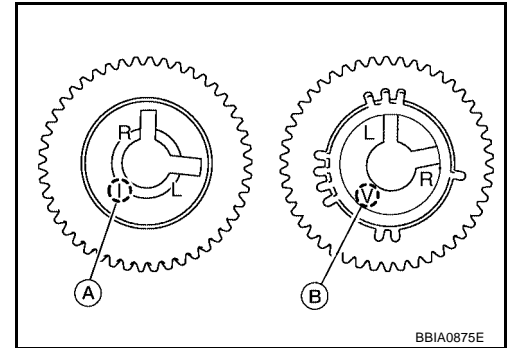

3. Install the crankshaft sprockets for both banks.

- Install LH bank crankshaft sprocket (B) and RH bank crankshaft sprocket (C) so that their flange side (A) (the larger diameter side without teeth) faces in the direction shown.

**NOTE:**

The same parts are used but facing directions are different.

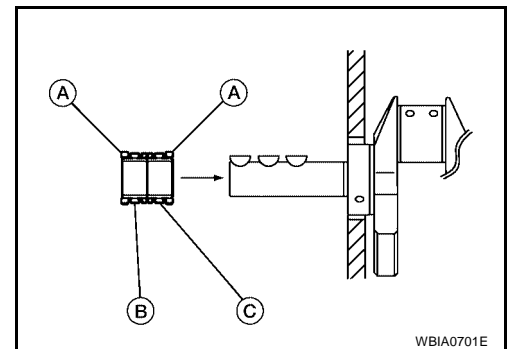

4. Install the timing chains and associated parts.

- Align the alignment mark on each sprocket and the timing chain for installation.

**CAUTION:**

- Before installing timing chain tensioner, it is possible to change the position of alignment mark on timing chain and each sprocket. After the alignment marks are aligned, keep them aligned by holding them by hand.
- Install the slack guides and tension guides onto the correct side by checking the identification mark on the surface.
- Install the timing chain tensioner with the plunger locked in with the stopper pin.

**CAUTION:**

- Before and after the installation of the timing chain tensioner, make sure that the alignment mark on the timing chain is not out of alignment.
- After installing the timing chain tensioner, remove the stopper pin to release the tensioner. Make sure the tensioner is released.
- To avoid chain-link skipping of the timing chain, do not move crankshaft or camshafts until the front cover is installed.

5. In the same way as for the RH bank, install the timing chain and associated parts on the LH bank.
6. Install the oil pump.

# TIMING CHAIN

7. Install the oil pump drive spacer as follows:

- Install so that the front mark on the front edge of the oil pump drive spacer faces the front of the engine.
- Insert the oil pump drive spacer according to the directions of the crankshaft key and the two flat surfaces of the oil pump inner rotor.
- If the positional relationship does not allow the insertion, rotate the oil pump inner rotor to allow the oil pump drive spacer to be inserted.

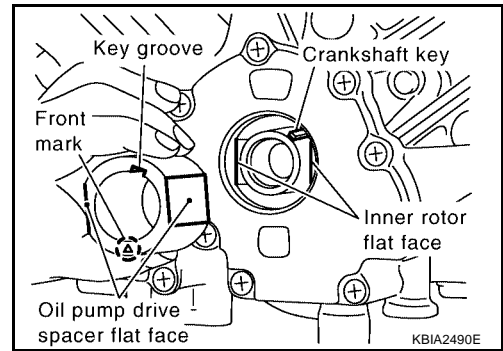

8. Install the front oil seal using suitable tool.

**CAUTION:**

**Do not scratch or make burrs on the circumference of the oil seal.**

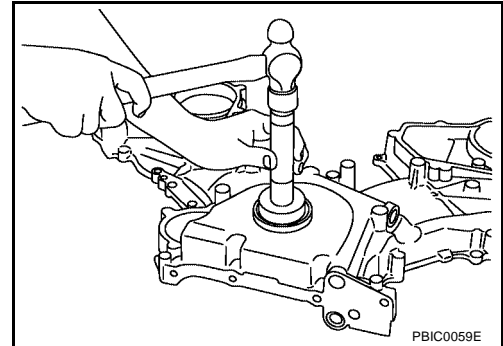

9. Install the chain tensioner cover.

- Apply liquid gasket as shown.

**Use Genuine RTV Silicone Sealant or equivalent. Refer to [GI-47, "Recommended Chemical Products and Sealants"](#)**

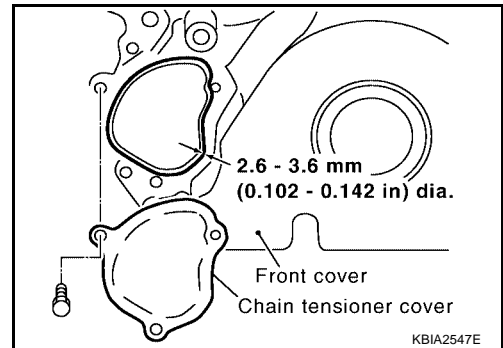

10. Install the front cover as follows:

- a. Install a new O-ring on the cylinder block.

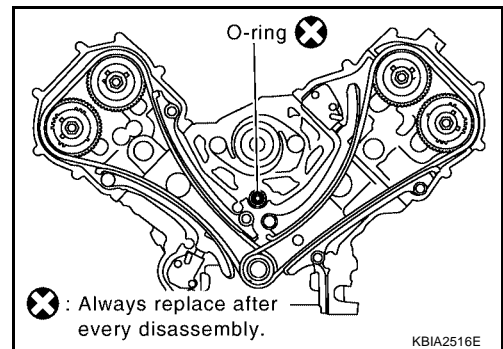

# TIMING CHAIN

- b. Apply liquid gasket as shown.  
**Use Genuine RTV Silicone Sealant or equivalent. Refer to [GI-47, "Recommended Chemical Products and Sealants"](#).**
- c. Check again that the timing alignment marks on the timing chain and on each sprocket are aligned. Then install the front cover.

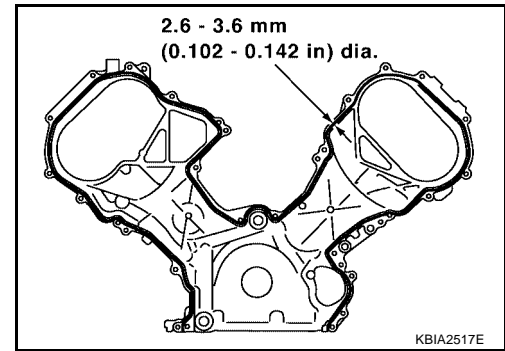

- d. Install the bolts in the numerical order shown.
- M6 × 50 mm (1.97 in) : No. 1, 20, 25, 26, 27**
  - M6 × 80 mm (3.15 in) : No. 4, 5, 7**
  - M6 × 20 mm (0.79 in) : Except the above**

- e. After tightening, re-tighten to the specified torque.

**CAUTION:**

**Be sure to wipe off any excessive liquid gasket leaking onto surface mating with oil pan.**

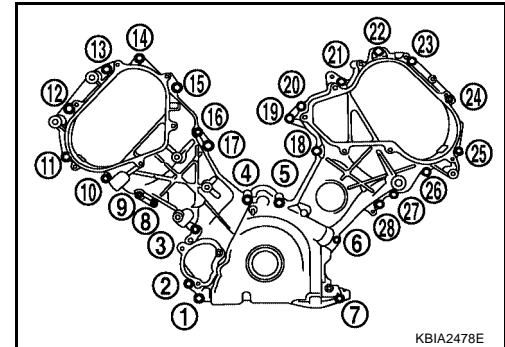

11. Install the timing chain case cover RH bank (A) and timing chain case cover LH bank (B) as follows:

- \*: Cross mark (c) that can not be seen after assembly

**D : 2.6 - 3.6 mm (0.102 - 0.142 in) dia.**

- a. Apply liquid gasket (a) as shown.  
**Use Genuine RTV Silicone Sealant or equivalent. Refer to [GI-47, "Recommended Chemical Products and Sealants"](#).**

**CAUTION:**

**The start and end of the application of the liquid gasket should be crossed at a position that cannot be seen after attaching the chain case cover.**

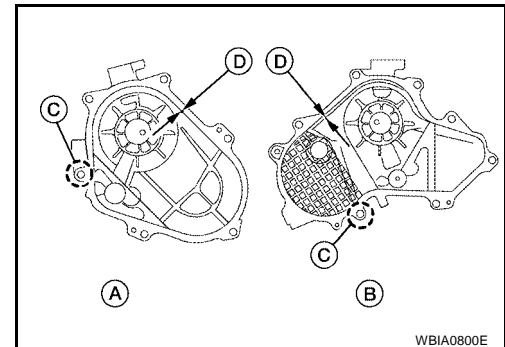

- b. Install the bolts in the numerical order shown.

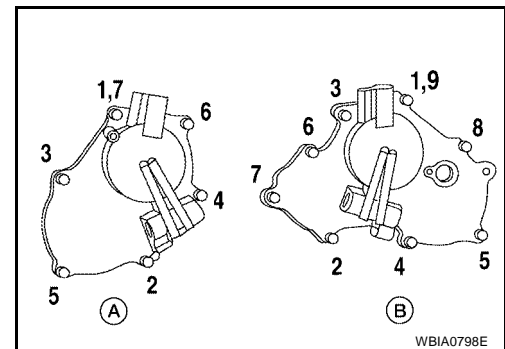

12. Install the crankshaft pulley.

- Install the key of the crankshaft.
- Insert the pulley by lightly tapping it.

**CAUTION:**

**Do not tap pulley on the side surface where the belt is installed (outer circumference).**

13. Tighten the crankshaft pulley bolt.

- Lock the crankshaft using suitable tool, then tighten the bolt.
- Perform the following steps for angular tightening:

## TIMING CHAIN

- a. Apply engine oil onto the threaded parts of the bolt and seating area.
- b. Select the one most visible notch of the four on the bolt flange. Corresponding to the selected notch, put a alignment mark (such as paint) on the crankshaft pulley.

### Crankshaft pulley bolt torque

**Step 1 : 93.1 N·m (9.5 kg-m, 69 ft-lb)**

**Step 2 : additional 90° (angle tightening)**

14. Rotate the crankshaft pulley in normal direction (clockwise when viewed from engine front) to check for parts interference.
15. Installation of the remaining components is in the reverse of order of removal.

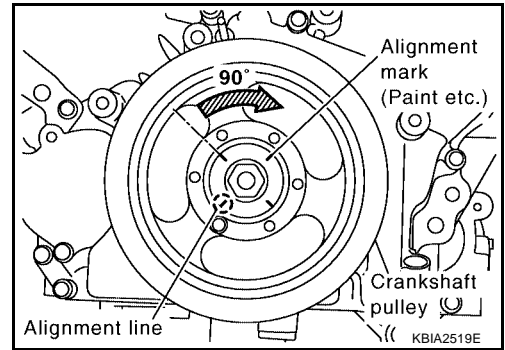

A

EM

C

D

E

F

G

H

I

J

K

L

M

# CAMSHAFT

## CAMSHAFT

PF1:13001

### Removal and Installation

EBS00U94

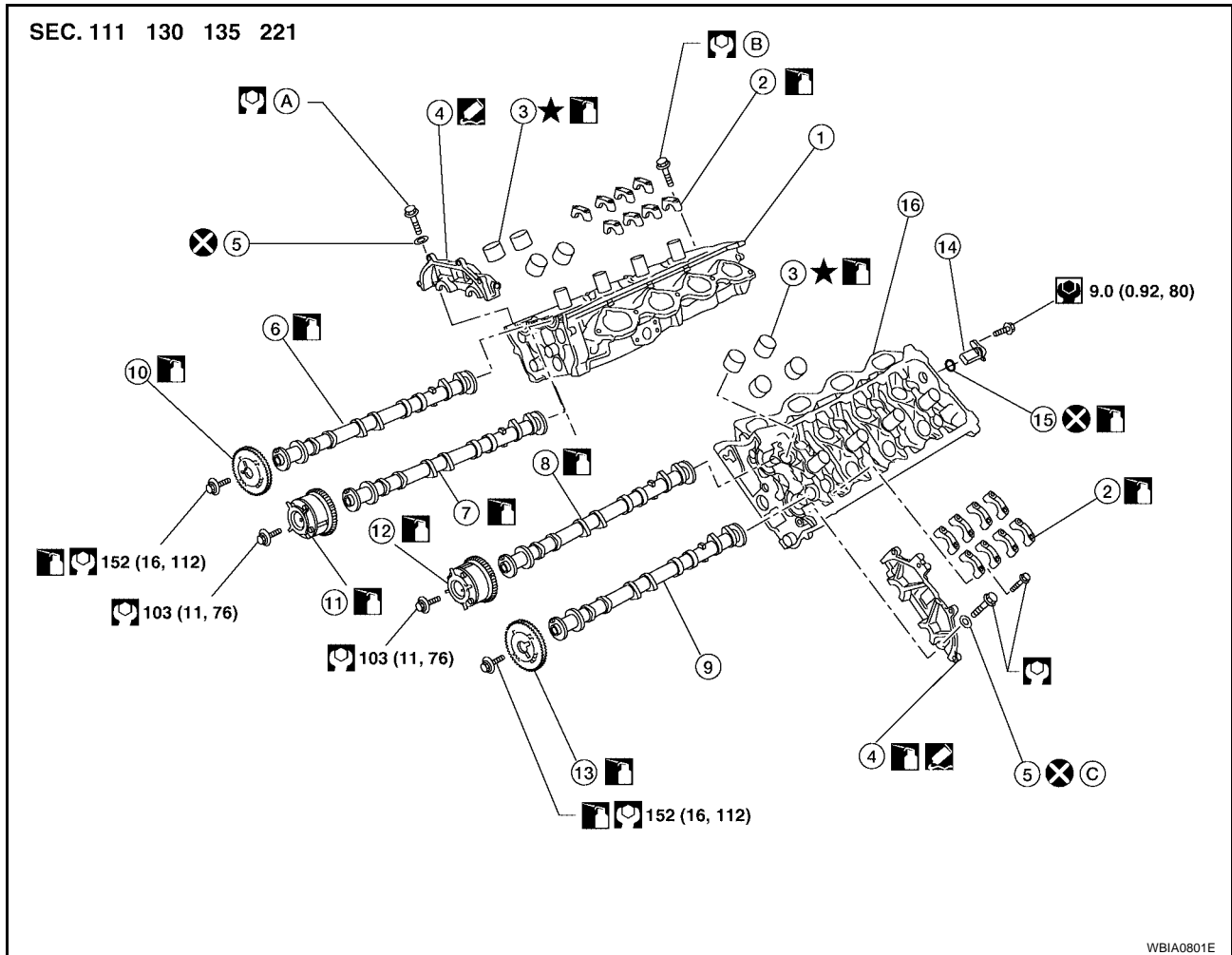

- |                                     |   |   |
|-------------------------------------|---|---|
| 1. Cylinder head RH bank            | 2. Camshaft bracket (No. 2, 3, 4, 5)      | 3. Valve lifter                           |
| 4. Camshaft bracket (No. 1)         | 5. Seal washer                            | 6. Camshaft RH bank (EXH)                 |
| 7. Camshaft RH bank (INT)           | 8. Camshaft LH bank (INT)                 | 9. Camshaft LH bank (EXH)                 |
| 10. Camshaft sprocket RH bank (EXH) | 11. Camshaft sprocket RH bank (INT) (VTC) | 12. Camshaft sprocket LH bank (INT) (VTC) |
| 13. Camshaft sprocket LH bank (EXH) | 14. Camshaft position sensor (PHASE)      | 15. O-ring                                |
| 16. Cylinder head LH bank           |   |   |

### REMOVAL

1. Remove the RH bank and LH bank rocker covers. Refer to [EM-35, "REMOVAL"](#).
2. Obtain compression TDC of No. 1 cylinder. Refer to [EM-37, "TIMING CHAIN"](#).
3. Remove the RH bank and LH bank timing chain case cover. Refer to [EM-38, "REMOVAL"](#).

# CAMSHAFT

4. Paint alignment marks on the RH bank (A) timing chain links (C) LH (B) timing chain links (D) and aligning with the camshaft sprocket alignment marks (E) and (F).

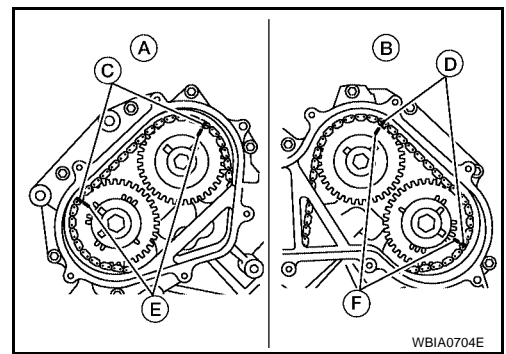

5. Remove the LH bank timing chain tensioner using the following steps.

**WARNING:**

**Plunger, spring, and spring seat pop out when squeezing return-proof clip without holding plunger head. It may cause serious injuries. Always hold plunger head when removing.**

- Squeeze return-proof clip ends using suitable tool and push the plunger into the tensioner body.
- Secure plunger using stopper pin.
  - Stopper pin is made from hard wire approximately 1 mm (0.04 in) in diameter.
- Remove the bolts and the timing chain tensioner.

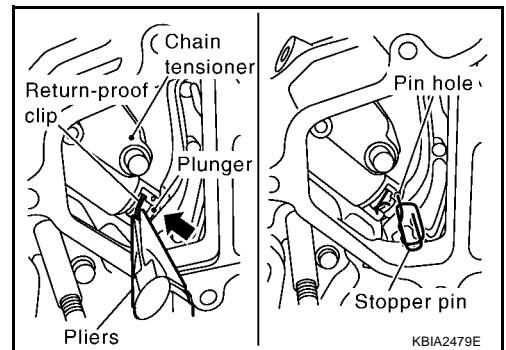

**NOTE:**

- Stop plunger in the fully extended position using return-proof clip 1 if stopper pin is removed.
- Push the plunger 2 into the tensioner body while squeezing the return-proof clip 1. Secure it using stopper pin 3.

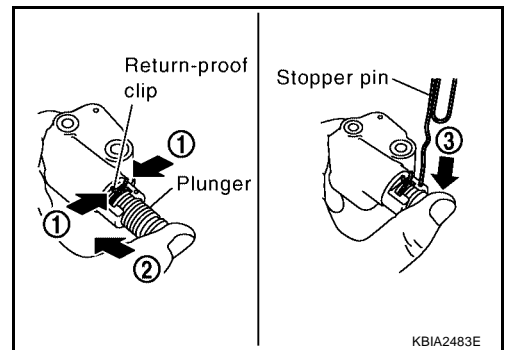

6. Remove the RH bank timing chain tensioner cover from the front cover using Tool.

**Tool number : KV10111100 (J-37228)**

**CAUTION:**

**Do not damage mating surfaces.**

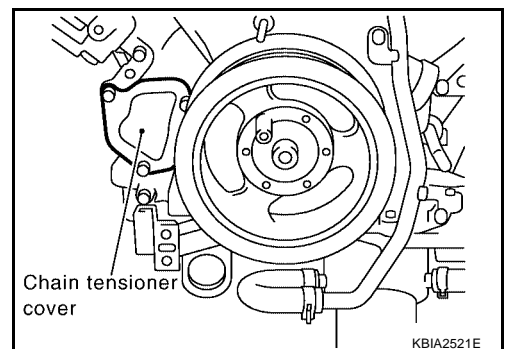

7. Remove the RH bank timing chain tensioner using the following steps.

**WARNING:**

**Plunger, spring, and spring seat pop out when squeezing return-proof clip without holding plunger head. It may cause serious injuries. Always hold plunger head when removing.**

# CAMSHAFT

- a. Squeeze return-proof clip ends using suitable tool and push the plunger into the tensioner body.
- b. Secure plunger using stopper pin.
  - Stopper pin is made from hard wire approximately 1 mm (0.04 in) in diameter.

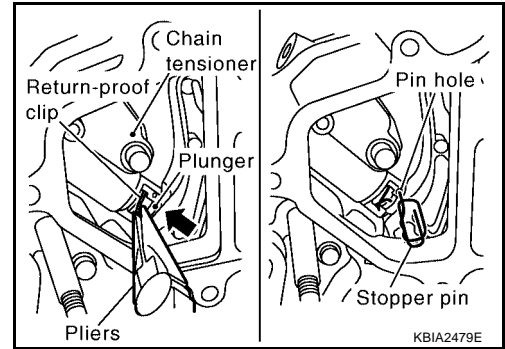

- c. Remove the bolts and the RH bank timing chain tensioner (A).

**NOTE:**

If it is difficult to push plunger on RH bank timing chain tensioner (A), remove the plunger under extended condition.

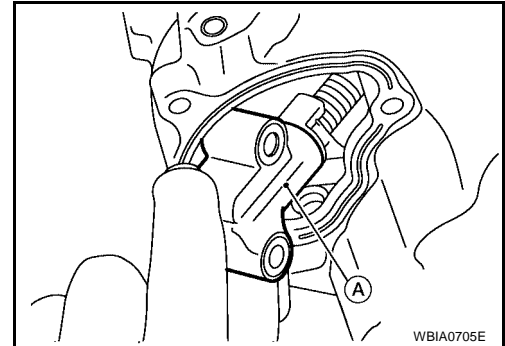

8. Loosen camshaft sprocket bolts as shown and remove camshaft sprockets.

**CAUTION:**

To avoid interference between valves and pistons, do not turn crankshaft or camshaft with timing chain disconnected.

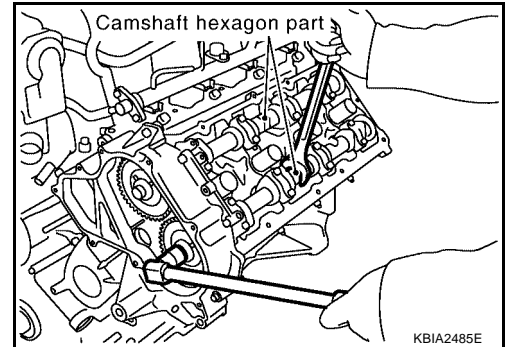

9. Remove the RH front cover bolts (A) and LH front cover bolts (B).

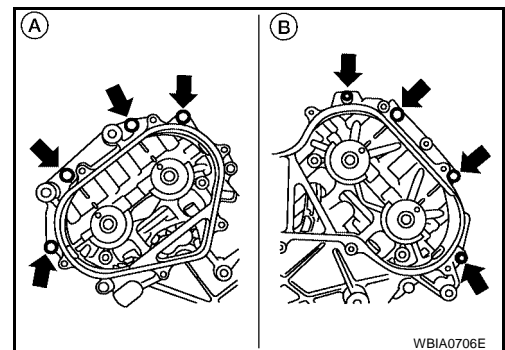



# CAMSHAFT

10. Remove RH (A) camshaft bracket bolts and LH (C) camshaft bracket bolts in the reverse of order shown to remove camshaft brackets.

- Remove No. 1 camshaft bracket.

**NOTE:**

The bottom and front surface of bracket will be stuck because of liquid gasket.

- ←: Engine front
- B: Exhaust
- D: Intake

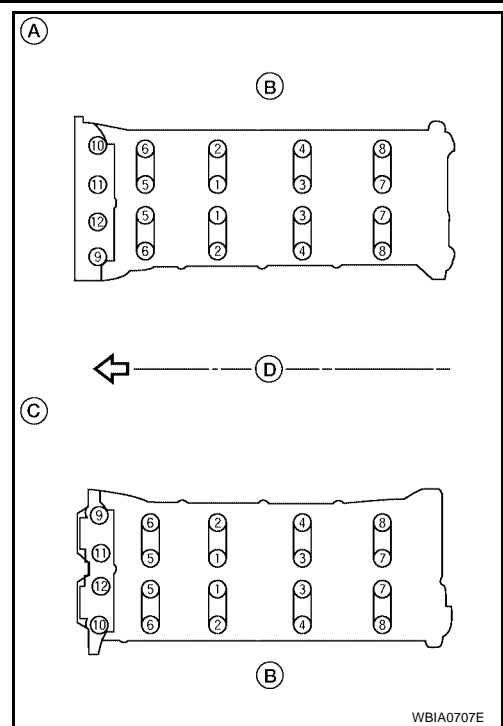

11. Remove the camshaft.

12. Remove the valve lifters if necessary.

- Correctly identify location where each part is removed from. Keep parts organized to avoid mixing them up.

## INSPECTION AFTER REMOVAL

### Camshaft Runout

1. Put V block on precise flat work bench, and support No. 1 and No. 5 journals of the camshaft.
2. Set dial indicator vertically to No. 3 journal.
3. Turn the camshaft to one direction, and measure the camshaft runout on dial indicator (total indicator reading).

**Camshaft runout : Less than 0.02 mm (0.0008 in)**

- If measurement exceeds specification, replace the camshaft.

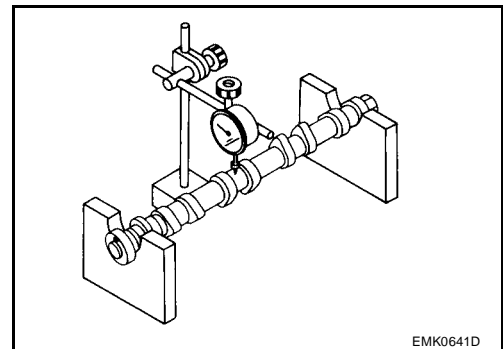

### Camshaft Cam Height

- Measure the camshaft cam height.

**Standard cam height (intake) : 44.865 - 45.055 mm (1.7663 - 1.7738 in)**

**Standard cam height (exhaust) : 45.075 - 45.265 mm (1.7746 - 1.7821 in)**

**Cam wear limit (intake & exhaust) : 0.02 mm (0.0008 in)**

- If measurement is not within the specifications, replace the camshaft.

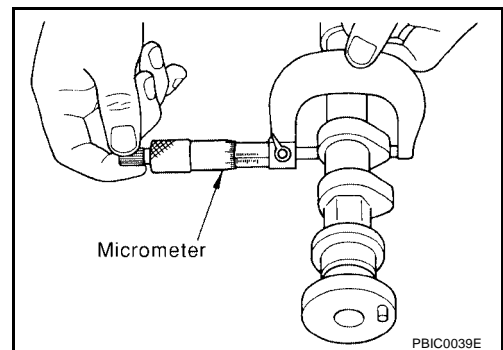

# CAMSHAFT

## Camshaft Journal Clearance

### Camshaft Journal Diameter

- Measure the diameter of the camshaft journal.

**Standard diameter : 25.950 - 25.970 mm  
(1.0217 - 1.0224 in)**

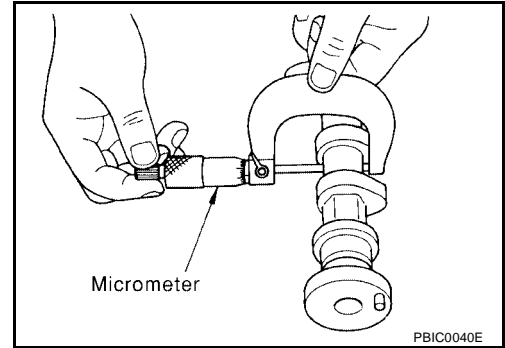

### Camshaft Bracket Inner Diameter

- Tighten the camshaft bracket bolt to the specified torque.
- Measure the inner diameter of the camshaft bracket.

**Standard : 26.000 - 26.021 mm (1.0236 - 1.0244 in)**

### Calculation of Camshaft Journal Clearance

(Journal clearance) = (camshaft bracket inner diameter) – (camshaft journal diameter)

**Standard : 0.030 - 0.071 mm (0.0012 - 0.0028 in)**

- If measurement is not within specification, replace either or both camshaft and cylinder head.

#### NOTE:

The inner diameter of the camshaft bracket is manufactured together with the cylinder head. Replace the whole cylinder head as an assembly.

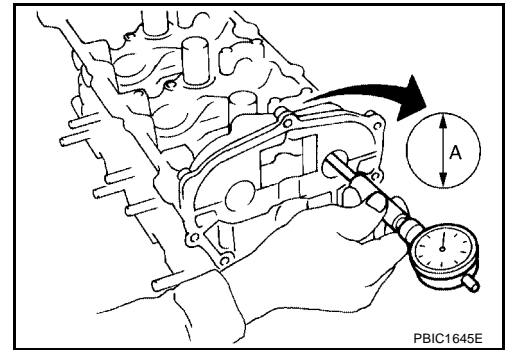

### Camshaft End Play

- Install dial gauge in the thrust direction on the front end of the camshaft. Measure the end play when the camshaft is moved forward/backward (in direction to axis).

**Standard : 0.115 - 0.188 mm (0.0045 - 0.0074 in)**

- If measurement is out of the specified range, replace the camshaft and measure again.
- If measurement is still out of the specified range, replace the cylinder head.

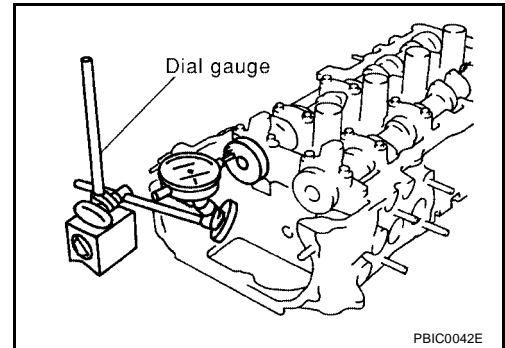

- Measure the following parts if end play is outside the specified value.

- Dimension "A" for camshaft No. 1 journal

**Standard : 30.500 - 30.548 mm (1.2008-1.2027 in)**

- Dimension "B" for cylinder head No. 1 journal

**Standard : 30.360 - 30.385 mm (1.1953-1.1963 in)**

- If measurements are not within specification, replace the camshaft and/or cylinder head.

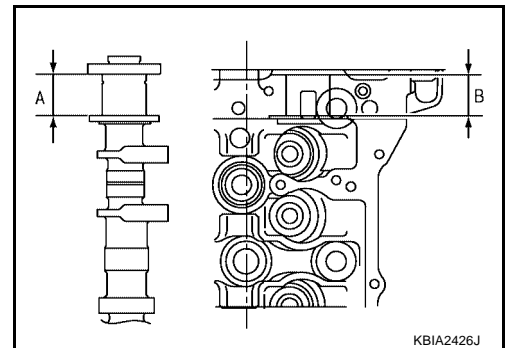

# CAMSHAFT

## Camshaft Sprocket Runout

1. Install the camshaft in the cylinder head.
2. Install the camshaft sprocket to the camshaft.
3. Measure the camshaft sprocket runout.

**Runout : Less than 0.15 mm (0.0059 in)**

- If measurement exceeds the specification, replace the camshaft sprocket.

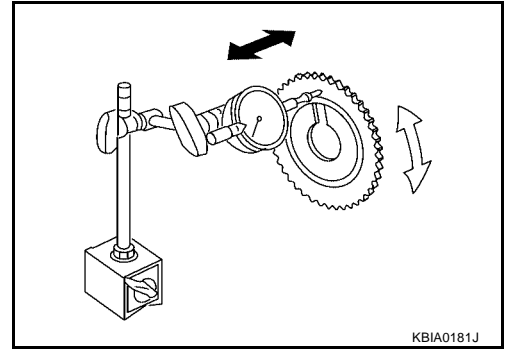

## Valve Lifter

Check if the surface of the valve lifter has any wear or cracks.

- If any damage is found, replace the valve lifter.
- Select the thickness of the head so that the valve clearance is within the standard when replacing. Refer to [EM-71, "Valve Guide Clearance"](#).

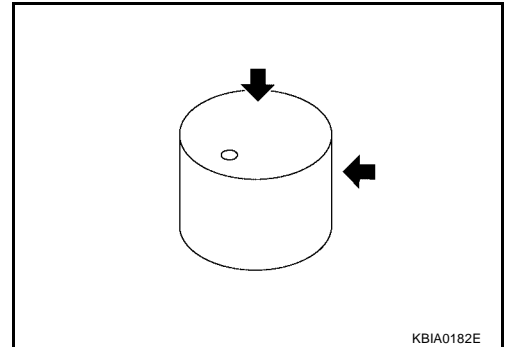

## Valve Lifter Clearance

### Valve Lifter Diameter

- Measure the diameter of the valve lifter.  
**Standard : 33.977 - 33.987 mm (1.3377 - 1.3381 in)**

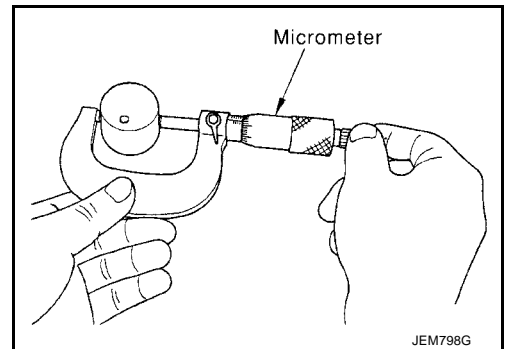

### Valve Lifter Hole Diameter

- Measure the diameter of the valve lifter hole of the cylinder head, using suitable tool.

**Standard : 34.000 - 34.016 mm (1.3386 - 1.3392 in)**

### Calculation of Valve Lifter Clearance

(Valve lifter clearance) = (valve lifter hole diameter) – (valve lifter diameter)

**Standard : 0.013 - 0.039 mm (0.0005 - 0.0015 in)**

- If the measurement is not within specification, referring to each specification of the valve lifter diameter and hole diameter, replace either or both the valve lifter and cylinder head.

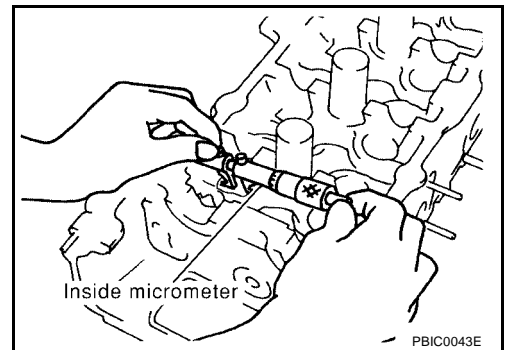

## INSTALLATION

1. Install the valve lifters if removed.
  - Install removed parts in their original locations.

# CAMSHAFT

2. Install the camshafts. Refer to the table below for identification of the RH and LH, and intake and exhaust.

Bank	INT EXH	Identification paint (front)	Identification paint (rear)	Identification rib
RH	INT	Pink	—	Yes
	EXH	—	Orange	Yes
LH	INT	Pink	—	No
	EXH	—	Orange	No

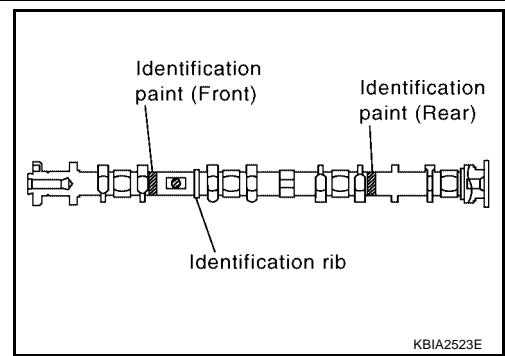

- Install so that the RH bank (B) dowel pins (A) and LH bank (C) dowel pins (A) at the front of the camshaft face are in the direction shown.

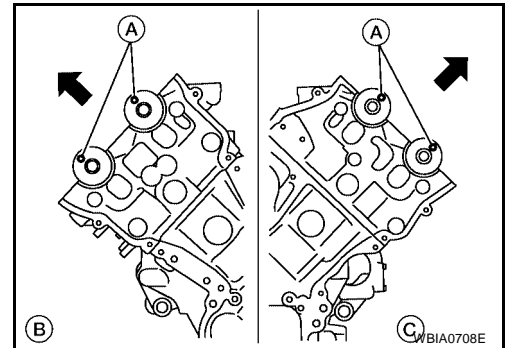

3. Install the RH bank (B) and LH bank (D) camshaft brackets.

- Install by referring to the installation location mark (E) on the upper surface.
- Install so that the installation location mark (E) can be correctly read when viewed from the intake manifold side.

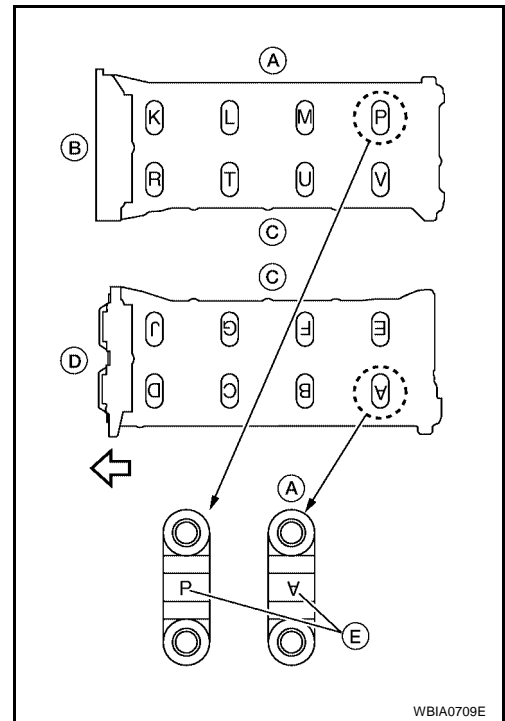

- Install No. 1 camshaft bracket using the following procedure:
- a: 11 mm (0.43 in)
- b: 2.0 - 3.0 mm (0.079 - 0.118 in) dia.

# CAMSHAFT

- Apply liquid gasket to No. 1 camshaft bracket as shown. Use **Genuine RTV Silicone Sealant or equivalent**. Refer to [GI-47, "Recommended Chemical Products and Sealants"](#).

**CAUTION:**

- After installation, be sure to wipe off any excessive liquid gasket leaking from part (C) and (D) both on RH and LH sides.
- Remove completely any excess of liquid gasket inside bracket.

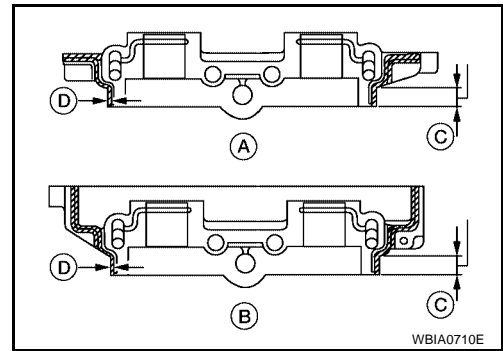

- a: 2.6 - 3.6 mm (0.102 - 0.142 in) dia.

- Apply liquid gasket (C) to the back side of the LH (A) bank front cover and RH (B) bank front cover as shown. Use **Genuine RTV Silicone Sealant or equivalent**. Refer to [GI-47, "Recommended Chemical Products and Sealants"](#).

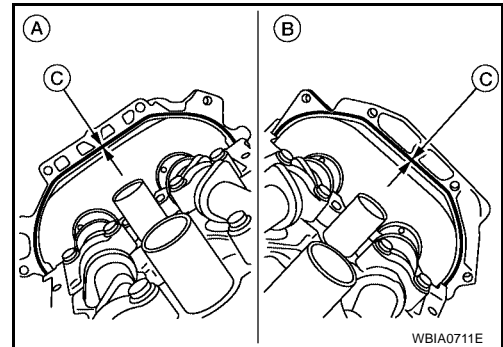

- Position No. 1 camshaft bracket close to the mounting position, and then install it to prevent from touching liquid gasket applied to each surface.

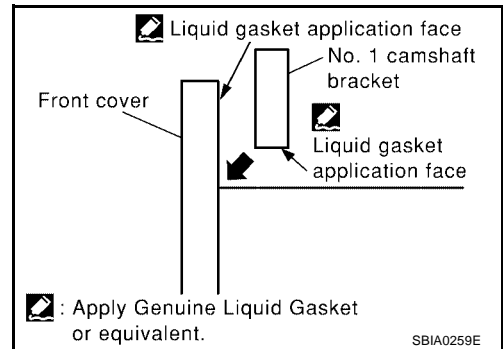

- Temporarily tighten the front cover bolts (4 for each bank) as shown.

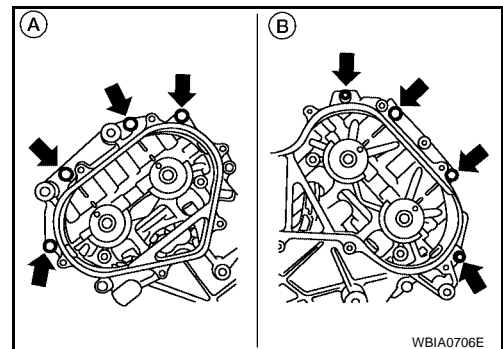

# CAMSHAFT

4. Tighten the camshaft bracket bolts as follows:

**Camshaft bracket bolts**

**Step 1 (bolts 9 - 12) : 2.0 N·m (0.2 kg-m, 17 in-lb)**

**Step 2 (bolts 1 - 8) : 2.0 N·m (0.2 kg-m, 17 in-lb)**

**Step 3 (all bolts) : 5.9 N·m (0.6 kg-m, 52 in-lb)**

**Step 4 (all bolts) : 10.4 N·m (1.1 kg-m, 92 in-lb)**

**CAUTION:**

After tightening the camshaft bracket bolts, be sure to wipe off excessive liquid gasket from the parts listed below.

- Mating surface of rocker cover
- Mating surface of front cover

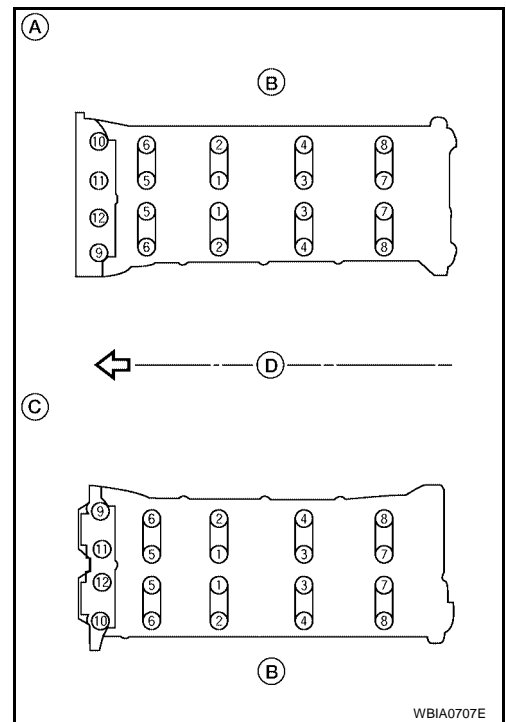

WBIA0707E

a. Tighten the front cover bolts (4 for each bank) as shown to the specified torque.

**Front cover bolts : 11.0 N·m (1.1 kg-m, 8 ft-lb)**

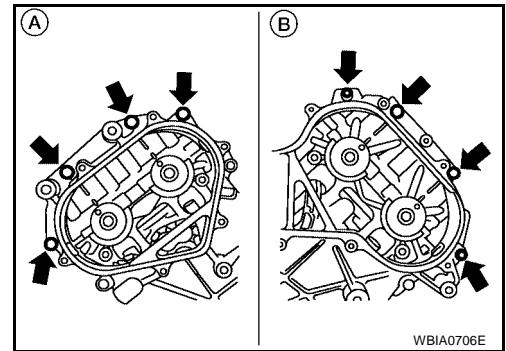

WBIA0706E

5. Install the camshaft sprockets using the following procedure:

- A: LH bank shown

a. Install the camshaft sprockets aligning them with the matching marks painted (B) on the timing chain (C) when removed. Align the camshaft sprocket key groove with the dowel pin on the camshaft front edge at the same time. Then temporarily tighten camshaft sprocket bolts.

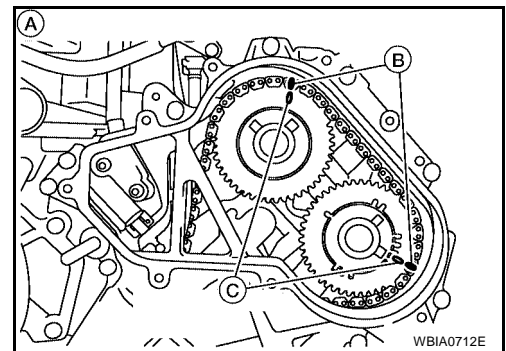

WBIA0712E

# CAMSHAFT

- Install the intake and exhaust side camshaft sprockets by selectively using the groove of the dowel pin according to the bank. (Common part used for both banks.)
  - B: Exhaust (V)
  - R: for RH bank
  - L: for LH bank
- b. Lock the hexagonal part of the camshaft in the same way as for removal, and tighten the camshaft sprocket bolts.
  - c. Check again that the timing alignment mark on the timing chain and on each sprocket are aligned.

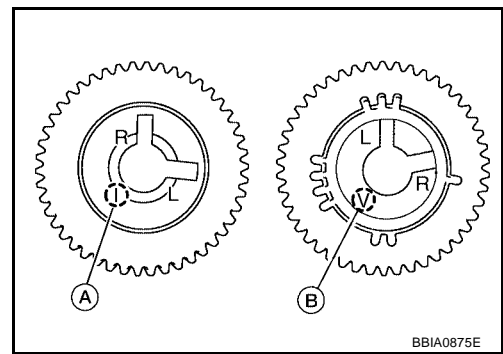

6. Install the chain tensioner using the following procedure:

**NOTE:**

LH is shown.

- a. Install the chain tensioner.
  - Compress the plunger and hold it using a stopper pin when installing.
  - Loosen the slack guide side timing chain by rotating the camshaft hexagonal part if mounting space is small.

**Chain tensioner bolts : 6.9 N·m (0.70 kg·m, 61 in·lb)**

- b. Remove the stopper pin and release the plunger, and then apply tension to the timing chain.
- c. Install the RH bank timing chain tensioner cover onto the front cover.

- Apply liquid gasket as shown.

**Use Genuine RTV Silicone Sealant or equivalent. Refer to [GI-47, "Recommended Chemical Products and Sealants"](#).**

**Tensioner cover bolts : 9.0 N·m (0.92 kg·m, 80 in·lb)**

7. Check and adjust valve clearances. Refer to [EM-107, "Valve Clearance"](#).
8. Installation of the remaining components is in the reverse order of removal.

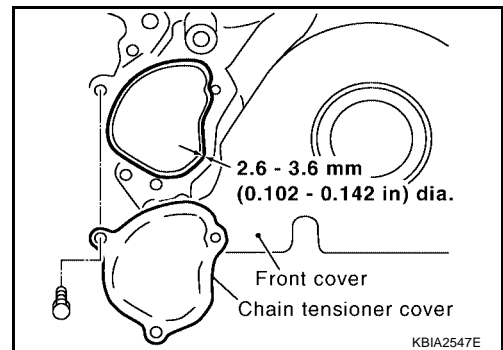
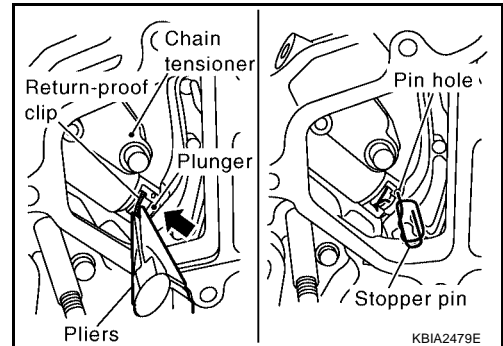

## Inspection after Installation

### INSPECTION OF CAMSHAFT SPROCKET (INT) OIL GROOVE

**CAUTION:**

- Perform this inspection only when DTC P0011 is detected in self-diagnostic results of CONSULT II and it is directed according to inspection procedure of EC section. Refer to.
  - Check when engine is cold so as to prevent burns from any splashing engine oil.
1. Check engine oil level. Refer to [LU-8, "OIL LEVEL"](#).
  2. Perform the following procedure so as to prevent the engine from being unintentionally started while checking.
    - a. Release fuel pressure. Refer to [EC-87, "FUEL PRESSURE RELEASE"](#).
    - b. Disconnect ignition coil and injector harness connectors if practical.
    3. Remove IVT control solenoid valve.
    4. Crank engine, and then make sure that engine oil comes out from IVT control cover oil hole. End cranking after checking.

**WARNING:**

**Be careful not to touch rotating parts (drive belts, idler pulley, and crankshaft pulley, etc.).**

**CAUTION:**

- Engine oil may squirt from IVT control solenoid valve installation hole during cranking. Use a shop cloth to prevent engine oil from splashing on worker, engine components and vehicle.

# CAMSHAFT

- Do not allow engine oil to get on rubber components such as drive belts or engine mount insulators. Immediately wipe off any splashed engine oil.
5. Clean oil groove between oil strainer and IVT control solenoid valve if engine oil does not come out from IVT control valve cover oil hole. Refer to [LU-7, "System Drawing"](#).
  6. Remove components between IVT control solenoid valve and camshaft sprocket (INT), and then check each oil groove for clogging.
    - Clean oil groove if necessary.
  7. After inspection, installation of the remaining components is in the reverse order of removal.

## Valve Clearance INSPECTION

EBS00U95

### NOTE:

Perform the following inspection after removal, installation or replacement of camshaft or valve-related parts, or if there are unusual engine conditions due to changes in valve clearance over time (starting, idling, and/or noise).

1. Warm up the engine. Then stop the engine.
2. Remove the engine cover and. Refer to [EM-12, "REMOVAL"](#).
3. Remove the battery cover [SC-9, "REMOVAL"](#).
4. Remove the air cleaner and air duct assembly [EM-15, "REMOVAL"](#).
5. Remove the RH bank and LH bank rocker covers using power tool. Refer to [EM-35, "REMOVAL"](#).
6. Turn the crankshaft pulley in the normal direction (clockwise when viewed from engine front) to align TDC identification notch (without paint mark) with timing indicator.

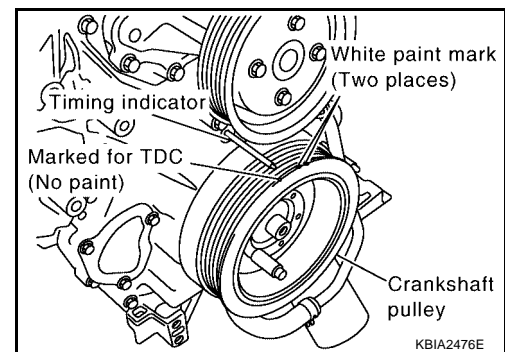

7. At this time, make sure both the intake and exhaust cam noses of No. 1 cylinder (top front on LH bank) face outside.
  - If they do not face outside, turn crankshaft pulley once more.

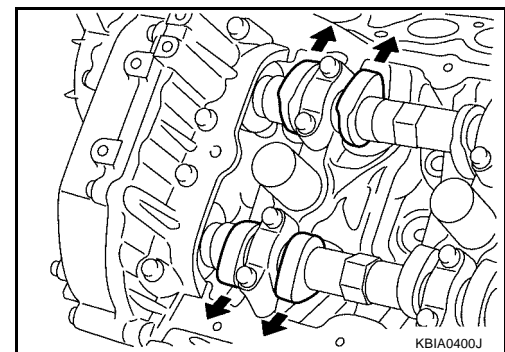



# CAMSHAFT

8. Measure valve clearances at the locations marked "x" as shown in the table below (locations indicated with black arrow).

- ←: Engine front
- ← (black): Measurable at No.1 cylinder compression top dead center
- ← (white): Measurable at No. 3 cylinder compression top dead center
- A: RH
- B: LH
- C: Exhaust
- D: Intake

**NOTE:**

Firing order 1-8-7-3-6-5-4-2

- No. 1 cylinder compression TDC

Measuring position (RH bank)		No. 2 cyl (E)	No. 4 cyl (F)	No. 6 cyl (G)	No. 8 cyl (H)
No. 1 cylinder at TDC	EXH				x
	INT	x	x		
Measuring position (LH bank)		No. 1 cyl (J)	No. 3 cyl (K)	No. 5 cyl (L)	No. 7 cyl (M)
No. 1 cylinder at TDC	INT	x		x	
	EXH	x			x

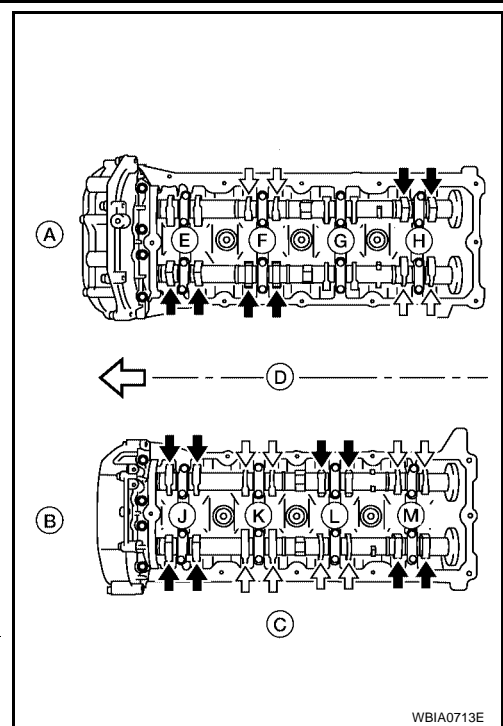

- Measure valve clearance using suitable tool. Refer to [EM-56](#), "[INSPECTION](#)".

**CAUTION:**

If the inspection was carried out with a cold engine, make sure the values with a fully warmed up engine are still within specifications.

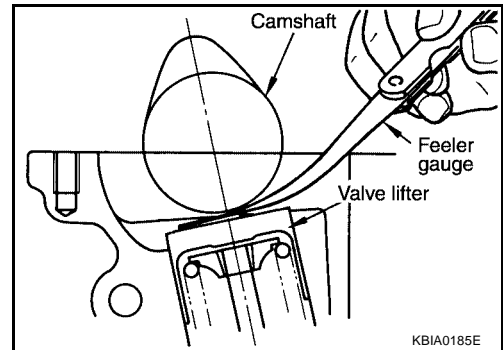

9. Turn the crankshaft pulley clockwise 270° from the position of No. 1 cylinder compression TDC to obtain No. 3 cylinder compression TDC.

# CAMSHAFT

10. Measure valve clearances at the locations marked "x" as shown in the table below (locations indicated with white arrow).

- ⇐: Engine front
- ⇐ (black): Measurable at No.1 cylinder compression top dead center
- ⇐ (white): Measurable at No. 3 cylinder compression top dead center
- A: RH
- B: LH
- C: Exhaust
- D: Intake

**NOTE:**

Firing order 1-8-7-2-3-6-5-4-2

- No. 3 cylinder compression TDC

Measuring position (RH bank)		No. 2 cyl (E)	No. 4 cyl (F)	No. 6 cyl (G)	No. 8 cyl (H)
No. 3 cylinder at TDC	EXH		x		
	INT				x
Measuring position (LH bank)		No. 1 cyl (J)	No. 3 cyl (K)	No. 5 cyl (L)	No. 7 cyl (M)
No. 3 cylinder at TDC	INT		x		x
	EXH		x	x	

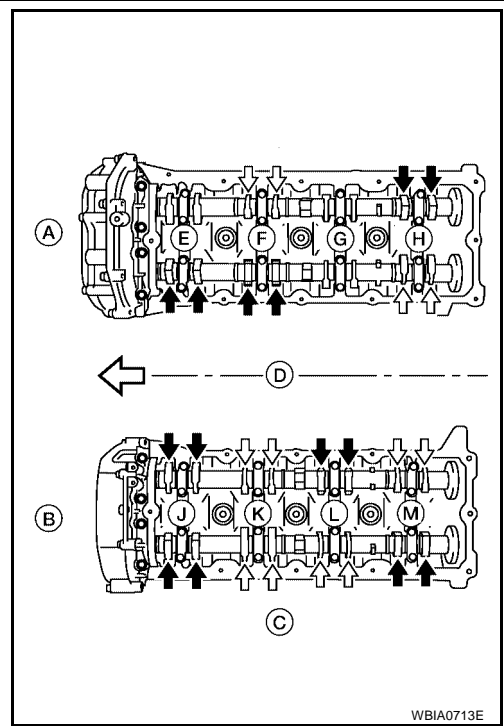

WBIA0713E

- Measure valve clearance using suitable tool. Refer to [EM-56. "INSPECTION"](#).

**CAUTION:**

If the inspection was carried out with a cold engine, make sure the values with a fully warmed up engine are still within specifications.

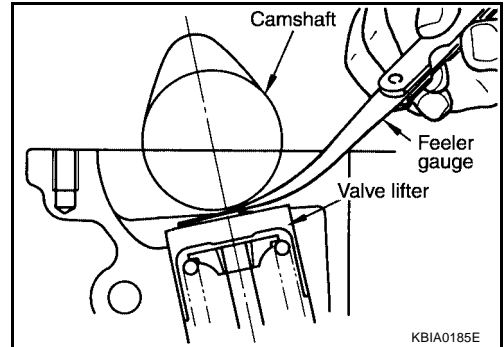

KBIA0185E

# CAMSHAFT

11. Turn the crankshaft pulley clockwise 90° from the position of No. 3 cylinder compression TDC (clockwise by 360° from the position of No. 1 cylinder compression TDC) to measure the intake and exhaust valve clearances of No. 6 cylinder and the exhaust valve clearance of No. 2 cylinder.

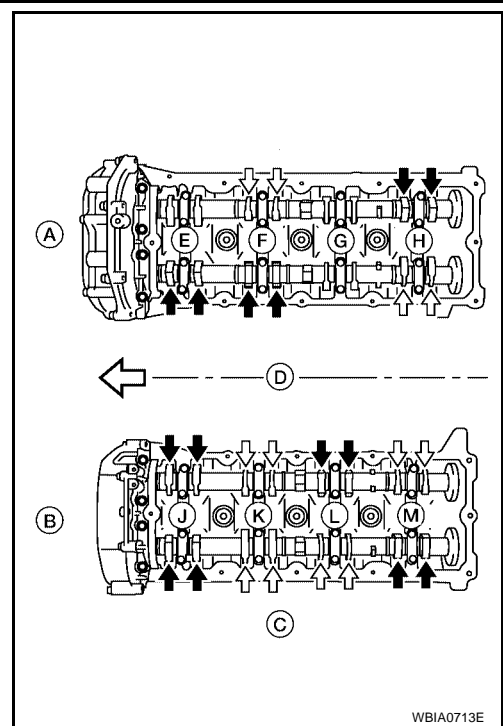

12. If out of specifications, adjust as necessary. Refer to [EM-59, "ADJUSTMENT"](#) .

## ADJUSTMENT

### NOTE:

- Perform adjustment depending on the selected head thickness of the valve lifter.
- The specified valve lifter thickness is the dimension at normal temperatures. Ignore dimensional differences caused by temperature. Use the specifications for hot engine condition to adjust.

1. Remove the camshaft. Refer to [EM-46, "REMOVAL"](#) .
2. Remove the valve lifters at the locations that are out of specification.
3. Measure the center thickness of the removed valve lifters using suitable tool.
4. Use the equation below to calculate the valve lifter thickness for replacement.

- Valve lifter thickness calculation:  
 $\text{Thickness of replacement valve lifter} = t1 + (C1 - C2)$   
 $t1 = \text{Thickness of removed valve lifter}$   
 $C1 = \text{Measured valve clearance}$   
 $C2 = \text{Standard valve clearance}$

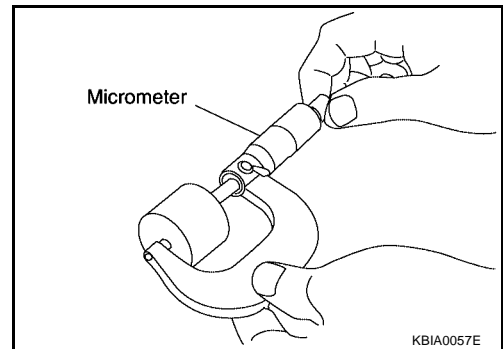

- Thickness of a new valve lifter can be identified by stamp marks on the reverse side (inside the cylinder). Stamp mark N788 indicates 7.88 mm (0.3102 in) in thickness.
- Available thickness of valve lifter: 25 sizes with range 7.88 to 8.36 mm (0.3102 to 0.3291 in) in steps of 0.02 mm (0.0008 in) (when manufactured at factory). Refer to [EM-108, "Available Valve Lifter"](#) .

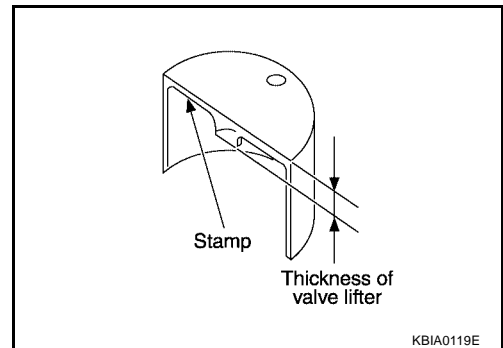

## CAMSHAFT

---

5. Install the selected valve lifter.
6. Install the camshaft.
7. Manually turn the crankshaft pulley a few turns.
8. Make sure the valve clearances for a cold engine are within specifications by referring to the specified values.
9. After completing the repair, check the valve clearances again with the specifications for a warmed engine. Make sure the values are within specifications. Refer to [EM-56, "Valve Clearance"](#) .

## OIL SEAL

### Removal and Installation of Valve Oil Seal

#### REMOVAL

1. Remove the camshaft relating to the valve oil seal to be removed. Refer to [EM-65, "CYLINDER HEAD"](#) .
2. Remove the valve lifters. Refer to [EM-46, "REMOVAL"](#) .
  - Correctly identify the location where each part is removed from. Keep parts organized to avoid mixing them up.
3. Turn the crankshaft until the cylinder requiring new oil seals is at TDC. This will prevent the valve from dropping into the cylinder.
4. Remove the valve collet using Tool.

**Tool number** : KV10116200 (J-26336-A)  
                   : KV10115900 (J-26336-20)  
                   : KV10109220 ( — )

**CAUTION:**  
**Do not damage the valve lifter holes.**

5. Remove the valve spring retainer and valve spring.

**CAUTION:**  
**Do not remove the valve spring seat from the valve spring.**

6. Remove the valve oil seal using Tool.

**Tool number** : KV10107902 (J-38959)

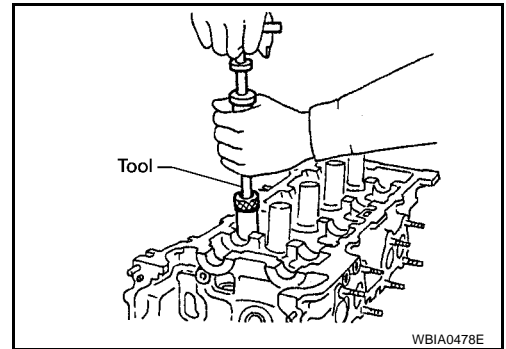
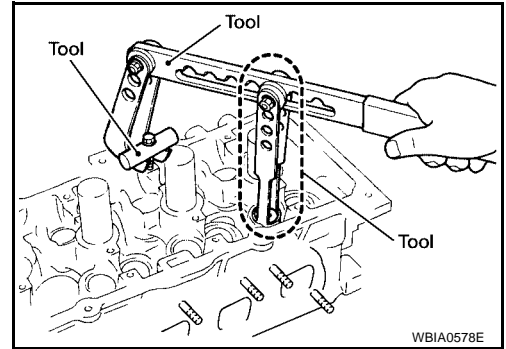

#### INSTALLATION

Installation is in the reverse order of removal.

- Install the valve oil seal using Tool.
- Apply new engine oil on the new valve oil seal joint and seal lip.
- Install the valve oil seal to the specified height "H".

**Height "H" (without valve spring installed)**  
**Intake and exhaust** : 14.3 - 14.9 mm (0.563 - 0.587 in)

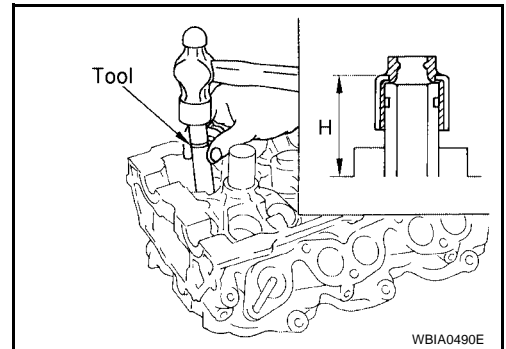

# OIL SEAL

EBS00U97

## Removal and Installation of Front Oil Seal

### REMOVAL

1. Remove the engine. Refer to [EM-76, "REMOVAL"](#) .
2. Remove the crankshaft pulley. Refer to [EM-38, "REMOVAL"](#) .
3. Remove the front oil seal using suitable tool.

**CAUTION:**

Do not damage front cover and oil pump drive spacer.

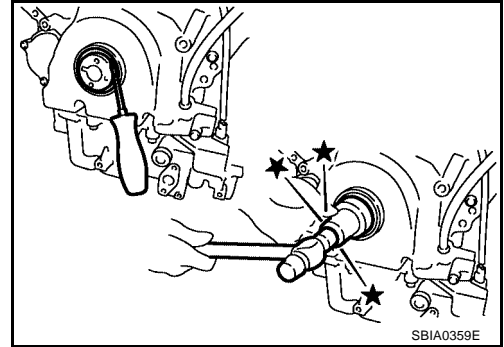

### INSTALLATION

1. Apply new engine oil to both the oil seal lip and dust seal lip of the new front oil seal.
2. Install the front oil seal.

- Install the front oil seal so that each seal lip is oriented as shown.

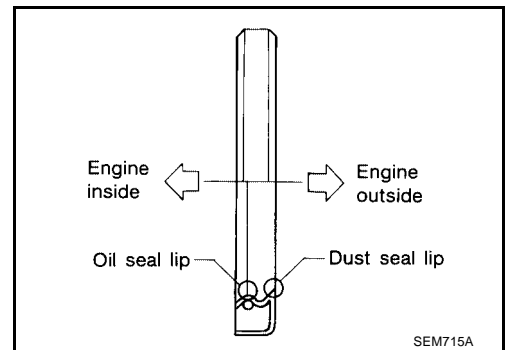

- Press-fit until the height of the front oil seal is level with the mounting surface using suitable tool.

**CAUTION:**

- Do not damage front timing chain case and crankshaft.
- Press-fit straight and avoid causing burrs or tilting oil seal.

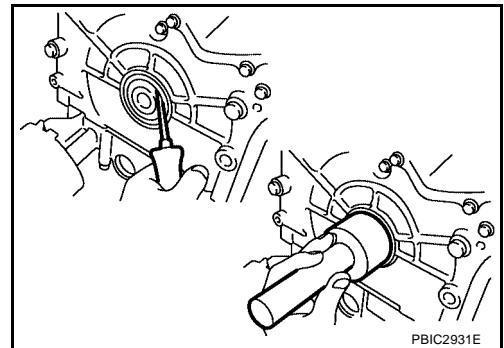

3. Installation of the remaining components is in the reverse order of removal.

# OIL SEAL

EBS00U98

## Removal and Installation of Rear Oil Seal

### REMOVAL

1. Remove the transmission assembly. Refer to [AT-238, "Removal and Installation \(2WD\)"](#) or [AT-241, "Removal and Installation \(4WD\)"](#).
2. Lock the drive plate using Tool A.

**Tool number** : — (J-47245)

#### **CAUTION:**

Do not damage the drive plate. Especially, avoid deforming and damaging the signal plate teeth (circumference position).

Keep magnetic materials away from signal plate.

#### **NOTE:**

Remove the bolts diagonally.

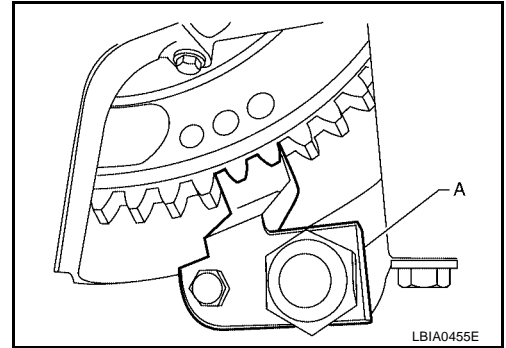

3. Remove the drive plate.

#### **CAUTION:**

Place the drive plate with the signal plate surface facing upward.

4. Remove the engine rear plate.
5. Remove the rear oil seal using suitable tool.

#### **CAUTION:**

Do not damage crankshaft or oil seal retainer surface.

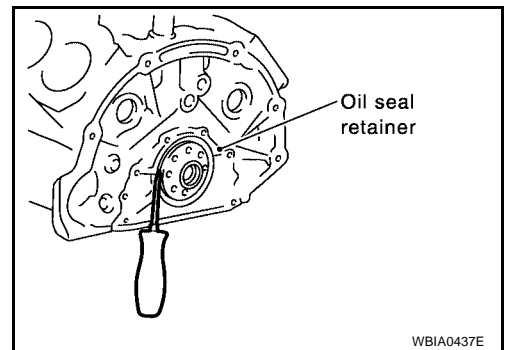

### INSTALLATION

1. Apply new engine oil to both the oil seal lip and dust seal lip of the new rear oil seal.
2. Install the rear oil seal.
  - Install the rear oil seal so that each seal lip is oriented as shown.

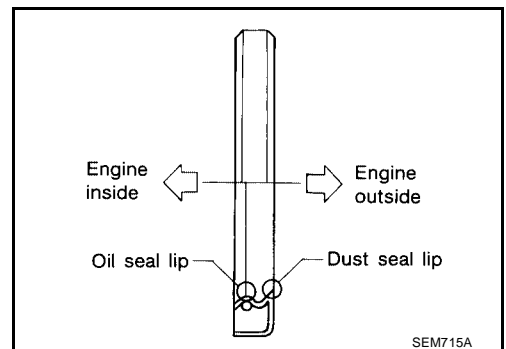

## OIL SEAL

- Press-fit the rear oil seal using suitable tool.

**CAUTION:**

- Do not damage the crankshaft or cylinder block.
- Press-fit the oil seal straight to avoid causing burrs or tilting.
- Do not touch grease applied onto the oil seal lip.
- Do not damage or scratch the outer circumference of the rear oil seal.
- Tap until flattened with the front edge of the oil seal retainer.

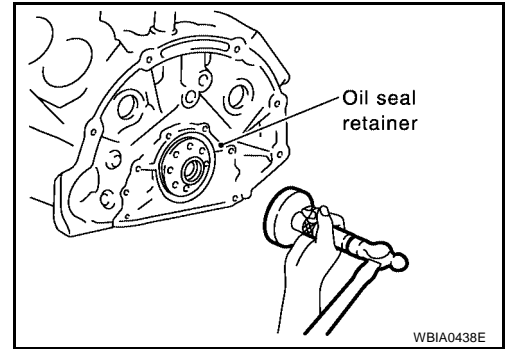

3. Installation of the remaining components is in the reverse order of removal.



# CYLINDER HEAD

PF11041

EBS00U99

## CYLINDER HEAD

### On-Vehicle Service

#### CHECKING COMPRESSION PRESSURE

1. Warm up the engine thoroughly. Then stop the engine.
2. Release the fuel pressure. Refer to [EC-87, "FUEL PRESSURE RELEASE"](#).

**CAUTION:**

If CONSULT-II is not used to release fuel pressure leave the fuel pump fuse disconnected until step 7.

3. Remove the spark plug from each cylinder. Refer to [EM-29, "REMOVAL"](#).
4. Connect the engine tachometer (not required in use of CONSULT-II).
5. Install the compression tester with Tool into the spark plug hole.

**Tool number : EG15050500 (J-45402)**

6. With the accelerator pedal fully depressed, turn the ignition switch to "START" for cranking. When the gauge pointer stabilizes, read the compression pressure and engine rpm. Perform these steps to check each cylinder.

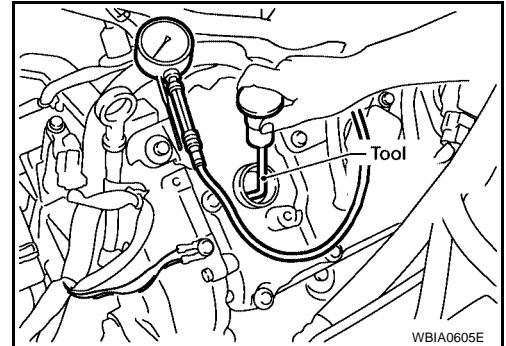

Unit: kPa (kg/cm<sup>2</sup>, psi) /rpm

Standard	Minimum	Deference limit between cylinders
1,520 (15.5, 220) / 200	1,324 (13.5, 192) / 200	98 (1.0, 14) / 200

**CAUTION:**

Always use a fully charged battery to obtain specified engine speed.

- If the engine speed is out of the specified range, check the battery liquid for proper gravity. Check the engine speed again with normal battery gravity.
  - If the compression pressure is below the minimum value, check the valve clearances and parts associated with the combustion chamber (valve, valve seat, piston, piston ring, cylinder bore, cylinder head, cylinder head gasket). After checking, measure the compression pressure again.
  - If some cylinders have low compression pressure, pour a small amount of engine oil into the spark plug hole of the cylinder to re-check it for compression.
    - If the added engine oil improves the compression, the piston rings may be worn out or damaged. Check the piston rings and replace if necessary.
    - If the compression pressure remains at a low level despite the addition of engine oil, the valves may be malfunctioning. Check the valves for damage. Replace the valve or valve seat accordingly.
  - If two adjacent cylinders have respectively low compression pressure and their compression remains low even after the addition of engine oil, the gaskets may be leaking, or a valve in adjacent cylinders may be damaged. Inspect and repair as required.
7. Install the components in the reverse order of removal.
  8. Start the engine and confirm that it runs smoothly.
  9. Perform trouble diagnosis. If DTC appears, erase it. Refer to [EC-31, "CAN COMMUNICATION"](#).

# CYLINDER HEAD

EBS00U9A

## Removal and Installation

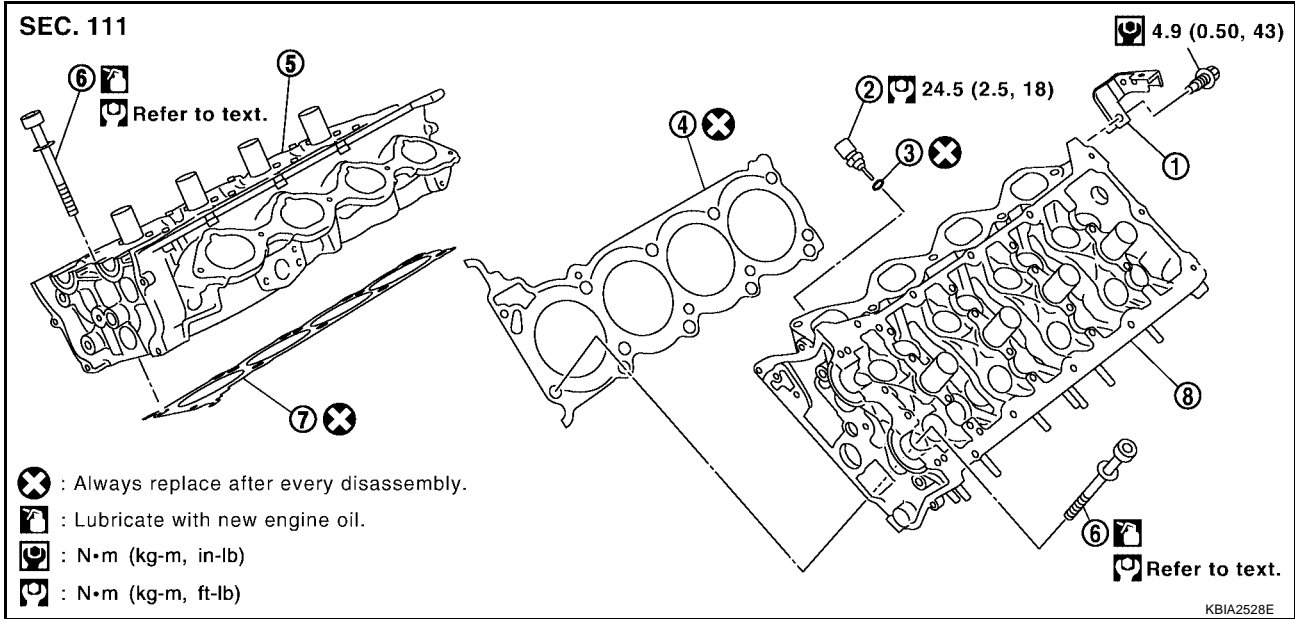

- |                              |                                      |                       |
|------------------------------|--------------------------------------|-----------------------|
| 1. Harness bracket           | 2. Engine coolant temperature sensor | 3. Washer             |
| 4. Cylinder head gasket (LH) | 5. Cylinder head (RH)                | 6. Cylinder head bolt |
| 7. Cylinder head gasket (RH) | 8. Cylinder head (LH)                |                       |

### REMOVAL

- Remove the engine assembly from the vehicle. Refer to [EM-76, "REMOVAL"](#).
- Remove the following components and related parts:
  - Drive belt auto tensioner drive belts and idler pulley. Refer to [EM-13, "REMOVAL"](#)
  - Thermostat housing and hose. Refer to [CO-21, "REMOVAL"](#).
  - Oil pan and oil strainer. Refer to [EM-24, "REMOVAL"](#).
  - Fuel tube and fuel injector assembly. Refer to [EM-31, "REMOVAL"](#).
  - Intake manifold. Refer to [EM-17, "REMOVAL"](#).
  - Rocker cover. Refer to [EM-35, "REMOVAL"](#).
- Remove the crankshaft pulley, front cover, oil pump, and timing chain. Refer to [EM-38, "REMOVAL"](#).
- Remove the camshaft sprockets and camshafts. Refer to [EM-46, "REMOVAL"](#).
- Remove the cylinder head bolts in reverse of order shown.

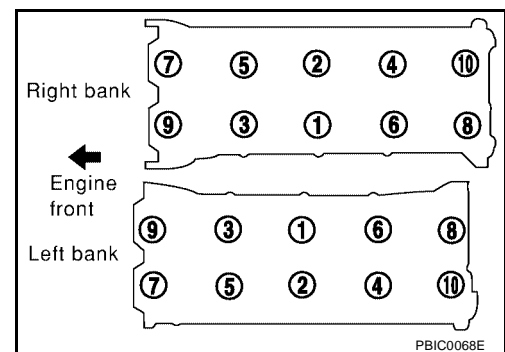

# CYLINDER HEAD

## INSPECTION AFTER REMOVAL

### Cylinder Head Bolts Diameter

- Cylinder head bolts are tightened by plastic zone tightening method. Whenever the size difference between d1 and d2 exceeds the limit, replace the bolt with a new one.

**Limit (d1 - d2) : 0.18 mm (0.0071 in)**

- If reduction of diameter appears in a position other than d2, use it as d2 point.

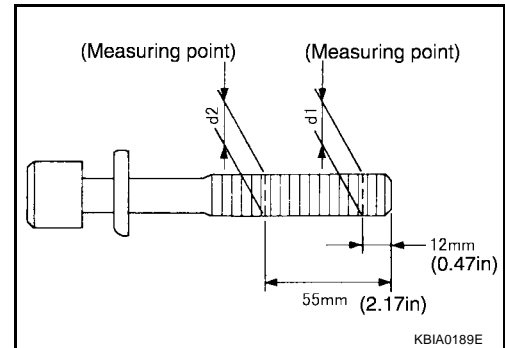

## INSTALLATION

1. Install a new cylinder head gasket.
2. Install the cylinder head. Follow the steps below to tighten the bolts in the numerical order shown.

### CAUTION:

- If cylinder head bolts are re-used, check their diameters before installation. Refer to [EM-67, "Cylinder Head Bolts Diameter"](#).

- a. Apply engine oil to threads and seating surface of the bolts.

**Step a : 98.1 N-m (10 kg-m, 72 ft-lb)**

**Step b : Loosen in the reverse order of tightening.**

**Step c : 44.1 N-m (4.5 kg-m, 33 ft-lb)**

- b. Measure the tightening angle using Tool.

**Tool number : KV10112100 (BT-8653-A)**

### CAUTION:

Measure the tightening angle using Tool. Do not measure visually.

**Step d : 60° clockwise**

**Step e : 60° clockwise**

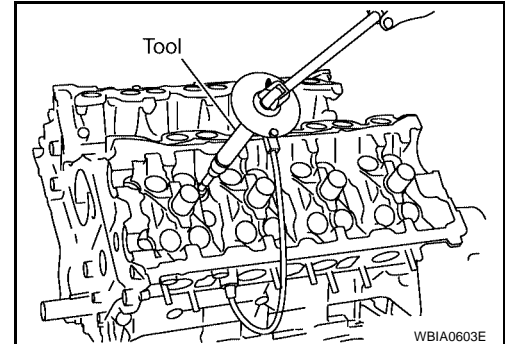
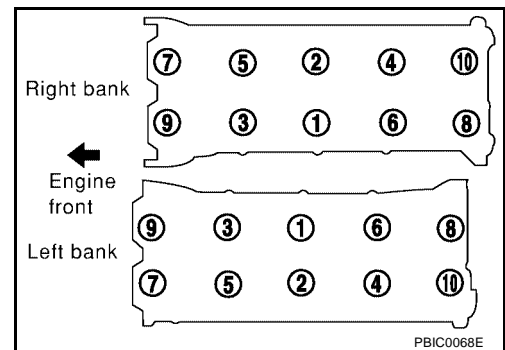

3. Installation of the remaining components is in the reverse order of removal.

# CYLINDER HEAD

## Disassembly and Assembly

EBS00U9B

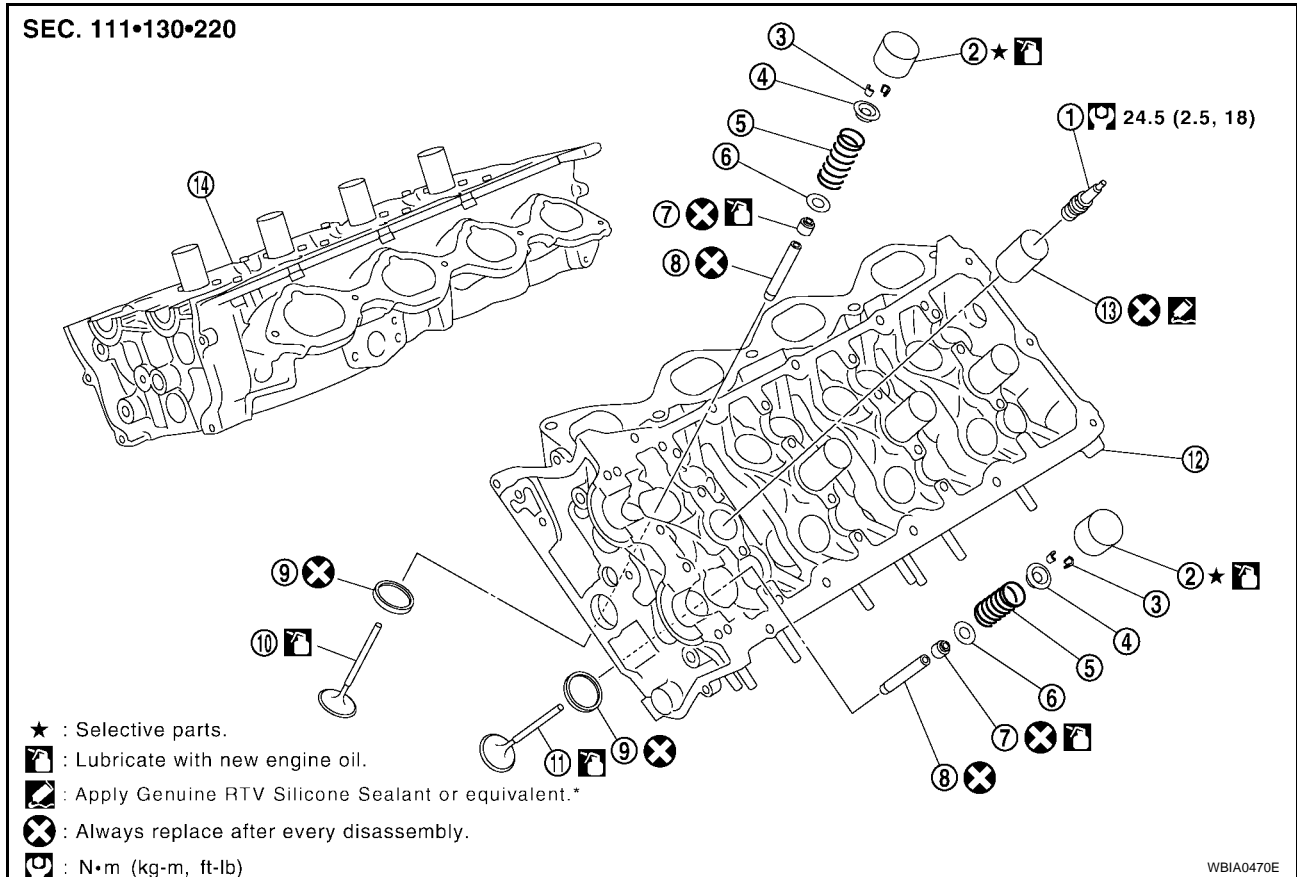

- |                          |                             |                             |
|--------------------------|-----------------------------|-----------------------------|
| 1. Spark plug            | 2. Valve lifter             | 3. Valve collet             |
| 4. Valve spring retainer | 5. Valve spring             | 6. Valve spring seat        |
| 7. Valve oil seal        | 8. Valve guide              | 9. Valve seat               |
| 10. Valve (INT)          | 11. Valve (EXH)             | 12. Cylinder head (LH bank) |
| 13. Spark plug tube      | 14. Cylinder head (RH bank) |                             |

### DISASSEMBLY

- Remove the spark plug. Refer to [EM-29, "REMOVAL"](#).
- Remove the valve lifter.
  - Identify the installation positions, and store them without mixing them up.
- Remove the valve collet using Tool.

**Tool number** : KV10116200 (J-26336-A)  
 : KV10115900 (J-26336-20)  
 : KV10109220 ( — )

### CAUTION:

**When working, take care not to damage valve lifter holes.**

- Remove the valve spring retainer, valve spring and valve spring seat.
- Inspect the valve guide clearance. Refer to [EM-71, "Valve Guide Clearance"](#).
- Push the valve stem to the combustion chamber side, and remove the valve.
  - Identify the installation positions, and store them without mixing them up.

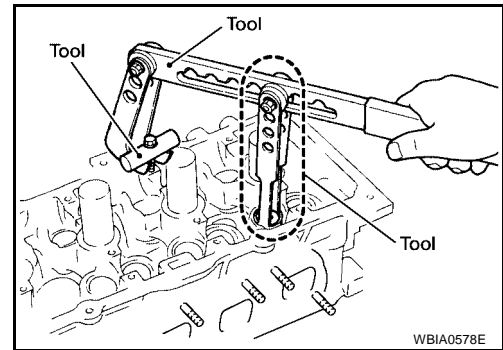

# CYLINDER HEAD

7. Remove the valve oil seal using Tool.

**Tool number : KV10107902 (J-38959)**

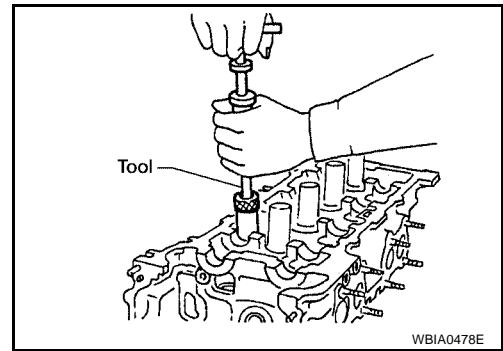

8. Replace the valve seat if necessary. Refer to [EM-73, "VALVE SEAT REPLACEMENT"](#).

9. Replace the valve guide if necessary. Refer to [EM-72, "VALVE GUIDE REPLACEMENT"](#).

10. Remove the spark plug tube, as necessary.

- Remove the spark plug tube out of the cylinder head using suitable tool.

### CAUTION:

- Do not damage the cylinder head.

- Do not remove the spark plug tube unless absolutely necessary. Once removed, the spark plug tube will be deformed and cannot be reused.

### ASSEMBLY

1. Install the valve guide if necessary. Refer to [EM-72, "VALVE GUIDE REPLACEMENT"](#).

2. Install the valve seat if necessary. Refer to [EM-73, "VALVE SEAT REPLACEMENT"](#).

3. Install the valve oil seal using Tool.

**Tool number : KV10115600 (J-38958)**

- Apply new engine oil on the new valve oil seal joint and seal lip.
- Install the valve oil seal to the specified height "H".

**Height "H" (without valve spring installed)**

**Intake and exhaust : 14.3 - 14.9 mm (0.563 - 0.587 in)**

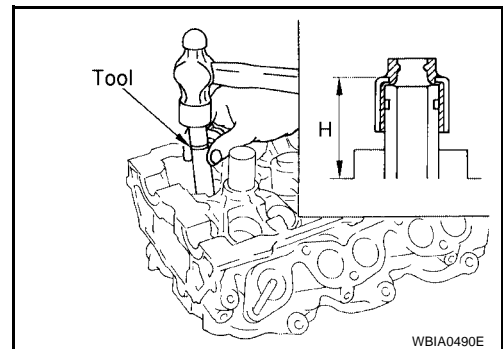

4. Install the valves in their original position.

5. Install the valve spring seats.

6. Install the valve springs.

- Install the narrow pitch end (paint mark side) to the cylinder head side.

7. Install the valve spring retainers.

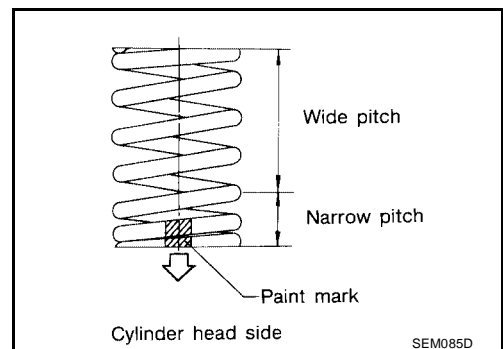

## CYLINDER HEAD

8. Install the valve collet using Tool.

**Tool number** : KV10116200 (J-26336-A)  
: KV10115900 (J-26336-20)  
: KV10109220 ( — )

**CAUTION:**

When working, take care not to damage valve lifter holes.

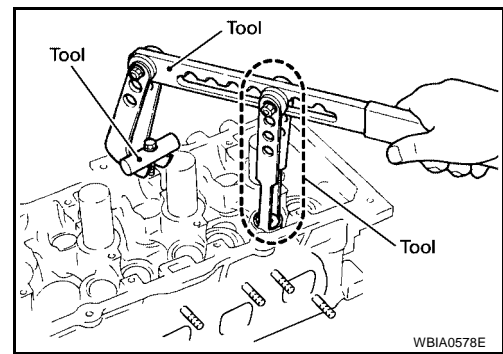

9. Install the valve lifters.

- Install the removed parts in their original locations.
- If installing new lifters, select the correct size lifter for proper valve clearance. Refer to [EM-71, "Valve Guide Clearance"](#).

10. Install the spark plug tube if necessary, following the procedure below.

- Remove any old liquid gasket adhering to the cylinder-head spark plug tube hole.
- Apply liquid gasket to area within approximately 12 mm (0.47 in) from the edge of the spark plug tube press-fit side.

**Use Genuine RTV Silicone Sealant or equivalent. Refer to [GI-47, "Recommended Chemical Products and Sealants"](#).**

- Press-fit the spark plug tube to the specified height "H" using suitable tool.

**Standard press-fit height "H"** : 38.4 - 39.4 mm  
(1.512 - 1.551 in)

**CAUTION:**

- When press-fitting, take care not to deform the spark plug tube.
- After press-fitting, wipe off any liquid gasket protruding onto the cylinder-head upper face.

11. Install the spark plugs.

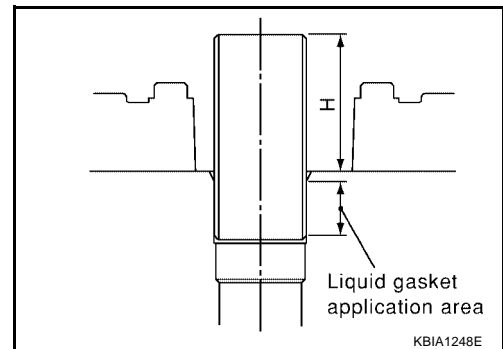

### Inspection After Disassembly CYLINDER HEAD DISTORTION

EBS00U9C

1. Remove any oil, scale, gasket, sealant and carbon deposits from the cylinder head surface.

**CAUTION:**

**Do not allow any debris to enter the oil or coolant passages.**

2. Measure the bottom surface of the cylinder head for distortion in six directions as shown, using suitable tools.

**Standard** : 0.03 mm (0.0012 in)

**Limit** : 0.1mm (0.004 in)

- If measurement exceeds the limit, replace the cylinder head.

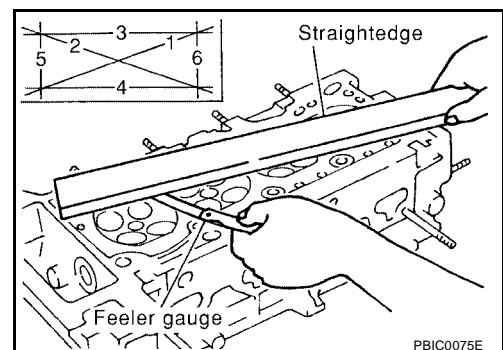

# CYLINDER HEAD

## VALVE DIMENSIONS

- Check the dimensions of each valve. Refer to [EM-71, "VALVE DIMENSIONS"](#) .
- If the dimensions are out of the standard, replace the valve.

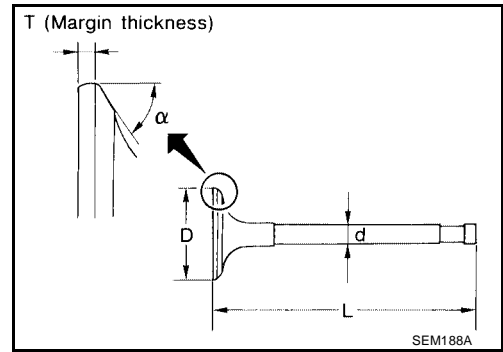

## VALVE GUIDE CLEARANCE

### Valve Stem Diameter

Measure the diameter of the valve stem using suitable tool.

#### Standard

**Intake : 5.965 - 5.980 mm (0.2348 - 0.2354 in)**

**Exhaust : 5.955 - 5.970 mm (0.2344 - 0.2350 in)**

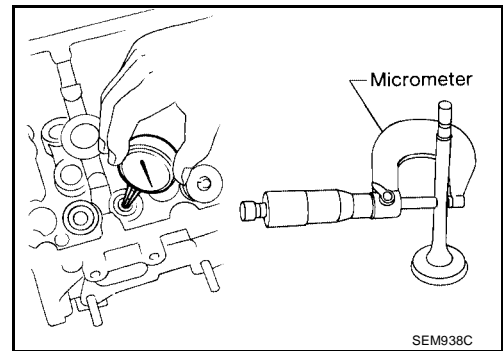

### Valve Guide Inside Diameter

Measure the inside diameter of the valve guide using suitable tool.

#### Standard

**Intake and Exhaust : 6.000 - 6.018 mm (0.2362 - 0.2369 in)**

### Valve Guide Clearance

- (Valve guide clearance) = (Valve guide inside diameter) – (Valve stem diameter).

#### Valve guide clearance:

##### Standard

**Intake : 0.020 - 0.053 mm (0.0008 - 0.0021 in)**

**Exhaust : 0.030 - 0.063 mm (0.0012 - 0.0025 in)**

##### Limit

**Intake : 0.08 mm (0.0031 in)**

**Exhaust : 0.09 mm (0.0035 in)**

- If the calculated value exceeds the limit, replace valve and/or valve guide. When the valve guide must be replaced, refer to [EM-72, "VALVE GUIDE REPLACEMENT"](#) .

# CYLINDER HEAD

## VALVE GUIDE REPLACEMENT

When the valve guide is removed, replace it with an oversized (0.2 mm, 0.008 in) valve guide.

1. To remove the valve guide, heat the cylinder head to 110° to 130°C (230° to 266°F) by soaking it in heated oil.

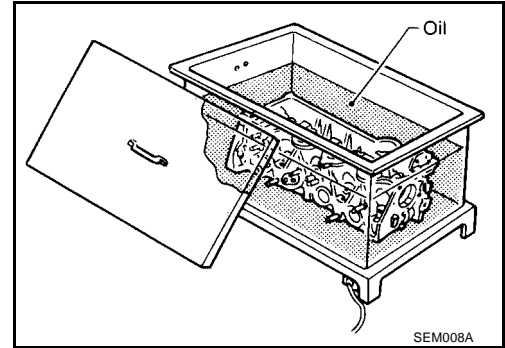

2. Remove the valve guide using suitable tool.

**CAUTION:**

Cylinder head contains heat. When working, wear protective equipment to avoid getting burned.

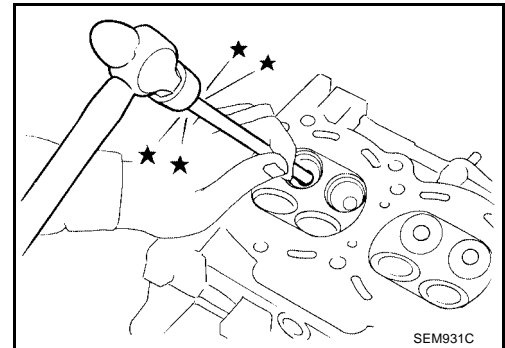

3. Ream the cylinder head valve guide hole using suitable tool.

**Valve guide hole diameter:**

**Standard**

Intake and exhaust : 9.975 - 9.996 mm (0.3927 - 0.3935 in)

**Oversize (service)**

Intake and exhaust : 10.175 - 10.196 mm (0.4006 - 0.4014 in)

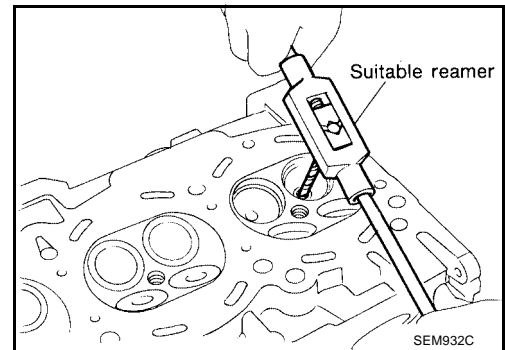

4. Heat the cylinder head to 110° to 130°C (230° to 266°F) by soaking it in heated oil.

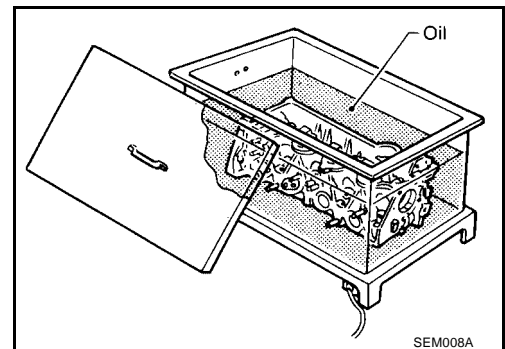



# CYLINDER HEAD

- Press the valve guide from the camshaft side to the dimensions as shown.

**CAUTION:**

Cylinder head contains heat. When working, wear protective equipment to avoid getting burned.

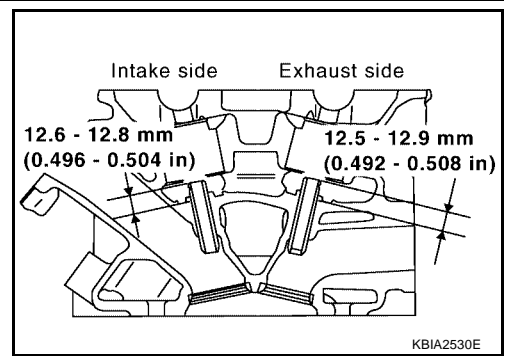

- Ream the cylinder head valve guide using suitable tool.

**Valve guide hole diameter:**

**Intake and exhaust : 6.000 - 6.018 mm  
(0.2362 - 0.2369 in)**

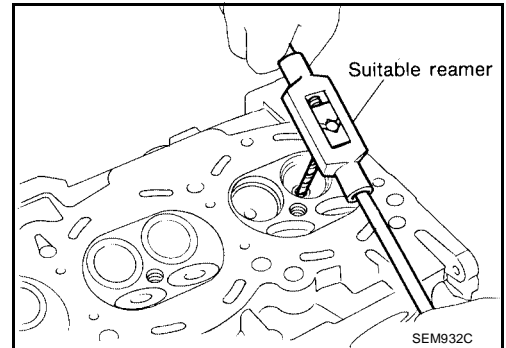

## VALVE SEAT CONTACT

- After confirming that the dimensions of the valve guides and valves are within specifications, perform this procedure.
- Apply prussian blue (or white lead) onto the contacting surface of the valve seat to check the condition of the valve contact on the surface.
- Check if the contact area band is continuous all around the circumference.
- If not, grind to adjust the valve fit and check again. If the contacting surface still has NG conditions even after the re-check, replace the valve seat.

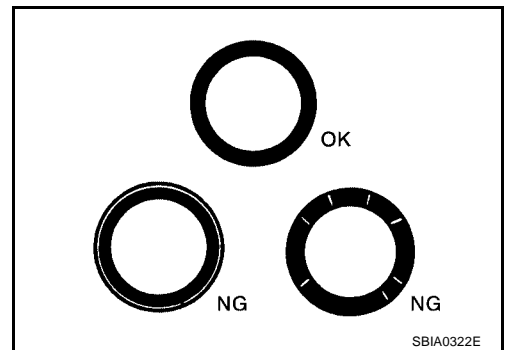

## VALVE SEAT REPLACEMENT

When the valve seat is removed, replace it with oversized (0.5 mm, 0.020 in) valve seat.

- Bore out the old seat until it collapses. Boring should not continue beyond the bottom face of the seat recess in the cylinder head. Set the machine depth stop to ensure this.
- Ream the cylinder head recess diameter for service valve seat.

**Oversize [0.5 mm (0.020 in)] (Service):**

**Intake : 38.500 - 38.516 mm (1.5157 - 1.5164 in)**

**Exhaust : 32.700 - 32.716 mm (1.2874 - 1.2880 in)**

- Be sure to ream in circles concentric to the valve guide center.
- This will enable valve seat to fit correctly.

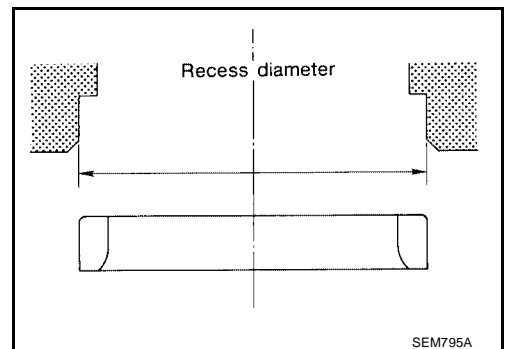

# CYLINDER HEAD

- Heat the cylinder head to 110° to 130°C (230° to 266°F) by soaking it in heated oil.

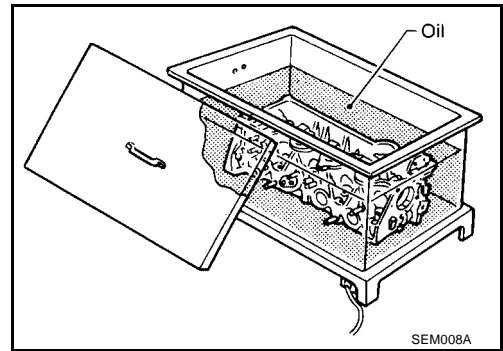

- Cool the valve seats well with dry ice. Force fit the valve seat into the cylinder head.

**CAUTION:**

- Avoid directly touching cold valve seats.
- Cylinder head contains heat. When working, wear protective equipment to avoid getting burned.

- Finish the seat to the specified dimensions using suitable tool. Refer to [EM-73, "VALVE SEAT CONTACT"](#).

**CAUTION:**

When using valve seat cutter, firmly grip the cutter handle with both hands. Then, press on the contacting surface all around the circumference to cut in a single drive. Improper pressure on the cutter or cutting many different times may result in stage valve seat.

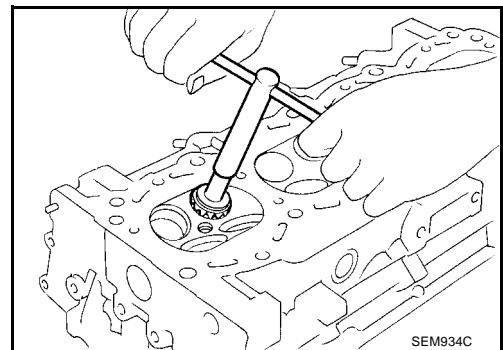

- Grind to obtain the dimensions indicated as shown.

- Using compound, grind to adjust valve fitting.

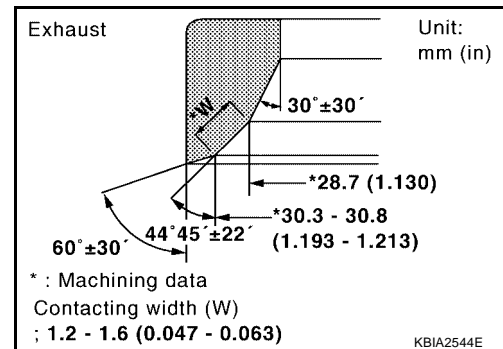
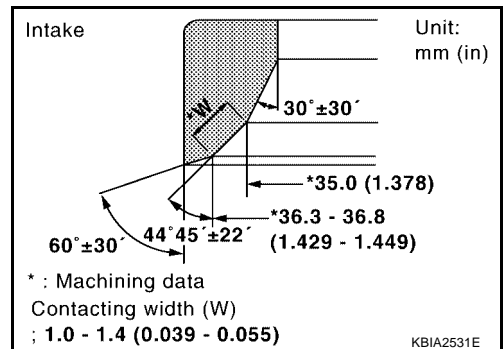

- Check again for normal contact. Refer to [EM-73, "VALVE SEAT CONTACT"](#).

# CYLINDER HEAD

## VALVE SPRING SQUARENESS

- Set try square along the side of valve spring and rotate the spring. Measure the maximum clearance between the top face of spring and try square.

**Limit : Less than 2.2 mm (0.087 in)**

- If measurement is not within specifications, replace the valve spring.

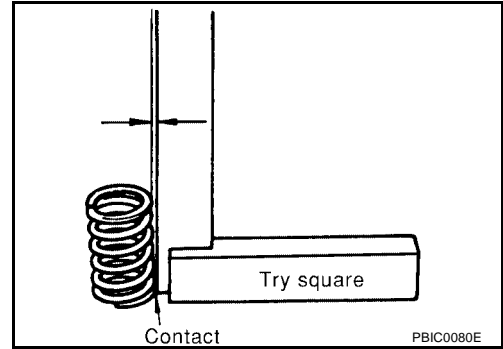

## VALVE SPRING DIMENSIONS AND VALVE SPRING PRESSURE LOAD

- Check the valve spring pressure at the specified spring height.

### Standard:

#### Intake and exhaust

Free height:	50.58 mm (1.9913 in)
Installation height:	37.0 mm (1.457 in)
Installation pressure:	165.8 - 187.0 N (16.9 - 19.1 kg, 37- 42 lb)
Height during valve open:	28.2 mm (1.110 in)
Load with valve open:	314.8 - 355.0 N (32.1 - 36.2 kg, 71 - 80 lb)

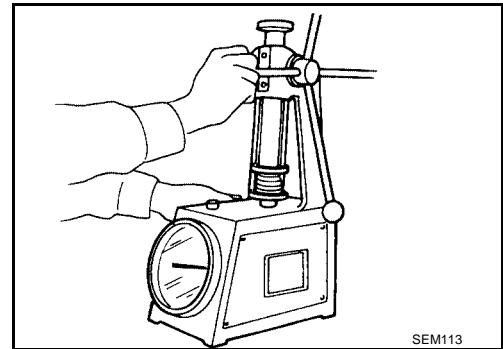

- If measurement is not within specifications, replace the valve spring.

# ENGINE ASSEMBLY

PF1:10001

## ENGINE ASSEMBLY

### Removal and Installation

EBS00U9D

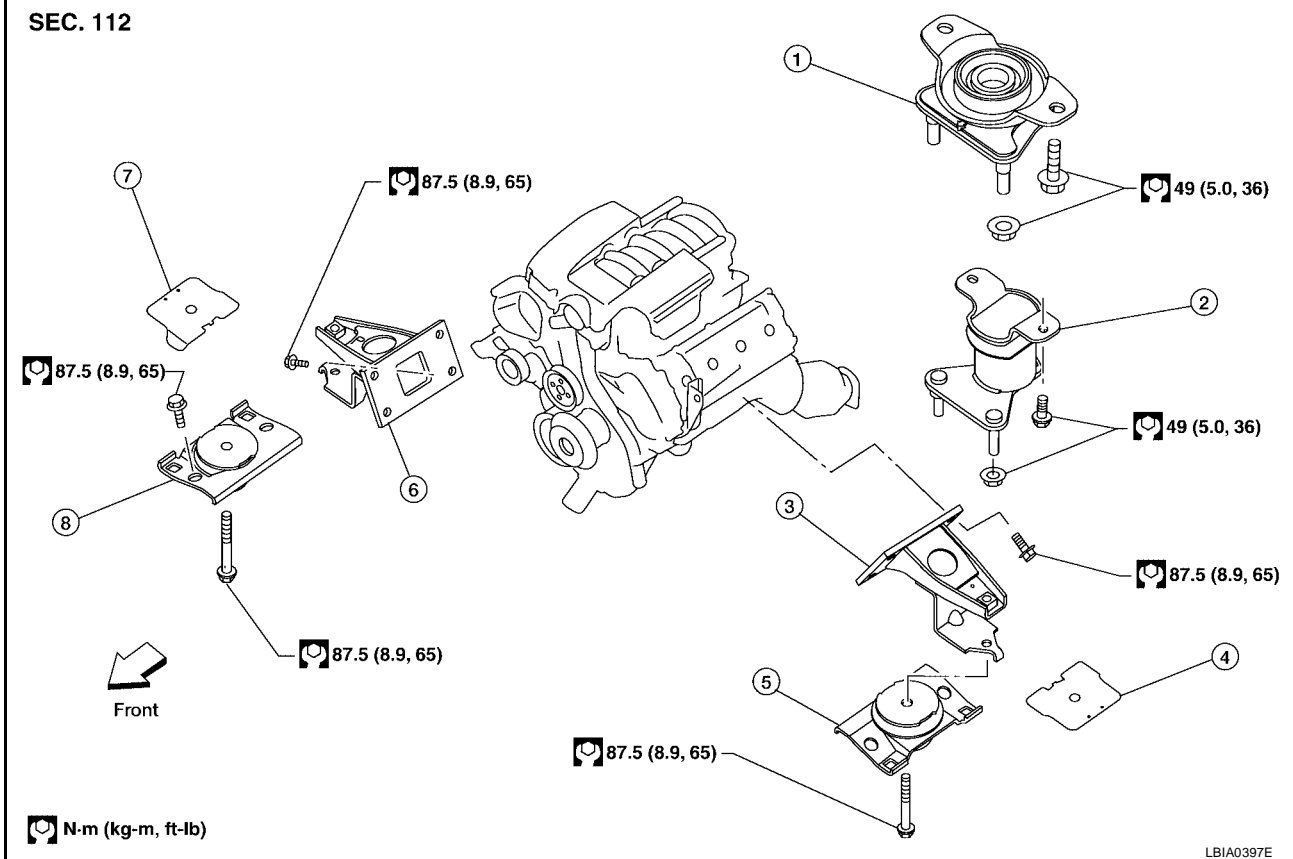

- |                                       |                                       |                               |
|---------------------------------------|---------------------------------------|-------------------------------|
| 1. Rear engine mounting insulator 4WD | 2. Rear engine mounting insulator 2WD | 3. LH engine mounting bracket |
| 4. LH heat shield plate               | 5. LH engine mounting insulator       | 6. RH engine mounting bracket |
| 7. RH heat shield plate               | 8. RH engine mounting insulator       |                               |

#### WARNING:

- Situate vehicle on a flat and solid surface.
- Place chocks at front and back of rear wheels.
- For engines not equipped with engine slingers, attach proper slingers and bolts described in PARTS CATALOG.

#### CAUTION:

- Always be careful to work safely, avoid forceful or uninstructed operations.
- Do not start working until exhaust system and engine coolant are cooled sufficiently.
- If items or work required are not covered by the engine section, refer to the applicable sections.
- Always use the support point specified for lifting.
- Use either 2-point lift type or separate type lift. If board-on type is used for unavoidable reasons, support at the rear axle jacking point with transmission jack or similar tool before starting work, in preparation for the backward shift of center of gravity.
- For supporting points for lifting and jacking point at rear axle, refer to [GI-42, "Garage Jack and Safety Stand"](#).

#### REMOVAL

##### Preparation

1. Drain the engine coolant. Refer to [CO-11, "DRAINING ENGINE COOLANT"](#).
2. Partially drain the A/T fluid. Refer to [AT-12, "Changing Automatic Transmission Fluid \(ATF\)"](#).
3. Release the fuel pressure. Refer to [EC-87, "FUEL PRESSURE RELEASE"](#).

# ENGINE ASSEMBLY

4. Remove the engine hood. Refer to [BL-13, "Removal and Installation of Hood Assembly"](#) .
5. Remove the cowl extension. Refer to [EI-18, "REMOVAL"](#) .
6. Remove the engine room cover using power tools.

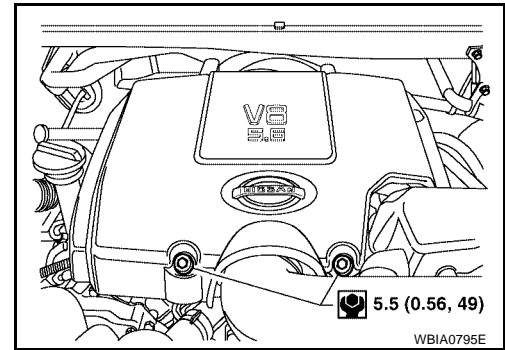

7. Remove the air duct and air cleaner case assembly. Refer to [EM-15, "REMOVAL"](#) .
8. Disconnect the vacuum hose between the vehicle and engine and set it aside.
9. Remove the radiator assembly and hoses. Refer to [CO-14, "REMOVAL"](#) .
10. Remove the drive belts. Refer to [EM-13, "REMOVAL"](#) .
11. Remove the fan blade. Refer to [CO-17, "REMOVAL"](#) .
12. Disconnect the engine room harness from the fuse box and set it aside.
13. Disconnect the ECM.
14. Disconnect the engine room harness from the engine side and set it aside.
15. Disconnect the engine harness grounds.
16. Disconnect the power steering reservoir tank from the engine and move it aside.
17. Disconnect the power steering oil pump from the engine. Move it aside and secure it using suitable wire or rope. Refer to [PS-22, "REMOVAL"](#) .
18. Remove the A/C compressor bolts and set the compressor aside. Refer to [ATC-225, "REMOVAL"](#) (ATC).
19. Disconnect the brake booster vacuum line.
20. Disconnect the EVAP line.
21. Disconnect the fuel hose at the engine side connection. Refer to [EM-31, "REMOVAL"](#) .
22. Disconnect the heater hoses at the cowl, and install plugs to avoid leakage of engine coolant.
23. Remove the A/T oil level indicator and indicator tube upper bolts.
24. Remove the front final drive assembly (4WD only). Refer to [FFD-12, "REMOVAL"](#) .
25. Remove the exhaust manifolds. Refer to [EM-21, "REMOVAL"](#) .
26. Install the engine slingers into the left bank cylinder head and right bank cylinder head.

**Engine slinger torque: 45.0 N-m (4.6 kg-m, 33 ft-lb)**

27. Remove the A/T. Refer to [AT-238, "REMOVAL"](#) or [AT-241, "REMOVAL"](#) .
28. Lift using a hoist and secure the engine in position.
29. Remove the engine assembly from the vehicle, avoid interference with the vehicle body.

**CAUTION:**

- **Before and during lifting, always check if any harnesses are left connected.**

30. Remove the parts that may restrict installation of the engine to the engine stand.

**NOTE:**

This procedure is described assuming that you use an engine stand mounting to the surface to which the transmission mounts.

- a. Remove the drive plate.
  - Holding the crankshaft pulley bolt, lock the crankshaft to remove the drive plate bolts.
  - Loosen the bolts diagonally.

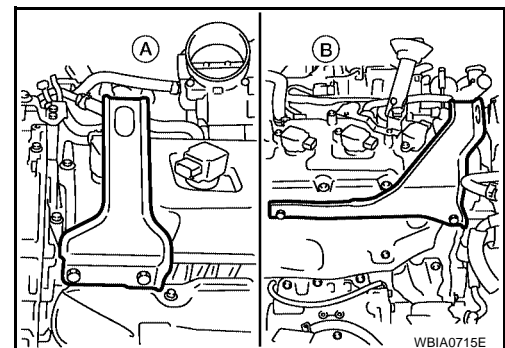

# ENGINE ASSEMBLY

**CAUTION:**

- Be careful not to damage the drive plate. Especially avoid deforming and damaging of the signal plate teeth (circumference position).
- Place the drive plate with the signal plate surface facing other than downward.
- Keep magnetic materials away from the signal plate.

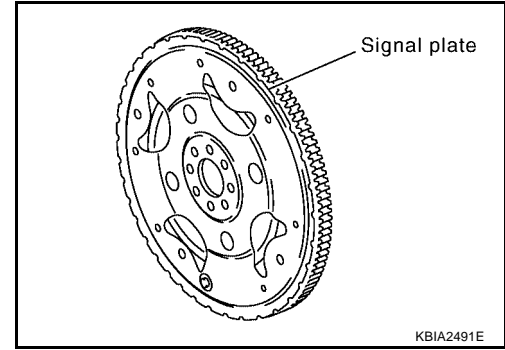

**CAUTION:**

Use an engine stand that has a load capacity [approximately 240kg (529 lb) or more] large enough for supporting the engine weight.

- If the load capacity of the stand is not adequate, remove the following parts beforehand to reduce the potential risk of overturning the stand.
  - Remove the fuel tube and fuel injector assembly. Refer to [EM-31, "REMOVAL"](#) .
  - Remove the intake manifold. Refer to [EM-17, "REMOVAL"](#) .
  - Remove the ignition coil. Refer to [EM-28, "REMOVAL"](#) .
  - Remove the rocker cover. Refer to [EM-35, "REMOVAL"](#) .
  - Other removable brackets.

**CAUTION:**

Before removing the hanging chains, make sure the engine stand is stable and there is no risk of overturning.

31. Remove the alternator. Refer to [SC-28, "REMOVAL"](#) .
32. Remove the engine mounting insulator and bracket using power tool.

## INSTALLATION

Installation is in the reverse order of removal.

**CAUTION:**

- When replacing an engine or transmission you must make sure the dowels are installed correctly during re-assembly.
- Improper alignment caused by missing dowels may cause vibration, oil leaks or breakage of drivetrain components.

## INSPECTION AFTER INSTALLATION

- Before starting the engine, check oil/fluid levels including engine coolant and engine oil. If the levels are lower than required quantity, fill to the specified level. Refer to [MA-11, "Fluids and Lubricants"](#) .
- Use procedure below to check for fuel leakage.
- Turn ignition switch ON (with engine stopped). With fuel pressure applied to the fuel piping, check for fuel leakage at the connection points.
- Start engine. With engine speed increased, check again for fuel leakage at connection points.
- Run engine to check for unusual noise and vibration.
- Warm up engine thoroughly to make sure there is no leakage of fuel, exhaust gas, or any oils/fluids including engine oil and engine coolant.
- Bleed air from passages in lines and hoses, such as in cooling system.
- After cooling down the engine, again check oil/fluid levels including engine oil and engine coolant. Refill to specified level if necessary.
- Summary of the inspection items:

Item	Before starting engine	Engine running	After engine stopped
Engine coolant	Level	Leakage	Level

# ENGINE ASSEMBLY

Engine oil	Level	Leakage	Level
Other oils and fluids*	Level	Leakage	Level
Fuel	Leakage	Leakage	Leakage
Exhaust gas	—	Leakage	—

A

**EM**

\*Transmission/transaxle/CVT fluid, power steering fluid, brake fluid, etc.

C

D

E

F

G

H

I

J

K

L

M

# CYLINDER BLOCK

PF11010

EBS00U9E

## CYLINDER BLOCK

### Disassembly and Assembly

SEC. 110•120•226

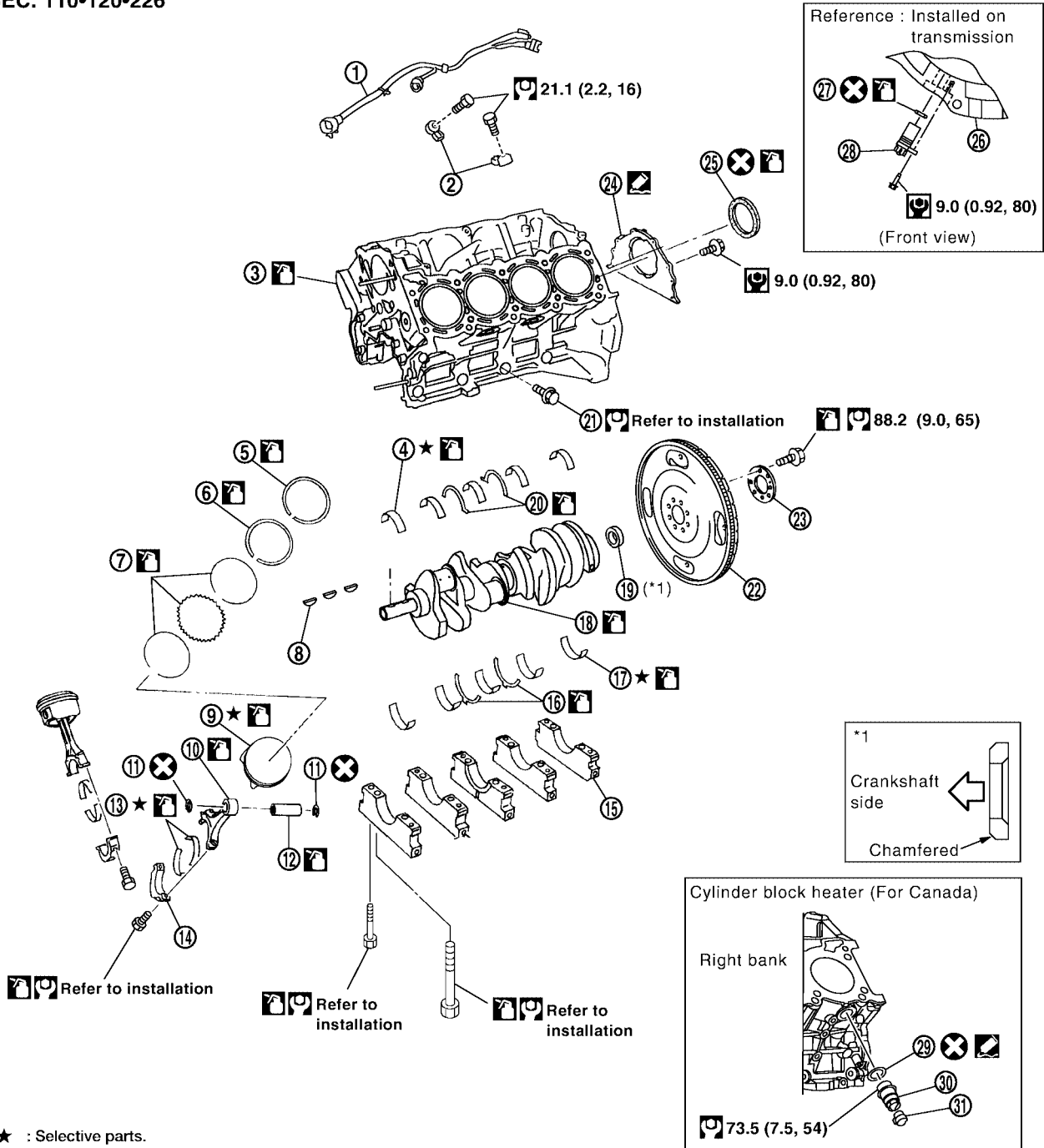

- ★ : Selective parts.
- ⊗ : Always replace after every disassembly.
- 🛢️ : Lubricate with new engine oil.
- 🔧 : Apply Genuine RTV Silicone Sealant or equivalent.\*
- 🔩 : N•m (kg-m, in-lb)
- 🔩 : N•m (kg-m, ft-lb)

- |                             |                   |                   |
|-----------------------------|-------------------|-------------------|
| 1. Knock sensor sub-harness | 2. Knock sensor   | 3. Cylinder block |
| 4. Main bearing upper       | 5. Top ring       | 6. Second ring    |
| 7. Oil ring                 | 8. Crankshaft key | 9. Piston         |
| 10. Connecting rod          | 11. Snap ring     | 12. Piston pin    |

WBIA0471E



# CYLINDER BLOCK

- |                                      |                                |                            |
|--------------------------------------|--------------------------------|----------------------------|
| 13. Connecting rod bearing           | 14. Connecting rod bearing cap | 15. Main bearing cap       |
| 16. Thrust bearing lower             | 17. Main bearing lower         | 18. Crankshaft             |
| 19. Pilot converter                  | 20. Thrust bearing upper       | 21. Side bolt              |
| 22. Drive plate                      | 23. Reinforcement plate        | 24. Rear oil seal retainer |
| 25. Rear oil seal                    | 26. Transmission               | 27. O-ring                 |
| 28. Crankshaft position sensor (POS) | 29. Gasket                     | 30. Cylinder block heater  |
| 31. Connector cap                    |                                |                            |

## DISASSEMBLY

### NOTE:

Explained here is how to disassemble with engine stand supporting transmission surface. When using different type of engine stand, some steps may be different.

1. Remove engine assembly and mount to engine stand. Refer to [EM-76, "REMOVAL"](#).

### CAUTION:

**Before removing the hanging chains, make sure engine stand is stable and there is no risk of over-turning.**

2. Drain engine oil. Refer to [LU-9, "CHANGING ENGINE OIL"](#).
3. Drain engine coolant by removing the cylinder block drain plugs "A", "B", "C" and "D" as shown.

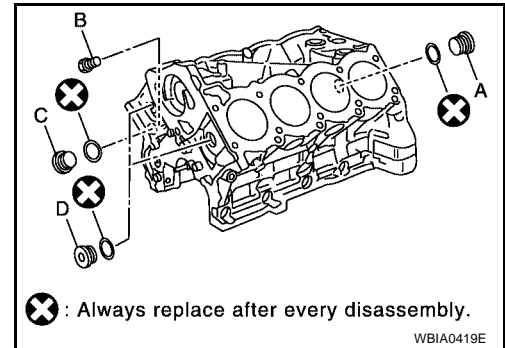

4. Remove the following components and associated parts (the parts referred to in step 1 are not included here).
  - Oil pan (upper and lower) and oil strainer. Refer to [EM-24, "REMOVAL"](#).
  - Crankshaft pulley, front cover and timing chain. Refer to [EM-38, "REMOVAL"](#).
  - Camshaft. Refer to [EM-46, "REMOVAL"](#).
  - Cylinder head. Refer to [EM-66, "REMOVAL"](#).

5. Remove knock sensor and sub harness.

### CAUTION:

**Carefully handle sensor, avoiding shocks.**

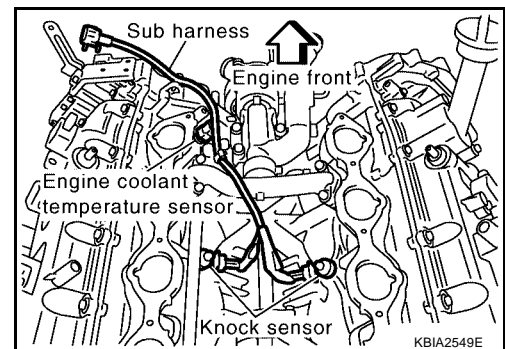

6. Check connecting rod side clearance. Refer to [EM-96, "CONNECTING ROD SIDE CLEARANCE"](#).
7. Remove piston and connecting rod assembly as follows.
  - a. Position the crankshaft pin corresponding to the connecting rod to be removed onto bottom dead center.
  - b. Remove connecting rod cap.

## CYLINDER BLOCK

- c. Push the piston and connecting rod assembly out to the cylinder head side using suitable tool.

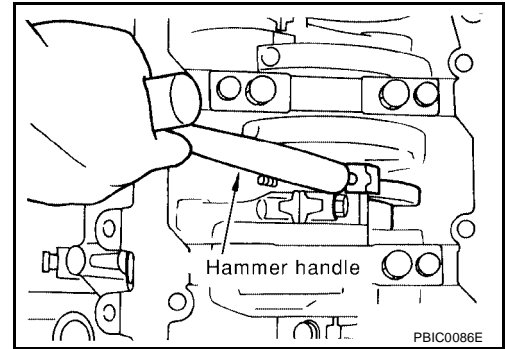

8. Remove connecting rod bearings.

**CAUTION:**

**When removing them, note the installation position. Keep them in the correct order.**

9. Check piston ring side clearance. Refer to [EM-97, "PISTON RING SIDE CLEARANCE"](#).

10. Remove piston rings from piston using suitable tool.

**CAUTION:**

- Do not damage piston.
- Do not damage piston rings by expanding them excessively.

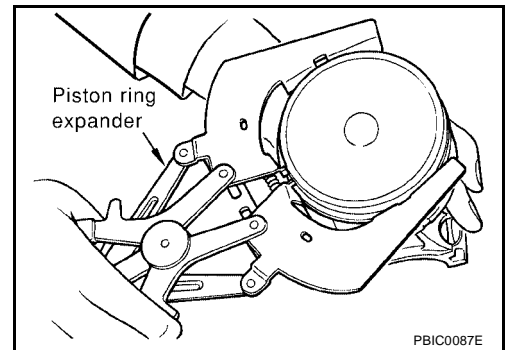

11. Remove piston from connecting rod as follows.

- a. Remove snap ring using suitable tool.

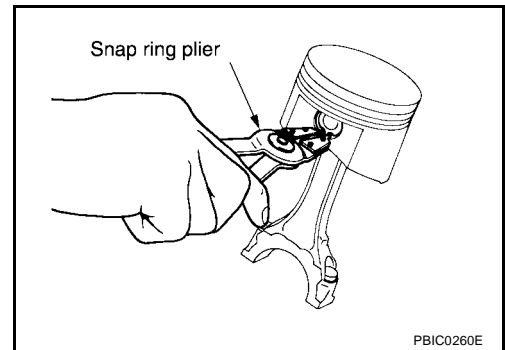

- b. Heat piston to 60° to 70°C (140° to 158°F) using suitable tool.

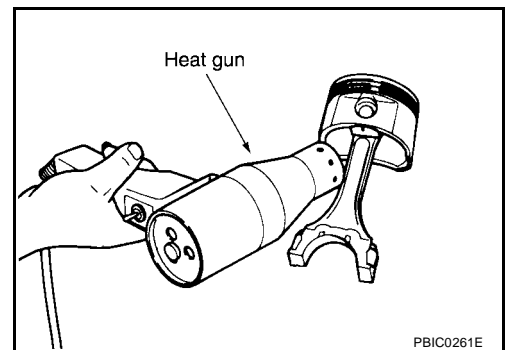

# CYLINDER BLOCK

- c. Push out piston pin using suitable tool.

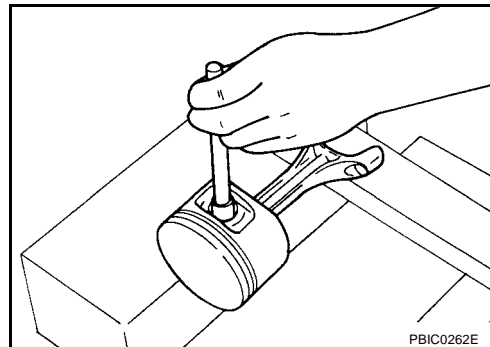

12. Separate and remove rear oil seal retainer from cylinder block.

**CAUTION:**  
Do not damage mating surface.

13. Remove rear oil seal from rear oil seal retainer.

14. Measure the crankshaft side clearance. Refer to [EM-96, "CRANKSHAFT END PLAY"](#).

15. Remove main bearing caps as follows:

- Loosen bolts in several different steps.

- Loosen side bolts (M10) starting from 30 to 21 to remove.
- Loosen main bearing cap sub bolts (M9) starting from 20 to 11 to remove.
- Loosen main bearing cap bolts (M12) starting from 10 to 1 to remove.

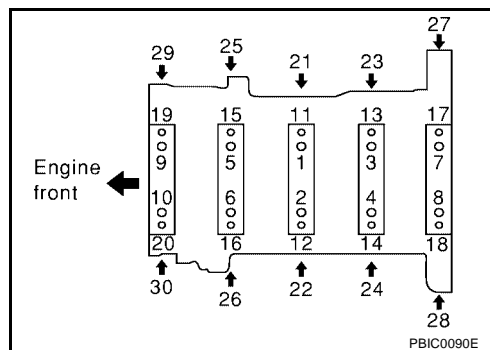

- d. Remove main bearing cap.

- Insert bolts (2) into bolt holes, and then remove main bearing cap by lifting up and shaking forward and backward.

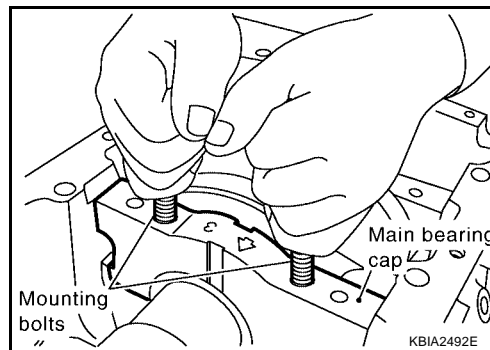

16. Remove crankshaft.

17. Remove the main bearings and thrust bearings from the cylinder block and main bearing caps.

- When removing them, note the installation position. Keep them in the correct order.

# CYLINDER BLOCK

18. Remove pilot converter using Tool if necessary.

**Tool number** : ST16610001 (J-23907)

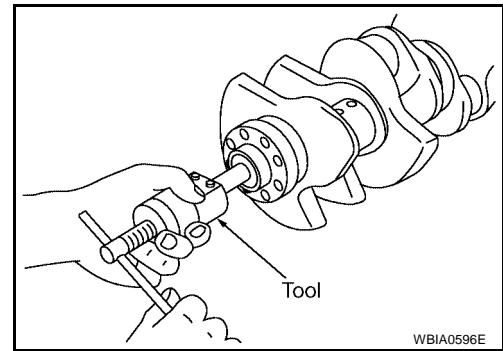

## ASSEMBLY

1. Fully air-blow the coolant and oil passages in the cylinder block, cylinder bore, and crankcase to remove any foreign material.

### CAUTION:

**Use goggles to protect your eyes.**

2. Install each plug to the cylinder block (only screw-type plugs are shown).

- Apply liquid gasket.

**Use Genuine Thread Sealant or equivalent. Refer to [GI-47, "Recommended Chemical Products and Sealants"](#).**

- Replace copper washers with new ones.
- Tighten each plug as specified below.

Part	Washer	Tightening torque
A	Yes	53.9 N·m (5.5 kg·m, 40 ft·lb)
B	No	19.6 N·m (2.0 kg·m, 15 ft·lb)
C	Yes	62.7 N·m (6.4 kg·m, 46 ft·lb)
D	Yes	62.7 N·m (6.4 kg·m, 46 ft·lb)

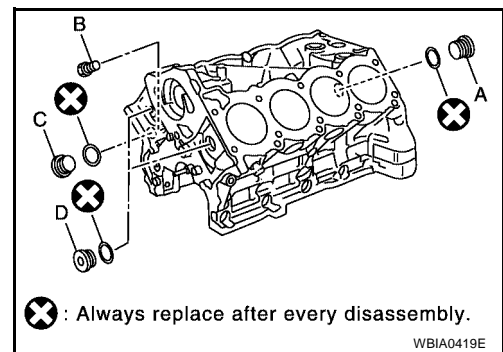

3. Install main bearings and thrust bearings.

a. Remove any dust, dirt, and oil on the bearing mating surfaces of the cylinder block and main bearing caps.

b. Install thrust bearings to both sides of the No. 3 journal housing on the cylinder block and main bearing caps

- Install thrust bearings with the oil groove facing the crankshaft arm (outside).
- Install thrust bearings with a protrusion in the center on the main bearing caps.

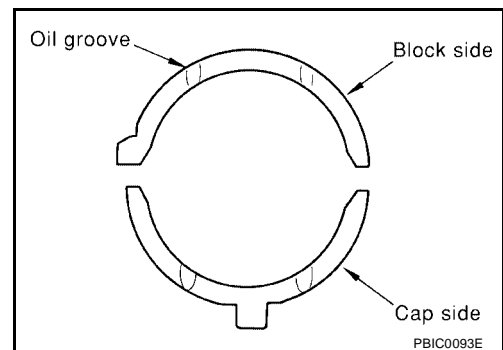

c. Install main bearings paying attention to the direction.

- Install the one with oil holes onto the cylinder block and the one without oil holes onto the main bearing cap.
- Before installing bearings, apply engine oil to bearing surface (inside). Do not apply oil to the back surface, but thoroughly clean it.
- When installing, align the bearing stopper to the notch.
- Ensure the oil holes on the cylinder block and those on the corresponding bearing are aligned.

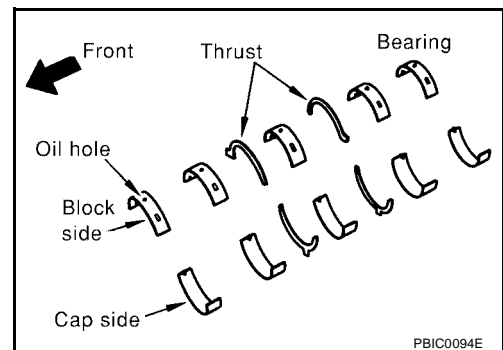

# CYLINDER BLOCK

4. Install pilot converter to the crankshaft using suitable tool.
5. Install crankshaft to the cylinder block.
  - While turning crankshaft by hand, make sure it turns smoothly.

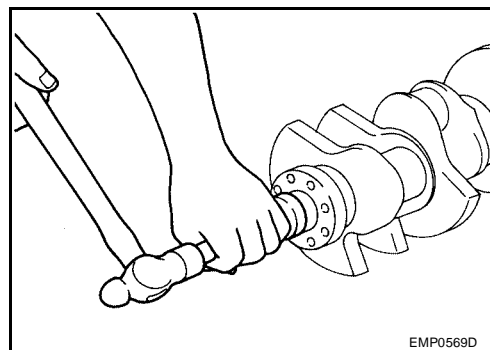

EMP0569D

6. Install main bearing caps.
  - Align the identification number to the journal position to install.
  - Install it with the front mark (indicated by the arrow) facing the front of engine.
  - Tap caps lightly to seat them in the installation position.

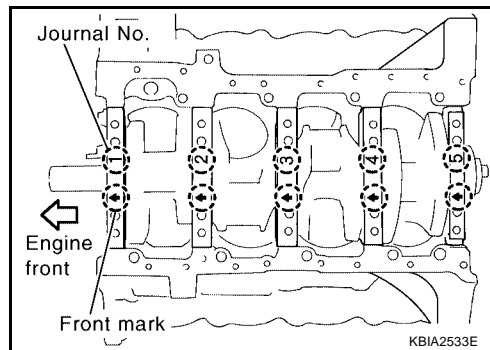

KBIA2533E

7. Follow the steps below to tighten each main bearing cap bolt.
  - a. Apply engine oil to threads and seating surfaces of bolts, and tighten all bolts temporarily.

**Main bearing cap bolts : 39.2 N-m (4.0 kg-m, 29 ft.-lb) in order of 1 to 10**

**Main bearing cap sub bolts in order of 11 to 20 : 29.4 N-m (3.0 kg-m, 22 ft.-lb)**

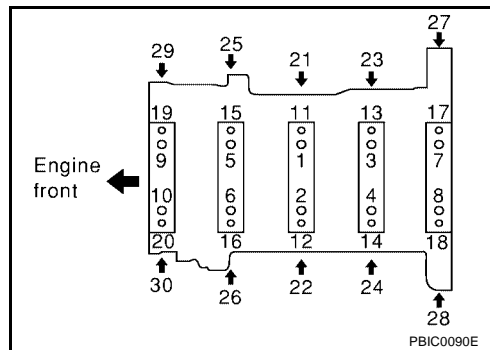

PBIC0090E

- b. Measure tightening angle using Tool.

**Tool number : KV10112100 (BT-8653-A)**

**CAUTION:**

**Measure tightening angle using Tool. Do not measure visually.**

**Main bearing cap bolts in order of 1 to 10 : 40°**

**Main bearing cap sub bolts in order of 11 to 20 : 30°**

**Side bolts in order of 21 to 30 : 49 N-m (5.0 kg-m, 36 ft.-lb)**

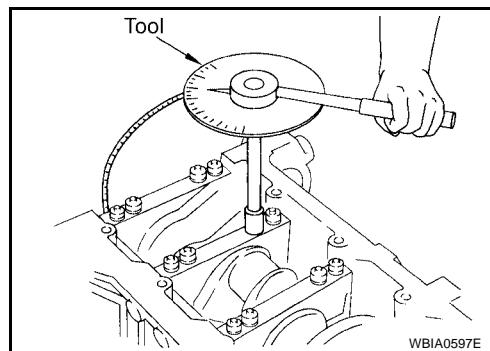

WBIA0597E

- Rotate crankshaft by hand after bolts are tightened. Check if it rotates smoothly.
  - Check crankshaft side clearance. Refer to [EM-96, "CRANKSHAFT END PLAY"](#).
8. Install rear oil seal to rear oil seal retainer.

**CAUTION:**

**Do not damage or scratch outer circumference of oil seal.**

# CYLINDER BLOCK

- Install new rear oil seal in the direction shown.

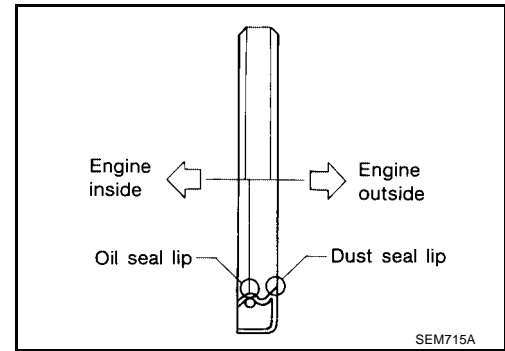

- Tap until flattened with the front edge of the rear oil seal retainer using suitable tool.
- Fit the rear oil seal until it is level with the rear end surface of rear oil seal retainer.

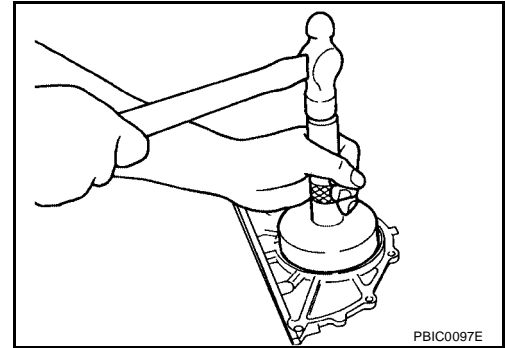

## 9. Install rear oil seal retainer.

- Apply liquid gasket thoroughly to rear oil seal retainer as shown.  
**Use Genuine RTV Silicone Sealant or equivalent. Refer to [GI-47, "Recommended Chemical Products and Sealants"](#).**
- Apply new engine oil on the lips of rear oil seal. Do not touch.

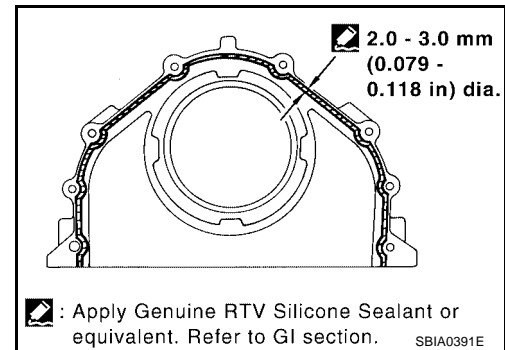

## 10. Install the piston to the connecting rod.

### a. Install the snap ring to the grooves of the piston rear side.

- Insert it fully into the groove to install.

### b. Install the piston to the connecting rod.

- Heat piston until piston pin can be pushed in by hand without excess force [approx. 60° to 70 C° (140° to 158 °F)]. From the front to the rear, insert the piston pin into the piston and the connecting rod.
- Assemble so that the front mark on the piston crown and the oil holes and cylinder No. on the connecting rod are positioned as shown.

### c. Install the snap ring to the grooves of the piston front side.

- Insert it fully into the groove to install.
- After installing, make sure connecting rod moves smoothly.

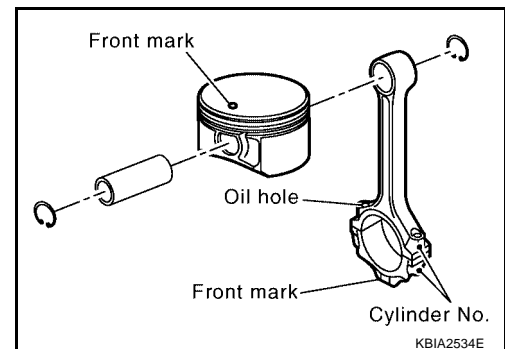

# CYLINDER BLOCK

11. Install piston rings.

**CAUTION:**

**Do not damage piston.**

- Position each ring with the gap as shown, referring to the piston front mark.
- Install the second ring with the stamped surface facing upward.

**Stamped mark      Second ring      : 2N**

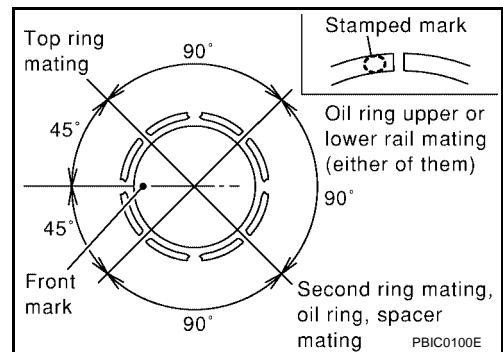

12. Install the connecting rod bearings to the connecting rod and connecting rod cap.

- When installing the connecting rod bearings, apply engine oil to the bearing surface (inside). Do not apply oil to the back surface, but thoroughly clean it.
- When installing, align the connecting rod bearing stopper protrusion with the cutout of the connecting rod to install.
- Check that the oil holes on the connecting rod and those on the corresponding bearing are aligned.

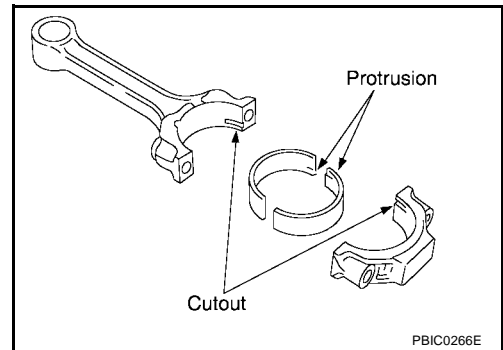

13. Install the piston and connecting rod assembly to the crankshaft using Tool.

**Tool number      : EM03470000 (J-8037)**

- Position the crankshaft pin corresponding to the connecting rod to be installed onto bottom dead center.
- Apply engine oil sufficiently to the cylinder bore, piston, and crankshaft pin.
- Match the cylinder position with the cylinder No. on the connecting rod to install.
- Install the piston with the front mark on the piston crown facing the front of the engine.

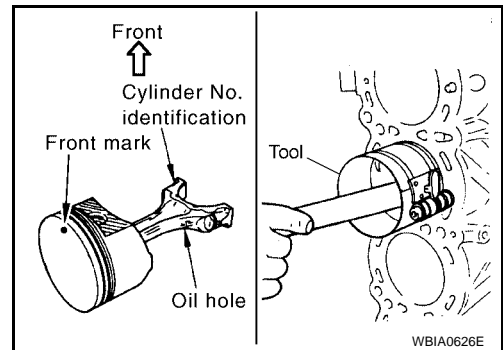

**CAUTION:**

**Be careful not to damage the crankshaft pin, resulting from an interference of the connecting rod big end.**

14. Install connecting rod cap.

- Match the stamped cylinder number marks on the connecting rod with those on the cylinder cap to install.

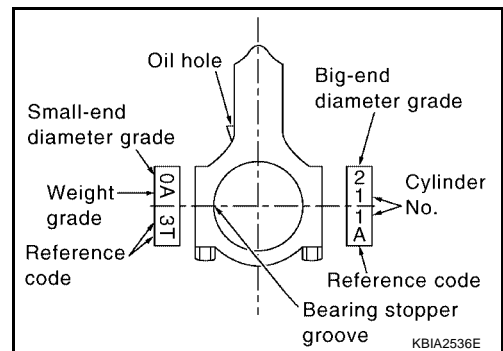

A  
EM  
C  
D  
E  
F  
G  
H  
I  
J  
K  
L  
M

# CYLINDER BLOCK

15. Tighten connecting rod bolts using Tool.

**Tool number** : KV10112100 (BT-8653-A)

### Connecting rod bolts

**Step 1** : 19.6 N·m (1.5 kg-m, 11 ft-lb)

**Step 2** : 90° clockwise

- Apply engine oil to threads and seats of connecting rod bolts.
- After tightening bolts, make sure the crankshaft rotates smoothly.
- Check connecting rod side clearance. Refer to [EM-96, "CONNECTING ROD SIDE CLEARANCE"](#).

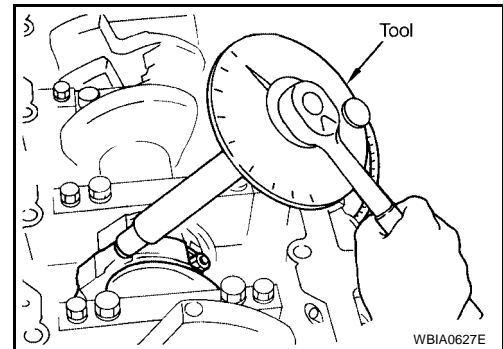

16. Install knock sensors.

### CAUTION:

**If knock sensor is dropped, replace it with a new one.**

- Make sure that there is no foreign material on the cylinder block mating surface and the back surface of knock sensor.
- Install it with its connector facing the center of the cylinder block side.
- Do not tighten knock sensor bolts while holding connector.
- Make sure knock sensor does not interfere with other parts.

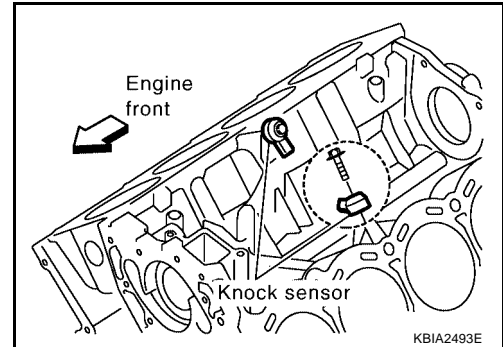

- Position the sub-harness as shown before installing intake manifold.

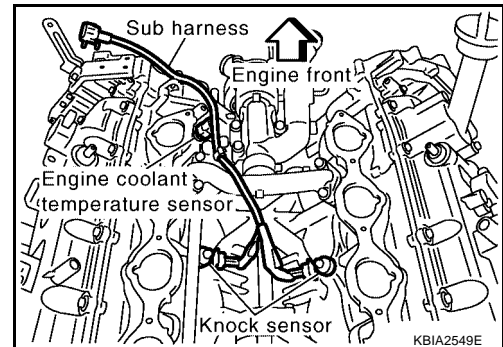

17. Installation of the remaining components is in the reverse order of removal.

18. Remove engine assembly from engine stand.

19. Install drive plate.

- Align dowel pin of crankshaft rear end with pin holes of each part to install.

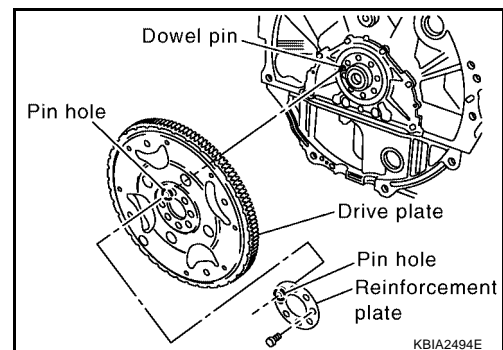



# CYLINDER BLOCK

- Install drive plate, reinforcement plate and pilot converter (if not installed in step 4) as shown.
- Face the chamfered or rounded edge side to the crankshaft.

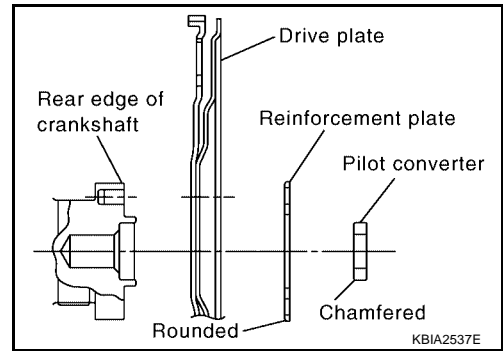

EBS00U9F

## How to Select Piston and Bearing DESCRIPTION

Connecting points	Connecting parts	Selection items	Selection methods
Between cylinder block to crankshaft	Main bearing	Main bearing grade (bearing thickness)	Determined by match of cylinder block bearing housing grade (Housing inside diameter) and crankshaft journal grade (journal outside diameter)
Between crankshaft to connecting rod	Connecting rod bearing	Connecting rod bearing grade (bearing thickness)	Connecting rod bearing grade = crankshaft pin grade (pin diameter). No grade exists for inside diameter of connecting rod large end.
Between cylinder block to piston	Piston and piston pin assembly. The piston is available together with piston pin as an assembly.	Piston grade (piston diameter)	Piston grade = cylinder bore grade (diameter of bore)
*Between piston to connecting rod	—	—	—

\*For the service parts, the grade for fitting cannot be selected between a piston pin and a connecting rod. (Only 0 grade is available.) The information at the shipment from the plant is described as a reference.

- The identification grade stamped on each part is the grade for the dimension measured in new condition. This grade cannot apply to reused parts.
- For reused or repaired parts, measure the dimension accurately. Determine the grade by comparing the measurement with the values of each selection table.
- For details of the measurement method of each part, the reuse standards, and the selection method of the selective fitting parts, refer to the text.

## HOW TO SELECT PISTON

### Piston Selective Fitting When New Cylinder Block is Used:

- Check the cylinder bore grade on the bottom face of the cylinder block, and select the piston of the same grade.

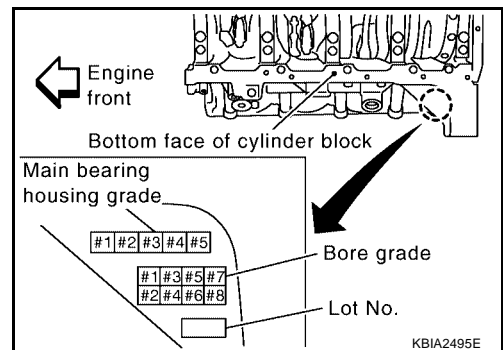

# CYLINDER BLOCK

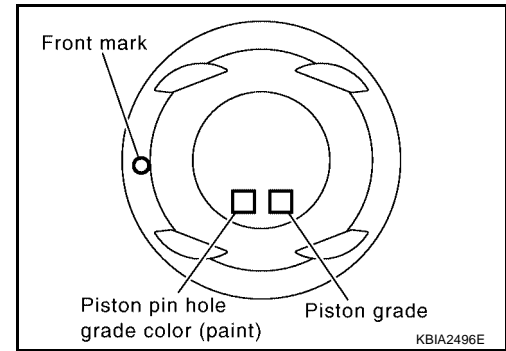

## When Cylinder Block is Reused

1. Measure cylinder block bore diameter.
2. Determine the bore grade by comparing the measurement with the values under the "Cylinder bore diameter" of the piston selection table. Use oversized piston if the clearance of standard grade piston is outside the specified value.

## Piston Selection Table

Unit: mm (in)

Grade number (Mark)	1	2	3
Cylinder bore diameter	98.000-98.010 (3.8583-3.8587)	98.010-98.020 (3.8587-3.8590)	93.020-98.030 (3.8590-3.8594)
Piston diameter	97.980-97.990 (3.8575-3.8579)	97.990-98.000 (3.8579-3.8583)	98.000-98.010 (3.8583-3.8587)

### CAUTION:

Oversize must be used in all cylinders when using oversized parts.

**Piston oversize (Service) : 0.20 mm (0.0079 in)**

### NOTE:

- The piston is available together with piston pin as an assembly.
- The piston pin (piston pin bore) grade is provided only for the parts installed at the plant. For service parts, no grades can be selected (only 0 grade is available).
- Hone the cylinder to obtain specified clearance between the piston and cylinder bore when using an oversized piston. Be sure to use the same oversized piston rings.

## HOW TO SELECT CONNECTING ROD BEARING

### When New Connecting Rod and Crankshaft are Used

1. Apply the big end inside diameter grade stamped on the connecting rod side face to the row in the "Connecting Rod Bearing Selection Table".

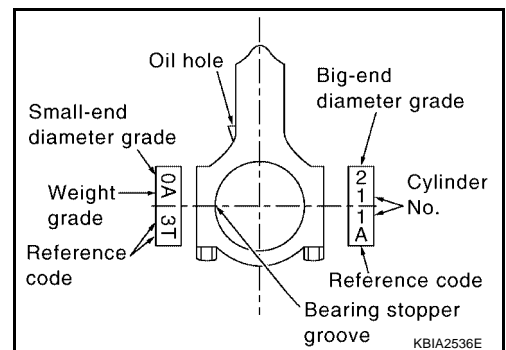

# CYLINDER BLOCK

- Apply the pin diameter grade stamped on the crankshaft front side to the column in the "Connecting Rod Bearing Selection Table".
- Read the symbol at the cross point of the selected row and column in the "Connecting Rod Bearing Selection Table".
- Apply the symbol obtained to the "Connecting Rod Bearing Grade Table" to select.

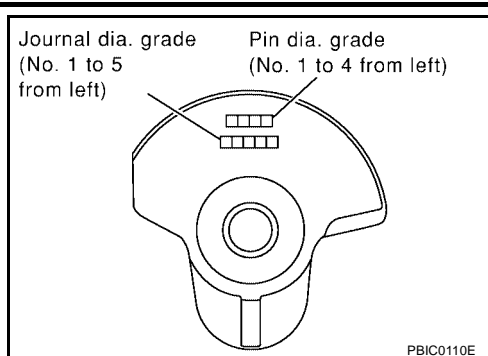

## When Crankshaft and Connecting Rod are Reused

- Measure dimensions of the big end inside diameter of the connecting rod and diameter of the crankshaft pin individually.
- Apply the measured dimension to the "Connecting Rod Bearing Selection Table".
- The following steps are the same as in "When New Connecting Rod and Crankshaft are Used". Refer to [EM-90, "HOW TO SELECT CONNECTING ROD BEARING"](#).

## Connecting Rod Bearing Selection Table

Mark	Outer diameter Unit: mm (in)	Connecting rod big end. inner diameter		Crankshaft pin outer diameter												
		Mark	Inner diameter Unit: mm (in)	0	1	2	3	4	5	6	7	8	9	A	B	C
0	53.968 – 53.974 (2.1247 – 2.1250)	0	57.000 – 57.001 (2.2441 – 2.2441)	0	0	0	0	0	0	1	1	1	1	1	1	2
1	53.962 – 53.968 (2.1245 – 2.1247)	1	57.001 – 57.002 (2.2441 – 2.2442)	1	1	1	1	1	1	2	2	2	2	2	2	3
2	53.956 – 53.962 (2.1243 – 2.1245)	2	57.002 – 57.003 (2.2442 – 2.2442)	2	2	2	2	2	2	3	3	3	3	3	3	3

KBIA2538E

## Connecting Rod Bearing Grade Table.

Grade number	Thickness "T" mm (in)	Identification color (mark)
0	1.500 - 1.503 (0.0591 - 0.0592)	Black
1	1.503 - 1.506 (0.0592 - 0.0593)	Brown
2	1.506 - 1.509 (0.0593 - 0.0594)	Green
3	1.509 - 1.512 (0.0594 - 0.0595)	Yellow

## Undersize Bearings Usage Guide

- When the specified oil clearance is not obtained with standard size connecting rod bearings, use undersize (US) bearings.
- When using undersize bearing, measure the bearing inside diameter with the bearing installed, and grind the crankshaft pin so that the oil clearance satisfies the standard.

# CYLINDER BLOCK

## Bearing undersize table

Unit: mm (in)

Undersize	Thickness
0.25 (0.0098)	1.627 - 1.635 (0.0641 - 0.0644)

### CAUTION:

In grinding the crankshaft pin to use undersize bearings, keep the fillet R (All crankshaft pins).

**Fillet R : 1.5 - 1.7 mm (0.059 - 0.067 in)**

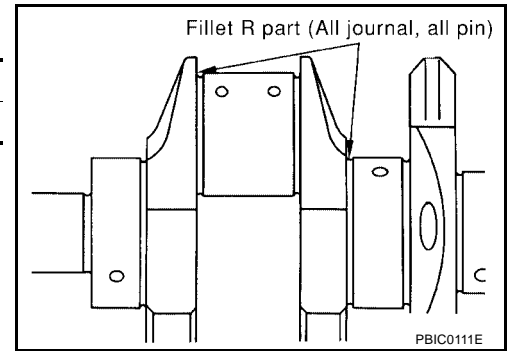

## HOW TO SELECT MAIN BEARING

### When New Cylinder Block and Crankshaft are Used

1. Apply the main bearing housing grade on the bottom face of the cylinder block to the row in "Main Bearings Selection Table".

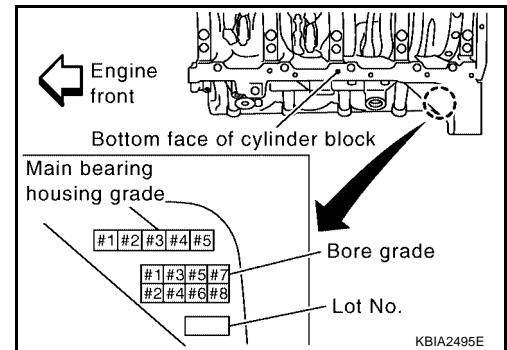

2. Apply the journal diameter grade on the crankshaft front to the column in "Main Bearings Selection Table".

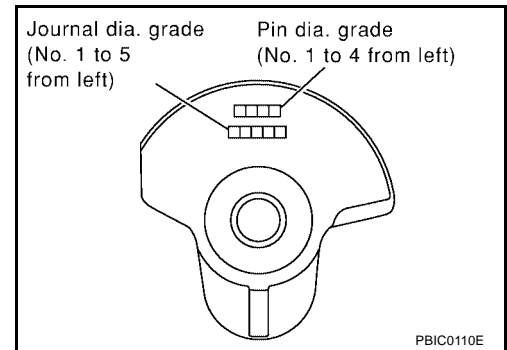

3. Read the symbol at the cross point of the selected row and column in the "Main Bearings Selection Table".

### CAUTION:

- Initial clearance for No. 1, 5 journal and No. 2, 3, 4 journal is different. Use two different selection lists for each part.
- No. 1, 5 journal and No. 2, 3, 4 journal have the same signs but different measures. Do not confuse them.

4. Apply the symbol to the "Main Bearings Grade Table" to select.

### NOTE:

- Grade list applies to all journals.
- Service parts are available as a set of both upper and lower.

### When Cylinder Block and Crankshaft are Reused

1. Measure the inside diameter of the cylinder block main bearings housing and the outside diameter of the crankshaft journal.
2. Apply measurement in above step 1 to "Main Bearings Selection Table".
3. The following steps are same as in "When New Cylinder Block and Crankshaft are Used". Refer to [EM-92, "HOW TO SELECT MAIN BEARING"](#).

# CYLINDER BLOCK

## Main Bearings Selection Table (No. 1 and No. 5 journal)

Cylinder block main bearing housing inner diameter		I.D. mark		Inner diameter Unit: mm (in)																							
				A	B	C	D	E	F	G	H	J	K	L	M	N	P	R	S	T	U	V	W	X	Y	4	7
Crankshaft journal outer diameter	I.D. mark	Outer diameter Unit: mm (in)		Inner diameter Unit: mm (in)																							
				A	B	C	D	E	F	G	H	J	K	L	M	N	P	R	S	T	U	V	W	X	Y	4	7
G	63.964 – 63.963 (2.5183 – 2.5182)	1	1	12	12	12	2	2	2	23	23	23	3	3	3	34	34	34	4	4	4	45	45	45	5	5	
H	63.963 – 63.962 (2.5182 – 2.5182)	1	12	12	12	2	2	2	23	23	23	3	3	3	34	34	34	4	4	4	45	45	45	5	5		
J	63.962 – 63.961 (2.5182 – 2.5181)	12	12	12	2	2	2	23	23	23	3	3	3	34	34	34	4	4	4	45	45	45	5	5	5		
K	63.961 – 63.960 (2.5181 – 2.5181)	12	12	2	2	2	23	23	23	3	3	3	34	34	34	4	4	4	45	45	45	5	5	5	5	56	
L	63.960 – 63.959 (2.5181 – 2.5181)	12	2	2	2	23	23	23	3	3	3	34	34	34	4	4	4	45	45	45	5	5	5	5	56	56	
M	63.959 – 63.958 (2.5181 – 2.5180)	2	2	2	23	23	23	3	3	3	34	34	34	4	4	4	45	45	45	5	5	5	5	56	56	56	
N	63.958 – 63.957 (2.5180 – 2.5180)	2	2	23	23	23	3	3	3	34	34	34	4	4	4	45	45	45	5	5	5	5	56	56	56	6	
P	63.957 – 63.956 (2.5180 – 2.5179)	2	23	23	23	3	3	3	34	34	34	4	4	4	45	45	45	5	5	5	5	56	56	56	6	6	
R	63.956 – 63.955 (2.5179 – 2.5179)	23	23	23	3	3	3	34	34	34	4	4	4	45	45	45	5	5	5	5	56	56	56	6	6	6	
S	63.955 – 63.954 (2.5179 – 2.5179)	23	23	3	3	3	34	34	34	4	4	4	45	45	45	5	5	5	5	56	56	56	6	6	6	67	
T	63.954 – 63.953 (2.5179 – 2.5178)	23	3	3	3	34	34	34	4	4	4	45	45	45	5	5	5	5	56	56	56	6	6	6	67	67	
U	63.953 – 63.952 (2.5178 – 2.5178)	3	3	3	34	34	34	4	4	4	45	45	45	5	5	5	5	56	56	56	6	6	6	67	67	67	
V	63.952 – 63.951 (2.5178 – 2.5178)	3	3	34	34	34	4	4	4	45	45	45	5	5	5	5	56	56	56	6	6	6	67	67	67	7	
W	63.951 – 63.950 (2.5178 – 2.5177)	3	34	34	34	4	4	4	45	45	45	5	5	5	5	56	56	56	6	6	6	67	67	67	7	7	
X	63.950 – 63.949 (2.5177 – 2.5177)	34	34	34	4	4	4	45	45	45	5	5	5	5	56	56	56	6	6	6	67	67	67	7	7	7	
Y	63.949 – 63.948 (2.5177 – 2.5176)	34	34	4	4	4	45	45	45	5	5	5	5	56	56	56	6	6	6	67	67	67	7	7	7	78	
1	63.948 – 63.947 (2.5176 – 2.5176)	34	4	4	4	45	45	45	5	5	5	5	56	56	56	6	6	6	67	67	67	7	7	7	78	78	
2	63.947 – 63.946 (2.5176 – 2.5176)	4	4	4	45	45	45	5	5	5	5	56	56	56	6	6	6	67	67	67	7	7	7	78	78	78	
3	63.946 – 63.945 (2.5176 – 2.5175)	4	4	45	45	45	5	5	5	5	56	56	56	6	6	6	67	67	67	7	7	7	78	78	78	8	
4	63.945 – 63.944 (2.5175 – 2.5175)	4	45	45	45	5	5	5	5	56	56	56	6	6	6	67	67	67	7	7	7	78	78	78	8	8	
5	63.944 – 63.943 (2.5175 – 2.5174)	45	45	45	5	5	5	56	56	56	6	6	6	67	67	67	7	7	7	7	78	78	78	8	8	8	
6	63.943 – 63.942 (2.5174 – 2.5174)	45	45	5	5	5	56	56	56	6	6	6	67	67	67	7	7	7	7	78	78	78	8	8	8	8	
7	63.942 – 63.941 (2.5174 – 2.5174)	45	5	5	5	56	56	56	6	6	6	67	67	67	7	7	7	7	78	78	78	8	8	8	8	8	
9	63.941 – 63.940 (2.5174 – 2.5173)	5	5	5	56	56	56	6	6	6	67	67	67	7	7	7	78	78	78	8	8	8	8	8	8	8	

WBIA0608E

A  
EM  
C  
D  
E  
F  
G  
H  
I  
J  
K  
L  
M

# CYLINDER BLOCK

## Main Bearings Selection Table (No. 2, 3 and 4 journal)

Cylinder block main bearing housing inner diameter  Crankshaft journal outer diameter		I.D. mark	A	B	C	D	E	F	G	H	J	K	L	M	N	P	R	S	T	U	V	W	X	Y	4	7	
		Inner diameter Unit: mm (in)	68.944 – 68.945 (2.7143 – 2.7144)	68.945 – 68.946 (2.7144 – 2.7144)	68.946 – 68.947 (2.7144 – 2.7144)	68.947 – 68.948 (2.7144 – 2.7145)	68.948 – 68.949 (2.7145 – 2.7145)	68.949 – 68.950 (2.7145 – 2.7146)	68.950 – 68.951 (2.7146 – 2.7146)	68.951 – 68.952 (2.7146 – 2.7146)	68.952 – 68.953 (2.7146 – 2.7147)	68.953 – 68.954 (2.7147 – 2.7147)	68.954 – 68.955 (2.7147 – 2.7148)	68.955 – 68.956 (2.7148 – 2.7148)	68.956 – 68.957 (2.7148 – 2.7148)	68.957 – 68.958 (2.7148 – 2.7149)	68.958 – 68.959 (2.7149 – 2.7149)	68.959 – 68.960 (2.7149 – 2.7150)	68.960 – 68.961 (2.7150 – 2.7150)	68.961 – 68.962 (2.7150 – 2.7150)	68.962 – 68.963 (2.7150 – 2.7151)	68.963 – 68.964 (2.7151 – 2.7151)	68.964 – 68.965 (2.7151 – 2.7152)	68.965 – 68.966 (2.7152 – 2.7152)	68.966 – 68.967 (2.7152 – 2.7152)	68.967 – 68.968 (2.7152 – 2.7153)	
I.D. mark	Outer diameter Unit: mm (in)																										
A	63.964 – 63.963 (2.5183 – 2.5182)	0	0	01	01	01	1	1	1	1	12	12	12	2	2	2	23	23	23	3	3	3	34	34	34	4	4
B	63.963 – 63.962 (2.5182 – 2.5182)	0	01	01	01	1	1	1	1	12	12	12	2	2	2	23	23	23	3	3	3	34	34	34	4	4	
C	63.962 – 63.961 (2.5182 – 2.5181)	01	01	01	1	1	1	12	12	12	2	2	2	23	23	23	3	3	3	34	34	34	4	4	4	4	
D	63.961 – 63.960 (2.5181 – 2.5181)	01	01	1	1	1	12	12	12	2	2	2	23	23	23	3	3	3	34	34	34	4	4	4	4	45	
E	63.960 – 63.959 (2.5181 – 2.5181)	01	1	1	1	12	12	12	2	2	2	23	23	23	3	3	3	34	34	34	4	4	4	4	45	45	
F	63.959 – 63.958 (2.5181 – 2.5180)	1	1	1	12	12	12	2	2	2	23	23	23	3	3	3	34	34	34	4	4	4	4	45	45	45	
G	63.958 – 63.957 (2.5180 – 2.5180)	1	1	12	12	12	2	2	2	23	23	23	3	3	3	34	34	34	4	4	4	45	45	45	5	5	
H	63.957 – 63.956 (2.5180 – 2.5179)	1	12	12	12	2	2	2	23	23	23	3	3	3	34	34	34	4	4	4	4	45	45	45	5	5	
J	63.956 – 63.955 (2.5179 – 2.5179)	12	12	12	2	2	2	23	23	23	3	3	3	34	34	34	4	4	4	4	45	45	45	5	5	5	
K	63.955 – 63.954 (2.5179 – 2.5179)	12	12	2	2	2	23	23	23	3	3	3	34	34	34	4	4	4	4	45	45	45	5	5	5	56	
L	63.954 – 63.953 (2.5179 – 2.5178)	12	2	2	2	23	23	23	3	3	3	34	34	34	4	4	4	4	45	45	45	5	5	5	5	56	
M	63.953 – 63.952 (2.5178 – 2.5178)	2	2	2	23	23	23	3	3	3	34	34	34	4	4	4	4	45	45	45	5	5	5	5	56	56	
N	63.952 – 63.951 (2.5178 – 2.5178)	2	2	23	23	23	3	3	3	34	34	34	4	4	4	4	45	45	45	5	5	5	5	56	56	56	
P	63.951 – 63.950 (2.5178 – 2.5177)	2	23	23	23	3	3	3	34	34	34	4	4	4	4	45	45	45	5	5	5	56	56	56	6	6	
R	63.950 – 63.949 (2.5177 – 2.5177)	23	23	23	3	3	3	34	34	34	4	4	4	4	45	45	45	5	5	5	56	56	56	6	6	6	
S	63.949 – 63.948 (2.5177 – 2.5176)	23	23	3	3	3	34	34	34	4	4	4	4	45	45	45	5	5	5	56	56	56	6	6	6	67	
T	63.948 – 63.947 (2.5176 – 2.5176)	23	3	3	3	34	34	34	4	4	4	4	45	45	45	5	5	5	56	56	56	6	6	6	6	67	
U	63.947 – 63.946 (2.5176 – 2.5176)	3	3	3	34	34	34	4	4	4	4	45	45	45	5	5	5	56	56	56	6	6	6	6	67	67	
V	63.946 – 63.945 (2.5176 – 2.5175)	3	3	34	34	34	4	4	4	4	45	45	45	5	5	5	56	56	56	6	6	6	6	6	67	67	
W	63.945 – 63.944 (2.5175 – 2.5175)	3	34	34	34	4	4	4	4	45	45	45	5	5	5	56	56	56	6	6	6	6	67	67	67	7	
X	63.944 – 63.943 (2.5175 – 2.5174)	34	34	34	4	4	4	4	45	45	45	5	5	5	56	56	56	6	6	6	6	67	67	67	7	7	
Y	63.943 – 63.942 (2.5174 – 2.5174)	34	34	4	4	4	4	45	45	45	5	5	5	56	56	56	6	6	6	6	67	67	67	7	7	78	
1	63.942 – 63.941 (2.5174 – 2.5174)	34	4	4	4	4	45	45	45	5	5	5	56	56	56	6	6	6	6	67	67	67	7	7	7	78	
2	63.941 – 63.940 (2.5174 – 2.5173)	4	4	4	45	45	45	5	5	5	5	56	56	56	6	6	6	6	67	67	67	7	7	7	78	78	

WBIA0609E

# CYLINDER BLOCK

## Main Bearings Grade Table (All Journals)

Unit: mm (in)

Grade number	UPR/LWR	Thickness	Identification color	Remarks
0	—	2.483 - 2.486 (0.0978 - 0.0979)	Black	Grade is the same for upper and lower bearings.
1	—	2.486 - 2.489 (0.0979 - 0.0980)	Brown	
2	—	2.489 - 2.492 (0.0980 - 0.0981)	Green	
3	—	2.492 - 2.495 (0.0981 - 0.0982)	Yellow	
4	—	2.495 - 2.498 (0.0982 - 0.0983)	Blue	
5	—	2.498 - 2.501 (0.0983 - 0.0985)	Pink	
6	—	2.501 - 2.504 (0.0985 - 0.0986)	Purple	
7	—	2.504 - 2.507 (0.0986 - 0.0987)	White	
8	—	2.507 - 2.510 (0.0987 - 0.0988)	Red	
01	UPR	2.483 - 2.486 (0.0978 - 0.0979)	Black	Grade and color are different for upper and lower bearings.
	LWR	2.486 - 2.489 (0.0979 - 0.0980)	Brown	
12	UPR	2.486 - 2.489 (0.0979 - 0.0980)	Brown	
	LWR	2.489 - 2.492 (0.0980 - 0.0981)	Green	
23	UPR	2.489 - 2.492 (0.0980 - 0.0981)	Green	
	LWR	2.492 - 2.495 (0.0981 - 0.0982)	Yellow	
34	UPR	2.492 - 2.495 (0.0981 - 0.0982)	Yellow	
	LWR	2.495 - 2.498 (0.0982 - 0.0983)	Blue	
45	UPR	2.495 - 2.498 (0.0982 - 0.0983)	Blue	
	LWR	2.498 - 2.501 (0.0983 - 0.0985)	Pink	
56	UPR	2.498 - 2.501 (0.0983 - 0.0985)	Pink	
	LWR	2.501 - 2.504 (0.0985 - 0.0986)	Purple	
67	UPR	2.501 - 2.504 (0.0985 - 0.0986)	Purple	
	LWR	2.504 - 2.507 (0.0986 - 0.0987)	White	
78	UPR	2.504 - 2.507 (0.0986 - 0.0987)	White	
	LWR	2.507 - 2.510 (0.0987 - 0.0988)	Red	

### Use Undersize Bearing Usage Guide

- Use undersize (US) bearing when the oil clearance with standard size main bearing is not within specification.
- When using undersize (US) bearing, measure the inside diameter of the bearing installed and grind the journal until the oil clearance falls within specification.

#### Bearing undersize table

Undersize	Thickness
0.25 (0.0098)	2.618 - 2.626 (0.1031 - 0.1034)

Unit: mm (in)

#### CAUTION:

**Do not damage fillet R when grinding crankshaft journal in order to use undersized bearing (All journals).**

**Fillet R : 1.5 - 1.7 mm (0.059 - 0.067 in)**

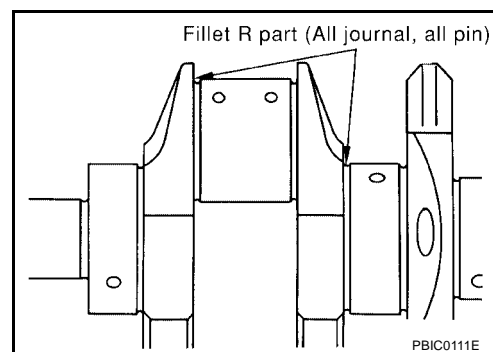

PBIC0111E

# CYLINDER BLOCK

EBS00U9G

## Inspection After Disassembly CRANKSHAFT END PLAY

- Move the crankshaft fully forward and backward and measure the clearance between the thrust bearings and crankshaft arm using suitable tool.

**Standard** : 0.10 - 0.26 mm (0.0039 - 0.0102 in)

**Limit** : 0.30 mm (0.0118 in)

- If measured value exceeds the repair limit, replace the thrust bearings, and measure again. If it still exceeds the repair limit, replace crankshaft also.

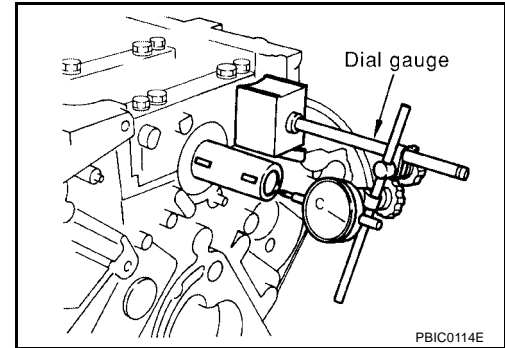

## CONNECTING ROD SIDE CLEARANCE

- Measure side clearance between the connecting rod and crankshaft arm using suitable tool.

**Standard** : 0.20 - 0.40 mm (0.0079 - 0.0157 in)

**Limit** : 0.40 mm (0.0157 in)

- If measured value exceeds the repair limit, replace the connecting rod bearings, and measure again. If it still exceeds the repair limit, replace the crankshaft also.

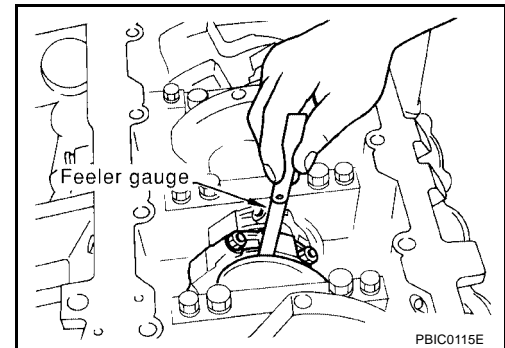

## PISTON AND PISTON PIN CLEARANCE

### Piston Pin Hole Diameter

- Measure diameter of piston pin hole using suitable tool.

**Standard** : 21.993 - 21.999 mm (0.8659 - 0.8661 in)

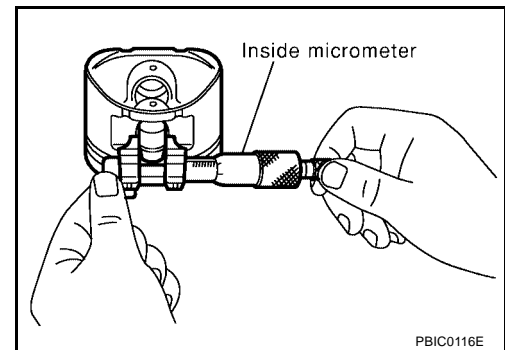

### Piston Pin Diameter

- Measure diameter of piston pin using suitable tool.

**Standard** : 21.989 - 21.995 mm (0.8657 - 0.8659 in)

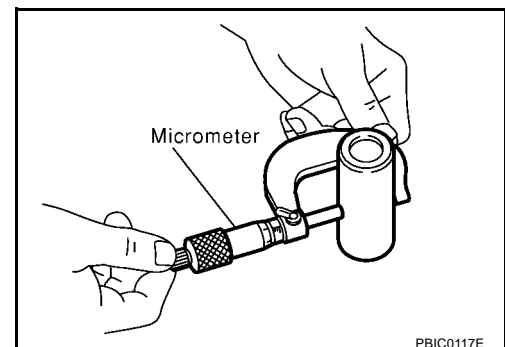



# CYLINDER BLOCK

## Piston and Piston Pin Clearance

(Piston pin clearance) = (Piston pin hole diameter) – (Piston pin diameter)

**Standard : 0.002 - 0.006 mm (0.0001 - 0.0002 in)**

- If clearance exceeds specification, replace either or both the piston/piston pin assembly and the connecting rod assembly with reference to the specification of each part.
- Refer to the piston selection table to replace piston/piston pin assembly. Refer to [EM-89, "HOW TO SELECT PISTON"](#).
- Refer to the connecting rod bearing selection table to replace connecting rod. Refer to [EM-90, "HOW TO SELECT CONNECTING ROD BEARING"](#).

### NOTE:

The connecting rod small end grade and piston pin hole (piston pin) grade are provided only for the parts installed at the plant. For service parts, no grades can be selected (only 0 grade is available).

- Refer to [EM-98, "CONNECTING ROD BUSHING OIL CLEARANCE \(SMALL END\)"](#) for the values for each grade at the plant.

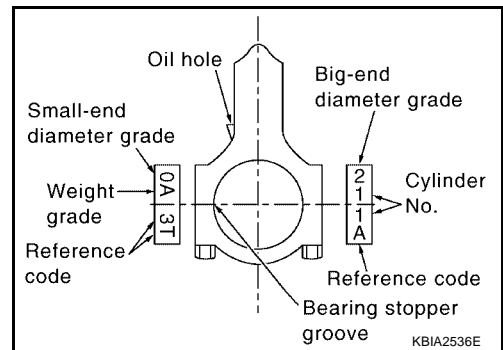
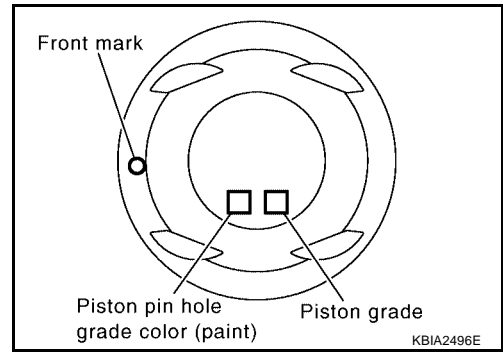

## PISTON RING SIDE CLEARANCE

- Measure side clearance of the piston ring and piston ring groove using suitable tool.

### Standard:

**Top ring : 0.035 - 0.085 mm (0.0014 - 0.0033 in)**

**2nd ring : 0.030 - 0.070 mm (0.0012 - 0.0028 in)**

**Oil ring : 0.015 - 0.050 mm (0.0006 - 0.0020 in)**

### Limit:

**Top ring : 0.11 mm (0.0043 in)**

**2nd ring : 0.10 mm (0.0039 in)**

- If out of specification, replace piston and/or piston ring assembly.

## PISTON RING END GAP

- Check if the diameter of the cylinder bore is within specification. Refer to [EM-101, "Piston to Cylinder Bore Clearance"](#).
- Insert the piston ring into the middle of the cylinder using the piston, and measure the gap.

### Standard

**Top ring : 0.23 - 0.33 mm (0.0091 - 0.0130 in)**

**2nd ring : 0.25 - 0.40 mm (0.0098 - 0.0157 in)**

**Oil ring : 0.20 - 0.60 mm (0.0079 - 0.0236 in)**

### Limit:

**Top ring : 0.56 mm (0.0220 in)**

**2nd ring : 0.52 mm (0.0205 in)**

**Oil ring : 0.96 mm (0.0378 in)**

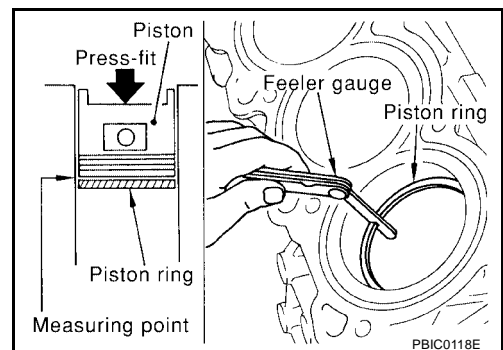
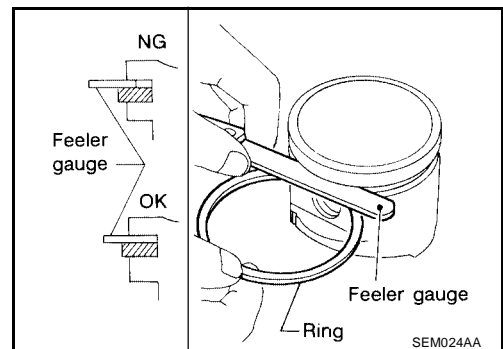

# CYLINDER BLOCK

- If out of specification, replace piston ring. If the gap still exceeds the limit even with a new ring, re-bore the cylinder and use oversized piston and piston ring.

## CONNECTING ROD BEND AND TORSION

- Check connecting rod alignment using suitable tool.

**Limit:**

**Bend**

: 0.15 mm (0.0059 in) per 100 mm (3.94 in) length

**Torsion**

: 0.30 mm (0.0118 in) per 100 mm (3.94 in) length

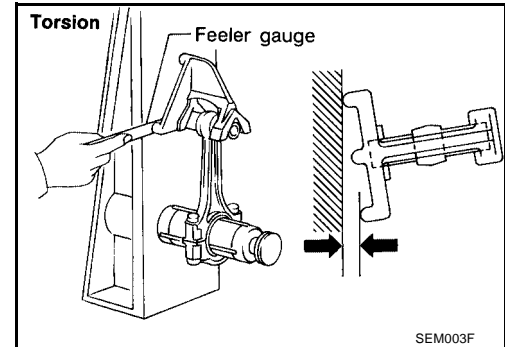

- If measurement exceeds the limit, replace connecting rod assembly.

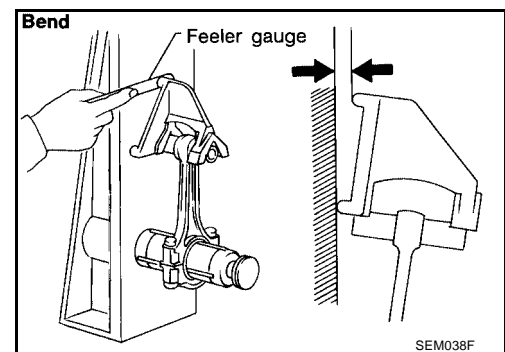

## CONNECTING ROD BEARING (BIG END)

- Install the connecting rod cap without the connecting rod bearing installed. After tightening the connecting rod bolt to the specified torque, measure the connecting rod large end inside diameter. Refer to [EM-84, "ASSEMBLY"](#).

**Standard** : 57.000 - 57.013 mm (2.2441 - 2.2446 in)

- If measurement exceeds the standard, replace connecting rod.

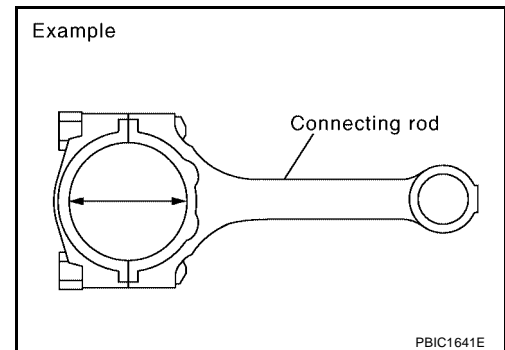

## CONNECTING ROD BUSHING OIL CLEARANCE (SMALL END)

### Connecting Rod Inside Diameter (Small End)

- Measure inside diameter of bushing using suitable tool.

**Standard** : 22.000 - 22.006 mm (0.8661 - 0.8664 in)

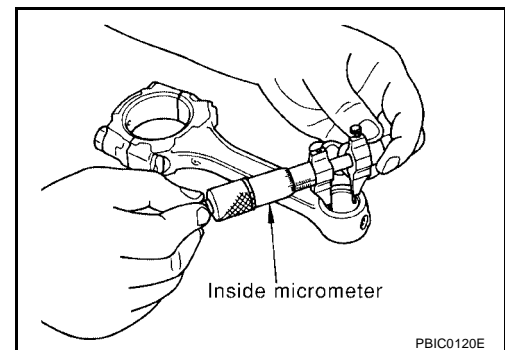

# CYLINDER BLOCK

## Piston Pin Diameter

- Measure diameter of piston pin using suitable tool.

**Standard : 21.989 - 21.995 mm (0.8657 - 0.8659 in)**

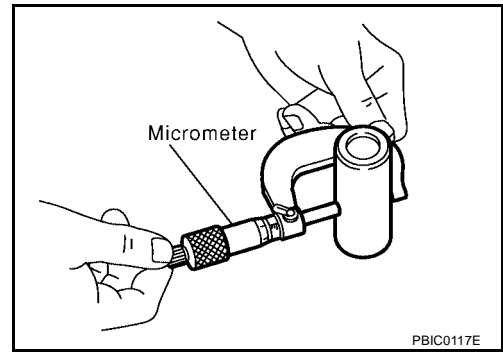

## Connecting Rod Bushing Oil Clearance (Small End)

(Connecting rod small end oil clearance) = (Inside diameter of connecting rod small end) – (Piston pin diameter)

**Standard : 0.005 - 0.017 mm (0.0002 - 0.0007 in)**

- If measured value exceeds the standard, replace the connecting rod assembly and/or piston and piston pin assembly.
- If replacing the piston and piston pin assembly, refer to the Table for Selective Fitting for Piston to select the piston corresponding to the applicable bore grade of the cylinder block to be used. Refer to [EM-89, "HOW TO SELECT PISTON"](#).

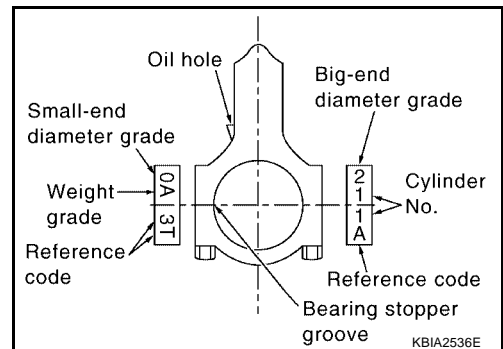

## Factory installed parts grading:

- Only grade 0 is available.

	Unit: mm (in)
Grade	0
Connecting rod bushing inside diameter	22.000 - 22.006 (0.8661 - 0.8664)
Piston pin diameter	21.989 - 21.995 (0.8657 - 0.8659)
Piston pin hole diameter	21.993 - 21.999 (0.8659 - 0.8661)

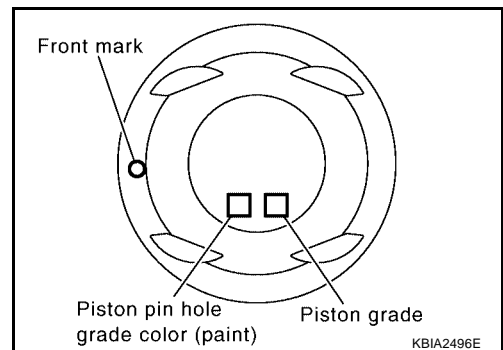

## CYLINDER BLOCK DISTORTION

- Remove any oil, scale, gasket, sealant and carbon deposits from the cylinder block surface.

### CAUTION:

**Do not allow any debris to enter the oil or coolant passages.**

- Measure block upper face for distortion in six directions as shown.

**Standard : 0.03 mm (0.0012 in)**

**Limit : 0.1 mm (0.004 in)**

- If measurement exceeds the limit, replace cylinder block.

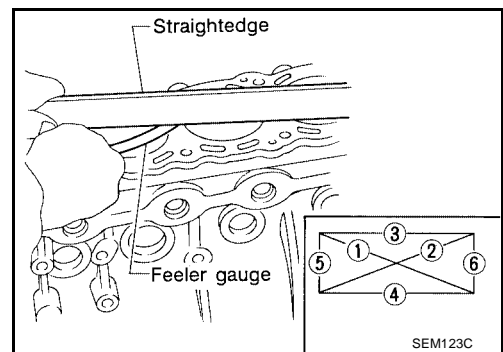

# CYLINDER BLOCK

## MAIN BEARING HOUSING INSIDE DIAMETER

- Install the main bearing caps with the main bearings removed, and tighten the bolts to the specified torque. Refer to [EM-84, "ASSEMBLY"](#).
- Measure inside diameter of main bearing housing.

**Standard** : 68.944 - 68.968 mm (2.7143 - 2.7153 in)

- If out of the standard, replace cylinder block and main bearing caps as an assembly.

### NOTE:

These components must be replaced as a single unit, because they were processed together.

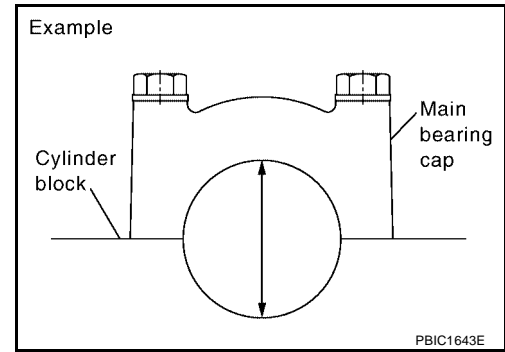

## PISTON TO CYLINDER BORE CLEARANCE

### Cylinder Bore Diameter

- Measure the cylinder bore for wear, out-of-round and taper at six different points on each cylinder ("X" and "Y" directions at "A", "B" and "C").

### NOTE:

When determining cylinder bore grade, measure cylinder bore at "B" position.

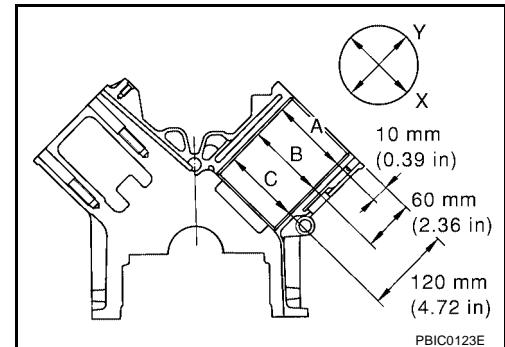

### Standard diameter:

98.000 - 98.030 mm (3.8583 - 3.8594 in)

### Wear limit:

0.20 mm (0.0079 in)

### Out-of-round (Difference between "X" and "Y"):

Limit: 0.015 mm (0.0006 in)

### Taper limit (Difference between "A" and "C"):

Limit: 0.010 mm (0.0004 in)

- If measured value exceeds the repair limit, or if there are scratches and/or seizure on the cylinder inner wall, hone or bore the inner wall.
- An oversize piston is provided. When using an oversize piston, hone the cylinder so that the clearance between the piston and cylinder satisfies the standard.

**Piston oversize Grade No. 0 (Service)** : 0.20 mm (0.0079 in)

- If oversize piston is used, use it for all cylinders with oversize piston rings.

### Piston Skirt Diameter

- Measure piston skirt diameter using suitable tool.

**Standard** : 97.980 - 98.010 mm (3.8575 - 3.8587 in)

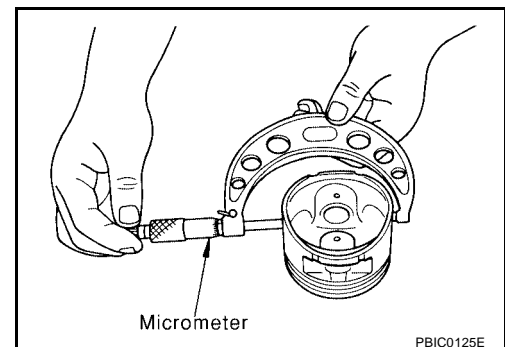
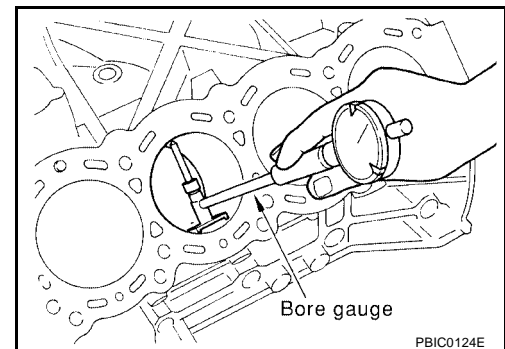

# CYLINDER BLOCK

- Measure point "H".

**Distance from the top : 39 mm (1.54 in)**

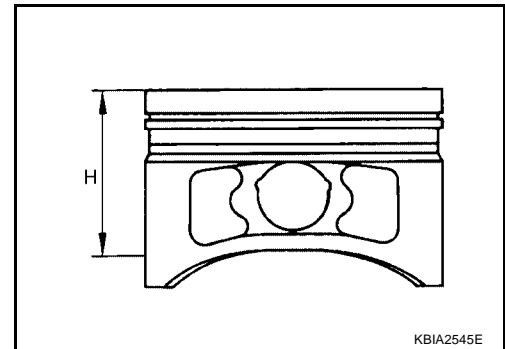

## Piston to Cylinder Bore Clearance

- Calculate by using diameter of the piston skirt and the cylinder bore diameter (direction X, position B).  
(Clearance) = (Cylinder bore diameter) – (piston skirt diameter)

**Standard : 0.010 - 0.030 mm (0.0004 - 0.0012 in)**

**Limit : 0.08 mm (0.0031 in)**

- If calculation exceeds the limit, replace piston/piston pin assembly.

## Reboring Cylinder Bore

1. Cylinder bore size is determined by adding piston-to-bore clearance to piston diameter "A".

**Rebored size calculation:  $D = A + B - C$**

**where,**

**D: Bored diameter**

**A: Piston diameter as measured**

**B: Piston - to - bore clearance (standard value)**

**C: Honing allowance 0.02 mm (0.0008 in)**

2. Install main bearing caps, and tighten them to the specified torque. Otherwise, cylinder bores may be distorted in final assembly.
3. Cut the cylinder bores.

### NOTE:

- When any cylinder needs boring, all other cylinders must also be bored.
- Do not cut too much out of cylinder bore at one time. Cut only 0.05 mm (0.0020 in) or so in diameter at a time.

- 4.hone cylinders to obtain the specified piston-to-bore clearance.
5. Measure finished cylinder bore for out-of-round and taper.

### NOTE:

Measurement should be done after cylinder bore cools down.

## CRANKSHAFT JOURNAL DIAMETER

- Measure diameter of crankshaft journals.

**Standard : 63.940 - 63.964 mm (2.5173 - 2.5183 in)**

- If measurement is out of standard, measure the main bearing oil clearance. Then use the undersize bearing. Refer to [EM-103, "MAIN BEARING OIL CLEARANCE"](#).

# CYLINDER BLOCK

## CRANKSHAFT PIN DIAMETER

- Measure diameter of crankshaft pin using suitable tool.

**Standard : 53.956 - 53.974 mm (2.1243 - 2.1250 in)**

- If measurement is out of standard, measure connecting rod bearing oil clearance. Then use undersize bearing. Refer to [EM-102, "CONNECTING ROD BEARING OIL CLEARANCE"](#) .

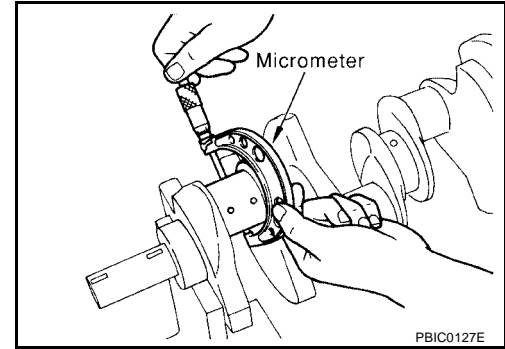

## OUT-OF-ROUND AND TAPER OF CRANKSHAFT

- Measure dimensions at four different points as shown on each journal and pin.
- Out-of-roundness is indicated by the difference in dimension between "X" and "Y" at "A" and "B".
- Taper is indicated by the difference in dimension between "A" and "B" at "X" and "Y".

### Limit

**Out-of-round (Difference between "X" and "Y")**

**: 0.002 mm (0.0001 in)**

**Taper (Difference between "A" and "B")**

**: 0.002 mm (0.0001 in)**

- If measured value exceeds the standard, correct or replace crankshaft.
- If corrected, measure the bearing oil clearance of the corrected journal or pin. Then select the main bearing or connecting rod bearing. Refer to [EM-103, "MAIN BEARING OIL CLEARANCE"](#) or [EM-102, "CONNECTING ROD BEARING OIL CLEARANCE"](#) .

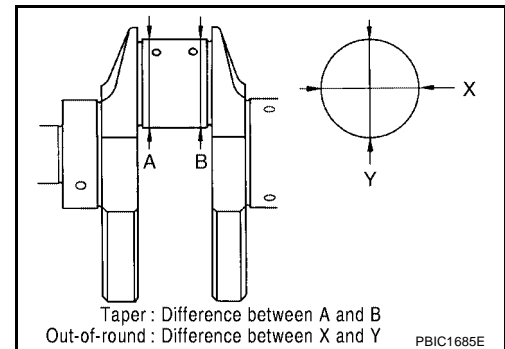

## CRANKSHAFT RUNOUT

- Place a V-block on a precise flat table to support the journals on both ends of the crankshaft.
- Measure at No. 3 journal using suitable tool.
- While rotating crankshaft, read the movement of the pointer.
- Half of the movement shows the runout.

**Limit : Less than 0.05 mm (0.002 in)**

- If measurement exceeds the limit, replace crankshaft.

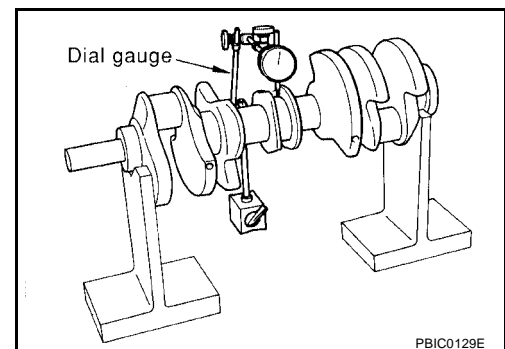

## CONNECTING ROD BEARING OIL CLEARANCE

### Method of Measurement

- Install connecting rod bearings to the connecting rod and cap. Tighten connecting rod bolts to the specified torque. Refer to [EM-84, "ASSEMBLY"](#) .

# CYLINDER BLOCK

Measure inside diameter of connecting rod bearing.  
(Oil clearance) = (Inside diameter of connecting rod bearing) – (Crankshaft pin diameter)

**Standard** : 0.020 - 0.039 mm (0.0008 - 0.0015 in)

**Limit** : 0.055 mm (0.0022 in)

- If clearance cannot be adjusted within the standard, grind crankshaft pin and use undersized bearing. Refer to [EM-92. "HOW TO SELECT MAIN BEARING"](#) .

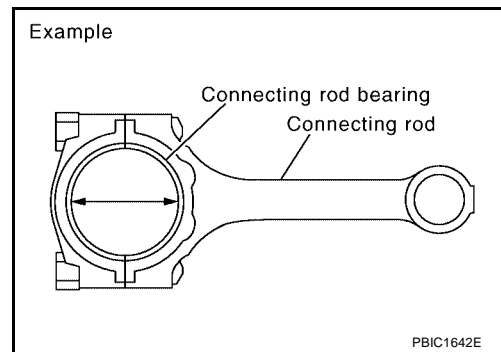

## Method of Using Plastigage

- Remove oil and dust on the crankshaft pin and surfaces of each bearing completely.
- Cut a plastigage slightly shorter than the bearing width, and place it in the crankshaft axial direction, avoiding oil holes.
- Install the connecting rod bearings to the connecting rod and connecting rod bearing cap, and tighten the connecting rod bolts to the specified torque.

### CAUTION:

**Do not rotate crankshaft with plastigage installed.**

- Remove the connecting rod bearing cap and bearings. Measure the plastigage width using the scale on the plastigage bag.

### NOTE:

The procedure when the measured value exceeds the repair limit is the same as that described in "Method of Measurement".

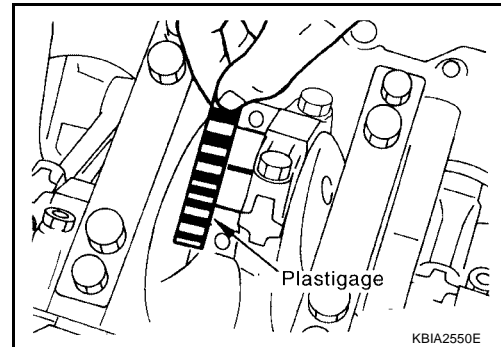

## MAIN BEARING OIL CLEARANCE

### Method of Measurement

- Install the main bearings to the cylinder block and main bearing cap. Measure the main bearing inside diameter with the bearing cap bolts tightened to the specified torque. Refer to [EM-84. "ASSEMBLY"](#) .

(Oil clearance) = (Inside diameter of main bearing) – (Crankshaft journal diameter)

### Standard:

**No. 1 and 5 journals**

: 0.001 - 0.011 mm (0.00004 - 0.0004 in)

**No. 2, 3 and 4 journals**

: 0.007 - 0.017 mm (0.0003 - 0.0007 in)

### Limit:

**No.1 and 5 journals**

: 0.021 mm (0.0008 in)

**No. 2, 3 and 4 journals**

: 0.027 mm (0.0011 in)

- If measured value exceeds the repair limit, select main bearings referring to the main bearing inside diameter and crankshaft journal diameter, so that the oil clearance satisfies the standard. Refer to [EM-92. "HOW TO SELECT MAIN BEARING"](#) .

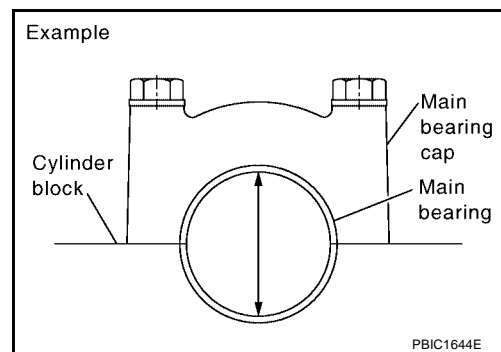

# CYLINDER BLOCK

## Method of Using Plastigage

- Remove oil and dust on the crankshaft journal and surfaces of each bearing completely.
- Cut a plastigage slightly shorter than the bearing width, and place it in crankshaft axial direction, avoiding oil holes.
- Install the main bearings to the cylinder block and main bearing cap, and tighten the main bearing bolts to the specified torque.

### CAUTION:

**Do not rotate crankshaft with plastigage installed.**

- Remove bearing cap and bearings. Measure plastigage width using the scale on the plastigage bag.

### NOTE:

The procedure when the measured value exceeds the repair limit is the same as that described in "Method of Measurement".

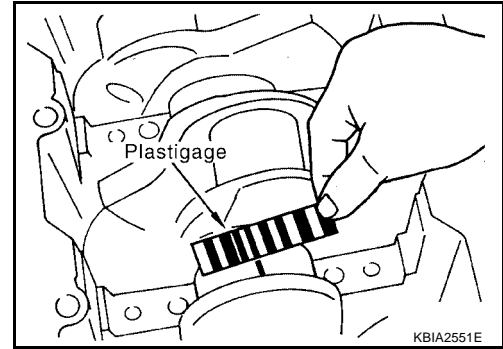

## CRUSH HEIGHT OF MAIN BEARING

- When the bearing cap is removed after being tightened to the specified torque with main bearings installed, the tip end of the bearing must protrude. Refer to [EM-84, "ASSEMBLY"](#) for the tightening procedure.

**Standard : There must be crush height**

- If standard is not met, replace main bearings.

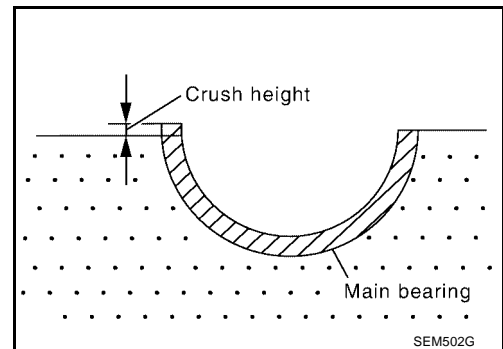

## CRUSH HEIGHT OF CONNECTING ROD BEARING

- When connecting rod bearing cap is removed after being tightened to the specified torque with the connecting rod bearings installed, the tip end of the bearing must protrude. Refer to [EM-84, "ASSEMBLY"](#) for tightening procedure.

**Standard : There must be crush height.**

- If standard is not met, replace connecting rod bearings.

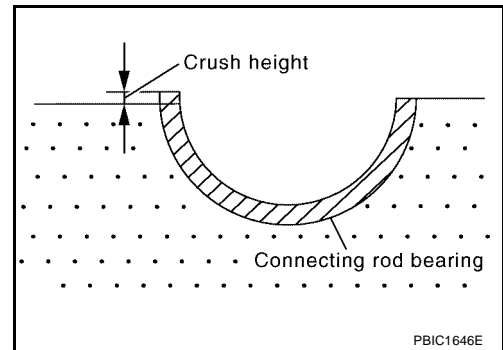

## MAIN BEARING CAP BOLT DIAMETER

- Check for bolts (M9 and M12) installed from lower side using the following procedure.

### NOTE:

- Side bolt (M10) is outside the target.
- Figure shows M12 bolt.
- Measure bolt diameter "d1" from tip of the bolt to dimension "a".
- Measure bolt diameter "d2" from the dimension between tip of the bolt and dimension "b" as base station to dimension "c".

### NOTE:

If a narrower part in the threads is determined by visual check, measure "d2" at that point.

- Calculate the difference between "d1" and "d2".

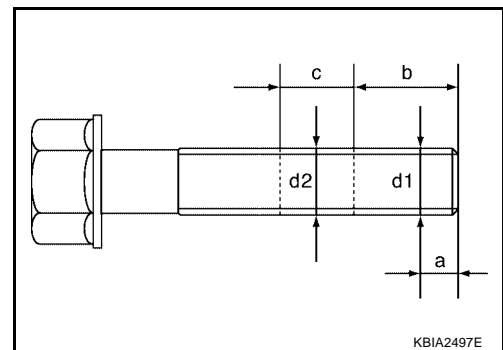



# CYLINDER BLOCK

## M9 bolt

Dimension "a"	: 9 mm (0.35 in)
Dimension "b"	: 15 mm (0.59 in)
Dimension "c"	: 20 mm (0.79 in)
Limit	: 0.10 mm (0.0039 in)

## M12 bolt

Dimension "a"	: 12 mm (0.47 in)
Dimension "b"	: 55 mm (2.17 in)
Dimension "c"	: 20 mm (0.79 in)
Limit	: 0.15 mm (0.0059 in)

- Replace applicable bolts if outside the limit.

## CONNECTING ROD BOLT DIAMETER

- Measure diameter "d" at position shown.
- When "d" is out of specifications (when it becomes thinner), replace bolt with a new one.

**Limit : 7.75 mm (0.3051 in) or less.**

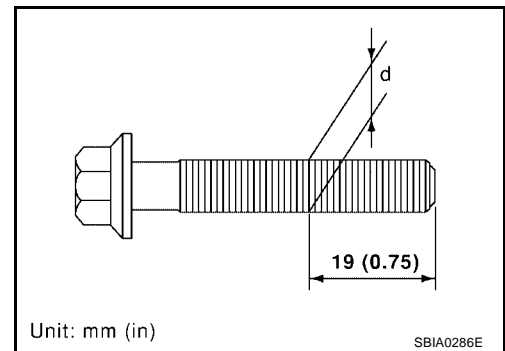

A

EM

C

D

E

F

G

H

I

J

K

L

M

# SERVICE DATA AND SPECIFICATIONS (SDS)

## SERVICE DATA AND SPECIFICATIONS (SDS)

PFP:00030

### Standard and Limit GENERAL SPECIFICATIONS

EBS00U9H

Cylinder arrangement		V-8
Displacement cm <sup>3</sup> (in <sup>3</sup> )		5,552 (338.80)
Bore and stroke mm (in)		98 x 92 (3.86 x 3.62)
Valve arrangement		DOHC
Firing order		1-8-7-3-6-5-4-2
Number of piston rings	Compression	2
	Oil	1
Number of main bearings		5
Compression ratio		9.8:1
Compression pressure kPa (kg/cm <sup>2</sup> , psi)/rpm	Standard	1,520 (15.5, 220)/200
	Minimum	1,324 (13.5, 192)/200
	Differential limit between cylinders	98 (1.0, 14)/200

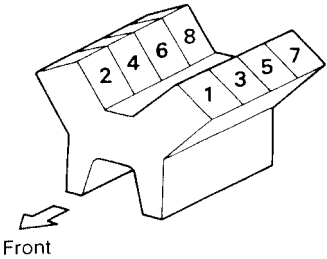
Cylinder number	 <p style="text-align: right;">SEM957C</p>
-----------------	---

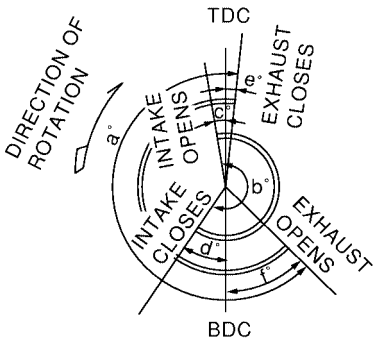
Valve timing	 <p style="text-align: right;">PBIC0187E</p>
--------------	--

Unit: degree

a	b	c	d	e	f
244°	232°	8°	60°	10°	54°

### DRIVE BELTS

Tension of drive belts	Auto adjustment by auto tensioner
------------------------	-----------------------------------

### EXHAUST MANIFOLD

Unit: mm (in)

Items	Exhaust manifold	Limit
Surface distortion	Exhaust manifold	0.3 (0.012)

# SERVICE DATA AND SPECIFICATIONS (SDS)

## CAMSHAFT AND CAMSHAFT BEARING

Unit: mm (in)

Items	Standard
Camshaft runout [TIR*]	Less than 0.02 (0.0008)

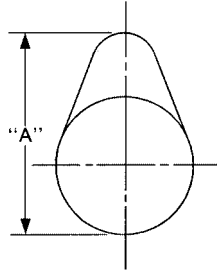

Camshaft cam height "A"	Intake	44.865 - 45.055 (1.7663 - 1.7738)
	Exhaust	45.075 - 45.265 (1.7746 - 1.7821)
	Cam wear limit	0.02 (0.0008)
Outside diameter of camshaft journal		25.950 - 25.970 (1.0217 - 1.0224)
Camshaft bracket inside diameter		26.000 - 26.021 (1.0236 - 1.0244)
Camshaft journal clearance		0.030 - 0.071 (0.0012 - 0.0028)
Camshaft end play		0.115 - 0.188 (0.0045 - 0.0074)
Camshaft sprocket runout [TIR*]		Less than 0.15 (0.0059)

\*: Total indicator reading

## Valve Lifter

Unit: mm (in)

Items	Standard
Valve lifter diameter	33.977 - 33.987 (1.3377 - 1.3381)
Valve lifter hole diameter	34.000 - 34.016 (1.3386 - 1.3392)
Clearance between lifter and lifter guide	0.013 - 0.039 (0.0005 - 0.0015)

## Valve Clearance

Unit: mm (in)

Items	Hot*	Cold
Intake	0.304 - 0.416 (0.012 - 0.016)	0.26 - 0.34 (0.010 - 0.013)
Exhaust	0.308 - 0.432 (0.012 - 0.017)	0.29 - 0.37 (0.011 - 0.015)

\*: Approximately 80°C (176°F)

# SERVICE DATA AND SPECIFICATIONS (SDS)

## Available Valve Lifter

Unit: mm (in)

Identification (stamped) Mark	Thickness
-------------------------------	-----------

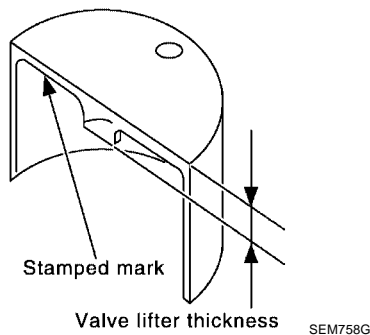

N788	7.88 (0.3102)
N790	7.90 (0.3110)
N792	7.92 (0.3118)
N794	7.94 (0.3126)
N796	7.96 (0.3134)
N798	7.98 (0.3142)
N800	8.00 (0.3150)
N802	8.02 (0.3157)
N804	8.04 (0.3165)
N806	8.06 (0.3173)
N808	8.08 (0.3181)
N810	8.10 (0.3189)
N812	8.12 (0.3197)
N814	8.14 (0.3205)
N816	8.16 (0.3213)
N818	8.18 (0.3220)
N820	8.20 (0.3228)
N822	8.22 (0.3236)
N824	8.24 (0.3244)
N826	8.26 (0.3252)
N828	8.28 (0.3260)
N830	8.30 (0.3268)
N832	8.32 (0.3276)
N834	8.34 (0.3283)
N836	8.36 (0.3291)

# SERVICE DATA AND SPECIFICATIONS (SDS)

## CYLINDER HEAD

Unit: mm (in)

Items	Standard	Limit
Head surface distortion	0.03 (0.0012)	0.1 (0.004)
Nominal cylinder head height "H"	126.3 (4.97)	

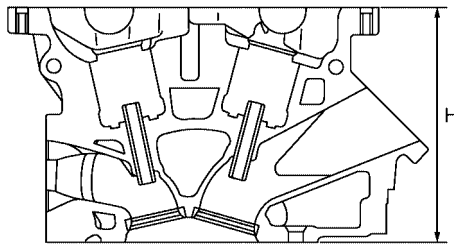

KBIA2554E

## Valve Dimensions

Unit: mm (in)

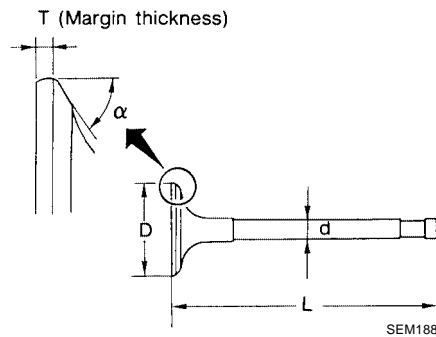

Valve head diameter "D"	Intake	37.0 - 37.3 (1.457 - 1.469)
	Exhaust	31.2 - 31.5 (1.228 - 1.240)
Valve length "L"	Intake	96.21 - 96.71 (3.7878 - 3.8075)
	Exhaust	93.74 - 94.24 (3.6905 - 3.7102)
Valve stem diameter "d"	Intake	5.965 - 5.980 (0.2348 - 0.2354)
	Exhaust	5.955 - 5.970 (0.2344 - 0.2350)
Valve seat angle " $\alpha$ "	Intake	45°15' - 45°45'
	Exhaust	
Valve margin "T"	Intake	1.1 (0.043)
	Exhaust	1.3 (0.051)

# SERVICE DATA AND SPECIFICATIONS (SDS)

## Valve Guide

Unit: mm (in)

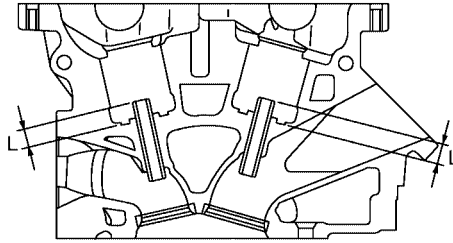

KBIA2555E

Items		Standard	Oversize [0.2 (0.008)] (service)
Valve guide	Outside diameter	10.023 - 10.034 (0.3946 - 0.3950)	10.223 - 10.234 (0.4025 - 0.4029)
	Inside diameter (Finished size)	6.000 - 6.018 (0.2362 - 0.2369)	—
Cylinder head valve guide hole diameter		9.975 - 9.996 (0.3927 - 0.3935)	10.175 - 10.196 (0.4006 - 0.4014)
Interference fit of valve guide		0.027 - 0.059 (0.0011 - 0.0023)	
Items		Standard	Limit
Stem to guide clearance	Intake	0.020 - 0.053 (0.0008 - 0.0021)	0.08 (0.0031)
	Exhaust	0.030 - 0.063 (0.0012 - 0.0025)	0.09 (0.0035)
Projection length "L"	Intake	12.6 - 12.8 (0.496 - 0.504)	
	Exhaust	12.5 - 12.9 (0.492 - 0.508)	

## Valve Seat

Unit: mm (in)

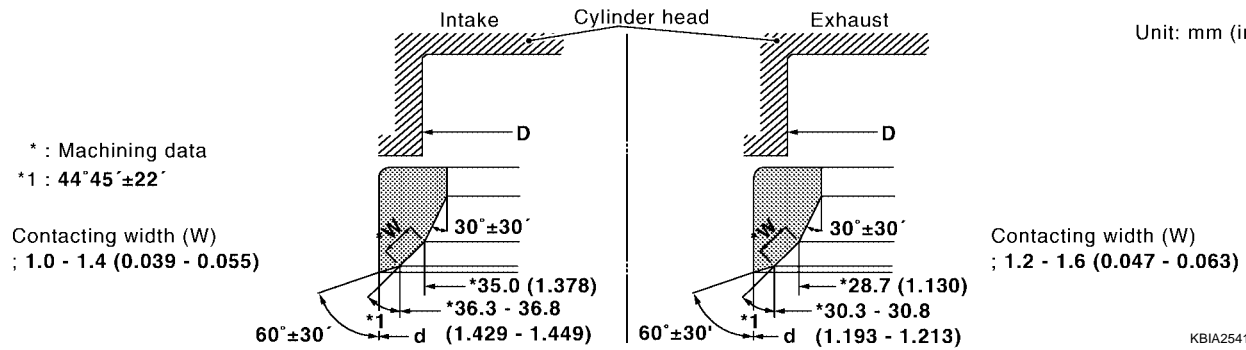

Items		Standard	Oversize [0.5 (0.020)] (Service)
Cylinder head seat recess diameter "D"	Intake	38.000 - 38.016 (1.4961 - 1.4967)	38.500 - 38.516 (1.5157 - 1.5164)
	Exhaust	32.200 - 32.216 (1.2677 - 1.2683)	32.700 - 32.716 (1.2874 - 1.2880)
Valve seat interference fit	Intake	0.081 - 0.113 (0.0032 - 0.0044)	
	Exhaust	0.064 - 0.096 (0.0025 - 0.0038)	
Valve seat diameter "d"	Intake	38.097 - 38.113 (1.4999 - 1.5005)	38.597 - 38.613 (1.5196 - 1.5202)
	Exhaust	32.280 - 32.296 (1.2709 - 1.2715)	32.780 - 32.796 (1.2905 - 1.2912)

## Valve Spring

Free height	mm (in)	50.58 (1.9913)
Pressure	N (kg, lb) at height mm (in)	165.8 - 187.0 (16.9 - 19.1, 37 - 42) at 37.0 (1.457)
	Valve open	314.8 - 355.0 (32.1 - 36.2, 71 - 80) at 28.2 (1.110)
Out-of-square	mm (in)	Less than 2.2 (0.087)

# SERVICE DATA AND SPECIFICATIONS (SDS)

## CYLINDER BLOCK

Unit: mm (in)

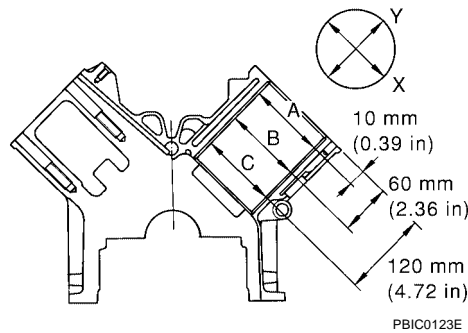

Surface flatness	Standard	0.03 (0.0012)	
	Limit	0.1 (0.004)	
Main bearing housing inside diameter	Standard	68.944 - 68.968 (2.7143 - 2.7153)	
Cylinder bore diameter	Standard	Grade No. 1	98.000 - 98.010 (3.8583 - 3.8587)
		Grade No. 2	98.010 - 98.020 (3.8587 - 3.8590)
		Grade No. 3	98.020 - 98.030 (3.8590 - 3.8594)
	Wear limit	0.20 (0.0079)	
Out-of-round (Difference between "X" and "Y")	Limit	0.015 (0.0006)	
Taper (Difference between "A" and "C")		0.010 (0.0004)	
Main journal inside diameter grade (Without bearing)	Grade No. A	68.944 - 68.945 (2.7143 - 2.7144)	
	Grade No. B	68.945 - 68.946 (2.7144 - 2.7144)	
	Grade No. C	68.946 - 68.947 (2.7144 - 2.7144)	
	Grade No. D	68.947 - 68.948 (2.7144 - 2.7145)	
	Grade No. E	68.948 - 68.949 (2.7145 - 2.7145)	
	Grade No. F	68.949 - 68.950 (2.7145 - 2.7146)	
	Grade No. G	68.950 - 68.951 (2.7146 - 2.7146)	
	Grade No. H	68.951 - 68.952 (2.7146 - 2.7146)	
	Grade No. J	68.952 - 68.953 (2.7146 - 2.7147)	
	Grade No. K	68.953 - 68.954 (2.7147 - 2.7147)	
	Grade No. L	68.954 - 68.955 (2.7147 - 2.7148)	
	Grade No. M	68.955 - 68.956 (2.7148 - 2.7148)	
	Grade No. N	68.956 - 68.957 (2.7148 - 2.7148)	
	Grade No. P	68.957 - 68.958 (2.7148 - 2.7149)	
	Grade No. R	68.958 - 68.959 (2.7149 - 2.7149)	
	Grade No. S	68.959 - 68.960 (2.7149 - 2.7150)	
	Grade No. T	68.960 - 68.961 (2.7150 - 2.7150)	
	Grade No. U	68.961 - 68.962 (2.7150 - 2.7150)	
	Grade No. V	68.962 - 68.963 (2.7150 - 2.7151)	
Grade No. W	68.963 - 68.964 (2.7151 - 2.7151)		
Grade No. X	68.964 - 68.965 (2.7151 - 2.7152)		
Grade No. Y	68.965 - 68.966 (2.7152 - 2.7152)		
Grade No. 4	68.966 - 68.967 (2.7152 - 2.7152)		
Grade No. 7	68.967 - 68.968 (2.7152 - 2.7153)		
Difference in bore diameter between cylinders	Standard	Less than 0.03 (0.0012)	

# SERVICE DATA AND SPECIFICATIONS (SDS)

## PISTON, PISTON RING AND PISTON PIN

### Available Piston

Unit: mm (in)

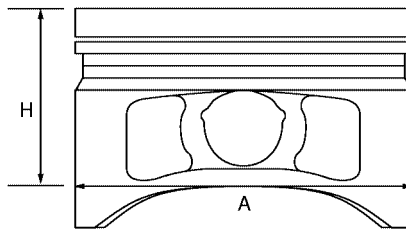

PBIC0188E

Items		Standard	Limit
Piston skirt diameter "A"	Grade No. 1	97.980 - 97.990 (3.8575 - 3.8579)	—
	Grade No. 2	97.990 - 98.000 (3.8579 - 3.8583)	—
	Grade No. 3	98.000 - 98.010 (3.8583 - 3.8587)	—
	Grade No. 0 (Service)	98.180 - 98.210 (3.8653 - 3.8665)	0.20 (0.0079)
"H" dimension		39 (1.54)	—
Piston pin hole diameter	Grade No. 0	21.993 - 21.999 (0.8659 - 0.8661)	—
Piston to cylinder bore clearance		0.010 - 0.030 (0.0004 - 0.0012)	0.08 (0.0031)

### Piston Ring

Unit: mm (in)

Items		Standard	Limit
Side clearance	Top	0.035 - 0.085 (0.0014 - 0.0033)	0.11 (0.0043)
	2nd	0.030 - 0.070 (0.0012 - 0.0028)	0.10 (0.0039)
	Oil ring	0.015 - 0.050 (0.0006 - 0.0020)	—
End gap	Top	0.23 - 0.33 (0.0091 - 0.0130)	0.56 (0.0220)
	2nd	0.25 - 0.40 (0.0098 - 0.0157)	0.52 (0.0205)
	Oil ring	0.20 - 0.60 (0.0079 - 0.0236)	0.96 (0.0378)

### Piston Pin

Unit: mm (in)

Items		Standard
Piston pin diameter	Grade No. 0	21.989 - 21.995 (0.8657 - 0.8659)
Piston to piston pin clearance		0.002 - 0.006 (0.0001 - 0.0002)
Connecting rod bushing oil clearance		0.005 - 0.017 (0.0002 - 0.0007)

### CONNECTING ROD

Unit: mm (in)

Items		Standard	Limit
Center distance		154.45 - 154.55 (6.08 - 6.08)	—
Bend [per 100 (3.94)]		—	0.15 (0.0059)
Torsion [per 100 (3.94)]		—	0.30 (0.0118)
Connecting rod bushing inside diameter* (small end)	Grade No. 0	22.000 - 22.006 (0.8661 - 0.8664)	—
Connecting rod big end inside diameter (without bearing)		57.000 - 57.013 (2.2441 - 2.2446)	—



# SERVICE DATA AND SPECIFICATIONS (SDS)

Side clearance		0.20 - 0.40 (0.0079 - 0.0157)	0.40 (0.0157)
Connecting rod bearing housing	Grade No. 0	57.000 - 57.001 (2.2441 - 2.2441)	
	Grade No. 1	57.001 - 57.002 (2.2441 - 2.2442)	
	Grade No. 2	57.002 - 57.003 (2.2442 - 2.2442)	
	Grade No. 3	57.003 - 57.004 (2.2442 - 2.2443)	
	Grade No. 4	57.004 - 57.005 (2.2443 - 2.2443)	
	Grade No. 5	57.005 - 57.006 (2.2443 - 2.2443)	
	Grade No. 6	57.006 - 57.007 (2.2443 - 2.2444)	
	Grade No. 7	57.007 - 57.008 (2.2444 - 2.2444)	
	Grade No. 8	57.008 - 57.009 (2.2444 - 2.2444)	
	Grade No. 9	57.009 - 57.010 (2.2444 - 2.2445)	
	Grade No. A	57.010 - 57.011 (2.2445 - 2.2445)	
	Grade No. B	57.011 - 57.012 (2.2445 - 2.2446)	
Grade No. C	57.012 - 57.013 (2.2446 - 2.2446)		

\*: After installing in connecting rod

## CRANKSHAFT

Unit: mm (in)

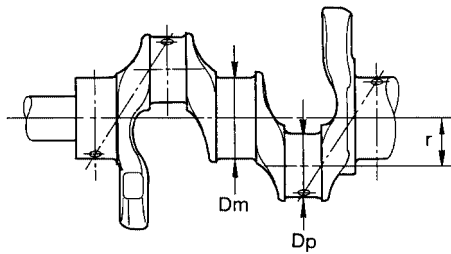

SEM645

Out-of-round : Difference between X and Y.  
Taper : Difference between A and B.

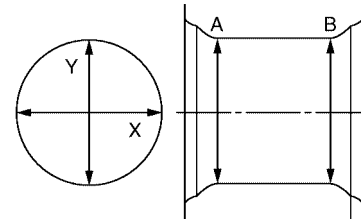

PBIC1686E

Main journal dia. "Dm" grade (No. 1 and 5)	Standard	Grade No. G	63.963 - 63.964 (2.5182 - 2.5183)
		Grade No. H	63.962 - 63.963 (2.5182 - 2.5182)
		Grade No. J	63.961 - 63.962 (2.5181 - 2.5182)
		Grade No. K	63.960 - 63.961 (2.5181 - 2.5181)
		Grade No. L	63.959 - 63.960 (2.5181 - 2.5181)
		Grade No. M	63.958 - 63.959 (2.5180 - 2.5181)
		Grade No. N	63.957 - 63.958 (2.5180 - 2.5180)
		Grade No. P	63.956 - 63.957 (2.5179 - 2.5180)
		Grade No. R	63.955 - 63.956 (2.5179 - 2.5179)
		Grade No. S	63.954 - 63.955 (2.5179 - 2.5179)
		Grade No. T	63.953 - 63.954 (2.5178 - 2.5179)
		Grade No. U	63.952 - 63.953 (2.5178 - 2.5178)
		Grade No. V	63.951 - 63.952 (2.5178 - 2.5178)
		Grade No. W	63.950 - 63.951 (2.5177 - 2.5178)
		Grade No. X	63.949 - 63.950 (2.5177 - 2.5177)
		Grade No. Y	63.948 - 63.949 (2.5176 - 2.5177)
		Grade No. 1	63.947 - 63.948 (2.5176 - 2.5176)
		Grade No. 2	63.946 - 63.947 (2.5176 - 2.5176)
		Grade No. 3	63.945 - 63.946 (2.5175 - 2.5176)
		Grade No. 4	63.944 - 63.945 (2.5175 - 2.5175)
Grade No. 5	63.943 - 63.944 (2.5174 - 2.5175)		
Grade No. 6	63.942 - 63.943 (2.5174 - 2.5174)		
Grade No. 7	63.941 - 63.942 (2.5174 - 2.5174)		
Grade No. 9	63.940 - 63.941 (2.5173 - 2.5174)		

# SERVICE DATA AND SPECIFICATIONS (SDS)

Main journal dia. "Dm" grade (No. 2, 3 and 4)	Standard	Grade No. A	63.963 - 63.964 (2.5182 - 2.5183)
		Grade No. B	63.962 - 63.963 (2.5182 - 2.5182)
		Grade No. C	63.961 - 63.962 (2.5181 - 2.5182)
		Grade No. D	63.960 - 63.961 (2.5181 - 2.5181)
		Grade No. E	63.959 - 63.960 (2.5181 - 2.5181)
		Grade No. F	63.958 - 63.959 (2.5180 - 2.5181)
		Grade No. G	63.957 - 63.958 (2.5180 - 2.5180)
		Grade No. H	63.956 - 63.957 (2.5179 - 2.5180)
		Grade No. J	63.955 - 63.956 (2.5179 - 2.5179)
		Grade No. K	63.954 - 63.955 (2.5179 - 2.5179)
		Grade No. L	63.953 - 63.954 (2.5178 - 2.5179)
		Grade No. M	63.952 - 63.953 (2.5178 - 2.5178)
		Grade No. N	63.951 - 63.952 (2.5178 - 2.5178)
		Grade No. P	63.950 - 63.951 (2.5177 - 2.5178)
		Grade No. R	63.949 - 63.950 (2.5177 - 2.5177)
		Grade No. S	63.948 - 63.949 (2.5176 - 2.5177)
		Grade No. T	63.947 - 63.948 (2.5176 - 2.5176)
Grade No. U	63.946 - 63.947 (2.5176 - 2.5176)		
Grade No. V	63.945 - 63.946 (2.5175 - 2.5176)		
Grade No. W	63.944 - 63.945 (2.5175 - 2.5175)		
Grade No. X	63.943 - 63.944 (2.5174 - 2.5175)		
Grade No. Y	63.942 - 63.943 (2.5174 - 2.5174)		
Grade No. 1	63.941 - 63.942 (2.5174 - 2.5174)		
Grade No. 2	63.940 - 63.941 (2.5173 - 2.5174)		
Pin journal dia. "Dp"	Standard	Grade No. 0	53.968 - 53.974 (2.1247 - 2.1250)
		Grade No. 1	53.962 - 53.968 (2.1245 - 2.1247)
		Grade No. 2	53.956 - 53.962 (2.1243 - 2.1245)
Center distance "r"			45.96 - 46.04 (1.8094 - 1.8126)
Out-of-round (Difference between "X" and "Y")	Limit	0.002 (0.0001)	
Taper (Difference between "A" and "B")		0.002 (0.0001)	
Runout [TIR*]		Less than 0.05 (0.002)	
Crankshaft end play	Standard	0.10 - 0.26 (0.0039 - 0.0102)	
	Limit	0.30 (0.0118)	

\*: Total indicator reading

## MAIN BEARING

Unit: mm (in)

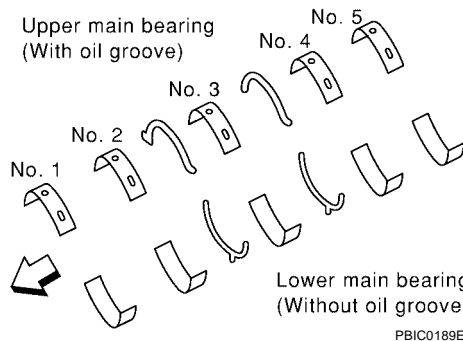

PBIC0189E

Grade number	UPR/LWR	Thickness	Identification color	Remarks
--------------	---------	-----------	----------------------	---------

## SERVICE DATA AND SPECIFICATIONS (SDS)

0	—	2.483 - 2.486 (0.0978 - 0.0979)	Black	Grade is the same for upper and lower bearings	A	
1	—	2.486 - 2.489 (0.0979 - 0.0980)	Brown		EM	
2	—	2.489 - 2.492 (0.0980 - 0.0981)	Green			C
3	—	2.492 - 2.495 (0.0981 - 0.0982)	Yellow			D
4	—	2.495 - 2.498 (0.0982 - 0.0983)	Blue			E
5	—	2.498 - 2.501 (0.0983 - 0.0985)	Pink			F
6	—	2.501 - 2.504 (0.0985 - 0.0986)	Purple			G
7	—	2.504 - 2.507 (0.0986 - 0.0987)	White			H
8	—	2.507 - 2.510 (0.0987 - 0.0988)	Red			I
01	UPR	2.483 - 2.486 (0.0978 - 0.0979)	Black	Grade is different for upper and lower bearings.		J
	LWR	2.486 - 2.489 (0.0979 - 0.0980)	Brown		K	
12	UPR	2.486 - 2.489 (0.0979 - 0.0980)	Brown		L	
	LWR	2.489 - 2.492 (0.0980 - 0.0981)	Green		M	
23	UPR	2.489 - 2.492 (0.0980 - 0.0981)	Green		N	
	LWR	2.492 - 2.495 (0.0981 - 0.0982)	Yellow		O	
34	UPR	2.492 - 2.495 (0.0981 - 0.0982)	Yellow		P	
	LWR	2.495 - 2.498 (0.0982 - 0.0983)	Blue		Q	
45	UPR	2.495 - 2.498 (0.0982 - 0.0983)	Blue		R	
	LWR	2.498 - 2.501 (0.0983 - 0.0985)	Pink		S	
56	UPR	2.498 - 2.501 (0.0983 - 0.0985)	Pink		T	
	LWR	2.501 - 2.504 (0.0985 - 0.0986)	Purple		U	
67	UPR	2.501 - 2.504 (0.0985 - 0.0986)	Purple		V	
	LWR	2.504 - 2.507 (0.0986 - 0.0987)	White		W	
78	UPR	2.504 - 2.507 (0.0986 - 0.0987)	White		X	
	LWR	2.507 - 2.510 (0.0987 - 0.0988)	Red		Y	

### Undersize

Unit: mm (in)

Undersize	Thickness	Main journal diameter
0.25 (0.0098)	2.618 - 2.626 (0.1031 - 0.1034)	Grind so that bearing clearance is the specified value.

### Main Bearing Oil Clearance

Unit: mm (in)

Items	Standard	Limit
Main bearing oil clearance	No.1 and 5	0.001 - 0.011 (0.00004 - 0.0004)
	No.2, 3 and 4	0.007 - 0.017 (0.0003 - 0.0007)

### Connecting Rod Bearing

Grade number	Thickness "T" mm (in)	Identification color (mark)
0	1.500 - 1.503 (0.0591 - 0.0592)	Black
1	1.503 - 1.506 (0.0592 - 0.0593)	Brown
2	1.506 - 1.509 (0.0593 - 0.0594)	Green
3	1.509 - 1.512 (0.0594 - 0.0595)	Yellow

### Undersize

Unit: mm (in)

Undersize	Thickness	Crank pin journal diameter "Dp"
0.25 (0.0098)	1.627 - 1.635 (0.0641 - 0.0644)	Grind so that bearing clearance is the specified value.

## SERVICE DATA AND SPECIFICATIONS (SDS)

### Connecting Rod Bearing Oil Clearance

Unit: mm (in)

Items	Standard	Limit
Connecting rod bearing oil clearance	0.020 - 0.039 (0.0008 - 0.0015)	0.055 (0.0022)