

SECTION **RSU**
 REAR SUSPENSION

A
B
C
D

RSU

CONTENTS

PRECAUTIONS	3	Circuit Inspection	19	F
Precautions for Supplemental Restraint System (SRS) "AIR BAG" and "SEAT BELT PRE-TENSIONER"	3	TROUBLE DIAGNOSES FOR SYMPTOMS	22	
Precautions for Rear Suspension	3	Load Leveling Rear Air Suspension System Does Not Operate	22	G
PREPARATION	4	CK SUSP Indicator Lamp Stays On When Ignition Switch Is Turned On	23	
Commercial Service Tools	4	REAR SUSPENSION ASSEMBLY	24	H
NOISE, VIBRATION, AND HARSHNESS (NVH)		Components	24	
TROUBLESHOOTING	5	On-Vehicle Inspection and Service	25	I
NVH Troubleshooting Chart	5	SHOCK ABSORBER INSPECTION (WITH AND WITHOUT THE AIR LEVELING SYSTEM)	25	
CAN COMMUNICATION	7	Wheel Alignment Inspection	26	J
System Description	7	PRELIMINARY INSPECTION	26	
TROUBLE DIAGNOSIS	8	GENERAL INFORMATION AND RECOMMENDATIONS	26	K
How to Perform Trouble Diagnoses for Quick and Accurate Repair	8	THE ALIGNMENT PROCESS	27	
INTRODUCTION	8	CAMBER	27	L
CLARIFY CONCERN	8	TOE-IN	27	
WORK FLOW	9	REAR SUSPENSION MEMBER	29	M
Component Parts and Harness Connector Location ..	10	Removal and Installation	29	
Wiring Diagram — A/SUSP —	11	REMOVAL	30	
Basic Inspection	13	INSPECTION AFTER REMOVAL	31	
AIR HOSES	13	INSTALLATION	32	
POWER SYSTEM TERMINAL LOOSENESS AND BATTERY INSPECTION	13	SHOCK ABSORBER	33	
CK SUSP INDICATOR LAMP INSPECTION	13	Removal and Installation	33	
CK SUSP Indicator Lamp Timing	13	REMOVAL	33	
Control Unit Input/Output Signal Standard	13	INSTALLATION	33	
CONSULT-II Function (AIR LEVELIZER)	14	Inspection	33	
CONSULT-II START PROCEDURE	14	SUSPENSION ARM	34	
SELF-DIAGNOSIS	14	Removal and Installation	34	
WORK SUPPORT	15	REMOVAL	34	
DATA MONITOR	15	INSPECTION AFTER REMOVAL	34	
ACTIVE TEST	15	INSTALLATION	35	
TROUBLE DIAGNOSIS FOR SELF-DIAGNOSTIC ITEMS	16	FRONT LOWER LINK	36	
Height Sensor System Inspection	16	Removal and Installation	36	
Exhaust Valve Solenoid System Inspection	17	REMOVAL	36	
Compressor Motor, Compressor Motor Relay and		INSPECTION AFTER REMOVAL	36	
		INSTALLATION	37	

REAR LOWER LINK & COIL SPRING	38	HEIGHT SENSOR	43
Removal and Installation	38	Removal and Installation	43
REMOVAL	38	REMOVAL	43
INSPECTION AFTER REMOVAL	39	INSTALLATION	44
INSTALLATION	39	CONTROL UNIT	45
STABILIZER BAR	40	Removal and Installation	45
Removal and Installation	40	REMOVAL	45
REMOVAL	40	INSTALLATION	45
INSPECTION AFTER REMOVAL	40	Initialization Procedure	45
INSTALLATION	40	SERVICE DATA AND SPECIFICATIONS (SDS)	46
REAR LOAD LEVELING AIR SUSPENSION COM-		Wheel Alignment (Unladen* ¹)	46
PRESSOR ASSEMBLY	41	Ball Joint	46
Removal and Installation	41	Wheelarch Height (Unladen* ¹)	47
REMOVAL	41		
INSTALLATION	42		

PRECAUTIONS

PRECAUTIONS

PF0:00001

Precautions for Supplemental Restraint System (SRS) “AIR BAG” and “SEAT BELT PRE-TENSIONER”

EES002HG

The Supplemental Restraint System such as “AIR BAG” and “SEAT BELT PRE-TENSIONER”, used along with a front seat belt, helps to reduce the risk or severity of injury to the driver and front passenger for certain types of collision. This system includes seat belt switch inputs and dual stage front air bag modules. The SRS system uses the seat belt switches to determine the front air bag deployment, and may only deploy one front air bag, depending on the severity of a collision and whether the front occupants are belted or unbelted. Information necessary to service the system safely is included in the SRS and SB section of this Service Manual.

WARNING:

- To avoid rendering the SRS inoperative, which could increase the risk of personal injury or death in the event of a collision which would result in air bag inflation, all maintenance must be performed by an authorized NISSAN/INFINITI dealer.
- Improper maintenance, including incorrect removal and installation of the SRS, can lead to personal injury caused by unintentional activation of the system. For removal of Spiral Cable and Air Bag Module, see the SRS section.
- Do not use electrical test equipment on any circuit related to the SRS unless instructed to in this Service Manual. SRS wiring harnesses can be identified by yellow and/or orange harnesses or harness connectors.

Precautions for Rear Suspension

EES002HH

- When installing the rubber bushings, the final tightening must be done under unladen condition and with the tires on level ground. Oil will shorten the life of the rubber bushings, so wipe off any spilled oil immediately.
- Unladen condition means the fuel tank, engine coolant and lubricants are at the full specification. The spare tire, jack, hand tools, and mats are in their designated positions.
- After installing suspension components, check the wheel alignment.
- Caulking nuts are not reusable. Always use new caulking nuts for installation. New caulking nuts are pre-oiled, do not apply any additional lubrication.

A
B
C
D
RSU
F
G
H
I
J
K
L
M

PREPARATION

PREPARATION

PFP:00002

Commercial Service Tools

EES002HI

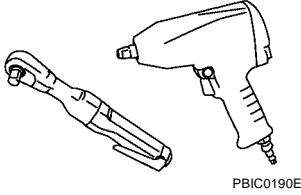
Tool name	Description
Power tool  PBIC0190E	Removing nuts and bolts

NOISE, VIBRATION, AND HARSHNESS (NVH) TROUBLESHOOTING

NOISE, VIBRATION, AND HARSHNESS (NVH) TROUBLESHOOTING

PFP:00003

NVH Troubleshooting Chart

EES002HJ

Use chart below to help you find the cause of the symptom. If necessary, repair or replace these parts.

A

B

C

D

RSU

F

G

H

I

J

K

L

M

CAN COMMUNICATION

CAN COMMUNICATION

PFP:23710

System Description

EES002HK

Refer to [LAN-4, "CAN Communication System"](#) .

A

B

C

D

RSU

F

G

H

I

J

K

L

M

TROUBLE DIAGNOSIS

How to Perform Trouble Diagnoses for Quick and Accurate Repair

EES002HL

INTRODUCTION

The rear load leveling air suspension system uses an electronic control unit to control major functions. The control unit accepts input signals from the height sensor and controls compressor and exhaust valve operation.

It is much more difficult to diagnose a rear load leveling air suspension system problem that occurs intermittently rather than continuously. Most intermittent problems are caused by poor electrical connections or faulty wiring. In this case, careful checking of suspicious circuits may help prevent the replacement of good parts.

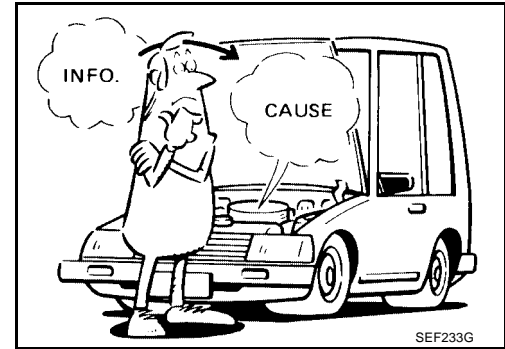

Before undertaking actual checks, take just a few minutes to talk with a customer who approaches with an air suspension system complaint. The customer is a very good source of information on such problems, especially intermittent ones. Through discussion with the customer, find out what symptoms are present and under what conditions they occur.

Start your diagnosis by looking for basic mechanical problems first. This is one of the best ways to troubleshoot concerns on an air suspension system equipped vehicle. Also check related Service Bulletins for information.

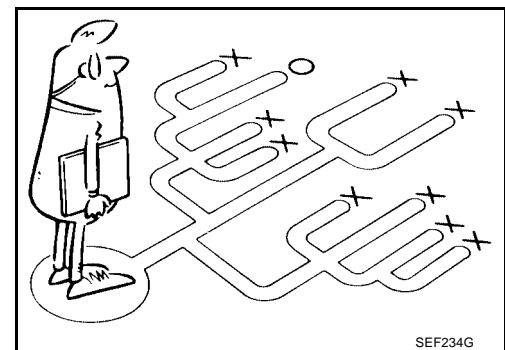

CLARIFY CONCERN

- A customer's description of a vehicle concern may vary depending on the individual. It is important to clarify the customer's concern.
- Ask the customer about what symptoms are present under what conditions. Use this information to reproduce the symptom.

KEY POINTS

- WHAT** Vehicle model
WHEN Date, Frequencies
WHERE Road conditions
HOW Operating conditions,
Weather conditions,
Symptoms

SBR339B

TROUBLE DIAGNOSIS

WORK FLOW

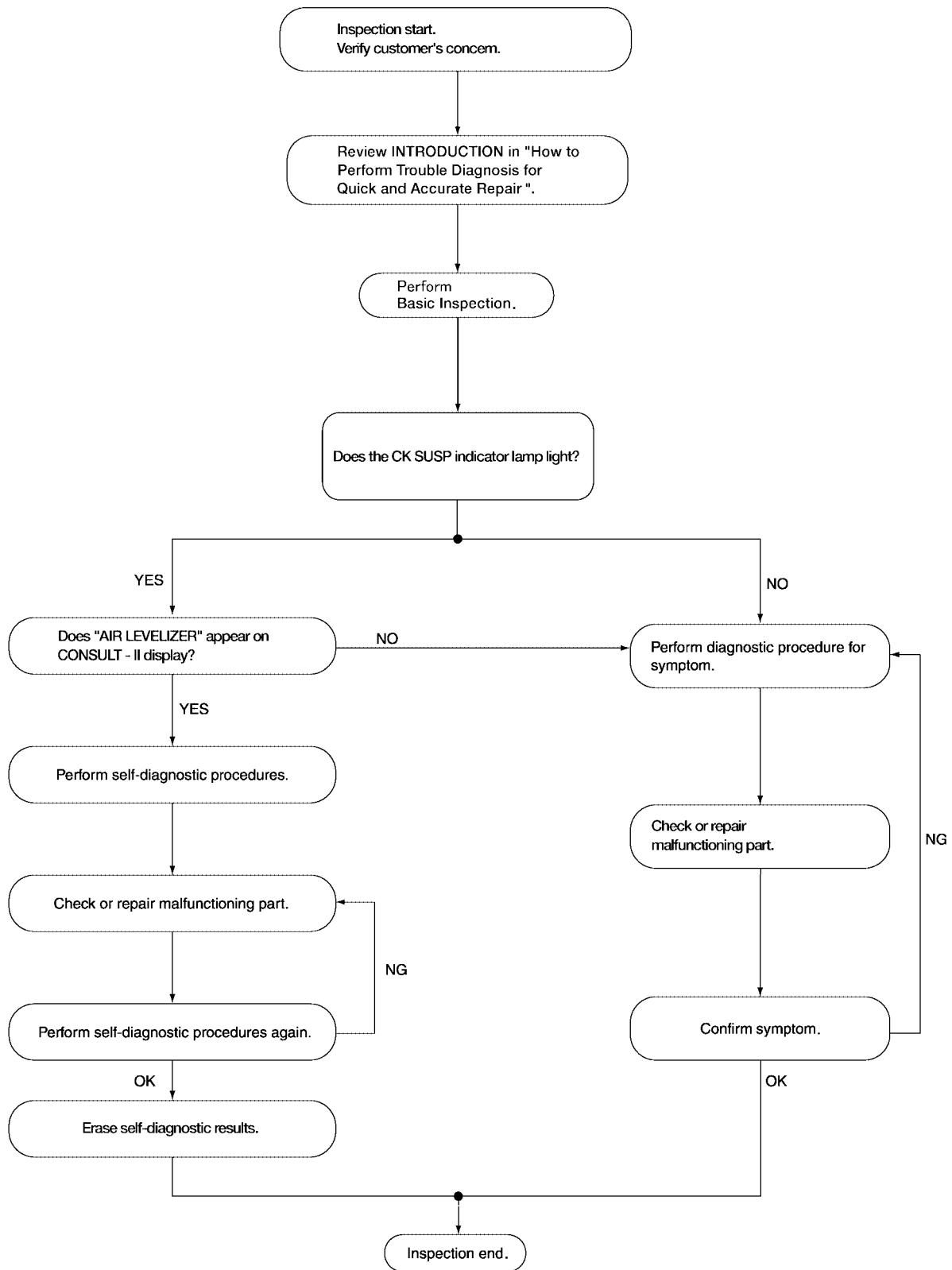

A

B

C

D

RSU

F

G

H

I

J

K

L

M

WEIA0077E

TROUBLE DIAGNOSIS

Component Parts and Harness Connector Location

EES002HM

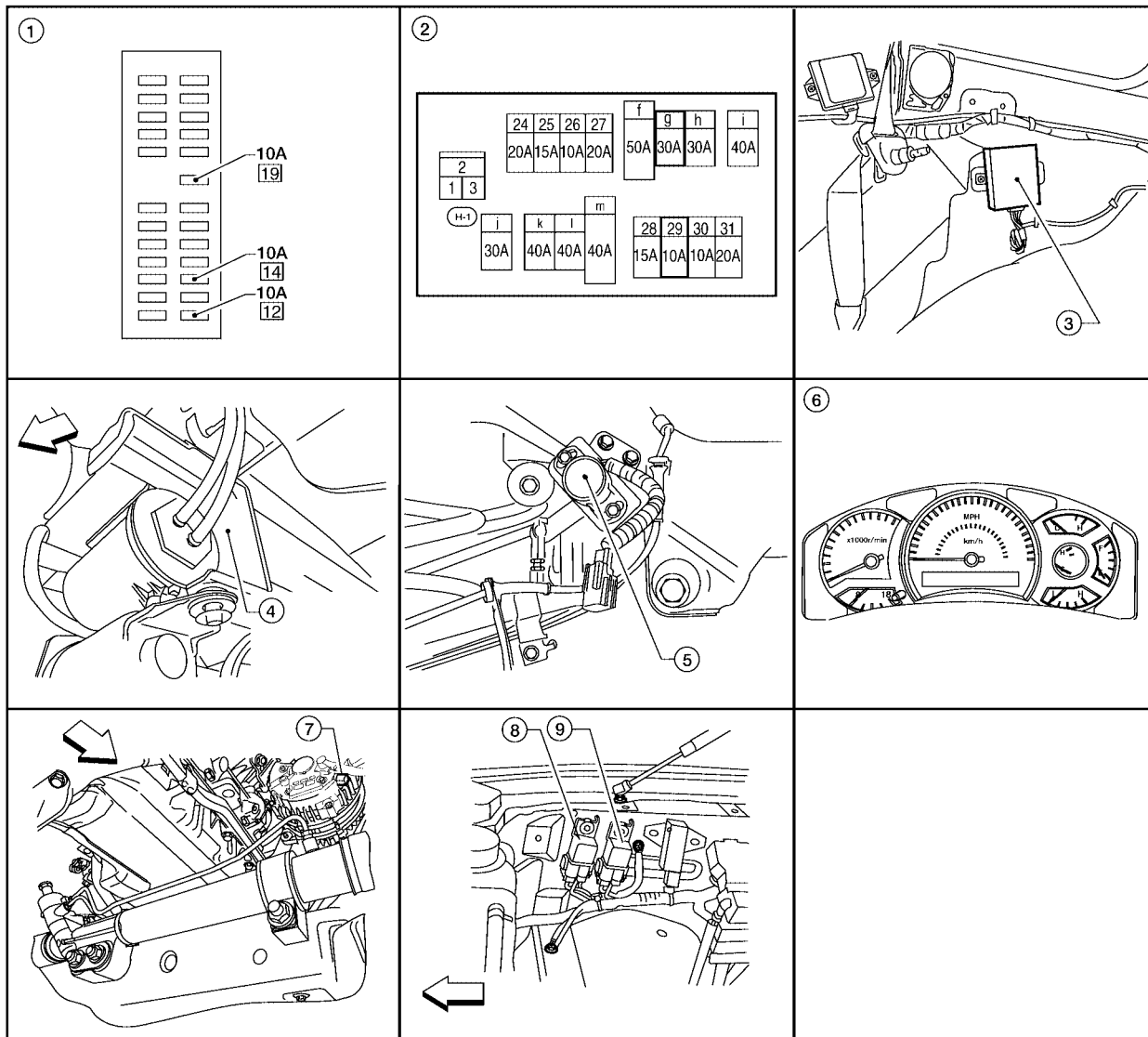

WEIA0149E

↔ Front

- | | | |
|--|---|---|
| 1. Fuse Block (J/B) | 2. Fuse and fusible link box | 3. Suspension control unit B3 (View with upper and lower luggage side finishers LH removed) |
| 4. Suspension air compressor and compressor motor relay C9 | 5. Height sensor C8 (View from under vehicle) | 6. Combination meter M24 |
| 7. Generator E205 (View from under vehicle) | 8. Suspension air compressor motor relay E130 (view with battery removed) | 9. Suspension air compressor motor relay E131 |

TROUBLE DIAGNOSIS

Wiring Diagram — A/SUSP —

EES002HN

RSU-A/SUSP-01

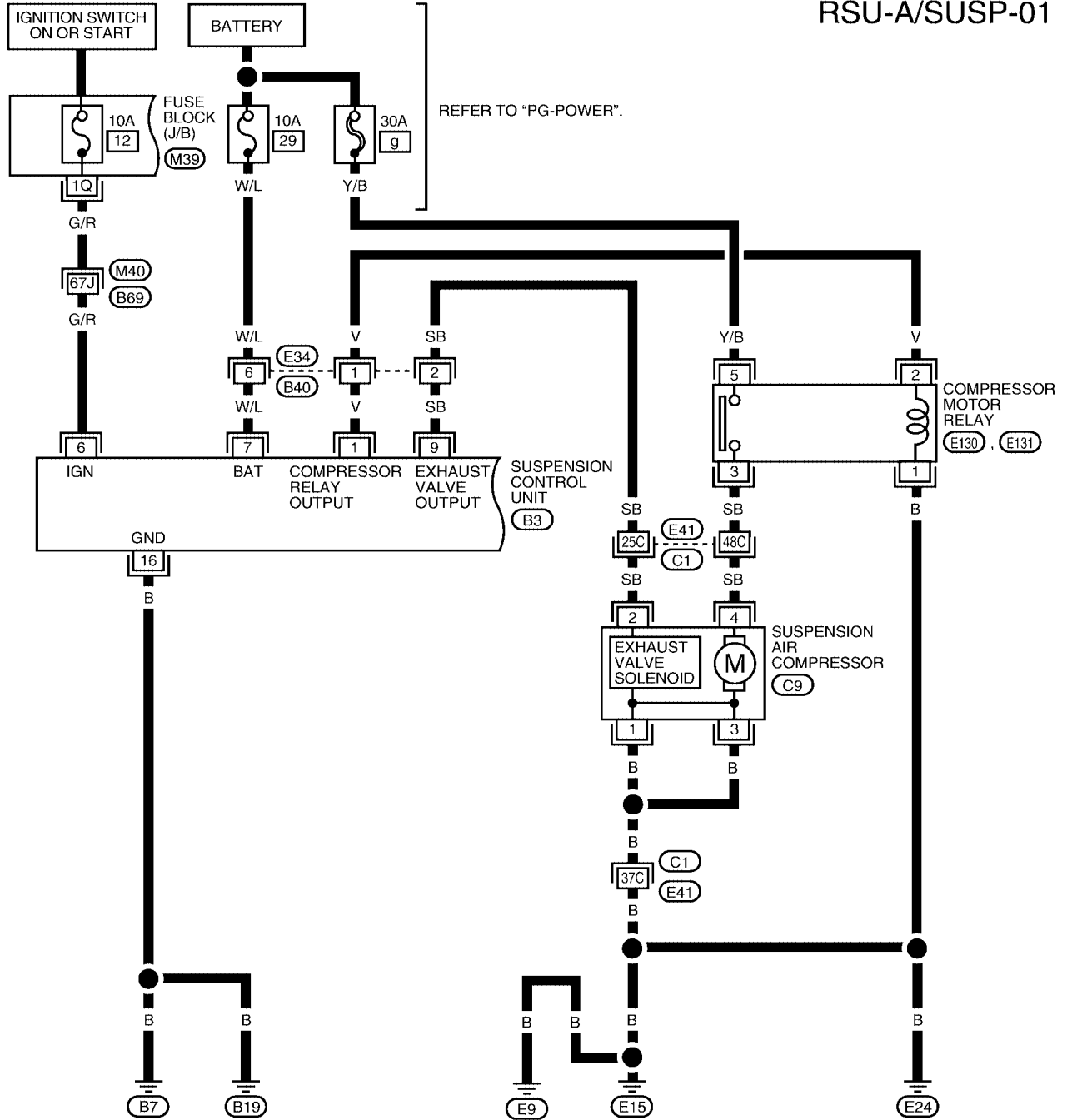

A
B
C
D
RSU
F
G
H
I
J
K
L
M

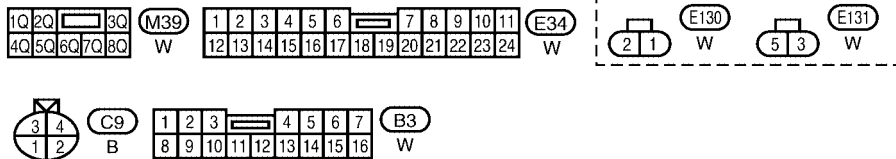

REFER TO THE FOLLOWING.
 (M40), (C1) - SUPER
 MULTIPLE JUNCTION (SMJ)

WEWA0053E

TROUBLE DIAGNOSIS

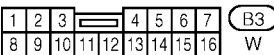
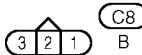
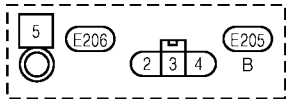
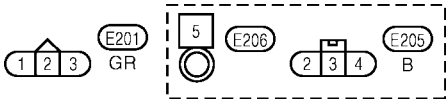
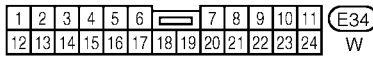
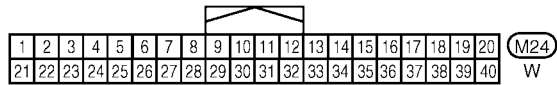
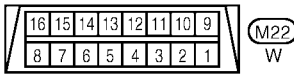
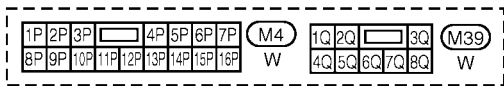
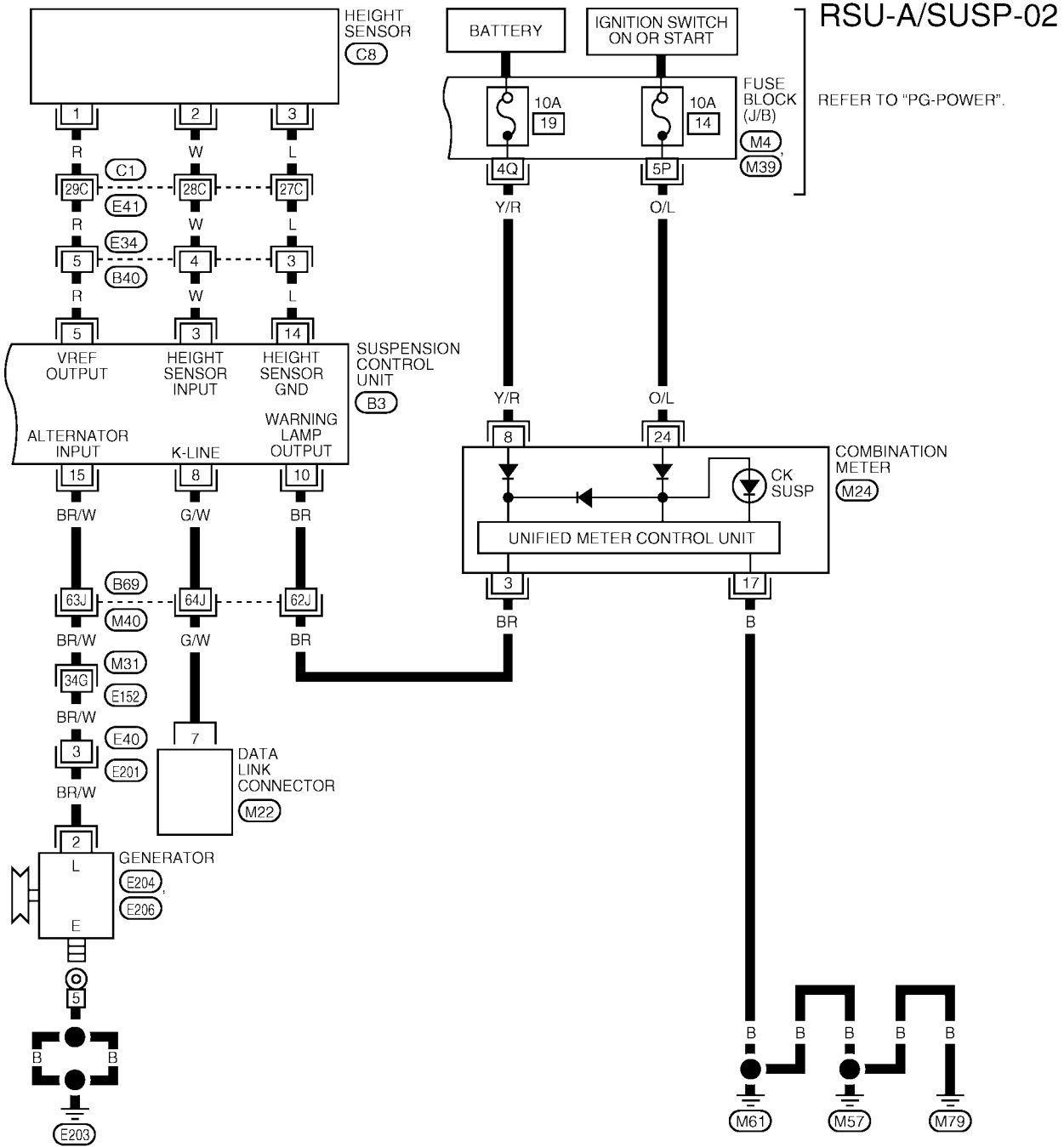

REFER TO THE FOLLOWING.
 (M31), (M40), (C1) - SUPER
 MULTIPLE JUNCTION (SMJ)

WEWA0069E

TROUBLE DIAGNOSIS

Basic Inspection

EES002HO

AIR HOSES

1. Check for pinched or damaged air hoses between the suspension air reservoir and each load leveling rear air suspension shock absorber. Reposition, repair or replace hoses as necessary.
2. Check the air hose connections at the suspension air reservoir and at the shock absorbers for leaks. If connections are leaking, repair or replace hoses as necessary.

POWER SYSTEM TERMINAL LOOSENESS AND BATTERY INSPECTION

Make sure the battery positive cable, negative cable and ground connection are not loose. In addition, make sure the battery is sufficiently charged.

CK SUSP INDICATOR LAMP INSPECTION

1. Make sure the CK SUSP indicator lamp turns on for approximately 2 seconds when the ignition switch is turned ON. If it does not, check the combination meter. Refer to [DI-5, "COMBINATION METERS"](#) .
2. Make sure the lamp turns off approximately 2 seconds after the ignition switch is turned ON. If the lamp does not turn off, conduct self-diagnosis of the suspension control unit. Refer to [RSU-14, "CONSULT-II Function \(AIR LEVELIZER\)"](#) .
3. After conducting the self-diagnosis, be sure to erase the error memory. Refer to [RSU-14, "CONSULT-II Function \(AIR LEVELIZER\)"](#) .

CK SUSP Indicator Lamp Timing

EES002HP

Condition	CK SUSP indicator lamp	Remarks
Ignition switch OFF	—	—
Ignition switch ON	X	Turns off after approximately 2 seconds.

X: ON

—: OFF

Control Unit Input/Output Signal Standard

EES002HQ

Terminal No.	Wire color	Item	Condition	Voltage (V) (Approx.)
1	V	Compressor relay output	Ignition switch ON or START	Battery voltage
3	W	Height sensor signal input		0.2V - 4.8V
5	R	Reference voltage		5V
6	G/R	Ignition power		Battery voltage
7	W/L	Battery power	—	
8	G/W	Diagnostic K-line	—	
9	SB	Exhaust valve output	Ignition switch ON or START	Battery voltage
10	BR	Warning lamp	—	
14	L	Height sensor ground	—	
15	BR/W	Generator L signal input	Engine running	
16	B	Suspension control unit ground	—	0V

TROUBLE DIAGNOSIS

CONSULT-II Function (AIR LEVELIZER)

EES002HR

CONSULT-II can display each diagnostic item using the diagnostic test modes shown following.

AIR LEVELIZER diagnostic mode	Description
WORK SUPPORT	Supports inspections and adjustments. Commands are transmitted to the suspension control unit for setting the status suitable for required operation, input/output signals are received from the suspension control unit and received data is displayed.
SELF-DIAG RESULTS	Displays suspension control unit self-diagnosis results.
DATA MONITOR	Displays suspension control unit input/output data in real time.
ACTIVE TEST	Operation of electrical loads can be checked by sending drive signal to them.
ECU PART NUMBER	Suspension control unit part number can be read.

CONSULT-II START PROCEDURE

Refer to [GI-38, "CONSULT-II Start Procedure"](#) .

SELF-DIAGNOSIS

Display Item List

Self-diagnostic item	Malfunction detecting condition	Check system
Vehicle height sensor [C1801]	Vehicle height sensor voltage is less than 0.2V or greater than 4.8V for more than 60 seconds.	Refer to RSU-16, "Height Sensor System Inspection" .
Compressor relay [C1802]	<ol style="list-style-type: none"> Driving transistor for compressor relay is off and monitor voltage continues high level for more than 10 seconds. Driving transistor for compressor relay is on and monitor voltage continues low level for more than 5 seconds. 	Refer to RSU-19, "Compressor Motor, Compressor Motor Relay and Circuit Inspection" .
Exhaust solenoid [C1803]	<ol style="list-style-type: none"> Driving transistor for exhaust solenoid is off and monitor voltage continues high level for more than 10 seconds. Driving transistor for exhaust solenoid is on and monitor voltage continues low level for more than 5 seconds. 	Refer to RSU-17, "Exhaust Valve Solenoid System Inspection" .
Vehicle height adjusting trouble (compressor) [C1804]	Continuous compressor relay ON time is more than 120 seconds.	Refer to RSU-19, "Compressor Motor, Compressor Motor Relay and Circuit Inspection" .
Vehicle height adjusting trouble (exhaust solenoid) [C1805]	Continuous exhaust solenoid ON time is more than 120 seconds.	Refer to RSU-17, "Exhaust Valve Solenoid System Inspection" .
Vehicle height sensor locking trouble [C1806]	Output sensor voltage variation $\pm 0.02V$ is more than 100 hour when vehicle height range is normal.	Refer to RSU-16, "Height Sensor System Inspection" .
Sensor 5V trouble [C1807]	Sensor reference voltage is less than 0.8V or more than 6V for 20 seconds.	Refer to RSU-16, "Height Sensor System Inspection" .
Integral time trouble by supplying air [C1808]	Integral discontinuous time on the compressor is more than 180 seconds.	Refer to RSU-19, "Compressor Motor, Compressor Motor Relay and Circuit Inspection" .

TROUBLE DIAGNOSIS

WORK SUPPORT

Display Item List

Item	Description	Condition
STANDARD HEIGHT LEVEL	Resets the vehicle height to the initialization flag setting stored in the suspension control unit.	Vehicle unladen RSU-47, "Wheelarch Height (Unladen*1)" , set in a horizontal position and not moving. NOTE: Do not take your eyes off the vehicle while CONSULT-II is processing.
ADJUST HEIGHT INI	Sets the height initialization flag in the suspension control unit when the control unit has been replaced or when the initialization flag has been cleared using the "CLEAR HEIGHT INI" procedure.	Vehicle unladen RSU-47, "Wheelarch Height (Unladen*1)" . Move vehicle forward and backward approx. 5 m (16.4 ft.) and rock vehicle from side to side. NOTE: Do not move vehicle while CONSULT-II is processing.
CLEAR HEIGHT INI	Clears the initialization flag in the suspension control unit.	Vehicle unladen RSU-47, "Wheelarch Height (Unladen*1)" .

DATA MONITOR

Display Item List

Test Item	Data monitor item selection	
	ALL SIGNALS	SELECTION FROM MENU
HEIGT SEN	X	X
HEIGT CALC	X	X
SEN FIX TIME	X	X
HEIGT INI VAL	X	X
COMPRESSOR	X	X
EXH SOLENOID	X	X
ACG L	X	X

X: Applicable
-: Not applicable

ACTIVE TEST

CAUTION:

- Do not perform active test while driving.

Display Item List

Test Item	Description
COMPRESSOR	OFF/ON
EXHAUST SOLENOID	OFF/ON
WARNING LAMP	OFF/ON

CAUTION:

The "COMPRESSOR" active test will remain ON until it is turned off using CONSULT-II. Allowing the compressor to run for an extended period of time may cause damage to air suspension system components due to excessive pressure in the air suspension system.

NOTE:

- "TEST IS STOPPED" is displayed approximately 10 seconds after operation starts for all active test items except "COMPRESSOR".
- After "TEST IS STOPPED" is displayed, to perform test again, repeat Step 6.

TROUBLE DIAGNOSIS FOR SELF-DIAGNOSTIC ITEMS

TROUBLE DIAGNOSIS FOR SELF-DIAGNOSTIC ITEMS

PFP:00000

Height Sensor System Inspection

EES002HS

INSPECTION PROCEDURE

1. SELF-DIAGNOSIS RESULT CHECK

Check self-diagnosis results.

Self-diagnosis results
C1801
C1806
C1807

Is the above displayed in the self-diagnosis display items?

YES >> GO TO 3.

NO >> GO TO 2.

2. DATA MONITOR CHECK

Conduct data monitor of "HEIGT SEN" to check if the status is normal.

HEIGT SEN	0.2V - 4.8V
-----------	-------------

OK or NG

OK >> Inspection End.

NG >> GO TO 3.

3. CONNECTOR INSPECTION

1. Disconnect suspension control unit connector B3 and height sensor C8.
2. Check the terminals for deformation, disconnection, looseness or damage.

OK or NG

OK >> GO TO 4.

NG >> Repair or replace as necessary.

4. CHECK HEIGHT SENSOR POWER

1. Reconnect the suspension control unit connector.
2. Turn the ignition switch ON.
3. Check voltage between height sensor connector C8 terminal 1 and ground.

Voltage : **Approx. 5V**

OK or NG

OK >> GO TO 5.

NG >> Check harness or connector for open or short. If OK, replace suspension control unit. Refer to [RSU-45](#), "[CONTROL UNIT](#)".

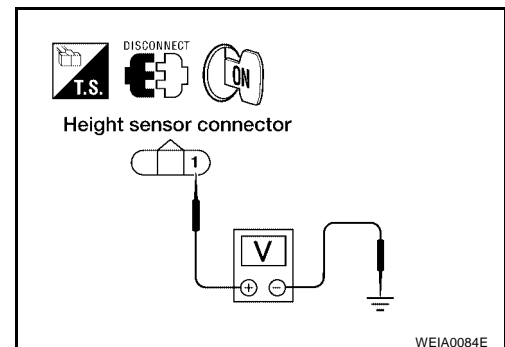

TROUBLE DIAGNOSIS FOR SELF-DIAGNOSTIC ITEMS

5. CHECK HEIGHT SENSOR GROUND

1. Turn ignition switch OFF.
2. Check continuity between height sensor connector C8 terminal 3 and ground.

3 - Ground

Continuity should exist.

OK or NG

- OK >> GO TO 6.
 NG >> Repair harness or connector.

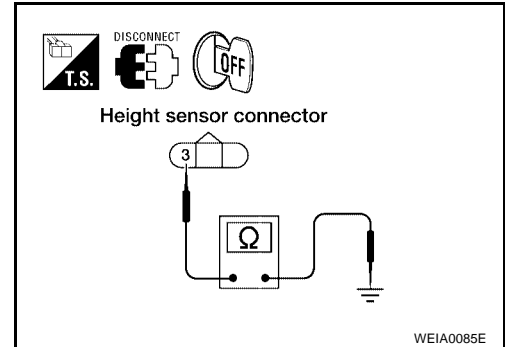

6. CHECK HEIGHT SENSOR SIGNAL CIRCUIT

1. Disconnect suspension control unit connector.
2. Check continuity between height sensor connector C8 terminal 2 and suspension control unit connector B3 terminal 3.

2 - 3

Continuity should exist.

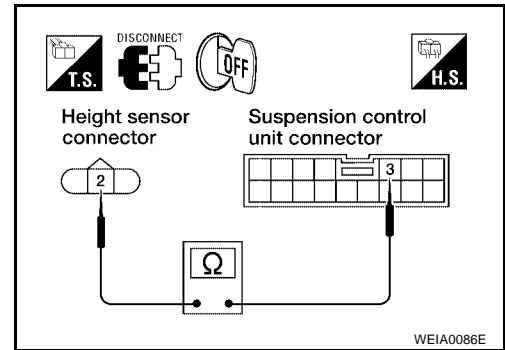

3. Check continuity between height sensor connector C8 terminal 2 and ground.

2 - Ground

Continuity should not exist.

OK or NG

- OK >> Replace the height sensor. Refer to [RSU-43, "HEIGHT SENSOR"](#).
 NG >> Repair harness or connector.

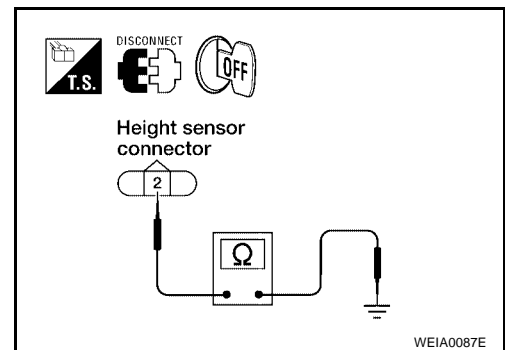

Exhaust Valve Solenoid System Inspection

EES002HT

INSPECTION PROCEDURE

1. SELF-DIAGNOSIS RESULT CHECK

Check self-diagnosis results.

Self-diagnosis results
C1803
C1805

Is the above displayed in the self-diagnosis display items?

- YES >> If code C1803 was retrieved during self-diagnosis, GO TO 3. If code C1805 was retrieved during self-diagnosis, GO TO 2.
 NO >> Inspection End.

TROUBLE DIAGNOSIS FOR SELF-DIAGNOSTIC ITEMS

2. CHECK SYSTEM OPERATION

1. Load vehicle to standard laden condition (with driver, front passenger, 2 passengers in second row seats and no cargo).
2. Conduct active test of "COMPRESSOR" to raise vehicle ride height to +20mm.

CAUTION:

The "COMPRESSOR" active test will remain ON until it is turned off using CONSULT-II. Allowing the compressor to run for an extended period of time may cause damage to air suspension system components due to excessive pressure in the air suspension system.

3. Return the rear load leveling air suspension system to normal operating mode.
4. Check self-diagnostic results.

Is code C1805 displayed again?

- YES >> GO TO 3.
NO >> Inspection End.

3. CONNECTOR INSPECTION

1. Turn ignition switch OFF.
2. Disconnect suspension control unit connector B3 and suspension air compressor C9.
3. Check the terminals for deformation, disconnection, looseness or damage.

OK or NG

- OK >> If code C1805 was retrieved during self-diagnosis, GO TO 4. If code C1803 was retrieved during self-diagnosis, GO TO 6.
NG >> Repair or replace as necessary.

4. AIR HOSE INSPECTION

Inspect for pinched or damaged air hoses between the suspension air reservoir and each load leveling rear air suspension shock absorber.

OK or NG

- OK >> GO TO 5.
NG >> Repair or replace as necessary.

5. EXHAUST VALVE SOLENOID INSPECTION

Apply 12V to suspension air compressor terminal 2 and ground to suspension air compressor terminal 1.

System air pressure should vent.

OK or NG

- OK >> GO TO 6.
NG >> Replace the suspension air compressor. Refer to [RSU-41, "REAR LOAD LEVELING AIR SUSPENSION COMPRESSOR ASSEMBLY"](#) .

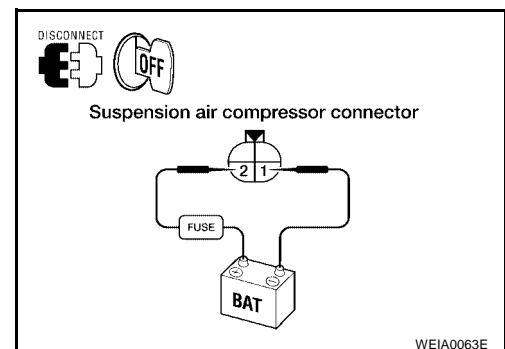

TROUBLE DIAGNOSIS FOR SELF-DIAGNOSTIC ITEMS

6. CHECK EXHAUST VALVE SOLENOID POWER AND GROUND

1. Reconnect the suspension control unit connector.
2. Turn the ignition switch ON.
3. Check voltage between suspension air compressor connector C9 terminal 2 and ground.

Voltage : **Approx. 12V**

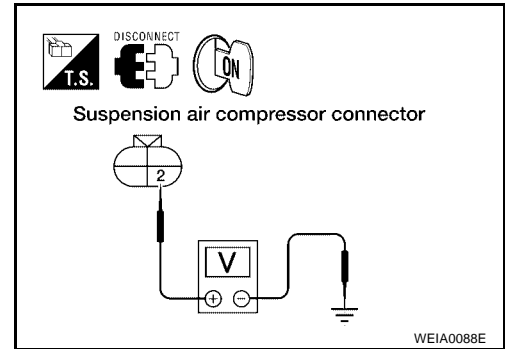

4. Turn ignition switch OFF.
5. Check continuity between suspension air compressor connector C9 terminal 1 and ground.

1 - Ground **Continuity should exist.**

OK or NG

- OK >> Replace the suspension control unit. Refer to [RSU-45](#), "[CONTROL UNIT](#)".
- NG >> Repair harness or connector.

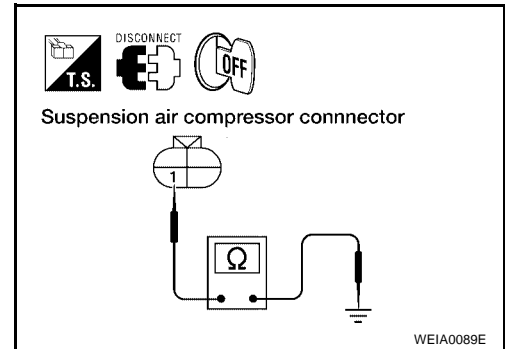

Compressor Motor, Compressor Motor Relay and Circuit Inspection

EES002HU

INSPECTION PROCEDURE

1. SELF-DIAGNOSIS RESULT CHECK

Check self-diagnosis results.

Self-diagnosis results
C1802
C1804
C1808

Is the above displayed in the self-diagnosis display items?

- YES >> If code C1802 was retrieved during self-diagnosis, GO TO 3. If code C1804 or C1808 was retrieved during self-diagnosis, GO TO 2.
- NO >> Inspection End.

2. CHECK SYSTEM OPERATION

1. Load vehicle to standard laden condition (with driver, front passenger, 2 passengers in second row seats and no cargo).
2. Conduct active test of "EXHAUST SOLENOID" to lower vehicle ride height to -20mm.
3. Return the rear load leveling air suspension system to normal operating mode.
4. Check self-diagnostic results.

Is code C1804 or C1808 displayed again?

- YES >> GO TO 3.
- NO >> Inspection End.

TROUBLE DIAGNOSIS FOR SELF-DIAGNOSTIC ITEMS

3. CONNECTOR INSPECTION

1. Turn ignition switch OFF.
2. Disconnect suspension control unit connector B3 and suspension air compressor C9.
3. Check the terminals for deformation, disconnection, looseness or damage.

OK or NG

- OK >> If code C1804 or C1808 was retrieved during self-diagnosis, GO TO 4. If code C1802 was retrieved during self-diagnosis, GO TO 6.
- NG >> Repair or replace as necessary.

4. AIR HOSE INSPECTION

Inspect for pinched or damaged air hoses between the suspension air reservoir and each load leveling rear air suspension shock absorber.

OK or NG

- OK >> GO TO 5.
- NG >> Repair or replace as necessary.

5. SUSPENSION AIR COMPRESSOR INSPECTION

Apply 12V to suspension air compressor terminal 2 and ground to suspension air compressor terminal 1.

System air pressure should vent.

OK or NG

- OK >> GO TO 6.
- NG >> Replace the suspension air compressor. Refer to [RSU-41, "REAR LOAD LEVELING AIR SUSPENSION COMPRESSOR ASSEMBLY"](#) .

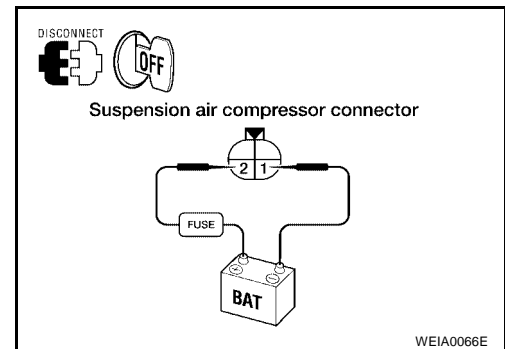

TROUBLE DIAGNOSIS FOR SELF-DIAGNOSTIC ITEMS

6. CHECK SUSPENSION AIR COMPRESSOR POWER AND GROUND

1. Connect suspension control unit connector B3.
2. Turn the ignition switch ON.
3. Check voltage between suspension air compressor connector C9 terminal 2 and ground.

Voltage : **Approx. 12V**

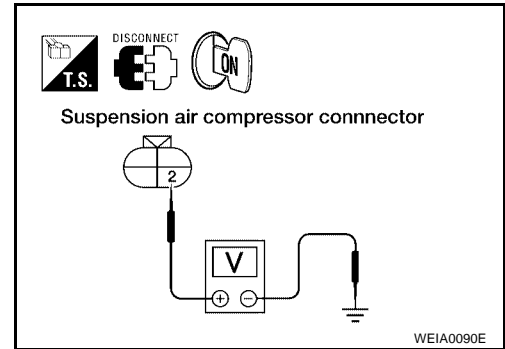

4. Turn ignition switch OFF.
5. Check continuity between suspension air compressor connector C9 terminal 1 and ground.

1 - Ground **Continuity should exist.**

OK or NG

- OK >> Replace the suspension control unit. Refer to [RSU-45](#), "[CONTROL UNIT](#)".
- NG >> Repair harness or connector.

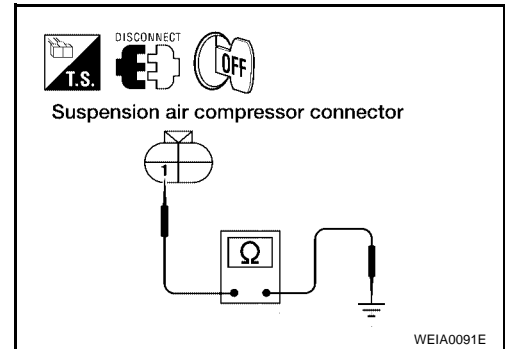

A

B

C

D

RSU

F

G

H

I

J

K

L

M

TROUBLE DIAGNOSES FOR SYMPTOMS

TROUBLE DIAGNOSES FOR SYMPTOMS

PFP:99999

Load Leveling Rear Air Suspension System Does Not Operate

EES002HV

1. CHECK WARNING LAMP ACTIVATION

Make sure warning lamp remains off while driving.

OK or NG

OK >> GO TO 2.

NG >> Carry out self-diagnosis. Refer to [RSU-14, "SELF-DIAGNOSIS"](#) .

2. CHECK FUSES AND FUSIBLE LINK

Check that the following fuses and fusible link are not blown.

Unit	Terminals	Signal name	Fuse and fusible link No.
Suspension control unit	6	Ignition switch ON or START	12 (10A)
	7	Battery power	29 (10A)
Compressor motor relay	5		g (30A)
Combination meter	24	Ignition switch ON or START	14 (10A)
	8	Battery power	19 (10A)

OK or NG

OK >> GO TO 3.

NG >> If fuse or fusible link is blown, be sure to eliminate cause of malfunction before installing new fuse or fusible link.

3. CHECK SUSPENSION CONTROL UNIT POWER AND GROUND

1. Turn the ignition switch ON.
2. Check voltage between suspension control unit connector B3 terminal 6 and ground and between suspension control unit connector B3 terminal 7 and ground.

Voltage : Approx. 12V

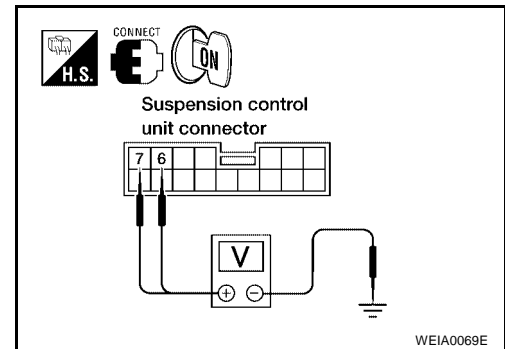

3. Turn the ignition switch OFF.
4. Check continuity between suspension control unit connector B3 terminal 16 and ground.

16 - Ground Continuity should exist.

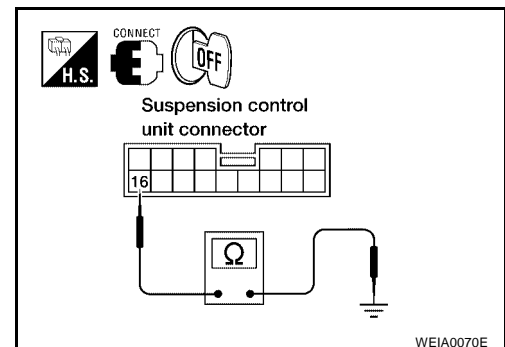

OK or NG

OK >> GO TO 4.

NG >> Repair harness or connector.

TROUBLE DIAGNOSES FOR SYMPTOMS

4. CHECK GENERATOR SIGNAL INPUT

1. Start the engine.
2. Check voltage between suspension control unit connector B3 terminal 15 and ground.

Voltage : **Approx. 12V**

OK or NG

- OK >> Replace the suspension control unit. Refer to [RSU-45, "CONTROL UNIT"](#) .
- NG >> Repair harness or connector.

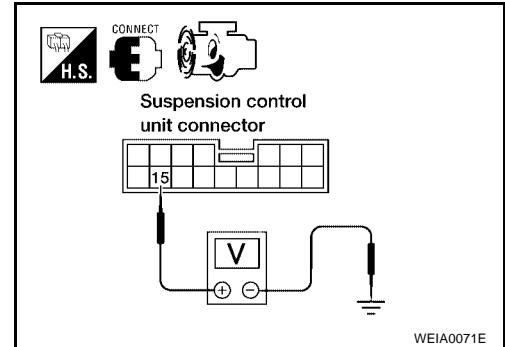

CK SUSP Indicator Lamp Stays On When Ignition Switch Is Turned On

EES002HW

1. CARRY OUT SELF-DIAGNOSIS

Carry out self-diagnosis. Refer to [RSU-14, "SELF-DIAGNOSIS"](#) .

Are malfunctions detected in self-diagnosis?

- YES >> Refer to [RSU-14, "Display Item List"](#) .
- NO >> Refer to [DI-27, "WARNING LAMPS"](#) .

REAR SUSPENSION ASSEMBLY

PFP:55020

REAR SUSPENSION ASSEMBLY

Components

EES002HX

Rear Suspension Without Rear Load Leveling Air Suspension System

SEC. 431 • 432

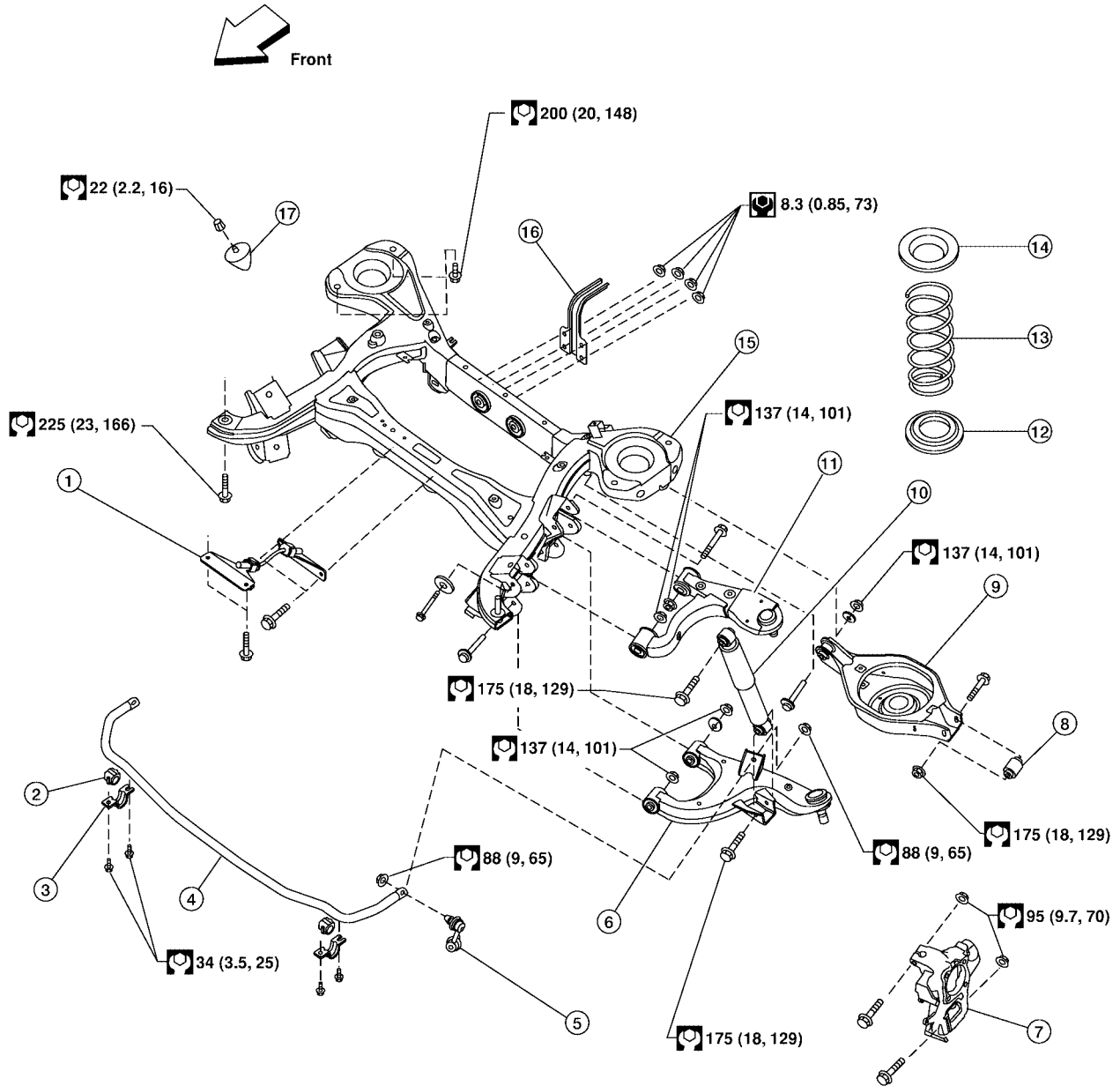

N·m (kg·m, in·lb)

N·m (kg·m, ft·lb)

WEIA0092E

REAR SUSPENSION ASSEMBLY

- | | | |
|---------------------------|---------------------------|----------------------------|
| 1. Seat belt latch anchor | 2. Stabilizer bar bushing | 3. Stabilizer bar clamp |
| 4. Stabilizer bar | 5. Connecting rod | 6. Front lower link |
| 7. Knuckle | 8. Bushing | 9. Rear lower link |
| 10. Shock absorber | 11. Suspension arm | 12. Lower rubber seat |
| 13. Coil spring | 14. Upper rubber seat | 15. Rear suspension member |
| 16. Spare tire bracket | 17. Bound bumper | |

Rear Load Leveling Air Suspension System

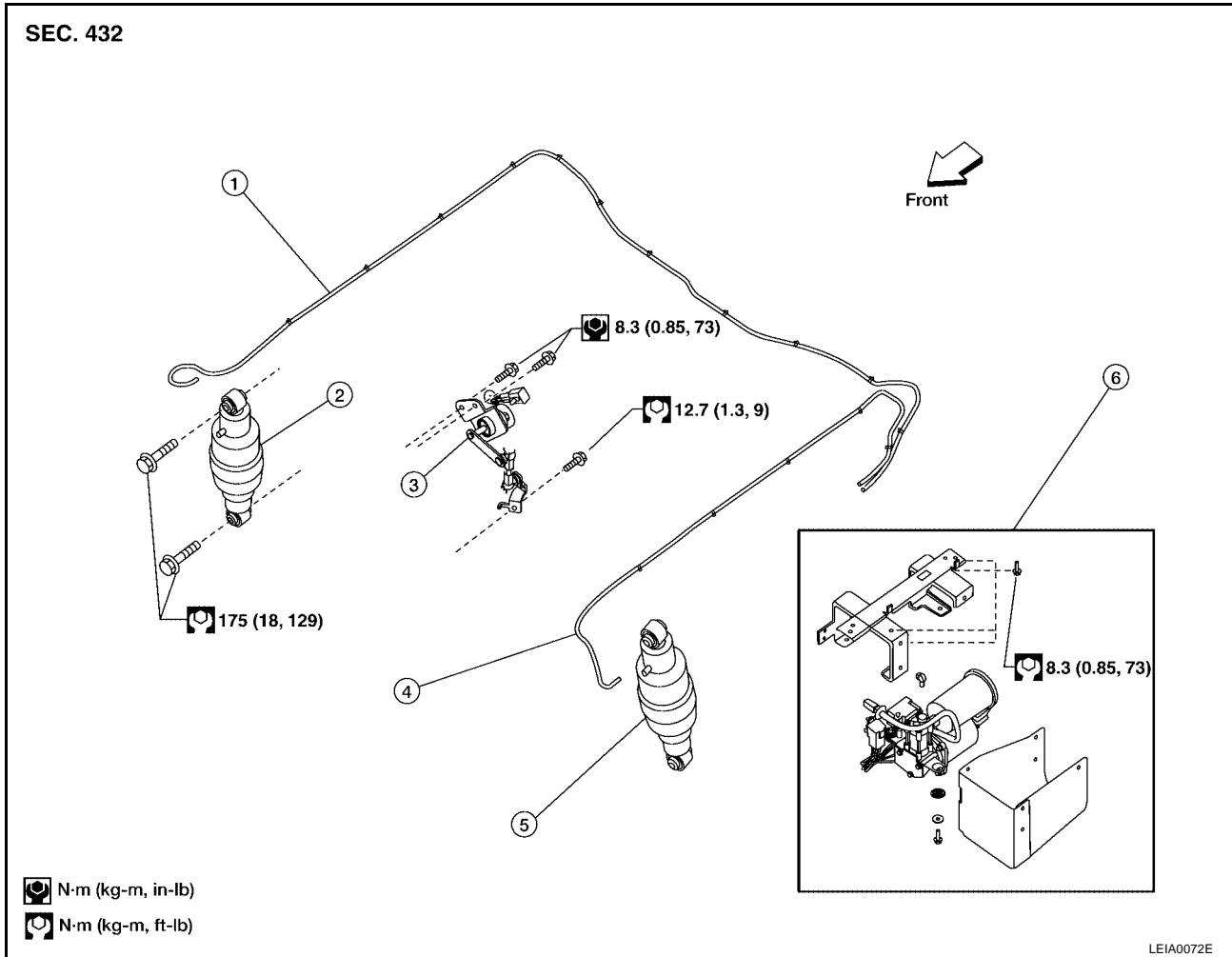

- | | | |
|---|-----------------------|--|
| 1. Rear load leveling air suspension hose, RH | 2. Shock absorber, RH | 3. Height sensor |
| 4. Rear load leveling air suspension hose, LH | 5. Shock absorber, LH | 6. Rear load leveling air suspension compressor assembly |

On-Vehicle Inspection and Service

EES002HY

Check all of the component mountings for any excessive looseness, or back lash. Check the components for any excessive wear, damage, or abnormal conditions. Repair or replace the components as necessary.

SHOCK ABSORBER INSPECTION (WITH AND WITHOUT THE AIR LEVELING SYSTEM)

- For vehicles without the rear load leveling air suspension system, check the shock absorbers for any oil leaks or damage, and replace as necessary.
- For vehicles with the rear load leveling air suspension system, check the shock absorbers for any air leaks or damage, and replace as necessary.
- For vehicles with the rear load leveling air suspension system, check the hoses for any air leaks or damage, and replace as necessary.

REAR SUSPENSION ASSEMBLY

EES002HZ

Wheel Alignment Inspection

Rear Wheel Alignment Adjusting Bolts

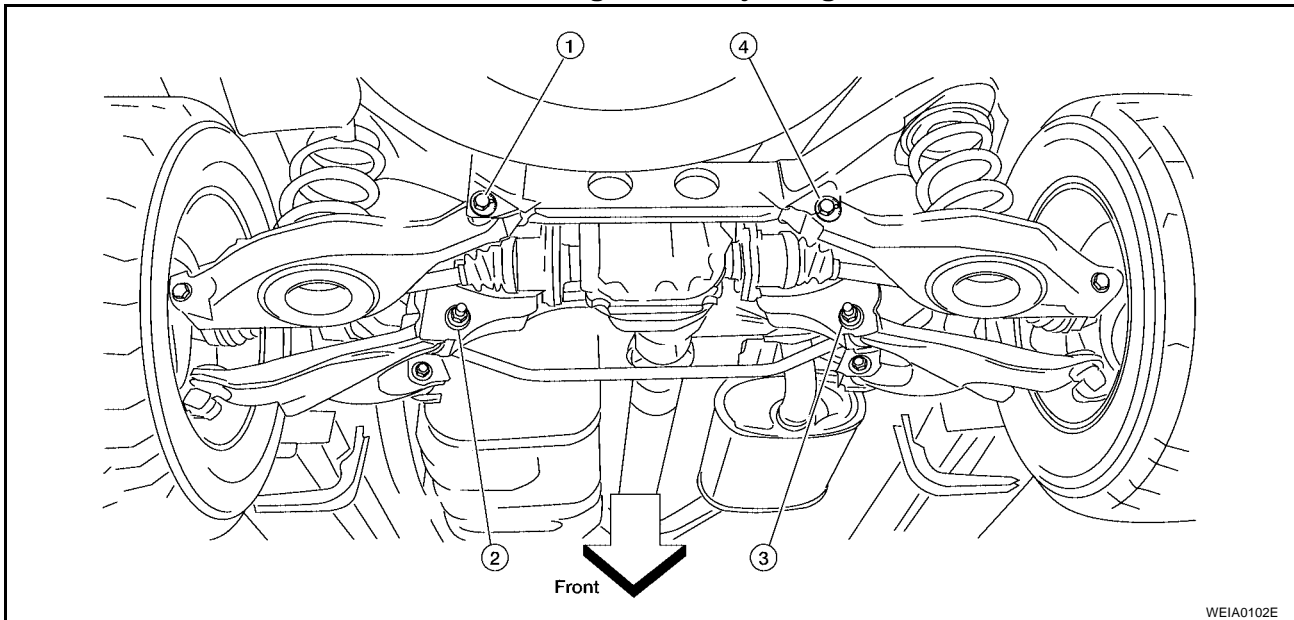

WEIA0102E

1. Rear lower link adjusting bolt, LH
2. Front lower link adjusting bolt, LH
3. Front lower link adjusting bolt, RH
4. Rear lower link adjusting bolt, RH

PRELIMINARY INSPECTION

WARNING:

Always adjust the alignment with the vehicle on a flat surface. Use CONSULT-II “EXHAUST SOLENOID” active test to release the air pressure from the rear load leveling air suspension system.

NOTE:

If alignment is out of specification, inspect and replace any damaged or worn rear suspension parts before making any adjustments.

1. Check and adjust the wheel alignment with the vehicle under unladen conditions. “Unladen conditions” means that the fuel, coolant, and lubricant are full; and that the spare tire, jack, hand tools and mats are in their designated positions.
2. Check the tires for incorrect air pressure and excessive wear.
3. Check the wheels for runout and damage.
4. Check the wheel bearing axial end play.

Axial end play : 0 mm (0 in)

5. Check the shock absorbers. Refer to [RSU-33, "Inspection"](#)
6. Check each mounting point of the suspension components for any excessive looseness or damage.
7. Check each link, arm, and the rear suspension member for any damage.
8. Check the vehicle height. Refer to [RSU-47, "Wheelarch Height \(Unladen*1\)"](#) .
 - If vehicle height is not within ± 10 mm (0.39 in) of the specification, perform the control unit initialization procedure. Refer to [RSU-45, "Initialization Procedure"](#) .

GENERAL INFORMATION AND RECOMMENDATIONS

1. A Four-Wheel Thrust Alignment should be performed.
 - This type of alignment is recommended for any NISSAN vehicle.
 - The four-wheel “thrust” process helps ensure that the vehicle is properly aligned and the steering wheel is centered.
 - The alignment machine itself should be capable of accepting any NISSAN vehicle.
 - The alignment machine should be checked to ensure that it is level.
2. Make sure the alignment machine is properly calibrated.
 - Your alignment machine should be regularly calibrated in order to give correct information.

REAR SUSPENSION ASSEMBLY

- Check with the manufacturer of your specific alignment machine for their recommended Service/Calibration Schedule.

THE ALIGNMENT PROCESS

IMPORTANT: Use only the alignment specifications listed in this Service Manual. Refer to [RSU-46, "Wheel Alignment \(Unladen*¹\)"](#) .

1. When displaying the alignment settings, many alignment machines use "indicators": (Green/red, plus or minus, Go/No Go). **Do NOT use these indicators.**
 - The alignment specifications programmed into your alignment machine that operate these indicators may not be correct.
 - This may result in an ERROR.
2. Some newer alignment machines are equipped with an optional "Rolling Compensation" method to "compensate" the sensors (alignment targets or head units). **Do NOT use this "Rolling Compensation" method.**
 - Use the "Jacking Compensation" method. After installing the alignment targets or head units, raise the vehicle and rotate the wheels 1/2 turn both ways.
 - See Instructions in the alignment machine you are using for more information.

CAMBER

1. Measure camber of both the right and left wheels with a suitable alignment gauge and adjust as necessary to specification.

Camber : Refer to [RSU-46, "Wheel Alignment \(Unladen*¹\)"](#) .

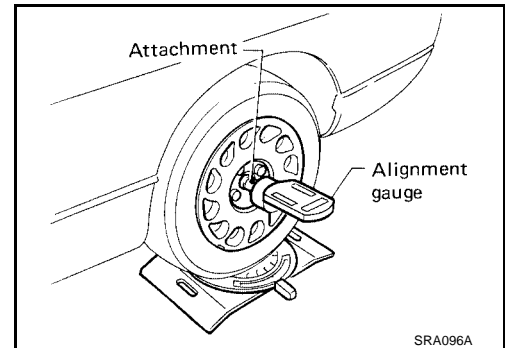

2. If outside of the specified value, adjust the camber using the adjusting bolt in the front lower link.

CAUTION:

After adjusting the camber then check the toe-in.

NOTE:

Camber changes about 0° 5' with each graduation of the adjusting bolt.

3. Tighten the adjusting bolt nuts to specification.

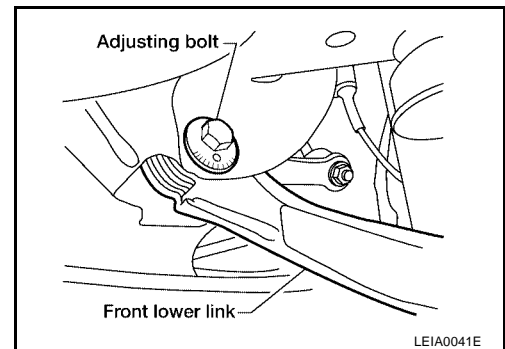

TOE-IN

1. Bounce the rear of the vehicle up and down two to three times to stabilize the vehicle height. Refer to [RSU-47, "Wheelarch Height \(Unladen*¹\)"](#) .
2. Push the vehicle straight ahead about 5 m (16 ft).
3. Put a mark on the base line of the tread (rear side) of both of the tires at the same height as the center of the hub. This will be the measuring points.
4. Measure the distance "A" (rear side) across from tire to tire.

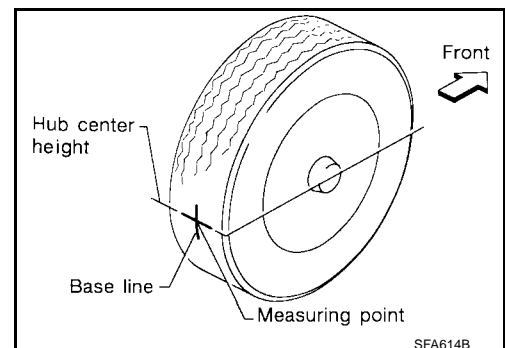

REAR SUSPENSION ASSEMBLY

5. Push the vehicle slowly ahead to rotate the wheels 180° (a half turn).
If the wheels are rotated more than 180° (a half turn), then repeat the above steps. Never push the vehicle backward.
6. Measure the distance "B" (front side) across from tire to tire.

Total toe-in : Refer to [RSU-46, "Wheel Alignment \(Unladen*1\)"](#) .

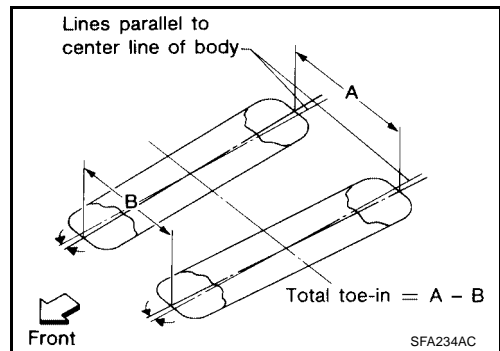

7. If the toe-in is outside the specified value, adjust the toe-in using the adjusting bolt in the rear lower link.

CAUTION:

Be sure to adjust equally on RH and LH sides using the adjusting bolt.

NOTE:

Toe changes about 1.5 mm (0.059 in) [one side] with each graduation of the adjusting bolt.

8. Tighten the adjusting bolt nuts to specification.

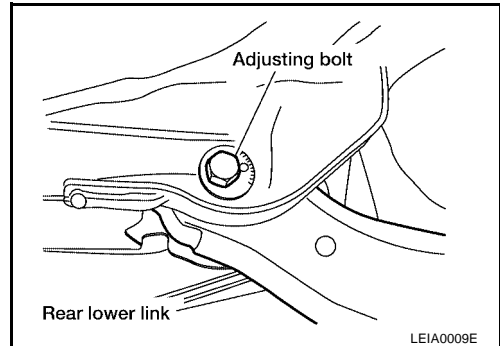

REAR SUSPENSION MEMBER

REAR SUSPENSION MEMBER

Removal and Installation

PFP:55501

EES00210

Rear Suspension Without Rear Load Leveling Air Suspension System

SEC. 431 • 432

A
B
C
D
RSU
F
G
H
I
J
K
L
M

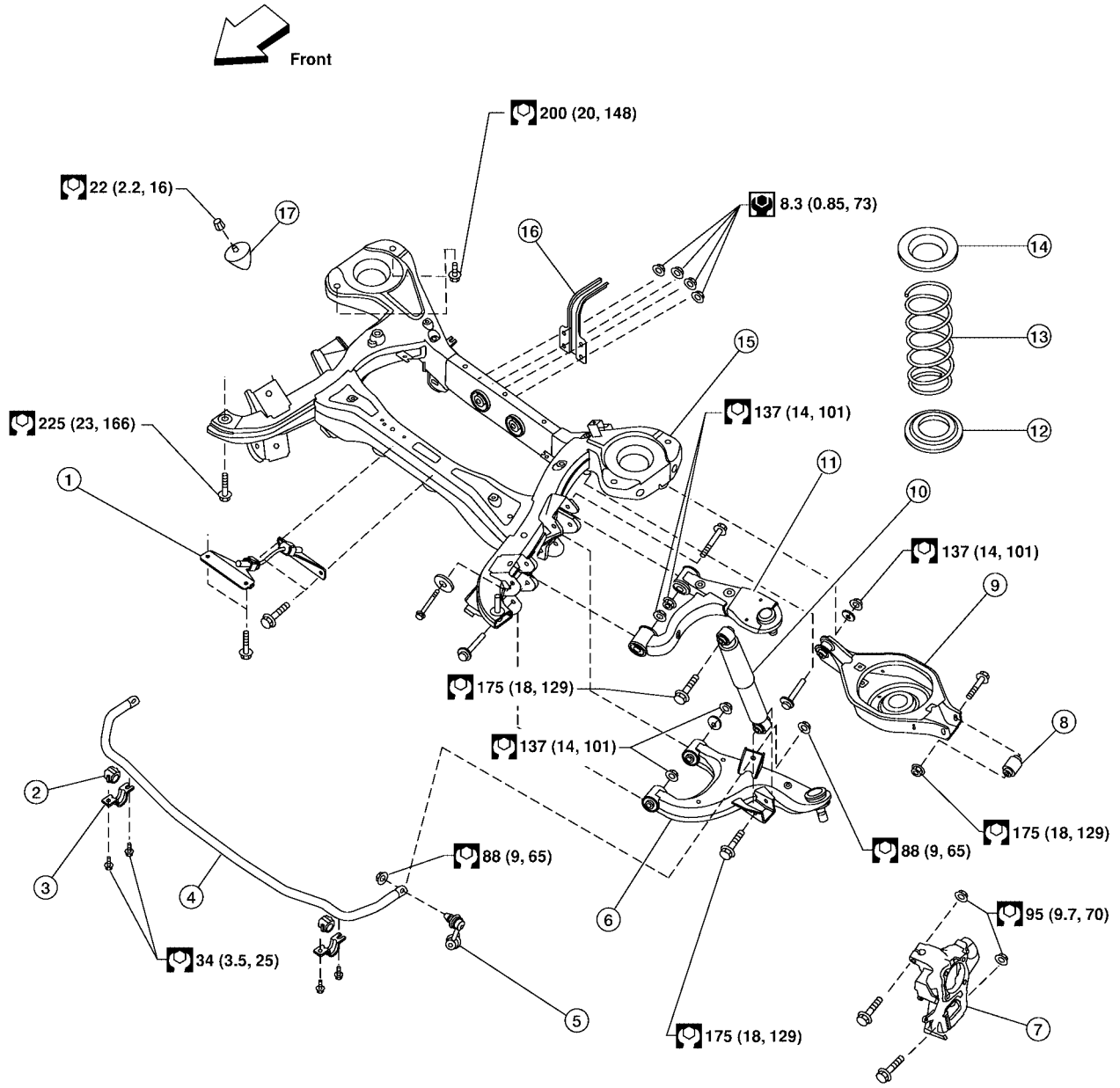

N·m (kg-m, in-lb)

N·m (kg-m, ft-lb)

WEIA0092E

REAR SUSPENSION MEMBER

- | | | |
|---------------------------|---------------------------|----------------------------|
| 1. Seat belt latch anchor | 2. Stabilizer bar bushing | 3. Stabilizer bar clamp |
| 4. Stabilizer bar | 5. Connecting rod | 6. Front lower link |
| 7. Knuckle | 8. Bushing | 9. Rear lower link |
| 10. Shock absorber | 11. Suspension arm | 12. Lower rubber seat |
| 13. Coil spring | 14. Upper rubber seat | 15. Rear suspension member |
| 16. Spare tire bracket | 17. Bound bumper | |

Rear Load Leveling Air Suspension System

SEC. 432

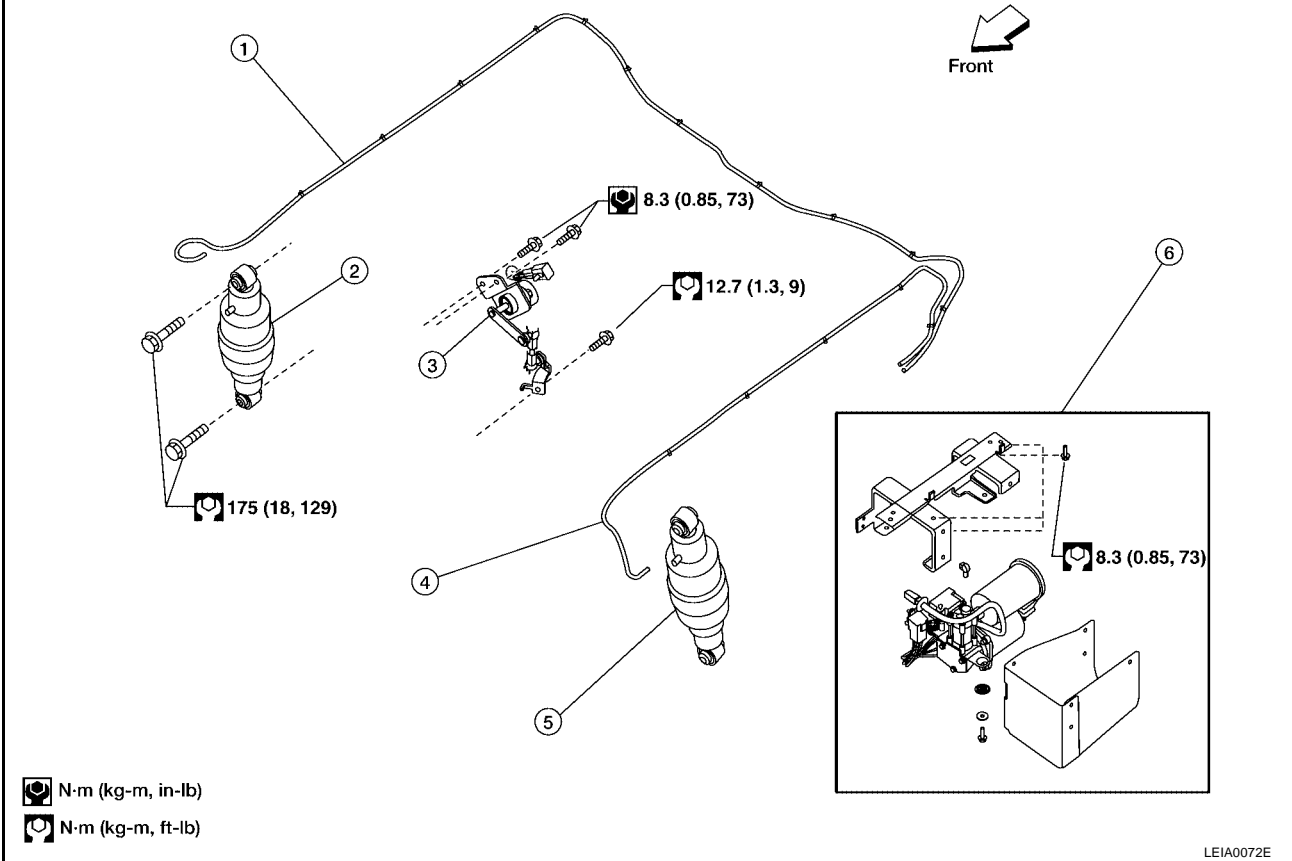

- | | | |
|---|-----------------------|--|
| 1. Rear load leveling air suspension hose, RH | 2. Shock absorber, RH | 3. Height sensor |
| 4. Rear load leveling air suspension hose, LH | 5. Shock absorber, LH | 6. Rear load leveling air suspension compressor assembly (includes the bracket and rubber cover) |

REMOVAL

1. If equipped with rear load leveling air suspension system, use CONSULT-II "EXHAUST SOLENOID" active test to release the air pressure from the rear load leveling air suspension system.
2. If equipped with the rear load leveling air suspension system, disconnect the electrical connectors for the height sensor and the rear load leveling air suspension compressor assembly.
3. If equipped with the rear load leveling air suspension system, unclip the rubber cover to access the rear load leveling air suspension compressor assembly.

REAR SUSPENSION MEMBER

4. If equipped with the rear load leveling air suspension system, disconnect the rear load leveling air suspension hoses at the rear load leveling air suspension compressor assembly.
 - To disconnect the hoses, push in on the lock ring using a suitable tool and pull the hose out.
5. Remove both of the rear wheel and tire assemblies using power tool.
6. Remove the brake caliper without disconnecting the brake hoses, using power tool. Reposition the brake caliper out of the way using a suitable wire. Refer to [BR-28, "Removal and Installation of Brake Caliper and Disc Rotor"](#) .

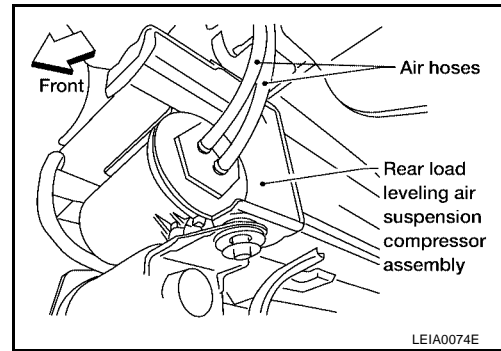

CAUTION:

- Do not crimp or stretch the brake hose when repositioning the brake caliper out of the way.
 - Do not press brake pedal while the brake caliper is removed.
7. Remove the spare tire.
 8. Disconnect the two rear ABS sensor electrical connectors.
 9. Remove the two rear drive shafts. Refer to [RAX-7, "REAR DRIVE SHAFT"](#) .
 10. Remove the rear final drive. Refer to [RFD-13, "REAR FINAL DRIVE ASSEMBLY"](#) .
 11. Remove the EVAP canister bolt from the top of the rear suspension member.
 12. Disconnect the parking brake cables from the brackets on the rear suspension member.
 13. Set a suitable jack to support each of the rear lower links and the coil spring tension.

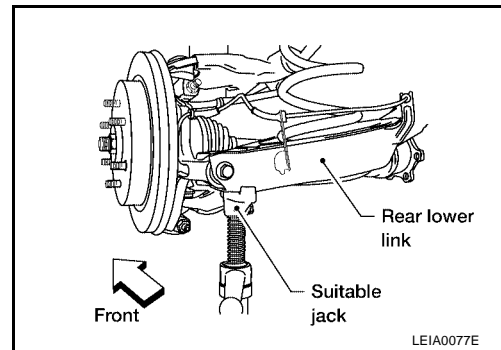

14. Remove both of the rear lower link outer bolts and lower the jack to remove the rear coil springs.
15. Remove the two bolts to disconnect the seat belt latch anchor from the rear suspension member.
16. Disconnect both of the connecting rods from the rear stabilizer bar.
17. Set a suitable jack under the rear suspension member.
18. Remove the six rear suspension member bolts.
19. Slowly lower the jack to remove the rear suspension member, suspension arm, front and rear lower links and stabilizer bar as an assembly.
20. If necessary, remove the suspension arm, spare tire bracket, height sensor, rear load leveling air suspension hoses, stabilizer bar, and front and rear lower links from the rear suspension member.

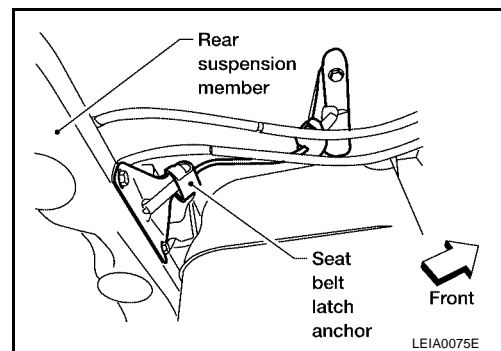

INSPECTION AFTER REMOVAL

Check rear suspension member for deformation, cracks, and other damage and replace if necessary.

REAR SUSPENSION MEMBER

INSTALLATION

Installation is in the reverse order of removal.

- When raising the rear suspension member assembly, use the locating pins to align the rear suspension member to the vehicle body.

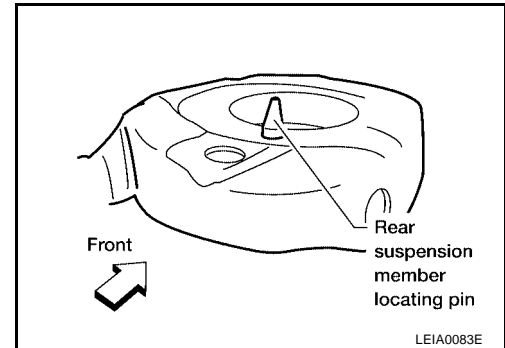

- When installing the upper and lower rubber seats for the rear coil springs, the arrow embossed on the rubber seats must point out toward the wheel and tire assembly.

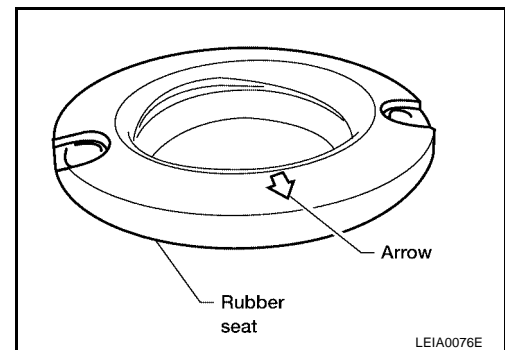

- To connect the rear load leveling air suspension hoses, the lock ring must be fully seated in the fitting. Insert the hose "B" into the lock ring "A" until the lock ring "A" is touching the hose "B" as shown. Pull on the hose to check that it is securely inserted.

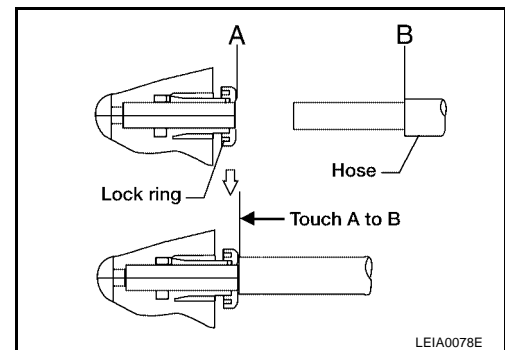

- Perform final tightening of nuts and bolts for the links (rubber bushing) under unladen condition (unladen condition means that the fuel tank, engine coolant and lubricants are at the full specification, and the spare tire, jack, hand tools, and mats are in their designated positions) with the tires on level ground.
- Check the wheel alignment. Refer to [RSU-26, "Wheel Alignment Inspection"](#)

SHOCK ABSORBER

PFP:56210

EES00211

SHOCK ABSORBER

Removal and Installation

REMOVAL

1. Remove the wheel and tire assembly using power tool. Refer to [WT-7, "Rotation"](#) .
2. If equipped with the rear load leveling air suspension system, use CONSULT-II "EXHAUST SOLENOID" active test to release the air pressure from the rear load leveling air suspension system.
3. If equipped with the rear load leveling air suspension system, disconnect the rear load leveling air suspension hose from the shock absorber.
 - To disconnect the hose, push in on the lock ring using a suitable tool and pull the air hose out.

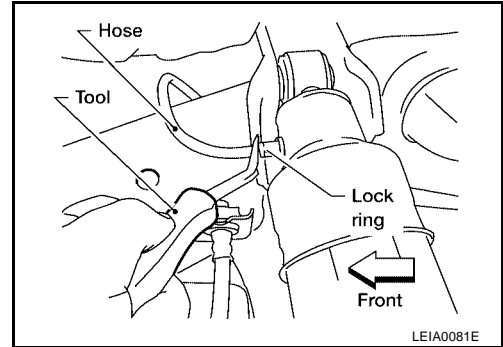

4. Remove the shock absorber upper and lower end bolts using power tool.
5. Remove the shock absorber.

CAUTION:

If equipped with the rear load leveling air suspension system, do not damage the rubber boot on the shock absorber.

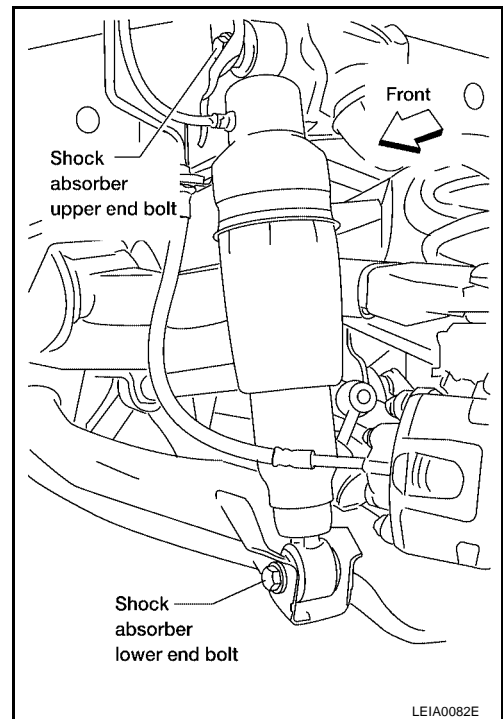

INSTALLATION

Installation is in the reverse order of removal.

- Tighten the shock absorber bolts to specification. Refer to [RSU-24, "Components"](#) .

Inspection

EES00212

- Check for oil leakage on welded or gland packing portions.
- If equipped with the rear load leveling air suspension system, check the shock absorber for any air leaks or damage to the rubber boot.
- Check the shock absorber for smooth operation through a full stroke, both compression and extension.
- Check piston rod for cracks, deformation or other damage and replace if necessary.

A
B
C
D
RSU
F
G
H
I
J
K
L
M

SUSPENSION ARM

SUSPENSION ARM

PFP:55501

Removal and Installation

EES00213

REMOVAL

1. Remove the rear suspension member assembly using power tool. Refer to [RSU-29, "REAR SUSPENSION MEMBER"](#) .

NOTE:

It is necessary to remove the rear suspension member to remove the front upper bolt from the suspension arm.

2. Remove the shock absorber upper end bolt.
3. Remove the suspension arm upper nuts and bolts on the suspension member side using power tool.

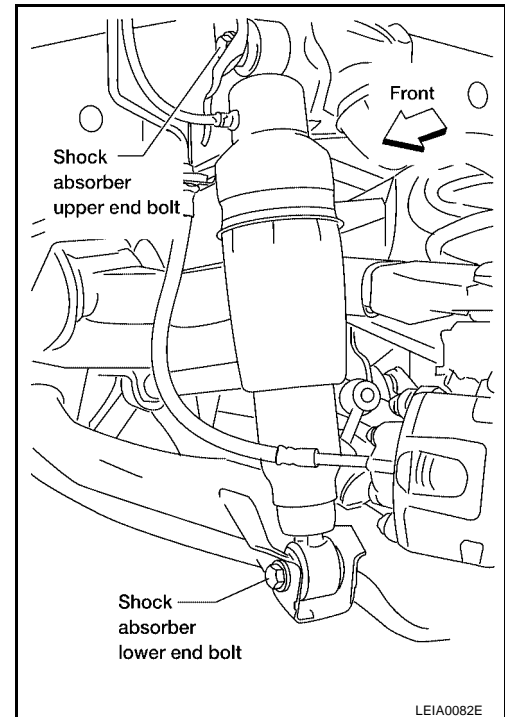

4. Remove the suspension arm pinch bolt and nut on the knuckle side using power tool.
5. Disconnect the suspension arm from the knuckle using a soft hammer.

CAUTION:

Do not damage the ball joint with the soft hammer.

6. Remove the suspension arm.

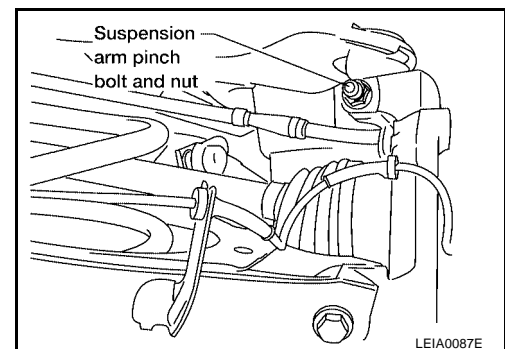

INSPECTION AFTER REMOVAL

- Check suspension arm for damage, cracks, deformation and replace if necessary.
- Check rubber bushing for damage, cracks and deformation. Replace suspension arm assembly if necessary.
- Before checking, turn ball joint at least 10 revolutions so that ball joint is properly broken in.

SUSPENSION ARM

- Check ball joint. Replace suspension arm assembly if any of the following exists:
 - Ball stud is worn.
 - Joint is hard to swing.
 - Play in axial direction is excessive.

Swinging force "A" : Refer to [RSU-46, "Ball Joint"](#) .

Turning force "B" : Refer to [RSU-46, "Ball Joint"](#) .

Vertical end play "C" : Refer to [RSU-46, "Ball Joint"](#) .

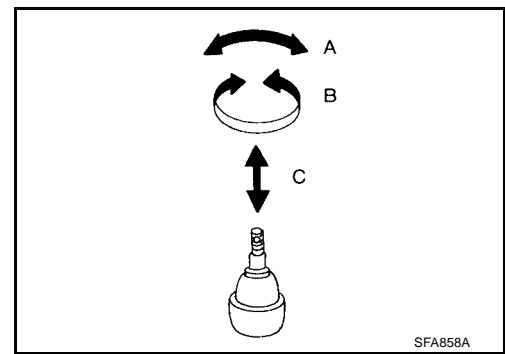

INSTALLATION

Installation is in the reverse order of removal.

- Tighten the nuts and bolts to specification. Refer to [RSU-24, "Components"](#) .
- Perform final tightening of nuts and bolts for the links (rubber bushing) under unladen condition (unladen condition means that the fuel tank, engine coolant and lubricants are at the full specification, and the spare tire, jack, hand tools, and mats are in their designated positions) with the tires on level ground.
- Check the wheel alignment. Refer to [RSU-26, "Wheel Alignment Inspection"](#) .

FRONT LOWER LINK

PF5:55110

EES00214

FRONT LOWER LINK

Removal and Installation

REMOVAL

1. Remove the wheel and tire assembly using power tool.
2. If equipped with rear load leveling air suspension system, use CONSULT-II "EXHAUST SOLENOID" active test to release the air pressure from the rear load leveling air suspension system.
3. Remove the shock absorber lower end bolt.
4. Remove the adjusting bolt and nut, and the bolt and nut, from the front lower link and rear suspension member using power tool.

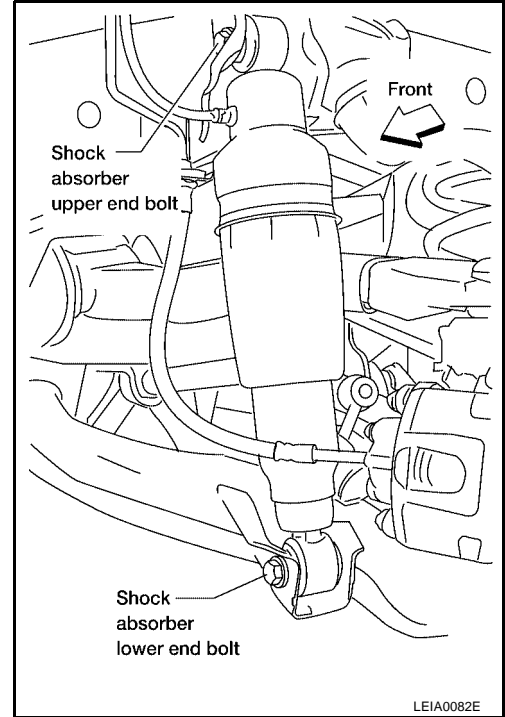

5. Remove the front lower link pinch bolt and nut on the knuckle side using power tool.
6. Disconnect the front lower link from the knuckle using a soft hammer.

CAUTION:

Do not damage the ball joint with the soft hammer.

7. Remove the front lower link.

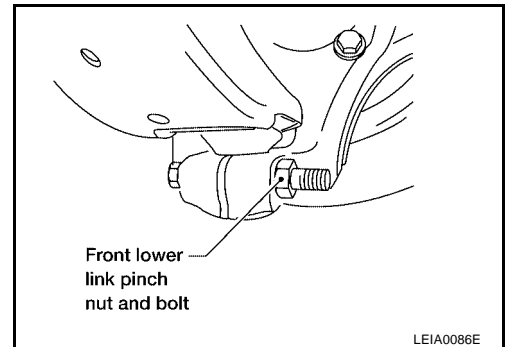

INSPECTION AFTER REMOVAL

- Check front lower link and bushing for any deformation, crack, or damage. Replace if necessary.
- Check rubber bushing for damage, cracks and deformation. Replace suspension arm assembly if necessary.
- Before checking, turn ball joint at least 10 revolutions so that ball joint is properly broken in.
- Check ball joint. Replace suspension arm assembly if any of the following exists:
 - Ball stud is worn.
 - Joint is hard to swing.
 - Play in axial direction is excessive.

Swinging force "A" : Refer to [RSU-46, "Ball Joint"](#) .

Turning force "B" : Refer to [RSU-46, "Ball Joint"](#) .

Vertical end play "C" : Refer to [RSU-46, "Ball Joint"](#) .

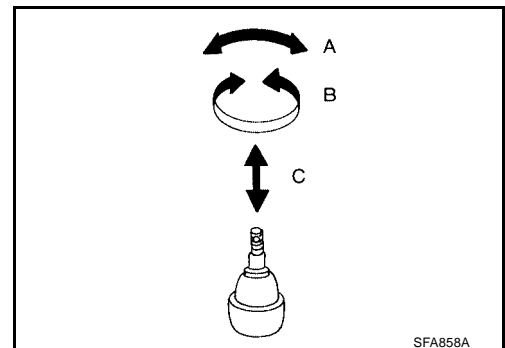

FRONT LOWER LINK

INSTALLATION

Installation is in the reverse order of removal.

- Tighten the nuts and bolts to specification. Refer to [RSU-24, "Components"](#) .
- Perform final tightening of nuts and bolts for the links (rubber bushing) under unladen condition (unladen condition means that the fuel tank, engine coolant and lubricants are at the full specification, and the spare tire, jack, hand tools, and mats are in their designated positions) with the tires on level ground.
- Check the wheel alignment. Refer to [RSU-26, "Wheel Alignment Inspection"](#) .

A

B

C

D

RSU

F

G

H

I

J

K

L

M

REAR LOWER LINK & COIL SPRING

REAR LOWER LINK & COIL SPRING

PF5:551B0

Removal and Installation REMOVAL

EES00215

1. Remove the wheel and tire assembly using power tool. Refer to [WT-7, "Rotation"](#).
2. If equipped with rear load leveling air suspension system, use CONSULT-II "EXHAUST SOLENOID" active test to release the air pressure from the rear load leveling air suspension system.
3. If equipped with the rear load leveling air suspension system, for removing the LH rear lower link and coil spring, remove the height sensor arm bracket bolt from the rear lower link.

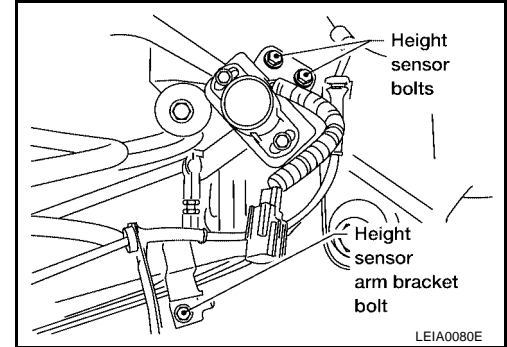

4. Set a suitable jack to relieve the coil spring tension and support the rear lower link.

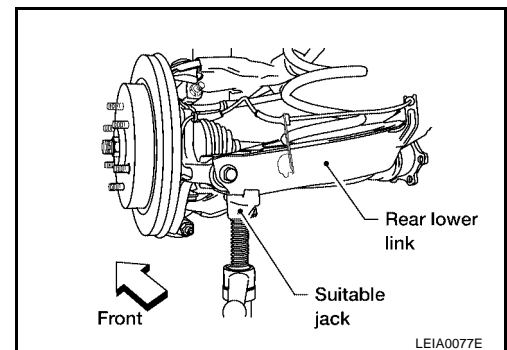

5. Loosen the rear lower link adjusting bolt and nut connected to the rear suspension member, using power tool.

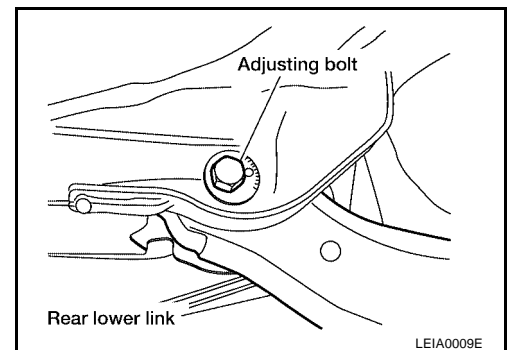

6. Remove the rear lower link bolt and nut from the knuckle using power tool.

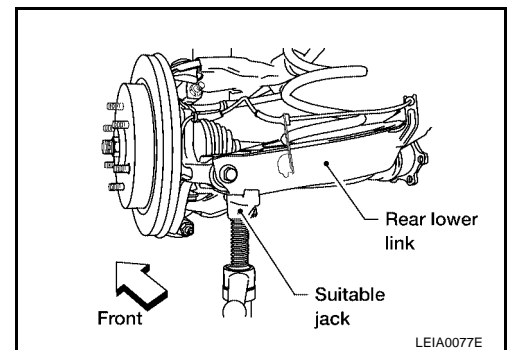

7. Slowly lower the suitable jack to release the coil spring tension. Then remove the upper rubber seat, coil spring and lower rubber seat from the rear lower link.

REAR LOWER LINK & COIL SPRING

- Remove the rear lower link adjusting bolt and nut from the rear suspension member using power tool, then remove the rear lower link.

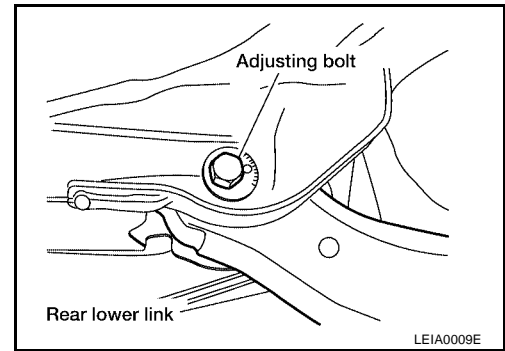

INSPECTION AFTER REMOVAL

Check the coil spring and rubber seats for deformation, cracks, or other damage and replace if necessary.

INSTALLATION

Installation is in the reverse order of removal.

- Tighten the nuts and bolts to specification. Refer to [RSU-24, "Components"](#) .
- When installing the upper and lower rubber seats for the rear coil springs, the arrow embossed on the rubber seats must point out toward the wheel and tire assembly.
- After installing the rear lower link and coil spring, check the wheel alignment and adjust if necessary. Refer to [RSU-26, "Wheel Alignment Inspection"](#) .

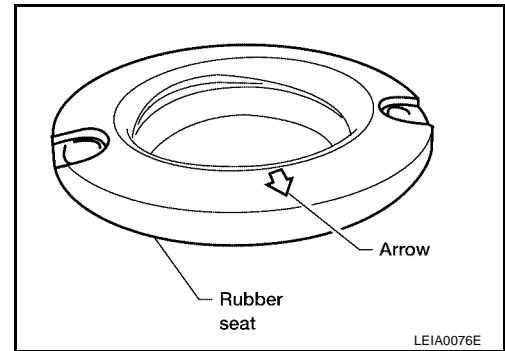

A
B
C
D

RSU

F
G
H
I
J
K
L
M

STABILIZER BAR

PFP:56230

EES00216

STABILIZER BAR

Removal and Installation

REMOVAL

1. Disconnect the stabilizer bar ends from the connecting rods using power tool.

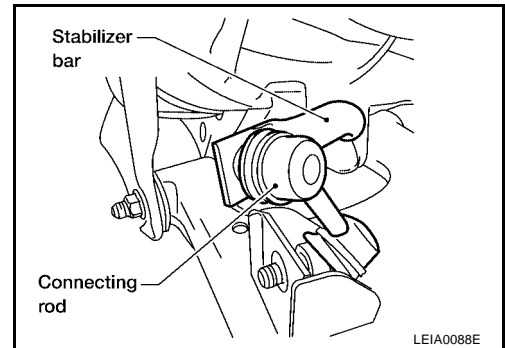

2. Remove the stabilizer bar clamps using power tool, and remove the stabilizer bar bushings.
3. Remove the stabilizer bar.

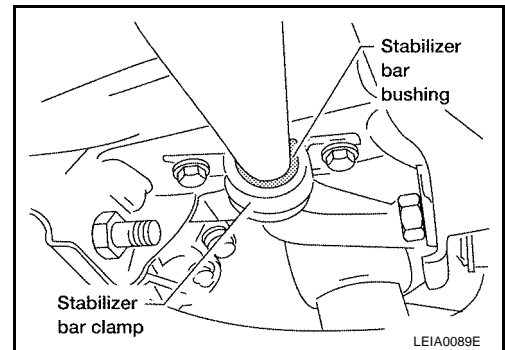

INSPECTION AFTER REMOVAL

- Check the stabilizer bar for any deformation, cracks, or damage and replace if necessary.
- Check the rubber bushings for deterioration, or cracks and replace if necessary.

INSTALLATION

Installation is in the reverse order of removal.

- Tighten the nuts and bolts to specification. Refer to [RSU-24, "Components"](#).
- Install the stabilizer bar with the ball joint sockets properly aligned.
- Install the stabilizer bar bushing and clamp so they are positioned inside of the sideslip prevention clamp on the stabilizer bar.

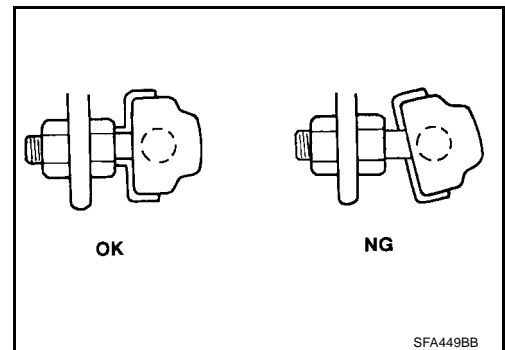

REAR LOAD LEVELING AIR SUSPENSION COMPRESSOR ASSEMBLY

REAR LOAD LEVELING AIR SUSPENSION COMPRESSOR ASSEMBLY

FPF:53400

Removal and Installation

EES00217

Rear Load Leveling Air Suspension System

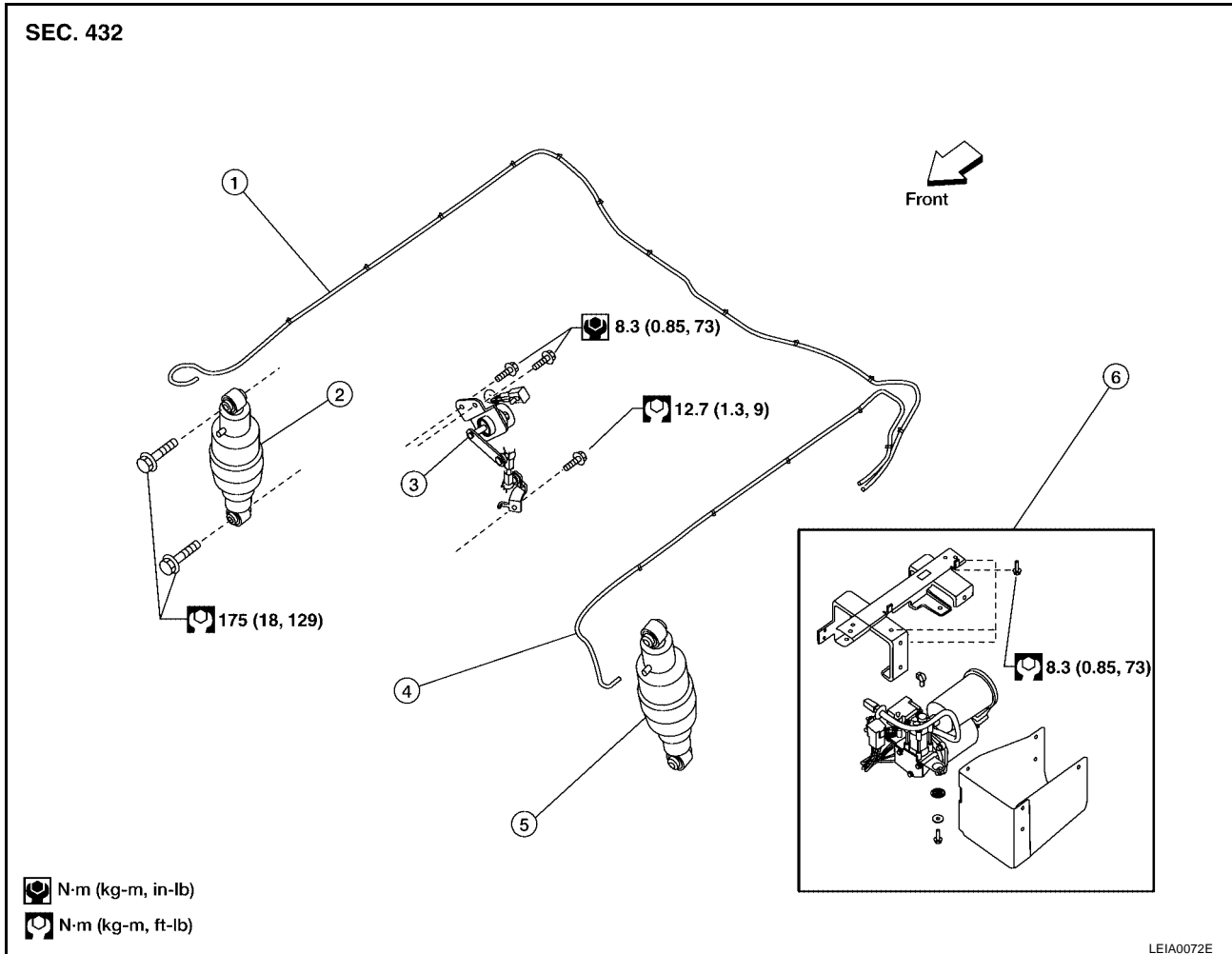

- | | | |
|---|-----------------------|--|
| 1. Rear load leveling air suspension hose, RH | 2. Shock absorber, RH | 3. Height sensor |
| 4. Rear load leveling air suspension hose, LH | 5. Shock absorber, LH | 6. Rear load leveling air suspension compressor assembly |

REMOVAL

- Use CONSULT-II "EXHAUST SOLENOID" active test to release the air pressure from the rear load leveling air suspension system.
- Disconnect the electrical connectors for the rear load leveling air suspension compressor assembly.
- Unclip the rubber cover to access the rear load leveling air suspension compressor assembly.
- Disconnect the rear load leveling air suspension hoses at the rear load leveling air suspension compressor assembly.
 - To disconnect the hoses, push in on the lock ring using a suitable tool and pull the hose out.

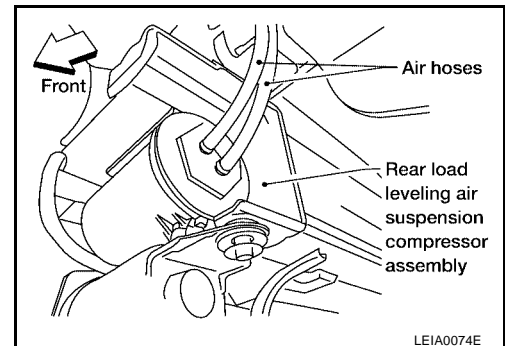

REAR LOAD LEVELING AIR SUSPENSION COMPRESSOR ASSEMBLY

5. Remove the four bolts that mount the rear load leveling air suspension compressor assembly to the underbody.

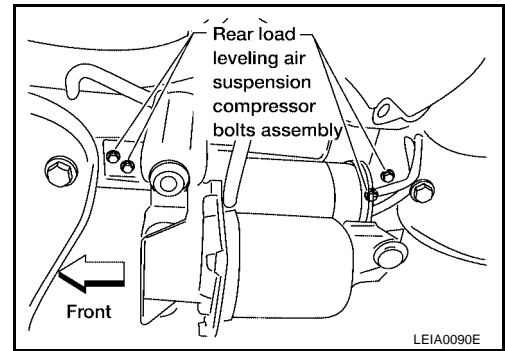

INSTALLATION

Installation is in the reverse order of removal.

- To connect the rear load leveling air suspension hoses, the lock ring must be fully seated in the fitting. Insert the hose "B" into the lock ring "A" until the lock ring "A" is touching the hose "B" as shown. Pull on the hose to check that it is securely inserted.

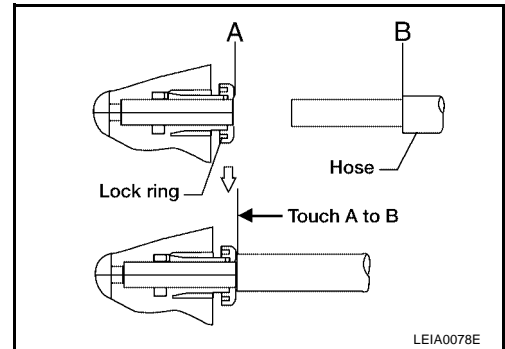

HEIGHT SENSOR

PF5:53820

EES00218

HEIGHT SENSOR

Removal and Installation

Rear Load Leveling Air Suspension System

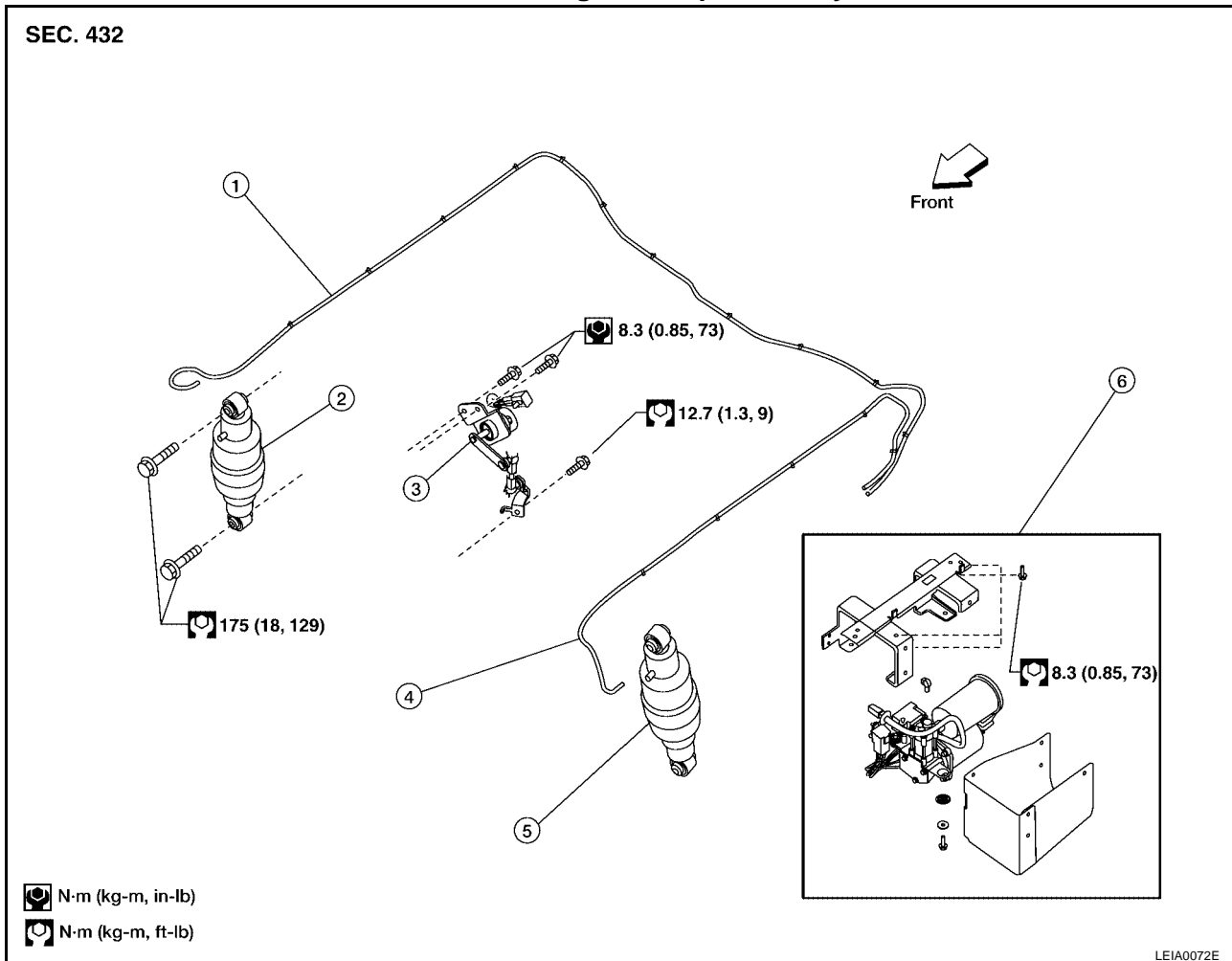

- | | | |
|---|-----------------------|--|
| 1. Rear load leveling air suspension hose, RH | 2. Shock absorber, RH | 3. Height sensor |
| 4. Rear load leveling air suspension hose, LH | 5. Shock absorber, LH | 6. Rear load leveling air suspension compressor assembly |

REMOVAL

1. Use CONSULT-II "EXHAUST SOLENOID" active test to release the air pressure from the rear load leveling air suspension system.
2. Disconnect the electrical connector for the height sensor.
3. Remove the two height sensor bolts and height sensor arm bracket bolt.
4. Remove the height sensor.

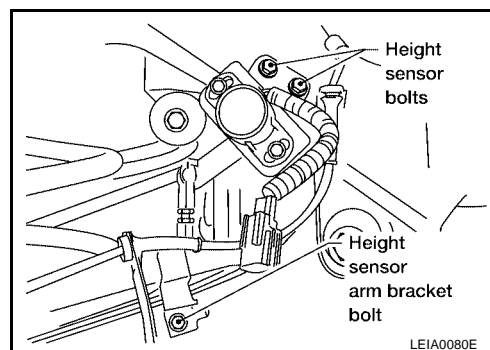

HEIGHT SENSOR

INSTALLATION

Installation is in the reverse order of removal.

1. Start the engine.
2. Use CONSULT-II to perform "STANDARD HEIGHT LEVEL" work support function.
3. Using data monitor of CONSULT-II, verify "HEIGT CALC" is at 0 mm.
4. Check the vehicle height. Refer to [RSU-47, "Wheelarch Height \(Unladen*¹\)"](#) . If vehicle height is not within ± 10 mm (0.39 in) of the specification, perform the initialization procedure. Refer to [RSU-45, "Initialization Procedure"](#) .

CONTROL UNIT

CONTROL UNIT

PFP:47850

Removal and Installation

EES00219

REMOVAL

1. Remove the rear LH interior trim panel. Refer to [EI-31, "BODY SIDE TRIM"](#) .
2. Disconnect the battery negative terminal.
3. Disconnect the suspension control unit electrical connector.
4. Remove the two bolts and remove the suspension control unit.

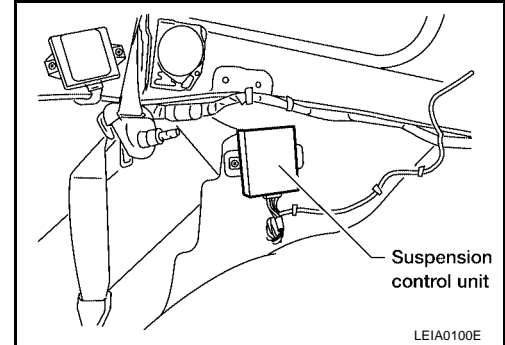

INSTALLATION

Installation is in the reverse order of removal.

Suspension control unit bolts : 6 N-m (0.6 kg-m, 53 in-lb)

Initialization Procedure

EES0021A

1. If control unit has been replaced, proceed to step 2. If control unit has not been replaced, use CONSULT-II "CLEAR HEIGHT INI" work support function to clear initialization flag and value. The CK SUSP warning lamp should illuminate. Using CONSULT-II "EXHAUST SOLENOID" active test, release the air pressure from the rear load leveling air suspension system.
2. Roll vehicle forward and backward.
3. Use CONSULT-II "ADJUST HEIGHT INI" work support function to set initialization condition.
4. Confirm that CK SUSP warning lamp is OFF.

SERVICE DATA AND SPECIFICATIONS (SDS)

SERVICE DATA AND SPECIFICATIONS (SDS)

PFP:00030

Wheel Alignment (Unladen*¹)

EES0021B

Applied model		Without air leveling	With air leveling
Camber Degree minute (decimal degree)	Minimum	- 0° 25' (- 0.4°)	- 1° 0' (- 1°)
	Nominal	0° 5' (0.1°)	- 0° 30' (- 0.5°)
	Maximum	0° 35' (0.6°)	0° 0' (0°)
	Cross camber	0° 45' (0.75°) or less	

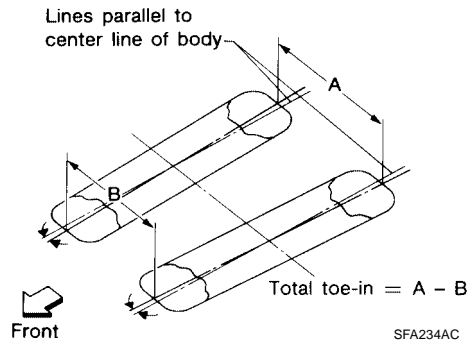

Total toe-in	Distance (A - B)	Minimum	- 2.4 mm (- 0.094 in)	0 mm (0 in)
		Nominal	0.9 mm (0.035 in)	3.3 mm (0.130 in)
		Maximum	4.2 mm (0.165 in)	6.6 mm (0.260 in)
		Cross toe	2 mm (0.079 in) or less	
	Angle (left side and right side) Degree minute (decimal degree)	Minimum	- 0° 5' (- 0.8°)	0° 0' (0°)
		Nominal	0° 2' (0.03°)	0° 7' (0.11°)
		Maximum	0° 9' (0.14°)	0° 14' (0.22°)
		Cross toe	0° 8' (0.14°) or less	

*1: Fuel tank, engine coolant and engine oil full. Spare tire, jack, hand tools and mats in designated positions.

Ball Joint

EES0021C

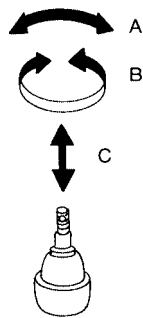

Swinging force (measurement point at cotter pin hole of ball stud) "A"	11.4 - 145.5 N (1.16 - 14.8 kg, 2.56 - 32.7 lb)
Turning torque "B"	0.5 - 6.4 N·m (0.06 - 0.65 kg·m, 5 - 56 in·lb)
Vertical end play "C"	0 mm (0 in)

SERVICE DATA AND SPECIFICATIONS (SDS)

Wheelarch Height (Unladen*¹)

EES002ID

Unit: mm (in)

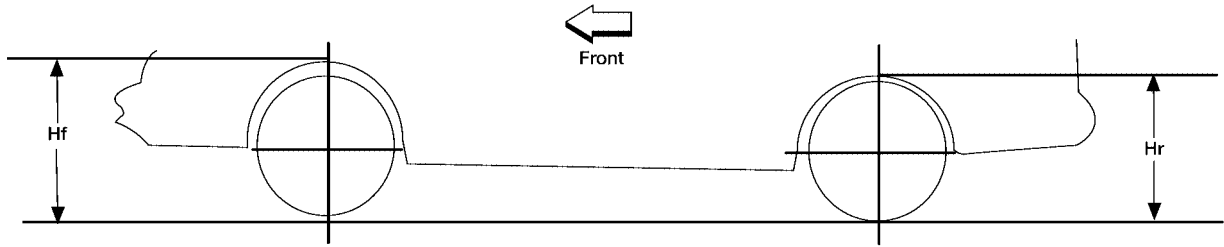

LEIA0085E

Suspension type	With air leveling* ²		Without air leveling	
	2WD	4WD	2WD	4WD
Applied model	2WD	4WD	2WD	4WD
Tire size	265/70R18	265/70R18	265/70R18	265/70R18
Front wheelarch height (Hf)	917 (36.10)	935 (36.81)	916 (36.06)	935 (36.81)
Rear wheelarch height (Hr)	916 (36.06)	936 (36.85)	937 (36.89)	957 (36.68)

*1: Fuel, radiator coolant and engine oil full. Spare tire, jack, hand tools and mats in designated positions.

*2: Verify the vehicle height. If vehicle height is not within ± 10 mm (0.39 in) of the specification, perform the control unit initialization procedure. Refer to [RSU-45, "Initialization Procedure"](#).

SERVICE DATA AND SPECIFICATIONS (SDS)
