

# SECTION **ADP**

## AUTOMATIC DRIVE POSITIONER

A  
B  
C  
D  
E  
F  
G  
H  
I  
K  
L  
M  
N  
O  
P

### CONTENTS

<b>BASIC INSPECTION</b> .....	4	EXIT ASSIST FUNCTION :	
<b>DIAGNOSIS AND REPAIR WORKFLOW</b> .....	4	Component Description .....	20
Work Flow .....	4	<b>ENTRY ASSIST FUNCTION</b> .....	21
<b>INSPECTION AND ADJUSTMENT</b> .....	7	ENTRY ASSIST FUNCTION : System Diagram .....	21
Preliminary Check .....	7	ENTRY ASSIST FUNCTION : System Description .....	21
Special Repair Requirement .....	7	ENTRY ASSIST FUNCTION : Component Parts Location .....	22
<b>FUNCTION DIAGNOSIS</b> .....	8	ENTRY ASSIST FUNCTION :	
<b>AUTOMATIC DRIVE POSITIONER SYSTEM</b> .....	8	Component Description .....	23
<b>AUTOMATIC DRIVE POSITIONER SYSTEM</b> .....	8	<b>DIAGNOSIS SYSTEM (DRIVER SEAT C/U)</b> ....	24
AUTOMATIC DRIVE POSITIONER SYSTEM :		Diagnosis Description .....	24
System Diagram .....	8	CONSULT-III Function .....	24
AUTOMATIC DRIVE POSITIONER SYSTEM :		<b>COMPONENT DIAGNOSIS</b> .....	27
Component Parts Location .....	9	<b>U1000 CAN COMM CIRCUIT</b> .....	27
AUTOMATIC DRIVE POSITIONER SYSTEM :		Description .....	27
System Description .....	9	DTC Logic .....	27
AUTOMATIC DRIVE POSITIONER SYSTEM :		Diagnosis Procedure .....	27
Component Description .....	10	Special Repair Requirement .....	27
<b>MANUAL FUNCTION</b> .....	11	<b>B2112 SLIDING MOTOR</b> .....	28
MANUAL FUNCTION : System Diagram .....	12	Description .....	28
MANUAL FUNCTION : System Description .....	12	DTC Logic .....	28
MANUAL FUNCTION : Component Parts Location .....	13	Diagnosis Procedure .....	28
MANUAL FUNCTION : Component Description ....	14	<b>B2113 RECLINING MOTOR</b> .....	29
<b>MEMORY FUNCTION</b> .....	15	Description .....	29
MEMORY FUNCTION : System Diagram .....	15	DTC Logic .....	29
MEMORY FUNCTION : System Description .....	15	Diagnosis Procedure .....	29
MEMORY FUNCTION : Component Parts Location .....	17	<b>B2114 SEAT LIFTER FR</b> .....	30
MEMORY FUNCTION : Component Description...	17	Description .....	30
<b>EXIT ASSIST FUNCTION</b> .....	18	DTC Logic .....	30
EXIT ASSIST FUNCTION : System Diagram .....	18	Diagnosis Procedure .....	30
EXIT ASSIST FUNCTION : System Description ....	19	<b>B2115 SEAT LIFTER RR</b> .....	31
EXIT ASSIST FUNCTION : Component Parts Location .....	20	Description .....	31
		DTC Logic .....	31

ADP

Diagnosis Procedure .....	31	Diagnosis Procedure .....	48
<b>B2117 ADJ PEDAL MOTOR .....</b>	<b>32</b>	Component Inspection .....	49
Description .....	32	<b>TILT SWITCH .....</b>	<b>50</b>
DTC Logic .....	32	Description .....	50
Diagnosis Procedure .....	32	Component Function Check .....	50
<b>B2120 ADJ PEDAL SENSOR .....</b>	<b>34</b>	Diagnosis Procedure .....	50
Description .....	34	Component Inspection .....	52
DTC Logic .....	34	<b>SEAT MEMORY SWITCH .....</b>	<b>53</b>
Diagnosis Procedure .....	34	Description .....	53
<b>B2126 DETENT SW .....</b>	<b>36</b>	Component Function Check .....	53
Description .....	36	Diagnosis Procedure .....	53
DTC Logic .....	36	Component Inspection .....	54
Diagnosis Procedure .....	36	<b>DOOR MIRROR REMOTE CONTROL</b>	
<b>B2128 UART COMMUNICATION LINE .....</b>	<b>38</b>	<b>SWITCH .....</b>	<b>55</b>
Description .....	38	<b>CHANGEOVER SWITCH .....</b>	<b>55</b>
DTC Logic .....	38	CHANGEOVER SWITCH : Description .....	55
Diagnosis Procedure .....	38	CHANGEOVER SWITCH : Component Function	
<b>POWER SUPPLY AND GROUND CIRCUIT ....</b>	<b>40</b>	Check .....	55
<b>BCM .....</b>	<b>40</b>	CHANGEOVER SWITCH : Diagnosis Procedure ...	55
BCM : Diagnosis Procedure .....	40	CHANGEOVER SWITCH : Component Inspec-	
BCM : Special Repair Requirement .....	40	tion .....	56
<b>DRIVER SEAT CONTROL UNIT .....</b>	<b>40</b>	<b>MIRROR SWITCH .....</b>	<b>57</b>
DRIVER SEAT CONTROL UNIT :		MIRROR SWITCH : Description .....	57
Diagnosis Procedure .....	40	MIRROR SWITCH : Component Function Check...	57
DRIVER SEAT CONTROL UNIT : Special Repair		MIRROR SWITCH : Diagnosis Procedure .....	57
Requirement .....	41	MIRROR SWITCH : Component Inspection .....	59
<b>AUTOMATIC DRIVE POSITIONER CONTROL</b>		<b>POWER SEAT SWITCH GROUND CIRCUIT ...</b>	<b>60</b>
<b>UNIT .....</b>	<b>41</b>	Diagnosis Procedure .....	60
AUTOMATIC DRIVE POSITIONER CONTROL		<b>DETENTION SWITCH .....</b>	<b>61</b>
UNIT : Diagnosis Procedure .....	41	Description .....	61
AUTOMATIC DRIVE POSITIONER CONTROL		Component Function Check .....	61
UNIT : Special Repair Requirement .....	41	Diagnosis Procedure .....	61
<b>SLIDING SWITCH .....</b>	<b>42</b>	<b>FRONT DOOR SWITCH (DRIVER SIDE) .....</b>	<b>63</b>
Description .....	42	Description .....	63
Component Function Check .....	42	Component Function Check .....	63
Diagnosis Procedure .....	42	Diagnosis Procedure .....	63
Component Inspection .....	43	Component Inspection .....	63
<b>RECLINING SWITCH .....</b>	<b>44</b>	<b>SLIDING SENSOR .....</b>	<b>65</b>
Description .....	44	Description .....	65
Component Function Check .....	44	Component Function Check .....	65
Diagnosis Procedure .....	44	Diagnosis Procedure .....	65
Component Inspection .....	45	<b>RECLINING SENSOR .....</b>	<b>67</b>
<b>LIFTING SWITCH (FRONT) .....</b>	<b>46</b>	Description .....	67
Description .....	46	Component Function Check .....	67
Component Function Check .....	46	Diagnosis Procedure .....	67
Diagnosis Procedure .....	46	<b>LIFTING SENSOR (FRONT) .....</b>	<b>69</b>
Component Inspection .....	47	Description .....	69
<b>LIFTING SWITCH (REAR) .....</b>	<b>48</b>	Component Function Check .....	69
Description .....	48	Diagnosis Procedure .....	69
Component Function Check .....	48	<b>LIFTING SENSOR (REAR) .....</b>	<b>71</b>

Description .....	71	Component Function Check .....	92	
Component Function Check .....	71	Diagnosis Procedure .....	92	A
Diagnosis Procedure .....	71	Component Inspection .....	93	
<b>TILT SENSOR .....</b>	<b>73</b>	<b>ECU DIAGNOSIS .....</b>	<b>94</b>	B
Description .....	73	<b>DRIVER SEAT CONTROL UNIT .....</b>	<b>94</b>	
Component Function Check .....	73	Reference Value .....	94	C
Diagnosis Procedure .....	73	Wiring Diagram .....	99	
<b>MIRROR SENSOR .....</b>	<b>75</b>	Fail Safe .....	111	D
<b>DRIVER SIDE .....</b>	<b>75</b>	DTC Index .....	112	
DRIVER SIDE : Description .....	75	<b>AUTOMATIC DRIVE POSITIONER CON-</b>		E
DRIVER SIDE : Component Function Check .....	75	<b>TROL UNIT .....</b>	<b>113</b>	
DRIVER SIDE : Diagnosis Procedure .....	75	Reference Value .....	113	F
<b>PASSENGER SIDE .....</b>	<b>77</b>	Wiring Diagram .....	116	
PASSENGER SIDE : Description .....	77	<b>BCM (BODY CONTROL MODULE) .....</b>	<b>129</b>	G
PASSENGER SIDE :		Reference Value .....	129	
Component Function Check .....	77	Wiring Diagram .....	129	H
PASSENGER SIDE : Diagnosis Procedure .....	77	DTC Inspection Priority Chart .....	129	
<b>SLIDING MOTOR .....</b>	<b>79</b>	DTC Index .....	129	I
Description .....	79	<b>SYMPTOM DIAGNOSIS .....</b>	<b>130</b>	
Component Function Check .....	79	<b>ADP SYSTEM SYMPTOMS .....</b>	<b>130</b>	
Diagnosis Procedure .....	79	Symptom Table .....	130	J
<b>RECLINING MOTOR .....</b>	<b>81</b>	<b>NORMAL OPERATING CONDITION .....</b>	<b>132</b>	
Description .....	81	Description .....	132	K
Component Function Check .....	81	<b>PRECAUTION .....</b>	<b>133</b>	
Diagnosis Procedure .....	81	<b>PRECAUTIONS .....</b>	<b>133</b>	ADP
<b>LIFTING MOTOR (FRONT) .....</b>	<b>83</b>	Precaution for Supplemental Restraint System (SRS) "AIR BAG" and "SEAT BELT PRE-TENSIONER" .....	133	
Description .....	83	Precaution for Work .....	133	L
Component Function Check .....	83	<b>ON-VEHICLE MAINTENANCE .....</b>	<b>134</b>	
Diagnosis Procedure .....	83	<b>PRE-INSPECTION FOR DIAGNOSTIC .....</b>	<b>134</b>	M
<b>LIFTING MOTOR (REAR) .....</b>	<b>85</b>	Basic Inspection .....	134	
Description .....	85	<b>PREPARATION .....</b>	<b>136</b>	N
Component Function Check .....	85	<b>PREPARATION .....</b>	<b>136</b>	
Diagnosis Procedure .....	85	Special Service Tool .....	136	O
<b>TILT MOTOR .....</b>	<b>87</b>	Commercial Service Tool .....	136	
Description .....	87	<b>REMOVAL AND INSTALLATION .....</b>	<b>137</b>	P
Component Function Check .....	87	<b>AUTOMATIC DRIVE POSITIONER .....</b>	<b>137</b>	
Diagnosis Procedure .....	87	Removal and Installation .....	137	
<b>DOOR MIRROR MOTOR .....</b>	<b>89</b>			
Description .....	89			
Component Function Check .....	89			
Diagnosis Procedure .....	89			
Component Inspection .....	91			
<b>SEAT MEMORY INDICATOR LAMP .....</b>	<b>92</b>			
Description .....	92			

# DIAGNOSIS AND REPAIR WORKFLOW

< BASIC INSPECTION >

## BASIC INSPECTION

### DIAGNOSIS AND REPAIR WORKFLOW

Work Flow

INFOID:000000001608017

WORK FLOW

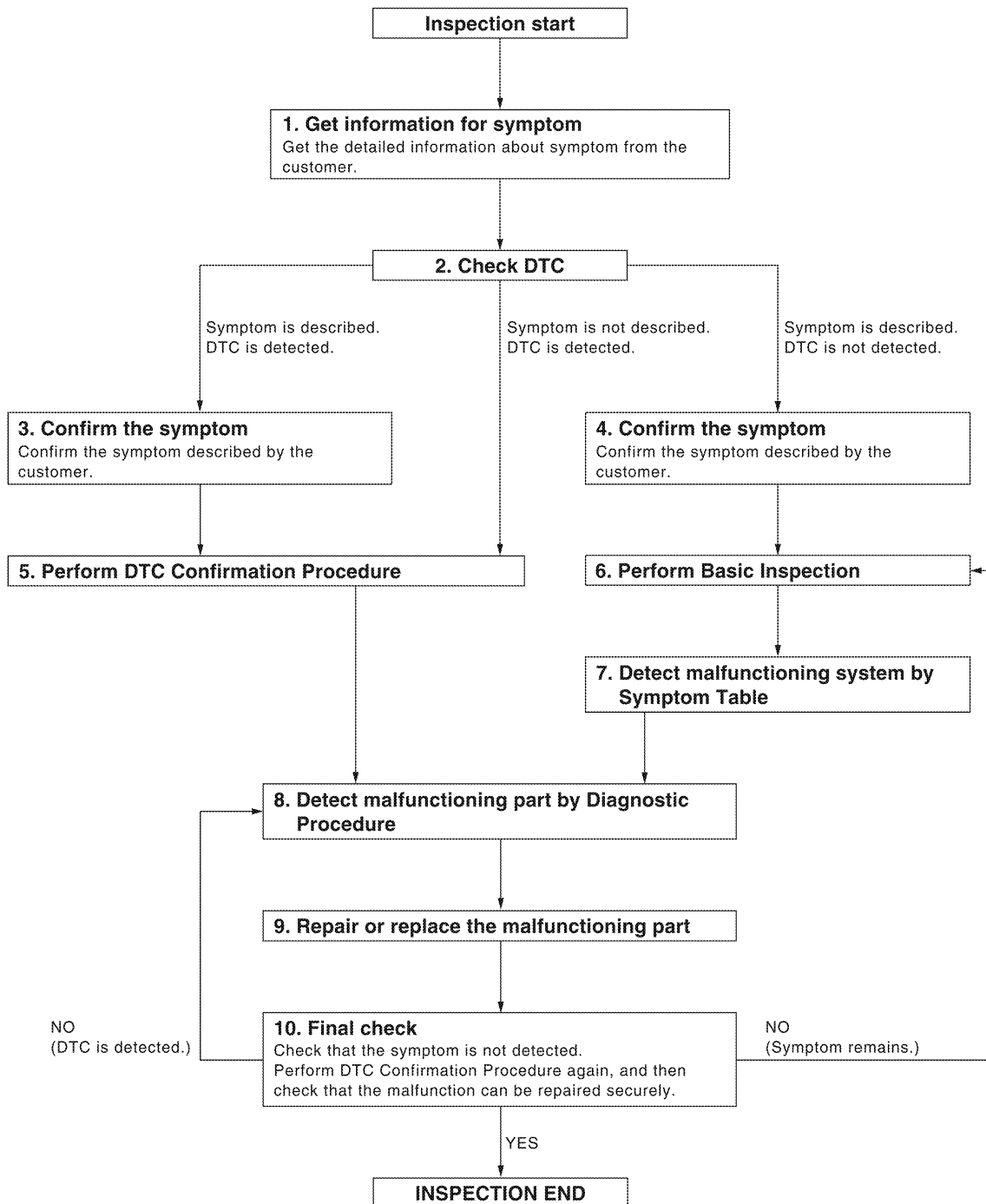

DETAILED FLOW

ALKIA0538GB

# DIAGNOSIS AND REPAIR WORKFLOW

< BASIC INSPECTION >

---

## 1.GET INFORMATION FOR SYMPTOM

---

Get the detailed information from the customer about the symptom (the condition and the environment when the incident/malfunction occurred).

>> GO TO 2.

---

## 2.CHECK DTC WITH AUTOMATIC DRIVE POSITIONER SYSTEM

---

Check "Self Diagnostic Result" with CONSULT-III.

Refer to [ADP-112. "DTC Index"](#).

Is any symptom described and any DTC is displayed?

Symptom is described, DTC is displayed.>>GO TO 3.

Symptom is not described, DTC is displayed.>>GO TO 7.

Symptom is described, DTC is not displayed.>>GO TO 4.

---

## 3.CONFIRM THE SYMPTOM

---

Try to confirm the symptom described by the customer.

>> GO TO 7.

---

## 4.CONFIRM THE SYMPTOM

---

Try to confirm the symptom described by the customer.

>> GO TO 5.

---

## 5.CHECK NORMAL OPERATING CONDITION

---

Check normal operating condition. Refer to [ADP-132. "Description"](#).

Is the incident normal operation?

YES >> INSPECTION END

NO >> GO TO 6.

---

## 6.PERFORM BASIC INSPECTION

---

Isolate the malfunctioning point with the basic inspection. Refer to [ADP-7. "Preliminary Check"](#).

>> GO TO 8.

---

## 7.PERFORM DTC CONFIRMATION PROCEDURE

---

Perform the confirmation procedure for the detected DTC.

Is the DTC displayed?

YES >> GO TO 9.

NO >> Check intermittent incident. Refer to [GI-39. "Intermittent Incident"](#).

---

## 8.PERFORM COMPONENT FUNCTION CHECK

---

Perform the component function check for the isolated malfunctioning point.

>> GO TO 9.

---

## 9.DETECT MALFUNCTIONING PART BY DIAGNOSTIC PROCEDURE

---

Isolate the malfunctioning point by performing the diagnosis procedure relevant to the symptom during the component diagnosis.

>> GO TO 10.

---

## 10.REPAIR OR REPLACE

---

Repair or replace the malfunctioning part.

A  
B  
C  
D  
E  
F  
G  
H  
I  
K  
L  
M  
N  
O  
P

ADP

## DIAGNOSIS AND REPAIR WORKFLOW

< BASIC INSPECTION >

---

>> GO TO 11.

### 11.FINAL CHECK

---

Perform the DTC confirmation procedure (if DTC is detected) or component function check (if no DTC is detected) again, and then check that the malfunction can be repaired securely.

Are all malfunctions corrected?

YES >> INSPECTION END

Symptom is detected.>> GO TO 4.

DTC is detected.>> GO TO 7.

# INSPECTION AND ADJUSTMENT

< BASIC INSPECTION >

## INSPECTION AND ADJUSTMENT

---

### Preliminary Check

INFOID:000000001608018

### 1. FOREIGN OBJECTS

---

Check the following:

- objects on or behind the seats that could cause binding
- objects under the seats that may be interfering with the seat's moving parts
- objects under pedals that may interfere with movement

Are there any foreign objects that could be causing interference?

- YES >> Remove objects.  
NO >> GO TO 2

### 2. WIRING CONNECTIONS

---

1. Disconnect harness connectors.
2. Check terminals for damage or loose connections.
3. Reconnect harness connectors.

Are any connectors damaged or loose?

- YES >> Repair or replace damaged parts.  
NO >> GO TO 3

### 3. POWER AND GROUND

---

Check power supply and ground circuits for control unit. Refer to [ADP-40. "DRIVER SEAT CONTROL UNIT : Diagnosis Procedure"](#).

Is the inspection result normal?

- YES >> Refer to [ADP-112. "DTC Index"](#).  
NO >> Repair or replace as necessary.

### Special Repair Requirement

INFOID:000000001608217

Refer to Owner's Manual for Automatic Drive Positioner system operating instructions.

ADP

# AUTOMATIC DRIVE POSITIONER SYSTEM

< FUNCTION DIAGNOSIS >

## FUNCTION DIAGNOSIS

AUTOMATIC DRIVE POSITIONER SYSTEM

AUTOMATIC DRIVE POSITIONER SYSTEM

AUTOMATIC DRIVE POSITIONER SYSTEM : System Diagram

INFOID:000000001608019

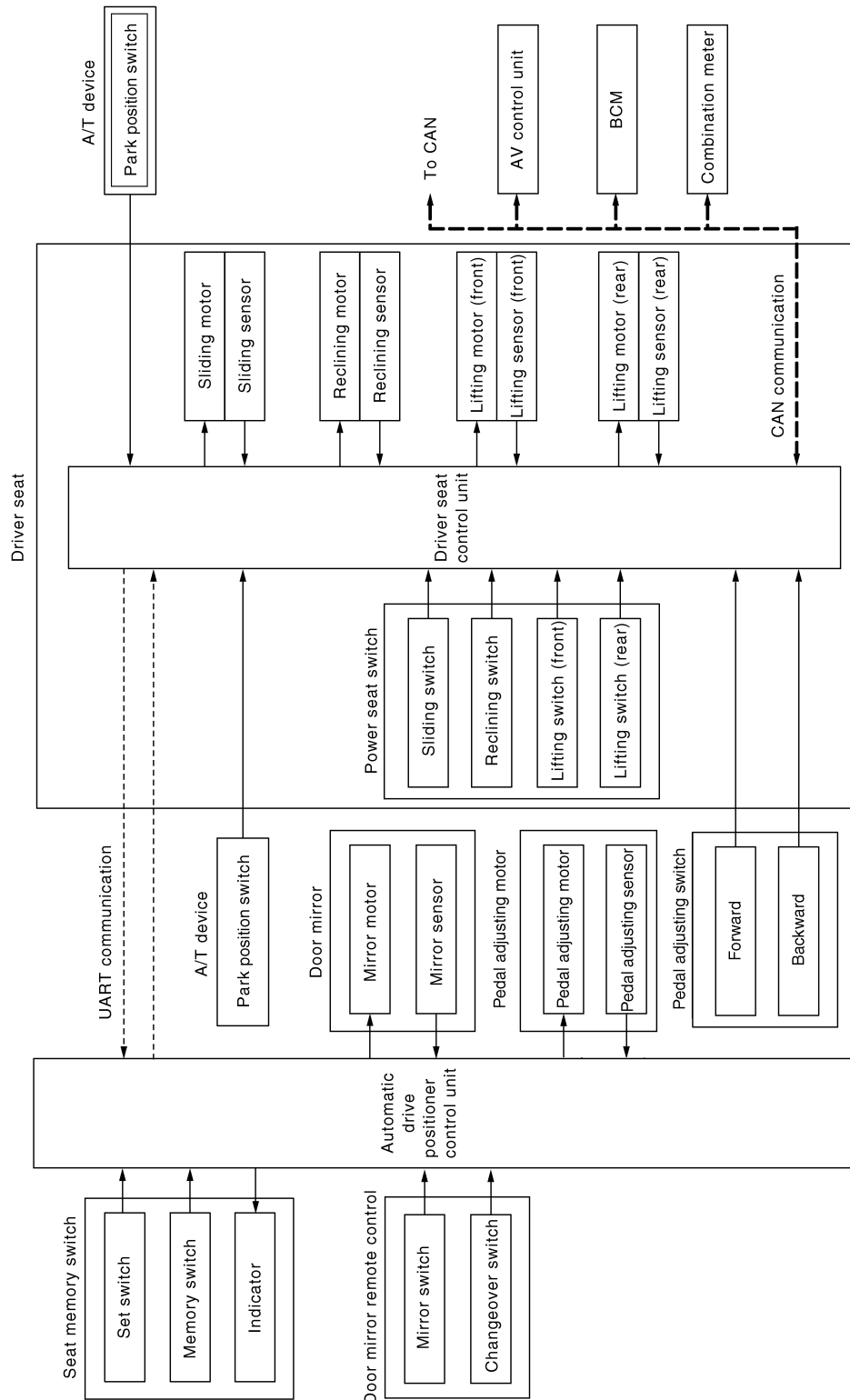

ALJIA0184GB



# AUTOMATIC DRIVE POSITIONER SYSTEM

< FUNCTION DIAGNOSIS >

## AUTOMATIC DRIVE POSITIONER SYSTEM : Component Parts Location INFOID:000000001608020

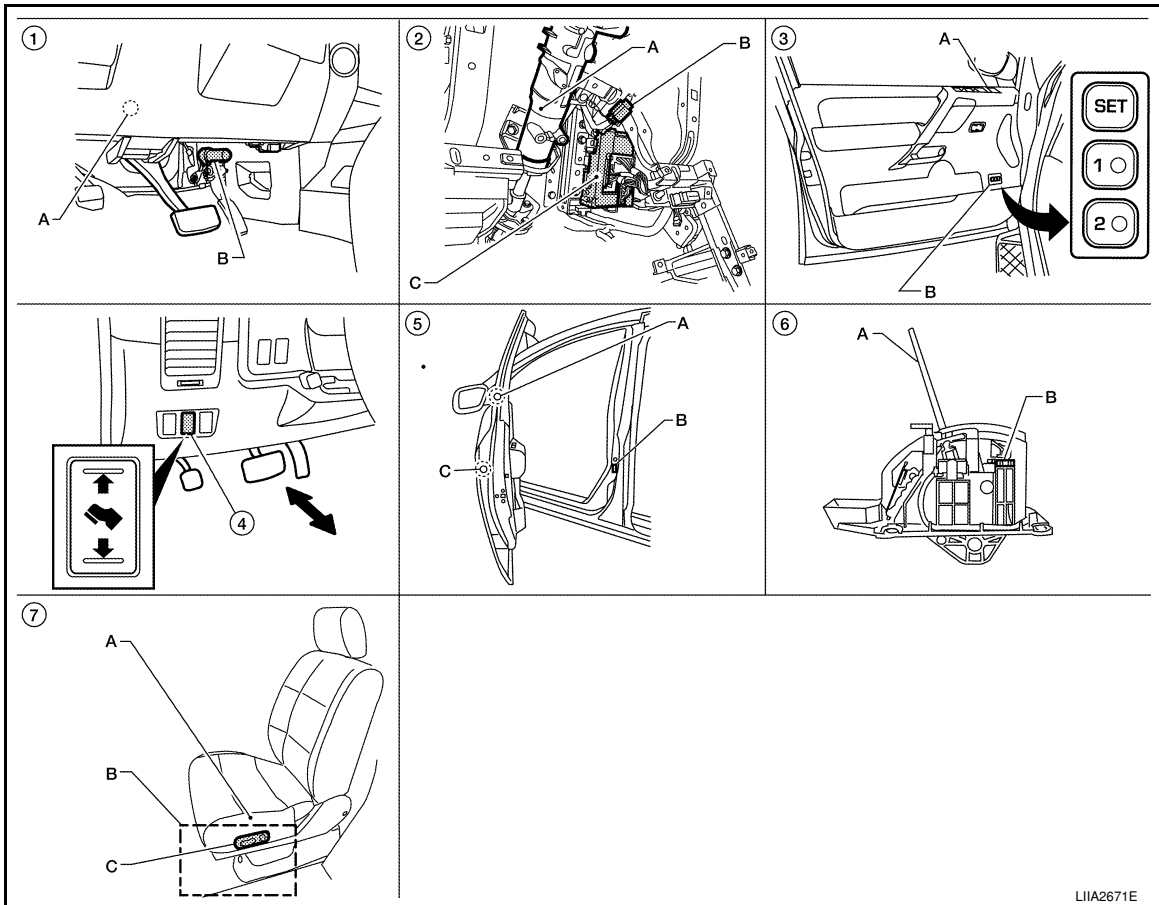

- |  |  |   |
|--|--|---|
| <p>1. A. Automatic drive positioner control unit M33, M34<br/>B. Pedal adjusting motor E109, E110</p> <p>4. Pedal adjusting switch M96</p> <p>7. A. Sliding motor LH B204 (driver seat view), reclining motor LH B205, lifting motor (front) B206, lifting motor (rear) B207<br/>B. Driver seat control unit B202, B203<br/>C. Power seat switch LH B208</p> | <p>2. A. Steering column<br/>B. Key switch and key lock solenoid M27<br/>C. BCM M18, M19, M20 (view with instrument panel removed)</p> <p>5. A. Door mirror LH D4, RH D107<br/>B. Front door switch LH B8<br/>C. Front door lock assembly LH (key cylinder switch) D14</p> | <p>3. A. Door mirror remote control switch D10<br/>B. Seat memory switch D5</p> <p>6. A. A/T selector lever<br/>B. A/T device (park position switch) M203</p> |
|--|--|---|

## AUTOMATIC DRIVE POSITIONER SYSTEM : System Description INFOID:000000001608021

### OUTLINE

The system automatically moves the driver seat, pedal assembly and door mirror position by the driver seat control unit and the automatic drive positioner control unit. The driver seat control unit corresponds with the automatic drive positioner control unit by UART communication.

# AUTOMATIC DRIVE POSITIONER SYSTEM

## < FUNCTION DIAGNOSIS >

Function	Description	
Manual function	The driving position (seat, pedal assembly and door mirror position) can be adjusted by using the power seat switch, pedal adjusting switch or door mirror remote control switch.	
Memory function	The seat, pedal assembly and outside mirror move to the stored driving position by pressing seat memory switch (1 or 2).	
Entry/Exit assist function	Exit	On exit, the seat moves backward.
	Entry	On entry, the seat returns from exiting position to the previous driving position.
Intelligent Key interlock function	Perform memory operation, exiting operation and entry operation by Intelligent Key unlock operation or driver side door request switch unlock operation .	

## AUTOMATIC DRIVE POSITIONER SYSTEM : Component Description

INFOID:000000001608022

### CONTROL UNITS

Item	Function
Driver seat control unit	<ul style="list-style-type: none"> <li>• Main unit of automatic drive positioner system</li> <li>• It is connected to the CAN.</li> <li>• It communicates with the automatic drive positioner control unit via UART communication.</li> </ul>
Automatic drive positioner control unit	<ul style="list-style-type: none"> <li>• It communicates with the driver seat control unit via UART communication.</li> <li>• Perform various controls with the instructions of driver seat control unit.</li> <li>• Perform the controls of the pedal adjusting, door mirror and the seat memory switch.</li> </ul>
BCM	Transmit the following status to the driver seat control unit via CAN communication. <ul style="list-style-type: none"> <li>• Front door LH: OPEN/CLOSE</li> <li>• Ignition switch position: ACC/ON</li> <li>• Door lock: UNLOCK (with Intelligent Key or remote keyless entry request switch operation)</li> <li>• Key ID</li> <li>• Key switch: Insert/Pull out Intelligent Key or ignition key</li> <li>• Starter: CRANKING/OTHER</li> </ul>
Combination meter	Transmit the vehicle speed signal to the driver seat control unit via CAN communication.
NAVI control unit/AV control unit	The setting change of auto drive positioner system can be performed on the display.
A/T device (park position switch)	Transmit the shift position signal (P range) to the driver seat control unit.

### INPUT PARTS

#### Switches

Item	Function
Key switch and ignition knob switch	The key switch is installed to detect the key inserted/removed status.
Front door switch LH	Detect front door (driver side) open/close status.
A/T device (park position switch)	Detect the P range position of A/T selector lever.
Set switch	The registration and system setting can be performed with its operation.
Seat memory switch 1/2	The registration and operation can be performed with its operation.
Power seat switch	The following switch is installed. <ul style="list-style-type: none"> <li>• Reclining switch</li> <li>• Lifting switch (front)</li> <li>• Lifting switch (rear)</li> <li>• Sliding switch</li> </ul> The specific parts can be operated with the operation of each switch.

# AUTOMATIC DRIVE POSITIONER SYSTEM

## < FUNCTION DIAGNOSIS >

Item	Function
Pedal adjusting switch	The following switch is installed. <ul style="list-style-type: none"><li>• Pedal forward</li><li>• Pedal backward</li></ul> The specific parts can be operated with the operation of each switch.
Door mirror remote control switch	The following switch is installed. <ul style="list-style-type: none"><li>• Mirror switch</li><li>• Changeover switch</li></ul> The specific parts can be operated with the operation of each switch.

### Sensors

Item	Function
Door mirror sensor (LH/RH)	Detect the up/down and left/right position of outside mirror face.
Pedal adjusting sensor	Detect the forward/backward position of pedal assembly.
Lifting sensor (front)	Detect the up/down position of seat lifting (front).
Lifting sensor (rear)	Detect the up/down position of seat lifting (rear).
Reclining sensor	Detect the tilt of seatback.
Sliding sensor	Detect the front/rear position of seat.

### OUTPUT PARTS

Item	Function
Door mirror motor (LH/RH)	Move the outside mirror face upward/downward and leftward/rightward.
Pedal adjusting motor	Move the pedal assembly forward/backward.
Lifting motor (front)	Move the seat lifting (front) upward/downward.
Lifting motor (rear)	Move the seat lifting (rear) upward/downward.
Reclining motor	Tilt and raise up the seatback.
Sliding motor	Slide the seat forward/backward.
Seat memory indicator	Illuminates or flashes according to the registration/operation status.

### MANUAL FUNCTION

A  
B  
C  
D  
E  
F  
G  
H  
I  
K  
L  
M  
N  
O  
P

ADP

# AUTOMATIC DRIVE POSITIONER SYSTEM

< FUNCTION DIAGNOSIS >

## MANUAL FUNCTION : System Diagram

INFOID:000000001608023

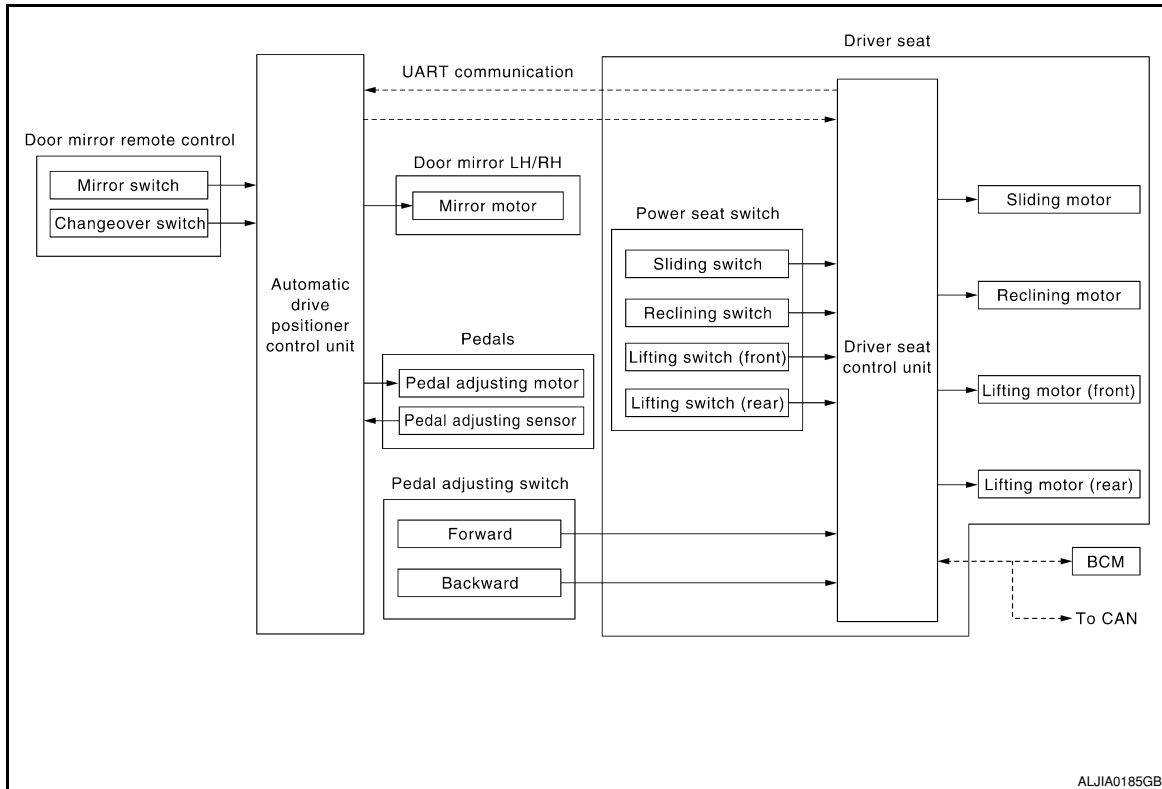

## MANUAL FUNCTION : System Description

INFOID:000000001608024

### OUTLINE

The driving position (seat, pedal assembly and door mirror position) can be adjusted manually with power seat switch, pedal adjusting switch and door mirror remote control switch.

### OPERATION PROCEDURE

1. Turn ignition switch ON.
2. Operate power seat switch, pedal adjusting switch or door mirror remote control switch.
3. The driver seat, pedal assembly or door mirror operates according to the operation of each switch.

### DETAIL FLOW

#### Seat

Order	Input	Output	Control unit condition
1	Power seat switch (sliding, lifting, reclining)	—	The power seat switch signal is inputted to the driver seat control unit when the power seat switch is operated.
2	—	Motors (sliding, lifting, reclining)	The driver seat control unit outputs signals to each motor according to the power seat switch input signal.

#### Adjustable pedals

Order	Input	Output	Control unit condition
1	Pedal adjusting switch	—	The pedal adjusting switch signal is input to the automatic drive positioner control unit when the pedal adjusting switch is operated.

# AUTOMATIC DRIVE POSITIONER SYSTEM

## < FUNCTION DIAGNOSIS >

Order	Input	Output	Control unit condition
2	—	Motor	The automatic drive positioner control unit actuates the motor according to the operation of the pedal adjusting switch signal from the driver seat control unit.
3	Sensors (forward, backward)	—	The automatic drive positioner control unit recognizes any operation limit of each actuator via each sensor and will not operate the actuator anymore at that time.

## Door Mirror

Order	Input	Output	Control unit condition
1	Door mirror remote control switch	—	The door mirror remote control switch signal is inputted to the automatic drive positioner control unit when the door mirror remote control switch is operated.
2	—	Motors (Door mirror motor)	The automatic drive positioner control unit actuates each motor according to the operation of the door mirror remote control switch.

### NOTE:

The door mirrors can be operated manually when ignition switch is in either ACC or ON position. The ignition switch signal (ACC/ON) is transmitted from BCM to the driver seat control unit via CAN communication and from the driver seat control unit to the automatic drive positioner control unit via UART communication.

## MANUAL FUNCTION : Component Parts Location

INFOID:000000001608025

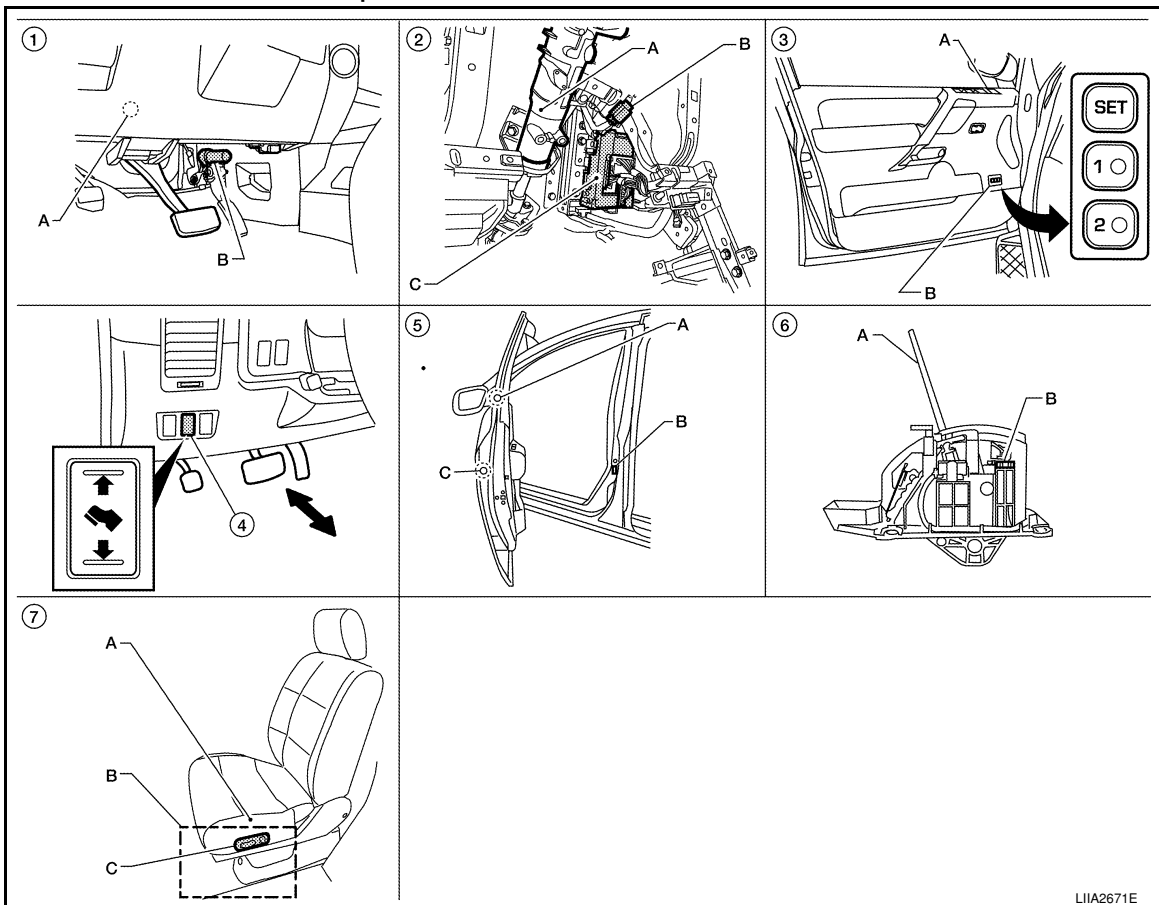

LIA2671E

# AUTOMATIC DRIVE POSITIONER SYSTEM

## < FUNCTION DIAGNOSIS >

- |  |   |   |
|--|---|---|
| 1. A. Automatic drive positioner control unit M33, M34<br>B. Pedal adjusting motor E109, E110  | 2. A. Steering column<br>B. Key switch and key lock solenoid M27<br>C. BCM M18, M19, M20 (view with instrument panel removed) | 3. A. Door mirror remote control switch D10<br>B. Seat memory switch D5 |
| 4. Pedal adjusting switch M96  | 5. A. Door mirror LH D4, RH D107<br>B. Front door switch LH B8<br>C. Front door lock assembly LH (key cylinder switch) D14    | 6. A. A/T selector lever<br>B. A/T device (park position switch) M203   |
| 7. A. Sliding motor LH B204 (driver seat view), reclining motor LH B205, lifting motor (front) B206, lifting motor (rear) B207<br>B. Driver seat control unit B202, B203<br>C. Power seat switch LH B208 |   |   |

## MANUAL FUNCTION : Component Description

INFOID:000000001608026

### CONTROL UNITS

Item	Function
Driver seat control unit	<ul style="list-style-type: none"> <li>Operates the specific seat motor with the signal from the power seat switch.</li> <li>Transmits the ignition switch signal (ACC/ON) via UART communication to the automatic drive positioner control unit.</li> <li>Transmits the pedal adjusting switch signal via UART communication to the automatic drive positioner control unit.</li> </ul>
Automatic drive positioner control unit	Operates the specific motor with the signal from driver seat control unit or door mirror remote control switch.
BCM	Recognizes the following status and transmits it to the driver seat control unit via CAN communication. <ul style="list-style-type: none"> <li>Ignition position: ACC/ON</li> </ul>

### INPUT PARTS

#### Switches

Item	Function
Power seat switch	The following switch is installed. <ul style="list-style-type: none"> <li>Reclining switch</li> <li>Lifting switch (front)</li> <li>Lifting switch (rear)</li> <li>Sliding switch</li> </ul> The specific parts can be operated with the operation of each switch.
Pedal adjusting switch	The following switch is installed. <ul style="list-style-type: none"> <li>Pedal forward</li> <li>Pedal backward</li> </ul> The specific parts can be operated with the operation of each switch.
Door mirror remote control switch	The following switch is installed. <ul style="list-style-type: none"> <li>Mirror switch</li> <li>Changeover switch</li> </ul> The specific parts can be operated with the operation of each switch.

#### Sensors

Item	Function
Pedal adjusting sensor	Detect the forward/backward position of pedal assembly.

### OUTPUT PARTS

# AUTOMATIC DRIVE POSITIONER SYSTEM

## < FUNCTION DIAGNOSIS >

Item	Function
Door mirror motor (LH/RH)	Move the outside mirror face upward/downward and leftward/rightward.
Pedal adjusting motor	Move the pedal assembly forward/backward.
Lifting motor (front)	Move the seat lifter (front) upward/downward.
Lifting motor (rear)	Move the seat lifter (rear) upward/downward.
Reclining motor	Tilt and raise up the seatback.
Sliding motor	Slide the seat forward/backward.

## MEMORY FUNCTION

### MEMORY FUNCTION : System Diagram

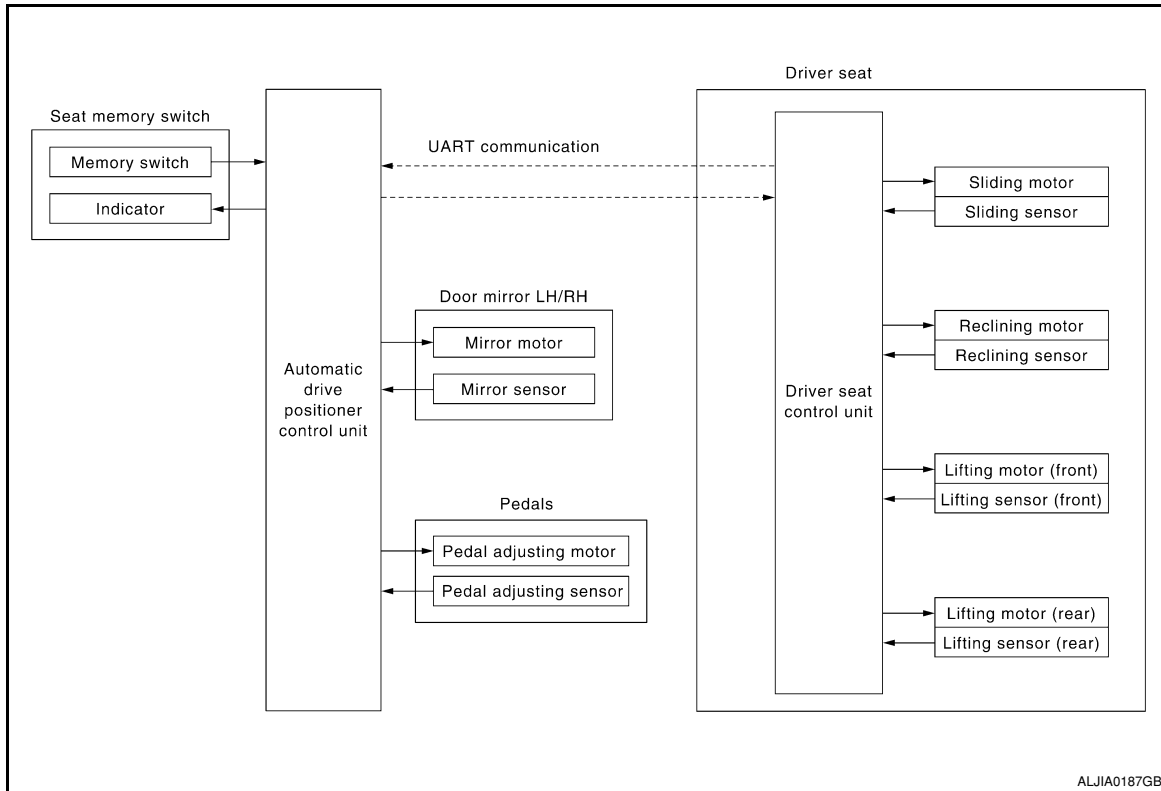

### MEMORY FUNCTION : System Description

INFOID:000000001608032

#### OUTLINE

The driver seat control unit can store the optimum driving positions (seat, pedal assembly and door mirror position) for 2 people. If the front seat position is changed, one-touch (pressing desired memory switch for more than 0.5 second) operation allows changing to the other driving position.

#### NOTE:

Further information for the memory storage procedure. Refer to Owner's Manual.

#### OPERATION PROCEDURE

1. Turn ignition switch ON
2. Press desired memory switch for more than 0.5 second.
3. Front seat LH, pedal assembly and door mirror will move to the memorized position.

#### OPERATION CONDITION

Satisfy all of the following items. The memory function is not performed if these items are not satisfied.

# AUTOMATIC DRIVE POSITIONER SYSTEM

## < FUNCTION DIAGNOSIS >

Item	Request status
Ignition position	ON
Switch inputs <ul style="list-style-type: none"> <li>• Power seat switch</li> <li>• Pedal adjusting switch</li> <li>• Door mirror control switch</li> <li>• Set switch</li> <li>• Seat memory switch</li> </ul>	OFF (Not operated)
A/T selector lever	P position

## DETAIL FLOW

Order	Input	Output	Control unit condition
1	Memory switch	—	The memory switch signal is inputted to the automatic drive positioner control unit when memory switch 1 or 2 is operated. Memory switch signal is input to driver seat control unit via UART communication.
2	—	Motors (seat, pedal adjusting, door mirror)	Driver seat control unit operates each motor of seat when it recognizes the memory switch pressed for 0.5 second or more and requests each motor operation to automatic drive positioner control unit via UART communication. The automatic drive positioner control unit operates each motor.
		Memory switch Indicator	Driver seat control unit requests the flashing of memory indicator to automatic drive positioner control unit via UART communication while either of the motors is operating. The automatic drive positioner control unit illuminates the memory indicator.
3	Sensors (seat, pedal adjusting, door mirror)	—	Driver seat control unit judges the operating seat position with each seat sensor input. The positions of the adjustable pedals and outside mirror are monitored with each sensor signal that is input from auto drive positioner control unit via UART communication. Driver seat control unit stops the operation of each motor when each part reaches the recorded address.
4	—	Memory switch Indicator	Driver seat control unit requests the illumination of memory indicator to auto drive positioner control unit via UART communication after all motors stop. The auto driving positioner control unit illuminates the memory indicator for 5 seconds.



# AUTOMATIC DRIVE POSITIONER SYSTEM

< FUNCTION DIAGNOSIS >

## MEMORY FUNCTION : Component Parts Location

INFOID:000000001608033

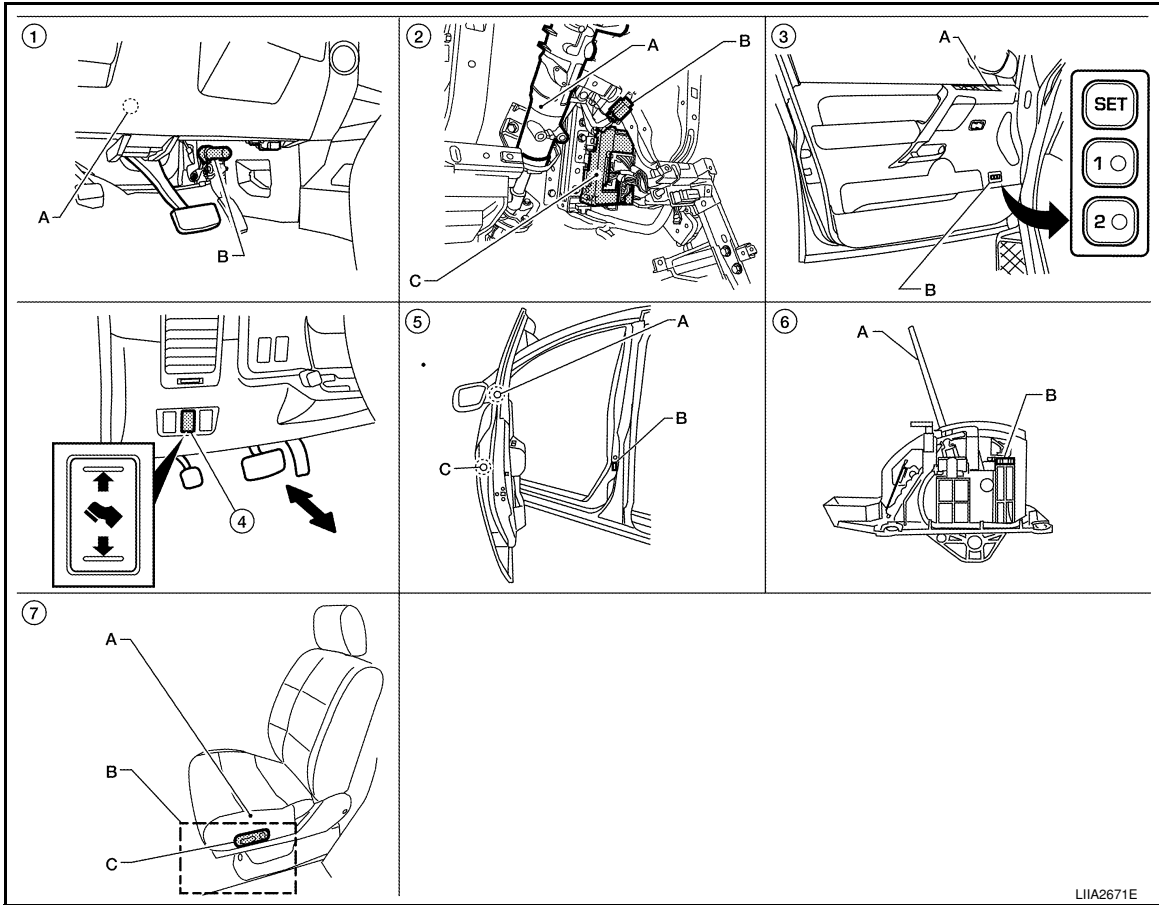

- |  |  |   |
|--|--|---|
| <p>1. A. Automatic drive positioner control unit M33, M34<br/>B. Pedal adjusting motor E109, E110</p> <p>4. Pedal adjusting switch M96</p> <p>7. A. Sliding motor LH B204 (driver seat view), reclining motor LH B205, lifting motor (front) B206, lifting motor (rear) B207<br/>B. Driver seat control unit B202, B203<br/>C. Power seat switch LH B208</p> | <p>2. A. Steering column<br/>B. Key switch and key lock solenoid M27<br/>C. BCM M18, M19, M20 (view with instrument panel removed)</p> <p>5. A. Door mirror LH D4, RH D107<br/>B. Front door switch LH B8<br/>C. Front door lock assembly LH (key cylinder switch) D14</p> | <p>3. A. Door mirror remote control switch D10<br/>B. Seat memory switch D5</p> <p>6. A. A/T selector lever<br/>B. A/T device (park position switch) M203</p> |
|--|--|---|

## MEMORY FUNCTION : Component Description

INFOID:0000000001608034

### CONTROL UNITS

Item	Function
Driver seat control unit	<ul style="list-style-type: none"> <li>The address of each part is recorded.</li> <li>Operates each motor of seat to the registered position.</li> <li>Requests the operations of pedal assembly and door mirror to automatic drive positioner control unit</li> </ul>
Automatic drive positioner control unit	Operates the pedal adjusting motor and door mirror with the instructions from the driver seat control.

### INPUT PARTS

A  
B  
C  
D  
E  
F  
G  
H  
I  
ADP  
K  
L  
M  
N  
O  
P

# AUTOMATIC DRIVE POSITIONER SYSTEM

## < FUNCTION DIAGNOSIS >

### Switches

Item	Function
Memory switch 1/2	The registration and memory function can be performed with its operation.

### Sensors

Item	Function
Door mirror sensor (LH/RH)	Detect the up/down and left/right position of outside mirror face.
Pedal adjusting sensor	Detect the forward/backward position of pedal assembly.
Lifting sensor (front)	Detect the up/down position of seat lifting (front).
Lifting sensor (rear)	Detect the up/down position of seat lifting (rear).
Reclining sensor	Detect the tilt of seatback.
Sliding sensor	Detect the front/rear position of seat.

## OUTPUT PARTS

Item	Function
Door mirror motor (LH/RH)	Move the outside mirror face upward/downward and leftward/rightward.
Pedal adjusting motor	Move the pedal assembly forward/backward.
Lifting motor (front)	Move the seat lifter (front) upward/downward.
Lifting motor (rear)	Move the seat lifter (rear) upward/downward.
Reclining motor	Tilt and raise up the seatback.
Sliding motor	Slide the seat forward/backward.
Memory indicator	Illuminates or blinks according to the registration/operation status.

## EXIT ASSIST FUNCTION

### EXIT ASSIST FUNCTION : System Diagram

INFOID:000000001608035

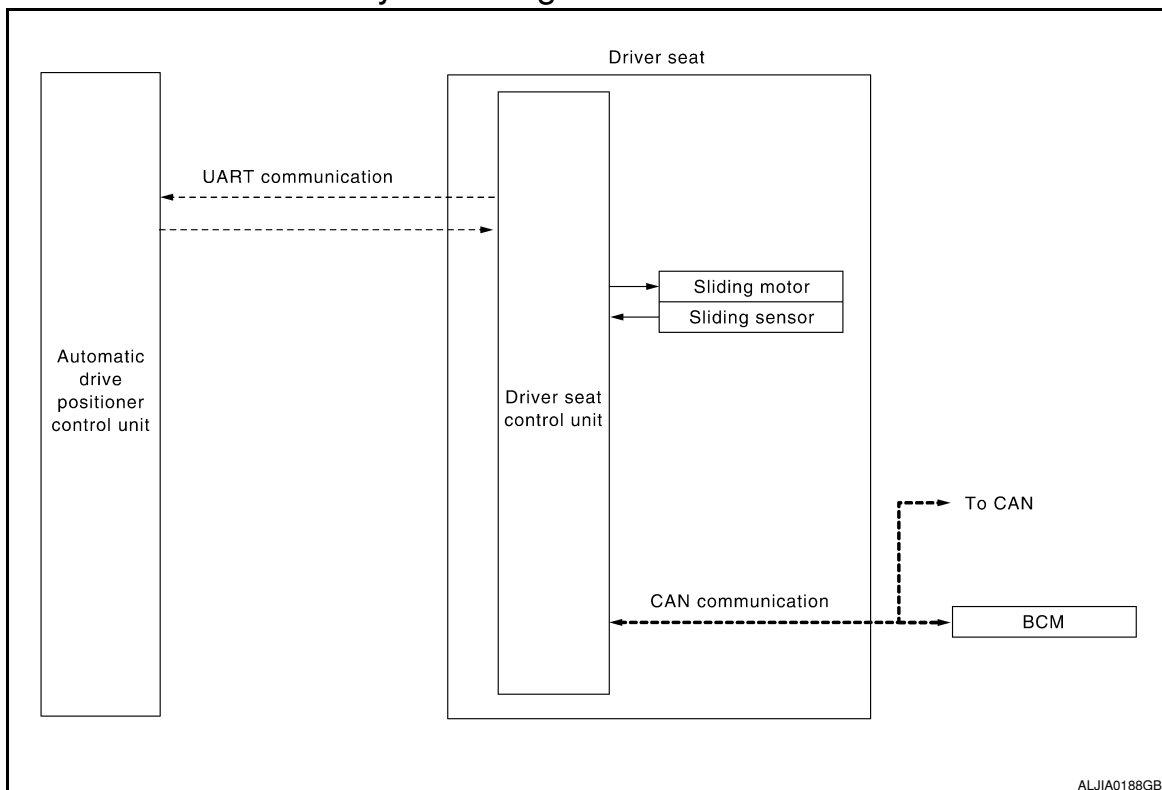

# AUTOMATIC DRIVE POSITIONER SYSTEM

< FUNCTION DIAGNOSIS >

## EXIT ASSIST FUNCTION : System Description

INFOID:000000001608036

### OUTLINE

When exiting, if the conditions are satisfied, the seat is moved backward from normal sitting position. The seat slide amount at entry/exit operation can be changed.

#### NOTE:

- This function is set to OFF before delivery (initial setting).
- Further information for the system setting procedure. Refer to Owner's Manual.

### OPERATION PROCEDURE

1. Open the driver door with ignition switch in OFF position.
2. Front seat LH will move to the exiting position.

### OPERATION CONDITION

Satisfy all of the following items. The exit assist function is not performed if these items are not satisfied.

Item	Request status
Ignition switch	OFF
System setting [Entry/exit assist function]	ON
Initialization	Done
Switch inputs <ul style="list-style-type: none"><li>• Power seat switch</li><li>• Pedal adjusting switch</li><li>• Door mirror remote control switch</li><li>• Set switch</li><li>• Seat memory switch</li></ul>	OFF (Not operated)
A/T selector lever	P position

### DETAIL FLOW

Order	Input	Output	Control unit condition
1	Front door switch LH	—	Driver seat control unit receives front door switch LH signal (open) from BCM via CAN communication.
2	—	Motor (seat sliding)	Driver seat control unit operates the seat sliding motor, which recognizes that the front door LH is opened with ignition switch OFF.

A  
B  
C  
D  
E  
F  
G  
H  
I  
K  
L  
M  
N  
O  
P

ADP

# AUTOMATIC DRIVE POSITIONER SYSTEM

< FUNCTION DIAGNOSIS >

## EXIT ASSIST FUNCTION : Component Parts Location

INFOID:000000001608037

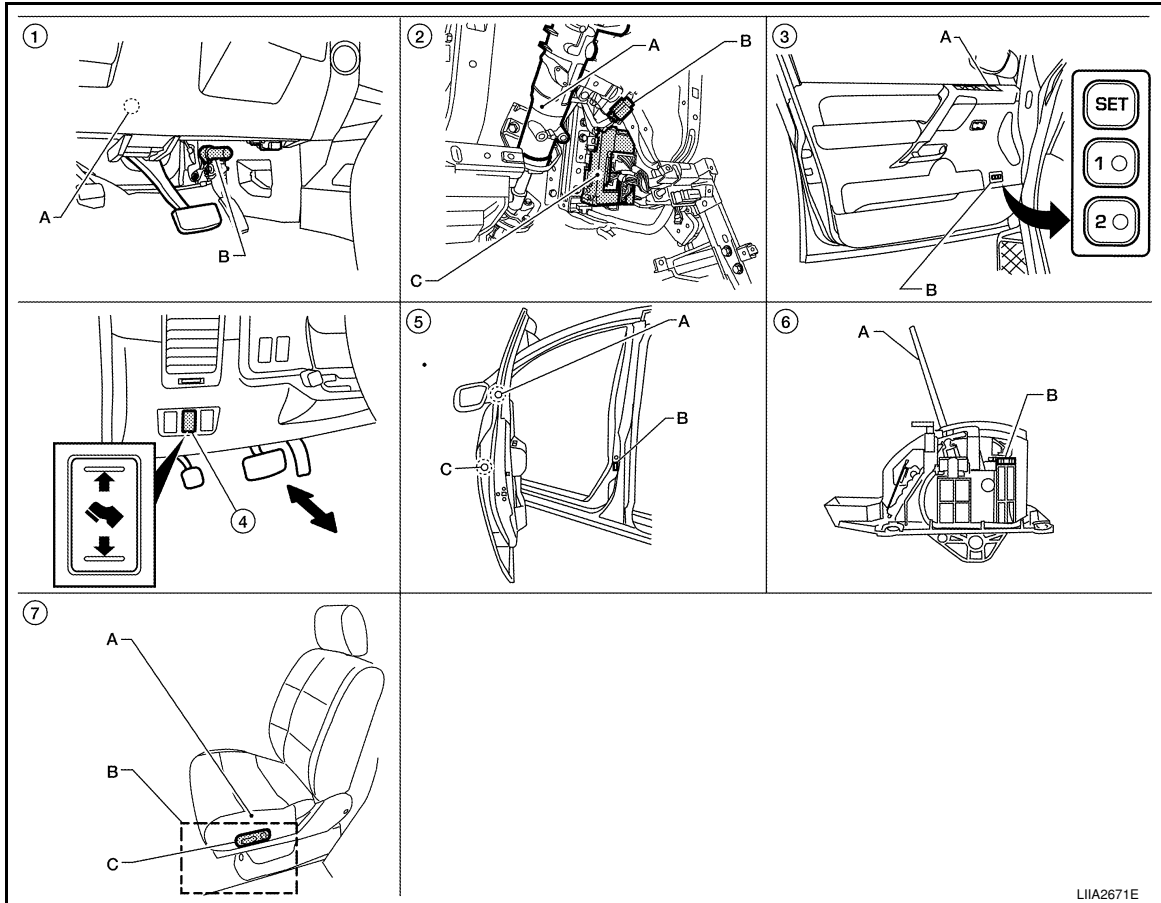

LIA2671E

- |  |  |   |
|--|--|---|
| <p>1. A. Automatic drive positioner control unit M33, M34<br/>B. Pedal adjusting motor E109, E110</p> <p>4. Pedal adjusting switch M96</p> <p>7. A. Sliding motor LH B204 (driver seat view), reclining motor LH B205, lifting motor (front) B206, lifting motor (rear) B207<br/>B. Driver seat control unit B202, B203<br/>C. Power seat switch LH B208</p> | <p>2. A. Steering column<br/>B. Key switch and key lock solenoid M27<br/>C. BCM M18, M19, M20 (view with instrument panel removed)</p> <p>5. A. Door mirror LH D4, RH D107<br/>B. Front door switch LH B8<br/>C. Front door lock assembly LH (key cylinder switch) D14</p> | <p>3. A. Door mirror remote control switch D10<br/>B. Seat memory switch D5</p> <p>6. A. A/T selector lever<br/>B. A/T device (park position switch) M203</p> |
|--|--|---|

## EXIT ASSIST FUNCTION : Component Description

INFOID:000000001608038

### CONTROL UNITS

Item	Function
Driver seat control unit	Operates the seat sliding motor for a constant amount.
BCM	Recognizes the following status and transmits it to the driver seat control unit via CAN communication. • Front door LH: OPEN/CLOSE

### INPUT PARTS

Switches

# AUTOMATIC DRIVE POSITIONER SYSTEM

## < FUNCTION DIAGNOSIS >

Item	Function
Front door switch LH	Detect front door LH open/close status.

### Sensors

Item	Function
Sliding sensor	Detect the front/rear position of seat.

### OUTPUT PARTS

Item	Function
Sliding motor	Slide the seat forward/backward.

## ENTRY ASSIST FUNCTION

### ENTRY ASSIST FUNCTION : System Diagram

INFOID:000000001608039

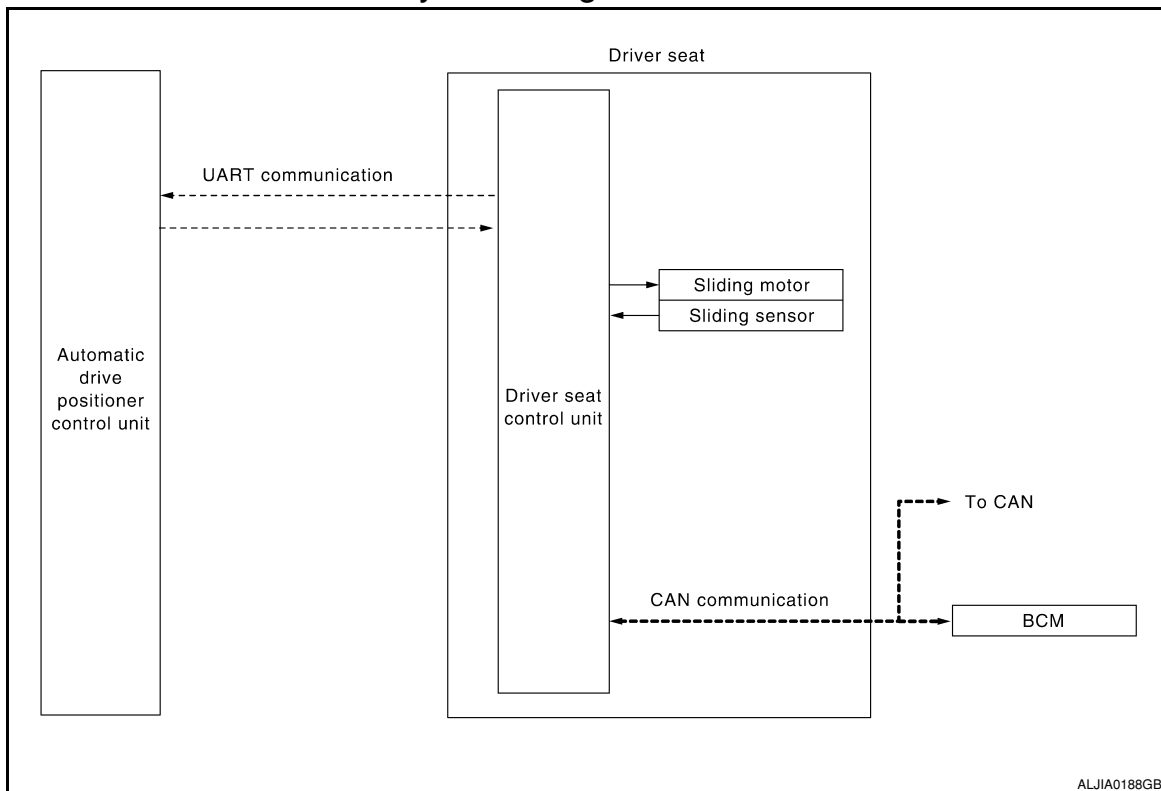

### ENTRY ASSIST FUNCTION : System Description

INFOID:000000001608040

#### OUTLINE

The seat is in the exiting position when either following condition (A or B) is satisfied, the seat returns from exiting position to the previous driving position.

#### NOTE:

- This function is set to OFF before delivery (initial setting).
- Further information for the system setting procedure. Refer to Owner's Manual.

#### OPERATION PROCEDURE

1. A: Turn the ignition switch ON.  
B: Turn the ignition switch from OFF to ACC after closing the driver door.
2. Front seat LH will return from the exiting position to entry position.

#### OPERATION CONDITION

Satisfy all of the following items. The entry assist function is not performed if these items are not satisfied.

# AUTOMATIC DRIVE POSITIONER SYSTEM

## < FUNCTION DIAGNOSIS >

Item	Request status
Seat	The vehicle is not moved after performing the exit assist function.
Switch inputs <ul style="list-style-type: none"> <li>• Power seat switch</li> <li>• Pedal adjusting switch</li> <li>• Door mirror control switch</li> <li>• Set switch</li> <li>• Memory switch</li> </ul>	OFF (Not operated)
A/T selector lever	P position

## DETAIL FLOW

Order	Input	Output	Control unit condition
1	Door switch/Ignition switch	—	Driver seat control unit receives the signals of ignition switch signal and front door switch from BCM via CAN communication.
2	—	Motor (sliding)	Driver seat control unit operates the sliding motor when the operating conditions are satisfied.
	Sensor (sliding)	—	Sensor monitors the operating positions of seat and then stops the operation of motor when seat reaches the recorded address.

## ENTRY ASSIST FUNCTION : Component Parts Location

INFOID:000000001608041

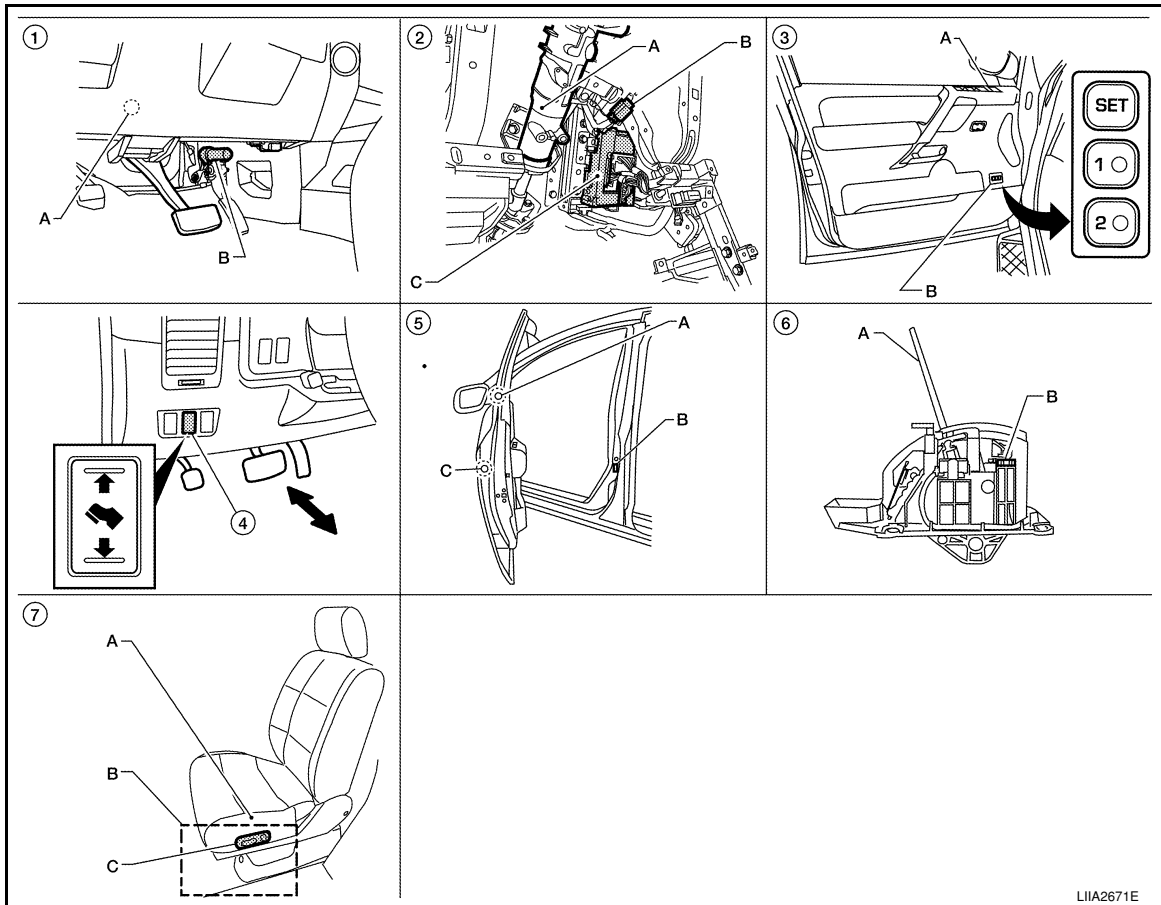

LIIA2671E

# AUTOMATIC DRIVE POSITIONER SYSTEM

## < FUNCTION DIAGNOSIS >

- |    |   |    |  |    |  |
|----|---|----|--|----|--|
| 1. | A. Automatic drive positioner control unit M33, M34<br>B. Pedal adjusting motor E109, E110  | 2. | A. Steering column<br>B. Key switch and key lock solenoid M27<br>C. BCM M18, M19, M20 (view with instrument panel removed) | 3. | A. Door mirror remote control switch D10<br>B. Seat memory switch D5 |
| 4. | Pedal adjusting switch M96  | 5. | A. Door mirror LH D4, RH D107<br>B. Front door switch LH B8<br>C. Front door lock assembly LH (key cylinder switch) D14    | 6. | A. A/T selector lever<br>B. A/T device (park position switch) M203   |
| 7. | A. Sliding motor LH B204 (driver seat view), reclining motor LH B205, lifting motor (front) B206, lifting motor (rear) B207<br>B. Driver seat control unit B202, B203<br>C. Power seat switch LH B208 |    |  |    |  |

A  
B  
C  
D  
E

## ENTRY ASSIST FUNCTION : Component Description

INFOID:000000001608042

### CONTROL UNITS

F

Item	Function
Driver seat control unit	According to the ignition signal and front door switch LH signal from BCM, • Operates the seat sliding motor for a constant amount.
BCM	Recognizes the following status and transmits it to the driver seat control unit via CAN communication. • Front door LH: OPEN/CLOSE • Ignition switch position: ACC/ON

G

H

### INPUT PARTS

#### Switches

Item	Function
Front door switch LH	Detect front door LH open/close status.

I

ADP

#### Sensors

Item	Function
Sliding sensor	Detect the front/rear position of seat.

K

L

### OUTPUT PARTS

Item	Function
Sliding motor	Slide the seat forward/backward.

M

N

O

P

# DIAGNOSIS SYSTEM (DRIVER SEAT C/U)

< FUNCTION DIAGNOSIS >

## DIAGNOSIS SYSTEM (DRIVER SEAT C/U)

### Diagnosis Description

INFOID:000000001608050

The auto drive positioner system can be checked and diagnosed for component operation with CONSULT-III.

### DIAGNOSTIC MODE

Diagnostic mode [AUTO DRIVE POS.]	Description
WORK SUPPORT	Changes the setting of each function.
SELF-DIAG RESULTS	Performs self-diagnosis for the auto drive positioner system and displays the results.
DATA MONITOR	Displays input signals transmitted from various switches and sensors to driver seat control unit in real time.
CAN DIAG SUPPORT MNTR	The result of transmit/receive diagnosis of CAN communication can be read.
ACTIVE TEST	Drive each output device.
ECU PART NUMBER	Displays part numbers of driver seat control unit parts.

### CONSULT-III Function

INFOID:000000001608051

### SELF-DIAGNOSIS RESULTS

Refer to [ADP-112. "DTC Index"](#).

### DATA MONITOR

Monitor Item	Unit	Main Signals	Selection From Menu	Contents
SET SW	"ON/OFF"	×	×	ON/OFF status judged from the setting switch signal.
MEMORY SW1	"ON/OFF"	×	×	ON/OFF status judged from the seat memory switch 1 signal.
MEMORY SW2	"ON/OFF"	×	×	ON/OFF status judged from the seat memory switch 2 signal.
SLIDE SW-FR	"ON/OFF"	×	×	ON/OFF status judged from the sliding switch (forward) signal.
SLIDE SW-RR	"ON/OFF"	×	×	ON/OFF status judged from the sliding switch (backward) signal.
RECLN SW-FR	"ON/OFF"	×	×	ON/OFF status judged from the reclining switch (forward) signal.
RECLN SW-RR	"ON/OFF"	×	×	ON/OFF status judged from the reclining switch (backward) signal.
LIFT FR SW-UP	"ON/OFF"	×	×	ON/OFF status judged from the lifting switch front (up) signal.
LIFT FR SW-DN	"ON/OFF"	×	×	ON/OFF status judged from the lifting switch front (down) signal.
LIFT RR SW-UP	"ON/OFF"	×	×	ON/OFF status judged from the lifting switch rear (up) signal.
LIFT RR SW-DN	"ON/OFF"	×	×	ON/OFF status judged from the lifting switch rear (down) signal.
MIR CON SW-UP	"ON/OFF"	×	×	ON/OFF status judged from the mirror switch (up) signal.
MIR CON SW-DN	"ON/OFF"	×	×	ON/OFF status judged from the mirror switch (down) signal.
MIR CON SW-RH	"ON/OFF"	×	×	ON/OFF status judged from the door mirror remote control switch (passenger side) signal.
MIR CON SW-LH	"ON/OFF"	×	×	ON/OFF status judged from the door mirror remote control switch (driver side) signal.



## DIAGNOSIS SYSTEM (DRIVER SEAT C/U)

### < FUNCTION DIAGNOSIS >

Monitor Item	Unit	Main Signals	Selection From Menu	Contents
MIR CHNG SW-R	"ON/OFF"	×	×	ON/OFF status judged from the door mirror remote control switch (switching to right) signal.
MIR CHNG SW-L	"ON/OFF"	×	×	ON/OFF status judged from the door mirror remote control switch (switching to left) signal.
PEDAL SW-FR	"ON/OFF"	×	×	ON/OFF status judged from the pedal adjusting switch (forward) signal.
PEDAL SW-RR	"ON/OFF"	×	×	ON/OFF status judged from the pedal adjusting switch (backward) signal.
DETENT SW	"ON/OFF"	×	×	The selector lever position "OFF (P position) / ON (other than P position)" judged from the detention switch signal.
STARTER SW	"ON/OFF"	×	×	Ignition key switch ON (START, ON) /OFF (ACC, OFF) status judged from the ignition switch signal.
SLIDE PULSE	—	—	×	Value (32768) when battery connections are standard. If it moves backward, the value increases. If it moves forward, the value decreases.
RECLN PULSE	—	—	×	Value (32768) when battery connections are standard. If it moves backward, the value increases. If it moves forward, the value decreases.
LIFT FR PULSE	—	—	×	Value (32768) when battery connections are standard. If it moves DOWN, the value increases. If it moves UP, the value decreases.
LIFT RR PULSE	—	—	×	Value (32768) when battery connections are standard. If it moves DOWN, the value increases. If it moves UP, the value decreases.
MIR/SEN RH U-D	"V"	—	×	Voltage input from door mirror sensor (passenger side) up/down is displayed.
MIR/SEN RH R-L	"V"	—	×	Voltage input from door mirror sensor (passenger side) left/right is displayed.
MIR/SEN LH U-D	"V"	—	×	Voltage input from door mirror sensor (driver side) up/down is displayed.
MIR/SEN LH R-L	"V"	—	×	Voltage input from door mirror sensor (driver side) left/right is displayed.
PEDAL SEN	"V"	—	×	Pedal position (voltage) judged from the pedal adjusting sensor signal is displayed.

### ACTIVE TEST

#### **CAUTION:**

**When driving vehicle, do not perform active test.**

Test item	Description
SEAT SLIDE	Activates/deactivates the sliding motor.
SEAT RECLINING	Activates/deactivates the reclining motor.
SEAT LIFTER FR	Activates/deactivates the lifting motor (front).
SEAT LIFTER RR	Activates/deactivates the lifting motor (rear).
ADJ PEDAL MOTOR	Activates/deactivates the pedal adjusting motor.
MIRROR MOTOR RH	Activates/deactivates the mirror motor (passenger side).
MIRROR MOTOR LH	Activates/deactivates the mirror motor (driver side).
MEMORY SW INDCTR	Turns ON/OFF the memory indicator.

### WORK SUPPORT

## DIAGNOSIS SYSTEM (DRIVER SEAT C/U)

### < FUNCTION DIAGNOSIS >

Work item	Content	Item
SEAT SLIDE VOLUME SET	The amount of seat sliding for entry/exit assist can be selected from 3 items.	40 mm
		80 mm
		150 mm
EXIT SEAT SLIDE SETTING	Entry/exit assist (seat) can be selected: ON (operated) – OFF (not operated)	ON
		OFF

# U1000 CAN COMM CIRCUIT

< COMPONENT DIAGNOSIS >

## COMPONENT DIAGNOSIS

### U1000 CAN COMM CIRCUIT

#### Description

INFOID:000000001608052

Refer to [LAN-4, "System Description"](#).

#### DTC Logic

INFOID:000000001608053

#### DTC DETECTION LOGIC

DTC	Trouble diagnosis name	DTC detecting condition	Possible cause
U1000	CAN COMM CIRCUIT	<ul style="list-style-type: none"><li>• Driver seat control unit cannot communicate to other control units.</li><li>• Driver seat control unit cannot communicate for more than the specified time.</li></ul>	<ul style="list-style-type: none"><li>• Harness or connectors (CAN communication line is open or shorted)</li></ul>

#### DTC CONFIRMATION PROCEDURE

##### 1. STEP 1

Turn ignition switch ON and wait at least 3 seconds.

>> GO TO 2

##### 2. STEP 2

Check "Self diagnostic result" with CONSULT-III.

Is the DTC detected?

YES >> Perform diagnosis procedure. Refer to [ADP-27, "Diagnosis Procedure"](#).

NO >> INSPECTION END

#### Diagnosis Procedure

INFOID:000000001608054

Refer to [LAN-14, "Trouble Diagnosis Flow Chart"](#).

#### Special Repair Requirement

INFOID:000000001608055

Refer to Owner's Manual.

A  
B  
C  
D  
E  
F  
G  
H  
I  
K  
L  
M  
N  
O  
P

ADP

# B2112 SLIDING MOTOR

< COMPONENT DIAGNOSIS >

## B2112 SLIDING MOTOR

### Description

INFOID:000000001608056

- The seat sliding motor is installed to the seat cushion frame.
- The seat sliding motor is installed with the driver seat control unit.
- Slides the seat frontward/rearward by changing the rotation direction of sliding motor.

### DTC Logic

INFOID:000000001608057

### DTC DETECTION LOGIC

DTC No.	Trouble diagnosis name	DTC detecting condition	Possible cause
B2112	SEAT SLIDE	The driver seat control unit detects the output of sliding motor output terminal for 0.1 second or more even if the sliding switch is not input.	<ul style="list-style-type: none"><li>• Driver seat control unit</li></ul>

### DTC CONFIRMATION PROCEDURE

#### 1. STEP 1

Turn ignition switch ON.

>> GO TO 2

#### 2. STEP 2

Check "Self diagnostic result" with CONSULT-III.

Is the DTC detected?

YES >> Perform diagnosis procedure. Refer to [ADP-28, "Diagnosis Procedure"](#).

NO >> INSPECTION END

#### **NOTE:**

First perform diagnosis for B2126 if B2126 is detected. Refer to [ADP-36, "Diagnosis Procedure"](#).

### Diagnosis Procedure

INFOID:000000001608058

#### 1. PERFORM DTC CONFIRMATION PROCEDURE

1. Turn ignition switch ON.
2. Check "Self diagnostic result" with CONSULT-III.
3. Erase the DTC.
4. Perform DTC confirmation procedure. Refer to [ADP-28, "DTC Logic"](#).

Is the DTC displayed again?

YES >> GO TO 2

NO >> Check intermittent incident. Refer to [GI-39, "Intermittent Incident"](#).

#### 2. CHECK COMPONENTS

Refer to [ADP-65, "Component Function Check"](#) and [ADP-79, "Component Function Check"](#).

>> INSPECTION END

# B2113 RECLINING MOTOR

< COMPONENT DIAGNOSIS >

## B2113 RECLINING MOTOR

### Description

INFOID:000000001608059

- The seat reclining motor is installed to the seatback frame.
- The seat reclining motor is activated with the driver seat control unit.
- Tilts the seatback frontward/rearward by changing the rotation direction of reclining motor.

### DTC Logic

INFOID:000000001608060

### DTC DETECTION LOGIC

DTC No.	Trouble diagnosis name	DTC detecting condition	Possible cause
B2113	SEAT RECLINING	The driver seat control unit detects the output of reclining motor output terminal for 0.1 second or more even if the reclining switch is not input.	• Driver seat control unit

### DTC CONFIRMATION PROCEDURE

#### 1. STEP 1

Turn ignition switch ON.

>> GO TO 2

#### 2. STEP 2

Check "Self diagnostic result" with CONSULT-III.

Is the DTC detected?

YES >> Perform diagnosis procedure. Refer to [ADP-29, "Diagnosis Procedure"](#).

NO >> INSPECTION END

#### **NOTE:**

First perform diagnosis for B2126 if B2126 is detected. Refer to [ADP-36, "Diagnosis Procedure"](#).

### Diagnosis Procedure

INFOID:000000001608061

#### 1. PERFORM DTC CONFIRMATION PROCEDURE

1. Turn ignition switch ON.
2. Check "Self diagnostic result" with CONSULT-III.
3. Erase the DTC.
4. Perform DTC confirmation procedure. Refer to [ADP-29, "DTC Logic"](#).

Is the DTC displayed again?

YES >> GO TO 2

NO >> Check intermittent incident. Refer to [GI-39, "Intermittent Incident"](#).

#### 2. CHECK COMPONENTS

Refer to [ADP-67, "Component Function Check"](#) and [ADP-81, "Component Function Check"](#).

>> INSPECTION END

# B2114 SEAT LIFTER FR

< COMPONENT DIAGNOSIS >

## B2114 SEAT LIFTER FR

### Description

INFOID:000000001652282

- The lifting motor (front) is installed to the seat cushion frame.
- The lifting motor (front) is activated with the driver seat control unit.
- Tilts the seat front up/down by changing the rotation direction of lifting motor (front).

### DTC Logic

INFOID:000000001652283

### DTC DETECTION LOGIC

DTC No.	Trouble diagnosis name	DTC detecting condition	Possible cause
B2114	SEAT LIFTER FR	The driver seat control unit detects the output of lifting motor (front) output terminal for 0.1 second or more even if the lifting switch is not input.	• Driver seat control unit

### DTC CONFIRMATION PROCEDURE

#### 1. STEP 1

Turn ignition switch ON.

>> GO TO 2

#### 2. STEP 2

Check "Self diagnostic result" with CONSULT-III.

Is the DTC detected?

YES >> Perform diagnosis procedure. Refer to [ADP-30, "Diagnosis Procedure"](#).

NO >> INSPECTION END

#### **NOTE:**

First perform diagnosis for B2126 if B2126 is detected. Refer to [ADP-36, "Diagnosis Procedure"](#).

### Diagnosis Procedure

INFOID:000000001652284

#### 1. PERFORM DTC CONFIRMATION PROCEDURE

1. Turn ignition switch ON.
2. Check "Self diagnostic result" with CONSULT-III.
3. Erase the DTC.
4. Perform DTC confirmation procedure. Refer to [ADP-30, "DTC Logic"](#).

Is the DTC displayed again?

YES >> GO TO 2

NO >> Check intermittent incident. Refer to [GI-39, "Intermittent Incident"](#).

#### 2. CHECK COMPONENTS

Refer to [ADP-69, "Component Function Check"](#) and [ADP-83, "Component Function Check"](#).

>> INSPECTION END

# B2115 SEAT LIFTER RR

< COMPONENT DIAGNOSIS >

## B2115 SEAT LIFTER RR

### Description

INFOID:000000001652394

- The lifting motor (rear) is installed to the seat cushion frame.
- The lifting motor (rear) is activated with the driver seat control unit.
- Tilts the seat rear up/down by changing the rotation direction of lifting motor (rear).

### DTC Logic

INFOID:000000001652395

### DTC DETECTION LOGIC

DTC No.	Trouble diagnosis name	DTC detecting condition	Possible cause
B2115	SEAT LIFTER RR	The driver seat control unit detects the output of lifting motor (rear) output terminal for 0.1 second or more even if the lifting switch is not input.	• Driver seat control unit

### DTC CONFIRMATION PROCEDURE

#### 1. STEP 1

Turn ignition switch ON.

>> GO TO 2

#### 2. STEP 2

Check "Self diagnostic result" with CONSULT-III.

Is the DTC detected?

YES >> Perform diagnosis procedure. Refer to [ADP-31, "Diagnosis Procedure"](#).

NO >> INSPECTION END

#### NOTE:

First perform diagnosis for B2126 if B2126 is detected. Refer to [ADP-36, "Diagnosis Procedure"](#).

### Diagnosis Procedure

INFOID:000000001652396

#### 1. PERFORM DTC CONFIRMATION PROCEDURE

1. Turn ignition switch ON.
2. Check "Self diagnostic result" with CONSULT-III.
3. Erase the DTC.
4. Perform DTC confirmation procedure. Refer to [ADP-31, "DTC Logic"](#).

Is the DTC displayed again?

YES >> GO TO 2

NO >> Check intermittent incident. Refer to [GI-39, "Intermittent Incident"](#).

#### 2. CHECK COMPONENTS

Refer to [ADP-71, "Component Function Check"](#) and [ADP-85, "Component Function Check"](#).

>> INSPECTION END

# B2117 ADJ PEDAL MOTOR

< COMPONENT DIAGNOSIS >

## B2117 ADJ PEDAL MOTOR

### Description

INFOID:000000001608062

- The pedal adjusting sensor is installed to pedal assembly.
- The resistance of pedal adjusting sensor is changed according to the forward/backward position of pedal assembly.
- The terminal voltage of automatic drive positioner control unit will be changed according to a change of pedal adjusting sensor resistance. Automatic drive positioner control unit calculates the pedal position from the voltage.

### DTC Logic

INFOID:000000001608063

### DTC DETECTION LOGIC

DTC No.	Trouble diagnosis name	DTC detecting condition	Possible cause
B2117	ADJ PEDAL SENSOR	When any manual or automatic operations are not performed, if motor operation is detected for 0.1 second or more, status is judged "Output error".	<ul style="list-style-type: none"><li>• Harness and connectors (pedal adjusting sensor circuit is opened/shorted, pedal adjusting sensor power supply circuit is opened/shorted.)</li><li>• Pedal adjusting sensor</li></ul>

### DTC CONFIRMATION PROCEDURE

#### 1. STEP 1

Turn ignition switch ON.

>> GO TO 2

#### 2. STEP 2

Check "Self diagnostic result" with CONSULT-III.

Is the DTC detected?

YES >> Perform diagnosis procedure. Refer to [ADP-32, "Diagnosis Procedure"](#).

NO >> INSPECTION END

### Diagnosis Procedure

INFOID:000000001608064

#### 1. CHECK PEDAL ADJUSTING MECHANISM

Check the following.

- Operation malfunction caused by pedal adjusting mechanism deformation or pinched harness or other foreign materials
- Operation malfunction and interference with other parts by poor installation

Is the inspection result normal

YES >> GO TO 2

NO >> Repair or replace the malfunctioning part and check again.

#### 2. CHECK FUNCTION

1. Turn ignition switch ON.
2. Check "ADJ PEDAL MOTOR" in "Active test" mode with CONSULT-III.

Test item	Description
ADJ PEDAL MOTOR	The pedal adjusting motor is activated by receiving the drive signal.

Is the inspection result normal?

YES >> Pedal adjusting motor circuit is OK.

NO >> GO TO 3



# B2117 ADJ PEDAL MOTOR

## < COMPONENT DIAGNOSIS >

### 3. CHECK PEDAL ADJUSTING MOTOR CIRCUIT HARNESS CONTINUITY

1. Turn ignition switch OFF.
2. Disconnect automatic drive positioner control unit and pedal adjusting motor.
3. Check continuity between automatic drive positioner control unit connector M34 (A) terminals 37, 45 and pedal adjusting motor connector E109 (B) terminals 1, 2.

**37 - 1 : Continuity should exist.**

**45 - 2 : Continuity should exist.**

4. Check continuity between automatic drive positioner control unit connector M34 (A) terminals 37, 45 and ground.

**37 - Ground : Continuity should not exist.**

**45 - Ground : Continuity should not exist.**

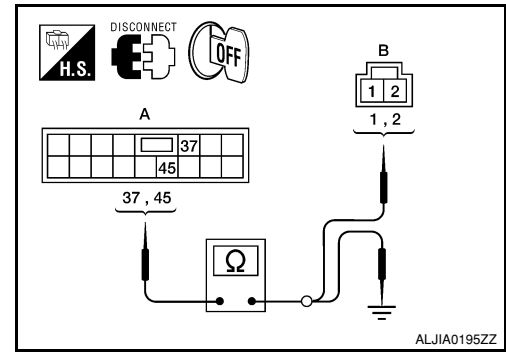

Is the inspection result normal?

YES >> GO TO 4

NO >> Repair or replace harness.

### 4. CHECK AUTOMATIC DRIVE POSITIONER CONTROL UNIT OUTPUT SIGNAL

1. Connect the automatic drive positioner control unit and pedal adjusting motor.
2. Check voltage between automatic drive positioner control unit connector and ground.

Connector	Terminals		Condition	Voltage (V) (Approx.)
	(+)	(-)		
M34	37	Ground	Pedal adjusting switch ON (FORWARD operation)	Battery voltage
			Other than above	0
	45		Pedal adjusting switch ON (BACKWARD operation)	Battery voltage
			Other than above	0

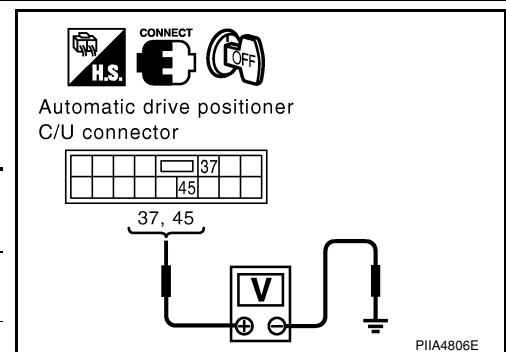

Is the inspection result normal?

YES >> Replace pedal adjusting motor.

NO >> GO TO 5

### 5. CHECK INTERMITTENT INCIDENT

Refer to [GI-39. "Intermittent Incident"](#).

Is the inspection result normal?

YES >> Replace automatic drive positioner control unit.

NO >> Repair or replace the malfunctioning part.

# B2120 ADJ PEDAL SENSOR

< COMPONENT DIAGNOSIS >

## B2120 ADJ PEDAL SENSOR

### Description

INFOID:000000001663472

- The pedal adjusting sensor is installed in the pedal assembly.
- The resistance of pedal adjusting sensor is changed according to the forward/backward position of pedal assembly.
- The terminal voltage of automatic drive positioner control unit will be changed according to a change of pedal adjusting sensor resistance. Automatic drive positioner control unit calculates the pedal assembly position from the voltage.

### DTC Logic

INFOID:000000001663473

### DTC DETECTION LOGIC

DTC No.	Trouble diagnosis name	DTC detecting condition	Possible cause
B2120	ADJ PEDAL SENSOR	The input voltage of pedal adjusting sensor is 0.5V or less or 4.5V or higher, for 0.5 seconds or more.	<ul style="list-style-type: none"><li>• Harness and connectors (Pedal adjusting sensor circuit is opened/shorted, pedal adjusting sensor power supply circuit is opened/shorted.)</li><li>• Pedal adjusting sensor</li></ul>

### DTC CONFIRMATION PROCEDURE

#### 1. STEP 1

Turn ignition switch ON.

>> GO TO 2

#### 2. STEP 2

Check "Self diagnostic result" with CONSULT-III.

Is the DTC is detected?

YES >> Perform diagnosis procedure. Refer to [ADP-34, "Diagnosis Procedure"](#).

NO >> INSPECTION END

### Diagnosis Procedure

INFOID:000000001663474

#### 1. CHECK PEDAL ADJUSTING SENSOR SIGNAL

1. Turn ignition switch ON.
2. Select "PEDAL SEN" in "Data monitor" mode with CONSULT-III.
3. Check the pedal adjusting sensor signal under the following condition.

Monitor item	Condition	Value
PEDAL SEN	Pedal position	Forward 0.5V
		Backward 4.5V

Is the value normal?

YES >> Pedal adjusting circuit is OK.

NO >> GO TO 2

#### 2. CHECK PEDAL ADJUSTING SENSOR CIRCUIT HARNESS CONTINUITY

# B2120 ADJ PEDAL SENSOR

## < COMPONENT DIAGNOSIS >

1. Disconnect automatic drive positioner control unit and pedal adjusting sensor.
2. Check continuity between automatic drive positioner connector M33, M34 terminals 8, 33, 41 and pedal adjusting sensor connector E110 terminals 3, 4, 5.

**8 - 4** : Continuity should exist.

**33 - 3** : Continuity should exist.

**41 - 5** : Continuity should exist.

3. Check continuity between automatic drive positioner control unit connector M33, M34 terminals 8, 33, 41 and ground.

**8 - Ground** : Continuity should not exist.

**33 - Ground** : Continuity should not exist.

**41 - Ground** : Continuity should not exist.

Is the inspection result normal?

- YES >> Replace pedal adjusting motor.  
NO >> Repair or replace harness.

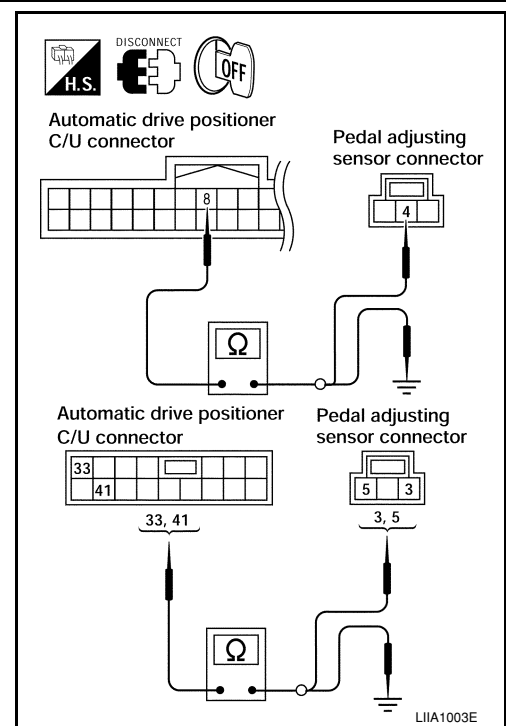

A  
B  
C  
D  
E  
F  
G  
H  
I  
K  
L  
M  
N  
O  
P

ADP

# B2126 DETENT SW

< COMPONENT DIAGNOSIS >

## B2126 DETENT SW

### Description

INFOID:000000001608068

- Park position switch is installed on A/T device. It is turned OFF when the A/T selector lever is in P position.
- The driver seat control unit judges that the A/T selector lever is in P position if continuity does not exist in this circuit.

### DTC Logic

INFOID:000000001608069

### DTC DETECTION LOGIC

DTC No.	Trouble diagnosis name	DTC detecting condition	Possible cause
B2126	DETENT SW	A/T selector lever is in P position and the vehicle speed of 7±4km/h is detected.	<ul style="list-style-type: none"><li>• Harness and connectors (Park position switch circuit is opened/shorted.)</li><li>• Park position switch</li><li>• Combination meter (CAN communication )</li></ul>

### DTC CONFIRMATION PROCEDURE

#### 1. STEP 1

Drive the vehicle at 7±4km/h or more.

>> GO TO 2

#### 2. STEP 2

Check "Self diagnostic result" with CONSULT-III.

Is the DTC detected?

- YES >> Perform diagnosis procedure. Refer to [ADP-36, "Diagnosis Procedure"](#).  
NO >> INSPECTION END

### Diagnosis Procedure

INFOID:000000001608070

#### 1. CHECK DTC

Check "Self diagnostic result" for BCM with CONSULT-III.

Are other DTCs detected?

- YES >> Check The DTC.  
NO >> GO TO 2

#### 2. CHECK DETENTION SWITCH SIGNAL

1. Turn ignition switch ON.
2. Select "DETENT SW" in "Data Monitor" mode with CONSULT-III.
3. Check detention switch signal under the following condition.

Monitor item	Condition		Status
DETENT SW	A/T selector lever	P position	OFF
		Other than above	ON

Is the status normal?

- YES >> A/T device (park position switch) circuit is OK.  
NO >> GO TO 3

#### 3. CHECK A/T DEVICE (PARK POSITION SWITCH) HARNESS

# B2126 DETENT SW

## < COMPONENT DIAGNOSIS >

1. Turn ignition switch OFF.
2. Disconnect A/T device and driver seat control unit.
3. Check continuity between A/T device connector M203 terminal 6 and driver seat control unit connector B203 terminal 21.

**6 - 21 : Continuity should exist.**

4. Check continuity between A/T device connector M203 terminal 6 and ground.

**6 - Ground : Continuity should not exist.**

Is the inspection result normal?

- YES >> GO TO 4  
 NO >> Repair or replace harness.

### 4. CHECK PARK POSITION SWITCH

Check continuity between A/T device (park position switch) terminals as follows.

Terminals		Condition	Continuity
5	6	P position	Yes
		Other than P position	No

Is the inspection result normal?

- YES >> GO TO 5  
 NO >> Replace A/T device. Refer to [TM-208. "Control Device Removal and Installation"](#).

### 5. CHECK INTERMITTENT INCIDENT

Refer to [GI-39. "Intermittent Incident"](#).

Is the inspection result normal?

- YES >> Replace driver seat control unit.  
 NO >> Repair or replace the malfunctioning part.

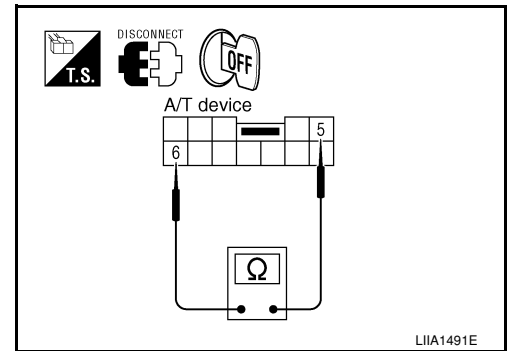
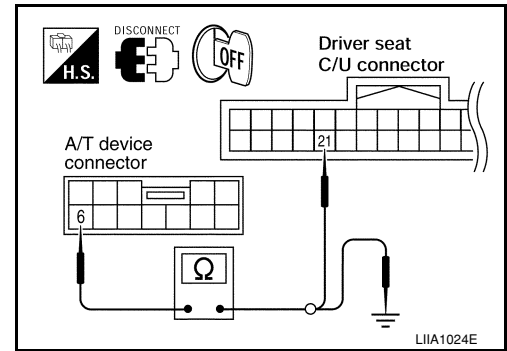

A  
B  
C  
D  
E  
F  
G  
H  
I  
K  
L  
M  
N  
O  
P

ADP

# B2128 UART COMMUNICATION LINE

< COMPONENT DIAGNOSIS >

## B2128 UART COMMUNICATION LINE

### Description

INFOID:000000001608075

Driver seat control unit performs UART communication with the automatic drive positioner control unit using 2 communication lines, TX and RX line. Driver seat control unit receives the operation signals of pedal adjusting switch, door mirror remote control switch, set switch and memory switch and the position signals of adjustable pedal sensor and door mirror sensor from the automatic drive positioner control unit and transmits the operation request signal.

### DTC Logic

INFOID:000000001608076

### DTC DETECTION LOGIC

DTC No.	Trouble diagnosis name	DTC detecting condition	Possible cause
B2128	UART COMM	The communication between driver seat control unit and automatic drive positioner control unit is interrupted for a period of time.	<ul style="list-style-type: none"> <li>• UART communication line (UART communication line is open or shorted)</li> <li>• Driver seat control unit</li> <li>• Automatic drive positioner control unit</li> </ul>

### DTC CONFIRMATION PROCEDURE

#### 1. STEP 1

Turn ignition switch ON.

>> GO TO 2

#### 2. STEP 2

Operate pedal adjusting switch for more than 2 seconds.

>> GO TO 3

#### 3. PROCEDURE 3

Check "Self diagnostic result" with CONSULT-III.

Is the DTC detected?

YES >> Perform diagnosis procedure. Refer to [ADP-38, "Diagnosis Procedure"](#).

NO >> INSPECTION END

### Diagnosis Procedure

INFOID:000000001608077

#### 1. CHECK UART COMMUNICATION LINE CONTINUITY

1. Turn ignition switch OFF.
2. Disconnect driver seat control unit and automatic drive positioner control unit.
3. Check continuity between driver seat control unit harness connector and automatic drive positioner control unit harness connector.

Driver seat control unit connector	Terminal	Automatic drive positioner control unit connector	Terminal	Continuity
B202	1	M33	10	Yes
	17		26	

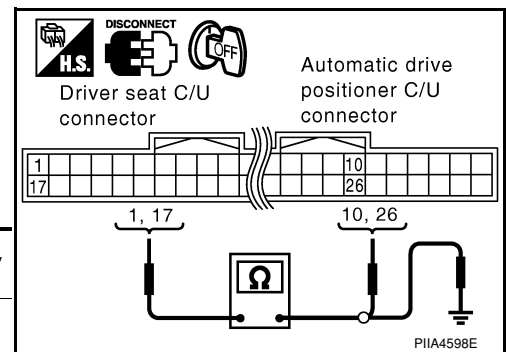

4. Check continuity between driver seat control unit harness connector and ground.

# B2128 UART COMMUNICATION LINE

## < COMPONENT DIAGNOSIS >

---

Driver seat control unit connector	Terminal	Ground	Continuity
B202	1		Ground
	17		

### Is the inspection result normal?

- YES >> Check intermittent incident. Refer to [GI-39. "Intermittent Incident"](#).
- NO >> Repair or replace harness.

A  
B  
C  
D  
E  
F  
G  
H  
I  
K  
L  
M  
N  
O  
P

ADP

# POWER SUPPLY AND GROUND CIRCUIT

< COMPONENT DIAGNOSIS >

## POWER SUPPLY AND GROUND CIRCUIT

### BCM

BCM : Diagnosis Procedure

INFOID:000000001608078

Refer to [BCS-32, "Diagnosis Procedure"](#).

BCM : Special Repair Requirement

INFOID:000000001608079

### 1. REQUIRED WORK WHEN REPLACING BCM

Initialize control unit. Refer to CONSULT-III Operation Manual.

>> Work end.

## DRIVER SEAT CONTROL UNIT

DRIVER SEAT CONTROL UNIT : Diagnosis Procedure

INFOID:000000001608080

### NOTE:

Do not disconnect the battery negative terminal and the driver seat control unit connector until DTC is confirmed with CONSULT-III.

### 1. CHECK POWER SUPPLY CIRCUIT

1. Turn ignition switch OFF.
2. Check voltage between driver seat control unit harness connector and ground.

Terminals		Power source	Condition	Voltage (V) (Approx.)
(+)	(-)			
Driver seat control unit connector	Terminal			
B202	6	START power supply	Ignition switch START	Battery voltage
B203	33	Battery power supply	Ignition switch OFF	
	40			

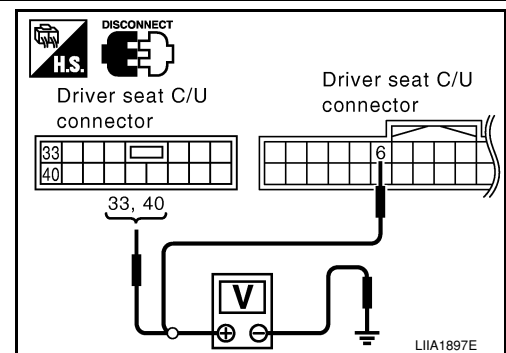

Is the inspection result normal?

YES >> GO TO 2.

NO >> Check the following.

- Repair or replace harness between driver seat control unit and fuse block (J/B).
- Circuit breaker.

### 2. CHECK GROUND CIRCUIT

Check continuity between the driver seat control unit harness connector and ground.

Driver seat control unit connector	Terminal	Ground	Continuity
B202	32	Ground	Yes
B203	48		

Is the inspection result normal?

YES >> Driver seat control unit power supply and ground circuit are OK.

NO >> Repair or replace harness.

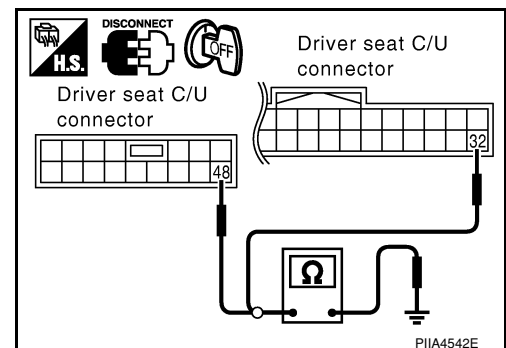



# POWER SUPPLY AND GROUND CIRCUIT

< COMPONENT DIAGNOSIS >

## DRIVER SEAT CONTROL UNIT : Special Repair Requirement

INFOID:000000001608081

### 1.PERFORM ADDITIONAL SERVICE

Perform additional service when removing battery negative terminal.

>> Refer to Owner's Manual.

## AUTOMATIC DRIVE POSITIONER CONTROL UNIT

### AUTOMATIC DRIVE POSITIONER CONTROL UNIT : Diagnosis Procedure

INFOID:000000001608082

#### NOTE:

Do not disconnect the battery negative terminal and the driver seat control unit connector until DTC is confirmed with CONSULT-III.

### 1.CHECK POWER SUPPLY CIRCUIT

1. Turn ignition switch OFF.
2. Check voltage between automatic drive positioner control unit harness connector and ground.

Terminals		Voltage (V) (Approx.)
(+)	(-)	
Automatic drive positioner control unit connector	Terminal	Ground
M33	34	
	39	Battery voltage

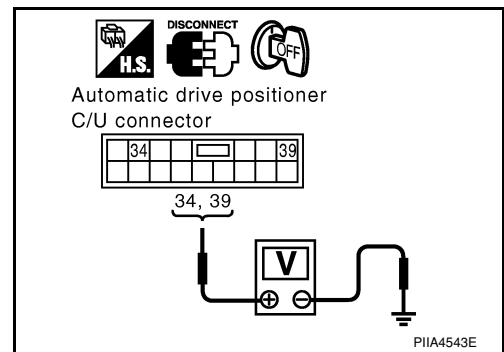

Is the inspection result normal?

- YES >> GO TO 2.  
NO >> Repair or replace harness.

### 2.CHECK GROUND CIRCUIT

Check continuity between the automatic drive positioner control unit harness connector and ground.

Automatic drive positioner control unit connector	Terminal	Ground	Continuity
M33	40	Ground	Yes
	48		

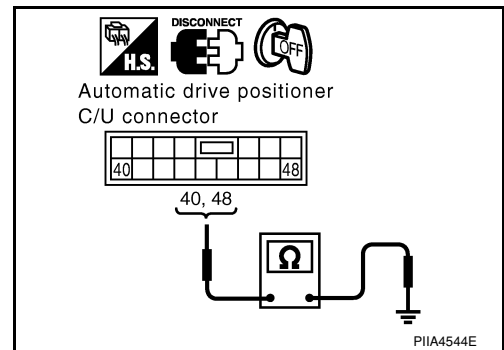

Is the inspection result normal?

- YES >> Automatic drive positioner control unit power supply and ground circuit are OK.  
NO >> Repair or replace harness.

## AUTOMATIC DRIVE POSITIONER CONTROL UNIT : Special Repair Requirement

INFOID:000000001608083

### 1.PERFORM ADDITIONAL SERVICE

Perform additional service when removing battery negative terminal.

>> Refer to Owner's Manual.

# SLIDING SWITCH

< COMPONENT DIAGNOSIS >

## SLIDING SWITCH

### Description

INFOID:000000001608085

Sliding switch is equipped to the power seat switch LH on the seat cushion side surface. The operation signal is input to the driver seat control unit when the sliding switch is operated.

### Component Function Check

INFOID:000000001608086

#### 1. CHECK FUNCTION

1. Select "SLIDE SW-FR", "SLIDE SW-RR" in "Data monitor" mode with CONSULT-III.
2. Check sliding switch signal under the following conditions.

Monitor item	Condition	Status	
SLIDE SW-FR	Sliding switch (forward)	Operate Release	ON OFF
	SLIDE SW-RR	Sliding switch (backward)	Operate Release

Is the indication normal?

YES >> INSPECTION END

NO >> Perform diagnosis procedure. Refer to [ADP-42, "Diagnosis Procedure"](#).

### Diagnosis Procedure

INFOID:000000001608087

#### 1. CHECK SLIDING SWITCH SIGNAL

1. Turn ignition switch ON.
2. Check voltage between driver seat control unit harness connector and ground.

Driver seat control unit connector	Terminals		Condition	Voltage (V) (Approx.)
	(+)	(-)		
B202	11	Ground	Operate (backward)	0
			Release	Battery voltage
	26		Operate (forward)	0
			Release	Battery voltage

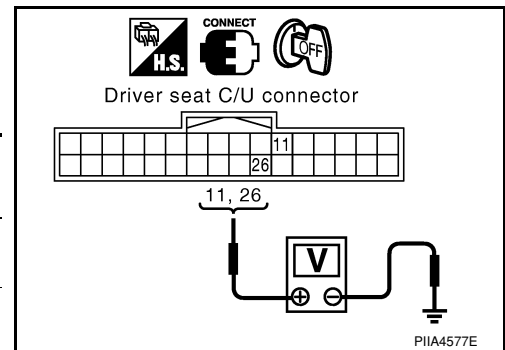

Is the inspection result normal?

YES >> GO TO 5

NO >> GO TO 2

#### 2. CHECK SLIDING SWITCH CIRCUIT

1. Turn ignition switch OFF.
2. Disconnect driver seat control unit and power seat switch LH.
3. Check continuity between driver seat control unit harness connector and power seat switch LH harness connector.

Driver seat control unit connector	Terminal	Power seat switch LH connector	Terminal	Continuity
B202	11	B208	7	Yes
	26		1	

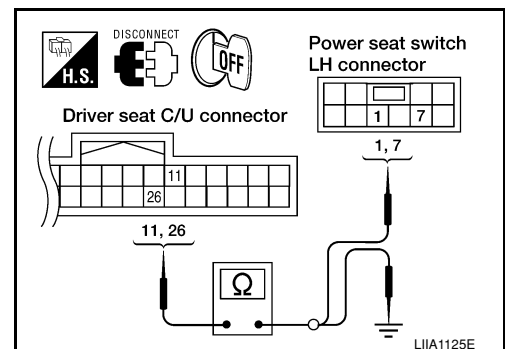

# SLIDING SWITCH

## < COMPONENT DIAGNOSIS >

4. Check continuity between driver seat control unit harness connector and ground.

Driver seat control unit connector	Terminal	Ground	Continuity
B202	11		
	26		

Is the inspection result normal?

- YES >> GO TO 3  
 NO >> Repair or replace harness.

### 3. CHECK DRIVER SEAT CONTROL UNIT OUTPUT

1. Connect the driver seat control unit.
2. Turn ignition switch ON.
3. Check voltage between driver seat control unit harness connector and ground.

Driver seat control unit connector	Terminals		Voltage (V) (Approx.)
	(+)	(-)	
B202	11	Ground	Battery voltage
	26		

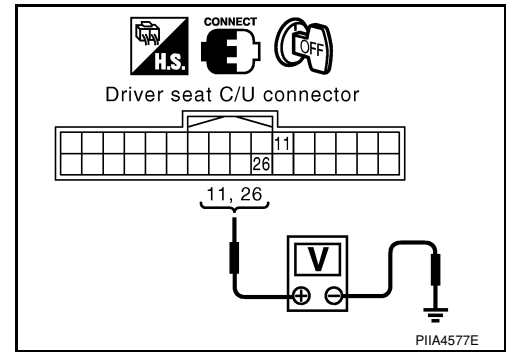

Is the inspection result normal?

- YES >> GO TO 4  
 NO >> Replace driver seat control unit.

### 4. CHECK SLIDING SWITCH

Refer to [ADP-43. "Component Inspection"](#).

Is the inspection result normal?

- YES >> GO TO 5  
 NO >> Replace power seat switch LH.

### 5. CHECK INTERMITTENT INCIDENT

Refer to [GI-39. "Intermittent Incident"](#).

Is the inspection result normal?

- YES >> Replace driver seat control unit.  
 NO >> Repair or replace malfunctioning part.

## Component Inspection

INFOID:000000001608088

### 1. CHECK SLIDING SWITCH

1. Turn ignition switch OFF.
2. Disconnect power seat switch LH.
3. Check continuity between power seat switch LH terminals.

Terminal	Condition	Continuity	
Power seat switch LH			
3	Sliding switch (backward)	Operate	Yes
		Release	No
	Sliding switch (forward)	Operate	Yes
		Release	No

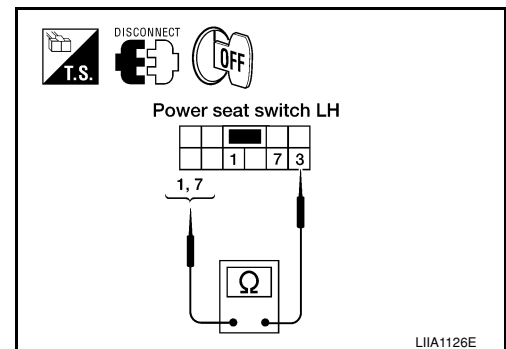

Is the inspection result normal?

- YES >> INSPECTION END  
 NO >> Replace power seat switch LH.

# RECLINING SWITCH

< COMPONENT DIAGNOSIS >

## RECLINING SWITCH

### Description

INFOID:000000001608089

Reclining switch is equipped to the power seat switch LH on the seat cushion side surface. The operation signal is input to the driver seat control unit when the reclining switch is operated.

### Component Function Check

INFOID:000000001608090

#### 1. CHECK FUNCTION

1. Select "RECLN SW-FR", "RECLN SW-RR" in "Data monitor" mode with CONSULT-III.
2. Check reclining switch signal under the following conditions.

Monitor item	Condition	Status	
RECLN SW-FR	Reclining switch (forward)	Operate Release	ON OFF
	RECLN SW-RR	Reclining switch (backward)	Operate Release

Is the indication normal?

YES >> INSPECTION END

NO >> Perform diagnosis procedure. Refer to [ADP-44, "Diagnosis Procedure"](#).

### Diagnosis Procedure

INFOID:000000001608091

#### 1. CHECK RECLINING SWITCH SIGNAL

1. Turn ignition switch ON.
2. Check voltage between driver seat control unit harness connector and ground.

Driver seat control unit connector	Terminals		Condition	Voltage (V) (Approx.)
	(+)	(-)		
B202	12	Ground	Operate (forward)	0
			Release	Battery voltage
	27		Operate (backward)	0
			Release	Battery voltage

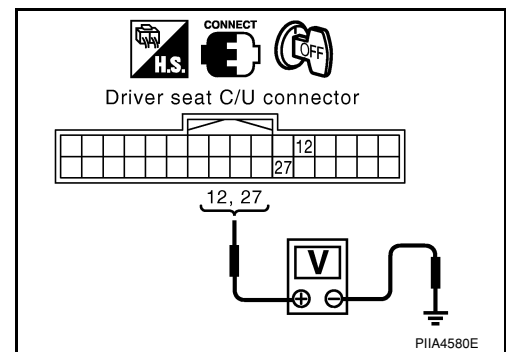

Is the inspection result normal?

YES >> GO TO 5

NO >> GO TO 2

#### 2. CHECK RECLINING SWITCH CIRCUIT

1. Turn ignition switch OFF.
2. Disconnect driver seat control unit and power seat switch LH.
3. Check continuity between driver seat control unit harness connector and power seat switch LH harness connector.

Driver seat control unit connector	Terminal	Power seat switch LH connector	Terminal	Continuity
B202	12	B208	9	Yes
	27		10	

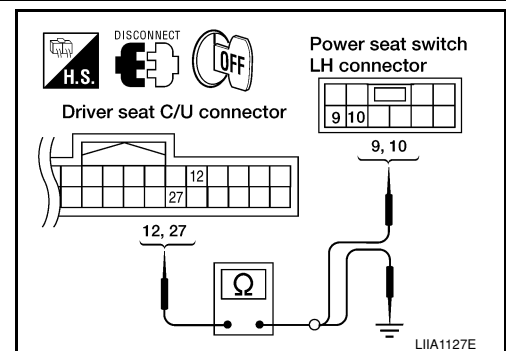

4. Check continuity between driver seat control unit harness connector and ground.

# RECLINING SWITCH

## < COMPONENT DIAGNOSIS >

Driver seat control unit connector	Terminal	Ground	Continuity
B202	12		Ground
	27		

Is the inspection result normal?

YES >> GO TO 3

NO >> Repair or replace harness.

### 3. CHECK DRIVER SEAT CONTROL UNIT OUTPUT

1. Connect the driver seat control unit connector.
2. Turn ignition switch ON.
3. Check voltage between driver seat control unit harness connector and ground.

Driver seat control unit connector	Terminals		Voltage (V) (Approx.)
	(+)	(-)	
B202	12	Ground	Battery voltage
	27		

Is the inspection result normal?

YES >> GO TO 4

NO >> Replace driver seat control unit.

### 4. CHECK RECLINING SWITCH

Refer to [ADP-45. "Component Inspection"](#).

Is the inspection result normal?

YES >> GO TO 5

NO >> Replace power seat switch LH.

### 5. CHECK INTERMITTENT INCIDENT

Refer to [GI-39. "Intermittent Incident"](#).

Is the inspection result normal?

YES >> Replace driver seat control unit.

NO >> Repair or replace the malfunctioning part.

## Component Inspection

INFOID:000000001608092

### 1. CHECK RECLINING SWITCH

1. Turn ignition switch OFF.
2. Disconnect power seat switch LH.
3. Check continuity between power seat switch LH terminals.

Terminals		Condition	Continuity	
Power seat switch LH				
3	9	Reclining switch (backward)	Operate	Yes
			Release	No
	10	Reclining switch (forward)	Operate	Yes
			Release	No

Is the inspection result normal?

YES >> INSPECTION END

NO >> Replace power seat switch LH.

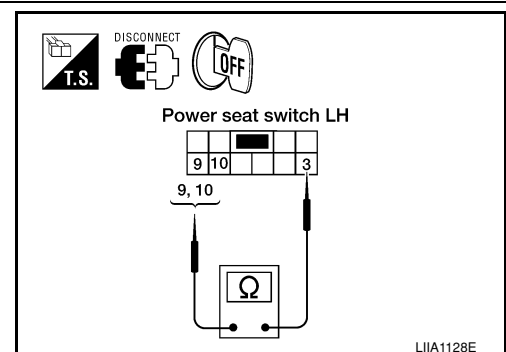
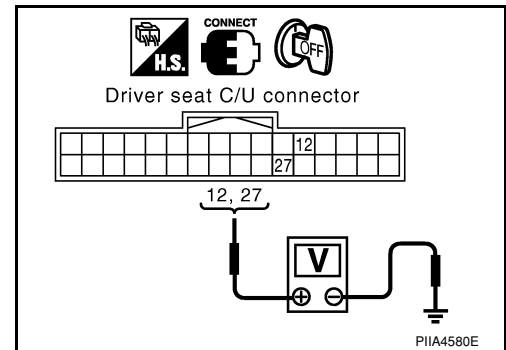

# LIFTING SWITCH (FRONT)

< COMPONENT DIAGNOSIS >

## LIFTING SWITCH (FRONT)

### Description

INFOID:000000001608093

Lifting switch (front) is equipped to the power seat switch LH on the seat cushion side surface. The operation signal is input to the driver seat control unit when the lifting switch (front) is operated.

### Component Function Check

INFOID:000000001608094

#### 1. CHECK FUNCTION

1. Select "LIFT FR SW-UP", "LIFT FR SW-DN" in "DATA MONITOR" mode with CONSULT-III.
2. Check lifting switch (front) signal under the following conditions.

Monitor item	Condition	Status
LIFT FR SW-UP	Lifting switch front (up)	Operate ON
		Release OFF
LIFT FR SW-DN	Lifting switch front (down)	Operate ON
		Release OFF

Is the indication normal?

YES >> INSPECTION END

NO >> Perform diagnosis procedure. Refer to [ADP-46, "Diagnosis Procedure"](#).

### Diagnosis Procedure

INFOID:000000001608095

#### 1. CHECK LIFTING SWITCH SIGNAL

1. Turn ignition switch ON.
2. Check voltage between driver seat control unit harness connector and ground.

Driver seat control unit connector	Terminals		Condition	Voltage (V) (Approx.)
	(+)	(-)		
B202	13	Ground	Operate (down)	0V
			Release	Battery voltage
	28		Operate (up)	0V
			Release	Battery voltage

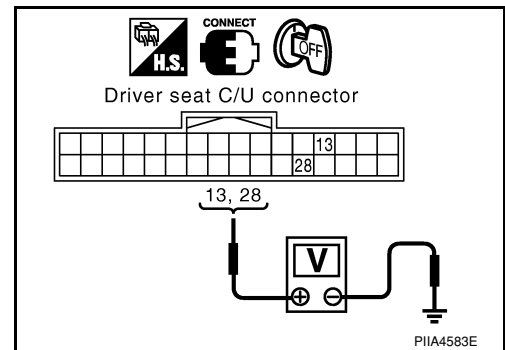

Is the inspection result normal?

YES >> GO TO 5

NO >> GO TO 2

#### 2. CHECK LIFTING SWITCH (FRONT) CIRCUIT

1. Turn ignition switch OFF.
2. Disconnect driver seat control unit and power seat switch LH.
3. Check continuity between driver seat control unit harness connector and power seat switch LH harness connector.

Driver seat control unit connector	Terminal	Power seat switch LH connector	Terminal	Continuity
B202	13	B208	5	Yes
	28		6	

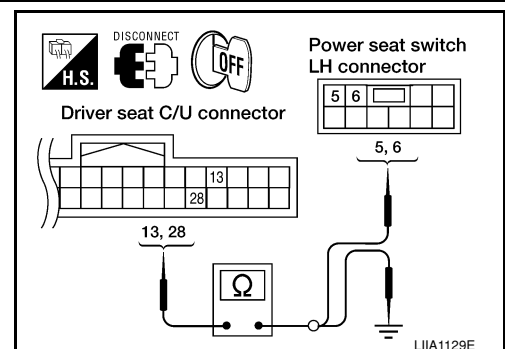

# LIFTING SWITCH (FRONT)

## < COMPONENT DIAGNOSIS >

4. Check continuity between driver seat control unit harness connector and ground.

Driver seat control unit connector	Terminal	Ground	Continuity
B202	13		
	28		

Is the inspection result normal?

- YES >> GO TO 3  
 NO >> Repair or replace harness.

### 3. CHECK DRIVER SEAT CONTROL UNIT OUTPUT

1. Connect the driver seat control unit.
2. Turn ignition switch ON.
3. Check voltage between driver seat control unit harness connector and ground.

Driver seat control unit connector	Terminals		Voltage (V) (Approx.)
	(+)	(-)	
B202	13	Ground	Battery voltage
	28		

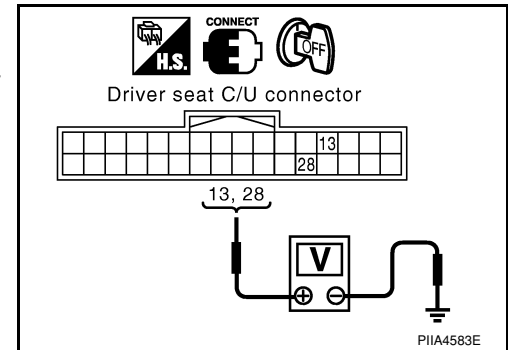

Is the inspection result normal?

- YES >> GO TO 4  
 NO >> Replace driver seat control unit.

### 4. CHECK LIFTING SWITCH (FRONT)

Refer to [ADP-47. "Component Inspection"](#).

Is the inspection result normal?

- YES >> GO TO 5  
 NO >> Replace power seat switch LH.

### 5. CHECK INTERMITTENT INCIDENT

Refer to [GI-39. "Intermittent Incident"](#).

Is the inspection result normal?

- YES >> Replace driver seat control unit.  
 NO >> Repair or replace the malfunctioning part.

## Component Inspection

INFOID:000000001608096

### 1. CHECK LIFTING SWITCH (FRONT)

1. Turn ignition switch OFF.
2. Disconnect power seat switch LH.
3. Check continuity between power seat switch LH terminals.

Terminal		Condition	Continuity
Power seat switch LH			
3	5	Lifting switch front (down)	Operate: Yes Release: No
		6	Lifting switch front (up)

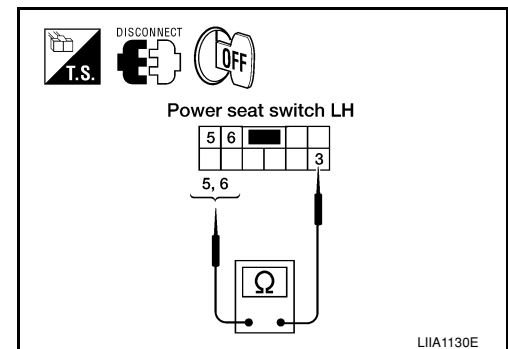

Is the inspection result normal?

- YES >> INSPECTION END  
 NO >> Replace power seat switch LH.

# LIFTING SWITCH (REAR)

< COMPONENT DIAGNOSIS >

## LIFTING SWITCH (REAR)

### Description

INFOID:000000001608097

Lifting switch (rear) is equipped to the power seat switch LH on the seat cushion side surface. The operation signal is inputted to the driver seat control unit when the lifting switch (rear) is operated.

### Component Function Check

INFOID:000000001608098

#### 1. CHECK FUNCTION

1. Select "LIFT RR SW-UP", "LIFT RR SW-DN" in "Data monitor" mode with CONSULT-III.
2. Check lifting switch (rear) signal under the following conditions.

Monitor item	Condition		Status
LIFT RR SW-UP	Lifting switch rear (up)	Operate	ON
		Release	OFF
LIFT RR SW-DN	Lifting switch rear (down)	Operate	ON
		Release	OFF

Is the indication normal?

YES >> INSPECTION END

NO >> Perform diagnosis procedure. Refer to [ADP-48, "Diagnosis Procedure"](#).

### Diagnosis Procedure

INFOID:000000001608099

#### 1. CHECK LIFTING SWITCH (REAR) SIGNAL

1. Turn ignition switch ON.
2. Check voltage between driver seat control unit harness connector and ground.

Driver seat control unit connector	Terminals		Condition	Voltage (V) (Approx.)
	(+)	(-)		
B202	14	Ground	Operate (down)	0
			Release	Battery voltage
	29		Operate (up)	0
			Release	Battery voltage

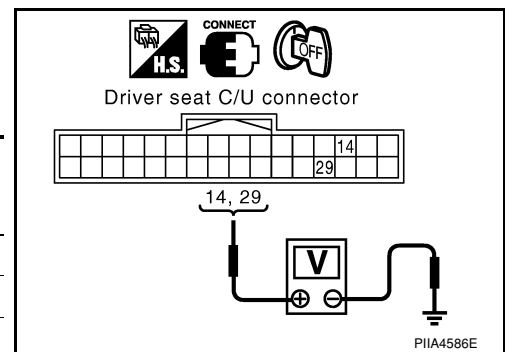

Is the inspection result normal?

YES >> GO TO 5

NO >> GO TO 2

#### 2. CHECK LIFTING SWITCH (REAR) CIRCUIT

1. Turn ignition switch OFF.
2. Disconnect driver seat control unit and power seat switch LH.
3. Check continuity between driver seat control unit harness connector and power seat switch LH harness connector.

Driver seat control unit connector	Terminal	Power seat switch LH connector	Terminal	Continuity
B202	14	B208	8	Yes
	29		2	

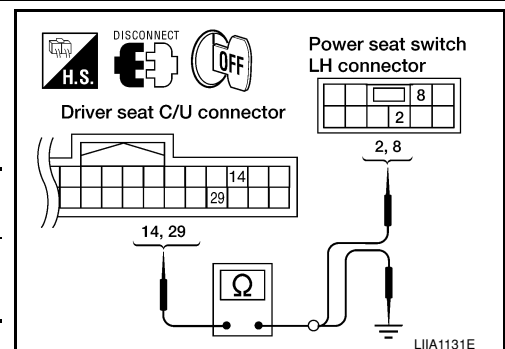

4. Check continuity between driver seat control unit harness connector and ground.



# LIFTING SWITCH (REAR)

## < COMPONENT DIAGNOSIS >

Driver seat control unit connector	Terminal	Ground	Continuity
B202	14		
	29		

Is the inspection result normal?

YES >> GO TO 3

NO >> Repair or replace harness.

### 3. CHECK DRIVER SEAT CONTROL UNIT OUTPUT

1. Connect the driver seat control unit.
2. Turn ignition switch ON.
3. Check voltage between driver seat control unit harness connector and ground.

Driver seat control unit connector	Terminals		Voltage (V) (Approx.)
	(+)	(-)	
B202	14	Ground	Battery voltage
	29		

Is the inspection result normal?

YES >> GO TO 4

NO >> Replace driver seat control unit.

### 4. CHECK LIFTING SWITCH (REAR)

Refer to [ADP-49. "Component Inspection"](#).

Is the inspection result normal?

YES >> GO TO 5

NO >> Replace power seat switch LH.

### 5. CHECK INTERMITTENT INCIDENT

Refer to [GI-39. "Intermittent Incident"](#).

Is the inspection result normal?

YES >> Replace driver seat control unit.

NO >> Repair or replace the malfunctioning part.

## Component Inspection

INFOID:000000001608100

### 1. CHECK LIFTING SWITCH (REAR)

1. Turn ignition switch OFF.
2. Disconnect power seat switch LH.
3. Check continuity between power seat switch LH terminals.

Terminal		Condition	Continuity
Power seat switch LH			
3	2	Lifting switch rear (up)	Operate: Yes
		Release	No
	8	Lifting switch rear (down)	Operate: Yes
		Release	No

Is the inspection result normal?

YES >> INSPECTION END

NO >> Replace power seat switch LH.

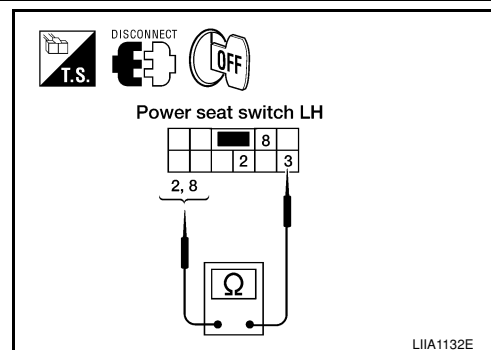
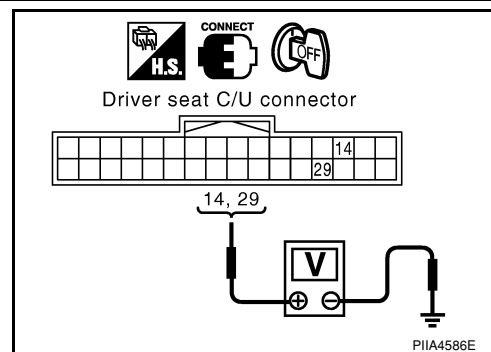

# TILT SWITCH

< COMPONENT DIAGNOSIS >

## TILT SWITCH

### Description

INFOID:000000001608101

Pedal adjusting switch is on the instrument panel. The operation signal is input to the driver seat control unit when the pedal adjusting switch is operated. The pedal adjusting switch signal is sent to the automatic drive positioner control unit via UART communication.

### Component Function Check

INFOID:000000001608102

#### 1. CHECK FUNCTION

1. Select "PEDAL SW-FR", "PEDAL SW-RR" in "Data monitor" mode with CONSULT-III.
2. Check pedal adjusting switch signal under the following conditions.

Monitor item	Condition	Status	
PEDAL SW-FR	Pedal adjusting switch (forward)	Operate	ON
		Release	OFF
PEDAL SW-RR	Pedal adjusting switch (backward)	Operate	ON
		Release	OFF

Is the indication normal?

YES >> INSPECTION END

NO >> Perform diagnosis procedure. Refer to [ADP-50. "Diagnosis Procedure"](#).

### Diagnosis Procedure

INFOID:000000001608103

#### 1. CHECK PEDAL ADJUSTING SWITCH SIGNAL

1. Turn ignition switch ON.
2. Check voltage between driver seat control unit harness connector and ground.

Driver seat control unit connector	Terminals		Condition	Voltage (V) (Approx.)
	(+)	(-)		
B202	15	Ground	Operate (backward)	0
			Release	Battery voltage
	30		Operate (forward)	0
			Release	Battery voltage

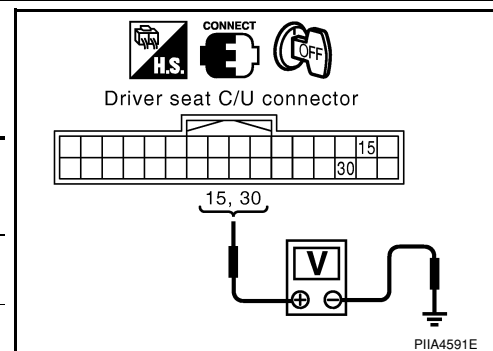

Is the inspection result normal?

YES >> GO TO 5

NO >> GO TO 2

#### 2. CHECK PEDAL ADJUSTING SWITCH CIRCUIT

# TILT SWITCH

## < COMPONENT DIAGNOSIS >

1. Turn ignition switch OFF.
2. Disconnect driver seat control unit and pedal adjusting switch.
3. Check continuity between driver seat control unit harness connector and pedal adjusting switch harness connector.

Driver seat control unit connector	Terminal	Pedal adjusting switch connector	Terminal	Continuity
B202	15	M96	2	Yes
	30		3	

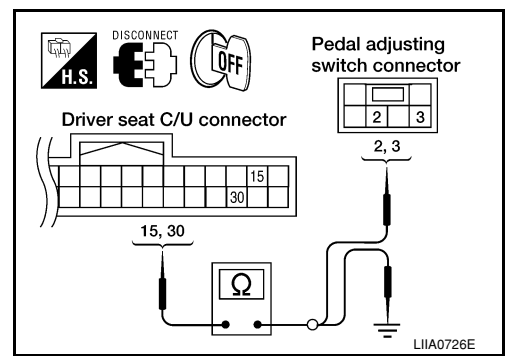

4. Check continuity between driver seat control unit harness connector and ground.

Driver seat control unit connector	Terminal	Ground	Continuity
B202	15	Ground	No
	30		

Is the inspection result normal?

- YES >> GO TO 3  
 NO >> Repair or replace harness.

### 3. CHECK DRIVER SEAT CONTROL UNIT OUTPUT

1. Connect the driver seat control unit.
2. Turn ignition switch ON.
3. Check voltage between driver seat control unit harness connector and ground.

Driver seat control unit connector	Terminals		Voltage (V) (Approx.)
	(+)	(-)	
B202	15	Ground	Battery voltage
	30		

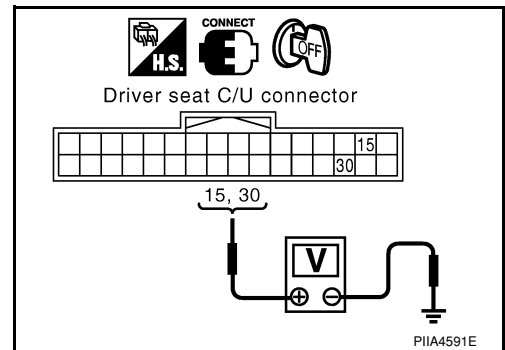

Is the inspection result normal?

- YES >> GO TO 4  
 NO >> Replace driver seat control unit.

### 4. CHECK PEDAL ADJUSTING SWITCH

Refer to [ADP-52. "Component Inspection"](#).

Is the inspection result normal?

- YES >> GO TO 5  
 NO >> Replace pedal adjusting switch.

### 5. CHECK PEDAL ADJUSTING SWITCH GROUND CIRCUIT

Check continuity between pedal adjusting switch connector M96 terminal 1 and ground.

**1 - Ground : Continuity should exist.**

Is the inspection result normal?

- YES >> GO TO 6  
 NO >> Replace or replace harness.

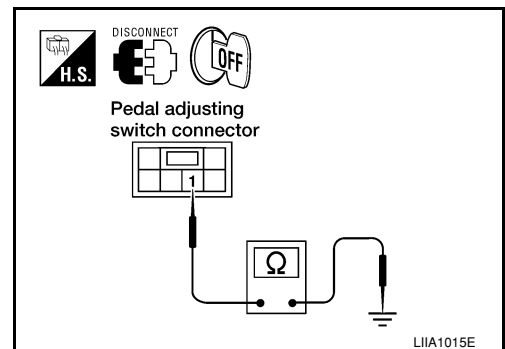

### 6. CHECK INTERMITTENT INCIDENT

# TILT SWITCH

## < COMPONENT DIAGNOSIS >

Refer to [GI-39. "Intermittent Incident"](#).

Is the inspection result normal?

- YES >> Replace automatic drive positioner control unit.
- NO >> Repair or replace the malfunctioning part.

## Component Inspection

INFOID:000000001608104

### 1. CHECK PEDAL ADJUSTING SWITCH

1. Turn ignition switch OFF.
2. Disconnect pedal adjusting switch.
3. Check continuity between pedal adjusting switch terminals.

Terminal		Condition	Continuity
Pedal adjusting switch			
1	2	Pedal adjusting switch (forward)	Operate: Yes Release: No
	3	Pedal adjusting switch (backward)	Operate: Yes Release: No

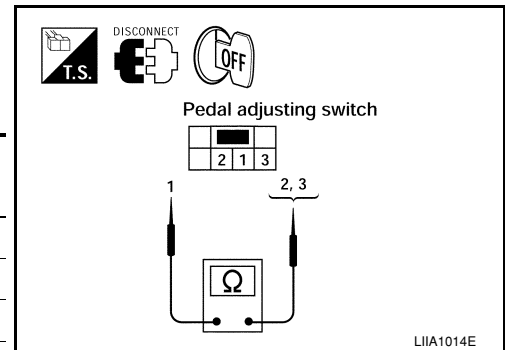

Is the inspection result normal?

- YES >> INSPECTION END
- NO >> Replace pedal adjusting switch.

# SEAT MEMORY SWITCH

< COMPONENT DIAGNOSIS >

## SEAT MEMORY SWITCH

### Description

INFOID:000000001608109

Memory switch is equipped on the seat memory switch installed to the front door LH trim. The operation signal is input to the automatic drive positioner control unit when the memory switch is operated.

### Component Function Check

INFOID:000000001608110

#### 1. CHECK FUNCTION

1. Select "MEMORY SW 1", "MEMORY SW 2", "SET SW" in "Data monitor" mode with CONSULT-III.
2. Check seat memory switch signal under the following conditions.

Monitor item	Condition		Status
MEMORY SW1	Memory switch 1	Push	ON
		Release	OFF
MEMORY SW2	Memory switch 2	Push	ON
		Release	OFF
SET SW	Set switch	Push	ON
		Release	OFF

Is the indication normal?

YES >> INSPECTION END

NO >> Perform diagnosis procedure. Refer to [ADP-53. "Diagnosis Procedure"](#).

### Diagnosis Procedure

INFOID:000000001608111

#### 1. CHECK MEMORY SWITCH CIRCUIT

1. Turn ignition switch OFF.
2. Disconnect automatic drive positioner control unit and seat memory switch.
3. Check continuity between automatic drive positioner control unit harness connector and seat memory switch harness connector.

Automatic drive positioner control unit connector	Terminal	Seat memory switch connector	Terminal	Continuity
M33	9	D5	1	Yes
	24		3	
	25		2	

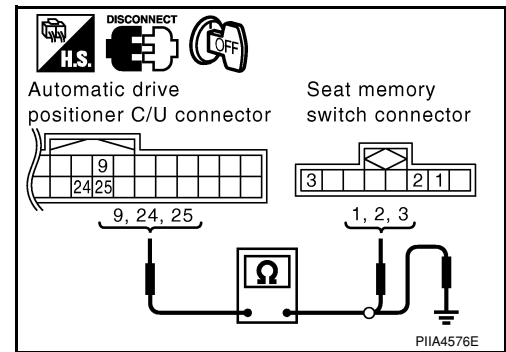

4. Check continuity between automatic drive positioner control unit harness connector and ground.

Automatic drive positioner control unit connector	Terminal	Continuity
M33	9	No
	24	
	25	

Is the inspection result normal?

YES >> GO TO 2

NO >> Repair or replace harness.

#### 2. CHECK MEMORY SWITCH GROUND CIRCUIT

# SEAT MEMORY SWITCH

## < COMPONENT DIAGNOSIS >

Check continuity between seat memory switch harness connector and ground.

Seat memory switch connector	Terminal	Ground	Continuity
D5	4		Yes

Is the inspection result normal?

- YES >> GO TO 3  
 NO >> Repair or replace harness.

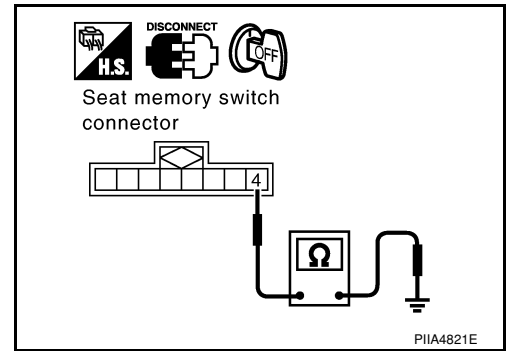

### 3. CHECK SEAT MEMORY SWITCH

Refer to [ADP-54, "Component Inspection"](#).

Is the inspection result normal?

- YES >> GO TO 4  
 NO >> Replace seat memory switch.

### 4. CHECK INTERMITTENT INCIDENT

Refer to [GI-39, "Intermittent Incident"](#).

Is the inspection result normal?

- YES >> Replace automatic drive positioner control unit.  
 NO >> Repair or replace the malfunctioning part.

## Component Inspection

INFOID:000000001608112

### 1. CHECK SEAT MEMORY SWITCH

1. Turn ignition switch OFF.
2. Disconnect seat memory switch.
3. Check continuity between seat memory switch terminals.

Terminal		Condition		Continuity
Seat memory switch				
4	1	Memory switch 1	Push	Yes
			Release	No
4	2	Memory switch 2	Push	Yes
			Release	No
4	3	Set switch	Push	Yes
			Release	No

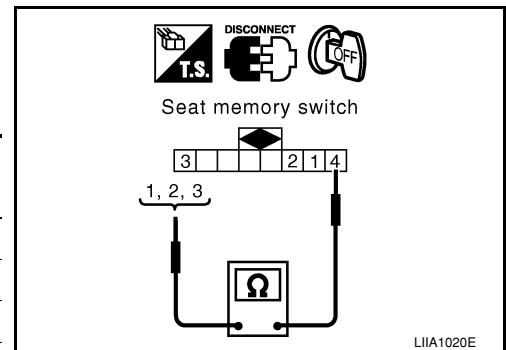

Is the inspection result normal?

- YES >> INSPECTION END  
 NO >> Replace seat memory switch.

# DOOR MIRROR REMOTE CONTROL SWITCH

< COMPONENT DIAGNOSIS >

## DOOR MIRROR REMOTE CONTROL SWITCH CHANGEOVER SWITCH

### CHANGEOVER SWITCH : Description

INFOID:000000001608113

Changeover switch is integrated into door mirror remote control switch.  
Changeover switch has three positions (L, N and R).  
It changes door mirror motor operation by transmitting control signal to automatic drive positioner control unit.

### CHANGEOVER SWITCH : Component Function Check

INFOID:000000001608114

#### 1. CHECK CHANGEOVER SWITCH FUNCTION

Check the operation on "MIR CHNG SW-R" or "MIR CHNG SW-L" in "DATA MONITOR" mode with CONSULT-III.

Refer to [ADP-24, "CONSULT-III Function"](#).

Is the inspection result normal?

- YES >> Changeover switch function is OK.
- NO >> Refer to [ADP-55, "CHANGEOVER SWITCH : Diagnosis Procedure"](#).

### CHANGEOVER SWITCH : Diagnosis Procedure

INFOID:000000001608115

#### 1. CHECK CHANGEOVER SWITCH SIGNAL

1. Turn ignition switch ON.
2. Check voltage between automatic drive positioner control unit connector and ground.

Terminals		(-)	Change over switch condition	Voltage (V) (Approx.)
(+)	Terminal			
Automatic drive positioner control unit connector  M33	2	Ground	RIGHT	0
			Other than above	5
	18		LEFT	0
			Other than above	5

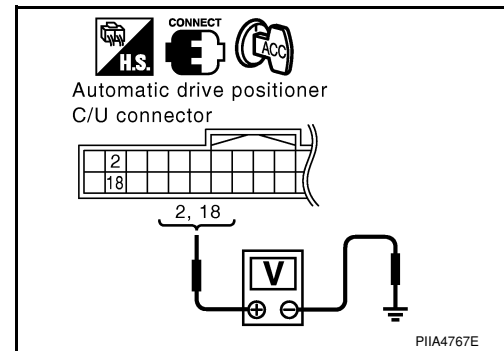

Is the inspection result normal?

- YES >> GO TO 6
- NO >> GO TO 2

#### 2. CHECK HARNESS CONTINUITY

1. Turn ignition switch OFF.
2. Disconnect automatic drive positioner control unit and door mirror remote control switch.
3. Check continuity between automatic drive positioner control unit connector and door mirror remote control switch connector.

Automatic drive positioner control unit connector	Terminal	Door mirror remote control switch connector	Terminal	Continuity
M33 (A)	2	D10 (B)	11	Yes
	18		10	

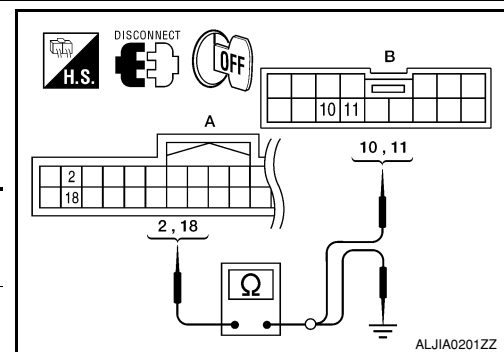

4. Check continuity between automatic drive positioner control unit connector and ground.

# DOOR MIRROR REMOTE CONTROL SWITCH

## < COMPONENT DIAGNOSIS >

Automatic drive positioner control unit connector	Terminal	Ground	Continuity
M33 (A)	2		
	18		

Is the inspection result normal?

YES >> GO TO 3

NO >> Repair or replace harness.

### 3. CHECK DOOR MIRROR REMOTE CONTROL SWITCH GROUND CIRCUIT

Check continuity between door mirror remote control switch connector and ground.

Door mirror remote control switch connector	Terminal	Ground	Continuity
D10	7		

Is the inspection result normal?

YES >> GO TO 4

NO >> Repair or replace harness.

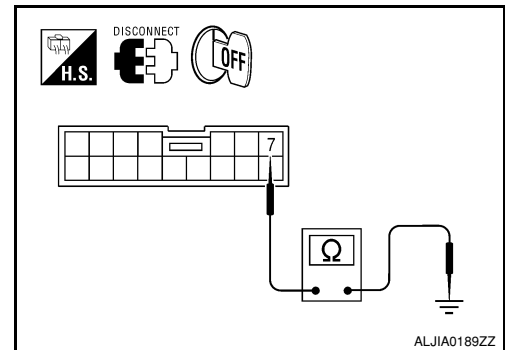

### 4. CHECK AUTOMATIC DRIVE POSITIONER CONTROL UNIT OUTPUT SIGNAL

1. Connect automatic drive positioner control unit.
2. Turn ignition switch ON.
3. Check voltage between automatic drive positioner control unit connector and ground.

Terminals		(-)	Voltage (V) (Approx.)
(+)	Terminal		
Automatic drive positioner control unit connector	2	Ground	5
	18		

Is the inspection result normal?

YES >> GO TO 5.

NO >> Replace automatic drive positioner control unit.

### 5. CHECK CHANGEOVER SWITCH

Check changeover switch.

Refer to [ADP-56, "CHANGEOVER SWITCH : Component Inspection"](#).

Is the inspection result normal?

YES >> Refer to [GI-39, "Intermittent Incident"](#).

NO >> Replace door mirror remote control switch.

### 6. CHECK INTERMITTENT INCIDENT

Check intermittent incident.

Refer to [GI-39, "Intermittent Incident"](#).

Is the inspection result normal?

YES >> Replace automatic drive positioner control unit.

NO >> Repair or replace the malfunctioning parts.

## CHANGEOVER SWITCH : Component Inspection

### 1. CHECK CHANGEOVER SWITCH

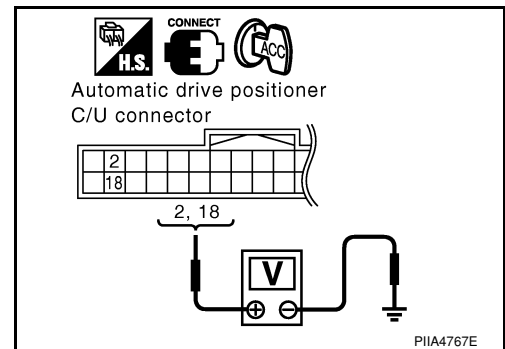



# DOOR MIRROR REMOTE CONTROL SWITCH

## < COMPONENT DIAGNOSIS >

Check door mirror remote control switch.

Terminal		Change over switch condition	Continuity
Door mirror remote control switch			
10	7	LEFT	Yes
		Other than above	No
11		RIGHT	Yes
		Other than above	No

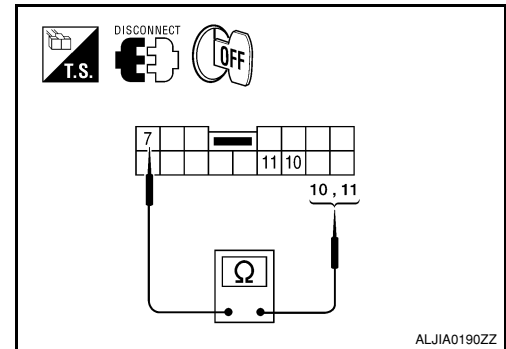

Is the inspection result normal?

YES >> INSPECTION END

NO >> Replace door mirror remote control switch.

## MIRROR SWITCH

### MIRROR SWITCH : Description

INFOID:000000001608117

It operates angle of the door mirror face.

It transmits mirror face adjust operation to automatic drive positioner control unit.

### MIRROR SWITCH : Component Function Check

INFOID:000000001608118

#### 1. CHECK MIRROR SWITCH FUNCTION

Check the operation on "MIR CON SW-UP/DN" and "MIR CON SW-RH/LH" in "DATA MONITOR" mode with CONSULT-III.

Refer to [ADP-24. "CONSULT-III Function"](#).

Is the inspection result normal?

YES >> Mirror switch function is OK.

NO >> Refer to [ADP-57. "MIRROR SWITCH : Diagnosis Procedure"](#).

### MIRROR SWITCH : Diagnosis Procedure

INFOID:000000001608119

#### 1. CHECK MIRROR SWITCH FUNCTION

1. Turn ignition switch ON.
2. Check voltage between automatic drive positioner control unit connector and ground.

Terminals		Mirror switch Condition	Voltage (V) (Approx.)
(+)	(-)		
Automatic drive positioner control unit connector	Terminal		
M33	Ground	UP	0
		Other than above	5
		LEFT	0
		Other than above	5
	Ground	DOWN	0
		Other than above	5
		RIGHT	0
		Other than above	5

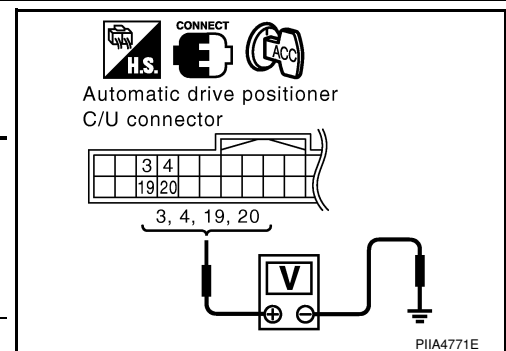

Is the inspection result normal?

YES >> GO TO 6

NO >> GO TO 2

#### 2. CHECK HARNESS CONTINUITY

A  
B  
C  
D  
E  
F  
G  
H  
I  
K  
L  
M  
N  
O  
P

# DOOR MIRROR REMOTE CONTROL SWITCH

## < COMPONENT DIAGNOSIS >

1. Turn ignition switch OFF.
2. Disconnect automatic drive positioner control unit and door mirror remote control switch.
3. Check continuity between automatic drive positioner control unit connector and door mirror remote control switch connector.

Automatic drive positioner control unit connector	Terminal	Door mirror remote control switch connector	Terminal	Continuity
M33 (A)	3	D10 (B)	15	Yes
	4		13	
	19		12	
	20		4	

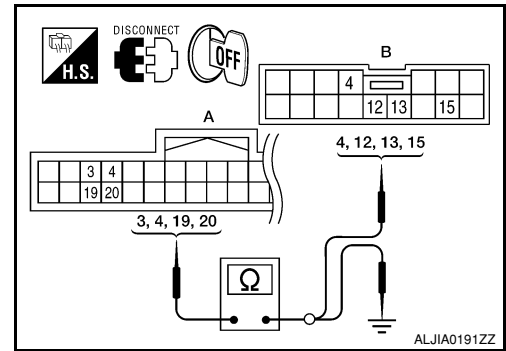

4. Check continuity between automatic drive positioner control unit connector and ground.

Automatic drive positioner control unit connector	Terminal	Ground	Continuity
M33 (A)	3	Ground	No
	4		
	19		
	20		

Is the inspection result normal?

- YES >> GO TO 3  
 NO >> Repair or replace harness.

### 3. CHECK DOOR MIRROR REMOTE CONTROL SWITCH GROUND CIRCUIT

Check continuity between door mirror remote control switch connector and ground.

Door mirror remote control switch connector	Terminal	Ground	Continuity
D10	7	Ground	Yes

Is the inspection result normal?

- YES >> GO TO 4  
 NO >> Repair or replace harness.

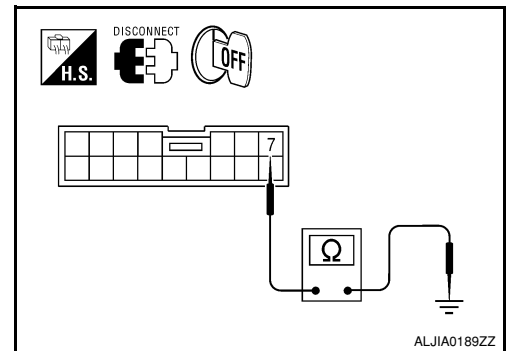

### 4. CHECK AUTOMATIC DRIVE POSITIONER CONTROL UNIT OUTPUT SIGNAL

1. Connect automatic drive positioner control unit.
2. Turn ignition switch ON.
3. Check voltage between automatic drive positioner control unit and ground.

Terminals		(-)	Voltage (V) (Approx.)
(+)	Terminal		
Automatic drive positioner control unit connector	3	Ground	5
	4		
	19		
	20		

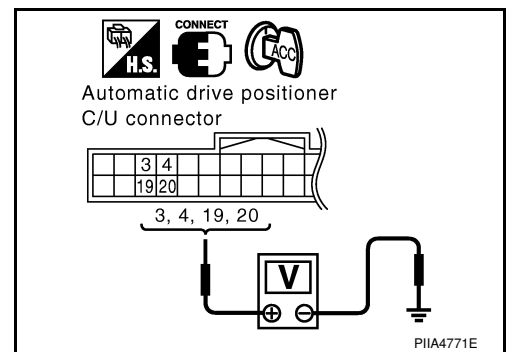

Is the inspection result normal?

# DOOR MIRROR REMOTE CONTROL SWITCH

## < COMPONENT DIAGNOSIS >

- YES >> GO TO 5
- NO >> Replace automatic drive positioner control unit.

### 5. CHECK MIRROR SWITCH

Check mirror switch.  
Refer to [ADP-59. "MIRROR SWITCH : Component Inspection"](#).

Is the inspection result normal?

- YES >> Refer to [GI-39. "Intermittent Incident"](#).
- NO >> Replace door mirror remote control switch.

### 6. CHECK INTERMITTENT INCIDENT

Check intermittent incident.  
Refer to [GI-39. "Intermittent Incident"](#).

Is the inspection result normal?

- YES >> Replace automatic drive positioner control unit.
- NO >> Repair or replace the malfunctioning parts.

## MIRROR SWITCH : Component Inspection

INFOID:000000001608120

### 1. CHECK MIRROR SWITCH

Check door mirror remote control switch.

Terminal		Mirror switch condition	Continuity
Door mirror remote control switch			
4	7	RIGHT	Yes
		Other than above	No
13	7	LEFT	Yes
		Other than above	No
15	7	UP	Yes
		Other than above	No
12	7	DOWN	Yes
		Other than above	No

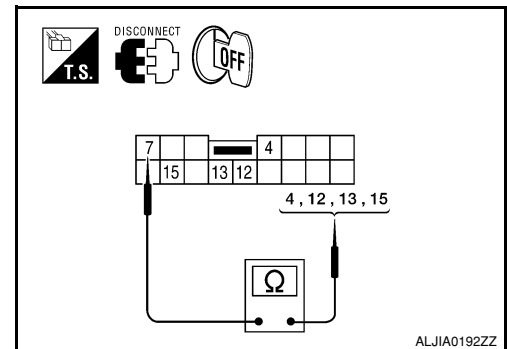

Is the inspection result normal?

- YES >> INSPECTION END
- NO >> Replace door mirror remote control switch.

# POWER SEAT SWITCH GROUND CIRCUIT

< COMPONENT DIAGNOSIS >

## POWER SEAT SWITCH GROUND CIRCUIT

### Diagnosis Procedure

INFOID:000000001608121

#### 1. CHECK POWER SEAT SWITCH LH GROUND CIRCUIT

1. Turn ignition switch OFF.
2. Disconnect power seat switch LH.
3. Check continuity between power seat switch LH connector and ground.

Power seat switch LH connector	Terminal	Ground	Continuity
B208	32		Yes

Is the inspection result normal?

- YES >> Check intermittent incident. Refer to [GI-39. "Intermittent Incident"](#).
- NO >> Repair or replace harness.

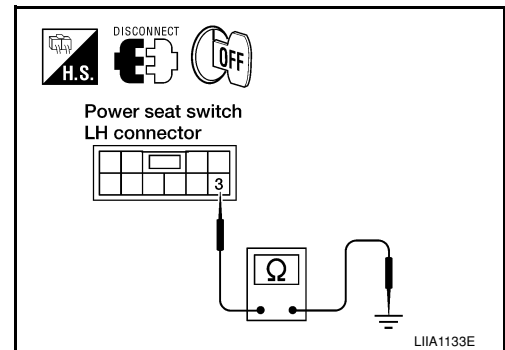

# DETENTION SWITCH

< COMPONENT DIAGNOSIS >

## DETENTION SWITCH

### Description

INFOID:000000001608126

Park position switch is installed on A/T device. It is turned OFF when the A/T selector lever is in P position. The driver seat control unit judges that the A/T selector lever is in P position if continuity does not exist in this circuit.

### Component Function Check

INFOID:000000001608127

#### 1. CHECK FUNCTION

1. Select "DETENT SW" signal in "Data monitor" mode with CONSULT-III.
2. Check park position switch signal under the following conditions.

Monitor item	Condition		Status
DETENT SW	A/T selector lever	P position	OFF
		Other than above	ON

Is the indication normal?

YES >> INSPECTION END

NO >> Perform diagnosis procedure. Refer to [ADP-61, "Diagnosis Procedure"](#).

### Diagnosis Procedure

INFOID:000000001608128

#### 1. CHECK DTC WITH "BCM"

Check "Self Diagnostic Result" for BCM with CONSULT-III.

Is any other DTC detected?

YES >> Check the DTC.

NO >> GO TO 2

#### 2. CHECK PARK POSITION SWITCH INPUT SIGNAL

1. Turn ignition switch ON.
2. Mechanical key must be removed from the key switch.
3. Check voltage between driver seat control unit harness connector and ground.

Driver seat control unit connector	Terminal		Condition	Voltage (V) (Approx.)
	(+)	(-)		
B202	21	Ground	A/T selector lever	Battery voltage
			Other than above	0V

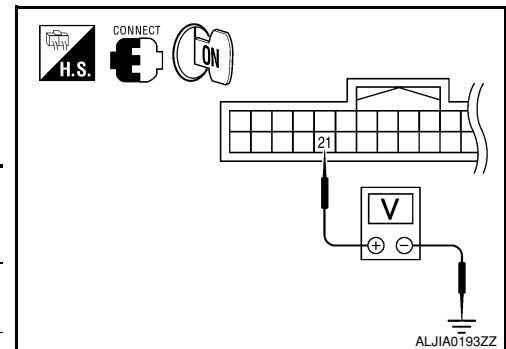

Is the inspection result normal?

YES >> GO TO 4

NO >> GO TO 3

#### 3. CHECK PARK POSITION SWITCH CIRCUIT

# DETENTION SWITCH

## < COMPONENT DIAGNOSIS >

1. Turn ignition switch OFF.
2. Disconnect driver seat control unit and A/T device.
3. Check continuity between driver seat control unit harness connector (A) and A/T device harness connector (B).

A		B		Continuity
Connector	Terminal	Connector	Terminal	
B202	21	M203	6	Yes

4. Check continuity between driver seat control unit harness connector (A) and ground.

A		—	Continuity
Connector	Terminal		
B202	21	Ground	No

Is the inspection result normal?

- YES >> GO TO 4  
 NO >> Repair or replace harness.

## 4. CHECK INTERMITTENT INCIDENT

Refer to [GI-39, "Intermittent Incident"](#).

Is the inspection result normal?

- YES >> Replace driver seat control unit.  
 NO >> Repair or replace the malfunctioning part.

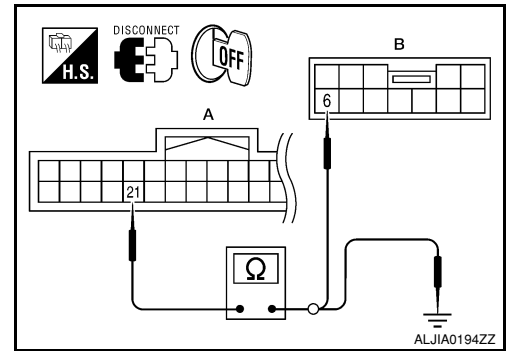

# FRONT DOOR SWITCH (DRIVER SIDE)

< COMPONENT DIAGNOSIS >

## FRONT DOOR SWITCH (DRIVER SIDE)

### Description

INFOID:000000001608133

Detects front door LH open/close condition.

### Component Function Check

INFOID:000000001608134

#### 1. CHECK FUNCTION

1. Select "DOOR SW-DR" in "Data monitor" mode with CONSULT-III.
2. Check the front door switch LH signal under the following conditions.

Monitor item	Condition		Status
DOOR SW-DR	Front door switch LH	Open	ON
		Close	OFF

Is the inspection result normal?

YES >> INSPECTION END

NO >> Perform diagnosis procedure. Refer to [ADP-63. "Diagnosis Procedure"](#).

### Diagnosis Procedure

INFOID:000000001608135

#### 1. CHECK FRONT DOOR SWITCH LH CIRCUIT

1. Disconnect BCM.
2. Check continuity between BCM connector and front door switch LH connector.

BCM connector	Terminal	Front door switch LH connector	Terminal	Continuity
M19	47	B8	2	Yes

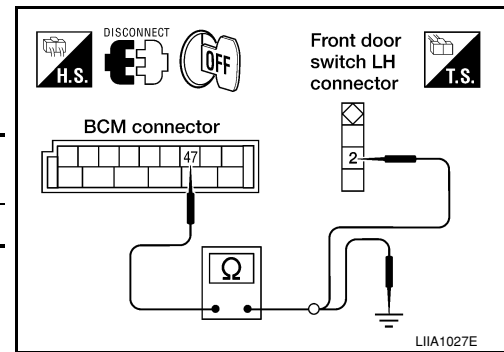

3. Check continuity between BCM connector and ground.

BCM connector	Terminal	Ground	Continuity
M19	47		No

Is the inspection result normal?

YES >> GO TO 2

NO >> Repair or replace harness.

#### 2. CHECK FRONT DOOR SWITCH LH

Refer to [ADP-63. "Component Inspection"](#).

Is the inspection result normal?

YES >> GO TO 3

NO >> Replace front door switch LH.

#### 3. CHECK INTERMITTENT INCIDENT

Refer to [GI-39. "Intermittent Incident"](#).

Is the inspection result normal?

YES >> Replace BCM. Refer to [BCS-54. "Removal and Installation"](#).

NO >> Repair or replace the malfunctioning part.

### Component Inspection

INFOID:000000001608136

#### 1. CHECK FRONT DOOR SWITCH LH

# FRONT DOOR SWITCH (DRIVER SIDE)

## < COMPONENT DIAGNOSIS >

1. Turn ignition switch OFF.
2. Disconnect front door switch LH.
3. Check continuity between front door switch LH terminals.

Terminal		Condition		Continuity
Front door switch LH				
2	Ground part of door switch	Front door switch LH	Pushed	No
			Released	Yes

Is the inspection result normal?

- YES >> INSPECTION END  
NO >> Replace front door switch LH.

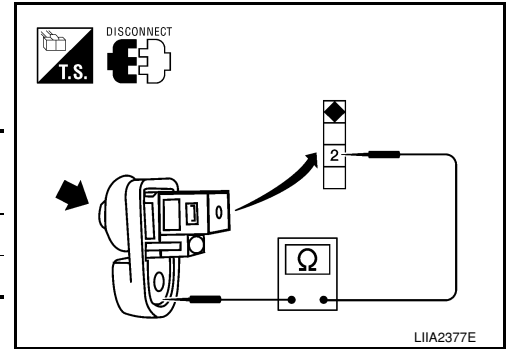



# SLIDING SENSOR

< COMPONENT DIAGNOSIS >

## SLIDING SENSOR

### Description

INFOID:000000001608137

- The sliding sensor is installed to the seat slide cushion frame.
- The pulse signal is input to the driver seat control unit when sliding is performed.
- The driver seat control unit counts the pulse and calculates the sliding amount of the seat.

### Component Function Check

INFOID:000000001608138

#### 1. CHECK FUNCTION

1. Select "SLIDE PULSE" in "Data monitor" mode with CONSULT-III.
2. Check sliding sensor signal under the following conditions.

Monitor item	Condition		Valve
SLIDE PULSE	Seat sliding	Operate (forward)	Change (increase)
		Operate (backward)	Change (decrease)
		Release	No change

Is the indication normal?

YES >> INSPECTION END

NO >> Perform diagnosis procedure. Refer to [ADP-65, "Diagnosis Procedure"](#).

### Diagnosis Procedure

INFOID:000000001608139

#### 1. CHECK SLIDING SENSOR SIGNAL

1. Turn ignition switch ON.
2. Read voltage signal between driver seat control unit harness connector and ground with oscilloscope.

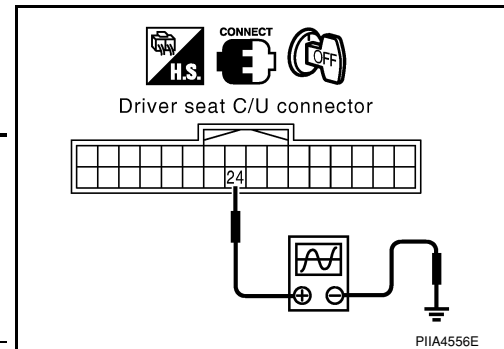

Terminals			Condition	Voltage signal
(+)		(-)		
Driver's seat control unit	Terminal			
B202	24	Ground	Seat sliding	
			Other than above	0 or 5

Is the inspection result normal?

YES >> GO TO 4

NO >> GO TO 2

#### 2. CHECK SLIDING SENSOR CIRCUITS

# SLIDING SENSOR

## < COMPONENT DIAGNOSIS >

1. Turn ignition switch OFF.
2. Disconnect driver seat control unit and sliding motor LH.
3. Check continuity between driver seat control unit harness connector and sliding motor LH harness connector.

Driver seat control unit connector	Terminal	Sliding motor LH connector	Terminal	Continuity
B202	16	B204	3	Yes
	24		2	
	31		1	

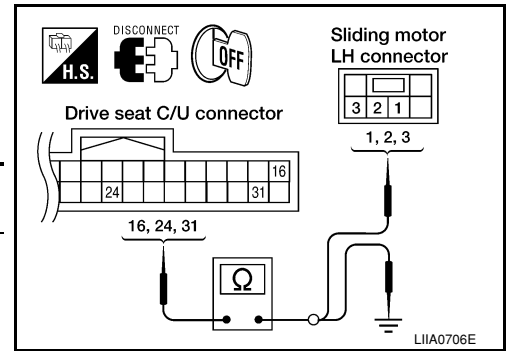

4. Check continuity between driver seat control unit harness connector and ground.

Driver seat control unit connector	Terminal		Continuity
B202	16	Ground	No
	24		
	31		

Is the inspection result normal?

- YES >> GO TO 3  
 NO >> Repair or replace harness.

### 3. CHECK SEAT OPERATION

1. Connect driver seat control unit and sliding motor LH.
2. Check seat operation (except sliding operation) with memory function.

Is the inspection result normal?

- YES >> Replace sliding motor LH. (Built in seat slide cushion frame).  
 NO >> Replace driver seat control unit.

### 4. CHECK INTERMITTENT INCIDENT

Refer to [GI-39. "Intermittent Incident"](#).

Is the inspection result normal?

- YES >> Replace driver seat control unit.  
 NO >> Repair or replace the malfunctioning part.

# RECLINING SENSOR

< COMPONENT DIAGNOSIS >

## RECLINING SENSOR

### Description

INFOID:000000001608140

- The reclining motor is installed to the seatback frame.
- The pulse signal is inputted to the driver seat control unit when the reclining is operated.
- The driver seat control unit counts the pulse and calculates the reclining amount of the seat.

### Component Function Check

INFOID:000000001608141

#### 1. CHECK FUNCTION

1. Select "RECLN PULSE" in "Data monitor" mode with CONSULT-III.
2. Check reclining sensor signal under the following conditions.

Monitor item	Condition		Value
RECLN PULSE	Seat reclining	Operate (forward)	Change (increase)
		Operate (backward)	Change (decrease)
		Release	No change

Is the indication normal?

YES >> INSPECTION END

NO >> Perform diagnosis procedure. Refer to [ADP-67, "Diagnosis Procedure"](#).

### Diagnosis Procedure

INFOID:000000001608142

#### 1. CHECK RECLINING SENSOR SIGNAL

1. Turn ignition switch ON.
2. Read voltage signal between driver seat control unit harness connector and ground with oscilloscope.

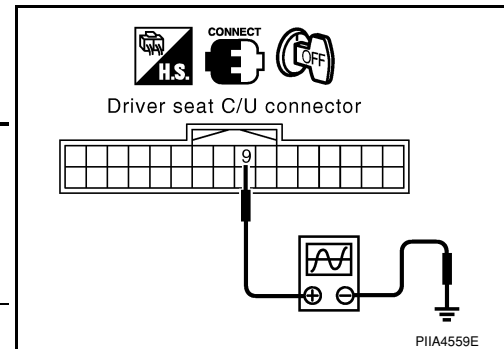

Terminals		Condition	Voltage signal
(+)	(-)		
Driver seat control unit	Terminal		
B202	9	Ground	<p>Operate</p> <p>Other than above</p> <p>0 or 5</p> <p>SIIA0692J</p>

Is the inspection result normal?

YES >> GO TO 4

NO >> GO TO 2

#### 2. CHECK RECLINING SENSOR CIRCUIT

# RECLINING SENSOR

## < COMPONENT DIAGNOSIS >

1. Turn ignition switch OFF.
2. Disconnect driver seat control unit and reclining motor LH.
3. Check continuity between driver seat control unit harness connector and reclining motor LH harness connector.

Driver seat control unit connector	Terminal	Reclining motor connector	Terminal	Continuity
B202	9	B205	1	Yes
	31		2	

4. Check continuity between driver seat control unit harness connector and ground.

Driver seat control unit connector	Terminal	Ground	Continuity
B202	9		No
	31		

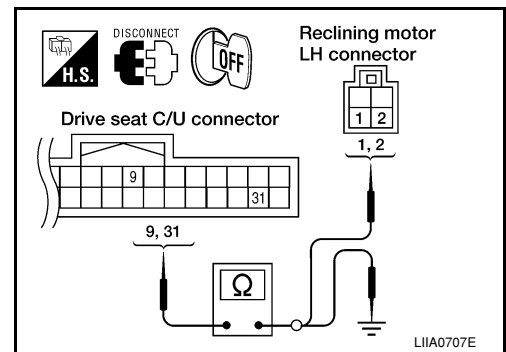

Is the inspection result normal?

- YES >> GO TO 3  
 NO >> Repair or replace harness.

### 3. CHECK SEAT OPERATION

1. Connect driver seat control unit and reclining motor LH connector.
2. Check seat operation (except reclining operation) with memory function.

Is the operation normal?

- YES >> Replace reclining motor LH. (Built in seat slide cushion frame.)  
 NO >> Replace driver seat control unit.

### 4. CHECK INTERMITTENT INCIDENT

Refer to [GI-39, "Intermittent Incident"](#).

Is the inspection result normal?

- YES >> Replace driver seat control unit.  
 NO >> Repair or replace the malfunctioning part.

# LIFTING SENSOR (FRONT)

< COMPONENT DIAGNOSIS >

## LIFTING SENSOR (FRONT)

### Description

INFOID:000000001608143

- The lifting sensor (front) is installed to the seat slide cushion frame.
- The pulse signal is input to the driver seat control unit when the lifting (front) is operated.
- The driver seat control unit counts the pulse and calculates the lifting (front) amount of the seat.

### Component Function Check

INFOID:000000001608144

#### 1. CHECK FUNCTION

1. Select "LIFT FR PULSE" in "Data monitor" mode with CONSULT-III.
2. Check the lifting sensor (front) signal under the following conditions.

Monitor item	Condition		Value
LIFT FR PULSE	Seat lifting (front)	Operate (up)	Change (increase)
		Operate (down)	Change (decrease)
		Release	No change

Is the indication normal?

YES >> INSPECTION END

NO >> Perform diagnosis procedure. Refer to [ADP-69, "Diagnosis Procedure"](#).

### Diagnosis Procedure

INFOID:000000001608145

#### 1. CHECK LIFTING SENSOR (FRONT) SIGNAL

1. Turn ignition switch ON.
2. Read the voltage signal between driver seat control unit harness connector and ground with an oscilloscope.

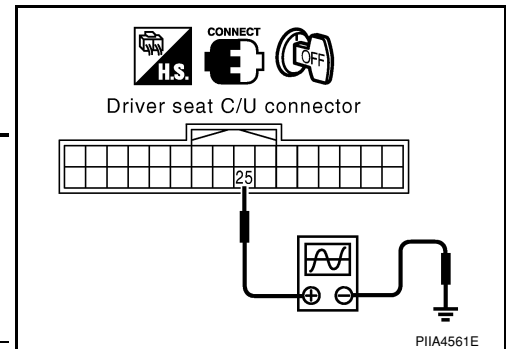

Terminals		(-)	Condition	Voltage signal
(+)	Terminal			
Driver seat control unit connector				
B202	25	Ground	Seat lifting (front)	<p>SIIA0691J</p>
			Other than above	0 or 5

Is the inspection result normal?

YES >> GO TO 4

NO >> GO TO 2

#### 2. CHECK LIFTING SENSOR (FRONT) CIRCUIT

# LIFTING SENSOR (FRONT)

## < COMPONENT DIAGNOSIS >

1. Turn ignition switch OFF.
2. Disconnect driver seat control unit and lifting motor (front).
3. Check continuity between driver seat control unit harness connector and lifting motor (front) harness connector.

Driver seat control unit connector	Terminal	Lifting motor (front) connector	Terminal	Continuity
B202	16	B206	3	Yes
	25		2	
	31		1	

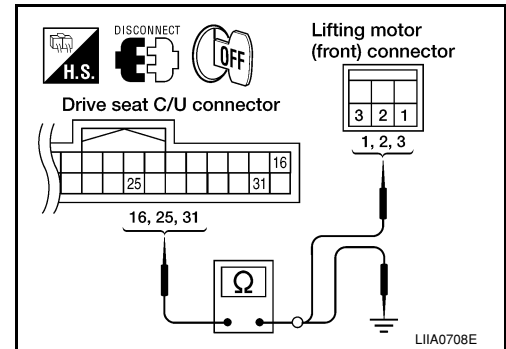

4. Check continuity between driver seat control unit harness connector and ground.

Driver seat control unit connector	Terminal	Ground	Continuity
B202	16	Ground	No
	25		
	31		

Is the inspection result normal?

- YES >> GO TO 3  
 NO >> Repair or replace harness.

### 3. CHECK SEAT OPERATION

1. Connect driver seat control unit and lifting motor (front) connector.
2. Check seat operation [except lifting (front) operation] with memory function.

Is the operation normal?

- YES >> Replace lifting motor (front). (Built in seat slide cushion frame.)  
 NO >> Replace driver seat control unit.

### 4. CHECK INTERMITTENT INCIDENT

Refer to [GI-39, "Intermittent Incident"](#).

Is the inspection result normal?

- YES >> Replace driver seat control unit.  
 NO >> Repair or replace the malfunctioning part.

# LIFTING SENSOR (REAR)

< COMPONENT DIAGNOSIS >

## LIFTING SENSOR (REAR)

### Description

INFOID:000000001608146

- The lifting sensor (rear) is installed to the seat slide cushion frame.
- The pulse signal is input to the driver seat control unit when the lifting (rear) is operated.
- The driver seat control unit counts the pulse and calculates the lifting (rear) amount of the seat.

### Component Function Check

INFOID:000000001608147

#### 1. CHECK FUNCTION

1. Select "LIFT RR PULSE" in "Data monitor" mode with CONSULT-III.
2. Check lifting sensor (rear) signal under the following conditions.

Monitor item	Condition		Value
LIFT RR PULSE	Seat lifting (rear)	Operate (up)	Change (increase)
		Operate (down)	Change (decrease)
	Release	No change	

Is the indication normal?

YES >> INSPECTION END

NO >> Perform diagnosis procedure. Refer to [ADP-71, "Diagnosis Procedure"](#).

### Diagnosis Procedure

INFOID:000000001608148

#### 1. CHECK LIFTING SENSOR (REAR) SIGNAL

1. Turn ignition switch OFF.
2. Read voltage signal between driver seat control unit harness connector and ground with oscilloscope.

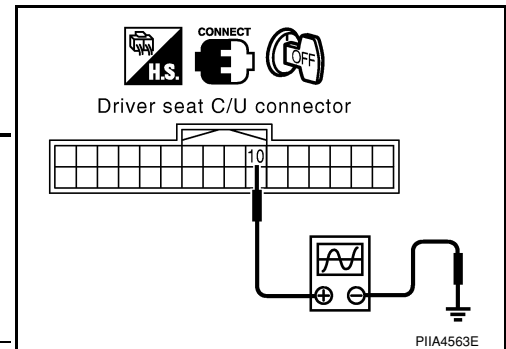

Terminals		Condition	Voltage signal
(+)	(-)		
Driver seat control unit connector	Terminal		
B202	10	Seat lifting (rear) Operate	<p>SIIA0693J</p>
		Other than above	0 or 5

Is the inspection result normal?

YES >> GO TO 4

NO >> GO TO 2

#### 2. CHECK LIFTING SENSOR (REAR) CIRCUIT

## LIFTING SENSOR (REAR)

### < COMPONENT DIAGNOSIS >

1. Turn ignition switch OFF.
2. Disconnect driver seat control unit and lifting motor (rear).
3. Check the continuity between driver seat control unit harness connector and lifting motor (rear) harness connector.

Driver seat control unit connector	Terminal	Lifting motor (rear) connector	Terminal	Continuity
B202	10	B207	2	Yes
	16		3	
	31		1	

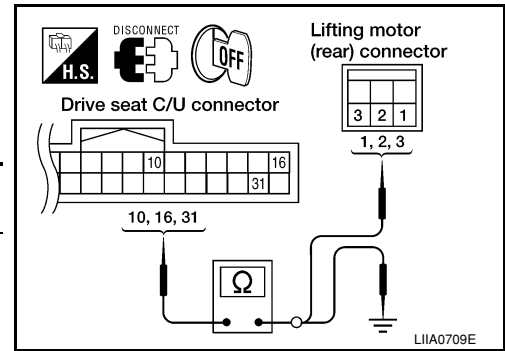

4. Check the continuity between driver seat control unit harness connector and ground.

Driver seat control unit connector	Terminal	Ground	Continuity
B202	10	Ground	No
	16		
	31		

Is the inspection result normal?

- YES >> GO TO 3  
 NO >> Repair or replace harness.

### 3. CHECK SEAT OPERATION

1. Connect driver seat control unit and lifting motor (rear) connector.
2. Check the seat operation [except lifting (rear) operation] with memory function.

Is the operation normal?

- YES >> Replace lifting motor (rear). (Built in seat slide cushion frame.)  
 NO >> Replace driver seat control unit.

### 4. CHECK INTERMITTENT INCIDENT

Refer to [GI-39. "Intermittent Incident"](#).

Is the inspection result normal?

- YES >> Replace driver seat control unit.  
 NO >> Repair or replace the malfunctioning part.



# TILT SENSOR

< COMPONENT DIAGNOSIS >

## TILT SENSOR

### Description

INFOID:000000001608149

- The pedal adjusting sensor is installed to the pedal assembly.
- The resistance of pedal adjusting sensor is changed according to the forward/backward position of pedal assembly.
- The terminal voltage of automatic drive positioner control unit will be changed according to a change of pedal adjusting sensor resistance. Automatic drive positioner control unit calculates the pedal assembly position from the voltage.

### Component Function Check

INFOID:000000001608150

#### 1. CHECK FUNCTION

1. Select "PEDAL SEN" in "Data monitor" mode with CONSULT-III.
2. Check the pedal sensor signal under the following condition.

Monitor item	Condition	Value
PEDAL SEN	Pedal position	Forward
		Backward
		0.5V
		4.5V

Is the indication normal?

YES >> INSPECTION END

NO >> Perform diagnosis procedure. Refer to [ADP-73, "Diagnosis Procedure"](#).

### Diagnosis Procedure

INFOID:000000001608151

#### 1. CHECK PEDAL ADJUSTING SENSOR SIGNAL

1. Turn ignition switch ON.
2. Check voltage between automatic drive positioner control unit harness connector and ground.

Terminal		(-)	Condition	Voltage (V) (Approx.)
(+)	Terminal			
Automatic drive positioner control unit				
M33	8	Ground	Pedal assembly position	
			Forward	0.5
			Backward	4.5

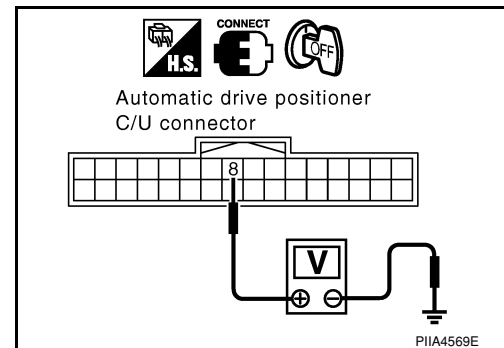

Is the inspection result normal?

YES >> GO TO 4

NO >> GO TO 2

#### 2. CHECK PEDAL ADJUSTING SENSOR CIRCUIT

# TILT SENSOR

## < COMPONENT DIAGNOSIS >

1. Turn ignition switch OFF.
2. Disconnect automatic drive positioner control unit and pedal adjusting sensor.
3. Check continuity between automatic drive positioner control unit harness connector and pedal adjusting sensor harness connector.

Automatic drive positioner control unit connector	Terminal	Pedal adjusting sensor connector	Terminal	Continuity
M33	8	E110	4	Yes
M34	33		3	
	41		5	

4. Check continuity between automatic drive positioner control unit harness connector and ground.

Automatic drive positioner control unit connector	Terminal	Ground	Continuity
M33	8	Ground	No
M34	33		
	41		

Is the inspection result normal?

- YES >> GO TO 3  
 NO >> Repair or replace harness.

### 3. CHECK DOOR MIRROR OPERATION

1. Connect automatic drive positioner control unit connector and pedal adjusting sensor connector.
2. Turn ignition switch ON.
3. Check door mirror operation with memory function.

Is the operation normal?

- YES >> Replace pedal adjusting sensor. (Built in pedal adjusting motor.)  
 NO >> Replace automatic drive positioner control unit.

### 4. CHECK INTERMITTENT INCIDENT

Refer to [GI-39. "Intermittent Incident"](#).

Is the inspection result normal?

- YES >> Replace automatic drive positioner control unit.  
 NO >> Repair or replace the malfunctioning part.

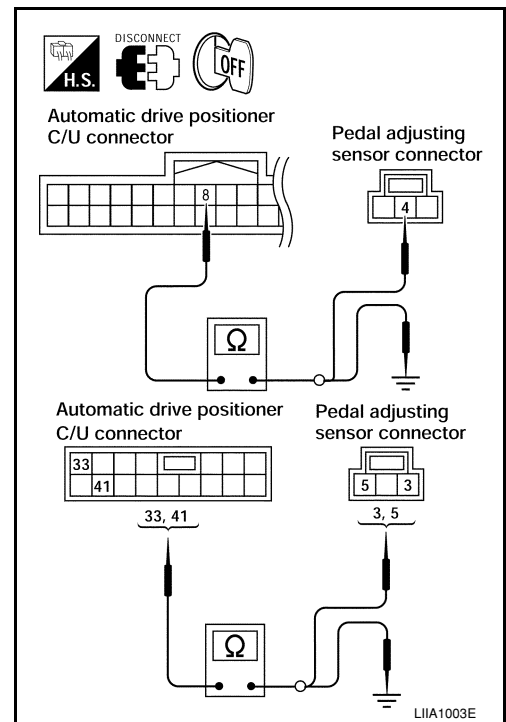

# MIRROR SENSOR

< COMPONENT DIAGNOSIS >

## MIRROR SENSOR

### DRIVER SIDE

#### DRIVER SIDE : Description

INFOID:000000001608155

- The mirror sensor LH is installed to the door mirror LH.
- The resistance of 2 sensors (horizontal and vertical) is changed when the door mirror LH is operated.
- Automatic drive positioner control unit calculates the door mirror position according to the change of the voltage of 2 sensor input terminals.

#### DRIVER SIDE : Component Function Check

INFOID:000000001608156

### 1. CHECK FUNCTION

1. Select "MIR/SEN LH U-D", "MIR/SEN LH R-L" in "Data monitor" with CONSULT-III.
2. Check mirror sensor (driver side) signal under the following condition.

Monitor item	Condition	Value
MIR/SEN LH U-D	Close to peak	3.4V
	Close to valley	0.6V
MIR/SEN LH R-L	Close to right edge	3.4V
	Close to left edge	0.6V

Is the indication normal?

YES >> INSPECTION END

NO >> Perform diagnosis procedure. Refer to [ADP-75. "DRIVER SIDE : Diagnosis Procedure"](#).

#### DRIVER SIDE : Diagnosis Procedure

INFOID:000000001608157

### 1. CHECK DOOR MIRROR LH SENSOR SIGNAL

1. Turn ignition switch ACC.
2. Check voltage between door mirror LH harness connector and ground.

Terminals		Condition	Voltage (V) (Approx.)
(+)	(-)		
Door mirror LH connector	Terminal	Door mirror LH	Close to peak
D4	7		Close to valley
	8		Close to right edge
	Ground		Close to left edge

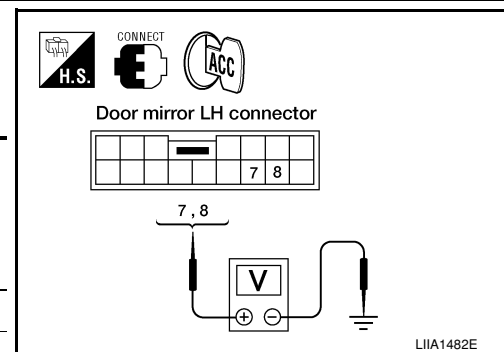

Is the inspection result normal?

YES >> GO TO 5.

NO >> GO TO 2.

### 2. CHECK DOOR MIRROR LH SENSOR CIRCUIT 1

# MIRROR SENSOR

## < COMPONENT DIAGNOSIS >

1. Turn ignition switch OFF.
2. Disconnect automatic drive positioner control unit and door mirror LH connector.
3. Check continuity between automatic drive positioner control unit harness connector and door mirror LH harness connector.

Automatic drive positioner control unit connector	Terminal	Door mirror LH connector	Terminal	Continuity
M33	6	D4	7	Yes
	22		8	

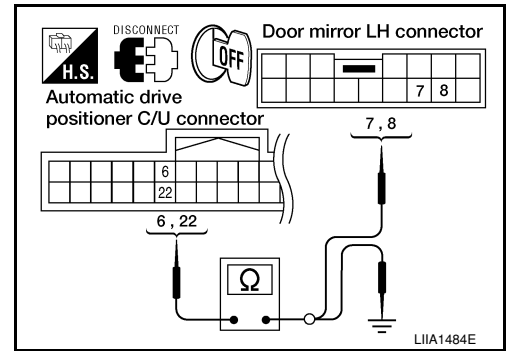

4. Check continuity between automatic drive positioner control unit harness connector and ground.

Automatic drive positioner control unit connector	Terminal	Ground	Continuity
M33	6	Ground	No
	22		

Is the inspection result normal?

YES >> GO TO 3.

NO >> Repair or replace harness.

## 3. CHECK DOOR MIRROR LH SENSOR CIRCUIT 2

1. Check continuity between automatic drive positioner control unit harness connector and door mirror LH harness connector.

Automatic drive positioner control unit connector	Terminal	Door mirror LH connector	Terminal	Continuity
M34	33	D4	5	Yes
	41		6	

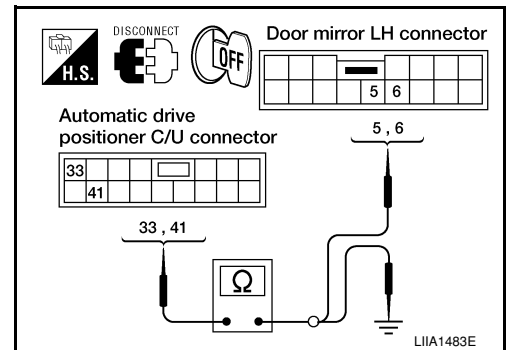

2. Check continuity between automatic drive positioner control unit harness connector and ground.

Automatic drive positioner control unit connector	Terminal	Ground	Continuity
M34	33	Ground	No
	41		

Is the inspection result normal?

YES >> GO TO 4.

NO >> Repair or replace harness.

## 4. CHECK PEDAL ADJUSTING OPERATION

1. Connect driver seat control unit connector and door mirror LH connector.
2. Turn ignition switch ON.
3. Check pedal adjusting operation with memory function.

Is the operation normal?

YES >> Replace door mirror sensor. (Built in door mirror LH.)

NO >> Replace automatic drive positioner control unit.

## 5. CHECK INTERMITTENT INCIDENT

Refer to [GI-39, "Intermittent Incident"](#).

Is the inspection result normal?

YES >> Replace automatic drive positioner control unit.

NO >> Repair or replace the malfunctioning part.

# MIRROR SENSOR

< COMPONENT DIAGNOSIS >

## PASSENGER SIDE

### PASSENGER SIDE : Description

INFOID:000000001608158

- The mirror sensor RH is installed to the door mirror RH.
- The resistance of 2 sensors (horizontal and vertical) is changed when the door mirror RH is operated.
- Automatic drive positioner control unit calculates the door mirror position according to the change of the voltage of 2 sensor input terminals.

### PASSENGER SIDE : Component Function Check

INFOID:000000001608159

#### 1. CHECK FUNCTION

1. Select "MIR/SEN RH U-D", "MIR/SEN RH R-L" in "Data monitor" with CONSULT-III.
2. Check the mirror sensor RH signal under the following conditions.

Monitor item	Condition	Value
MIR/SEN RH U-D	Close to peak	3.4V
	Close to valley	0.6V
MIR/SEN RH R-L	Close to right edge	3.4V
	Close to left edge	0.6V

Is the indication normal?

YES >> INSPECTION END

NO >> Perform diagnosis procedure. Refer to [ADP-77. "PASSENGER SIDE : Diagnosis Procedure"](#).

### PASSENGER SIDE : Diagnosis Procedure

INFOID:000000001608160

#### 1. CHECK DOOR MIRROR RH SENSOR SIGNAL

1. Turn ignition switch ACC.
2. Check voltage between door mirror RH harness connector and ground.

Terminals		(-)	Condition	Voltage (V) (Approx.)	
(+)	Terminal				
Door mirror RH con- nector		Ground	Door mirror RH	Close to peak	3.4
	7		Close to valley	0.6	
	8		Close to right edge	3.4	
			Close to left edge	0.6	

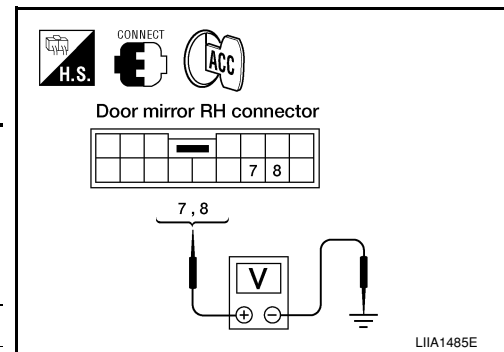

Is the inspection result normal?

YES >> GO TO 5

NO >> GO TO 2

#### 2. CHECK DOOR MIRROR RH SENSOR HARNESS CONTINUITY

# MIRROR SENSOR

## < COMPONENT DIAGNOSIS >

1. Turn ignition switch OFF.
2. Disconnect automatic drive positioner control unit and door mirror RH.
3. Check continuity between automatic drive positioner control unit harness connector and door mirror RH harness connector.

Automatic drive positioner control unit connector	Terminal	Door mirror RH connector	Terminal	Continuity
M33	5	D107	7	Yes
	21		8	

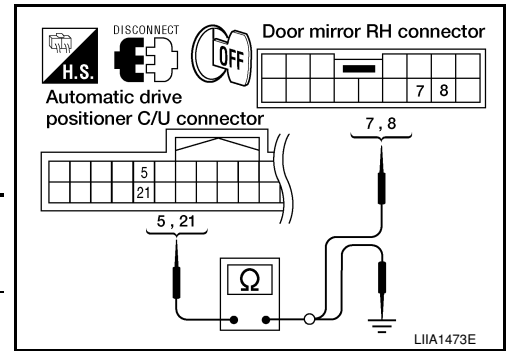

4. Check continuity between automatic drive positioner control unit harness connector and ground.

Automatic drive positioner control unit connector	Terminal	Ground	Continuity
M33	5	Ground	No
	21		

Is the inspection result normal?

YES >> GO TO 3

NO >> Repair or replace harness.

## 3. CHECK DOOR MIRROR RH SENSOR POWER SUPPLY CIRCUIT

1. Check continuity between automatic drive positioner control unit harness connector and door mirror RH harness connector.

Automatic drive positioner control unit connector	Terminal	Door mirror RH connector	Terminal	Continuity
M34	33	D107	5	Yes
	41		6	

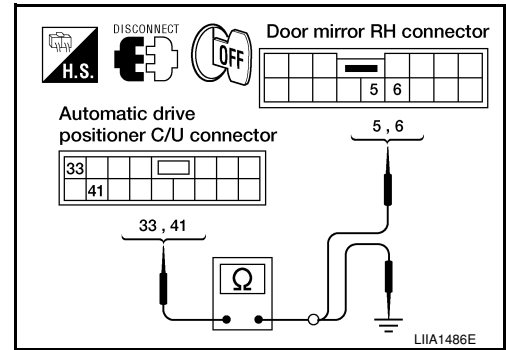

2. Check continuity between automatic drive positioner control unit harness connector and ground.

Automatic drive positioner control unit connector	Terminal	Ground	Continuity
M34	33	Ground	No
	41		

Is the inspection result normal?

YES >> GO TO 4

NO >> Repair or replace harness.

## 4. CHECK PEDAL ADJUSTING OPERATION

1. Connect driver seat control unit connector and door mirror RH connector.
2. Turn ignition switch ON.
3. Check pedal adjusting operation with memory function.

Is the operation normal?

YES >> Replace door mirror sensor. (Built in door mirror RH.)

NO >> Replace automatic drive positioner control unit.

## 5. CHECK INTERMITTENT INCIDENT

Refer to [GI-39, "Intermittent Incident"](#).

Is the inspection result normal?

YES >> Replace automatic drive positioner control unit.

NO >> Repair or replace the malfunctioning part.

# SLIDING MOTOR

< COMPONENT DIAGNOSIS >

## SLIDING MOTOR

### Description

INFOID:000000001608161

- The sliding motor LH is installed to the seat cushion frame.
- The sliding motor LH is installed with the driver seat control unit.
- The seat is slid forward/backward by changing the rotation direction of sliding motor LH.

### Component Function Check

INFOID:000000001608162

#### 1. CHECK FUNCTION

1. Select "SEAT SLIDE" in "Active test" mode with CONSULT-III.
2. Check the sliding motor LH operation.

Test Item		Description	
SEAT SLIDE	OFF	Seat sliding	Stop
	FR		Forward
	RR		Backward

Is the operation of relevant parts normal?

YES >> INSPECTION END

NO >> Perform diagnosis procedure. Refer to [ADP-79, "Diagnosis Procedure"](#).

### Diagnosis Procedure

INFOID:000000001608163

#### 1. CHECK SLIDING MOTOR LH POWER SUPPLY

1. Turn the ignition switch ACC.
2. Perform "Active test" ("SEAT SLIDE") with CONSULT-III
3. Check voltage between driver seat control unit harness connector and ground.

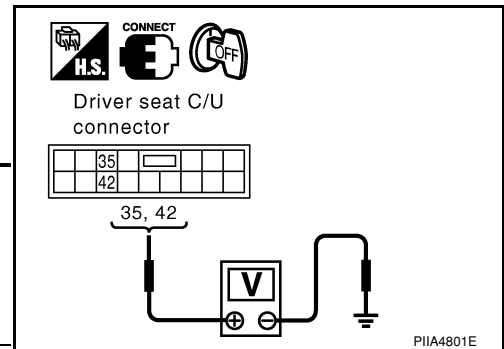

Terminal (+)		Terminal (-)	Test Item	Voltage (V) (Approx.)
Driver seat control unit connector	Terminal			
B203	35	Ground	SEAT SLIDE OFF	0
			FR (forward)	Battery voltage
			RR (backward)	0
	42		SEAT SLIDE OFF	0
			FR (forward)	0
			RR (backward)	Battery voltage

Is the inspection result normal?

YES >> Replace sliding motor LH. (Built in seat slide cushion frame.)

NO >> GO TO 2

#### 2. CHECK SLIDING MOTOR LH CIRCUIT

# SLIDING MOTOR

## < COMPONENT DIAGNOSIS >

1. Turn ignition switch OFF.
2. Disconnect driver seat control unit and sliding motor LH.
3. Check continuity between driver seat control unit harness connector and sliding motor LH harness connector.

Driver seat control unit connector	Terminal	Sliding motor LH connector	Terminal	Continuity
B203	35	B204	6	Yes
	42		4	

4. Check continuity between driver seat control unit harness connector and ground.

Driver seat control unit connector	Terminal	Ground	Continuity
B203	35	Ground	No
	42		

Is the inspection result normal?

- YES >> GO TO 3  
 NO >> Repair or replace harness.

### 3. CHECK INTERMITTENT INCIDENT

Refer to [GI-39, "Intermittent Incident"](#).

Is the inspection result normal?

- YES >> Replace driver seat control unit.  
 NO >> Repair or replace the malfunctioning part.

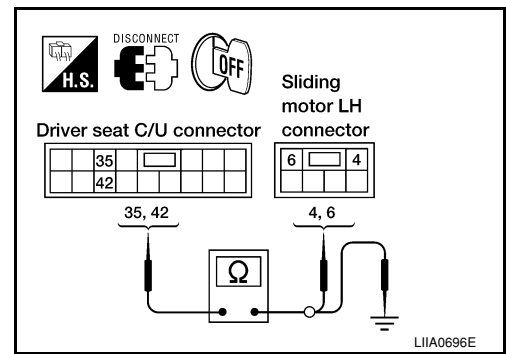



# RECLINING MOTOR

< COMPONENT DIAGNOSIS >

## RECLINING MOTOR

### Description

INFOID:000000001608164

- The reclining motor LH is installed to the seat back frame.
- The reclining motor LH is activated with the driver seat control unit.
- The seatback is reclined forward/backward by changing the rotation direction of reclining motor LH.

### Component Function Check

INFOID:000000001608165

#### 1. CHECK FUNCTION

1. Select "SEAT RECLINING" in "Active test" mode with CONSULT-III.
2. Check the reclining motor LH operation.

Test Item		Description	
SEAT RECLINING	OFF	Seat reclining	Stop
	FR		Forward
	RR		Backward

Is the operation of relevant parts normal?

YES >> INSPECTION END

NO >> Perform diagnosis procedure. Refer to [ADP-81, "Diagnosis Procedure"](#).

### Diagnosis Procedure

INFOID:000000001608166

#### 1. CHECK RECLINING MOTOR LH POWER SUPPLY

1. Turn the ignition switch ACC.
2. Perform "Active test" ("SEAT RECLINING") with CONSULT-III
3. Check voltage between driver seat control unit harness connector and ground.

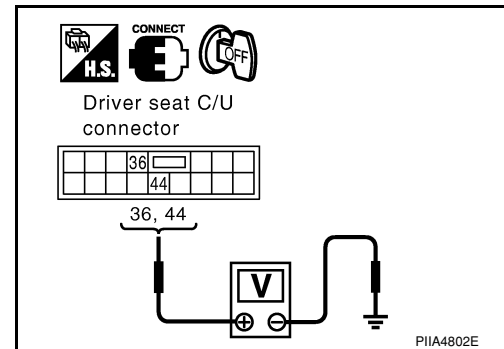

Terminal (+)		Terminal (-)	Test Item	Voltage (V) (Approx.)
Driver seat control unit connector	Terminal			
B203	36	Ground	SEAT RECLINING OFF	0
			SEAT RECLINING FR (forward)	Battery voltage
			SEAT RECLINING RR (backward)	0
	44		SEAT RECLINING OFF	0
			SEAT RECLINING FR (forward)	0
			SEAT RECLINING RR (backward)	Battery voltage

Is the inspection result normal?

YES >> Replace reclining motor LH. (Built in seat back frame.)

NO >> GO TO 2

#### 2. CHECK RECLINING MOTOR LH CIRCUIT

# RECLINING MOTOR

## < COMPONENT DIAGNOSIS >

1. Turn ignition switch OFF.
2. Disconnect driver seat control unit connector and recling motor LH.
3. Check continuity between driver seat control unit harness connector and reclining motor harness connector.

Driver seat control unit connector	Terminal	Reclining motor LH connector	Terminal	Continuity
B203	36	B205	4	Yes
	44		3	

4. Check continuity between driver seat control unit harness connector and ground.

Driver seat control unit connector	Terminal	Ground	Continuity
B203	36	Ground	No
	44		

Is the inspection result normal?

- YES >> GO TO 3  
 NO >> Repair or replace harness.

### 3. CHECK INTERMITTENT INCIDENT

Refer to [GI-39. "Intermittent Incident"](#).

Is the inspection result normal?

- YES >> Replace driver seat control unit.  
 NO >> Repair or replace the malfunctioning part.

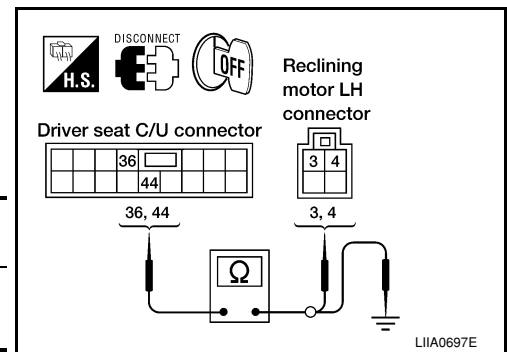

# LIFTING MOTOR (FRONT)

< COMPONENT DIAGNOSIS >

## LIFTING MOTOR (FRONT)

### Description

INFOID:000000001608167

- The lifting motor (front) is installed to the seat slide cushion frame.
- The lifting motor (front) is activated with the driver seat control unit.
- The lifter (front) is moved upward/downward by changing the rotation direction of lifting motor (front).

### Component Function Check

INFOID:000000001608168

#### 1. CHECK FUNCTION

1. Select "SEAT LIFTER FR" in "Active test" mode with CONSULT-III.
2. Check the lifting motor (front) operation.

Test Item		Description	
SEAT LIFTER FR	OFF	Seat lifting (front)	Stop
	UP		Upward
	DWN		Downward

Is the operation of relevant parts normal?

YES >> INSPECTION END

NO >> Perform diagnosis procedure. Refer to [ADP-83, "Diagnosis Procedure"](#).

### Diagnosis Procedure

INFOID:000000001608169

#### 1. CHECK LIFTING MOTOR (FRONT) POWER SUPPLY

1. Turn the ignition switch ACC.
2. Perform "Active test" ("SEAT LIFTER FR") with CONSULT-III.
3. Check voltage between driver seat control unit harness connector and ground.

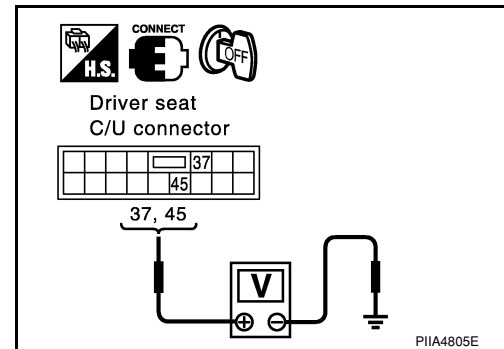

Terminal (+)		Terminal (-)	Test Item	Voltage (V) (Approx.)	
Driver seat control unit connector	Terminal				
B203	37	Ground	SEAT LIFTER FR	OFF	0
			UP	0	
			DWN (down)	Battery voltage	
	45		SEAT LIFTER FR	OFF	0
			UP	Battery voltage	
			DWN (down)	0	

Is the inspection result normal?

YES >> Replace lifting motor (front). (Built in seat slide cushion frame.)

NO >> GO TO 2

#### 2. CHECK LIFTING MOTOR (FRONT) CIRCUIT

# LIFTING MOTOR (FRONT)

## < COMPONENT DIAGNOSIS >

1. Turn ignition switch OFF.
2. Disconnect driver seat control unit and lifting motor (front) connectors.
3. Check continuity between driver seat control unit harness connector and lifting motor (front) harness connector.

Driver seat control unit connector	Terminal	Lifting motor (front) connector	Terminal	Continuity
B203	37	B206	6	Yes
	45		4	

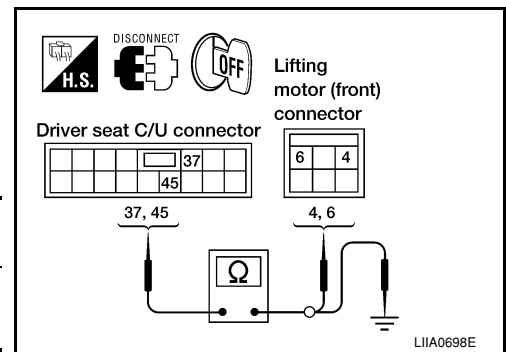

4. Check continuity between driver seat control unit harness connector and ground.

Driver seat control unit connector	Terminal	Ground	Continuity
B203	37	Ground	No
	45		

Is the inspection result normal?

- YES >> GO TO 3  
 NO >> Repair or replace harness.

### 3. CHECK INTERMITTENT INCIDENT

Refer to [GI-39. "Intermittent Incident"](#).

Is the inspection result normal?

- YES >> Replace driver seat control unit.  
 NO >> Repair or replace the malfunctioning part.

# LIFTING MOTOR (REAR)

< COMPONENT DIAGNOSIS >

## LIFTING MOTOR (REAR)

### Description

INFOID:000000001608170

- The lifting motor (rear) is installed to the seat slide cushion frame.
- The lifting motor (rear) is activated with the driver seat control unit.
- The seat lifter (rear) is moved upward/downward by changing the rotation direction of lifting motor (rear).

### Component Function Check

INFOID:000000001608171

#### 1. CHECK FUNCTION

1. Select "SEAT LIFTER RR" in "Active test" mode with CONSULT-III.
2. Check the lifting motor (rear) operation.

Test Item		Description	
SEAT LIFTER RR	OFF	Seat lifting (rear)	Stop
	UP		Upward
	DWN		Downward

Is the operation of relevant parts normal?

YES >> INSPECTION END

NO >> Perform diagnosis procedure. Refer to [ADP-85. "Diagnosis Procedure"](#).

### Diagnosis Procedure

INFOID:000000001608172

#### 1. CHECK LIFTING MOTOR (REAR) POWER SUPPLY

1. Turn the ignition switch OFF.
2. Perform "Active test" ("SEAT LIFTER RR") with CONSULT-III
3. Check voltage between driver seat control unit harness connector and ground.

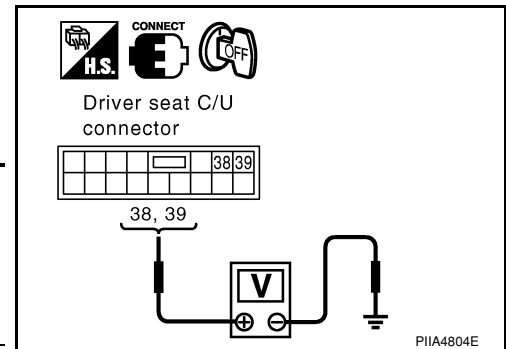

Terminal (+)		Terminal (-)	Test Item	Voltage (V) (Approx.)
Driver seat control unit connector	Terminal			
B203	38	Ground	SEAT LIFTER RR OFF	0
			SEAT LIFTER RR UP	Battery voltage
			SEAT LIFTER RR DWN (down)	0
	39		SEAT LIFTER RR OFF	0
			SEAT LIFTER RR UP	0
			SEAT LIFTER RR DWN (down)	Battery voltage

Is the inspection result normal?

YES >> Replace lifting motor (rear). (Built in seat slide cushion frame.)

NO >> GO TO 2

#### 2. CHECK LIFTING MOTOR (REAR) CIRCUIT

## LIFTING MOTOR (REAR)

### < COMPONENT DIAGNOSIS >

1. Disconnect driver seat control unit connector and lifting motor (rear).
2. Check continuity between driver seat control unit harness connector and lifting motor (rear) harness connector.

Driver seat control unit connector	Terminal	Lifting motor (rear) connector	Terminal	Continuity
B203	38	B207	6	Yes
	39		4	

3. Check continuity between driver seat control unit harness connector and ground.

Driver seat control unit connector	Terminal	Ground	Continuity
B203	38	Ground	No
	39		

Is the inspection result normal?

- YES >> GO TO 3  
 NO >> Repair or replace harness.

### 3. CHECK INTERMITTENT INCIDENT

Refer to [GI-39, "Intermittent Incident"](#).

Is the inspection result normal?

- YES >> Replace driver seat control unit.  
 NO >> Repair or replace the malfunctioning part.

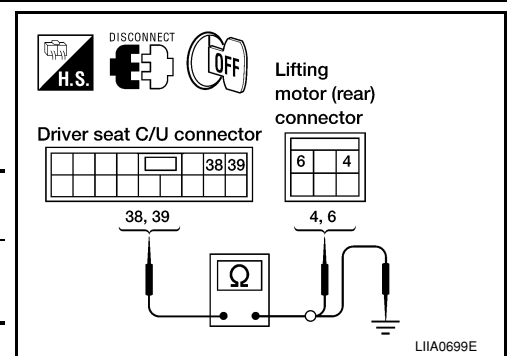

# TILT MOTOR

< COMPONENT DIAGNOSIS >

## TILT MOTOR

### Description

INFOID:000000001608173

- The pedal adjusting motor is installed to the pedal assembly.
- The pedal adjusting motor is activated with the automatic drive positioner control unit.
- The pedal assembly is adjusted forward/backward by changing the rotation direction of pedal adjusting motor.

### Component Function Check

INFOID:000000001608174

#### 1. CHECK FUNCTION

1. Select "ADJ PEDAL MOTOR" in "Active test" mode with CONSULT-III.
2. Check the pedal adjusting motor operation.

Test item		Description	
ADJ PEDAL MOTOR	OFF	Pedal adjusting motor	Stop
	FR		Forward
	RR		Backward

Is the operation of relevant parts normal?

YES >> INSPECTION END

NO >> Perform diagnosis procedure. Refer to [ADP-87, "Diagnosis Procedure"](#).

### Diagnosis Procedure

INFOID:000000001608175

#### 1. CHECK PEDAL ADJUSTING MOTOR POWER SUPPLY

1. Turn the ignition switch OFF.
2. Perform "Active test" ("ADJ PEDAL MOTOR") with CONSULT-III.
3. Check voltage between automatic drive positioner control unit harness connector and ground.

Terminal (+)		Terminal (-)	Test Item	Voltage (V) (Approx.)	
Automatic drive positioner control unit connector	Terminal				
M34	37	Ground	ADJ PED-AL MOTOR	OFF	0
			RR (backward)	0	
			FR (forward)	Battery voltage	
	45		ADJ PED-AL MOTOR	OFF	0
			RR (backward)	Battery voltage	
			FR (forward)	0	

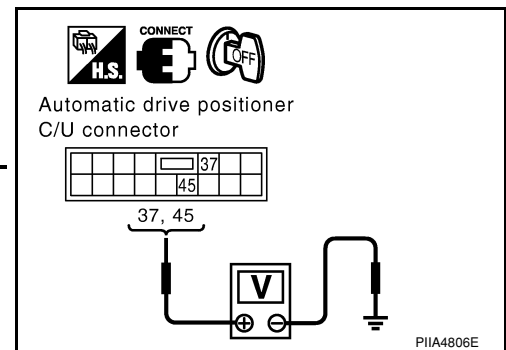

Is the inspection result normal?

YES >> Replace pedal adjusting motor.

NO >> GO TO 2

#### 2. CHECK PEDAL ADJUSTING MOTOR CIRCUIT

# TILT MOTOR

## < COMPONENT DIAGNOSIS >

1. Disconnect automatic drive positioner control unit and pedal adjusting motor.
2. Check continuity between automatic drive positioner control unit harness connector and pedal adjusting motor harness connector.

Automatic drive positioner control unit connector	Terminal	Pedal adjusting motor connector	Terminal	Continuity
M34 (A)	37	E109 (B)	1	Yes
	45		2	

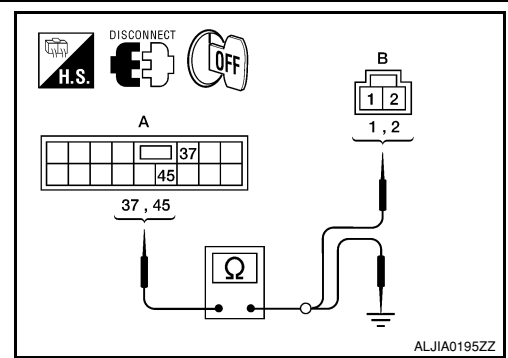

3. Check continuity between automatic drive positioner control unit harness connector and ground.

Automatic drive positioner control unit connector	Terminal	Ground	Continuity
M34 (A)	37	Ground	No
	45		

Is the inspection result normal?

- YES >> GO TO 3  
 NO >> Repair or replace harness.

### 3. CHECK INTERMITTENT INCIDENT

Refer to [GI-39. "Intermittent Incident"](#).

Is the inspection result normal?

- YES >> Replace automatic drive positioner control unit.  
 NO >> Repair or replace the malfunctioning part.



# DOOR MIRROR MOTOR

< COMPONENT DIAGNOSIS >

## DOOR MIRROR MOTOR

### Description

INFOID:000000001608179

It makes mirror face operate from side to side and up and down with the electric power that automatic drive positioner control unit supplies.

### Component Function Check

INFOID:000000001608180

#### 1. CHECK DOOR MIRROR MOTOR FUNCTION

Check the operation with "MIRROR MOTOR RH" and "MIRROR MOTOR LH" in "ACTIVE TEST" mode with CONSULT-III

Refer to [ADP-24, "CONSULT-III Function"](#).

Is the inspection result normal?

YES >> Door mirror motor function is OK.

NO >> Refer to [ADP-89, "Diagnosis Procedure"](#).

### Diagnosis Procedure

INFOID:000000001608181

#### 1. CHECK DOOR MIRROR MOTOR INPUT SIGNAL

1. Turn ignition switch ON.
2. Check voltage between door mirror connector and ground.

Terminals		(-)	Door mirror remote control switch condition	Voltage (V) (Approx.)
(+)	Terminal			
Door mirror connector	1	Ground	UP	Battery voltage
			Other than above	0
	2		LEFT	Battery voltage
			Other than above	0
	3		DOWN / RIGHT	Battery voltage
			Other than above	0

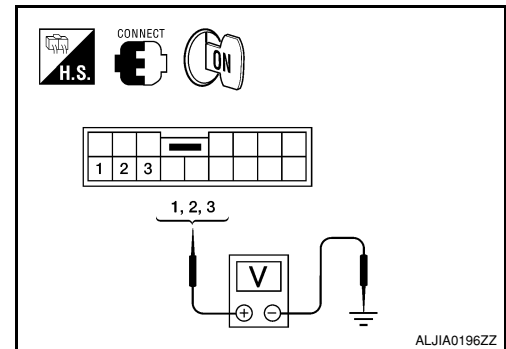

Is the inspection result normal?

YES >> Refer to [ADP-91, "Component Inspection"](#).

NO >> GO TO 2

#### 2. CHECK HARNESS CONTINUITY

1. Turn ignition switch OFF.
2. Disconnect automatic drive positioner control unit connector and door mirror.
3. Check continuity between automatic drive positioner control unit connector and door mirror connector.

Door mirror LH

Automatic drive positioner control unit connector	Terminal	Door mirror LH connector	Terminal	Continuity
M33	16	D4	3	Yes
	31		1	
	32		2	

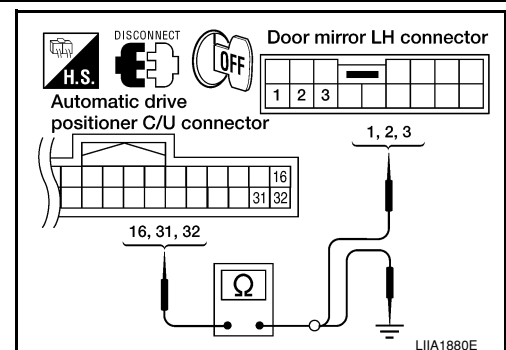

# DOOR MIRROR MOTOR

## < COMPONENT DIAGNOSIS >

Door mirror RH

Automatic drive positioner control unit connector	Terminal	Door mirror RH connector	Terminal	Continuity
M33	14	D107	1	Yes
	15		2	
	30		3	

4. Check continuity between automatic drive positioner control unit connector and ground.

Door mirror LH

Automatic drive positioner control unit connector	Terminal	Ground	Continuity
M33	16	Ground	No
	31		
	32		

Door mirror RH

Automatic drive positioner control unit connector	Terminal	Ground	Continuity
M33	14	Ground	No
	15		
	30		

Is the inspection result normal?

YES >> GO TO 3

NO >> Repair or replace harness.

### 3. CHECK AUTOMATIC DRIVE POSITIONER CONTROL UNIT OUTPUT SIGNAL

1. Connect automatic drive positioner control unit.
2. Turn ignition switch ON.
3. Check voltage between automatic drive positioner control unit connector and ground.

Door mirror LH

Terminals		(-)	Mirror switch condition	Voltage (V) (Approx.)
(+)	Terminal			
Automatic drive positioner control unit connector	16	Ground	DOWN / RIGHT	Battery voltage
			Other than above	0
	31		UP	Battery voltage
			Other than above	0
	32		LEFT	Battery voltage
			Other than above	0

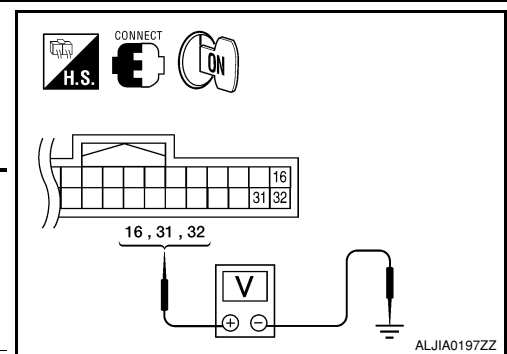
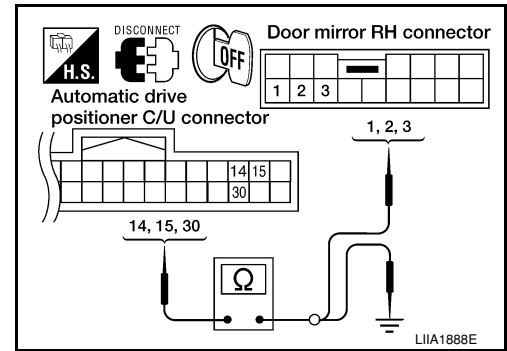

# DOOR MIRROR MOTOR

## < COMPONENT DIAGNOSIS >

Door mirror RH				
Terminals		(-)	Mirror switch condition	Voltage (V) (Approx.)
(+)	Terminal			
Automatic drive positioner control unit connector  M33	14	Ground	UP	Battery voltage
			Other than above	0
	15		LEFT	Battery voltage
			Other than above	0
	30		DOWN / RIGHT	Battery voltage
			Other than above	0

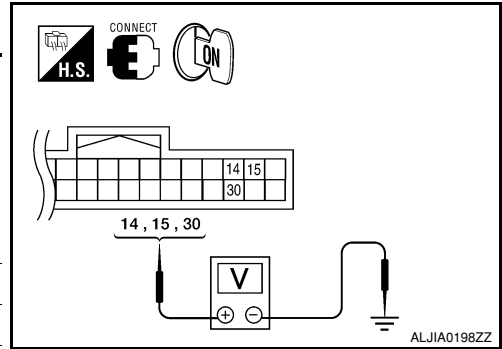

Is the inspection result normal?

- YES >> GO TO 4.
- NO >> Replace automatic drive positioner control unit.

### 4. CHECK DOOR MIRROR MOTOR

Check door mirror motor.  
Refer to [ADP-91, "Component Inspection"](#).

Is the inspection result normal?

- YES >> Refer to [GI-39, "Intermittent Incident"](#).
- NO >> Replace door mirror. Refer to [MIR-20, "Door Mirror Assembly"](#).

## Component Inspection

INFOID:000000001608182

### 1. CHECK DOOR MIRROR MOTOR-I

Check that door mirror motor does not trap foreign objects and does not have any damage.  
Refer to [MIR-20, "Door Mirror Assembly"](#).

Is the inspection result normal?

- YES >> GO TO 2
- NO >> Replace door mirror. Refer to [MIR-20, "Door Mirror Assembly"](#).

### 2. CHECK DOOR MIRROR MOTOR-II

1. Turn ignition switch OFF.
2. Disconnect door mirror.
3. Apply 12V to each power supply terminal of door mirror motor.

Door mirror connector	Terminal		Operational direction
	(+)	(-)	
D4 (LH) D107 (RH)	3	2	RIGHT
	2	3	LEFT
	1	3	UP
	3	1	DOWN

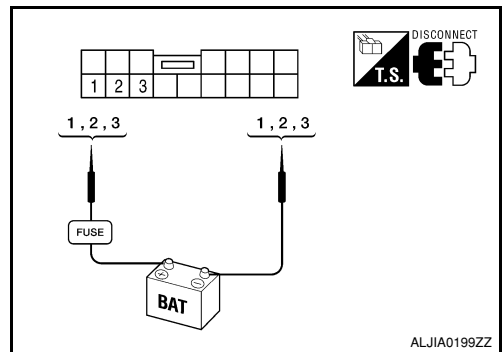

Is the inspection result normal?

- YES >> INSPECTION END.
- NO >> Replace door mirror. Refer to [MIR-20, "Door Mirror Assembly"](#).

# SEAT MEMORY INDICATOR LAMP

< COMPONENT DIAGNOSIS >

## SEAT MEMORY INDICATOR LAMP

### Description

INFOID:000000001608186

- Memory switch is equipped on the seat memory switch installed to the driver side door trim. The operation signal is inputted to the automatic drive positioner control unit when the memory switch is operated.
- The status of automatic drive positioner system can be checked according to the illuminating/flashing status.

### Component Function Check

INFOID:000000001608187

#### 1. CHECK FUNCTION

1. Select "MEMORY SW INDCTR" in "Active test" mode with CONSULT-III.
2. Check the memory indicator operation.

Test item		Description	
MEMORY SW INDCTR	OFF	Memory switch indicator	OFF
	ON-1		Indicator 1: ON
	ON-2		Indicator 2: ON

Is the operation of relevant parts normal?

YES >> INSPECTION END

NO >> Perform diagnosis procedure. Refer to [ADP-92. "Diagnosis Procedure"](#).

### Diagnosis Procedure

INFOID:000000001608188

#### 1. CHECK SEAT MEMORY INDICATOR CIRCUIT

1. Turn ignition switch OFF.
2. Disconnect automatic drive positioner control unit and seat memory switch.
3. Check continuity between automatic drive positioner control unit harness connector and seat memory switch harness connector.

Automatic drive positioner control unit connector	Terminal	Seat memory switch connector	Terminal	Continuity
M33	12	D5	6	Yes
	13		7	

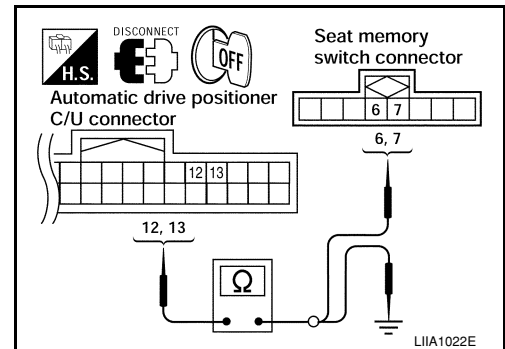

4. Check continuity between automatic drive positioner control unit harness connector and ground.

Automatic drive positioner connector	Terminal	Ground	Continuity
M33	12	Ground	No
	13		

Is the inspection result normal?

YES >> GO TO 2

NO >> Repair or replace harness.

#### 2. CHECK MEMORY INDICATOR POWER SUPPLY

# SEAT MEMORY INDICATOR LAMP

## < COMPONENT DIAGNOSIS >

Check voltage between seat memory switch harness connector and ground.

Seat memory switch connector	Terminals		Voltage (V) (Approx.)
	(+)	(-)	
D5	5	Ground	Battery voltage

Is the inspection result normal?

YES >> GO TO 3

NO >> Check the following.

- Fuse
- Harness for open or short between memory indicator and fuse.

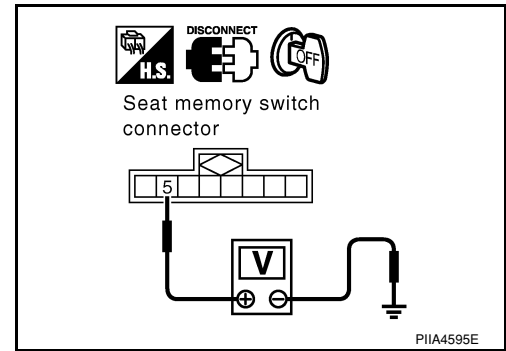

### 3. CHECK MEMORY INDICATOR

Refer to [ADP-93. "Component Inspection"](#).

Is the inspection result normal?

YES >> GO TO 4

NO >> Replace seat memory switch.

### 4. CHECK INTERMITTENT INCIDENT

Refer to [GI-39. "Intermittent Incident"](#).

Is the inspection result normal?

YES >> Replace automatic drive positioner control unit.

NO >> Repair or replace the malfunctioning part.

## Component Inspection

INFOID:000000001608189

### 1. CHECK SEAT MEMORY INDICATOR

1. Disconnect seat memory switch.
2. Check continuity between seat memory switch terminals.

Terminal		Continuity
Seat memory switch		
(+)	(-)	
6	5	Yes
7		

Is the inspection result normal?

YES >> INSPECTION END

NO >> Replace seat memory switch.

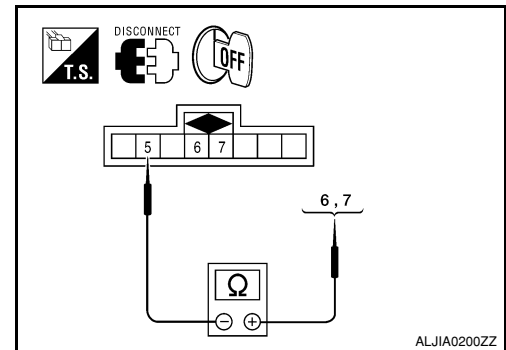

A  
B  
C  
D  
E  
F  
G  
H  
I  
K  
L  
M  
N  
O  
P

ADP

# DRIVER SEAT CONTROL UNIT

< ECU DIAGNOSIS >

## ECU DIAGNOSIS

### DRIVER SEAT CONTROL UNIT

Reference Value

INFOID:000000001608190

VALUES ON THE DIAGNOSIS TOOL

CONSULT-III MONITOR ITEM

Monitor Item	Condition	Value/Status	
SET SW	Set switch	Push	ON
		Release	OFF
MEMORY SW1	Memory switch 1	Push	ON
		Release	OFF
MEMORY SW2	Memory switch 2	Push	ON
		Release	OFF
SLIDE SW-FR	Sliding switch (front)	Operate	ON
		Release	OFF
SLIDE SW-RR	Sliding switch (rear)	Operate	ON
		Release	OFF
RECLN SW-FR	Reclining switch (front)	Operate	ON
		Release	OFF
RECLN SW-RR	Reclining switch (rear)	Operate	ON
		Release	OFF
LIFT FR SW-UP	Lifting switch front (up)	Operate	ON
		Release	OFF
LIFT FR SW-DN	Lifting switch front (down)	Operate	ON
		Release	OFF
LIFT RR SW-UP	Lifting switch rear (up)	Operate	ON
		Release	OFF
LIFT RR SW-DN	Lifting switch rear (down)	Operate	ON
		Release	OFF
MIR CON SW-UP	Mirror switch	Up	ON
		Other than above	OFF
MIR CON SW-DN	Mirror switch	Down	ON
		Other than above	OFF
MIR CON SW-RH	Mirror switch	Right	ON
		Other than above	OFF
MIR CON SW-LH	Mirror switch	Left	ON
		Other than above	OFF
MIR CHNG SW-R	Changeover switch	Right	ON
		Other than above	OFF
MIR CHNG SW-L	Changeover switch	Left	ON
		Other than above	OFF
PEDAL SW-FR	Pedal adjusting switch	Forward	ON
		Other than above	OFF
PEDAL SW-RR	Pedal adjusting switch	Backward	ON
		Other than above	OFF

# DRIVER SEAT CONTROL UNIT

## < ECU DIAGNOSIS >

Monitor Item	Condition		Value/Status
DETENT SW	AT selector lever	P position	OFF
		Other than above	ON
STARTER SW	Ignition position	Cranking	ON
		Other than above	OFF
SLIDE PULSE	Seat sliding	Forward	The numeral value decreases
		Backward	The numeral value increases
		Other than above	No change to numeral value
RECLN PULSE	Seat reclining	Forward	The numeral value decreases
		Backward	The numeral value increases
		Other than above	No change to numeral value
LIFT FR PULSE	Seat lifter (front)	Up	The numeral value decreases
		Down	The numeral value increases
		Other than above	No change to numeral value
LIFT RR PULSE	Seat lifter (rear)	Up	The numeral value decreases
		Down	The numeral value increases
		Other than above	No change to numeral value
MIR/SEN RH U-D	Door mirror (passenger side)	Close to peak	3.4
		Close to valley	0.6
MIR/SEN RH R-L	Door mirror (passenger side)	Close to left edge	3.4
		Close to right edge	0.6
MIR/SEN LH U-D	Door mirror (driver side)	Close to peak	3.4
		Close to valley	0.6
MIR/SEN LH R-L	Door mirror (driver side)	Close to left edge	0.6
		Close to right edge	3.4
PEDAL SEN	pedal position	Forward	0.5
		Backward	4.5

## TERMINAL LAYOUT

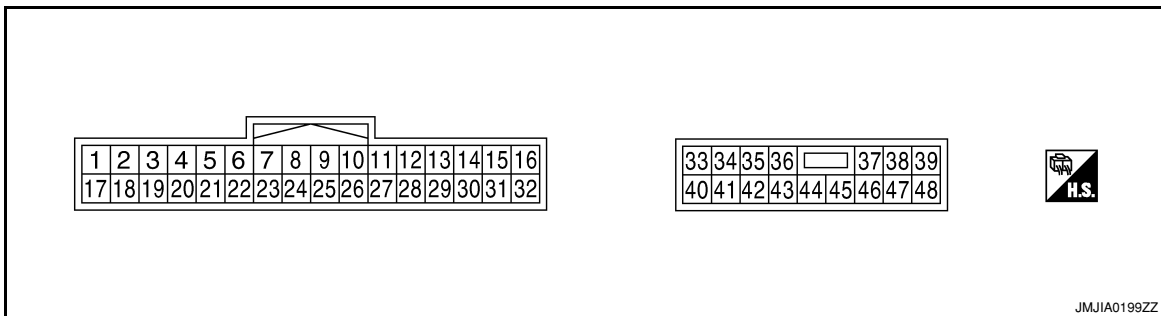

## PHYSICAL VALUES

# DRIVER SEAT CONTROL UNIT

## < ECU DIAGNOSIS >

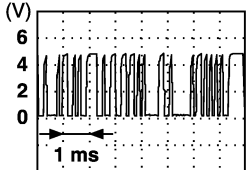
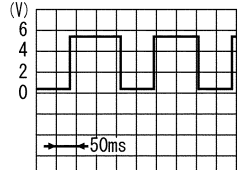
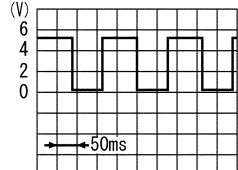
Terminal No.		Wire color	Description		Condition	Voltage (V) (Approx)
+	-		Signal name	Input/Output		
1	Ground	L	UART LINE (RX)	Input	Ignition switch ON	 PIIA4813E
3	—	L	CAN-H	—	—	—
6	Ground	O	Ignition switch (START)	Input	Ignition switch	OFF 0
					START	Battery voltage
9	Ground	L/R	Reclining sensor signal	Input	Seat reclining	 SIIA0692J
					Operate	0 or 5
10	Ground	W	Lifting sensor (rear) signal	Input	Seat lifting (rear)	 SIIA0693J
					Operate	0 or 5
11	Ground	R/B	Sliding switch backward signal	Input	Sliding switch	Operate (backward) 0
					Release	Battery voltage
12	Ground	O/B	Reclining switch backward signal	Input	Reclining switch	Operate (backward) 0
					Release	Battery voltage
13	Ground	L/B	Lifting switch (front) down signal	Input	Lifting switch (front)	Operate (down) 0
					Release	Battery voltage
14	Ground	GW	Lifting switch (rear) down signal	Input	Lifting switch (rear)	Operate (down) 0
					Release	Battery voltage
15	Ground	L/Y	Pedal switch backward signal	Input	Pedal switch	Operate (backward) 0
					Release	Battery voltage
16	Ground	W	Sensor power supply	Output	—	5



# DRIVER SEAT CONTROL UNIT

## < ECU DIAGNOSIS >

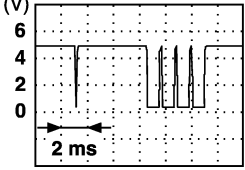
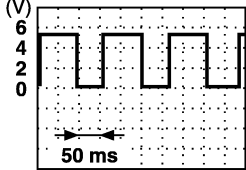
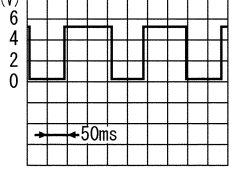
Terminal No.		Wire color	Description		Condition	Voltage (V) (Approx)	
+	-		Signal name	Input/Output			
17	Ground	W	UART LINE (TX)	Output	Ignition switch ON	 PIIA4814E	
19	—	P	CAN-L	—	—	—	
21	Ground	L/R	A/T device (park position switch)	Input	A/T selector lever	P position	0
						Except P position	Battery voltage
24	Ground	Y/G	Sliding sensor signal	Input	Seat sliding	Operate	 PIIA3277E
						Stop	0 or 5
25	Ground	LG	Lifting sensor (front) signal	Input	Seat lifting (front)	Operate	 SIIA0691J
						Stop	0 or 5
26	Ground	P/B	Sliding switch forward signal	Input	Sliding switch	Operate (forward)	0
						Release	Battery voltage
27	Ground	G/B	Reclining switch forward signal	Input	Reclining switch	Operate (forward)	0
						Release	Battery voltage
28	Ground	Y/B	Lifting switch (front) up signal	Input	Seat lifting switch (front)	Operate (up)	0
						Release	Battery voltage
29	Ground	R/W	Lifting switch (rear) up signal	Input	Seat lifting switch (rear)	Operate (up)	0
						Release	Battery voltage
30	Ground	R	Pedal switch forward signal	Input	Pedal switch	Operate (forward)	0
						Release	Battery voltage
31	Ground	L/Y	Sensor ground	—	—	0	
32	Ground	B	Ground (signal)	—	—	0	
33	Ground	L/B	Battery power source (C/B)	Input	—	Battery voltage	

A  
B  
C  
D  
E  
F  
G  
H  
I  
K  
L  
M  
N  
O  
P

ADP

# DRIVER SEAT CONTROL UNIT

## < ECU DIAGNOSIS >

Terminal No.		Wire color	Description		Condition	Voltage (V) (Approx)
+	-		Signal name	Input/ Output		
35	Ground	V/W	Sliding motor forward output signal	Output	Seat sliding	Operate (forward) Battery voltage
					Release	0
36	Ground	Y/G	Reclining motor forward output signal	Output	Seat reclining	Operate (forward) Battery voltage
					Release	0
37	Ground	BR	Lifting motor (front) down output signal	Output	Seat lifting (front)	Operate (down) Battery voltage
					Stop	0
38	Ground	B/W	Lifting motor (rear) up output signal	Output	Seat lifting (rear)	Operate (up) Battery voltage
					Stop	0
39	Ground	Y	Lifting motor (rear) down output signal	Output	Seat lifting (rear)	Operate (down) Battery voltage
					Stop	0
40	Ground	Y/R	Power source (Fuse)	Input	—	Battery voltage
42	Ground	O/B	Sliding motor backward output signal	Output	Seat sliding	Operate (backward) Battery voltage
					Stop	0
44	Ground	Y/R	Reclining motor backward output signal	Output	Seat reclining	Operate (backward) Battery voltage
					Stop	0
45	Ground	GR	Lifting motor (front) up output signal	Output	Seat lifting (front)	Operate (up) Battery voltage
					Stop	0
48	Ground	B/W	Ground (power)	—	—	0

# DRIVER SEAT CONTROL UNIT

< ECU DIAGNOSIS >

## Wiring Diagram

INFOID:000000001608191

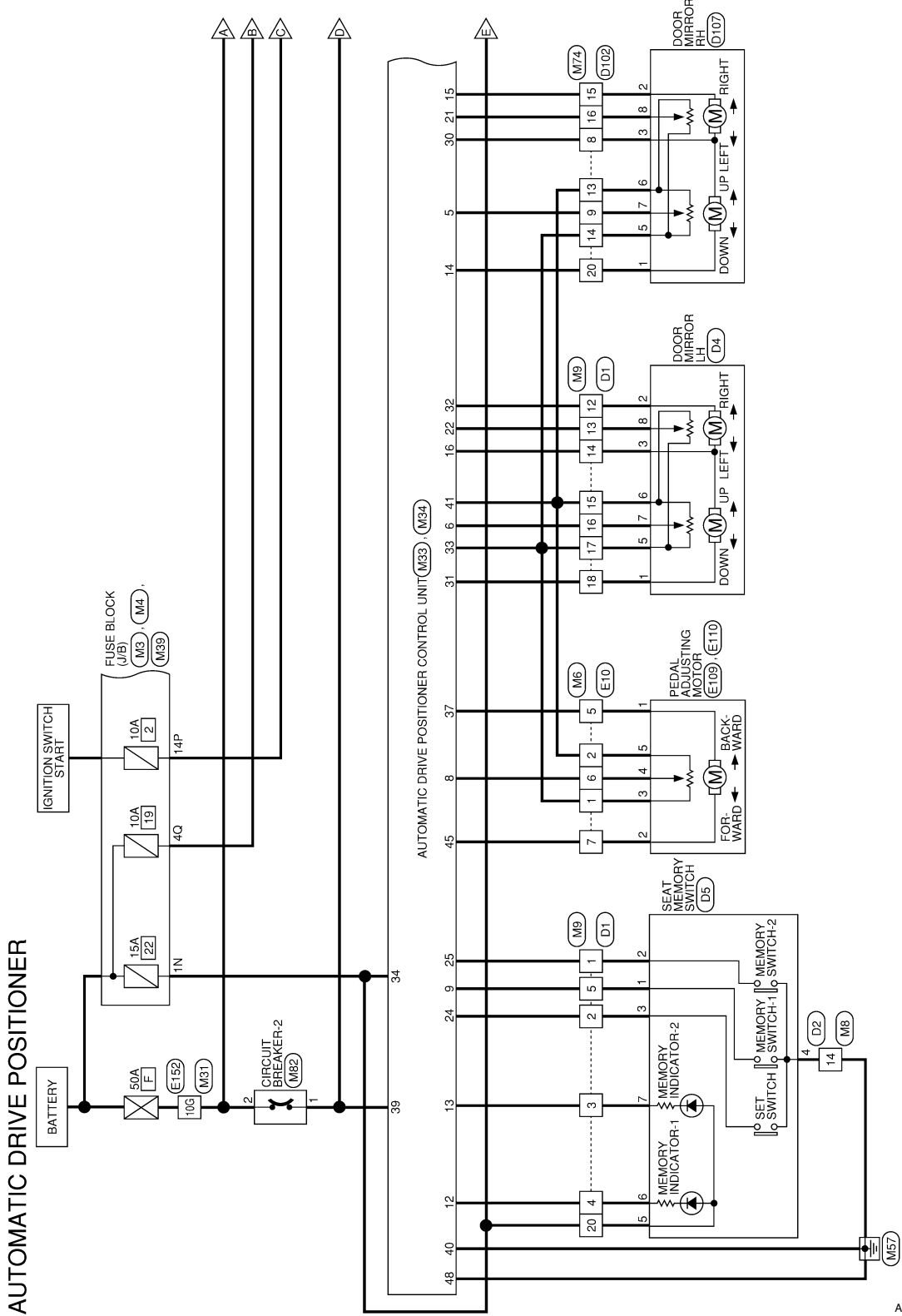

ALJWA0015GB

A  
B  
C  
D  
E  
F  
G  
H  
I  
ADP  
K  
L  
M  
N  
O  
P

# DRIVER SEAT CONTROL UNIT

< ECU DIAGNOSIS >

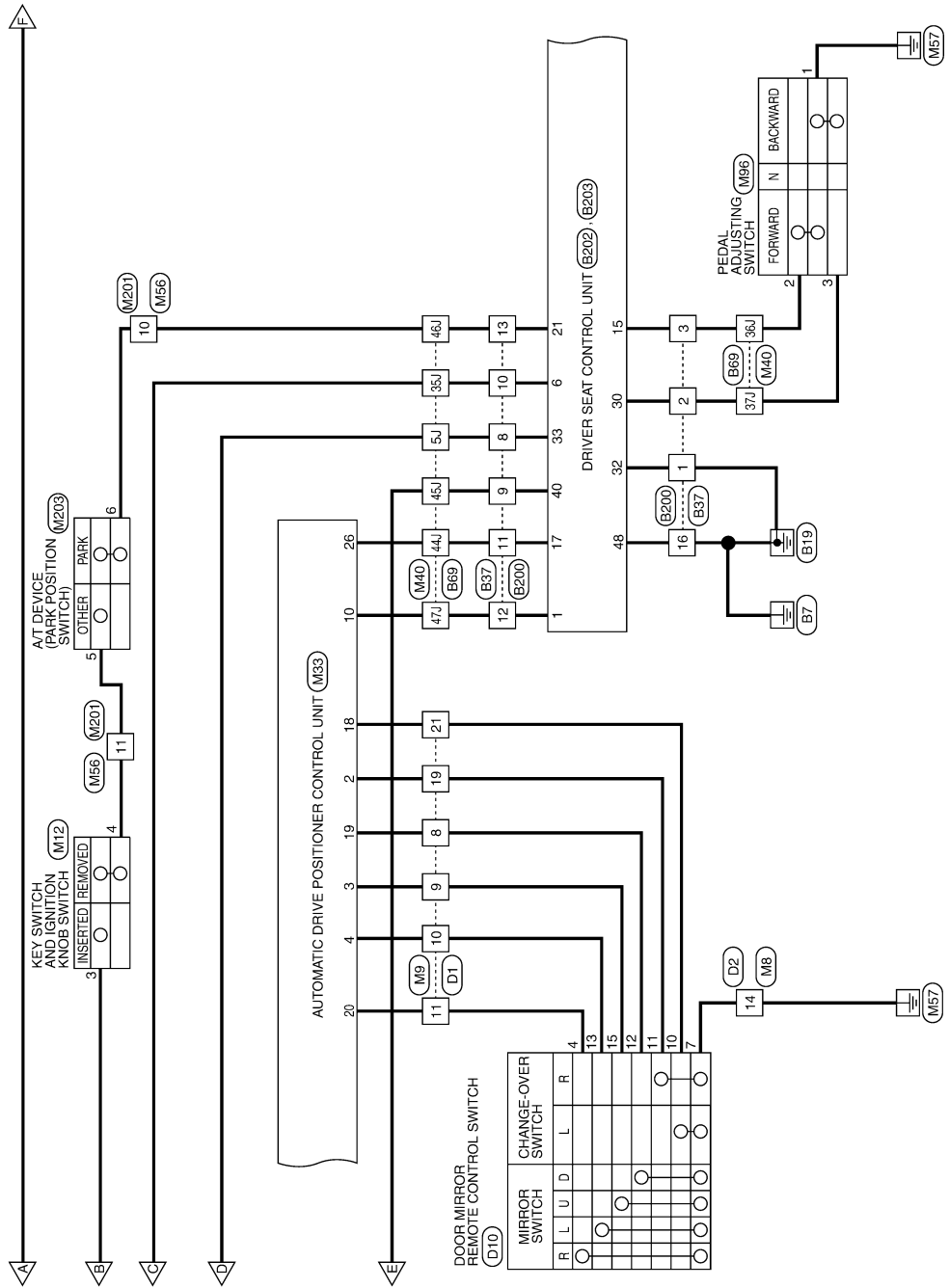

ALJWA0016GB

# DRIVER SEAT CONTROL UNIT

< ECU DIAGNOSIS >

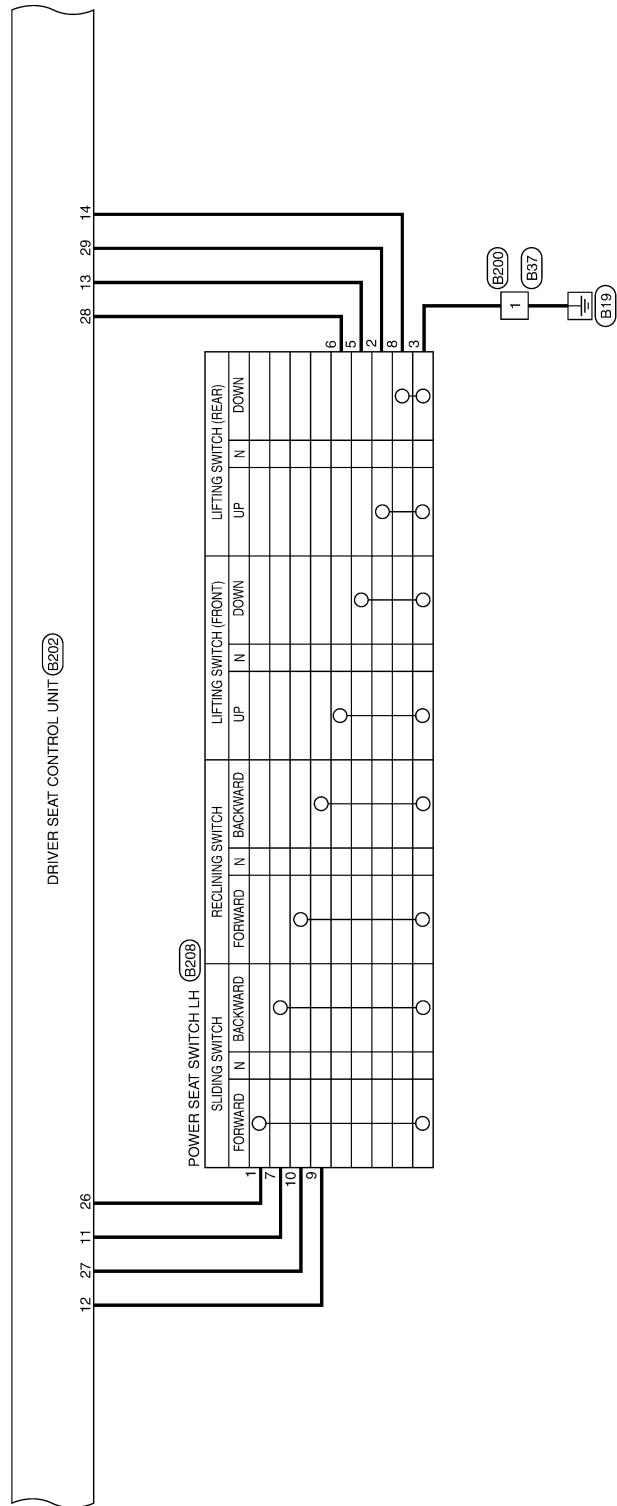

A  
B  
C  
D  
E  
F  
G  
H  
I  
ADP  
K  
L  
M  
N  
O  
P

ALJWA0017GB

# DRIVER SEAT CONTROL UNIT

< ECU DIAGNOSIS >

— : DATA LINE

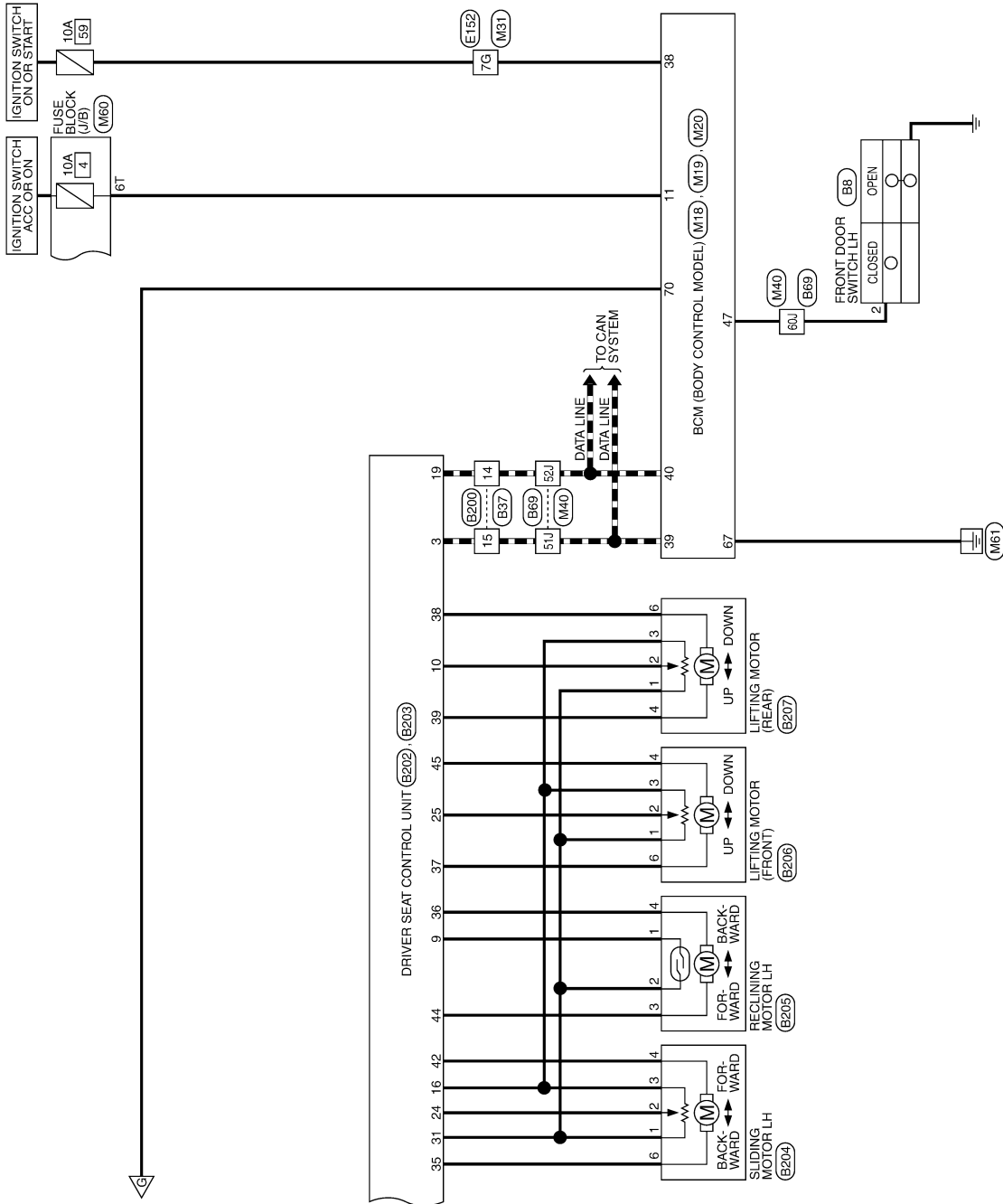

ALJWA0018GB

# DRIVER SEAT CONTROL UNIT

< ECU DIAGNOSIS >

## AUTOMATIC DRIVE POSITIONER CONNECTORS

Connector No.	M3
Connector Name	FUSE BLOCK (J/B)
Connector Color	WHITE

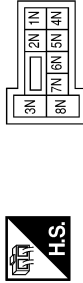

Connector No.	M4
Connector Name	FUSE BLOCK (J/B)
Connector Color	WHITE

Terminal No.	Color of Wire	Signal Name
1N	Y/R	-

Terminal No.	Color of Wire	Signal Name
14P	O	AUTO_DRPO

Connector No.	M6
Connector Name	WIRE TO WIRE
Connector Color	WHITE

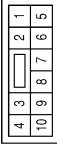

Terminal No.	Color of Wire	Signal Name
1	W/L	-
2	W/G	-
5	G	-
6	BR/Y	-
7	R	-

Connector No.	M8
Connector Name	WIRE TO WIRE
Connector Color	WHITE

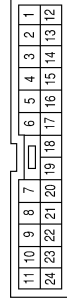
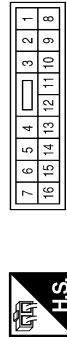

Connector No.	M9
Connector Name	WIRE TO WIRE
Connector Color	WHITE

Terminal No.	Color of Wire	Signal Name
14	B	-

Terminal No.	Color of Wire	Signal Name
1	P/L	-
2	G/O	-
3	Y/G	-
4	P	-
5	LG/B	-

Terminal No.	Color of Wire	Signal Name
8	SB	-
9	Y/B	-
10	V/W	-
11	GR	-
12	B/R	-
13	G	-
14	O	-
15	W/G	-
16	L/Y	-
17	W/L	-
18	R	-
19	LG	-
20	Y/R	-
21	BR/W	-

ALJIA0106GB

A  
B  
C  
D  
E  
F  
G  
H  
I  
K  
L  
M  
N  
O  
P



# DRIVER SEAT CONTROL UNIT

< ECU DIAGNOSIS >

Connector No.	M12
Connector Name	KEY SWITCH AND IGNITION KNOB SWITCH
Connector Color	GRAY

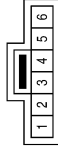

Terminal No.	Color of Wire	Signal Name
3	Y	-
4	B/R	-

Connector No.	M18
Connector Name	BCM (BODY CONTROL MODULE)
Connector Color	WHITE

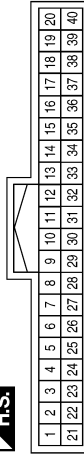

Terminal No.	Color of Wire	Signal Name
11	O	ACC SW
38	W/L	IGN SW
39	L	CAN-H
40	P	CAN-L

Connector No.	M19
Connector Name	BCM (BODY CONTROL MODULE)
Connector Color	WHITE



Terminal No.	Color of Wire	Signal Name
47	SB	DOOR SW (DR)

Connector No.	M20
Connector Name	BCM (BODY CONTROL MODULE)
Connector Color	BLACK

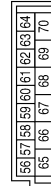

Terminal No.	Color of Wire	Signal Name
67	B	GND (POWER)

Connector No.	M31
Connector Name	WIRE TO WIRE
Connector Color	WHITE

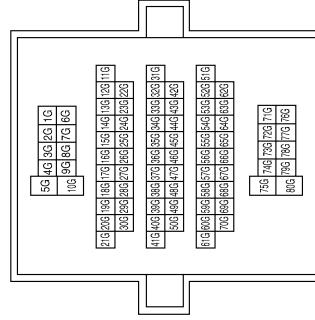

Terminal No.	Color of Wire	Signal Name
7G	W/L	-
10G	W/B	-

ALJIA0107GB



# DRIVER SEAT CONTROL UNIT

< ECU DIAGNOSIS >

Connector No.	M33
Connector Name	AUTOMATIC DRIVE POSITION CONTROL UNIT
Connector Color	WHITE

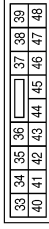

Terminal No.	Color of Wire	Signal Name
10	L	TX
12	P	MEMORY1_IND
13	Y/G	MEMORY2_IND
14	GR/R	RH_MTR_(UP-DN)
15	V/R	RH_MTR(LT)
16	O	LH_MTR_(COM)
18	BR/W	MIR_SELECT_SW_LH
19	SB	MIR_MANU_SW_DN
20	GR	MIR_MANU_SW_LH
21	L/W	HORIZONTAL_SENS
22	G	HORIZONTAL_SENS
24	G/O	SET_SW
25	P/L	MEMORY2_SW
26	W	RX
30	Y	RH_MTR_(COM)
31	R	LH_MTR_(UP-DWN)
32	BR	LH_MTR_(LT)

Connector No.	M33
Connector Name	AUTOMATIC DRIVE POSITION CONTROL UNIT
Connector Color	WHITE

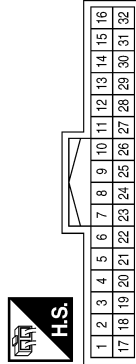

Terminal No.	Color of Wire	Signal Name
2	LG	MIR_SELECT_SW_RH
3	Y/B	MIR_MANU_SW_UP
4	V/W	MIR_MANU_SW_LH
5	R/B	VERTICAL_SENS_RH
6	L/Y	VERTICAL_SENS_LH
8	BR/Y	PEDAL_POTENTIATION
9	LG/B	MEMORY1_SW

Terminal No.	Color of Wire	Signal Name
33	W/L	MEMORY(POT_FEED)
34	Y/R	BAT_(FUSE)
37	G	FORWARD
39	L/B	BAT(PTC)
40	B/W	GND(SIG)
41	W/G	MEMORY(POT_RET)
45	R	PEDAL_POTENTIATION
48	B	GND(POWER)

Connector No.	M40
Connector Name	WIRE TO WIRE
Connector Color	WHITE

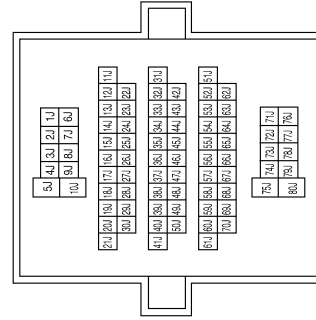

Connector No.	M39
Connector Name	FUSE BLOCK (J/B)
Connector Color	WHITE



Terminal No.	Color of Wire	Signal Name
4Q	Y/R	-

ALJIA0108GB

A  
B  
C  
D  
E  
F  
G  
H  
I  
ADP  
K  
L  
M  
N  
O  
P

# DRIVER SEAT CONTROL UNIT

< ECU DIAGNOSIS >

Connector No.	M74
Connector Name	WIRE TO WIRE
Connector Color	BROWN

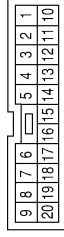

Terminal No.	Color of Wire	Signal Name
8	Y	-
9	R/B	-
13	W/G	-
14	W/L	-
15	V/R	-
16	L/W	-
20	GR/R	-

Connector No.	M60
Connector Name	FUSE BLOCK (J/B)
Connector Color	WHITE

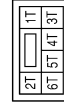

Terminal No.	Color of Wire	Signal Name
6T	O	-

Connector No.	M56
Connector Name	WIRE TO WIRE
Connector Color	WHITE



Terminal No.	Color of Wire	Signal Name
10	L/R	-
11	B/R	-

Connector No.	M201
Connector Name	WIRE TO WIRE
Connector Color	WHITE

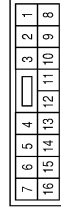

Terminal No.	Color of Wire	Signal Name
10	L/R	-
11	R/B	-

Connector No.	M96
Connector Name	PEDAL ADJUSTING SWITCH
Connector Color	BROWN



Terminal No.	Color of Wire	Signal Name
1	W/R	-
2	SB	-
3	V	-

Connector No.	M82
Connector Name	CIRCUIT BREAKER-2
Connector Color	GRAY



Terminal No.	Color of Wire	Signal Name
1	L/B	-
2	W/B	-

ALJIA0109GB

# DRIVER SEAT CONTROL UNIT

< ECU DIAGNOSIS >

Connector No.	E109
Connector Name	PEDAL ADJUSTING MOTOR
Connector Color	GRAY



Terminal No.	Color of Wire	Signal Name
1	G	-
2	R	-

Connector No.	E10
Connector Name	WIRE TO WIRE
Connector Color	WHITE

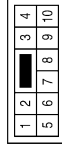

Terminal No.	Color of Wire	Signal Name
1	W/L	-
2	W/G	-
5	G	-
6	BR/Y	-
7	R	-

Connector No.	M203
Connector Name	A/T DEVICE
Connector Color	WHITE

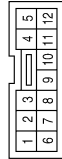

Terminal No.	Color of Wire	Signal Name
5	R/B	-
6	L/R	-

Terminal No.	Color of Wire	Signal Name
7G	L/W	-
10G	W/B	-

Connector No.	E152
Connector Name	WIRE TO WIRE
Connector Color	WHITE

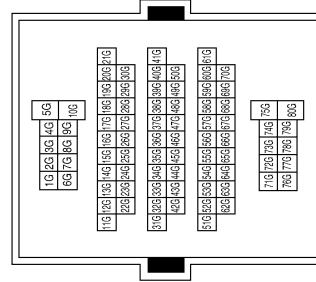

Connector No.	E110
Connector Name	PEDAL ADJUSTING SENSOR
Connector Color	GRAY



Terminal No.	Color of Wire	Signal Name
3	W/L	-
4	BR/Y	-
5	W/G	-

ALJJA0110GB

A  
B  
C  
D  
E  
F  
G  
H  
I  
K  
L  
M  
N  
O  
P

# DRIVER SEAT CONTROL UNIT

< ECU DIAGNOSIS >

Connector No.	B8
Connector Name	FRONT DOOR SWITCH LH
Connector Color	WHITE

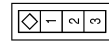

Terminal No.	Color of Wire	Signal Name
2	SB	-

Connector No.	B37
Connector Name	WIRE TO WIRE
Connector Color	WHITE

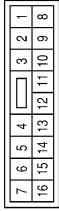

Terminal No.	Color of Wire	Signal Name
1	L/B	-
2	B/W	-
3	L/Y	-

Terminal No.	Color of Wire	Signal Name
8	L/B	-
9	Y/R	-
10	O	-
11	W	-
12	L	-
13	L/R	-
14	P	-
15	L	-
16	B/W	-

Connector No.	B69
Connector Name	WIRE TO WIRE
Connector Color	WHITE

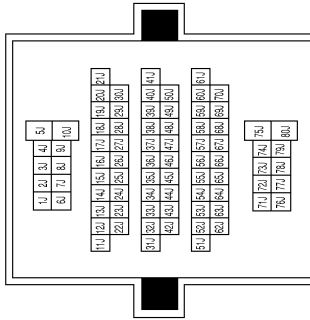

Terminal No.	Color of Wire	Signal Name
5J	L/B	-
35J	O	-
36J	L/Y	-
37J	R	-
44J	W	-
45J	Y/R	-
46J	L/R	-
47J	L	-
51J	L	-
52J	P	-
60J	SB	-

Connector No.	B200
Connector Name	WIRE TO WIRE
Connector Color	WHITE



Terminal No.	Color of Wire	Signal Name
1	L/B	-
2	B/W	-
3	L/Y	-
8	Y/R	-
9	Y/R	-
10	O	-
11	W	-
12	L	-
13	L/R	-
14	P	-
15	L	-
16	B/W	-

ALJIA0111GB

# DRIVER SEAT CONTROL UNIT

< ECU DIAGNOSIS >

Terminal No.	Color of Wire	Signal Name
17	W	TX
19	P	CAN-L
21	L/R	P_RANGE_SW
24	Y/G	SLIDING MOTOR SENSOR
25	LG	FRONT LIFTING MOTOR SENSOR
26	P/B	SLIDE(FR)
27	G/B	RECLINE(FR)
28	Y/B	FRONT LIFT(UP)
29	R/W	REAR LIFT(UP)
30	R	PEDAL_FORWARD
31	L/Y	GND (SENSOR)
32	B	GND

Terminal No.	Color of Wire	Signal Name
1	L	RX
3	L	CAN-H
6	O	ST_SW
9	L/R	RECLINING MOTOR SENSOR
10	W	REAR LIFTING MOTOR SENSOR
11	R/B	SLIDE(RR)
12	O/B	RECLINE(RR)
13	L/B	FRONT LIFT(DOWN)
14	G/W	REAR LIFT(DOWN)
15	L/Y	PEDAL_BACK
16	W	POWER SUPPLY (SENSOR)

Connector No.	B202
Connector Name	DRIVER SEAT CONTROL UNIT
Connector Color	WHITE



1	2	3	4	5	6	7	8	9	10	11	12	13	14	15	16
17	18	19	20	21	22	23	24	25	26	27	28	29	30	31	32

Connector No.	B204
Connector Name	SLIDING MOTOR LH
Connector Color	WHITE



6	4	
3	2	1

Terminal No.	Color of Wire	Signal Name
1	L/Y	-
2	Y/G	-
3	W	-
4	O/B	-
6	V/W	-

Terminal No.	Color of Wire	Signal Name
33	L/B	BAT(PTC)
35	V/W	SLIDING MOTOR(FR)
36	Y/G	RECLINING MOTOR (FR)
37	BR	FRONT LIFTING MOTOR(DOWN)
38	B/W	REAR LIFTING MOTOR (UP)
39	Y	REAR LIFTING MOTOR (DOWN)
40	Y/R	BAT (FUSE)
42	O/B	SLIDING MOTOR(RR)
44	Y/R	RECLINING MOTOR (RR)
45	GR	FRONT LIFTING MOTOR (UP)
48	B/W	GND (POWER)

Connector No.	B203
Connector Name	DRIVER SEAT CONTROL UNIT
Connector Color	WHITE



33	34	35	36	37	38	39		
40	41	42	43	44	45	46	47	48

A  
B  
C  
D  
E  
F  
G  
H  
I  
K  
L  
M  
N  
O  
P

ADP

# DRIVER SEAT CONTROL UNIT

< ECU DIAGNOSIS >

Connector No.	B207
Connector Name	LIFTING MOTOR (REAR)
Connector Color	GRAY



Terminal No.	Color of Wire	Signal Name
1	L/Y	-
2	W	-
3	W	-
4	Y	-
6	B/W	-

Connector No.	B206
Connector Name	LIFTING MOTOR (FRONT)
Connector Color	WHITE



Terminal No.	Color of Wire	Signal Name
1	L/Y	-
2	LG	-
3	W	-
4	GR	-
6	BR	-

Connector No.	B205
Connector Name	RECLINING MOTOR LH
Connector Color	WHITE



Terminal No.	Color of Wire	Signal Name
1	L/R	-
2	L/Y	-
3	Y/R	-
4	Y/G	-

Terminal No.	Color of Wire	Signal Name
9	Y/B	-
10	V/W	-
11	GR	-
12	BR	-
13	G	-
14	O	-
15	W/G	-
16	L/Y	-
17	W/L	-
18	R	-
19	LG	-
20	Y/R	-
21	BR/W	-

Connector No.	D1
Connector Name	WIRE TO WIRE
Connector Color	WHITE

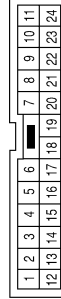

Terminal No.	Color of Wire	Signal Name
1	R/G	-
2	G/O	-
3	Y/G	-
4	P	-
5	LG/B	-
8	SB	-

Connector No.	B208
Connector Name	POWER SEAT SWITCH LH
Connector Color	WHITE



Terminal No.	Color of Wire	Signal Name
1	P/B	-
2	R/W	-
3	B	-
5	L/B	-
6	Y/B	-
7	R/B	-
8	G/W	-
9	O/B	-
10	G/B	-

ALJIA0166GB

# DRIVER SEAT CONTROL UNIT

< ECU DIAGNOSIS >

Connector No.	D5
Connector Name	SEAT MEMORY SWITCH
Connector Color	WHITE



Terminal No.	Color of Wire	Signal Name
1	LG/B	SET 1
2	P/L	SET 2
3	G/O	SET SW
4	B	GND
5	Y/R	-
6	P	IND1
7	Y/G	IND2

Connector No.	D4
Connector Name	DOOR MIRROR LH
Connector Color	WHITE



Terminal No.	Color of Wire	Signal Name
1	R	-
2	BR	-
3	O	-
5	W/L	-
6	W/G	-
7	L/Y	-
8	G	-

Connector No.	D2
Connector Name	WIRE TO WIRE
Connector Color	WHITE



Terminal No.	Color of Wire	Signal Name
14	B	-

Connector No.	D107
Connector Name	DOOR MIRROR RH
Connector Color	WHITE



Terminal No.	Color of Wire	Signal Name
1	GR/R	-
2	V/R	-
3	Y	-
5	W/L	-
6	W/G	-
7	R/B	-
8	L/W	-

Connector No.	D102
Connector Name	WIRE TO WIRE
Connector Color	BROWN



Terminal No.	Color of Wire	Signal Name
8	Y	-
9	R/B	-
13	W/G	-
14	W/L	-
15	V/R	-
16	L/W	-
20	GR/R	-

Connector No.	D10
Connector Name	DOOR MIRROR REMOTE CONTROL SWITCH
Connector Color	WHITE



Terminal No.	Color of Wire	Signal Name
4	GR	-
7	B	-
10	BR/W	-
11	LG	-
12	SB	-
13	V/W	-
15	Y/B	-

ALJIA0167GB

## Fail Safe

The fail-safe mode may be activated if the following symptoms are observed.

### FAIL-SAFE MODE

When any manual and automatic operations are not performed, if any motor operations of front seat LH or pedals are detected for T2 or more, status is judged "Output error".

A  
B  
C  
D  
E  
F  
G  
H  
I  
K  
L  
M  
N  
O  
P

ADP

# DRIVER SEAT CONTROL UNIT

## < ECU DIAGNOSIS >

OPERATED PORTION	T2
Seat sliding	Approx. 0.1 sec.
Seat reclining	Same as above
Seat lifting (Front)	Same as above
Seat lifting (Rear)	Same as above
Pedal adjust	Same as above

### NOTE:

The front seat LH position and pedal adjustment functions (see the following table) operate simultaneously in the order of priority.

Priority	Function	Priority	Function
1	Seat sliding, (door mirror LH/RH)*	4	Seat lifter-FR
2	Pedal	5	Seat lifter-RR
3	Seat reclining		

\*: In conjunction with sliding the seat, the door mirrors are positioned.

### CANCEL OF FAIL-SAFE MODE

The mode is cancelled when the A/T selector lever is shifted to P position from any other position.

### DTC Index

INFOID:000000001608193

CONSULT-III display	Timing*1		Item	Reference page
	Current mal-function	Previous mal-function		
CAN COMM CIRCUIT [U1000]	0	1-39	CAN communication	<a href="#">ADP-27</a>
SEAT SLIDE [B2112]	0	1-39	Seat slide motor output	<a href="#">ADP-28</a>
SEAT RECLINING [B2113]	0	1-39	Seat reclining motor output	<a href="#">ADP-29</a>
SEAT LIFTER FRONT [B2114]	0	1-39	Seat lifting motor front output	<a href="#">ADP-32</a>
SEAT LIFTER REAR [B2115]	0	1-39	Seat lifting motor rear output	<a href="#">ADP-32</a>
ADJ PEDAL MOTOR [B2117]	0	1-39	Pedal adjusting motor output	<a href="#">ADP-32</a>
ADJ PEDAL SENSOR [B2120]	0	1-39	Pedal adjusting sensor input	<a href="#">ADP-32</a>
DETENT SW [B2126]	0	1-39	Park position switch condition	<a href="#">ADP-36</a>
UART COMM [B2128]	0	1-39	UART communication	<a href="#">ADP-38</a>

\*1:

- 0: Current malfunction is present
- 1-39: Displayed if any previous malfunction is present when current condition is normal. The numeral value increases by one at each IGN ON to OFF cycle from 1 to 39. The counter remains at 39 even if the number of cycles exceeds it. However, the counter is reset to 1 if any malfunction is detected again, the normal operation is resumed and the ignition switch is turned from OFF to ON.



# AUTOMATIC DRIVE POSITIONER CONTROL UNIT

< ECU DIAGNOSIS >

## AUTOMATIC DRIVE POSITIONER CONTROL UNIT

Reference Value

INFOID:000000001608194

### TERMINAL LAYOUT

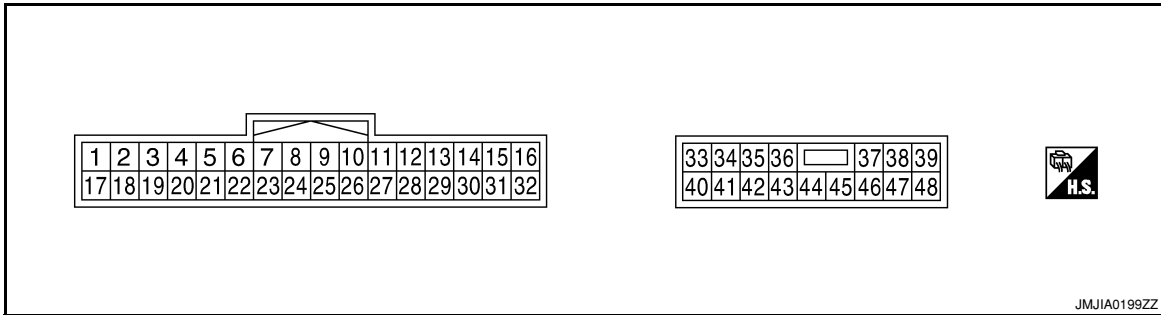

### PHYSICAL VALUES

Terminal No.		Wire color	Description		Condition	Voltage (V) (Approx.)	
+	-		Signal name	Input/Output			
2	Ground	LG	Changeover switch RH signal	Input	Changeover switch position	RH	0
						Neutral or LH	5
3	Ground	Y/B	Mirror switch up signal	Input	Mirror switch	Operated (up)	0
						Other than above	5
4	Ground	V/W	Mirror switch left signal	Input	Mirror switch	Operated (left)	0
						Other than above	5
5	Ground	R/B	Door mirror sensor (RH) up/down signal	Input	Door mirror RH position	Peak	3.4
						Valley	0.6
6	Ground	L/Y	Door mirror sensor (LH) up/down signal	Input	Door mirror LH position	Peak	3.4
						Valley	0.6
8	Ground	BR/Y	Pedal sensor input signal	Input	Pedal sensor	Forward	0.5
						Backward	4.5
9	Ground	LG/B	Memory switch 1 signal	Input	Memory switch 1	Push	0
						Other than above	5
10	Ground	L	UART LINE (TX)	Output	Ignition switch ON		
12	Ground	P	Memory indicator 1 signal	Output	Memory indicator 1	Illuminate	0
						Other than above	Battery voltage

A  
B  
C  
D  
E  
F  
G  
H  
I  
K  
L  
M  
N  
O  
P

ADP

# AUTOMATIC DRIVE POSITIONER CONTROL UNIT

## < ECU DIAGNOSIS >

Terminal No.		Wire color	Description		Condition	Voltage (V) (Approx.)
+	-		Signal name	Input/ Output		
13	Ground	Y/G	Memory indicator 2 signal	Output	Memory indicator 2	Illuminate 0
					Other than above	Battery voltage
14	Ground	GR/R	Door mirror motor (RH) up output signal	Output	Door mirror RH	Operate (up) 1.5 - Battery voltage
					Other than above	0
15	Ground	V/R	Door mirror motor (RH) left output signal	Output	Door mirror RH	Operate (left) 1.5 - Battery voltage
					Other than above	0
16	Ground	O	Door mirror motor (LH) down output signal	Output	Door mirror (LH)	Operate (down) 1.5 - Battery voltage
						Other than above
			Door mirror motor (LH) right output signal			Operate (right) 1.5 - Battery voltage
						Other than above
18	Ground	BR/W	Changeover switch LH signal	Input	Changeover switch position	LH 0
						Neutral or RH 5
19	Ground	SB	Mirror switch down signal	Input	Mirror switch	Operate (down) 0
						Other than above 5
20	Ground	GR	Mirror switch right signal	Input	Mirror switch	Operate (right) 0
						Other than above 5
21	Ground	L/W	Door mirror sensor (RH) left/right signal	Input	Door mirror RH position	Left edge 3.4
						Right edge 0.6
22	Ground	G	Door mirror sensor (LH) left/right signal	Input	Door mirror LH position	Left edge 0.6
						Right edge 3.4
24	Ground	G/O	Set switch signal	Input	Set switch	Push 0
						Other than above 5
25	Ground	P/L	Memory switch 2 signal	Input	Memory switch 2	Push 0
						Other than above 5
26	Ground	W	UART LINE (RX)	Input	Ignition switch ON	<p>The diagram shows a square wave signal on a grid. The vertical axis is labeled (V) with values 0, 2, 4, 6. The horizontal axis is labeled with a 2 ms interval. The signal is high (approx. 5V) during the 2 ms pulse and low (0V) otherwise.</p>

PIIA4814E

# AUTOMATIC DRIVE POSITIONER CONTROL UNIT

## < ECU DIAGNOSIS >

Terminal No.		Wire color	Description		Condition	Voltage (V) (Approx.)	
+	-		Signal name	Input/ Output			
30	Ground	Y	Door mirror motor (RH) down output signal	Output	Door mirror (RH)	Operate (down)	1.5 - Battery voltage
						Other than above	0
			Door mirror motor (RH) right output signal			Operate (right)	1.5 - Battery voltage
						Other than above	0
31	Ground	R	Door mirror motor (LH) up output signal	Output	Door mirror (LH)	Operate (up)	1.5 - Battery voltage
						Other than above	0
32	Ground	BR	Door mirror motor (LH) left output signal	Output	Door mirror (LH)	Operate (left)	1.5 - Battery voltage
						Other than above	0
33	Ground	W/L	Sensor power supply	Input	—	5	
34	Ground	Y/R	Battery power source	Input	—	Battery voltage	
37	Ground	G	Pedal adjusting motor forward output signal	Output	Pedal adjusting motor	Operate (forward)	Battery voltage
						Other than above	0
39	Ground	L/B	Battery power source		—	Battery voltage	
40	Ground	B/W	Ground	—	—	0	
41	Ground	W/B	Sensor ground	—	—	0	
45	Ground	R	Pedal adjusting motor backward output signal	Output	Pedal adjusting motor	Operate (back-ward)	Battery voltage
						Other than above	0
48	Ground	B	Ground	—	—	0	

A  
B  
C  
D  
E  
F  
G  
H  
I  
K  
L  
M  
N  
O  
P

ADP

# AUTOMATIC DRIVE POSITIONER CONTROL UNIT

< ECU DIAGNOSIS >

## Wiring Diagram

INFOID:000000001608195

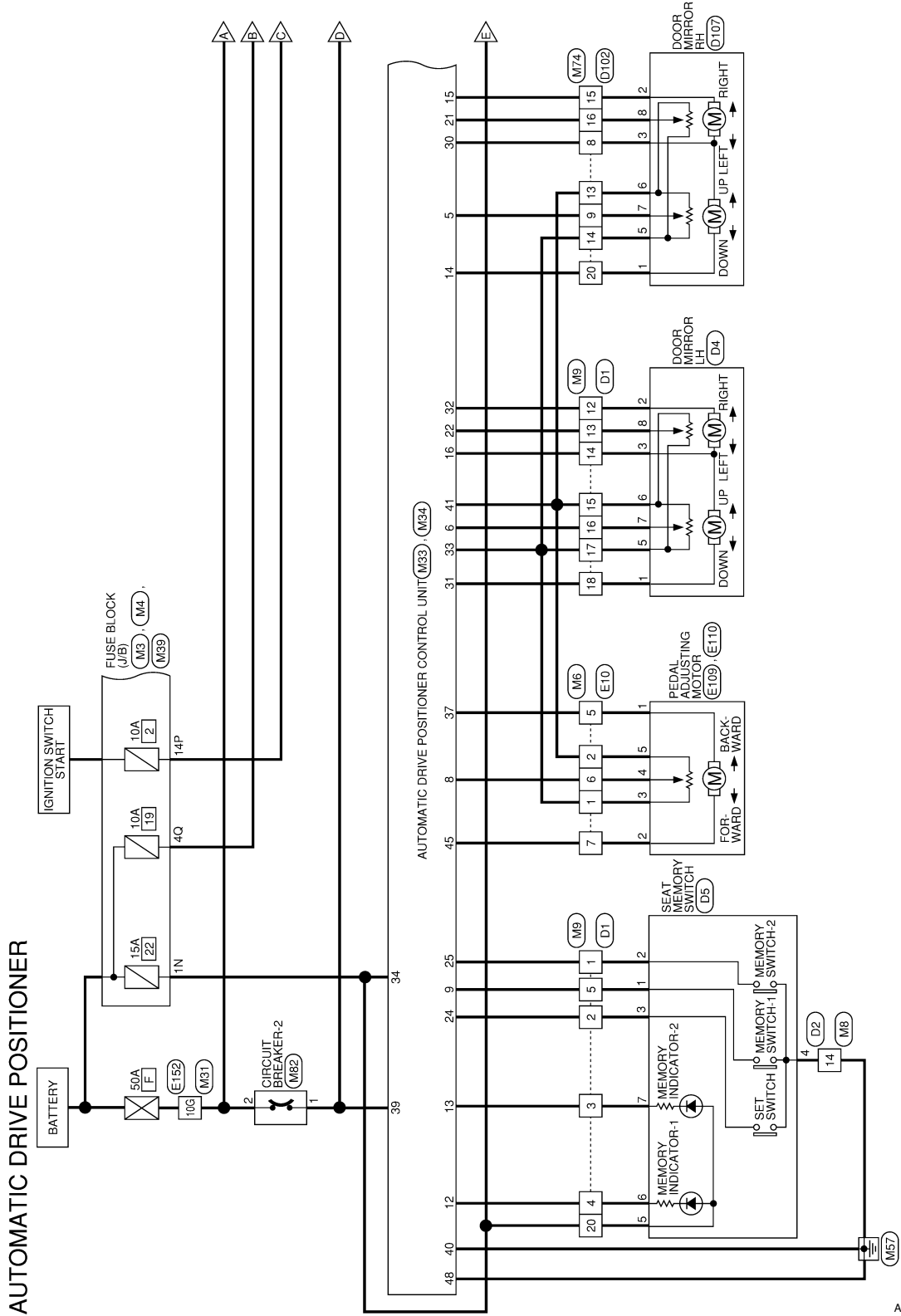

ALJWA0015GB

# AUTOMATIC DRIVE POSITIONER CONTROL UNIT

< ECU DIAGNOSIS >

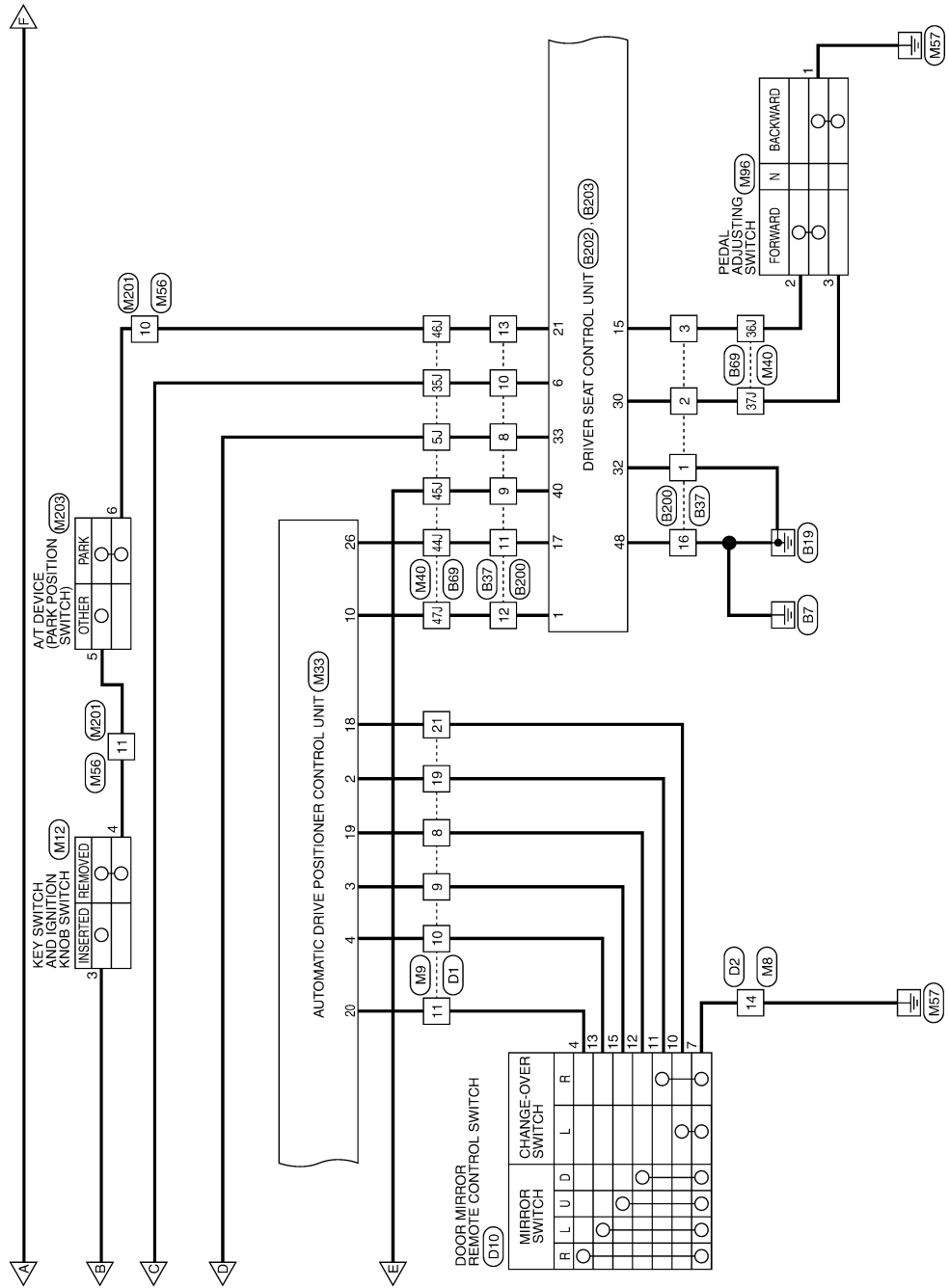

A  
B  
C  
D  
E  
F  
G  
H  
I  
ADP  
K  
L  
M  
N  
O  
P

ALJWA0016GB

# AUTOMATIC DRIVE POSITIONER CONTROL UNIT

< ECU DIAGNOSIS >

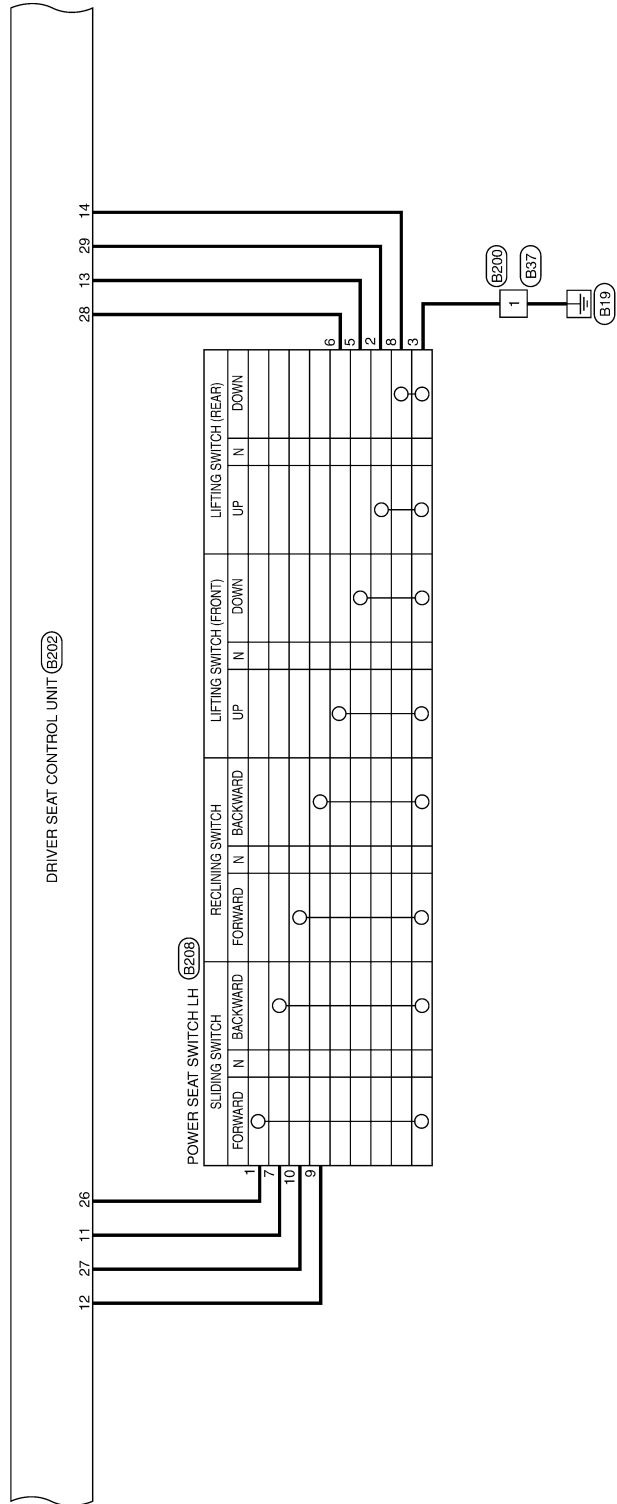

ALJWA0017GB

# AUTOMATIC DRIVE POSITIONER CONTROL UNIT

< ECU DIAGNOSIS >

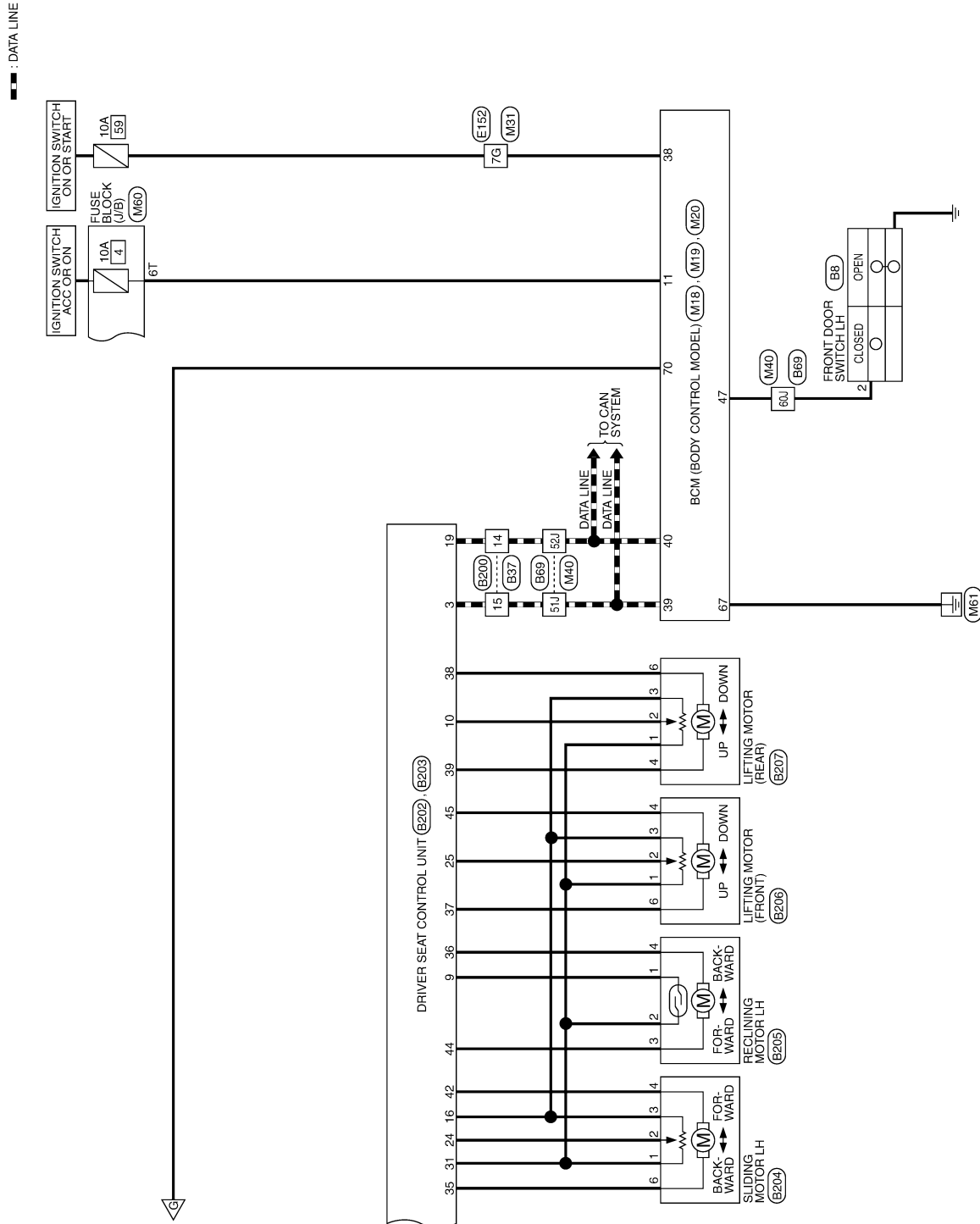

ALJWA0018GB

A  
B  
C  
D  
E  
F  
G  
H  
I  
K  
L  
M  
N  
O  
P

ADP

# AUTOMATIC DRIVE POSITIONER CONTROL UNIT

< ECU DIAGNOSIS >

## AUTOMATIC DRIVE POSITIONER CONNECTORS

Connector No.	M3
Connector Name	FUSE BLOCK (J/B)
Connector Color	WHITE

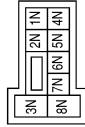

Terminal No.	Color of Wire	Signal Name
1N	Y/R	-

Connector No.	M4
Connector Name	FUSE BLOCK (J/B)
Connector Color	WHITE



Terminal No.	Color of Wire	Signal Name
14P	O	AUTO_DRPO

Connector No.	M6
Connector Name	WIRE TO WIRE
Connector Color	WHITE



Terminal No.	Color of Wire	Signal Name
1	W/L	-
2	W/G	-
5	G	-
6	BR/Y	-
7	R	-

Connector No.	M8
Connector Name	WIRE TO WIRE
Connector Color	WHITE

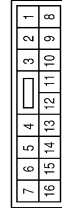

Terminal No.	Color of Wire	Signal Name
14	B	-

Connector No.	M9
Connector Name	WIRE TO WIRE
Connector Color	WHITE

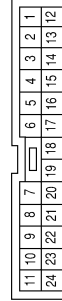

Terminal No.	Color of Wire	Signal Name
1	P/L	-
2	G/O	-
3	Y/G	-
4	P	-
5	LG/B	-

Terminal No.	Color of Wire	Signal Name
8	SB	-
9	Y/B	-
10	V/W	-
11	GR	-
12	B/R	-
13	G	-
14	O	-
15	W/G	-
16	L/Y	-
17	W/L	-
18	R	-
19	LG	-
20	Y/R	-
21	BR/W	-

ALJIA0106GB



# AUTOMATIC DRIVE POSITIONER CONTROL UNIT

< ECU DIAGNOSIS >

Connector No.	M19
Connector Name	BCM (BODY CONTROL MODULE)
Connector Color	WHITE



Terminal No.	Color of Wire	Signal Name
47	SB	DOOR SW (DR)

Connector No.	M18
Connector Name	BCM (BODY CONTROL MODULE)
Connector Color	WHITE

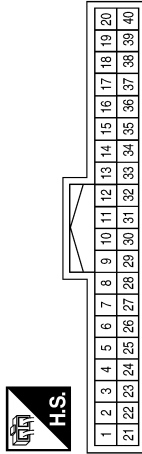

Terminal No.	Color of Wire	Signal Name
11	O	ACC SW
38	W/L	IGN SW
39	L	CAN-H
40	P	CAN-L

Connector No.	M12
Connector Name	KEY SWITCH AND IGNITION KNOB SWITCH
Connector Color	GRAY

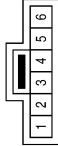

Terminal No.	Color of Wire	Signal Name
3	Y	-
4	B/R	-

Terminal No.	Color of Wire	Signal Name
7G	W/L	-
10G	W/B	-

Connector No.	M31
Connector Name	WIRE TO WIRE
Connector Color	WHITE

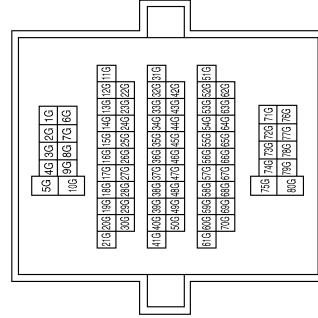

Connector No.	M20
Connector Name	BCM (BODY CONTROL MODULE)
Connector Color	BLACK

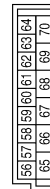

Terminal No.	Color of Wire	Signal Name
67	B	GND (POWER)

ALJIA0107GB

A  
B  
C  
D  
E  
F  
G  
H  
I  
ADP  
K  
L  
M  
N  
O  
P

# AUTOMATIC DRIVE POSITIONER CONTROL UNIT

< ECU DIAGNOSIS >

Connector No.	M34
Connector Name	AUTOMATIC DRIVE POSITION CONTROL UNIT
Connector Color	WHITE



Terminal No.	Color of Wire	Signal Name
33	W/L	MEMORY(POT_FEED)
34	Y/R	BAT_(FUSE)
37	G	FORWARD
39	L/B	BAT(PTC)
40	B/W	GND(SIG)
41	W/G	MEMORY(POT_RET)
45	R	PEDAL_POTENTION
48	B	GND(POWER)

Terminal No.	Color of Wire	Signal Name
5J	L/B	-
35J	O	-
36J	L/Y	-
37J	R	-
44J	W	-
45J	Y/R	-
46J	L/R	-
47J	L	-
51J	L	-
52J	P	-
60J	SB	-

Terminal No.	Color of Wire	Signal Name
10	L	TX
12	P	MEMORY1_IND
13	Y/G	MEMORY2_IND
14	GR/R	RH_MTR_(UP-DN)
15	V/R	RH_MTR(LT)
16	O	LH_MTR_(COM)
18	BR/W	MIR_SELECT_SW_LH
19	SB	MIR_MANU_SW_DN
20	GR	MIR_MANU_SW_LH
21	L/W	HORIZONTAL_SENS
22	G	HORIZONTAL_SENS
24	G/O	SET_SW
25	P/L	MEMORY2_SW
26	W	RX
30	Y	RH_MTR_(COM)
31	R	LH_MTR_(UP-DWN)
32	BR	LH_MTR_(LT)

Connector No.	M40
Connector Name	WIRE TO WIRE
Connector Color	WHITE

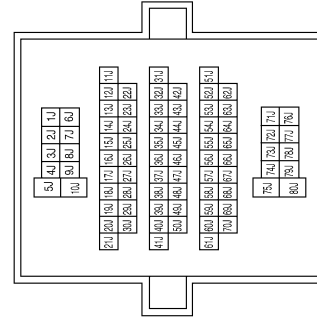

Connector No.	M33
Connector Name	AUTOMATIC DRIVE POSITION CONTROL UNIT
Connector Color	WHITE

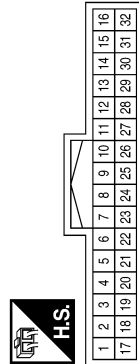

Terminal No.	Color of Wire	Signal Name
2	LG	MIR_SELECT_SW_RH
3	Y/B	MIR_MANU_SW_UP
4	V/W	MIR_MANU_SW_LH
5	R/B	VERTICAL_SENS_RH
6	L/Y	VERTICAL_SENS_LH
8	BR/Y	PEDAL_POTENTION
9	LG/B	MEMORY1_SW

Connector No.	M39
Connector Name	FUSE BLOCK (J/B)
Connector Color	WHITE



Terminal No.	Color of Wire	Signal Name
4Q	Y/R	-

# AUTOMATIC DRIVE POSITIONER CONTROL UNIT

< ECU DIAGNOSIS >

Connector No.	M74
Connector Name	WIRE TO WIRE
Connector Color	BROWN

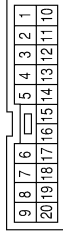

Terminal No.	Color of Wire	Signal Name
8	Y	-
9	R/B	-
13	W/G	-
14	W/L	-
15	V/R	-
16	L/W	-
20	GR/R	-

Connector No.	M60
Connector Name	FUSE BLOCK (J/B)
Connector Color	WHITE

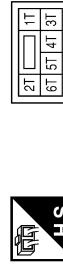

Terminal No.	Color of Wire	Signal Name
6T	O	-

Connector No.	M56
Connector Name	WIRE TO WIRE
Connector Color	WHITE



Terminal No.	Color of Wire	Signal Name
10	L/R	-
11	B/R	-

Connector No.	M201
Connector Name	WIRE TO WIRE
Connector Color	WHITE

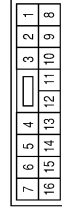

Terminal No.	Color of Wire	Signal Name
10	L/R	-
11	R/B	-

Connector No.	M96
Connector Name	PEDAL ADJUSTING SWITCH
Connector Color	BROWN



Terminal No.	Color of Wire	Signal Name
1	W/R	-
2	SB	-
3	V	-

Connector No.	M82
Connector Name	CIRCUIT BREAKER-2
Connector Color	GRAY



Terminal No.	Color of Wire	Signal Name
1	L/B	-
2	W/B	-

ALJIA0109GB

A  
B  
C  
D  
E  
F  
G  
H  
I  
K  
L  
M  
N  
O  
P

ADP

# AUTOMATIC DRIVE POSITIONER CONTROL UNIT

< ECU DIAGNOSIS >

Connector No.	E109
Connector Name	PEDAL ADJUSTING MOTOR
Connector Color	GRAY



Terminal No.	Color of Wire	Signal Name
1	G	-
2	R	-

Connector No.	E10
Connector Name	WIRE TO WIRE
Connector Color	WHITE

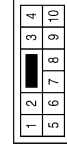

Terminal No.	Color of Wire	Signal Name
1	W/L	-
2	W/G	-
5	G	-
6	BR/Y	-
7	R	-

Connector No.	M203
Connector Name	A/T DEVICE
Connector Color	WHITE

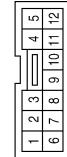

Terminal No.	Color of Wire	Signal Name
5	R/B	-
6	L/R	-

Terminal No.	Color of Wire	Signal Name
7G	L/W	-
10G	W/B	-

Connector No.	E152
Connector Name	WIRE TO WIRE
Connector Color	WHITE

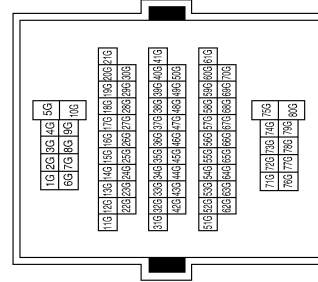

Connector No.	E110
Connector Name	PEDAL ADJUSTING SENSOR
Connector Color	GRAY



Terminal No.	Color of Wire	Signal Name
3	W/L	-
4	BR/Y	-
5	W/G	-

ALJIA0110GB

# AUTOMATIC DRIVE POSITIONER CONTROL UNIT

## < ECU DIAGNOSIS >

Connector No.	B8
Connector Name	FRONT DOOR SWITCH LH
Connector Color	WHITE

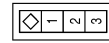

Terminal No.	Color of Wire	Signal Name
2	SB	-

Connector No.	B37
Connector Name	WIRE TO WIRE
Connector Color	WHITE

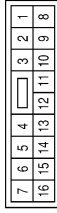

Terminal No.	Color of Wire	Signal Name
1	L/B	-
2	B/W	-
3	L/Y	-

Terminal No.	Color of Wire	Signal Name
8	L/B	-
9	Y/R	-
10	O	-
11	W	-
12	L	-
13	L/R	-
14	P	-
15	L	-
16	B/W	-

Connector No.	B69
Connector Name	WIRE TO WIRE
Connector Color	WHITE

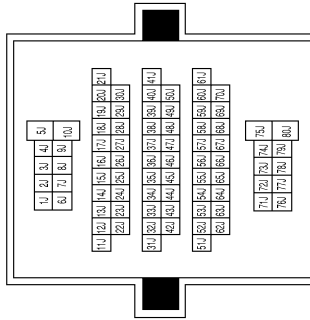

Terminal No.	Color of Wire	Signal Name
5J	L/B	-
35J	O	-
36J	L/Y	-
37J	R	-
44J	W	-
45J	Y/R	-
46J	L/R	-
47J	L	-
51J	L	-
52J	P	-
60J	SB	-

Connector No.	B200
Connector Name	WIRE TO WIRE
Connector Color	WHITE

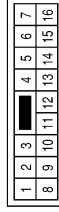

Terminal No.	Color of Wire	Signal Name
1	L/B	-
2	B/W	-
3	L/Y	-
8	Y/R	-
9	Y/R	-
10	O	-
11	W	-
12	L	-
13	L/R	-
14	P	-
15	L	-
16	B/W	-

ALJIA0111GB

A  
B  
C  
D  
E  
F  
G  
H  
I  
ADP  
K  
L  
M  
N  
O  
P

# AUTOMATIC DRIVE POSITIONER CONTROL UNIT

< ECU DIAGNOSIS >

Terminal No.	Color of Wire	Signal Name
17	W	TX
19	P	CAN-L
21	L/R	P_RANGE_SW
24	Y/G	SLIDING MOTOR SENSOR
25	LG	FRONT LIFTING MOTOR SENSOR
26	P/B	SLIDE(FR)
27	G/B	RECLINE(FR)
28	Y/B	FRONT LIFT(UP)
29	R/W	REAR LIFT(UP)
30	R	PEDAL_FORWARD
31	L/Y	GND (SENSOR)
32	B	GND

Terminal No.	Color of Wire	Signal Name
1	L	RX
3	L	CAN-H
6	O	ST_SW
9	L/R	RECLINING MOTOR SENSOR
10	W	REAR LIFTING MOTOR SENSOR
11	R/B	SLIDE(RR)
12	O/B	RECLINE(RR)
13	L/B	FRONT LIFT(DOWN)
14	G/W	REAR LIFT(DOWN)
15	L/Y	PEDAL_BACK
16	W	POWER SUPPLY (SENSOR)

Connector No.	B202
Connector Name	DRIVER SEAT CONTROL UNIT
Connector Color	WHITE

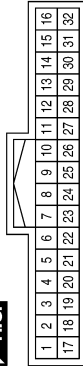

Connector No.	B204
Connector Name	SLIDING MOTOR LH
Connector Color	WHITE



Terminal No.	Color of Wire	Signal Name
1	L/Y	-
2	Y/G	-
3	W	-
4	O/B	-
6	V/W	-

Terminal No.	Color of Wire	Signal Name
33	L/B	BAT(PTC)
35	V/W	SLIDING MOTOR(FR)
36	Y/G	RECLINING MOTOR (FR)
37	BR	FRONT LIFTING MOTOR(DOWN)
38	B/W	REAR LIFTING MOTOR (UP)
39	Y	REAR LIFTING MOTOR (DOWN)
40	Y/R	BAT (FUSE)
42	O/B	SLIDING MOTOR(RR)
44	Y/R	RECLINING MOTOR (RR)
45	GR	FRONT LIFTING MOTOR (UP)
48	B/W	GND (POWER)

Connector No.	B203
Connector Name	DRIVER SEAT CONTROL UNIT
Connector Color	WHITE



ALJIA0112GB

# AUTOMATIC DRIVE POSITIONER CONTROL UNIT

< ECU DIAGNOSIS >

Connector No.	B207
Connector Name	LIFTING MOTOR (REAR)
Connector Color	GRAY



Terminal No.	Color of Wire	Signal Name
1	L/Y	-
2	W	-
3	W	-
4	Y	-
6	B/W	-

Connector No.	B206
Connector Name	LIFTING MOTOR (FRONT)
Connector Color	WHITE



Terminal No.	Color of Wire	Signal Name
1	L/Y	-
2	LG	-
3	W	-
4	GR	-
6	BR	-

Connector No.	B205
Connector Name	RECLINING MOTOR LH
Connector Color	WHITE



Terminal No.	Color of Wire	Signal Name
1	L/R	-
2	L/Y	-
3	Y/R	-
4	Y/G	-

Terminal No.	Color of Wire	Signal Name
9	Y/B	-
10	V/W	-
11	GR	-
12	BR	-
13	G	-
14	O	-
15	W/G	-
16	L/Y	-
17	W/L	-
18	R	-
19	LG	-
20	Y/R	-
21	BR/W	-

Connector No.	D1
Connector Name	WIRE TO WIRE
Connector Color	WHITE

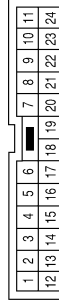

Terminal No.	Color of Wire	Signal Name
1	R/G	-
2	G/O	-
3	Y/G	-
4	P	-
5	LG/B	-
8	SB	-

Connector No.	B208
Connector Name	POWER SEAT SWITCH LH
Connector Color	WHITE



Terminal No.	Color of Wire	Signal Name
1	P/B	-
2	R/W	-
3	B	-
5	L/B	-
6	Y/B	-
7	R/B	-
8	G/W	-
9	O/B	-
10	G/B	-

ALJIA0166GB

A  
B  
C  
D  
E  
F  
G  
H  
I  
ADP  
K  
L  
M  
N  
O  
P

# AUTOMATIC DRIVE POSITIONER CONTROL UNIT

< ECU DIAGNOSIS >

Connector No.	D5
Connector Name	SEAT MEMORY SWITCH
Connector Color	WHITE



Terminal No.	Color of Wire	Signal Name
1	LG/B	SET 1
2	P/L	SET 2
3	G/O	SET SW
4	B	GND
5	Y/R	-
6	P	IND1
7	Y/G	IND2

Connector No.	D4
Connector Name	DOOR MIRROR LH
Connector Color	WHITE



Terminal No.	Color of Wire	Signal Name
1	R	-
2	BR	-
3	O	-
5	W/L	-
6	W/G	-
7	L/Y	-
8	G	-

Connector No.	D2
Connector Name	WIRE TO WIRE
Connector Color	WHITE



Terminal No.	Color of Wire	Signal Name
14	B	-

Connector No.	D107
Connector Name	DOOR MIRROR RH
Connector Color	WHITE



Terminal No.	Color of Wire	Signal Name
1	GR/R	-
2	V/R	-
3	Y	-
5	W/L	-
6	W/G	-
7	R/B	-
8	L/W	-

Connector No.	D102
Connector Name	WIRE TO WIRE
Connector Color	BROWN



Terminal No.	Color of Wire	Signal Name
8	Y	-
9	R/B	-
13	W/G	-
14	W/L	-
15	V/R	-
16	L/W	-
20	GR/R	-

Connector No.	D10
Connector Name	DOOR MIRROR REMOTE CONTROL SWITCH
Connector Color	WHITE

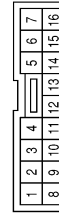

Terminal No.	Color of Wire	Signal Name
4	GR	-
7	B	-
10	BR/W	-
11	LG	-
12	SB	-
13	V/W	-
15	Y/B	-

ALJIA0167GB



# BCM (BODY CONTROL MODULE)

< ECU DIAGNOSIS >

## BCM (BODY CONTROL MODULE)

### Reference Value

INFOID:000000001608196

### VALUES ON THE DIAGNOSIS TOOL

#### CONSULT-III MONITOR ITEM

Monitor Item	Condition	Value/Status
DOOR SW-DR	Front door LH closed	Off
	Front door LH opened	On

### TERMINAL LAYOUT

For terminal layout information, refer to [BCS-41, "Terminal Layout"](#).

### PHYSICAL VALUES

For physical value information, refer to [BCS-41, "Physical Values"](#).

### Wiring Diagram

INFOID:000000001608197

For wiring information, refer to [BCS-47, "Wiring Diagram"](#).

### DTC Inspection Priority Chart

INFOID:000000001608199

For DTC priority information, refer to [BCS-50, "DTC Inspection Priority Chart"](#).

### DTC Index

INFOID:000000001608200

For DTC information, refer to [BCS-51, "DTC Index"](#).

A

B

C

D

E

F

G

H

I

ADP

K

L

M

N

O

P

# ADP SYSTEM SYMPTOMS

< SYMPTOM DIAGNOSIS >

## SYMPTOM DIAGNOSIS

### ADP SYSTEM SYMPTOMS

#### Symptom Table

INFOID:000000001608201

**NOTE:**

Always perform the “Basic Inspection” before performing diagnosis in the following table. Refer to [ADP-4](#), “Work Flow”.

#### SYMPTOM 1

Symptom	Diagnosis procedure	Reference page
Manual functions (for specific part) do not operate	Sliding operation	Check sliding switch. <a href="#">ADP-42</a>
	Reclining operation	Check reclining switch. <a href="#">ADP-44</a>
	Lifting operation (front)	Check lifting switch (front). <a href="#">ADP-46</a>
	Lifting operation (rear)	Check lifting switch (rear). <a href="#">ADP-48</a>
	Pedal operation	1. Check pedal adjusting switch. <a href="#">ADP-50</a>
		2. Check pedal adjusting sensor. <a href="#">ADP-73</a>
	Door mirror operation	1. Changeover switch. <a href="#">ADP-55</a>
2. Mirror switch <a href="#">ADP-57</a>		
All parts of seat	Check power seat switch ground circuit. <a href="#">ADP-60</a>	

#### SYMPTOM 2

Symptom	Diagnosis procedure	Reference page
Memory functions (for specific part) do not operate	Sliding operation	Check sliding sensor. <a href="#">ADP-65</a>
	Reclining operation	Check reclining sensor. <a href="#">ADP-67</a>
	Lifting operation (front)	Check lifting sensor (front). <a href="#">ADP-69</a>
	Lifting operation (rear)	Check lifting sensor (rear). <a href="#">ADP-71</a>
	Pedal operation	Check pedal adjusting sensor. <a href="#">ADP-73</a>
	Door mirror operation	Check door mirror sensor. Driver side: <a href="#">ADP-75</a> Passenger side: <a href="#">ADP-77</a>

#### SYMPTOM 3

Symptom	Diagnosis procedure	Reference page
Memory functions and manual functions (for specific part) do not operate	Sliding operation	Check sliding motor. <a href="#">ADP-79</a>
	Reclining operation	Check reclining motor. <a href="#">ADP-81</a>
	Lifting operation (front)	Check lifting motor (front). <a href="#">ADP-83</a>
	Lifting operation (rear)	Check lifting motor (rear). <a href="#">ADP-85</a>
	Pedal operation	Check pedal adjusting motor. <a href="#">ADP-87</a>
	Door mirror operation	Check door mirror motor. <a href="#">ADP-89</a>

#### SYMPTOM 4

# ADP SYSTEM SYMPTOMS

## < SYMPTOM DIAGNOSIS >

Symptom	Diagnosis procedure	Reference page
Entry/Exit assist function does not operate.	1. Check system setting.	<a href="#">ADP-19</a>
	2. Perform initialization.	<a href="#">ADP-20</a>
	3. Check front door switch (driver side).	<a href="#">ADP-63</a>
Intelligent Key interlock function does not operate. (Other automatic operations and Intelligent Key system are normal)	1. Check door lock function.	<a href="#">DLK-19</a>
	2. Perform memory storing.	<a href="#">ADP-9</a>

## SYMPTOM 5

Symptom	Diagnosis procedure	Reference page
Memory indicators 1 and/or 2 do not illuminate.	1. Check seat memory switch.	<a href="#">ADP-53</a>
	2. Check seat memory indicator.	<a href="#">ADP-92</a>

## SYMPTOM 6

Symptom	Diagnosis procedure	Reference page
Memory operation does not operate.	Check A/T device (park position switch).	<a href="#">ADP-61</a>

A  
B  
C  
D  
E  
F  
G  
H  
I  
K  
L  
M  
N  
O  
P

ADP

## NORMAL OPERATING CONDITION

< SYMPTOM DIAGNOSIS >

### NORMAL OPERATING CONDITION

#### Description

INFOID:000000001608202

The following symptoms are normal operations, and they do not indicate a malfunction.

Symptom	Cause	Action to take	Reference page
Entry/Exit assist function does not operate.	No initialization has been performed.	Perform initialization.	<a href="#">ADP-18</a>
	Entry/exit assist function is disabled. <b>NOTE:</b> The entry/exit assist function is disabled before delivery (initial setting).	Change the settings.	<a href="#">ADP-21</a>
Entry assist function does not operate.	Manual operation with power seat switch was performed after exit assist function execution.	Perform the memory function.	<a href="#">ADP-21</a>
Memory function, entry/exit assist function or Intelligent Key interlock function does not operate.	The operating conditions are not fulfilled.	Fulfill the operation conditions.	Memory function: <a href="#">ADP-15</a>
			Exit assist function: <a href="#">ADP-19</a>
			Entry assist function: <a href="#">ADP-21</a>
			Intelligent Key interlock function: <a href="#">ADP-9</a>

# PRECAUTIONS

< PRECAUTION >

## PRECAUTION

### PRECAUTIONS

#### Precaution for Supplemental Restraint System (SRS) "AIR BAG" and "SEAT BELT PRE-TENSIONER"

INFOID:000000001537395

The Supplemental Restraint System such as "AIR BAG" and "SEAT BELT PRE-TENSIONER", used along with a front seat belt, helps to reduce the risk or severity of injury to the driver and front passenger for certain types of collision. This system includes seat belt switch inputs and dual stage front air bag modules. The SRS system uses the seat belt switches to determine the front air bag deployment, and may only deploy one front air bag, depending on the severity of a collision and whether the front occupants are belted or unbelted. Information necessary to service the system safely is included in the SR and SB section of this Service Manual.

#### **WARNING:**

- **To avoid rendering the SRS inoperative, which could increase the risk of personal injury or death in the event of a collision which would result in air bag inflation, all maintenance must be performed by an authorized NISSAN/INFINITI dealer.**
- **Improper maintenance, including incorrect removal and installation of the SRS, can lead to personal injury caused by unintentional activation of the system. For removal of Spiral Cable and Air Bag Module, see the SR section.**
- **Do not use electrical test equipment on any circuit related to the SRS unless instructed to in this Service Manual. SRS wiring harnesses can be identified by yellow and/or orange harnesses or harness connectors.**

#### Precaution for Work

INFOID:000000001537396

- When removing or disassembling each component, be careful not to damage or deform it. If a component may be subject to interference, be sure to protect it with a shop cloth.
- When removing (disengaging) components with a screwdriver or similar tool, be sure to wrap the component with a shop cloth or vinyl tape to protect it.
- Protect the removed parts with a shop cloth and keep them.
- Replace a deformed or damaged clip.
- If a part is specified as a non-reusable part, always replace it with new one.
- Be sure to tighten bolts and nuts securely to the specified torque.
- After re-installation is completed, be sure to check that each part works normally.
- Follow the steps below to clean components.
  - Water soluble foul: Dip a soft cloth into lukewarm water, and wring the water out of the cloth to wipe the fouled area.  
Then rub with a soft and dry cloth.
  - Oily foul: Dip a soft cloth into lukewarm water with mild detergent (concentration: within 2 to 3%), and wipe the fouled area.  
Then dip a cloth into fresh water, and wring the water out of the cloth to wipe the detergent off. Then rub with a soft and dry cloth.
- Do not use organic solvent such as thinner, benzene, alcohol, or gasoline.
- For genuine leather seats, use a genuine leather seat cleaner.

# PRE-INSPECTION FOR DIAGNOSTIC

< ON-VEHICLE MAINTENANCE >

## ON-VEHICLE MAINTENANCE

### PRE-INSPECTION FOR DIAGNOSTIC

#### Basic Inspection

INFOID:000000001611773

#### 1. CHECK POWER SUPPLY AND DROUND CIRCUIT

Check the power supply and ground circuit as shown below.

- Driver seat control unit :Refer to [ADP-40, "DRIVER SEAT CONTROL UNIT : Diagnosis Procedure"](#).
- Automatic drive positioner control unit: Refer to [ADP-41, "AUTOMATIC DRIVE POSITIONER CONTROL UNIT : Diagnosis Procedure"](#).

Is the inspection result normally?

YES >> GO TO 2

NO >> Repair or replace the malfunctioning part.

#### 2. CHECK MANUAL FUNCTION

Check the manual function operations by operating the relevant switches as shown below.

- Seat (slide, reclining, lifting front, lifting rear)
- Pedal assembly (forward, backward)
- Door mirror

Do all manual functions operate normally?

YES >> GO TO 3

NO (Seat, pedal, door mirror)>>Go to SYMPTOM 1, refer to [ADP-130, "Symptom Table"](#). And, GO TO 4 if the result of SYMPTOM 1 is OK.

#### 3. CHECK MEMORY FUNCTION 1

Register the seat positions (refer to Owner's Manual) and check that all parts of the seat, pedals, and door mirrors move to their memory positions correctly.

Are the operations normal?

YES >> Check each malfunction according to the instruction of the SYMPTOM 4, refer to [ADP-130, "Symptom Table"](#).

No (memory indicator operates normally)>> Go to SYMPTOM 2, refer to [ADP-130, "Symptom Table"](#).

No (memory indicator does not operate normally either)>> GO TO 5

#### 4. CHECK MEMORY FUNCTION 2

Register the seat positions (refer to Owner's Manual) and check that all parts of the seat, pedals, and door mirrors move to their memory positions correctly.

Are the operations normal?

YES >> Check intermittent incident. Refer to [GI-39, "Intermittent Incident"](#).

NO >> GO TO 7

#### 5. CHECK SEAT MEMORY SWITCH/MEMORY INDICATOR

Check the seat memory switch/memory switch indicator of the SYMPTOM 5, refer to [ADP-130, "Symptom Table"](#).

Is the inspection result normal?

YES >> GO TO 6

NO >> Repair or replace the malfunctioning part.

#### 6. CHECK OPERATION CONDITION

Check the memory operation conditions (refer to [ADP-9, "AUTOMATIC DRIVE POSITIONER SYSTEM : System Description"](#)).

Are all operation conditions fulfilled?

YES >> Go to SYMPTOM 6, refer to [ADP-130, "Symptom Table"](#).

NO >> Fulfill the operation conditions. Refer to [ADP-9, "AUTOMATIC DRIVE POSITIONER SYSTEM : System Description"](#).

#### 7. CHECK MECHANISM

# PRE-INSPECTION FOR DIAGNOSTIC

## < ON-VEHICLE MAINTENANCE >

---

Check for the following.

- Mechanism deformation or pinched foreign materials.
- Interference with other parts because of poor installation.

Is any malfunction present in the relevant parts?

- YES >> Go to SYMPTOM 3, refer to [ADP-130, "Symptom Table"](#).  
NO >> Repair or replace the malfunctioning part.

A

B

C

D

E

F

G

H

I

ADP

K

L

M

N

O

P

# PREPARATION

< PREPARATION >



## PREPARATION

### PREPARATION

#### Special Service Tool

INFOID:000000001537397

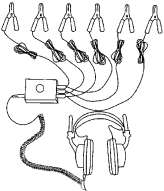
The actual shapes of Kent-Moore tools may differ from those of special service tools illustrated here.

Tool number (Kent-Moore No.) Tool name	Description
<p>— (J-39570) Chassis ear</p>  <p style="text-align: right;">SIIA0993E</p>	<p>Locating the noise</p>
<p>— (J-43980) NISSAN Squeak and Rattle Kit</p>  <p style="text-align: right;">SIIA0994E</p>	<p>Repairing the cause of noise</p>

#### Commercial Service Tool

INFOID:000000001537398

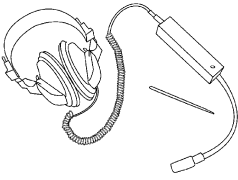
(Kent-Moore No.) Tool name	Description
<p>(J-39565) Engine ear</p>  <p style="text-align: right;">SIIA0995E</p>	<p>Locating the noise</p>



# AUTOMATIC DRIVE POSITIONER

< REMOVAL AND INSTALLATION >

---

## REMOVAL AND INSTALLATION

### AUTOMATIC DRIVE POSITIONER

#### Removal and Installation

INFOID:000000001537445

Refer to [ACC-3, "Removal and Installation"](#) and [BR-19, "Removal and Installation"](#).

A

B

C

D

E

F

G

H

I

ADP

K

L

M

N

O

P