

SECTION **BRM**
BODY REPAIR

A
B
C
D
E
F
G
H
I
J
L
M
N
O
P

CONTENTS

SERVICE INFORMATION	2	Body Sealing	12
BODY REPAIR	2	Body Construction	16
Body Mounting	2	Body Alignment	16
Body Exterior Paint Color	3	Handling Precaution for Plastics	31
Body Component Parts	4	Precaution in Repairing High Strength Steel	34
Corrosion Protection	9	Foam Repair	36
		Replacement Operation	37

BRM

BODY REPAIR

< SERVICE INFORMATION >

SERVICE INFORMATION

BODY REPAIR

Body Mounting

INFOID:000000003229748

When removing, be sure to replace bolts and nuts (sealant applied bolts or self-lock nuts are used for all mounting).

SEC. 930

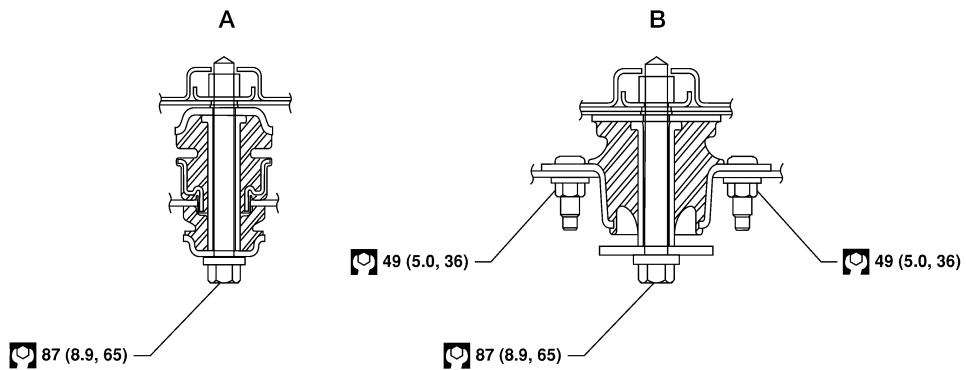
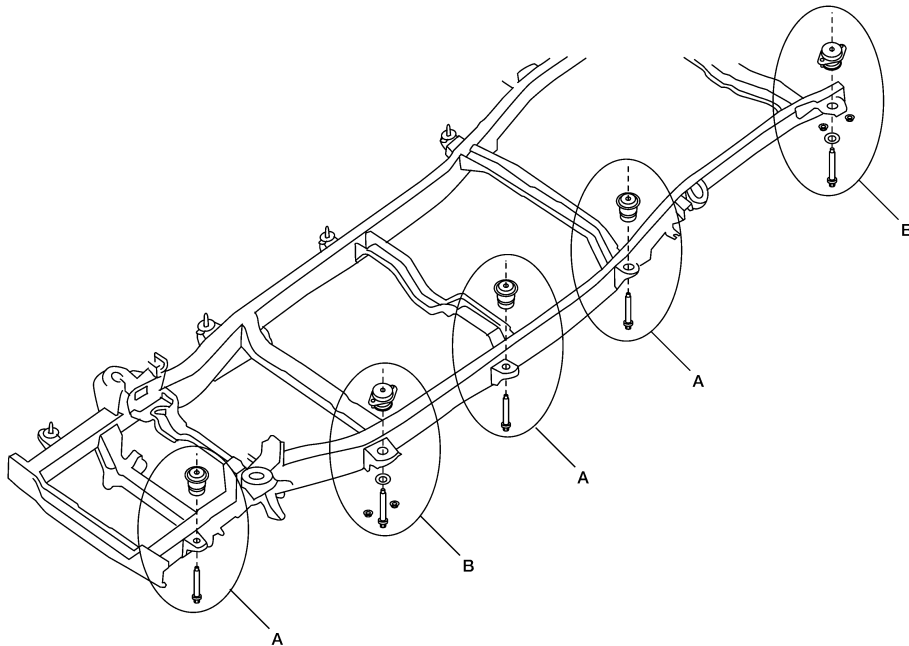

 N·m (kg-m, ft-lb)

LIIA1564E

BODY REPAIR

< SERVICE INFORMATION >

Body Exterior Paint Color

INFOID:000000001537381

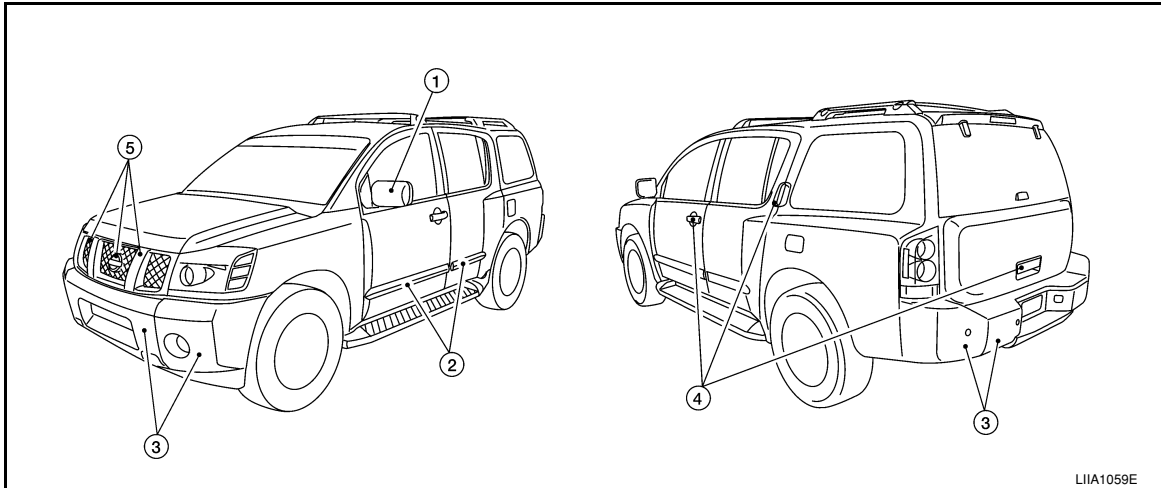

LIA1059E

Component			Color code	A15	B18	BW9	G10	K11	K12	KY2	Q10
			Description	Red Brawn	Deep Water Blue	Majestic Blue	Galaxy	Smoke	Silver Lightening	Granite	Blizzard
			Type	M	M	M	M	M	M	M	S
			Clear coat	t	t	t	t	t	t	t	t
1	Outside mirror	Body	Body color	A15	B18	BW9	G10	K11	K12	KY2	Q10
		Base	Black	KH3	KH3	KH3	KH3	KH3	KH3	KH3	KH3
2	Side Guard Molding		Body color	A15	B18	BW9	G10	K11	K12	KY2	Q10
3	Bumpers	Fascias	Body color	A15	B18	BW9	G10	K11	K12	KY2	Q10
		Center	Chromium plate	Cr2P	Cr2P	Cr2P	Cr2P	Cr2P	Cr2P	Cr2P	Cr2P
4	Outside handles	Front	Chromium plate	Cr2P	Cr2P	Cr2P	Cr2P	Cr2P	Cr2P	Cr2P	Cr2P
		Rear	Body color	A15	B18	BW9	G10	K11	K12	KY2	Q10
5	Radiator grille	Center and emblem	Chromium plate	Cr2P	Cr2P	Cr2P	Cr2P	Cr2P	Cr2P	Cr2P	Cr2P
		Center	Black	KH3	KH3	KH3	KH3	KH3	KH3	KH3	KH3

M: Metallic; S-Solid; 2S: 2-Coat Solid, 2P: 2-Coat Pearl; 3P: 3-Coat Pearl; t: New Cross Linking Clear Coat

A
B
C
D
E
F
G
H
I
J
K
L
M
N
O
P

BRM

BODY REPAIR

< SERVICE INFORMATION >

Body Component Parts

INFOID:000000001537382

UNDERBODY COMPONENT PARTS

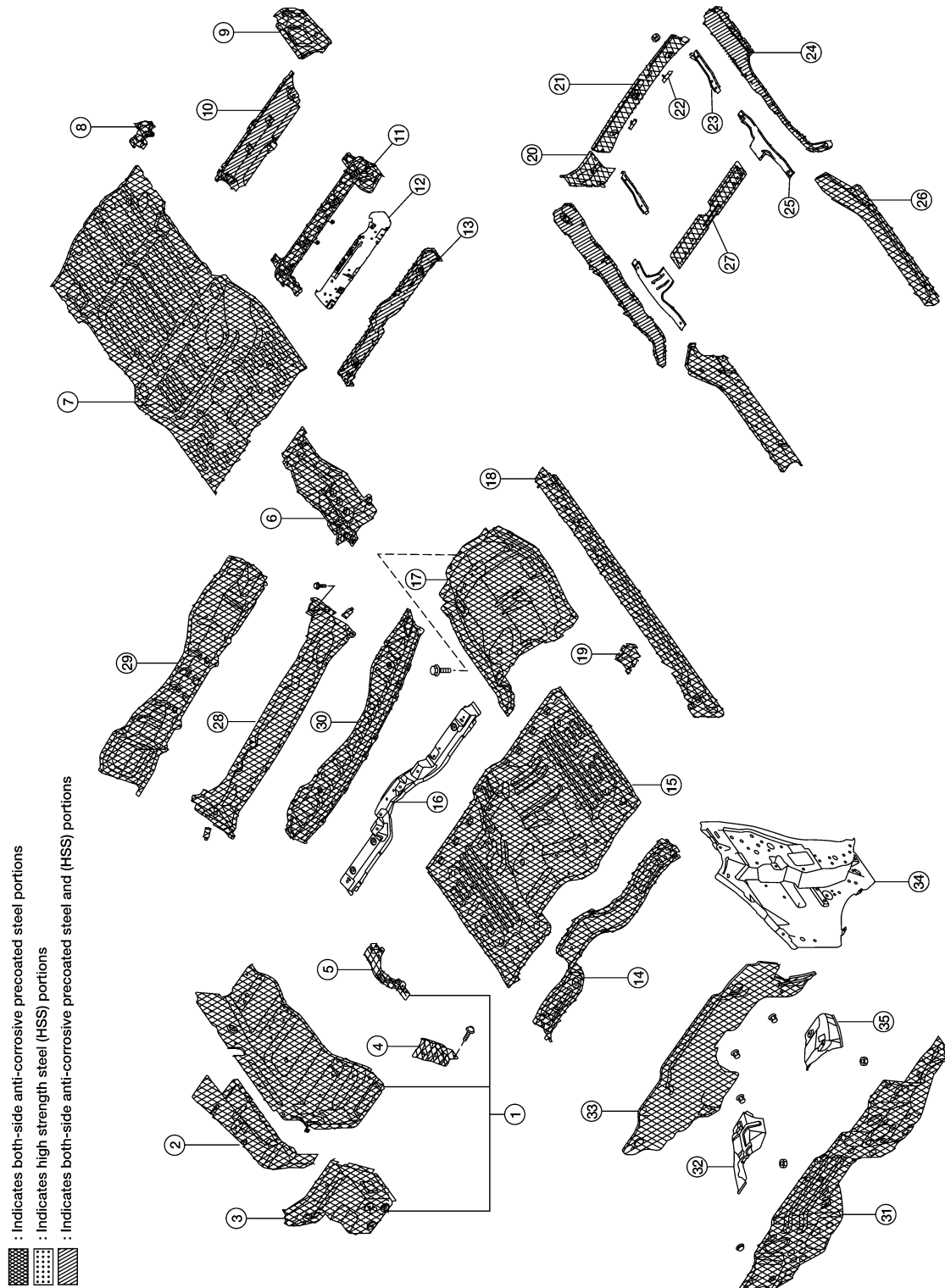

LIA0908E

1. Hoodledge assembly (RH, LH)
2. Hoodledge reinforcement (RH, LH)
3. Body mounting bracket (RH, LH)
4. Hoodledge front brace (RH), Battery mounting bracket (LH)

BRM-4

BODY REPAIR



< SERVICE INFORMATION >

5. Harness connector bracket	A
6. Rear floor reinforcement	
7. Rear floor	
8. Rear floor reinforcement	
9. Rear floor side (RH, LH)	B
10. Crossmember	
11. Second seat rear crossmember	C
12. Second seat front crossmember	
13. Rear front seat crossmember	
14. Second Body crossmember	D
15. Front floor	
16. Front seat front crossmember	
17. Front floor reinforcement	E
18. Outer sill (RH, LH)	
19. Second crossmember extension	F
20. Rear crossmember end	
21. Rear lower crossmember end	
22. Rear crossmember end (RH, LH)	G
23. Rear side member rear reinforcement (RH, LH)	
24. Rear side member (RH, LH)	
25. Rear side member reinforcement (RH, LH)	H
26. Inner sill extension (RH, LH)	
27. Rear crossmember	
28. Upper dash top	I
29. Upper dash bottom	
30. Cowl top	J
31. Lower dash	
32. Lower dash insulator (RH)	
33. Lower dash reinforcement	BRM
34. Side dash (RH, LH)	
35. Lower dash insulator	L

BODY REPAIR

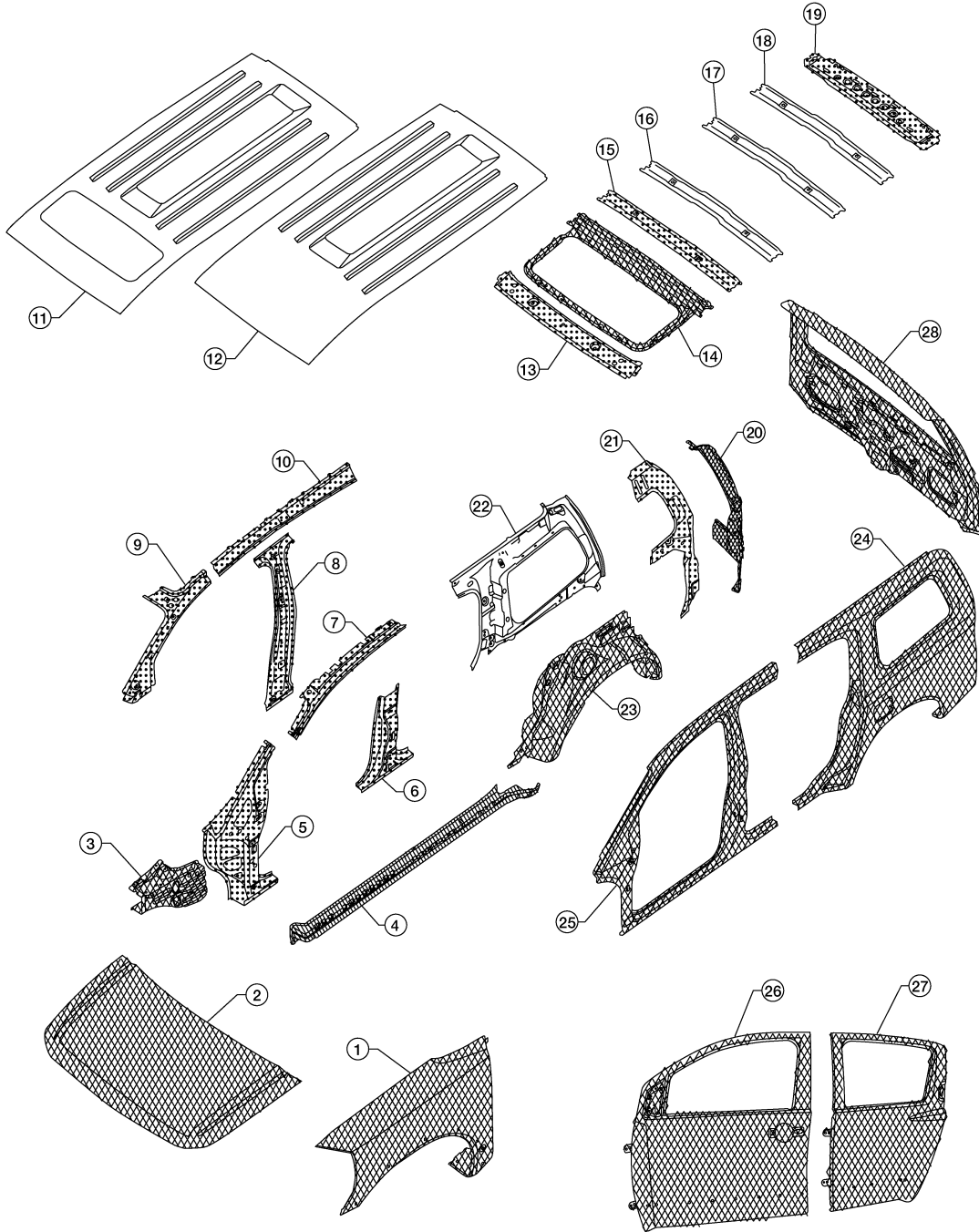
< SERVICE INFORMATION > BODY COMPONENT PARTS



-  : Indicates both-side anti-corrosive pre-coated steel portions
-  : Indicates high strength steel (HSS) portions
-  : Indicates both-side anti-corrosive pre-coated steel and (HSS) portions

WIIA0299E

1. Front fender (RH, LH)
2. Hood assembly
3. Rear hoodledge reinforcement (RH, LH)
4. Outer sill reinforcement (RH, LH)

BODY REPAIR

< SERVICE INFORMATION >

- | | |
|--|---|
| 5. Front pillar hinge brace (RH, LH) | A |
| 6. Center pillar hinge brace | |
| 7. Outer front pillar reinforcement (RH, LH) | |
| 8. Center inner pillar (RH, LH) | B |
| 9. Front inner pillar upper (RH, LH) | |
| 10. Inner roof side rail (RH, LH) | |
| 11. Roof with sunroof opening | C |
| 12. Roof | |
| 13. Front roof rail | |
| 14. Sunroof reinforcement | D |
| 15. Roof 1st bow | |
| 16. Roof 2nd bow | |
| 17. Roof 3rd bow | E |
| 18. Roof 4th bow | |
| 19. Rear roof rail | |
| 20. Main back pillar (RH, LH) | F |
| 21. Back pillar reinforcement (RH, LH) | |
| 22. Rear inner side panel (RH, LH) | G |
| 23. Rear wheel housing (RH, LH) | |
| 24. Rear body side outer (RH, LH) | |
| 25. Front body side outer (RH, LH) | H |
| 26. Front door assembly (RH, LH) | |
| 27. Rear door assembly (RH, LH) | |
| 28. Lift gate assembly | I |

J

BRM

L

M

N

O

P

BODY REPAIR

< SERVICE INFORMATION > FRAME COMPONENT PARTS

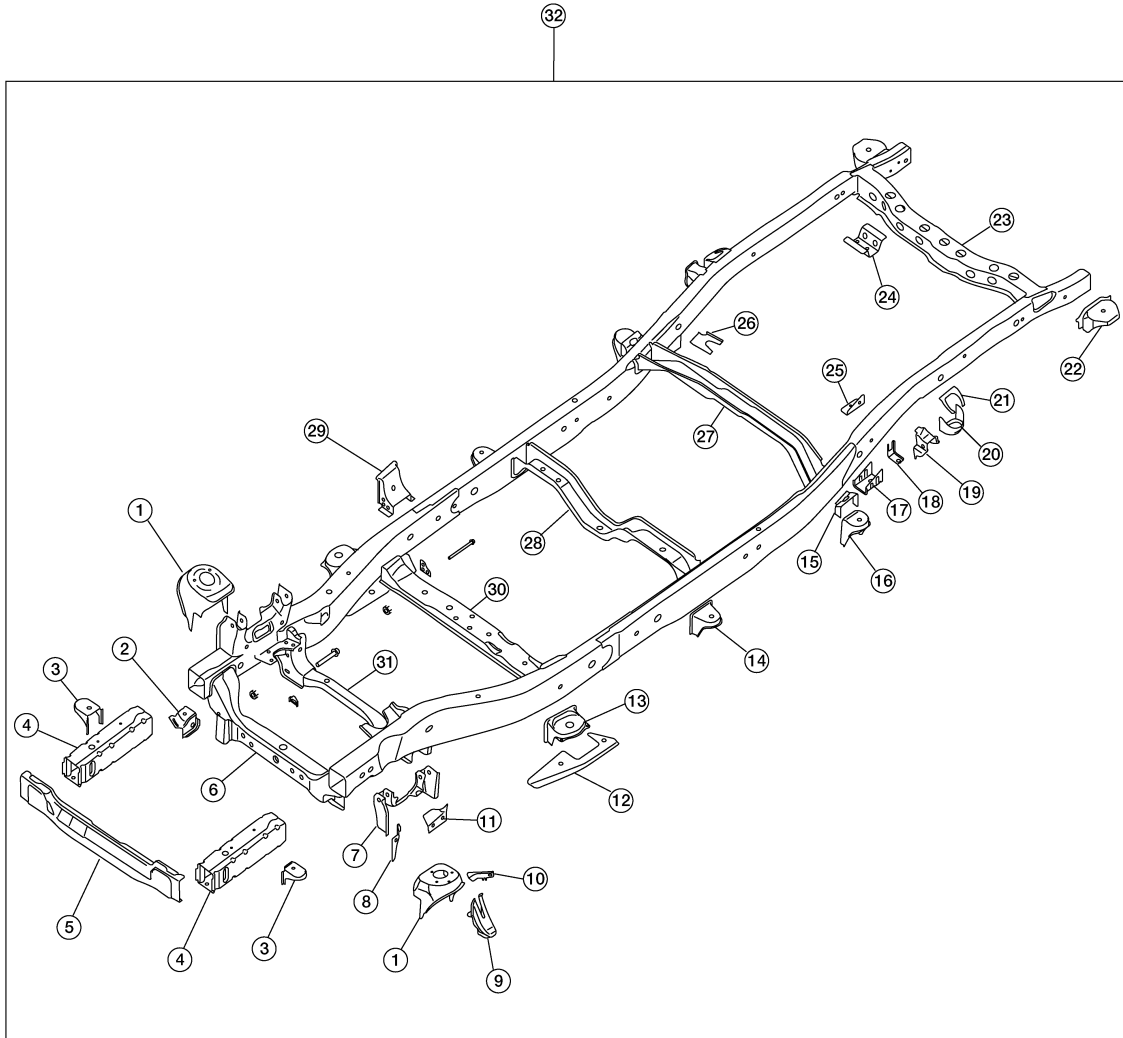

LIA1594E

1. Front shock absorber bracket RH/LH
2. Front differential mounting bracket RH/LH
3. 1st cab mounting bracket RH/LH
4. Front side member extension assembly RH/LH
5. 1st crossmember assembly

BRM-8

BODY REPAIR

< SERVICE INFORMATION >

6. 2nd crossmember assembly
7. Front upper link mounting bracket RH/LH
8. Panhard rod bracket reinforcement
9. Bound bumper bracket RH/LH
10. Front brake hose bracket RH/LH
11. Panhard rod reinforcement
12. 4th crossmember gusset RH/LH
13. 2nd cab mounting bracket RH/LH
14. 3rd cab mounting bracket RH/LH
15. 4th cab mounting reinforcement RH/LH
16. 4th cab mounting bracket RH/LH
17. Rear suspension mounting bracket RH/LH
18. Rear brake hose bracket
19. Rear shock absorber bracket assembly RH/LH
20. Rear bound bumper bracket RH/LH
21. Rear bracket bumper reinforcement RH/LH
22. Cab mounting bracket assembly RH/LH
23. 9th crossmember assembly
24. Exhaust bracket assembly
25. Canister bracket, LH
26. 7th crossmember reinforcement
27. 7th crossmember assembly
28. 6th crossmember assembly
29. 4th crossmember gusset RH/LH
30. 4th crossmember assembly
31. 3rd crossmember assembly
32. Frame assembly

A
B
C
D
E
F
G
H
I
J

Corrosion Protection

INFOID:000000001537383

BRM

DESCRIPTION

To provide improved corrosion prevention, the following anti-corrosive measures have been implemented in NISSAN production plants. When repairing or replacing body panels, it is necessary to use the same anti-corrosive measures.

L
M
N
O
P

ANTI-CORROSIVE PRECOATED STEEL (GALVANNEALED STEEL)

To improve repairability and corrosion resistance, a new type of anti-corrosive pre-coated steel sheet has been adopted replacing conventional zinc-coated steel sheet.

Galvannealed steel is electroplated and heated to form Zinc-iron alloy, which provides excellent and long term corrosion resistance with cationic electrode position primer.

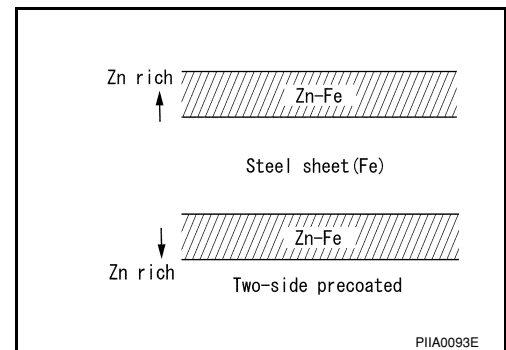

Nissan Genuine Service Parts are fabricated from galvannealed steel. Therefore, it is recommended that GENUINE NISSAN PARTS or equivalent be used for panel replacement to maintain the anti-corrosive performance built into the vehicle at the factory.

PHOSPHATE COATING TREATMENT AND CATIONIC ELECTRODEPOSITION PRIMER

BODY REPAIR

< SERVICE INFORMATION >

A phosphate coating treatment and a cationic electrodeposition primer, which provide excellent corrosion protection, are employed on all body components.

CAUTION:

Confine paint removal during welding operations to an absolute minimum.

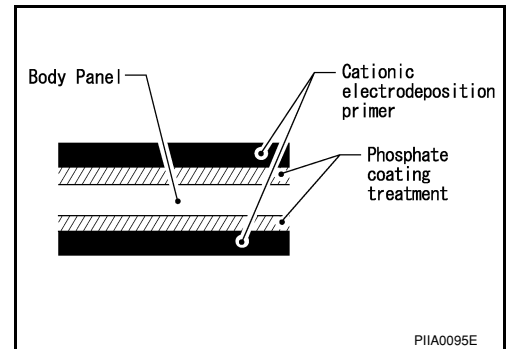

Nissan Genuine Service Parts are also treated in the same manner. Therefore, it is recommended that GENUINE NISSAN PARTS or equivalent be used for panel replacement to maintain anti-corrosive performance built into the vehicle at the factory.

ANTI-CORROSIVE WAX



To improve corrosion resistance, anti-corrosive wax is applied inside the body sill and inside other closed sections. Accordingly, when replacing these parts, be sure to apply anti-corrosive wax to the appropriate areas of

BODY REPAIR

< SERVICE INFORMATION >

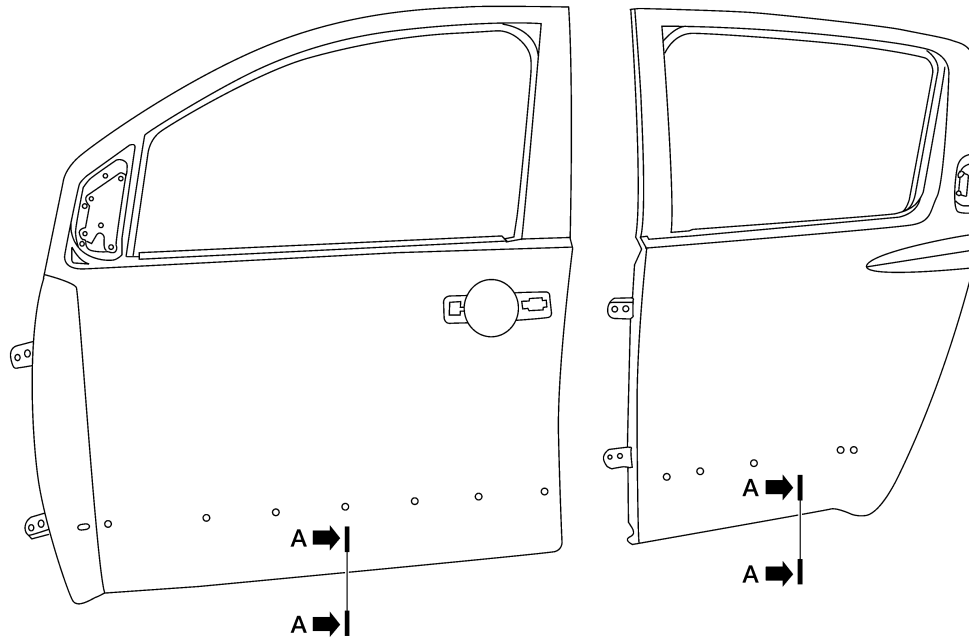
the new parts. Select an excellent anti-corrosive wax which will penetrate after application and has a long shelf life.



 : Indicates outside body sealant
 : Indicates anti-corrosive wax coated portions

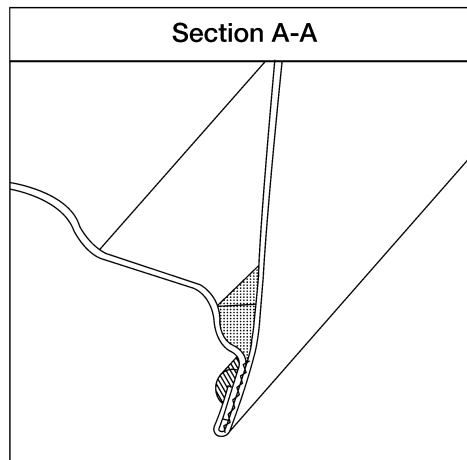

LIA0905E

UNDERCOATING

The underside of the floor and wheelhouse are undercoated to prevent rust, vibration, noise and stone chipping. Therefore, when such a panel is replaced or repaired, apply undercoating to that part. Use an undercoating which is rust preventive, soundproof, vibration-proof, shock-resistant, adhesive, and durable.

Precautions in undercoating

1. Do not apply undercoating to any place unless specified (such as the areas above the muffler and three way catalyst which are subjected to heat).
2. Do not undercoat the exhaust pipe or other parts which become hot.
3. Do not undercoat rotating parts.

A
B
C
D
E
F
G
H
I
J
L
M
N
O
P

BRM

BODY REPAIR

< SERVICE INFORMATION >

4. Apply bitumen wax after applying undercoating.

 : Indicates undercoated portions.

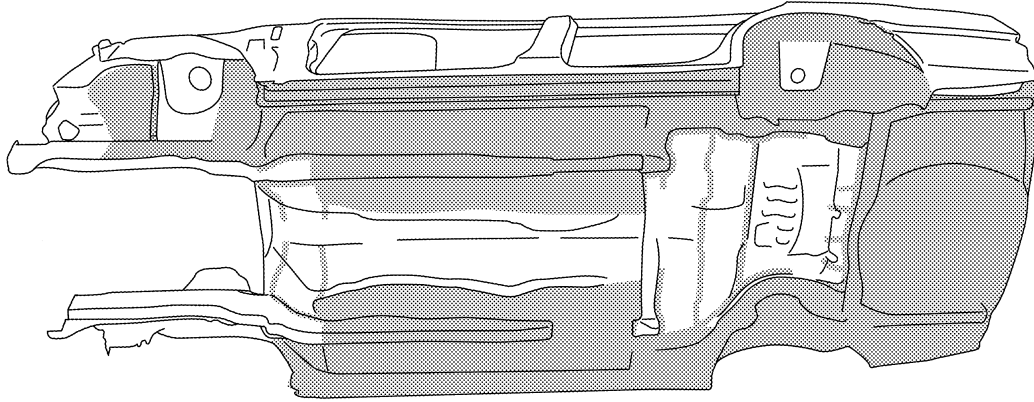

LIA0129E

INFOID:000000001537384

Body Sealing

DESCRIPTION

BODY REPAIR

< SERVICE INFORMATION >

The following figure shows the areas which are sealed at the factory. Sealant which has been applied to these areas should be smooth and free from cuts or gaps. Care should be taken not to apply an excess amount of sealant and not to allow other unaffected parts to come into contact with the sealant.

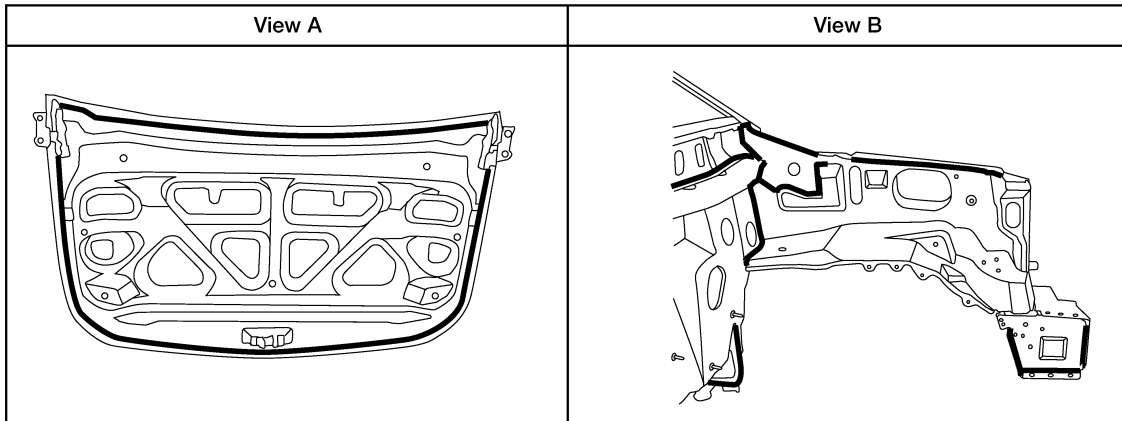
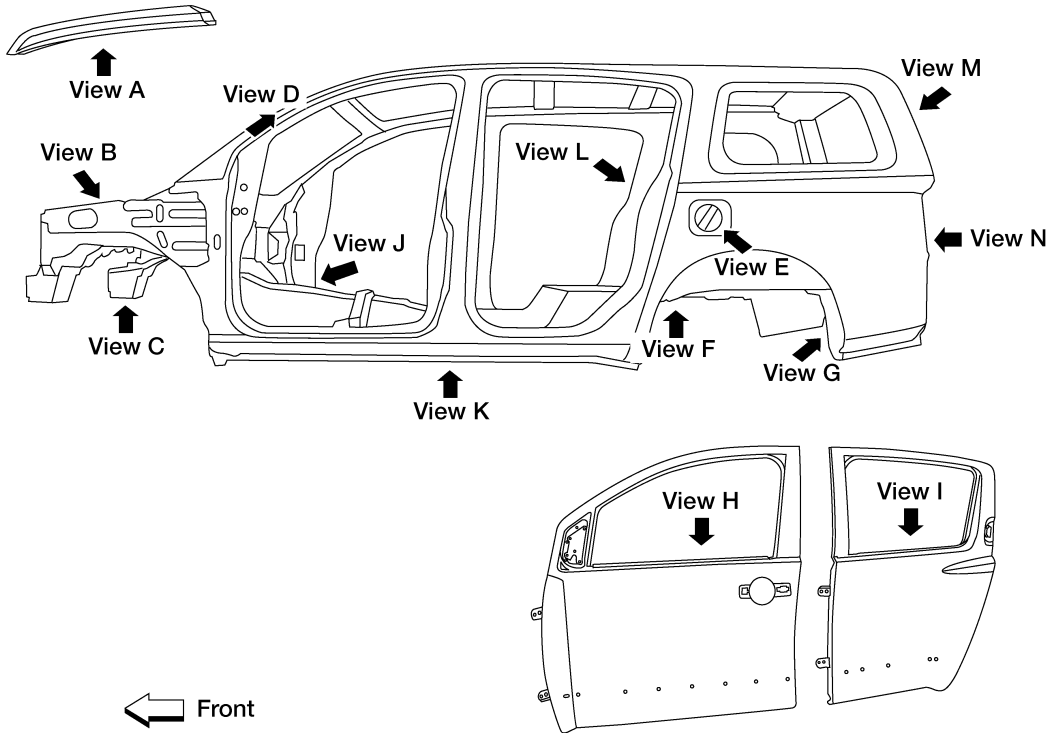

WI1A0300E

A
B
C
D
E
F
G
H
I
J
L
M
N
O
P

BRM

BODY REPAIR

< SERVICE INFORMATION >

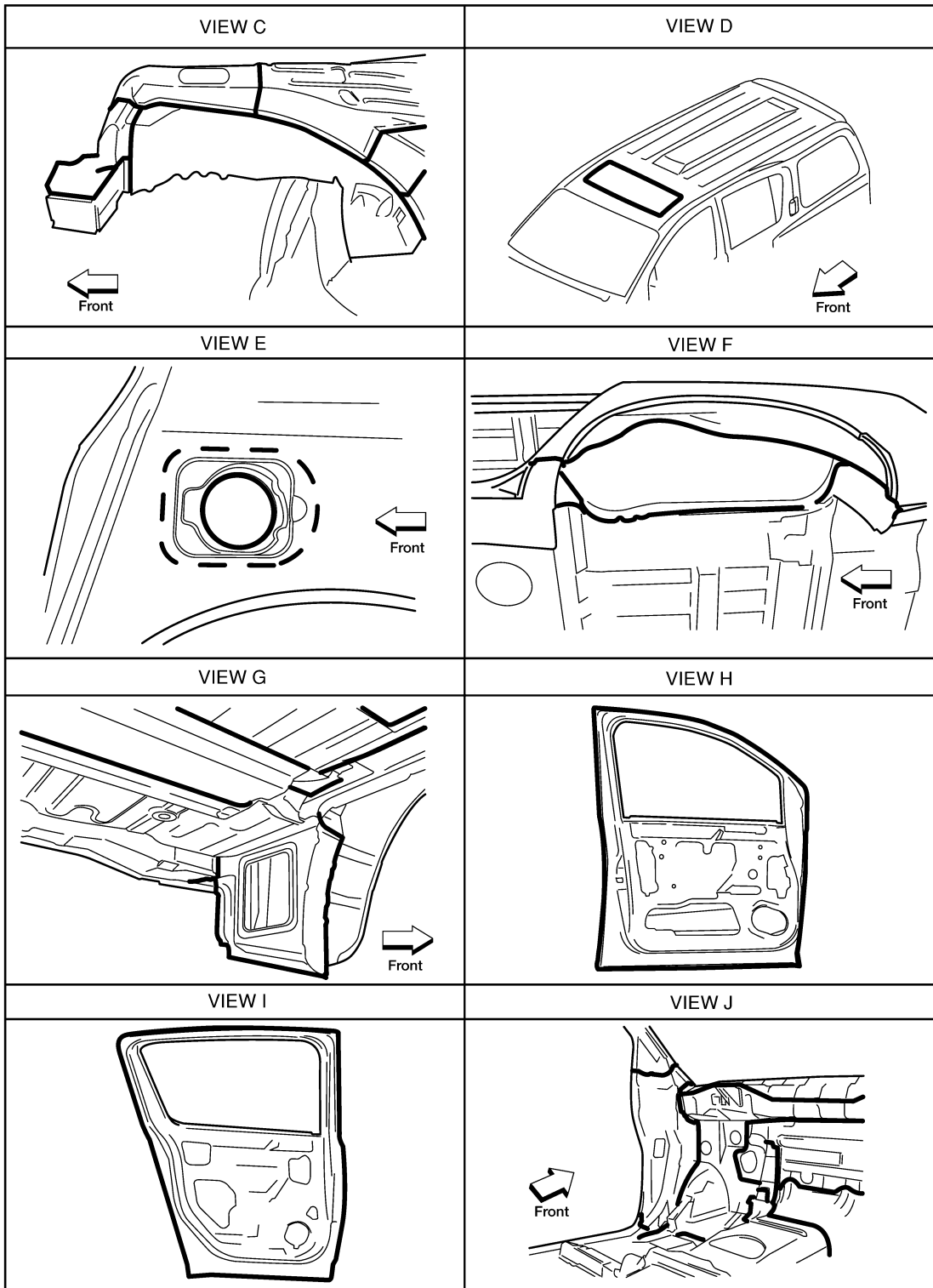

WIA0278E

BODY REPAIR

< SERVICE INFORMATION >

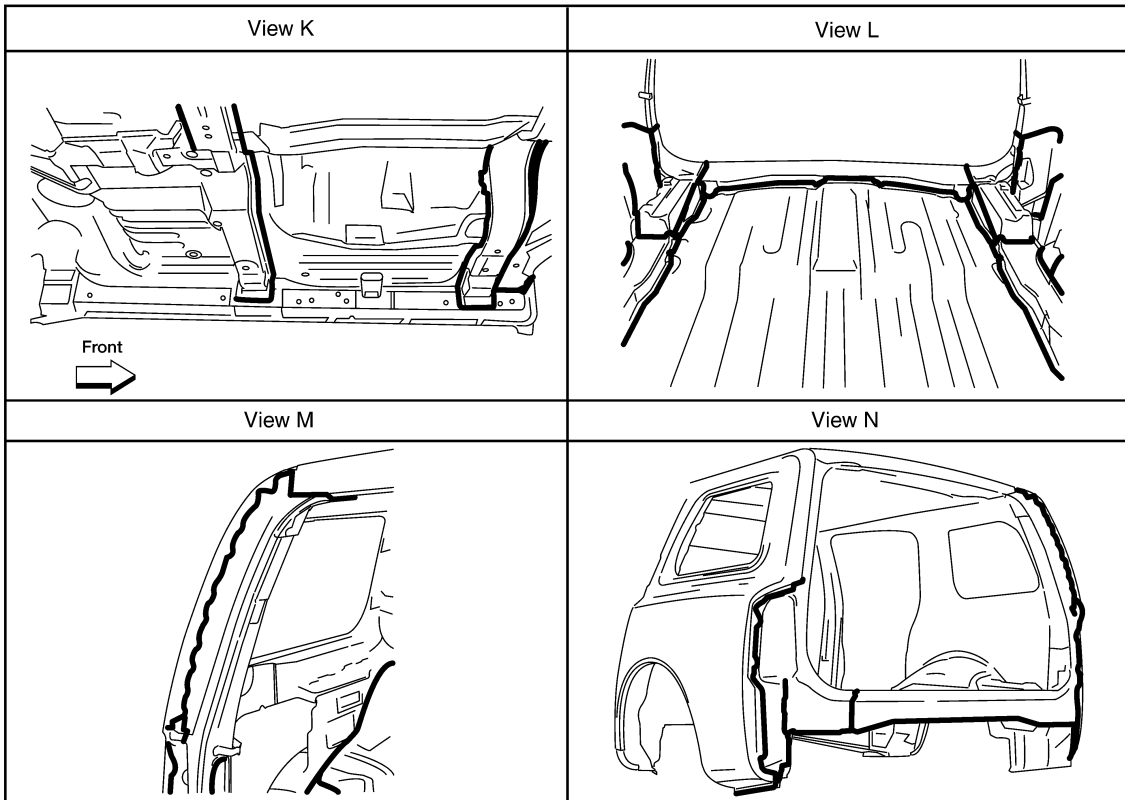

A
B
C
D
E
F
G
H
I
J
L
M
N
O
P

BRM

LIA0912E

BODY REPAIR

< SERVICE INFORMATION >

Body Construction

INFOID:000000001537385

BODY CONSTRUCTION

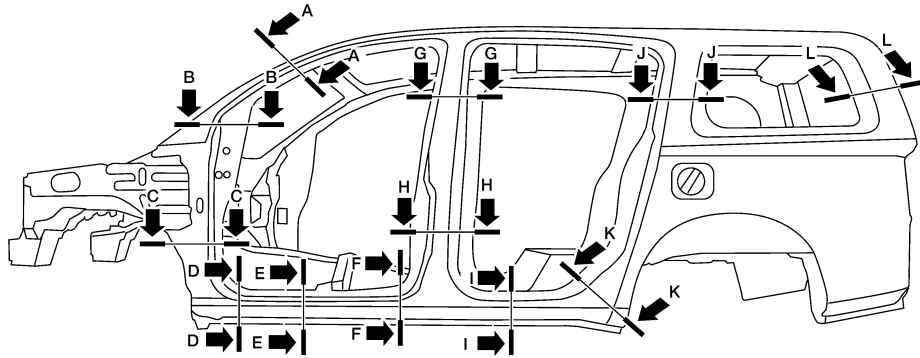

Section A-A	Section B-B	Section C-C	Section D-D
Section E-E	Section F-F	Section G-G	Section H-H
Section I-I	Section J-J	Section K-K	Section L-L

LIA1113E

Body Alignment

INFOID:000000001537386

BODY CENTER MARKS

BODY REPAIR

< SERVICE INFORMATION >

A mark has been placed on each part of the body to indicate the vehicle center. When repairing parts damaged by an accident which might affect the vehicle frame (members, pillars, etc.), more accurate and effective repair will be possible by using these marks together with body alignment specifications.

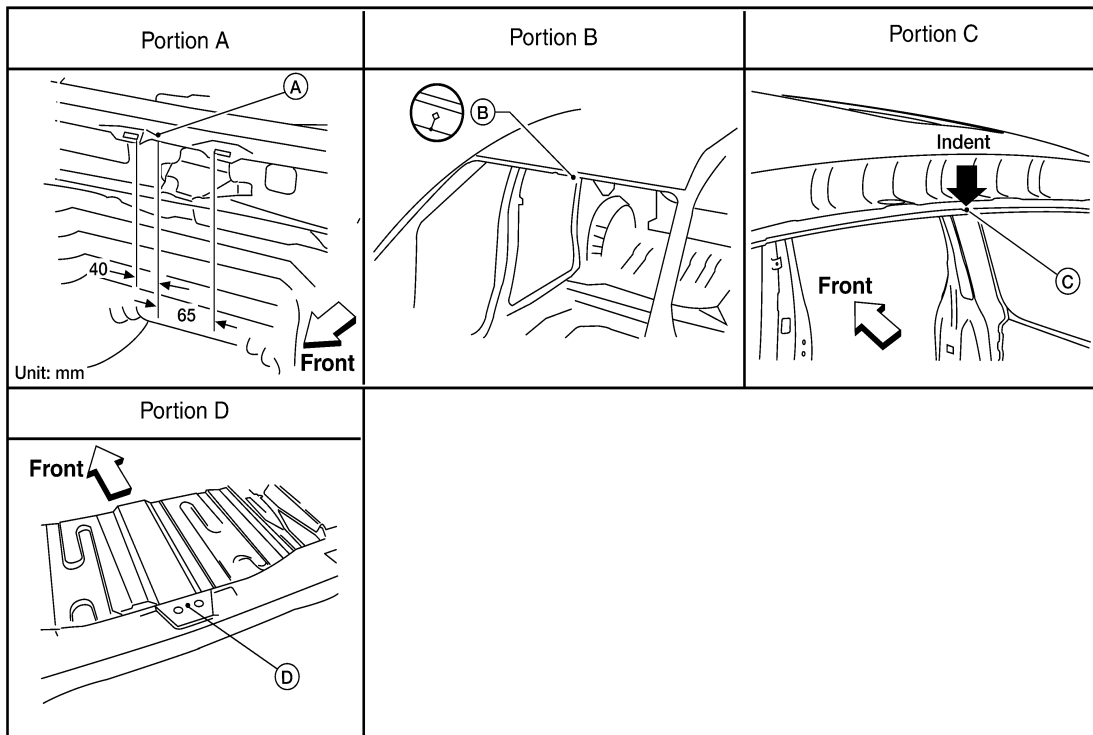
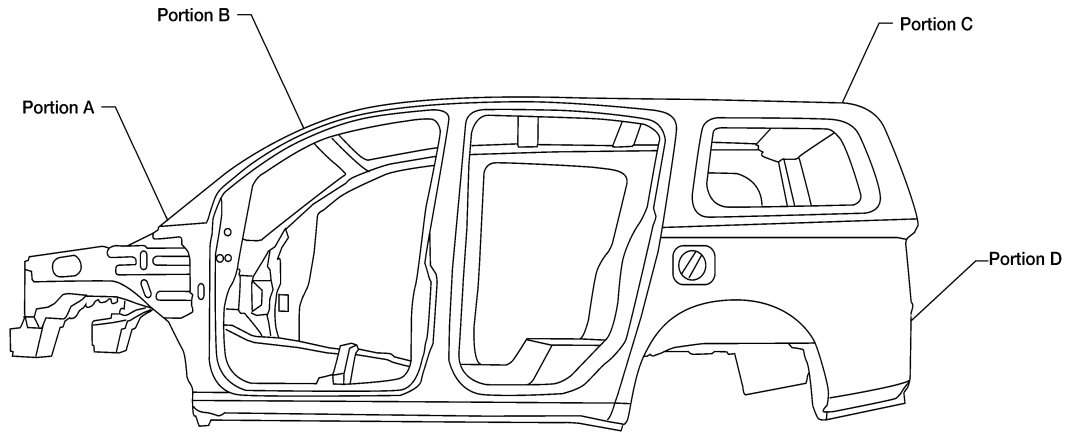

PANEL PARTS MATCHING MARKS

LIA1440E

A
B
C
D
E
F
G
H
I
J
L
M
N
O
P

BRM

BODY REPAIR

< SERVICE INFORMATION >

A mark has been placed on each body panel to indicate the parts matching positions. When repairing parts damaged by an accident which might affect the vehicle structure (members, pillars, etc.), more accurate and effective repair will be possible by using these marks together with body alignment specifications.

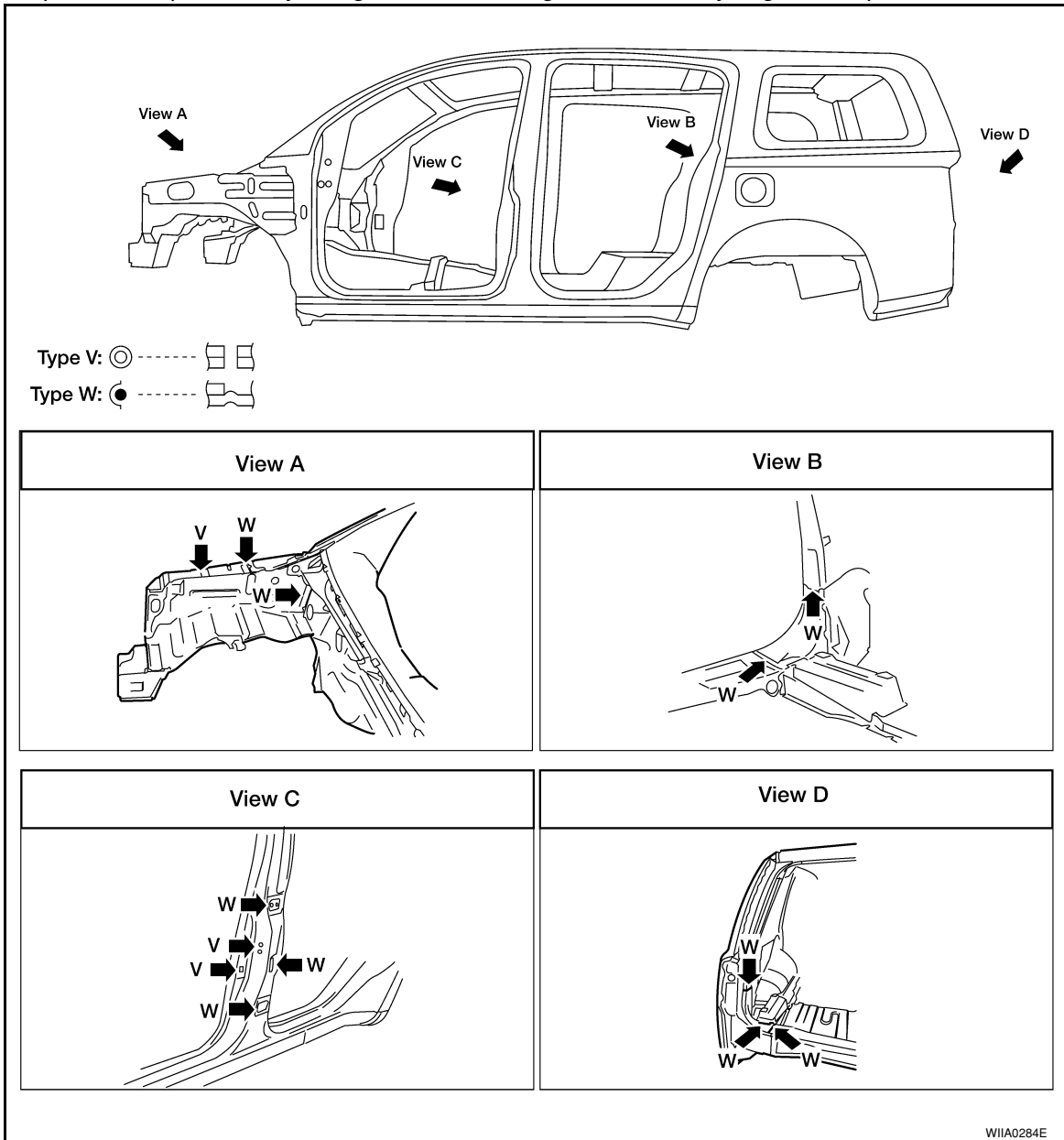

DESCRIPTION

- All dimensions indicated in the figures are actual.
- When using a tracking gauge, adjust both pointers to equal length. Then check the pointers and gauge itself to make sure there is no free play.
- When a measuring tape is used, check to be sure there is no elongation, twisting or bending.
- Measurements should be taken at the center of the mounting holes.
- An asterisk (*) following the value at the measuring point indicates that the measuring point on the other side is symmetrically the same value.
- The coordinates of the measurement points are the distances measured from the standard line of "X", "Y" and "Z".

BODY REPAIR

< SERVICE INFORMATION >

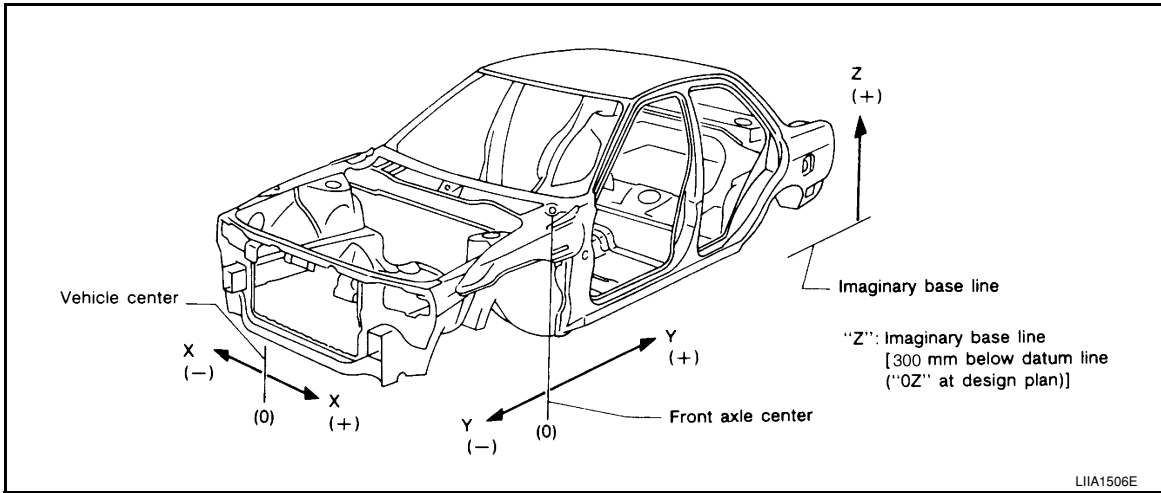

Engine Compartment

A
B
C
D
E
F
G
H
I
J
L
M
N
O
P

BRM

BODY REPAIR

< SERVICE INFORMATION >

MEASUREMENT

Figures marked with a (*) indicate symmetrically identical dimensions on both right and left hand sides of the vehicle.

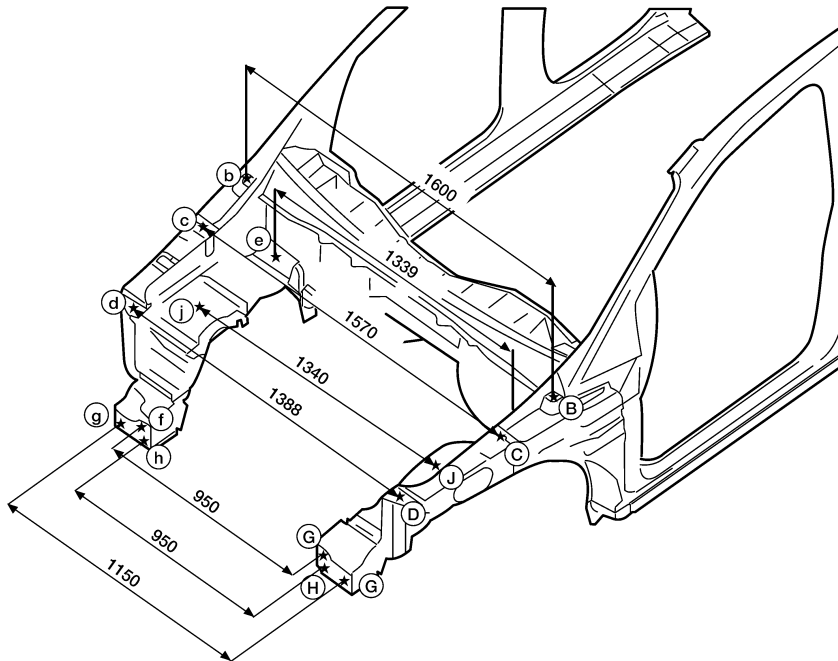
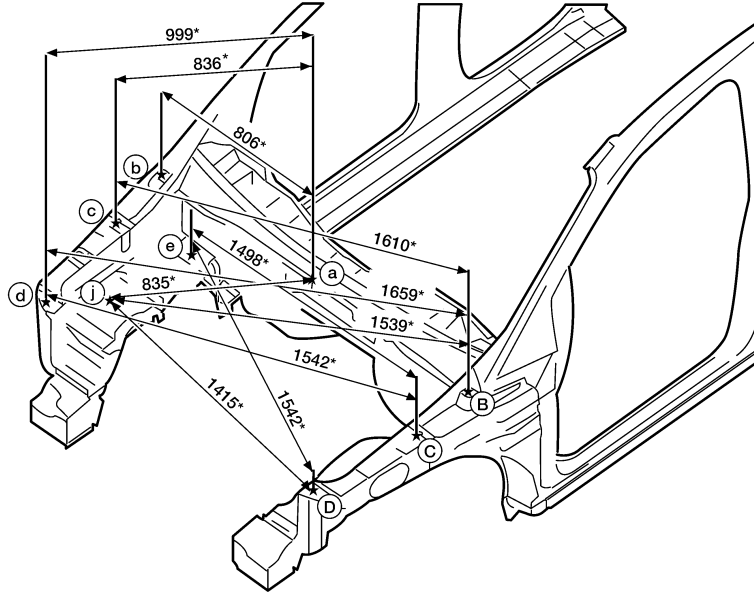

Unit: mm

WIIA0551E

BODY REPAIR

< SERVICE INFORMATION >

MEASUREMENT POINTS

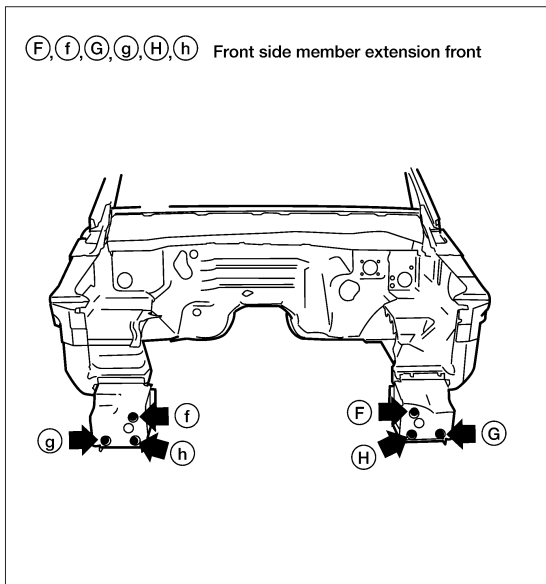
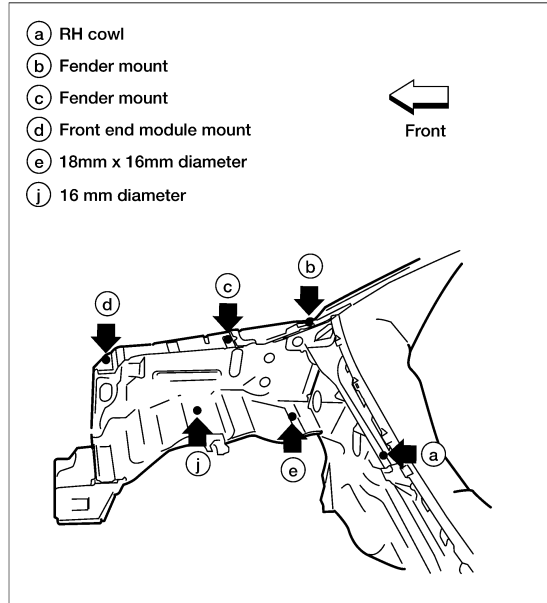
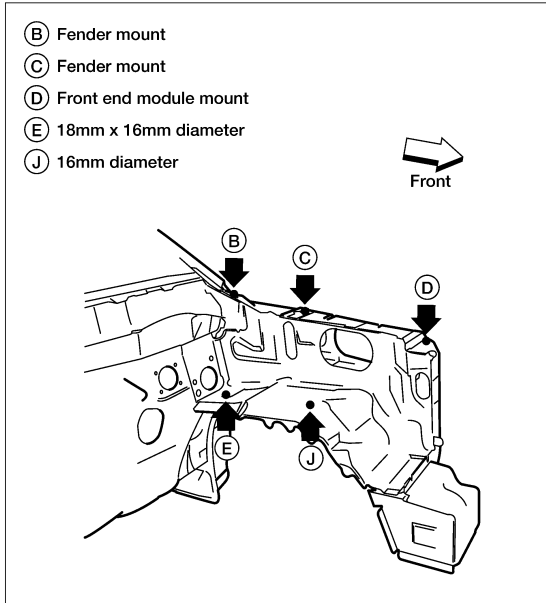

Underbody

WIA0279E

A
B
C
D
E
F
G
H
I
J
BRM
L
M
N
O
P

BODY REPAIR

< SERVICE INFORMATION >

MEASUREMENT

Figures marked with a (*) indicate symmetrically identical dimensions on both right and left hand sides of the vehicle.

As viewed from underside.

All dimensions indicated in this figure are actual.

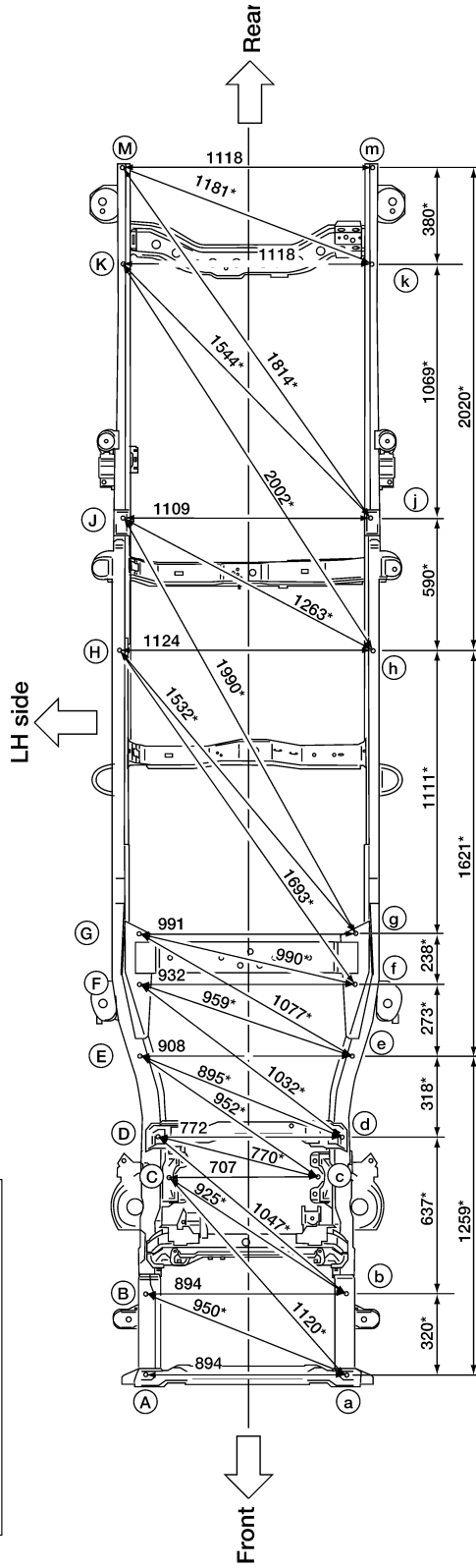

Unit: mm

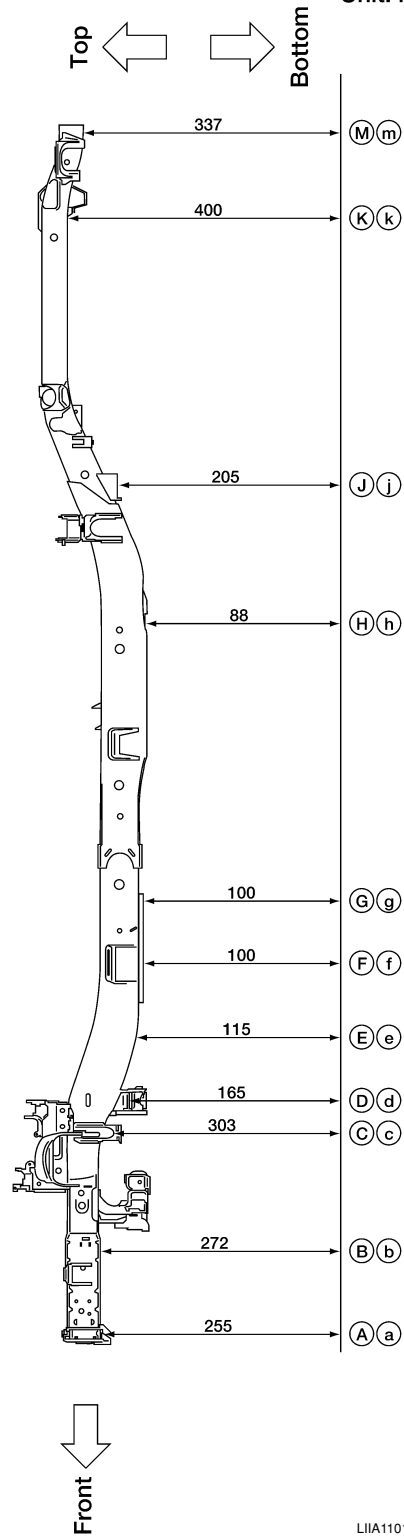

LIA1101E

BODY REPAIR

< SERVICE INFORMATION >

MEASUREMENT POINTS

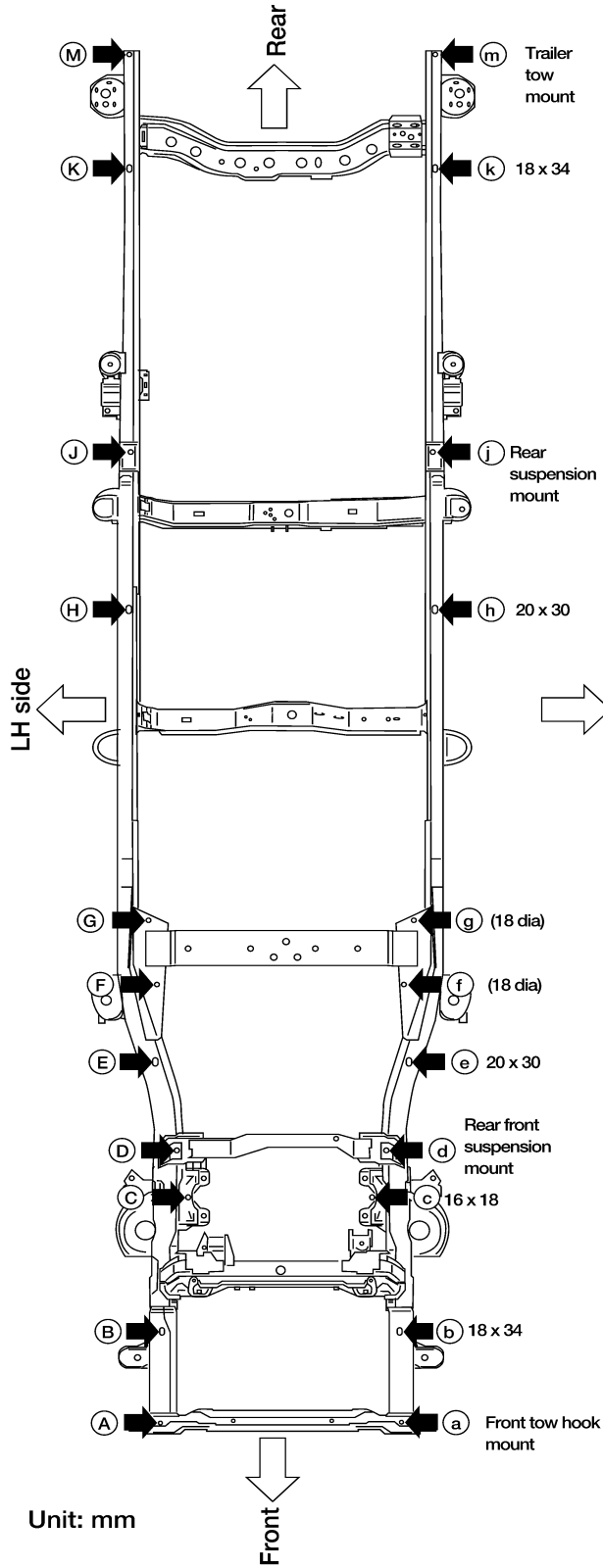

Coordinates:

- (A, a)
X : ± 447
Y : -745
Z : 255
- (B, b)
X : ± 447
Y : -427
Z : 272
- (C, c)
X : ± 353
Y : 35
Z : 303
- (D, d)
X : ± 386
Y : 198
Z : 165
- (E, e)
X : ± 454
Y : 504
Z : 115
- (F, f)
X : ± 466
Y : 777
Z : 100
- (G, g)
X : ± 495
Y : 1013
Z : 100
- (H, h)
X : ± 562
Y : 2122
Z : 88
- (J, j)
X : ± 555
Y : 2700
Z : 205
- (K, k)
X : ± 559
Y : 3751
Z : 400
- (M, m)
X : ± 559
Y : 4126
Z : 337

A
B
C
D
E
F
G
H
I
J
K
L
M
N
O
P

BRM

LIA1508E

BODY REPAIR

< SERVICE INFORMATION >

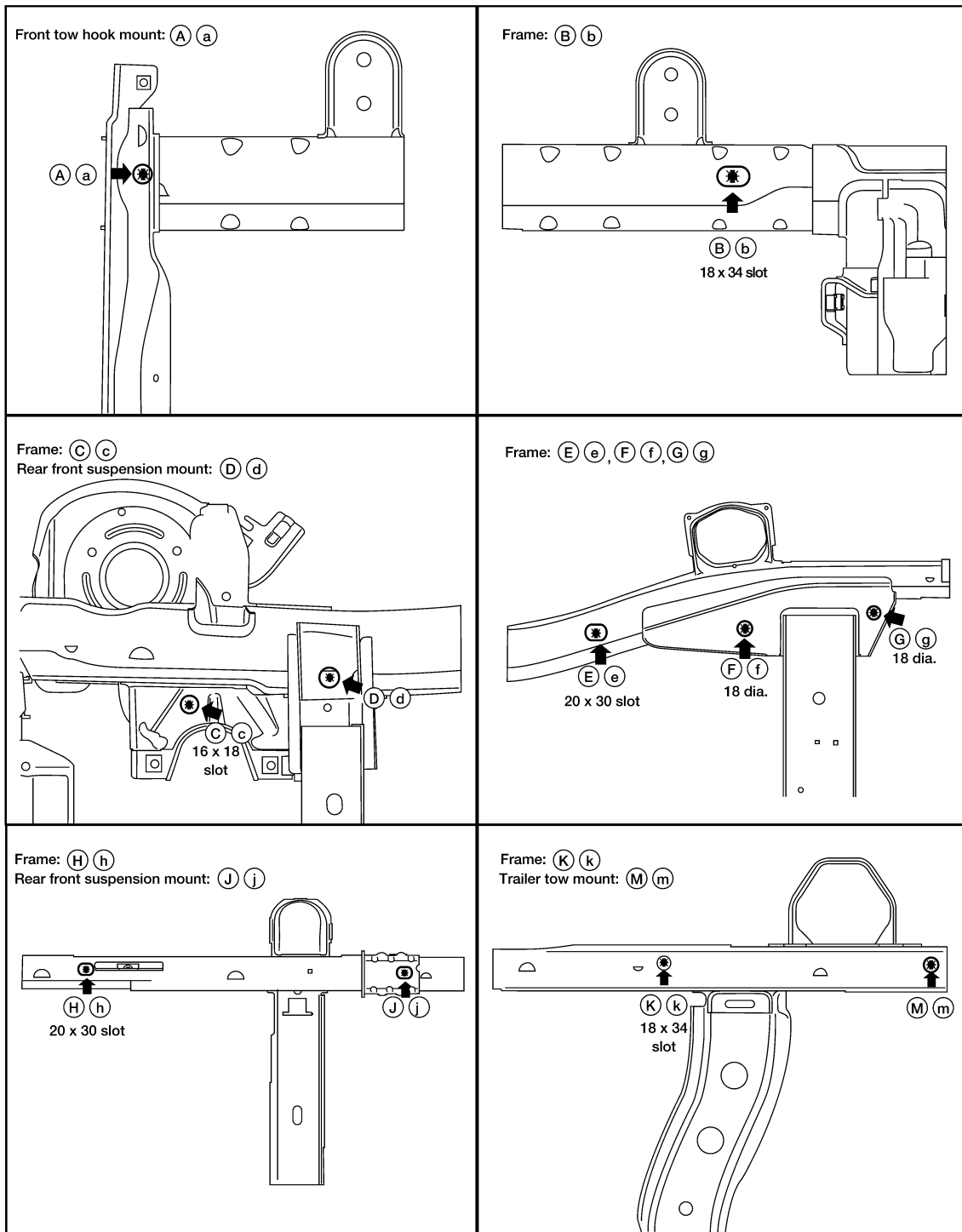

Coordinates:		(A) (a)	(B) (b)	(C) (c)	(D) (d)	(E) (e)	(F) (f)	(G) (g)	(H) (h)	(J) (j)	(K) (k)	(M) (m)
X :	±	447	447	353	386	454	466	495	562	555	559	559
Y :		-747	-427	35	198	504	777	1013	2122	2700	3751	4126
Z :		255	272	303	165	115	100	100	88	205	400	337

Unit: mm

LIIA1509E

Passenger Compartment

BODY REPAIR

< SERVICE INFORMATION >

MEASUREMENT

Figures marked with a (*) indicate symmetrically identical dimensions on both right and left hand sides of the vehicle.

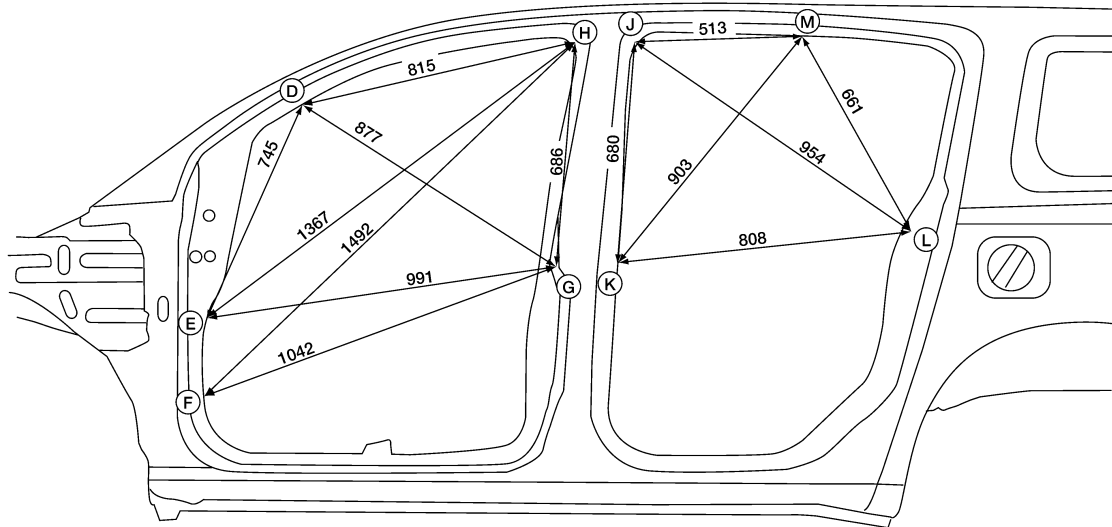
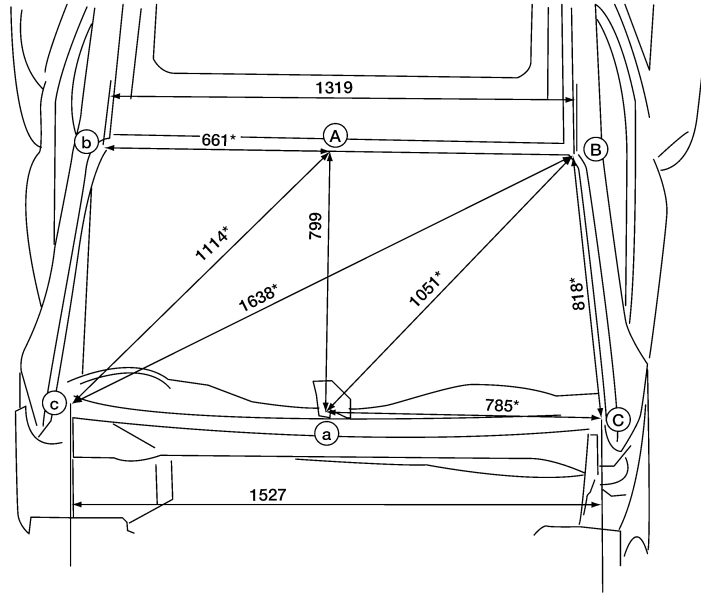

Unit: mm

LIA1510E

A
B
C
D
E
F
G
H
I
J
L
M
N
O
P

BRM

BODY REPAIR

< SERVICE INFORMATION >

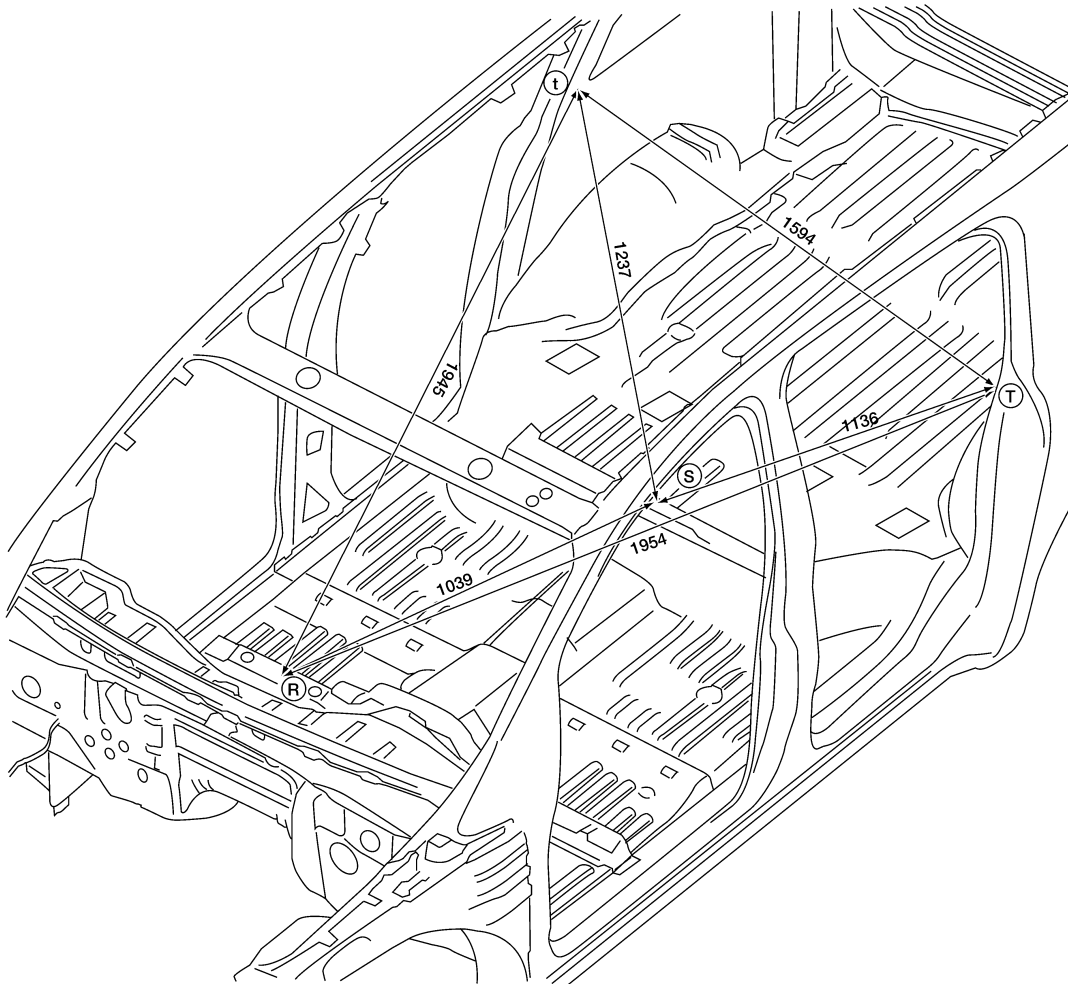

Unit : mm

LIA1105E

BODY REPAIR

< SERVICE INFORMATION >

MEASUREMENT POINTS

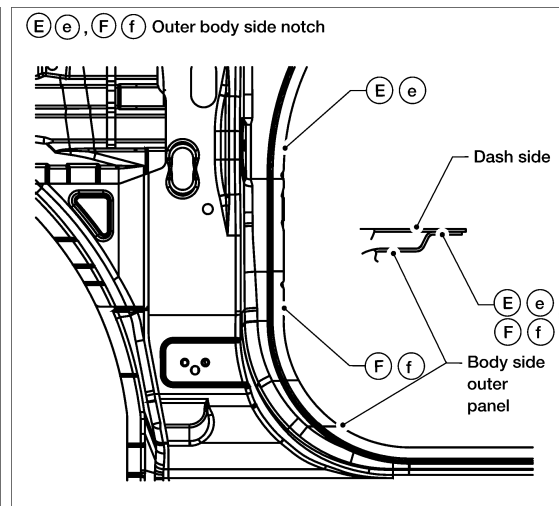
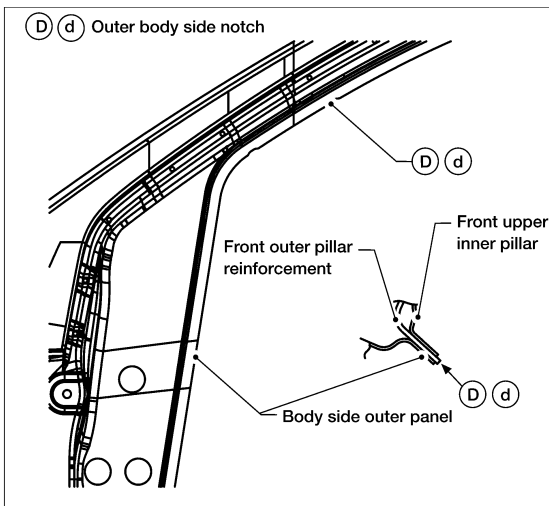
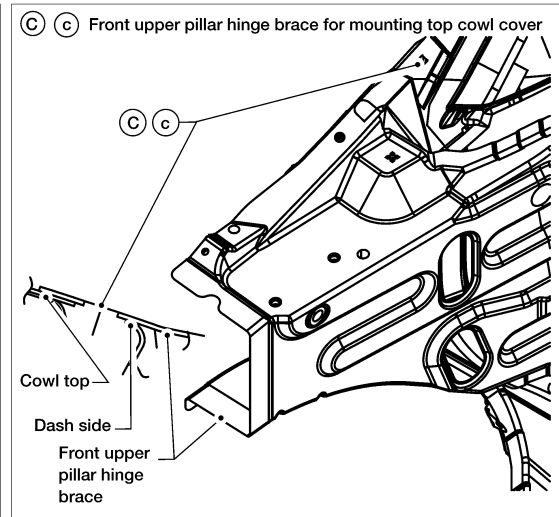
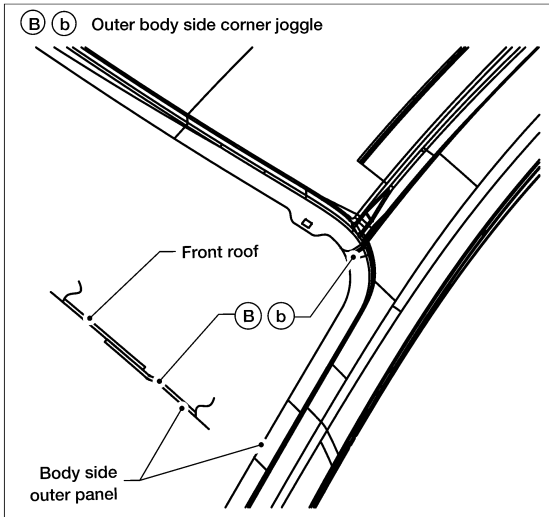
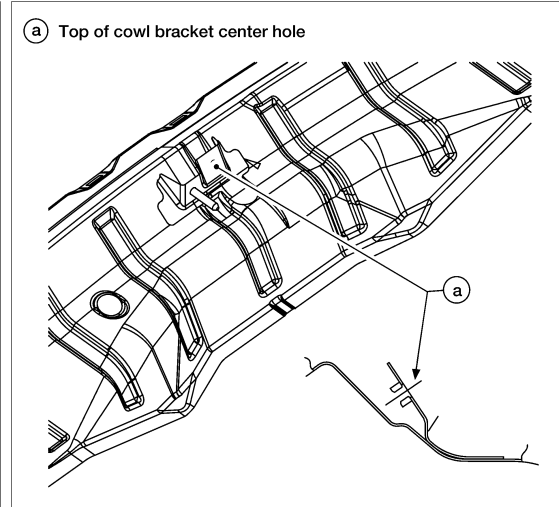
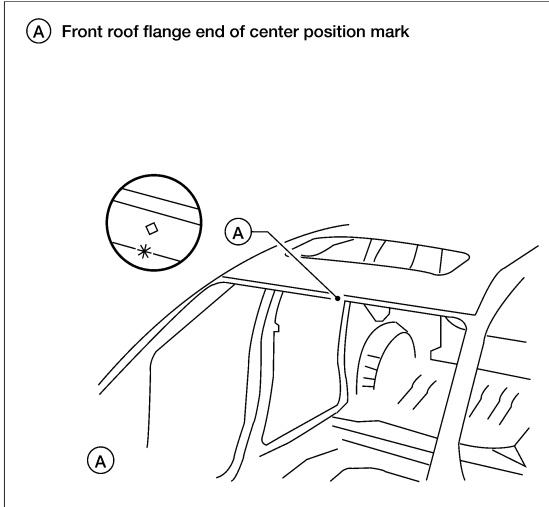

LIA1103E

A
B
C
D
E
F
G
H
I
J
K
L
M
N
O
P

BRM

BODY REPAIR

< SERVICE INFORMATION >

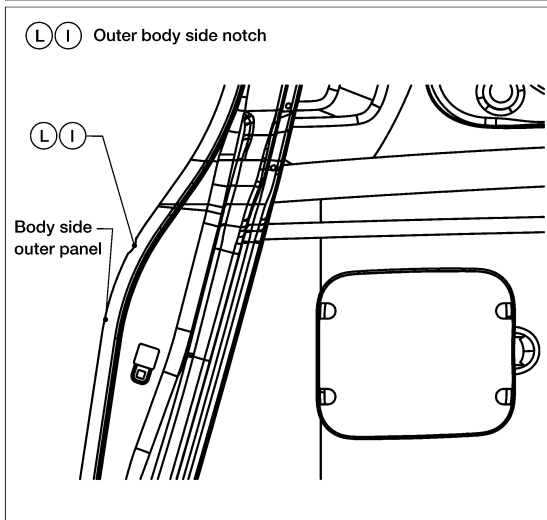
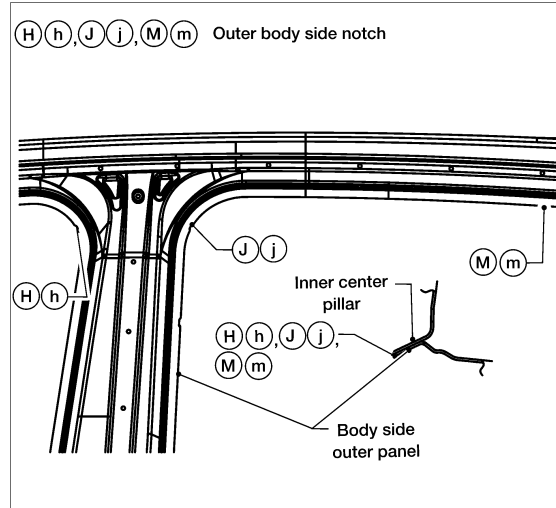
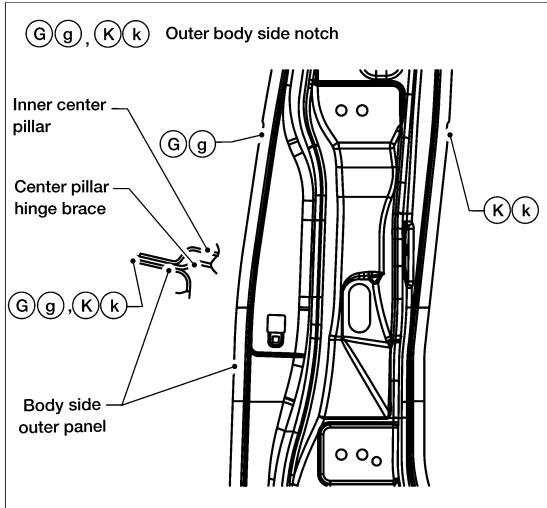

LIA1104E

BODY REPAIR

< SERVICE INFORMATION >

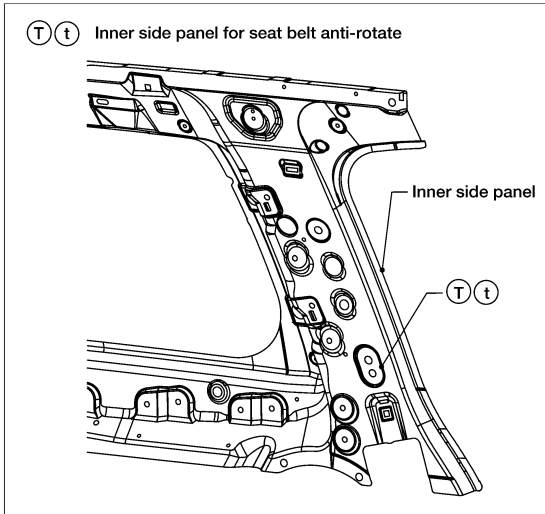
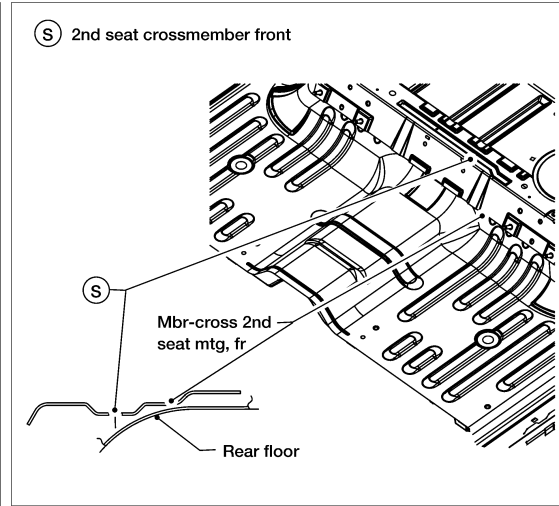
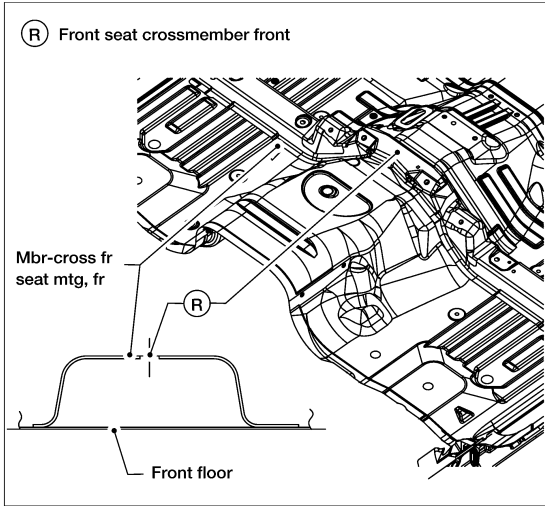

A
B
C
D
E
F
G
H
I
J
L
M
N
O
P

BRM

LIA1106E

Rear Body

BODY REPAIR

< SERVICE INFORMATION >

MEASUREMENT

Figures marked with a (*) indicate symmetrically identical dimensions on both right and left hand sides of the vehicle.

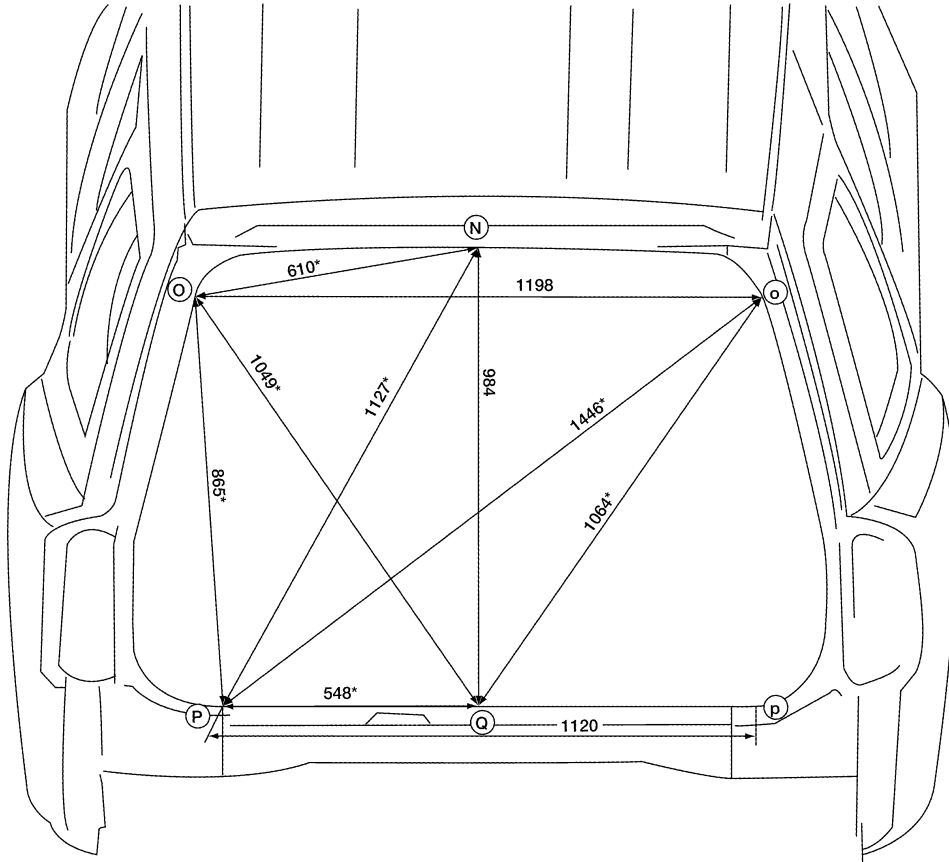

Unit: mm

LIA1511E

BODY REPAIR

< SERVICE INFORMATION >

MEASUREMENT POINTS

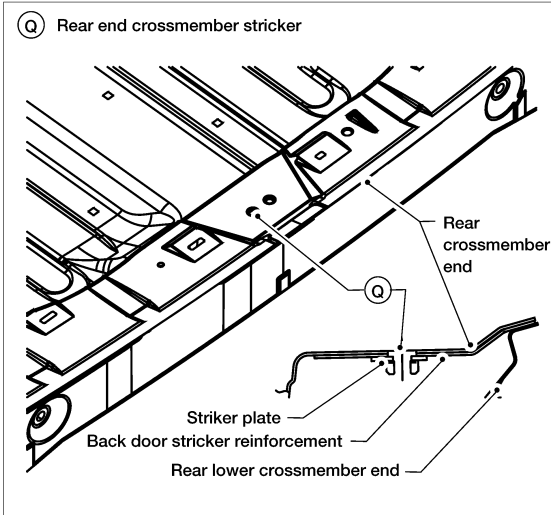
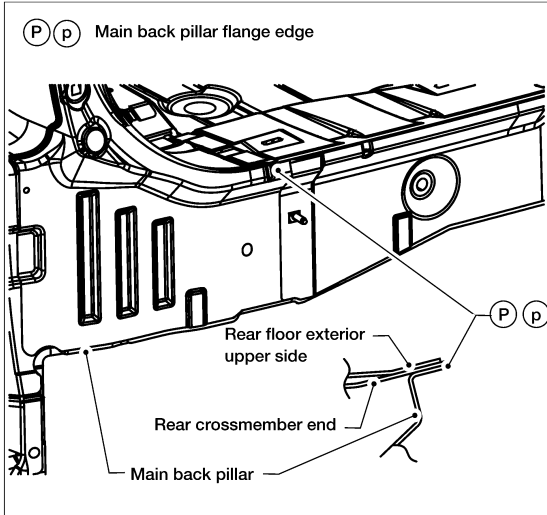
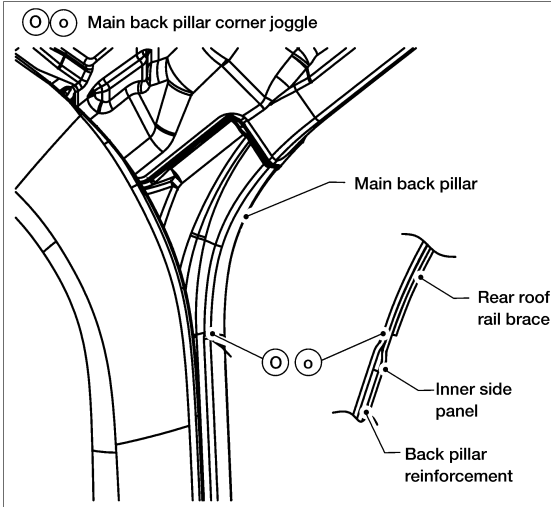
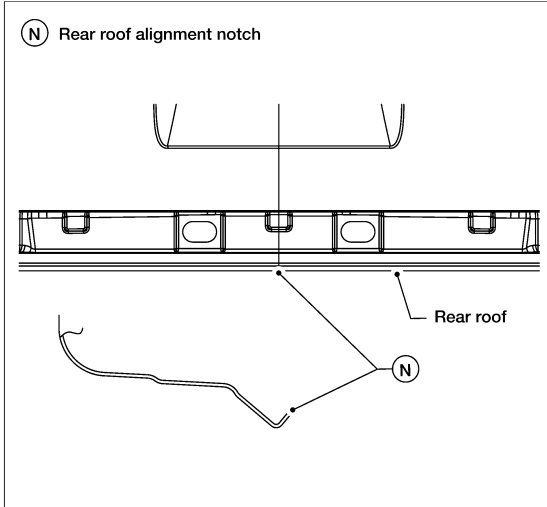

A
B
C
D
E
F
G
H
I
J
L
M
N
O
P

BRM

Handling Precaution for Plastics

HANDLING PRECAUTIONS FOR PLASTICS

LIA1107E

INFOID:000000001537387

BODY REPAIR

< SERVICE INFORMATION >

Abbreviation	Material name	Heatresisting temperature °C (°F)	Resistance to gasoline and solvents	Other cautions
PE	Polyethylene	60 (140)	Gasoline and most solvents are harmless if applied for a very short time (wipe up quickly).	Flammable
PVC	Polyvinyl Chloride	80 (176)	Same as above.	Poison gas is emitted when burned.
EPM/EPDM	Ethylene Propylene (Diene) rubber	80 (176)	Same as above.	Flammable
TPO/TPR	Thermoplastic Olefine/ Thermoplastic Rubber	80 (176)	Same as above.	Flammable
PP	Polypropylene	90 (194)	Same as above.	Flammable, avoid battery acid.
UP	Polyester thermoset	90 (194)	Same as above.	Flammable
PS	Polystyrene	80 (176)	Avoid solvents.	Flammable
ABS	Acrylonitrile Butadiene Styrene resin	80 (176)	Avoid gasoline and solvents.	
AES	Acrylonitrile Ethylene Styrene	80 (176)	Same as above.	
PMMA	Polymethyl Methacrylate	85 (185)	Same as above.	
AAS	Acrylonitrile Acrylic Styrene	85 (185)	Same as above.	
AS	Acrylonitrile Styrene	85 (185)	Same as above.	
EVA	Polyvinyl Ethyl Acetate	90 (194)	Same as above.	
ASA	Acrylonitrile Styrene Acrylate	100 (222)	Same as above.	Flammable
PPO/PPE	Polyphenylene Oxide/ Polyphenylene Ether	110 (230)	Same as above.	
PC	Polycarbonate	120 (248)	Same as above.	
PAR	Polyacrylate	180 (356)	Same as above.	
L-LDPE	Linear Low Density PE	45 (100)	Gasoline and most solvents are harmless.	Flammable
PUR	Polyurethane	90 (194)	Same as above.	
TPU	Thermoplastic Urethane	110 (230)	Same as above.	
PPC	Polypropylene Composite	115 (239)	Same as above.	Flammable
POM	Polyacetal	120 (248)	Same as above.	Avoid battery acid.
PBT+PC	Polybutylene Terephthalate+Polycarbonate	120 (248)	Same as above.	Flammable
PA	Polyamide (Nylon)	140 (284)	Same as above.	Avoid immersing in water.
PBT	Polybutylene Terephthalate	140 (284)	Same as above.	
FRP	Fiber Reinforced Plastics	170 (338)	Same as above.	Avoid battery acid.
PET	Polyethylene Terephthalate	180 (356)	Same as above.	
PEI	Polyetherimide	200 (392)	Same as above.	

1. When repairing and painting a portion of the body adjacent to plastic parts, consider their characteristics (influence of heat and solvent) and remove them if necessary or take suitable measures to protect them.
2. Plastic parts should be repaired and painted using methods suiting the materials' characteristics.

BODY REPAIR

< SERVICE INFORMATION >

LOCATION OF PLASTIC PARTS

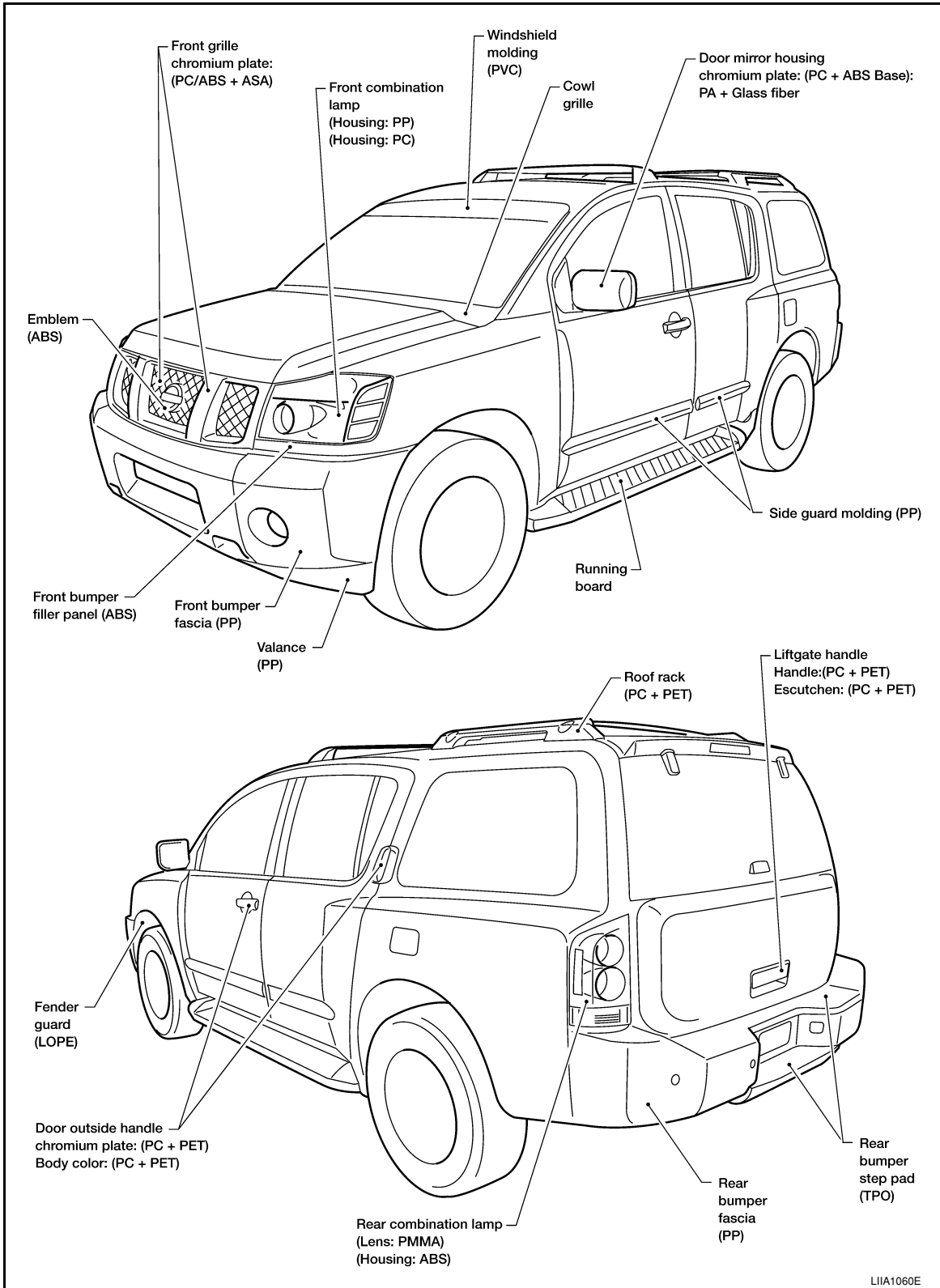

A
B
C
D
E
F
G
H
I
J
BRM
L
M
N
O
P

BODY REPAIR

< SERVICE INFORMATION >

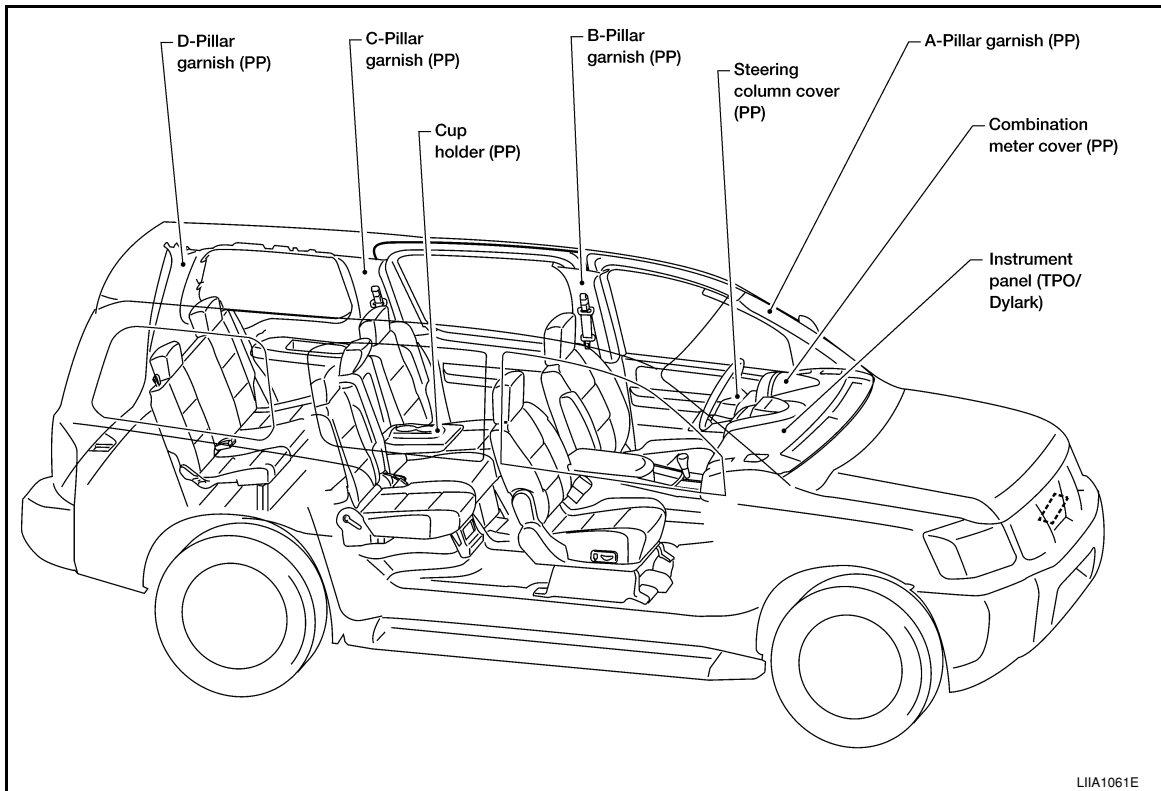

Precaution in Repairing High Strength Steel

INFOID:000000001537388

High strength steel is used for body panels in order to reduce vehicle weight.

Accordingly, precautions in repairing automotive bodies made of high strength steel are described below:

High strength steel (hss) used in nissan vehicles

Tensile strength	Nissan/Infiniti designation	Major applicable parts
373 N/mm ² (38kg/mm ² , 54klb/sq in)	SP130	<ul style="list-style-type: none"> • Front inner pillar upper • Front pillar hinge brace • Outer front pillar reinforcement • Other reinforcements
785-981 N/mm ² (80-100kg/mm ² 114-142klb/sq in)	SP150	<ul style="list-style-type: none"> • Outer sill reinforcement • Main back pillar

SP130 is the most commonly used HSS.

SP150 HSS is used only on parts that require much more strength.

Read the following precautions when repairing HSS:

1. Additional points to consider

- The repair of reinforcements (such as side members) by heating is not recommended since it may weaken the component. When heating is unavoidable, do not heat HSS parts above 550°C (1,022°F). Verify heating temperature with a thermometer. (Crayon-type and other similar type thermometer are appropriate.)

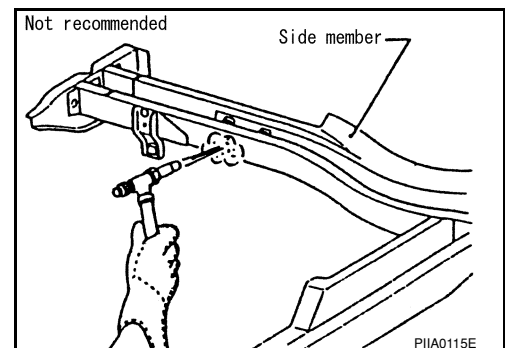

BODY REPAIR

< SERVICE INFORMATION >

- When straightening body panels, use caution in pulling any HSS panel. Because HSS is very strong, pulling may cause deformation in adjacent portions of the body. In this case, increase the number of measuring points, and carefully pull the HSS panel.

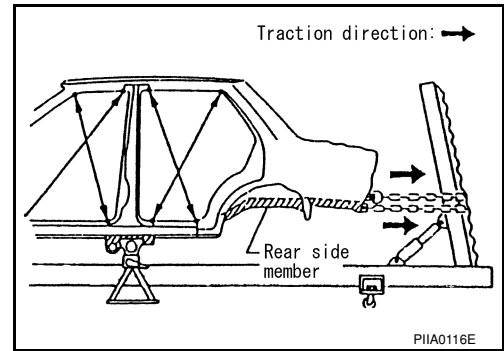

- When cutting HSS panels, avoid gas (torch) cutting if possible. Instead, use a saw to avoid weakening surrounding areas due to heat. If gas (torch) cutting is unavoidable, allow a minimum margin of 50 mm (1.97in).

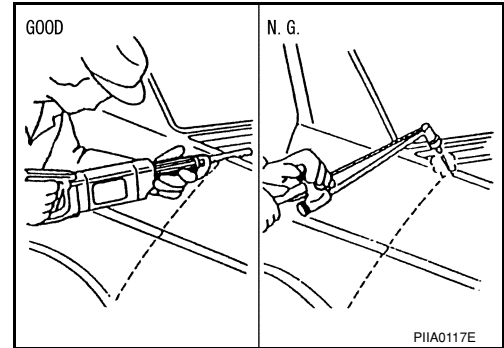

- When welding HSS panels, use spot welding whenever possible in order to minimize weakening surrounding areas due to heat. If spot welding is impossible, use M.I.G. welding. Do not use gas (torch) welding because it is inferior in welding strength.

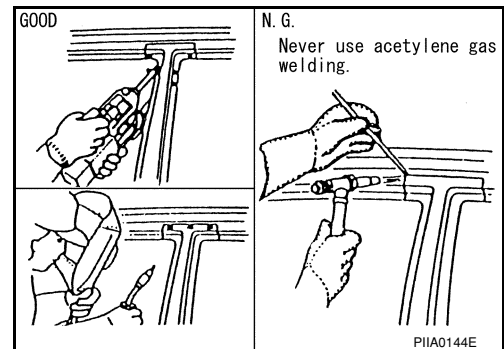

- The spot weld on HSS panels is harder than that of an ordinary steel panel. Therefore, when cutting spot welds on a HSS panel, use a low speed high torque drill (1,000 to 1,200 rpm) to increase drill bit durability and facilitate the operation.
- SP150 HSS panels with a tensile strength of 785 to 981 N/mm² (80 to 100 kg/mm², 114 to 142 klb/sq in), used as reinforcement in the door guard beams, is too strong to repair. When these HSS parts are damaged, the outer panels also sustain substantial damage; therefore, the assembly parts must be replaced.

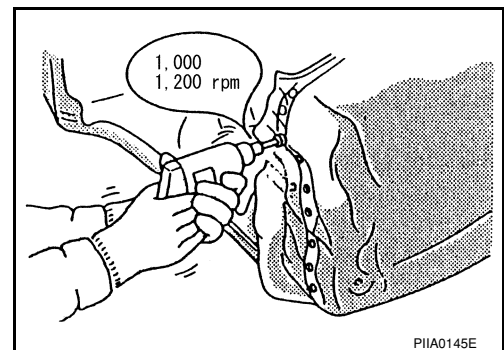

BODY REPAIR

< SERVICE INFORMATION >

2. Precautions in spot welding HSS

This work should be performed under standard working conditions. Always note the following when spot welding HSS:

- The electrode tip diameter must be sized properly according to the metal thickness.

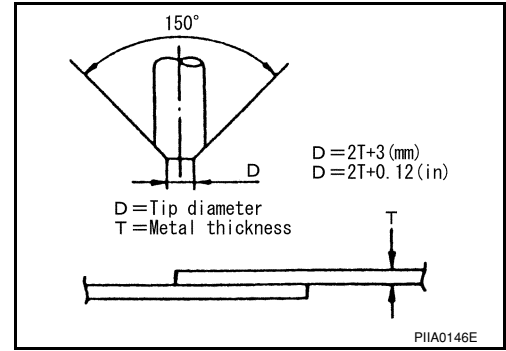

- The panel surfaces must fit flush to each other, leaving no gaps.

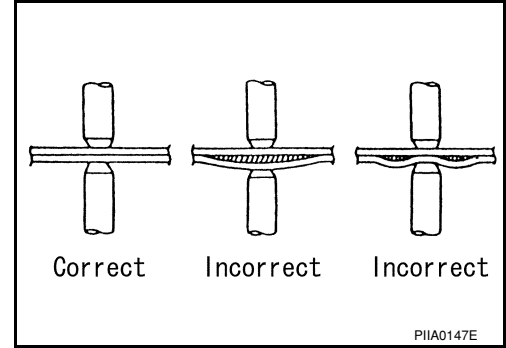

- Follow the specifications for the proper welding pitch.

Thickness (t)	Minimum pitch (ℓ)
0.6 (0.024)	10 (0.39) or over
0.8 (0.031)	12 (0.47) or over
1.0 (0.039)	18 (0.71) or over
1.2 (0.047)	20 (0.79) or over
1.6 (0.063)	27 (1.06) or over
1.8 (0.071)	31 (1.22) or over

Unit:mm

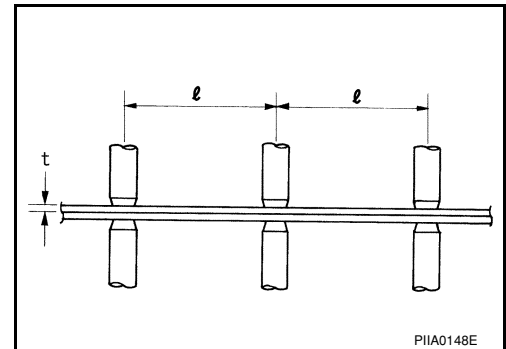

Foam Repair

INFOID:000000001537389

During factory body assembly, foam insulators are installed in certain body panels and locations around the vehicle. Use the following procedure(s) to replace any factory-installed foam insulators.

URETHANE FOAM APPLICATIONS

Use commercially available spray foam for sealant (foam material) repair of material used on vehicle. Read instructions on product for fill procedures.

FILL PROCEDURES

- Fill procedures after installation of service part.
 - Remove foam material remaining on vehicle side.
 - Clean area in which foam was removed.
 - Install service part.

BODY REPAIR

< SERVICE INFORMATION >

- Insert nozzle into hole near fill area and fill foam material or fill in enough to close gap with the service part.

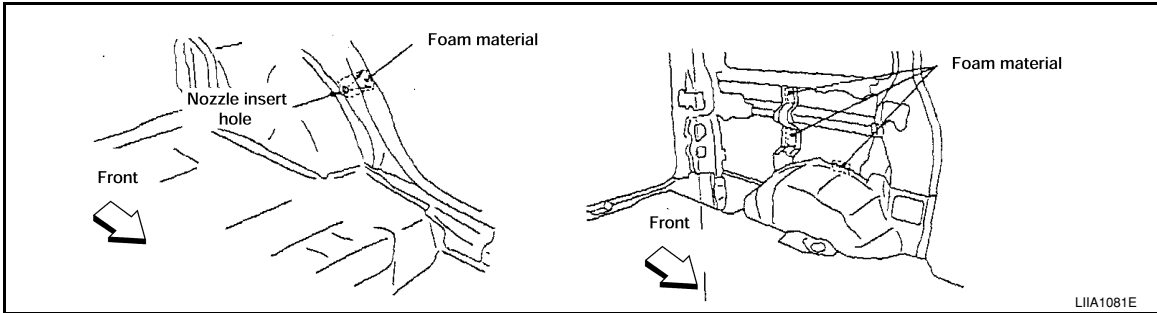

2. Fill procedures before installation of service part.
 - Remove foam material remaining on vehicle side.
 - Clean area in which foam was removed.
 - Fill foam material on wheelhouse outer side.

NOTE:

Fill in enough to close gap with service part while avoiding flange area.

- Install service part.

NOTE:

Refer to label for information on working times.

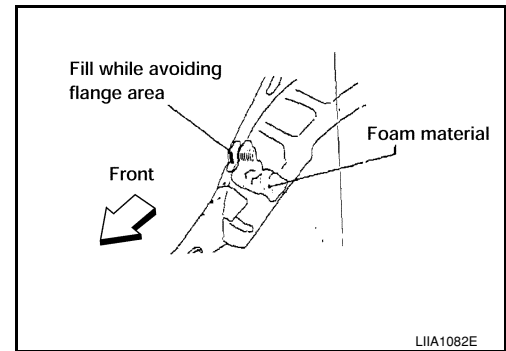

Replacement Operation

INFOID:000000001537390

DESCRIPTION

This section is prepared for technicians who have attained a high level of skill and experience in repairing collision-damaged vehicles and also use modern service tools and equipment. Persons unfamiliar with body repair techniques should not attempt to repair collision-damaged vehicles by using this section.

Technicians are also encouraged to read Body Repair Manual (Fundamentals) in order to ensure that the original functions and quality of the vehicle can be maintained. The Body Repair Manual (Fundamentals) contains additional information, including cautions and warnings, that are not including in this manual. Technicians should refer to both manuals to ensure proper repairs.

Please note that this information is prepared for worldwide usage, and as such, certain procedures may not apply in some regions or countries.







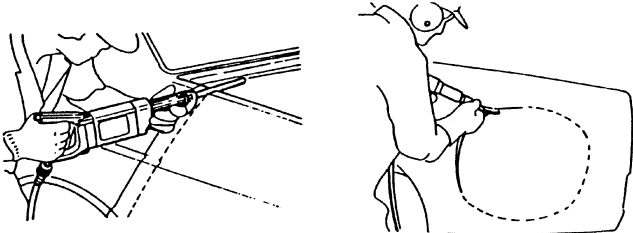
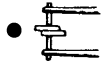

A
B
C
D
E
F
G
H
I
J
L
M
N
O
P

BRM

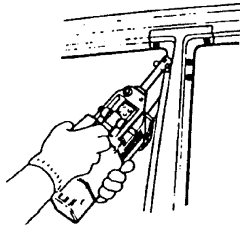
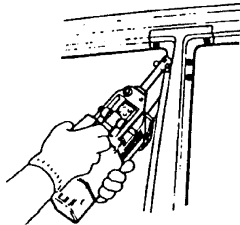
BODY REPAIR

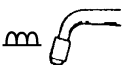
< SERVICE INFORMATION >

The symbols used in this section for cutting and welding / brazing operations are shown below.

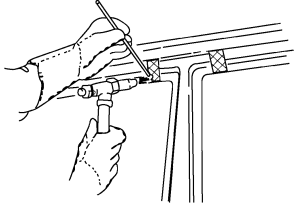
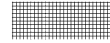
 Saw cut or air chisel cut	
<p>Spot weld</p> <p>●●●● 2-spot welds</p>  <p>●●●● 3-spot welds</p> 	<p>2-spot welds (2-panel overlapping portions)</p>  <p>3-spot welds (3-panel overlapping portions)</p> 
<p>■ ■ ■ ■ MIG plug weld</p>  <p>MIG seam weld/ Point weld</p> 	
<p>▨ ▨ ▨ ▨ Brazing</p> 	
<p>▨ ▨ ▨ ▨ Soldering</p> 	
<p>———— Sealing</p>	

PIIA0149E

BODY REPAIR

< SERVICE INFORMATION >

- Front pillar butt joint can be determined anywhere within shaded area as shown in the figure. The best location for the butt joint is at position A due to the construction of the vehicle. Refer to the front pillar section.

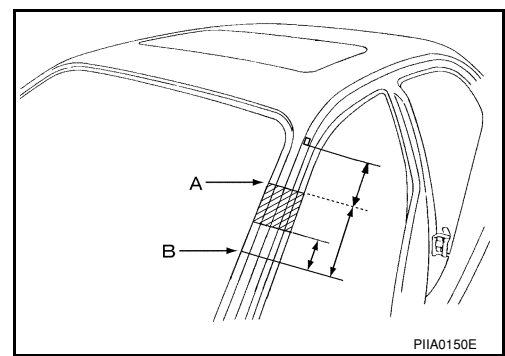

- Determine cutting position and record distance from the locating indent. Use this distance when cutting the service part. Cut outer front pillar over 60 mm above inner front pillar cut position.

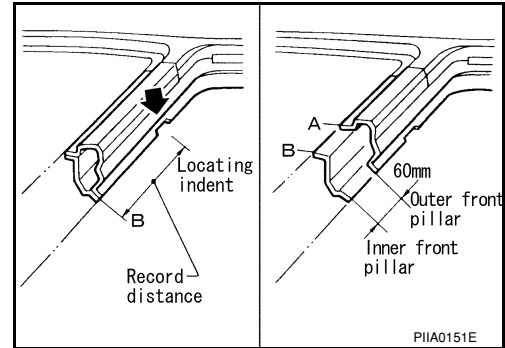

- Prepare a cutting jig to make outer pillar easier to cut. Also, this will permit service part to be accurately cut at joint position.

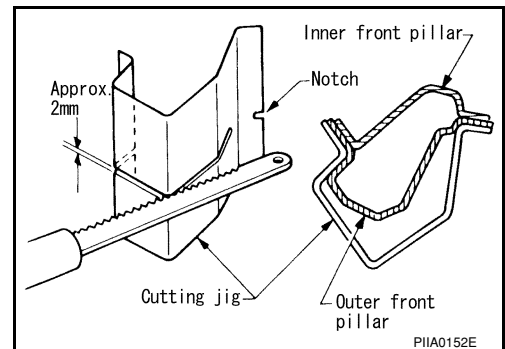

- An example of cutting operation using a cutting jig is as follows.

1. Mark cutting lines.
A: Cut position of outer pillar
B: Cut position of inner pillar
2. Align cutting line with notch on jig. Clamp jig to pillar.
3. Cut outer pillar along groove of jig. (At position A)
4. Remove jig and cut remaining portions.
5. Cut inner pillar at position B in same manner.

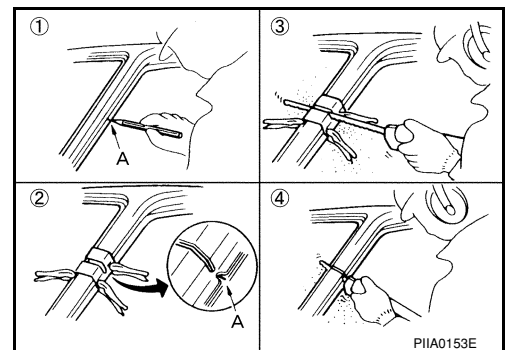

HOODLEDGE

BODY REPAIR

< SERVICE INFORMATION >

- Work after radiator core support has been removed.

Service Joint

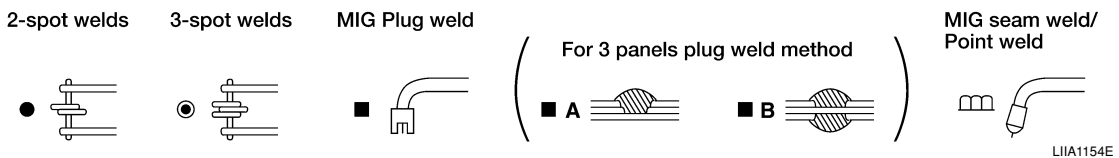
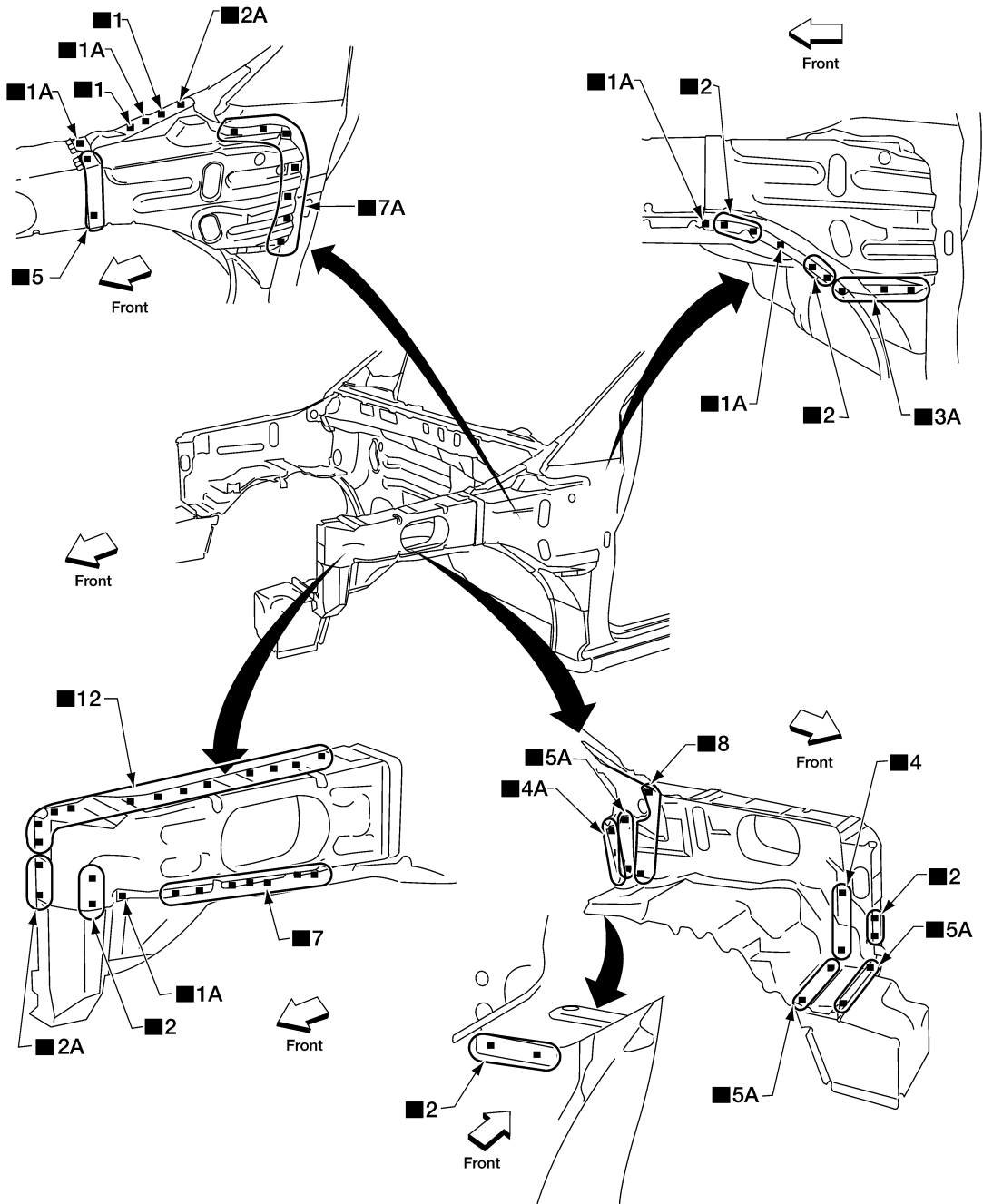

FRONT PILLAR

BODY REPAIR

< SERVICE INFORMATION >

- Work after rear hoodledge reinforcement has been removed.

Service Joint

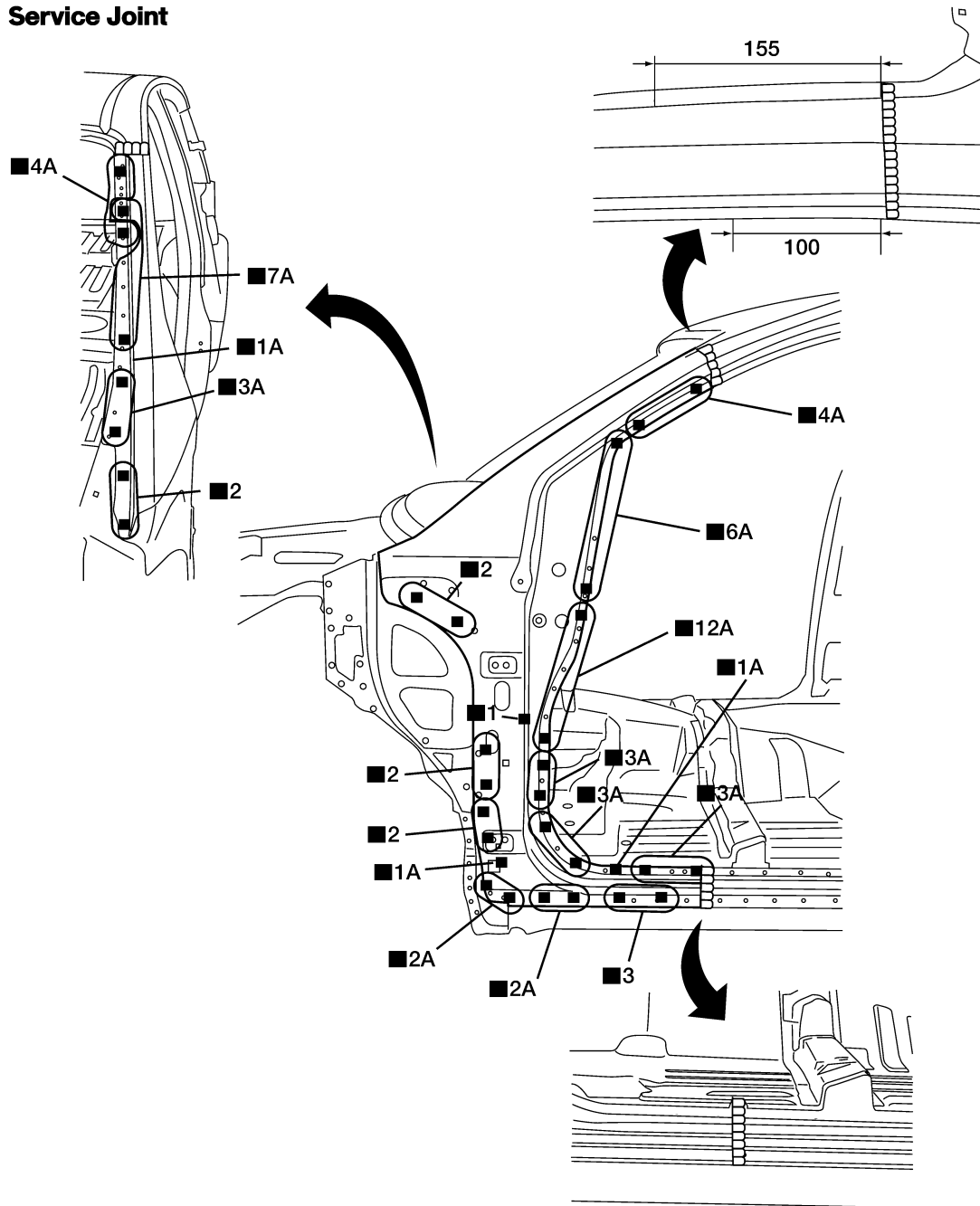

Unit : mm

2-spot welds

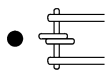

3-spot welds

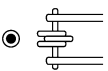

MIG Plug weld

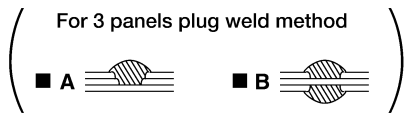
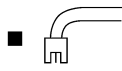

MIG seam weld/
Point weld



LIA1108E

A
B
C
D
E
F
G
H
I
J
BRM
L
M
N
O
P

BODY REPAIR

< SERVICE INFORMATION >

Service Joint

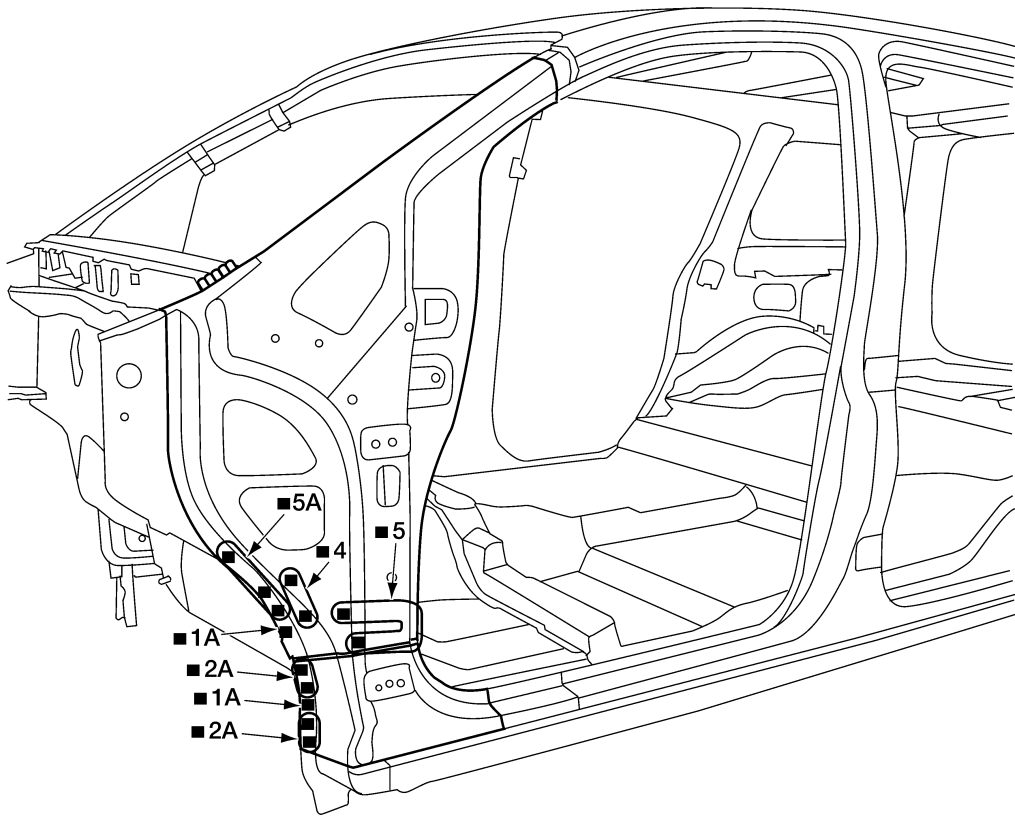

Unit : mm

2-spot welds

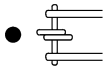

3-spot welds

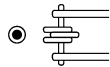

MIG Plug weld

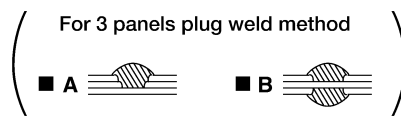
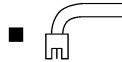

MIG seam weld/
Point weld



LIA1109E

BODY REPAIR

< SERVICE INFORMATION >

Service Joint

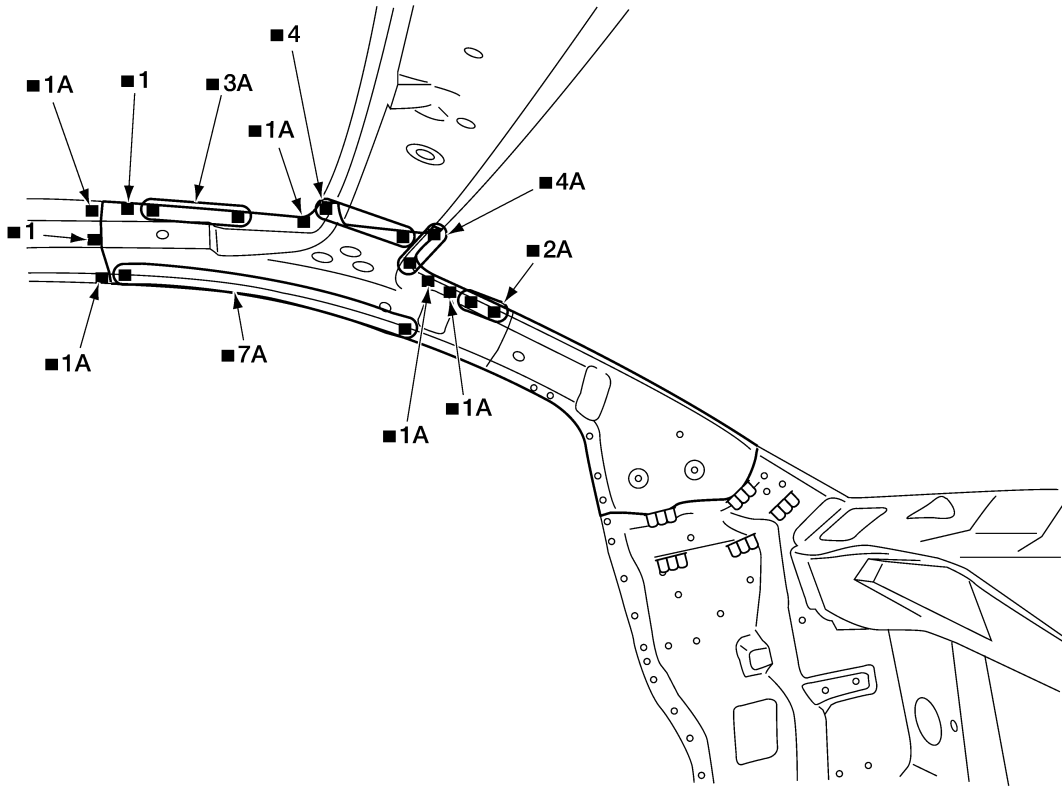

A
B
C
D
E
F
G
H
I
J

BRM

L
M
N
O
P

Unit : mm

2-spot welds

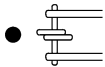

3-spot welds

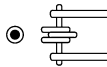

MIG Plug weld

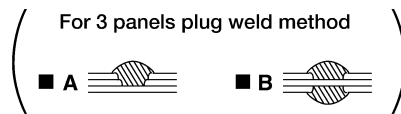
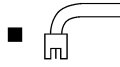

MIG seam weld/
Point weld



LIA1110E

BODY REPAIR

< SERVICE INFORMATION >

CENTER PILLAR

Service Joint

* Reinforcement is retained with the same welds as the b-pillar outer sheet metal.

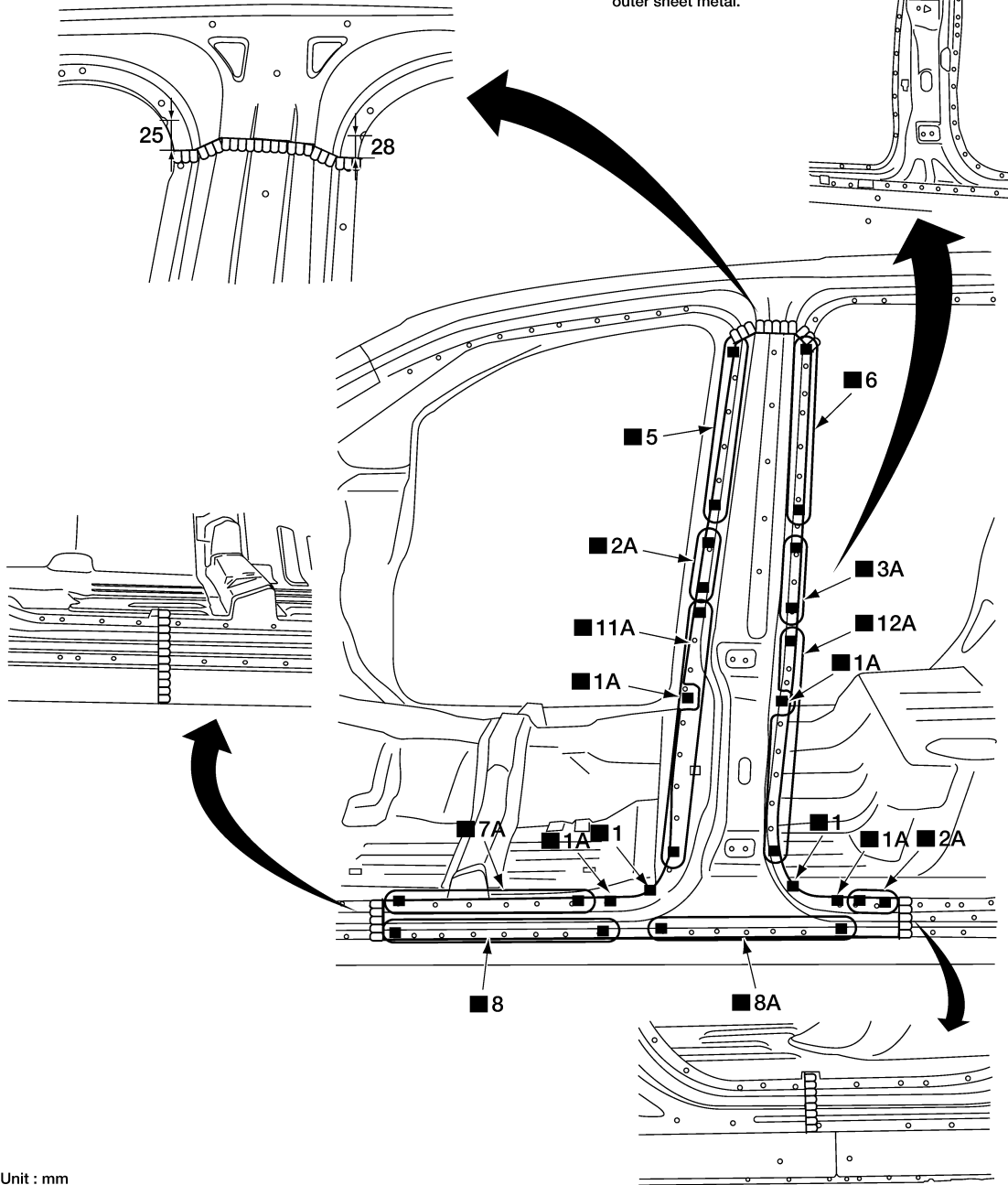

Unit : mm

2-spot welds

3-spot welds

MIG Plug weld

For 3 panels plug weld method

MIG seam weld/
Point weld

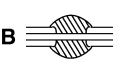

LIA1111E

BODY REPAIR

< SERVICE INFORMATION >

Service Joint

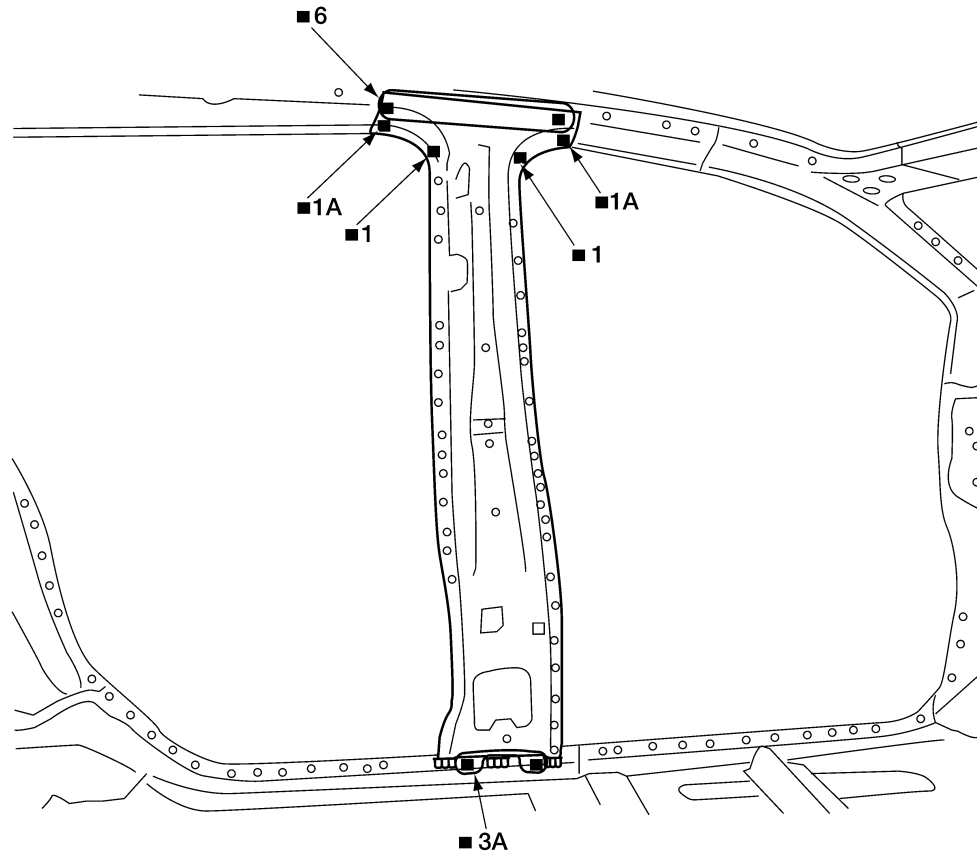

A
B
C
D
E
F
G
H
I
J

BRM

L
M
N
O
P

Unit : mm

2-spot welds

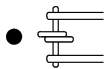

3-spot welds

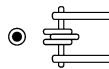

MIG Plug weld

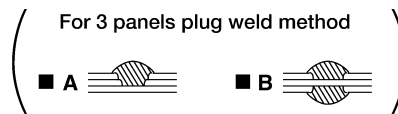
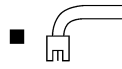

MIG seam weld/
Point weld



LIA1112E

BODY REPAIR

< SERVICE INFORMATION >

OUTER SILL

Service Joint

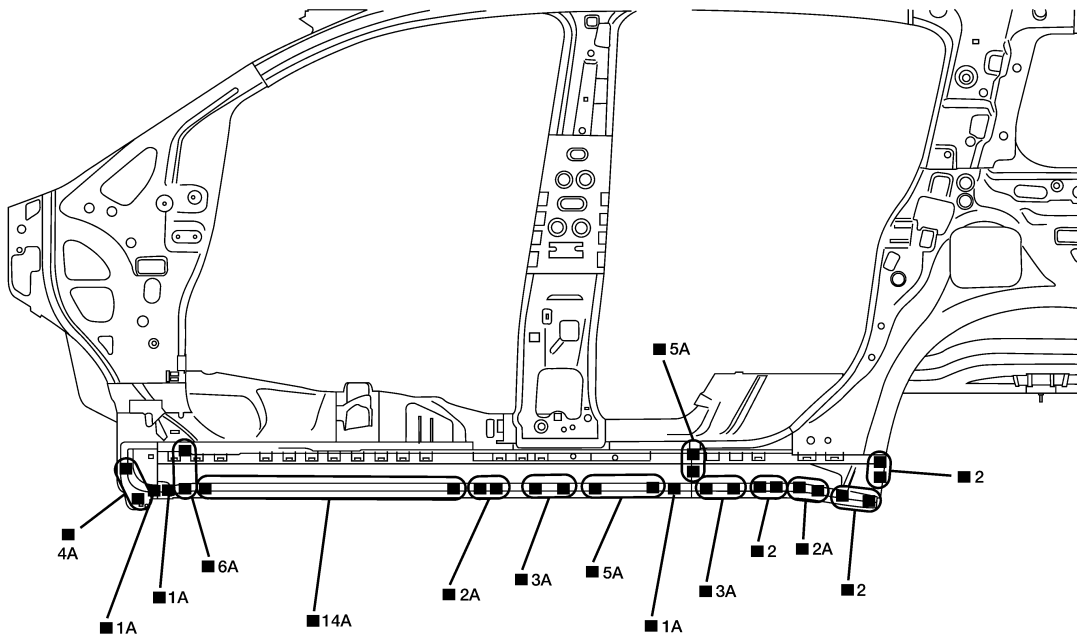

2-spot welds

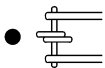

3-spot welds

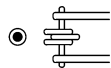

MIG Plug weld

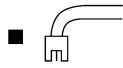

For 3 panels plug weld method



MIG seam weld/
Point weld



LIA1118E

BODY REPAIR

< SERVICE INFORMATION >

REAR FENDER

Service Joint

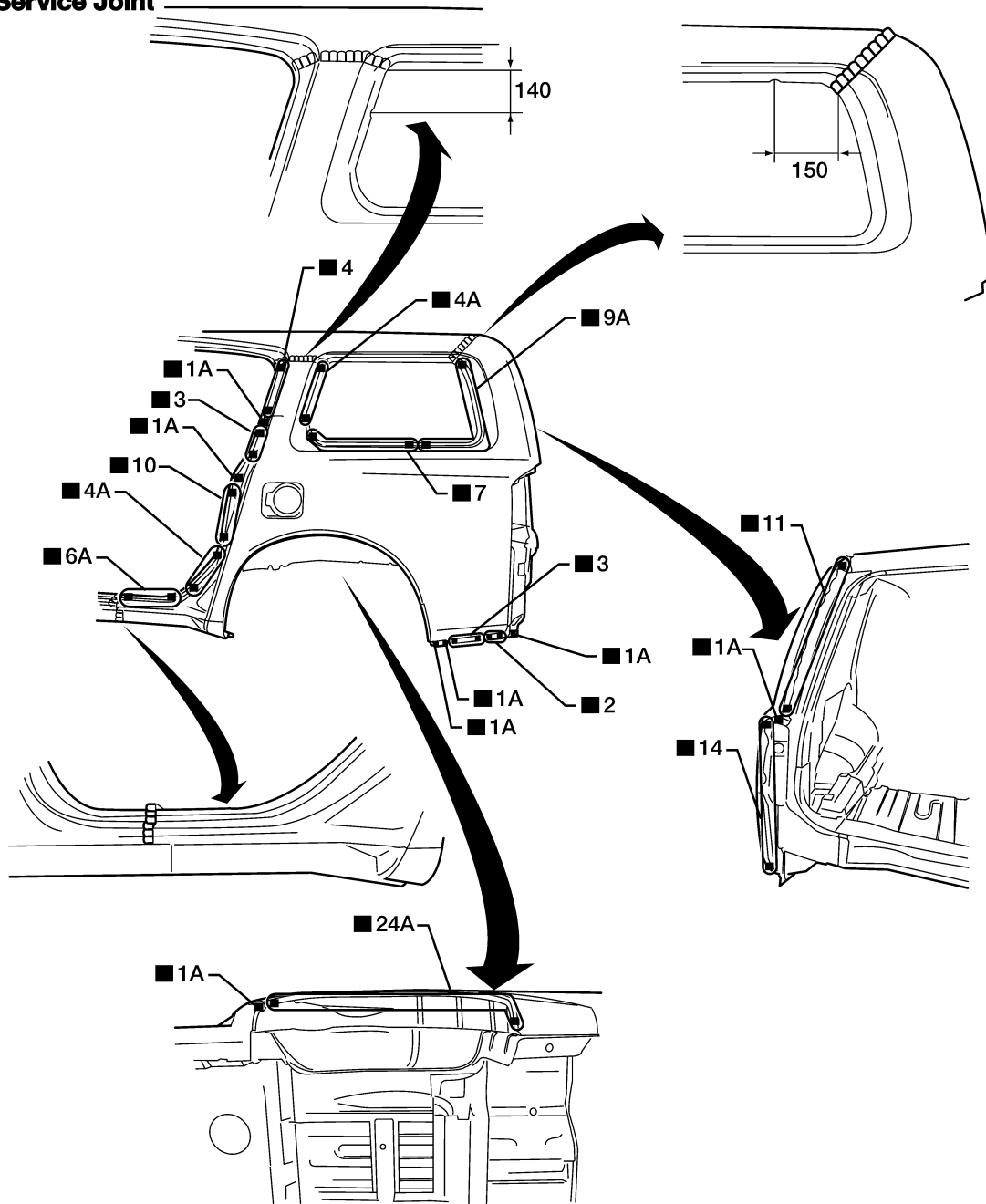

2-spot welds

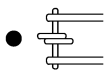

3-spot welds

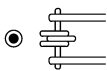

MIG Plug weld

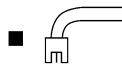

For 3 panels plug weld method

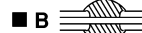

MIG seam weld/
Point weld



WIIA0285E

A
B
C
D
E
F
G
H
I
J
BRM
L
M
N
O
P

BODY REPAIR

< SERVICE INFORMATION >

Service Joint

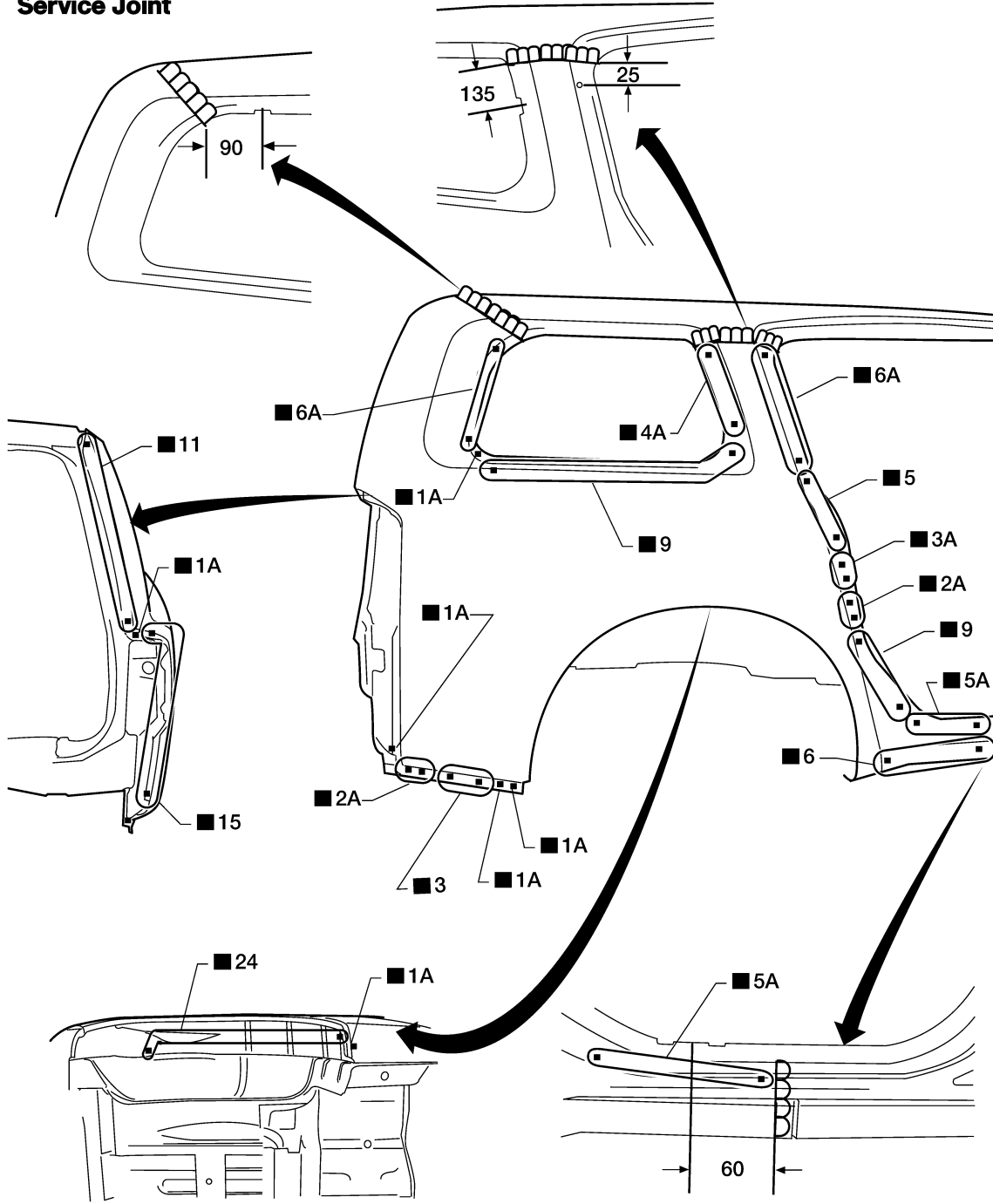

2-spot welds

3-spot welds

MIG Plug weld

For 3 panels plug weld method

MIG seam weld/
Point weld

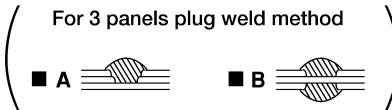
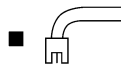
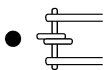

WIA0283E

BODY REPAIR

< SERVICE INFORMATION >

REAR SIDE MEMBER

Service Joint

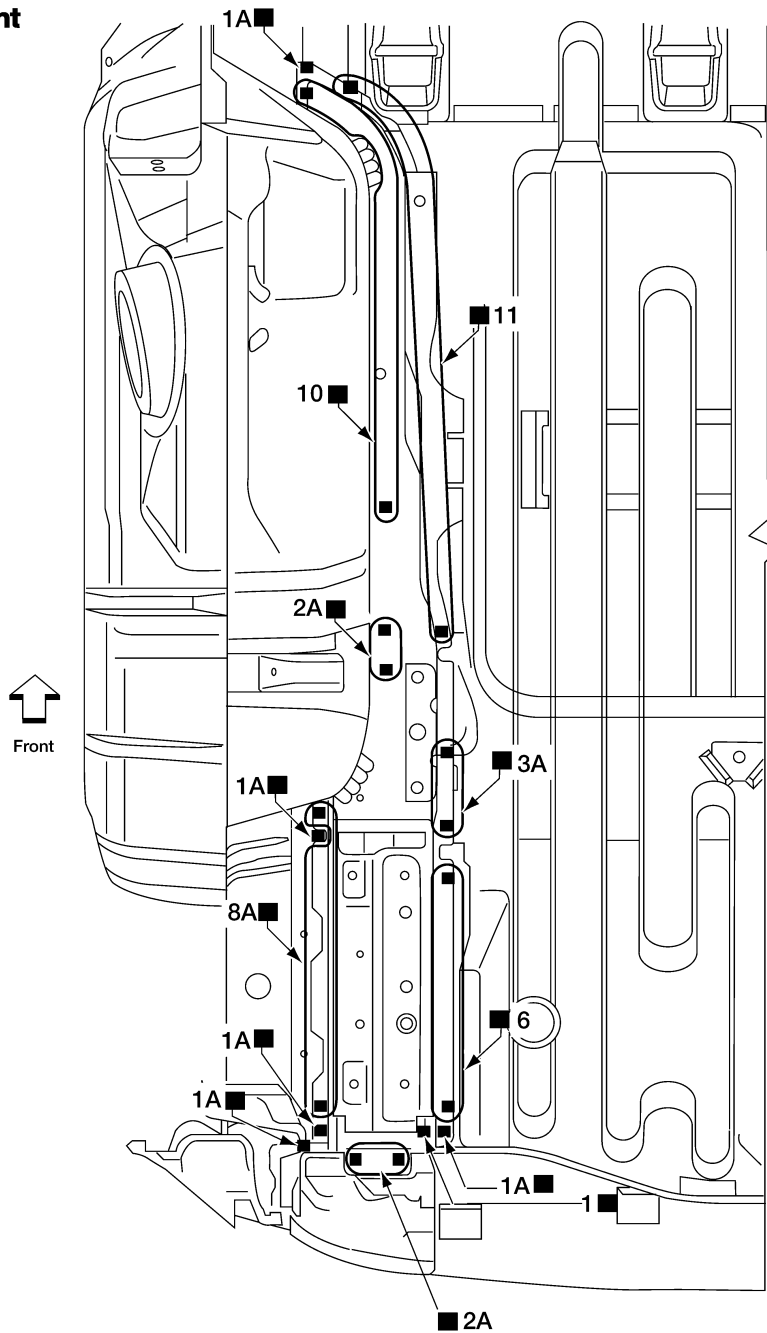

Unit : mm

2-spot welds

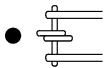

3-spot welds

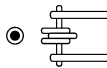

MIG Plug weld

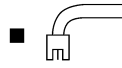

For 3 panels plug weld method



MIG seam weld/
Point weld



REAR FLOOR REAR

A
B
C
D
E
F
G
H
I
J
K
L
M
N
O
P

BRM

BODY REPAIR

< SERVICE INFORMATION >

Service Joint

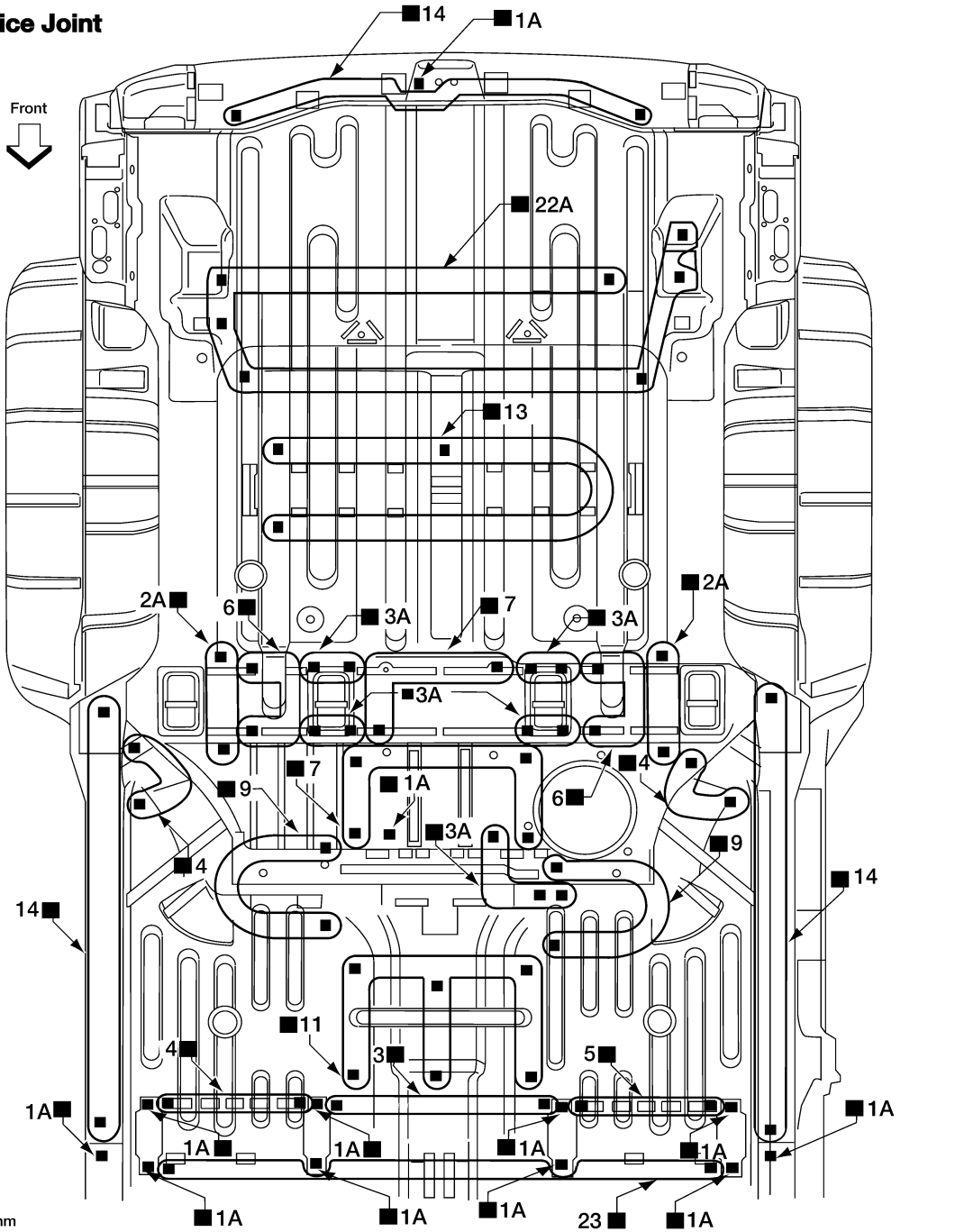

Unit : mm

2-spot welds

3-spot welds

MIG Plug weld

(For 3 panels plug weld method)

MIG seam weld/
Point weld

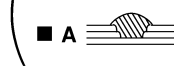
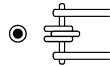
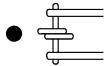

WIA0282E

CRUSH HORN

BRM-50

BODY REPAIR

< SERVICE INFORMATION >

- Work after 1st crossmember has been removed.

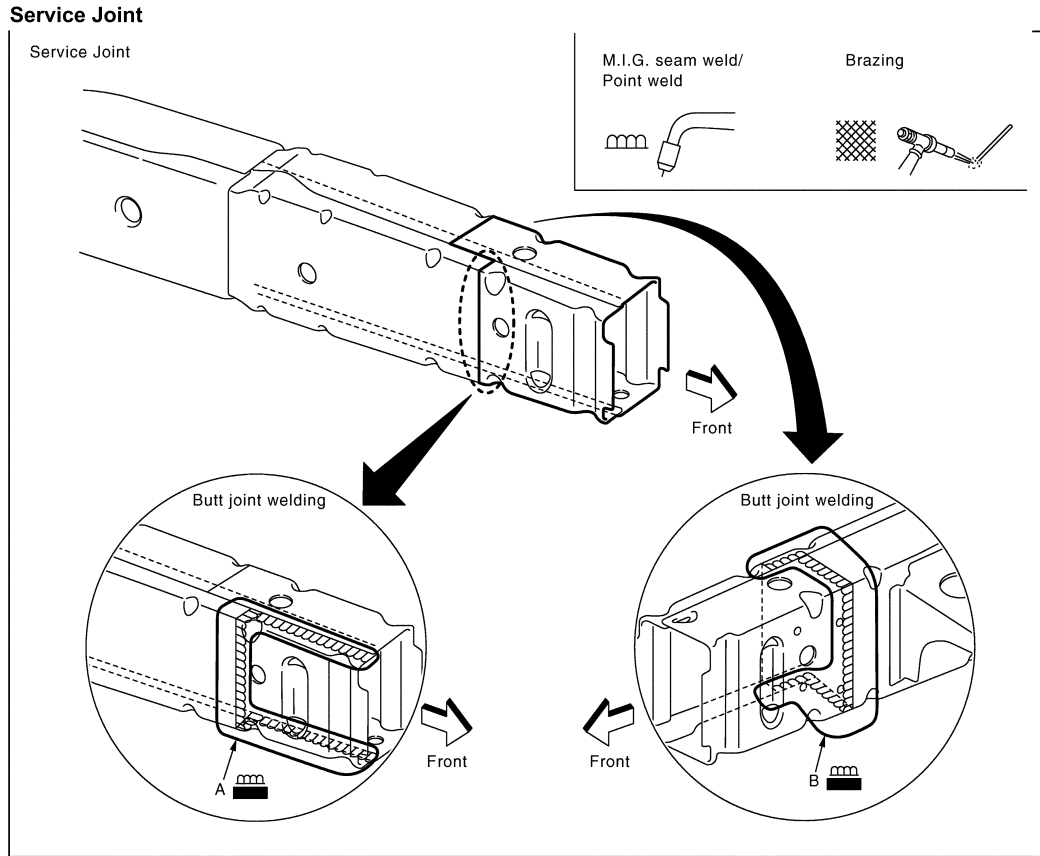

Portions to be welded:

- A. Inner side rail crush horn, inner side rail crush horn and outer side rail crush horn.
- B. Outer side rail crush horn, outer side rail crush horn and inner side rail crush horn.

Removal Notes

A
B
C
D
E
F
G
H
I
J
L
M
N
O
P

BRM

BODY REPAIR

< SERVICE INFORMATION >

- Scribe a straight line on the outer side rail crush horn and inner side rail crush horn along the hole center as shown in the figure.

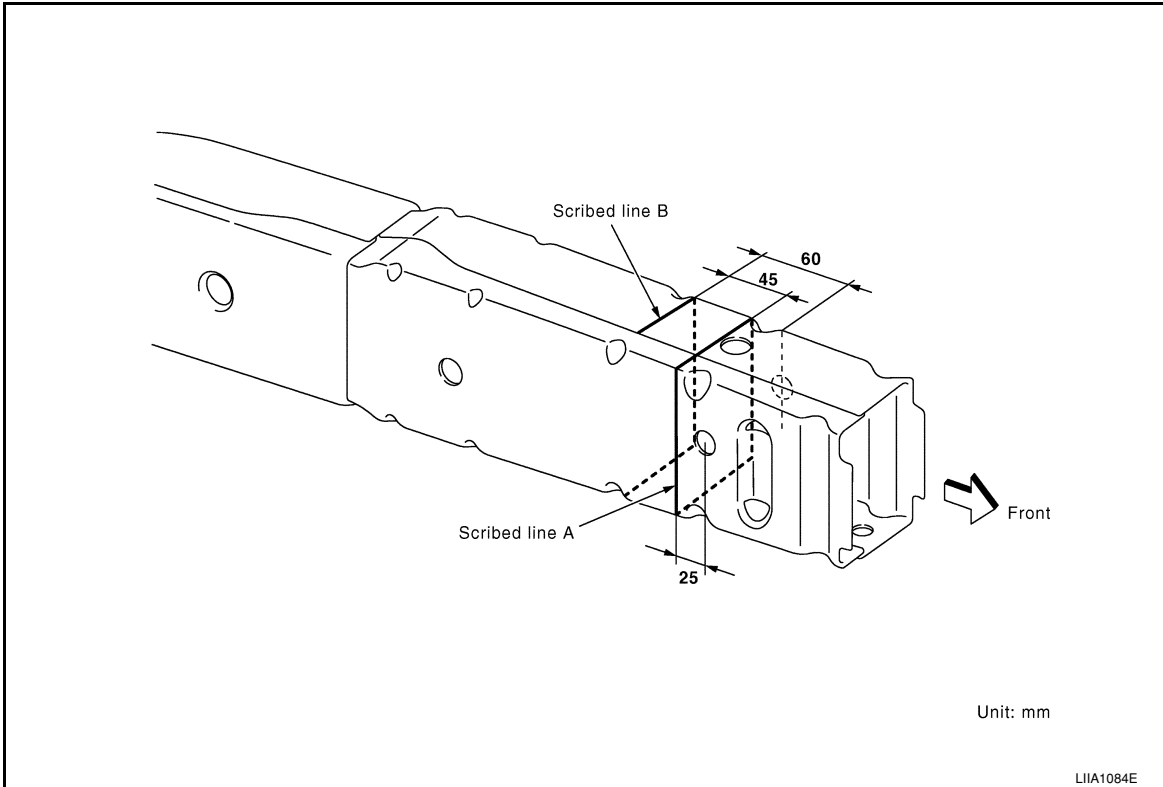

- Cut off outer side rail crush horn and inner side rail crush horn along scribed line A. Do not cut on the hole.

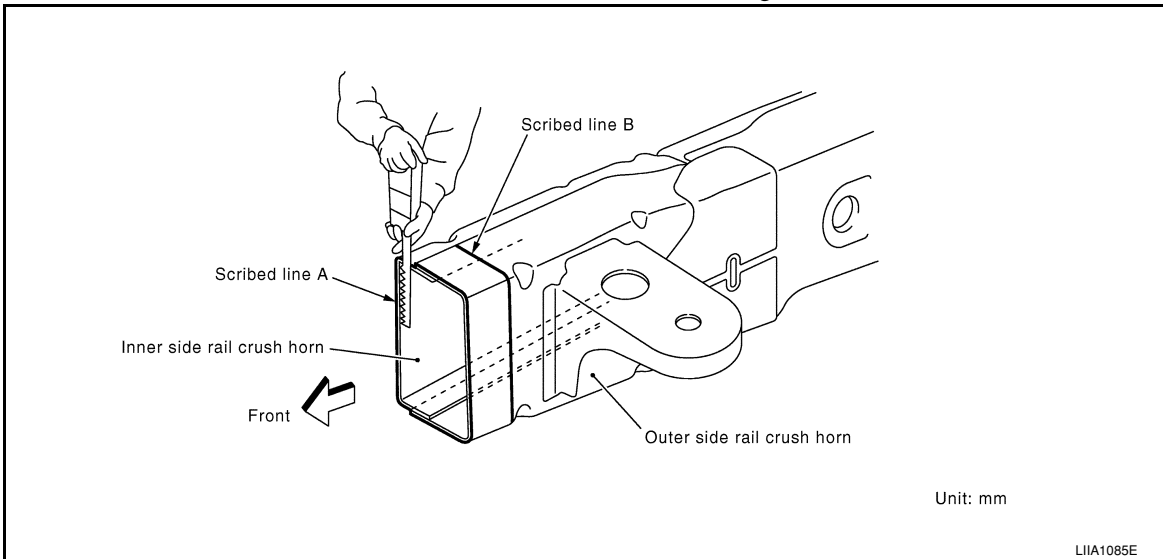

- Cut inner side rail crush horn at 45 mm backward cut position of cut line A. (along line B)

BODY REPAIR

< SERVICE INFORMATION >

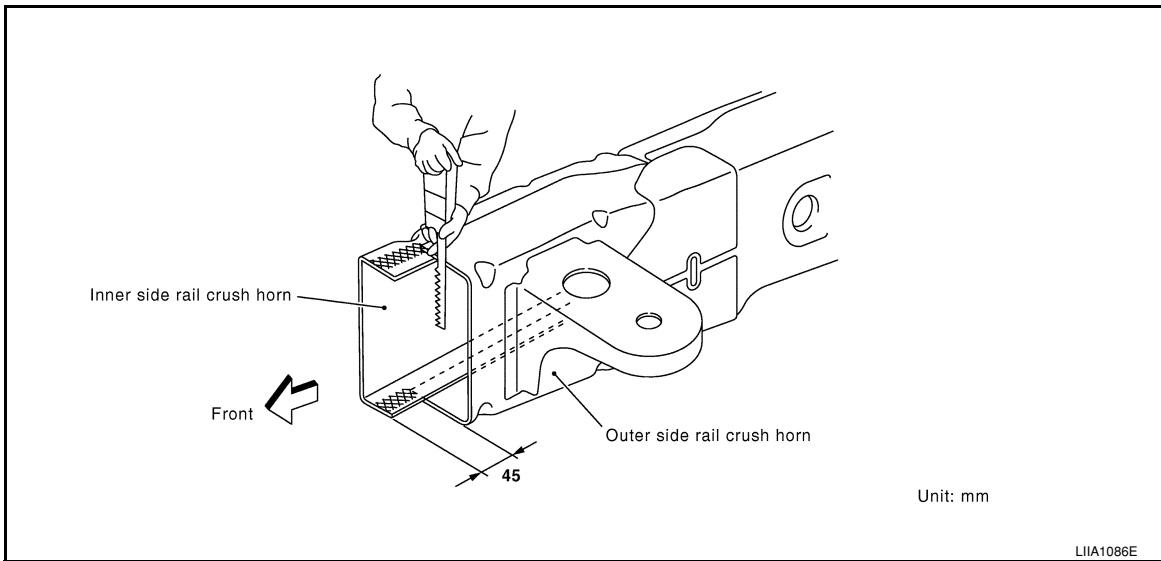

- After removing outer panel, dress area on the inner panel surface with a sander or equivalent.

Installation Notes

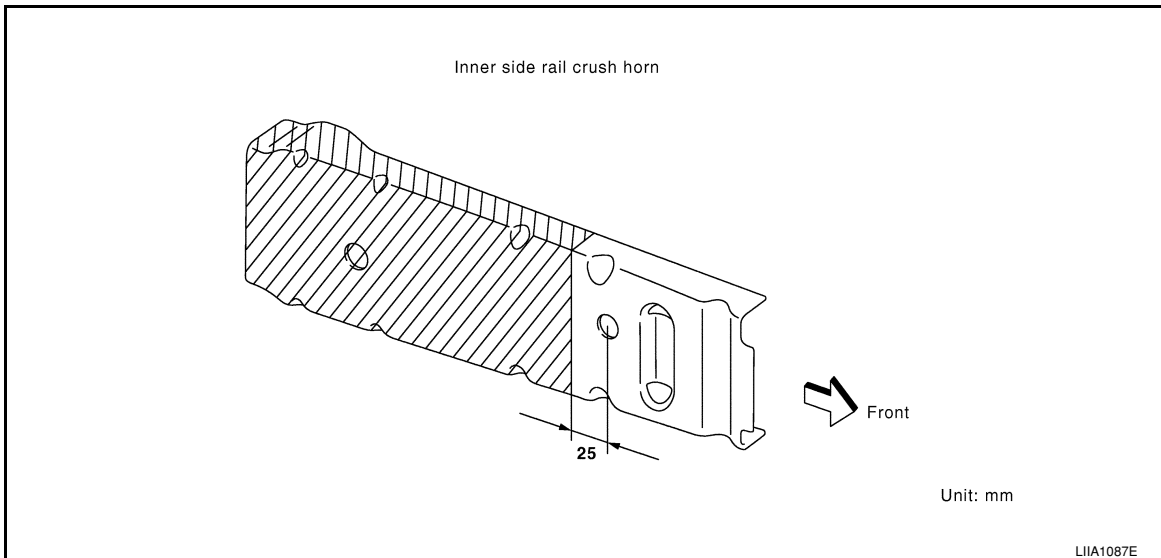

- Scribe a straight line on the inner side rail crush horn along the hole center as shown in the figure. Cut off inner side rail crush horn along scribed line.

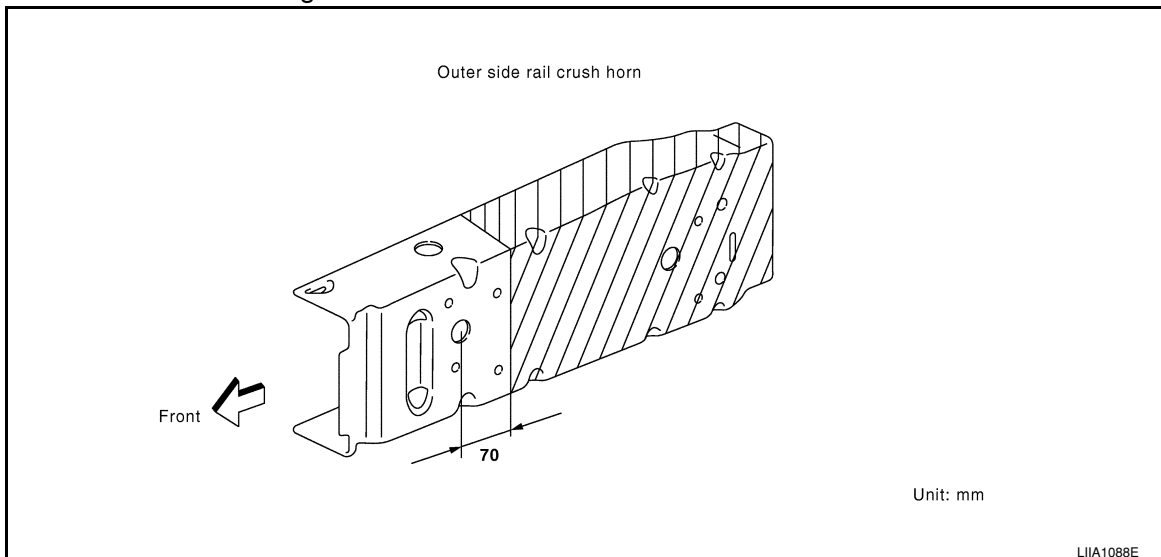

- Scribe a straight line on the outer side rail crush horn along the hole center as shown in the figure. Cut off outer side rail crush horn along scribed line.

A
B
C
D
E
F
G
H
I
J
L
M
N
O
P

BRM

BODY REPAIR

< SERVICE INFORMATION >

- Weld part to be butt-welded and seam-welded corner to corner as shown in the figure.

