

SECTION **EX**
EXHAUST SYSTEM

A

EX

C

D

E

CONTENTS

PRECAUTION	2	Commercial Service Tool	4	F
PRECAUTIONS	2	ON-VEHICLE MAINTENANCE	5	
Precaution for Supplemental Restraint System (SRS) "AIR BAG" and "SEAT BELT PRE-TEN- SIONER"	2	EXHAUST SYSTEM	5	G
Precaution for Liquid Gasket	2	Checking Exhaust System	5	
PREPARATION	4	ON-VEHICLE REPAIR	6	H
PREPARATION	4	EXHAUST SYSTEM	6	
Special Service Tool	4	Removal and Installation	6	I
				J
				K
				L
				M
				N
				O
				P

PRECAUTIONS

< PRECAUTION >

PRECAUTION

PRECAUTIONS

Precaution for Supplemental Restraint System (SRS) "AIR BAG" and "SEAT BELT PRE-TENSIONER"

INFOID:000000001538754

The Supplemental Restraint System such as "AIR BAG" and "SEAT BELT PRE-TENSIONER", used along with a front seat belt, helps to reduce the risk or severity of injury to the driver and front passenger for certain types of collision. This system includes seat belt switch inputs and dual stage front air bag modules. The SRS system uses the seat belt switches to determine the front air bag deployment, and may only deploy one front air bag, depending on the severity of a collision and whether the front occupants are belted or unbelted. Information necessary to service the system safely is included in the SR and SB section of this Service Manual.

WARNING:

- To avoid rendering the SRS inoperative, which could increase the risk of personal injury or death in the event of a collision which would result in air bag inflation, all maintenance must be performed by an authorized NISSAN/INFINITI dealer.
- Improper maintenance, including incorrect removal and installation of the SRS, can lead to personal injury caused by unintentional activation of the system. For removal of Spiral Cable and Air Bag Module, see the SR section.
- Do not use electrical test equipment on any circuit related to the SRS unless instructed to in this Service Manual. SRS wiring harnesses can be identified by yellow and/or orange harnesses or harness connectors.

Precaution for Liquid Gasket

INFOID:000000001538755

REMOVAL OF LIQUID GASKET SEALING

- After removing the bolts and nuts, separate the mating surface and remove the old liquid gasket sealing using Tool.

Tool number : KV10111100 (J-37228)

CAUTION:

Do not damage the mating surfaces.

- Tap the seal cutter to insert it (1).
- In areas where the Tool is difficult to use, lightly tap to slide it (2).

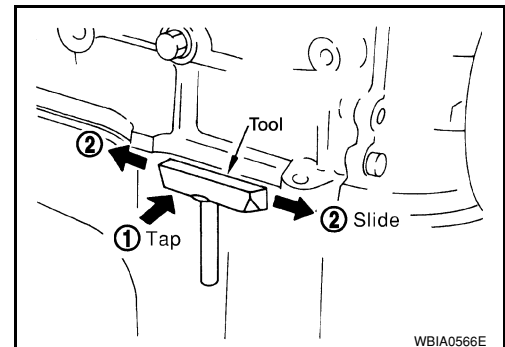

LIQUID GASKET APPLICATION PROCEDURE

1. Remove the old liquid gasket adhering to the gasket application surface and the mating surface using suitable tool.
 - Remove the liquid gasket completely from the groove of the liquid gasket application surface, bolts, and bolt holes.
2. Thoroughly clean the mating surfaces and remove adhering moisture, grease and foreign material.

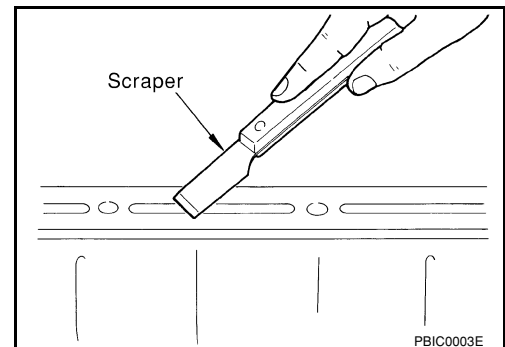

PRECAUTIONS

< PRECAUTION >

3. Attach the liquid gasket tube to the Tool.

Tool number : WS39930000 (—)

Use Genuine RTV Silicone Sealant or equivalent. Refer to GI-15, "Recommended Chemical Products and Sealants".

4. Apply the liquid gasket without breaks to the specified location with the specified dimensions.

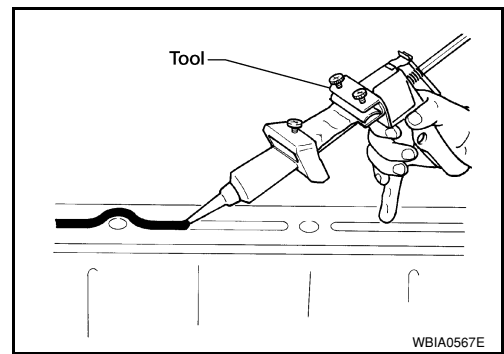

- If there is a groove for the liquid gasket application, apply the liquid gasket to the groove.
- As for the bolt holes, normally apply the liquid gasket inside the holes. If specified in the procedure, it should also be applied outside the holes.
- Within five minutes of liquid gasket application, install the mating component.
- If the liquid gasket protrudes, wipe it off immediately.
- Do not retighten after the installation.
- Wait 30 minutes or more after installation before refilling the engine with engine oil and engine coolant.

CAUTION:

If there are specific instructions in this manual, observe them.

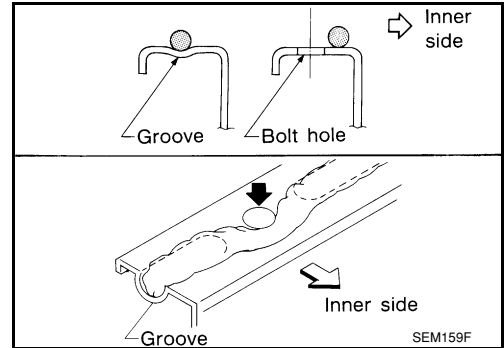

A

EX

C

D

E

F

G

H

I

J

K

L

M

N

O

P

PREPARATION

< PREPARATION >

PREPARATION

PREPARATION

Special Service Tool

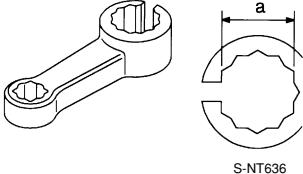

INFOID:000000001538756

The actual shapes of Kent-Moore tools may differ from those of special service tools illustrated here.

Tool number (Kent-Moore No.) Tool name	Description
KV10114400 (J-38365) Heated oxygen sensor wrench <div style="text-align: center;">  <p>S-NT636</p> </div>	Loosening or tightening heated oxygen sensors: a: 22 mm (0.87 in)

Commercial Service Tool

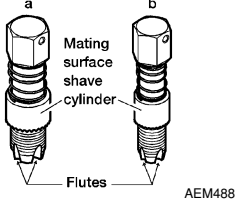
INFOID:000000001538757

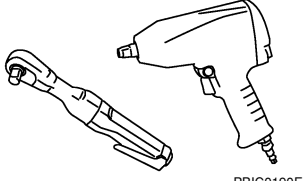
(Kent-Moore No.) Tool name	Description
(J-43897-18) (J-43897-12) Oxygen sensor thread cleaner <div style="text-align: center;">  <p>AEM488</p> </div>	Reconditioning the exhaust system threads before installing a new heated oxygen sensor (Use with anti-seize lubricant shown below): a: J-43897-18 (18 mm, 0.71 in) dia. b: J-43897-12 (12 mm, 0.47 in) dia.
Anti-seize lubricant (Permatex 133AR or equivalent meeting MIL specification MIL-A-907) <div style="text-align: center;">  <p>AEM489</p> </div>	Lubricating oxygen sensor thread cleaning tool when reconditioning exhaust system threads
Power tool <div style="text-align: center;">  <p>PBIC0190E</p> </div>	Loosening nuts and bolts

EXHAUST SYSTEM

< ON-VEHICLE MAINTENANCE >

ON-VEHICLE MAINTENANCE

EXHAUST SYSTEM

Checking Exhaust System

INFOID:000000001538758

Check exhaust pipes, muffler and mounting for improper attachment, leaks, cracks, damage or deterioration.

- If anything is found, repair or replace damaged parts.

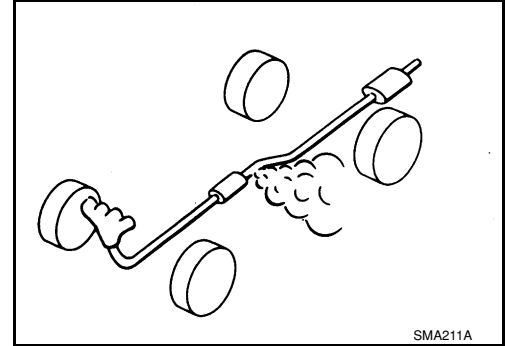

A

EX

C

D

E

F

G

H

I

J

K

L

M

N

O

P

EXHAUST SYSTEM

< ON-VEHICLE REPAIR >

ON-VEHICLE REPAIR

EXHAUST SYSTEM

Removal and Installation

INFOID:000000001538759

Exhaust System

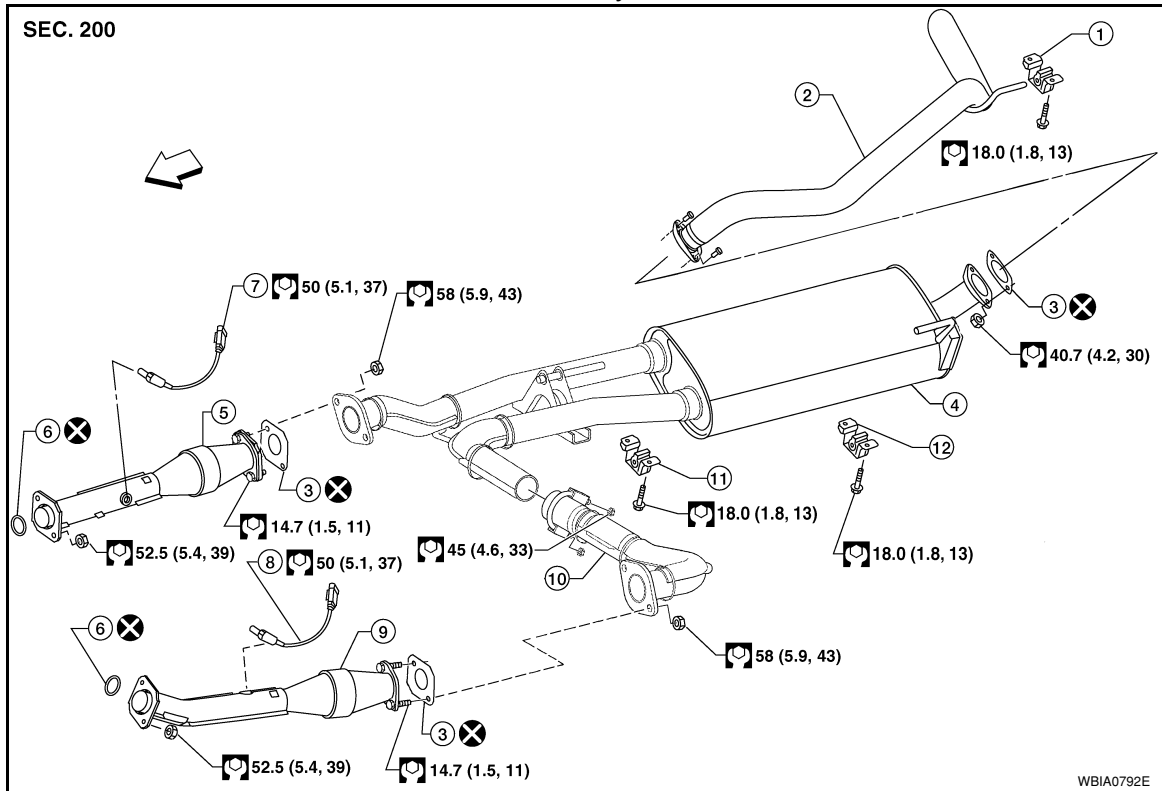

- | | | |
|------------------------------------|------------------------------------|---------------------------------|
| 1. Tailpipe hanger bracket | 2. Tailpipe | 3. Gasket |
| 4. Main muffler | 5. Right front exhaust tube | 6. Ring gasket |
| 7. Heated oxygen sensor 2 (bank 2) | 8. Heated oxygen sensor 2 (bank 1) | 9. Left front exhaust tube |
| 10. Center exhaust tube | 11. Muffler hanger bracket front | 12. Muffler hanger bracket rear |

CAUTION:

- Be sure to use genuine exhaust system parts or equivalents which are specially designed for heat resistance, corrosion resistance, and shape.
- Perform the operation with the exhaust system fully cooled. The system will be hot just after the engine stops.
- Be careful not to cut your hand on the heat insulator edge.

REMOVAL

Remove exhaust system components using power tool.

INSTALLATION

Installation is in the reverse order of removal.

CAUTION:

- Always replace exhaust gaskets with new ones when reassembling.
- Before installing a new heated oxygen sensor, clean and lube the exhaust tube threads using Tool.

Tool number A: — (J-43897-18)
 B: — (J-43897-12)

- Discard any heated oxygen sensor which has been dropped from a height of more than 0.5 m (19.7 in) onto a hard surface such as a concrete floor; replace with a new one.

EXHAUST SYSTEM

< ON-VEHICLE REPAIR >

- Do not over-torque the heated oxygen sensor. Doing so may damage the heated oxygen sensor, resulting in the MIL coming on.
- If any mounting insulator is badly deformed, repair or replace it. If deposits such as mud pile up on the mounting insulators, clean and inspect them.
- Temporarily tighten the nuts on the exhaust manifold side and the bolts on the vehicle side. Check each part for interference with other components, and then tighten the nuts and bolts to specification.

A

EX

INSPECTION AFTER INSTALLATION

- With the engine running, check exhaust tube joints for gas leakage and unusual noises.
- Check to ensure that mounting brackets and mounting rubbers are installed properly and free from undue stress. Improper installation could result in excessive noise and vibration.

C

D

E

F

G

H

I

J

K

L

M

N

O

P