

A
FL
C

SECTION **FL**

FUEL SYSTEM

CONTENTS

PRECAUTION	2	REMOVAL AND INSTALLATION	6	F
PRECAUTIONS	2	FUEL TANK	6	
Precaution for Supplemental Restraint System (SRS) "AIR BAG" and "SEAT BELT PRE-TENSIONER"	2	Removal and Installation	6	G
FUEL SYSTEM	3	FUEL LEVEL SENSOR UNIT, FUEL FILTER AND FUEL PUMP ASSEMBLY	11	H
General Precaution	3	Removal and Installation	11	
PREPARATION	4	DISASSEMBLY AND ASSEMBLY	16	
PREPARATION	4	FUEL LEVEL SENSOR UNIT, FUEL FILTER AND FUEL PUMP ASSEMBLY	16	I
Special Service Tool	4	Disassembly and Assembly	16	
Commercial Service Tool	4	SERVICE DATA AND SPECIFICATIONS (SDS)	17	J
BASIC INSPECTION	5	SERVICE DATA AND SPECIFICATIONS (SDS)	17	K
FUEL SYSTEM	5	Standard and Limit	17	L
Checking Fuel Line	5			

PRECAUTIONS

< PRECAUTION >

PRECAUTION

PRECAUTIONS

Precaution for Supplemental Restraint System (SRS) "AIR BAG" and "SEAT BELT PRE-TENSIONER"

INFOID:000000001381607

The Supplemental Restraint System such as "AIR BAG" and "SEAT BELT PRE-TENSIONER", used along with a front seat belt, helps to reduce the risk or severity of injury to the driver and front passenger for certain types of collision. This system includes seat belt switch inputs and dual stage front air bag modules. The SRS system uses the seat belt switches to determine the front air bag deployment, and may only deploy one front air bag, depending on the severity of a collision and whether the front occupants are belted or unbelted. Information necessary to service the system safely is included in the SR and SB section of this Service Manual.

WARNING:

- **To avoid rendering the SRS inoperative, which could increase the risk of personal injury or death in the event of a collision which would result in air bag inflation, all maintenance must be performed by an authorized NISSAN/INFINITI dealer.**
- **Improper maintenance, including incorrect removal and installation of the SRS, can lead to personal injury caused by unintentional activation of the system. For removal of Spiral Cable and Air Bag Module, see the SR section.**
- **Do not use electrical test equipment on any circuit related to the SRS unless instructed to in this Service Manual. SRS wiring harnesses can be identified by yellow and/or orange harnesses or harness connectors.**

FUEL SYSTEM

< PRECAUTION >

FUEL SYSTEM

General Precaution

INFOID:000000001534438

WARNING:

When replacing fuel line parts, be sure to observe the following.

- Put a "CAUTION: FLAMMABLE" sign in the workshop.
- Be sure to work in a well ventilated area and furnish workshop with a CO₂ fire extinguisher.
- Do not smoke while servicing fuel system. Keep open flames and sparks away from the work area.

CAUTION:

- Before removing fuel line parts, carry out the following procedures:
 - Put drained fuel in an explosion-proof container and put the lid on securely. Keep the container in safe area.
 - Release fuel pressure from the fuel lines. Refer to [EC-478. "Fuel Pressure Check"](#).
 - Disconnect the battery negative terminal.
 - Always replace O-rings and clamps with new ones.
 - Do not kink or twist hoses when they are being installed.
 - After connecting the fuel tube quick connectors, make sure the quick connectors are secure.
Ensure that the connector and resin tube do not contact any adjacent parts.
- After installing tubes, make sure there is no fuel leakage at connections in the following steps.
 - Apply fuel pressure to fuel lines with turning ignition switch ON (with engine stopped). Then check for fuel leaks at connections.
 - Start the engine and rev it up and check for fuel leaks at connections.
- Use only a Genuine NISSAN fuel filler cap as a replacement. If an incorrect fuel filler cap is used, the MIL may come on.
- For servicing "Evaporative Emission System" parts, refer to [EC-482. "Removal and Installation"](#).
- For servicing "On Board Refueling Vapor Recovery (ORVR)" parts, refer to [EC-480. "How to Detect Fuel Vapor Leakage"](#).

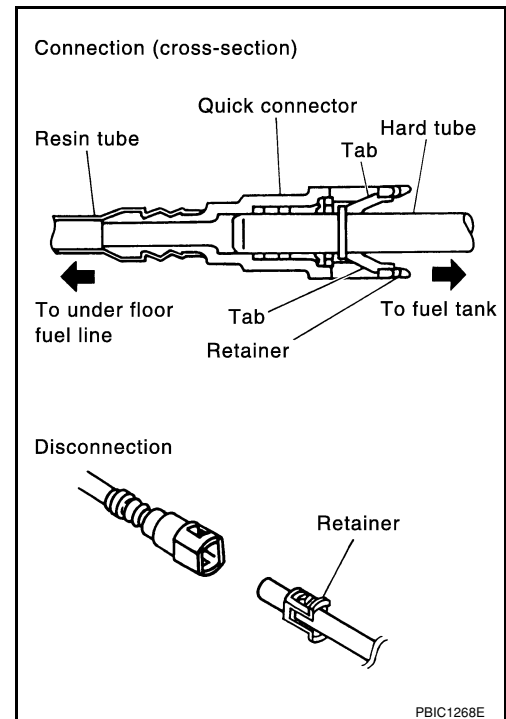

PREPARATION

< PREPARATION >

PREPARATION

PREPARATION

Special Service Tool

INFOID:000000001381609

The actual shapes of the Kent-Moore tools may differ from those of the special tools illustrated here.

Tool number (Kent-Moore No.) Tool name	Description
— (J-46536) Fuel tank lock ring tool	Removing and installing fuel tank lock ring

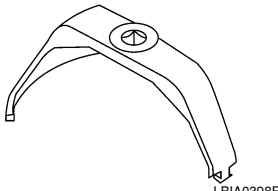

Commercial Service Tool

INFOID:000000001381610

Tool name	Description
Power tool	Loosening bolts and nuts

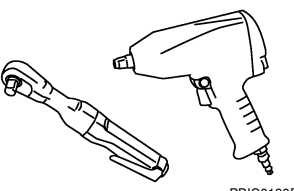

FUEL SYSTEM

< BASIC INSPECTION >

BASIC INSPECTION

FUEL SYSTEM

Checking Fuel Line

INFOID:000000001381669

Inspect fuel lines, fuel filler cap and fuel tank for improper attachment, leaks, cracks, damage, loose connections, chafing or deterioration.

If necessary, repair or replace damaged parts.

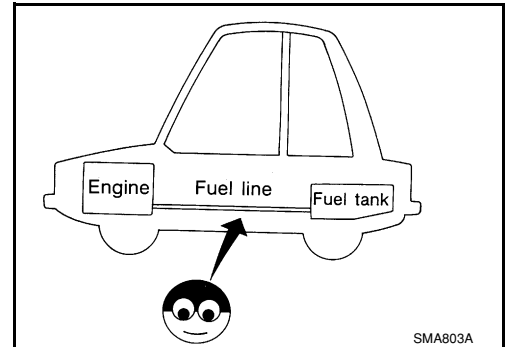

A

FL

C

D

E

F

G

H

I

J

K

L

M

N

O

P

FUEL TANK

< REMOVAL AND INSTALLATION >

REMOVAL AND INSTALLATION

FUEL TANK

Removal and Installation

INFOID:000000001381612

SEC. 172 • 747

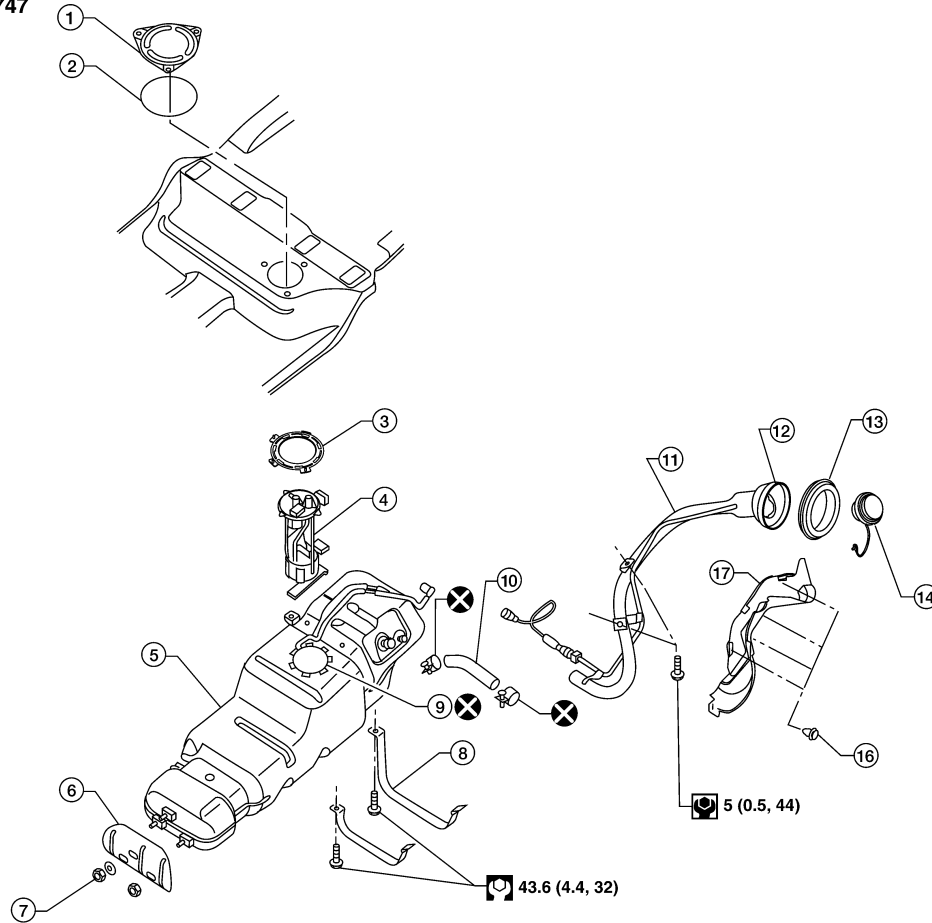

: N·m (kg-m, ft-lb)

: N·m (kg-m, in-lb)

: Always replace after every disassembly

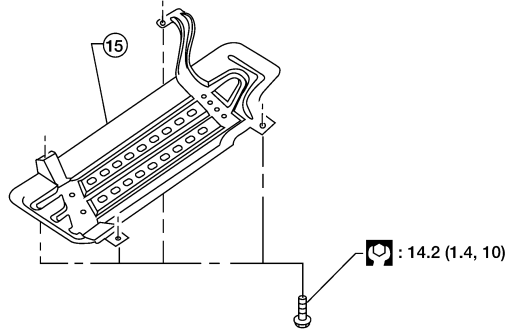

LBIA0384E

- | | | |
|---|---------------------------------|--|
| 1. Inspection hole cover | 2. Inspection hole cover O-ring | 3. Lock ring |
| 4. Fuel level sensor, fuel filter, and fuel pump assembly | 5. Fuel tank | 6. Fuel tank protector |
| 7. Fuel tank protector clips | 8. Fuel tank straps | 9. Fuel level sensor, fuel filter, and fuel pump assembly O-ring |

FUEL TANK

< REMOVAL AND INSTALLATION >

- | | | |
|------------------------------|-----------------------------|----------------------|
| 10. Fuel filler hose | 11. Fuel filler pipe | 12. Fuel filler cup |
| 13. Fuel filler hose grommet | 14. Fuel filler cap | 15. Fuel tank shield |
| 16. Clip | 17. Fuel filler pipe shield | |

REMOVAL

WARNING:

Follow the “General Precautions” before working on the fuel system. Refer to [FL-3, "General Precaution"](#).

1. Drain the fuel from the fuel tank, if necessary.
 - Position the vehicle so it is level.
2. Remove the fuel filler cap to release the pressure from inside the fuel tank.
3. Check the fuel level on level gauge. If the fuel gauge indicates more than the level as shown (full or almost full), drain the fuel from the fuel tank until the fuel gauge indicates the level as shown, or less.
 - If the fuel pump does not operate, use the following procedure to drain the fuel to the specified level after disconnecting the fuel filler hose from the fuel filler pipe.
- a. Insert a suitable hose of less than 15 mm (0.59 in) diameter into the fuel filler pipe through the fuel filler opening to drain the fuel from fuel filler pipe.
- b. Insert a suitable hose into the fuel tank through the fuel filler hose to drain the fuel from the fuel tank.
 - As a guide, the fuel level reaches the fuel gauge position as shown, or less, when approximately 14 liters (3 3/4 US gal, 3 1/8 Imp gal) of fuel are drained from the fuel tank.
4. Remove the LH rear wheel and tire. Refer to [WT-36, "Rotation"](#).
5. Remove the four clips and remove the fuel filler pipe shield.

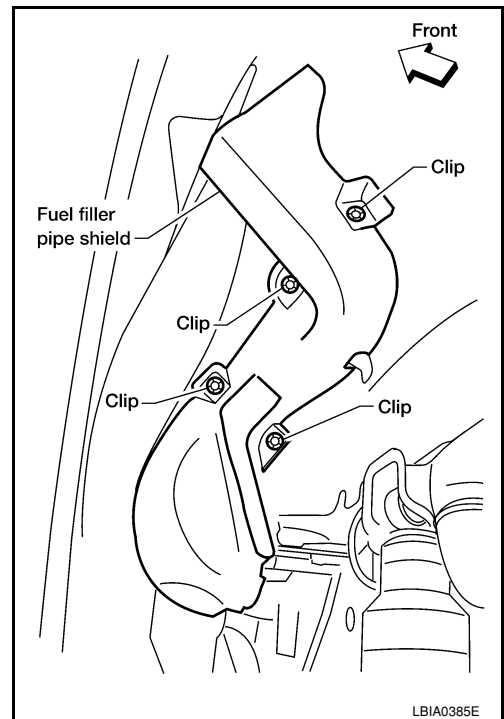
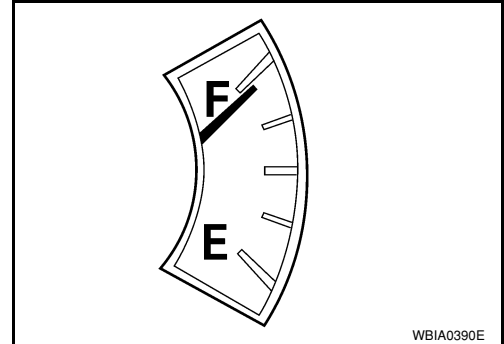

FUEL TANK

< REMOVAL AND INSTALLATION >

6. Disconnect the fuel filler hose from the fuel filler pipe and disconnect the vent hose quick connector.

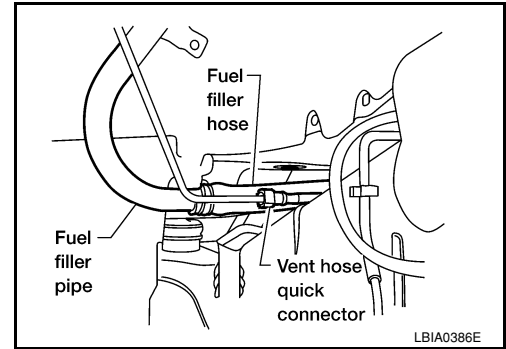

7. Release the fuel pressure from the fuel lines. Refer to [EC-478. "Fuel Pressure Check"](#).
8. Disconnect the battery negative terminal.
9. Remove the second row LH rear seat and the third row rear seat. Refer to [SE-54. "Second Row Outboard"](#), [SE-58. "LH Side Seat"](#) (w/o power folding), [SE-62. "LH Side Seat"](#) (power folding).
10. Remove the second and third row rear seat belt buckles mounted on the floor. Refer to [SB-6. "Removal and Installation of Second Row Seat Belt"](#), [SB-8. "Removal and Installation of Third Row Seat Belt"](#).
11. Remove the LH center pillar trim, the LH rear trim panel, and the LH rear side door kick plate and weather stripping. Refer to [INT-13. "Removal and Installation"](#).
12. Remove the second row rear center console and base. Refer to [SE-54. "Second Row Center"](#).
13. Reposition the floor carpet out of the way to access the inspection hole cover, located under the center LH rear seat.
14. Remove the inspection hole cover by turning the retainers 90° degrees clockwise.
 - Remove the O-ring.

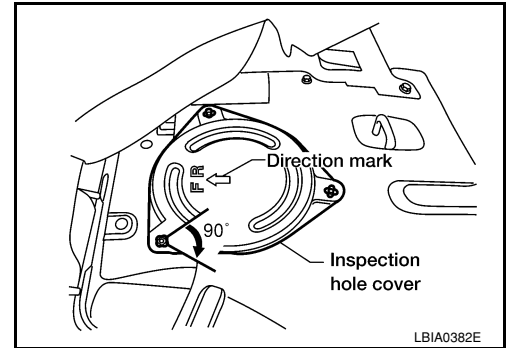

15. Disconnect the fuel level sensor, fuel filter, and fuel pump assembly electrical connector, the EVAP hose, and the fuel feed hose.

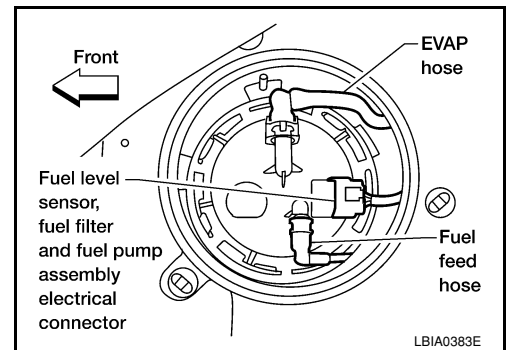

FUEL TANK

< REMOVAL AND INSTALLATION >

Disconnect the quick connector as follows:

- Hold the sides of the connector, push in tabs and pull out the tube.
- If the connector and the tube are stuck together, push and pull several times until they start to move. Then disconnect them by pulling.

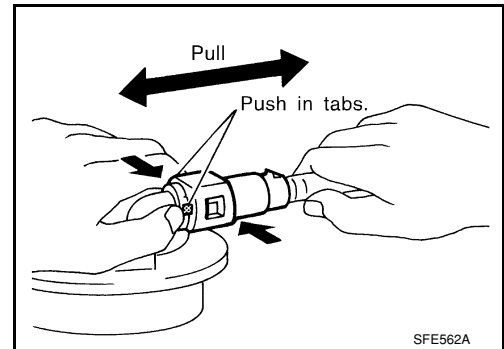

CAUTION:

- The quick connector can be disconnected when the tabs are completely depressed. Do not twist the quick connector more than necessary.
- Do not use any tools to disconnect the quick connector.
- Keep the resin tube away from heat. Be especially careful when welding near the tube.
- Prevent any acid liquids such as battery electrolyte, from getting on the resin tube.
- Do not bend or twist the resin tube during connection.
- Do not remove the remaining retainer on the hard tube (or the equivalent) except when the resin tube or the retainer is replaced.
- When the resin tube or hard tube, or the equivalent, is replaced, also replace the retainer with a new one (white colored retainer).

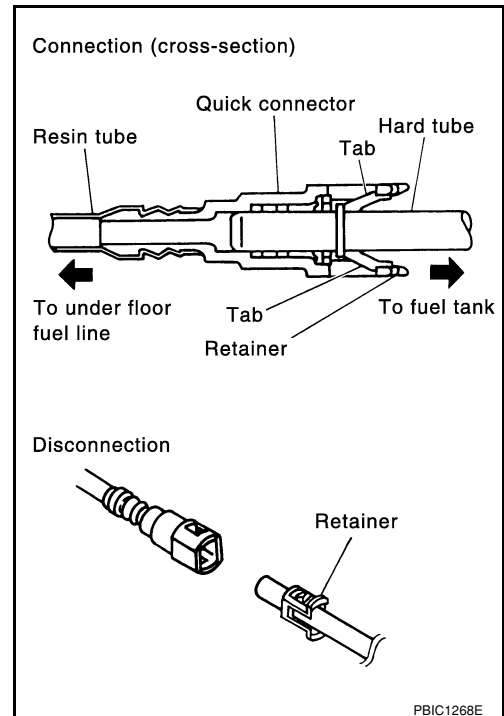

- To keep the quick connector clean and to avoid damage and contamination from foreign materials, cover the quick connector with plastic bags or suitable material as shown.

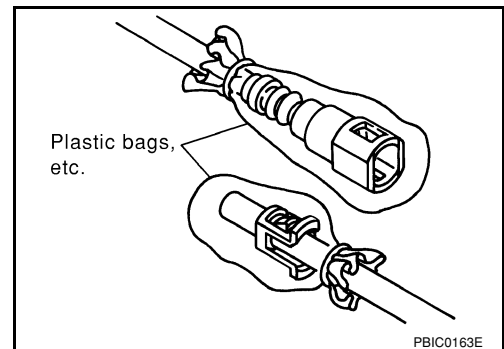

16. Remove the four bolts and remove the fuel tank shield.
17. Remove the propeller shaft. Refer to [DLN-182. "Removal and Installation"](#) (2F1310), [DLN-190. "Removal and Installation"](#) (2S1410).
18. Disconnect fuel filler hose, and vent hose at the fuel tank side.

FUEL TANK

< REMOVAL AND INSTALLATION >

19. Remove the fuel tank strap bolts while supporting the fuel tank with a suitable lift jack.

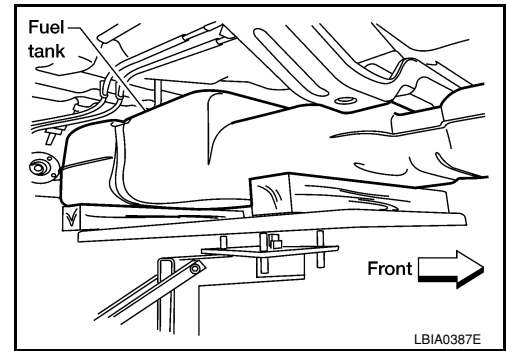

20. Disconnect the EVAP hose from the molded clip in the top of the fuel tank while lowering the fuel tank.
21. Lower the fuel tank using a suitable lift jack and remove it.

22. If necessary, remove the lock ring using Tool.

Tool number : — (J-46536)

23. If necessary, remove the fuel level sensor, fuel filter, and fuel pump assembly. Discard the fuel level sensor, fuel filter, and fuel pump assembly O-ring.

CAUTION:

- Do not bend the float arm during removal.
- Avoid impacts such as dropping when handling the components.

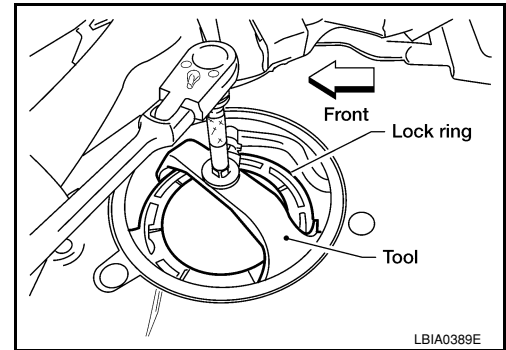

INSTALLATION

Installation is in the reverse order of removal.

- For installation, use a new fuel level sensor, fuel filter, and fuel pump assembly O-ring.
- Connect the quick connector as follows:
 - Check the connection for any damage or foreign materials.
 - Align the connector with the pipe, then insert the connector straight into the pipe until a click is heard.
 - After connecting the quick connector, make sure that the connection is secure by checking as follows:
 - Pull the tube and the connector to make sure they are securely connected.
 - Visually inspect the connector to make sure the two retainer tabs are securely connected.

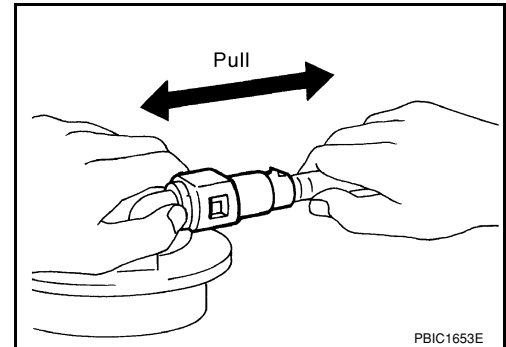

INSPECTION AFTER INSTALLATION

1. Turn the ignition switch ON but do not start engine, then check the fuel pipe and hose connections for leaks while applying fuel pressure.
2. Start the engine and rev it above idle, then check that there are no fuel leaks at any of the fuel pipe and hose connections.

FUEL LEVEL SENSOR UNIT, FUEL FILTER AND FUEL PUMP ASSEMBLY

< REMOVAL AND INSTALLATION >

FUEL LEVEL SENSOR UNIT, FUEL FILTER AND FUEL PUMP ASSEMBLY

Removal and Installation

INFOID:000000001381613

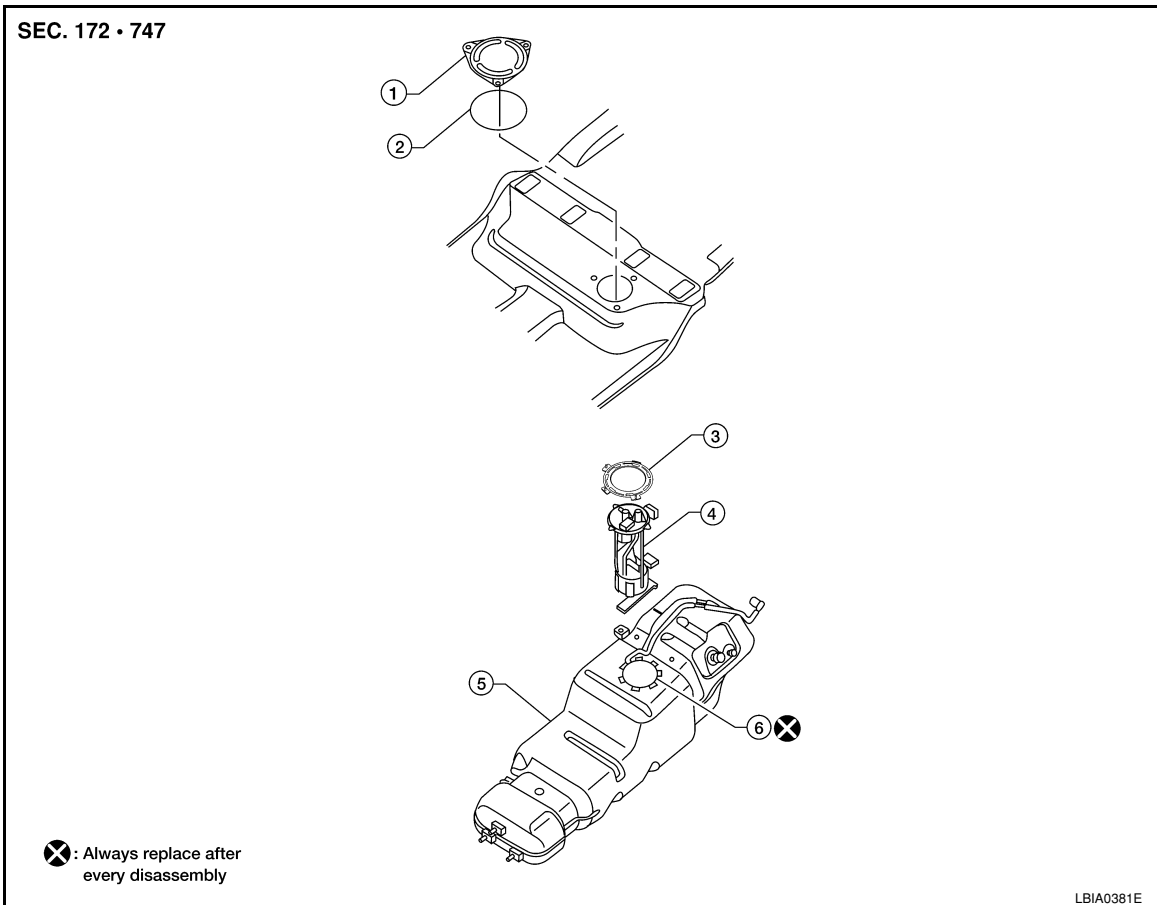

- | | | |
|---|---------------------------------|--|
| 1. Inspection hole cover | 2. Inspection hole cover O-ring | 3. Lock ring |
| 4. Fuel level sensor, fuel filter, and fuel pump assembly | 5. Fuel tank | 6. Fuel level sensor, fuel filter, and fuel pump assembly O-ring |

REMOVAL

WARNING:

Follow the "General Precautions" before working on the fuel system. Refer to [FL-3, "General Precaution"](#).

1. Remove the fuel filler cap to release the pressure from inside the fuel tank.
2. Check the fuel level on level gauge. If the fuel gauge indicates more than the level as shown (full or almost full), drain the fuel from the fuel tank until the fuel gauge indicates the level as shown, or less.
 - If the fuel pump does not operate, use the following procedure to drain the fuel to the specified level.
- a. Insert a suitable hose of less than 15 mm (0.59 in) diameter into the fuel filler pipe through the fuel filler opening to drain the fuel from fuel filler pipe.
- b. Remove the LH rear wheel and tire. Refer to [WT-36, "Rotation"](#).

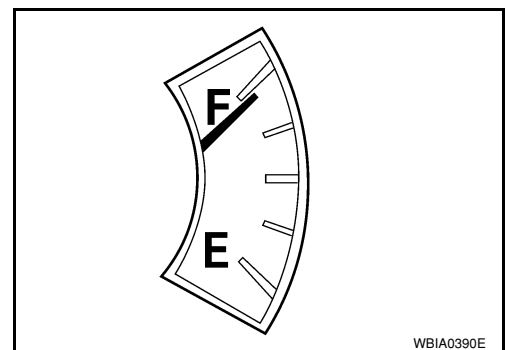

FUEL LEVEL SENSOR UNIT, FUEL FILTER AND FUEL PUMP ASSEMBLY

< REMOVAL AND INSTALLATION >

- c. Remove the fuel filler pipe shield.

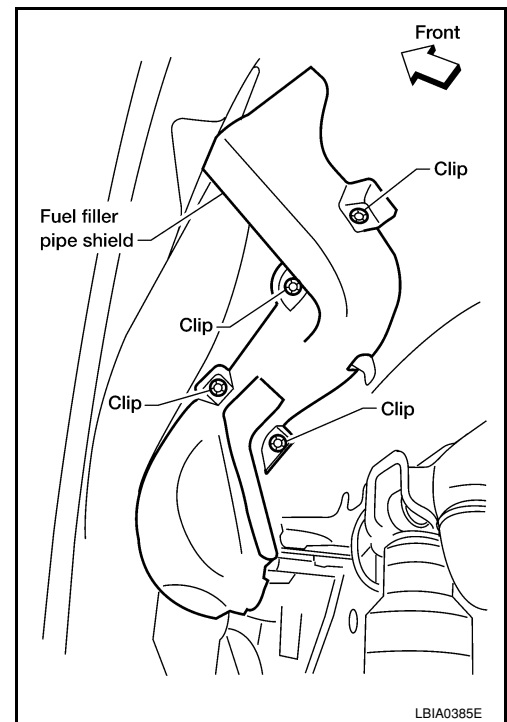

- d. Disconnect the fuel filler hose from the fuel filler pipe.

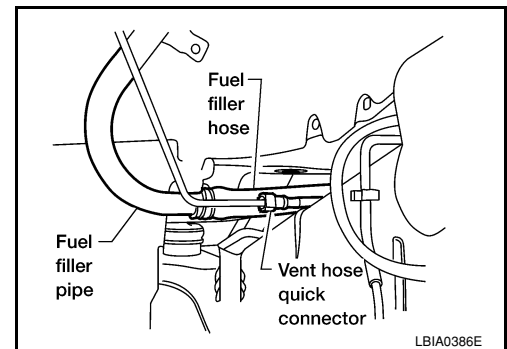

- e. Insert a suitable hose into the fuel tank through the fuel filler hose to drain the fuel from the fuel tank.
- As a guide, the fuel level reaches the fuel gauge position as shown, or less, when approximately 14 liters (3 3/4 US gal, 3 1/8 Imp gal) of fuel are drained from the fuel tank.
3. Release the fuel pressure from the fuel lines. Refer to [EC-478. "Fuel Pressure Check"](#) .
 4. Disconnect the battery negative terminal.
 5. Remove the second row LH rear seat and the third row rear seat. Refer to [SE-54. "Second Row Outboard"](#), [SE-58. "LH Side Seat"](#) (w/o power folding), [SE-62. "LH Side Seat"](#) (power folding).
 6. Remove the second and third row rear seat belt buckles mounted on the floor. Refer to [SB-6. "Removal and Installation of Second Row Seat Belt"](#).
 7. Remove the LH center pillar trim, the LH rear trim panel, and the LH rear side door kick plate and weather stripping. Refer to [INT-13. "Removal and Installation"](#).
 8. Remove the second row rear center console and base, if equipped. Refer to [SE-54. "Second Row Center"](#) .
 9. Reposition the floor carpet out of the way to access the inspection hole cover, located under the center LH rear seat.

FUEL LEVEL SENSOR UNIT, FUEL FILTER AND FUEL PUMP ASSEMBLY

< REMOVAL AND INSTALLATION >

10. Remove the inspection hole cover by turning the retainers 90° degrees clockwise.
 - Remove the O-ring.

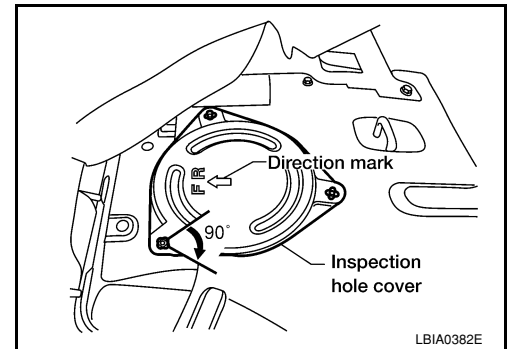

11. Disconnect the fuel level sensor, fuel filter, and fuel pump assembly electrical connector, the EVAP hose, and the fuel feed hose.

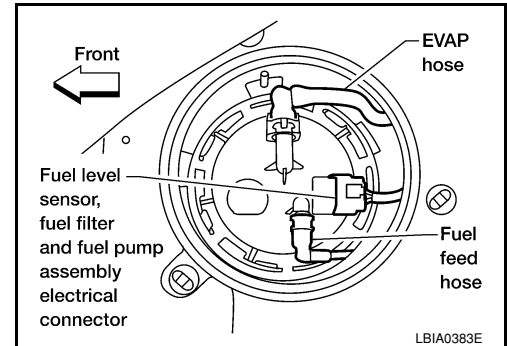

Disconnect the quick connector as follows:

- Hold the sides of the connector, push in tabs and pull out the tube.
- If the connector and the tube are stuck together, push and pull several times until they start to move. Then disconnect them by pulling.

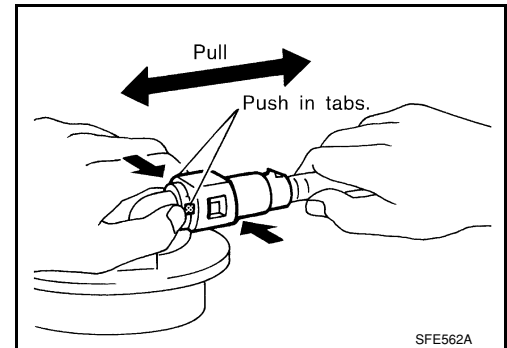

CAUTION:

A
FL
C
D
E
F
G
H
I
J
K
L
M
N
O
P

FUEL LEVEL SENSOR UNIT, FUEL FILTER AND FUEL PUMP ASSEMBLY

< REMOVAL AND INSTALLATION >

- The quick connector can be disconnected when the tabs are completely depressed. Do not twist the quick connector more than necessary.
- Do not use any tools to disconnect the quick connector.
- Keep the resin tube away from heat. Be especially careful when welding near the tube.
- Prevent any acid liquids such as battery electrolyte, from getting on the resin tube.
- Do not bend or twist the resin tube during connection.
- Do not remove the remaining retainer on the hard tube (or the equivalent) except when the resin tube or the retainer is replaced.
- When the resin tube or hard tube, or the equivalent, is replaced, also replace the retainer with a new one (white colored retainer).

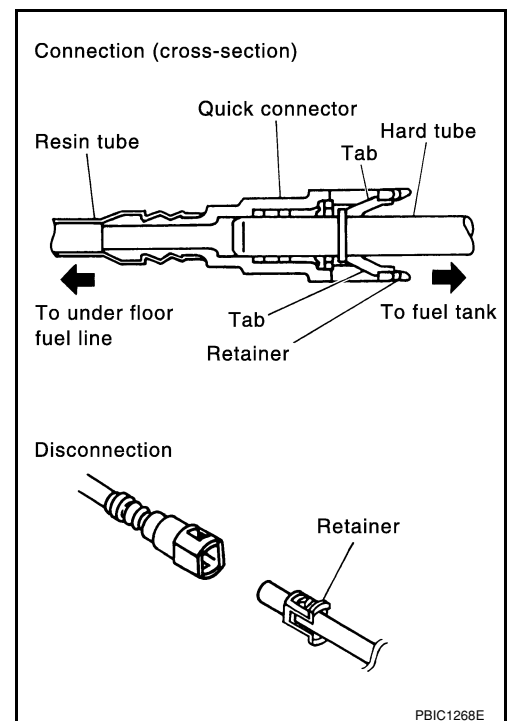

- To keep the quick connector clean and to avoid damage and contamination from foreign materials, cover the quick connector with plastic bags or suitable material as shown.

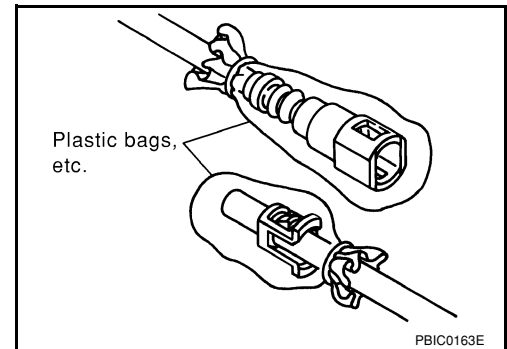

12. Remove the lock ring using Tool.

Tool number : — (J-46536)

13. Remove the fuel level sensor, fuel filter, and fuel pump assembly. Remove and discard the fuel level sensor, fuel filter, and fuel pump assembly O-ring.

CAUTION:

- Do not bend the float arm during removal.
- Avoid impacts such as dropping when handling the components.

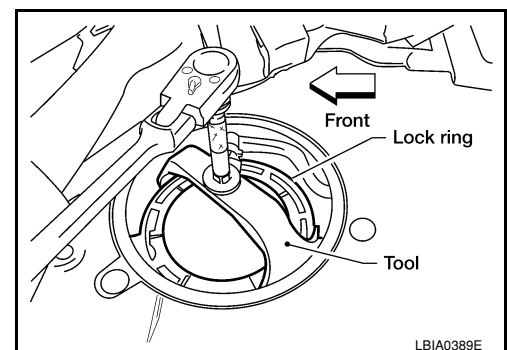

INSTALLATION

Installation is in the reverse order of removal.

- For installation, use a new fuel level sensor, fuel filter, and fuel pump assembly O-ring.
- Connect the quick connector as follows:
 - Check the connection for any damage or foreign materials.
 - Align the connector with the pipe, then insert the connector straight into the pipe until a click is heard.

FUEL LEVEL SENSOR UNIT, FUEL FILTER AND FUEL PUMP ASSEMBLY

< REMOVAL AND INSTALLATION >

- After connecting the quick connector, make sure that the connection is secure by checking as follows:
- Pull the tube and the connector to make sure they are securely connected.
- Visually inspect the connector to make sure the two retainer tabs are securely connected.

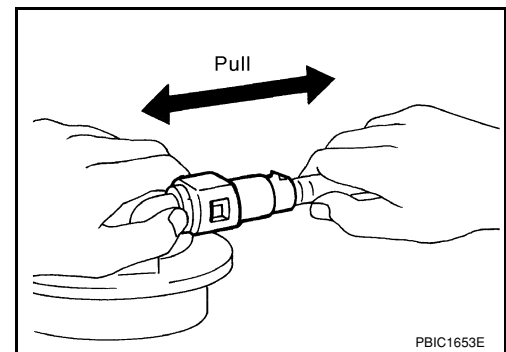

INSPECTION AFTER INSTALLATION

1. Turn the ignition switch ON but do not start engine, then check the fuel pipes and hose connections for leaks while applying fuel pressure to the system.
2. Start the engine and rev it above idle speed, then check that there are no fuel leaks at any of the fuel pipe and hose connections.

A

FL

C

D

E

F

G

H

I

J

K

L

M

N

O

P

FUEL LEVEL SENSOR UNIT, FUEL FILTER AND FUEL PUMP ASSEMBLY

< DISASSEMBLY AND ASSEMBLY >

DISASSEMBLY AND ASSEMBLY

FUEL LEVEL SENSOR UNIT, FUEL FILTER AND FUEL PUMP ASSEMBLY

Disassembly and Assembly

INFOID:000000001381616

Fuel Level Sender Unit

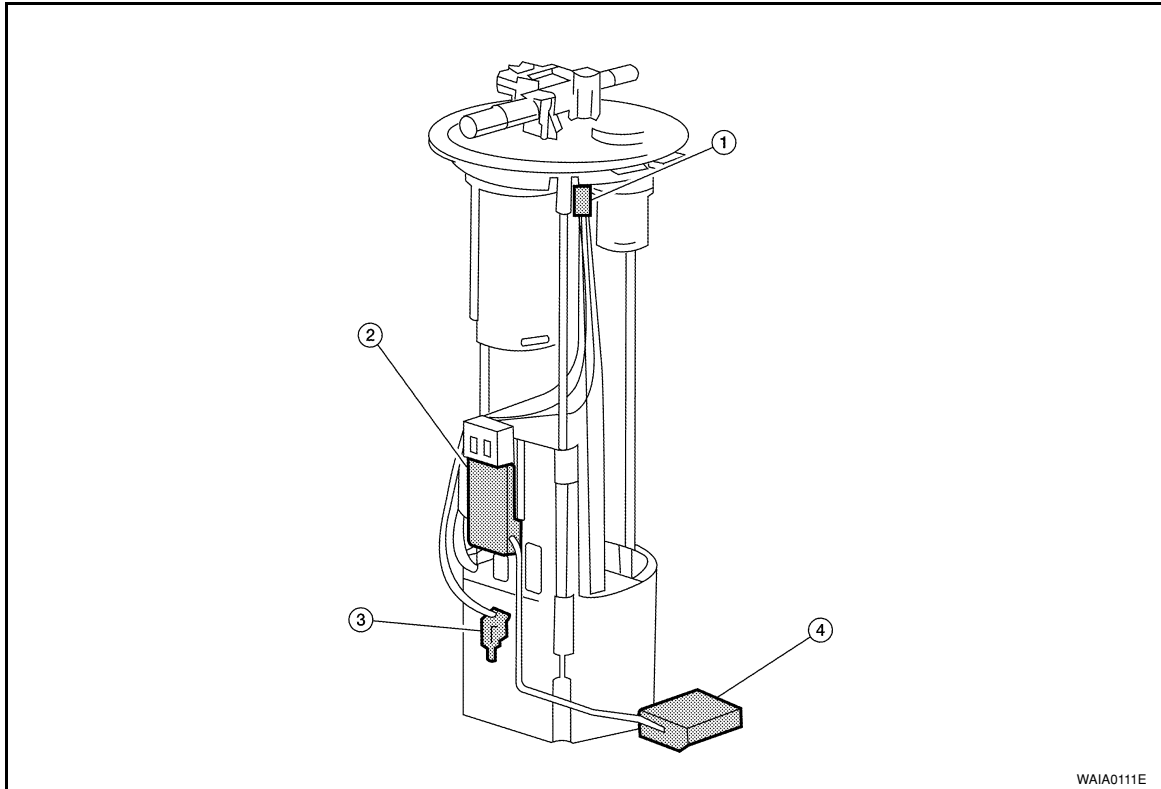

1. Harness connector

2. Sending unit module

3. Fuel sensor

4. Floater arm assembly

Disassembly

1. Disconnect the harness connectors (1).
2. Remove the fuel sensor (3) from the pump assembly.
3. Remove the sending unit module (2) and floater arm assembly(5).

Assembly

Assembly is the reverse order of disassembly.

SERVICE DATA AND SPECIFICATIONS (SDS)

< SERVICE DATA AND SPECIFICATIONS (SDS)

SERVICE DATA AND SPECIFICATIONS (SDS)

SERVICE DATA AND SPECIFICATIONS (SDS)

Standard and Limit

INFOID:000000001381611

A

FL

Fuel tank capacity	105.8 ℓ (28 US gal, 23 1/4 Imp gal)
--------------------	-------------------------------------

C

D

E

F

G

H

I

J

K

L

M

N

O

P