

SECTION HAC

HEATER & AIR CONDITIONING CONTROL SYSTEM

CONTENTS

AUTOMATIC AIR CONDITIONER	COMPONENT DIAGNOSIS	24	A
BASIC INSPECTION	MODE DOOR MOTOR	24	B
DIAGNOSIS AND REPAIR WORKFLOW	System Description	24	C
How to Perform Trouble Diagnosis For Quick And Accurate Repair	Mode Door Motor (Front) Component Function Check	25	D
INSPECTION AND ADJUSTMENT	Mode Door Motor (Front) Diagnosis Procedure	26	E
Operational Check (Front)	AIR MIX DOOR MOTOR	30	F
Operational Check (Rear)	System Description	30	G
FUNCTION DIAGNOSIS	Air Mix Door Motor Component Function Check	31	H
FUNCTION INFORMATION	Air Mix Door Motor (Driver) Diagnosis Procedure.....	32	HAC
Component Part Location	Air Mix Door Motor (Passenger) Diagnosis Proce- dure	35	J
Symptom Table	INTAKE DOOR MOTOR	40	K
REFRIGERATION SYSTEM	System Description	40	L
Refrigerant Cycle	Intake Door Motor Component Function Check	41	M
Refrigerant System Protection	Intake Door Motor Diagnosis Procedure	42	N
AUTOMATIC AIR CONDITIONER SYSTEM	DEFROSTER DOOR MOTOR CIRCUIT	44	O
Control System Diagram	System Description	44	P
Control System Description	Defroster Door Motor Component Function Check	45	
Discharge Air Flow (Front)	Defroster Door Motor Diagnosis Procedure	45	
Discharge Air Flow (Rear)	BLOWER MOTOR CONTROL SYSTEM	49	
Switches And Their Control Function (Front)	System Description	49	
Switches And Their Control Function (Rear)	Front Blower Motor Component Function Check	50	
CAN COMMUNICATION SYSTEM	Front Blower Motor Diagnosis Procedure	51	
System Description	Front Blower Motor Component Inspection	54	
DIAGNOSIS SYSTEM (HVAC)	Rear Blower Motor Description	55	
CONSULT-III Function (HVAC)	Rear Blower motor Component Function Check	56	
DIAGNOSIS SYSTEM (BCM)	Rear Air Control (Front) Diagnosis Procedure #1	57	
CONSULT-III Function (BCM)	Rear Air Control (Rear) Diagnosis Procedure #2	58	
SELF-DIAGNOSIS FUNCTION	Rear Blower Motor Component Inspection	59	
A/C Auto Amp. Self-Diagnosis	REAR AIR CONTROL SYSTEM	61	
A/C and AV Switch Assembly Self-Diagnosis	Rear Air Control System Description	61	
A/C System Self-Diagnosis Code Chart	Rear Air Control Component Function Check	61	
	Air Mix Door Motor (Rear) Diagnosis Procedure	62	
	Mode Door Motor (Rear) Diagnosis Procedure	66	

MAGNET CLUTCH	71	ECU DIAGNOSIS	90
System Description	71	AIR CONDITIONER CONTROL	90
Magnet Clutch Component Function Check	71	A/C Auto Amp. Terminals Reference Values	90
Magnet Clutch Diagnosis Procedure	72	Wiring Diagram	92
WATER VALVE CIRCUIT	76	SYMPTOM DIAGNOSIS	108
Description	76	AIR CONDITIONER CONTROL	108
Water Valve Diagnosis Procedure	76	Symptom Matrix Chart	108
AMBIENT SENSOR	78	INSUFFICIENT COOLING	109
Component Description	78	Component Function Check	109
Ambient Sensor Diagnosis Procedure	78	Performance Test Diagnoses	110
Ambient Sensor Component Inspection	79	Performance Chart	112
IN-VEHICLE SENSOR	81	Test Reading	113
Component Description	81	Trouble Diagnoses for Unusual Pressure	114
In-Vehicle Sensor Diagnosis Procedure	81	INSUFFICIENT HEATING	117
In-Vehicle Sensor Component Inspection	83	Component Function Check	117
OPTICAL SENSOR	84	NOISE	119
Component Description	84	Component Function Check	119
Optical Sensor Diagnosis Procedure	84	MEMORY FUNCTION DOES NOT OPERATE.	121
INTAKE SENSOR	86	Memory Function Check	121
System Description	86	PRECAUTION	122
Intake Sensor Diagnosis Procedure	86	PRECAUTIONS	122
Intake Sensor Component Inspection	87	Supplemental Restraint System (SRS) "AIR BAG" and "SEAT BELT PRE-TENSIONER"	122
POWER SUPPLY AND GROUND CIRCUIT FOR CONTROLLER	88	Working with HFC-134a (R-134a)	122
Component Description	88	Precaution for Service Equipment	123
A/C Auto Amp. Component Function Check	88		
A/C Auto Amp Power and Ground Diagnosis Pro- cedure	89		

BASIC INSPECTION

DIAGNOSIS AND REPAIR WORKFLOW

How to Perform Trouble Diagnosis For Quick And Accurate Repair

INFOID:000000001277492

WORK FLOW

1. LISTEN TO CUSTOMER COMPLAINT

Listen to customer complaint. Get detailed information about the conditions and environment when the symptom occurs.

>> GO TO 2

2. CHECK FOR SERVICE BULLETINS

Check for any service bulletins.

>> GO TO 3.

3. VERIFY THE SYMPTOM WITH OPERATIONAL CHECK

Verify the symptom with operational check. Refer to [HAC-4. "Operational Check \(Front\)"](#).

Can a symptom be duplicated?

YES >> GO TO 4

NO >> GO TO 5

4. GO TO APPROPRIATE TROUBLE DIAGNOSIS

Go to appropriate trouble diagnosis. Refer to [HAC-108. "Symptom Matrix Chart"](#).

Can a symptom be duplicated?

>> GO TO 5.

5. PERFORM THE A/C AUTO AMP SELF-DIAGNOSIS

Perform A/C auto amp. self-diagnosis. Refer to [HAC-22. "A/C Auto Amp. Self-Diagnosis"](#).

>> If any diagnostic trouble codes set. Refer to [HAC-23. "A/C System Self-Diagnosis Code Chart"](#).

>> Confirm the repair by performing operational check. Refer to [HAC-4. "Operational Check \(Front\)"](#).

A
B
C
D
E
F
G
H
HAC
J
K
L
M
N
O
P

INSPECTION AND ADJUSTMENT

Operational Check (Front)

INFOID:000000001277704

The purpose of the operational check is to confirm that the system operates properly.

Conditions : Engine running and at normal operating temperature

CHECKING MEMORY FUNCTION

1. Set the temperature to 32° (90°F).
2. Press the OFF switch.
3. Turn ignition switch OFF.
4. Turn ignition switch ON.
5. Press the AUTO switch.
6. Confirm that the set temperature remains at previous temperature.
7. Press the OFF switch.

If NG, go to trouble diagnosis procedure for [HAC-121. "Memory Function Check"](#).

If OK, continue with next check.

CHECKING BLOWER

1. Press the blower speed control switch (+) once, blower should operate on low speed. The fan display should have one bar lit (on display).
2. Press the blower speed control switch (+) again, and continue checking blower speed and fan display until all speeds are checked.
3. Leave blower on maximum speed.

If NG, go to trouble diagnosis procedure for [HAC-51. "Front Blower Motor Diagnosis Procedure"](#).

If OK, continue with next check.

CHECKING DISCHARGE AIR

1. Press MODE switch four times and the DEF  switch.
2. Each position indicator should change shape (on display).
3. Confirm that discharge air comes out according to the air distribution table. Refer to [HAC-15. "Discharge Air Flow \(Front\)"](#)

Mode door position is checked in the next step.



If NG, go to trouble diagnosis procedure for [HAC-26. "Mode Door Motor \(Front\) Diagnosis Procedure"](#).

If OK, continue the check.

NOTE:

Confirm that the compressor clutch is engaged (sound or visual inspection) and intake door position is at fresh when the DEF or D/F is selected.





CHECKING RECIRCULATION ( ,  ONLY)

1. Press recirculation () switch one time. Recirculation indicator should illuminate.
2. Press recirculation () switch one more time. Recirculation indicator should go off.
3. Listen for intake door position change (blower sound should change slightly).

If NG, go to trouble diagnosis procedure for [HAC-42. "Intake Door Motor Diagnosis Procedure"](#).

If OK, continue the check.

NOTE:

Confirm that the compressor clutch is engaged (sound or visual inspection) and intake door position is at fresh when the DEF or D/F is selected. REC () is not allowed in DEF () D/F () or FOOT ().

CHECKING TEMPERATURE DECREASE

1. Rotate temperature control dial (drive or passenger) counterclockwise until 18°C (60°F) is displayed.
2. Check for cold air at appropriate discharge air outlets.

INSPECTION AND ADJUSTMENT

[AUTOMATIC AIR CONDITIONER]

< BASIC INSPECTION >

If NG, listen for sound of air mix door motor operation. If OK, go to trouble diagnosis procedure for [HAC-109, "Component Function Check"](#). If air mix door motor appears to be malfunctioning, go to [HAC-31, "Air Mix Door Motor Component Function Check"](#).

If OK, continue the check.

CHECKING TEMPERATURE INCREASE

1. Rotate temperature control dial clockwise (drive or passenger) until 32°C (90°F) is displayed.
2. Check for hot air at appropriate discharge air outlets.

If NG, listen for sound of air mix door motor operation. If OK, go to trouble diagnosis procedure for [HAC-117, "Component Function Check"](#). If air mix door motor appears to be malfunctioning, go to [HAC-31, "Air Mix Door Motor Component Function Check"](#).

If OK, continue with next check.

CHECK A/C SWITCH

1. Press A/C switch when AUTO switch is ON, or in manual mode.
2. A/C switch indicator will turn ON.
 - Confirm that the compressor clutch engages (sound or visual inspection).

NOTE:

If current mode setting is DEF or D/F, compressor clutch will already be engaged and cannot be turned off.

If NG, go to trouble diagnosis procedure for [HAC-72, "Magnet Clutch Diagnosis Procedure"](#).

If OK, continue with next check.

CHECKING AUTO MODE

1. Press AUTO switch.
2. Display should indicate AUTO.
 - If ambient temperature is warm, and selected temperature is cool, confirm that the compressor clutch engages (sound or visual inspection). (Discharge air and blower speed will depend on ambient, in-vehicle, and set temperatures.)

If NG, go to trouble diagnosis procedure for [HAC-89, "A/C Auto Amp Power and Ground Diagnosis Procedure"](#), then if necessary, trouble diagnosis procedure for [HAC-72, "Magnet Clutch Diagnosis Procedure"](#).

If all operational checks are OK (symptom cannot be duplicated), go to malfunction Simulation Tests in [HAC-3, "How to Perform Trouble Diagnosis For Quick And Accurate Repair"](#) and perform tests as outlined to simulate driving conditions environment. If symptom appears. Refer to [HAC-108, "Symptom Matrix Chart"](#), and perform applicable trouble diagnosis procedures.

Operational Check (Rear)

INFOID:000000001277705

The purpose of the operational check is to confirm that the system operates properly.

Conditions : Engine running and at normal operating temperature

CHECKING REAR BLOWER MOTOR

1. Turn the ignition switch ON.
2. Rotate rear air control (front) blower control dial to low speed.
3. Rotate the blower control dial clockwise and continue checking blower speed until all speeds are checked.
4. Leave blower on maximum speed.
5. Press the REAR CTRL switch from the rear air control (front).
6. Rotate rear air control (rear) blower control dial to low speed.
7. Rotate the blower control dial clockwise and continue checking blower speed until all speeds are checked.
8. Leave blower on maximum speed.

If NG, go to trouble diagnosis procedure for [HAC-56, "Rear Blower motor Component Function Check"](#).

If OK, continue with next check.

CHECKING REAR DISCHARGE AIR

INSPECTION AND ADJUSTMENT

< BASIC INSPECTION >

[AUTOMATIC AIR CONDITIONER]

1. The REAR CTRL indicator must be off. Press each rear air control (front) mode door switches and confirm the discharge air comes out relative to the icon on each switch and according to the air distribution table. Refer to [HAC-15, "Discharge Air Flow \(Rear\)"](#).
2. Press the REAR CTRL switch (indicator on) from the rear air control (front).
3. Press each rear air control (rear) mode door switches and confirm the discharge air comes out relative to the icon on each switch and according to the air distribution table. Refer to [HAC-15, "Discharge Air Flow \(Rear\)"](#).

Air mix door position is checked in the next step.

If NG, go to [HAC-31, "Air Mix Door Motor Component Function Check"](#).

If OK, continue with next check.

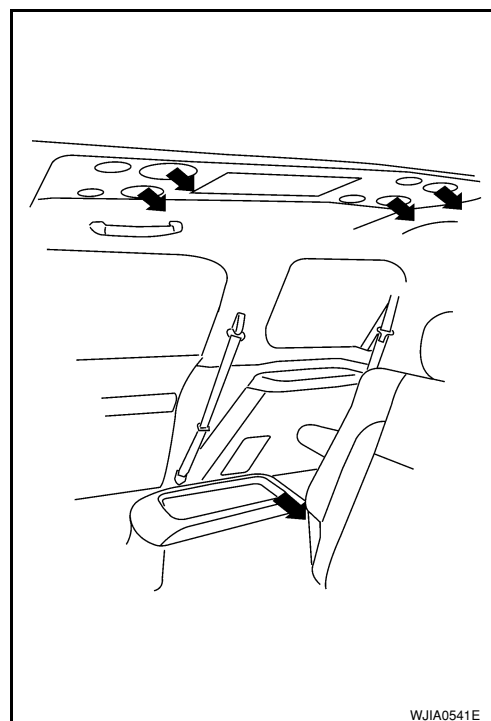

CHECKING REAR TEMPERATURE DECREASE

1. Press the REAR CTRL switch (indicator off).
2. Rotate the rear air control (front) temperature control dial counterclockwise to maximum cold.
3. Check for cold air at appropriate discharge air outlets.
4. Press the REAR CTRL switch (indicator on) from the rear air control (front).
5. Rotate the rear air control (rear) temperature control dial counterclockwise to maximum cold.
6. Check for cold air at appropriate discharge air outlets.

If NG, listen for sound of air mix door motor operation. If OK, go to trouble diagnosis procedure for [HAC-31, "Air Mix Door Motor Component Function Check"](#). If air mix door motor appears to be malfunctioning, go to [HAC-62, "Air Mix Door Motor \(Rear\) Diagnosis Procedure"](#).

If OK, continue with next check.

CHECKING REAR TEMPERATURE INCREASE

1. Press the REAR CTRL switch (indicator off).
2. Rotate the rear air control (front) temperature control dial clockwise to maximum heat.
3. Check for hot air at appropriate discharge air outlets.
4. Press the REAR CTRL switch (indicator on) from the rear air control (front).
5. Rotate the rear air control (rear) temperature control dial clockwise to maximum heat.
6. Check for hot air at appropriate discharge air outlets.

If NG, listen for sound of air mix door motor operation. If OK, go to trouble diagnosis procedure for [HAC-31, "Air Mix Door Motor Component Function Check"](#). If air mix door motor appears to be malfunctioning, go to [HAC-62, "Air Mix Door Motor \(Rear\) Diagnosis Procedure"](#).

If NG, go to trouble diagnosis procedure for [HAC-117, "Component Function Check"](#).

If all operational checks are OK (symptom cannot be duplicated), go to [HAC-3, "How to Perform Trouble Diagnosis For Quick And Accurate Repair"](#) and perform tests as outlined. If symptom appears, refer to [HAC-108, "Symptom Matrix Chart"](#) and perform applicable trouble diagnosis procedures.

FUNCTION DIAGNOSIS

FUNCTION INFORMATION

Component Part Location

INFOID:000000001277494

ENGINE COMPARTMENT

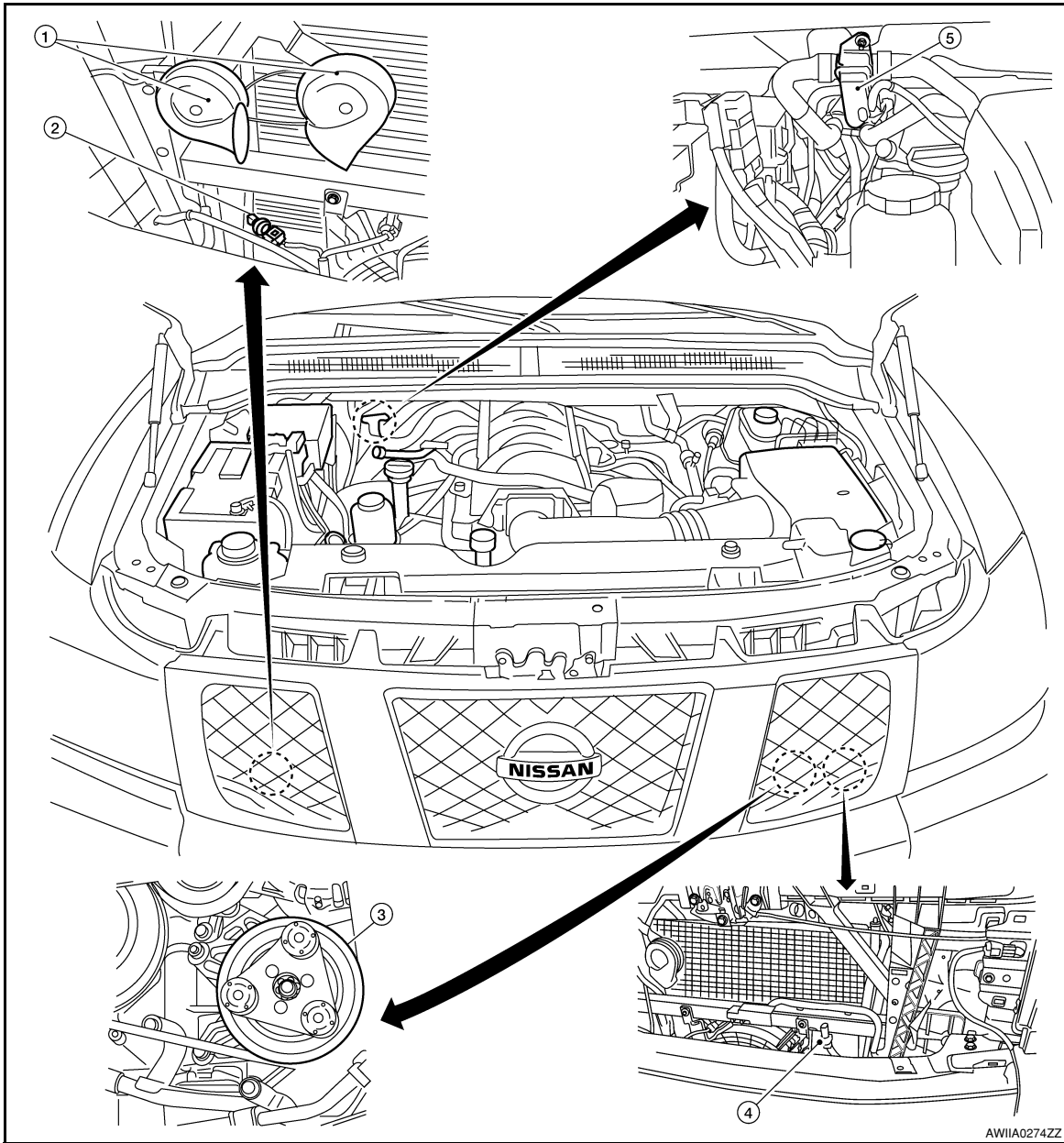

- 1. Horn (view with grille removed)
- 2. Refrigerant pressure sensor E111
- 3. A/C Compressor F3
- 4. Ambient sensor E1 (view with grille removed)
- 5. Water valve F68

A
B
C
D
E
F
G
H
HAC
J
K
L
M
N
O
P

FUNCTION INFORMATION

< FUNCTION DIAGNOSIS >

[AUTOMATIC AIR CONDITIONER]

PASSENGER COMPARTMENT

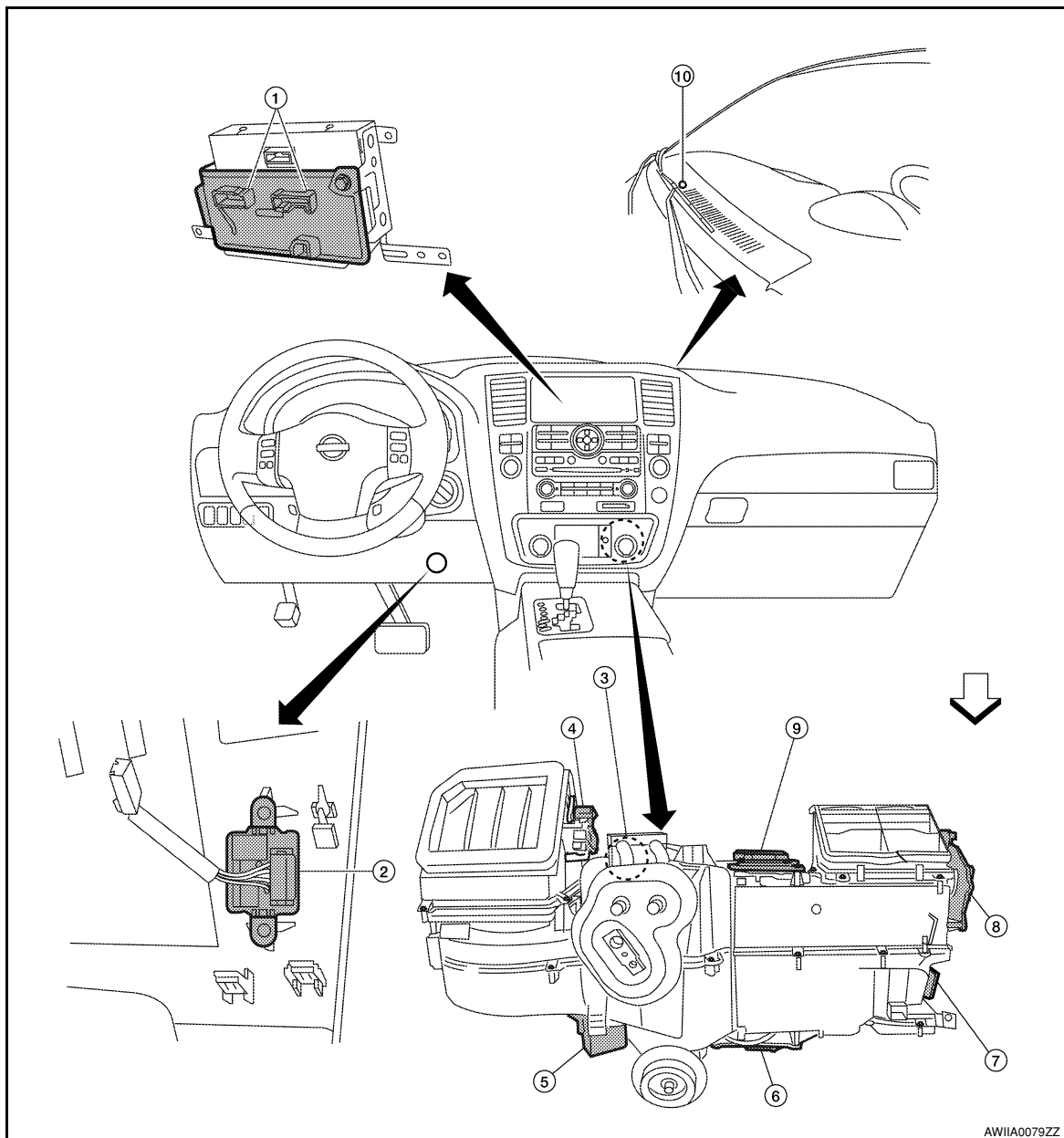

AWIIA0079ZZ

- | | | |
|---------------------------------|---|--|
| 1. A/C Auto amp. M49, M50 | 2. In-vehicle sensor M32 | 3. Intake sensor M146 |
| 4. Intake door motor M58 | 5. Variable blower control (front) M122 | 6. Air mix door motor (passenger) M143 |
| 7. Mode door motor (front) M142 | 8. Defroster door motor M144 | 9. Air mix door motor (driver) M147 |
| 10. Optical sensor M302 | ← :Front | |

FUNCTION INFORMATION

< FUNCTION DIAGNOSIS >

[AUTOMATIC AIR CONDITIONER]

REAR PASSENGER COMPARTMENT

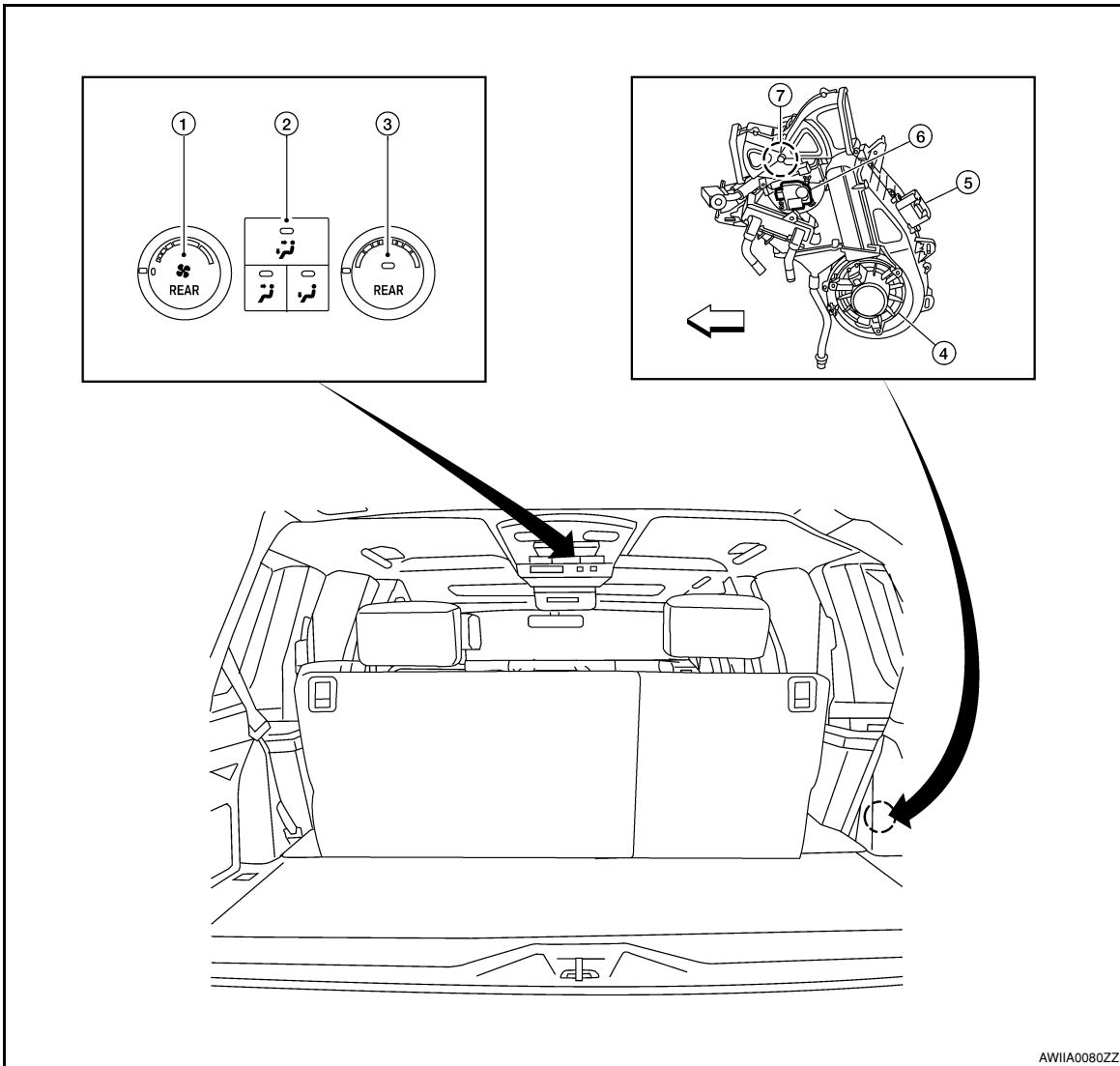

- 1. Rear temperature control (rear)
 - 2. Rear mode switch (rear)
 - 3. Rear blower control (rear)
 - 4. Rear blower motor B134
 - 5. Variable blower control (rear) B133
 - 6. Air mix door motor (B155)
 - 7. Mode door motor rear (B156)
- ← : Front

Symptom Table

INFOID:000000001277495

Symptom	Reference Page	
A/C system does not come on.	Go to Trouble Diagnosis Procedure for A/C System. HAC-88	
A/C system display is malfunctioning (with NAVI).	Go to Navigation System. AV-339	
A/C system display is malfunctioning (without NAVI).	Go to Base Audio System. AV-36	
A/C system cannot be controlled.	Go to Self-diagnosis Function. HAC-22	
Air outlet does not change.	Go to Trouble Diagnosis Procedure for Mode Door Motor. HAC-25	
Mode door motor is malfunctioning.		
Discharge air temperature does not change.	Go to Trouble Diagnosis Procedure for Air Mix Door Motor. HAC-31	
Air mix door motor is malfunctioning.		

A

B

C

D

E

F

G

H

HAC

J

K

L

M

N

O

P

FUNCTION INFORMATION

< FUNCTION DIAGNOSIS >

[AUTOMATIC AIR CONDITIONER]

Symptom	Reference Page	
Intake door does not change.	Go to Trouble Diagnosis Procedure for Intake Door Motor.	HAC-41
Intake door motor is malfunctioning.		
Defroster door motor is malfunctioning.	Go to Trouble Diagnosis Procedure for Defroster Door Motor.	HAC-45
Front blower motor operation is malfunctioning.	Go to Trouble Diagnosis Procedure for Front Blower Motor.	HAC-50
Rear blower motor operation is malfunctioning.	Go to Trouble Diagnosis Procedure for Rear Blower Motor.	HAC-56
Rear air discharge outlet does not change.	Go to Trouble Diagnosis Procedure for Mode Door Motor (rear).	HAC-61
Rear air temperature does not change.	Go to Trouble Diagnosis Procedure for Air Mix Door Motor (rear).	HAC-61
Magnet clutch does not engage.	Go to Trouble Diagnosis Procedure for Magnet Clutch.	HAC-71
Insufficient cooling	Go to Trouble Diagnosis Procedure for Insufficient Cooling.	HAC-109
Insufficient heating	Go to Trouble Diagnosis Procedure for Insufficient Heating.	HAC-117
Noise	Go to Trouble Diagnosis Procedure for Noise.	HAC-119
Self-diagnosis cannot be performed.	Go to Trouble Diagnosis Procedure for Self-diagnosis.	HAC-88
Memory function does not operate.	Go to Trouble Diagnosis Procedure for Memory Function.	HAC-121

REFRIGERATION SYSTEM

< FUNCTION DIAGNOSIS >

[AUTOMATIC AIR CONDITIONER]

REFRIGERATION SYSTEM

Refrigerant Cycle

INFOID:000000001277496

Refer to [HA-16. "Refrigerant Cycle"](#).

Refrigerant System Protection

INFOID:000000001277497

Refer to [HA-16. "Refrigerant System Protection"](#).

A

B

C

D

E

F

G

H

HAC

J

K

L

M

N

O

P

AUTOMATIC AIR CONDITIONER SYSTEM

< FUNCTION DIAGNOSIS >

[AUTOMATIC AIR CONDITIONER]

AUTOMATIC AIR CONDITIONER SYSTEM

Control System Diagram

INFOID:000000001277498

CONTROL SYSTEM

The control system consists of input sensors, switches, the A/C auto amp.(microcomputer) and outputs. The relationship of these components is shown in the figure below:

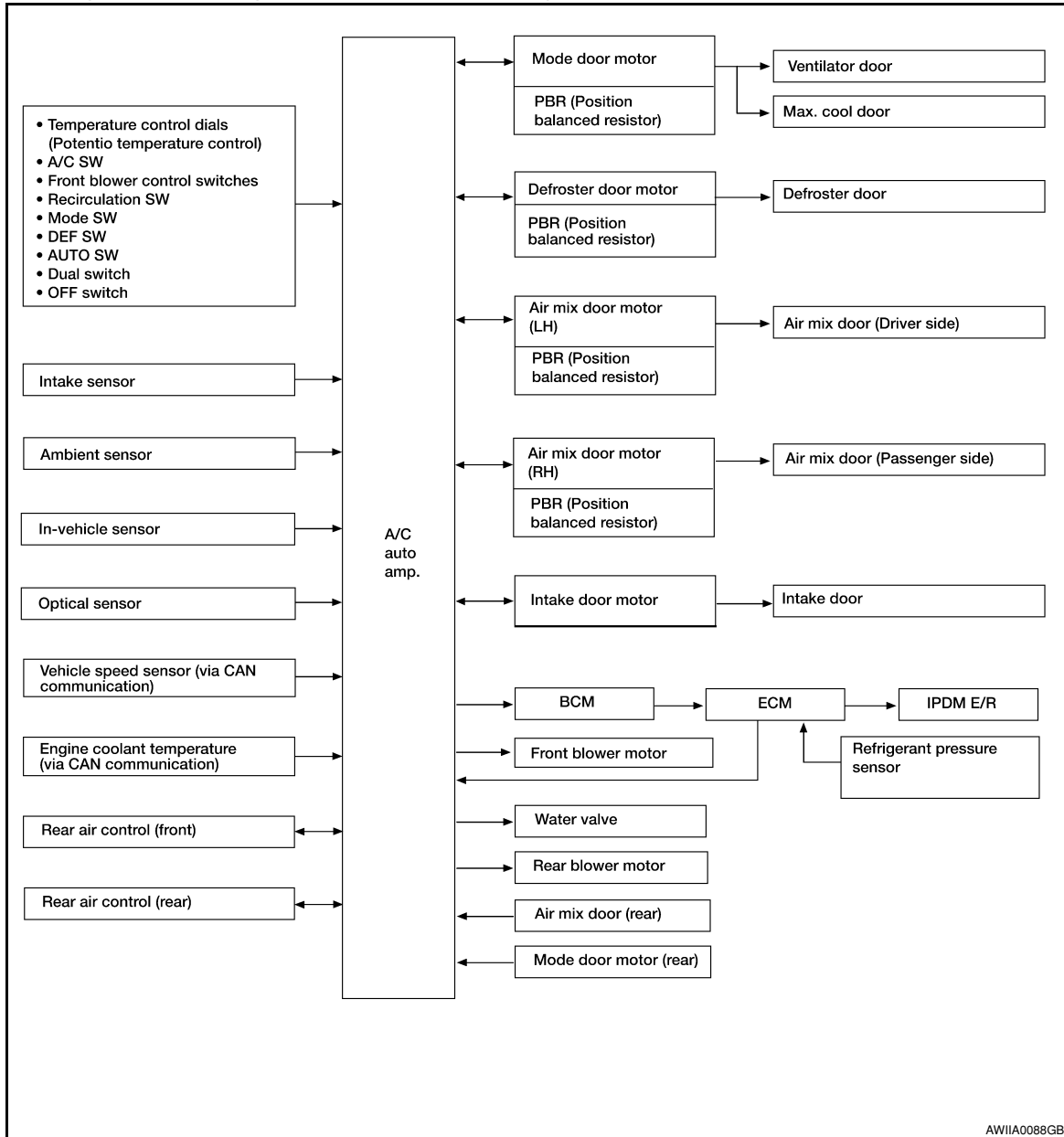

Control System Description

INFOID:000000001277499

CONTROL OPERATION

AUTOMATIC AIR CONDITIONER SYSTEM

< FUNCTION DIAGNOSIS >

[AUTOMATIC AIR CONDITIONER]

A/C auto amp.

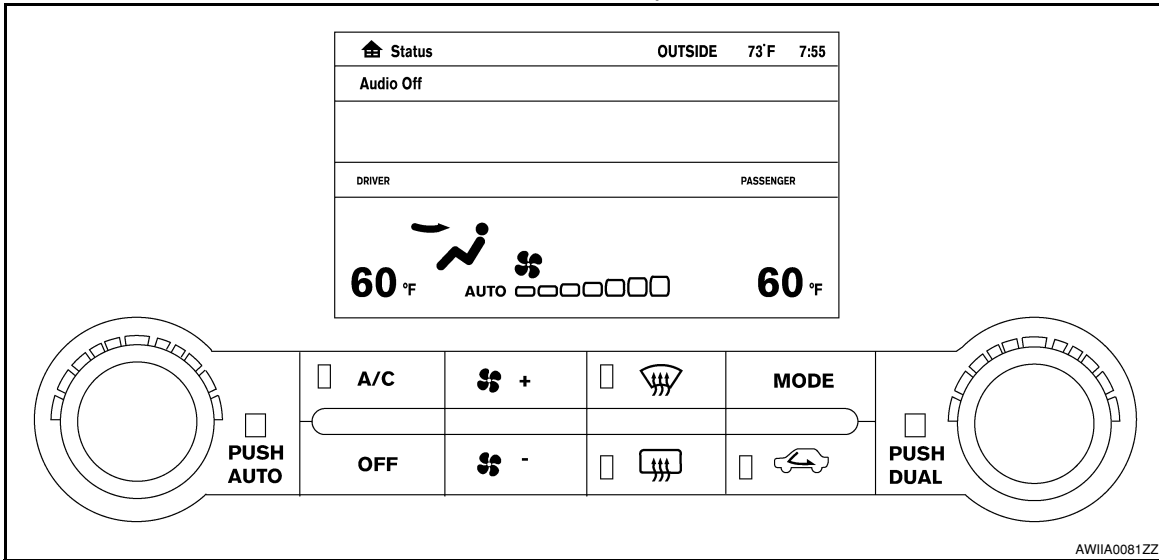

DISPLAY SCREEN

Displays the operational status of the system.

AUTO SWITCH

- The compressor, intake door, air mix doors, outlet doors and blower speed are automatically controlled so that the in-vehicle temperature will reach, and be maintained at the set temperature selected by the operator.
- When pressing AUTO switch, air inlet, air outlet, blower speed, and discharge air temperature are automatically controlled.

TEMPERATURE CONTROL DIAL (DRIVER)

Increases or decreases the set temperature.

TEMPERATURE CONTROL DIAL (PASSENGER)

Increases or decreases the set temperature.

RECIRCULATION () SWITCH

- When REC switch is ON, REC switch indicator turns ON, and air inlet is set to REC.
- When REC switch is turned OFF, or when compressor is turned from ON to OFF, REC switch is automatically turned OFF. REC mode can be re-entered by pressing REC switch again.
- REC switch is not operated when DEF switch is turned ON, at the D/F position, or in floor position.

DEFROSTER () SWITCH

Positions the air outlet doors to the defrost position. Also positions the intake doors to the outside air position, and turns A/C compressor ON.

REAR WINDOW DEFOGGER SWITCH

When switch is ON, rear window and door mirrors are defogged.

OFF SWITCH

The compressor and blower are OFF, the intake doors are set to the outside air position, and the air outlet doors are set to the foot (75% foot and 25% defrost) position.

A/C SWITCH

The compressor is ON or OFF.

(Pressing the A/C switch when the AUTO switch is ON will turn off the A/C switch and compressor.)

MODE SWITCH

Controls the air discharge outlets.

FRONT BLOWER CONTROL SWITCHES

Manually control the blower speed.

A
B
C
D
E
F

G
H

HAC

J

K

L

M

N

O

P

AUTOMATIC AIR CONDITIONER SYSTEM

< FUNCTION DIAGNOSIS >

[AUTOMATIC AIR CONDITIONER]

Rear Air Controls

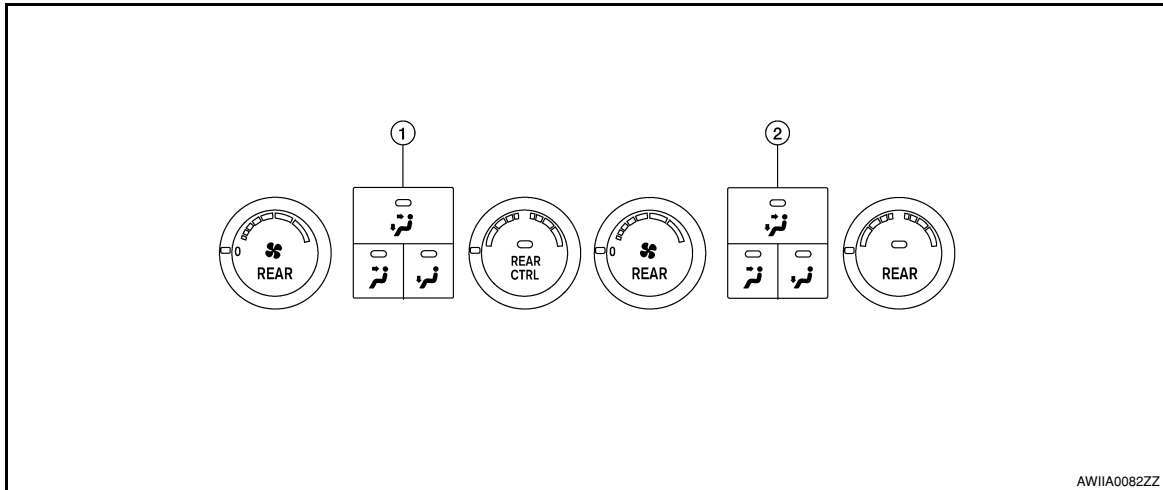

1. Rear air control (front)

2. Rear air control (rear)

REAR TEMPERATURE CONTROL DIAL (FRONT/REAR)

The temperature increases or decreases the set temperature.

REAR MODE SWITCHES (FRONT/REAR)

Controls the air discharge outlets.

REAR BLOWER CONTROL DIAL (FRONT)

When the REAR CTRL switch is in the off (indicator off) the rear air control (front) controls the rear blower motor speed regardless of the rear air control (rear) blower control dial (rear) position. The rear air control (front) controls the blower motor speed.

REAR BLOWER CONTROL DIAL (REAR)

When the REAR CTRL switch is in the on (indicator on) the rear air control (rear) controls the rear blower motor speed regardless of the rear air control (front) blower control dial (front) position. The rear air control (rear) controls the blower motor speed.

MAGNET CLUTCH CONTROL

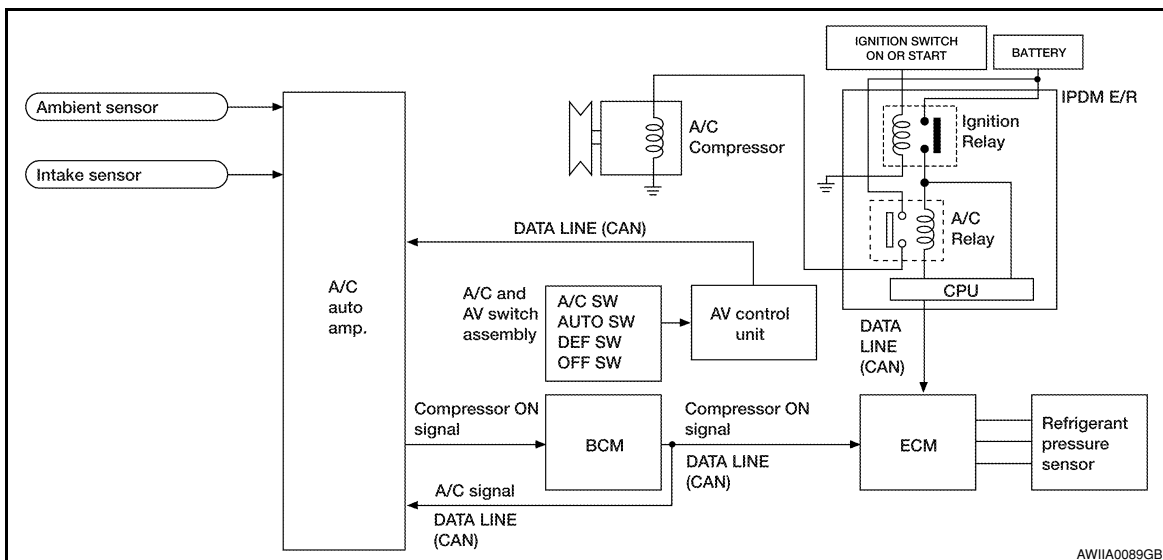

When A/C switch or DEF switch is pressed, A/C auto amp. inputs compressor ON signal to BCM.

BCM sends compressor ON signal to ECM and A/C auto amp., via CAN communication line.

ECM judges whether compressor can be turned ON, based on each sensor status (refrigerant pressure sensor signal, throttle angle sensor, etc.). If it judges compressor can be turned ON, it sends compressor ON signal to IPDM E/R, via CAN communication line.

AUTOMATIC AIR CONDITIONER SYSTEM

< FUNCTION DIAGNOSIS >





[AUTOMATIC AIR CONDITIONER]

Upon receipt of compressor ON signal from ECM, IPDM E/R turns air conditioner relay ON to operate compressor.

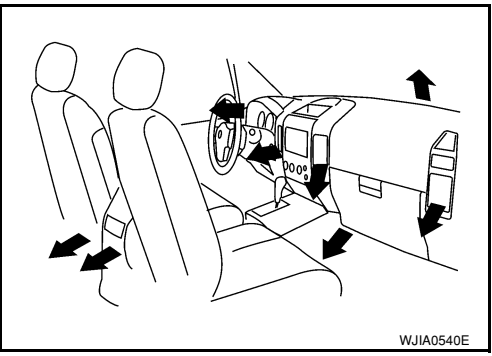
Discharge Air Flow (Front)

INFOID:000000001338007



Mode door position	Air outlet/distribution		
	Vent	Foot	Defroster
	95%	5%	—
	60%	40%	—
	—	70%	30%
	—	60%	40%
	—	10%	90%

Discharge Air Flow (Rear)

INFOID:000000001338023

A
B
C
D
E
F
G
H
HAC
J
K
L
M
N
O
P

AUTOMATIC AIR CONDITIONER SYSTEM

< FUNCTION DIAGNOSIS >

[AUTOMATIC AIR CONDITIONER]

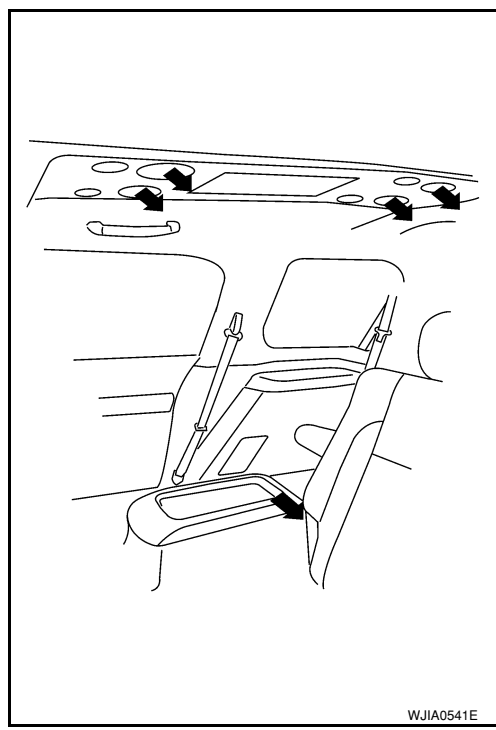

Mode door position	Air outlet/distribution	
	Vent	Foot
	100%	—
	50%	50%
	—	100%

AUTOMATIC AIR CONDITIONER SYSTEM

< FUNCTION DIAGNOSIS >

[AUTOMATIC AIR CONDITIONER]

Switches And Their Control Function (Front)

INFOID:000000001338021

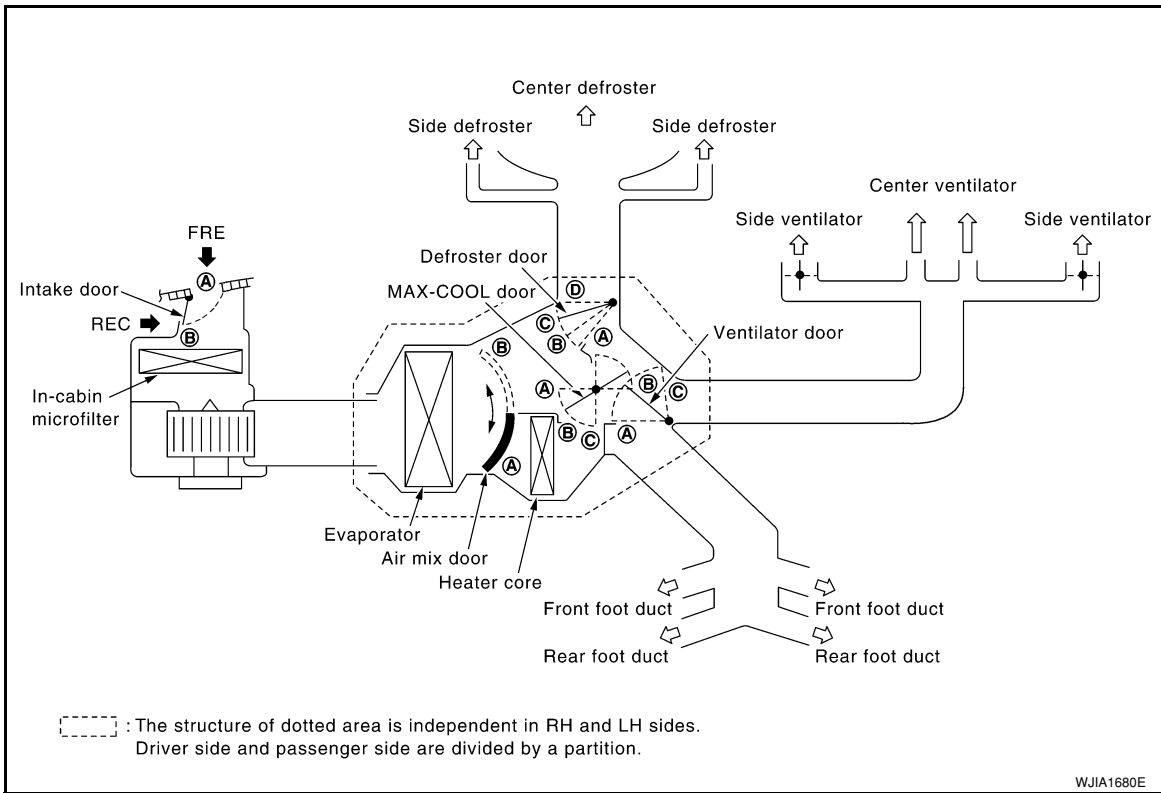

Position or switch	MODE SW				DEF SW		REC SW		Temperature control dial			OFF SW
	VENT	B/L	FOOT	D/F	ON	OFF	ON	OFF				OFF
Ventilator door	(A)	(B)	(C)	(C)	(C)	—	—	—	—	—	—	(C)
MAX-COOL door	(A)	(B)	(B)	(B)	(C)	—	—	—	—	—	—	(B)
Defroster door	(D)	(D)	(D _{or} C)	(B)	(A)	—	—	—	—	—	—	(C)
Intake door	—				(B)	—	(A)	(B)	—	—	—	(B)
Air mix door	—				—	—	—	—	(A)	AUTO	(B)	—

AWIA0083GB

AUTOMATIC AIR CONDITIONER SYSTEM

< FUNCTION DIAGNOSIS >



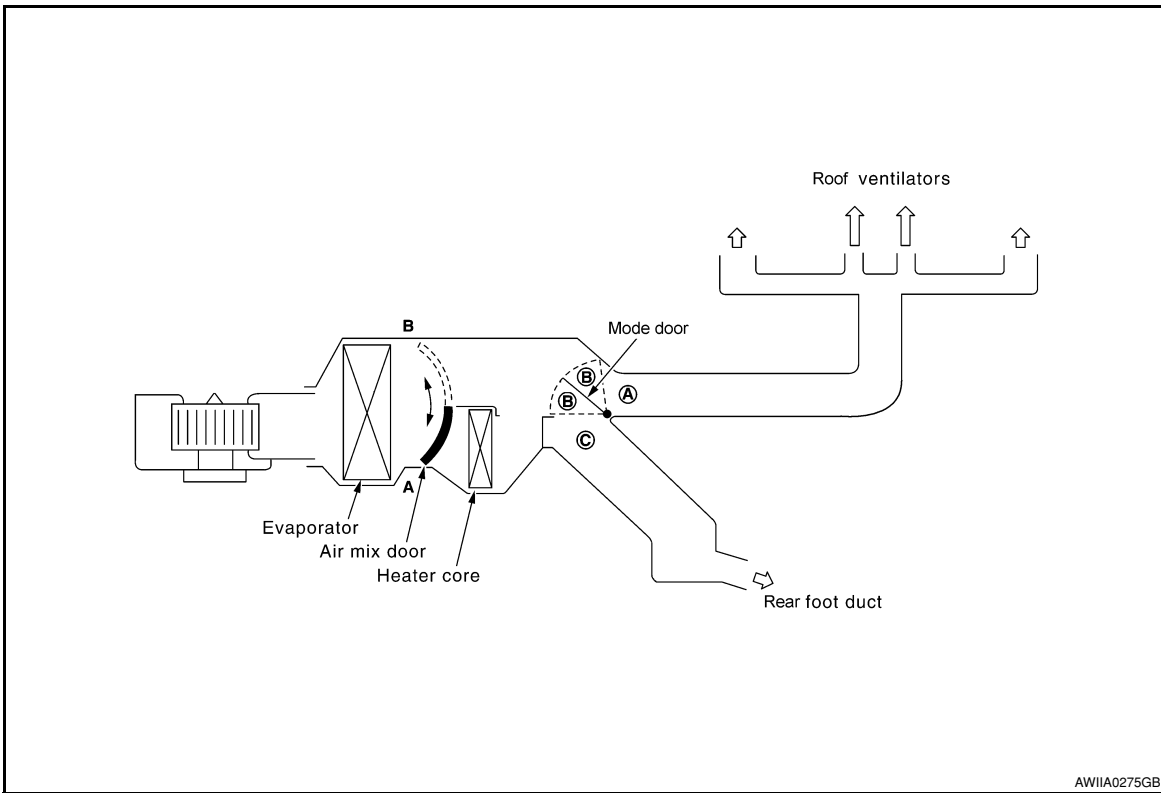

[AUTOMATIC AIR CONDITIONER]

Switches And Their Control Function (Rear)

INFOID:000000001338022

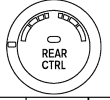

AWIA0275GB

Position or switch	MODE SW			Temp Control Dial			OFF SW
	VENT	B/L	FOOT				
Door							
Mode door	Ⓒ	Ⓑ	Ⓐ	—			Ⓒ
Air mix door	—			Ⓐ	AUTO	Ⓑ	—

AWIA0084GB

CAN COMMUNICATION SYSTEM

System Description

INFOID:000000001277502

Refer to [LAN-4. "System Description"](#).

A

B

C

D

E

F

G

H

HAC

J

K

L

M

N

O

P

DIAGNOSIS SYSTEM (HVAC)

< FUNCTION DIAGNOSIS >

[AUTOMATIC AIR CONDITIONER]

DIAGNOSIS SYSTEM (HVAC)

CONSULT-III Function (HVAC)

INFOID:000000001277503

CONSULT-III can display each diagnostic item using the diagnostic test modes shown following.

Diagnostic mode	Description
SELF-DIAG RESULTS	Displays A/C auto amp. self-diagnosis results.
DATA MONITOR	Displays A/C auto amp. input/output data in real time.
CAN DIAG SUPPORT MNTR	The result of transmit/receive diagnosis of CAN communication can be read.
ECU PART NUMBER	A/C auto amp. part number can be read.

SELF-DIAGNOSIS

Display Item List

DTC	Description	Reference page
B2573	Battery voltage out of range	CHG-10, "Inspection Procedure"
B2578	In-vehicle sensor circuit out of range (low)	HAC-81, "In-Vehicle Sensor Diagnosis Procedure"
B2579	In-vehicle sensor circuit out of range (high)	
B257B	Ambient sensor circuit short	HAC-78, "Ambient Sensor Diagnosis Procedure"
B257C	Ambient sensor circuit open	
B257F	Optical sensor (Driver) circuit open or short	HAC-84, "Optical Sensor Diagnosis Procedure"
B2580	Optical sensor (Passenger) circuit open or short	
B2581	Intake sensor circuit short	HAC-86, "Intake Sensor Diagnosis Procedure"
B2582	Intake sensor circuit open	
U1000	CAN bus fault	LAN-14, "Trouble Diagnosis Flow Chart"

DATA MONITOR

Display Item List

Monitor item	Value	Contents
BATT VIA CAN	"V"	Displays battery voltage signal.
IGN VIA CAN	"ON/OFF"	Displays ignition switch signal.
DVR SUNLD SEN	"w/m2"	Displays optical sensor (driver) signal.
PAS SUNLD SEN	"w/m2"	Displays optical sensor (passenger) signal.
AMB TEMP SEN	"°C"	Displays ambient sensor signal.
EVAP TEMP SEN	"°C"	Displays intake sensor signal.
INCAR TMP SEN	"°C"	Displays in-vehicle sensor signal.
RR TEMPSET FR	"V"	Displays air mix door (front) set point signal.
RR TEMPSET RR	"V"	Displays air mix door (rear) set point signal.
MODE FDBCK	"V"	Displays mode door motor feedback signal.
DVR MIX FDBCK	"V"	Displays air mix door motor (driver) feedback signal.
PAS MIX FDBCK	"V"	Displays air mix door motor (passenger) feedback signal.
RR FDBCK	"V"	Displays air mix door motor (rear) feedback signal.
DEF FDBCK	"V"	Displays defroster door motor feedback signal.

DIAGNOSIS SYSTEM (BCM)

< FUNCTION DIAGNOSIS >

[AUTOMATIC AIR CONDITIONER]

DIAGNOSIS SYSTEM (BCM)

CONSULT-III Function (BCM)

INFOID:000000001277788

CONSULT-II can display each diagnostic item using the diagnostic test modes shown following.

BCM diagnostic test item	Diagnostic mode	Description
Inspection by part	WORK SUPPORT	Supports inspections and adjustments. Commands are transmitted to the BCM for setting the status suitable for required operation, input/output signals are received from the BCM and received data is displayed.
	DATA MONITOR	Displays BCM input/output data in real time.
	ACTIVE TEST	Operation of electrical loads can be checked by sending drive signal to them.
	SELF-DIAG RESULTS	Displays BCM self-diagnosis results.
	CAN DIAG SUPPORT MNTR	The result of transmit/receive diagnosis of CAN communication can be read.
	ECU PART NUMBER	BCM part number can be read.
	CONFIGURATION	Performs BCM configuration read/write functions.

DATA MONITOR

Display Item List

Monitor item name "operation or unit"	Contents
IGN ON SW "ON/OFF"	Displays "IGN Position (ON)/OFF, ACC Position (OFF)" status as judged from ignition switch signal.
COMP ON SIG "ON/OFF"	Displays "COMP (ON)/COMP (OFF)" status as judged from air conditioner switch signal.
FAN ON SIG "ON/OFF"	Displays "FAN (ON)/FAN (OFF)" status as judged from blower motor switch signal.

SELF-DIAGNOSIS FUNCTION

< FUNCTION DIAGNOSIS >

[AUTOMATIC AIR CONDITIONER]

SELF-DIAGNOSIS FUNCTION

A/C Auto Amp. Self-Diagnosis

INFOID:000000001277504

A/C SYSTEM SELF-DIAGNOSIS FUNCTION

The self-diagnosis function is built into the A/C auto amp. to quickly locate the cause of malfunctions.

DESCRIPTION

The self-diagnostic system diagnoses sensors, CAN system, and battery voltage on A/C auto amp. Refer to applicable sections (items) for details. Fault codes (if any are present) will be displayed in the ambient temperature display area. Refer to [HAC-23. "A/C System Self-Diagnosis Code Chart"](#).

SELF-DIAGNOSTIC MODE

NOTE:

Radio must be off.

1. On the A/C and AV switch assembly, press the "SETTING" button and twist the volume knob clockwise and counterclockwise until the Self-Diagnosis screen shows on the display.
2. Scroll down to "Confirmation/Adjustment" and press the "ENTER" button.
3. Scroll down to "Climate Control" and press the "ENTER" button.
4. The fan bars will flash on the display during the self-test, and then the fault codes will display in the ambient temperature area. They will continue scrolling until diagnostic mode is exited.
5. Exit by pressing the "BACK" button on A/C and AV switch assembly until display returns to its normal operation screen. HVAC system will be OFF.

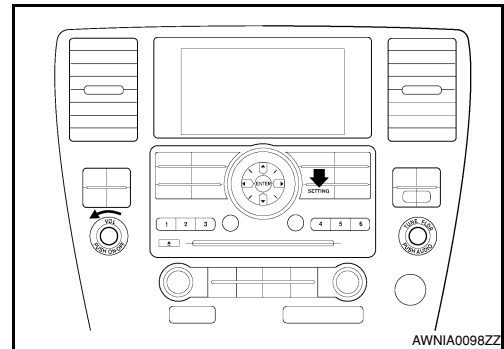

The self-diagnostic system diagnoses sensors, CAN system, and battery voltage on A/C auto amp. Refer to applicable sections (items) for details. Fault codes (if any are present) will be displayed in the ambient temperature display area. Refer to [HAC-23. "A/C System Self-Diagnosis Code Chart"](#).

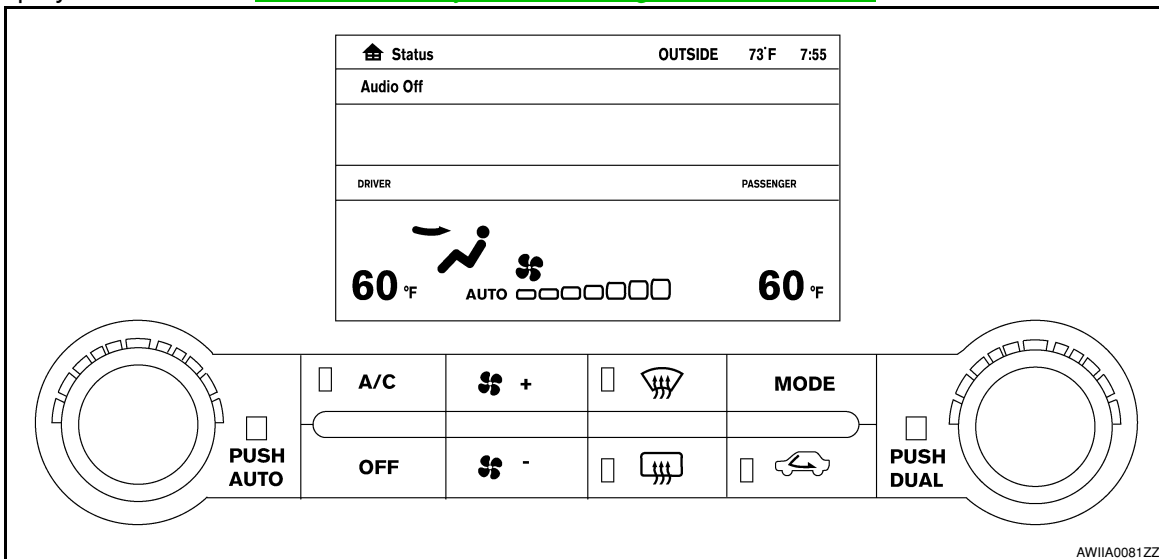

A/C and AV Switch Assembly Self-Diagnosis

INFOID:000000001315100

A/C and AV switch assembly self-diagnosis function

The ON/OFF operation (continuity) of each switch in the A/C and AV switch assembly can be checked.

Self-diagnosis mode

SELF-DIAGNOSIS FUNCTION

[AUTOMATIC AIR CONDITIONER]

< FUNCTION DIAGNOSIS >

- Press the “BACK” switch and the “UP” switch within 10 seconds after turning the ignition switch from OFF to ACC and hold them for 3 seconds or more. Then the buzzer sounds, all indicators of the preset switch illuminate, and the self-diagnosis mode starts.
- The continuity of each switch and control dials (A/C and AV switch assembly only) at the ON position can be checked by pressing each switch and turning each control dial. The buzzer sounds and LED's will illuminate if the switch is normal.

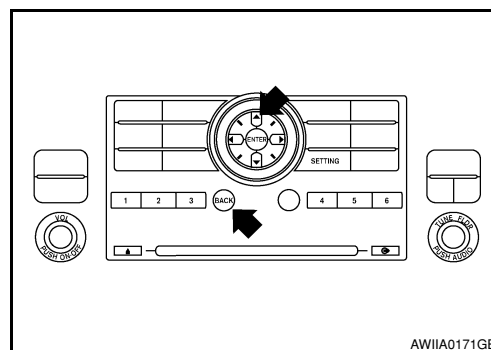

Finishing self-diagnosis mode

Self-diagnosis mode is canceled when turning the ignition switch OFF.

A/C System Self-Diagnosis Code Chart

INFOID:000000001337755

SELF-DIAGNOSTIC CODE CHART

Code No.	Reference page	
03	Battery voltage out of range	CHG-10. "Inspection Procedure"
30	In-vehicle sensor circuit out of range (low)	HAC-81. "In-Vehicle Sensor Diagnosis Procedure"
31	In-vehicle sensor circuit out of range (high)	
40	Ambient sensor circuit short	HAC-78. "Ambient Sensor Diagnosis Procedure"
41	Ambient sensor circuit open	
50	Optical sensor (Driver) circuit open or short	HAC-84. "Optical Sensor Diagnosis Procedure"
52	Optical sensor (Passenger) circuit open or short	
56	Intake sensor circuit short	HAC-86. "Intake Sensor Diagnosis Procedure"
57	Intake sensor circuit open	
80	CAN bus fault	LAN-14. "Trouble Diagnosis Flow Chart"

COMPONENT DIAGNOSIS

MODE DOOR MOTOR

System Description

INFOID:000000001277507

SYSTEM DESCRIPTION

Component Parts

Mode door control system components are:

- A/C auto amp.
- A/C and AV switch assembly
- Mode door motor (front)
- PBR (built into mode door motor)
- In-vehicle sensor
- Ambient sensor
- Optical sensor
- Intake sensor

System Operation

The mode door position (vent, B/L, foot, D/F, and defrost) is set by the A/C auto amp. by means of the mode door motor (front). When a mode door position is selected on the A/C auto amp., voltage is applied to one circuit of the mode door motor (front) while ground is applied to the other circuit, causing the mode door motor (front) to rotate. The direction of rotation is determined by which circuit has voltage applied to it, and which one has ground applied to it. The A/C auto amp. monitors the mode door position by measuring the voltage signal on the PBR circuit.

In AUTO mode the mode door position is set by the A/C auto amp. which determines the proper position based on inputs from the in-vehicle sensor, ambient sensor, optical sensor, intake sensor, and the temperature selected by the driver or passenger.

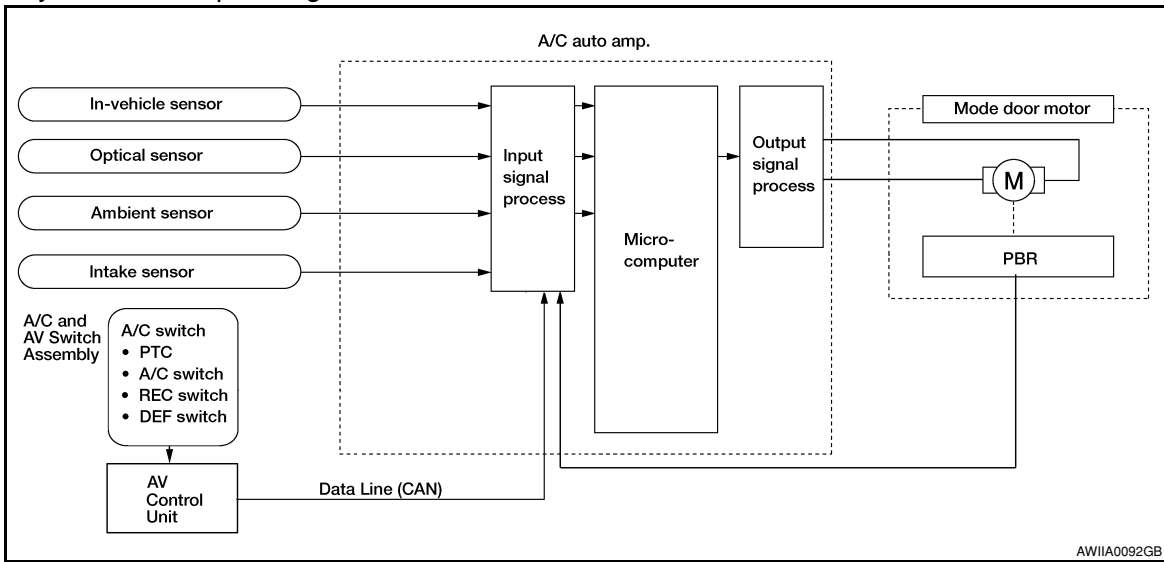

Mode Door Control Specification

COMPONENT DESCRIPTION

Mode Door Motor (Front)

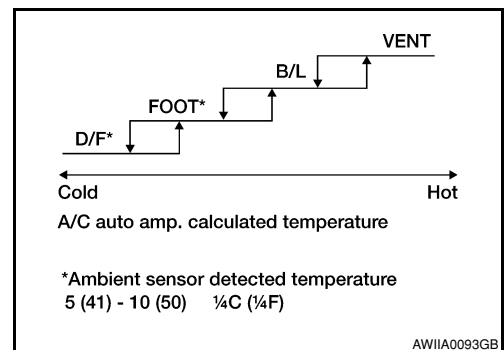

MODE DOOR MOTOR

< COMPONENT DIAGNOSIS >

[AUTOMATIC AIR CONDITIONER]

The mode door motor (front) is attached to the heater & cooling unit assembly. It rotates so that air is discharged from the outlet as indicated by the A/C auto amp. Motor rotation is conveyed to a link which activates the mode door.

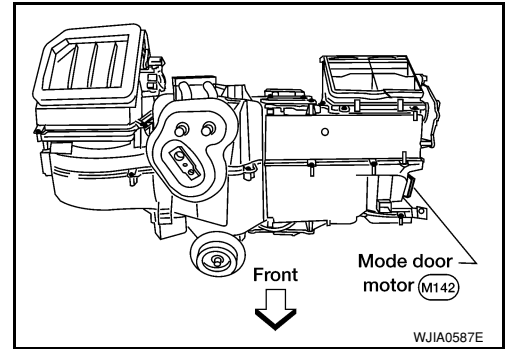

Mode Door Motor (Front) Component Function Check



INFOID:000000001277832

INSPECTION FLOW

1. CONFIRM SYMPTOM BY PERFORMING OPERATIONAL CHECK - DISCHARGE AIR

1. Press mode switch four times and then press the  (DEF) switch. Each position indicator should change shape (on display).
2. Confirm that discharge air comes out according to the air distribution table. Refer to [HAC-15. "Discharge Air Flow \(Front\)"](#).

NOTE:

Confirm that the compressor clutch is engaged (visual inspection) and intake door position is at FRESH  when DEF () or D/F () is selected.

Can a symptom be duplicated?

- YES >> GO TO 3.
- NO >> GO TO 2.

2. PERFORM COMPLETE OPERATIONAL CHECK

Perform a complete operational check and check for any symptoms. Refer to [HAC-4. "Operational Check \(Front\)"](#).

Can a symptom be duplicated?

- YES >> Refer to [HAC-3. "How to Perform Trouble Diagnosis For Quick And Accurate Repair"](#).
- NO >> System OK.

3. CHECK FOR SERVICE BULLETINS

Check for any service bulletins.

>> GO TO 4.

4. CHECK MODE DOOR OPERATION

Check and verify mode door mechanism for smooth operation in each mode.

Is the inspection result normal?

- YES >> GO TO 5.
- NO >> Repair as necessary.

5. PERFORM A/C AUTO AMP. SELF-DIAGNOSIS

Perform self-diagnosis to check for any codes. Refer to [HAC-22. "A/C Auto Amp. Self-Diagnosis"](#).

Are any self-diagnosis codes present?

- YES >> Refer to [HAC-23. "A/C System Self-Diagnosis Code Chart"](#).
- NO >> GO TO 6.

6. PERFORM A/C AND AV SWITCH ASSEMBLY SELF-DIAGNOSIS

Perform self-diagnosis to check the A/C and AV switch assembly. Refer to [HAC-22. "A/C and AV Switch Assembly Self-Diagnosis"](#).

Is the inspection result normal?

- YES >> Replace A/C and AV switch assembly. Refer to [VTL-7. "Removal and Installation"](#).
- NO >> GO TO 6.

A
B
C
D
E
F
G
H
HAC
J
K
L
M
N
O
P

MODE DOOR MOTOR

[AUTOMATIC AIR CONDITIONER]

< COMPONENT DIAGNOSIS >

7. CHECK THE MODE DOOR MOTOR (FRONT) PBR CIRCUIT

Perform diagnostic procedure for the mode door motor (front). Refer to [HAC-25. "Mode Door Motor \(Front\) Component Function Check"](#).

Is the inspection result normal?

YES >> GO TO 8.

NO >> Repair PBR circuit or replace motor. Refer to [HAC-26. "Mode Door Motor \(Front\) Diagnosis Procedure"](#).

8. RECHECK FOR CODES

Perform A/C auto amp. self-diagnosis. Refer to [HAC-22. "A/C Auto Amp. Self-Diagnosis"](#).

Are any self-diagnostic codes present?

YES >> Refer to [HAC-23. "A/C System Self-Diagnosis Code Chart"](#).

NO >> GO TO 9.

9. RECHECK FOR SYMPTOMS

Perform a complete operational check and check for any symptoms. Refer to [HAC-4. "Operational Check \(Front\)"](#).

Does another symptom exist?

YES >> Repair as necessary.

NO >> Replace A/C auto amp. Refer to [VTL-7. "Removal and Installation"](#).

Mode Door Motor (Front) Diagnosis Procedure

INFOID:000000001277508

SYMPTOM:

- Air outlet does not change.
- Mode door motor does not operate normally.

1. CHECK A/C AUTO AMP. FOR POWER AND GROUND

1. Turn ignition switch ON.
2. Press the mode switch to the B/L (↺) mode.
3. Check voltage between A/C auto amp. A/C auto amp. harness connector M49 terminal 19 and terminal 20 while pressing the mode switch to the floor (↵) mode.

Connector	Terminals		Condition	Voltage (Approx.)
	(+)	(-)		
A/C auto amp.: M49	20	19	Press mode switch	Battery voltage

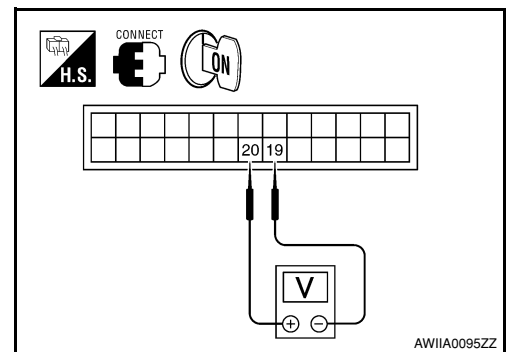

Is the inspection result normal?

YES >> GO TO 4.

NO >> GO TO 3.

2. CHECK MODE DOOR MOTOR CIRCUITS FOR SHORT TO GROUND

1. Turn ignition switch OFF.
2. Disconnect the A/C auto amp. harness connector.
3. Check continuity between A/C auto amp. harness connector M49 terminal 19, 20 and ground.

19 - Ground : Continuity should not exist.

20 - Ground : Continuity should not exist.

Is the inspection result normal?

YES >> Replace A/C auto amp. Refer to [VTL-7. "Removal and Installation"](#).

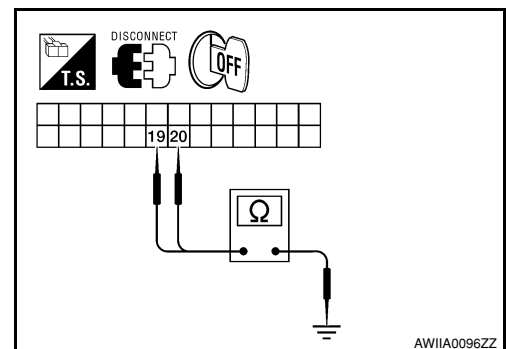

MODE DOOR MOTOR

[AUTOMATIC AIR CONDITIONER]

< COMPONENT DIAGNOSIS >

NO >> Repair or replace harness as necessary.

3. CHECK A/C AUTO AMP. FOR GROUND AND POWER

1. Press the mode switch to the D/F () mode.
2. Check voltage between A/C auto amp. harness connector M49 terminal 19 and terminal 20 while pressing the mode switch to the vent () mode.

Connector	Terminals		Condition	Voltage (Approx.)
	(+)	(-)		
A/C auto amp.: M49	19	20	Press mode switch	Battery voltage

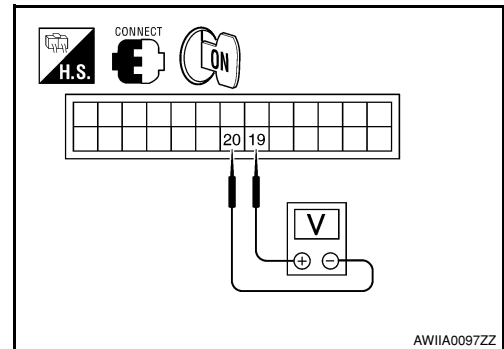

Is the inspection result normal?

YES >> GO TO 5.

NO >> Replace A/C auto amp. Refer to [VTL-7, "Removal and Installation"](#).

4. CHECK MODE DOOR MOTOR AND CIRCUITS FOR OPEN

1. Turn ignition switch OFF.
2. Disconnect the A/C auto amp. harness connector.
3. Check continuity between A/C auto amp. harness connector M49 terminal 19 and terminal 20.

Continuity should exist.

Is the inspection result normal?

YES >> GO TO 7.

NO >> GO TO 6.

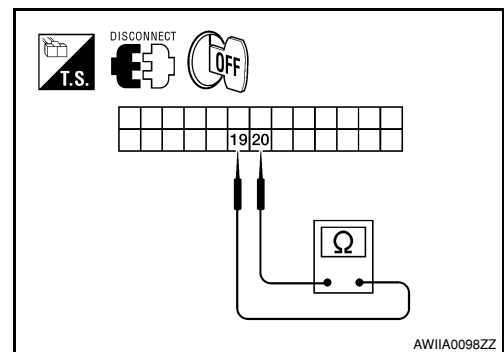

5. CHECK MODE DOOR MOTOR CIRCUITS FOR OPEN

1. Disconnect the mode door motor harness connector.
2. Check continuity between A/C auto amp. harness connector M49 (A) terminal 19, 20 and the mode door motor harness connector M142 (B) terminal 5, 6.

5 - 19 : Continuity should exist.

6 - 20 : Continuity should exist.

Is the inspection result normal?

YES >> Replace mode door motor. Refer to [VTL-24, "Removal and Installation"](#).

NO >> Repair or replace harness as necessary.

6. CHECK A/C AUTO AMP. FOR PBR POWER AND GROUND

1. Reconnect A/C auto amp. harness connector.
2. Turn ignition switch ON.
3. Check voltage between A/C auto amp. harness connector M50 (A) terminal 28 and M49 (B) terminal 3.

Connector	Terminals		Voltage (Approx.)
	(+)	(-)	
A/C auto amp.: M49, M50	28	3	5V

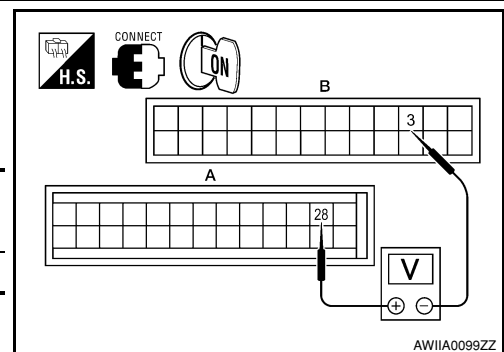

Is the inspection result normal?

YES >> GO TO 9.

NO >> GO TO 8.

A
B
C
D
E
F
G
H
HAC
J
K
L
M
N
O
P

MODE DOOR MOTOR

< COMPONENT DIAGNOSIS >

[AUTOMATIC AIR CONDITIONER]

7. CHECK PBR REFERENCE VOLTAGE CIRCUIT FOR SHORT TO GROUND

1. Turn ignition switch OFF.
2. Disconnect the A/C auto amp. harness connector.
3. Check continuity between A/C auto amp. harness connector M50 terminal 28 and ground.

Continuity should not exist.

Is the inspection result normal?

- YES >> Replace A/C auto amp. Refer to [VTL-7, "Removal and Installation"](#).
- NO >> Repair or replace harness as necessary.

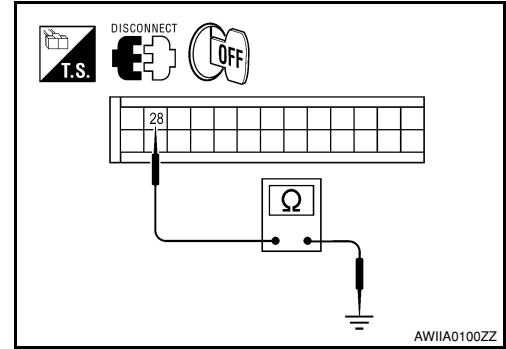

8. CHECK PBR REFERENCE VOLTAGE AND GROUND CIRCUITS

1. Turn ignition switch OFF.
2. Disconnect the A/C auto amp. harness connector.
3. Check continuity between A/C auto amp. harness connector M50 (A) terminal 28 and M49 (B) terminal 3.

Continuity should exist.

Is the inspection result normal?

- YES >> GO TO 11.
- NO >> GO TO 10

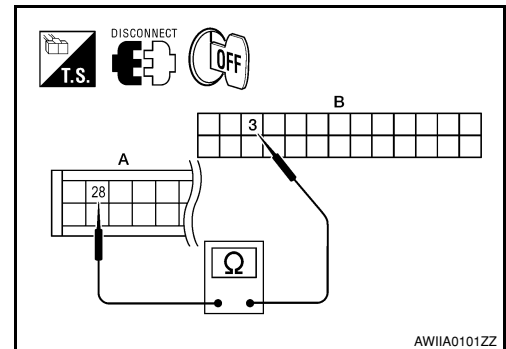

9. CHECK PBR REFERENCE VOLTAGE CIRCUIT FOR OPEN

1. Disconnect the mode door motor harness connector.
2. Check continuity between mode door motor harness connector M142 (B) terminal 3, 1 and A/C auto amp. harness connector M49 (C) terminal 3, M50 (A) terminal 28.

28 - 1 : Continuity should exist.

3 - 3 : Continuity should exist.

Is the inspection result normal?

- YES >> Replace mode door motor. Refer to [VTL-24, "Removal and Installation"](#).
- NO >> Repair or replace harness as necessary.

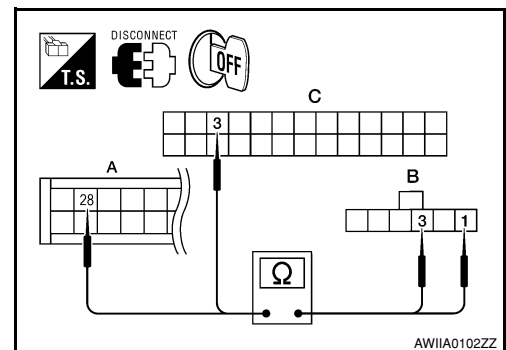

10. CHECK PBR FEEDBACK VOLTAGE

1. Reconnect the A/C auto amp. harness connector.
2. Turn ignition switch ON.
3. Check voltage between A/C auto amp. harness connector M49 terminal 7 and ground while cycling mode switch through all modes.

Voltage : Approx. 1V - 4.5V

Is the inspection result normal?

- YES >> GO TO 13.
- NO >> GO TO 12.

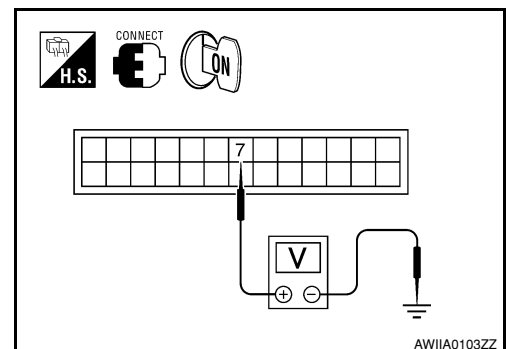

11. CHECK PBR FEEDBACK SIGNAL CIRCUIT FOR SHORT TO GROUND

MODE DOOR MOTOR

[AUTOMATIC AIR CONDITIONER]

< COMPONENT DIAGNOSIS >

1. Turn ignition switch OFF.
2. Disconnect A/C auto amp. harness connector.
3. Check continuity between A/C auto amp. harness connector M49 terminal 7 and ground.

Continuity should not exist.

Is the inspection result normal?

- YES >> Replace A/C auto amp. Refer to [VTL-7, "Removal and Installation"](#).
- NO >> Repair or replace harness as necessary.

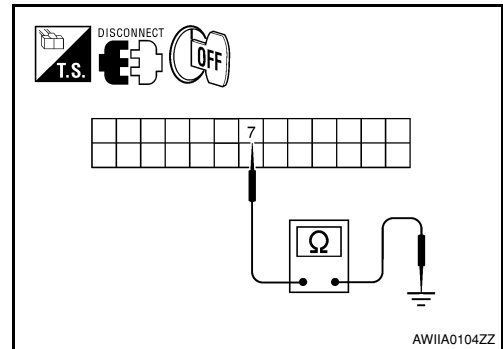

12. CHECK PBR FEEDBACK CIRCUIT FOR OPEN

1. Turn ignition switch OFF.
2. Disconnect the mode door motor harness connector and A/C auto amp. harness connector.
3. Check continuity between mode door motor harness connector M142 terminal 2 and A/C auto amp. harness connector M49 terminal 7.

Continuity should exist.

Is the inspection result normal?

- YES >> Replace mode door motor. Refer to [VTL-24, "Removal and Installation"](#).
- NO >> Repair or replace harness as necessary.

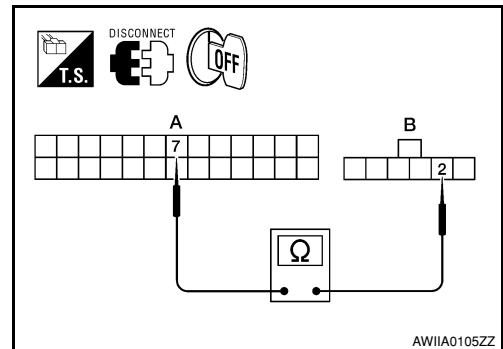

A
B
C
D
E
F
G
H
J
K
L
M
N
O
P

HAC

AIR MIX DOOR MOTOR

< COMPONENT DIAGNOSIS >

[AUTOMATIC AIR CONDITIONER]

AIR MIX DOOR MOTOR

System Description

INFOID:000000001277509

SYSTEM DESCRIPTION

SYMPTOM:

- Discharge air temperature does not change.
- Air mix door motor does not operate.

SYSTEM DESCRIPTION

Component Parts

Air mix door control system components are:

- A/C auto amp.
- A/C and AV switch assembly
- Air mix door motors (driver, passenger, and rear)
- PBR (built-into air mix door motors)
- In-vehicle sensor
- Ambient sensor
- Optical sensor
- Intake sensor

System Operation

The A/C auto amp. receives data from the temperature selected by the driver side, passenger side, and rear. The A/C auto amp. then applies a voltage to one circuit of the appropriate air mix door motor, while ground is applied to the other circuit, causing the appropriate air mix door motor to rotate. The direction of rotation is determined by which circuit has voltage applied to it, and which one has ground applied to it. The A/C auto amp. monitors the air mix door positions by measuring the voltage signal on the PBR circuits of each door.

In AUTO mode the air mix, intake, mode door, and defrost door positions are set by the A/C auto amp. which determines the proper position based on inputs from the in-vehicle sensor, ambient sensor, optical sensor, intake sensor, and the temperature selected by the driver and front and rear passengers.

Subsequently, HOT/COLD or DEFROST/VENT or FRESH/RECIRCULATION operation is selected. The new door position data is returned to the A/C auto amp.

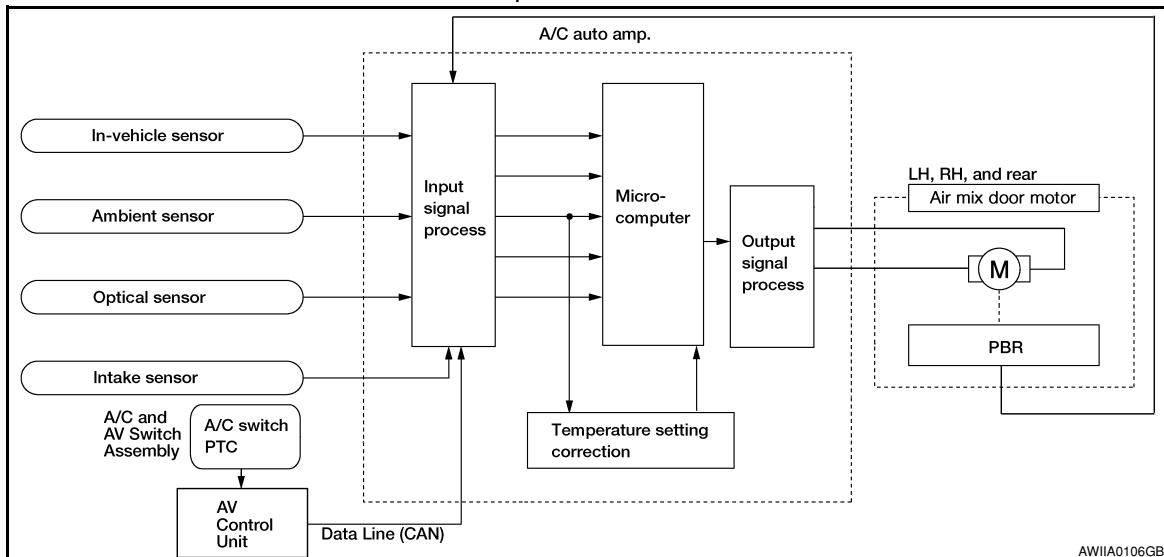

AIR MIX DOOR MOTOR

< COMPONENT DIAGNOSIS >

[AUTOMATIC AIR CONDITIONER]

Air Mix Door Control Specification

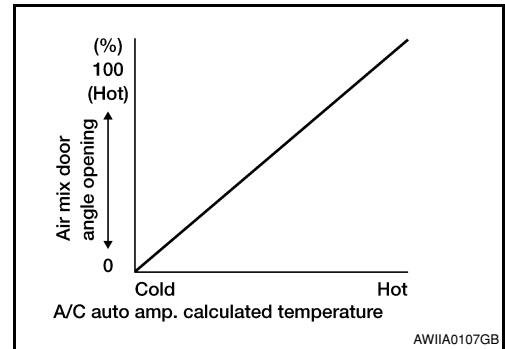

COMPONENT DESCRIPTION

Air Mix Door Motors (front)

The driver (1) and passenger (2) air mix door motors are attached to the front heater & cooling unit assembly. These motors rotate so that the air mix door is opened or closed to a position set by the A/C auto amp. Motor rotation is then conveyed through a shaft and the air mix door position is then fed back to the A/C auto amp. by the PBR built into the air mix door motors.

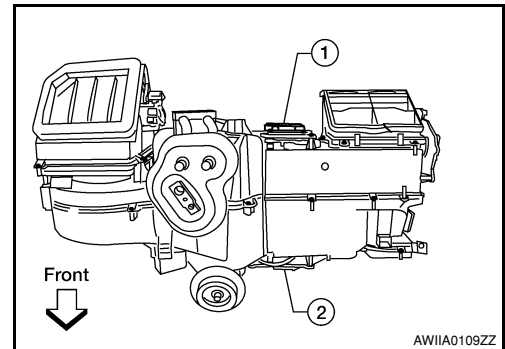

Air Mix Door Motor (rear)

The air mix door motor (rear) (1) is attached to the rear heater & cooling unit assembly. These motors rotate so that the air mix door is opened or closed to a position set by the front (or rear) air control. Motor rotation is then conveyed through a shaft and the air mix door position is then fed back to the A/C auto amp. by the PBR built into the air mix door motors.

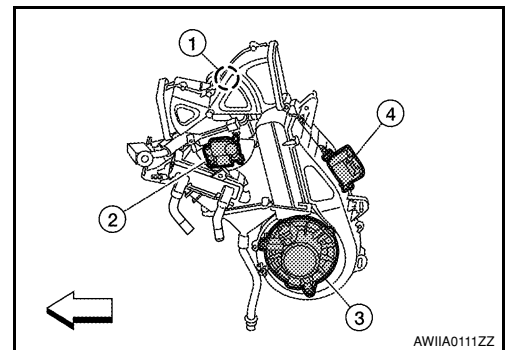

Air Mix Door Motor Component Function Check

INFOID:000000001277838

INSPECTION FLOW

1. CONFIRM SYMPTOM BY PERFORMING OPERATIONAL CHECK - TEMPERATURE INCREASE

1. Turn the temperature control dial (driver) clockwise until 32°C (90°F) is displayed.
2. Check for hot air at discharge air outlets.

>> GO TO 2.

2. CONFIRM SYMPTOM BY PERFORMING OPERATIONAL CHECK - TEMPERATURE DECREASE

1. Turn the temperature control dial (driver) counterclockwise until 18°C (60°F) is displayed.
2. Check for cold air at discharge air outlets.

Can a symptom be duplicated?

- YES >> GO TO 4.
NO >> GO TO 3.

3. PERFORM COMPLETE OPERATIONAL CHECK

AIR MIX DOOR MOTOR

[AUTOMATIC AIR CONDITIONER]

< COMPONENT DIAGNOSIS >

Perform a complete operational check and check for any symptoms. Refer to [HAC-4, "Operational Check \(Front\)"](#).

Can a symptom be duplicated?

- YES >> Refer to [HAC-3, "How to Perform Trouble Diagnosis For Quick And Accurate Repair"](#).
NO >> System OK.

4. CHECK FOR SERVICE BULLETINS

Check for any service bulletins.

>> GO TO 5.

5. CHECK AIR MIX DOOR OPERATION

Check and verify air mix door mechanism for smooth operation from 18°C (60°F) to 32°C (90°F) in each mode.

Is the inspection result normal?

- YES >> GO TO 6.
NO >> Repair as necessary.

6. PERFORM SELF-DIAGNOSIS

Perform self-diagnosis to check for any codes. Refer to [HAC-22, "A/C and AV Switch Assembly Self-Diagnosis"](#).

Are any self-diagnosis codes present?

- YES >> Refer to [HAC-23, "A/C System Self-Diagnosis Code Chart"](#).
NO >> GO TO 7.

7. CHECK THE AIR MIX DOOR MOTOR PBR CIRCUIT

Perform diagnostic procedure for the air mix door motors. Refer to [HAC-31, "Air Mix Door Motor Component Function Check"](#).

Is the inspection result normal?

- YES >> GO TO 8.
NO >> Repair PBR circuit or replace air mix door motor. Refer to [VTL-26, "Removal and Installation"](#).

8. RECHECK FOR CODES

Perform self-diagnosis. Refer to [HAC-22, "A/C and AV Switch Assembly Self-Diagnosis"](#).

Are any self-diagnostic codes present?

- YES >> Refer to [HAC-23, "A/C System Self-Diagnosis Code Chart"](#).
NO >> GO TO 9.

9. RECHECK FOR ANY SYMPTOMS

Perform a complete operational check for any symptoms. Refer to [HAC-4, "Operational Check \(Front\)"](#).

Does another symptom exist?

- YES >> Refer to [HAC-3, "How to Perform Trouble Diagnosis For Quick And Accurate Repair"](#).
NO >> Replace A/C auto amp. Refer to [VTL-7, "Removal and Installation"](#).

Air Mix Door Motor (Driver) Diagnosis Procedure

INFOID:000000001277510

SYMPTOM:

- Discharge air temperature does not change.
- Air mix door motor does not operate.

DIAGNOSTIC PROCEDURE FOR AIR MIX DOOR MOTOR (DRIVER)

1. CHECK A/C AUTO AMP. FOR POWER AND GROUND

AIR MIX DOOR MOTOR

[AUTOMATIC AIR CONDITIONER]

< COMPONENT DIAGNOSIS >

1. Turn ignition switch ON.
2. Rotate temperature control dial (driver) to 32°C (90°F).
3. Check voltage between A/C auto amp. harness connector M49 terminal 17 and terminal 18 while rotating temperature control dial (driver) to 18°C (60°F).

Connector	Terminals		Condition	Voltage (Approx.)
	(+)	(-)		
A/C auto amp.: M49	17	18	Rotate temp control dial	Battery voltage

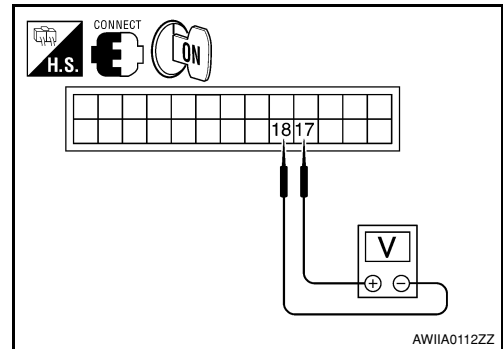

Is the inspection result normal?

- YES >> GO TO 4.
NO >> GO TO 3.

2.CHECK AIR MIX DOOR MOTOR (DRIVER) CIRCUITS FOR SHORT TO GROUND

1. Turn ignition switch OFF.
2. Disconnect the A/C auto amp. harness connector.
3. Check continuity between A/C auto amp. harness connector M49 terminal 17, 18 and ground.

17 - Ground : Continuity should not exist.
18 - Ground : Continuity should not exist.

Is the inspection result normal?

- YES >> Replace A/C auto amp. Refer to [VTL-7. "Removal and Installation"](#).
NO >> Repair or replace harness as necessary.

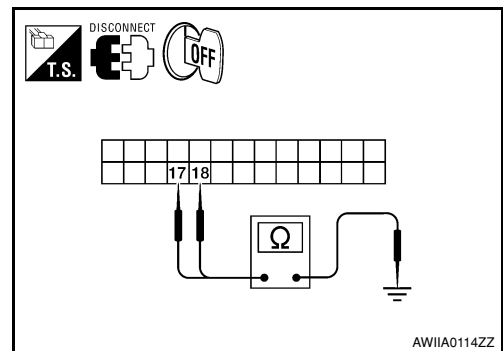

3.CHECK A/C AUTO AMP. FOR POWER AND GROUND

1. Turn ignition switch ON.
2. Rotate temperature control dial (driver) to 32°C (90°F).
3. Check voltage between A/C auto amp. harness connector M49 terminal 17 and terminal 18 while rotating temperature control dial (driver) to 18°C (60°F).

Connector	Terminals		Condition	Voltage (Approx.)
	(+)	(-)		
A/C auto amp.: M49	18	17	Rotate temp control dial	Battery voltage

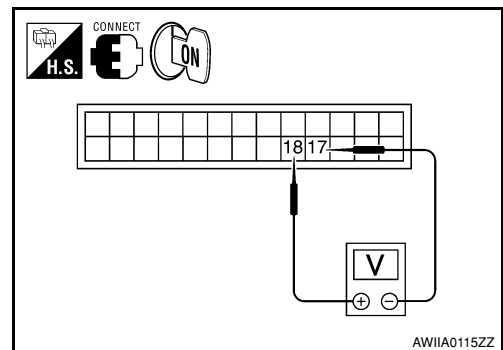

Is the inspection result normal?

- YES >> GO TO 5.
NO >> Replace A/C auto amp. Refer to [VTL-7. "Removal and Installation"](#).

4.CHECK AIR MIX DOOR MOTOR (DRIVER) CIRCUITS FOR OPEN

1. Turn ignition switch OFF.
2. Disconnect the A/C auto amp. harness connector.
3. Check continuity between A/C auto amp. harness connector M49 terminal 17 and terminal 18.

Continuity should exist.

Is the inspection result normal?

- YES >> GO TO 7.
NO >> GO TO 6.

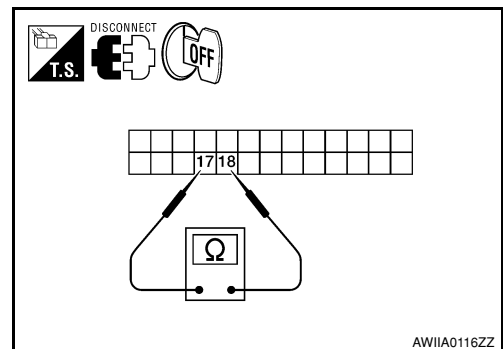

5.CHECK AIR MIX DOOR MOTOR (DRIVER) CIRCUITS FOR OPEN

A
B
C
D
E
F
G
H
HAC
J
K
L
M
N
O
P

AIR MIX DOOR MOTOR

[AUTOMATIC AIR CONDITIONER]

< COMPONENT DIAGNOSIS >

1. Disconnect the air mix door motor (driver) harness connector.
2. Check continuity between A/C auto amp. harness connector M49 (A) terminal 17, 18 and the air mix door motor (driver) harness connector M147 (B) terminal 1, 6.

17 - 1 : Continuity should exist.

18 - 6 : Continuity should exist.

Is the inspection result normal?

YES >> Replace air mix door motor (driver). Refer to [VTL-26. "Removal and Installation"](#).

NO >> Repair or replace harness as necessary.

6. CHECK A/C AUTO AMP. FOR PBR POWER AND GROUND

1. Reconnect A/C auto amp. harness connector.
2. Turn ignition switch ON.
3. Check voltage between A/C auto amp. harness connector M50 (A) terminal 28 and M49 (B) terminal 3.

Connector	Terminals		Voltage (Approx.)
	(+)	(-)	
A/C auto amp.: M50, M49	28	3	5V

Is the inspection result normal?

YES >> GO TO 9.

NO >> GO TO 8.

7. CHECK PBR REFERENCE VOLTAGE CIRCUIT FOR SHORT TO GROUND

1. Turn ignition switch OFF.
2. Disconnect the A/C auto amp. harness connector.
3. Check continuity between A/C auto amp. harness connector M50 terminal 28 and ground.

Continuity should not exist.

Is the inspection result normal?

YES >> Replace A/C auto amp. Refer to [VTL-7. "Removal and Installation"](#).

NO >> Repair or replace harness as necessary.

8. CHECK PBR REFERENCE VOLTAGE AND GROUND CIRCUITS

1. Turn ignition switch OFF.
2. Disconnect the A/C auto amp. harness connector.
3. Check continuity between A/C auto amp. harness connector M50 (A) terminal 28 and M49 (B) terminal 3.

Continuity should exist.

Is the inspection result normal?

YES >> GO TO 11.

NO >> GO TO 10.

9. CHECK PBR REFERENCE VOLTAGE CIRCUIT FOR OPEN

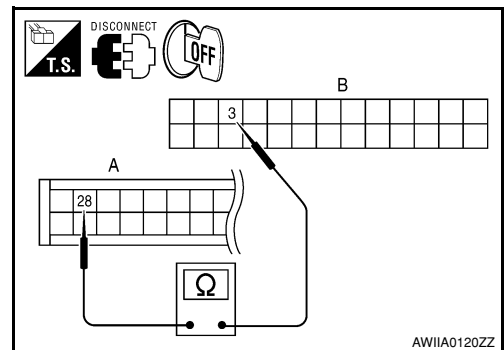
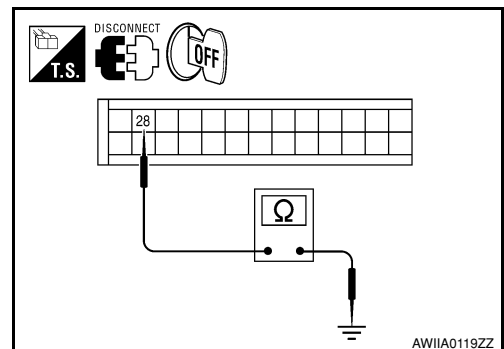
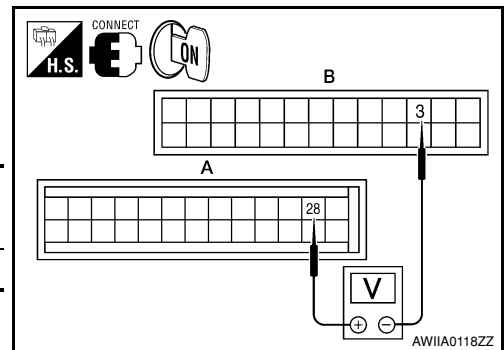
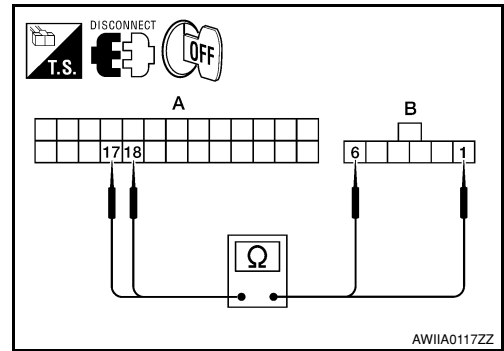

AIR MIX DOOR MOTOR

[AUTOMATIC AIR CONDITIONER]

< COMPONENT DIAGNOSIS >

1. Disconnect the air mix door motor (driver) harness connector.
2. Check continuity between air mix door motor (driver) harness connector M147 (B) terminal 3, 2 and A/C auto amp. harness connector M49 (C) terminal 3 and M50 (A) terminal 28.

28 - 3 : Continuity should exist.

3 - 2 : Continuity should exist.

Is the inspection result normal?

YES >> Replace air mix door motor (driver). Refer to [VTL-26, "Removal and Installation"](#).

NO >> Repair or replace harness as necessary.

10. CHECK PBR FEEDBACK VOLTAGE

1. Reconnect the A/C auto amp. harness connector.
2. Turn ignition switch ON.
3. Check voltage between A/C auto amp. harness connector M49 terminal 6 and ground while rotating temperature control dial from 32°C (90°F) to 18°C (60°F).

Voltage : Approx. .5V - 4.5V

Is the inspection result normal?

YES >> GO TO 13.

NO >> GO TO 12.

11. CHECK PBR FEEDBACK SIGNAL CIRCUIT FOR SHORT TO GROUND

1. Turn ignition switch OFF.
2. Disconnect A/C auto amp. harness connector.
3. Check continuity between A/C auto amp. harness connector M49 terminal 6 and ground.

Continuity should not exist.

Is the inspection result normal?

YES >> Replace A/C auto amp. Refer to [VTL-7, "Removal and Installation"](#).

NO >> Repair or replace harness as necessary.

12. CHECK PBR FEEDBACK CIRCUIT FOR OPEN

1. Turn ignition switch OFF.
2. Disconnect the air mix door motor (driver) harness connector and A/C auto amp. harness connector.
3. Check continuity between air mix door motor (driver) harness connector M147 (B) terminal 4 and A/C auto amp. harness connector M49 (A) terminal 6.

Continuity should exist.

Is the inspection result normal?

YES >> Replace air mix door motor (driver). Refer to [VTL-26, "Removal and Installation"](#).

NO >> Repair or replace harness as necessary.

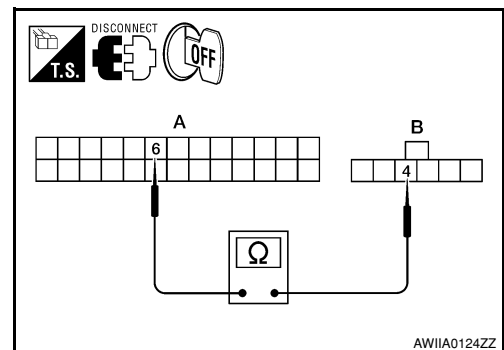
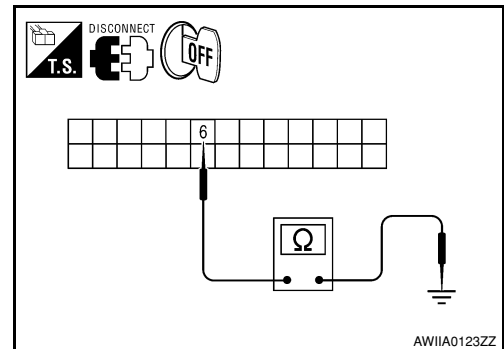
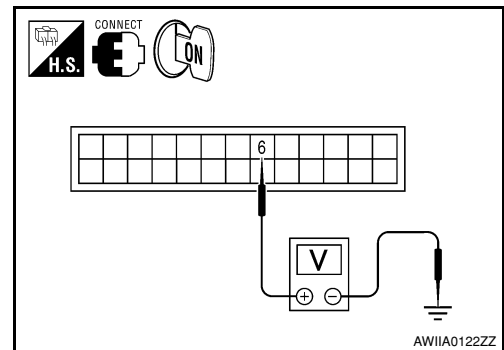
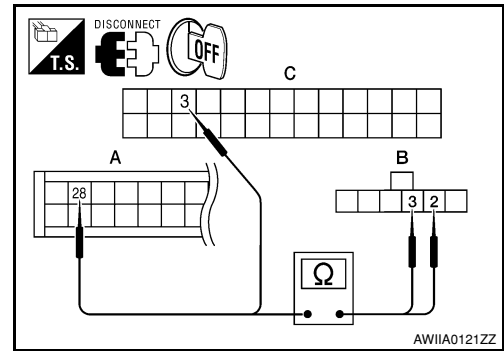

Air Mix Door Motor (Passenger) Diagnosis Procedure

INFOID:000000001277839

SYMPTOM:

- Discharge air temperature does not change.
- Air mix door motor does not operate.

AIR MIX DOOR MOTOR

[AUTOMATIC AIR CONDITIONER]

< COMPONENT DIAGNOSIS >

DIAGNOSTIC PROCEDURE FOR AIR MIX DOOR MOTOR (PASSENGER)

1. CHECK A/C AUTO AMP. FOR POWER AND GROUND

1. Turn ignition switch ON.
2. Rotate temperature control dial (passenger) to 32°C (90°F).
3. Check voltage between A/C auto amp. harness connector M49 terminal 14 and terminal 2 while rotating temperature control dial (passenger) to 18° C (60° F).

Connector	Terminals		Condition	Voltage (Approx.)
	(+)	(-)		
A/C auto amp.: M49	2	14	Rotate temp control dial	Battery voltage

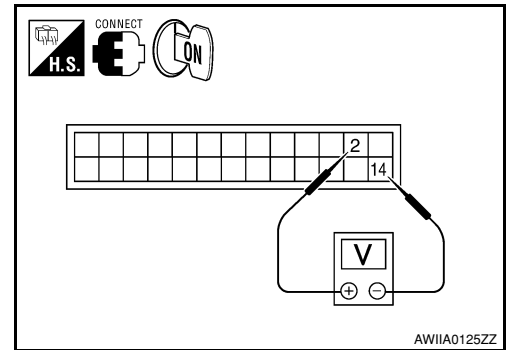

Is the inspection result normal?

- OK >> GO TO 4.
NG >> GO TO 3.

2. CHECK AIR MIX DOOR MOTOR (PASSENGER) CIRCUITS FOR SHORT TO GROUND

1. Turn ignition switch OFF.
2. Disconnect the A/C auto amp. harness connector.
3. Check continuity between A/C auto amp. harness connector M49 terminal 14, 2 and ground.

- 14 - Ground : Continuity should not exist.**
2 - Ground : Continuity should not exist.

Is the inspection result normal?

- YES >> Replace A/C auto amp. Refer to [VTL-7, "Removal and Installation"](#).
NO >> Repair or replace harness as necessary.

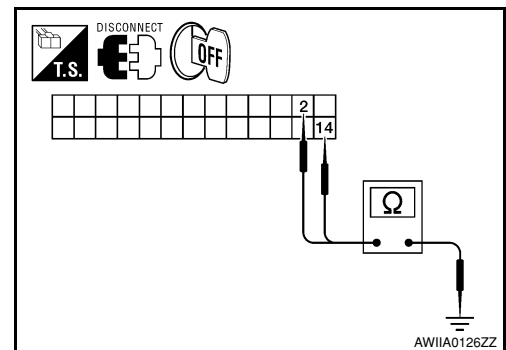

3. CHECK A/C AUTO AMP. FOR POWER AND GROUND

1. Turn ignition switch ON.
2. Rotate temperature control dial (passenger) to 18°C (60°F).
3. Check voltage between A/C auto amp. harness connector M49 terminal 14 and terminal 2 while rotating temperature control dial (passenger) to 32°C (90°F).

Connector	Terminals		Condition	Voltage (Approx.)
	(+)	(-)		
A/C auto amp.: M49	14	2	Rotate temp control dial	Battery voltage

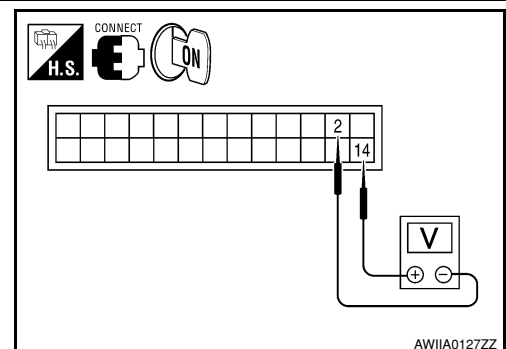

Is the inspection result normal?

- YES >> GO TO 5.
NO >> Replace A/C auto amp. Refer to [VTL-7, "Removal and Installation"](#).

4. CHECK AIR MIX DOOR MOTOR (PASSENGER) CIRCUITS FOR OPEN

AIR MIX DOOR MOTOR

[AUTOMATIC AIR CONDITIONER]

< COMPONENT DIAGNOSIS >

1. Turn ignition switch OFF.
2. Disconnect the A/C auto amp. harness connector.
3. Check continuity between A/C auto amp. harness connector M50 terminal 14 and terminal 2.

Continuity should exist.

Is the inspection result normal?

- YES >> GO TO 7.
NO >> GO TO 6.

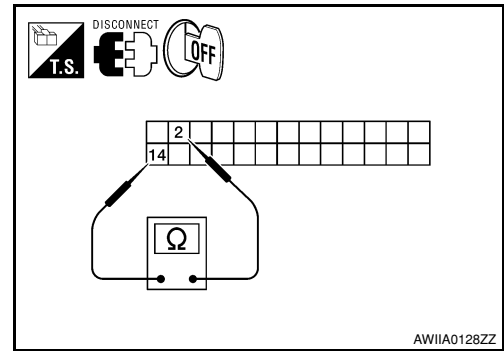

5. CHECK AIR MIX DOOR MOTOR (PASSENGER) CIRCUITS FOR OPEN

1. Disconnect the air mix door motor (passenger) harness connector.
2. Check continuity between A/C auto amp. harness connector M49 terminal 14, 2 and the air mix door motor (passenger) harness connector M143 terminal 1, 6.

- 14 - 1 : Continuity should exist.**
2 - 6 : Continuity should exist.

Is the inspection result normal?

- YES >> Replace air mix door motor (passenger). Refer to [VTL-26. "Removal and Installation"](#) .
NO >> Repair or replace harness as necessary.

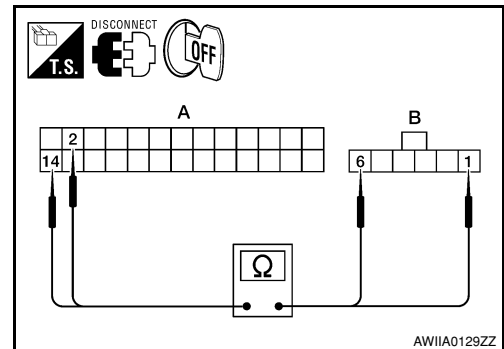

6. CHECK A/C AUTO AMP. FOR PBR POWER AND GROUND

1. Reconnect A/C auto amp. harness connector.
2. Turn ignition switch ON.
3. Check voltage between A/C auto amp. harness connector M50 (A) terminal 28 and M49 (B) terminal 3.

Connector	Terminals		Voltage (Approx.)
	(+)	(-)	
A/C auto amp.: M49	28	3	5V

Is the inspection result normal?

- YES >> GO TO 9.
NO >> GO TO 8.

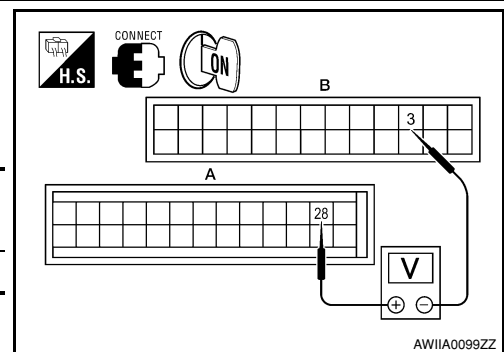

7. CHECK PBR REFERENCE VOLTAGE CIRCUIT FOR SHORT TO GROUND

1. Turn ignition switch OFF.
2. Disconnect the A/C auto amp. harness connector.
3. Check continuity between A/C auto amp. harness connector M49 terminal 29 and ground.

Continuity should not exist.

Is the inspection result normal?

- YES >> Replace A/C auto amp. Refer to [VTL-7. "Removal and Installation"](#) .
NO >> Repair or replace harness as necessary.

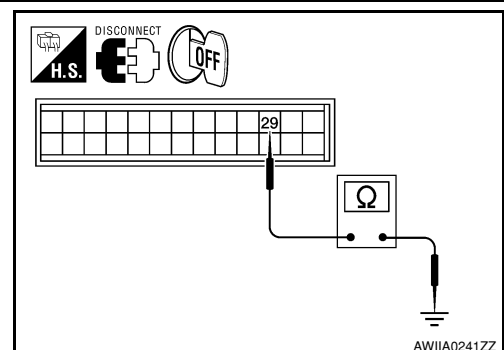

8. CHECK PBR REFERENCE VOLTAGE AND GROUND CIRCUITS

AIR MIX DOOR MOTOR

[AUTOMATIC AIR CONDITIONER]

< COMPONENT DIAGNOSIS >

1. Turn ignition switch OFF.
2. Disconnect the A/C auto amp. harness connector.
3. Check continuity between A/C auto amp. harness connector M50 (A) terminal 28 and M49 (B) terminal 3.

Continuity should exist.

Is the inspection result normal?

- YES >> GO TO 11.
NO >> GO TO 10.

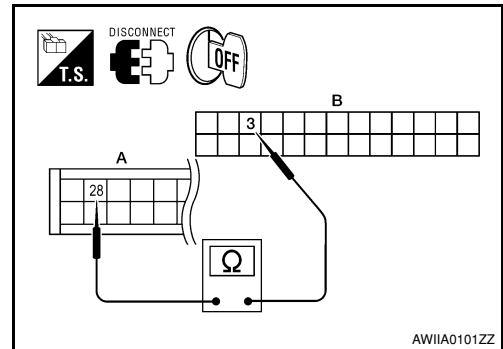

9. CHECK PBR REFERENCE VOLTAGE CIRCUIT FOR OPEN

1. Disconnect the air mix door motor (passenger) harness connector.
2. Check continuity between air mix door motor (passenger) harness connector M143 (B) terminal 3, 2 and A/C auto amp. harness connector M49 (C) terminal 3 and M50 terminal 28.

28 - 3 : Continuity should exist.

3 - 2 : Continuity should exist.

Is the inspection result normal?

- YES >> Replace air mix door motor (passenger). Refer to [VTL-26. "Removal and Installation"](#) .
NO >> Repair or replace harness as necessary.

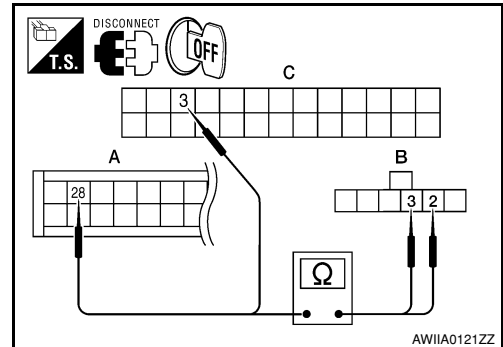

10. CHECK PBR FEEDBACK VOLTAGE

1. Reconnect the A/C auto amp. harness connector.
2. Turn ignition switch ON.
3. Check voltage between A/C auto amp. harness connector M50 terminal 29 and ground while rotating temperature control dial (passenger) from 32°C (90° F) to 18° (60° F).

Voltage : Approx. .5V - 4.5V

Is the inspection result normal?

- YES >> GO TO 13.
NO >> GO TO 12.

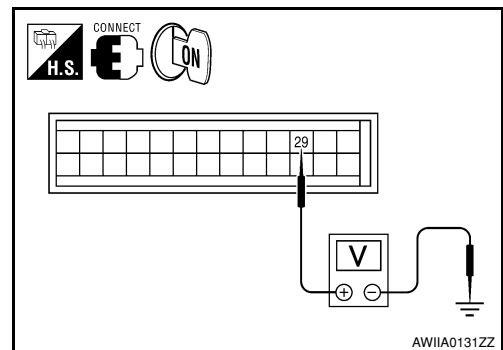

11. CHECK PBR FEEDBACK SIGNAL CIRCUIT FOR SHORT TO GROUND

1. Turn ignition switch OFF.
2. Disconnect A/C auto amp. harness connector.
3. Check continuity between A/C auto amp. harness connector M50 terminal 29 and ground.

Continuity should not exist.

Is the inspection result normal?

- YES >> Replace A/C auto amp. Refer to [VTL-7. "Removal and Installation"](#) .
NO >> Repair or replace harness as necessary.

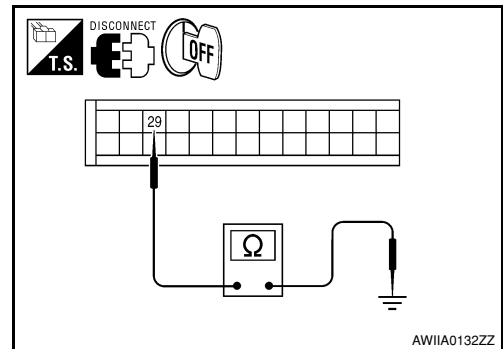

12. CHECK PBR FEEDBACK CIRCUIT FOR OPEN

AIR MIX DOOR MOTOR

[AUTOMATIC AIR CONDITIONER]

< COMPONENT DIAGNOSIS >

1. Turn ignition switch OFF.
2. Disconnect the air mix door motor (passenger) harness connector and A/C auto amp. harness connector.
3. Check continuity between air mix door motor (passenger) harness connector M143 terminal 4 and A/C auto amp. harness connector M50 terminal 29.

Continuity should exist.

Is the inspection result normal?

- YES >> Replace air mix door motor (passenger). Refer to [VTL-26, "Removal and Installation"](#).
- NO >> Repair or replace harness as necessary.

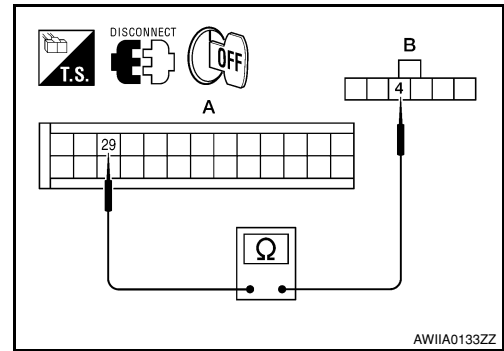

A
B
C
D
E
F
G
H
J
K
L
M
N
O
P

HAC

INTAKE DOOR MOTOR

< COMPONENT DIAGNOSIS >

[AUTOMATIC AIR CONDITIONER]

INTAKE DOOR MOTOR

System Description

INFOID:000000001277511

SYSTEM DESCRIPTION

SYMPTOM:

- Intake door motor does not operate normally.
- Intake door does not change.

SYSTEM DESCRIPTION

Component Parts

Intake door control system components are:

- A/C auto amp.
- A/C and AV switch assembly
- Intake door motor (PRB built into the intake door motor)
- In-vehicle sensor
- Ambient sensor
- Optical sensor
- Intake sensor

System Operation

The intake door control determines the intake door position based on the position of the recirculation switch. When the recirculation switch is depressed the intake door motor rotates closing off the fresh air inlet and recirculating the cabin air. If the recirculation switch is depressed again, the intake door motor rotates in the opposite direction, again allowing fresh air into the cabin.

In the AUTO mode, the A/C auto amp. determines the intake door position based on the ambient temperature, the intake air temperature and the in-vehicle temperature. When the DEF, D/F, FLOOR or OFF switches are pushed, the A/C auto amp. sets the intake door at the fresh position.

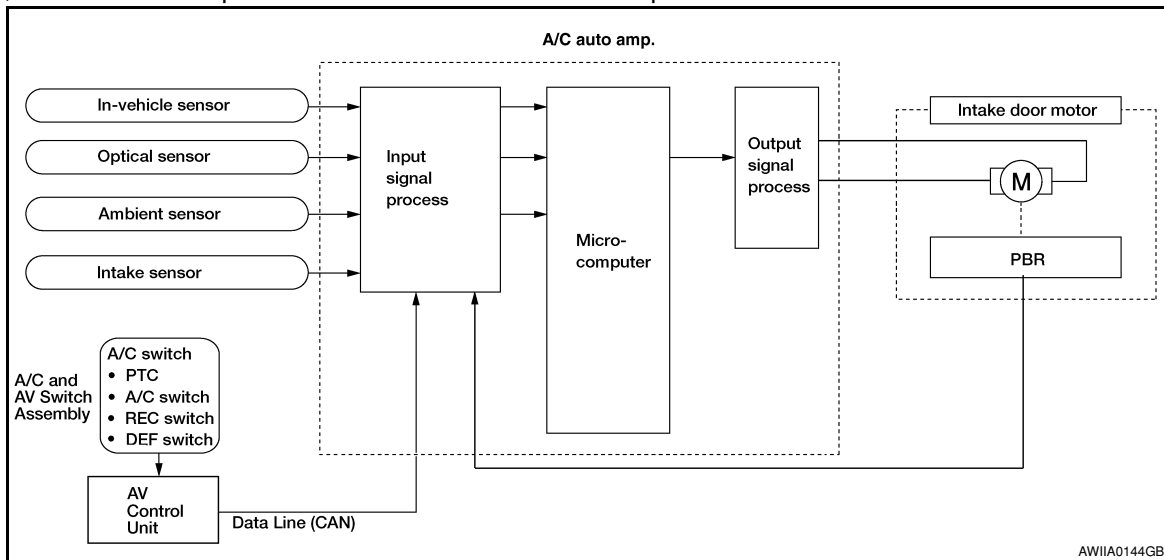

Intake Door Control Specification

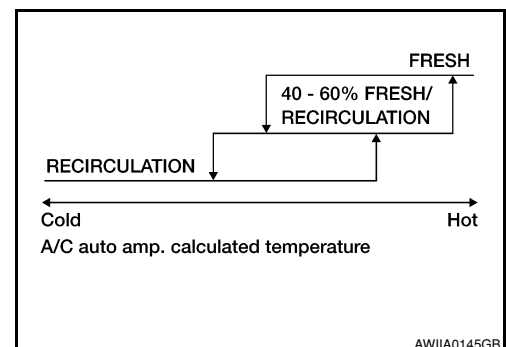

INTAKE DOOR MOTOR

[AUTOMATIC AIR CONDITIONER]

< COMPONENT DIAGNOSIS >

COMPONENT DESCRIPTION

Intake door motor

The intake door motor is attached to the intake unit. It rotates so that air is drawn from inlets set by the A/C auto amp. Motor rotation is conveyed to a lever which activates the intake door.

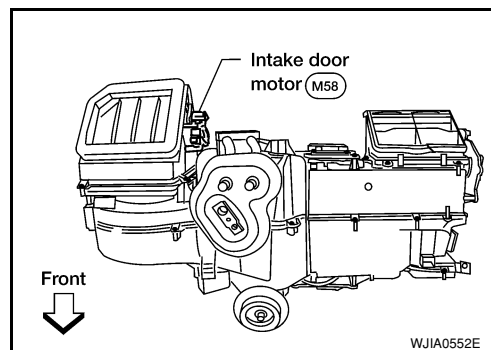





Intake Door Motor Component Function Check

INFOID:000000001277841

INSPECTION FLOW

1. CONFIRM SYMPTOM BY PERFORMING OPERATIONAL CHECK - REC ()

1. Press the mode switch to vent mode ().
2. Press REC () switch. The REC () indicator should illuminate.
3. Press REC () switch again. The REC () indicator should go out.
4. Listen for intake door position change (you should hear blower sound change slightly).

Can a symptom be duplicated?

- YES >> GO TO 3.
- NO >> GO TO 2.

2. PERFORM COMPLETE OPERATIONAL CHECK

Perform a complete operational check and check for any symptoms. Refer to [HAC-4. "Operational Check \(Front\)"](#).

Can a symptom be duplicated?

- YES >> Refer to [HAC-3. "How to Perform Trouble Diagnosis For Quick And Accurate Repair"](#).
- NO >> System OK.

3. CHECK FOR SERVICE BULLETINS

Check for any service bulletins.

>> GO TO 4.

4. CHECK INTAKE DOOR OPERATION

Check and verify intake door mechanism for smooth operation.

Is the inspection result normal?

- YES >> GO TO 5.
- NO >> Repair intake door mechanism.

5. PERFORM SELF-DIAGNOSIS

Perform self-diagnosis to check for any codes. Refer to [HAC-22. "A/C and AV Switch Assembly Self-Diagnosis"](#).

Are any self-diagnosis codes present?

- YES >> Refer to [HAC-23. "A/C System Self-Diagnosis Code Chart"](#).
- NO >> GO TO 6.

6. RECHECK FOR ANY SYMPTOMS

Perform a complete operational check for any symptoms. Refer to [HAC-4. "Operational Check \(Front\)"](#).

Does another symptom exist?

- YES >> Refer to [HAC-3. "How to Perform Trouble Diagnosis For Quick And Accurate Repair"](#).
- NO >> Replace A/C auto amp. Refer to [VTL-7. "Removal and Installation"](#).

INTAKE DOOR MOTOR

[AUTOMATIC AIR CONDITIONER]

< COMPONENT DIAGNOSIS >

INFOID:000000001277512

Intake Door Motor Diagnosis Procedure

SYMPTOM:

- Intake door does not change.
- Intake door motor does not operate normally.

DIAGNOSTIC PROCEDURE FOR INTAKE DOOR MOTOR

1. CHECK A/C AUTO AMP. FOR POWER AND GROUND

1. Turn ignition switch ON.
2. Check voltage between A/C auto amp. harness connector M49 terminal 21 and terminal 22 while placing the HVAC system into self-diagnostic mode.

Connector	Terminals		Condition	Voltage (Approx.)
	(+)	(-)		
A/C auto amp.: M49	21	22	Self-diagnostic mode	Battery voltage

Is the inspection result normal?

- OK >> GO TO 4.
NO >> GO TO 3.

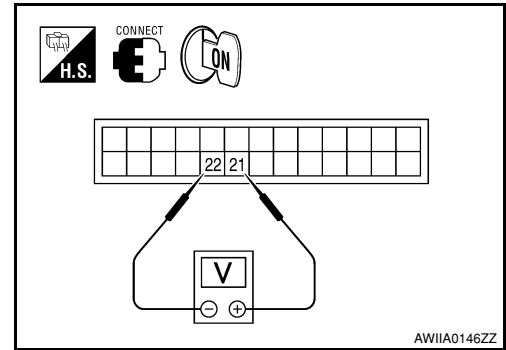

2. CHECK INTAKE DOOR MOTOR CIRCUITS FOR SHORT TO GROUND

1. Turn ignition switch OFF.
2. Disconnect the A/C auto amp. harness connector.
3. Check continuity between A/C auto amp. harness connector M49 terminal 21, 22 and ground.

- 21 - Ground : Continuity should not exist.**
22 - Ground : Continuity should not exist.

Is the inspection result normal?

- OK >> Replace A/C auto amp. Refer to [VTL-7, "Removal and Installation"](#).
NO >> Repair or replace harness as necessary.

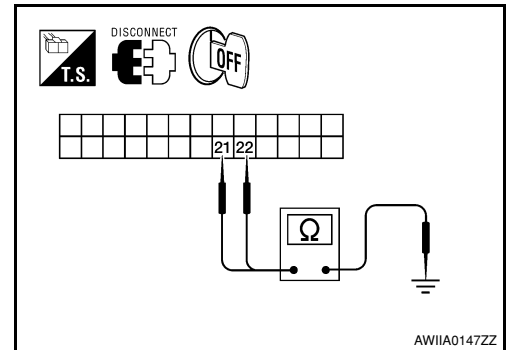

3. CHECK A/C AUTO AMP. FOR GROUND AND POWER

1. Press the BACK button to back out of self-diagnostic mode.
2. Check voltage between A/C auto amp. harness connector M49 terminal 21 and terminal 22 while placing the HVAC system into self-diagnostic mode.

Connector	Terminals		Condition	Voltage (Approx.)
	(+)	(-)		
A/C auto amp.: M49	22	21	Self-diagnostic mode	Battery voltage

Is the inspection result normal?

- OK >> GO TO 5.
NO >> Replace A/C auto amp. Refer to [VTL-7, "Removal and Installation"](#).

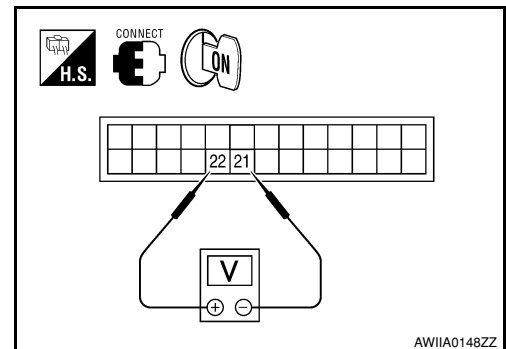

4. CHECK INTAKE DOOR MOTOR AND CIRCUITS FOR OPEN

INTAKE DOOR MOTOR

[AUTOMATIC AIR CONDITIONER]

< COMPONENT DIAGNOSIS >

1. Turn ignition switch OFF.
2. Disconnect the A/C auto amp. harness connector.
3. Check continuity between A/C auto amp. harness connector M49 terminal 21 and terminal 22.

Continuity should exist.

Is the inspection result normal?

- OK >> Replace intake door motor. Refer to [VTL-22. "Removal and Installation"](#).
- NO >> GO TO 6.

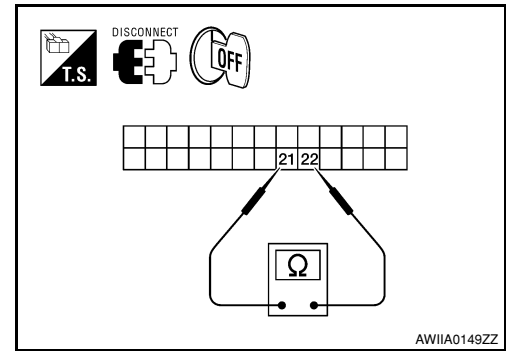

5. CHECK INTAKE DOOR MOTOR CIRCUITS FOR OPEN

1. Disconnect the intake door motor harness connector.
2. Check continuity between A/C auto amp. harness connector M49 (A) terminal 21, 22 and the intake door motor harness connector M58 (B) terminal 1, 6.

21 - 6 : Continuity should exist.

22 - 1 : Continuity should exist.

Is the inspection result normal?

- YES >> Replace intake door motor. Refer to [VTL-22. "Removal and Installation"](#).
- NO >> Repair or replace harness as necessary.

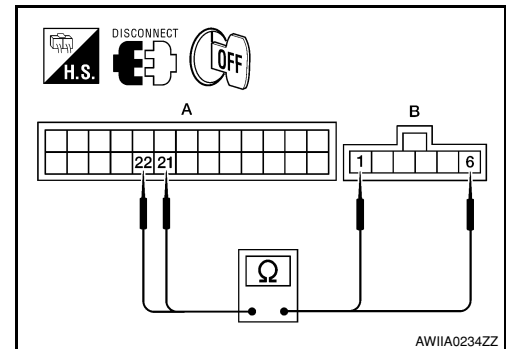

A
B
C
D
E
F
G
H
J
K
L
M
N
O
P

HAC

DEFROSTER DOOR MOTOR CIRCUIT

< COMPONENT DIAGNOSIS >

[AUTOMATIC AIR CONDITIONER]

DEFROSTER DOOR MOTOR CIRCUIT

System Description

INFOID:000000001303716

SYSTEM DESCRIPTION

Component Parts

Defroster door control system components are:

- A/C auto amp.
- A/C and AV switch assembly
- Defroster door motor
- PBR (Built into defroster door motor)
- In-vehicle sensor
- Ambient sensor
- Optical sensor
- Intake sensor

System Operation

The A/C auto amp. determines defroster door position based on the position of the defroster switch. When the defroster switch is depressed, the defroster door motor rotates directing air to the defroster ducts. When any mode other than defroster is selected, the defroster motor rotates in the opposite direction closing off air flow to the defroster ducts.

In the AUTO mode, the A/C auto amp. determines defroster door position based on the ambient temperature, the intake air temperature and the in-vehicle temperature.

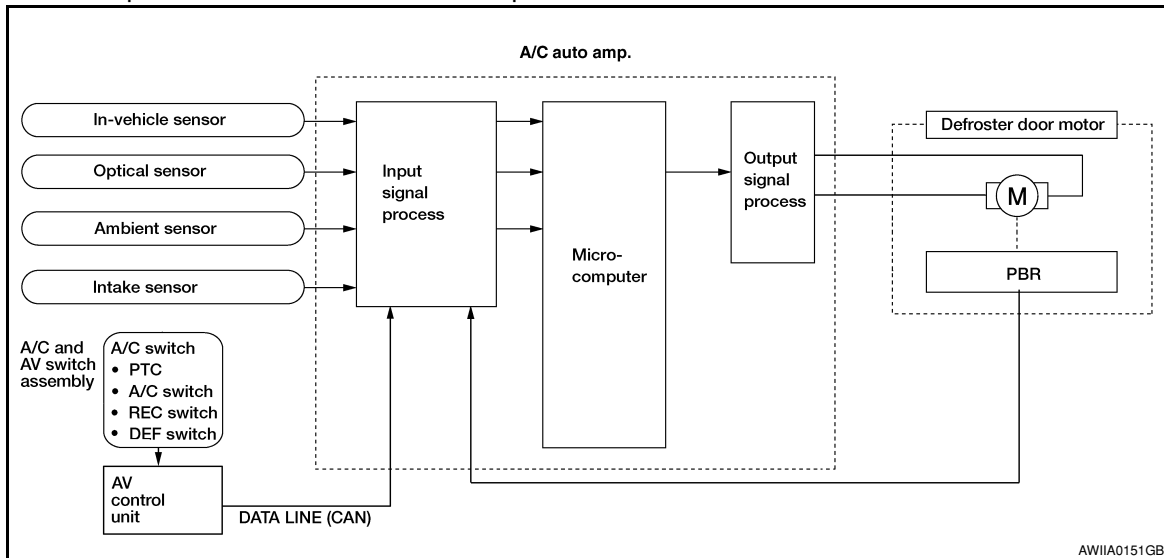

COMPONENT DESCRIPTION

Defroster door motor

The defroster door motor is attached to the front heater & cooling unit assembly. The A/C auto amp. sends a voltage to rotate to the defroster door directing the air flow either to the defroster ducts, or to the floor ducts, depending on which way the voltage and ground are applied to the motor leads. Motor rotation is conveyed to a lever which activates the defroster door.

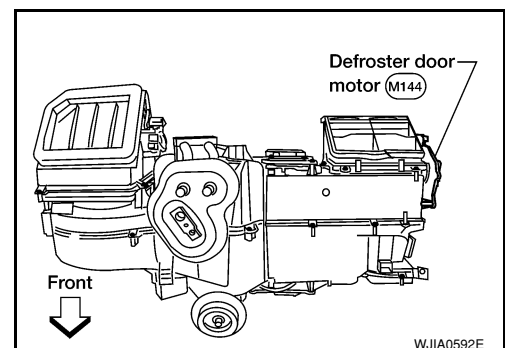

DEFROSTER DOOR MOTOR CIRCUIT

< COMPONENT DIAGNOSIS >



[AUTOMATIC AIR CONDITIONER]

Defroster Door Motor Component Function Check

INFOID:000000001303717

INSPECTION FLOW

1. CONFIRM SYMPTOM BY PERFORMING OPERATIONAL CHECK - DEFROSTER DOOR

1. Press the mode switch and select vent ().
2. Press the defrost switch (). Defroster indicator should illuminate (on display).
3. Listen for defroster door position change (blower sound should change slightly).

Can the symptom be duplicated?

- YES >> GO TO 3.
- NO >> GO TO 2.

2. CHECK FOR ANY SYMPTOMS

Perform a complete operational check for any symptoms. Refer to [HAC-4. "Operational Check \(Front\)".](#)

Does another symptom exist?

- YES >> Refer to [HAC-3. "How to Perform Trouble Diagnosis For Quick And Accurate Repair".](#)
- NO >> SYSTEM OK.

3. CHECK FOR SERVICE BULLETINS

Check for any service bulletins.

>> GO TO 4.

4. CHECK DEFROSTER DOOR MOTOR

Perform diagnostic procedure for defroster door motor. Refer to [HAC-45. "Defroster Door Motor Component Function Check".](#)

Is the inspection result normal?

- YES >> GO TO 5.
- NO >> Repair PBR circuit or replace defroster door motor. Refer to [VTL-21. "Removal and Installation".](#)

5. CHECK DEFROSTER DOOR OPERATION

Check and verify defroster door mechanism for smooth operation.

Is the inspection result normal?

- YES >> Replace defroster door motor. Refer to [VTL-21. "Removal and Installation".](#)
- NO >> Repair defroster door mechanism.

Defroster Door Motor Diagnosis Procedure



INFOID:000000001303718

SYMPTOM:

- Defroster door does not change.
- Defroster door motor does not operate normally.

DIAGNOSTIC PROCEDURE FOR DEFROSTER DOOR MOTOR

1. CHECK A/C AUTO AMP. FOR POWER AND GROUND

1. Turn ignition switch ON.
2. Press the defroster switch ().
3. Check voltage between A/C auto amp. harness connector M49 terminal 24 and terminal 23 and press the defroster switch () again.

Connector	Terminals		Condition	Voltage (Approx.)
	(+)	(-)		
A/C auto amp.: M49	24	23	Press defroster switch	Battery voltage

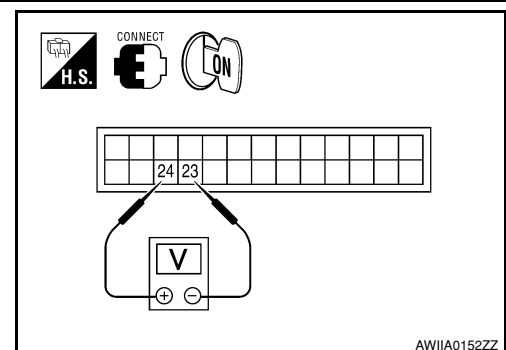

DEFROSTER DOOR MOTOR CIRCUIT

[AUTOMATIC AIR CONDITIONER]

< COMPONENT DIAGNOSIS >

Is the inspection result normal?

- YES >> GO TO 4.
- NO >> GO TO 3.

2. CHECK DEFROSTER DOOR MOTOR CIRCUITS FOR SHORT TO GROUND

1. Turn ignition switch OFF.
2. Disconnect the A/C auto amp. harness connector.
3. Check continuity between A/C auto amp. harness connector M49 terminal 23, 24 and ground.

- 23 - Ground : Continuity should not exist.**
- 24 - Ground : Continuity should not exist.**

Is the inspection result normal?

- YES >> Replace A/C auto amp. Refer to [VTL-7. "Removal and Installation"](#)
- NO >> Repair or replace harness as necessary.

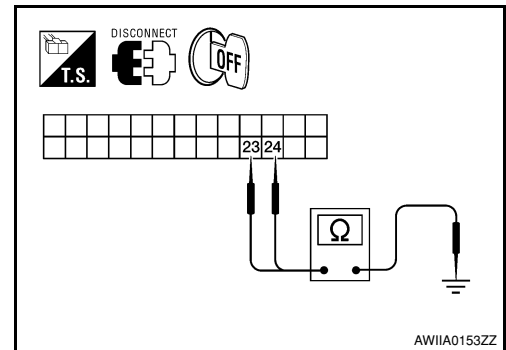

AWIIA0153ZZ

3. CHECK A/C AUTO AMP. FOR GROUND AND POWER

1. Press the defroster switch (☞).
2. Check voltage between A/C auto amp. harness connector M49 terminal 23 and terminal 24 and press the defroster switch (☞) again.

Connector	Terminals		Condition	Voltage (Approx.)
	(+)	(-)		
A/C auto amp.: M49	23	24	Press defroster switch	Battery voltage

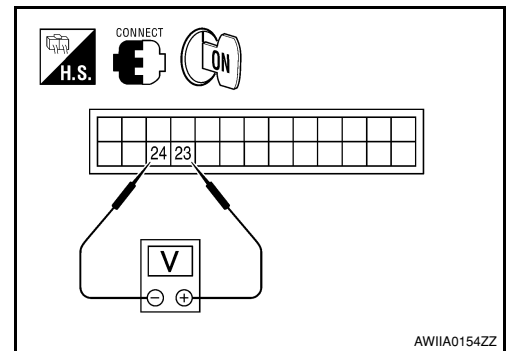

AWIIA0154ZZ

Is the inspection result normal?

- YES >> GO TO 5.
- NO >> Replace A/C auto amp. Refer to [VTL-7. "Removal and Installation"](#).

4. CHECK DEFROSTER DOOR MOTOR AND CIRCUITS FOR OPEN

1. Turn ignition switch OFF.
2. Disconnect the A/C auto amp. harness connector.
3. Check continuity between A/C auto amp. harness connector M49 terminal 23 and terminal 24.

Continuity should exist.

Is the inspection result normal?

- YES >> GO TO 7.
- NO >> GO TO 6.

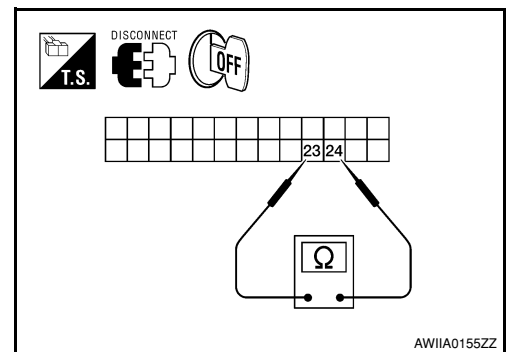

AWIIA0155ZZ

5. CHECK DEFROSTER DOOR MOTOR CIRCUITS FOR OPEN

1. Disconnect the defroster door motor harness connector.
2. Check continuity between A/C auto amp. harness connector M49 terminal 23, 24 and the defroster door motor harness connector M144 terminal 1, 6.

- 23 - 1 : Continuity should exist.**
- 24 - 6 : Continuity should exist.**

Is the inspection result normal?

- YES >> Replace defroster door motor. Refer to [VTL-21. "Removal and Installation"](#).

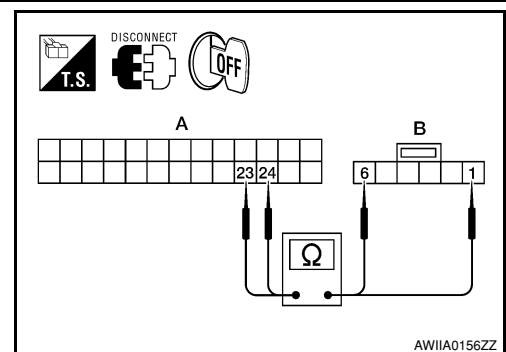

AWIIA0156ZZ

DEFROSTER DOOR MOTOR CIRCUIT

[AUTOMATIC AIR CONDITIONER]

< COMPONENT DIAGNOSIS >

NO >> Repair or replace harness as necessary.

6. CHECK A/C AUTO AMP. FOR PBR POWER AND GROUND

1. Reconnect A/C auto amp. harness connector.
2. Turn ignition switch ON.
3. Check voltage between A/C auto amp. harness connector M50 (A) terminal 28 and M49 (B) terminal 3.

Connector	Terminals		Voltage (Approx.)
	(+)	(-)	
A/C auto amp.: M50, M49	28	3	5V

Is the inspection result normal?

YES >> GO TO 9.

NO >> GO TO 8.

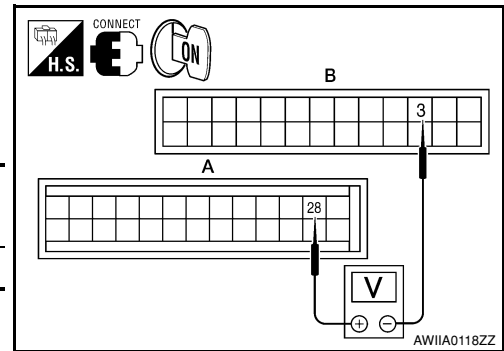

7. CHECK PBR REFERENCE VOLTAGE CIRCUIT FOR SHORT TO GROUND

1. Turn ignition switch OFF.
2. Disconnect the A/C auto amp. harness connector.
3. Check continuity between A/C auto amp. harness connector M50 terminal 28 and ground.

Continuity should not exist.

Is the inspection result normal?

YES >> Replace A/C auto amp. Refer to [VTL-7, "Removal and Installation"](#).

NO >> Repair or replace harness as necessary.

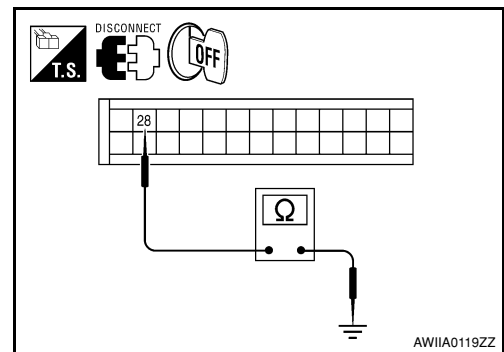

8. CHECK PBR REFERENCE VOLTAGE AND GROUND CIRCUITS

1. Turn ignition switch OFF.
2. Disconnect the A/C auto amp. harness connector.
3. Check continuity between A/C auto amp. harness connector M50 terminal 28 (A) and M49 (B) terminal 3.

Continuity should exist.

Is the inspection result normal?

YES >> GO TO 11.

NO >> GO TO 10.

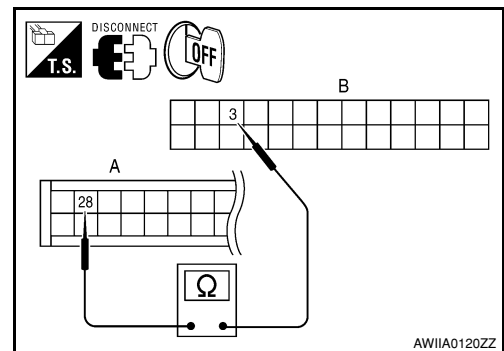

9. CHECK PBR REFERENCE VOLTAGE CIRCUIT FOR OPEN

1. Disconnect the defroster door motor harness connector.
2. Check continuity between defroster door motor harness connector M144 (B) terminal 3, 2 and A/C auto amp. harness connector M50 (A) terminal 28, and M49 (C) terminal 3.

28 - 3 : Continuity should exist.

3 - 2 : Continuity should exist.

Is the inspection result normal?

YES >> Replace defroster door motor. Refer to [VTL-21, "Removal and Installation"](#).

NO >> Repair or replace harness as necessary.

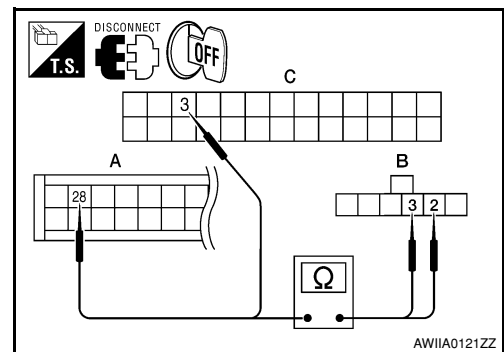

10. CHECK PBR FEEDBACK VOLTAGE

A
B
C
D
E
F
G
H
HAC
J
K
L
M
N
O
P

DEFROSTER DOOR MOTOR CIRCUIT

[AUTOMATIC AIR CONDITIONER]

< COMPONENT DIAGNOSIS >

1. Reconnect the A/C auto amp. harness connector.
2. Turn ignition switch ON.
3. Check voltage between A/C auto amp. harness connector M49 terminal 10 and ground while cycling defroster switch on and off.

Voltage : **Approx. 1V - 4.5V**

Is the inspection result normal?

- YES >> GO TO 13.
NO >> GO TO 12.

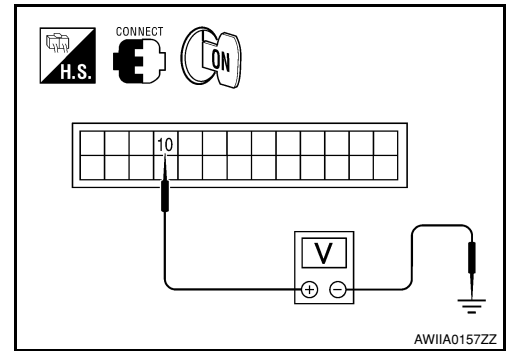

11. CHECK PBR FEEDBACK SIGNAL CIRCUIT FOR SHORT TO GROUND

1. Turn ignition switch OFF.
2. Disconnect A/C auto amp. harness connector.
3. Check continuity between A/C auto amp. harness connector M49 terminal 10 and ground.

Continuity should not exist.

Is the inspection result normal?

- YES >> Replace A/C auto amp. Refer to [VTL-7. "Removal and Installation"](#).
NO >> Repair or replace harness as necessary.

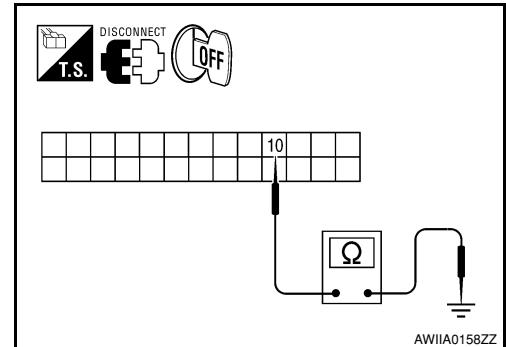

12. CHECK PBR FEEDBACK CIRCUIT FOR OPEN

1. Turn ignition switch OFF.
2. Disconnect the defroster door motor harness connector and A/C auto amp. harness connector.
3. Check continuity between defroster door motor harness connector M144 (B) terminal 4 and A/C auto amp. harness connector M49 (A) terminal 10

Continuity should exist.

Is the inspection result normal?

- YES >> Replace defroster door motor. Refer to [VTL-21. "Removal and Installation"](#).
NO >> Repair or replace harness as necessary.

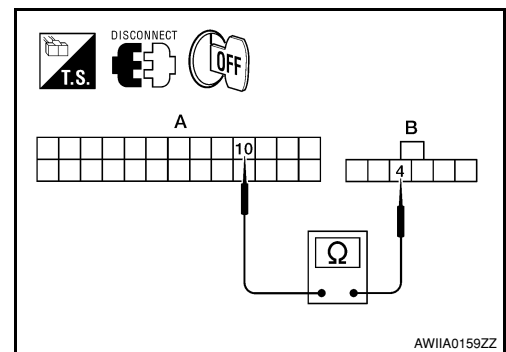

BLOWER MOTOR CONTROL SYSTEM

< COMPONENT DIAGNOSIS >

[AUTOMATIC AIR CONDITIONER]

BLOWER MOTOR CONTROL SYSTEM

System Description

INFOID:000000001277796

SYSTEM DESCRIPTION

Component Parts

Blower speed control system components are:

- A/C auto amp.
- A/C and AV switch assembly
- Variable blower control
- Front blower motor relay
- Front blower motor
- In-vehicle sensor
- Ambient sensor
- Optical sensor
- Intake sensor

System Operation

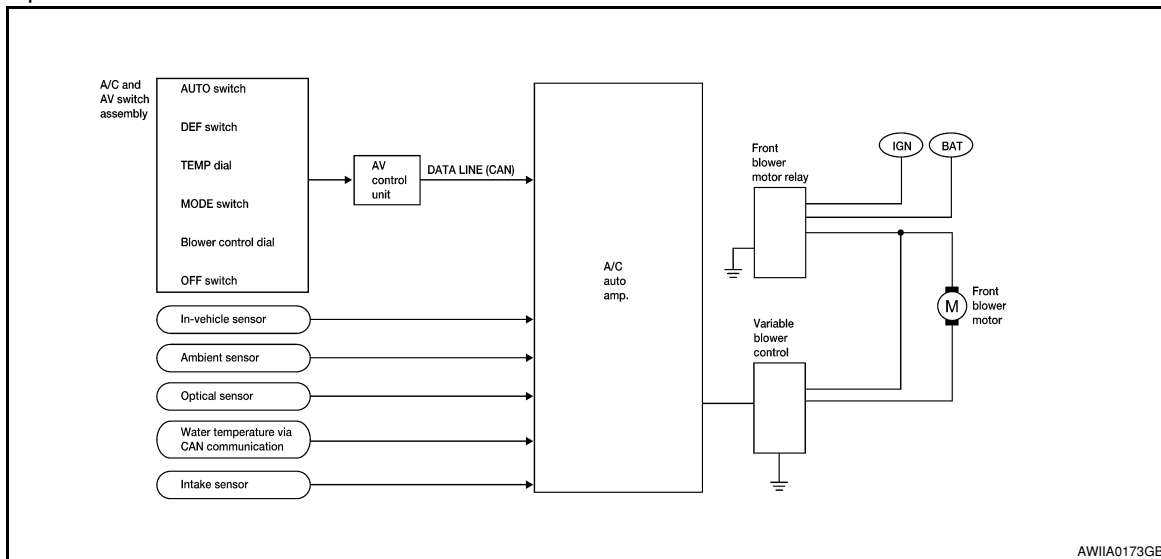

Automatic Mode

In the automatic mode, the blower motor speed is calculated by the A/C auto amp. and variable blower control based on input from the in-vehicle sensor, optical sensor, intake sensor and ambient sensor, and potentiometer temperature control (PTC).

When the air flow is increased, the blower motor speed is adjusted gradually to prevent a sudden increase in air flow.

In addition to manual air flow control and the usual automatic air flow control, starting air flow control, low water temperature starting control and high passenger compartment temperature starting control are available.

Starting Blower Speed Control

Start up from cold soak condition (Automatic mode).

In a cold start up condition where the engine coolant temperature is below 50°C (122°F), the blower will not operate at blower speed 1 for a short period of time (up to 210 seconds). The exact start delay time varies depending on the ambient and engine coolant temperatures.

In the most extreme case (very low ambient temperature) the blower starting delay will be 210 seconds as described above. After the coolant temperature reaches 50°C (122°F), or the 210 seconds has elapsed, the blower speed will increase to the objective blower speed.

Start up from usual operating or hot soak condition (Automatic mode).

The blower will begin operation momentarily after the AUTO switch is pushed. The blower speed will gradually rise to the objective speed over a time period of 3 seconds or less (actual time depends on the objective blower speed).

A

B

C

D

E

F

G

H

HAC

J

K

L

M

N

O

P

BLOWER MOTOR CONTROL SYSTEM

[AUTOMATIC AIR CONDITIONER]

< COMPONENT DIAGNOSIS >

Blower Speed Compensation - Sunload

When the in-vehicle temperature and the set temperature are very close, the blower will be operating at low speed. The speed will vary depending on the sunload. During conditions of low or no sunload, the blower operates at low speed. During high sunload conditions, the A/C auto amp. causes the blower speed to increase.

Blower Speed Control Specification

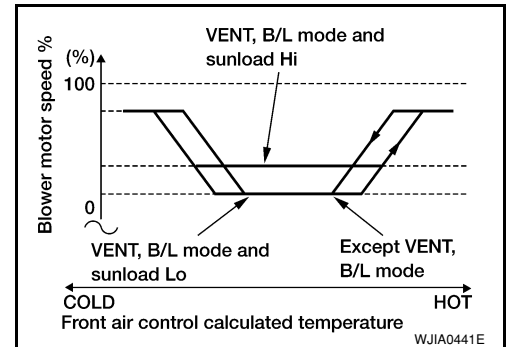

COMPONENT DESCRIPTION

Variable Blower Control

The variable blower control is located on the cooling unit. The variable blower control receives a gate voltage from the A/C auto amp. to steplessly maintain the blower motor voltage in the 0 to 5 volt range (approx.).

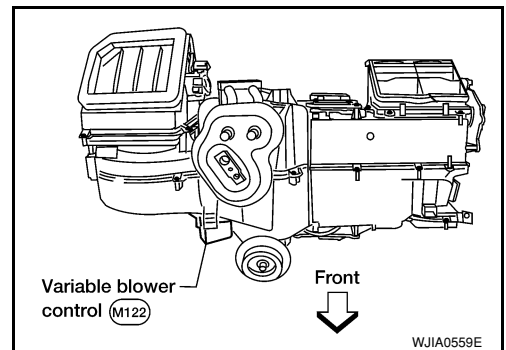

Front Blower Motor Component Function Check

INFOID:000000001277797

INSPECTION FLOW

1. CONFIRM SYMPTOM BY PERFORMING OPERATIONAL CHECK - FRONT BLOWER

1. Push blower motor (+) switch. Blower motor should operate.
2. Rotate the front blower control dial clockwise, and continue checking blower speed and fan symbol until all speeds are checked.

Can the symptom be duplicated?

- YES >> GO TO 3.
NO >> GO TO 2.

2. CHECK FOR ANY SYMPTOMS

Perform a complete operational check for any symptoms. Refer to [HAC-4, "Operational Check \(Front\)"](#).

Does another symptom exist?

- YES >> Refer to [HAC-3, "How to Perform Trouble Diagnosis For Quick And Accurate Repair"](#).
NO >> System OK.

3. CHECK FOR SERVICE BULLETINS

Check for any service bulletins.

>> GO TO 4.

4. PERFORM A/C AUTO AMP. SELF-DIAGNOSIS

Perform self-diagnosis to check for any codes. Refer to [HAC-22, "A/C Auto Amp. Self-Diagnosis"](#).

Are any self-diagnosis codes present?

BLOWER MOTOR CONTROL SYSTEM

[AUTOMATIC AIR CONDITIONER]

< COMPONENT DIAGNOSIS >

- YES >> Refer to [HAC-23. "A/C System Self-Diagnosis Code Chart"](#).
- NO >> GO TO 5.

5.PERFORM A/C AND AV SWITCH ASSEMBLY SELF-DIAGNOSIS

Perform self-diagnosis to check the A/C and AV switch assembly. Refer to [HAC-22. "A/C and AV Switch Assembly Self-Diagnosis"](#).

Is the inspection results normal?

- YES >> GO TO 6.
- NO >> Replace A/C and AV switch assembly. Refer to [VTL-7. "Removal and Installation"](#)

6.CHECK BLOWER MOTOR OPERATION

Check and verify blower motor operates manually in all speeds.

Does blower motor operate in all speeds?

- YES >> GO TO 7.
- NO >> Refer to [HAC-51. "Front Blower Motor Diagnosis Procedure"](#).

7.CHECK ENGINE COOLANT TEMPERATURE SENSOR CIRCUIT

Check engine coolant temperature sensor circuit. Refer to [EC-126. "Diagnosis Procedure"](#).

Is the inspection results normal?

- YES >> GO TO 8.
- NO >> Replace enging coolant temperature sensor.

8.RECHECK FOR ANY SYMPTOMS

Perform a complete operational check for any symptoms. Refer to [HAC-4. "Operational Check \(Front\)"](#).

Does another symptom exist?

- YES >> Refer to [HAC-3. "How to Perform Trouble Diagnosis For Quick And Accurate Repair"](#) .
- NO >> Replace A/C auto amp. Refer to [VTL-7. "Removal and Installation"](#).

Front Blower Motor Diagnosis Procedure

INFOID:000000001277798

SYMPTOM: Blower motor operation is malfunctioning.

DIAGNOSTIC PROCEDURE FOR BLOWER MOTOR

SYMPTOM: Blower motor operation is malfunctioning under starting blower speed control.

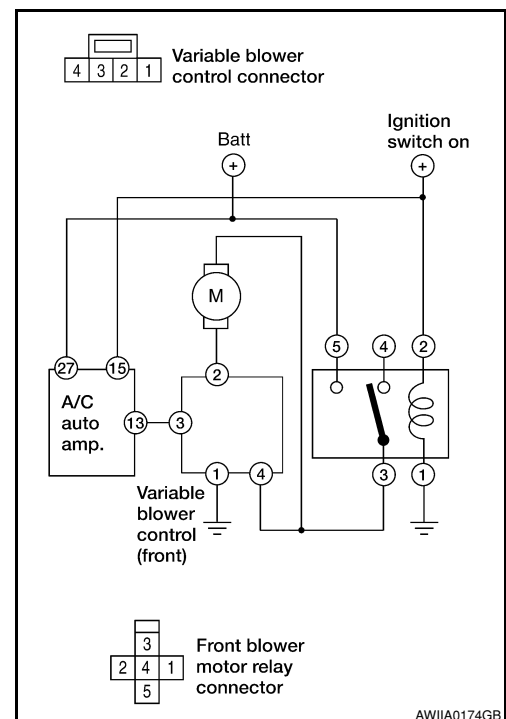

1.CHECK FUSES

BLOWER MOTOR CONTROL SYSTEM

[AUTOMATIC AIR CONDITIONER]

< COMPONENT DIAGNOSIS >

Check 20A fuses [No. 24 and 27 (Located in the fuse and fusible link box)]. For fuse layout. Refer to [PG-64](#), "[Terminal Arrangement](#)".

Fuses are good.

Is the inspection result normal?

- YES >> GO TO 3.
- NO >> GO TO 9.

2. CHECK FRONT BLOWER MOTOR POWER SUPPLY CIRCUIT

1. Turn ignition switch OFF.
2. Disconnect front blower motor connector.
3. Turn ignition switch ON.
4. Press the A/C switch.
5. Press the front blower control "+" switch to maximum speed.
6. Check voltage between front blower motor harness connector M62 terminal 2 and ground.

2 - Ground : Battery voltage

Is the inspection result normal?

- YES >> GO TO 10.
- NO >> GO TO 3.

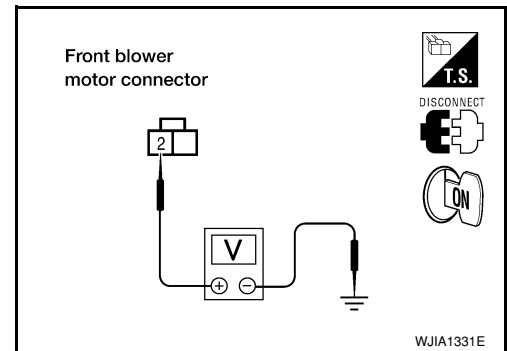

3. CHECK FRONT BLOWER MOTOR RELAY (SWITCH SIDE) POWER SUPPLY CIRCUIT

1. Turn ignition switch OFF.
2. Disconnect front blower motor relay.
3. Check voltage between front blower motor relay harness connector M107 terminal 5 and ground.

5 - Ground : Battery voltage

Is the inspection result normal?

- YES >> GO TO 4.
- NO >> Repair harness or connector.

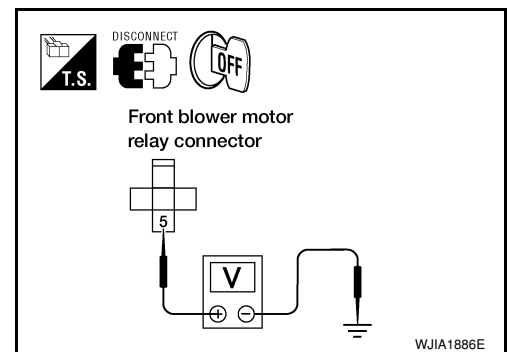

4. CHECK FRONT BLOWER MOTOR RELAY

Turn ignition switch OFF.

Check front blower motor relay. Refer to [HAC-54](#), "[Front Blower Motor Component Inspection](#)".

Is the inspection result normal?

- YES >> GO TO 5.
- NO >> Replace front blower motor relay.

5. CHECK FRONT BLOWER MOTOR RELAY (SWITCH SIDE) CIRCUIT FOR OPEN

Check continuity between front blower motor relay harness connector M107 terminal 3 and front blower motor harness connector M62 terminal 2.

3 - 2 : Continuity should exist.

Is the inspection result normal?

- YES >> GO TO 6.
- NO >> Repair harness or connector.

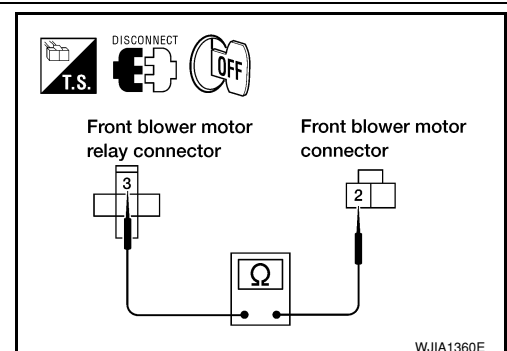

6. CHECK VARIABLE BLOWER CONTROL POWER SUPPLY CIRCUIT FOR OPEN

BLOWER MOTOR CONTROL SYSTEM

[AUTOMATIC AIR CONDITIONER]

< COMPONENT DIAGNOSIS >

1. Disconnect variable blower control harness connector.
2. Check continuity between front blower motor relay harness connector M107 (A) terminals 3 and variable blower control harness connector M122 (B) terminal 4.

3 - 4 : Continuity should exist.

Is the inspection result normal?

- YES >> GO TO 7.
NO >> Repair harness or connector.

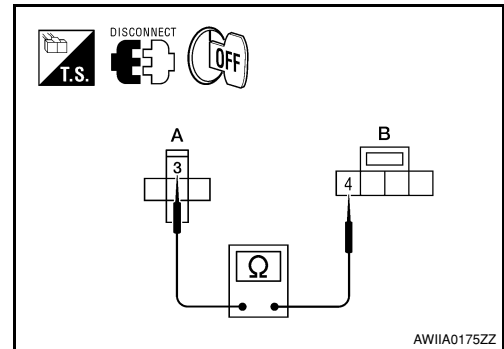

7. CHECK VARIABLE BLOWER CONTROL SIGNAL CIRCUIT

1. Disconnect A/C auto amp. connector.
2. Check continuity between A/C auto amp. harness connector M49 (B) terminal 13 and variable blower control harness connector M122 (A) terminal 3.

13 - 3 : Continuity should exist.

Is the inspection result normal?

- YES >> GO TO 8.
NO >> Repair harness or connector.

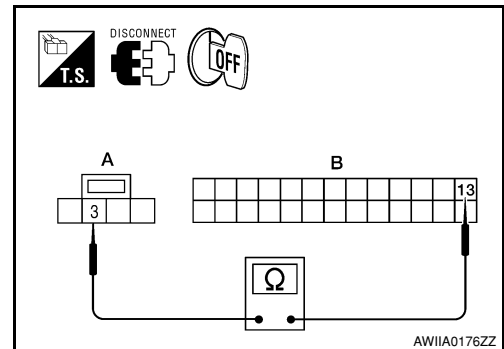

8. CHECK FRONT BLOWER MOTOR RELAY (COIL SIDE) POWER SUPPLY

1. Turn ignition switch ON.
2. Check voltage between front blower motor relay harness connector M107 terminal 2 and ground.

2 - Ground : Battery voltage

Is the inspection result normal?

- YES >> GO TO 9.
NO >> Repair front blower motor ground circuit or connector.

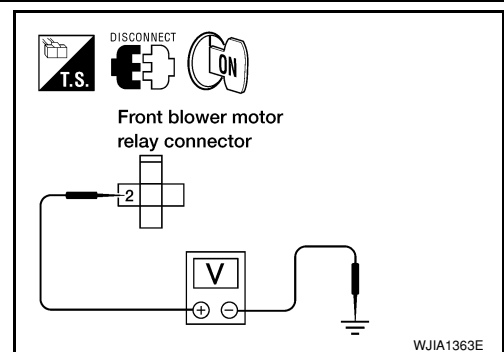

9. REPLACE FUSES

1. Replace fuses.
2. Activate the front blower motor.

Does the fuse blow?

- YES >> GO TO 10.
NO >> Inspection End.

10. CHECK FRONT BLOWER MOTOR POWER SUPPLY CIRCUIT FOR SHORT

1. Turn ignition switch OFF.
2. Disconnect front blower motor connector and variable blower control connector.
3. Check continuity between variable blower control harness connector M122 terminal 4 and ground.

4 - Ground : Continuity should not exist.

Is the inspection result normal?

- YES >> GO TO 11.
NO >> Repair harness or connector.

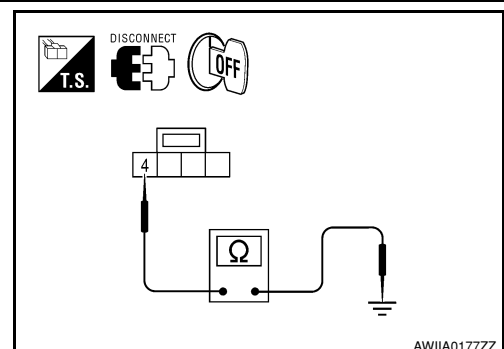

11. CHECK VARIABLE BLOWER CONTROL SIGNAL CIRCUIT

A
B
C
D
E
F
G
H
HAC
J
K
L
M
N
O
P

BLOWER MOTOR CONTROL SYSTEM

[AUTOMATIC AIR CONDITIONER]

< COMPONENT DIAGNOSIS >

1. Disconnect A/C auto amp. connector.
2. Check continuity between A/C auto amp. harness connector M49 (B) terminal 13 and variable blower control harness connector M122 (A) terminal 3.

13 - 3 : Continuity should exist.

Is the inspection result normal?

YES >> GO TO 12.

NO >> Repair harness or connector.

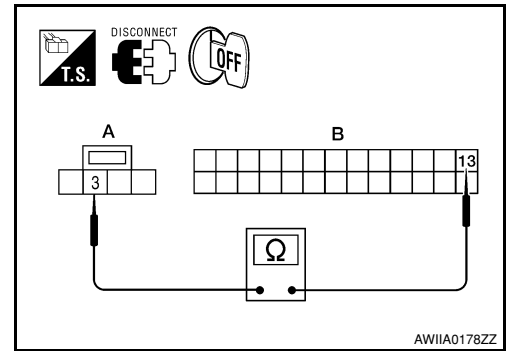

12. CHECK FRONT BLOWER MOTOR

Check front blower motor. Refer to [HAC-54, "Front Blower Motor Component Inspection"](#).

Is the inspection result normal?

YES >> GO TO 13.

NO >> Replace front blower motor. Refer to [VTL-12, "Removal and Installation"](#).

13. CHECK BLOWER MOTOR GROUND CIRCUIT

Check continuity between front blower motor harness connector M62 terminal 1 and variable blower control harness connector M122 terminal 2.

1 - 2 : Continuity should exist.

Is the inspection result normal?

YES >> GO TO 14.

NO >> Repair harness or connector.

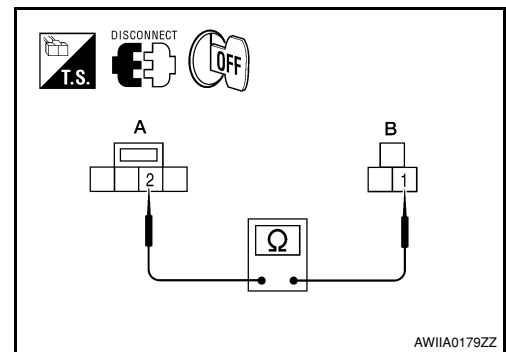

14. CHECK VARIABLE BLOWER CONTROL GROUND CIRCUIT

Check continuity between variable blower control harness connector M122 terminal 1 and ground.

1 - Ground : Continuity should exist.

Is the inspection result normal?

YES >> Replace variable blower control. Refer to [VTL-29, "Removal and Installation"](#).

NO >> Repair harness or connector.

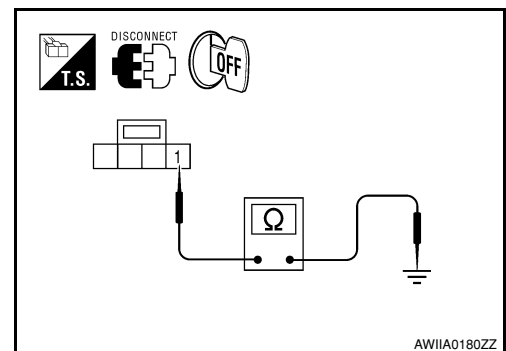

Front Blower Motor Component Inspection

INFOID:000000001277842

COMPONENT INSPECTION

BLOWER MOTOR CONTROL SYSTEM

[AUTOMATIC AIR CONDITIONER]

< COMPONENT DIAGNOSIS >

Check continuity between terminals by supplying 12 volts and ground to coil side terminals of relay.

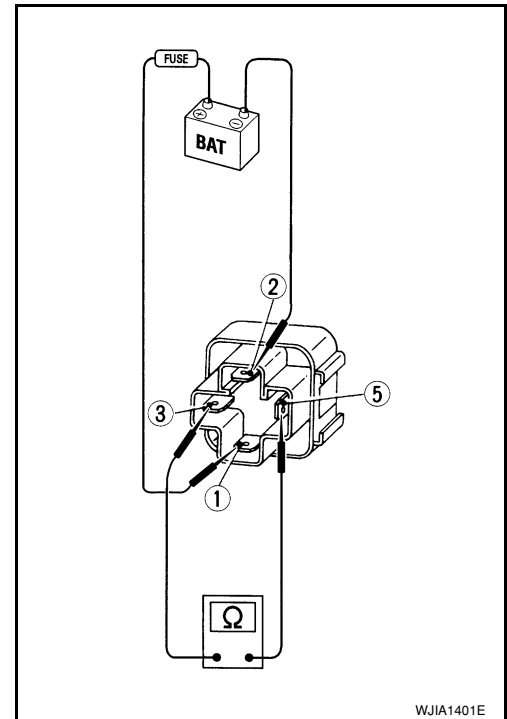

Front Blower Motor

Confirm smooth rotation of the blower motor.

- Ensure that there are no foreign particles inside the blower unit.
- Apply 12 volts to terminal 2 and ground to terminal 1 and verify that the motor operates freely and quietly.

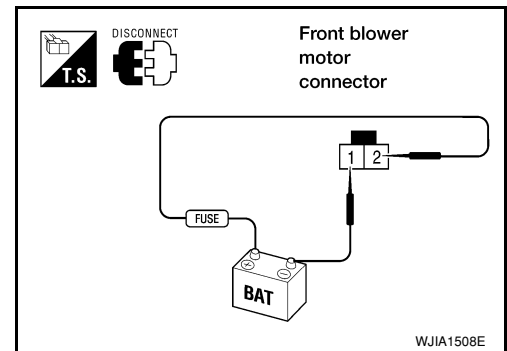

Rear Blower Motor Description

SYSTEM DESCRIPTION

Component Parts

Rear blower speed control system components are:

- A/C auto amp.
- A/C and AV switch assembly
- Rear air control (front)
- Rear air control (rear)
- Variable blower control (rear)
- Rear blower motor
- Rear blower motor relay

A
B
C
D
E
F
G
H
HAC
J
K
L
M
N
O
P

BLOWER MOTOR CONTROL SYSTEM

[AUTOMATIC AIR CONDITIONER]

< COMPONENT DIAGNOSIS >

System Operation

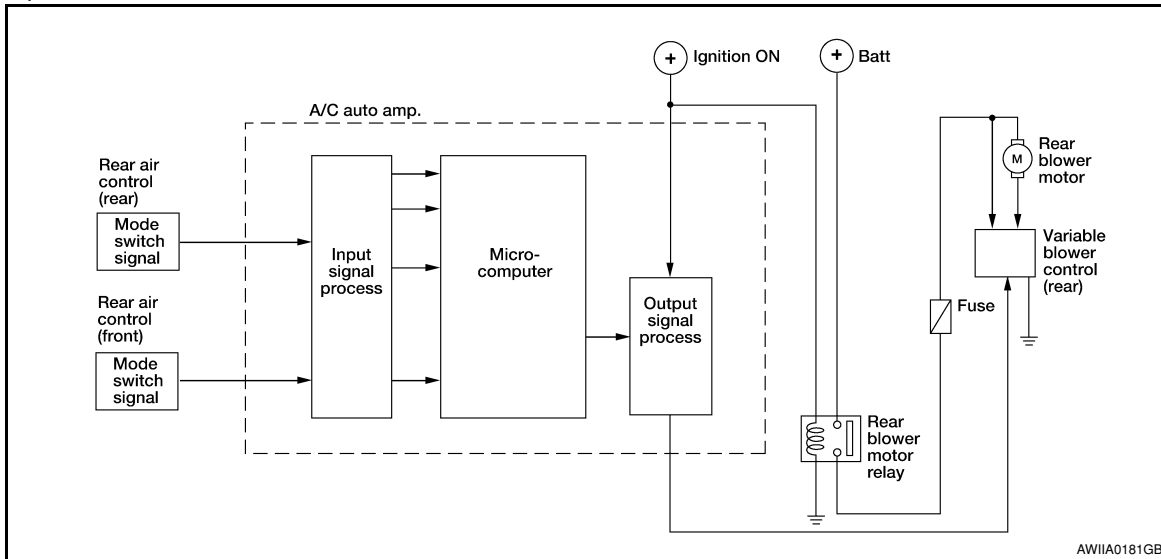

Rear Blower Control

When the rear blower control dial (front) REAR CTRL switch is pressed (indicator on), it allows the rear air control (rear) to control the rear blower motor speed. If the REAR CTRL switch is off (indicator off), the rear air control (front) controls the rear blower motor speed regardless of the rear air control (rear) position.

Rear Blower motor Component Function Check

INFOID:000000001277844

INSPECTION FLOW

SYMPTOM:

- Rear blower motor does not operate from the rear air control (front) and the rear air control (rear).
- Rear blower motor operates from rear air control (front) only.
- Rear blower motor operates in high at all times.

INSPECTION FLOW

1. CHECK FOR SERVICE BULLETINS

Check for any service bulletins.

>> GO TO 2.

2. CONFIRM SYMPTOM BY PERFORMING REAR BLOWER MOTOR OPERATIONAL CHECK FROM REAR AIR CONTROL (FRONT)

1. Turn ignition switch ON.
2. Turn the rear air control (front) blower control dial to the lowest speed and check for rear blower operation (REAR CTRL indicator off).
3. Continue checking that rear blower speed increases as the rear blower control dial is rotated clockwise.

Does the rear blower motor operate correctly?

YES >> GO TO 3.

NO >> Check the rear blower motor operation. Refer to [HAC-56. "Rear Blower motor Component Function Check"](#).

3. CONFIRM SYMPTOM BY PERFORMING REAR BLOWER MOTOR OPERATIONAL CHECK FROM REAR AIR CONTROL (REAR)

1. Press the REAR CTRL switch (indicator on) on the rear air control (front) to send control of the rear blower motor back the rear air control (rear).
2. Turn the rear air control (rear) blower control dial to the lowest speed and check for rear blower operation.
3. Continue checking that rear blower speed increases as the rear blower control dial is rotated clockwise.

Does the rear blower motor operate correctly?

YES >> GO TO 4.

BLOWER MOTOR CONTROL SYSTEM

[AUTOMATIC AIR CONDITIONER]

< COMPONENT DIAGNOSIS >

NO >> • Check the rear air control (rear). Refer to [HAC-58. "Rear Air Control \(Rear\) Diagnosis Procedure #2"](#).

4. RECHECK FOR ANY SYMPTOMS

Perform a complete operational check for any symptoms. Refer to [HAC-5. "Operational Check \(Rear\)"](#).

Does another symptom exist?

YES >> Refer to [HAC-3. "How to Perform Trouble Diagnosis For Quick And Accurate Repair"](#).

NO >> INSPECTION END.

Rear Air Control (Front) Diagnosis Procedure #1

INFOID:000000001277932

REAR BLOWER MOTOR INOPERATIVE/ON AT ALL TIMES.

1. CHECK FUSES

Check 10A fuse [No. 19 (Located in the fuse block J/B)].

Fuse is good.

Is the inspection result normal?

YES >> GO TO 2.

NO >> GO TO 6.

2. CHECK REAR AIR CONTROL (FRONT) POWER SUPPLY

1. Disconnect rear air control (front) harness connector.
2. Turn ignition switch ON.
3. Check voltage between rear air control (front) harness connector R108 terminal 1 and ground.

Battery voltage should exist.

Is the inspection result normal?

YES >> GO TO 3.

NO >> Repair harness or connector.

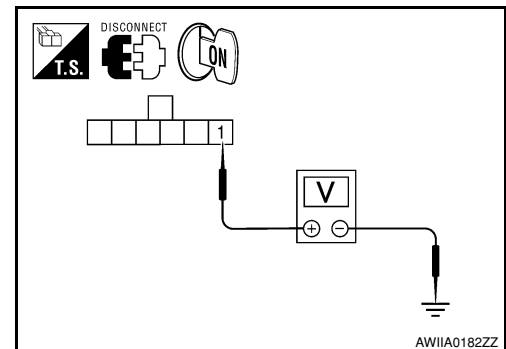

3. CHECK REAR AIR CONTROL (FRONT) LIN BUS VOLTAGE

Check voltage between rear air control (front) harness connector R108 terminal 5 and ground.

Battery voltage should exist.

Is the inspection result normal?

YES >> GO TO 4.

NO >> Repair harness or connector.

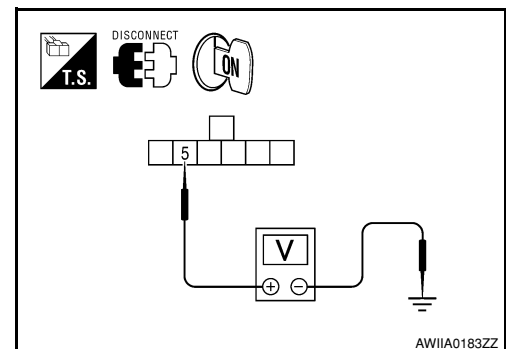

4. CHECK REAR AIR CONTROL (FRONT) GROUND CIRCUIT

BLOWER MOTOR CONTROL SYSTEM

[AUTOMATIC AIR CONDITIONER]

< COMPONENT DIAGNOSIS >

1. Turn ignition switch OFF.
2. Check continuity between rear air control (front) harness connector R108 terminal 6 and ground.

Continuity should exist.

Is the inspection result normal?

- YES >> GO TO 5.
NO >> Repair harness or connector.

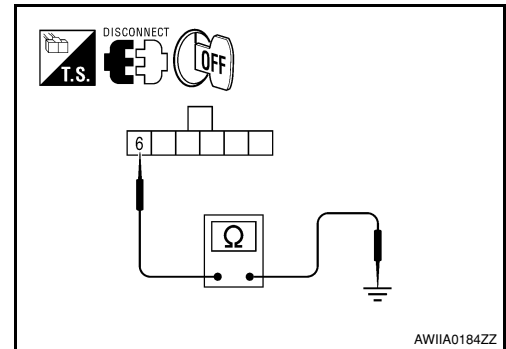

5. CHECK REAR AIR CONTROL (FRONT) LIN BUS CIRCUIT FOR OPEN

1. Disconnect A/C auto amp. connector.
2. Check continuity between A/C auto amp. harness connector M50 (A) terminal 48 and rear air control (front) harness connector R108 (B) terminal 5.

Continuity should exist.

Is the inspection result normal?

- YES >> Replace A/C auto amp. Refer to [VTL-7. "Removal and Installation"](#).
NO >> Repair harness or connector.

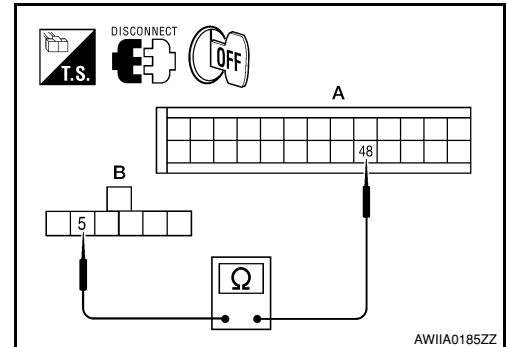

6. REPLACE FUSE

1. Replace fuse.
2. Activate the rear blower motor.

Does the fuse blow?

- YES >> GO TO 7.
NO >> Inspection End.

7. CHECK REAR AIR CONTROL (FRONT) POWER SUPPLY CIRCUIT FOR SHORT

1. Turn ignition switch OFF.
2. Disconnect rear air control (front), (rear), and A/C auto amp. connectors.
3. Check continuity between rear air control (front) harness connector R108 terminal 1 and ground.

1 - Ground : Continuity should not exist.

Is the inspection result normal?

- YES >> Repair harness or connector for a short.
NO >> System OK.

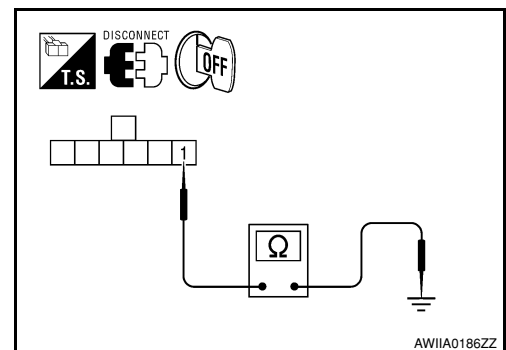

Rear Air Control (Rear) Diagnosis Procedure #2

INFOID:000000001277845

REAR AIR CONTROL (REAR) INOPERATIVE

1. CHECK REAR AIR CONTROL (FRONT) POWER SUPPLY

BLOWER MOTOR CONTROL SYSTEM

[AUTOMATIC AIR CONDITIONER]

< COMPONENT DIAGNOSIS >

1. Disconnect rear air control (rear) harness connector.
2. Turn ignition switch ON.
3. Check voltage between rear air control (rear) harness connector R209 terminal 1 and ground.

Battery voltage should exist.

Is the inspection results normal?

- YES >> GO TO 2.
NO >> Repair harness or connector.

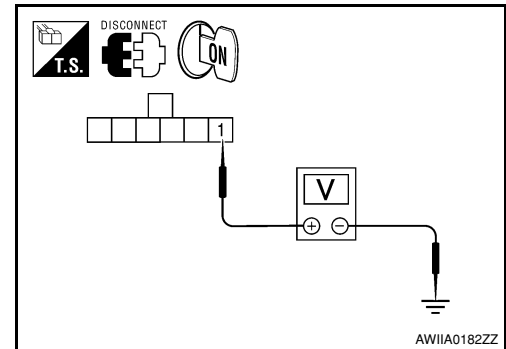

2.CHECK REAR AIR CONTROL (FRONT) LIN BUS CIRCUIT

- Check voltage between rear air control (front) harness connector R209 terminal 5 and ground.

Battery voltage should exist.

Is the inspection results normal?

- YES >> GO TO 3.
NO >> GO TO 4.

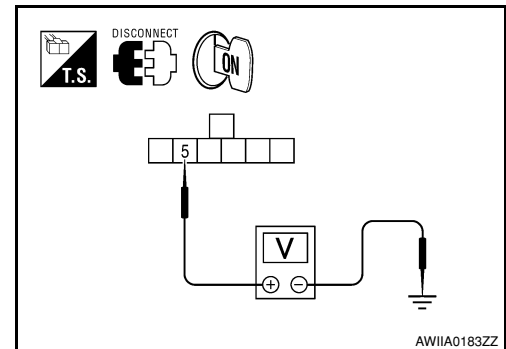

3.CHECK REAR AIR CONTROL (FRONT) GROUND CIRCUIT

1. Turn ignition switch OFF.
2. Check continuity between rear air control (front) harness connector R209 terminal 6 and ground.

Continuity should exist.

Is the inspection results normal?

- YES >> GO TO 4.
NO >> Repair harness or connector.

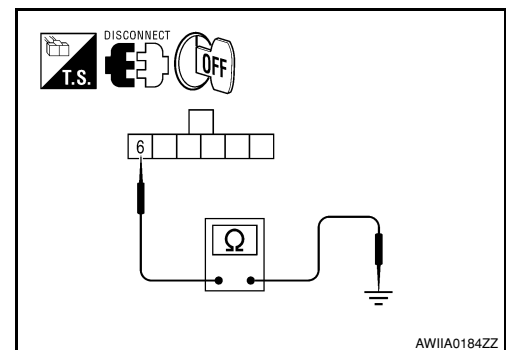

4.CHECK REAR AIR CONTROL (REAR) LIN BUS CIRCUIT FOR OPEN

1. Disconnect A/C auto amp. connector.
2. Check continuity between A/C auto amp. harness connector M50 (A) terminal 47 and rear air control (rear) harness connector R209 (B) terminal 5.

Continuity should exist.

Is the inspection results normal?

- YES >> Replace A/C auto amp. Refer to [VTL-7, "Removal and Installation"](#).
NO >> Repair harness or connector.

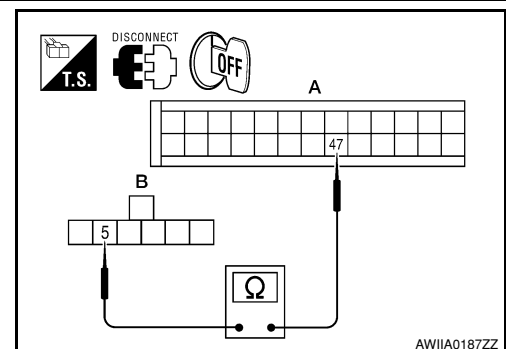

Rear Blower Motor Component Inspection

INFOID:000000001277853

COMPONENT INSPECTION

Rear Blower Motor Relay

A
B
C
D
E
F
G
H
HAC
J
K
L
M
N
O
P

BLOWER MOTOR CONTROL SYSTEM

[AUTOMATIC AIR CONDITIONER]

< COMPONENT DIAGNOSIS >

Check circuit continuity between terminals by supplying 12 volts and ground to coil side terminals of relays.

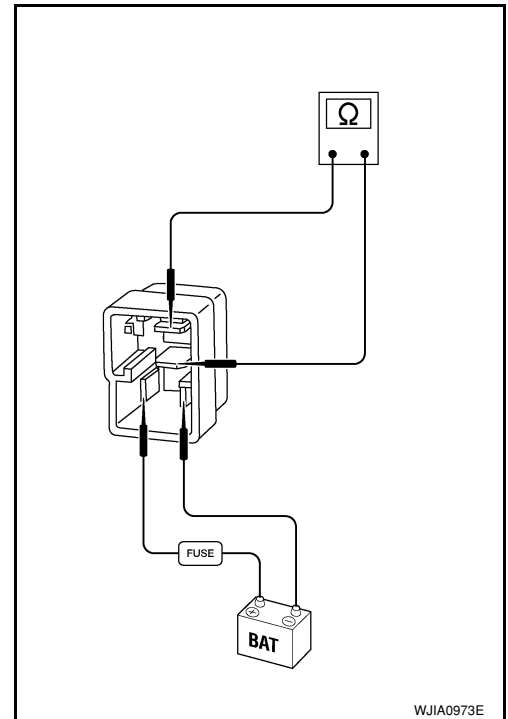

Rear Blower Motor

Check that there are no foreign particles inside the intake unit.
Apply 12 volts to terminal 2 and ground to terminal 1 and ensure that the blower motor rotates freely and quietly.

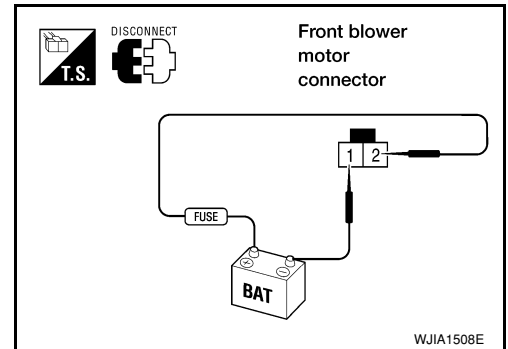

REAR AIR CONTROL SYSTEM

< COMPONENT DIAGNOSIS >

[AUTOMATIC AIR CONDITIONER]

REAR AIR CONTROL SYSTEM

Rear Air Control System Description

INFOID:000000001277849

SYSTEM DESCRIPTION

Component Parts

Rear air control system components are:

- A/C auto amp.
- Rear air control (front)
- Rear air control (rear)
- Air mix door motor (rear)
- Mode door motor (rear)

System Operation

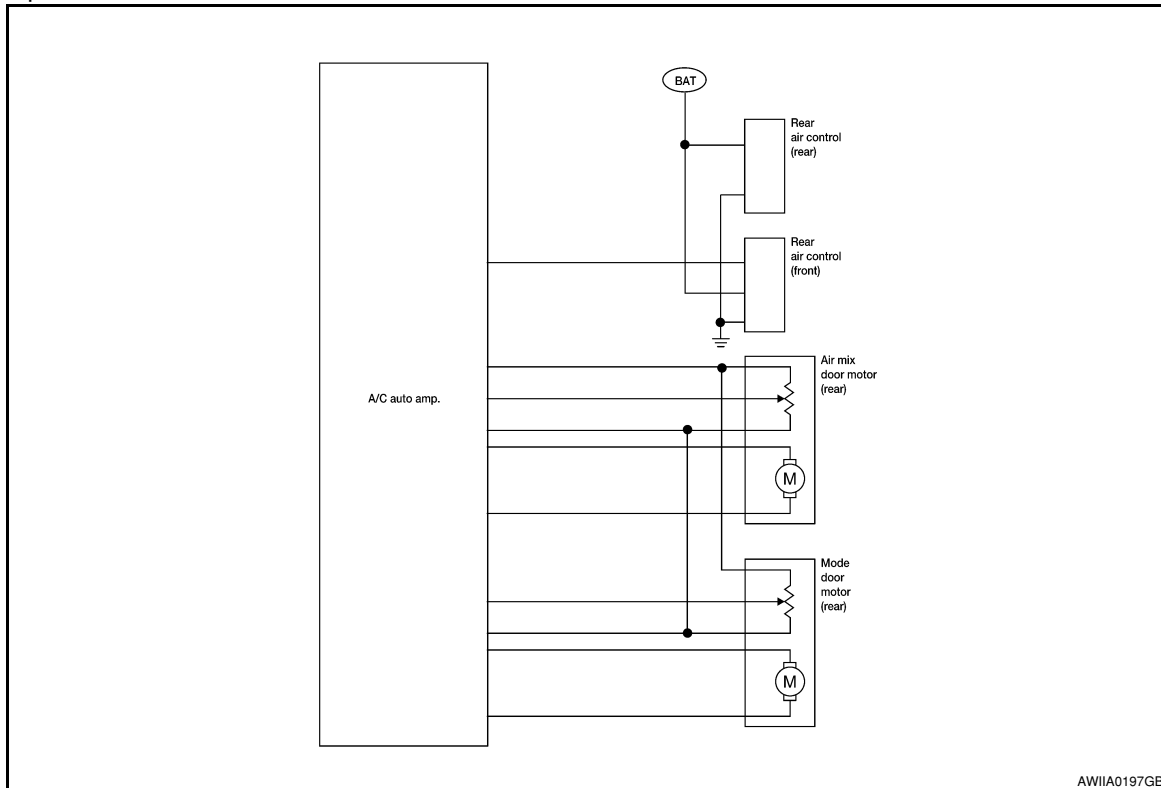

Rear Air Control

When the REAR CTRL indicator is off the rear air control (front) will control all rear blower motor speeds and the rear temperature and mode operations. When the REAR CTRL switch is pressed (indicator on), the rear air control (rear) will control all the rear blower motor speeds and the rear temperature and mode operations.

Rear Air Control Component Function Check

INFOID:000000001277851

SYMPTOM:

- Temperature cannot be adjusted from the rear air controls.
- Mode cannot be adjusted from the rear air controls.

INSPECTION FLOW

1. CHECK FOR SERVICE BULLETINS

Check for any service bulletins.

>> GO TO 2.

2. CONFIRM SYMPTOM BY PERFORMING REAR AIR CONTROL (FRONT) AIR MIX DOOR MOTOR OPERATIONAL CHECK

REAR AIR CONTROL SYSTEM

[AUTOMATIC AIR CONDITIONER]

< COMPONENT DIAGNOSIS >

1. Start and run engine to operating temperature.
2. Turn the rear blower motor to maximum speed from the rear air control (front).
3. Turn rear air control (front) temperature control dial clockwise and then counterclockwise (REAR CTRL indicator off).
4. Check for hot air at rear discharge air outlets in the maximum heat position and cold air at discharge air outlets in the maximum cold position.

Does the rear air control (front) operate properly?

YES >> GO TO 3.

NO >> Check rear air control (front). Refer to [HAC-62. "Air Mix Door Motor \(Rear\) Diagnosis Procedure"](#).

3.CONFIRM SYMPTOM BY PERFORMING REAR AIR CONTROL (REAR) AIR MIX DOOR MOTOR OPERATIONAL CHECK

1. Press the REAR CTRL switch on rear air control (front) to send control to the rear air control (rear).
2. Turn rear air control (rear) temperature control dial slowly clockwise and then counterclockwise (REAR CTRL indicator on).
3. Check for hot air at rear discharge air outlets in the maximum heat position and cold air at rear discharge air outlets in the maximum cold position.

Does the rear air control (rear) operate properly?

YES >> GO TO 4.

NO >> Check rear air control (rear). Refer to [HAC-58. "Rear Air Control \(Rear\) Diagnosis Procedure #2"](#).

4.CONFIRM SYMPTOM BY PERFORMING REAR AIR CONTROL (FRONT) MODE OPERATIONAL CHECK

1. Press the REAR CTRL switch on rear air control (front) (REAR CTRL indicator off).
2. Press each mode switch and check for proper air discharge at the appropriate locations.

Does the rear air control (front) operate properly?

YES >> GO TO 5.

NO >> Check mode door motor (rear). Refer to [HAC-66. "Mode Door Motor \(Rear\) Diagnosis Procedure"](#).

5.CONFIRM SYMPTOM BY PERFORMING REAR AIR CONTROL (REAR) MODE OPERATIONAL CHECK

1. Press the REAR CTRL switch on rear air control (front) to send control to the rear air control (rear).
2. Press each mode switch and check for proper air discharge at the appropriate locations.

Does the rear air control (rear) operate properly?

YES >> System OK.

NO >> Replace rear air control (rear). Refer to [VTL-7. "Removal and Installation"](#).

Air Mix Door Motor (Rear) Diagnosis Procedure

INFOID:000000001277850

DIAGNOSTIC PROCEDURE FOR INOPERATIVE AIR MIX DOOR MOTOR (REAR)

SYMPTOM:

- Temperature control (rear) operation is malfunctioning.

1.CHECK REAR AIR CONTROL (FRONT) POWER SUPPLY

1. Disconnect rear air control (front) harness connector.
2. Turn ignition switch ON.
3. Check voltage between rear air control (front) harness connector R108 terminal 1 and ground.

Battery voltage should exist.

Is the inspection result normal?

YES >> GO TO 2.

NO >> Repair harness or connector.

2.CHECK REAR AIR CONTROL (FRONT) LIN BUS VOLTAGE

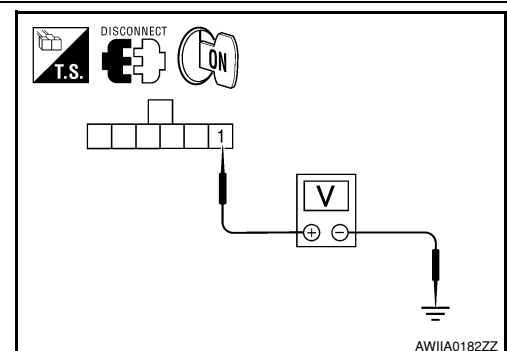

REAR AIR CONTROL SYSTEM

[AUTOMATIC AIR CONDITIONER]

< COMPONENT DIAGNOSIS >

Check voltage between rear air control (front) harness connector R108 terminal 5 and ground.

Battery voltage should exist.

Is the inspection result normal?

YES >> GO TO 3.

NO >> GO TO 4.

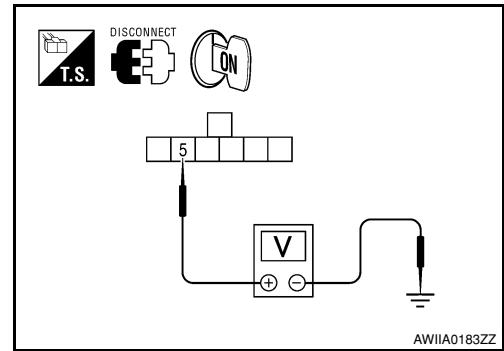

3. CHECK REAR AIR CONTROL (FRONT) GROUND CIRCUIT

1. Turn ignition switch OFF.
2. Check continuity between rear air control (front) harness connector R108 terminal 6 and ground.

Continuity should exist.

Is the inspection result normal?

YES >> GO TO 5.

NO >> Repair harness or connector.

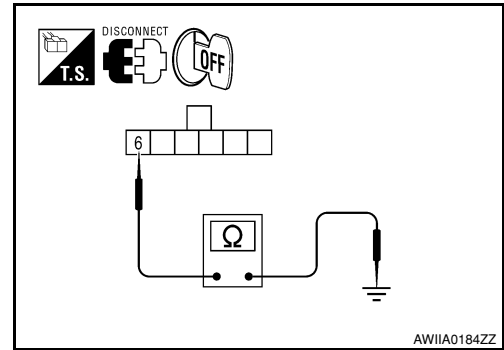

4. CHECK LIN BUS VOLTAGE CIRCUIT FOR OPEN

1. Disconnect the mode door motor (rear) harness connector.
2. Check continuity between rear air control (front) harness connector R108 (B) terminal 5 and A/C auto amp. harness connector M50 (A) terminal 48.

48 - 5 : Continuity should exist.

Is the inspection result normal?

YES >> Replace A/C auto amp. Refer to [VTL-7. "Removal and Installation"](#).

NO >> Repair or replace harness as necessary.

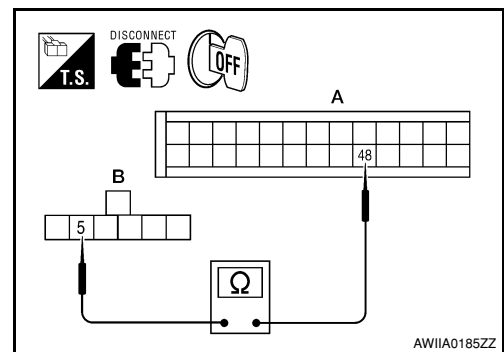

5. CHECK A/C AUTO AMP. FOR POWER AND GROUND FOR AIR MIX DOOR MOTOR (REAR)

1. Reconnect all disconnected parts.
2. Turn ignition switch ON.
3. Rotate temperature control dial (rear) to maximum heat.
4. Check voltage between A/C auto amp. harness connector M50 terminal 49 and terminal 50 while rotating temperature control dial (front) to maximum cold.

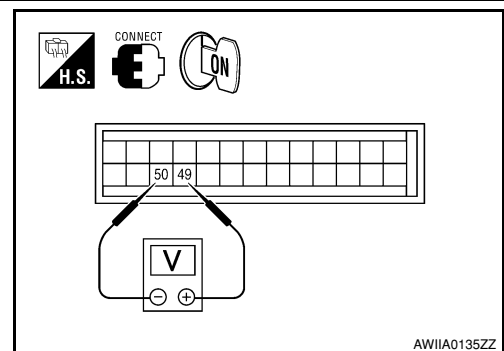

Connector	Terminals		Condition	Voltage (Approx.)
	(+)	(-)		
A/C auto amp.: M50	49	50	Rotate temp control dial	Battery voltage

Is the inspection result normal?

YES >> GO TO 9.

NO >> GO TO 6.

6. CHECK AIR MIX DOOR MOTOR (REAR) CIRCUITS FOR OPEN

A
B
C
D
E
F
G
H
HAC
J
K
L
M
N
O
P

REAR AIR CONTROL SYSTEM

[AUTOMATIC AIR CONDITIONER]

< COMPONENT DIAGNOSIS >

1. Turn ignition switch OFF.
2. Disconnect the A/C auto amp. harness connector.
3. Check continuity between A/C auto amp. harness connector M50 terminal 49 and terminal 50.

Continuity should exist.

Is the inspection result normal?

- YES >> Replace A/C auto amp. Refer to [VTL-7, "Removal and Installation"](#).
- NO >> GO TO 7.

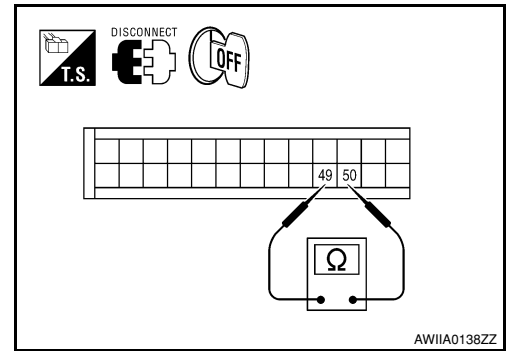

AWIIA0138ZZ

7. CHECK AIR MIX DOOR MOTOR (REAR) CIRCUITS FOR SHORT TO GROUND

1. Turn ignition switch OFF.
2. Disconnect the air mix door motor (rear) harness connector.
3. Check continuity between A/C auto amp. harness connector M50 terminal 49, 50 and ground.

49 - Ground : Continuity should not exist.

50 - Ground : Continuity should not exist.

Is the inspection result normal?

- YES >> GO TO 8.
- NO >> Repair or replace harness as necessary.

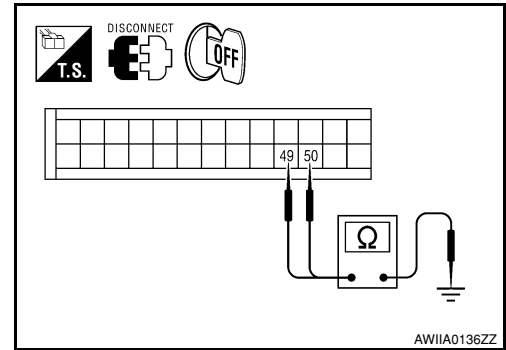

AWIIA0136ZZ

8. CHECK AIR MIX DOOR MOTOR (REAR) CIRCUITS FOR OPEN

1. Disconnect the air mix door motor (rear) harness connector.
2. Check continuity between A/C auto amp. harness connector M50 terminal 49, 50 and the air mix door motor (rear) harness connector B155 terminal 1, 6.

49 - 1 : Continuity should exist.

50 - 6 : Continuity should exist.

Is the inspection result normal?

- YES >> Replace air mix door motor (rear). Refer to [VTL-26, "Removal and Installation"](#).
- NO >> Repair or replace harness as necessary.

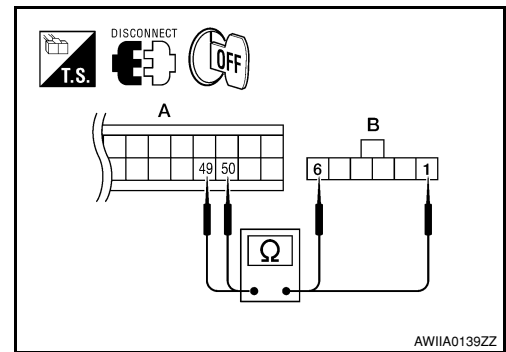

AWIIA0139ZZ

9. CHECK A/C AUTO AMP. POWER AND GROUND FOR AIR MIX DOOR MOTOR (REAR)

1. Rotate temperature control dial (front) to maximum cold.
2. Check voltage between A/C auto amp. harness connector M50 terminal 49 and terminal 50 while rotating temperature control dial (rear) to maximum heat.

Connector	Terminals		Condition	Voltage (Approx.)
	(+)	(-)		
A/C auto amp.: M50	50	49	Rotate temp control dial	Battery voltage

Is the inspection result normal?

- YES >> GO TO 10.
- NO >> Replace A/C auto amp. Refer to [VTL-7, "Removal and Installation"](#).

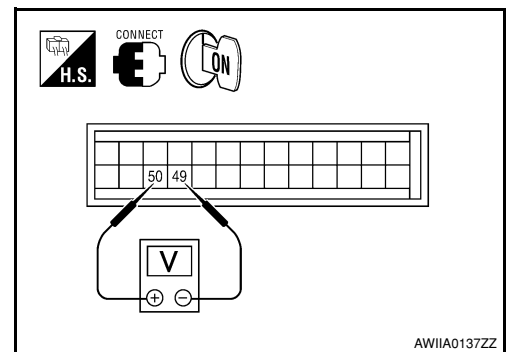

AWIIA0137ZZ

10. CHECK A/C AUTO AMP. FOR AIR MIX DOOR MOTOR (REAR) PBR POWER AND GROUND

REAR AIR CONTROL SYSTEM

[AUTOMATIC AIR CONDITIONER]

< COMPONENT DIAGNOSIS >

1. Check voltage between A/C auto amp. harness connector M50 (A) terminal 28 and M49 (B) terminal 3.

Connector	Terminals		Voltage (Approx.)
	(+)	(-)	
A/C auto amp.: M49, M50	28	3	5V

Is the inspection result normal?

- YES >> GO TO 14.
NO >> GO TO 11.

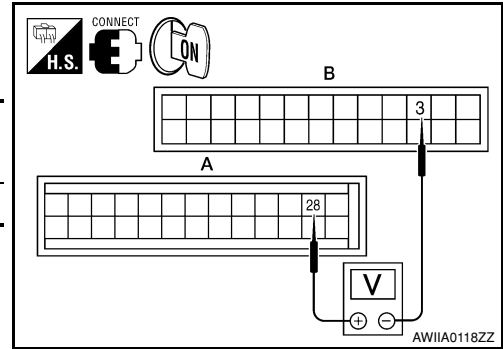

11. CHECK PBR REFERENCE VOLTAGE AND GROUND CIRCUITS

1. Turn ignition switch OFF.
2. Disconnect the A/C auto amp. harness connector.
3. Check continuity between A/C auto amp. harness connector M50 (A) terminal 28 and M49 (B) terminal 3.

Continuity should exist.

Is the inspection result normal?

- YES >> GO TO 13.
NO >> GO TO 12.

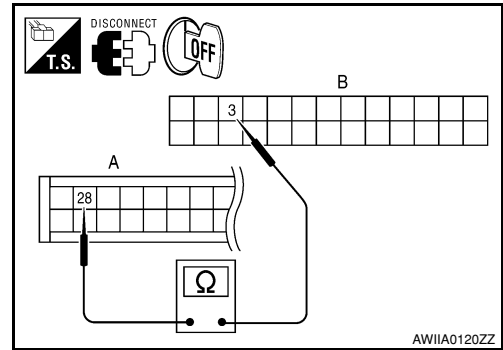

12. CHECK PBR REFERENCE VOLTAGE CIRCUIT FOR OPEN

1. Disconnect the air mix door motor (rear) harness connector.
2. Check continuity between air mix door motor (rear) harness connector B155 (B) terminal 3, 2 and A/C auto amp. harness connector M50 (A) terminal 28 and M49 (C) terminal 3.

28 - 3 : Continuity should exist.

3 - 2 : Continuity should exist.

Is the inspection result normal?

- YES >> Replace air mix door motor (rear). Refer to [VTL-26. "Removal and Installation"](#).
NO >> Repair or replace harness as necessary.

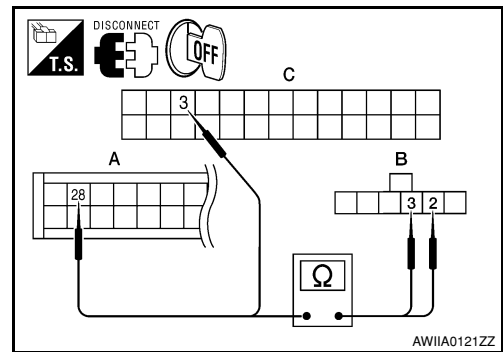

13. CHECK PBR REFERENCE VOLTAGE CIRCUIT FOR SHORT TO GROUND

Check continuity between A/C auto amp. harness connector M50 terminal 28 and ground.

Continuity should not exist.

Is the inspection result normal?

- YES >> Replace A/C auto amp. [VTL-7. "Removal and Installation"](#).
NO >> Repair or replace harness as necessary.

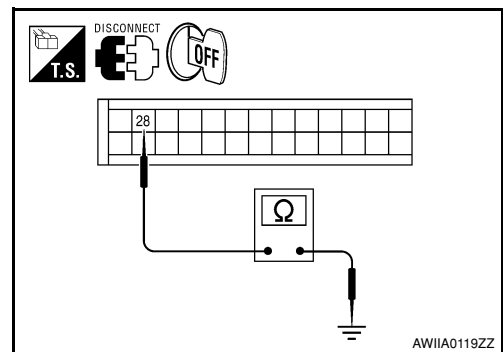

14. CHECK PBR FEEDBACK VOLTAGE

REAR AIR CONTROL SYSTEM

[AUTOMATIC AIR CONDITIONER]

< COMPONENT DIAGNOSIS >

Check voltage between A/C auto amp. harness connector M50 terminal 33 and ground while rotating temperature control dial (rear) from maximum cold to maximum heat.

Voltage : **Approx. 1V - 4.5V**

Is the inspection result normal?

- YES >> System OK.
- NO >> GO TO 15.

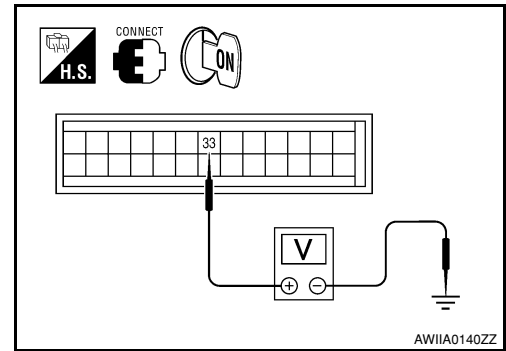

15. CHECK PBR FEEDBACK CIRCUIT FOR OPEN

1. Turn ignition switch OFF.
2. Disconnect the air mix door motor (rear) harness connector and A/C auto amp. harness connector.
3. Check continuity between air mix door motor (rear) harness connector B155 (B) terminal 4 and A/C auto amp. harness connector M50 (A) terminal 33.

Continuity should exist.

Is the inspection result normal?

- YES >> GO TO 16.
- NO >> Repair or replace harness as necessary.

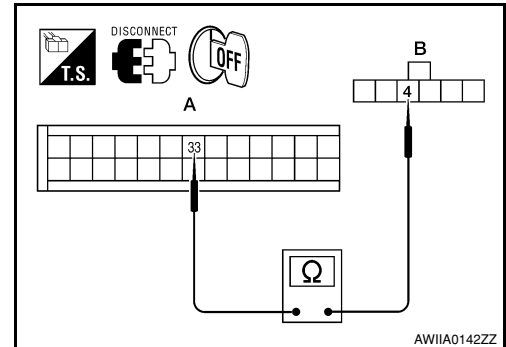

16. CHECK PBR FEEDBACK SIGNAL CIRCUIT FOR SHORT TO GROUND

Check continuity between A/C auto amp. harness connector M50 terminal 33 and ground.

Continuity should not exist.

Is the inspection result normal?

- YES >> Replace A/C auto amp. Refer to [VTL-7. "Removal and Installation"](#).
- NO >> Repair or replace harness as necessary.

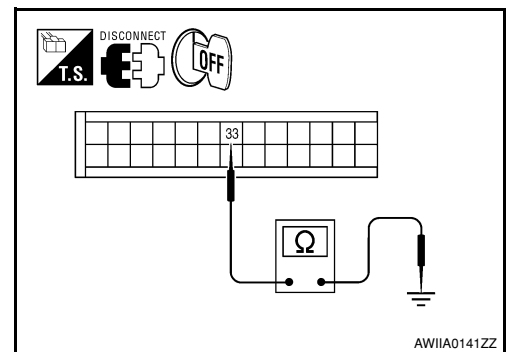

Mode Door Motor (Rear) Diagnosis Procedure

INFOID:000000001277852

DIAGNOSTIC PROCEDURE INOPERATIVE MODE DOOR MOTOR (REAR)

1. CHECK REAR AIR CONTROL (FRONT) POWER SUPPLY

1. Disconnect rear air control (front) harness connector.
2. Turn ignition switch ON.
3. Check voltage between rear air control (front) harness connector R108 terminal 1 and ground.

Battery voltage should exist.

Is the inspection results normal?

- YES >> GO TO 2.
- NO >> Repair harness or connector.

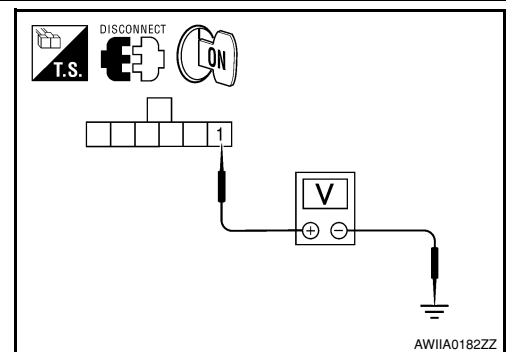

2. CHECK REAR AIR CONTROL (FRONT) LIN BUS VOLTAGE

REAR AIR CONTROL SYSTEM

[AUTOMATIC AIR CONDITIONER]

< COMPONENT DIAGNOSIS >

Check voltage between rear air control (front) harness connector R108 terminal 5 and ground.

Battery voltage should exist.

Is the inspection results normal?

YES >> GO TO 3.

NO >> GO TO 4.

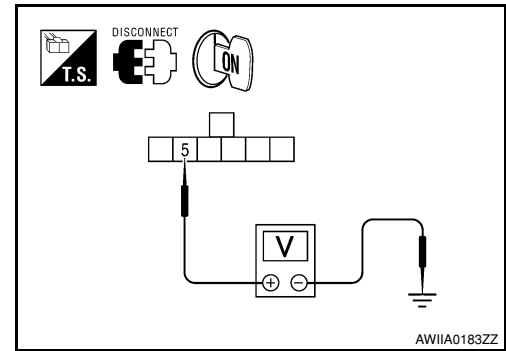

3. CHECK REAR AIR CONTROL (FRONT) GROUND CIRCUITS

1. Turn ignition switch OFF.
2. Check continuity between rear air control (front) harness connector R108 terminal 6 and ground.

Continuity should exist.

Is the inspection results normal?

YES >> GO TO 5.

NO >> Repair harness or connector.

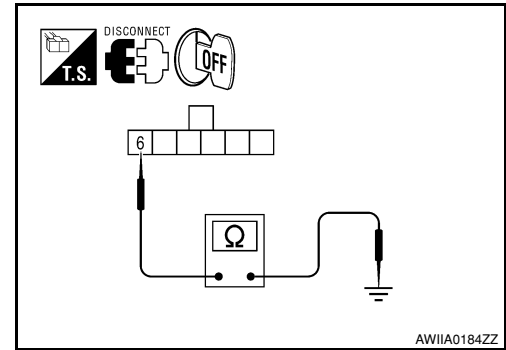

4. CHECK LIN BUS VOLTAGE CIRCUIT FOR OPEN

1. Disconnect the mode door motor (rear) harness connector.
2. Check continuity between rear air control (front) harness connector R108 (B) terminal 5 and A/C auto amp. harness connector M50 (A) terminal 48.

48 - 5 : Continuity should exist.

Is the inspection result normal?

YES >> Replace A/C auto amp. Refer to [VTL-7. "Removal and Installation"](#).

NO >> Repair or replace harness as necessary.

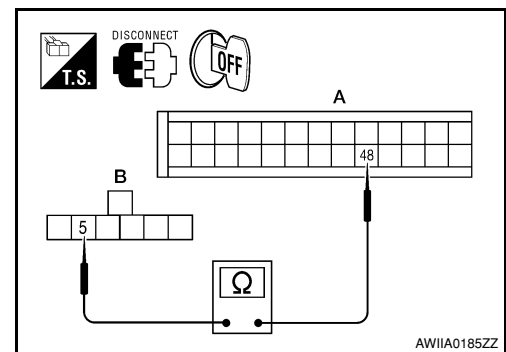

5. CHECK A/C AUTO AMP. POWER AND GROUND FOR MODE DOOR MOTOR (REAR)

1. Reconnect all disconnected parts.
2. Turn ignition switch ON.
3. Press the mode switch to the FLOOR (⬇️) mode.
4. Check voltage between A/C auto amp. harness connector M50 terminal 43 and terminal 44 while pressing the mode switch to the vent (⬆️) mode.

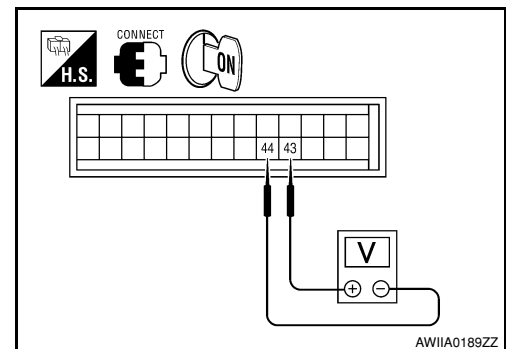

Connector	Terminals		Condition	Voltage (Approx.)
	(+)	(-)		
A/C auto amp.: M50	43	44	Press mode switch (rear)	Battery voltage

Is the inspection result normal?

YES >> GO TO 9.

NO >> GO TO 6.

6. CHECK MODE DOOR MOTOR AND CIRCUITS FOR OPEN

A
B
C
D
E
F
G
H
HAC
J
K
L
M
N
O
P

REAR AIR CONTROL SYSTEM

[AUTOMATIC AIR CONDITIONER]

< COMPONENT DIAGNOSIS >

1. Turn ignition switch OFF.
2. Disconnect the A/C auto amp. harness connector.
3. Check continuity between A/C auto amp. harness connector M50 terminal 43 and terminal 44.

Continuity should exist.

Is the inspection result normal?

- YES >> Replace A/C auto amp.
 NO >> GO TO 7.

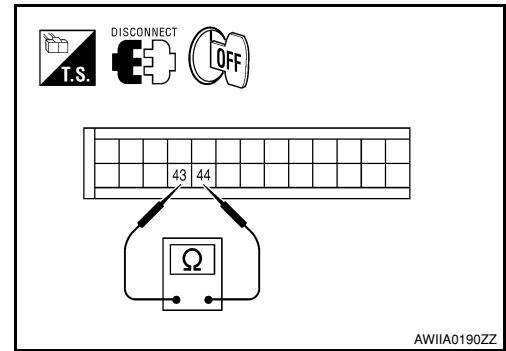

7. CHECK MODE DOOR MOTOR CIRCUITS FOR SHORT TO GROUND

1. Disconnect the A/C auto amp. harness connector and mode door motor (rear) harness connector
2. Check continuity between A/C auto amp. harness connector M50 terminal 43, 44 and ground.

43 - Ground : Continuity should not exist.

44 - Ground : Continuity should not exist.

Is the inspection result normal?

- YES >> GO TO 8.
 NO >> Repair or replace harness as necessary.

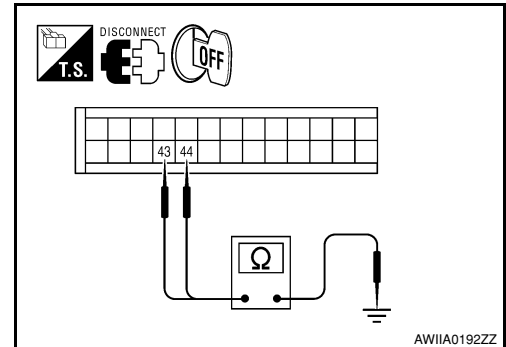

8. CHECK MODE DOOR MOTOR CIRCUITS FOR OPEN

Check continuity between A/C auto amp. harness connector M50 (A) terminal 43, 44 and the mode door motor (rear) harness connector B156 (B) terminal 5, 6.

5 - 43 : Continuity should exist.

6 - 44 : Continuity should exist.

Is the inspection result normal?

- YES >> Replace mode door motor. Refer to [VTL-24. "Removal and Installation"](#).
 NO >> Repair or replace harness as necessary.

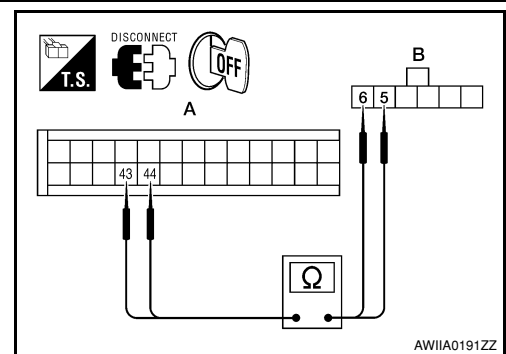

9. CHECK A/C AUTO AMP. POWER AND GROUND FOR MODE DOOR MOTOR (REAR)

Check voltage between A/C auto amp. harness connector M50 terminal 43 and terminal 44 while pressing the mode switch to the FLOOR (⬇️) mode.

Connector	Terminals		Condition	Voltage (Approx.)
	(+)	(-)		
A/C auto amp.: M50	44	43	Press mode switch (rear)	Battery voltage

Is the inspection result normal?

- YES >> GO TO 10.
 NO >> Replace A/C auto amp. Refer to [VTL-7. "Removal and Installation"](#).

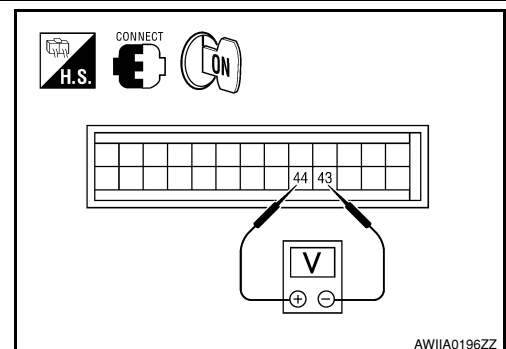

10. CHECK A/C AUTO AMP. FOR MODE DOOR MOTOR (REAR) PBR POWER AND GROUND

REAR AIR CONTROL SYSTEM

[AUTOMATIC AIR CONDITIONER]

< COMPONENT DIAGNOSIS >

Check voltage between A/C auto amp. harness connector M50 (A) terminal 28 and M49 (B) terminal 3.

Connector	Terminals		Voltage (Approx.)
	(+)	(-)	
A/C auto amp.: M49, M50	28	3	5V

Is the inspection result normal?

- YES >> GO TO 14.
NO >> GO TO 11.

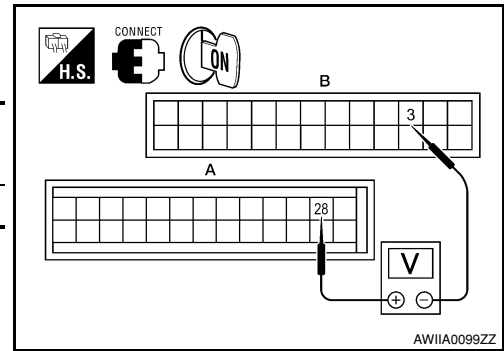

11. CHECK PBR REFERENCE VOLTAGE AND GROUND CIRCUITS

- Turn ignition switch OFF.
- Disconnect the A/C auto amp. harness connector.
- Check continuity between A/C auto amp. harness connector M50 (A) terminal 28 and M49 (B) terminal 3.

Continuity should exist.

Is the inspection result normal?

- YES >> GO TO 13.
NO >> GO TO 12

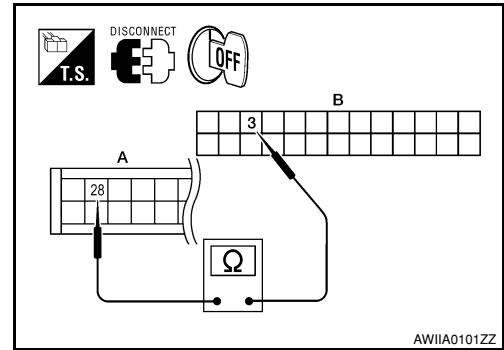

12. CHECK PBR REFERENCE VOLTAGE CIRCUIT FOR OPEN

- Disconnect the mode door motor (rear) harness connector.
- Check continuity between mode door motor (rear) harness connector B156 (B) terminal 3, 1 and A/C auto amp. harness connector M49 (C) terminal 3, M50 (A) terminal 28.

28 - 1 : Continuity should exist.
3 - 3 : Continuity should exist.

Is the inspection result normal?

- YES >> Replace mode door motor (rear). Refer to [VTL-24. "Removal and Installation"](#).
NO >> Repair or replace harness as necessary.

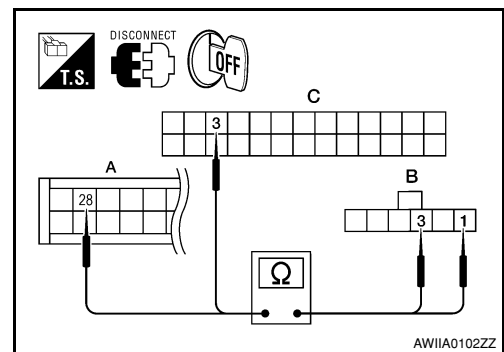

13. CHECK PBR REFERENCE VOLTAGE CIRCUIT FOR SHORT TO GROUND

- Turn ignition switch OFF.
- Disconnect the A/C auto amp. harness connector.
- Check continuity between A/C auto amp. harness connector M50 terminal 28 and ground.

Continuity should not exist.

Is the inspection result normal?

- YES >> Replace the A/C auto amp.
NO >> Repair or replace harness as necessary.

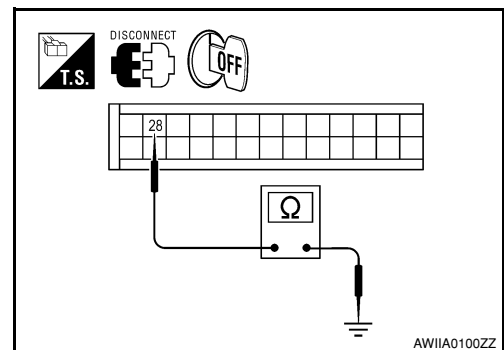

14. CHECK PBR FEEDBACK VOLTAGE

A
B
C
D
E
F
G
H
HAC
J
K
L
M
N
O
P

REAR AIR CONTROL SYSTEM

[AUTOMATIC AIR CONDITIONER]

< COMPONENT DIAGNOSIS >

Check voltage between A/C auto amp. harness connector M50 terminal 30 and ground while cycling mode switch through all modes.

Voltage : **Approx. 1V - 4.5V**

Is the inspection result normal?

- YES >> System OK.
- NO >> GO TO 15.

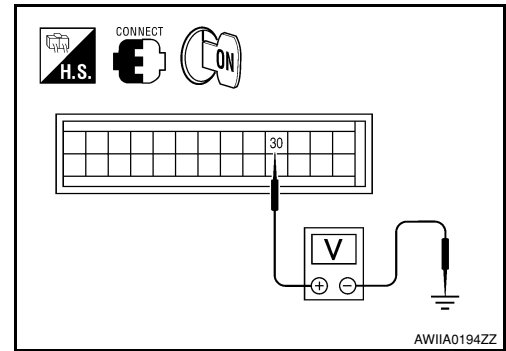

15. CHECK PBR FEEDBACK CIRCUIT FOR OPEN

1. Turn ignition switch OFF.
2. Disconnect the mode door motor harness connector and A/C auto amp. harness connector.
3. Check continuity between mode door motor harness connector B156 terminal 2 and A/C auto amp. harness connector M50 terminal 30.

Continuity should exist.

Is the inspection result normal?

- YES >> GO TO 16.
- NO >> Repair or replace harness as necessary.

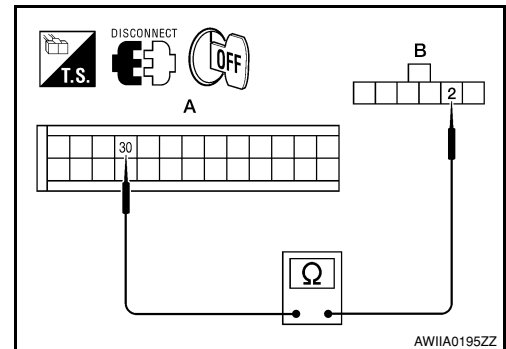

16. CHECK PBR FEEDBACK SIGNAL CIRCUIT FOR SHORT TO GROUND

Check continuity between A/C auto amp. harness connector M50 terminal 30 and ground.

Continuity should not exist.

Is the inspection result normal?

- YES >> Replace A/C auto amp. Refer to [VTL-7. "Removal and Installation"](#).
- NO >> Repair or replace harness as necessary.

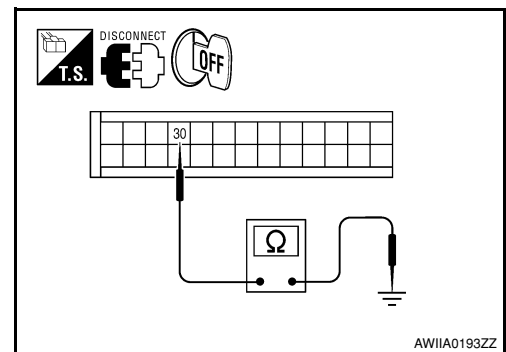

MAGNET CLUTCH

< COMPONENT DIAGNOSIS >

[AUTOMATIC AIR CONDITIONER]

MAGNET CLUTCH

System Description

INFOID:000000001277516

SYSTEM DESCRIPTION

The A/C auto amp. controls compressor operation based on ambient and intake temperature and a signal from ECM.

Low Temperature Protection Control

The A/C auto amp. will turn the compressor ON or OFF as determined by a signal detected by the intake sensor and the ambient sensor.

When intake air temperature is higher than the preset value, the compressor turns ON. The compressor turns OFF when intake air temperature is lower than the preset value. That preset value is dependent on the ambient temperature, refer to the following table.



Ambient temperature °C (°F)	Compressor ON intake temperature °C (°F)	Compressor OFF intake temperature °C (°F)
0 (32)	5.5 (42)	5.0 (41)
10 (50)	5.5 (42)	5.0 (41)
20 (68)	5.5 (42)	5.0 (41)
30 (86)	4.0 (39)	3.5 (38)
40 (104)	3.5 (38)	3.0 (37)
50 (122)	3.5 (38)	3.0 (37)

Magnet Clutch Component Function Check

INFOID:000000001277517

INSPECTION FLOW

1. CONFIRM SYMPTOM BY PERFORMING OPERATIONAL CHECK - MAGNET CLUTCH

1. Turn ignition switch ON.
2. Press the A/C switch.
3. Press vent switch ().
4. Display shows , A/C. Confirm that the compressor clutch engages (sound or visual inspection). (Discharge air and blower speed will depend on ambient, in-vehicle and set temperatures.)

Can the symptom be duplicated?

YES >> GO TO 3.

NO >> GO TO 2.

2. CHECK FOR ANY SYMPTOMS

Perform a complete operational check for any symptoms. Refer to [HAC-4, "Operational Check \(Front\)"](#).

Does another symptom exist?

YES >> Refer to [HAC-3, "How to Perform Trouble Diagnosis For Quick And Accurate Repair"](#).

NO >> System OK.

3. CHECK FOR SERVICE BULLETINS

Check for any service bulletins.

>> GO TO 4.

4. PERFORM SELF-DIAGNOSIS

Perform self-diagnosis to check for any codes. Refer to [HAC-22, "A/C Auto Amp. Self-Diagnosis"](#).

Are any self-diagnosis codes present?

YES >> Refer to [HAC-23, "A/C System Self-Diagnosis Code Chart"](#).

NO >> GO TO 5.

5. CHECK AMBIENT SENSOR

A
B
C
D
E
F
G
H

HAC

J
K
L
M
N
O
P

MAGNET CLUTCH

[AUTOMATIC AIR CONDITIONER]

< COMPONENT DIAGNOSIS >

Check and verify ambient sensor circuit. Refer to [HAC-78. "Ambient Sensor Diagnosis Procedure"](#).

>> GO TO 6.

6. CHECK INTAKE SENSOR

Check and verify intake sensor circuit. Refer to [HAC-86. "Intake Sensor Diagnosis Procedure"](#).

>> GO TO 7.

7. RECHECK FOR ANY SYMPTOMS

Perform a complete operational check for any symptoms. Refer to [HAC-4. "Operational Check \(Front\)"](#).

Does another symptom exist?

YES >> Refer to [HAC-3. "How to Perform Trouble Diagnosis For Quick And Accurate Repair"](#).

NO >> Replace A/C auto amp. Refer to [VTL-7. "Removal and Installation"](#).

Magnet Clutch Diagnosis Procedure

INFOID:000000001277518

DIAGNOSTIC PROCEDURE FOR MAGNET CLUTCH

SYMPTOM: Magnet clutch does not engage when A/C switch is ON.

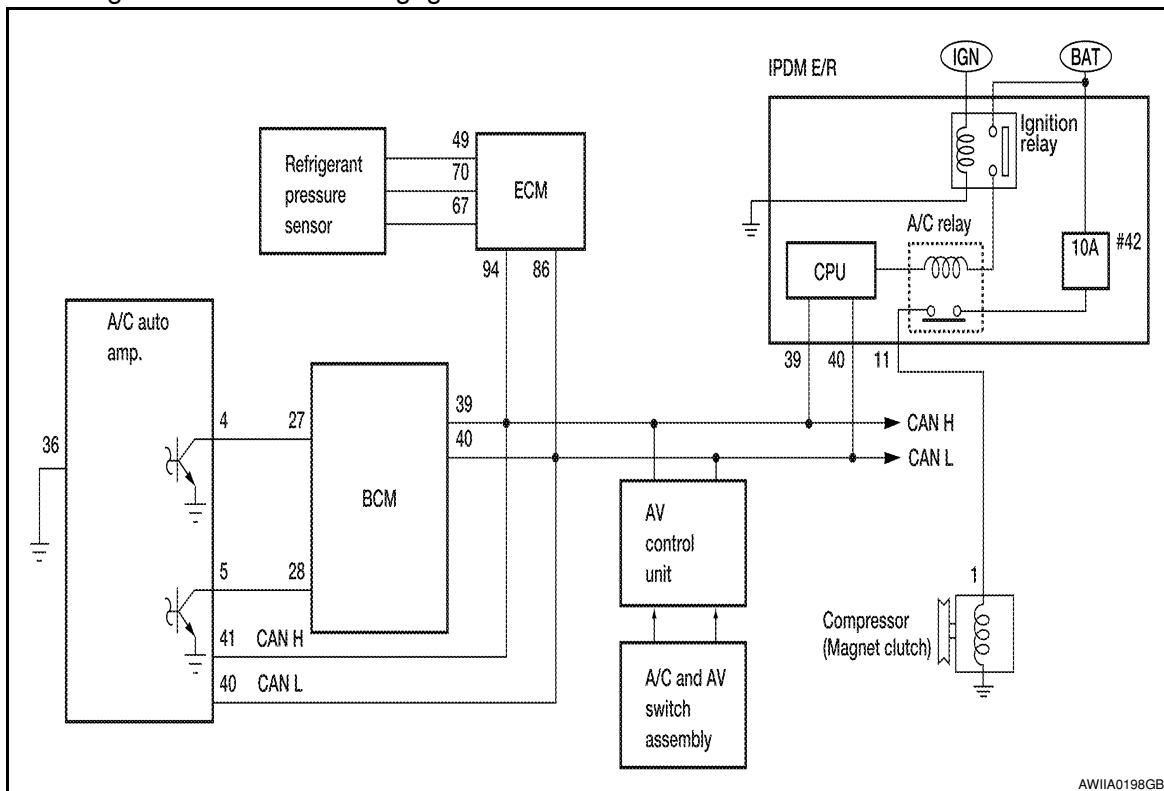

1. CHECK INTAKE AND AMBIENT SENSOR CIRCUITS

Check intake and ambient sensors. Refer to [HAC-22. "A/C and AV Switch Assembly Self-Diagnosis"](#).

Is the inspection result normal?

YES >> GO TO 2.

NO >> • Malfunctioning intake sensor. Refer to [HAC-86. "Intake Sensor Diagnosis Procedure"](#).
• Malfunctioning ambient sensor. Refer to [HAC-78. "Ambient Sensor Diagnosis Procedure"](#).

2. PERFORM AUTO ACTIVE TEST

Refer to XX-XX, IN PG.

Does magnet clutch operate?

YES >> • WITH CONSULT-III
GO TO 5.
• WITHOUT CONSULT-III

MAGNET CLUTCH

[AUTOMATIC AIR CONDITIONER]

< COMPONENT DIAGNOSIS >

GO TO 6.

NO >> Check 10A fuse (No. 42, located in IPDM E/R), and GO TO 3.

3. CHECK CIRCUIT CONTINUITY BETWEEN IPDM E/R AND COMPRESSOR

1. Turn ignition switch OFF.
2. Disconnect IPDM E/R connector and compressor (magnet clutch) connector.
3. Check continuity between IPDM E/R harness connector E119 terminal 11 and A/C compressor harness connector F3 terminal 1.

11 - 1 : Continuity should exist.

Is the inspection result normal?

YES >> GO TO 4.

NO >> Repair harness or connector.

4. CHECK MAGNET CLUTCH CIRCUIT

Check for operation sound when applying battery voltage direct current to terminal.

Is the inspection result normal?

YES >> Replace IPDM E/R. Refer to XX-XX.

NO >> Replace magnet clutch. Refer to [HA-31. "Removal and Installation for Compressor Clutch"](#).

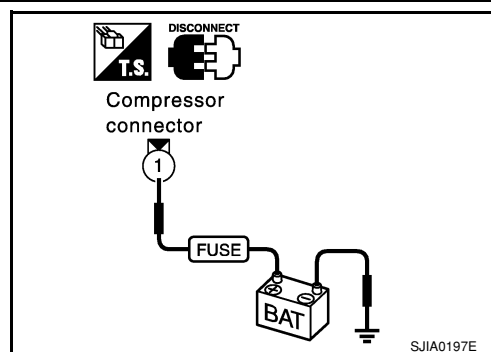
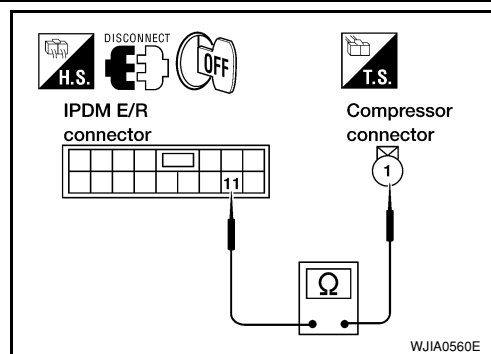

5. CHECK BCM INPUT (COMPRESSOR ON) SIGNAL

Check compressor ON/OFF signal. Refer to [HAC-20. "CONSULT-III Function \(HVAC\)"](#).

A/C SW ON : COMP ON SIG ON

A/C SW OFF : COMP ON SIG OFF

Is the inspection result normal?

YES >> GO TO 8.

NO >> GO TO 6.

6. CHECK CIRCUIT CONTINUITY BETWEEN BCM AND A/C AUTO AMP.

1. Turn ignition switch OFF.
2. Disconnect BCM connector and A/C auto amp. connector.
3. Check continuity between BCM harness connector M18 (A) terminal 27 and A/C auto amp. harness connector M49 (B) terminal 4.
- 4.

27 - 4 Continuity should exist.

Is the inspection result normal?

YES >> GO TO 7.

NO >> Repair harness or connector.

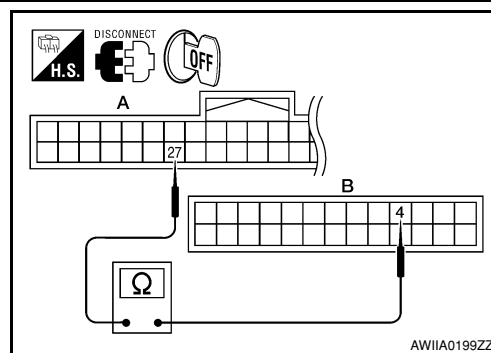

7. CHECK VOLTAGE FOR A/C AUTO AMP. (A/C COMPRESSOR ON SIGNAL)

MAGNET CLUTCH

[AUTOMATIC AIR CONDITIONER]

< COMPONENT DIAGNOSIS >

1. Reconnect BCM connector and A/C auto amp. connector.
2. Turn ignition switch ON.
3. Check voltage between A/C auto amp. harness connector M49 terminal 4 and ground.

Terminals			Condition	Voltage
(+)		(-)		
A/C auto amp. connector	Terminal No.			
M49	4	Ground	A/C switch: ON	Approx. 0V
			A/C switch: OFF	Approx. 5V

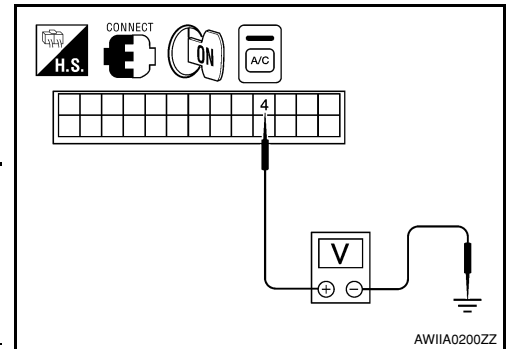

Is the inspection result normal?

YES >> GO TO 8.

NO-1 >> If the voltage is approx. 5V when A/C switch is ON, replace A/C auto amp. Refer to [VTL-7, "Removal and Installation"](#).

NO-2 >> If the voltage is approx. 0V when A/C switch is OFF, replace BCM. Refer to [BCS-54, "Removal and Installation"](#).

8. CHECK REFRIGERANT PRESSURE SENSOR

1. Start engine.
2. Check voltage between ECM harness connector F54 terminal 70 and ground.

Terminals			Condition	Voltage
(+)		(-)		
ECM connector	Terminal No.			
F54	70	Ground	A/C switch: ON	Approx. 0.36 - 3.88V

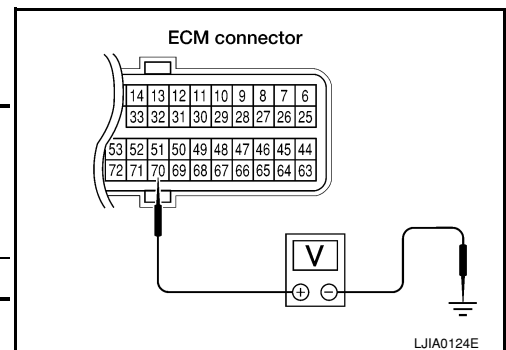

Is the inspection result normal?

YES >> GO TO 9.

NO >> Refer to [EC-411, "Diagnosis Procedure"](#).

9. CHECK BCM INPUT (FAN ON) SIGNAL

Check FAN ON/OFF signal. Refer to [HAC-20, "CONSULT-III Function \(HVAC\)"](#).

**FRONT BLOWER CONTROL : FAN ON SIG ON
DIAL ON**

**FRONT BLOWER CONTROL : FAN ON SIG OFF
DIAL OFF**

Is the inspection result normal?

YES >> GO TO 12.

NO >> GO TO 10.

10. CHECK CIRCUIT CONTINUITY BETWEEN BCM AND A/C AUTO AMP.

MAGNET CLUTCH

[AUTOMATIC AIR CONDITIONER]

< COMPONENT DIAGNOSIS >

1. Turn ignition switch OFF.
2. Disconnect BCM connector and A/C auto amp. connector.
3. Check continuity between BCM harness connector M18 (A) terminal 28 and A/C auto amp. harness connector M49 terminal 5.

28 - 5

Continuity should exist.

Is the inspection result normal?

YES >> GO TO 11.

NO >> Repair harness or connector.

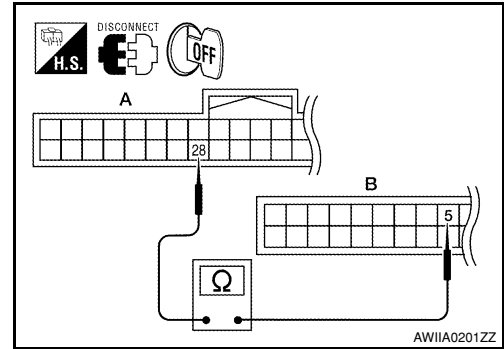

11. CHECK VOLTAGE FOR A/C AUTO AMP. (FAN ON SIGNAL)

1. Reconnect BCM connector and A/C auto amp. connector.
2. Turn ignition switch ON.
3. Check voltage between A/C auto amp. harness connector M49 terminal 5 and ground.

Terminals		(-)	Condition	Voltage
(+) A/C auto amp. connector				
A/C auto amp. connector	Terminal No.			
M49	5	Ground	A/C switch: ON Blower motor operates	Approx. 0V
			A/C switch: OFF	Approx. 5V

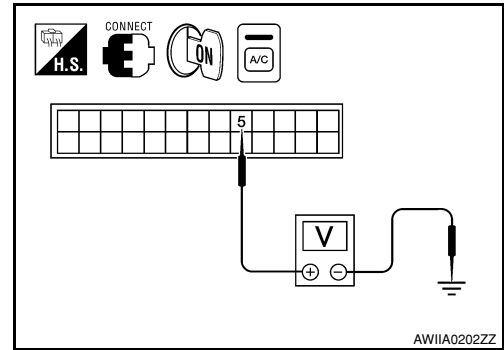

Is the inspection result normal?

YES >> GO TO 12.

NO-1 >> If the voltage is approx. 5V when blower motor is ON, replace A/C auto amp. Refer to [VTL-7. "Removal and Installation"](#).

NO-2 >> If the voltage is approx. 0V when blower motor is OFF, replace BCM. Refer to [BCS-54. "Removal and Installation"](#).

12. CHECK CAN COMMUNICATION

Check CAN communication. Refer to [LAN-4. "System Description"](#).

- BCM – ECM
- ECM – IPDM E/R
- ECM – A/C auto amp.

Is the inspection result normal?

YES >> Inspection End.

NO >> Repair or replace malfunctioning part(s).

A
B
C
D
E
F
G
H
J
K
L
M
N
O
P

HAC

WATER VALVE CIRCUIT

< COMPONENT DIAGNOSIS >

[AUTOMATIC AIR CONDITIONER]

WATER VALVE CIRCUIT

Description

INFOID:000000001322703

COMPONENT DESCRIPTION

Water Valve

The water valve (1) cuts the flow of engine coolant to the front and rear heater cores to allow for maximum cooling during A/C operation. It is controlled by the A/C auto amp.

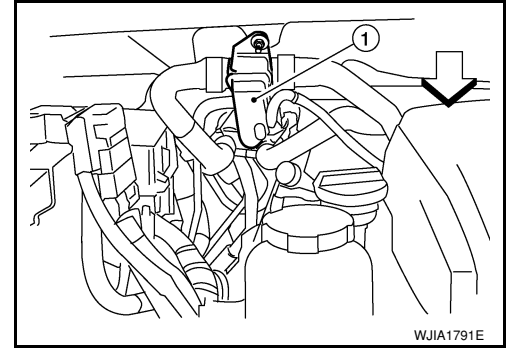

Water Valve Diagnosis Procedure

INFOID:000000001322704

DIAGNOSTIC PROCEDURE FOR WATER VALVE

1. CHECK WATER VALVE POWER AND GROUND CIRCUITS

1. Disconnect water valve connector F68.
2. Turn ignition switch ON.
3. Rotate temperature control dial (driver) to 32°C (90°F).
4. Check voltage between water valve harness connector F68 terminal 1 and terminal 2 while rotating temperature control dial (driver) to 16°C (60°F).

Connector	Terminals		Condition	Voltage (Approx.)
	(+)	(-)		
Water valve: F68	2	1	Rotate temperature control dial	Battery voltage

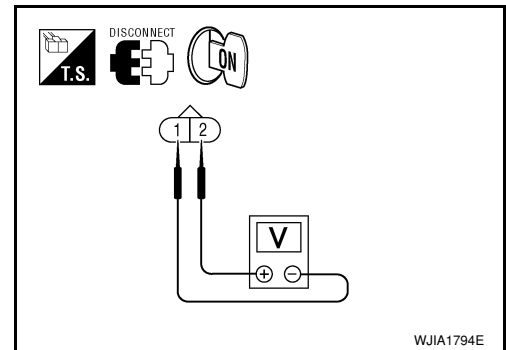

Is the inspection result normal?

- YES >> GO TO 3.
NO >> GO TO 2.

2. CHECK WATER VALVE CONTROL OUTPUT CIRCUIT

1. Turn ignition switch OFF.
2. Disconnect A/C auto amp. connector M50.
3. Check continuity between water valve harness connector F68 (A) terminal 2 and A/C auto amp. harness connector M50 (B) terminal 46.

2 - 46 : Continuity should exist.

4. Check continuity between water valve harness connector F68 terminal 2 and ground.

2 - Ground : Continuity should not exist.

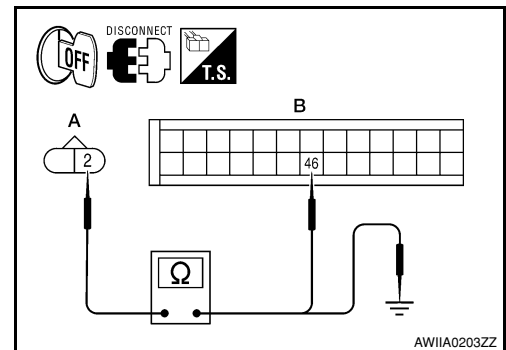

Is the inspection result normal?

- YES >> Replace A/C auto amp. Refer to [VTL-7, "Removal and Installation"](#).
NO >> Repair harness or connector.

3. CHECK WATER VALVE POWER AND GROUND CIRCUITS

WATER VALVE CIRCUIT

[AUTOMATIC AIR CONDITIONER]

< COMPONENT DIAGNOSIS >

1. Rotate temperature control dial (driver) to 16°C (60°F).
2. Check voltage between water valve harness connector F68 terminal 1 and terminal 2 while rotating temperature control dial (driver) to 32°C (90°F).

Connector	Terminals		Condition	Voltage (Approx.)
	(+)	(-)		
Water valve: F68	1	2	Rotate temperature control dial	Battery voltage

Is the inspection result normal?

- YES >> Replace the water valve.
 NO >> GO TO 4.

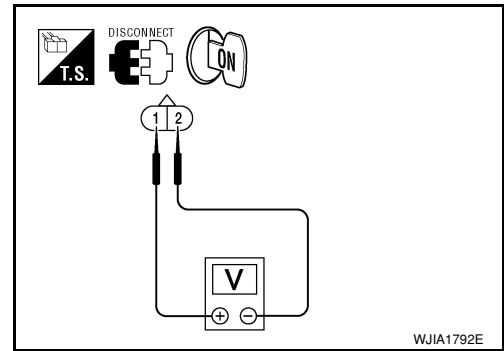

4. CHECK WATER VALVE CONTROL OUTPUT CIRCUIT

1. Turn ignition switch OFF.
2. Disconnect A/C auto amp. connector M50.
3. Check continuity between water valve harness connector F68 (A) terminal 1 and A/C auto amp. harness connector M50 (B) terminal 45.

1 - 45 : Continuity should exist.

4. Check continuity between water valve harness connector F68 (A) terminal 1 and ground.

1 - Ground : Continuity should not exist.

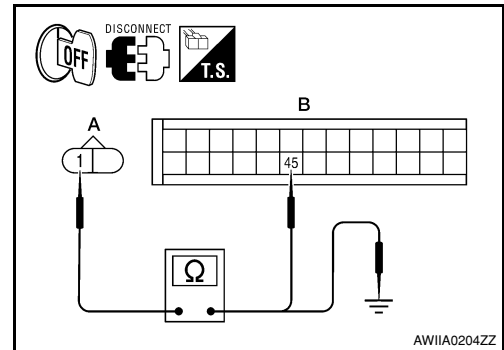

Is the inspection result normal?

- YES >> Replace A/C auto amp. Refer to [VTL-7, "Removal and Installation"](#).
 NO >> Repair harness or connector.

A
B
C
D
E
F
G
H
J
K
L
M
N
O
P

HAC

AMBIENT SENSOR

Component Description

INFOID:000000001277519

COMPONENT DESCRIPTION

Ambient Sensor

The ambient sensor is attached on the radiator core support (left side). It detects ambient temperature and converts it into a value which is then input into the A/C auto amp.

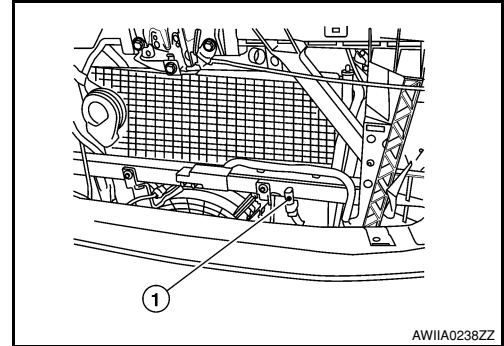

AMBIENT TEMPERATURE INPUT PROCESS

The A/C auto amp. includes a processing circuit for the ambient sensor input. However, when the temperature detected by the ambient sensor increases quickly, the processing circuit retards the A/C auto amp. function. It only allows the A/C auto amp. to recognize an ambient temperature increase of 0.33°C (0.6°F) per 100 seconds.

This prevents constant adjustments due to momentary conditions, such as stopping after high speed driving. Although the actual ambient temperature has not changed, the temperature detected by the ambient sensor will increase. This is because the heat from the engine compartment can radiate to the front grille area, location of the ambient sensor.

Ambient Sensor Diagnosis Procedure

INFOID:000000001277520

DIAGNOSTIC PROCEDURE FOR AMBIENT SENSOR

SYMPTOM: Ambient sensor circuit is open or shorted. (40 or 41 is indicated on A/C auto amp. as a result of conducting the A/C auto amp. self-diagnosis)

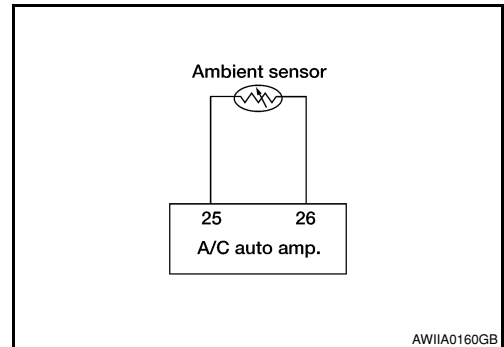

1. CHECK VOLTAGE BETWEEN AMBIENT SENSOR AND GROUND

1. Disconnect ambient sensor connector.
2. Turn ignition switch ON.
3. Check voltage between ambient sensor harness connector E1 terminal 1 and ground.

1 - Ground : Approx. 5V

Is the inspection result normal?

- YES >> GO TO 3.
NO >> GO TO 5.

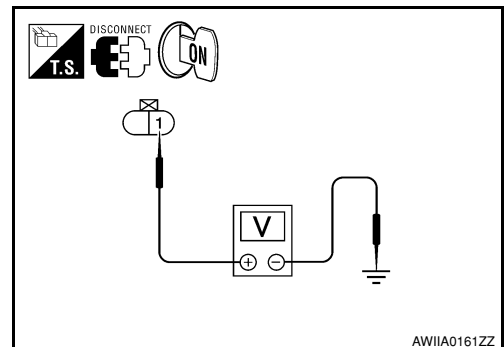

2. CHECK CIRCUIT CONTINUITY BETWEEN AMBIENT SENSOR AND A/C AUTO AMP.

AMBIENT SENSOR

[AUTOMATIC AIR CONDITIONER]

< COMPONENT DIAGNOSIS >

1. Turn ignition switch OFF.
2. Disconnect A/C auto amp. connector.
3. Check continuity between ambient sensor harness connector E1 (B) terminal 1 and A/C auto amp. harness connector M49 (A) terminal 25.

1 - 25 : Continuity should exist.

Is the inspection result normal?

- YES >> GO TO 4.
NO >> Repair harness or connector.

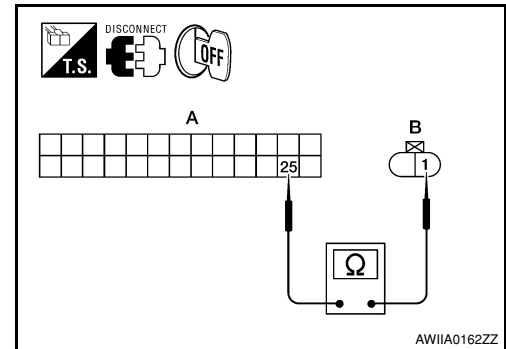

3. CHECK AMBIENT SENSOR

Check the Ambient Sensor Circuit. Refer to [HAC-79, "Ambient Sensor Component Inspection"](#).

Is the inspection result normal?

- YES >> 1. Replace A/C auto amp. Refer to [VTL-7, "Removal and Installation"](#).
2. GO TO [HAC-22, "A/C Auto Amp. Self-Diagnosis"](#) and perform self-diagnosis.
NO >> 1. Replace ambient sensor.
2. GO TO [HAC-22, "A/C Auto Amp. Self-Diagnosis"](#) and perform self-diagnosis.

4. CHECK CIRCUIT CONTINUITY BETWEEN AMBIENT SENSOR AND A/C AUTO AMP.

1. Turn ignition switch OFF.
2. Disconnect A/C auto amp. connector.
3. Check continuity between ambient sensor harness connector E1 (B) terminal 2 and A/C auto amp. harness connector M49 (A) terminal 26.

2 - 26 : Continuity should exist.

4. Check continuity between ambient sensor harness connector E1 (B) terminal 2 and ground.

2 - Ground : Continuity should not exist.

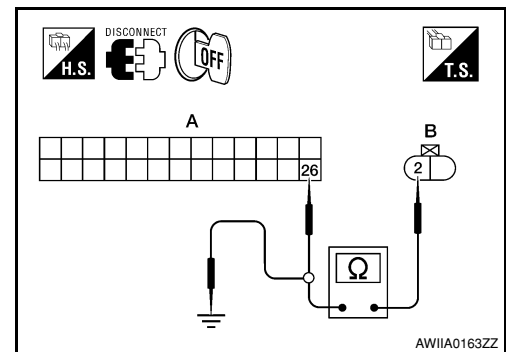

Is the inspection result normal?

- YES >> 1. Replace A/C auto amp. Refer to [VTL-7, "Removal and Installation"](#).
2. GO TO [HAC-22, "A/C Auto Amp. Self-Diagnosis"](#) and perform self-diagnosis.
NO >> Repair harness or connector.

Ambient Sensor Component Inspection

INFOID:000000001277521

COMPONENT INSPECTION

Ambient Sensor

A
B
C
D
E
F
G
H
HAC
J
K
L
M
N
O
P

AMBIENT SENSOR

< COMPONENT DIAGNOSIS >

[AUTOMATIC AIR CONDITIONER]

After disconnecting ambient sensor (1) connector E1, measure resistance between terminals 1 and 2 at sensor component side, using the table below.

Temperature °C (°F)	Resistance kΩ
-15 (5)	12.73
-10 (14)	9.92
-5 (23)	7.80
0 (32)	6.19
5 (41)	4.95
10 (50)	3.99
15 (59)	3.24
20 (68)	2.65
25 (77)	2.19
30 (86)	1.81
35 (95)	1.51
40 (104)	1.27
45 (113)	1.07

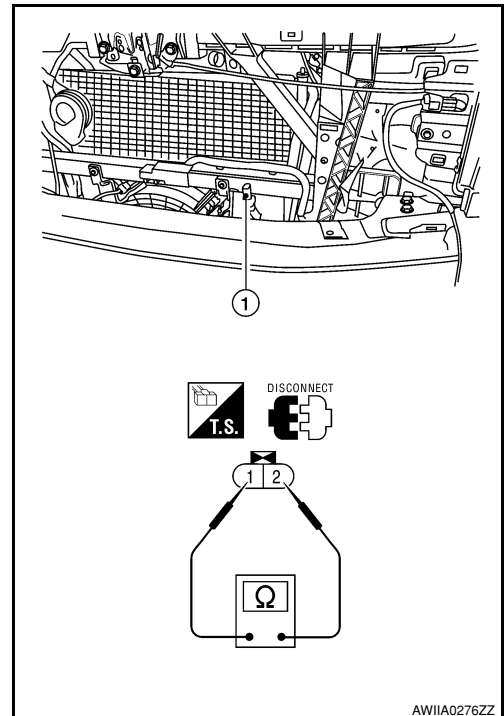

AW1IA0276ZZ

If NG, replace ambient sensor. Refer to [HA-44. "Removal and Installation"](#)

< COMPONENT DIAGNOSIS >

IN-VEHICLE SENSOR

Component Description

INFOID:000000001277522

COMPONENT DESCRIPTION

In-vehicle Sensor

The in-vehicle sensor (1) is located on the lower instrument panel LH. It converts variations in temperature of passenger compartment air (drawn in through the integrated fan) into a resistance value. It is then input into the A/C auto amp.

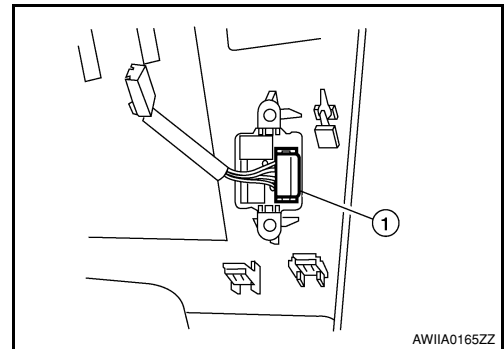
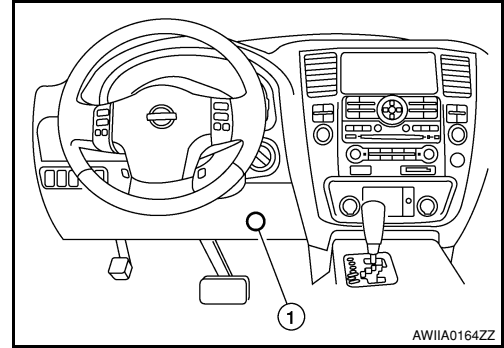

In-Vehicle Sensor Diagnosis Procedure

INFOID:000000001277523

DIAGNOSTIC PROCEDURE FOR IN-VEHICLE SENSOR

SYMPTOM: In-vehicle sensor circuit is open or shorted. Using the CONSULT-III, DTC B2578 or B2579 is displayed. Without a CONSULT-III, code 30, 31, 44 or 46 is indicated on A/C auto amp. as a result of conducting self-diagnosis.

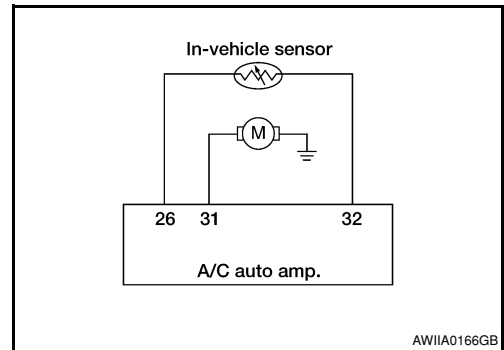

1. CHECK IN-VEHICLE SENSOR CIRCUIT

Is self-diagnosis DTC B2578 or B2579 (with CONSULT-III) or code 30, 31 44 or 46 (without CONSULT-III) present?

YES or NO Is the inspection result normal?

YES >> GO TO 7.

NO >> GO TO 3.

2. CHECK VOLTAGE BETWEEN IN-VEHICLE SENSOR AND GROUND

IN-VEHICLE SENSOR

[AUTOMATIC AIR CONDITIONER]

< COMPONENT DIAGNOSIS >

1. Disconnect in-vehicle sensor connector.
2. Turn ignition switch ON.
3. Check voltage between in-vehicle sensor harness connector M32 terminal 4 and ground.

4 - Ground : **Approx. 5V.**

Is the inspection result normal?

- YES >> GO TO 4.
NO >> GO TO 6.

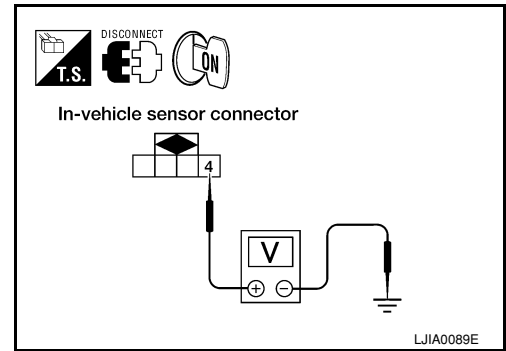

3. CHECK CIRCUIT CONTINUITY BETWEEN IN-VEHICLE SENSOR AND A/C AUTO AMP.

1. Turn ignition switch OFF.
2. Disconnect A/C auto amp. connector M49.
3. Check continuity between in-vehicle sensor harness connector M32 (B) terminal 1 and A/C auto amp. harness connector M49 (A) terminal 26.

1 - 26 : **Continuity should exist.**

Is the inspection result normal?

- YES >> GO TO 5.
NO >> Repair harness or connector.

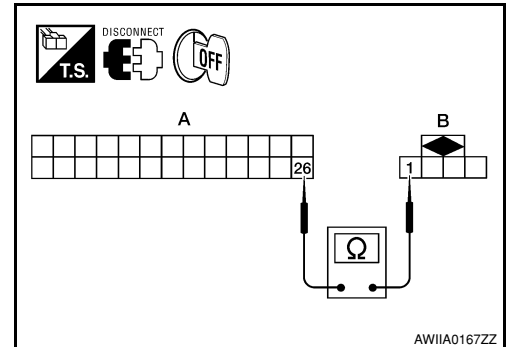

4. CHECK IN-VEHICLE SENSOR

Check in-vehicle sensor. Refer to [HAC-83, "In-Vehicle Sensor Component Inspection"](#).

Is the inspection result normal?

- YES >> 1. Replace A/C auto amp. Refer to [VTL-7, "Removal and Installation"](#).
2. Go to [HAC-22, "A/C Auto Amp. Self-Diagnosis"](#) and perform self-diagnosis.
NO >> 1. Replace in-vehicle sensor. Refer to [VTL-9, "Removal and Installation"](#).
2. Go to [HAC-22, "A/C Auto Amp. Self-Diagnosis"](#) and perform self-diagnosis.

5. CHECK CIRCUIT CONTINUITY BETWEEN IN-VEHICLE SENSOR AND A/C AUTO AMP.

1. Turn ignition switch OFF.
2. Disconnect A/C auto amp. connector.
3. Check continuity between in-vehicle sensor harness connector M32 (B) terminal 4 and A/C auto amp. harness connector M50 (A) terminal 32.

4 - 32 : **Continuity should exist.**

4. Check continuity between in-vehicle sensor harness connector M32 (B) terminal 4 and ground.

4 - Ground : **Continuity should not exist.**

Is the inspection result normal?

- YES >> 1. Replace A/C auto amp. Refer to [VTL-7, "Removal and Installation"](#).
2. Go to [HAC-22, "A/C Auto Amp. Self-Diagnosis"](#) and perform self-diagnosis.
NO >> Repair harness or connector.

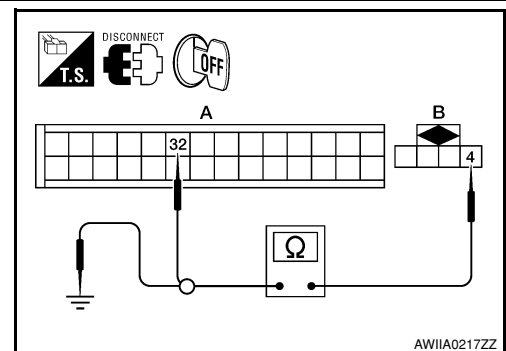

6. CHECK CIRCUIT CONTINUITY BETWEEN IN-VEHICLE SENSOR MOTOR AND A/C AUTO AMP. (SELF-DIAGNOSIS CODES 30, 31, 44, 46 OR DTC B2578, B2579)

IN-VEHICLE SENSOR

[AUTOMATIC AIR CONDITIONER]

< COMPONENT DIAGNOSIS >

1. Turn ignition switch OFF.
2. Disconnect A/C auto amp. connector and in-vehicle sensor connector.
3. Check continuity between in-vehicle sensor harness connector M32 (B) terminal 3 and A/C auto amp. harness connector M50 (A) terminal 31.

3 - 31 : Continuity should exist.

4. Check continuity between in-vehicle sensor harness connector M32 (B) terminal 3 and ground.

2 - Ground : Continuity should exist.

3 - Ground : Continuity should not exist.

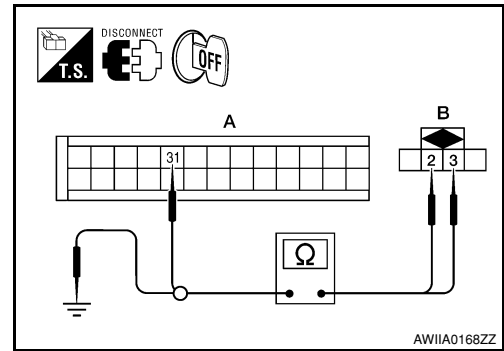

Is the inspection result normal?

- YES >> 1. Replace A/C auto amp. Refer to [VTL-7, "Removal and Installation"](#).
 2. Go to [HAC-22, "A/C Auto Amp. Self-Diagnosis"](#) and perform self-diagnosis.
- NO >> Repair harness or connector.

In-Vehicle Sensor Component Inspection

INFOID:000000001277524

COMPONENT INSPECTION

In-vehicle Sensor

After disconnecting in-vehicle sensor connector M32, measure resistance between terminals 1 and 4 at sensor component side, using the table below.

Temperature °C (°F)	Resistance kΩ
-15 (5)	21.40
-10 (14)	16.15
-5 (23)	12.29
0 (32)	9.41
5 (41)	7.27
10 (50)	5.66
15 (59)	4.45
20 (68)	3.51
25 (77)	2.79
30 (86)	2.24
35 (95)	1.80
40 (104)	1.45
45 (113)	1.18

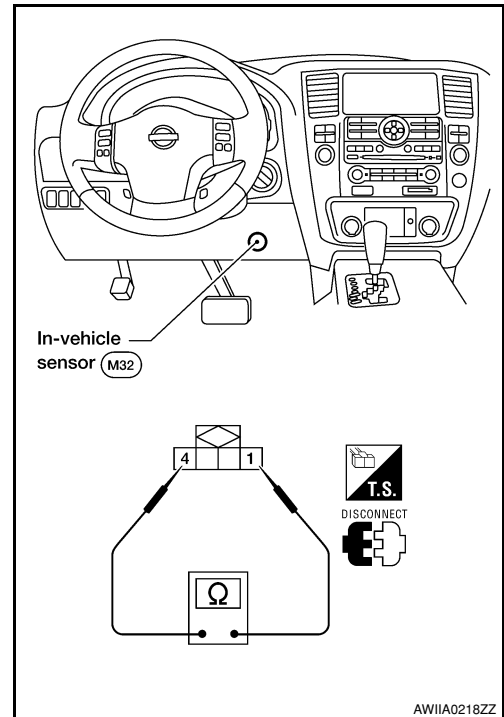

If NG, replace in-vehicle sensor. Refer to [VTL-9, "Removal and Installation"](#)

OPTICAL SENSOR

Component Description

INFOID:000000001277525

COMPONENT DESCRIPTION

The optical sensor is located in the center of the defroster grille. It detects sunload entering through windshield by means of a photo diode. The sensor converts the sunload into a current value which is then input into the A/C auto amp.

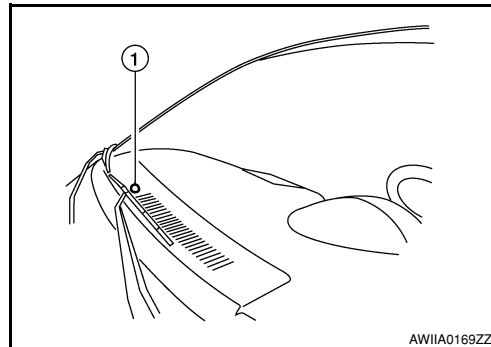

OPTICAL INPUT PROCESS

The A/C auto amp. includes a processing circuit which averages the variations in detected sunload over a period of time. This prevents adjustments in the ATC system operation due to small or quick variations in detected sunload.

For example, consider driving along a road bordered by an occasional group of large trees. The sunload detected by the optical sensor will vary whenever the trees obstruct the sunlight. The processing circuit averages the detected sunload over a period of time, so that the (insignificant) effect of the trees momentarily obstructing the sunlight does not cause any change in the ATC system operation. On the other hand, shortly after entering a long tunnel, the system will recognize the change in sunload, and the system will react accordingly.

Optical Sensor Diagnosis Procedure

INFOID:000000001277526

DIAGNOSTIC PROCEDURE FOR OPTICAL SENSOR

SYMPTOM: Optical sensor circuit is open or shorted. Using the CONSULT-III, DTC B257F or B2580 is displayed. Without a CONSULT-III, code 50 or 52 is indicated on A/C auto amp. as a result of conducting self-diagnosis.

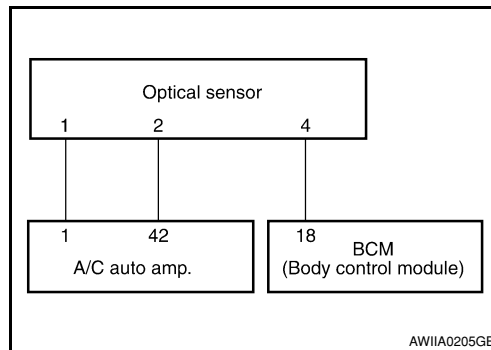

1. CHECK CIRCUIT CONTINUITY BETWEEN OPTICAL SENSOR AND A/C AUTO AMP.

1. Turn ignition switch OFF.
2. Disconnect A/C auto amp. connector and optical sensor connector.
3. Check continuity between optical sensor harness connector M302 (B) terminals 1 and 2 and A/C auto amp. harness connector M50 (C) terminal 42 and M49 (A) terminal 1.

1 - 1 : Continuity should exist.
2 - 42 : Continuity should exist.

4. Check continuity between optical sensor harness connector M302 terminal 1 and 2 and ground.

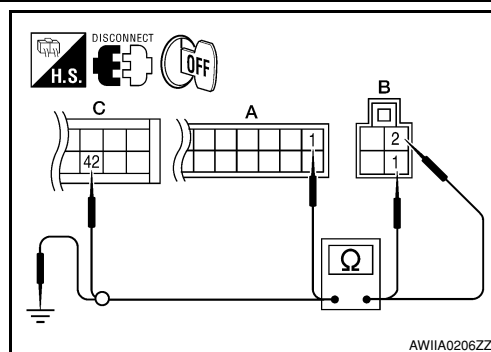

OPTICAL SENSOR

[AUTOMATIC AIR CONDITIONER]

< COMPONENT DIAGNOSIS >

1, 2 - Ground. : Continuity should not exist.

Is the inspection result normal?

YES >> GO TO 2.

NO >> Repair harness or connector.

2. CHECK CIRCUIT CONTINUITY BETWEEN OPTICAL SENSOR AND BCM

1. Disconnect BCM connector.
2. Check continuity between optical sensor harness connector M302 (B) terminal 4 and BCM harness connector M18 (A) terminal 18.

4 - 18 : Continuity should exist.

3. Check continuity between optical sensor harness connector M302 (A) terminal 4 and ground.

4 - Ground : Continuity should not exist.

Is the inspection result normal?

YES >> Replace optical sensor. Refer to [VTL-10. "Removal and Installation"](#).

NO >> Repair harness or connector.

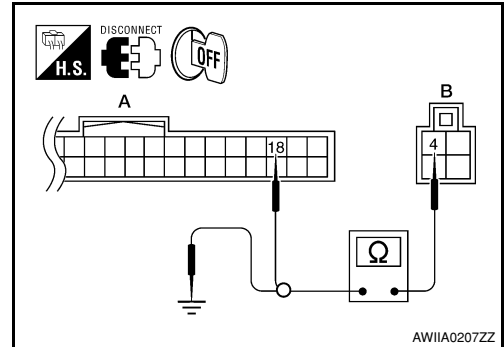

A
B
C
D
E
F
G
H
J
K
L
M
N
O
P

HAC

INTAKE SENSOR

< COMPONENT DIAGNOSIS >

[AUTOMATIC AIR CONDITIONER]

INTAKE SENSOR

System Description

INFOID:000000001277528

COMPONENT DESCRIPTION

Intake Sensor

The intake sensor is located on the heater & cooling unit assembly. It converts temperature of air after it passes through the evaporator into a resistance value which is then input to the A/C auto amp.

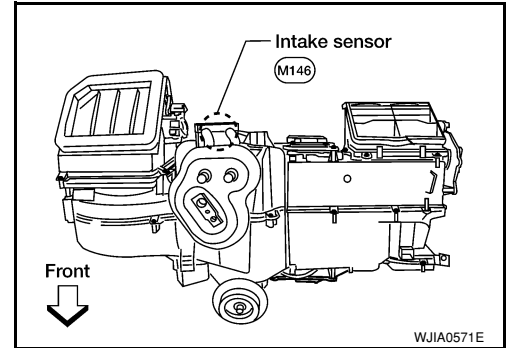

Intake Sensor Diagnosis Procedure

INFOID:000000001277530

DIAGNOSTIC PROCEDURE FOR INTAKE SENSOR

SYMPTOM: Intake sensor circuit is open or shorted. Using the CONSULT-III, DTC B2581 or B2582 is displayed. Without a CONSULT-III, code 56 or 57 is indicated on A/C auto amp. as a result of conducting self-diagnosis.

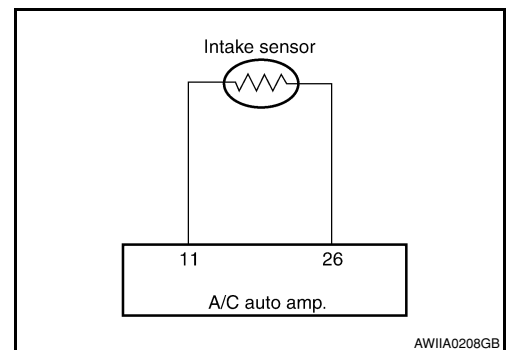

1. CHECK VOLTAGE BETWEEN INTAKE SENSOR AND GROUND

1. Disconnect intake sensor connector.
2. Turn ignition switch ON.
3. Check voltage between intake sensor harness connector M146 terminal 2 and ground.

2 - Ground : Approx. 5V

Is the inspection result normal?

- YES >> GO TO 3.
NO >> GO TO 4.

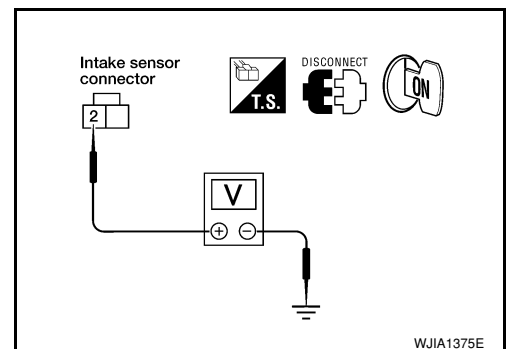

2. CHECK CIRCUIT CONTINUITY BETWEEN INTAKE SENSOR AND A/C AUTO AMP.

1. Turn ignition switch OFF.
2. Disconnect A/C auto amp. connector.
3. Check continuity between intake sensor harness connector M146 (B) terminal 1 and A/C auto amp. harness connector M49 (A) terminal 26.

1 - 26 : Continuity should exist.

Is the inspection result normal?

- YES >> GO TO 4.
NO >> Repair harness or connector.

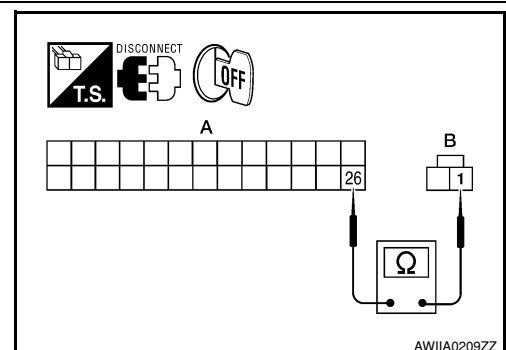

INTAKE SENSOR

< COMPONENT DIAGNOSIS >

[AUTOMATIC AIR CONDITIONER]

3. CHECK INTAKE SENSOR

Check intake sensor. Refer to [HAC-87. "Intake Sensor Component Inspection"](#).

Is the inspection result normal?

- YES >> 1. Replace A/C auto amp. Refer to [VTL-7. "Removal and Installation"](#).
 2. Go to [HAC-22. "A/C Auto Amp. Self-Diagnosis"](#) and perform self-diagnosis.
- NO >> 1. Replace intake sensor. Refer to [VTL-11. "Removal and Installation"](#).
 2. Go to [HAC-22. "A/C Auto Amp. Self-Diagnosis"](#) and perform self-diagnosis.

4. CHECK CIRCUIT CONTINUITY BETWEEN INTAKE SENSOR AND A/C AUTO AMP.

- Turn ignition switch OFF.
- Disconnect A/C auto amp. connector.
- Check continuity between intake sensor harness connector M146 (B) terminal 2 and A/C auto amp. harness connector M49 (A) terminal 11.

2 - 11 : Continuity should exist.

- Check continuity between intake sensor harness connector M146 terminal 2 and ground.

2 - Ground : Continuity should not exist.

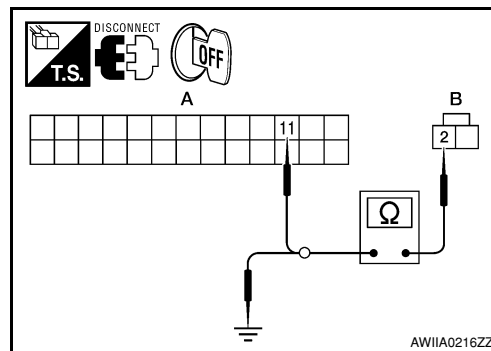

Is the inspection result normal?

- YES >> 1. Replace A/C auto amp. Refer to [VTL-7. "Removal and Installation"](#).
 2. Go to [HAC-22. "A/C Auto Amp. Self-Diagnosis"](#) and perform self-diagnosis.
- NO >> Repair harness or connector.

Intake Sensor Component Inspection

INFOID:000000001277854

HAC

COMPONENT INSPECTION

Intake Sensor

After disconnecting intake sensor connector, measure resistance between terminals 1 and 2 at sensor harness side, using the table below.

Temperature °C (°F)	Resistance kΩ
-15 (5)	209.0
-10 (14)	160.0
-5 (23)	123.0
0 (32)	95.8
5 (41)	74.9
10 (50)	58.9
15 (59)	46.7
20 (68)	37.3
25 (77)	30.0
30 (86)	24.2
35 (95)	19.7
40 (104)	16.1
45 (113)	13.2

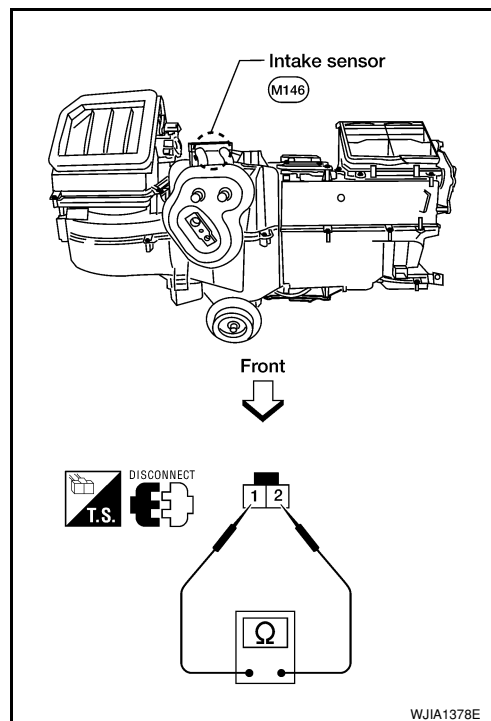

If NG, replace intake sensor. Refer to [VTL-11. "Removal and Installation"](#).

POWER SUPPLY AND GROUND CIRCUIT FOR CONTROLLER

< COMPONENT DIAGNOSIS >

[AUTOMATIC AIR CONDITIONER]

POWER SUPPLY AND GROUND CIRCUIT FOR CONTROLLER

Component Description

INFOID:000000001277531

COMPONENT DESCRIPTION

A/C auto amp.

The A/C auto amp. has a built-in microcomputer which processes information sent from various sensors needed for air conditioner operation. The air mix door motors, mode door motor, intake door motor, defroster door motor, blower motor and compressor are then controlled.

The A/C auto amp. is unitized with control mechanisms. When the various switches and temperature dials are operated, data is input to the A/C auto amp.

Self-diagnostic functions are also built into the A/C auto amp. to provide quick check of malfunctions in the auto air conditioner system.

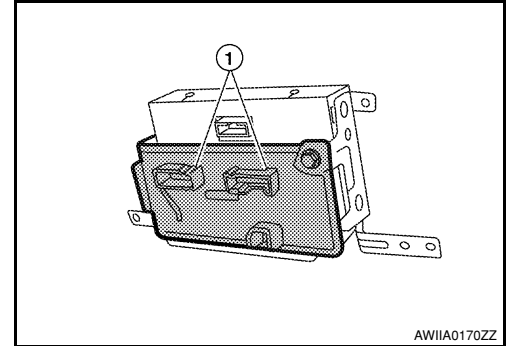

Potential Temperature Control (PTC)

There are two PTCs (driver and passenger) built into the A/C auto amp. They can be set at an interval of 0.5°C (1.0°F) in the 18°C (60°F) to 32°C (90°F) temperature range by rotating the temperature dial. The set temperature is displayed.

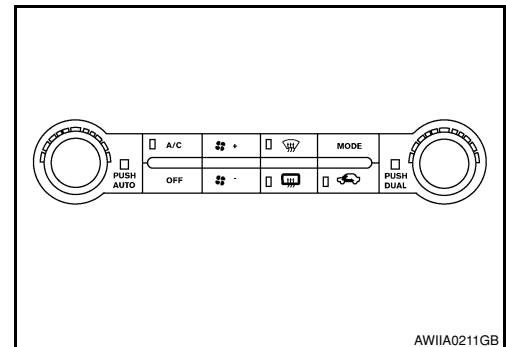

A/C Auto Amp. Component Function Check

INFOID:000000001277532

SYMPTOM: A/C system does not come on.

INSPECTION FLOW

1. CONFIRM SYMPTOM BY PERFORMING OPERATIONAL CHECK - AUTO MODE

1. Press AUTO switch.
2. Display should indicate AUTO. Confirm that the compressor clutch engages (sound or visual inspection). (Discharge air and blower speed will depend on ambient, in-vehicle and set temperatures.)

Can a symptom be duplicated?

- YES >> GO TO 3.
NO >> GO TO 2.

2. PERFORM COMPLETE OPERATIONAL CHECK

Perform a complete operational check and check for any symptoms. Refer to [HAC-4, "Operational Check \(Front\)"](#).

Can a symptom be duplicated?

- YES >> Refer to [HAC-3, "How to Perform Trouble Diagnosis For Quick And Accurate Repair"](#).
NO >> System OK.

3. CHECK FOR SERVICE BULLETINS

Check for any service bulletins.

>> GO TO 4.

4. CHECK POWER AND GROUND CIRCUIT

POWER SUPPLY AND GROUND CIRCUIT FOR CONTROLLER

[AUTOMATIC AIR CONDITIONER]

< COMPONENT DIAGNOSIS >

Check main power supply and ground circuit. Refer to [HAC-89. "A/C Auto Amp Power and Ground Diagnosis Procedure"](#).

Is the inspection result normal?

YES >> System OK.

NO >> Replace A/C auto amp. Refer to [VTL-7. "Removal and Installation"](#).

A/C Auto Amp Power and Ground Diagnosis Procedure

INFOID:000000001277533

DIAGNOSTIC PROCEDURE FOR A/C SYSTEM

SYMPTOM: A/C system does not come on.

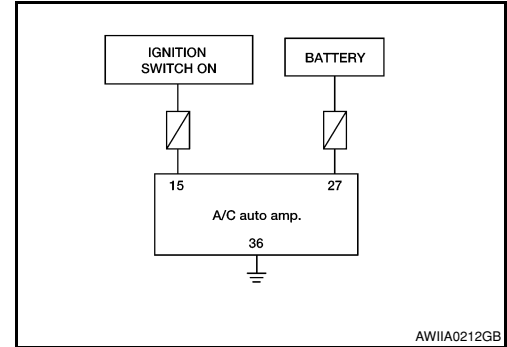

1. CHECK POWER SUPPLY CIRCUITS FOR A/C AUTO AMP.

1. Disconnect A/C auto amp. connectors.
2. Check voltage between A/C auto amp. harness connector M49 (B) terminal 15 and M50 (A) terminal 27, and ground.

Terminals		Ignition switch position			
(+)		(-)	OFF	ACC	ON
A/C auto amp. connector	Terminal No.				
M49	15	Ground	Approx. 0V	Approx. 0V	Battery voltage
M50	27		Battery voltage	Battery voltage	Battery voltage

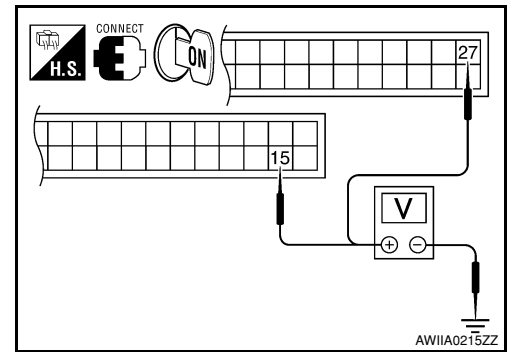

Is the inspection result normal?

YES >> GO TO 3.

NO >> Check 10A fuses [Nos. 8 and 19, located in the fuse block (J/B)]. Refer to [PG-64. "Terminal Arrangement"](#).

- If fuses are OK, check harness for open circuit. Repair or replace as necessary.
- If fuses are NG, replace fuse and check harness for short circuit. Repair or replace as necessary.

2. CHECK GROUND CIRCUIT FOR A/C AUTO AMP.

1. Turn ignition switch OFF.
2. Check continuity between A/C auto amp. harness connector M50 terminal 36 and ground.

36 - Ground : Continuity should exist.

Is the inspection result normal?

OK >> Replace A/C auto amp. Refer to [VTL-7. "Removal and Installation"](#).

NG >> Repair harness or connector.

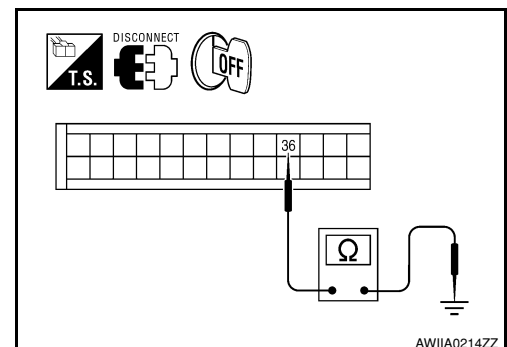

AIR CONDITIONER CONTROL

[AUTOMATIC AIR CONDITIONER]

< ECU DIAGNOSIS >

ECU DIAGNOSIS

AIR CONDITIONER CONTROL

A/C Auto Amp. Terminals Reference Values

INFOID:000000001277534

Measure voltage between each terminal and ground by following Terminals and Reference Value for A/C auto amp. (1).

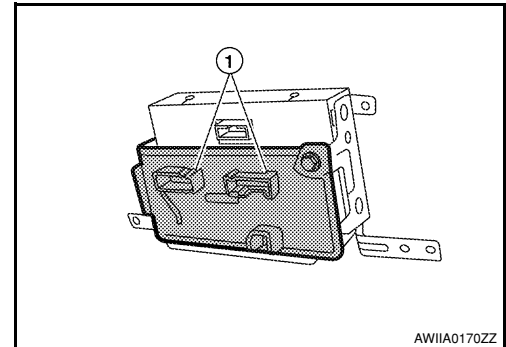

A/C AUTO AMP. HARNESS CONNECTOR TERMINAL LAYOUT

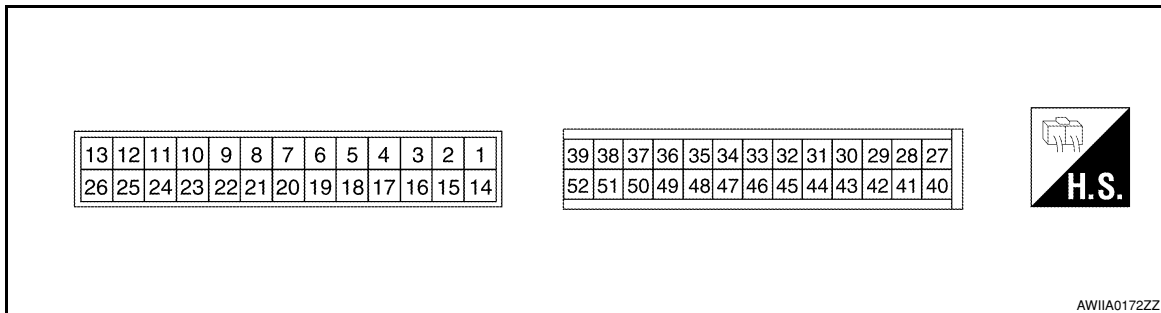

TERMINALS AND RERERENCE VALUES FOR A/C AUTO AMP.

Terminal No.	Wire color	Item	Ignition switch	Condition	Voltage (V) (Approx.)
1	G/O	Optical sensor (driver)	ON	-	0 - 5V
2	L	Air mix door motor (passenger)	ON	-	Battery voltage
3	P	V ref ACTR (ground)	ON	-	5V
4	W/R	Compressor ON signal	ON	A/C switch OFF	5V
			ON	A/C switch ON	0V
5	L/R	Fan ON signal	ON	Blower switch OFF	5V
			ON	Blower switch ON	0V
6	SB	Air mix door motor (driver) feedback	ON	-	0 - 5V
7	GR	Mode door motor feedback	ON	-	0 - 5V
8	R/L	Illumination +	ON	Park lamps ON	Battery voltage
9	BR	Illumination -	-	Park lamps ON	 PIIA2344E
10	LG/B	Defroster door motor feedback	ON	-	0 - 5V
11	L/B	Intake sensor	ON	-	0 - 5V
12	G/Y	Variable blower control (rear)	ON	-	0 - 5V
13	G/R	Variable blower control (front)	ON	-	0 - 5V

AIR CONDITIONER CONTROL

< ECU DIAGNOSIS >

[AUTOMATIC AIR CONDITIONER]

Terminal No.	Wire color	Item	Ignition switch	Condition	Voltage (V) (Approx.)	
14	G/W	Air mix door motor (passenger) CW	ON	Clockwise rotation	Battery voltage	A
15	Y/G	Power supply for IGN	ON	-	Battery voltage	B
17	W/G	Air mix door motor (driver) CW	ON	Clockwise rotation	Battery voltage	B
18	G	Air mix door motor (driver) CCW	ON	Counterclockwise rotation	Battery voltage	
19	BR/W	Mode door motor CW (front)	ON	Clockwise rotation	Battery voltage	C
20	P/L	Mode door motor CCW	ON	Counterclockwise rotation	Battery voltage	
21	G/B	Intake door motor CCW	ON	Counterclockwise rotation	Battery voltage	D
22	O	Intake door motor CW	ON	Clockwise rotation	Battery voltage	D
23	LG	Defroster door motor CW	ON	Clockwise rotation	Battery voltage	
24	P/B	Defroster door motor CCW	ON	Counterclockwise rotation	Battery voltage	E
25	P	Ambient sensor	ON	-	0 - 5V	
26	V/R	Sensor ground	ON	-	0V	
27	Y/R	Power supply for BAT	-	-	Battery voltage	F
28	Y	V ref ACTR (5V)	ON	-	0 - 5V	
29	R/W	Air mix door motor (passenger) feedback	ON	-	0 - 5V	G
30	R/Y	Mode door motor (Rear) feedback	ON	-	0 - 5V	
31	BR/Y	In-vehicle sensor motor (+)	ON	-	Battery voltage	H
32	LG/R	In-vehicle sensor signal	ON	-	0 - 5V	
33	R/Y	Air mix door motor (Rear) feedback	ON	-	0 - 5V	
36	B	Ground	-	-	0V	HAC
40	P	CAN-L	ON	-	0 - 5V	
41	L	CAN-H	ON	-	0 - 5V	
42	W/V	Optical sensor (passenger)	ON	-	0 - 5V	J
43	GR/R	Mode door motor (Rear) CW	ON	Clockwise rotation	Battery voltage	
44	L/Y	Mode door motor (Rear) CCW	ON	Counterclockwise rotation	Battery voltage	K
45	Y/L	Water valve	ON	Water valve open	Battery voltage	L
				Water valve closed	0V	
46	W/G	Water valve	ON	Water valve open	0V	
				Water valve closed	Battery voltage	
47	O	LIN BUS (rear)	ON	-	Battery voltage	M
48	O	LIN BUS (front)	ON	-	Battery voltage	
49	GR/R	Air mix door motor (Rear) CW	ON	Clockwise rotation	Battery voltage	N
50	L/Y	Air mix door motor (Rear) CCW	ON	Counterclockwise rotation	Battery voltage	

AIR CONDITIONER CONTROL

[AUTOMATIC AIR CONDITIONER]

< ECU DIAGNOSIS >

Wiring Diagram

INFOID:000000001277535

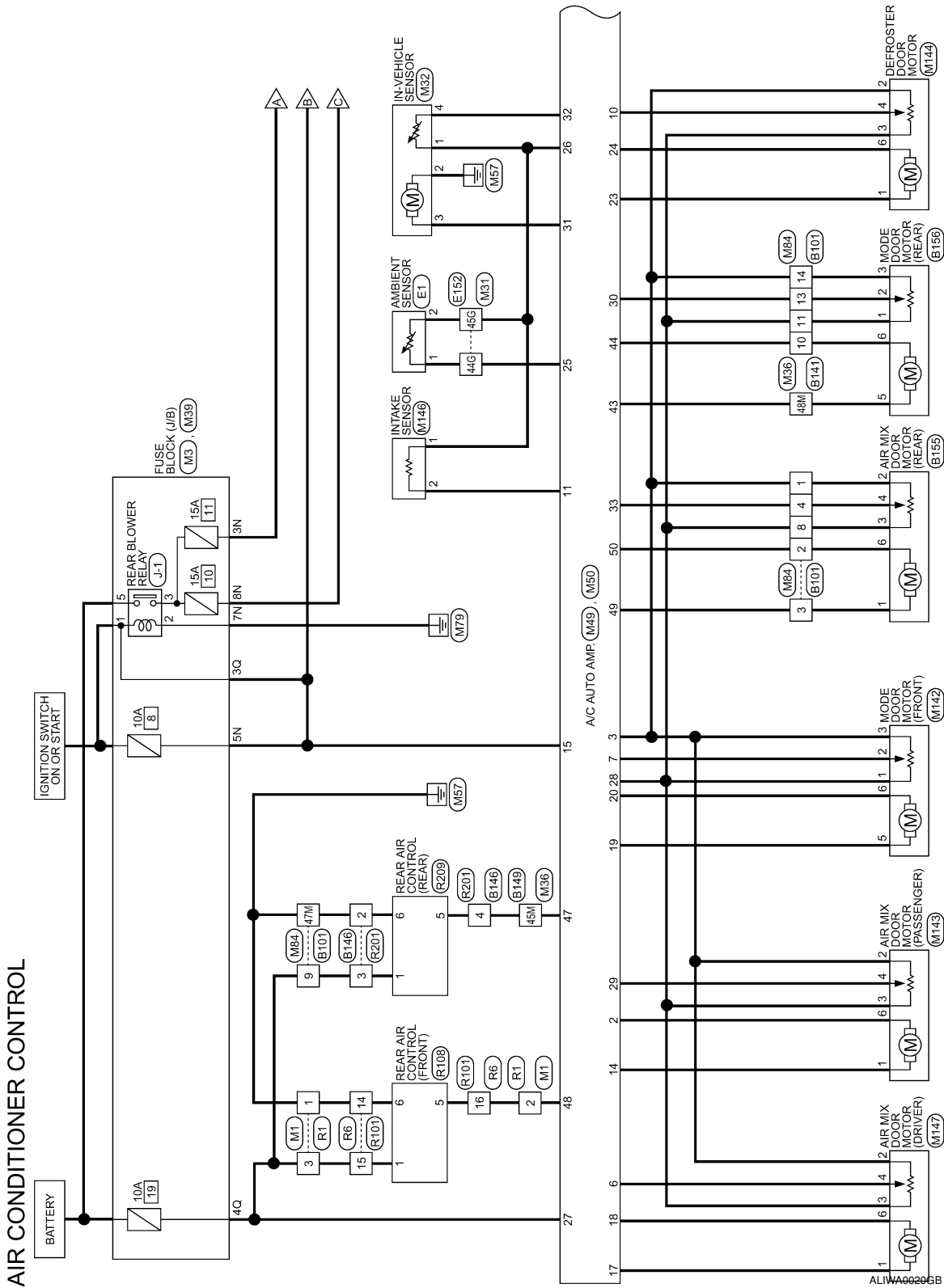

ALWIA00295B

AIR CONDITIONER CONTROL

[AUTOMATIC AIR CONDITIONER]

< ECU DIAGNOSIS >

--- : DATA LINE

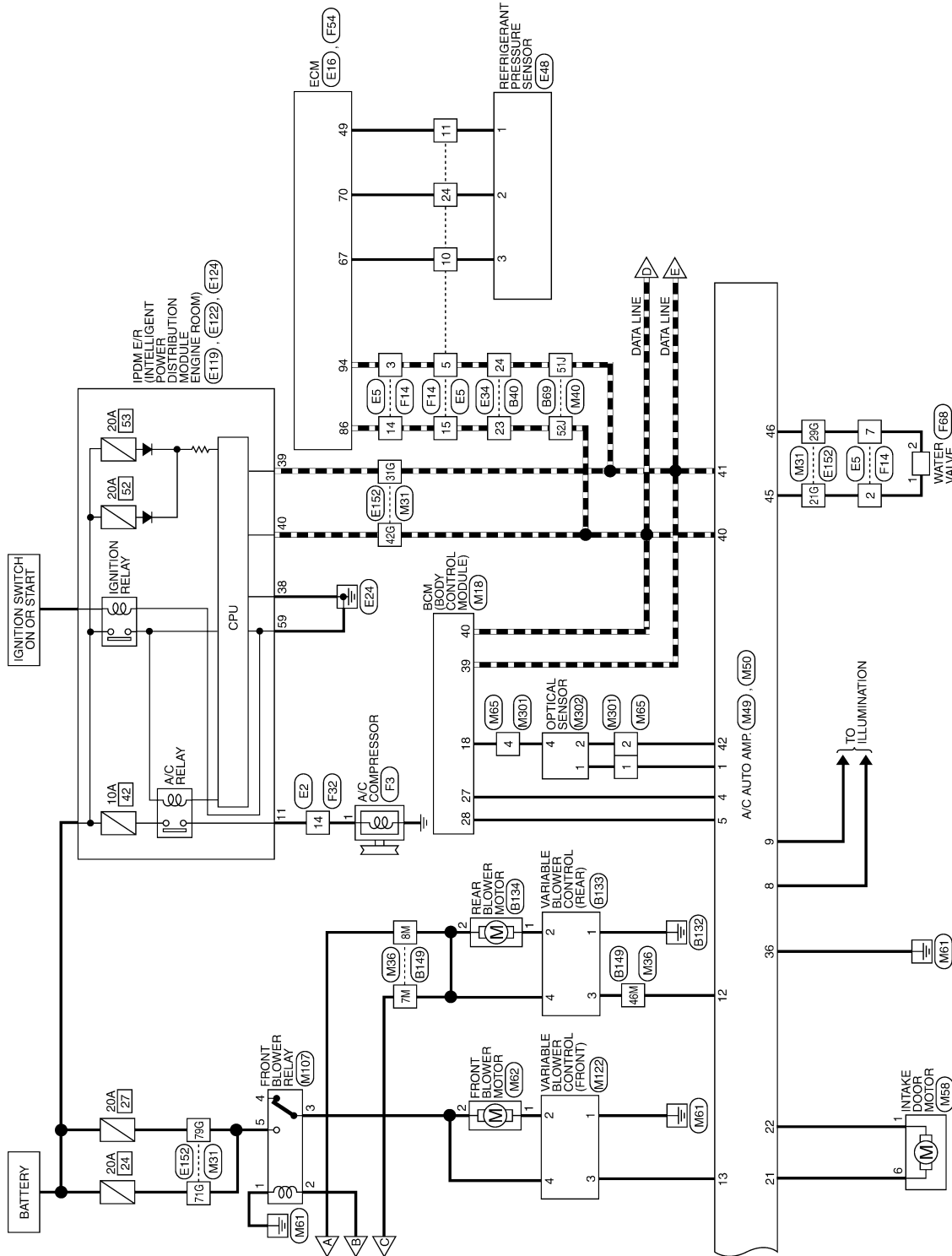

ALIWA0021GB

A
B
C
D
E
F
G
H
I
J
K
L
M
N
O
P

HAC

AIR CONDITIONER CONTROL

[AUTOMATIC AIR CONDITIONER]

< ECU DIAGNOSIS >

 : WITHOUT NAVI
 : WITH NAVI
 : DATA LINE

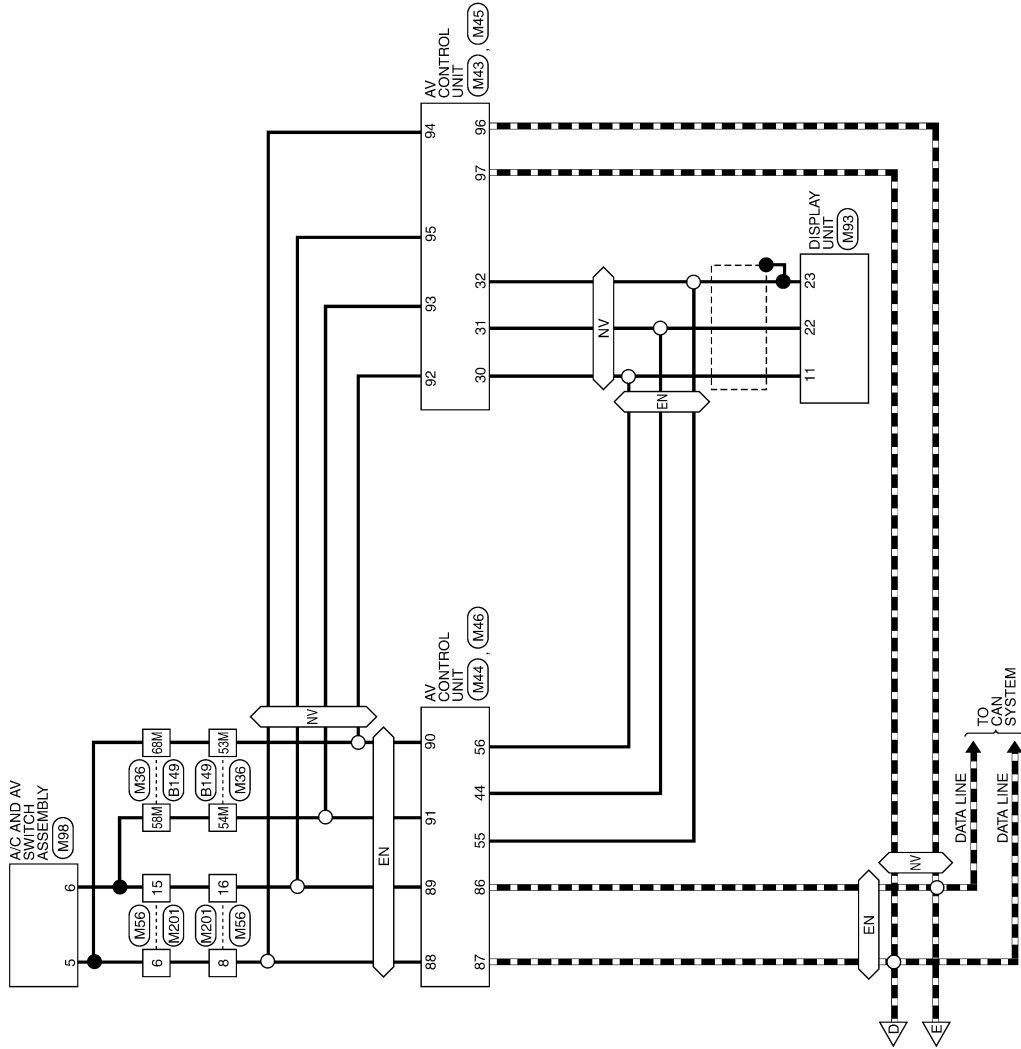

ALIWA0031GB

AIR CONDITIONER CONTROL

[AUTOMATIC AIR CONDITIONER]

< ECU DIAGNOSIS >

AIR CONDITIONER CONTROL CONNECTORS

Connector No.	M1
Connector Name	WIRE TO WIRE
Connector Color	WHITE

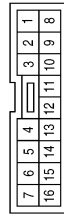

Terminal No.	Color of wire	Signal Name
1	B	-
2	O	-
3	GR	-

Connector No.	M3
Connector Name	FUSE BLOCK (J/B)
Connector Color	WHITE

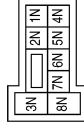

Terminal No.	Color of wire	Signal Name
3N	SB	-
5N	Y/G	-
7N	B	-
8N	L/R	-

Connector No.	M18
Connector Name	BCM (BODY CONTROL MODULE)
Connector Color	WHITE

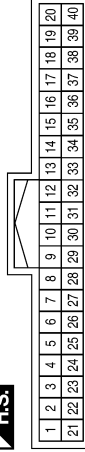

Terminal No.	Color of wire	Signal Name
18	P	SIG_GND
27	W/R	AC_SW
28	L/R	BLR_FAN_SW
39	L	CAN-H
40	P	CAN-L

Connector No.	M31
Connector Name	WIRE TO WIRE
Connector Color	WHITE

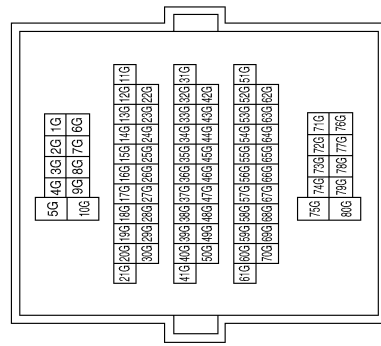

Terminal No.	Color of wire	Signal Name
21G	Y/L	-
29G	W/G	-
31G	L	-
42G	P	-
44G	P	-
45G	V/R	-
71G	P	-
79G	P	-

ALIIA0046GB

A
B
C
D
E
F
G
H
HAC
J
K
L
M
N
O
P

AIR CONDITIONER CONTROL

[AUTOMATIC AIR CONDITIONER]

< ECU DIAGNOSIS >

Connector No.	M32
Connector Name	IN-VEHICLE SENSOR
Connector Color	WHITE

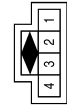

Terminal No.	Color of Wire	Signal Name
1	V/R	-
2	B	-
3	BR/Y	-
4	LG/R	-

Connector No.	M36
Connector Name	WIRE TO WIRE
Connector Color	WHITE

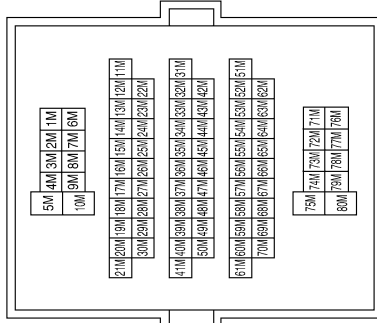

Terminal No.	Color of Wire	Signal Name
7M	L/R	-
8M	SB	-
45M	O/R	-
46M	G/Y	-
47M	B	-
48M	GR/R	-
53M	W/L	-
54M	P/B	-
58M	P/B	-
68M	W/L	-

Connector No.	M39
Connector Name	FUSE BLOCK (J/B)
Connector Color	WHITE

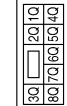

Terminal No.	Color of Wire	Signal Name
3Q	Y/G	-
4Q	Y/R	-

Connector No.	M40
Connector Name	WIRE TO WIRE
Connector Color	WHITE

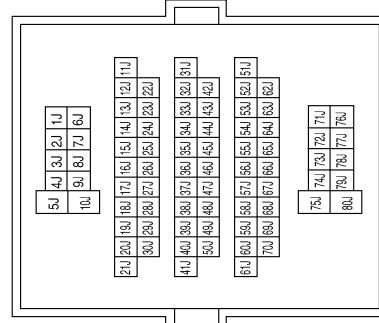

Terminal No.	Color of Wire	Signal Name
51J	L	-
52J	P	-

AIR CONDITIONER CONTROL

[AUTOMATIC AIR CONDITIONER]

< ECU DIAGNOSIS >

Connector No.	M45
Connector Name	AUDIO CONTROL UNIT (WITH NAVI)
Connector Color	WHITE

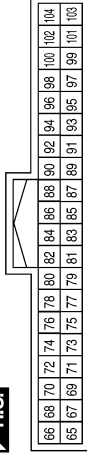
Terminal No.	Color of Wire	Signal Name
92	L/W	M_CAN2-H
93	B/P	M_CAN2-L
94	W/L	M_CAN1-H
95	P/B	M_CAN1-L
96	L	CAN-H
97	P	CAN-L

Connector No.	M44
Connector Name	AUDIO CONTROL UNIT (WITHOUT NAVI)
Connector Color	WHITE

Terminal No.	Color of Wire	Signal Name
44	LG	DISP IT
55	SHIELD	SHIELD
56	V	IT_DISP

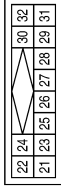
Connector No.	M43
Connector Name	AUDIO CONTROL UNIT (WITH NAVI)
Connector Color	WHITE

Terminal No.	Color of Wire	Signal Name
30	V	IT_DISP
31	LG	DISP_IT
32	SHIELD	SHIELD

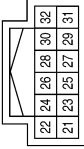
Terminal No.	Color of Wire	Signal Name
86	L	CAN-H
87	P	CAN-L
88	W/L	M_CAN1-H
89	P/B	M_CAN1-L
90	L/W	M_CAN2-H
91	B/P	M_CAN2-L

Connector No.	M46
Connector Name	AUDIO CONTROL UNIT (WITHOUT NAVI)
Connector Color	WHITE

ALIIA0048GB

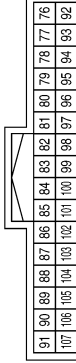
A
B
C
D
E
F
G
H
HAC
J
K
L
M
N
O
P

AIR CONDITIONER CONTROL

[AUTOMATIC AIR CONDITIONER]

< ECU DIAGNOSIS >

Connector No.	M49
Connector Name	A/C AUTO AMP.
Connector Color	BLACK

13	12	11	10	9	8	7	6	5	4	3	2	1
26	25	24	23	22	21	20	19	18	17	16	15	14



Terminal No.	Color of Wire	Signal Name
1	G/O	SUNLOAD_SEN_LEFT(DR)
2	L	TEMP_DOOR_B_FR_RH
3	P	V_REF_RETURN (GND)
4	W/R	AC_REQUEST

Connector No.	M50
Connector Name	A/C AUTO AMP.
Connector Color	BLUE

39	38	37	36	35	34	33	32	31	30	29	28	27
52	51	50	49	48	47	46	45	44	43	42	41	40



Terminal No.	Color of Wire	Signal Name
27	Y/R	B
28	Y	V_REF.ACTR(5V)

Terminal No.	Color of Wire	Signal Name
5	L/R	FAN_ON
6	SB	TEMP_DOOR_F_FEEDBACK_FR_LH
7	GR	FLOOR_FEEDBACK
8	R/L	ILL+
9	BR	ILL-
10	LG/B	PANEL_DEFROST_FEEDBACK
11	L/B	EVAP_AIR_TEMP_SENS
12	G/Y	AUX_VBC
13	G/R	FR_VBC
14	GW	TEMP_DOOR_A_FR_RH

Terminal No.	Color of Wire	Signal Name
15	Y/G	IGN
17	W/G	TEMP_DOOR_A_FR_LH
18	G	TEMP_DOOR_B_FR_LH
19	BR/W	FLOOR_DR_A
20	P/L	FLOOR_DR_B
21	G/B	RECIRC_DOOR_A
22	O	RECIRC_DOOR_B
23	LG	PANEL_DEFROST_DOOR_A
24	P/B	PANEL_DEFROST_DOOR_B
25	P	AMB_TEMP_SENS
26	V/R	SENSOR_RETURN
27	Y/R	B

Terminal No.	Color of Wire	Signal Name
29	R/W	TEMP_DR_FEEDBACK_FR_RH
30	R/Y	AUX_MODE_FEEDBACK
31	BR/Y	INCAR_MTR+
32	LG/R	INCAR_TEMP_SEN
33	R/Y	AUX_TEMP_FEEDBACK
36	B	GND
40	P	CAN-L
41	L	CAN-H

Terminal No.	Color of Wire	Signal Name
42	W/V	SUNLOAD_SEN_RIGHT(PASS)
43	GR/R	AUX_MODE_A
44	L/Y	AUX_MODE_B
45	Y/L	WATER_VAVLE_CLOSE_A
46	W/G	WATER_VAVLE_OPEN_B
47	O	RR_LIN_BUS
48	O	FR_LIN_BUS
49	GR/R	AUX_TEMP_A
50	L/Y	AUX_TEMP_B

ALIHA0049GB

AIR CONDITIONER CONTROL

[AUTOMATIC AIR CONDITIONER]

< ECU DIAGNOSIS >

Connector No.	M62
Connector Name	FRONT BLOWER MOTOR
Connector Color	BLACK



Terminal No.	Color of Wire	Signal Name
1	L/W	-
2	W/L	-

Connector No.	M58
Connector Name	INTAKE DOOR MOTOR
Connector Color	BLACK

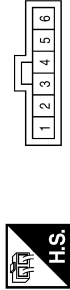

Terminal No.	Color of Wire	Signal Name
1	O	-
6	G/B	-

Connector No.	M56
Connector Name	WIRE TO WIRE
Connector Color	WHITE

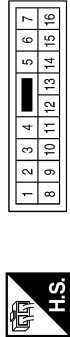

Terminal No.	Color of Wire	Signal Name
6	W/L	-
8	W/L	-
15	P/B	-
16	P/B	-

Connector No.	M93
Connector Name	DISPLAY UNIT
Connector Color	WHITE

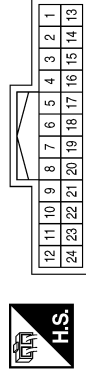

Terminal No.	Color of Wire	Signal Name
11	V	IT-DISP
22	LG	DISP-IT
23	SHIELD	SHIELD

Connector No.	M84
Connector Name	WIRE TO WIRE
Connector Color	BLACK

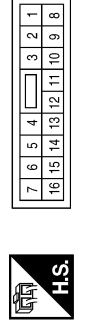

Terminal No.	Color of Wire	Signal Name
1	P	-
2	L/Y	-
3	GR/R	-
4	R/Y	-
8	Y	-
10	L/Y	-
11	W/G	-
13	R/Y	-
14	P	-

Connector No.	M65
Connector Name	WIRE TO WIRE
Connector Color	WHITE

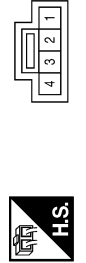

Terminal No.	Color of Wire	Signal Name
1	G/O	-
2	W/V	-
4	P	-

ALIIA0050GB

A
B
C
D
E
F
G
H
HAC
J
K
L
M
N
O
P

AIR CONDITIONER CONTROL

[AUTOMATIC AIR CONDITIONER]

< ECU DIAGNOSIS >

Connector No.	M122
Connector Name	VARIABLE BLOWER CONTROL (FRONT)
Connector Color	WHITE

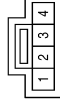

Terminal No.	Color of Wire	Signal Name
1	B/W	-
2	L/W	-
3	G/R	-
4	W/L	-

Connector No.	M107
Connector Name	FRONT BLOWER RELAY
Connector Color	BLACK

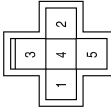

Terminal No.	Color of Wire	Signal Name
1	B	-
2	Y/G	-
3	W/L	-
5	GR	-

Connector No.	M98
Connector Name	A/C AND AV SWITCH ASSEMBLY
Connector Color	WHITE

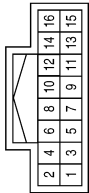

Terminal No.	Color of Wire	Signal Name
5	W/L	-
6	P/B	-

Connector No.	M144
Connector Name	DEFROSTER DOOR MOTOR
Connector Color	BLACK

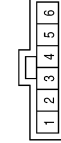

Terminal No.	Color of Wire	Signal Name
1	LG	-
2	P	-
3	Y	-
4	LG/B	-
6	P/B	-

Connector No.	M143
Connector Name	AIR MIX DOOR MOTOR (PASSENGER)
Connector Color	BLACK

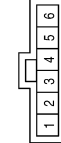

Terminal No.	Color of Wire	Signal Name
1	G/W	-
2	P	-
3	Y	-
4	R/W	-
6	L	-

Connector No.	M142
Connector Name	MODE DOOR MOTOR (FRONT)
Connector Color	BLACK

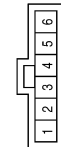

Terminal No.	Color of Wire	Signal Name
1	Y	-
2	GR	-
3	P	-
5	BR/W	-
6	P/L	-

ALIIA0051GB

AIR CONDITIONER CONTROL

[AUTOMATIC AIR CONDITIONER]

< ECU DIAGNOSIS >

Connector No.	M201
Connector Name	WIRE TO WIRE
Connector Color	WHITE

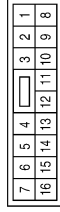

Terminal No.	Color of Wire	Signal Name
6	W/L	-
8	W/L	-
15	P/B	-
16	P/B	-

Connector No.	M147
Connector Name	AIR MIX DOOR MOTOR (DRIVER)
Connector Color	BLACK

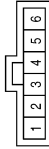

Terminal No.	Color of Wire	Signal Name
1	W/G	-
2	P	-
3	Y	-
4	SB	-
6	G	-

Connector No.	M146
Connector Name	INTAKE SENSOR
Connector Color	GRAY



Terminal No.	Color of Wire	Signal Name
1	V/R	-
2	L/B	-

Connector No.	J-1
Connector Name	REAR BLOWER MOTOR RELAY
Connector Color	BLUE



Terminal No.	Color of Wire	Signal Name
1	Y/G	-
2	B	-
3	B	-
5	B	-

Connector No.	M302
Connector Name	OPTICAL SENSOR
Connector Color	WHITE



Terminal No.	Color of Wire	Signal Name
1	G/O	-
2	W/V	-
4	P	-

Connector No.	M301
Connector Name	WIRE TO WIRE
Connector Color	WHITE

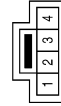

Terminal No.	Color of Wire	Signal Name
1	G/O	-
2	W/V	-
4	P	-

ALIIA0052GB

A
B
C
D
E
F
G
H
HAC
J
K
L
M
N
O
P

AIR CONDITIONER CONTROL

[AUTOMATIC AIR CONDITIONER]

< ECU DIAGNOSIS >

Connector No.	E5
Connector Name	WIRE TO WIRE
Connector Color	WHITE

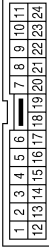

Terminal No.	Color of Wire	Signal Name
2	Y/L	-
3	L	-
5	L	-
7	W/G	-
10	B	-
11	R/Y	-
14	P	-
15	P	-
24	B/W	-

Connector No.	E2
Connector Name	WIRE TO WIRE
Connector Color	WHITE

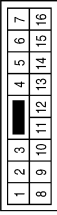

Terminal No.	Color of Wire	Signal Name
14	Y/B	-

Connector No.	E1
Connector Name	AMBIENT SENSOR
Connector Color	GRAY



Terminal No.	Color of Wire	Signal Name
1	P	-
2	V/R	-

Connector No.	E48
Connector Name	REFRIGERANT PRESSURE SENSOR
Connector Color	BLACK



Terminal No.	Color of Wire	Signal Name
1	R/Y	-
2	B/W	-
3	B	-

Connector No.	E34
Connector Name	WIRE TO WIRE
Connector Color	WHITE



Terminal No.	Color of Wire	Signal Name
23	P	-
24	L	-

Connector No.	E16
Connector Name	ECM
Connector Color	BLACK

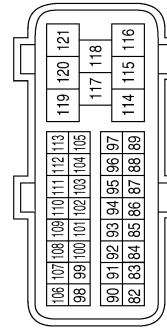

Terminal No.	Color of Wire	Signal Name
86	P	CAN-L
94	L	CAN-H

ALIIA0053GB

AIR CONDITIONER CONTROL

[AUTOMATIC AIR CONDITIONER]

< ECU DIAGNOSIS >

Connector No.	E124
Connector Name	IPDM E/R (INTELLIGENT POWER DISTRIBUTION MODULE ENGINE ROOM)
Connector Color	BLACK



Terminal No.	Color of Wire	Signal Name
59	B	GND (PWR)

Connector No.	E122
Connector Name	IPDM E/R (INTELLIGENT POWER DISTRIBUTION MODULE ENGINE ROOM)
Connector Color	WHITE

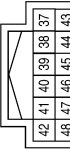

Terminal No.	Color of Wire	Signal Name
38	B	GND (SIG)
39	L	CAN-H
40	P	CAN-L

Connector No.	E119
Connector Name	IPDM E/R (INTELLIGENT POWER DISTRIBUTION MODULE ENGINE ROOM)
Connector Color	WHITE

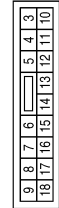

Terminal No.	Color of Wire	Signal Name
11	Y/B	AC_COMP

Connector No.	F3
Connector Name	A/C COMPRESSOR
Connector Color	BLACK



Terminal No.	Color of Wire	Signal Name
1	Y/B	-

Terminal No.	Color of Wire	Signal Name
21G	Y/L	-
29G	W/G	-
31G	L	-
42G	P	-
44G	P	-
45G	V/R	-
71G	GR	-
79G	P	-

Connector No.	E152
Connector Name	WIRE TO WIRE
Connector Color	WHITE

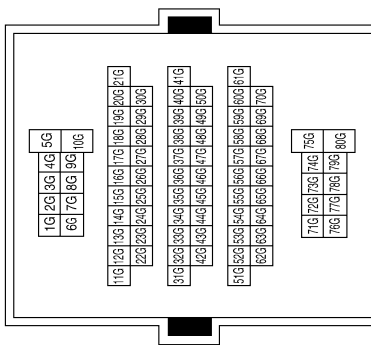

ALIIA0054GB

A
B
C
D
E
F
G
H
HAC
J
K
L
M
N
O
P

AIR CONDITIONER CONTROL

[AUTOMATIC AIR CONDITIONER]

< ECU DIAGNOSIS >

Connector No.	F54
Connector Name	ECM
Connector Color	BLACK



63	64	65	66	67	68	69	70	71	72	73	74	75	76	77	78	79	80	81	2	1
44	45	46	47	48	49	50	51	52	53	54	55	56	57	58	59	60	61	62	3	
25	26	27	28	29	30	31	32	33	34	35	36	37	38	39	40	41	42	43	5	4
6	7	8	9	10	11	12	13	14	15	16	17	18	19	20	21	22	23	24		

Terminal No.	Color of Wire	Signal Name
49	R/Y	AVCC (PDPRES)
50	B	TPS1
51	W	QA+
67	B	GND-A
70	B/W	PD PRESS

Connector No.	F32
Connector Name	WIRE TO WIRE
Connector Color	WHITE



7	6	5	4	3	2	1		
16	15	14	13	12	11	10	9	8

Terminal No.	Color of Wire	Signal Name
14	Y/B	-

Connector No.	F14
Connector Name	WIRE TO WIRE
Connector Color	WHITE



11	10	9	8	7	6	5	4	3	2	1		
24	23	22	21	20	19	18	17	16	15	14	13	12

Terminal No.	Color of Wire	Signal Name
2	Y/L	-
3	L	-
5	L	-
7	W/G	-
10	B	-
11	R/Y	-
14	P	-
15	P	-
24	B/W	-

Connector No.	B40
Connector Name	WIRE TO WIRE
Connector Color	WHITE



1	2	3	4	5	6	7	8	9	10	11		
12	13	14	15	16	17	18	19	20	21	22	23	24

Terminal No.	Color of Wire	Signal Name
23	P	-
24	L	-

Connector No.	F68
Connector Name	WATER VALVE
Connector Color	GRAY



Terminal No.	Color of Wire	Signal Name
1	Y/L	-
2	W/G	-

ALIIA0055GB

AIR CONDITIONER CONTROL

[AUTOMATIC AIR CONDITIONER]

< ECU DIAGNOSIS >

Connector No.	B101
Connector Name	WIRE TO WIRE
Connector Color	WHITE

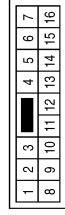

Terminal No.	Color of Wire	Signal Name
1	P	-
2	LY	-
3	GR/R	-
4	R/Y	-
8	Y	-
10	LY	-
11	W/G	-
13	R/Y	-
14	P	-

Terminal No.	Color of Wire	Signal Name
51J	L	-
52J	P	-

Connector No.	B69
Connector Name	WIRE TO WIRE
Connector Color	WHITE

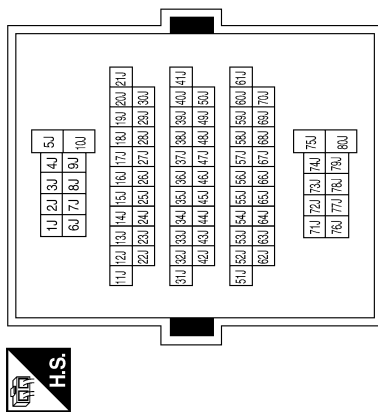

Connector No.	B146
Connector Name	WIRE TO WIRE
Connector Color	BROWN

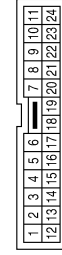

Terminal No.	Color of Wire	Signal Name
2	B	-
3	W/G	-
4	O/R	-

Connector No.	B134
Connector Name	REAR BLOWER MOTOR
Connector Color	WHITE



Terminal No.	Color of Wire	Signal Name
1	L/B	-
2	L/R	-

Connector No.	B133
Connector Name	VARIABLE BLOWER CONTROL (REAR)
Connector Color	WHITE

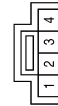

Terminal No.	Color of Wire	Signal Name
1	B	-
2	L/B	-
3	G/Y	-
4	W/L	-

ALIA0056GB

A
B
C
D
E
F
G
H
HAC
J
K
L
M
N
O
P

AIR CONDITIONER CONTROL

[AUTOMATIC AIR CONDITIONER]

< ECU DIAGNOSIS >

Connector No.	B155
Connector Name	AIR MIX DOOR MOTOR (REAR)
Connector Color	BLACK



Terminal No.	Color of Wire	Signal Name
1	GR/R	-
2	P	-
3	Y	-
4	R/Y	-
6	L/Y	-

Terminal No.	Color of Wire	Signal Name
7M	L/R	-
8M	L/R	-
45M	O/R	-
46M	G/Y	-
47M	B	-
48M	GR/R	-
53M	W/L	-
54M	P/B	-
58M	P/B	-
68M	W/L	-

Connector No.	B149
Connector Name	WIRE TO WIRE
Connector Color	WHITE

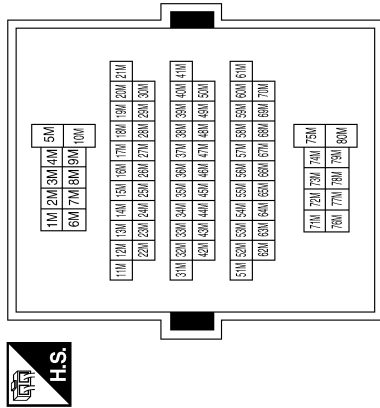

Connector No.	R6
Connector Name	WIRE TO WIRE
Connector Color	WHITE

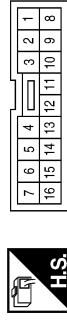

Terminal No.	Color of Wire	Signal Name
14	B	-
15	GR	-
16	O	-

Connector No.	R1
Connector Name	WIRE TO WIRE
Connector Color	WHITE

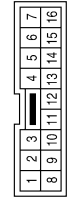

Terminal No.	Color of Wire	Signal Name
1	B	-
2	O	-
3	GR	-

Connector No.	B156
Connector Name	MODE DOOR MOTOR (REAR)
Connector Color	BLACK

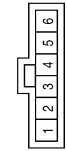

Terminal No.	Color of Wire	Signal Name
1	Y	-
2	R/Y	-
3	P	-
5	GR/R	-
6	L/Y	-

ALIIA0057GB

AIR CONDITIONER CONTROL

[AUTOMATIC AIR CONDITIONER]

< ECU DIAGNOSIS >

Connector No.	R201
Connector Name	WIRE TO WIRE
Connector Color	BROWN

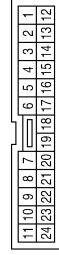

Terminal No.	Color of Wire	Signal Name
2	B	-
3	W/G	-
4	O/R	-

Connector No.	R108
Connector Name	REAR AIR CONTROL (FRONT)
Connector Color	BLACK

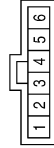

Terminal No.	Color of Wire	Signal Name
1	GR	-
5	O	-
6	B	-

Connector No.	R101
Connector Name	WIRE TO WIRE
Connector Color	WHITE

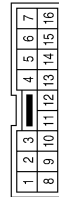

Terminal No.	Color of Wire	Signal Name
14	B	-
15	GR	-
16	O	-

Connector No.	R209
Connector Name	REAR AIR CONTROL L (REAR)
Connector Color	BLACK

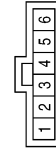

Terminal No.	Color of Wire	Signal Name
1	W/G	-
5	O/R	-
6	B	-

A
B
C
D
E
F
G
H
HAC
J
K
L
M
N
O
P

ALIIA0058GB

AIR CONDITIONER CONTROL

[AUTOMATIC AIR CONDITIONER]

< SYMPTOM DIAGNOSIS >

SYMPTOM DIAGNOSIS

AIR CONDITIONER CONTROL

Symptom Matrix Chart

INFOID:000000001277536

SYMPTOM TABLE

Symptom	Reference Page
A/C system does not come on.	Go to Trouble Diagnosis Procedure for A/C System. HAC-88
A/C system display is malfunctioning. (W NAVI)	Go to Navigation System. AV-338
A/C system display is malfunctioning. (W/O NAVI)	Go to Display System. AV-154
A/C system cannot be controlled.	Go to Self-diagnosis Function. HAC-22
Air outlet does not change.	Go to Trouble Diagnosis Procedure for Mode Door Motor. HAC-25
Mode door motor is malfunctioning.	
Discharge air temperature does not change.	Go to Trouble Diagnosis Procedure for Air Mix Door Motor. HAC-31
Air mix door motor is malfunctioning.	
Intake door does not change.	Go to Trouble Diagnosis Procedure for Intake Door Motor. HAC-41
Intake door motor is malfunctioning.	
Defroster door motor is malfunctioning.	Go to Trouble Diagnosis Procedure for Defroster Door Motor. HAC-45
Front blower motor operation is malfunctioning.	Go to Trouble Diagnosis Procedure for Front Blower Motor. HAC-50
Rear blower motor operation is malfunctioning.	Go to Trouble Diagnosis Procedure for Rear Blower Motor. HAC-56
Rear discharge air temperature and/or air outlet does not change.	Go to Trouble Diagnosis Procedure for Rear Air Control circuit. HAC-61
Magnet clutch does not engage.	Go to Trouble Diagnosis Procedure for Magnet Clutch. HAC-71
Insufficient cooling	Go to Trouble Diagnosis Procedure for Insufficient Cooling. HAC-109
Insufficient heating	Go to Trouble Diagnosis Procedure for Insufficient Heating. HAC-117
Noise	Go to Trouble Diagnosis Procedure for Noise. HAC-119
Self-diagnosis cannot be performed.	Go to Trouble Diagnosis Procedure for Self-diagnosis. HAC-88
Memory function does not operate.	Go to Trouble Diagnosis Procedure for Memory Function. HAC-121

INSUFFICIENT COOLING

[AUTOMATIC AIR CONDITIONER]

< SYMPTOM DIAGNOSIS >

INSUFFICIENT COOLING

Component Function Check

INFOID:000000001277538

SYMPTOM: Insufficient cooling

INSPECTION FLOW

1. CONFIRM SYMPTOM BY PERFORMING OPERATIONAL CHECK - TEMPERATURE DECREASE

1. Press the AUTO switch.
2. Turn temperature control dial (driver) counterclockwise until 16° C (60° F) is displayed.
3. Check for cold air at discharge air outlets.

Can the symptom be duplicated?

- YES >> GO TO 3.
NO >> GO TO 2.

2. CHECK FOR ANY SYMPTOMS

Perform a complete operational check for any symptoms. Refer to [HAC-4. "Operational Check \(Front\)"](#).

Does another symptom exist?

- YES >> Refer to [HAC-108. "Symptom Matrix Chart"](#).
NO >> System OK.

3. CHECK FOR SERVICE BULLETINS

Check for any service bulletins.

>> GO TO 3.

4. PERFORM SELF-DIAGNOSIS

Perform self-diagnosis Refer to [HAC-22. "A/C Auto Amp. Self-Diagnosis"](#).

Is the inspection result normal?

- YES >> GO TO 5.
NO >> Refer to [HAC-23. "A/C System Self-Diagnosis Code Chart"](#).

5. CHECK DRIVE BELTS

Check compressor belt tension. Refer to [EM-12. "Checking Drive Belts"](#).

Is the inspection result normal?

- OK >> GO TO 6.
NG >> Adjust or replace compressor belt. Refer to [EM-12. "Removal and Installation"](#).

6. CHECK AIR MIX DOOR OPERATION

Check and verify air mix door mechanism for smooth operation. Refer to [HAC-31. "Air Mix Door Motor Component Function Check"](#)

Does air mix door operate correctly?

- YES >> GO TO 7.
NO >> Check air mix door motor circuit. Refer to [HAC-32. "Air Mix Door Motor \(Driver\) Diagnosis Procedure"](#) or [HAC-35. "Air Mix Door Motor \(Passenger\) Diagnosis Procedure"](#).

7. CHECK COOLING FAN MOTOR OPERATION

Check and verify cooling fan motor for smooth operation. Refer to [EC-386. "Component Inspection"](#).

Does cooling fan motor operate correctly?

- YES >> GO TO 8.
NO >> Check cooling fan motor. Refer to [EC-385. "Diagnosis Procedure"](#).

8. CHECK WATER VALVE OPERATION

Check and verify water valve for smooth operation. Refer to [HAC-76. "Description"](#).

Does water valve operate correctly?

- YES >> GO TO 8.

A

B

C

D

E

F

G

H

HAC

J

K

L

M

N

O

P

INSUFFICIENT COOLING

[AUTOMATIC AIR CONDITIONER]

< SYMPTOM DIAGNOSIS >

NO >> Check water valve circuit. Refer to [HAC-76. "Water Valve Diagnosis Procedure"](#).

9.CHECK RECOVERY/RECYCLING EQUIPMENT BEFORE USAGE

Check recovery/recycling equipment before connecting to vehicle. Verify there is no pressure in the recovery/recycling equipment by checking the gauges. If pressure exists, recover refrigerant from equipment lines.

>> GO TO 9.

10.CHECK REFRIGERANT PURITY

1. Connect recovery/recycling equipment to vehicle.
2. Confirm refrigerant purity in supply tank using recovery/recycling and refrigerant identifier.

Is the inspection result normal?

YES >> GO TO 10.

NO >> Check contaminated refrigerant. Refer to [HAC-122. "Working with HFC-134a \(R-134a\)"](#).

11.CHECK FOR EVAPORATOR FREEZE UP

Start engine and run A/C. Check for evaporator freeze up.

Does evaporator freeze up?

YES >> Perform performance test diagnoses. Refer to [HAC-110. "Performance Test Diagnoses"](#).

NO >> GO TO 11.

12.CHECK REFRIGERANT PRESSURE

Check refrigerant pressure with manifold gauge connected. Refer to [HAC-113. "Test Reading"](#).

Is the inspection result normal?

YES >> Perform performance test diagnoses. Refer to [HAC-110. "Performance Test Diagnoses"](#).

NO >> GO TO 12.

13.CHECK AIR DUCTS

Check ducts for air leaks.

Is the inspection result normal?

YES >> System OK.

NO >> Repair air leaks.

Performance Test Diagnoses

INFOID:000000001277537

INSUFFICIENT COOLING

< SYMPTOM DIAGNOSIS >

[AUTOMATIC AIR CONDITIONER]

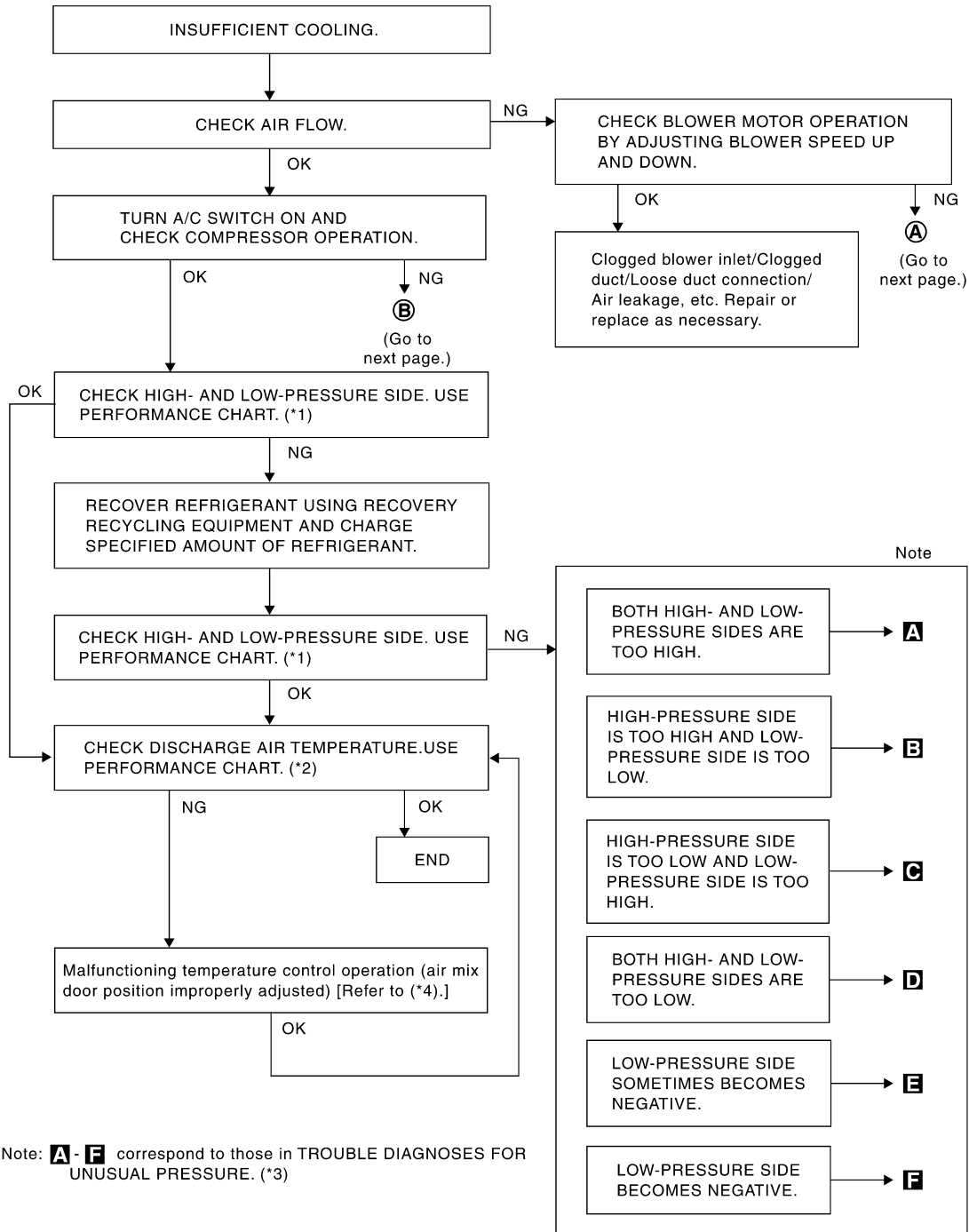

RJIA1601E

*1 [HAC-112. "Performance Chart"](#)

*2 [HAC-113. "Test Reading"](#)

*3 [HAC-114. "Trouble Diagnoses for Unusual Pressure"](#)

*4 [HAC-31. "Air Mix Door Motor Component Function Check"](#)

A
B
C
D
E
F
G
H
HAC
J
K
L
M
N
O
P

INSUFFICIENT COOLING

< SYMPTOM DIAGNOSIS >

[AUTOMATIC AIR CONDITIONER]

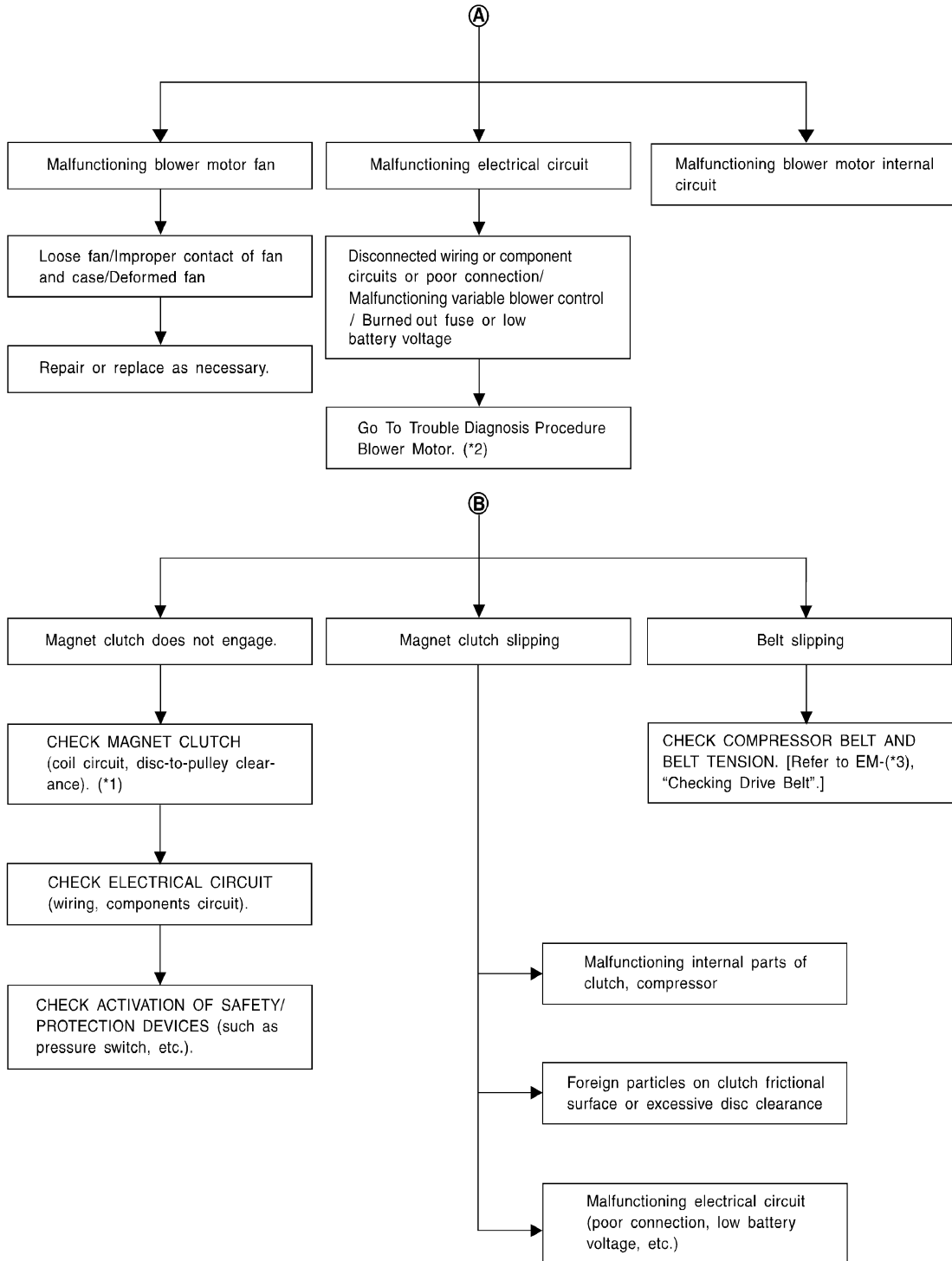

WJIA1371E

*1 [HA-31. "Removal and Installation for Compressor Clutch"](#)

*2 [HAC-50. "Front Blower Motor Component Function Check"](#)

*3 [EM-12. "Checking Drive Belts"](#)

Performance Chart

INFOID:000000001337954

Test Condition



HAC-112

INSUFFICIENT COOLING

< SYMPTOM DIAGNOSIS >

[AUTOMATIC AIR CONDITIONER]

Testing must be performed as follows:

Vehicle location	Indoors or in the shade (in a well-ventilated place)
Doors	Closed
Door window	Open
Hood	Open
TEMP.	Max. COLD
Mode switch	 (Ventilation) set
Recirculation (REC) switch	 (Recirculation) set
 Blower speed	Max. speed set
Engine speed	Idle speed

Operate the air conditioning system for 10 minutes before taking measurements.

Test Reading

INFOID:000000001337955

Recirculating-to-discharge Air Temperature Table

Inside air (Recirculating air) at blower assembly inlet		Discharge air temperature at center ventilator °C (°F)
Relative humidity %	Air temperature °C (°F)	
50 - 60	20 (68)	9.9 - 13.9 (50 - 57)
	25 (77)	14.6 - 18.6 (58 - 65)
	30 (86)	16.8 - 21.8 (62 - 71)
	35 (95)	21.1 - 27.1 (70 - 81)
	40 (104)	25.3 - 31.5 (78 - 89)
60 - 70	20 (68)	11.4 - 15.2 (53 - 59)
	25 (77)	15.5 - 20.0 (60 - 68)
	30 (86)	19.9 - 25.0 (68 - 77)
	35 (95)	24.5 - 29.6 (76 - 85)
	40 (104)	28.7 - 34.9 (84 - 95)

Ambient Air Temperature-to-operating Pressure Table

Ambient air		High-pressure (Discharge side) kPa (kg/cm ² , psi)	Low-pressure (Suction side) kPa (kg/cm ² , psi)
Relative humidity %	Air temperature °C (°F)		
50 - 70	20 (68)	1020 - 1250 (10.4 - 12.7, 147.9 - 181.3)	160 - 190 (1.63 - 1.94, 23.2 - 27.6)
	25 (77)	1236 - 1510 (12.6 - 15.4, 179.2 - 219)	206 - 245 (2.1 - 2.5, 29.9 - 35.6)
	30 (86)	1569 - 1,922 (16.0 - 19.6, 227.6 - 278.8)	265 - 324 (2.7 - 3.3, 38.4 - 46.9)
	35 (95)	1,697 - 2079 (17.3 - 21.2, 246.1 - 301.5)	304 - 363 (3.1 - 3.7, 44.1 - 52.6)
	40 (104)	1971 - 2403 (20.1 - 24.5, 285.9 - 348.5)	373 - 451 (3.8 - 4.6, 54.0 - 65.4)

INSUFFICIENT COOLING

< SYMPTOM DIAGNOSIS >

[AUTOMATIC AIR CONDITIONER]

Trouble Diagnoses for Unusual Pressure

INFOID:000000001337956

Whenever system's high and/or low side pressure is unusual, diagnose using a manifold gauge. The marker above the gauge scale in the following tables indicates the standard (usual) pressure range. Since the standard (usual) pressure, however, differs from vehicle to vehicle, refer to above table (Ambient air temperature-to-operating pressure table).

Both High- and Low-pressure Sides are Too High

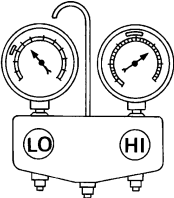
Gauge indication	Refrigerant cycle	Probable cause	Corrective action
<p>Both high- and low-pressure sides are too high.</p>  <p>AC359A</p>	Pressure is reduced soon after water is splashed on condenser.	Excessive refrigerant charge in refrigeration cycle	Reduce refrigerant until specified pressure is obtained.
	Air suction by cooling fan is insufficient.	Insufficient condenser cooling performance ↓ 1. Condenser fins are clogged. 2. Improper fan rotation of cooling fan	<ul style="list-style-type: none"> Clean condenser. Check and repair cooling fan if necessary.
	<ul style="list-style-type: none"> Low-pressure pipe is not cold. When compressor is stopped high-pressure value quickly drops by approximately 196 kPa (2 kg/cm², 28 psi). It then decreases gradually thereafter. 	Poor heat exchange in condenser (After compressor operation stops, high-pressure decreases too slowly.) ↓ Air in refrigeration cycle	Evacuate and recharge system.
	Engine tends to overheat.	Engine cooling systems malfunction.	Check and repair engine cooling system.
	<ul style="list-style-type: none"> An area of the low-pressure pipe is colder than areas near the evaporator outlet. Plates are sometimes covered with frost. 	<ul style="list-style-type: none"> Excessive liquid refrigerant on low-pressure side Excessive refrigerant discharge flow Expansion valve is open a little compared with the specification. ↓ Improper expansion valve adjustment	Replace expansion valve.

High-pressure Side is Too High and Low-pressure Side is Too Low

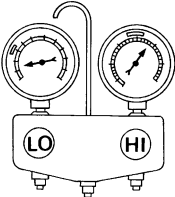
Gauge indication	Refrigerant cycle	Probable cause	Corrective action
<p>High-pressure side is too high and low-pressure side is too low.</p>  <p>AC360A</p>	Upper side of condenser and high-pressure side are hot, however, liquid tank is not so hot.	High-pressure tube or parts located between compressor and condenser are clogged or crushed.	<ul style="list-style-type: none"> Check and repair or replace malfunctioning parts. Check oil for contamination.

High-pressure Side is Too Low and Low-pressure Side is Too High

INSUFFICIENT COOLING

< SYMPTOM DIAGNOSIS >

[AUTOMATIC AIR CONDITIONER]

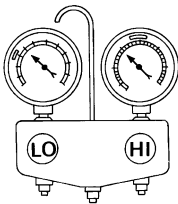
Gauge indication	Refrigerant cycle	Probable cause	Corrective action
High-pressure side is too low and low-pressure side is too high.  AC356A	High- and low-pressure sides become equal soon after compressor operation stops.	Compressor pressure operation is improper. ↓ Damaged inside compressor packings.	Replace compressor.
	No temperature difference between high- and low-pressure sides.	Compressor pressure operation is improper. ↓ Damaged inside compressor packings.	Replace compressor.

Both High- and Low-pressure Sides are Too Low

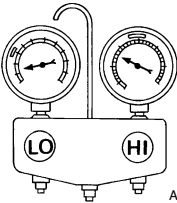
Gauge indication	Refrigerant cycle	Probable cause	Corrective action
Both high- and low-pressure sides are too low.  AC353A	<ul style="list-style-type: none"> There is a big temperature difference between liquid tank outlet and inlet. Outlet temperature is extremely low. Liquid tank inlet and expansion valve are frosted. 	Liquid tank inside is slightly clogged.	<ul style="list-style-type: none"> Replace liquid tank. Check oil for contamination.
	<ul style="list-style-type: none"> Temperature of expansion valve inlet is extremely low as compared with areas near liquid tank. Expansion valve inlet may be frosted. Temperature difference occurs somewhere in high-pressure side. 	High-pressure pipe located between liquid tank and expansion valve is clogged.	<ul style="list-style-type: none"> Check and repair malfunctioning parts. Check oil for contamination.
	Expansion valve and liquid tank are warm or only cool when touched.	Low refrigerant charge. ↓ Leaking fittings or components.	Check refrigerant system for leaks. Refer to HA-23, "Checking of Refrigerant Leaks" .
	There is a big temperature difference between expansion valve inlet and outlet while the valve itself is frosted.	Expansion valve closes a little compared with the specification. ↓ 1. Improper expansion valve adjustment. 2. Malfunctioning expansion valve. 3. Outlet and inlet may be clogged.	<ul style="list-style-type: none"> Remove foreign particles by using compressed air. Check oil for contamination.
	An area of the low-pressure pipe is colder than areas near the evaporator outlet.	Low-pressure pipe is clogged or crushed.	<ul style="list-style-type: none"> Check and repair malfunctioning parts. Check oil for contamination.
	Air flow volume is too low.	Evaporator is frozen.	<ul style="list-style-type: none"> Check intake sensor circuit. Refer to HAC-86, "Intake Sensor Diagnosis Procedure". Repair evaporator fins. Replace evaporator. Refer to HAC-50, "Front Blower Motor Component Function Check".

Low-pressure Side Sometimes Becomes Negative

INSUFFICIENT COOLING

< SYMPTOM DIAGNOSIS >

[AUTOMATIC AIR CONDITIONER]

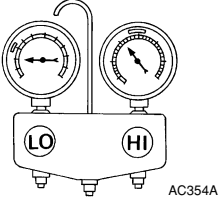
Gauge indication	Refrigerant cycle	Probable cause	Corrective action
<p>Low-pressure side sometimes becomes negative.</p>  <p style="text-align: right; font-size: small;">AC354A</p>	<ul style="list-style-type: none"> • Air conditioning system does not function and does not cyclically cool the compartment air. • The system constantly functions for a certain period of time after compressor is stopped and restarted. 	<p>Refrigerant does not discharge cyclically.</p> <p>↓</p> <p>Moisture is frozen at expansion valve outlet and inlet.</p> <p>↓</p> <p>Water is mixed with refrigerant.</p>	<ul style="list-style-type: none"> • Drain water from refrigerant or replace refrigerant. • Replace liquid tank.

Low-pressure Side Becomes Negative

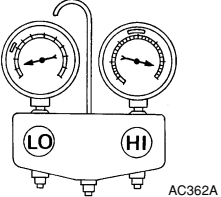
Gauge indication	Refrigerant cycle	Probable cause	Corrective action
<p>Low-pressure side becomes negative.</p>  <p style="text-align: right; font-size: small;">AC362A</p>	<p>Liquid tank or front/rear side of expansion valve's pipe is frosted or dewed.</p>	<p>High-pressure side is closed and refrigerant does not flow.</p> <p>↓</p> <p>Expansion valve or liquid tank is frosted.</p>	<p>Leave the system at rest until no frost is present. Start it again to check whether or not the malfunction is caused by water or foreign particles.</p> <ul style="list-style-type: none"> • If water is the cause, initially cooling is okay. Then the water freezes causing a blockage. Drain water from refrigerant or replace refrigerant. • If due to foreign particles, remove expansion valve and remove the particles with dry and compressed air (not shop air). • If either of the above methods cannot correct the malfunction, replace expansion valve. • Replace liquid tank. • Check oil for contamination.

INSUFFICIENT HEATING

< SYMPTOM DIAGNOSIS >

[AUTOMATIC AIR CONDITIONER]

INSUFFICIENT HEATING

Component Function Check

INFOID:000000001277542

SYMPTOM: Insufficient heating

INSPECTION FLOW

1. CONFIRM SYMPTOM BY PERFORMING OPERATIONAL CHECK - TEMPERATURE INCREASE

1. Press the AUTO switch.
2. Turn the temperature control dial (driver) clockwise until 32° C (90° F) is displayed.
3. Check for hot air at discharge air outlets.

Can this symptom be duplicated?

YES >> GO TO 2.

NO >> Perform complete system operational check. Refer to [HAC-4, "Operational Check \(Front\)"](#).

2. CHECK FOR SERVICE BULLETINS

Check for any service bulletins.

>> GO TO 3.

3. PERFORM SELF-DIAGNOSIS

Perform self-diagnosis. Refer to [HAC-22, "A/C Auto Amp. Self-Diagnosis"](#).

Is the inspection results normal?

YES >> GO TO 4.

NO >> Refer to [HAC-23, "A/C System Self-Diagnosis Code Chart"](#).

4. CHECK ENGINE COOLING SYSTEM

1. Check for proper engine coolant level. Refer to [CO-10, "Inspection"](#).
2. Check hoses for leaks or kinks.
3. Check radiator cap. Refer to [CO-10, "Inspection"](#).
4. Check for air in cooling system.

>> GO TO 5.

5. CHECK AIR MIX DOOR OPERATION

Check the operation of the air mix door.

Is the inspection result normal?

YES >> GO TO 6.

NO >> Check the air mix door motor circuit. Refer to [HAC-31, "Air Mix Door Motor Component Function Check"](#).

6. CHECK AIR DUCTS

Check for disconnected or leaking air ducts.

Is the inspection result normal?

YES >> GO TO 7.

NO >> Repair all disconnected or leaking air ducts.

7. CHECK HEATER HOSE TEMPERATURES

1. Start engine and warm it up to normal operating temperature.
2. Touch both the inlet and outlet heater hoses.

Is the inspection result normal?

YES >> Hot inlet hose and a warm outlet hose: GO TO 8.

NO >> • Inlet hose cold: GO TO 11.
• Both hoses warm: GO TO 9.

8. CHECK ENGINE COOLANT SYSTEM

Check engine control temperature sensor. Refer to [EC-127, "Component Inspection"](#).

A

B

C

D

E

F

G

H

HAC

J

K

L

M

N

O

P

INSUFFICIENT HEATING

[AUTOMATIC AIR CONDITIONER]

< SYMPTOM DIAGNOSIS >

Is the inspection result normal?

YES >> System OK.

NO >> Repair or replace as necessary. Retest.

9.CHECK HEATER HOSES

Check heater hoses for proper installation.

Is the inspection result normal?

YES >> System OK.

NO >> 1. Back flush heater core.

2. Drain the water from the system.

3. Refill system with new engine coolant. Refer to [CO-11, "Changing Engine Coolant"](#).

4. GO TO 10 to retest.

10.CHECK HEATER HOSE TEMPERATURES

1. Start engine and warm it up to normal operating temperature.

2. Touch both the inlet and outlet heater hoses.

Is the inspection result normal?

YES >> System OK.

NO >> Replace heater core. Refer to [VTL-19, "Removal and Installation"](#).

11.CHECK WATER VALVE

Check the operation of the water valve. Refer to [HAC-76, "Water Valve Diagnosis Procedure"](#).

Is the inspection result normal?

YES >> System OK.

NO >> Replace water valve.

NOISE

Component Function Check

INFOID:000000001277544

SYMPTOM: Noise

INSPECTION FLOW

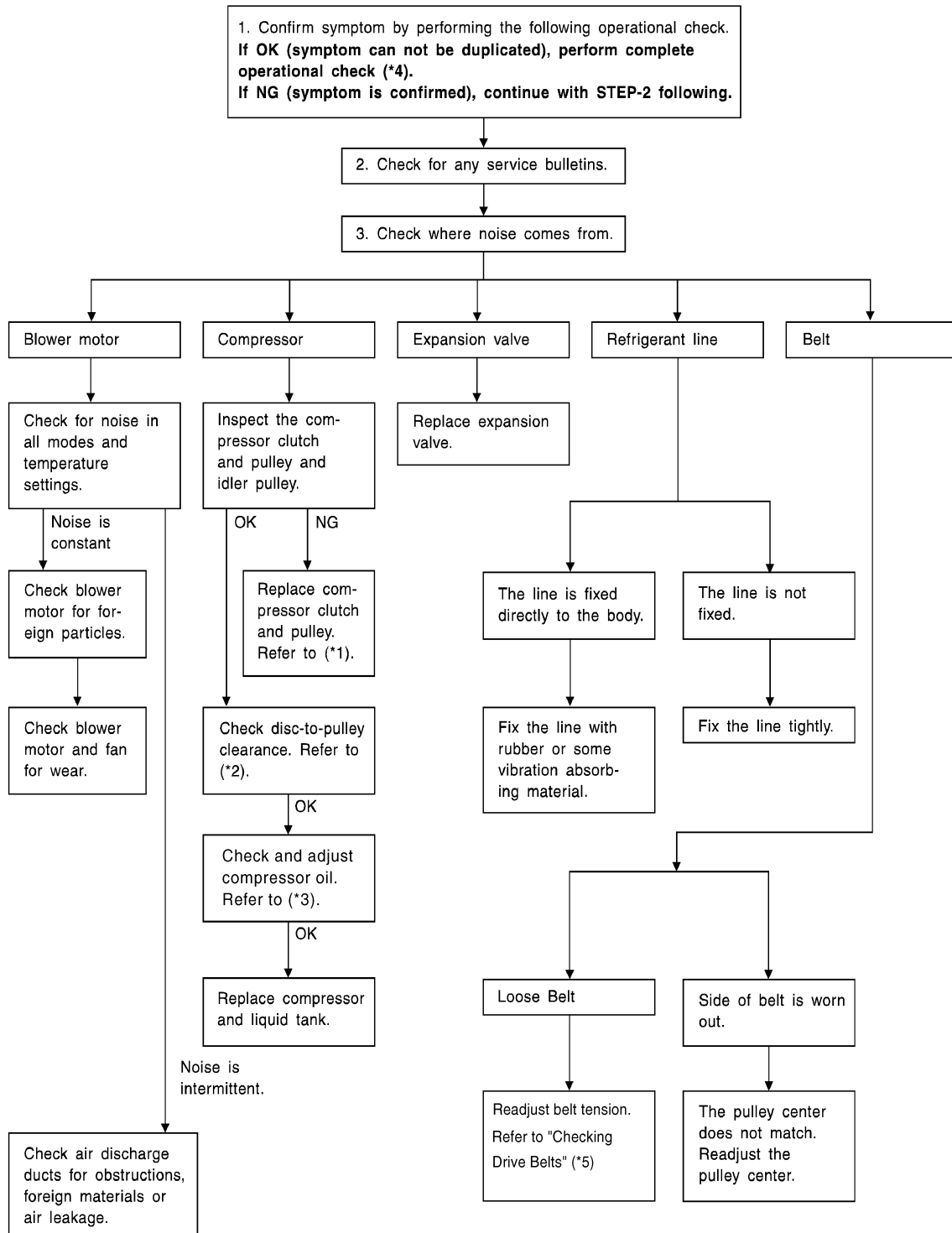

A
B
C
D
E
F
G
H
HAC
J
K
L
M
N
O
P

NOISE

< SYMPTOM DIAGNOSIS >

[AUTOMATIC AIR CONDITIONER]

- *1 [HA-31. "Removal and Installation for Compressor Clutch"](#)
- *2 [HA-31. "Removal and Installation for Compressor Clutch"](#)
- *3 [HA-18. "Maintenance of Oil in Compressor"](#)
- *4 [HAC-4. "Operational Check \(Front\)"](#) or [HAC-5. "Operational Check \(Rear\)"](#)
- *5 [EM-12. "Checking Drive Belts"](#)

MEMORY FUNCTION DOES NOT OPERATE

< SYMPTOM DIAGNOSIS >

[AUTOMATIC AIR CONDITIONER]

MEMORY FUNCTION DOES NOT OPERATE

Memory Function Check

INFOID:000000001277548

SYMPTOM: Memory function does not operate.

INSPECTION FLOW

1. CONFIRM SYMPTOM BY PERFORMING OPERATIONAL CHECK - MEMORY FUNCTION

1. Set the temperature to 32°C (90°F).
2. Rotate the front blower control dial (driver) to turn system OFF.
3. Turn ignition switch OFF.
4. Turn ignition switch ON.
5. Press the AUTO switch.
6. Confirm that the set temperature remains at previous temperature.
7. Rotate the front blower control dial (LH) to turn system OFF.

Can the symptom be duplicated?

- YES >> GO TO 3.
NO >> GO TO 2.

2. PERFORM COMPLETE OPERATIONAL CHECK

Perform a complete operational check and check for any symptoms. Refer to [HAC-4, "Operational Check \(Front\)"](#).

Can a symptom be duplicated?

- YES >> Refer to [HAC-3, "How to Perform Trouble Diagnosis For Quick And Accurate Repair"](#).
NO >> System OK.

3. CHECK FOR SERVICE BULLETINS

Check for any service bulletins.

>> GO TO 4.

4. PERFORM SELF-DIAGNOSIS

Perform self-diagnosis to check for any codes. Refer to [HAC-22, "A/C Auto Amp. Self-Diagnosis"](#).

Are any self-diagnosis codes present?

- YES >> Refer to [HAC-23, "A/C System Self-Diagnosis Code Chart"](#).
NO >> GO TO 5.

5. CHECK POWER AND GROUND CIRCUIT

Check main power supply and ground circuit. Refer to [HAC-88, "A/C Auto Amp. Component Function Check"](#).

Is the inspection result normal?

- YES >> GO TO 6.
NO >> Repair or replace as necessary.

6. RECHECK FOR SYMPTOMS

Perform a complete operational check for any symptoms. Refer to [HAC-4, "Operational Check \(Front\)"](#).

Does another symptom exist?

- YES >> Refer to [HAC-3, "How to Perform Trouble Diagnosis For Quick And Accurate Repair"](#).
NO >> Replace A/C Auto amp. Refer to [VTL-7, "Removal and Installation"](#).

PRECAUTION

PRECAUTIONS

Supplemental Restraint System (SRS) "AIR BAG" and "SEAT BELT PRE-TENSIONER"

INFOID:000000001277549

The Supplemental Restraint System such as "AIR BAG" and "SEAT BELT PRE-TENSIONER", used along with a front seat belt, helps to reduce the risk or severity of injury to the driver and front passenger for certain types of collision. This system includes seat belt switch inputs and dual stage front air bag modules. The SRS system uses the seat belt switches to determine the front air bag deployment, and may only deploy one front air bag, depending on the severity of a collision and whether the front occupants are belted or unbelted. Information necessary to service the system safely is included in the SR and SB section of this Service Manual.

WARNING:

- To avoid rendering the SRS inoperative, which could increase the risk of personal injury or death in the event of a collision which would result in air bag inflation, all maintenance must be performed by an authorized NISSAN/INFINITI dealer.
- Improper maintenance, including incorrect removal and installation of the SRS, can lead to personal injury caused by unintentional activation of the system. For removal of Spiral Cable and Air Bag Module, see the SR section.
- Do not use electrical test equipment on any circuit related to the SRS unless instructed to in this Service Manual. SRS wiring harnesses can be identified by yellow and/or orange harnesses or harness connectors.

Working with HFC-134a (R-134a)

INFOID:000000001277551

WARNING:

- CFC-12 (R-12) refrigerant and HFC-134a (R-134a) refrigerant are not compatible. If the refrigerants are mixed compressor failure is likely to occur. Refer to [HA-4, "Contaminated Refrigerant"](#). To determine the purity of HFC-134a (R-134a) in the vehicle and recovery tank, use Refrigerant Recovery/ Recycling Recharging equipment and Refrigerant Identifier.
- Use only specified oil for the HFC-134a (R-134a) A/C system and HFC-134a (R-134a) components. If oil other than that specified is used, compressor failure is likely to occur.
- The specified HFC-134a (R-134a) oil rapidly absorbs moisture from the atmosphere. The following handling precautions must be observed:
 - When removing refrigerant components from a vehicle, immediately cap (seal) the component to minimize the entry of moisture from the atmosphere.
 - When installing refrigerant components to a vehicle, do not remove the caps (unseal) until just before connecting the components. Connect all refrigerant loop components as quickly as possible to minimize the entry of moisture into system.
 - Only use the specified oil from a sealed container. Immediately reseal containers of oil. Without proper sealing, oil will become moisture saturated and should not be used.
 - Avoid breathing A/C refrigerant and oil vapor or mist. Exposure may irritate eyes, nose and throat. Remove HFC-134a (R-134a) from the A/C system using certified service equipment meeting requirements of SAE J2210 [HFC-134a (R-134a) recycling equipment], or J2209 [HFC-134a (R-134a) recycling equipment], If accidental system discharge occurs, ventilate work area before resuming service. Additional health and safety information may be obtained from refrigerant and oil manufacturers.
 - Do not allow A/C oil to come in contact with styrofoam parts. Damage may result.

CONTAMINATED REFRIGERANT

If a refrigerant other than pure HFC-134a (R-134a) is identified in a vehicle, your options are:

- Explain to the customer that environmental regulations prohibit the release of contaminated refrigerant into the atmosphere.
- Explain that recovery of the contaminated refrigerant could damage your service equipment and refrigerant supply.
- Suggest the customer return the vehicle to the location of previous service where the contamination may have occurred.
- If you choose to perform the repair, recover the refrigerant using only **dedicated equipment and containers. Do not recover contaminated refrigerant into your existing service equipment.** If your facility does

PRECAUTIONS

[AUTOMATIC AIR CONDITIONER]

< PRECAUTION >

not have dedicated recovery equipment, you may contact a local refrigerant product retailer for available service. This refrigerant must be disposed of in accordance with all federal and local regulations. In addition, replacement of all refrigerant system components on the vehicle is recommended.

- If the vehicle is within the warranty period, the air conditioner warranty is void. Please contact NISSAN Customer Affairs for further assistance.

Precaution for Service Equipment

INFOID:000000001277552

MANIFOLD GAUGE SET

Be certain that the gauge face indicates R-134a or 134a. Make sure the gauge set has 1/2"-16 ACME threaded connections for service hoses. Confirm the set has been used only with refrigerant HFC-134a (R-134a) along with specified oil.

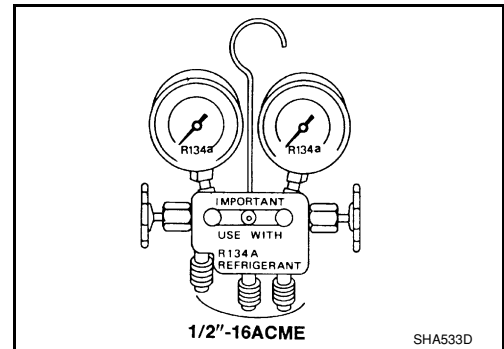

SERVICE HOSES

Be certain that the service hoses display the markings described (colored hose with black stripe). All hoses must include positive shut-off devices (either manual or automatic) near the end of the hoses opposite the manifold gauge.

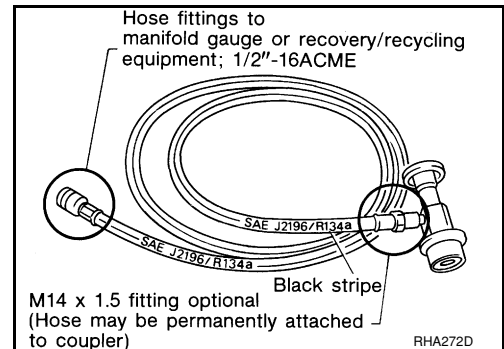

SERVICE COUPLERS

Never attempt to connect HFC-134a (R-134a) service couplers to a CFC-12 (R-12) A/C system. The HFC-134a (R-134a) couplers will not properly connect to the CFC-12 (R-12) system. However, if an improper connection is attempted, discharging and contamination may occur.

Shut-off valve rotation	A/C service valve
Clockwise	Open
Counterclockwise	Close

