

SECTION **PB**
PARKING BRAKE SYSTEM

A
B
C
D
E
PB
G
H
I
J
K
L
M
N
O
P

CONTENTS

PREPARATION	2	Removal and Installation	5
PREPARATION	2	PARKING BRAKE SHOE	7
Commercial Service Tool	2	Removal and Installation	7
ON-VEHICLE MAINTENANCE	3	SERVICE DATA AND SPECIFICATIONS (SDS)	9
PARKING BRAKE SYSTEM	3	SERVICE DATA AND SPECIFICATIONS (SDS)	9
On-Vehicle Service	3	Parking Brake	9
ON-VEHICLE REPAIR	5	Parking Brake Control	9
PARKING BRAKE CONTROL	5		
Component	5		

PREPARATION

< PREPARATION >

PREPARATION

PREPARATION

Commercial Service Tool

INFOID:000000001531298

The actual shapes of Kent-Moore tools may differ from those of special service tools illustrated here.

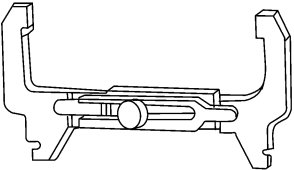
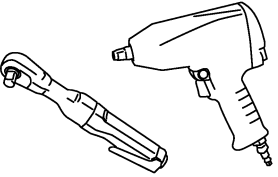
Tool number (Kent-Moore No.) Tool name		Description
— (J-21177-A) Brake drum clearance gauge	 WFIA0167E	Measuring rear rotor drum to parking brake shoe clearance
Power tool	 PBIC0190E	Loosening bolts and nuts

PARKING BRAKE SYSTEM

< ON-VEHICLE MAINTENANCE >

ON-VEHICLE MAINTENANCE

PARKING BRAKE SYSTEM

On-Vehicle Service

INFOID:000000001531299

PEDAL STROKE

- When parking brake pedal is operated with the specified force, make sure the stroke is within the specified number of notches. Check by listening and counting the ratchet clicks.

Pedal stroke : 3 – 4 notches [under force of 196 N (20.0 kg-f, 44.1 lb-f)]

INSPECTION

- Make sure the components are attached properly, checking for looseness or backlash.
- Check parking brake pedal assembly for bends, damage and cracks, and replace if necessary.
- Check cable for wear and damage, and replace if necessary.
- Check parking brake warning lamp switch for malfunction, and replace if necessary. Refer to [MWI-44, "Wiring Diagram"](#).

ADJUSTMENT

1. Remove the lower instrument panel LH. Refer to [IP-11, "Removal and Installation"](#).
2. Partially engage parking brake pedal to access adjusting nut.
3. Insert a deep socket wrench to rotate adjusting nut and loosen cable sufficiently. Then, disengage the parking brake pedal.

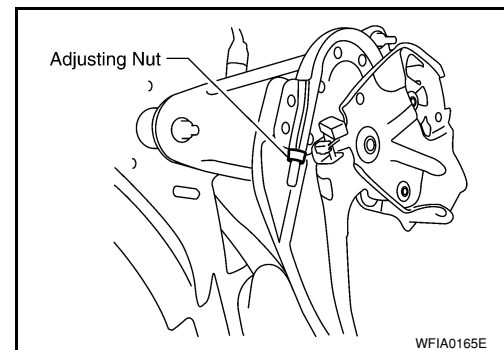

4. Remove the wheel and tire using power tool.
5. Remove the disc rotor and measure inner diameter at widest point using Tool.

Tool number : — (J-21177-A)

6. Transfer measurement less 0.6 mm to the parking brake shoes and adjust accordingly.
7. Using wheel nuts, secure the disc rotor to the hub to prevent it from tilting.
8. Rotate the disc rotor to make sure there is no drag.
9. Adjust cable as follows:
 - a. Operate pedal 10 or more times with a force of 490 N (50 kg-f, 110 lb-f).
 - b. Rotate adjusting nut with deep socket to adjust pedal stroke to specification.

Pedal stroke : 3 – 4 notches [under force of 196 N (20.0 kg-f, 44.1 lb-f)]

- c. With parking brake pedal completely disengaged, make sure there is no drag on the parking brake.
10. Install the disc rotor.
 11. Install the wheel and tire using power tool.

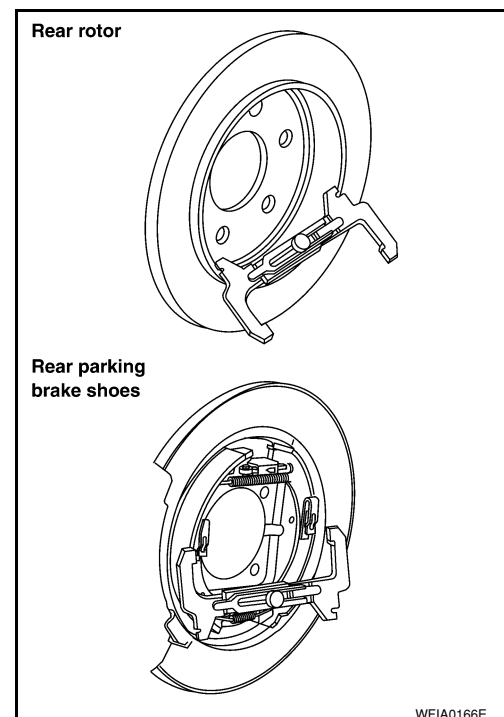

PARKING BRAKE SYSTEM

< ON-VEHICLE MAINTENANCE >

12. Install the lower instrument panel LH. Refer to [IP-11. "Removal and Installation"](#).

PARKING BRAKE CONTROL

< ON-VEHICLE REPAIR >

ON-VEHICLE REPAIR PARKING BRAKE CONTROL

Component

INFOID:000000001531300

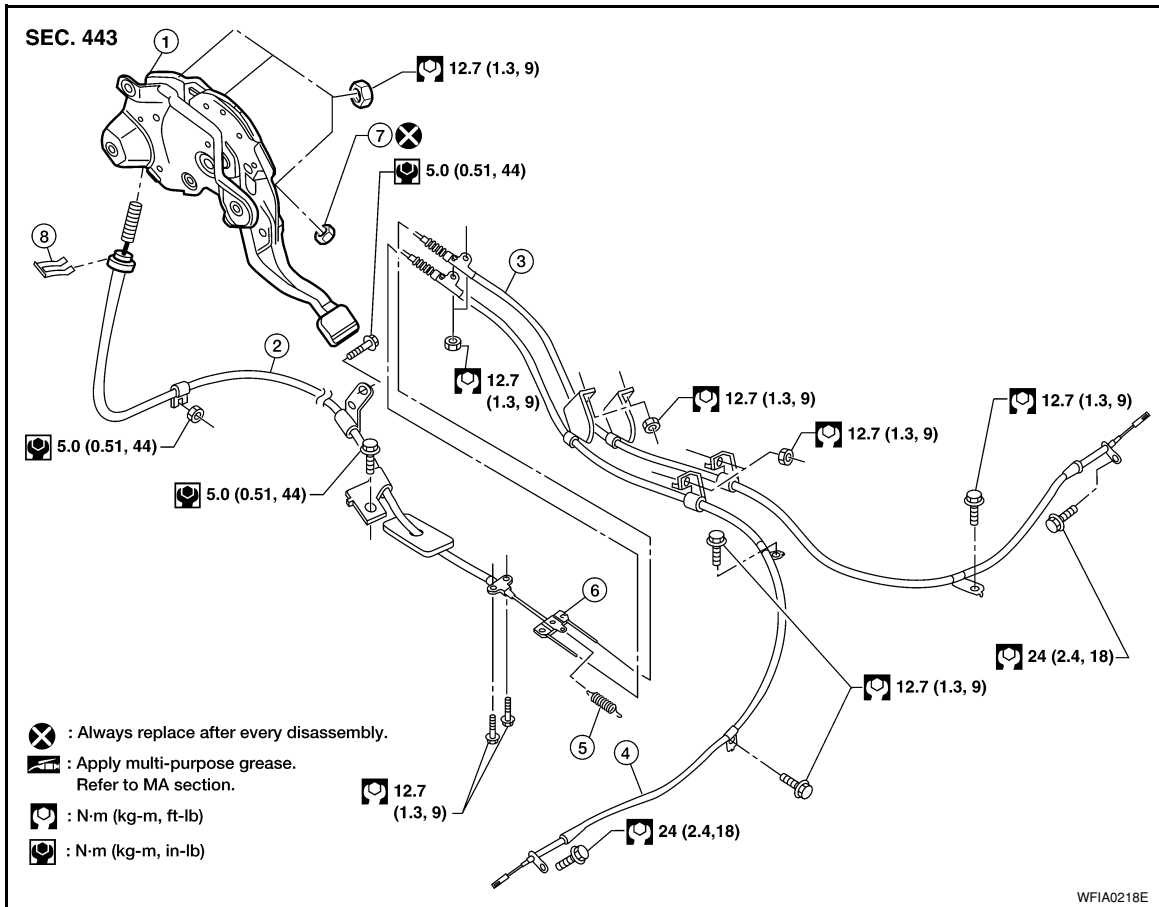

- | | | |
|--------------------|------------------|---------------------|
| 1. Pedal assembly | 2. Front cable | 3. Right rear cable |
| 4. Left rear cable | 5. Return spring | 6. Equalizer |
| 7. Adjusting nut | 8. Lock plate | |

Removal and Installation

INFOID:000000001531301

REMOVAL

1. Remove lower instrument panel. Refer to [IP-11. "Removal and Installation"](#).
2. On models with floor shift, remove center console. Refer to [IP-19. "Removal and Installation"](#).
3. Remove floor trim. Refer to [INT-15. "Removal and Installation"](#).
4. Remove adjusting nut.
5. Remove the lock plate from the front cable.
6. Remove front cable retaining bolts and nut.
7. Disconnect return spring from equalizer.
8. Disconnect right and left rear cables from equalizer.
9. Remove rear disc rotors. Refer to [BR-41. "Removal and Installation of Brake Caliper and Disc Rotor"](#).
10. Remove parking brake shoe, and remove rear cable from toggle lever. Refer to [PB-5. "Component"](#).

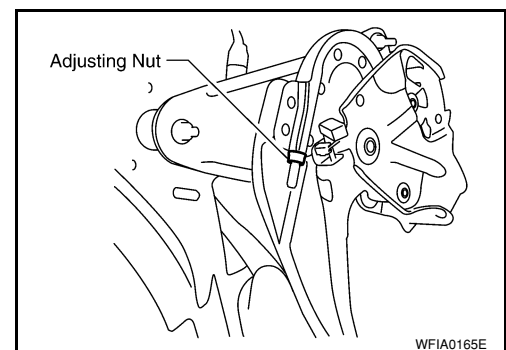

PARKING BRAKE CONTROL

< ON-VEHICLE REPAIR >

11. Remove right and left rear cables retaining bolts and nuts, then remove right and left rear cables.

INSTALLATION

Installation is in the reverse order of removal.

CAUTION:

Do not reuse adjusting nut after removing it.

- Adjust parking brake. Refer to [PB-3, "On-Vehicle Service"](#).

PARKING BRAKE SHOE

< ON-VEHICLE REPAIR >

PARKING BRAKE SHOE

Removal and Installation

INFOID:000000001531302

COMPONENTS

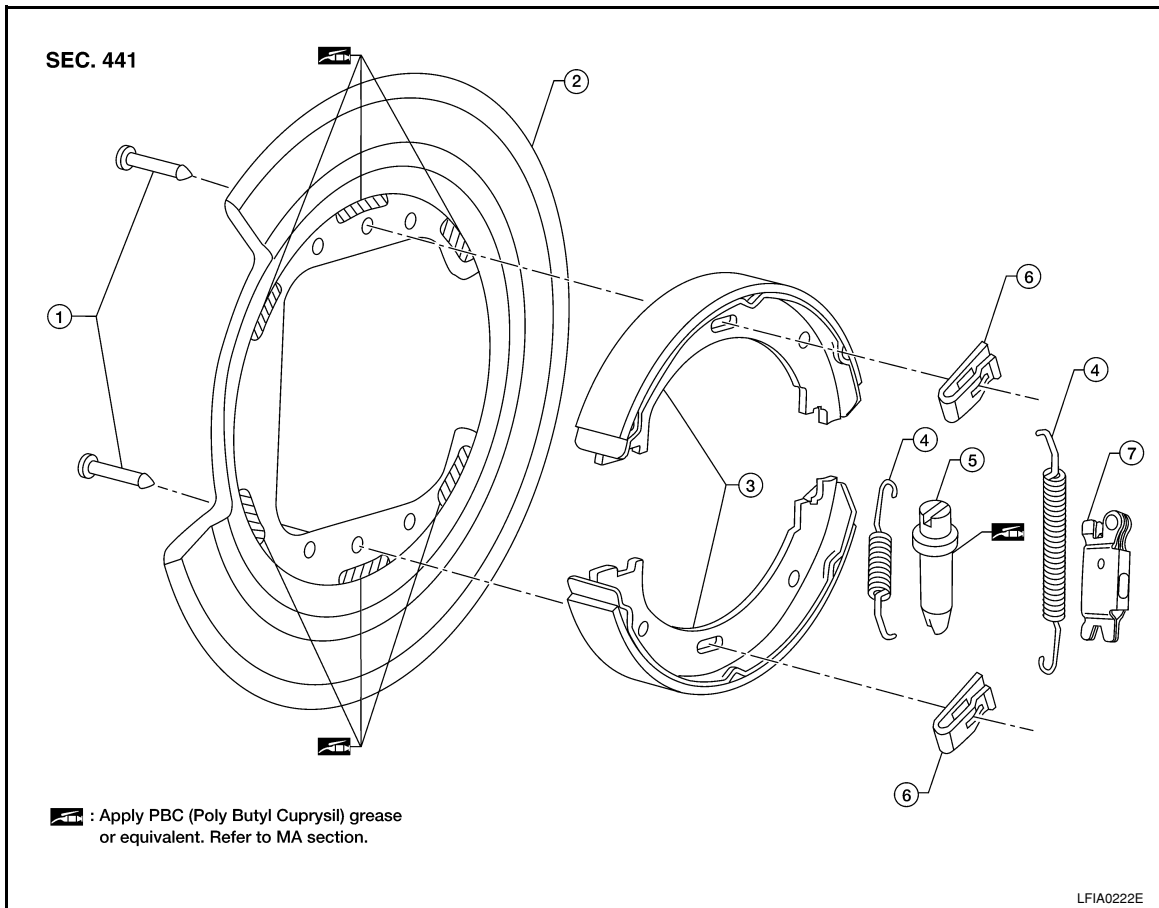

- | | | |
|---------------------|---------------|--------------|
| 1. Anti-rattle pins | 2. Back plate | 3. Shoes |
| 4. Return springs | 5. Adjuster | 6. Retainers |
| 7. Toggle lever | | |

REMOVAL

WARNING:

Clean the brakes with a vacuum dust collector to minimize the hazard of airborne particles or other materials.

NOTE:

Remove the disc rotor only with the parking brake pedal completely in the released position.

1. Remove the rear disc rotor. Refer to [BR-41. "Removal and Installation of Brake Caliper and Disc Rotor"](#).
2. Remove the return springs.
3. Remove the adjuster.
4. Disconnect the rear cable from the toggle lever, if necessary.
 - Remove pin retainer and withdraw cable end from toggle lever.
5. Remove the retainers, anti-rattle pins and shoes.

INSPECTION AFTER REMOVAL

Lining Thickness Inspection

PARKING BRAKE SHOE

< ON-VEHICLE REPAIR >

- Check thickness of lining.

Standard thickness "A" : 3.79 ± 0.21 mm
(0.149 ± 0.008 in)
Wear limit thickness "A" : 0.5 mm (0.020 in)

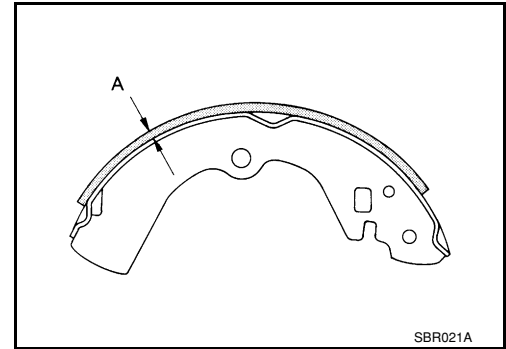

Disc Rotor Inner Diameter Inspection

- Check inner diameter inside drum area of disc rotor.

Standard inner diameter : 205 ± 0.13 mm (8.07 ± 0.01 in)
Wear limit of inner diameter : 205.7 mm (8.10 in)

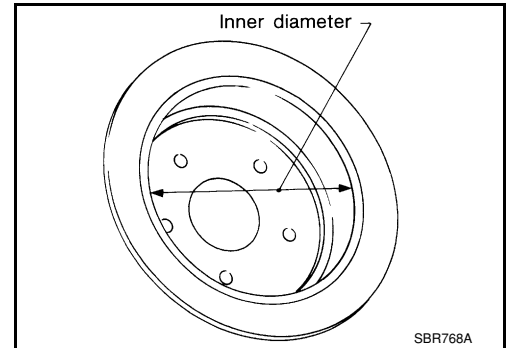

Other Inspections

- Check shoe sliding surface on back plate for excessive wear and damage.
- Check anti-rattle pins for excessive wear and corrosion.
- Check return springs for sagging.
- Check adjuster for rough operation.
- When disassembling adjuster, apply PBC (Poly Butyl Cuprysil) grease or equivalent to the threads.
- Check either visually or with a vernier caliper to see if there is any excessive wear, cracks, or damage inside drum area of disc rotor.

INSTALLATION

Installation is in the reverse order of removal.

- Refer to "COMPONENTS" and apply brake grease to the specified points during assembly.
- Assemble adjuster so that threaded part expands when rotating it in the direction shown by the arrow.
- Shorten adjuster by rotating it.

NOTE:

After replacing brake shoes or disc rotors, or if brakes do not function well, perform break-in operation as follows.

1. Adjust parking brake pedal stroke. Refer to [PB-3, "On-Vehicle Service"](#).

CAUTION:

- To prevent lining from getting too hot, allow a cool off period of approximately 5 minutes after every break-in operation.
- Do not perform excessive break-in operations, because it may cause uneven or early wear of lining.

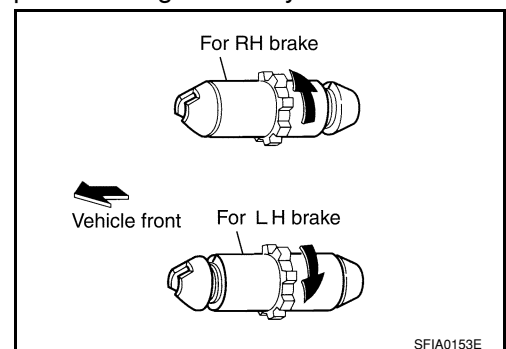

2. Perform parking brake burnishing operation by driving the vehicle forward under the following conditions:

- Vehicle speed at 40 km/h (25 MPH)
- Parking brake operating force of 196 N (20.0 kg-f, 44.1 lb-f) set
- For a period of 30 seconds

3. After burnishing operation, check pedal stroke of parking brake. Readjust if it is no longer at the specified stroke. Refer to [PB-3, "On-Vehicle Service"](#).

SERVICE DATA AND SPECIFICATIONS (SDS)

< SERVICE DATA AND SPECIFICATIONS (SDS)

SERVICE DATA AND SPECIFICATIONS (SDS)

SERVICE DATA AND SPECIFICATIONS (SDS)

Parking Brake

INFOID:000000001531303

Unit: mm (in)

Type		Disc rotor with inner drum
Brake lining	Standard thickness (new)	3.79 ± 0.21 (0.149 ± 0.008)
	Wear limit thickness	0.5 (0.020)
Drum inner diameter (disc)	Standard inner diameter (new)	205 ± 0.13 (8.07 ± 0.01)
	Wear limit of inner diameter	205.7 (8.10)

Parking Brake Control

INFOID:000000001531304

Control type	Foot pedal
Number of notches [under force of 196 N (20.0 kg-f, 44.1 lb-f)]	3 – 4 notches
Number of notches when warning lamp switch comes on	1 notch