

# SECTION **PWC**

## POWER WINDOW CONTROL SYSTEM

A  
B  
C  
D  
E  
F  
G  
H  
I  
J  
L  
M  
N  
O  
P

### CONTENTS

<p><b>BASIC INSPECTION</b> ..... 4</p> <p><b>DIAGNOSIS AND REPAIR WORKFLOW</b> ..... 4</p> <p style="padding-left: 20px;">Work Flow .....4</p> <p><b>FUNCTION DIAGNOSIS</b> ..... 6</p> <p><b>POWER WINDOW SYSTEM</b> ..... 6</p> <p style="padding-left: 20px;">System Diagram .....6</p> <p style="padding-left: 20px;">System Description .....6</p> <p style="padding-left: 20px;">Component Parts Location .....8</p> <p style="padding-left: 20px;">Component Description .....9</p> <p><b>DIAGNOSIS SYSTEM (BCM)</b> .....10</p> <p><b>COMMON ITEM</b> .....10</p> <p style="padding-left: 20px;">COMMON ITEM : CONSULT-III Function (BCM - COMMON ITEM) ..... 10</p> <p><b>RETAINED PWR</b> .....10</p> <p style="padding-left: 20px;">RETAINED PWR : CONSULT-III Function (BCM - RETAINED PWR) ..... 10</p> <p><b>COMPONENT DIAGNOSIS</b> .....11</p> <p><b>POWER SUPPLY AND GROUND CIRCUIT</b> .....11</p> <p><b>POWER WINDOW MAIN SWITCH</b> ..... 11</p> <p style="padding-left: 20px;">POWER WINDOW MAIN SWITCH : Description.... 11</p> <p style="padding-left: 20px;">POWER WINDOW MAIN SWITCH : Component Function Check ..... 11</p> <p style="padding-left: 20px;">POWER WINDOW MAIN SWITCH : Diagnosis Procedure ..... 11</p> <p style="padding-left: 20px;">POWER WINDOW MAIN SWITCH : Component Inspection ..... 14</p> <p><b>FRONT POWER WINDOW SWITCH</b> ..... 15</p> <p style="padding-left: 20px;">FRONT POWER WINDOW SWITCH : Description ..... 15</p> <p style="padding-left: 20px;">FRONT POWER WINDOW SWITCH : Component Function Check ..... 15</p> <p style="padding-left: 20px;">FRONT POWER WINDOW SWITCH : Diagnosis Procedure ..... 15</p>	<p><b>REAR POWER WINDOW SWITCH</b> .....17</p> <p style="padding-left: 20px;">REAR POWER WINDOW SWITCH : Description....17</p> <p style="padding-left: 20px;">REAR POWER WINDOW SWITCH : Component Function Check .....17</p> <p style="padding-left: 20px;">REAR POWER WINDOW SWITCH : Diagnosis Procedure .....17</p> <p style="padding-left: 20px;">REAR POWER WINDOW SWITCH : Component Inspection .....19</p> <p><b>POWER WINDOW MOTOR</b> .....20</p> <p><b>DRIVER SIDE</b> .....20</p> <p style="padding-left: 20px;">DRIVER SIDE : Description .....20</p> <p style="padding-left: 20px;">DRIVER SIDE : Component Function Check .....20</p> <p style="padding-left: 20px;">DRIVER SIDE : Diagnosis Procedure .....20</p> <p style="padding-left: 20px;">DRIVER SIDE : Component Inspection .....21</p> <p><b>PASSENGER SIDE</b> .....21</p> <p style="padding-left: 20px;">PASSENGER SIDE : Description .....21</p> <p style="padding-left: 20px;">PASSENGER SIDE : Component Function Check .....21</p> <p style="padding-left: 20px;">PASSENGER SIDE : Diagnosis Procedure .....21</p> <p style="padding-left: 20px;">PASSENGER SIDE : Component Inspection .....22</p> <p><b>REAR LH</b> .....23</p> <p style="padding-left: 20px;">REAR LH : Description .....23</p> <p style="padding-left: 20px;">REAR LH : Component Function Check .....23</p> <p style="padding-left: 20px;">REAR LH : Diagnosis Procedure .....23</p> <p style="padding-left: 20px;">REAR LH : Component Inspection .....24</p> <p><b>REAR RH</b> .....24</p> <p style="padding-left: 20px;">REAR RH : Description .....24</p> <p style="padding-left: 20px;">REAR RH : Component Function Check .....24</p> <p style="padding-left: 20px;">REAR RH : Diagnosis Procedure .....25</p> <p style="padding-left: 20px;">REAR RH : Component Inspection .....26</p> <p><b>ENCODER</b> .....27</p> <p><b>DRIVER SIDE</b> .....27</p> <p style="padding-left: 20px;">DRIVER SIDE : Description .....27</p> <p style="padding-left: 20px;">DRIVER SIDE : Component Function Check .....27</p> <p style="padding-left: 20px;">DRIVER SIDE : Diagnosis Procedure .....27</p>
--	--

PWC

<b>PASSENGER SIDE</b> .....	29	Description .....	48
PASSENGER SIDE : Description .....	29	Diagnosis Procedure .....	48
PASSENGER SIDE : Component Function Check .....	29		
PASSENGER SIDE : Diagnosis Procedure .....	29		
<b>DOOR SWITCH</b> .....	33		
Description .....	33		
Component Function Check .....	33		
Diagnosis Procedure .....	33		
Component Inspection .....	34		
<b>DOOR KEY CYLINDER SWITCH</b> .....	35		
Description .....	35		
Component Function Check .....	35		
Diagnosis Procedure .....	35		
Component Inspection .....	36		
<b>POWER WINDOW SERIAL LINK</b> .....	38		
<b>POWER WINDOW MAIN SWITCH</b> .....	38		
POWER WINDOW MAIN SWITCH : Description .....	38		
POWER WINDOW MAIN SWITCH : Component Function Check .....	38		
POWER WINDOW MAIN SWITCH : Diagnosis Procedure .....	38		
<b>FRONT POWER WINDOW SWITCH</b> .....	39		
FRONT POWER WINDOW SWITCH : Description .....	39		
FRONT POWER WINDOW SWITCH : Component Function Check .....	39		
FRONT POWER WINDOW SWITCH : Diagnosis Procedure .....	40		
<b>POWER WINDOW LOCK SWITCH</b> .....	42		
Description .....	42		
Component Function Check .....	42		
<b>REAR POWER VENT WINDOW SWITCH CIRCUIT CHECK</b> .....	43		
Description .....	43		
Diagnosis Procedure .....	43		
<b>REAR POWER VENT WINDOW MOTOR LH CIRCUIT CHECK</b> .....	44		
Description .....	44		
Diagnosis Procedure .....	44		
<b>REAR POWER VENT WINDOW MOTOR RH CIRCUIT CHECK</b> .....	45		
Description .....	45		
Diagnosis Procedure .....	45		
<b>REAR POWER VENT WINDOW RELAY (OPEN) CHECK</b> .....	46		
Description .....	46		
Diagnosis Procedure .....	46		
<b>REAR POWER VENT WINDOW RELAY (CLOSE) CHECK</b> .....	48		
		<b>ECU DIAGNOSIS</b> .....	50
		<b>BCM (BODY CONTROL MODULE)</b> .....	50
		Reference Value .....	50
		<b>POWER WINDOW MAIN SWITCH</b> .....	51
		Reference Value .....	51
		Wiring Diagram .....	53
		Fail Safe .....	63
		<b>FRONT POWER WINDOW SWITCH</b> .....	65
		Reference Value .....	65
		Wiring Diagram .....	67
		Fail Safe .....	77
		<b>SYMPTOM DIAGNOSIS</b> .....	79
		<b>NONE OF THE POWER WINDOWS CAN BE OPERATED USING ANY SWITCH</b> .....	79
		Diagnosis Procedure .....	79
		<b>DRIVER SIDE POWER WINDOW ALONE DOES NOT OPERATE</b> .....	80
		Diagnosis Procedure .....	80
		<b>FRONT PASSENGER SIDE POWER WINDOW ALONE DOES NOT OPERATE</b> .....	81
		Diagnosis Procedure .....	81
		<b>REAR LH SIDE POWER WINDOW ALONE DOES NOT OPERATE</b> .....	82
		Diagnosis Procedure .....	82
		<b>REAR RH SIDE POWER WINDOW ALONE DOES NOT OPERATE</b> .....	83
		Diagnosis Procedure .....	83
		<b>ANTI-PINCH SYSTEM DOES NOT OPERATE NORMALLY (DRIVER SIDE)</b> .....	84
		Diagnosis Procedure .....	84
		<b>ANTI-PINCH SYSTEM DOES NOT OPERATE NORMALLY (PASSENGER SIDE)</b> .....	85
		Diagnosis Procedure .....	85
		<b>AUTO OPERATION DOES NOT OPERATE BUT MANUAL OPERATE NORMALLY (DRIVER SIDE)</b> .....	86
		Diagnosis Procedure .....	86
		<b>AUTO OPERATION DOES NOT OPERATE BUT MANUAL OPERATE NORMALLY (PASSENGER SIDE)</b> .....	87
		Diagnosis Procedure .....	87
		<b>POWER WINDOW RETAINED POWER OPERATION DOES NOT OPERATE PROPERLY</b> .....	88

Diagnosis Procedure .....	88	<b>PRECAUTION .....</b>	<b>93</b>	A
<b>DOES NOT OPERATE BY KEY CYLINDER SWITCH .....</b>	<b>89</b>	<b>PRECAUTIONS .....</b>	<b>93</b>	B
Diagnosis Procedure .....	89	Precaution for Supplemental Restraint System (SRS) "AIR BAG" and "SEAT BELT PRE-TENSIONER" .....	93	B
<b>KEYLESS POWER WINDOW DOWN DOES NOT OPERATE .....</b>	<b>90</b>	<b>ON-VEHICLE REPAIR .....</b>	<b>94</b>	C
Diagnosis Procedure .....	90	<b>POWER WINDOW MAIN SWITCH .....</b>	<b>94</b>	C
<b>POWER WINDOW LOCK SWITCH DOES NOT FUNCTION .....</b>	<b>91</b>	Removal and Installation .....	94	D
Diagnosis Procedure .....	91	<b>FRONT POWER WINDOW SWITCH .....</b>	<b>95</b>	D
<b>REAR POWER VENT WINDOWS DO NOT OPERATE .....</b>	<b>92</b>	Removal and Installation .....	95	E
Diagnosis Procedure .....	92	<b>REAR POWER WINDOW SWITCH .....</b>	<b>96</b>	E
		Removal and Installation .....	96	F
				G
				H
				I
				J
				L
				M
				N
				O
				P

# DIAGNOSIS AND REPAIR WORKFLOW

< BASIC INSPECTION >

## BASIC INSPECTION

### DIAGNOSIS AND REPAIR WORKFLOW

Work Flow

INFOID:000000001611961

WORK FLOW

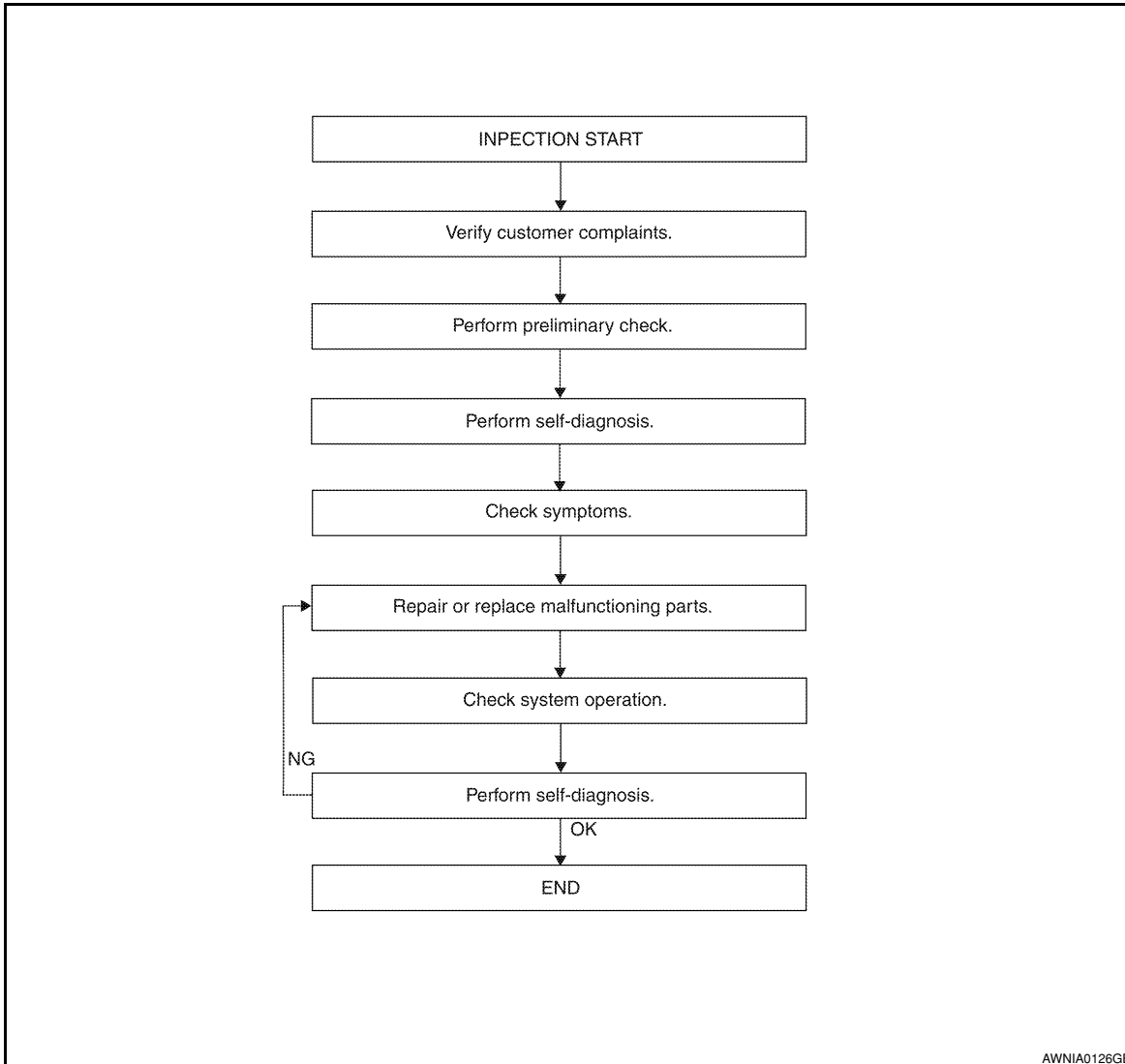

AWNIA0126GE

DETAILED FLOW

### 1. CUSTOMER INFORMATION

Interview the customer to obtain detailed information about the symptom.

>> GO TO 2

### 2. PRELIMINARY CHECK

Perform preliminary check. Refer to [SE-5, "Preliminary Check"](#).

>> GO TO 3

### 3. SELF-DIAGNOSIS

Perform self-diagnosis. Refer to [SE-29, "DTC Index"](#).

# DIAGNOSIS AND REPAIR WORKFLOW

< BASIC INSPECTION >

---

>> GO TO 4

## 4. SYMPTOM

---

Check for symptoms. Refer to [SE-31. "Symptom Table"](#).

>> GO TO 5

## 5. MALFUNCTIONING PARTS

---

Repair or replace the applicable parts.

>> GO TO 6

## 6. SYSTEM OPERATION

---

Check system operation.

>> GO TO 7

## 7. SELF-DIAGNOSIS

---

Perform self-diagnosis. Refer to [SE-29. "DTC Index"](#).

Are any fault codes indicated?

YES >> GO TO 5

NO >> Inspection End.

A

B

C

D

E

F

G

H

I

J

PWC

L

M

N

O

P

# POWER WINDOW SYSTEM

< FUNCTION DIAGNOSIS >

## FUNCTION DIAGNOSIS

### POWER WINDOW SYSTEM

#### System Diagram

INFOID:000000001611857

#### FRONT WINDOW ANTI-PINCH SYSTEM

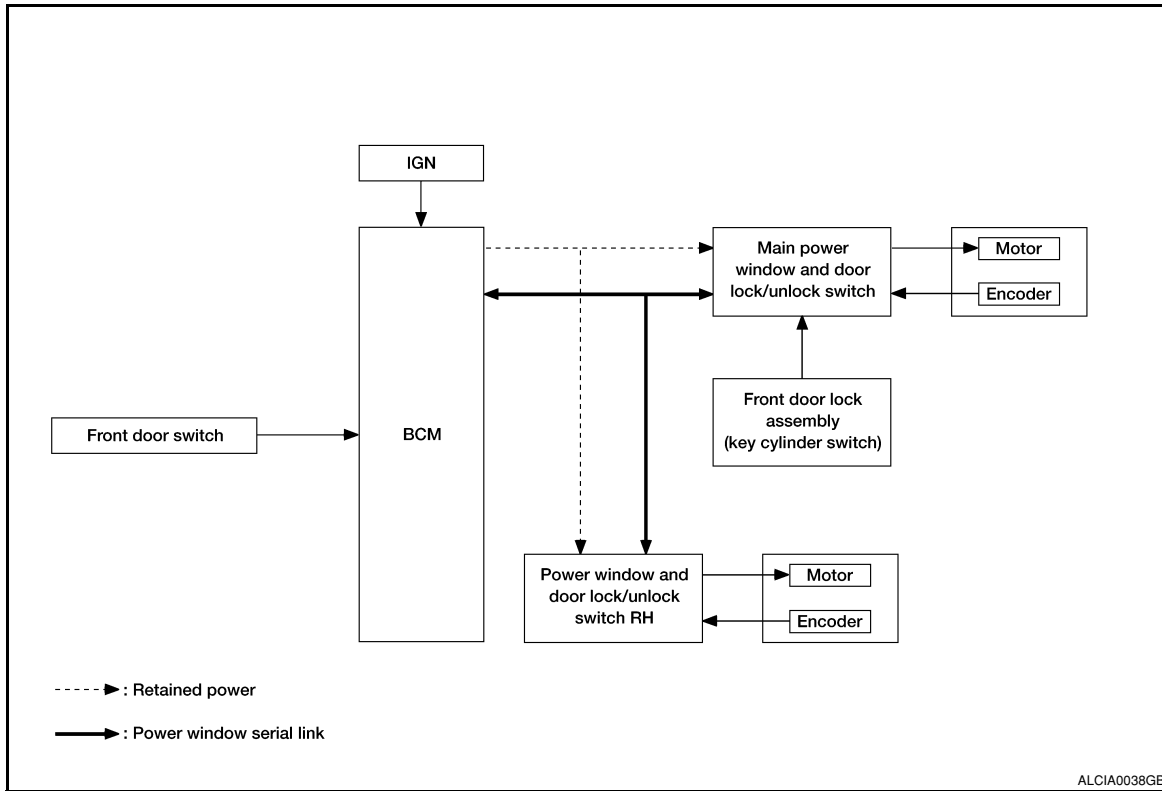

#### System Description

INFOID:000000001611858

#### POWER WINDOW MAIN SWITCH INPUT/OUTPUT SIGNAL CHART

Item	Input signal to main power window and door lock/unlock switch	Main power window and door lock/unlock switch function	Actuator
Key cylinder switch	LOCK/UNLOCK signal (more than 1.5 seconds over)	Power window control	Front power window motor
Encoder	Encoder pulse signal		
Main power window and door lock/unlock switch	Front power window motor LH UP/DOWN signal		
Power window and door lock/unlock switch RH	Front power window motor RH UP/DOWN signal		
BCM	RAP signal		
Rear power window switch	Rear power window motor UP/DOWN signal		Rear power window motor

#### POWER WINDOW AND DOOR LOCK/UNLOCK SWITCH INPUT/OUTPUT SIGNAL CHART

# POWER WINDOW SYSTEM

## < FUNCTION DIAGNOSIS >

Item	Input signal to front power window switch	Front power window switch function	Actuator
Power window and door lock/unlock switch RH	Front power window motor RH UP/DOWN signal	Power window control	Front power window motor RH
Encoder	Encoder pulse signal		
BCM	RAP signal		

### POWER WINDOW OPERATION

- Power window system is operable during the retained power operation timer after turning ignition switch ON and OFF.
- Main power window and door lock/unlock switch can open/close all windows.
- Power window and door lock unlock switch RH & rear power window switches LH and RH can open/close the corresponding windows.

### REAR POWER VENT WINDOW OPERATION (IF EQUIPPED)

- Rear power vent window system is operable during the retained power operation timer after turning ignition switch ON and OFF.
- Rear power vent window switch can open/close the rear power vent window LH and RH.

### POWER WINDOW AUTO-OPERATION (FRONT LH & RH)

- AUTO UP/DOWN operation can be performed when main power window and door lock/unlock switch & power window and door lock/unlock switch RH turns to AUTO.
- Encoder continues detecting the movement of power window motor and transmits to power window switch as the encoder pulse signal while power window motor is operating.
- Power window switch reads the changes of encoder signal and stops AUTO operation when door glass is at fully opened/closed position.
- Power window motor is operable in case encoder is malfunctioning.

### RETAINED POWER OPERATION

- Retained power operation is an additional power supply function that enables power window system to operate during the 45 seconds even when ignition switch is turned OFF

#### Retained power function cancel conditions

- Front door CLOSE (door switch OFF)→OPEN (door switch ON).
- When ignition switch is ON.
- When timer time passes. (45 seconds)

### POWER WINDOW LOCK

Ground circuit inside main power window and door lock/unlock switch shuts off when power window lock switch is ON. This inhibits power window switch operation except with the main power window and door lock/unlock switch.

### ANTI-PINCH OPERATION (FRONT LH & RH)

- Pinch foreign material in the door glass during AUTO-UP operation, and it is the anti-pinch function that lowers the door glass 150 mm (5.91 in) or 2 seconds when detected.
- Encoder continues detecting the movement of power window motor and transmits to power window switch as the encoder pulse signal while power window motor is operating.
- Resistance is applied to the power window motor rotation that changes the frequency of encoder pulse signal if foreign material is trapped in the door glass.
- Power window switch controls to lower the window glass for 150 mm (5.91 in) or 2 seconds after it detects encoder pulse signal frequency change.

### OPERATION CONDITION

- When all door glass AUTO-UP operation is performed (anti-pinch function does not operate just before the door glass closes and is fully closed)

#### NOTE:

Depending on environment and driving conditions, if a similar impact or load is applied to the door glass, it may lower.

### KEY CYLINDER SWITCH OPERATION

A  
B  
C  
D  
E  
F  
G  
H  
I  
J

PWC

L  
M  
N  
O  
P

# POWER WINDOW SYSTEM

## < FUNCTION DIAGNOSIS >

Hold the door key cylinder to the LOCK or UNLOCK direction for more than 1 second to OPEN or CLOSE front power windows when ignition switch is OFF. In addition, it stops when key position is moved to NEUTRAL when operating.

### OPERATION CONDITION

- Ignition switch OFF
- Hold door key cylinder to LOCK position for more than 1 second to perform CLOSE operation of the door glass.
- Hold door key cylinder to UNLOCK position for more than 1 second to perform OPEN operation of the door glass.

### KEYLESS POWER WINDOW DOWN OPERATION (FRONT LH & RH)

Front power windows open when the unlock button on Intelligent Key or keyfob is activated and kept pressed for more than 3<sup>(NOTE)</sup> seconds with the ignition switch OFF. The windows keep opening if the unlock button is continuously pressed.

The power window opening stops when the following operations are performed:

- When the unlock button is kept pressed more than 15 seconds.
- When the ignition switch is turned ON while the power window opening is operated.
- When the unlock button is released.

While retained power operation activate, keyless power window down function cannot be operated.

### NOTE:

Keyless power window down operation mode can be changed by "PW DOWN SET" mode in "WORK SUPPORT". Refer to [DLK-40. "INTELLIGENT KEY : CONSULT-III Function \(BCM - INTELLIGENT KEY\)"](#) with Intelligent Key or [DLK-38. "REMOTE KEYLESS ENTRY : CONSULT-III Function \(BCM - RKE\)"](#) with remote keyless entry system.

### NOTE:

Use CONSULT-III to change settings.  
MODE1 (3sec)/MODE2 (OFF)/MODE3 (5sec)

## Component Parts Location

INFOID:000000001611859

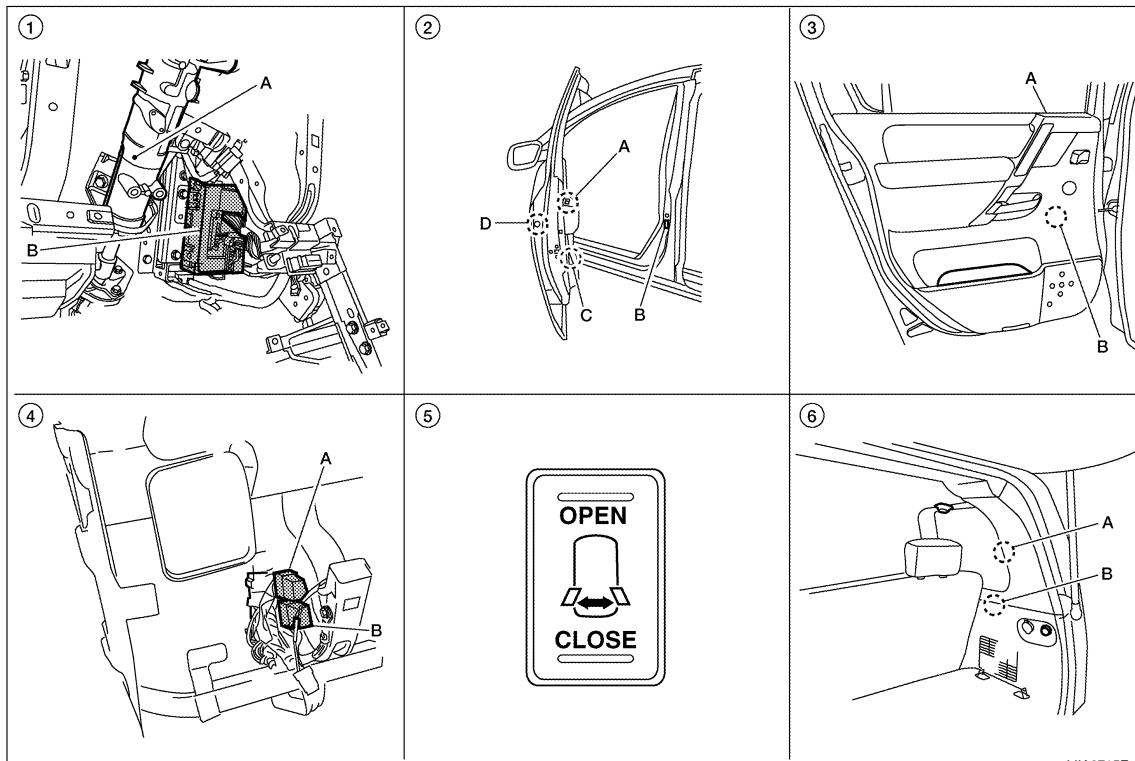

LIA2715E



# POWER WINDOW SYSTEM

## < FUNCTION DIAGNOSIS >

- |  |   |  |             |
|--|---|--|-------------|
| 1. A. Steering column<br>B. BCM M18, M19, M20 (view with instrument panel removed)           | 2. A. Main power window and door lock/unlock switch D7, D8<br>Power window and door lock/unlock switch RH D105<br>B. Front door switch LH B8, RH B108<br>C. Front power window motor LH D9, RH D104<br>D. Front door lock actuator LH (key cylinder switch) | 3. A. Rear power window switch LH D203, RH D303<br>B. Rear power window motor LH D204, RH D304 | A<br>B<br>C |
| 4. A. Rear power vent window relay (CLOSE) M89<br>B. Rear power vent window relay (OPEN) M87 | 5. Rear power vent window switch M95  | 6. A. Rear power vent window motor LH B52, RH B150<br>B. Condenser-3 B119<br>Condenser-4 B120  | D<br>E      |

## Component Description

INFOID:000000001611860

## FRONT WINDOW ANTI-PINCH SYSTEM

Component	Function
BCM	<ul style="list-style-type: none"> <li>Supplies power supply to power window switch.</li> <li>Controls retained power.</li> </ul>
Main power window and door lock/unlock switch	<ul style="list-style-type: none"> <li>Directly controls all power window motor of all doors.</li> <li>Controls anti-pinch operation of front power window LH.</li> </ul>
Power window and door lock/unlock switch RH	<ul style="list-style-type: none"> <li>Controls front power window motor RH.</li> <li>Controls anti-pinch operation of front power window RH.</li> </ul>
Rear power window switch	<ul style="list-style-type: none"> <li>Controls rear power window motors LH and RH.</li> </ul>
Front power window motor LH	<ul style="list-style-type: none"> <li>Integrates the ENCODER POWER and WINDOW MOTOR.</li> <li>Starts operating with signals from main power window and door lock/unlock switch.</li> <li>Transmits power window motor rotation as a pulse signal to main power window and door lock/unlock switch.</li> </ul>
Front power window motor RH	Starts operating with signals from main power window and door lock/unlock switch & power window and door lock/unlock switch RH.
Rear power window motor	Starts operating with signals from main power window and door lock/unlock switch & rear power window switch.
Front door lock assembly LH (key cylinder switch)	Transmits operation condition of key cylinder switch to power window main switch.
Front door switch LH or RH	Detects door open/close condition and transmits to BCM.

PWC

# DIAGNOSIS SYSTEM (BCM)

< FUNCTION DIAGNOSIS >

## DIAGNOSIS SYSTEM (BCM)

### COMMON ITEM

COMMON ITEM : CONSULT-III Function (BCM - COMMON ITEM)

INFOID:000000001611861

### APPLICATION ITEM

CONSULT-III performs the following functions via CAN communication with BCM.

Diagnosis mode	Function Description
WORK SUPPORT	Changes the setting for each system function.
SELF-DIAG RESULTS	Displays the diagnosis results judged by BCM. Refer to <a href="#">BCS-51, "DTC Index"</a> .
CAN DIAG SUPPORT MNTR	Monitors the reception status of CAN communication viewed from BCM.
DATA MONITOR	The BCM input/output signals are displayed.
ACTIVE TEST	The signals used to activate each device are forcibly supplied from BCM.
ECU IDENTIFICATION	The BCM part number is displayed.
CONFIGURATION	This function is not used even though it is displayed.

### SYSTEM APPLICATION

BCM can perform the following functions for each system.

#### NOTE:

It can perform the diagnosis modes except the following for all sub system selection items.

System	Sub system selection item	Diagnosis mode		
		WORK SUPPORT	DATA MONITOR	ACTIVE TEST
BCM	BCM	×		
RAP system	RETAINED PWR		×	

### RETAINED PWR

RETAINED PWR : CONSULT-III Function (BCM - RETAINED PWR)

INFOID:000000001611862

### Data monitor

Monitor Item	Description
DOOR SW-DR	Indicates [ON/OFF] condition of front door switch LH.
DOOR SW-AS	Indicates [ON/OFF] condition of front door switch RH.

# POWER SUPPLY AND GROUND CIRCUIT

< COMPONENT DIAGNOSIS >

## COMPONENT DIAGNOSIS

### POWER SUPPLY AND GROUND CIRCUIT

#### POWER WINDOW MAIN SWITCH

#### POWER WINDOW MAIN SWITCH : Description

INFOID:000000001611863

- BCM supplies power.
- It operates each power window motor via corresponding power window switch and makes window move up/down when main power window and door lock/unlock switch is operated.

#### POWER WINDOW MAIN SWITCH : Component Function Check

INFOID:000000001611864

#### Main Power Window And Door Lock/Unlock Switch

#### 1. CHECK MAIN POWER WINDOW AND DOOR LOCK/UNLOCK SWITCH FUNCTION

Does power window motor operate with main power window and door lock/unlock switch operation?

Is the inspection result normal?

- YES >> Main power window and door lock/unlock switch power supply and ground circuit are OK.  
 NO >> Refer to [PWC-11, "POWER WINDOW MAIN SWITCH : Diagnosis Procedure"](#).

#### POWER WINDOW MAIN SWITCH : Diagnosis Procedure

INFOID:000000001611865

#### Main Power Window And Door Lock/Unlock Switch Power Supply Circuit Check

#### 1. CHECK POWER SUPPLY CIRCUIT

1. Turn ignition switch ON.
2. Check voltage between main power window and door lock/unlock switch connectors (A and B) and ground.

Terminal (+)		Terminal (-)	Voltage (V) (Approx.)
Main power window and door lock/unlock switch connector	Terminal		
D7 (A)	10	Ground	Battery voltage
D8 (B)	19		

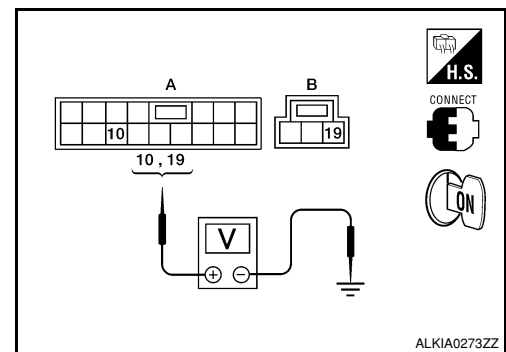

Is the measurement value within the specification?

- YES >> GO TO 3  
 NO >> GO TO 2

#### 2. CHECK HARNESS CONTINUITY

1. Turn ignition switch OFF.
2. Disconnect BCM and main power window and door lock/unlock switch.
3. Check continuity between BCM connector (A) and main power window and door lock/unlock switch connectors (B and C).

BCM connector	Terminal	Main power window and door lock/unlock switch connector	Terminal	Continuity
M20 (A)	68	D7 (B)	10	Yes
	69	D8 (C)	19	

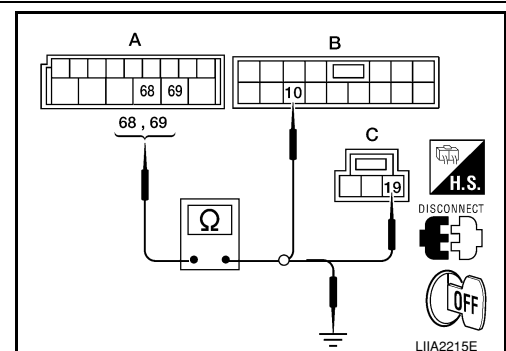

4. Check continuity between BCM connector (A) and ground.

A  
B  
C  
D  
E  
F  
G  
H  
I  
J  
PWC  
L  
M  
N  
O  
P

# POWER SUPPLY AND GROUND CIRCUIT

## < COMPONENT DIAGNOSIS >

BCM connector	Terminal	Ground	Continuity
M20 (A)	68		Ground
	69		

Is the inspection result normal?

YES >> GO TO 4

NO >> Repair or replace harness.

### 3. CHECK GROUND CIRCUIT

1. Turn ignition switch OFF.
2. Disconnect main power window and door lock/unlock switch.
3. Check continuity between main power window and door lock/unlock switch connector and ground.

Main power window and door lock/unlock switch connector	Terminal	Ground	Continuity
D8	17		Ground

Is the inspection result normal?

YES >> Replace main power window and door lock/unlock switch. Refer to [PWC-94. "Removal and Installation"](#).

NO >> Repair or replace harness.

### 4. CHECK BCM OUTPUT SIGNAL

1. Connect BCM.
2. Turn ignition switch ON.
3. Check voltage between BCM connector and ground.

Terminals		(-)	Voltage (V) (Approx.)
(+)			
BCM connector	Terminal	Ground	Battery voltage
M20	68		
	69		

Is the measurement value within the specification?

YES >> Check main power window and door lock/unlock switch output signal (rear power window switch LH) GO TO 5

YES >> Check main power window and door lock/unlock switch output signal (rear power window switch RH) GO TO 6

NO >> Replace BCM. Refer to [BCS-54. "Removal and Installation"](#).

### 5. CHECK MAIN POWER WINDOW AND DOOR LOCK/UNLOCK SWITCH OUTPUT SIGNAL (REAR POWER WINDOW SWITCH LH)

1. Turn ignition switch ON.
2. Check voltage between main power window and door lock/unlock switch connector and ground.

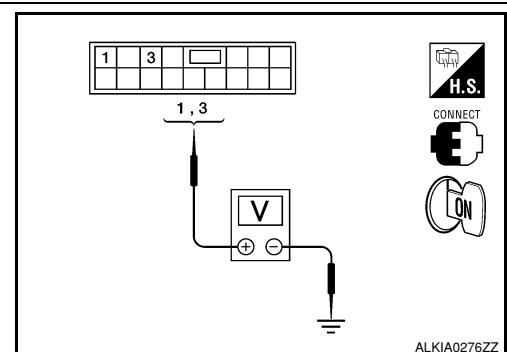
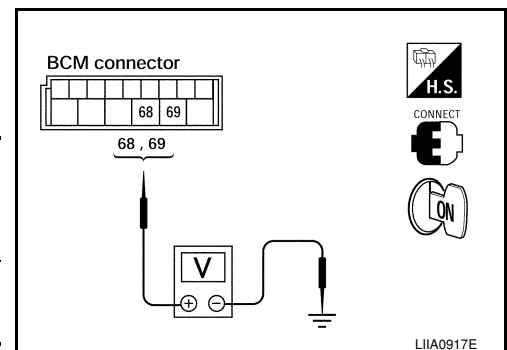
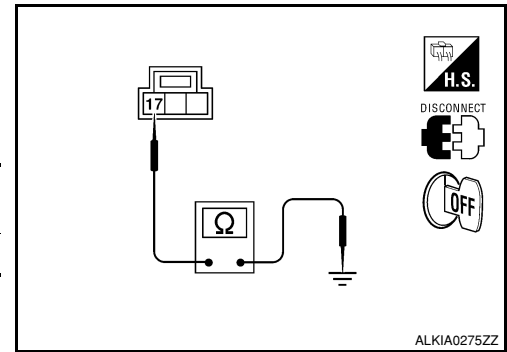

# POWER SUPPLY AND GROUND CIRCUIT

## < COMPONENT DIAGNOSIS >

Terminal		Window condition	Voltage (V) (Approx.)
(+)	(-)		
Main power window and door lock/unlock switch connector	Terminal		
D7	1	UP	Battery voltage
		DOWN	0
	3	UP	0
		DOWN	Battery voltage

Is the measurement value within the specification?

YES >> GO TO 7

NO >> Replace main power window and door lock/unlock switch. Refer to [PWC-94, "Removal and Installation"](#).

### 6. CHECK MAIN POWER WINDOW AND DOOR LOCK/UNLOCK SWITCH OUTPUT SIGNAL (REAR POWER WINDOW SWITCH RH)

- Turn ignition switch ON.
- Check voltage between main power window and door lock/unlock switch connector and ground.

Terminal		Window condition	Voltage (V) (Approx.)
(+)	(-)		
Main power window and door lock/unlock switch connector	Terminal		
D7	7	UP	Battery voltage
		DOWN	0
	5	UP	0
		DOWN	Battery voltage

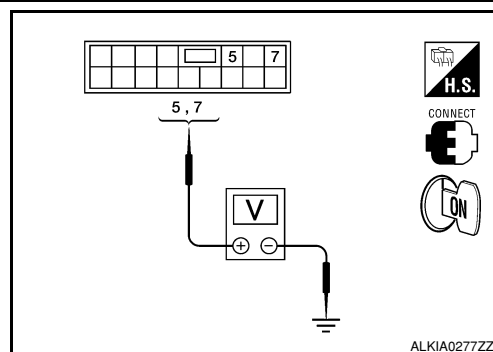

Is the measurement value within the specification?

YES >> GO TO 8

NO >> Replace main power window and door lock/unlock switch. Refer to [PWC-94, "Removal and Installation"](#).

### 7. CHECK HARNESS CONTINUITY (REAR POWER WINDOW SWITCH LH)

- Turn ignition switch OFF.
- Disconnect rear power window switch LH.
- Check continuity between main power window and door lock/unlock switch connector and rear power window switch LH connector.

Main power window and door lock/unlock switch connector	Terminal	Rear power window switch LH connector	Terminal	Continuity
D7	1	D203	2	Yes
	3		3	

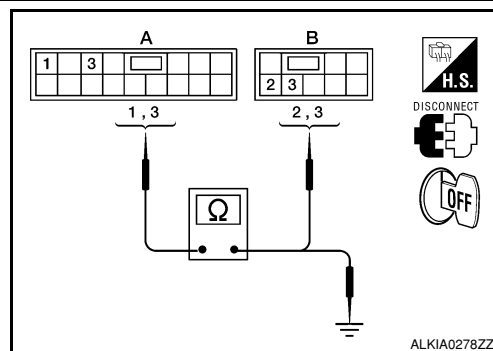

- Check continuity between main power window and door lock/unlock switch connector and ground.

# POWER SUPPLY AND GROUND CIRCUIT

## < COMPONENT DIAGNOSIS >

Main power window and door lock/unlock switch connector	Terminal	Ground	Continuity
D7	1		Ground
	3		

Is the inspection result normal?

YES >> GO TO 9

NO >> Repair or replace harness.

### 8. CHECK HARNESS CONTINUITY (REAR POWER WINDOW SWITCH RH)

- Turn ignition switch OFF.
- Disconnect rear power window switch RH.
- Check continuity between main power window and door lock/unlock switch connector and rear power window switch RH connector.

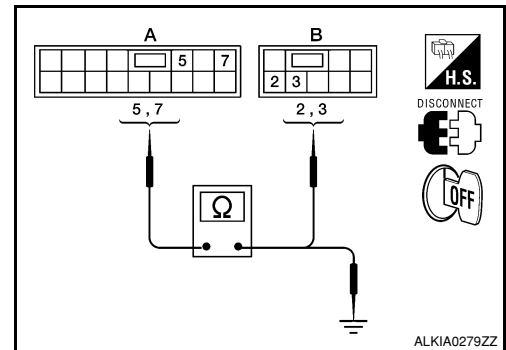

Main power window and door lock/unlock switch connector	Terminal	Rear power window switch RH connector	Terminal	Continuity
D7	5	D303	3	Yes
	7		2	

- Check continuity between main power window and door lock/unlock switch connector and ground.

Main power window and door lock/unlock switch connector	Terminal	Ground	Continuity
D7	5		Ground
	7		

Is the inspection result normal?

YES >> GO TO 9

NO >> Repair or replace harness.

### 9. CHECK MAIN POWER WINDOW AND DOOR LOCK/UNLOCK SWITCH

Check main power window and door lock/unlock switch.

Refer to [PWC-14, "POWER WINDOW MAIN SWITCH : Component Inspection"](#).

Is the inspection result normal?

YES >> Check intermittent incident. Refer to [GI-39, "Intermittent Incident"](#).

NO >> Replace main power window and door lock/unlock switch. Refer to [PWC-94, "Removal and Installation"](#).

## POWER WINDOW MAIN SWITCH : Component Inspection

INFOID:000000001611866

### 1. CHECK MAIN POWER WINDOW AND DOOR LOCK/UNLOCK SWITCH

- Check main power window and door lock/unlock switch.

Terminal	Main power window and door lock/unlock switch condition	Continuity
10	1	UP
10	7	
1	3	NEUTRAL
5	7	
10	3	DOWN
10	5	

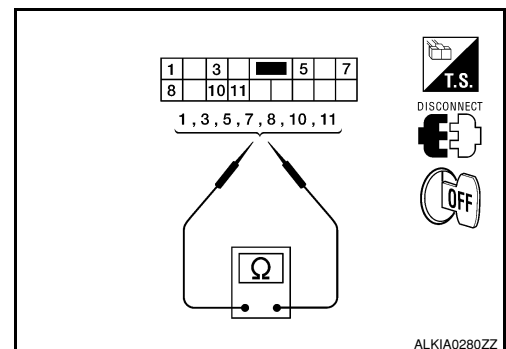

# POWER SUPPLY AND GROUND CIRCUIT

## < COMPONENT DIAGNOSIS >

2. Check continuity between main power window and door lock/unlock switch (power window lock switch). (Lock operation).

Terminal	Main power window and door lock/unlock switch condition	Continuity
3	Rear LH	UP
5	Rear RH	
1	Rear LH	NEUTRAL
3	Rear RH	
5	Rear LH	DOWN
7	Rear RH	

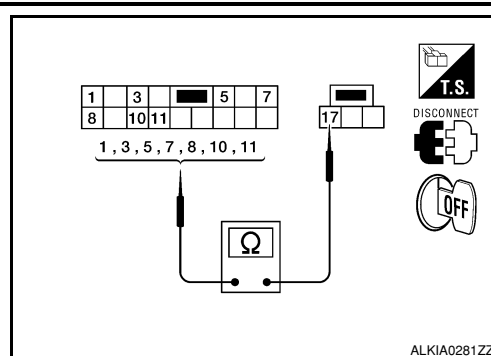

3. Check continuity between main power window and door lock/unlock switch (power window lock switch). (Unlock operation).

Terminal	Main power window and door lock/unlock switch condition	Continuity
3	Rear LH	UP
5	Rear RH	
1	Rear LH	NEUTRAL
3	Rear RH	
5	Rear LH	DOWN
7	Rear RH	

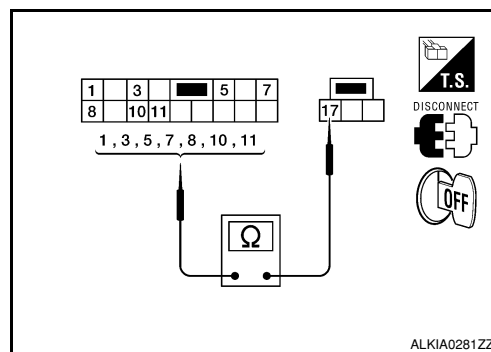

Is the inspection result normal?

YES >> Main power window and door lock/unlock switch is OK.

NO >> Replace main power window and door lock/unlock switch. Refer to [PWC-94. "Removal and Installation"](#).

## FRONT POWER WINDOW SWITCH

### FRONT POWER WINDOW SWITCH : Description

INFOID:000000001611868

- BCM supplies power.
- Front power window motor RH will be operated if power window and door lock/unlock switch RH is operated.

### FRONT POWER WINDOW SWITCH : Component Function Check

INFOID:000000001611869

#### Power Window And Door Lock/Unlock Switch RH

##### 1. CHECK FRONT POWER WINDOW MOTOR RH FUNCTION

Does front power window motor RH operate with power window and door lock/unlock switch RH operation?

Is the inspection result normal?

YES >> Power window and door lock/unlock switch RH power supply and ground circuit are OK.

NO >> Refer to [PWC-15. "FRONT POWER WINDOW SWITCH : Diagnosis Procedure"](#).

### FRONT POWER WINDOW SWITCH : Diagnosis Procedure

INFOID:000000001611870

#### Power Window And Door Lock/Unlock Switch RH Power Supply Circuit Check

##### 1. CHECK POWER SUPPLY CIRCUIT

A  
B  
C  
D  
E  
F  
G  
H  
I  
J

PWC

L  
M  
N  
O  
P

# POWER SUPPLY AND GROUND CIRCUIT

## < COMPONENT DIAGNOSIS >

1. Turn ignition switch ON.
2. Check voltage between power window and door lock/unlock switch RH connector and ground.

Terminal			Voltage (V) (Approx.)
(+)		(-)	
Power window and door lock/unlock switch RH connector	Terminal		
D105	10	Ground	Battery voltage

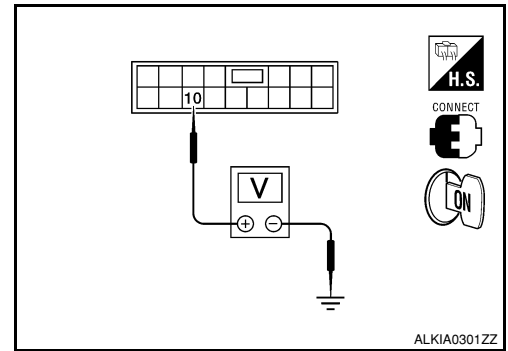

Is the measurement value within the specification?

- YES >> GO TO 3  
NO >> GO TO 2

## 2. CHECK HARNESS CONTINUITY

1. Turn ignition switch OFF.
2. Disconnect BCM and power window and door lock/unlock switch RH.
3. Check continuity between BCM connector (A) and power window and door lock/unlock switch RH connector (B).

BCM connector	Terminal	Power window and door lock/unlock switch RH connector	Terminal	Continuity
M20 (A)	69	D105 (B)	10	Yes

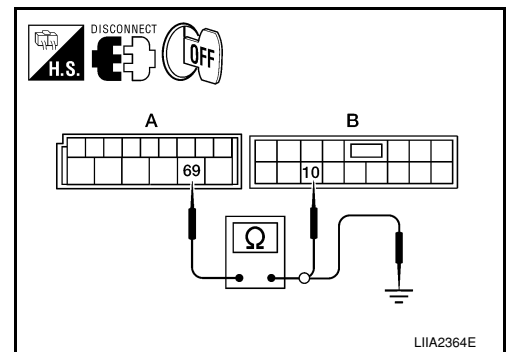

4. Check continuity between BCM connector (A) and ground.

BCM connector	Terminal	Ground	Continuity
M20 (A)	69		No

Is the inspection result normal?

- YES >> GO TO 4  
NO >> Repair or replace harness.

## 3. CHECK GROUND CIRCUIT

1. Turn ignition switch OFF.
2. Disconnect power window and door lock/unlock switch RH.
3. Check continuity between power window and door lock/unlock switch RH connector and ground.

Power window and door lock/unlock switch RH	Terminal	Ground	Continuity
D105	11		Yes

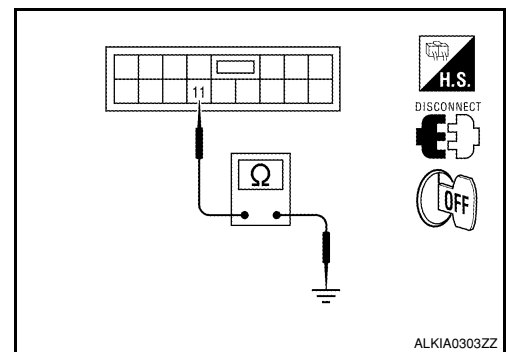

Is the inspection result normal?

- YES >> Replace power window and door lock/unlock switch RH.  
Refer to [PWC-95. "Removal and Installation"](#).  
NO >> Repair or replace harness.

## 4. CHECK BCM OUTPUT SIGNAL



# POWER SUPPLY AND GROUND CIRCUIT

## < COMPONENT DIAGNOSIS >

1. Connect BCM.
2. Turn ignition switch ON.
3. Check voltage between BCM connector and ground.

Terminals		(-)	Voltage (V) (Approx.)
(+)			
BCM connector	Terminal		
M20	69	Ground	Battery voltage

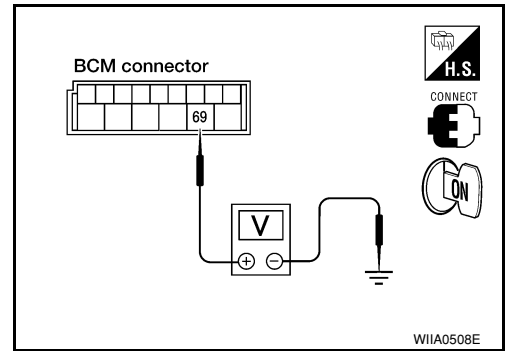

Is the measurement value within the specification?

YES >> Replace power window and door lock/unlock switch RH.  
Refer to [PWC-95. "Removal and Installation"](#).

NO >> Replace BCM. Refer to [BCS-54. "Removal and Installation"](#).

## REAR POWER WINDOW SWITCH

### REAR POWER WINDOW SWITCH : Description

INFOID:000000001611872

- BCM supplies power.
- Rear power window motor will be operated if rear power window switch is operated. Rear power window switch.

### REAR POWER WINDOW SWITCH : Component Function Check

INFOID:000000001611873

#### Rear Power Window Switch

#### 1. CHECK REAR POWER WINDOW MOTOR FUNCTION

Does rear power window motor operate with rear power window switch operation?

Is the inspection result normal?

YES >> Rear power window switch power supply and ground circuit are OK.

NO >> Refer to [PWC-17. "REAR POWER WINDOW SWITCH : Diagnosis Procedure"](#).

### REAR POWER WINDOW SWITCH : Diagnosis Procedure

INFOID:000000001611874

#### Rear Power Window Switch Power Supply Circuit Check

#### 1. CHECK POWER SUPPLY CIRCUIT

Check voltage between rear power window switch connector and ground.

Terminal		(-)	Condition	Voltage (V) (Approx.)
(+)				
Rear power window switch connector	Terminal			
LH	D203	1	Ignition switch ON	Battery voltage
RH	D303			

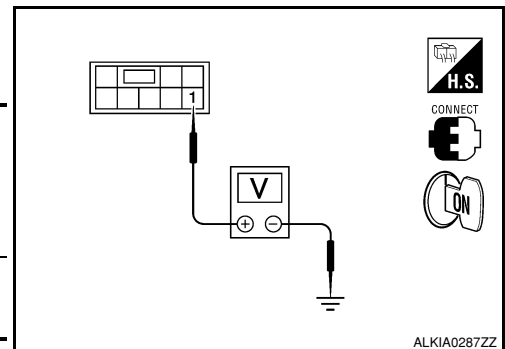

Is the measurement value within the specification?

YES >> GO TO 2 (Rear power window switch LH)

YES >> GO TO 3 (Rear power window switch RH)

NO >> GO TO 4

#### 2. CHECK HARNESS CONTINUITY (REAR POWER WINDOW SWITCH LH)

A  
B  
C  
D  
E  
F  
G  
H  
I  
J  
L  
M  
N  
O  
P

# POWER SUPPLY AND GROUND CIRCUIT

## < COMPONENT DIAGNOSIS >

1. Turn ignition switch OFF.
2. Disconnect main power window and door lock/unlock switch and rear power window switch LH.
3. Check continuity between main power window and door lock/unlock switch connector (A) and rear power window switch LH connector (B).

Main power window and door lock/unlock switch connector	Terminal	Rear power window switch LH connector	Terminal	Continuity
D7 (A)	1	D203 (B)	2	Yes
	3		3	

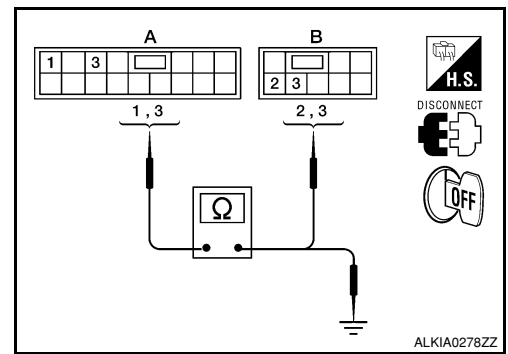

4. Check continuity between main power window and door lock/unlock switch connector (A) and ground.

Main power window and door lock/unlock switch connector	Terminal	Ground	Continuity
D7 (A)	1	Ground	No
	3		

Is the inspection result normal?

YES >> Check intermittent incident. Refer to [GI-39. "Intermittent Incident"](#).

NO >> Repair or replace harness.

### 3. CHECK HARNESS CONTINUITY (REAR POWER WINDOW SWITCH RH)

1. Turn ignition switch OFF.
2. Disconnect main power window and door lock/unlock switch and rear power window switch RH.
3. Check continuity between main power window and door lock/unlock switch connector (A) and rear power window switch RH connector (B).

Main power window and door lock/unlock switch connector	Terminal	Rear power window switch RH connector	Terminal	Continuity
D7 (A)	5	D303 (B)	3	Yes
	7		2	

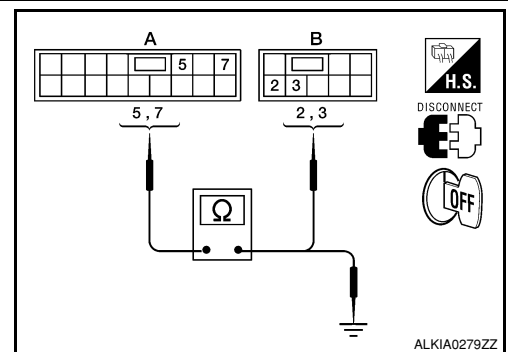

4. Check continuity between main power window and door lock/unlock switch connector (A) and ground.

Main power window and door lock/unlock switch connector	Terminal	Ground	Continuity
D7 (A)	5	Ground	No
	7		

Is the inspection result normal?

YES >> Check intermittent incident. Refer to [GI-39. "Intermittent Incident"](#).

NO >> Repair or replace harness.

### 4. CHECK HARNESS CONTINUITY

# POWER SUPPLY AND GROUND CIRCUIT

## < COMPONENT DIAGNOSIS >

1. Disconnect BCM and rear power window switch.
2. Check continuity between BCM connector (A) and rear power window switch connector (B).

BCM connector	Terminal	Rear power window switch connector		Terminal	Continuity
M20 (A)	68	LH	D203 (B)	1	Yes
		RH	D303 (B)		

3. Check continuity between BCM connector (A) and ground.

BCM connector	Terminal	Ground	Continuity
M20 (A)	68		No

Is the inspection result normal?

YES >> GO TO 5

NO >> Repair or replace harness.

## 5. CHECK REAR POWER WINDOW SWITCH

Check rear power window switch.

Refer to [PWC-19, "REAR POWER WINDOW SWITCH : Component Inspection"](#).

Is the inspection result normal?

YES >> Check intermittent incident. Refer to [GI-39, "Intermittent Incident"](#).

NO >> Replace rear power window switch. Refer to [PWC-96, "Removal and Installation"](#).

## REAR POWER WINDOW SWITCH : Component Inspection

INFOID:000000001611875

### COMPONENT INSPECTION

#### 1. CHECK REAR POWER WINDOW SWITCH

Check rear power window switch.

Terminal	Power window switch condition	Continuity
1	5	Yes
3	4	
3	4	
5	2	
1	4	
5	2	

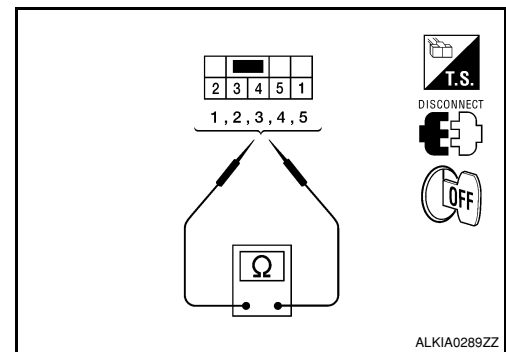

Is the inspection result normal?

YES >> Rear power window switch is OK.

NO >> Replace rear power window switch. Refer to [PWC-96, "Removal and Installation"](#).

A  
B  
C  
D  
E  
F  
G  
H  
I  
J  
L  
M  
N  
O  
P

PWC

# POWER WINDOW MOTOR

< COMPONENT DIAGNOSIS >

## POWER WINDOW MOTOR DRIVER SIDE

### DRIVER SIDE : Description

INFOID:000000001611876

Door glass moves UP/DOWN by receiving the signal from power window main switch.

### DRIVER SIDE : Component Function Check

INFOID:000000001611877

#### 1. CHECK POWER WINDOW MOTOR CIRCUIT

Does front power window motor LH operate with operating main power window and door lock/unlock switch?  
Is the inspection result normal?

- YES >> Front power window motor LH is OK.  
NO >> Refer to [PWC-20. "DRIVER SIDE : Diagnosis Procedure"](#).

### DRIVER SIDE : Diagnosis Procedure

INFOID:000000001611878

#### Front Power Window Motor LH Circuit Check

##### 1. CHECK MAIN POWER WINDOW AND DOOR LOCK/UNLOCK SWITCH OUTPUT SIGNAL

1. Disconnect front power window motor LH.
2. Turn ignition switch ON.
3. Check voltage between front power window motor LH connector and ground.

Terminal (+)		Terminal (-)	Main power window and door lock/unlock switch condition	Voltage (V) (Approx.)
Power window motor LH connector	Terminal			
D9	2	Ground	UP	Battery voltage
			DOWN	0
	1		UP	0
			DOWN	Battery voltage

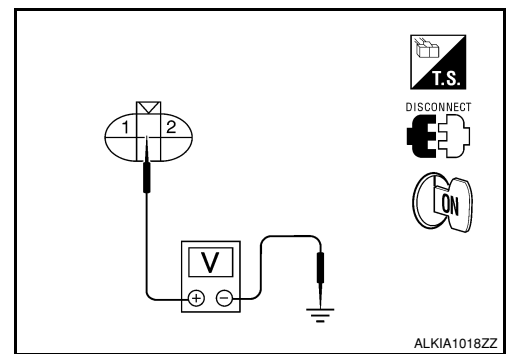

Is the measurement value within the specification?

- YES >> GO TO 2  
NO >> Replace main power window and door lock/unlock switch. Refer to [PWC-94. "Removal and Installation"](#).

##### 2. CHECK HARNESS CONTINUITY

1. Turn ignition switch OFF.
2. Disconnect main power window and door lock/unlock switch and front power window motor LH.
3. Check continuity between main power window and door lock/unlock switch connector (A) and front power window motor connector LH (B).

Main power window and door lock/unlock switch connector	Terminal	Front power window motor LH connector	Terminal	Continuity
D7 (A)	8	D9 (B)	2	Yes
	11		1	

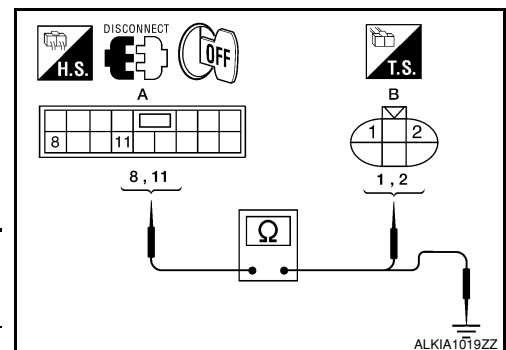

4. Check continuity between main power window and door lock/unlock switch connector (A) and ground.

# POWER WINDOW MOTOR

## < COMPONENT DIAGNOSIS >

Main power window and door lock/unlock switch connector	Terminal	Ground	Continuity
D7 (A)	8		No
	11		

Is the inspection result normal?

YES >> GO TO 3

NO >> Repair or replace harness.

### 3. CHECK POWER WINDOW MOTOR

Check front power window motor LH.

Refer to [PWC-21, "DRIVER SIDE : Component Inspection"](#).

Is the inspection result normal?

YES >> Check intermittent incident. Refer to [GI-39, "Intermittent Incident"](#).

NO >> Replace power window motor LH. Refer to [GW-14, "Removal and Installation"](#).

### DRIVER SIDE : Component Inspection

INFOID:000000001611879

#### COMPONENT INSPECTION

##### 1. CHECK FRONT POWER WINDOW MOTOR LH

Does motor operate by connecting the battery voltage directly to power window motor?

Terminal		Motor condition
(+)	(-)	
1	2	DOWN
2	1	UP

Is the inspection result normal?

YES >> Front power window motor LH is OK.

NO >> Replace front power window motor LH. Refer to [GW-14, "Removal and Installation"](#).

### PASSENGER SIDE

#### PASSENGER SIDE : Description

INFOID:000000001611881

Door glass moves UP/DOWN by receiving the signal from main power window and door lock/unlock switch or power window and door lock/unlock switch RH.

#### PASSENGER SIDE : Component Function Check

INFOID:000000001611882

##### 1. CHECK POWER WINDOW MOTOR CIRCUIT

Does power window motor operate with operating main power window and door lock/unlock switch or power window and door lock/unlock switch RH?

Is the inspection result normal?

YES >> Front power window motor RH is OK.

NO >> Refer to [PWC-21, "PASSENGER SIDE : Diagnosis Procedure"](#).

#### PASSENGER SIDE : Diagnosis Procedure

INFOID:000000001611883

Front Power Window Motor RH Circuit Check

##### 1. CHECK FRONT POWER WINDOW SWITCH RH OUTPUT SIGNAL

A  
B  
C  
D  
E  
F  
G  
H  
I  
J  
L  
M  
N  
O  
P



# POWER WINDOW MOTOR

## < COMPONENT DIAGNOSIS >

1. Disconnect front power window motor RH.
2. Turn ignition switch ON.
3. Check voltage between front power window motor RH connector and ground.

Terminal (+)		Terminal (-)	Front power window motor RH condition	Voltage (V) (Approx.)
Front power window motor RH connector	Terminal			
D104	2	Ground	UP	Battery voltage
			DOWN	0
	1		UP	0
			DOWN	Battery voltage

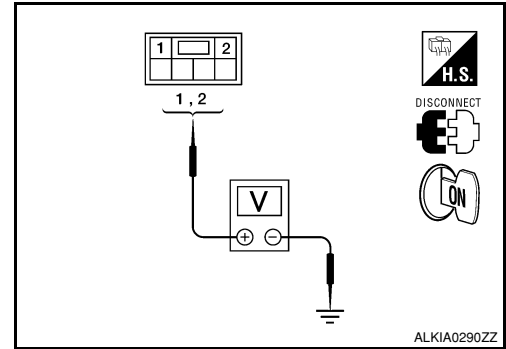

Is the measurement value within the specification?

YES >> GO TO 2

NO >> Replace power window and door lock/unlock switch RH. Refer to [PWC-95. "Removal and Installation"](#).

## 2. CHECK HARNESS CONTINUITY

1. Turn ignition switch OFF.
2. Disconnect power window and door lock/unlock switch RH.
3. Check continuity between power window and door lock/unlock switch RH connector (A) and front power window motor RH connector (B).

Power window and door lock/unlock switch RH connector	Terminal	Front power window motor RH connector	Terminal	Continuity
D105 (A)	8	D104 (B)	2	Yes
	9		1	

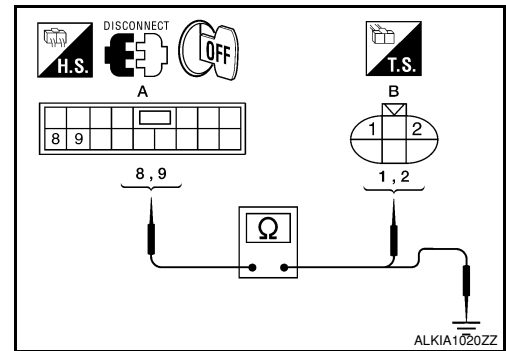

4. Check continuity between power window and door lock/unlock switch RH connector (A) and ground.

Power window and door lock/unlock switch RH connector	Terminal	Ground	Continuity
D105 (A)	8	Ground	No
	9		

Is the inspection result normal?

YES >> GO TO 3

NO >> Repair or replace harness.

## 3. CHECK FRONT POWER WINDOW MOTOR RH

Check front power window motor RH.

Refer to [PWC-22. "PASSENGER SIDE : Component Inspection"](#).

Is the inspection result normal?

YES >> Check intermittent incident. Refer to [GI-39. "Intermittent Incident"](#).

NO >> Replace front power window motor RH. Refer to [GW-14. "Removal and Installation"](#).

## PASSENGER SIDE : Component Inspection

INFOID:000000001611884

### COMPONENT INSPECTION

#### 1. CHECK FRONT POWER WINDOW MOTOR RH

Does motor operate by connecting the battery voltage directly to front power window motor RH?

# POWER WINDOW MOTOR

## < COMPONENT DIAGNOSIS >

Terminal		Motor condition
(+)	(-)	
1	2	DOWN
2	1	UP

Is the inspection result normal?

YES >> Front power window motor RH is OK.

NO >> Replace front power window motor RH. Refer to [GW-14. "Removal and Installation"](#).

## REAR LH

### REAR LH : Description

INFOID:000000001611886

Door glass moves UP/DOWN by receiving the signal from power window main switch or rear power window switch LH.

### REAR LH : Component Function Check

INFOID:000000001611887

#### 1. CHECK REAR POWER WINDOW MOTOR LH CIRCUIT

Does rear power window motor LH operate with main power window and door lock/unlock switch or rear power window switch LH?

Is the inspection result normal?

YES >> Rear power window motor LH is OK.

NO >> Refer to [PWC-23. "REAR LH : Diagnosis Procedure"](#)

### REAR LH : Diagnosis Procedure

INFOID:000000001611888

#### Power Window Motor Circuit Check

##### 1. CHECK REAR POWER WINDOW SWITCH OUTPUT SIGNAL

1. Disconnect rear power window motor LH.
2. Turn ignition switch ON.
3. Check voltage between rear power window motor LH connector and ground.

Terminal		Window condition	Voltage (V) (Approx.)
(+)	(-)		
Rear power window motor LH connector  D204	1	UP	Battery voltage
		DOWN	0
	2	UP	0
		DOWN	Battery voltage

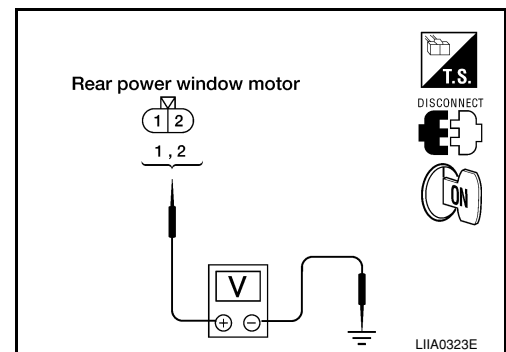

Is the measurement value within the specification?

YES >> GO TO 2

NO >> Check rear power window switch LH. Refer to [PWC-17. "REAR POWER WINDOW SWITCH : Component Function Check"](#).

##### 2. CHECK HARNESS CONTINUITY

# POWER WINDOW MOTOR

## < COMPONENT DIAGNOSIS >

1. Turn ignition switch OFF.
2. Disconnect rear power window switch LH.
3. Check continuity between rear power window switch LH connector (A) and rear power window motor LH connector (B).

Rear power window switch LH connector	Terminal	Rear power window motor LH connector	Terminal	Continuity
D203 (A)	5	D204 (B)	2	Yes
	4		1	

4. Check continuity between rear power window switch LH connector (A) and ground.

Rear power window switch LH connector	Terminal	Ground	Continuity
D203 (A)	5	Ground	No
	4		

Is the inspection result normal?

- YES >> GO TO 3  
 NO >> Repair or replace harness.

### 3. CHECK REAR POWER WINDOW MOTOR LH

Check rear power window motor LH.

Refer to [PWC-24, "REAR LH : Component Inspection"](#).

Is the inspection result normal?

- YES >> Check intermittent incident. Refer to [GI-39, "Intermittent Incident"](#).  
 NO >> Replace rear power window motor LH. Refer to [GW-17, "Removal and Installation"](#).

## REAR LH : Component Inspection

INFOID:000000001611889

### COMPONENT INSPECTION

#### 1. CHECK REAR POWER WINDOW MOTOR LH

Does motor operate by connecting the battery voltage directly to rear power window motor LH?

Terminal		Motor condition
(+)	(-)	
2	1	DOWN
1	2	UP

Is the inspection result normal?

- YES >> Rear power window motor LH is OK.  
 NO >> Replace rear power window motor LH. Refer to [GW-17, "Removal and Installation"](#).

## REAR RH

### REAR RH : Description

INFOID:000000001611890

Door glass moves UP/DOWN by receiving the signal from main power window and door lock/unlock switch or rear power window switch RH.

### REAR RH : Component Function Check

INFOID:000000001611891

#### 1. CHECK REAR POWER WINDOW MOTOR RH CIRCUIT

Does rear power window motor RH operate with operating main power window and door lock/unlock switch or rear power window switch RH?

Is the inspection result normal?

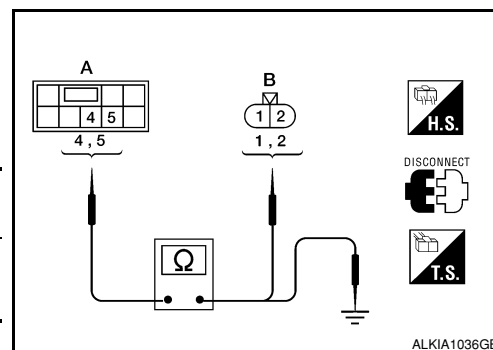



# POWER WINDOW MOTOR

## < COMPONENT DIAGNOSIS >

- YES >> Rear power window motor RH is OK.  
 NO >> Refer to [PWC-25. "REAR RH : Diagnosis Procedure"](#).

### REAR RH : Diagnosis Procedure

INFOID:000000001611892

#### Rear Power Window Motor RH Circuit Check

### 1. CHECK REAR POWER WINDOW SWITCH RH OUTPUT SIGNAL

1. Disconnect rear power window motor RH.
2. Turn ignition switch ON.
3. Check voltage between rear power window motor RH connector and ground.

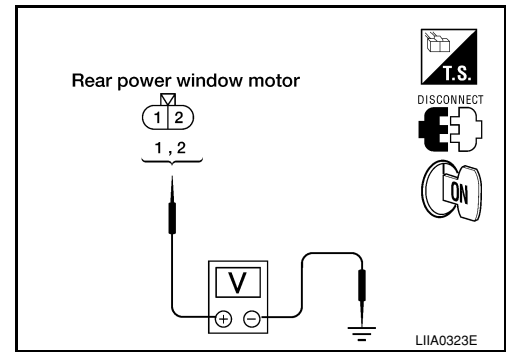

Terminal (+)		Terminal (-)	Rear power window switch RH condition	Voltage (V) (Approx.)
Rear power window motor RH connector	Terminal			
D304	1	Ground	UP	Battery voltage
			DOWN	0
	2		UP	0
			DOWN	Battery voltage

Is the measurement value within the specification?

- YES >> GO TO 2  
 NO >> Check rear power window switch RH. Refer to [PWC-17. "REAR POWER WINDOW SWITCH : Component Function Check"](#).

### 2. CHECK HARNESS CONTINUITY

1. Turn ignition switch OFF.
2. Disconnect rear power window switch RH.
3. Check continuity between rear power window switch RH connector (A) and rear power window motor RH connector (B).

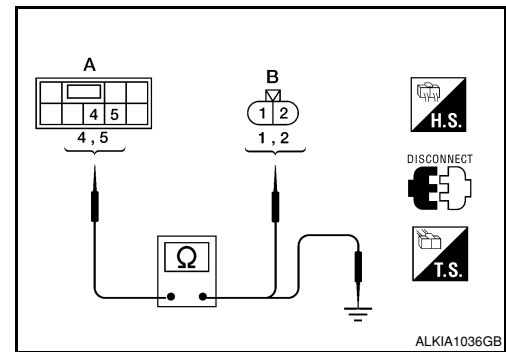

Rear power window switch RH connector	Terminal	Rear power window motor RH connector	Terminal	Continuity
D303 (A)	5	D304 (B)	2	Yes
	4		1	

4. Check continuity between rear power window switch RH connector (A) and ground.

Rear power window switch RH connector	Terminal	Ground	Continuity
D303 (A)	5	Ground	No
	4		

Is the inspection result normal?

- YES >> GO TO 3  
 NO >> Repair or replace harness.

### 3. CHECK REAR POWER WINDOW MOTOR RH

Check rear power window motor RH.  
 Refer to [PWC-26. "REAR RH : Component Inspection"](#).

Is the inspection result normal?

- YES >> Check intermittent incident. Refer to [GI-39. "Intermittent Incident"](#).  
 NO >> Replace rear power window motor RH. Refer to [GW-17. "Removal and Installation"](#).

A  
B  
C  
D  
E  
F  
G  
H  
I  
J  
PWC  
L  
M  
N  
O  
P

# POWER WINDOW MOTOR

< COMPONENT DIAGNOSIS >

REAR RH : Component Inspection

INFOID:000000001611893

COMPONENT INSPECTION

## 1. CHECK REAR POWER WINDOW MOTOR RH

Does motor operate by connecting the battery voltage directly to rear power window motor RH?

Terminal		Motor condition
(+)	(-)	
2	1	DOWN
1	2	UP

Is the inspection result normal?

YES >> Rear power window motor RH is OK.

NO >> Replace rear power window motor RH. Refer to [GW-17, "Removal and Installation"](#).

# ENCODER

< COMPONENT DIAGNOSIS >

## ENCODER DRIVER SIDE

### DRIVER SIDE : Description

INFOID:000000001611894

Detects condition of the front power window motor LH operation and transmits to main power window and door lock/unlock switch as pulse signal.

### DRIVER SIDE : Component Function Check

INFOID:000000001611895

#### 1. CHECK ENCODER OPERATION

Does front door glass LH perform AUTO open/close operation normally when operating main power window and door lock/unlock switch?

Is the inspection result normal?

YES >> Encoder operation is OK.

NO >> Refer to [PWC-27, "DRIVER SIDE : Diagnosis Procedure"](#)

### DRIVER SIDE : Diagnosis Procedure

INFOID:000000001611896

#### Encoder Circuit Check

#### 1. CHECK ENCODER OPERATION

1. Turn ignition switch ON.
2. Check signal between main power window and door lock/unlock switch connector and ground with oscilloscope.

Terminals		Signal (Reference value)
(+)	(-)	
Main power window and door lock/unlock switch connector	Terminal	
D7	9	Ground
	13	
		Refer to following signal

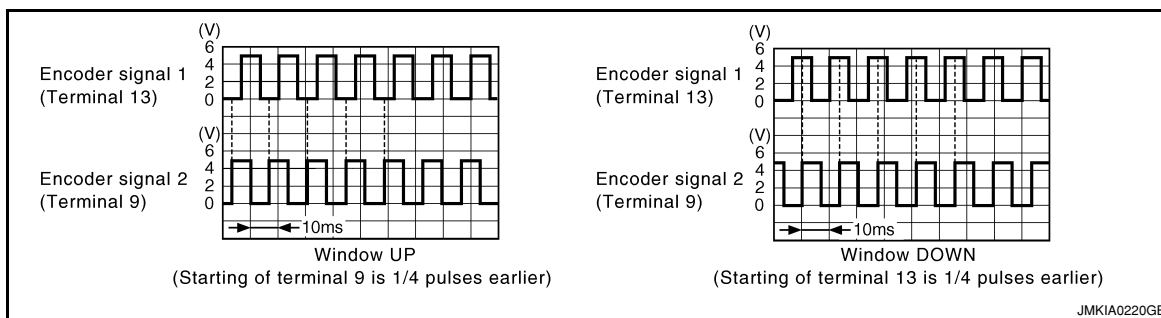
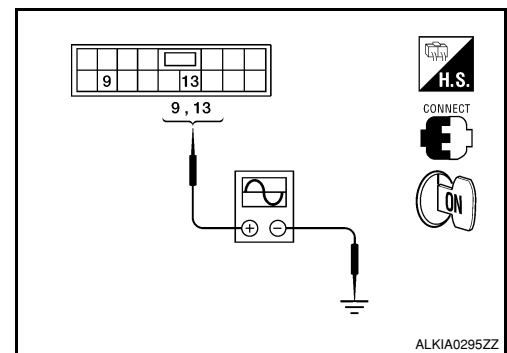

Is the inspection result normal?

YES >> Check intermittent incident. Refer to [GI-39, "Intermittent Incident"](#).

NO >> GO TO 2

#### 2. CHECK FRONT POWER WINDOW MOTOR LH POWER SUPPLY

# ENCODER

## < COMPONENT DIAGNOSIS >

1. Turn ignition switch ON.
2. Check voltage between front power window motor LH connector and ground.

Terminal (+)		Terminal (-)	Voltage (V) (Approx.)
Front power window motor LH connector	Terminal		
D9	4	Ground	10

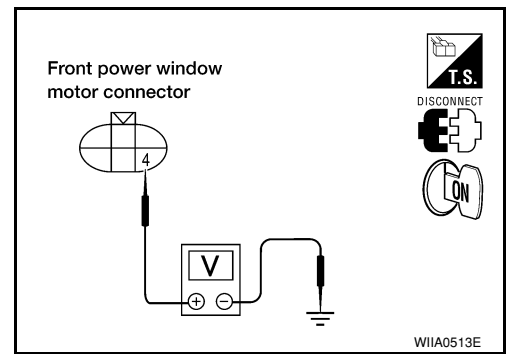

Is the measurement value within the specification?

- YES >> GO TO 4  
NO >> GO TO 3

### 3. CHECK HARNESS CONTINUITY 1

1. Turn ignition switch OFF.
2. Disconnect main power window and door lock/unlock switch and front power window motor LH.
3. Check continuity between main power window and door lock/unlock switch connector (A) and front power window motor LH connector (B).

Main power window and door lock/unlock switch connector	Terminal	Front power window motor LH connector	Terminal	Continuity
D7 (A)	15	D9 (B)	4	Yes

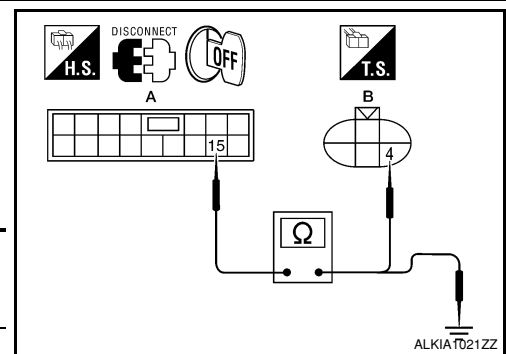

4. Check continuity between main power window and door lock/unlock switch connector (A) and ground.

Main power window and door lock/unlock switch connector	Terminal	Ground	Continuity
D7 (A)	15		No

Is the inspection result normal?

- YES >> Replace main power window and door lock/unlock switch. Refer to [PWC-94, "Removal and Installation"](#).  
NO >> Repair or replace harness.

### 4. CHECK GROUND CIRCUIT

1. Turn ignition switch OFF.
2. Disconnect front power window motor LH.
3. Check continuity between front power window motor LH connector and ground.

Front power window motor LH connector	Terminal	Ground	Continuity
D9	6		Yes

Is the inspection result normal?

- YES >> GO TO 6  
NO >> GO TO 5

### 5. CHECK HARNESS CONTINUITY 2

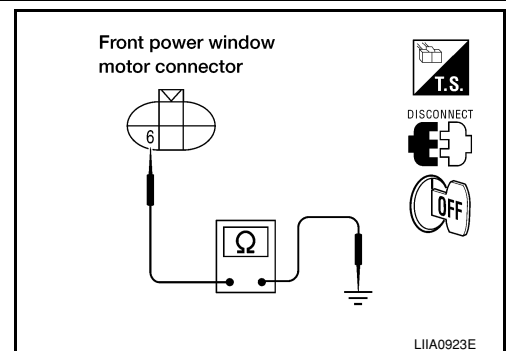

# ENCODER

## < COMPONENT DIAGNOSIS >

1. Disconnect main power window and door lock/unlock switch.
2. Check continuity between main power window and door lock/unlock switch connector and front power window motor LH connector.

Main power window and door lock/unlock switch connector	Terminal	Front power window motor LH connector	Terminal	Continuity
D7	2	D9	6	Yes

Is the inspection result normal?

- YES >> Replace main power window and door lock/unlock switch. Refer to [PWC-94, "Removal and Installation"](#).
- NO >> Repair or replace harness.

### 6. CHECK HARNESS CONTINUITY 3

1. Disconnect main power window and door lock/unlock switch.
2. Check continuity between main power window and door lock/unlock switch connector (A) and front power window motor LH connector (B).

Main power window and door lock/unlock switch connector	Terminal	Front power window motor LH connector	Terminal	Continuity
D7 (A)	9	D9 (B)	5	Yes
	13		3	

3. Check continuity between main power window and door lock/unlock switch connector (A) and ground.

Main power window and door lock/unlock switch connector	Terminal	Ground	Continuity
D7 (A)	9	Ground	No
	13		

Is the inspection result normal?

- YES >> Replace front power window motor LH. Refer to [GW-14, "Removal and Installation"](#).
- NO >> Repair or replace harness.

## PASSENGER SIDE

### PASSENGER SIDE : Description

INFOID:000000001611897

Detects condition of the front power window motor RH operation and transmits to power window and door lock/unlock switch RH as pulse signal.

### PASSENGER SIDE : Component Function Check

INFOID:000000001611898

#### 1. CHECK ENCODER OPERATION

Does front door glass RH perform AUTO open/close operation normally when operating power window and door lock/unlock switch RH?

Is the inspection result normal?

- YES >> Encoder operation is OK.
- NO >> Refer to [PWC-29, "PASSENGER SIDE : Diagnosis Procedure"](#).

### PASSENGER SIDE : Diagnosis Procedure

INFOID:000000001611899

#### 1. CHECK ENCODER SIGNAL

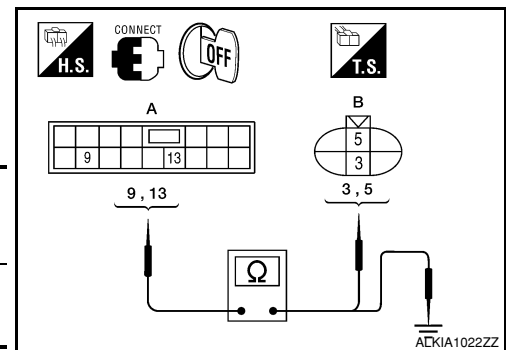
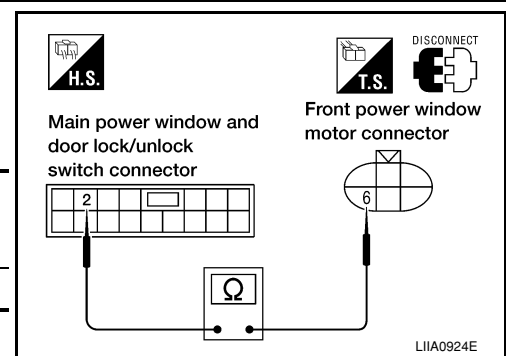

A  
B  
C  
D  
E  
F  
G  
H  
I  
J  
L  
M  
N  
O  
P

PWC

# ENCODER

## < COMPONENT DIAGNOSIS >

1. Turn ignition switch ON.
2. Check signal between power window and door lock/unlock switch RH connector and ground with oscilloscope.

Terminals			Signal (Reference value)
(+)		(-)	
Power window and door lock/unlock switch RH connector	Terminal		Refer to following signal
D105	12	Ground	
	15		

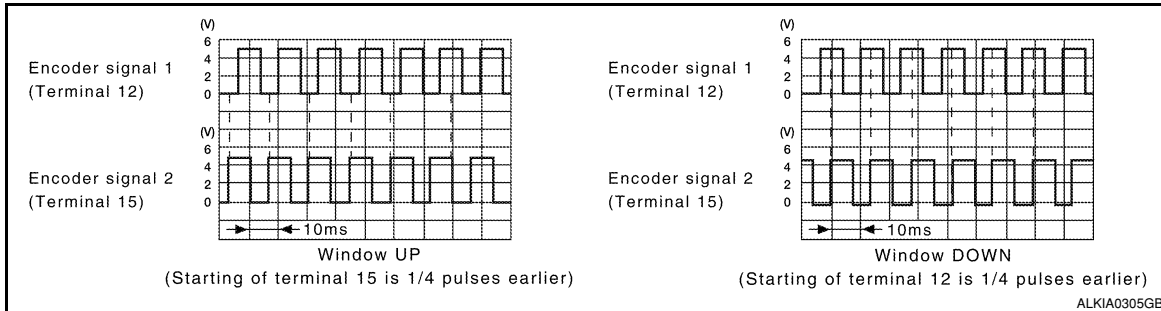
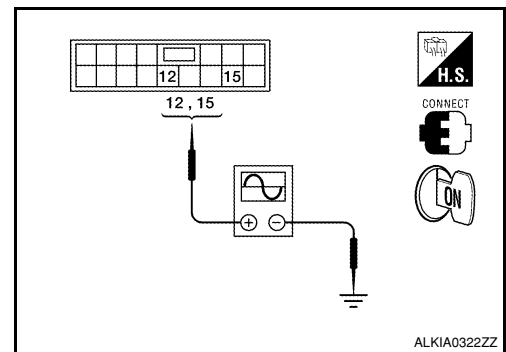

Is the inspection result normal?

- YES >> Check intermittent incident. Refer to [GI-39. "Intermittent Incident"](#).  
 NO >> GO TO 2

## 2. CHECK FRONT POWER WINDOW MOTOR RH POWER SUPPLY

1. Turn ignition switch ON.
2. Check voltage between front power window motor RH connector and ground.

Terminal			Voltage (V) (Approx.)
(+)		(-)	
Front power window motor RH connector	Terminal		10
D105	4	Ground	

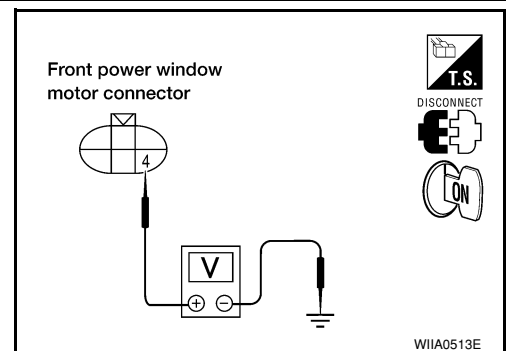

Is the measurement value within the specification?

- YES >> GO TO 4  
 NO >> GO TO 3

## 3. CHECK HARNESS CONTINUITY 1

1. Turn ignition switch OFF.
2. Disconnect power window and door lock/unlock switch RH and front power window motor RH.
3. Check continuity between power window and door lock/unlock switch RH connector (A) and front power window motor RH connector (B).

Power window and door lock/unlock switch RH connector	Terminal	Front power window motor RH connector	Terminal	Continuity
D105 (A)	4	D104 (B)	4	Yes

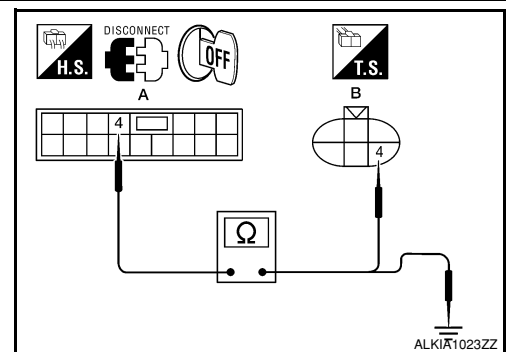

4. Check continuity between power window and door lock/unlock switch RH connector (A) and ground.

# ENCODER

## < COMPONENT DIAGNOSIS >

Power window and door lock/unlock switch RH connector	Terminal	Ground	Continuity
D105 (A)	4		No

Is the inspection result normal?

YES >> Replace power window and door lock/unlock switch RH. Refer to [PWC-95. "Removal and Installation"](#).

NO >> Repair or replace harness.

### 4. CHECK GROUND CIRCUIT

1. Turn ignition switch OFF.
2. Disconnect front power window motor RH.
3. Check continuity between front power window motor RH connector and ground.

Front power window motor RH connector	Terminal	Ground	Continuity
D104	6		Yes

Is the inspection result normal?

YES >> GO TO 6

NO >> GO TO 5

### 5. CHECK HARNESS CONTINUITY 2

1. Disconnect power window and door lock/unlock switch RH.
2. Check continuity between power window and door lock/unlock switch RH connector and front power window motor RH connector.

Power window and door lock/unlock switch RH connector	Terminal	Front power window motor RH connector	Terminal	Continuity
D105	3	D104	6	Yes

Is the inspection result normal?

YES >> Replace power window and door lock/unlock switch RH. Refer to [PWC-95. "Removal and Installation"](#).

NO >> Repair or replace harness.

### 6. CHECK HARNESS CONTINUITY 3

1. Disconnect power window and door lock/unlock switch RH.
2. Check continuity between power window and door lock/unlock switch RH connector (A) and front power window motor RH connector (B).

Power window and door lock/unlock switch RH connector	Terminal	Front power window motor RH connector	Terminal	Continuity
D105 (A)	12	D104 (B)	3	Yes
	15		5	

3. Check continuity between power window and door lock/unlock switch RH connector (A) and ground.

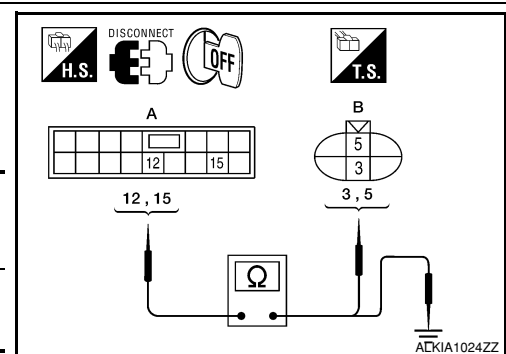
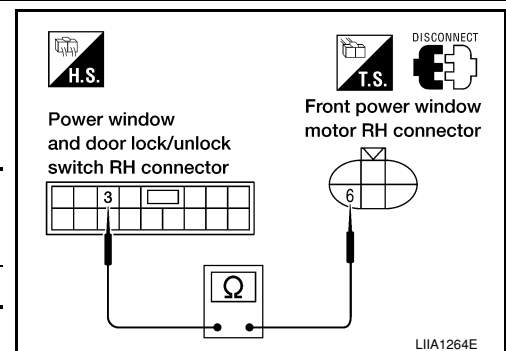
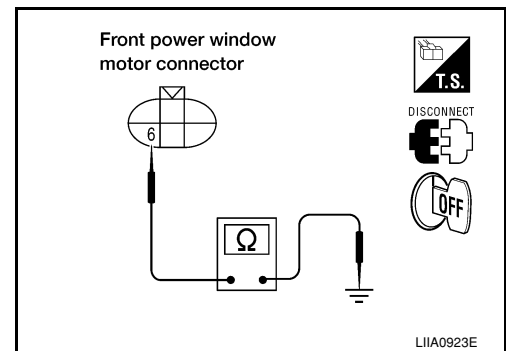

# ENCODER

## < COMPONENT DIAGNOSIS >

---

Power window and door lock/unlock switch RH connector	Terminal	Ground	Continuity
D105 (A)	12		
	15		

Is the inspection result normal?

- YES >> Replace front power window motor RH. Refer to [GW-14. "Removal and Installation"](#).  
NO >> Repair or replace harness.



# DOOR SWITCH

< COMPONENT DIAGNOSIS >

## DOOR SWITCH

### Description

INFOID:000000001611900

Detects door open/close condition and transmits the signal to BCM.

### Component Function Check

INFOID:000000001611901

#### 1. CHECK FRONT DOOR SWITCH INPUT SIGNAL

Check ("DOOR SW-DR" and "DOOR SW-AS") in "DATA MONITOR" mode with CONSULT-III. Refer to [PWC-10. "RETAINED PWR : CONSULT-III Function \(BCM - RETAINED PWR\)"](#).

Monitor item	Condition	
DOOR SW-DR	OPEN	: ON
	CLOSE	: OFF
DOOR SW-AS	OPEN	: ON
	CLOSE	: OFF

Is the inspection result normal?

- YES >> Front door switch circuit is OK.
- NO >> Refer to [PWC-33. "Diagnosis Procedure"](#).

### Diagnosis Procedure

INFOID:000000001611902

#### 1. CHECK FRONT DOOR SWITCH

Check voltage between BCM connector and ground.

Terminals		Door condition	Voltage (V) (Approx.)	
(+)	(-)			
BCM connector	Terminal			
M18	12	Front door RH	OPEN	0
			CLOSE	Battery voltage
M19	47	Front door LH	OPEN	0
			CLOSE	Battery voltage

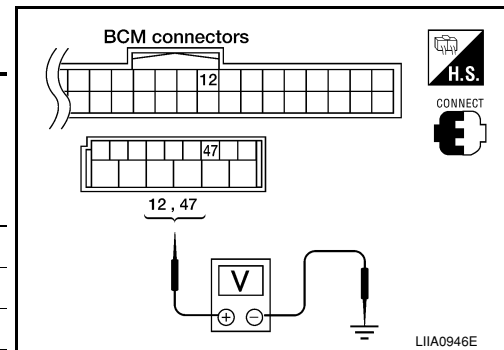

Is the measurement value within the specification?

- YES >> Replace BCM. Refer to [BCS-54. "Removal and Installation"](#).
- NO >> GO TO 2

#### 2. CHECK HARNESS CONTINUITY

1. Turn ignition switch OFF.
2. Disconnect BCM and front door switch.
3. Check continuity between BCM connector and front door switch connector.

BCM connector	Terminal	Front door switch connector	Terminal	Continuity
M18	12	RH: B108	2	Yes
M19	47	LH: B8		

4. Check continuity between front door switch connector and ground.

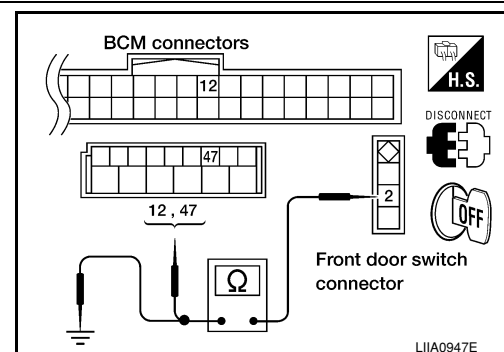

# DOOR SWITCH

## < COMPONENT DIAGNOSIS >

Front door switch connector	Terminal	Ground	Continuity
B8 (LH)	2		Ground
B108 (RH)			

Is the inspection result normal?

YES >> GO TO 3

NO >> Repair or replace harness.

### 3. CHECK BCM OUTPUT SIGNAL

1. Connect BCM connector.
2. Check voltage between BCM connector and ground.

Terminal		(-)	Voltage (V) (Approx.)
(+)			
BCM connector	Terminal	Ground	Battery voltage
M18	12		
M19	47		

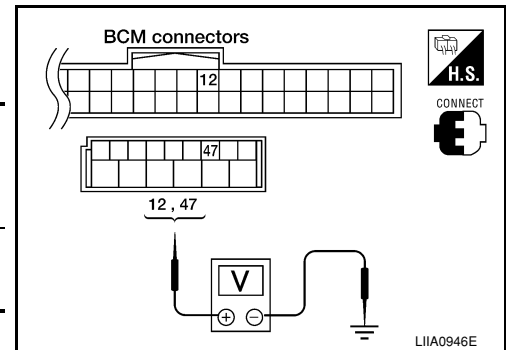

Is the measurement value within the specification?

YES >> GO TO 4

NO >> Replace BCM. Refer to [BCS-54, "Removal and Installation"](#).

### 4. CHECK FRONT DOOR SWITCH

Check front door switch.

Refer to [PWC-34, "Component Inspection"](#).

Is the inspection result normal?

YES >> Check intermittent incident. Refer to [GI-39, "Intermittent Incident"](#).

NO >> Replace front door switch.

## Component Inspection

INFOID:000000001611903

### 1. CHECK FRONT DOOR SWITCH

Check front door switches.

Terminal		Door switch	Continuity
Door switches			
2	Ground part of door switch	Pressed	No
		Released	Yes

Is the inspection result normal?

YES >> Front door switch is OK.

NO >> Replace front door switch.

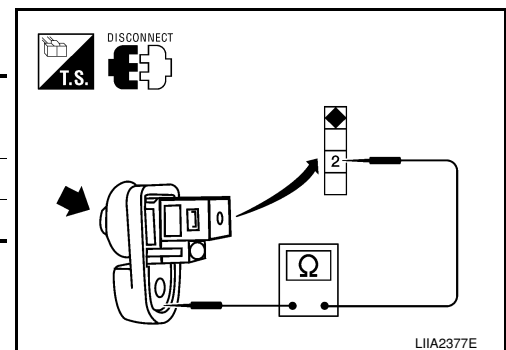

# DOOR KEY CYLINDER SWITCH

< COMPONENT DIAGNOSIS >

## DOOR KEY CYLINDER SWITCH

### Description

INFOID:000000001611904

Main power window and door lock/unlock switch detects condition of the door key cylinder and transmits to BCM as the LOCK or UNLOCK signals.

### Component Function Check

INFOID:000000001611905

### 1. CHECK DOOR KEY CYLINDER SWITCH INPUT SIGNAL

Check ("KEY CYL LK-SW", "KEY CYL UN-SW") in "DATA MONITOR" mode for "POWER DOOR LOCK SYSTEM" with CONSULT-III. Refer to [BCS-16, "COMMON ITEM : CONSULT-III Function \(BCM - COMMON ITEM\)"](#).

Monitor item	Condition
KEY CYL LK-SW	Lock : ON
	Neutral / Unlock : OFF
KEY CYL UN-SW	Unlock : ON
	Neutral / Lock : OFF

Is the inspection result normal?

- YES >> Key cylinder switch is OK.  
 NO >> Refer to [PWC-35, "Diagnosis Procedure"](#).

### Diagnosis Procedure

INFOID:000000001611906

### 1. CHECK DOOR KEY CYLINDER SWITCH INPUT SIGNAL

- Turn ignition switch ON.
- Check voltage between main power window and door lock/unlock switch connector and ground.

Terminals		Key position	Voltage (V) (Approx.)
(+)	(-)		
Main power window and door lock/unlock switch connector	Terminal		
	D7	Ground	
	4	Lock	0
		Neutral/Unlock	5
	6	Unlock	0
		Neutral/Lock	5

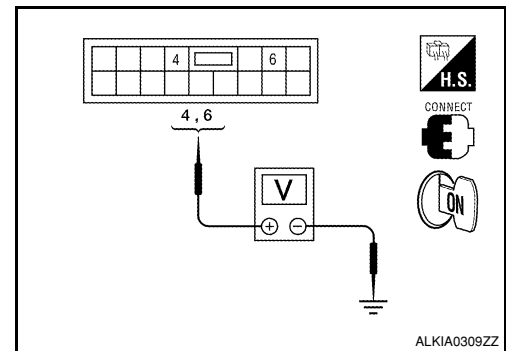

Is the measurement value within the specification?

- YES >> Replace main power window and door lock/unlock switch.  
 NO >> GO TO 2

### 2. CHECK DOOR KEY CYLINDER SIGNAL CIRCUIT

# DOOR KEY CYLINDER SWITCH

## < COMPONENT DIAGNOSIS >

1. Turn ignition switch OFF.
2. Disconnect main power window and door lock/unlock switch and front door lock assembly LH (key cylinder switch).
3. Check continuity between main power window and door lock/unlock switch connector (A) and front door lock assembly LH (key cylinder switch) connector (B).

Main power window and door lock/unlock switch connector	Terminal	Front door lock assembly LH (key cylinder switch) connector	Terminal	Continuity
D7 (A)	4	D14 (B)	1	Yes
	6		6	

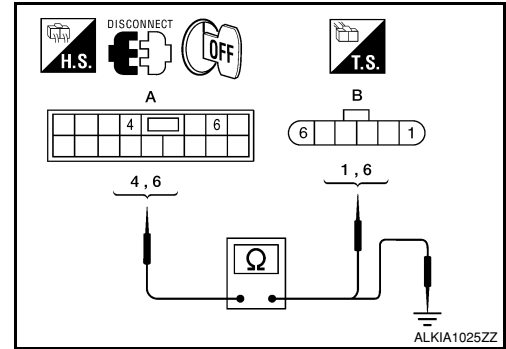

4. Check continuity between main power window and door lock/unlock switch connector (A) and ground.

Main power window and door lock/unlock switch connector	Terminal	Ground	Continuity
D7 (A)	4	Ground	No
	6		

Is the inspection result normal?

YES >> GO TO 3

NO >> Repair or replace harness.

## 3. CHECK DOOR KEY CYLINDER SWITCH GROUND CIRCUIT

Check continuity between front door lock assembly LH (key cylinder switch) connector and ground.

Front door lock assembly LH (key cylinder switch) connector	Terminal	Ground	Continuity
D14	5	Ground	Yes

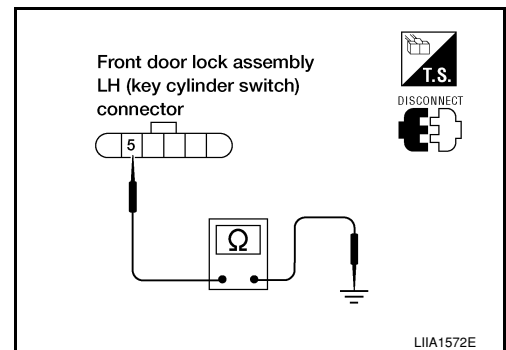

Is the inspection result normal?

YES >> GO TO 4

NO >> Repair or replace harness.

## 4. CHECK DOOR KEY CYLINDER SWITCH

Check door key cylinder switch.

Refer to [PWC-36. "Component Inspection"](#).

Is the inspection result normal?

YES >> Check intermittent incident. Refer to [GI-39. "Intermittent Incident"](#).

NO >> Replace front door lock assembly LH (door key cylinder switch).

## Component Inspection

INFOID:000000001611907

## COMPONENT INSPECTION

### 1. CHECK DOOR KEY CYLINDER SWITCH

# DOOR KEY CYLINDER SWITCH

## < COMPONENT DIAGNOSIS >

Check front door lock assembly LH (key cylinder switch).

Terminal		Key position	Continuity
Front door lock assembly LH (key cylinder switch) connector			
6	5	Unlock	Yes
		Neutral/Lock	No
1	5	Lock	Yes
		Neutral/Unlock	No

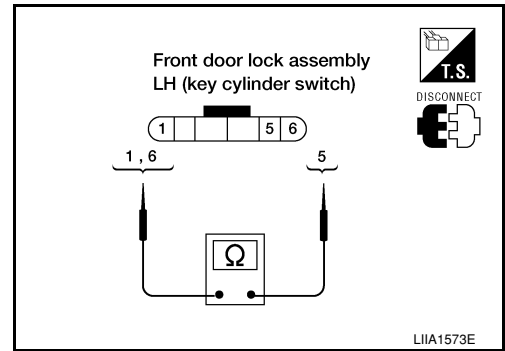

### Is the inspection result normal?

YES >> Key cylinder switch is OK.

NO >> Replace front door lock assembly LH (key cylinder switch).

A  
B  
C  
D  
E  
F  
G  
H  
I  
J  
L  
M  
N  
O  
P

PWC

# POWER WINDOW SERIAL LINK

< COMPONENT DIAGNOSIS >

## POWER WINDOW SERIAL LINK

### POWER WINDOW MAIN SWITCH

#### POWER WINDOW MAIN SWITCH : Description

INFOID:000000001611909

Main power window and door lock/unlock switch, power window and door lock/unlock switch RH and BCM transmit and receive the signal by power window serial link.

The signal mentioned below is transmitted from BCM to main power window and door lock/unlock switch and power window and door lock/unlock switch RH

- Keyless power window down signal

The signal mentioned below is transmitted from main power window and door lock/unlock switch to power window and door lock/unlock switch RH

- Front door window RH operation signal
- Power window control by key cylinder switch signal
- Power window lock switch signal
- Retained power operation signal

#### POWER WINDOW MAIN SWITCH : Component Function Check

INFOID:000000001611910

##### 1. CHECK MAIN POWER WINDOW AND DOOR LOCK/UNLOCK SWITCH OUTPUT SIGNAL

Check ("CDL LOCK SW", "CDL UNLOCK SW") in "DATA MONITOR" mode for "POWER DOOR LOCK SYSTEM" with CONSULT-III. Refer to [BCS-16, "COMMON ITEM : CONSULT-III Function \(BCM - COMMON ITEM\)"](#).

Monitor item	Condition
CDL LOCK SW	LOCK : ON
	UNLOCK : OFF
CDL UNLOCK SW	LOCK : OFF
	UNLOCK : ON

Is the inspection result normal?

YES >> Power window serial link is OK.

NO >> Refer to [PWC-38, "POWER WINDOW MAIN SWITCH : Diagnosis Procedure"](#).

#### POWER WINDOW MAIN SWITCH : Diagnosis Procedure

INFOID:000000001611911

##### Power Window Serial Link Check

##### 1. CHECK MAIN POWER WINDOW AND DOOR LOCK/UNLOCK SWITCH OUTPUT SIGNAL

1. Remove Intelligent Key or ignition key, and close front door LH and RH.
2. Check signal between BCM connector and ground with oscilloscope when door lock and unlock switch (LH and RH) is turned to "LOCK" or "UNLOCK".
3. Check that signals which are shown in the figure below can be detected during 10 second just after door lock and unlock switch (LH and RH) is turned to "LOCK" or "UNLOCK".

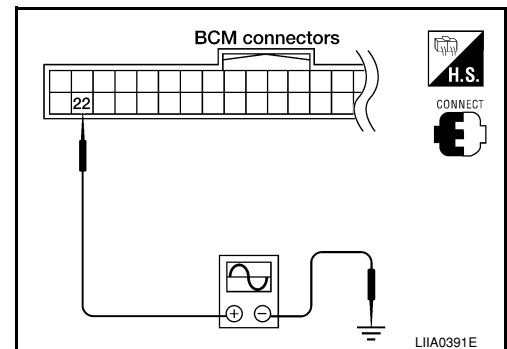

# POWER WINDOW SERIAL LINK

## < COMPONENT DIAGNOSIS >

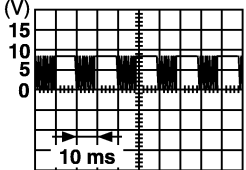
Terminal		Signal (Reference value)
(+)	(-)	
BCM connector	Terminal	
M18	22	 <p style="text-align: right; font-size: small;">PIIA1297E</p>

Is the inspection result normal?

- YES >> Power window serial link is OK.  
 NO >> GO TO 2

### 2. CHECK POWER WINDOW SERIAL LINK CIRCUIT

- Turn ignition switch OFF.
- Disconnect BCM and main power window and door lock/unlock switch.
- Check continuity between BCM connector (A) and main power window and door lock/unlock switch connector (B).

BCM connector	Terminal	Main power window and door lock/unlock switch connector	Terminal	Continuity
M18 (A)	22	D7 (B)	14	Yes

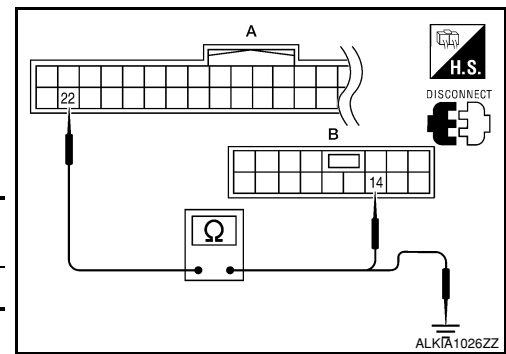

- Check continuity between BCM connector (A) and ground.

BCM connector	Terminal	Ground	Continuity
M18 (A)	22		No

Is the inspection result normal?

- YES >> Replace main power window and door lock/unlock switch. Refer to [PWC-94. "Removal and Installation"](#).  
 NO >> Repair or replace harness.

## FRONT POWER WINDOW SWITCH

### FRONT POWER WINDOW SWITCH : Description

INFOID:000000001611912

Main power window and door lock/unlock switch, power window and door lock/unlock switch RH and BCM transmit and receive the signal by power window serial link.

The signal mentioned below is transmitted from BCM to main power window and door lock/unlock switch and power window and door lock/unlock switch RH

- Keyless power window down signal

The signal mentioned below is transmitted from main power window and door lock/unlock switch to power window and door lock/unlock switch RH

- Front door window RH operation signal
- Power window control by key cylinder switch signal
- Retained power operation signal
- Power window lock switch signal

### FRONT POWER WINDOW SWITCH : Component Function Check

INFOID:000000001611913

- CHECK POWER WINDOW AND DOOR LOCK/UNLOCK SWITCH RH OUTPUT SIGNAL

A  
B  
C  
D  
E  
F  
G  
H  
I  
J  
L  
M  
N  
O  
P

PWC

# POWER WINDOW SERIAL LINK

## < COMPONENT DIAGNOSIS >

Check ("CDL LOCK SW", "CDL UNLOCK SW") in "DATA MONITOR" mode for "POWER DOOR LOCK SYSTEM" with CONSULT-III. Refer to [BCS-16, "COMMON ITEM : CONSULT-III Function \(BCM - COMMON ITEM\)"](#).

Monitor item	Condition	
CDL LOCK SW	LOCK	: ON
	UNLOCK	: OFF
CDL UNLOCK SW	LOCK	: OFF
	UNLOCK	: ON

### Is the inspection result normal?

YES >> Power window serial link is OK.

NO >> Refer to [PWC-40, "FRONT POWER WINDOW SWITCH : Diagnosis Procedure"](#).

## FRONT POWER WINDOW SWITCH : Diagnosis Procedure

INFOID:000000001611914

### Power Window Serial Link Check

#### 1. CHECK POWER WINDOW AND DOOR LOCK/UNLOCK SWITCH RH

1. Remove Intelligent Key or ignition key, and close the front door LH and RH.
2. Check signal between BCM connector and ground with oscilloscope when door lock and unlock switch (LH and RH) is turned to "LOCK" or "UNLOCK".
3. Check that signals which are shown in the figure below can be detected during 10 second just after door lock and unlock switch (LH and RH) is turned to "LOCK" or "UNLOCK".

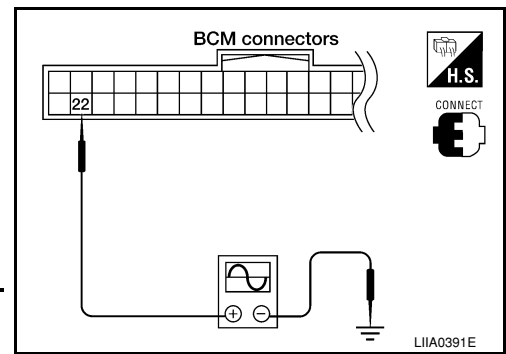

Terminal		Signal (Reference value)
(+)	(-)	
BCM connector	Terminal	
M18	2	Ground

PIIA1297E

### Is the inspection result normal?

YES >> Power window serial link is OK.

NO >> GO TO 2

#### 2. CHECK POWER WINDOW SERIAL LINK CIRCUIT

1. Turn ignition switch OFF.
2. Disconnect BCM.
3. Check continuity between BCM connector (A) and power window and door lock/unlock switch RH connector (B).

BCM connector	Terminal	Power window and door lock/unlock switch RH connector	Terminal	Continuity
M18 (A)	22	D105 (B)	16	Yes

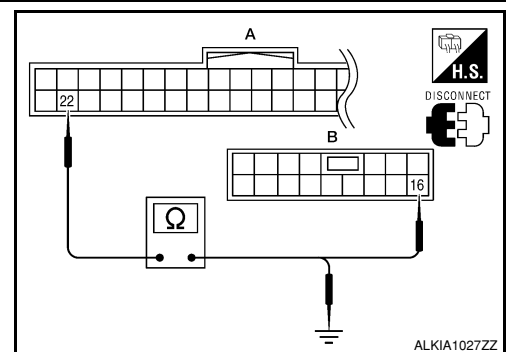



# POWER WINDOW SERIAL LINK

## < COMPONENT DIAGNOSIS >

4. Check continuity between BCM connector (A) and ground.

BCM connector	Terminal	Ground	Continuity
M18 (A)	22		No

Is the inspection result normal?

- YES >> Replace main power window and door lock/unlock switch. Refer to [PWC-94, "Removal and Installation"](#).
- NO >> Repair or replace harness.

A  
B  
C  
D  
E  
F  
G  
H  
I  
J  
L  
M  
N  
O  
P

PWC

# POWER WINDOW LOCK SWITCH

< COMPONENT DIAGNOSIS >

---

## POWER WINDOW LOCK SWITCH

### Description

INFOID:000000001611915

Ground circuit of main power window and door lock/unlock switch shuts off if power window lock switch of main power window and door lock/unlock switch is operated. This inhibits all operation, except for the main switch.

### Component Function Check

INFOID:000000001611916

#### 1. CHECK POWER WINDOW LOCK SIGNAL

---

Exchanges for a normal main power window and door lock/unlock switch, and operation is checked.

Does power window lock operate?

- YES >> Replace main power window and door lock/unlock switch. Refer to [PWC-94. "Removal and Installation"](#).
- NO >> Check condition of harness and connector.

# REAR POWER VENT WINDOW SWITCH CIRCUIT CHECK

< COMPONENT DIAGNOSIS >

## REAR POWER VENT WINDOW SWITCH CIRCUIT CHECK

### Description

INFOID:000000001611938

Rear power vent window motor LH and RH will be operated if rear power vent window switch is operated.

### Diagnosis Procedure

INFOID:000000001611940

#### 1. CHECK REAR POWER VENT WINDOW SWITCH OPERATION

1. Turn ignition switch OFF.
2. Disconnect rear power vent window switch.
3. Check continuity between rear power vent window switch terminals 1, 3 and 4.

Terminals		Condition	Continuity
3	1	Rear power vent window switch is pressed OPEN.	Yes
4	1	Rear power vent window switch is pressed CLOSE.	Yes

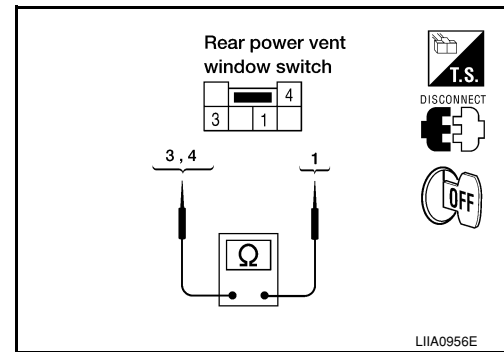

Is the inspection result normal?

YES >> GO TO 2.

NO >> Replace rear power vent window switch.

#### 2. CHECK REAR POWER VENT WINDOW SWITCH CIRCUIT HARNESS CONTINUITY

Check continuity between rear power vent window switch connector M95 terminal 1 and ground.

**1 - Ground**

**: Continuity should exist.**

Is the inspection result normal?

YES >> Rear power vent window switch circuit harness OK.

NO >> Repair or replace harness.

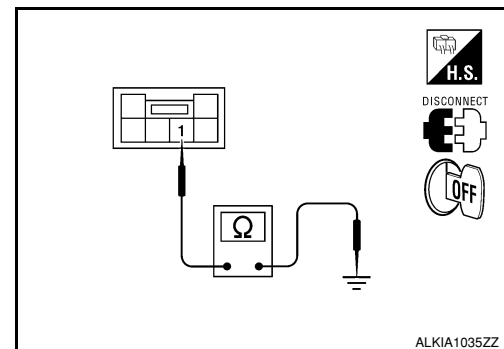

A  
B  
C  
D  
E  
F  
G  
H  
I  
J  
L  
M  
N  
O  
P

PWC

# REAR POWER VENT WINDOW MOTOR LH CIRCUIT CHECK

< COMPONENT DIAGNOSIS >

## REAR POWER VENT WINDOW MOTOR LH CIRCUIT CHECK

### Description

INFOID:000000001611944

Rear power vent windows OPEN/CLOSE by receiving the signal from rear power vent window switch.

### Diagnosis Procedure

INFOID:000000001611946

#### 1. CHECK REAR POWER VENT WINDOW LH SIGNAL

1. Turn ignition switch OFF.
2. Disconnect rear power vent window motor LH.
3. Turn ignition switch ON.
4. Check voltage between rear power vent window motor LH connector B52 terminals 1, 2 and ground.

Connector	Terminals		Condition	Voltage (V) (Approx.)
	(+)	(-)		
B52	1	Ground	Opening	Battery voltage
			Closing	0
	2		Opening	0
			Closing	Battery voltage

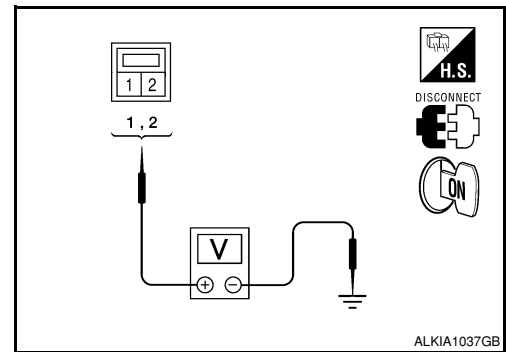

Is the inspection result normal?

- YES >> Replace rear power vent window motor LH. Refer to [GW-20. "Removal and Installation \(with Rear Power Vent Windows\)"](#).
- NO >> Repair or replace harness.

# REAR POWER VENT WINDOW MOTOR RH CIRCUIT CHECK

< COMPONENT DIAGNOSIS >

## REAR POWER VENT WINDOW MOTOR RH CIRCUIT CHECK

### Description

INFOID:000000001611957

Rear power vent windows OPEN/CLOSE by receiving the signal from rear power vent window switch.

### Diagnosis Procedure

INFOID:000000001611949

#### 1. CHECK REAR POWER VENT WINDOW SWITCH RH SIGNAL

1. Turn ignition switch OFF.
2. Disconnect rear power vent window motor RH.
3. Turn ignition switch ON.
4. Check voltage between rear power vent window motor LH connector B150 terminals 1, 2 and ground.

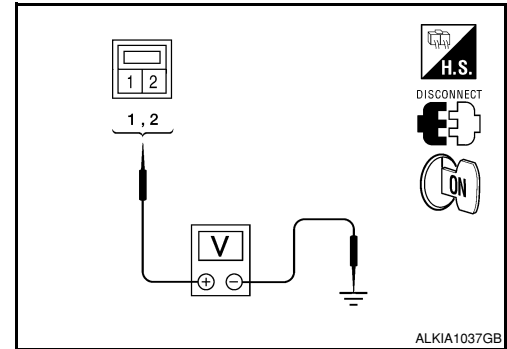

Connector	Terminals		Condition	Voltage (V) (Approx.)
	(+)	(-)		
B150	1	Ground	Opening	Battery voltage
			Closing	0
	2		Opening	0
			Closing	Battery voltage

Is the inspection result normal?

- YES >> Replace rear power vent window motor RH. Refer to [GW-20. "Removal and Installation \(with Rear Power Vent Windows\)".](#)
- NO >> Repair or replace harness.

A  
B  
C  
D  
E  
F  
G  
H  
I  
J

PWC

L  
M  
N  
O  
P

# REAR POWER VENT WINDOW RELAY (OPEN) CHECK

< COMPONENT DIAGNOSIS >

## REAR POWER VENT WINDOW RELAY (OPEN) CHECK

### Description

INFOID:000000001611958

Rear power vent windows OPEN/CLOSE by receiving the signal from rear power vent window switch.

### Diagnosis Procedure

INFOID:000000001611952

#### 1. CHECK REAR POWER VENT WINDOW RELAY (OPEN) POWER SUPPLY CIRCUIT

1. Turn ignition switch OFF.
2. Disconnect rear power vent window relay (OPEN).
3. Turn ignition switch ON.
4. Check voltage between rear power vent window relay (OPEN) connector and ground.

Connector	Terminals		Voltage (V) (Approx.)
	(+)	(-)	
M87	1	Ground	Battery voltage
	5		

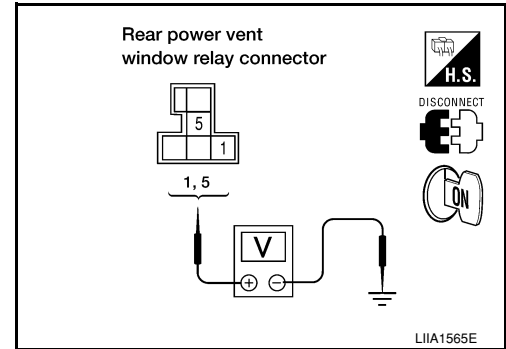

Is the inspection result normal?

- YES >> GO TO 2  
 NO >> Repair or replace harness.

#### 2. CHECK REAR POWER VENT WINDOW RELAY (OPEN)

Check continuity between rear power vent window relay (OPEN) terminals 3 and 4, 3 and 5.

Terminals	Condition	Continuity
3 4	12V direct current supply between terminals 1 and 2	No
	No current supply	Yes
3 5	12V direct current supply between terminals 1 and 2	Yes
	No current supply	No

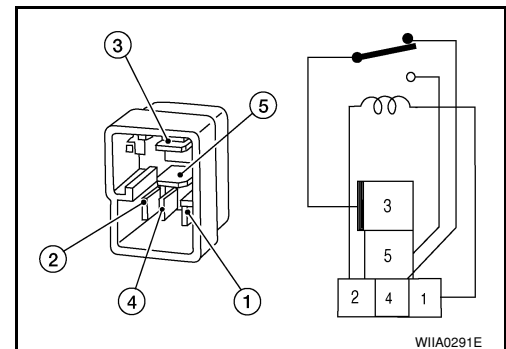

Is the inspection result normal?

- YES >> GO TO 3  
 NO >> Replace rear power vent window relay (OPEN).

#### 3. CHECK REAR POWER VENT WINDOW RELAY (OPEN) GROUND CIRCUIT

Check continuity between rear power vent window relay (OPEN) connector M87 terminal 4 and ground.

**4 - Ground : Continuity should exist.**

Is the inspection result normal?

- YES >> GO TO 4  
 NO >> Repair or replace harness.

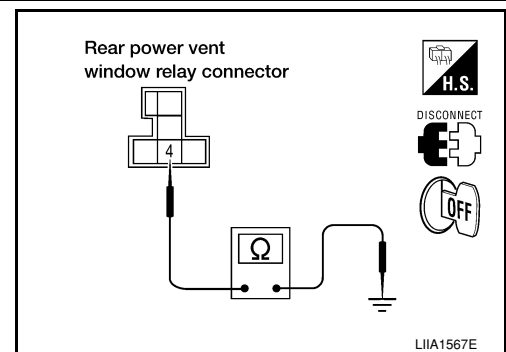

#### 4. CHECK REAR POWER VENT WINDOW RELAY (OPEN) CIRCUIT

# REAR POWER VENT WINDOW RELAY (OPEN) CHECK

## < COMPONENT DIAGNOSIS >

1. Disconnect rear power vent window switch.
2. Check continuity between rear power vent window relay (OPEN) connector M87 terminal 2 and rear power vent window switch connector M95 terminal 3.

**2 - 3**

**: Continuity should exist.**

Is the inspection result normal?

- YES >> Replace rear power vent window switch.  
NO >> Repair or replace harness.

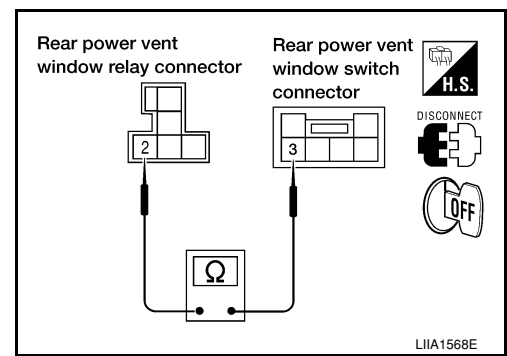

A  
B  
C  
D  
E  
F  
G  
H  
I  
J  
L  
M  
N  
O  
P

PWC

# REAR POWER VENT WINDOW RELAY (CLOSE) CHECK

< COMPONENT DIAGNOSIS >

## REAR POWER VENT WINDOW RELAY (CLOSE) CHECK

### Description

INFOID:000000001611959

Rear power vent windows OPEN/CLOSE by receiving the signal from rear power vent window switch.

### Diagnosis Procedure

INFOID:000000001611955

#### 1. CHECK REAR POWER VENT WINDOW RELAY (CLOSE) POWER SUPPLY CIRCUIT

1. Turn ignition switch OFF.
2. Disconnect rear power vent window relay (CLOSE).
3. Turn ignition switch ON.
4. Check voltage between rear power vent window relay (CLOSE) connector and ground.

Connector	Terminals		Voltage (V) (Approx.)
	(+)	(-)	
M89	1	Ground	Battery voltage
	5		

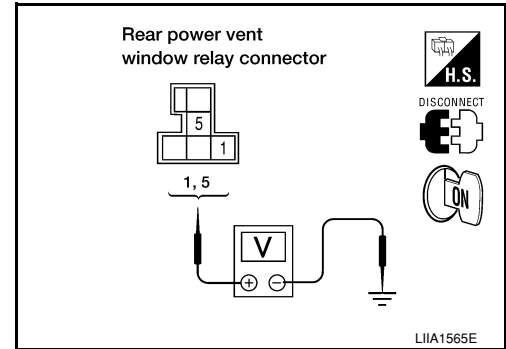

Is the inspection result normal?

- YES >> GO TO 2  
 NO >> Repair or replace harness.

#### 2. CHECK REAR POWER VENT WINDOW RELAY (CLOSE)

Check continuity between rear power vent window relay (CLOSE) terminals 3 and 4, 3 and 5.

Terminals		Condition	Continuity
3	4	12V direct current supply between terminals 1 and 2	No
		No current supply	Yes
3	5	12V direct current supply between terminals 1 and 2	Yes
		No current supply	No

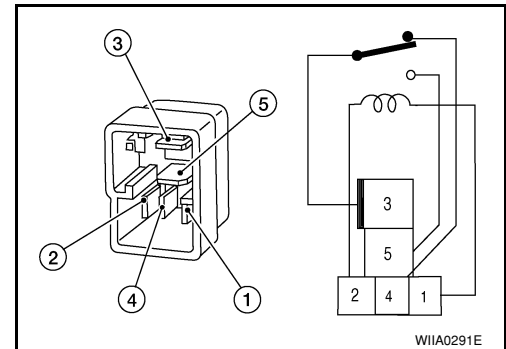

Is the inspection result normal?

- YES >> GO TO 3  
 NO >> Replace rear power vent window relay (CLOSE).

#### 3. CHECK REAR POWER VENT WINDOW RELAY (CLOSE) GROUND CIRCUIT

Check continuity between rear power vent window relay (CLOSE) connector M89 terminal 4 and ground.

**4 - Ground : Continuity should exist.**

Is the inspection result normal?

- YES >> GO TO 4  
 NO >> Repair or replace harness.

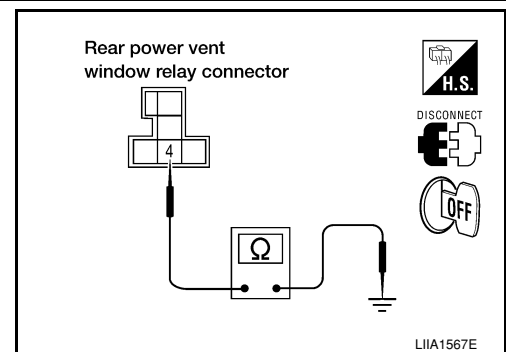

#### 4. CHECK REAR POWER VENT WINDOW RELAY (CLOSE) CIRCUIT



# REAR POWER VENT WINDOW RELAY (CLOSE) CHECK

## < COMPONENT DIAGNOSIS >

1. Disconnect rear power vent window switch.
2. Check continuity between rear power vent window relay (CLOSE) connector M89 terminal 2 and rear power vent window switch M95 terminal 4.

**2 - 4**

**: Continuity should exist.**

Is the inspection result normal?

- YES >> Replace rear power vent window switch.  
NO >> Repair or replace harness.

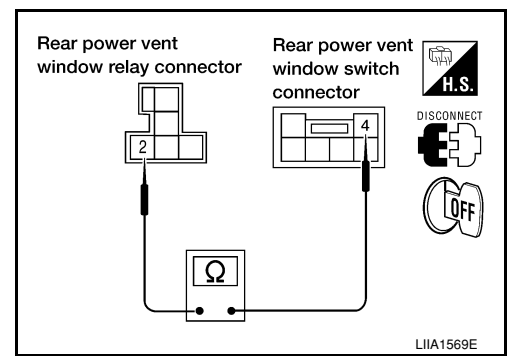

A  
B  
C  
D  
E  
F  
G  
H  
I  
J  
L  
M  
N  
O  
P

PWC

# BCM (BODY CONTROL MODULE)

< ECU DIAGNOSIS >

## ECU DIAGNOSIS

### BCM (BODY CONTROL MODULE)

Reference Value

INFOID:000000001611918

#### VALUES ON THE DIAGNOSIS TOOL

##### CONSULT-III MONITOR ITEM

Monitor Item	Condition	Value/Status
DOOR SW-DR	Front door LH closed	OFF
	Front door LH opened	ON
DOOR SW-AS	Front door RH closed	OFF
	Front door RH opened	ON
KEY CYL LK-SW	Other than front door key cylinder LH LOCK position	OFF
	Front door key cylinder LH LOCK position	ON
KEY CYL UN-SW	Other than front door key cylinder LH UNLOCK position	OFF
	Front door key cylinder LH UNLOCK position	ON
KEY CYL SW-TR	<b>NOTE:</b> The item is indicated, but not monitored.	OFF

#### TERMINAL LAYOUT

Refer to [BCS-41, "Terminal Layout"](#).

#### PHYSICAL VALUES

Refer to [BCS-41, "Physical Values"](#).

# POWER WINDOW MAIN SWITCH

< ECU DIAGNOSIS >

## POWER WINDOW MAIN SWITCH

Reference Value

INFOID:000000001611919

### TERMINAL LAYOUT

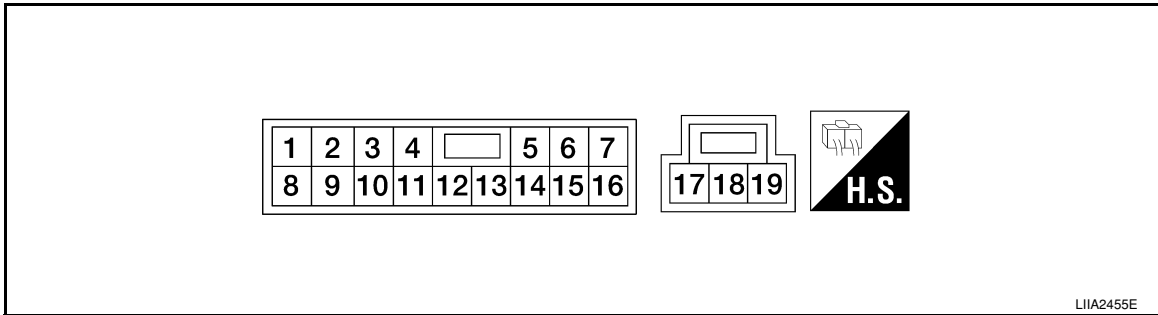

### PHYSICAL VALUES

#### MAIN POWER WINDOW AND DOOR LOCK/UNLOCK SWITCH

Terminal No. (Wire color)		Description		Condition	Voltage [V] (Approx.)
+	-	Signal name	Input/ Output		
1 (R/Y)	Ground	Rear power window motor LH UP signal	Output	When rear LH switch in power window main switch is operated UP.	Battery voltage
2 (W/B)	Ground	Encoder ground	—	—	0
3 (R/B)	Ground	Rear power window motor LH DOWN signal	Output	When rear LH switch in power window main switch is operated DOWN.	Battery voltage
4 (L)	Ground	Door key cylinder switch LH LOCK signal	Input	Key position (Neutral → Locked)	5 → 0
5 (L)	Ground	Rear power window motor RH DOWN signal	Output	When rear RH switch in power window main switch is operated DOWN.	Battery voltage
6 (R)	Ground	Door key cylinder switch LH UNLOCK signal	Input	Key position (Neutral → Unlocked)	5 → 0
7 (R)	Ground	Rear power window motor RH UP signal	Output	When rear RH switch in power window main switch is operated UP.	Battery voltage
8 (G/R)	11	Front door power window motor LH UP signal	Output	When front LH switch in power window main switch is operated UP.	Battery voltage
9 (O)	2	Encoder pulse signal 2	Input	When power window motor operates.	

JMKIA0070GB

A  
B  
C  
D  
E  
F  
G  
H  
I  
J  
L  
M  
N  
O  
P

PWC

# POWER WINDOW MAIN SWITCH

## < ECU DIAGNOSIS >

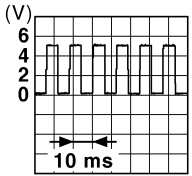
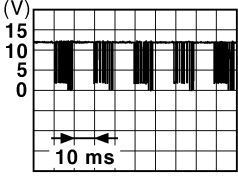
Terminal No. (Wire color)		Description		Condition	Voltage [V] (Approx.)
+	-	Signal name	Input/ Output		
10 (W/L)	Ground	RAP signal	Input	IGN SW ON	Battery voltage
				Within 45 second after ignition switch is turned to OFF.	Battery voltage
				When front LH or RH door is opened during retained power operation.	0
11 (G/W)	8	Front door power window motor LH DOWN signal	Output	When front LH switch in power window main switch is operated DOWN.	Battery voltage
13 (G/Y)	2	Encoder pulse signal 1	Input	When power window motor operates.	 <small>JMKIA0070GB</small>
14 (LG/W)	Ground	Power window serial link	Input/ Output	IGN SW ON or power window timer operating.	 <small>JPMIA0013GB</small>
15 (BR)	Ground	Encoder power supply	Output	When ignition switch ON or power window timer operates.	10
17 (B)	Ground	Ground	—	—	0
19 (W/R)	Ground	Battery power supply	Input	—	Battery voltage

# POWER WINDOW MAIN SWITCH

< ECU DIAGNOSIS >

## Wiring Diagram

INFOID:000000001611920

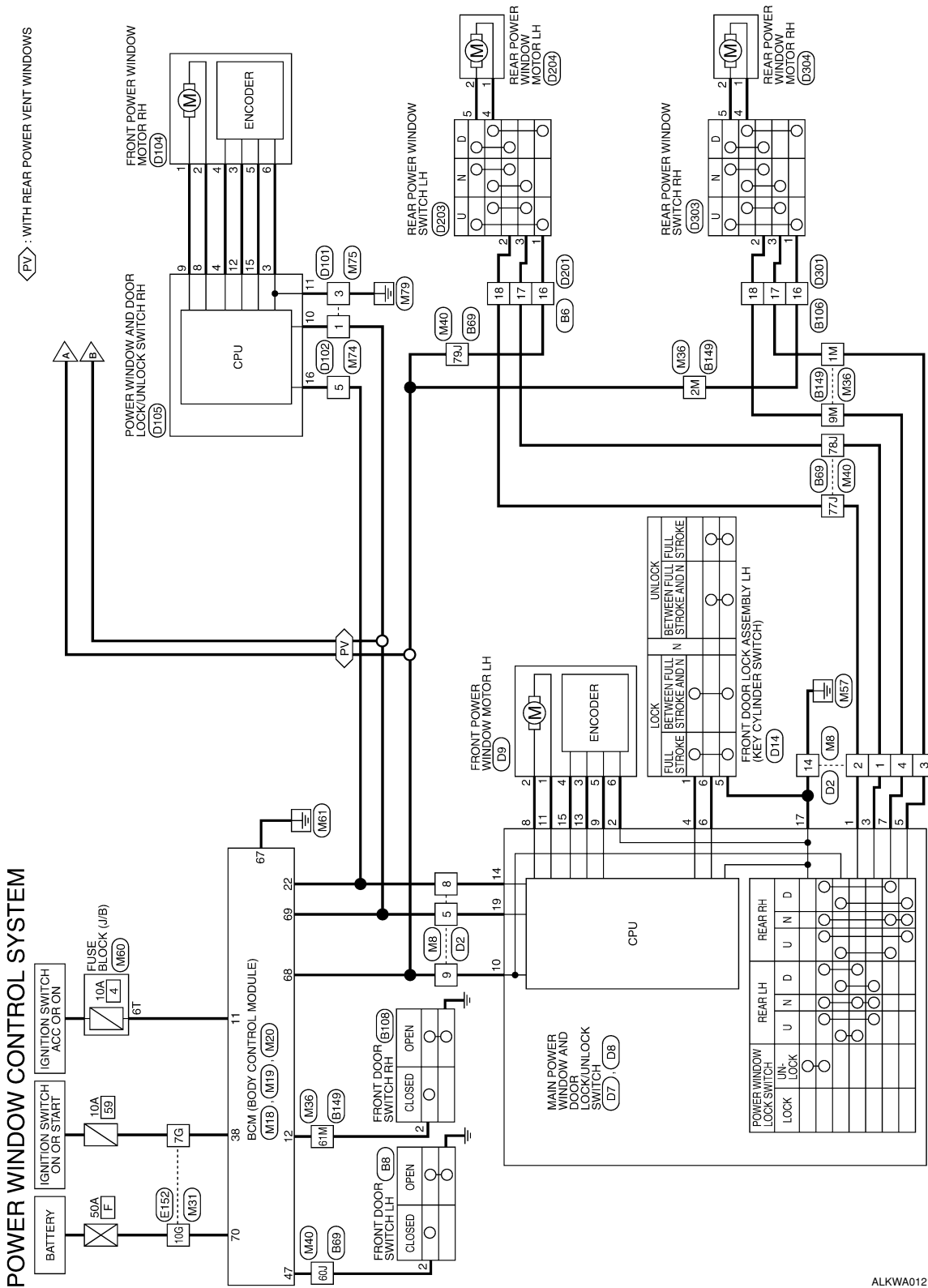

A  
B  
C  
D  
E  
F  
G  
H  
I  
J  
K  
L  
M  
N  
O  
P

PWC

ALKWA0121GE

# POWER WINDOW MAIN SWITCH

< ECU DIAGNOSIS >

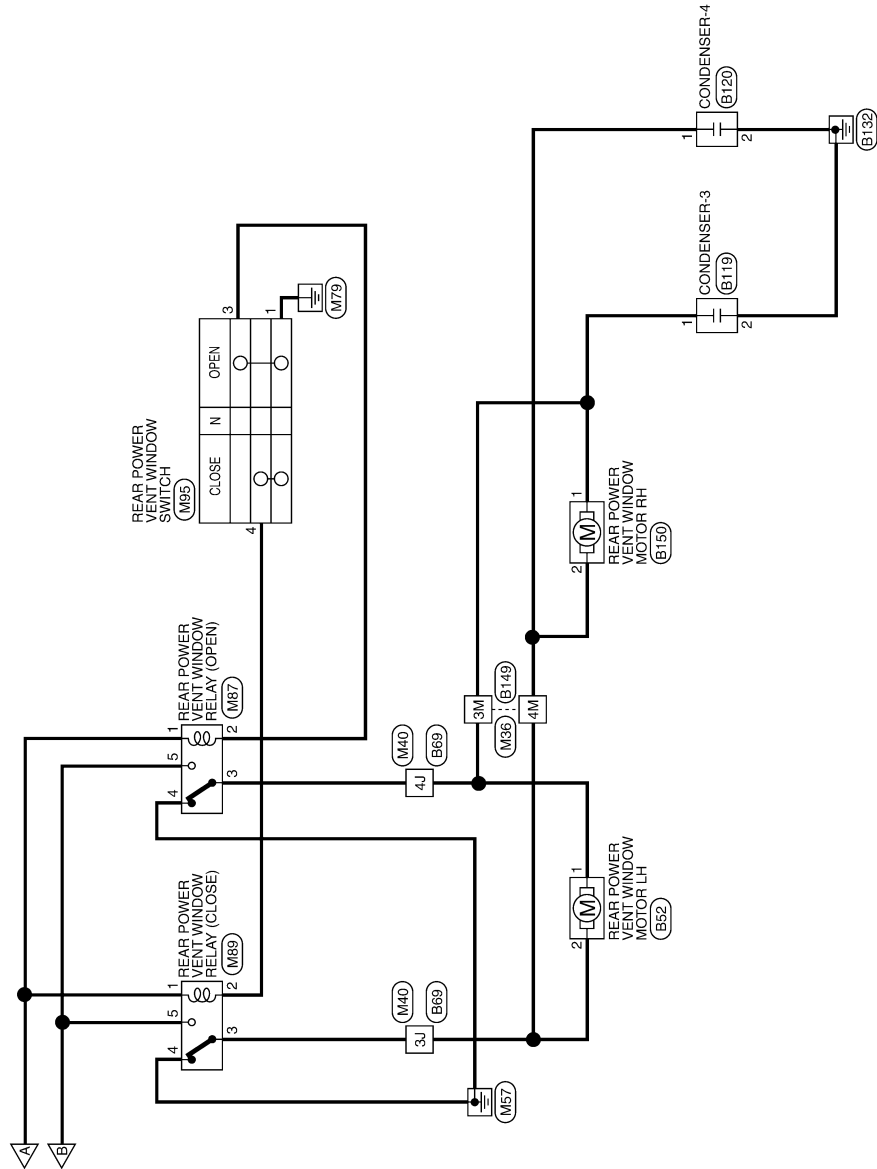

ALKWA0122GE

# POWER WINDOW MAIN SWITCH

< ECU DIAGNOSIS >

## POWER WINDOW SYSTEM / WHITH FRONT LEFT AND RIGHT POWER WINDOW ANTI-PINCH SYSTEM CONNECTORS

Connector No.	M4
Connector Name	FUSE BLOCK (J/B)
Connector Color	WHITE

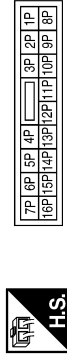

Terminal No.	Color of Wire	Signal Name
4P	G/B	-
15P	W/R	-

Connector No.	M6
Connector Name	WIRE TO WIRE
Connector Color	WHITE



Terminal No.	Color of Wire	Signal Name
7	W	-

Connector No.	M8
Connector Name	WIRE TO WIRE
Connector Color	WHITE

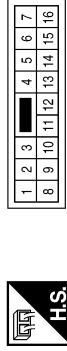

Terminal No.	Color of Wire	Signal Name
1	L	-
7	V	-
11	B	-
12	O	-
13	R	-
14	LG	-
15	Y	-
16	P	-

Connector No.	M18
Connector Name	BCM (BODY CONTROL MODULE)
Connector Color	WHITE

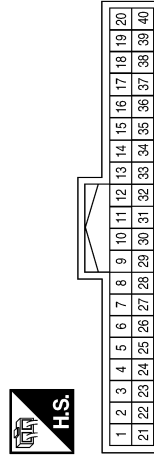

Terminal No.	Color of Wire	Signal Name
11	G/B	ACC SW
12	LG	DOOR SW (AS)
22	V	BUS
38	W/R	IGN SW

Connector No.	M19
Connector Name	BCM (BODY CONTROL MODULE)
Connector Color	WHITE

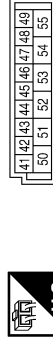

Terminal No.	Color of Wire	Signal Name
47	GR	DOOR SW (DR)

Connector No.	M20
Connector Name	BCM (BODY CONTROL MODULE)
Connector Color	BLACK



Terminal No.	Color of Wire	Signal Name
67	B	GND
68	O	POWER WINDOW POWER SUPPLY (RAP)
69	L	POWER WINDOW POWER SUPPLY (BAT)
70	W	BAT (F/L)

ALKIA0877GB

# POWER WINDOW MAIN SWITCH

< ECU DIAGNOSIS >

Terminal No.	Color of Wire	Signal Name
57M	LG	-
77M	W	-
78M	Y	-
79M	P	-

Connector No.	M36
Connector Name	WIRE TO WIRE
Connector Color	WHITE

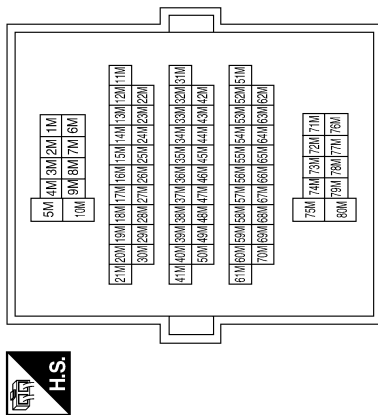

Terminal No.	Color of Wire	Signal Name
10J	W	-
61J	GR	-
75J	R	-
80J	LG	-

Connector No.	M40
Connector Name	WIRE TO WIRE
Connector Color	WHITE

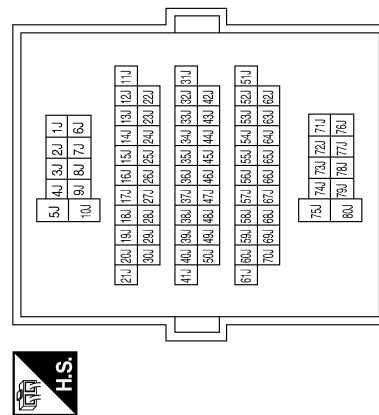

Connector No.	M75
Connector Name	WIRE TO WIRE
Connector Color	WHITE

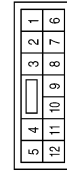

Terminal No.	Color of Wire	Signal Name
1	Y	-
5	V	-
12	B	-

ALKIA0878GB



# POWER WINDOW MAIN SWITCH

< ECU DIAGNOSIS >

Connector No.	E10
Connector Name	WIRE TO WIRE
Connector Color	WHITE

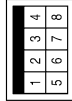

Terminal No.	Color of Wire	Signal Name
7	W	-

Connector No.	B6
Connector Name	WIRE TO WIRE
Connector Color	WHITE

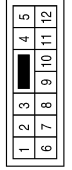

Terminal No.	Color of Wire	Signal Name
6	W	-
7	R	-
8	LG	-
9	B	-

Connector No.	B8
Connector Name	FRONT DOOR SWITCH LH
Connector Color	WHITE



Terminal No.	Color of Wire	Signal Name
2	GR	-

Connector No.	B69
Connector Name	WIRE TO WIRE
Connector Color	WHITE

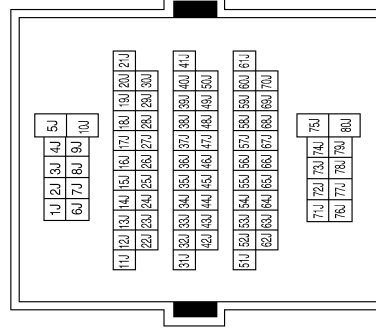

Terminal No.	Color of Wire	Signal Name
10J	W	-
61J	GR	-
75J	R	-
80J	LG	-

Connector No.	B106
Connector Name	WIRE TO WIRE
Connector Color	WHITE

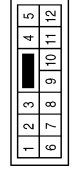

Terminal No.	Color of Wire	Signal Name
6	W	-
7	Y	-
8	P	-
9	B	-

ALKIA0879GB

A B C D E F G H I J L M N O P

# POWER WINDOW MAIN SWITCH

< ECU DIAGNOSIS >

Connector No.	B108
Connector Name	FRONT DOOR SWITCH RH
Connector Color	WHITE

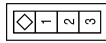

Terminal No.	Color of Wire	Signal Name
2	LG	-

Connector No.	B149
Connector Name	WIRE TO WIRE
Connector Color	WHITE

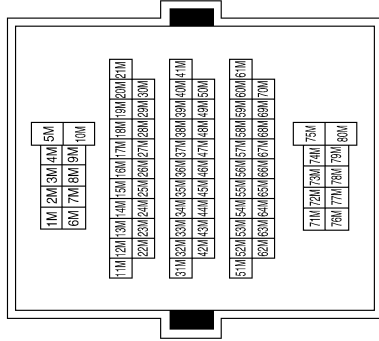

Terminal No.	Color of Wire	Signal Name
57M	LG	-
77M	W	-
78M	Y	-
79M	P	-

Connector No.	D2
Connector Name	WIRE TO WIRE
Connector Color	WHITE

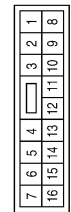

Terminal No.	Color of Wire	Signal Name
1	L	-
7	V	-
11	B	-
12	W/R	-
13	R	-
14	LG	-
15	Y	-
16	P	-

Connector No.	D7
Connector Name	MAIN POWER WINDOW AND DOOR LOCK/UNLOCK SWITCH
Connector Color	WHITE

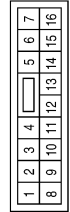

Terminal No.	Color of Wire	Signal Name
1	R	UP
2	BR	ENCODER AND LIMIT SW GND
3	LG	DOWN
4	SB	KEY CYL LOCK SW
5	P	DOWN
6	R/W	KEY CYL UNLOCK SW

Terminal No.	Color of Wire	Signal Name
7	Y	UP
8	O	UP
9	Y	LIMIT SW
10	W/R	RAP
11	GR	DOWN
13	LB	PULSE
14	V	POWER WINDOW SERIAL LINK
15	W/R	ENCODER POWER

ALKIA0880GB

# POWER WINDOW MAIN SWITCH

< ECU DIAGNOSIS >

Connector No.	D8
Connector Name	MAIN POWER WINDOW AND DOOR LOCK/UNLOCK SWITCH
Connector Color	WHITE

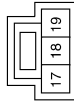

Terminal No.	Color of Wire	Signal Name
17	B	GND
19	L	BAT

Connector No.	D9
Connector Name	FRONT POWER WINDOW MOTOR LH
Connector Color	BLACK

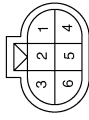

Terminal No.	Color of Wire	Signal Name
1	GR	-
2	O	-
3	W/R	-
4	BR	-
5	Y	-
6	LB	-

Connector No.	D14
Connector Name	FRONT DOOR LOCK ASSEMBLY LH (KEY CYLINDER SWITCH)
Connector Color	GRAY

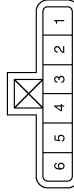

Terminal No.	Color of Wire	Signal Name
3	SB	-
4	B	-
5	R/W	-

Connector No.	D101
Connector Name	WIRE TO WIRE
Connector Color	WHITE

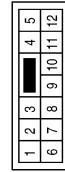

Terminal No.	Color of Wire	Signal Name
1	Y	-
5	V	-
12	L	-

Connector No.	D104
Connector Name	FRONT POWER WINDOW MOTOR RH
Connector Color	BLACK

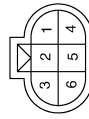

Terminal No.	Color of Wire	Signal Name
1	G	-
2	L	-
3	W/R	-
4	BR	-
5	Y	-
6	LB	-

ALKIA0881GB

A B C D E F G H I J L M N O P

PWC

# POWER WINDOW MAIN SWITCH

< ECU DIAGNOSIS >

Connector No.	D105
Connector Name	POWER WINDOW AND DOOR LOCK/UNLOCK SWITCH RH
Connector Color	WHITE

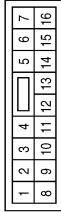

Terminal No.	Color of Wire	Signal Name
3	BR	ENCODER AND LIMIT SW GND
4	W/R	ENCODER POWER
8	L	UP
9	G	DOWN
10	Y	BAT
11	B	GND

Terminal No.	Color of Wire	Signal Name
12	LB	PULSE
15	Y	LIMIT SW
16	V	POWER WINDOW SERIAL LINK

Connector No.	D201
Connector Name	WIRE TO WIRE
Connector Color	WHITE

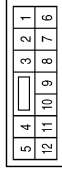

Terminal No.	Color of Wire	Signal Name
6	W	-
7	LG	-
8	R	-
9	B	-

Connector No.	D203
Connector Name	REAR POWER WINDOW SWITCH LH
Connector Color	WHITE

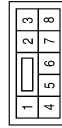

Terminal No.	Color of Wire	Signal Name
2	B	-
4	LB	-
5	R	-
6	Y	-
7	L	-
8	W	-

Connector No.	D204
Connector Name	REAR POWER WINDOW MOTOR LH
Connector Color	BLACK



Terminal No.	Color of Wire	Signal Name
1	Y	-
2	L	-

Connector No.	D301
Connector Name	WIRE TO WIRE
Connector Color	WHITE

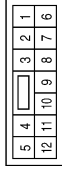

Terminal No.	Color of Wire	Signal Name
6	W	-
7	Y	-
8	P	-
9	B	-

ALKIA0882GB

# POWER WINDOW MAIN SWITCH

< ECU DIAGNOSIS >

Connector No.	D304
Connector Name	REAR POWER WINDOW MOTOR RH
Connector Color	BLACK



Terminal No.	Color of Wire	Signal Name
1	Y	-
2	L	-

Connector No.	D303
Connector Name	REAR POWER WINDOW SWITCH RH
Connector Color	WHITE



Terminal No.	Color of Wire	Signal Name
2	B	-
4	Y	-
5	P	-
6	Y	-
7	L	-
8	W	-

A  
B  
C  
D  
E  
F  
G  
H  
I  
J  
L  
M  
N  
O  
P

PWC

ALKIA0883GB

# POWER WINDOW MAIN SWITCH

< ECU DIAGNOSIS >

Connector No.	D105
Connector Name	POWER WINDOW AND DOOR LOCK/UNLOCK SWITCH RH
Connector Color	WHITE



1	2	3	4	5	6	7		
8	9	10	11	12	13	14	15	16

Terminal No.	Color of Wire	Signal Name
1	-	-
2	-	-
3	W/B	-
4	G/R	-

Terminal No.	Color of Wire	Signal Name
5	-	-
6	-	-
7	-	-
8	L	-
9	G	-
10	W/R	-
11	B	GND
12	G/Y	-
13	-	-
14	-	-
15	G/W	-
16	LG/W	ANTI_PINCH_SERIAL_LINK

Connector No.	D201
Connector Name	WIRE TO WIRE
Connector Color	WHITE



1	2	3	4	5	6	7	8	9	10
11	12	13	14	15	16	17	18		

Terminal No.	Color of Wire	Signal Name
16	W/L	-
17	R/B	-
18	R/Y	-

Connector No.	D203
Connector Name	REAR POWER WINDOW SWITCH LH
Connector Color	WHITE



2	3	4	5	7
---	---	---	---	---

Terminal No.	Color of Wire	Signal Name
1	W/L	BAT
2	R/Y	UP
3	R/B	DOWN
4	G	DOWN
5	L	UP

Connector No.	D204
Connector Name	REAR POWER WINDOW MOTOR LH
Connector Color	GRAY



Terminal No.	Color of Wire	Signal Name
1	G	-
2	L	-

Connector No.	D301
Connector Name	WIRE TO WIRE
Connector Color	WHITE



1	2	3	4	5	6	7	8	9	10
11	12	13	14	15	16	17	18		

Terminal No.	Color of Wire	Signal Name
16	W/L	-
17	L	-
18	R	-

ALKIA0884GB

# POWER WINDOW MAIN SWITCH

< ECU DIAGNOSIS >

A  
B  
C  
D  
E  
F  
G  
H  
I  
J  
L  
M  
N  
O  
P

Connector No.	D304
Connector Name	REAR POWER WINDOW MOTOR RH
Connector Color	GRAY



Terminal No.	Color of Wire	Signal Name
1	Y/B	-
2	BR	-

Connector No.	D303
Connector Name	REAR POWER WINDOW SWITCH RH
Connector Color	WHITE

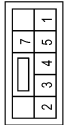

Terminal No.	Color of Wire	Signal Name
1	W/L	BAT
2	R	UP
3	L	DOWN
4	Y/B	DOWN
5	BR	UP

PWC

## Fail Safe

ALKIA0885GB

INFOID:000000001611921

### FAIL-SAFE CONTROL

Switches to fail-safe control when malfunction is detected in encoder signal that detects up/down speed and direction of door glass. Switches to fail-safe control when error beyond regulation value is detected between the fully closed position and the actual position of the glass.

# POWER WINDOW MAIN SWITCH

## < ECU DIAGNOSIS >

Error	Error condition
Pulse sensor malfunction	When only one side of pulse signal is being detected for more than the specified value.
Both pulse sensors malfunction	When both pulse signals have not been detected for more than the specified value during glass open/close operation.
Pulse direction malfunction	When the pulse signal that is detected during glass open/close operation detects the opposite condition of power window motor operating direction.
Glass recognition position malfunction 1	When it detects the error between glass fully closed position in power window switch memory and actual fully closed position during glass open/close operation is more than the specified value.
Glass recognition position malfunction 2	When it detects pulse count more than the value of glass full stroke during glass open/close operation.
Malfunction of not yet updated closed position of glass	When glass open/close operation is continuously performed without fully closing more than the specified value (approximately 10 strokes).

It changes to condition before initialization and the following functions do not operate when switched to fail-safe control.

- Auto-up operation
- Anti-pinch function
- Retained power function

Perform initial operation to recover when switched to fail-safe mode. However, it switches back to fail-safe control when malfunction is found in power window switch or in motor.



# FRONT POWER WINDOW SWITCH

< ECU DIAGNOSIS >

## FRONT POWER WINDOW SWITCH

Reference Value

INFOID:000000001611922

### TERMINAL LAYOUT

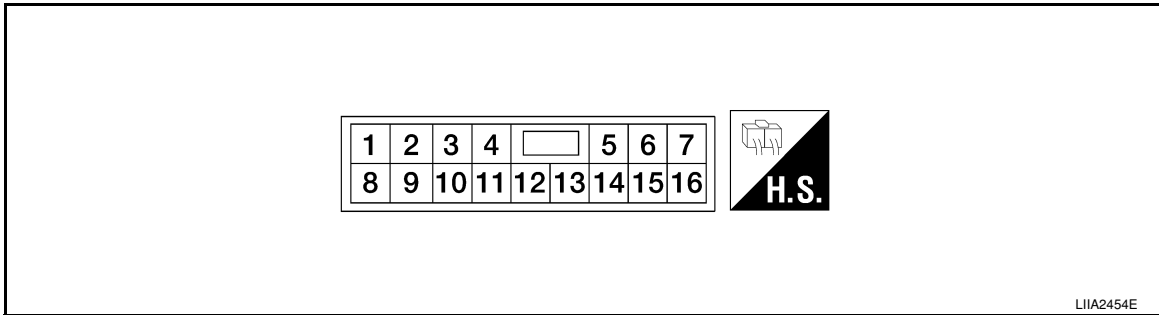

### PHYSICAL VALUES

#### POWER WINDOW AND DOOR LOCK/UNLOCK SWITCH RH

Terminal No. (Wire color)		Description		Condition	Voltage [V] (Approx.)
+	-	Signal name	Input/ Output		
3 (W/B)	Ground	Encoder ground	—	—	0
4 (G/R)	Ground	Encoder power supply	Output	When ignition switch ON or power window timer operates	10
8 (L)	9	Power window motor UP signal	Output	When power window motor is UP at operated.	Battery voltage
9 (G)	8	Power window motor DOWN signal	Output	When power window motor is DOWN at operated.	Battery voltage
10 (W/R)	Ground	Battery power supply	Input	—	Battery voltage
11 (B)	Ground	Ground	—	—	0
12 (G/Y)	3	Encoder pulse signal 1	Input	When power window motor operates.	

JMKIA0070GB

A  
B  
C  
D  
E  
F  
G  
H  
I  
J  
L  
M  
N  
O  
P

PWC

# FRONT POWER WINDOW SWITCH

## < ECU DIAGNOSIS >

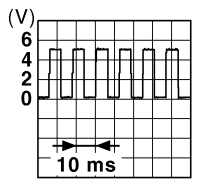
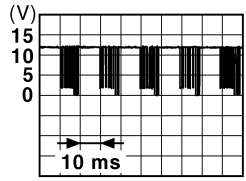
Terminal No. (Wire color)		Description		Condition	Voltage [V] (Approx.)
+	-	Signal name	Input/ Output		
15 (G/W)	3	Encoder pulse signal 2	Input	When power window motor operates.	 <p style="text-align: right; font-size: small;">JMKIA0070GB</p>
16 (LG/W)	Ground	Power window serial link	Input/ Output	IGN SW ON or power window timer operating.	 <p style="text-align: right; font-size: small;">JPMIA0013GB</p>

# FRONT POWER WINDOW SWITCH

< ECU DIAGNOSIS >

## Wiring Diagram

INFOID:000000001611923

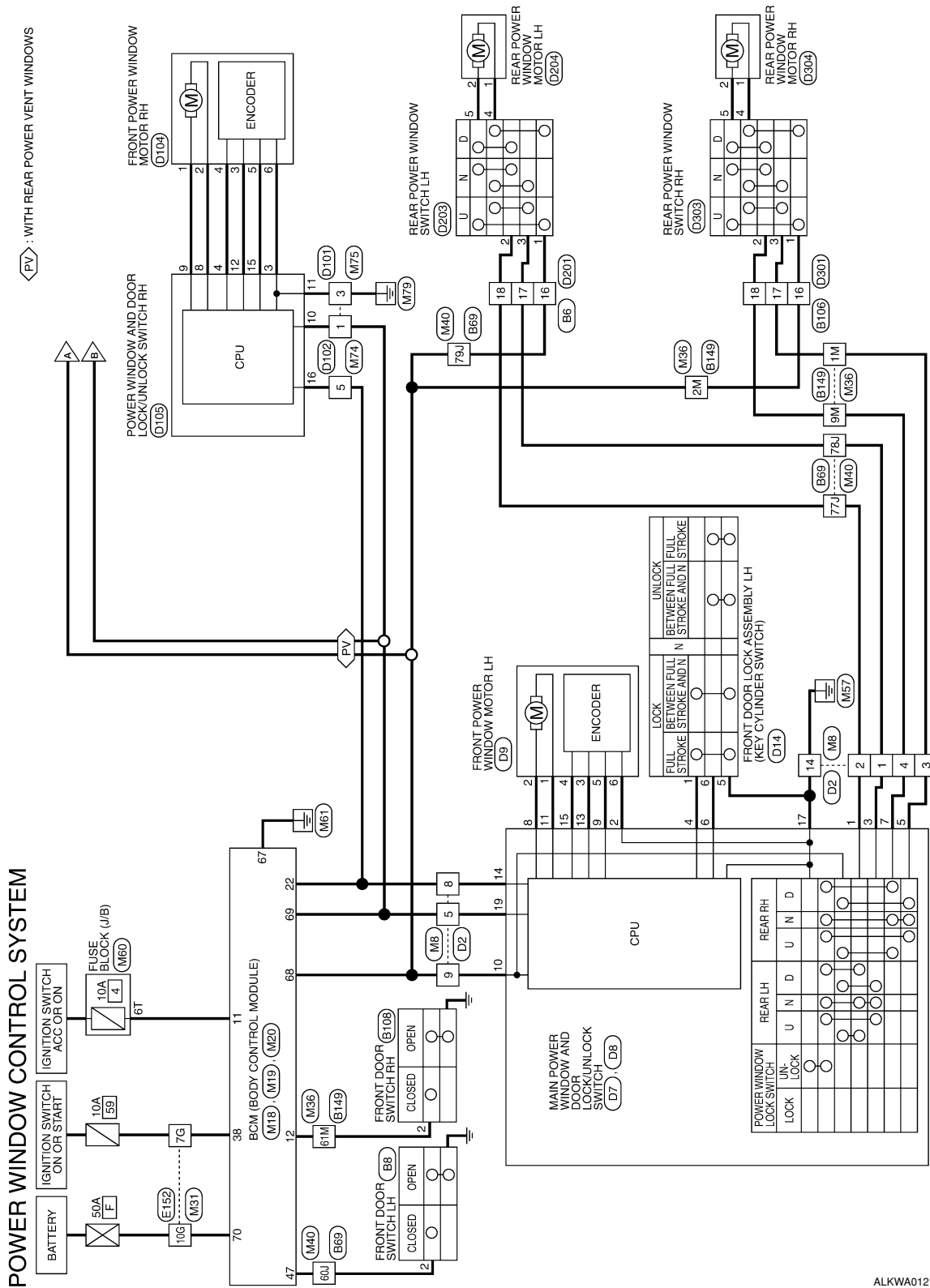

A  
B  
C  
D  
E  
F  
G  
H  
I  
J  
L  
M  
N  
O  
P

### PWC

ALKWA0121GE

# FRONT POWER WINDOW SWITCH

< ECU DIAGNOSIS >

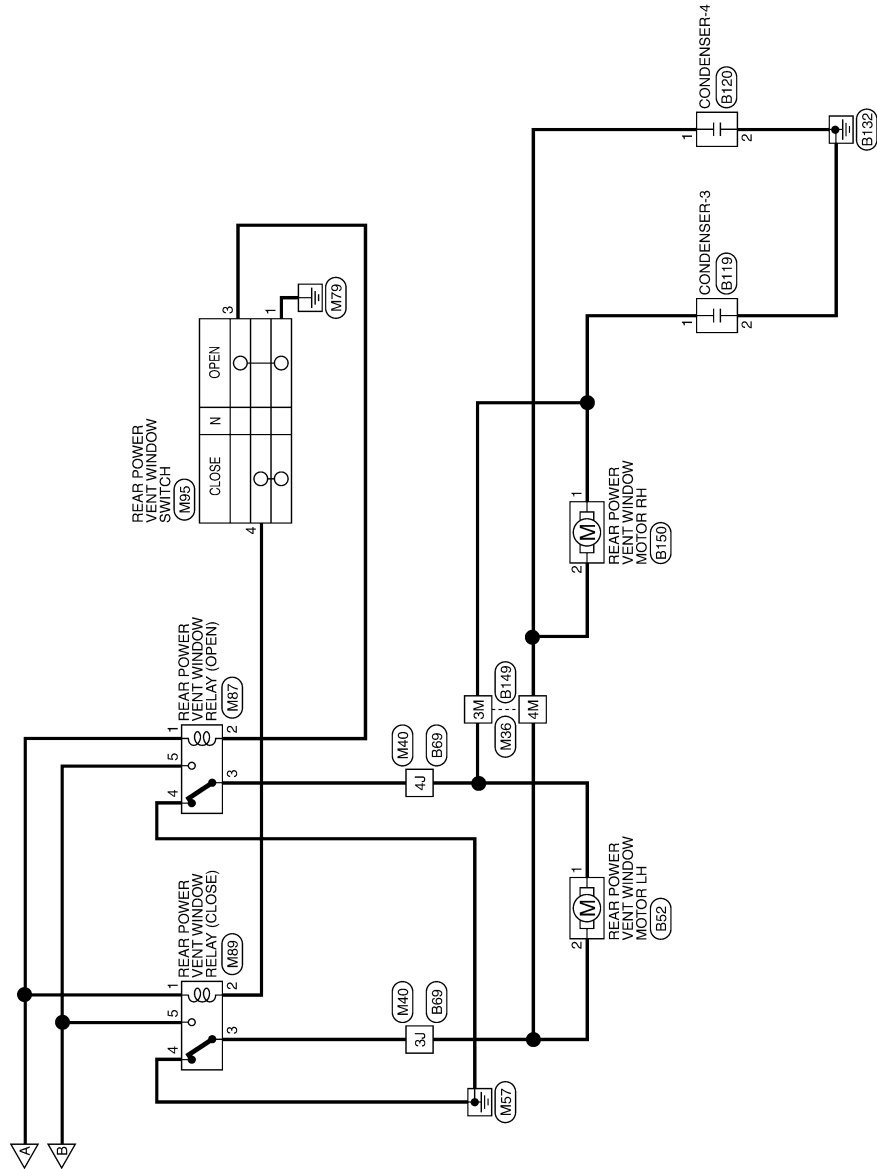

ALKWA0122GE

# FRONT POWER WINDOW SWITCH

< ECU DIAGNOSIS >

## POWER WINDOW SYSTEM / WHITH FRONT LEFT AND RIGHT POWER WINDOW ANTI-PINCH SYSTEM CONNECTORS

Connector No.	M4
Connector Name	FUSE BLOCK (J/B)
Connector Color	WHITE

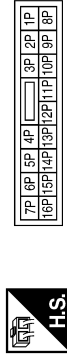

Terminal No.	Color of Wire	Signal Name
4P	G/B	-
15P	W/R	-

Connector No.	M6
Connector Name	WIRE TO WIRE
Connector Color	WHITE



Terminal No.	Color of Wire	Signal Name
7	W	-

Connector No.	M8
Connector Name	WIRE TO WIRE
Connector Color	WHITE

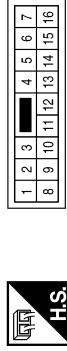

Terminal No.	Color of Wire	Signal Name
1	L	-
7	V	-
11	B	-
12	O	-
13	R	-
14	LG	-
15	Y	-
16	P	-

Connector No.	M18
Connector Name	BCM (BODY CONTROL MODULE)
Connector Color	WHITE

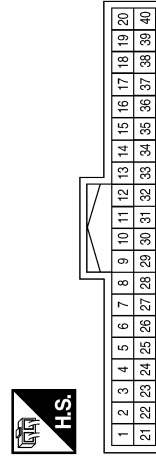

Terminal No.	Color of Wire	Signal Name
11	G/B	ACC SW
12	LG	DOOR SW (AS)
22	V	BUS
38	W/R	IGN SW

Connector No.	M19
Connector Name	BCM (BODY CONTROL MODULE)
Connector Color	WHITE

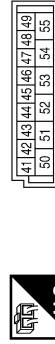

Terminal No.	Color of Wire	Signal Name
47	GR	DOOR SW (DR)

Connector No.	M20
Connector Name	BCM (BODY CONTROL MODULE)
Connector Color	BLACK



Terminal No.	Color of Wire	Signal Name
67	B	GND
68	O	POWER WINDOW POWER SUPPLY (RAP)
69	L	POWER WINDOW POWER SUPPLY (BAT)
70	W	BAT (F/L)

ALKIA0877GB

# FRONT POWER WINDOW SWITCH

< ECU DIAGNOSIS >

Terminal No.	Color of Wire	Signal Name
57M	LG	-
77M	W	-
78M	Y	-
79M	P	-

Connector No.	M36
Connector Name	WIRE TO WIRE
Connector Color	WHITE

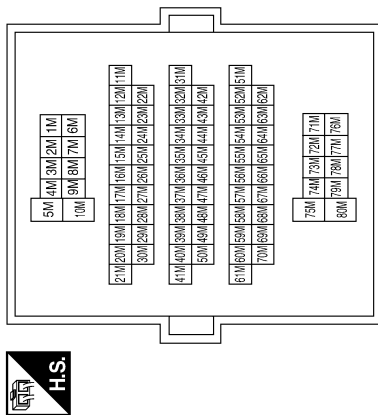

Connector No.	M75
Connector Name	WIRE TO WIRE
Connector Color	WHITE

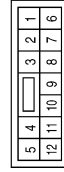

Terminal No.	Color of Wire	Signal Name
1	Y	-
5	V	-
12	B	-

Terminal No.	Color of Wire	Signal Name
10J	W	-
61J	GR	-
75J	R	-
80J	LG	-

Connector No.	M40
Connector Name	WIRE TO WIRE
Connector Color	WHITE

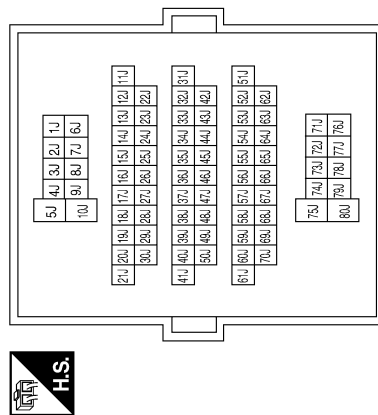

ALKIA0878GB

# FRONT POWER WINDOW SWITCH

< ECU DIAGNOSIS >

Connector No.	E10
Connector Name	WIRE TO WIRE
Connector Color	WHITE

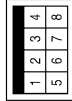

Terminal No.	Color of Wire	Signal Name
7	W	-

Connector No.	B6
Connector Name	WIRE TO WIRE
Connector Color	WHITE

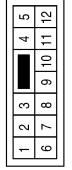

Terminal No.	Color of Wire	Signal Name
6	W	-
7	R	-
8	LG	-
9	B	-

Connector No.	B8
Connector Name	FRONT DOOR SWITCH LH
Connector Color	WHITE



Terminal No.	Color of Wire	Signal Name
2	GR	-

Connector No.	B69
Connector Name	WIRE TO WIRE
Connector Color	WHITE

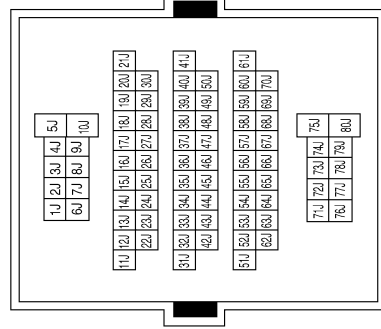

Terminal No.	Color of Wire	Signal Name
10J	W	-
61J	GR	-
75J	R	-
80J	LG	-

Connector No.	B106
Connector Name	WIRE TO WIRE
Connector Color	WHITE

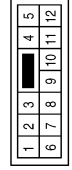

Terminal No.	Color of Wire	Signal Name
6	W	-
7	Y	-
8	P	-
9	B	-

ALKIA0879GB

A  
B  
C  
D  
E  
F  
G  
H  
I  
J  
L  
M  
N  
O  
P

# FRONT POWER WINDOW SWITCH

< ECU DIAGNOSIS >

Connector No.	B108
Connector Name	FRONT DOOR SWITCH RH
Connector Color	WHITE



Terminal No.	Color of Wire	Signal Name
2	LG	-

Connector No.	B149
Connector Name	WIRE TO WIRE
Connector Color	WHITE

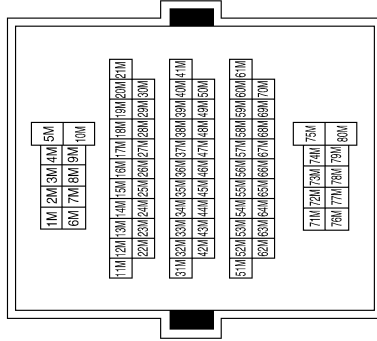

Terminal No.	Color of Wire	Signal Name
57M	LG	-
77M	W	-
78M	Y	-
79M	P	-

Connector No.	D2
Connector Name	WIRE TO WIRE
Connector Color	WHITE

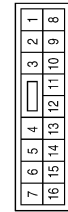

Terminal No.	Color of Wire	Signal Name
1	L	-
7	V	-
11	B	-
12	W/R	-
13	R	-
14	LG	-
15	Y	-
16	P	-

Connector No.	D7
Connector Name	MAIN POWER WINDOW AND DOOR LOCK/UNLOCK SWITCH
Connector Color	WHITE

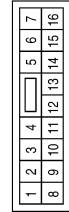

Terminal No.	Color of Wire	Signal Name
1	R	UP
2	BR	ENCODER AND LIMIT SW GND
3	LG	DOWN
4	SB	KEY CYL LOCK SW
5	P	DOWN
6	R/W	KEY CYL UNLOCK SW

Terminal No.	Color of Wire	Signal Name
7	Y	UP
8	O	UP
9	Y	LIMIT SW
10	W/R	RAP
11	GR	DOWN
13	LB	PULSE
14	V	POWER WINDOW SERIAL LINK
15	W/R	ENCODER POWER

ALKIA0880GB



# FRONT POWER WINDOW SWITCH

< ECU DIAGNOSIS >

Connector No.	D8
Connector Name	MAIN POWER WINDOW AND DOOR LOCK/UNLOCK SWITCH
Connector Color	WHITE



Terminal No.	Color of Wire	Signal Name
17	B	GND
19	L	BAT

Connector No.	D9
Connector Name	FRONT POWER WINDOW MOTOR LH
Connector Color	BLACK



Terminal No.	Color of Wire	Signal Name
1	GR	-
2	O	-
3	W/R	-
4	BR	-
5	Y	-
6	LB	-

Connector No.	D14
Connector Name	FRONT DOOR LOCK ASSEMBLY LH (KEY CYLINDER SWITCH)
Connector Color	GRAY

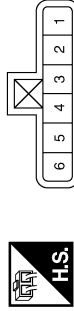

Terminal No.	Color of Wire	Signal Name
3	SB	-
4	B	-
5	R/W	-

Connector No.	D101
Connector Name	WIRE TO WIRE
Connector Color	WHITE

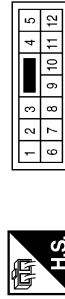

Terminal No.	Color of Wire	Signal Name
1	Y	-
5	V	-
12	L	-

Connector No.	D104
Connector Name	FRONT POWER WINDOW MOTOR RH
Connector Color	BLACK



Terminal No.	Color of Wire	Signal Name
1	G	-
2	L	-
3	W/R	-
4	BR	-
5	Y	-
6	LB	-

ALKIA0881GB

A B C D E F G H I J L M N O P

PWC

# FRONT POWER WINDOW SWITCH

< ECU DIAGNOSIS >

Connector No.	D105
Connector Name	POWER WINDOW AND DOOR LOCK/UNLOCK SWITCH RH
Connector Color	WHITE

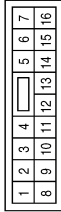

Terminal No.	Color of Wire	Signal Name
3	BR	ENCODER AND LIMIT SW GND
4	W/R	ENCODER POWER
8	L	UP
9	G	DOWN
10	Y	BAT
11	B	GND

Terminal No.	Color of Wire	Signal Name
12	LB	PULSE
15	Y	LIMIT SW
16	V	POWER WINDOW SERIAL LINK

Connector No.	D201
Connector Name	WIRE TO WIRE
Connector Color	WHITE

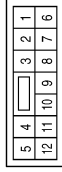

Terminal No.	Color of Wire	Signal Name
6	W	-
7	LG	-
8	R	-
9	B	-

Connector No.	D203
Connector Name	REAR POWER WINDOW SWITCH LH
Connector Color	WHITE

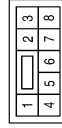

Terminal No.	Color of Wire	Signal Name
2	B	-
4	LB	-
5	R	-
6	Y	-
7	L	-
8	W	-

Connector No.	D204
Connector Name	REAR POWER WINDOW MOTOR LH
Connector Color	BLACK



Terminal No.	Color of Wire	Signal Name
1	Y	-
2	L	-

Connector No.	D301
Connector Name	WIRE TO WIRE
Connector Color	WHITE

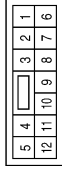

Terminal No.	Color of Wire	Signal Name
6	W	-
7	Y	-
8	P	-
9	B	-

ALKIA0882GB

# FRONT POWER WINDOW SWITCH

< ECU DIAGNOSIS >

Connector No.	D304
Connector Name	REAR POWER WINDOW MOTOR RH
Connector Color	BLACK



Terminal No.	Color of Wire	Signal Name
1	Y	-
2	L	-

Connector No.	D303
Connector Name	REAR POWER WINDOW SWITCH RH
Connector Color	WHITE

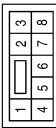

Terminal No.	Color of Wire	Signal Name
2	B	-
4	Y	-
5	P	-
6	Y	-
7	L	-
8	W	-

A  
B  
C  
D  
E  
F  
G  
H  
I  
J  
L  
M  
N  
O  
P

PWC

ALKIA0883GB

# FRONT POWER WINDOW SWITCH

< ECU DIAGNOSIS >

Connector No.	D105
Connector Name	POWER WINDOW AND DOOR LOCK/UNLOCK SWITCH RH
Connector Color	WHITE



1	2	3	4	5	6	7		
8	9	10	11	12	13	14	15	16

Terminal No.	Color of Wire	Signal Name
1	-	-
2	-	-
3	W/B	-
4	G/R	-

Terminal No.	Color of Wire	Signal Name
5	-	-
6	-	-
7	-	-
8	L	-
9	G	-
10	W/R	-
11	B	GND
12	G/Y	-
13	-	-
14	-	-
15	G/W	-
16	LG/W	ANTI_PINCH_SERIAL_LINK

Connector No.	D201
Connector Name	WIRE TO WIRE
Connector Color	WHITE



1	2	3	4	5	6	7	8	9	10
11	12	13	14	15	16	17	18		

Terminal No.	Color of Wire	Signal Name
16	W/L	-
17	R/B	-
18	R/Y	-

Connector No.	D203
Connector Name	REAR POWER WINDOW SWITCH LH
Connector Color	WHITE



2	3	4	5	7
---	---	---	---	---

Terminal No.	Color of Wire	Signal Name
1	W/L	BAT
2	R/Y	UP
3	R/B	DOWN
4	G	DOWN
5	L	UP

Connector No.	D204
Connector Name	REAR POWER WINDOW MOTOR LH
Connector Color	GRAY



Terminal No.	Color of Wire	Signal Name
1	G	-
2	L	-

Connector No.	D301
Connector Name	WIRE TO WIRE
Connector Color	WHITE



1	2	3	4	5	6	7	8	9	10
11	12	13	14	15	16	17	18		

Terminal No.	Color of Wire	Signal Name
16	W/L	-
17	L	-
18	R	-

ALKIA0884GB

# FRONT POWER WINDOW SWITCH

< ECU DIAGNOSIS >

A  
B  
C  
D  
E  
F  
G  
H  
I  
J  
L  
M  
N  
O  
P

Connector No.	D304
Connector Name	REAR POWER WINDOW MOTOR RH
Connector Color	GRAY



Terminal No.	Color of Wire	Signal Name
1	Y/B	-
2	BR	-

Connector No.	D303
Connector Name	REAR POWER WINDOW SWITCH RH
Connector Color	WHITE

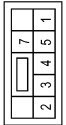

Terminal No.	Color of Wire	Signal Name
1	W/L	BAT
2	R	UP
3	L	DOWN
4	Y/B	DOWN
5	BR	UP

PWC

## Fail Safe

ALKIA0885GB

INFOID:000000001611924

### FAIL-SAFE CONTROL

Switches to fail-safe control when malfunction is detected in encoder signal that detects up/down speed and direction of door glass. Switches to fail-safe control when error beyond regulation value is detected between the fully closed position and the actual position of the glass.

# FRONT POWER WINDOW SWITCH

## < ECU DIAGNOSIS >

Error	Error condition
Pulse sensor malfunction	When only one side of pulse signal is being detected for more than the specified value.
Both pulse sensors malfunction	When both pulse signals have not been detected for more than the specified value during glass open/close operation.
Pulse direction malfunction	When the pulse signal that is detected during glass open/close operation detects the opposite condition of power window motor operating direction.
Glass recognition position malfunction 1	When it detects the error between glass fully closed position in power window switch memory and actual fully closed position during glass open/close operation is more than the specified value.
Glass recognition position malfunction 2	When it detects pulse count more than the value of glass full stroke during glass open/close operation.
Malfunction of not yet updated closed position of glass	When glass open/close operation is continuously performed without fully closing more than the specified value (approximately 10 strokes).

It changes to condition before initialization and the following functions do not operate when switched to fail-safe control.

- Auto-up operation
- Anti-pinch function
- Retained power function

Perform initial operation to recover when switched to fail-safe mode. However, it switches back to fail-safe control when malfunction is found in power window switch or in motor.

# NONE OF THE POWER WINDOWS CAN BE OPERATED USING ANY SWITCH

< SYMPTOM DIAGNOSIS >

## SYMPTOM DIAGNOSIS

NONE OF THE POWER WINDOWS CAN BE OPERATED USING ANY SWITCH

### Diagnosis Procedure

INFOID:000000001611925

#### 1. CHECK BCM POWER SUPPLY AND GROUND CIRCUIT

Check BCM power supply and ground circuit.

Refer to [BCS-32, "Diagnosis Procedure"](#).

Is the inspection result normal?

YES >> GO TO 2

NO >> Repair or replace the malfunctioning parts.

#### 2. CHECK MAIN POWER WINDOW AND DOOR LOCK/UNLOCK SWITCH POWER SUPPLY AND GROUND CIRCUIT

Check power window switch main power supply and ground circuit.

Refer to [PWC-11, "POWER WINDOW MAIN SWITCH : Component Function Check"](#).

Is the inspection result normal?

YES >> GO TO 3

NO >> Repair or replace the malfunctioning parts.

#### 3. CHECK MAIN POWER WINDOW AND DOOR LOCK/UNLOCK SWITCH SERIAL CIRCUIT

Check main power window and door lock/unlock switch serial circuit.

Refer to [PWC-11, "POWER WINDOW MAIN SWITCH : Component Function Check"](#).

Is the inspection result normal?

YES >> GO TO 4

NO >> Repair or replace the malfunctioning parts.

#### 4. CHECK MAIN POWER WINDOW AND DOOR LOCK/UNLOCK SWITCH

Check main power window and door lock/unlock switch.

Refer to [PWC-11, "POWER WINDOW MAIN SWITCH : Component Function Check"](#).

Is the inspection result normal?

YES >> Inspection End.

NO >> Check intermittent incident. Refer to [GI-39, "Intermittent Incident"](#).

A  
B  
C  
D  
E  
F  
G  
H  
I  
J  
L  
M  
N  
O  
P

PWC

## DRIVER SIDE POWER WINDOW ALONE DOES NOT OPERATE

< SYMPTOM DIAGNOSIS >

---

### DRIVER SIDE POWER WINDOW ALONE DOES NOT OPERATE

#### Diagnosis Procedure

INFOID:000000001611926

#### 1. CHECK FRONT POWER WINDOW MOTOR LH

---

Check front power window motor LH.

Refer to [PWC-20, "DRIVER SIDE : Component Function Check"](#).

Is the inspection result normal?

YES >> Inspection End.

NO >> Check intermittent incident. Refer to [GI-39, "Intermittent Incident"](#).



# FRONT PASSENGER SIDE POWER WINDOW ALONE DOES NOT OPERATE

< SYMPTOM DIAGNOSIS >

## FRONT PASSENGER SIDE POWER WINDOW ALONE DOES NOT OPERATE

### Diagnosis Procedure

INFOID:000000001611927

#### 1. CHECK POWER WINDOW AND DOOR LOCK/UNLOCK SWITCH RH

Check power window and door lock/unlock switch RH.

Refer to [PWC-15, "FRONT POWER WINDOW SWITCH : Component Function Check"](#).

Is the inspection result normal?

YES >> GO TO 2

NO >> Repair or replace the malfunctioning parts.

#### 2. CHECK POWER WINDOW AND DOOR LOCK/UNLOCK SWITCH RH SERIAL LINK CIRCUIT

Check power window and door lock/unlock switch RH serial link circuit.

Refer to [PWC-39, "FRONT POWER WINDOW SWITCH : Component Function Check"](#).

Is the inspection result normal?

YES >> GO TO 3

NO >> Repair or replace the malfunctioning parts.

#### 3. CHECK FRONT POWER WINDOW MOTOR RH CIRCUIT

Check front power window motor RH circuit.

Refer to [PWC-21, "PASSENGER SIDE : Component Function Check"](#).

Is the inspection result normal?

YES >> Inspection End.

NO >> Check intermittent incident. Refer to [GI-39, "Intermittent Incident"](#).

A  
B  
C  
D  
E  
F  
G  
H  
I  
J  
L  
M  
N  
O  
P

PWC

# REAR LH SIDE POWER WINDOW ALONE DOES NOT OPERATE

< SYMPTOM DIAGNOSIS >

---

## REAR LH SIDE POWER WINDOW ALONE DOES NOT OPERATE

### Diagnosis Procedure

INFOID:000000001611928

#### 1. CHECK REAR POWER WINDOW SWITCH LH

---

Check rear power window switch LH.

Refer to [PWC-17, "REAR POWER WINDOW SWITCH : Component Function Check"](#).

Is the inspection result normal?

YES >> GO TO 2

NO >> Repair or replace the malfunctioning parts.

#### 2. CHECK REAR POWER WINDOW MOTOR LH

---

Check rear power window motor LH.

Refer to [PWC-23, "REAR LH : Component Function Check"](#).

Is the inspection result normal?

YES >> Inspection End.

NO >> Check intermittent incident. Refer to [GI-39, "Intermittent Incident"](#).

# REAR RH SIDE POWER WINDOW ALONE DOES NOT OPERATE

< SYMPTOM DIAGNOSIS >

## REAR RH SIDE POWER WINDOW ALONE DOES NOT OPERATE

### Diagnosis Procedure

INFOID:000000001611929

#### 1. CHECK REAR POWER WINDOW SWITCH RH

Check rear power window switch RH.

Refer to [PWC-17, "REAR POWER WINDOW SWITCH : Component Function Check"](#).

Is the inspection result normal?

YES >> GO TO 2

NO >> Repair or replace the malfunctioning parts.

#### 2. CHECK REAR POWER WINDOW MOTOR RH

Check rear power window motor RH.

Refer to [PWC-24, "REAR RH : Component Function Check"](#).

Is the inspection result normal?

YES >> Inspection End.

NO >> Check intermittent incident. Refer to [GI-39, "Intermittent Incident"](#).

A  
B  
C  
D  
E  
F  
G  
H  
I  
J  
L  
M  
N  
O  
P

PWC

# ANTI-PINCH SYSTEM DOES NOT OPERATE NORMALLY (DRIVER SIDE)

< SYMPTOM DIAGNOSIS >

## ANTI-PINCH SYSTEM DOES NOT OPERATE NORMALLY (DRIVER SIDE)

---

### Diagnosis Procedure

INFOID:000000001611930

#### 1. CHECK DOOR WINDOW SLIDING PART

---

- A foreign material adheres to window glass or glass run rubber.
- Glass run rubber wear or deformation.
- Sash is tilted too much or not enough.

Is the inspection result normal?

YES >> GO TO 2

NO >> Repair or replace the malfunctioning parts.

#### 2. CHECK ENCODER CIRCUIT

---

Check encoder circuit.

Refer to [PWC-27. "DRIVER SIDE : Component Function Check"](#).

Is the inspection result normal?

YES >> Inspection End.

NO >> Check intermittent incident. Refer to [GI-39. "Intermittent Incident"](#).

# ANTI-PINCH SYSTEM DOES NOT OPERATE NORMALLY (PASSENGER SIDE)

< SYMPTOM DIAGNOSIS >

## ANTI-PINCH SYSTEM DOES NOT OPERATE NORMALLY (PASSENGER SIDE)

### Diagnosis Procedure

INFOID:000000001611931

#### 1. CHECK DOOR WINDOW SLIDING PART

- A foreign material adheres to window glass or glass run rubber.
- Glass run rubber wear or deformation.
- Sash is tilted too much or not enough.

Is the inspection result normal?

YES >> GO TO 2

NO >> Repair or replace the malfunctioning parts.

#### 2. CHECK ENCODER CIRCUIT

Check encoder circuit.

Refer to [PWC-29. "PASSENGER SIDE : Component Function Check"](#).

Is the inspection result normal?

YES >> Inspection End.

NO >> Check intermittent incident. Refer to [GI-39. "Intermittent Incident"](#).

A  
B  
C  
D  
E  
F  
G  
H  
I  
J  
L  
M  
N  
O  
P

PWC

# AUTO OPERATION DOES NOT OPERATE BUT MANUAL OPERATE NORMALLY (DRIVER SIDE)

< SYMPTOM DIAGNOSIS >

---

## AUTO OPERATION DOES NOT OPERATE BUT MANUAL OPERATE NORMALLY (DRIVER SIDE)

### Diagnosis Procedure

INFOID:000000001611932

#### 1. CHECK ENCODER

---

Check encoder.

Refer to [PWC-27, "DRIVER SIDE : Component Function Check"](#).

Is the inspection result normal?

YES >> Inspection End.

NO >> Check intermittent incident. Refer to [GI-39, "Intermittent Incident"](#).

# AUTO OPERATION DOES NOT OPERATE BUT MANUAL OPERATE NORMALLY (PASSENGER SIDE)

< SYMPTOM DIAGNOSIS >

## AUTO OPERATION DOES NOT OPERATE BUT MANUAL OPERATE NORMALLY (PASSENGER SIDE)

### Diagnosis Procedure

INFOID:000000001611933

#### 1. CHECK ENCODER

Check encoder.

Refer to [PWC-29, "PASSENGER SIDE : Component Function Check"](#).

Is the inspection result normal?

YES >> Inspection End.

NO >> Check intermittent incident. Refer to [GI-39, "Intermittent Incident"](#).

A  
B  
C  
D  
E  
F  
G  
H  
I  
J  
L  
M  
N  
O  
P

PWC

# POWER WINDOW RETAINED POWER OPERATION DOES NOT OPERATE PROPERLY

< SYMPTOM DIAGNOSIS >

---

## POWER WINDOW RETAINED POWER OPERATION DOES NOT OPERATE PROPERLY

### Diagnosis Procedure

INFOID:000000001611934

#### 1. CHECK FRONT DOOR SWITCH

---

Check front door switch.

Refer to [PWC-33. "Component Function Check"](#).

Is the inspection result normal?

YES >> Inspection End.

NO >> Check intermittent incident. Refer to [GI-39. "Intermittent Incident"](#).



# DOES NOT OPERATE BY KEY CYLINDER SWITCH

< SYMPTOM DIAGNOSIS >

---

## DOES NOT OPERATE BY KEY CYLINDER SWITCH

### Diagnosis Procedure

INFOID:000000001611935

#### 1. CHECK FRONT DOOR LOCK ASSEMBLY LH (KEY CYLINDER SWITCH)

---

Check front door lock assembly LH (key cylinder switch).

Refer to [PWC-35, "Component Function Check"](#).

Is the inspection result normal?

YES >> Inspection End.

NO >> Check intermittent incident. Refer to [GI-39, "Intermittent Incident"](#).

A  
B  
C  
D  
E  
F  
G  
H  
I  
J  
L  
M  
N  
O  
P

PWC

# KEYLESS POWER WINDOW DOWN DOES NOT OPERATE

< SYMPTOM DIAGNOSIS >

---

## KEYLESS POWER WINDOW DOWN DOES NOT OPERATE

### Diagnosis Procedure

INFOID:000000001611936

#### 1. CHECK INTELLIGENT KEY OR KEYFOB FUNCTION

---

Check Intelligent Key or keyfob function.

Refer to [DLK-40. "INTELLIGENT KEY : CONSULT-III Function \(BCM - INTELLIGENT KEY\)"](#) with Intelligent Key or [DLK-38. "REMOTE KEYLESS ENTRY : CONSULT-III Function \(BCM - RKE\)"](#) with remote keyless entry system.

Is the inspection result normal?

- YES >> Check intermittent incident. Refer to [GI-39. "Intermittent Incident"](#).
- NO >> Replace BCM. Refer to [BCS-54. "Removal and Installation"](#).

# POWER WINDOW LOCK SWITCH DOES NOT FUNCTION

< SYMPTOM DIAGNOSIS >

---

## POWER WINDOW LOCK SWITCH DOES NOT FUNCTION

### Diagnosis Procedure

INFOID:000000001611937

#### 1. REPLACE MAIN POWER WINDOW AND DOOR LOCK/UNLOCK SWITCH

---

Replace main power window and door lock/unlock switch.

Refer to [PWC-94, "Removal and Installation"](#).

Is the inspection result normal?

YES >> Inspection End.

NO >> Check intermittent incident. Refer to [GI-39, "Intermittent Incident"](#).

A  
B  
C  
D  
E  
F  
G  
H  
I  
J  
L  
M  
N  
O  
P

PWC

# REAR POWER VENT WINDOWS DO NOT OPERATE

< SYMPTOM DIAGNOSIS >

---

## REAR POWER VENT WINDOWS DO NOT OPERATE

### Diagnosis Procedure

INFOID:000000001611956

#### 1. CHECK BCM POWER SUPPLY AND GROUND CIRCUIT

---

Check BCM power supply and ground circuit.  
Refer to [BCS-32, "Diagnosis Procedure"](#).

Is the inspection result normal?

YES >> GO TO 2  
NO >> Repair or replace the malfunctioning parts.

#### 2. CHECK REAR POWER VENT WINDOW SWITCH

---

Check rear power vent window switch.  
Refer to [PWC-43, "Diagnosis Procedure"](#).

Is the inspection result normal?

YES >> GO TO 3  
NO >> Repair or replace the malfunctioning parts.

#### 3. CHECK REAR POWER VENT WINDOW MOTOR CIRCUIT

---

Check rear power vent window motor circuit.  
Refer to [PWC-44, "Diagnosis Procedure"](#) and [PWC-45, "Diagnosis Procedure"](#).

Is the inspection result normal?

YES >> GO TO 4  
NO >> Repair or replace the malfunctioning parts.

#### 4. CHECK REAR POWER VENT WINDOW RELAY

---

Check rear power vent window relay.  
Refer to [PWC-46, "Diagnosis Procedure"](#) and [PWC-48, "Diagnosis Procedure"](#).

Is the inspection result normal?

YES >> Inspection End.  
NO >> Check intermittent incident. Refer to [GI-39, "Intermittent Incident"](#).

# PRECAUTIONS

< PRECAUTION >

## PRECAUTION

### PRECAUTIONS

#### Precaution for Supplemental Restraint System (SRS) "AIR BAG" and "SEAT BELT PRE-TENSIONER"

INFOID:000000001534585

The Supplemental Restraint System such as "AIR BAG" and "SEAT BELT PRE-TENSIONER", used along with a front seat belt, helps to reduce the risk or severity of injury to the driver and front passenger for certain types of collision. This system includes seat belt switch inputs and dual stage front air bag modules. The SRS system uses the seat belt switches to determine the front air bag deployment, and may only deploy one front air bag, depending on the severity of a collision and whether the front occupants are belted or unbelted. Information necessary to service the system safely is included in the SR and SB section of this Service Manual.

#### **WARNING:**

- **To avoid rendering the SRS inoperative, which could increase the risk of personal injury or death in the event of a collision which would result in air bag inflation, all maintenance must be performed by an authorized NISSAN/INFINITI dealer.**
- **Improper maintenance, including incorrect removal and installation of the SRS, can lead to personal injury caused by unintentional activation of the system. For removal of Spiral Cable and Air Bag Module, see the SR section.**
- **Do not use electrical test equipment on any circuit related to the SRS unless instructed to in this Service Manual. SRS wiring harnesses can be identified by yellow and/or orange harnesses or harness connectors.**

A  
B  
C  
D  
E  
F  
G  
H  
I  
J  
L  
M  
N  
O  
P

PWC

# POWER WINDOW MAIN SWITCH

< ON-VEHICLE REPAIR >

## ON-VEHICLE REPAIR

### POWER WINDOW MAIN SWITCH

#### Removal and Installation

INFOID:000000001534586

#### REMOVAL

1. Remove the power window main switch finisher (2) from the door finisher LH. Refer to Body INTERIOR.
2. Using a screwdriver (A), remove the power window main switch (1) screws, then release from the finisher (2).

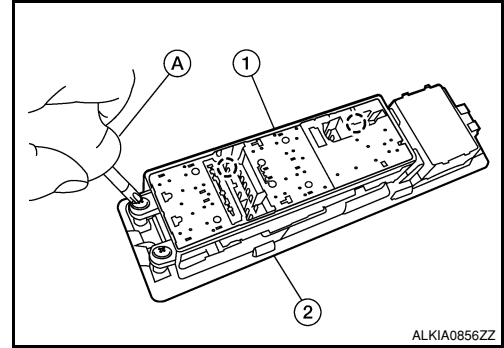

#### INSTALLATION

Install in the reverse order of removal.

# FRONT POWER WINDOW SWITCH

< ON-VEHICLE REPAIR >

## FRONT POWER WINDOW SWITCH

### Removal and Installation

INFOID:000000001534587

#### REMOVAL

1. Remove the front power window switch finisher (2) from the front door finisher RH. Refer to BODY DOOR FINISHER.
2. Using a suitable tool (A), release the tabs and remove the front power window switch (1).

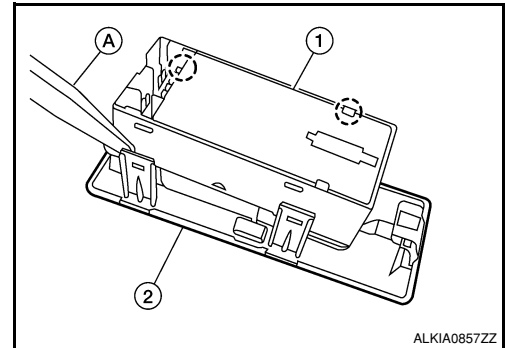

#### INSTALLATION

Install in the reverse order of removal.

A  
B  
C  
D  
E  
F  
G  
H  
I  
J  
L  
M  
N  
O  
P

PWC

# REAR POWER WINDOW SWITCH

< ON-VEHICLE REPAIR >

## REAR POWER WINDOW SWITCH

### Removal and Installation

INFOID:000000001534588

#### REMOVAL

1. Remove the rear power window switch finisher (1) from the rear door finisher. Refer to BODY DOOR FINISHER.
2. Using a suitable tool (A), release the tabs and remove the rear power window switch (2).

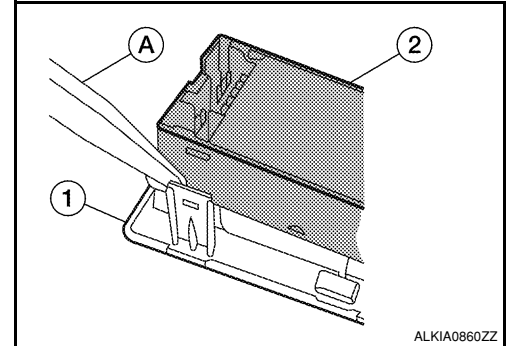

#### INSTALLATION

Installation is in the reverse order of removal.