

TM
SECTION
TRANSAXLE & TRANSMISSION

A
B
C

TM

CONTENTS

E

BASIC INSPECTION	6	DTC Confirmation Procedure	39	
DIAGNOSIS AND REPAIR WORKFLOW	6	Diagnosis Procedure	39	
Work Flow	6	DTC P0615 START SIGNAL CIRCUIT	40	G
Diagnostic Work Sheet	7	Description	40	
FUNCTION DIAGNOSIS	9	CONSULT-III Reference Value in Data Monitor		
A/T CONTROL SYSTEM	9	Mode	40	H
Cross-Sectional View (2WD models)	9	On Board Diagnosis Logic	40	
Cross-Sectional View (4WD models)	10	Possible Cause	40	
Shift Mechanism	10	DTC Confirmation Procedure	40	
TCM Function	21	Diagnosis Procedure	40	I
CAN Communication	22	DTC P0700 TCM	43	
Input/Output Signal of TCM	23	Description	43	J
Line Pressure Control	23	On Board Diagnosis Logic	43	
Shift Control	25	Possible Cause	43	
Lock-up Control	26	DTC Confirmation Procedure	43	
Engine Brake Control	27	Diagnosis Procedure	43	K
Control Valve	27	DTC P0705 PARK/NEUTRAL POSITION		
Component Parts Location	29	SWITCH	44	L
A/T SHIFT LOCK SYSTEM	30	Description	44	
System Description	30	CONSULT-III Reference Value in Data Monitor		
Component Parts Location	30	Mode	44	M
ON BOARD DIAGNOSTIC (OBD) SYSTEM	31	On Board Diagnosis Logic	44	
Introduction	31	Possible Cause	44	
OBD-II Function for A/T System	31	DTC Confirmation Procedure	44	
One or Two Trip Detection Logic of OBD-II	31	Diagnosis Procedure	44	N
OBD-II Diagnostic Trouble Code (DTC)	31	DTC P0717 TURBINE REVOLUTION SEN-		
Malfunction Indicator Lamp (MIL)	32	SOR	47	O
DIAGNOSIS SYSTEM (TCM)	33	Description	47	
CONSULT-III Function (TRANSMISSION)	33	CONSULT-III Reference Value in Data Monitor		
COMPONENT DIAGNOSIS	39	Mode	47	P
DTC U1000 CAN COMMUNICATION LINE	39	On Board Diagnosis Logic	47	
Description	39	Possible Cause	47	
On Board Diagnosis Logic	39	DTC Confirmation Procedure	47	
Possible Cause	39	Diagnosis Procedure	47	
DTC P0720 VEHICLE SPEED SENSOR A/		DTC P0720 VEHICLE SPEED SENSOR A/		
(REVOLUTION SENSOR)	49	(REVOLUTION SENSOR)	49	

Description	49	Diagnosis Procedure	64
CONSULT-III Reference Value in Data Monitor		DTC P0744 A/T TCC S/V FUNCTION (LOCK-UP)	66
Mode	49	Description	66
On Board Diagnosis Logic	49	CONSULT-III Reference Value in Data Monitor	
Possible Cause	49	Mode	66
DTC Confirmation Procedure	49	On Board Diagnosis Logic	66
Diagnosis Procedure	50	Possible Cause	66
DTC P0725 ENGINE SPEED SIGNAL	52	DTC Confirmation Procedure	66
Description	52	Diagnosis Procedure	67
CONSULT-III Reference Value in Data Monitor		DTC P0745 LINE PRESSURE SOLENOID VALVE	68
Mode	52	Description	68
On Board Diagnosis Logic	52	CONSULT-III Reference Value in Data Monitor	
Possible Cause	52	Mode	68
DTC Confirmation Procedure	52	On Board Diagnosis Logic	68
Diagnosis Procedure	52	Possible Cause	68
DTC P0731 A/T 1ST GEAR FUNCTION	54	DTC Confirmation Procedure	68
Description	54	Diagnosis Procedure	68
On Board Diagnosis Logic	54	DTC P1705 THROTTLE POSITION SENSOR..	70
Possible Cause	54	Description	70
DTC Confirmation Procedure	54	CONSULT-III Reference Value in Data Monitor	
Diagnosis Procedure	55	Mode	70
DTC P0732 A/T 2ND GEAR FUNCTION	56	On Board Diagnosis Logic	70
Description	56	Possible Cause	70
On Board Diagnosis Logic	56	DTC Confirmation Procedure	70
Possible Cause	56	Diagnosis Procedure	70
DTC Confirmation Procedure	56	DTC P1710 A/T FLUID TEMPERATURE SENSOR CIRCUIT	72
Diagnosis Procedure	57	Description	72
DTC P0733 A/T 3RD GEAR FUNCTION	58	CONSULT-III Reference Value in Data Monitor	
Description	58	Mode	72
On Board Diagnosis Logic	58	On Board Diagnosis Logic	72
Possible Cause	58	Possible Cause	72
DTC Confirmation Procedure	58	DTC Confirmation Procedure	72
Diagnosis Procedure	59	Diagnosis Procedure	72
DTC P0734 A/T 4TH GEAR FUNCTION	60	Component Inspection	74
Description	60	DTC P1721 VEHICLE SPEED SENSOR MTR..	76
On Board Diagnosis Logic	60	Description	76
Possible Cause	60	CONSULT-III Reference Value in Data Monitor	
DTC Confirmation Procedure	60	Mode	76
Diagnosis Procedure	61	On Board Diagnosis Logic	76
DTC P0735 A/T 5TH GEAR FUNCTION	62	Possible Cause	76
Description	62	DTC Confirmation Procedure	76
On Board Diagnosis Logic	62	Diagnosis Procedure	76
Possible Cause	62	DTC P1730 A/T INTERLOCK	78
DTC Confirmation Procedure	62	Description	78
Diagnosis Procedure	63	On Board Diagnosis Logic	78
DTC P0740 TORQUE CONVERTER CLUTCH SOLENOID VALVE	64	Possible Cause	78
Description	64	DTC Confirmation Procedure	78
CONSULT-III Reference Value in Data Monitor		Judgement of A/T Interlock	78
Mode	64	Diagnosis Procedure	78
On Board Diagnosis Logic	64	DTC P1731 A/T 1ST ENGINE BRAKING	80
Possible Cause	64		
DTC Confirmation Procedure	64		

Description	80	Description	92	
CONSULT-III Reference Value in Data Monitor		CONSULT-III Reference Value in Data Monitor		A
Mode	80	Mode	92	
On Board Diagnosis Logic	80	On Board Diagnosis Logic	92	
Possible Cause	80	Possible Cause	92	B
DTC Confirmation Procedure	80	DTC Confirmation Procedure	92	
Diagnosis Procedure	80	Diagnosis Procedure	93	
DTC P1752 INPUT CLUTCH SOLENOID VALVE	82	MAIN POWER SUPPLY AND GROUND CIRCUIT	94	C
Description	82	Diagnosis Procedure	94	
CONSULT-III Reference Value in Data Monitor				
Mode	82	CLOSED THROTTLE POSITION AND WIDE OPEN THROTTLE POSITION CIRCUIT	96	TM
On Board Diagnosis Logic	82	CONSULT-III Reference Value in Data Monitor		
Possible Cause	82	Mode	96	E
DTC Confirmation Procedure	82	Diagnosis Procedure	96	
Diagnosis Procedure	82			
DTC P1757 FRONT BRAKE SOLENOID VALVE	84	BRAKE SIGNAL CIRCUIT	97	F
Description	84	CONSULT-III Reference Value in Data Monitor		
CONSULT-III Reference Value in Data Monitor		Mode	97	
Mode	84	Diagnosis Procedure	97	G
On Board Diagnosis Logic	84			
Possible Cause	84	TOW MODE SWITCH	98	
DTC Confirmation Procedure	84	Description	98	H
Diagnosis Procedure	84	Diagnosis Procedure	98	
DTC P1762 DIRECT CLUTCH SOLENOID VALVE	86	A/T SHIFT LOCK SYSTEM	99	I
Description	86	Wiring Diagram - A/T Shift Lock System (With I-Key)	100	
CONSULT-III Reference Value in Data Monitor		Wiring Diagram - A/T Shift Lock System (Without I-Key)	105	J
Mode	86	Terminals And Reference Values	111	
On Board Diagnosis Logic	86	Component Description	111	
Possible Cause	86			
DTC Confirmation Procedure	86	ECU DIAGNOSIS	114	K
Diagnosis Procedure	86	TCM	114	
DTC P1767 HIGH AND LOW REVERSE CLUTCH SOLENOID VALVE	88	Reference Value	114	L
Description	88	Wiring Diagram — A/T CONTROL SYSTEM —	116	
CONSULT-III Reference Value in Data Monitor		Fail-Safe	125	
Mode	88	DTC Inspection Priority Chart	127	M
On Board Diagnosis Logic	88	DTC No. Index	127	
Possible Cause	88	DTC Alphabetical Index	128	
DTC Confirmation Procedure	88			
Diagnosis Procedure	88	SYMPTOM DIAGNOSIS	130	N
DTC P1772 LOW COAST BRAKE SOLENOID VALVE	90	SYSTEM SYMPTOM	130	
Description	90	A/T Check Indicator Lamp Does Not Come On	130	O
CONSULT-III Reference Value in Data Monitor		Engine Cannot Be Started in "P" or "N" Position	130	
Mode	90	In "P" Position, Vehicle Moves When Pushed	131	
On Board Diagnosis Logic	90	In "N" Position, Vehicle Moves	131	P
Possible Cause	90	Large Shock("N" to "D" Position)	133	
DTC Confirmation Procedure	90	Vehicle Does Not Creep Backward in "R" Position	135	
Diagnosis Procedure	90	Vehicle Does Not Creep Forward in "D" Position	137	
DTC P1774 LOW COAST BRAKE SOLENOID VALVE FUNCTION	92	Vehicle Cannot Be Started from D1	140	
		A/T Does Not Shift: D1→D2	142	
		A/T Does Not Shift: D2→D3	143	
		A/T Does Not Shift: D3→D4	145	
		A/T Does Not Shift: D4→D5	147	
		A/T Does Not Perform Lock-up	149	

A/T Does Not Hold Lock-up Condition	151	4WD : Checking of A/T Position	206
Lock-up Is Not Released	152	ON-VEHICLE REPAIR	208
Engine Speed Does Not Return to Idle	153	SHIFT CONTROL SYSTEM	208
A/T Does Not Shift: 5th gear → 4th gear	154	Control Device Removal and Installation	208
A/T Does Not Shift: 4th gear → 3rd gear	156	Adjustment of A/T Position	209
A/T Does Not Shift: 3rd gear → 2nd gear	158	Checking of A/T Position	209
A/T Does Not Shift: 2nd gear → 1st gear	159	KEY INTERLOCK CABLE	210
Vehicle Does Not Decelerate By Engine Brake	161	Component	210
Symptom Table	163	Removal and Installation	210
PRECAUTION	185	AIR BREATHER HOSE	213
PRECAUTIONS	185	Removal and Installation	213
Precaution for Supplemental Restraint System (SRS) "AIR BAG" and "SEAT BELT PRE-TEN- SIONER"	185	OIL PAN	215
Precautions for On Board Diagnosis (OBD) Sys- tem of A/T and Engine	185	Oil Pan	215
Precautions	185	CONTROL VALVE WITH TCM	217
Service Notice or Precautions	186	Control Valve with TCM and A/T Fluid Tempera- ture Sensor 2	217
PREPARATION	188	REAR OIL SEAL	226
PREPARATION	188	Rear Oil Seal	226
Special Service Tool	188	REMOVAL AND INSTALLATION	227
Commercial Service Tool	189	TRANSMISSION ASSEMBLY	227
ON-VEHICLE MAINTENANCE	190	Removal and Installation (2WD)	227
A/T FLUID	190	Removal and Installation (4WD)	229
Checking the A/T Fluid (ATF)	190	DISASSEMBLY AND ASSEMBLY	233
Changing the A/T Fluid (ATF)	192	OVERHAUL	233
A/T FLUID COOLER	194	Component	233
A/T Fluid Cooler Cleaning	194	Oil Channel	240
Inspection	196	Location of Adjusting Shims, Needle Bearings, Thrust Washers and Snap Rings	242
STALL TEST	197	DISASSEMBLY	245
Inspection and Judgment	197	Disassembly	245
LINE PRESSURE TEST	199	REPAIR FOR COMPONENT PARTS	263
Inspection and Judgment	199	Oil Pump	263
ROAD TEST	201	Front Sun Gear, 3rd One-Way Clutch	265
Description	201	Front Carrier, Input Clutch, Rear Internal Gear	267
Check Before Engine Is Started	201	Mid Sun Gear, Rear Sun Gear, High and Low Re- verse Clutch Hub	272
Check At Idle	201	High and Low Reverse Clutch	277
Cruise Test - Part 1	202	Direct Clutch	279
Cruise Test - Part 2	204	ASSEMBLY	282
Cruise Test - Part 3	205	Assembly (1)	282
Vehicle Speed When Shifting Gears	205	Adjustment	295
Vehicle Speed When Performing and Releasing Complete Lock-up	205	Assembly (2)	297
A/T POSITION	206	SERVICE DATA AND SPECIFICATIONS	
2WD	206	(SDS)	304
2WD : Adjustment of A/T Position	206	SERVICE DATA AND SPECIFICATIONS	
2WD : Checking of A/T Position	206	(SDS)	304
4WD	206		
4WD : Adjustment of A/T Position	206		

General Specification	304	Turbine Revolution Sensor	305
Vehicle Speed at Which Gear Shifting Occurs	304	Vehicle Speed Sensor A/T (Revolution Sensor) ...	305
Vehicle Speed at Which Lock-up Occurs/Releases	304	Reverse Brake	305
Stall Speed	305	Total End Play	305
Line Pressure	305	Torque Converter	306

A

B

C

TM

E

F

G

H

I

J

K

L

M

N

O

P

DIAGNOSIS AND REPAIR WORKFLOW

< BASIC INSPECTION >

BASIC INSPECTION

DIAGNOSIS AND REPAIR WORKFLOW

Work Flow

INFOID:000000001530026

INTRODUCTION

The TCM receives a signal from the vehicle speed sensor, accelerator pedal position sensor (throttle position sensor) or PNP switch. Then provides shift control or lock-up control via A/T solenoid valves. The TCM also communicates with the ECM by means of a signal sent from sensing elements used with the OBD-related parts of the A/T system for malfunction-diagnostic purposes. The TCM is capable of diagnosing malfunctioning parts while the ECM can store malfunctions in its memory.

Input and output signals must always be correct and stable in the operation of the A/T system. The A/T system must be in good operating condition and be free of valve seizure, solenoid valve malfunction, etc.

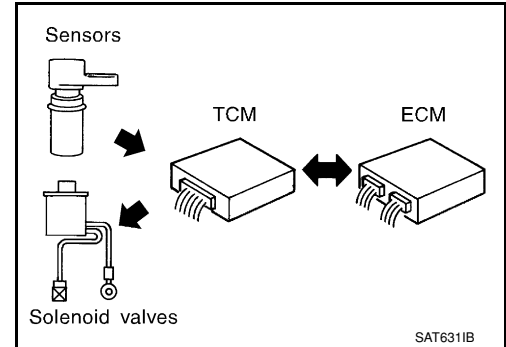

It is much more difficult to diagnose an error that occurs intermittently rather than continuously. Most intermittent errors are caused by poor electric connections or improper wiring. In this case, careful checking of suspected circuits may help prevent the replacement of good parts.

A visual check only may not find the cause of the errors. A road test with CONSULT-III (or GST) or a circuit tester connected should be performed. Follow the "DETAILED FLOW".

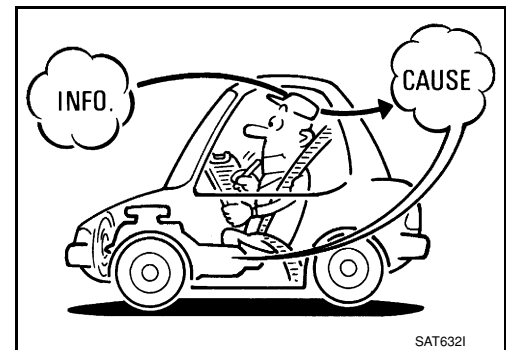

Before undertaking actual checks, take a few minutes to talk with a customer who approaches with a driveability complaint. The customer can supply good information about such errors, especially intermittent ones. Find out what symptoms are present and under what conditions they occur. A "Diagnostic work sheet" as shown on the example (Refer to [TM-7](#)) should be used.

Start your diagnosis by looking for "conventional" errors first. This will help troubleshoot driveability errors on an electronically controlled engine vehicle.

Also check related Service bulletins.

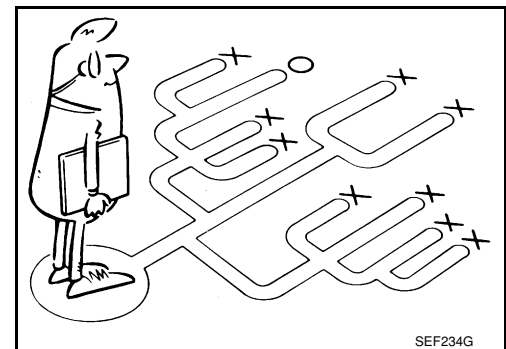

DETAILED FLOW

1. COLLECT THE INFORMATION FROM THE CUSTOMER

Get the detailed information from the customer about the symptom (the condition and the environment when the incident/malfunction occurred) using diagnosis worksheet. Refer to [TM-7, "Diagnostic Work Sheet"](#).

>> GO TO 2.

2. CHECK SYMPTOM 1

Check the following items based on the information obtained from the customer.

- Fail-safe. Refer to [TM-125, "Fail-Safe"](#).
- A/T fluid inspection. Refer to [TM-190, "Checking the A/T Fluid \(ATF\)"](#).
- Stall test. Refer to [TM-197, "Inspection and Judgment"](#).
- Line pressure test. Refer to [TM-199, "Inspection and Judgment"](#).

DIAGNOSIS AND REPAIR WORKFLOW

< BASIC INSPECTION >

>> GO TO 3.

3. CHECK DTC

1. Check DTC.
2. Perform the following procedure if DTC is detected.
 - Record DTC.
 - Erase DTC. Refer to [TM-31, "OBD-II Diagnostic Trouble Code \(DTC\)"](#).

Is any DTC detected?

YES >> GO TO 4.

NO >> GO TO 6.

4. PERFORM DIAGNOSTIC PROCEDURE

Perform "Diagnosis Procedure" for the displayed DTC.

>> GO TO 5.

5. PERFORM DTC CONFIRMATION PROCEDURE

Perform "DTC CONFIRMATION PROCEDURE".

Is DTC detected?

YES >> GO TO 4.

NO >> GO TO 6.

6. CHECK SYMPTOM 2

Try to confirm the symptom described by the customer.

Is any malfunction present?

YES >> GO TO 7.

NO >> INSPECTION END

7. ROAD TEST

Perform "ROAD TEST". Refer to [TM-201, "Description"](#).

>> GO TO 8.

8. CHECK SYMPTOM 3

Try to confirm the symptom described by the customer.

Is any malfunction present?

YES >> GO TO 2.

NO >> INSPECTION END

Diagnostic Work Sheet

INFOID:000000001530027

INFORMATION FROM CUSTOMER

KEY POINTS

- **WHAT**..... Vehicle and A/T model
- **WHEN**..... Date, Frequencies
- **WHERE**..... Road conditions
- **HOW**..... Operating conditions, Symptoms

Customer name MR/MS	Model and Year	VIN
Trans. Model	Engine	Mileage
Malfunction Date	Manuf. Date	In Service Date
Frequency	<input type="checkbox"/> Continuous <input type="checkbox"/> Intermittent (times a day)	

DIAGNOSIS AND REPAIR WORKFLOW

< BASIC INSPECTION >

Symptoms	<input type="checkbox"/> Vehicle does not move. (<input type="checkbox"/> Any position <input type="checkbox"/> Particular position)	
	<input type="checkbox"/> No up-shift (<input type="checkbox"/> 1st → 2nd <input type="checkbox"/> 2nd → 3rd <input type="checkbox"/> 3rd → 4th <input type="checkbox"/> 4th → 5th)	
	<input type="checkbox"/> No down-shift (<input type="checkbox"/> 5th → 4th <input type="checkbox"/> 4th → 3rd <input type="checkbox"/> 3rd → 2nd <input type="checkbox"/> 2nd → 1st)	
	<input type="checkbox"/> Lock-up malfunction	
	<input type="checkbox"/> Shift point too high or too low.	
	<input type="checkbox"/> Shift shock or slip (<input type="checkbox"/> N → D <input type="checkbox"/> N → R <input type="checkbox"/> Lock-up <input type="checkbox"/> Any drive position)	
	<input type="checkbox"/> Noise or vibration	
	<input type="checkbox"/> No kick down	
	<input type="checkbox"/> No pattern select	
	<input type="checkbox"/> Others ()	
Malfunction indicator lamp (MIL)	<input type="checkbox"/> Continuously lit	<input type="checkbox"/> Not lit

DIAGNOSTIC WORK SHEET

1	<input type="checkbox"/> Read the item on cautions concerning fail-safe and understand the customer's complaint.		TM-125
2	<input type="checkbox"/> A/T fluid inspection, stall test and line pressure test		
	<input type="checkbox"/> A/T fluid inspection		TM-190
	<input type="checkbox"/> Leak (Repair leak location.)		
	<input type="checkbox"/> State		
	<input type="checkbox"/> Amount		
3	<input type="checkbox"/> Stall test		
	<input type="checkbox"/> Torque converter one-way clutch	<input type="checkbox"/> 1st one-way clutch	
	<input type="checkbox"/> Front brake	<input type="checkbox"/> 3rd one-way clutch	
	<input type="checkbox"/> High and low reverse clutch	<input type="checkbox"/> Engine	TM-197
	<input type="checkbox"/> Low coast brake	<input type="checkbox"/> Line pressure low	
	<input type="checkbox"/> Forward brake	<input type="checkbox"/> Except for input clutch and direct clutch, clutches and brakes OK	
	<input type="checkbox"/> Reverse brake		
	<input type="checkbox"/> Forward one-way clutch		
	<input type="checkbox"/> Line pressure test - Suspected part:		TM-199
4	<input type="checkbox"/> Perform self-diagnosis. — Check detected items to repair or replace malfunctioning part.		TM-33
	<input type="checkbox"/> Perform road test.		
	5-1	<input type="checkbox"/> Check before engine is started	TM-201
	5-2	<input type="checkbox"/> Check at idle	TM-201
5	5-3	Cruise test	<input type="checkbox"/> Part 1 TM-202
			<input type="checkbox"/> Part 2 TM-204
			<input type="checkbox"/> Part 3 TM-205
	<input type="checkbox"/> Check malfunction phenomena to repair or replace malfunctioning part after completing all road test. Refer to TM-163 . " Symptom Table ".		
5	<input type="checkbox"/> Drive vehicle to check that the malfunction phenomenon has been resolved.		
6	<input type="checkbox"/> Erase the results of the self-diagnosis from the TCM and the ECM.		TM-31

A/T CONTROL SYSTEM

< FUNCTION DIAGNOSIS >

FUNCTION DIAGNOSIS

A/T CONTROL SYSTEM

Cross-Sectional View (2WD models)

INFOID:000000001534240

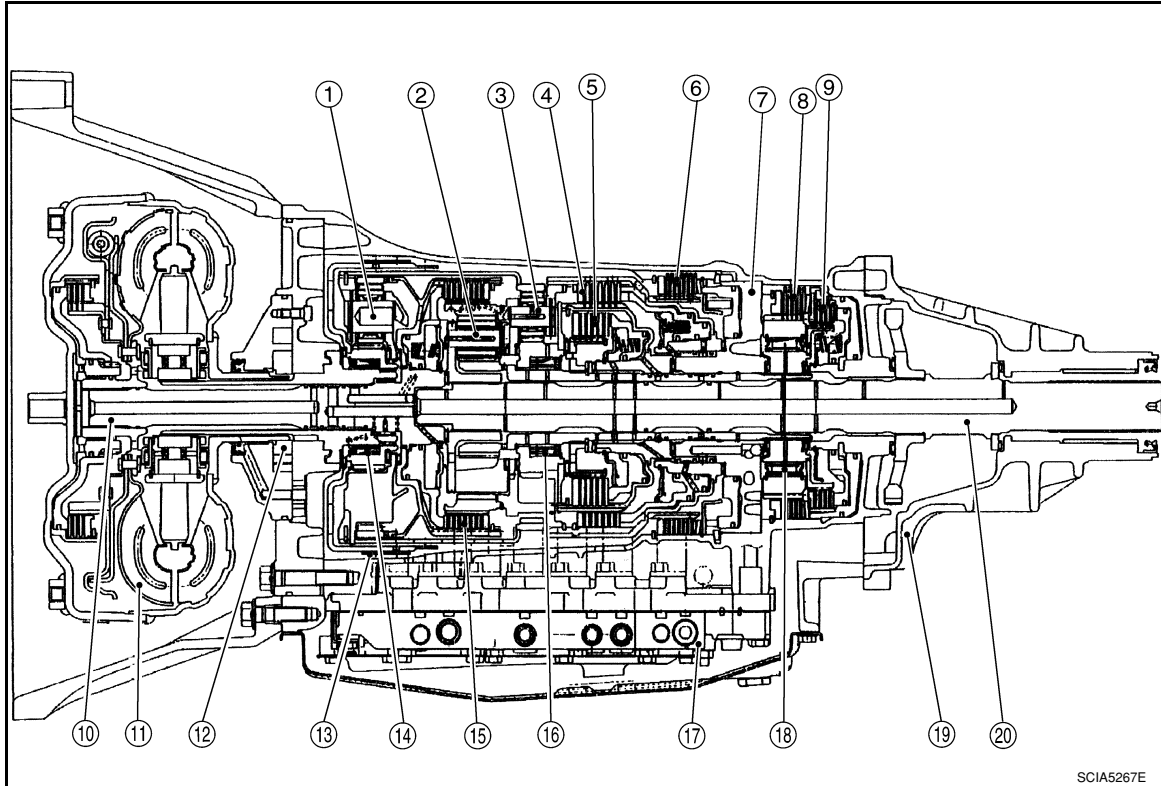

- | | | |
|-------------------------|--------------------------------|----------------------------|
| 1. Front planetary gear | 2. Mid planetary gear | 3. Rear planetary gear |
| 4. Direct clutch | 5. High and low reverse clutch | 6. Reverse brake |
| 7. Drum support | 8. Forward brake | 9. Low coast brake |
| 10. Input shaft | 11. Torque converter | 12. Oil pump |
| 13. Front brake | 14. 3rd one-way clutch | 15. Input clutch |
| 16. 1st one-way clutch | 17. Control valve with TCM | 18. Forward one-way clutch |
| 19. Rear extension | 20. Output shaft | |

A/T CONTROL SYSTEM

< FUNCTION DIAGNOSIS >

Cross-Sectional View (4WD models)

INFOID:000000001534241

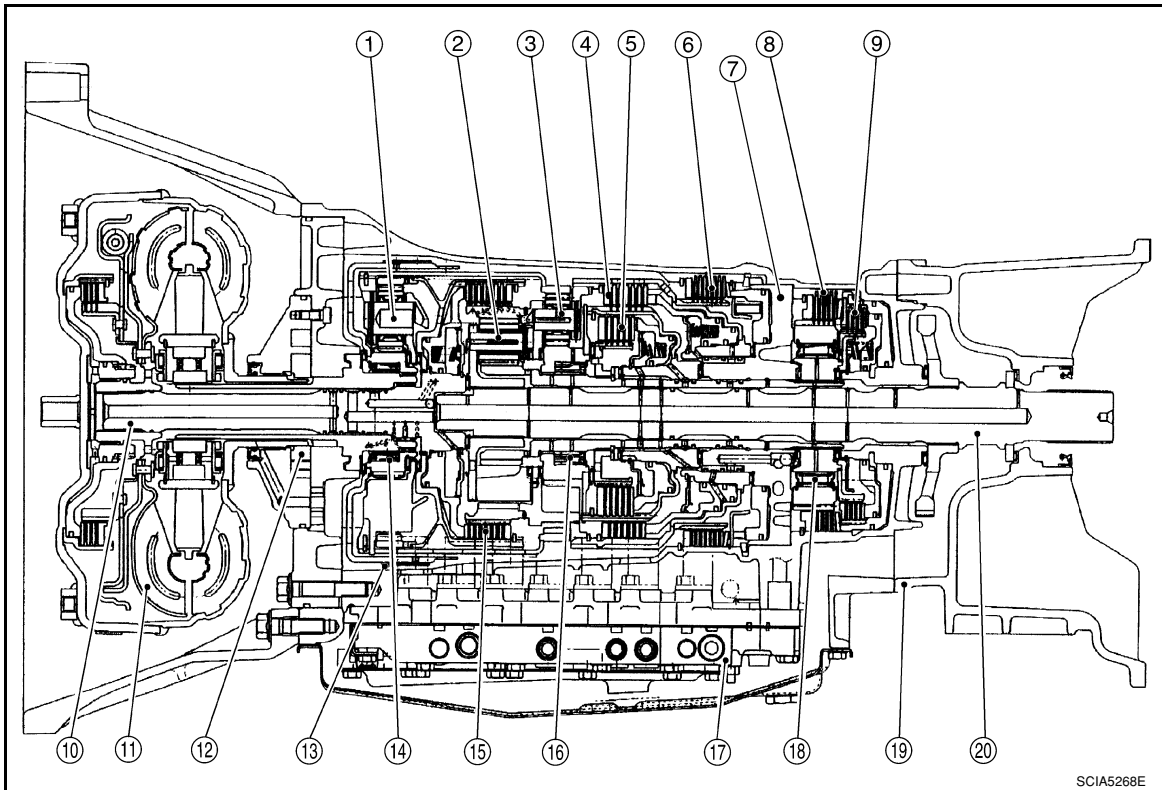

- | | | |
|-------------------------|--------------------------------|----------------------------|
| 1. Front planetary gear | 2. Mid planetary gear | 3. Rear planetary gear |
| 4. Direct clutch | 5. High and low reverse clutch | 6. Reverse brake |
| 7. Drum support | 8. Forward brake | 9. Low coast brake |
| 10. Input shaft | 11. Torque converter | 12. Oil pump |
| 13. Front brake | 14. 3rd one-way clutch | 15. Input clutch |
| 16. 1st one-way clutch | 17. Control valve with TCM | 18. Forward one-way clutch |
| 19. Adapter case | 20. Output shaft | |

Shift Mechanism

INFOID:000000001534242

The automatic transmission uses compact triple planetary gear systems to improve power-transmission efficiency, simplify construction and reduce weight. It also employs an optimum shift control and super wide gear ratios. They improve starting performance and acceleration during medium and high-speed operation.

CONSTRUCTION

A/T CONTROL SYSTEM

< FUNCTION DIAGNOSIS >

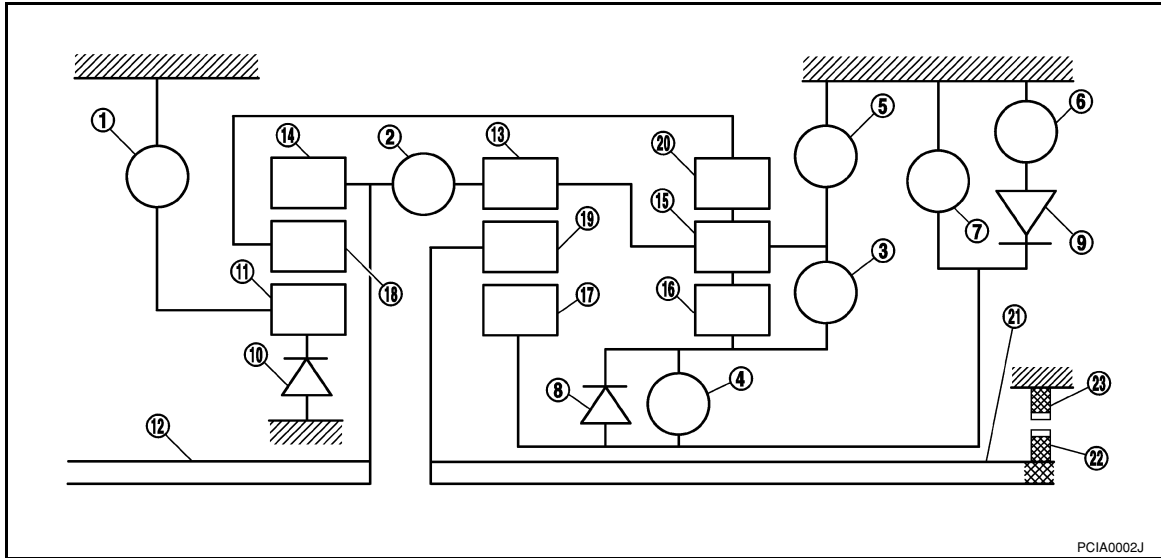

- | | | |
|--------------------------------|-------------------------|---------------------------|
| 1. Front brake | 2. Input clutch | 3. Direct clutch |
| 4. High and low reverse clutch | 5. Reverse brake | 6. Forward brake |
| 7. Low coast brake | 8. 1st one-way clutch | 9. Forward one-way clutch |
| 10. 3rd one-way clutch | 11. Front sun gear | 12. Input shaft |
| 13. Mid internal gear | 14. Front internal gear | 15. Rear carrier |
| 16. Rear sun gear | 17. Mid sun gear | 18. Front carrier |
| 19. Mid carrier | 20. Rear internal gear | 21. Output shaft |
| 22. Parking gear | 23. Parking pawl | |

FUNCTION OF CLUTCH AND BRAKE

Name of the Part	Abbreviation	Function
Front brake (1)	FR/B	Fastens the front sun gear (11).
Input clutch (2)	I/C	Connects the input shaft (12), the front internal gear (14) and the mid internal gear (13).
Direct clutch (3)	D/C	Connects the rear carrier (15) and the rear sun gear (16).
High and low reverse clutch (4)	HLR/C	Connects the mid sun gear (17) and the rear sun gear (16).
Reverse brake (5)	R/B	Fastens the rear carrier (15).
Forward brake (6)	Fwd/B	Fastens the mid sun gear (17).
Low coast brake (7)	LC/B	Fastens the mid sun gear (17).
1st one-way clutch (8)	1st OWC	Allows the rear sun gear (16) to turn freely forward relative to the mid sun gear (17) but fastens it for reverse rotation.
Forward one-way clutch (9)	Fwd OWC	Allows the mid sun gear (17) to turn freely in the forward direction but fastens it for reverse rotation.
3rd one-way clutch (10)	3rd OWC	Allows the front sun gear (11) to turn freely in the forward direction but fastens it for reverse rotation.

CLUTCH AND BAND CHART

Shift position	I/C	HLR/C	D/C	R/B	FR/B	LC/B	Fwd/B	1st OWC	Fwd OWC	3rd OWC	Remarks
P		△			△						PARK POSITION
R		○		○	○			☆		☆	REVERSE POSITION

A/T CONTROL SYSTEM

< FUNCTION DIAGNOSIS >

Shift position		I/C	HLR/C	D/C	R/B	FR/B	LC/B	Fwd/B	1st OWC	Fwd OWC	3rd OWC	Remarks
N			△			△						NEUTRAL POSITION
D	1st		△*			△	△**	○	☆	☆	☆	Automatic shift 1↔2↔3↔4↔5
	2nd			○		△		○		☆	☆	
	3rd		○	○		○		△	★		☆	
	4th	○	○	○				△	★			
	5th	○	○			○		△	★		★	
4	1st		△*			△	△**	○	☆	☆	☆	Automatic shift 1↔2↔3↔4
	2nd			○		△		○		☆	☆	
	3rd		○	○		○		△	★		☆	
	4th	○	○	○				△	★			
3	1st		△*			△	△**	○	☆	☆	☆	Automatic shift 1↔2↔3↔4
	2nd			○		△		○		☆	☆	
	3rd		○	○		○		△	★		☆	
	4th	○	○	○				△	★			
2	1st		△*			△	△**	○	☆	☆	☆	Automatic shift 1↔2↔3↔4
	2nd			○		○	○	○		☆	☆	
	3rd		○	○		○		△	★		☆	
	4th	○	○	○				△	★			
1	1st		○			○	○	○	☆	☆	☆	Locks (held stationary in 1st gear) 1↔2↔3↔4
	2nd			○		○	○	○		☆	☆	
	3rd		○	○		○		△	★		☆	
	4th	○	○	○				△	★			

- ○—Operates
- ☆—Operates during “progressive” acceleration.
- ★—Operates and effects power transmission while coasting.
- △—Line pressure is applied but does not affect power transmission.
- △*—Operates under conditions shown in HLR/C Operating Condition
- △**—Operates under conditions shown in LC/B Operating Condition. Delay control is applied during D (4,3,2,1) ⇒N shift.

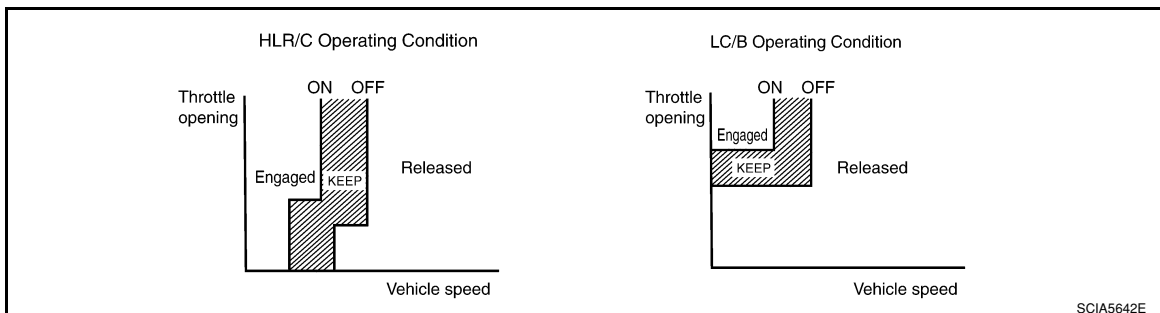

POWER TRANSMISSION

“N” Position

A/T CONTROL SYSTEM

< FUNCTION DIAGNOSIS >

Since both the forward brake and the reverse brake are released, torque from the input shaft drive is not transmitted to the output shaft.

“P” Position

- The same as for the “N” position, both the forward brake and the reverse brake are released, so torque from the input shaft drive is not transmitted to the output shaft.
- The parking pawl linked with the select lever meshes with the parking gear and fastens the output shaft mechanically.

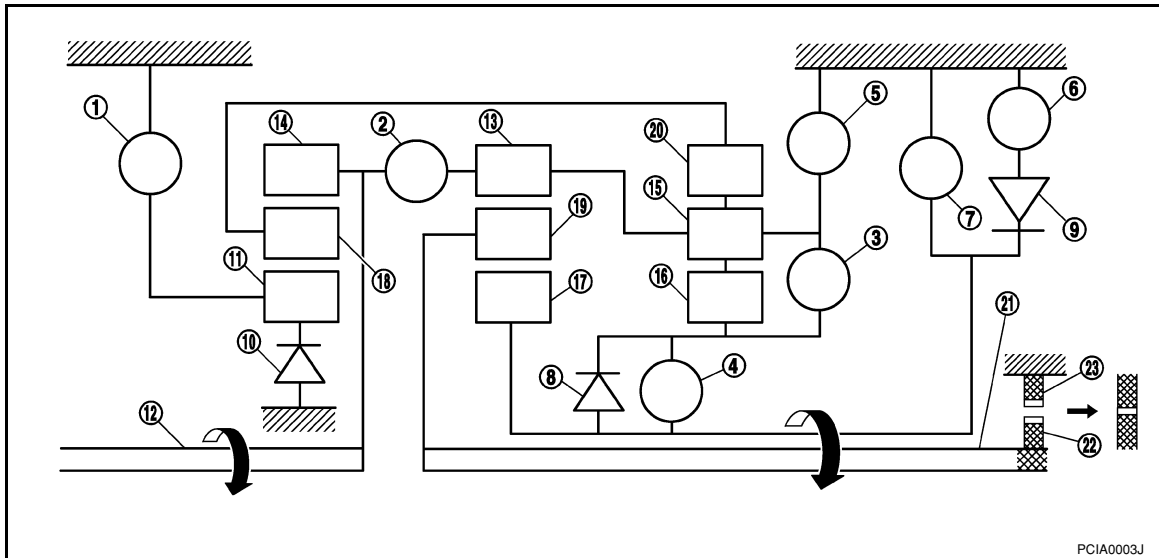

- | | | |
|--------------------------------|-------------------------|---------------------------|
| 1. Front brake | 2. Input clutch | 3. Direct clutch |
| 4. High and low reverse clutch | 5. Reverse brake | 6. Forward brake |
| 7. Low coast brake | 8. 1st one-way clutch | 9. Forward one-way clutch |
| 10. 3rd one-way clutch | 11. Front sun gear | 12. Input shaft |
| 13. Mid internal gear | 14. Front internal gear | 15. Rear carrier |
| 16. Rear sun gear | 17. Mid sun gear | 18. Front carrier |
| 19. Mid carrier | 20. Rear internal gear | 21. Output shaft |
| 22. Parking gear | 23. Parking pawl | |

“D”, “4”, “3”, “2” Positions 1st Gear

- The forward brake and the forward one-way clutch regulate reverse rotation of the mid sun gear.
- The 1st one-way clutch regulates reverse rotation of the rear sun gear.
- The 3rd one-way clutch regulates reverse rotation of the front sun gear.
- During deceleration, the mid sun gear turns forward, so the forward one-way clutch idles and the engine brake is not activated.

A/T CONTROL SYSTEM

< FUNCTION DIAGNOSIS >

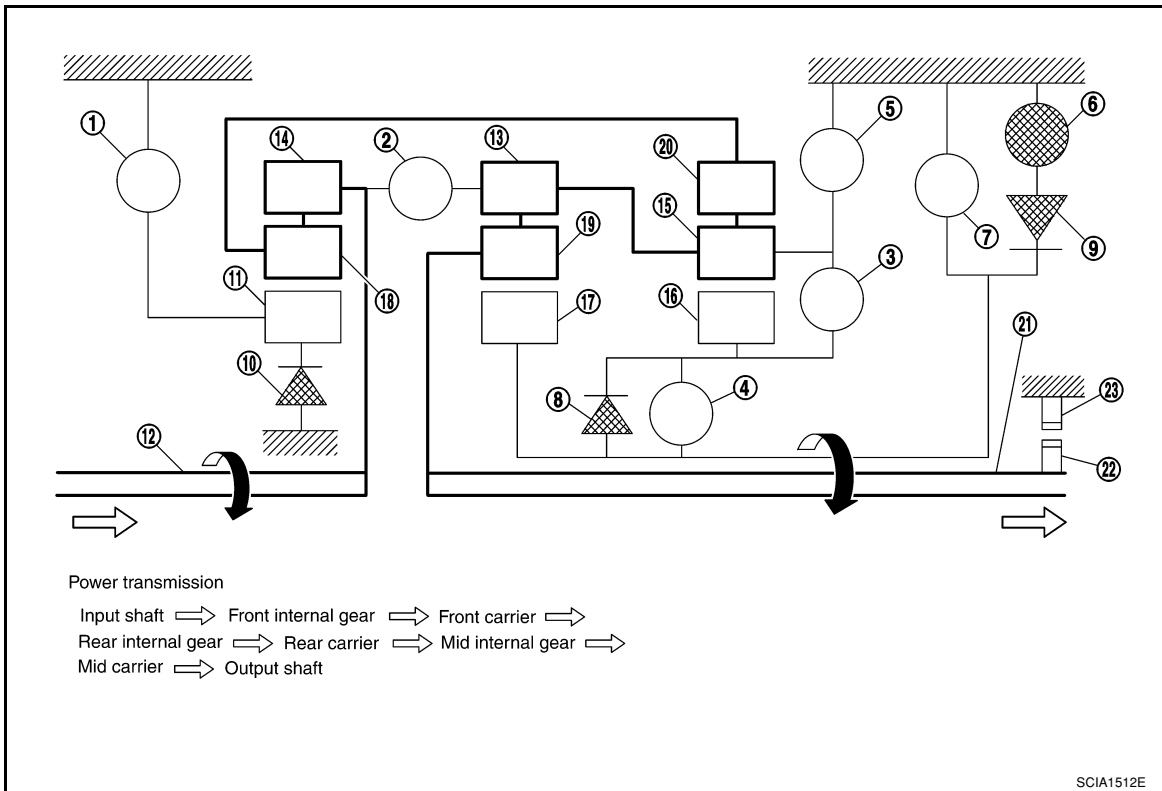

- | | | |
|--------------------------------|-------------------------|---------------------------|
| 1. Front brake | 2. Input clutch | 3. Direct clutch |
| 4. High and low reverse clutch | 5. Reverse brake | 6. Forward brake |
| 7. Low coast brake | 8. 1st one-way clutch | 9. Forward one-way clutch |
| 10. 3rd one-way clutch | 11. Front sun gear | 12. Input shaft |
| 13. Mid internal gear | 14. Front internal gear | 15. Rear carrier |
| 16. Rear sun gear | 17. Mid sun gear | 18. Front carrier |
| 19. Mid carrier | 20. Rear internal gear | 21. Output shaft |
| 22. Parking gear | 23. Parking pawl | |

"1" Position 1st Gear

- The front brake fastens the front sun gear.
- The forward brake and the forward one-way clutch regulate reverse rotation of the mid sun gear.
- High and low reverse clutch connects the rear sun gear and the mid sun gear.
- The low coast brake fastens the mid sun gear.
- During deceleration, the low coast brake regulates forward rotation of the mid sun gear and the engine brake functions.

A/T CONTROL SYSTEM

< FUNCTION DIAGNOSIS >

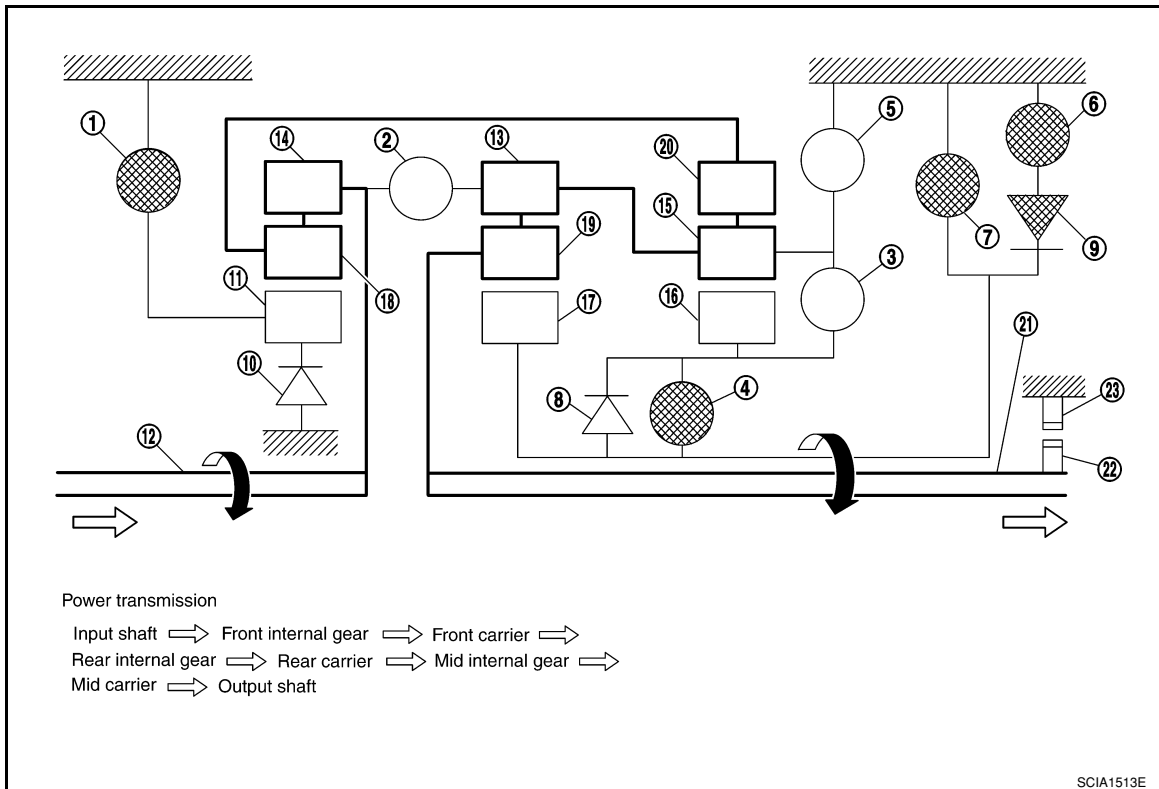

- | | | |
|--------------------------------|-------------------------|---------------------------|
| 1. Front brake | 2. Input clutch | 3. Direct clutch |
| 4. High and low reverse clutch | 5. Reverse brake | 6. Forward brake |
| 7. Low coast brake | 8. 1st one-way clutch | 9. Forward one-way clutch |
| 10. 3rd one-way clutch | 11. Front sun gear | 12. Input shaft |
| 13. Mid internal gear | 14. Front internal gear | 15. Rear carrier |
| 16. Rear sun gear | 17. Mid sun gear | 18. Front carrier |
| 19. Mid carrier | 20. Rear internal gear | 21. Output shaft |
| 22. Parking gear | 23. Parking pawl | |

“D”, “4”, “3” Positions 2nd Gear

- The forward brake and the forward one-way clutch regulate reverse rotation of the mid sun gear.
- The 3rd one-way clutch regulates reverse rotation of the front sun gear.
- The direct clutch is coupled and the rear carrier and rear sun gear are connected.
- During deceleration, the mid sun gear turns forward, so the forward one-way clutch idles and engine brake is not activated.

A/T CONTROL SYSTEM

< FUNCTION DIAGNOSIS >

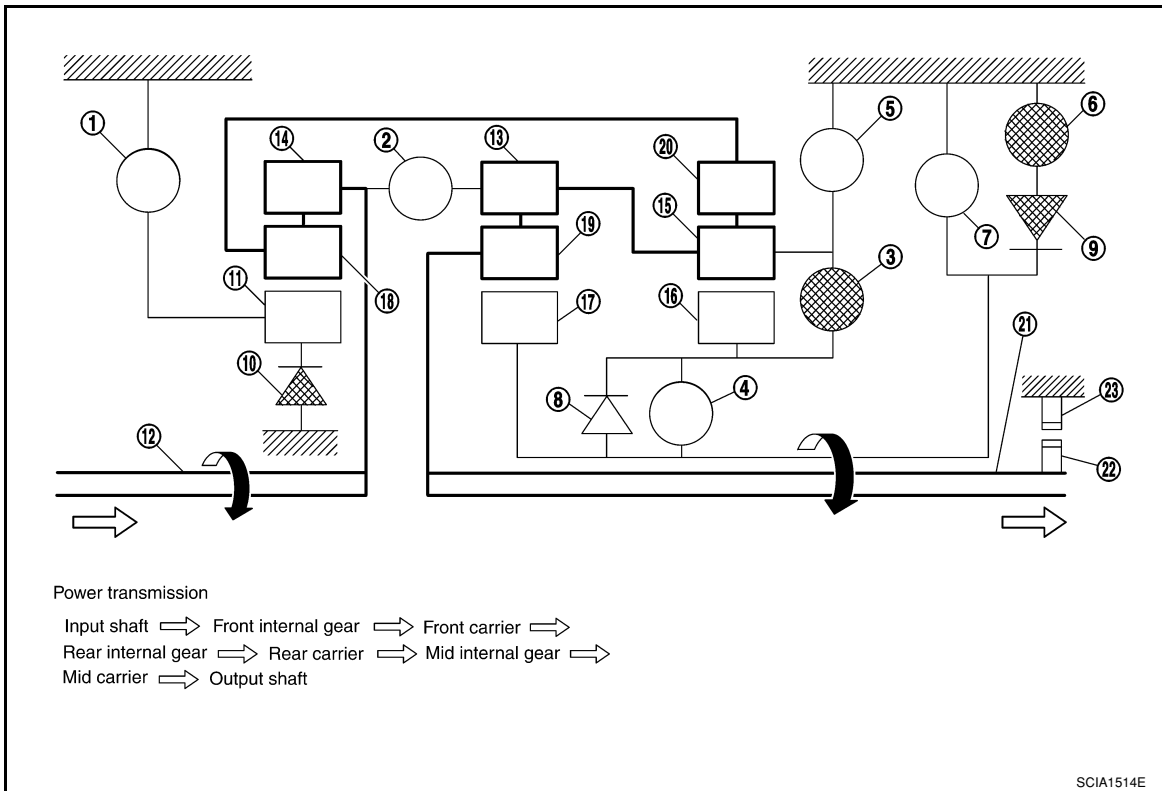

- | | | |
|--------------------------------|-------------------------|---------------------------|
| 1. Front brake | 2. Input clutch | 3. Direct clutch |
| 4. High and low reverse clutch | 5. Reverse brake | 6. Forward brake |
| 7. Low coast brake | 8. 1st one-way clutch | 9. Forward one-way clutch |
| 10. 3rd one-way clutch | 11. Front sun gear | 12. Input shaft |
| 13. Mid internal gear | 14. Front internal gear | 15. Rear carrier |
| 16. Rear sun gear | 17. Mid sun gear | 18. Front carrier |
| 19. Mid carrier | 20. Rear internal gear | 21. Output shaft |
| 22. Parking gear | 23. Parking pawl | |

"2", "1" Positions 2nd Gear

- The front brake fastens the front sun gear.
- The forward brake and the forward one-way clutch regulate reverse rotation of the mid sun gear.
- The direct clutch is coupled, and the rear carrier and rear sun gear are connected.
- The low coast brake fastens the mid sun gear.
- During deceleration, the low coast brake regulates forward rotation of the mid sun gear and the engine brake functions.

A/T CONTROL SYSTEM

< FUNCTION DIAGNOSIS >

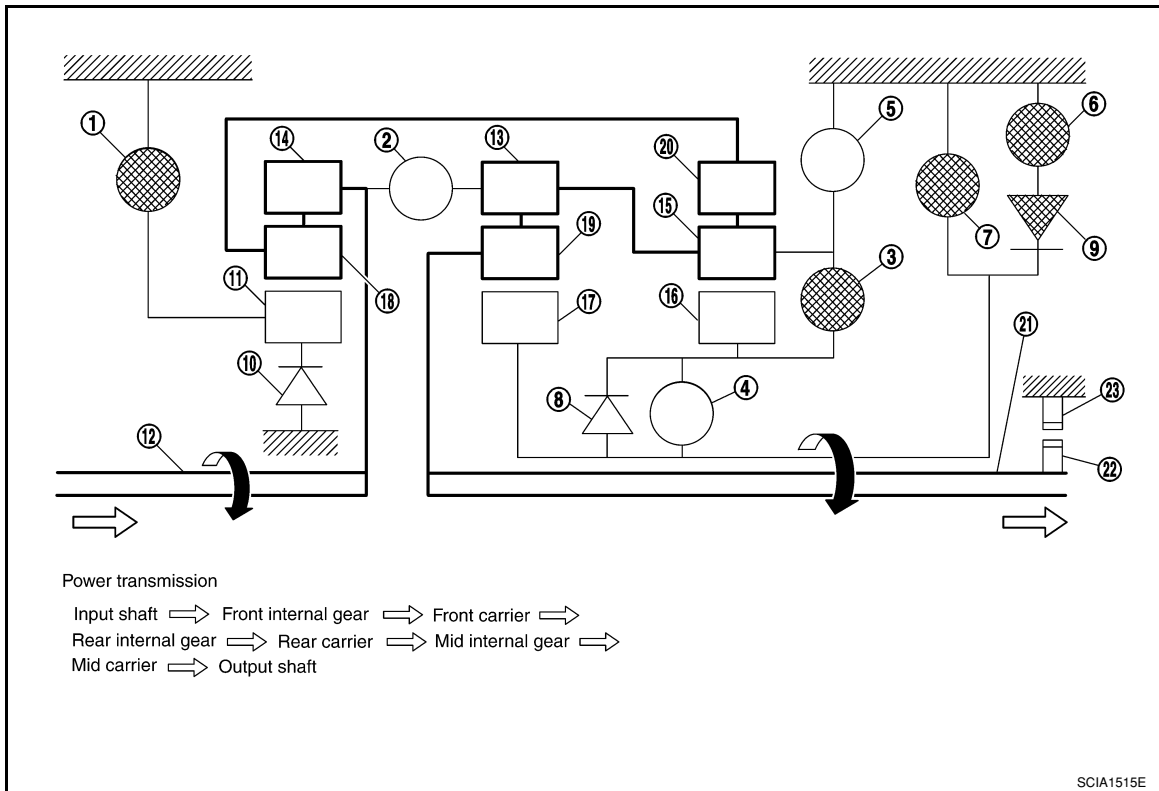

- | | | |
|--------------------------------|-------------------------|---------------------------|
| 1. Front brake | 2. Input clutch | 3. Direct clutch |
| 4. High and low reverse clutch | 5. Reverse brake | 6. Forward brake |
| 7. Low coast brake | 8. 1st one-way clutch | 9. Forward one-way clutch |
| 10. 3rd one-way clutch | 11. Front sun gear | 12. Input shaft |
| 13. Mid internal gear | 14. Front internal gear | 15. Rear carrier |
| 16. Rear sun gear | 17. Mid sun gear | 18. Front carrier |
| 19. Mid carrier | 20. Rear internal gear | 21. Output shaft |
| 22. Parking gear | 23. Parking pawl | |

“D”, “4”, “3” Positions 3rd Gear

- The front brake fastens the front sun gear.
- The direct clutch is coupled, and the rear carrier and rear sun gear are connected.
- The high and low reverse clutch is coupled and the mid sun gear and rear sun gear are connected.

A/T CONTROL SYSTEM

< FUNCTION DIAGNOSIS >

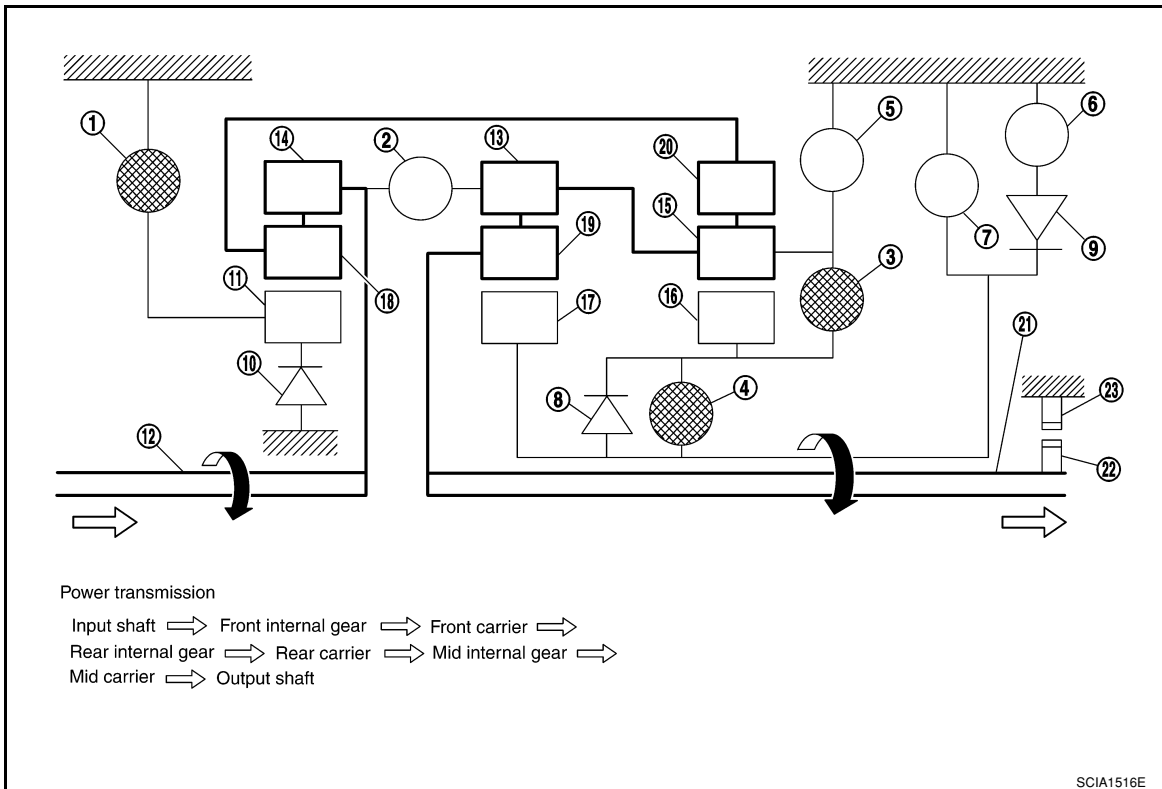

- | | | |
|--------------------------------|-------------------------|---------------------------|
| 1. Front brake | 2. Input clutch | 3. Direct clutch |
| 4. High and low reverse clutch | 5. Reverse brake | 6. Forward brake |
| 7. Low coast brake | 8. 1st one-way clutch | 9. Forward one-way clutch |
| 10. 3rd one-way clutch | 11. Front sun gear | 12. Input shaft |
| 13. Mid internal gear | 14. Front internal gear | 15. Rear carrier |
| 16. Rear sun gear | 17. Mid sun gear | 18. Front carrier |
| 19. Mid carrier | 20. Rear internal gear | 21. Output shaft |
| 22. Parking gear | 23. Parking pawl | |

“D”, “4” Positions 4th Gear

- The direct clutch is coupled, and the rear carrier and rear sun gear are connected.
- The high and low reverse clutch is coupled and the mid sun gear and rear sun gear are connected.
- The input clutch is coupled and the front internal gear and mid internal gear are connected.
- The drive power is conveyed to the front internal gear, mid internal gear, and rear carrier and the three planetary gears rotate forward as one unit.

A/T CONTROL SYSTEM

< FUNCTION DIAGNOSIS >

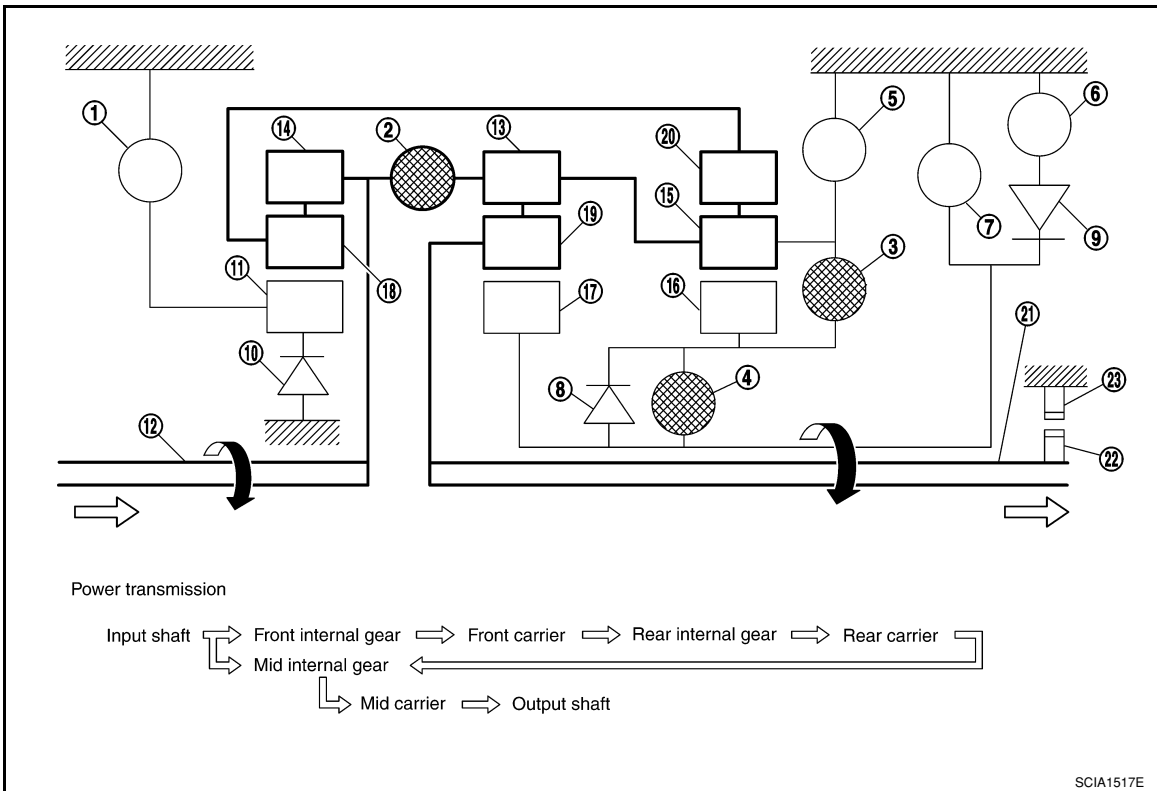

- | | | |
|--------------------------------|-------------------------|---------------------------|
| 1. Front brake | 2. Input clutch | 3. Direct clutch |
| 4. High and low reverse clutch | 5. Reverse brake | 6. Forward brake |
| 7. Low coast brake | 8. 1st one-way clutch | 9. Forward one-way clutch |
| 10. 3rd one-way clutch | 11. Front sun gear | 12. Input shaft |
| 13. Mid internal gear | 14. Front internal gear | 15. Rear carrier |
| 16. Rear sun gear | 17. Mid sun gear | 18. Front carrier |
| 19. Mid carrier | 20. Rear internal gear | 21. Output shaft |
| 22. Parking gear | 23. Parking pawl | |

“D” Position 5th Gear

- The front brake fastens the front sun gear.
- The input clutch is coupled and the front internal gear and mid internal gear are connected.
- The high and low reverse clutch is coupled and the mid sun gear and rear sun gear are connected.

A/T CONTROL SYSTEM

< FUNCTION DIAGNOSIS >

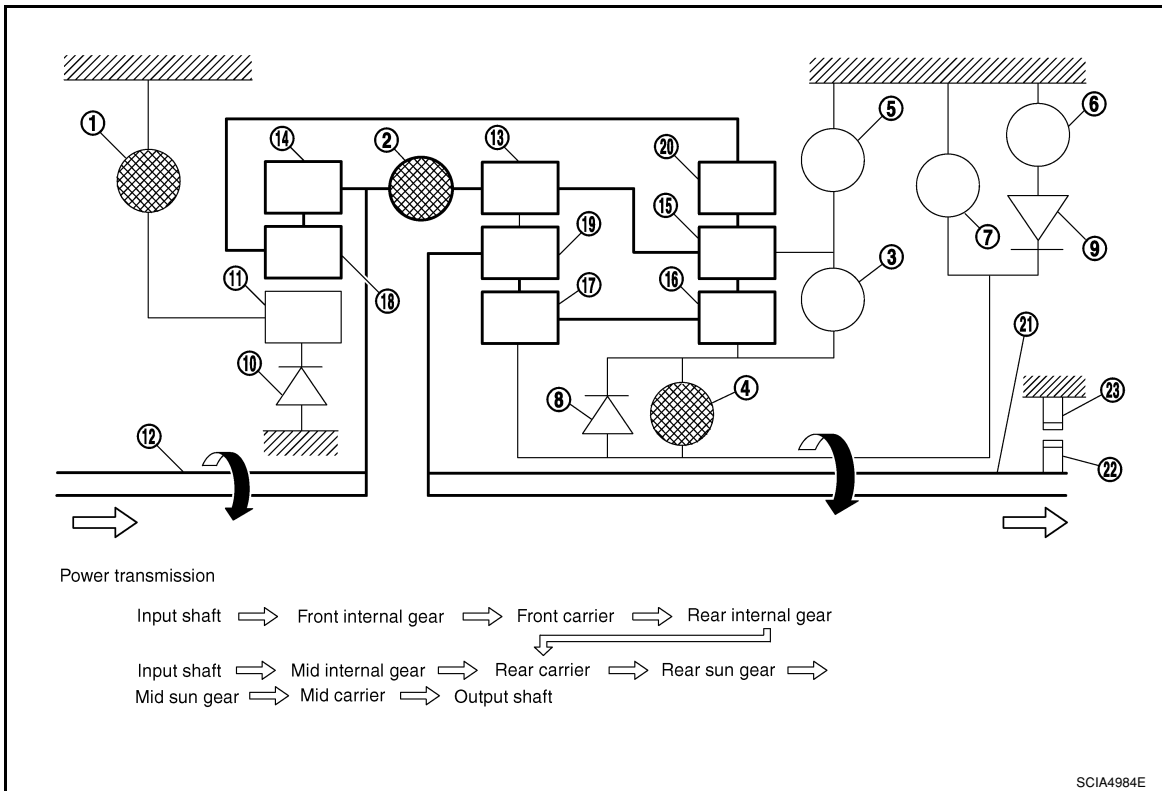

- | | | |
|--------------------------------|-------------------------|---------------------------|
| 1. Front brake | 2. Input clutch | 3. Direct clutch |
| 4. High and low reverse clutch | 5. Reverse brake | 6. Forward brake |
| 7. Low coast brake | 8. 1st one-way clutch | 9. Forward one-way clutch |
| 10. 3rd one-way clutch | 11. Front sun gear | 12. Input shaft |
| 13. Mid internal gear | 14. Front internal gear | 15. Rear carrier |
| 16. Rear sun gear | 17. Mid sun gear | 18. Front carrier |
| 19. Mid carrier | 20. Rear internal gear | 21. Output shaft |
| 22. Parking gear | 23. Parking pawl | |

"R" Position

- The front brake fastens the front sun gear.
- The high and low reverse clutch is coupled, and the mid sun gear and rear sun gear are connected.
- The reverse brake fastens the rear carrier.

A/T CONTROL SYSTEM

< FUNCTION DIAGNOSIS >

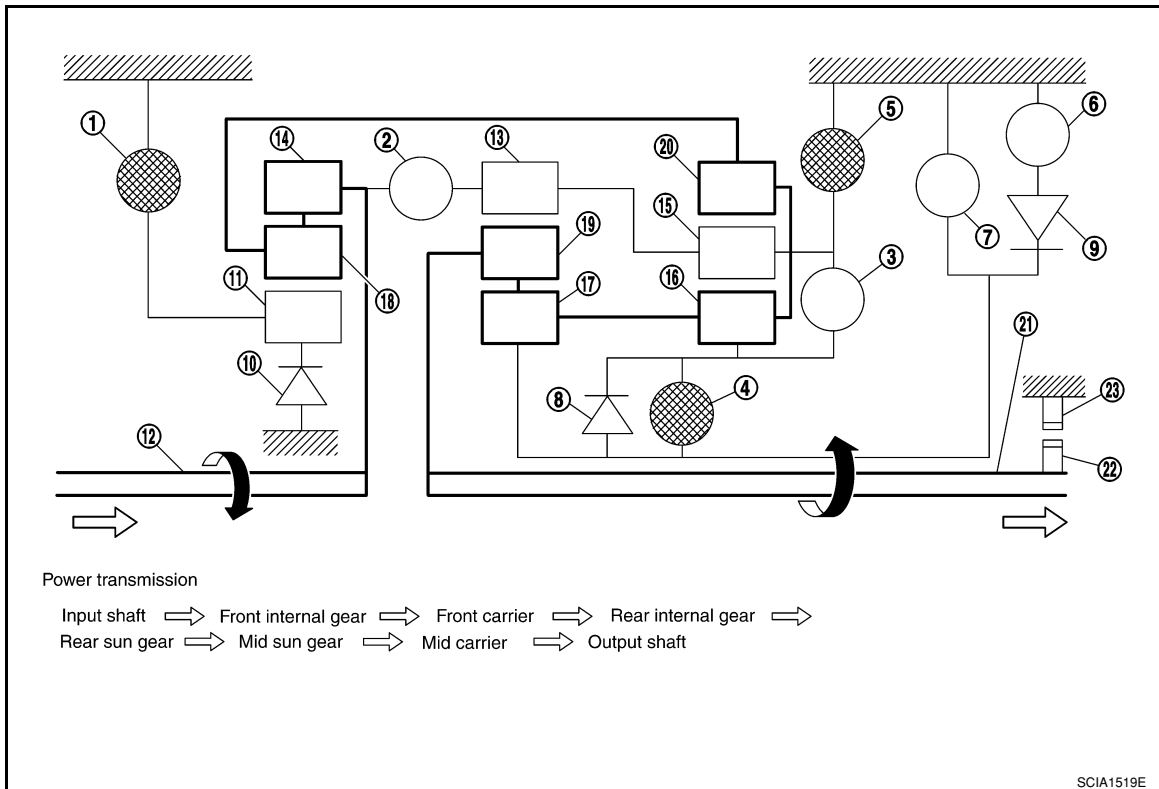

- | | | |
|--------------------------------|-------------------------|---------------------------|
| 1. Front brake | 2. Input clutch | 3. Direct clutch |
| 4. High and low reverse clutch | 5. Reverse brake | 6. Forward brake |
| 7. Low coast brake | 8. 1st one-way clutch | 9. Forward one-way clutch |
| 10. 3rd one-way clutch | 11. Front sun gear | 12. Input shaft |
| 13. Mid internal gear | 14. Front internal gear | 15. Rear carrier |
| 16. Rear sun gear | 17. Mid sun gear | 18. Front carrier |
| 19. Mid carrier | 20. Rear internal gear | 21. Output shaft |
| 22. Parking gear | 23. Parking pawl | |

TCM Function

INFOID:000000001532024

The function of the TCM is to:

- Receive input signals sent from various switches and sensors.
- Determine required line pressure, shifting point, lock-up operation, and engine brake operation.
- Send required output signals to the respective solenoids.

CONTROL SYSTEM OUTLINE

The automatic transmission senses vehicle operating conditions through various sensors or signals. It always controls the optimum shift position and reduces shifting and lock-up shocks.

A/T CONTROL SYSTEM

< FUNCTION DIAGNOSIS >

SENSORS (or SIGNALS)		TCM		ACTUATORS
PNP switch Accelerator pedal position sensor Closed throttle position signal Wide open throttle position signal Engine speed signal A/T fluid temperature sensor Revolution sensor Vehicle speed signal Stop lamp switch signal Turbine revolution sensor 1st position switch signal 4th position switch signal ATF pressure switch 2 signal Tow mode switch signal	⇒	Shift control Line pressure control Lock-up control Engine brake control Timing control Fail-safe control Self-diagnosis CONSULT-III communication line Duet-EA control CAN system	⇒	Input clutch solenoid valve Direct clutch solenoid valve Front brake solenoid valve High and low reverse clutch solenoid valve Low coast brake solenoid valve Torque converter clutch solenoid valve Line pressure solenoid valve A/T CHECK indicator lamp Starter relay Back-up lamp relay

CONTROL SYSTEM DIAGRAM

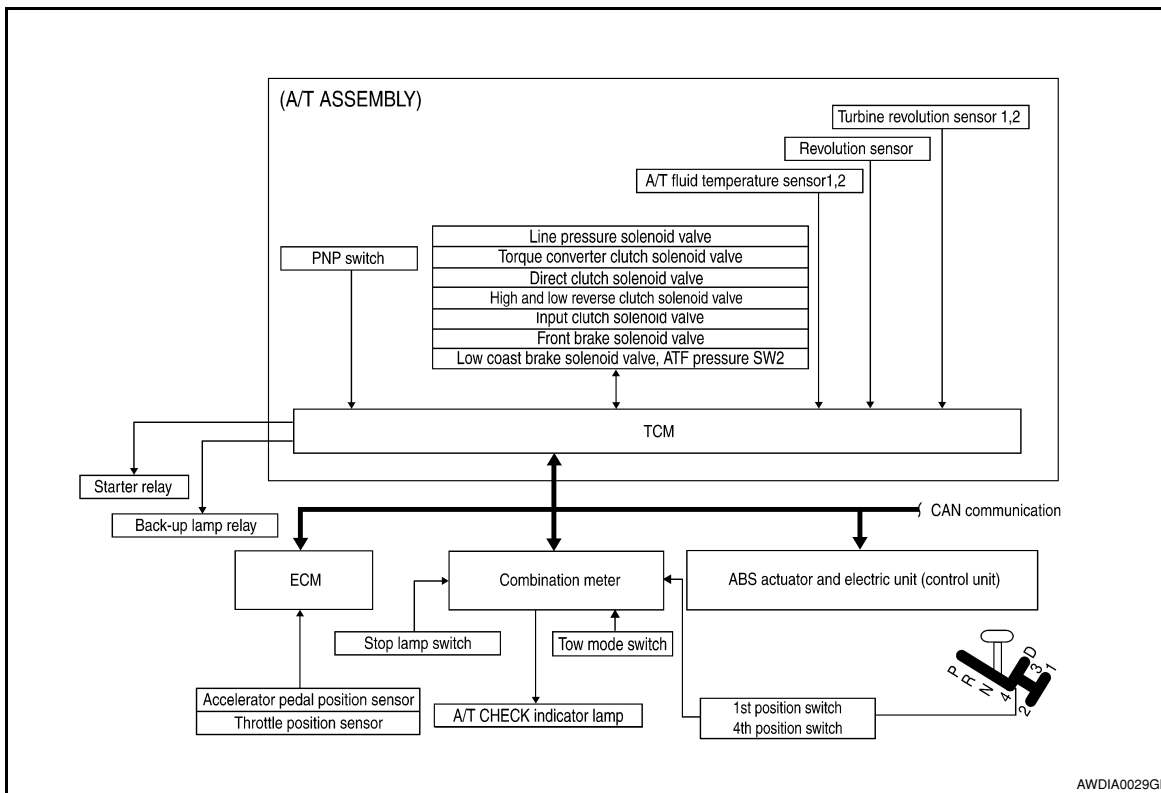

CAN Communication

INFOID:000000001532023

SYSTEM DESCRIPTION

CAN (Controller Area Network) is a serial communication line for real time application. It is an on-vehicle multiplex communication line with high data communication speed and excellent error detection ability. Many electronic control units are equipped onto a vehicle, and each control unit shares information and links with other control units during operation (not independent). In CAN communication, control units are connected with 2 communication lines (CAN H line, CAN L line) allowing a high rate of information transmission with less wiring. Each control unit transmits/receives data but selectively reads required data only. For details, refer to [LAN-4, "System Description"](#).

A/T CONTROL SYSTEM

< FUNCTION DIAGNOSIS >

Input/Output Signal of TCM

INFOID:000000001532022

Control item		Line pressure control	Vehicle speed control	Shift control	Lock-up control	Engine brake control	Fail-safe function (*3)	Self-diagnostics function	
Input	Accelerator pedal position signal (*4)	X	X	X	X	X	X	X	
	Vehicle speed sensor A/T (revolution sensor)	X	X	X	X		X	X	
	Vehicle speed sensor MTR(*1) (*4)	X	X	X	X			X	
	Closed throttle position signal(*4)	(*2) X	(*2) X		X	(*2) X		X	
	Wide open throttle position signal(*4)	(*2) X	(*2) X			(*2) X		X	
	Turbine revolution sensor 1	X	X		X		X	X	
	Turbine revolution sensor 2 (for 4th speed only)	X	X		X		X	X	
	Engine speed signals(*4)				X			X	
	PNP switch	X	X	X	X	X	X	X	
	A/T fluid temperature sensors 1, 2	X	X	X	X	X	X	X	
	ASCD	Operation signal(*4)		X	X	X	X		
		Overdrive cancel signal(*4)		X		X	X		
		TCM power supply voltage signal	X	X	X	X	X		X
Out-put	Direct clutch solenoid (ATF pressure switch 5)		X	X			X	X	
	Input clutch solenoid (ATF pressure switch 3)		X	X			X	X	
	High and low reverse clutch solenoid (ATF pressure switch 6)		X	X			X	X	
	Front brake solenoid (ATF pressure switch 1)		X	X			X	X	
	Low coast brake solenoid (ATF pressure switch 2)		X	X		X	X	X	
	Line pressure solenoid	X	X	X	X	X	X	X	
	TCC solenoid				X		X	X	
	Starter relay						X	X	

*1: Spare for vehicle speed sensor-A/T (revolution sensor)

*2: Spare for accelerator pedal position signal

*3: If these input and output signals are different, the TCM triggers the fail-safe function.

*4: CAN communications

Line Pressure Control

INFOID:000000001532021

- When an input torque signal equivalent to the engine drive force is sent from the ECM to the TCM, the TCM controls the line pressure solenoid.

A/T CONTROL SYSTEM

< FUNCTION DIAGNOSIS >

- This line pressure solenoid controls the pressure regulator valve as the signal pressure and adjusts the pressure of the operating oil discharged from the oil pump to the line pressure most appropriate to the driving state.

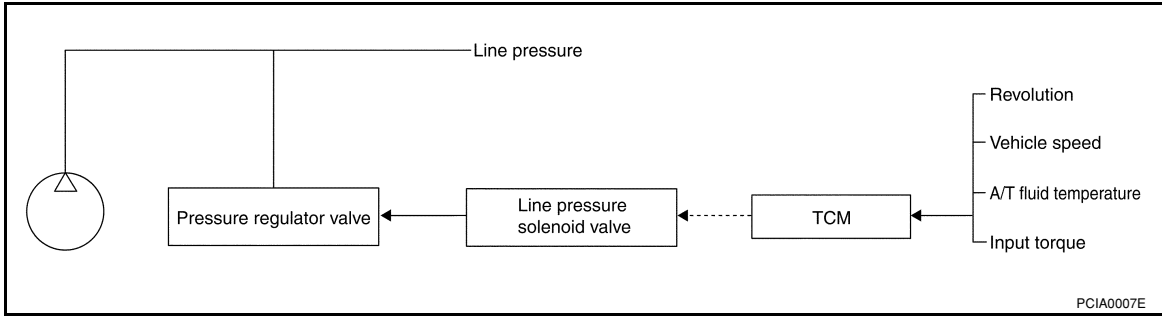

LINE PRESSURE CONTROL IS BASED ON THE TCM LINE PRESSURE CHARACTERISTIC PATTERN

- The TCM has stored in memory a number of patterns for the optimum line pressure characteristic for the driving state.
- In order to obtain the most appropriate line pressure characteristic to meet the current driving state, the TCM controls the line pressure solenoid current value and thus controls the line pressure.

Normal Control

Each clutch is adjusted to the necessary pressure to match the engine drive force.

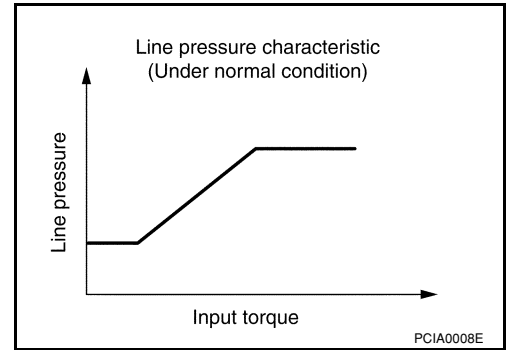

Back-up Control (Engine Brake)

When the select operation is performed during driving and the transmission is shifted down, the line pressure is set according to the vehicle speed.

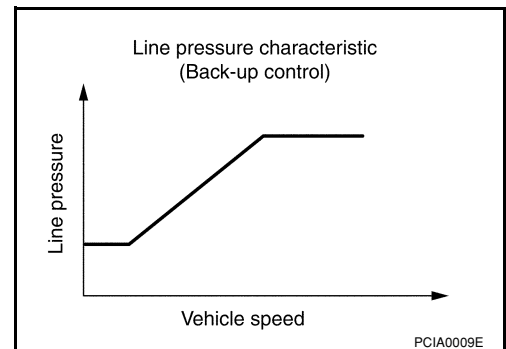

During Shift Change

A/T CONTROL SYSTEM

< FUNCTION DIAGNOSIS >

The necessary and adequate line pressure for shift change is set. For this reason, line pressure pattern setting corresponds to input torque and gearshift selection. Also, line pressure characteristic is set according to engine speed, during engine brake operation.

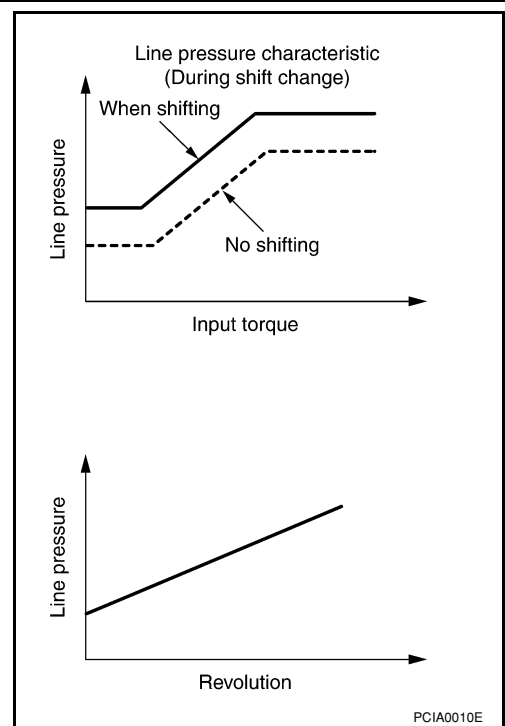

At Low Fluid Temperature

When the A/T fluid temperature drops below the prescribed temperature, in order to speed up the action of each friction element, the line pressure is set higher than the normal line pressure characteristic.

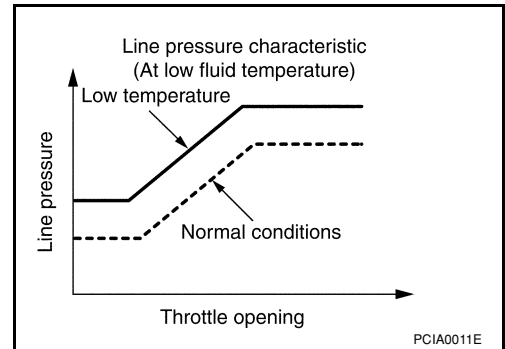

Shift Control

INFOID:000000001532020

The clutch pressure control solenoid is controlled by the signals from the switches and sensors. Thus, the clutch pressure is adjusted to be appropriate to the engine load state and vehicle driving state. It becomes possible to finely control the clutch hydraulic pressure with high precision and a smoother shift change characteristic is attained.

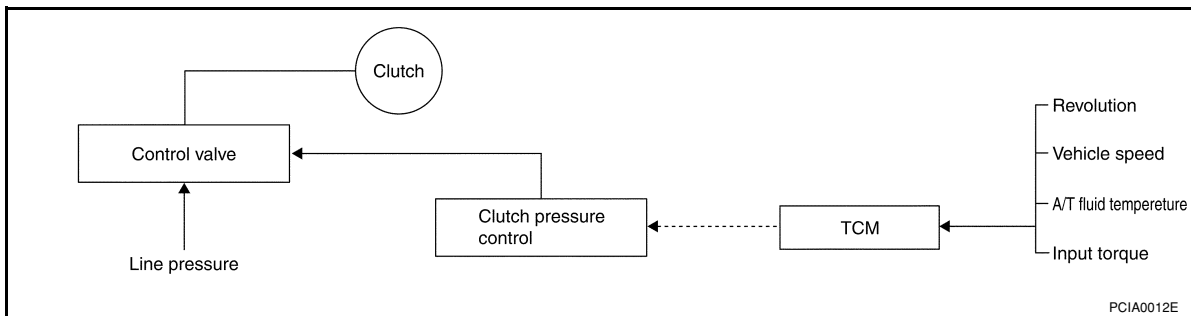

SHIFT CHANGE

The clutch is controlled with the optimum timing and oil pressure by the engine speed, engine torque information, etc.

Shift Change System Diagram

A/T CONTROL SYSTEM

< FUNCTION DIAGNOSIS >

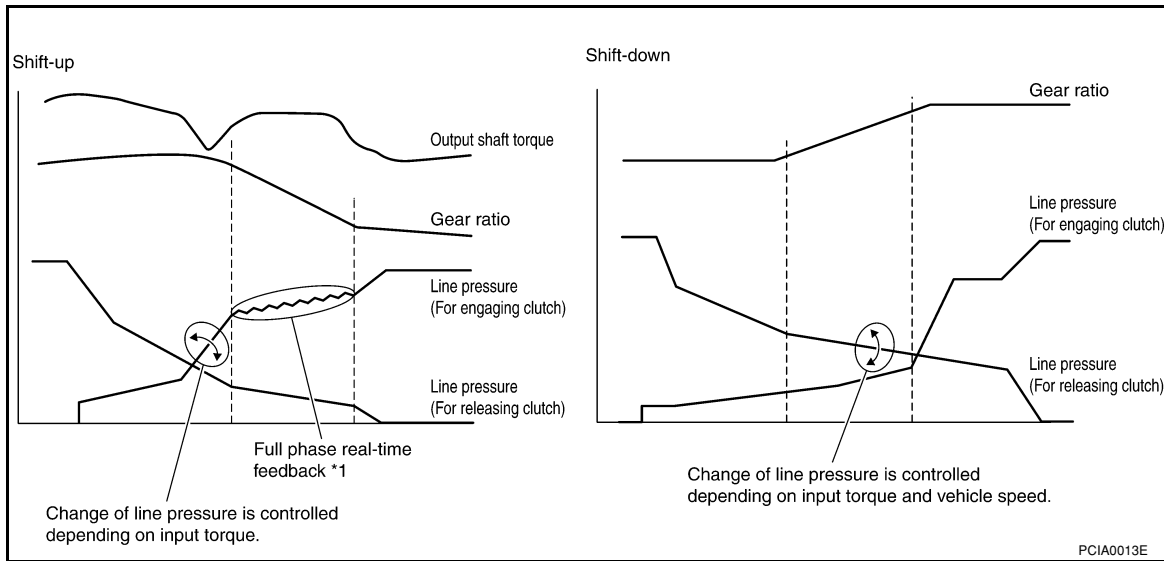

*1: Full phase real-time feedback control monitors movement of gear ratio at gear change, and controls oil pressure at real-time to achieve the best gear ratio.

Lock-up Control

INFOID:000000001532019

The torque converter clutch piston in the torque converter is engaged to eliminate torque converter slip to increase power transmission efficiency.

The torque converter clutch control valve operation is controlled by the torque converter clutch solenoid valve, which is controlled by a signal from TCM, and the torque converter clutch control valve engages or releases the torque converter clutch piston.

Lock-up Operation Condition Table

Select lever	D position		4 position	3 position	2 position
Gear position	5	4	4	3	2
Lock-up	×	—	×	×	×
Slip lock-up	×	×	—	—	—

TORQUE CONVERTER CLUTCH CONTROL VALVE CONTROL

Lock-up Control System Diagram

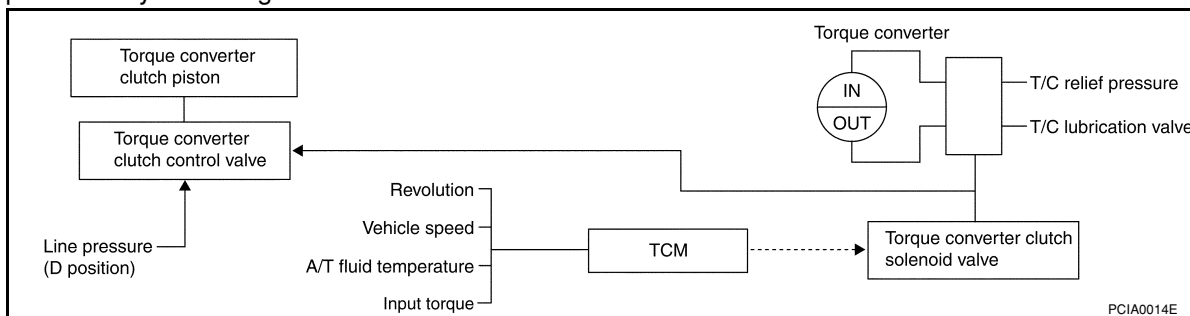

Lock-up Released

- In the lock-up released state, the torque converter clutch control valve is set into the unlocked state by the torque converter clutch solenoid and the lock-up apply pressure is drained. In this way, the torque converter clutch piston is not coupled.

Lock-up Applied

- In the lock-up applied state, the torque converter clutch control valve is set into the locked state by the torque converter clutch solenoid and lock-up apply pressure is generated. In this way, the torque converter clutch piston is pressed and coupled.

SMOOTH LOCK-UP CONTROL

A/T CONTROL SYSTEM

< FUNCTION DIAGNOSIS >

When shifting from the lock-up released state to the lock-up applied state, the current output to the torque converter clutch solenoid is controlled with the TCM. In this way, when shifting to the lock-up applied state, the torque converter clutch is temporarily set to the half-clutched state to reduce the shock.

Half-clutched State

- The current output from the TCM to the torque converter clutch solenoid is varied to gradually increase the torque converter clutch solenoid pressure. In this way, the lock-up apply pressure gradually rises and while the torque converter clutch piston is put into half-clutched status, the torque converter clutch piston operating pressure is increased and the coupling is completed smoothly.

Slip Lock-up Control

- In the slip region, the torque converter clutch solenoid current is controlled with the TCM to put it into the half-clutched state. This absorbs the engine torque fluctuation and lock-up operates from low speed. This raises the fuel efficiency for 4th and 5th gears at both low speed and when the accelerator has a low degree of opening.

Engine Brake Control

INFOID:000000001532018

- The forward one-way clutch transmits the drive force from the engine to the rear wheels. But the reverse drive from the rear wheels is not transmitted to the engine because the one-way clutch is idling. Therefore, the low coast brake solenoid is operated to prevent the forward one-way clutch from idling and the engine brake is operated in the same manner as conventionally.

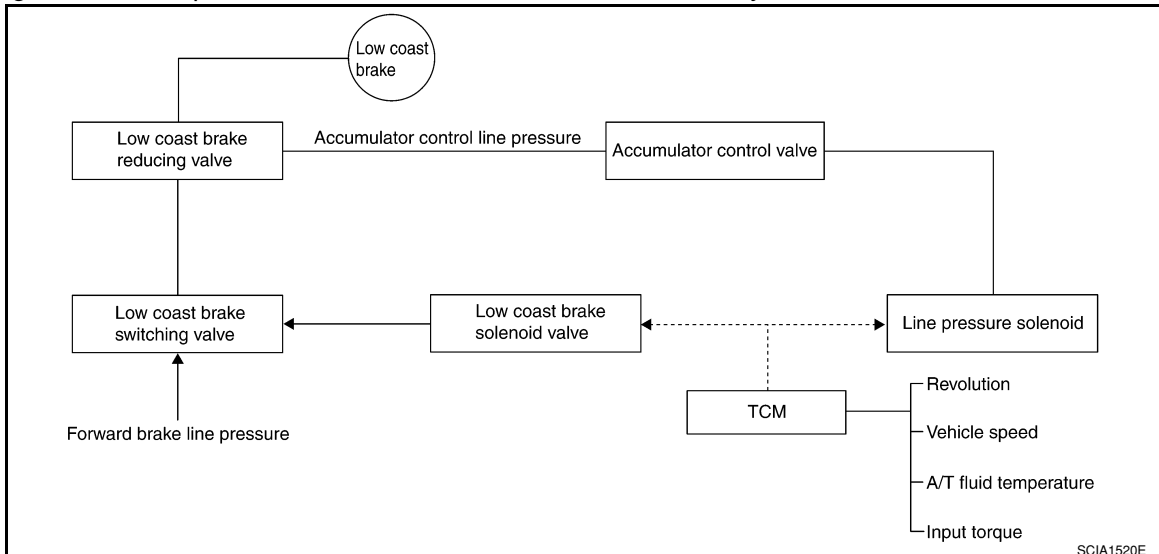

- The operation of the low coast brake solenoid switches the low coast brake switching valve and controls the coupling and releasing of the low coast brake. The low coast brake reducing valve controls the low coast brake coupling force.

Control Valve

INFOID:000000001532017

FUNCTION OF CONTROL VALVE

Name	Function
Torque converter regulator valve	In order to prevent the pressure supplied to the torque converter from being excessive, the line pressure is adjusted to the optimum pressure (torque converter operating pressure).
Pressure regulator valve Pressure regulator plug Pressure regulator sleeve	Adjusts the oil discharged from the oil pump to the optimum pressure (line pressure) for the driving state.
Front brake control valve	When the front brake is coupled, adjusts the line pressure to the optimum pressure (front brake pressure) and supplies it to the front brake. (In 1st, 2nd, 3rd, and 5th gears, adjusts the clutch pressure.)
Accumulator control valve	Adjusts the pressure (accumulator control pressure) acting on the accumulator piston and low coast reducing valve to the pressure appropriate to the driving state.

A/T CONTROL SYSTEM

< FUNCTION DIAGNOSIS >

Name	Function
Pilot valve A	Adjusts the line pressure and produces the constant pressure (pilot pressure) required for line pressure control, shift change control, and lock-up control.
Pilot valve B	Adjusts the line pressure and produces the constant pressure (pilot pressure) required for shift change control.
Low coast brake switching valve	During engine braking, supplies the line pressure to the low coast brake reducing valve.
Low coast brake reducing valve	When the low coast brake is coupled, adjusts the line pressure to the optimum pressure (low coast brake pressure) and supplies it to the low coast brake.
N-R accumulator	Produces the stabilizing pressure for when N-R is selected.
Direct clutch piston switching valve	Operates in 4th gear and switches the direct clutch coupling capacity.
High and low reverse clutch control valve	When the high and low reverse clutch is coupled, adjusts the line pressure to the optimum pressure (high and low reverse clutch pressure) and supplies it to the high and low reverse clutch. (In 1st, 3rd, 4th and 5th gears, adjusts the clutch pressure.)
Input clutch control valve	When the input clutch is coupled, adjusts the line pressure to the optimum pressure (input clutch pressure) and supplies it to the input clutch. (In 4th and 5th gears, adjusts the clutch pressure.)
Direct clutch control valve	When the direct clutch is coupled, adjusts the line pressure to the optimum pressure (direct clutch pressure) and supplies it to the direct clutch. (In 2nd, 3rd, and 4th gears, adjusts the clutch pressure.)
TCC control valve TCC control plug TCC control sleeve	Switches the lock-up to operating or released. Also, by performing the lock-up operation transiently, lock-up smoothly.
Torque converter lubrication valve	Operates during lock-up to switch the torque converter, cooling, and lubrication system oil path.
Cool bypass valve	Allows excess oil to bypass cooler circuit without being fed into it.
Line pressure relief valve	Discharges excess oil from line pressure circuit.
N-D accumulator	Produces the stabilizing pressure for when N-D is selected.
Manual valve	Sends line pressure to each circuit according to the select position. The circuits to which the line pressure is not sent drain.

FUNCTION OF PRESSURE SWITCH

Name	Function
Pressure switch 2 (LC/B)	Detects any malfunction in the low coast brake hydraulic pressure. When it detects any malfunction, it puts the system into fail-safe mode.

A/T CONTROL SYSTEM

< FUNCTION DIAGNOSIS >

Component Parts Location

INFOID:000000001530995

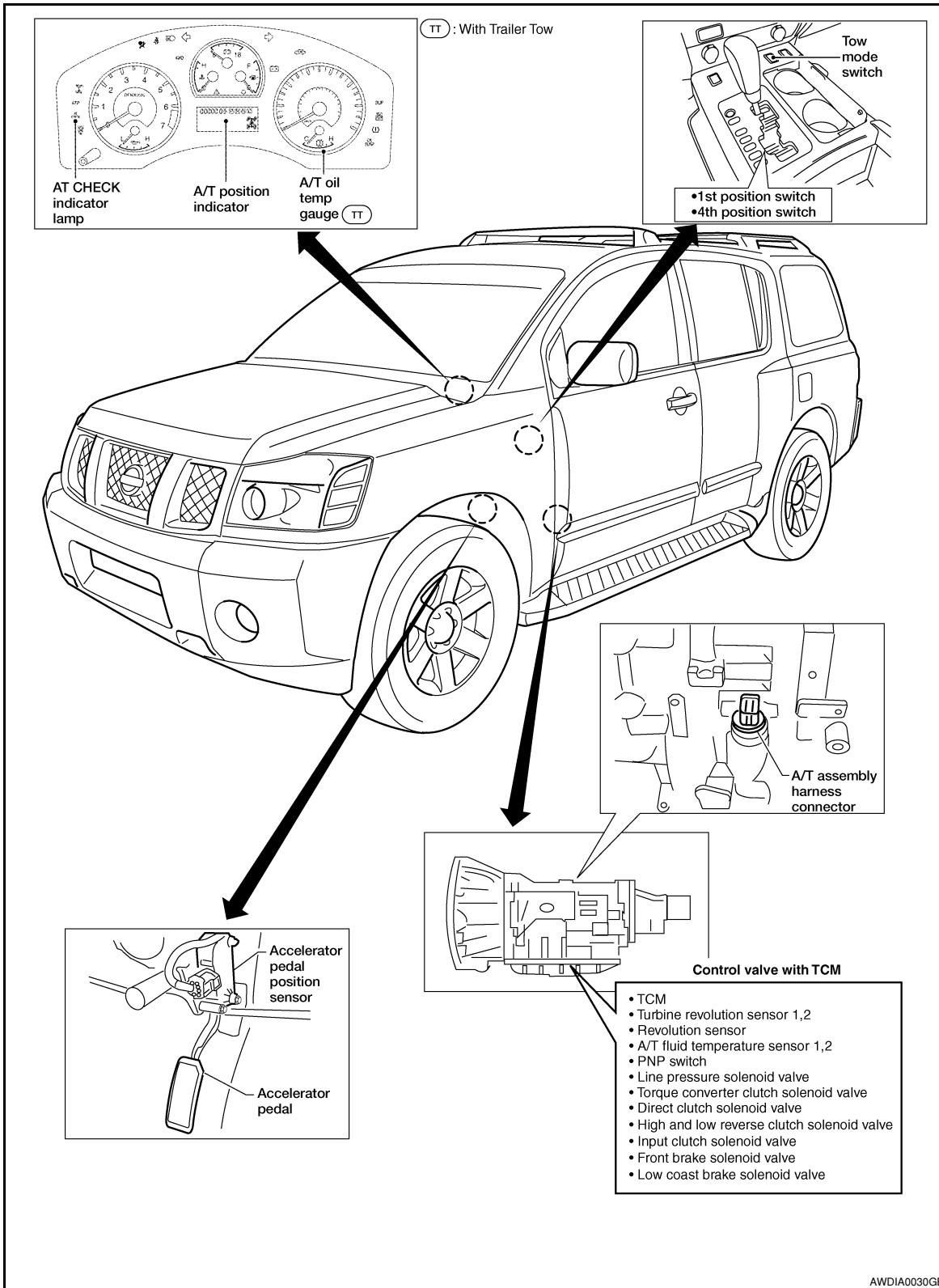

A
B
C
TM
E
F
G
H
I
J
K
L
M
N
O
P

A/T SHIFT LOCK SYSTEM

< FUNCTION DIAGNOSIS >

A/T SHIFT LOCK SYSTEM

System Description

INFOID:000000001611768

- The electrical key interlock mechanism also operates as a shift lock:
With the ignition switch turned to ON, the selector lever cannot be shifted from "P" (parking) to any other position unless the brake pedal is depressed.
With the key removed, the selector lever cannot be shifted from "P" to any other position.
The key cannot be removed unless the selector lever is placed in "P".
- The shift lock and key interlock mechanisms are controlled by the ON-OFF operation of the shift lock solenoid and by the operation of the rotator and slider located inside the key cylinder, respectively.

Component Parts Location

INFOID:000000001611767

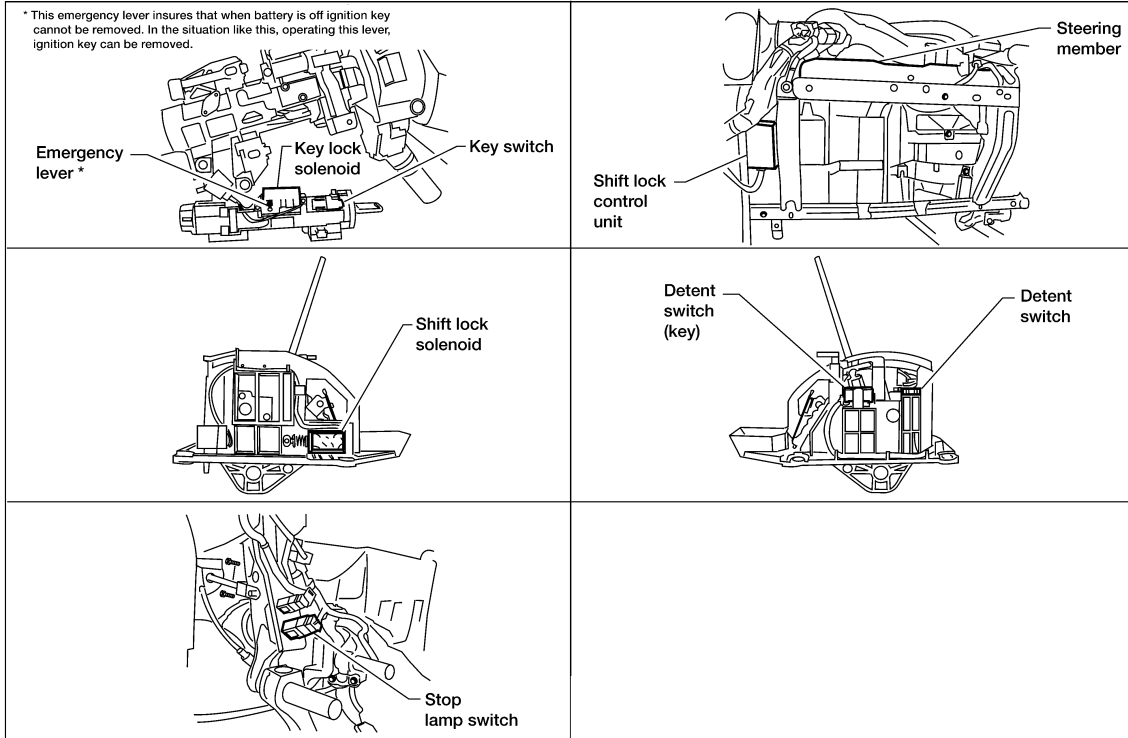

LCIA0326E

ON BOARD DIAGNOSTIC (OBD) SYSTEM

< FUNCTION DIAGNOSIS >

ON BOARD DIAGNOSTIC (OBD) SYSTEM

Introduction

INFOID:000000001530952

The A/T system has two self-diagnostic systems.

The first is the emission-related on board diagnostic system (OBD-II) performed by the TCM in combination with the ECM. The malfunction is indicated by the MIL (malfunction indicator lamp) and is stored as a DTC in the ECM memory but not the TCM memory.

The second is the TCM original self-diagnosis indicated by the A/T CHECK indicator lamp. The malfunction is stored in the TCM memory. The detected items are overlapped with OBD-II self-diagnostic items. For detail, refer to [TM-33. "CONSULT-III Function \(TRANSMISSION\)"](#).

OBD-II Function for A/T System

INFOID:000000001530953

The ECM provides emission-related on board diagnostic (OBD-II) functions for the A/T system. One function is to receive a signal from the TCM used with OBD-related parts of the A/T system. The signal is sent to the ECM when a malfunction occurs in the corresponding OBD-related part. The other function is to indicate a diagnostic result by means of the MIL (malfunction indicator lamp) on the instrument panel. Sensors, switches and solenoid valves are used as sensing elements.

The MIL automatically illuminates in One or Two Trip Detection Logic when a malfunction is sensed in relation to A/T system parts.

One or Two Trip Detection Logic of OBD-II

INFOID:000000001530954

ONE TRIP DETECTION LOGIC

If a malfunction is sensed during the first test drive, the MIL will illuminate and the malfunction will be stored in the ECM memory as a DTC. The TCM is not provided with such a memory function.

TWO TRIP DETECTION LOGIC

When a malfunction is sensed during the first test drive, it is stored in the ECM memory as a 1st trip DTC (diagnostic trouble code) or 1st trip freeze frame data. At this point, the MIL will not illuminate. — 1st Trip

If the same malfunction as that experienced during the first test drive is sensed during the second test drive, the MIL will illuminate. — 2nd Trip

The "Trip" in the "One or Two Trip Detection Logic" means a driving mode in which self-diagnosis is performed during vehicle operation.

OBD-II Diagnostic Trouble Code (DTC)

INFOID:000000001530955

HOW TO READ DTC AND 1ST TRIP DTC

DTC and 1st trip DTC can be read by the following methods.

( with **CONSULT-III** or ( **GST**) CONSULT-III or GST (Generic Scan Tool) Examples: P0705, P0720 etc.

These DTC are prescribed by SAE J2012.

(CONSULT-III also displays the malfunctioning component or system.)

- **1st trip DTC No. is the same as DTC No.**
- **Output of the diagnostic trouble code indicates that the indicated circuit has a malfunction. However, in case of the Mode II and GST, they do not indicate whether the malfunction is still occurring or occurred in the past and returned to normal.**
CONSULT-III can identify them as shown below, therefore, CONSULT-III (if available) is recommended.

Freeze Frame Data and 1st Trip Freeze Frame Data

The ECM has a memory function, which stores the driving condition such as fuel system status, calculated load value, engine coolant temperature, short term fuel trim, long term fuel trim, engine speed and vehicle speed at the moment the ECM detects a malfunction.

Data which are stored in the ECM memory, along with the 1st trip DTC, are called 1st trip freeze frame data, and the data, stored together with the DTC data, are called freeze frame data and displayed on CONSULT-III or GST. The 1st trip freeze frame data can only be displayed on the CONSULT-III screen, not on the GST. For detail, refer to [TM-31](#).

Only one set of freeze frame data (either 1st trip freeze frame data of freeze frame data) can be stored in the ECM. 1st trip freeze frame data is stored in the ECM memory along with the 1st trip DTC. There is no priority for 1st trip freeze frame data and it is updated each time a different 1st trip DTC is detected. However, once freeze frame data (2nd trip detection/MIL on) is stored in the ECM memory, 1st trip freeze frame data is no

ON BOARD DIAGNOSTIC (OBD) SYSTEM

< FUNCTION DIAGNOSIS >

longer stored. Remember, only one set of freeze frame data can be stored in the ECM. The ECM has the following priorities to update the data.

Priority	Items	
1	Freeze frame data	Misfire — DTC: P0300 - P0306 Fuel Injection System Function — DTC: P0171, P0172, P0174, P0175
2		Except the above items (Includes A/T related items)
3	1st trip freeze frame data	

Both 1st trip freeze frame data and freeze frame data (along with the DTC) are cleared when the ECM memory is erased.

HOW TO ERASE DTC

The diagnostic trouble code can be erased by CONSULT-III, GST or ECM DIAGNOSTIC TEST MODE as described following.

- **If the battery cable is disconnected, the diagnostic trouble code will be lost within 24 hours.**
- **When you erase the DTC, using CONSULT-III or GST is easier and quicker than switching the mode selector on the ECM.**

The following emission-related diagnostic information is cleared from the ECM memory when erasing DTC related to OBD-II. For details, refer to [EC-48. "Emission-related Diagnostic Information"](#).

- **Diagnostic trouble codes (DTC)**
- **1st trip diagnostic trouble codes (1st trip DTC)**
- **Freeze frame data**
- **1st trip freeze frame data**
- **System readiness test (SRT) codes**
- **Test values**

HOW TO ERASE DTC (WITH CONSULT-III)

1. The emission related diagnostic information in the TCM and ECM can be erased by selection of "ALL ERASE" in the "Description" of "FINAL CHECK" mode with CONSULT-III.

HOW TO ERASE DTC (WITH GST)

1. If the ignition switch stays "ON" after repair work, be sure to turn ignition switch "OFF" once. Wait at least 10 seconds and then turn it "ON" (engine stopped) again.
2. Select Mode 4 with the Generic Scan Tool (GST). For details refer to [EC-78. "Generic Scan Tool \(GST\) Function"](#).

HOW TO ERASE DTC (NO TOOLS)

1. Disconnect battery for 24 hours.
2. Reconnect battery.

Malfunction Indicator Lamp (MIL)

INFOID:000000001530956

DESCRIPTION

The MIL is located on the instrument panel.

1. The MIL will light up when the ignition switch is turned "ON" without the engine running. This is a bulb check.
 - If the MIL does not light up, refer to [EC-60. "Malfunction Indicator Lamp \(MIL\)"](#).
2. When the engine is started, the MIL should go off. If the MIL remains on, the on board diagnostic system has detected an engine system malfunction.

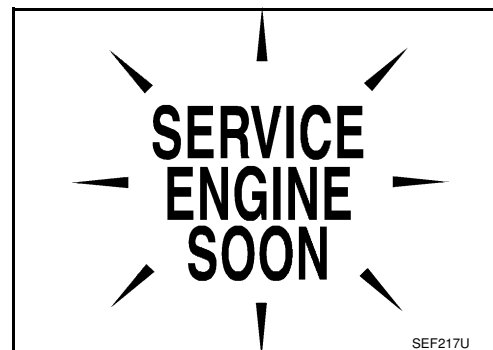

DIAGNOSIS SYSTEM (TCM)

< FUNCTION DIAGNOSIS >

DIAGNOSIS SYSTEM (TCM)

CONSULT-III Function (TRANSMISSION)

INFOID:000000001532061

CONSULT-III can display each diagnostic item using the diagnostic test modes shown following.

TCM diagnostic mode	Description
WORK SUPPORT	Supports inspections and adjustments. Commands are transmitted to the TCM for setting the status suitable for required operation, input/output signals are received from the TCM and received data is displayed.
SELF-DIAG RESULTS	Displays TCM self-diagnosis results.
DATA MONITOR	Displays TCM input/output data in real time.
CAN DIAG SUPPORT MNTR	The result of transmit/receive diagnosis of CAN communication can be read.
ACTIVE TEST	Operation of electrical loads can be checked by sending drive signal to them.
FUNCTION TEST	Conducted by CONSULT-III instead of a technician to determine whether each system is "OK" or "NG".
ECU PART NUMBER	TCM part number can be read.

SELF-DIAGNOSTIC RESULT MODE

Operation Procedure

After performing SELF-DIAGNOSTIC RESULT MODE, place check marks for results on the [TM-7. "Diagnostic Work Sheet"](#). Reference pages are provided following the items.

Display Items List

X: Applicable, —: Not applicable

Items (CONSULT-III screen terms)	Malfunction is detected when...	TCM self-diagnosis	OBD-II (DTC)	Reference page
		"TRANSMISSION" with CONSULT-III	MIL indicator lamp*1, "ENGINE" with CONSULT-III or GST	
CAN COMM CIRCUIT	<ul style="list-style-type: none"> When a malfunction is detected in CAN communications 	U1000	U1000	TM-39
STARTER RELAY/ CIRC	<ul style="list-style-type: none"> If this signal is ON other than in P or N position, this is judged to be a malfunction. (And if it is OFF in P or N position, this too is judged to be a malfunction.) 	P0615	—	TM-40
TCM	<ul style="list-style-type: none"> TCM is malfunctioning. 	P0700	P0700	TM-43
PNP SW/CIRC	<ul style="list-style-type: none"> PNP switch 1-4 signals input with impossible pattern "P" position is detected from N position without any other position being detected in between. 	P0705	P0705	TM-44
TURBINE REV S/CIRC	<ul style="list-style-type: none"> TCM does not receive the proper voltage signal from the sensor. TCM detects an irregularity only at position of 4th gear for turbine revolution sensor 2. 	P0717	P0717	TM-47
VEH SPD SEN/CIR AT (Revolution sensor)	<ul style="list-style-type: none"> Signal from vehicle speed sensor A/T (Revolution sensor) not input due to cut line or the like Unexpected signal input during running After ignition switch is turned ON, unexpected signal input from vehicle speed sensor MTR before the vehicle starts moving 	P0720	P0720	TM-50
ENGINE SPEED SIG	<ul style="list-style-type: none"> TCM does not receive the CAN communication signal from the ECM. 	P0725	—	TM-52
A/T 1ST GR FNCTN	<ul style="list-style-type: none"> A/T cannot shift to 1st gear 	P0731	P0731	TM-55
A/T 2ND GR FNCTN	<ul style="list-style-type: none"> A/T cannot shift to 2nd gear 	P0732	P0732	TM-57

DIAGNOSIS SYSTEM (TCM)

< FUNCTION DIAGNOSIS >

Items (CONSULT-III screen terms)	Malfunction is detected when...	TCM self-diagnosis	OBD-II (DTC)	Reference page
		"TRANSMISSION" with CONSULT-III	MIL indicator lamp*1, "ENGINE" with CONSULT-III or GST	
A/T 3RD GR FNCTN	<ul style="list-style-type: none"> A/T cannot shift to 3rd gear 	P0733	P0733	TM-59
A/T 4TH GR FNCTN	<ul style="list-style-type: none"> A/T cannot shift to 4th gear 	P0734	P0734	TM-61
A/T 5TH GR FNCTN	<ul style="list-style-type: none"> A/T cannot shift to 5th gear 	P0735	P0735	TM-63
TCC SOLENOID/CIRC	<ul style="list-style-type: none"> Normal voltage not applied to solenoid due to cut line, short, or the like 	P0740	P0740	TM-64
A/T TCC S/V FNCTN	<ul style="list-style-type: none"> A/T cannot perform lock-up even if electrical circuit is good. TCM detects as irregular by comparing difference value with slip rotation. 	P0744	P0744*2	TM-67
L/PRESS SOL/CIRC	<ul style="list-style-type: none"> Normal voltage not applied to solenoid due to cut line, short, or the like TCM detects as irregular by comparing target value with monitor value. 	P0745	P0745	TM-68
TP SEN/CIRC A/T	<ul style="list-style-type: none"> TCM does not receive the proper accelerator pedal position signals (input by CAN communication) from ECM. 	P1705	P1705	TM-70
ATF TEMP SEN/CIRC	<ul style="list-style-type: none"> During running, the ATF temperature sensor signal voltage is excessively high or low 	P1710	P0710	TM-72
VEH SPD SE/CIR·MTR	<ul style="list-style-type: none"> Signal (CAN communication) from vehicle speed sensor MTR not input due to cut line or the like Unexpected signal input during running 	P1721	—	TM-76
A/T INTERLOCK	<ul style="list-style-type: none"> Except during shift change, the gear position and ATF pressure switch states are monitored and comparative judgement made. 	P1730	P1730	TM-78
A/T 1ST E/BRAKING	<ul style="list-style-type: none"> Each ATF pressure switch and solenoid current is monitored and if a pattern is detected having engine braking 1st gear other than in the "1" position, a malfunction is detected. 	P1731	—	TM-80
I/C SOLENOID/CIRC	<ul style="list-style-type: none"> Normal voltage not applied to solenoid due to functional malfunction, cut line, short, or the like TCM detects as irregular by comparing target value with monitor value. 	P1752	P1752	TM-82
FR/B SOLENOID/CIRC	<ul style="list-style-type: none"> Normal voltage not applied to solenoid due to functional malfunction, cut line, short, or the like TCM detects as irregular by comparing target value with monitor value. 	P1757	P1757	TM-84
D/C SOLENOID/CIRC	<ul style="list-style-type: none"> Normal voltage not applied to solenoid due to cut line, short, or the like TCM detects as irregular by comparing target value with monitor value. 	P1762	P1762	TM-86
HLR/C SOL/CIRC	<ul style="list-style-type: none"> Normal voltage not applied to solenoid due to functional malfunction, cut line, short, or the like TCM detects as irregular by comparing target value with monitor value. 	P1767	P1767	TM-88
LC/B SOLENOID/CIRC	<ul style="list-style-type: none"> Normal voltage not applied to solenoid due to functional malfunction, cut line, short, or the like 	P1772	P1772	TM-90

DIAGNOSIS SYSTEM (TCM)

< FUNCTION DIAGNOSIS >

Items (CONSULT-III screen terms)	Malfunction is detected when...	TCM self-diagnosis	OBD-II (DTC)	Reference page
		"TRANSMISSION" with CONSULT-III	MIL indicator lamp*1, "ENGINE" with CONSULT-III or GST	
LC/B SOLENOID FNCT	<ul style="list-style-type: none"> TCM detects an improper voltage drop when it tries to operate the solenoid valve. Condition of ATF pressure switch 2 is different from monitor value, and relation between gear position and actual gear ratio is irregular. 	P1774	P1774*2	TM-93
NO DTC IS DETECTED FURTHER TESTING MAY BE REQUIRED	<ul style="list-style-type: none"> No NG item has been detected. 	X	X	

*1: Refer to [EC-60. "Malfunction Indicator Lamp \(MIL\)"](#).

*2: These malfunctions cannot be displayed MIL if another malfunction is assigned to MIL.

DATA MONITOR MODE

Display Items List

X: Standard, —: Not applicable

Monitored item (Unit)	Monitor Item Selection			Remarks
	ECU INPUT SIGNALS	MAIN SIGNALS	SELECTION FROM MENU	
VHCL/S SE·A/T (km/h)	X	X	X	Revolution sensor
VHCL/S SE·MTR (km/h)	X	—	X	
ACCELE POSI (0.0/8)	X	—	X	Accelerator pedal position signal
THROTTLE POSI (0.0/8)	X	X	X	Degree of opening for accelerator recognized by the TCM For fail-safe operation, the specific value used for control is displayed.
CLSD THL POS (ON-OFF display)	X	—	X	Signal input with CAN communications
W/O THL POS (ON-OFF display)	X	—	X	
BRAKE SW (ON-OFF display)	X	—	X	Stop lamp switch
GEAR	—	X	X	Gear position recognized by the TCM updated after gear-shifting
ENGINE SPEED (rpm)	X	X	X	
TURBINE REV (rpm)	X	X	X	
OUTPUT REV (rpm)	X	X	X	
GEAR RATIO	—	X	X	
TC SLIP SPEED (rpm)	—	X	X	Difference between engine speed and torque converter input shaft speed
F SUN GR REV (rpm)	—	—	X	
F CARR GR REV (rpm)	—	—	X	
ATF TEMP SE 1 (V)	X	—	X	
ATF TEMP SE 2 (V)	X	—	X	
ATF TEMP 1 (°C)	—	X	X	
ATF TEMP 2 (°C)	—	X	X	
BATTERY VOLT (V)	X	—	X	
ATF PRES SW 2 (ON-OFF display)	X	X	X	(for LC/B solenoid)

DIAGNOSIS SYSTEM (TCM)

< FUNCTION DIAGNOSIS >

Monitored item (Unit)	Monitor Item Selection			Remarks
	ECU INPUT SIGNALS	MAIN SIGNALS	SELECTION FROM MENU	
PNP SW 1 (ON-OFF display)	X	—	X	
PNP SW 2 (ON-OFF display)	X	—	X	
PNP SW 3 (ON-OFF display)	X	—	X	
PNP SW 4 (ON-OFF display)	X	—	X	
SLCT LVR POSI	—	X	X	Selector lever position is recognized by the TCM. For fail-safe operation, the specific value used for control is displayed.
1 POSITION SW (ON-OFF display)	X	—	X	1st position switch
OD CONT SW (ON-OFF display)	X	—	X	4th position switch
POWERSHIFT SW (ON-OFF display)	X	—	X	Not mounted but displayed.
HOLD SW (ON-OFF display)	X	—	X	
MANU MODE SW (ON-OFF display)	X	—	X	
NON M-MODE SW (ON-OFF display)	X	—	X	
UP SW LEVER (ON-OFF display)	X	—	X	
DOWN SW LEVER (ON-OFF display)	X	—	X	
SFT UP ST SW (ON-OFF display)	—	—	X	
SFT DWN ST SW (ON-OFF display)	—	—	X	
ASCD-OD CUT (ON-OFF display)	—	—	X	ICC (Intelligent cruise control)
ASCD-CRUISE (ON-OFF display)	—	—	X	
ABS SIGNAL (ON-OFF display)	—	—	X	
ACC OD CUT (ON-OFF display)	—	—	X	
ACC SIGNAL (ON-OFF display)	—	—	X	
TCS GR/P KEEP (ON-OFF display)	—	—	X	
TCS SIGNAL 2 (ON-OFF display)	—	—	X	
TCS SIGNAL 1 (ON-OFF display)	—	—	X	
TCC SOLENOID (A)	—	X	X	
LINE PRES SOL (A)	—	X	X	
I/C SOLENOID (A)	—	X	X	
FR/B SOLENOID (A)	—	X	X	
D/C SOLENOID (A)	—	X	X	
HLR/C SOL (A)	—	X	X	
ON OFF SOL (ON-OFF display)	—	—	X	LC/B solenoid
TCC SOL MON (A)	—	—	X	
L/P SOL MON (A)	—	—	X	
I/C SOL MON (A)	—	—	X	
FR/B SOL MON (A)	—	—	X	
D/C SOL MON (A)	—	—	X	
HLR/C SOL MON (A)	—	—	X	
ONOFF SOL MON (ON-OFF display)	—	—	X	LC/B solenoid
P POSI IND (ON-OFF display)	—	—	X	
R POSI IND (ON-OFF display)	—	—	X	
N POSI IND (ON-OFF display)	—	—	X	

DIAGNOSIS SYSTEM (TCM)

< FUNCTION DIAGNOSIS >

Monitored item (Unit)	Monitor Item Selection			Remarks	
	ECU IN-PUT SIG-NALS	MAIN SIG-NALS	SELEC-TION FROM MENU		
D POSI IND (ON-OFF display)	—	—	X		A
4TH POSI IND (ON-OFF display)	—	—	X		B
3RD POSI IND (ON-OFF display)	—	—	X		C
2ND POSI IND (ON-OFF display)	—	—	X		
1ST POSI IND (ON-OFF display)	—	—	X		TM
MANU MODE IND (ON-OFF display)	—	—	X	Not mounted but displayed.	
POWER M LAMP (ON-OFF display)	—	—	X		
F-SAFE IND/L (ON-OFF display)	—	—	X		E
ATF WARN LAMP (ON-OFF display)	—	—	X		
BACK-UP LAMP (ON-OFF display)	—	—	X		F
STARTER RELAY (ON-OFF display)	—	—	X		
PNP SW3 MON (ON-OFF display)	—	—	X		
C/V CLB ID1	—	—	X		G
C/V CLB ID2	—	—	X		
C/V CLB ID3	—	—	X		H
UNIT CLB ID1	—	—	X		
UNIT CLB ID2	—	—	X		I
UNIT CLB ID3	—	—	X		
TRGT GR RATIO	—	—	X		
TRGT PRES TCC (kPa)	—	—	X		J
TRGT PRES L/P (kPa)	—	—	X		
TRGT PRES I/C (kPa)	—	—	X		K
TRGT PRE FR/B (kPa)	—	—	X		
TRGT PRES D/C (kPa)	—	—	X		L
TRG PRE HLR/C (kPa)	—	—	X		
SHIFT PATTERN	—	—	X		M
DRV CST JUDGE	—	—	X		
START RLY MON	—	—	X		N
NEXT GR POSI	—	—	X		
SHIFT MODE	—	—	X		O
MANU GR POSI	—	—	X		
VEHICLE SPEED (km/h)	—	X	X	Vehicle speed recognized by the TCM.	
Voltage (V)	—	—	X	Displays the value measured by the voltage probe.	P
Frequency (Hz)	—	—	X	The value measured by the pulse probe is displayed.	
DUTY-HI (high) (%)	—	—	X		
DUTY-LOW (low) (%)	—	—	X		
PLS WIDTH-HI (ms)	—	—	X		
PLS WIDTH-LOW (ms)	—	—	X		

DTC WORK SUPPORT MODE

Display Items List

DIAGNOSIS SYSTEM (TCM)

< FUNCTION DIAGNOSIS >

DTC work support item	Description	Check item
1ST GR FUNCTN P0731	Following items for "" be confirmed. • Self-diagnosis status (whether the diagnosis is being performed or not) • Self-diagnosis result (OK or NG)	<ul style="list-style-type: none"> • Input clutch solenoid valve • Front brake solenoid valve • Direct clutch solenoid valve • High and low reverse clutch solenoid valve • Each clutch • Hydraulic control circuit valve
2ND GR FUNCTN P0732	Following items for "" be confirmed. • Self-diagnosis status (whether the diagnosis is being performed or not) • Self-diagnosis result (OK or NG)	
3RD GR FUNCTN P0733	Following items for "" be confirmed. • Self-diagnosis status (whether the diagnosis is being performed or not) • Self-diagnosis result (OK or NG)	
4TH GR FUNCTN P0734	Following items for "" be confirmed. • Self-diagnosis status (whether the diagnosis is being performed or not) • Self-diagnosis result (OK or NG)	
5TH GR FUNCTN P0735	Following items for "" be confirmed. • Self-diagnosis status (whether the diagnosis is being performed or not) • Self-diagnosis result (OK or NG)	

DTC U1000 CAN COMMUNICATION LINE

< COMPONENT DIAGNOSIS >

COMPONENT DIAGNOSIS

DTC U1000 CAN COMMUNICATION LINE

Description

INFOID:000000001530431

CAN (Controller Area Network) is a serial communication line for real time application. It is an on-vehicle multiplex communication line with high data communication speed and excellent malfunction detection ability. Many electronic control units are equipped onto a vehicle, and each control unit shares information and links with other control units during operation (not independent). In CAN communication, control units are connected with 2 communication lines (CAN H line, CAN L line) allowing a high rate of information transmission with less wiring. Each control unit transmits/receives data but selectively reads required data only.

On Board Diagnosis Logic

INFOID:000000001530432

- This is an OBD-III self-diagnostic item.
- Diagnostic trouble code "U1000 CAN COMM CIRCUIT" with CONSULT-III is detected when TCM cannot communicate to other control units.

Possible Cause

INFOID:000000001530433

Harness or connectors
(CAN communication line is open or shorted.)

DTC Confirmation Procedure

INFOID:000000001530434

NOTE:

If "DTC Confirmation Procedure" has been previously performed, always turn ignition switch "OFF" and wait at least 10 seconds before performing the next test.

After the repair, perform the following procedure to confirm the malfunction is eliminated.

④ WITH CONSULT-III

1. Turn ignition switch "ON". (Do not start engine.)
2. Select "DATA MONITOR" mode for "ENGINE" with CONSULT-III.
3. Start engine and wait for at least 6 seconds.
4. If DTC is detected, go to [TM-39, "Diagnosis Procedure"](#).

④ WITH GST

Follow the procedure "WITH CONSULT-III".

Diagnosis Procedure

INFOID:000000001530436

1. CHECK CAN COMMUNICATION CIRCUIT

④ With CONSULT-III

1. Turn ignition switch "ON" and start engine.
2. Select "SELF-DIAG RESULTS" mode for "TRANSMISSION" with CONSULT-III.

Is any malfunction of the "CAN COMM CIRCUIT" indicated?

YES >> Print out CONSULT-III screen, GO TO LAN section. Refer to [LAN-14, "Trouble Diagnosis Flow Chart"](#).

NO >> **INSPECTION END**

DTC P0615 START SIGNAL CIRCUIT

< COMPONENT DIAGNOSIS >

DTC P0615 START SIGNAL CIRCUIT

Description

INFOID:000000001530437

- TCM prohibits cranking other than at “P” or “N” position.

CONSULT-III Reference Value in Data Monitor Mode

INFOID:000000001530438

Item name	Condition	Display value
STARTER RELAY	Selector lever in “N”, “P” position.	ON
	Selector lever in other position.	OFF

On Board Diagnosis Logic

INFOID:000000001530439

- This is not an OBD-II self-diagnostic item.
- Diagnostic trouble code “P0615 STARTER RELAY/CIRC” with CONSULT-III is detected when park/neutral (PNP) relay (starter relay) is switched “ON” other than at “P” or “N” position. (Or when switched “OFF” at “P” or “N” position).

Possible Cause

INFOID:000000001530440

- Harness or connectors
[The park/neutral position (PNP) relay (starter relay) and TCM circuit is open or shorted.]
- Park/neutral position (PNP) relay (starter relay)

DTC Confirmation Procedure

INFOID:000000001530441

NOTE:

If “DTC Confirmation Procedure” has been previously performed, always turn ignition switch “OFF” and wait at least 10 seconds before performing the next test.

After the repair, perform the following procedure to confirm the malfunction is eliminated.

④ WITH CONSULT-III

1. Turn ignition switch “ON”. (Do not start engine.)
2. Select “DATA MONITOR” mode for “TRANSMISSION” with CONSULT-III.
3. Start engine.
4. Drive vehicle for at least 2 consecutive seconds.
5. If DTC is detected, go to [TM-40, "Diagnosis Procedure"](#).

Diagnosis Procedure

INFOID:000000001530443

1. CHECK STARTER RELAY

④ With CONSULT-III

1. Turn ignition switch “ON”. (Do not start engine.)
2. Select “SELECTION FROM MENU” in “DATA MONITOR” mode for “TRANSMISSION” with CONSULT-III and check monitor “STARTER RELAY” ON/OFF.

Item name	Condition	Display value
STARTER RELAY	Selector lever in “N”, “P” positions.	ON
	Selector lever in other positions.	OFF

⊗ Without CONSULT-III

DTC P0615 START SIGNAL CIRCUIT

< COMPONENT DIAGNOSIS >

1. Turn ignition switch "ON". (Do not start engine.)
2. Check voltage between the IPDM E/R connector and ground.

Item	Connector	Terminal	Shift position	Voltage (Approx.)
Starter relay	E122	48	Ground	Battery voltage
			"N" and "P"	0V

OK or NG

- OK >> GO TO 5.
 NG >> GO TO 2.

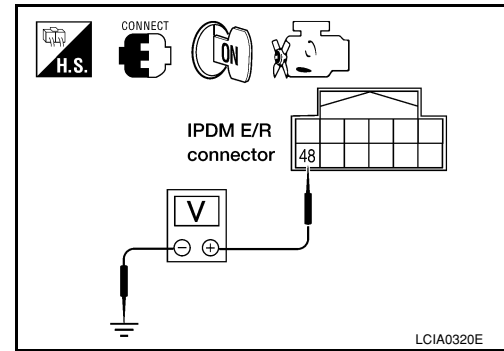

2. CHECK HARNESS BETWEEN A/T ASSEMBLY HARNESS CONNECTOR AND IPDM E/R CONECTOR.

1. Turn ignition switch OFF.
2. Disconnect A/T assembly harness connector and IPDM E/R connector.

Item	Connector	Terminal	Continuity
A/T assembly harness connector	F9	9	Yes
IPDM E/R connector	E122	48	

3. Check continuity between A/T assembly harness connector and IPDM E/R connector.
4. If OK, check harness for short to ground and short to power.
5. Reinstall any part removed.

OK or NG

- OK >> GO TO 3.
 NG >> Repair open circuit or short to ground or short to power in harness or connectors.

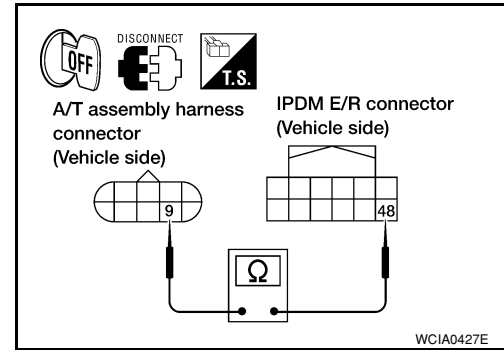

3. CHECK TERMINAL CORD ASSEMBLY

1. Remove control valve with TCM. Refer to [TM-217, "Control Valve with TCM and A/T Fluid Temperature Sensor 2"](#)
2. Disconnect A/T assembly harness connector and TCM connector.
3. Check continuity between A/T assembly harness connector terminal and TCM connector terminal.

Item	Connector	Terminal	Continuity
A/T assembly harness connector	F9	9	Yes
TCM connector	F502	8	

4. If OK, check harness for short to ground and short to power.
5. Reinstall any part removed.

OK or NG

- OK >> GO TO 4.
 NG >> Replace open circuit or short to ground and short to power in harness or connectors.

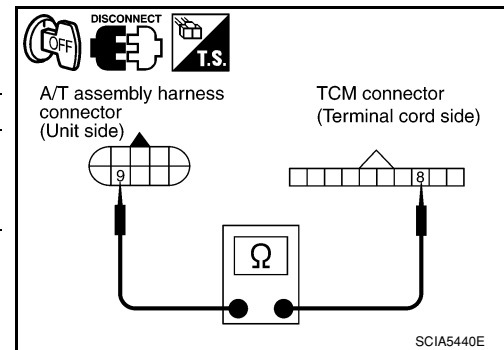

4. DETECT MALFUNCTIONING ITEM

Check the following items:

- Starter relay, Refer to [STR-7, "System Description"](#).
- IPDM E/R, Refer to [PCS-19, "Physical Values"](#).

OK or NG

- OK >> Replace the control valve with TCM. Refer to [TM-217, "Control Valve with TCM and A/T Fluid Temperature Sensor 2"](#).
- NG >> Repair or replace damaged parts.

5. CHECK DTC

Perform "DTC Confirmation Procedure".

DTC P0615 START SIGNAL CIRCUIT

< COMPONENT DIAGNOSIS >

- Refer to [TM-40. "DTC Confirmation Procedure"](#).

OK or NG

OK >> **INSPECTION END**
NG >> GO TO 2.

DTC P0700 TCM

< COMPONENT DIAGNOSIS >

DTC P0700 TCM

Description

INFOID:000000001530444

The TCM consists of a microcomputer and connectors for signal input and output and for power supply. The TCM controls the A/T.

On Board Diagnosis Logic

INFOID:000000001530445

- This is an OBD-II self-diagnostic item.
- Diagnostic trouble code "P0700 TCM" with CONSULT-III is detected when the TCM is malfunctioning.

Possible Cause

INFOID:000000001530446

TCM.

DTC Confirmation Procedure

INFOID:000000001530447

NOTE:

If "DTC Confirmation Procedure" has been previously performed, always turn ignition switch "OFF" and wait at least 10 seconds before performing the next test.

After the repair, perform the following procedure to confirm the malfunction is eliminated.

④ WITH CONSULT-III

1. Turn ignition switch "ON". (Do not start engine.)
2. Select "DATA MONITOR" mode for "TRANSMISSION" with CONSULT-III.
3. Start engine.
4. Run engine for at least 2 consecutive seconds at idle speed.
5. If DTC is detected, go to [TM-43. "Diagnosis Procedure"](#).

④ WITH GST

Follow the procedure "With CONSULT-III".

Diagnosis Procedure

INFOID:000000001530448

1. CHECK DTC

④ With CONSULT-III

1. Turn ignition switch "ON". (Do not start engine.)
2. Select "SELF DIAG RESULTS" mode for "TRANSMISSION" with CONSULT-III.
3. Touch "ERASE".
4. Turn ignition switch "OFF" and wait at least 10 seconds.
5. Perform DTC Confirmation Procedure, [TM-43. "DTC Confirmation Procedure"](#).

Is the "TCM" displayed again?

YES >> Replace the control valve with TCM. Refer to [TM-217. "Control Valve with TCM and A/T Fluid Temperature Sensor 2"](#).

NO >> **INSPECTION END**

DTC P0705 PARK/NEUTRAL POSITION SWITCH

< COMPONENT DIAGNOSIS >

DTC P0705 PARK/NEUTRAL POSITION SWITCH

Description

INFOID:000000001530453

- The park/neutral position (PNP) switch includes a transmission position switch.
- The transmission range switch detects the selector lever position and sends a signal to the TCM.

CONSULT-III Reference Value in Data Monitor Mode

INFOID:000000001530454

Item name	Condition	Display value
SLCTLVR POSI	Selector lever in "N","P" positions.	N/P
	Selector lever in "R" position.	R
	Selector lever in "D" position.	D
	Selector lever in "4" position.	4
	Selector lever in "3" position.	3
	Selector lever in "2" position.	2
	Selector lever in "1" position.	1

On Board Diagnosis Logic

INFOID:000000001530455

- This is an OBD-II self-diagnostic item.
- Diagnostic trouble code "P0705 PNP SW/CIRC" with CONSULT-III is detected under the following conditions.
 - When TCM does not receive the correct voltage signal from the PNP switch 1, 2, 3, 4 based on the gear position.
 - When no other position but "P" position is detected from "N" positions.

Possible Cause

INFOID:000000001530456

- Harness or connectors
[The park/neutral position (PNP) switch 1, 2, 3, 4 and TCM circuit is open or shorted.]
- Park/neutral position (PNP) switch 1, 2, 3, 4

DTC Confirmation Procedure

INFOID:000000001530457

CAUTION:

Always drive vehicle at a safe speed.

NOTE:

If "DTC Confirmation Procedure" has been previously performed, always turn ignition switch "OFF" and wait at least 10 seconds before performing the next test.

After the repair, perform the following procedure to confirm the malfunction is eliminated.

WITH CONSULT-III

1. Turn ignition switch "ON". (Do not start engine.)
2. Select "DATA MONITOR" mode for "ENGINE" with CONSULT-III.
3. Start engine.
4. Drive vehicle and maintain the following conditions for at least 2 consecutive seconds.
THRTL POS SEN: More than 1.2V
5. If DTC is detected, go to [TM-44. "Diagnosis Procedure"](#).

WITH GST

Follow the procedure "With CONSULT-III".

Diagnosis Procedure

INFOID:000000001530459

1. CHECK PNP SW CIRCUIT

With CONSULT-III

1. Turn ignition switch "ON". (Do not start engine.)

DTC P0705 PARK/NEUTRAL POSITION SWITCH

< COMPONENT DIAGNOSIS >

2. Select "SELECTION FROM MENU" in "DATA MONITOR" mode for "TRANSMISSION" with CONSULT-III.
3. Check if correct selector lever position (N/P, R or D) is displayed as selector lever is moved into each position.

Item name	Condition	Display value
SLCTLVR POSI	Selector lever in "N", "P" positions.	N/P
	Selector lever in "R" position.	R
	Selector lever in "D" position.	D
	Selector lever in "4" position.	4
	Selector lever in "3" position.	3
	Selector lever in "2" position.	2
	Selector lever in "1" position.	1

OK or NG

- OK >> GO TO 5.
- NG >> GO TO 2.

2. CHECK TCM POWER SUPPLY AND GROUND CIRCUIT

Perform TCM power supply and ground circuit. Refer to [TM-94, "Diagnosis Procedure"](#).

OK or NG

- OK >> GO TO 3.
- NG >> Repair or replace damaged parts.

3. DETECT MALFUNCTIONING ITEM

Check the following items:

- A/T assembly harness connector pin terminals for damage or loose connection with harness connector.

OK or NG

- OK >> GO TO 4.
- NG >> Repair or replace damaged parts.

4. CHECK SUB-HARNESS

1. Remove control valve with TCM. Refer to [TM-217, "Control Valve with TCM and A/T Fluid Temperature Sensor 2"](#).
2. Disconnect park/neutral position switch connector and TCM connector.
3. Check continuity between park/neutral position switch connector terminals and TCM connector terminals.

Item	Connector	Terminal	Continuity
Park/neutral position switch connector	F505	1	Yes
TCM connector	F503	13	
Park/neutral position switch connector	F505	2	
TCM connector	F503	11	
Park/neutral position switch connector	F505	3	Yes
TCM connector	F503	12	
Park/neutral position switch connector	F505	5	Yes
TCM connector	F503	14	

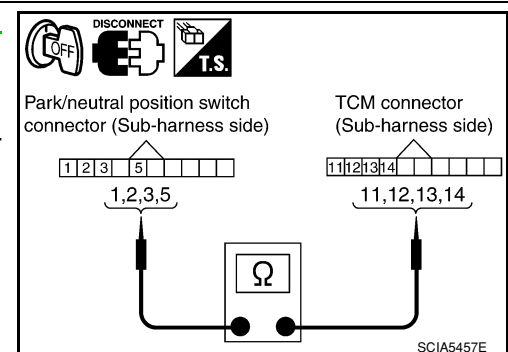

4. If OK, check harness for short to ground and short to power.
5. Reinstall any part removed.

OK or NG

DTC P0705 PARK/NEUTRAL POSITION SWITCH

< COMPONENT DIAGNOSIS >

- OK >> Replace the control valve with TCM. Refer to [TM-217. "Control Valve with TCM and A/T Fluid Temperature Sensor 2"](#).
- NG >> Replace open circuit or short to ground and short to power in harness or connectors.

5.CHECK DTC

Perform "DTC Confirmation Procedure".

- Refer to [TM-44. "DTC Confirmation Procedure"](#).

OK or NG

- OK >> **INSPECTION END**
- NG >> GO TO 2.

DTC P0717 TURBINE REVOLUTION SENSOR

< COMPONENT DIAGNOSIS >

DTC P0717 TURBINE REVOLUTION SENSOR

Description

INFOID:000000001530460

The turbine revolution sensor detects input shaft rpm (revolutions per minute). It is located on the input side of the automatic transmission. Monitors revolution of sensor 1 and sensor 2 for non-standard conditions.

CONSULT-III Reference Value in Data Monitor Mode

INFOID:000000001530461

Item name	Condition	Display value (rpm)
TURBINE REV	During driving (lock-up ON)	Approximately matches the engine speed.

On Board Diagnosis Logic

INFOID:000000001530462

- This is an OBD-II self-diagnostic item.
- Diagnostic trouble code “P0717 TURBINE REV S/CIRC” with CONSULT-III is detected under the following conditions.
 - When TCM does not receive the proper voltage signal from the sensor.
 - When TCM detects an irregularity only at position of 4th gear for turbine revolution sensor 2.

Possible Cause

INFOID:000000001530463

- Harness or connectors
(The sensor circuit is open or shorted.)
- Turbine revolution sensor 1, 2

DTC Confirmation Procedure

INFOID:000000001530464

CAUTION:

Always drive vehicle at a safe speed.

NOTE:

If “DTC Confirmation Procedure” has been previously performed, always turn ignition switch “OFF” and wait at least 10 seconds before performing the next test.

After the repair, perform the following procedure to confirm the malfunction is eliminated.

④ WITH CONSULT-III

1. Turn ignition switch “ON”. (Do not start engine.)
2. Select “DATA MONITOR” mode for “TRANSMISSION” with CONSULT-III.
3. Start engine and maintain the following conditions for at least 5 consecutive seconds.
 - VHCL SPEED SE: 40 km/h (25 MPH) or more**
 - ENGINE SPEED: 1,500 rpm or more**
 - ACCELE POS: 0.5/8 or more**
 - Selector lever: “D” position**
 - Gear position (Turbine revolution sensor 1): 4th or 5th position**
 - Gear position (Turbine revolution sensor 2): All position**
 - Driving location: Driving the vehicle uphill (increased engine load) will help maintain the driving conditions required for this test.**
4. If DTC is detected, go to [TM-47, "Diagnosis Procedure"](#).

④ WITH GST

Follow the procedure “With CONSULT-III”.

Diagnosis Procedure

INFOID:000000001530465

1. CHECK INPUT SIGNAL

④ With CONSULT-III

1. Start engine.
2. Select “ECU INPUT SIGNALS” in “DATA MONITOR” mode for “TRANSMISSION” with CONSULT-III.
3. Vehicle start and read out the value of “TURBINE REV”.

DTC P0717 TURBINE REVOLUTION SENSOR

< COMPONENT DIAGNOSIS >

Item name	Condition	Display value (rpm)
TURBINE REV	During driving (lock-up ON)	Approximately matches the engine speed.

OK or NG

- OK >> GO TO 4.
- NG >> GO TO 2.

2. CHECK TCM POWER SUPPLY AND GROUND CIRCUIT

Check TCM power supply and ground circuit. Refer to [TM-94, "Diagnosis Procedure"](#).

OK or NG

- OK >> GO TO 3.
- NG >> Repair or replace damaged parts.

3. DETECT MALFUNCTIONING ITEM

Check the following items:

- The A/T assembly harness connector pin terminals for damage or loose connection with harness connector.

OK or NG

- OK >> Replace the control valve with TCM. Refer to [TM-217, "Control Valve with TCM and A/T Fluid Temperature Sensor 2"](#).
- NG >> Repair or replace damaged parts.

4. CHECK DTC

Perform "DTC Confirmation Procedure".

- Refer to [TM-47, "DTC Confirmation Procedure"](#).

OK or NG

- OK >> **INSPECTION END**
- NG >> GO TO 2.

DTC P0720 VEHICLE SPEED SENSOR A/T (REVOLUTION SENSOR)

< COMPONENT DIAGNOSIS >

DTC P0720 VEHICLE SPEED SENSOR A/T (REVOLUTION SENSOR)

Description

INFOID:000000001530466

The revolution sensor detects the revolution of the idler gear parking pawl lock gear and emits a pulse signal. The pulse signal is sent to the TCM which converts it into vehicle speed.

CONSULT-III Reference Value in Data Monitor Mode

INFOID:000000001530467

Item name	Condition	Display value (km/h)
VHCL/S SE·A/T	During driving	Approximately matches the speedometer reading.

On Board Diagnosis Logic

INFOID:000000001530468

- This is an OBD-II self-diagnostic item.
- Diagnostic trouble code “P0720 VEH SPD SEN/CIR AT” with CONSULT-III is detected under the following conditions.
 - When TCM does not receive the proper voltage signal from the sensor.
 - After ignition switch is turned “ON”, irregular signal input from vehicle speed sensor MTR before the vehicle starts moving.

Possible Cause

INFOID:000000001530469

- Harness or connectors
(The sensor circuit is open or shorted.)
- Revolution sensor
- Vehicle speed sensor MTR

DTC Confirmation Procedure

INFOID:000000001530470

CAUTION:

- Always drive vehicle at a safe speed.
- Be careful not to rev engine into the red zone on the tachometer.

NOTE:

If “DTC Confirmation Procedure” has been previously performed, always turn ignition switch “OFF” and wait at least 10 seconds before performing the next test.

After the repair, perform the following procedure to confirm the malfunction is eliminated.

Ⓟ WITH CONSULT-III

1. Turn ignition switch “ON”. (Do not start engine.)
2. Select “DATA MONITOR” mode for “TRANSMISSION” with CONSULT-III.
3. Drive vehicle and check for an increase of “VHCL/S SE·A/T” value in response to “VHCL/S SE·MTR” value.
If the check result is NG, go to [TM-50. "Diagnosis Procedure"](#).
If the check result is OK, go to following step.
4. Select “DATA MONITOR” mode for “ENGINE” with CONSULT-III.
5. Start engine and maintain the following conditions for at least 5 consecutive seconds.
VHCL SPEED SE: 30 km/h (19 MPH) or more
THRTL POS SEN: More than 1.0/8
Selector lever: “D” position
Driving location: Driving the vehicle uphill (increased engine load) will help maintain the driving conditions required for this test.
If the check result is NG, go to [TM-50. "Diagnosis Procedure"](#).
If the check result is OK, go to following step.
6. Maintain the following conditions for at least 5 consecutive seconds.
ENGINE SPEED: 3,500 rpm or more
THRTL POS SEN: More than 1.0/8
Selector lever: “D” position
Driving location: Driving the vehicle uphill (increased engine load) will help maintain the driving conditions required for this test.
If the check result is NG, go to [TM-50. "Diagnosis Procedure"](#).

DTC P0720 VEHICLE SPEED SENSOR A/T (REVOLUTION SENSOR)

< COMPONENT DIAGNOSIS >

 WITH GST

Follow the procedure "With CONSULT-III".

Diagnosis Procedure

INFOID:000000001530472

1. CHECK INPUT SIGNAL

 With CONSULT-III

1. Turn ignition switch "ON".
2. Select "ECU INPUT SIGNALS" in "DATA MONITOR" mode for "TRANSMISSION" with CONSULT-III.
3. Start the engine.
4. Read out the value of "VHCL/S SE·A/T" while driving.
Check the value changes according to driving speed.

Item name	Condition	Display value (km/h)
VHCL/S SE·A/T	During driving	Approximately matches the speedometer reading.

OK or NG

- OK >> GO TO 6.
NG >> GO TO 2.

2. CHECK TCM POWER SUPPLY AND GROUND CIRCUIT

Check TCM power supply and ground circuit. Refer to [TM-94, "Diagnosis Procedure"](#).

OK or NG

- OK >> GO TO 3.
NG >> Repair or replace damaged parts.

3. DETECT MALFUNCTIONING ITEM

Check the following items:

- The A/T assembly harness connector pin terminals for damage or loose connection with harness connector.

OK or NG

- OK >> GO TO 4.
NG >> Repair or replace damaged parts.

4. CHECK SUB-HARNESS

1. Remove control valve with TCM. Refer to [TM-217, "Control Valve with TCM and A/T Fluid Temperature Sensor 2"](#).
2. Disconnect park/neutral position switch connector and TCM connector.
3. Check continuity between park/neutral position switch connector terminals and TCM connector terminals.

Item	Connector	Terminal	Continuity
Park/neutral position switch connector	F505	8	Yes
TCM connector	F503	20	
Park/neutral position switch connector	F505	9	Yes
TCM connector	F503	17	
Park/neutral position switch connector	F505	10	Yes
TCM connector	F503	16	

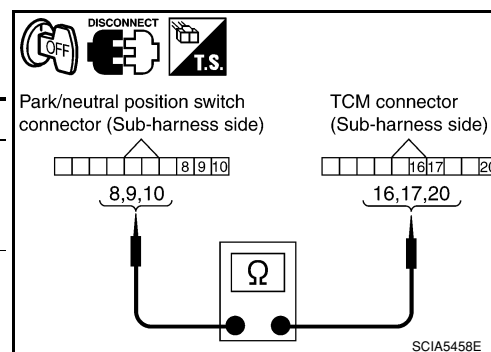

4. If OK, check harness for short to ground and short to power.
5. Reinstall any part removed.

OK or NG

- OK >> GO TO 5.
NG >> Replace open circuit or short to ground and short to power in harness or connectors.

DTC P0720 VEHICLE SPEED SENSOR A/T (REVOLUTION SENSOR)

< COMPONENT DIAGNOSIS >

5. REPLACE THE REVOLUTION SENSOR AND CHECK DTC

1. Replace the revolution sensor. Refer to [TM-245, "Disassembly"](#).
2. Perform "DTC Confirmation Procedure". Refer to [TM-49, "DTC Confirmation Procedure"](#).

OK or NG

OK >> **INSPECTION END**

NG >> Replace the control valve with TCM. Refer to [TM-217, "Control Valve with TCM and A/T Fluid Temperature Sensor 2"](#).

6. CHECK DTC

Perform "DTC Confirmation Procedure".

- Refer to [TM-49, "DTC Confirmation Procedure"](#).

OK or NG

OK >> **INSPECTION END**

NG >> GO TO 2.

A
B
C
TM
E
F
G
H
I
J
K
L
M
N
O
P

DTC P0725 ENGINE SPEED SIGNAL

< COMPONENT DIAGNOSIS >

DTC P0725 ENGINE SPEED SIGNAL

Description

INFOID:000000001530477

The engine speed signal is sent from the ECM to the TCM.

CONSULT-III Reference Value in Data Monitor Mode

INFOID:000000001530478

Item name	Condition	Display value (rpm)
ENGINE SPEED	Engine running	Closely matches the tachometer reading.

On Board Diagnosis Logic

INFOID:000000001530479

- This is not an OBD-II self-diagnostic item.
- Diagnostic trouble code “P0725 ENGINE SPEED SIG” with CONSULT-III is detected when TCM does not receive the ignition signal from ECM during engine cranking or running.

Possible Cause

INFOID:000000001530480

Harness or connectors
(The ECM to the TCM circuit is open or shorted.)

DTC Confirmation Procedure

INFOID:000000001530481

CAUTION:

Always drive vehicle at a safe speed.

NOTE:

If “DTC Confirmation Procedure” has been previously performed, always turn ignition switch “OFF” and wait at least 10 seconds before performing the next test.

After the repair, perform the following procedure to confirm the malfunction is eliminated.

④ WITH CONSULT-III

1. Turn ignition switch “ON” and select “DATA MONITOR” mode for “TRANSMISSION” with CONSULT-III.
2. Start engine and maintain the following conditions for at least 10 consecutive seconds.
VHCL SPEED SE: 10 km/h (6 MPH) or more
ACCELE POSI: More than 1/8
Selector lever: “D” position
3. If DTC is detected, go to [TM-52. "Diagnosis Procedure"](#).

Diagnosis Procedure

INFOID:000000001530482

1. CHECK CAN COMMUNICATION LINE

Perform the self-diagnosis. Refer to [TM-33. "CONSULT-III Function \(TRANSMISSION\)"](#).

Is a malfunction in the CAN communication indicated in the results?

- YES >> Check CAN communication line. Refer to [TM-39](#).
NO >> GO TO 2.

2. CHECK DTC WITH TCM

④ With CONSULT-III

1. Start engine.
2. Select “ECU INPUT SIGNALS” in “DATA MONITOR” mode for “TRANSMISSION” with CONSULT-III.
3. While monitoring engine speed, check for engine speed change corresponding to wide-open throttle position signal.

Item name	Condition	Display value (rpm)
ENGINE SPEED	Engine running	Closely matches the tachometer reading.

OK or NG

- OK >> GO TO 3.

DTC P0725 ENGINE SPEED SIGNAL

< COMPONENT DIAGNOSIS >

- NG >> Check the ignition signal circuit.
• Refer to [EC-399, "Diagnosis Procedure"](#).

3.CHECK DTC

- Perform "DTC Confirmation Procedure".
• Refer to [TM-52, "DTC Confirmation Procedure"](#).

OK or NG

- OK >> **INSPECTION END**
NG >> GO TO 4.

4.CHECK TCM POWER SUPPLY AND GROUND CIRCUIT

- Check TCM power supply and ground circuit. Refer to [TM-94, "Diagnosis Procedure"](#).

OK or NG

- OK >> GO TO 5.
NG >> Repair or replace damaged parts.

5.DETECT MALFUNCTIONING ITEM

- Check the following items:
• The A/T assembly harness connector pin terminals for damage or loose connection with harness connector.

OK or NG

- OK >> Replace the control valve with TCM. Refer to [TM-217, "Control Valve with TCM and A/T Fluid Temperature Sensor 2"](#).
NG >> Repair or replace damaged parts.

A
B
C
TM
E
F
G
H
I
J
K
L
M
N
O
P

DTC P0731 A/T 1ST GEAR FUNCTION

< COMPONENT DIAGNOSIS >

DTC P0731 A/T 1ST GEAR FUNCTION

Description

INFOID:000000001537313

This malfunction is detected when the A/T does not shift into 1st gear position as instructed by TCM. This is not only caused by electrical malfunction (circuits open or shorted) but also by mechanical malfunction such as control valve sticking, improper solenoid valve operation.

On Board Diagnosis Logic

INFOID:000000001537314

- This is an OBD-II self-diagnostic item.
- Diagnostic trouble code “P0731 A/T 1ST GR FNCTN” is detected when TCM detects any inconsistency in the actual gear ratio.

Possible Cause

INFOID:000000001537315

- Harness or connectors
(Solenoid circuits are open or shorted.)
- Input clutch solenoid valve
- Front brake solenoid valve
- Direct clutch solenoid valve
- High and low reverse clutch solenoid valve
- Each clutch
- Hydraulic control circuit

DTC Confirmation Procedure

INFOID:000000001537316

CAUTION:

Always drive vehicle at a safe speed.

NOTE:

If “DTC Confirmation Procedure” has been previously performed, always turn ignition switch OFF and wait at least 10 seconds before performing the next test.

After the repair, perform the following procedure to confirm the malfunction is eliminated.

WITH CONSULT-III

1. Start the engine and select “DATA MONITOR” mode for “TRANSMISSION” with CONSULT-III.
2. Make sure that “ATF TEMP 1” is within the following range.
ATF TEMP 1: 20°C – 140°C
If out of range, drive vehicle to warm ATF or stop engine to cool ATF.
3. Select “1ST GR FNCTN P0731” of “DTC WORK SUPPORT” mode for “TRANSMISSION” with CONSULT-III.
4. Drive vehicle and maintain the following conditions.
VEHICLE SPEED: 10 km/h (6 MPH) or more
ACCELE POSI: 0.6/8 or more
ENGINE SPEED: TURBINE REV – 50 rpm or more
TURBINE REV: 300 rpm or more
GEAR: “1” position
MANU MODE SW: ON
5. Keep the current driving status for at least 5 consecutive seconds if CONSULT-III screen changes from “OUT OF CONDITION” to “TESTING”.
CAUTION:
If “TESTING” does not appear on CONSULT-III for a long time, select “SELF-DIAG RESULTS”. In case a 1st trip DTC other than P0731 is shown, refer to “[TM-127, “DTC No. Index”](#)”.
If “COMPLETED RESULT NG” is detected, go to [TM-55, “Diagnosis Procedure”](#).
If “STOP VEHICLE” is detected, go to the following step.
6. Stop vehicle.
7. Drive vehicle in “D” position allowing it to shift from 1st to 5th gear and check shift timing and shift shock.
 - Touch “OK” to complete the inspection when normally shifted from the 1st to 5th gear.
 - Touch “NG” when an unusual shift shock, etc. occurs in spite of shifting from the 1st to 5th gear. Go to [TM-201, “Description”](#).
 - Perform [TM-33, “CONSULT-III Function \(TRANSMISSION\)”](#) when not shifted from the 1st to 5th gear. (Neither “OK” nor “NG” are indicated.)

DTC P0731 A/T 1ST GEAR FUNCTION

< COMPONENT DIAGNOSIS >

Diagnosis Procedure

INFOID:000000001537317

1. CHECK CAN COMMUNICATION LINE

Perform self-diagnosis. Refer to [TM-33, "CONSULT-III Function \(TRANSMISSION\)"](#).

Is a malfunction in the CAN communication indicated in the results?

- YES >> Check CAN communication line. Refer to [TM-39, "Diagnosis Procedure"](#).
- NO >> GO TO 2.

2. CHECK TCM POWER SUPPLY AND GROUND CIRCUIT

Check TCM power supply and ground circuit. Refer to [TM-94, "Diagnosis Procedure"](#).

OK or NG

- OK >> GO TO 3.
- NG >> Repair or replace damaged parts.

3. DETECT MALFUNCTION ITEM

Check A/T assembly harness connector pin terminals for damage or loose connection with harness connector.

OK or NG

- OK >> GO TO 4.
- NG >> Repair or replace damaged parts.

4. REPLACE CONTROL VALVE WITH TCM

1. Replace control valve with TCM. Refer to [TM-217, "Control Valve with TCM and A/T Fluid Temperature Sensor 2"](#).
2. Perform [TM-54, "DTC Confirmation Procedure"](#).

OK or NG

- OK >> **INSPECTION END**
- NG >> Confirm malfunction phenomena by "ROAD TEST" to repair malfunctioning part. Refer to [TM-201, "Description"](#).

A
B
C
TM
E
F
G
H
I
J
K
L
M
N
O
P

DTC P0732 A/T 2ND GEAR FUNCTION

< COMPONENT DIAGNOSIS >

DTC P0732 A/T 2ND GEAR FUNCTION

Description

INFOID:000000001537318

This malfunction is detected when the A/T does not shift into 2nd gear position as instructed by TCM. This is not only caused by electrical malfunction (circuits open or shorted) but also by mechanical malfunction such as control valve sticking, improper solenoid valve operation.

On Board Diagnosis Logic

INFOID:000000001537319

- This is an OBD-II self-diagnostic item.
- Diagnostic trouble code “P0732 A/T 2ND GR FNCTN” detected when TCM detects any inconsistency in the actual gear ratio.

Possible Cause

INFOID:000000001537320

- Harness or connectors
(Solenoid circuits are open or shorted.)
- Input clutch solenoid valve
- Front brake solenoid valve
- Direct clutch solenoid valve
- High and low reverse clutch solenoid valve
- Each clutch
- Hydraulic control circuit

DTC Confirmation Procedure

INFOID:000000001537321

CAUTION:

Always drive vehicle at a safe speed.

NOTE:

If “DTC Confirmation Procedure” has been previously performed, always turn ignition switch OFF and wait at least 10 seconds before performing the next test.

After the repair, perform the following procedure to confirm the malfunction is eliminated.

WITH CONSULT-III

1. Start the engine and select “DATA MONITOR” mode for “TRANSMISSION” with CONSULT-III.
2. Make sure that “ATF TEMP 1” is within the following range.
ATF TEMP 1: 20°C – 140°C
If out of range, drive vehicle to warm ATF or stop engine to cool ATF.
3. Select “2ND GR FNCTN P0732” of “DTC WORK SUPPORT” mode for “TRANSMISSION” with CONSULT-III.
4. Drive vehicle and maintain the following conditions.
VEHICLE SPEED: 10 km/h (6 MPH) or more
ACCELE POSI: 0.6/8 or more
ENGINE SPEED: TURBINE REV – 50 rpm or more
TURBINE REV: 300 rpm or more
GEAR: “2” position
MANU MODE SW: ON
5. Keep the current driving status for at least 5 consecutive seconds if CONSULT-III screen changes from “OUT OF CONDITION” to “TESTING”.
CAUTION:
If “TESTING” does not appear on CONSULT-III for a long time, select “SELF-DIAG RESULTS”. In case a 1st trip DTC other than P0732 is shown, refer to “[TM-127, “DTC No. Index”](#)”.
If “COMPLETED RESULT NG” is detected, go to [TM-57, “Diagnosis Procedure”](#).
If “STOP VEHICLE” is detected, go to the following step.
6. Stop vehicle.
7. Drive vehicle in “D” position allowing it to shift from 1st to 5th gear and check shift timing and shift shock.
 - Touch “OK” to complete the inspection when normally shifted from the 1st to 5th gear.
 - Touch “NG” when an unusual shift shock, etc. occurs in spite of shifting from the 1st to 5th gear. Go to [TM-201, “Description”](#).
 - Perform [TM-33, “CONSULT-III Function \(TRANSMISSION\)”](#) when not shifted from the 1st to 5th gear. (Neither “OK” nor “NG” are indicated.)

DTC P0732 A/T 2ND GEAR FUNCTION

< COMPONENT DIAGNOSIS >

Diagnosis Procedure

INFOID:000000001537322

1. CHECK CAN COMMUNICATION LINE

Perform self-diagnosis. Refer to [TM-33, "CONSULT-III Function \(TRANSMISSION\)"](#).

Is a malfunction in the CAN communication indicated in the results?

YES >> Check CAN communication line. Refer to [TM-39, "Diagnosis Procedure"](#).

NO >> GO TO 2.

2. CHECK TCM POWER SUPPLY AND GROUND CIRCUIT

Check TCM power supply and ground circuit. Refer to [TM-94, "Diagnosis Procedure"](#).

OK or NG

OK >> GO TO 3.

NG >> Repair or replace damaged parts.

3. DETECT MALFUNCTION ITEM

Check A/T assembly harness connector pin terminals for damage or loose connection with harness connector.

OK or NG

OK >> GO TO 4.

NG >> Repair or replace damaged parts.

4. REPLACE CONTROL VALVE WITH TCM

1. Replace control valve with TCM. Refer to [TM-217, "Control Valve with TCM and A/T Fluid Temperature Sensor 2"](#).

2. Perform [TM-56, "DTC Confirmation Procedure"](#).

OK or NG

OK >> **INSPECTION END**

NG >> Confirm malfunction phenomena by "ROAD TEST" to repair malfunctioning part. Refer to [TM-201, "Description"](#).

A
B
C
TM
E
F
G
H
I
J
K
L
M
N
O
P

DTC P0733 A/T 3RD GEAR FUNCTION

< COMPONENT DIAGNOSIS >

DTC P0733 A/T 3RD GEAR FUNCTION

Description

INFOID:000000001537323

This malfunction is detected when the A/T does not shift into 3rd gear position as instructed by TCM. This is not only caused by electrical malfunction (circuits open or shorted) but also by mechanical malfunction such as control valve sticking, improper solenoid valve operation.

On Board Diagnosis Logic

INFOID:000000001537324

- This is an OBD-II self-diagnostic item.
- Diagnostic trouble code “P0733 A/T 3RD GR FNCTN” is detected when TCM detects any inconsistency in the actual gear ratio.

Possible Cause

INFOID:000000001537325

- Harness or connectors
(Solenoid circuits are open or shorted.)
- Input clutch solenoid valve
- Front brake solenoid valve
- Direct clutch solenoid valve
- High and low reverse clutch solenoid valve
- Each clutch
- Hydraulic control circuit

DTC Confirmation Procedure

INFOID:000000001537326

CAUTION:

Always drive vehicle at a safe speed.

NOTE:

If “DTC Confirmation Procedure” has been previously performed, always turn ignition switch OFF and wait at least 10 seconds before performing the next test.

After the repair, perform the following procedure to confirm the malfunction is eliminated.

WITH CONSULT-III

1. Start the engine and select “DATA MONITOR” mode for “TRANSMISSION” with CONSULT-III.
2. Make sure that “ATF TEMP 1” is within the following range.
ATF TEMP 1: 20°C – 140°C
If out of range, drive vehicle to warm ATF or stop engine to cool ATF.
3. Select “3RD GR FNCTN P0733” of “DTC WORK SUPPORT” mode for “TRANSMISSION” with CONSULT-III.
4. Drive vehicle and maintain the following conditions.
VEHICLE SPEED: 10 km/h (6 MPH) or more
ACCELE POSI: 0.6/8 or more
ENGINE SPEED: TURBINE REV – 50 rpm or more
TURBINE REV: 300 rpm or more
GEAR: “3” position
MANU MODE SW: ON
5. Keep the current driving status for at least 5 consecutive seconds if CONSULT-III screen changes from “OUT OF CONDITION” to “TESTING”.
CAUTION:
If “TESTING” does not appear on CONSULT-III for a long time, select “SELF-DIAG RESULTS”. In case a 1st trip DTC other than P0732 is shown, refer to [“TM-127, “DTC No. Index”](#)”.
If “COMPLETED RESULT NG” is detected, go to [TM-59, “Diagnosis Procedure”](#).
If “STOP VEHICLE” is detected, go to the following step.
6. Stop vehicle.
7. Drive vehicle in “D” position allowing it to shift from 1st to 5th gear and check shift timing and shift shock.
 - Touch “OK” to complete the inspection when normally shifted from the 1st to 5th gear.
 - Touch “NG” when an unusual shift shock, etc. occurs in spite of shifting from the 1st to 5th gear. Go to [TM-201, “Description”](#).
 - Perform [TM-33, “CONSULT-III Function \(TRANSMISSION\)”](#) when not shifted from the 1st to 5th gear. (Neither “OK” nor “NG” are indicated.)

DTC P0733 A/T 3RD GEAR FUNCTION

< COMPONENT DIAGNOSIS >

Diagnosis Procedure

INFOID:000000001537327

1. CHECK CAN COMMUNICATION LINE

Perform self-diagnosis. Refer to [TM-33, "CONSULT-III Function \(TRANSMISSION\)"](#).

Is a malfunction in the CAN communication indicated in the results?

YES >> Check CAN communication line. Refer to [TM-39, "Diagnosis Procedure"](#).

NO >> GO TO 2.

2. CHECK TCM POWER SUPPLY AND GROUND CIRCUIT

Check TCM power supply and ground circuit. Refer to [TM-94, "Diagnosis Procedure"](#).

OK or NG

OK >> GO TO 3.

NG >> Repair or replace damaged parts.

3. DETECT MALFUNCTION ITEM

Check A/T assembly harness connector pin terminals for damage or loose connection with harness connector.

OK or NG

OK >> GO TO 4.

NG >> Repair or replace damaged parts.

4. REPLACE CONTROL VALVE WITH TCM

1. Replace control valve with TCM. Refer to [TM-217, "Control Valve with TCM and A/T Fluid Temperature Sensor 2"](#).

2. Perform [TM-58, "DTC Confirmation Procedure"](#).

OK or NG

OK >> **INSPECTION END**

NG >> Confirm malfunction phenomena by "ROAD TEST" to repair malfunctioning part. Refer to [TM-201, "Description"](#).

A
B
C
TM
E
F
G
H
I
J
K
L
M
N
O
P

DTC P0734 A/T 4TH GEAR FUNCTION

< COMPONENT DIAGNOSIS >

DTC P0734 A/T 4TH GEAR FUNCTION

Description

INFOID:000000001537328

This malfunction is detected when the A/T does not shift into 4th gear position as instructed by TCM. This is not only caused by electrical malfunction (circuits open or shorted) but also by mechanical malfunction such as control valve sticking, improper solenoid valve operation.

On Board Diagnosis Logic

INFOID:000000001537329

- This is an OBD-II self-diagnostic item.
- Diagnostic trouble code “P0734 A/T 4TH GR FNCTN” is detected when TCM detects any inconsistency in the actual gear ratio.

Possible Cause

INFOID:000000001537330

- Harness or connectors
(Solenoid circuits are open or shorted.)
- Input clutch solenoid valve
- Front brake solenoid valve
- Direct clutch solenoid valve
- High and low reverse clutch solenoid valve
- Each clutch
- Hydraulic control circuit

DTC Confirmation Procedure

INFOID:000000001537331

CAUTION:

Always drive vehicle at a safe speed.

NOTE:

If “DTC Confirmation Procedure” has been previously performed, always turn ignition switch OFF and wait at least 10 seconds before performing the next test.

After the repair, perform the following procedure to confirm the malfunction is eliminated.

WITH CONSULT-III

1. Start the engine and select “DATA MONITOR” mode for “TRANSMISSION” with CONSULT-III.
2. Make sure that “ATF TEMP 1” is within the following range.
ATF TEMP 1: 20°C – 140°C
If out of range, drive vehicle to warm ATF or stop engine to cool ATF.
3. Select “4TH GR FNCTN P0734” of “DTC WORK SUPPORT” mode for “TRANSMISSION” with CONSULT-III.
4. Drive vehicle and maintain the following conditions.
VEHICLE SPEED: 10 km/h (6 MPH) or more
ACCELE POSI: 0.6/8 or more
ENGINE SPEED: TURBINE REV – 50 rpm or more
TURBINE REV: 300 rpm or more
GEAR: “4” position
MANU MODE SW: ON
5. Keep the current driving status for at least 5 consecutive seconds if CONSULT-III screen changes from “OUT OF CONDITION” to “TESTING”.
CAUTION:
If “TESTING” does not appear on CONSULT-III for a long time, select “SELF-DIAG RESULTS”. In case a 1st trip DTC other than P0734 is shown, refer to “[TM-127, “DTC No. Index”](#)”.
If “COMPLETED RESULT NG” is detected, go to [TM-61, “Diagnosis Procedure”](#).
If “STOP VEHICLE” is detected, go to the following step.
6. Stop vehicle.
7. Drive vehicle in “D” position allowing it to shift from 1st to 5th gear and check shift timing and shift shock.
 - Touch “OK” to complete the inspection when normally shifted from the 1st to 5th gear.
 - Touch “NG” when an unusual shift shock, etc. occurs in spite of shifting from the 1st to 5th gear. Go to [TM-201, “Description”](#).
 - Perform [TM-33, “CONSULT-III Function \(TRANSMISSION\)”](#) when not shifted from the 1st to 5th gear. (Neither “OK” nor “NG” are indicated.)

DTC P0734 A/T 4TH GEAR FUNCTION

< COMPONENT DIAGNOSIS >

Diagnosis Procedure

INFOID:000000001537332

1. CHECK CAN COMMUNICATION LINE

Perform self-diagnosis. Refer to [TM-33, "CONSULT-III Function \(TRANSMISSION\)"](#).

Is a malfunction in the CAN communication indicated in the results?

YES >> Check CAN communication line. Refer to [TM-39, "Diagnosis Procedure"](#).

NO >> GO TO 2.

2. CHECK TCM POWER SUPPLY AND GROUND CIRCUIT

Check TCM power supply and ground circuit. Refer to [TM-94, "Diagnosis Procedure"](#).

OK or NG

OK >> GO TO 3.

NG >> Repair or replace damaged parts.

3. DETECT MALFUNCTION ITEM

Check A/T assembly harness connector pin terminals for damage or loose connection with harness connector.

OK or NG

OK >> GO TO 4.

NG >> Repair or replace damaged parts.

4. REPLACE CONTROL VALVE WITH TCM

1. Replace control valve with TCM. Refer to [TM-217, "Control Valve with TCM and A/T Fluid Temperature Sensor 2"](#).

2. Perform [TM-60, "DTC Confirmation Procedure"](#).

OK or NG

OK >> **INSPECTION END**

NG >> Confirm malfunction phenomena by "ROAD TEST" to repair malfunctioning part. Refer to [TM-201, "Description"](#).

A
B
C
TM
E
F
G
H
I
J
K
L
M
N
O
P

DTC P0735 A/T 5TH GEAR FUNCTION

< COMPONENT DIAGNOSIS >

DTC P0735 A/T 5TH GEAR FUNCTION

Description

INFOID:000000001537333

This malfunction is detected when the A/T does not shift into 5th gear position as instructed by TCM. This is not only caused by electrical malfunction (circuits open or shorted) but also by mechanical malfunction such as control valve sticking, improper solenoid valve operation.

On Board Diagnosis Logic

INFOID:000000001537334

- This is an OBD-II self-diagnostic item.
- Diagnostic trouble code “P0735 A/T 5TH GR FNCTN” is detected when TCM detects any inconsistency in the actual gear ratio.

Possible Cause

INFOID:000000001537335

- Harness or connectors
(Solenoid circuits are open or shorted.)
- Input clutch solenoid valve
- Front brake solenoid valve
- Direct clutch solenoid valve
- High and low reverse clutch solenoid valve
- Each clutch
- Hydraulic control circuit

DTC Confirmation Procedure

INFOID:000000001537336

CAUTION:

Always drive vehicle at a safe speed.

NOTE:

If “DTC Confirmation Procedure” has been previously performed, always turn ignition switch OFF and wait at least 10 seconds before performing the next test.

After the repair, perform the following procedure to confirm the malfunction is eliminated.

WITH CONSULT-III

1. Start the engine and select “DATA MONITOR” mode for “TRANSMISSION” with CONSULT-III.
2. Make sure that “ATF TEMP 1” is within the following range.
ATF TEMP 1: 20°C – 140°C
If out of range, drive vehicle to warm ATF or stop engine to cool ATF.
3. Select “5TH GR FNCTN P0735” of “DTC WORK SUPPORT” mode for “TRANSMISSION” with CONSULT-III.
4. Drive vehicle and maintain the following conditions.
VEHICLE SPEED: 10 km/h (6 MPH) or more
ACCELE POSI: 0.6/8 or more
ENGINE SPEED: TURBINE REV – 50 rpm or more
TURBINE REV: 300 rpm or more
GEAR: “5” position
MANU MODE SW: ON
5. Keep the current driving status for at least 5 consecutive seconds if CONSULT-III screen changes from “OUT OF CONDITION” to “TESTING”.
CAUTION:
If “TESTING” does not appear on CONSULT-III for a long time, select “SELF-DIAG RESULTS”. In case a 1st trip DTC other than P0735 is shown, refer to “[TM-127, “DTC No. Index”](#)”.
If “COMPLETED RESULT NG” is detected, go to [TM-63, “Diagnosis Procedure”](#).
If “STOP VEHICLE” is detected, go to the following step.
6. Stop vehicle.
7. Drive vehicle in “D” position allowing it to shift from 1st to 5th gear and check shift timing and shift shock.
 - Touch “OK” to complete the inspection when normally shifted from the 1st to 5th gear.
 - Touch “NG” when an unusual shift shock, etc. occurs in spite of shifting from the 1st to 5th gear. Go to [TM-201, “Description”](#).
 - Perform [TM-33, “CONSULT-III Function \(TRANSMISSION\)”](#) when not shifted from the 1st to 5th gear. (Neither “OK” nor “NG” are indicated.)

DTC P0735 A/T 5TH GEAR FUNCTION

< COMPONENT DIAGNOSIS >

Diagnosis Procedure

INFOID:000000001537337

1. CHECK CAN COMMUNICATION LINE

Perform self-diagnosis. Refer to [TM-33, "CONSULT-III Function \(TRANSMISSION\)"](#).

Is a malfunction in the CAN communication indicated in the results?

YES >> Check CAN communication line. Refer to [TM-39, "Diagnosis Procedure"](#).

NO >> GO TO 2.

2. CHECK TCM POWER SUPPLY AND GROUND CIRCUIT

Check TCM power supply and ground circuit. Refer to [TM-94, "Diagnosis Procedure"](#).

OK or NG

OK >> GO TO 3.

NG >> Repair or replace damaged parts.

3. DETECT MALFUNCTION ITEM

Check A/T assembly harness connector pin terminals for damage or loose connection with harness connector.

OK or NG

OK >> GO TO 4.

NG >> Repair or replace damaged parts.

4. REPLACE CONTROL VALVE WITH TCM

1. Replace control valve with TCM. Refer to [TM-217, "Control Valve with TCM and A/T Fluid Temperature Sensor 2"](#).

2. Perform [TM-62, "DTC Confirmation Procedure"](#).

OK or NG

OK >> **INSPECTION END**

NG >> Confirm malfunction phenomena by "ROAD TEST" to repair malfunctioning part. Refer to [TM-201, "Description"](#).

A
B
C
TM
E
F
G
H
I
J
K
L
M
N
O
P

DTC P0740 TORQUE CONVERTER CLUTCH SOLENOID VALVE

< COMPONENT DIAGNOSIS >

DTC P0740 TORQUE CONVERTER CLUTCH SOLENOID VALVE

Description

INFOID:000000001530483

- The torque converter clutch solenoid valve is activated, with the gear in D4, D5 by the TCM in response to signals sent from the vehicle speed sensor and accelerator pedal position sensor (throttle position sensor). Torque converter clutch piston operation will then be controlled.
- Lock-up operation, however, is prohibited when A/T fluid temperature is too low.
- When the accelerator pedal is depressed (less than 1/8) in lock-up condition, the engine speed should not change abruptly. If there is a big jump in engine speed, there is no lock-up.

CONSULT-III Reference Value in Data Monitor Mode

INFOID:000000001530484

Item name	Condition	Display value (Approx.)
TCC SOLENOID	When performing slip lock-up	0.2 - 0.4 A
	When performing lock-up	0.4 - 0.6 A

On Board Diagnosis Logic

INFOID:000000001530485

- This is an OBD-II self-diagnostic item.
- Diagnostic trouble code "P0740 TCC SOLENOID/CIRC" with CONSULT-III is detected under the following conditions.
 - When TCM detects an improper voltage drop when it tries to operate the solenoid valve.
 - When TCM detects as irregular by comparing target value with monitor value.

Possible Cause

INFOID:000000001530486

- Torque converter clutch solenoid valve
- Harness or connectors
(The solenoid circuit is open or shorted.)

DTC Confirmation Procedure

INFOID:000000001530487

CAUTION:

Always drive vehicle at a safe speed.

NOTE:

If "DTC Confirmation Procedure" has been previously performed, always turn ignition switch "OFF" and wait at least 10 seconds before performing the next test.

After the repair, perform the following procedure to confirm the malfunction is eliminated.

④ WITH CONSULT-III

1. Turn ignition switch "ON". (Do not start engine.)
2. Select "DATA MONITOR" mode for "ENGINE" with CONSULT-III.
3. Start engine and maintain the following conditions for at least 5 consecutive seconds.

VHCL SPEED SE: 80 km/h (50 MPH) or more

ACCELE POS: 0.5/8 - 1.0/8

SELECTOR LEVER: "D" position

Driving location: Driving the vehicle uphill (increased engine load) will help maintain the driving conditions required for this test.

4. If DTC is detected go to [TM-64, "Diagnosis Procedure"](#).

④ WITH GST

Follow the procedure "With CONSULT-III".

Diagnosis Procedure

INFOID:000000001530488

1. CHECK INPUT SIGNAL

④ With CONSULT-III

1. Turn ignition switch "ON".
2. Select "MAIN SIGNALS" in "DATA MONITOR" mode for "TRANSMISSION" with CONSULT-III.

DTC P0740 TORQUE CONVERTER CLUTCH SOLENOID VALVE

< COMPONENT DIAGNOSIS >

3. Start engine.
4. Read out the value of "TCC SOLENOID" while driving.

Item name	Condition	Display value (Approx.)
TCC SOLENOID	When performing slip lock-up	0.2 - 0.4 A
	When performing lock-up	0.4 - 0.6 A

OK or NG

- OK >> GO TO 4.
NG >> GO TO 2.

2. CHECK TCM POWER SUPPLY AND GROUND CIRCUIT

Check TCM power supply and ground circuit. Refer to [TM-94, "Diagnosis Procedure"](#).

OK or NG

- OK >> GO TO 3.
NG >> Repair or replace damaged parts.

3. DETECT MALFUNCTIONING ITEM

Check the following items:

- The A/T assembly harness connector pin terminals for damage or loose connection with harness connector.

OK or NG

- OK >> Replace the control valve with TCM. Refer to [TM-217, "Control Valve with TCM and A/T Fluid Temperature Sensor 2"](#).
NG >> Repair or replace damaged parts.

4. CHECK DTC

Perform "DTC Confirmation Procedure".

- Refer to [TM-64, "DTC Confirmation Procedure"](#).

OK or NG

- OK >> **INSPECTION END**
NG >> GO TO 2.

A
B
C
TM
E
F
G
H
I
J
K
L
M
N
O
P

DTC P0744 A/T TCC S/V FUNCTION (LOCK-UP)

< COMPONENT DIAGNOSIS >

DTC P0744 A/T TCC S/V FUNCTION (LOCK-UP)

Description

INFOID:000000001530489

This malfunction is detected when the A/T does not shift into 5th gear position or the torque converter clutch does not lock-up as instructed by the TCM. This is not only caused by electrical malfunction (circuits open or shorted) but also by mechanical malfunction such as control valve sticking, improper solenoid valve operation, etc.

CONSULT-III Reference Value in Data Monitor Mode

INFOID:000000001530490

Item name	Condition	Display value (Approx.)
TCC SOLENOID	When performing slip lock-up	0.2 - 0.4 A
	When performing lock-up	0.4 - 0.6 A

On Board Diagnosis Logic

INFOID:000000001530491

- This is an OBD-II self-diagnostic item.
- Diagnostic trouble code "P0744 A/T TCC S/V FNCTN" with CONSULT-III is detected under the following conditions.
 - When A/T cannot perform lock-up even if electrical circuit is good.
 - When TCM detects as irregular by comparing difference value with slip rotation.

Possible Cause

INFOID:000000001530492

- Harness or connectors
(The solenoid circuit is open or shorted.)
- Torque converter clutch solenoid valve
- Hydraulic control circuit

DTC Confirmation Procedure

INFOID:000000001530493

CAUTION:

Always drive vehicle at a safe speed.

NOTE:

If "DTC Confirmation Procedure" has been previously performed, always turn ignition switch "OFF" and wait at least 10 seconds before performing the next test.

After the repair, perform the following procedure to confirm the malfunction is eliminated.

WITH CONSULT-III

1. Start engine and Select "TCC S/V FNCTN CHECK" of "DTC WORK SUPPORT" mode for "TRANSMISSION" with CONSULT-III and touch "START".
2. Accelerate vehicle to more than 80 km/h (50 MPH) and maintain the following condition continuously until "TESTING" has turned to "COMPLETE". (It will take approximately 30 seconds after "TESTING" shows.)
ACCELE POSI: More than 1.0/8 (at all times during step 4)
TCC SOLENOID: 0.4 - 0.6 A
Selector lever: "D" position
[Reference speed: Constant speed of more than 80 km/h (50 MPH)]
 - Make sure "GEAR" shows "5".
 - For shift schedule, refer to [TM-304, "Vehicle Speed at Which Lock-up Occurs/Releases"](#).
 - If "TESTING" does not appear on CONSULT-III for a long time, select "SELF-DIAG RESULTS". In case a 1st trip DTC other than P0744 is shown, refer to applicable "TROUBLE DIAGNOSIS FOR DTC".
3. Make sure that "OK" is displayed. (If "NG" is displayed, refer to "DIAGNOSTIC PROCEDURE".)
Refer to [TM-67, "Diagnosis Procedure"](#).
Refer to shift schedule, [TM-304, "Vehicle Speed at Which Lock-up Occurs/Releases"](#).

WITH GST

Follow the procedure "With CONSULT-III".

DTC P0744 A/T TCC S/V FUNCTION (LOCK-UP)

< COMPONENT DIAGNOSIS >

Diagnosis Procedure

INFOID:000000001530494

1. CHECK INPUT SIGNAL

Ⓜ With CONSULT-III

1. Turn ignition switch "ON".
2. Select "MAIN SIGNALS" in "DATA MONITOR" mode for "TRANSMISSION" with CONSULT-III.
3. Start the engine.
4. Read out the value of "TCC SOLENOID" while driving.

Item name	Condition	Display value (Approx.)
TCC SOLENOID	When performing slip lock-up	0.2 - 0.4 A
	When performing lock-up	0.4 - 0.6 A

OK or NG

- OK >> GO TO 4.
NG >> GO TO 2.

2. CHECK TCM POWER SUPPLY AND GROUND CIRCUIT

Check TCM power supply and ground circuit. Refer to [TM-94, "Diagnosis Procedure"](#).

OK or NG

- OK >> GO TO 3.
NG >> Repair or replace damaged parts.

3. DETECT MALFUNCTIONING ITEM

Check the following items:

- The A/T assembly harness connector pin terminals for damage or loose connection with harness connector.

OK or NG

- OK >> Replace the control valve with TCM. Refer to [TM-217, "Control Valve with TCM and A/T Fluid Temperature Sensor 2"](#).
NG >> Repair or replace damaged parts.

4. CHECK DTC

Perform "DTC Confirmation Procedure".

- Refer to [TM-66, "DTC Confirmation Procedure"](#).

OK or NG

- OK >> **INSPECTION END**
NG >> GO TO 2.

DTC P0745 LINE PRESSURE SOLENOID VALVE

< COMPONENT DIAGNOSIS >

DTC P0745 LINE PRESSURE SOLENOID VALVE

Description

INFOID:000000001530499

The line pressure solenoid valve regulates the oil pump discharge pressure to suit the driving condition in response to a signal sent from the TCM.

The line pressure duty cycle value is not consistent when the closed throttle position signal is “ON”. To confirm the line pressure duty cycle at low pressure, the accelerator (throttle) should be open until the closed throttle position signal is “OFF”.

CONSULT-III Reference Value in Data Monitor Mode

INFOID:000000001530500

Item name	Condition	Display value (Approx.)
LINE PRES SOL	During driving	0.2 - 0.6 A

On Board Diagnosis Logic

INFOID:000000001530501

- This is an OBD-II self-diagnostic item.
- Diagnostic trouble code “P0745 L/PRESS SOL/CIRC” with CONSULT-III is detected under the following conditions.
 - When TCM detects an improper voltage drop when it tries to operate the solenoid valve.
 - When TCM detects as irregular by comparing target value with monitor value.

Possible Cause

INFOID:000000001530502

- Harness or connectors
(The solenoid circuit is open or shorted.)
- Line pressure solenoid valve

DTC Confirmation Procedure

INFOID:000000001530503

NOTE:

If “DTC Confirmation Procedure” has been previously performed, always turn ignition switch “OFF” and wait at least 10 seconds before performing the next test.

After the repair, perform the following procedure to confirm the malfunction is eliminated.

Ⓟ WITH CONSULT-III

1. Turn ignition switch “ON” and select “DATA MONITOR” mode for “ENGINE” with CONSULT-III.
2. Engine start and wait at least 5 second.
3. If DTC is detected, go to [TM-68, "Diagnosis Procedure"](#).

Ⓟ WITH GST

Follow the procedure “With CONSULT-III”.

Diagnosis Procedure

INFOID:000000001530504

1. CHECK INPUT SIGNAL

Ⓟ With CONSULT-III

1. Turn ignition switch “ON”.
2. Select “MAIN SIGNALS” in “DATA MONITOR” mode for “TRANSMISSION” with CONSULT-III.
3. Start the engine.
4. Read out the value of “LINE PRES SOL” while driving.

Item name	Condition	Display value (Approx.)
LINE PRES SOL	During driving	0.2 - 0.6 A

OK or NG

- OK >> GO TO 4.
- NG >> GO TO 2.

DTC P0745 LINE PRESSURE SOLENOID VALVE

< COMPONENT DIAGNOSIS >

2. CHECK TCM POWER SUPPLY AND GROUND CIRCUIT

Check TCM power supply and ground circuit. Refer to [TM-94, "Diagnosis Procedure"](#).

OK or NG

OK >> GO TO 3.

NG >> Repair or replace damaged parts.

3. DETECT MALFUNCTIONING ITEM

Check the following items:

- The A/T assembly harness connector pin terminals for damage or loose connection with harness connector.

OK or NG

OK >> Replace the control valve with TCM. Refer to [TM-217, "Control Valve with TCM and A/T Fluid Temperature Sensor 2"](#).

NG >> Repair or replace damaged parts.

4. CHECK DTC

Perform "DTC Confirmation Procedure".

- Refer to [TM-68, "DTC Confirmation Procedure"](#).

OK or NG

OK >> **INSPECTION END**

NG >> GO TO 2.

A
B
C
TM
E
F
G
H
I
J
K
L
M
N
O
P

DTC P1705 THROTTLE POSITION SENSOR

< COMPONENT DIAGNOSIS >

DTC P1705 THROTTLE POSITION SENSOR

Description

INFOID:000000001530505

Electric throttle control actuator consists of throttle control motor, accelerator pedal position sensor, throttle position sensor, etc. The actuator sends a signal to the ECM, and ECM sends signals to TCM with CAN communication.

CONSULT-III Reference Value in Data Monitor Mode

INFOID:000000001530506

Item name	Condition	Display value (Approx.)
ACCELE POSI	Released accelerator pedal.	0.0/8
	Fully depressed accelerator pedal.	8/8

On Board Diagnosis Logic

INFOID:000000001530507

- This is not an OBD-II self-diagnostic item.
- Diagnostic trouble code "P1705 TP SEN/CIRC A/T" with CONSULT-III is detected when TCM does not receive the proper accelerator pedal position signals (input by CAN communication) from ECM.

Possible Cause

INFOID:000000001530508

Harness or connectors
(The sensor circuit is open or shorted.)

DTC Confirmation Procedure

INFOID:000000001530509

NOTE:

If "DTC Confirmation Procedure" has been previously performed, always turn ignition switch "OFF" and wait at least 10 seconds before performing the next test.

After the repair, perform the following procedure to confirm the malfunction is eliminated.

Ⓟ WITH CONSULT-III

1. Turn ignition switch "ON". (Do not start engine.)
2. Select "DATA MONITOR" mode for "TRANSMISSION" with CONSULT-III.
3. Start engine and let it idle for 1 second.
4. If DTC is detected, go to [TM-70, "Diagnosis Procedure"](#).

Diagnosis Procedure

INFOID:000000001530510

1. CHECK CAN COMMUNICATION LINE

Perform the self-diagnosis. Refer to [TM-33, "CONSULT-III Function \(TRANSMISSION\)"](#).

Is a malfunction in the CAN communication indicated in the results?

- YES >> Check CAN communication line. Refer to [TM-39](#).
NO >> GO TO 2.

2. CHECK DTC WITH TCM

Ⓟ With CONSULT-III

1. Turn ignition switch "ON". (Do not start engine.)
2. Select "ECU INPUT SIGNALS" in "DATA MONITOR" mode for "TRANSMISSION" with CONSULT-III.
3. Depress accelerator pedal and read out the value of "ACCELE POSI".

Item name	Condition	Display value (Approx.)
ACCELE POSI	Released accelerator pedal.	0.0/8
	Fully depressed accelerator pedal.	8/8

4. Select "SELF-DIAG RESULTS" mode for "TRANSMISSION" with CONSULT-III. Refer to [TM-33, "CONSULT-III Function \(TRANSMISSION\)"](#).

DTC P1705 THROTTLE POSITION SENSOR

< COMPONENT DIAGNOSIS >

OK or NG

- OK >> GO TO 4.
- NG >> GO TO 3.

3.CHECK DTC WITH ECM

With CONSULT-III

1. Turn ignition switch "ON". (Do not start engine.)
2. Select "SELF-DIAG RESULTS" mode for "ENGINE" with CONSULT-III. Refer to [TM-33, "CONSULT-III Function \(TRANSMISSION\)"](#).

OK or NG

- OK >> GO TO 4.
- NG >> Check the DTC detected item. Refer to [TM-127, "DTC No. Index"](#).
 - If CAN communication line is detected, go to [TM-39, "Diagnosis Procedure"](#).

4.CHECK DTC

Perform "DTC Confirmation Procedure".

- Refer to [TM-70, "DTC Confirmation Procedure"](#).

OK or NG

- OK >> **INSPECTION END**
- NG >> GO TO 5.

5.CHECK TCM POWER SUPPLY AND GROUND CIRCUIT

Check TCM power supply and ground circuit. Refer to [TM-94, "Diagnosis Procedure"](#).

OK or NG

- OK >> GO TO 6.
- NG >> Repair or replace damaged parts.

6.DETECT MALFUNCTIONING ITEM

Check the following items:

- The A/T assembly harness connector pin terminals for damage or loose connection with harness connector.

OK or NG

- OK >> Replace the control valve with TCM. Refer to [TM-217, "Control Valve with TCM and A/T Fluid Temperature Sensor 2"](#).
- NG >> Repair or replace damaged parts.

A
B
C
TM
E
F
G
H
I
J
K
L
M
N
O
P

DTC P1710 A/T FLUID TEMPERATURE SENSOR CIRCUIT

< COMPONENT DIAGNOSIS >

DTC P1710 A/T FLUID TEMPERATURE SENSOR CIRCUIT

Description

INFOID:000000001530511

The A/T fluid temperature sensor detects the A/T fluid temperature and sends a signal to the TCM.

CONSULT-III Reference Value in Data Monitor Mode

INFOID:000000001530512

Item name	Condition °C (°F)	Display value (Approx.)
ATF TEMP SE 1	0 (32) - 20 (68) - 80 (176)	3.3 - 2.7 - 0.9 V
ATF TEMP SE 2		3.3 - 2.5 - 0.7 V

On Board Diagnosis Logic

INFOID:000000001530513

- This is an OBD-II self-diagnostic item.
- Diagnostic trouble code “P1710 (A/T), P0710 (ENGINE) ATF TEMP SEN/CIRC” with CONSULT-III is detected when TCM receives an excessively low or high voltage from the sensor.

Possible Cause

INFOID:000000001530514

- Harness or connectors
(The sensor circuit is open or shorted.)
- A/T fluid temperature sensors 1, 2

DTC Confirmation Procedure

INFOID:000000001530515

CAUTION:

Always drive vehicle at a safe speed.

NOTE:

If “DTC Confirmation Procedure” has been previously performed, always turn ignition switch “OFF” and wait at least 10 seconds before performing the next test.

After the repair, perform the following procedure to confirm the malfunction is eliminated.

Ⓟ WITH CONSULT-III

1. Turn ignition switch “ON”. (Do not start engine.)
2. Select “DATA MONITOR” mode for “ENGINE” with CONSULT-III.
3. Start engine and maintain the following conditions for at least 10 minutes (Total). (It is not necessary to maintain continuously.)
VHCL SPEED SE: 10 km/h (6 MPH) or more
THRTL POS SEN: More than 1.0/8
Selector lever: “D” position
4. If DTC is detected, go to [TM-72. "Diagnosis Procedure"](#).

Ⓟ WITH GST

Follow the procedure “With CONSULT-III”.

Diagnosis Procedure

INFOID:000000001530517

1. CHECK A/T FLUID TEMPERATURE SENSOR 1 SIGNAL

Ⓟ With CONSULT-III

1. Start engine.
2. Select “ECU INPUT SIGNALS” in “DATA MONITOR” mode for “TRANSMISSION” with CONSULT-III.
3. Read out the value of “ATF TEMP SE 1”.

Item name	Condition °C (°F)	Display value (Approx.)
ATF TEMP SE 1	0 (32) - 20 (68) - 80 (176)	3.3 - 2.7 - 0.9 V

OK or NG

- OK >> GO TO 2.
- NG >> GO TO 3.

DTC P1710 A/T FLUID TEMPERATURE SENSOR CIRCUIT

< COMPONENT DIAGNOSIS >

2. CHECK A/T FLUID TEMPERATURE SENSOR 2 SIGNAL

With CONSULT-III

1. Start engine.
2. Select "ECU INPUT SIGNALS" in "DATA MONITOR" mode for "TRANSMISSION" with CONSULT-III.
3. Read out the value of "ATF TEMP SE 2".

Item name	Condition °C (°F)	Display value (Approx.)
ATF TEMP SE 2	0 (32) - 20 (68) - 80 (176)	3.3 - 2.5 - 0.7 V

OK or NG

- OK >> GO TO 8.
 NG >> GO TO 5.

3. CHECK A/T FLUID TEMPERATURE SENSOR 1

Check A/T fluid temperature sensor 1. Refer to [TM-74, "Component Inspection"](#).

OK or NG

- OK >> GO TO 4.
 NG >> Replace the control valve with TCM. Refer to [TM-217, "Control Valve with TCM and A/T Fluid Temperature Sensor 2"](#).

4. CHECK SUB-HARNESS

1. Disconnect park/neutral position switch connector and TCM connector.
2. Check continuity between park/neutral position switch connector terminals and TCM connector terminals.

Item	Connector	Terminal	Continuity
Park/neutral position switch connector	F505	6	Yes
TCM connector	F503	19	
Park/neutral position switch connector	F505	7	Yes
TCM connector	F503	18	

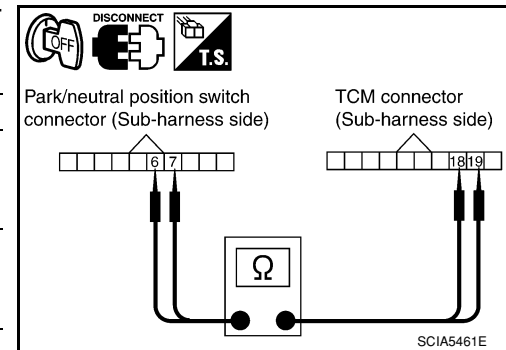

3. If OK, check harness for short to ground and short to power.

OK or NG

- OK >> GO TO 7.
 NG >> Replace open circuit or short to ground and short to power in harness or connectors.

5. CHECK A/T FLUID TEMPERATURE SENSOR 2

Check A/T fluid temperature sensor 2. Refer to [TM-217, "Control Valve with TCM and A/T Fluid Temperature Sensor 2"](#).

OK or NG

- OK >> GO TO 6.
 NG >> Replace the A/T fluid temperature sensor 2. Refer to [TM-217, "Control Valve with TCM and A/T Fluid Temperature Sensor 2"](#).

6. CHECK TERMINAL CORD ASSEMBLY

1. Disconnect A/T fluid temperature sensor 2 connector and TCM connector.

DTC P1710 A/T FLUID TEMPERATURE SENSOR CIRCUIT

< COMPONENT DIAGNOSIS >

- Check continuity between A/T fluid temperature sensor 2 connector terminals and TCM connector terminals.

Item	Connector	Terminal	Continuity
A/T fluid temperature sensor 2 connector	F507	1	Yes
TCM connector	F502	3	
A/T fluid temperature sensor 2 connector	F507	2	Yes
TCM connector	F502	5	

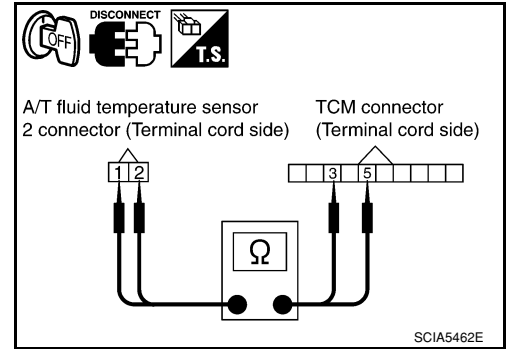

- If OK, check harness for short to ground and short to power.

OK or NG

- OK >> GO TO 7.
- NG >> Replace open circuit or short to ground and short to power in harness or connectors.

7. CHECK TCM POWER SUPPLY AND GROUND CIRCUIT

- Check TCM power supply and ground circuit. Refer to [TM-94. "Diagnosis Procedure"](#).
- Reinstall any part removed.

OK or NG

- OK >> Replace the control valve with TCM. Refer to [TM-217. "Control Valve with TCM and A/T Fluid Temperature Sensor 2"](#).
- NG >> Repair or replace damaged parts.

8. CHECK DTC

Perform "DTC Confirmation Procedure".

- Refer to [TM-72. "DTC Confirmation Procedure"](#).

OK or NG

- OK >> **INSPECTION END**
- NG >> GO TO 1.

Component Inspection

INFOID:000000001530518

A/T FLUID TEMPERATURE SENSOR 1

- Remove control valve with TCM. Refer to [TM-217. "Control Valve with TCM and A/T Fluid Temperature Sensor 2"](#).
- Check resistance between terminals.

Name	Terminal	Temperature °C (°F)	Resistance (Approx.) (kΩ)
A/T fluid temperature sensor 1	6-7	0 (32)	15
		20 (68)	6.5
		80 (176)	0.9

- If NG, replace the control valve with TCM. Refer to [TM-217. "Control Valve with TCM and A/T Fluid Temperature Sensor 2"](#)

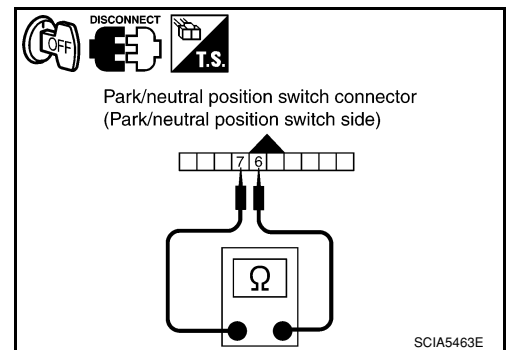

A/T FLUID TEMPERATURE SENSOR 2

- Remove A/T fluid temperature sensor 2. Refer to [TM-217. "Control Valve with TCM and A/T Fluid Temperature Sensor 2"](#).

DTC P1710 A/T FLUID TEMPERATURE SENSOR CIRCUIT

< COMPONENT DIAGNOSIS >

2. Check resistance between terminals.

Name	Terminal	Temperature °C (°F)	Resistance (Approx.) (kΩ)
A/T fluid temperature sensor 2	1-2	0 (32)	10
		20 (68)	4
		80 (176)	0.5

3. If NG, replace the A/T fluid temperature sensor 2. Refer to [TM-217, "Control Valve with TCM and A/T Fluid Temperature Sensor 2"](#).

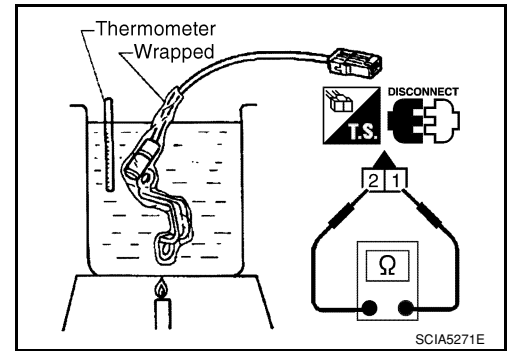

A

B

C

TM

E

F

G

H

I

J

K

L

M

N

O

P

DTC P1721 VEHICLE SPEED SENSOR MTR

< COMPONENT DIAGNOSIS >

DTC P1721 VEHICLE SPEED SENSOR MTR

Description

INFOID:000000001530519

The vehicle speed sensor·MTR signal is transmitted from combination meter to TCM by CAN communication line. The signal functions as an auxiliary device to the revolution sensor when it is malfunctioning. The TCM will then use the vehicle speed sensor·MTR signal.

CONSULT-III Reference Value in Data Monitor Mode

INFOID:000000001530520

Item name	Condition	Display value (km/h)
VHCL/S SE·MTR	During driving	Approximately matches the speedometer reading.

On Board Diagnosis Logic

INFOID:000000001530521

- This is not an OBD-II self-diagnostic item.
- Diagnostic trouble code “P1721 VHE SPD SE·MTR” with CONSULT-III is detected when TCM does not receive the proper vehicle speed sensor MTR signal (input by CAN communication) from combination meter.

Possible Cause

INFOID:000000001530522

Harness or connectors
(The sensor circuit is open or shorted.)

DTC Confirmation Procedure

INFOID:000000001530523

CAUTION:

Always drive vehicle at a safe speed.

NOTE:

If “DTC Confirmation Procedure” has been previously performed, always turn ignition switch “OFF” and wait at least 10 seconds before performing the next test.

After the repair, perform the following procedure to confirm the malfunction is eliminated.

Ⓟ WITH CONSULT-III

1. Turn ignition switch “ON”. (Do not start engine.)
2. Select “DATA MONITOR” mode for “TRANSMISSION” with CONSULT-III.
3. Start engine and maintain the following conditions for at least 5 consecutive seconds.
ACCELE POS: 1/8 or less
VHCL SPEED SE: 30 km/h (17 MPH) or more
4. If DTC is detected, go to [TM-76. "Diagnosis Procedure"](#).

Diagnosis Procedure

INFOID:000000001530524

1.CHECK CAN COMMUNICATION LINE

Perform the self-diagnosis. Refer [TM-33. "CONSULT-III Function \(TRANSMISSION\)"](#).

Is a malfunction in the CAN communication indicated in the results?

- YES >> Check CAN communication line. Refer to [TM-39](#).
NO >> GO TO 2.

2.CHECK INPUT SIGNAL

Ⓟ With CONSULT-III

1. Start engine.
2. Select “ECU INPUT SIGNALS” in “DATA MONITOR” mode for “TRANSMISSION” with CONSULT-III.
3. Drive vehicle and read out the value of “VHCL/S SE·MTR”.

Item name	Condition	Display value (Approx.)(km/h)
VHCL/S SE·MTR	During driving	Approximately matches the speedometer reading.

OK or NG

DTC P1721 VEHICLE SPEED SENSOR MTR

< COMPONENT DIAGNOSIS >

- OK >> GO TO 4.
- NG >> GO TO 3.

A

3.CHECK COMBINATION METERS

Check combination meter. Refer to [MWI-4. "Work Flow"](#).

B

OK or NG

- OK >> GO TO 4.
- NG >> Repair or replace damaged parts.

C

4.CHECK DTC

Perform "DTC Confirmation Procedure".

- Refer to [TM-76. "DTC Confirmation Procedure"](#).

TM

OK or NG

- OK >> **INSPECTION END**
- NG >> GO TO 5.

E

5.CHECK TCM POWER SUPPLY AND GROUND CIRCUIT

Check TCM power supply and ground circuit. Refer to [TM-94. "Diagnosis Procedure"](#).

F

OK or NG

- OK >> GO TO 6.
- NG >> Repair or replace damaged parts.

G

6.DETECT MALFUNCTIONING ITEM

Check the following items:

- The A/T assembly harness connector pin terminals for damage or loose connection with harness connector.

H

OK or NG

- OK >> Replace the control valve with TCM. Refer to [TM-217. "Control Valve with TCM and A/T Fluid Temperature Sensor 2"](#).
- NG >> Repair or replace damaged parts.

I

J

K

L

M

N

O

P

DTC P1730 A/T INTERLOCK

< COMPONENT DIAGNOSIS >

DTC P1730 A/T INTERLOCK

Description

INFOID:000000001530842

- Fail-safe function to detect interlock conditions.

On Board Diagnosis Logic

INFOID:000000001530843

- This is an OBD-II self-diagnostic item.
- Diagnostic trouble code “P1730 A/T INTERLOCK” with CONSULT-III is detected when TCM does not receive the proper voltage signal from the sensor and switch.
- TCM monitors and compares gear position and conditions of each ATF pressure switch when gear is steady.

Possible Cause

INFOID:000000001530844

- Harness or connectors
(The solenoid and switch circuit is open or shorted.)
- Low coast brake solenoid valve
- ATF pressure switch 2

DTC Confirmation Procedure

INFOID:000000001530845

NOTE:

If “DTC Confirmation Procedure” has been previously performed, always turn ignition switch “OFF” and wait at least 10 seconds before performing the next test.

After the repair, perform the following procedure to confirm the malfunction is eliminated.

Ⓟ WITH CONSULT-III

1. Turn ignition switch “ON”. (Do not start engine.)
2. Select “DATA MONITOR” mode for “TRANSMISSION” with CONSULT-III.
3. Start engine.
4. Drive vehicle and maintain the following conditions for at least 2 consecutive seconds.
Selector lever: “D” position
5. If DTC is detected, go to [TM-6. "Work Flow"](#).

Ⓟ WITH GST

Follow the procedure “With CONSULT-III”.

Judgement of A/T Interlock

INFOID:000000001530846

- When A/T Interlock is judged to be malfunctioning, the vehicle should be fixed in 2nd gear, and should be set in a condition in which it can travel.

NOTE:

When the vehicle is driven fixed in 2nd gear, a turbine revolution sensor malfunction is displayed, but this is not a turbine revolution sensor malfunction.

- When interlock is detected at the 3rd gear or more, it is locked at the 2nd gear.

Diagnosis Procedure

INFOID:000000001530847

1.SELF-DIAGNOSIS

Ⓟ With CONSULT-III

1. Drive vehicle.
2. Stop vehicle and turn ignition switch “OFF”.
3. Turn ignition switch “ON”.
4. Select “SELF-DIAG RESULTS” mode for “TRANSMISSION” with CONSULT-III.

OK or NG

- OK >> GO TO 2.
- NG >> Check low coast brake solenoid valve circuit and function. Refer to [TM-90. "Diagnosis Procedure"](#), [TM-93. "Diagnosis Procedure"](#).

2.CHECK DTC

Perform “DTC Confirmation Procedure”.

DTC P1730 A/T INTERLOCK

< COMPONENT DIAGNOSIS >

- Refer to [TM-78. "DTC Confirmation Procedure"](#).

OK or NG

- OK >> **INSPECTION END**
- NG >> GO TO 3.

3. CHECK TCM POWER SUPPLY AND GROUND CIRCUIT

Check TCM power supply and ground circuit. Refer to [TM-94. "Diagnosis Procedure"](#).

OK or NG

- OK >> GO TO 4.
- NG >> Repair or replace damaged parts.

4. DETECT MALFUNCTIONING ITEM

Check the following items:

- The A/T assembly harness connector pin terminals for damage or loose connection with harness connector.

OK or NG

- OK >> Replace the control valve with TCM. Refer to [TM-217. "Control Valve with TCM and A/T Fluid Temperature Sensor 2"](#).
- NG >> Repair or replace damaged parts.

A
B
C
TM
E
F
G
H
I
J
K
L
M
N
O
P

DTC P1731 A/T 1ST ENGINE BRAKING

< COMPONENT DIAGNOSIS >

DTC P1731 A/T 1ST ENGINE BRAKING

Description

INFOID:000000001530848

Fail-safe function to prevent sudden decrease in speed by engine brake other than at "1" position.

CONSULT-III Reference Value in Data Monitor Mode

INFOID:000000001530849

Item name	Condition	Display value
ON OFF SOL	Low coast brake engaged. Refer to TM-10 .	ON
	Low coast brake disengaged. Refer to TM-10 .	OFF
ATF PRES SW 2	Low coast brake engaged. Refer to TM-10 .	ON
	Low coast brake disengaged. Refer to TM-10 .	OFF

On Board Diagnosis Logic

INFOID:000000001530850

- This is not an OBD-II self-diagnostic item.
- Diagnostic trouble code "P1731 A/T 1ST E/BRAKING" with CONSULT-III is detected under the following conditions.
 - When TCM does not receive the proper voltage signal from the sensor.
 - When TCM monitors ATF pressure switch 2 and solenoid monitor value, and detects as irregular when engine brake of 1st gear acts other than at 1 position.

Possible Cause

INFOID:000000001530851

- Harness or connectors
(The sensor circuit is open or shorted.)
- Low coast brake solenoid valve
- ATF pressure switch 2

DTC Confirmation Procedure

INFOID:000000001530852

NOTE:

If "DTC Confirmation Procedure" has been previously preformed, always turn ignition switch "OFF" and wait at least 10 seconds before performing the next test.

After the repair, perform the following procedure to confirm the malfunction is eliminated.

④ WITH CONSULT-III

1. Turn ignition switch "ON". (Do not start engine.)
2. Select "DATA MONITOR" mode for "TRANSMISSION" with CONSULT-III.
3. Start engine.
4. Drive vehicle and maintain the following conditions for at least 2 consecutive seconds.
ENGINE SPEED: 1,200 rpm
Selector lever: "1" position
Gear position: 1st gear
5. If DTC is detected, go to [TM-80. "Diagnosis Procedure"](#).

Diagnosis Procedure

INFOID:000000001530853

1. CHECK INPUT SIGNALS

④ With CONSULT-III

1. Start the engine.
2. Select "SELECTION FROM MENU" in "DATA MONITOR" for "TRANSMISSION" with CONSULT-III
3. Drive vehicle in the "1" position (1st gear), and confirm the ON/OFF actuation of "ATF PRES SW 2" and "ON OFF SOL".

DTC P1731 A/T 1ST ENGINE BRAKING

< COMPONENT DIAGNOSIS >

Item name	Condition	Display value
ON OFF SOL	Low coast brake engaged. Refer to TM-10 .	ON
	Low coast brake disengaged. Refer to TM-10 .	OFF
ATF PRES SW 2	Low coast brake engaged. Refer to TM-10 .	ON
	Low coast brake disengaged. Refer to TM-10 .	OFF

OK or NG

OK >> GO TO 4.

NG >> GO TO 2.

2. CHECK TCM POWER SUPPLY AND GROUND CIRCUIT

Check TCM power supply and ground circuit. Refer to [TM-94, "Diagnosis Procedure"](#).

OK or NG

OK >> GO TO 3.

NG >> Repair or replace damaged parts.

3. DETECT MALFUNCTIONING ITEM

Check the following items:

- The A/T assembly harness connector pin terminals for damage or loose connection with harness connector.

OK or NG

OK >> Replace the control valve with TCM. Refer to [TM-217, "Control Valve with TCM and A/T Fluid Temperature Sensor 2"](#).

NG >> Repair or replace damaged parts.

4. CHECK DTC

Perform "DTC Confirmation Procedure".

- Refer to [TM-80, "DTC Confirmation Procedure"](#).

OK or NG

OK >> **INSPECTION END**

NG >> GO TO 2.

A
B
C
TM
E
F
G
H
I
J
K
L
M
N
O
P

DTC P1752 INPUT CLUTCH SOLENOID VALVE

< COMPONENT DIAGNOSIS >

DTC P1752 INPUT CLUTCH SOLENOID VALVE

Description

INFOID:000000001530854

Input clutch solenoid valve is controlled by the TCM in response to signals sent from the PNP switch, vehicle speed sensor and accelerator pedal position sensor (throttle position sensor). Gears will then be shifted to the optimum position.

CONSULT-III Reference Value in Data Monitor Mode

INFOID:000000001530855

Item name	Condition	Display value (Approx.)
I/C SOLENOID	Input clutch disengaged. Refer to TM-82 .	0.6 - 0.8 A
	Input clutch engaged. Refer to TM-82 .	0 - 0.05 A

On Board Diagnosis Logic

INFOID:000000001530856

- This is an OBD-II self-diagnostic item.
- Diagnostic trouble code "P1752 I/C SOLENOID/CIRC" with CONSULT-III is detected under the following conditions.
 - When TCM detects an improper voltage drop when it tries to operate the solenoid valve.
 - When TCM detects as irregular by comparing target value with monitor value.

Possible Cause

INFOID:000000001530857

- Harness or connectors
(The solenoid circuit is open or shorted.)
- Input clutch solenoid valve

DTC Confirmation Procedure

INFOID:000000001530858

CAUTION:

Always drive vehicle at a safe speed.

NOTE:

If "DTC Confirmation Procedure" has been previously performed, always turn ignition switch "OFF" and wait at least 10 seconds before performing the next test.

After the repair, perform the following procedure to confirm the malfunction is eliminated.

WITH CONSULT-III

1. Turn ignition switch "ON". (Do not start engine.)
2. Select "DATA MONITOR" mode for "TRANSMISSION" with CONSULT-III.
3. Start engine.
4. Drive vehicle and maintain the following conditions for at least 5 consecutive seconds.
 - ACCELE POS: 1.5/8 - 2.0/8**
 - Selector lever: "D" position**
 - Gear position: 3rd ⇒ 4th Gear (I/C ON/OFF)**
 - Driving location: Driving the vehicle uphill (increased engine load) will help maintain the driving conditions required for this test.**
5. If DTC is detected go to [TM-82, "Diagnosis Procedure"](#).

WITH GST

Follow the procedure "With CONSULT-III".

Diagnosis Procedure

INFOID:000000001530859

1. CHECK INPUT SIGNAL

With CONSULT-III

1. Turn ignition switch "ON".
2. Select "MAIN SIGNALS" in "DATA MONITOR" mode for "TRANSMISSION" with CONSULT-III.
3. Start the engine.
4. Read out the value of "I/C SOLENOID" while driving.

DTC P1752 INPUT CLUTCH SOLENOID VALVE

< COMPONENT DIAGNOSIS >

Item name	Condition	Display value (Approx.)
I/C SOLENOID	Input clutch disengaged. Refer to TM-82 .	0.6 - 0.8 A
	Input clutch engaged. Refer to TM-82 .	0 - 0.05 A

OK or NG

- OK >> GO TO 4.
- NG >> GO TO 2.

2. CHECK TCM POWER SUPPLY AND GROUND CIRCUIT

Check TCM power supply and ground circuit. Refer to [TM-94, "Diagnosis Procedure"](#).

OK or NG

- OK >> GO TO 3.
- NG >> Repair or replace damaged parts.

3. DETECT MALFUNCTIONING ITEM

Check the following items:

- The A/T assembly harness connector pin terminals for damage or loose connection with harness connector.

OK or NG

- OK >> Replace the control valve with TCM. Refer to [TM-217, "Control Valve with TCM and A/T Fluid Temperature Sensor 2"](#).
- NG >> Repair or replace damaged parts.

4. CHECK DTC

Perform "DTC Confirmation Procedure".

- Refer to [TM-82, "DTC Confirmation Procedure"](#).

OK or NG

- OK >> **INSPECTION END**
- NG >> GO TO 2.

A
B
C
TM
E
F
G
H
I
J
K
L
M
N
O
P

DTC P1757 FRONT BRAKE SOLENOID VALVE

< COMPONENT DIAGNOSIS >

DTC P1757 FRONT BRAKE SOLENOID VALVE

Description

INFOID:000000001530866

Front brake solenoid valve is controlled by the TCM in response to signals sent from the PNP switch, vehicle speed sensor and accelerator pedal position sensor (throttle position sensor). Gears will then be shifted to the optimum position.

CONSULT-III Reference Value in Data Monitor Mode

INFOID:000000001530867

Item name	Condition	Display value (Approx.)
FR/B SOLENOID	Front brake engaged. Refer to TM-84	0.6 - 0.8 A
	Front brake disengaged. Refer to TM-84	0 - 0.05 A

On Board Diagnosis Logic

INFOID:000000001530868

- This is an OBD-II self-diagnostic item.
- Diagnostic trouble code “P1757 FR/B SOLENOID/CIRC” with CONSULT-III is detected under the following conditions.
 - When TCM detects an improper voltage drop when it tries to operate the solenoid valve.
 - When TCM detects as irregular by comparing target value with monitor value.

Possible Cause

INFOID:000000001530869

- Harness or connectors
(The solenoid circuit is open or shorted.)
- Front brake solenoid valve

DTC Confirmation Procedure

INFOID:000000001530870

CAUTION:

Always drive vehicle at a safe speed.

NOTE:

If “DTC Confirmation Procedure” has been previously performed, always turn ignition switch “OFF” and wait at least 10 seconds before performing the next test.

After the repair, perform the following procedure to confirm the malfunction is eliminated.

④ WITH CONSULT-III

1. Turn ignition switch “ON”. (Do not start engine.)
2. Select “DATA MONITOR” mode for “TRANSMISSION” with CONSULT-III.
3. Start engine.
4. Drive vehicle and maintain the following conditions for at least 5 consecutive seconds.
 - ACCELE POS: 1.5/8 - 2.0/8**
 - Selector lever: “D” position**
 - Gear position: 3rd ⇒ 4th Gear (FR/B ON/OFF)**
 - Driving location: Driving the vehicle uphill (increased engine load) will help maintain the driving conditions required for this test.**
5. If DTC is detected go to [TM-84, "Diagnosis Procedure"](#).

④ WITH GST

Follow the procedure “With CONSULT-III”.

Diagnosis Procedure

INFOID:000000001530871

1. CHECK INPUT SIGNAL

④ With CONSULT-III

1. Turn ignition switch “ON”.
2. Select “MAIN SIGNALS” in “DATA MONITOR” mode for “TRANSMISSION” with CONSULT-III.
3. Start engine.
4. Read out the value of “FR/B SOLENOID” while driving.

DTC P1757 FRONT BRAKE SOLENOID VALVE

< COMPONENT DIAGNOSIS >

Item name	Condition	Display value (Approx.)
FR/B SOLENOID	Front brake engaged. Refer to TM-10	0.6 - 0.8 A
	Front brake disengaged. Refer to TM-10	0 - 0.05 A

OK or NG

- OK >> GO TO 4.
- NG >> GO TO 2.

2. CHECK TCM POWER SUPPLY AND GROUND CIRCUIT

Check TCM power supply and ground circuit. Refer to [TM-94, "Diagnosis Procedure"](#).

OK or NG

- OK >> GO TO 3.
- NG >> Repair or replace damaged parts.

3. DETECT MALFUNCTIONING ITEM

Check the following items:

- The A/T assembly harness connector pin terminals for damage or loose connection with harness connector.

OK or NG

- OK >> Replace the control valve with TCM. Refer to [TM-217, "Control Valve with TCM and A/T Fluid Temperature Sensor 2"](#).
- NG >> Repair or replace damaged parts.

4. CHECK DTC

Perform "DTC Confirmation Procedure".

- Refer to [TM-84, "DTC Confirmation Procedure"](#).

OK or NG

- OK >> **INSPECTION END**
- NG >> GO TO 2.

A
B
C
TM
E
F
G
H
I
J
K
L
M
N
O
P

DTC P1762 DIRECT CLUTCH SOLENOID VALVE

< COMPONENT DIAGNOSIS >

DTC P1762 DIRECT CLUTCH SOLENOID VALVE

Description

INFOID:000000001530878

Direct clutch solenoid valve is controlled by the TCM in response to signals sent from the PNP switch, vehicle speed sensor and accelerator pedal position sensor (throttle position sensor). Gears will then be shifted to the optimum position.

CONSULT-III Reference Value in Data Monitor Mode

INFOID:000000001530879

Item name	Condition	Display value (Approx.)
D/C SOLENOID	Direct clutch disengaged. Refer to TM-10	0.6 - 0.8 A
	Direct clutch engaged. Refer to TM-10	0 - 0.05 A

On Board Diagnosis Logic

INFOID:000000001530880

- This is an OBD-II self-diagnostic item.
- Diagnostic trouble code "P1762 D/C SOLENOID/CIRC" with CONSULT-III is detected under the following conditions.
 - When TCM detects an improper voltage drop when it tries to operate the solenoid valve.
 - When TCM detects as irregular by comparing target value with monitor value.

Possible Cause

INFOID:000000001530881

- Harness or connectors
(The solenoid circuit is open or shorted.)
- Direct clutch solenoid valve

DTC Confirmation Procedure

INFOID:000000001530882

NOTE:

If "DTC Confirmation Procedure" has been previously performed, always turn ignition switch "OFF" and wait at least 10 seconds before performing the next test.

After the repair, perform the following procedure to confirm the malfunction is eliminated.

Ⓟ WITH CONSULT-III

1. Turn ignition switch "ON". (Do not start engine.)
2. Select "DATA MONITOR" mode for "TRANSMISSION" with CONSULT-III.
3. Start engine.
4. Drive vehicle and maintain the following conditions for at least 5 consecutive seconds.
ACCELE POS: 1.5/8 - 2.0/8
Selector lever: "D" position
Gear position: 1st ⇒ 2nd Gear (D/C ON/OFF)
Driving location: Driving the vehicle uphill (increased engine load) will help maintain the driving conditions required for this test.
5. If DTC is detected, go to [TM-86. "Diagnosis Procedure"](#).

Ⓟ WITH GST

Follow the procedure "With CONSULT-III".

Diagnosis Procedure

INFOID:000000001530883

1. CHECK INPUT SIGNAL

Ⓟ With CONSULT-III

1. Turn ignition switch "ON".
2. Select "MAIN SIGNALS" in "DATA MONITOR" mode for "TRANSMISSION" with CONSULT-III.
3. Start the engine.
4. Read out the value of "D/C SOLENOID" while driving.

DTC P1762 DIRECT CLUTCH SOLENOID VALVE

< COMPONENT DIAGNOSIS >

Item name	Condition	Display value (Approx.)
D/C SOLENOID	Direct clutch disengaged. Refer to TM-10	0.6 - 0.8 A
	Direct clutch engaged. Refer to TM-10	0 - 0.05 A

OK or NG

- OK >> GO TO 4.
- NG >> GO TO 2.

2. CHECK TCM POWER SUPPLY AND GROUND CIRCUIT

Check TCM power supply and ground circuit. Refer to [TM-94, "Diagnosis Procedure"](#).

OK or NG

- OK >> GO TO 3.
- NG >> Repair or replace damaged parts.

3. DETECT MALFUNCTIONING ITEM

Check the following items:

- The A/T assembly harness connector pin terminals for damage or loose connection with harness connector.

OK or NG

- OK >> Replace the control valve with TCM. Refer to [TM-217, "Control Valve with TCM and A/T Fluid Temperature Sensor 2"](#).
- NG >> Repair or replace damaged parts.

4. CHECK DTC

Perform "DTC Confirmation Procedure".

- Refer to [TM-86, "DTC Confirmation Procedure"](#).

OK or NG

- OK >> **INSPECTION END**
- NG >> GO TO 2.

A
B
C
TM
E
F
G
H
I
J
K
L
M
N
O
P

DTC P1767 HIGH AND LOW REVERSE CLUTCH SOLENOID VALVE

< COMPONENT DIAGNOSIS >

DTC P1767 HIGH AND LOW REVERSE CLUTCH SOLENOID VALVE

Description

INFOID:000000001530890

High and low reverse clutch solenoid valve is controlled by the TCM in response to signals sent from the PNP switch, vehicle speed sensor and accelerator pedal position sensor (throttle position sensor). Gears will then be shifted to the optimum position.

CONSULT-III Reference Value in Data Monitor Mode

INFOID:000000001530891

Item name	Condition	Display value (Approx.)
HLR/C SOL	High and low reverse clutch disengaged. Refer to TM-10	0.6 - 0.8 A
	High and low reverse clutch engaged. Refer to TM-10	0 - 0.05 A

On Board Diagnosis Logic

INFOID:000000001530892

- This is an OBD-II self-diagnostic item.
- Diagnostic trouble code “P1767 HLR/C SOL/CIRC” with CONSULT-III or is detected under the following conditions.
 - When TCM detects an improper voltage drop when it tries to operate the solenoid valve.
 - When TCM detects as irregular by comparing target value with monitor value.

Possible Cause

INFOID:000000001530893

- Harness or connectors
(The solenoid circuit is open or shorted.)
- High and low reverse clutch solenoid valve

DTC Confirmation Procedure

INFOID:000000001530894

CAUTION:

Always drive vehicle at a safe speed.

NOTE:

If “DTC Confirmation Procedure” has been previously performed, always turn ignition switch “OFF” and wait at least 10 seconds before performing the next test.

After the repair, perform the following procedure to confirm the malfunction is eliminated.

WITH CONSULT-III

1. Turn ignition switch “ON”. (Do not start engine.)
2. Select “DATA MONITOR” mode for “TRANSMISSION” with CONSULT-III.
3. Start engine.
4. Drive vehicle and maintain the following conditions for at least 5 consecutive seconds.
 - ACCELE POS: 1.5/8 - 2.0/8**
 - Selector lever: “D” position**
 - Gear position: 2nd ⇒ 3rd Gear (HLR/C ON/OFF)**
 - Driving location: Driving the vehicle uphill (increased engine load) will help maintain the driving conditions required for this test.**
5. If DTC is detected, go to [TM-88, "Diagnosis Procedure"](#).

WITH GST

Follow the procedure “With CONSULT-III”.

Diagnosis Procedure

INFOID:000000001530895

1. CHECK INPUT SIGNAL

With CONSULT-III

1. Turn ignition switch “ON”.
2. Select “MAIN SIGNALS” in “DATA MONITOR” mode for “TRANSMISSION” with CONSULT-III.
3. Start the engine.
4. Read out the value of “HLR/C SOLENOID” while driving.

DTC P1767 HIGH AND LOW REVERSE CLUTCH SOLENOID VALVE

< COMPONENT DIAGNOSIS >

Item name	Condition	Display value (Approx.)
HLR/C SOL	High and low reverse clutch disengaged. Refer to TM-10	0.6 - 0.8 A
	High and low reverse clutch engaged. Refer to TM-10	0 - 0.05 A

OK or NG

OK >> GO TO 4.

NG >> GO TO 2.

2. CHECK TCM POWER SUPPLY AND GROUND CIRCUIT

Check TCM power supply and ground circuit Refer to [TM-94, "Diagnosis Procedure"](#).

OK or NG

OK >> GO TO 3.

NG >> Repair or replace damaged parts.

3. DETECT MALFUNCTIONING ITEM

Check the following items:

- The A/T assembly harness connector pin terminals for damage or loose connection with harness connector.

OK or NG

OK >> Replace the control valve with TCM. Refer to [TM-217, "Control Valve with TCM and A/T Fluid Temperature Sensor 2"](#).

NG >> Repair or replace damaged parts.

4. CHECK DTC

Perform "DTC Confirmation Procedure".

- Refer to [TM-88, "DTC Confirmation Procedure"](#).

OK or NG

OK >> **INSPECTION END**

NG >> GO TO 2.

A
B
C
TM
E
F
G
H
I
J
K
L
M
N
O
P

DTC P1772 LOW COAST BRAKE SOLENOID VALVE

< COMPONENT DIAGNOSIS >

DTC P1772 LOW COAST BRAKE SOLENOID VALVE

Description

INFOID:000000001530902

Low coast brake solenoid valve is turned “ON” or “OFF” by the TCM in response to signals sent from the PNP switch, vehicle speed sensor and accelerator pedal position sensor (throttle position sensor). Gears will then be shifted to the optimum position.

CONSULT-III Reference Value in Data Monitor Mode

INFOID:000000001530903

Item name	Condition	Display value
ON OFF SOL	Low coast brake engaged. Refer to TM-10	ON
	Low coast brake disengaged. Refer to TM-10	OFF

On Board Diagnosis Logic

INFOID:000000001530904

- This is an OBD-II self-diagnostic item.
- Diagnostic trouble code “P1772 LC/B SOLENOID/CIRC” with CONSULT-III is detected when TCM detects an improper voltage drop when it tries to operate the solenoid valve.

Possible Cause

INFOID:000000001530905

- Harness or connectors
(The solenoid circuit is open or shorted.)
- Low coast brake solenoid valve

DTC Confirmation Procedure

INFOID:000000001530906

NOTE:

If “DTC Confirmation Procedure” has been previously performed, always turn ignition switch “OFF” and wait at least 10 seconds before performing the next test.

After the repair, perform the following procedure to confirm the malfunction is eliminated.

Ⓟ WITH CONSULT-III

1. Turn ignition switch “ON”. (Do not start engine.)
2. Select “DATA MONITOR” mode for “ENGINE” with CONSULT-III.
3. Start engine.
4. Drive vehicle and maintain the following conditions for at least 5 consecutive seconds.
Selector lever: “1” or “2”
Gear position: “1st” or “2nd” gear (LC/B ON/OFF)
5. If DTC is detected, go to [TM-90, "Diagnosis Procedure"](#).

Ⓟ WITH GST

Follow the procedure “With CONSULT-III”.

Diagnosis Procedure

INFOID:000000001530907

1. CHECK INPUT SIGNAL

Ⓟ With CONSULT-III

1. Turn ignition switch “ON”.
2. Select “SELECTION FROM MENU” in “DATA MONITOR” mode for “TRANSMISSION” with CONSULT-III.
3. Start the engine.
4. Read out the value of “ON OFF SOL” while driving.

Item name	Condition	Display value
ON OFF SOL	Low coast brake engaged. Refer to TM-10	ON
	Low coast brake disengaged. Refer to TM-10	OFF

OK or NG

OK >> GO TO 4.

DTC P1772 LOW COAST BRAKE SOLENOID VALVE

< COMPONENT DIAGNOSIS >

NG >> GO TO 2.

2.CHECK TCM POWER SUPPLY AND GROUND CIRCUIT

Check TCM power supply and ground circuit. Refer to [TM-94, "Diagnosis Procedure"](#).

OK or NG

OK >> GO TO 3.

NG >> Repair or replace damaged parts.

3.DETECT MALFUNCTIONING ITEM

Check the following items:

- The A/T assembly harness connector pin terminals for damage or loose connection with harness connector.

OK or NG

OK >> Replace the control valve with TCM. Refer to [TM-217, "Control Valve with TCM and A/T Fluid Temperature Sensor 2"](#).

NG >> Repair or replace damaged parts.

4.CHECK DTC

Perform "DTC Confirmation Procedure".

- Refer to [TM-90, "DTC Confirmation Procedure"](#).

OK or NG

OK >> **INSPECTION END**

NG >> GO TO 2.

A
B
C
TM
E
F
G
H
I
J
K
L
M
N
O
P

DTC P1774 LOW COAST BRAKE SOLENOID VALVE FUNCTION

< COMPONENT DIAGNOSIS >

DTC P1774 LOW COAST BRAKE SOLENOID VALVE FUNCTION

Description

INFOID:000000001530908

- Low coast brake solenoid valve is turned “ON” or “OFF” by the TCM in response to signals sent from the PNP switch, vehicle speed sensor and accelerator pedal position sensor (throttle position sensor). Gears will then be shifted to the optimum position.
- This is not only caused by electrical malfunction (circuits open or shorted) but also by mechanical malfunction such as control valve sticking, improper solenoid valve operation.

CONSULT-III Reference Value in Data Monitor Mode

INFOID:000000001530909

Item name	Condition	Display value
ON OFF SOL	Low coast brake engaged. Refer to TM-10	ON
	Low coast brake disengaged. Refer to TM-10	OFF
ATF PRES SW 2	Low coast brake engaged. Refer to TM-10	ON
	Low coast brake disengaged. Refer to TM-10	OFF

On Board Diagnosis Logic

INFOID:000000001530910

- This is an OBD-II self-diagnostic item.
- Diagnostic trouble code “P1774 LC/B SOLENOID FNCT” with CONSULT-III is detected under the following conditions.
 - When TCM detects that actual gear ratio is irregular, and relation between gear position and condition of ATF pressure switch 2 is irregular during depressing accelerator pedal. (Other than during shift change)
 - When TCM detects that relation between gear position and condition of ATF pressure switch 2 is irregular during releasing accelerator pedal. (Other than during shift change)

Possible Cause

INFOID:000000001530911

- Harness or connectors
(The solenoid and switch circuits are open or shorted.)
- Low coast brake solenoid valve
- ATF pressure switch 2

DTC Confirmation Procedure

INFOID:000000001530912

CAUTION:

Always drive vehicle at a safe speed.

NOTE:

If “DTC Confirmation Procedure” has been previously performed, always turn ignition switch “OFF” and wait at least 10 seconds before performing the next test.

After the repair, perform the following procedure to confirm the malfunction is eliminated.

WITH CONSULT-III

1. Start engine.
2. Accelerate vehicle to maintain the following conditions.
Selector lever: “1” or “2” position
Gear position: “1st” or “2nd” gear (LC/B ON/OFF)
3. Perform step “2” again.
4. Turn ignition switch “OFF”, then perform step “1” to “3” again.
5. Check “SELF-DIAG RESULTS” mode for “TRANSMISSION” with CONSULT-III. If DTC (P1774) is detected, refer to [TM-93, "Diagnosis Procedure"](#).
If DTC (P1772) is detected, go to [TM-90, "Diagnosis Procedure"](#).

WITH GST

Follow the procedure “With CONSULT-III”.

DTC P1774 LOW COAST BRAKE SOLENOID VALVE FUNCTION

< COMPONENT DIAGNOSIS >

Diagnosis Procedure

INFOID:000000001530913

1. CHECK INPUT SIGNALS

Ⓜ With CONSULT-III

1. Start the engine.
2. Select "SELECTION FROM MENU" in "DATA MONITOR" mode for "TRANSMISSION" with CONSULT-III.
3. Drive vehicle in the "1" or "2" position ("11" or "22" gear) and confirm the ON/OFF actuation of the "ATF PRES SW 2" and "ON OFF SOL".

Item name	Condition	Display value
ON OFF SOL	Low coast brake engaged. Refer to TM-10	ON
	Low coast brake disengaged. Refer to TM-10	OFF
ATF PRES SW 2	Low coast brake engaged. Refer to TM-10	ON
	Low coast brake disengaged. Refer to TM-10	OFF

OK or NG

- OK >> GO TO 4.
NG >> GO TO 2.

2. CHECK TCM POWER SUPPLY AND GROUND CIRCUIT

Check TCM power supply and ground circuit. Refer to [TM-94, "Diagnosis Procedure"](#).

OK or NG

- OK >> GO TO 3.
NG >> Repair or replace damaged parts.

3. DETECT MALFUNCTIONING ITEM

Check the following items:

- The A/T assembly harness connector pin terminals for damage or loose connection with harness connector.

OK or NG

- OK >> Replace the control valve with TCM. Refer to [TM-217, "Control Valve with TCM and A/T Fluid Temperature Sensor 2"](#).
NG >> Repair or replace damaged parts.

4. CHECK DTC

Perform "DTC Confirmation Procedure".

- Refer to [TM-92, "DTC Confirmation Procedure"](#).

OK or NG

- OK >> **INSPECTION END**
NG >> GO TO 2.

MAIN POWER SUPPLY AND GROUND CIRCUIT

< COMPONENT DIAGNOSIS >

MAIN POWER SUPPLY AND GROUND CIRCUIT

Diagnosis Procedure

INFOID:000000001530939

1. CHECK TCM POWER SOURCE STEP 1

1. Turn ignition switch OFF.
2. Disconnect A/T assembly harness connector.
3. Check voltage between A/T assembly harness connector terminals and ground.

Item	Connector	Terminal	Voltage
TCM	F9	1 - Ground	Battery voltage
		2 - Ground	
		6 - Ground	0V

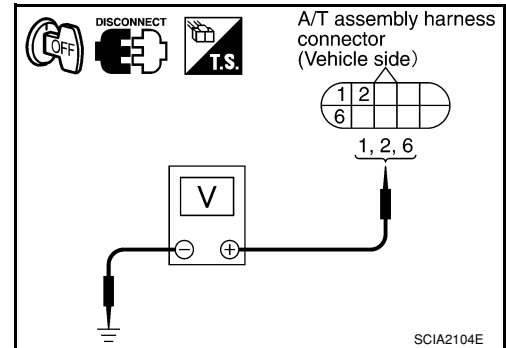

OK or NG

- OK >> GO TO 2.
 NG >> GO TO 3.

2. CHECK TCM POWER SOURCE STEP 2

1. Disconnect A/T assembly harness connector.
2. Turn ignition switch ON. (Do not start engine.)
3. Check voltage between A/T assembly harness connector terminals and ground.

Item	Connector	Terminal	Voltage
TCM	F9	1 - Ground	Battery voltage
		2 - Ground	
		6 - Ground	

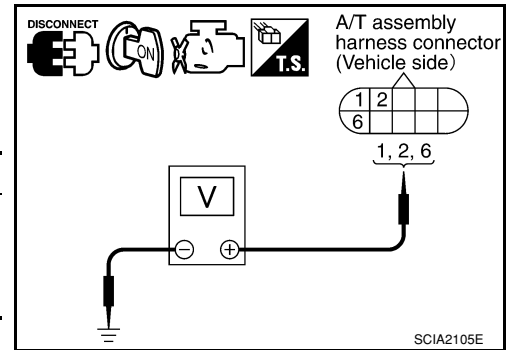

OK or NG

- OK >> GO TO 4.
 NG >> GO TO 3.

3. DETECT MALFUNCTIONING ITEM

Check the following items:

- Harness for short or open between battery and A/T assembly harness connector terminals 1, 2
- Harness for short or open between ignition switch and A/T assembly harness connector terminal 6
- 10A fuse [No. 3, located in the fuse block (J/B)] and 10A fuse (No. 49, located in the IPDM E/R)
- Ignition switch

OK or NG

- OK >> GO TO 4.
 NG >> Repair or replace damaged parts.

4. CHECK TCM GROUND CIRCUIT

1. Turn ignition switch OFF.
2. Disconnect A/T assembly harness connector.
3. Check continuity between A/T assembly harness connector F9 terminals 5, 10 and ground.

Continuity should exist.

If OK, check harness for short to ground and short to power.

OK or NG

- OK >> GO TO 5.
 NG >> Repair open circuit or short to ground or short to power in harness or connectors.

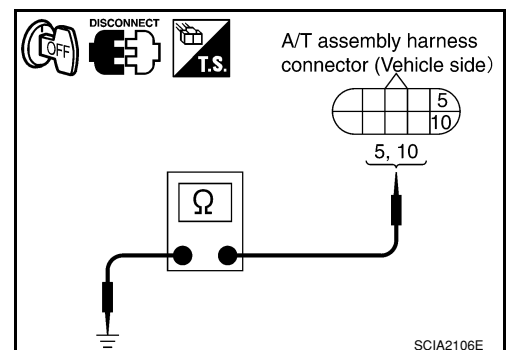

MAIN POWER SUPPLY AND GROUND CIRCUIT

< COMPONENT DIAGNOSIS >

5. DETECT MALFUNCTIONING ITEM

Check the following items:

- The A/T assembly harness connector terminals for damage or loose connection with harness connector.

OK or NG

OK >> GO TO 6.

NG >> Repair or replace damaged parts.

6. PERFORM SELF-DIAGNOSIS

Perform self-diagnosis. Refer to [TM-33. "CONSULT-III Function \(TRANSMISSION\)"](#).

OK or NG

OK >> **INSPECTION END**

NG-1 >> Self-diagnosis does not activate: GO TO 7.

NG-2 >> DTC is displayed: Check the malfunctioning system. Refer to [TM-33. "CONSULT-III Function \(TRANSMISSION\)"](#).

7. CHECK TERMINAL CORD ASSEMBLY

1. Remove control valve with TCM. Refer to [TM-217. "Control Valve with TCM and A/T Fluid Temperature Sensor 2"](#).
2. Disconnect A/T assembly harness connector and TCM connector.
3. Check continuity between A/T assembly harness connector terminals and TCM connector terminals.

Item	Connector	Terminal	Continuity
A/T assembly harness connector	F9	1	Yes
TCM connector	F502	9	
A/T assembly harness connector	F9	2	Yes
TCM connector	F502	10	
A/T assembly harness connector	F9	6	Yes
TCM connector	F502	4	

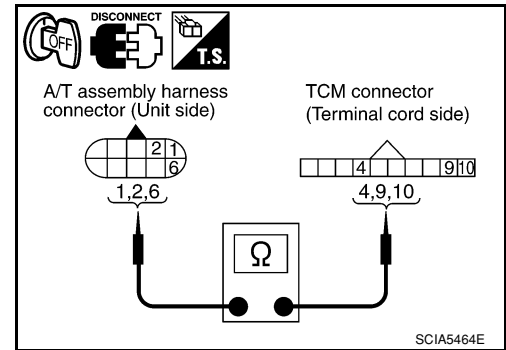

4. Check continuity between A/T assembly harness connector terminals and TCM connector terminals.

Item	Connector	Terminal	Continuity
A/T assembly harness connector	F9	5	Yes
TCM connector	F504	21	
A/T assembly harness connector	F9	10	Yes
TCM connector	F504	22	

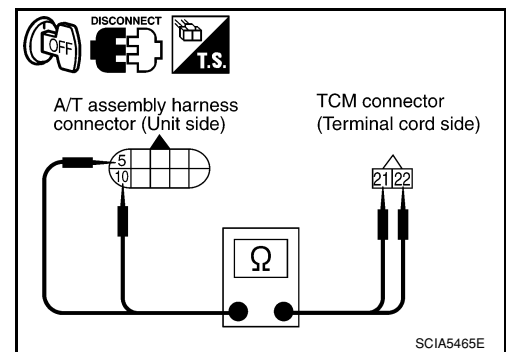

5. If OK, check harness for short to ground and short to power.

OK or NG

OK >> Replace the control valve with TCM. Refer to [TM-217. "Control Valve with TCM and A/T Fluid Temperature Sensor 2"](#).

NG >> Replace open circuit or short to ground and short to power in harness or connectors.

CLOSED THROTTLE POSITION AND WIDE OPEN THROTTLE POSITION CIRCUIT

< COMPONENT DIAGNOSIS >

CLOSED THROTTLE POSITION AND WIDE OPEN THROTTLE POSITION CIRCUIT

CONSULT-III Reference Value in Data Monitor Mode

INFOID:000000001530940

Item name	Condition	Display value
CLSD THL POS	Released accelerator pedal.	ON
	Fully depressed accelerator pedal.	OFF
W/O THL POS	Fully depressed accelerator pedal.	ON
	Released accelerator pedal.	OFF

Diagnosis Procedure

INFOID:000000001530941

1. CHECK CAN COMMUNICATION LINE

Perform the self-diagnosis. Refer to [TM-33. "CONSULT-III Function \(TRANSMISSION\)"](#).

Is a malfunction in the CAN communication indicated in the results?

- YES >> Check CAN communication line. Refer to [TM-39](#).
NO >> GO TO 2.

2. CHECK THROTTLE POSITION SIGNAL CIRCUIT

Ⓢ With CONSULT-III

1. Turn ignition switch "ON". (Do not start engine.)
2. Select "ECU INPUT SIGNALS" in "DATA MONITOR" mode for "TRANSMISSION" with CONSULT-III.
3. Depress accelerator pedal and read out the value of "CLSD THL POS" and "W/O THL POS".

Accelerator Pedal Operation	Monitor Item	
	CLSD THL POS	W/O THL POS
Released	ON	OFF
Fully depressed	OFF	ON

OK or NG

- OK >> **INSPECTION END**
NG >> Check the following items. If NG, repair or replace damaged parts.
- Perform the self-diagnosis for "ENGINE" with CONSULT-III.
 - Open circuit or short to ground or short to power in harness or connectors.
 - Pin terminals for damage or loose connection with harness connector.

BRAKE SIGNAL CIRCUIT

< COMPONENT DIAGNOSIS >

BRAKE SIGNAL CIRCUIT

CONSULT-III Reference Value in Data Monitor Mode

INFOID:000000001530942

Item name	Condition	Display value
BRAKE SW	Depressed brake pedal.	ON
	Released brake pedal.	OFF

Diagnosis Procedure

INFOID:000000001530943

1. CHECK CAN COMMUNICATION LINE

Perform the self-diagnosis. Refer to [TM-33, "CONSULT-III Function \(TRANSMISSION\)"](#).

Is a malfunction in the CAN communication indicated in the results?

- YES >> Check CAN communication line. Refer to [TM-39, "Diagnosis Procedure"](#).
- NO >> GO TO 2.

2. CHECK STOP LAMP SWITCH CIRCUIT

With CONSULT-III

1. Turn ignition switch "ON". (Do not start engine.)
2. Select "ECU INPUT SIGNALS" in "DATA MONITOR" mode for "TRANSMISSION" with CONSULT-III.
3. Read out ON/OFF switching action of the "BRAKE SW".

OK or NG

- OK >> **INSPECTION END**
- NG >> GO TO 3.

3. CHECK STOP LAMP SWITCH

Check continuity between stop lamp switch terminals 1 and 2.

Condition	Continuity
When brake pedal is depressed	Yes
When brake pedal is released	No

Check stop lamp switch after adjusting brake pedal — refer to [BR-14, "Inspection and Adjustment"](#).

OK or NG

- OK >> Check stop lamp switch circuit.
- NG >> Repair or replace stop lamp switch.

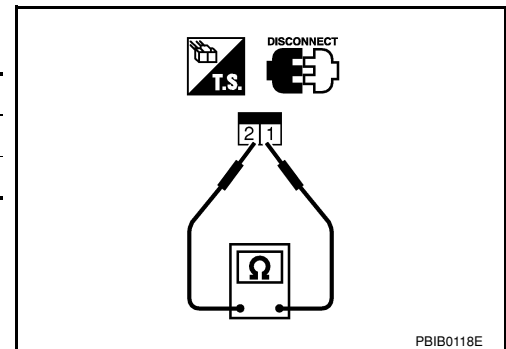

TOW MODE SWITCH

< COMPONENT DIAGNOSIS >

TOW MODE SWITCH

Description

INFOID:000000001530944

When tow mode switch is "ON", tow mode switch signals are sent to TCM from combination meter by CAN communication line. Then it's a tow mode condition.

Diagnosis Procedure

INFOID:000000001530946

1. CHECK CAN COMMUNICATION LINE

Perform the self-diagnosis. Refer to [TM-33. "CONSULT-III Function \(TRANSMISSION\)"](#).

Is any malfunction in the CAN communication indicated in the results?

- YES >> Check CAN communication line. Refer to [TM-39](#).
- NO >> GO TO 2.

2. CHECK POWER SOURCE

1. Turn ignition switch "ON". (Do not start engine.)
2. Check the voltage between tow mode switch connector M67 terminal 1 and ground.

Condition	Tow mode switch	Data (Approx.)
When ignition switch is turned to "ON"	ON	0V
	OFF	Battery voltage

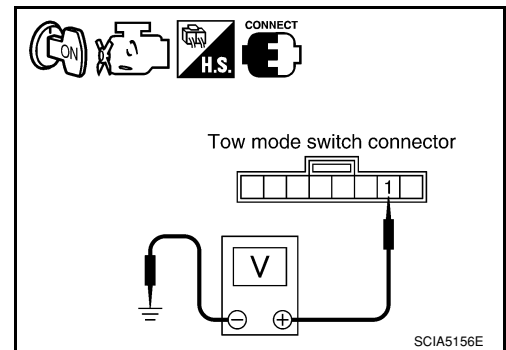

OK or NG

- OK >> **INSPECTION END**
- NG >> GO TO 3.

3. CHECK TOW MODE SWITCH

1. Turn ignition switch "OFF".
2. Disconnect tow mode switch connector.
3. Check continuity between tow mode switch connector M67 terminals 1 and 2.

Condition	Continuity
Tow mode switch "ON"	Yes
Tow mode switch "OFF"	No

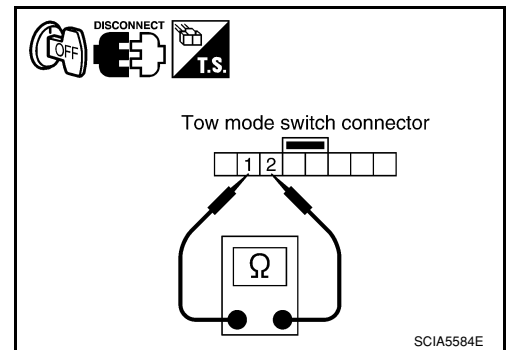

OK or NG

- OK >> GO TO 4.
- NG >> Repair or replace tow mode switch.

4. DETECT MALFUNCTIONING ITEM

Check the following items. If any items are damaged, repair or replace damaged parts.

- Harness for short or open between combination meter connector terminal 35 and tow mode switch connector terminal 1.
- Harness for short or open between tow mode switch connector terminal 2 and ground.

OK or NG

- OK >> GO TO 5.
- NG >> Repair or replace damaged parts.

5. CHECK COMBINATION METER

Check the combination meter. Refer to [TM-6. "Work Flow"](#).

OK or NG

- OK >> **INSPECTION END**
- NO >> Repair or replace damaged parts.

A/T SHIFT LOCK SYSTEM

< COMPONENT DIAGNOSIS >

A/T SHIFT LOCK SYSTEM

A

B

C

TM

E

F

G

H

I

J

K

L

M

N

O

P

A/T SHIFT LOCK SYSTEM

< COMPONENT DIAGNOSIS >

Wiring Diagram - A/T Shift Lock System (With I-Key)

A/T SHIFT LOCK SYSTEM

< COMPONENT DIAGNOSIS >

INFOID:000000001611769

A/T SHIFT LOCK SYSTEM (WITH INTELLIGENT KEY SYSTEM)

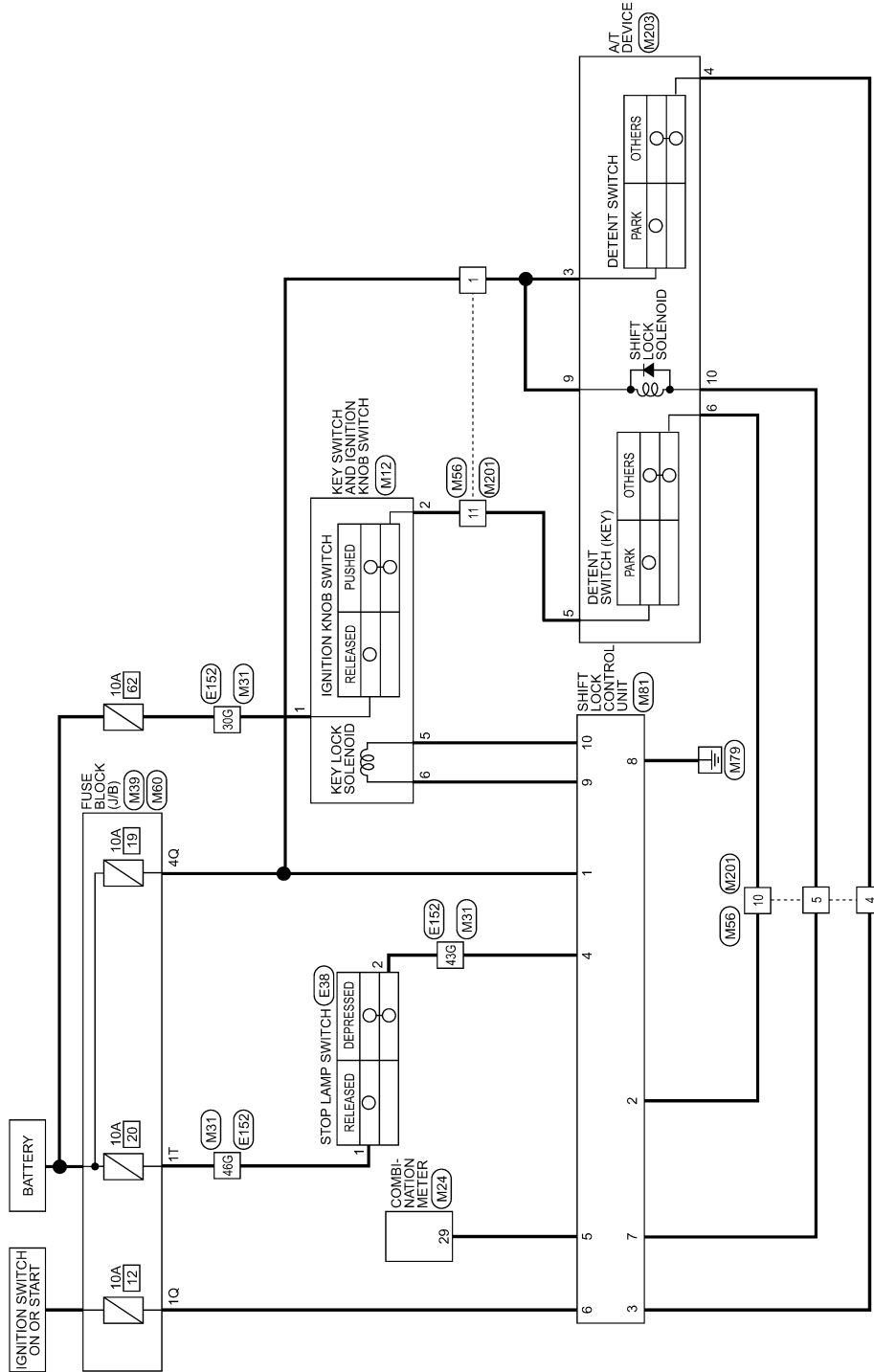

10A	12
10A	20
10A	62

29	1G
76	6G
59	10
131	12
116	
59	24
203	26
59	34
330	31G
59	44
453	42G
59	54
320	51G
59	64
330	62G
726	71G
770	76G

signal Name	-
signal Name	-

10A	12
10A	20
10A	62

signal Name	-
signal Name	-

A
B
C
TM
E
F
G
H
I
J
K
L
M
N
O
P

A/T SHIFT LOCK SYSTEM

< COMPONENT DIAGNOSIS >

Connector No.	M81
Connector Name	SHIFT LOCK CONTROL UNIT
Connector Color	GRAY

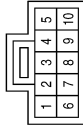

Terminal No.	Color of Wire	Signal Name
1	Y/R	BAT (+)
2	L/R	DETENT SW (KEY)
3	GR	DETENT SW
4	R/G	STOP LAMP SWITCH
5	W/R	8P_VSP
6	G/R	IGN SW
7	R/W	SHIFT LOCK SOL
8	B	GND
9	G/W	KEY LOCK SOL OUTPUT (LOCK)
10	W/G	KEY LOCK SOL OUTPUT (UNLOCK)

Connector No.	M201
Connector Name	WIRE TO WIRE
Connector Color	WHITE

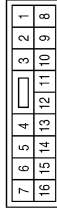

Terminal No.	Color of Wire	Signal Name
1	Y/R	-
4	GR	-
5	R/W	-
10	L/R	-
11	B/R	-

Connector No.	M203
Connector Name	A/T DEVICE
Connector Color	WHITE

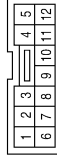

Terminal No.	Color of Wire	Signal Name
3	Y/R	-
4	G/R	-
5	B/R	-
6	L/R	-
9	Y/R	-
10	R/W	-

Connector No.	E38
Connector Name	STOP LAMP SWITCH
Connector Color	BLACK



Terminal No.	Color of Wire	Signal Name
1	R/Y	-
2	R/G	-

Connector No.	E152
Connector Name	WIRE TO WIRE
Connector Color	WHITE

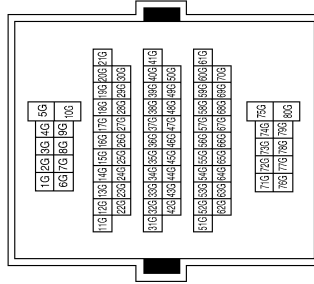

Terminal No.	Color of Wire	Signal Name
43G	R/G	-
46G	R/Y	-

A/T SHIFT LOCK SYSTEM

< COMPONENT DIAGNOSIS >

A/T SHIFT LOCK SYSTEM - WITH INTELLIGENT KEY SYSTEM CONNECTORS

Connector No.	M12
Connector Name	KEY SWITCH AND IGNITION KNOB SWITCH
Connector Color	GRAY

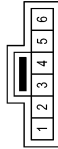

Terminal No.	Color of Wire	Signal Name
1	Y	-
2	R/B	-
5	W/G	-
6	R	-

Connector No.	M24
Connector Name	COMBINATION METER
Connector Color	WHITE

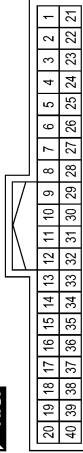

Terminal No.	Color of Wire	Signal Name
29	W/R	SPEED_8P

Connector No.	M31
Connector Name	FUSE BLOCK (J/B)
Connector Color	WHITE

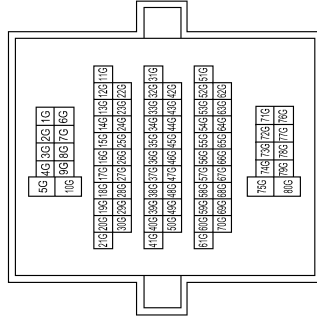

Terminal No.	Color of Wire	Signal Name
30G	Y	-
43G	R/G	-
46G	R/Y	-

Connector No.	M39
Connector Name	FUSE BLOCK (J/B)
Connector Color	WHITE



Terminal No.	Color of Wire	Signal Name
1Q	G/R	-
4Q	Y/R	-

Connector No.	M56
Connector Name	WIRE TO WIRE
Connector Color	WHITE

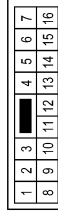

Terminal No.	Color of Wire	Signal Name
1	Y/R	-
4	GR	-
5	R/W	-
10	L/R	-
11	R/B	-

Connector No.	M60
Connector Name	FUSE BLOCK (J/B)
Connector Color	WHITE

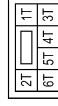

Terminal No.	Color of Wire	Signal Name
1T	R/Y	-

ALDIA0126GB

A
B
C
TM
E
F
G
H
I
J
K
L
M
N
O
P

A/T SHIFT LOCK SYSTEM

< COMPONENT DIAGNOSIS >

Connector No.	M81
Connector Name	SHIFT LOCK CONTROL UNIT
Connector Color	GRAY

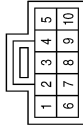

Terminal No.	Color of Wire	Signal Name
1	Y/R	BAT (+)
2	L/R	DETENT SW (KEY)
3	GR	DETENT SW
4	R/G	STOP LAMP SWITCH
5	W/R	8P VSP
6	G/R	IGN SW
7	R/W	SHIFT LOCK SOL
8	B	GND
9	G/W	KEY LOCK SOL OUTPUT (LOCK)
10	W/G	KEY LOCK SOL OUTPUT (UNLOCK)

Connector No.	M201
Connector Name	WIRE TO WIRE
Connector Color	WHITE

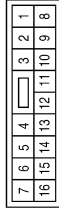

Terminal No.	Color of Wire	Signal Name
1	Y/R	-
4	GR	-
5	R/W	-
10	L/R	-
11	R/B	-

Connector No.	M203
Connector Name	A/T DEVICE
Connector Color	WHITE

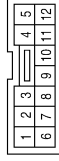

Terminal No.	Color of Wire	Signal Name
3	Y/R	-
4	G/R	-
5	R/B	-
6	L/R	-
9	Y/R	-
10	R/W	-

Connector No.	E38
Connector Name	STOP LAMP SWITCH
Connector Color	BLACK



Terminal No.	Color of Wire	Signal Name
1	R/Y	-
2	R/G	-

Connector No.	E152
Connector Name	WIRE TO WIRE
Connector Color	WHITE

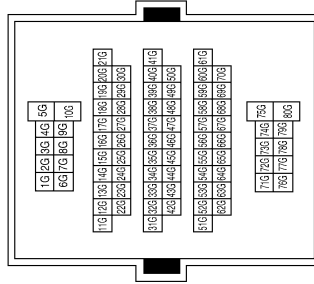

Terminal No.	Color of Wire	Signal Name
30G	Y	-
43G	R/G	-
46G	R/Y	-

A/T SHIFT LOCK SYSTEM

< COMPONENT DIAGNOSIS >

Wiring Diagram - A/T Shift Lock System (Without I-Key)

INFOID:000000001530949

A/T SHIFT LOCK SYSTEM (WITHOUT INTELLIGENT KEY SYSTEM)

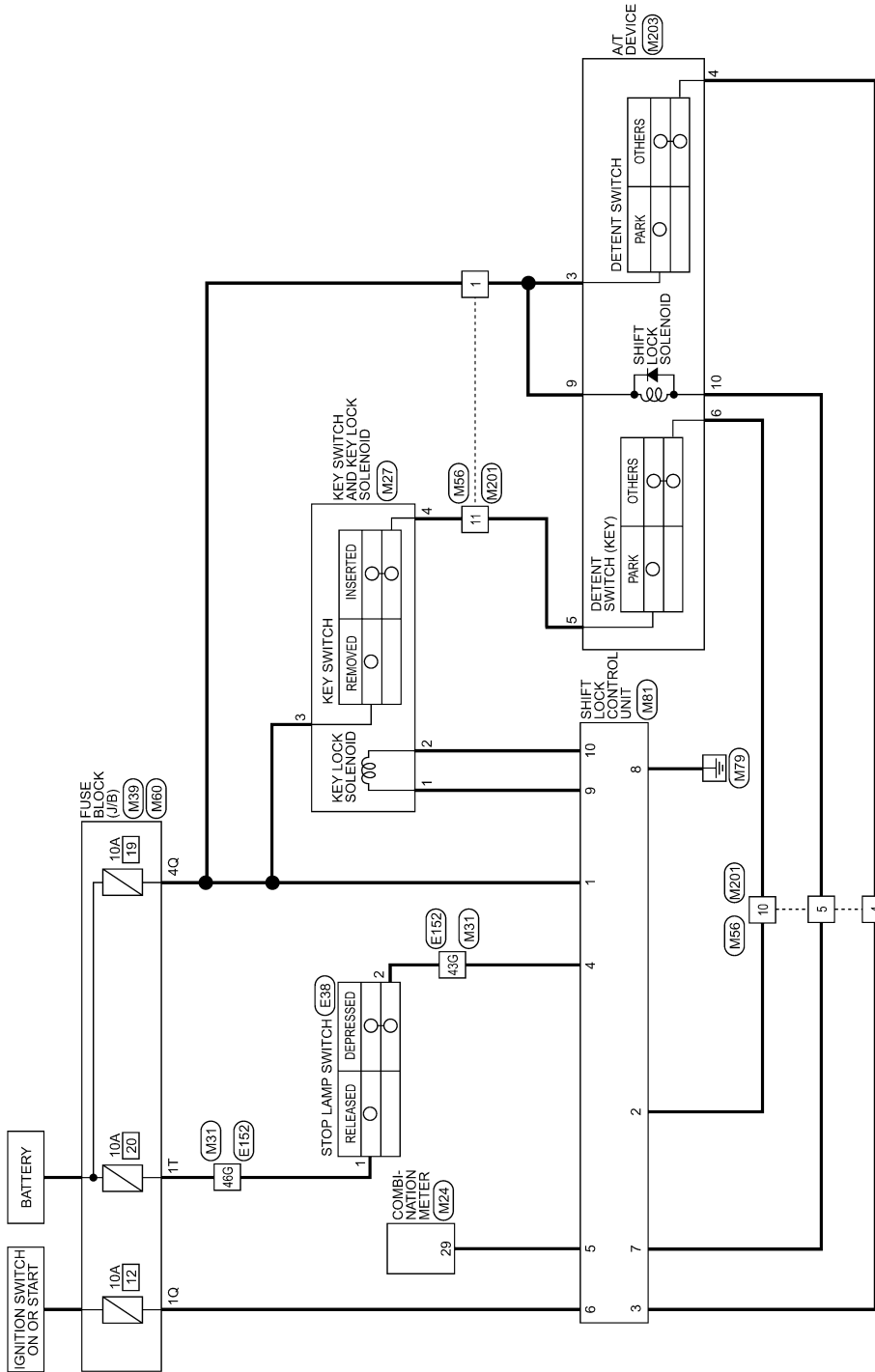

ALDWA0031GE

A
B
C
TM
E
F
G
H
I
J
K
L
M
N
O
P

A/T SHIFT LOCK SYSTEM

< COMPONENT DIAGNOSIS >

A/T SHIFT LOCK SYSTEM (WITH INTELLIGENT KEY SYSTEM)

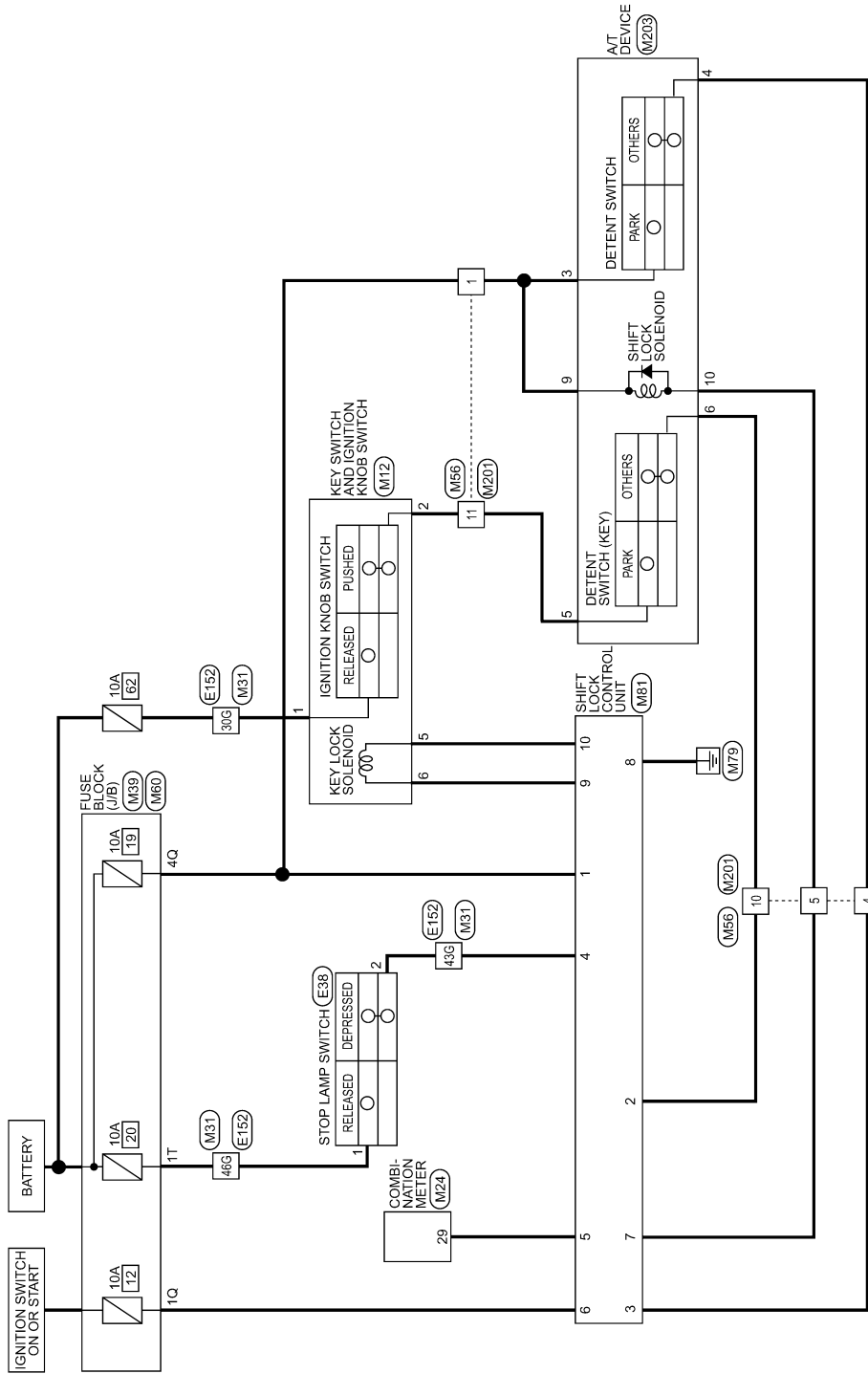

ALDWA0032GE

A/T SHIFT LOCK SYSTEM

< COMPONENT DIAGNOSIS >

A/T SHIFT LOCK SYSTEM - WITHOUT INTELLIGENT KEY SYSTEM CONNECTORS

Connector No.	M24
Connector Name	COMBINATION METER
Connector Color	WHITE

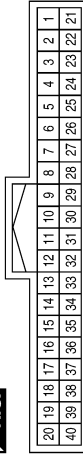

Terminal No.	Color of Wire	Signal Name
29	W/R	SPEED_8P

Connector No.	M27
Connector Name	KEY SWITCH KEY LOCK SOLENOID
Connector Color	WHITE

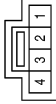

Terminal No.	Color of Wire	Signal Name
1	G/W	-
2	W/G	-
3	Y/R	-
4	B/R	-

Connector No.	M31
Connector Name	FUSE BLOCK (J/B)
Connector Color	WHITE

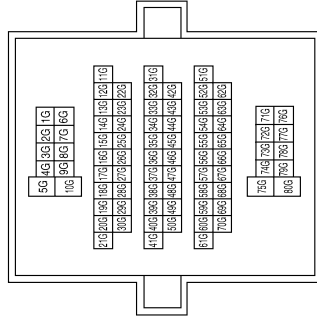

Terminal No.	Color of Wire	Signal Name
43G	R/G	-
46G	R/Y	-

Connector No.	M39
Connector Name	FUSE BLOCK (J/B)
Connector Color	WHITE

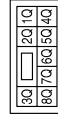

Terminal No.	Color of Wire	Signal Name
1Q	G/R	-
4Q	Y/R	-

Connector No.	M56
Connector Name	WIRE TO WIRE
Connector Color	WHITE

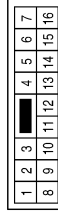

Terminal No.	Color of Wire	Signal Name
1	Y/R	-
4	GR	-
5	R/W	-
10	L/R	-
11	R/B	-

Connector No.	M60
Connector Name	FUSE BLOCK (J/B)
Connector Color	WHITE



Terminal No.	Color of Wire	Signal Name
1T	R/Y	-

ALDIA0124GB

A/T SHIFT LOCK SYSTEM

< COMPONENT DIAGNOSIS >

Connector No.	M81
Connector Name	SHIFT LOCK CONTROL UNIT
Connector Color	GRAY

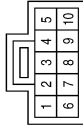

Terminal No.	Color of Wire	Signal Name
1	Y/R	BAT (+)
2	L/R	DETENT SW (KEY)
3	GR	DETENT SW
4	R/G	STOP LAMP SWITCH
5	W/R	8P_VSP
6	G/R	IGN SW
7	R/W	SHIFT LOCK SOL
8	B	GND
9	G/W	KEY LOCK SOL OUTPUT (LOCK)
10	W/G	KEY LOCK SOL OUTPUT (UNLOCK)

Connector No.	M201
Connector Name	WIRE TO WIRE
Connector Color	WHITE

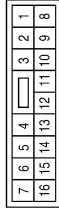

Terminal No.	Color of Wire	Signal Name
1	Y/R	-
4	GR	-
5	R/W	-
10	L/R	-
11	B/R	-

Connector No.	M203
Connector Name	A/T DEVICE
Connector Color	WHITE

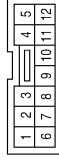

Terminal No.	Color of Wire	Signal Name
3	Y/R	-
4	G/R	-
5	B/R	-
6	L/R	-
9	Y/R	-
10	R/W	-

Connector No.	E38
Connector Name	STOP LAMP SWITCH
Connector Color	BLACK



Terminal No.	Color of Wire	Signal Name
1	R/Y	-
2	R/G	-

Connector No.	E152
Connector Name	WIRE TO WIRE
Connector Color	WHITE

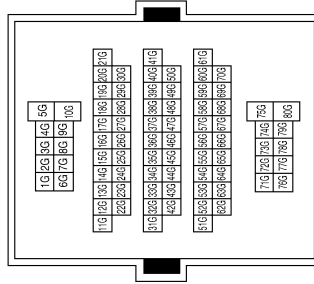

Terminal No.	Color of Wire	Signal Name
43G	R/G	-
46G	R/Y	-

A/T SHIFT LOCK SYSTEM

< COMPONENT DIAGNOSIS >

A/T SHIFT LOCK SYSTEM - WITH INTELLIGENT KEY SYSTEM CONNECTORS

Connector No.	M12
Connector Name	KEY SWITCH AND IGNITION KNOB SWITCH
Connector Color	GRAY

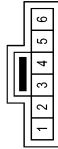

Terminal No.	Color of Wire	Signal Name
1	Y	-
2	R/B	-
5	W/G	-
6	R	-

Connector No.	M24
Connector Name	COMBINATION METER
Connector Color	WHITE

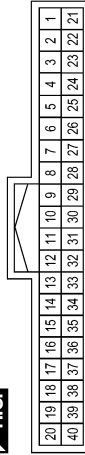

Terminal No.	Color of Wire	Signal Name
29	W/R	SPEED_8P

Connector No.	M31
Connector Name	FUSE BLOCK (J/B)
Connector Color	WHITE

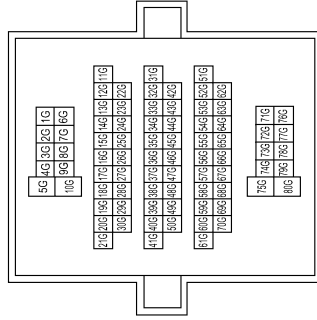

Terminal No.	Color of Wire	Signal Name
30G	Y	-
43G	R/G	-
46G	R/Y	-

Connector No.	M39
Connector Name	FUSE BLOCK (J/B)
Connector Color	WHITE



Terminal No.	Color of Wire	Signal Name
1Q	G/R	-
4Q	Y/R	-

Connector No.	M56
Connector Name	WIRE TO WIRE
Connector Color	WHITE

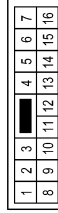

Terminal No.	Color of Wire	Signal Name
1	Y/R	-
4	GR	-
5	R/W	-
10	L/R	-
11	R/B	-

Connector No.	M60
Connector Name	FUSE BLOCK (J/B)
Connector Color	WHITE

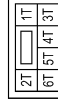

Terminal No.	Color of Wire	Signal Name
1T	R/Y	-

ALDIA0126GB

A/T SHIFT LOCK SYSTEM

< COMPONENT DIAGNOSIS >

Connector No.	M81
Connector Name	SHIFT LOCK CONTROL UNIT
Connector Color	GRAY

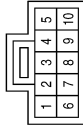

Terminal No.	Color of Wire	Signal Name
1	Y/R	BAT (+)
2	L/R	DETENT SW (KEY)
3	GR	DETENT SW
4	R/G	STOP LAMP SWITCH
5	W/R	8P VSP
6	G/R	IGN SW
7	R/W	SHIFT LOCK SOL
8	B	GND
9	G/W	KEY LOCK SOL OUTPUT (LOCK)
10	W/G	KEY LOCK SOL OUTPUT (UNLOCK)

Connector No.	M201
Connector Name	WIRE TO WIRE
Connector Color	WHITE

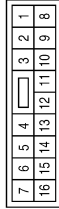

Terminal No.	Color of Wire	Signal Name
1	Y/R	-
4	GR	-
5	R/W	-
10	L/R	-
11	R/B	-

Connector No.	M203
Connector Name	A/T DEVICE
Connector Color	WHITE

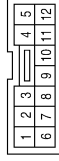

Terminal No.	Color of Wire	Signal Name
3	Y/R	-
4	G/R	-
5	R/B	-
6	L/R	-
9	Y/R	-
10	R/W	-

Connector No.	E38
Connector Name	STOP LAMP SWITCH
Connector Color	BLACK



Terminal No.	Color of Wire	Signal Name
1	R/Y	-
2	R/G	-

Connector No.	E152
Connector Name	WIRE TO WIRE
Connector Color	WHITE

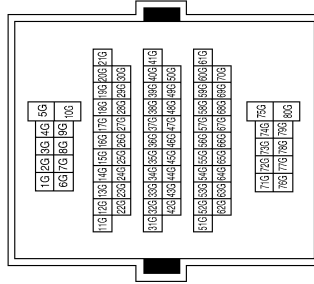

Terminal No.	Color of Wire	Signal Name
30G	Y	-
43G	R/G	-
46G	R/Y	-

A/T SHIFT LOCK SYSTEM

< COMPONENT DIAGNOSIS >

Terminals And Reference Values

INFOID:000000001530950

SHIFT LOCK HARNESS CONNECTOR TERMINALS LAYOUT

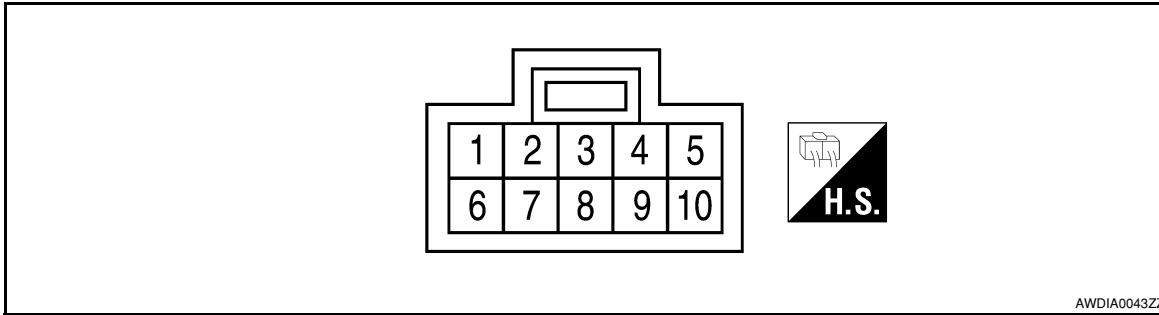

SHIFT LOCK CONTROL UNIT INSPECTION TABLE

Data are reference values.

TER-MINAL NO.	WIRE COLOR	ITEM	CONDITION	VOLTAGE (Approx.)
1	Y/R	Power source	Ignition switch: "ON"	Battery voltage
			Ignition switch: "OFF"	Battery voltage
2	L/R	Detention switch (for key)	When selector lever is not in "P" position with key inserted.	Battery voltage
			Except the above	0V
3	GR	Detention switch (for shift)	When selector lever is not in "P" position	Battery voltage
			Except the above	0V
4	R/G	Stop lamp switch	When brake pedal is depressed	Battery voltage
			When brake pedal is released	0V
5	W/R	Vehicle speed signal	—	—
6	G/R	Ignition signal	Ignition switch: "OFF"	0V
			Ignition switch: "ON"	Battery voltage
7	R/W	Shift lock solenoid	When brake pedal is depressed with ignition switch "ON".	0V
			When brake pedal is depressed.	Battery voltage
8	B	Ground	Always	0V
9	R	Key lock solenoid	When the selector lever is set to a position other than the "P" position, and the key switch is turned from "ON" to "OFF"	Battery voltage for approx. 0.1 sec. (Note)
			Except the above	0V
10	W/G	Key unlock solenoid	When ignition switch is not in "ON" position with key inserted.	Battery voltage for approx. 0.1 sec. (Note)
			Except the above	0V

NOTE:

Confirm that the pointer swings only momentarily because the output time is so short. If the inspection is done with an oscilloscope, it should be observed that the power source voltage lasts for 3.5 to 10 ms.

Component Description

INFOID:000000001530951

SHIFT LOCK SOLENOID

A/T SHIFT LOCK SYSTEM

< COMPONENT DIAGNOSIS >

- Check operation by applying battery voltage to A/T device terminal 9 and ground to terminal 10.

CAUTION:

Be sure to apply the voltage of the correct polarity to the respective terminals. Otherwise, the part may be damaged.

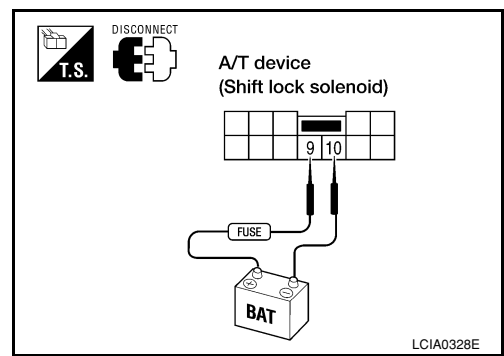

DETENTION SWITCH

For key:

- Check continuity between terminals of the A/T device.

Condition	Terminal No.	Continuity
When selector lever is "P" position.	5 - 6	No
When selector lever is not "P" position.		Yes

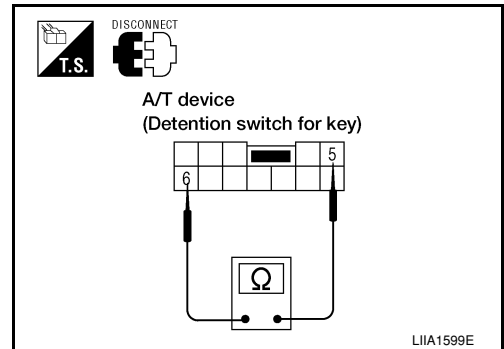

DETENTION SWITCH

For shift:

- Check continuity between terminals of the A/T device.

Condition	Terminal No.	Continuity
When selector lever is "P" position.	3 - 4	No
When selector lever is not "P" position.		Yes

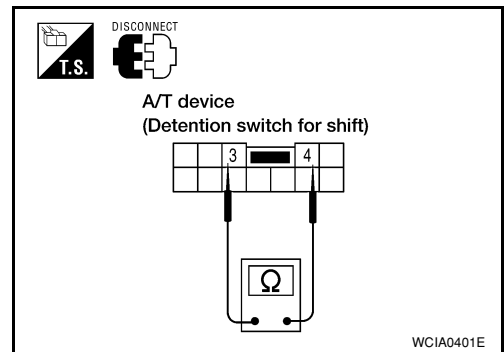

KEY LOCK SOLENOID

Key lock

- Check operation by applying battery voltage to key switch and key lock solenoid terminal 1 and ground to terminal 2.

CAUTION:

Be careful not to cause burnout of the harness.

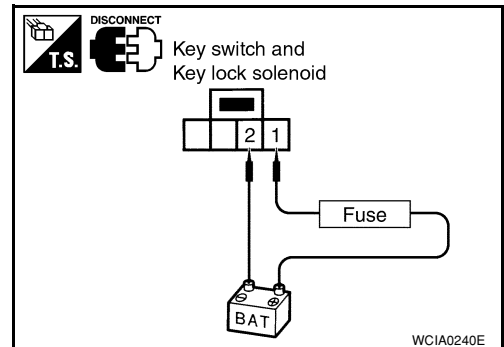

Key unlock

A/T SHIFT LOCK SYSTEM

< COMPONENT DIAGNOSIS >

- Check operation by applying battery voltage to key switch and key lock solenoid terminal 2 and ground to terminal 1.

CAUTION:

Be careful not to cause burnout of the harness.

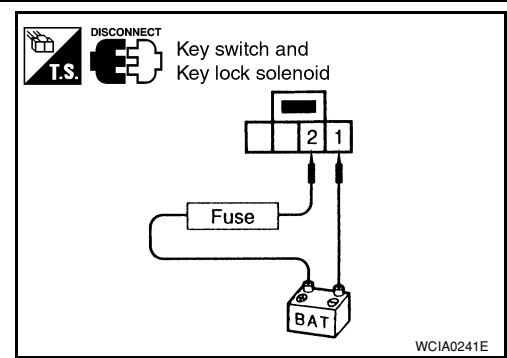

KEY SWITCH

- Check continuity between terminals of the key switch and key lock solenoid.

Condition	Terminal No.	Continuity
Key inserted	3 - 4	Yes
Key withdrawn		No

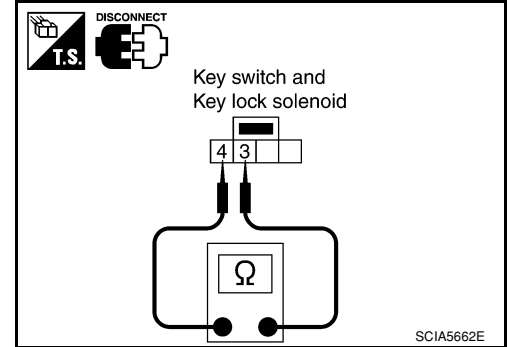

STOP LAMP SWITCH

- Check continuity between terminals of the stop lamp switch harness connector.

Condition	Terminal No.	Continuity
When brake pedal is depressed	1 - 2	Yes
When brake pedal is released		No

Check stop lamp switch after adjusting brake pedal.

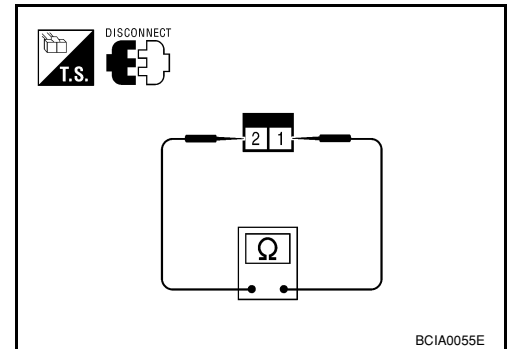

A
B
C
TM
E
F
G
H
I
J
K
L
M
N
O
P

ECU DIAGNOSIS**TCM****Reference Value**

INFOID:000000001530139

REFERENCE VALUES**NOTICE:**

- The CONSULT-III electrically displays shift timing and lock-up timing (that is, operation timing of each solenoid).
Check for time difference between actual shift timing and the CONSULT-III display. If the difference is noticeable, mechanical parts (except solenoids, sensors, etc.) may be malfunctioning. Check mechanical parts using applicable diagnostic procedures.
- Shift schedule (which implies gear position) displayed on CONSULT-III and that indicated in Service Manual may differ slightly. This occurs because of the following reasons:
 - Actual shift schedule has more or less tolerance or allowance,
 - Shift schedule indicated in Service Manual refers to the point where shifts start, and
 - Gear position displayed on CONSULT-III indicates the point where shifts are completed.
- Display of solenoid valves on CONSULT-III changes at the start of shifting, while gear position is displayed upon completion of shifting (which is computed by TCM).

Item name	Condition	Display value (Approx.)
ATF TEMP SE 1	0°C (32° F) - 20°C (68°F) - 80°C (176°F)	3.3 - 2.7 - 0.9 V
ATF TEMP SE 2		3.3 - 2.5 - 0.7 V
TCC SOLENOID	When perform slip lock-up	0.2 - 0.4 A
	When perform lock-up	0.4 - 0.6 A
SLCT LVR POSI	Selector lever in "N", "P" position.	N/P
	Selector lever in "R" position.	R
	Selector lever in "D" position.	D
	Selector lever in "4" position.	4
	Selector lever in "3" position.	3
	Selector lever in "2" position.	2
SLCT LVR POSI	Selector lever in "1" position.	1
VHCL/S SE·A/T	During driving	Approximately matches the speedometer reading.
ENGINE SPEED	Engine running	Closely matches the tachometer reading.
LINE PRES SOL	During driving	0.2 - 0.6 A
TURBINE REV	During driving (lock-up ON)	Approximately matches the engine speed.
VHCL/S SE·MTR	During driving	Approximately matches the speedometer reading.
ATF PRES SW 2	Low coast brake engaged. Refer to TM-10	ON
	Low coast brake disengaged. Refer to TM-10	OFF
I/C SOLENOID	Input clutch disengaged. Refer to TM-10	0.6 - 0.8 A
	Input clutch engaged. Refer to TM-10	0 - 0.05 A
FR/B SOLENOID	Front brake engaged. Refer to TM-10	0.6 - 0.8 A
	Front brake disengaged. Refer to TM-10	0 - 0.05 A
D/C SOLENOID	Direct clutch disengaged. Refer to TM-10	0.6 - 0.8 A
	Direct clutch engaged. Refer to TM-10	0 - 0.05 A
HLR/C SOL	High and low reverse clutch disengaged. Refer to TM-10	0.6 - 0.8 A
	High and low reverse clutch engaged. Refer to TM-10	0 - 0.05 A

TCM

< ECU DIAGNOSIS >



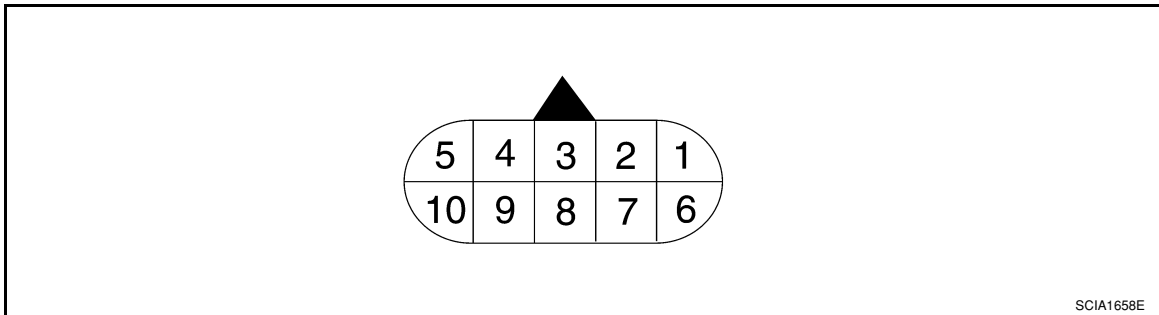

Item name	Condition	Display value (Approx.)
ON OFF SOL	Low coast brake engaged. Refer to TM-10	ON
	Low coast brake disengaged. Refer to TM-10	OFF
STARTER RELAY	Selector lever in "N","P" position.	ON
	Selector lever in other position.	OFF
ACCELE POSI	Released accelerator pedal.	0.0/8
	Fully depressed accelerator pedal.	8/8
CLSD THL POS	Released accelerator pedal.	ON
	Fully depressed accelerator pedal.	OFF
W/O THL POS	Fully depressed accelerator pedal.	ON
	Released accelerator pedal.	OFF
BRAKE SW	Depressed brake pedal.	ON
	Released brake pedal.	OFF

A/T ASSEMBLY HARNESS CONNECTOR TERMINAL LAYOUT



TERMINALS AND REFERENCE VALUES FOR TCM

Data are reference value and are measured between each terminal and ground.

Terminal No.	Wire color	Item	Condition	Data (Pyrex.)
1	P	Power supply (Memory back-up)	Always	Battery voltage
2	P	Power supply (Memory back-up)	Always	Battery voltage
3	L	CAN-H	-	-
4	G/W	K-line (CONSULT-III signal)	The terminal is connected to the data link connector for CONSULT-III.	
5	B	Ground	Always	0V
6	Y/R	Power supply		Battery voltage
				0V
7	R	Back-up lamp relay		0V
				Battery voltage
8	P	CAN-L	-	-
9	B/R	Starter relay		Battery voltage
				0V
10	B	Ground	Always	0V

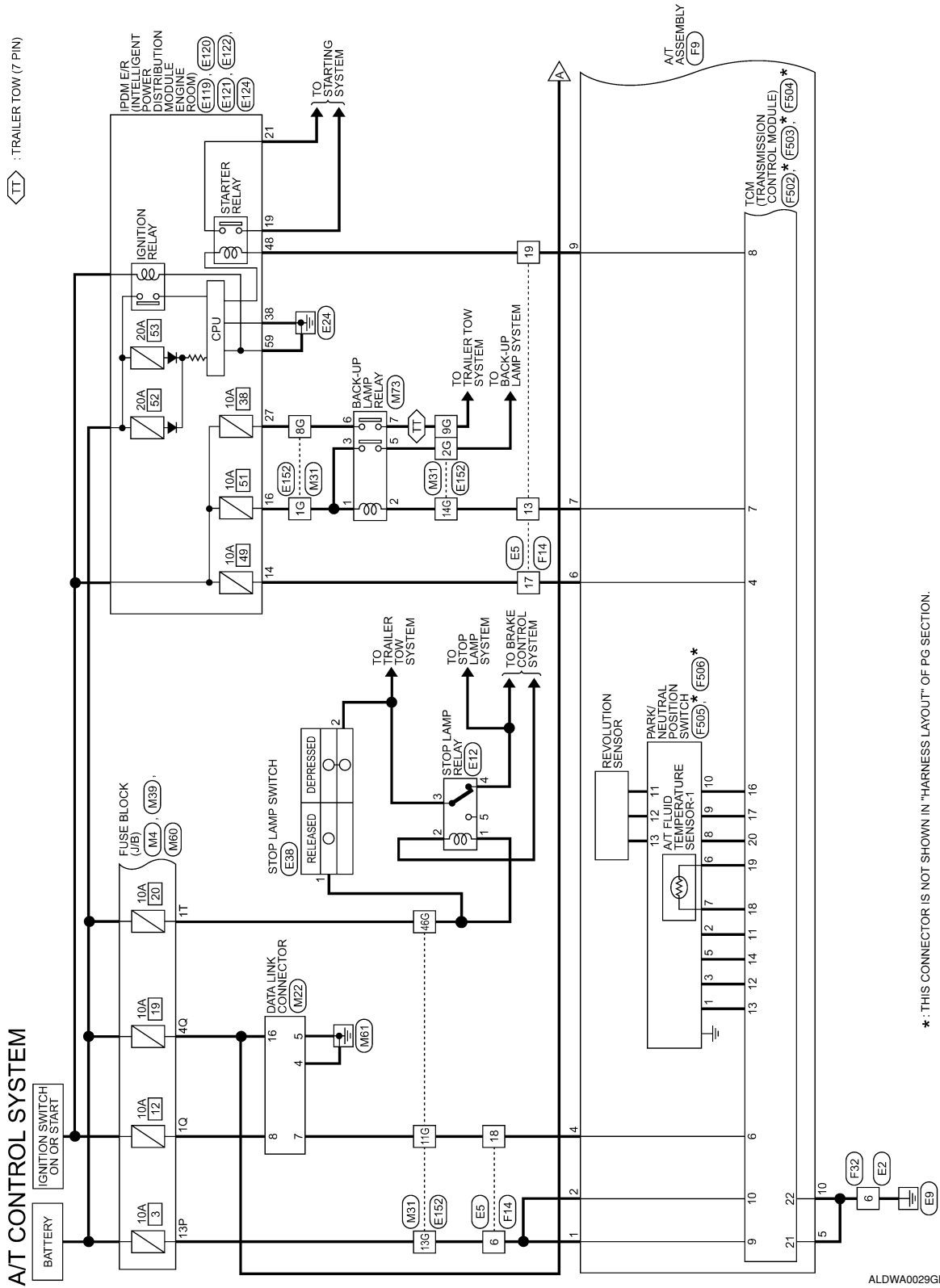

TT : TRAILER TOW (7 PIN)
 — : DATA LINE

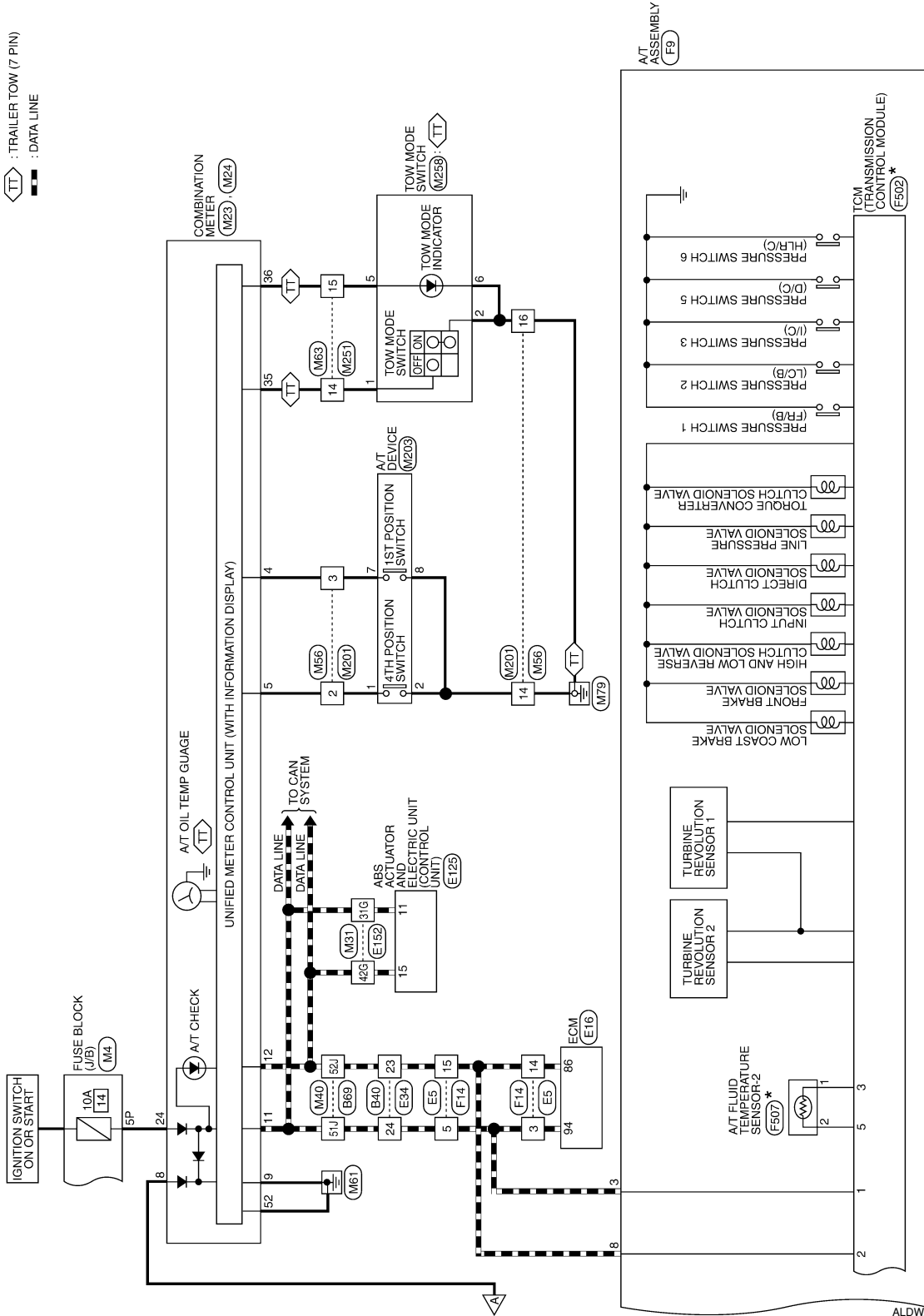

* : THIS CONNECTOR IS NOT SHOWN IN "HARNES LAYOUT" OF PG SECTION.

ALDWA0030GE

A
 B
 C
TM
 E
 F
 G
 H
 I
 J
 K
 L
 M
 N
 O
 P

A/T CONTROL SYSTEM CONNECTORS

Connector No.	M4
Connector Name	FUSE BLOCK (J/B)
Connector Color	WHITE

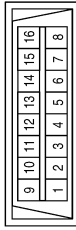
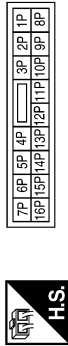

Connector No.	M22
Connector Name	DATA LINK CONNECTOR
Connector Color	WHITE



Connector No.	M23
Connector Name	COMBINATION METER
Connector Color	WHITE

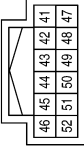

Terminal No.	Color of Wire	Signal Name
5P	O/B	-
13P	P	-

Terminal No.	Color of Wire	Signal Name
4	B	BODY_GND
5	B	ENG_GND
7	G/W	K-LINE
8	G/R	IGN_SW
16	Y/R	+B

Terminal No.	Color of Wire	Signal Name
52	B	-

Connector No.	M24
Connector Name	COMBINATION METER
Connector Color	WHITE

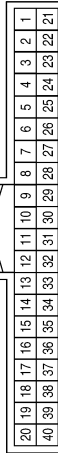

Terminal No.	Color of Wire	Signal Name
4	Y/G	-
5	SB	-
8	Y/R	-
9	B	-
11	L	CAN-H
12	P	CAN-L
24	O/L	-
35	LG/R	TOW_SW_STATUS
36	Y/V	TOW_IND

Connector No.	M31
Connector Name	WIRE TO WIRE
Connector Color	WHITE

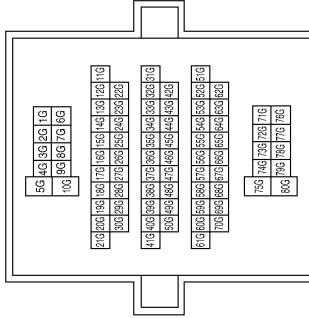

Terminal No.	Color of Wire	Signal Name
1G	G	-
2G	G/W	-
8G	W/B	-
9G	Y/R	-
11G	G/W	-
13G	P	-
14G	R	-
31G	L	-
42G	P	-
46G	R/Y	-

Connector No.	M56
Connector Name	WIRE TO WIRE
Connector Color	WHITE

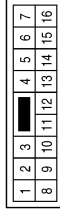

Terminal No.	Color of Wire	Signal Name
2	SB	-
3	Y/G	-
14	B	-
16	GR/R	-

Connector No.	M40
Connector Name	WIRE TO WIRE
Connector Color	WHITE

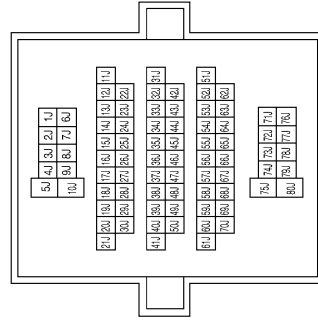

Terminal No.	Color of Wire	Signal Name
51J	L	-
52J	P	-

Connector No.	M39
Connector Name	FUSE BLOCK (J/B)
Connector Color	WHITE

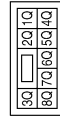

Terminal No.	Color of Wire	Signal Name
1Q	G/R	-
4Q	Y/R	-

Connector No.	M73
Connector Name	BACK-UP LAMP RELAY
Connector Color	BROWN



Terminal No.	Color of Wire	Signal Name
1	G	-
2	R	-
3	G	-
5	G/W	-
6	W/B	-
7	Y/R	-

Connector No.	M63
Connector Name	WIRE TO WIRE
Connector Color	BROWN

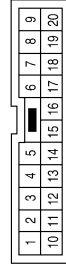

Terminal No.	Color of Wire	Signal Name
14	LG/R	-
15	Y/V	-

Connector No.	M60
Connector Name	FUSE BLOCK (J/B)
Connector Color	WHITE

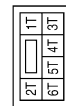

Terminal No.	Color of Wire	Signal Name
1T	R/Y	-

ALDIA0118GB

Connector No.	M251
Connector Name	WIRE TO WIRE
Connector Color	BROWN

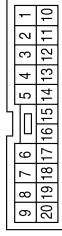

Terminal No.	Color of Wire	Signal Name
14	LG/R	-
15	Y/V	-

Connector No.	M203
Connector Name	A/T DEVICE
Connector Color	WHITE

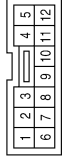

Terminal No.	Color of Wire	Signal Name
1	SB	-
2	B	-
7	Y/G	-
8	B	-

Connector No.	M201
Connector Name	WIRE TO WIRE
Connector Color	WHITE

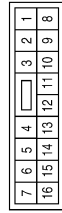

Terminal No.	Color of Wire	Signal Name
2	SB	-
3	Y/G	-
14	B	-
16	GR/R	-

Connector No.	E5
Connector Name	WIRE TO WIRE
Connector Color	WHITE

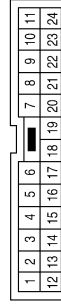

Terminal No.	Color of Wire	Signal Name
3	L	-
5	L	-
6	P	-
13	R	-
14	P	-
15	P	-
17	Y/R	-
18	G/W	-
19	B/R	-

Connector No.	E2
Connector Name	WIRE TO WIRE
Connector Color	WHITE



Terminal No.	Color of Wire	Signal Name
6	B	-

Connector No.	M258
Connector Name	TOW MODE SWITCH
Connector Color	GRAY

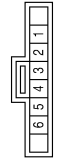

Terminal No.	Color of Wire	Signal Name
1	LG/R	-
2	B	-
5	Y/V	-
6	B	-

Connector No.	E34
Connector Name	WIRE TO WIRE
Connector Color	WHITE

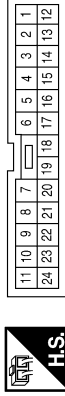

Terminal No.	Color of Wire	Signal Name
23	P	-
24	L	-

Connector No.	E16
Connector Name	ECM
Connector Color	BLACK

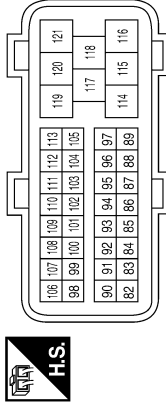

Terminal No.	Color of Wire	Signal Name
86	P	CAN-L
94	L	CAN-H

Connector No.	E12
Connector Name	STOP LAMP RELAY
Connector Color	BLACK



Terminal No.	Color of Wire	Signal Name
1	R/Y	-
2	L/W	-
3	R/G	-
4	R/B	-
5	-	-

Connector No.	E120
Connector Name	IPDM E/R (INTELLIGENT POWER DISTRIBUTION MODULE ENGINE ROOM)
Connector Color	WHITE

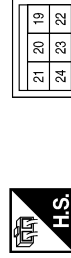

Terminal No.	Color of Wire	Signal Name
19	W/R	STARTER MTR
21	BR	IGN SW (ST)

Connector No.	E119
Connector Name	IPDM E/R (INTELLIGENT POWER DISTRIBUTION MODULE ENGINE ROOM)
Connector Color	WHITE

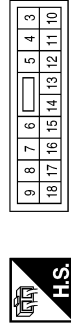

Terminal No.	Color of Wire	Signal Name
14	Y/R	A/T CU IGN SUPPLY
16	G	REVERSE LAMP

Connector No.	E38
Connector Name	STOP LAMP SWITCH
Connector Color	BLACK



Terminal No.	Color of Wire	Signal Name
1	R/Y	-
2	R/G	-

Connector No.	E121
Connector Name	IPDM E/R (INTELLIGENT POWER DISTRIBUTION MODULE ENGINE ROOM)
Connector Color	BROWN

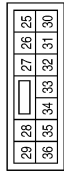

Terminal No.	Color of Wire	Signal Name
27	W/B	TTOW REV LAMP

Connector No.	E122
Connector Name	IPDM E/R (INTELLIGENT POWER DISTRIBUTION MODULE ENGINE ROOM)
Connector Color	WHITE

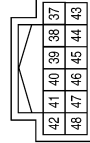

Terminal No.	Color of Wire	Signal Name
38	B	GND (SIG)
48	B/R	INHIBIT SW

Connector No.	E124
Connector Name	IPDM E/R (INTELLIGENT POWER DISTRIBUTION MODULE ENGINE ROOM)
Connector Color	BLACK



Terminal No.	Color of Wire	Signal Name
59	B	GND (PWR)

Connector No.	E125
Connector Name	ABS ACTUATOR AND ELECTRIC UNIT (CONTROL UNIT)
Connector Color	BLACK

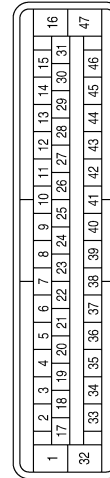

Terminal No.	Color of Wire	Signal Name
11	L	CAN-H
15	P	CAN-L

Connector No.	E152
Connector Name	WIRE TO WIRE
Connector Color	WHITE

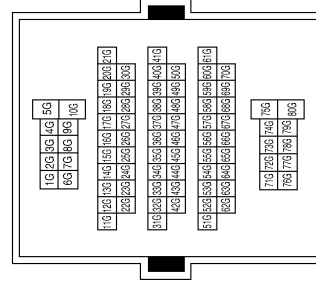

Terminal No.	Color of Wire	Signal Name
1G	G	-
2G	G/W	-
8G	W/B	-
9G	Y/R	-
11G	G/W	-
13G	P	-
14G	R	-
31G	L	-
42G	P	-
46G	R/Y	-

Connector No.	F32
Connector Name	WIRE TO WIRE
Connector Color	WHITE

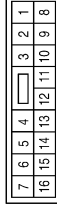

Terminal No.	Color of Wire	Signal Name
6	B	-

Connector No.	F14
Connector Name	WIRE TO WIRE
Connector Color	WHITE

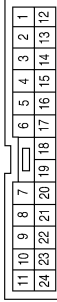

Terminal No.	Color of Wire	Signal Name
3	L	-
5	L	-
6	P	-
13	R	-
14	P	-
15	P	-
17	Y/R	-
18	G/W	-
19	B/R	-

Connector No.	F9
Connector Name	A/T ASSEMBLY
Connector Color	GREEN

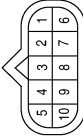

Terminal No.	Color of Wire	Signal Name
1	P	-
2	P	-
3	L	CAN-H
4	V	-
5	B	GND
6	Y/R	-
7	R	-
8	P	CAN-L
9	B/R	-
10	B	GND

Terminal No.	Color of Wire	Signal Name
1	BR	CAN-H
2	L/Y	CAN-L
3	W/Y	ATF SENS 2-
4	R	VIGN
5	W/R	ATF SENS 2+
6	L	K-LINE
7	R	REV LAMP RLY
8	G	START-RLY
9	W	STAND BY SUPPLY-1
10	GR	STAND BY SUPPLY-2

Connector No.	F502
Connector Name	TCM (TRANSMISSION CONTROL MODULE)
Connector Color	GRAY

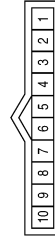

ALDIA0122GB

Connector No.	F505
Connector Name	PARK/NEUTRAL POSITION SWITCH
Connector Color	GRAY

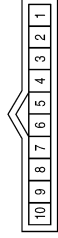

Terminal No.	Color of Wire	Signal Name
1	BR	S1
2	W	S4
3	GR	S2
5	L	S3
6	G	-
7	O	-
8	Y	C2
9	R	C1
10	B	C3

Connector No.	F504
Connector Name	TCM (TRANSMISSION CONTROL MODULE)
Connector Color	WHITE



Terminal No.	Color of Wire	Signal Name
21	B	POWER GND-1
22	Y	POWER GND-2

Connector No.	F503
Connector Name	TCM (TRANSMISSION CONTROL MODULE)
Connector Color	GREEN



Terminal No.	Color of Wire	Signal Name
11	W	INH-SW4
12	GR	INH-SW2
13	BR	INH-SW1
14	L	INH-SW3
16	B	REV SEN GND
17	R	REV SEN VOUT
18	O	ATF SENS 1-
19	G	ATF SENS 1+
20	Y	REV SEN VIN

Connector No.	B40
Connector Name	WIRE TO WIRE
Connector Color	WHITE

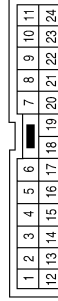

Terminal No.	Color of Wire	Signal Name
23	P	-
24	L	-

Connector No.	F507
Connector Name	AT FLUID TEMPERATURE SENSOR-2
Connector Color	WHITE



Terminal No.	Color of Wire	Signal Name
1	W/Y	-
2	W/R	-

Connector No.	F506
Connector Name	PARK/NEUTRAL POSITION SWITCH
Connector Color	GRAY



Terminal No.	Color of Wire	Signal Name
11	B	C3 (GND)
12	W	C2 (VOUT)
13	R	C1 (VIN)

A
B
C
TM
E
F
G
H
I
J
K
L
M
N
O
P

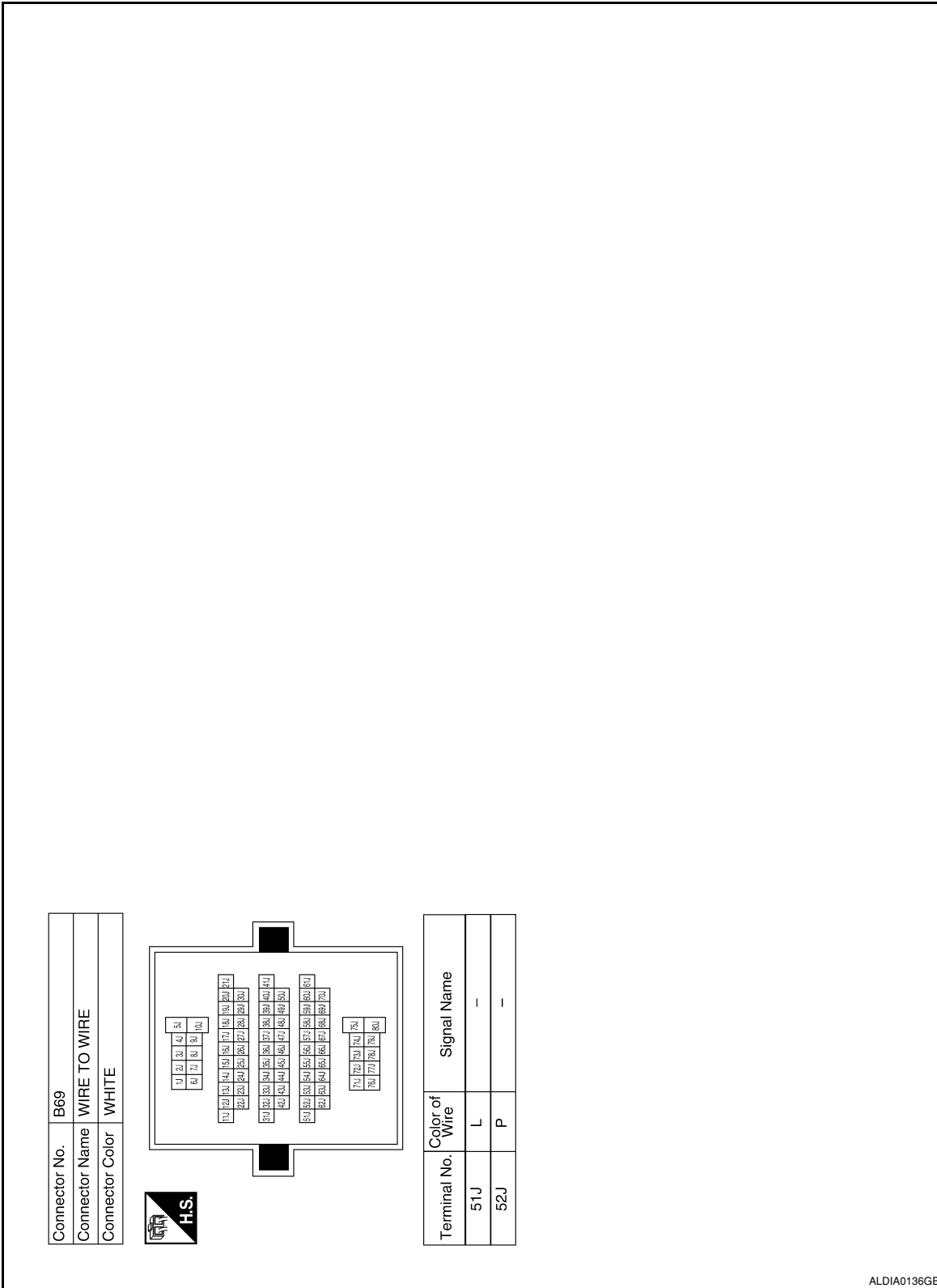

Fail-Safe

INFOID:000000001530141

The TCM has an electrical fail-safe mode. This mode makes it possible to operate even if there is an error in a main electronic control input/output signal circuit.

The TCM has an electrical fail-safe mode. This mode makes it possible to operate even if there is an error in a main electronic control input/output signal circuit. In fail-safe mode the transmission is fixed in 2nd, 4th or 5th (depending on the breakdown position), so the customer should feel “slipping” or “poor acceleration”.

TCM

< ECU DIAGNOSIS >

Even when the electronic circuits are normal, under special conditions (for example, when slamming on the brake with the wheels spinning drastically and stopping the tire rotation), the transmission can go into fail-safe mode. If this happens, switch "OFF" the ignition switch for 10 seconds, then switch it "ON" again to return to the normal shift pattern. Therefore, the customer's vehicle has returned to normal, so handle according to the "diagnostics flow" (Refer to [TM-6, "Work Flow"](#)).

FAIL-SAFE FUNCTION

If any malfunction occurs in a sensor or solenoid, this function controls the A/T to mark driving possible.

Vehicle Speed Sensor

- Signals are input from two systems - from vehicle speed sensor A/T (revolution sensor) installed on the transmission and from combination meter so normal driving is possible even if there is a malfunction in one of the systems. And if vehicle speed sensor A/T (revolution sensor) has unusual cases, 5th gear is prohibited.

Accelerator Pedal Position Sensor

- If there is a malfunction in one of the systems, the accelerator opening angle is controlled by ECM according to a pre-determined accelerator angle to make driving possible. And if there are malfunctions in tow systems, the engine speed is fixed by ECM to a pre-determined engine speed to make driving possible.

Throttle Position Sensor

- If there is a malfunction in one of the systems, the accelerator opening angle is controlled by ECM according to a pre-determined accelerator angle to make driving possible. And if there are malfunctions in tow systems, the accelerator opening angle is controlled by the idle signal sent from the ECM which is based on input indicating either idle condition or off-idle condition (pre-determined accelerator opening) in order to make driving possible.

PNP Switch

- In the unlikely event that a malfunction signal enters the TCM, the position indicator is switched "OFF", the starter relay is switched "OFF" (starter starting is disabled), the back-up lamp relay switched "OFF" (back-up lamp is OFF) and the position is fixed to the "D" range to make driving possible.

Starter Relay

- The starter relay is switched "OFF". (Starter starting is disabled.)

A/T Interlock

- If there is an A/T interlock judgment malfunction, the transmission is fixed in 2nd gear to make driving possible.

NOTE:

When the vehicle is driven fixed in 2nd gear, a turbine revolution sensor malfunction is displayed, but this is not a turbine revolution sensor malfunction.

- When the interlock is detected at the 3rd gear or more, it is locked at the 2nd gear.

A/T 1st Engine Braking

- When there is an A/T first gear engine brake judgment malfunction, the low coast brake solenoid is switched "OFF" to avoid the engine brake operation.

Line Pressure Solenoid

- The solenoid is switched "OFF" and the line pressure is set to the maximum hydraulic pressure to make driving possible.

Torque Converter Clutch Solenoid

- The solenoid is switched "OFF" to release the lock-up.

Low Coast Brake Solenoid

- When a (electrical or functional) malfunction occurs, in order to make driving possible, the engine brake is not applied in 1st and 2nd gear.

Input Clutch Solenoid

- If a (electrical or functional) malfunction occurs with the solenoid either "ON" or "OFF", the transmission is held in 4th gear to make driving possible.

Direct Clutch Solenoid

- If a (electrical or functional) malfunction occurs with the solenoid either "ON" or "OFF", the transmission is held in 4th gear to make driving possible.

Front Brake Solenoid

TCM

< ECU DIAGNOSIS >

- If a (electrical or functional) malfunction occurs with the solenoid “ON”, in order to make driving possible, the A/T is held in 5th gear; if the solenoid is OFF, 4th gear.

High and Low Reverse Clutch Solenoid

- If a (electrical or functional) malfunction occurs with the solenoid either “ON” or “OFF”, the transmission is held in 4th gear to make driving possible.

Turbine Revolution Sensor 1 or 2

- The control is the same as if there were no turbine revolution sensors, 5th gear is prohibited.

DTC Inspection Priority Chart

INFOID:000000001530142

If some DTCs are displayed at the same time, perform inspections one by one based on the following priority chart.

NOTE:

If DTC U1000 is displayed with other DTCs, first perform the trouble diagnosis for DTC U1000. Refer to [TM-39. "Diagnosis Procedure"](#).

Priority	Detected items (DTC)
1	U1000 CAN communication line
2	Except above

DTC No. Index

INFOID:000000001536761

NOTE:

If DTC U1000 is displayed with other DTC, first perform the trouble diagnosis for DTC U1000. Refer to [TM-39. "Diagnosis Procedure"](#).

DTC		Items (CONSULT- III screen terms)	Reference page
OBD- II	Except OBD- II		
CONSULT- III GST (*1)	CONSULT- III only "TRANSMISSION"		
—	P0615	STARTER RELAY/CIRC	TM-40
P0700	P0700	TCM	TM-43
P0705	P0705	PNP SW/CIRC	TM-44
P0710	P1710	ATF TEMP SEN/CIRC	TM-72
P0717	P0717	TURBINE REV S/CIRC	TM-47
P0720	P0720	VEH SPD SEN/CIR AT	TM-50
—	P0725	ENGINE SPEED SIG	TM-52
P0731	P0731	A/T 1ST GR FNCTN	TM-55
P0732	P0732	A/T 2ND GR FNCTN	TM-57
P0733	P0733	A/T 3RD GR FNCTN	TM-59
P0734	P0734	A/T 4TH GR FNCTN	TM-61
P0735	P0735	A/T 5TH GR FNCTN	TM-63
P0740	P0740	TCC SOLENOID/CIRC	TM-64
P0744	P0744	A/T TCC S/V FNCTN	TM-67
P0745	P0745	L/PRESS SOL/CIRC	TM-68
—	P1705	TP SEN/CIRC A/T	TM-70
—	P1721	VEH SPD SE/CIR·MTR	TM-76
P1730	P1730	A/T INTERLOCK	TM-78
—	P1731	A/T 1ST E/BRAKING	TM-80
P1752	P1752	I/C SOLENOID/CIRC	TM-82
P1757	P1757	FR/B SOLENOID/CIRC	TM-84

TCM

< ECU DIAGNOSIS >

DTC		Items (CONSULT- III screen terms)	Reference page
OBD- II	Except OBD- II		
CONSULT- III GST (*1)	CONSULT- III only "TRANSMISSION"		
P1762	P1762	D/C SOLENOID/CIRC	TM-86
P1767	P1767	HLR/C SOL/CIRC	TM-88
P1772	P1772	LC/B SOLENOID/CIRC	TM-90
P1774 (2*)	P1774	LC/B SOLENOID FNCT	TM-93
U1000	U1000	CAN COMM CIRCUIT	TM-39

*1: These numbers are prescribed by SAE J2012.

*2: These malfunctions cannot be displayed MIL if another malfunction is assigned to MIL.

DTC Alphabetical Index

INFOID:000000001530143

NOTE:

If DTC U1000 is displayed with other DTC, first perform the trouble diagnosis for DTC U1000. Refer to [TM-39, "Diagnosis Procedure"](#).

Items (CONSULT- III screen terms)	DTC		Reference page
	OBD- II	Except OBD- II	
	CONSULT- III GST (*1)	CONSULT- III only "TRANSMISSION"	
A/T 1ST E/BRAKING	—	P1731	TM-80
ATF 1ST GR FNCTN	P0731	P0731	TM-55
ATF 2ND GR FNCTN	P0732	P0732	TM-57
ATF 3RD GR FNCTN	P0733	P0733	TM-59
ATF 4TH GR FNCTN	P0734	P0734	TM-61
ATF 5TH GR FNCTN	P0735	P0735	TM-63
A/T INTERLOCK	P1730	P1730	TM-78
A/T TCC S/V FNCTN	P0744	P0744	TM-67
ATF TEMP SEN/CIRC	P0710	P1710	TM-72
CAN COMM CIRCUIT	U1000	U1000	TM-39
D/C SOLENOID/CIRC	P1762	P1762	TM-86
ENGINE SPEED SIG	—	P0725	TM-52
FR/B SOLENOID/CIRC	P1757	P1757	TM-84
HLR/C SOL/CIRC	P1767	P1767	TM-88
I/C SOLENOID/CIRC	P1752	P1752	TM-82
L/PRESS SOL/CIRC	P0745	P0745	TM-68
LC/B SOLENOID/CIRC	P1772	P1772	TM-90
LC/B SOLENOID FNCT	P1774	P1774	TM-93
PNP SW/CIRC	P0705	P0705	TM-44
STARTER RELAY/CIRC	—	P0615	TM-40
TCC SOLENOID/CIRC	P0740	P0740	TM-64
TCM	P0700	P0700	TM-43
TP SEN/CIRC A/T	—	P1705	TM-70
TURBINE REV S/CIRC	P0717	P0717	TM-47
VEH SPD SE/CIR·MTR	—	P1721	TM-76
VEH SPD SEN/CIR AT	P0720	P0720	TM-50

TCM

< ECU DIAGNOSIS >

*1: These numbers are prescribed by SAE J2012.

*2: These malfunctions cannot be displayed MIL if another malfunction is assigned to MIL.

A

B

C

TM

E

F

G

H

I

J

K

L

M

N

O

P

SYSTEM SYMPTOM

< SYMPTOM DIAGNOSIS >

SYMPTOM DIAGNOSIS

SYSTEM SYMPTOM

A/T Check Indicator Lamp Does Not Come On

INFOID:000000001534556

SYMPTOM:

AT CHECK indicator lamp does not come on for about 2 seconds when turning ignition switch to "ON".

DIAGNOSTIC PROCEDURE

1. CHECK CAN COMMUNICATION LINE

Perform the self-diagnosis. Refer to [TM-33. "CONSULT-III Function \(TRANSMISSION\)"](#).

Is a malfunction in the CAN communication indicated in the results?

YES >> Check CAN communication line. Refer to [TM-22. "CAN Communication"](#).

NO >> GO TO 2.

2. CHECK A/T CHECK INDICATOR LAMP CIRCUIT

Check the combination meter. Refer to [MWI-5. "METER SYSTEM : System Description"](#).

OK or NG

OK >> GO TO 3.

NG >> Repair or replace damaged parts.

3. CHECK TCM POWER SUPPLY AND GROUND CIRCUIT

Check TCM power supply and ground circuit. Refer to [TM-94. "Diagnosis Procedure"](#).

OK or NG

OK >> **INSPECTION END**

NG >> Repair or replace damaged parts.

Engine Cannot Be Started in "P" or "N" Position

INFOID:000000001534555

SYMPTOM:

- Engine cannot be started with selector lever in "P" or "N" position.
- Engine can be started with selector lever in "D" or "R" position.

DIAGNOSTIC PROCEDURE

1. CHECK SELF-DIAGNOSIS RESULTS

Perform self-diagnosis. Refer to [TM-33. "CONSULT-III Function \(TRANSMISSION\)"](#).

Do the self-diagnosis results indicate PNP switch?

YES >> Check the malfunctioning system. Refer to [TM-44. "Diagnosis Procedure"](#).

NO >> GO TO 2.

2. CHECK CONTROL CABLE

Check the control cable.

- Refer to [TM-206. "2WD : Checking of A/T Position"](#) (2WD) or [TM-206. "4WD : Checking of A/T Position"](#) (4WD).

OK or NG

OK >> GO TO 3.

NG >> Adjust control cable. Refer to [TM-206. "2WD : Adjustment of A/T Position"](#) (2WD) or [TM-206. "4WD : Adjustment of A/T Position"](#) (4WD).

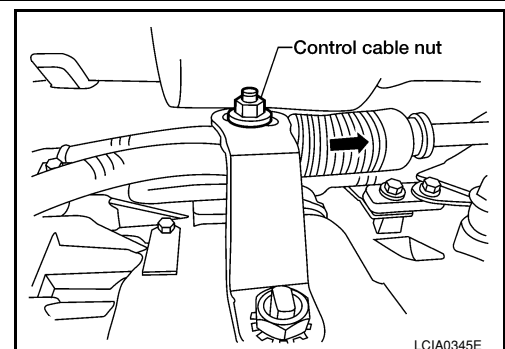

3. CHECK STARTING SYSTEM

Check the starting system. Refer to [STR-4. "Work Flow"](#).

SYSTEM SYMPTOM

< SYMPTOM DIAGNOSIS >

OK or NG

- OK >> **INSPECTION END**
- NG >> Repair or replace damaged parts.

In "P" Position, Vehicle Moves When Pushed

INFOID:000000001534554

SYMPTOM:

Even though the selector lever is set in the "P" position, the parking mechanism is not actuated, allowing the vehicle to be moved when it is pushed.

DIAGNOSTIC PROCEDURE

1. CHECK PNP SWITCH CIRCUIT

Perform self-diagnosis. Refer to [TM-33. "CONSULT-III Function \(TRANSMISSION\)"](#).

Do the self-diagnosis results indicate PNP switch?

- YES >> Check the malfunctioning system. Refer to [TM-44. "Diagnosis Procedure"](#).
- NO >> GO TO 2.

2. CHECK CONTROL CABLE

Check the control cable.

- Refer to [TM-206. "2WD : Checking of A/T Position"](#) (2WD) or [TM-206. "4WD : Checking of A/T Position"](#) (4WD).

OK or NG

- OK >> GO TO 3.
- NG >> Adjust control cable. Refer to [TM-206. "2WD : Adjustment of A/T Position"](#) (2WD) or [TM-206. "4WD : Adjustment of A/T Position"](#) (4WD).

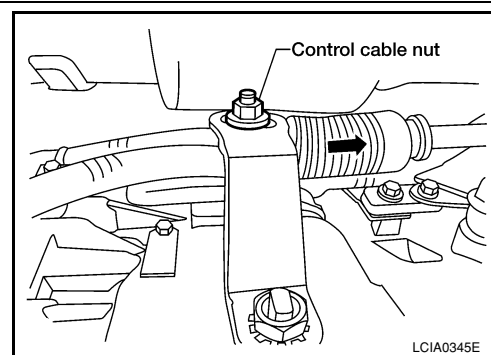

3. CHECK A/T FLUID CONDITION

1. Remove oil pan. Refer to [TM-215. "Oil Pan"](#).
2. Check A/T fluid condition. Refer to [TM-190. "Checking the A/T Fluid \(ATF\)"](#).

OK or NG

- OK >> **INSPECTION END**
- NG >> GO TO 4.

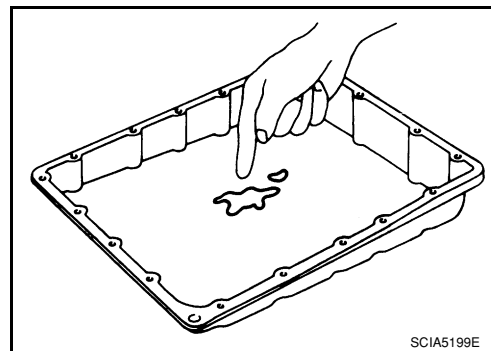

4. DETECT MALFUNCTIONING ITEM

- Check the malfunction items. If any items are damaged, repair or replace damaged parts. Refer to [TM-163. "Symptom Table"](#) (Symptom No. 58).

OK or NG

- OK >> **INSPECTION END**
- NG >> Repair or replace damaged parts.

In "N" Position, Vehicle Moves

INFOID:000000001534553

SYMPTOM:

Vehicle moves forward or backward when selecting "N" position.

DIAGNOSTIC PROCEDURE

1. CHECK PNP SWITCH CIRCUIT

SYSTEM SYMPTOM

< SYMPTOM DIAGNOSIS >

Perform self-diagnosis. Refer to [TM-33. "CONSULT-III Function \(TRANSMISSION\)"](#).

Do the self-diagnostic results indicate PNP switch?

- YES >> Check the malfunctioning system. Refer to [TM-44. "Diagnosis Procedure"](#).
- NO >> GO TO 2.

2.CHECK CONTROL CABLE

Check the control cable.

- Refer to [TM-206. "2WD : Checking of A/T Position"](#) (2WD) or [TM-206. "4WD : Checking of A/T Position"](#) (4WD).

OK or NG

- OK >> GO TO 3.
- NG >> Adjust control cable. Refer to [TM-206. "2WD : Adjustment of A/T Position"](#) (2WD) or [TM-206. "4WD : Adjustment of A/T Position"](#) (4WD).

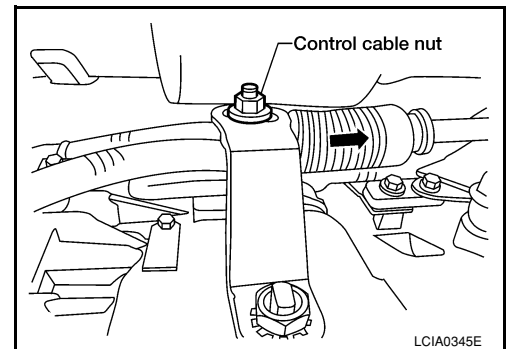

3.CHECK A/T FLUID LEVEL

Check A/T fluid level. Refer to [TM-190. "Checking the A/T Fluid \(ATF\)"](#).

OK or NG

- OK >> GO TO 4.
- NG >> Refill ATF.

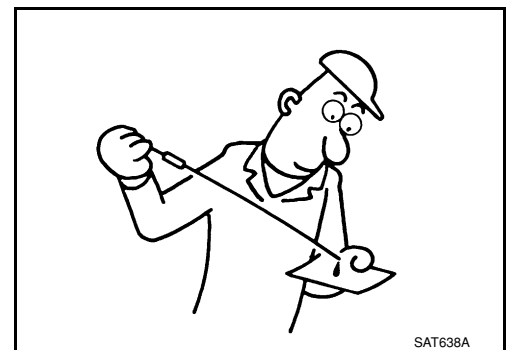

4.CHECK A/T FLUID CONDITION

1. Remove oil pan. Refer to [TM-215. "Oil Pan"](#).
2. Check A/T fluid condition. Refer to [TM-190. "Checking the A/T Fluid \(ATF\)"](#).

OK or NG

- OK >> GO TO 5.
- NG >> Check the malfunction items. If any items are damaged, repair or replace damaged parts. Refer to [TM-163. "Symptom Table"](#) (Symptom No. 60).

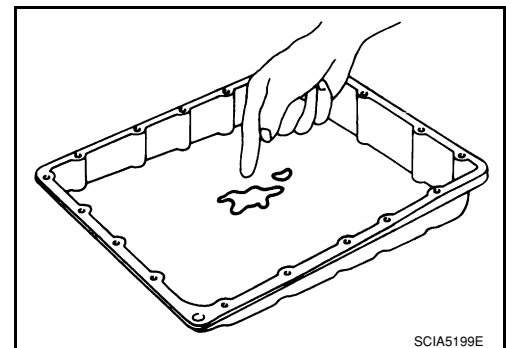

5.CHECK SYMPTOM

Check again. Refer to [TM-6. "Work Flow"](#).

OK or NG

- OK >> **INSPECTION END**
- NG >> GO TO 6.

6.PERFORM TCM INSPECTION

1. Perform TCM input/output signals inspection. Refer to [TM-114. "Reference Value"](#).
2. If NG, recheck A/T assembly harness connector terminals for damage or loose connection with harness connector.

OK or NG

- OK >> **INSPECTION END**
- NG >> Repair or replace damaged parts.

SYSTEM SYMPTOM

< SYMPTOM DIAGNOSIS >

Large Shock("N" to "D" Position)

INFOID:000000001534552

SYMPTOM:

A noticeable shock occurs when the selector lever is shifted from the "N" to "D" position.

DIAGNOSTIC PROCEDURE

1.CHECK SELF-DIAGNOSTIC RESULTS

Perform self-diagnosis. Refer to [TM-33, "CONSULT-III Function \(TRANSMISSION\)"](#).

Do the self-diagnostic results indicate A/T fluid temperature sensor, engine speed signal, accelerator pedal position sensor, front brake solenoid valve, CAN communication line?

YES >> Check the malfunctioning system. Refer to [TM-72, "Diagnosis Procedure"](#), [TM-52, "Diagnosis Procedure"](#), [TM-70, "Diagnosis Procedure"](#), [TM-84, "Diagnosis Procedure"](#), [TM-39, "Diagnosis Procedure"](#).

NO >> GO TO 2.

2.ENGINE IDLE SPEED

Check the engine idle speed. Refer to [EC-21, "Idle Speed and Ignition Timing Check"](#).

OK or NG

OK >> GO TO 3.

NG >> Repair.

3.CHECK CONTROL CABLE

Check the control cable.

• Refer to [TM-206, "2WD : Checking of A/T Position"](#) (2WD) or [TM-206, "4WD : Checking of A/T Position"](#) (4WD).

OK or NG

OK >> GO TO 4.

NG >> Adjust control cable. Refer to [TM-206, "2WD : Adjustment of A/T Position"](#) (2WD) or [TM-206, "4WD : Adjustment of A/T Position"](#) (4WD).

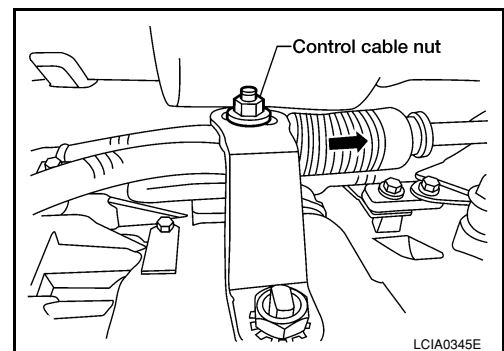

4.CHECK A/T FLUID LEVEL

Check the A/T fluid level. Refer to [TM-190, "Checking the A/T Fluid \(ATF\)"](#).

OK or NG

OK >> GO TO 5.

NG >> Refill ATF.

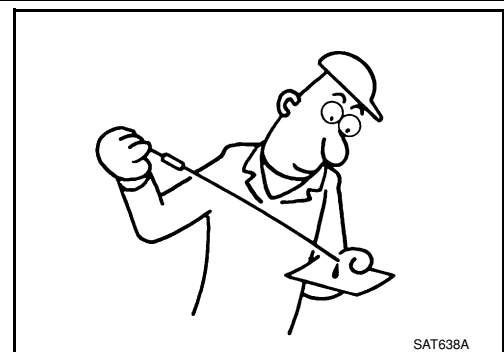

5.CHECK LINE PRESSURE

SYSTEM SYMPTOM

< SYMPTOM DIAGNOSIS >

Check line pressure at idle with selector lever in "D" position. Refer to [TM-199, "Inspection and Judgment"](#).

OK or NG

- OK >> GO TO 8.
- NG - 1 >> Line pressure high: GO TO 6.
- NG - 2 >> Line pressure low: GO TO 7.

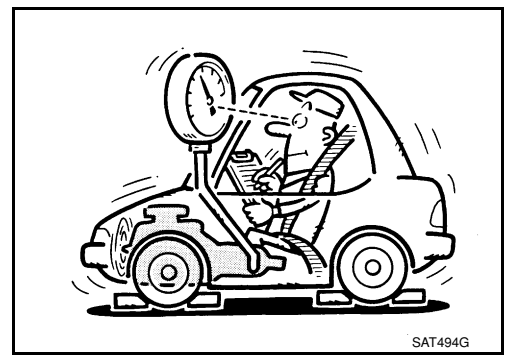

6. DETECT MALFUNCTIONING ITEM

1. Check control valve with TCM. Refer to [TM-217, "Control Valve with TCM and A/T Fluid Temperature Sensor 2"](#).
2. Disassemble A/T. Refer to [TM-245, "Disassembly"](#).
3. Check the following items:
 - Oil pump assembly. Refer to [TM-263, "Oil Pump"](#).

OK or NG

- OK >> GO TO 8.
- NG >> Repair or replace damaged parts.

7. DETECT MALFUNCTIONING ITEM

1. Check control valve with TCM. Refer to [TM-217, "Control Valve with TCM and A/T Fluid Temperature Sensor 2"](#).
2. Disassemble A/T. Refer to [TM-245, "Disassembly"](#).
3. Check the following items:
 - Oil pump assembly. Refer to [TM-263, "Oil Pump"](#).
 - Power train system. Refer to [TM-245, "Disassembly"](#).
 - Transmission case. Refer to [TM-245, "Disassembly"](#).

OK or NG

- OK >> GO TO 8.
- NG >> Repair or replace damaged parts.

8. CHECK A/T FLUID CONDITION

1. Remove oil pan. Refer to [TM-215, "Oil Pan"](#).
2. Check A/T fluid condition. Refer to [TM-190, "Checking the A/T Fluid \(ATF\)"](#).

OK or NG

- OK >> GO TO 10.
- NG >> GO TO 9.

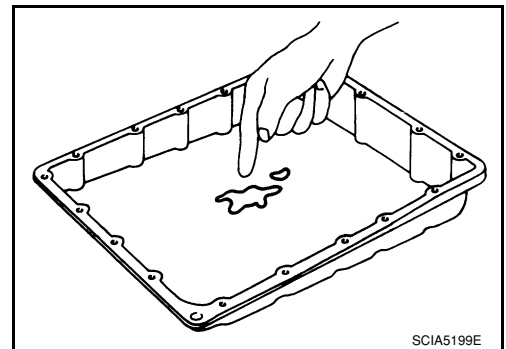

9. DETECT MALFUNCTIONING ITEM

- Check the malfunction items. If any items are damaged, repair or replace damaged parts. Refer to [TM-163, "Symptom Table"](#) (Symptom No.1).

OK or NG

- OK >> GO TO 10.
- NG >> Repair or replace damaged parts.

10. CHECK SYMPTOM

Check again. Refer to [TM-6, "Work Flow"](#).

OK or NG

SYSTEM SYMPTOM

< SYMPTOM DIAGNOSIS >

- OK >> **INSPECTION END**
NG >> GO TO 11.

11.PERFORM TCM INSPECTION

1. Perform TCM input/output signals inspection. Refer to [TM-114, "Reference Value"](#).
2. If NG, recheck A/T assembly harness connector terminals for damage or loose connection with harness connector.

OK or NG

- OK >> **INSPECTION END**
NG >> Repair or replace damaged parts.

Vehicle Does Not Creep Backward in "R" Position

INFOID:000000001534551

SYMPTOM:

The vehicle does not creep in the "R" position. Or an extreme lack of acceleration is observed.

DIAGNOSTIC PROCEDURE

1.CHECK SELF-DIAGNOSTIC RESULTS

Perform self-diagnosis. Refer to [TM-33, "CONSULT-III Function \(TRANSMISSION\)"](#).

Do the self-diagnostic results indicate accelerator pedal position sensor, high and low reverse clutch solenoid valve, CAN communication line, PNP switch?

- YES >> Check the malfunctioning system. Refer to [TM-70, "Diagnosis Procedure"](#), [TM-88, "Diagnosis Procedure"](#), [TM-44, "Diagnosis Procedure"](#), [TM-39, "Diagnosis Procedure"](#).
- NO >> GO TO 2.

2.CHECK CONTROL CABLE

Check the control cable.

- Refer to [TM-206, "2WD : Checking of A/T Position"](#) (2WD) or [TM-206, "4WD : Checking of A/T Position"](#) (4WD).

OK or NG

- OK >> GO TO 3.
NG >> Adjust control cable. Refer to [TM-206, "2WD : Adjustment of A/T Position"](#) (2WD) or [TM-206, "4WD : Adjustment of A/T Position"](#) (4WD).

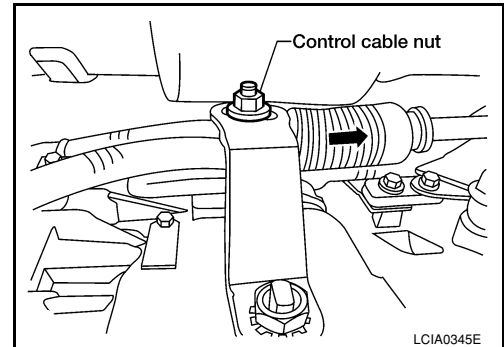

3.CHECK A/T FLUID LEVEL

Check A/T fluid level. Refer to [TM-190, "Checking the A/T Fluid \(ATF\)"](#).

OK or NG

- OK >> GO TO 4.
NG >> Refill ATF.

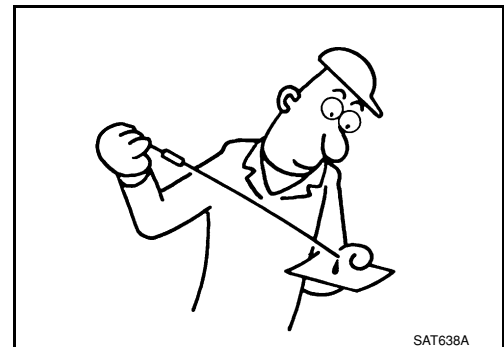

4.CHECK STALL TEST

Check stall revolution with selector lever in "1" and "R" positions.

SYSTEM SYMPTOM

< SYMPTOM DIAGNOSIS >

Refer to [TM-197, "Inspection and Judgment"](#).

OK or NG

- OK >> GO TO 6.
- OK in "1" position, NG in "R" position>>GO TO 5.
- NG in both "1" and "R" positions>>GO TO 8.

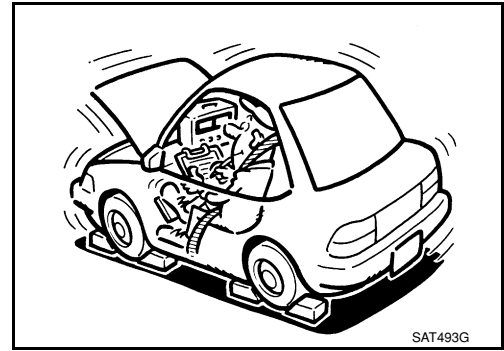

5. DETECT MALFUNCTIONING ITEM

1. Disassemble A/T. Refer to [TM-245, "Disassembly"](#).
2. Check the following items:
 - Reverse brake. Refer to [TM-245, "Disassembly"](#).

OK or NG

- OK >> GO TO 9.
- NG >> Repair or replace damaged parts.

6. CHECK LINE PRESSURE

Check the line pressure with the engine idling. Refer to [TM-199, "Inspection and Judgment"](#).

OK or NG

- OK >> GO TO 9.
- NG - 1 >> Line pressure high. GO TO 7.
- NG - 2 >> Line pressure low. GO TO 8.

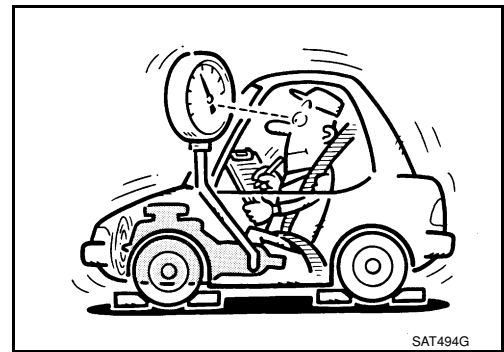

7. DETECT MALFUNCTIONING ITEM

1. Check control valve with TCM. Refer to [TM-217, "Control Valve with TCM and A/T Fluid Temperature Sensor 2"](#).
2. Disassemble A/T. Refer to [TM-245, "Disassembly"](#).
3. Check the following items:
 - Oil pump assembly. Refer to [TM-263, "Oil Pump"](#).

OK or NG

- OK >> GO TO 9.
- NG >> Repair or replace damaged parts.

8. DETECT MALFUNCTIONING ITEM

1. Check control valve with TCM. Refer to [TM-217, "Control Valve with TCM and A/T Fluid Temperature Sensor 2"](#).
2. Disassemble A/T. Refer to [TM-245, "Disassembly"](#).
3. Check the following items:
 - Oil pump assembly. Refer to [TM-263, "Oil Pump"](#).
 - Power train system. Refer to [TM-245, "Disassembly"](#).
 - Transmission case. Refer to [TM-245, "Disassembly"](#).

OK or NG

- OK >> GO TO 9.
- NG >> Repair or replace damaged parts.

9. CHECK A/T FLUID CONDITION

1. Remove oil pan. Refer to [TM-215, "Oil Pan"](#).

SYSTEM SYMPTOM

< SYMPTOM DIAGNOSIS >

2. Check A/T fluid condition. Refer to [TM-190. "Checking the A/T Fluid \(ATF\)".](#)

OK or NG

- OK >> GO TO 10.
NG >> GO TO 13.

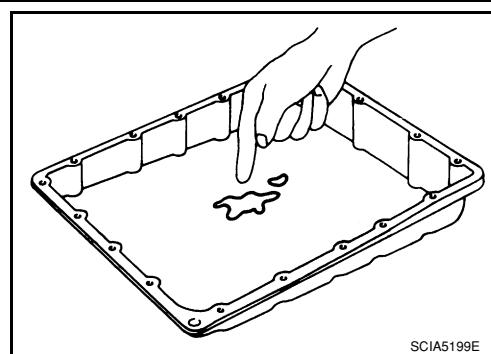

10. DETECT MALFUNCTIONING ITEM

- Check the malfunction items. If any items are damaged, repair or replace damaged parts. Refer to [TM-163. "Symptom Table"](#) (Symptom No.43).

OK or NG

- OK >> GO TO 11.
NG >> Repair or replace damaged parts.

11. CHECK SYMPTOM

Check again. Refer to [TM-6. "Work Flow"](#).

OK or NG

- OK >> **INSPECTION END**
NG >> GO TO 12.

12. PERFORM TCM INSPECTION

1. Perform TCM input/output signals inspection. Refer to [TM-217. "Control Valve with TCM and A/T Fluid Temperature Sensor 2"](#).
2. If NG, recheck A/T assembly harness connector terminals for damage or loose connection with harness connector.

OK or NG

- OK >> **INSPECTION END**
NG >> Repair or replace damaged parts.

13. DETECT MALFUNCTIONING ITEM

- Check the malfunction items. If any items are damaged, repair or replace damaged parts. Refer to [TM-163. "Symptom Table"](#) (Symptom No.43).

OK or NG

- OK >> GO TO 11.
NG >> Repair or replace damaged parts.

Vehicle Does Not Creep Forward in "D" Position

INFOID:000000001534550

SYMPTOM:

Vehicle does not creep forward when selecting "D" position.

DIAGNOSTIC PROCEDURE

1. CHECK SELF-DIAGNOSTIC RESULTS

Perform self-diagnosis. Refer to [TM-33. "CONSULT-III Function \(TRANSMISSION\)"](#).

Do the self-diagnostic results indicate accelerator pedal position sensor, CAN communication line, PNP switch?

- YES >> Check the malfunctioning system. Refer to [TM-70. "Diagnosis Procedure"](#), [TM-44. "Diagnosis Procedure"](#), [TM-39. "Diagnosis Procedure"](#).
NO >> GO TO 2.

2. CHECK CONTROL CABLE

SYSTEM SYMPTOM

< SYMPTOM DIAGNOSIS >

Check the control cable.

- Refer to [TM-206, "2WD : Checking of A/T Position"](#) (2WD) or [TM-206, "4WD : Checking of A/T Position"](#) (4WD).

OK or NG

OK >> GO TO 3.

NG >> Adjust control cable. Refer to [TM-206, "2WD : Adjustment of A/T Position"](#) (2WD) or [TM-206, "4WD : Adjustment of A/T Position"](#) (4WD).

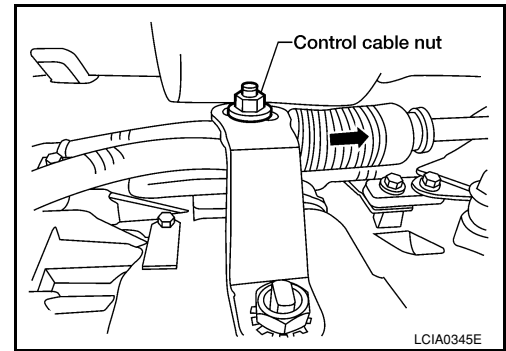

3. CHECK A/T FLUID LEVEL

Check A/T fluid level. Refer to [TM-190, "Checking the A/T Fluid \(ATF\)"](#).

OK or NG

OK >> GO TO 4.

NG >> Refill ATF.

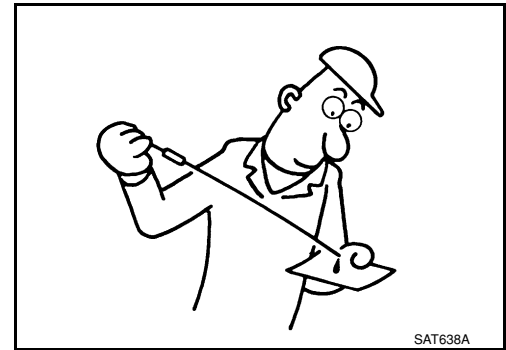

4. CHECK STALL TEST

Check stall revolution with selector lever in "D" position. Refer to [TM-197, "Inspection and Judgment"](#).

OK or NG

OK >> GO TO 5.

NG >> GO TO 7.

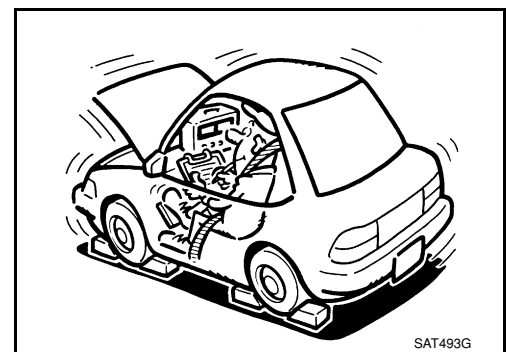

5. CHECK LINE PRESSURE

Check line pressure at idle with selector lever in "D" position. Refer to [TM-199, "Inspection and Judgment"](#).

OK or NG

OK >> GO TO 8.

NG - 1 >> Line pressure high. GO TO 6.

NG - 2 >> Line pressure low. GO TO 7.

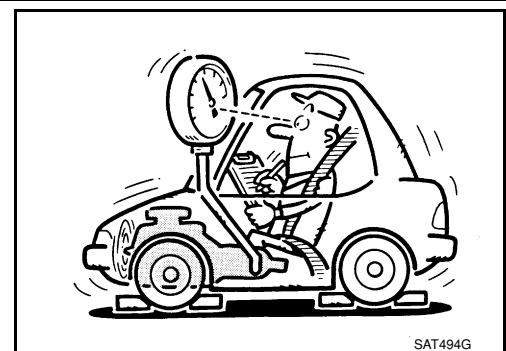

6. DETECT MALFUNCTIONING ITEM

1. Check control valve with TCM. Refer to [TM-217, "Control Valve with TCM and A/T Fluid Temperature Sensor 2"](#).
2. Disassemble A/T. Refer to [TM-245, "Disassembly"](#).
3. Check the following items:
 - Oil pump assembly. Refer to [TM-215, "Oil Pan"](#).

OK or NG

OK >> GO TO 8.

SYSTEM SYMPTOM

< SYMPTOM DIAGNOSIS >

NG >> Repair or replace damaged parts.

7. DETECT MALFUNCTIONING ITEM

1. Check control valve with TCM. Refer to [TM-217, "Control Valve with TCM and A/T Fluid Temperature Sensor 2"](#).
2. Disassemble A/T. Refer to [TM-245, "Disassembly"](#).
3. Check the following items:
 - Oil pump assembly. Refer to [TM-263, "Oil Pump"](#).
 - Power train system. Refer to [TM-245, "Disassembly"](#).
 - Transmission case. Refer to [TM-245, "Disassembly"](#).

OK or NG

OK >> GO TO 8.

NG >> Repair or replace damaged parts.

8. CHECK A/T FLUID CONDITION

1. Remove oil pan. Refer to [TM-263, "Oil Pump"](#).
2. Check A/T fluid condition. Refer to [TM-190, "Checking the A/T Fluid \(ATF\)"](#).

OK or NG

OK >> GO TO 9.

NG >> GO TO 12.

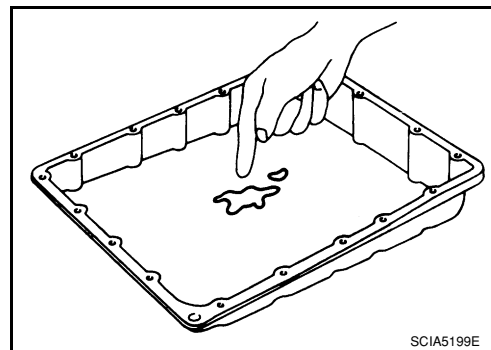

9. DETECT MALFUNCTIONING ITEM

- Check the malfunction items. If any items are damaged, repair or replace damaged parts. Refer to [TM-163, "Symptom Table"](#) (Symptom No.43).

OK or NG

OK >> GO TO 10.

NG >> Repair or replace damaged parts.

10. CHECK SYMPTOM

Check again. Refer to [TM-6, "Work Flow"](#).

OK or NG

OK >> **INSPECTION END**

NG >> GO TO 11.

11. PERFORM TCM INSPECTION

1. Perform TCM input/output signals inspection. Refer to [TM-114, "Reference Value"](#).
2. If NG, recheck A/T assembly harness connector terminals for damage or loose connection with harness connector.

OK or NG

OK >> **INSPECTION END**

NG >> Repair or replace damaged parts.

12. DETECT MALFUNCTIONING ITEM

- Check the malfunction items. If any items are damaged, repair or replace damaged parts. Refer to [TM-163, "Symptom Table"](#) (Symptom No.43).

OK or NG

OK >> GO TO 10.

NG >> Repair or replace damaged parts.

SYSTEM SYMPTOM

< SYMPTOM DIAGNOSIS >

Vehicle Cannot Be Started from D1

INFOID:000000001534549

SYMPTOM:

Vehicle cannot be started from D1 on cruise test - Part 1.

DIAGNOSTIC PROCEDURE

1. CONFIRM THE SYMPTOM

Check if vehicle creeps in "R" position.

OK or NG

OK >> GO TO 2.

NG >> Refer to [TM-135. "Vehicle Does Not Creep Backward in "R" Position"](#).

2. CHECK SELF-DIAGNOSTIC RESULTS

Perform self-diagnosis. Refer to [TM-33. "CONSULT-III Function \(TRANSMISSION\)"](#).

Is any malfunction detected by self-diagnostic results?

YES >> Check the malfunctioning system.

NO >> GO TO 3.

3. CHECK ACCELERATOR PEDAL POSITION (APP) SENSOR

Check accelerator pedal position (APP) sensor. Refer to [TM-70. "Diagnosis Procedure"](#).

OK or NG

OK >> GO TO 4.

NG >> Repair or replace accelerator pedal position (APP) sensor.

4. CHECK A/T FLUID LEVEL

Check A/T fluid level. Refer to [TM-190. "Checking the A/T Fluid \(ATF\)"](#).

OK or NG

OK >> GO TO 5.

NG >> Refill ATF.

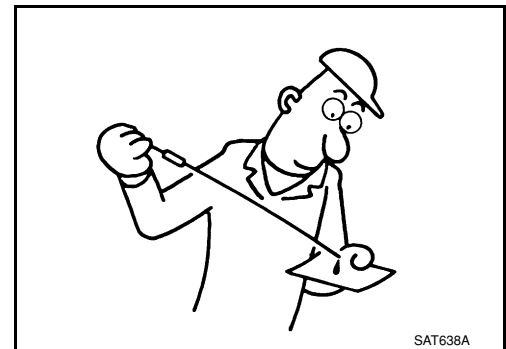

5. CHECK LINE PRESSURE

Check line pressure at the engine stall point. Refer to [TM-199. "Inspection and Judgment"](#).

OK or NG

OK >> GO TO 8.

NG - 1 >> Line pressure high. GO TO 6.

NG - 2 >> Line pressure low. GO TO 7.

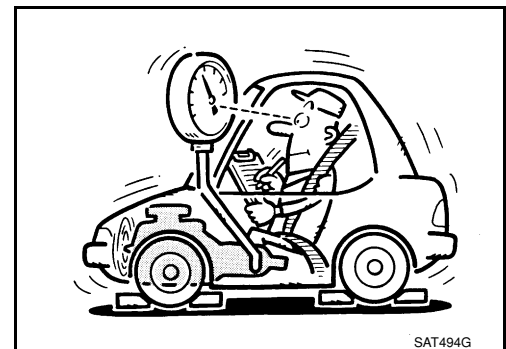

6. DETECT MALFUNCTIONING ITEM

1. Check control valve with TCM. Refer to [TM-217. "Control Valve with TCM and A/T Fluid Temperature Sensor 2"](#).

2. Disassemble A/T. Refer to [TM-245. "Disassembly"](#).

3. Check the following items:

- Oil pump assembly. Refer to [TM-263. "Oil Pump"](#).

OK or NG

SYSTEM SYMPTOM

< SYMPTOM DIAGNOSIS >

- OK >> GO TO 8.
NG >> Repair or replace damaged parts.

7. DETECT MALFUNCTIONING ITEM

1. Check control valve with TCM. Refer to [TM-217, "Control Valve with TCM and A/T Fluid Temperature Sensor 2"](#).
2. Disassemble A/T. Refer to [TM-245, "Disassembly"](#).
3. Check the following items:
 - Oil pump assembly. Refer to [TM-263, "Oil Pump"](#).
 - Power train system. Refer to [TM-245, "Disassembly"](#).
 - Transmission case. Refer to [TM-245, "Disassembly"](#).

OK or NG

- OK >> GO TO 8.
NG >> Repair or replace damaged parts.

8. CHECK A/T FLUID CONDITION

1. Remove oil pan. Refer to [TM-215, "Oil Pan"](#).
2. Check A/T fluid condition. Refer to [TM-190, "Checking the A/T Fluid \(ATF\)"](#).

OK or NG

- OK >> GO TO 9.
NG >> GO TO 12.

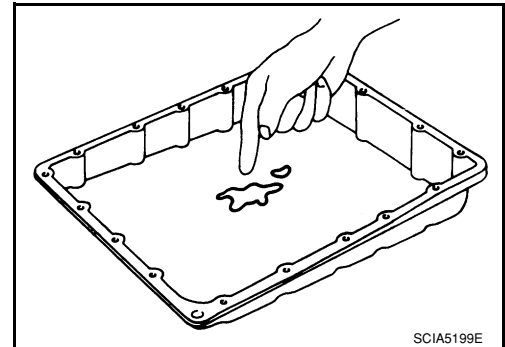

9. DETECT MALFUNCTIONING ITEM

- Check the malfunction items. If any items are damaged, repair or replace damaged parts. Refer to [TM-163, "Symptom Table"](#) (Symptom No.23).

OK or NG

- OK >> GO TO 10.
NG >> Repair or replace damaged parts.

10. CHECK SYMPTOM

Check again. Refer to [TM-202, "Cruise Test - Part 1"](#), [TM-204, "Cruise Test - Part 2"](#).

OK or NG

- OK >> **INSPECTION END**
NG >> GO TO 11.

11. PERFORM TCM INSPECTION

1. Perform TCM input/output signals inspection. Refer to [TM-114, "Reference Value"](#).
2. If NG, recheck A/T assembly harness connector terminals for damage or loose connection with harness connector.

OK or NG

- OK >> **INSPECTION END**
NG >> Repair or replace damaged parts.

12. DETECT MALFUNCTIONING ITEM

- Check the malfunction items. If any items are damaged, repair or replace damaged parts. Refer to [TM-163, "Symptom Table"](#) (Symptom No.23).

OK or NG

- OK >> GO TO 10.
NG >> Repair or replace damaged parts.

SYSTEM SYMPTOM

< SYMPTOM DIAGNOSIS >

A/T Does Not Shift: D1→D2

INFOID:000000001534548

SYMPTOM:

The vehicle does not shift-up from the D1 to D2 gear at the specified speed.

DIAGNOSTIC PROCEDURE

1. CONFIRM THE SYMPTOM

Check if vehicle creeps forward in "D" position and vehicle can be started from D1.

OK or NG

OK >> GO TO 2.

NG >> Refer to [TM-137, "Vehicle Does Not Creep Forward in "D" Position"](#), [TM-140, "Vehicle Cannot Be Started from D1"](#).

2. CHECK SELF-DIAGNOSTIC RESULTS

Perform self-diagnosis. Refer to [TM-33, "CONSULT-III Function \(TRANSMISSION\)"](#).

Do the self-diagnostic results indicate, direct clutch solenoid valve, accelerator pedal position sensor, vehicle speed sensor A/T (revolution sensor) and vehicle speed sensor MTR?

YES >> Check the malfunctioning system. Refer to [TM-86, "Diagnosis Procedure"](#), [TM-70, "Diagnosis Procedure"](#), [TM-50, "Diagnosis Procedure"](#), [TM-76, "Diagnosis Procedure"](#).

NO >> GO TO 3.

3. CHECK A/T FLUID LEVEL

Check A/T fluid level. Refer to [TM-190, "Checking the A/T Fluid \(ATF\)"](#).

OK or NG

OK >> GO TO 4.

NG >> Refill ATF.

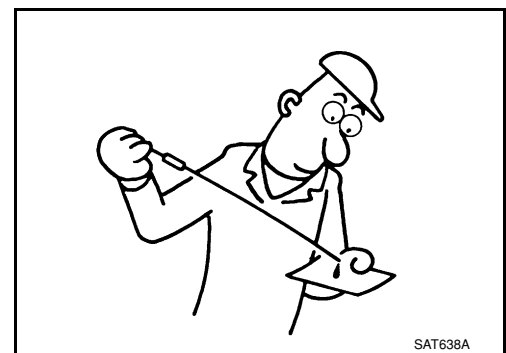

4. CHECK LINE PRESSURE

Check line pressure at the engine stall point. Refer to [TM-199, "Inspection and Judgment"](#).

OK or NG

OK >> GO TO 7.

NG - 1 >> Line pressure high. GO TO 5.

NG - 2 >> Line pressure low. GO TO 6.

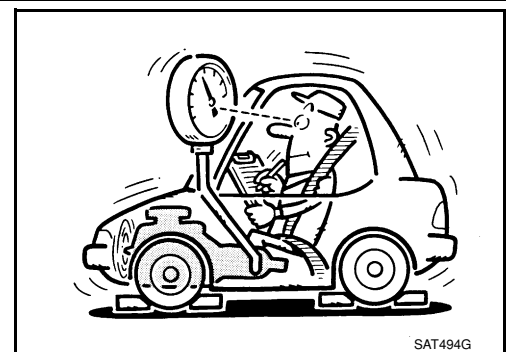

5. DETECT MALFUNCTIONING ITEM

1. Check control valve with TCM. Refer to [TM-217, "Control Valve with TCM and A/T Fluid Temperature Sensor 2"](#).

2. Disassemble A/T. Refer to [TM-245, "Disassembly"](#).

3. Check the following items:

- Oil pump assembly. Refer to [TM-263, "Oil Pump"](#).

OK or NG

OK >> GO TO 7.

NG >> Repair or replace damaged parts.

6. DETECT MALFUNCTIONING ITEM

SYSTEM SYMPTOM

< SYMPTOM DIAGNOSIS >

1. Check control valve with TCM. Refer to [TM-217. "Control Valve with TCM and A/T Fluid Temperature Sensor 2"](#).
2. Disassemble A/T. Refer to [TM-245. "Disassembly"](#).
3. Check the following items:
 - Oil pump assembly. Refer to [TM-263. "Oil Pump"](#).
 - Power train system. Refer to [TM-245. "Disassembly"](#).
 - Transmission case. Refer to [TM-245. "Disassembly"](#).

OK or NG

- OK >> GO TO 7.
NG >> Repair or replace damaged parts.

7. CHECK A/T FLUID CONDITION

1. Remove oil pan. Refer to [TM-217. "Control Valve with TCM and A/T Fluid Temperature Sensor 2"](#).
2. Check A/T fluid condition. Refer to [TM-190. "Checking the A/T Fluid \(ATF\)"](#).

OK or NG

- OK >> GO TO 8.
NG >> GO TO 11.

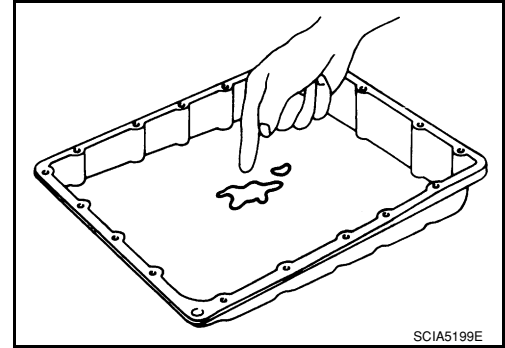

8. DETECT MALFUNCTIONING ITEM

- Check the malfunction items. If any items are damaged, repair or replace damaged parts. Refer to [TM-163. "Symptom Table"](#) (Symptom No.10).

OK or NG

- OK >> GO TO 9.
NG >> Repair or replace damaged parts.

9. CHECK SYMPTOM

Check again. Refer to [TM-202. "Cruise Test - Part 1"](#), [TM-204. "Cruise Test - Part 2"](#), [TM-205. "Cruise Test - Part 3"](#)

OK or NG

- OK >> **INSPECTION END**
NG >> GO TO 10.

10. PERFORM TCM INSPECTION

1. Perform TCM input/output signals inspection. Refer to [TM-114. "Reference Value"](#).
2. If NG, recheck A/T assembly harness connector terminals for damage or loose connection with harness connector.

OK or NG

- OK >> **INSPECTION END**
NG >> Repair or replace damaged parts.

11. DETECT MALFUNCTIONING ITEM

- Check the malfunction items. If any items are damaged, repair or replace damaged parts. Refer to [TM-163. "Symptom Table"](#) (Symptom No.10).

OK or NG

- OK >> GO TO 9.
NG >> Repair or replace damaged parts.

A/T Does Not Shift: D2→D3

INFOID:000000001534547

SYMPTOM:

The vehicle does not shift-up from D2 to D3 gear at the specified speed.

SYSTEM SYMPTOM

< SYMPTOM DIAGNOSIS >

DIAGNOSTIC PROCEDURE

1. CONFIRM THE SYMPTOM

Check if vehicle creeps forward in "D" position and vehicle can be started from D1.

OK or NG

OK >> GO TO 2.

NG >> Refer to [TM-137. "Vehicle Does Not Creep Forward in "D" Position"](#), [TM-140. "Vehicle Cannot Be Started from D1"](#).

2. CHECK SELF-DIAGNOSTIC RESULTS

Perform self-diagnosis. Refer to [TM-33. "CONSULT-III Function \(TRANSMISSION\)"](#).

Do the self-diagnostic results indicate high and low reverse clutch solenoid valve, accelerator pedal position sensor, vehicle speed sensor A/T (revolution sensor) and vehicle speed sensor MTR?

YES >> Check the malfunctioning system. Refer to [TM-50. "Diagnosis Procedure"](#), [TM-70. "Diagnosis Procedure"](#), [TM-88. "Diagnosis Procedure"](#), [TM-76. "Diagnosis Procedure"](#).

NO >> GO TO 3.

3. CHECK A/T FLUID LEVEL

Check A/T fluid level. Refer to [TM-190. "Checking the A/T Fluid \(ATF\)"](#).

OK or NG

OK >> GO TO 4.

NG >> Refill ATF.

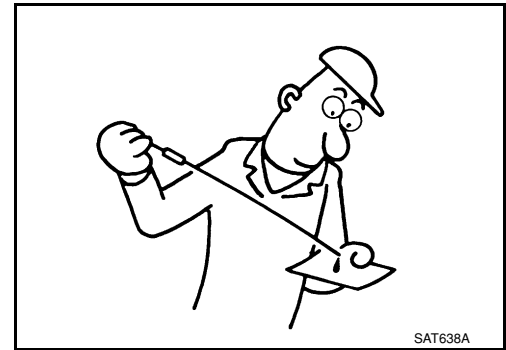

4. CHECK LINE PRESSURE

Check line pressure at the engine stall point. Refer to [TM-199. "Inspection and Judgment"](#).

OK or NG

OK >> GO TO 7.

NG - 1 >> Line pressure high. GO TO 5.

NG - 2 >> Line pressure low. GO TO 6.

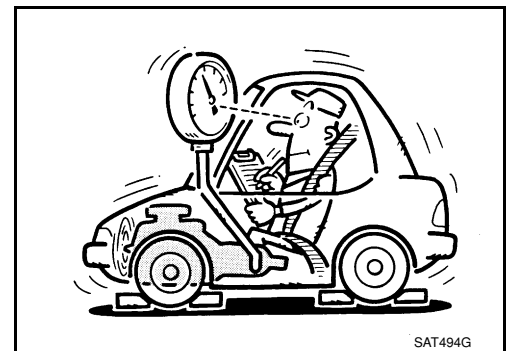

5. DETECT MALFUNCTIONING ITEM

1. Check control valve with TCM. Refer to [TM-217. "Control Valve with TCM and A/T Fluid Temperature Sensor 2"](#).

2. Disassemble A/T. Refer to [TM-245. "Disassembly"](#).

3. Check the following items:

- Oil pump assembly. Refer to [TM-263. "Oil Pump"](#).

OK or NG

OK >> GO TO 7.

NG >> Repair or replace damaged parts.

6. DETECT MALFUNCTIONING ITEM

1. Check control valve with TCM. Refer to [TM-217. "Control Valve with TCM and A/T Fluid Temperature Sensor 2"](#).

2. Disassemble A/T. Refer to [TM-245. "Disassembly"](#).

3. Check the following items:

- Oil pump assembly. Refer to [TM-263. "Oil Pump"](#).

SYSTEM SYMPTOM

< SYMPTOM DIAGNOSIS >

- Power train system. Refer to [TM-245, "Disassembly"](#).
- Transmission case. Refer to [TM-245, "Disassembly"](#).

OK or NG

- OK >> GO TO 7.
- NG >> Repair or replace damaged parts.

7.CHECK A/T FLUID CONDITION

1. Remove oil pan. Refer to [TM-215, "Oil Pan"](#).
2. Check A/T fluid condition. Refer to [TM-190, "Checking the A/T Fluid \(ATF\)"](#).

OK or NG

- OK >> GO TO 8.
- NG >> GO TO 11.

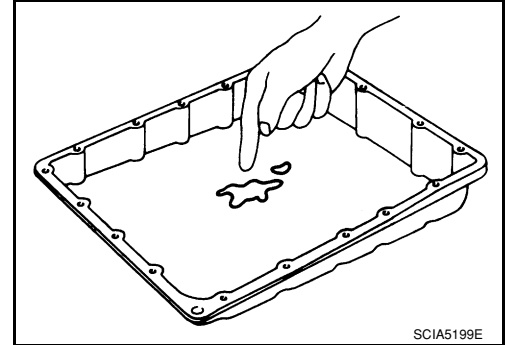

8.DETECT MALFUNCTIONING ITEM

- Check the malfunction items. If any items are damaged, repair or replace damaged parts. Refer to [TM-163, "Symptom Table"](#) (Symptom No.11).

OK or NG

- OK >> GO TO 9.
- NG >> Repair or replace damaged parts.

9.CHECK SYMPTOM

Check again. Refer to [TM-202, "Cruise Test - Part 1"](#), [TM-204, "Cruise Test - Part 2"](#), [TM-205, "Cruise Test - Part 3"](#)

OK or NG

- OK >> **INSPECTION END**
- NG >> GO TO 10.

10.PERFORM TCM INSPECTION

1. Perform TCM input/output signals inspection. Refer to [TM-114, "Reference Value"](#).
2. If NG, recheck A/T assembly harness connector terminals for damage or loose connection with harness connector.

OK or NG

- OK >> **INSPECTION END**
- NG >> Repair or replace damaged parts.

11.DETECT MALFUNCTIONING ITEM

- Check the malfunction items. If any items are damaged, repair or replace damaged parts. Refer to [TM-163, "Symptom Table"](#) (Symptom No.11).

OK or NG

- OK >> GO TO 9.
- NG >> Repair or replace damaged parts.

A/T Does Not Shift: D3→D4

INFOID:000000001534546

SYMPTOM:

- The vehicle does not shift-up from the D3 to D4 gear at the specified speed.
- The vehicle does not shift-up from the D3 to D4 gear unless A/T is warmed up.

DIAGNOSTIC PROCEDURE

1.CONFIRM THE SYMPTOM

SYSTEM SYMPTOM

< SYMPTOM DIAGNOSIS >

Check if vehicle creeps forward in "D" position and vehicle can be started from D1.

OK or NG

OK >> GO TO 2.

NG >> Refer to [TM-137. "Vehicle Does Not Creep Forward in "D" Position"](#), [TM-140. "Vehicle Cannot Be Started from D1"](#).

2.CHECK SELF-DIAGNOSTIC RESULTS

Perform self-diagnosis. Refer to [TM-33. "CONSULT-III Function \(TRANSMISSION\)"](#).

Do the self-diagnostic results indicate front brake solenoid valve, input clutch solenoid valve, accelerator pedal position sensor, vehicle speed sensor A/T (revolution sensor) and vehicle speed sensor MTR?

YES >> Check the malfunctioning system. Refer to [TM-50. "Diagnosis Procedure"](#), [TM-70. "Diagnosis Procedure"](#), [TM-76. "Diagnosis Procedure"](#), [TM-82. "Diagnosis Procedure"](#), [TM-84. "Diagnosis Procedure"](#).

NO >> GO TO 3.

3.CHECK A/T FLUID LEVEL

Check A/T fluid level. Refer to [TM-190. "Checking the A/T Fluid \(ATF\)"](#).

OK or NG

OK >> GO TO 4.

NG >> Refill ATF.

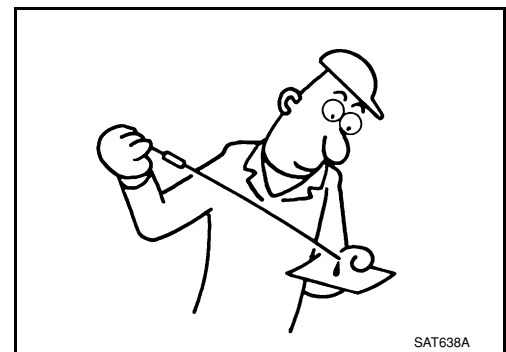

4.CHECK LINE PRESSURE

Check line pressure at the engine stall point. Refer to [TM-199. "Inspection and Judgment"](#).

OK or NG

OK >> GO TO 7.

NG - 1 >> Line pressure high. GO TO 5.

NG - 2 >> Line pressure low. GO TO 6.

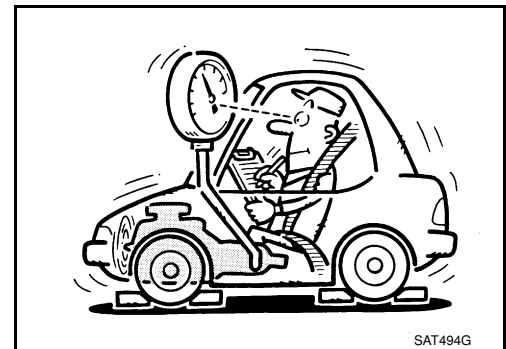

5.DETECT MALFUNCTIONING ITEM

1. Check control valve with TCM. Refer to [TM-217. "Control Valve with TCM and A/T Fluid Temperature Sensor 2"](#).

2. Disassemble A/T. Refer to [TM-245. "Disassembly"](#).

3. Check the following items:

- Oil pump assembly. Refer to [TM-263. "Oil Pump"](#).

OK or NG

OK >> GO TO 7.

NG >> Repair or replace damaged parts.

6.DETECT MALFUNCTIONING ITEM

1. Check control valve with TCM. Refer to [TM-217. "Control Valve with TCM and A/T Fluid Temperature Sensor 2"](#).

2. Disassemble A/T. Refer to [TM-245. "Disassembly"](#).

3. Check the following items:

- Oil pump assembly. Refer to [TM-263. "Oil Pump"](#).

- Power train system. Refer to [TM-245. "Disassembly"](#).

- Transmission case. Refer to [TM-245. "Disassembly"](#).

SYSTEM SYMPTOM

< SYMPTOM DIAGNOSIS >

OK or NG

- OK >> GO TO 7.
NG >> Repair or replace damaged parts.

7. CHECK A/T FLUID CONDITION

1. Remove oil pan. Refer to [TM-215, "Oil Pan"](#).
2. Check A/T fluid condition. Refer to [TM-190, "Checking the A/T Fluid \(ATF\)"](#).

OK or NG

- OK >> GO TO 8.
NG >> GO TO 11.

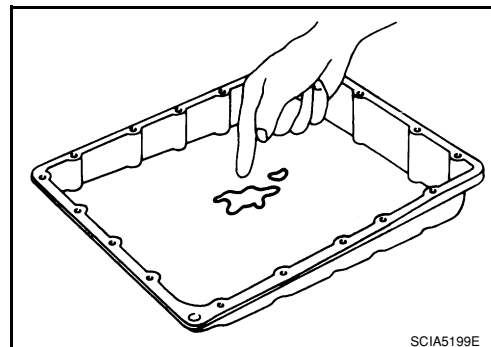

8. DETECT MALFUNCTIONING ITEM

- Check the malfunction items. If any items are damaged, repair or replace damaged parts. Refer to [TM-163, "Symptom Table"](#) (Symptom No.12).

OK or NG

- OK >> GO TO 9.
NG >> Repair or replace damaged parts.

9. CHECK SYMPTOM

Check again. Refer to [TM-202, "Cruise Test - Part 1"](#), [TM-204, "Cruise Test - Part 2"](#), [TM-205, "Cruise Test - Part 3"](#)

OK or NG

- OK >> **INSPECTION END**
NG >> GO TO 10.

10. PERFORM TCM INSPECTION

1. Perform TCM input/output signals inspection. Refer to [TM-114, "Reference Value"](#).
2. If NG, recheck A/T assembly harness connector terminals for damage or loose connection with harness connector.

OK or NG

- OK >> **INSPECTION END**
NG >> Repair or replace damaged parts.

11. DETECT MALFUNCTIONING ITEM

- Check the malfunction items. If any items are damaged, repair or replace damaged parts. Refer to [TM-163, "Symptom Table"](#) (Symptom No.12).

OK or NG

- OK >> GO TO 9.
NG >> Repair or replace damaged parts.

A/T Does Not Shift: D4→D5

INFOID:000000001534545

SYMPTOM:

- The vehicle does not shift-up from the D4 to D5 gear at the specified speed.
- The vehicle does not shift-up from the D4 to D5 gear unless A/T is warmed up.

DIAGNOSTIC PROCEDURE

1. CONFIRM THE SYMPTOM

Check if vehicle creeps forward in "D" position and vehicle can be started from D1.

OK or NG

SYSTEM SYMPTOM

< SYMPTOM DIAGNOSIS >

- OK >> GO TO 2.
NG >> Refer to [TM-137, "Vehicle Does Not Creep Forward in "D" Position"](#), [TM-140, "Vehicle Cannot Be Started from D1"](#).

2.CHECK SELF-DIAGNOSTIC RESULTS

Perform self-diagnosis. Refer to [TM-33, "CONSULT-III Function \(TRANSMISSION\)"](#).

Do the self-diagnostic results indicate front brake solenoid valve, direct clutch solenoid valve, accelerator pedal position sensor, turbine revolution sensor, vehicle speed sensor A/T (revolution sensor) and vehicle speed sensor MTR?

- YES >> Check the malfunctioning system. Refer to [TM-50, "Diagnosis Procedure"](#), [TM-47, "Diagnosis Procedure"](#), [TM-70, "Diagnosis Procedure"](#), [TM-76, "Diagnosis Procedure"](#), [TM-84, "Diagnosis Procedure"](#), [TM-86, "Diagnosis Procedure"](#).

- NO >> GO TO 3.

3.CHECK A/T FLUID LEVEL

Check A/T fluid level. Refer to [TM-190, "Checking the A/T Fluid \(ATF\)"](#).

OK or NG

- OK >> GO TO 4.
NG >> Refill ATF.

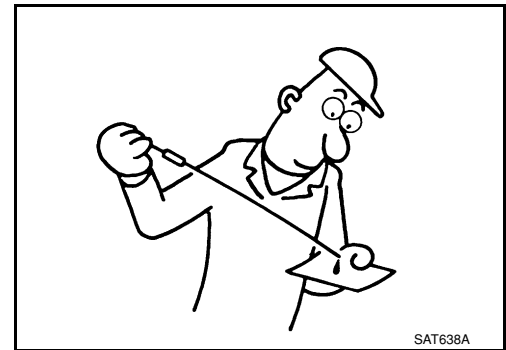

4.CHECK LINE PRESSURE

Check line pressure at the engine stall point. Refer to [TM-199, "Inspection and Judgment"](#).

OK or NG

- OK >> GO TO 7.
NG - 1 >> Line pressure high. GO TO 5.
NG - 2 >> Line pressure low. GO TO 6.

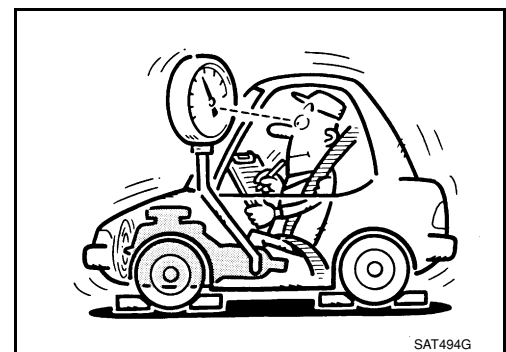

5.DETECT MALFUNCTIONING ITEM

1. Check control valve with TCM. Refer to [TM-217, "Control Valve with TCM and A/T Fluid Temperature Sensor 2"](#).
2. Disassemble A/T. Refer to [TM-245, "Disassembly"](#).
3. Check the following items:
 - Oil pump assembly. Refer to [TM-263, "Oil Pump"](#).

OK or NG

- OK >> GO TO 7.
NG >> Repair or replace damaged parts.

6.DETECT MALFUNCTIONING ITEM

1. Check control valve with TCM. Refer to [TM-217, "Control Valve with TCM and A/T Fluid Temperature Sensor 2"](#).
2. Disassemble A/T. Refer to [TM-245, "Disassembly"](#).
3. Check the following items:
 - Oil pump assembly. Refer to [TM-263, "Oil Pump"](#).
 - Power train system. Refer to [TM-245, "Disassembly"](#).
 - Transmission case. Refer to [TM-245, "Disassembly"](#).

OK or NG

SYSTEM SYMPTOM

< SYMPTOM DIAGNOSIS >

- OK >> GO TO 7.
NG >> Repair or replace damaged parts.

7. CHECK A/T FLUID CONDITION

1. Remove oil pan. Refer to [TM-217, "Control Valve with TCM and A/T Fluid Temperature Sensor 2"](#).
2. Check A/T fluid condition. Refer to [TM-190, "Checking the A/T Fluid \(ATF\)"](#).

OK or NG

- OK >> GO TO 8.
NG >> GO TO 11.

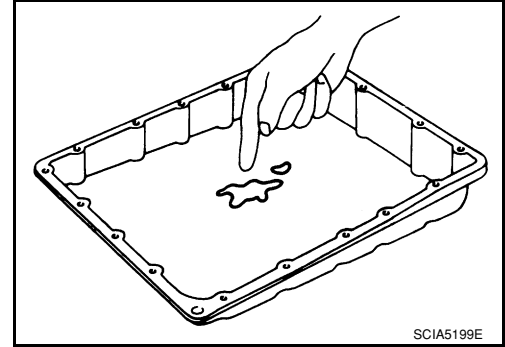

8. DETECT MALFUNCTIONING ITEM

- Check the malfunction items. If any items are damaged, repair or replace damaged parts. Refer to [TM-163, "Symptom Table"](#) (Symptom No.13).

OK or NG

- OK >> GO TO 9.
NG >> Repair or replace damaged parts.

9. CHECK SYMPTOM

Check again. Refer to [TM-202, "Cruise Test - Part 1"](#).

OK or NG

- OK >> **INSPECTION END**
NG >> GO TO 10.

10. PERFORM TCM INSPECTION

1. Perform TCM input/output signals inspection. Refer to [TM-114, "Reference Value"](#).
2. If NG, recheck A/T assembly harness connector terminals for damage or loose connection with harness connector.

OK or NG

- OK >> **INSPECTION END**
NG >> Repair or replace damaged parts.

11. DETECT MALFUNCTIONING ITEM

- Check the malfunction items. If any items are damaged, repair or replace damaged parts. Refer to [TM-163, "Symptom Table"](#) (Symptom No.13).

OK or NG

- OK >> GO TO 9.
NG >> Repair or replace damaged parts.

A/T Does Not Perform Lock-up

INFOID:000000001534544

SYMPTOM:

A/T does not perform lock-up at the specified speed.

DIAGNOSTIC PROCEDURE

1. CHECK SELF-DIAGNOSTIC RESULTS

Perform self-diagnosis. Refer to [TM-33, "CONSULT-III Function \(TRANSMISSION\)"](#).

Do the self-diagnostic results indicate torque converter clutch solenoid valve, engine speed signal, turbine revolution sensor, accelerator pedal position sensor, CAN communication?

SYSTEM SYMPTOM

< SYMPTOM DIAGNOSIS >

YES >> Check the malfunctioning system. Refer to [TM-47, "Diagnosis Procedure"](#), [TM-52, "Diagnosis Procedure"](#), [TM-64, "Diagnosis Procedure"](#), [TM-70, "Diagnosis Procedure"](#), [TM-39, "Diagnosis Procedure"](#).

NO >> GO TO 2.

2.CHECK A/T FLUID LEVEL

Check A/T fluid level. Refer to [TM-190, "Checking the A/T Fluid \(ATF\)"](#).

OK or NG

OK >> GO TO 3.

NG >> Refill ATF.

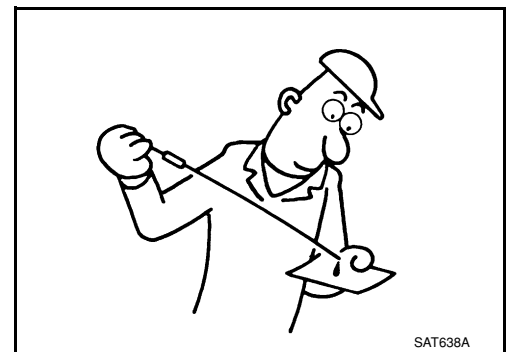

3.CHECK LINE PRESSURE

Check line pressure at the engine stall point. Refer to [TM-199, "Inspection and Judgment"](#).

OK or NG

OK >> GO TO 6.

NG - 1 >> Line pressure high. GO TO 4.

NG - 2 >> Line pressure low. GO TO 5.

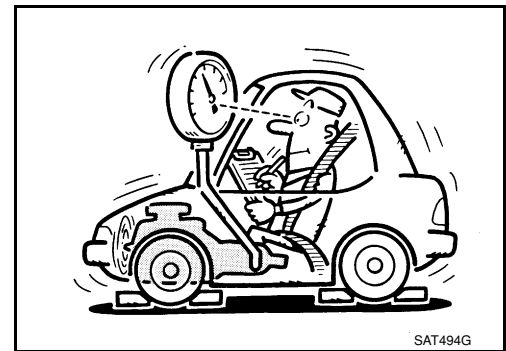

4.DETECT MALFUNCTIONING ITEM

1. Check control valve with TCM. Refer to [TM-217, "Control Valve with TCM and A/T Fluid Temperature Sensor 2"](#).

2. Disassemble A/T. Refer to [TM-245, "Disassembly"](#).

3. Check the following items:

- Oil pump assembly. Refer to [TM-263, "Oil Pump"](#).

OK or NG

OK >> GO TO 7.

NG >> Repair or replace damaged parts.

5.DETECT MALFUNCTIONING ITEM

1. Check control valve with TCM. Refer to [TM-217, "Control Valve with TCM and A/T Fluid Temperature Sensor 2"](#).

2. Disassemble A/T. Refer to [TM-245, "Disassembly"](#).

3. Check the following items:

- Oil pump assembly. Refer to [TM-263, "Oil Pump"](#).

- Power train system. Refer to [TM-245, "Disassembly"](#).

- Transmission case. Refer to [TM-245, "Disassembly"](#).

OK or NG

OK >> GO TO 7.

NG >> Repair or replace damaged parts.

6.CHECK A/T FLUID CONDITION

1. Remove oil pan. Refer to [TM-217, "Control Valve with TCM and A/T Fluid Temperature Sensor 2"](#).

SYSTEM SYMPTOM

< SYMPTOM DIAGNOSIS >

2. Check A/T fluid condition. Refer to [TM-190. "Checking the A/T Fluid \(ATF\)".](#)

OK or NG

- OK >> GO TO 7.
- NG >> GO TO 10.

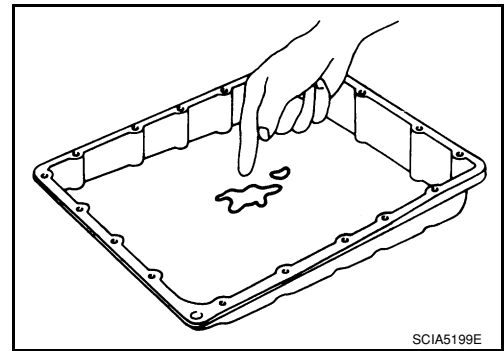

7. DETECT MALFUNCTIONING ITEM

- Check the malfunction items. If any items are damaged, repair or replace damaged parts. Refer to [TM-163. "Symptom Table"](#) (Symptom No.24).

OK or NG

- OK >> GO TO 8.
- NG >> Repair or replace damaged parts.

8. CHECK SYMPTOM

Check again. Refer to [TM-202. "Cruise Test - Part 1"](#).

OK or NG

- OK >> **INSPECTION END**
- NG >> GO TO 9.

9. PERFORM TCM INSPECTION

1. Perform TCM input/output signals inspection. Refer to [TM-114. "Reference Value"](#).
2. If NG, recheck A/T assembly harness connector terminals for damage or loose connection with harness connector.

OK or NG

- OK >> **INSPECTION END**
- NG >> Repair or replace damaged parts.

10. DETECT MALFUNCTIONING ITEM

- Check the malfunction items. If any items are damaged, repair or replace damaged parts. Refer to [TM-163. "Symptom Table"](#) (Symptom No.24).

OK or NG

- OK >> GO TO 8.
- NG >> Repair or replace damaged parts.

A/T Does Not Hold Lock-up Condition

INFOID:000000001534543

SYMPTOM:

The lock-up condition cannot be maintained for more than 30 seconds.

DIAGNOSTIC PROCEDURE

1. CHECK SELF-DIAGNOSTIC RESULTS

Perform self-diagnosis. Refer to [TM-33. "CONSULT-III Function \(TRANSMISSION\)"](#).

Do the self-diagnostic results indicate torque converter clutch solenoid valve, engine speed signal, turbine revolution sensor, CAN communication?

- YES >> Check the malfunctioning system. Refer to [TM-39. "Diagnosis Procedure"](#), [TM-47. "Diagnosis Procedure"](#), [TM-52. "Diagnosis Procedure"](#), [TM-64. "Diagnosis Procedure"](#).
- NO >> GO TO 2.

2. CHECK A/T FLUID LEVEL

SYSTEM SYMPTOM

< SYMPTOM DIAGNOSIS >

Check A/T fluid level. Refer to [TM-190, "Checking the A/T Fluid \(ATF\)"](#).

OK or NG

- OK >> GO TO 3.
- NG >> Refill ATF.

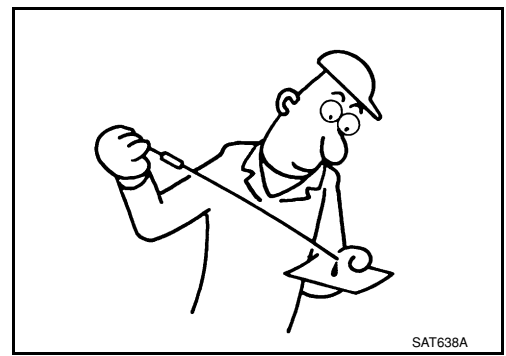

3.CHECK A/T FLUID CONDITION

1. Remove oil pan. Refer to [TM-217, "Control Valve with TCM and A/T Fluid Temperature Sensor 2"](#).
2. Check A/T fluid condition. Refer to [TM-190, "Checking the A/T Fluid \(ATF\)"](#).

OK or NG

- OK >> GO TO 4.
- NG >> GO TO 7.

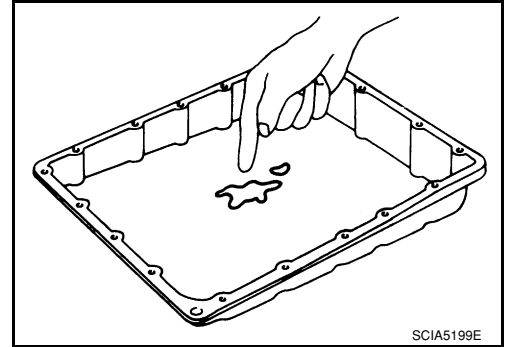

4.DETECT MALFUNCTIONING ITEM

- Check the malfunction items. If any items are damaged, repair or replace damaged parts. Refer to [TM-163, "Symptom Table"](#) (Symptom No.25).

OK or NG

- OK >> GO TO 5.
- NG >> Repair or replace damaged parts.

5.CHECK SYMPTOM

Check again. Refer to [TM-202, "Cruise Test - Part 1"](#).

OK or NG

- OK >> **INSPECTION END**
- NG >> GO TO 6.

6.PERFORM TCM INSPECTION

1. Perform TCM input/output signals inspection. Refer to [TM-114, "Reference Value"](#).
2. If NG, recheck A/T assembly harness connector terminals for damage or loose connection with harness connector.

OK or NG

- OK >> **INSPECTION END**
- NG >> Repair or replace damaged parts.

7.DETECT MALFUNCTIONING ITEM

- Check the malfunction items. If any items are damaged, repair or replace damaged parts. Refer to [TM-163, "Symptom Table"](#) (Symptom No.25).

OK or NG

- OK >> GO TO 5.
- NG >> Repair or replace damaged parts.

Lock-up Is Not Released

INFOID:000000001534542

SYMPTOM:

The lock-up condition cannot be cancelled even after releasing the accelerator pedal.

SYSTEM SYMPTOM

< SYMPTOM DIAGNOSIS >

DIAGNOSTIC PROCEDURE

1. CHECK SELF-DIAGNOSTIC RESULTS

Perform self-diagnosis. Refer to [TM-33. "CONSULT-III Function \(TRANSMISSION\)"](#).

Do the self-diagnostic results indicate torque converter clutch solenoid valve, engine speed signal, turbine revolution sensor, CAN communication?

YES >> Check the malfunctioning system. Refer to [TM-64. "Diagnosis Procedure"](#), [TM-52. "Diagnosis Procedure"](#), [TM-47. "Diagnosis Procedure"](#), [TM-39. "Diagnosis Procedure"](#).

NO >> GO TO 2.

2. CHECK SYMPTOM

Check again. Refer to [TM-202. "Cruise Test - Part 1"](#).

OK or NG

OK >> **INSPECTION END**

NG >> GO TO 3.

3. PERFORM TCM INSPECTION

1. Perform TCM input/output signals inspection. Refer to [TM-114. "Reference Value"](#).

2. If NG, recheck A/T assembly harness connector terminals for damage or loose connection with harness connector.

OK or NG

OK >> **INSPECTION END**

NG >> Repair or replace damaged parts.

Engine Speed Does Not Return to Idle

INFOID:000000001534541

SYMPTOM:

When a shift-down is performed, the engine speed does not smoothly return to the idling speed.

DIAGNOSTIC PROCEDURE

1. CHECK A/T FLUID LEVEL

Check A/T fluid level. Refer to [TM-190. "Checking the A/T Fluid \(ATF\)"](#).

OK or NG

OK >> GO TO 2.

NG >> Refill ATF.

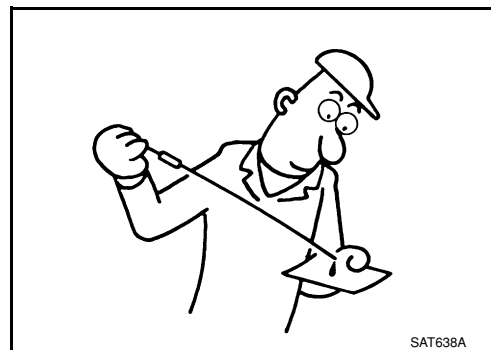

SAT638A

2. CHECK SELF-DIAGNOSTIC RESULTS

Perform self-diagnosis. Refer to [TM-33. "CONSULT-III Function \(TRANSMISSION\)"](#).

Do the self-diagnostic results indicate front brake solenoid valve, direct clutch solenoid valve, accelerator pedal position sensor, vehicle speed sensor A/T (revolution sensor) and vehicle speed sensor MTR?

YES >> Check the malfunctioning system. Refer to [TM-84. "Diagnosis Procedure"](#), [TM-86. "Diagnosis Procedure"](#), [TM-70. "Diagnosis Procedure"](#), [TM-50. "Diagnosis Procedure"](#), [TM-76. "Diagnosis Procedure"](#).

NO >> GO TO 3.

3. CHECK A/T FLUID CONDITION

1. Remove oil pan. Refer to [TM-217. "Control Valve with TCM and A/T Fluid Temperature Sensor 2"](#).

SYSTEM SYMPTOM

< SYMPTOM DIAGNOSIS >

2. Check A/T fluid condition. Refer to [TM-190. "Checking the A/T Fluid \(ATF\)".](#)

OK or NG

- OK >> GO TO 4.
- NG >> GO TO 7.

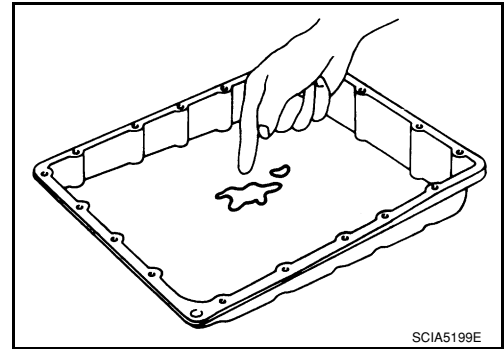

4. DETECT MALFUNCTIONING ITEM

- Check the malfunction items. If any items are damaged, repair or replace damaged parts. Refer to [TM-163. "Symptom Table"](#) (Symptom No.65).

OK or NG

- OK >> GO TO 5.
- NG >> Repair or replace damaged parts.

5. CHECK SYMPTOM

Check again. Refer to [TM-202. "Cruise Test - Part 1"](#)

OK or NG

- OK >> **INSPECTION END**
- NG >> GO TO 6.

6. PERFORM TCM INSPECTION

1. Perform TCM input/output signals inspection. Refer to [TM-114. "Reference Value"](#).
2. If NG, recheck A/T assembly harness connector terminals for damage or loose connection with harness connector.

OK or NG

- OK >> **INSPECTION END**
- NG >> Repair or replace damaged parts.

7. DETECT MALFUNCTIONING ITEM

- Check the malfunction items. If any items are damaged, repair or replace damaged parts. Refer to [TM-163. "Symptom Table"](#) (Symptom No.65).

OK or NG

- OK >> GO TO 5.
- NG >> Repair or replace damaged parts.

A/T Does Not Shift: 5th gear → 4th gear

INFOID:000000001534539

SYMPTOM:

When shifted from D5 to 4 position, does not downshift from 5th to 4th gears.

DIAGNOSTIC PROCEDURE

1. CHECK SELF-DIAGNOSIS RESULTS

Perform self-diagnosis. Refer to [TM-33. "CONSULT-III Function \(TRANSMISSION\)"](#).

Do the self-diagnosis results indicate PNP switch?

- YES >> Check the malfunctioning system. Refer to [TM-70. "Diagnosis Procedure"](#).
- NO >> GO TO 2.

2. CHECK 4TH POSITION SWITCH CIRCUIT

With CONSULT-III

1. Turn ignition switch "ON".
2. Select "ECU INPUT SIGNALS" in "DATA MONITOR" mode for "TRANSMISSION" with CONSULT-III.
3. Read out "OD CONT SW" switch moving selector lever to each position.

SYSTEM SYMPTOM

< SYMPTOM DIAGNOSIS >

Monitor item	Condition	Display value
OD CONT SW	When setting the selector lever to "4" and "3" position.	ON
	When setting selector lever to other positions.	OFF

⊗ Without CONSULT-III

- Turn ignition switch "ON". (Do not start engine)
- Check voltage between A/T device harness connector terminal and ground.

Item	Connector No.	Terminal No.	Condition	Data (Approx.)
4th position switch	M203	1 - Ground	When setting the selector lever to "4" and "3" position.	0V
			When setting selector lever to other positions.	Battery voltage

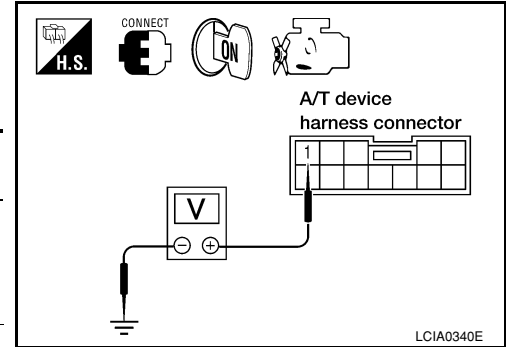

OK or NG

- OK >> GO TO 3.
- NG >> Repair or replace damaged parts.

3. CHECK A/T FLUID LEVEL

Check the A/T fluid level. Refer to [TM-190, "Checking the A/T Fluid \(ATF\)"](#).

OK or NG

- OK >> GO TO 4.
- NG >> Refill ATF.

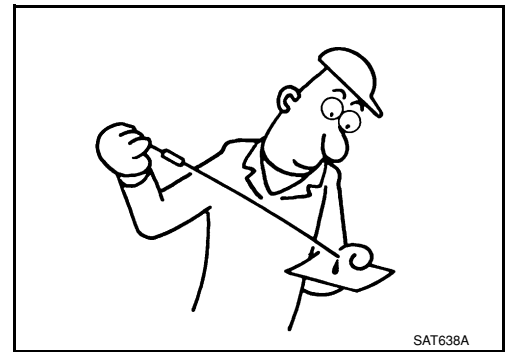

4. CHECK CONTROL CABLE

Check the control cable.

- Refer to [TM-209, "Checking of A/T Position"](#).

OK or NG

- OK >> GO TO 5.
- NG >> Adjust control cable. Refer to [TM-209, "Adjustment of A/T Position"](#).

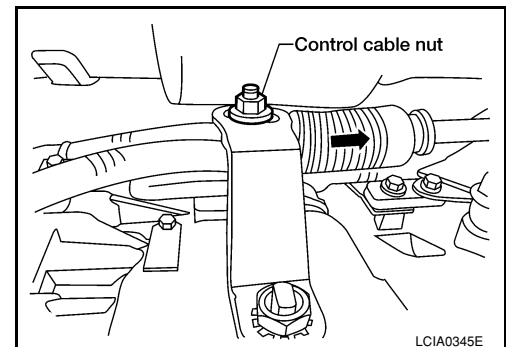

5. CHECK A/T FLUID CONDITION

- Remove oil pan. Refer to [TM-217, "Control Valve with TCM and A/T Fluid Temperature Sensor 2"](#).

SYSTEM SYMPTOM

< SYMPTOM DIAGNOSIS >

2. Check A/T fluid condition. Refer to [TM-190. "Checking the A/T Fluid \(ATF\)".](#)

OK or NG

- OK >> GO TO 6.
- NG >> GO TO 9.

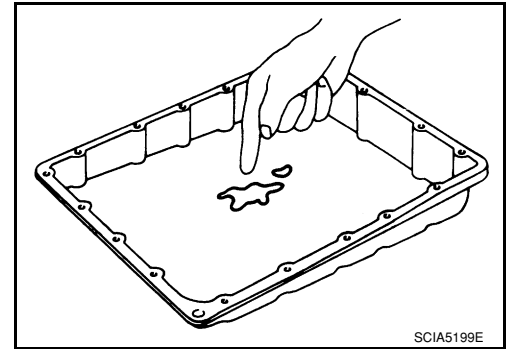

6. DETECT MALFUNCTIONING ITEM

- Check the malfunction items. If any items are damaged, repair or replace damaged parts. Refer to [TM-163. "Symptom Table"](#) (Symptom No.14).

OK or NG

- OK >> GO TO 7.
- NG >> Repair or replace damaged parts.

7. CHECK SYMPTOM

Check again. Refer to [TM-205. "Cruise Test - Part 3"](#).

OK or NG

- OK >> **INSPECTION END**
- NG >> GO TO 8.

8. PERFORM TCM INSPECTION

1. Perform TCM input/output signals inspection. Refer to [TM-114. "Reference Value"](#).
2. If NG, recheck A/T assembly harness connector terminals for damage or loose connection with harness connector.

OK or NG

- OK >> **INSPECTION END**
- NG >> Repair or replace damaged parts.

9. DETECT MALFUNCTIONING ITEM

- Check the malfunction items. If any items are damaged, repair or replace damaged parts. Refer to [TM-163. "Symptom Table"](#) (Symptom No.14).

OK or NG

- OK >> GO TO 7.
- NG >> Repair or replace damaged parts.

A/T Does Not Shift: 4th gear → 3rd gear

INFOID:000000001534538

SYMPTOM:

When shifted from 44 to 33 position, does not downshift from 4th to 3rd gears.

DIAGNOSTIC PROCEDURE

1. CHECK SELF-DIAGNOSIS RESULTS

Perform self-diagnosis. Refer to [TM-33. "CONSULT-III Function \(TRANSMISSION\)"](#).

Do the self-diagnosis results indicate PNP switch?

- YES >> Check the malfunctioning system. Refer to [TM-44. "Diagnosis Procedure"](#).
- NO >> GO TO 2.

2. CHECK A/T FLUID LEVEL

SYSTEM SYMPTOM

< SYMPTOM DIAGNOSIS >

Check the A/T fluid level. Refer to [TM-190. "Checking the A/T Fluid \(ATF\)".](#)

OK or NG

- OK >> GO TO 3.
- NG >> Refill ATF.

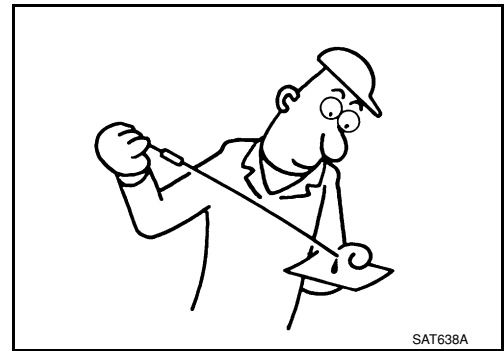

3. CHECK CONTROL CABLE

Check the control cable.

- Refer to [TM-209. "Checking of A/T Position".](#)

OK or NG

- OK >> GO TO 4.
- NG >> Adjust control cable. Refer to [TM-209. "Adjustment of A/T Position".](#)

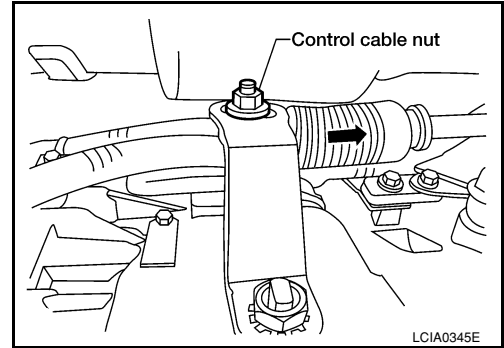

4. CHECK A/T FLUID CONDITION

1. Remove oil pan. Refer to [TM-217. "Control Valve with TCM and A/T Fluid Temperature Sensor 2".](#)
2. Check A/T fluid condition. Refer to [TM-190. "Checking the A/T Fluid \(ATF\)".](#)

OK or NG

- OK >> GO TO 5.
- NG >> GO TO 8.

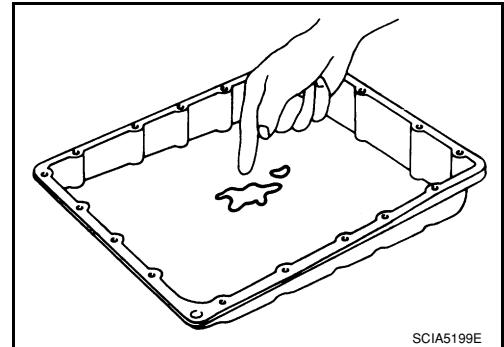

5. DETECT MALFUNCTIONING ITEM

- Check the malfunction items. If any items are damaged, repair or replace damaged parts. Refer to [TM-163. "Symptom Table"](#) (Symptom No.15).

OK or NG

- OK >> GO TO 6.
- NG >> Repair or replace damaged parts.

6. CHECK SYMPTOM

Check again. Refer to [TM-205. "Cruise Test - Part 3".](#)

OK or NG

- OK >> **INSPECTION END**
- NG >> GO TO 7.

7. PERFORM TCM INSPECTION

1. Perform TCM input/output signals inspection. Refer to [TM-114. "Reference Value".](#)
2. If NG, recheck A/T assembly harness connector terminals for damage or loose connection with harness connector.

OK or NG

- OK >> **INSPECTION END**

A
B
C
TM
E
F
G
H
I
J
K
L
M
N
O
P

SYSTEM SYMPTOM

< SYMPTOM DIAGNOSIS >

NG >> Repair or replace damaged parts.

8. DETECT MALFUNCTIONING ITEM

- Check the malfunction items. If any items are damaged, repair or replace damaged parts. Refer to [TM-163, "Symptom Table"](#) (Symptom No.15).

OK or NG

OK >> GO TO 6.

NG >> Repair or replace damaged parts.

A/T Does Not Shift: 3rd gear → 2nd gear

INFOID:000000001534536

SYMPTOM:

When shifted from 33 to 22 position, does not downshift from 3rd to 2nd gears.

DIAGNOSTIC PROCEDURE

1. CHECK SELF-DIAGNOSIS RESULTS

Perform self-diagnosis. Refer to [TM-33, "CONSULT-III Function \(TRANSMISSION\)"](#).

Do the self-diagnosis results indicate PNP switch?

YES >> Check the malfunctioning system. Refer to [TM-44, "Diagnosis Procedure"](#).

NO >> GO TO 2.

2. CHECK A/T FLUID LEVEL

Check the A/T fluid level. Refer to [TM-190, "Checking the A/T Fluid \(ATF\)"](#).

OK or NG

OK >> GO TO 3.

NG >> Refill ATF.

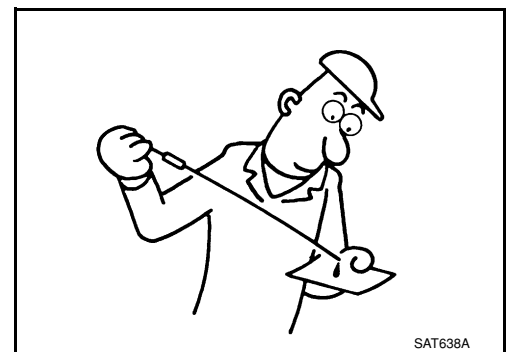

3. CHECK CONTROL CABLE

Check the control cable.

- Refer to [TM-209, "Checking of A/T Position"](#).

OK or NG

OK >> GO TO 4.

NG >> Adjust control cable. Refer to [TM-209, "Adjustment of A/T Position"](#).

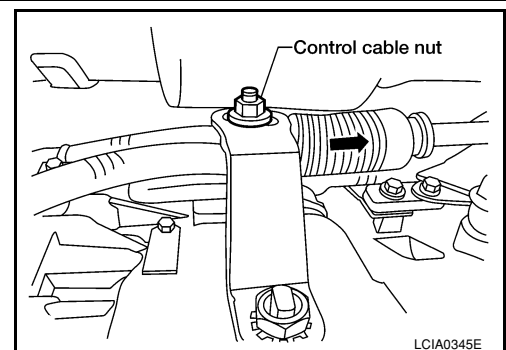

4. CHECK A/T FLUID CONDITION

1. Remove oil pan. Refer to [TM-217, "Control Valve with TCM and A/T Fluid Temperature Sensor 2"](#).

SYSTEM SYMPTOM

< SYMPTOM DIAGNOSIS >

2. Check A/T fluid condition. Refer to [TM-190. "Checking the A/T Fluid \(ATF\)".](#)

OK or NG

- OK >> GO TO 5.
- NG >> GO TO 8.

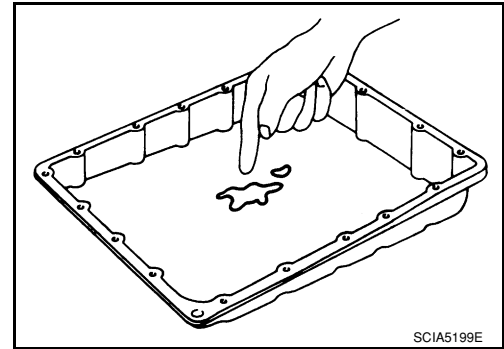

5. DETECT MALFUNCTIONING ITEM

- Check the malfunction items. If any items are damaged, repair or replace damaged parts. Refer to [TM-163. "Symptom Table"](#) (Symptom No.16).

OK or NG

- OK >> GO TO 6.
- NG >> Repair or replace damaged parts.

6. CHECK SYMPTOM

Check again. Refer to [TM-205. "Cruise Test - Part 3"](#).

OK or NG

- OK >> **INSPECTION END**
- NG >> GO TO 7.

7. PERFORM TCM INSPECTION

1. Perform TCM input/output signals inspection. Refer to [TM-114. "Reference Value"](#).
2. If NG, recheck A/T assembly harness connector terminals for damage or loose connection with harness connector.

OK or NG

- OK >> **INSPECTION END**
- NG >> Repair or replace damaged parts.

8. DETECT MALFUNCTIONING ITEM

- Check the malfunction items. If any items are damaged, repair or replace damaged parts. Refer to [TM-163. "Symptom Table"](#) (Symptom No.16).

OK or NG

- OK >> GO TO 6.
- NG >> Repair or replace damaged parts.

A/T Does Not Shift: 2nd gear → 1st gear

INFOID:000000001534535

SYMPTOM:

When shifted from 2nd to 1st position, does not downshift from 2nd to 1st gears.

DIAGNOSTIC PROCEDURE

1. CHECK SELF-DIAGNOSIS RESULTS

Perform self-diagnosis. Refer to [TM-33. "CONSULT-III Function \(TRANSMISSION\)"](#).

Do the self-diagnosis results indicate PNP switch?

- YES >> Check the malfunctioning system. Refer to [TM-44. "Diagnosis Procedure"](#).
- NO >> GO TO 2.

2. CHECK 1ST POSITION SWITCH CIRCUIT

With CONSULT-III

1. Turn ignition switch "ON".
2. Select "ECU INPUT SIGNALS" in "DATA MONITOR" mode for "TRANSMISSION" with CONSULT-III.
3. Read out "1 POSITION SW" switch moving selector lever to each position.

SYSTEM SYMPTOM

< SYMPTOM DIAGNOSIS >

Monitor item	Condition	Display value
1 POSITION SW	When setting the selector lever to "1" position.	ON
	When setting selector lever to other positions.	OFF

⊗ Without CONSULT-III

- Turn ignition switch "ON". (Do not start engine)
- Check voltage between A/T device harness connector terminal and ground.

Item	Connector No.	Terminal No.	Condition	Data (Approx.)
1st position switch	M203	7 - Ground	When setting the selector lever to "1" position.	0V
			When setting selector lever to other positions.	Battery voltage

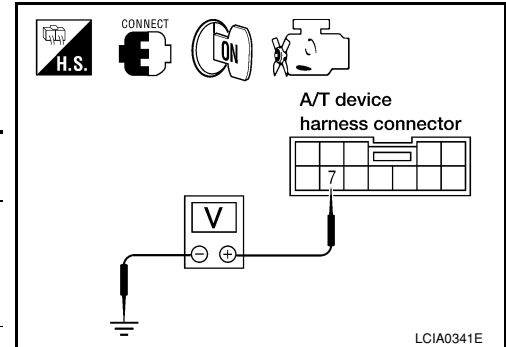

OK or NG

- OK >> GO TO 3.
- NG >> Repair or replace damaged parts.

3. CHECK A/T FLUID LEVEL

Check the A/T fluid level. Refer to [TM-190, "Checking the A/T Fluid \(ATF\)"](#).

OK or NG

- OK >> GO TO 4.
- NG >> Refill ATF.

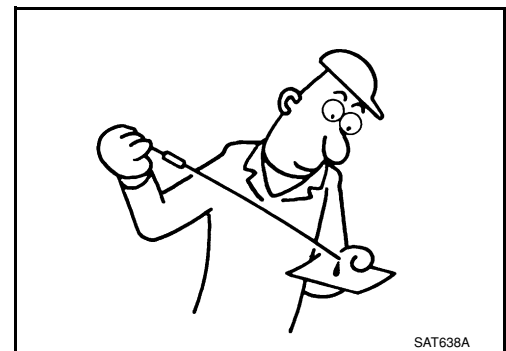

4. CHECK CONTROL CABLE

Check the control cable.

- Refer to [TM-209, "Checking of A/T Position"](#).

OK or NG

- OK >> GO TO 5.
- NG >> Adjust control cable. Refer to [TM-209, "Adjustment of A/T Position"](#).

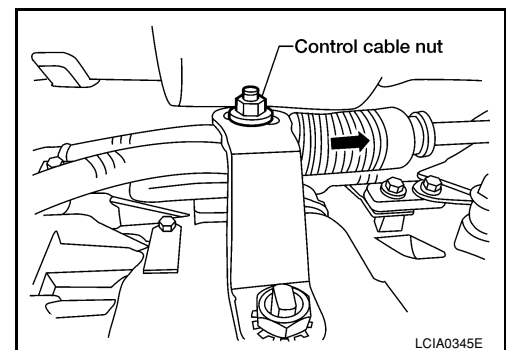

5. CHECK A/T FLUID CONDITION

- Remove oil pan. Refer to [TM-217, "Control Valve with TCM and A/T Fluid Temperature Sensor 2"](#).

SYSTEM SYMPTOM

< SYMPTOM DIAGNOSIS >

2. Check A/T fluid condition. Refer to [TM-190, "Checking the A/T Fluid \(ATF\)"](#).

OK or NG

- OK >> GO TO 6.
- NG >> GO TO 9.

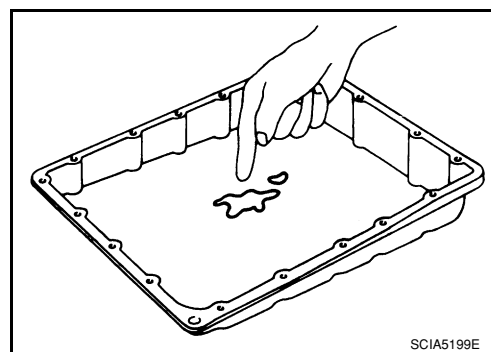

6. DETECT MALFUNCTIONING ITEM

- Check the malfunction items. If any items are damaged, repair or replace damaged parts. Refer to [TM-163, "Symptom Table"](#) (Symptom No.17).

OK or NG

- OK >> GO TO 7.
- NG >> Repair or replace damaged parts.

7. CHECK SYMPTOM

Check again. Refer to [TM-204, "Cruise Test - Part 2"](#)

OK or NG

- OK >> **INSPECTION END**
- NG >> GO TO 8.

8. PERFORM TCM INSPECTION

1. Perform TCM input/output signals inspection. Refer to [TM-114, "Reference Value"](#)
2. If NG, recheck A/T assembly harness connector terminals for damage or loose connection with harness connector.

OK or NG

- OK >> **INSPECTION END**
- NG >> Repair or replace damaged parts.

9. DETECT MALFUNCTIONING ITEM

- Check the malfunction items. If any items are damaged, repair or replace damaged parts. Refer to [TM-163, "Symptom Table"](#) (Symptom No.17).

OK or NG

- OK >> GO TO 7.
- NG >> Repair or replace damaged parts.

Vehicle Does Not Decelerate By Engine Brake

INFOID:000000001534534

SYMPTOM:

No engine brake is applied when the gear is shifted from the 22 to 11.

DIAGNOSTIC PROCEDURE

1. CHECK SELF-DIAGNOSIS RESULTS

Perform self-diagnosis.

Do the self-diagnosis results indicate PNP switch?

- YES >> Check the malfunctioning system. Refer to [TM-44, "Diagnosis Procedure"](#).
- NO >> GO TO 2.

2. CHECK 1ST POSITION SWITCH CIRCUIT

With CONSULT-III

1. Turn ignition switch "ON".
2. Select "ECU INPUT SIGNALS" in "DATA MONITOR" mode for "TRANSMISSION" with CONSULT-III.
3. Read out "1 POSITION SW" moving switch selector lever to each position.

SYSTEM SYMPTOM

< SYMPTOM DIAGNOSIS >

Monitor item	Condition	Display value
1 POSITION SW	When setting the selector lever to "1" position.	ON
	When setting selector lever to other positions.	OFF

⊗ Without CONSULT-III

- Turn ignition switch "ON". (Do not start engine)
- Check voltage between A/T device harness connector terminal and ground.

Item	Connector No.	Terminal No.	Condition	Data (Approx.)
1st position switch	M203	7 - Ground	When setting the selector lever to "1" position.	0V
			When setting selector lever to other positions.	Battery voltage

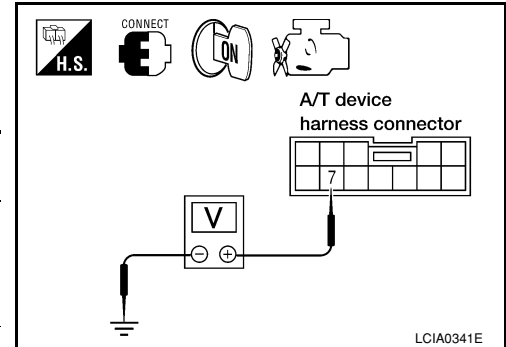

OK or NG

- OK >> GO TO 3.
- NG >> Repair or replace damaged parts.

3. CHECK A/T FLUID LEVEL

Check the A/T fluid level. Refer to [TM-190. "Checking the A/T Fluid \(ATF\)".](#)

OK or NG

- OK >> GO TO 4.
- NG >> Refill ATF.

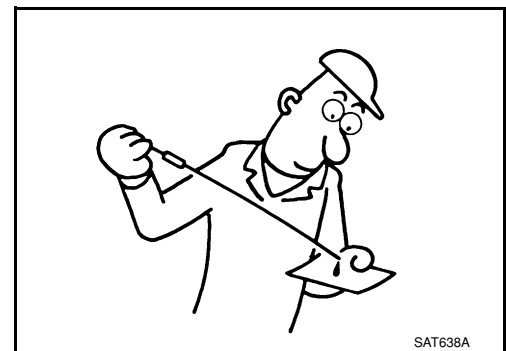

4. CHECK CONTROL CABLE

Check the control cable.

- Refer to [TM-206. "2WD : Checking of A/T Position".](#)

OK or NG

- OK >> GO TO 5.
- NG >> Adjust control cable. Refer to [TM-206. "2WD : Adjustment of A/T Position".](#)

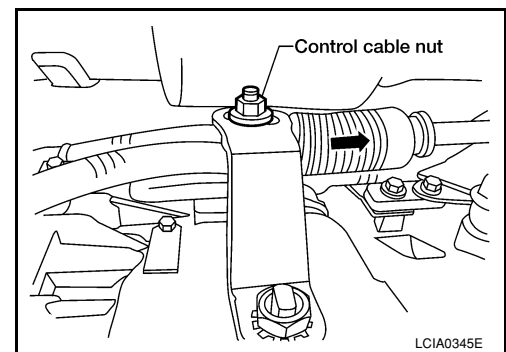

5. CHECK A/T FLUID CONDITION

- Remove oil pan. Refer to [TM-217. "Control Valve with TCM and A/T Fluid Temperature Sensor 2".](#)

SYSTEM SYMPTOM

< SYMPTOM DIAGNOSIS >

2. Check A/T fluid condition. Refer to [TM-190, "Checking the A/T Fluid \(ATF\)"](#).

OK or NG

- OK >> GO TO 6.
- NG >> GO TO 9.

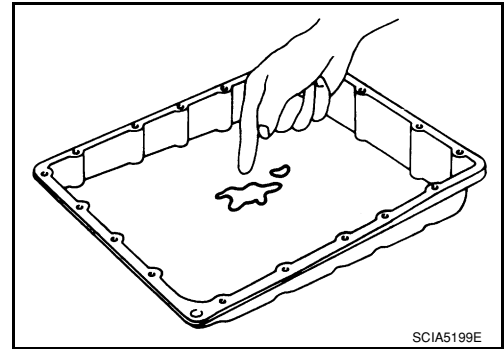

6. DETECT MALFUNCTIONING ITEM

- Check the malfunction items. If any items are damaged, repair or replace damaged parts. Refer to [TM-163, "Symptom Table"](#) ((Symptom No.53).

OK or NG

- OK >> GO TO 7.
- NG >> Repair or replace damaged parts.

7. CHECK SYMPTOM

Check again. Refer to [TM-205, "Cruise Test - Part 3"](#)

OK or NG

- OK >> **INSPECTION END**
- NG >> GO TO 8.

8. PERFORM TCM INSPECTION

1. Perform TCM input/output signals inspection. Refer to [TM-114, "Reference Value"](#)
2. If NG, recheck A/T assembly harness connector terminals for damage or loose connection with harness connector.

OK or NG

- OK >> **INSPECTION END**
- NG >> Repair or replace damaged parts.

9. DETECT MALFUNCTIONING ITEM

- Check the malfunction items. If any items are damaged, repair or replace damaged parts. Refer to [TM-163, "Symptom Table"](#) (Symptom No.53).

OK or NG

- OK >> GO TO 7.
- NG >> Repair or replace damaged parts.

Symptom Table

INFOID:000000001530135

- The diagnostics item numbers show the sequence for inspection. Inspect in order from item 1.
- Overhaul and inspect inside the A/T only if A/T fluid condition is NG. Refer to [TM-190, "Checking the A/T Fluid \(ATF\)"](#).

SYSTEM SYMPTOM

< SYMPTOM DIAGNOSIS >

No.	Items	Symptom	Condition	Diagnostic Item	Reference page
1		Large shock. ("N"→"D" position) Refer to TM-133 . "Large Shock("N" to "D" Position)" .	ON vehicle	1. Engine idle speed	EC-21
				2. Engine speed signal	TM-52
				3. Accelerator pedal position sensor	TM-70
				4. Control cable adjustment	TM-209
				5. ATF temperature sensor	TM-72
				6. Front brake solenoid valve	TM-84
				7. CAN communication line	LAN-4
				8. Fluid level and state	TM-190
				9. Line pressure test	TM-199
				10. Control valve with TCM	TM-217
			OFF vehicle	11. Forward brake (Parts behind drum support is impossible to perform inspection by disassembly. Refer to TM-9 , TM-10 .	TM-245
2	Shift Shock	Shock is too large when changing D1→D2.	ON vehicle	1. Accelerator pedal position sensor	TM-70
				2. Control cable adjustment	TM-209
				3. Direct clutch solenoid valve	TM-86
				4. CAN communication line	LAN-4
				5. Engine speed signal	TM-52
				6. Turbine revolution sensor	TM-47
				7. Vehicle speed sensor A/T and vehicle speed sensor MTR	TM-49 , TM-76
				8. Fluid level and state	TM-190
				9. Control valve with TCM	TM-217
			OFF vehicle	10. Direct clutch	TM-279
3		Shock is too large when changing D2→D3.	ON vehicle	1. Accelerator pedal position sensor	TM-70
				2. Control cable adjustment	TM-209
				3. High and low reverse clutch solenoid valve	TM-88
				4. CAN communication line	LAN-4
				5. Engine speed signal	TM-52
				6. Turbine revolution sensor	TM-47
				7. Vehicle speed sensor A/T and vehicle speed sensor MTR	TM-49 , TM-76
				8. Fluid level and state	TM-190
				9. Control valve with TCM	TM-217
			OFF vehicle	10. High and low reverse clutch	TM-277

SYSTEM SYMPTOM

< SYMPTOM DIAGNOSIS >

No.	Items	Symptom	Condition	Diagnostic Item	Reference page
4		Shock is too large when changing D3→D4.	ON vehicle	1. Accelerator pedal position sensor	TM-70
				2. Control cable adjustment	TM-209
				3. Input clutch solenoid valve	TM-82
				4. CAN communication line	LAN-4
				5. Engine speed signal	TM-52
				6. Turbine revolution sensor	TM-47
				7. Vehicle speed sensor A/T and vehicle speed sensor MTR	TM-49 , TM-76
				8. Fluid level and state	TM-190
				9. Control valve with TCM	TM-217
			OFF vehicle	10. Input clutch	TM-267
5	Shift Shock	Shock is too large when changing D4→D5.	ON vehicle	1. Accelerator pedal position sensor	TM-70
				2. Control cable adjustment	TM-209
				3. Front brake solenoid valve	TM-84
				4. CAN communication line	LAN-4
				5. Engine speed signal	TM-52
				6. Turbine revolution sensor	TM-47
				7. Vehicle speed sensor A/T and vehicle speed sensor MTR	TM-49 , TM-76
				8. Fluid level and state	TM-190
				9. Control valve with TCM	TM-217
			OFF vehicle	10. Front brake (brake band)	TM-233
				11. Input clutch	TM-267
6		Shock is too large for downshift when accelerator pedal is pressed.	ON vehicle	1. Accelerator pedal position sensor	TM-70
				2. Control cable adjustment	TM-209
				3. CAN communication line	LAN-4
				4. Engine speed signal	TM-52
				5. Turbine revolution sensor	TM-47
				6. Vehicle speed sensor A/T and vehicle speed sensor MTR	TM-49 , TM-76
				7. Fluid level and state	TM-190
				8. Control valve with TCM	TM-217
			OFF vehicle	9. Front brake (brake band)	TM-233
				10. Input clutch	TM-267
				11. High and low reverse clutch	TM-277
				12. Direct clutch	TM-279

A
B
C
TM
E
F
G
H
I
J
K
L
M
N
O
P

SYSTEM SYMPTOM

< SYMPTOM DIAGNOSIS >

No.	Items	Symptom	Condition	Diagnostic Item	Reference page
7		Shock is too large for upshift when accelerator pedal is released.	ON vehicle	1. Accelerator pedal position sensor	TM-70
				2. Control cable adjustment	TM-209
				3. Engine speed signal	TM-52
				4. CAN communication line	LAN-4
				5. Turbine revolution sensor	TM-47
				6. Vehicle speed sensor A/T and vehicle speed sensor MTR	TM-49, TM-76
				7. Fluid level and state	TM-190
				8. Control valve with TCM	TM-217
			OFF vehicle	9. Front brake (brake band)	TM-233
				10. Input clutch	TM-267
				11. High and low reverse clutch	TM-277
				12. Direct clutch	TM-279
8	Shift Shock	Shock is too large for lock-up.	ON vehicle	1. Accelerator pedal position sensor	TM-70
				2. Control cable adjustment	TM-209
				3. Engine speed signal	TM-52
				4. CAN communication line	LAN-4
				5. Turbine revolution sensor	TM-47
				6. Vehicle speed sensor A/T and vehicle speed sensor MTR	TM-49, TM-76
				7. Torque converter clutch solenoid valve	TM-64
				8. Fluid level and state	TM-190
				9. Control valve with TCM	TM-217
			OFF vehicle	10. Torque converter	TM-245
9		Shock is too large during engine brake.	ON vehicle	1. Accelerator pedal position sensor	TM-70
				2. Control cable adjustment	TM-209
				3. CAN communication line	LAN-4
				4. Fluid level and state	TM-190
				5. Control valve with TCM	TM-217
			OFF vehicle	6. Front brake (brake band)	TM-233
				7. Input clutch	TM-267
				8. High and low reverse clutch	TM-277
				9. Direct clutch	TM-279

SYSTEM SYMPTOM

< SYMPTOM DIAGNOSIS >

No.	Items	Symptom	Condition	Diagnostic Item	Reference page
10		Gear does not change from D → D2. Refer to TM-142 , " A/T Does Not Shift: D1→D2 ".	ON vehicle	1. Fluid level and state	TM-190
				2. Vehicle speed sensor A/T and vehicle speed sensor MTR	TM-49 , TM-76
				3. Direct clutch solenoid valve	TM-86
				4. Line pressure test	TM-199
				5. CAN communication line	LAN-4
				6. Control valve with TCM	TM-217
			OFF vehicle	7. Direct clutch	TM-279
11		Gear does not change from D → D3. Refer to TM-143 , " A/T Does Not Shift: D2→D3 ".	ON vehicle	1. Fluid level and state	TM-190
				2. Vehicle speed sensor A/T and vehicle speed sensor MTR	TM-49 , TM-76
				3. High and low reverse clutch solenoid valve	TM-88
				4. Line pressure test	TM-199
				5. CAN communication line	LAN-4
				6. Control valve with TCM	TM-217
			OFF vehicle	7. High and low reverse clutch	TM-277
12	No Up Shift	Gear does not change from D → D4. Refer to TM-145 , " A/T Does Not Shift: D3→D4 ".	ON vehicle	1. Fluid level and state	TM-190
				2. Vehicle speed sensor A/T and vehicle speed sensor MTR	TM-49 , TM-76
				3. Input clutch solenoid valve	TM-82
				4. Front brake solenoid valve	TM-84
				5. Line pressure test	TM-199
				6. CAN communication line	LAN-4
				7. Control valve with TCM	TM-217
			OFF vehicle	8. Input clutch	TM-267
13		Gear does not change from D → D5. Refer to TM-147 , " A/T Does Not Shift: D4→D5 ".	ON vehicle	1. Fluid level and state	TM-190
				2. Vehicle speed sensor A/T and vehicle speed sensor MTR	TM-49 , TM-76
				3. Front brake solenoid valve	TM-84
				4. Direct clutch solenoid valve	TM-86
				5. Turbine revolution sensor	TM-47
				6. Line pressure test	TM-199
				7. CAN communication line	LAN-4
				8. Control valve with TCM	TM-217
			OFF vehicle	9. Front brake (brake band)	TM-233
				10. Input clutch	TM-267

A
B
C
TM
E
F
G
H
I
J
K
L
M
N
O
P

SYSTEM SYMPTOM

< SYMPTOM DIAGNOSIS >

No.	Items	Symptom	Condition	Diagnostic Item	Reference page
14	No Down Shift	In "D" or "4" range, does not downshift to 4th gear. Refer to TM-154, "A/T Does Not Shift: 5th gear → 4th gear" .	ON vehicle	1. Fluid level and state	TM-190
				2. Vehicle speed sensor A/T and vehicle speed sensor MTR	TM-49, TM-76
				3. Front brake solenoid valve	TM-84
				4. Direct clutch solenoid valve	TM-86
				5. CAN communication line	LAN-4
				6. Line pressure test	TM-199
				7. Control valve with TCM	TM-217
			OFF vehicle	8. Front brake (brake band)	TM-233
				9. Input clutch	TM-267
15	No Down Shift	In "D" or "3" range, does not downshift to 3rd gear. Refer to TM-156, "A/T Does Not Shift: 4th gear → 3rd gear" .	ON vehicle	1. Fluid level and state	TM-190
				2. Vehicle speed sensor A/T and vehicle speed sensor MTR	TM-49, TM-76
				3. Input clutch solenoid valve	TM-82
				4. Front brake solenoid valve	TM-84
				5. CAN communication line	LAN-4
				6. Line pressure test	TM-199
				7. Control valve with TCM	TM-217
			OFF vehicle	8. Input clutch	TM-267
16	No Down Shift	In "D" or "2" range, does not downshift to 2nd gear. Refer to TM-158, "A/T Does Not Shift: 3rd gear → 2nd gear" .	ON vehicle	1. Fluid level and state	TM-190
				2. Vehicle speed sensor A/T and vehicle speed sensor MTR	TM-49, TM-76
				3. High and low reverse clutch solenoid valve	TM-88
				4. CAN communication line	LAN-4
				5. Line pressure test	TM-199
				6. Control valve with TCM	TM-217
			OFF vehicle	7. High and low reverse clutch	TM-277
17	No Down Shift	In "D" or "1" range, does not downshift to 1st gear. Refer to TM-159, "A/T Does Not Shift: 2nd gear → 1st gear" .	ON vehicle	1. Fluid level and state	TM-190
				2. Vehicle speed sensor A/T and vehicle speed sensor MTR	TM-49, TM-76
				3. Direct clutch solenoid valve	TM-86
				4. CAN communication line	LAN-4
				5. Line pressure test	TM-199
				6. Control valve with TCM	TM-217
			OFF vehicle	7. Direct clutch	TM-279

SYSTEM SYMPTOM

< SYMPTOM DIAGNOSIS >

No.	Items	Symptom	Condition	Diagnostic Item	Reference page
18	Slips/Will Not engage	When "D" position, remains in 1st gear.	ON vehicle	1. Fluid level and state	TM-190
				2. Vehicle speed sensor A/T and vehicle speed sensor MTR	TM-49, TM-76
				3. Direct clutch solenoid valve	TM-86
				4. Line pressure test	TM-199
				5. CAN communication line	LAN-4
				6. Control valve with TCM	TM-217
			OFF vehicle	7. 3rd one-way clutch	TM-265
				8. 1st one-way clutch	TM-272
				9. Gear system	TM-233
				10. Reverse brake	TM-245
				11. Forward one-way clutch (Parts behind drum support is impossible to perform inspection by disassembly. Refer to TM-9, TM-10)	TM-245
				12. Forward brake (Parts behind drum support is impossible to perform inspection by disassembly. Refer to TM-9, TM-10)	TM-245
19	Slips/Will Not engage	When "D" position, remains in 2nd gear.	ON vehicle	1. Fluid level and state	TM-190
				2. Vehicle speed sensor A/T and vehicle speed sensor MTR	TM-49, TM-76
				3. Low coast brake solenoid valve	TM-90
				4. Line pressure test	TM-199
				5. CAN communication line	LAN-4
				6. Control valve with TCM	TM-217
			OFF vehicle	7. 3rd one-way clutch	TM-265
				8. Gear system	TM-233
				9. Direct clutch	TM-279
				10. Forward brake (Parts behind drum support is impossible to perform inspection by disassembly. Refer to TM-9, TM-10)	TM-245

A
B
C
TM
E
F
G
H
I
J
K
L
M
N
O
P

SYSTEM SYMPTOM

< SYMPTOM DIAGNOSIS >

No.	Items	Symptom	Condition	Diagnostic Item	Reference page
20		When "D" position, re- mains in 3rd gear.	ON vehicle	1. Fluid level and state	TM-190
				2. Vehicle speed sensor A/T and vehicle speed sensor MTR	TM-49 , TM-76
				3. Line pressure test	TM-199
				4. CAN communication line	LAN-4
				5. Control valve with TCM	TM-217
			OFF vehicle	6. 3rd one-way clutch	TM-265
				7. Gear system	TM-233
				8. High and low reverse clutch	TM-277
				9. Forward one-way clutch (Parts behind drum support is impossible to perform inspection by disassembly. Refer to TM-9 , TM-10)	TM-245
				10. Forward brake (Parts behind drum support is impossible to perform inspection by disassembly. Refer to TM-9 , TM-10)	TM-245
21	Slips/Will Not en- gage	When "D" position, re- mains in 4th gear.	ON vehicle	1. Fluid level and state	TM-190
				2. Vehicle speed sensor A/T and vehicle speed sensor MTR	TM-49 , TM-76
				3. Input clutch solenoid valve	TM-82
				4. Direct clutch solenoid valve	TM-86
				5. High and low reverse clutch solenoid valve	TM-88
				6. Low coast brake solenoid valve	TM-90
				7. Front brake solenoid valve	TM-84
				8. Line pressure test	TM-199
				9. CAN communication line	LAN-4
				10. Control valve with TCM	TM-217
			OFF vehicle	11. Input clutch	TM-267
				12. Gear system	TM-233
				13. High and low reverse clutch	TM-277
				14. Direct clutch	TM-279

SYSTEM SYMPTOM

< SYMPTOM DIAGNOSIS >

No.	Items	Symptom	Condition	Diagnostic Item	Reference page
22		When "D" position, remains in 5th gear.	ON vehicle	1. Fluid level and state	TM-190
				2. Vehicle speed sensor A/T and vehicle speed sensor MTR	TM-49 , TM-76
				3. Front brake solenoid valve	TM-84
				4. Line pressure test	TM-199
				5. CAN communication line	LAN-4
				6. Control valve with TCM	TM-217
			OFF vehicle	7. Front brake (brake band)	TM-233
				8. Input clutch	TM-267
				9. Gear system	TM-233
				10. High and low reverse clutch	TM-277
23	Slips/Will Not Engage	Vehicle cannot be started from D1. Refer to TM-140 , " Vehicle Cannot Be Started from D1 ".	ON vehicle	1. Fluid level and state	TM-190
				2. Accelerator pedal position sensor	TM-70
				3. Line pressure test	TM-199
				4. CAN communication line	LAN-4
				5. Control valve with TCM	TM-217
			OFF vehicle	6. Torque converter	TM-245
				7. Oil pump assembly	TM-263
				8. 3rd one-way clutch	TM-265
				9. 1st one-way clutch	TM-272
				10. Gear system	TM-233
				11. Reverse brake	TM-245
				12. Forward one-way clutch (Parts behind drum support is impossible to perform inspection by disassembly. Refer to TM-9 , TM-10)	TM-245
				13. Forward brake (Parts behind drum support is impossible to perform inspection by disassembly. Refer to TM-9 , TM-10)	TM-245
24		Does not lock-up. Refer to TM-149 , " A/T Does Not Perform Lock-up ".	ON vehicle	1. Fluid level and state	TM-190
				2. Line pressure test	TM-199
				3. Engine speed signal	TM-52
				4. Turbine revolution sensor	TM-47
				5. Torque converter clutch solenoid valve	TM-64
				6. CAN communication line	LAN-4
				7. Control valve with TCM	TM-217
			OFF vehicle	8. Torque converter	TM-245
				9. Oil pump assembly	TM-263

A
B
C
TM
E
F
G
H
I
J
K
L
M
N
O
P

SYSTEM SYMPTOM

< SYMPTOM DIAGNOSIS >

No.	Items	Symptom	Condition	Diagnostic Item	Reference page
25		Does not hold lock-up condition. Refer to TM-151 , " A/T Does Not Hold Lock-up Condition ".	ON vehicle	1. Fluid level and state	TM-190
				2. Line pressure test	TM-199
				3. Engine speed signal	TM-52
				4. Turbine revolution sensor	TM-47
				5. Torque converter clutch solenoid valve	TM-64
				6. CAN communication line	LAN-4
				7. Control valve with TCM	TM-217
			OFF vehicle	8. Torque converter	TM-245
				9. Oil pump assembly	TM-263
26	Slips/Will Not engage	Lock-up is not released. Refer to TM-152 , " Lock-up Is Not Released ".	ON vehicle	1. Fluid level and state	TM-190
				2. Line pressure test	TM-199
				3. Engine speed signal	TM-52
				4. Turbine revolution sensor	TM-47
				5. Torque converter clutch solenoid valve	TM-64
				6. CAN communication line	LAN-4
				7. Control valve with TCM	TM-217
			OFF vehicle	8. Torque converter	TM-245
				9. Oil pump assembly	TM-263
27		No shock at all or the clutch slips when vehicle changes speed D1 → D2.	ON vehicle	1. Fluid level and state	TM-190
				2. Vehicle speed sensor A/T and vehicle speed sensor MTR	TM-49 , TM-76
				3. Direct clutch solenoid valve	TM-86
				4. CAN communication line	LAN-4
				5. Line pressure test	TM-199
				6. Control valve with TCM	TM-217
			OFF vehicle	7. Torque converter	TM-245
				8. Oil pump assembly	TM-263
				9. 3rd one-way clutch	TM-265
				10. Gear system	TM-233
				11. Direct clutch	TM-279
				12. Forward brake (Parts behind drum support is impossible to perform inspection by disassembly. Refer to TM-9 , TM-10)	TM-245

SYSTEM SYMPTOM

< SYMPTOM DIAGNOSIS >

No.	Items	Symptom	Condition	Diagnostic Item	Reference page
28	Slips/Will Not engage	No shock at all or the clutch slips when vehicle changes speed D2 → D3.	ON vehicle	1. Fluid level and state	TM-190
				2. Vehicle speed sensor A/T and vehicle speed sensor MTR	TM-49 , TM-76
				3. High and low reverse clutch solenoid valve	TM-88
				4. CAN communication line	LAN-4
				5. Line pressure test	TM-199
				6. Control valve with TCM	TM-217
			OFF vehicle	7. Torque converter	TM-245
				8. Oil pump assembly	TM-263
				9. 3rd one-way clutch	TM-265
				10. Gear system	TM-233
				11. High and low reverse clutch	TM-277
				12. Forward one- way clutch (Parts behind drum support is impossible to perform inspection by disassembly. Refer to TM-9 , TM-10)	TM-245
				13. Forward brake (Parts behind drum support is impossible to perform inspection by disassembly. Refer to TM-9 , TM-10)	TM-245
29		No shock at all or the clutch slips when vehicle changes speed D3 → D4.	ON vehicle	1. Fluid level and state	TM-190
				2. Vehicle speed sensor A/T and vehicle speed sensor MTR	TM-49 , TM-76
				3. Input clutch solenoid valve	TM-82
				4. Front brake solenoid valve	TM-84
				5. CAN communication line	LAN-4
				6. Line pressure test	TM-199
				7. Control valve with TCM	TM-217
			OFF vehicle	8. Torque converter	TM-245
				9. Oil pump assembly	TM-263
				10. Input clutch	TM-267
				11. Gear system	TM-233
				12. High and low reverse clutch	TM-277
				13. Direct clutch	TM-279

A
B
C
TM
E
F
G
H
I
J
K
L
M
N
O
P

SYSTEM SYMPTOM

< SYMPTOM DIAGNOSIS >

No.	Items	Symptom	Condition	Diagnostic Item	Reference page
30	Slips/Will Not engage	No shock at all or the clutch slips when vehicle changes speed D4 → D5.	ON vehicle	1. Fluid level and state	TM-190
				2. Vehicle speed sensor A/T and vehicle speed sensor MTR	TM-49 , TM-76
				3. Front brake solenoid valve	TM-84
				4. Direct clutch solenoid valve	TM-86
				5. CAN communication line	LAN-4
				6. Line pressure test	TM-199
				7. Control valve with TCM	TM-217
			OFF vehicle	8. Torque converter	TM-245
				9. Oil pump assembly	TM-263
				10. Front brake (brake band)	TM-233
				11. Input clutch	TM-267
				12. Gear system	TM-233
				13. High and low reverse clutch	TM-277
31	Slips/Will Not engage	When you press the accelerator pedal and shift speed D5→ D4 the engine idles or the transmission slips.	ON vehicle	1. Fluid level and state	TM-190
				2. Vehicle speed sensor A/T and vehicle speed sensor MTR	TM-49 , TM-76
				3. Front brake solenoid valve	TM-84
				4. Direct clutch solenoid valve	TM-86
				5. CAN communication line	LAN-4
				6. Line pressure test	TM-199
				7. Control valve with TCM	TM-217
			OFF vehicle	8. Torque converter	TM-245
				9. Oil pump assembly	TM-263
				10. Input clutch	TM-267
				11. Gear system	TM-233
				12. High and low reverse clutch	TM-277
				13. Direct clutch	TM-279

SYSTEM SYMPTOM

< SYMPTOM DIAGNOSIS >

No.	Items	Symptom	Condition	Diagnostic Item	Reference page
32	Slips/Will Not engage	When you press the accelerator pedal and shift speed D4→ D3 the engine idles or the transmission slips.	ON vehicle	1. Fluid level and state	TM-190
				2. Vehicle speed sensor A/T and vehicle speed sensor MTR	TM-49 , TM-76
				3. Input clutch solenoid valve	TM-82
				4. Front brake solenoid valve	TM-84
				5. CAN communication line	LAN-4
				6. Line pressure test	TM-199
				7. Control valve with TCM	TM-217
			OFF vehicle	8. Torque converter	TM-245
				9. Oil pump assembly	TM-263
				10. 3rd one-way clutch	TM-265
				11. Gear system	TM-233
				12. High and low reverse clutch	TM-277
				13. Forward one- way clutch (Parts behind drum support is impossible to perform inspection by disassembly. Refer to TM-9 , TM-10)	TM-245
				14. Forward brake (Parts behind drum support is impossible to perform inspection by disassembly. Refer to TM-9 , TM-10)	TM-245
33		When you press the accelerator pedal and shift speed D3→ D2 the engine idles or the transmission slips.	ON vehicle	1. Fluid level and state	TM-190
				2. Vehicle speed sensor A/T and vehicle speed sensor MTR	TM-49 , TM-76
				3. High and low reverse clutch solenoid valve	TM-88
				4. Direct clutch solenoid valve	TM-86
				5. CAN communication line	LAN-4
				6. Line pressure test	TM-199
				7. Control valve with TCM	TM-217
			OFF vehicle	8. Torque converter	TM-245
				9. Oil pump assembly	TM-263
				10. 3rd one-way clutch	TM-263
				11. Gear system	TM-233
				12. Direct clutch	TM-279
				13. Forward brake (Parts behind drum support is impossible to perform inspection by disassembly. Refer to TM-9 , TM-10)	TM-245

A
B
C
TM
E
F
G
H
I
J
K
L
M
N
O
P

SYSTEM SYMPTOM

< SYMPTOM DIAGNOSIS >

No.	Items	Symptom	Condition	Diagnostic Item	Reference page
34	Slips/Will Not Engage	When you press the accelerator pedal and shift speed D ₂ → D ₁ the engine idles or the transmission slips.	ON vehicle	1. Fluid level and state	TM-190
				2. Vehicle speed sensor A/T and vehicle speed sensor MTR	TM-49 , TM-76
				3. Direct clutch solenoid valve	TM-86
				4. CAN communication line	LAN-4
				5. Line pressure test	TM-199
				6. Control valve with TCM	TM-217
			OFF vehicle	7. Torque converter	TM-263
				8. Oil pump assembly	TM-263
				9. 3rd one-way clutch	TM-265
				10. 1st one-way clutch	TM-272
				11. Gear system	TM-233
				12. Reverse brake	TM-245
				13. Forward one- way clutch (Parts behind drum support is impossible to perform inspection by disassembly. Refer to TM-9 , TM-10)	TM-245
				14. Forward brake (Parts behind drum support is impossible to perform inspection by disassembly. Refer to TM-9 , TM-10)	TM-245
35	With selector lever in "D" position, acceleration is extremely poor.		ON vehicle	1. Fluid level and state	TM-190
				2. Line pressure test	TM-199
				3. Accelerator pedal position sensor	TM-70
				4. CAN communication line	LAN-4
				5. PNP switch	TM-44
				6. Control cable adjustment	TM-209
				7. Control valve with TCM	TM-217
			OFF vehicle	8. Torque converter	TM-245
				9. Oil pump assembly	TM-263
				10. 1st one-way clutch	TM-272
				11. Gear system	TM-233
				12. Reverse brake	TM-245
				13. Forward one- way clutch (Parts behind drum support is impossible to perform inspection by disassembly. Refer to TM-9 , TM-10)	TM-245
				14. Forward brake (Parts behind drum support is impossible to perform inspection by disassembly. Refer to TM-9 , TM-10)	TM-245

SYSTEM SYMPTOM

< SYMPTOM DIAGNOSIS >

No.	Items	Symptom	Condition	Diagnostic Item	Reference page	
36		With selector lever in "R" position, acceleration is extremely poor.	ON vehicle	1. Fluid level and state	TM-190	A
				2. Line pressure test	TM-199	B
				3. Accelerator pedal position sensor	TM-70	C
				4. High and low reverse clutch solenoid valve	TM-88	
				5. CAN communication line	LAN-4	
				6. PNP switch	TM-44	
				7. Control cable adjustment	TM-209	TM
				8. Control valve with TCM	TM-217	
			OFF vehicle	9. Gear system	TM-233	
				10. Output shaft	TM-245	E
				11. Reverse brake	TM-245	
37	Slips/Will Not Engage	While starting off by accelerating in 1st, engine races or slippage occurs.	ON vehicle	1. Fluid level and state	TM-190	F
				2. Line pressure test	TM-199	
				3. Accelerator pedal position sensor	TM-70	
				4. CAN communication line	LAN-4	G
				5. Control valve with TCM	TM-217	
			OFF vehicle	6. Torque converter	TM-245	H
				7. Oil pump assembly	TM-263	
				8. 3rd one-way clutch	TM-265	
				9. 1st one-way clutch	TM-272	I
				10. Gear system	TM-233	
				11. Reverse brake	TM-245	
				12. Forward one-way clutch (Parts behind drum support is impossible to perform inspection by disassembly. Refer to TM-9 , TM-10)	TM-245	J
				13. Forward brake (Parts behind drum support is impossible to perform inspection by disassembly. Refer to TM-9 , TM-10)	TM-245	K
38		While accelerating in 2nd, engine races or slippage occurs.	ON vehicle	1. Fluid level and state	TM-190	L
				2. Line pressure test	TM-199	
				3. Accelerator pedal position sensor	TM-70	
				4. CAN communication line	LAN-4	M
				5. Direct clutch solenoid valve	TM-86	
				6. Control valve with TCM	TM-217	
			OFF vehicle	7. Torque converter	TM-245	N
				8. Oil pump assembly	TM-263	
				9. 3rd one-way clutch	TM-263	
				10. Gear system	TM-233	O
				11. Direct clutch	TM-279	
				12. Forward brake (Parts behind drum support is impossible to perform inspection by disassembly. Refer to TM-9 , TM-10)	TM-245	P

SYSTEM SYMPTOM

< SYMPTOM DIAGNOSIS >

No.	Items	Symptom	Condition	Diagnostic Item	Reference page
39	Slips/Will Not Engage	While accelerating in 3rd, engine races or slippage occurs.	ON vehicle	1. Fluid level and state	TM-190
				2. Line pressure test	TM-199
				3. Accelerator pedal position sensor	TM-70
				4. CAN communication line	LAN-4
				5. High and low reverse clutch solenoid valve	TM-88
				6. Control valve with TCM	TM-217
			OFF vehicle	7. Torque converter	TM-245
				8. Oil pump assembly	TM-263
				9. 3rd one-way clutch	TM-265
				10. Gear system	TM-233
				11. High and low reverse clutch	TM-277
				12. Forward one- way clutch (Parts behind drum support is impossible to perform inspection by disassembly. Refer to TM-9 , TM-10)	TM-245
				13. Forward brake (Parts behind drum support is impossible to perform inspection by disassembly. Refer to TM-9 , TM-10)	TM-245
40		While accelerating in 4th, engine races or slippage occurs.	ON vehicle	1. Fluid level and state	TM-190
				2. Line pressure test	TM-199
				3. Accelerator pedal position sensor	TM-70
				4. CAN communication line	LAN-4
				5. Input clutch solenoid valve	TM-82
				6. Control valve with TCM	TM-217
			OFF vehicle	7. Torque converter	TM-245
				8. Oil pump assembly	TM-263
				9. Input clutch	TM-267
				10. Gear system	TM-233
				11. High and low reverse clutch	TM-277
				12. Direct clutch	TM-279

SYSTEM SYMPTOM

< SYMPTOM DIAGNOSIS >

No.	Items	Symptom	Condition	Diagnostic Item	Reference page				
41		While accelerating in 5th, engine races or slippage occurs.	ON vehicle	1. Fluid level and state	TM-190				
				2. Line pressure test	TM-199				
				3. Accelerator pedal position sensor	TM-70				
				4. CAN communication line	LAN-4				
				5. Front brake solenoid valve	TM-84				
				6. Control valve with TCM	TM-217				
			OFF vehicle	7. Torque converter	TM-245				
				8. Oil pump assembly	TM-263				
				9. Front brake (brake band)	TM-233				
				10. Input clutch	TM-267				
				11. Gear system	TM-233				
				12. High and low reverse clutch	TM-277				
42	Slips/Will Not Engage	Slips at lock-up.	ON vehicle	1. Fluid level and state	TM-190				
				2. Line pressure test	TM-199				
				3. Engine speed signal	TM-52				
				4. Turbine revolution sensor	TM-47				
				5. Torque converter clutch solenoid valve	TM-64				
				6. CAN communication line	LAN-4				
				7. Control valve with TCM	TM-217				
			OFF vehicle	8. Torque converter	TM-245				
				9. Oil pump assembly	TM-263				
				43		No creep at all. Refer to TM-135 . " Vehicle Does Not Creep Backward in "R" Position ", TM-137 . " Vehicle Does Not Creep Forward in "D" Position "	ON vehicle	1. Fluid level and state	TM-190
								2. Line pressure test	TM-199
								3. Accelerator pedal position sensor	TM-70
4. Direct clutch solenoid valve	TM-86								
5. PNP switch	TM-44								
6. CAN communication line	LAN-4								
7. Control cable adjustment	TM-209								
8. Control valve with TCM	TM-217								
OFF vehicle	9. Torque converter	TM-245							
	10. Oil pump assembly	TM-263							
	11. 1st one-way clutch	TM-272							
	12. Gear system	TM-233							
	13. Reverse brake	TM-245							
	14. Direct clutch	TM-279							
	15. Forward one-way clutch (Parts behind drum support is impossible to perform inspection by disassembly. Refer to TM-9 , TM-10)	TM-245							
	16. Forward brake (Parts behind drum support is impossible to perform inspection by disassembly. Refer to TM-9 , TM-10)	TM-245							

A
B
C
TM
E
F
G
H
I
J
K
L
M
N
O
P

SYSTEM SYMPTOM

< SYMPTOM DIAGNOSIS >

No.	Items	Symptom	Condition	Diagnostic Item	Reference page
44		Vehicle cannot run in all positions.	ON vehicle	1. Fluid level and state	TM-190
				2. Line pressure test	TM-199
				3. PNP switch	TM-44
				4. Control cable adjustment	TM-209
				5. Control valve with TCM	TM-217
			OFF vehicle	6. Oil pump assembly	TM-263
				7. Gear system	TM-233
				8. Output shaft	TM-245
45	Slips/Will Not Engage	With selector lever in "D" position, driving is not possible.	ON vehicle	1. Fluid level and state	TM-190
				2. Line pressure test	TM-199
				3. PNP switch	TM-44
				4. Control cable adjustment	TM-209
				5. Control valve with TCM	TM-217
			OFF vehicle	6. Torque converter	TM-245
				7. Oil pump assembly	TM-263
				8. 1st one-way clutch	TM-272
				9. Gear system	TM-233
				10. Reverse brake	TM-245
				11. Forward one- way clutch (Parts behind drum support is impossible to perform inspection by disassembly. Refer to TM-9 , TM-10)	TM-245
				12. Forward brake (Parts behind drum support is impossible to perform inspection by disassembly. Refer to TM-9 , TM-10)	TM-245
46		With selector lever in "R" position, driving is not possible.	ON vehicle	1. Fluid level and state	TM-190
				2. Line pressure test	TM-199
				3. PNP switch	TM-44
				4. Control cable adjustment	TM-209
				5. Control valve with TCM	TM-217
			OFF vehicle	6. Gear system	TM-233
				7. Output shaft	TM-245
				8. Reverse brake	TM-245
47	Others	Shift point is high in "D" position.	ON vehicle	1. Vehicle speed sensor A/T and vehicle speed sensor MTR	TM-49 , TM-76
				2. Accelerator pedal position sensor	TM-70
				3. CAN communication line	LAN-4
				4. ATF temperature sensor	TM-72
				5. Control valve with TCM	TM-217

SYSTEM SYMPTOM

< SYMPTOM DIAGNOSIS >

No.	Items	Symptom	Condition	Diagnostic Item	Reference page
48		Shift point is low in "D" position.	ON vehicle	1. Vehicle speed sensor A/T and vehicle speed sensor MTR	TM-49 , TM-76
				2. Accelerator pedal position sensor	TM-70
				3. CAN communication line	LAN-4
				4. Control valve with TCM	TM-217
49		Judder occurs during lock-up.	ON vehicle	1. Fluid level and state	TM-190
				2. Engine speed signal	TM-52
				3. Turbine revolution sensor	TM-47
				4. Vehicle speed sensor A/T and vehicle speed sensor MTR	TM-49 , TM-76
			OFF vehicle	5. Accelerator pedal position sensor	TM-70
				6. CAN communication line	LAN-4
				7. Torque converter clutch solenoid valve	TM-64
				8. Control valve with TCM	TM-217
50	Others	Strange noise in "R" position.	ON vehicle	1. Fluid level and state	TM-190
				2. Engine speed signal	TM-52
				3. CAN communication line	LAN-4
				4. Control valve with TCM	TM-217
			OFF vehicle	5. Torque converter	TM-245
				6. Oil pump assembly	TM-263
				7. Gear system	TM-233
				8. High and low reverse clutch	TM-277
				9. Reverse brake	TM-245
51		Strange noise in "N" position.	ON vehicle	1. Fluid level and state	TM-190
				2. Engine speed signal	TM-52
				3. CAN communication line	LAN-4
				4. Control valve with TCM	TM-217
			OFF vehicle	5. Torque converter	TM-245
				6. Oil pump assembly	TM-263
				7. Gear system	TM-233
52		Strange noise in "D" position.	ON vehicle	1. Fluid level and state	TM-190
				2. Engine speed signal	TM-52
				3. CAN communication line	LAN-4
				4. Control valve with TCM	TM-217
			OFF vehicle	5. Torque converter	TM-245
				6. Oil pump assembly	TM-263
				7. Gear system	TM-233
				8. Forward brake (Parts behind drum support is impossible to perform inspection by disassembly. Refer to TM-9 , TM-10)	TM-245

A
B
C
TM
E
F
G
H
I
J
K
L
M
N
O
P

SYSTEM SYMPTOM

< SYMPTOM DIAGNOSIS >

No.	Items	Symptom	Condition	Diagnostic Item	Reference page
53		Vehicle dose not decelerate by engine brake. Refer to TM-161, "Vehicle Does Not Decelerate By Engine Brake" .	ON vehicle	1. PNP switch	TM-44
				2. Fluid level and state	TM-190
				3. Control cable adjustment	TM-209
				4. 1st position switch	TM-161
				5. CAN communication line	LAN-4
				6. Control valve with TCM	TM-217
			OFF vehicle	7. Input clutch	TM-267
				8. High and low reverse clutch	TM-277
				9. Direct clutch	TM-279
54	Others	Engine brake does not operate in "2" position.	ON vehicle	1. PNP switch	TM-44
				2. Fluid level and state	TM-190
				3. Control cable adjustment	TM-209
				5. CAN communication line	LAN-4
				6. Control valve with TCM	TM-217
				OFF vehicle	7. Front brake (brake band)
			8. Input clutch		TM-267
			9. High and low reverse clutch		TM-277
			55		Engine brake does not operate in "1" position.
2. Fluid level and state	TM-190				
3. Control cable adjustment	TM-209				
4. 1st position switch	TM-161				
5. CAN communication line	LAN-4				
6. Control valve with TCM	TM-217				
OFF vehicle	7. Input clutch	TM-267			
	8. High and low reverse clutch	TM-277			
	9. Direct clutch	TM-279			

SYSTEM SYMPTOM

< SYMPTOM DIAGNOSIS >

No.	Items	Symptom	Condition	Diagnostic Item	Reference page
56	Others	Maximum speed low.	ON vehicle	1. Fluid level and state	TM-190
				2. Line pressure test	TM-199
				3. Accelerator pedal position sensor	TM-70
				4. CAN communication line	LAN-4
				5. Direct clutch solenoid valve	TM-86
				6. Control valve with TCM	TM-217
			OFF vehicle	7. Torque converter	TM-245
				8. Oil pump assembly	TM-263
				9. Input clutch	TM-267
				10. Gear system	TM-233
				11. High and low reverse clutch	TM-277
				12. Direct clutch	TM-279
				13. Forward one- way clutch (Parts behind drum support is impossible to perform inspection by disassembly. Refer to TM-9 , TM-10)	TM-245
				14 Forward brake (Parts behind drum support is impossible to perform inspection by disassembly. Refer to TM-9 , TM-10)	TM-245
57	Others	Extremely large creep.	ON vehicle	1. Engine idle speed	TM-52
				2. CAN communication line	LAN-4
			OFF vehicle	3. Torque converter	TM-245
			58	Others	With selector lever in "P" position, vehicle does not enter parking condition or, with selector lever in another position, parking condition is not cancelled. Refer to TM-131 , " In "P" Position, Vehicle Moves When Pushed ".
2. Control cable adjustment	TM-209				
OFF vehicle	3. Parking pawl components	TM-210			
59	Others	Vehicle runs with transmission in "P" position.			
			2. Fluid level and state	TM-190	
			3. Control cable adjustment	TM-209	
			4. Control valve with TCM	TM-217	
			5. Parking pawl components	TM-210	
			OFF vehicle	6. Gear system	TM-233

A
B
C
TM
E
F
G
H
I
J
K
L
M
N
O
P

SYSTEM SYMPTOM

< SYMPTOM DIAGNOSIS >

No.	Items	Symptom	Condition	Diagnostic Item	Reference page
60		Vehicle runs with transmission in "N" position. Refer to TM-131, "In "N" Position, Vehicle Moves" .	ON vehicle	1. PNP switch	TM-44
				2. Fluid level and state	TM-190
				3. Control cable adjustment	TM-209
				4. Control valve with TCM	TM-217
			OFF vehicle	5. Input clutch	TM-267
				6. Gear system	TM-233
				7. Direct clutch	TM-279
				8. Reverse brake	TM-245
				9. Forward one- way clutch (Parts behind drum support is impossible to perform inspection by disassembly. Refer to TM-9, TM-10)	TM-245
				10. Forward brake (Parts behind drum support is impossible to perform inspection by disassembly. Refer to TM-9, TM-10)	TM-245
61	Others	Engine does not start in "N" or "P" position. Refer to TM-130, "Engine Cannot Be Started in "P" or "N" Position" .	ON vehicle	1. Ignition switch and starter	
				2. Control cable adjustment	TM-209
				3. PNP switch	TM-44
62	Others	Engine starts in positions other than "N" or "P".	ON vehicle	1. Ignition switch and starter	
				2. Control cable adjustment	TM-209
				3. PNP switch	TM-44
63		Engine stall.	ON vehicle	1. Fluid level and state	TM-190
				2. Engine speed signal	TM-52
				3. Turbine revolution sensor	TM-47
				4. Torque converter clutch solenoid valve	TM-64
				5. CAN communication line	LAN-4
				6. Control valve with TCM	TM-217
			OFF vehicle	7. Torque converter	TM-245
64		Engine stalls when select lever shifted "N" → "D", "R".	ON vehicle	1. Fluid level and state	TM-190
				2. Engine speed signal	TM-52
				3. Turbine revolution sensor	TM-47
				4. Torque converter clutch solenoid valve	TM-64
				5. CAN communication line	LAN-4
				6. Control valve with TCM	TM-217
			OFF vehicle	7. Torque converter	TM-245
65	Others	Engine speed does not return to idle. Refer to TM-153, "Engine Speed Does Not Return to Idle" .	ON vehicle	1. Fluid level and state	TM-190
				2. Direct clutch solenoid valve	TM-86
				3. Front brake solenoid valve	TM-84
				4. Accelerator pedal position sensor	TM-70
				5. Vehicle speed sensor A/T and vehicle speed sensor MTR	TM-49, TM-76
				6. CAN communication line	LAN-4
				7. Control valve with TCM	TM-217
			OFF vehicle	8. Front brake (brake band)	TM-233
				9. Direct clutch	TM-279

PRECAUTIONS

< PRECAUTION >

PRECAUTION

PRECAUTIONS

Precaution for Supplemental Restraint System (SRS) "AIR BAG" and "SEAT BELT PRE-TENSIONER"

INFOID:000000001530131

The Supplemental Restraint System such as "AIR BAG" and "SEAT BELT PRE-TENSIONER", used along with a front seat belt, helps to reduce the risk or severity of injury to the driver and front passenger for certain types of collision. This system includes seat belt switch inputs and dual stage front air bag modules. The SRS system uses the seat belt switches to determine the front air bag deployment, and may only deploy one front air bag, depending on the severity of a collision and whether the front occupants are belted or unbelted. Information necessary to service the system safely is included in the SR and SB section of this Service Manual.

WARNING:

- To avoid rendering the SRS inoperative, which could increase the risk of personal injury or death in the event of a collision which would result in air bag inflation, all maintenance must be performed by an authorized NISSAN/INFINITI dealer.
- Improper maintenance, including incorrect removal and installation of the SRS, can lead to personal injury caused by unintentional activation of the system. For removal of Spiral Cable and Air Bag Module, see the SR section.
- Do not use electrical test equipment on any circuit related to the SRS unless instructed to in this Service Manual. SRS wiring harnesses can be identified by yellow and/or orange harnesses or harness connectors.

Precautions for On Board Diagnosis (OBD) System of A/T and Engine

INFOID:000000001530132

The ECM has an on board diagnostic system. It will light up the malfunction indicator lamp (MIL) to warn the driver of a malfunction causing emission deterioration.

CAUTION:

- Be sure to turn the ignition switch OFF and disconnect the battery cable from the negative terminal before any repair or inspection work. The open/short circuit of related switches, sensors, solenoid valves, etc. will cause the MIL to light up.
- Be sure to connect and lock the connectors securely after work. A loose (unlocked) connector will cause the MIL to light up due to an open circuit. (Be sure the connector is free from water, grease, dirt, bent terminals, etc.)
- Be sure to route and secure the harnesses properly after work. Interference of the harness with a bracket, etc. may cause the MIL to light up due to a short circuit.
- Be sure to connect rubber tubes properly after work. A misconnected or disconnected rubber tube may cause the MIL to light up due to a malfunction of the EGR system or fuel injection system, etc.
- Be sure to erase the unnecessary malfunction information (repairs completed) from the TCM and ECM before returning the vehicle to the customer.

Precautions

INFOID:000000001530133

- Before connecting or disconnecting the A/T assembly harness connector, turn ignition switch "OFF" and disconnect negative battery cable. Because battery voltage is applied to TCM even if ignition switch is turned "OFF".

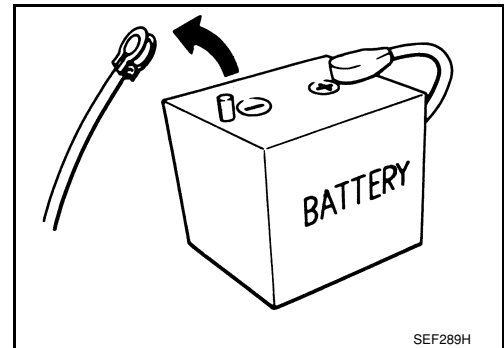

PRECAUTIONS

< PRECAUTION >

- After performing each TROUBLE DIAGNOSIS, perform “DTC (Diagnostic Trouble Code) CONFIRMATION PROCEDURE”. If the repair is completed the DTC should not be displayed in the “DTC CONFIRMATION PROCEDURE”.

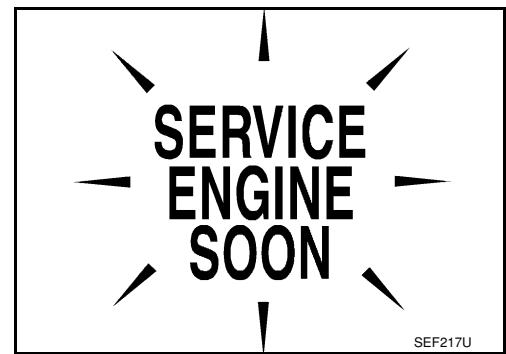

- Always use the specified brand of ATF. Refer to [MA-10. "Fluids and Lubricants"](#).
- Use paper rags not cloth rags during work.
- After replacing the ATF, dispose of the waste oil using the methods prescribed by law, ordinance, etc.
- Before proceeding with disassembly, thoroughly clean the outside of the transmission. It is important to prevent the internal parts from becoming contaminated by dirt or other foreign matter.
- Disassembly should be done in a clean work area.
- Use lint-free cloth or towels for wiping parts clean. Common shop rags can leave fibers that could interfere with the operation of the transmission.
- Place disassembled parts in order for easier and proper assembly.
- All parts should be carefully cleaned with a general purpose, non-flammable solvent before inspection or reassembly.
- Gaskets, seals and O-rings should be replaced any time the transmission is disassembled.
- It is very important to perform functional tests whenever they are indicated.
- The valve body contains precision parts and requires extreme care when parts are removed and serviced. Place disassembled valve body parts in order for easier and proper assembly. Care will also prevent springs and small parts from becoming scattered or lost.
- Properly installed valves, sleeves, plugs, etc. will slide along bores in valve body under their own weight.
- Before assembly, apply a coat of recommended ATF to all parts. Apply petroleum jelly to protect O-rings and seals, or hold bearings and washers in place during assembly. Do not use grease.
- Extreme care should be taken to avoid damage to O-rings, seals and gaskets when assembling.
- Clean or replace ATF cooler if excessive foreign material is found in oil pan or clogging strainer. Refer to [TM-194. "A/T Fluid Cooler Cleaning"](#).
- After overhaul, refill the transmission with new ATF.
- When the A/T drain plug is removed, only some of the fluid is drained. Old A/T fluid will remain in torque converter and ATF cooling system.

Always follow the procedures under “Changing A/T Fluid” in the AT section when changing A/T fluid. Refer to [TM-190. "Checking the A/T Fluid \(ATF\)"](#), [TM-192. "Changing the A/T Fluid \(ATF\)"](#).

Service Notice or Precautions

INFOID:000000001530134

ATF COOLER SERVICE

If A/T fluid contains frictional material (clutches, bands, etc.), or if an A/T is repaired, overhauled, or replaced, inspect and clean the A/T fluid cooler mounted in the radiator or replace the radiator. Flush cooler lines using cleaning solvent and compressed air after repair. For A/T fluid cooler cleaning procedure, refer to [TM-194. "A/T Fluid Cooler Cleaning"](#). For radiator replacement, refer to [CO-15. "Removal and Installation"](#).

CHECKING AND CHANGING A/T FLUID SERVICE

Increase ATF temperature by 80°C (176°F) once, and then check ATF level in 65°C (149°F) when adjusting ATF level.

NOTE:

JA60 uses both systems of a water-cooling and of an air-cooling. Air-cooling system has a by-pass valve. When ATF temperature is not over 50°C (122°F) with water-cooling system OFF, it does not flow to air-cooling system. If ATF level is set without the flow of ATF, the level will be 10mm lower than the standard. Therefore, piping should be filled with ATF when adjusting level.

OBD-II SELF-DIAGNOSIS

- A/T self-diagnosis is performed by the TCM in combination with the ECM. Refer to the table on [TM-33. "CONSULT-III Function \(TRANSMISSION\)"](#) for the indicator used to display each self-diagnostic result.

PRECAUTIONS

< PRECAUTION >

- The self-diagnostic results indicated by the MIL are automatically stored in both the ECM and TCM memories.
Always perform the procedure on [TM-31, "OBD-II Diagnostic Trouble Code \(DTC\)"](#) to complete the repair and avoid unnecessary blinking of the MIL.
For details of OBD-II, refer to [TM-31, "OBD-II Function for A/T System"](#).
- **Certain systems and components, especially those related to OBD, may use the new style slide-locking type harness connector. For description and how to disconnect, refer to [PG-59, "Description"](#).**

A
B
C
TM
E
F
G
H
I
J
K
L
M
N
O
P

PREPARATION

< PREPARATION >

PREPARATION

PREPARATION

Special Service Tool

INFOID:000000001534523

The actual shapes of Kent-Moore tools may differ from those of special service tools illustrated here.

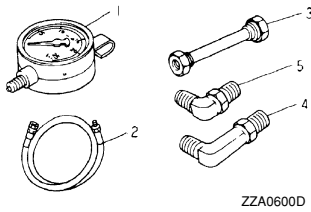
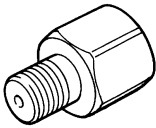
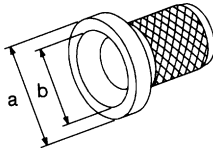
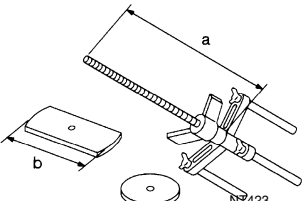
Tool number (Kent-Moore No.) Tool name	Description
<p>ST2505S001 (J-34301-C) Oil pressure gauge set 1. ST25051001 (—) Oil pressure gauge 2. ST25052000 (—) Hose 3. ST25053000 (—) Joint pipe 4. ST25054000 (—) Adapter 5. ST25055000 (—) Adapter</p>  <p style="text-align: right; font-size: small;">ZZA0600D</p>	<p>Measuring line pressure</p>
<p>KV31103600 (J-45674) Joint pipe adapter (With ST25054000)</p>  <p style="text-align: right; font-size: small;">ZZA1227D</p>	<p>Measuring line pressure</p>
<p>ST33400001 (J-26082) Drift</p>  <p style="text-align: right; font-size: small;">NT086</p>	<ul style="list-style-type: none"> • Installing rear oil seal (2WD models) • Installing oil pump housing oil seal <p>a: 60 mm (2.36 in) dia. b: 47 mm (1.85 in) dia.</p>
<p>KV31102400 (J-34285 and J-34285-87) Clutch spring compressor</p>  <p style="text-align: right; font-size: small;">NT423</p>	<p>Installing reverse brake return spring retainer</p> <p>a: 320 mm (12.60 in) b: 174 mm (6.85 in)</p>

PREPARATION

< PREPARATION >

Tool number (Kent-Moore No.) Tool name	Description
ST25850000 (J-25721-A) Sliding hammer <div data-bbox="609 296 933 485" style="text-align: center;"> <p>NT422</p> </div>	Remove oil pump assembly a: 179 mm (7.05 in) b: 70 mm (2.76 in) c: 40 mm (1.57 in) d: M12X1.75P
— (J-47002) Transmission jack adapter kit 1. — (J-47002-2) Center bracket 2. — (J-47002-3) Adapter plate 3. — (J-47002-4) Adapter block <div data-bbox="609 583 933 793" style="text-align: center;"> <p>WCIA0499E</p> </div>	Assist in removal of transmission and transfer case as one assembly using only one transmission jack.

Commercial Service Tool

INFOID:000000001534524

Tool name	Description
Power tool <div data-bbox="625 1045 917 1234" style="text-align: center;"> <p>PBIC0190E</p> </div>	Loosening bolts and nuts
Drift <div data-bbox="657 1325 885 1486" style="text-align: center;"> <p>NT083</p> </div>	Installing manual shaft seals a: 22 mm (0.87 in) dia.
Drift <div data-bbox="649 1560 885 1717" style="text-align: center;"> <p>SCIA5338E</p> </div>	Installing rear oil seal (4WD models) a: 64 mm (2.52 in) dia.

A/T FLUID

< ON-VEHICLE MAINTENANCE >

ON-VEHICLE MAINTENANCE

A/T FLUID

Checking the A/T Fluid (ATF)

INFOID:000000001542643

CAUTION:

If using the vehicle for towing, the A/T fluid must be replaced as specified. Refer to [MA-6, "Introduction of Periodic Maintenance"](#).

1. Before driving, the A/T fluid level can be checked at A/T fluid temperatures of 30° to 50° C (86° to 122° F) using the "COLD" range on the A/T fluid level gauge as follows:
 - a. Park the vehicle on a level surface and set the parking brake.
 - b. Start the engine and move the selector lever through each gear position. Shift the selector lever into the "P" position.
 - c. Check the A/T fluid level with the engine idling.
 - d. Remove the A/T fluid level gauge and wipe it clean with a lint-free paper.

CAUTION:

When wiping the A/T fluid from the A/T fluid level gauge, always use a lint-free paper, not a cloth.

- e. Re-insert the A/T fluid level gauge into the A/T fluid charging pipe until the cap contacts the top of the A/T fluid charging pipe as shown.

CAUTION:

To check A/T fluid level, insert the A/T fluid level gauge until the cap contacts the top of the A/T fluid charging pipe, with the gauge reversed from the normal inserted position.

- f. Remove the A/T fluid level gauge and note the A/T fluid level. If the A/T fluid level is at low side of range, add A/T fluid to the transmission through the A/T fluid charging pipe.

CAUTION:

Do not overfill the transmission with A/T fluid.

- g. Install the A/T fluid level gauge and the A/T fluid level gauge bolt.

A/T fluid level gauge bolt : Refer to [TM-227, "Removal and Installation \(2WD\)"](#) or [TM-229, "Removal and Installation \(4WD\)"](#)

2. Warm up the engine and transmission.
3. Check for any A/T fluid leaks.
4. Drive the vehicle to increase the A/T fluid temperature to 80° C (176° F).

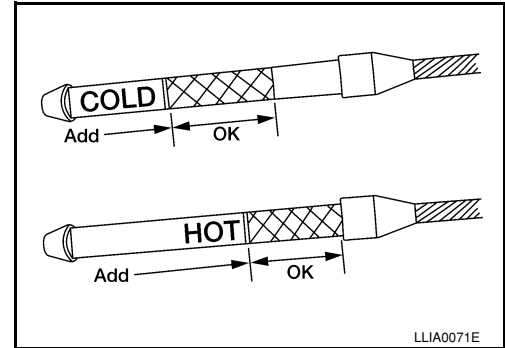

LLIA0071E

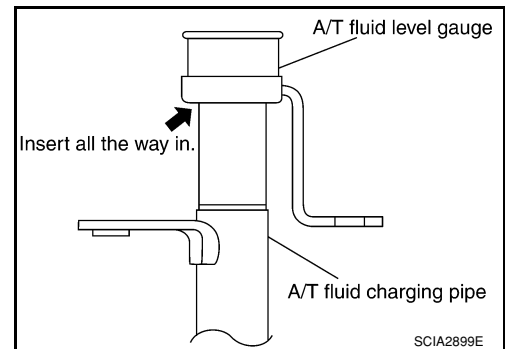

SCIA2899E

A/T FLUID

< ON-VEHICLE MAINTENANCE >

- Allow the A/T fluid temperature to fall to approximately 65°C (149°F). Use the CONSULT-II to monitor the A/T fluid temperature as follows:

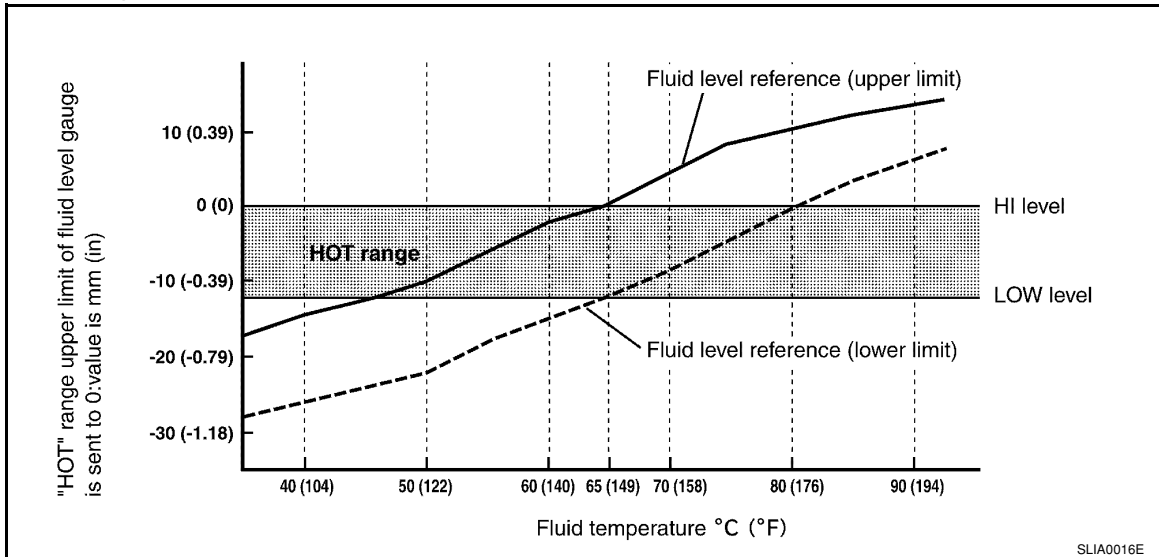

NOTE:

The A/T fluid level will be significantly affected by the A/T fluid temperature as shown. Therefore monitor the A/T fluid temperature data using the CONSULT-II.

- Connect CONSULT-II to data link connector.
 - Select "MAIN SIGNALS" in "DATA MONITOR" mode for "A/T" with CONSULT-II.
 - Read out the value of "ATF TEMP 1".
- Re-check the A/T fluid level at A/T fluid temperatures of approximately 65°C (149°F) using the "HOT" range on the A/T fluid level gauge as shown. The HOT range is between 50° - 80° C (122° - 176° F).

CAUTION:

- When wiping the A/T fluid from the A/T fluid level gauge, always use lint-free paper, not a cloth.

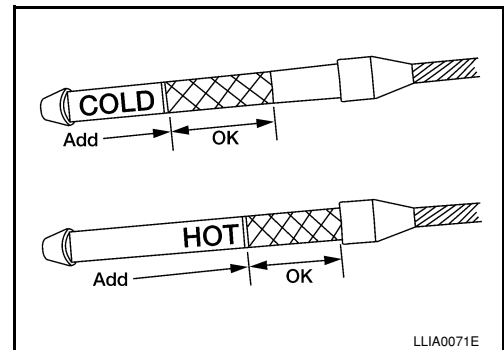

- To check the A/T fluid level, insert the A/T fluid level gauge until the cap contacts the top of the A/T fluid charging pipe, with the gauge reversed from the normal inserted position as shown.

- Check the A/T fluid condition.
 - If the A/T fluid is very dark or has some burned smell, there may be an internal problem with the transmission. Refer to [TM-194, "A/T Fluid Cooler Cleaning"](#). Flush the transmission cooling system after repairing the transmission.
 - If the A/T fluid contains frictional material (clutches, bands, etc.), replace the radiator and flush the transmission cooler lines using cleaning solvent and compressed air after repairing the transmission.

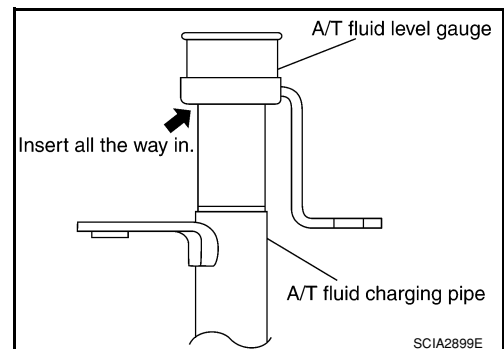

- Install the A/T fluid level gauge in the A/T fluid charging pipe.
- Tighten the A/T fluid level gauge bolt to specification.

A/T fluid level gauge bolt : Refer to [TM-227, "Removal and Installation \(2WD\)"](#) or [TM-229, "Removal and Installation \(4WD\)"](#)

A/T FLUID

< ON-VEHICLE MAINTENANCE >

Changing the A/T Fluid (ATF)

INFOID:000000001542644

CAUTION:

If using the vehicle for towing, the A/T fluid must be replaced as specified. Refer to [MA-6, "Introduction of Periodic Maintenance"](#).

1. Drive the vehicle to warm up the A/T fluid to approximately 80° C (176° F).
2. Stop the engine.
3. Remove the A/T fluid level gauge.
4. Drain the A/T fluid from the drain plug hole, then install the drain plug with a new gasket. Refill the transmission with new A/T fluid. Always refill with the same volume as the drained A/T fluid. Use the A/T fluid level gauge to check the A/T fluid level as shown. Add A/T fluid as necessary.

Drain plug : Refer to [TM-233, "Component"](#).

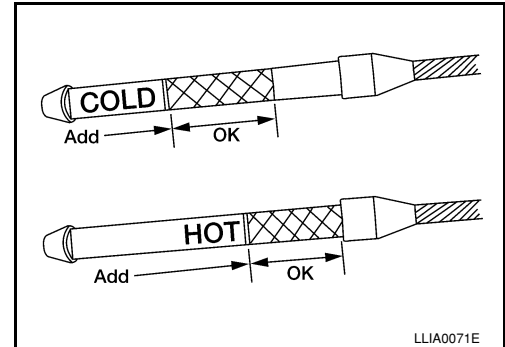

- To flush out the old A/T fluid from the transmission oil coolers, pour new A/T fluid into the A/T fluid charging pipe with the engine idling and at the same time drain the old A/T fluid from the auxiliary transmission oil cooler hose return line.
- When the color of the A/T fluid coming out of the auxiliary transmission oil cooler hose return line is about the same as the color of the new A/T fluid, flushing out the old A/T fluid is complete. The amount of new A/T fluid used for flushing should be 30% to 50% increase of the specified capacity.

A/T fluid grade and capacity : Refer to [MA-10, "Fluids and Lubricants"](#).

CAUTION:

- Use only Genuine NISSAN Matic J ATF and do not mix with other fluids.
 - Using A/T fluid other than Genuine NISSAN Matic J ATF will cause deterioration in driveability and automatic transmission durability, and may damage the automatic transmission, which is not covered by the warranty.
 - When filling the transmission with A/T fluid, do not spill the A/T fluid on any heat generating parts such as the exhaust manifold.
 - Do not reuse the drain plug gasket.
5. Install the A/T fluid level gauge and tighten the A/T fluid level gauge bolt to specification.

A/T fluid level gauge bolt : Refer to [TM-227, "Removal and Installation \(2WD\)"](#) or [TM-229, "Removal and Installation \(4WD\)"](#).

6. Drive the vehicle to warm up the A/T fluid to approximately 80° C (176° F).
7. Check the fluid level and condition. If the A/T fluid is still dirty, repeat steps 2 through 6.

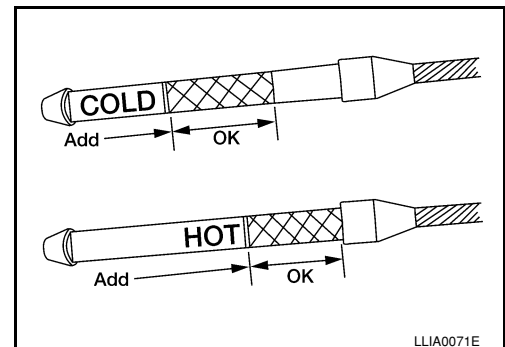

8. Install the A/T fluid level gauge in the A/T fluid charging pipe and install the A/T fluid level gauge bolt.
9. Tighten the A/T fluid level gauge bolt to specification.

A/T FLUID

< ON-VEHICLE MAINTENANCE >

A/T fluid level gauge bolt : Refer to [TM-227, "Removal and Installation \(2WD\)"](#) or [TM-229, "Removal and Installation \(4WD\)"](#).

A

B

C

TM

E

F

G

H

I

J

K

L

M

N

O

P

A/T FLUID COOLER

< ON-VEHICLE MAINTENANCE >

A/T FLUID COOLER

A/T Fluid Cooler Cleaning

INFOID:000000001542645

Whenever an A/T is repaired, overhauled, or replaced, the A/T fluid cooler mounted in the radiator must be inspected and cleaned.

Metal debris and friction material, if present, can become trapped in the A/T fluid cooler. This debris can contaminate the newly serviced A/T or, in severe cases, can block or restrict the flow of A/T fluid. In either case, malfunction of the newly serviced A/T may result.

Debris, if present, may build up as A/T fluid enters the cooler inlet. It will be necessary to back flush the cooler through the cooler outlet in order to flush out any built up debris.

A/T FLUID COOLER CLEANING PROCEDURE

1. Position a drain pan under the A/T inlet and outlet fluid cooler tube to cooler hose connection.
2. Put a different color matching mark on each cooler tube to cooler hose connection.

CAUTION:

Use paint to make the matching mark. Do not damage the tubes or hose.

3. Disconnect the fluid cooler inlet and outlet rubber hoses from the steel cooler tubes.

NOTE:

Replace the cooler hoses if rubber material from the hose remains on the tube fitting.

4. Drain any A/T fluid from the cooler hose.

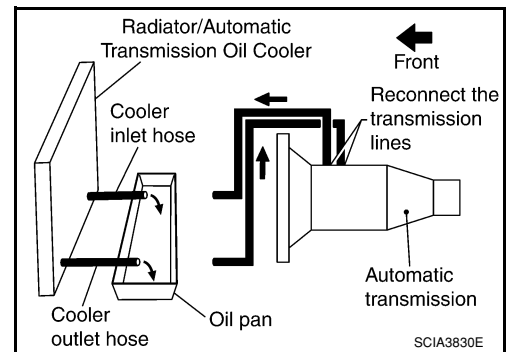

5. Insert the extension adapter hose of a can of Transmission Cooler Cleaner (Nissan P/N 999MP-AM006) into the cooler outlet hose.

CAUTION:

- Wear safety glasses and rubber gloves when spraying the Transmission Cooler Cleaner.
- Spray cooler cleaner only with adequate ventilation.
- Avoid contact with eyes and skin.
- Do not breath vapors or spray mist.

6. Hold the hose and can as high as possible and spray Transmission Cooler Cleaner in a continuous stream into the cooler outlet hose until fluid flows out of the cooler inlet hose for 5 seconds.

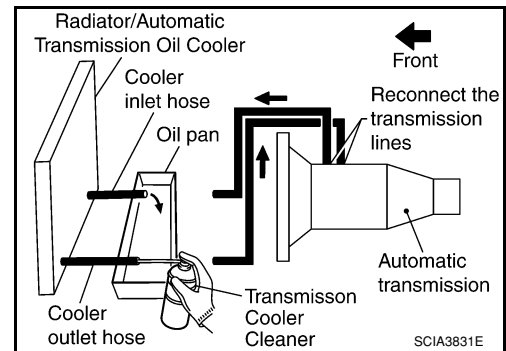

7. Insert the tip of an air gun into the end of the cooler outlet hose.
8. Wrap a shop rag around the tip of the air gun and the cooler outlet hose.

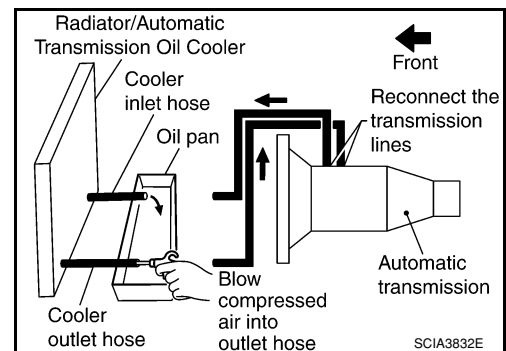

9. Blow compressed air regulated to 5 - 9 kg/cm² (70 - 130 psi) through the cooler outlet hose for 10 seconds to force out any remaining fluid.

10. Repeat steps 5 through 9 three additional times.

11. Position an oil pan under the banjo bolts that connect the fluid cooler tubes to the A/T.

12. Remove the banjo bolts.

A/T FLUID COOLER

< ON-VEHICLE MAINTENANCE >

13. Flush each steel line from the cooler side back toward the A/T by spraying Transmission Cooler Cleaner in a continuous stream for 5 seconds.
14. Blow compressed air regulated to 5 - 9 kg/cm² (70 - 130 psi) through each steel line from the cooler side back toward the A/T for 10 seconds to force out any remaining fluid.
15. Ensure all debris is removed from the steel cooler lines.
16. Ensure all debris is removed from the banjo bolts and fittings.
17. Perform A/T fluid cooler diagnosis procedure.

A/T FLUID COOLER DIAGNOSIS PROCEDURE

NOTE:

Insufficient cleaning of the cooler inlet hose exterior may lead to inaccurate debris identification.

1. Position a drain pan under the A/T inlet and outlet fluid cooler tube to cooler hose connection.
2. Clean the exterior and tip of the cooler inlet hose.
3. Put a different color matching mark on each cooler tube to cooler hose connection to aid in assembly.

CAUTION:

Use paint to make the matching mark. Do not damage the tubes or hose.

4. Disconnect the fluid cooler inlet and outlet rubber hoses from the steel cooler tubes.

NOTE:

Replace the cooler hoses if rubber material from the hose remains on the tube fitting.

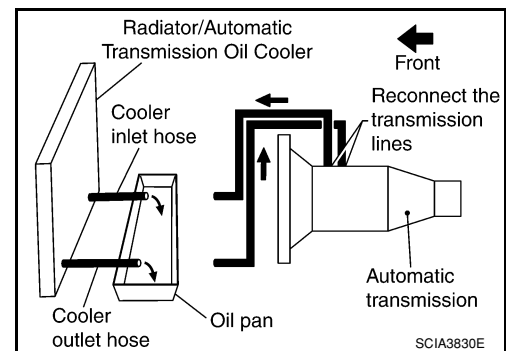

5. Insert the extension adapter hose of a can of Transmission Cooler Cleaner (Nissan P/N 999MP-AM006) into the cooler outlet hose.

CAUTION:

- Wear safety glasses and rubber gloves when spraying the Transmission Cooler Cleaner.
- Spray cooler cleaner only with adequate ventilation.
- Avoid contact with eyes and skin.
- Do not breath vapors or spray mist.

6. Hold the hose and can as high as possible and spray Transmission Cooler Cleaner in a continuous stream into the cooler outlet hose until fluid flows out of the cooler inlet hose for 5 seconds.
7. Tie a common white, basket-type coffee filter to the end of the cooler inlet hose.

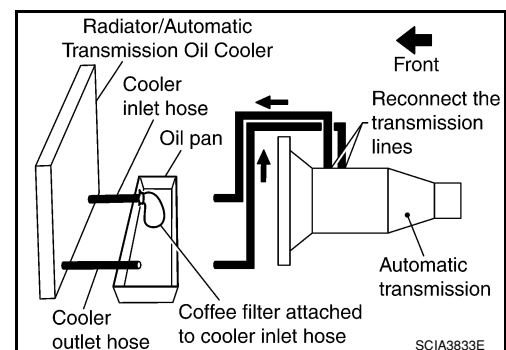
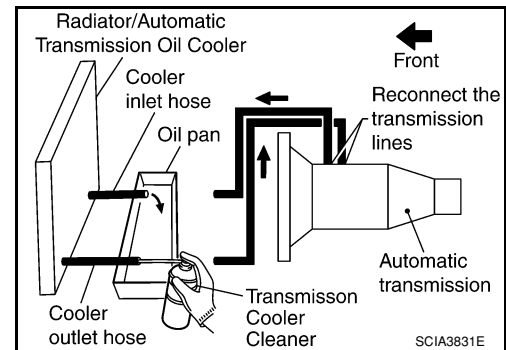

A/T FLUID COOLER

< ON-VEHICLE MAINTENANCE >

8. Insert the tip of an air gun into the end of the cooler outlet hose.
9. Wrap a shop rag around the air gun tip and end of cooler outlet hose.
10. Blow compressed air regulated to 5 - 9 kg/cm² (70 - 130 psi) through the cooler outlet hose to force any remaining A/T fluid into the coffee filter.
11. Remove the coffee filter from the end of the cooler inlet hose.
12. Perform A/T fluid cooler inspection. Refer to [TM-194, "A/T Fluid Cooler Cleaning"](#).

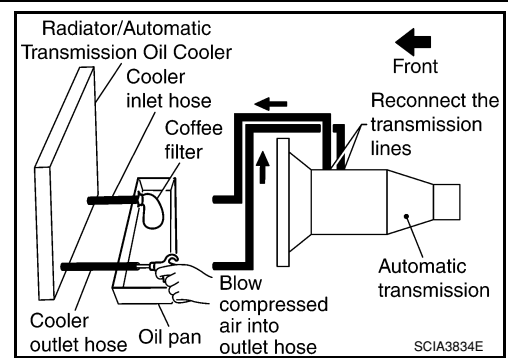

A/T FLUID COOLER INSPECTION PROCEDURE

1. Inspect the coffee filter for debris.
 - a. If small metal debris less than 1mm (0.040 in) in size or metal powder is found in the coffee filter, this is normal. If normal debris is found, the A/T fluid cooler/radiator can be re-used and the procedure is ended.
 - b. If one or more pieces of debris are found that are over 1mm (0.040 in) in size and/or peeled clutch facing material is found in the coffee filter, the fluid cooler is not serviceable. The A/T fluid cooler/radiator must be replaced and the inspection procedure is ended. Refer to [CO-15, "Removal and Installation"](#).

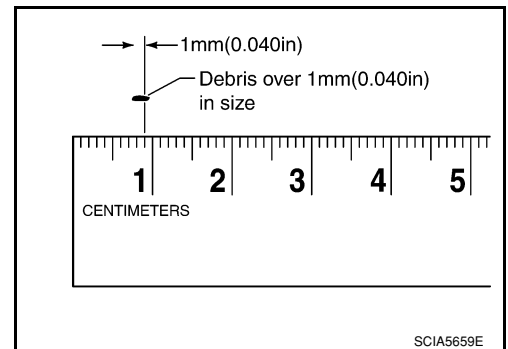
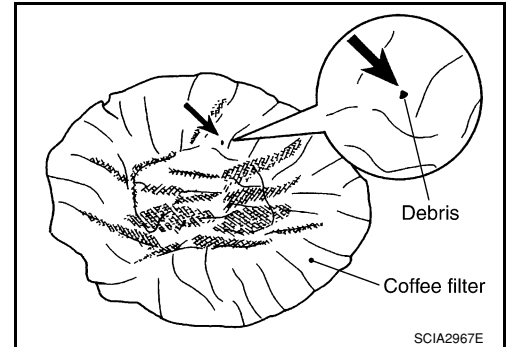

A/T FLUID COOLER FINAL INSPECTION

After performing all procedures, ensure that all remaining oil is cleaned from all components.

Inspection

INFOID:000000001530118

After performing all procedures, ensure that all remaining oil is cleaned from all components.

STALL TEST

< ON-VEHICLE MAINTENANCE >

STALL TEST

Inspection and Judgment

INFOID:000000001530119

A/T FLUID CHECK

Fluid Leakage and Fluid Level Check

- Inspect for fluid leakage and check the fluid level. Refer to [TM-190. "Checking the A/T Fluid \(ATF\)".](#)

Fluid Condition Check

Inspect the fluid condition.

Fluid condition	Conceivable Cause	Required Operation
Varnished (viscous varnish state)	Clutch, brake scorched	Replace the ATF and check the A/T main unit and the vehicle for malfunctions (wire harnesses, cooler pipes, etc.)
Milky white or cloudy	Water in the fluid	Replace the ATF and check for places where water is getting in.
Large amount of metal powder mixed in	Unusual wear of sliding parts within A/T	Replace the ATF and check for improper operation of the A/T.

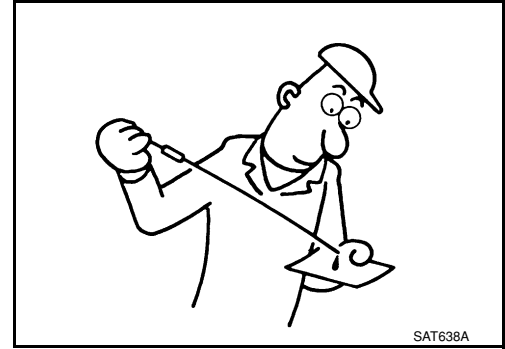

STALL TEST

Stall Test Procedure

1. Inspect the amount of engine oil. Replenish the engine oil if necessary.
2. Drive for about 10 minutes to warm up the vehicle so that the A/T fluid temperature is 50 to 80°C (122 to 176°F). Inspect the amount of ATF. Replenish if necessary.

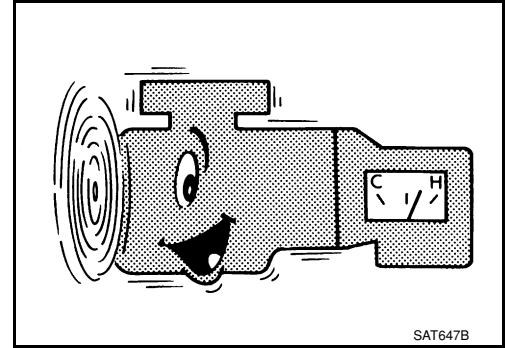

3. Securely engage the parking brake so that the tires do not turn.

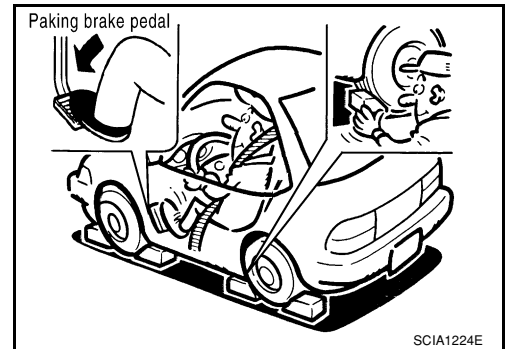

A
B
C
TM
E
F
G
H
I
J
K
L
M
N
O
P

STALL TEST

< ON-VEHICLE MAINTENANCE >

4. Engine start, apply foot brake, and place selector lever in "D" position.
5. While holding down the foot brake, gradually press down the accelerator pedal.
6. Quickly read off the stall speed, then quickly remove your foot from the accelerator pedal.

CAUTION:

Do not hold down the accelerator pedal for more than 5 seconds during this test.

7. Move the selector lever to the "N" position.
8. Cool down the ATF.

CAUTION:

Run the engine at idle for at least one minute.

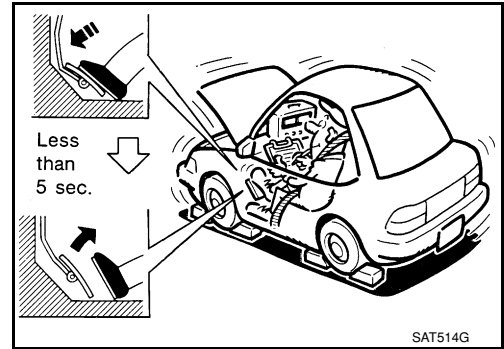

Stall speed: 2,350 - 2,650 rpm

Judgement of Stall Test

	Selector lever position		Expected problem location
	D	R	
Stall rotation	H	O	<ul style="list-style-type: none"> • Forward brake • Forward one-way clutch • 1st one-way clutch • 3rd one-way clutch
	O	H	<ul style="list-style-type: none"> • Reverse brake
	L	L	<ul style="list-style-type: none"> • Engine and torque converter one-way clutch
	H	H	<ul style="list-style-type: none"> • Line pressure low

O: Stall speed within standard value position

H: Stall speed higher than standard value

L: Stall speed lower than standard value

Stall test standard value position

Does not shift-up D position 1 → 2	Slipping in 2nd, 3rd, 4th gears	Direct clutch slippage
Does not shift-up D position 2 → 3	Slipping in 3rd, 4th, 5th gears	High and low reverse clutch slippage
Does not shift-up D position 3 → 4	Slipping in 4th, 5th gears	Input clutch slippage
Does not shift-up D position 4 → 5	Slipping in 5th gear	Front brake slippage

LINE PRESSURE TEST

< ON-VEHICLE MAINTENANCE >

LINE PRESSURE TEST

Inspection and Judgment

INFOID:000000001530120

LINE PRESSURE TEST

Line Pressure Test Port

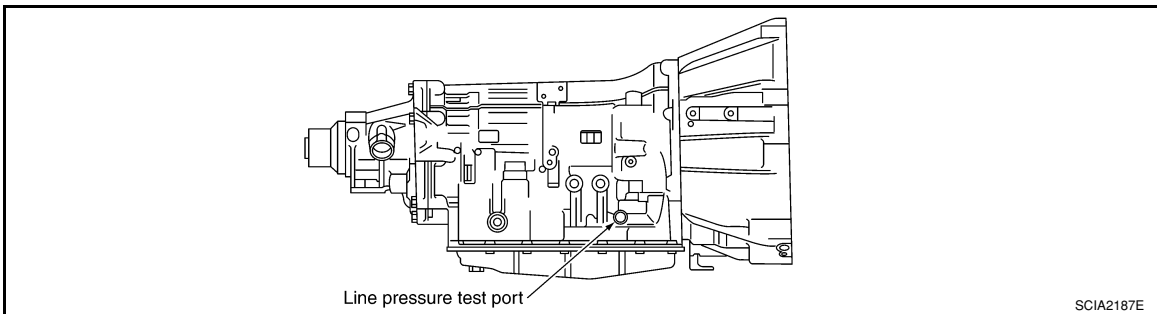

Line Pressure Test Procedure

1. Inspect the amount of engine oil and replenish if necessary.
2. Drive the car for about 10 minutes to warm it up so that the ATF reaches in range of 50 to 80°C (122 to 176°F), then inspect the amount of ATF and replenish if necessary.

NOTE:

The automatic fluid temperature rises in range of 50 to 80°C (122 to 176°F) during 10 minutes of driving.

3. After warming up remove the oil pressure detection plug and install the Tool.

CAUTION:

When using the oil pressure gauge, be sure to use the O-ring attached to the oil pressure detection plug.

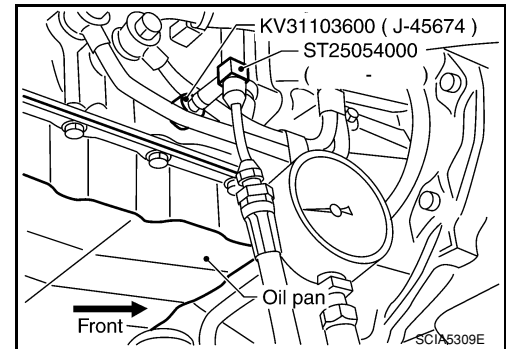

4. Securely engage the parking brake so that the tires do not turn.

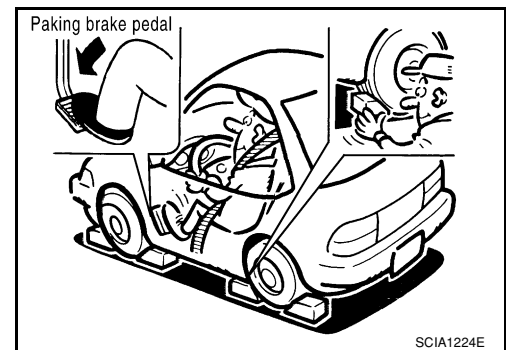

A
B
C
TM
E
F
G
H
I
J
K
L
M
N
O
P

LINE PRESSURE TEST

< ON-VEHICLE MAINTENANCE >

5. Start the engine, then measure the line pressure at both idle and the stall speed.
 - CAUTION:**
 - Keep the brake pedal pressed all the way down during measurement.
 - When measuring the line pressure at the stall speed, refer to [TM-197, "Inspection and Judgment"](#).
6. After the measurements are complete, install the oil pressure detection plug and tighten to the regulation torque below.

Oil pressure detection plug :7.3 N·m (0.74 kg-m, 65 in-lb)

CAUTION:
Do not reuse the O-ring.

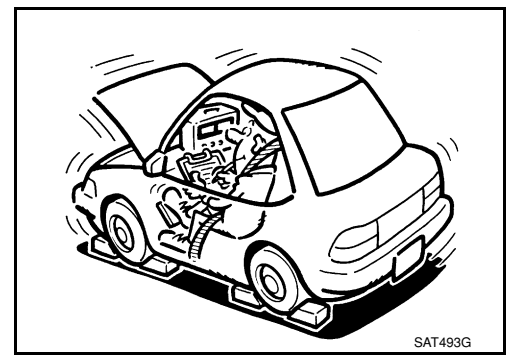

Line Pressure

Engine speed	Line pressure [kPa (kg/cm ² , psi)]	
	R position	D position
At idle speed	425 - 465 (4.3 - 4.7, 62 - 67)	379 - 428 (3.9 - 4.4, 55 - 62)
At stall speed	1,605 - 1,950 (16.4 - 19.9, 233 - 283)	1,310 - 1,500 (13.4 - 15.3, 190 - 218)

Judgement of Line Pressure Test

Judgement		Possible cause
Idle speed	Low for all positions (P, R, N, D)	Possible causes include malfunctions in the pressure supply system and low oil pump output. For example <ul style="list-style-type: none"> • Oil pump wear • Pressure regulator valve or plug sticking or spring fatigue • Oil strainer ⇒ oil pump ⇒ pressure regulator valve passage oil leak • Engine idle speed too low
	Only low for a specific position	Possible causes include an oil pressure leak in a passage or device related to the position after the pressure is distributed by the manual valve.
	High	Possible causes include a sensor malfunction or malfunction in the line pressure adjustment function. For example <ul style="list-style-type: none"> • Accelerator pedal position signal malfunction • ATF temperature sensor malfunction • Line pressure solenoid malfunction (sticking in "OFF" state, filter clog, cut line) • Pressure regulator valve or plug sticking
Stall speed	Oil pressure does not rise higher than the oil pressure for idle.	Possible causes include a sensor malfunction or malfunction in the pressure adjustment function. For example <ul style="list-style-type: none"> • Accelerator pedal position signal malfunction • TCM breakdown • Line pressure solenoid malfunction (shorting, sticking in "ON" state) • Pressure regulator valve or plug sticking • Pilot valve sticking or pilot filter clogged
	The pressure rises, but does not enter the standard position.	Possible causes include malfunctions in the pressure supply system and malfunction in the pressure adjustment function. For example <ul style="list-style-type: none"> • Accelerator pedal position signal malfunction • Line pressure solenoid malfunction (sticking, filter clog) • Pressure regulator valve or plug sticking • Pilot valve sticking or pilot filter clogged
	Only low for a specific position	Possible causes include an oil pressure leak in a passage or device related to the position after the pressure is distributed by the manual valve.

ROAD TEST

< ON-VEHICLE MAINTENANCE >

ROAD TEST

Description

INFOID:000000001530121

ROAD TEST

- The road test inspects overall performance of the A/T and analyzes possible malfunction causes.
- The road test is carried out in the following three stages.

1. Check before engine is started. Refer to [TM-201](#).
2. Check at idle. Refer to [TM-201](#).
3. Cruise test
 - Inspect all the items from Part 1 to Part 3. Refer to [TM-202](#), [TM-204](#), [TM-205](#).
- Before beginning the road test, check the test procedure and inspection items.
- Test all inspection items until the symptom is uncovered. Diagnose NG items when all road tests are complete.

Check Before Engine Is Started

INFOID:000000001530122

1.CHECK AT CHECK INDICATOR LAMP

1. Park vehicle on level surface.
2. Move selector lever to "P" position.
3. Turn ignition switch to "OFF" position and wait at least 10 seconds.
4. Turn ignition switch to "ON" position. (Do not start engine.)

Does AT CHECK indicator lamp light up for about 2 seconds?

- YES >> 1. Turn ignition switch to "OFF" position.
2. Carry out the self-diagnostics and record all NG items on the diagnostics worksheet. Refer to [TM-33, "CONSULT-III Function \(TRANSMISSION\)"](#).
3. Go to [TM-201, "Check At Idle"](#).
- NO >> Stop the road test and go to [TM-130, "A/T Check Indicator Lamp Does Not Come On"](#).

Check At Idle

INFOID:000000001530123

1.CHECK STARTING THE ENGINE

1. Park vehicle on level surface.
2. Move selector lever to "P" or "N" position.
3. Turn ignition switch to "OFF" position.
4. Turn ignition switch to "START" position.

Does the engine start?

- YES >> GO TO 2.
- NO >> Stop the road test and go to [TM-130, "Engine Cannot Be Started in "P" or "N" Position"](#).

2.CHECK STARTING THE ENGINE

1. Turn ignition switch to "ON" position.
2. Move selector lever in "D", "4", "3", "2", "1" or "R" position.
3. Turn ignition switch to "START" position.

Does the engine start in either position?

- YES >> Stop the road test and go to [TM-130, "Engine Cannot Be Started in "P" or "N" Position"](#).
- NO >> GO TO 3.

3.CHECK "P" POSITION FUNCTIONS

1. Move selector lever to "P" position.
2. Turn ignition switch to "OFF" position.
3. Release the parking brake.
4. Push the vehicle forward or backward.
5. Engage the parking brake.

When you push the vehicle with disengaging the parking brake, does it move?

ROAD TEST

< ON-VEHICLE MAINTENANCE >

- YES >> Enter a check mark at "In "P" Position Vehicle Moves When Pushed" on the diagnostics worksheet, then continue the road test.
- NO >> GO TO 4.

4.CHECK "N" POSITION FUNCTIONS

1. Start the engine.
2. Move selector lever to "N" position.
3. Release the parking brake.

Does vehicle move forward or backward?

- YES >> Enter a check mark at "In "N" Position Vehicle Moves" on the diagnostics worksheet, then continue the road test.
- NO >> GO TO 5.

5.CHECK SHIFT SHOCK

1. Engage the brake.
2. Move selector lever to "D" position.

When the transmission is shifted from "N" to "D", is there an excessive shock?

- YES >> Enter a check mark at "Large Shock ("N" to "D" Position) on the diagnostics worksheet, then continue the road test.
- NO >> GO TO 6.

6.CHECK "R" POSITION FUNCTIONS

1. Engage the brake.
2. Move selector lever to "R" position.
3. Release the brake for 4 to 5 seconds.

Does the vehicle creep backward?

- YES >> GO TO 7.
- NO >> Enter a check mark at "Vehicle Does Not Creep Backward In "R" Position" on the diagnostics worksheet, then continue the road test.

7.CHECK "D" POSITION FUNCTIONS

Inspect whether the vehicle creeps forward when the transmission is put into the "D" position.

Does the vehicle creep forward in the "D" positions?

- YES >> Go to [TM-202. "Cruise Test - Part 1"](#), [TM-204. "Cruise Test - Part 2"](#), and [TM-205. "Cruise Test - Part 3"](#).
- NO >> Enter a check mark at "Vehicle Does Not Creep Forward in "D" Position" on the diagnostics worksheet, then continue the road test.

Cruise Test - Part 1

INFOID:000000001530124

1.CHECK STARTING OUT FROM D1

1. Drive the vehicle for about 10 minutes to warm up the engine oil and ATF.
Appropriate temperature for the ATF: 50 - 80°C (122 - 176°F)
2. Park the vehicle on a level surface.
3. Move selector lever to "P" position.
4. Start the engine.
5. Move selector lever to "D" position.
6. Press the accelerator pedal about half way down to accelerate the vehicle.

With CONSULT-III

Read off the gear positions.

Starts from D1?

- YES >> GO TO 2.
- NO >> Enter a check mark at "Vehicle Cannot be Started From D1" on the diagnostics worksheet, then continue the road test.

2.CHECK SHIFT-UP D1 → D2

Press down the accelerator pedal about half way and inspect if the vehicle shifts up (D1 → D2) at the appropriate speed.

ROAD TEST

< ON-VEHICLE MAINTENANCE >

- Refer to [TM-304. "Vehicle Speed at Which Gear Shifting Occurs"](#).

With CONSULT-III

Read the gear position, throttle degree of opening, and vehicle speed.

Does the A/T shift-up D1 → D2 at the correct speed?

YES >> GO TO 3.

NO >> Enter a check mark at "A/T Does Not Shift: D1 → D2" on the diagnostics worksheet, then continue the road test.

3.CHECK SHIFT-UP D2 → D3

Press down the accelerator pedal about half way and inspect if the vehicle shifts up (D2 → D3) at the appropriate speed.

- Refer to [TM-304. "Vehicle Speed at Which Gear Shifting Occurs"](#).

With CONSULT-III

Read the gear position, throttle degree of opening, and vehicle speed.

Does the A/T shift-up D2 → D3 at the correct speed?

YES >> GO TO 4.

NO >> Enter a check mark at "A/T Does Not Shift: D2 → D3" on the diagnostics worksheet, then continue the road test.

4.CHECK SHIFT-UP D3 → D4

Press down the accelerator pedal about half way and inspect if the vehicle shifts up (D3 → D4) at the appropriate speed.

- Refer to [TM-304. "Vehicle Speed at Which Gear Shifting Occurs"](#).

With CONSULT-III

Read the gear position, throttle degree of opening, and vehicle speed.

Does the A/T shift-up D3 → D4 at the correct speed?

YES >> GO TO 5.

NO >> Enter a check mark at "A/T Does Not Shift: D3 → D4" on the diagnostics worksheet, then continue the road test.

5.CHECK SHIFT-UP D4 → D5

Press down the accelerator pedal about half way and inspect if the vehicle shifts up (D4 → D5) at the appropriate speed.

- Refer to [TM-304. "Vehicle Speed at Which Gear Shifting Occurs"](#).

With CONSULT-III

Read the gear position, throttle degree of opening, and vehicle speed.

Does the A/T shift-up D4 → D5 at the correct speed?

YES >> GO TO 6.

NO >> Enter a check mark at "A/T Does Not Shift: D4 → D5" on the diagnostics worksheet, then continue the road test.

6.CHECK LOCK-UP

When releasing accelerator pedal from D5, check lock-up from D5 to L/U.

- Refer to [TM-304. "Vehicle Speed at Which Gear Shifting Occurs"](#).

With CONSULT-III

Select "TCC SOLENOID 0.00A" with the "MAIN SIGNAL" mode for A/T.

Does it lock-up?

YES >> GO TO 7.

NO >> Enter a check mark at "A/T Does Not Perform Lock-up" on the diagnostics worksheet, then continue the road test.

7.CHECK LOCK-UP HOLD

Does it maintain lock-up status?

YES >> GO TO 8.

ROAD TEST

< ON-VEHICLE MAINTENANCE >

NO >> Enter a check mark at "A/T Does Not Hold Lock-up Condition" on the diagnostics worksheet, then continue the road test.

8. CHECK LOCK-UP RELEASE

Check lock-up cancellation by depressing brake pedal lightly to decelerate.

With CONSULT-III

Select "TCC SOLENOID 0.00A" with the "MAIN SIGNAL" mode for A/T.

Does lock-up cancel?

YES >> GO TO 9.

NO >> Enter a check mark at "Lock-up Is Not Released" on the diagnostics worksheet, then continue the road test.

9. CHECK SHIFT-DOWN D5 → D4

Decelerate by pressing lightly on the brake pedal.

With CONSULT-III

Read the gear position and engine speed.

When the A/T shift-down D5 → D4, does the engine speed drop smoothly back to idle?

YES >> 1. Stop the vehicle.

2. Go to Cruise test - Part 2 (Refer to AT 58).

NO >> Enter a check mark at "Engine Speed Does Not Return to Idle" on the diagnostics worksheet, then continue the road test. Go to Cruise test - Part 2 (Refer to AT 58).

Cruise Test - Part 2

INFOID:000000001530125

1. CHECK STARTING FROM D1

1. Move selector lever the "D" position.

2. Accelerate at half throttle.

With CONSULT-III

Read the gear position.

Does it start from D1?

YES >> GO TO 2.

NO >> Enter a check mark at "Vehicle Cannot Be Started From D1" on the diagnostics worksheet, then continue the road test.

2. CHECK SHIFT-UP D1 → D2

Press the accelerator pedal down all the way and inspect whether or not the transmission shifts up (D1 → D2) at the correct speed.

• Refer to [TM-304, "Vehicle Speed at Which Gear Shifting Occurs"](#).

With CONSULT-III

Read the gear position, throttle position and vehicle speed.

Does the A/T shift-up D1 → D2 at the correct speed?

YES >> GO TO 3.

NO >> Enter a check mark at "Vehicle Does Not Shift: D1 → D2" on the diagnostics worksheet, then continue the road test.

3. CHECK SHIFT-UP D2 → D3

Press the accelerator pedal down all the way and inspect whether or not the transmission shifts up (D2 → D3) at the correct speed.

• Refer to [TM-304, "Vehicle Speed at Which Gear Shifting Occurs"](#).

With CONSULT-III

Read the gear position, throttle position and vehicle speed.

Does the A/T shift-up D2 → D3 at the correct speed?

YES >> GO TO 4.

NO >> Enter a check mark at "Vehicle Does Not Shift: D2 → D3" on the diagnostics worksheet, then continue the road test.

4. CHECK SHIFT-UP D3 → D4 AND ENGINE BRAKE

ROAD TEST

< ON-VEHICLE MAINTENANCE >

When the transmission changes speed D3 → D4, return the accelerator pedal.

Does the A/T shift-up D3 → D4 and apply the engine brake?

YES >> 1. Stop the vehicle.

2. See [TM-205, "Cruise Test - Part 3"](#).

NO >> Enter a check mark at "Vehicle Does Not Shift: D3 → D4" on the diagnostics worksheet, then continue the road test.

Cruise Test - Part 3

INFOID:000000001530126

1. CHECK SHIFT-DOWN

During D5 driving, move gear selector from D → 4 → 3 → 2 → 1.

 **With CONSULT-III**

Read the gear position.

Is downshifting correctly performed?

YES >> GO TO 2.

NO >> Enter a check mark at "Vehicle does not shift" at the corresponding position (5th → 4th, 4th → 3rd, 3rd → 2nd, 2nd → 1st) on the diagnostics worksheet, then continue the road test.

2. CHECK ENGINE BRAKE

Does engine braking effectively reduce speed in 11 position?

YES >> 1. Stop the vehicle.

2. Carry out the self-diagnostics. Refer to [TM-33, "CONSULT-III Function \(TRANSMISSION\)"](#).

NO >> Enter a check mark at "Vehicle Does Not Decelerate By Engine Brake" on the diagnostics worksheet, then continue trouble diagnosis.

Vehicle Speed When Shifting Gears

INFOID:000000001534644

Refer to [TM-205, "Vehicle Speed When Shifting Gears"](#).

Vehicle Speed When Performing and Releasing Complete Lock-up

INFOID:000000001534645

Refer to [TM-205, "Vehicle Speed When Performing and Releasing Complete Lock-up"](#).

A
B
C
TM
E
F
G
H
I
J
K
L
M
N
O
P

A/T POSITION

< ON-VEHICLE MAINTENANCE >

A/T POSITION

2WD

2WD : Adjustment of A/T Position

INFOID:000000001542646

1. Loosen nut of control cable.
2. Place the manual lever and selector lever in "P" position.
3. Push the control cable in the direction shown with a force of 9.8 N (1kg, 2.2 lb), and release it. This is in the natural state, tighten control cable nut to specifications.

Control cable nut : 14.5 N·m (1.5 kg-m, 11 ft-lb)

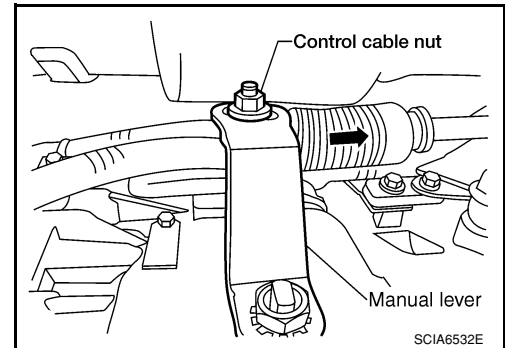

2WD : Checking of A/T Position

INFOID:000000001542647

With the selector lever in the "P" position, turn the ignition switch to the ON position with the engine OFF. Confirm that the following conditions apply.

- The selector lever can be shifted from the "P" position only when the brake pedal is depressed.
- The selector lever stops at each position with the feel of engagement when it is moved through all the positions.
- There is no excessive effort, sticking, noise or rattle.
- The actual position of the selector lever matches the position shown by the shift position indicator and the A/T body.
- The back-up lamps illuminate only when the selector lever is placed in the "R" position.
- The back-up lamps do not illuminate when the selector lever is pushed against the "R" position when in the "P" or "N" position.
- The engine can only be started with the selector lever in the "P" and "N" positions.
- The A/T is locked completely when in the "P" position.

4WD

4WD : Adjustment of A/T Position

INFOID:000000001542648

1. Loosen nut of control cable.
2. Place the manual lever and selector lever in "P" position.
3. Push the control cable in the direction shown with a force of 9.8 N (1kg, 2.2 lb), and release it. This is in the natural state, tighten control cable nut to specifications.

Control cable nut : 14.5 N·m (1.5 kg-m, 11 ft-lb)

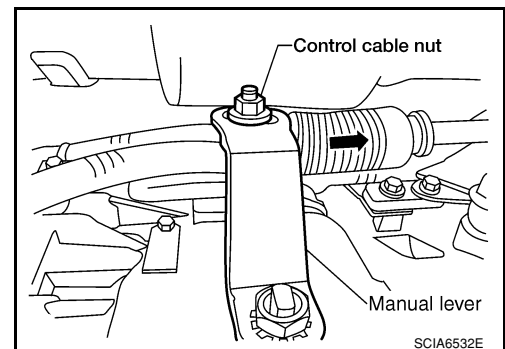

4WD : Checking of A/T Position

INFOID:000000001542649

With the selector lever in the "P" position, turn the ignition switch to the ON position with the engine OFF. Confirm that the following conditions apply.

- The selector lever can be shifted from the "P" position only when the brake pedal is depressed.
- The selector lever stops at each position with the feel of engagement when it is moved through all the positions.
- There is no excessive effort, sticking, noise or rattle.
- The actual position of the selector lever matches the position shown by the shift position indicator and the A/T body.

A/T POSITION

< ON-VEHICLE MAINTENANCE >

- The back-up lamps illuminate only when the selector lever is placed in the “R” position.
- The back-up lamps do not illuminate when the selector lever is pushed against the “R” position when in the “P” or “N” position.
- The engine can only be started with the selector lever in the “P” and “N” positions.
- The A/T is locked completely when in the “P” position.

A

B

C

TM

E

F

G

H

I

J

K

L

M

N

O

P

SHIFT CONTROL SYSTEM

< ON-VEHICLE REPAIR >

ON-VEHICLE REPAIR

SHIFT CONTROL SYSTEM

Control Device Removal and Installation

INFOID:000000001542542

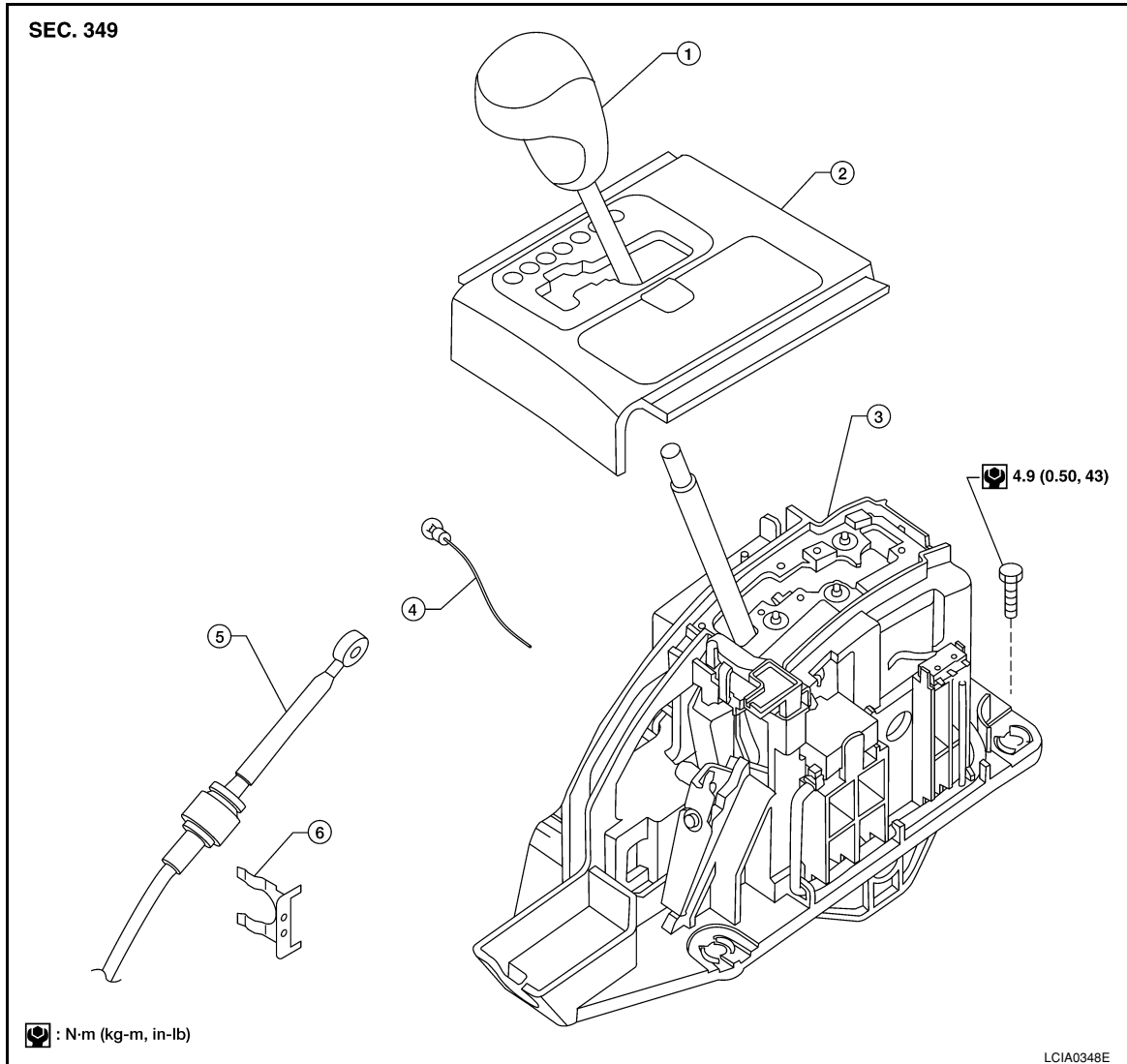

- | | | |
|----------------------|-------------------------------|----------------------------|
| 1. Select lever knob | 2. A/T console finisher | 3. Control device assembly |
| 4. Position lamp | 5. A/T selector control cable | 6. Lock plate |

REMOVAL

1. Remove negative battery terminal. Refer to [PG-67. "Removal and Installation"](#).
2. Remove A/T finisher. Refer to [IP-18. "Removal and Installation"](#).
3. Disconnect selector control cable.
4. Disconnect A/T device harness connector.
5. Remove control device assembly.

INSTALLATION

- Installation is in reverse order of removal. Be careful of the following:
- After installation is completed, adjust and check A/T position.

SHIFT CONTROL SYSTEM

< ON-VEHICLE REPAIR >

Adjustment of A/T Position

INFOID:000000001542543

1. Loosen nut of control cable.
2. Place PNP switch and selector lever in "P" position.
3. After pushing the control cable in the direction shown with a force of 9.8 N·m (1kg-m, 2.2 lb-ft), release it. This is in the natural state, tighten control cable nut to specifications.

Control cable nut : 14.5 N·m (1.5 kg-m, 11 ft-lb)

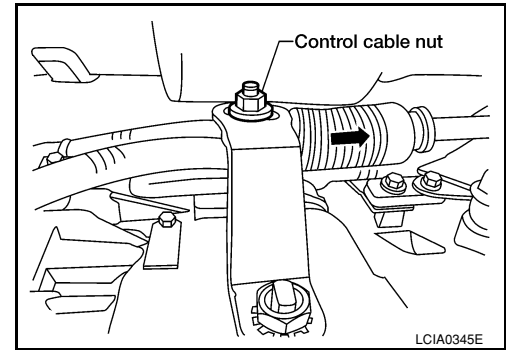

Checking of A/T Position

INFOID:000000001542544

1. Place selector lever in "P" position, and turn ignition switch ON (engine stop).
2. Make sure selector lever can be shifted to other than "P" position when brake pedal is depressed. Also make sure selector lever can be shifted from "P" position only when brake pedal is depressed.
3. Move the selector lever and check for excessive effort, sticking, noise or rattle.
4. Confirm the selector lever stops at each position with the feel of engagement when it is moved through all the positions. Check whether or not the actual position the selector lever is in matches the position shown by the shift position indicator and the transmission body.
5. The method of operating the lever to individual positions correctly should be as shown.
6. Confirm the back-up lamps illuminate only when lever is placed in the "R" position. Confirm the back-up lamps does not illuminate when selector lever is pushed against "R" position in the "P" or "N" position.
7. Confirm the engine can only be started with the selector lever in the "P" and "N" positions.
8. Make sure transmission is locked completely in "P" position.

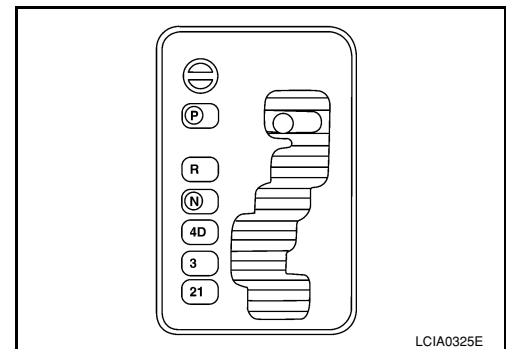

KEY INTERLOCK CABLE

< ON-VEHICLE REPAIR >

KEY INTERLOCK CABLE

Component

INFOID:000000001542652

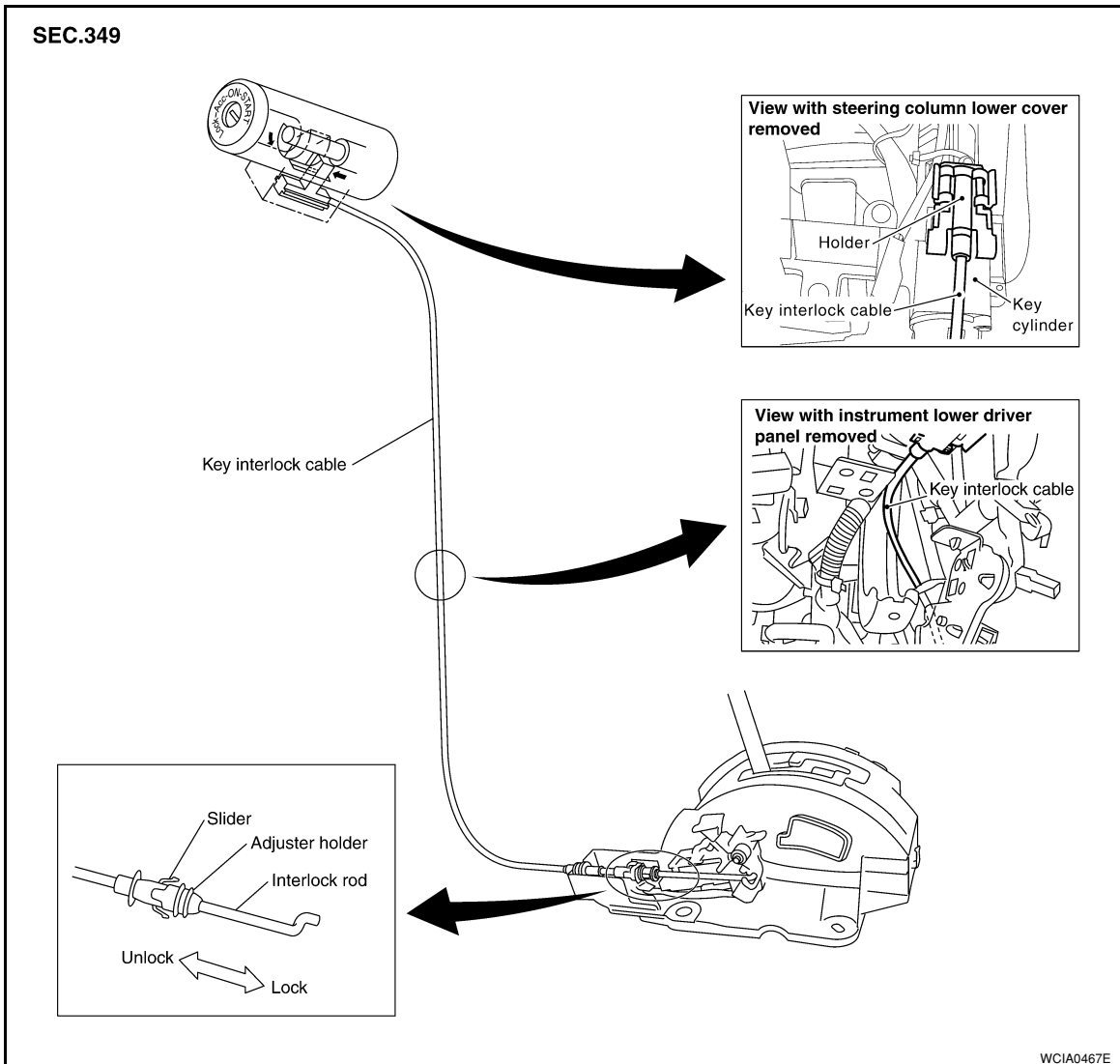

CAUTION:

- Install key interlock cable in such a way that it will not be damaged by sharp bends, twists or interference with adjacent parts.
- After installing key interlock cable to control device, make sure that casing cap and bracket are firmly secured in their positions. If casing cap can be removed with an external load of less than 39 N (4.0 kg, 8.8 lb), replace key interlock cable with new one.

Removal and Installation

INFOID:000000001542653

REMOVAL

KEY INTERLOCK CABLE

< ON-VEHICLE REPAIR >

1. Unlock slider from adjuster holder by squeezing lock tabs.
2. Remove casing cap from bracket of control device assembly and remove interlock rod from adjuster holder.

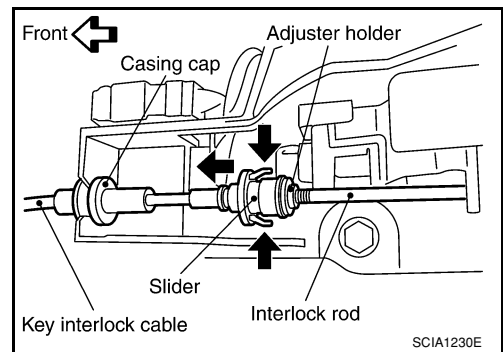

3. Remove holder from key cylinder and remove key interlock cable.

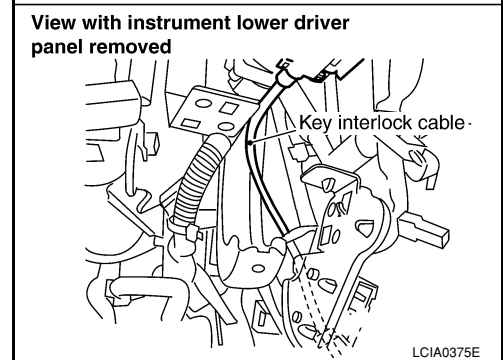
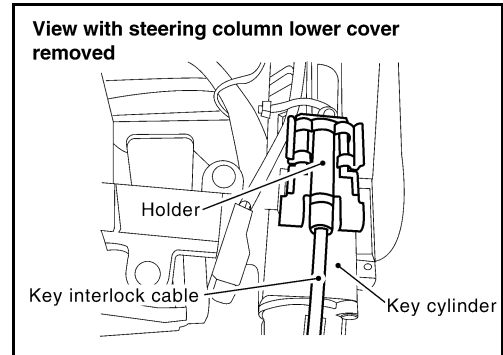

INSTALLATION

1. Set key interlock cable to key cylinder and install holder.
2. Turn ignition key to "LOCK" position.
3. Set selector lever to "P" position.

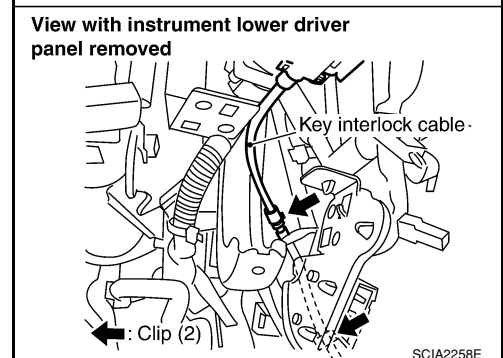
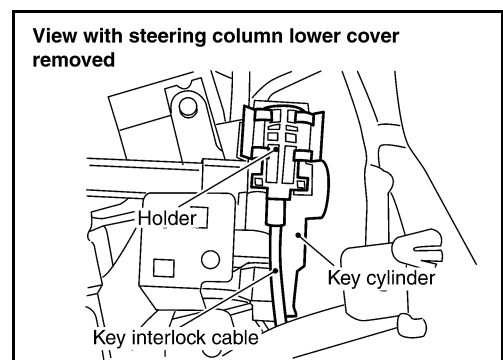

A
B
C
TM
E
F
G
H
I
J
K
L
M
N
O
P

KEY INTERLOCK CABLE

< ON-VEHICLE REPAIR >

4. Insert interlock rod into adjuster holder.
5. Install casing cap to bracket.
6. Move slider in order to secure adjuster holder to interlock rod.

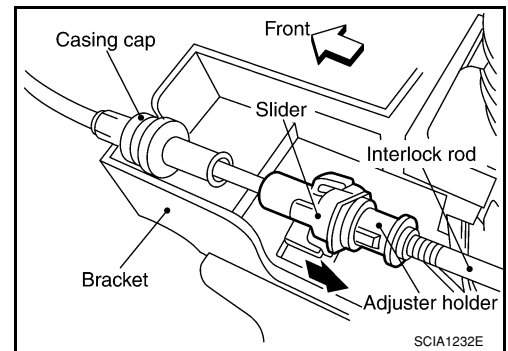

AIR BREATHER HOSE

< ON-VEHICLE REPAIR >

AIR BREATHER HOSE

Removal and Installation

INFOID:000000001542654

VK56DE Models 2WD

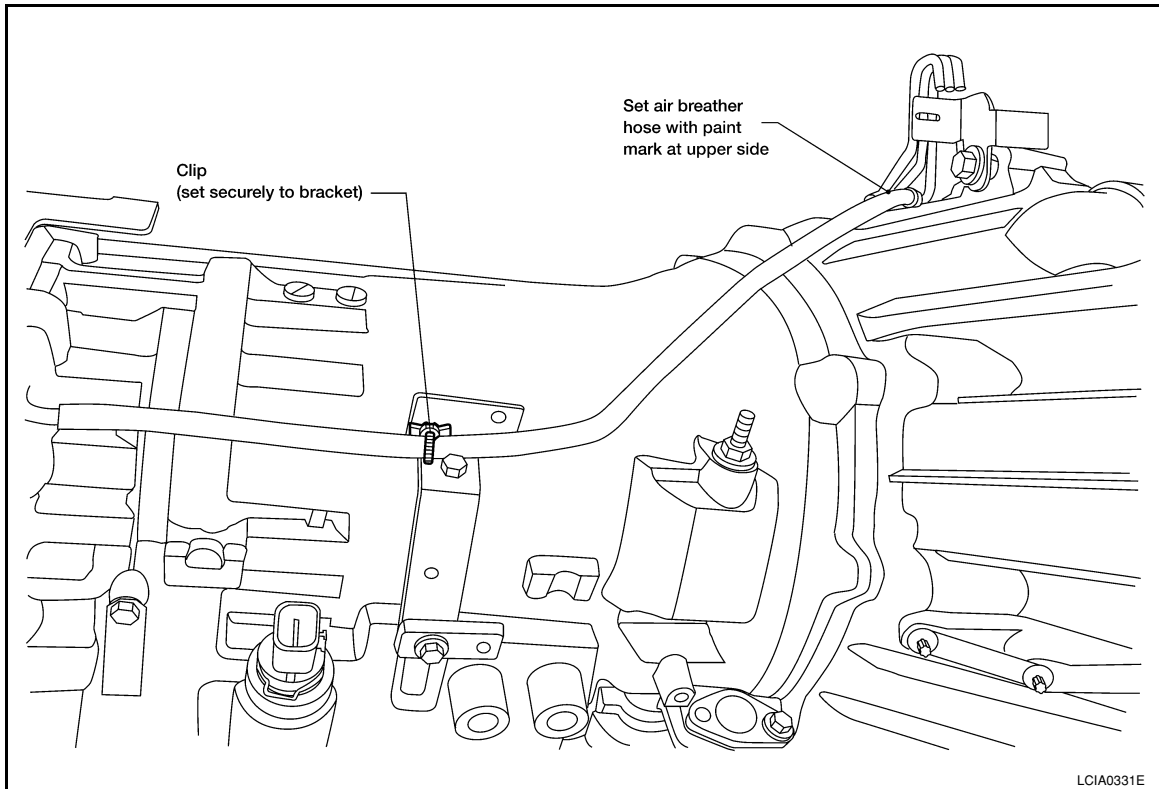

CAUTION:

- Install air breather hose with paint mark at upper side.
- When installing the air breather hose, do not crush or block by folding or bending the hose.
- When inserting the hose to the transmission tube, be sure to insert it fully until its end reaches the tube bend portion.
- Make sure clip is securely installed to bracket.

VK56DE Models 4WD

A
B
C
TM
E
F
G
H
I
J
K
L
M
N
O
P

AIR BREATHER HOSE

< ON-VEHICLE REPAIR >

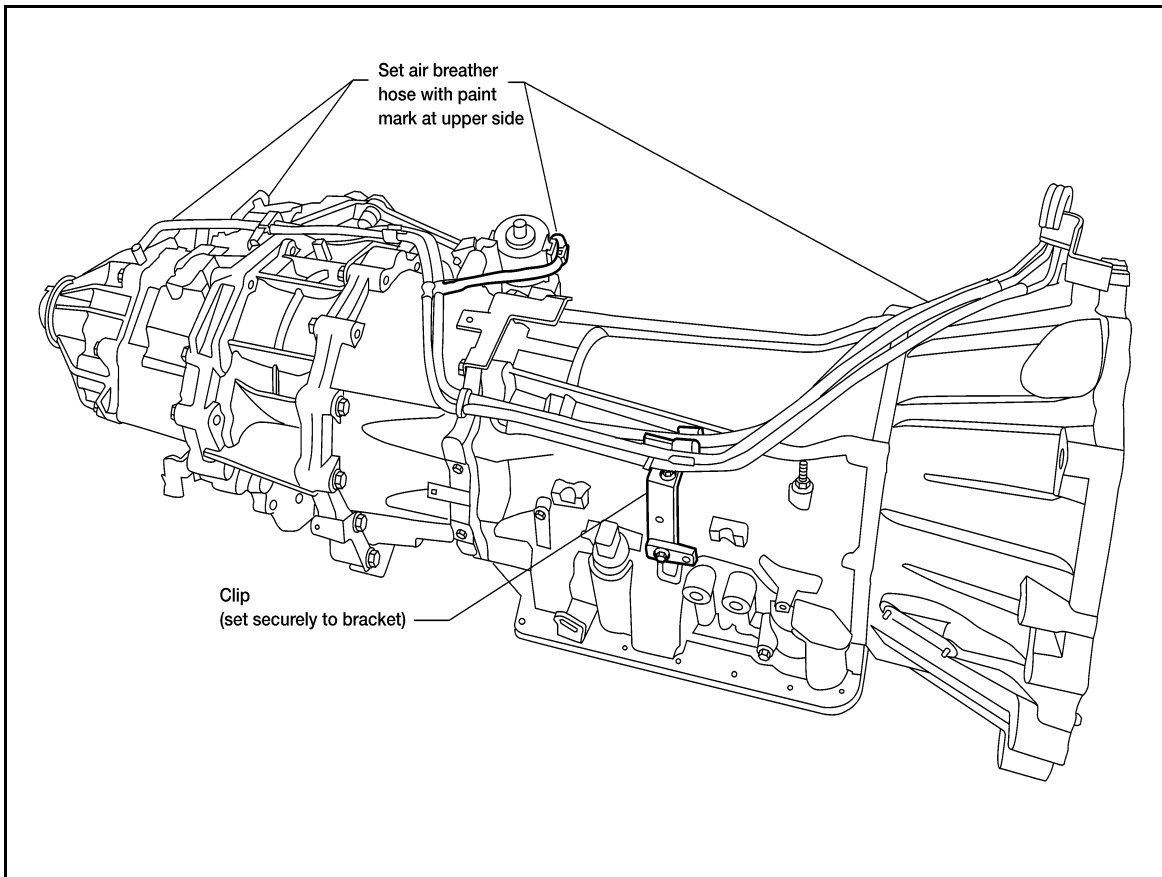

CAUTION:

- Install air breather hose with paint mark at upper side.
- When installing the air breather hose, do not crush or block by folding or bending the hose.
- When inserting the hose to the transmission tube, be sure to insert it fully until its end reaches the tube bend portion.
- Make sure clip is securely installed to bracket.

OIL PAN

< ON-VEHICLE REPAIR >

OIL PAN

Oil Pan

INFOID:000000001542642

REMOVAL AND INSTALLATION

Removal

1. Drain A/T fluid. Refer to [TM-192. "Changing the A/T Fluid \(ATF\)"](#).
2. Remove oil pan clips (1).
3. Remove oil pan (2).
4. Remove oil pan gasket.
 - ⇨ Vehicle front
 - ➔ Oil pan bolts
 - ● Drain plug (3)

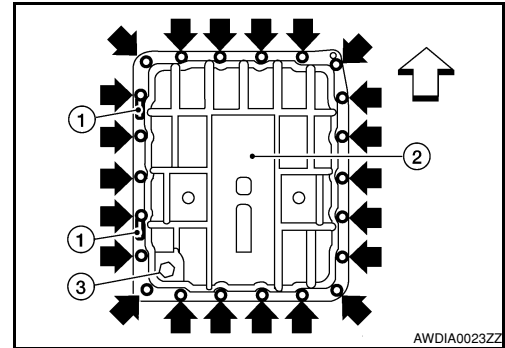

5. Check for foreign materials in oil pan to help determine cause of malfunction. If the A/T fluid is very dark, has some burned smell, or contains foreign particles then friction material (clutches, band) may need replacement. A tacky film that will not wipe clean indicates varnish build up. Varnish can cause valves, servo, and clutches to stick and can inhibit pump pressure.

CAUTION:

If friction material is detected, flush the transmission cooler after repair. Refer to [TM-194. "A/T Fluid Cooler Cleaning"](#).

6. Remove magnets from oil pan.

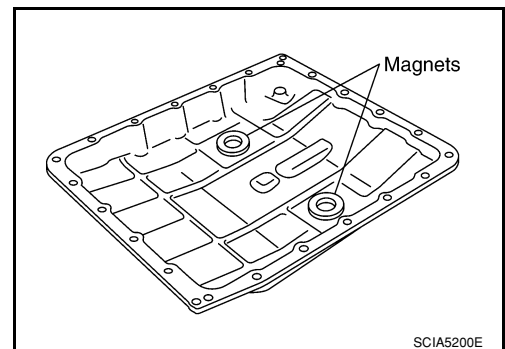

Installation

1. Install the oil pan magnets as shown.

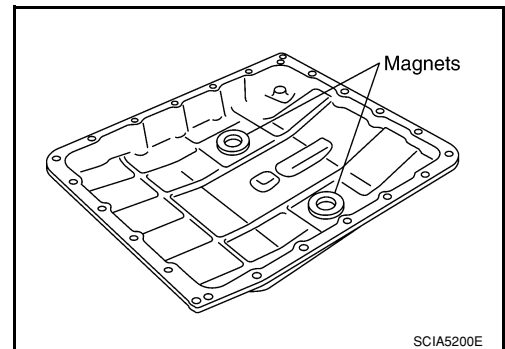

A
B
C
TM
E
F
G
H
I
J
K
L
M
N
O
P

OIL PAN

< ON-VEHICLE REPAIR >

2. Install the oil pan (2) new oil pan gasket.

- ⇨ : Vehicle Front
- ➡ : Oil pan bolts
- ○ : Clips (1)
- ● : Drain plug (3)

CAUTION:

- Be sure the oil drain plug is located to the rear of the transmission assembly.
- Before installing oil pan bolts, remove any traces of old sealant from the sealing surfaces and threaded holes.
- Do not reuse old gasket, replace with a new one.
- Always replace the oil pan bolts as they are self-sealing.
- Partially install the oil pan bolts in a criss-cross pattern to prevent dislocation of the gasket.

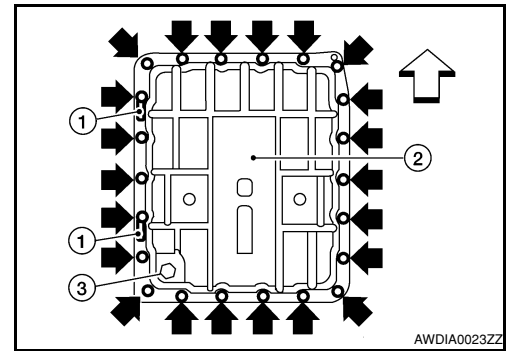

3. Install oil pan bolts and clips tighten in numerical order as shown.

Oil pan bolts : 7.9 N·m (0.81 kg-m, 70 in-lb)

4. Install drain plug with new gasket to oil pan and tighten to specification.

Drain plug : 34 N·m (3.5 kg-m, 25 ft-lb)

CAUTION:

Do not reuse drain plug gasket.

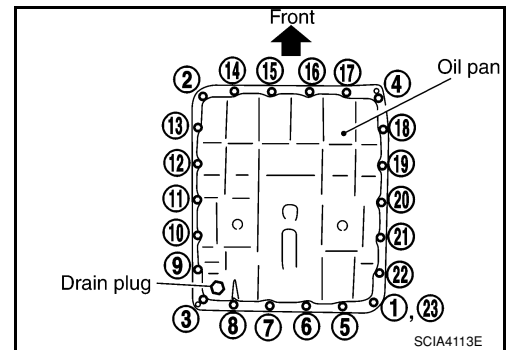

5. Refill the A/T with fluid and check for fluid leakage. Refer to [TM-190. "Checking the A/T Fluid \(ATF\)".](#)

CONTROL VALVE WITH TCM

< ON-VEHICLE REPAIR >

CONTROL VALVE WITH TCM

Control Valve with TCM and A/T Fluid Temperature Sensor 2

INFOID:000000001542650

COMPONENTS

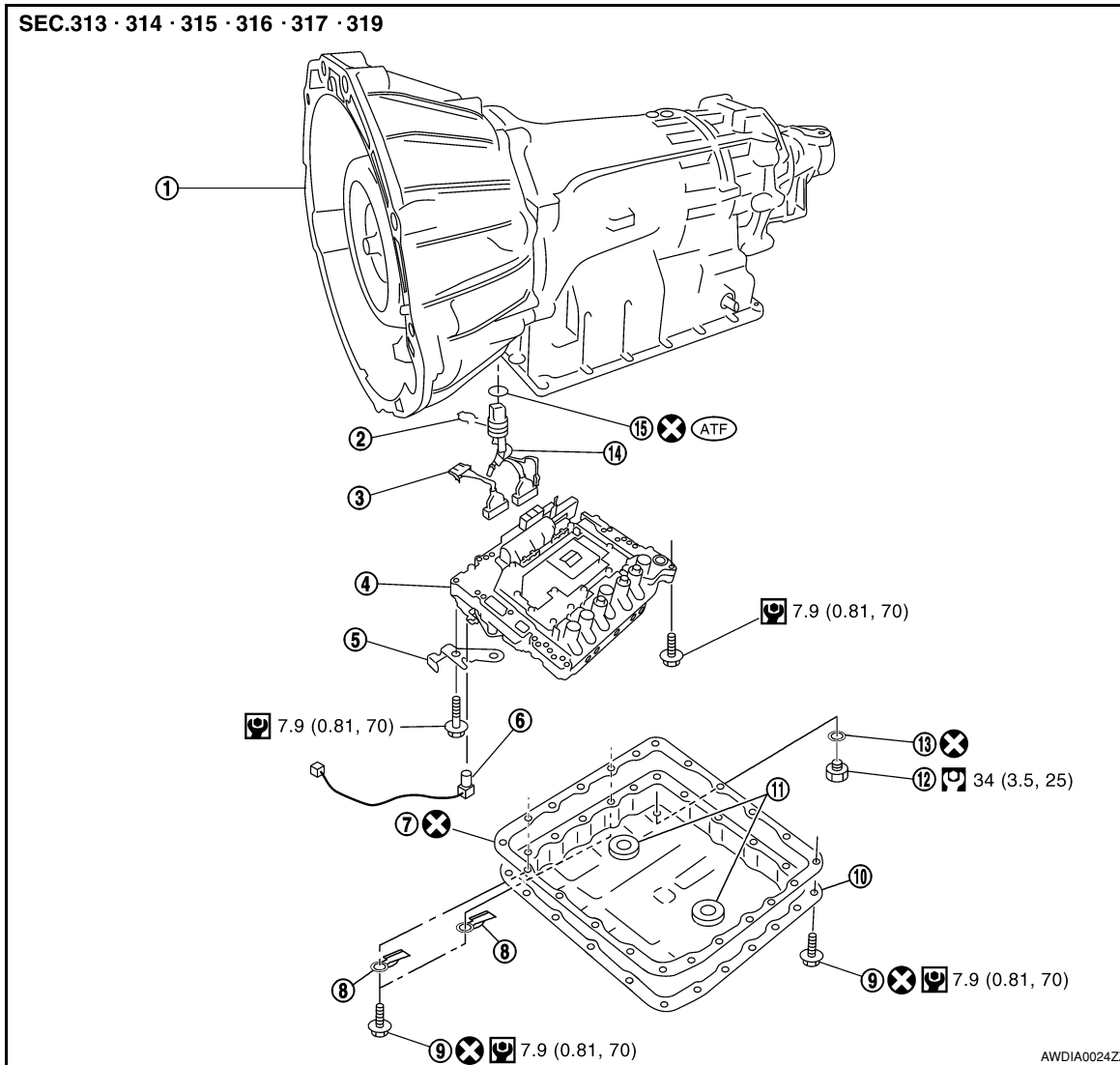

- | | | |
|---------------------------|----------------------------|-----------------------------------|
| 1. Transmission | 2. Snap ring | 3. Sub-harness |
| 4. Control valve with TCM | 5. Bracket | 6. A/T fluid temperature sensor 2 |
| 7. Oil pan gasket | 8. Brackets | 9. Oil pan bolt |
| 10. Oil pan | 11. Magnet | 12. Drain plug |
| 13. Drain plug gasket | 14. Terminal cord assembly | 15. O-ring |

CONTROL VALVE WITH TCM REMOVAL AND INSTALLATION

Removal

1. Disconnect negative battery terminal.
2. Drain A/T fluid. Refer to [TM-192. "Changing the A/T Fluid \(ATF\)".](#)
3. Disconnect A/T assembly harness connector.

CONTROL VALVE WITH TCM

< ON-VEHICLE REPAIR >

4. Remove snap ring from A/T assembly harness connector.

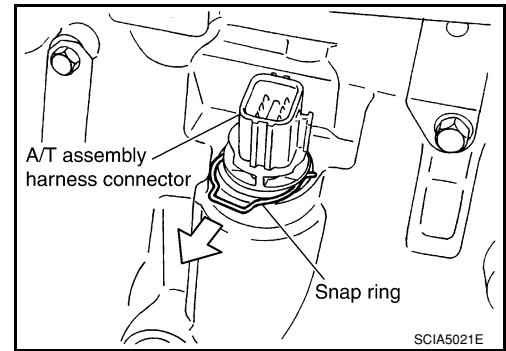

5. Push A/T assembly harness connector.

CAUTION:
Do not damage connector.

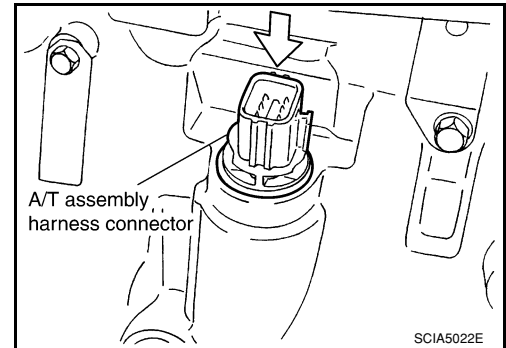

6. Remove oil pan and oil pan gasket. Refer to [TM-215, "Oil Pan"](#).

7. Disconnect A/T fluid temperature sensor 2 connector (A).

CAUTION:
Do not damage connector.

8. Straighten the four terminal clips to free the terminal cord assembly for A/T fluid temperature sensor 2 harness.

• ➡ : Terminal clip

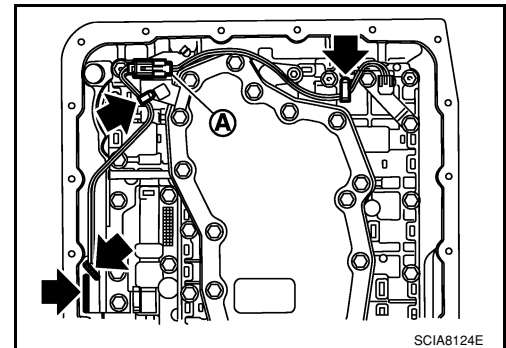

9. Straighten terminal clip to free the revolution sensor harness.

10. Disconnect revolution sensor connector.

CAUTION:
Do not damage connector.

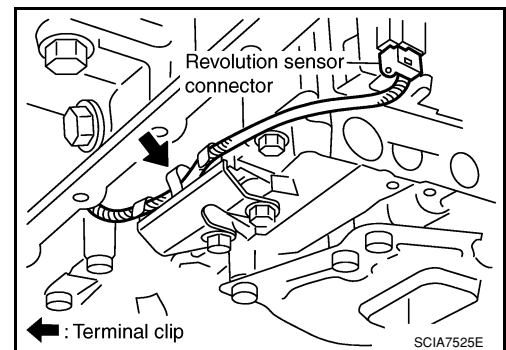

CONTROL VALVE WITH TCM

< ON-VEHICLE REPAIR >

11. Remove bolts (A), (B) and (C) from control valve with TCM.

• ➡ : Front

Bolt symbol	Length mm (in)	Number of bolts
A	42 (1.65)	5
B	55 (2.17)	6
C	40 (1.57)	1

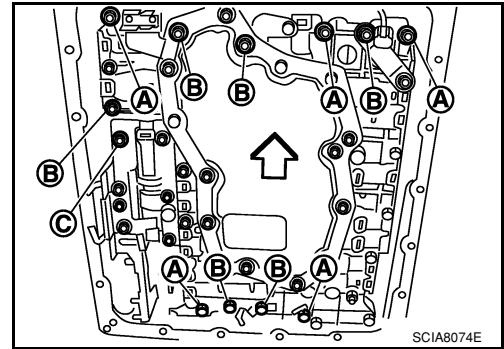

12. Remove control valve with TCM from transmission case.

CAUTION:

When removing, be careful with the manual valve notch and manual plate height. Remove it vertically.

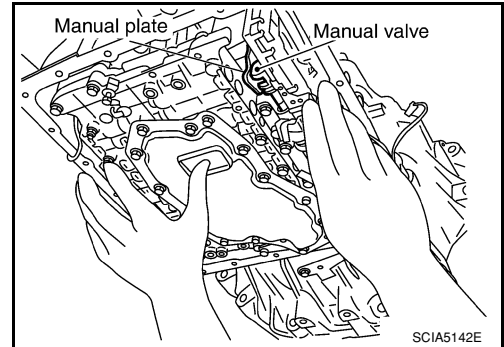

13. Remove A/T fluid temperature sensor 2 with bracket from control valve with TCM.

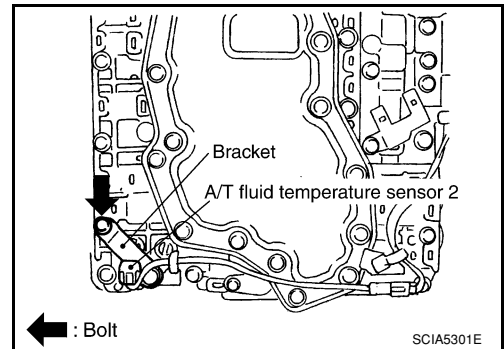

14. Remove bracket from A/T fluid temperature sensor 2.

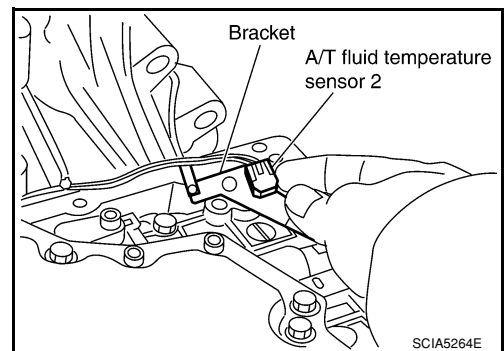

15. Remove O-ring from A/T assembly harness connector.

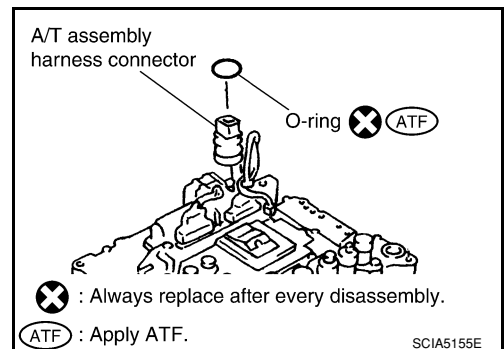

A
B
C
TM
E
F
G
H
I
J
K
L
M
N
O
P

CONTROL VALVE WITH TCM

< ON-VEHICLE REPAIR >

16. Disconnect TCM connectors.

CAUTION:

Do not damage connectors.

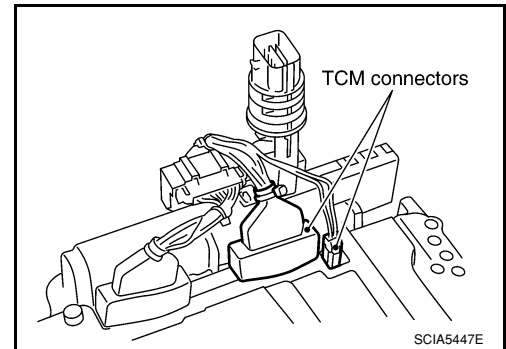

17. Remove A/T assembly harness connector from control valve with TCM using suitable tool.

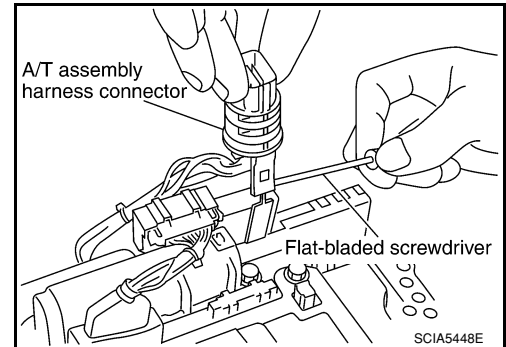

18. Disconnect TCM connector and park/neutral position switch connector

CAUTION:

Do not damage connectors.

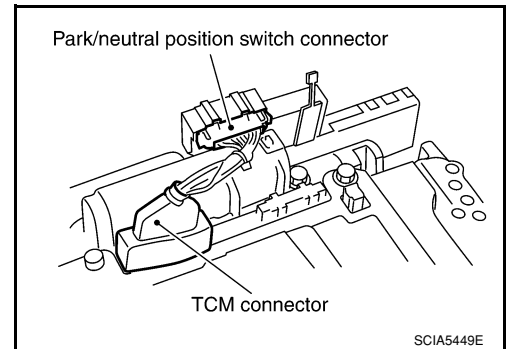

Installation

CAUTION:

After completing installation, check A/T fluid leakage and fluid level. Refer to [TM-190, "Checking the A/T Fluid \(ATF\)"](#).

1. Connect TCM connector and park/neutral position switch connector.

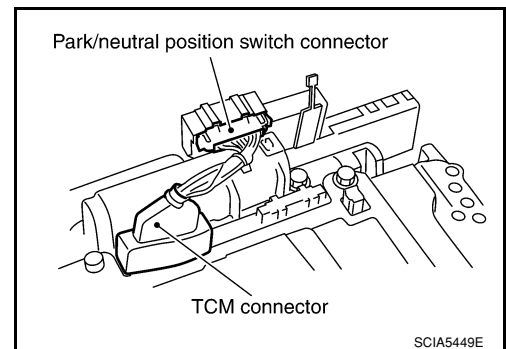

CONTROL VALVE WITH TCM

< ON-VEHICLE REPAIR >

2. Install A/T assembly harness connector to control valve with TCM.

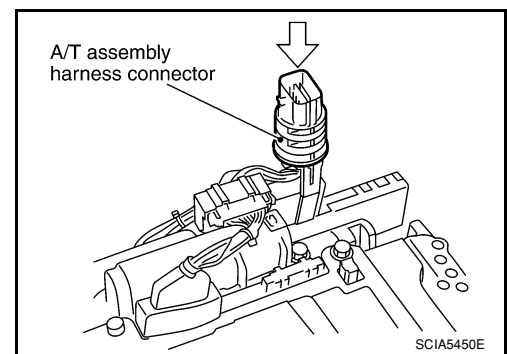

3. Connect TCM connector.

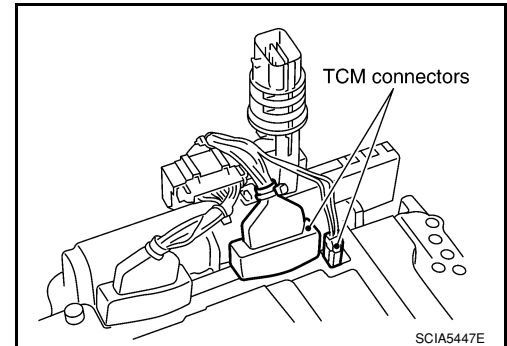

4. Install new O-ring in A/T assembly harness connector.

CAUTION:

- Do not reuse O-ring.
- Apply ATF to O-ring.

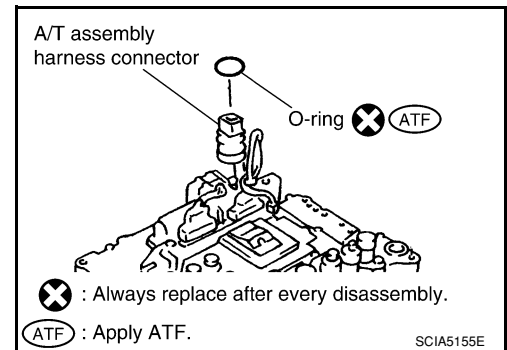

5. Install A/T fluid temperature sensor 2 to bracket.

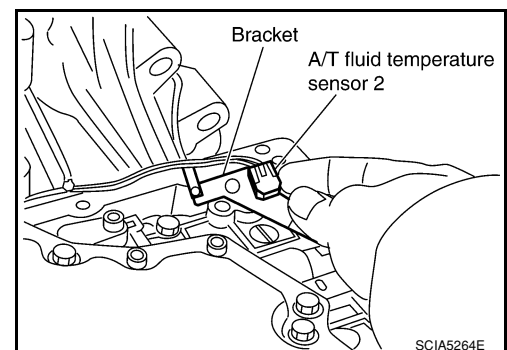

6. Install A/T fluid temperature sensor 2 (with bracket) to control valve with TCM. Tighten A/T fluid temperature sensor 2 bolt to the specified torque. Refer to "COMPONENTS".

CAUTION:

Adjust bolt hole of bracket to bolt hole of control valve with TCM.

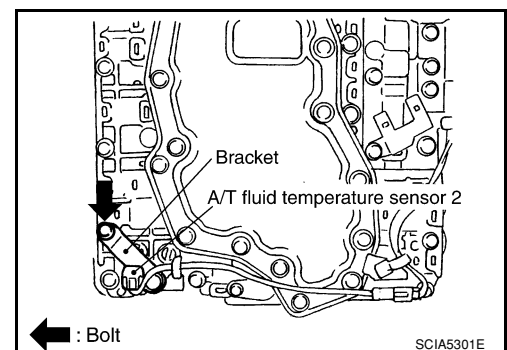

A
B
C
TM
E
F
G
H
I
J
K
L
M
N
O
P

CONTROL VALVE WITH TCM

< ON-VEHICLE REPAIR >

7. Install control valve with TCM in transmission case.

CAUTION:

- Make sure that turbine revolution sensor is securely installed into turbine revolution sensor hole.
- Hang down revolution sensor harness toward outside so as not to disturb installation of control valve with TCM.
- Adjust A/T assembly harness connector of control valve with TCM to terminal hole of transmission case.

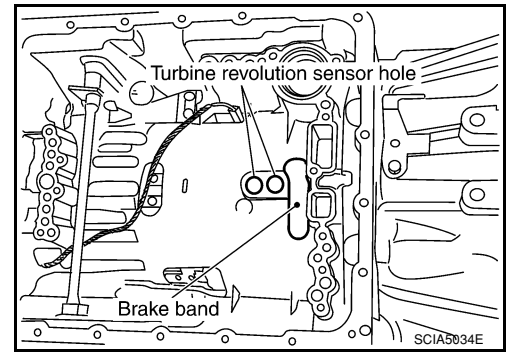

- Assemble it so that manual valve cutout is engaged with manual plate projection.

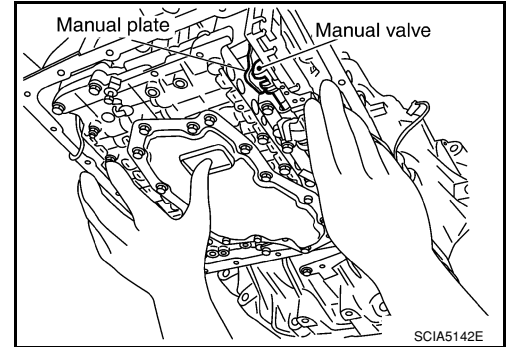

8. Install bolts (A), (B) and (C) in control valve with TCM.

- ➡ : Front

Bolt symbol	Length mm (in)	Number of bolts
A	42 (1.65)	5
B	55 (2.17)	6
C	40 (1.57)	1

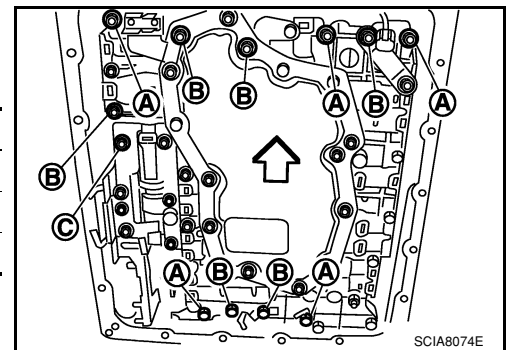

9. Tighten bolt (1), (2) and (3) temporarily to prevent dislocation. After that tighten them in order (1 → 2 → 3). Then tighten other bolts.

- ➡ : Front

10. Tighten control valve with TCM bolts to the specified torque. Refer to "COMPONENTS".

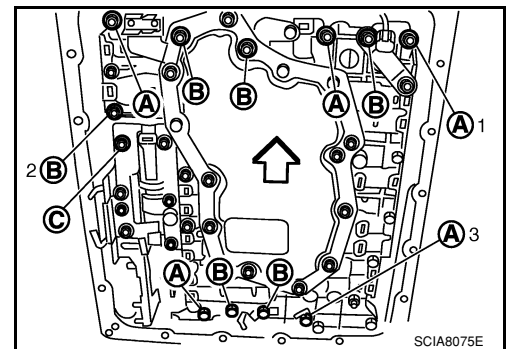

CONTROL VALVE WITH TCM

< ON-VEHICLE REPAIR >

11. Connect A/T fluid temperature sensor 2 connector (A).
12. Securely fasten terminal cord assembly and A/T fluid temperature sensor 2 harness with terminal clips
 - ➡ : Terminal clip

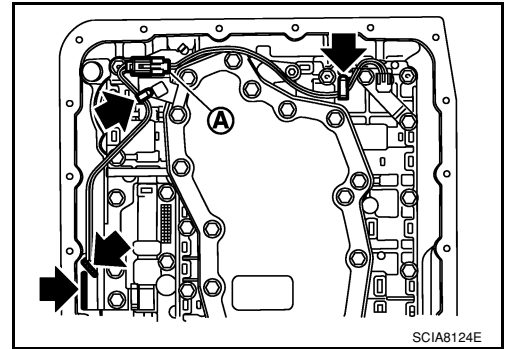

13. Connect revolution sensor connector.

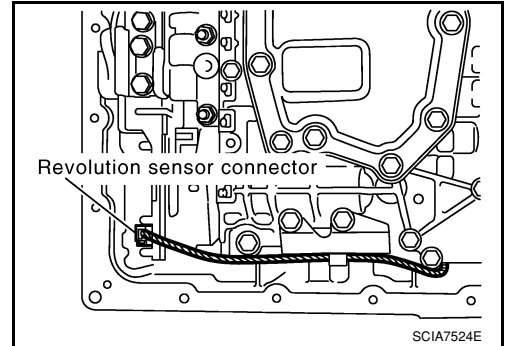

14. Securely fasten revolution sensor harness with terminal clip.

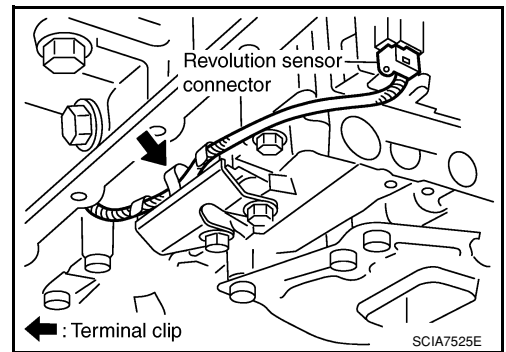

15. Install oil pan to transmission case. Refer to [TM-215, "Oil Pan"](#).
16. Pull up A/T assembly harness connector.
CAUTION:
Do not damage connector.

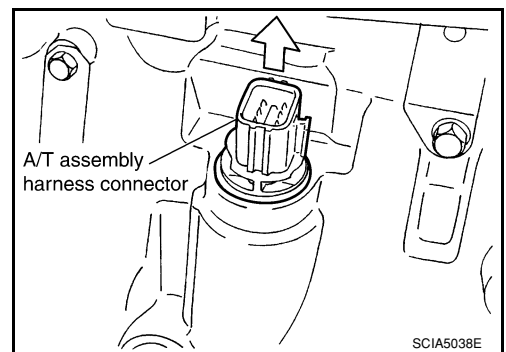

A
B
C
TM
E
F
G
H
I
J
K
L
M
N
O
P

CONTROL VALVE WITH TCM

< ON-VEHICLE REPAIR >

17. Install snap ring to A/T assembly harness connector.
18. Connect A/T assembly harness connector.
19. Connect the negative battery terminal.
20. Refill the A/T with fluid and check the fluid level and for fluid leakage. Refer to [TM-190, "Checking the A/T Fluid \(ATF\)"](#).

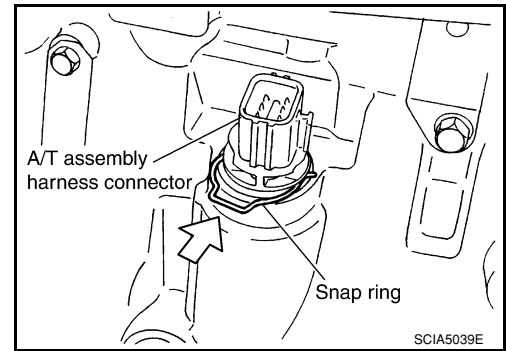

REMOVAL AND INSTALLATION OF A/T FLUID TEMPERATURE SENSOR 2

Removal

1. Disconnect negative battery terminal.
2. Remove oil pan and oil pan gasket. Refer to [TM-215, "Oil Pan"](#).
3. Disconnect A/T fluid temperature sensor 2 connector (A).

CAUTION:
Do not damage connector.

4. Straighten terminal clip ➡ to free A/T fluid temperature sensor 2 harness.

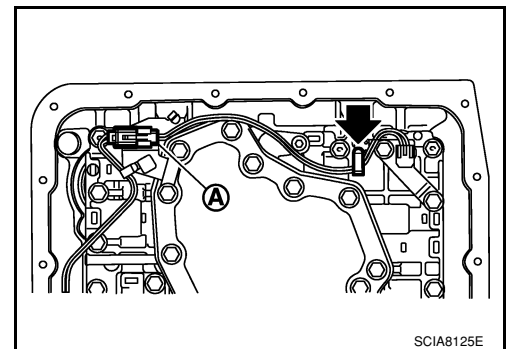

5. Remove A/T fluid temperature sensor 2 with bracket from control valve with TCM.

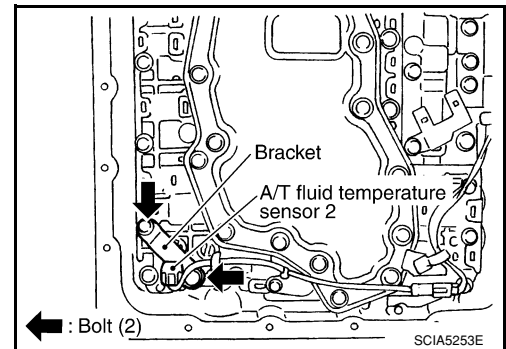

6. Remove bracket from A/T fluid temperature sensor 2.

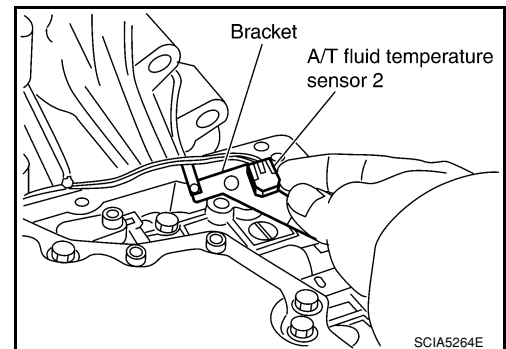

Installation

CAUTION:

After completing installation, check A/T fluid leakage and fluid level. Refer to [TM-190, "Checking the A/T Fluid \(ATF\)"](#).

CONTROL VALVE WITH TCM

< ON-VEHICLE REPAIR >

1. Install A/T fluid temperature sensor 2 to bracket.

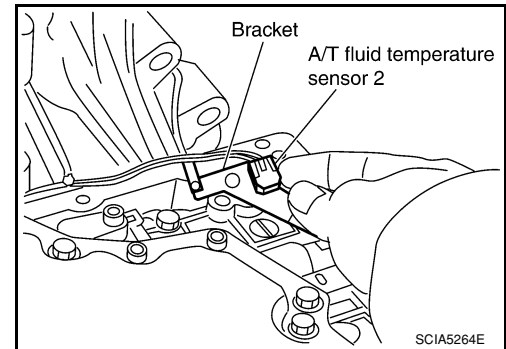

2. Install A/T fluid temperature sensor 2 (with bracket) in control valve with TCM. Tighten A/T fluid temperature sensor 2 bolt to the specified torque. Refer to "COMPONENTS".

CAUTION:

Adjust bolt hole of bracket to bolt hole of control valve with TCM.

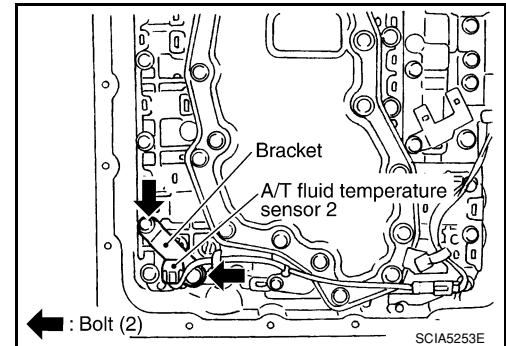

3. Connect A/T fluid temperature sensor 2 connector (A).
4. Securely fasten A/T fluid temperature sensor 2 harness with terminal clip ➡.

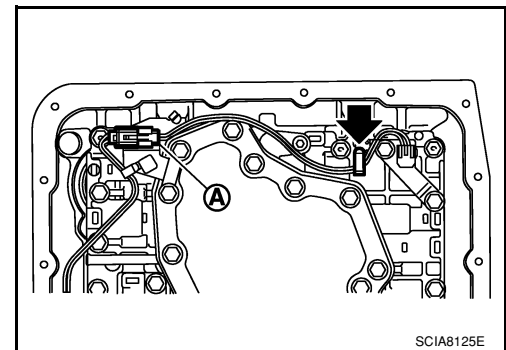

5. Install oil pan to transmission case. Refer to [TM-215, "Oil Pan"](#).
6. Connect the negative battery terminal.
7. Refill the A/T with fluid and check the fluid level and for fluid leakage. Refer to [TM-190, "Checking the A/T Fluid \(ATF\)"](#).

REAR OIL SEAL

< ON-VEHICLE REPAIR >

REAR OIL SEAL

Rear Oil Seal

INFOID:000000001542651

REMOVAL AND INSTALLATION

Removal

1. Remove rear propeller shaft. Refer to [DLN-190. "Removal and Installation"](#).
2. Remove transfer from transmission (4WD models). Refer to [TM-229. "Removal and Installation \(4WD\)"](#).
3. Remove rear oil seal using suitable tool.

CAUTION:

Do not scratch rear extension assembly (2WD models) or adapter case assembly (4WD models).

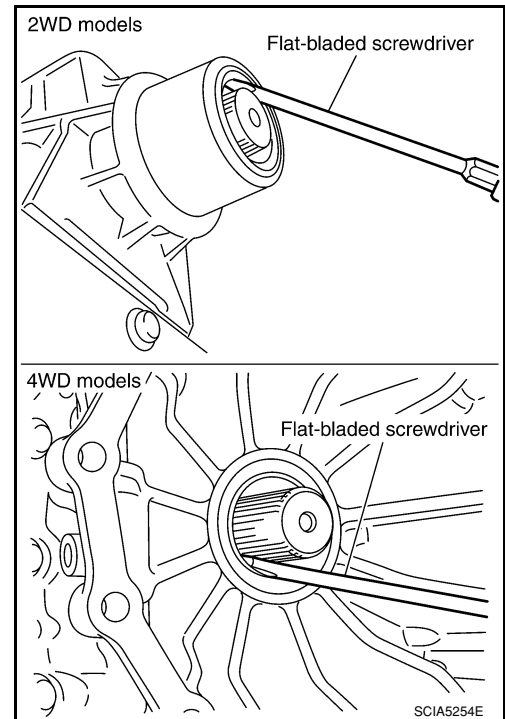

Installation

1. Install new rear oil seal until it is flush into the rear extension case (2WD models) using Tool or adapter case (4WD models) using suitable tool.

Tool number : ST33400001 (J-26082)

CAUTION:

- Apply ATF to rear oil seal.
- Do not reuse rear oil seal.

2. Install transfer to transmission (4WD models). Refer to [TM-229. "Removal and Installation \(4WD\)"](#).
3. Install rear propeller shaft. Refer to [DLN-190. "Removal and Installation"](#).
4. Check the A/T fluid level and for fluid leakage. Refer to [TM-190. "Checking the A/T Fluid \(ATF\)"](#).

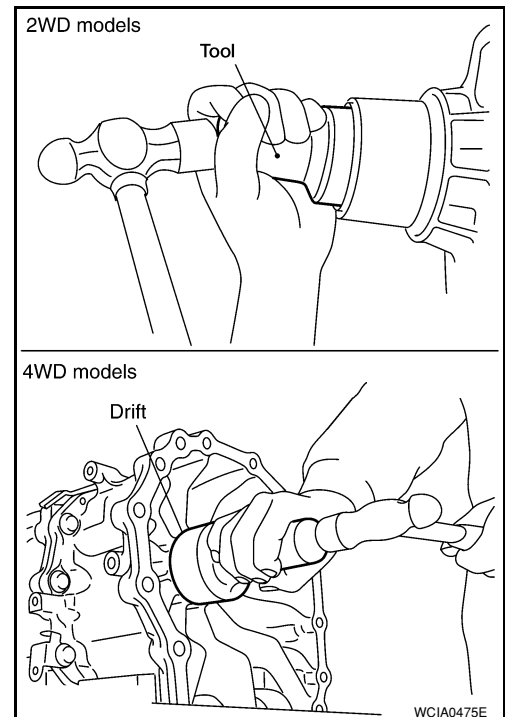

TRANSMISSION ASSEMBLY

< REMOVAL AND INSTALLATION >

REMOVAL AND INSTALLATION

TRANSMISSION ASSEMBLY

Removal and Installation (2WD)

INFOID:000000001546697

COMPONENTS

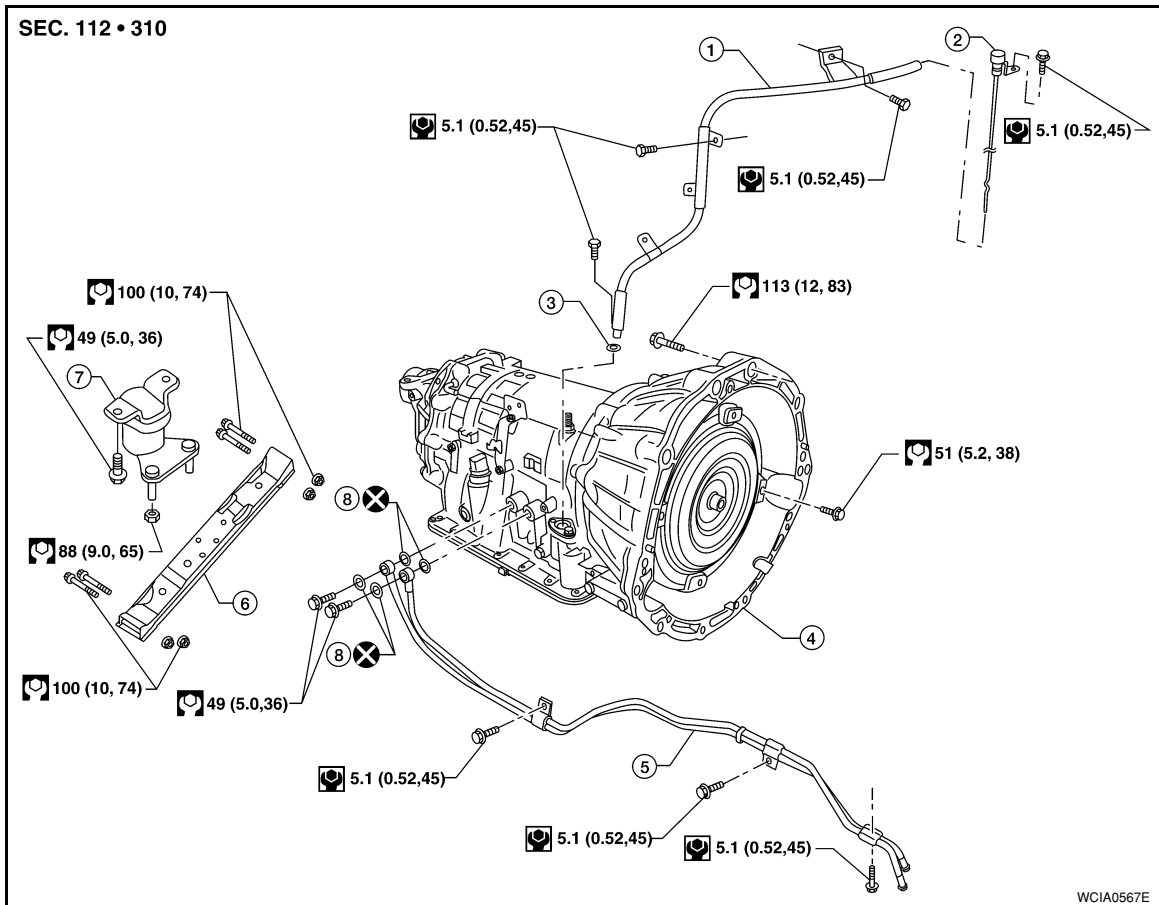

- | | | |
|-----------------------------|------------------------|---------------------|
| 1. A/T fluid indicator pipe | 2. A/T fluid indicator | 3. O-ring |
| 4. Transmission assembly | 5. Fluid cooler tube | 6. A/T cross member |
| 7. Insulator | 8. Copper washers | |

REMOVAL

CAUTION:

When removing the A/T assembly from engine, first remove the crankshaft position sensor (POS) from the A/T assembly.

Be careful not to damage sensor edge.

1. Disconnect the negative battery terminal.
2. Remove engine cover.
3. Remove A/T fluid indicator gauge.
4. Remove undercovers using power tool.
5. Remove exhaust front tube and center muffler using power tool. Refer to [EX-6, "Removal and Installation"](#).
6. Remove rear propeller shaft. Refer to [DLN-190, "Removal and Installation"](#).
7. Remove A/T control cable. Refer to [TM-208, "Control Device Removal and Installation"](#).

TRANSMISSION ASSEMBLY

< REMOVAL AND INSTALLATION >

8. Remove crankshaft position sensor (POS) from A/T assembly.

CAUTION:

- Do not subject it to impact by dropping or hitting it.
- Do not disassemble.
- Do not allow metal filings or foreign material to get on the sensor front edge magnetic area.
- Do not place in an area affected by magnetism.

9. Remove fluid cooler tube.
10. Remove dust cover from converter housing.

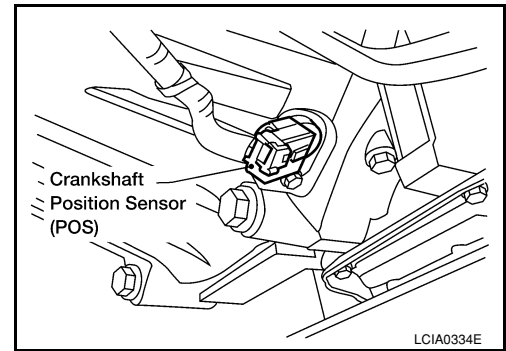

11. Turn crankshaft to access and remove the four bolts for drive plate and torque converter.

CAUTION:

When turning crankshaft, turn it clockwise as viewed from the front of the engine.

12. Support A/T assembly with a transmission jack.

CAUTION:

When setting the transmission jack, be careful not to allow it to collide against the drain plug.

13. Remove cross member using power tool.
14. Remove air breather hose. Refer to [TM-213, "Removal and Installation"](#).
15. Disconnect A/T assembly connector.
16. Remove A/T fluid indicator pipe from A/T assembly.
17. Plug any openings such as the A/T fluid indicator pipe hole.
18. Remove the A/T assembly to engine bolts using power tool.
19. Remove A/T assembly from vehicle using transmission jack.

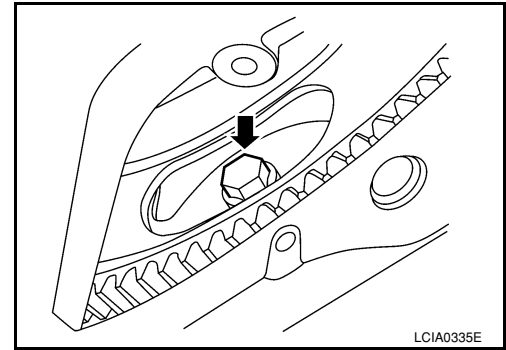

CAUTION:

- Secure torque converter to prevent it from dropping.
- Secure A/T assembly to a transmission jack.

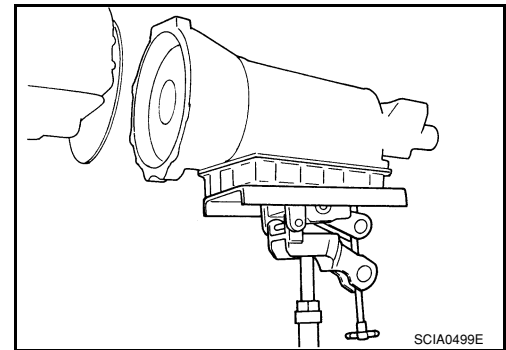

INSPECTION

Installation and Inspection of Torque Converter

- After inserting a torque converter to a transmission, be sure to check dimension A to ensure it is within specifications.

Dimension A : 24.0 mm (0.94 in) or more

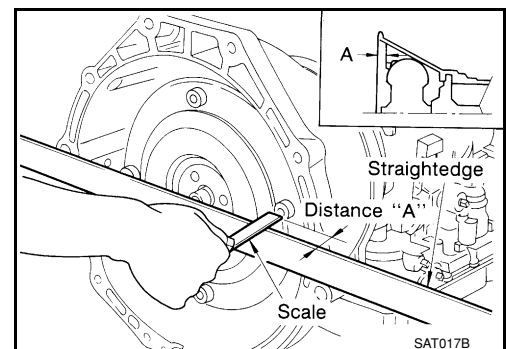

INSTALLATION

Installation of the remaining components is in the reverse order of the removal, while paying attention to the following:

TRANSMISSION ASSEMBLY

< REMOVAL AND INSTALLATION >

- When installing transmission to the engine, attach the bolts in the order as shown.

Transmission to engine bolts : 113 N·m (12 kg-m, 83 ft-lb)

CAUTION:

- When replacing an engine or transmission you must make sure the dowels are installed correctly during re-assembly.
- Improper alignment caused by missing dowels may cause vibration, oil leaks or breakage of drivetrain components.

NOTE:

- *: No.2 bolt also secures air breather vent.

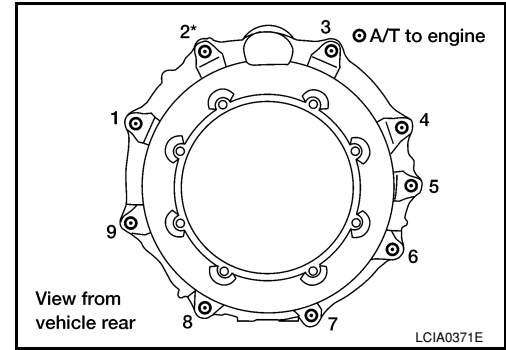

CAUTION:

- When turning crankshaft, turn it clockwise as viewed from the front of the engine.
- After converter is installed to drive plate, rotate crankshaft several turns and check to be sure that transmission rotates freely without binding.

NOTE:

- Align the positions of bolts for drive plate with those of the torque converter, and temporarily tighten the bolts. Then tighten the bolts with the specified torque.
- Install crankshaft position sensor (POS).
- After completing installation check fluid leakage, fluid level and the positions of A/T. Refer to [TM-190. "Checking the A/T Fluid \(ATF\)"](#), [TM-209. "Checking of A/T Position"](#) and [TM-209. "Adjustment of A/T Position"](#).

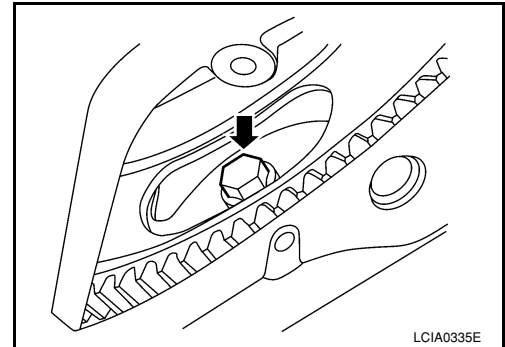

Removal and Installation (4WD)

COMPONENTS

TRANSMISSION ASSEMBLY

< REMOVAL AND INSTALLATION >

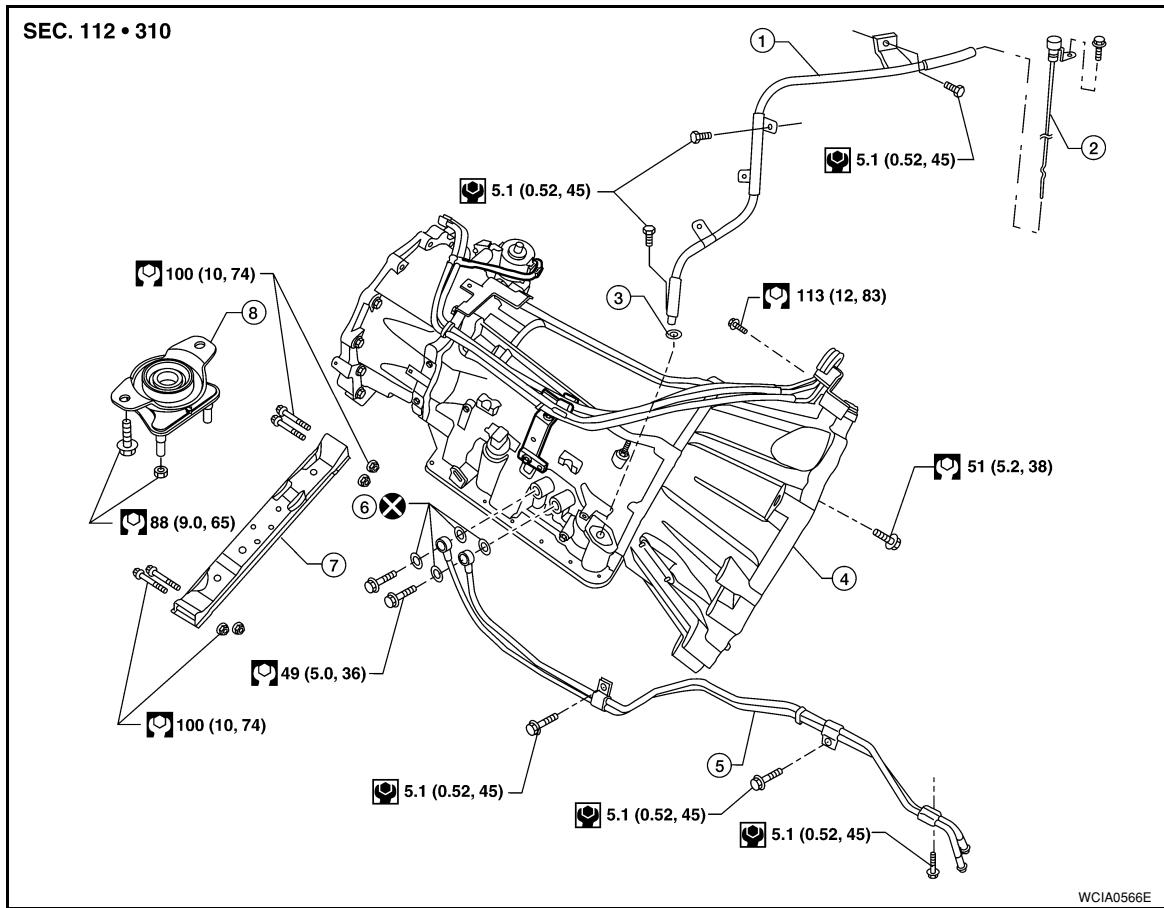

- | | | |
|-----------------------------|------------------------|------------------|
| 1. A/T fluid indicator pipe | 2. A/T fluid indicator | 3. O-ring |
| 4. Transmission assembly | 5. Fluid cooler tube | 6. Copper washer |
| 7. A/T cross member | 8. Insulator | |

REMOVAL

CAUTION:

When removing the A/T assembly from engine, first remove the crankshaft position sensor (POS) from the A/T assembly.

Be careful not to damage sensor edge.

1. Disconnect the negative battery terminal.
2. Remove engine cover using power tool.
3. Remove A/T fluid indicator.
4. Remove undercovers using power tool.
5. Remove exhaust front tube and center muffler using power tool. Refer to [EX-6. "Removal and Installation"](#).
6. Remove propeller shafts. Refer to [DLN-182. "Removal and Installation"](#) and [DLN-190. "Removal and Installation"](#).
7. Remove A/T control cable. Refer to [TM-208. "Control Device Removal and Installation"](#).

TRANSMISSION ASSEMBLY

< REMOVAL AND INSTALLATION >

8. Remove crankshaft position sensor (POS) from A/T assembly.

CAUTION:

- Do not subject it to impact by dropping or hitting it.
- Do not disassemble.
- Do not allow metal filings or foreign material to get on the sensor's front edge magnetic area.
- Do not place in an area affected by magnetism.

9. Disconnect A/T fluid cooler tube from A/T assembly.
10. Remove dust cover from converter housing.

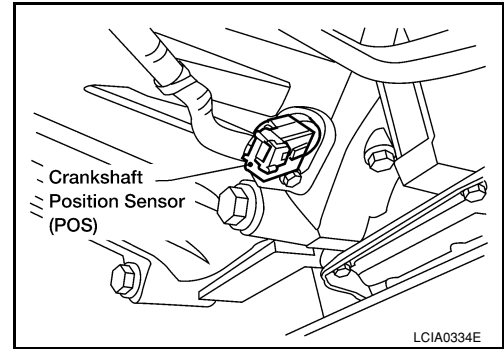

11. Turn crankshaft, and remove the four bolts for drive plate and torque converter.

CAUTION:

When turning crankshaft, turn it clockwise as viewed from the front of the engine.

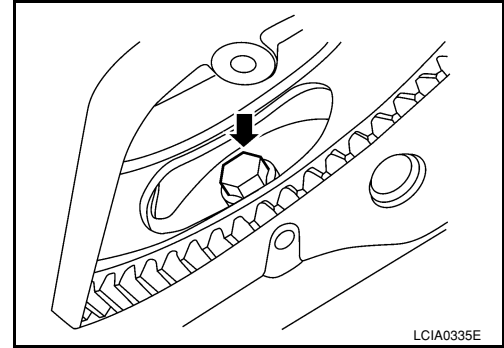

12. Support A/T assembly using transmission jack and Tool.

Tool number : — (J-47002)

CAUTION:

When setting the transmission jack, be careful not to allow it to collide against the drain plug.

NOTE:

The actual special service tool may differ from tool shown.

13. Remove cross member using power tool.
14. Tilt the transmission slightly to keep the clearance between body and transmission, then disconnect air breather hose from A/T fluid indicator pipe. Refer to "REMOVAL".
15. Disconnect A/T assembly connector and transfer unit connector.
16. Remove A/T fluid indicator pipe.
17. Plug any openings such as the fluid charging pipe hole.
18. Remove A/T assembly to engine bolts using power tool.
19. Remove A/T assembly with transfer from vehicle.

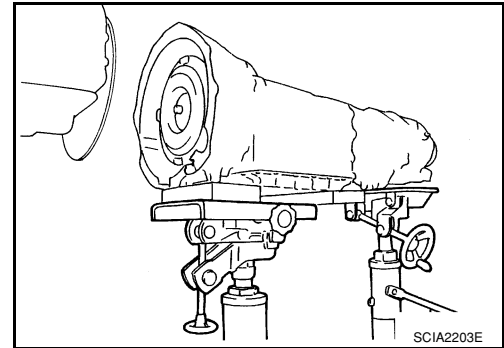

CAUTION:

- Secure torque converter to prevent it from dropping.
- Secure A/T assembly to transmission jack.

20. Remove transfer from A/T assembly. Refer to [DLN-139, "Removal and Installation"](#).

INSPECTION

Installation and Inspection of Torque Converter

A
B
C
TM
E
F
G
H
I
J
K
L
M
N
O
P

TRANSMISSION ASSEMBLY

< REMOVAL AND INSTALLATION >

- After inserting a torque converter to a transmission, be sure to check dimension A to ensure it is within specifications.

Dimension A : 24.0 mm (0.94 in) or more

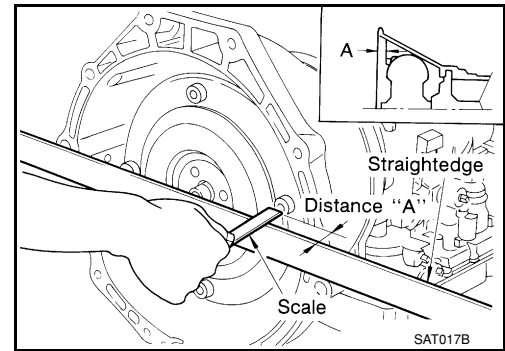

INSTALLATION

Installation of the remaining components is in the reverse order of removal, while paying attention to the following:

- When installing transmission to the engine, attach the bolts as shown.

Transmission to engine bolts : 113 N·m (12 kg-m, 83 ft-lb)

CAUTION:

- When replacing an engine or transmission you must make sure the dowels are installed correctly during re-assembly.
- Improper alignment caused by missing dowels may cause vibration, oil leaks or breakage of drivetrain components.

NOTE:

*: No.2 bolt also secures air breather vent.

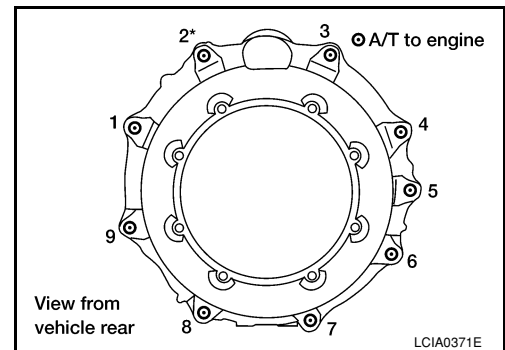

- Align the positions of bolts for drive plate with those of the torque converter, and temporarily tighten the bolts. Then tighten the bolts with the specified torque.

CAUTION:

- When turning crankshaft, turn it clockwise as viewed from the front of the engine.
- After converter is installed to drive plate, rotate crankshaft several turns and check to be sure that transmission rotates freely without binding.
- Install crankshaft position sensor (POS).
- After completing installation, check fluid leakage, fluid level, and the positions of A/T. Refer to [TM-190, "Checking the A/T Fluid \(ATF\)"](#), [TM-209, "Checking of A/T Position"](#) and [TM-209, "Adjustment of A/T Position"](#).

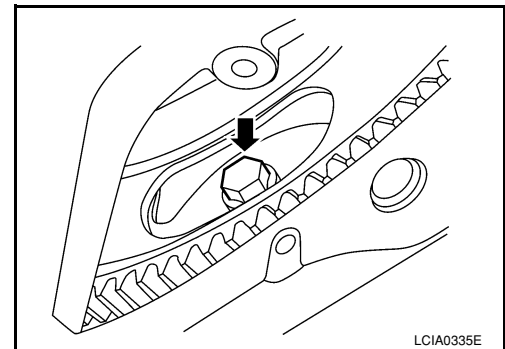

OVERHAUL

< DISASSEMBLY AND ASSEMBLY >

DISASSEMBLY AND ASSEMBLY

OVERHAUL

Component

INFOID:000000001547080

SEC.311•313•314•315

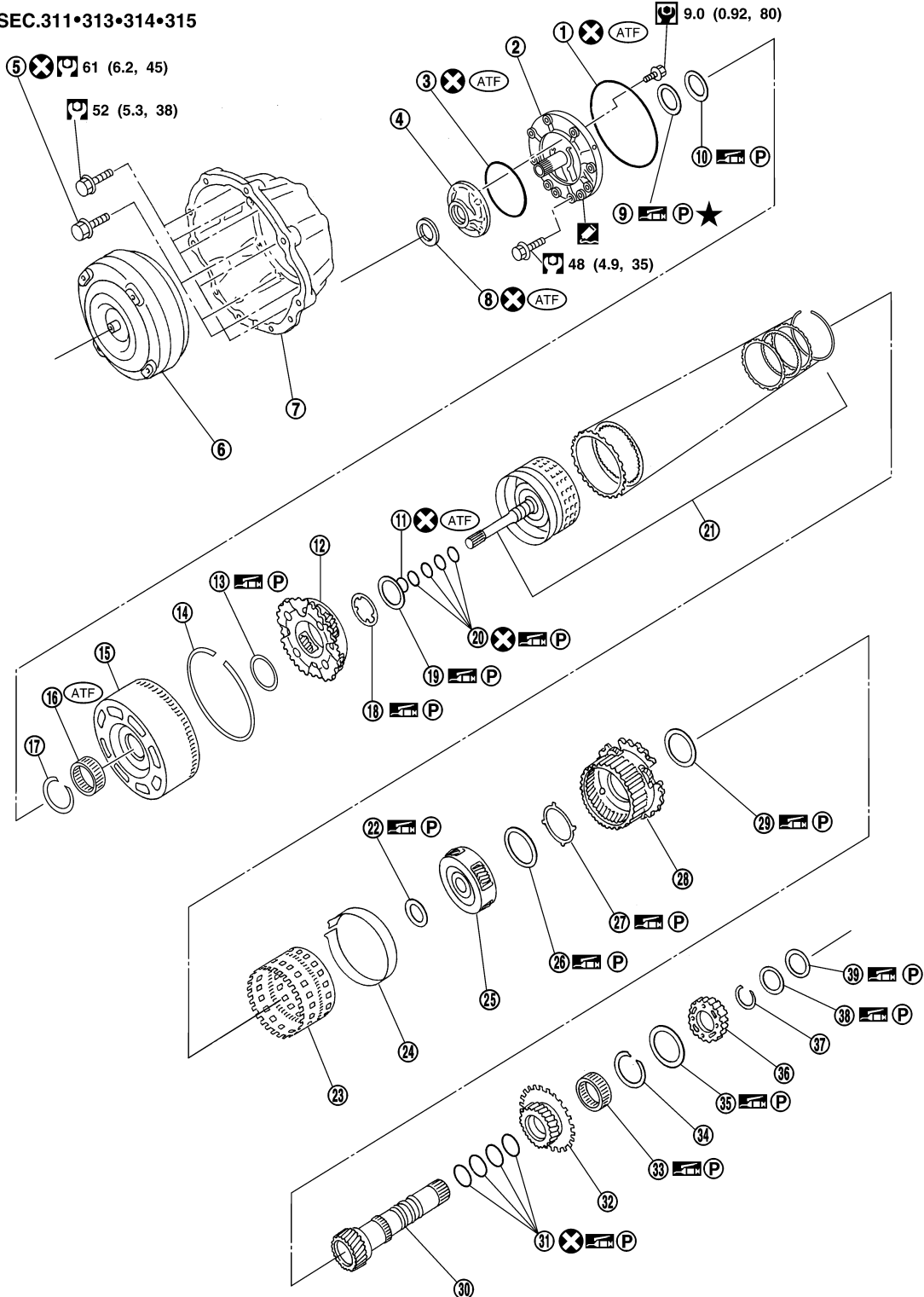

A
B
C
TM
E
F
G
H
I
J
K
L
M
N
O
P

WCIA0661E

OVERHAUL

< DISASSEMBLY AND ASSEMBLY >

- | | | |
|---------------------------|------------------------------|-------------------------------------|
| 1. O-ring | 2. Oil pump cover | 3. O-ring |
| 4. Oil pump housing | 5. Self-sealing bolts | 6. Torque converter |
| 7. Converter housing | 8. Oil pump housing oil seal | 9. Bearing race |
| 10. Needle bearing | 11. O-ring | 12. Front carrier assembly |
| 13. Needle bearing | 14. Snap ring | 15. Front sun gear |
| 16. 3rd one-way clutch | 17. Snap ring | 18. Bearing race |
| 19. Needle bearing | 20. Seal ring | 21. Input clutch assembly |
| 22. Needle bearing | 23. Rear internal gear | 24. Brake band |
| 25. Mid carrier assembly | 26. Needle bearing | 27. Bearing race |
| 28. Rear carrier assembly | 29. Needle bearing | 30. Mid sun gear |
| 31. Seal ring | 32. Rear sun gear | 33. 1st one-way clutch |
| 34. Snap ring | 35. Needle bearing | 36. High and low reverse clutch hub |
| 37. Snap ring | 38. Bearing race | 39. Needle bearing |

OVERHAUL

< DISASSEMBLY AND ASSEMBLY >

SEC.315•316

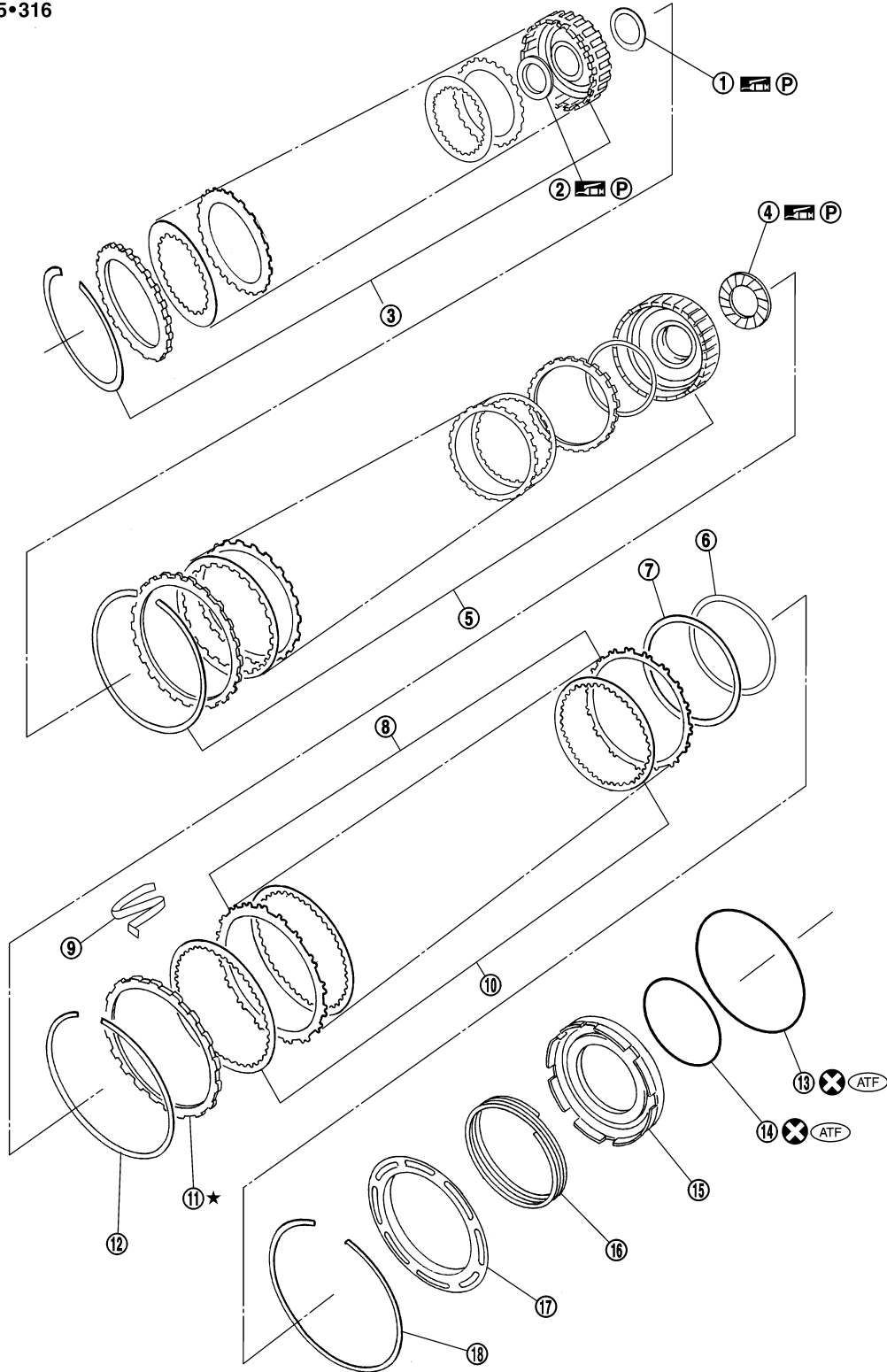

- | | | |
|-------------------------------|-----------------------------------|---|
| 1. Needle bearing | 2. Bearing race | 3. High and low reverse clutch assembly |
| 4. Needle bearing | 5. Direct clutch assembly | 6. Reverse brake dish plate |
| 7. Reverse brake dish plate | 8. Reverse brake driven plate | 9. N-spring |
| 10. Reverse brake drive plate | 11. Reverse brake retaining plate | 12. Snap ring |
| 13. D-ring | 14. D-ring | 15. Reverse brake piston |
| 16. Return spring | 17. Spring retainer | 18. Snap ring |

SCIA7001E

OVERHAUL

< DISASSEMBLY AND ASSEMBLY >

VK56DE models for 2WD

SEC.313 · 314 · 315 · 316 · 317 · 319

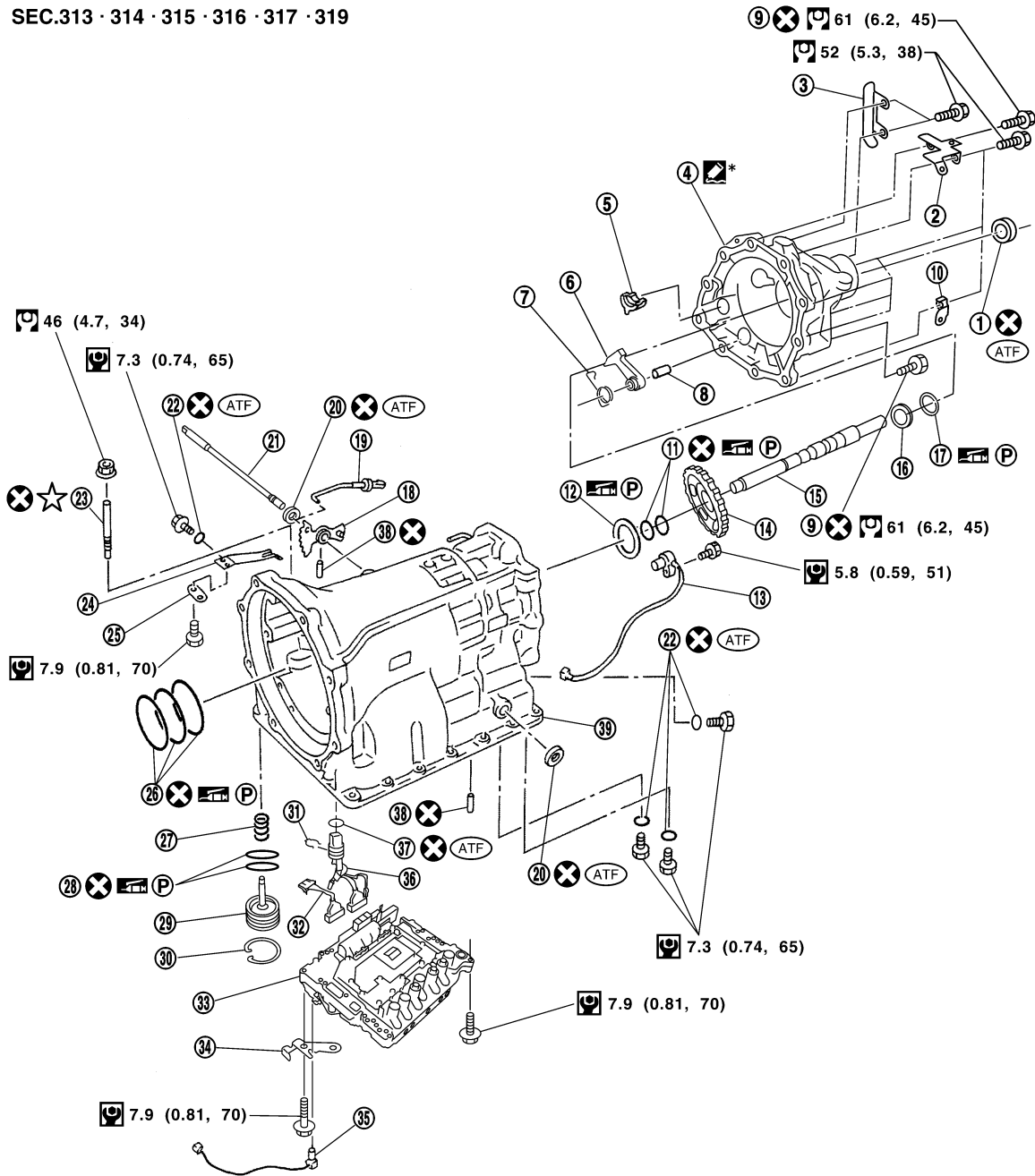

AWDIA0027GB

- | | | |
|-----------------------|-----------------------------|----------------------|
| 1. Rear oil seal | 2. Bracket | 3. Bracket |
| 4. Adapter case | 5. Parking actuator support | 6. Parking pawl |
| 7. Return spring | 8. Pawl shaft | 9. Self-sealing bolt |
| 10. Seal ring | 11. Needle bearing | 12. Gasket |
| 13. Revolution sensor | 14. Parking gear | 15. Output shaft |

OVERHAUL

< DISASSEMBLY AND ASSEMBLY >

- | | | | |
|-------------------|------------------------------------|----------------------------|---|
| 16. Bearing race | 17. Needle bearing | 18. Manual plate | |
| 19. Parking rod | 20. Manual shaft oil seal | 21. Manual shaft | A |
| 22. O-ring | 23. Band servo anchor end pin | 24. Detent spring | |
| 25. Spacer | 26. Seal ring | 27. Snap ring | B |
| 28. Return spring | 29. O-ring | 30. Servo assembly | |
| 31. Snap ring | 32. Sub-harness | 33. Control valve with TCM | |
| 34. Bracket | 35. A/T fluid temperature sensor 2 | 36. Terminal cord assembly | C |
| 37. O-ring | 38. Retaining pin | 39. Transmission case | |

*: Apply Genuine Anaerobic Liquid Gasket or equivalent.
Refer to [GI-15. "Recommended Chemical Products and Sealants"](#).

VK56DE models for 4WD

TM

E

F

G

H

I

J

K

L

M

N

O

P

OVERHAUL

< DISASSEMBLY AND ASSEMBLY >

SEC.313 · 314 · 315 · 316 · 317 · 319

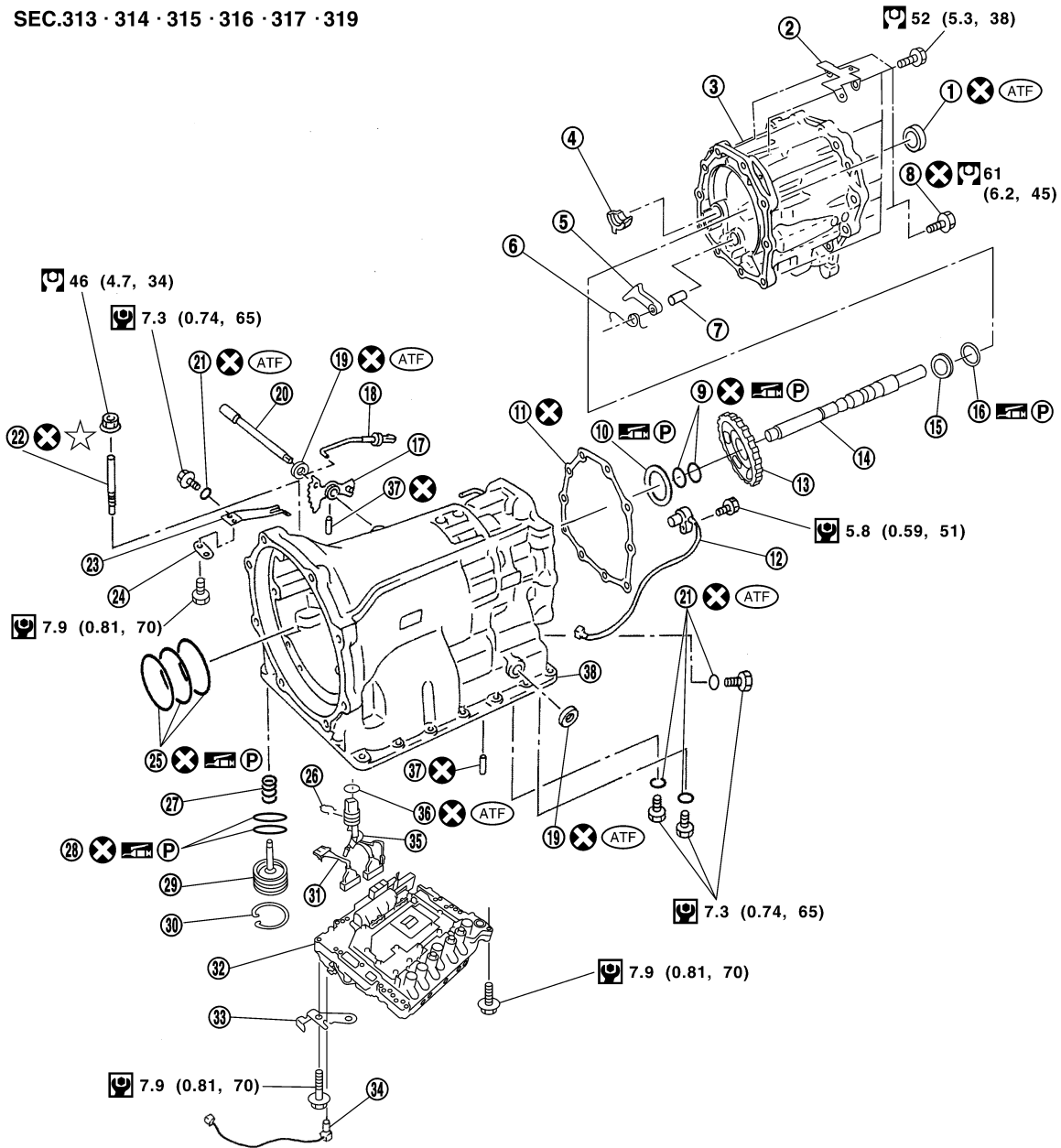

- | | | |
|-----------------------------|----------------------|-----------------------|
| 1. Rear oil seal | 2. Bracket | 3. Adapter case |
| 4. Parking actuator support | 5. Parking pawl | 6. Return spring |
| 7. Pawl shaft | 8. Self-sealing bolt | 9. Seal ring |
| 10. Needle bearing | 11. Gasket | 12. Revolution sensor |
| 13. Parking gear | 14. Output shaft | 15. Bearing race |
| 16. Needle bearing | 17. Manual plate | 18. Parking rod |

AWDIA0026GB

OVERHAUL

< DISASSEMBLY AND ASSEMBLY >

- | | | |
|------------------------------------|----------------------------|-------------------|
| 19. Manual shaft oil seal | 20. Manual shaft | 21. O-ring |
| 22. Band servo anchor end pin | 23. Detent spring | 24. Spacer |
| 25. Seal ring | 26. Snap ring | 27. Return spring |
| 28. O-ring | 29. Servo assembly | 30. Snap ring |
| 31. Sub-harness | 32. Control valve with TCM | 33. Bracket |
| 34. A/T fluid temperature sensor 2 | 35. Terminal cord assembly | 36. O-ring |
| 37. Retaining pin | 38. Transmission case | |

A

B

C

TM

E

F

G

H

I

J

K

L

M

N

O

P

OVERHAUL

< DISASSEMBLY AND ASSEMBLY >

Oil Channel

INFOID:000000001547081

2WD models

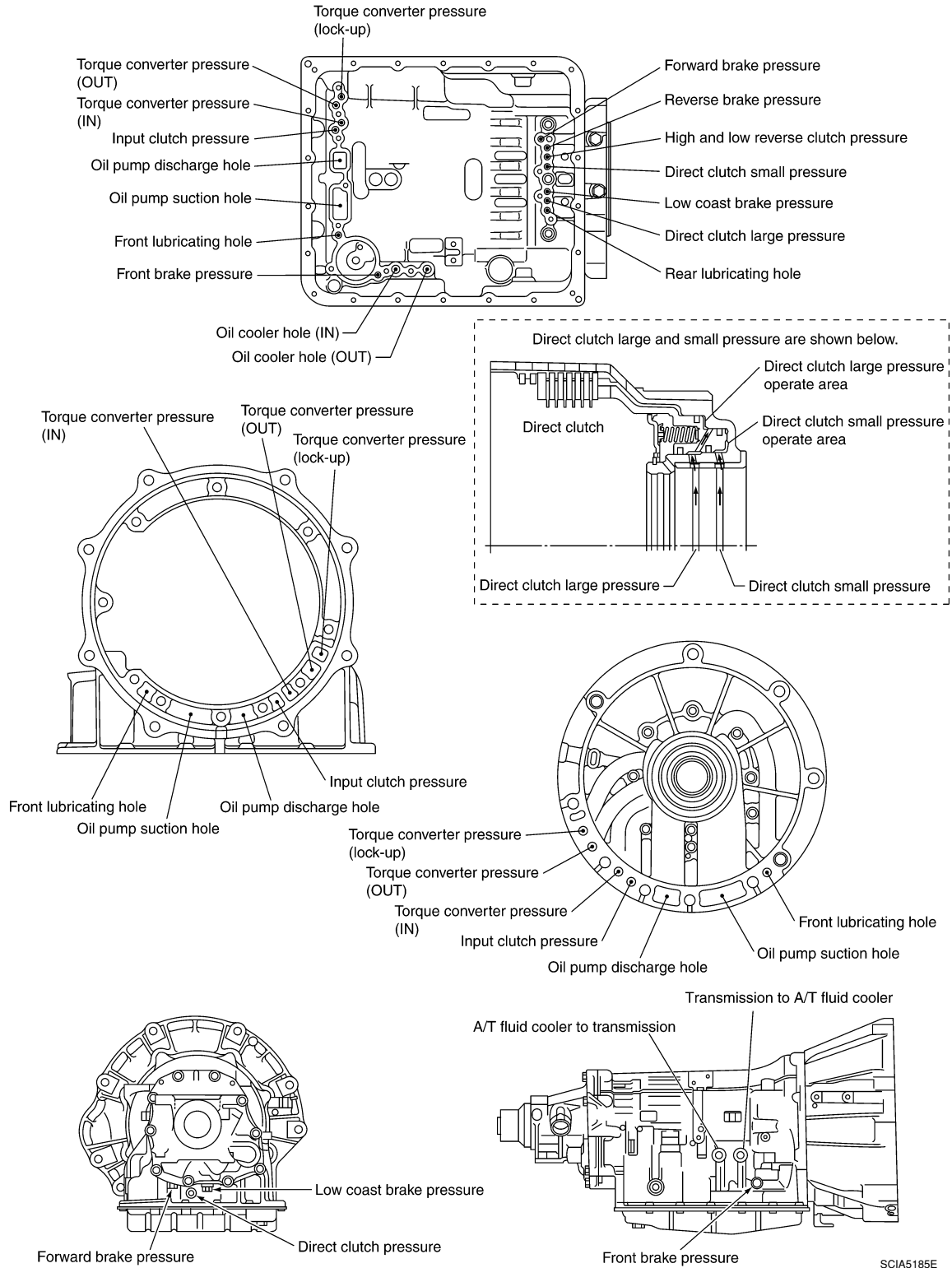

SCIA5185E

OVERHAUL

< DISASSEMBLY AND ASSEMBLY >

4WD models

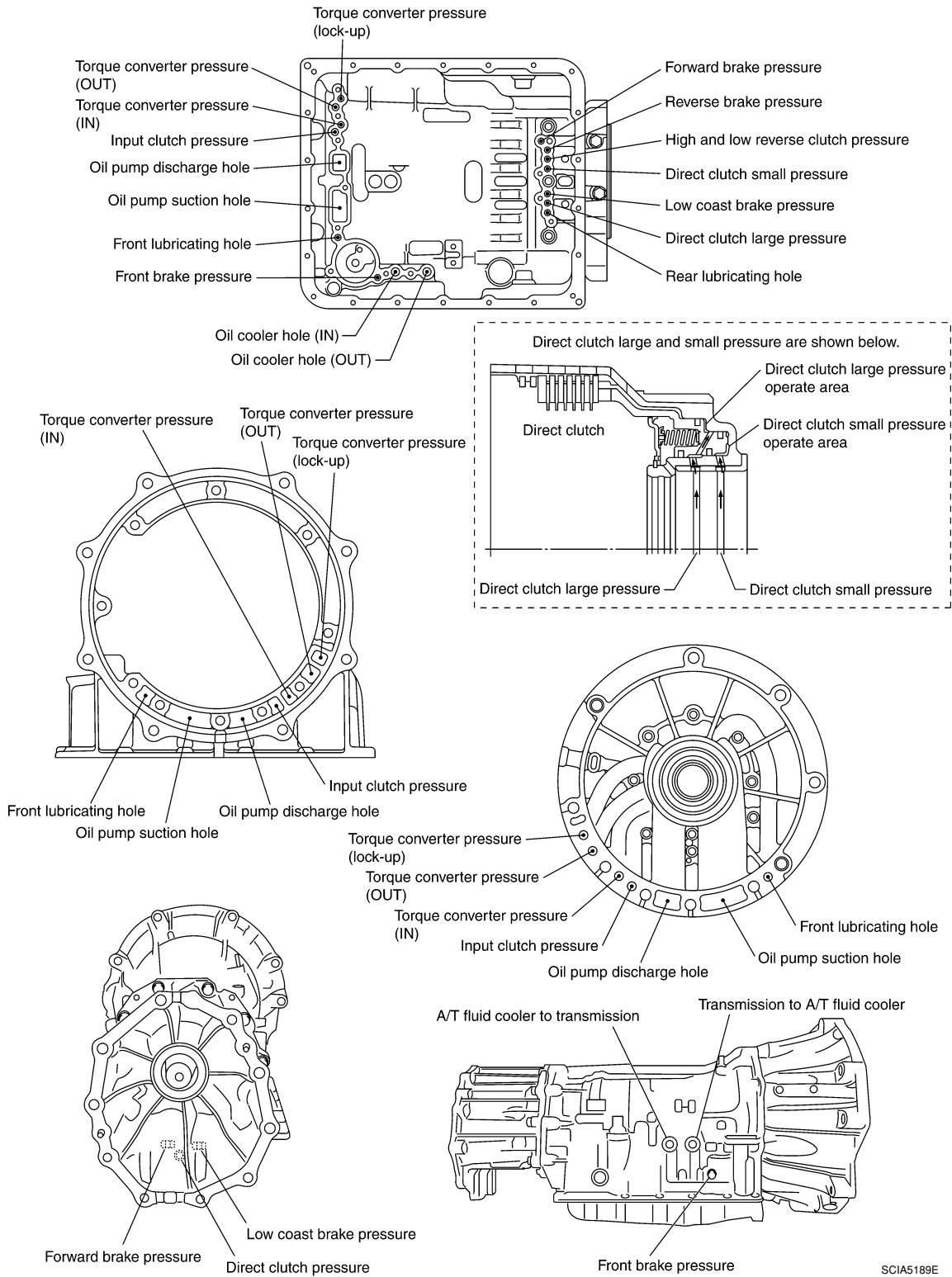

A

B

C

TM

E

F

G

H

I

J

K

L

M

N

O

P

OVERHAUL

< DISASSEMBLY AND ASSEMBLY >

Location of Adjusting Shims, Needle Bearings, Thrust Washers and Snap Rings

INFOID:000000001547082

VK56DE models 2WD

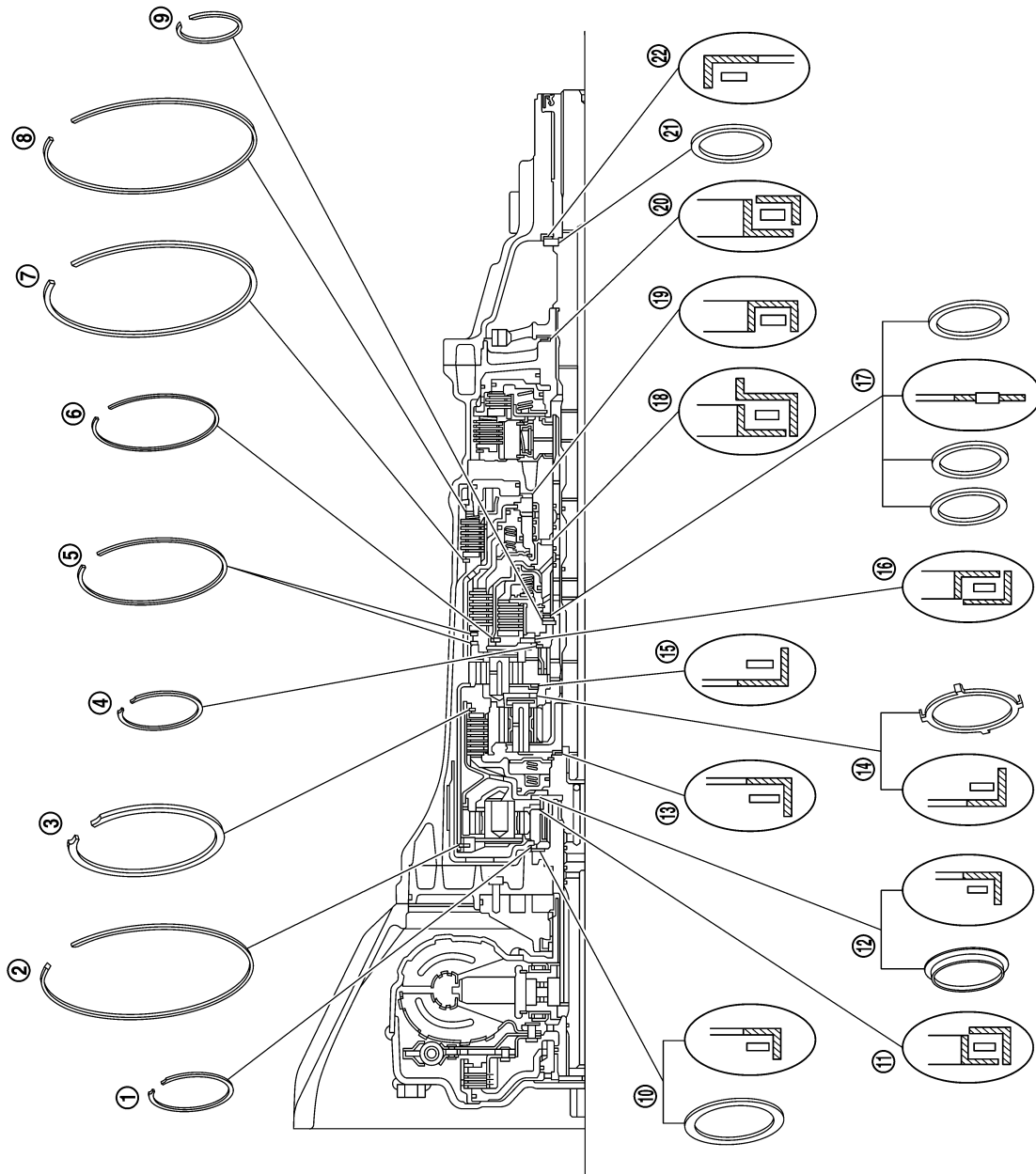

WCIA0560E

- | | | |
|------------------------------------|------------------------------------|------------------------------------|
| 1. Outer diameter 68 mm (2.68 in) | 2. Outer diameter 182 mm (7.17 in) | 3. Outer diameter 172 mm (6.77 in) |
| 4. Outer diameter 71 mm (2.80 in) | 5. Outer diameter 169 mm (6.65 in) | 6. Outer diameter 134 mm (5.28 in) |
| 7. Outer diameter 181 mm (7.13 in) | 8. Outer diameter 181 mm (7.13 in) | 9. Outer diameter 48 mm (1.89 in) |

OVERHAUL

< DISASSEMBLY AND ASSEMBLY >

- | | | |
|------------------------------------|------------------------------------|------------------------------------|
| 10. Outer diameter 80 mm (3.15 in) | 11. Outer diameter 77 mm (3.03 in) | 12. Outer diameter 77 mm (3.03 in) |
| 13. Outer diameter 47 mm (1.85 in) | 14. Outer diameter 84 mm (3.31 in) | 15. Outer diameter 84 mm (3.31 in) |
| 16. Outer diameter 92 mm (3.62 in) | 17. Outer diameter 60 mm (2.36 in) | 18. Outer diameter 63 mm (2.48 in) |
| 19. Outer diameter 92 mm (3.62 in) | 20. Outer diameter 65 mm (2.56 in) | 21. Bearing race |
| 22. Outer diameter 60 mm (2.36 in) | | |

VK56DE models 4WD

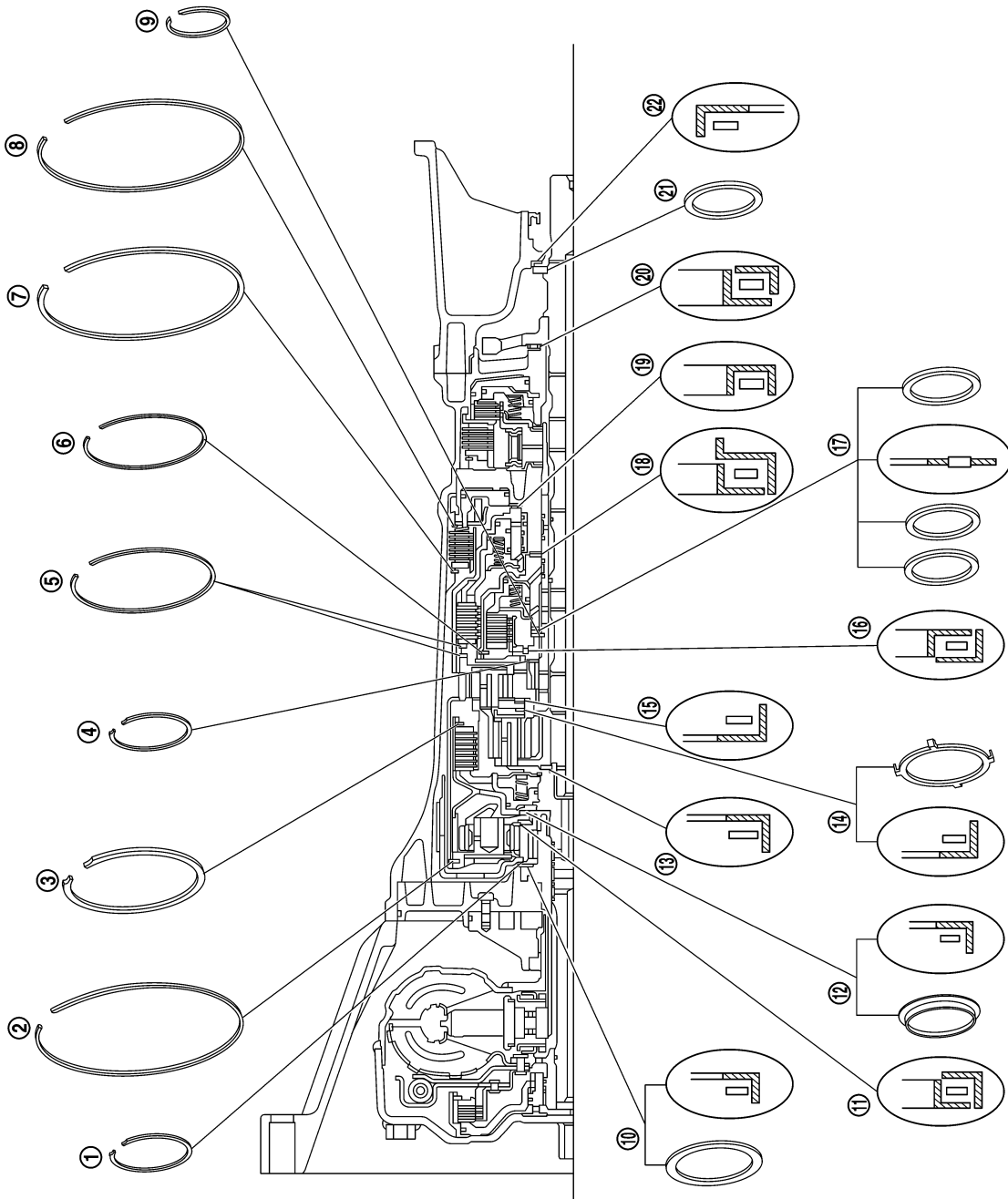

A
B
C
TM
E
F
G
H
I
J
K
L
M
N
O
P

OVERHAUL

< DISASSEMBLY AND ASSEMBLY >

1. Outer diameter 68 mm (2.68 in)
2. Outer diameter 182 mm (7.17 in)
3. Outer diameter 172 mm (6.77 in)
4. Outer diameter 71 mm (2.80 in)
5. Outer diameter 169 mm (6.65 in)
6. Outer diameter 134 mm (5.28 in)
7. Outer diameter 181 mm (7.13 in)
8. Outer diameter 181 mm (7.13 in)
9. Outer diameter 48 mm (1.89 in)
10. Outer diameter 80 mm (3.15 in)
11. Outer diameter 77 mm (3.03 in)
12. Outer diameter 77 mm (3.03 in)
13. Outer diameter 47 mm (1.85 in)
14. Outer diameter 84 mm (3.31 in)
15. Outer diameter 84 mm (3.31 in)
16. Outer diameter 92 mm (3.62 in)
17. Outer diameter 60 mm (2.36 in)
18. Outer diameter 63 mm (2.48 in)
19. Outer diameter 92 mm (3.62 in)
20. Outer diameter 65 mm (2.56 in)
21. Bearing race
22. Outer diameter 60 mm (2.36 in)

DISASSEMBLY

< DISASSEMBLY AND ASSEMBLY >

DISASSEMBLY

Disassembly

INFOID:000000001547083

CAUTION:

Do not disassemble parts behind Drum Support. Refer to [TM-9, "Cross-Sectional View \(2WD models\)"](#).

1. Drain A/T fluid through drain plug.
2. Remove torque converter by holding it firmly and turing while pulling straight out.

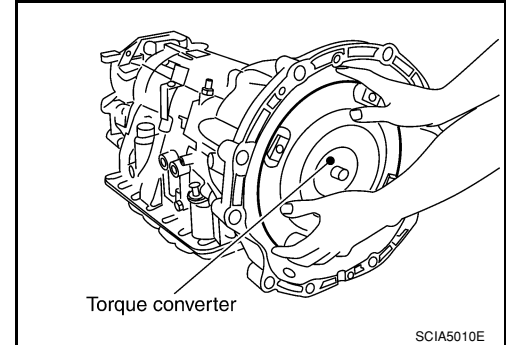

3. Check torque converter one-way clutch using a check tool as shown.
 - a. Insert a check tool into the groove of bearing support built into one-way clutch outer race.
 - b. While holding bearing support with a check tool, rotate one-way clutch spline using suitable tool.
 - c. Make sure that inner race rotates clockwise only. If not, replace torque converter assembly.

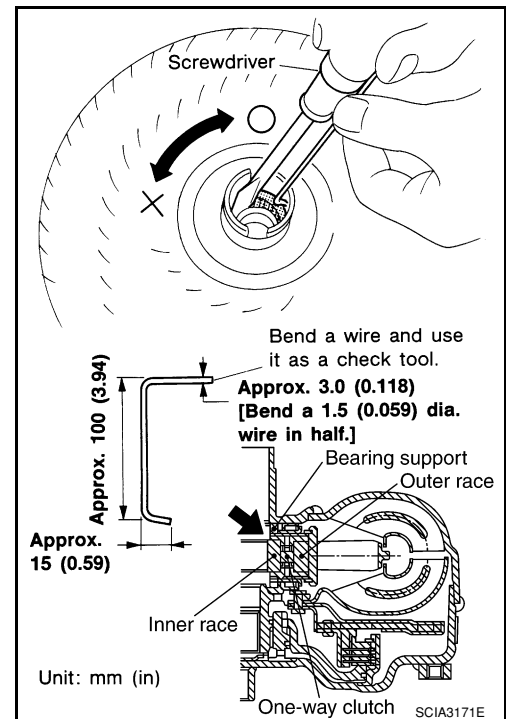

4. Remove bolts and converter housing from transmission case.

CAUTION:

Do not scratch converter housing.

- Self-sealing bolt (A)

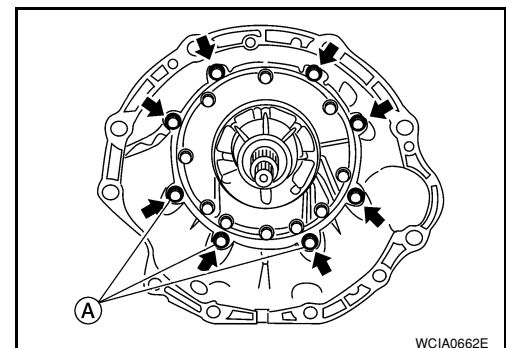

DISASSEMBLY

< DISASSEMBLY AND ASSEMBLY >

5. Remove O-ring from input clutch assembly.

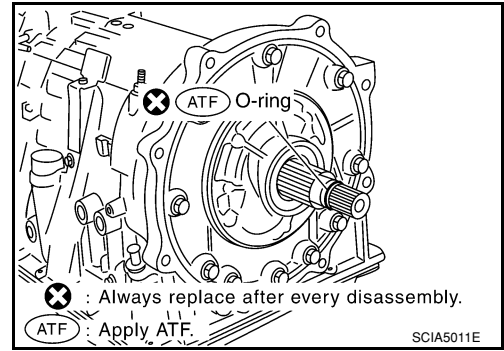

6. Remove oil pump assembly to transmission case bolts.

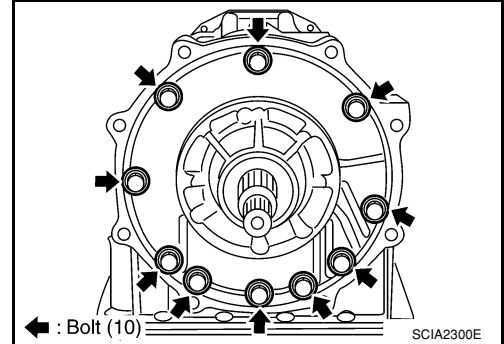

7. Remove the oil pump assembly evenly from the transmission case using Tools.

Tool number : ST25850000 (J-25721-A)

CAUTION:

- Fully tighten the sliding hammer screws.
- Make sure that bearing race is installed to the oil pump assembly edge surface.

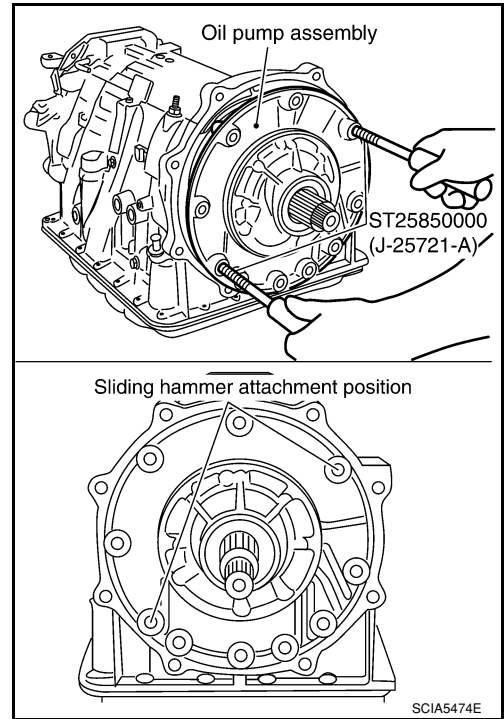

8. Remove O-ring from oil pump assembly.

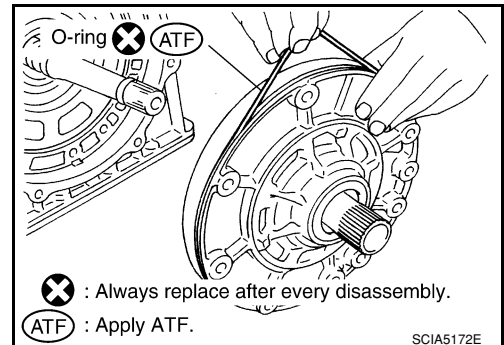

DISASSEMBLY

< DISASSEMBLY AND ASSEMBLY >

9. Remove bearing race from oil pump assembly.

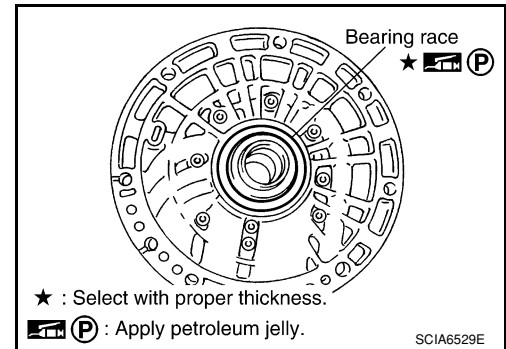

10. Remove needle bearing from front sun gear.

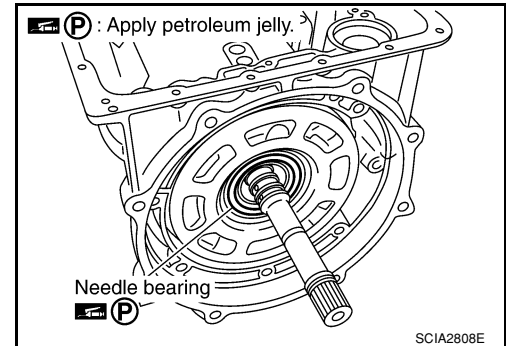

11. Remove front sun gear assembly from front carrier assembly.
NOTE:
Remove front sun gear by rotating it left and right.

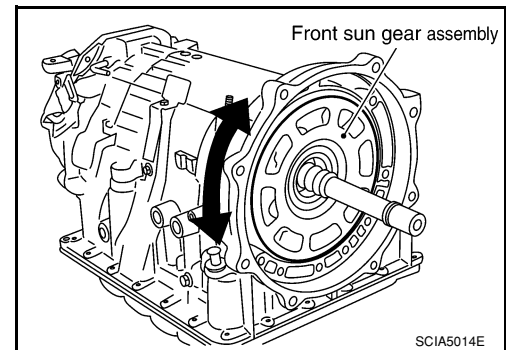

12. Remove seal rings from input clutch assembly.

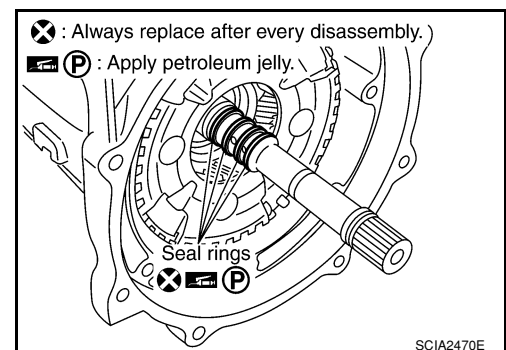

13. Remove front carrier assembly (with input clutch assembly and rear internal gear) from rear carrier assembly.
CAUTION:
Do not remove it with needle bearing.

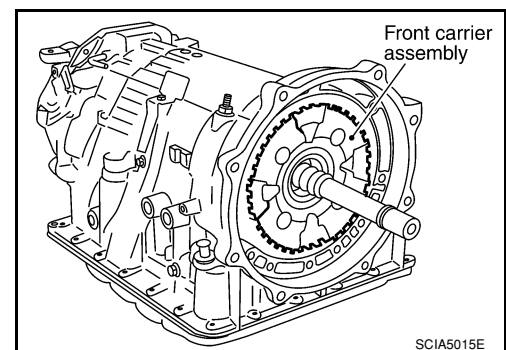

A
B
C
TM
E
F
G
H
I
J
K
L
M
N
O
P

DISASSEMBLY

< DISASSEMBLY AND ASSEMBLY >

14. Loosen lock nut and remove band servo anchor end pin from transmission case.

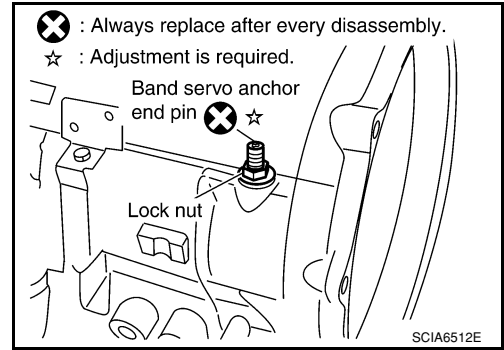

15. Remove brake band from transmission case.

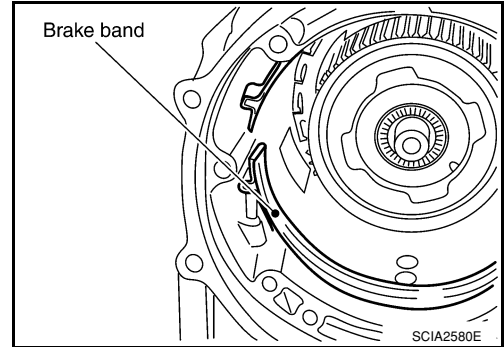

CAUTION:

- To prevent brake linings from cracking or peeling, do not stretch the flexible band unnecessarily. When removing the brake band, always secure it with a clip as shown.
- Check brake band facing for damage, cracks, wear or burns.

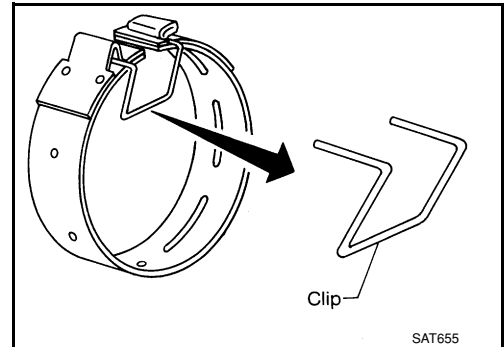

16. Remove mid carrier assembly and rear carrier assembly as a unit.

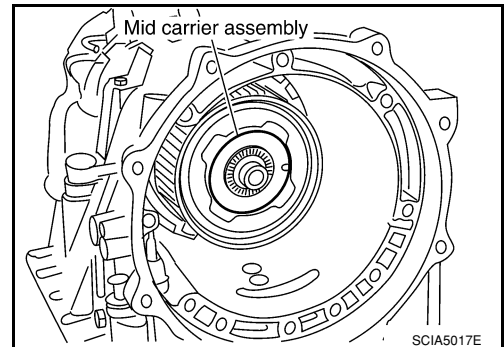

DISASSEMBLY

< DISASSEMBLY AND ASSEMBLY >

17. Remove mid carrier assembly from rear carrier assembly.

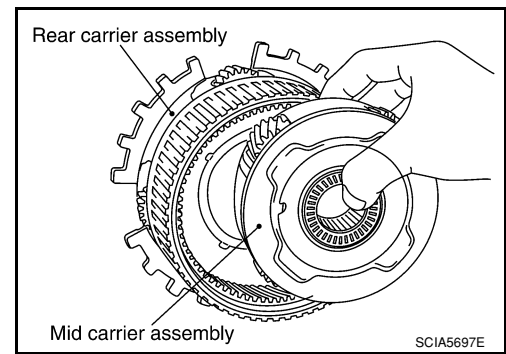

18. Remove needle bearing (front side) from mid carrier assembly.

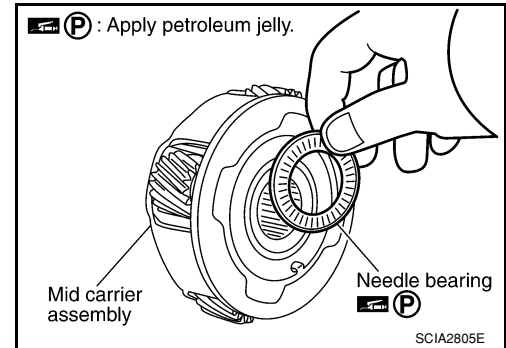

19. Remove needle bearing (rear side) from mid carrier assembly.

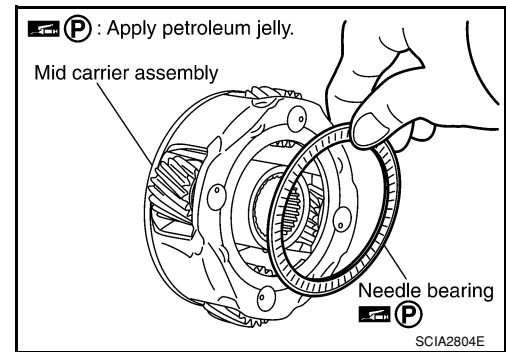

20. Remove bearing race from rear carrier assembly.

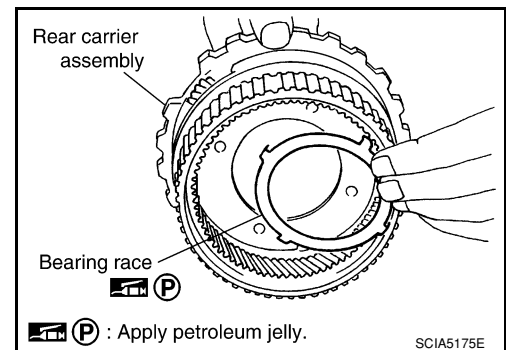

21. Remove needle bearing from rear carrier assembly.

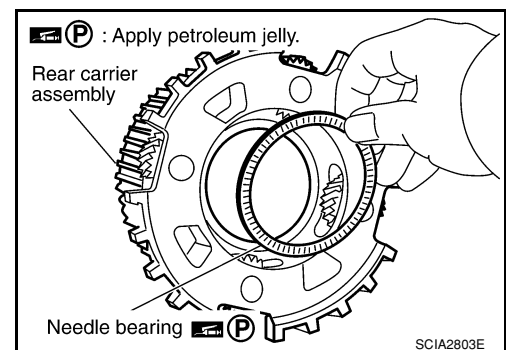

A
B
C
TM
E
F
G
H
I
J
K
L
M
N
O
P

DISASSEMBLY

< DISASSEMBLY AND ASSEMBLY >

22. Remove mid sun gear assembly, rear sun gear assembly and high and low reverse clutch hub as a unit.

CAUTION:

Remove them with bearing race and needle bearing.

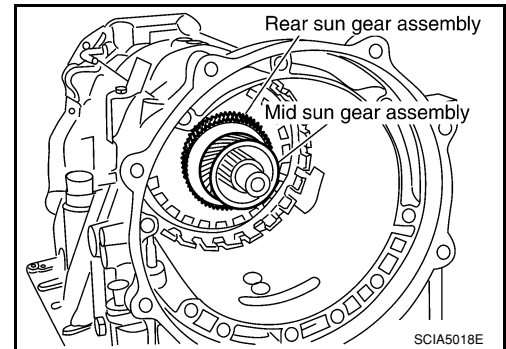

23. Remove high and low reverse clutch assembly from direct clutch assembly.

CAUTION:

Make sure that needle bearing is installed to the high and low reverse clutch assembly edge surface.

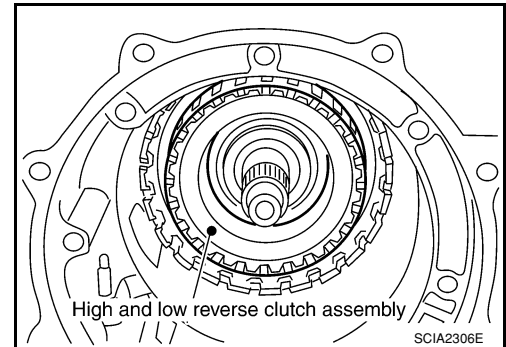

24. Remove needle bearing from drum support.

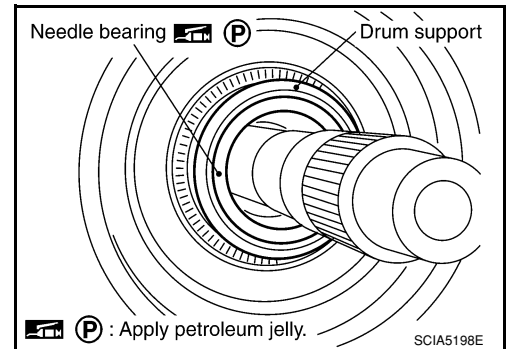

25. Remove direct clutch assembly from reverse brake.

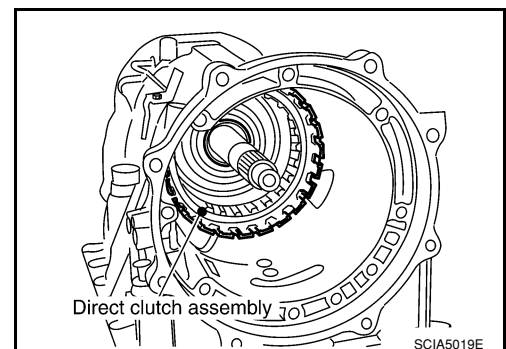

26. Remove snap ring from A/T assembly harness connector.

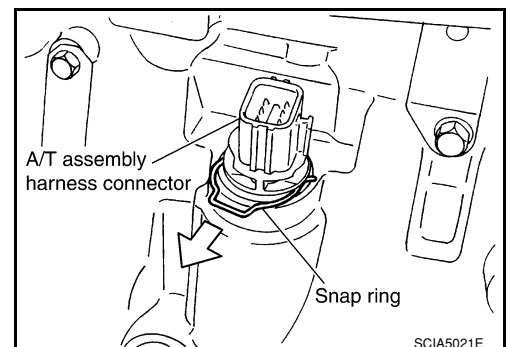

DISASSEMBLY

< DISASSEMBLY AND ASSEMBLY >

27. Push A/T assembly harness connector.

CAUTION:

Do not damage connector.

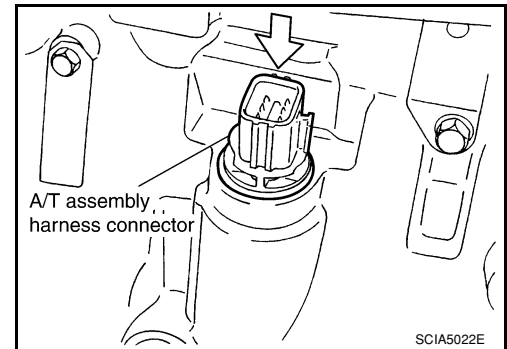

28. Remove oil pan and oil pan gasket. Refer to [TM-215, "Oil Pan"](#).

29. Check foreign materials in oil pan to help determine causes of malfunction. If the A/T fluid is very dark, smells burned, or contains foreign particles, the frictional material (clutches, band) may need replacement. A tacky film that will not wipe clean indicates varnish build up. Varnish can cause valves, servo, and clutches to stick and can inhibit pump pressure.

• **If frictional material is detected, perform A/T fluid cooler cleaning. Refer to [TM-194, "A/T Fluid Cooler Cleaning"](#).**

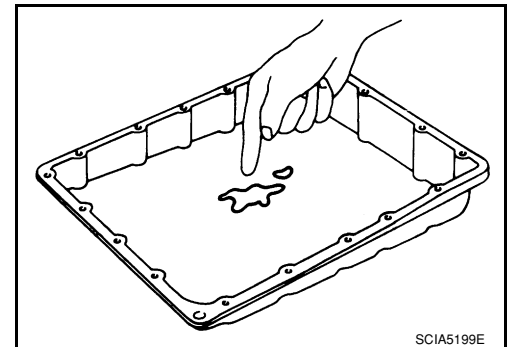

30. Remove magnets from oil pan.

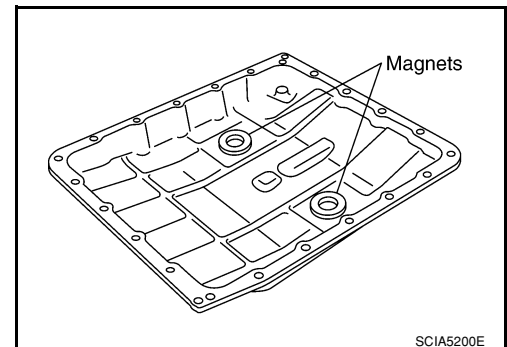

31. Disconnect A/T fluid temperature sensor 2 connector (A).

CAUTION:

Do not damage connector.

32. Straighten terminal clip ➡ to free terminal cord assembly and A/T fluid temperature sensor 2 harness.

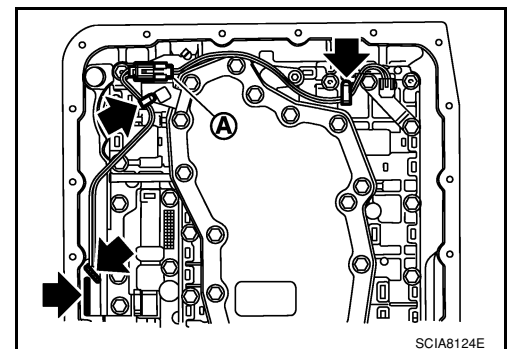

A
B
C
TM
E
F
G
H
I
J
K
L
M
N
O
P

DISASSEMBLY

< DISASSEMBLY AND ASSEMBLY >

33. Disconnect revolution sensor connector.

CAUTION:

Do not damage connector.

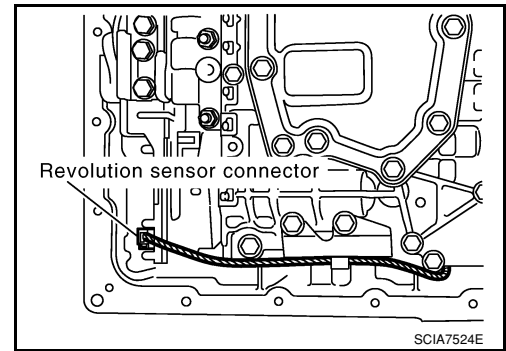

34. Straighten terminal clip to free revolution sensor harness.

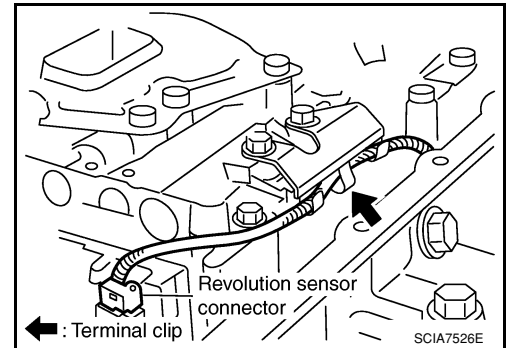

35. Remove bolts (A), (B) and (C) from control valve with TCM.

• ➡ : Front

Bolt symbol	Length mm (in)	Number of bolts
A	42 (1.65)	5
B	55 (2.17)	6
C	40 (1.57)	1

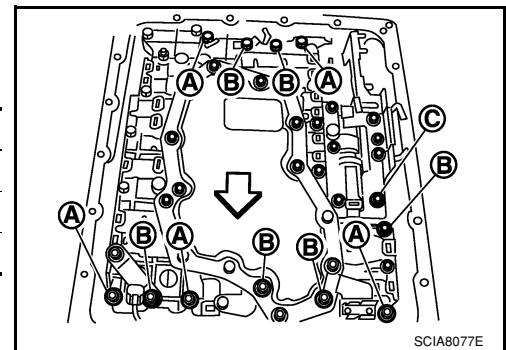

36. Remove control valve with TCM from transmission case.

CAUTION:

When removing, be careful with the manual valve notch and manual plate height. Remove it vertically.

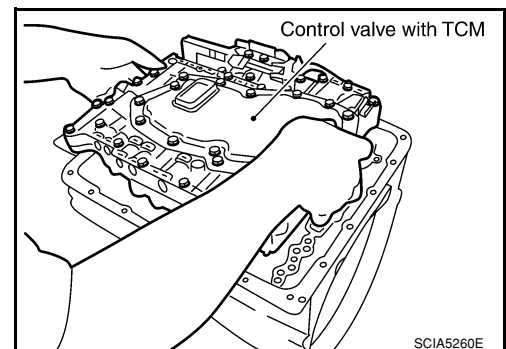

37. Remove A/T fluid temperature sensor 2 with bracket from control valve with TCM.

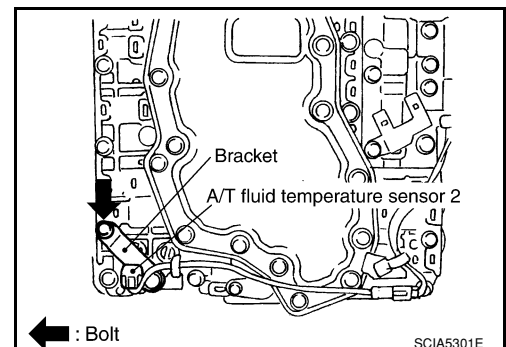

DISASSEMBLY

< DISASSEMBLY AND ASSEMBLY >

38. Remove bracket from A/T fluid temperature sensor 2.

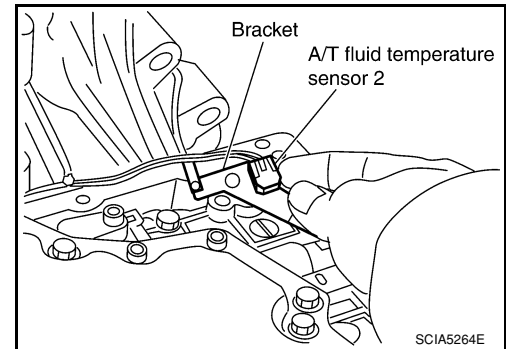

39. Remove O-ring from A/T assembly harness connector.

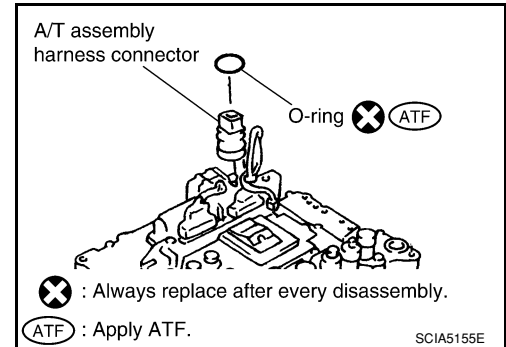

40. Disconnect TCM connectors.
CAUTION:
Do not damage connectors.

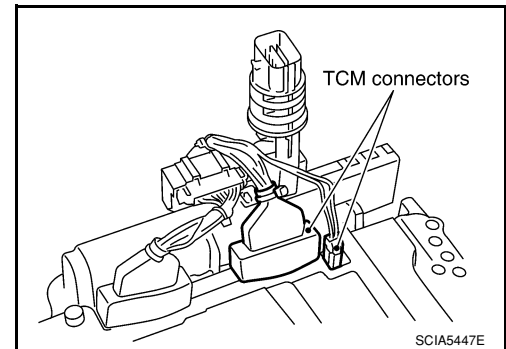

41. Remove A/T assembly harness connector from control valve with TCM using suitable tool.

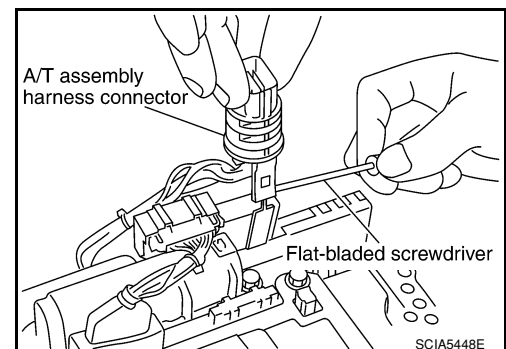

42. Disconnect TCM connector and park/neutral position switch connector.
CAUTION:
Do not damage connectors.

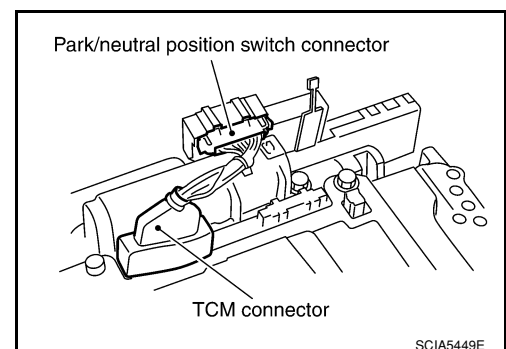

A
B
C
TM
E
F
G
H
I
J
K
L
M
N
O
P

DISASSEMBLY

< DISASSEMBLY AND ASSEMBLY >

43. Remove rear extension assembly (2WD models) or adapter case assembly (4WD models) according to the following procedures.

a. **2WD models**

- i. Remove bolts (1) and (2) for rear extension assembly and transmission case.
- Self-sealing bolts (2)

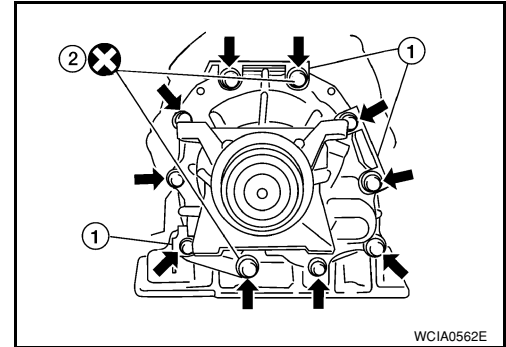

- ii. Tap rear extension assembly with soft hammer.

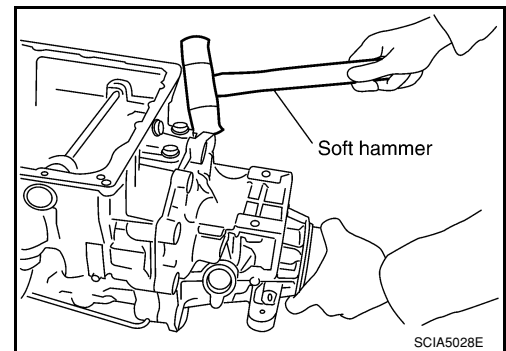

- iii. Remove rear extension assembly (with needle bearing) from transmission case.

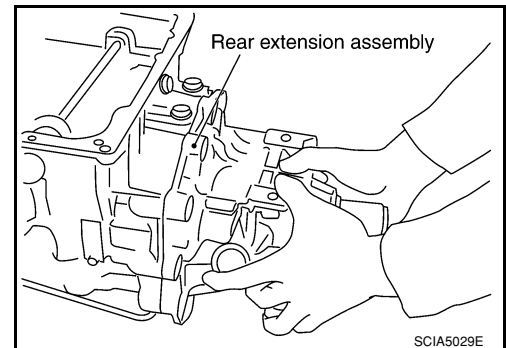

DISASSEMBLY

< DISASSEMBLY AND ASSEMBLY >

b. 4WD models

- i. Remove adapter case to transmission case bolts (1) and terminal bracket (1).
 - Self-sealing bolt (2)

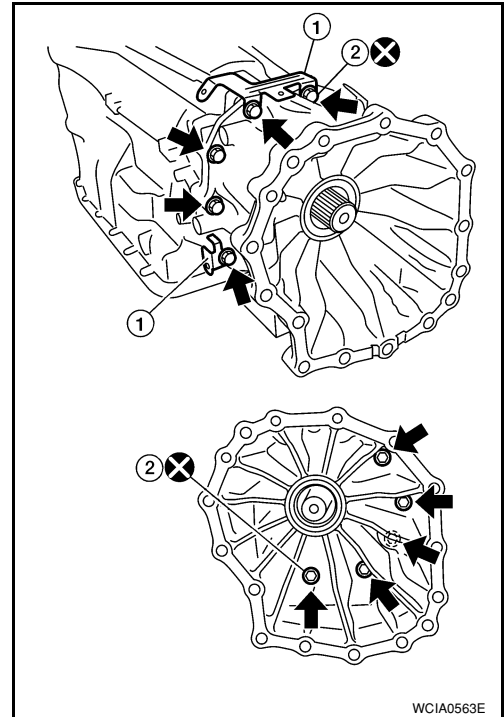

- ii. Tap adapter case assembly using suitable tool.

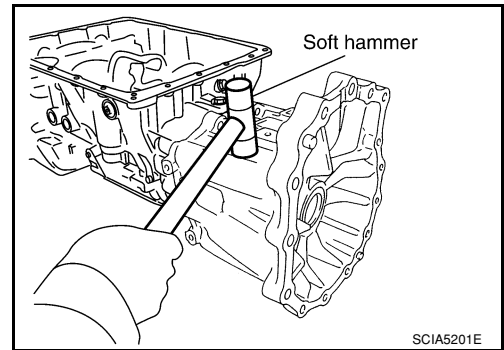

- iii. Remove adapter case assembly (with needle bearing) from transmission case.

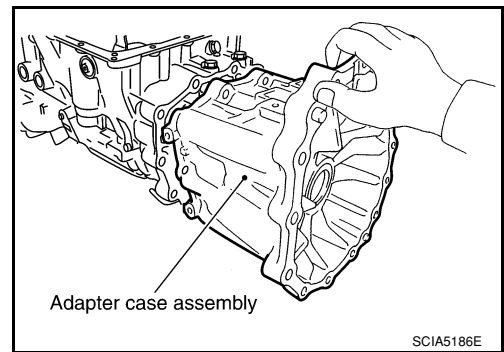

- iv. Remove gasket from transmission case.

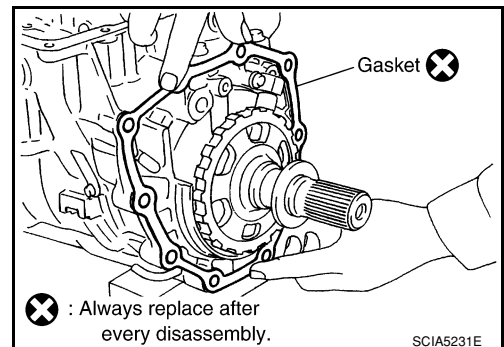

A
B
C
TM
E
F
G
H
I
J
K
L
M
N
O
P

DISASSEMBLY

< DISASSEMBLY AND ASSEMBLY >

44. Remove bearing race from output shaft.

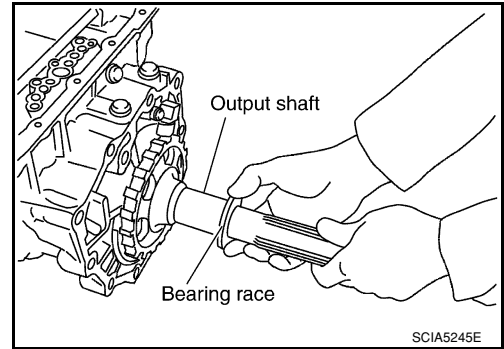

45. Remove output shaft from transmission case by rotating left and right.

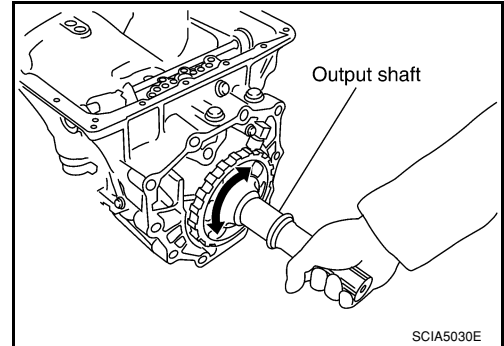

46. Remove parking gear from output shaft.

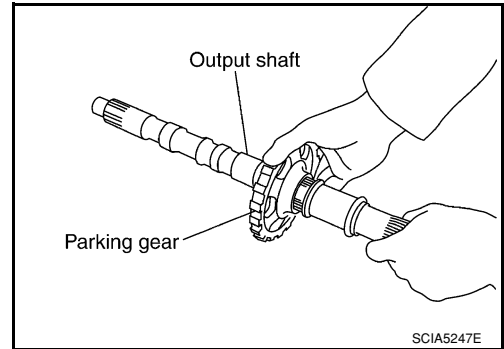

47. Remove seal rings from output shaft.

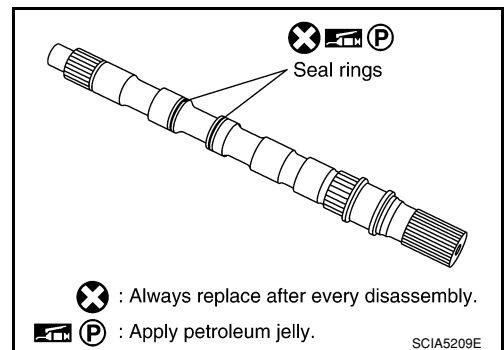

48. Remove needle bearing from transmission case.

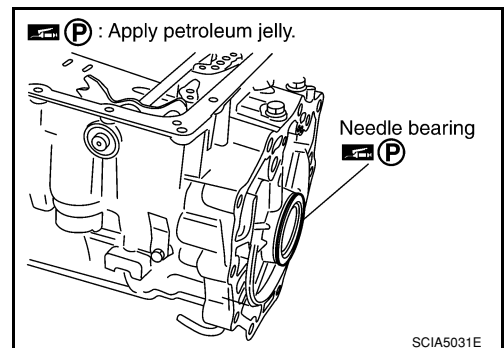

DISASSEMBLY

< DISASSEMBLY AND ASSEMBLY >

49. Remove revolution sensor from transmission case.

CAUTION:

- Do not subject it to impact by dropping or hitting it.
- Do not disassemble.
- Do not allow metal filings or any foreign material to get on the sensor's front edge magnetic area.
- Do not place in an area affected by magnetism.

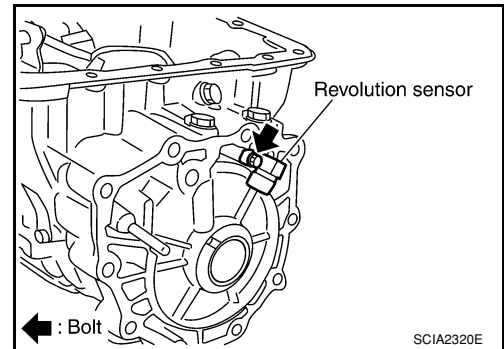

50. Remove reverse brake snap ring using two flat-bladed screwdrivers.

NOTE:

Press out snap ring from the transmission case oil pan side gap using a flat-bladed screwdriver, and remove it using a another screwdriver.

51. Remove reverse brake retaining plate from transmission case.

- Check facing for burns, cracks or damage. If necessary, replace the plate.

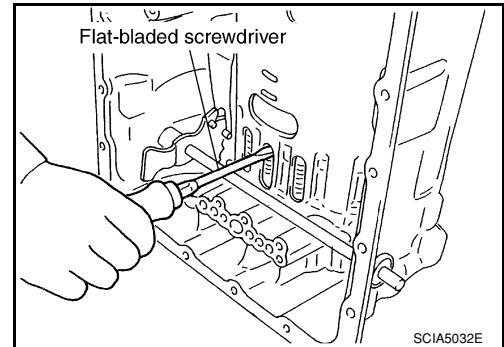

52. Remove N-spring from transmission case.

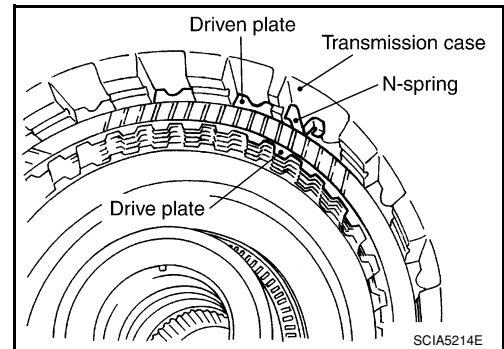

53. Remove reverse brake drive plates, driven plates and dish plate from transmission case.

- Check facing for burns, cracks or damage. If necessary, replace the plate.

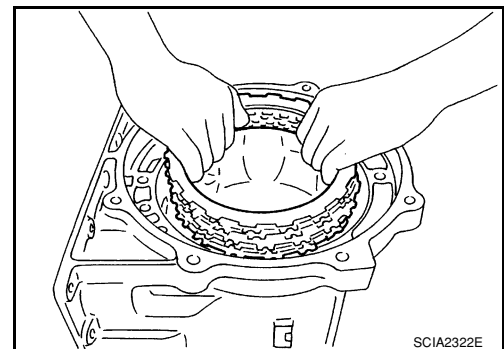

54. Remove snap ring using suitable tool.

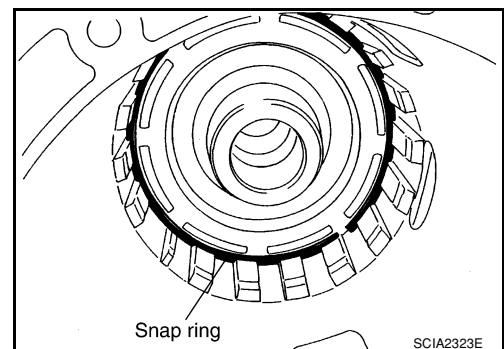

A

B

C

TM

E

F

G

H

I

J

K

L

M

N

O

P

DISASSEMBLY

< DISASSEMBLY AND ASSEMBLY >

55. Remove spring retainer and return spring from transmission case.

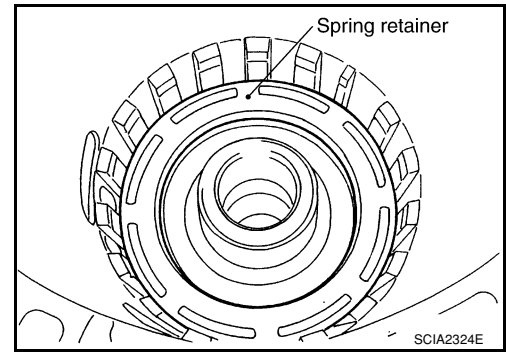

56. Remove seal rings from drum support.

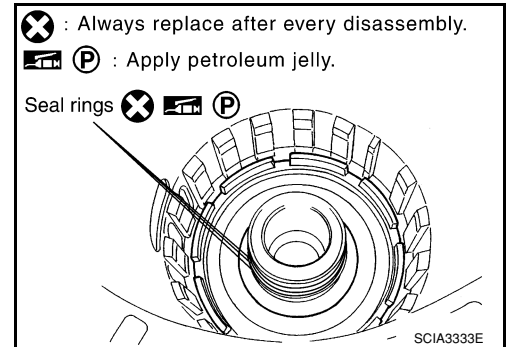

57. Remove needle bearing from drum support edge surface.

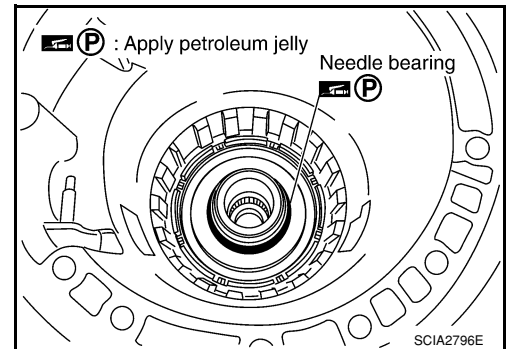

58. Remove reverse brake piston from transmission case using compressed air. Refer to [TM-240. "Oil Channel"](#).

CAUTION:

Care should be taken not to abruptly blow air. It makes the piston incline, and as a result, it becomes hard to disassemble the pistons.

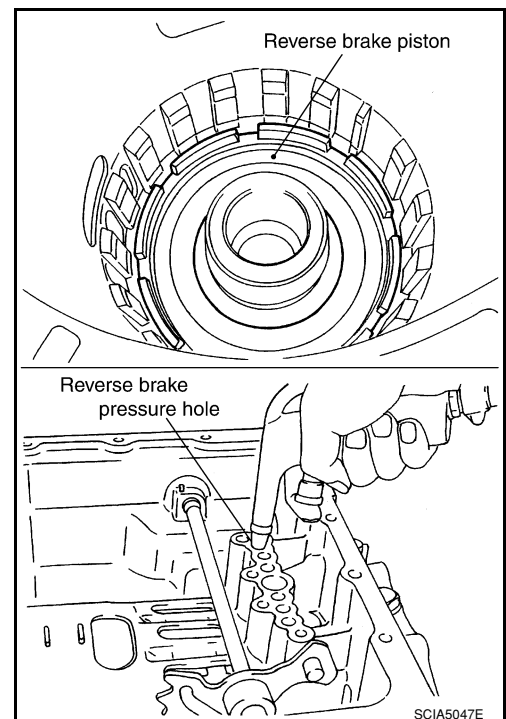

DISASSEMBLY

< DISASSEMBLY AND ASSEMBLY >

59. Remove D-rings from reverse brake piston.

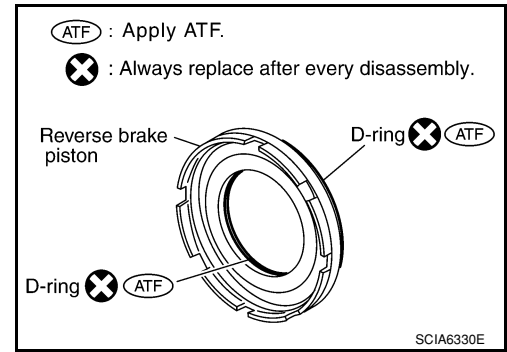

60. Knock out retaining pin using suitable tool.

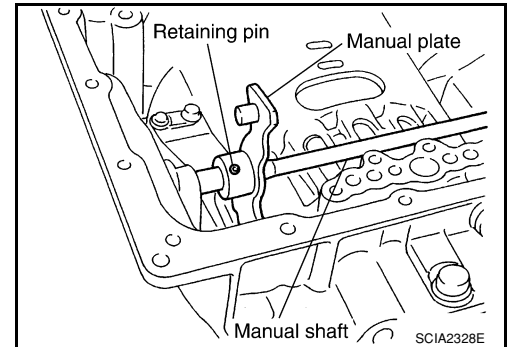

61. Remove manual shaft retaining pin using suitable tool.

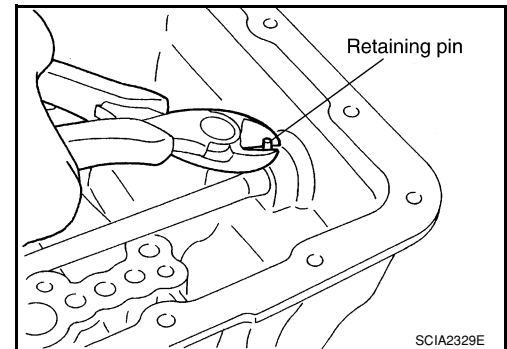

62. Remove manual plate (with parking rod) from manual shaft.

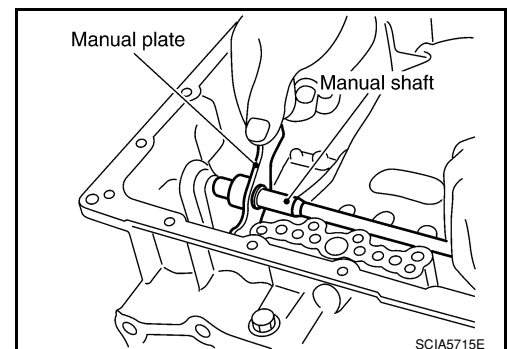

63. Remove parking rod from manual plate.

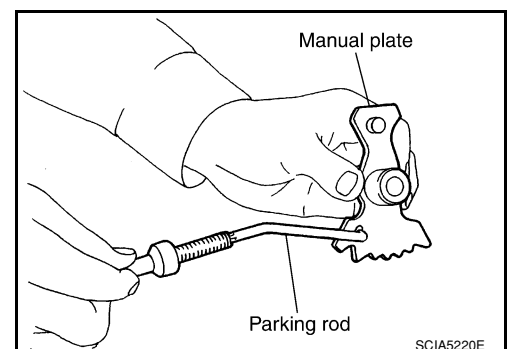

A
B
C
TM
E
F
G
H
I
J
K
L
M
N
O
P

DISASSEMBLY

< DISASSEMBLY AND ASSEMBLY >

64. Remove manual shaft from transmission case.

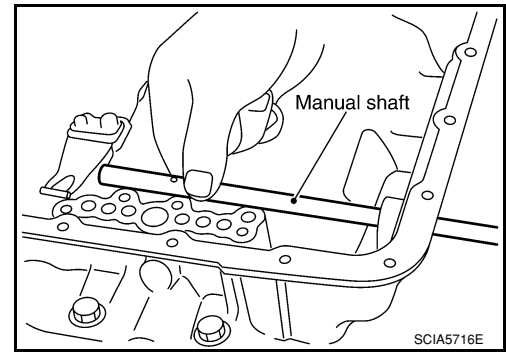

65. Remove manual shaft oil seals using suitable tool.

CAUTION:

Do not scratch transmission case.

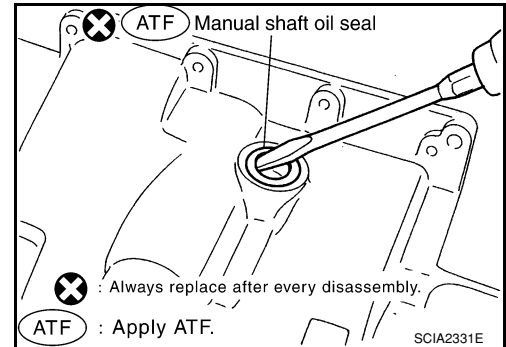

66. Remove detent spring and spacer from transmission case.

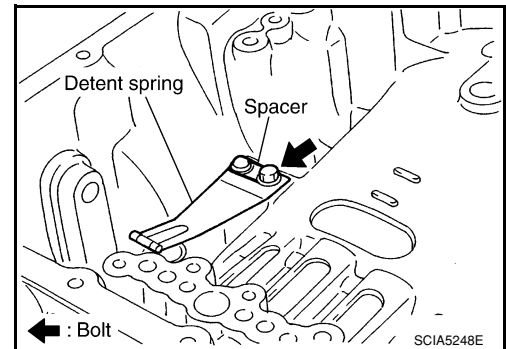

67. Remove snap ring from transmission case using suitable tool.

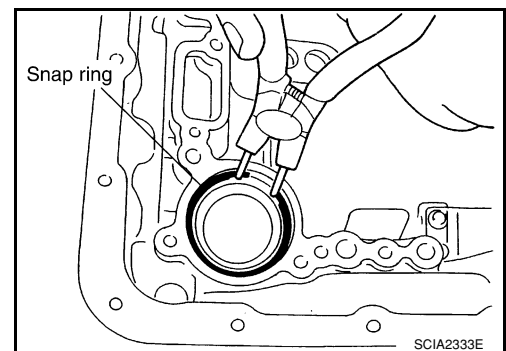

68. Remove servo assembly (with return spring) from transmission case.

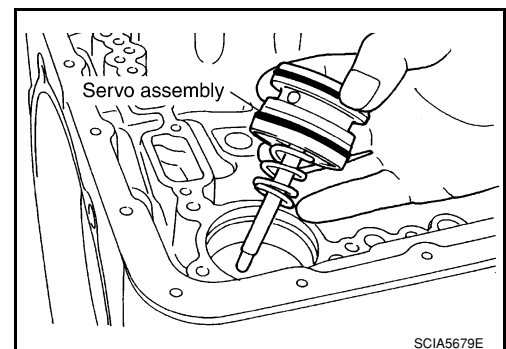

DISASSEMBLY

< DISASSEMBLY AND ASSEMBLY >

69. Remove return spring from servo assembly.

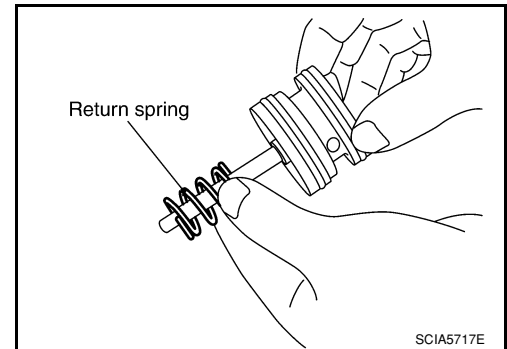

70. Remove O-rings from servo assembly.

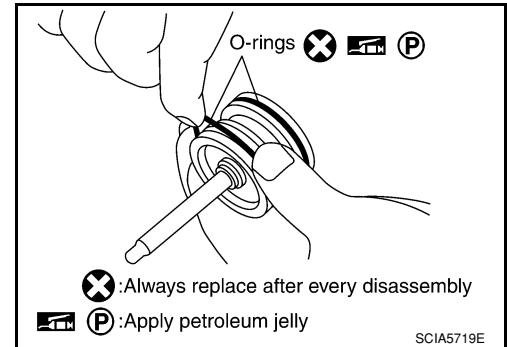

71. Remove needle bearing (1) from rear extension (2WD models) or adapter case (4WD models).

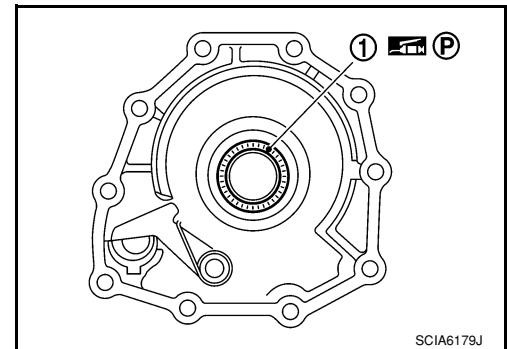

72. Remove parking actuator support from rear extension (2WD models) or adapter case (4WD models).

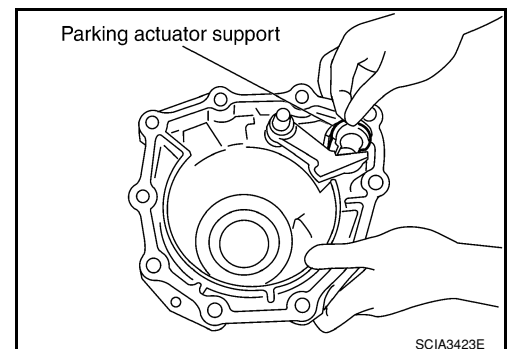

73. Remove parking pawl (with return spring) and pawl shaft from rear extension (2WD models) or adapter case (4WD models).

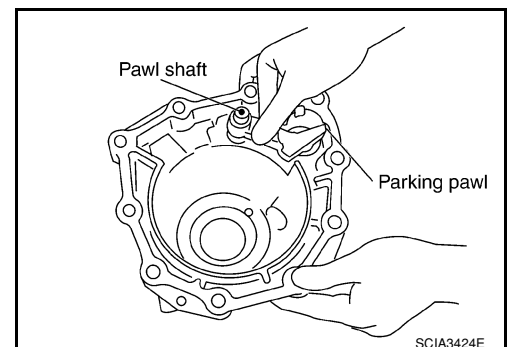

A
B
C
TM
E
F
G
H
I
J
K
L
M
N
O
P

DISASSEMBLY

< DISASSEMBLY AND ASSEMBLY >

74. Remove return spring (1) from parking pawl (2).

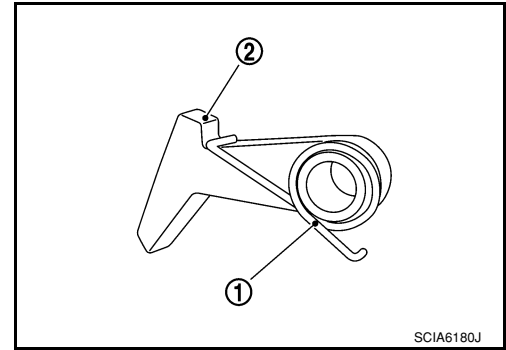

75. Remove rear oil seal from rear extension (2WD models) or adapter case (4WD models) using suitable tool.

CAUTION:

Do not scratch rear extension (2WD models) or adapter case (4WD models).

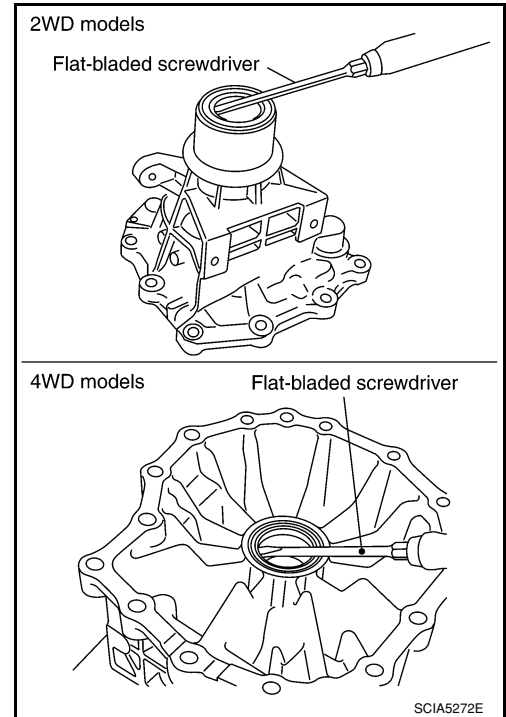

REPAIR FOR COMPONENT PARTS

< DISASSEMBLY AND ASSEMBLY >

REPAIR FOR COMPONENT PARTS

Oil Pump

INFOID:000000001546719

COMPONENTS

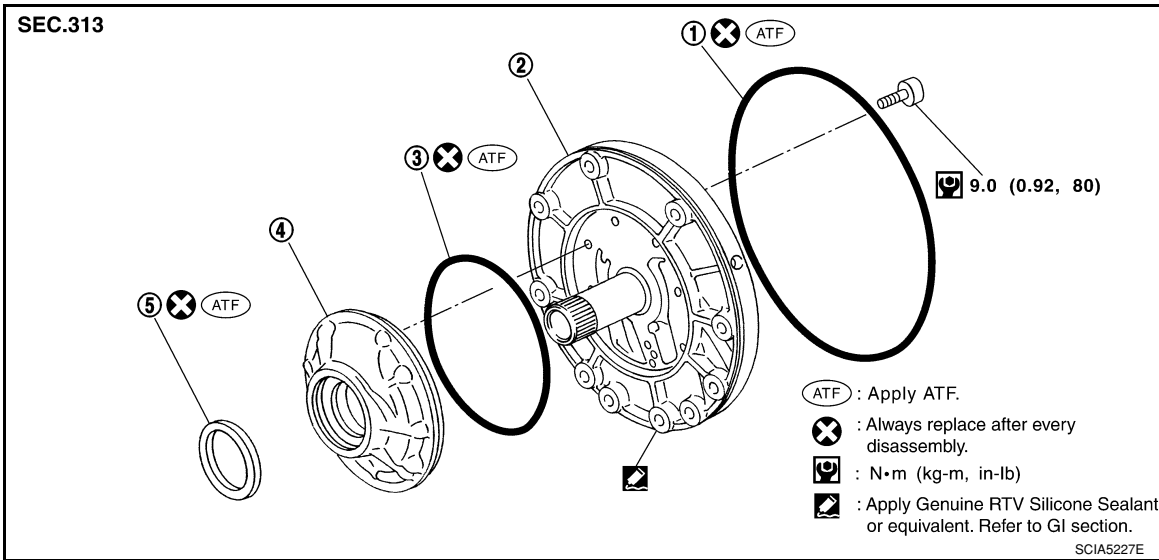

- | | | |
|---------------------|------------------------------|-----------|
| 1. O-ring | 2. Oil pump cover | 3. O-ring |
| 4. Oil pump housing | 5. Oil pump housing oil seal | |

DISASSEMBLY

- Remove oil pump housing from oil pump cover.

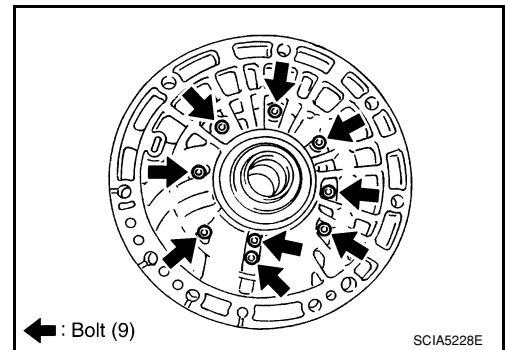

- Remove oil pump housing oil seal using suitable tool.
CAUTION:
Be careful not to scratch oil pump housing.

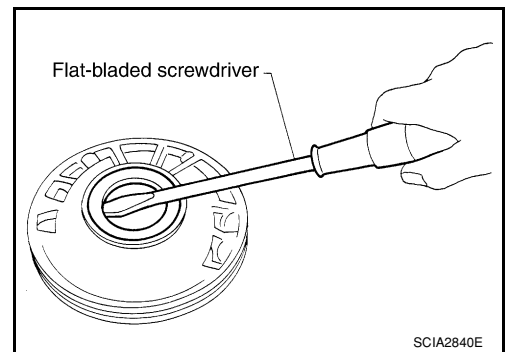

A
B
C
TM
E
F
G
H
I
J
K
L
M
N
O
P

REPAIR FOR COMPONENT PARTS

< DISASSEMBLY AND ASSEMBLY >

3. Remove O-ring from oil pump housing.

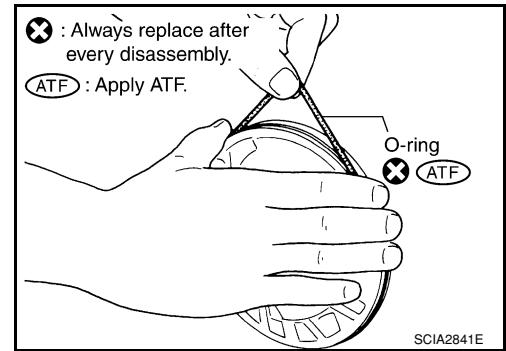

4. Remove O-ring from oil pump cover.

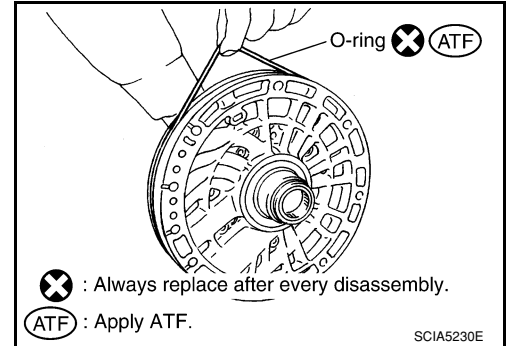

ASSEMBLY

1. Install new O-ring to oil pump cover.

CAUTION:

- Do not reuse O-ring.
- Apply ATF to O-ring.

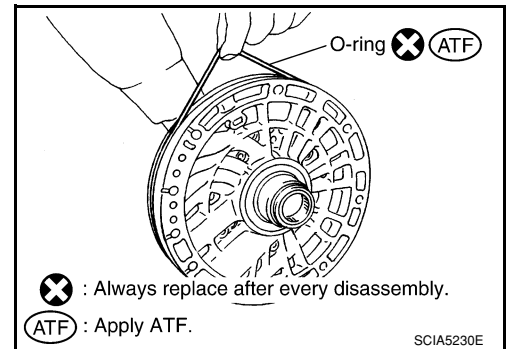

2. Install new O-ring to oil pump housing.

CAUTION:

- Do not reuse O-ring.
- Apply ATF to O-ring.

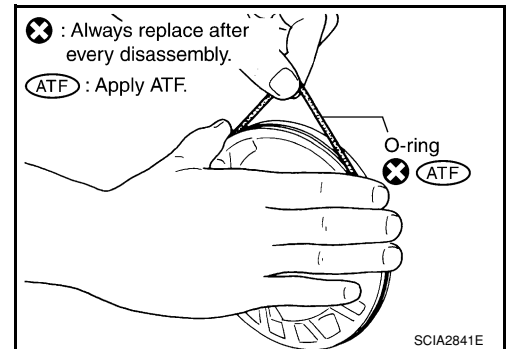

REPAIR FOR COMPONENT PARTS

< DISASSEMBLY AND ASSEMBLY >

3. Install new oil pump housing oil seal to the oil pump housing using Tool.

CAUTION:

- Do not reuse oil seal.
- Apply ATF to oil seal.

Tool number : ST33400001 (J-26082)

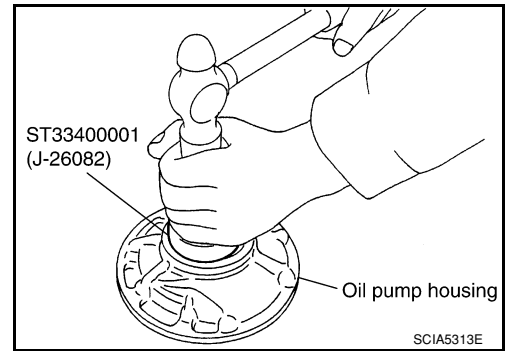

4. Install oil pump housing in oil pump cover. Tighten oil pump housing bolts to the specified torque. Refer to [TM-233, "Component"](#).

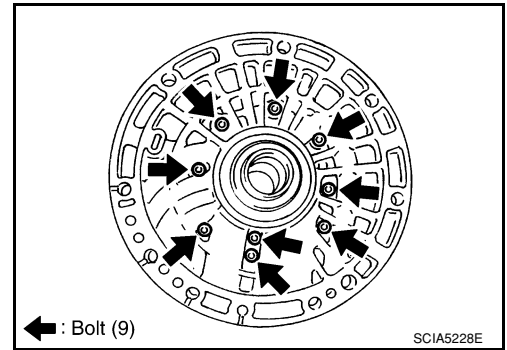

Front Sun Gear, 3rd One-Way Clutch

INFOID:000000001546720

COMPONENTS

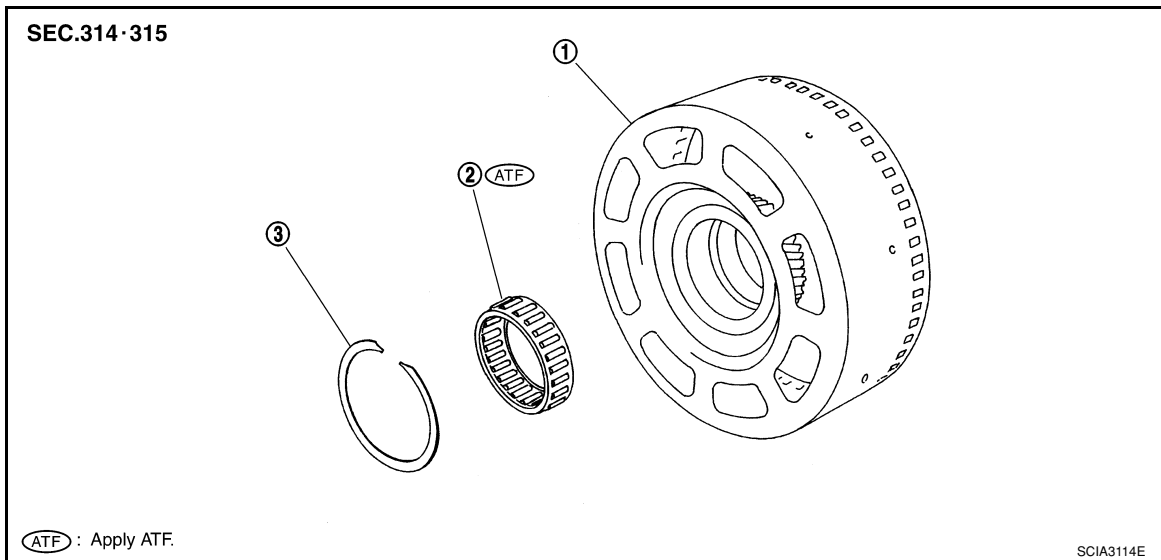

1. Front sun gear
2. 3rd one-way clutch
3. Snap ring

DISASSEMBLY

A
B
C
TM
E
F
G
H
I
J
K
L
M
N
O
P

REPAIR FOR COMPONENT PARTS

< DISASSEMBLY AND ASSEMBLY >

1. Remove snap ring from front sun gear using suitable tool.

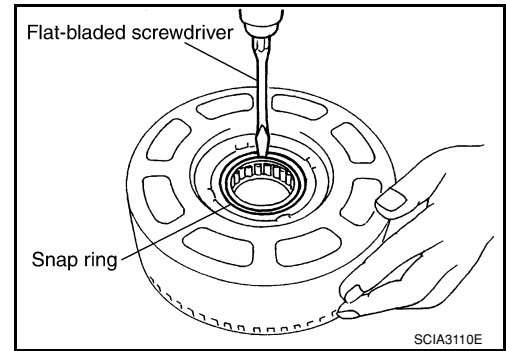

2. Remove 3rd one-way clutch from front sun gear.

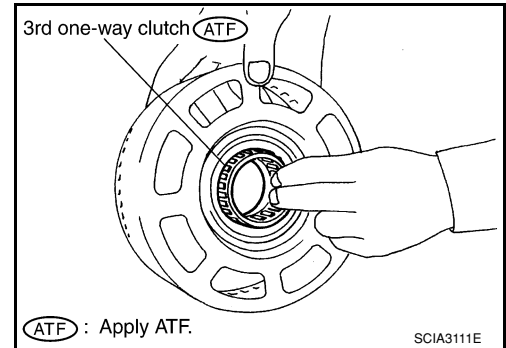

INSPECTION

3rd One-way Clutch

- Check frictional surface for wear or damage.

CAUTION:

If necessary, replace the 3rd one-way clutch.

Front Sun Gear Snap Ring

- Check for deformation, fatigue or damage.

CAUTION:

If necessary, replace the snap ring.

Front Sun Gear

- Check for deformation, fatigue or damage.

CAUTION:

If necessary, replace the front sun gear.

ASSEMBLY

1. Install 3rd one-way clutch in front sun gear.

CAUTION:

Apply ATF to 3rd one-way clutch.

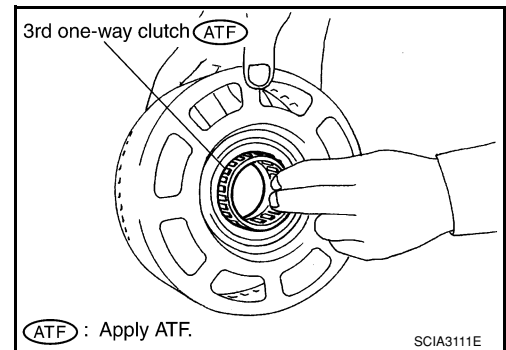

REPAIR FOR COMPONENT PARTS

< DISASSEMBLY AND ASSEMBLY >

2. Install snap ring in front sun gear using suitable tool.

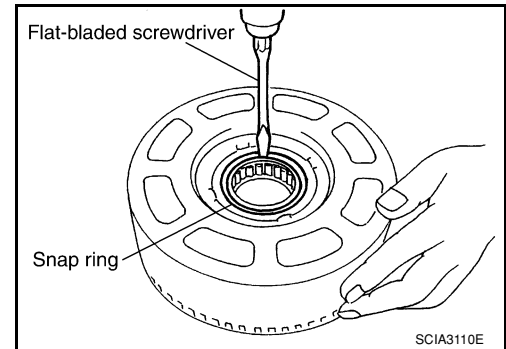

3. Check operation of 3rd one-way clutch.
 - a. Hold oil pump assembly and turn front sun gear.
 - b. Check 3rd one-way clutch for correct locking and unlocking directions.

CAUTION:

If not as shown, check installation direction of 3rd one-way clutch.

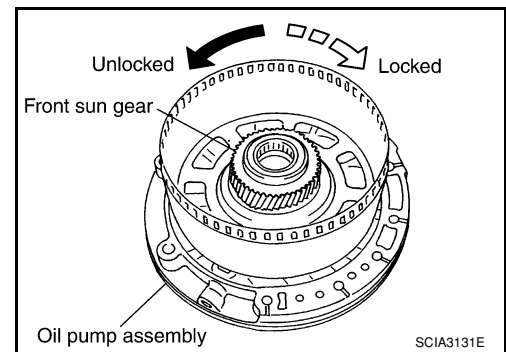

Front Carrier, Input Clutch, Rear Internal Gear

COMPONENTS

INFOID:000000001546721

A
B
C
TM
E
F
G
H
I
J
K
L
M
N
O
P

REPAIR FOR COMPONENT PARTS

< DISASSEMBLY AND ASSEMBLY >

SEC.314·315

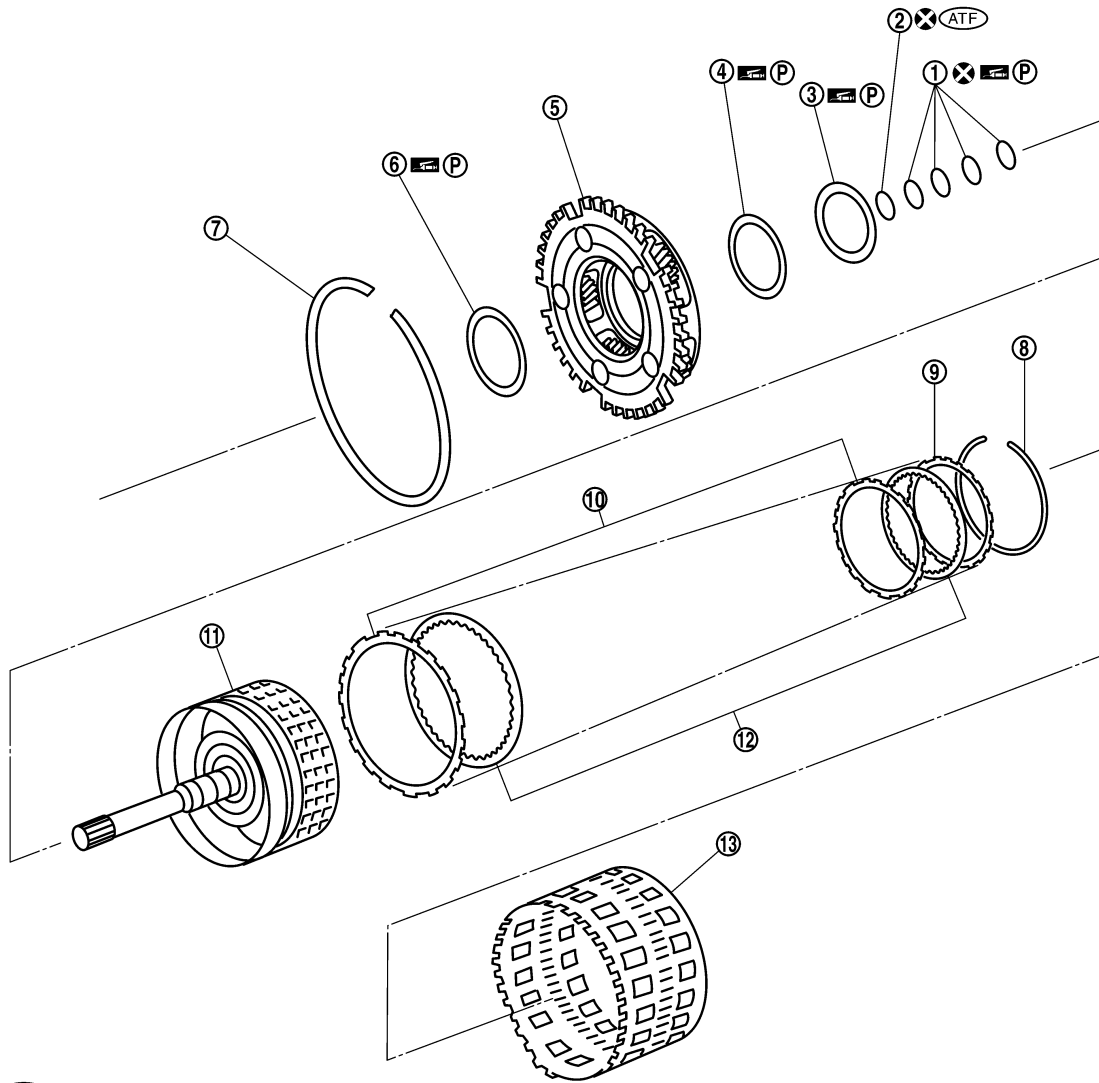

(ATF) : Apply ATF

(P) : Apply petroleum jelly.

(X) : Always replace after every disassembly.

SCIA5244E

- | | | |
|------------------------|---------------------------|--------------------|
| 1. Seal ring | 2. O-ring | 3. Needle bearing |
| 4. Bearing race | 5. Front carrier assembly | 6. Needle bearing |
| 7. Snap ring | 8. Snap ring | 9. Retaining plate |
| 10. Driven plate | 11. Input clutch drum | 12. Drive plate |
| 13. Rear internal gear | | |

DISASSEMBLY

REPAIR FOR COMPONENT PARTS

< DISASSEMBLY AND ASSEMBLY >

1. Compress snap ring using suitable tool.
2. Remove front carrier assembly and input clutch assembly from rear internal gear.
3. Remove front carrier assembly from input clutch assembly.

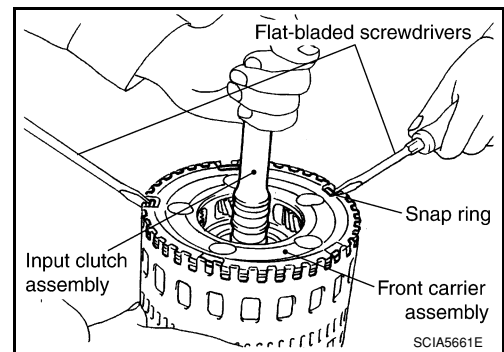

- a. Remove bearing race from front carrier assembly.

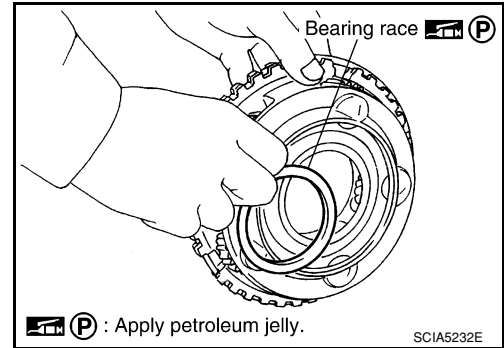

- b. Remove needle bearing from front carrier assembly.

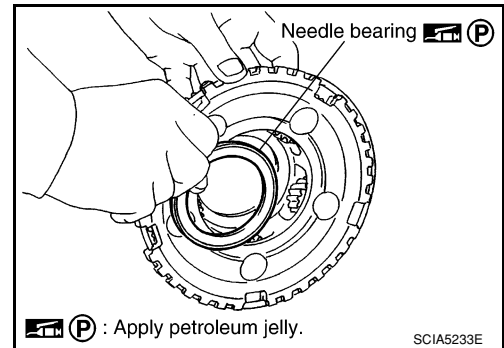

- c. Remove snap ring from front carrier assembly.
CAUTION:
Do not expand snap ring excessively.

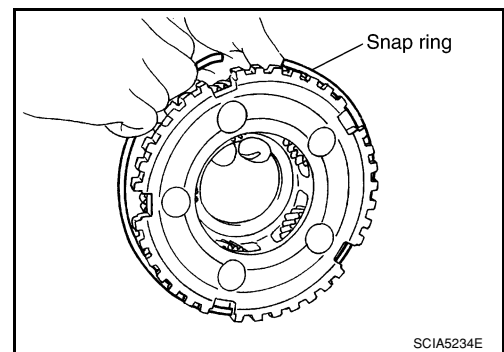

4. Disassemble input clutch assembly.

 - a. Remove O-ring and seal rings from input clutch assembly.

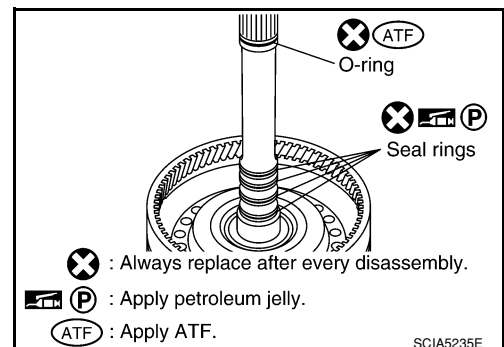

A
B
C
TM

E
F
G
H
I
J
K

L
M
N
O
P

REPAIR FOR COMPONENT PARTS

< DISASSEMBLY AND ASSEMBLY >

b. Remove needle bearing from input clutch assembly.

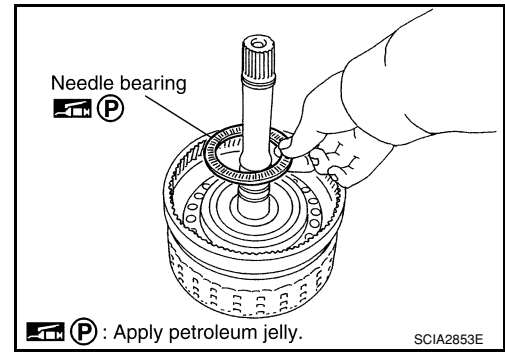

c. Remove snap ring from input clutch drum using suitable tool.

d. Remove drive plates, driven plates and retaining plate from input clutch drum.

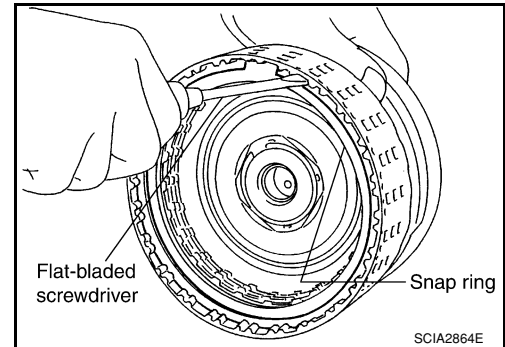

INSPECTION

Front Carrier Snap Ring

- Check for deformation, fatigue or damage.

CAUTION:

If necessary, replace the snap ring.

Input Clutch Snap Ring

- Check for deformation, fatigue or damage.

CAUTION:

If necessary, replace the input clutch assembly.

Input Clutch Drum

- Check for deformation, fatigue or damage or burns.

CAUTION:

If necessary, replace the input clutch assembly.

Input Clutch Drive Plates

- Check facing for burns, cracks or damage.

CAUTION:

If necessary, replace the input clutch assembly.

Input Clutch Retaining Plate and Driven Plates

- Check facing for burns, cracks or damage.

CAUTION:

If necessary, replace the input clutch assembly.

Front Carrier Assembly

- Check for deformation, fatigue or damage.

CAUTION:

If necessary, replace the front carrier assembly.

Rear Internal Gear

- Check for deformation, fatigue or damage.

CAUTION:

If necessary, replace the rear internal gear.

ASSEMBLY

1. Install input clutch.

REPAIR FOR COMPONENT PARTS

< DISASSEMBLY AND ASSEMBLY >

- a. Install drive plates, driven plates and retaining plate in input clutch drum.

CAUTION:

Take care with order of plates.

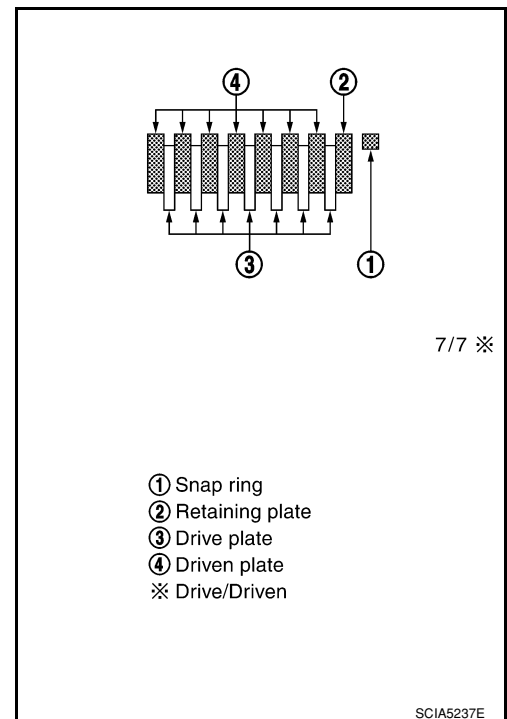

- b. Install snap ring in input clutch drum using suitable tool.

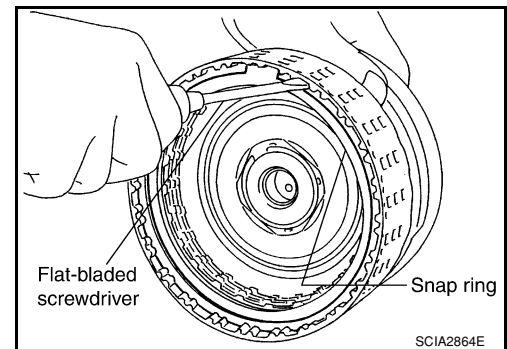

- c. Install needle bearing in input clutch assembly.

CAUTION:

Apply petroleum jelly to needle bearing.

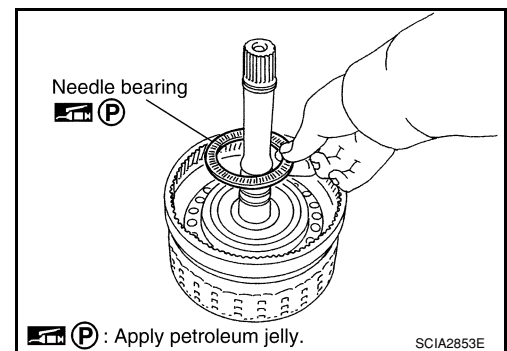

- d. Install new O-ring and new seal rings in input clutch assembly.

CAUTION:

- Do not reuse O-ring and seal rings.
- Apply ATF to O-ring.
- Apply petroleum jelly to seal rings.

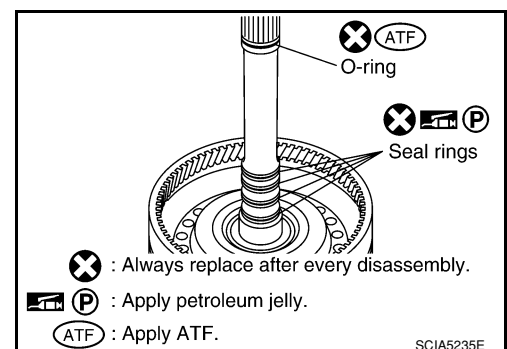

REPAIR FOR COMPONENT PARTS

< DISASSEMBLY AND ASSEMBLY >

2. Install front carrier assembly.
 - a. Install snap ring to front carrier assembly.
CAUTION:
Do not expand snap ring excessively.

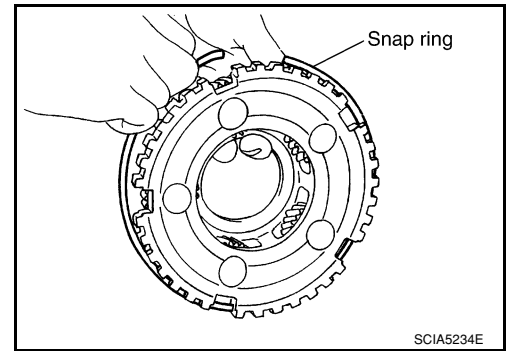

- b. Install needle bearing in front carrier assembly.
CAUTION:
 - Take care with the direction of needle bearing. Refer to [TM-242, "Location of Adjusting Shims, Needle Bearings, Thrust Washers and Snap Rings"](#).
 - Apply petroleum jelly to needle bearing.

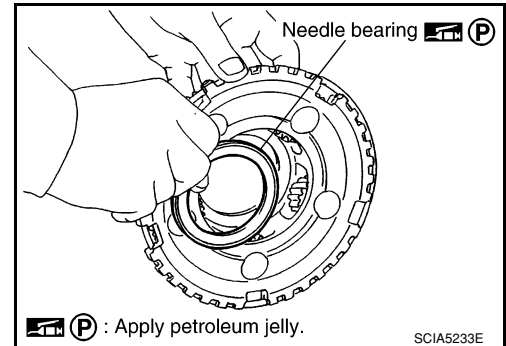

- c. Install bearing race in front carrier assembly.
CAUTION:
Apply petroleum jelly to bearing race.
 - d. Install front carrier assembly to input clutch assembly.

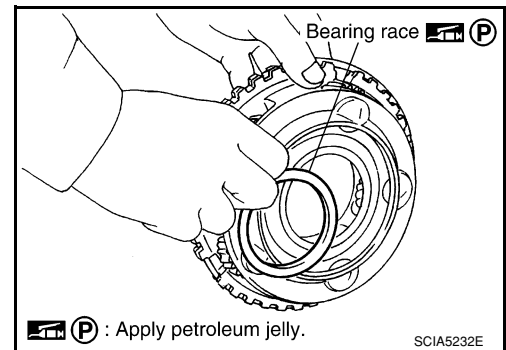

3. Compress snap ring using suitable tool.
4. Install front carrier assembly and input clutch assembly to rear internal gear.

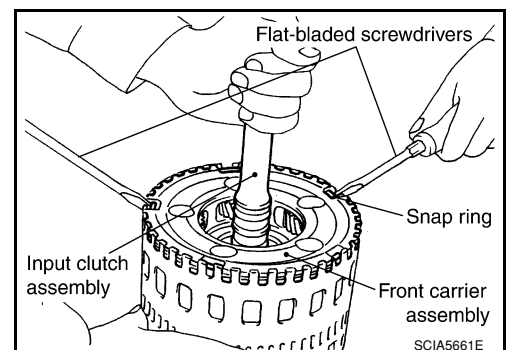

Mid Sun Gear, Rear Sun Gear, High and Low Reverse Clutch Hub

INFOID:000000001546722

COMPONENTS

REPAIR FOR COMPONENT PARTS

< DISASSEMBLY AND ASSEMBLY >

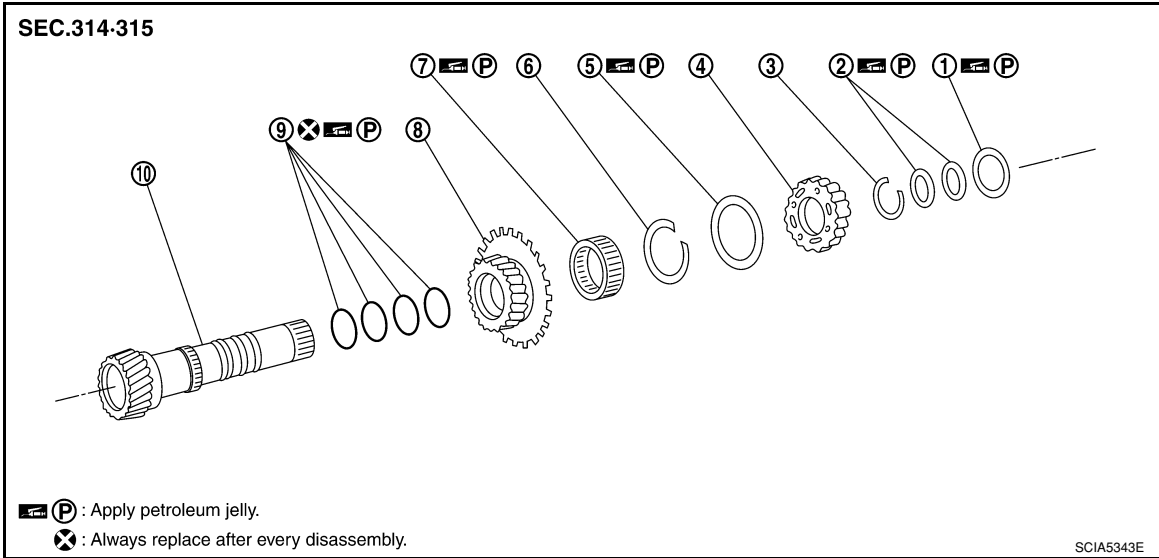

- | | | |
|------------------------------------|-------------------|--------------|
| 1. Needle bearing | 2. Bearing race | 3. Snap ring |
| 4. High and low reverse clutch hub | 5. Needle bearing | 6. Snap ring |
| 7. 1st one-way clutch | 8. Rear sun gear | 9. Seal ring |
| 10. Mid sun gear | | |

DISASSEMBLY

- Remove needle bearing and bearing races from high and low reverse clutch hub.

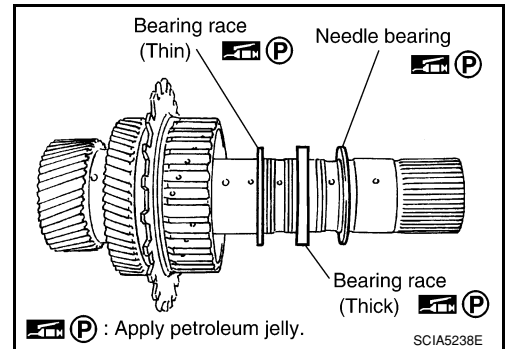

- Remove snap ring from mid sun gear assembly using suitable tool.

CAUTION:

Do not expand snap ring excessively.

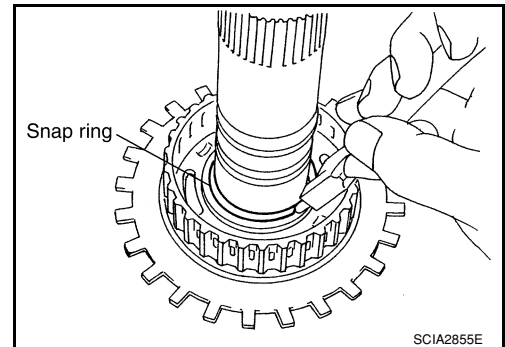

A
B
C
TM
E
F
G
H
I
J
K
L
M
N
O
P

REPAIR FOR COMPONENT PARTS

< DISASSEMBLY AND ASSEMBLY >

3. Remove high and low reverse clutch hub from mid sun gear assembly.

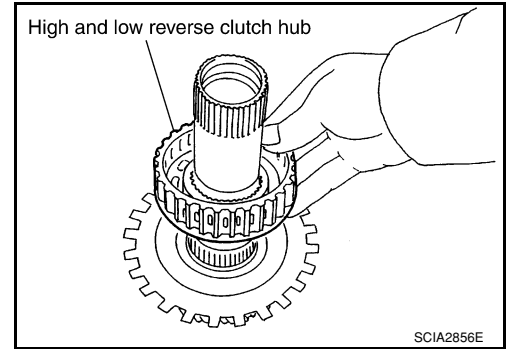

- a. Remove needle bearing from high and low reverse clutch hub.

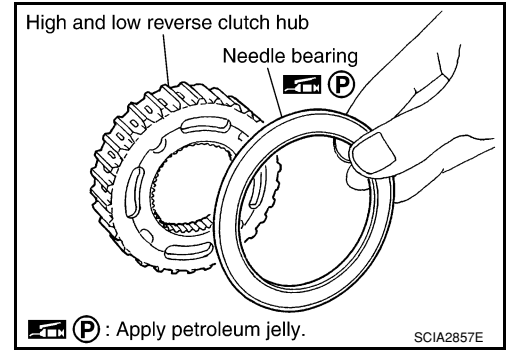

4. Remove rear sun gear assembly from mid sun gear assembly.

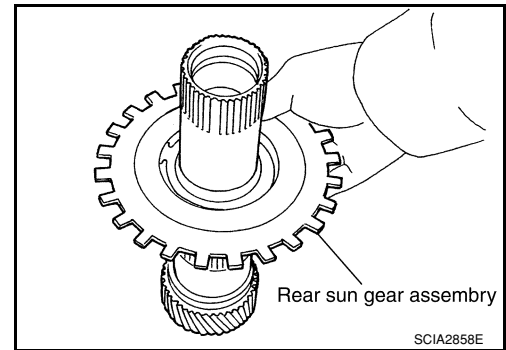

- a. Remove snap ring from rear sun gear using suitable tool.

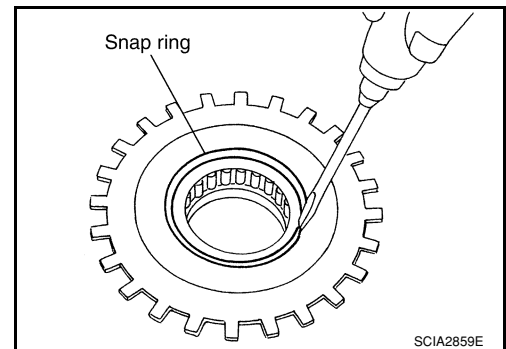

REPAIR FOR COMPONENT PARTS

< DISASSEMBLY AND ASSEMBLY >

- b. Remove 1st one-way clutch from rear sun gear.

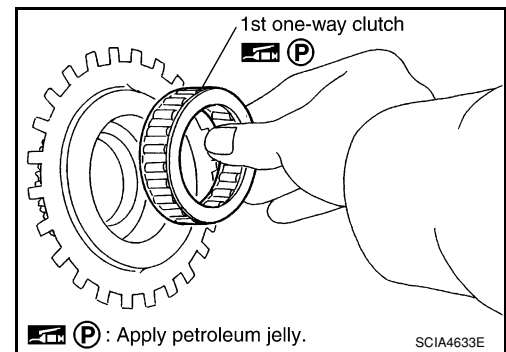

5. Remove seal rings from mid sun gear.

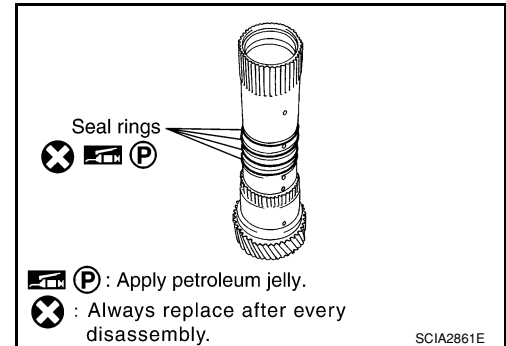

INSPECTION

High and Low Reverse Clutch Hub Snap Ring, Rear Sun Gear Snap Ring

- Check for deformation, fatigue or damage.

CAUTION:

If necessary, replace the snap ring.

1st One-way Clutch

- Check frictional surface for wear or damage.

CAUTION:

If necessary, replace the 1st one-way clutch.

Mid Sun Gear

- Check for deformation, fatigue or damage.

CAUTION:

If necessary, replace the mid sun gear.

Rear Sun Gear

- Check for deformation, fatigue or damage.

CAUTION:

If necessary, replace the rear sun gear.

High and Low Reverse Clutch Hub

- Check for deformation, fatigue or damage.

CAUTION:

If necessary, replace the high and low reverse clutch hub.

ASSEMBLY

A
B
C
TM
E
F
G
H
I
J
K
L
M
N
O
P

REPAIR FOR COMPONENT PARTS

< DISASSEMBLY AND ASSEMBLY >

1. Install new seal rings to mid sun gear.

CAUTION:

- Do not reuse seal rings.
- Apply petroleum jelly to seal rings.

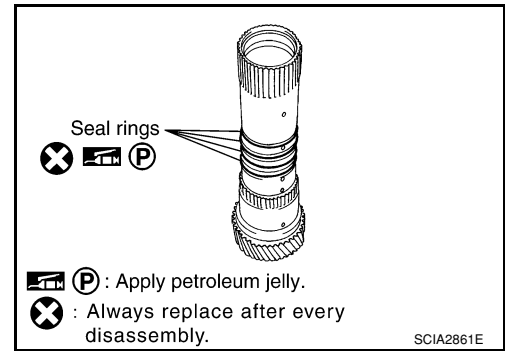

2. Install 1st one-way clutch to rear sun gear.

CAUTION:

- Apply petroleum jelly to 1st one-way clutch.

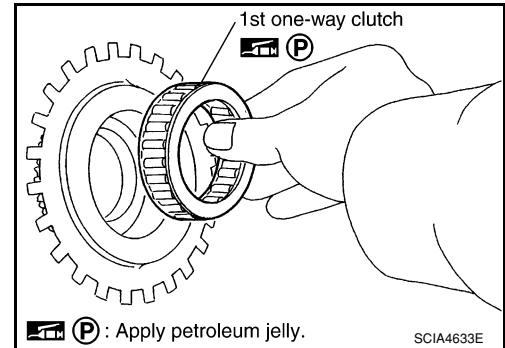

3. Install snap ring to rear sun gear using suitable tool.

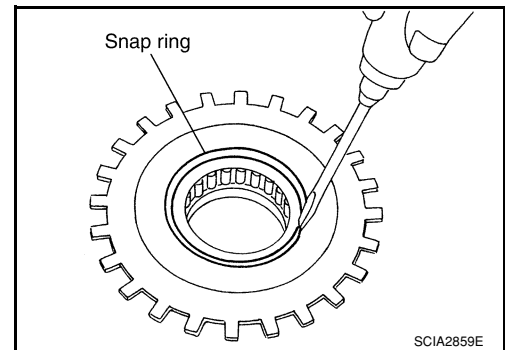

4. Install rear sun gear assembly to mid sun gear assembly.

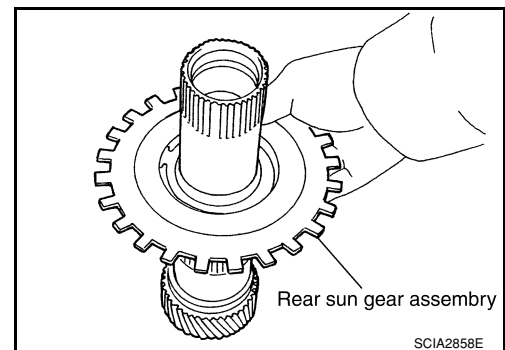

5. Install needle bearing to high and low reverse clutch hub.

CAUTION:

- Take care with the direction of needle bearing. Refer to [TM-242, "Location of Adjusting Shims, Needle Bearings, Thrust Washers and Snap Rings"](#).
- Apply petroleum jelly to needle bearing.

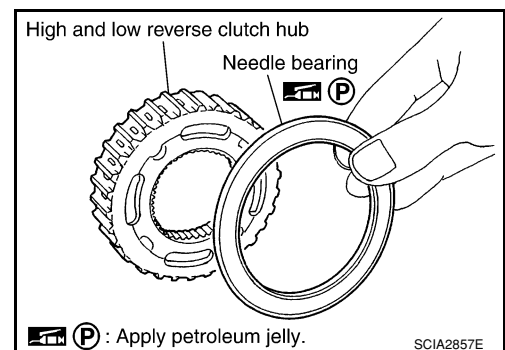

REPAIR FOR COMPONENT PARTS

< DISASSEMBLY AND ASSEMBLY >

6. Install high and low reverse clutch hub to mid sun gear assembly.

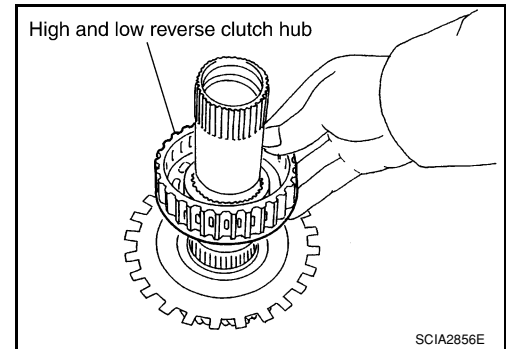

7. Install snap ring to mid sun gear assembly using suitable tool.
CAUTION:
Do not expand snap ring excessively.

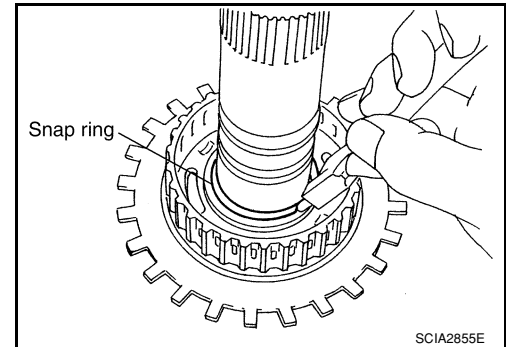

8. Check operation of 1st one-way clutch.
a. Hold mid sun gear and turn rear sun gear.
b. Check 1st one-way clutch for correct locking and unlocking directions.
CAUTION:
If not as shown, check installation direction of 1st one-way clutch.

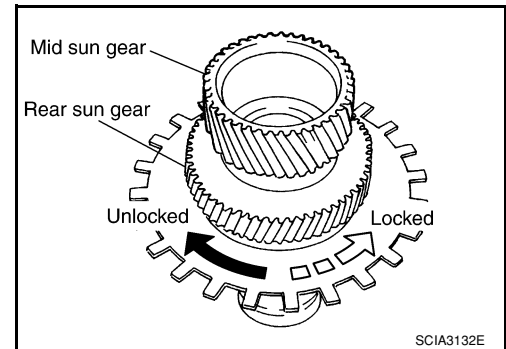

9. Install needle bearing and bearing races to high and low reverse clutch hub.
CAUTION:
• Apply petroleum jelly to needle bearing and bearing races.
• Take care with order of bearing races.

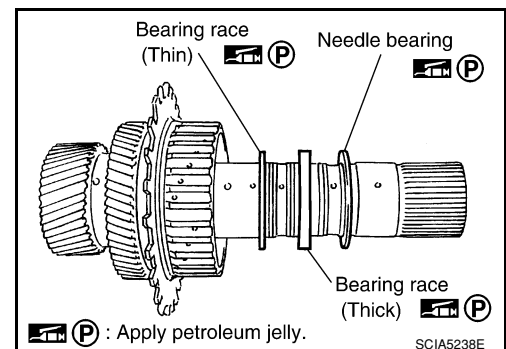

High and Low Reverse Clutch

COMPONENTS

INFOID:000000001546723

A
B
C
TM
E
F
G
H
I
J
K
L
M
N
O
P

REPAIR FOR COMPONENT PARTS

< DISASSEMBLY AND ASSEMBLY >

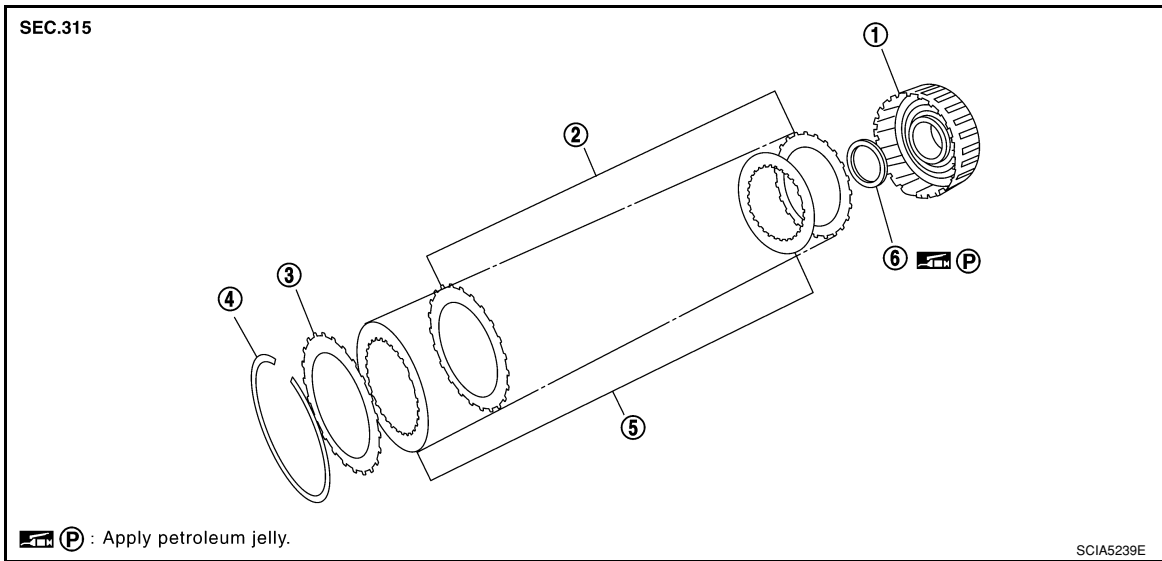

- | | | |
|-------------------------------------|-----------------|--------------------|
| 1. High and low reverse clutch drum | 2. Driven plate | 3. Retaining plate |
| 4. Snap ring | 5. Drive plate | 6. Bearing race |

DISASSEMBLY

1. Remove bearing race from high and low reverse clutch drum.

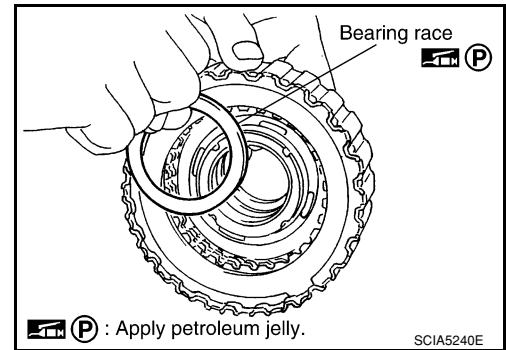

2. Remove snap ring from high and low reverse clutch drum using suitable tool.
3. Remove drive plates, driven plates and retaining plate from high and low reverse clutch drum.

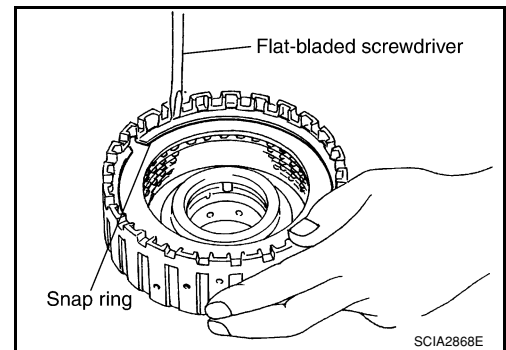

INSPECTION

- Check the following, and replace high and low reverse clutch assembly if necessary.

High and Low Reverse Clutch Snap Ring

- Check for deformation, fatigue or damage.

High and Low Reverse Clutch Drive Plates

- Check facing for burns, cracks or damage.

High and Low Reverse Clutch Retaining Plate and Driven Plates

- Check facing for burns, cracks or damage.

ASSEMBLY

REPAIR FOR COMPONENT PARTS

< DISASSEMBLY AND ASSEMBLY >

1. Install drive plates, driven plates and retaining plate in high and low reverse clutch drum.

CAUTION:

Take care with the order of plates.

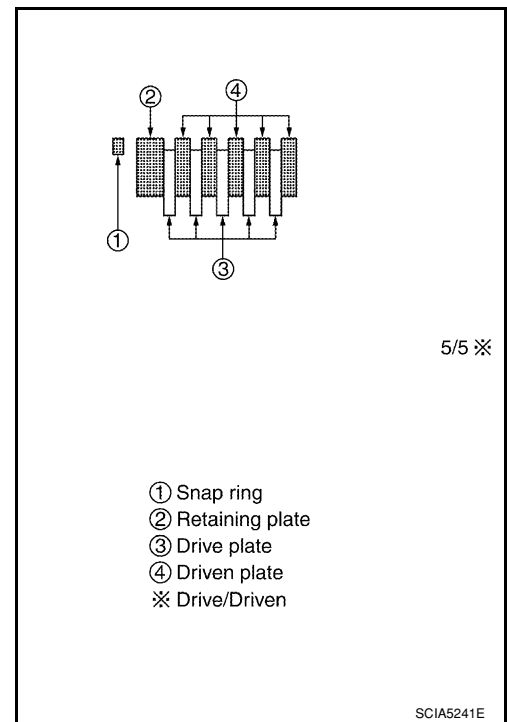

2. Install snap ring in high and low reverse clutch drum using suitable tool.

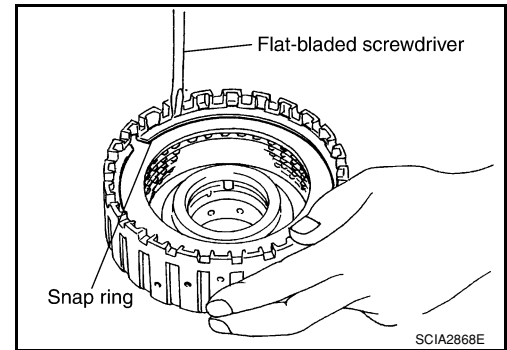

3. Install bearing race to high and low reverse clutch drum.

CAUTION:

Apply petroleum jelly to bearing race.

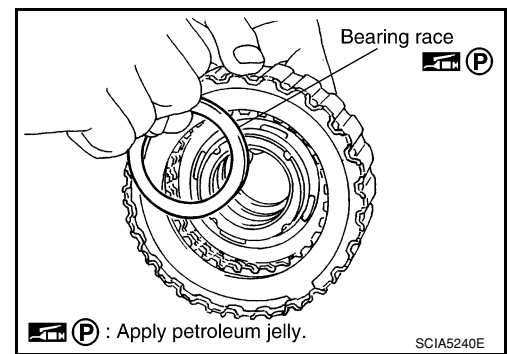

Direct Clutch

COMPONENTS

INFOID:000000001546724

A
B
C
TM
E
F
G
H
I
J
K
L
M
N
O
P

REPAIR FOR COMPONENT PARTS

< DISASSEMBLY AND ASSEMBLY >

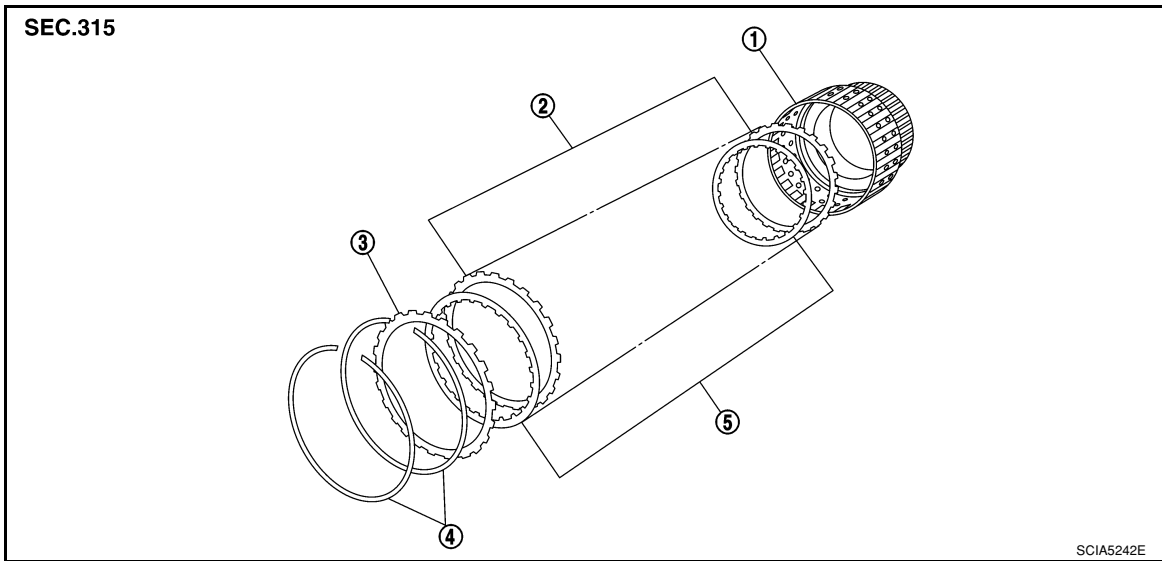

- | | | |
|-----------------------|-----------------|--------------------|
| 1. Direct clutch drum | 2. Driven plate | 3. Retaining plate |
| 4. Snap ring | 5. Drive plate | |

DISASSEMBLY

1. Remove snap rings from direct clutch drum using suitable tool.
2. Remove drive plates, driven plates and retaining plate from direct clutch drum.

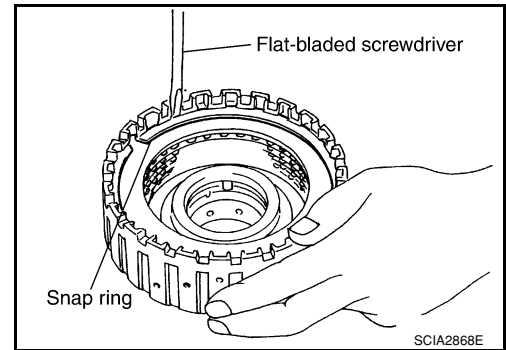

INSPECTION

- **Check the following, and replace direct clutch assembly if necessary.**

Direct Clutch Snap Rings

- Check for deformation, fatigue or damage.

Direct Clutch Drive Plates

- Check facing for burns, cracks or damage.

Direct Clutch Retaining Plate and Driven Plates

- Check facing for burns, cracks or damage.

ASSEMBLY

REPAIR FOR COMPONENT PARTS

< DISASSEMBLY AND ASSEMBLY >

1. Install drive plates, driven plates and retaining plate in direct clutch drum.

CAUTION:

Take care with the order of plates.

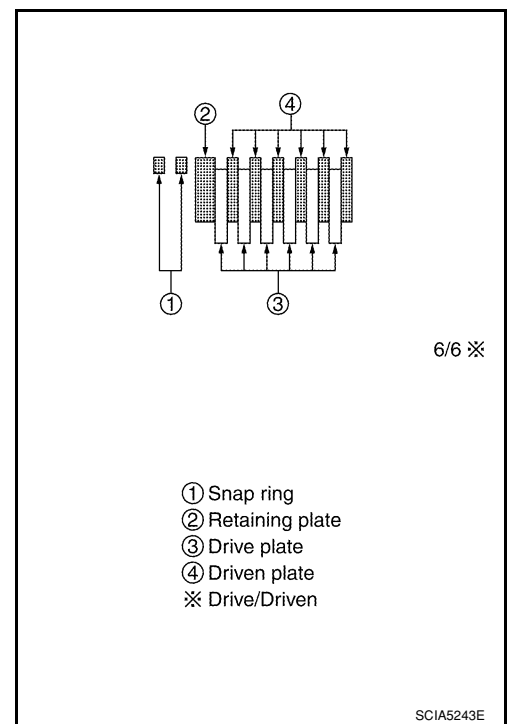

2. Install snap rings in direct clutch drum using suitable tool.

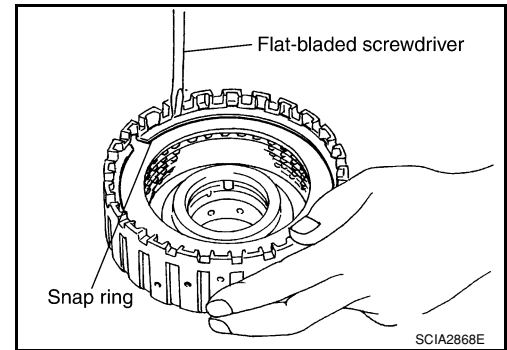

A
B
C
TM
E
F
G
H
I
J
K
L
M
N
O
P

ASSEMBLY

< DISASSEMBLY AND ASSEMBLY >

ASSEMBLY

Assembly (1)

INFOID:000000001547084

1. Drive manual shaft oil seals into the transmission case until they are flush using suitable tool.

CAUTION:

- Apply ATF to manual shaft oil seals.
- Do not reuse manual shaft oil seals.

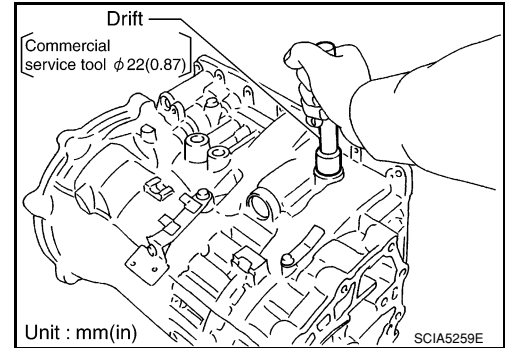

2. Install detent spring and spacer in transmission case and secure with the bolt.

Bolt : 7.9 N·m (0.81 kg-m, 70 in-lb)

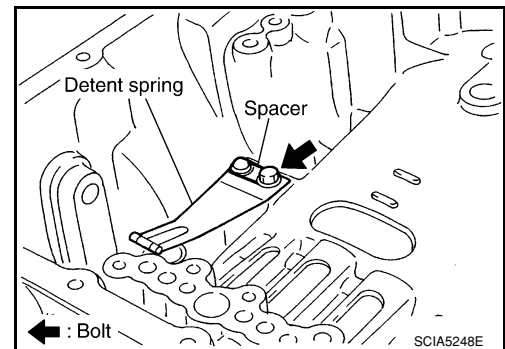

3. Install manual shaft to transmission case.

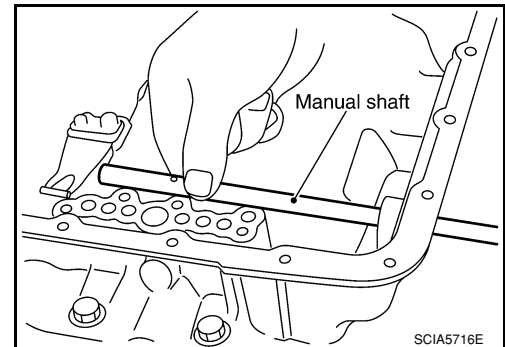

4. Install parking rod to manual plate.

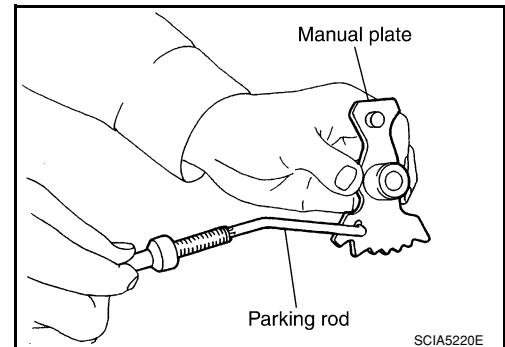

ASSEMBLY

< DISASSEMBLY AND ASSEMBLY >

5. Install manual plate (with parking rod) to manual shaft.

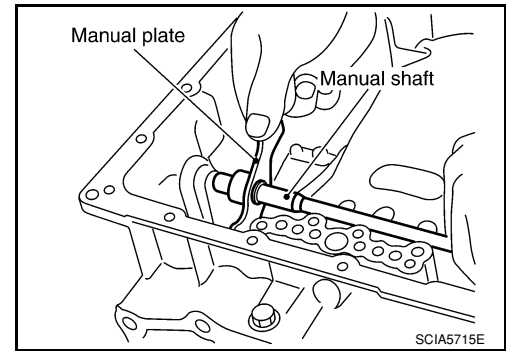

6. Install retaining pin into the manual plate and manual shaft.
- Align pinhole of the manual plate to pinhole of the manual shaft using suitable tool.
 - Tap the retaining pin into the manual plate using suitable tool.
- CAUTION:**
- Drive retaining pin to 2 ± 0.5 mm (0.08 ± 0.020 in) over the manual plate.
 - Do not reuse retaining pin.

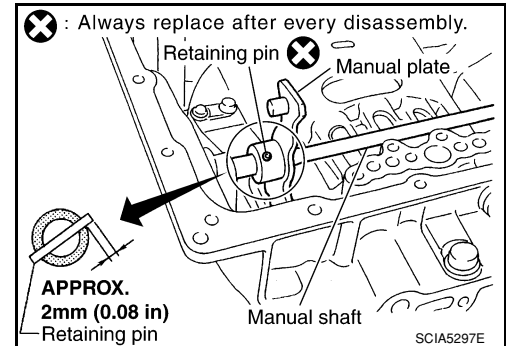

7. Install retaining pin into the transmission case and manual shaft.
- Align pinhole of the transmission case to pinhole of the manual shaft using suitable tool.
 - Tap the retaining pin into the transmission case using suitable tool.
- CAUTION:**
- Drive retaining pin to 5 ± 1 mm (0.20 ± 0.04 in) over the transmission case.
 - Do not reuse retaining pin.

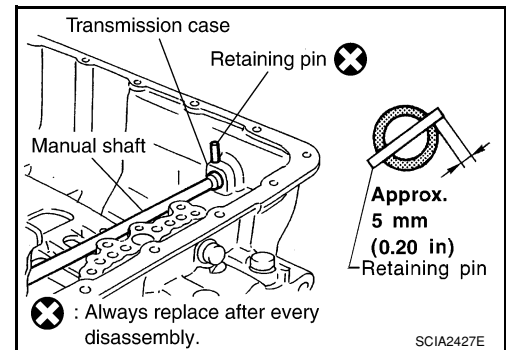

8. Install O-rings to servo assembly.
- CAUTION:**
- Do not reuse O-rings.
 - Apply petroleum jelly to O-rings.

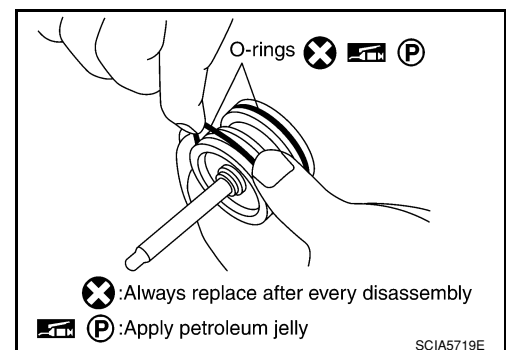

9. Install return spring to servo assembly.

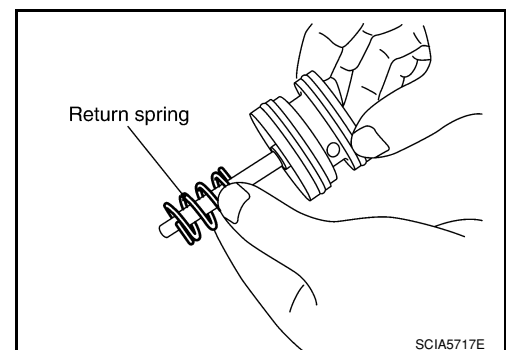

A
B
C
TM
E
F
G
H
I
J
K
L
M
N
O
P

ASSEMBLY

< DISASSEMBLY AND ASSEMBLY >

10. Install servo assembly in transmission case.

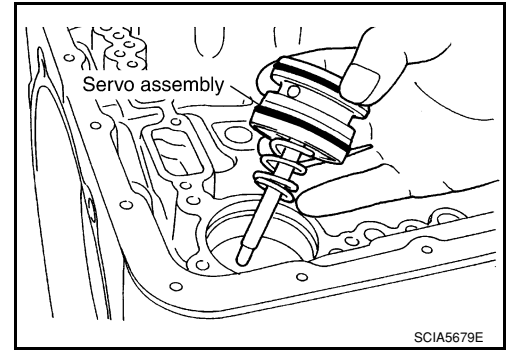

11. Install snap ring to transmission case using suitable tool.

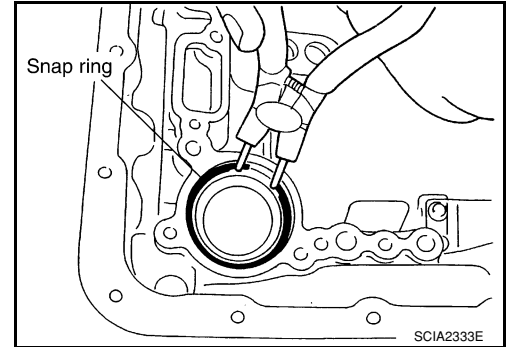

12. Install D-rings in reverse brake piston.

CAUTION:

- Do not reuse D-rings.
- Apply ATF to D-rings.

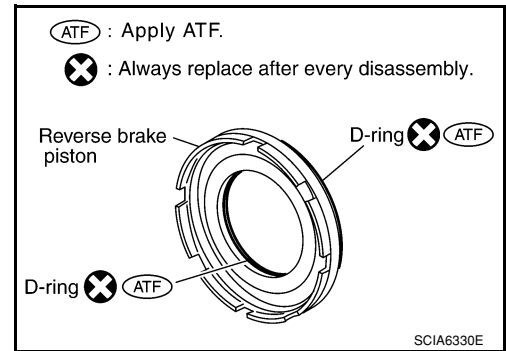

13. Install reverse brake piston in transmission case.

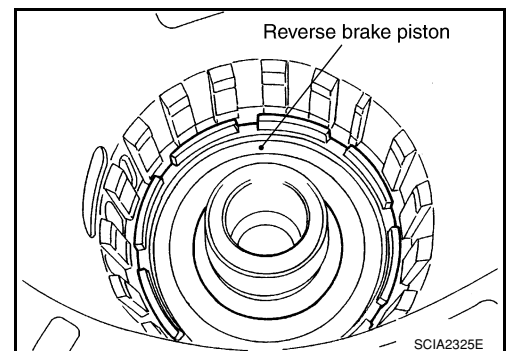

14. Install needle bearing to drum support edge surface.

CAUTION:

- Apply petroleum jelly to needle bearing.

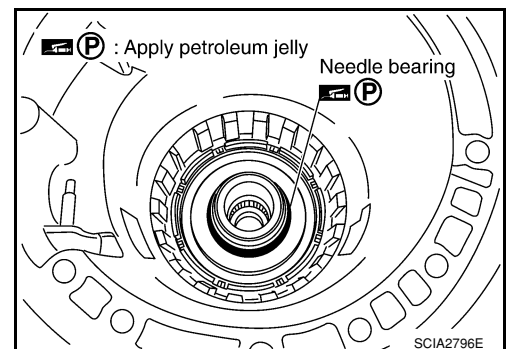

ASSEMBLY

< DISASSEMBLY AND ASSEMBLY >

15. Install seal rings to drum support.

CAUTION:

- Do not reuse seal rings.
- Apply petroleum jelly to seal rings.

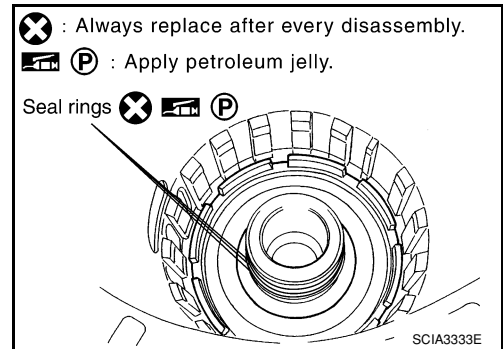

16. Install spring retainer and return spring in transmission case.

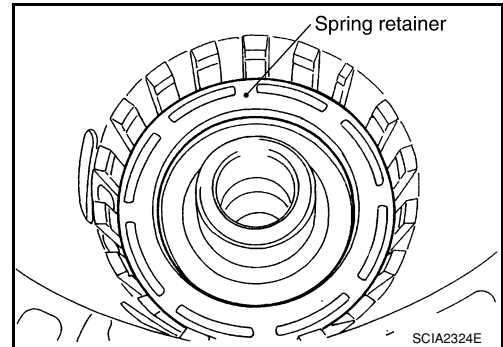

17. Install snap ring in transmission case while compressing return spring using Tool.

Tool number : KV31102400 (J-34285 and J-34285-87)

CAUTION:

Securely assemble them using a flat-bladed screwdriver so that snap ring tension is slightly weak.

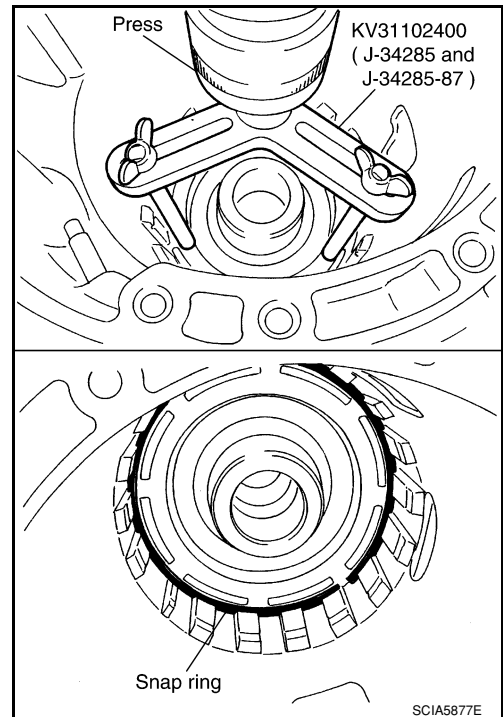

18. Install reversr brake drive plates driven plates and dish plates in transmission case.

CAUTION:

ASSEMBLY

< DISASSEMBLY AND ASSEMBLY >

Take care with order of plates.

- Snap ring (1)
- Retaining plate (2)
- Drive plate (3)
- Driven plate (4)
- Dish plate (5)
- Driveplate/Driven plate: 7/7

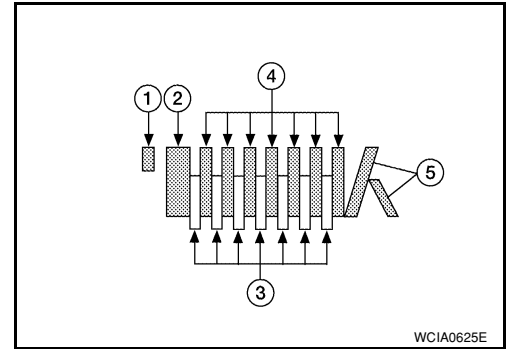

19. Assemble N-spring.

20. Install reverse brake retaining plate in transmission case.

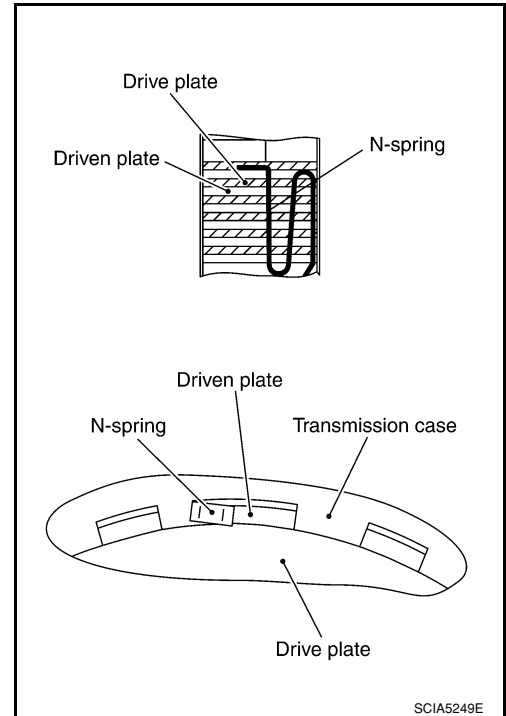

21. Install snap ring in transmission case.

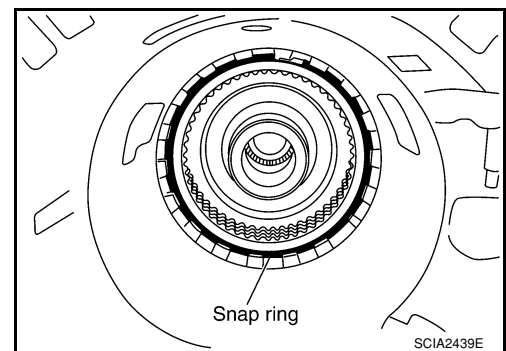

22. Measure clearance (A) between retaining plate and snap ring. If not within specified clearance, select proper retaining plate.

Clearance "A" : 0.7 - 1.1mm (0.028 - 0.043 in)
Retaining plate : Refer to [TM-305, "Reverse Brake"](#).

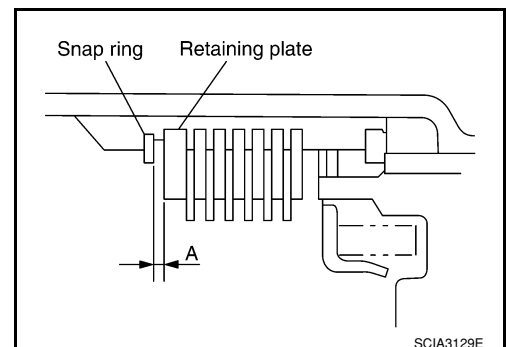

ASSEMBLY

< DISASSEMBLY AND ASSEMBLY >

23. Install needle bearing to transmission case.

CAUTION:

- Take care with the direction of needle bearing. Refer to [TM-242, "Location of Adjusting Shims, Needle Bearings, Thrust Washers and Snap Rings"](#).
- Apply petroleum jelly to needle bearing.

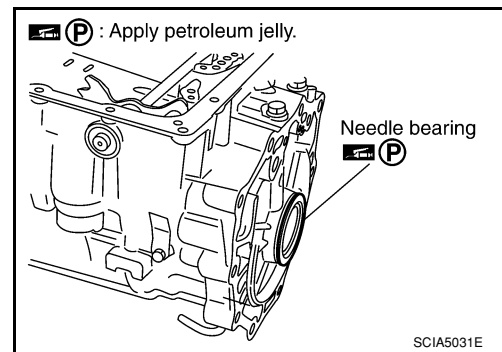

24. Install revolution sensor to transmission case and tighten bolt to specified torque.

Revolution sensor bolt : 5.8 N·m (0.59 kg-m, 51 in-lb)

CAUTION:

- Do not subject sensor to impact by dropping or hitting it.
- Do not disassemble sensor.
- Do not allow metal filings or any foreign material to get on the sensor's front edge magnetic area.
- Do not place sensor in an area affected by magnetism.

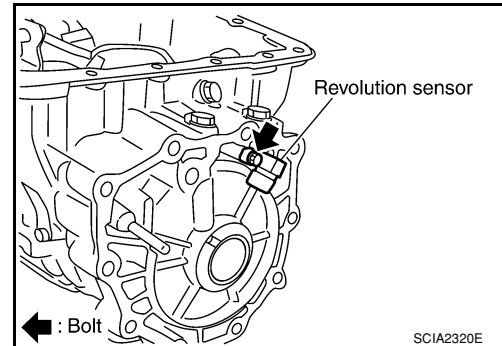

25. Install new rear oil seal until it is flush into the rear extension case (2WD models) using Tool or adapter case (4WD models) using suitable tool.

Tool number : ST33400001 (J-26082)

CAUTION:

- Apply ATF to rear oil seal.
- Do not reuse rear oil seal.

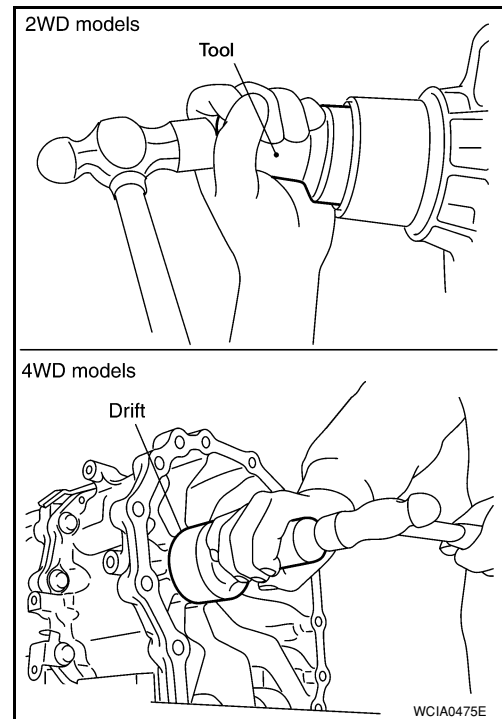

26. Install return spring (1) to parking pawl (2).

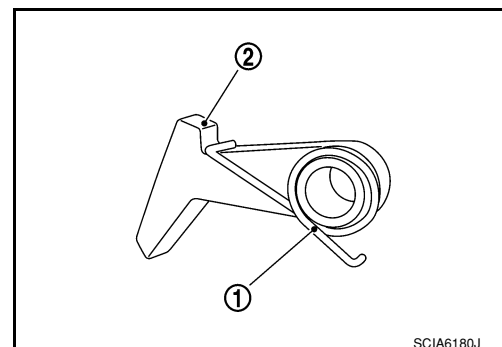

A
B
C
TM
E
F
G
H
I
J
K
L
M
N
O
P

ASSEMBLY

< DISASSEMBLY AND ASSEMBLY >

27. Install parking pawl (with return spring) and pawl shaft to rear extension (2WD models) or adapter case (4WD models).

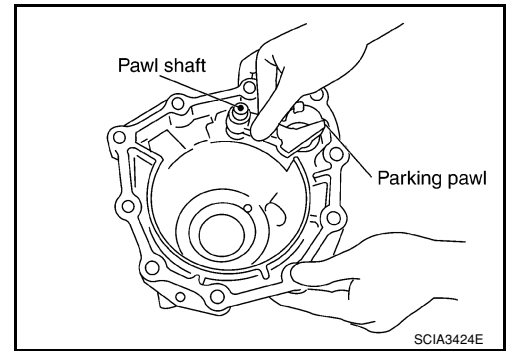

28. Install parking actuator support to rear extension (2WD models) or adapter case (4WD models).

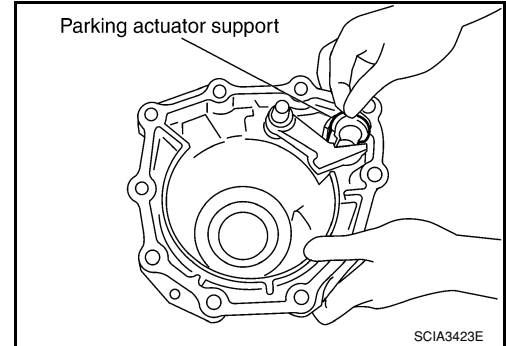

29. Install needle bearing (1) to rear extension (2WD models) or adapter case (4WD models).

CAUTION:

Apply petroleum jelly to needle bearing.

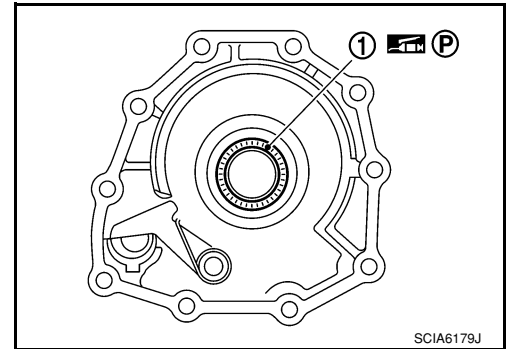

30. Install seal rings to output shaft.

CAUTION:

- Do not reuse seal rings.
- Apply petroleum jelly to seal rings.

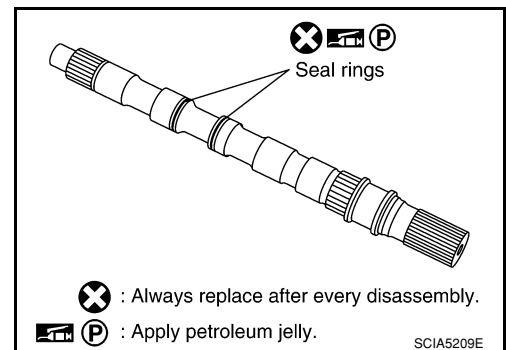

31. Install parking gear to output shaft.

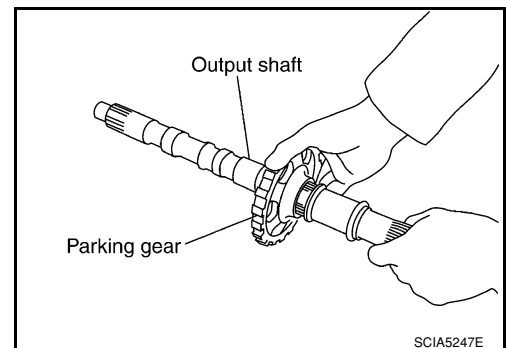

ASSEMBLY

< DISASSEMBLY AND ASSEMBLY >

32. Install output shaft in transmission case.

CAUTION:

Do not mistake front of shaft for rear because both sides look similar (thinner end is front side).

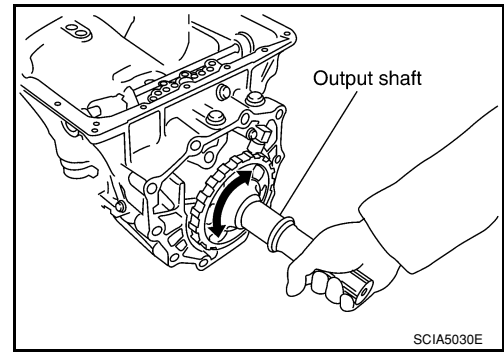

33. Install bearing race to output shaft.

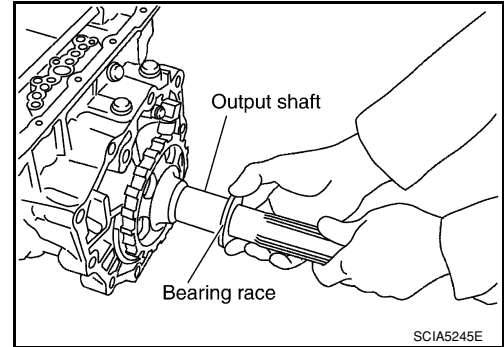

34. Install rear extension assembly (2WD models) or adapter case assembly (4WD models) according to the following procedures.

a. **2WD models**

- i. Apply recommended sealant (Genuine Anaerobic Liquid Gasket or equivalent. Refer to [GI-15. "Recommended Chemical Products and Sealants"](#).) to rear extension assembly as shown.

CAUTION:

Completely remove all moisture, oil, old sealant and any foreign material from the transmission case and rear extension assembly mating surfaces.

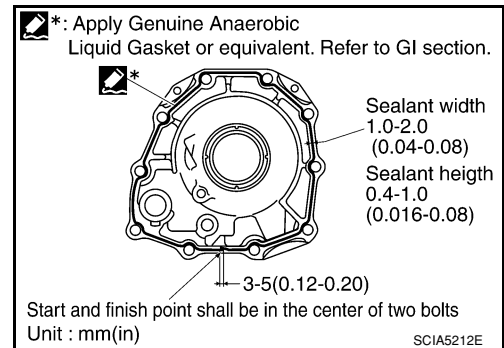

- ii. Install rear extension assembly to transmission case.

CAUTION:

Insert the tip of parking rod between the parking pawl and the parking actuator support when assembling the rear extension assembly.

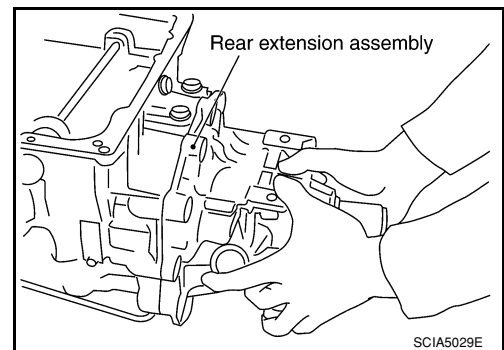

A
B
C
TM
E
F
G
H
I
J
K
L
M
N
O
P

ASSEMBLY

< DISASSEMBLY AND ASSEMBLY >

- iii. Tighten rear extension assembly bolts (1) and (2) to specified torque.

Rear extension assembly bolt : 52 N·m (5.3 kg-m, 38 ft-lb)

Self-sealing bolt : 61 N·m (6.2 kg-m, 45 ft-lb)

CAUTION:

Do not reuse self-sealing bolt.

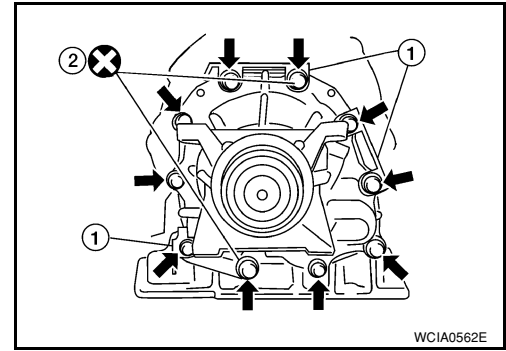

- b. **4WD models**

- i. Install gasket onto transmission case.

CAUTION:

- Completely remove all moisture, oil, old gasket and any foreign material from the transmission case and adapter case assembly mating surfaces.
- Do not reuse gasket.

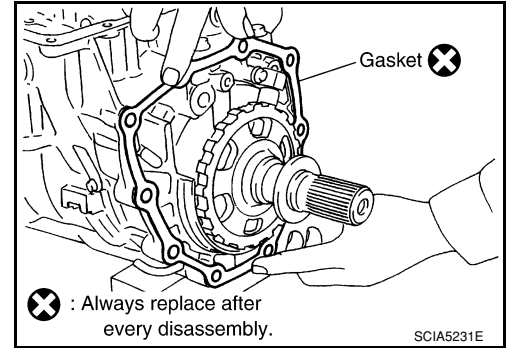

- ii. Install adapter case assembly to transmission case.

CAUTION:

Insert the tip of parking rod between the parking pawl and the parking actuator support when assembling the rear extension assembly.

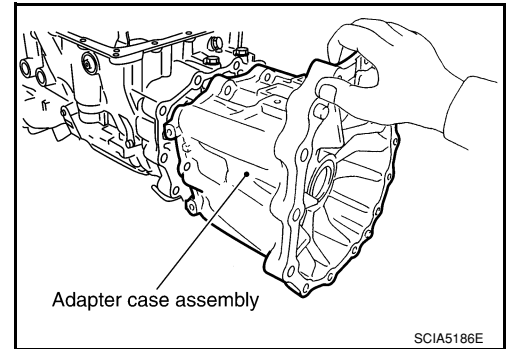

- iii. Tighten adapter case assembly to specified torque.

CAUTION:

Do not reuse self-sealing bolt (2).

Adapter case assembly bolt : 52 N·m (5.3 kg-m, 38 ft-lb)

Self-sealing bolt : 61 N·m (6.2 kg-m, 45 ft-lb)

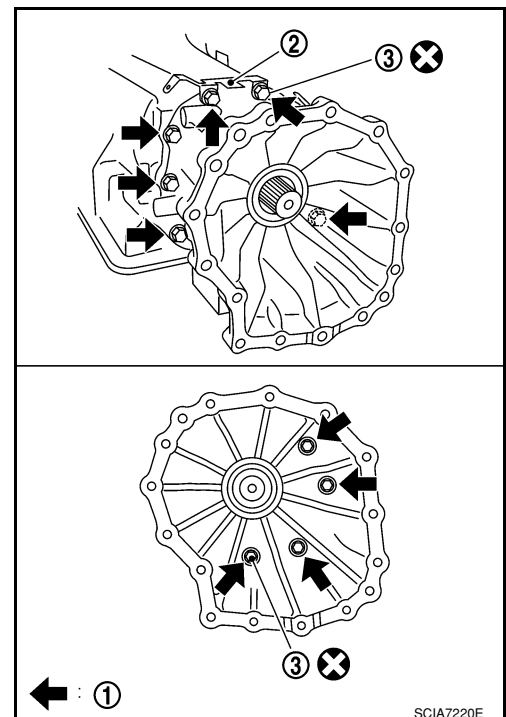

ASSEMBLY

< DISASSEMBLY AND ASSEMBLY >

35. Install direct clutch assembly in reverse brake.

CAUTION:

Make sure that drum support edge surface and direct clutch inner boss edge surface come to almost same place.

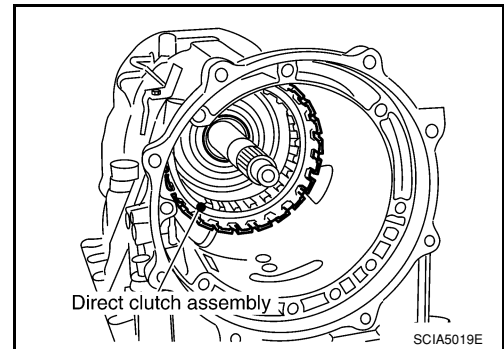

36. Install needle bearing in drum support.

CAUTION:

Apply petroleum jelly to needle bearing.

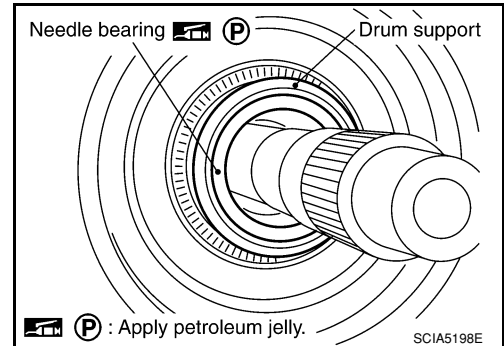

37. Install high and low reverse clutch assembly in direct clutch.

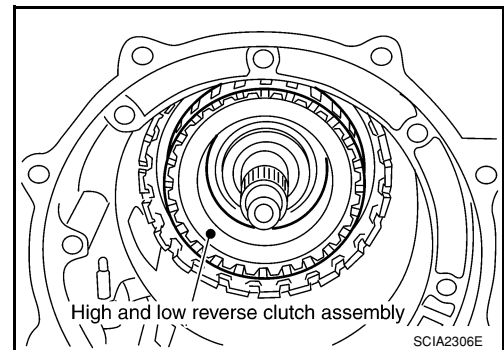

38. Align the drive plate using suitable tool.

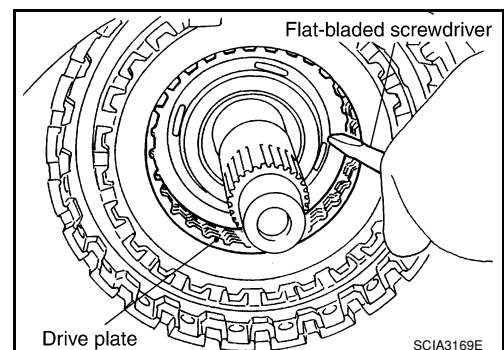

39. Install high and low reverse clutch hub, mid sun gear assembly and rear sun gear assembly as a unit.

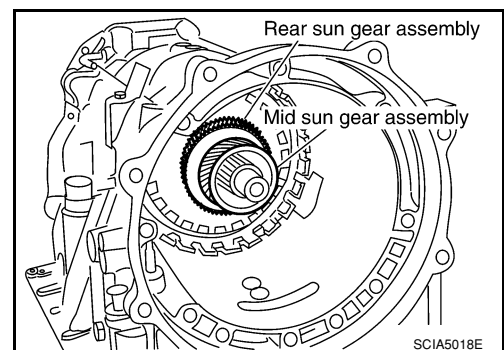

A

B

C

TM

E

F

G

H

I

J

K

L

M

N

O

P

ASSEMBLY

< DISASSEMBLY AND ASSEMBLY >

CAUTION:

Make sure that portion "A" of high and low reverse clutch drum protrudes approximately 2 mm (0.08 in) beyond portion "B" of rear sun gear.

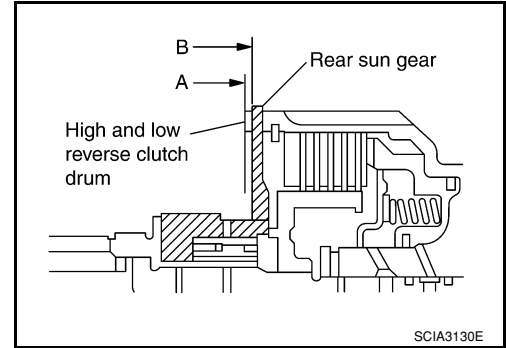

40. Install needle bearing in rear carrier assembly.

CAUTION:

Apply petroleum jelly to needle bearing.

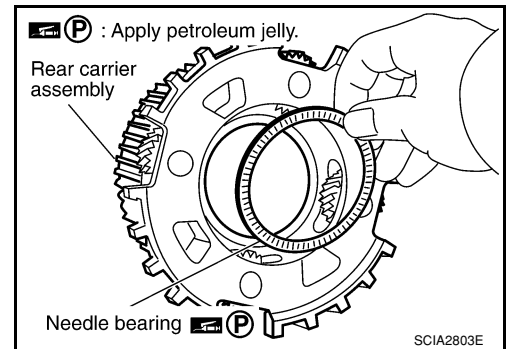

41. Install bearing race in rear carrier assembly.

CAUTION:

Apply petroleum jelly to bearing race.

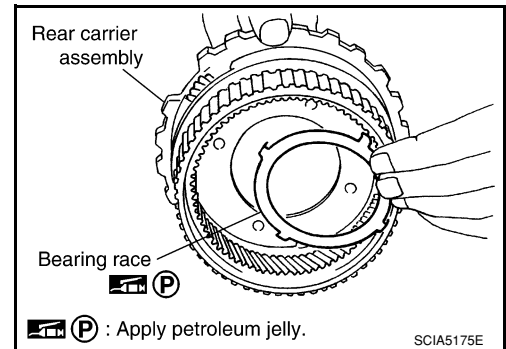

42. Install rear carrier assembly in direct clutch drum.

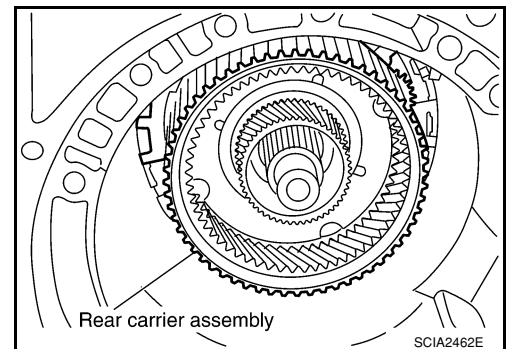

ASSEMBLY

< DISASSEMBLY AND ASSEMBLY >

43. Install needle bearing (rear side) to mid carrier assembly.

CAUTION:

Apply petroleum jelly to needle bearing.

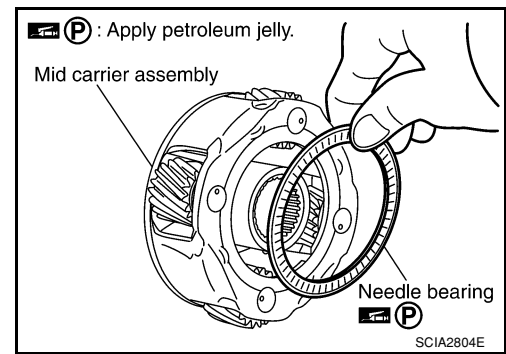

44. Install needle bearing (front side) to mid carrier assembly.

CAUTION:

Apply petroleum jelly to needle bearing.

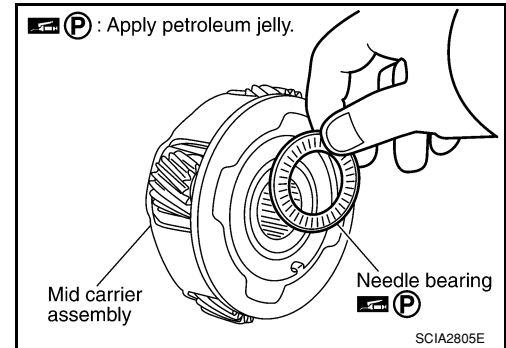

45. Install mid carrier assembly in rear carrier assembly.

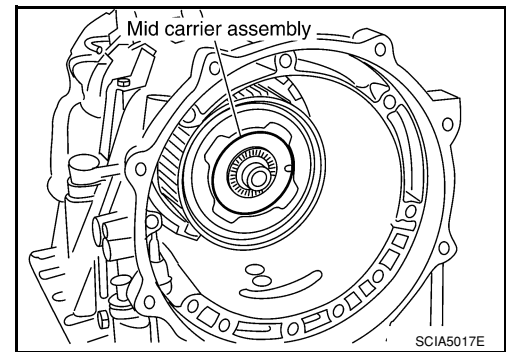

46. Install front carrier assembly, input clutch assembly and rear internal gear as a unit.

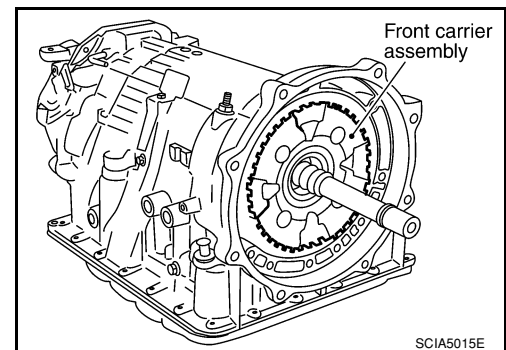

47. Install seal rings in input clutch assembly.

CAUTION:

- Do not reuse seal rings.
- Apply petroleum jelly to seal rings.

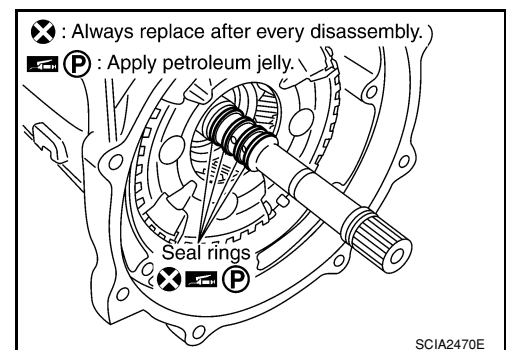

A
B
C
TM
E
F
G
H
I
J
K
L
M
N
O
P

ASSEMBLY

< DISASSEMBLY AND ASSEMBLY >

48. Install band servo anchor end pin and lock nut in transmission case.

CAUTION:

Do not reuse band servo anchor end pin.

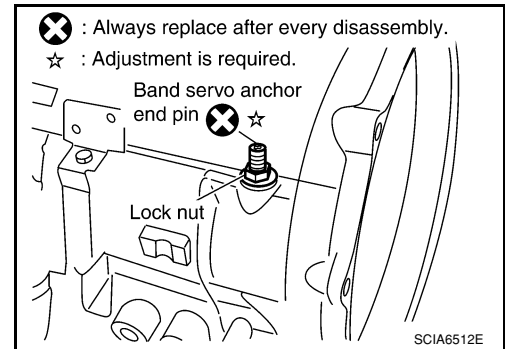

49. Install brake band in transmission case.

CAUTION:

Install it so that the identification to avoid incorrect installation faces the servo side.

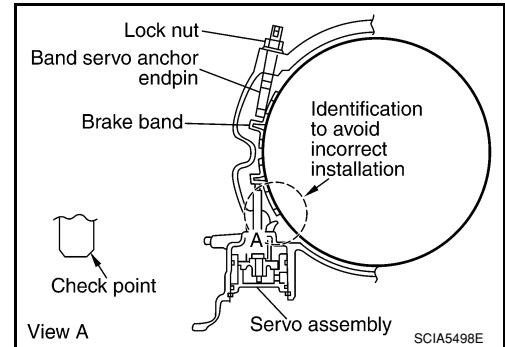

50. Install front sun gear to front carrier assembly.

CAUTION:

Apply ATF to front sun gear bearing and 3rd one-way clutch end bearing.

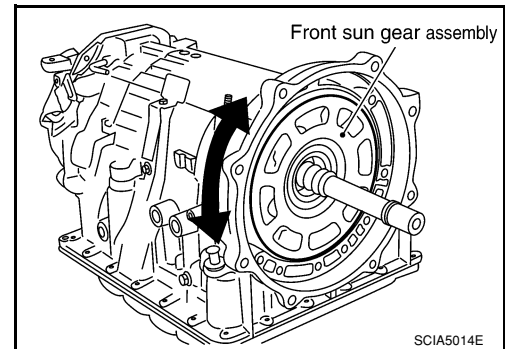

51. Install needle bearing to front sun gear.

CAUTION:

Apply petroleum jelly to needle bearing.

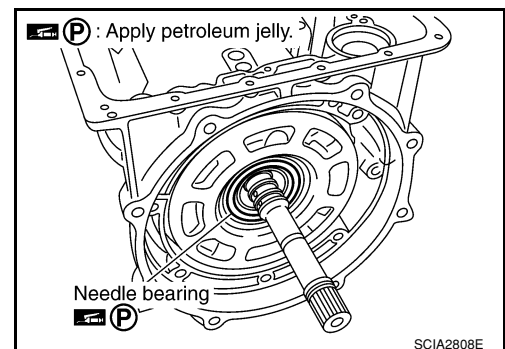

52. Adjust brake band tilting using a clip so that brake band contacts front sun gear drum evenly.

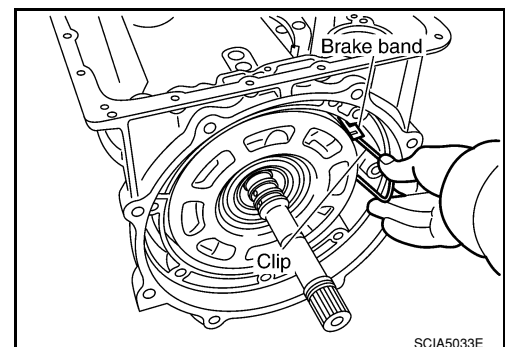

ASSEMBLY

< DISASSEMBLY AND ASSEMBLY >

53. Adjust brake band.

- a. Loosen lock nut.
- b. Tighten band servo anchor end pin to specified torque.

Anchor end pin : 5.0 N·m (0.51 kg-m, 44 in-lb)

- c. Back off band servo anchor end pin three turns.
- d. Holding band servo anchor end pin, tighten lock nut to specified torque.

Lock nut : 46 N·m (4.7 kg-m, 34 ft-lb)

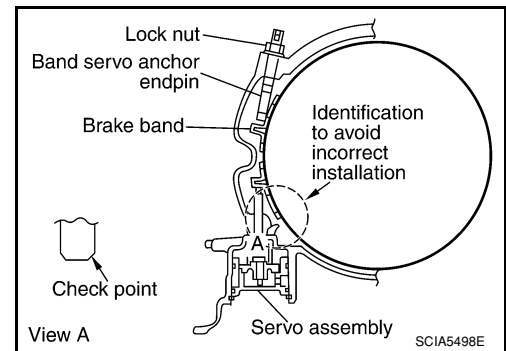

Adjustment

INFOID:000000001547085

TOTAL END PLAY

- Measure clearance between front sun gear and bearing race for oil pump cover.
- Select proper thickness of bearing race so that end play is within specifications.

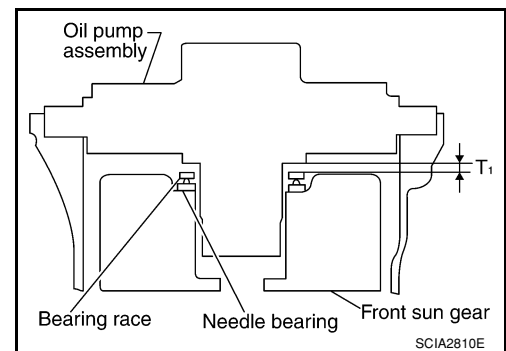

1. Measure dimensions "K" and "L" and then calculate dimension "J".

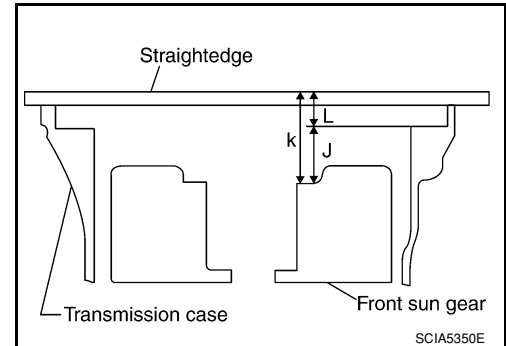

- a. Measure dimension "K".

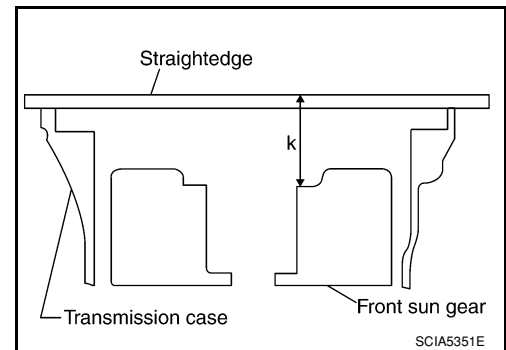

ASSEMBLY

< DISASSEMBLY AND ASSEMBLY >

- b. Measure dimension "L".
- c. Calculate dimension "J".

"J": Distance between oil pump fitting surface of transmission case and needle bearing mating surface of front sun gear.

$$J = K - L$$

- 2. Measure dimensions "M1" and "M2" and then calculate dimension "M".

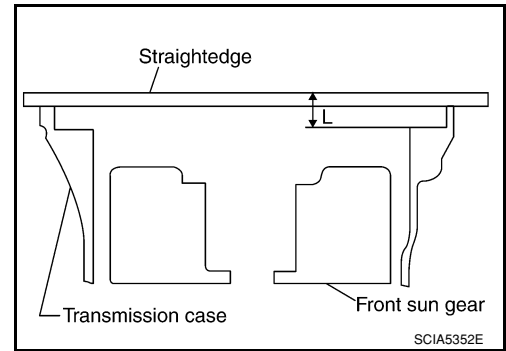

- a. Place bearing race and needle bearing on oil pump assembly.

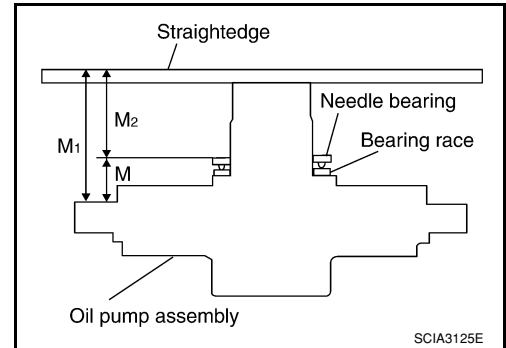

- b. Measure dimension "M1".

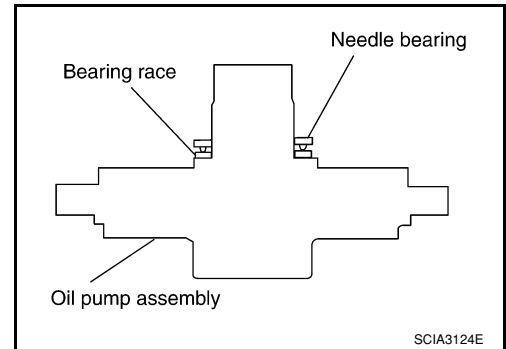

- c. Measure dimension "M2".

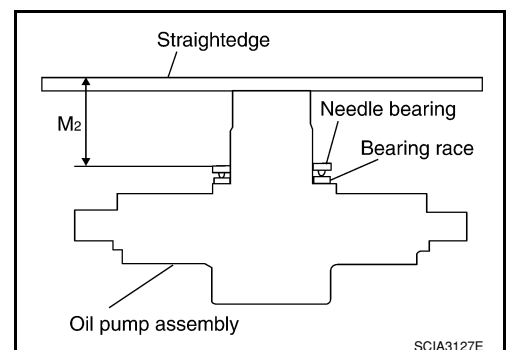
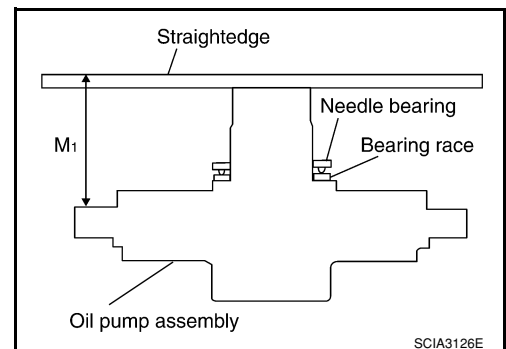

ASSEMBLY

< DISASSEMBLY AND ASSEMBLY >

d. Calculate dimension "M".

"M": Distance between transmission case fitting surface of oil pump and needle bearing on oil pump.

$$M = M_1 - M_2$$

3. Adjust total end play "T1".

$$T_1 = J - M$$

Total end play "T1" : 0.25 - 0.55 mm (0.0098 - 0.0217 in)

- Select proper thickness of bearing race so that total end play is within specifications.

Bearing races :Refer to [TM-304, "General Specification"](#).

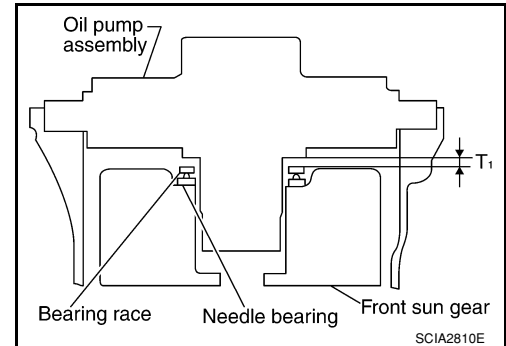
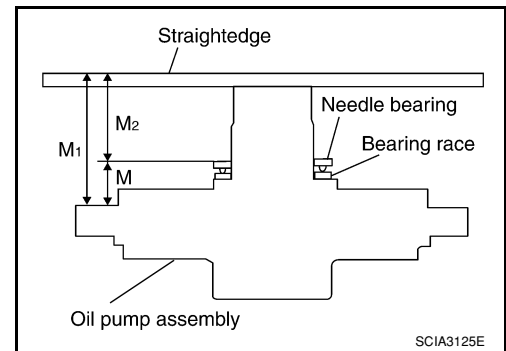

Assembly (2)

1. Install O-ring to oil pump assembly.

CAUTION:

- Do not reuse O-ring.
- Apply ATF to O-ring.

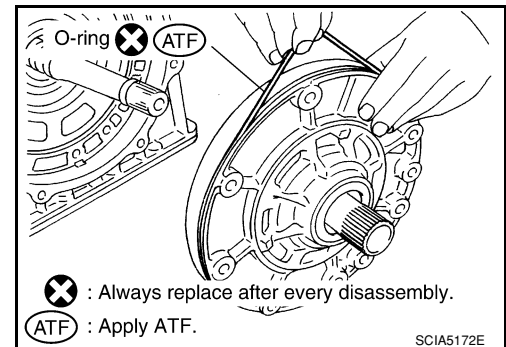

2. Install bearing race to oil pump assembly.

CAUTION:

Apply petroleum jelly to bearing race.

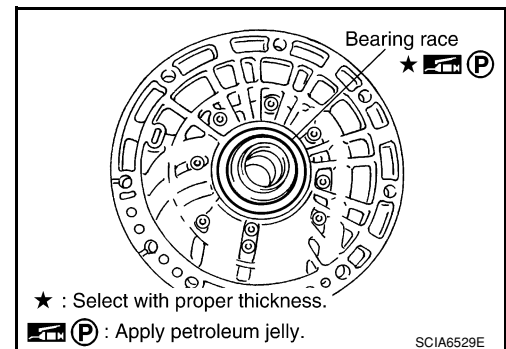

ASSEMBLY

< DISASSEMBLY AND ASSEMBLY >

3. Install oil pump assembly in transmission case.

CAUTION:

Apply ATF to oil pump bearing.

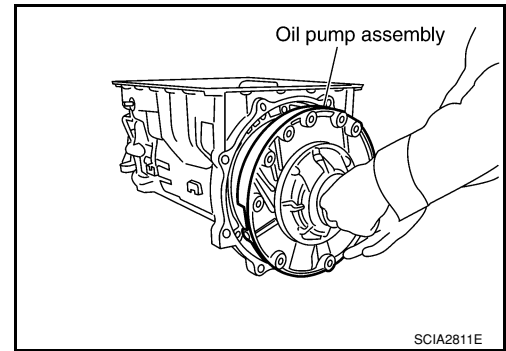

4. Apply recommended sealant (Genuine RTV Silicone Sealant or equivalent. Refer to [GI-15. "Recommended Chemical Products and Sealants"](#).) to oil pump assembly as shown.

CAUTION:

Completely remove all moisture, oil, old sealant and any foreign material from the oil pump bolts and oil pump bolt mating surfaces.

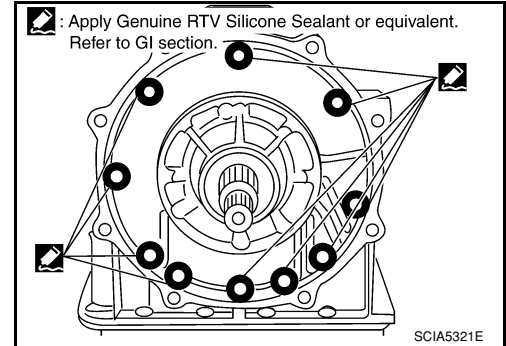

5. Tighten oil pump bolts to specified torque.

Oil pump bolts : 48 N·m (4.9 kg-m, 35 ft-lb)

CAUTION:

Apply ATF to oil pump bushing.

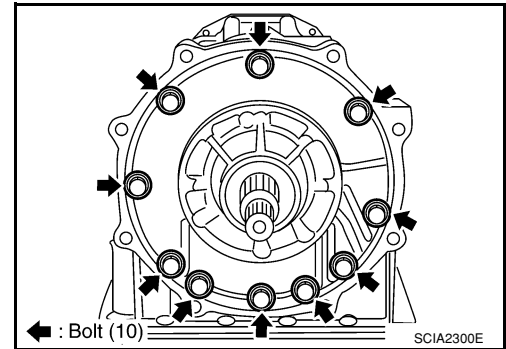

6. Install O-ring to input clutch assembly.

CAUTION:

- Do not reuse O-ring.
- Apply ATF to O-ring.

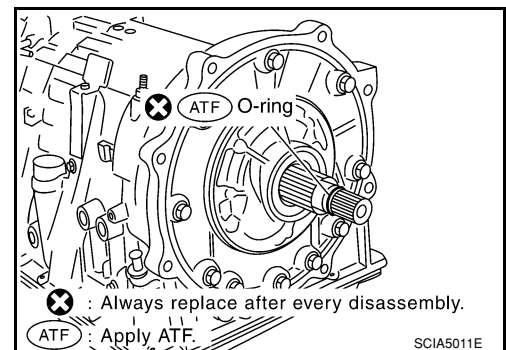

7. Install converter housing to transmission case and tighten bolts to specified torque.

Converter housing bolt : 52 N·m (5.3 kg-m, 38 ft-lb)

Self-sealing bolt (A) : 61 N·m (6.2 kg-m, 45 ft-lb)

CAUTION:

Do not reuse self-sealing bolt (A).

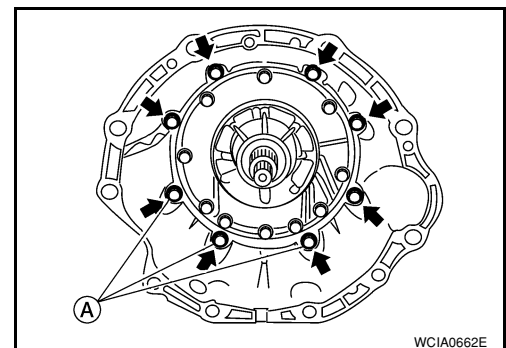

ASSEMBLY

< DISASSEMBLY AND ASSEMBLY >

8. Make sure that brake band does not close turbine revolution sensor hole.

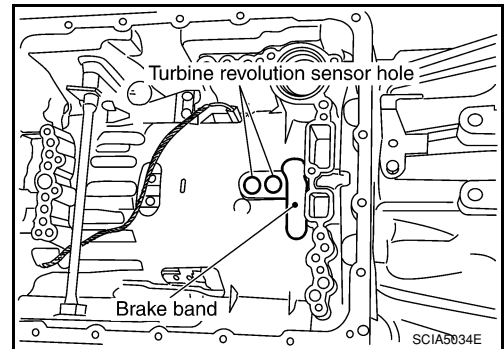

9. Install control valve with TCM.
 - a. Connect TCM connector and park/neutral position switch connector.

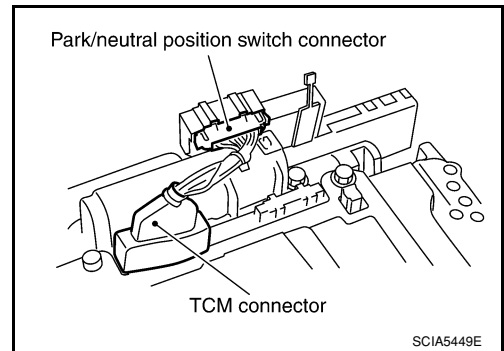

- b. Install A/T assembly harness connector to control valve with TCM.

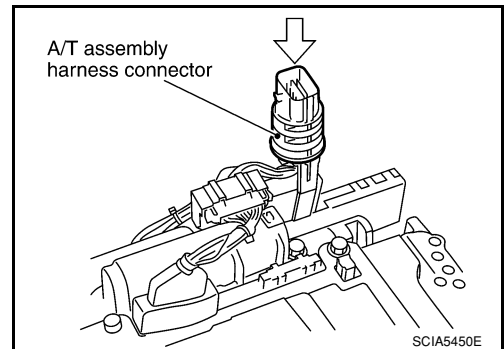

- c. Connect TCM connectors.

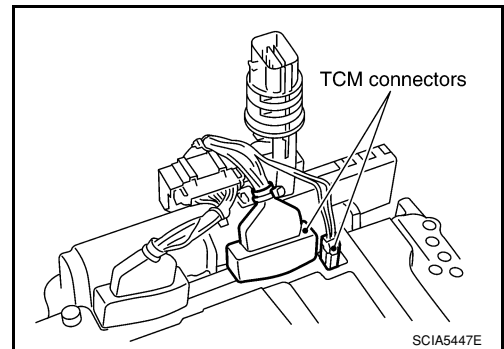

A
B
C
TM
E
F
G
H
I
J
K
L
M
N
O
P

ASSEMBLY

< DISASSEMBLY AND ASSEMBLY >

d. Install O-ring to A/T assembly harness connector.

CAUTION:

- Do not reuse O-ring.
- Apply ATF to O-ring.

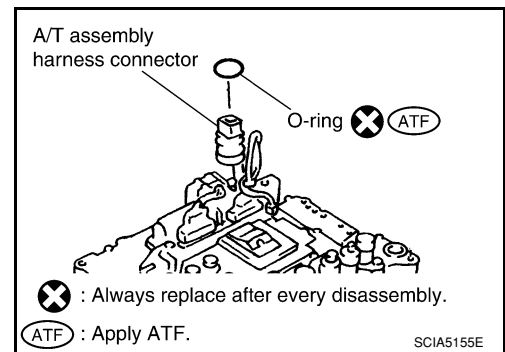

e. Install A/T fluid temperature sensor 2 to bracket.

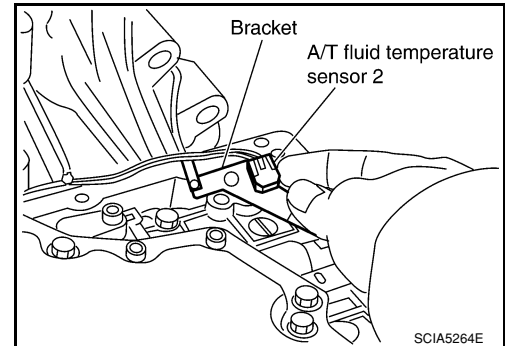

f. Install A/T fluid temperature sensor 2 (with bracket) to control valve with TCM and tighten bolt to specified torque.

Bracket bolt : 7.9 N·m (0.81 kg-m, 70 in-lb)

CAUTION:

Adjust bolt hole of bracket to bolt hole of control valve.

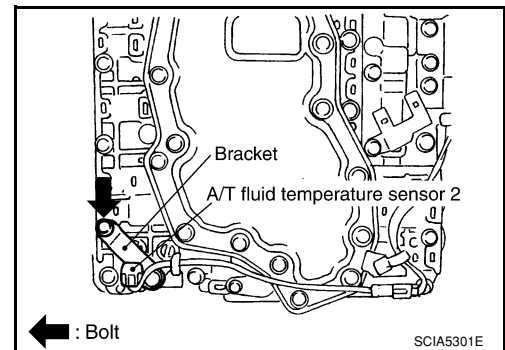

g. Install control valve with TCM in transmission case.

CAUTION:

- Make sure that turbine revolution sensor is securely installed into turbine revolution sensor hole.
- Hang down revolution sensor harness toward outside so as not to disturb installation of control valve with TCM.
- Adjust A/T assembly harness connector of control valve with TCM to terminal hole of transmission case.

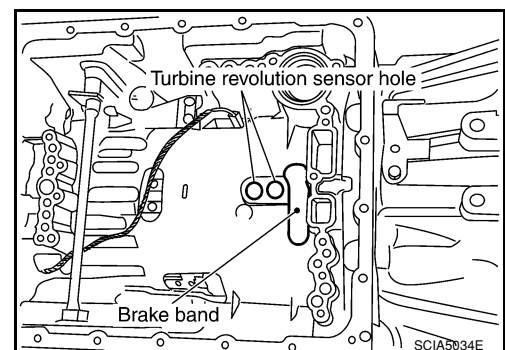

- Assemble it so that manual valve cutout is engaged with manual plate projection.

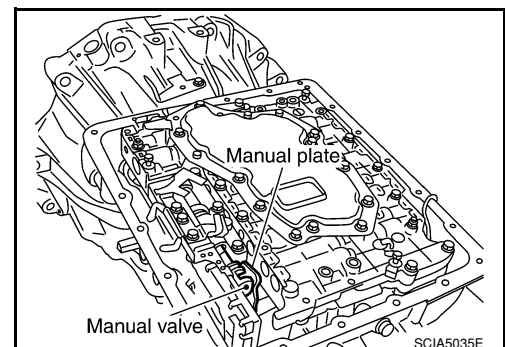

ASSEMBLY

< DISASSEMBLY AND ASSEMBLY >

h. Install bolts (A), (B) and (C) to control valve with TCM.

- ⇨ : Front

Bolt symbol	Length mm (in)	Number of bolts
A	42 (1.65)	5
B	55 (2.17)	6
C	40 (1.57)	1

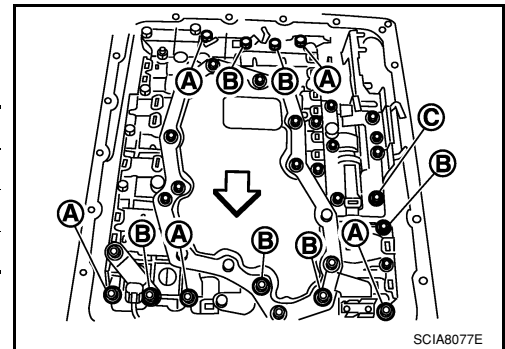

SCIA8077E

A
B
C

TM

i. Tighten bolt (A), (B) and (C) temporarily to prevent dislocation. After that tighten them in order (A → B → C), and then tighten other bolts.

Bolts : 7.9 N·m (0.81 kg-m, 70 in-lb)

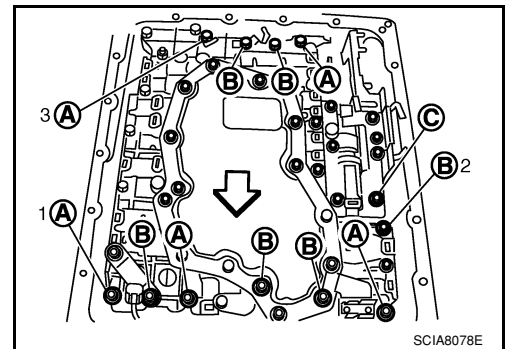

SCIA8078E

E
F
G

H

10. Connect A/T fluid temperature sensor 2 connector (A).

11. Securely fasten terminal cord assembly and A/T fluid temperature sensor 2 harness with terminal clips.

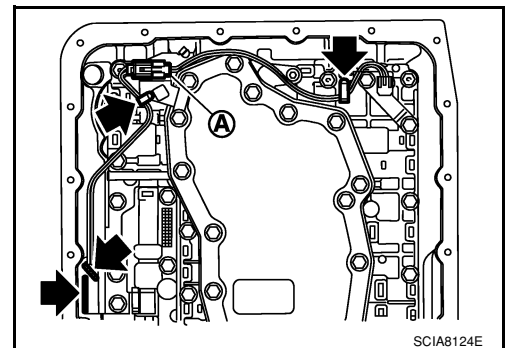

SCIA8124E

I
J
K

L

12. Connect revolution sensor connector.

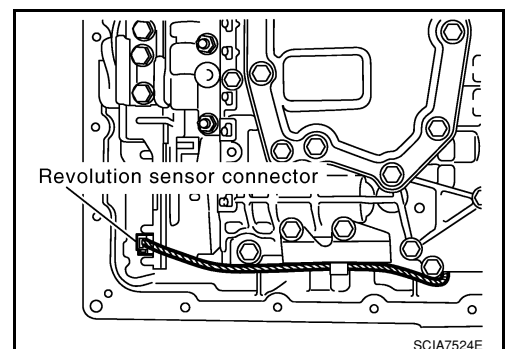

SCIA7524E

M
N
O

P

ASSEMBLY

< DISASSEMBLY AND ASSEMBLY >

13. Securely fasten revolution sensor harness with terminal clip.

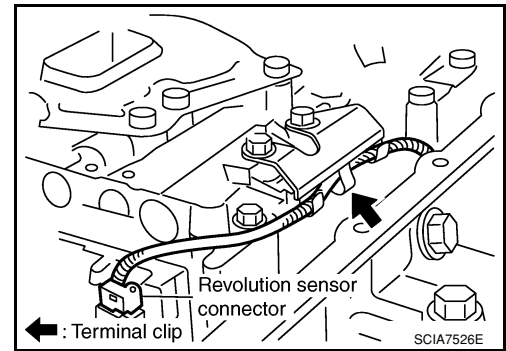

14. Pull down A/T assembly harness connector.

CAUTION:
Do not damage connector.

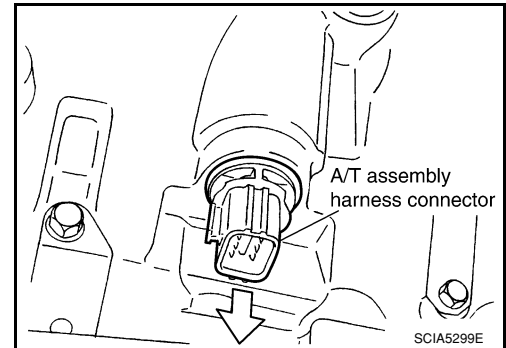

15. Install snap ring to A/T assembly harness connector.

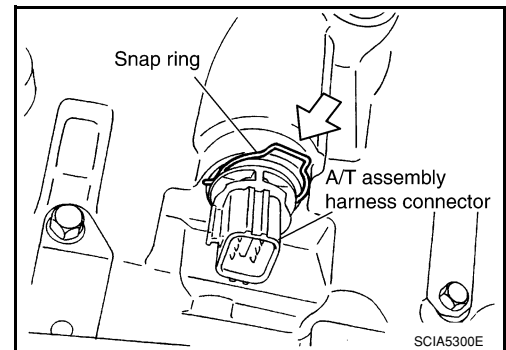

16. Install magnets in oil pan.

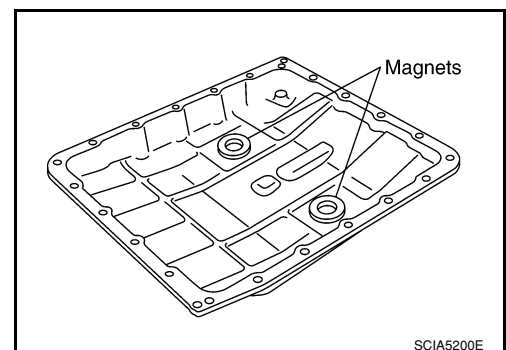

17. Install oil pan to transmission case. Refer to [TM-215. "Oil Pan"](#).

18. Install torque converter.

ASSEMBLY

< DISASSEMBLY AND ASSEMBLY >

- a. Pour ATF into torque converter.

NOTE:

- Approximately 2 liters (2-1/8 US qt. 1-3/4 Imp qt) of fluid is required for a new torque converter.
- When reusing old torque converter, add the same amount of fluid as was drained.

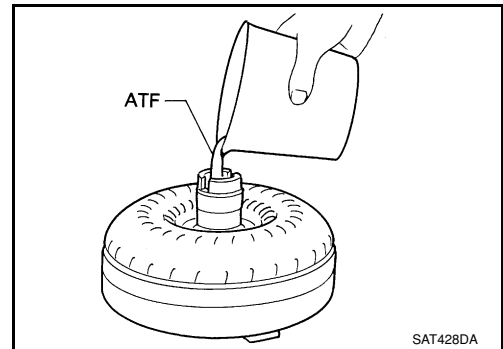

- b. Install torque converter while aligning notches of torque converter with notches of oil pump.

CAUTION:

Install torque converter while rotating it.

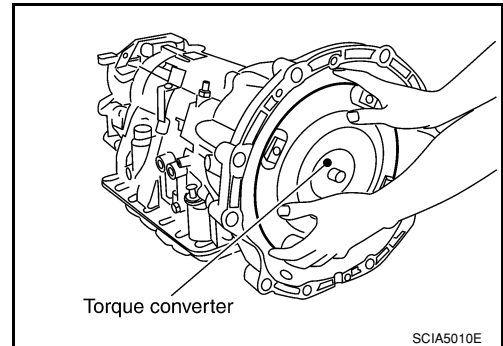

- c. Measure distance "A" to make sure that torque converter is in proper position.

Distance "A" : 24.0 mm (0.94 in) or more

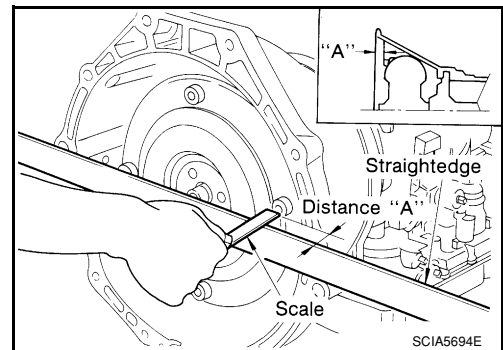

A
B
C
TM
E
F
G
H
I
J
K
L
M
N
O
P

SERVICE DATA AND SPECIFICATIONS (SDS)

< SERVICE DATA AND SPECIFICATIONS (SDS)

SERVICE DATA AND SPECIFICATIONS (SDS)

SERVICE DATA AND SPECIFICATIONS (SDS)

General Specification

INFOID:000000001530028

Applied model		2WD	4WD
Automatic transmission model	RE5R05A		
Transmission model code number	95X8D	95X8E	
Stall torque ratio	2.0 : 1		
Transmission gear ratio	1st	3.827	
	2nd	2.368	
	3rd	1.520	
	4th	1.000	
	5th	0.834	
	Reverse	2.613	
Recommended fluid	Genuine NISSAN Matic J ATF* ¹		
Fluid capacity	10.6 liter (11-1/4 US qt, 9-3/8 Imp qt)* ²		

CAUTION:

- Use only Genuine NISSAN Matic J ATF. Do not mix with other fluid.
- Using ATF other than Genuine NISSAN Matic J ATF will cause deterioration driveability and A/T durability, and may damage the A/T, which is not covered by the NISSAN new vehicle limited warranty.

*1: Refer to [MA-10. "Fluids and Lubricants"](#).

*2: The fluid capacity is the reference value. Check the fluid level with A/T fluid level gauge.

Vehicle Speed at Which Gear Shifting Occurs

INFOID:000000001530029

Throttle position	Vehicle speed km/h (MPH)							
	D1→D2	D2→D3	D3→D4	D4→D5	D5→D4	D4→D3	D3→D2	D2→D1
Full throttle	57 - 61 (35 - 38)	93 - 101 (58 - 63)	140 - 150 (87 - 93)	202 - 212 (126 - 132)	198 - 208 (123 - 129)	130 - 140 (81 - 87)	79 - 87 (49 - 54)	31 - 35 (19 - 22)
Half throttle	39 - 43 (24 - 27)	71 - 77 (44 - 48)	108 - 116 (67 - 72)	139 - 147 (86 - 91)	105 - 113 (65 - 70)	47 - 55 (29 - 34)	30 - 36 (19 - 22)	9 - 13 (6 - 8)

• At half throttle, the accelerator opening is 4/8 of the full opening.

Vehicle Speed at Which Lock-up Occurs/Releases

INFOID:000000001530030

Final gear ratio	Throttle position	Vehicle speed km/h (MPH)	
		Lock-up ON	Lock-up OFF
2.937	Closed throttle	65 - 73 (40 - 45)	62 - 70 (39 - 44)
	Half throttle	177 - 185 (110 - 115)	136 - 144 (85 - 90)
3.357	Closed throttle	57 - 65 (35 - 40)	54 - 62 (34 - 39)
	Half throttle	161 - 169 (100 - 105)	118 - 126 (74 - 79)

• At closed throttle, the accelerator opening is less than 1/8 condition. (Closed throttle position signal OFF)

• At half throttle, the accelerator opening is 4/8 of the full opening.

SERVICE DATA AND SPECIFICATIONS (SDS)

< SERVICE DATA AND SPECIFICATIONS (SDS)

Stall Speed

INFOID:000000001530031

Stall speed	2,700 – 3,000 rpm
-------------	-------------------

Line Pressure

INFOID:000000001530032

Engine speed	Line pressure kPa (kg/cm ² , psi)	
	"R" position	"D" and "M" positions
At idle speed	425 – 465 (4.3 – 4.7, 62 – 67)	379 – 428 (3.9 – 4.4, 55 – 62)
At stall speed	1,605 – 1,950 (16.4 – 19.9, 233 – 283)	1,310 – 1,500 (13.4 – 15.3, 190 – 218)

Turbine Revolution Sensor

INFOID:000000001530033

Name	Condition	Data (Approx.)
Turbine revolution sensor 1	When running at 50 km/h (31 MPH) in 4th speed with the closed throttle position signal OFF.	1.3 kHz
Turbine revolution sensor 2	When running at 20 km/h (12 MPH) in 1st speed with the closed throttle position signal OFF.	

Vehicle Speed Sensor A/T (Revolution Sensor)

INFOID:000000001530034

Name	Condition	Data (Approx.)
Revolution sensor	When running at 20 km/h (12 MPH).	185 Hz

Reverse Brake

INFOID:000000001530035

Model code number	97X2E, 97X3A	
Number of drive plates	6	
Number of driven plates	6	
Clearance mm (in)	Standard	0.7 – 1.1 (0.028 – 0.043)
Thickness of retaining plates	Thickness mm (in)	
	4.2 (0.165)	
	4.4 (0.173)	
	4.6 (0.181)	
	4.8 (0.189)	
	5.0 (0.197)	
		5.2 (0.205)

Total End Play

INFOID:000000001530036

Total end play mm (in)	0.25 – 0.55 (0.0098 – 0.0217)
------------------------	-------------------------------

BEARING RACE FOR ADJUSTING TOTAL END PLAY

Thickness mm (in)
0.8 (0.031)
1.0 (0.039)
1.2 (0.047)
1.4 (0.055)
1.6 (0.063)
1.8 (0.071)

SERVICE DATA AND SPECIFICATIONS (SDS)

< SERVICE DATA AND SPECIFICATIONS (SDS)

Torque Converter

INFOID:000000001530037

Distance between end of converter housing and torque converter mm (in)	25.0 (0.98) or more
--	---------------------