

SCS

SECTION

SUSPENSION CONTROL SYSTEM

A
B
C
D

SCS

CONTENTS

| | | | | |
|--|----|--|----|---|
| BASIC INSPECTION | 3 | Description | 13 | |
| DIAGNOSIS AND REPAIR WORKFLOW | 3 | DTC Logic | 13 | |
| Work Flow | 3 | Diagnosis Procedure | 13 | |
| FUNCTION DIAGNOSIS | 5 | C1806 VEHICLE HEIGHT SENSOR LOCK- ING MALFUNCTION | 14 | G |
| SUSPENSION CONTROL SYSTEM | 5 | Description | 14 | |
| System Diagram | 5 | DTC Logic | 14 | H |
| System Description | 5 | Diagnosis Procedure | 14 | |
| Component Parts Location | 6 | C1807 SENSOR 5V MALFUNCTION | 15 | I |
| Component Description | 6 | Description | 15 | |
| DIAGNOSIS SYSTEM (SUSPENSION CON- TROL UNIT) | 7 | DTC Logic | 15 | J |
| CONSULT-III Function | 7 | Diagnosis Procedure | 15 | |
| COMPONENT DIAGNOSIS | 9 | C1808 INTEGRAL TIME MALFUNCTION SUPPLYING AIR | 16 | K |
| C1801 VEHICLE HEIGHT SENSOR | 9 | Description | 16 | |
| Description | 9 | DTC Logic | 16 | |
| DTC Logic | 9 | Diagnosis Procedure | 16 | |
| Diagnosis Procedure | 9 | POWER SUPPLY AND GROUND CIRCUIT | 17 | L |
| C1802 COMPRESSOR RELAY | 10 | SUSPENSION CONTROL UNIT | 17 | |
| Description | 10 | SUSPENSION CONTROL UNIT : Diagnosis Pro- cedure | 17 | M |
| DTC Logic | 10 | SUSPENSION AIR COMPRESSOR | 17 | |
| Diagnosis Procedure | 10 | SUSPENSION AIR COMPRESSOR : Diagnosis Procedure | 17 | N |
| C1803 EXHAUST SOLENOID | 11 | HEIGHT SENSOR | 18 | |
| Description | 11 | HEIGHT SENSOR : Diagnosis Procedure | 18 | O |
| DTC Logic | 11 | COMPRESSOR MOTOR RELAY | 20 | |
| Diagnosis Procedure | 11 | Description | 20 | P |
| C1804 HEIGHT ADJUSTING MALFUNCTION (COMPRESSOR) | 12 | Component Function Check | 20 | |
| Description | 12 | Diagnosis Procedure | 20 | |
| DTC Logic | 12 | HEIGHT SENSOR SIGNAL CIRCUIT | 22 | |
| Diagnosis Procedure | 12 | Description | 22 | |
| C1805 HEIGHT ADJUSTING MALFUNCTION (EXH SOLENOID) | 13 | Component Function Check | 22 | |
| | | Diagnosis Procedure | 22 | |

| | | | |
|---|-----------|--|-----------|
| EXHAUST VALVE SOLENOID CIRCUIT | 23 | SUSPENSION CONTROL SYSTEM INOPER- | |
| Description | 23 | ACTIVE | 36 |
| Component Function Check | 23 | Description | 36 |
| Diagnosis Procedure | 23 | Diagnosis Procedure | 36 |
| CK SUSP WARNING INDICATOR CONTROL | | SUSPENSION CONTROL SYSTEM DOES | |
| CIRCUIT | 25 | NOT RAISE | 37 |
| Description | 25 | Description | 37 |
| Component Function Check | 25 | Diagnosis Procedure | 37 |
| Diagnosis Procedure | 25 | SUSPENSION CONTROL SYSTEM DOES | |
| ECU DIAGNOSIS | 27 | NOT LOWER | 38 |
| SUSPENSION CONTROL UNIT | 27 | Description | 38 |
| Reference Value | 27 | Diagnosis Procedure | 38 |
| Wiring Diagram | 28 | PRECAUTION | 39 |
| DTC Index | 33 | PRECAUTIONS | 39 |
| SYMPTOM DIAGNOSIS | 35 | Precaution for Supplemental Restraint System | |
| SUSPENSION CONTROL SYSTEM | 35 | (SRS) "AIR BAG" and "SEAT BELT PRE-TEN- | |
| Symptom Table | 35 | SIONER" | 39 |
| | | Precaution for Rear Suspension | 39 |

DIAGNOSIS AND REPAIR WORKFLOW

< BASIC INSPECTION >

BASIC INSPECTION

DIAGNOSIS AND REPAIR WORKFLOW

Work Flow

INFOID:000000003710235

OVERALL SEQUENCE

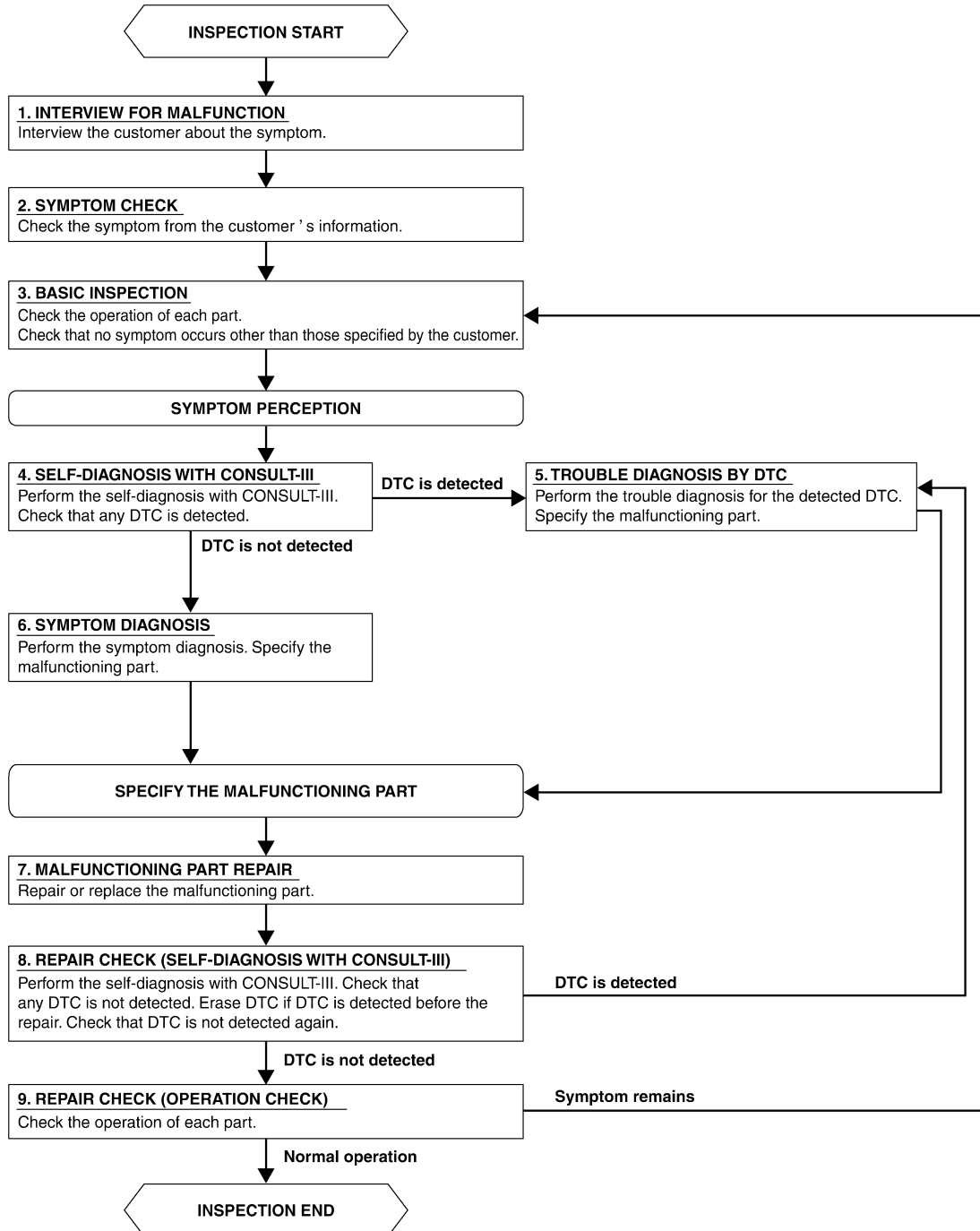

A
B
C
D
E
F
G
H
I
J
K
L
M
N
O
P

SCS

DETAILED FLOW

ALEIA0041GB

DIAGNOSIS AND REPAIR WORKFLOW

< BASIC INSPECTION >

1. INTERVIEW FOR MALFUNCTION

Interview the customer about the symptom.

>> GO TO 2.

2. SYMPTOM CHECK

Verify the symptom from the customer's information.

>> GO TO 3.

3. BASIC INSPECTION

Check the operation of each part. Check that no symptoms occur other than those specified by the customer.

>> GO TO 4.

4. SELF-DIAGNOSIS WITH CONSULT-III

Perform the self diagnosis with CONSULT-III. Check that any DTC is detected.

Is any DTC detected?

YES >> GO TO 5.

NO >> GO TO 6.

5. TROUBLE DIAGNOSIS BY DTC

Perform the trouble diagnosis for the detected DTC. Specify the malfunctioning part.

>> GO TO 7.

6. SYMPTOM DIAGNOSIS

Perform the symptom diagnosis. Specify the malfunctioning part.

>> GO TO 7.

7. MALFUNCTIONING PART REPAIR

Repair or replace the malfunctioning part.

>> GO TO 8.

8. REPAIR CHECK (SELF-DIAGNOSIS WITH CONSULT-III)

Perform the self diagnosis with CONSULT-III. Verified that no DTCs are detected. Erase all DTCs detected prior to the repair. Verify that DTC is not detected again.

Is any DTC detected?

YES >> GO TO 5.

NO >> GO TO 9.

9. REPAIR CHECK (OPERATION CHECK)

Check the operation of each part.

Does it operate normally?

YES >> Inspection End.

NO >> GO TO 3.

SUSPENSION CONTROL SYSTEM

< FUNCTION DIAGNOSIS >

FUNCTION DIAGNOSIS

SUSPENSION CONTROL SYSTEM

System Diagram

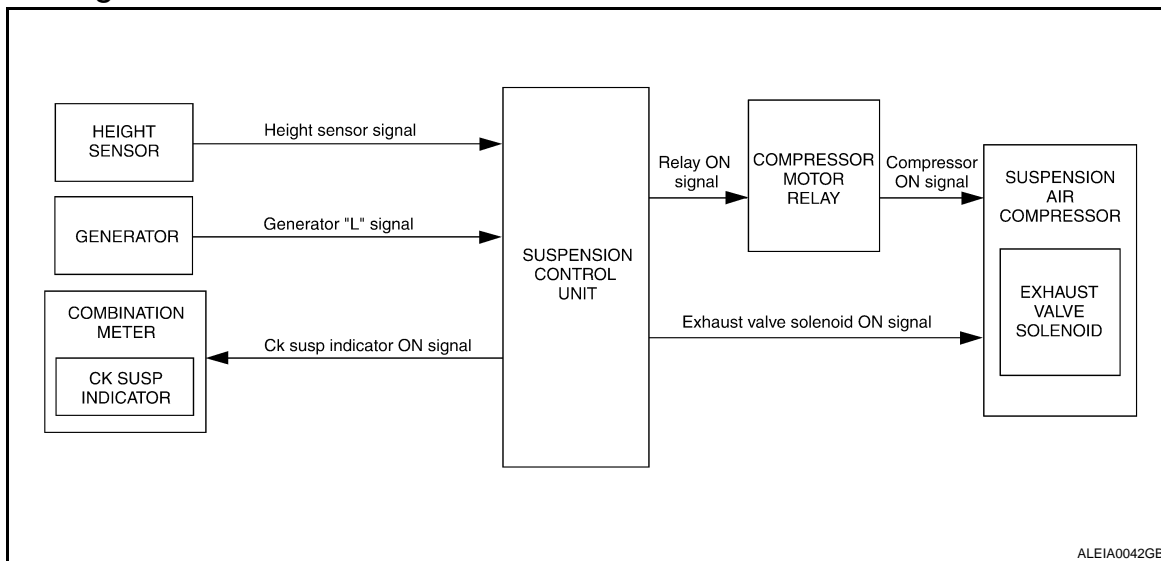

System Description

INFOID:0000000003710237

SUSPENSION CONTROL SYSTEM

The suspension control system consists of the following components

- Suspension control unit
- Compressor motor relay
- Suspension air compressor
- Exhaust valve solenoid (built into suspension air compressor)
- Height sensor

The suspension control unit monitors vehicle ride height as indicated by the height sensor. The suspension control unit actuates the compressor motor relay to raise the vehicle ride height. The suspension control unit actuates the exhaust valve solenoid to lower the vehicle ride height.

CK SUSP INDICATOR LAMP

The CK SUSP indicator lamp ground is controlled by the suspension control unit. The indicator lamp will come on for 2 seconds when the ignition switch is turned ON. If the indicator lamp does not turn OFF there is a fault detected. Refer to [SCS-7, "CONSULT-III Function"](#).

SUSPENSION CONTROL SYSTEM

< FUNCTION DIAGNOSIS >

Component Parts Location

INFOID:000000003710238

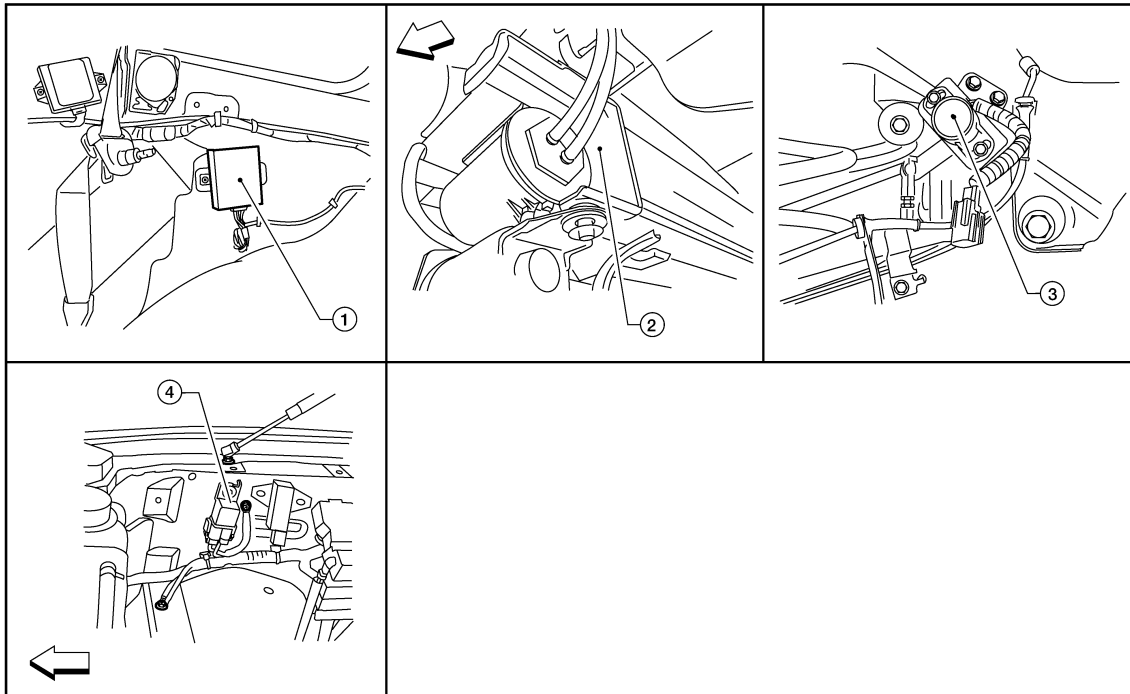

ALEIA0044ZZ

←:Front

1. Suspension control unit B3 (view with upper and lower luggage side finishers LH removed)
2. Suspension air compressor C9 (view under vehicle behind LH rear suspension)
3. Height sensor C8 (view under vehicle at LH rear suspension)
4. Compressor motor relay E130, E131 (view with battery removed)

Component Description

INFOID:000000003710239

| Part name | Description |
|--|---|
| Suspension control unit | <ul style="list-style-type: none"> • Monitors height sensor input to determine vehicle height. • Actuates the compressor motor relay or exhaust valve solenoid to raise or lower the vehicle accordingly. • Sends a ground signal to the combination meter to activate the CK SUSP indicator lamp. |
| Suspension air compressor (with built in exhaust valve solenoid) | <ul style="list-style-type: none"> • When the compressor is actuated, it pumps air into the system to raise the rear suspension. • When the exhaust valve solenoid is actuated, it vents air from the system to lower the rear suspension. |
| Height sensor | Provides vehicle height input to the suspension control unit. |

DIAGNOSIS SYSTEM (SUSPENSION CONTROL UNIT)

< FUNCTION DIAGNOSIS >

DIAGNOSIS SYSTEM (SUSPENSION CONTROL UNIT)

CONSULT-III Function

INFOID:000000003710240

CONSULT-III can display each diagnostic item using the diagnostic test modes shown following.

| AIR LEVELIZER diagnosis mode | Description |
|------------------------------|--|
| WORK SUPPORT | Supports inspection and adjustment. Commands are transmitted to the suspension control unit for setting the status suitable for required operation, input/output signals are received from the suspension control unit and received data is displayed. |
| SELF-DIAG RESULTS | Displays suspension control unit self-diagnosis results. |
| DATA MONITOR | Displays suspension control unit input/output data in real time. |
| ACTIVE TEST | Operation of electrical loads can be checked by sending drive signal to them. |
| ECU PART NUMBER | The part number of suspension control unit can be checked. |

A

B

C

D

SCS

WORK SUPPORT

Display Item List

| Item | Description | Condition |
|-----------------------|---|---|
| STANDARD HEIGHT LEVEL | Resets the vehicle height to the initialization flag setting stored in the suspension control unit. | Vehicle unladen, set in a horizontal position and not moving. NOTE: Do not take your eyes off the vehicle while CONSULT-III is processing. |
| ADJUST HEIGHT INI | Sets the height initialization flag in the suspension control unit when the control unit has been replaced or when the initialization flag has been cleared using the "CLEAR HEIGHT INI" procedure. | Vehicle unladen, move vehicle forward and backward approx. 5 m (16.4 ft) and rock vehicle side to side. NOTE: Do not move vehicle while CONSULT-III is processing. |
| CLEAR HEIGHT INI | Clears the initialization flag in the suspension control unit. | Vehicle unladen. |

F

G

H

I

J

DATA MONITOR

Display Item List

| Display item [unit] | ALL SIGNALS | SELECTION FROM MENU |
|-----------------------|-------------|---------------------|
| HEIGT SEN [V] | X | X |
| HEIGT CALC [mm] | X | X |
| SEN FIX TIME [HR] | X | X |
| HEIGT INI VAL [V] | X | X |
| COMPRESSOR [ON/OFF] | X | X |
| EXH SOLENOID [ON/OFF] | X | X |
| ACG L [ON/OFF] | X | X |

L

M

N

O

ACTIVE TEST

CAUTION:

Do not perform active test while driving.

Display Item List

| Test Item | Description |
|------------|-------------|
| COMPRESSOR | ON/OFF |

P

DIAGNOSIS SYSTEM (SUSPENSION CONTROL UNIT)

< FUNCTION DIAGNOSIS >

| | |
|------------------|--------|
| EXHAUST SOLENOID | ON/OFF |
| WARNING LAMP | ON/OFF |

CAUTION:

The "COMPRESSOR active test will remain ON until it is turned off using CONSULT-III. Allowing the compressor to run for an extended period of time may cause damage to the suspension control system components due to excessive pressure.

NOTE:

- "TEST IS STOPPED" is displayed approximately 10 seconds after operation starts for all active test items except "COMPRESSOR".
- After "TEST IS STOPPED" is displayed, to perform test again, repeat step 6.

C1801 VEHICLE HEIGHT SENSOR

< COMPONENT DIAGNOSIS >

COMPONENT DIAGNOSIS

C1801 VEHICLE HEIGHT SENSOR

Description

INFOID:000000003710241

The vehicle height sensor operates on a 5 volt reference signal from the suspension control unit. The suspension control unit also provides ground to the height sensor. Depending on vehicle height, the height sensor signal should have between 0.2V and 4.8V.

DTC Logic

INFOID:000000003710242

DTC DETECTION LOGIC

| DTC | Display contents of CONSULT-III | Diagnostic item is detected when ... | Probable malfunction location |
|-------|---------------------------------|--|---|
| C1801 | VEHICLE HEIGHT SENSOR | Vehicle height sensor voltage is less than 0.2V or greater than 4.8V for more than 60 seconds. | <ul style="list-style-type: none">Height sensor power/ground supply. Refer to SCS-18, "HEIGHT SENSOR : Diagnosis Procedure".Height sensor signal circuit. Refer to SCS-22, "Component Function Check". |

SCS

Diagnosis Procedure

INFOID:000000003710243

1. CHECK HEIGHT SENSOR OPERATION

CONSULT-III

- Turn ignition switch ON
- Select "HEIGT SEN" of AIR LEVELIZER data monitor test item.

HEIGHT SEN : 0.2V - 4.8V

Is the HEIGHT SEN voltage within the given range?

- YES >> Height sensor is operating normally.
NO >> Refer to [SCS-22, "Diagnosis Procedure"](#).

C1802 COMPRESSOR RELAY

< COMPONENT DIAGNOSIS >

C1802 COMPRESSOR RELAY

Description

INFOID:000000003710244

The compressor motor relay is controlled by the suspension control unit. The suspension control unit supplies voltage to the coil side of the relay to activate it. The compressor motor relay, when activated, supplies power to the suspension air compressor.

DTC Logic

INFOID:000000003710245

DTC DETECTION LOGIC

| DTC | Display contents of CONSULT-III | Diagnostic item is detected when ... | Probable malfunction location |
|-------|---------------------------------|--|---|
| C1802 | COMPRESSOR RELAY | <ul style="list-style-type: none">Driving transistor for the compressor relay is OFF and monitor voltage continues at a high level for more than 10 seconds.Driving transistor for the compressor relay is ON and monitor voltage continues at a low level for more than 5 seconds. | Compressor motor relay. Refer to SCS-20, "Component Function Check" . |

Diagnosis Procedure

INFOID:000000003710246

1. CHECK COMPRESSOR MOTOR RELAY OPERATION

CAUTION:

The "COMPRESSOR" active test will remain ON until it is turned off using CONSULT-III. Allowing the compressor to run for an extended period of time may cause damage to the air levelizer system components due to excessive air pressure.

CONSULT-III

- Turn ignition ON.
- Select "COMPRESSOR" of AIR LEVELIZER active test items.
- While operating test item, check that the suspension air compressor turns ON.

ON : Compressor turns ON

OFF : Compressor turns OFF

Does the suspension air compressor operate properly?

- YES >> Compressor motor relay and suspension air compressor are operating normally.
NO >> Refer to [SCS-20, "Diagnosis Procedure"](#).

C1803 EXHAUST SOLENOID

< COMPONENT DIAGNOSIS >

C1803 EXHAUST SOLENOID

Description

INFOID:000000003710247

The exhaust valve solenoid controls the vent function of the suspension control system. The exhaust valve solenoid is built into the suspension air compressor. The suspension control unit supplies voltage to the exhaust valve solenoid to activate it.

DTC Logic

INFOID:000000003710248

DTC DETECTION LOGIC

| DTC | Display contents of CONSULT-III | Diagnostic item is detected when ... | Probable malfunction location |
|-------|---------------------------------|--|--|
| C1803 | EXHAUST SOLENOID | <ul style="list-style-type: none">Driving transistor for the exhaust valve solenoid is OFF and monitor voltage continues at a high level for more than 10 seconds.Driving transistor for the exhaust valve solenoid is ON and monitor voltage continues at a low level for more than 5 seconds. | Open or short circuit in the exhaust valve solenoid control circuit. Refer to SCS-23, "Component Function Check" . |

SCS

Diagnosis Procedure

INFOID:000000003710249

1. CHECK EXHAUST SOLENOID OPERATION

CAUTION:

While operating this active test, the suspension control system will vent air pressure and the vehicle ride height will lower. Ensure the area around the vehicle is free from obstructions before beginning test.

CONSULT-III

1. Ensure the suspension control system has air pressure and is not drooping in the rear.
2. Select "EXHAUST SOLENOID" of AIR LEVELIZER active test items.
3. While operating test item, check that the exhaust valve solenoid opens to vent air from the system. The vehicle should lower when the exhaust valve solenoid is activated.

ON : Air vents and vehicle ride height lowers

OFF : No air vents and vehicle ride height remains constant

Does the system vent properly?

- YES >> Exhaust valve solenoid is operating normally.
NO >> Refer to [SCS-23, "Description"](#).

C1804 HEIGHT ADJUSTING MALFUNCTION (COMPRESSOR)

< COMPONENT DIAGNOSIS >

C1804 HEIGHT ADJUSTING MALFUNCTION (COMPRESSOR)

Description

INFOID:000000003710250

The compressor motor relay is controlled by the suspension control unit. The suspension control unit supplies voltage to the coil side of the relay to activate it. The compressor motor relay, when activated, supplies power to the suspension air compressor.

DTC Logic

INFOID:000000003710251

DTC DETECTION LOGIC

| DTC | Display contents of CONSULT-III | Diagnostic item is detected when ... | Probable malfunction location |
|-------|---|---|---|
| C1804 | VEHICLE HEIGHT ADJUSTING MALFUNCTION (COMPRESSOR) | Continuous compressor relay ON time is more than 120 seconds. | Compressor motor relay. Refer to SCS-20 , " Component Function Check ". |

Diagnosis Procedure

INFOID:000000003710252

1. CHECK COMPRESSOR MOTOR RELAY OPERATION

CAUTION:

The "COMPRESSOR" active test will remain ON until it is turned off using CONSULT-III. Allowing the compressor to run for an extended period of time may cause damage to the air levelizer system components due to excessive air pressure.

CONSULT-III

1. Turn ignition ON.
2. Select "COMPRESSOR" of AIR LEVELIZER active test items.
3. While operating test item, check that the suspension air compressor turns ON.

ON : Compressor turns ON

OFF : Compressor turns OFF

Does the suspension air compressor operate properly?

- YES >> Compressor motor relay and suspension air compressor are operating normally.
NO >> Refer to [SCS-20](#), "[Diagnosis Procedure](#)".

C1805 HEIGHT ADJUSTING MALFUNCTION (EXH SOLENOID)

< COMPONENT DIAGNOSIS >

C1805 HEIGHT ADJUSTING MALFUNCTION (EXH SOLENOID)

Description

INFOID:000000003710253

The exhaust valve solenoid controls the vent function of the suspension control system. The exhaust valve solenoid is built into the suspension air compressor. The suspension control unit supplies voltage to the exhaust valve solenoid to activate it.

DTC Logic

INFOID:000000003710254

DTC DETECTION LOGIC

| DTC | Display contents of CONSULT-III | Diagnostic item is detected when ... | Probable malfunction location |
|-------|---|---|---|
| C1805 | VEHICLE HEIGHT ADJUSTING MALFUNCTION (EXHAUST SOLENOID) | Continuous exhaust valve solenoid ON time is more than 120 seconds. | Short to power in the exhaust valve solenoid control circuit. Refer to SCS-23, "Component Function Check" . |

SCS

Diagnosis Procedure

INFOID:000000003710255

1. CHECK EXHAUST SOLENOID OPERATION

CAUTION:

While operating this active test, the suspension control system will vent air pressure and the vehicle ride height will lower. Ensure the area around the vehicle is free from obstructions before beginning test.

CONSULT-III

1. Ensure the suspension control system has air pressure and is not drooping in the rear.
2. Select "EXHAUST SOLENOID" of AIR LEVELIZER active test items.
3. While operating test item, check that the exhaust valve solenoid opens to vent air from the system. The vehicle should lower when the exhaust valve solenoid is activated.

ON : Air vents and vehicle ride height lowers

OFF : No air vents and vehicle ride height remains constant

Does the system vent properly?

- YES >> Exhaust valve solenoid is operating normally.
NO >> Refer to [SCS-23, "Description"](#).

C1806 VEHICLE HEIGHT SENSOR LOCKING MALFUNCTION

< COMPONENT DIAGNOSIS >

C1806 VEHICLE HEIGHT SENSOR LOCKING MALFUNCTION

Description

INFOID:000000003710256

The vehicle height sensor operates on a 5 volt reference signal from the suspension control unit. The suspension control unit also provides ground to the height sensor.

DTC Logic

INFOID:000000003710257

DTC DETECTION LOGIC

| DTC | Display contents of CONSULT-III | Diagnostic item is detected when ... | Probable malfunction location |
|-------|---|---|---|
| C1806 | VEHICLE HEIGHT SENSOR LOCKING MALFUNCTION | Output sensor voltage variation $\pm 0.02V$ is more than 100 seconds when vehicle height range is normal. | <ul style="list-style-type: none">Height sensor power/ground supply. Refer to SCS-18, "HEIGHT SENSOR : Diagnosis Procedure".Charging system malfunction. Refer to CHG-7, "Inspection Procedure". |

Diagnosis Procedure

INFOID:000000003710258

1. CHECK HEIGHT SENSOR OPERATION

CONSULT-III

- Turn ignition switch ON
- Select "HEIGT SEN" of AIR LEVELIZER data monitor test item.

HEIGHT SEN : 0.2V - 4.8V with no more than $\pm 0.02V$ variation

Is the HEIGHT SEN voltage within the given range?

- YES >> Height sensor is operating normally.
NO >> Refer to [SCS-22, "Diagnosis Procedure"](#).

C1807 SENSOR 5V MALFUNCTION

< COMPONENT DIAGNOSIS >

C1807 SENSOR 5V MALFUNCTION

Description

INFOID:000000003710259

The vehicle height sensor operates on a 5 volt reference signal from the suspension control unit. The suspension control unit also provides ground to the height sensor.

DTC Logic

INFOID:000000003710260

DTC DETECTION LOGIC

| DTC | Display contents of CONSULT-III | Diagnostic item is detected when ... | Probable malfunction location |
|-------|---------------------------------|--|--|
| C1807 | SENSOR 5V MALFUNCTION | Sensor reference voltage is less than 0.8V or more than 6V for 20 seconds. | <ul style="list-style-type: none"> Height sensor power/ground supply. Refer to SCS-18. "HEIGHT SENSOR : Diagnosis Procedure". Charging system malfunction. Refer to CHG-7. "Inspection Procedure". |

Diagnosis Procedure

INFOID:000000003710261

1. POWER SUPPLY CIRCUIT CHECK

1. Disconnect height sensor connector C8.
2. Turn the ignition switch ON.
3. Check voltage between the height sensor connector C8 terminal 1 and ground.

| (+) | | (-) | Voltage |
|-----------|----------|--------|---------|
| Connector | Terminal | | |
| C8 | 1 | Ground | 5V |

Is 5V present?

- YES >> System is working normally.
 NO >> Check harness or connector for open or short. If OK, replace the suspension control unit. Refer to [RSU-26. "Removal and Installation"](#).

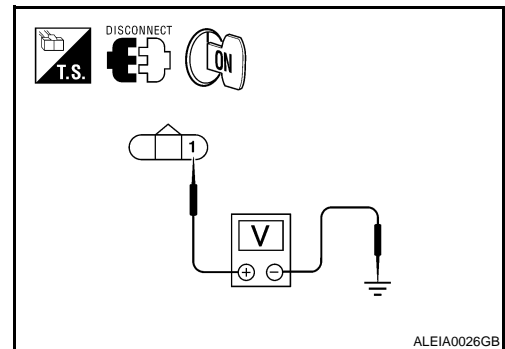

C1808 INTEGRAL TIME MALFUNCTION SUPPLYING AIR

< COMPONENT DIAGNOSIS >

C1808 INTEGRAL TIME MALFUNCTION SUPPLYING AIR

Description

INFOID:000000003710262

The suspension air compressor is supplied power by the compressor motor relay. The suspension control unit supplies power to the compressor motor relay in order to activate the relay and subsequently activate the suspension air compressor.

DTC Logic

INFOID:000000003710263

DTC DETECTION LOGIC

| DTC | Display contents of CONSULT-III | Diagnostic item is detected when ... | Probable malfunction location |
|-------|---|---|--|
| C1808 | INTEGRAL TIME MALFUNCTION SUPPLYING AIR | A suspension air compressor ON request has been in effect for 180 seconds and the suspension air compressor has not activated during that time. | <ul style="list-style-type: none">Compressor motor relay. Refer to SCS-20, "Diagnosis Procedure".Suspension air compressor. Refer to SCS-17, "SUSPENSION AIR COMPRESSOR : Diagnosis Procedure". |

Diagnosis Procedure

INFOID:000000003710264

1. CHECK COMPRESSOR MOTOR RELAY OPERATION

CAUTION:

The "COMPRESSOR" active test will remain ON until it is turned off using CONSULT-III. Allowing the compressor to run for an extended period of time may cause damage to the air levelizer system components due to excessive air pressure.

CONSULT-III

- Turn ignition ON.
- Select "COMPRESSOR" of AIR LEVELIZER active test items.
- While operating test item, check that the suspension air compressor turns ON.

ON : Compressor turns ON

OFF : Compressor turns OFF

Does the suspension air compressor operate properly?

- YES >> Compressor motor relay and suspension air compressor are operating normally.
NO >> Refer to [SCS-20, "Diagnosis Procedure"](#).

POWER SUPPLY AND GROUND CIRCUIT

< COMPONENT DIAGNOSIS >

POWER SUPPLY AND GROUND CIRCUIT SUSPENSION CONTROL UNIT

SUSPENSION CONTROL UNIT : Diagnosis Procedure

INFOID:000000003710265

1. CHECK FUSES

Check that the following fuses of the suspension control unit are not are not blown.

| Unit | Terminals | Signal name | Fuse No. |
|-------------------------|-----------|-----------------------------|----------|
| Suspension control unit | 7 | Battery power | 29 |
| | 6 | Ignition switch ON or START | 12 |

Are the fuses OK?

YES >> GO TO 2.

NO >> If fuse is blown, be sure to eliminate cause of malfunction before installing new fuse.

2. POWER SUPPLY CIRCUIT CHECK

1. Disconnect suspension control unit connector B3.
2. Check voltage between the suspension control unit connector B3 and ground.

| (+) | | (-) | OFF | ACC | ON |
|-----------|----------|--------|-----------------|-----------------|-----------------|
| Connector | Terminal | | | | |
| B3 | 7 | Ground | Battery voltage | Battery voltage | Battery voltage |
| | 6 | Ground | 0V | 0V | Battery voltage |

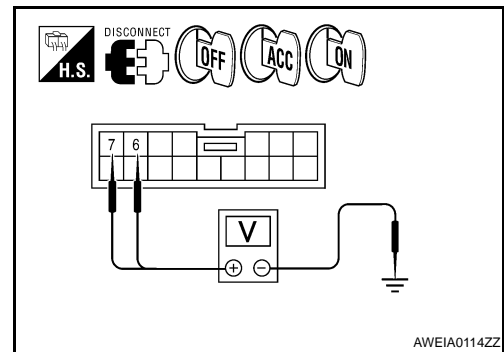

Are the voltage results as specified?

YES >> GO TO 3.

NO >> • Check connector housings for disconnected or loose terminals.
• Repair harness or connector.

3. GROUND CIRCUIT CHECK

1. Turn ignition switch OFF.
2. Check continuity between suspension control unit harness connector B3 and ground.

| Connector | Terminal | — | Continuity |
|-----------|----------|--------|------------|
| B3 | 16 | Ground | Yes |

Is continuity present?

YES >> Inspection End.

NO >> Repair harness or connector.

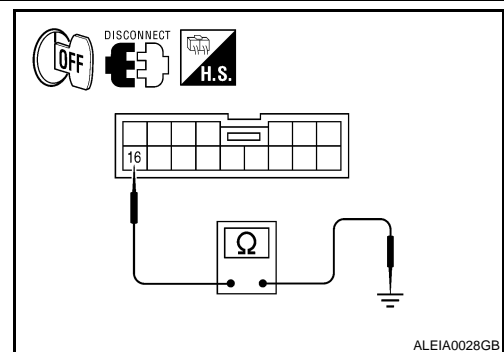

SUSPENSION AIR COMPRESSOR

SUSPENSION AIR COMPRESSOR : Diagnosis Procedure

INFOID:000000003710266

1. CHECK COMPRESSOR MOTOR RELAY OPERATION

CONSULT-III

POWER SUPPLY AND GROUND CIRCUIT

< COMPONENT DIAGNOSIS >

1. Disconnect the suspension air compressor connector C9.
2. Turn ignition switch ON.
3. Select "COMPRESSOR" under AIR LEVELIZER active test items.
4. While operating the test item, check voltage at the suspension air compressor connector C9 terminal 4.

| (+) | | (-) | Voltage |
|-----------|----------|--------|-----------------|
| Connector | Terminal | | |
| C9 | 4 | Ground | Battery Voltage |

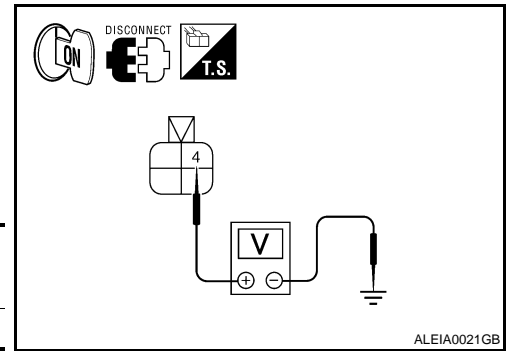

Is battery voltage present?

- YES >> GO TO 3.
NO >> GO TO 2.

2.COMPRESSOR MOTOR RELAY POWER SUPPLY CIRCUIT CHECK

1. Turn ignition switch OFF.
2. Disconnect the compressor motor relay connector.
3. Check continuity between compressor motor relay connector E131 (A) terminal 3 and suspension air compressor connector C9 (B) terminal 4.

| A | | B | | Continuity |
|-----------|----------|-----------|----------|------------|
| Connector | Terminal | Connector | Terminal | |
| E131 | 3 | C9 | 4 | Yes |

4. Check continuity between compressor motor relay connector E131 (A) terminal 3 and ground.

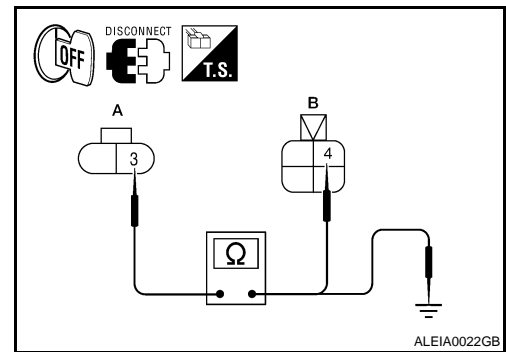

| A | | — | Continuity |
|-----------|----------|--------|------------|
| Connector | Terminal | | |
| E131 | 3 | Ground | No |

Are the continuity test results as specified?

- YES >> Check compressor motor relay. Refer to [SCS-20. "Diagnosis Procedure"](#).
NO >> Repair harness or connector.

3.GROUND CIRCUIT CHECK

1. Turn ignition switch OFF.
2. Check continuity between suspension air compressor connector C9 terminals 1 and 3 and ground.

| Connector | Terminal | — | Continuity |
|-----------|----------|--------|------------|
| C9 | 1 | Ground | Yes |
| | 3 | | |

Is continuity present?

- YES >> Inspection End.
NO >> Repair harness or connector.

HEIGHT SENSOR

HEIGHT SENSOR : Diagnosis Procedure

1.POWER SUPPLY CIRCUIT CHECK

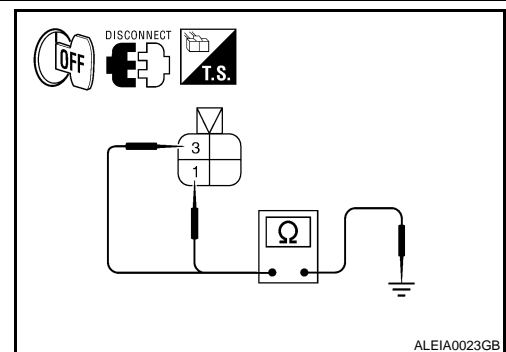

INFOID:000000003710267

POWER SUPPLY AND GROUND CIRCUIT

< COMPONENT DIAGNOSIS >

1. Disconnect height sensor connector C8.
2. Turn the ignition switch ON.
3. Check voltage between the height sensor connector C8 terminal 1 and ground.

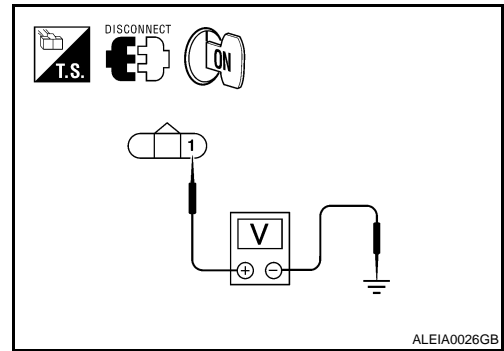

| (+) | | (-) | Voltage |
|-----------|----------|--------|---------|
| Connector | Terminal | | |
| C8 | 1 | Ground | 5V |

Is 5V present?

YES >> GO TO 2.

NO >> Check harness or connector for open or short. If OK, replace the suspension control unit. Refer to [RSU-26. "Removal and Installation"](#)

2. GROUND CIRCUIT CHECK

1. Turn ignition switch OFF.
2. Check continuity between height sensor connector C8 terminal 3 and ground.

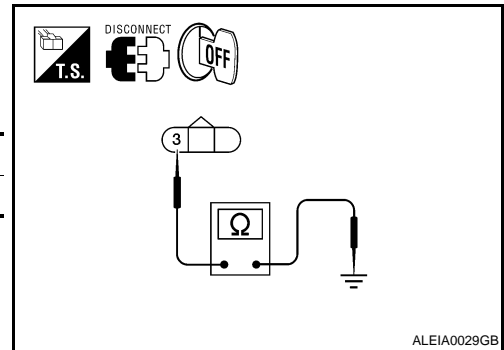

| Connector | Terminal | — | Continuity |
|-----------|----------|--------|------------|
| C8 | 3 | Ground | Yes |

Is continuity present?

YES >> Ground circuit is OK.

NO >> Repair harness or connector.

A
B
C
D
SCS
F
G
H
I
J
K
L
M
N
O
P

COMPRESSOR MOTOR RELAY

< COMPONENT DIAGNOSIS >

COMPRESSOR MOTOR RELAY

Description

INFOID:000000003710268

Receives suspension air compressor ON signal from suspension control unit. When activated, the compressor motor relay supplies power to the suspension air compressor.

Component Function Check

INFOID:000000003710269

1. CHECK COMPRESSOR MOTOR RELAY OPERATION

CAUTION:

The "COMPRESSOR" active test will remain ON until it is turned off using CONSULT-III. Allowing the compressor to run for an extended period of time may cause damage to the suspension control system components due to excessive air pressure.

CONSULT-III

1. Turn ignition ON.
2. Select "COMPRESSOR" of AIR LEVELIZER active test items.
3. While operating test item, check that the suspension air compressor turns ON.

ON : Compressor turns ON

OFF : Compressor turns OFF

Does the suspension air compressor operate properly?

- YES >> Compressor motor relay and suspension air compressor are operating normally.
 NO >> Refer to [SCS-20, "Diagnosis Procedure"](#).

Diagnosis Procedure

INFOID:000000003710270

1. CHECK COMPRESSOR "ON" SIGNAL FROM SUSPENSION CONTROL UNIT

CONSULT-III

1. Turn ignition switch ON.
2. Disconnect compressor motor relay connector E130.
3. Select "COMPRESSOR" of AIR LEVELIZER active test items.
4. While operating test item, check voltage to compressor motor relay connector E130 terminal 2.

| (+) | | (-) | Voltage |
|-----------|----------|--------|-----------------|
| Connector | Terminal | | |
| E130 | 2 | Ground | Battery voltage |

Is battery voltage present while operating test item?

- YES >> GO TO 3.
 NO >> GO TO 2.

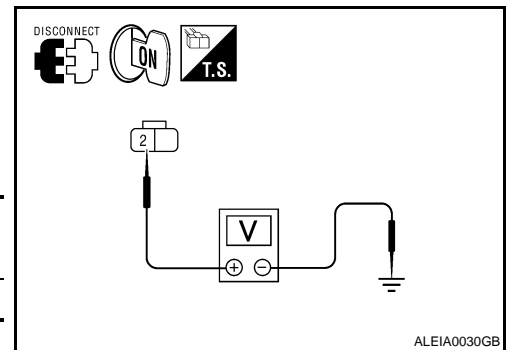

ALEIA0030GB

2. CHECK COMPRESSOR "ON" SIGNAL CIRCUIT

1. Turn ignition switch OFF.
2. Disconnect suspension control unit connector B3.
3. Check continuity between suspension control unit connector B3 (A) terminal 1 and compressor motor relay connector E130 (B) terminal 2.

| A | | B | | Continuity |
|-----------|----------|-----------|----------|------------|
| Connector | Terminal | Connector | Terminal | |
| B3 | 1 | E130 | 2 | Yes |

4. Check continuity between suspension control unit connector B3 (A) terminal 1 and ground.

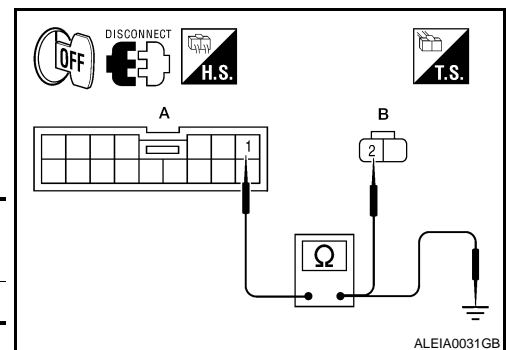

ALEIA0031GB

COMPRESSOR MOTOR RELAY

< COMPONENT DIAGNOSIS >

| A | | — | Continuity |
|-----------|----------|--------|------------|
| Connector | Terminal | | |
| B3 | 1 | Ground | No |

Are the continuity test results as specified?

- YES >> Replace the suspension control unit. Refer to [RSU-26. "Removal and Installation"](#).
 NO >> Repair harness or connector.

3.CHECK COMPRESSOR MOTOR RELAY GROUND

- Turn ignition switch OFF.
- Check continuity between compressor motor relay connector E130 terminal 1 and ground.

| Connector | Terminal | — | Continuity |
|-----------|----------|--------|------------|
| E130 | 1 | Ground | Yes |

Is continuity present?

- YES >> GO TO 4.
 NO >> Repair harness or connector.

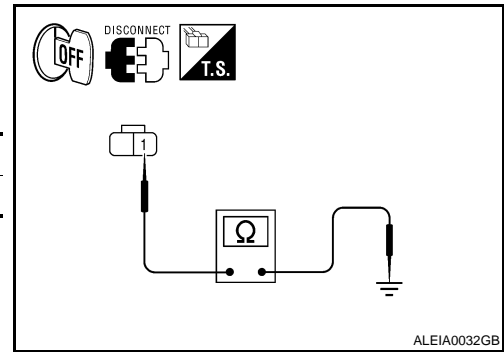

4.CHECK COMPRESSOR MOTOR RELAY POWER SUPPLY

- Disconnect compressor motor relay connector E131.
- Check voltage between compressor motor relay E131 terminal 5 and ground.

| (+) | | (-) | Voltage |
|-----------|----------|--------|-----------------|
| Connector | Terminal | | |
| E131 | 5 | Ground | Battery voltage |

Is battery voltage present?

- YES >> GO TO 5.
 NO >> Inspect fuse and repair harness or connector.

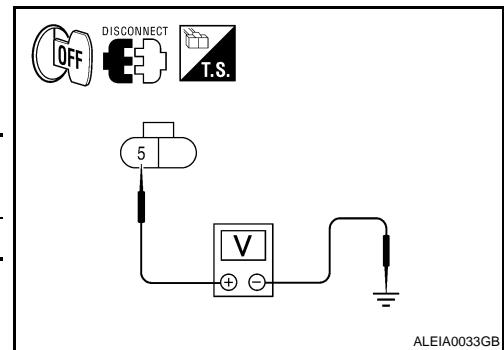

5.CHECK COMPRESSOR MOTOR RELAY OUTPUT

- Connect compressor motor relay connectors E130 and E131.
- Disconnect suspension air compressor connector C9.
- Turn ignition ON.
- Select "COMPRESSOR" of AIR LEVELIZER active test items.
- Check voltage between compressor motor relay C9 terminal 4 and ground.

| (+) | | (-) | Voltage |
|-----------|----------|--------|-----------------|
| Connector | Terminal | | |
| C9 | 4 | Ground | Battery voltage |

Is battery voltage present?

- YES >> Compressor motor relay is functioning properly.
 NO >> GO TO 6.

6.CHECK AIR COMPRESSOR POWER SUPPLY CIRCUIT

Check the air compressor power supply circuit. Refer to [SCS-17. "SUSPENSION AIR COMPRESSOR : Diagnosis Procedure"](#).

Does the power supply circuit test OK?

- YES >> Replace the compressor motor relay.
 NO >> Repair harness or connector.

A
B
C
D
SCS
F
G
H
I
J
K
L
M
N
O
P

HEIGHT SENSOR SIGNAL CIRCUIT

< COMPONENT DIAGNOSIS >

HEIGHT SENSOR SIGNAL CIRCUIT

Description

INFOID:000000003710271

Supplies vehicle height input to the suspension control unit.

Component Function Check

INFOID:000000003710272

1.CHECK HEIGHT SENSOR OPERATION

CONSULT-III

1. Select "HEIGT SEN" of AIR LEVELIZER data monitor test item.
2. While monitoring test item, add or take away weight from the rear of the vehicle. Check that the voltage value changes with vehicle height.

HEIGHT SEN : Voltage changes with vehicle height

Is the HEIGHT SEN data monitor responding normally?

- YES >> Height sensor is operating normally.
 NO >> Refer to [SCS-22, "Diagnosis Procedure"](#).

Diagnosis Procedure

INFOID:000000003710273

1.CHECK HEIGHT SENSOR POWER AND GROUND SUPPLY

Check height sensor power and ground supply. Refer to [SCS-18, "HEIGHT SENSOR : Diagnosis Procedure"](#).

Are the inspection results normal?

- YES >> GO TO 2.
 NO >> Repair harness or connector.

2.CHECK HEIGHT SENSOR SIGNAL CIRCUIT

1. Disconnect suspension control unit connector B3 and height sensor connector C8.
2. Check continuity between suspension control unit connector B3 (A) terminal 3 and height sensor connector C8 (B) terminal 2.

| A | | B | | Continuity |
|-----------|----------|-----------|----------|------------|
| Connector | Terminal | Connector | Terminal | |
| B3 | 3 | C8 | 2 | Yes |

3. Check continuity between display unit harness connector B3 (A) terminal 3 and ground.

| A | | — | Continuity |
|-----------|----------|--------|------------|
| Connector | Terminal | | |
| B3 | 3 | Ground | No |

Are the continuity results as specified?

- YES >> Replace the height sensor. Refer to [RSU-24, "Removal and Installation"](#).
 NO >> Repair harness or connector.

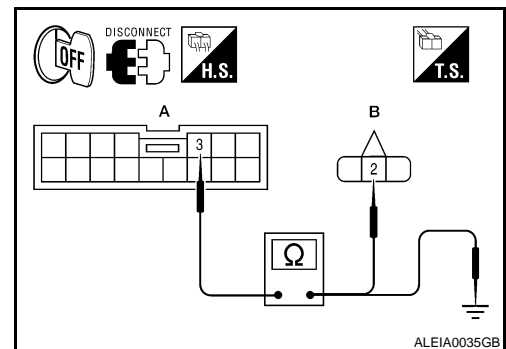

EXHAUST VALVE SOLENOID CIRCUIT

< COMPONENT DIAGNOSIS >

EXHAUST VALVE SOLENOID CIRCUIT

Description

INFOID:000000003710274

Receives exhaust valve solenoid signal from suspension control unit. When activated, the exhaust valve solenoid releases air pressure from the suspension control system.

Component Function Check

INFOID:000000003710275

1. CHECK EXHAUST SOLENOID OPERATION

CAUTION:

While operating this active test, the suspension control system will vent air pressure and the vehicle ride height will lower. Ensure the area around the vehicle is free from obstructions before beginning test.

CONSULT-III

1. Ensure the suspension control system has air pressure and is not drooping in the rear.
2. Select "EXHAUST SOLENOID" of AIR LEVELIZER active test items.
3. While operating test item, check that the exhaust valve solenoid opens to vent air from the system. The vehicle should lower when the exhaust valve solenoid is activated.

ON : Air vents and vehicle ride height lowers

OFF : No air vents and vehicle ride height remains constant

Does the system vent properly?

YES >> Exhaust valve solenoid is operating normally.

NO >> Refer to [SCS-23, "Diagnosis Procedure"](#).

Diagnosis Procedure

INFOID:000000003710276

1. CHECK EXHAUST VALVE SOLENOID SIGNAL

CONSULT-III

1. Connect suspension control unit connector B3.
2. Turn ignition switch ON.
3. Select "EXHAUST SOLENOID" of AIR LEVELIZER active test items.
4. While test item is operating, check signal between suspension air compressor connector C9 terminal 2 and ground.

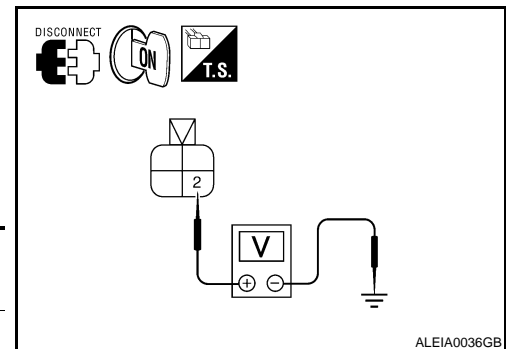

| (+) | | (-) | Voltage |
|-----------|----------|--------|-----------------|
| Connector | Terminal | | |
| C9 | 2 | Ground | Battery voltage |

Is battery voltage present?

YES >> GO TO 3.

NO >> GO TO 2.

2. CHECK CONTINUITY OF EXHAUST VALVE SOLENOID CIRCUIT

1. Turn ignition switch OFF.
2. Disconnect suspension control unit connector B3 and suspension air compressor connector C9.
3. Check continuity between suspension control unit connector B3 (A) terminal 9 and suspension air compressor connector C9 (B) terminal 2.

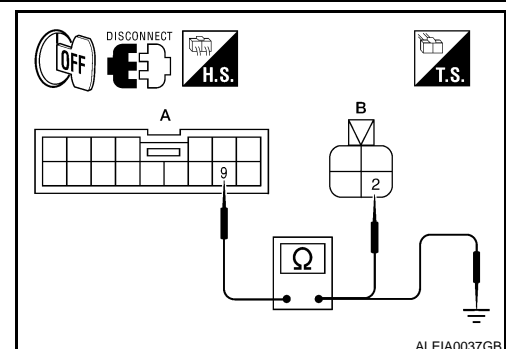

| A | | B | | Continuity |
|-----------|----------|-----------|----------|------------|
| Connector | Terminal | Connector | Terminal | |
| B3 | 9 | C9 | 2 | Yes |

A
B
C
D
E
F
G
H
I
J
K
L
M
N
O
P

SCS

EXHAUST VALVE SOLENOID CIRCUIT

< COMPONENT DIAGNOSIS >

4. Check continuity between suspension control unit connector B3 (A) terminal 9 and ground.

| A | | — | Continuity |
|-----------|----------|--------|------------|
| Connector | Terminal | | |
| B3 | 9 | Ground | No |

Are the continuity test results as specified?

- YES >> Replace the suspension control unit. Refer to [RSU-26, "Removal and Installation"](#).
 NO >> Repair harness or connector.

3. CHECK SUSPENSION AIR COMPRESSOR GROUND

1. Turn ignition switch OFF.
2. Check continuity between suspension air compressor connector C9 terminals 1 and 3 and ground.

| Connector | Terminal | — | Continuity |
|-----------|----------|--------|------------|
| C9 | 1 | Ground | Yes |
| | 3 | | |

Is continuity present?

- YES >> Replace the suspension air compressor. Refer to [RSU-22, "Removal and Installation"](#).
 NO >> Repair harness or connector.

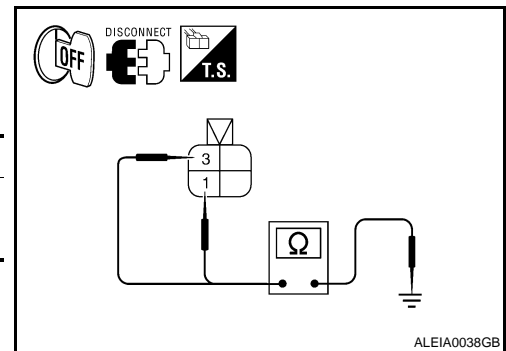

CK SUSP WARNING INDICATOR CONTROL CIRCUIT

< COMPONENT DIAGNOSIS >

CK SUSP WARNING INDICATOR CONTROL CIRCUIT

Description

INFOID:000000003710277

The CK SUSP warning lamp is controlled by a ground signal provided to the combination meter by the suspension control unit.

Component Function Check

INFOID:000000003710278

1. CHECK WARNING LAMP OPERATION

CONSULT-III

1. Turn ignition ON.
2. Select "WARNING LAMP" of AIR LEVELIZER active test items.
3. While operating test item, check that the warning lamp activates.

ON : Warning lamp turns ON

OFF : Warning lamp turns OFF

Does the warning lamp operate properly?

YES >> Warning lamp is operating normally.

NO >> Refer to [SCS-25, "Diagnosis Procedure"](#).

Diagnosis Procedure

INFOID:000000003710279

1. PERFORM SUSPENSION CONTROL SYSTEM SELF-DIAGNOSIS

CONSULT-III

1. Turn ignition ON.
2. Perform SELF DIAGNOSIS function of AIR LEVELIZER system.

Are any DTC's present?

YES >> Refer to [SCS-33, "DTC Index"](#).

- NO >>
- If warning lamp is always ON, GO TO 2.
 - If warning lamp is always OFF, GO TO 3.

2. CHECK SUSPENSION CONTROL UNIT WARNING LAMP CONTROL

1. Turn ignition OFF.
2. Disconnect the suspension control unit connector B3.
3. Turn ignition ON.

Does the CK SUSP warning lamp turn ON?

YES >> GO TO 3.

NO >> Replace the suspension control unit. Refer to [RSU-26, "Removal and Installation"](#).

3. CHECK CONTINUITY OF WARNING LAMP CONTROL CIRCUIT

1. Turn ignition switch OFF.
2. Disconnect suspension control unit connector B3 and combination meter connector M24.
3. Check continuity between suspension control unit connector B3 (A) terminal 10 and combination meter connector M24 (B) terminal 3.

| A | | B | | Continuity |
|-----------|----------|-----------|----------|------------|
| Connector | Terminal | Connector | Terminal | |
| B3 | 10 | M24 | 3 | Yes |

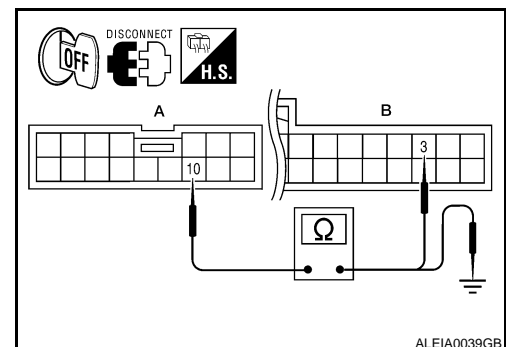

4. Check continuity between suspension control unit connector B3 (A) terminal 10 and ground.

CK SUSP WARNING INDICATOR CONTROL CIRCUIT

< COMPONENT DIAGNOSIS >

| A | | — | Continuity |
|-----------|----------|--------|------------|
| Connector | Terminal | | |
| B3 | 10 | Ground | No |

Are the continuity test results as specified?

YES >> Replace the combination meter. Refer to [MWI-105. "Removal and Installation"](#).

NO >> Repair harness or connector.

SUSPENSION CONTROL UNIT

< ECU DIAGNOSIS >

ECU DIAGNOSIS

SUSPENSION CONTROL UNIT

Reference Value

INFOID:000000003710280

TERMINAL LAYOUT

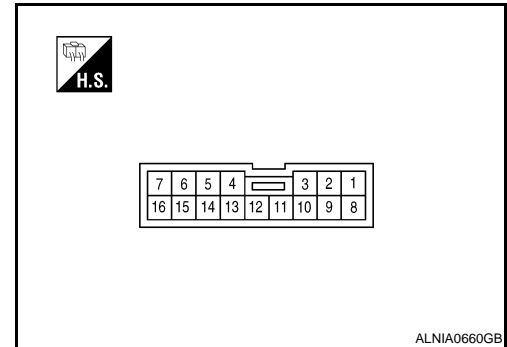

PHYSICAL VALUES

| Terminal (Wire color) | | Description | | Condition | | Reference value (Approx.) |
|--------------------------|--------|-----------------------------------|------------------|--------------------------------------|---|------------------------------|
| + | - | Signal name | Input/ Output | | | |
| 1 (V) | Ground | Compressor relay output | Output | Ignition switch ON | Air levelizer raising vehicle ride height | Battery voltage |
| 3 (W) | Ground | Height sensor input | Input | Ignition switch ON | — | 0.2V - 4.8V |
| 5 (R) | Ground | VREF output (height sen- sor) | Output | Ignition switch ON | — | 5V |
| 6 (G/R) | Ground | IGN power supply | Input | Ignition switch ON or START | — | Battery voltage |
| 7 (W/L) | Ground | BAT power supply | Input | Ignition switch OFF | — | Battery voltage |
| 8 (G/W) | Ground | Diagnostic K-line | Input/ Output | — | — | — |
| 9 (SB) | Ground | Exhaust valve output | Output | Ignition switch ON | Air levelizer lowering vehi- cle ride height (venting) | Battery voltage |
| 10 (BR) | Ground | Warning lamp output | Output | Ignition switch ON | Warning lamp ON | 0V |
| | | | | | Warning lamp OFF | Battery voltage |
| 14 (L) | Ground | Height sensor ground | Output | Ignition switch ON | — | Less than 0.2V |
| 15 (BR/W) | Ground | Generator input | Input | Ignition switch ON | Charge light ON | 0V |
| | | | | | Charge light OFF | Battery voltage |
| 16 (B) | Ground | Suspension control unit ground | Input | Ignition switch ON | — | Less than 0.2V |

SUSPENSION CONTROL UNIT

< ECU DIAGNOSIS >

Wiring Diagram

INFOID:000000003710281

SUSPENSION CONTROL SYSTEM

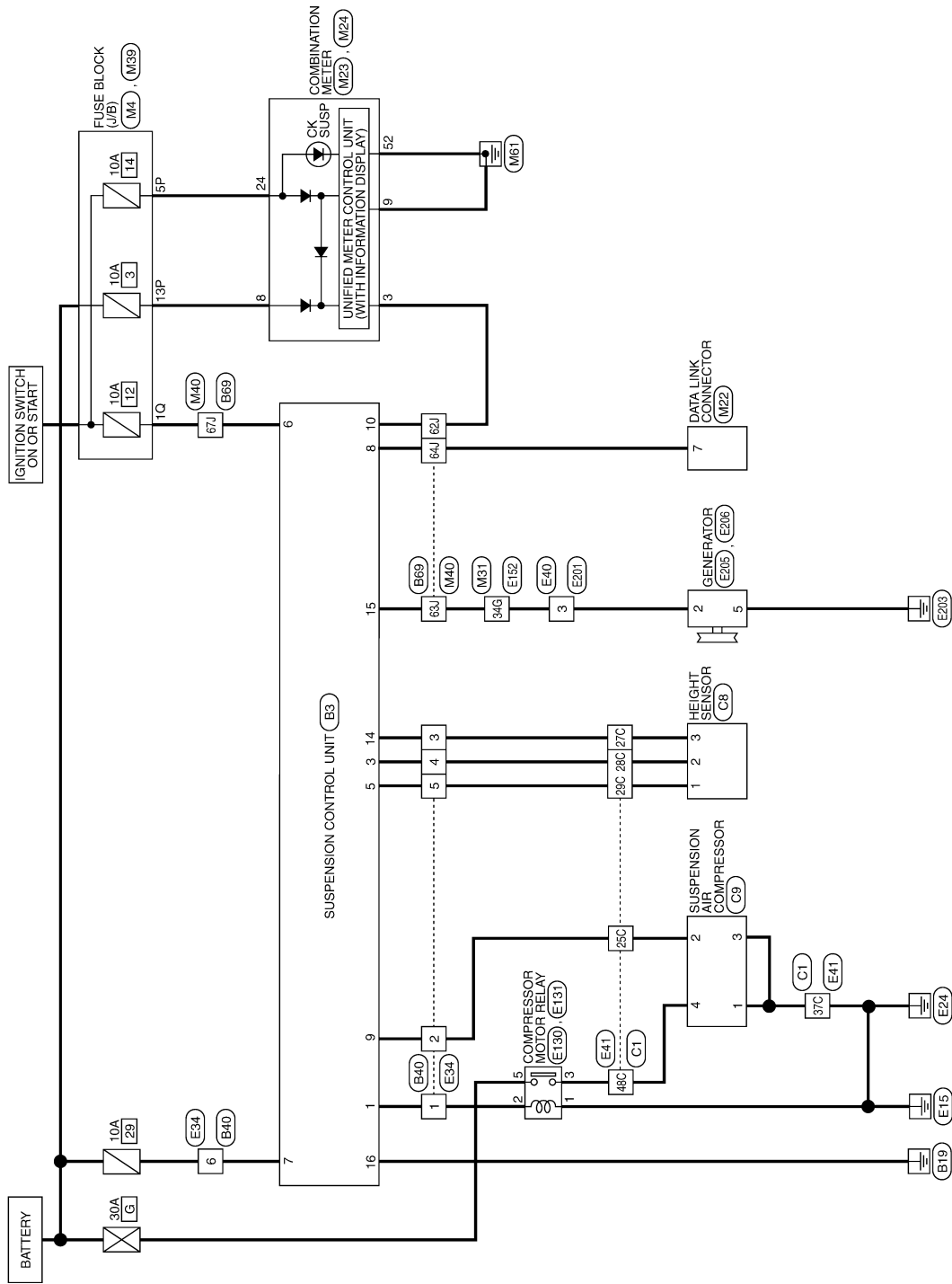

ABEWA0007GE

SUSPENSION CONTROL UNIT

< ECU DIAGNOSIS >

SUSPENSION CONTROL SYSTEM CONNECTORS

| | |
|-----------------|------------------|
| Connector No. | M4 |
| Connector Name | FUSE BLOCK (J/B) |
| Connector Color | WHITE |



| Terminal No. | Color of Wire | Signal Name |
|--------------|---------------|-------------|
| 5P | O/L | - |
| 13P | P | - |

| | |
|-----------------|---------------------|
| Connector No. | M22 |
| Connector Name | DATA LINK CONNECTOR |
| Connector Color | WHITE |

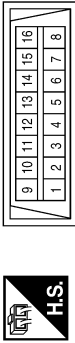

| Terminal No. | Color of Wire | Signal Name |
|--------------|---------------|-------------|
| 7 | G/W | - |

| | |
|-----------------|-------------------|
| Connector No. | M23 |
| Connector Name | COMBINATION METER |
| Connector Color | WHITE |

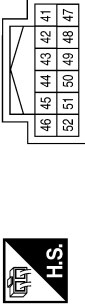

| Terminal No. | Color of Wire | Signal Name |
|--------------|---------------|-------------|
| 52 | B | ILL GND |

| | |
|-----------------|-------------------|
| Connector No. | M24 |
| Connector Name | COMBINATION METER |
| Connector Color | WHITE |

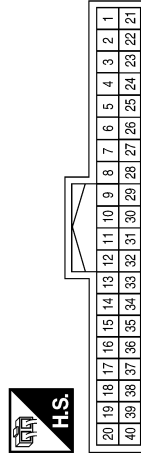

| Terminal No. | Color of Wire | Signal Name |
|--------------|---------------|-------------------|
| 3 | BR | AIR LEVELIZER |
| 8 | Y/R | BATTERY (TYPE A*) |
| 8 | P | BATTERY (TYPE B*) |
| 9 | B | GND |
| 24 | O/L | RUN START |

| | |
|-----------------|------------------|
| Connector No. | M31 |
| Connector Name | FUSE BLOCK (J/B) |
| Connector Color | WHITE |

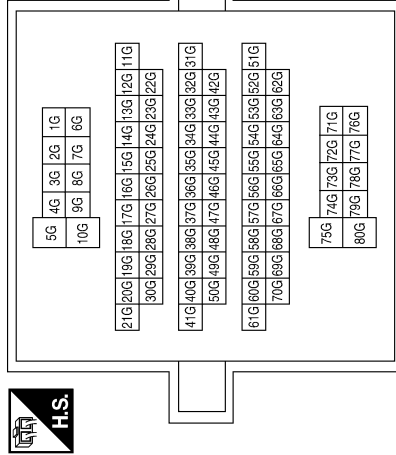

| Terminal No. | Color of Wire | Signal Name |
|--------------|---------------|-------------|
| 34G | BR/W | - |

| | |
|-----------------|------------------|
| Connector No. | M39 |
| Connector Name | FUSE BLOCK (J/B) |
| Connector Color | WHITE |

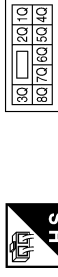

| Terminal No. | Color of Wire | Signal Name |
|--------------|---------------|-------------|
| 1Q | G/R | - |

* : REFER TO HARNESS LAYOUT OF PG SECTION FOR DEFINITION OF TYPE A AND TYPE B.

AAEIA0010GB

SUSPENSION CONTROL UNIT

< ECU DIAGNOSIS >

| | |
|-----------------|--------------|
| Connector No. | M40 |
| Connector Name | WIRE TO WIRE |
| Connector Color | WHITE |

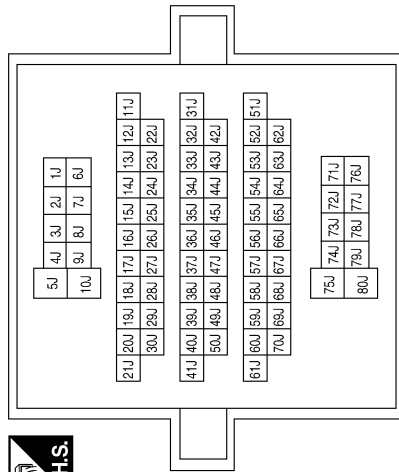

| Terminal No. | Color of Wire | Signal Name |
|--------------|---------------|-------------|
| 62J | BR | - |
| 63J | BR/W | - |
| 64J | G/W | - |
| 67J | G/R | - |

| | |
|-----------------|--------------|
| Connector No. | E34 |
| Connector Name | WIRE TO WIRE |
| Connector Color | WHITE |

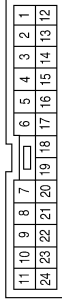

| Terminal No. | Color of Wire | Signal Name |
|--------------|---------------|-------------|
| 1 | V | - |
| 2 | SB | - |
| 3 | L | - |
| 4 | W | - |
| 5 | R | - |
| 6 | W/L | - |

| | |
|-----------------|--------------|
| Connector No. | E40 |
| Connector Name | WIRE TO WIRE |
| Connector Color | BLACK |



| | |
|-----------------|--------------|
| Connector No. | E41 |
| Connector Name | WIRE TO WIRE |
| Connector Color | GRAY |

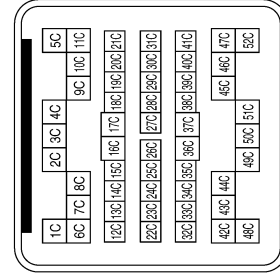

| Terminal No. | Color of Wire | Signal Name |
|--------------|---------------|-------------|
| 3 | BR/W | - |

| Terminal No. | Color of Wire | Signal Name |
|--------------|---------------|-------------|
| 25C | SB | - |
| 27C | L | - |
| 28C | W | - |
| 29C | R | - |
| 37C | B | - |
| 48C | SB | - |

SUSPENSION CONTROL UNIT

< ECU DIAGNOSIS >

| | |
|-----------------|------------------------|
| Connector No. | E130 |
| Connector Name | COMPRESSOR MOTOR RELAY |
| Connector Color | WHITE |



| Terminal No. | Color of Wire | Signal Name |
|--------------|---------------|-------------|
| 1 | B | - |
| 2 | V | - |

| | |
|-----------------|------------------------|
| Connector No. | E131 |
| Connector Name | COMPRESSOR MOTOR RELAY |
| Connector Color | WHITE |



| Terminal No. | Color of Wire | Signal Name |
|--------------|---------------|-------------|
| 3 | SB | - |
| 5 | Y/B | - |

| | |
|-----------------|--------------|
| Connector No. | E152 |
| Connector Name | WIRE TO WIRE |
| Connector Color | WHITE |

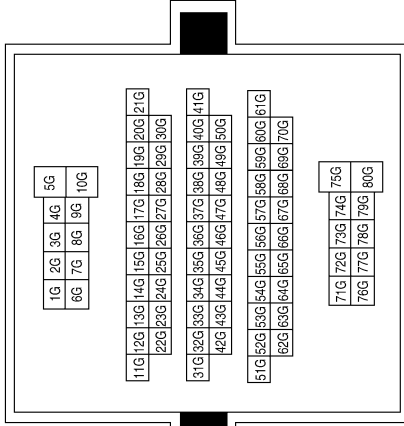

| Terminal No. | Color of Wire | Signal Name |
|--------------|---------------|-------------|
| 34G | BR/W | - |

| | |
|-----------------|--------------|
| Connector No. | E201 |
| Connector Name | WIRE TO WIRE |
| Connector Color | BLACK |



| Terminal No. | Color of Wire | Signal Name |
|--------------|---------------|-------------|
| 3 | BR/W | - |

| | |
|-----------------|-----------|
| Connector No. | E205 |
| Connector Name | GENERATOR |
| Connector Color | BLACK |



| Terminal No. | Color of Wire | Signal Name |
|--------------|---------------|-------------|
| 2 | BR/W | - |

| | |
|-----------------|-----------|
| Connector No. | E206 |
| Connector Name | GENERATOR |
| Connector Color | - |



| Terminal No. | Color of Wire | Signal Name |
|--------------|---------------|-------------|
| 5 | B | - |

AAEIA0003GB

A B C D E F G H I J K L M N O P

SCS

SUSPENSION CONTROL UNIT

< ECU DIAGNOSIS >

| | |
|-----------------|--------------|
| Connector No. | C1 |
| Connector Name | WIRE TO WIRE |
| Connector Color | GRAY |

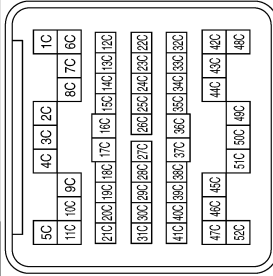

| Terminal No. | Color of Wire | Signal Name |
|--------------|---------------|-------------|
| 25C | SB | - |
| 27C | L | - |
| 28C | W | - |
| 29C | R | - |
| 37C | B | - |
| 48C | SB | - |

| | |
|-----------------|---------------|
| Connector No. | C8 |
| Connector Name | HEIGHT SENSOR |
| Connector Color | BLACK |



| Terminal No. | Color of Wire | Signal Name |
|--------------|---------------|-------------|
| 1 | R | - |
| 2 | W | - |
| 3 | L | - |

| | |
|-----------------|---------------------------|
| Connector No. | C9 |
| Connector Name | SUSPENSION AIR COMPRESSOR |
| Connector Color | BLACK |

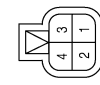

| Terminal No. | Color of Wire | Signal Name |
|--------------|---------------|-------------|
| 1 | B | - |
| 2 | SB | - |
| 3 | B | - |
| 4 | SB | - |

| | |
|-----------------|-------------------------|
| Connector No. | B3 |
| Connector Name | SUSPENSION CONTROL UNIT |
| Connector Color | WHITE |

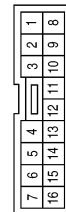

| Terminal No. | Color of Wire | Signal Name |
|--------------|---------------|-------------------------|
| 1 | V | COMPRESSOR RELAY OUTPUT |
| 2 | - | - |
| 3 | W | HEIGHT SENSOR INPUT |

| Terminal No. | Color of Wire | Signal Name |
|--------------|---------------|----------------------|
| 4 | - | - |
| 5 | R | VREF OUTPUT |
| 6 | G/R | IGN |
| 7 | W/L | BAT |
| 8 | G/W | K-LINE |
| 9 | SB | EXHAUST VALVE OUTPUT |
| 10 | BR | WARNING LAMP OUTPUT |
| 11 | - | - |
| 12 | - | - |
| 13 | - | - |
| 14 | L | HEIGHT SENSOR GND |
| 15 | BR/W | ALTERNATOR INPUT |
| 16 | B | GND |

| | |
|-----------------|--------------|
| Connector No. | B40 |
| Connector Name | WIRE TO WIRE |
| Connector Color | WHITE |

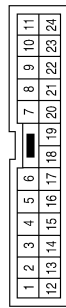

| Terminal No. | Color of Wire | Signal Name |
|--------------|---------------|-------------|
| 1 | V | - |
| 2 | SB | - |
| 3 | L | - |
| 4 | W | - |
| 5 | R | - |
| 6 | W/L | - |

ABEIA0020GB

SUSPENSION CONTROL UNIT

< ECU DIAGNOSIS >

A
B
C
D
F
G
H
I
J
K
L
M
N
O
P

SCS

| Terminal No. | Color of Wire | Signal Name |
|--------------|---------------|-------------|
| 62J | BR | - |
| 63J | BR/W | - |
| 64J | G/W | - |
| 67J | G/R | - |

| | |
|-----------------|--------------|
| Connector No. | B69 |
| Connector Name | WIRE TO WIRE |
| Connector Color | WHITE |

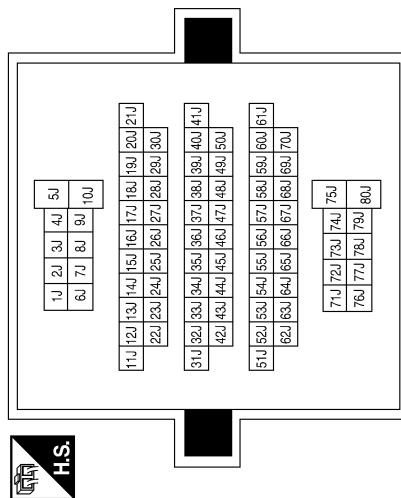

ABEIA0021GB

INFOID:000000003710282

DTC Index

Self-diagnosis results display item

| CONSULT-III display | Malfunction | Reference page |
|-------------------------------|--|--|
| Vehicle height sensor [C1801] | Vehicle height sensor voltage is less than 0.2V or greater than 4.8V for more than 60 seconds. | SCS-9 , "Diagnosis Procedure" . |

SUSPENSION CONTROL UNIT

< ECU DIAGNOSIS >

| | | |
|--|---|---|
| Compressor relay [C1802] | <ul style="list-style-type: none"> • Driving transistor for compressor relay is OFF and monitor voltage continues at a high level for more than 10 seconds. • Driving transistor for compressor relay is ON and monitor voltage continues at a low level for more than 5 seconds. | SCS-10. "Diagnosis Procedure". |
| Exhaust solenoid [C1803] | <ul style="list-style-type: none"> • Driving transistor for exhaust valve solenoid is OFF and monitor voltage continues at a high level for more than 10 seconds. • Driving transistor for exhaust valve solenoid is ON and monitor voltage continues at a low level for more than 5 seconds. | SCS-11. "Diagnosis Procedure". |
| Vehicle height adjusting malfunction (compressor)[C1804] | Continuous compressor relay ON time is more than 120 seconds. | SCS-12. "Diagnosis Procedure". |
| Vehicle height adjusting malfunction (exhaust solenoid)[C1805] | Continuous exhaust valve solenoid ON time is more than 120 seconds. | SCS-13. "Diagnosis Procedure". |
| Vehicle height sensor locking malfunction [C1806] | Output sensor voltage variation $\pm 0.02V$ is more than 100 seconds when vehicle height range is normal. | SCS-14. "Diagnosis Procedure". |
| Sensor 5V malfunction [C1807] | Sensor reference voltage is less than 0.8V or more than 6V for 20 seconds. | SCS-15. "Diagnosis Procedure". |
| Integral time malfunction by supplying air [C1808] | A suspension air compressor ON request has been in effect for 180 seconds and the suspension air compressor has not activated during that time. | SCS-16. "Diagnosis Procedure". |

SUSPENSION CONTROL SYSTEM

< SYMPTOM DIAGNOSIS >

SYMPTOM DIAGNOSIS

SUSPENSION CONTROL SYSTEM

Symptom Table

INFOID:000000003710283

AIR LEVELIZER

| Symptom | Possible cause | Reference page |
|--|--|--|
| Inoperative | <ul style="list-style-type: none"> • Suspension control unit • Compressor motor relay • Suspension air compressor | SCS-36. "Diagnosis Procedure". |
| System does not raise | <ul style="list-style-type: none"> • Suspension control unit • Height sensor • Compressor motor relay • Suspension air compressor • Leak in system • Restriction in system | SCS-37. "Diagnosis Procedure". |
| System does not lower | <ul style="list-style-type: none"> • Suspension control unit • Height sensor • Compressor motor relay • Suspension air compressor • Restriction in system | SCS-38. "Diagnosis Procedure". |
| CK SUSP indicator lamp always ON with key ON | <ul style="list-style-type: none"> • CK SUSP indicator lamp control circuit • Suspension control unit | SCS-25. "Description". |

A
B
C
D
E
F
G
H
I
J
K
L
M
N
O
P

SCS

SUSPENSION CONTROL SYSTEM INOPERATIVE

< SYMPTOM DIAGNOSIS >

SUSPENSION CONTROL SYSTEM INOPERATIVE

Description

INFOID:000000003710284

The suspension control system does not activate. It does not raise or lower the vehicle in response to ride height changes.

Diagnosis Procedure

INFOID:000000003710285

1. SUSPENSION CONTROL UNIT POWER AND GROUND INSPECTION

Check the suspension control unit power and ground supply. Refer to [SCS-17. "SUSPENSION CONTROL UNIT : Diagnosis Procedure"](#).

Does the suspension control unit power and ground pass inspection?

YES >> GO TO 2.

NO >> Repair or replace the malfunctioning part.

2. CHECK HEIGHT SENSOR SIGNAL INPUT

ⓂCONSULT-III DATA MONITOR

1. Turn ignition switch ON.
2. Select "HEIGT SEN" of AIR LEVELIZER data monitor item.
3. Check the monitor status.

HEIGT SEN : 0.2V - 4.8V

Is the height sensor voltage normal?

YES >> GO TO 3.

NO >> Check height sensor signal circuit. Refer to [SCS-22. "Diagnosis Procedure"](#).

3. CHECK GENERATOR "L" CIRCUIT SIGNAL

ⓂCONSULT-III DATA MONITOR

1. Start the engine.
2. Select "ACG L" of AIR LEVELIZER data monitor item.
3. Check the monitor status.

**ACG L : OFF with charge light OFF
: ON with charge light ON**

Is the generator "L" signal operating normally?

YES >> GO TO 4.

NO >> Check generator L circuit. Refer to [CHG-11. "Diagnosis Procedure"](#).

4. SUSPENSION AIR COMPRESSOR POWER AND GROUND INSPECTION

Check the suspension air compressor power and ground supply. Refer to [SCS-17. "SUSPENSION AIR COMPRESSOR : Diagnosis Procedure"](#).

Does the suspension air compressor power and ground pass inspection?

YES >> System is operating normally.

NO >> Repair or replace the malfunctioning part.

SUSPENSION CONTROL SYSTEM DOES NOT RAISE

< SYMPTOM DIAGNOSIS >

SUSPENSION CONTROL SYSTEM DOES NOT RAISE

Description

INFOID:000000003710286

The suspension control system does not raise the vehicle in accordance with ride height changes.

Diagnosis Procedure

INFOID:000000003710287

1. SUSPENSION CONTROL UNIT POWER AND GROUND INSPECTION

Check the suspension control unit power and ground supply. Refer to [SCS-17, "SUSPENSION CONTROL UNIT : Diagnosis Procedure"](#).

Does the suspension control unit power and ground pass inspection?

YES >> GO TO 2.

NO >> Repair or replace the malfunctioning part.

2. CHECK HEIGHT SENSOR SIGNAL INPUT

 CONSULT-III DATA MONITOR

1. Turn ignition ON.
2. Select "HEIGT SEN" of AIR LEVELIZER data monitor item.
3. Check the monitor status.

HEIGT SEN : 0.2V - 4.8V

Is the height sensor voltage normal?

YES >> GO TO 3.

NO >> Check height sensor signal circuit. Refer to [SCS-22, "Diagnosis Procedure"](#).

3. SUSPENSION AIR COMPRESSOR POWER AND GROUND INSPECTION

Check the suspension air compressor power and ground supply. Refer to [SCS-17, "SUSPENSION AIR COMPRESSOR : Diagnosis Procedure"](#).

Does the suspension air compressor power and ground pass inspection?

YES >> Inspect for a weak compressor, leak or restriction in the system. Repair or replace malfunctioning part.

NO >> Repair or replace the malfunctioning part.

A
B
C
D
SCS
F
G
H
I
J
K
L
M
N
O
P

SUSPENSION CONTROL SYSTEM DOES NOT LOWER

< SYMPTOM DIAGNOSIS >

SUSPENSION CONTROL SYSTEM DOES NOT LOWER

Description

INFOID:000000003710288

The suspension control system does not lower the vehicle in accordance with ride height changes.

Diagnosis Procedure

INFOID:000000003710289

1. SUSPENSION CONTROL UNIT POWER AND GROUND INSPECTION

Check the suspension control unit power and ground supply. Refer to [SCS-17, "SUSPENSION CONTROL UNIT : Diagnosis Procedure"](#).

Does the suspension control unit power and ground pass inspection?

YES >> GO TO 2.

NO >> Repair or replace the malfunctioning part.

2. CHECK HEIGHT SENSOR SIGNAL INPUT

④CONSULT-III DATA MONITOR

1. Turn ignition ON.
2. Select "HEIGT SEN" of AIR LEVELIZER data monitor item.
3. Check the monitor status.

HEIGT SEN : 0.2V - 4.8V

Is the height sensor voltage normal?

YES >> GO TO 3.

NO >> Check height sensor signal circuit. Refer to [SCS-22, "Diagnosis Procedure"](#).

3. EXHAUST VALVE SOLENOID CIRCUIT INSPECTION

Check the exhaust valve solenoid circuit. Refer to [SCS-23, "Component Function Check"](#).

Does the exhaust valve solenoid circuit pass inspection?

YES >> Inspect for a restriction in the system. repair or replace the malfunctioning part.

NO >> Repair or replace the malfunctioning part.

PRECAUTIONS

< PRECAUTION >

PRECAUTION

PRECAUTIONS

Precaution for Supplemental Restraint System (SRS) "AIR BAG" and "SEAT BELT PRE-TENSIONER"

INFOID:000000003710290

The Supplemental Restraint System such as "AIR BAG" and "SEAT BELT PRE-TENSIONER", used along with a front seat belt, helps to reduce the risk or severity of injury to the driver and front passenger for certain types of collision. This system includes seat belt switch inputs and dual stage front air bag modules. The SRS system uses the seat belt switches to determine the front air bag deployment, and may only deploy one front air bag, depending on the severity of a collision and whether the front occupants are belted or unbelted. Information necessary to service the system safely is included in the SR and SB section of this Service Manual.

WARNING:

- To avoid rendering the SRS inoperative, which could increase the risk of personal injury or death in the event of a collision which would result in air bag inflation, all maintenance must be performed by an authorized NISSAN/INFINITI dealer.
- Improper maintenance, including incorrect removal and installation of the SRS, can lead to personal injury caused by unintentional activation of the system. For removal of Spiral Cable and Air Bag Module, see the SR section.
- Do not use electrical test equipment on any circuit related to the SRS unless instructed to in this Service Manual. SRS wiring harnesses can be identified by yellow and/or orange harnesses or harness connectors.

Precaution for Rear Suspension

INFOID:000000003710291

- When installing the rubber bushings, the final tightening must be done under unladen condition and with the tires on level ground. Oil will shorten the life of the rubber bushings, so wipe off any spilled oil immediately.
- Unladen condition means the fuel tank, engine coolant and lubricants are at the full specification. The spare tire, jack, hand tools, and mats are in their designated positions.
- After installing suspension components, check the wheel alignment.
- Caulking nuts are not reusable. Always use new caulking nuts for installation. New caulking nuts are pre-oiled, do not apply any additional lubrication.

A
B
C
D
SCS
F
G
H
I
J
K
L
M
N
O
P