

FRONT AXLE & FRONT SUSPENSION

SECTION FA

CONTENTS

PRECAUTIONS AND PREPARATION2	Auto-lock Free-running Hub14	
Precautions2	Wheel Hub and Rotor Disc.....14	CL
Special Service Tools2	Knuckle Spindle16	
Commercial Service Tools3	Drive Shaft19	MT
NOISE, VIBRATION AND HARSHNESS (NVH)	Shock Absorber25	
TROUBLESHOOTING4	Torsion Bar Spring25	
NVH Troubleshooting Chart.....4	Stabilizer Bar27	AT
FRONT SUSPENSION SYSTEM5	Upper Link28	
ON-VEHICLE SERVICE6	Tension Rod.....29	TF
Front Axle and Front Suspension Parts6	Lower Link30	
Front Wheel Bearing.....6	Upper Ball Joint and Lower Ball Joint.....31	
Front Wheel Alignment7	SERVICE DATA AND SPECIFICATIONS (SDS)32	PD
Drive Shaft.....11	General Specifications32	
FRONT AXLE12	Inspection and Adjustment32	
Manual-lock Free-running Hub13		

FA

RA

BR

ST

RS

BT

HA

EL

IDX

PRECAUTIONS AND PREPARATION

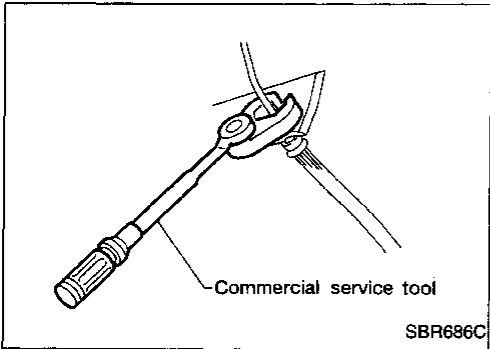

Precautions

- When installing rubber parts, final tightening must be carried out under unladen condition* with tires on ground.
- * Fuel, radiator coolant and engine oil full. Spare tire, jack, hand tools and mats in designated positions.
- Use flare nut wrench when removing and installing brake tubes.
- After installing removed suspension parts, check wheel alignment and adjust if necessary.
- Always torque brake lines when installing.

Special Service Tools

The actual shapes of Kent-Moore tools may differ from those of special service tools illustrated here.

Tool number (Kent-Moore No.) Tool name	Description
ST29020001 (J24319-01) Gear arm puller	<div style="display: flex; justify-content: space-between;"> <div style="width: 30%;"> </div> <div style="width: 60%;"> <p>Removing ball joint for knuckle spindle</p> <p>a: 34 mm (1.34 in) b: 6.5 mm (0.256 in) c: 61.5 mm (2.421 in)</p> </div> </div>
HT72520000 (J25730-B) Ball joint remover	<div style="display: flex; justify-content: space-between;"> <div style="width: 30%;"> </div> <div style="width: 60%;"> <p>Removing tie-rod outer end</p> <p>a: 33 mm (1.30 in) b: 50 mm (1.97 in) r: R11.5 mm (0.453 in)</p> </div> </div>
KV401021S0 (—) Bearing race drift	<div style="display: flex; justify-content: space-between;"> <div style="width: 30%;"> </div> <div style="width: 60%;"> <p>Installing wheel bearing outer race</p> </div> </div>
KV40105400 (J36001) Wheel bearing lock nut wrench	<div style="display: flex; justify-content: space-between;"> <div style="width: 30%;"> </div> <div style="width: 60%;"> <p>Removing and installing wheel bearing lock nut</p> </div> </div>
KV40106800 (—) Lower link bushing puller	<div style="display: flex; justify-content: space-between;"> <div style="width: 30%;"> </div> <div style="width: 60%;"> <p>Removing and installing lower link bushing</p> </div> </div>

PRECAUTIONS AND PREPARATION

Commercial Service Tools

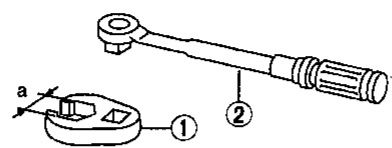
Tool name	Description
<p>① Flare nut crowfoot ② Torque wrench</p>	<p>Removing and installing each brake piping</p>  <p>NT360</p> <p>a: 10 mm (0.39 in)</p>

GI

MA

EM

LC

EC

FE

CL

MT

AT

TF

PD

FA

RA

BR

ST

RS

BT

HA

EL

IDX

FRONT SUSPENSION SYSTEM

SEC. 391•400•401

When installing rubber parts, final tightening must be carried out under unladen condition* with tires on ground.

- * Fuel, radiator coolant and engine oil full.
- Spare tire, jack, hand tools and mats in designated positions.

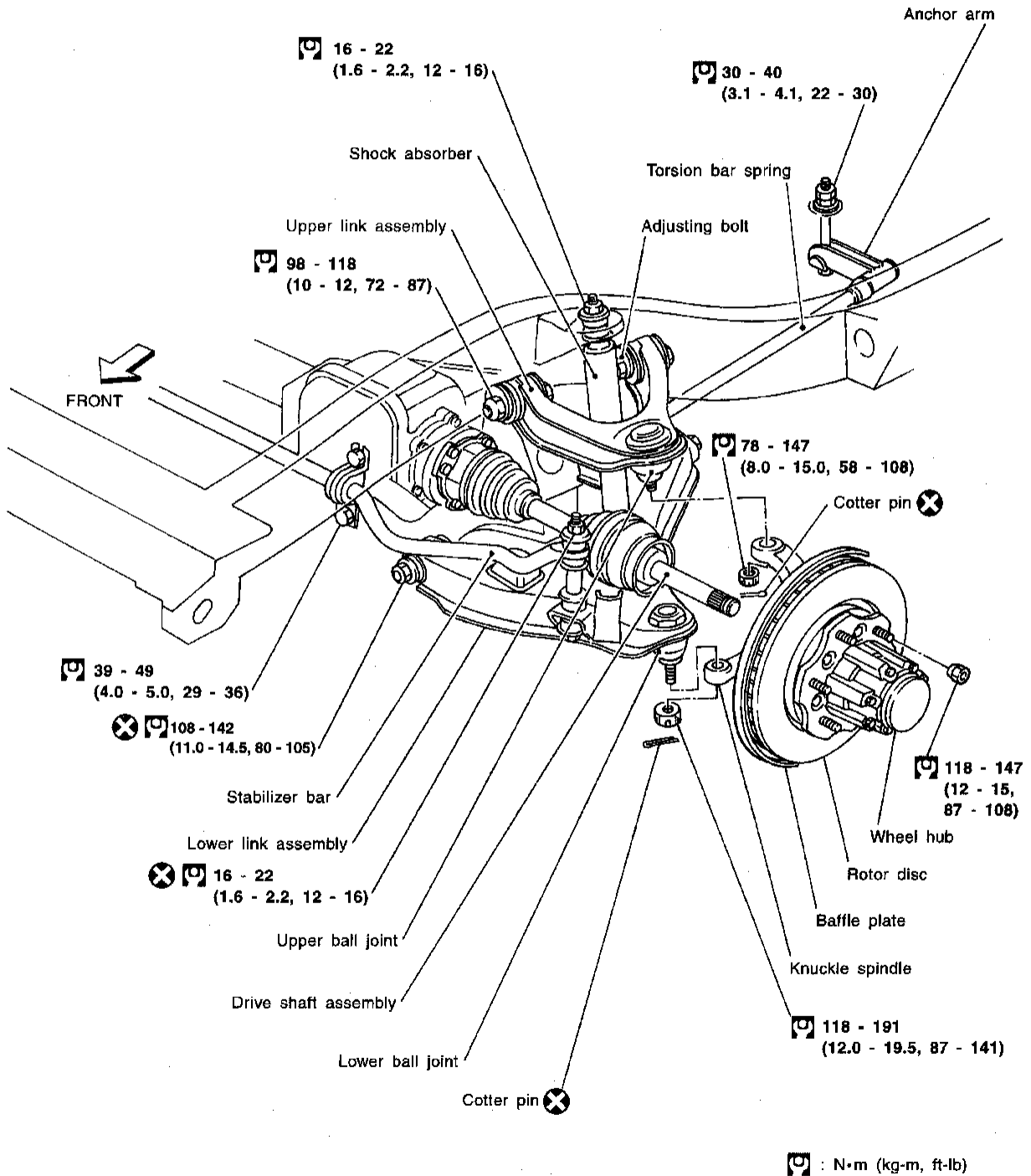

GI
MA
EM
LC
EC
FE
CL
MT
AT
TF
PD
FA
RA
BR
ST
RS
BT
HA
EL
IDX

ON-VEHICLE SERVICE

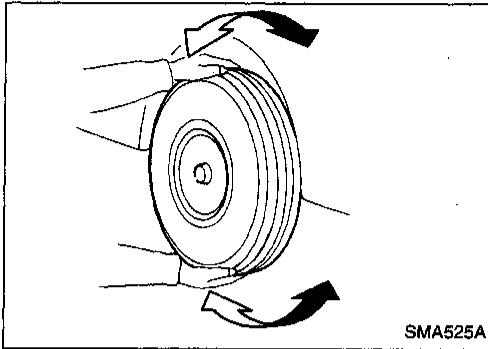

Front Axle and Front Suspension Parts

Check front axle and front suspension parts for excessive play, cracks, wear and other damage.

- Shake each front wheel to check for excessive play. If looseness is noted, adjust wheel bearing end play, then check ball joint end play.
- Make sure that the cotter pin is inserted.
- Retighten all nuts and bolts to the specified torque.
- ☐: Refer to "FRONT SUSPENSION SYSTEM", FA-5.
- Check front axle and front suspension parts for wear, cracks and other damage.
- Check shock absorber for oil leakage and other damage.
- Check suspension ball joint for grease leakage and ball joint dust cover for cracks and other damage.

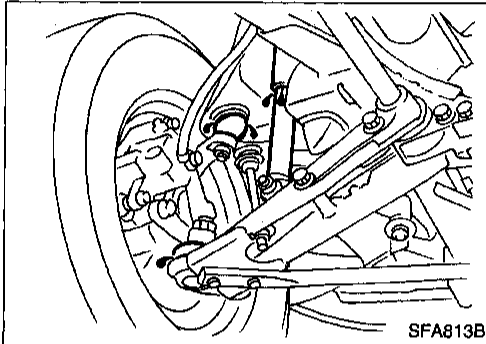

Front Wheel Bearing

- Check that wheel bearings operate smoothly.
- Check axial end play.
Axial end play: 0 mm (0 in)
- Adjust wheel bearing preload if there is any axial end play or wheel bearing does not turn smoothly.

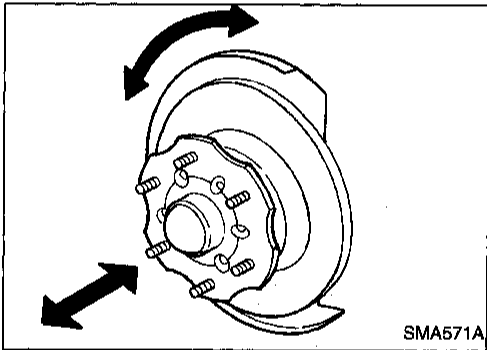

PRELOAD ADJUSTMENT

Adjust wheel bearing preload after wheel bearing has been replaced or front axle has been reassembled.

Adjust wheel bearing preload as follows:

1. Before adjustment, thoroughly clean all parts to prevent dirt entry.

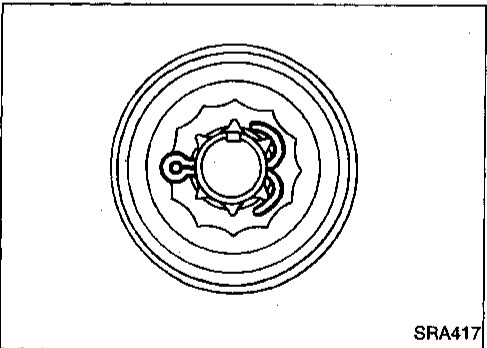

2. Apply multi-purpose grease sparingly to the following parts:
 - Threaded portion of spindle
 - Contact surface between wheel bearing washer and outer wheel bearing
 - Grease seal lip
 - Wheel hub (as shown at left) 18 - 23 g (0.63 - 0.81 oz)

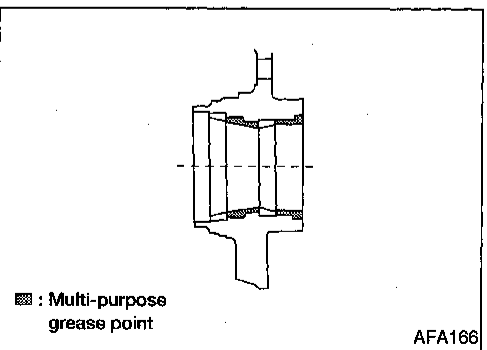

ON-VEHICLE SERVICE

Front Wheel Bearing (Cont'd)

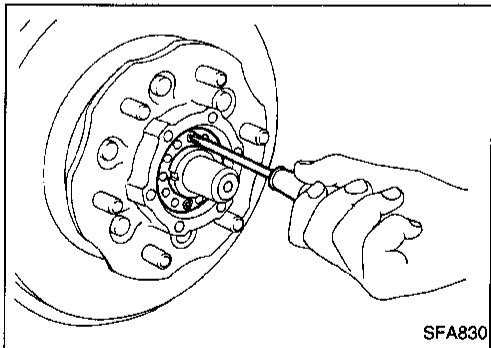
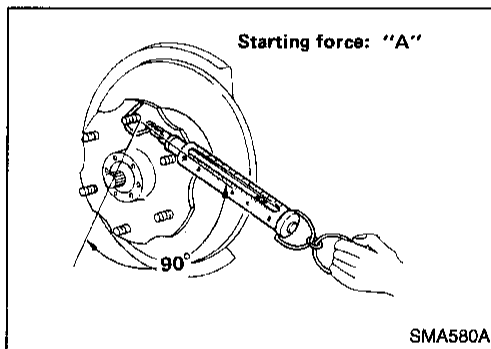
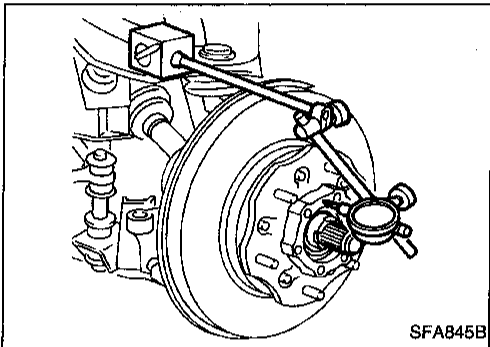
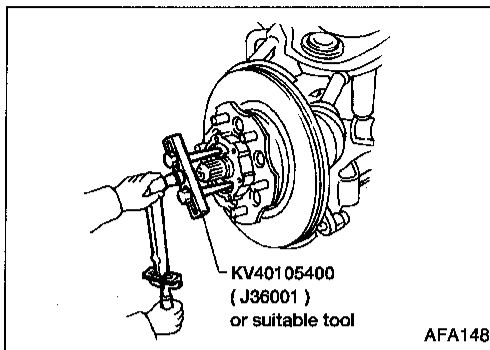

3. Tighten wheel bearing lock nut with Tool.
Ⓜ: 78 - 98 N·m (8 - 10 kg-m, 58 - 72 ft-lb)
4. Turn wheel hub several times in both directions.
5. Loosen wheel bearing lock nut so that torque becomes 0 N·m (0 kg-m, 0 ft-lb).
6. Retighten wheel bearing lock nut with Tool.
Ⓜ: 0.5 - 1.5 N·m (0.05 - 0.15 kg-m, 4.3 - 13.0 in-lb)

7. Turn wheel hub several times in both directions.
8. Retighten wheel bearing lock nut with Tool.
Ⓜ: 0.5 - 1.5 N·m (0.05 - 0.15 kg-m, 4.3 - 13.0 in-lb)
9. Measure wheel bearing axial end play.
Axial end play: 0 mm (0 in)

10. Measure starting force "A" at wheel hub bolt.

11. Install lock washer by tightening the lock nut within 15 to 30 degrees.
12. Turn wheel hub several times in both directions to seat wheel bearing correctly.
13. Measure starting force "B" at wheel hub bolt. Refer to step 10.
14. Wheel bearing preload "C" can be calculated as shown below.

$$C = B - A$$

Wheel bearing preload "C":

7.06 - 20.99 N (0.72 - 2.14 kg, 1.59 - 4.72 lb)

15. Repeat steps 3 through 14 until correct axial end play and wheel bearing preload are obtained.
16. Tighten screws.
Ⓜ: 1.2 - 1.8 N·m (0.12 - 0.18 kg-m, 10.4 - 15.6 in-lb)
17. Install free-running hub.

Front Wheel Alignment

Before checking front wheel alignment, make a preliminary inspection (Unladen*).

*: Fuel, radiator coolant and engine oil full. Spare tire, jack, hand tools and mats in designated positions.

GI

MA

EM

LC

EC

FE

CL

MT

AT

TF

PD

FA

RA

BR

ST

RS

BT

HA

EL

IDX

ON-VEHICLE SERVICE

Front Wheel Alignment (Cont'd)

PRELIMINARY INSPECTION

1. Check tires for wear and proper inflation.
2. Check outside and inside wheel runout.
Wheel runout average
 $[(\text{Outside runout value} + \text{Inside runout value}) \times 0.5]:$
Refer to SDS, FA-32.
3. Check front wheel bearings for looseness.
4. Check front suspension for looseness.
5. Check steering linkage for looseness.
6. Check that front shock absorbers work properly by using the standard bounce test.
7. Measure vehicle height (Unladen): $H = A - B$ mm (in)
Refer to SDS, FA-33.
 - a. Exercise the front suspension by bouncing the front of the vehicle 4 or 5 times to ensure that the vehicle is in a neutral height attitude.
 - b. Measure wheel alignment.
Refer to SDS, FA-33.
 - c. If wheel alignment is not as specified, adjust vehicle posture.
Refer to SDS, FA-33.
 - d. Adjust wheel alignment.
Refer to SDS, FA-33.

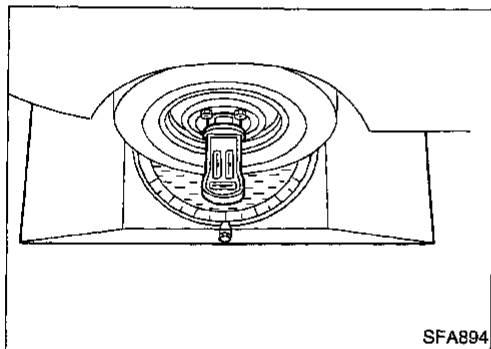
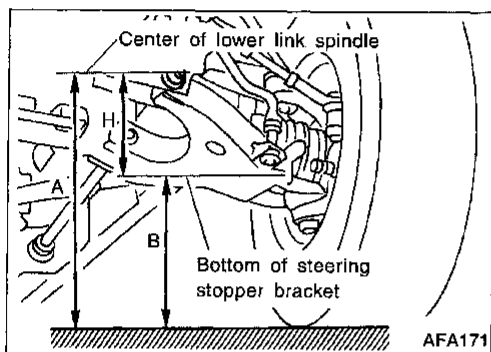
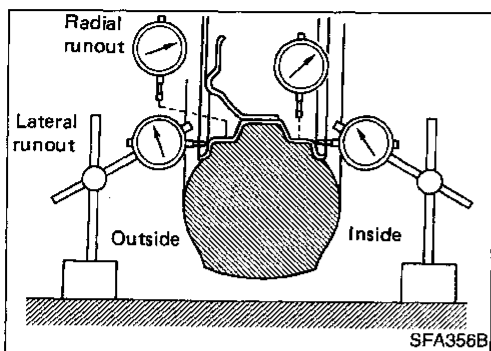

CAMBER, CASTER AND KINGPIN INCLINATION

Before checking camber, caster or kingpin inclination, move vehicle up and down on turning radius gauge to minimize friction. Ensure that the vehicle is in correct posture.

- Measure camber, caster and kingpin inclination of both right and left wheels with a suitable alignment gauge and adjust in accordance with the following procedures.

Camber, Caster and Kingpin inclination:
Refer to SDS, FA-33.

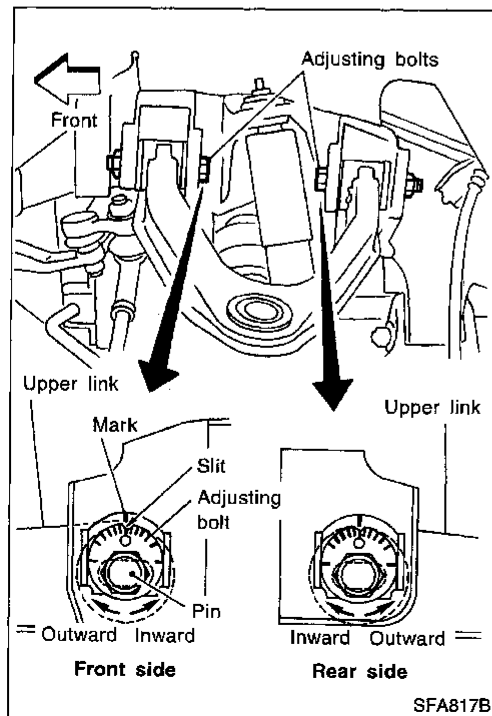

- In the following two cases, temporarily tighten the adjusting bolts while aligning the matching marks with the slits as shown in the figure at the left and measure the camber, caster and kingpin inclination:
 - (1) When replacing the upper link or other suspension parts with new ones
 - (2) When matching marks were not painted on adjusting bolts before suspension disassembly procedures
- If matching marks were already painted during suspension disassembly, align the matching marks with the slits, then temporarily tighten the adjusting bolts. Measure the camber, caster and kingpin inclination.

ON-VEHICLE SERVICE

Front Wheel Alignment (Cont'd)

ADJUSTMENT

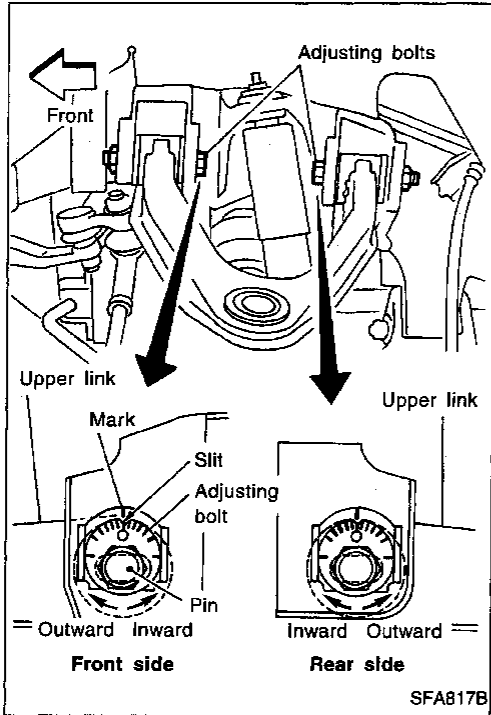

1. Both camber and caster angles are adjusted by adjusting bolts.
 - If the kingpin inclination is outside specifications, check the front suspension parts for wear or damage. Replace faulty parts with new ones.
2. From the measured value, read the coordinate (or: graduation) at the intersecting point in the graph.
 - a. If the coordinate (or: graduation) at the intersecting point is positive, move the pin outward by turning the corresponding adjusting bolt by the indicated graduation.
 - b. If the coordinate (or: graduation) at the intersecting point is negative, move the pin inward by turning the corresponding adjusting bolt by the indicated graduation.
 After properly moving the pin(s), tighten the front and rear adjusting bolts to specifications.
3. Re-measure to ensure that the camber and caster are within specified tolerances.

[Example]

- a. Measured values corresponding with the two values indicated below:

Camber angle: $-0^{\circ}06'$ (-0.10°)

Caster angle: $2^{\circ}10'$ (2.17°)

- b. Apply the above two values to the graph and determine point "A".
- c. The coordinate (or: graduation) indicates that both the front and rear adjusting bolts must be turned outward by 3 graduations. Turn the adjusting bolts by the amount corresponding with the 3 graduations.

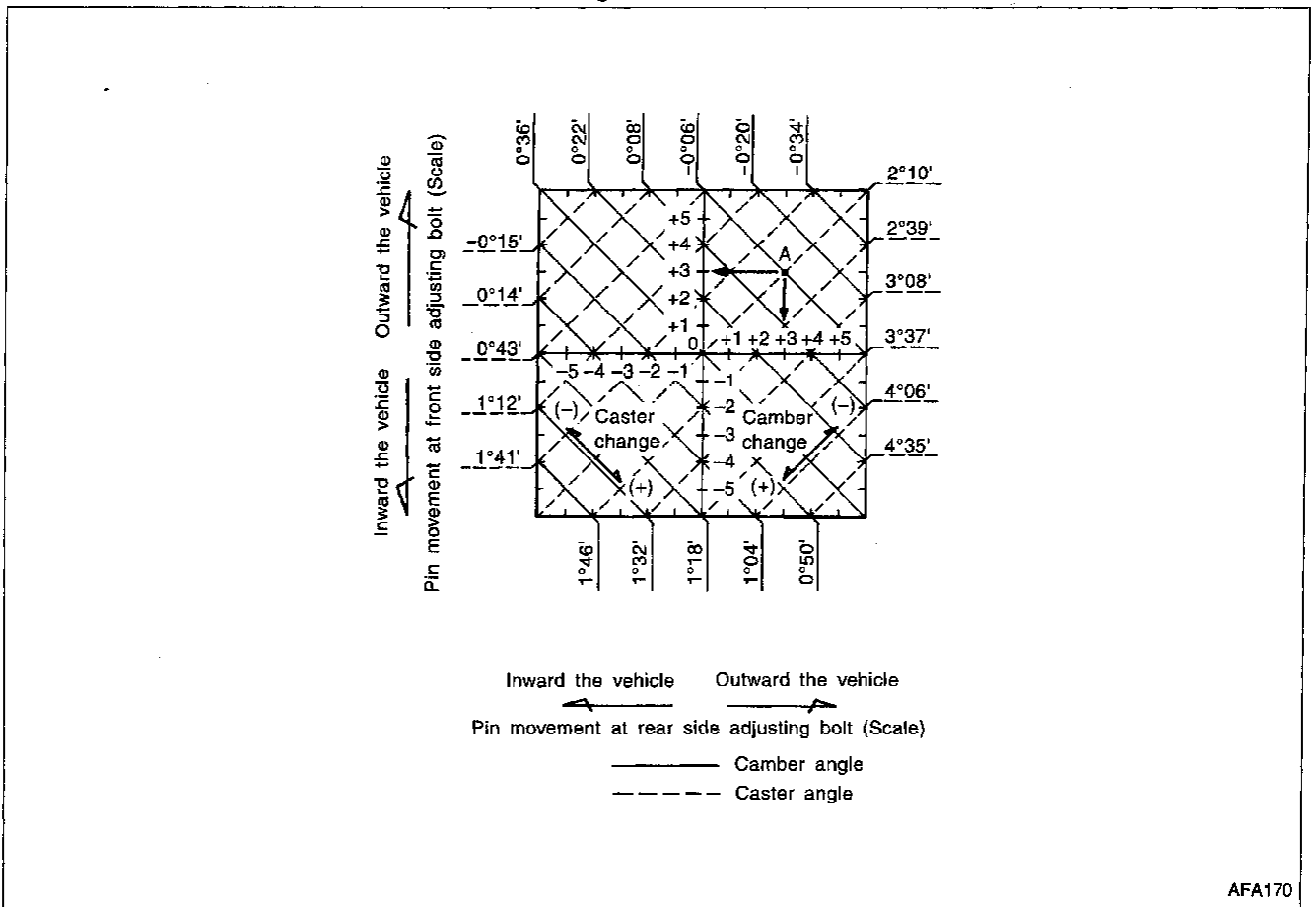

ON-VEHICLE SERVICE

Front Wheel Alignment (Cont'd)

TOE-IN

Measure toe-in using the following procedure.

WARNING:

- Always perform the following procedure on a flat surface.
 - Make sure that no one is in front of the vehicle before pushing it.
1. Bounce front of vehicle up and down to stabilize the posture.
 2. Push the vehicle straight ahead about 5 m (16 ft).
 3. Put a mark on base line of the tread (rear side) of both tires at the same height of hub center. This mark is a measuring point.
 4. Measure distance "A" (rear side).
 5. Push the vehicle slowly ahead to rotate the wheels 180 degrees (1/2 turn).
 - If the wheels have rotated more than 180 degrees (1/2 turn), try the above procedure again from the beginning. Never push vehicle backward.
 6. Measure distance "B" (front side).

Total toe-in:

Refer to SDS, FA-33.

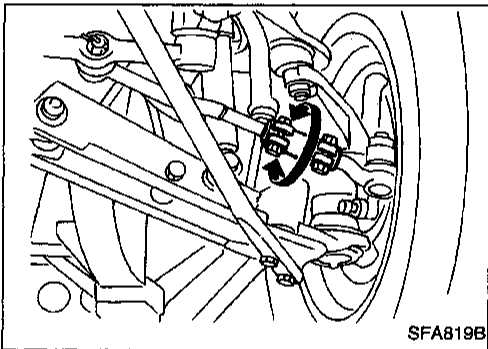
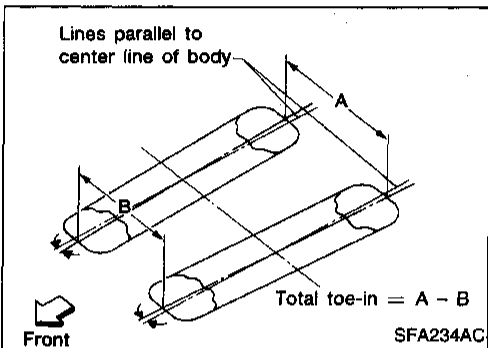
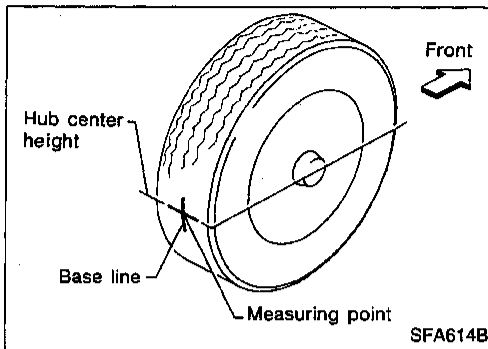

7. Adjust toe-in by varying the length of both steering tie-rods.
 - a. Loosen clamp bolts or lock nuts.
 - b. Adjust toe-in by turning both the left and right tie-rod tubes equal amounts.

Make sure that the tie-rod bars are screwed into the tie-rod tube more than 35 mm (1.38 in).

Make sure that the tie-rods are the same length.

Standard length (A = B):

297.6 mm (11.72 in)

- c. Tighten clamp bolts or lock nuts, then torque them.

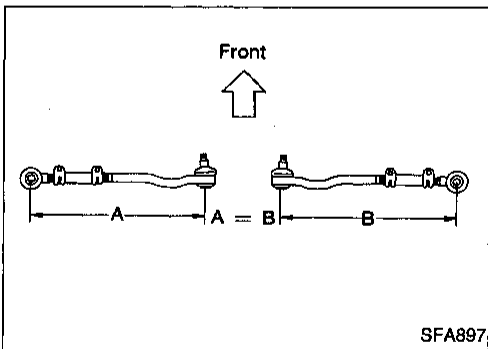

ON-VEHICLE SERVICE

Front Wheel Alignment (Cont'd)

FRONT WHEEL TURNING ANGLE

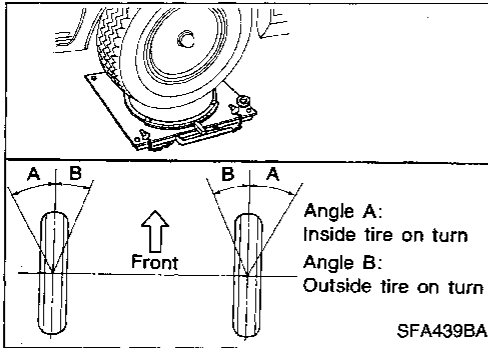

1. Set wheels in straight-ahead position. Then move vehicle forward until front wheels rest properly on turning radius gauge.
2. Rotate steering wheel all the way right and left; measure turning angle.
 - On power steering models, turn steering wheel to full lock and apply force (at circumference of steering wheel) of 98 - 147 N (10 - 15 kg, 22 - 33 lb) with engine at idle.
 - **Do not hold the steering wheel at full lock for more than 15 seconds.**
3. Adjust stopper bolt if necessary.

Wheel turning angle (Full turn):
Refer to SDS, FA-33.

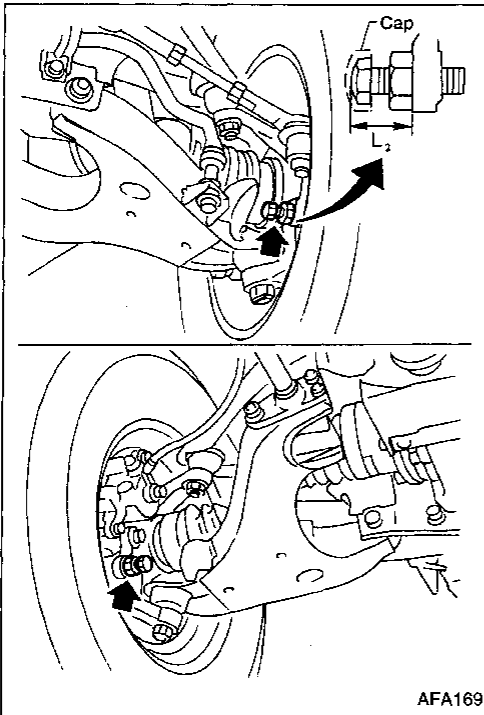

Standard length "L₂":

Except P265/70R15 tire:
26.5 mm (1.043 in)

(Length before cap is mounted)

P265/70R15 tire:

30.0 mm (1.2 in)

(Length before cap is mounted)

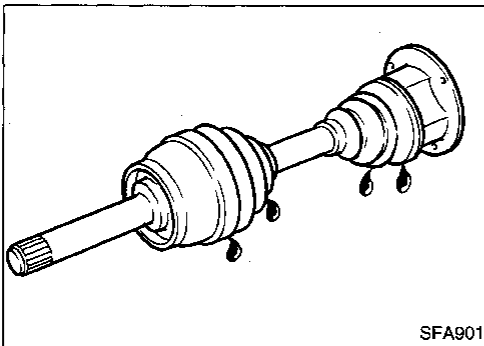

Drive Shaft

- Check for grease leakage and damage.

GI
MA
EM
LC
EC
FE
CL
MT
AT
TF
PD
FA
RA
BR
ST
RS
BT
HA
EL
IDX

FRONT AXLE

SEC. 391 • 400

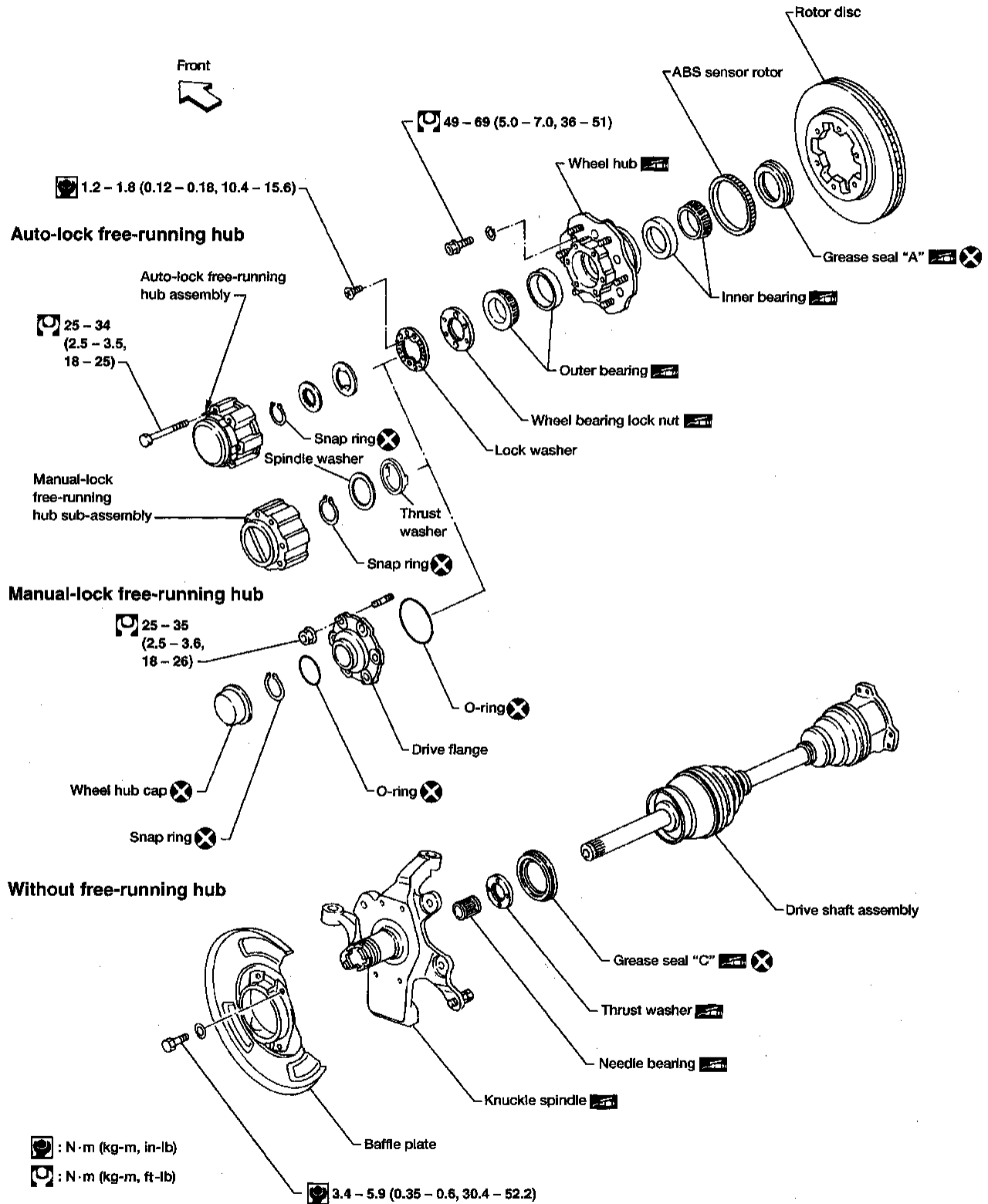

AFA168

FRONT AXLE

Manual-lock Free-running Hub

SEC. 400

*: Lubricating parts

When installing manual-lock free-running hub, use multi-purpose grease.

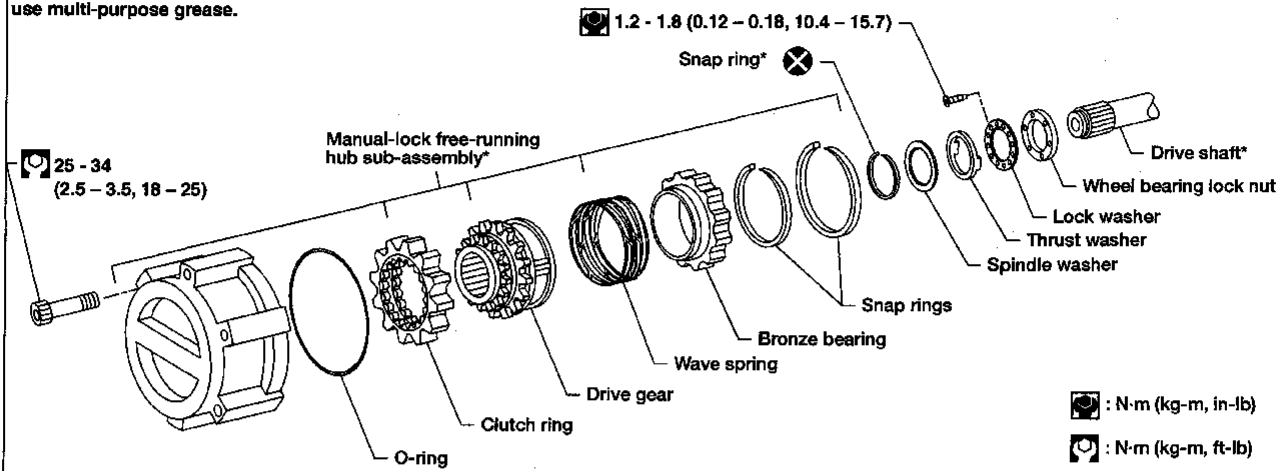

AFA174

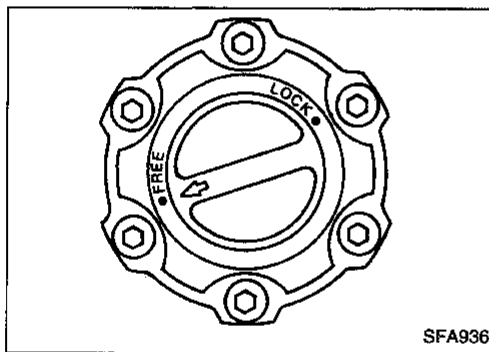

REMOVAL AND INSTALLATION

1. Set knob of manual-lock free-running hub in the FREE position.
2. Remove manual-lock free-running hub.
3. When installing manual-lock free-running hub, make sure the hub is in the FREE position.

Apply multi-purpose grease to the parts shown in the above illustration.

4. Check operation of manual-lock free-running hub after installation.

INSPECTION

- Check that the knob moves smoothly and freely.
- Check that the clutch moves smoothly in the body.

GI
MA
EM
LC
EC
FE
CL
MT
AT
TF
PD
FA
RA
BR
ST
RS
BT
HA
EL
IDX

FRONT AXLE

Auto-lock Free-running Hub

SEC. 400

* : Lubricating parts
When installing auto-lock free-running hub,
use NISSAN GENUINE GREASE (KRC 19-00025)
or equivalent grease.

Auto-lock free-running hub assembly

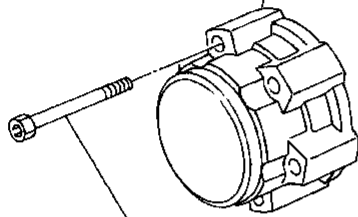

25 - 34 (2.5 - 3.5, 18 - 25)

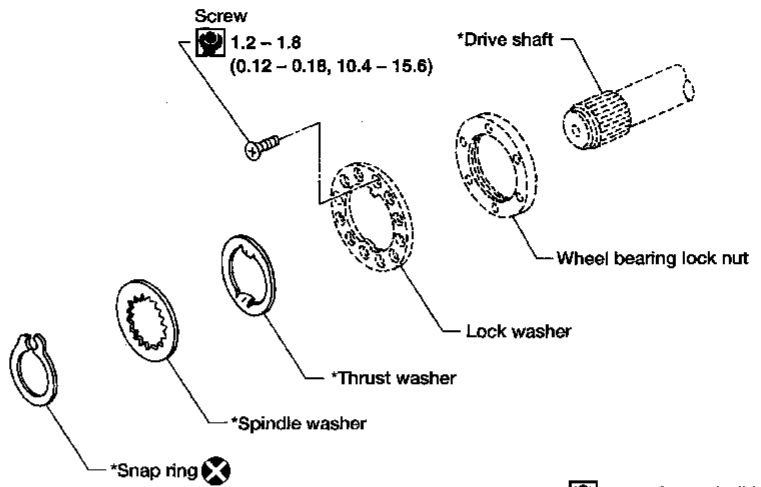

: N·m (kg-m, in-lb)

: N·m (kg-m, ft-lb)

AFA142

REMOVAL AND INSTALLATION

1. Set auto-lock free-running hub in the FREE position.
2. Remove auto-lock free-running hub.

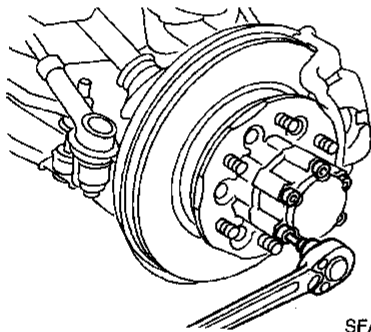

SFA828B

3. Remove snap ring.
4. Remove spindle washer and thrust washer.
5. After installing auto-lock free-running hub, check operation.

When installing it, apply recommended grease to the parts shown in the above illustration.

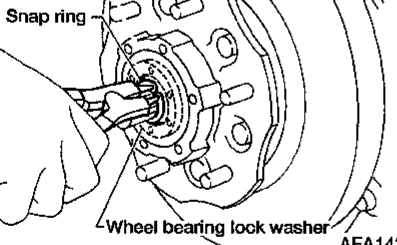

AFA143

Wheel Hub and Rotor Disc

REMOVAL AND INSTALLATION

1. Remove free-running hub assembly.
Refer to "Auto-lock Free-running Hub", FA-14, or "Manual-lock Free-running Hub", FA-13.
2. Remove brake caliper assembly without disconnecting hydraulic line.

Be careful not to depress brake pedal, or piston will pop out. Make sure brake hose is not twisted.

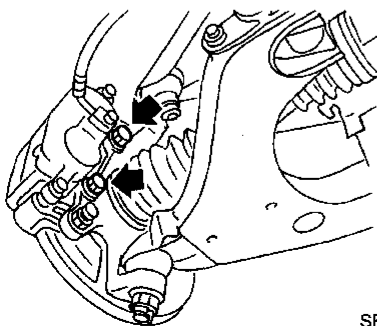

SFA825B

FRONT AXLE

Wheel Hub and Rotor Disc (Cont'd)

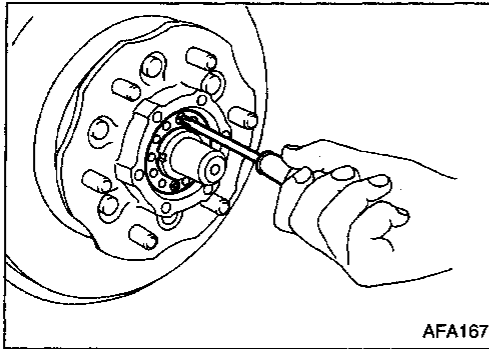

3. Remove lock washer.

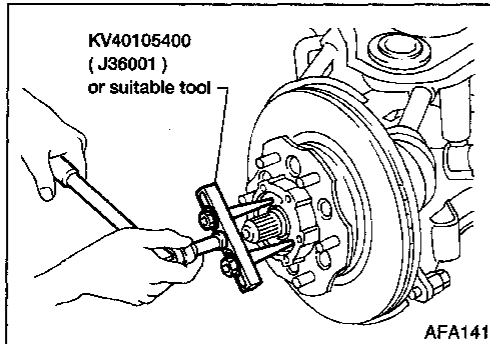

4. Remove wheel bearing lock nut with Tool.

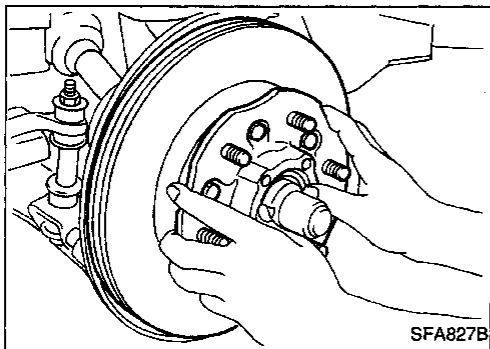

5. Remove wheel hub and wheel bearing.

Be careful not to drop outer bearing.

6. After installing wheel hub and wheel bearing, adjust wheel bearing preload.
Refer to "PRELOAD ADJUSTMENT", "Front Wheel Bearing", "ON-VEHICLE SERVICE", FA-6.

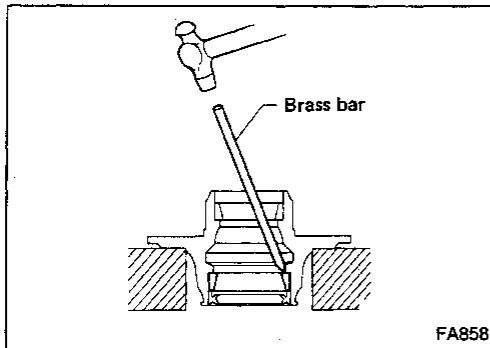

DISASSEMBLY

- Remove bearing outer races with suitable brass bar.

INSPECTION

Thoroughly clean wheel bearings and wheel hub.

Wheel bearings

- Make sure wheel bearings roll freely and are free from noise, cracks, pitting and wear.

Wheel hub

- Check wheel hub for cracks by using a magnetic exploration or dyeing test.

GI
MA
EM
LC
EC
FE
CL
MT
AT
TF
PD
FA
RA
BR
ST
RS
BT
HA
EL
IDX

FRONT AXLE

Wheel Hub and Rotor Disc (Cont'd)

ASSEMBLY

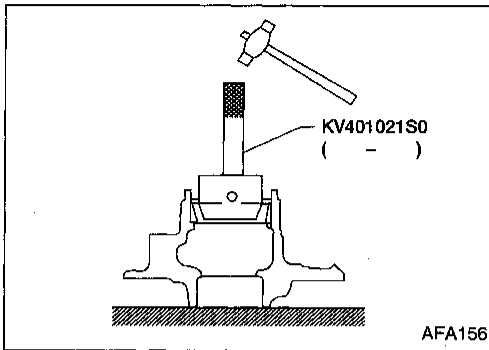

1. Install bearing outer race with Tool until it seats in hub.

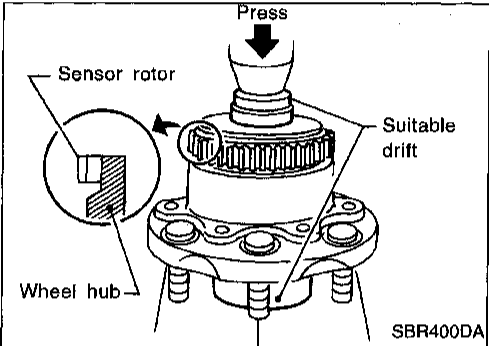

2. Install the sensor rotor using suitable drift and press. (Models with ABS)
Always replace sensor rotor with new one.
Pay attention to the direction of front sensor rotor as shown in figure.

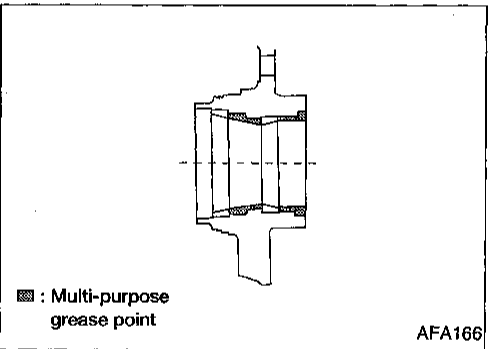

3. Pack multi-purpose grease in wheel hub and hub cap.

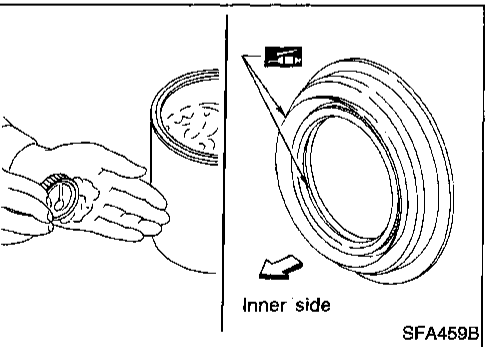

4. Apply multi-purpose grease to each bearing cone.
5. Pack grease seal lip with multi-purpose grease, then install it into wheel hub with suitable drift.

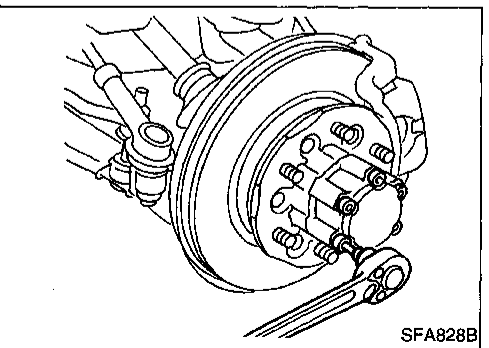

Knuckle Spindle

REMOVAL

1. Remove free-running hub assembly.
Refer to "Auto-lock Free-running Hub", FA-14, or "Manual-lock Free-running Hub", FA-13.
2. Remove wheel hub and rotor disc.
Refer to "Wheel Hub and Rotor Disc", FA-14.

FRONT AXLE

Knuckle Spindle (Cont'd)

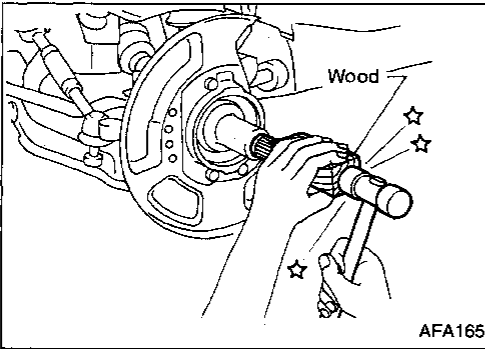

3. Separate drive shaft from knuckle spindle by slightly tapping drive shaft end.

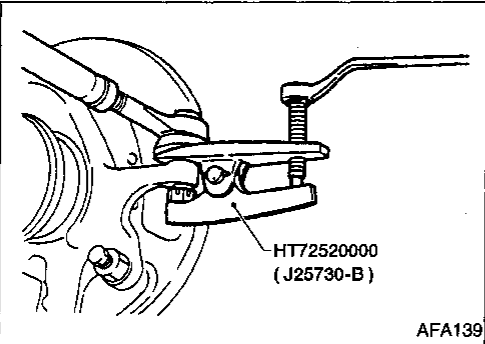

4. Separate tie-rod from knuckle spindle with Tool.
Install stud nut conversely on stud bolt so as not to damage stud bolt.

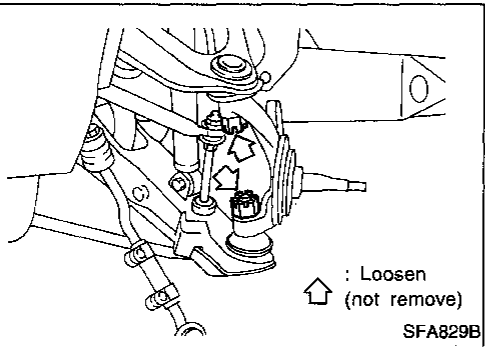

5. Separate knuckle spindle from ball joints.
a. Loosen (do not remove) upper and lower ball joint tightening nuts.

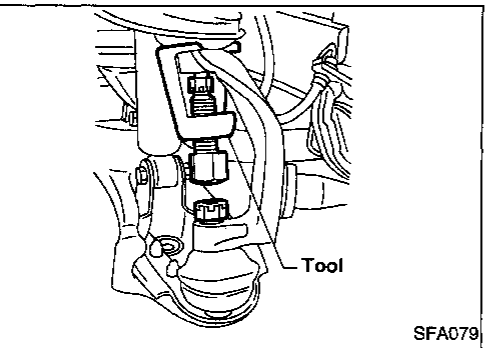

- b. Separate knuckle spindle from upper and lower ball joint studs with Tool.

During above operation, never remove ball joint nuts which are loosened in step (a) above.

Tool:

HT72520000 (J25730-B)

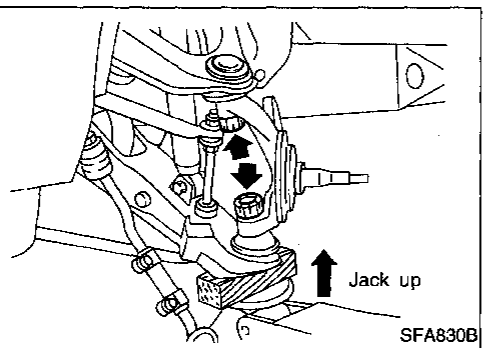

- c. Remove ball joint tightening nuts.

Support lower link with jack.

- d. Remove knuckle spindle from upper and lower links.

INSPECTION

Knuckle spindle

- Check knuckle spindle for deformation, cracks and other damage by using a magnetic exploration or dyeing test.

GI
MA
EM
LC
EC
FE
CL
MT
AT
TF
PD
FA
RA
BR
ST
RS
BT
HA
EL
IDX

FRONT AXLE

Knuckle Spindle (Cont'd)

Needle bearing

- Check needle bearing for wear, scratches, pitting, flaking and burn marks.

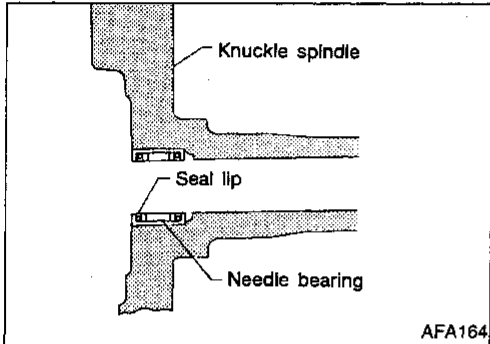

INSTALLATION

1. Install needle bearing into knuckle spindle.

Make sure that needle bearing is facing in the proper direction. Apply multi-purpose grease.

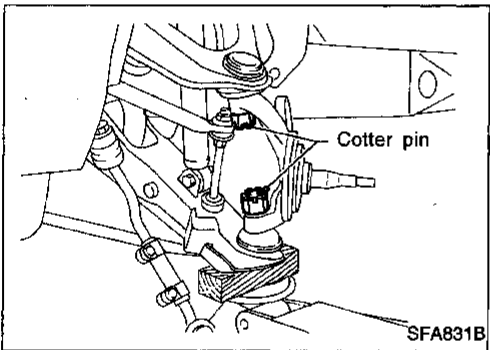

2. Install knuckle spindle to upper and lower ball joints with lower link jacked up.

CAUTION:

Make sure that oil and grease do not come into contact with tapered areas of ball joint, knuckle spindle and threads of ball joint.

3. Connect tie-rod to knuckle spindle.

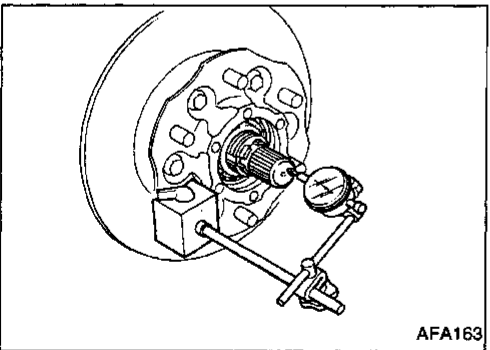

4. After installing knuckle spindle, adjust wheel bearing preload. Refer to "PRELOAD ADJUSTMENT", "Front Wheel Bearing", "ON-VEHICLE SERVICE", FA-6.

5. After installing drive shaft, check drive shaft axial end play.

Do not reuse snap ring once it has been removed.

Refer to "Drive Shaft", FA-19.

FRONT AXLE

Drive Shaft

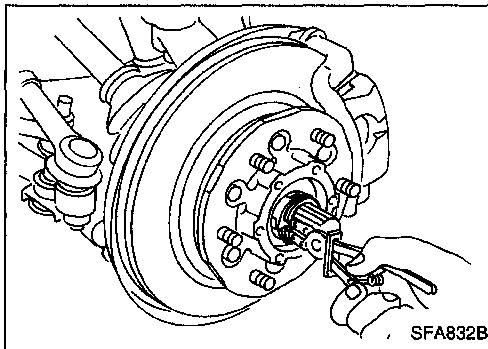
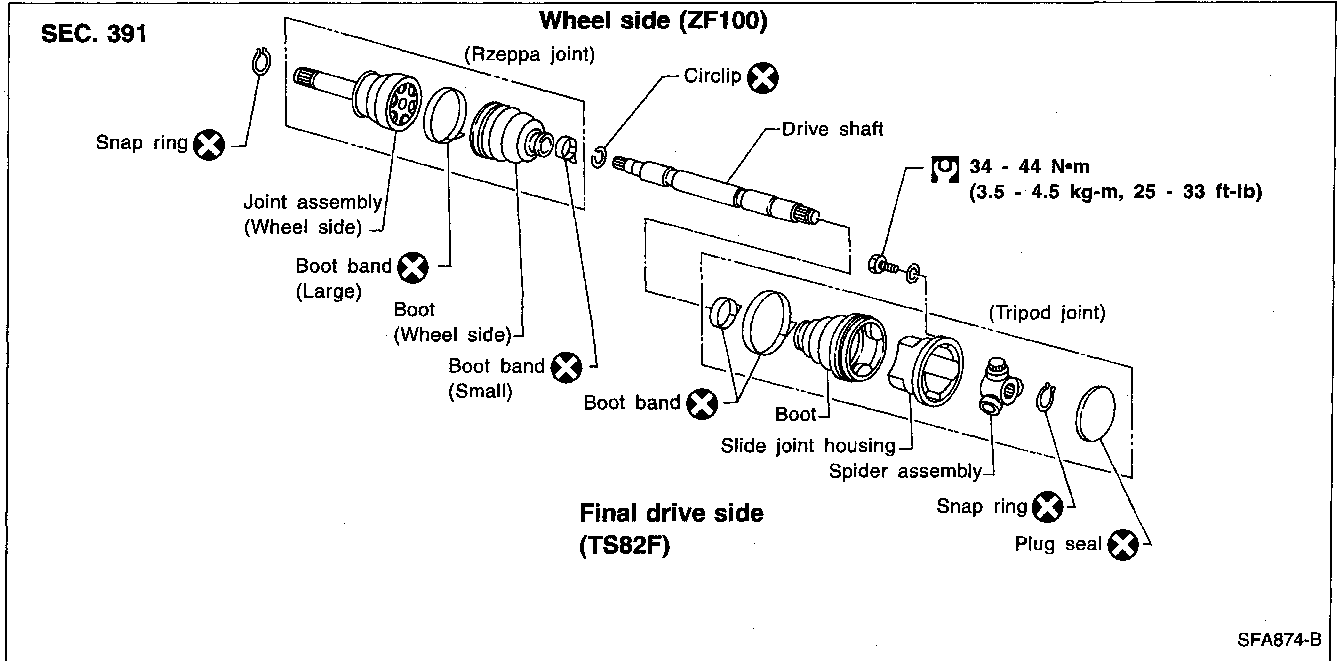

REMOVAL

1. Remove free-running hub or drive flange and snap ring. Refer to "Auto-lock Free-running Hub", FA-14, or "Manual-lock Free-running Hub", FA-13.
2. Remove torsion bar spring. Refer to "Torsion Bar Spring", "FRONT AXLE", FA-25.
3. Remove shock absorber lower fixing bolt.
4. Remove lower link fixing bolts.

Support lower link with jack.

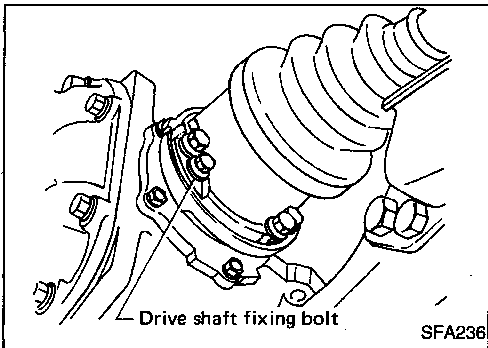

5. Remove bolts fixing drive shaft to final drive.

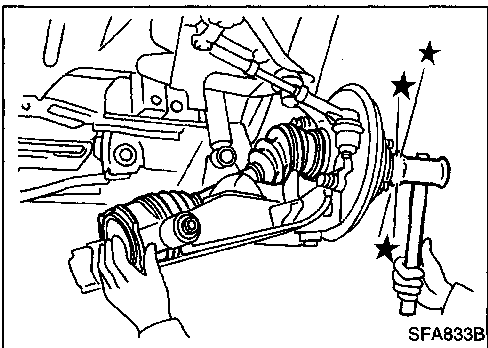

6. Separate drive shaft from knuckle spindle by slightly tapping end of drive shaft.

FRONT AXLE

Drive Shaft (Cont'd) DISASSEMBLY

Final drive side (TS82F)

1. Remove plug seal from slide joint housing by lightly tapping around slide joint housing.
2. Remove boot bands.

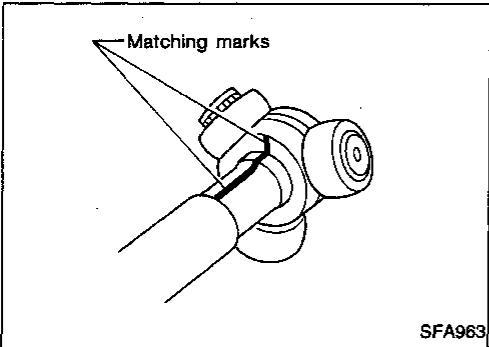
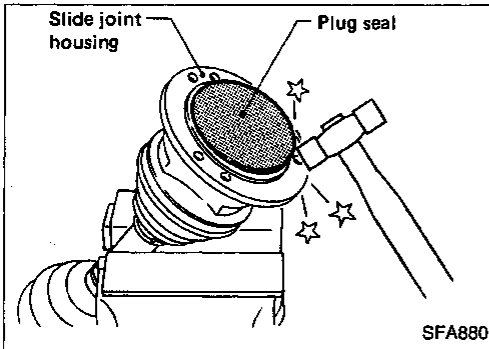

3. Move boot and slide joint housing toward wheel side, and put matching marks.

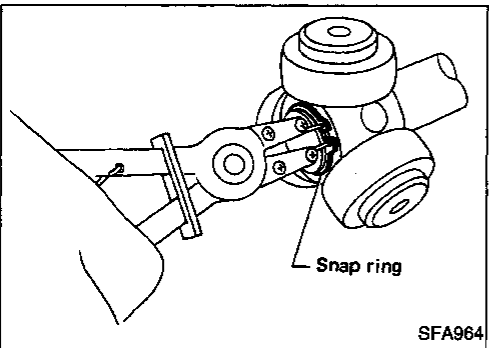

4. Remove snap ring.

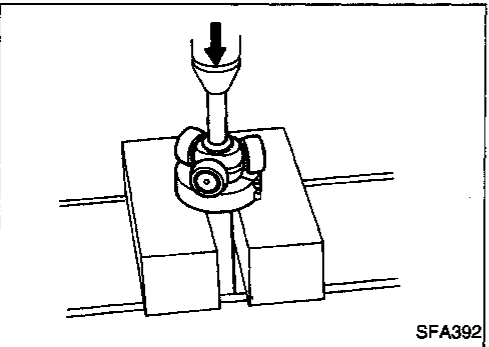

5. Detach spider assembly with press.

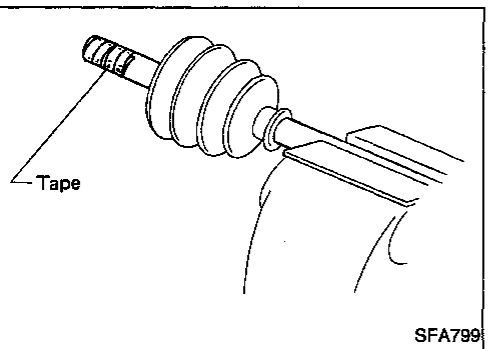

6. Draw out boot.
Cover drive shaft serration with tape to prevent damaging the boot.

FRONT AXLE

Drive Shaft (Cont'd)

Wheel side (ZF100)

CAUTION:

The joint on the wheel side cannot be disassembled.

- Before separating joint assembly, put matching marks on drive shaft and joint assembly.
- Separate joint assembly with suitable tool.

Be careful not to damage threads on drive shaft.

- Remove boot bands.

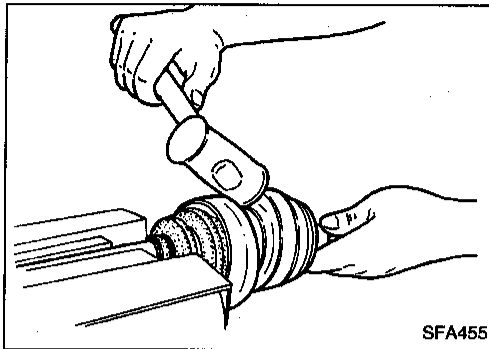

INSPECTION

Thoroughly clean all parts in cleaning solvent, and dry with compressed air. Check parts for evidence of deformation and other damage.

Drive shaft

Replace drive shaft if it is twisted or cracked.

Boot

Check boot for fatigue, cracks and wear. Replace boot with new boot bands.

Joint assembly (Final drive side)

- Replace any parts of double offset joint which show signs of scorching, rust, wear or excessive play.
- Check serration for deformation. Replace if necessary.
- Check slide joint housing for any damage. Replace if necessary.

Joint assembly (Wheel side)

Replace joint assembly if it is deformed or damaged.

ASSEMBLY

- After drive shaft has been assembled, ensure that it moves smoothly over its entire range without binding.
- Use NISSAN GENUINE GREASE or equivalent after every overhaul.

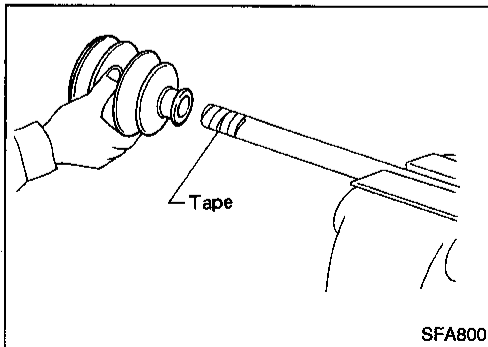

Final drive side (TS82F)

1. Install new small boot band, boot and side joint housing to drive shaft.

Cover drive shaft serration with tape to prevent damaging boot during installation.

FRONT AXLE

Drive Shaft (Cont'd)

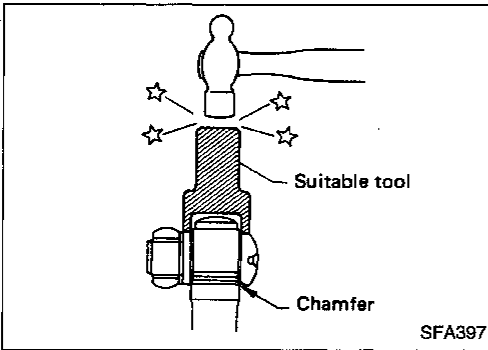

2. Install spider assembly securely, making sure marks are properly aligned.
- **Press-fit with spider assembly serration chamfer facing shaft.**
3. Install new snap ring.

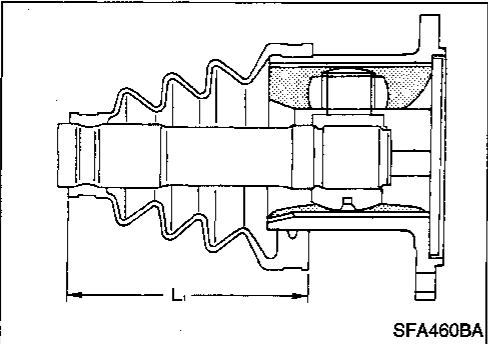

4. Pack with grease.
**Specified amount of grease:
95 - 105 g (3.35 - 3.70 oz)**
5. Make sure that the boot is properly installed on the drive shaft groove. Set the boot so that it does not swell or deform when its length is "L₁".
Length "L₁": 95 - 97 mm (3.74 - 3.82 in)

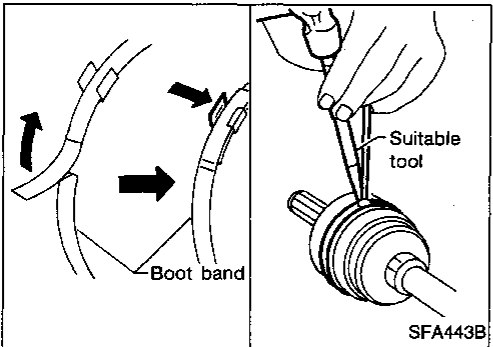

6. Lock new large boot band securely with a suitable tool, then lock new small boot band.
7. Install new plug seal to slide joint housing by lightly tapping it.
Apply sealant to mating surface of plug seal.

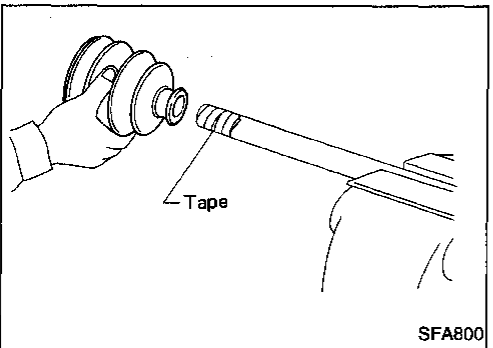

Wheel side (ZF100)

1. Install new small boot band and boot on drive shaft.
Cover drive shaft serration with tape to prevent damaging boot during installation.

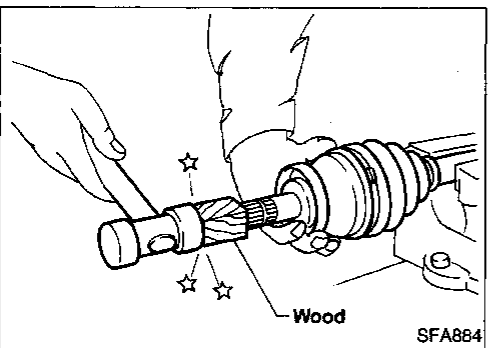

2. Set joint assembly onto drive shaft by lightly tapping it. Install joint assembly securely, ensuring that marks which were made during disassembly are properly aligned.

FRONT AXLE

Drive Shaft (Cont'd)

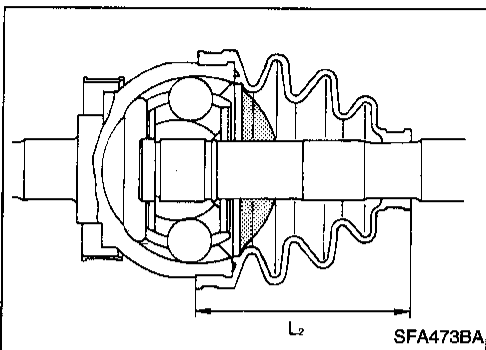

3. Pack drive shaft with specified amount of grease.
Specified amount of grease:
135 - 145 g (4.76 - 5.11 oz)
4. Make sure that the boot is properly installed on the drive shaft groove. Set the boot so that it does not swell or deform when its length is "L₂".
Length "L₂": 96 - 98 mm (3.78 - 3.86 in)
5. Lock new large boot band securely with a suitable tool.
6. Lock new small boot band.

INSTALLATION

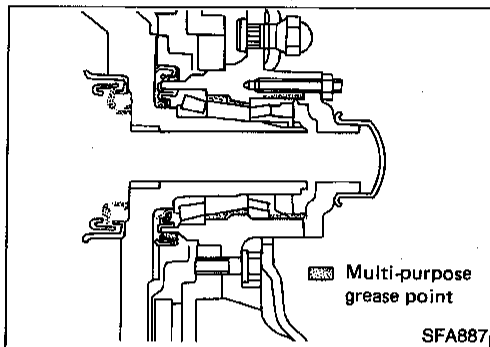

1. Apply multi-purpose grease.

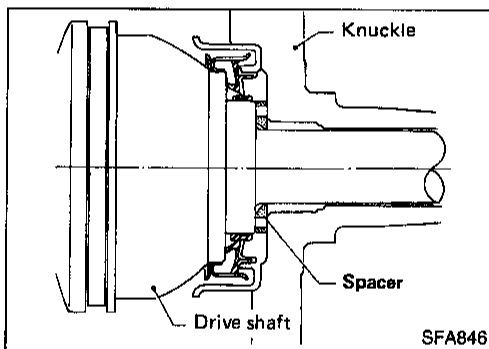

2. Install bearing spacer onto drive shaft.
Make sure that the bearing spacer is facing in the proper direction.

3. After installing wheel hub and wheel bearing, adjust wheel bearing preload. Refer to "PRELOAD ADJUSTMENT", "Front Wheel Bearing", "ON-VEHICLE SERVICE", FA-6.

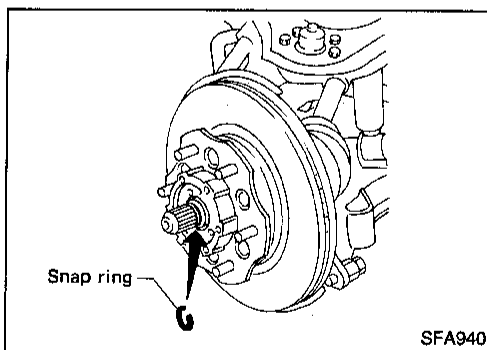

4. When installing drive shaft, adjust drive shaft axial end play by selecting a suitable snap ring.
 - a. Temporarily install new snap ring on drive shaft in the same thickness as it was installed before removal.

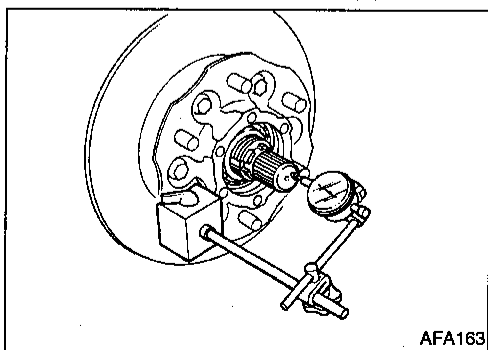

- b. Set dial gauge on drive shaft end.
- c. Measure axial end play of drive shaft.
Axial end play:
0.45 mm (0.0177 in) or less
- d. If axial end play is not within the specified limit, select another snap ring.

1.1 mm (0.043 in)	1.3 mm (0.051 in)
1.5 mm (0.059 in)	1.7 mm (0.067 in)
1.9 mm (0.075 in)	2.1 mm (0.083 in)
2.3 mm (0.091 in)	

FRONT AXLE Drive Shaft (Cont'd)

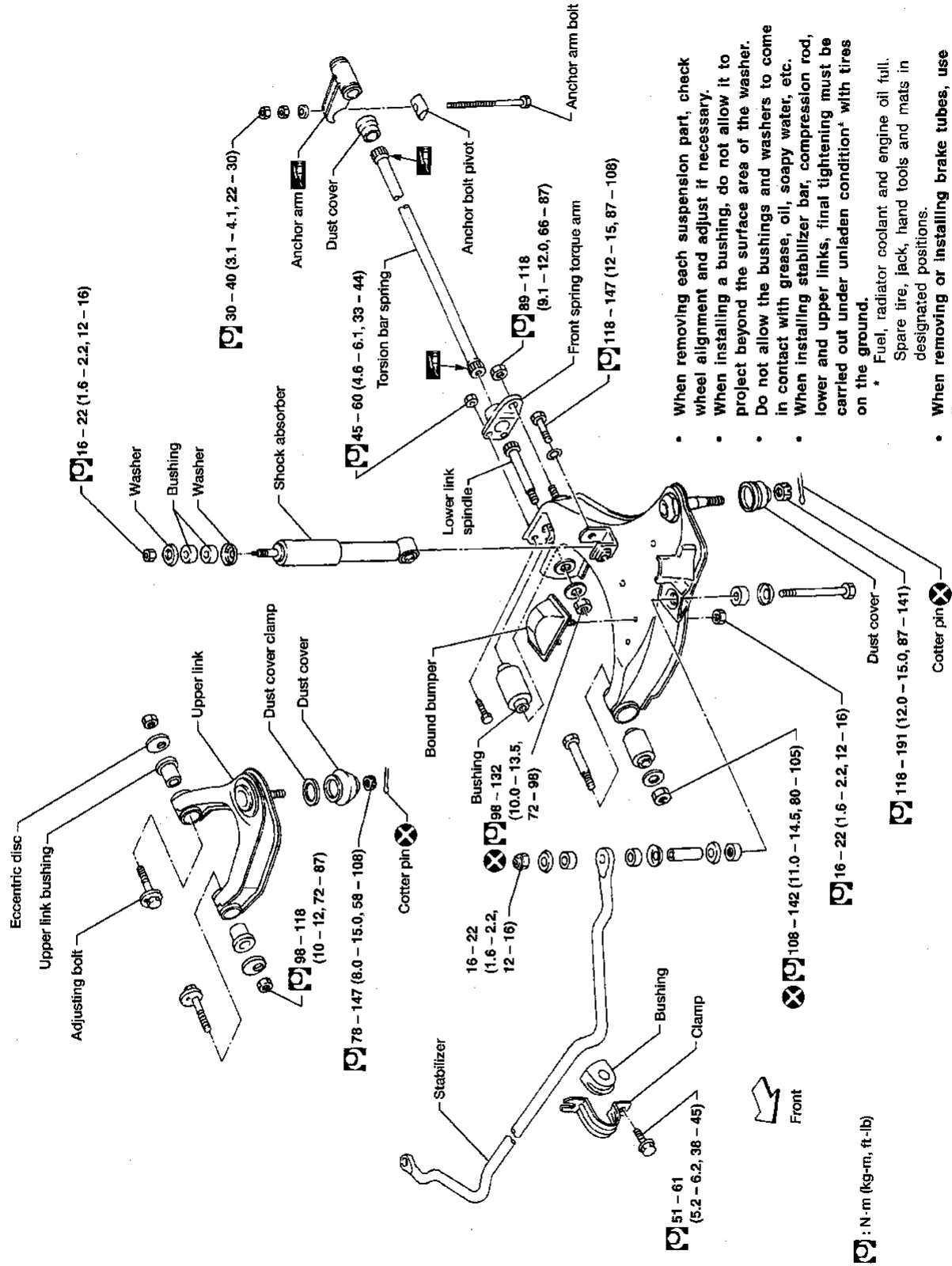

- When removing each suspension part, check wheel alignment and adjust if necessary.
- When installing a bushing, do not allow it to project beyond the surface area of the washer.
- Do not allow the bushings and washers to come in contact with grease, oil, soapy water, etc.
- When installing stabilizer bar, compression rod, lower and upper links, final tightening must be carried out under unladen condition* with tires on the ground.
- * Fuel, radiator coolant and engine oil full.
- Spare tire, jack, hand tools and mats in designated positions.
- When removing or installing brake tubes, use flare nut torque wrench.

SEC. 401

FRONT AXLE

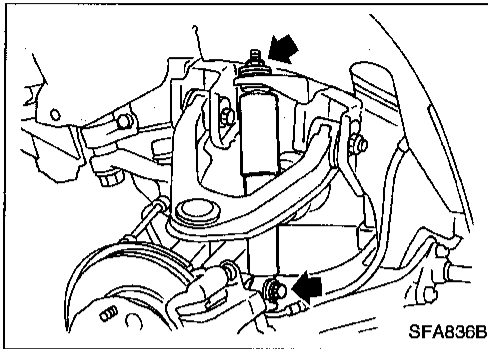

Shock Absorber

REMOVAL AND INSTALLATION

1. Support lower link with jack.
2. Remove bolt and nut that hold shock absorber.

INSPECTION

Except for nonmetallic parts, clean all parts with suitable solvent and dry with compressed air.

Use compressed air to blow dirt and dust off of nonmetallic parts.

- Check for oil leakage and cracks. Replace if necessary.
- Check piston rod for cracks, deformation and other damage. Replace if necessary.
- Check rubber parts for wear, cracks, damage and deformation. Replace if necessary.

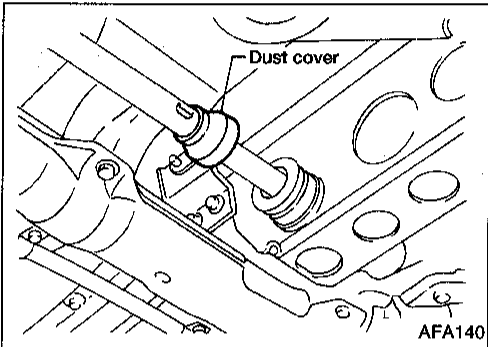

Torsion Bar Spring

REMOVAL

1. Move dust cover.
2. Paint matching marks on the torsion bar spring and the corresponding arm.

Always use paint to place the matching mark; do not scribe the affected parts.

3. Measure anchor bolt protrusion "L" and remove the lock nut and adjusting nut.

Before removing the nuts, ensure that twisting force is eliminated from the torsion bar springs.

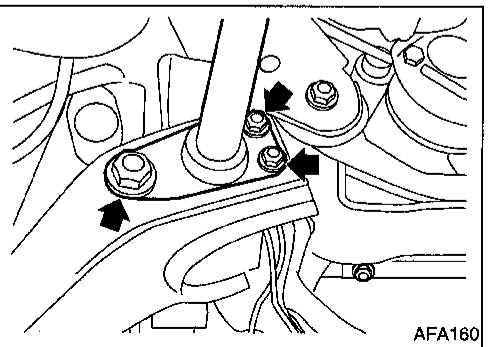
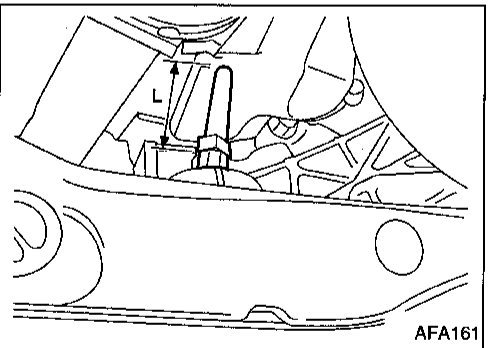
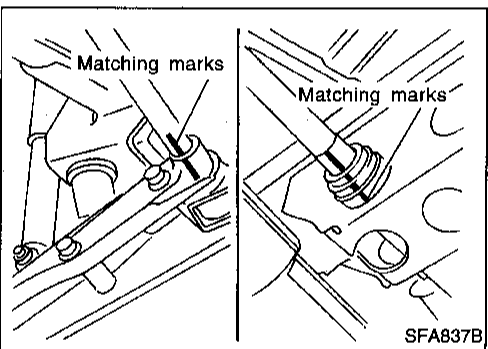

4. Remove torsion bar spring.
 - Remove torque arm fixing nuts, then withdraw torsion bar spring forward with torque arm.

GI

MA

EM

LC

EC

FE

CL

MT

AT

TF

PD

FA

RA

BR

ST

RS

BT

HA

EL

IDX

FRONT AXLE

Torsion Bar Spring (Cont'd)

INSPECTION

- Check torsion bar spring for wear, twist, bend and other damage.
- Check serrations of each part for cracks, wear, twist and other damage.
- Check dust cover for cracks.

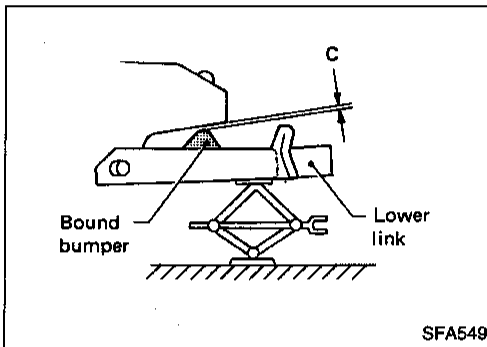

INSTALLATION AND ADJUSTMENT

Adjustment of anchor arm adjusting nut is in tightening direction only.

Do not adjust by loosening anchor arm adjusting nut.

1. Coat multi-purpose grease on the serration of torsion bar spring.
2. Place lower link in the position where bound bumper clearance "C" is 0.

Clearance "C": 0 mm (0 in)

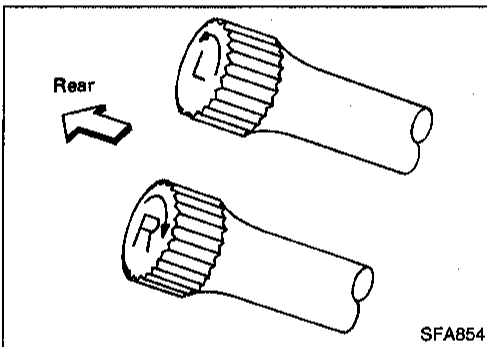

3. Install torsion bar spring with torque arm.

Be sure to install right and left torsion bar springs correctly.

4. While aligning the anchor arm with the matching mark, install the anchor arm to the torsion bar spring.
If a new torsion bar spring or anchor arm is installed, adjust anchor arm length to the dimension indicated in the figure at the left.

Standard length "G":

25 - 39 mm (0.98 - 1.54 in)

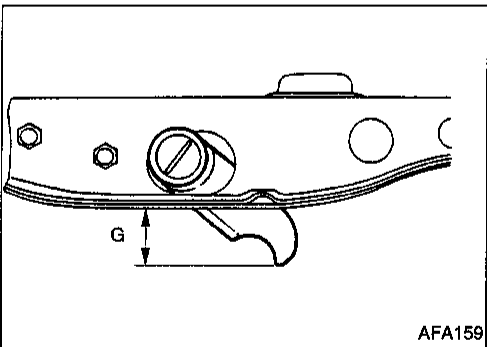

FRONT AXLE

Torsion Bar Spring (Cont'd)

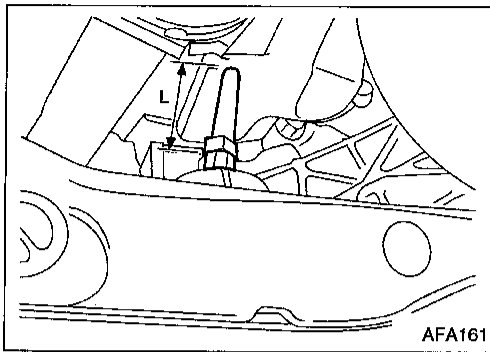

5. Tighten the adjusting nut so the torsion bar length corresponds with dimension "L" previously measured during torsion bar removal. Tighten the lock nut to specifications.
If a new torsion bar spring or anchor arm is installed, tighten the adjusting nut to the dimension indicated in the figure at the left, then tighten the lock nut to specifications.

Standard length "L":
70 mm (2.76 in)

6. Bounce vehicle with tires on ground (Unladen) to eliminate friction of suspension.
7. Measure vehicle posture "H".
 - a. Exercise the front suspension by bouncing the front of the vehicle 4 or 5 times to ensure that the vehicle is in a neutral height attitude.
 - b. Measure vehicle posture ... Dimension "H".
 $H = A - B$ mm (in) "Unladen"
Refer to "WHEEL ALIGNMENT (Unladen)", "SDS", FA-33.

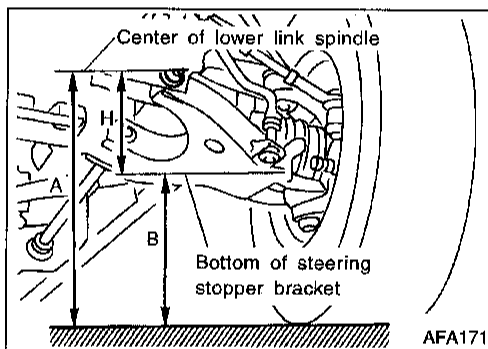

8. If height of the vehicle is not within allowable limit, adjust vehicle posture.
Refer to "WHEEL ALIGNMENT (Unladen)", "SDS", FA-33.
9. Check wheel alignment if necessary.
Refer to "WHEEL ALIGNMENT (Unladen)", "SDS", FA-33.

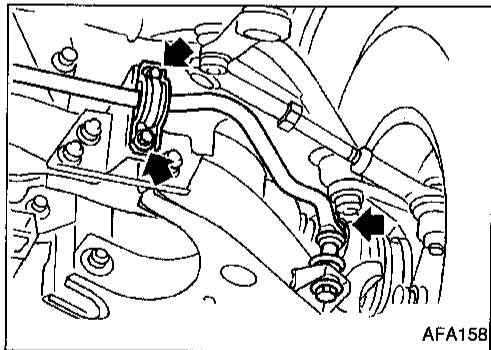

Stabilizer Bar

REMOVAL

- Remove stabilizer bar connecting bolts and clamp bolts.

INSPECTION

- Check stabilizer bar for twist and deformation. Replace if necessary.
- Check rubber bushing for cracks, wear and deterioration. Replace if necessary.

FRONT AXLE

Stabilizer Bar (Cont'd)

INSTALLATION

- Install bushing outside of white mark painted on stabilizer.

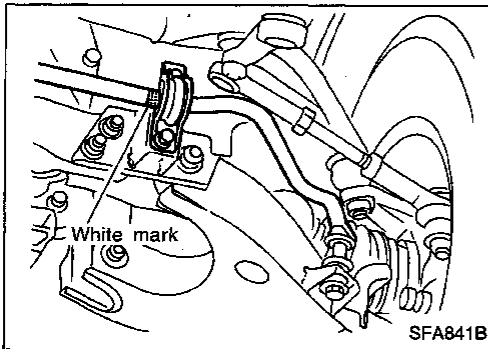

Upper Link

REMOVAL

1. Remove shock absorber. Refer to "Shock Absorber", FA-25.
2. Separate upper ball joint stud from knuckle spindle.

Support lower link with jack.

Refer to "Knuckle Spindle", "FRONT AXLE", FA-16.

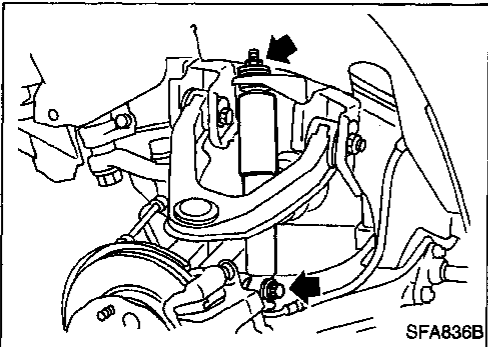

3. Put matching marks on adjusting bolts and remove adjusting bolts.

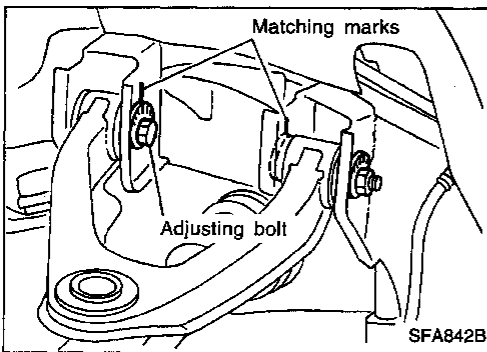

INSTALLATION

1. While aligning the adjusting bolts with the matching marks, install the upper link.
If a new upper link or any other suspension part is installed, align the matching mark with the slit as indicated in the figure at the left, then install the upper link.
Refer to "Front Wheel Alignment", "ON-VEHICLE SERVICE", FA-7.
2. Install shock absorber.
3. Tighten adjusting bolts under unladen condition with tires on ground.
4. After installing, check wheel alignment. Adjust if necessary.
Refer to FA-7.

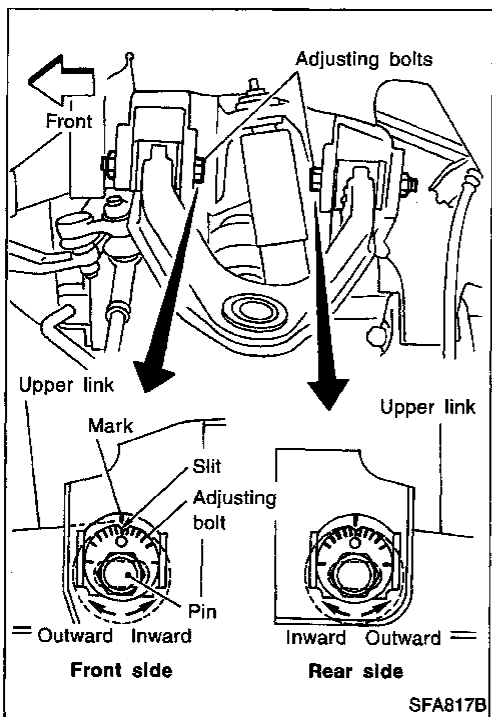

FRONT AXLE

Upper Link (Cont'd)

DISASSEMBLY

- Press out upper link bushings.

INSPECTION

- Check adjusting bolts and rubber bushings for damage. Replace if necessary.
- Check upper link for deformation and cracks. Replace if necessary.

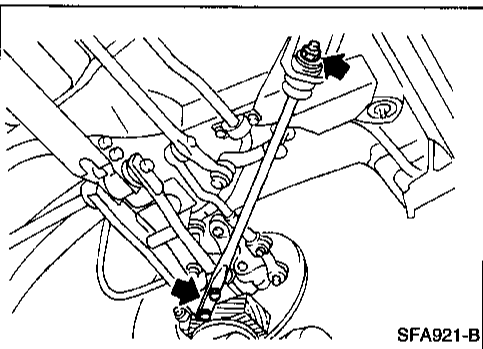
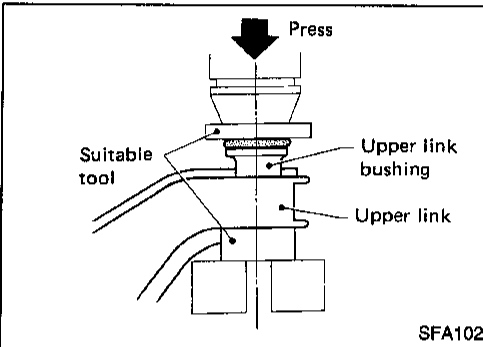
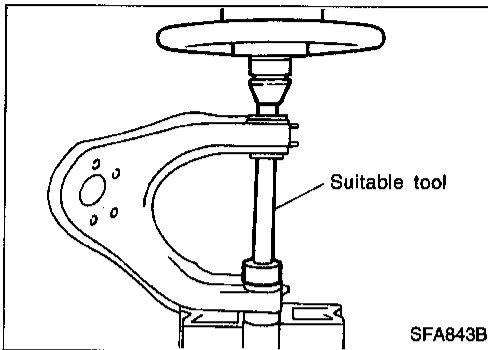

Tension Rod

REMOVAL AND INSTALLATION

1. Remove fixing nuts on lower link and frame.
Support lower link with jack.

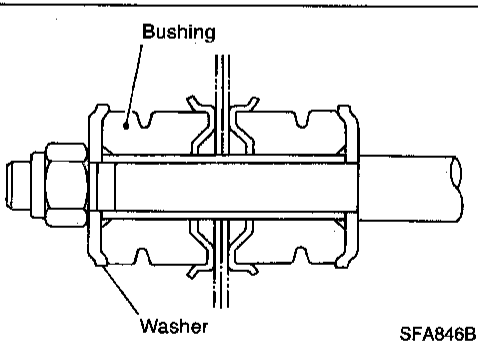

2. Install tension rod.

Make sure that the bushings and washers are installed properly.

INSPECTION

- Check tension rod for deformation and cracks. Replace if necessary.
- Check rubber bushings for damage. Replace if necessary.

GI

MA

EM

LC

EC

FE

CL

MT

AT

TF

PD

FA

RA

BR

ST

RS

BT

HA

EL

IDX

FRONT AXLE

Tension Rod (Cont'd)

Lower Link

REMOVAL AND INSTALLATION

1. Remove torsion bar spring. Refer to "REMOVAL", "Torsion Bar Spring", FA-25.

Make matching marks and measure dimension "L" when loosening adjusting nut until there is no tension on torsion bar spring.

2. Remove shock absorber lower fixing bolt.
3. Remove stabilizer bar connecting bolt.
4. Separate drive shaft from front final drive. Refer to "Drive Shaft", "FRONT AXLE", FA-19.
5. Separate lower link ball joint from knuckle spindle. Refer to "Knuckle Spindle", "FRONT AXLE", FA-16.

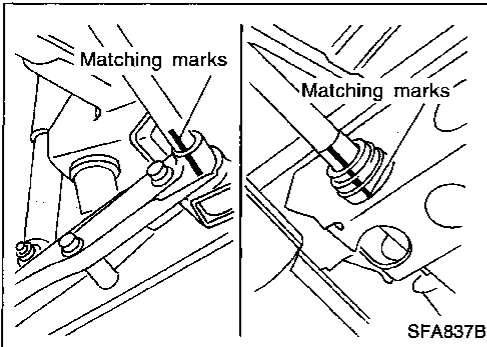

SFA837B

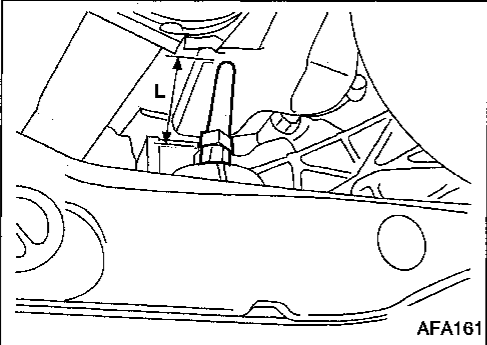

AFA161

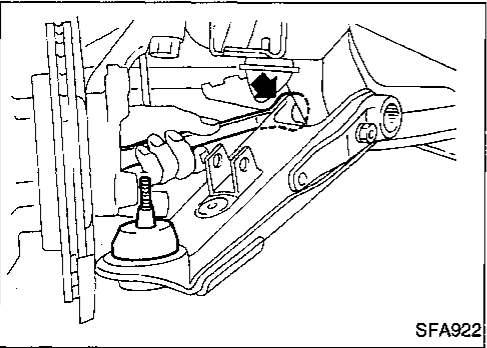

SFA922

6. Remove front lower link fixing nut.

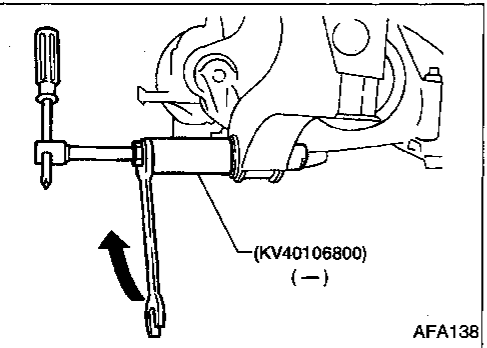

AFA138

7. Remove bushing of lower link spindle from frame with Tool.
8. After installing lower link, adjust wheel alignment and vehicle height. Refer to "Front Wheel Alignment", "ON-VEHICLE SERVICE", FA-7.

INSPECTION

Lower link and lower link spindle

- Check for deformation and cracks. Replace if necessary.

Lower link bushing

- Check for distortion and damage. Replace if necessary.

FRONT AXLE

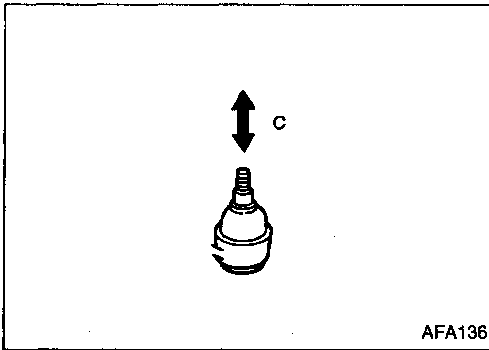

Upper Ball Joint and Lower Ball Joint

REMOVAL AND INSTALLATION

- Separate knuckle spindle from upper and lower links. Refer to "Knuckle Spindle", "FRONT AXLE", FA-16.

INSPECTION

- Check joints for play. If ball is worn and play in axial direction is excessive or joint is hard to swing, replace as a upper link or lower link.

Axial end play "C":

Upper link

0 mm (0 in)

Lower link

0.2 mm (0.008 in) or less

- Check dust cover for damage. Replace dust cover and dust cover clamp if necessary.

GI

MA

EM

LC

EC

FE

CL

MT

AT

TF

PD

FA

RA

BR

ST

RS

BT

HA

EL

IDX

SERVICE DATA AND SPECIFICATIONS (SDS)

General Specifications

Suspension type	Independent double wishbone torsion bar spring
Shock absorber type	Double-acting hydraulic
Stabilizer	Standard equipment

Inspection and Adjustment

WHEEL BEARING

Wheel bearing lock nut		
Tightening torque		78 - 98 (8 - 10, 58 - 72)
	N-m (kg-m, ft-lb)	
Retightening torque after loosening wheel bearing lock nut		0.5 - 1.5 (0.05 - 0.15, 0.4 - 1.1)
	N-m (kg-m, ft-lb)	
Axial end play	mm (in)	0 (0)
Starting force at wheel hub bolt		A
	N (kg, lb)	
Turning angle	degree	15° - 30°
Starting force at wheel hub bolt		B
	N (kg, lb)	
Wheel bearing preload at wheel hub bolt		
	N (kg, lb)	7.06 - 20.99 (0.72 - 2.14, 1.59 - 4.72)
B - A		

UPPER BALL JOINT

Vertical end play "C"	mm (in)	0 (0)
-----------------------	---------	-------

LOWER BALL JOINT

Vertical end play "C"	mm (in)	0.2 (0.008 in) or less
-----------------------	---------	------------------------

WHEEL RUNOUT AVERAGE*

Wheel type		Aluminum	Steel
Radial runout limit	mm (in)	0.3 (0.012)	0.8 (0.031)
Lateral runout limit	mm (in)	0.3 (0.012)	0.8 (0.031)

* Wheel runout average = (Outside runout value + Inside runout value) x 0.5

SERVICE DATA AND SPECIFICATIONS (SDS)

Inspection and Adjustment (Cont'd)

WHEEL ALIGNMENT (Unladen*1)

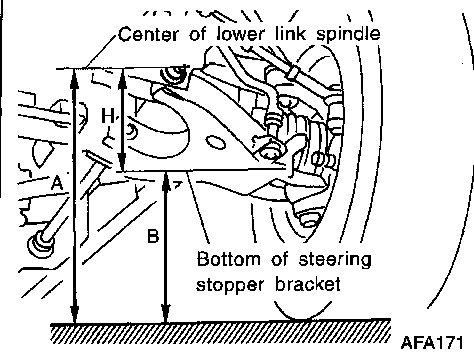
Camber	Minimum		0°06' (0.10°)	
	Nominal		0°36' (0.60°)	
	Maximum		1°06' (1.10°)	
	Left and right difference		45' (0.75°) or less	
Caster	Minimum		1°40' (1.67°)	
	Nominal		2°10' (2.17°)	
	Maximum		2°40' (2.67°)	
	Left and right difference		45' (0.75°) or less	
Kingpin inclination	Minimum		10°18' (10.30°)	
	Nominal		10°48' (10.80°)	
	Maximum		11°18' (11.30°)	
Total toe-in	Distance (A - B)	Radial tire	Minimum	3 (0.12)
			Nominal	4 (0.16)
			Maximum	5 (0.20)
	Angle (left plus right)	Radial tire	Minimum	15' (0.25°)
			Nominal	20' (0.33°)
			Maximum	25' (0.42°)
Wheel turning angle	Inside	Degree minute (Decimal degree)	Except P265/70R15	
			Minimum	33°06' (33.10°)
			Nominal	35°06' (35.10°)
			Maximum	35°06' (35.10°)
	Outside	Degree minute (Decimal degree)	P265/70R15	
			Minimum	31°12' (31.20°)
			Nominal	33°12' (33.20°)
			Maximum	33°12' (33.20°)
Vehicle posture	Lower arm pivot height (H)	mm (in)	45.5 - 49.5 (1.791 - 1.949)	
				

*2: On power steering models, wheel turning force (at circumference of steering wheel) of 98 to 147 N (10 to 15 kg, 22 to 33 lb) with engine idle.

SERVICE DATA AND SPECIFICATIONS (SDS)

Inspection and Adjustment (Cont'd)

DRIVE SHAFT

Drive shaft joint type	
Final drive side	TS82F
Wheel side	ZF100
Fixed joint axial end play limit mm (in)	1 (0.04)
Diameter mm (in)	
Wheel side (D ₁)	29.0 (1.142)
Grease	
Quality	Nissan genuine grease or equivalent
Capacity g (oz)	
Final drive side	95 - 105 (3.35 - 3.70)
Wheel side	135 - 145 (4.76 - 5.11)
Boot length mm (in)	
Final drive side (L ₁)	95 - 97 (3.74 - 3.82)
Wheel side (L ₂)	96 - 98 (3.78 - 3.86)

Final drive side

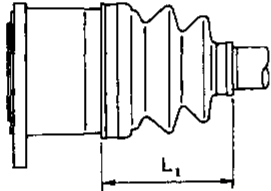

Wheel side

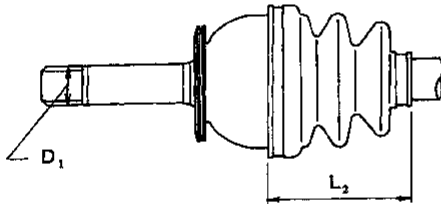

SFA877A

Drive shaft axial end play

Drive shaft axial end play mm (in)	0.45 (0.0177) or less
---------------------------------------	-----------------------

Drive shaft end snap ring

Thickness mm (in)	Part No.
1.1 (0.043)	39253-88G10
1.3 (0.051)	39253-88G11
1.5 (0.059)	39253-88G12
1.7 (0.067)	39253-88G13
1.9 (0.075)	39253-88G14
2.1 (0.083)	39253-88G15
2.3 (0.091)	39253-88G16