

SECTION MA

CONTENTS

| | |
|---|--|
| PRECAUTIONS AND PREPARATION2 | Checking Clutch Fluid Level and Leaks.....18 |
| Supplemental Restraint System (SRS) | Checking M/T Oil.....18 |
| “AIR BAG”.....2 | Changing M/T Oil.....18 |
| Special Service Tool.....2 | Checking Water Entry.....18 |
| Commercial Service Tool.....2 | Checking A/T Fluid.....18 |
| GENERAL MAINTENANCE3 | Changing A/T Fluid.....19 |
| PERIODIC MAINTENANCE5 | Checking Transfer Fluid.....19 |
| Schedule 1.....6 | Changing Transfer Fluid.....20 |
| Schedule 2.....7 | Checking Propeller Shaft.....20 |
| RECOMMENDED FLUIDS AND LUBRICANTS8 | Checking Differential Gear Oil.....20 |
| Fluids and Lubricants.....8 | Changing Differential Gear Oil.....21 |
| SAE Viscosity Number.....9 | Balancing Wheels.....21 |
| Antifreeze Coolant Mixture Ratio.....9 | Tire Rotation.....21 |
| ENGINE MAINTENANCE10 | Checking Brake Fluid Level and Leaks.....22 |
| Checking Drive Belts.....10 | Checking Brake System.....22 |
| Changing Engine Coolant.....11 | Checking Disc Brake.....22 |
| Checking Fuel Lines.....13 | Checking Drum Brake.....22 |
| Changing Fuel Filter.....13 | Checking Steering Gear and Linkage.....23 |
| Changing Air Cleaner Filter.....14 | Checking Power Steering Fluid and Lines.....23 |
| Changing Engine Oil.....14 | Lubricating Hood Latches, Locks and Hinges.....24 |
| Changing Oil Filter.....15 | Checking Seat Belts, Buckles, Retractors, |
| Changing Spark Plugs.....15 | Anchors and Adjusters.....25 |
| Checking EVAP Vapor Lines.....17 | SERVICE DATA AND SPECIFICATIONS (SDS)26 |
| CHASSIS AND BODY MAINTENANCE18 | Engine Maintenance.....26 |
| Checking Exhaust System.....18 | Chassis and Body Maintenance.....26 |

PRECAUTIONS AND PREPARATION

Supplemental Restraint System (SRS) “AIR BAG”

The Supplemental Restraint System “AIR BAG”, used along with a seat belt, helps to reduce the risk or severity of injury to the driver and front passenger in a frontal collision. The Supplemental Restraint System consists of air bag modules (located in the center of the steering wheel and in the instrument panel on the passenger side), a diagnosis sensor unit, a crash zone sensor, warning lamp, wiring harness and spiral cable. The vehicle is equipped with a passenger air bag deactivation switch. Because no rear seat exists where a rear-facing child restraint can be placed, the switch is designed to turn off the passenger air bag so that a rear-facing child restraint can be used in the front passenger seat. The switch is located in the center of the instrument panel, near the ashtray. When the switch is turned to the ON position, the passenger air bag is enabled and could inflate in a frontal collision. When the switch is turned to the OFF position, the passenger air bag is disabled and will not inflate in a frontal collision. A passenger air bag OFF indicator on the instrument panel lights up when the passenger air bag is switched OFF. The driver air bag always remains enabled and is not affected by the passenger air bag deactivation switch.

Information necessary to service the system safely is included in the **RS section** of this Service Manual.

WARNING:

- To avoid rendering the SRS inoperative, which could increase the risk of personal injury or death in the event of a collision which would result in air bag inflation, all maintenance should be performed by an authorized NISSAN dealer.
- Improper maintenance, including incorrect removal and installation of the SRS, can lead to personal injury caused by unintentional activation of the system.
- Do not use electrical test equipment on any circuit related to the SRS unless instructed to in this Service Manual. SRS wiring harnesses are covered with yellow insulation either just before the harness connectors or on the complete harness, for easy identification.
- The vehicle is equipped with a passenger air bag deactivation switch which can be operated by the customer. When the passenger air bag is switched OFF, the passenger air bag is disabled and will not inflate in a frontal collision. When the passenger air bag is switched ON, the passenger air bag is enabled and could inflate in a frontal collision. After SRS maintenance or repair, make sure the passenger air bag deactivation switch is in the same position (ON or OFF) as when the vehicle arrived for service.

Special Service Tool

The actual shapes of Kent-Moore tools may differ from those of special service tools illustrated here.

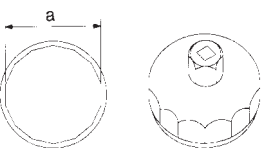
| Tool number (Kent-Moore No.) Tool name | Description | |
|---|---|---|
| KV10105801 (J38956) Oil filter cap wrench |  | Removing oil filter a: 64.3 mm (2.531 in) |
| | NT375 | |

Commercial Service Tool

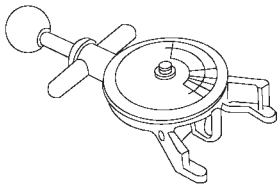
| Tool name (Kent-Moore No.) | Description | |
|-------------------------------|---|-----------------------------|
| Belt tension gauge |  | Checking drive belt tension |
| | AMA126 | |

GENERAL MAINTENANCE

General maintenance includes those items which should be checked during the normal day-to-day operation of the vehicle. They are essential if the vehicle is to continue operating properly. The owners can perform checks and inspections themselves or they can have their NISSAN dealers do them.

| Item | Reference page | Code |
|--|----------------|----------|
| OUTSIDE THE VEHICLE | | |
| The maintenance items listed here should be performed from time to time, unless otherwise specified. | | |
| Tires Check the pressure, including the spare, with a gauge periodically when at a service station, and adjust to the specified pressure if necessary. Check carefully for damage, cuts and excessive wear. | — | LC |
| Wheel nuts When checking the tires, make sure no nuts are missing, and check for any loose nuts. Tighten if necessary. | — | EC |
| Tire rotation Tires should be rotated every 12,000 km (7,500 miles). | MA-21 | |
| Wheel alignment and balance If the vehicle pulls to either side while driving on a straight and level road, or if you detect uneven or abnormal tire wear, there may be a need for wheel alignment. If the steering wheel or seat vibrates at normal highway speeds, wheel balancing may be needed. | MA-21, FA-7 | FE CL |
| Windshield wiper blades Check for cracks and wear if they do not wipe properly. | — | |
| Doors and engine hood Check that all doors, engine hood and tailgate operate smoothly. Also make sure that all latches lock securely; lubricate if necessary. Make sure that the secondary latch keeps the hood from opening when the primary latch is released. When driving in areas using road salt or other corrosive materials, check lubrication frequently. | MA-24 | MT AT |
| Lamps Make sure that the headlamps, stop lamps, tail lamps, turn signal lamps, and other lamps are all operating properly and installed securely. Also check headlamp aim. | — | TF |
| INSIDE THE VEHICLE | | |
| The maintenance items listed here should be checked on a regular basis, such as when performing periodic maintenance, cleaning the vehicle, etc. | | |
| Warning lamps and buzzers/chimes Make sure that all warning lamps and buzzers/chimes are operating properly. | — | PD |
| Windshield wiper and washer Check that the wipers and washer operate properly and that the wipers do not streak. | — | FA |
| Windshield defroster Check that the air comes out of the defroster outlets properly and in sufficient quantity when operating the heater or air conditioner. | — | RA |
| Steering wheel Check that it has the specified play. Be sure to check for changes in the steering condition, such as excessive play, hard steering or strange noises. Free play: Less than 35 mm (1.38 in) | ST-7 | BR |
| Seats Check seat position controls such as seat adjusters, seatback recliner, etc. to make sure they operate smoothly and that all latches lock securely in every position. Check that the head restraints move up and down smoothly and that the locks (if equipped) hold securely in all latched positions. Check jump seats for smooth operation. | — | ST |
| Seat belts Check that all parts of the seat belt system (e.g., buckles, anchors, adjusters and retractors) operate properly and smoothly and are installed securely. Check the belt webbing for cuts, fraying, wear and damage. | MA-25 RS-6 | RS |
| Accelerator pedal Check the pedal for smooth operation and make sure the pedal does not catch or require uneven effort. Keep the floor mats away from the pedal | — | BT |
| Clutch pedal Make sure the pedal operates smoothly and check that it has the proper free play. | CL-5 | HA |
| Brakes Check that the brakes do not pull the vehicle to one side when applied. | — | |
| Brake pedal and booster Check the pedal for smooth operation and make sure that it has the proper distance under it when depressed fully. Check the brake booster function. Be sure to keep floor mats away from the pedal. | BR-11, 16 | EL |
| Parking brake Check that the lever has the proper travel and make sure that the vehicle is held securely on a fairly steep hill when only the parking brake is applied. | BR-27 | IDX |

GENERAL MAINTENANCE

| Item | Reference page |
|---|----------------|
| Automatic transmission “Park” mechanism Check that the lock release button on the selector lever operates properly and smoothly. On a fairly steep hill check that the vehicle is held securely with the selector lever in the “P” position without applying any brakes. | — |
| UNDER THE HOOD AND VEHICLE The maintenance items listed here should be checked periodically (e.g., each time you check the engine oil or refuel). | |
| Windshield washer fluid Check that there is adequate fluid in the tank. | — |
| Engine coolant level Check the coolant level when the engine is cold. | MA-11 |
| Radiator and hoses Check the front of the radiator and clean off any dirt, insects, leaves, etc., that may have accumulated. Make sure that the hoses have no cracks, deformation, deterioration or loose connections. | — |
| Brake and clutch fluid levels Make sure that the brake and clutch fluid levels are between the “MAX” and “MIN” lines on the reservoirs. | MA-18, 22 |
| Battery Check the fluid level in each cell. It should be between the “MAX” and “MIN” lines. | — |
| Engine drive belts Make sure that no belt is frayed, worn, cracked or oily. | MA-10 |
| Engine oil level Check the level on the dipstick after parking the vehicle on a level spot and turning off the engine. | MA-14 |
| Power steering fluid level and lines Check the level on the dipstick with the engine off. Check the lines for improper attachment, leaks, cracks, etc. | MA-23 |
| Automatic transmission fluid level Check the level on the dipstick after putting the selector lever in “P” with the engine idling. | MA-18 |
| Exhaust system Make sure that there are no loose supports, cracks or holes. If the sound of the exhaust seems unusual or there is a smell of exhaust fumes, immediately locate the trouble and correct it. | MA-18 |
| Underbody The underbody is frequently exposed to corrosive substances such as those used on icy roads or to control dust. It is very important to remove these substances, otherwise rust will form on the floor pan, frame, fuel lines and around the exhaust system. At the end of winter, the underbody should be thoroughly flushed with plain water, being careful to clean those areas where mud and dirt can easily accumulate. | — |
| Fluid leaks Check under the vehicle for fuel, oil, water and other fluid leaks after the vehicle has been parked for a while. Water dripping from the air conditioner after use is normal. If any leaks or gasoline fumes are evident, check for the cause and correct it immediately. | — |

PERIODIC MAINTENANCE

Two different maintenance schedules are provided, and should be used, depending upon the conditions under which the vehicle is mainly operated. **After 60,000 miles (96,000 km) or 48 months, continue the periodic maintenance at the same mileage/time intervals.**

GI

MA

SCHEDULE 1

Follow Periodic Maintenance Schedule 1 if your driving habits frequently include one or more of the following driving conditions:

EM

- Repeated short trips of less than 5 miles (8 km).
- Repeated short trips of less than 10 miles (16 km) with outside temperatures remaining below freezing.
- Operating in hot weather in stop-and-go “rush hour” traffic.
- Extensive idling and/or low speed driving for long distances, such as police, taxi or door-to-door delivery use.
- Driving in dusty conditions.
- Driving on rough, muddy, or salt spread roads.
- Towing a trailer, using a camper or a car-top carrier.

LC

EC

FE

SCHEDULE 2

Follow Periodic Maintenance Schedule 2 if none of the driving conditions shown in Schedule 1 apply to your driving habits.

CL

Maintenance for off-road driving

Whenever you drive off-road through sand, mud or water, more frequent maintenance may be required of the following items:

MT

- ▲ Brake pads and rotors
- ▲ Brake lining and drums
- ▲ Brake lines and hoses
- ▲ Wheel bearing grease and free-running hub grease
- ▲ Differential gear oil, transmission and transfer fluid
- ▲ Steering linkage
- ▲ Propeller shaft and drive shafts
- ▲ Air cleaner filter
- ▲ Clutch housing (Check water entry. Refer to MA-18.)

AT

TF

PD

FA

RA

BR

ST

RS

BT

HA

EL

IDX

PERIODIC MAINTENANCE

Schedule 1

Abbreviations: R = Replace I = Inspect I = Inspect. Correct or replace if necessary. []: At the mileage intervals only

| | MAINTENANCE INTERVAL | | | | | | | | | | | | Reference page | | | | | |
|--|-------------------------------|-------------|-------------|---------------|------------|---------------|--------------|---------------|------------|---------------|--------------|---------------|----------------|------------|---------------|--------------|---------------|--------------------|
| | Miles x 1,000 (km x 1,000) | 3.75 (6) | 7.5 (12) | 11.25 (18) | 15 (24) | 18.75 (30) | 22.5 (36) | 26.25 (42) | 30 (48) | 33.75 (54) | 37.5 (60) | 41.25 (66) | | 45 (72) | 48.75 (78) | 52.5 (84) | 56.25 (90) | 60 (96) |
| Perform at number of miles, kilometers or months, whichever comes first. | Months | 3 | 6 | 9 | 12 | 15 | 18 | 21 | 24 | 27 | 30 | 33 | 36 | 39 | 42 | 45 | 48 | |
| Emission control system maintenance | | | | | | | | | | | | | | | | | | |
| Drive belts | | | | | | | | | | | I* | | | | | | I* | MA-10 |
| Air cleaner filter | See NOTE (1) | | | | | | | | | | [R] | | | | | | [R] | MA-14 |
| EVAP vapor lines | | | | | | | | | | | I* | | | | | | I* | MA-17 |
| Fuel lines | | | | | | | | | | | I* | | | | | | I* | MA-13 |
| Fuel filter | See NOTE (2)* | | | | | | | | | | | | | | | | | MA-13 |
| Engine coolant | See NOTE (3) | | | | | | | | | | | | | | | | R* | MA-11 |
| Engine oil | | R | R | R | R | R | R | R | R | R | R | R | R | R | R | R | R | MA-14 |
| Engine oil filter (Use part No. 15208 31U00 or equivalent) | | R | R | R | R | R | R | R | R | R | R | R | R | R | R | R | R | MA-15 |
| Spark plugs (PLATINUM-TIPPED type) | | | | | | | | | | | | | | | | | [R] | MA-15 |
| Timing belt | See NOTE (4) | | | | | | | | | | | | | | | | | |
| Chassis and body maintenance | | | | | | | | | | | | | | | | | | |
| Brake lines & cables | | | | | | | | | | | I | | | | | | I | MA-22 |
| Brake pads, rotors, drums & linings | | | | | | | | | | | I | | | | | | I | MA-22 |
| Automatic transmission, transfer fluid & differential gear oil | | | | | | | | | | | I | | | | | | I | MA-18, 19, 20 |
| Manual transmission oil | | | | | | | | | | | | | | | | | R | MA-18 |
| Steering gear (box) & linkage, axle & suspension parts | | | | | | | | | | | I | | | | | | I | MA-23, FA-5, RA-4 |
| Tire rotation | See NOTE (5) | | | | | | | | | | | | | | | | | MA-21 |
| Drive shaft boots & propeller shaft | | | | | | | | | | | I | | | | | | I | MA-20, FA-12, PD-9 |
| Front wheel bearing grease & free-running hub grease | See NOTE (6) | | | | | | | | | | R | | | | | | R | FA-7, 14, 15 |
| Exhaust system | | | | | | | | | | | I | | | | | | I | MA-18 |
| Air bag system | See NOTE (7) | | | | | | | | | | | | | | | | | RS-12 |

NOTE: (1) If operating mainly in dusty conditions, more frequent maintenance may be required.
(2) If vehicle is operated under extremely adverse weather conditions or in areas where ambient temperatures are either extremely low or extremely high, the filters might become clogged. In such an event, replace them immediately.
(3) After 60,000 miles (96,000 km) or 48 months, replace every 30,000 miles (48,000 km) or 24 months.
(4) Replace every 105,000 miles (169,000 km).
(5) Refer to "Tire rotation" under the "General maintenance" heading earlier in this section.
(6) If operating frequently in water, replace grease every 3,750 miles (6,000 km) or 3 months.
(7) Inspect the air bag system 10 years after the date of manufacture noted on the FMVSS certification label.
 ★ Maintenance items and intervals with "*" are recommended by NISSAN for reliable vehicle operation. The owner need not perform such maintenance in order to maintain the emission warranty or manufacturer recall liability. Other maintenance items and intervals are required.

PERIODIC MAINTENANCE

Schedule 2

GI MA EM LC EC FE CL MT AT TF PD FA RA BR ST RS BT HA EL IDX

Abbreviations: R = Replace I = Inspect I* = Inspect. Correct or replace if necessary. []: At the mileage intervals only

| MAINTENANCE OPERATION | MAINTENANCE INTERVAL | | | | | | | | | | Reference page | |
|--|----------------------|---------------|---------------|------------|--------------|------------|--------------|------------|---|---|----------------|--------------------|
| | 7.5 (12) | 15 (24) | 22.5 (36) | 30 (48) | 37.5 (60) | 45 (72) | 52.5 (84) | 60 (96) | | | | |
| Perform at number of miles, kilometers or months, whichever comes first. | Miles x 1,000 | Miles x 1,000 | Miles x 1,000 | Months | | | | | | | | |
| Emission control system maintenance | | | | | | | | | | | | |
| Drive belts | | | | I* | | | | | | | | MA-10 |
| Air cleaner filter | | | | [R] | | | | | | | | MA-14 |
| EVAP vapor lines | | | | I* | | | | | | | | MA-17 |
| Fuel lines | | | | I* | | | | | | | | MA-13 |
| Fuel filter | | | | | | | | | | | | MA-13 |
| Engine coolant | | | | | | | | | | | | MA-11 |
| Engine oil | | R | R | R | R | R | R | R | R | R | R | MA-14 |
| Engine oil filter (Use part No. 15208 31U00 or equivalent) | | R | R | R | R | R | R | R | R | R | R | MA-15 |
| Spark plugs (PLATINUM-TIPPED type) | | | | | | | | | | | [R] | MA-15 |
| Timing belt | | | | | | | | | | | | |
| Chassis and body maintenance | | | | | | | | | | | | |
| Brake lines & cables | | I | I | I | I | I | I | I | I | I | I | MA-22 |
| Brake pads, rotors, drums & linings | | I | I | I | I | I | I | I | I | I | I | MA-22 |
| Automatic transmission, transfer fluid & differential gear oil | | I | I | I | I | I | I | I | I | I | I | MA-18, 19, 20 |
| Manual transmission oil | | | | | | | | | | | | MA-18 |
| Steering gear (box) & linkage, axle & suspension parts | | | | | | | | | | | | MA-23, FA-5, RA-4 |
| Tire rotation | | | | | | | | | | | | MA-21 |
| Drive shaft boots & propeller shaft | | I | I | I | I | I | I | I | I | I | I | MA-20, FA-12, PD-9 |
| Front wheel bearing grease & free-running hub grease | | I | I | R | R | I | I | R | R | R | R | FA-7, 14, 15 |
| Exhaust system | | | | | | | | | | | | MA-18 |
| Air bag system | | | | | | | | | | | | RS-12 |

NOTE: (1) If vehicle is operated under extremely adverse weather conditions or in areas where ambient temperatures are either extremely low or extremely high, the filters might become clogged. In such an event, replace them immediately.
(2) After 60,000 miles (96,000 km) or 48 months, replace every 30,000 miles (48,000 km) or 24 months.
(3) Replace every 105,000 miles (169,000 km).
(4) Refer to "Tire rotation" under the "General maintenance" heading earlier in this section.
(5) Inspect the air bag system 10 years after the date of manufacture noted on the FMVSS certification label.
 ★ Maintenance items and intervals with "*" are recommended by NISSAN for reliable vehicle operation. The owner need not perform such maintenance in order to maintain the emission warranty or manufacturer recall liability. Other maintenance items and intervals are required.

RECOMMENDED FLUIDS AND LUBRICANTS

Fluids and Lubricants

| | | Capacity (Approximate) | | | Recommended Fluids and Lubricants |
|-------------------------------------|--------------------|------------------------|-----------------|---------|---|
| | | US measure | Imp measure | Liter | |
| Engine oil | | | | | <ul style="list-style-type: none"> ● API Certification Mark*1 ● API grade SG/SH Energy Conserving I & II or API grade SJ, Energy Conserving *1 ● ILSAC grade GF-I & GF-II *1 |
| Drain and refill | | | | | |
| | With oil filter | 3-1/2 qt | 2-7/8 qt | 3.3 | |
| | Without oil filter | 3-1/8 qt | 2-5/8 qt | 3.0 | |
| Dry engine (engine overhaul) | | 4 qt | 3-3/8 qt | 3.8 | |
| Cooling system (With reservoir) | | 11-5/8 qt | 9-5/8 qt | 10.95 | 50% Genuine NISSAN antifreeze coolant or equivalent 50% Demineralized or distilled water |
| Manual transmission gear oil | FS5R30A | 10-3/4 pt | 9 pt | 5.1 | API GL-4 Viscosity SAE 75W-90 only |
| Transfer fluid | TX10A | 2-3/8 qt | 2 qt | 2.2 | Nissan Matic "D" (Continental U.S. and Alaska) or Canada NISSAN Automatic Transmission Fluid *2 or API GL-4*1 |
| Manual steering fluid | | 1-3/8 pt | 1-1/8 pt | 0.62 | API GL-4*1, SAE #80 |
| Differential carrier gear oil | | | | | Standard differential gear: API GL-5*1 |
| | Rear: H233B | 5-7/8 pt | 4-7/8 pt | 2.8 | |
| | Front: R200A | 3-1/8 pt | 2-5/8 pt | 1.5 | |
| Automatic transmission fluid | | 9 qt | 7-1/2 qt | 8.5 | Nissan Matic "D" (Continental U.S. and Alaska) or Canada Nissan Automatic Transmission Fluid *2 |
| Power steering fluid | PB59K | 33.8-37.2 fl oz | 35.2-38.7 fl oz | 1.0-1.1 | Genuine NISSAN PSF II or equivalent *4 |
| Brake and clutch fluid | | — | — | — | Genuine Nissan Brake Fluid*3 or equivalent DOT 3 (US FMVSS No. 116) |
| Propeller shaft grease | | — | — | — | NLGI No. 2 (Molybdenum disulphide Lithium soap base) |
| Multi-purpose grease | | — | — | — | NLGI No. 2 (Lithium soap base) |
| Free-running hub grease (Auto-lock) | | — | — | — | Genuine Nissan grease or equivalent |

*1: For further details, see "SAE Viscosity Number".

*2: Dexron™ III/Mercon™ or equivalent may also be used. Outside the continental United States and Alaska contact a NISSAN dealership for more information regarding suitable fluids, including recommended brand(s) of Dexron™ III/Mercon™ Automatic Transmission Fluid.

*3: Available in mainland U.S.A. through your Nissan dealer.

*4: Genuine NISSAN PSF, Canada NISSAN Automatic Transmission Fluid, Dexron™ III/Mercon™, or equivalent. ATF may also be used.

SAE Viscosity Number

GI

MA

EM

LC

EC

FE

CL

MT

AT

TF

PD

FA

RA

BR

ST

RS

BT

HA

EL

IDX

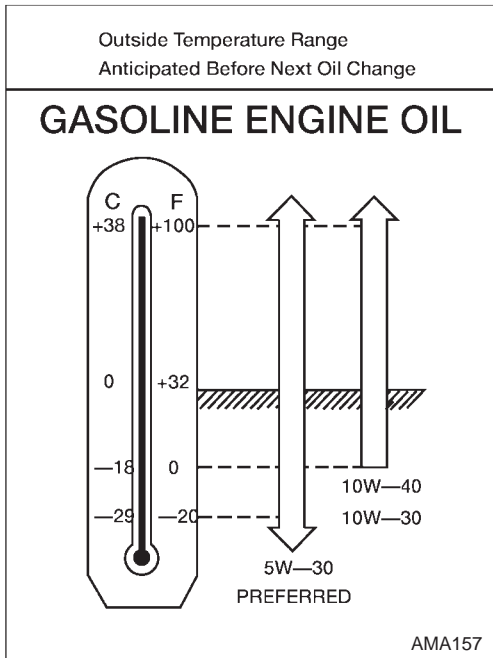

SAE 5W-30 viscosity oil is preferred for all temperatures. SAE 10W-30, 10W-40 viscosity oil may be used if the ambient temperature is above -18°C (0°F).

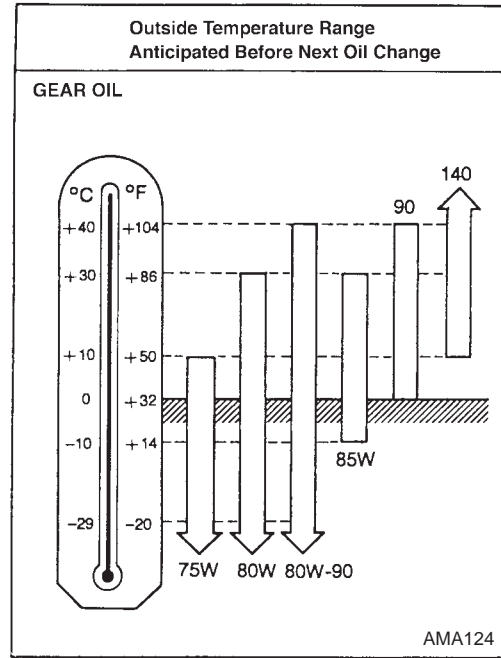

75W-90 for transfer and 80W-90 for differential are preferable if the ambient temperature is below 40°C (104°F).

Antifreeze Coolant Mixture Ratio

The engine cooling system is filled at the factory with a high-quality, year-round, antifreeze coolant solution. The antifreeze solution contains rust and corrosion inhibitors. Additional cooling system additives are not necessary.

CAUTION:

When adding or replacing coolant, be sure to use only Genuine NISSAN antifreeze or equivalent with the proper mixture ratio of 50% antifreeze 50% Demineralized water or distilled water.

| Outside temperature down to | | Genuine NISSAN Antifreeze or equivalent | Demineralized water or distilled water |
|-----------------------------|-----|---|--|
| °C | °F | | |
| -35 | -30 | 50% | 50% |

Other types of coolant solutions may damage the cooling system.

ENGINE MAINTENANCE

Checking Drive Belts

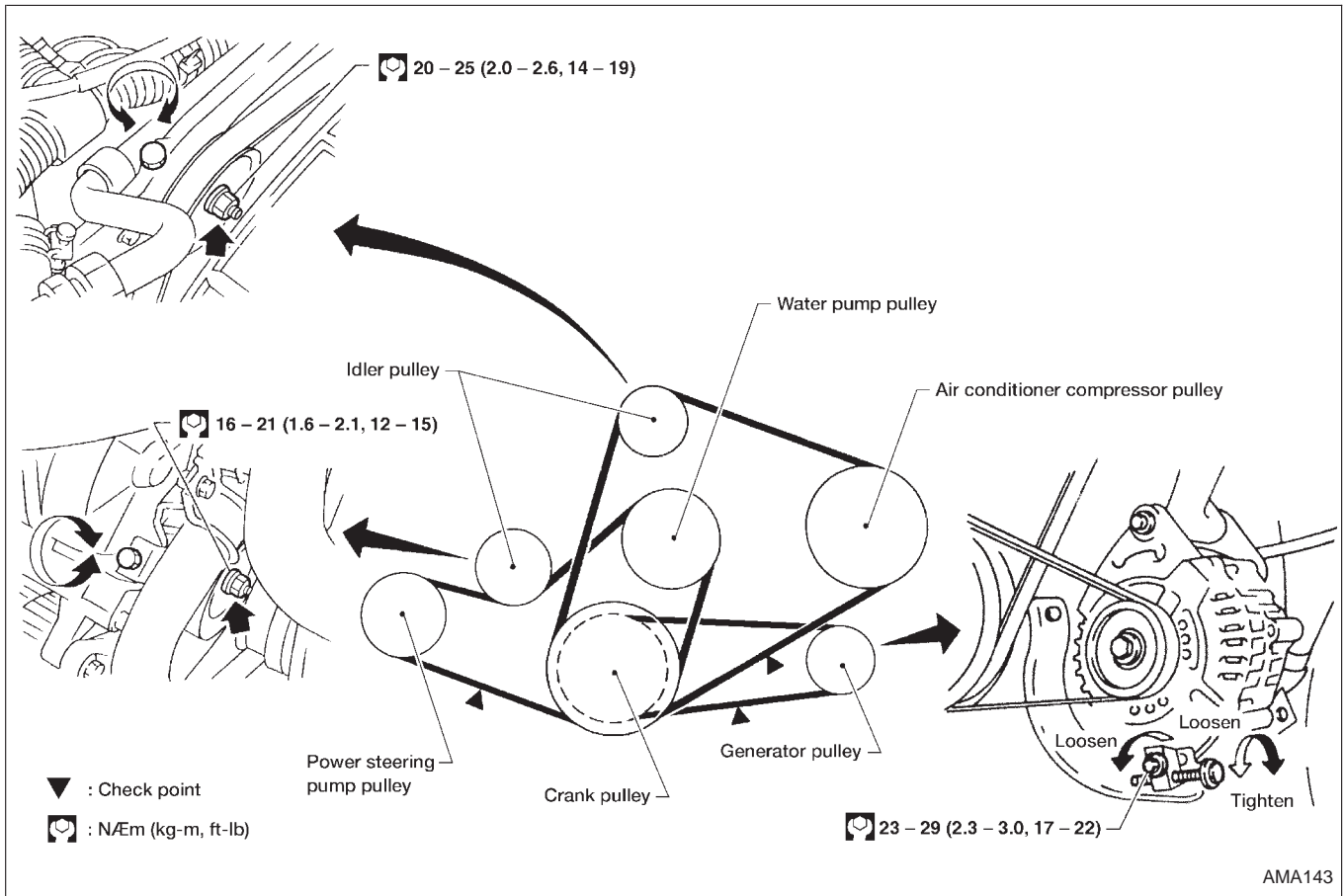

1. Inspect belt for cracks, fraying, wear and oil. If necessary, replace.
2. Inspect drive belt deflection or tension at a point on the belt midway between pulleys.
Check belt tension using belt tension gauge (BT3373-F or equivalent).

Inspect drive belt deflection or tension when engine is cold.
Adjust if belt deflections exceed the limit or if belt tension is not within specifications.

Drive belt tension can be checked at other points on the belt.

DRIVE BELT DEFLECTION AND TENSION

| | Deflection adjustment | | Unit: mm (in) | Tension adjustment *1 | | Unit: N (kg, lb) |
|----------------------------|-----------------------|-------------------------------|--------------------------------|-----------------------|--|--|
| | Used belt | | | Used belt | New belt | |
| | Limit | After adjustment | Limit | | | After adjustment |
| Generator | 11 (0.43) | 7 - 8 (0.24 - 0.31) | 6 - 7 (0.24 - 0.28) | 226 (23, 51) | 554.1 - 642.4 (56.5 - 65.5, 124.6 - 144.4) | 671.8 - 760.0 (68.5 - 77.5, 151.0 - 170.9) |
| Air conditioner compressor | 18 (0.71) | 12 - 13 (0.47 - 0.51) | 10.5 - 11.5 (0.413 - 0.453) | 196 (20, 44) | 495.3 - 583.5 (50.5 - 59.5, 111.4 - 131.2) | 603.1 - 691.4 (61.5 - 70.5, 135.6 - 155.5) |
| Power steering oil pump | 15 (0.59) | 9.5 - 10.5 (0.374 - 0.413) | 8 - 9 (0.31 - 0.35) | 275 (28, 62) | 554.1 - 642.4 (56.5 - 65.5, 124.6 - 144.4) | 671.8 - 760.0 (68.5 - 77.5, 151.0 - 170.9) |
| Applied pushing force | 98 N (10 kg, 22 lb) | | | — | | |

*1: If belt tension gauge cannot be installed at check point shown, check belt tension at a different location on the belt.

ENGINE MAINTENANCE

GI

MA

EM

LC

EC

FE

CL

MT

AT

TF

PD

FA

RA

BR

ST

RS

BT

HA

EL

IDX

Changing Engine Coolant

WARNING:

To avoid the danger of being scalded, never change the coolant when the engine is hot.

—DRAINING ENGINE COOLANT—

1. Set air conditioning system as follows to prevent coolant from remaining in the system.
 - a. Turn ignition switch "ON" and set temperature controller to maximum hot position.
 - b. Wait 10 seconds before turning ignition switch "OFF".
2. Open radiator drain plug at the bottom of radiator and remove radiator filler cap.

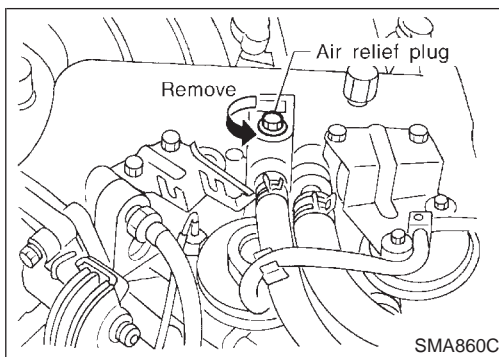
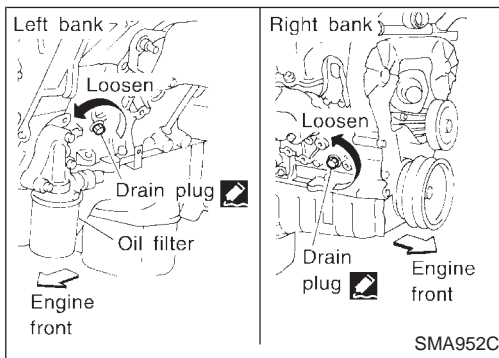
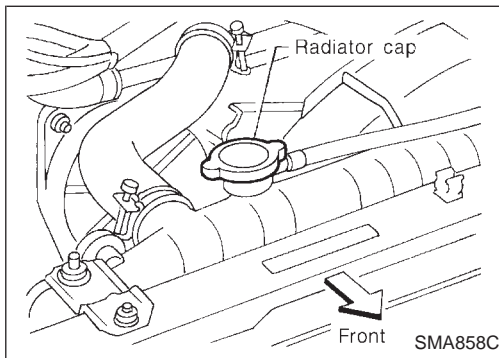
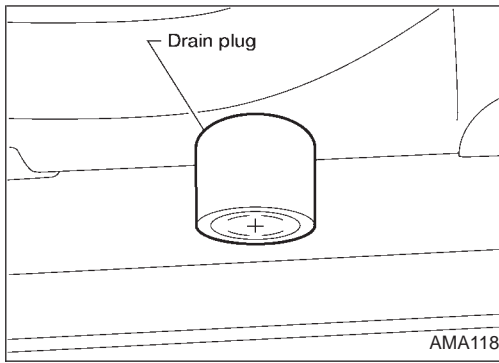

3. Remove reservoir tank, drain coolant, then clean reservoir tank.
Install it temporarily.

- **Be careful not to allow coolant to contact drive belts.**

4. Remove cylinder block drain plug and air relief plug.
5. Check drained coolant for contaminants such as rust, corrosion or discoloration.
If contaminated, flush engine cooling system.
Refer to "FLUSHING COOLING SYSTEM" MA-12.

ENGINE MAINTENANCE

Changing Engine Coolant (Cont'd)

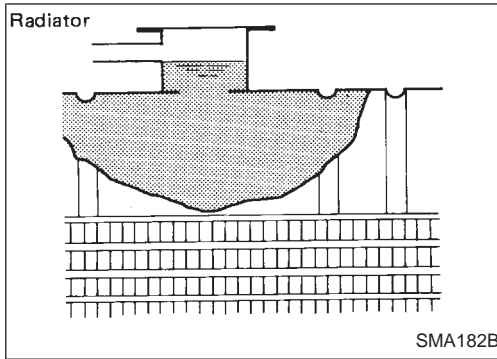

—REFILLING ENGINE COOLANT—

6. Install reservoir tank, radiator drain plug, and cylinder block drain plugs.
 - **Apply sealant to the thread of cylinder block drain plug.**
Ⓐ: 34.3 - 44.1 N·m (3.5 - 4.5 kg-m, 25 - 33 ft-lb)

7. Fill radiator slowly with coolant until coolant spills from the air relief plug, then install air relief plug.
8. Fill radiator and reservoir tank to specified level.

Air relief plug:

Ⓐ: 7 - 8 N·m (0.7 - 0.8 kg-m, 61 - 69 in-lb)

Pour coolant through coolant filler neck slowly to allow air in system to escape.

- Use Genuine Nissan antifreeze coolant or equivalent mixed with demineralized water or distilled water.

Refer to “RECOMMENDED FLUIDS AND LUBRICANTS”, MA-8.

Coolant capacity (Without reservoir tank):

9.1 ℓ (9-5/8 US qt, 8 Imp qt)

Reservoir tank capacity (for MAX level):

1.85 ℓ (2 US qt, 1-5/8 Imp qt)

9. Warm up engine to normal operating temperature without radiator cap installed.
10. Run engine at 3,000 rpm for 10 seconds and return to idle speed.
 - Repeat two or three times.

Watch coolant temperature gauge so as not to overheat the engine.

11. Stop engine and cool it down.
 - Cool down using a fan to reduce the time.
 - If necessary, refill radiator up to filler neck with coolant.
12. Refill reservoir tank to Max line with coolant.
13. Repeat step 10 through step 12 two or more times with radiator cap installed until coolant level no longer drops.
14. Check cooling system for leaks with engine running.
15. Warm up engine, and check for sound of coolant flow while running engine from idle up to 3,000 rpm with heater temperature control set at several positions between COOL and HOT.
 - Sound may be noticeable at heater water cock.
16. If sound is heard, bleed air from cooling system by repeating steps 10 through 12 with installing radiator cap until coolant level no longer drops.

- **Clean excess coolant from engine.**

—FLUSHING COOLING SYSTEM—

1. Open air relief plug.
2. Fill radiator with water until water spills from the air relief hole, then close air relief plug. Fill radiator and reservoir tank with water and reinstall radiator cap.
3. Run engine and warm it up sufficiently.
4. Rev engine two or three times under no-load.
5. Stop engine and wait until it cools down.
6. Drain water.
7. Repeat step 1 through 6 until clear water begins to drain from radiator.

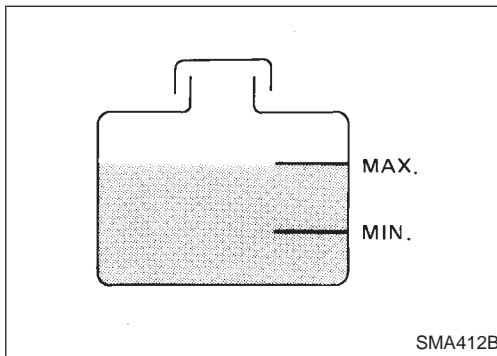

ENGINE MAINTENANCE

GI

MA

EM

LC

EC

FE

CL

MT

AT

TF

PD

FA

RA

BR

ST

RS

BT

HA

EL

IDX

Checking Fuel Lines

Inspect fuel lines and tank for improper attachment, leaks, cracks, damage, chafing and deterioration. If necessary, repair or replace faulty parts.

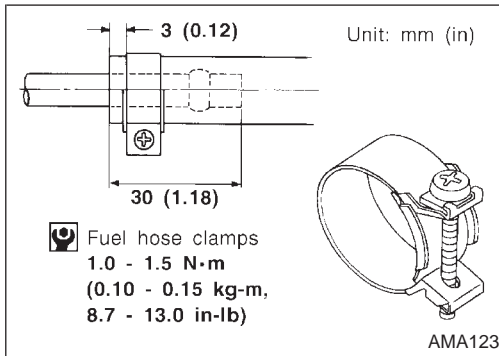
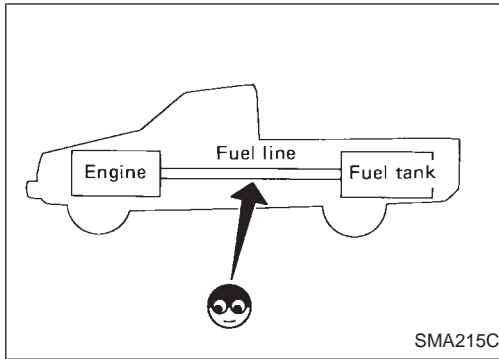

CAUTION:

Tighten high-pressure rubber hose clamp so that clamp end is 3 mm (0.12 in) from hose end.

Tightening torque specifications are the same for all rubber hose clamps.

Ensure that the screw does not contact adjacent parts.

For the quick connector, refer to FE section (“Fuel Tank”, “FUEL SYSTEM”).

Changing Fuel Filter

WARNING:

Before removing fuel filter, release fuel pressure from fuel line.

1. Start engine.
2. Perform “FUEL PRESSURE RELEASE” in “WORK SUPPORT” mode to release fuel pressure to zero.
3. After engine stalls, crank engine two or three times to make sure that fuel pressure is released.
4. Turn ignition switch “OFF”.

OR

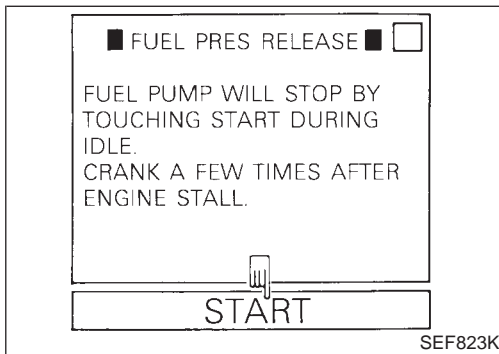

WARNING:

Before removing fuel filter, release fuel pressure from fuel line.

1. Remove fuse for fuel pump.
2. Start engine.
3. After engine stalls, crank engine two or three times to make sure that fuel pressure is released.
4. Turn ignition switch OFF and install fuse for fuel pump.

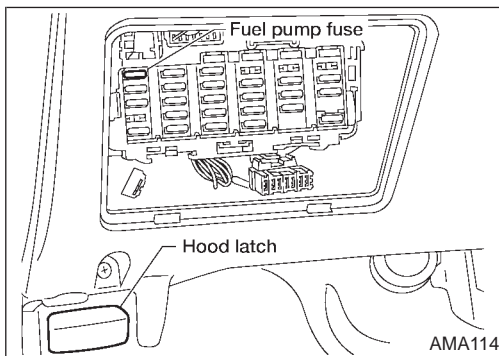

5. Loosen fuel hose clamps.
6. Replace fuel filter.

- Be careful not to spill fuel over engine compartment. Place a shop towel to absorb fuel.
- Use a high-pressure fuel filter. Do not use a synthetic resinous fuel filter.

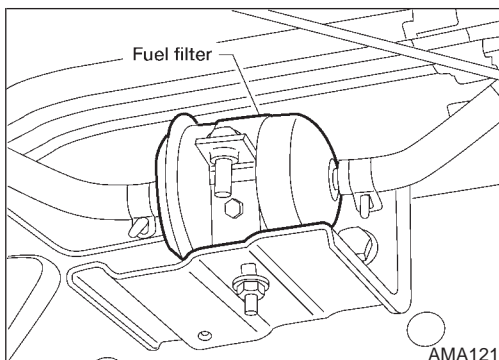

ENGINE MAINTENANCE

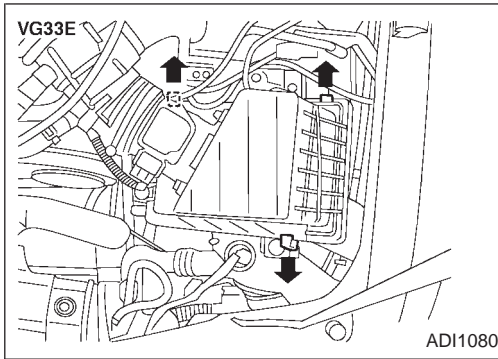

Changing Air Cleaner Filter

The viscous paper type filter does not need cleaning between renewals.

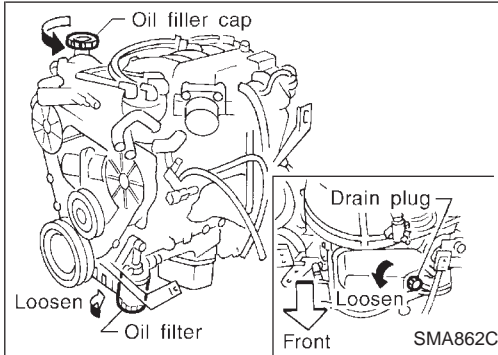

Changing Engine Oil

WARNING:

- Be careful not to burn yourself, as the engine oil is hot.
- Prolonged and repeated contact with used engine oil may cause skin cancer; try to avoid direct skin contact with used oil. If skin contact is made, wash thoroughly with soap or hand cleaner as soon as possible.

1. Warm up engine, and check for oil leakage from engine components.
2. Stop engine.
3. Remove drain plug and oil filler cap.
4. Drain oil and refill with new engine oil.

Oil specification and viscosity:

- API Certification Mark
- API grade SG/SH Energy Conserving II or API grade SJ Energy Conserving.
- ILSAC grade GF-II
- Refer to "RECOMMENDED FLUIDS AND LUBRICANTS", MA-8.

Oil capacity (Approximately):

Unit: ℓ (US qt, Imp qt)

| | |
|------------------------------|--------------------|
| Drain and refill | |
| with oil filter change | 3.3 (3-1/2, 2-7/8) |
| without oil filter change | 3.0 (3-1/8, 2-5/8) |
| Dry engine (engine overhaul) | 3.8 (4, 3-3/8) |

CAUTION:

- Be sure to clean drain plug and install with new washer.
Drain plug:
: 29 - 39 N·m (3.0 - 4.0 kg-m, 22 - 29 ft-lb)
- The refill capacity depends on the oil temperature and drain time. Use these specifications for reference only. Always use the dipstick to determine when the proper amount of oil is in the engine.

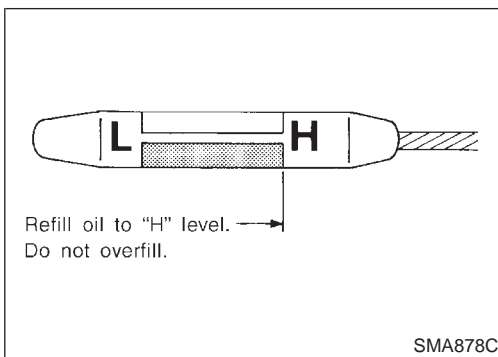

5. Warm up engine and check area around drain plug and oil filter for oil leakage.
6. Stop engine
7. Check oil level.

ENGINE MAINTENANCE

GI

MA

EM

LC

EC

FE

CL

MT

AT

TF

PD

FA

RA

BR

ST

RS

BT

HA

EL

IDX

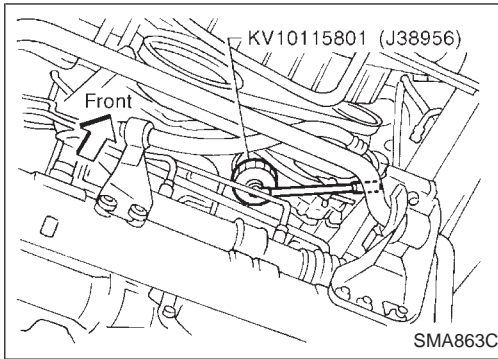

Changing Oil Filter

1. Remove oil filter with Tool.

WARNING:

Be careful not to burn yourself, as the engine and engine oil are hot.

The filter is a full-flow cartridge type and is provided with a relief valve.

Refer to LC section (“Oil Filter”, “ENGINE LUBRICATION SYSTEM”).

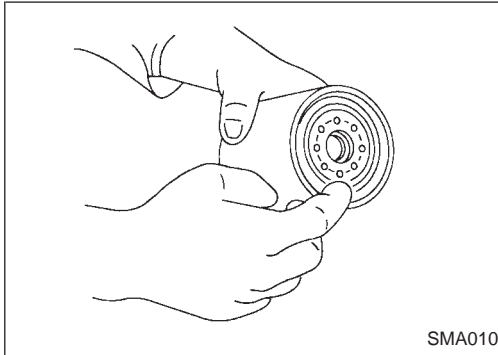

2. Clean oil filter mounting surface on cylinder block. Coat rubber seal of new oil filter with engine oil.

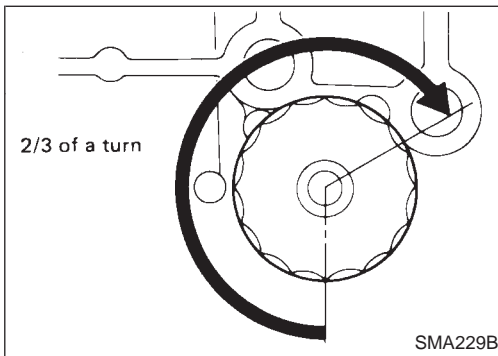

3. Screw in the oil filter until a slight resistance is felt, then tighten additionally more than 2/3 of a turn.

4. Add engine oil.

Refer to “Changing Engine Oil”, MA-14.

- Clean excess oil from engine.

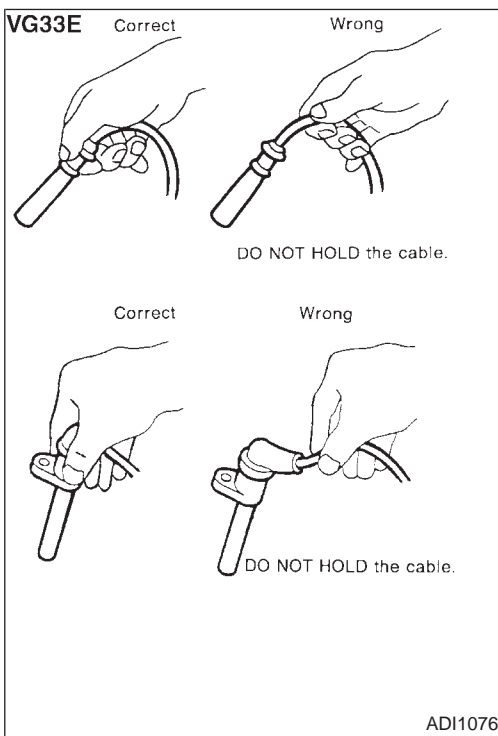

Changing Spark Plugs

1. Disconnect ignition wires from spark plugs at boot. Do not pull on the wire.

ENGINE MAINTENANCE

Changing Spark Plugs (Cont'd)

2. Remove spark plugs with spark plug wrench.

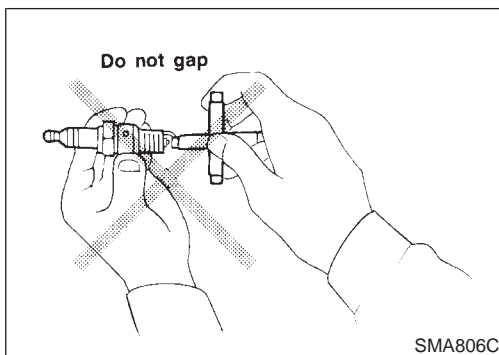
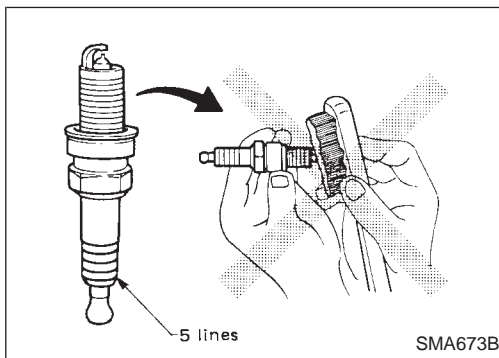
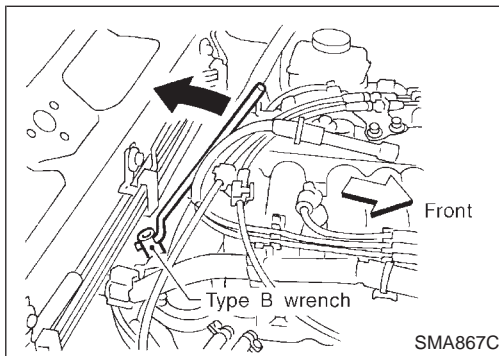
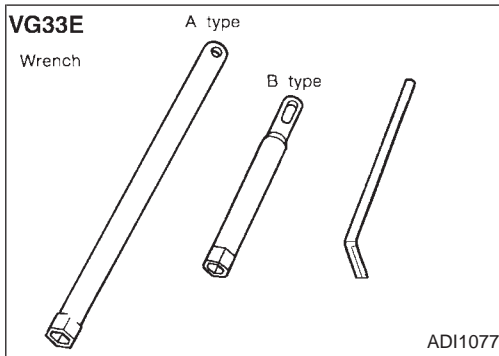
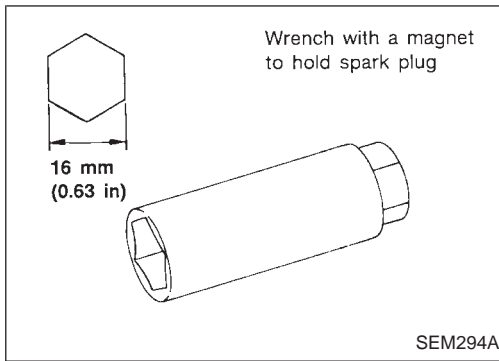

- Spark plug wrench set is available in tool kit provided on vehicle.
A type is for spark plugs except for No. 6 cylinder. B type is for No. 6 cylinder. Refer to section 995 of PARTS CATALOG for tool kit.

Spark plug:

| | |
|---------------|----------|
| Make | NGK |
| Standard type | FR5AP-10 |
| Cold type | FR6AP-10 |
| Hot type | FR4AP-10 |

Use standard type spark plug under normal conditions. The hot type spark plug is suitable when fouling occurs with the standard spark plug under conditions such as:

- frequent engine starts
- low ambient temperature

The cold type spark plug is suitable when spark knock occurs with the standard spark plug under conditions such as:

- extended highway driving
- frequent high engine revolution
- **Do not use a wire brush for cleaning.**
- **If plug tip is covered with carbon, spark plug cleaner may be used.**

Cleaner air pressure:

Less than 588 kPa (6 kg/cm², 85 psi)

Cleaning time:

Less than 20 seconds

- **Checking and adjusting plug gap is not required between change intervals.**

ENGINE MAINTENANCE

Changing Spark Plugs (Cont'd)

When installing spark plugs to No. 2 and 4 cylinders, securely fit each ignition wire mounting hole onto the ignition wire fixing pin.

Spark plug:

: 20 - 29 N·m

(2.0 - 3.0 kg-m, 14 - 22 ft-lb)

GI

MA

EM

LC

EC

FE

CL

MT

AT

TF

PD

FA

RA

BR

ST

RS

BT

HA

EL

IDX

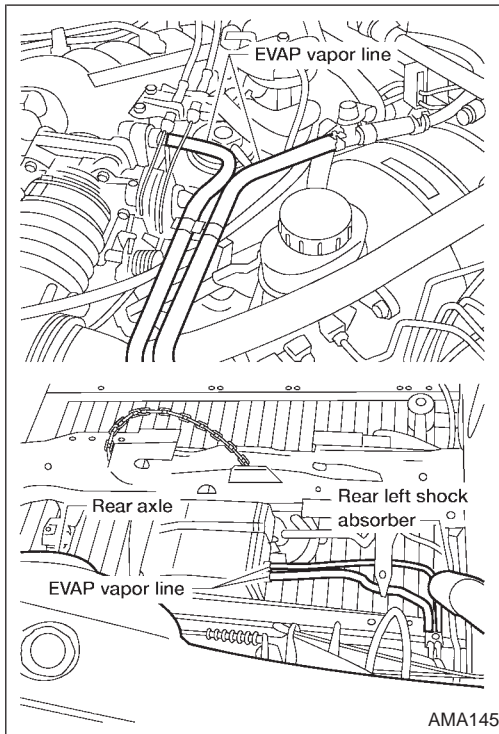
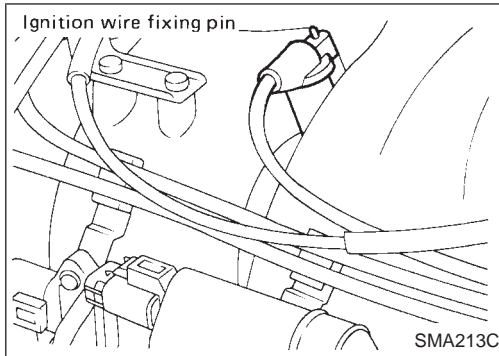

Checking EVAP Vapor Lines

1. Visually inspect EVAP vapor lines for improper attachment and for cracks, damage, loose connections, chafing and deterioration.
2. Inspect fuel tank filler cap vacuum relief valve for clogging, sticking, etc.

Refer to EC section (“EVAPORATIVE EMISSION SYSTEM”).

CHASSIS AND BODY MAINTENANCE

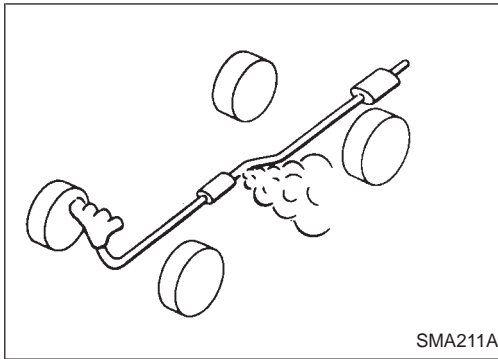

Checking Exhaust System

Check exhaust pipes, muffler and mounting for improper attachment, leaks, cracks, damage, loose connections, chafing and deterioration.

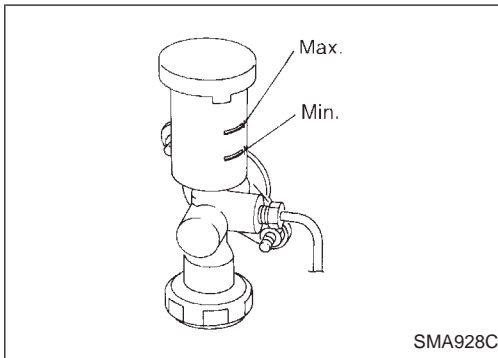

Checking Clutch Fluid Level and Leaks

If fluid level is extremely low, check clutch system for leaks.

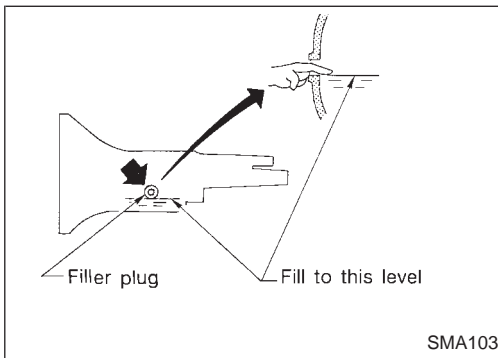

Checking M/T Oil

Check for oil leakage and oil level.

Never start engine while checking oil level.

Filler plug:

: 25 - 34 N-m (2.5 - 3.5 kg-m, 18 - 25 ft-lb)

Changing M/T Oil

1. Drain oil from drain plug and refill with new gear oil.
2. Check oil level.

Oil grade and viscosity:

API GL-4. Refer to "RECOMMENDED FLUIDS AND LUBRICANTS", MA-8.

Oil capacity:

FS5R30A

5.1 l (10-3/4 US pt, 9 Imp pt)

Drain plug:

: 25 - 34 N-m (2.5 - 3.5 kg-m, 18 - 25 ft-lb)

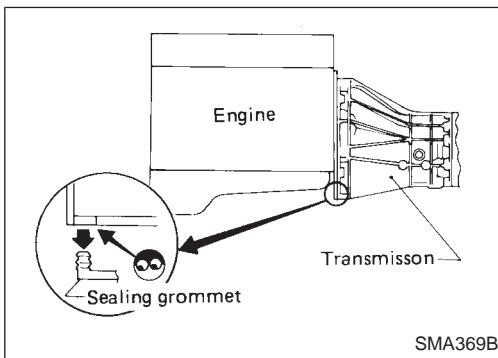

Checking Water Entry

Check water entry in the clutch housing by removing the sealing grommet after driving in deep water or mud.

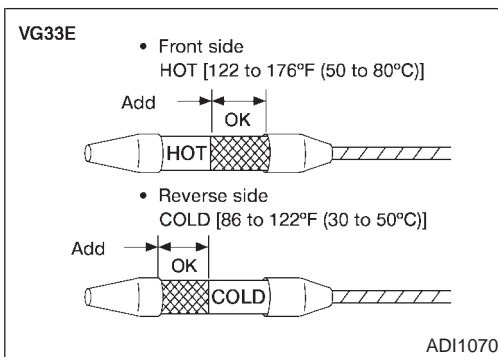

Checking A/T Fluid

1. Warm up engine.
2. Check for fluid leakage.
3. Before driving, fluid level can be checked at fluid temperatures of 30 to 50°C (86 to 122°F) using "COLD" range on dipstick.
 - a. Park vehicle on level surface and set parking brake.
 - b. Start engine and move selector lever through each gear position. Leave selector lever in "P" position.
 - c. Check fluid level with engine idling.
 - d. Remove dipstick and note reading. If level is at low side of either range, add fluid to the charging pipe.

CHASSIS AND BODY MAINTENANCE

Checking A/T Fluid (Cont'd)

- e. Reinsert dipstick into charging pipe as far as it will go.
- f. Remove dipstick and note reading. If reading is at low side of range, add fluid to the charging pipe.

Do not overfill.

4. Drive vehicle for approximately 5 minutes in urban areas.
5. Recheck fluid level at fluid temperatures of 50° to 80°C (122° to 176°F) using "HOT" range on dipstick.
6. Check fluid condition.
 - If fluid is very dark or smells burned, refer to AT section for checking operation of A/T. Flush cooling system after repair of A/T.
 - If A/T fluid contains frictional material (clutches, bands, etc.), replace radiator and flush cooler line using cleaning solvent and compressed air after repair of A/T. Refer to LC section ("Radiator", "ENGINE COOLING SYSTEM").

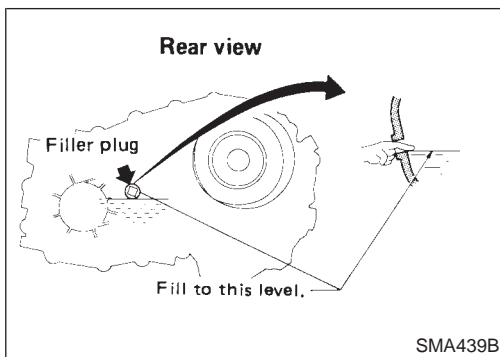
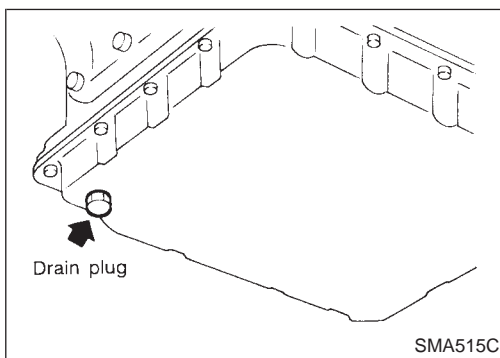

Changing A/T Fluid

1. Warm up A/T fluid.
2. Stop engine.
3. Drain A/T fluid from drain plug and refill with new A/T fluid. Measure amount of fluid drained and refill with equal amount of new fluid.

Fluid grade and viscosity:

Nissan Matic "D" (Continental U.S. and Alaska) or Genuine Nissan Automatic Transmission Fluid (Canada). Refer to "RECOMMENDED FLUIDS AND LUBRICANTS", MA-8.

Fluid capacity (With torque converter):

8.5 l (9 US qt, 7-1/2 Imp qt)

Drain plug:

⌚: 29 - 39 N·m (3.0 - 4.0 kg-m, 22 - 29 ft-lb)

4. Run engine at idle speed for five minutes.
5. Check fluid level and condition. Refer to "Checking A/T Fluid". If fluid is still dirty, repeat steps 2 through 5, MA-18.

Checking Transfer Fluid

Check for fluid leakage and fluid level.

Automatic Transmission Fluid is used for the transfer in the factory.

Never start engine while checking fluid level.

Filler plug:

⌚: 25 - 34 N·m (2.5 - 3.5 kg-m, 18 - 25 ft-lb)

CHASSIS AND BODY MAINTENANCE

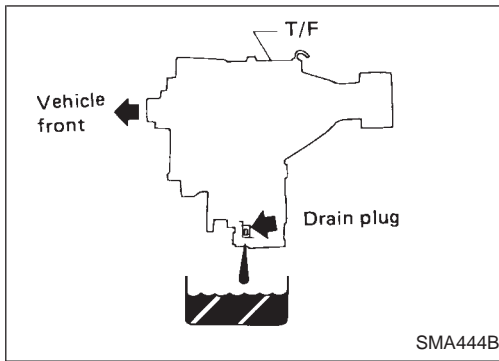

Changing Transfer Fluid

When changing transfer fluid completely, use the following fluid.

Fluid grade:

Nissan Matic "D" (Continental U.S. and Alaska) or Genuine Nissan Automatic Transmission Fluid (Canada) or API GL-4. Refer to "RECOMMENDED FLUIDS AND LUBRICANTS", MA-8.

Fluid capacity:

2.2 l (2-3/8 US qt, 2 Imp qt)

Drain plug:

⌚: 25 - 34 N·m (2.5 - 3.5 kg·m, 18 - 25 ft·lb)

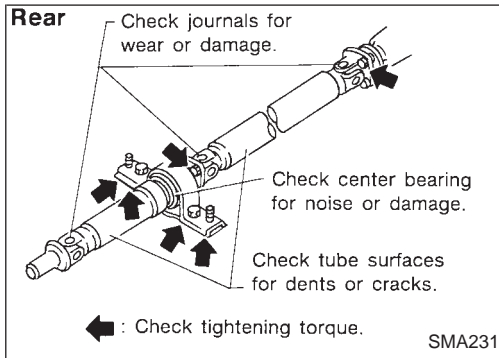

Checking Propeller Shaft

Check propeller shaft for damage, looseness and grease leakage.

Tightening torque: Refer to PD section.

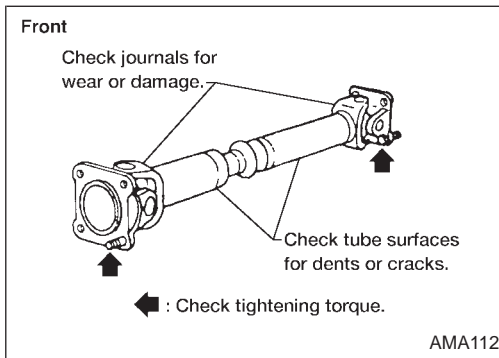

Checking Differential Gear Oil

Check for oil leakage and oil level.

Filler plug:

Front

⌚: 59 - 98 N·m (6 - 10 kg·m, 43 - 72 ft·lb)

Rear

⌚: 59 - 98 N·m (6 - 10 kg·m, 43 - 72 ft·lb)

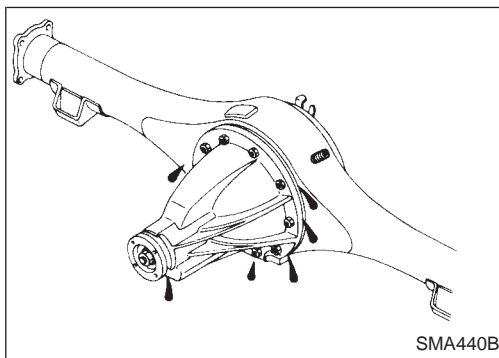

CHASSIS AND BODY MAINTENANCE

GI

MA

EM

LC

EC

FE

CL

MT

AT

TF

PD

FA

RA

BR

ST

RS

BT

HA

EL

IDX

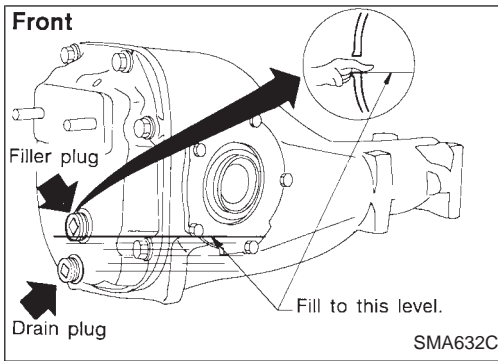

Changing Differential Gear Oil

1. Drain oil from drain plug and refill with new gear oil.
2. Check oil level.

Oil grade and viscosity:

See "RECOMMENDED FLUIDS AND LUBRICANTS", MA-8.

Oil capacity:

Front

1.5 l (3-1/8 US pt, 2-5/8 Imp pt)

Rear

2.8 l (5-7/8 US pt, 4-7/8 Imp pt)

Drain plug:

Front

: 59 - 98 N·m (6 - 10 kg-m, 43 - 72 ft-lb)

Rear

: 59 - 98 N·m (6 - 10 kg-m, 43 - 72 ft-lb)

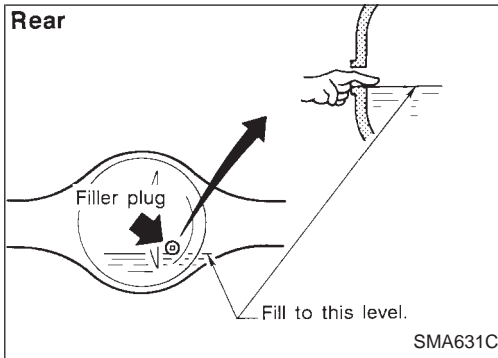

Balancing Wheels

Adjust wheel balance using the road wheel center.

Wheel balance (Maximum allowable unbalance):

Refer to SDS, MA-26.

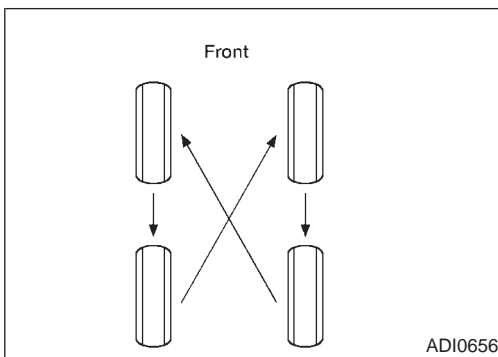

Tire Rotation

- After rotating the tires, adjust the tire pressure.
- Retighten the wheel nuts when the vehicle has been driven for 1,000 km (600 miles) (also in cases of a flat tire, etc.).
- **Do not include the T-type spare tire when rotating the tires.**

Wheel nuts:

: 118 - 147 N·m (12 - 15 kg-m, 87 - 108 ft-lb)

CHASSIS AND BODY MAINTENANCE

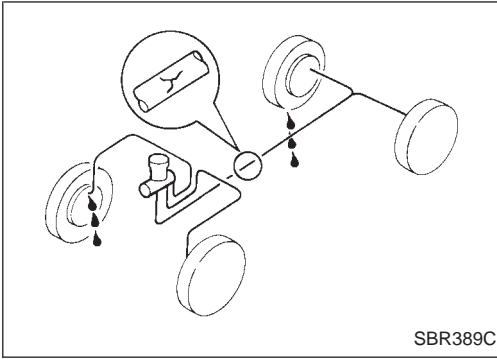

Checking Brake Fluid Level and Leaks

If fluid level is extremely low, check brake system for leaks.

Checking Brake System

Check brake fluid lines and parking brake cables for improper attachment, leaks, chafing, abrasion and deterioration, etc.

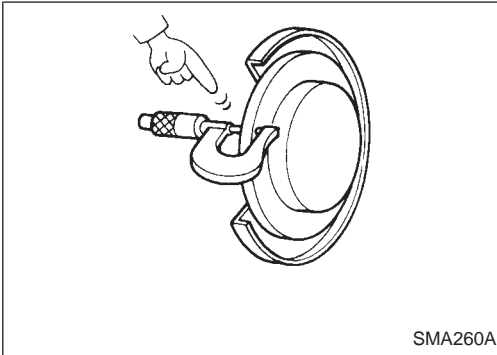

Checking Disc Brake

ROTOR

Check condition and thickness.

Minimum thickness: CL28VD 24 mm (0.94 in)

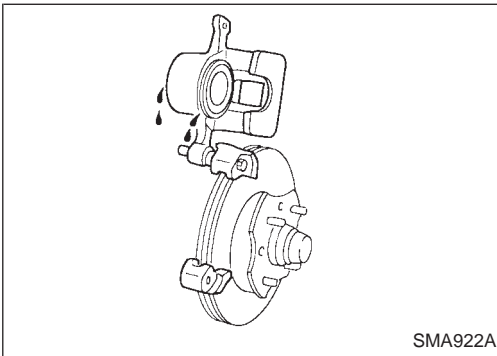

CALIPER

Check for leakage.

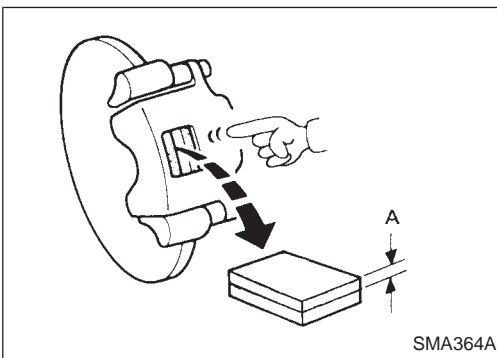

PAD

Measure wear and check for damage.

Minimum thickness: 2 mm (0.08 in)

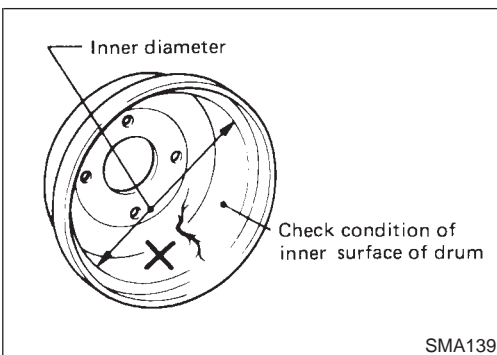

Checking Drum Brake

WHEEL CYLINDER

Check operation and for leakage.

DRUM

Check condition of inner surface.

Drum repair limit (Maximum inner diameter):
LT30A 296.5 mm (11.67 in)

CHASSIS AND BODY MAINTENANCE

Checking Drum Brake (Cont'd)

LINING

Measure wear and check for damage.

Lining wear limit (Minimum thickness):
1.5 mm (0.059 in)

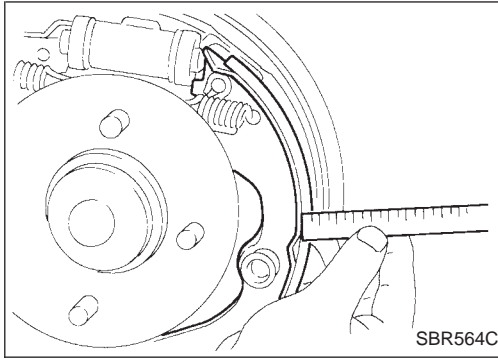

Checking Steering Gear and Linkage

STEERING GEAR

- Check gear housing and boots for looseness, damage and grease leakage.
- Check connection with steering column for looseness.

STEERING LINKAGE

- Check ball joint, dust cover and other component parts for looseness, wear, damage and grease leakage.

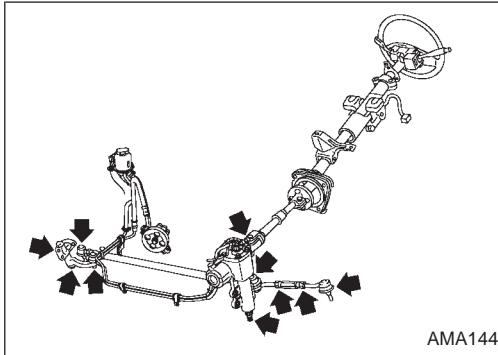

Checking Power Steering Fluid and Lines

- Check fluid level with engine off.
- Check fluid level on reservoir. Use "HOT" range at fluid temperatures of 50 to 80°C (122 to 176°F). Use "COLD" range at fluid temperatures of 0 to 30°C (32 to 86°F).

CAUTION:

- Do not overfill.
- Recommended fluid is Genuine NISSAN PSF II or equivalent.

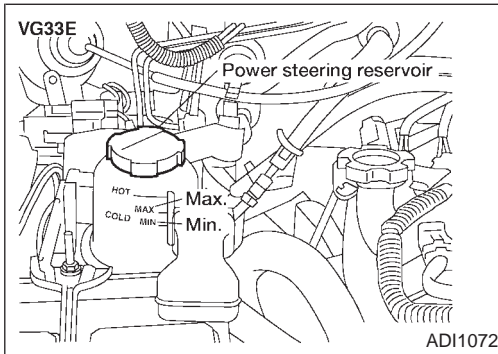

- Check lines for improper attachment, leaks, cracks, damage, loose connections, chafing and deterioration.

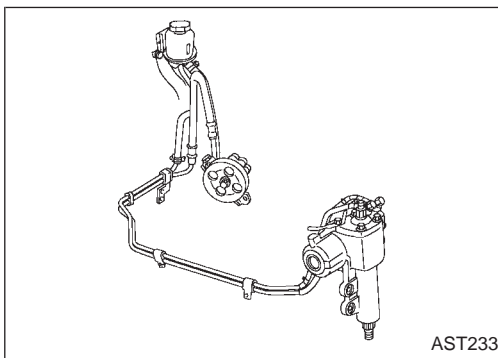

GI

MA

EM

LC

EC

FE

CL

MT

AT

TF

PD

FA

RA

BR

ST

RS

BT

HA

EL

IDX

Checking Seat Belts, Buckles, Retractors, Anchors and Adjusters

GI

MA

EM

LC

EC

FE

CL

MT

AT

TF

PD

FA

RA

BR

ST

RS

BT

HA

EL

IDX

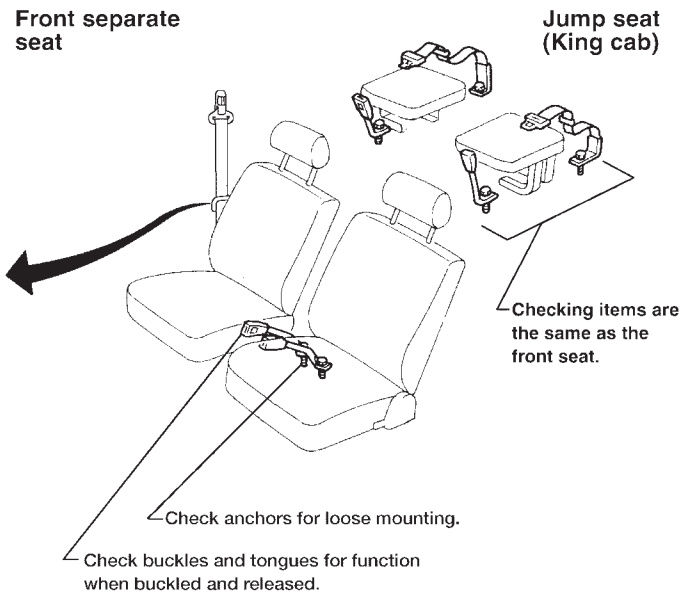
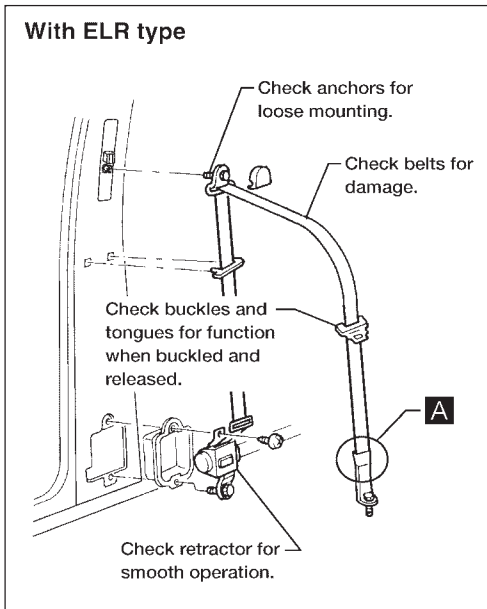

Front bench seat (Including split seat)

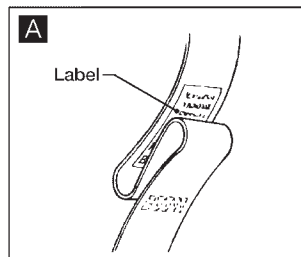
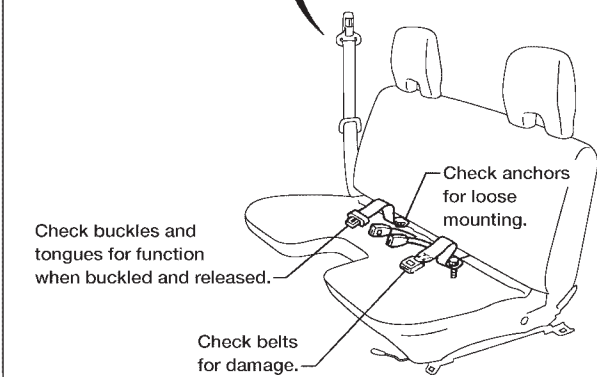

For front seat belt, shock absorber type belt has been used. Replace the belt when loop has been pulled out and "REPLACE BELT" is visible because this seat belt has a loop of webbing under the sleeve.

CAUTION:

1. If the vehicle has collided or overturned, replace the entire belt assembly, regardless of nature of accident.
2. If the condition of any component of a seat belt is questionable, do not repair seat belt, but replace it as a belt assembly.
3. If webbing is cut, frayed, or damaged, replace belt assembly.
4. Do not spill drinks, oil, etc. on inner lap belt buckle. Never oil tongue and buckle.
5. Use a NISSAN genuine seat belt assembly.

Anchor bolt:

: 24 - 31 N•m (2.4 - 3.1 kg-m, 17 - 23 ft-lb)

For details, refer to "Seat Belt Inspection", "SEAT BELTS" in RS section.

AMA119

SERVICE DATA AND SPECIFICATIONS (SDS)

Engine Maintenance

INSPECTION AND ADJUSTMENT

DRIVE BELT DEFLECTION AND TENSION

| | Deflection adjustment | | Unit: mm (in) | Tension adjustment *1 | | Unit: N (kg, lb) |
|-------------------------------|-----------------------|-------------------------------|--------------------------------|-----------------------|--|--|
| | Used belt | | New belt | Used belt | | New belt |
| | Limit | After adjustment | | Limit | After adjustment | |
| Generator | 11 (0.43) | 7 - 8 (0.24 - 0.31) | 6 - 7 (0.24 - 0.28) | 226 (23, 51) | 554.1 - 642.4 (56.5 - 65.5, 124.6 - 144.4) | 671.8 - 760.0 (68.5 - 77.5, 151.0 - 170.9) |
| Air conditioner compressor | 18 (0.71) | 12 - 13 (0.47 - 0.51) | 10.5 - 11.5 (0.413 - 0.453) | 196 (20, 44) | 495.3 - 583.5 (50.5 - 59.5, 111.4 - 131.2) | 603.1 - 691.4 (61.5 - 70.5, 135.6 - 155.5) |
| Power steering oil pump | 15 (0.59) | 9.5 - 10.5 (0.374 - 0.413) | 8 - 9 (0.31 - 0.35) | 275 (28, 62) | 554.1 - 642.4 (56.5 - 65.5, 124.6 - 144.4) | 671.8 - 760.0 (68.5 - 77.5, 151.0 - 170.9) |
| Applied pushing force | 98 N (10 kg, 22 lb) | | | — | | |

*1: If belt tension gauge cannot be installed at check point shown, check belt tension at a different location on the belt.

Spark plug

| | |
|---------------|----------|
| Standard type | FR5AP-10 |
| Cold type | FR6AP-10 |
| Hot type | FR4AP-10 |

Chassis and Body Maintenance

INSPECTION AND ADJUSTMENT

Wheel balance

| | | |
|--------------------------------|--------------------------------------|----------------------|
| Maximum allowable unbalance | Dynamic (At rim flange) g (oz) | 10 (0.35) (one side) |
| | Static g (oz) | 20 (0.71) |