

# PROPELLER SHAFT & DIFFERENTIAL CARRIER

## SECTION PD

### CONTENTS

<b>PREPARATION</b> .....	3
Special Service Tools .....	3
<b>NOISE, VIBRATION AND HARSHNESS (NVH)</b>	
<b>TROUBLESHOOTING</b> .....	7
NVH Troubleshooting Chart.....	7

**PROPELLER SHAFT**

<b>PROPELLER SHAFT</b> .....	8
On-vehicle Service.....	10
Removal and Installation.....	10
Inspection.....	10
Disassembly.....	11
Assembly .....	12

**FINAL DRIVE**

<b>ON-VEHICLE SERVICE</b> .....	14
Front Oil Seal Replacement (Front final drive: Model R180A) .....	14
Rear Cover Gasket Replacement (Rear final drive: Model C200) .....	14
<b>REMOVAL AND INSTALLATION (Front final drive)</b> .....	15
Removal.....	15
Installation.....	15
<b>REMOVAL AND INSTALLATION (Rear final drive)</b> ....	16
Removal.....	16
Installation.....	16

**R180A**

<b>FRONT FINAL DRIVE</b> .....	17
<b>DISASSEMBLY</b> .....	18
Pre-inspection.....	18
Final Drive Housing .....	18
Differential Case .....	20

Extension Tube and Differential Side Shaft .....	21
<b>INSPECTION</b> .....	23
Ring Gear and Drive Pinion .....	23
Differential Case Assembly.....	23
Bearing.....	23
<b>ADJUSTMENT</b> .....	24
Side Bearing Preload.....	24
Pinion Gear Height and Pinion Bearing Preload.....	25
Tooth Contact.....	29
<b>ASSEMBLY</b> .....	30
Extension Tube and Differential Side Shaft .....	30
Differential Case .....	30
Final Drive Housing .....	31

**H190A**

<b>REAR FINAL DRIVE</b> .....	35
<b>DISASSEMBLY</b> .....	36
Pre-inspection .....	36
Differential Carrier.....	36
Differential Case .....	38
<b>INSPECTION</b> .....	40
Ring Gear and Drive Pinion .....	40
Differential Case Assembly.....	40
Bearing.....	40
<b>ADJUSTMENT</b> .....	41
Side Bearing Preload.....	41
Pinion Gear Height .....	42
Tooth Contact.....	46
<b>ASSEMBLY</b> .....	47
Differential Case .....	47
Differential Carrier.....	48

**C200**

<b>REAR FINAL DRIVE</b> .....	52
2WD models .....	52

GI  
MA  
EM  
LC  
EC  
FE  
CL  
MT  
AT  
TF  
PD  
FA  
RA  
BR  
ST  
RS  
BT  
HA  
EL  
IDX

# CONTENTS (Cont'd.)

4WD models .....	53	Tooth Contact.....	64
<b>DISASSEMBLY</b> .....	54	<b>ASSEMBLY</b> .....	65
Pre-inspection .....	54	Differential Case .....	65
Differential Carrier.....	54	Differential Carrier.....	66
Differential Case .....	56	<b>SERVICE DATA AND SPECIFICATIONS (SDS)</b> .....	70
<b>INSPECTION</b> .....	58	Propeller Shaft.....	70
Ring Gear and Drive Pinion .....	58	Final Drive.....	71
Differential Case Assembly.....	58	General Specifications .....	71
Bearing.....	58	Inspection And Adjustment (R180A) .....	72
<b>ADJUSTMENT</b> .....	59	Inspection And Adjustment (H190A) .....	73
Side Bearing Preload.....	59	Inspection And Adjustment (C200) .....	74
Pinion Gear Height .....	60		

# PREPARATION

## Special Service Tools

GI

The actual shapes of Kent-Moore tools may differ from those of special service tools illustrated here.

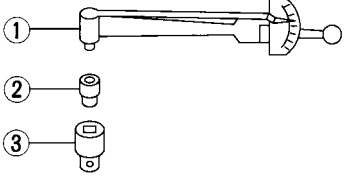
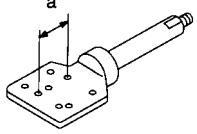
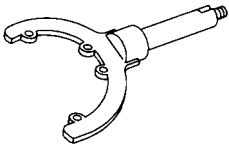
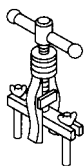
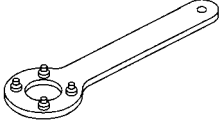
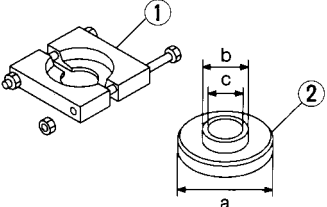
Tool number (Kent-Moore No.) Tool name	Description	Unit application		
		R180A	H190A	C200
ST3127S000 (See J25765-A) Preload gauge ① GG91030000 (J25765) Torque wrench ② HT62940000 ( — ) Socket adapter ③ HT62900000 ( — ) Socket adapter	 <p>Measuring pinion bearing preload and total preload</p> <p>NT124</p>	X	X	X
KV38100800 (J25604-01), (J34310) Differential attachment	 <p>Mounting final drive (To use, make a new hole.)</p> <p>NT119</p> <p><b>a: 152 mm (5.98 in)</b></p>	X	—	—
ST06310000 (J25602-01) Differential attachment	 <p>Mounting final drive</p> <p>NT140</p>	—	X	—
ST33290001 (J25810-A) Side bearing outer race puller	 <p>Removing side bearing outer race and side oil seal</p> <p>NT076</p>	X	—	—
ST38060002 (J34311) Drive pinion flange wrench	 <p>Removing and installing propeller shaft lock nut and drive pinion lock nut</p> <p>NT113</p>	X	X	X
ST3090S000 ( — ) Drive pinion rear inner race puller set ① ST30031000 (J22912-01) Puller ② ST30901000 (J26010-01) Base	 <p>Removing and installing drive pinion rear inner cone</p> <p>NT527</p> <p><b>a: 79 mm (3.11 in) dia.</b>  <b>b: 45 mm (1.77 in) dia.</b>  <b>c: 35 mm (1.38 in) dia.</b></p>	X	X	X

MA

EM

LC

EC

FE

CL

MT

AT

TF

**PD**

FA

RA

BR

ST

RS

BT

HA

EL

IDX

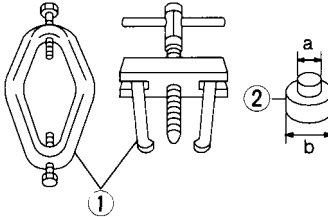
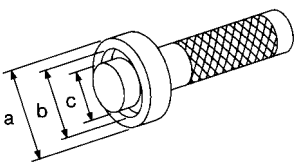
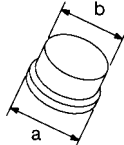
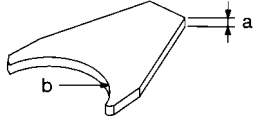
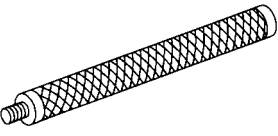
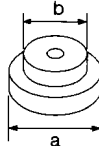
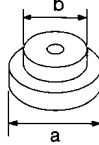

# PREPARATION

## Special Service Tools (Cont'd)

Tool number (Kent-Moore No.) Tool name	Description	Unit application			
		R180A	H190A	C200	
ST3306S001 Differential side bearing puller set ① ST33051001 (J22888-20) Body ② ST33061000 (J8107-2) Adapter	 <p>NT072</p> <p><b>a: 28.5 mm (1.122 in) dia.</b> <b>b: 38 mm (1.50 in) dia.</b></p>	Removing and installing differential side bearing inner cone	X	X	X
ST33230000 (J25805-01) Differential side bearing drift	 <p>NT085</p> <p><b>a: 51 mm (2.01 in) dia.</b> <b>b: 41 mm (1.61 in) dia.</b> <b>c: 28.5 mm (1.122 in) dia.</b></p>	Installing side bearing inner cone	X	X	X
ST33081000 ( — ) Side bearing puller adapter	 <p>NT431</p> <p><b>a: 43 mm (1.69 in) dia.</b> <b>b: 33.5 mm (1.319 in) dia.</b></p>	Installing side bearing inner cone	—	—	X
KV38100600 (J25267) Side bearing spacer drift	 <p>NT528</p> <p><b>a: 8 mm (0.31 in)</b> <b>b: R42.5 mm (1.673 in)</b></p>	Installing side bearing spacer	—	—	X
ST30611000 (J25742-1) Drift	 <p>NT090</p>	Installing pinion rear bearing outer race	X	X	X
ST30621000 (J25742-5) Drift	 <p>NT073</p> <p><b>a: 79 mm (3.11 in) dia.</b> <b>b: 59 mm (2.32 in) dia.</b></p>	Installing pinion rear bearing outer race	X	X	X
ST30701000 (J25742-2) Drift	 <p>NT073</p> <p><b>a: 61.5 mm (2.421 in) dia.</b> <b>b: 41 mm (1.61 in) dia.</b></p>	Installing pinion front bearing outer race	X	—	—

# PREPARATION

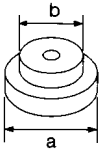
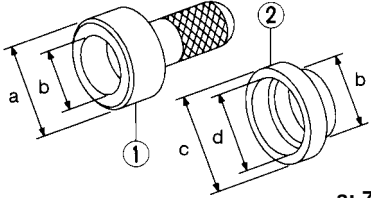
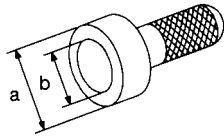
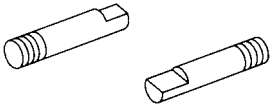
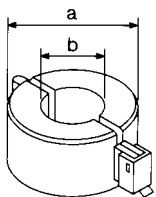
## Special Service Tools (Cont'd)

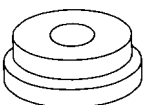
Tool number (Kent-Moore No.) Tool name	Description	Unit application		
		R180A	H190A	C200
ST30613000 (J25742-3) Drift	 <p>Installing pinion front bearing outer race</p> <p><b>a: 72 mm (2.83 in) dia.</b> <b>b: 48 mm (1.89 in) dia.</b></p>	—	X	X
KV381025S0 ( — ) Oil seal fitting tool ① ST30720000 (J25405) Drift bar ② KV38102510 ( — ) Drift	 <p>Installing front oil seal</p> <p><b>a: 77 mm (3.03 in) dia.</b> <b>b: 55 mm (2.17 in) dia.</b> <b>c: 71 mm (2.80 in) dia.</b> <b>d: 65 mm (2.56 in) dia.</b></p>	X	X	—
KV38100500 (J25273) Gear carrier front oil seal drift	 <p>Installing front oil seal</p> <p><b>a: 85 mm (3.35 in) dia.</b> <b>b: 60 mm (2.36 in) dia.</b></p>	—	—	X
ST33720000 (J25817) Differential side retainer guide	 <p>Installing side retainer</p>	X	—	—
ST33270000 (J25809) Side oil seal drift	 <p>Installing side oil seal</p> <p><b>a: 62 mm (2.44 in) dia.</b> <b>b: 28 mm (1.10 in) dia.</b></p>	X	—	—
(J34309) Differential shim selector	 <p>Adjusting bearing pre-load and gear height</p>	X	X	X
(J25269-4) Side bearing discs (2 req'd)	 <p>Selecting pinion height adjusting washer</p>	X	—	X

# PREPARATION

## Special Service Tools (Cont'd)

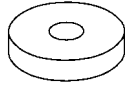
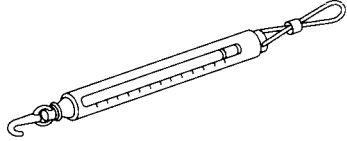
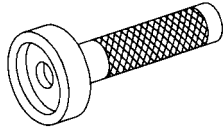
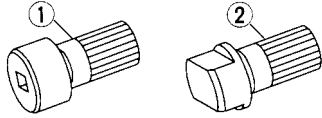
Tool number (Kent-Moore No.) Tool name	Description	Unit application			
		R180A	H190A	C200	
(J25269-18) Side bearing discs (2 req'd)	 NT135	Selecting pinion height adjusting washer	—	X	—
(J8129) Spring gauge	 NT127	Measuring carrier turning torque	X	X	X
(J35764) Gear carrier side oil seal drift	 NT120	Installing side oil seal	X	—	—
KV381051S0 ( — ) Rear axle shaft dummy ① KV38105110 ( — ) Torque wrench side ② KV38105120 ( — ) Vice side	 NT142	Checking differential torque on limited slip differential	—	X	X

NOISE, VIBRATION AND HARSHNESS (NVH) TROUBLESHOOTING

NVH Troubleshooting Chart

Use the chart below to help you find the cause of the symptom. If necessary, repair or replace these parts.

Symptom	PROPPELLER SHAFT	Noise								PROPELLER SHAFT		DIFFERENTIAL													
		Shake	Vibration	Uneven rotation torque	Center bearing improper installation	Excessive center bearing axial end play	Center bearing mounting (insulator) cracks, damage or deterioration	Excessive joint angle	Rotation imbalance	Excessive runout	Rough gear tooth	Improper gear contact	Tooth surfaces worn	Incorrect backlash	Companion flange excessive runout	Improper gear oil	PROPELLER SHAFT	DIFFERENTIAL	DRIVE SHAFT	AXLE AND SUSPENSION	TIRES	ROAD WHEEL	BRAKES	STEERING	
		X	X	X	X	X	X	X	X									X	X	X	X	X	X	X	X
			X			X												X	X	X	X	X	X	X	X
		X	X	X	X	X	X	X										X	X	X	X				X
	DIFFERENTIAL	Noise								X	X	X	X	X	X	X		X	X	X	X	X	X	X	X

X : Applicable

Reference page

Possible cause and SUSPECTED PARTS

- GI
- MA
- EM
- LC
- EG
- FE
- CL
- MT
- AT
- TF
- PD
- FA
- RA
- BR
- ST
- RS
- BT
- HA
- EL
- IDX

Front propeller shaft (Model 2F1310)

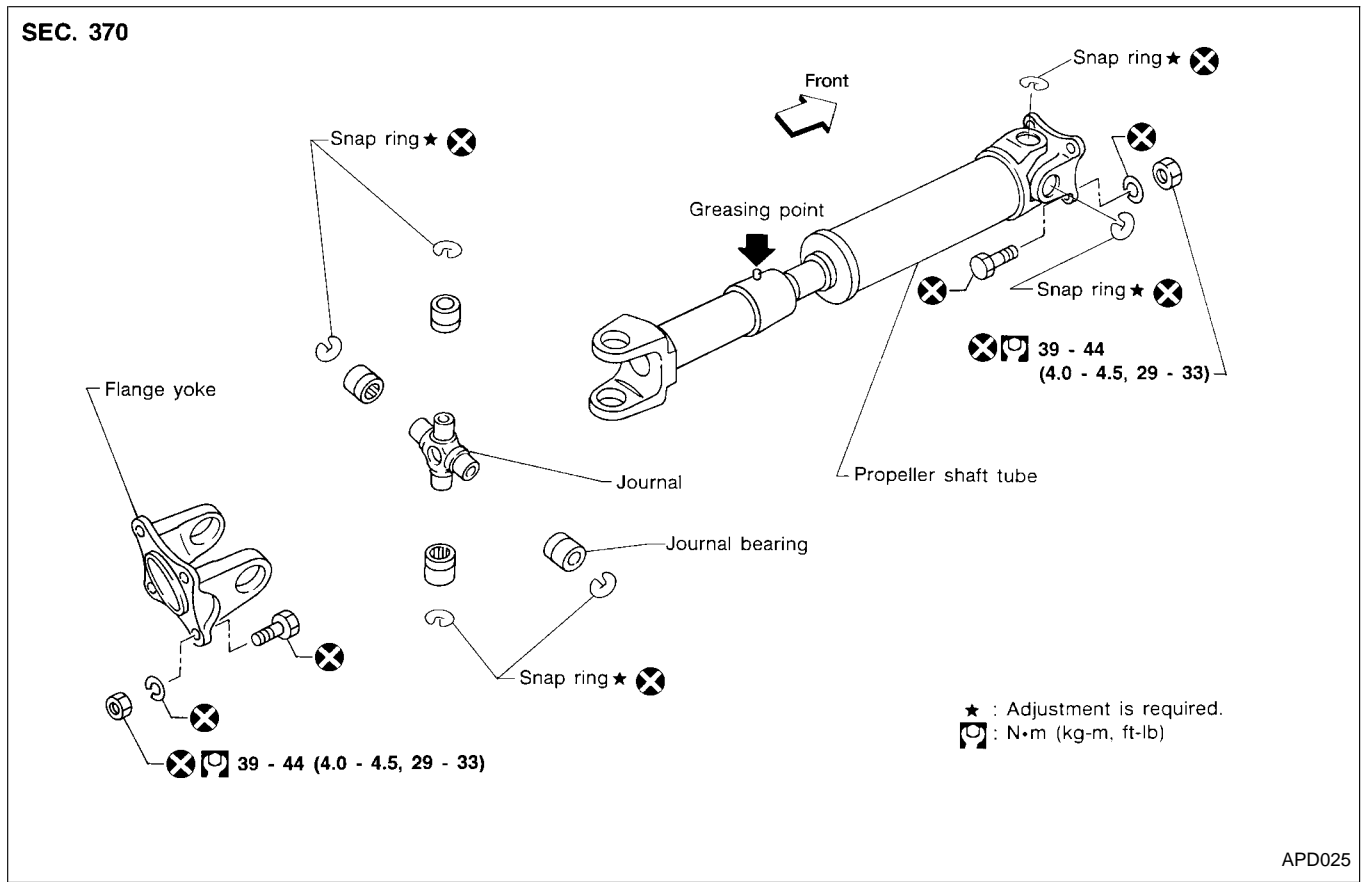

APD025

Rear propeller shaft (Model 2S1310)

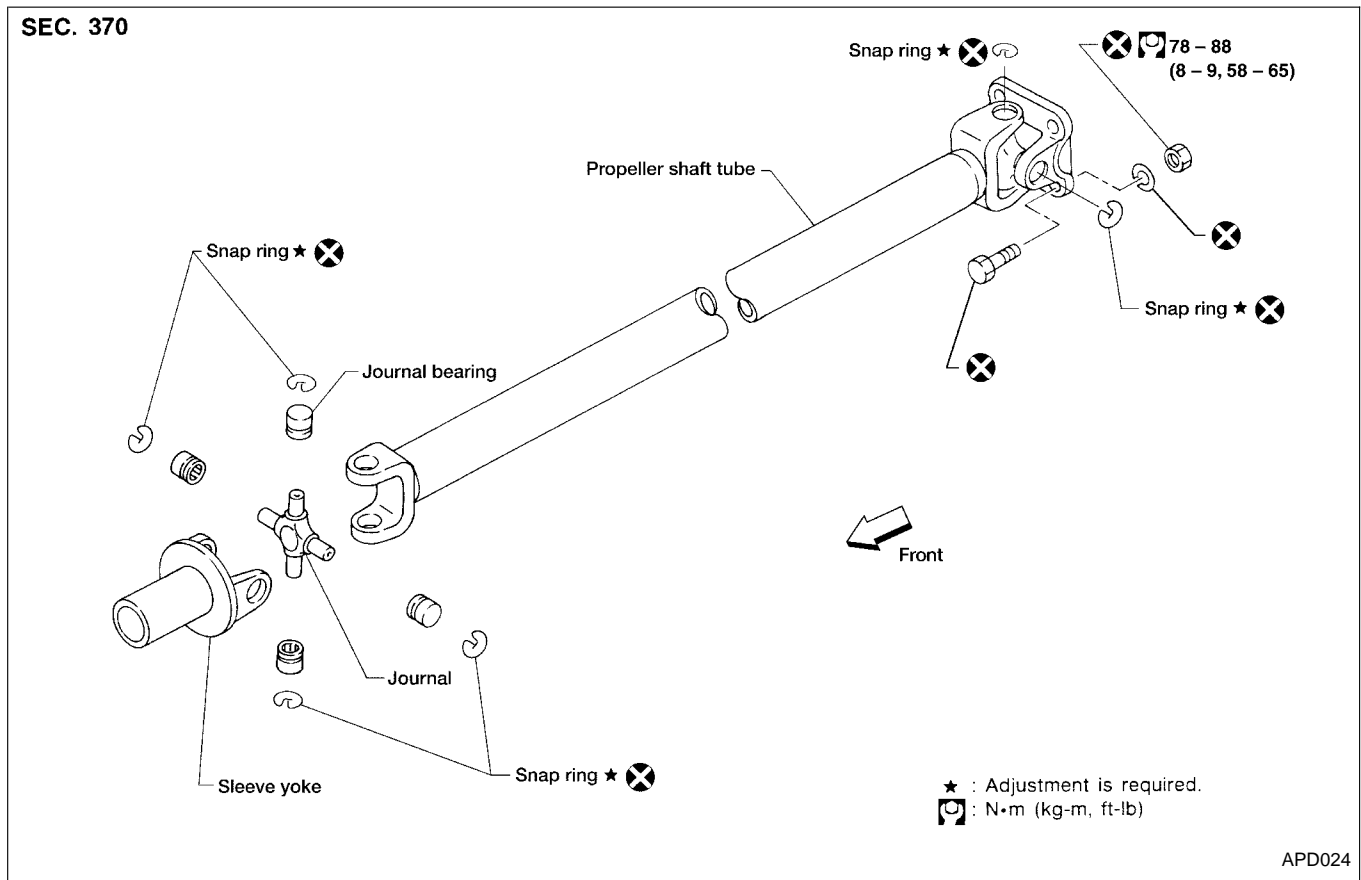

APD024



Rear propeller shaft (Model 3S1310)

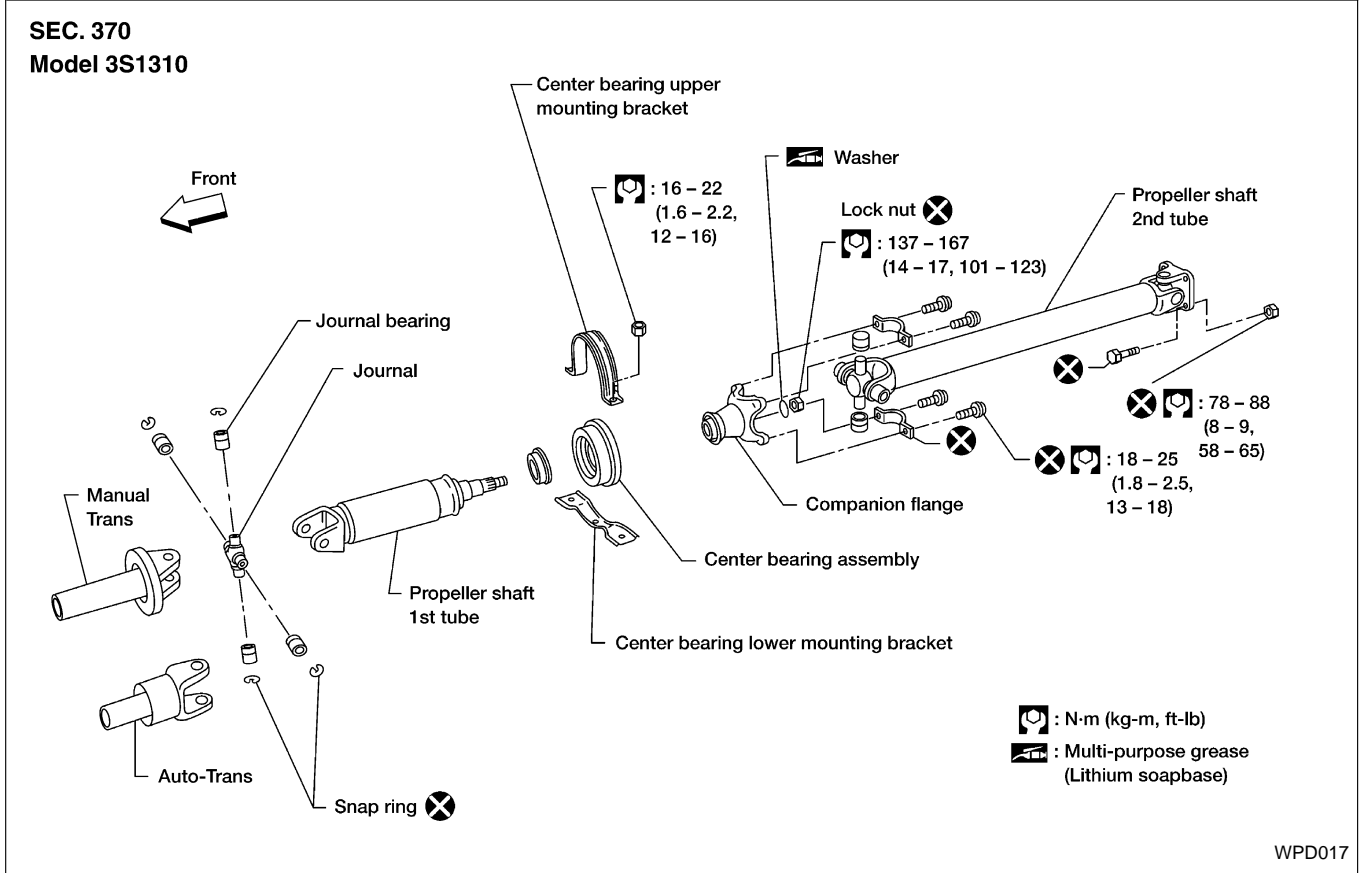

GI  
MA  
EM  
LC  
EC  
FE  
CL  
MT  
AT  
TF  
PD  
FA  
RA  
BR  
ST  
RS  
BT  
HA  
EL  
IDX

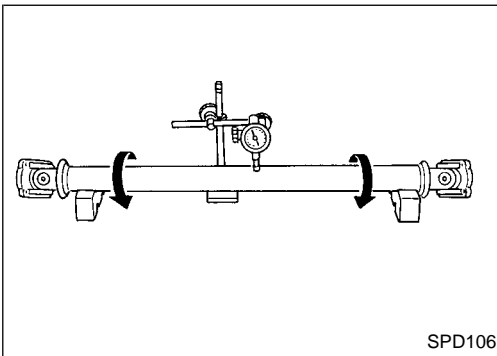
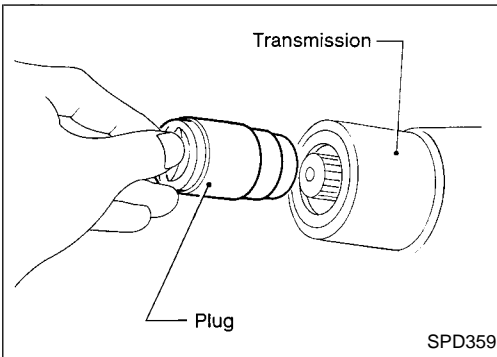
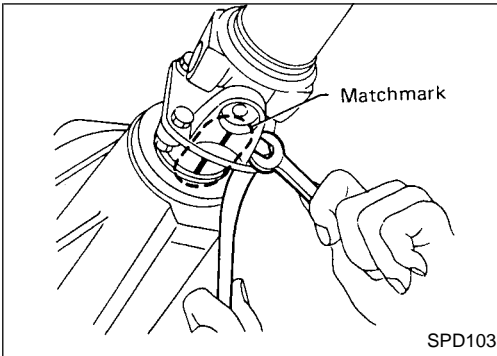
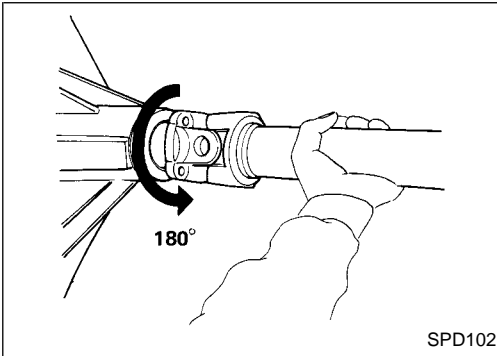
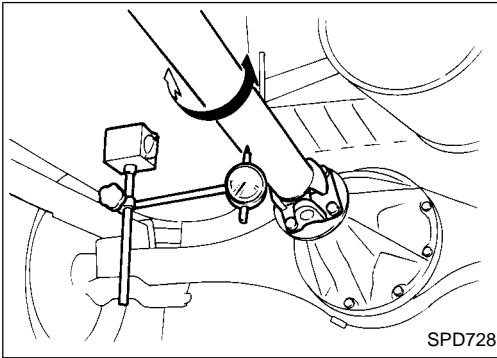

## On-vehicle Service

### PROPELLER SHAFT VIBRATION

If vibration is present at high speed, inspect propeller shaft runout first.

1. Raise rear end of vehicle until wheels are clear of the ground.
2. Measure propeller shaft runout at several points along propeller shaft by rotating final drive companion flange using hands.
3. If runout exceeds specifications, disconnect propeller shaft at final drive companion flange. Rotate companion flange 180 degrees, then reconnect propeller shaft.

**Runout limit: 0.6 mm (0.024 in)**

4. Check runout again. If runout still exceeds the limit, replace propeller shaft assembly.
5. Perform road test.

### APPEARANCE CHECKING

- Inspect propeller shaft tube surface for dents or cracks and replace as necessary.
- Check center bearing for noise or damage and replace as necessary.

## Removal and Installation

1. Place matching marks on flanges, then separate propeller shaft from final drive.

2. Remove propeller shaft.

- **Insert plug into rear oil seal after removing rear propeller shaft.**

## Inspection

- Inspect propeller shaft runout. If runout exceeds the limit, replace propeller shaft assembly.

**Runout limit: 0.6 mm (0.024 in)**

**Inspection (Cont'd)**

- Inspect journal axial play.  
If play exceeds the limit, replace propeller shaft assembly.  
**Journal axial play:**  
**0.02 mm (0.0008 in) or less**

GI  
MA  
EM  
LC  
EC  
FE  
CL  
MT  
AT  
TF  
PD  
FA  
RA  
BR  
ST  
RS  
BT  
HA  
EL  
IDX

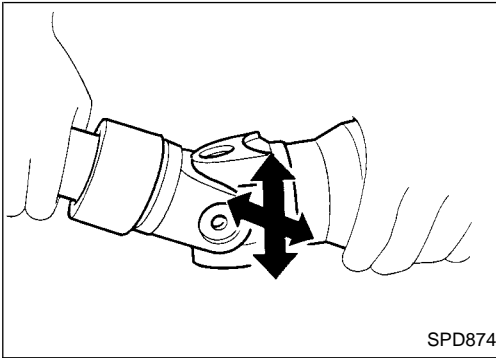

**Disassembly**

**CENTER BEARING**

1. Place matching marks on flanges, then separate 2nd tube from 1st tube.
2. Place matching marks on the flange and shaft.

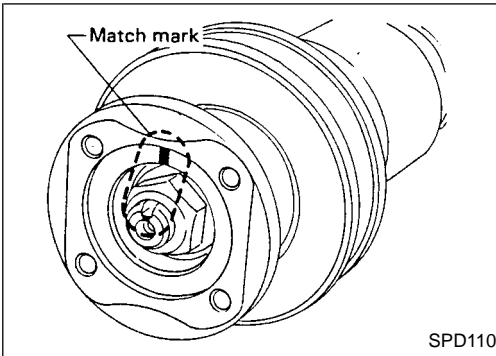
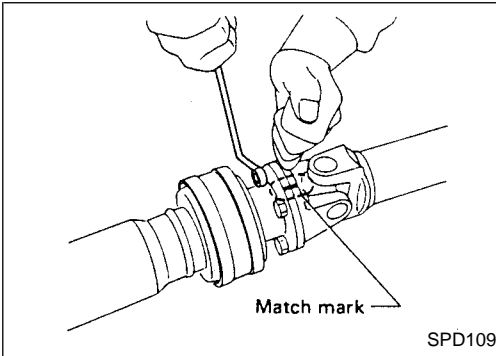

3. Remove locking nut using Tool.  
**Tool number:**  
**ST38060002 (J34311)**
4. Remove companion flange using puller.

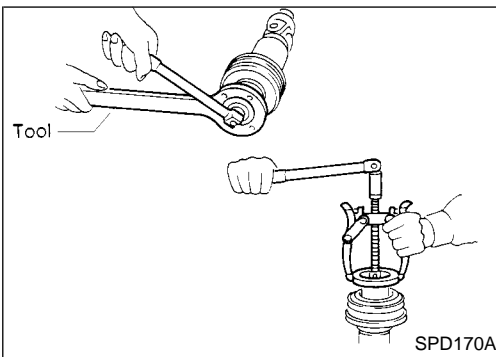

5. Remove center bearing using Tool and press.  
**Tool number: ST30031000 (J22912-01)**

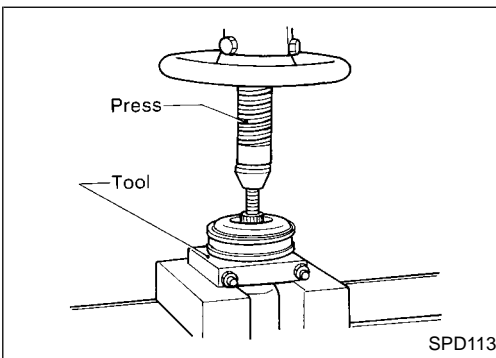

**Disassembly (Cont'd)**

**JOURNAL**

**NOTE:**

1. Place matching marks on propeller shaft and flange or yoke.

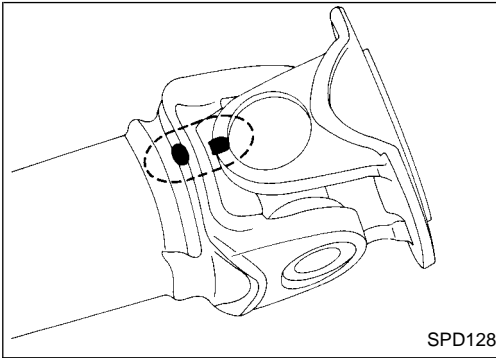

2. Remove snap ring.

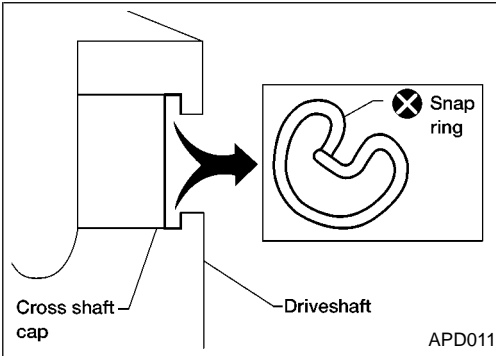

3. Remove pushed out journal bearing by lightly tapping yoke with a hammer, taking care not to damage journal and yoke hole.

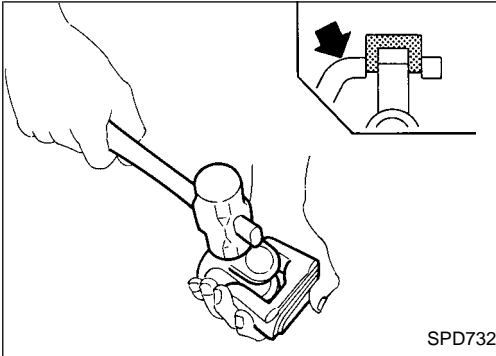

4. Remove bearing at opposite side in above operation. **Put marks on disassembled parts so that they can be reinstalled in their original positions.**

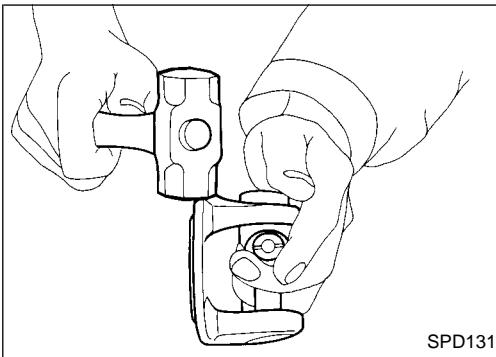

**Assembly**

**CENTER BEARING**

- When installing center bearing, position the "F" mark on center bearing toward front of vehicle.
- **Apply a coat of multi-purpose lithium grease containing molybdenum disulfide to the end face of the center bearing and both sides of the washer.**

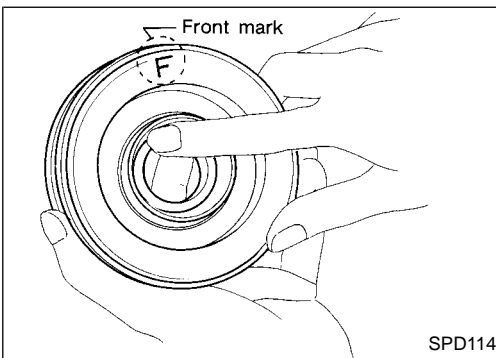

**Assembly (Cont'd)**

GI  
MA  
EM  
LC  
EC  
FE  
CL  
MT  
AT  
TF  
PD  
FA  
RA  
BR  
ST  
RS  
BT  
HA  
EL  
IDX

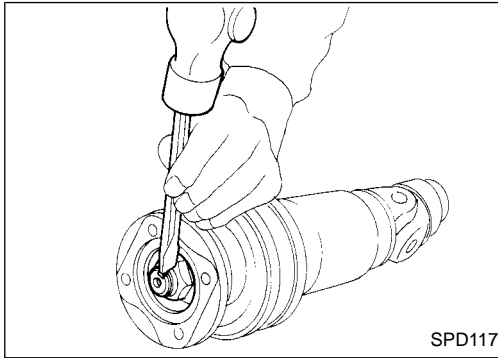

- Stake the nut. Always use new one.
- Align match marks when assembling tubes.

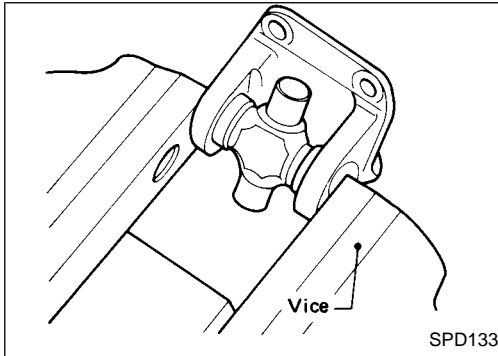

**JOURNAL**

1. Assemble journal bearing. Apply recommended multi-purpose grease on bearing inner surface.

**When assembling, be careful that needle bearing does not fall down.**

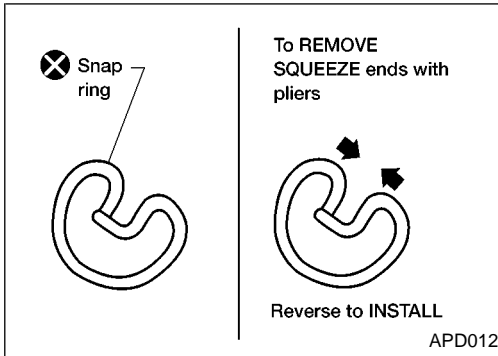

2. Select snap ring that will provide specified play in axial direction of journal, and install them. Refer to SDS, PD-70.

**Select snap rings with a difference in thickness at both sides within 0.06 mm (0.0024 in).**

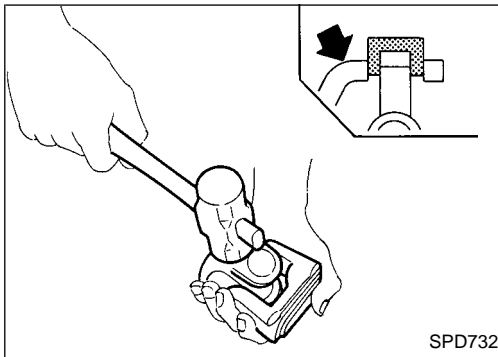

3. Adjust thrust clearance between bearing and snap ring to zero by tapping yoke.

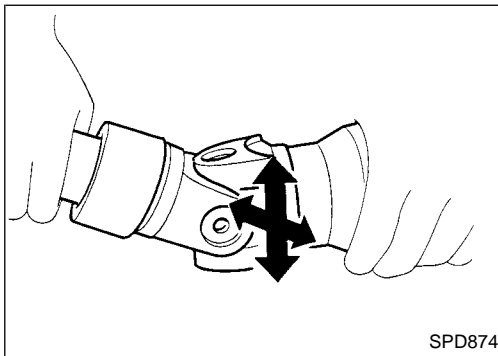

4. Check to see that journal moves smoothly and check for axial play.  
**Axial play: 0.02 mm (0.0008 in) or less**

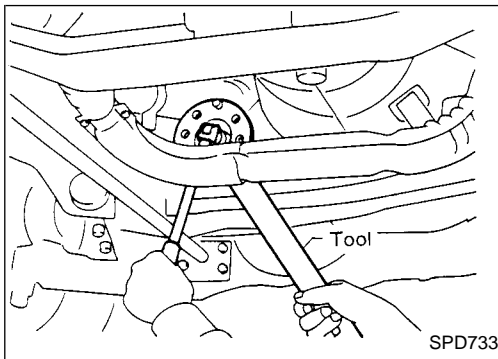

### Front Oil Seal Replacement (Front final drive: Model R180A)

1. Remove front propeller shaft.
2. Loosen drive pinion nut.  
**Tool number: ST38060002 (J34311)**

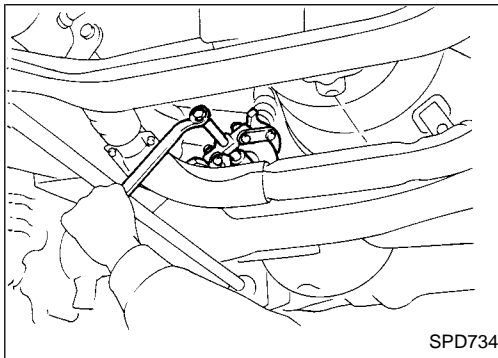

3. Remove companion flange using puller.

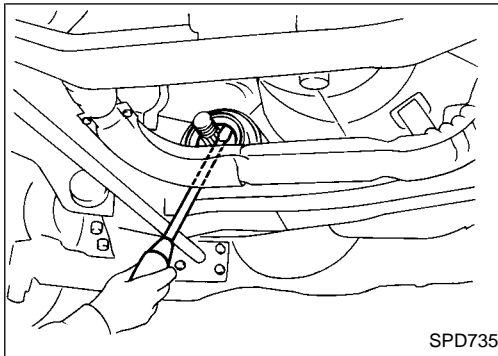

4. Remove front oil seal.

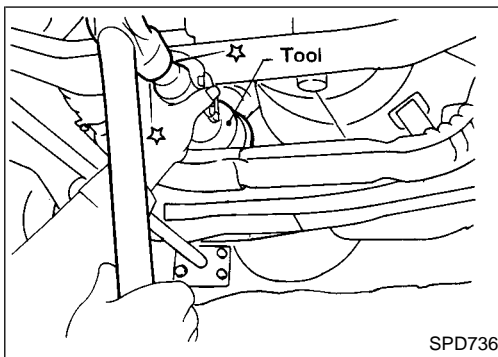

5. Apply multi-purpose grease to cavity at sealing lips of oil seal. Press front oil seal into carrier.

**Tool number:**  
**ST30720000 (J25405)**

6. Install companion flange and drive pinion nut.
7. Install propeller shaft.

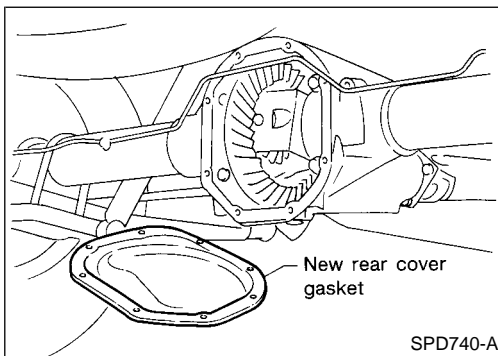

### Rear Cover Gasket Replacement (Rear final drive: Model C200)

1. Drain gear oil.
2. Remove rear cover and rear cover gasket.
3. Install new rear cover gasket and rear cover.
4. Fill final drive with recommended gear oil.

GI

MA

EM

LC

EC

FE

CL

MT

AT

TF

PD

FA

RA

BR

ST

RS

BT

HA

EL

IDX

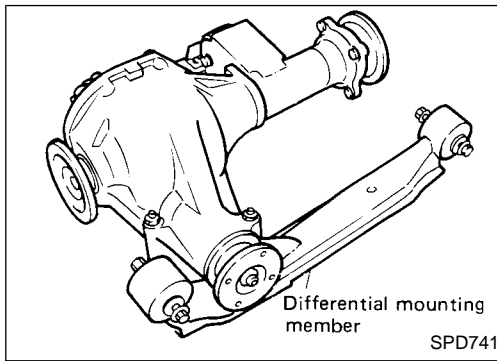

### Removal

1. Remove front propeller shaft.
2. Separate drive shaft from front final drive. Refer to FA section ["Drive Shaft", "FRONT AXLE (4WD)"].
3. Remove engine mounting bolts and raise up engine.
4. Remove front final drive together with differential mounting member.

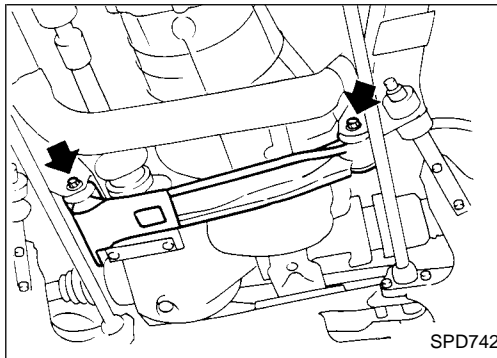

### Installation

1. Install front final drive assembly together with differential mounting member.

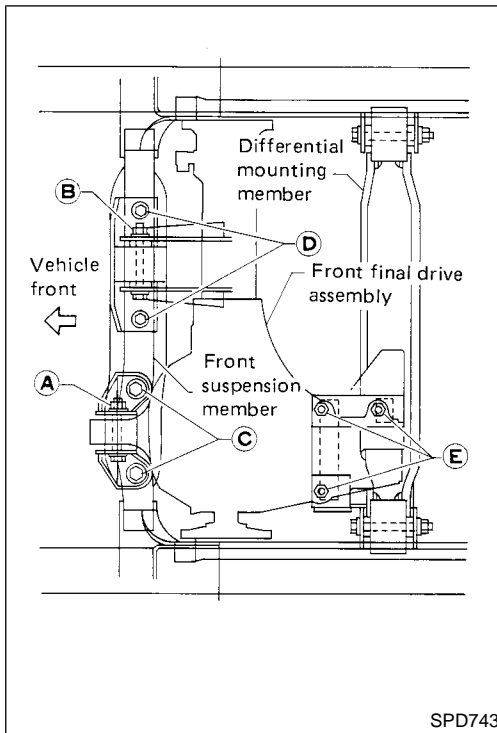

2. Tighten front final drive securing bolts and nuts by following the procedure to prevent drive train vibration.
  - a. Temporarily tighten nut (A).
  - b. Temporarily tighten nut (B).
  - c. Tighten bolt (C) to the torque of 68 to 87 N·m (6.9 to 8.9 kg-m, 50 to 64 ft-lb).
  - d. Tighten bolt (D) to the torque of 68 to 87 N·m (6.9 to 8.9 kg-m, 50 to 64 ft-lb).
  - e. Tighten nut (A) to the torque of 68 to 87 N·m (6.9 to 8.9 kg-m, 50 to 64 ft-lb).
  - f. Tighten nut (B) to the torque of 68 to 87 N·m (6.9 to 8.9 kg-m, 50 to 64 ft-lb).
  - g. Tighten nut (E) to the torque of 68 to 87 N·m (6.9 to 8.9 kg-m, 50 to 64 ft-lb).
3. Install drive shaft. Refer to FA section ["Drive Shaft", "FRONT AXLE (4WD)"].
4. Install front propeller shaft.

## Removal

- Remove propeller shaft.

### Plug front end of transfer.

- Remove axle shaft.  
Refer to RA section ("REAR AXLE").

### CAUTION:

- Be careful not to damage spline, sleeve yoke and front oil seal when removing propeller shaft.
- Before removing the final drive assembly or rear axle assembly, disconnect the ABS sensor harness connector from the assembly and move it away from the final drive/rear axle assembly area. Failure to do so may result in the sensor wires being damaged and the sensor becoming inoperative.

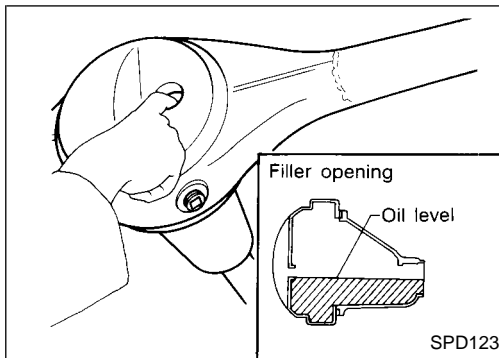

## Installation

- Fill final drive with recommended gear oil.



SEC. 381

- ☆ : Adjustment is required.
- ★ : Using locking agent [Locktite (stud lock) or equivalent]
- [N·m (kg-m, ft-lb)] : N·m (kg-m, ft-lb)
- [N·m (kg-m, in-lb)] : N·m (kg-m, in-lb)
- [Apply recommended sealant (Nissan genuine part: KP610-00250) or equivalent.]

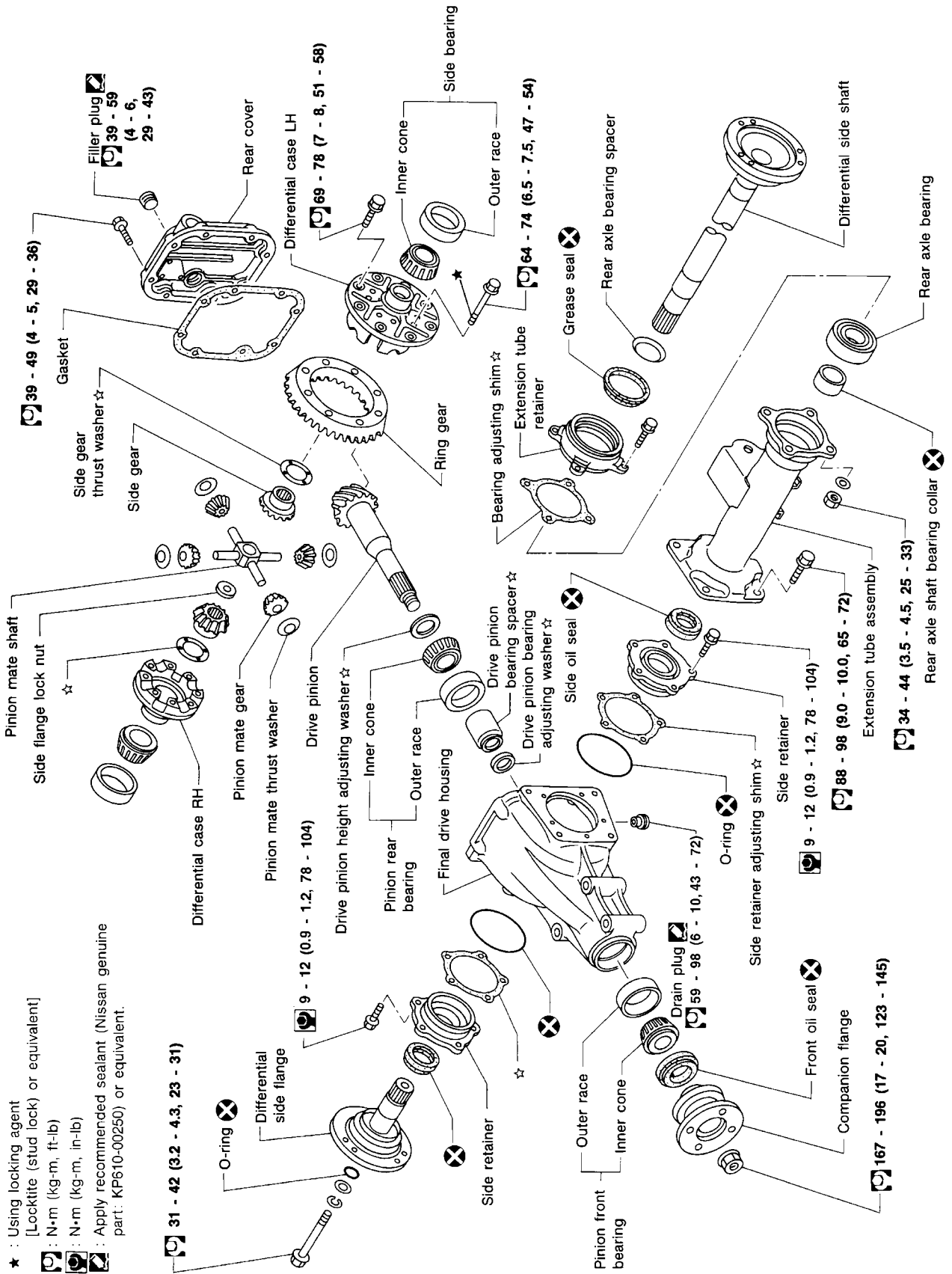

GI  
MA  
EM  
LC  
EC  
FE  
CL  
MT  
AT  
TF  
PD  
FA  
RA  
BR  
ST  
RS  
BT  
HA  
EL  
IDX

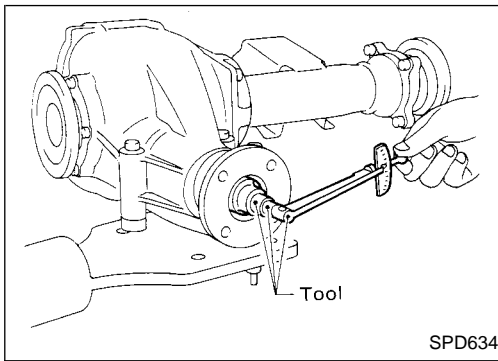

## Pre-inspection

Before disassembling final drive, perform the following inspection.

- Total preload
  - a. Turn drive pinion in both directions several times to set bearing rollers.
  - b. Check total preload with Tool.

**Tool number: ST3127S000 (J25765-A)**

**Total preload:**

**1.2 - 2.3 N·m**

**(12 - 23 kg-cm, 10 - 20 in-lb)**

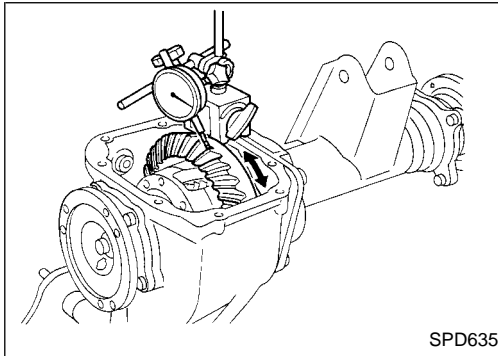

- Ring gear-to-drive pinion backlash  
Check backlash of ring gear with a dial indicator at several points.

**Ring gear-to-drive pinion backlash:**

**0.13 - 0.18 mm (0.0051 - 0.0071 in)**

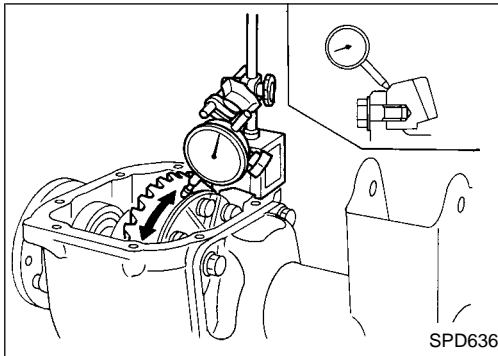

- Ring gear runout  
Check runout of ring gear with a dial indicator.

**Runout limit:**

**0.05 mm (0.0020 in)**

- Tooth contact  
Check tooth contact. Refer to "ADJUSTMENT", PD-29.

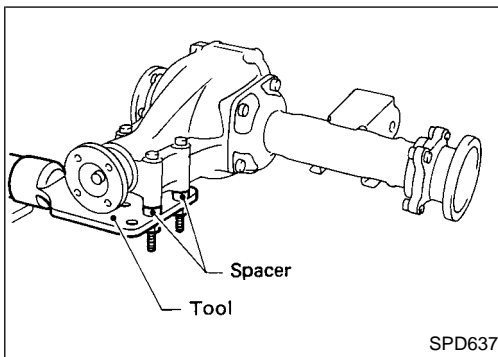

## Final Drive Housing

1. Using three spacers [20 mm (0.79 in)], mount final drive assembly on Tool.

**Tool number:**

**KV38100800 (J34310), (J25604-01)**

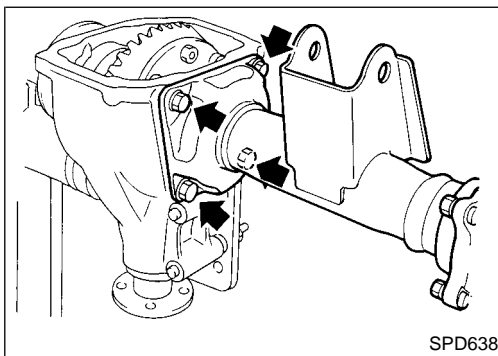

2. Remove extension tube and differential side shaft assembly.

## Final Drive Housing (Cont'd)

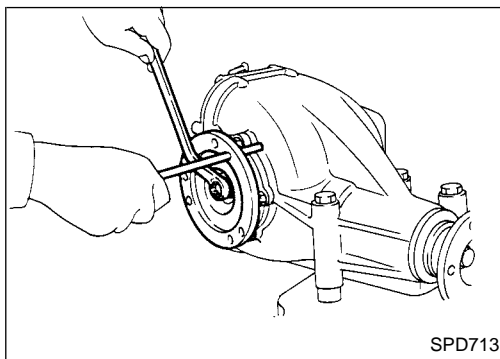

3. Remove differential side flange.

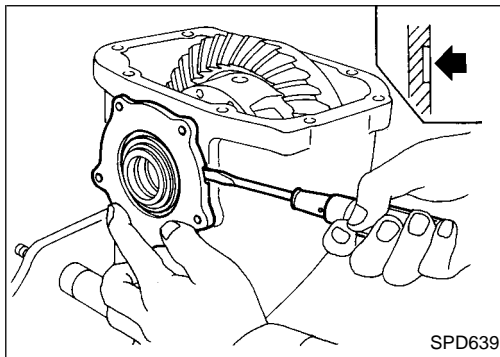

4. Mark side retainers for identification. Remove side retainers. **Be careful not to confuse right and left side retainers and shims.**

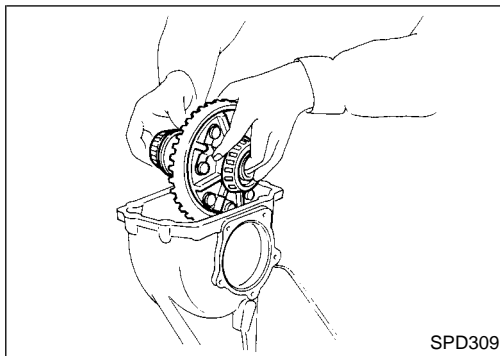

5. Extract differential case from final drive housing.

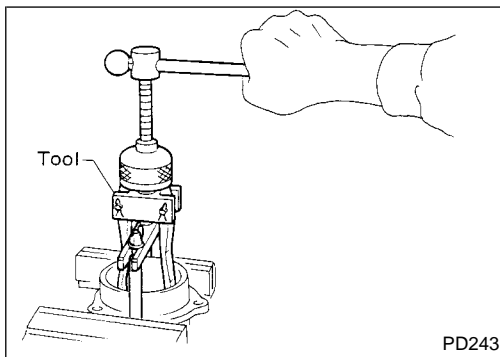

6. Remove side outer races.

**Tool number: ST33290001 (J25810-A)**

**Keep the side bearing outer races together with their respective inner cones — do not mix them up.**

7. Remove side oil seal.

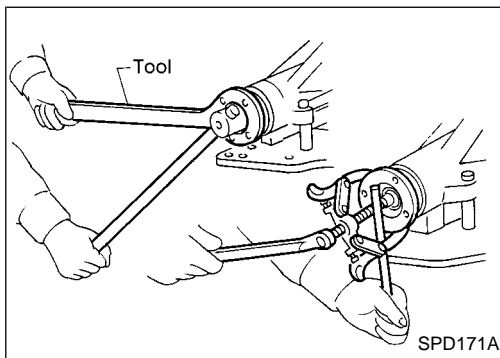

8. Loosen drive pinion nut.

**Tool number: ST38060002 (J34311)**

9. Remove companion flange with puller.

GI

MA

EM

LC

EC

FE

CL

MT

AT

TF

PD

FA

RA

BR

ST

RS

BT

HA

EL

IDX

**Final Drive Housing (Cont'd)**

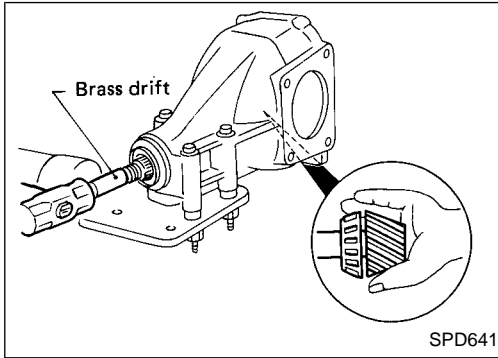

10. Take out drive pinion together with pinion rear bearing inner cone, drive pinion bearing spacer and pinion bearing adjusting washer.

11. Remove front oil seal and pinion front bearing inner cone.

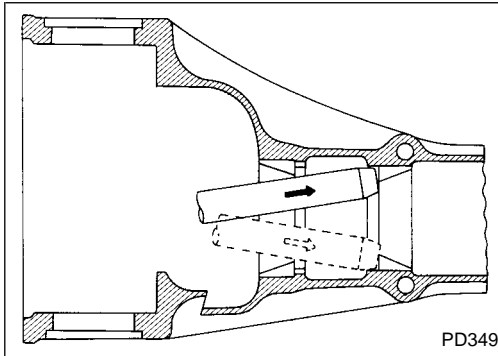

12. Remove pinion front and rear bearing outer races with brass drift.

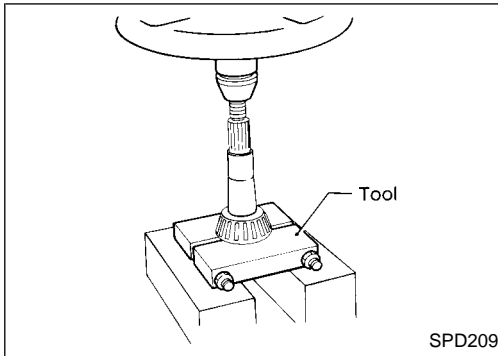

13. Remove pinion rear bearing inner cone and drive pinion adjusting washer.

**Tool number: ST30031000 (J22912-01)**

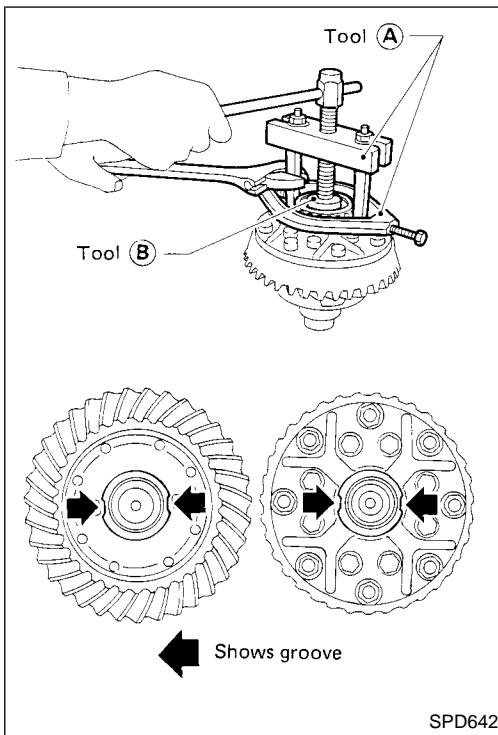

**Differential Case**

1. Remove side bearing inner cones.

**To prevent damage to bearing, engage puller jaws in grooves.**

**Tool numbers:**

(A) ST33051001 (J22888-20)

(B) ST33061000 (J8107-2)

## Differential Case (Cont'd)

Be careful not to confuse the right and left hand parts.

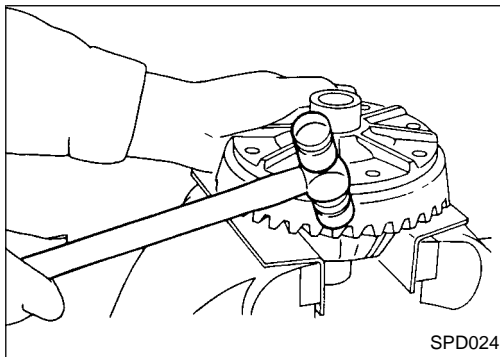
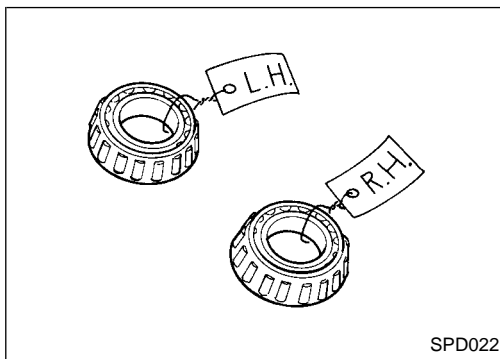

2. Loosen ring gear bolts in a criss-cross fashion.
3. Tap ring gear off differential case with a soft hammer.  
**Tap evenly all around to keep ring gear from binding.**

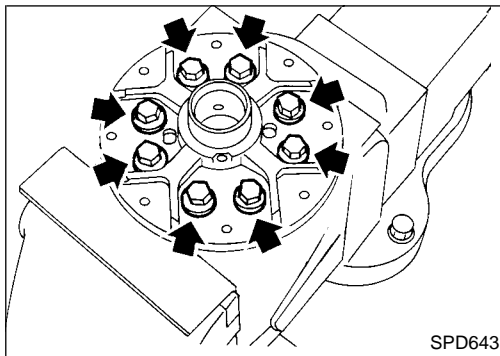

4. Separate differential case LH and RH.  
**Put match marks on both differential case LH and RH sides prior to separating them.**

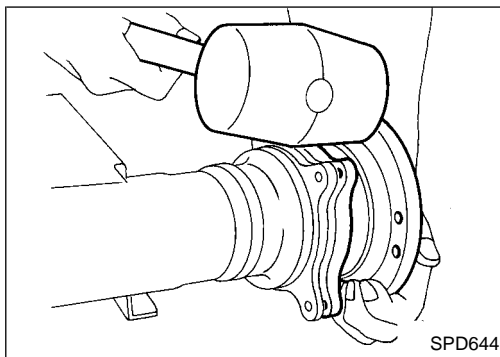

## Extension Tube and Differential Side Shaft

1. Remove differential side shaft assembly from extension tube.

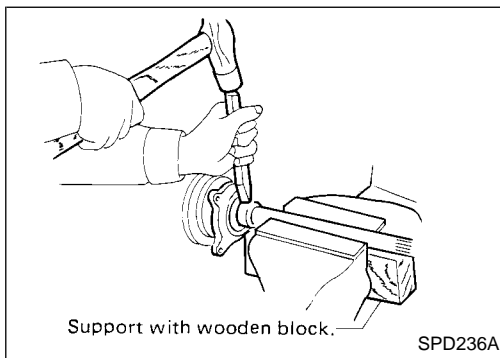

2. Cut rear axle bearing collar with cold chisel. Be careful not to damage differential side shaft.

GI

MA

EM

LC

EC

FE

CL

MT

AT

TF

PD

FA

RA

BR

ST

RS

BT

HA

EL

IDX

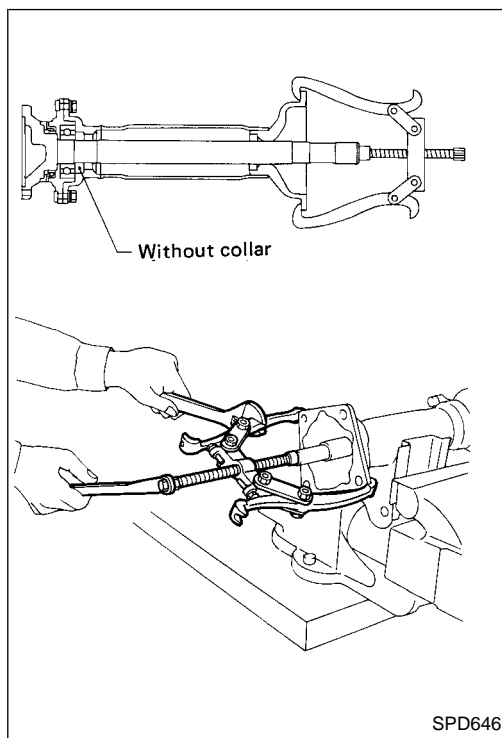
**Extension Tube and Differential Side Shaft  
(Cont'd)**

3. Reinstall differential side shaft into extension tube and secure with bolts. Remove rear axle bearing by drawing out differential side shaft from rear axle bearing with puller.

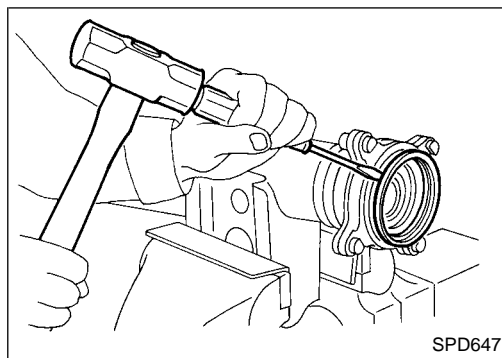

4. Remove grease seal.

## Ring Gear and Drive Pinion

Check gear teeth for scoring, cracking or chipping.  
If any damaged part is evident, replace ring gear and drive pinion as a set (hypoid gear set).

GI

MA

EM

LC

EC

FE

CL

MT

AT

TF

**PD**

FA

RA

BR

ST

RS

BT

HA

EL

IDX

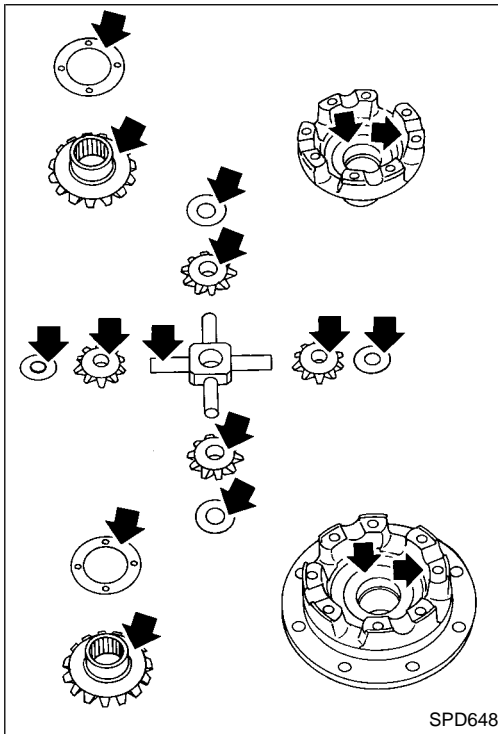

## Differential Case Assembly

Check mating surfaces of differential case, side gears, pinion mate gears, pinion mate shaft and thrust washers.

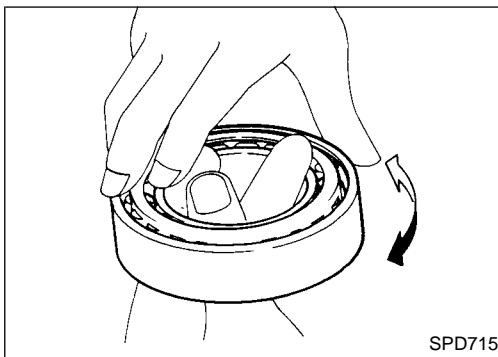

## Bearing

1. Thoroughly clean bearing.
2. Check bearing for wear, scratches, pitting or flaking. Check tapered roller bearing for smooth rotation. If damaged, replace outer race and inner cone as a set.

For quiet and reliable final drive operation, the following five adjustments must be made correctly:

1. Side bearing preload
2. Pinion gear height
3. Pinion bearing preload
4. Ring gear-to-pinion backlash. Refer to "ASSEMBLY", PD-33.
5. Ring and pinion gear tooth contact pattern.

### Side Bearing Preload

**A selection of carrier side retainer adjusting shims is required for successful completion of this procedure.**

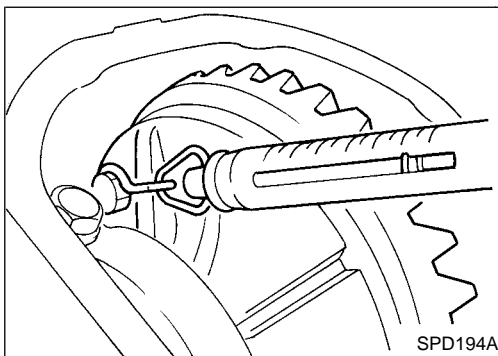
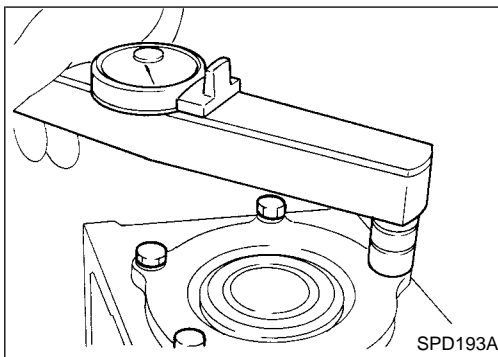
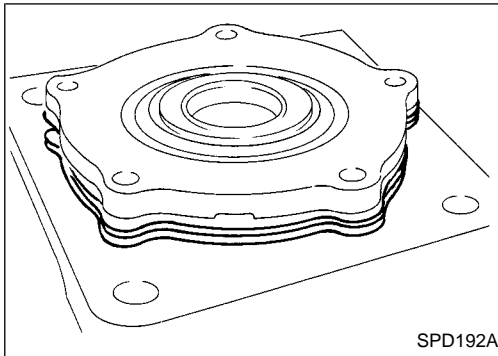
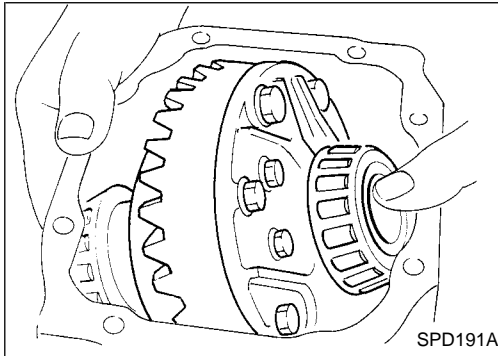

1. Make sure all parts are clean. Also make sure the bearings are well lubricated with light oil or type "DEXRON™" automatic transmission fluid.
2. Install differential carrier and side bearing assembly into the final drive housing.
3. Place all of the original side retainer adjusting shims onto the side bearing retainer that goes at the ring gear end of the carrier.
4. Install both bearing retainers onto the final drive housing and torque the retainer bolts.  
**Bolt torque specification:**  
: 9 - 12 N·m (0.9 - 1.2 kg·m, 78 - 104 in-lb)
5. Turn the carrier several times to seat the bearings.
6. Measure the carrier turning torque with a spring gauge, J8129, at the ring gear retainer bolt.  
**Turning torque specification:**  
 34.3 - 39.2 N (3.5 - 4.0 kg, 7.7 - 8.8 lb)  
 of pulling force at the ring gear bolt



Side Bearing Preload (Cont'd)

7. If the turning torque measured is incorrect, establish the correct bearing preload by adding to or subtracting from the total amount of shim thickness.
  - Increase shim thickness to decrease turning torque on the carrier.
  - Decrease shim thickness to increase turning torque on the carrier.

GI  
MA  
EM  
LC  
EC  
FE  
CL  
MT  
AT  
TF  
PD  
FA  
RA  
BR  
ST  
RS  
BT  
HA  
EL  
IDX

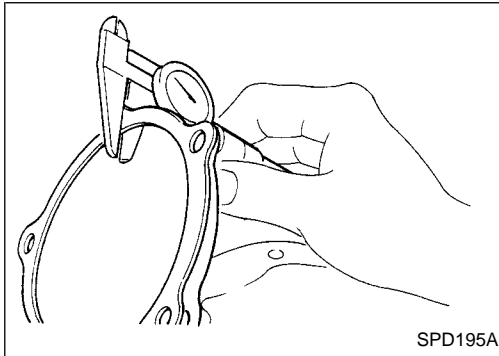

8. Record the correct, selected total thickness of the side retainer adjusting shims, and remove the carrier and bearings from the final drive housing. Save all shims for later re-use.

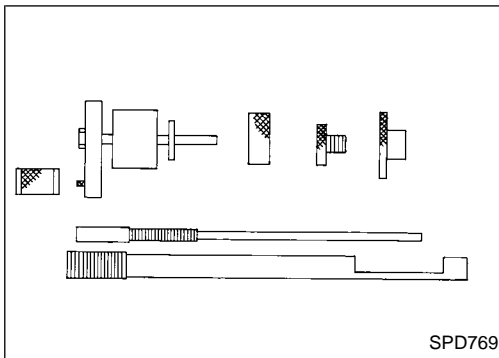

Pinion Gear Height and Pinion Bearing Preload

1. Make sure all parts are clean and that the bearings are well lubricated.
2. Assemble the pinion gear bearings into the pinion pre-load shim selector tool, J34309.
  - **Front Pinion Bearing** — make sure the J34309-3 front pinion bearing seat is secured tightly against the J34309-2 gauge anvil. Then turn the front pinion bearing pilot, J34309-7, to secure the bearing in its proper position.

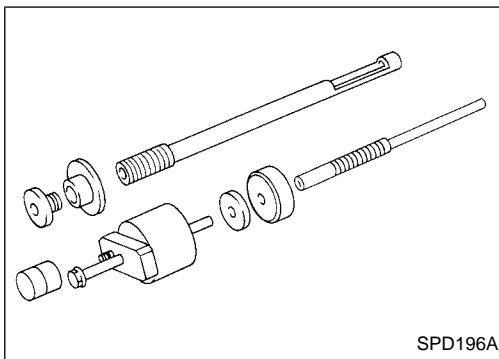

- **Rear Pinion Bearing** — the rear pinion bearing pilot, J34309-8, is used to center the rear pinion bearing only. The rear pinion bearing locking seat, J34309-4, is used to lock the bearing to the assembly.

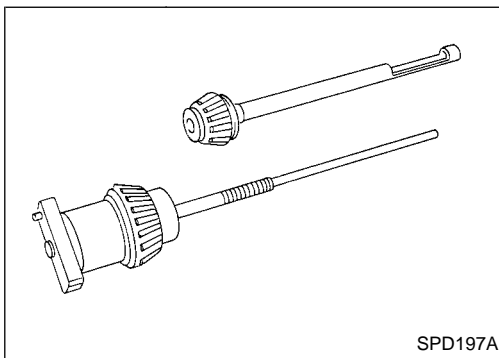

## Pinion Gear Height and Pinion Bearing Preload (Cont'd)

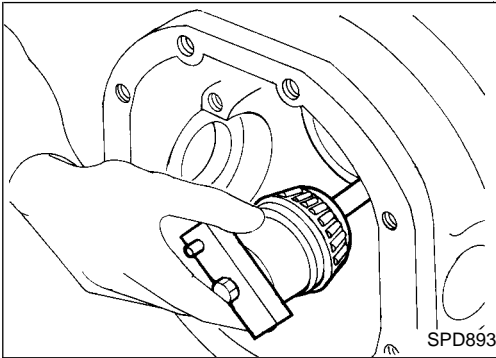

SPD893

- Place the pinion preload shim selector tool gauge screw, J34309-1, with the pinion rear bearing inner cone installed, into the final drive housing.

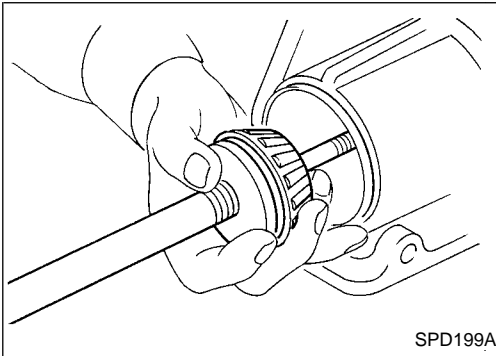

SPD199A

- Install the J34309-2 gauge anvil with the front pinion bearing into the final drive housing and assemble it to the J34309-1 gauge screw. Make sure that the J34309-16 gauge plate will turn a full 360 degrees, and tighten the two sections by hand.

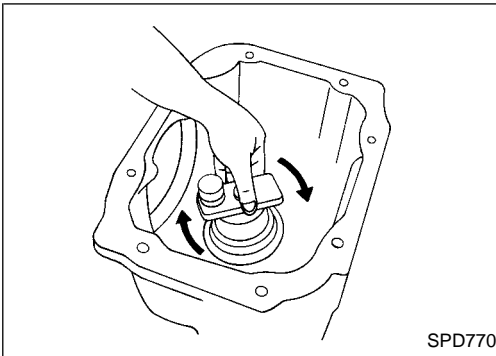

SPD770

- Turn the assembly several times to seat the bearings.

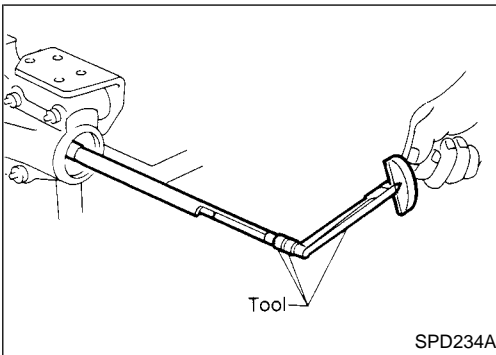

SPD234A

- Measure the turning torque at the end of the J34309-2 shaft using Tool.

**Tool number: ST3127S000 (J25765-A)**

**Turning torque specification:**

**0.6 - 1.0 N·m (6 - 10 kg-cm, 5.2 - 8.7 in-lb)**

- Place the J34309-10 "R180A" pinion height adapter onto the gauge plate and tighten it by hand.

**CAUTION:**

**Make sure all machined surfaces are clean.**

### PINION BEARING PRELOAD WASHER SELECTION

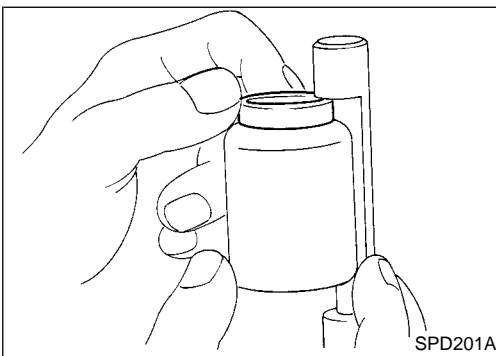

SPD201A

- Place the solid pinion bearing adjusting spacer squarely into the recessed portion of the J34309-2 gauge anvil.

## Pinion Gear Height and Pinion Bearing Preload (Cont'd)

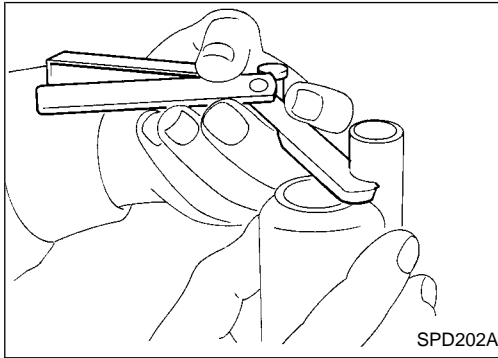

9. Select the correct thickness of pinion bearing preload adjusting washer using a standard gauge of 6 mm (0.24 in) and J34309-101 feeler gauge. The exact total measure you get with the gauges is the thickness of the adjusting washer required. Select the correct washer.

**Drive pinion bearing adjusting washer:  
Refer to SDS, PD-72.**

10. Set the selected pinion bearing preload adjusting washer aside for use when assembling the pinion and bearings into the final drive housing.

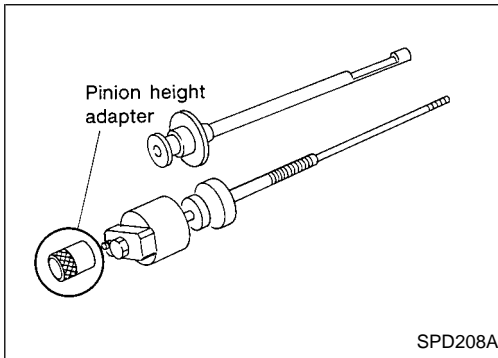

### PINION HEIGHT ADJUSTING WASHER SELECTION

11. Place the J34309-10 pinion height adapter onto the gauge plate and tighten by hand.

**CAUTION:**

**Make sure all machined surfaces are clean.**

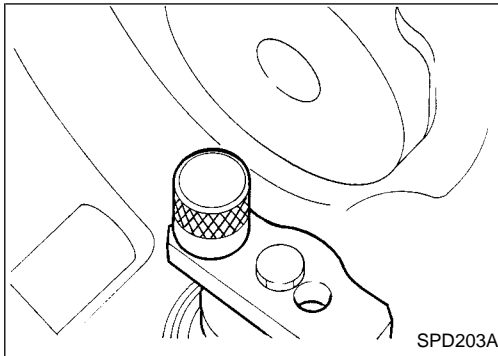

12. Position firmly the side bearing discs, J25269-4, and arbor into the side bearing bores.

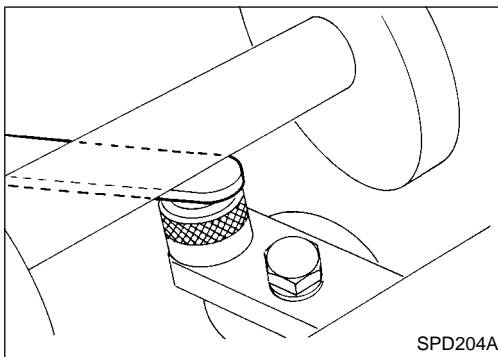

13. Select the correct standard pinion height adjusting washer thickness using a standard gauge of 3 mm (0.12 in) and J34309-101 feeler gauge. Measure the distance between the J34309-10 "R180A" pinion height adapter and the arbor.

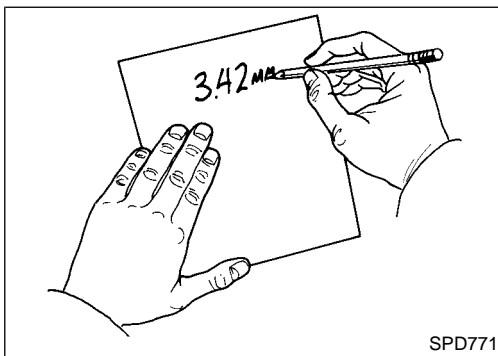

14. Write down your exact total measurement.

**Pinion Gear Height and Pinion Bearing Preload (Cont'd)**

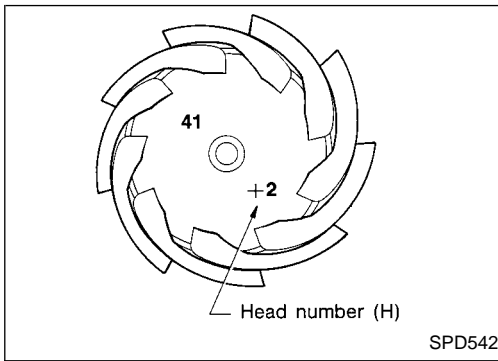

15. Correct the pinion height washer size by referring to the “pinion head number”.

There are two numbers painted on the pinion gear. The first one refers to the pinion and ring gear as a matched set and should be the same as the number on the ring gear. The second number is the “pinion head height number”, and it refers to the ideal pinion height from standard for quietest operation. Use the following chart to determine the correct pinion height washer.

Pinion Head Height Number	Add or Remove from the Standard Pinion Height Washer Thickness Measurement
-6	Add 0.06 mm (0.0024 in)
-5	Add 0.05 mm (0.0020 in)
-4	Add 0.04 mm (0.0016 in)
-3	Add 0.03 mm (0.0012 in)
-2	Add 0.02 mm (0.0008 in)
-1	Add 0.01 mm (0.0004 in)
0	Use the selected washer thickness
+1	Subtract 0.01 mm (0.0004 in)
+2	Subtract 0.02 mm (0.0008 in)
+3	Subtract 0.03 mm (0.0012 in)
+4	Subtract 0.04 mm (0.0016 in)
+5	Subtract 0.05 mm (0.0020 in)
+6	Subtract 0.06 mm (0.0024 in)

16. Select the correct pinion height washer.

**Drive pinion height adjusting washer:  
Refer to SDS, PD-72.**

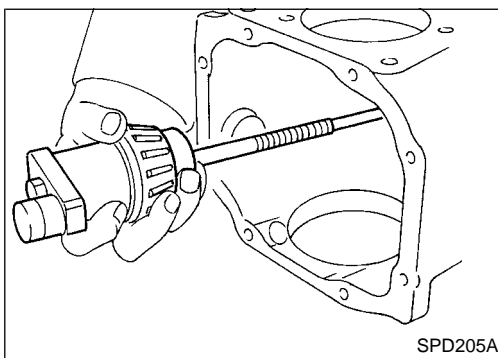

17. Remove the J34309 pinion preload shim selector tool from the final drive housing and disassemble to retrieve the pinion bearings.

**Tooth Contact**

Gear tooth contact pattern check is necessary to verify correct relationship between ring gear and drive pinion.

Hypoid gear sets which are not positioned properly may be noisy, or have short life, or both. With a pattern check, the most desirable contact for low noise level and long life can be assured.

GI  
MA  
EM  
LC  
EC  
FE  
CL  
MT  
AT  
TF  
PD  
FA  
RA  
BR  
ST  
RS  
BT  
HA  
EL  
IDX

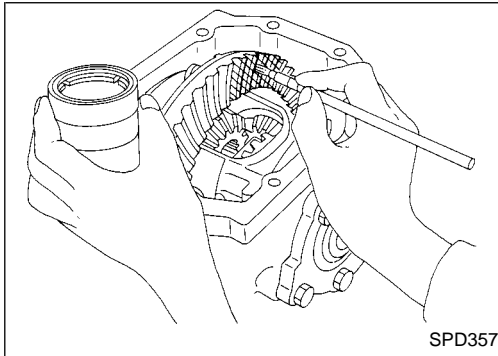

1. Thoroughly clean ring gear and drive pinion teeth.
2. Sparingly apply a mixture of powdered ferric oxide and oil or equivalent to 3 or 4 teeth of ring gear drive side.

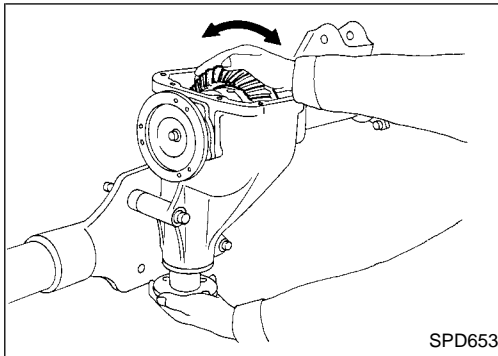

3. Hold companion flange steady and rotate the ring gear in both directions.

Usually the pattern will be correct if shims are correctly calculated and the backlash is correct. However, in rare cases, trial and error processes may be employed to obtain a correct pattern. The tooth pattern is the best indication of how well a differential has been set up.

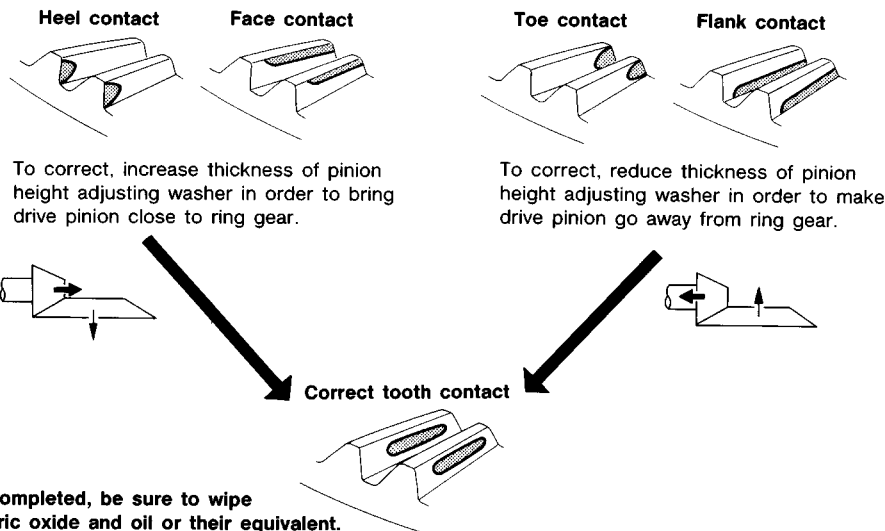

When adjustment is completed, be sure to wipe off completely the ferric oxide and oil or their equivalent.

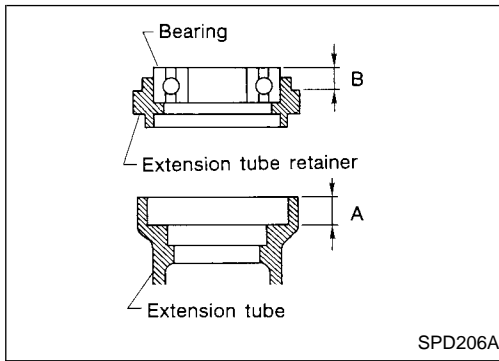

### Extension Tube and Differential Side Shaft

1. Measure rear axle bearing end play.  
**Rear axle bearing end play (A - B):**  
**0.1 mm (0.0039 in) or less**  
 The end play can be adjusted with bearing adjusting shim.  
**Available bearing adjusting shims:**  
**Refer to SDS, PD-72.**

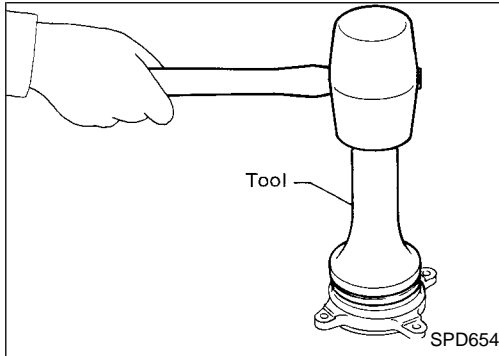

2. Install grease seal.  
**Tool number: (J35764)**

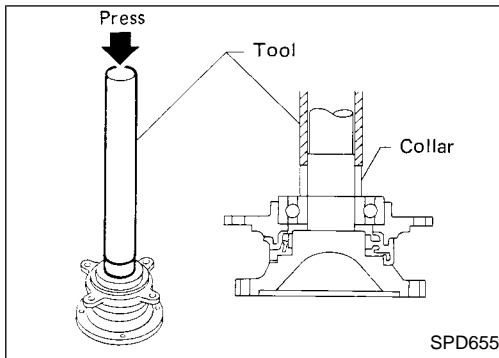

3. Install extension tube retainer, rear axle bearing and rear axle shaft bearing collar on differential side shaft.
4. Install differential side shaft assembly into extension tube.

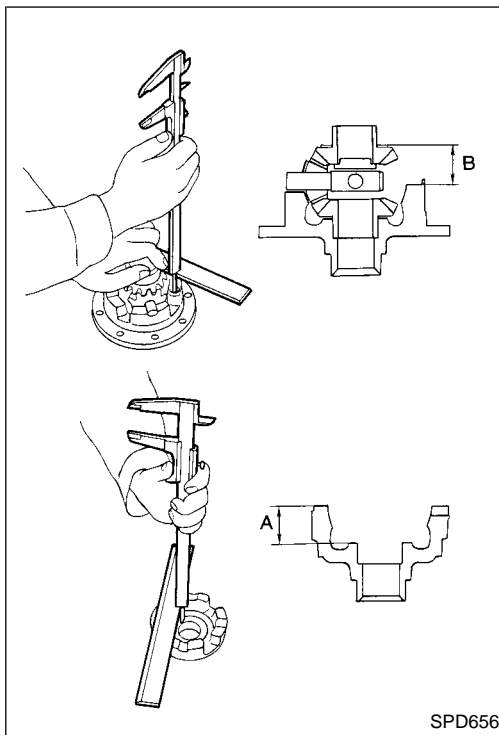

### Differential Case

1. Measure clearance between side gear thrust washer and differential case.  
**Clearance between side gear thrust washer and differential case (A - B):**  
**Less than 0.15 mm (0.0059 in)**  
 The clearance can be adjusted with side gear thrust washer.  
**Available side gear thrust washers:**  
**Refer to SDS, PD-72.**
2. Apply gear oil to gear tooth surfaces and thrust surfaces and check to see they turn properly.

Differential Case (Cont'd)

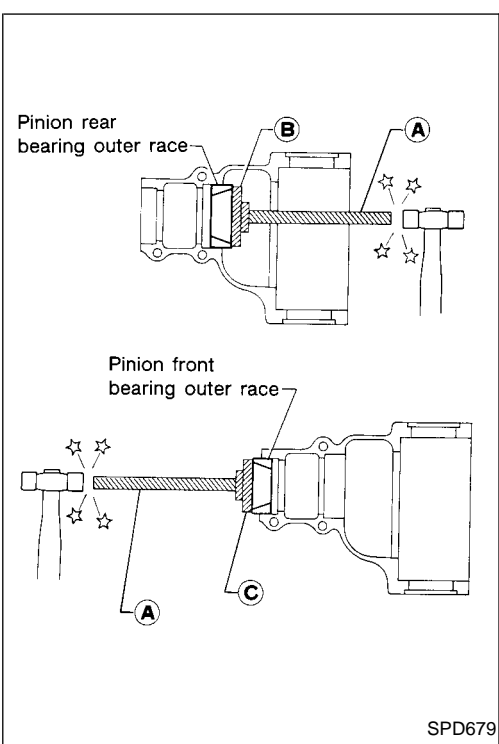
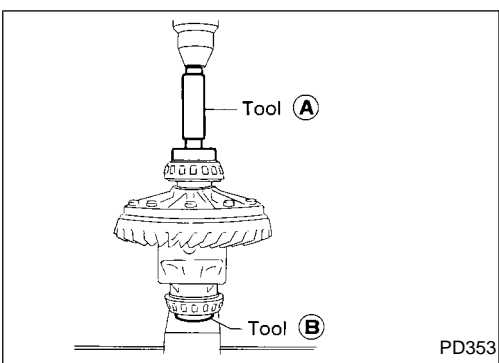
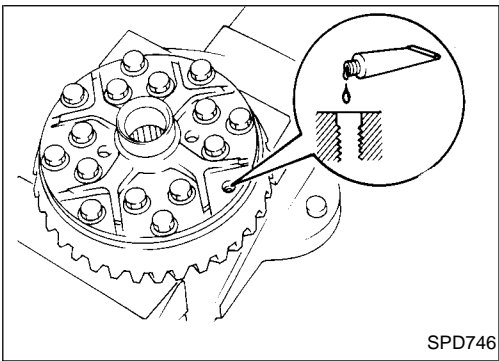
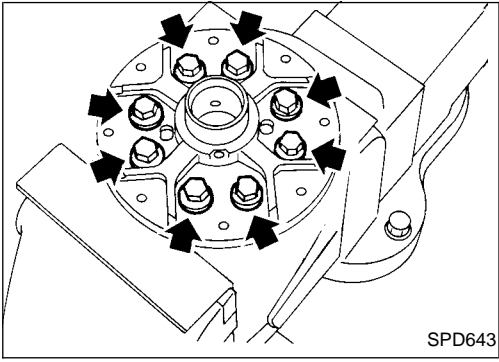

3. Install differential case LH and RH.

4. Place differential case on ring gear.  
 5. Apply locking agent [Locktite (stud lock) or equivalent] to ring gear bolts, and install them.

**Tighten bolts in a criss-cross fashion, lightly tapping bolt head with a hammer.**

6. Press-fit side bearing inner cones on differential case with Tools.

- Tool numbers:**  
 (A) ST33230000 (J25805-01)  
 (B) ST33061000 (J8107-2)

Final Drive Housing

1. Press-fit front and rear bearing outer races with Tools.

- Tool numbers:**  
 (A) ST30611000 (J25742-1)  
 (B) ST30621000 (J25742-5)  
 (C) ST30701000 (J25742-2)

GI  
 MA  
 EM  
 LC  
 EC  
 FE  
 CL  
 MT  
 AT  
 TF  
**PD**  
 FA  
 RA  
 BR  
 ST  
 RS  
 BT  
 HA  
 EL  
 IDX

**Final Drive Housing (Cont'd)**

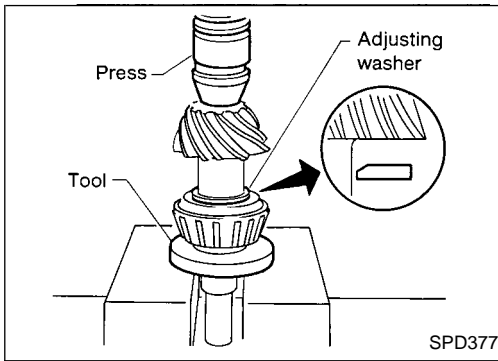

2. Select pinion bearing adjusting washer and drive pinion bearing spacer. Refer to "ADJUSTMENT", PD-25.
3. Install drive pinion height adjusting washer in drive pinion, and press-fit pinion rear bearing inner cone in it, using press and Tool.

**Tool number: ST30901000 (J26010-01)**

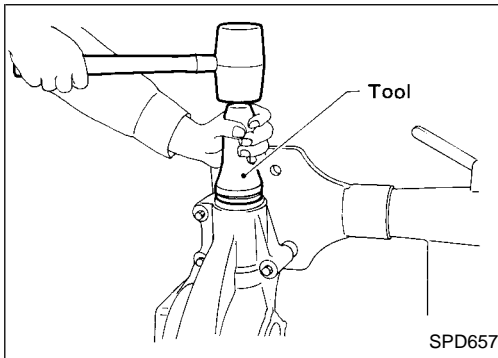

4. Place pinion front bearing inner cone in final drive housing.
5. Apply multi-purpose grease to cavity at sealing lips of oil seal. Install front oil seal.

**Tool number: ST30720000 (J25405)**

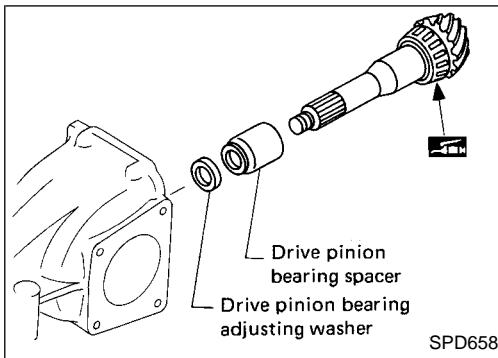

6. Place drive pinion bearing spacer, pinion bearing adjusting washer and drive pinion in final drive housing.

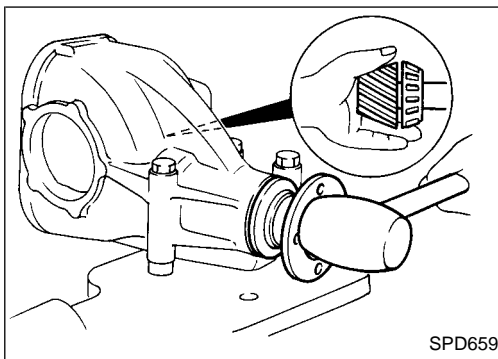

7. Insert companion flange into drive pinion by tapping the companion flange with a soft hammer.

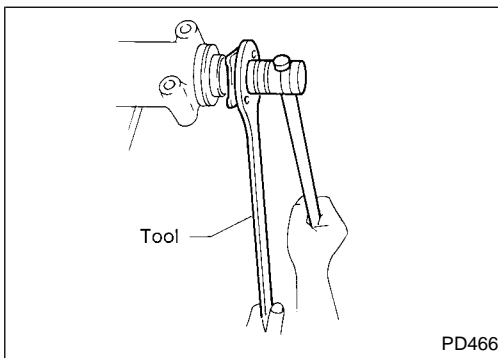

8. Tighten pinion nut to the specified torque. **The threaded portion of drive pinion and pinion nut should be free from oil or grease.**

**Tool number: ST38060002 (J34311)**



**Final Drive Housing (Cont'd)**

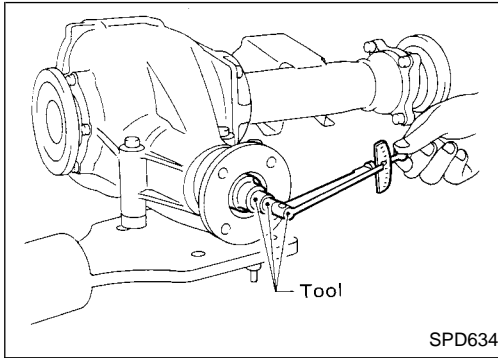

9. Turn drive pinion in both directions several revolutions and measure pinion bearing preload.

**Tool number: ST3127S000 (J25765-A)**

**Pinion bearing preload:**

**1.1 - 1.7 N·m (11 - 17 kg·cm, 9.5 - 14.8 in·lb)**

**When pinion bearing preload is outside the specifications, replace pinion bearing adjusting washer and spacer with a different thickness.**

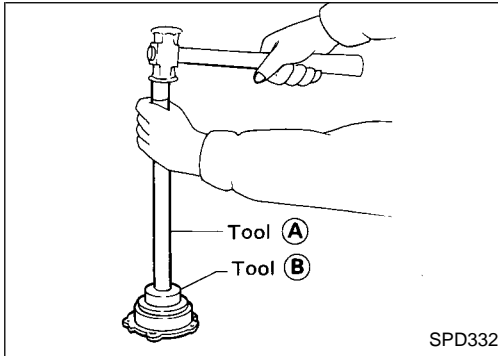

10. Select side retainer adjusting shim.  
Refer to "ADJUSTMENT", PD-24.

11. Press-fit side bearing outer race into side retainer.

**Tool numbers:**

**(A) ST30611000 (J25742-1)**

**(B) ST30621000 (J25742-5)**

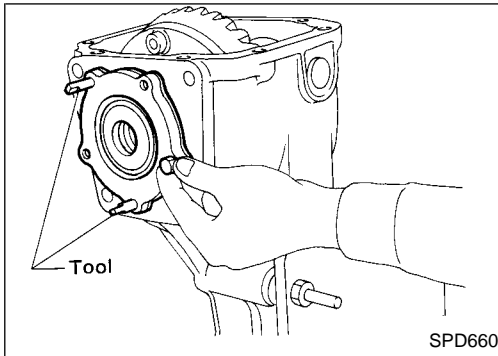

12. Install side oil seal to side retainer.

**Tool number: ST33270000 (J25809)**

13. Install differential case assembly.

14. Place side retainer adjusting shims (refer to "ADJUSTMENT", PD-24), and O-ring on side retainer, and install them in final drive housing.

**Tool number: ST33720000 (J25817)**

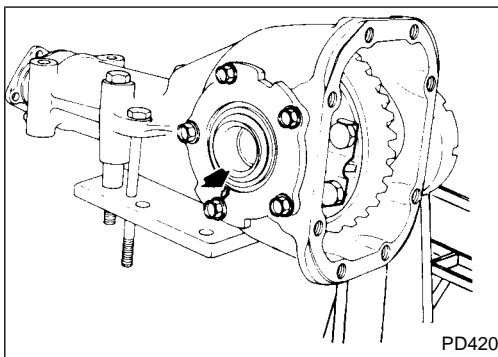

- Align arrows stamped on side retainer and final drive housing.

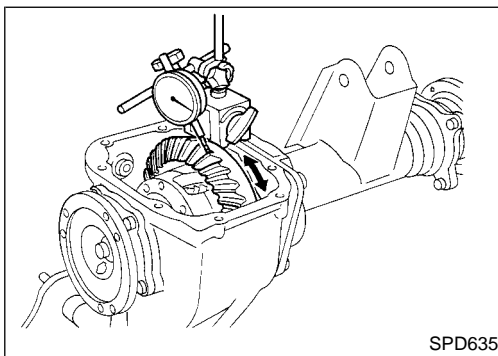

15. Measure ring gear-to-drive pinion backlash with a dial indicator.

**Ring gear-to-drive pinion backlash:**

**0.13 - 0.18 mm (0.0051 - 0.0071 in)**

- If backlash is too small, decrease thickness of right shim and increase thickness of left shim by the same amount.
- If backlash is too great, reverse the above procedure.

**Never change the total amount of shims as it will change the bearing preload.**

GI  
MA  
EM  
LC  
EC  
FE  
CL  
MT  
AT  
TF  
PD  
FA  
RA  
BR  
ST  
RS  
BT  
HA  
EL  
IDX

## Final Drive Housing (Cont'd)

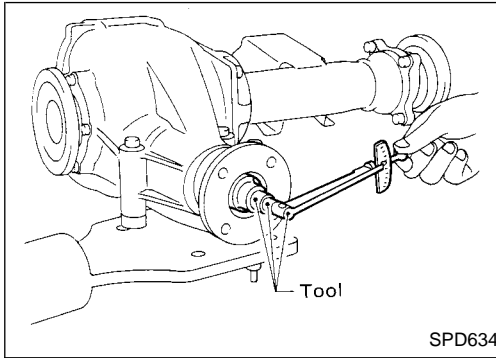

SPD634

16. Check total preload with Tool.

**When checking preload, turn drive pinion in both directions several times to set bearing rollers.**

**Tool number: ST3127S000 (J25765-A)**

**Total preload:**

**1.2 - 2.3 N·m**

**(12 - 23 kg-cm, 10 - 20 in-lb)**

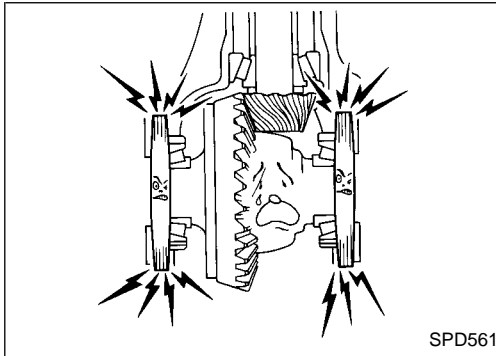

SPD561

- If preload is too great, add the same amount of shim to each side.
- If preload is too small, remove the same amount of shim from each side.

**Never add or remove a different number of shims for each side as it will change ring gear-to-drive pinion backlash.**

17. Recheck ring gear-to-drive pinion backlash because increase or decrease in thickness of shims will cause change of ring gear to pinion backlash.

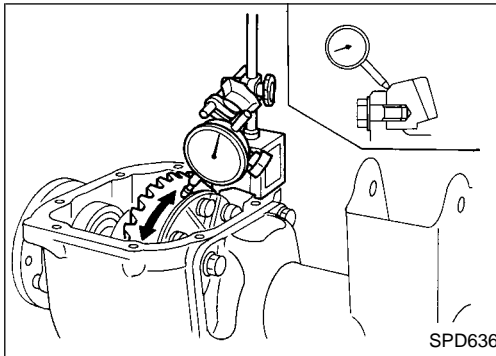

SPD636

18. Check runout of ring gear with a dial indicator.

**Runout limit:**

**0.05 mm (0.0020 in)**

- If backlash varies excessively in different places, the variance may have resulted from foreign matter caught between the ring gear and the differential case.
- If the backlash varies greatly when the runout of the ring gear is within a specified range, the hypoid gear set or differential case should be replaced.

19. Check tooth contact. Refer to "ADJUSTMENT", PD-29.

20. Install rear cover and gasket.

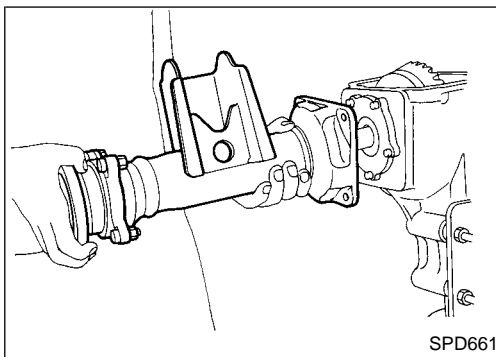

SPD661

21. Install extension tube and differential side shaft assembly.

SEC.380

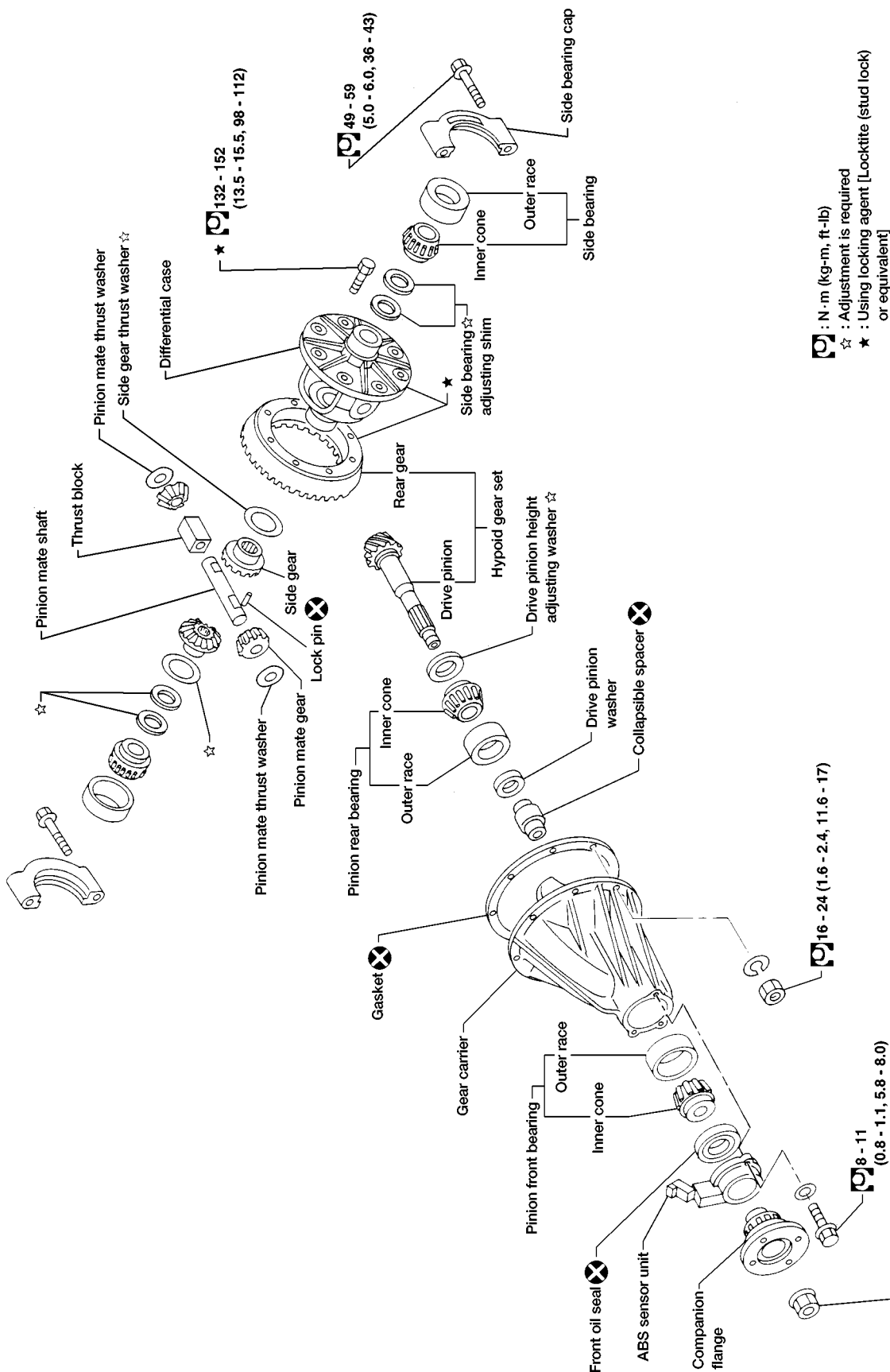

⊗ : N · m (kg-m, ft-lb)  
 ☆ : Adjustment is required  
 ☆ : Using locking agent [Locktite (stud lock) or equivalent]

Tighten pinion nut until total preload of 1.2 - 2.2 N·m (12 - 22 kg-m, 10 - 19 in-lb) is obtained.

GI  
 MA  
 EM  
 LC  
 EC  
 FE  
 CL  
 MT  
 AT  
 TF  
**PD**  
 FA  
 RA  
 BR  
 ST  
 RS  
 BT  
 HA  
 EL  
 IDX

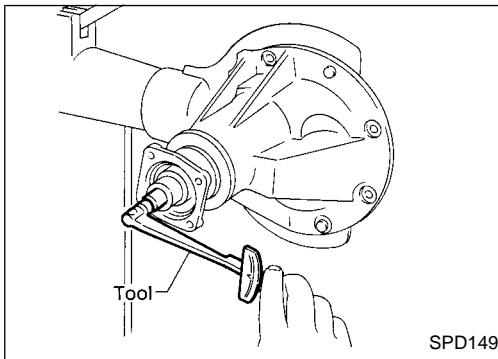

SPD149

## Pre-inspection

Before disassembling final drive, perform the following inspection.

- Total preload
  - a. Turn drive pinion in both directions several revolutions to seat bearing rollers correctly.
  - b. Check total preload with Tool.

**Tool number: ST3127S000 (J25765-A)**

**Total preload:**

**1.2 - 2.2 N·m**

**(12 - 22 kg-cm, 10 - 19 in-lb)**

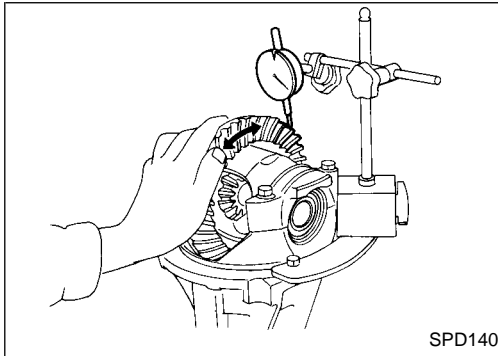

SPD140

- Ring gear-to-drive pinion backlash  
Check backlash of ring gear with a dial indicator at several points.

**Ring gear-to-drive pinion backlash:**

**0.13 - 0.18 mm (0.0051 - 0.0071 in)**

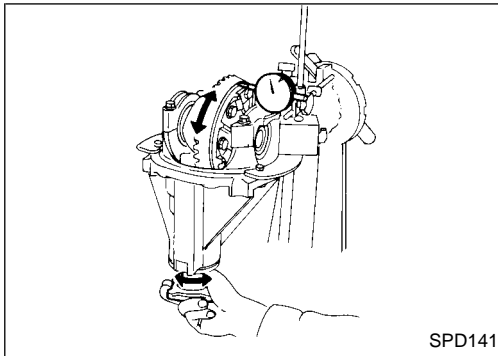

SPD141

- Ring gear runout  
Check runout of ring gear with a dial indicator.

**Runout limit:**

**0.08 mm (0.0031 in)**

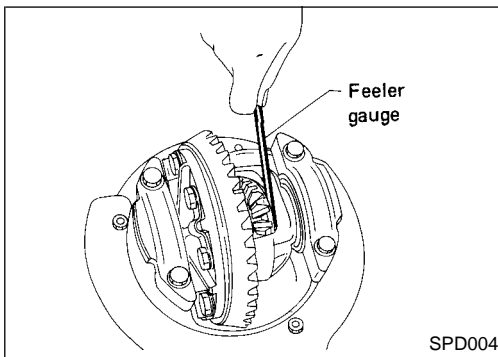

SPD004

- Tooth contact  
Check tooth contact. Refer to "ADJUSTMENT", PD-46.
- Side gear-to-pinion mate gear backlash  
Measure clearance between side gear thrust washer and differential case with a feeler gauge.

**Clearance between side gear thrust washer and differential case:**

**Less than 0.15 mm (0.0059 in)**

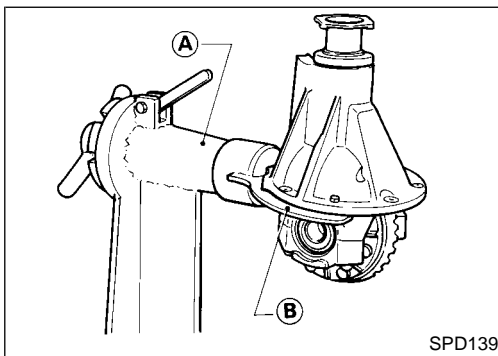

SPD139

## Differential Carrier

1. Mount differential carrier on Tools.

**Tool numbers:**

**(A) ST0501S000 ( — )**

**(B) ST06310000 (J25602-01)**

## Differential Carrier (Cont'd)

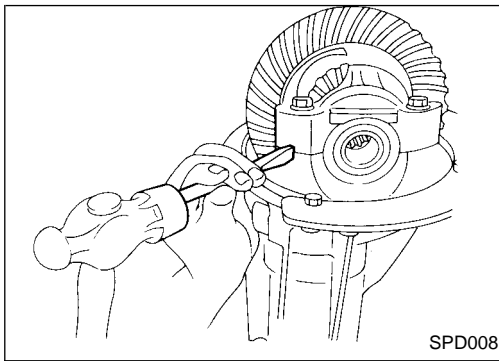

- Put match marks on one side of side bearing cap with paint or punch to ensure that it is replaced in proper position during reassembly.

**Bearing caps are line-bored during manufacture and should be put back in their original places.**

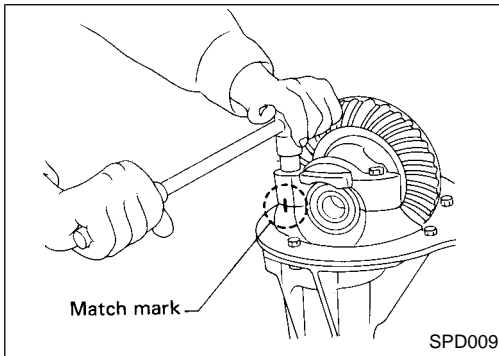

- Remove side bearing caps.

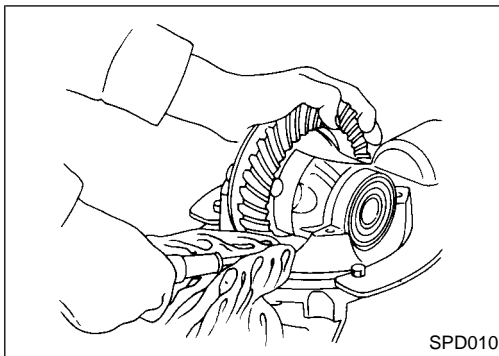

- Remove differential case assembly with a pry bar.

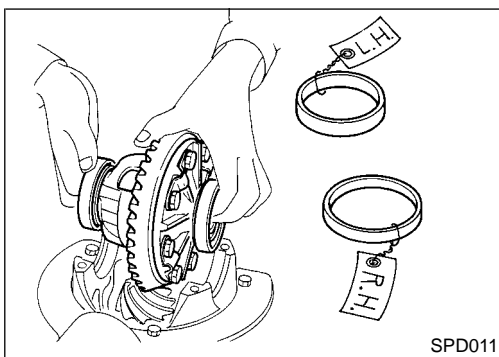

**Keep the side bearing outer races together with their respective inner cones — do not mix them up.**

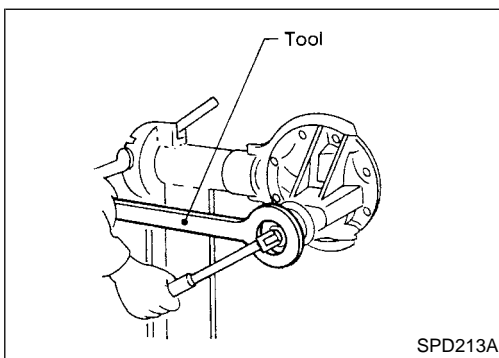

- Remove drive pinion nut with Tool.  
**Tool number: ST38060002 (J34311)**
- Remove companion flange with puller.

GI

MA

EM

LC

EC

FE

CL

MT

AT

TF

PD

FA

RA

BR

ST

RS

BT

HA

EL

IDX

**Differential Carrier (Cont'd)**

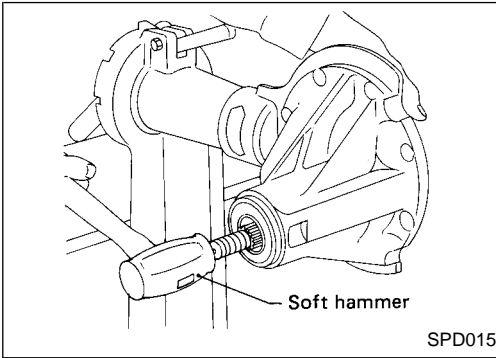

7. Remove drive pinion with soft hammer.
8. Remove oil seal.

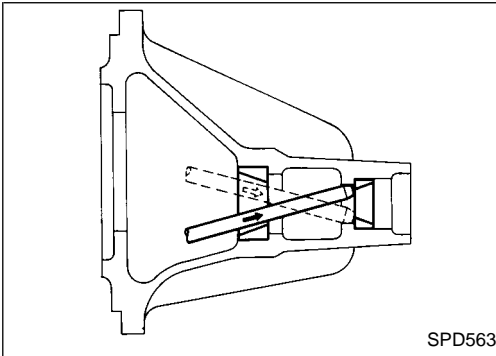

9. Remove pinion bearing outer races with a brass drift.

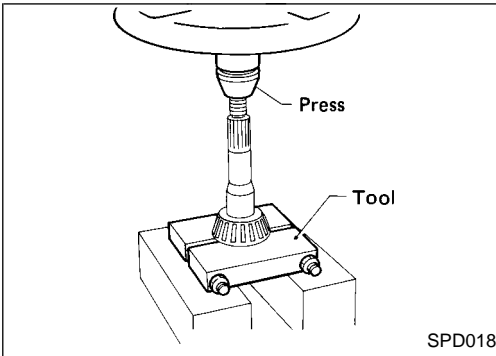

10. Pull out rear bearing inner cone with a press and Tool.  
**Tool number: ST30031000 (J22912-01)**

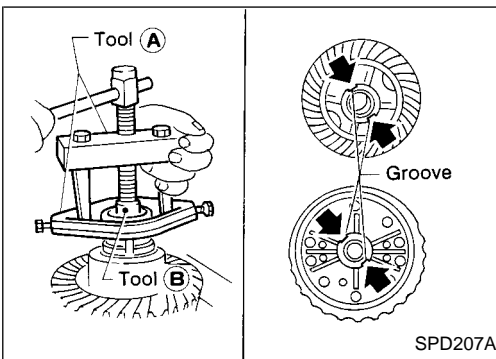

**Differential Case**

1. Remove side bearing inner cones.  
**To prevent damage to bearing, engage puller jaws in groove.**

**Tool numbers:**

- (A) ST33051001 (J22888-20)
- (B) ST33061000 (J8107-2)

**Be careful not to confuse the left and right hand parts.**

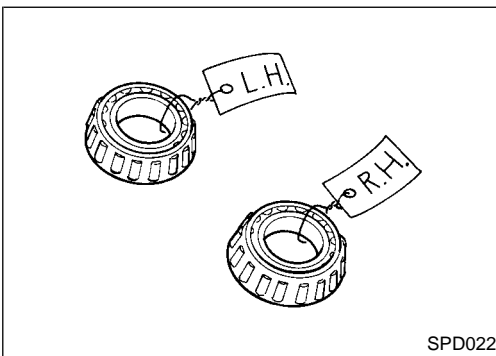

## Differential Case (Cont'd)

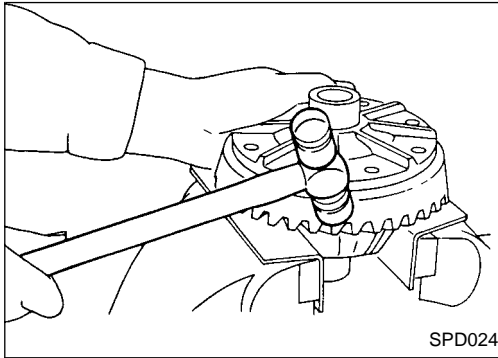

2. Spread out lock straps and loosen ring gear bolts in a criss-cross fashion.
  3. Tap ring gear off differential case with a soft hammer.
- Tap evenly all around to keep ring gear from binding.**

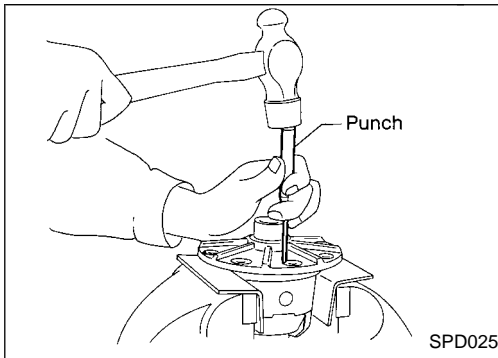

4. Drive out pinion mate shaft lock pin, with Tool from ring gear side.
- Lock pin is calked at pin hole mouth on differential case.**

GI

MA

EM

LC

EC

FE

CL

MT

AT

TF

**PD**

FA

RA

BR

ST

RS

BT

HA

EL

IDX

## Ring Gear and Drive Pinion

Check gear teeth for scoring, cracking or chipping.  
If any damaged part is evident, replace ring gear and drive pinion as a set (hypoid gear set).

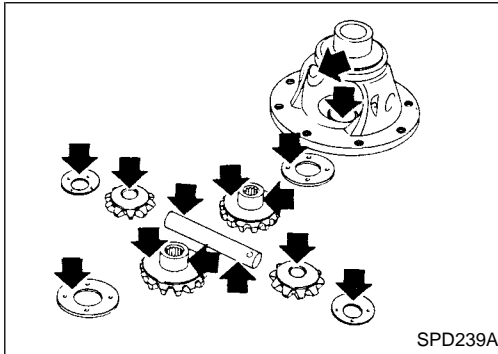

## Differential Case Assembly

Check mating surfaces of differential case, side gears, pinion mate gears, pinion mate shaft, and thrust washers.

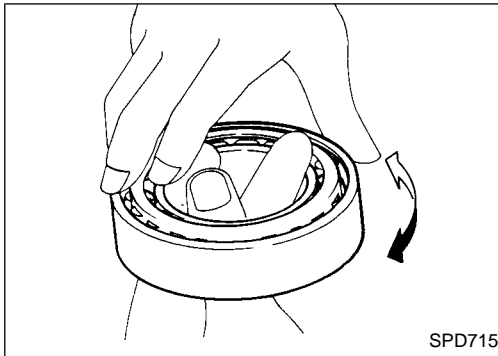

## Bearing

1. Thoroughly clean bearing.
2. Check bearings for wear, scratches, pitting or flaking. Check tapered roller bearing for smooth rotation. If damaged, replace outer race and inner cone as a set.



For quiet and reliable final drive operation, the following five adjustments must be made correctly:

1. Side bearing preload
2. Pinion gear height
3. Pinion bearing preload. Refer to "ASSEMBLY", PD-50.
4. Ring gear-to-pinion backlash. Refer to "ASSEMBLY", PD-50.
5. Ring and pinion gear tooth contact pattern

## Side Bearing Preload

A selection of carrier side bearing preload shims is required for successful completion of this procedure.

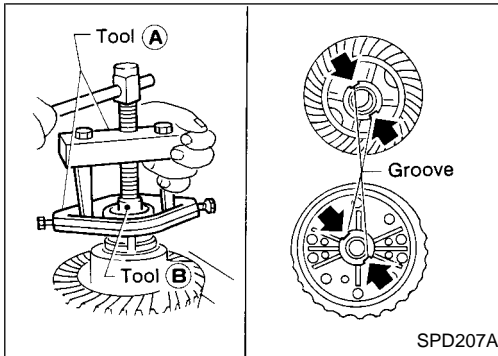

1. Make sure all parts are clean and that the bearings are well lubricated with light oil or type "DEXRON™" automatic transmission fluid.
2. Remove side bearing inner cones.

**To prevent damage to bearing, engage puller jaws in grooves.**

**Tool numbers:**

- Ⓐ ST33051001 (J22888-20)
- Ⓑ ST33061000 (J8107-2)

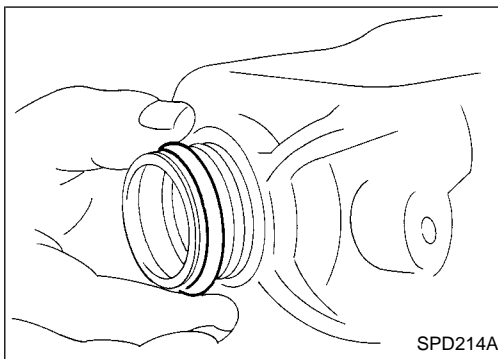

3. Reinstall all of the original side bearing adjusting shims on the carrier side, away from the ring gear.

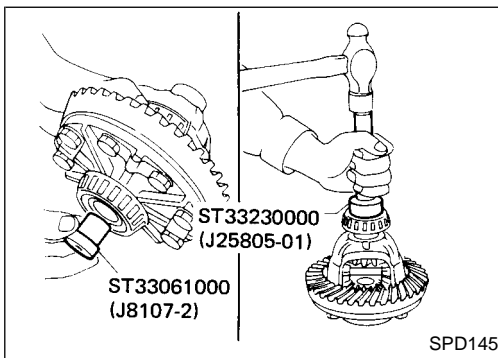

4. Reinstall the carrier side bearing using Tools J25805-01 and J8107-2. Press on the bearings.

## Side Bearing Preload (Cont'd)

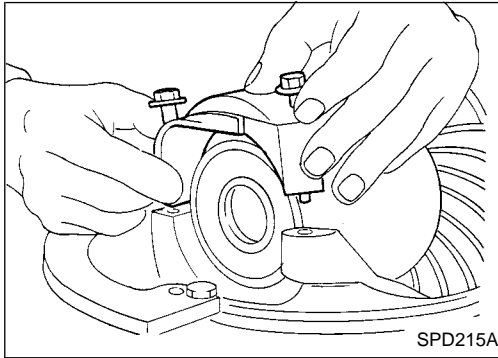

5. Install carrier and bearings into the final drive housing. Install side bearing caps. Torque the bolts and tap on the caps with a soft hammer to seat the bearings.

**Side bearing cap bolt torque specification:**  
 49 - 59 N·m (5 - 6 kg·m, 36 - 43 ft·lb)

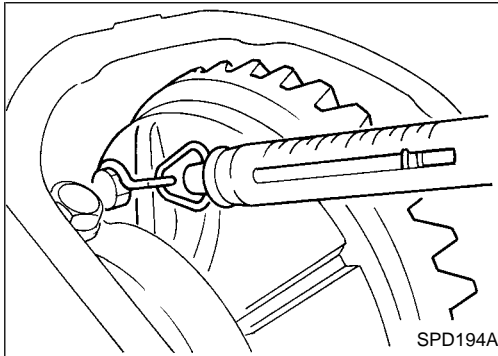

6. After turning the carrier several times to seat the bearings, measure carrier turning force with spring gauge J8129.

**Turning force specification:**  
 34.3 - 39.2 N (3.5 - 4.0 kg, 7.7 - 8.8 lb)  
 of pulling force at the ring gear bolt

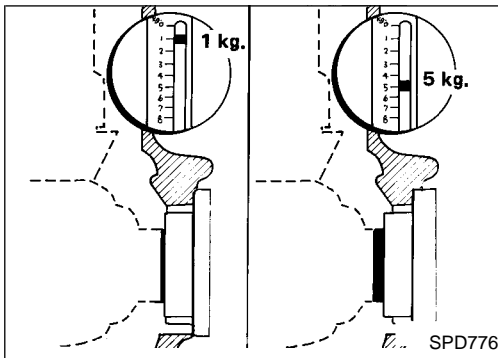

7. If necessary, correct the carrier bearing preload by adding to or subtracting from the total amount of shim thickness. Add shim thickness to increase turning force on the carrier. Subtract shim thickness to decrease turning force on the carrier.

## Pinion Gear Height

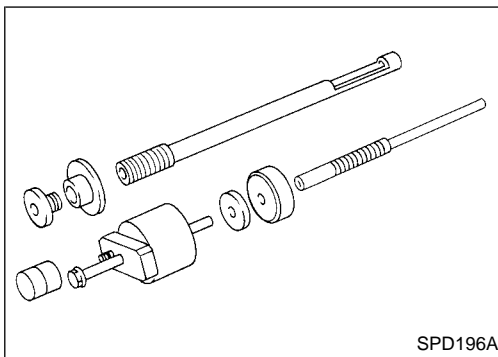

1. Make sure all parts are clean and that the bearings are well lubricated.
2. Assemble the pinion gear bearings into the pinion pre-load shim selector Tool, J34309.

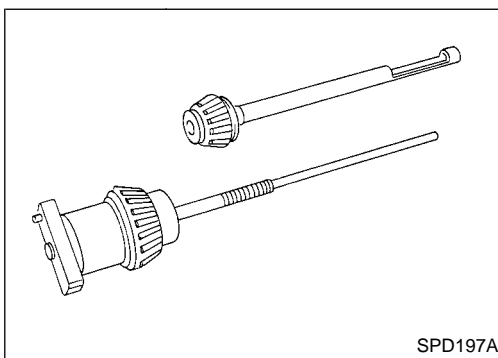

- **Front Pinion Bearing** — make sure the J34309-3 front pinion bearing is secured tightly against the J34309-2 gauge anvil. Then turn the front pinion bearing pilot J34309-5 to secure the bearing in its proper position.
- **Rear Pinion Bearing** — the rear pinion bearing pilot, J34309-15, is used to center the rear pinion bearing only. The rear pinion bearing locking seat, J34309-4 is used to lock the bearing to the assembly.

Pinion Gear Height (Cont'd)

GI  
MA  
EM  
LC  
EC  
FE  
CL  
MT  
AT  
TF  
PD  
FA  
RA  
BR  
ST  
RS  
BT  
HA  
EL  
IDX

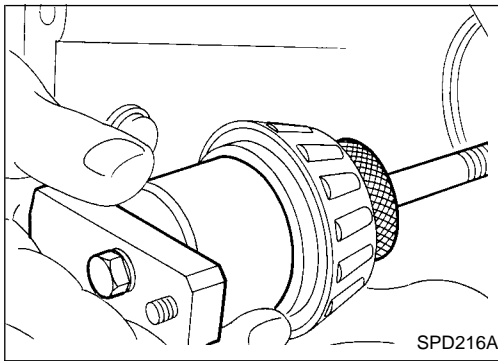

3. Place the pinion pre-load shim selector Tool J34309-1 gauge screw assembly with the pinion rear bearing inner cone installed into the final drive housing.

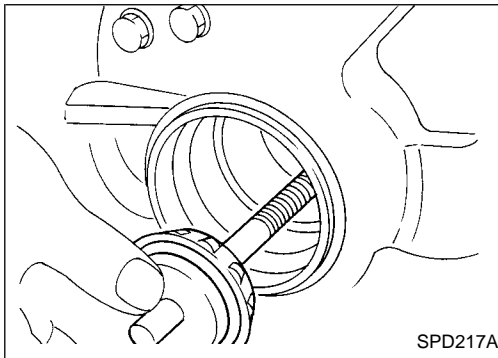

4. Assemble the front pinion bearing inner cone and the J34309-2 gauge anvil together with the J34309-1 gauge screw in the final drive housing. Make sure that the pinion height gauge plate, J34309-16, will turn a full 360 degrees, and tighten the two sections together by hand.

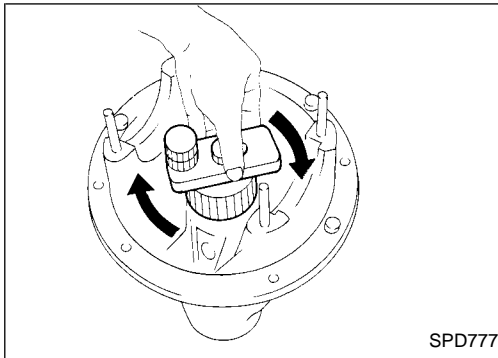

5. Turn the assembly several times to seat the bearings.

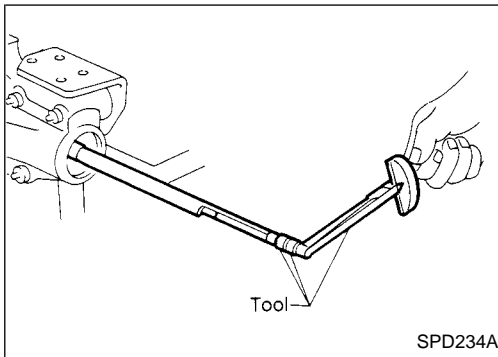

6. Measure the turning torque at the end of the J34309-2 gauge anvil using Tool.

**Tool number: ST3127S000 (J25765-A)**

**Turning torque specification:**

**1.0 - 1.3 N·m**

**(10 - 13 kg·cm, 8.7 - 11.3 in·lb)**

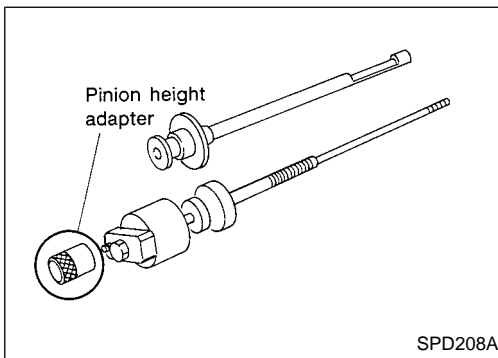

7. Place the J34309-14 pinion height adapter onto the gauge plate and tighten it by hand.

**CAUTION:**

**Make sure all machined surfaces are clean.**

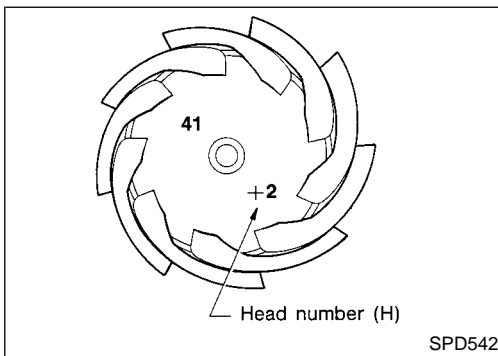
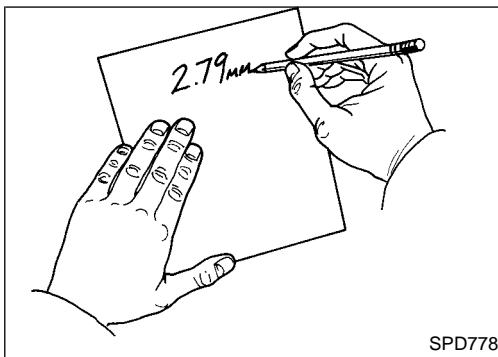
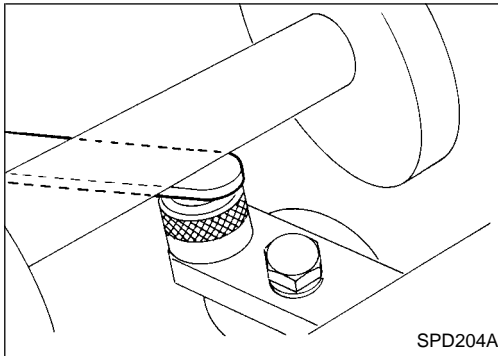
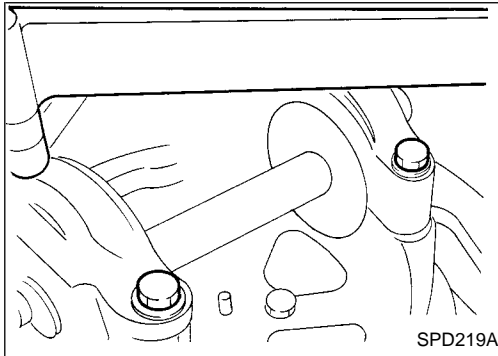
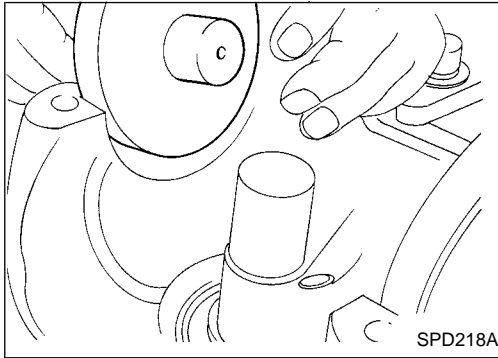
**Pinion Gear Height (Cont'd)****PINION HEIGHT ADJUSTING WASHER SELECTION**

8. Now, position the side bearing discs, J25269-18, and arbor firmly into the side bearing bores.

9. Install the side bearing caps and torque the cap bolts.

**Specification:**

**49 - 59 N·m (5 - 6 kg·m, 36 - 43 ft·lb)**

10. Select the correct standard pinion height adjusting washer thickness by using J34309-101 feeler gauge. Measure the gap between the J34309-14 pinion height adapter and the arbor.

11. Write down your exact total measurement.

12. Correct the pinion height washer size by referring to the “pinion head number”.

**There are two numbers painted on the pinion gear. The first one refers to the pinion and ring gear as a matched set and should be the same as the number on the ring gear. The second number is the “pinion head height number,” and it refers to the ideal pinion height from standard for quietest operation.**

**Pinion Gear Height (Cont'd)**

Use the following chart to determine the correct pinion height washer.

Pinion Head Height Number	Add or Remove from the Standard Pinion Height Washer Thickness Measurement
-6	Add 0.06 mm (0.0024 in)
-5	Add 0.05 mm (0.0020 in)
-4	Add 0.04 mm (0.0016 in)
-3	Add 0.03 mm (0.0012 in)
-2	Add 0.02 mm (0.0008 in)
-1	Add 0.01 mm (0.0004 in)
0	Use the selected washer thickness
+1	Subtract 0.01 mm (0.0004 in)
+2	Subtract 0.02 mm (0.0008 in)
+3	Subtract 0.03 mm (0.0012 in)
+4	Subtract 0.04 mm (0.0016 in)
+5	Subtract 0.05 mm (0.0020 in)
+6	Subtract 0.06 mm (0.0024 in)

13. Select the correct pinion height washer.

**Drive pinion height adjusting washer:  
Refer to SDS, PD-73.**

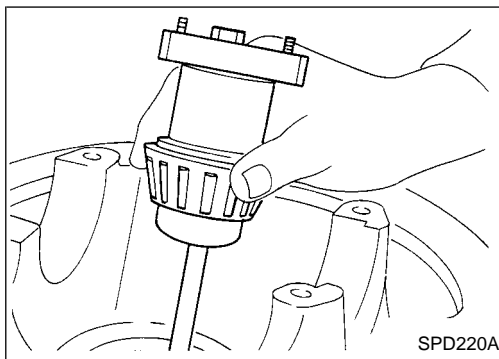

14. Remove the J34309 pinion preload shim selector Tool from the final drive housing and disassemble to retrieve the pinion bearings.

GI  
MA  
EM  
LC  
EC  
FE  
CL  
MT  
AT  
TF  
PD  
FA  
RA  
BR  
ST  
RS  
BT  
HA  
EL  
IDX

**Tooth Contact**

Checking of gear tooth contact pattern is necessary to verify correct relationship between ring gear and drive pinion. Hypoid gear sets which are not positioned properly may be noisy, or have short life, or both. With a pattern check, the most desirable contact for low noise level and long life can be assured.

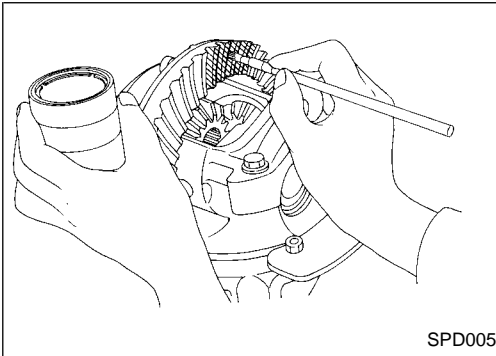

1. Thoroughly clean ring gear and drive pinion teeth.
2. Sparingly apply a mixture of powdered ferric oxide and oil or equivalent to 3 or 4 teeth of ring gear drive side.

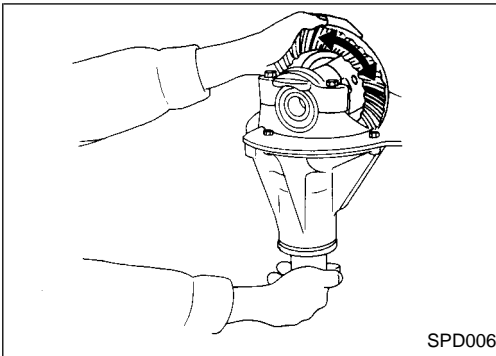

3. Hold companion flange steady and rotate the ring gear in both directions.

Usually the pattern will be correct if shims are correctly calculated and the backlash is correct. However, in rare cases, trial and error processes may be employed to obtain a correct pattern. The tooth pattern is the best indication of how well a differential has been set up.

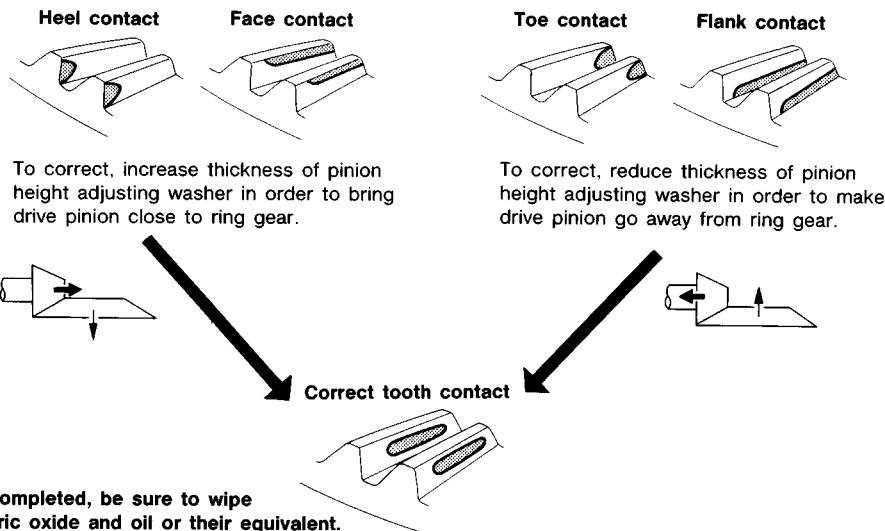

When adjustment is completed, be sure to wipe off completely the ferric oxide and oil or their equivalent.

GI  
MA  
EM  
LC  
EC  
FE  
CL  
MT  
AT  
TF  
PD  
FA  
RA  
BR  
ST  
RS  
BT  
HA  
EL  
IDX

**Differential Case**

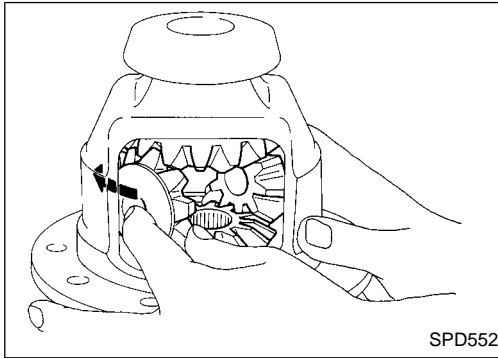

1. Install side gears, pinion mate gears and thrust washers into differential case.

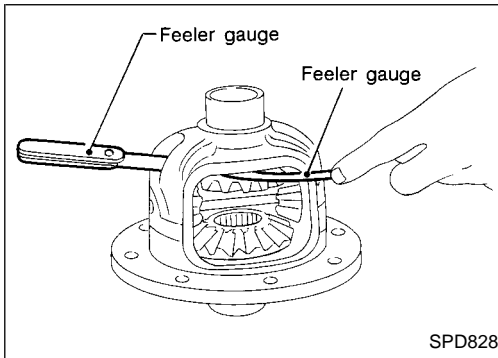

2. Fit pinion mate shaft to differential case so that it meets lock pin holes.
3. Adjust backlash between side gear and pinion mate gear by selecting side gear thrust washer. Refer to SDS, PD-73.

**Backlash between side gear and pinion mate gear (Clearance between side gear thrust washer and differential case):**

**Less than 0.15 mm (0.0059 in)**

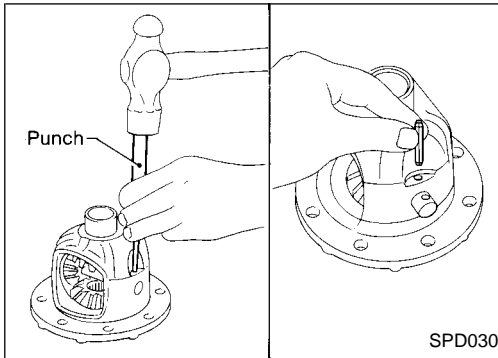

4. Install pinion mate shaft lock pin with a punch. **Make sure lock pin is flush with case.**

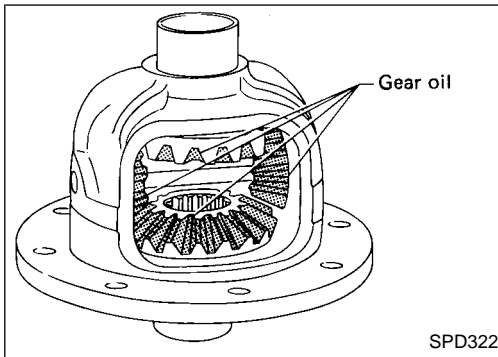

5. Apply gear oil to gear tooth surfaces and thrust surfaces and check to see they turn properly.

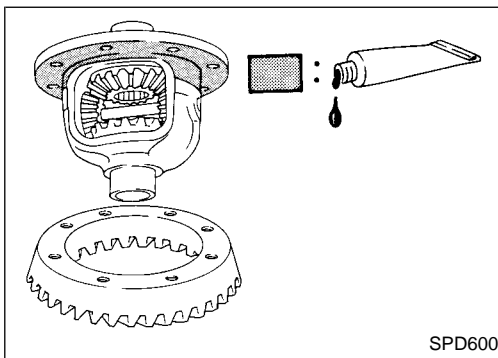

6. Apply locking agent [Lockite (stud lock) or equivalent] to contacting surfaces of ring gear and differential case, then place differential case on ring gear.

## Differential Case (Cont'd)

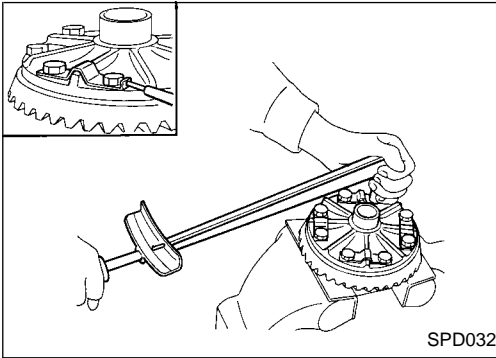

7. Apply a small amount of locking agent (described on previous page) to ring gear bolts.
8. Install new lock straps and ring gear bolts.
  - **Tighten bolts in a criss-cross fashion, lightly tapping bolt head with a hammer.**
  - **Then bend up lock straps to lock the bolts in place.**

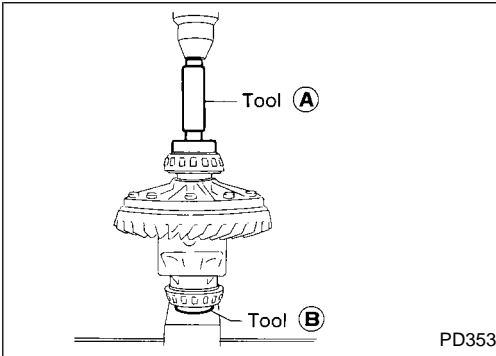

9. Select side bearing adjusting shims. Refer to "ADJUSTMENT", PD-41.
10. Install the shims behind each bearing and press on side bearing inner cones with Tools.

**Tool numbers:**

- Ⓐ ST33230000 (J25805-01)
- Ⓑ ST33061000 (J8107-2)

## Differential Carrier

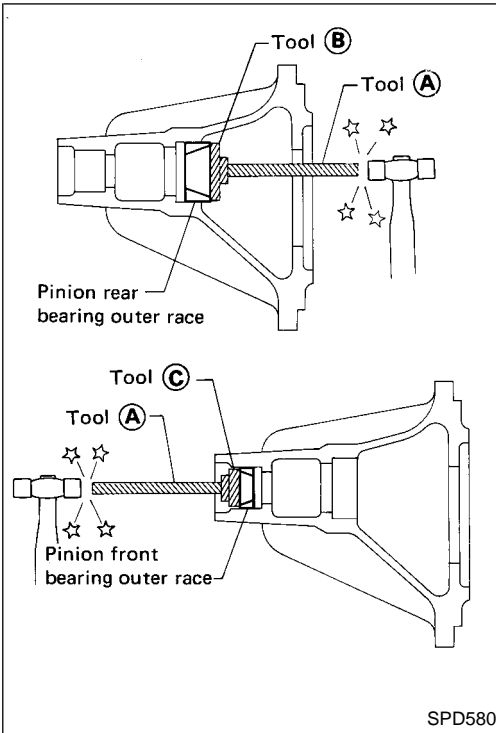

1. Press-fit front and rear bearing outer races with Tools.

**Tool numbers:**

- Ⓐ ST30611000 (J25742-1)
- Ⓑ ST30621000 (J25742-5)
- Ⓒ ST30613000 (J25742-3)

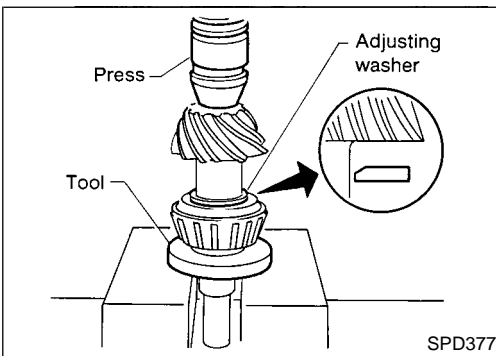

2. Select pinion height adjusting washer. Refer to "ADJUSTMENT", PD-42.
3. Install pinion height adjusting washer in drive pinion, and press-fit rear bearing inner cone with press and Tool.

**Tool number: ST30901000 (J26010-01)**



Differential Carrier (Cont'd)

GI  
MA  
EM  
LC  
EC  
FE  
CL  
MT  
AT  
TF  
PD  
FA  
RA  
BR  
ST  
RS  
BT  
HA  
EL  
IDX

4. Place pinion front bearing inner cone in gear carrier.

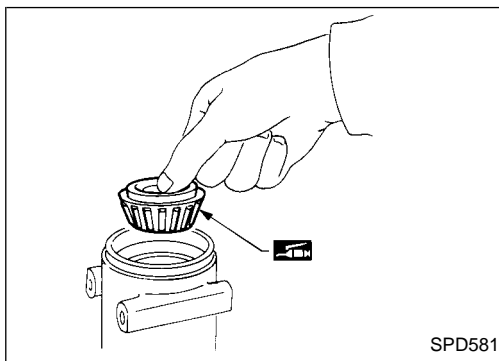

5. Apply multi-purpose grease to cavity at sealing lips of oil seal. Install front oil seal.

Tool numbers:

(A) ST30720000 (J25405)

(B) KV38102510 ( — )

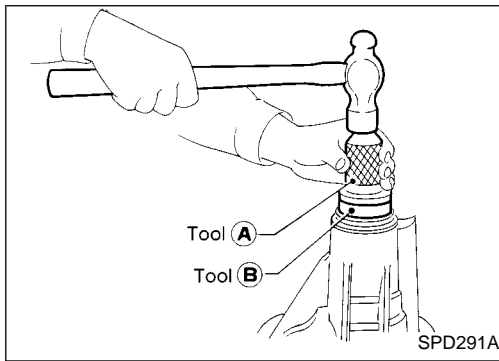

6. Install drive pinion washer, collapsible spacer and drive pinion in gear carrier.

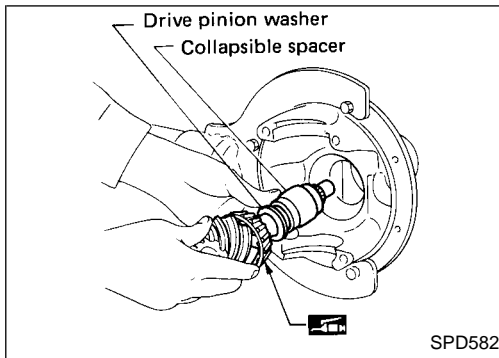

7. Install companion flange and hold it firmly. Insert pinion into companion flange by tapping its head with a soft hammer.

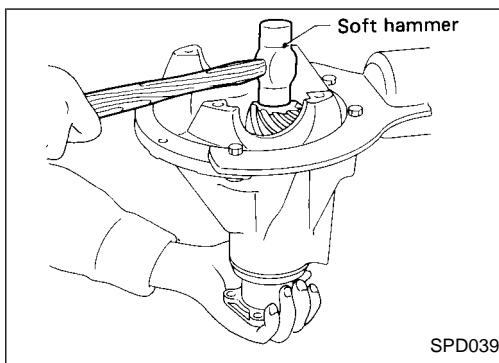

8. Temporarily tighten pinion nut until there is no axial play. The threaded portion of drive pinion and pinion nut should be free from oil or grease.

Tool number: ST38060002 (J34311)

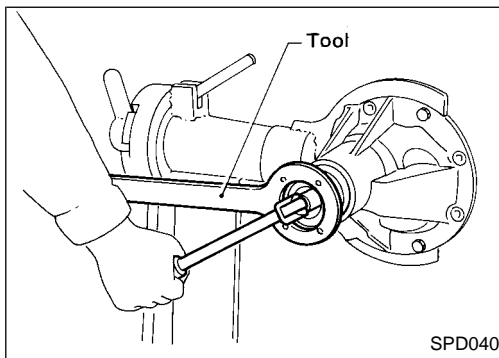

## Differential Carrier (Cont'd)

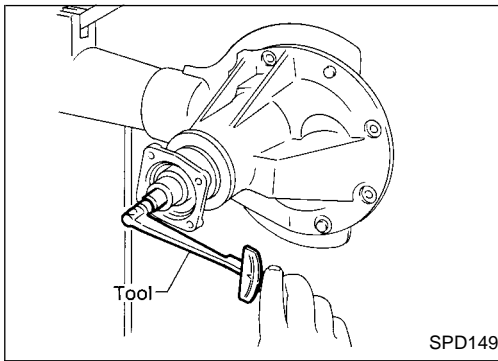

9. Tighten pinion nut by degrees to the specified preload while checking the preload with Tools.

**When checking preload, turn drive pinion in both directions several times to seat bearing rollers correctly.**

**Pinion bearing preload:**

1.1 - 1.6 N·m (11 - 16 kg-cm, 9.5 - 13.9 in-lb)

**Tool number: ST3127S000 (J25765-A)**

**CAUTION:**

The preload is achieved by the permanent setting of the collapsible spacer. So, if an overpreload results from turning of the pinion nut excessively, the spacer should be replaced by new one.

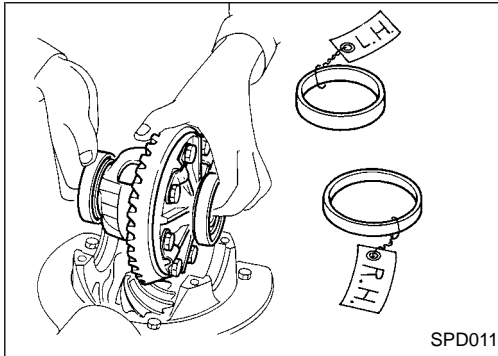

10. Install differential case assembly with side bearing outer races into gear carrier.

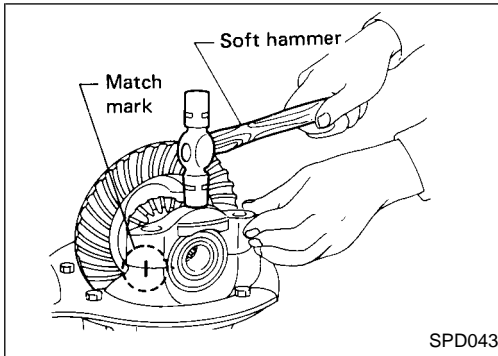

11. Align mark on bearing cap with that on gear carrier and install bearing cap on gear carrier.

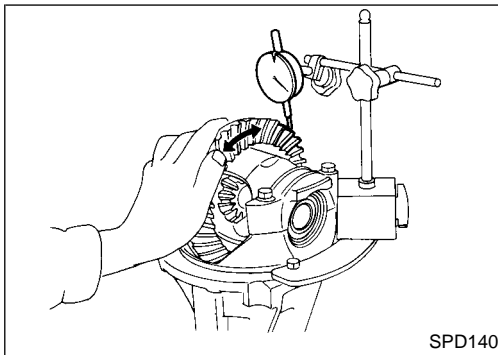

12. Measure ring gear-to-drive pinion backlash with a dial indicator.

**Ring gear-to-drive pinion backlash:**

0.13 - 0.18 mm (0.0051 - 0.0071 in)

- If backlash is too small, decrease thickness of left shim and increase thickness of right shim by the same amount.
- If backlash is too great, reverse the above procedure.

**Never change the total amount of shims as it will change the bearing preload.**

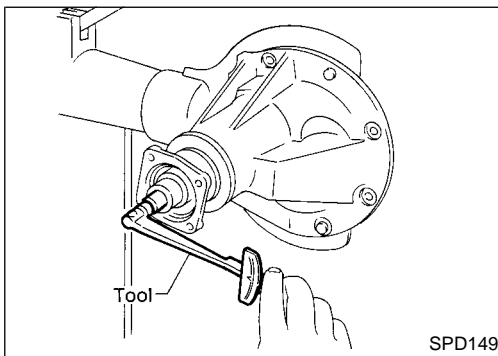

13. Check total preload with Tool.

**When checking preload, turn drive pinion in both directions several times to set bearing rollers.**

**Tool number: ST3127S000 (J25765-A)**

**Total preload:**

1.2 - 2.2 N·m (12 - 22 kg-cm, 10 - 19 in-lb)

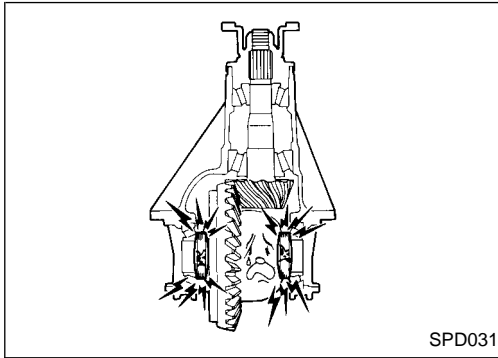
**Differential Carrier (Cont'd)**

- If preload is too great, remove the same amount of shims from each side.
- If preload is too small, add the same amount of shims to each side.

**Never add or remove a different number of shims for each side as it will change ring gear-to-drive pinion backlash.**

14. Recheck ring gear-to-drive pinion backlash because an increase or decrease in thickness of shims will cause change of ring gear-to-pinion backlash.

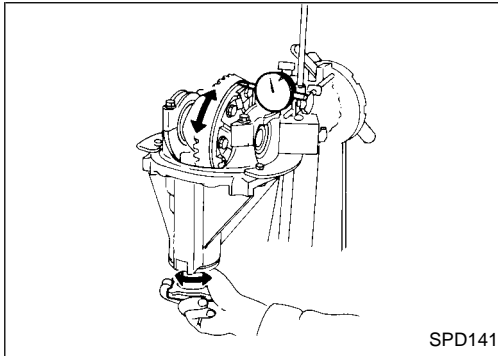

15. Check runout of ring gear with a dial indicator.

**Runout limit: 0.08 mm (0.0031 in)**

- If backlash varies excessively in different places, the variance may have resulted from foreign matter caught between the ring gear and the differential case.
  - If the backlash varies greatly when the runout of the ring gear is within a specified range, the hypoid gear set or differential case should be replaced.
16. Check tooth contact.  
Refer to "ADJUSTMENT", PD-46.

GI

MA

EM

LC

EC

FE

CL

MT

AT

TF

**PD**

FA

RA

BR

ST

RS

BT

HA

EL

IDX

## 2WD models

### SEC. 380

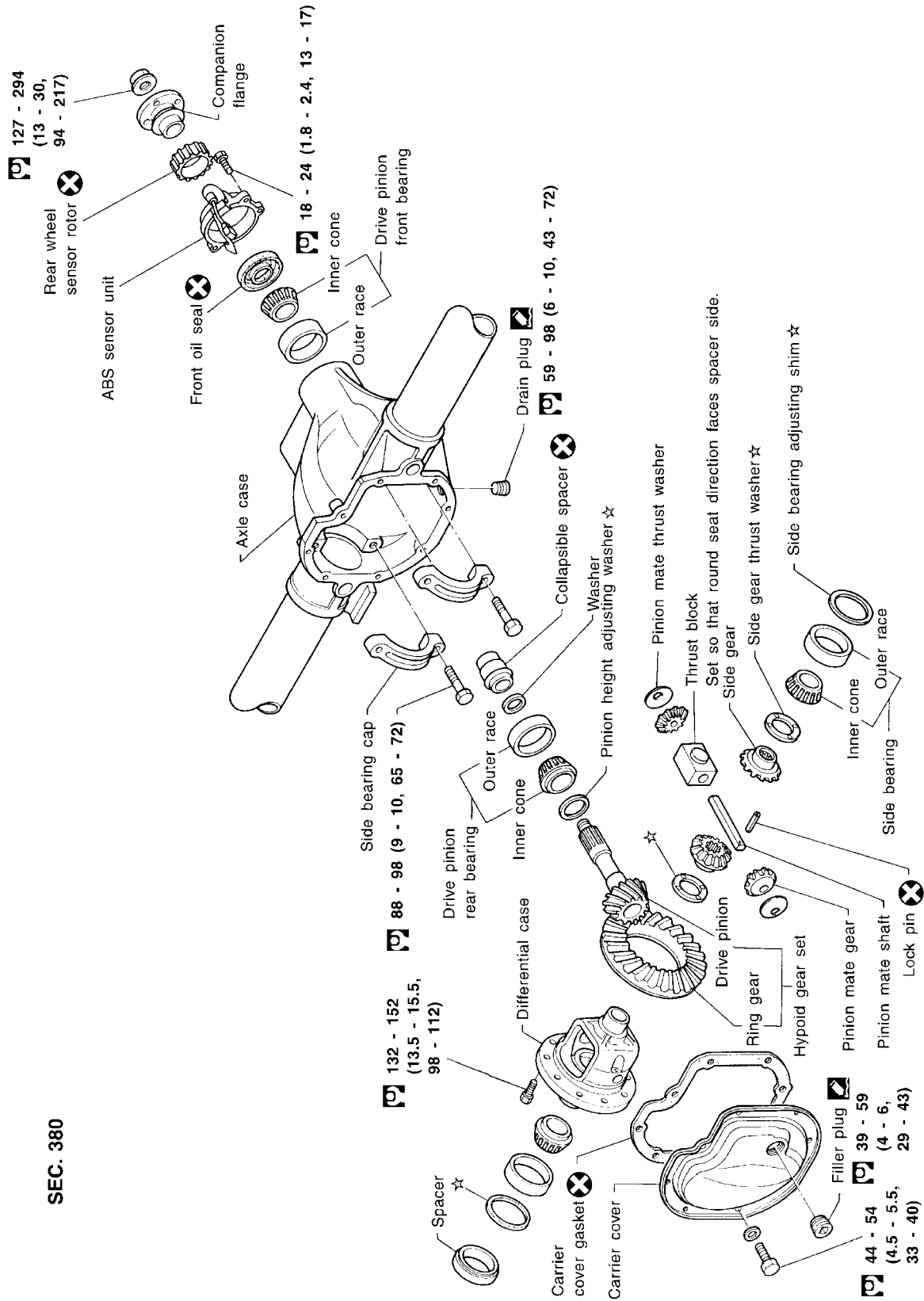

: N·m (kg-m, ft-lb)  
 : Always replace when disassembled.  
 : Adjustment is required.

4WD models

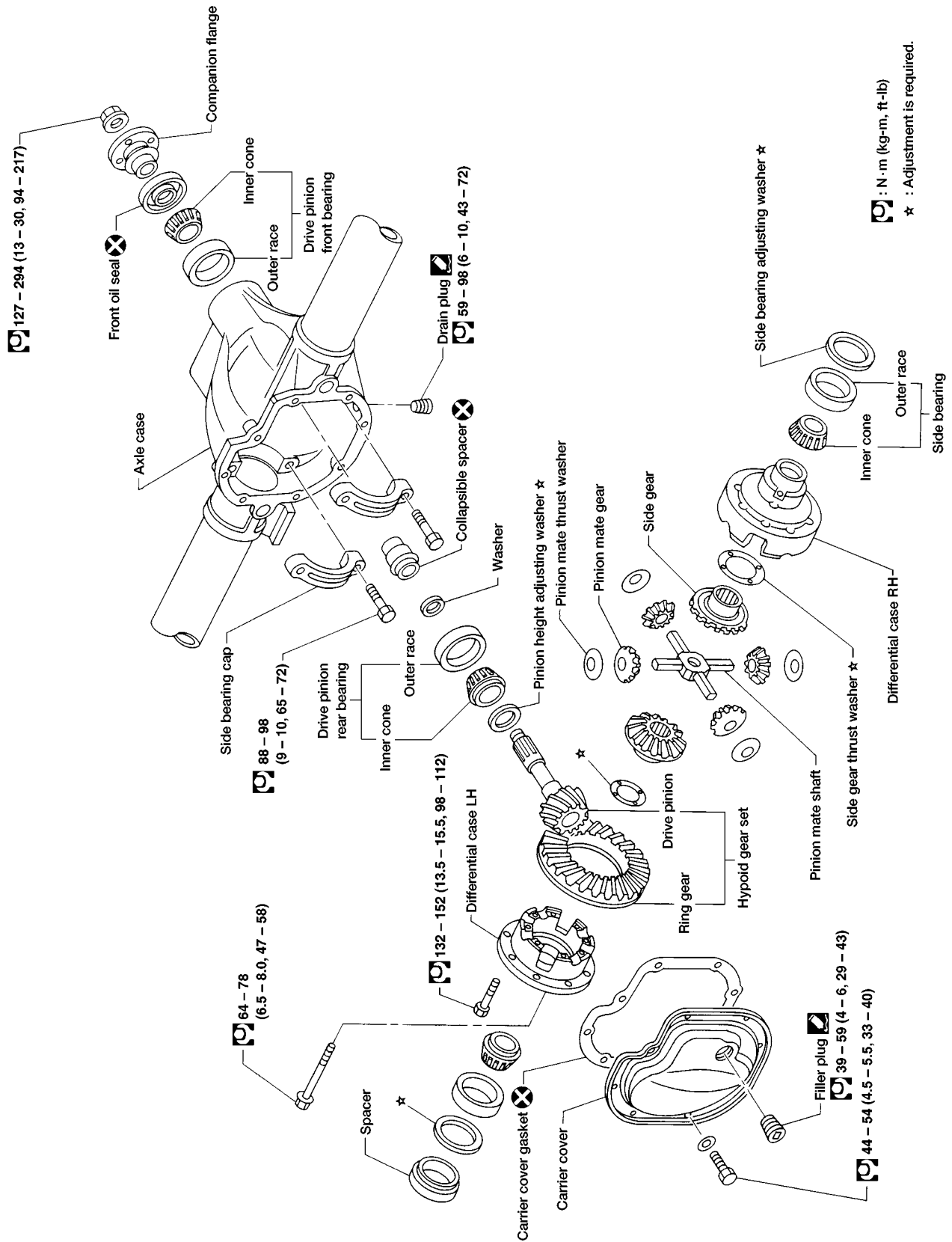

SEC.380

GI  
MA  
EM  
LC  
EC  
FE  
CL  
MT  
AT  
TF  
PD  
FA  
RA  
BR  
ST  
RS  
BT  
HA  
EL  
IDX

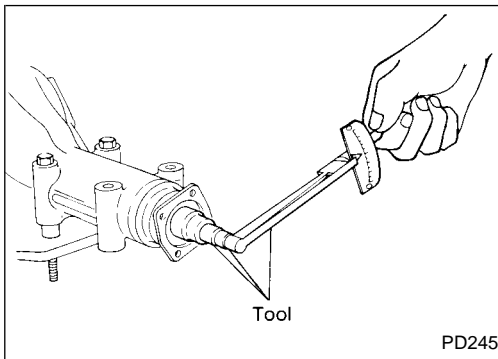

## Pre-inspection

Before disassembling final drive, perform the following inspection.

- Total preload
  - a. Turn drive pinion in both directions several times to set bearing rollers.
  - b. Check total preload with Tool.

**Tool number: ST3127S000 (J25765-A)**

**Total preload:**

**1.2 - 2.3 N·m**

**(12 - 23 kg-cm, 10 - 20 in-lb)**

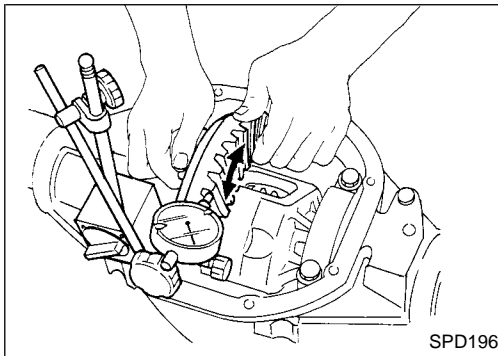

- Ring gear-to-drive pinion backlash.  
Check backlash of ring gear with a dial indicator at several points.

**Ring gear-to-drive pinion backlash:**

**0.13 - 0.18 mm (0.0051 - 0.0071 in)**

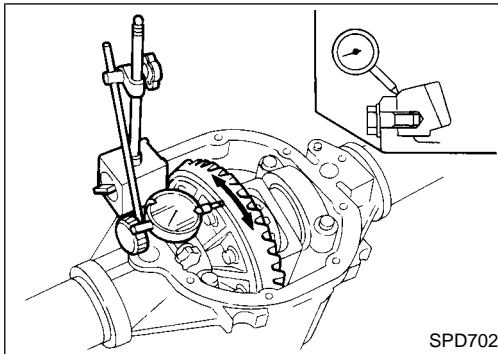

- Ring gear runout  
Check runout of ring gear with a dial indicator.

**Runout limit: 0.05 mm (0.0020 in)**

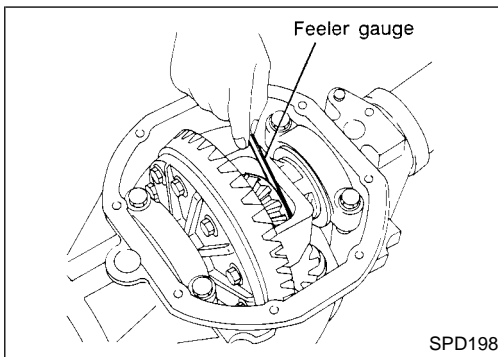

- Tooth contact  
Check tooth contact. Refer to "ADJUSTMENT", PD-64.
- Side gear-to-pinion mate gear backlash  
Measure clearance between side gear thrust washer and differential case with a feeler gauge.

**Clearance between side gear thrust washer and differential case:**

**Less than 0.15 mm (0.0059 in)**

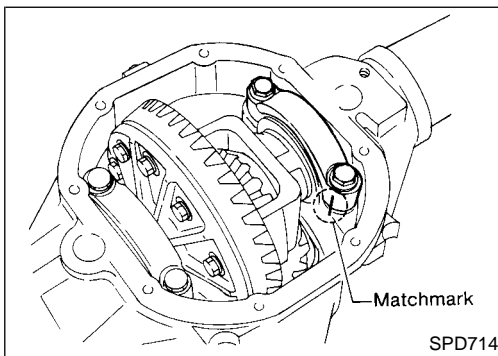

## Differential Carrier

1. Remove rear cover and rear cover gasket.
2. Put match marks on one side of side bearing cap with paint or punch to ensure that it is replaced in proper position during reassembly.

**Bearing caps are line-bored during manufacture and should be put back in their original places.**

## Differential Carrier (Cont'd)

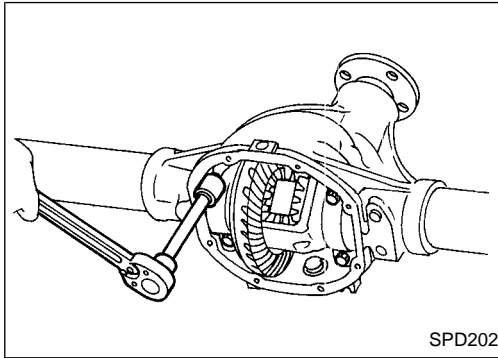

3. Remove side bearing caps.

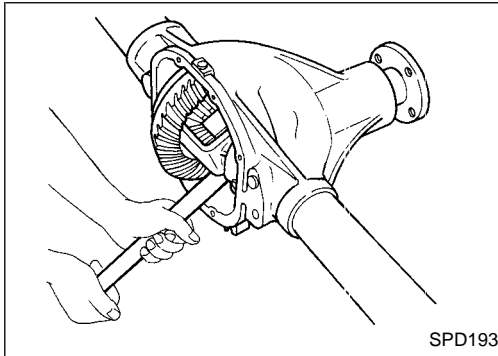

4. Remove differential case assembly with pry bar.

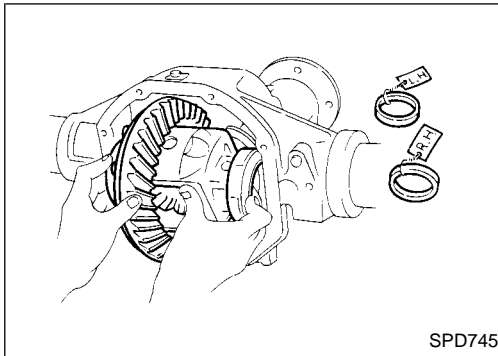

Keep the side bearing outer races together with their respective inner cones — do not mix them up.

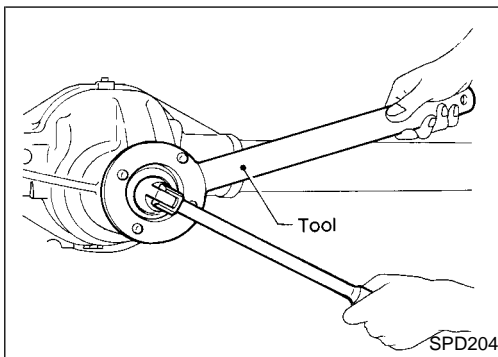

5. Remove pinion nut with Tool.  
**Tool number: ST38060002 (J34311)**

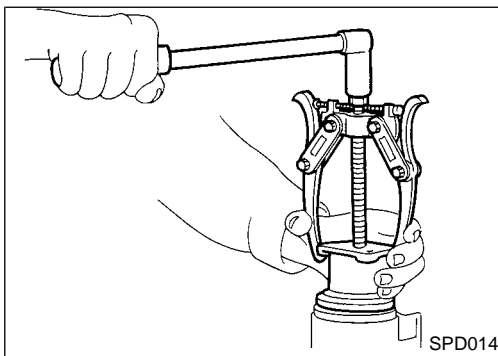

6. Remove companion flange with puller.

GI

MA

EM

LC

EC

FE

CL

MT

AT

TF

PD

FA

RA

BR

ST

RS

BT

HA

EL

IDX

Differential Carrier (Cont'd)

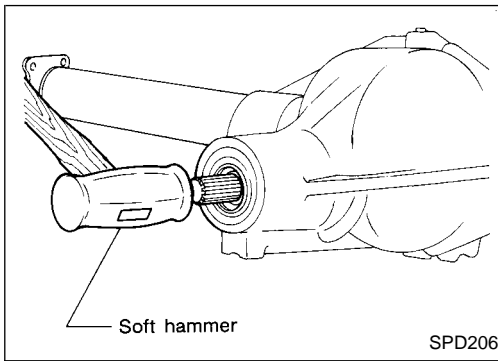

7. Remove drive pinion with soft hammer.
8. Remove front oil seal and pinion front bearing inner cone.

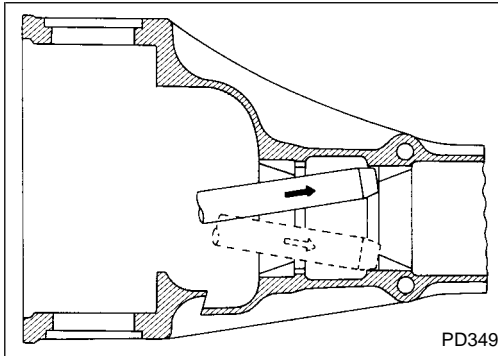

9. Remove pinion bearing outer races with a brass drift.

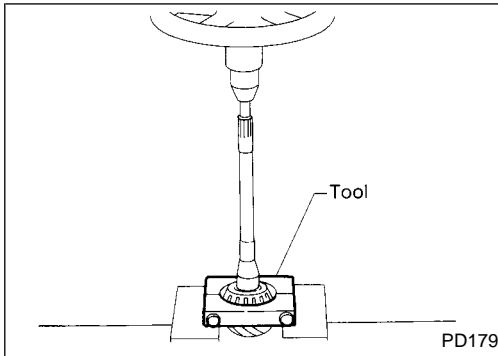

10. Remove pinion rear bearing inner cone and pinion height adjusting washer.

**Tool number: ST30031000 (J22912-01)**

Differential Case

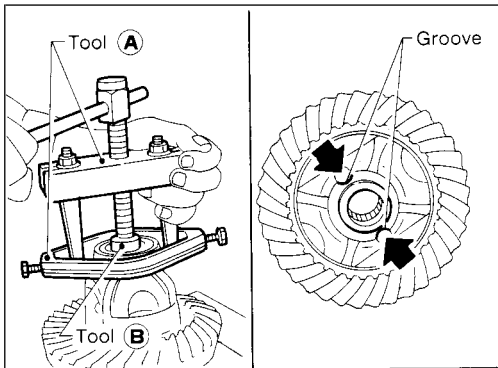

1. Remove side bearing inner cones.
- To prevent damage to bearing, engage puller jaws in grooves.**

**Tool numbers:**

- (A) ST33051001 (J22888-20)
- (B) ST33061000 (J8107-2)

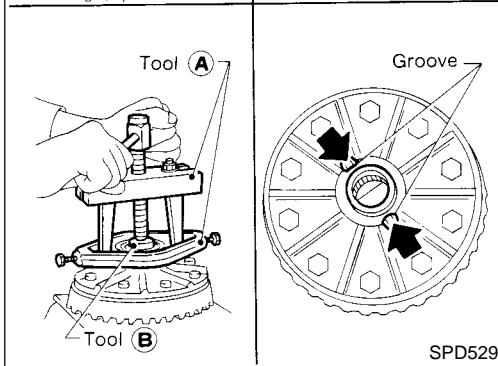



## Differential Case (Cont'd)

Be careful not to confuse the right and left hand parts.

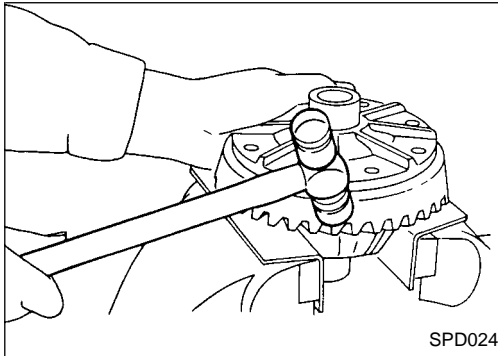
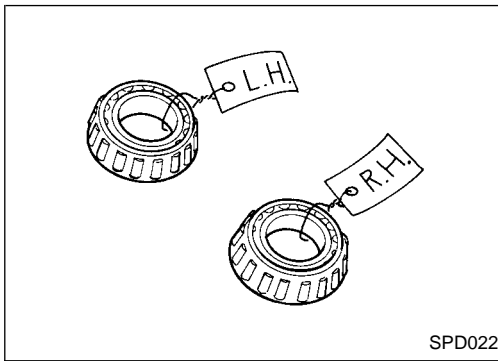

2. Loosen ring gear bolts in a criss-cross fashion.
3. Tap ring gear off the differential case with a soft hammer.

**Tap evenly all around to keep ring gear from binding.**

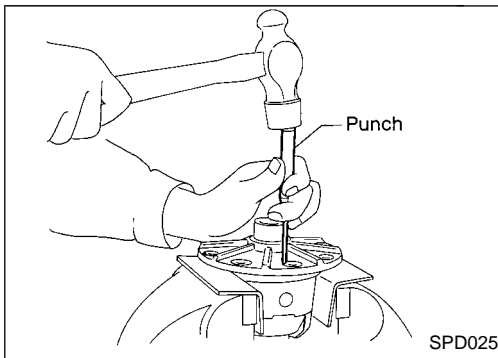

4. Punch off pinion mate shaft lock pin from ring gear side.  
**Lock pin is calked at pin hole mouth on differential case.**

GI

MA

EM

LC

EC

FE

CL

MT

AT

TF

PD

FA

RA

BR

ST

RS

BT

HA

EL

IDX

## Ring Gear and Drive Pinion

Check gear teeth for scoring, cracking or chipping. If any damaged part is evident, replace ring gear and drive pinion as a set (hypoid gear set).

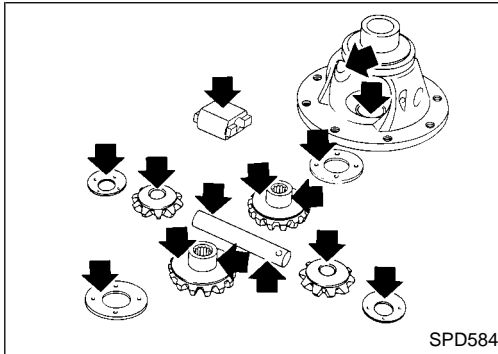

## Differential Case Assembly

Check mating surfaces of differential case, side gears, pinion mate gears, pinion mate shaft, thrust block and thrust washers.

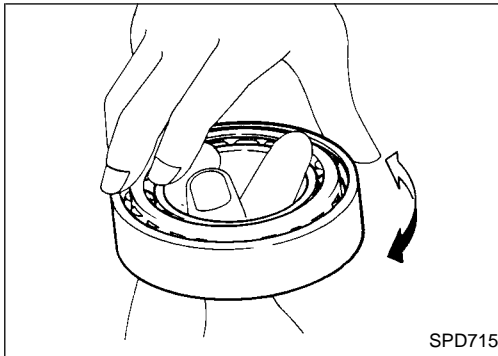

## Bearing

1. Thoroughly clean bearing.
2. Check bearings for wear, scratches, pitting or flaking. Check tapered roller bearing for smooth rotation. If damaged, replace outer race and inner cone as a set.

For quiet and reliable final drive operation, the following five adjustments must be made correctly.

1. Side bearing preload
2. Pinion gear height
3. Pinion bearing preload. Refer to "ASSEMBLY", PD-67.
4. Ring gear-to-pinion backlash. Refer to "ASSEMBLY", PD-68.
5. Ring and pinion gear tooth contact pattern

## Side Bearing Preload

A selection of carrier side bearing preload shims is required for successful completion of this procedure.

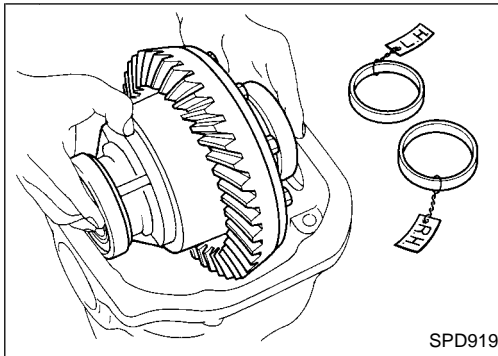

SPD919

1. Make sure all parts are clean. Make sure, also, the bearings are well lubricated with light oil or type "DEXRON™" automatic transmission fluid.
2. Place the differential carrier, with side bearings and bearing races installed, into the final drive housing.

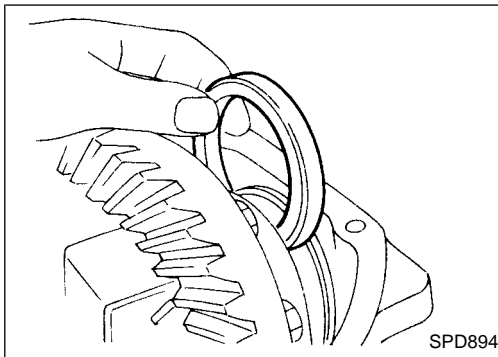

SPD894

3. Put the side bearing spacer in place.

**CAUTION:**

Side bearing spacer is placed on either the right or left depending upon final drive gear ratio. Be sure to replace it on the correct side.

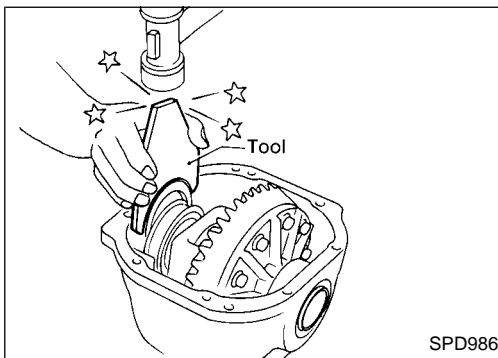

SPD986

4. Use Tool to place original carrier side bearing preload shims on the carrier end, opposite the ring gear.

**Tool number: KV38100600 (J25267)**

GI  
MA  
EM  
LC  
EC  
FE  
CL  
MT  
AT  
TF  
PD  
FA  
RA  
BR  
ST  
RS  
BT  
HA  
EL  
IDX

## ADJUSTMENT

### Side Bearing Preload (Cont'd)

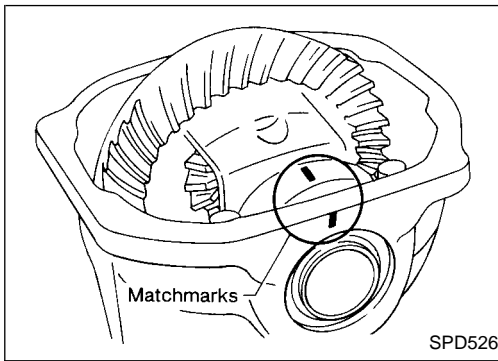

5. Install the side bearing cap in their correct locations and torque the bearing cap retaining bolts.

**Specification:**

**88 - 98 N·m**

**(9.0 - 10.0 kg·m, 65 - 72 ft·lb)**

6. Turn the carrier several times to seat the bearings.

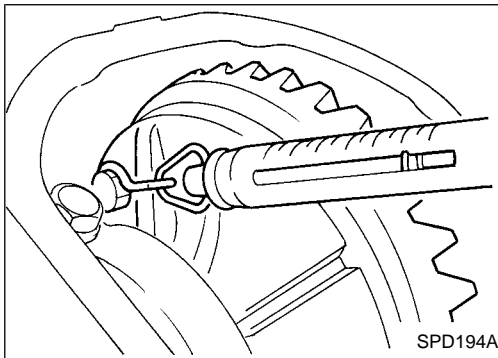

7. Measure the turning torque of the carrier at the ring gear retaining bolts with a spring gauge, J8129.

**Specification:**

**34.3 - 39.2 N**

**(3.5 - 4.0 kg, 7.7 - 8.8 lb)**

**of pulling force at the ring gear bolt**

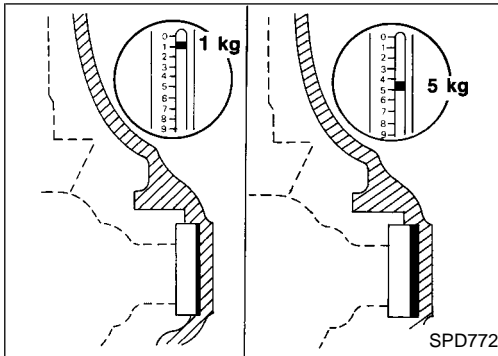

8. If the turning torque is not within the specifications, correct the torque as follows:

- If the turning torque is less than the specified range, install washers of greater thickness.
  - If the turning torque is greater than the specification, install thinner washers.
  - See the SDS section for washer dimensions and part numbers.
9. Record the total amount of washer thickness required for the correct carrier side bearing preload.

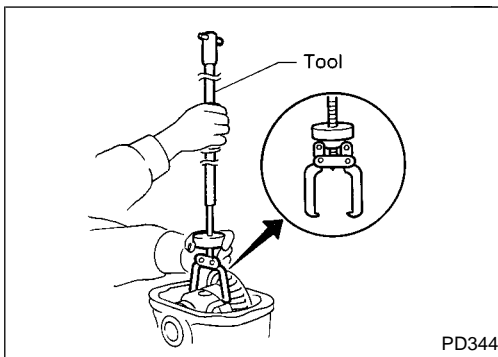

10. Remove the carrier from the final drive housing. Save the selected preload washers for later use during the assembly of the final drive unit.

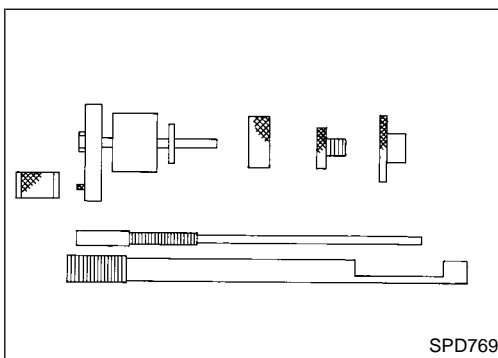

### Pinion Gear Height

1. Make sure all parts are clean and that the bearings are well lubricated.
2. Assemble the pinion gear bearings into the pinion preload shim selector Tool, J34309.

## Pinion Gear Height (Cont'd)

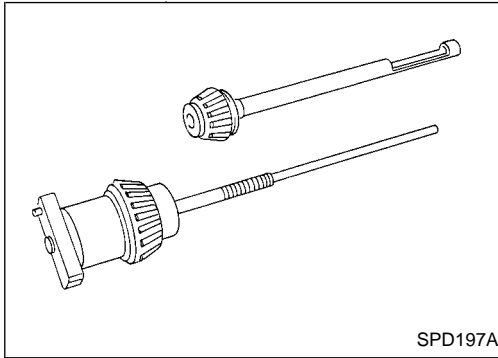

- **Front pinion bearing** — make sure the J34309-3 front pinion bearing seat is secured tightly against the J34309-2 gauge anvil. Then turn the front pinion bearing pilot, J34309-5, to secure the bearing in its proper position.
- **Rear pinion bearing** — the rear pinion bearing pilot, J34309-8, is used to center the rear pinion bearing only. The rear pinion bearing locking seat, J34309-4, is used to lock the bearing to the assembly.

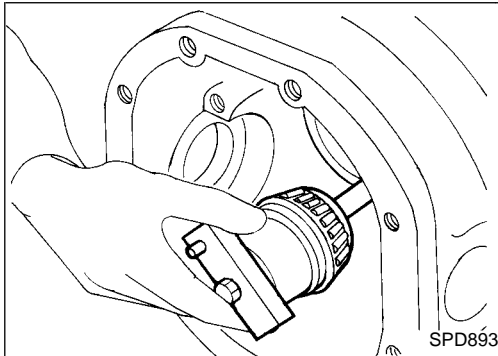

3. Install the pinion rear bearing inner cone into the final drive housing. Then place the pinion preload shim selector Tool, J34309-1, gauge screw assembly.

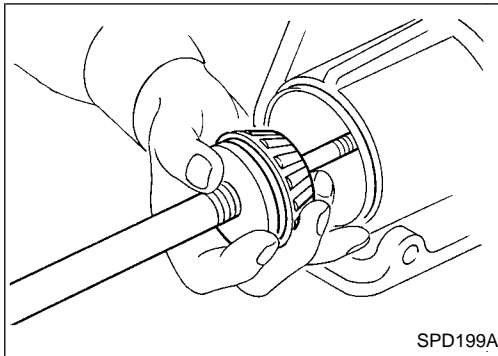

4. Assemble the front pinion bearing inner cone and the J34309-2 gauge anvil. Assemble them together with the J34309-1 gauge screw in the final drive housing. Make sure that the pinion height gauge plate, J34309-16, will turn a full 360 degrees. Tighten the two sections together by hand.

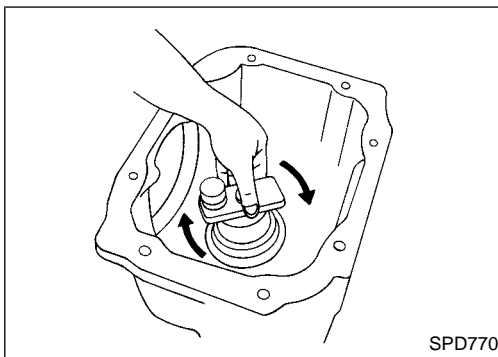

5. Turn the assembly several times to seat the bearings.

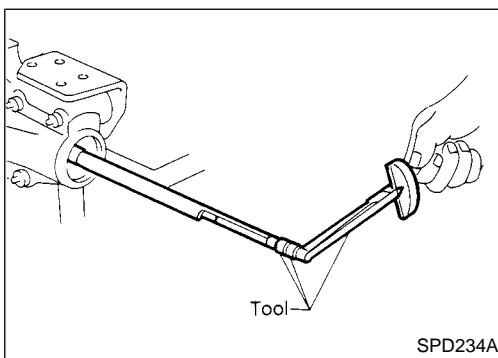

6. Measure the turning torque at the end of the J34309-2 gauge anvil using Tool.

**Tool number: ST3127S000 (J25765-A)**

**Turning torque specification:**

**1.0 - 1.3 N·m**

**(10 - 13 kg-cm, 8.7 - 11.3 in-lb)**

GI  
MA  
EM  
LC  
EC  
FE  
CL  
MT  
AT  
TF  
PD  
FA  
RA  
BR  
ST  
RS  
BT  
HA  
EL  
IDX

**Pinion Gear Height (Cont'd)**

7. Place the J34309-11 pinion height adapter onto the gauge plate and tighten it by hand.

**CAUTION:**

**Make sure all machined surfaces are clean.**

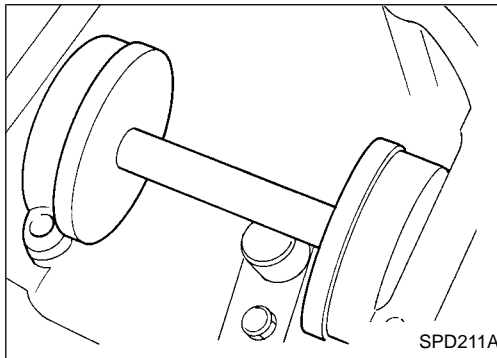
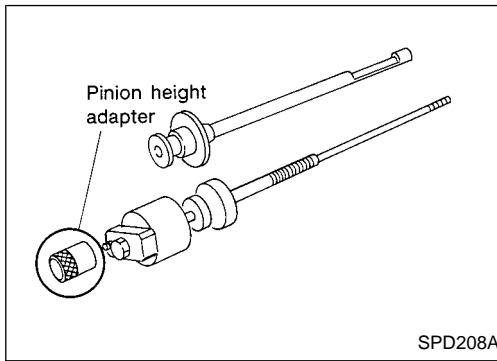
**PINION HEIGHT ADJUSTING WASHER SELECTION**

8. Now, position the side bearing discs, J25269-4, and arbor firmly into the side bearing bores. Install the side bearing caps and tighten the cap bolts to proper torque.

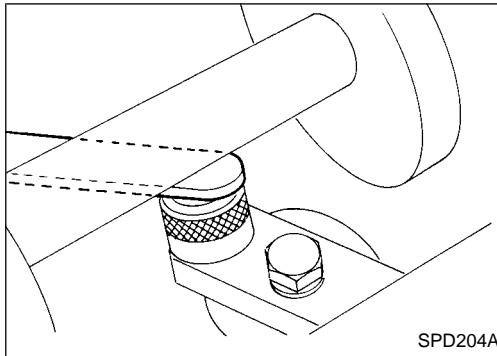

9. Select the correct standard pinion height adjusting washer thickness. Select by using a standard gauge of 3 mm (0.12 in) and J34309-101 feeler gauge. Measure the distance between the J34309-11 pinion height adapter including the standard gauge and the arbor.

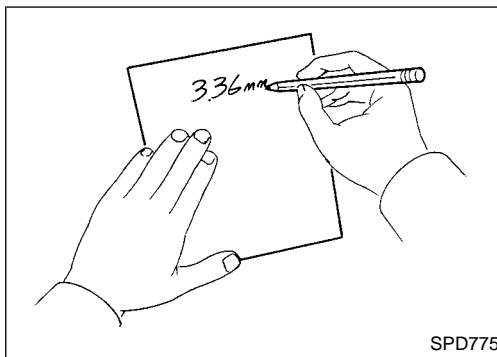

10. Write down your exact measurement (the value of feeler gauge).

**Pinion Gear Height (Cont'd)**

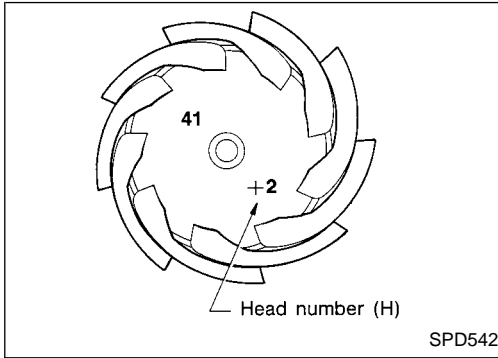

11. Correct the pinion height washer size by referring to the “pinion head number”.

There are two numbers painted on the pinion gear. The first one refers to the pinion and ring gear as a matched set. This number should be the same as the number on the ring gear. The second number is the “pinion head height number”. It refers to the ideal pinion height from standard for quietest operation. Use the following chart to determine the correct pinion height washer.

Use the following chart to determine the correct pinion height washer:

Pinion head height number	Add or remove from the standard pinion height washer thickness measurement
-6	Add 0.06 mm (0.0024 in)
-5	Add 0.05 mm (0.0020 in)
-4	Add 0.04 mm (0.0016 in)
-3	Add 0.03 mm (0.0012 in)
-2	Add 0.02 mm (0.0008 in)
-1	Add 0.01 mm (0.0004 in)
0	Use the selected washer thickness
+1	Subtract 0.01 mm (0.0004 in)
+2	Subtract 0.02 mm (0.0008 in)
+3	Subtract 0.03 mm (0.0012 in)
+4	Subtract 0.04 mm (0.0016 in)
+5	Subtract 0.05 mm (0.0020 in)
+6	Subtract 0.06 mm (0.0024 in)

12. Select the correct pinion height washer.

**Drive pinion height adjusting washer:  
Refer to SDS, PD-74.**

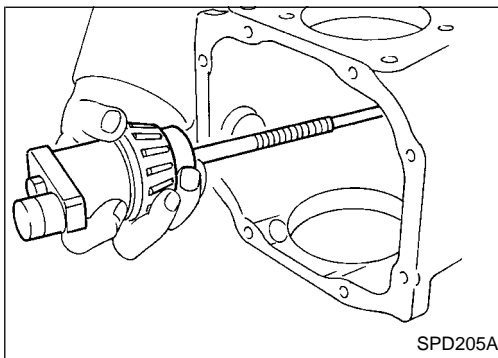

13. Remove the J34309 pinion preload shim selector Tool from the final drive housing. Then disassemble to retrieve the pinion bearings.

GI  
MA  
EM  
LC  
EC  
FE  
CL  
MT  
AT  
TF  
PD  
FA  
RA  
BR  
ST  
RS  
BT  
HA  
EL  
IDX

### Tooth Contact

Checking gear tooth contact pattern is necessary to verify correct relationship between ring gear and drive pinion.

Hypoid gear set which is not positioned properly may be noisy, or have short life or both. With the checking of gear tooth contact pattern, the most desirable contact for low noise level and long life can be assured.

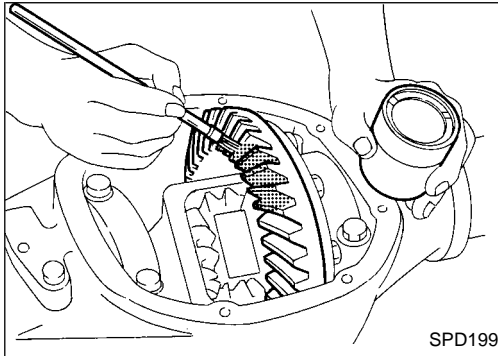

1. Thoroughly clean ring gear and drive pinion teeth.
2. Sparingly apply a mixture of powdered ferric oxide and oil or equivalent to 3 or 4 teeth of ring gear drive side.

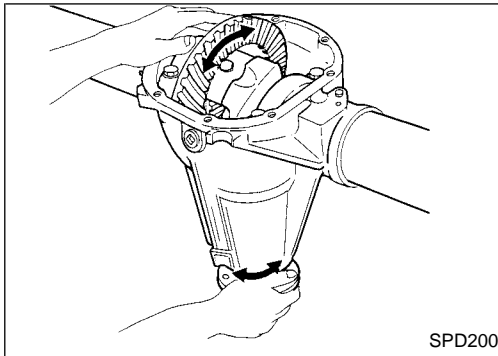

3. Hold companion flange steady and rotate the ring gear in both directions.

Usually the pattern will be correct if shims are correctly calculated and the backlash is correct. However, in rare cases, trial and error processes may be employed to obtain a correct pattern. The tooth pattern is the best indication of how well a differential has been set up.

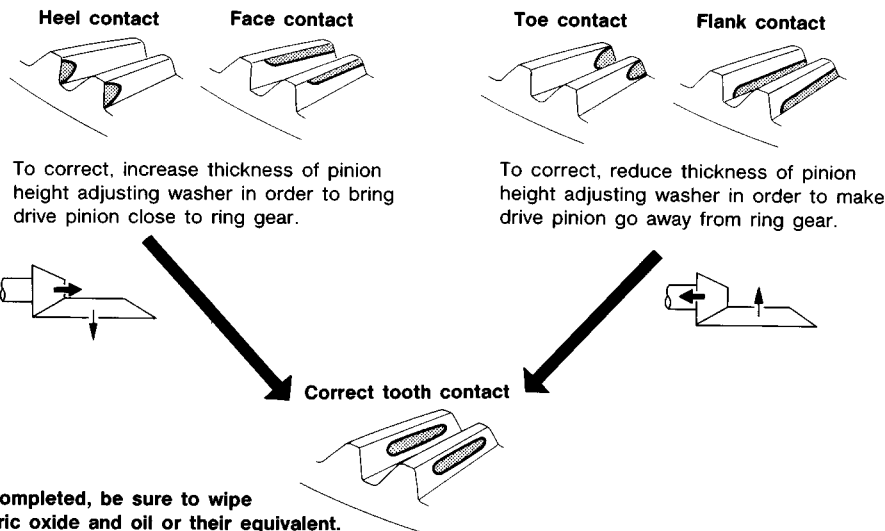

When adjustment is completed, be sure to wipe off completely the ferric oxide and oil or their equivalent.



GI  
MA  
EM  
LC  
EC  
FE  
CL  
MT  
AT  
TF  
PD  
FA  
RA  
BR  
ST  
RS  
BT  
HA  
EL  
IDX

**Differential Case**

1. Measure clearance between side gear thrust washer and differential case.

**Clearance between side gear thrust washer and differential case (A – B):**

**Less than 0.15 mm (0.0059 in)**

The clearance can be adjusted with side gear thrust washer. Refer to SDS, PD-74.

2. Apply gear oil to gear tooth surfaces and thrust surfaces and check to see they turn properly.

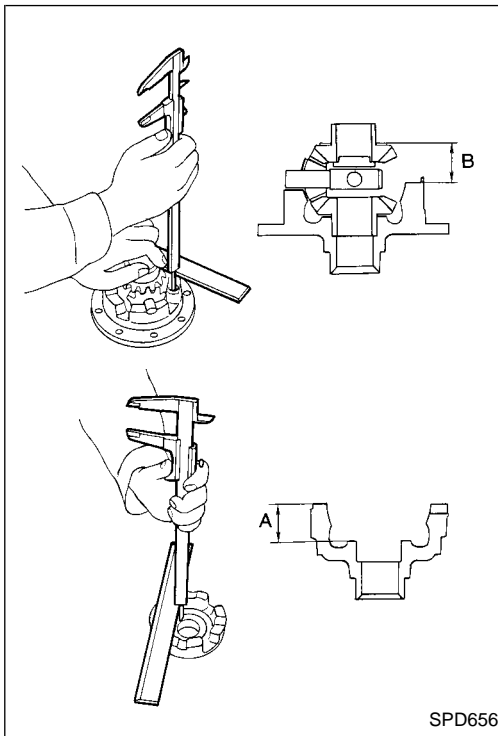

SPD656

3. Install differential case LH and RH.

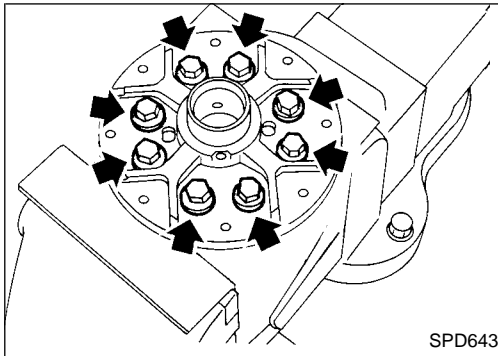

SPD643

4. Place differential case on ring gear.
5. Apply locking agent [Locktite (stud lock) or equivalent] to ring gear bolts, and install them.

**Tighten bolts in a criss-cross fashion, lightly tapping bolt head with a hammer.**

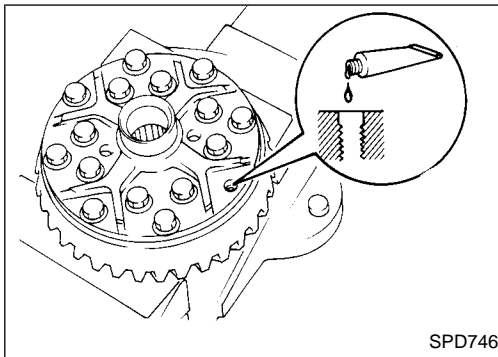

SPD746

6. Press-fit side bearing inner cones on differential case with Tool.

**Tool numbers:**

- Ⓐ ST33230000 (J25805-01)
- Ⓑ ST33061000 (J8107-2)

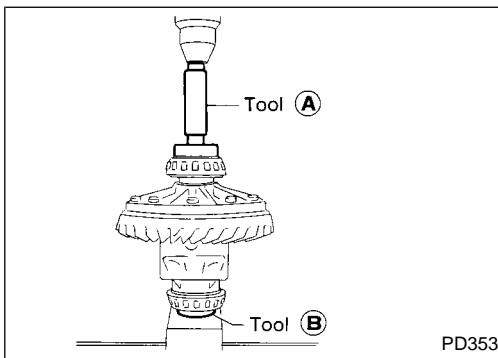

PD353

### Differential Carrier

1. Press-fit front and rear bearing outer races with Tools.

**Tool numbers:**

- (A) ST30611000 (J25742-1)
- (B) ST30621000 (J25742-5)
- (C) ST30613000 (J25742-3)

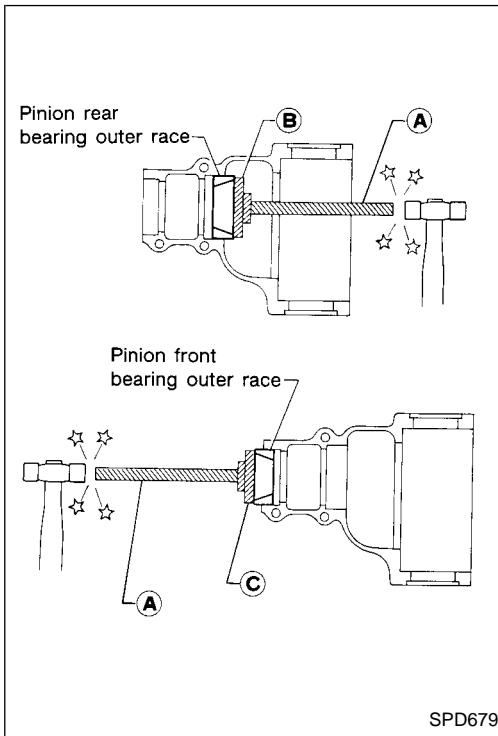

2. Select pinion height adjusting washer. Refer to "ADJUSTMENT", PD-60.
3. Install pinion height adjusting washer in drive pinion, and press-fit rear bearing inner cone in it, with press and Tool.

**Tool number: ST30901000 (J26010-01)**

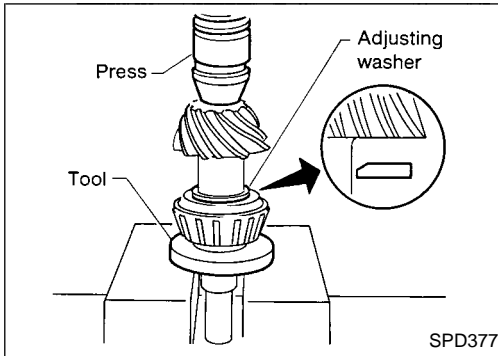

4. Place pinion front bearing inner cone in gear carrier.

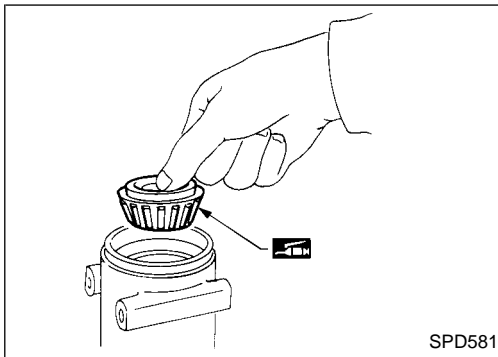

5. Apply multi-purpose grease to cavity at sealing lips of oil seal. Install front oil seal.

**Tool number: KV38100500 (J25273)**

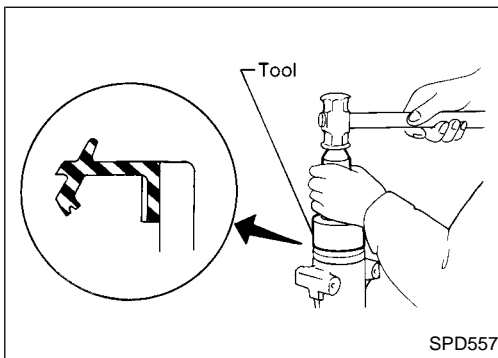

Differential Carrier (Cont'd)

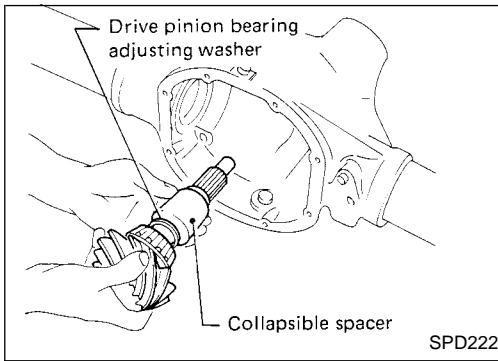

6. Place drive pinion bearing spacer, drive pinion bearing adjusting washer and drive pinion in gear carrier.

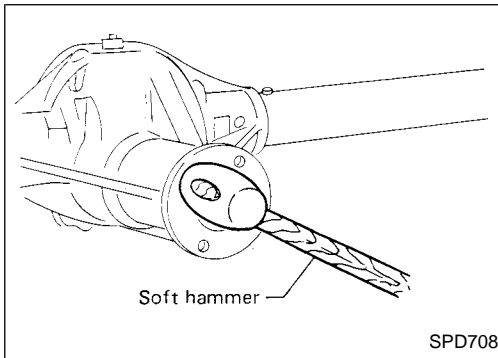

7. Insert companion flange into drive pinion by tapping the companion flange with a soft hammer.

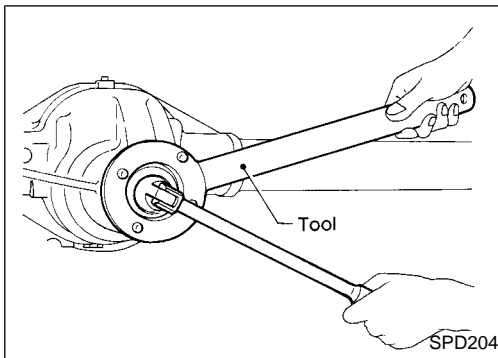

8. Tighten pinion nut to 127 N·m (13 kg-m, 94 ft-lb).  
**The threaded portion of drive pinion and pinion nut should be free from oil or grease.**  
**Tool number: ST38060002 (J34311)**

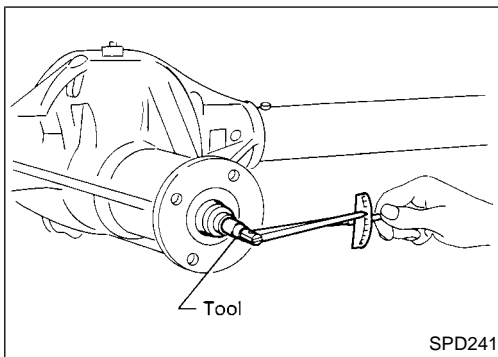

9. Tighten the pinion nut by very small degrees until the specified preload is achieved. When checking the preload, turn the drive pinion in both directions several times to set the bearing rollers.  
**Tool number: ST3127S000 (J25765-A)**  
**Pinion bearing preload:**  
 1.1 - 1.7 N·m  
 (11 - 17 kg-cm, 9.5 - 14.8 in-lb)

**This procedure will have to be repeated if:**

- **Maximum preload is achieved before the minimum pinion nut torque is reached.**
- **Minimum preload is not achieved before maximum pinion nut torque is reached.**

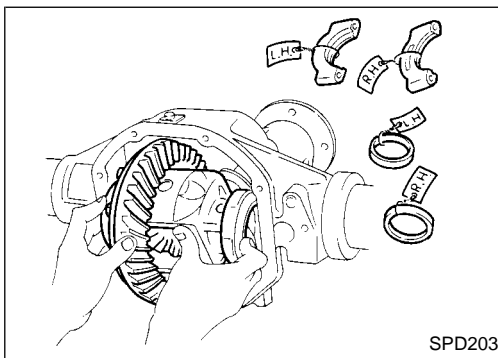

10. Select side bearing adjusting washer. Refer to Adjustment PD-59.
11. Install differential case assembly with side bearing outer races into gear carrier.

GI  
 MA  
 EM  
 LC  
 EC  
 FE  
 CL  
 MT  
 AT  
 TF  
 PD  
 FA  
 RA  
 BR  
 ST  
 RS  
 BT  
 HA  
 EL  
 IDX

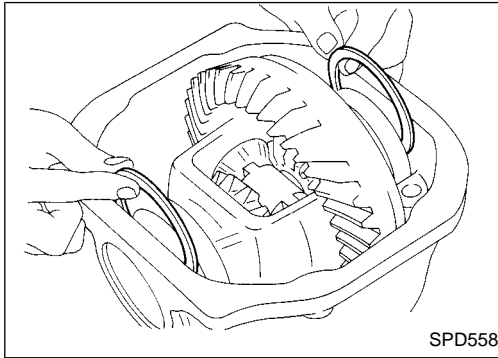
**Differential Carrier (Cont'd)**

12. Insert left and right side bearing adjusting washers in place between side bearing and carrier.

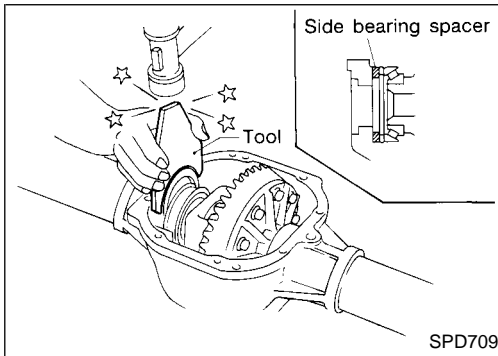

13. Drive in side bearing spacer with Tool.  
**Tool number: KV38100600 (J25267)**

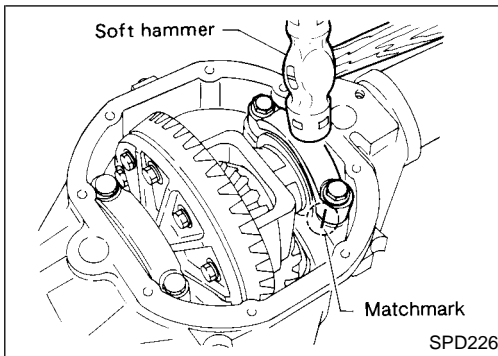

14. Align mark on bearing cap with that on gear carrier and install bearing cap on gear carrier.

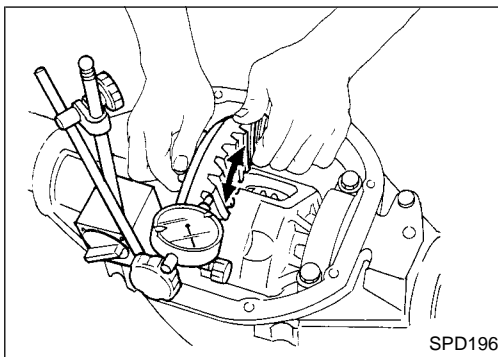

15. Measure ring gear-to-drive pinion backlash with a dial indicator.  
**Ring gear-to-drive pinion backlash:**  
**0.13 - 0.18 mm**  
**(0.0051 - 0.0071 in)**

- If backlash is too small, decrease thickness of right shim and increase thickness of left shim by the same amount.  
If backlash is too great, reverse the above procedure.

**Never change the total amount of shims as it will change the bearing preload.**

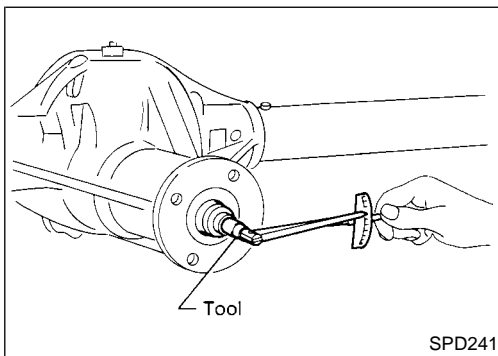

16. Check total preload with Tool.  
**When checking preload, turn drive pinion in both directions several times to seat bearing rollers correctly.**

**Total preload:**  
**1.2 - 2.3 N·m**  
**(12 - 23 kg-cm, 10 - 20 in-lb)**  
**Tool number: ST3127S000 (J25765-A)**

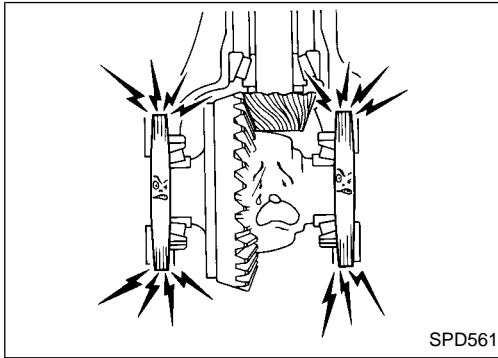
**Differential Carrier (Cont'd)**

- If preload is too great, remove the same amount of shim from each side.
- If preload is too small, add the same amount of shim to each side.

**Never add or remove a different number of shims for each side as it will change ring gear-to-drive pinion backlash.**

17. Recheck ring gear-to-drive pinion backlash because increase or decrease in thickness of shims will cause change of ring gear-to-pinion backlash.

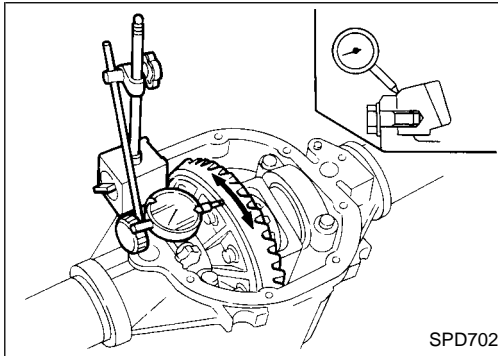

18. Check runout of ring gear with a dial indicator.

**Runout limit:**

**0.05 mm (0.0020 in)**

- If backlash varies excessively in different places, the variance may have resulted from foreign matter caught between the ring gear and the differential case.
  - If the backlash varies greatly when the runout of the ring gear is within a specified range, the hypoid gear set or differential case should be replaced.
19. Check tooth contact.  
Refer to "ADJUSTMENT", PD-64.
  20. Install rear cover and gasket.

GI

MA

EM

LC

EC

FE

CL

MT

AT

TF

**PD**

FA

RA

BR

ST

RS

BT

HA

EL

IDX

# SERVICE DATA AND SPECIFICATIONS (SDS)

## Propeller Shaft

### GENERAL SPECIFICATIONS

#### 2WD models

Applied model	Standard wheelbase		Long wheelbase		
	M/T	A/T	M/T	A/T	
Propeller shaft model	2S1310		3S1310		
Number of joints	2		3		
Coupling method with transmission	Sleeve type				
Type of journal bearings	Solid type (disassembly type)				
Shaft length (Spider to spider)	1st	1323.3	549.6	644.7	549.6
	mm (in)	2nd	—	675.5	975.5
Shaft diameter	1st	88.9	63.5		
	mm (in)	2nd	—	63.5	

#### 4WD models

Location	Front		Rear	
	Standard wheelbase	Long wheelbase	Standard wheelbase	Long wheelbase
Applied model	2F1310		2S1310	3S1310
Number of joints	2			3
Coupling method with transmission	Flange type		Sleeve type	
Type of journal bearings	Solid type (disassembly type)			
Shaft length (Spider to spider)	1st	542	968	392.1
	mm (in)	2nd	—	873.9
Shaft diameter	1st	63.5		
	mm (in)	2nd	—	63.5

### SERVICE DATA

Unit: mm (in)

Propeller shaft runout limit	0.6 (0.024)
Journal axial play	0.02 (0.0008) or less

### Snap ring

Unit: mm (in)

Thickness	Color	Part number
1.99 (0.0783)	White	37146-C9400
2.02 (0.0795)	Yellow	37147-C9400
2.05 (0.0807)	Red	37148-C9400
2.08 (0.0819)	Green	37149-C9400
2.11 (0.0831)	Blue	37150-C9400
2.14 (0.0843)	Light brown	37151-C9400
2.17 (0.0854)	Black	37152-C9400
2.20 (0.0866)	No paint	37153-C9400

# SERVICE DATA AND SPECIFICATIONS (SDS)

## Final Drive

### GENERAL SPECIFICATIONS

#### 2WD models

Transmission	M/T		A/T	
	Regular cab	King cab	Regular cab	King cab
Body type				
Final drive model	H190A	H190A	H190A	C200
	2-pinion	2-pinion	2-pinion	2-pinion
Gear ratio	3.545	3.700	3.889	4.375
Number of teeth (Ring gear/drive pinion)	39/11	37/10	35/9	35/8
Oil capacity (Approx.)   (US pt, Imp pt)	1.5 (3-1/8, 2-5/8)	1.3 (2-3/4, 2-1/4)	1.5 (3-1/8, 2-5/8)	1.3 (2-3/4, 2-1/4)

#### 4WD models

Front final drive	R180A
	4-pinion
Gear ratio	4.625
Oil capacity (Approx.)   (US pt, Imp pt)	1.3 (2-3/4, 2-1/4)
Rear final drive	C200
	4-pinion
Gear ratio	4.625
Number of teeth (Ring gear/drive pinion)	37/8
Oil capacity (Approx.)   (US pt, Imp pt)	1.3 (2-3/4, 2-1/4)

GI  
MA  
EM  
LC  
EC  
FE  
CL  
MT  
AT  
TF  
PD  
FA  
RA  
BR  
ST  
RS  
BT  
HA  
EL  
IDX

# SERVICE DATA AND SPECIFICATIONS (SDS)

## Final Drive (Cont'd)

### INSPECTION AND ADJUSTMENT (R180A)

#### Ring gear runout

Ring gear runout limit	mm (in)	0.05 (0.0020)
------------------------	---------	---------------

#### Axle bearing adjustment

Axle bearing end play	mm (in)	0 - 0.1 (0 - .0039 or less)
-----------------------	---------	-----------------------------

##### Available axle bearing adjusting shims

Thickness mm (in)	Part number
0.10 (0.0039)	38233-01G11
0.20 (0.0079)	38233-01G12
0.30 (0.0118)	38233-01G13
0.40 (0.0157)	38233-01G14

#### Side gear adjustment

Side gear backlash (Clearance between side gear and differential case)	mm (in)	Less than 0.15 (0.0059)
---	---------	-------------------------

##### Available side gear thrust washers

Thickness mm (in)	Part number
0.75 (0.0295)	38424-W2010
0.78 (0.0307)	38424-W2011
0.81 (0.0319)	38424-W2012
0.84 (0.0331)	38424-W2013
0.87 (0.0343)	38424-W2014
0.90 (0.0354)	38424-W2015
0.93 (0.0366)	38424-W2016
0.96 (0.0378)	38424-W2017

#### Side bearing adjustment

Differential carrier assembly turning resistance	N (kg, lb)	34.3 - 39.2 (3.5 - 4.0, 7.7 - 8.8)
--	------------	---------------------------------------

Side bearing adjusting method	Adjusting shim
-------------------------------	----------------

##### Available side retainer shims

Thickness mm (in)	Part number
0.20 (0.0079)	38453-01G00
0.25 (0.0098)	38453-01G01
0.30 (0.0118)	38453-01G02
0.40 (0.0157)	38453-01G03
0.50 (0.0197)	38453-01G04

#### Total preload adjustment

Total preload	N·m (kg-cm, in-lb)	1.2 - 2.3 (12 - 23, 10 - 20)
---------------	--------------------	---------------------------------

Ring gear backlash	mm (in)	0.13 - 0.18 (0.0051 - 0.0071)
--------------------	---------	----------------------------------

### Drive pinion height adjustment

#### Available pinion height adjusting washers

Thickness mm (in)	Part number
3.09 (0.1217)	38154-P6017
3.12 (0.1228)	38154-P6018
3.15 (0.1240)	38154-P6019
3.18 (0.1252)	38154-P6020
3.21 (0.1264)	38154-P6021
3.24 (0.1276)	38154-P6022
3.27 (0.1287)	38154-P6023
3.30 (0.1299)	38154-P6024
3.33 (0.1311)	38154-P6025
3.36 (0.1323)	38154-P6026
3.39 (0.1335)	38154-P6027
3.42 (0.1346)	38154-P6028
3.45 (0.1358)	38154-P6029
3.48 (0.1370)	38154-P6030
3.51 (0.1382)	38154-P6031
3.54 (0.1394)	38154-P6032
3.57 (0.1406)	38154-P6033
3.60 (0.1417)	38154-P6034
3.63 (0.1429)	38154-P6035
3.66 (0.1441)	38154-P6036

### Drive pinion preload adjustment

Drive pinion bearing preload adjusting method	Adjusting washer and spacer
Drive pinion preload N·m (kg-cm, in-lb)	
Without front oil seal	1.0 - 1.6 (10 - 16, 8.7 - 14)
With front oil seal	1.1 - 1.7 (11 - 17, 9.5 - 14.8)

#### Available drive pinion bearing preload adjusting washers

Thickness mm (in)	Part number
6.58 - 6.60 (0.2591 - 0.2598)	38127-01G00
6.56 - 6.58 (0.2583 - 0.2591)	38127-01G01
6.54 - 6.56 (0.2575 - 0.2583)	38127-01G02
6.52 - 6.54 (0.2567 - 0.2575)	38127-01G03
6.50 - 6.52 (0.2559 - 0.2567)	38127-01G04
6.48 - 6.50 (0.2551 - 0.2559)	38127-01G05
6.46 - 6.48 (0.2543 - 0.2551)	38127-01G06
6.44 - 6.46 (0.2535 - 0.2543)	38127-01G07
6.42 - 6.44 (0.2528 - 0.2535)	38127-01G08
6.40 - 6.42 (0.2520 - 0.2528)	38127-01G09
6.38 - 6.40 (0.2512 - 0.2520)	38127-01G10
6.36 - 6.38 (0.2504 - 0.2512)	38127-01G11
6.34 - 6.36 (0.2496 - 0.2504)	38127-01G12
6.32 - 6.34 (0.2488 - 0.2496)	38127-01G13
6.30 - 6.32 (0.2480 - 0.2488)	38127-01G14

#### Available drive pinion bearing preload adjusting spacers

Length mm (in)	Part number
52.20 (2.0551)	38130-78500
52.40 (2.0630)	38131-78500
52.60 (2.0709)	38132-78500
52.80 (2.0787)	38133-78500
53.00 (2.0866)	38134-78500
53.20 (2.0945)	38135-78500



# SERVICE DATA AND SPECIFICATIONS (SDS)

## Final Drive (Cont'd)

### INSPECTION AND ADJUSTMENT (H190A)

#### Ring gear runout

Ring gear runout limit	mm (in)	0.08 (0.0031)
------------------------	---------	---------------

#### Side gear adjustment

Side gear backlash (Clearance between side gear to differential case)	mm (in)	Less than 0.15 (0.0059)
--	---------	-------------------------

#### Available side gear thrust washers

Thickness mm (in)	Part number
0.75 (0.0295)	38424-E3000
0.80 (0.0315)	38424-E3001
0.85 (0.0335)	38424-E3002
0.90 (0.0354)	38424-E3003

#### Drive pinion height adjustment

#### Available drive pinion height adjusting washers

Thickness mm (in)	Part number
2.58 (0.1016)	38154-P6000
2.61 (0.1028)	38154-P6001
2.64 (0.1039)	38154-P6002
2.67 (0.1051)	38154-P6003
2.70 (0.1063)	38154-P6004
2.73 (0.1075)	38154-P6005
2.76 (0.1087)	38154-P6006
2.79 (0.1098)	38154-P6007
2.82 (0.1110)	38154-P6008
2.85 (0.1122)	38154-P6009
2.88 (0.1134)	38154-P6010
2.91 (0.1146)	38154-P6011
2.94 (0.1157)	38154-P6012
2.97 (0.1169)	38154-P6013
3.00 (0.1181)	38154-P6014
3.03 (0.1193)	38154-P6015
3.06 (0.1205)	38154-P6016
3.09 (0.1217)	38154-P6017
3.12 (0.1228)	38154-P6018
3.15 (0.1240)	38154-P6019
3.18 (0.1252)	38154-P6020

#### Drive pinion preload adjustment

Drive pinion bearing preload adjusting method	Collapsible spacer
Drive pinion preload N·m (kg-cm, in-lb)	1.1 - 1.6 (11 - 16, 9.5 - 13.9)
With front oil seal	

#### Side bearing adjustment

Differential carrier assembly turning resistance N (kg, lb)	34.3 - 39.2 (3.5 - 4.0, 7.7 - 8.8)
Side bearing adjusting method	Adjusting shim

#### Available side bearing adjusting shims

Thickness mm (in)	Part number
0.10 (0.0039)	38455-61200
0.12 (0.0047)	38453-61201
0.15 (0.0059)	38453-61202
0.17 (0.0067)	38453-61203
0.20 (0.0079)	38456-61200
0.25 (0.0098)	38453-61204
0.30 (0.0118)	38453-61205
0.40 (0.0157)	38453-61206
0.50 (0.0197)	38457-61200

#### Total preload adjustment

Total preload N·m (kg-cm, in-lb)	1.2 - 2.2 (12 - 22, 10 - 19)
Ring gear backlash mm (in)	0.13 - 0.18 (0.0051 - 0.0071)

GI

MA

EM

LC

EC

FE

CL

MT

AT

TF

PD

FA

RA

BR

ST

RS

BT

HA

EL

IDX

# SERVICE DATA AND SPECIFICATIONS (SDS)

## Final Drive (Cont'd)

### INSPECTION AND ADJUSTMENT (C200)

#### Ring gear runout

Ring gear runout limit	mm (in)	0.05 (0.0020)
------------------------	---------	---------------

#### Side gear adjustment

Side gear backlash (Clearance between side gear and differential case)	mm (in)	Less than 0.15 (0.0059)
---	---------	-------------------------

##### Available side gear thrust washers (2WD)

Thickness mm (in)	Part number
0.75 (0.0295)	38424-N3110
0.78 (0.0307)	38424-N3111
0.81 (0.0319)	38424-N3112
0.84 (0.0331)	38424-N3113
0.87 (0.0343)	38424-N3114
0.90 (0.0354)	38424-N3115
0.93 (0.0366)	38424-N3116

##### Available side gear thrust washers (4WD)

Thickness mm (in)	Part number
0.75 (0.0295)	38424-E3000
0.80 (0.0315)	38424-E3001
0.85 (0.0335)	38424-E3002
0.90 (0.0354)	38424-E3003

#### Side bearing adjustment

Differential carrier assembly turning resistance	N (kg, lb)	34.3 - 39.2 (3.5 - 4.0, 7.7 - 8.8)
--	------------	---------------------------------------

##### Available side bearing adjusting washers

Thickness mm (in)	Part number
2.00 (0.0787)	38453-N3100
2.05 (0.0807)	38453-N3101
2.10 (0.0827)	38453-N3102
2.15 (0.0846)	38453-N3103
2.20 (0.0866)	38453-N3104
2.25 (0.0886)	38453-N3105
2.30 (0.0906)	38453-N3106
2.35 (0.0925)	38453-N3107
2.40 (0.0945)	38453-N3108
2.45 (0.0965)	38453-N3109
2.50 (0.0984)	38453-N3110
2.55 (0.1004)	38453-N3111
2.60 (0.1024)	38453-N3112

### Drive pinion height adjustment

#### Available pinion height adjusting washers

Thickness mm (in)	Part number
3.09 (0.1217)	38154-P6017
3.12 (0.1228)	38154-P6018
3.15 (0.1240)	38154-P6019
3.18 (0.1252)	38154-P6020
3.21 (0.1264)	38154-P6021
3.24 (0.1276)	38154-P6022
3.27 (0.1287)	38154-P6023
3.30 (0.1299)	38154-P6024
3.33 (0.1311)	38154-P6025
3.36 (0.1323)	38154-P6026
3.39 (0.1335)	38154-P6027
3.42 (0.1346)	38154-P6028
3.45 (0.1358)	38154-P6029
3.48 (0.1370)	38154-P6030
3.51 (0.1382)	38154-P6031
3.54 (0.1394)	38154-P6032
3.57 (0.1406)	38154-P6033
3.60 (0.1417)	38154-P6034
3.63 (0.1429)	38154-P6035
3.66 (0.1441)	38154-P6036

### Drive pinion preload adjustment

Drive pinion bearing preload adjusting method	Collapsible spacer
Drive pinion preload N·m (kg-cm, in-lb)	
Without front oil seal	1.0 - 1.6 (10 - 16, 8.7 - 14)
With front oil seal	1.1 - 1.7 (11 - 17, 9.5 - 15)

### Total preload adjustment

Total preload N·m (kg-cm, in-lb)	
	1.2 - 2.3 (12 - 23, 10 - 20)
Ring gear backlash	mm (in)
	0.13 - 0.18 (0.0051 - 0.0071)