

A
B
C

SECTION **PR**

PROPELLER SHAFT

PR

CONTENTS

PREPARATION 2	Inspection 9	F
Special Service Tools 2	Disassembly 9	
NOISE, VIBRATION, AND HARSHNESS (NVH)	CENTER BEARING 9	
TROUBLESHOOTING 3	JOURNAL 10	G
NVH Troubleshooting Chart 3	Assembly 11	
ON-VEHICLE SERVICE 4	CENTER BEARING 11	
Propeller Shaft Vibration 4	JOURNAL 12	H
Appearance Checking 5	SERVICE DATA AND SPECIFICATIONS (SDS) 13	
PROPELLER SHAFT ASSEMBLY 6	General Specifications 13	
Components 6	2WD KA24DE MODELS 13	
FRONT PROPELLER SHAFT 6	2WD VG33E AND VG33ER MODELS 13	I
REAR PROPELLER SHAFT 7	4WD MODELS 13	
Removal and Installation 8	Service Data 14	J

E

F

G

H

I

J

K

L

M

PREPARATION

PREPARATION

PFP:00002

Special Service Tools

EDS000CG

The actual shapes of Kent-Moore tools may differ from those of special service tools illustrated here.

Tool number (Kent-Moore No.) Tool name	Description
KV38108300 (J-44195) Companion flange wrench	Removing and installing propeller shaft lock nut, and drive pinion lock nut
ST3090S000 (—) Drive pinion rear inner race puller set 1 ST30031000 (J22912-01) Puller 2 ST30901000 (J26010-01) Base	Removing and installing drive pinion rear inner cone a: 79 mm (3.11 in) dia. b: 45 mm (1.77 in) dia. c: 35 mm (1.38 in) dia.
KV40106500 (J-45073) Rear axle shaft bearing puller	Removing wheel bearing, wheel bearing lock nut and ABS sensor rotor

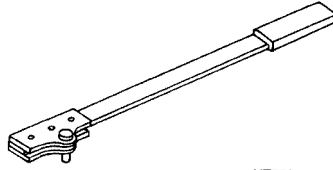

NT771

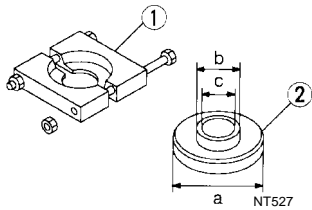

NT527

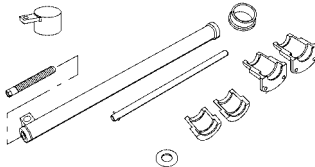

LPD022

ON-VEHICLE SERVICE

PF0:0000

EDS000CJ

ON-VEHICLE SERVICE

Propeller Shaft Vibration

If vibration is present at high speed, inspect propeller shaft runout first.

1. Raise rear end of vehicle until wheels are clear of the ground.
2. Measure propeller shaft runout at several points along propeller shaft by rotating final drive companion flange with hands.

Runout limit : 0.6 mm (0.024 in)

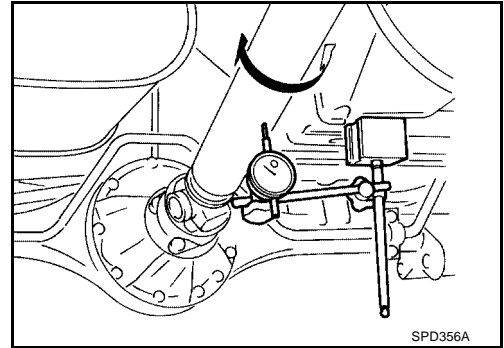

Propeller shaft runout measuring points:

KA24DE engine

Unit: mm (in)

Distance		A	B	C
3S1310 (King Cab)	A/T	226 (8.90)	485 (19.09)	485 (19.09)
	M/T	274 (10.79)	485 (19.09)	485 (19.09)

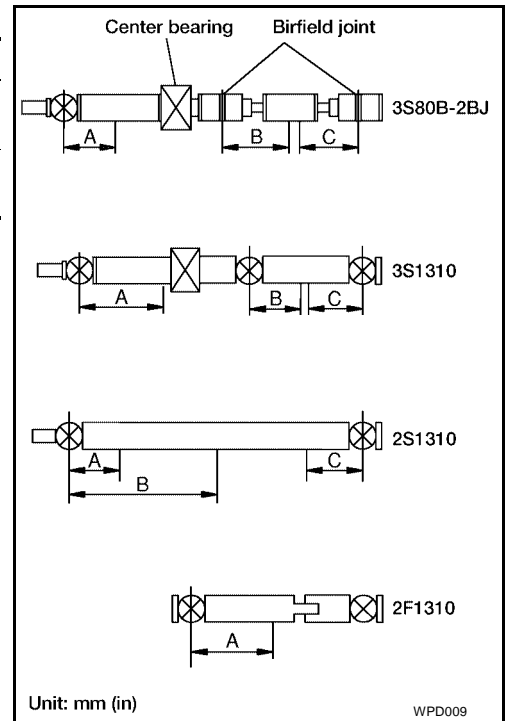

VG33E engine

Unit: mm (in)

Distance		A	B	C
3S1310 (2WD)	A/T	241 (9.49)	491 (19.33)	491 (19.33)
	M/T	288 (11.34)	491 (19.33)	491 (19.33)
2S1310 (4WD)	All	237 (9.33)	623.5 (24.55)	237 (9.33)
2F1310 (4WD)	A/T	271 (10.67)	—	—
	M/T	271 (10.67)	—	—

ON-VEHICLE SERVICE

VG33ER engine

Unit: mm (in)

Distance		A	B	C
3S80B-2BJ (2WD, Except Crew Cab Long Bed)	All	162 (6.38)	240 (9.45)	240 (9.45)
3S1310 (2WD, Crew Cab Long Bed)	All	241 (9.49)	491 (19.33)	491 (19.33)
2S1310 (4WD)	All	237 (9.33)	623.5 (24.55)	237 (9.33)
2F1310 (4WD)	A/T	271 (10.67)	—	—
	M/T	271 (10.67)	—	—

3. If runout exceeds specifications, disconnect propeller shaft at final drive companion flange; then rotate companion flange 180 degrees and reconnect propeller shaft.
4. Check runout again. If runout still exceeds specifications, replace propeller shaft assembly.
5. Perform road test.

Appearance Checking

EDS000CK

- Inspect propeller shaft tube surface for dents or cracks. If damaged, replace propeller shaft assembly.
- If center bearing is noisy or damaged, replace center bearing.

A
B
C
PR
E
F
G
H
I
J
K
L
M

PROPELLER SHAFT ASSEMBLY

PFP:37000

EDS000H1

PROPELLER SHAFT ASSEMBLY

Components FRONT PROPELLER SHAFT

SEC. 370
Model 2F1310

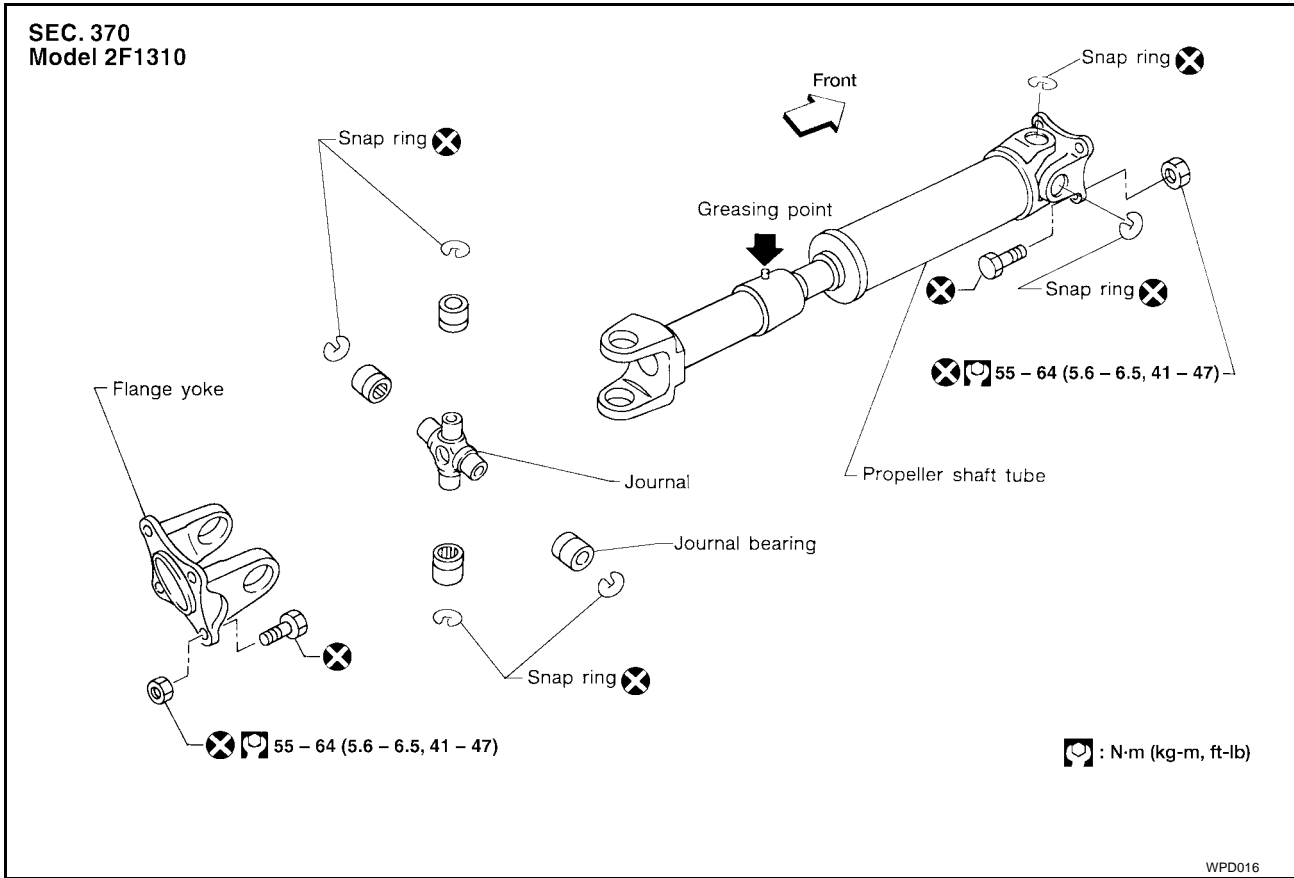

PROPELLER SHAFT ASSEMBLY

REAR PROPELLER SHAFT

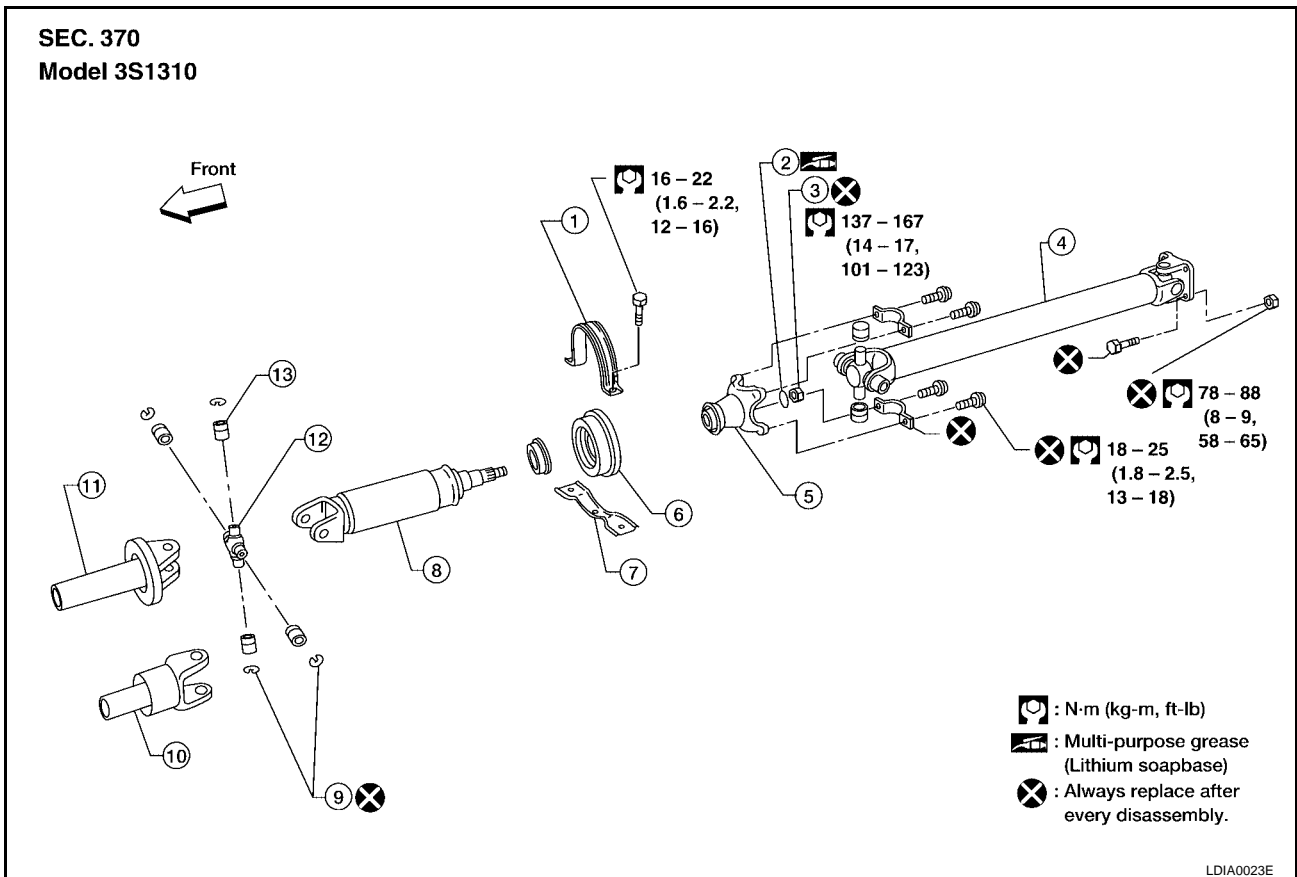
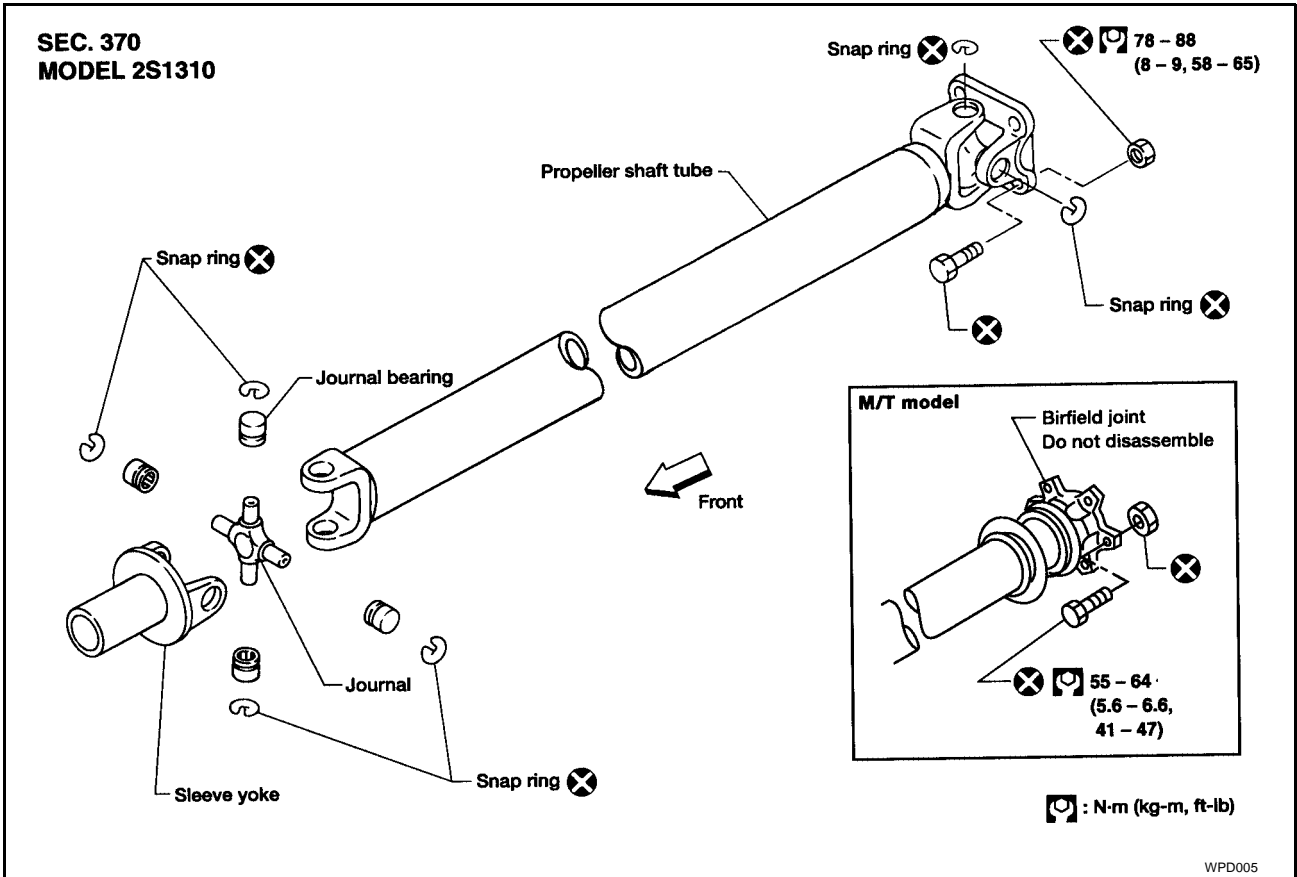

A
B
C
PR
E
F
G
H
I
J
K
L
M

PROPELLER SHAFT ASSEMBLY

- | | | |
|--|-----------------------------|----------------------------|
| 1. Center bearing upper mounting bracket | 2. Washer | 3. Lock nut |
| 4. Propeller shaft 2nd tube | 5. Companion flange | 6. Center bearing assembly |
| 7. Center bearing lower mounting bracket | 8. Propeller shaft 1st tube | 9. Snap ring |
| 10. Sleeve yoke (A/T) | 11. Sleeve yoke (M/T) | 12. Journal |
| 13. Journal bearing | | |

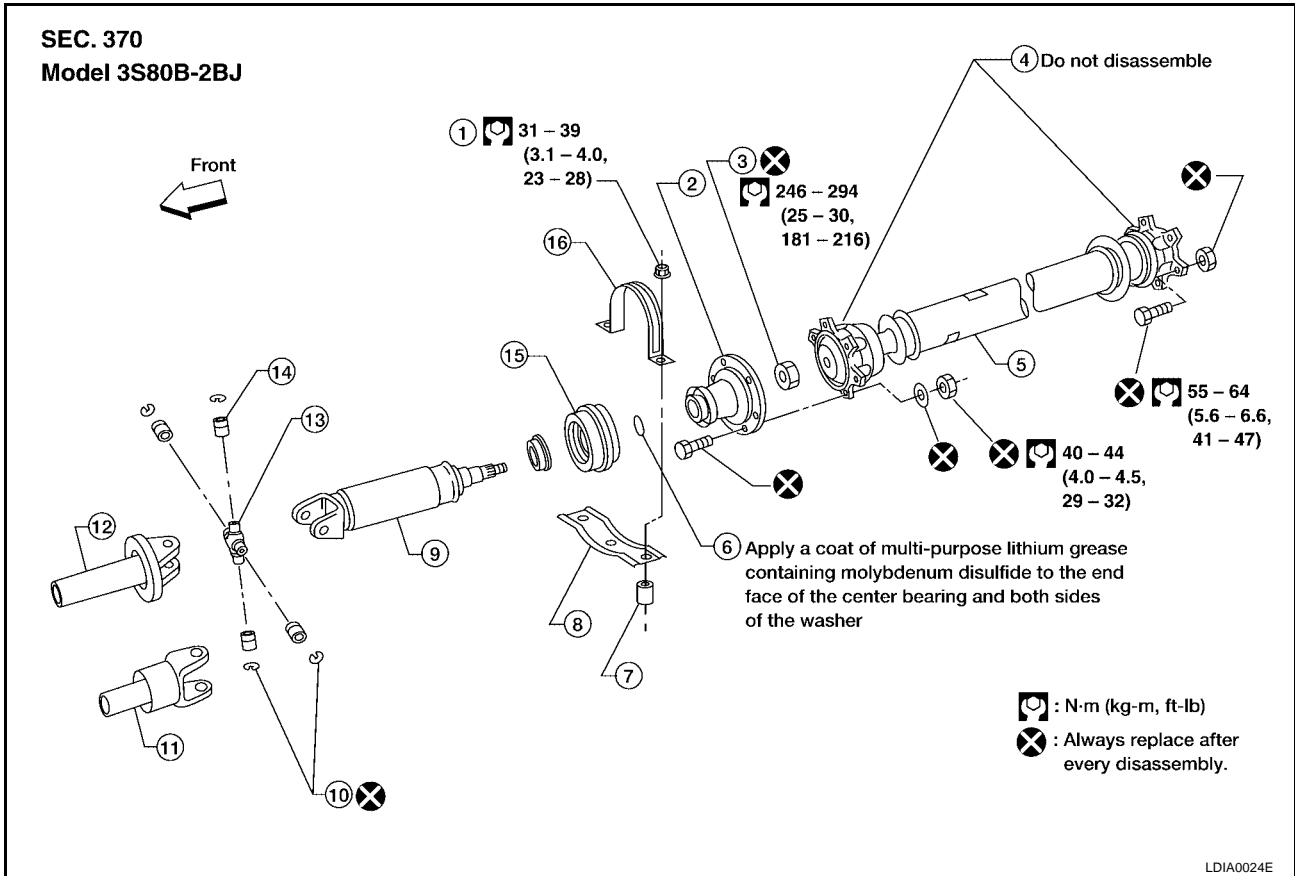

- | | | |
|---|--|-------------------------------|
| 1. Lock nut | 2. Companion flange | 3. Lock nut |
| 4. Birfield joint | 5. Propeller shaft second tube | 6. Washer |
| 7. Spacer | 8. Center bearing lower mounting bracket | 9. Propeller shaft first tube |
| 10. Snap ring | 11. Sleeve yoke (A/T) | 12. Sleeve yoke (M/T) |
| 13. Journal | 14. Journal bearing | 15. Center bearing assembly |
| 16. Center bearing upper mounting bracket | | |

Removal and Installation

- Put match marks on flanges and separate propeller shaft from final drive.

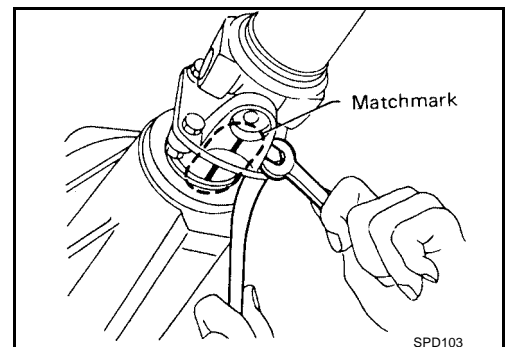

PROPELLER SHAFT ASSEMBLY

2. Remove propeller shaft.
Insert plug into rear oil seal after removing rear propeller shaft.

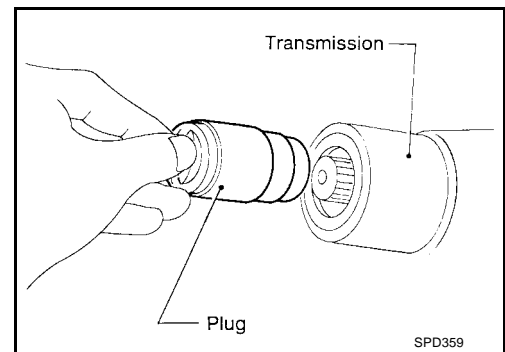

EDS000H3

Inspection

- Inspect propeller shaft runout. If runout exceeds specifications, replace propeller shaft assembly.

Runout limit : 0.6 mm (0.024 in)

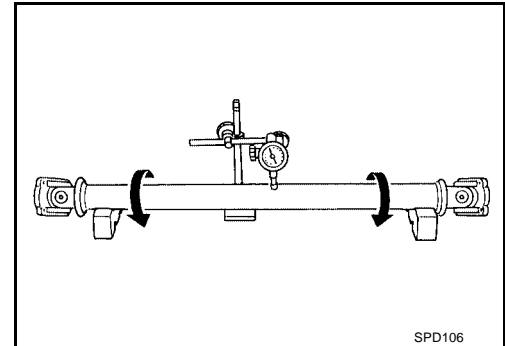

- If the play exceeds specifications, replace propeller shaft assembly.

Journal axial play : 0.02 mm (0.0008 in) or less

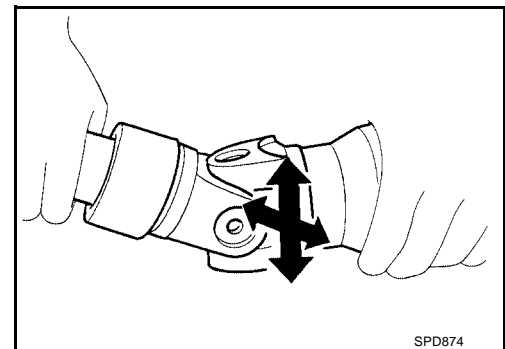

EDS000H4

Disassembly CENTER BEARING

1. Put match marks on flanges, and separate 2nd tube from 1st tube.

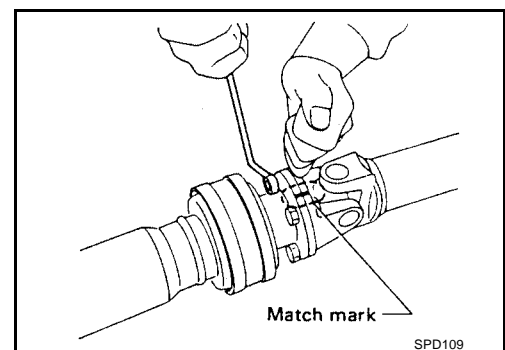

A
B
C
PR
E
F
G
H
I
J
K
L
M

PROPELLER SHAFT ASSEMBLY

2. Put match marks on the flange and shaft.

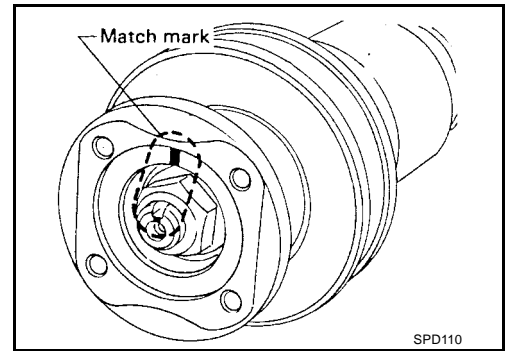

3. Remove locking nut with Tool.

Tool number : KV38108300 (J-44195)

4. Remove companion flange with puller.

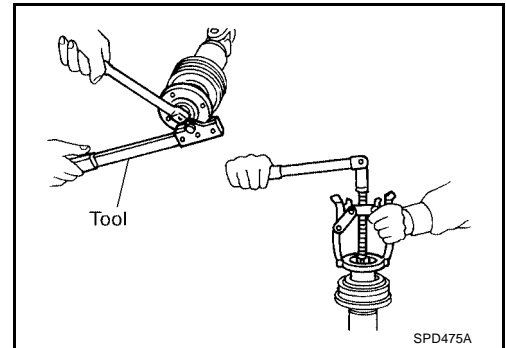

5. Remove center bearing with Tool and press.

Tool number : ST30031000 (J22912-01)

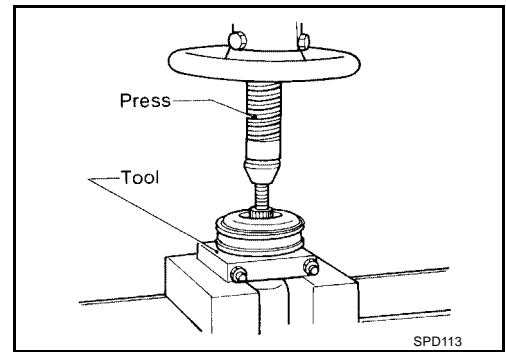

JOURNAL

1. Put match marks on shaft and flange or yoke.

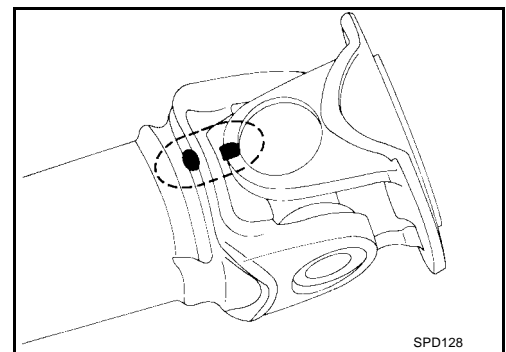

2. Remove snap ring.

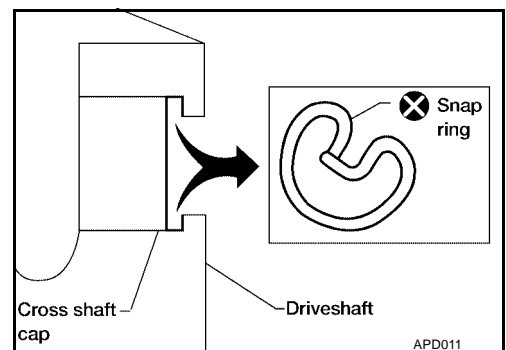

PROPELLER SHAFT ASSEMBLY

3. Remove pushed out journal bearing by lightly tapping yoke with a hammer, taking care not to damage journal and yoke hole.

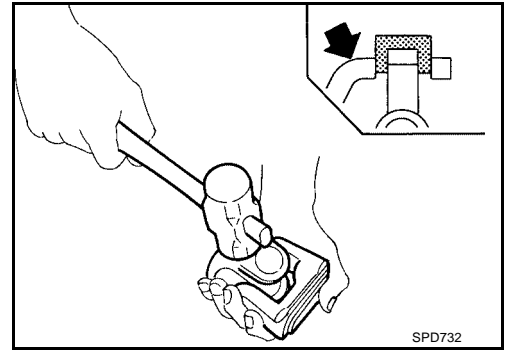

4. Remove bearing at opposite side in above operation. **Put marks on disassembled parts so that they can be reinstalled in their original positions from which they were removed.**

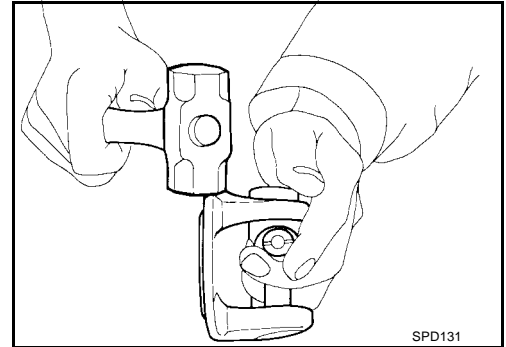

Assembly CENTER BEARING

1. When installing center bearing, position the "F" mark on center bearing toward front of vehicle. **Apply a coat of multi-purpose lithium grease containing molybdenum disulfide to the end face of the center bearing and both sides of the washer.**

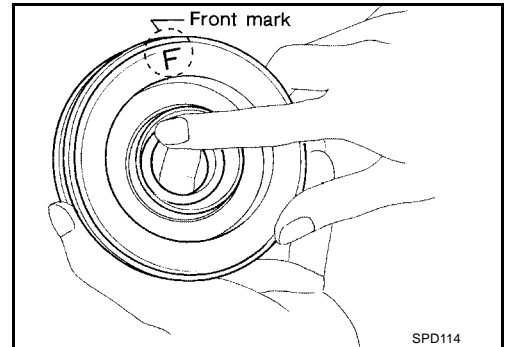

2. Stake the nut. Always use a new one.
3. Align match marks when assembling tubes.

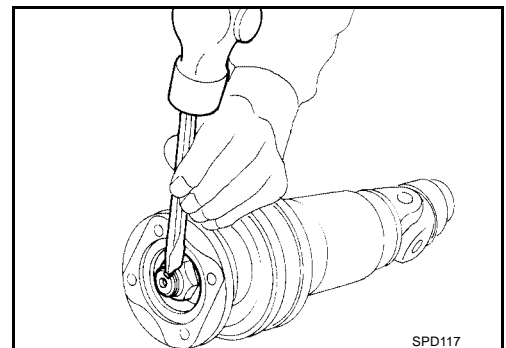

A
B
C
PR

E
F
G
H

I
J
K
L

M

PROPELLER SHAFT ASSEMBLY

JOURNAL

1. Assemble journal bearing. Apply recommended multi-purpose grease on bearing inner surface.
When assembling, be careful that needle bearing does not fall down.

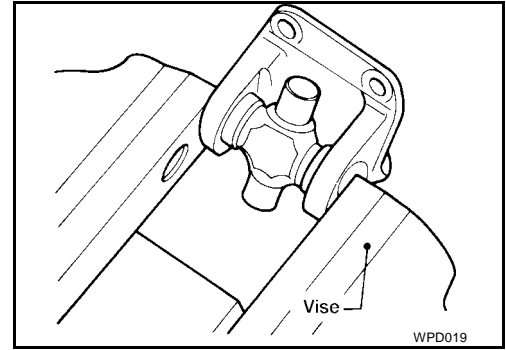

2. Install new snap rings.

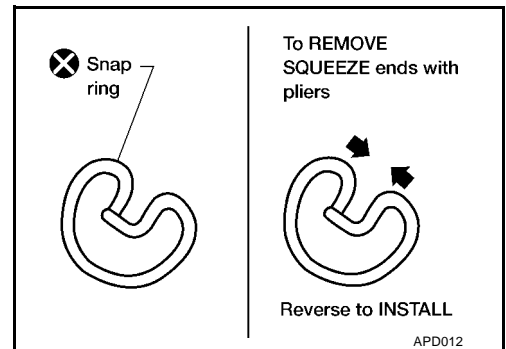

3. Adjust thrust clearance between bearing and snap ring to zero by tapping yoke.

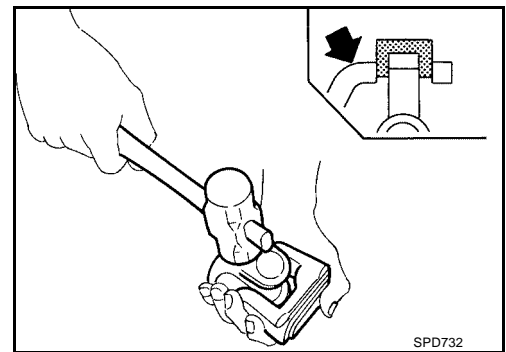

4. Check to see that journal moves smoothly and check for axial play.

Axial play : 0.02 mm (0.0008 in) or less

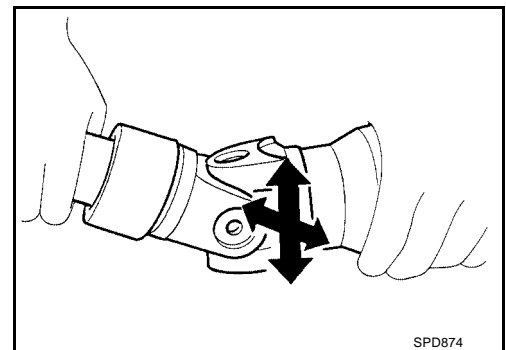

SERVICE DATA AND SPECIFICATIONS (SDS)

SERVICE DATA AND SPECIFICATIONS (SDS)

PF0:00030

General Specifications 2WD KA24DE MODELS

EDS000CP

Propeller shaft model		M/T	A/T
		3S1310	
Number of joints		3	
Coupling method with transmission		Sleeve type	
Type of journal bearings		Solid type (disassembly type)	
Shaft length (Spider to spider) mm (in)	1st tube	644.7 (25.38)	549.6 (21.64)
	2nd tube	970.3 (38.20)	970.3 (38.20)
Shaft diameter mm (in)	1st tube	63.5 (2.50)	63.5 (2.50)
	2nd tube	63.5 (2.50)	63.5 (2.50)

2WD VG33E AND VG33ER MODELS

Grade		XE, SE				SC			
Transmission		M/T		A/T		M/T		A/T	
Model		K/C, C/C	C/C Long bed	SK/C, C/C	C/ C Long bed	K/C, C/C	C/C Long bed	K/C, C/C	C/C Long bed
Propeller shaft model		3S1310				3S80B-2BJ	3S1310	3S80B-2BJ	3S1310
Number of joints		3				3			
Coupling method with transmission		Sleeve type							
Type of journal bearings		Solid type (disassembly type)				Solid type (disassembly type without Birfield joint)	Solid type (disassembly type)	Solid type (disassembly type without Birfield joint)	Solid type (disassembly type)
Distance between yokes mm (in)		80 (3.15)							
Shaft length (Spider to spider) mm (in)	1st tube	661 (26.02)	1043 (41.06)	566 (22.28)	948 (37.32)	681 (26.81)	1043 (41.06)	586 (23.07)	948 (37.32)
	2nd tube	982.3 (38.67)		984.3 (38.75)	984.2 (38.75)	980 (38.58)	982.3 (38.67)	980 (38.58)	984.2 (38.75)
Shaft outer diameter mm (in)	1st tube	63.5 (2.50)	76.2 (2.99)	63.5 (2.50)	76.2 (2.99)	75 (2.95)	76.2 (2.99)	75 (2.95)	76.2 (2.99)
	2nd tube	63.5 (2.50)				65 (2.56)	63.5 (2.50)	65 (2.56)	63.5 (2.50)

4WD MODELS

Grade		XE, SE			SC		
Location		Front	Rear		Front	Rear	
Model		All	K/C, C/C	C/C Long bed	All	K/C, C/C	C/C Long bed
Propeller shaft model		2F1310	2S1310	3S1310	2F1310	2S1310	3S1310
Number of joints		2	2	3	2	2	3
Coupling method with transmission		Flange type	Sleeve type		Flange type	Sleeve type	
Type of journal bearings		Solid type (disassembly type)					
Distance between yokes mm (in)		71 (2.80)	80 (3.15)		71 (2.80)	80 (3.15)	
Shaft length (Spider to spider) mm (in)	1st tube	522 (20.55)	1247 (49.09)	637 (25.07)	522 (20.55)	1247 (49.09)	637 (25.07)
	2nd tube	—	—	989 (38.93)	—	—	989 (38.93)

SERVICE DATA AND SPECIFICATIONS (SDS)

Grade	XE, SE			SC		
Shaft outer diameter mm (in)	1st tube	50.8 (2.00)	76.2 (3.00)	50.8 (2.00)	88.9 (3.50)	76.2 (3.00)
	2nd tube	—	— 76.2 (3.00)	—	—	76.2 (3.00)

Service Data

EDS000CQ

Unit: mm (in)

Propeller shaft runout limit	0.6 (0.024)
Journal axial play	0.02 (0.0008) or less