

SECTION **AV**

AUDIO, VISUAL & TELEPHONE SYSTEM

CONTENTS

PRECAUTIONS	2	Trouble Diagnoses	14	F
Precautions for Supplemental Restraint System (SRS) "AIR BAG" and "SEAT BELT PRE-TENSIONER"	2	AUDIO UNIT (EXCEPT CREW CAB WITH AMPLIFIER)	14	G
Wiring Diagrams and Trouble Diagnosis	2	AUDIO UNIT (CREW CAB WITH AMPLIFIER)... ..	15	H
AUDIO	3	Inspection	15	I
System Description	3	SPEAKER	15	J
KING CAB WITH BASE AUDIO SYSTEM	3	ANTENNA	15	
KING CAB WITH PREMIUM AUDIO SYSTEM.....	3	AUDIO UNIT	16	
CREW CAB WITHOUT AMPLIFIER	3	AUDIO UNIT VOLTAGES	16	
CREW CAB WITH AMPLIFIER	4	AMPLIFIER VOLTAGES	16	
Schematic — With Audio Amplifier	5	STEERING WHEEL AUDIO CONTROL SWITCH RESISTANCE CHECK	17	
Wiring Diagram — AUDIO —	6	AUDIO ANTENNA	18	
KING CAB WITH BASE AUDIO SYSTEM	6	Location of Antenna	18	
KING CAB WITH PREMIUM AUDIO SYSTEM.....	7	Fixed Antenna Rod Replacement	18	
CREW CAB WITHOUT AMPLIFIER	9	REMOVAL	18	
CREW CAB WITH AMPLIFIER	11	INSTALLATION	18	

A
B
C
D
E
F
G
H
I
J
L
M

AV

PRECAUTIONS

PRECAUTIONS

PF0:00001

Precautions for Supplemental Restraint System (SRS) “AIR BAG” and “SEAT BELT PRE-TENSIONER”

EKS006X4

The Supplemental Restraint System such as “AIR BAG” and “SEAT BELT PRE-TENSIONER”, used along with a front seat belt, helps to reduce the risk or severity of injury to the driver and front passenger for certain types of collision. This system may include seat belt switch inputs and dual stage front air bag modules. If equipped with dual stage front air bag modules, the SRS system uses the seat belt switches to determine the front air bag deployment, and may only deploy one front air bag, depending on the severity of a collision and whether the front occupants are belted or unbelted. Information necessary to service the system safely is included in the SRS and SB section of this Service Manual.

The vehicle may be equipped with a passenger air bag deactivation switch. Because no rear seat exists where a rear-facing child restraint can be placed, the switch is designed to turn off the passenger air bag so that a rear-facing child restraint can be used in the front passenger seat. The switch is located in the center of the instrument panel, near the ashtray. When the switch is turned to the ON position, the passenger air bag is enabled and could inflate for certain types of collision. When the switch is turned to the OFF position, the passenger air bag is disabled and will not inflate. A passenger air bag OFF indicator on the instrument panel lights up when the passenger air bag is switched OFF. The driver air bag always remains enabled and is not affected by the passenger air bag deactivation switch.

WARNING:

- To avoid rendering the SRS inoperative, which could increase the risk of personal injury or death in the event of a collision which would result in air bag inflation, all maintenance must be performed by an authorized NISSAN/INFINITI dealer.
- Improper maintenance, including incorrect removal and installation of the SRS, can lead to personal injury caused by unintentional activation of the system. For removal of Spiral Cable and Air Bag Module, see the SRS section.
- Do not use electrical test equipment on any circuit related to the SRS unless instructed to in this Service Manual. SRS wiring harnesses can be identified by yellow and/or orange harness connectors.
- The vehicle may be equipped with a passenger air bag deactivation switch which can be operated by the customer. When the passenger air bag is switched OFF, the passenger air bag is disabled and will not inflate. When the passenger air bag is switched ON, the passenger air bag is enabled and could inflate for certain types of collision. After SRS maintenance or repair, make sure the passenger air bag deactivation switch is in the same position (ON or OFF) as when the vehicle arrived for service.

Wiring Diagrams and Trouble Diagnosis

EKS006X5

When you read wiring diagrams, refer to the following:

- [GI-13, "How to Read Wiring Diagrams"](#)
- [PG-9, "POWER SUPPLY ROUTING"](#)

When you perform trouble diagnosis, refer to the following:

- [GI-9, "HOW TO FOLLOW TEST GROUPS IN TROUBLE DIAGNOSES"](#)
- [GI-25, "How to Perform Efficient Diagnosis for an Electrical Incident"](#)

Check for any Service bulletins before servicing the vehicle.

AUDIO

System Description

Refer to Owner's Manual for audio system operating instructions.

KING CAB WITH BASE AUDIO SYSTEM

Power is supplied at all times

- through 15A fuse (No. 41, located in the fuse and fusible link box)
- to audio unit terminal 6.

With the ignition switch in the ACC or ON position, power is supplied

- through 10A fuse [No. 18, located in the fuse block (J/B)]
- to audio unit terminal 10.

Ground is supplied through the case of the audio unit.

With the audio unit ON, audio signals are supplied

- through audio unit terminals 2, 4, 14 and 16
- to front door speakers and pillar tweeters.

KING CAB WITH PREMIUM AUDIO SYSTEM

Power is supplied at all times

- through 15A fuse (No. 41, located in the fuse and fusible link box)
- to audio unit terminal 6 and

With the ignition switch in the ACC or ON position, power is supplied

- through 10A fuse [No. 18, located in the fuse block (J/B)]
- to audio unit terminal 10.

Ground is supplied through the case of the audio unit.

With the audio unit ON, audio signals are supplied

- through audio unit terminals 2, 4, 14 and 16
- to door speakers and pillar tweeters and
- to subwoofer amplifier terminals 2 and 4.

When the steering wheel audio control switches are pushed, audio signals are supplied

- through audio unit terminal 23
- to steering wheel audio control switch terminal 15 and
- through steering audio control switch terminal 16
- to audio unit terminal 9.

CREW CAB WITHOUT AMPLIFIER

Power is supplied at all times

- through 15A fuse (No. 41, located in the fuse and fusible link box)
- to audio unit terminal 6.

With the ignition switch in the ACC or ON position, power is supplied

- through 10A fuse [No. 18, located in the fuse block (J/B)]
- to audio unit terminal 10.

Ground is supplied through the case of the audio unit.

With the audio unit ON, audio signals are supplied

- through audio unit terminals 2, 4, 14 and 16
- to front door speakers, pillar tweeters and rear door speakers.

When the steering wheel audio control switches are pushed, audio signals are supplied

- through audio unit terminal 23
- to steering wheel audio control switch terminal 15 and
- through steering audio control switch terminal 16
- to audio unit terminal 24.

A

B

C

D

E

F

G

H

I

J

AV

L

M

AUDIO

CREW CAB WITH AMPLIFIER

Power is supplied at all times

- through 15A fuse (No. 41, located in fuse and fusible link box)
- to audio unit terminal 6 and
- through 30A fusible link (letter h, located in fuse and fusible link box)
- to audio amplifier terminals 5 and 12.

With the ignition switch in the ACC or ON position, power is supplied

- through 10A fuse [No. 18, located in fuse block (J/B)]
- to audio unit terminal 10.

Ground is supplied through the case of the audio unit.

Ground is also supplied

- through audio amplifier terminals 4 and 11
- to body grounds M14 and M68.

With the audio unit ON, audio signals are supplied

- through audio unit terminals 1, 2, 3, 4, 12, 13, 14, 15 and 16
- to audio amplifier terminals 13, 15, 16, 17, 20, 21, 22, 23, and 24
- through amplifier terminals 1, 2, 3, and 9
- to front door speakers, pillar tweeters, rear speakers and subwoofer.

When the steering wheel audio control switches are pushed, audio signals are supplied

- through audio unit terminal 23
- to steering wheel audio control switch terminal 15 and
- through steering audio control switch terminal 16
- to audio unit terminal 24.

AUDIO

Schematic — With Audio Amplifier

EKS006X7

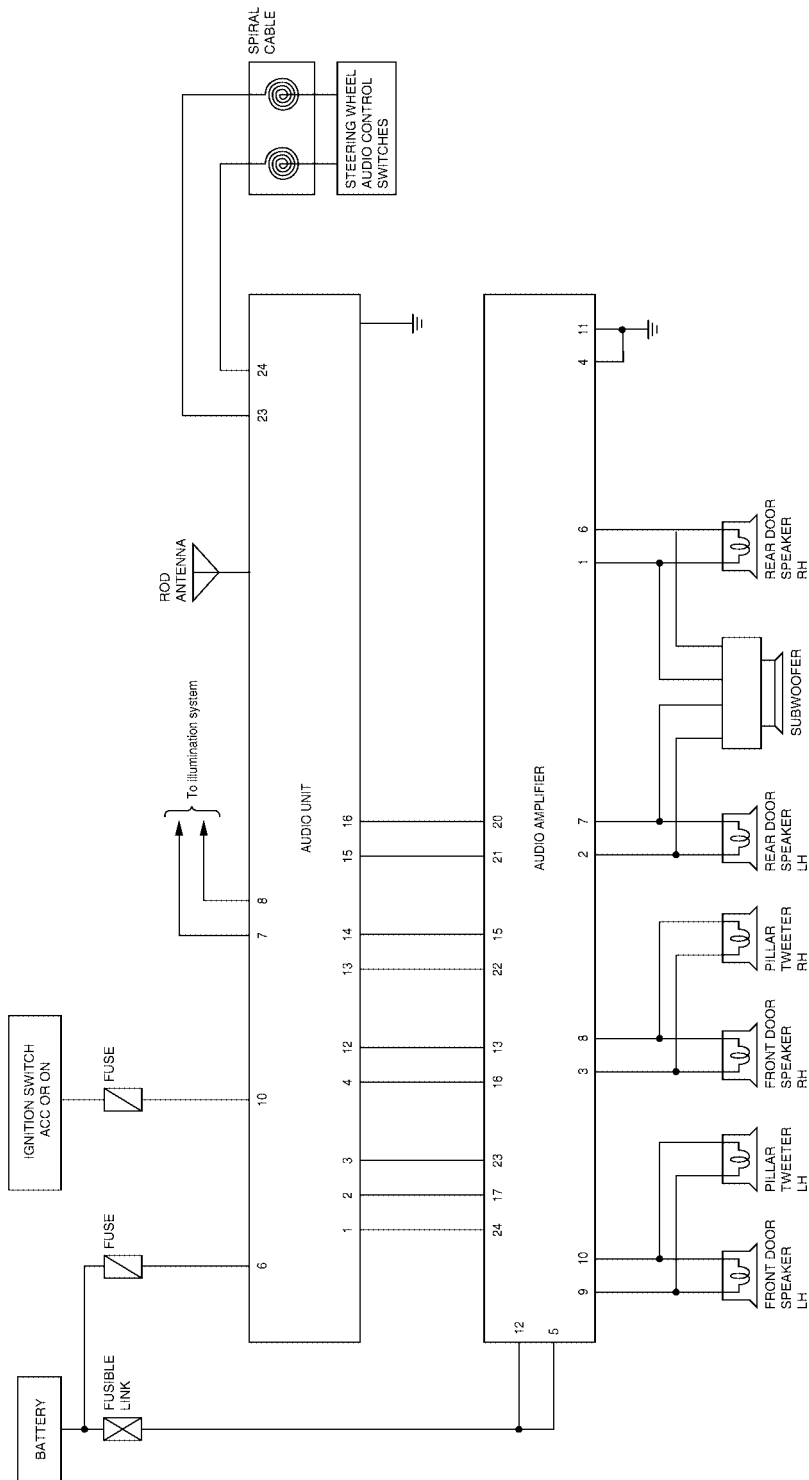

A
B
C
D
E
F
G
H
I
J
L
M

AV

WKWA0307E

AUDIO

Wiring Diagram — AUDIO — KING CAB WITH BASE AUDIO SYSTEM

EKS006X8

AV-AUDIO-01

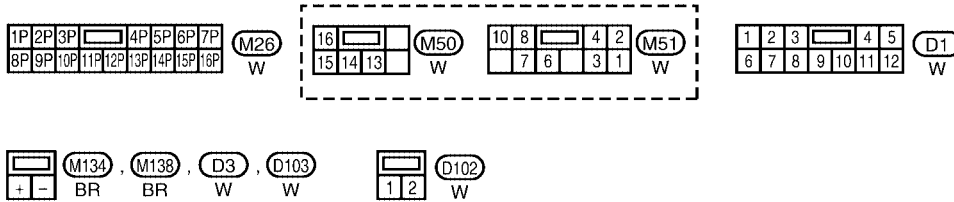
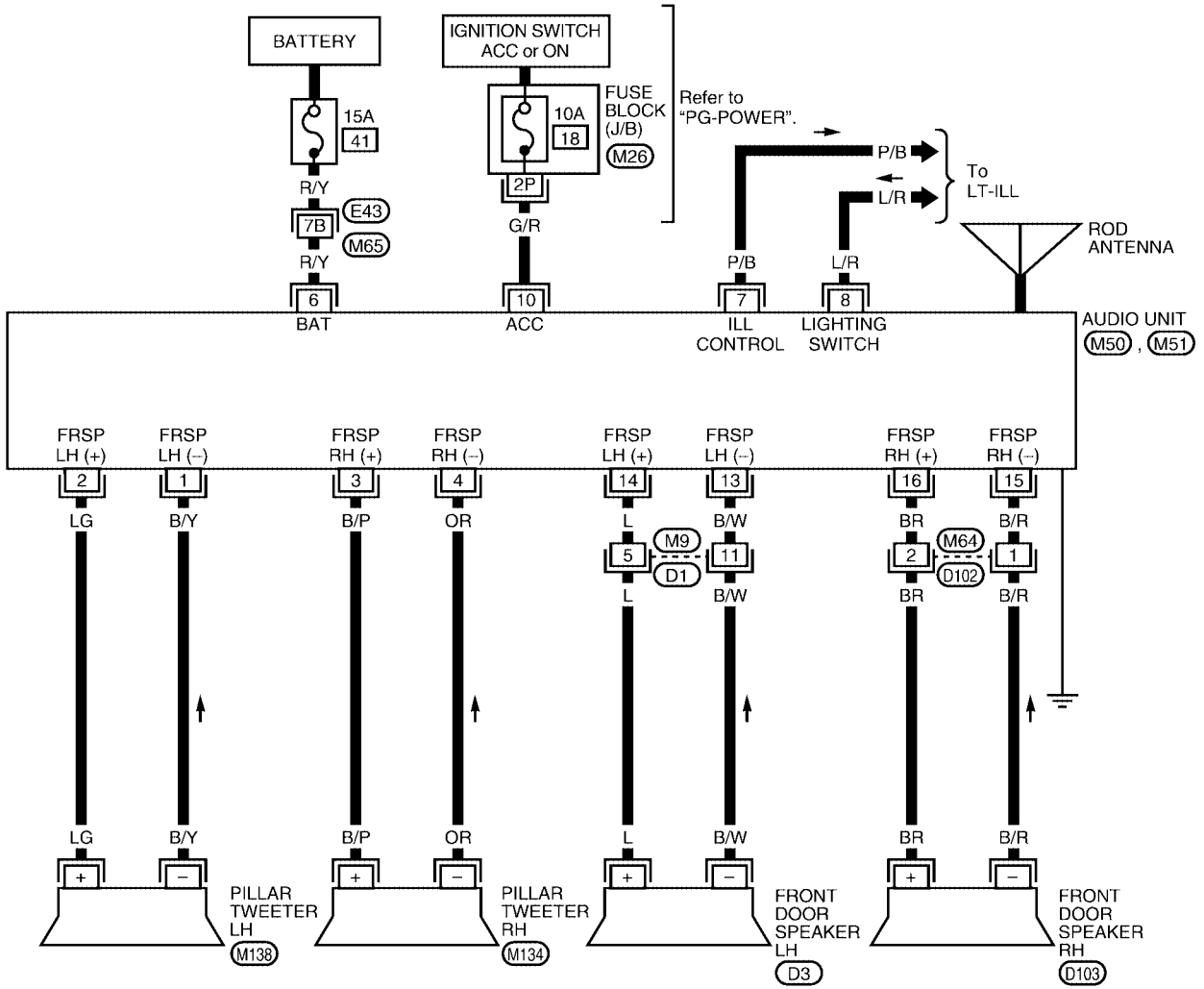

Refer to the following.
 (E43) - SUPER
 MULTIPLE JUNCTION (SMJ)

WKWA0308E

AUDIO

KING CAB WITH PREMIUM AUDIO SYSTEM

AV-AUDIO-02

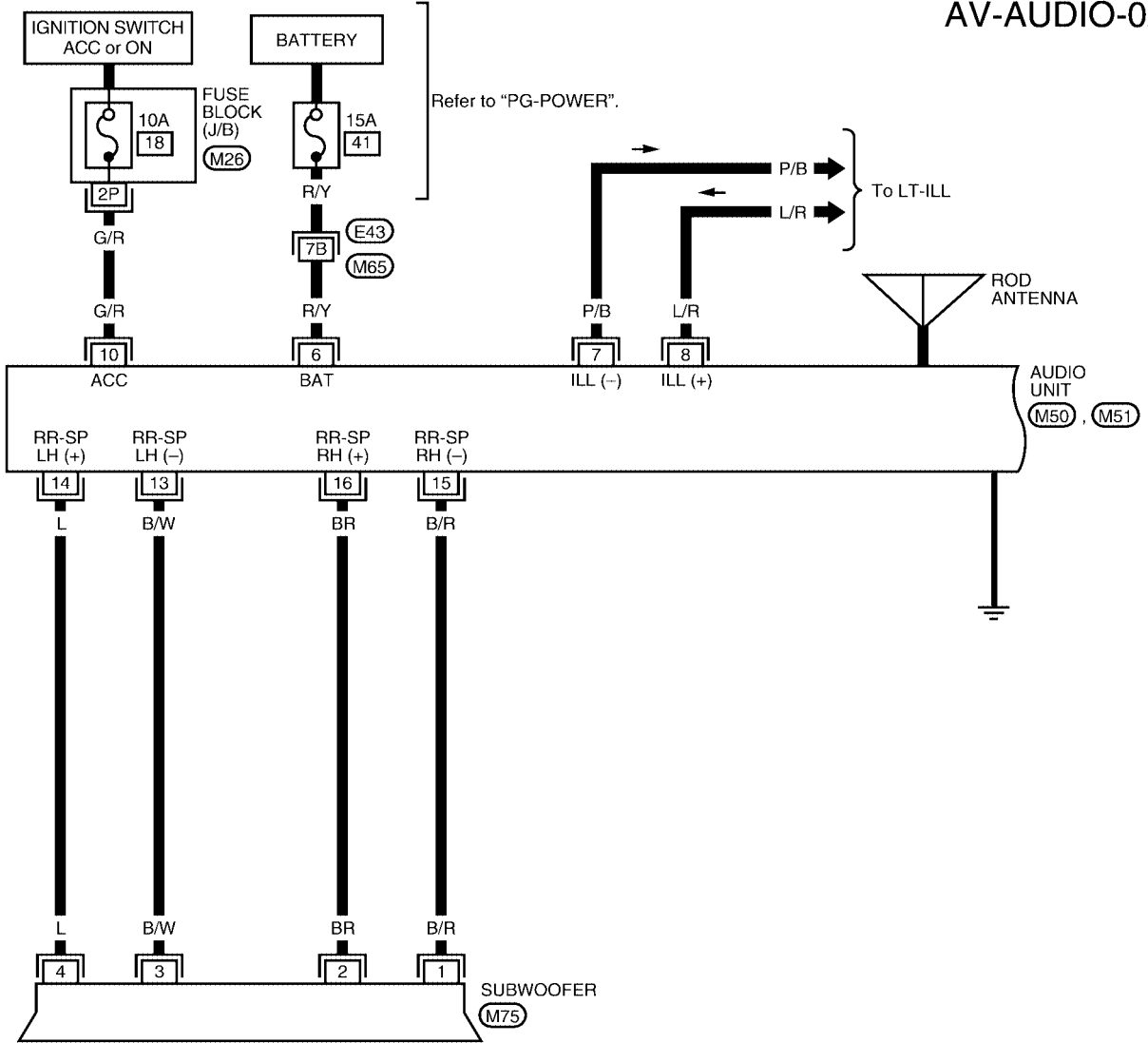

A
B
C
D
E
F
G
H
I
J
AV
L
M

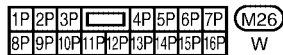

(M26) W

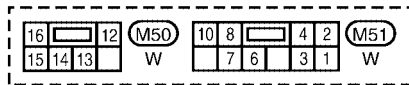

(M50) W

(M51) W



(M75) W

Refer to the following.
(E43) - SUPER MULTIPLE JUNCTION (SMJ)

AUDIO

AV -AUDIO-03

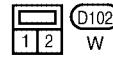
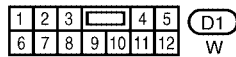
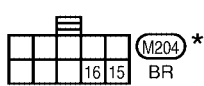
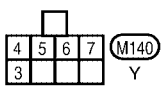
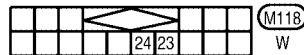
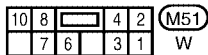
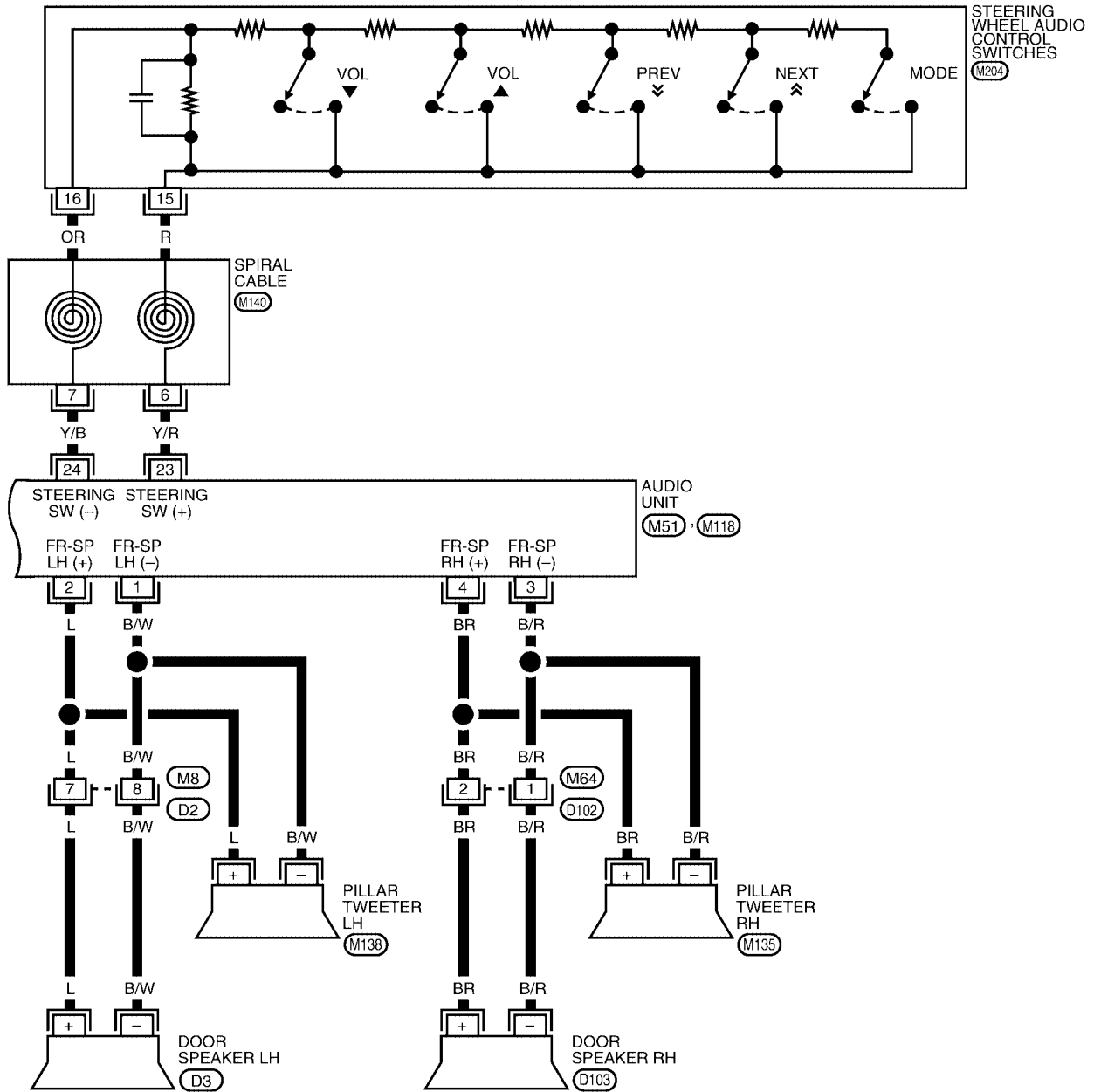

*: This connector is not shown in "HARNESS LAYOUT" of PG section.

WKWA0310E

AUDIO

CREW CAB WITHOUT AMPLIFIER

AV -AUDIO-04

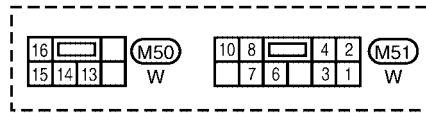
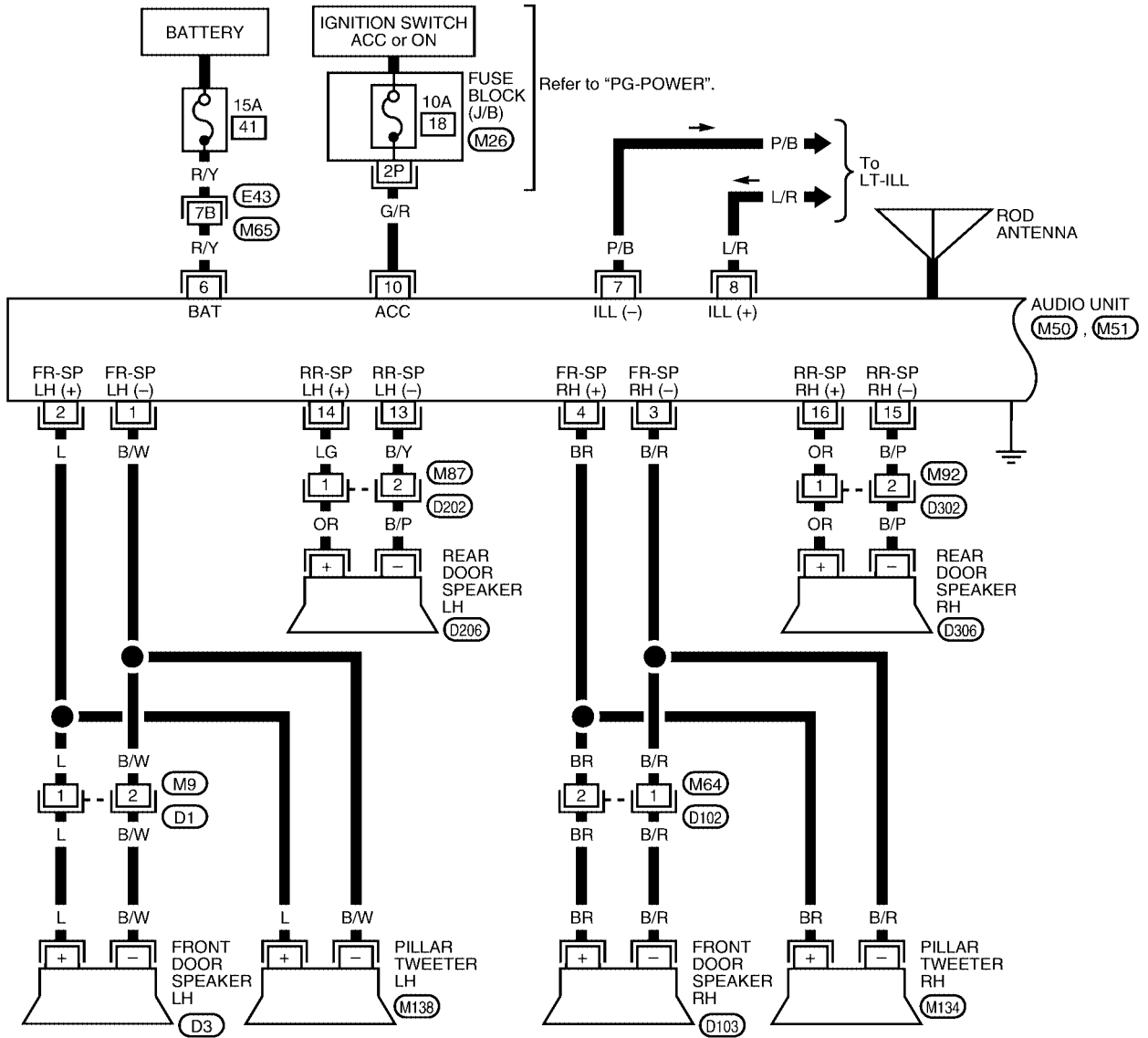

Refer to the following.
 (E43) - SUPER
 MULTIPLE JUNCTION (SMJ)

WKWA0311E

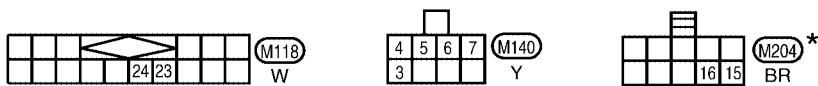
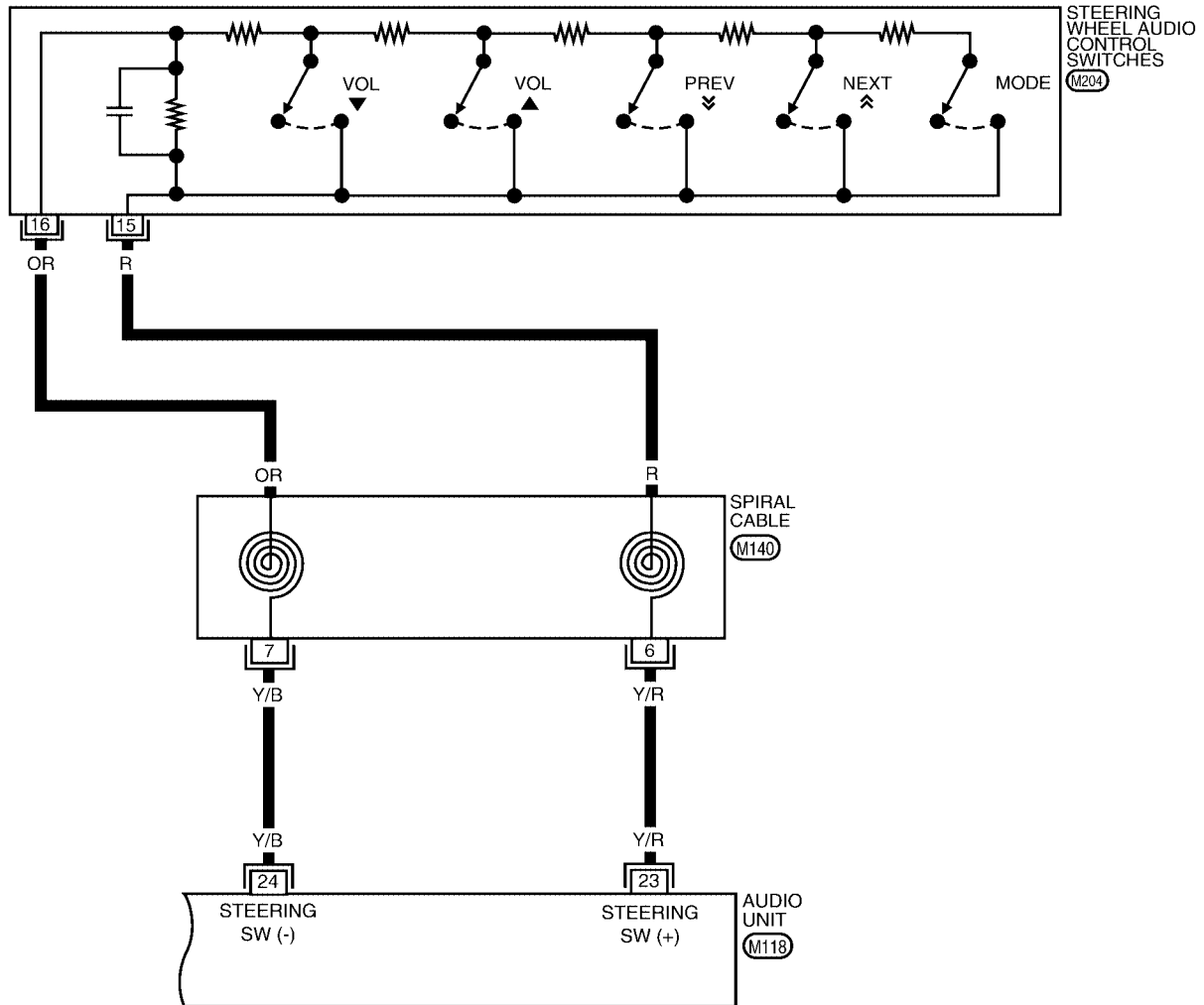

★: This connector is not shown in "HARNESS LAYOUT" of PG section.

AUDIO

CREW CAB WITH AMPLIFIER

AV-AUDIO-06

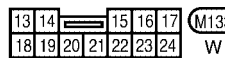
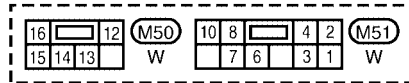
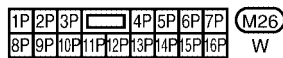
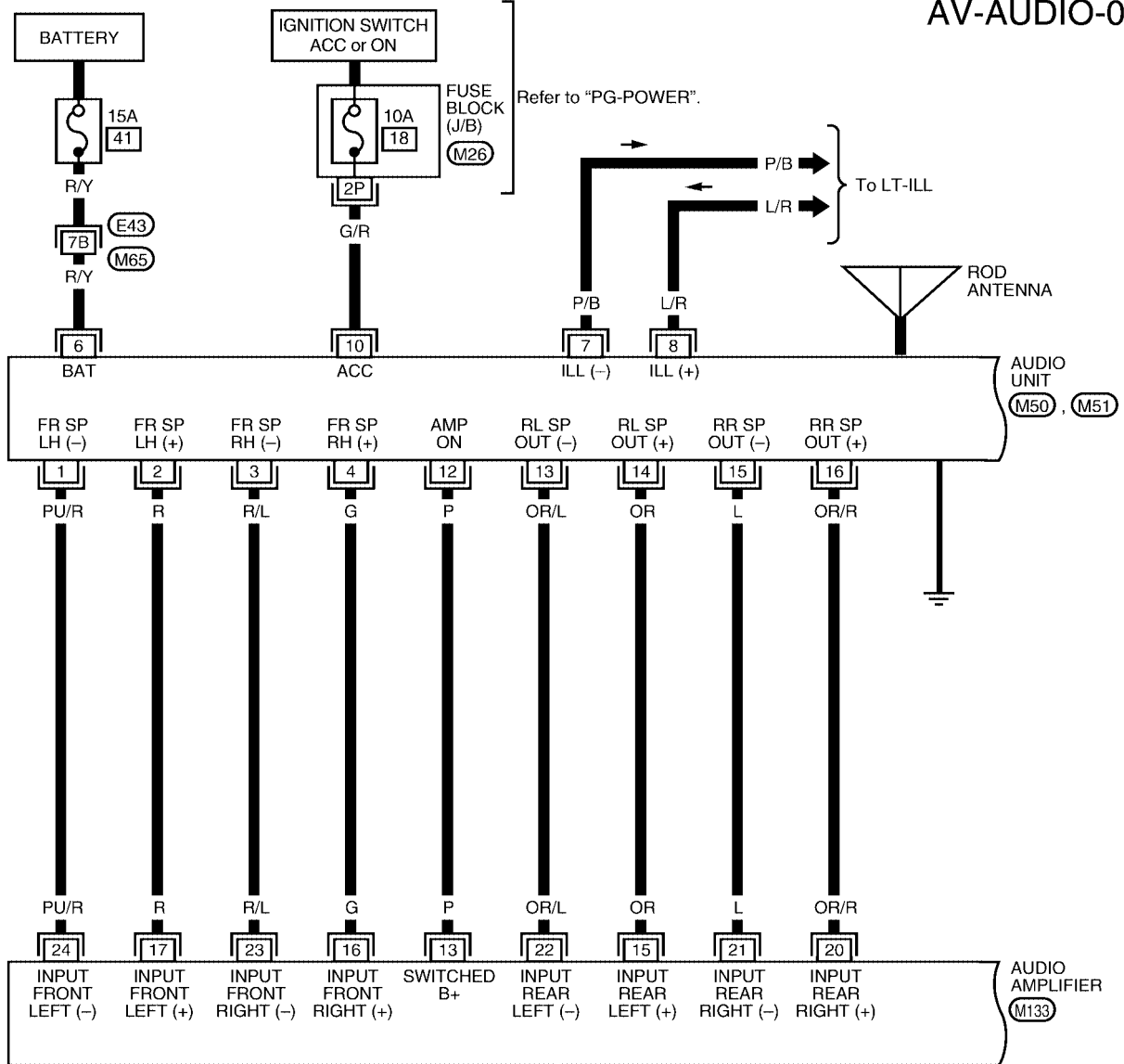

Refer to the following.
 (E43) - SUPER
 MULTIPLE JUNCTION (SMJ)

A
B
C
D
E
F
G
H
I
J
AV
L
M

AUDIO

AV-AUDIO-08

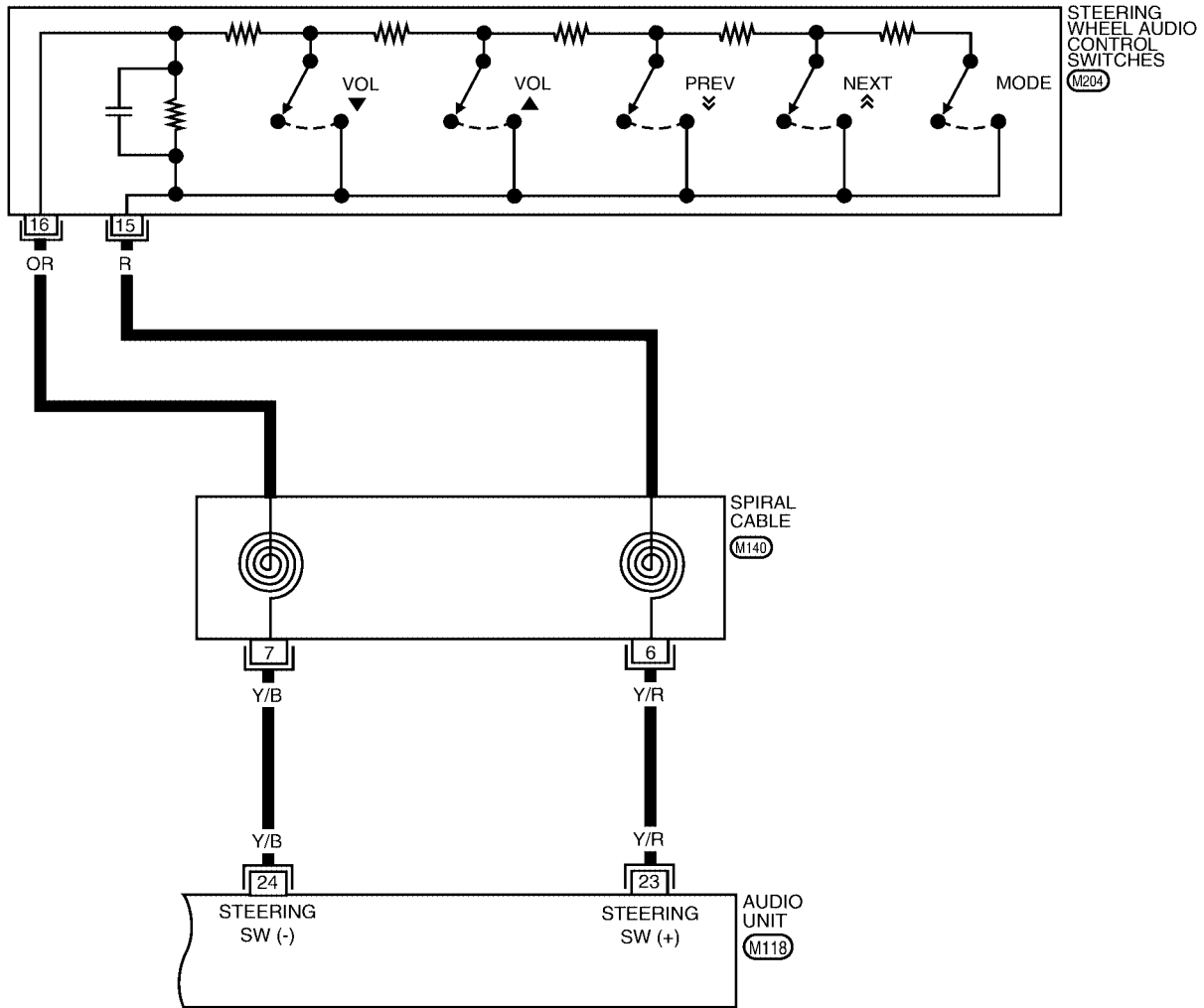

A
B
C
D
E
F
G
H
I
J
AV
L
M

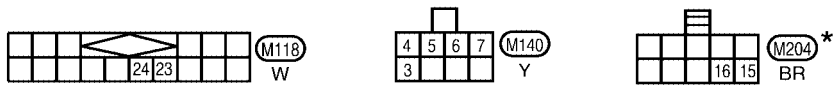

*: This connector is not shown in "HARNESS LAYOUT" of PG section.

AUDIO

EKS006X9

Trouble Diagnoses AUDIO UNIT (EXCEPT CREW CAB WITH AMPLIFIER)

Symptom	Possible causes	Repair order
Audio unit inoperative (no digital display and no sound from speakers).	<ol style="list-style-type: none"> 1. 10A fuse 2. Poor audio unit case ground 3. Audio unit 	<ol style="list-style-type: none"> 1. Check 10A fuse [No. 18, located in fuse block (J/B)]. Turn ignition switch ON and verify that battery positive voltage is present at terminal 10 of audio unit. 2. Check audio unit case ground. 3. Remove audio unit for repair.
Audio unit controls are operational, but no sound is heard from any speaker.	<ol style="list-style-type: none"> 1. Audio unit output 2. Audio unit 	<ol style="list-style-type: none"> 1. Check audio unit output voltages. 2. Remove audio unit for repair.
Audio unit presets are lost when ignition switch is turned OFF.	<ol style="list-style-type: none"> 1. 15A fuse 2. Audio unit 	<ol style="list-style-type: none"> 1. Check 15A fuse (No. 41, located in fuse and fusible link box) and verify that battery positive voltage is present at terminal 6 of audio unit. 2. Remove audio unit for repair.
Individual speaker is noisy or inoperative.	<ol style="list-style-type: none"> 1. Speaker 2. Audio unit output 3. Speaker circuit 4. Audio unit 	<ol style="list-style-type: none"> 1. Check speaker. 2. Check audio unit output voltages. 3. Check wires for open or short between audio unit and speaker. 4. Remove audio unit for repair.
Subwoofer speaker is noisy or inoperative (king cab models with premium audio system).	<ol style="list-style-type: none"> 1. Speaker 2. Speaker circuit 3. Audio unit output 	<ol style="list-style-type: none"> 1. Check speaker. 2. Check wires for open or short between audio unit and speaker. 3. Check audio unit output voltages to speaker.
Audio unit stations are weak or noisy.	<ol style="list-style-type: none"> 1. Antenna 2. Poor audio unit ground 3. Audio unit 	<ol style="list-style-type: none"> 1. Check antenna. 2. Check audio unit ground. 3. Remove audio unit for repair.
Audio unit generates noise in AM and FM modes with engine running.	<ol style="list-style-type: none"> 1. Poor audio unit ground 2. Loose or missing ground bonding straps 3. Ignition condenser or rear window defogger noise suppressor condenser (Crew Cab models) 4. Generator 5. Ignition coil or secondary wiring 6. Audio unit 	<ol style="list-style-type: none"> 1. Check audio unit ground. 2. Check ground bonding straps. 3. Replace ignition condenser or rear window defogger noise suppressor condenser (Crew Cab models). 4. Check generator. 5. Check ignition coil and secondary wiring. 6. Remove audio unit for repair.
Audio unit generates noise in AM and FM modes with accessories on (switch pops and motor noise).	<ol style="list-style-type: none"> 1. Poor audio unit ground 2. Antenna 3. Accessory ground 4. Faulty accessory 	<ol style="list-style-type: none"> 1. Check audio unit ground. 2. Check antenna. 3. Check accessory ground. 4. Replace accessory.
Steering wheel audio control switch does not operate (except base audio system).	<ol style="list-style-type: none"> 1. Steering wheel audio control switch 2. Audio unit output 3. Steering wheel audio control switch circuit 4. Audio unit 	<ol style="list-style-type: none"> 1. Check steering wheel audio control switch, refer to AV-17. "STEERING WHEEL AUDIO CONTROL SWITCH RESISTANCE CHECK". 2. Check audio unit output voltage. 3. Check harness between audio unit and steering switch. 4. Remove audio unit for repair.

AUDIO

AUDIO UNIT (CREW CAB WITH AMPLIFIER)

Symptom	Possible causes	Repair order	
Audio unit inoperative (no digital display and no sound from speakers).	1. 10A fuse 2. Poor audio unit case ground 3. Audio unit	1. Check 10A fuse [No. 18, located in fuse block (J/B)]. Turn ignition switch ON and verify that battery positive voltage is present at terminal 10 of audio unit. 2. Check audio unit case ground. 3. Remove audio unit for repair.	A B
Audio unit controls are operational, but no sound is heard from any speaker.	1. 30A fusible link 2. Audio amplifier ground 3. Audio amplifier	1. Check 30A fusible link (letter h, located in fuse and fusible link box). Verify battery positive voltage is present at terminal 5 and 12. 2. Check harness continuity between audio amplifier terminals 4 and 11, and ground. 3. Remove audio amplifier for repair.	C D
Audio unit presets are lost when ignition switch is turned OFF.	1. 15A fuse 2. Audio unit	1. Check 15A fuse (No. 41, located in fuse and fusible link box) and verify that battery positive voltage is present at terminal 6 of audio unit. 2. Remove audio unit for repair.	E
Individual speaker is noisy or inoperative.	1. Each speaker 2. Output circuit to each speaker	1. Check speaker. 2. Check the output circuit to each speaker – between audio unit and audio amplifier – between audio amplifier and each speaker	F G
Audio unit stations are weak or noisy.	1. Antenna 2. Poor audio unit ground 3. Audio unit	1. Check antenna. 2. Check audio unit ground. 3. Remove audio unit for repair.	H
Audio unit generates noise in AM and FM modes with engine running.	1. Poor audio unit ground 2. Loose or missing ground bonding straps 3. Ignition condenser or rear window defogger noise suppressor condenser 4. Generator 5. Ignition coil or secondary wiring 6. Audio unit	1. Check audio unit ground. 2. Check ground bonding straps. 3. Replace ignition condenser or rear window defogger noise suppressor condenser. 4. Check generator. 5. Check ignition coil and secondary wiring. 6. Remove audio unit for repair.	I J
Audio unit generates noise in AM and FM modes with accessories on (switch pops and motor noise).	1. Poor audio unit ground 2. Antenna 3. Accessory ground 4. Faulty accessory	1. Check audio unit ground. 2. Check antenna. 3. Check accessory ground. 4. Replace accessory.	AV L
Steering wheel audio control switch does not operate.	1. Steering wheel audio control switch 2. Audio unit output 3. Steering wheel audio control switch circuit 4. Audio unit	1. Check steering wheel audio control switch, refer to AV-17, "STEERING WHEEL AUDIO CONTROL SWITCH RESISTANCE CHECK" . 2. Check audio unit output voltage. 3. Check harness between audio unit and steering switch. 4. Remove audio unit for repair.	M

Inspection SPEAKER

EKS006XA

1. Disconnect speaker harness connector.
2. Measure the resistance between speaker terminals + and –.
 - The resistance should be 2 - 4Ω.
3. Using jumper wires, momentarily connect a 9V battery between speaker terminals + and –.
 - A momentary hum or pop should be heard.

ANTENNA

1. Using a jumper wire, clip an auxiliary ground between antenna and body.
 - If reception improves, check antenna ground (at body surface).

AUDIO

- If reception does not improve, check main feeder cable for short circuit or open circuit.

AUDIO UNIT

All voltage inspections are made with:

- Ignition switch ON or ACC
- Audio unit ON
- Audio unit connected (If removed for inspection, supply a ground to the case using a jumper wire.)

AUDIO UNIT VOLTAGES

Terminal	Wire color		Voltage (V) (Approx.)		
	2-Door Models	4-Door Models	2-Door Models with Base Audio System	2-Door Models with Premium Audio System	4-Door Models
1	B/W	B/W	5 - 7.5	5 - 7.5	5 - 7.5
2	L	L	5 - 7.5	5 - 7.5	5 - 7.5
3	B/R	B/R	5 - 7.5	5 - 7.5	5 - 7.5
4	BR	BR	5 - 7.5	5 - 7.5	5 - 7.5
5	—	—	—	—	—
6	R/Y	R/Y	10.8 - 15.6	10.8 - 15.6	10.8 - 15.6
7	P/B	P/B	0 (Illumination)	0 (Illumination)	0 (Illumination)
8	L/R	L/R	0 - 12 (Illumination)	0 - 12 (Illumination)	0 - 12 (Illumination)
9	—	—	—	—	—
10	G/R	G/R	10.8 - 15.6	10.8 - 15.6	10.8 - 15.6
11	—	—	—	—	—
12	P*	—	—	10.5	—
13	B/Y	B/Y	5 - 7.5	5 - 7.5	5 - 7.5
14	LG	LG	5 - 7.5	5 - 7.5	5 - 7.5
15	B/P	B/P	5 - 7.5	5 - 7.5	5 - 7.5
16	OR	OR	5 - 7.5	5 - 7.5	5 - 7.5

*: With amplifier only.

AMPLIFIER VOLTAGES

Terminal	Wire color	Voltage (V) (Approx.)
1	OR	5 - 7.5
2	LG	5 - 7.5
3	BR	5 - 7.5
4	B	Body ground
5	SB	Battery
6	B/P	5 - 7.5
7	B/Y	5 - 7.5
8	R/R	5 - 7.5
9	L	5 - 7.5
10	B/W	5 - 7.5
11	B	Body ground
12	L	Battery
13	P	10.5
15	OR	5 - 7.5
16	G	5 - 7.5
17	R	5 - 7.5

AUDIO

20	OR/R	5 - 7.5
21	L	5 - 7.5
22	OR/L	5 - 7.5
23	R/L	5 - 7.5
24	PU/R	5 - 7.5

STEERING WHEEL AUDIO CONTROL SWITCH RESISTANCE CHECK

	Terminal No.	Resistance (Ω) (Approx.)
VOLUM (DOWN) SW	15 - 16	21.7 - 22.2
VOLUM (UP) SW		69.3 - 70.7
PREVIOUS SW		108.9 - 111.1
NEXT SW		158.4 - 161.6
MODE SW		326.7 - 333.3

A
B
C
D
E
F
G
H
I
J
L
M

AV

AUDIO ANTENNA

AUDIO ANTENNA

PFP:28200

Location of Antenna

EKS006XB

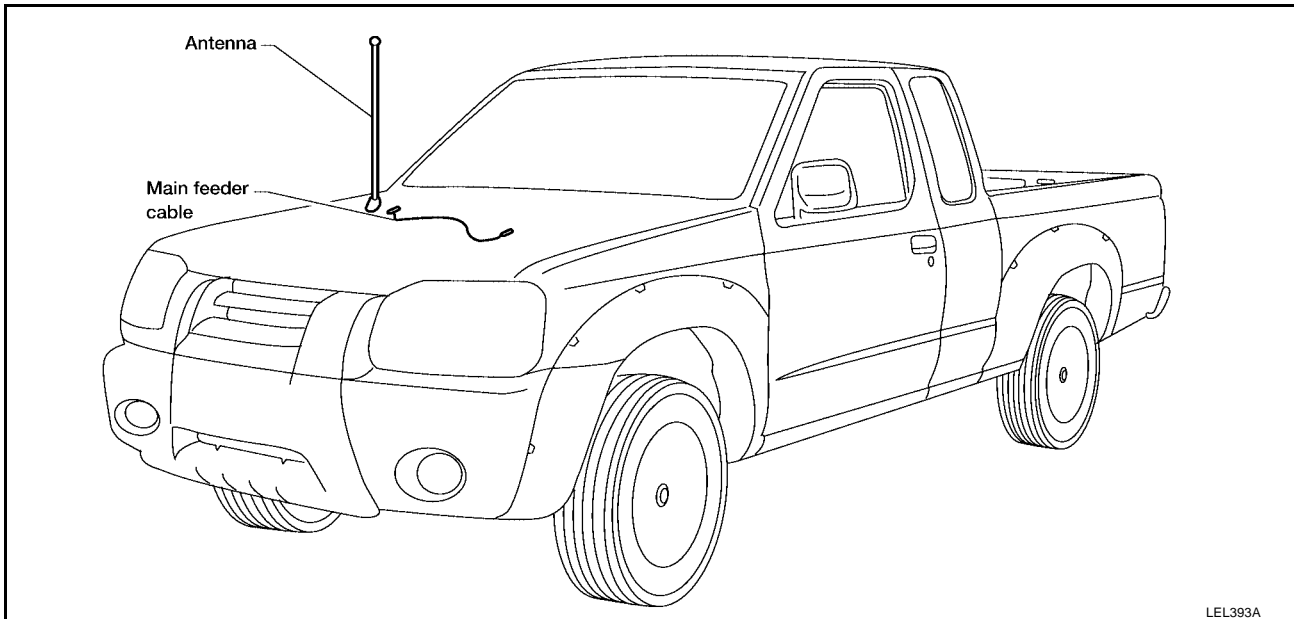

Fixed Antenna Rod Replacement REMOVAL

EKS006XC

1. Remove antenna rod.
2. Remove rubber seal.
3. Remove cowl screen top seal.
4. Remove right wiper arm.
5. Remove right cowl to grille.
6. Remove antenna base bolts.
7. Remove right fender splash shield.
8. Remove audio unit.
9. Disconnect antenna cable from audio unit.
10. Remove attachment clip from fender apron.
11. Remove antenna base and cable.

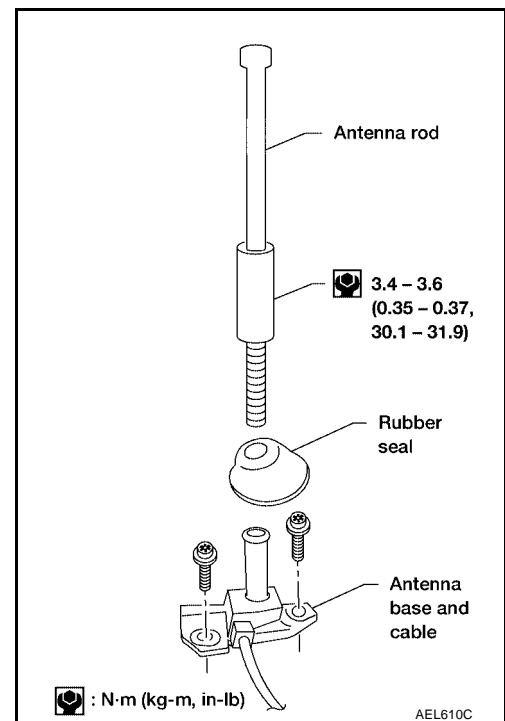

INSTALLATION

Install in reverse order of removal.

CAUTION:

Always properly tighten the antenna rod during installation or the antenna rod may bend or break during vehicle operation.