

SECTION **FFD**  
FRONT FINAL DRIVE

A  
B  
C  
FFD

CONTENTS

<b>PREPARATION</b> .....	<b>2</b>	BLY .....	13	F
Special Service Tools .....	2	REMOVAL OF DRIVE PINION ASSEMBLY .....	15	
<b>NOISE, VIBRATION, AND HARSHNESS (NVH)</b>		DISASSEMBLY OF DIFFERENTIAL CASE		
<b>TROUBLESHOOTING</b> .....	<b>5</b>	ASSEMBLY .....	16	G
NVH Troubleshooting Chart .....	5	DISASSEMBLY OF DIFFERENTIAL SIDE		
<b>FRONT OIL SEAL</b> .....	<b>6</b>	SHAFT .....	17	H
Removal and Installation .....	6	INSPECTION .....	18	
REMOVAL .....	6	ADJUSTMENT OF DIFFERENTIAL CASE		
INSTALLATION .....	6	ASSEMBLY .....	19	I
<b>REAR COVER GASKET</b> .....	<b>8</b>	SIDE BEARING PRELOAD .....	19	
Removal and Installation .....	8	DRIVE PINION GEAR HEIGHT AND PINION		
REMOVAL .....	8	BEARING PRELOAD .....	21	J
INSTALLATION .....	8	TOOTH CONTACT .....	25	
<b>FRONT FINAL DRIVE ASSEMBLY</b> .....	<b>9</b>	INSTALLATION OF DRIVE PINION ASSEMBLY..	26	K
Removal and Installation .....	9	ASSEMBLY OF DIFFERENTIAL SIDE SHAFT...	28	
REMOVAL .....	9	ASSEMBLY OF DIFFERENTIAL CASE ASSEM-		
INSTALLATION .....	9	LBLY .....	28	L
Components .....	11	INSTALLATION OF DIFFERENTIAL CASE		
Pre-Inspection .....	12	ASSEMBLY .....	30	M
TOTAL PRELOAD .....	12	<b>SERVICE DATA AND SPECIFICATIONS (SDS)</b> .....	<b>33</b>	
RING GEAR TO DRIVE PINION BACKLASH ...	12	General Specifications .....	33	
RING GEAR RUNOUT .....	13	Ring Gear Runout .....	33	
TOOTH CONTACT .....	13	Side Gear Adjustment .....	33	
SIDE GEAR TO DRIVE PINION GEAR BACK-		Side Bearing Adjustment .....	33	
LASH .....	13	Total Preload Adjustment .....	33	
Disassembly and Assembly .....	13	Drive Pinion Height Adjustment .....	34	
REMOVAL OF DIFFERENTIAL CASE ASSEM-		Drive Pinion Preload Adjustment .....	34	

# PREPARATION

PFP:00002

EDS0012A



## PREPARATION

### Special Service Tools

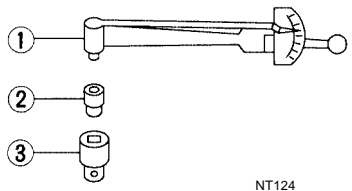
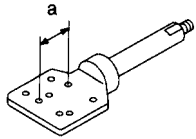
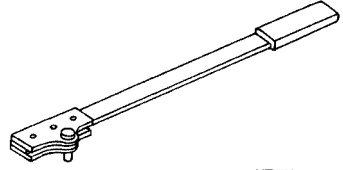
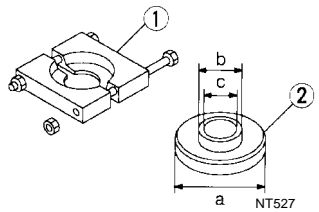
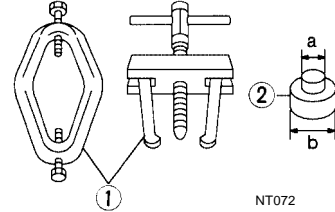
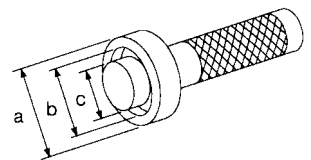
The actual shapes of Kent-Moore tools may differ from those of special service tools illustrated here.

Tool number (Kent-Moore No.) Tool name		Description
ST3127S000 (See J25765-A) Preload gauge 1 GG91030000 (J25765) Torque wrench 2 HT62940000 ( — ) Socket adapter 3 HT62900000 ( — ) Socket adapter	 <p style="text-align: right;">NT124</p>	Measuring pinion bearing preload and total preload
KV38100800 (J34310, J25604-01) Differential attachment	 <p style="text-align: right;">NT119</p>	Mounting final drive housing (To use, make a new hole.) <b>a: 152 mm (5.98 in)</b>
KV38108300 (J-44195) Companion flange wrench	 <p style="text-align: right;">NT771</p>	Removing and installing propeller shaft lock nut, and drive pinion nut
ST3090S000 ( — ) Drive pinion rear inner race puller set 1 ST30031000 (J22912-01) Puller 2 ST30901000 (J26010-01) Base	 <p style="text-align: right;">NT527</p>	Removing and installing drive pinion rear inner cone <b>a: 79 mm (3.11 in) dia.</b> <b>b: 45 mm (1.77 in) dia.</b> <b>c: 35 mm (1.38 in) dia.</b>
ST3306S001 Differential side bearing puller set 1 ST33051001 (J22888-20) Body 2 ST33061000 (J8107-2) Adapter	 <p style="text-align: right;">NT072</p>	Removing and installing differential side bearing inner cone <b>a: 28.5 mm (1.122 in) dia.</b> <b>b: 38 mm (1.50 in) dia.</b>
KV38100300 (J25523) Differential side bearing drift	 <p style="text-align: right;">NT085</p>	Installing side bearing inner cone <b>a: 54 mm (2.13 in) dia.</b> <b>b: 46 mm (1.81 in) dia.</b> <b>c: 32 mm (1.26 in) dia.</b>

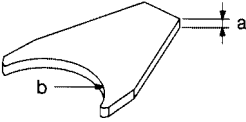
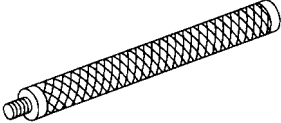
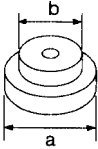
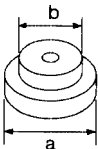
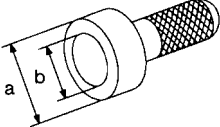
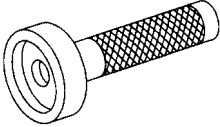
# PREPARATION

Tool number (Kent-Moore No.) Tool name	Description	
KV38100600 (J25267) Side bearing spacer drift   NT528	Installing side bearing spacer <b>a: 8 mm (0.31 in)</b> <b>b: R42.5 mm (1.673 in)</b>	A B C
ST30611000 (J25742-1) Drift   NT090	Installing drive pinion rear bearing outer race and drive pinion front bearing outer race (Use with ST30621000 or ST30613000)	FFD E
ST30621000 (J25742-5) Drift   NT073	Installing drive pinion rear bearing outer race (Use with ST30611000) <b>a: 79 mm (3.11 in) dia.</b> <b>b: 59 mm (2.32 in) dia.</b>	F G H
ST30613000 (J25742-3) Drift   NT073	Installing drive pinion front bearing outer race (Use with ST30611000) <b>a: 72 mm (2.83 in) dia.</b> <b>b: 48 mm (1.89 in) dia.</b>	H I J
KV38100500 (J25273) Gear carrier front oil seal drift   NT115	Installing front oil seal and side flange oil seal <b>a: 85 mm (3.35 in) dia.</b> <b>b: 60 mm (2.36 in) dia.</b>	K L
KV38100200 (J26233) Gear carrier side oil seal drift   NT120	Installing side oil seal	M
(J34309) Differential shim selector   NT134	Adjusting bearing pre-load and gear height	

# PREPARATION

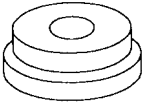
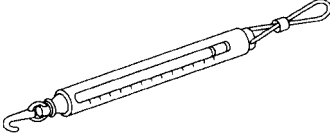
Tool number (Kent-Moore No.) Tool name	Description
<p>(J25269-4) Side bearing discs (2 Req'd)</p>  <p>NT136</p>	Selecting drive pinion height adjusting washer
<p>(J8129) Spring gauge</p>  <p>NT127</p>	Measuring differential case assembly turning resistance

# NOISE, VIBRATION, AND HARSHNESS (NVH) TROUBLESHOOTING

## NOISE, VIBRATION, AND HARSHNESS (NVH) TROUBLESHOOTING

PF0:00003

### NVH Troubleshooting Chart

EDS0012B

Use the chart below to help you find the cause of the symptom. If necessary, repair or replace these parts.

Symptom			Possible cause and SUSPECTED PARTS																
Symptom	DIFFERENTIAL	Noise	x	x	x	x	x	x	x	x	x	x	x	x	x	x	x	x	x
Reference page																			

x: Applicable

A  
B  
C  
FFD  
E  
F  
G  
H  
I  
J  
K  
L  
M

# FRONT OIL SEAL

PF3:38189

EDS0012C

## FRONT OIL SEAL

### Removal and Installation

#### REMOVAL

1. Remove front propeller shaft. Refer to [PR-8, "Removal and Installation"](#) .
2. Loosen drive pinion nut while holding the companion flange using Tool.

**Tool number** : **KV38108300 (J-44195)**

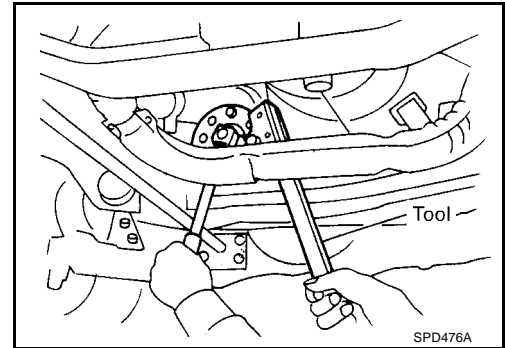

3. Remove companion flange using a suitable puller.

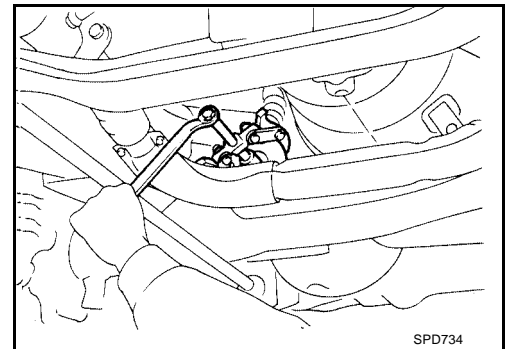

4. Remove front oil seal.

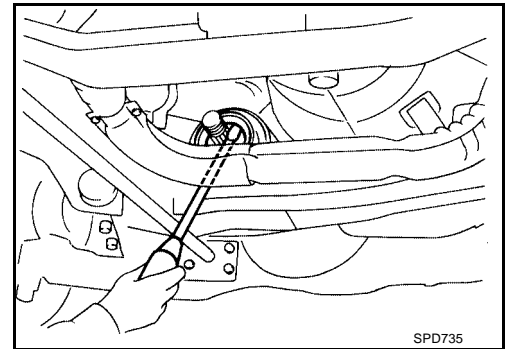

#### INSTALLATION

1. Apply multi-purpose grease to cavity at sealing lips of front oil seal. Press front oil seal into final drive housing using Tool.

**Tool number** : **KV38100500 (J25273)**

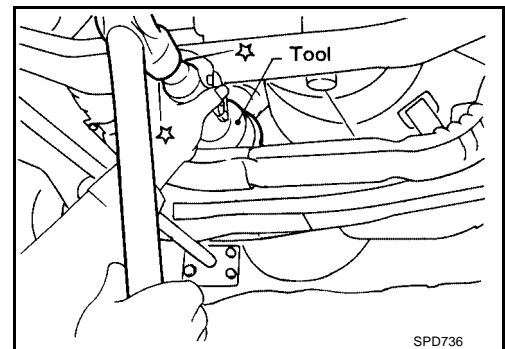

## FRONT OIL SEAL

2. Install companion flange and drive pinion nut. Tighten drive pinion nut while holding the companion flange using Tool.

**Tool number** : KV38108300 (J-44195)

**Drive pinion nut** : 186 - 294 N·m (19 - 30 kg·m,  
137 - 217 ft·lb)

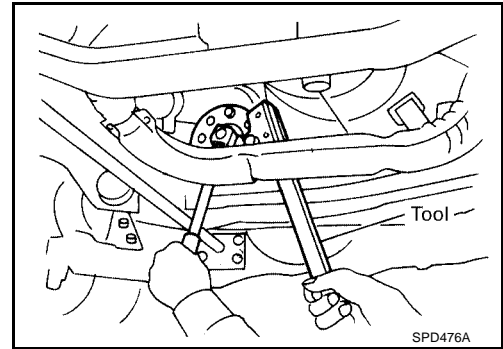

3. Install the front propeller shaft. Refer to [PR-8, "Removal and Installation"](#) .

A  
B  
C

FFD

E  
F  
G  
H  
I  
J  
K  
L  
M

# REAR COVER GASKET

---

## REAR COVER GASKET

PF3:38320

### Removal and Installation

EDS0012D

#### REMOVAL

1. Drain gear oil. Refer to [MA-40, "Changing Differential Gear Oil"](#) .
2. Remove rear cover and rear cover gasket.

#### INSTALLATION

1. Install new rear cover gasket and rear cover.

**Rear cover bolt : 39 - 49 N·m (4 - 5 kg·m, 29 - 36 ft·lb)**

2. Fill final drive with recommended gear oil. Refer to [MA-12, "RECOMMENDED FLUIDS AND LUBRICANTS"](#) .



# FRONT FINAL DRIVE ASSEMBLY

PFP:38500

EDS0012E

## FRONT FINAL DRIVE ASSEMBLY

### Removal and Installation

#### REMOVAL

1. Remove front propeller shaft. Refer to [PR-8, "Removal and Installation"](#).

**CAUTION:**

Be careful not to damage spline, sleeve yoke and front oil seal when removing propeller shaft.

2. Separate drive shaft from front final drive. Refer to [FAX-20, "Removal"](#).
3. Remove engine mounting bolts and raise up engine. Refer to [EM-46, "Removal and Installation"](#) for KA24DE or [EM-128, "Removal and Installation"](#) for VG33E or VG33ER.

4. Remove front final drive with differential mounting member as an assembly.

**CAUTION:**

Before removing the final drive assembly or rear axle assembly, disconnect the ABS sensor harness connector from the assembly and move it away from the final drive/rear axle assembly area. Failure to do so may result in the sensor wires being damaged and the sensor becoming inoperative.

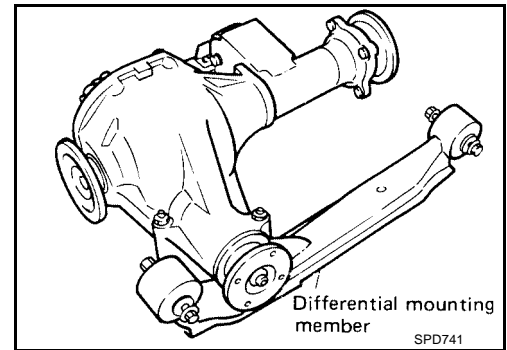

#### INSTALLATION

1. Install front final drive assembly with differential mounting member as an assembly.

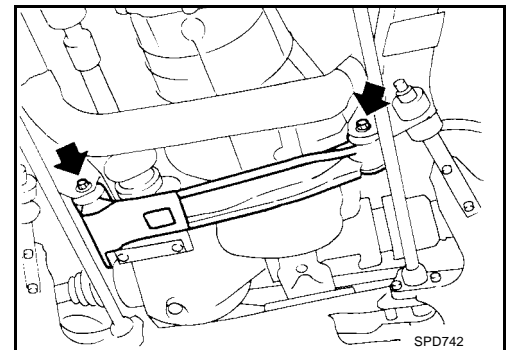

2. Tighten front final drive bolts and nuts in the alpha order shown to prevent drive train vibration.

#### Front final drive bolts

- Step 1 : Temporarily tighten nut A
- Step 2 : Temporarily tighten nut B
- Step 3 : 68 to 87 N·m (6.9 to 8.9 kg·m, 50 to 64 ft·lb)  
(bolt C)
- Step 4 : 68 to 87 N·m (6.9 to 8.9 kg·m, 50 to 64 ft·lb)  
(bolt D)
- Step 5 : 68 to 87 N·m (6.9 to 8.9 kg·m, 50 to 64 ft·lb)  
(nut A)
- Step 6 : 68 to 87 N·m (6.9 to 8.9 kg·m, 50 to 64 ft·lb)  
(nut B)
- Step 7 : 68 to 87 N·m (6.9 to 8.9 kg·m, 50 to 64 ft·lb)  
(bolt E)

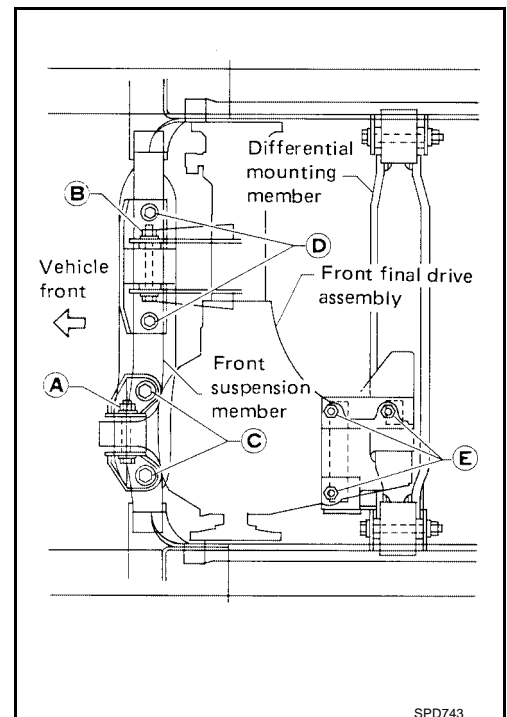

## FRONT FINAL DRIVE ASSEMBLY

---

3. Lower engine and install engine mounting bolts. Refer to [EM-46, "Removal and Installation"](#) for KA24DE or [EM-128, "Removal and Installation"](#) for VG33E or VG33ER.
4. Install drive shaft. Refer to [FAX-25, "Installation"](#) .
5. Install front propeller shaft. Refer to [PR-8, "Removal and Installation"](#) .

# FRONT FINAL DRIVE ASSEMBLY

EDS0012F

## Components

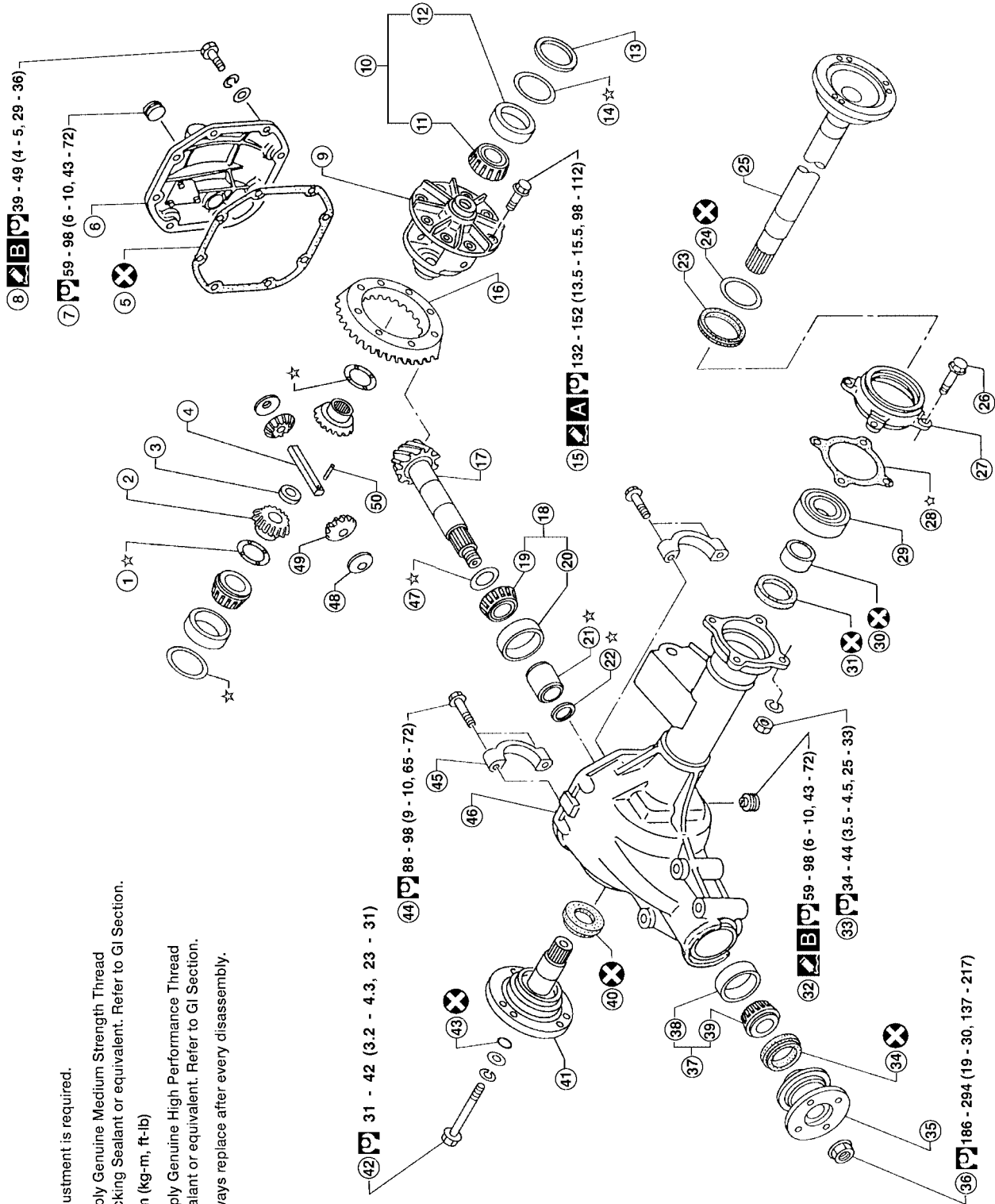

### SEC. 381

- ☆ : Adjustment is required.
- : Apply Genuine Medium Strength Thread Locking Sealant or equivalent. Refer to GI Section.
- : Apply Genuine High Performance Thread Sealant or equivalent. Refer to GI Section.
- : Always replace after every disassembly.

A  
B  
C  
FFD  
E  
F  
G  
H  
I  
J  
K  
L  
M

WDIA0016E

# FRONT FINAL DRIVE ASSEMBLY

- |   |  |   |
|---|--|---|
| 1. Side gear thrust washer                        | 2. Side gear                             | 3. Side flange lock nut                           |
| 4. Drive pinion mate shaft                        | 5. Gasket                                | 6. Rear cover                                     |
| 7. Filler plug                                    | 8. Rear cover bolts                      | 9. Differential case                              |
| 10. Side bearing                                  | 11. Inner cone                           | 12. Outer race                                    |
| 13. Side bearing spacer                           | 14. Side bearing adjusting shims         | 15. Ring gear bolt                                |
| 16. Ring gear                                     | 17. Drive pinion                         | 18. Drive pinion rear bearing                     |
| 19. Inner cone                                    | 20. Outer race                           | 21. Drive pinion bearing preload adjusting spacer |
| 22. Drive pinion bearing preload adjusting washer | 23. Grease seal                          | 24. Front axle bearing spacer                     |
| 25. Differential side shaft                       | 26. Extension tube retainer bolt         | 27. Extension tube retainer                       |
| 28. Bearing adjusting shim                        | 29. Front axle bearing                   | 30. Front axle bearing collar                     |
| 31. Oil seal                                      | 32. Drain plug                           | 33. Extension tube retainer nut                   |
| 34. Front oil seal                                | 35. Companion flange                     | 36. Drive pinion nut                              |
| 37. Drive pinion front bearing                    | 38. Outer race                           | 39. Inner cone                                    |
| 40. Side flange oil seal                          | 41. Differential side flange             | 42. Differential side flange bolt                 |
| 43. O-ring  | 44. Side bearing cap bolt                | 45. Side bearing cap                              |
| 46. Final drive housing                           | 47. Drive pinion height adjusting washer | 48. Drive pinion mate thrust washer               |
| 49. Drive pinion mate gear                        | 50. Drive pinion mate shaft lock pin     |   |

## Pre-Inspection

EDS0012G

Before disassembling final drive, perform the following inspections.

### TOTAL PRELOAD

- Turn drive pinion in both directions several times to set bearing rollers.
- Check total preload with Tool.

**Tool number : ST3127S000 (J25765-A)**

**Total preload : 1.4 - 1.7 N-m (14 - 17 kg-cm, 12 - 15 in-lb)**

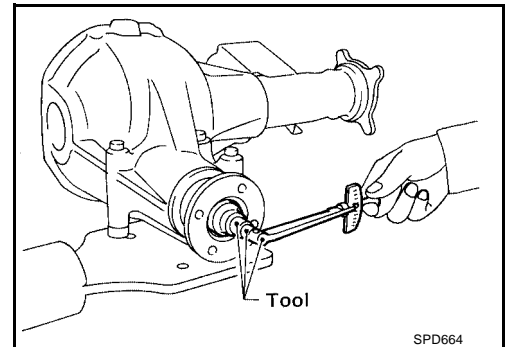

### RING GEAR TO DRIVE PINION BACKLASH

- Check backlash of ring gear with a dial indicator at several points.

**Ring gear to drive pinion backlash : 0.10 - 0.15 mm (0.0039 - 0.0059 in)**

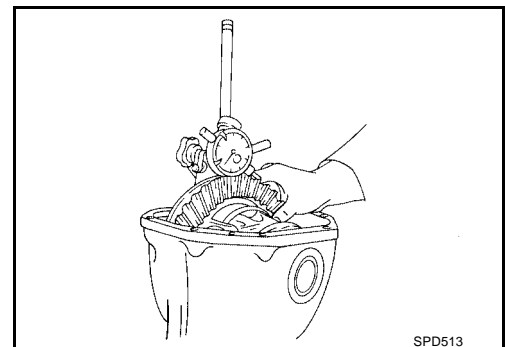

# FRONT FINAL DRIVE ASSEMBLY

## RING GEAR RUNOUT

- Check runout of ring gear with a dial indicator.

**Ring gear runout limit : 0.05 mm (0.0020 in)**

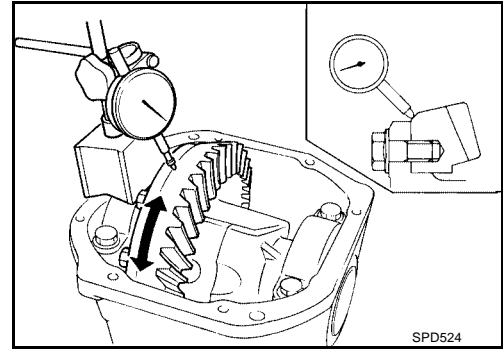

A  
B  
C

FFD

## TOOTH CONTACT

Check tooth contact. Refer to [FFD-25, "TOOTH CONTACT"](#).

## SIDE GEAR TO DRIVE PINION GEAR BACKLASH

- Measure clearance between side gear thrust washer and differential case using a feeler gauge.

**Side gear to pinion mate gear backlash : Less than 0.15 mm (0.0059 in)**

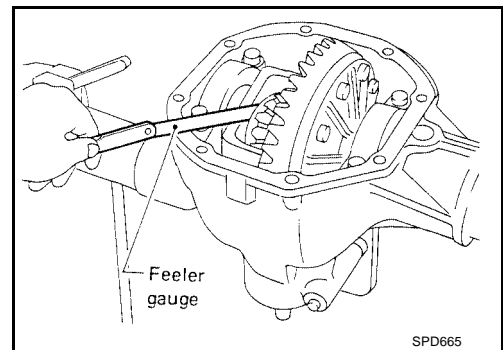

E  
F  
G  
H  
I

## Disassembly and Assembly

### REMOVAL OF DIFFERENTIAL CASE ASSEMBLY

1. Using three spacers [20 mm (0.79 in)], mount final drive assembly on Tool.

**Tool number : KV38100800 (J34310, J25604-01)**

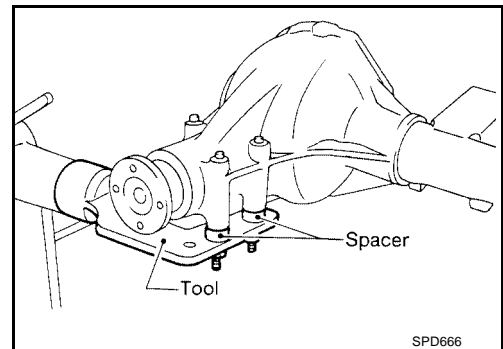

J  
K  
L  
M

2. Remove extension tube retainer bolts.
3. Tap on the back of the flange with a hammer to remove differential side shaft assembly.

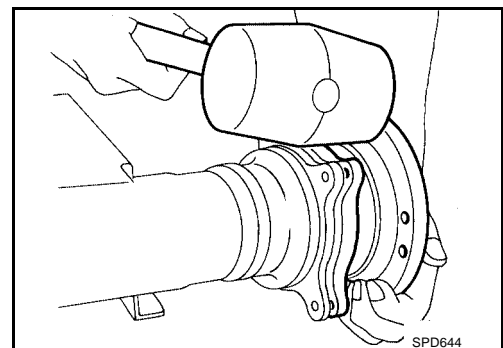

## FRONT FINAL DRIVE ASSEMBLY

4. Remove differential side flange while holding the differential side flange with a suitable tool.

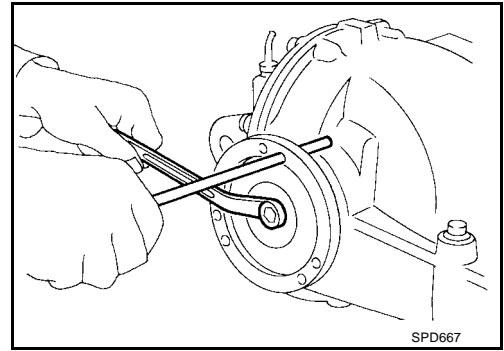

5. Remove rear cover and gasket.
6. Put match marks on one side of side bearing cap with paint or punch to ensure that it is replaced in proper position during assembly.

**NOTE:**

Bearing caps are line-bored during manufacture and should be put back in their original places.

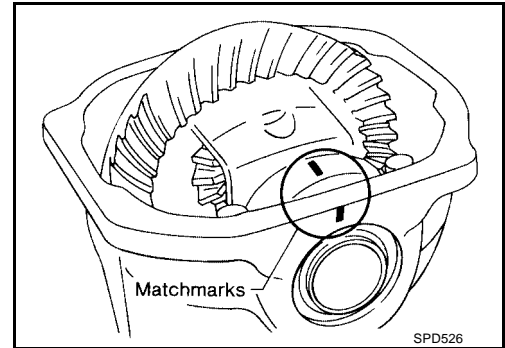

7. Remove side bearing caps.

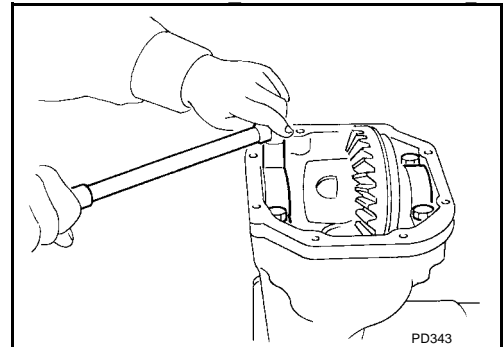

8. Remove differential case assembly with a pry bar.

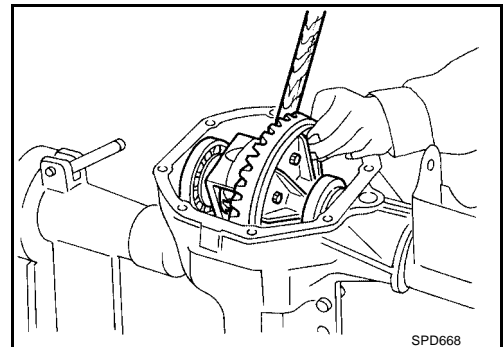

# FRONT FINAL DRIVE ASSEMBLY

## CAUTION:

- Be careful to keep the side bearing outer races together with their respective inner cones — do not mix them up.
- Side bearing spacer is placed on either the left or right depending upon final drive gear ratio. It should be labeled so that it may be replaced correctly.

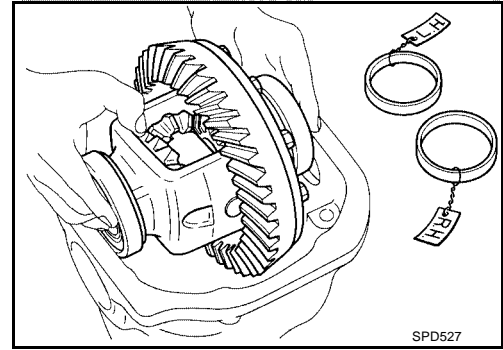

A  
B  
C

FFD

## REMOVAL OF DRIVE PINION ASSEMBLY

1. Loosen drive pinion nut while holding companion flange using Tool.

**Tool number : KV38108300 (J-44195)**

2. Remove companion flange with suitable puller.

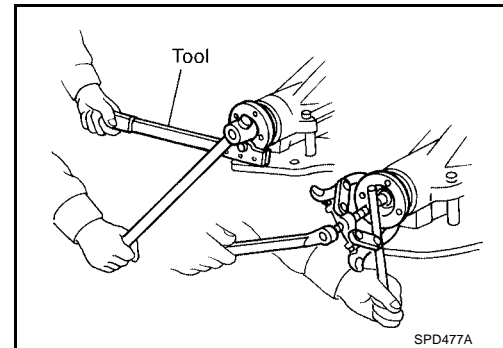

E  
F  
G  
H

3. Take out drive pinion together with drive pinion rear bearing inner cone, drive pinion bearing spacer and drive pinion bearing preload adjusting washer.

## CAUTION:

**Use a brass drift to prevent damage to the drive pinion threads.**

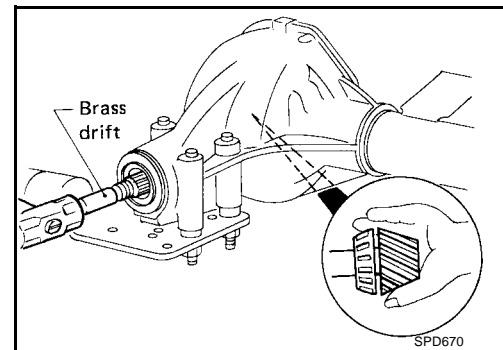

I  
J  
K  
L

4. Remove front oil seal and drive pinion front bearing inner cone.
5. Remove drive pinion bearing outer races with a brass drift.

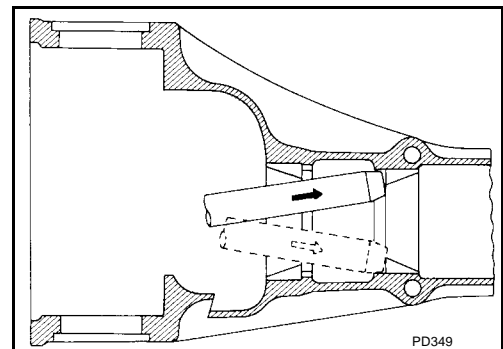

M

# FRONT FINAL DRIVE ASSEMBLY

6. Remove drive pinion rear bearing inner cone and drive pinion height adjusting washer using Tool.

**Tool number** : ST30031000 (J22912-01)

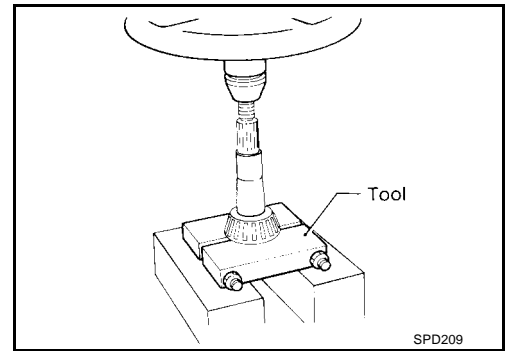

## DISASSEMBLY OF DIFFERENTIAL CASE ASSEMBLY

1. Remove side bearing inner cones using Tool.

**CAUTION:**

To prevent damage to bearing, engage puller jaws in grooves.

**Tool numbers**

**A** : ST33051001 (J22888-20)

**B** : ST33061000 (J8107-2)

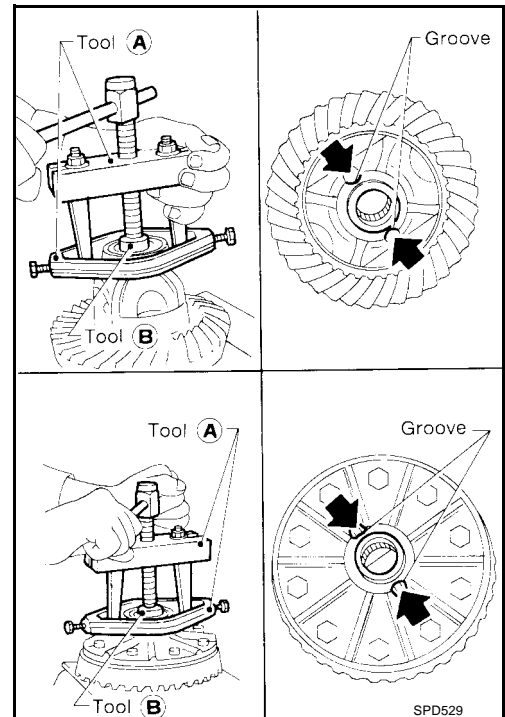

**NOTE:**

- Be careful not to confuse the right-hand and left-hand parts.
- Keep bearing and bearing race for each side together.

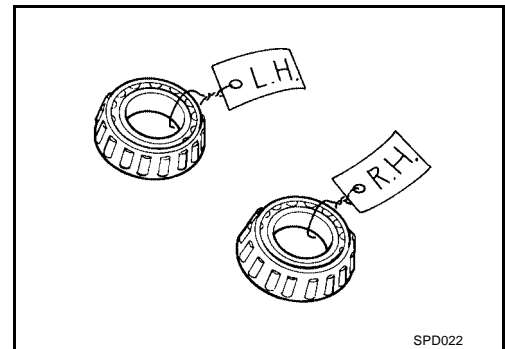



## FRONT FINAL DRIVE ASSEMBLY

2. Loosen ring gear bolts in a crisscross pattern.
3. Tap ring gear off the differential case with a soft hammer.
  - Tap evenly all around to keep ring gear from binding.

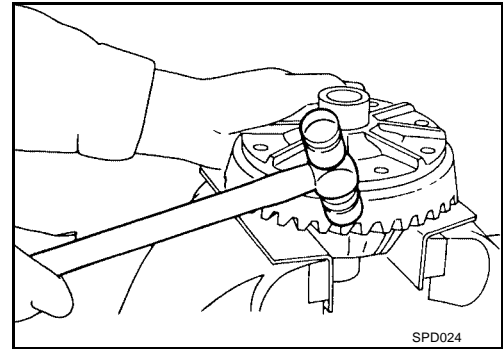

4. Punch off pinion mate shaft lock pin from differential case.
  - Lock pin is caulked at pin hole mouth on differential case.

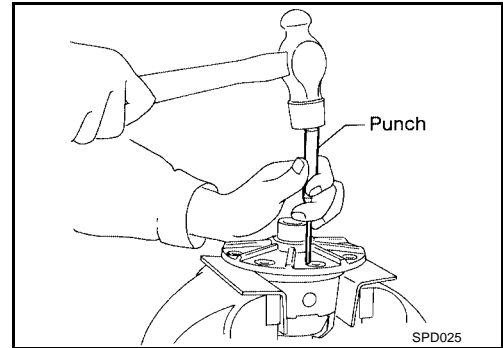

### DISASSEMBLY OF DIFFERENTIAL SIDE SHAFT

1. Cut front axle bearing collar with cold chisel.  
**CAUTION:**  
Be careful not to damage differential side shaft.

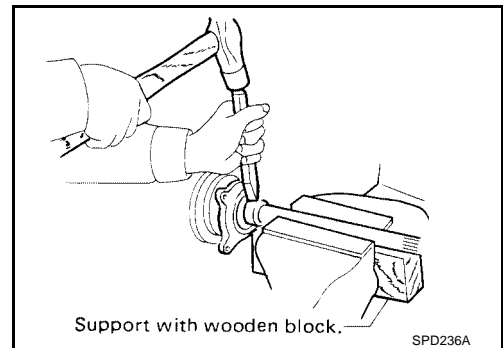

A  
B  
C  
FFD

E  
F  
G

H  
I  
J

K  
L  
M

## FRONT FINAL DRIVE ASSEMBLY

2. Reinstall differential side shaft into extension tube and secure with bolts. Remove front axle bearing by drawing out differential side shaft from front axle bearing with puller.

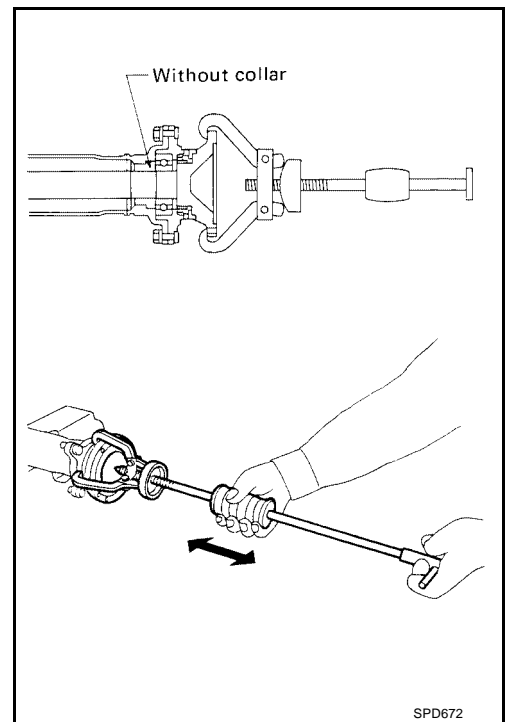

3. Remove grease seal.

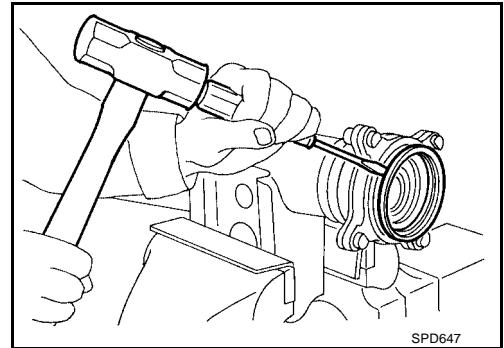

4. Remove extension tube retainer.
5. Remove oil seal.

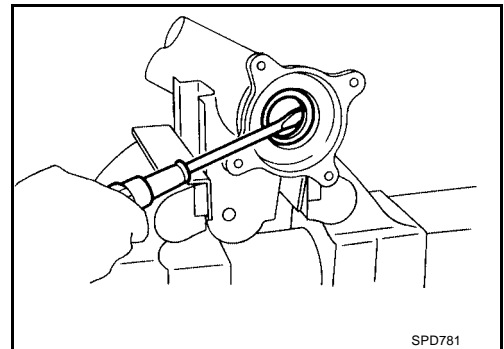

### INSPECTION

#### Ring gear and drive pinion

Check gear teeth for scoring, cracking or chipping. If any damaged part is evident, replace ring gear and drive pinion as a set (hypoid gear set).

# FRONT FINAL DRIVE ASSEMBLY

## Differential case assembly

Check mating surfaces of differential case, side gears, pinion mate gears, pinion mate shaft and thrust washers.

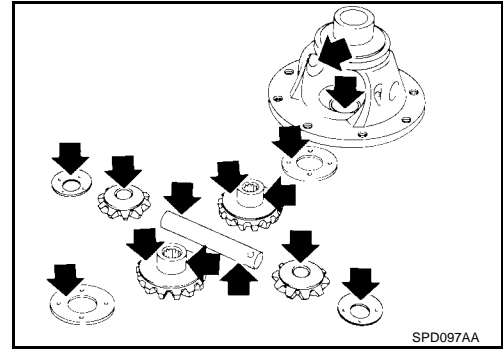

## Bearing

1. Thoroughly clean bearing.
2. Check bearing for wear, scratches, pitting or flaking. Check tapered roller bearing for smooth rotation. If damaged, replace outer race and inner cone as a set.

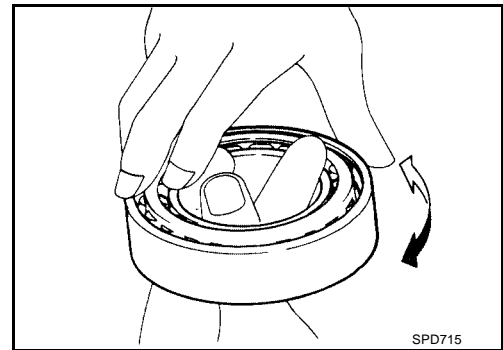

## ADJUSTMENT OF DIFFERENTIAL CASE ASSEMBLY

For quiet and reliable final drive operation, the following five adjustments must be made correctly:

1. Side bearing preload. Refer to [FFD-19, "SIDE BEARING PRELOAD"](#) .
2. Pinion gear height. Refer to [FFD-21, "DRIVE PINION GEAR HEIGHT AND PINION BEARING PRELOAD"](#) .
3. Pinion bearing preload. Refer to [FFD-21, "DRIVE PINION GEAR HEIGHT AND PINION BEARING PRELOAD"](#) .
4. Ring gear to drive pinion backlash. Refer to [FFD-33, "Total Preload Adjustment"](#) .
5. Ring and pinion gear tooth contact pattern. Refer to [FFD-25, "TOOTH CONTACT"](#) .

## SIDE BEARING PRELOAD

### NOTE:

A selection of carrier side bearing adjusting washers are required for successful completion of this procedure.

1. Make sure all parts are clean and that the bearings are well lubricated with light oil or "DEXRON™" automatic transmission fluid or equivalent. Refer to [MA-12, "RECOMMENDED FLUIDS AND LUBRICANTS"](#) .
2. Place the differential carrier assembly, with side bearings and bearing races installed, into the final drive housing.

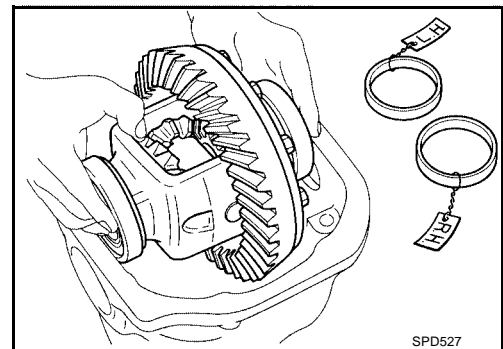

# FRONT FINAL DRIVE ASSEMBLY

3. Put the side bearing spacer in place.

**CAUTION:**

Side bearing spacer is placed on either the right or left depending upon final drive gear ratio. Be sure to replace it on the correct side.

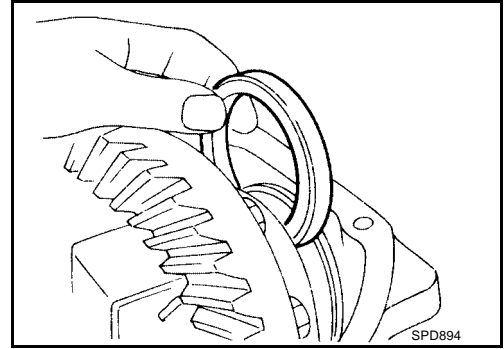

4. Install original side bearing adjusting shims on the differential case assembly end, opposite the ring gear using Tool.

**Tool number : KV38100600 (J25267)**

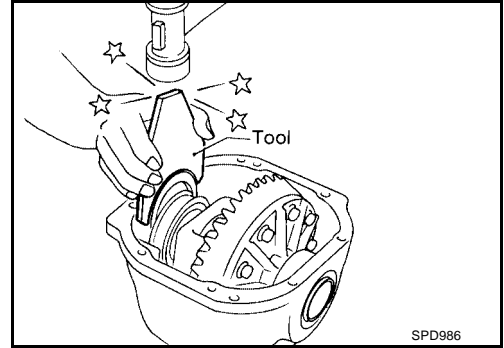

5. Install the side bearing caps in their correct locations and tighten the bearing cap bolts.

**Bearing cap bolts : 88 - 98 N·m (9 - 10 kg·m, 65 - 72 ft·lb)**

6. Turn the differential case assembly several times to seat the bearings.

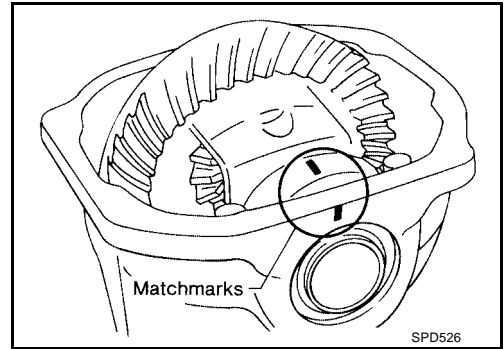

7. Measure the differential case assembly turning resistance at the ring gear bolts using Tool.

**Differential case assembly turning resistance : 34.3 - 39.2 N (3.5 - 4.0 kg, 7.7 - 8.8 lb) of pulling force at the ring gear bolt**

**Tool number (J8129)**

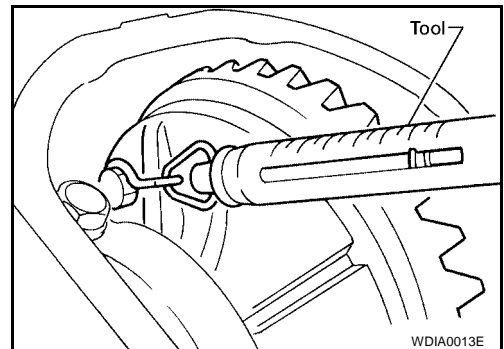

8. If the differential case assembly turning resistance is not within the specification range, increase or decrease the total thickness of the side bearing adjusting shims until the turning resistance is correct. If the turning resistance is less than the specified range, install side bearing adjusting shims of greater thickness; if the turning resistance is greater than the specification, install thinner side bearing adjusting shims. Refer to [FFD-33, "Side Bearing Adjustment"](#).

9. Record the total amount of side bearing adjusting shim thickness required for the correct side bearing preload.

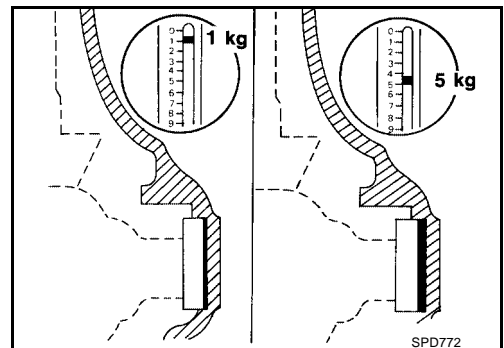

# FRONT FINAL DRIVE ASSEMBLY

10. Remove the differential case assembly from the final drive housing, saving the selected side bearing adjusting shims for later use during the assembly of the final drive unit.

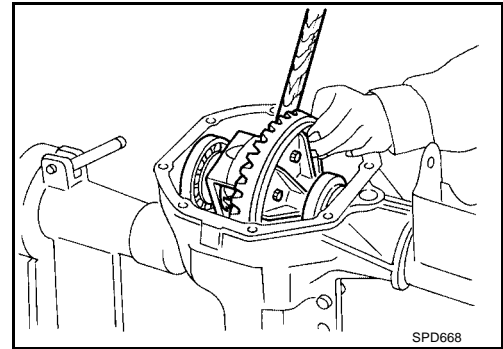

## DRIVE PINION GEAR HEIGHT AND PINION BEARING PRELOAD

1. Make sure all parts are clean and that the bearings are well lubricated.
2. Assemble the pinion gear bearings into Tool.

**Tool number (J34309)**

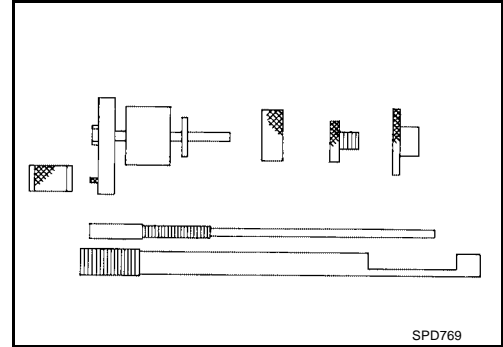

- **Drive Pinion Front Bearing** — make sure the J34309-3 front pinion bearing seat is secured tightly against the J34309-2 gauge anvil. Then turn the front pinion bearing pilot, J34309-5, to secure the bearing in its proper position.
- **Drive Pinion Rear Bearing** — the rear pinion bearing pilot, J34309-15, is used to center the rear pinion bearing only. The rear pinion bearing locking seat, J34309-4, is used to lock the bearing to the assembly.

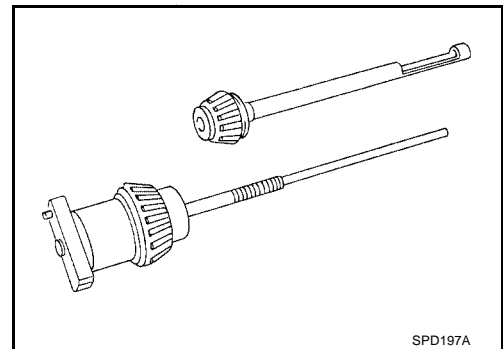

3. Place the differential shim selector tool, J34309, gauge screw assembly with the pinion rear bearing inner cone installed into the final drive housing.

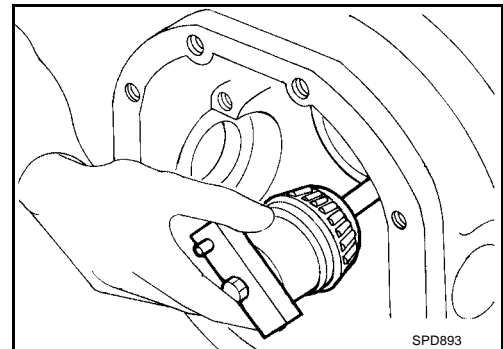

A  
B  
C  
FFD

E  
F  
G  
H  
I  
J  
K  
L  
M

# FRONT FINAL DRIVE ASSEMBLY

4. Assemble the drive pinion front bearing inner cone and the J34309-2 gauge anvil together with the J34309-1 gauge screw in the final drive housing. Make sure that the pinion height gauge plate, J34309-16, will turn a full 360 degrees, and tighten the two sections together by hand.

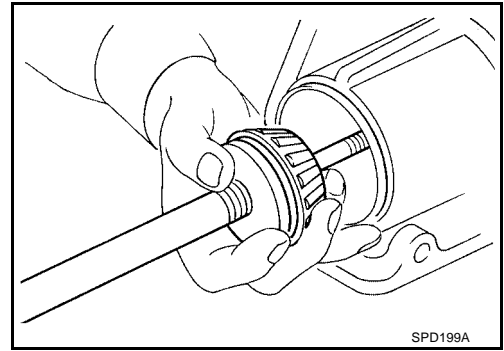

5. Turn the assembly several times to seat the bearings.

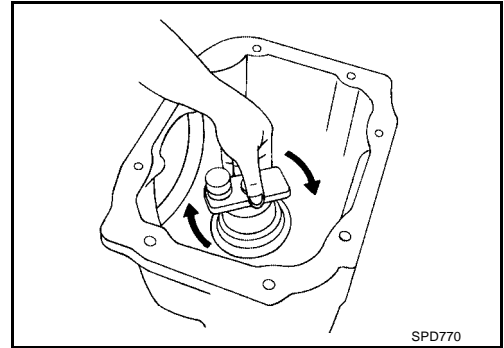

6. Measure the drive pinion preload without front oil seal resistance at the end of the J34309-2 gauge anvil using Tool.

**Drive pinion preload** : 1.0 - 1.3 N·m (10 - 13 kg·cm,  
**without front oil seal** 8.7 - 11.3 in·lb  
**resistance**

**Tool number** ST3127S000 (J25765-A)

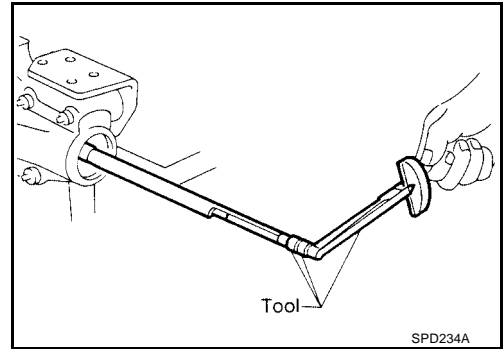

7. Place the J34309-1 "R200A" pinion height adapter onto the gauge plate and tighten it by hand.

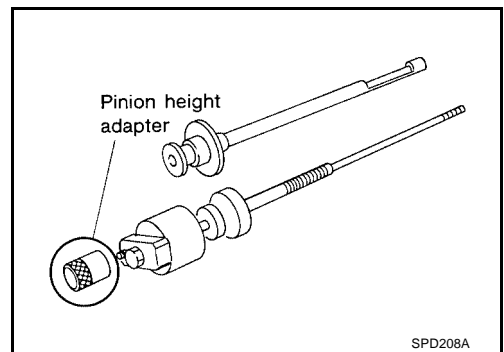

## DRIVE PINION BEARING PRELOAD WASHER SELECTION

### CAUTION:

Make sure all machined surfaces are clean.

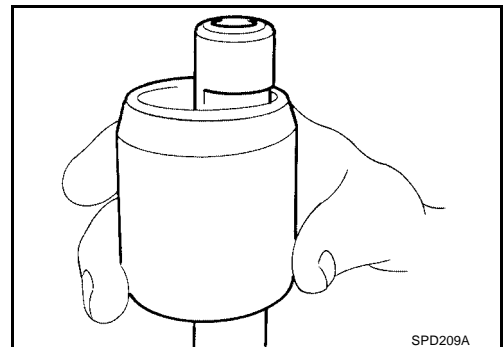

# FRONT FINAL DRIVE ASSEMBLY

8. Place the solid pinion bearing spacer, small end first, over the J34309-2 gauge anvil and seat the small end squarely against the tip of the J34309-1 gauge screw in the tool recessed portion.

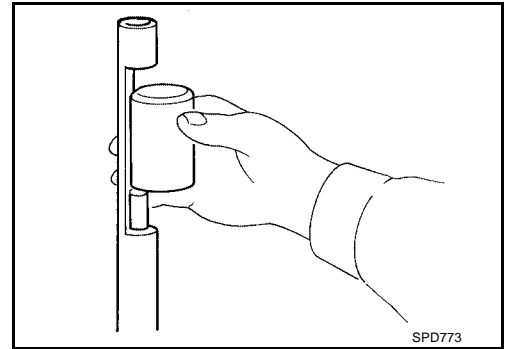

9. Select the correct thickness of drive pinion bearing preload adjusting washer using a standard gauge of 3.5 mm (0.138 in) and J34309-101 feeler gauge. The exact measure is the thickness of the drive pinion adjusting washer required. Select the correct drive pinion bearing preload adjusting washer.

**Drive pinion bearing preload adjusting washer** : Refer to [FFD-34, "Drive Pinion Preload Adjustment"](#) .

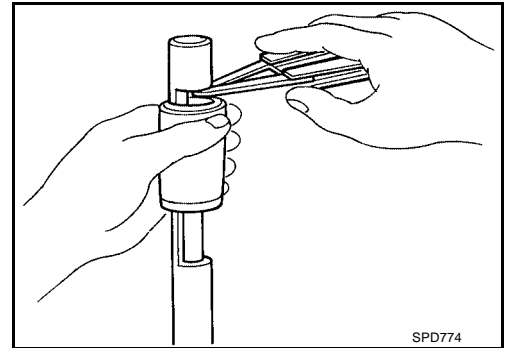
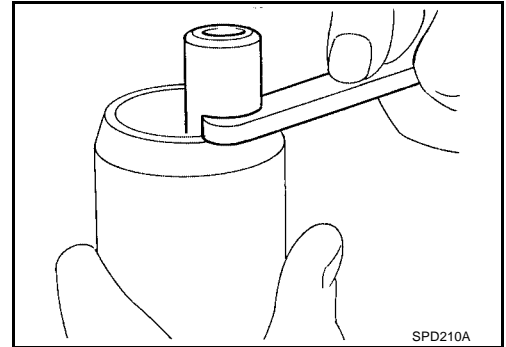

10. Set the selected, correct drive pinion bearing preload adjusting washer aside for use when assembling the drive pinion and bearings into the final drive.

## DRIVE PINION HEIGHT ADJUSTING WASHER SELECTION

11. Position the side bearing discs, J25269-4, and arbor firmly into the side bearing bores.

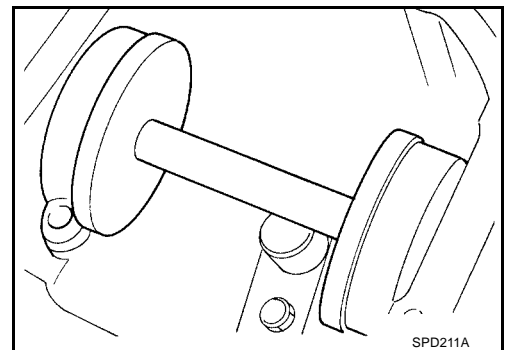

A  
B  
C  
FFD

E  
F  
G  
H  
I  
J  
K  
L  
M

# FRONT FINAL DRIVE ASSEMBLY

12. Install the side bearing caps and tighten the side bearing cap bolts.

**Side bearing cap bolts : 88 - 98 N-m (9 - 10 kg-m, 65 - 72 ft-lb)**

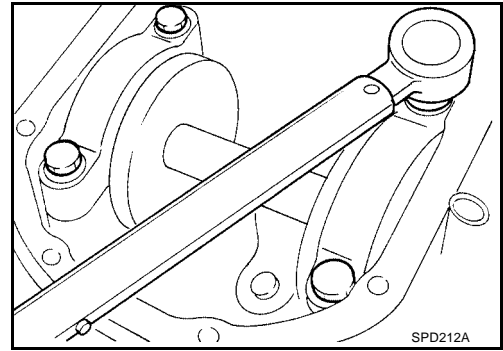

13. Select the correct drive pinion height adjusting washer thickness by using a standard gauge of 3.0 mm (0.118 in) and J34309-101 feeler gauge. Measure the gap between the J34309-11 "R200A" pinion height adapter and the arbor.

14. Write down the exact total measurement.

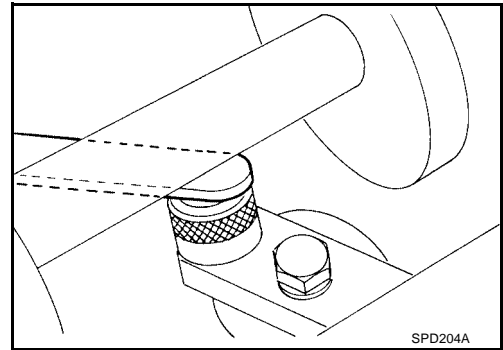

15. Correct the drive pinion height adjusting washer size by referring to the "drive pinion head number".

- There are two numbers painted on the drive pinion. The first one refers to the drive pinion and ring gear as a matched set and should be the same as the number on the ring gear. The second number is the "drive pinion head height number", and it refers to the ideal drive pinion height for quietest operation.
- Use the following chart to determine the correct drive pinion height adjusting washer.

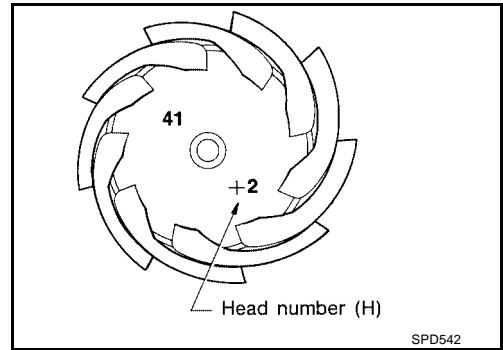

Drive Pinion Head Height Number	Add or Remove from the Drive Pinion Height Adjusting Washer Thickness Measurement
-6	Add 0.06 mm (0.0024 in)
-5	Add 0.05 mm (0.0020 in)
-4	Add 0.04 mm (0.0016 in)
-3	Add 0.03 mm (0.0012 in)
-2	Add 0.02 mm (0.0008 in)
-1	Add 0.01 mm (0.0004 in)
0	Use the selected washer thickness
+1	Subtract 0.01 mm (0.0004 in)
+2	Subtract 0.02 mm (0.0008 in)
+3	Subtract 0.03 mm (0.0012 in)
+4	Subtract 0.04 mm (0.0016 in)
+5	Subtract 0.05 mm (0.0020 in)
+6	Subtract 0.06 mm (0.0024 in)

16. Select the correct drive pinion height adjusting washer.

**Drive pinion height adjusting washer : Refer to [FFD-34, "Drive Pinion Height Adjustment"](#) .**



# FRONT FINAL DRIVE ASSEMBLY

- Remove the J34309 pinion preload shim selector tool from the final drive housing and disassemble to retrieve the pinion bearings.

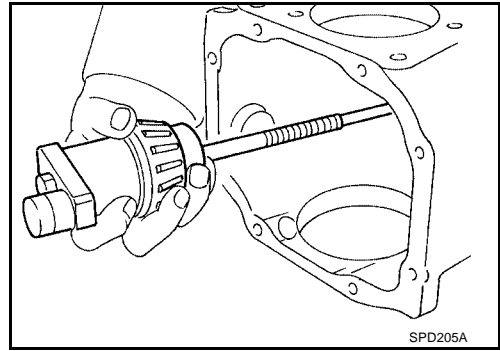

## TOOTH CONTACT

Gear tooth contact pattern check is necessary to verify correct relationship between ring gear and drive pinion. Hypoid gear sets which are not positioned properly in relation to one another may be noisy, or have short life, or both. With a pattern check, the most desirable contact for low noise level and long life can be assured.

- Thoroughly clean ring gear and drive pinion teeth.
- Sparingly apply a mixture of powdered ferric oxide and oil or equivalent to 3 or 4 teeth of ring gear drive side.

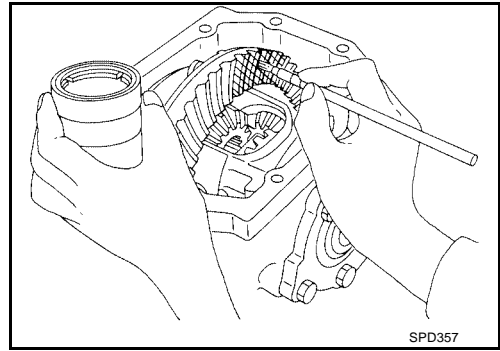

- Hold companion flange steady by hand and rotate the ring gear in both directions.

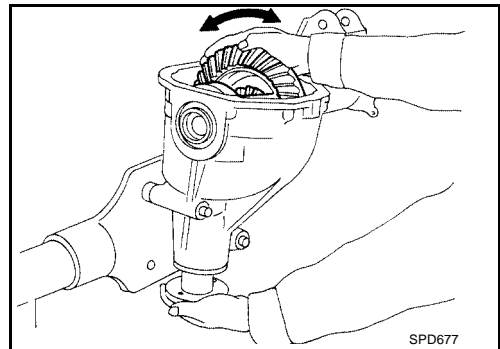

Usually the pattern will be correct if shims are correctly calculated and the backlash is correct. However, in rare cases, trial and error processes may be employed to obtain a correct pattern. The tooth pattern is the best indication of how well a differential has been set up.

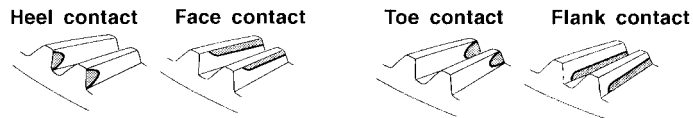

To correct, increase thickness of pinion height adjusting washer in order to bring drive pinion close to ring gear.

To correct, reduce thickness of pinion height adjusting washer in order to make drive pinion go away from ring gear.



Correct tooth contact

When adjustment is completed, be sure to wipe off completely the ferric oxide and oil or their equivalent.

SPD007-B

A  
B  
C  
FFD  
E  
F  
G  
H  
I  
J  
K  
L  
M

# FRONT FINAL DRIVE ASSEMBLY

## INSTALLATION OF DRIVE PINION ASSEMBLY

1. Press-fit front and rear bearing outer races using Tools.

**Tool number**

- A** : ST30611000 (J25742-1)  
**B** : ST30621000 (J25742-5)  
**C** : ST30613000 (J25742-3)

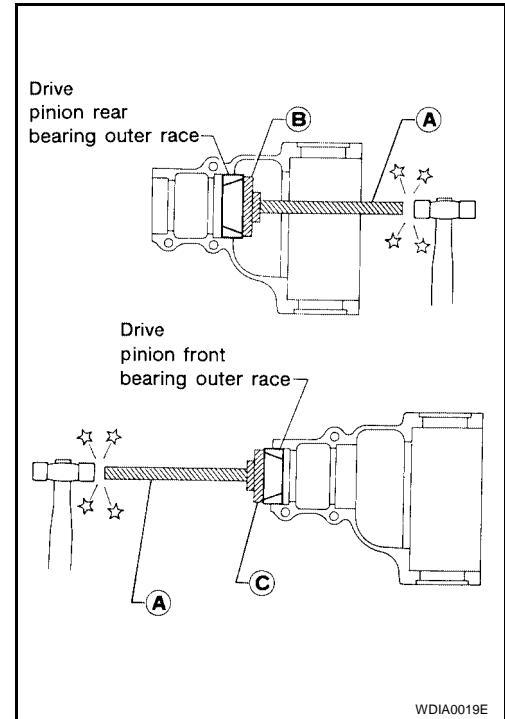

2. Select drive pinion height adjusting washer and drive pinion bearing preload adjusting washer. Refer to [FFD-21, "DRIVE PINION GEAR HEIGHT AND PINION BEARING PRELOAD"](#).
3. Install drive pinion height adjusting washer on drive pinion, and press-fit drive pinion rear bearing inner cone in it, using press and Tool.

**Tool number** : ST30901000 (J26010-01)

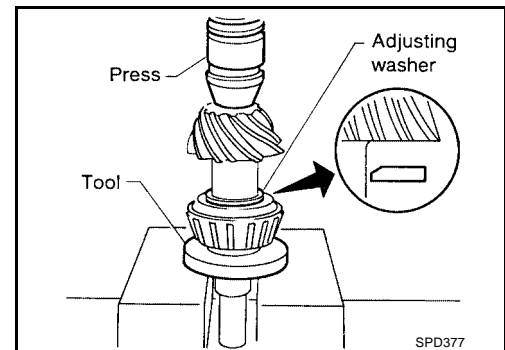

4. Place drive pinion front bearing inner cone in final drive housing.

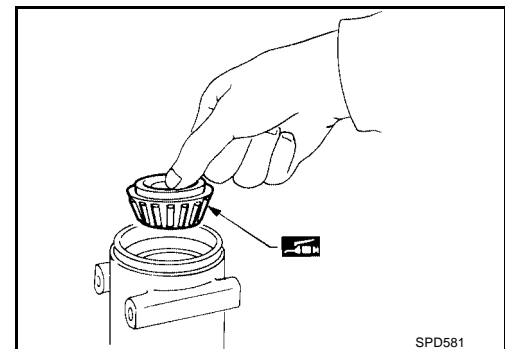

5. Apply multi-purpose grease to cavity at sealing lips of front oil seal. Install front oil seal using Tool.

**Tool number** : KV38100500 (J25273)

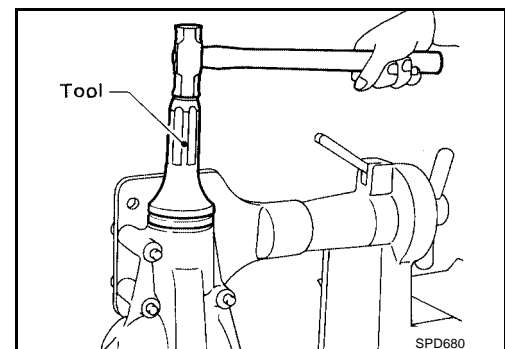

## FRONT FINAL DRIVE ASSEMBLY

6. Place drive pinion bearing preload adjusting spacer, drive pinion bearing preload adjusting washer and drive pinion in final drive housing.

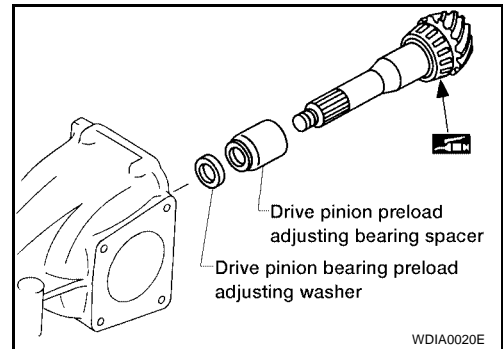

7. Insert companion flange into drive pinion by tapping the companion flange with a soft hammer.

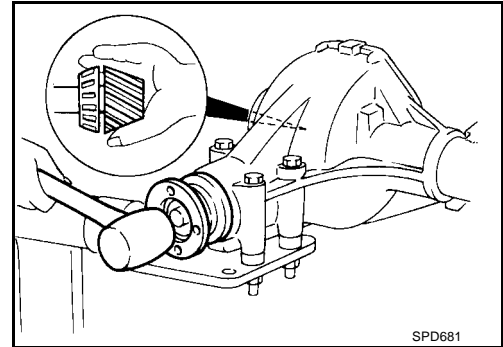

8. Tighten drive pinion nut while holding companion flange with Tool.

- The threaded portion of drive pinion and pinion nut should be free from oil or grease.

**Tool number : KV38108300 (J-44195)**

**Drive pinion nut : 186 - 294 N-m (19 - 30 kg-m,  
137 - 217 ft-lb)**

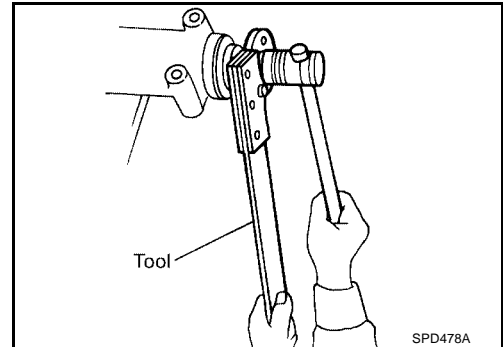

9. Turn drive pinion in both directions several revolutions, and measure drive pinion bearing preload with front oil seal resistance using Tool.

**Drive pinion bearing preload with front oil seal resistance : 1.1 - 1.4 N-m (11 - 14 kg-cm,  
9.5 - 12.2 in-lb)**

**Tool number : ST3127S000 (J25765-A)**

- When drive pinion bearing preload with front oil seal resistance is outside the specifications, replace drive pinion bearing preload adjusting washer and spacer with a different thickness.

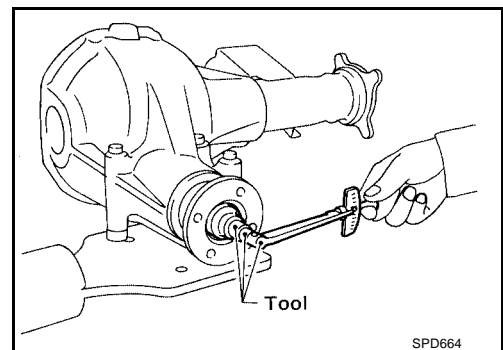

A  
B  
C  
FFD

E  
F  
G

H  
I  
J

K  
L  
M

# FRONT FINAL DRIVE ASSEMBLY

## ASSEMBLY OF DIFFERENTIAL SIDE SHAFT

1. Install oil seal using Tool.

**Tool number**

**: KV38100200 (J26233)**

### SEC. 380

No. of discs and plates (One side)

Model	H233B
Friction disc	2
Friction plate	5
Spring plate	2
Spacer	1

13  
WDIA0017E

2. Install grease seal with suitable tool.

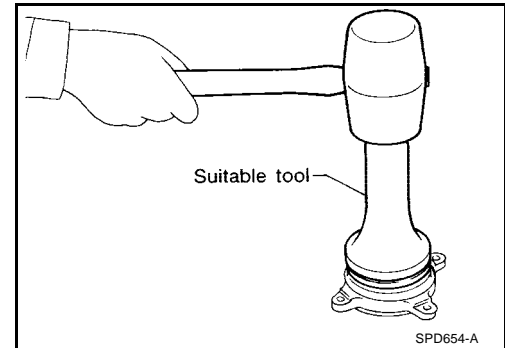

3. Install extension tube retainer, front axle bearing and front axle bearing collar on differential side shaft using a suitable tool.

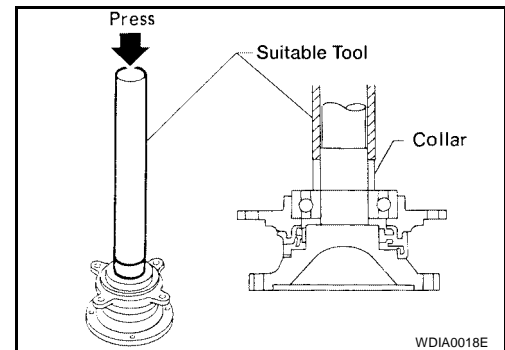

## ASSEMBLY OF DIFFERENTIAL CASE ASSEMBLY

1. Install side gears, pinion mate gears and pinion mate thrust washers into differential case.

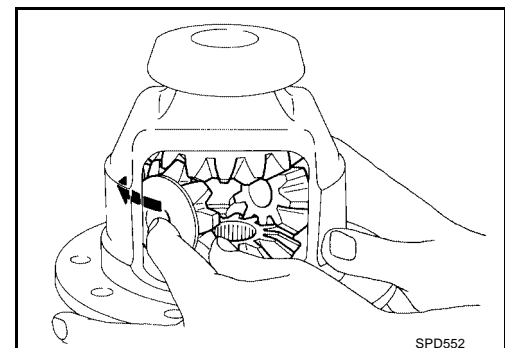

# FRONT FINAL DRIVE ASSEMBLY

2. Fit pinion mate shaft to differential case so that it meets drive pinion mate shaft lock pin holes.
3. Adjust backlash between side gear and drive pinion mate gear by selecting side gear thrust washer. Refer to [FFD-33, "Side Gear Adjustment"](#) .

**Side gear to drive pinion mate gear (Clearance between side gear thrust washer and differential case) : Less than 0.15 mm (0.0059 in)**

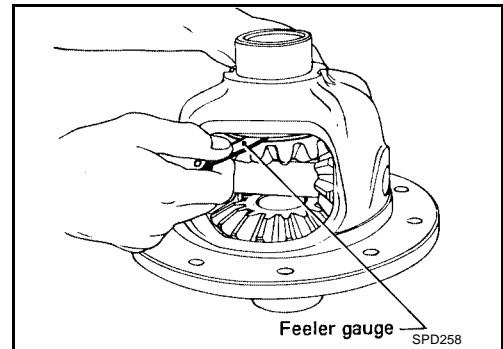

4. Install drive pinion mate shaft lock pin with a punch.
  - Make sure drive pinion mate shaft lock pin is flush with case.

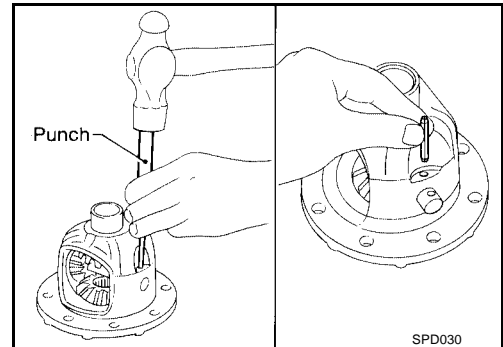

5. Apply gear oil to gear tooth surfaces and thrust surfaces and check to see they turn properly.

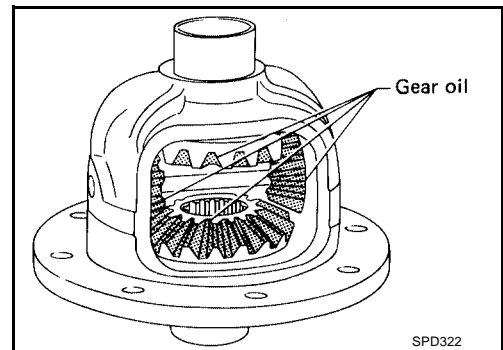

6. Install differential case assembly on ring gear.
7. Apply Genuine Medium Strength Thread Locking Sealant or equivalent to ring gear bolts, and install them.
  - Refer to [MA-12, "RECOMMENDED FLUIDS AND LUBRICANTS"](#) .
  - Tighten ring gear bolts in a crisscross pattern.

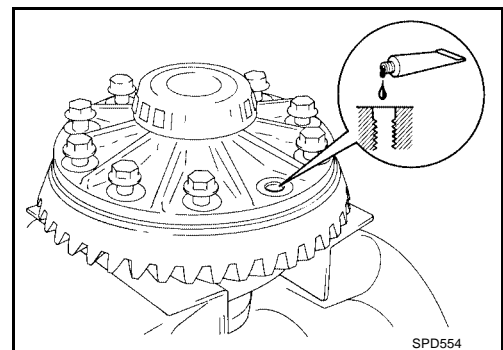

8. Press-fit side bearing inner cones on differential case with Tool.

**Tool numbers**

**A : KV38100300 (J25523)**

**B : ST33061000 (J8107-2)**

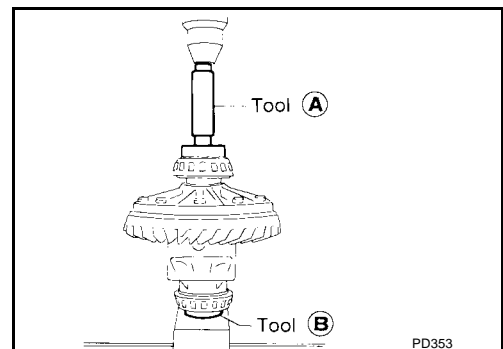

A  
B  
C  
FFD  
E  
F  
G  
H  
I  
J  
K  
L  
M

# FRONT FINAL DRIVE ASSEMBLY

## INSTALLATION OF DIFFERENTIAL CASE ASSEMBLY

1. Select side bearing adjusting washer. Refer to [FFD-19, "SIDE BEARING PRELOAD"](#) .
2. Install differential case assembly with side bearing outer races into final drive housing.

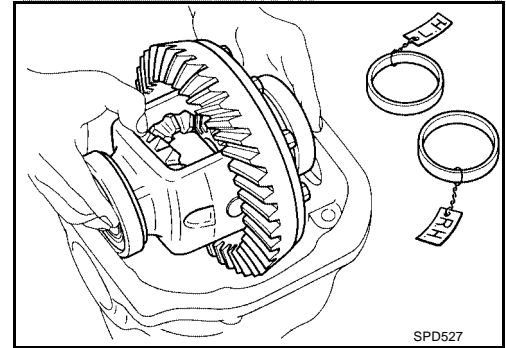

3. Insert left and right side bearing adjusting shims in place between side bearing outer races and final drive housing.

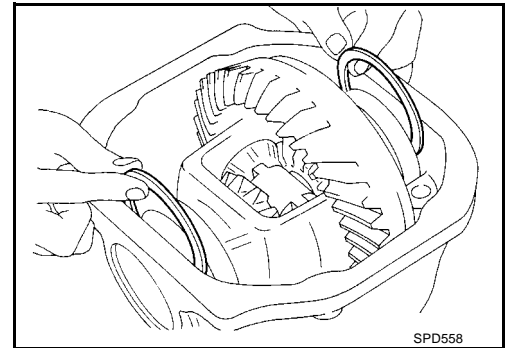

4. Drive in side bearing spacer using Tool.

**Tool number : KV38100600 (J25267)**

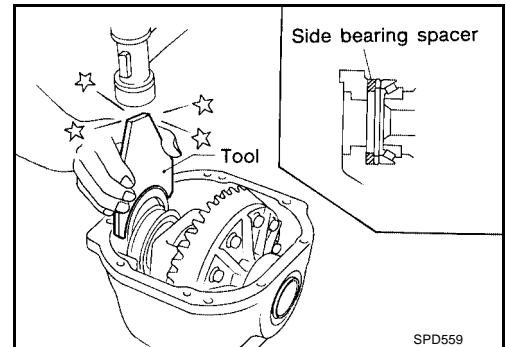

5. Align mark on bearing cap with that on final drive housing and install bearing cap on final drive housing.

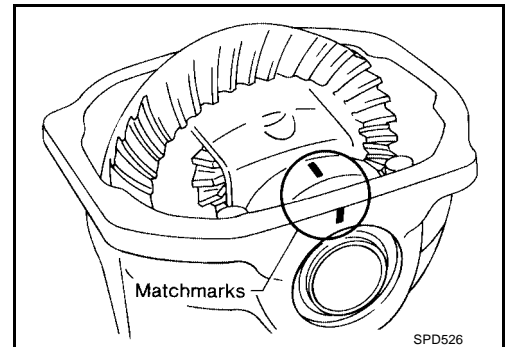

# FRONT FINAL DRIVE ASSEMBLY

6. Apply multi-purpose grease to cavity at sealing lips of side flange oil seal. Install side flange oil seal using Tool.

**Tool number : KV38100200 (J26233)**

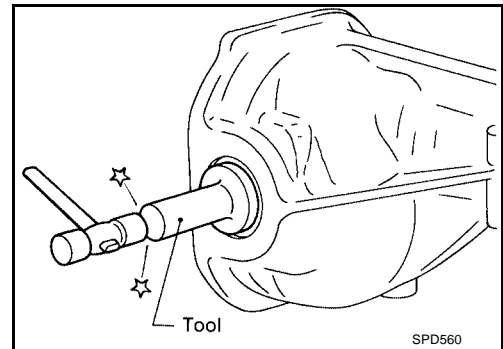

7. Measure ring gear to drive pinion backlash with a dial indicator.

**Ring gear to drive pinion backlash : 0.10 - 0.15 mm (0.0039 - 0.0059 in)**

- If backlash is too small, decrease thickness of right side bearing adjusting shim and increase thickness of left side bearing adjusting shim by the same amount.
- If backlash is too great, reverse the above procedure.
- Never change the total amount of side bearing adjusting shims as it will change the bearing preload.

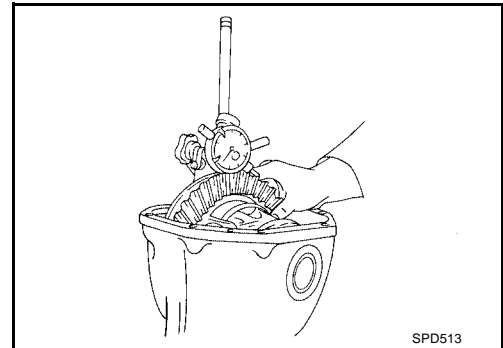

8. Check total preload using Tool.

- When checking preload, turn drive pinion in both directions several times to set bearing rollers.

**Total preload : 1.4 - 1.7 N·m (14 - 17 kg-cm, 12 - 15 in-lb)**

**Tool number : ST3127S000 (J25765-A)**

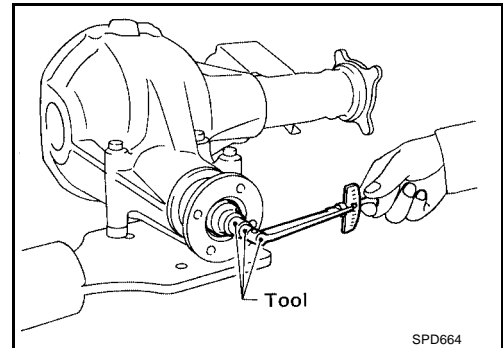

- If preload is too great, remove the same amount of side bearing adjusting shim from each side.
- If preload is too small, add the same amount of side bearing adjusting shim to each side.
- Never add or remove a different number of side bearing adjusting shims for each side as it will change ring gear to drive pinion backlash.

9. Recheck ring gear to drive pinion backlash because increase or decrease in thickness of side bearing adjusting shims will cause change of ring gear to drive pinion backlash.

- If the backlash varies greatly when the runout of the ring gear is within a specified range, the hypoid gear set or differential case should be replaced.

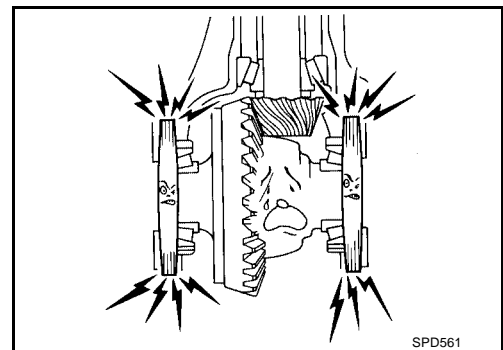

A  
B  
C

FFD

E

F

G

H

I

J

K

L

M

## FRONT FINAL DRIVE ASSEMBLY

10. Check ring gear runout with a dial indicator.

**Ring gear runout limit : 0.05 mm (0.0020 in)**

- If ring gear runout varies excessively in different places, the variance may have resulted from foreign matter caught between the ring gear and the differential case.

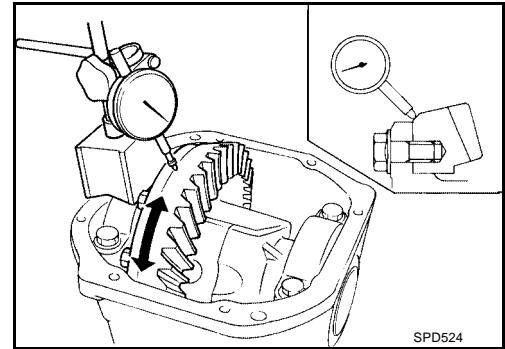

11. Check tooth contact. Refer to [FFD-25, "TOOTH CONTACT"](#).

12. Install rear cover and a new gasket.

**Rear cover bolts : 39 - 49 N·m (4 - 5 kg·m, 29 - 36 ft·lb)**

13. Install differential side shaft assembly.

**Extension tube retainer bolt and nut : 34 - 44 N·m (3.5 - 4.5 kg·m, 25 - 33 ft·lb)**

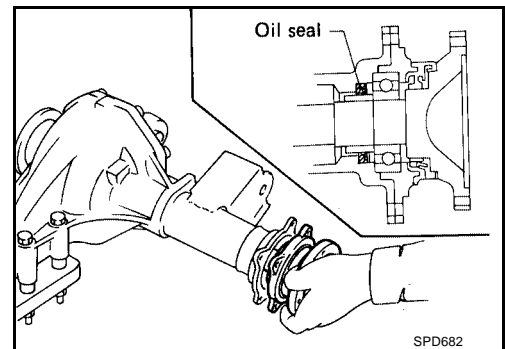

14. Install differential side flange.

**Differential side flange bolt : 31 - 42 N·m (3.2 - 4.3 kg·m, 23 - 31 ft·lb)**



# SERVICE DATA AND SPECIFICATIONS (SDS)

## SERVICE DATA AND SPECIFICATIONS (SDS)

PF0:00030

### General Specifications

EDS0012I

Engine	VG33E		VG33ER
Vehicle grade	XE	SE	SC
Front final drive	R200A		
	2-pinion		
Gear ratio	4.636	4.900	4.636
Number of teeth (Ring gear/drive pinion)	51/11	49/10	51/11
Oil capacity (Approx.) ℓ (US pt, Imp pt)	1.75 (3-3/4, 3-1/8)		

### Ring Gear Runout

EDS0012J

Ring gear runout limit mm (in)	0.05 (0.0020)
--------------------------------	---------------

### Side Gear Adjustment

EDS0012K

Side gear to pinion mate gear backlash (Clearance between side gear thrust washer and differential case) mm (in)	Less than 0.15 (0.0059)	
Available side gear thrust shims	Thickness mm (in)	Part number*
	0.75 (0.0295)	38424-N3110
	0.78 (0.0307)	38424-N3111
	0.81 (0.0319)	38424-N3112
	0.84 (0.0331)	38424-N3113
	0.87 (0.0343)	38424-N3114
	0.90 (0.0354)	38424-N3115
	0.93 (0.0366)	38424-N3116

\*Always check with the Parts Department for the latest parts information.

### Side Bearing Adjustment

EDS0012L

Differential carrier assembly turning resistance N (kg, lb)	34.3 - 39.2 (3.5 - 4.0, 7.7 - 8.8)	
Available side bearing adjusting washers	Thickness mm (in)	Part number*
	2.00 (0.0787)	38453-N3100
	2.05 (0.0807)	38453-N3101
	2.10 (0.0827)	38453-N3102
	2.15 (0.0846)	38453-N3103
	2.20 (0.0866)	38453-N3104
	2.25 (0.0886)	38453-N3105
	2.30 (0.0906)	38453-N3106
	2.35 (0.0925)	38453-N3107
	2.40 (0.0945)	38453-N3108
	2.45 (0.0965)	38453-N3109
	2.50 (0.0984)	38453-N3110
	2.55 (0.1004)	38453-N3111
2.60 (0.1024)	38453-N3112	

\*Always check with the Parts Department for the latest parts information.

### Total Preload Adjustment

EDS0012M

Total preload N·m (kg·cm, in·lb)	1.4 - 1.7 (14 - 17, 12 - 15)
Ring gear to drive pinion backlash mm (in)	0.10 - 0.15 (0.0039 - 0.0059)

# SERVICE DATA AND SPECIFICATIONS (SDS)

## Drive Pinion Height Adjustment

EDS0012N

	Thickness mm (in)	Part number*
Available drive pinion height adjusting washers	3.09 (0.1217)	38154-P6017
	3.12 (0.1228)	38154-P6018
	3.15 (0.1240)	38154-P6019
	3.18 (0.1252)	38154-P6020
	3.21 (0.1264)	38154-P6021
	3.24 (0.1276)	38154-P6022
	3.27 (0.1287)	38154-P6023
	3.30 (0.1299)	38154-P6024
	3.33 (0.1311)	38154-P6025
	3.36 (0.1323)	38154-P6026
	3.39 (0.1335)	38154-P6027
	3.42 (0.1346)	38154-P6028
	3.45 (0.1358)	38154-P6029
	3.48 (0.1370)	38154-P6030
	3.51 (0.1382)	38154-P6031
	3.54 (0.1394)	38154-P6032
	3.57 (0.1406)	38154-P6033
	3.60 (0.1417)	38154-P6034
3.63 (0.1429)	38154-P6035	
3.66 (0.1441)	38154-P6036	

\*Always check with the Parts Department for the latest parts information.

## Drive Pinion Preload Adjustment

EDS0012O

Drive pinion bearing preload adjusting method	Adjusting washer and spacer	
Drive pinion preload with front oil seal N·m (kg·cm, in·lb)	1.1 - 1.4 (11 - 14, 9.5 - 12.2)	
Drive pinion preload without front oil seal N·m (kg·cm, in·lb)	1.0 - 1.3 (10 - 13, 8.7 - 11.3)	
Available drive pinion bearing preload adjusting washers	Thickness mm (in)	Part number*
	3.81 (0.1500)	38125-61001
	3.83 (0.1508)	38126-61001
	3.85 (0.1516)	38127-61001
	3.87 (0.1524)	38128-61001
	3.89 (0.1531)	38129-61001
	3.91 (0.1539)	38130-61001
	3.93 (0.1547)	38131-61001
	3.95 (0.1555)	38132-61001
	3.97 (0.1563)	38133-61001
	3.99 (0.1571)	38134-61001
	4.01 (0.1579)	38135-61001
	4.03 (0.1587)	38136-61001
	4.05 (0.1594)	38137-61001
	4.07 (0.1602)	38138-61001
4.09 (0.1610)	38139-61001	
Available drive pinion bearing preload adjusting spacers	Length mm (in)	Part number*
	54.50 (2.1457)	38165-B4000
	54.80 (2.1575)	38165-B4001
	55.10 (2.1693)	38165-B4002
	55.40 (2.1811)	38165-B4003
	55.70 (2.1929)	38165-B4004
56.00 (2.2047)	38165-61001	

\*Always check with the Parts Department for the latest parts information.