

LT  
**SECTION**  
**LIGHTING SYSTEM**

A  
B  
C  
D  
E  
F  
G  
H  
I  
J  
LT  
L  
M

**CONTENTS**

<p><b>PRECAUTIONS</b> ..... 2</p> <p style="padding-left: 20px;">Precautions for Supplemental Restraint System (SRS) “AIR BAG” and “SEAT BELT PRE-TENSIONER” ..... 2</p> <p style="padding-left: 20px;">Wiring Diagrams and Trouble Diagnosis ..... 2</p> <p><b>COMBINATION SWITCH</b> ..... 3</p> <p style="padding-left: 20px;">Check ..... 3</p> <p style="padding-left: 20px;">Replacement ..... 4</p> <p><b>HEADLAMP (FOR USA)</b> ..... 5</p> <p style="padding-left: 20px;">System Description ..... 5</p> <p style="padding-left: 40px;">LOW BEAM OPERATION ..... 5</p> <p style="padding-left: 40px;">HIGH BEAM OPERATION/FLASH-TO-PASS OPERATION ..... 5</p> <p style="padding-left: 40px;">VEHICLE SECURITY SYSTEM ..... 5</p> <p style="padding-left: 20px;">Wiring Diagram — H/LAMP — ..... 6</p> <p style="padding-left: 20px;">Trouble Diagnoses ..... 7</p> <p style="padding-left: 20px;">Bulb Replacement ..... 8</p> <p style="padding-left: 20px;">Aiming Adjustment ..... 8</p> <p style="padding-left: 40px;">LOW BEAM ..... 8</p> <p><b>HEADLAMP (FOR CANADA) — DAYTIME LIGHT SYSTEM —</b> ..... 10</p> <p style="padding-left: 20px;">System Description (For Canada) ..... 10</p> <p style="padding-left: 40px;">HEADLAMP OPERATION ..... 10</p> <p style="padding-left: 40px;">DAYTIME LIGHT OPERATION ..... 11</p> <p style="padding-left: 40px;">OPERATION (FOR CANADA) ..... 11</p> <p style="padding-left: 20px;">Circuit Diagram ..... 12</p> <p style="padding-left: 20px;">Wiring Diagram — DTRL — ..... 13</p> <p style="padding-left: 20px;">Trouble Diagnoses ..... 16</p> <p style="padding-left: 40px;">DAYTIME LIGHT CONTROL UNIT INSPECTION TABLE ..... 16</p> <p style="padding-left: 20px;">Bulb Replacement ..... 16</p> <p style="padding-left: 20px;">Aiming Adjustment ..... 16</p> <p><b>PARKING, LICENSE AND TAIL LAMPS</b> ..... 17</p> <p style="padding-left: 20px;">Wiring Diagram — TAIL/L — ..... 17</p> <p><b>STOP LAMP</b> ..... 18</p> <p style="padding-left: 20px;">Wiring Diagram — STOP/L — ..... 18</p> <p><b>BACK-UP LAMP</b> ..... 19</p> <p style="padding-left: 20px;">Wiring Diagram — BACK/L — ..... 19</p>	<p><b>FRONT FOG LAMP</b> ..... 20</p> <p style="padding-left: 20px;">System Description ..... 20</p> <p style="padding-left: 40px;">FRONT FOG LAMP OPERATION ..... 20</p> <p style="padding-left: 20px;">Wiring Diagram — F/FOG — ..... 21</p> <p style="padding-left: 20px;">Aiming Adjustment ..... 22</p> <p style="padding-left: 20px;">Removal and Installation ..... 23</p> <p style="padding-left: 20px;">Bulb Replacement ..... 23</p> <p><b>TURN SIGNAL AND HAZARD WARNING LAMPS..</b> 24</p> <p style="padding-left: 20px;">System Description ..... 24</p> <p style="padding-left: 40px;">TURN SIGNAL OPERATION ..... 24</p> <p style="padding-left: 40px;">HAZARD LAMP OPERATION ..... 24</p> <p style="padding-left: 40px;">REMOTE KEYLESS ENTRY SYSTEM OPERATION ..... 25</p> <p style="padding-left: 20px;">Wiring Diagram — TURN — ..... 26</p> <p style="padding-left: 20px;">Trouble Diagnoses ..... 28</p> <p style="padding-left: 20px;">Electrical Components Inspection ..... 29</p> <p style="padding-left: 40px;">COMBINATION FLASHER UNIT CHECK ..... 29</p> <p><b>ILLUMINATION</b> ..... 30</p> <p style="padding-left: 20px;">System Description ..... 30</p> <p style="padding-left: 20px;">Wiring Diagram — ILL — ..... 31</p> <p><b>INTERIOR ROOM LAMP</b> ..... 33</p> <p style="padding-left: 20px;">Component Parts and Harness Connector Location.. 33</p> <p style="padding-left: 20px;">System Description ..... 34</p> <p style="padding-left: 40px;">MODELS WITHOUT POWER DOOR LOCKS ... 34</p> <p style="padding-left: 40px;">MODELS WITH POWER DOOR LOCKS ..... 34</p> <p style="padding-left: 40px;">ON-OFF CONTROL ..... 36</p> <p style="padding-left: 40px;">BATTERY SAVER ..... 36</p> <p style="padding-left: 20px;">Wiring Diagram — ROOM/L — ..... 37</p> <p style="padding-left: 40px;">MODELS WITHOUT POWER DOOR LOCKS ... 37</p> <p style="padding-left: 40px;">MODELS WITH POWER DOOR LOCKS ..... 39</p> <p style="padding-left: 20px;">Trouble Diagnosis ..... 41</p> <p><b>BULB SPECIFICATIONS</b> ..... 43</p> <p style="padding-left: 20px;">Bulb Specifications ..... 43</p> <p style="padding-left: 40px;">HEADLAMP ..... 43</p> <p style="padding-left: 40px;">EXTERIOR LAMP ..... 43</p> <p style="padding-left: 40px;">INTERIOR LAMP ..... 43</p>
---	--

# PRECAUTIONS

## PRECAUTIONS

PF0:00001

### Precautions for Supplemental Restraint System (SRS) “AIR BAG” and “SEAT BELT PRE-TENSIONER”

EKS006V3

The Supplemental Restraint System such as “AIR BAG” and “SEAT BELT PRE-TENSIONER”, used along with a front seat belt, helps to reduce the risk or severity of injury to the driver and front passenger for certain types of collision. This system may include seat belt switch inputs and dual stage front air bag modules. If equipped with dual stage front air bag modules, the SRS system uses the seat belt switches to determine the front air bag deployment, and may only deploy one front air bag, depending on the severity of a collision and whether the front occupants are belted or unbelted. Information necessary to service the system safely is included in the SRS and SB section of this Service Manual.

The vehicle may be equipped with a passenger air bag deactivation switch. Because no rear seat exists where a rear-facing child restraint can be placed, the switch is designed to turn off the passenger air bag so that a rear-facing child restraint can be used in the front passenger seat. The switch is located in the center of the instrument panel, near the ashtray. When the switch is turned to the ON position, the passenger air bag is enabled and could inflate for certain types of collision. When the switch is turned to the OFF position, the passenger air bag is disabled and will not inflate. A passenger air bag OFF indicator on the instrument panel lights up when the passenger air bag is switched OFF. The driver air bag always remains enabled and is not affected by the passenger air bag deactivation switch.

#### **WARNING:**

- To avoid rendering the SRS inoperative, which could increase the risk of personal injury or death in the event of a collision which would result in air bag inflation, all maintenance must be performed by an authorized NISSAN/INFINITI dealer.
- Improper maintenance, including incorrect removal and installation of the SRS, can lead to personal injury caused by unintentional activation of the system. For removal of Spiral Cable and Air Bag Module, see the SRS section.
- Do not use electrical test equipment on any circuit related to the SRS unless instructed to in this Service Manual. SRS wiring harnesses can be identified by yellow and/or orange harnesses or harness connectors.
- The vehicle may be equipped with a passenger air bag deactivation switch which can be operated by the customer. When the passenger air bag is switched OFF, the passenger air bag is disabled and will not inflate. When the passenger air bag is switched ON, the passenger air bag is enabled and could inflate for certain types of collision. After SRS maintenance or repair, make sure the passenger air bag deactivation switch is in the same position (ON or OFF) as when the vehicle arrived for service.

### Wiring Diagrams and Trouble Diagnosis

EKS006V4

When you read wiring diagrams, refer to the following:

- [GI-13, "How to Read Wiring Diagrams"](#)
- [PG-9, "POWER SUPPLY ROUTING"](#)

When you perform trouble diagnosis, refer to the following:

- [GI-9, "HOW TO FOLLOW TEST GROUPS IN TROUBLE DIAGNOSES"](#)
- [GI-25, "How to Perform Efficient Diagnosis for an Electrical Incident"](#)

Check for any Service bulletins before servicing the vehicle.

# COMBINATION SWITCH

## COMBINATION SWITCH

Check

PFP:25567

EKS006V6

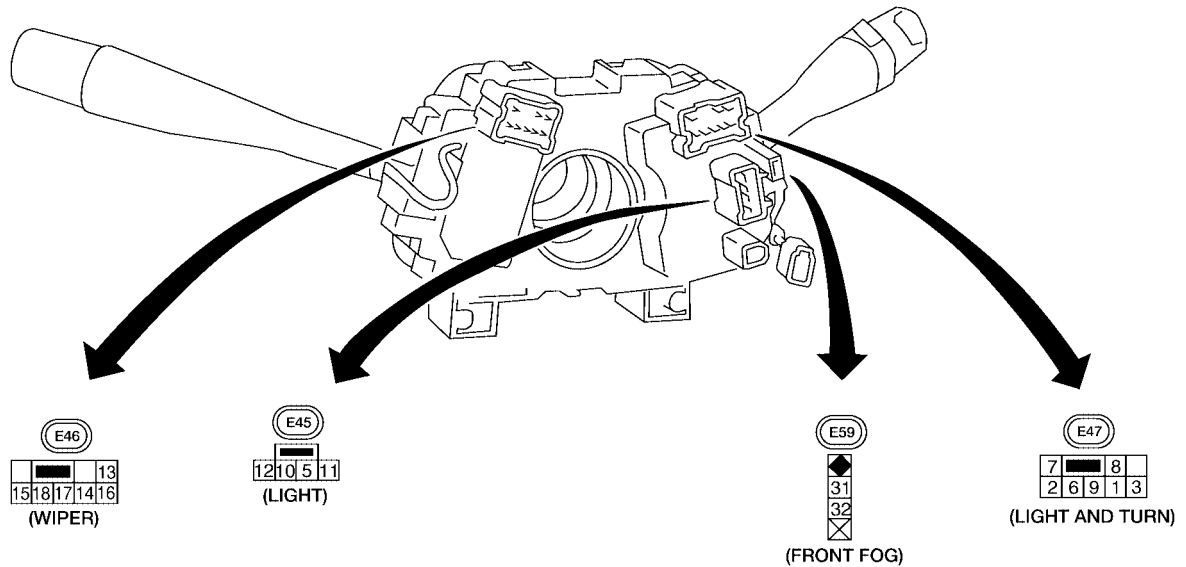
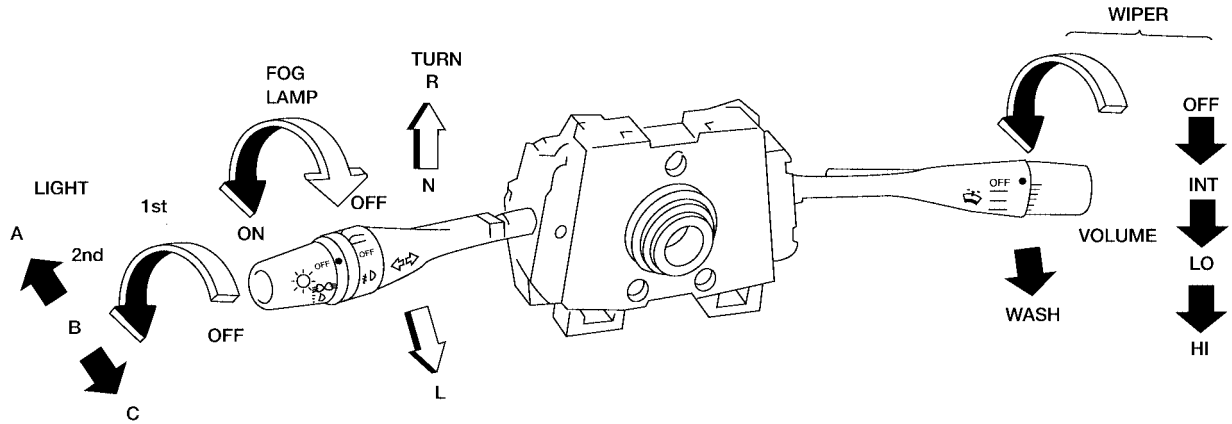

FRONT WIPER AND WASHER SWITCH (WITH INTERMITTENT OPERATION)

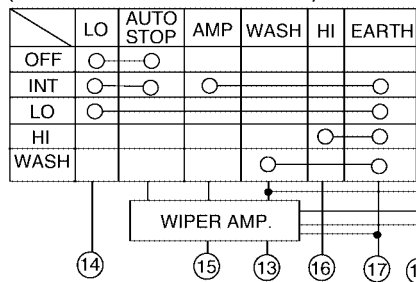

VARIABLE INTERMITTENT WIPER VOLUME

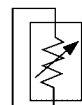

LIGHTING SWITCH

	OFF			1ST			2ND		
	A	B	C	A	B	C	A	B	C
5	<input type="checkbox"/>			<input type="checkbox"/>			<input type="checkbox"/>		
6		<input type="checkbox"/>			<input type="checkbox"/>		<input type="checkbox"/>	<input type="checkbox"/>	<input type="checkbox"/>
7			<input type="checkbox"/>			<input type="checkbox"/>		<input type="checkbox"/>	<input type="checkbox"/>
8		<input type="checkbox"/>			<input type="checkbox"/>		<input type="checkbox"/>	<input type="checkbox"/>	<input type="checkbox"/>
9			<input type="checkbox"/>			<input type="checkbox"/>		<input type="checkbox"/>	<input type="checkbox"/>
10								<input type="checkbox"/>	<input type="checkbox"/>
11				<input type="checkbox"/>	<input type="checkbox"/>	<input type="checkbox"/>	<input type="checkbox"/>	<input type="checkbox"/>	<input type="checkbox"/>
12				<input type="checkbox"/>	<input type="checkbox"/>	<input type="checkbox"/>	<input type="checkbox"/>	<input type="checkbox"/>	<input type="checkbox"/>

TURN SIGNAL LAMP SWITCH

	R	N	L
	<input type="checkbox"/>	<input type="checkbox"/>	<input type="checkbox"/>
1	<input type="checkbox"/>	<input type="checkbox"/>	<input type="checkbox"/>
2	<input type="checkbox"/>	<input type="checkbox"/>	<input type="checkbox"/>
3			<input type="checkbox"/>

FRONT FOG LAMP SWITCH

	OFF	ON
31	<input type="checkbox"/>	<input type="checkbox"/>
32		<input type="checkbox"/>

WKIA0296E

# COMBINATION SWITCH

EKS006V7

## Replacement

For removal and installation of spiral cable, refer to [SRS-42, "DRIVER AIR BAG MODULE AND SPIRAL CABLE"](#) .

- Each switch can be replaced without removing combination switch base.

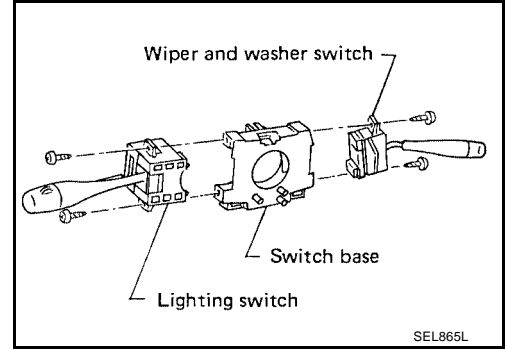

- To remove combination switch base, remove base attaching screws.

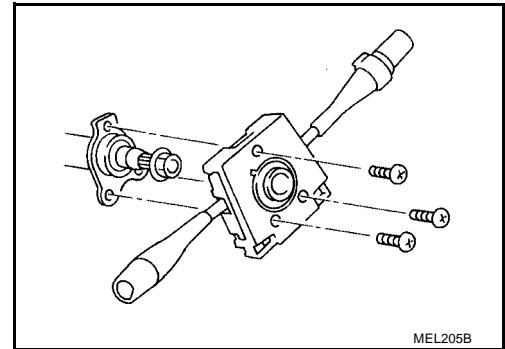

- Before installing the steering wheel, align the turn signal cancel tab with the notch of the combination switch. Refer to [SRS-42, "DRIVER AIR BAG MODULE AND SPIRAL CABLE"](#) .

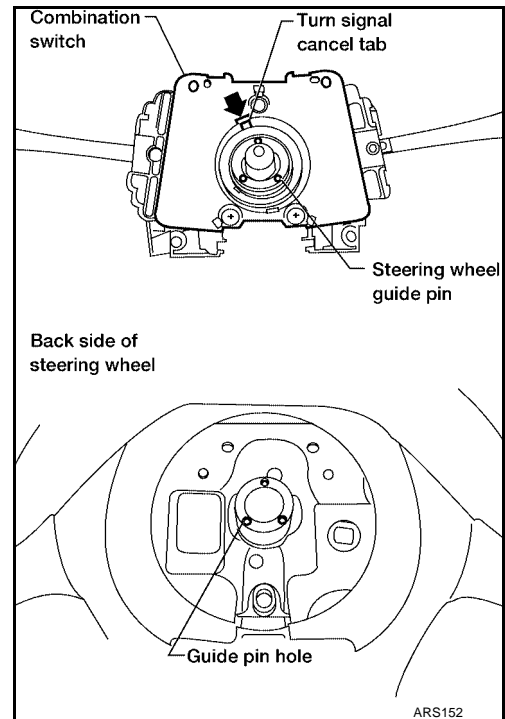

# HEADLAMP (FOR USA)

PF:26010

## HEADLAMP (FOR USA)

### System Description

EKS006V8

The headlamps are controlled by the lighting switch which is built into the combination switch. Power is supplied at all times

- through 15A fuse (No. 37, located in the fuse and fusible link box)
- to lighting switch terminal 8 and
- through 15A fuse (No. 38, located in the fuse and fusible link box)
- to lighting switch terminal 5.

### LOW BEAM OPERATION

With the lighting switch in the headlamp ON (2ND) position and low beam (B) position, power is supplied

- from lighting switch terminal 7
- to headlamp LH terminal D and
- from lighting switch terminal 10
- to headlamp RH terminal D.

Ground is supplied to headlamp LH/RH terminal E through body grounds E12 and E54. With power and ground supplied, the low beams illuminate.

### HIGH BEAM OPERATION/FLASH-TO-PASS OPERATION

With the lighting switch in the flash-to-pass (C) position or the headlamp ON (2ND) position and high beam (A) position, power is supplied

- from lighting switch terminal 6
- to headlamp LH terminal M and
- from lighting switch terminal 9
- to headlamp RH terminal M and
- to combination meter terminal 11 for the high beam indicator.

Ground is supplied to terminal 10 of the combination meter through body grounds M14 and M68.

Ground is supplied to headlamp LH/RH terminal E through body grounds E12 and E54.

With power and ground supplied, the high beams and the high beam indicator illuminate.

### VEHICLE SECURITY SYSTEM

The vehicle security system will flash the high beams if the system is triggered. Refer to [BL-45, "System Description"](#).

A  
B  
C  
D  
E  
F  
G  
H  
I  
J  
LT  
L  
M

# HEADLAMP (FOR USA)

## Wiring Diagram — H/LAMP —

EKS006V9

LT-H/LAMP-01

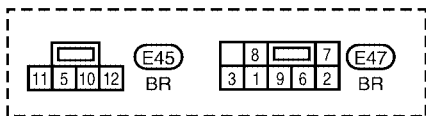
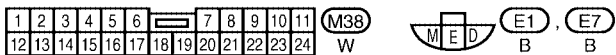
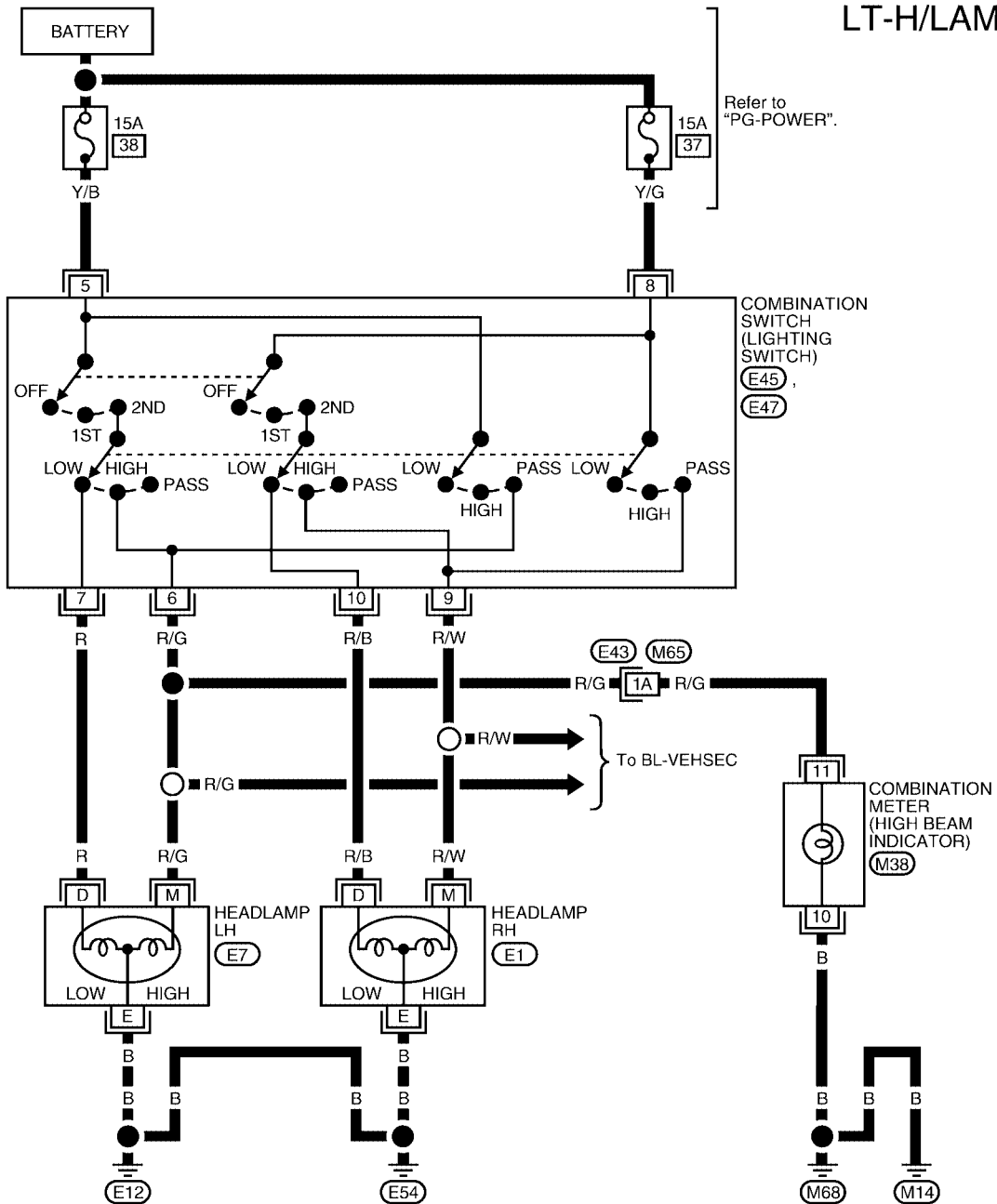

Refer to the following.  
 (E43) - SUPER  
 MULTIPLE JUNCTION (SMJ)

# HEADLAMP (FOR USA)

## Trouble Diagnoses

EKS006VA

Symptom	Possible cause	Repair order
Neither headlamp LH nor headlamp RH operate.	1. Lighting switch	1. Check lighting switch.
Headlamp LH does not operate, but headlamp RH operates properly.	1. Bulb 2. Headlamp LH ground circuit 3. 15A fuse 4. Lighting switch	1. Check bulb. 2. Check continuity between headlamp LH terminal E and grounds E12 and E54. 3. Check 15A fuse (No. 38, located in fuse and fusible link box). Verify battery positive voltage is present at terminal 5 of lighting switch. 4. Check lighting switch.
Headlamp RH does not operate, but headlamp LH operates properly.	1. Bulb 2. Headlamp RH ground circuit 3. 15A fuse 4. Lighting switch	1. Check bulb. 2. Check continuity between headlamp RH terminal E and grounds E12 and E54. 3. Check 15A fuse (No. 37, located in fuse and fusible link box). Verify battery positive voltage is present at terminal 8 of lighting switch. 4. Check lighting switch.
High beam LH does not operate, but low beam LH operates.	1. Bulb 2. Open in high beam LH circuit 3. Lighting switch	1. Check bulb. 2. Check R/G wire between lighting switch terminal 6 and headlamp LH terminal M for an open circuit. 3. Check lighting switch.
Low beam LH does not operate, but high beam LH operates.	1. Bulb 2. Open in low beam LH circuit 3. Lighting switch	1. Check bulb. 2. Check R wire between lighting switch terminal 7 and headlamp LH terminal D for an open circuit. 3. Check lighting switch.
High beam RH does not operate, but low beam RH operates.	1. Bulb 2. Open in high beam RH circuit 3. Lighting switch	1. Check bulb. 2. Check R/W wire between lighting switch terminal 9 and headlamp RH terminal M for an open circuit. 3. Check lighting switch.
Low beam RH does not operate, but high beam RH operates.	1. Bulb 2. Open in low beam RH circuit 3. Lighting switch	1. Check bulb. 2. Check R/B wire between lighting switch terminal 10 and headlamp RH terminal D for an open circuit. 3. Check lighting switch.
High beam indicator does not work.	1. Bulb 2. High beam indicator ground circuit 3. Open in high beam circuit	1. Check bulb in combination meter. 2. Check continuity between combination meter terminal 10 and grounds M14 and M68. 3. Check R/G wire between lighting switch terminal 6 and combination meter terminal 11 for an open circuit.

A  
B  
C  
D  
E  
F  
G  
H  
I  
J  
LT  
L  
M

# HEADLAMP (FOR USA)

## Bulb Replacement

EKS006VB

The headlamp is a semi-sealed beam type which uses a replaceable halogen bulb. The bulb can be replaced from the engine compartment side without removing the headlamp body.

- **Grasp only the plastic base when handling the bulb. Never touch the glass envelope.**
1. Disconnect the battery cable.
  2. Disconnect the harness connector from the back side of the bulb.
  3. Remove bulb retaining ring.
  4. Remove the headlamp bulb carefully. Do not shake or rotate the bulb when removing it.
  5. Install in the reverse order of removal.

### CAUTION:

**Do not leave headlamp reflector without bulb for a long period of time. Dust, moisture, smoke, etc. entering headlamp body may affect the performance of the headlamp. Remove headlamp bulb from the headlamp reflector just before a replacement bulb is installed.**

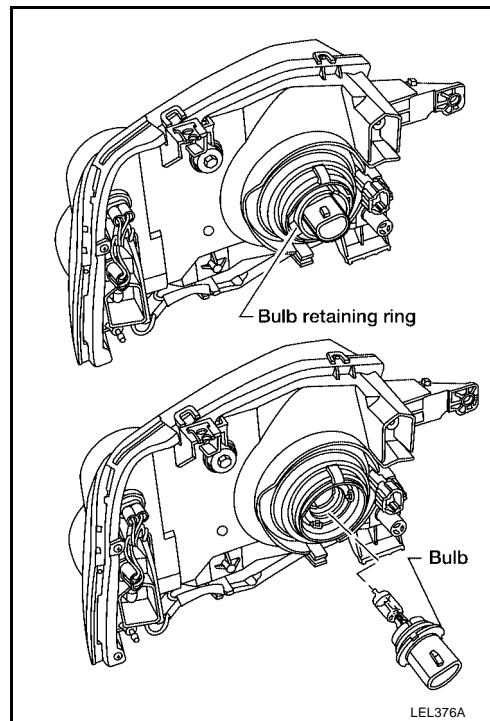

## Aiming Adjustment

EKS006VC

When performing headlamp aiming adjustment, use an aiming wall screen.

**For details, refer to local regulations.**

Before performing aiming adjustment, check the following.

1. **Keep all tires inflated to correct pressures.**
2. **Place vehicle on flat surface.**
3. **See that the vehicle is unloaded (except for full levels of coolant, engine oil and fuel, and spare tire, jack, and tools). Have the driver or equivalent weight placed in the driver's seat.**

## LOW BEAM

### NOTE:

The horizontal headlamp aim cannot be adjusted. Only vertical aim is adjustable.

1. Turn headlamp low beam on.
2. Use adjusting screw to adjust the vertical aim of the lamp.
  - **Cover the opposite lamp and ensure fog lamps, if equipped, are turned off.**

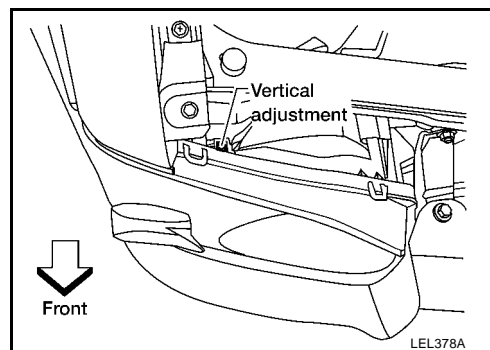



# HEADLAMP (FOR USA)

- Adjust beam pattern until cut-off line (top edge of illumination area) is positioned at same height off ground as bulb center (on H-line). Measure cut-off line within distance A on H-line. See aiming chart following.

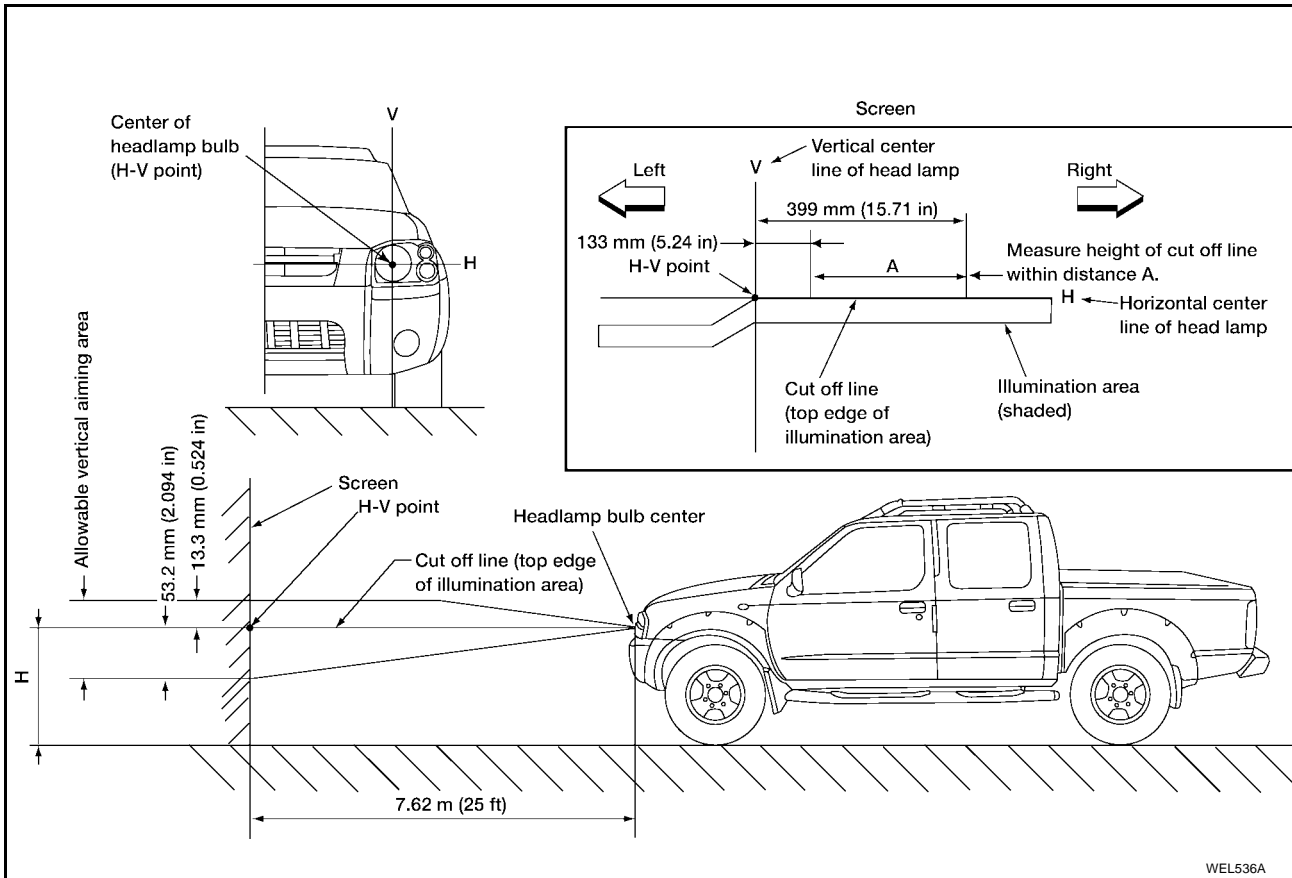

If the vehicle front body has been repaired and/or the headlamp assembly has been replaced, check aiming. Use the aiming chart shown in the figure.

- **Basic illuminating area (shaded) for adjustment should be within the range shown on the aiming chart. Adjust headlamps accordingly.**

A  
B  
C  
D  
E  
F  
G  
H  
I  
J  
LT  
L  
M

## HEADLAMP (FOR CANADA) — DAYTIME LIGHT SYSTEM —

PF2:26010

### System Description (For Canada)

EKS006VD

The headlamp system for Canada vehicles contains a daytime light control unit that activates the high beam headlamps at approximately half illumination whenever the engine is running. If the parking brake is applied before the engine is started the daytime lights will not be illuminated. The daytime lights will illuminate once the parking brake is released. Thereafter, the daytime lights will continue to operate when the parking brake is applied. If the daytime light control unit receives a ground signal from the generator, the daytime lights will not be illuminated. The daytime lights will illuminate once a battery positive voltage signal is sent to the daytime light control unit from the generator.

Power is supplied at all times

- through 15A fuse (No. 38, located in the fuse and fusible link box)
- to daytime light control unit terminal 3 and
- to lighting switch terminal 5.

Power is also supplied at all times

- through 15A fuse (No. 37, located in the fuse and fusible link box)
- to daytime light control unit terminal 2 and
- to lighting switch terminal 8.

With the ignition switch in the ON or START position, power is supplied

- through 10A fuse [No. 5, located in the fuse block (J/B)]
- to daytime light control unit terminal 12.

With the ignition switch in the START position, power is supplied

- through 7.5A fuse [No. 7, located in the fuse block (J/B)]
- to daytime light control unit terminal 1.

Ground is supplied to daytime light control unit terminal 9 through body grounds E12 and E54.

### HEADLAMP OPERATION

#### Low Beam Operation

When the lighting switch is turned to the headlamp ON (2ND) position, low beam (B), power is supplied

- from lighting switch terminal 10
- to headlamp RH terminal D and
- to daytime light control unit terminal 4.

Ground is supplied to headlamp RH terminal E through body grounds E12 and E54.

Also, when the lighting switch is turned to the headlamp ON (2ND) position, low beam (B), power is supplied

- from lighting switch terminal 7
- to headlamp LH terminal D.

Ground is supplied

- to headlamp LH terminal E
- from daytime light control unit terminal 7
- through daytime light control unit terminal 9
- through body grounds E12 and E54.

With power and ground supplied, the low beam headlamps illuminate.

#### High Beam Operation/Flash-to-pass Operation

When the lighting switch is turned to the headlamp ON (2ND) position, high beam (A) or flash-to-pass (C) position, power is supplied

- from lighting switch terminal 9
- to headlamp RH terminal M and
- to daytime light control unit terminal 8.

Also, when the lighting switch is turned to the headlamp ON (2ND) position, high beam (A) or flash-to-pass (C) position, power is supplied

- from lighting switch terminal 6
- to combination meter terminal 11 for the high beam indicator and

# HEADLAMP (FOR CANADA) — DAYTIME LIGHT SYSTEM —

- to daytime light control unit terminal 5
- through daytime light control unit terminal 6
- to headlamp LH terminal M.

Ground is supplied in the same manner as low beam operation.

Ground is supplied to combination meter terminal 10 through body grounds M14 and M68.

With power and ground supplied, the high beam headlamps and high beam indicator illuminate.

## DAYTIME LIGHT OPERATION

With the engine running, the lighting switch in the OFF or 1ST position and parking brake released, power is supplied

- through daytime light control unit terminal 6
- to headlamp LH terminal M
- through headlamp LH terminal E
- to daytime light control unit terminal 7
- through daytime light control unit terminal 8
- to headlamp RH terminal M.

Ground is supplied to headlamp RH terminal E through body grounds E12 and E54.

Because the high beam headlamps are now wired in series, they operate at half illumination.

## OPERATION (FOR CANADA)

After starting the engine with the lighting switch in the OFF or parking lamp (1ST) position, the headlamp high beams automatically turn on. Lighting switch operations other than the above are the same as conventional light systems.

Engine		With engine stopped									With engine running								
		OFF			1ST			2ND			OFF			1ST			2ND		
		A	B	C	A	B	C	A	B	C	A	B	C	A	B	C	A	B	C
Lighting switch	High beam	X	X	O	X	X	O	O	X	O	△	△	O	△*	△*	O	O	X	O
	Low beam	X	X	X	X	X	X	X	O	X	X	X	X	X	X	X	X	O	X
Clearance and tail lamp		X	X	X	O	O	O	O	O	O	X	X	X	O	O	O	O	O	O
License and instrument illumination lamp		X	X	X	O	O	O	O	O	O	X	X	X	O	O	O	O	O	O

- A: High beam position
- B: Low beam position
- C: Flash-to-pass position
- O : Lamp ON
- X : Lamp OFF
- △ : Lamp dims. (Added functions)
- \*: When starting the engine with the parking brake released, the daytime lights will come ON. When starting the engine with the parking brake applied, the daytime lights won't come ON.

# HEADLAMP (FOR CANADA) — DAYTIME LIGHT SYSTEM —

## Circuit Diagram

EKS006VE

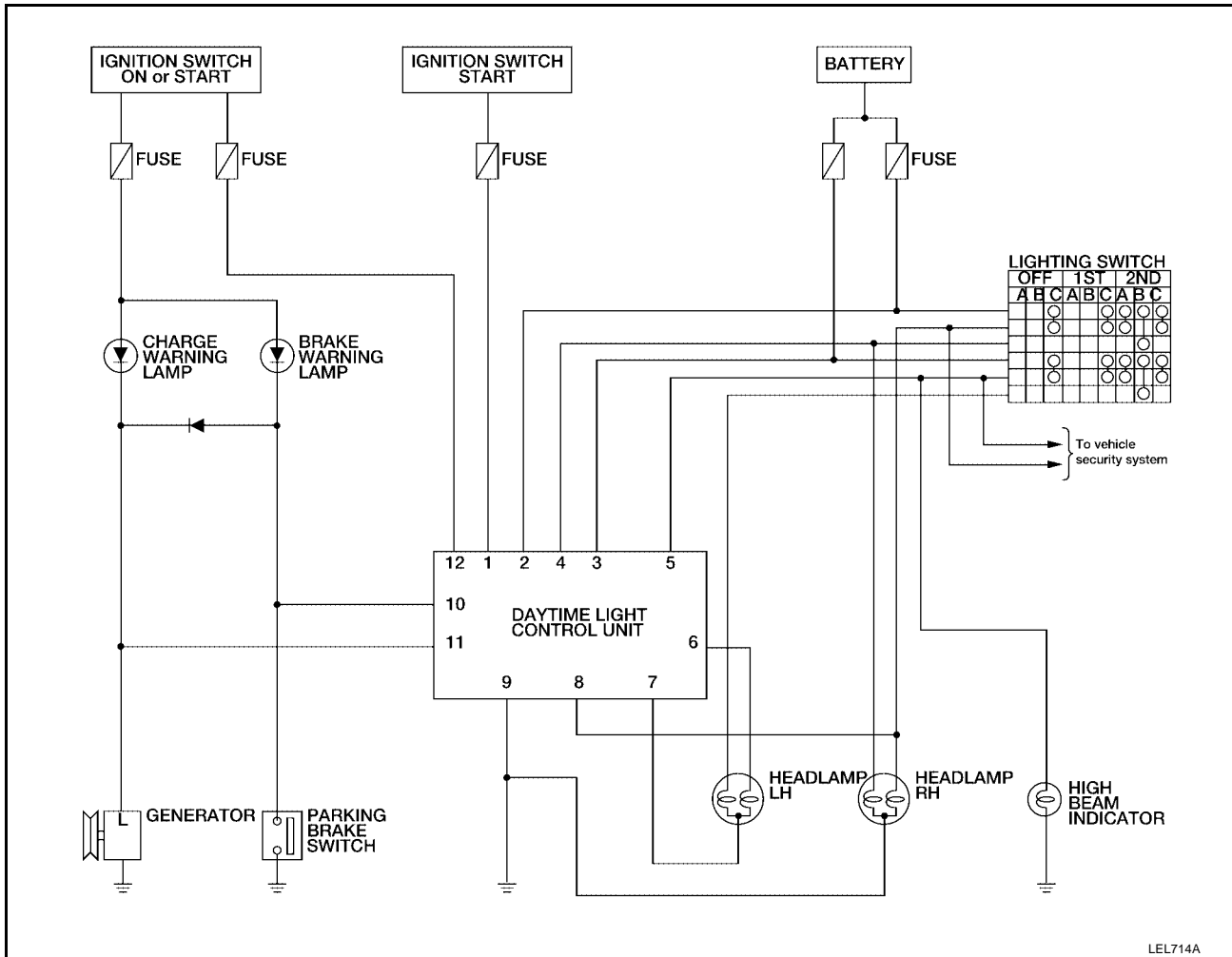

LEL714A

# HEADLAMP (FOR CANADA) — DAYTIME LIGHT SYSTEM —

## Wiring Diagram — DTRL —

EKS006VF

LT-DTRL-01

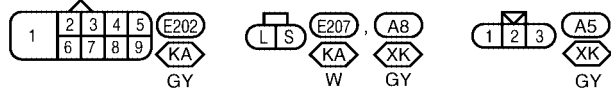
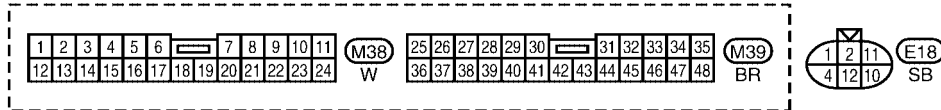
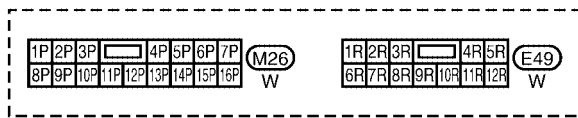
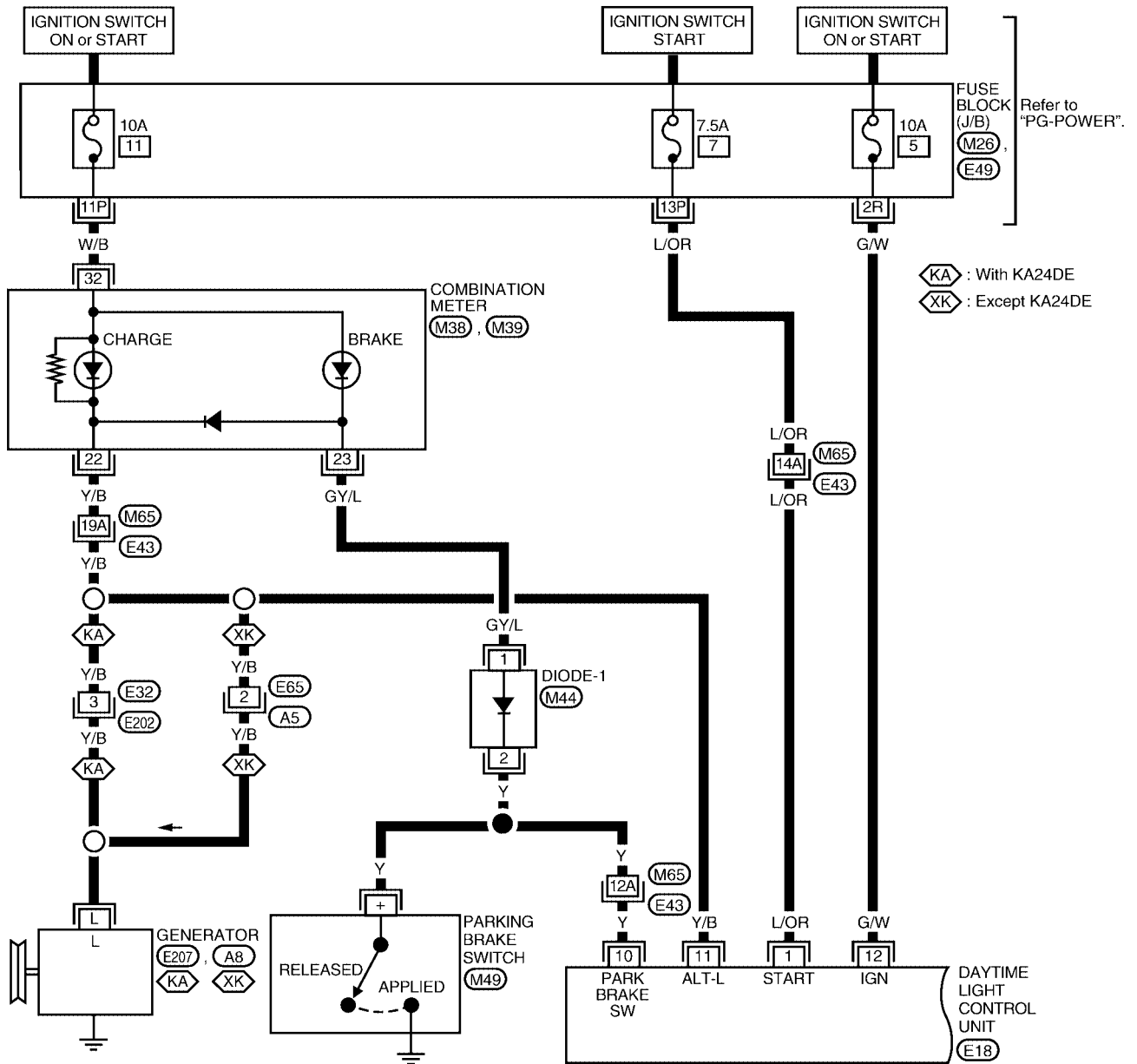

Refer to the following.  
 (E43) - SUPER MULTIPLE JUNCTION (SMJ)

WKWA1098E

# HEADLAMP (FOR CANADA) — DAYTIME LIGHT SYSTEM —

LT-DTRL-02

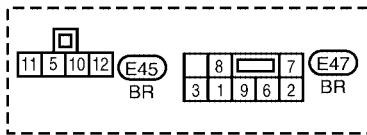
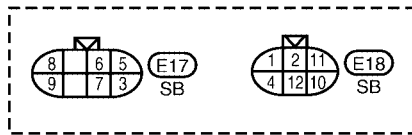
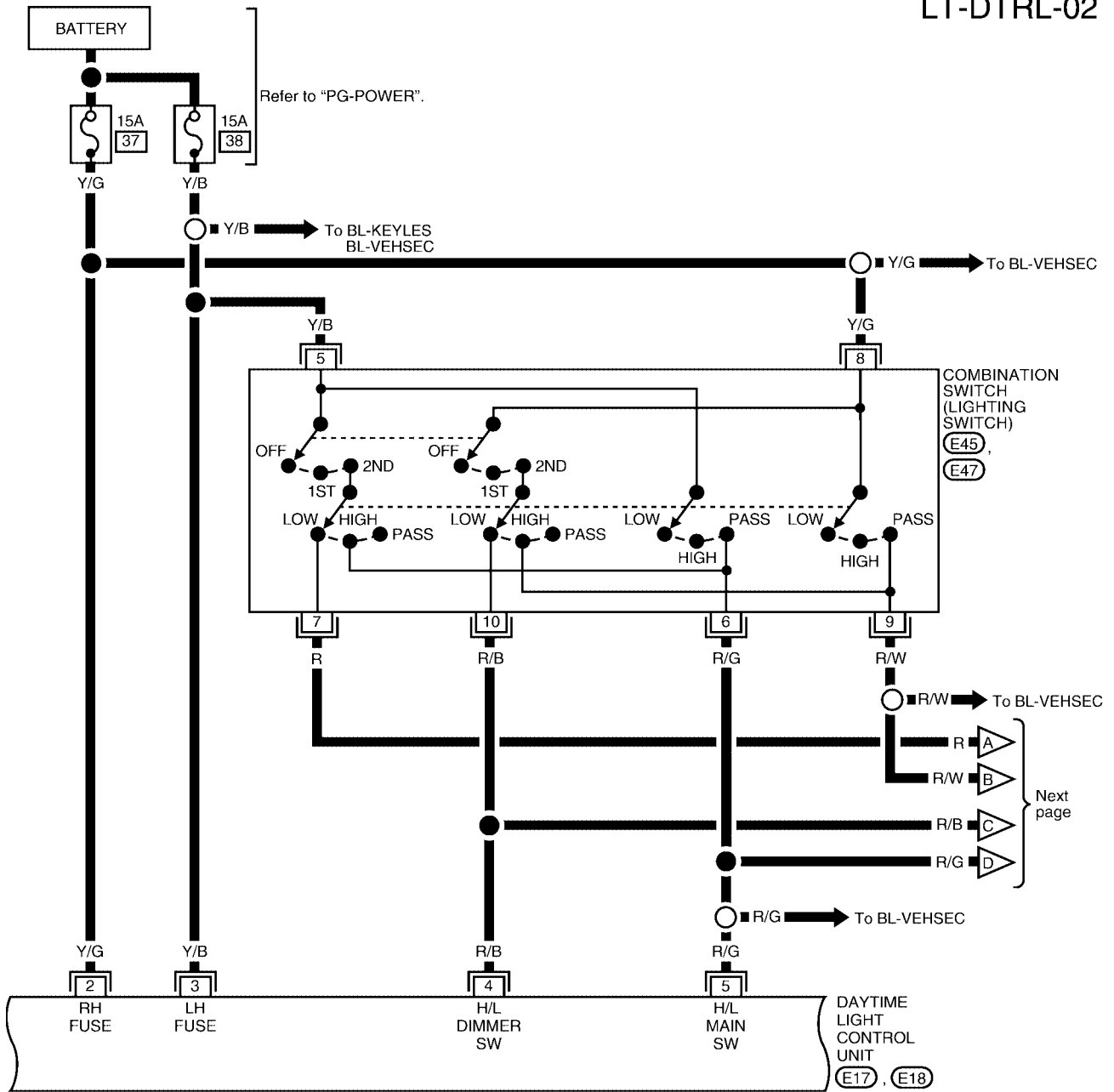

# HEADLAMP (FOR CANADA) — DAYTIME LIGHT SYSTEM —

LT-DTRL-03

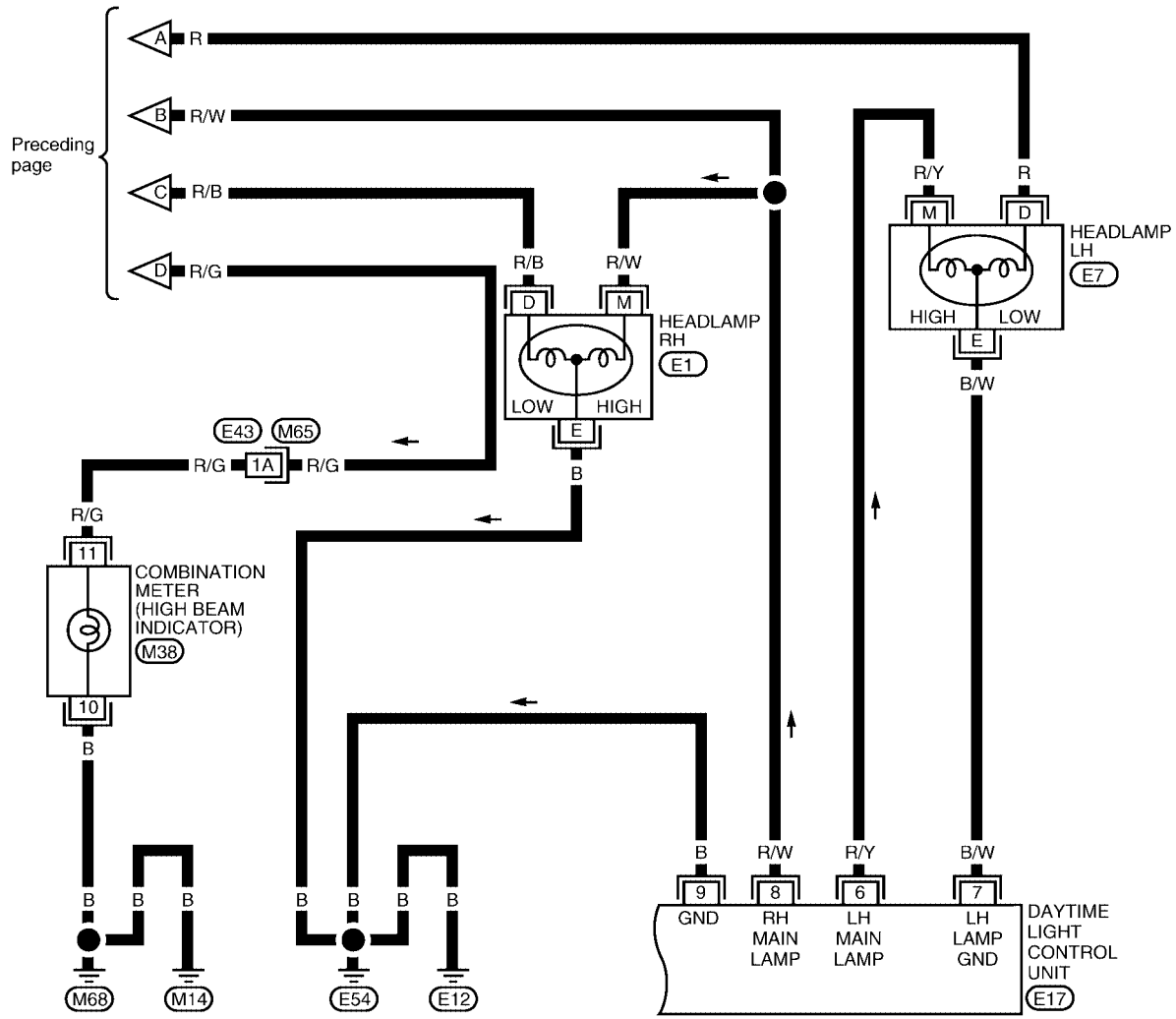

1	2	3	4	5	6	7	8	9	10	11		
12	13	14	15	16	17	18	19	20	21	22	23	24

(M38) W



Refer to the following.  
 (E43) - SUPER  
 MULTIPLE JUNCTION (SMJ)

A  
B  
C  
D  
E  
F  
G  
H  
I  
J  
LT  
L  
M

# HEADLAMP (FOR CANADA) — DAYTIME LIGHT SYSTEM —

## Trouble Diagnoses DAYTIME LIGHT CONTROL UNIT INSPECTION TABLE

EKS006VG

Terminal No.	Wire color	Item	Condition	Voltage (Approx.)
1	L/OR	Ignition switch start signal	Ignition switch in START position	12
			All other conditions	0
2	Y/G	Power source for headlamp RH	—	12
3	Y/B	Power source for headlamp LH	—	12
4	R/B	Lighting switch headlamp RH low beam output	Lighting switch in the headlamp ON (2ND) position and low beam (B) position	12
			All other conditions	0
5	R/G	Lighting switch headlamp LH high beam output	Lighting switch in the flash-to-pass (C) position or headlamp ON (2ND) position and high beam (A) position	12
			All other conditions	0
6	R/Y	Headlamp LH high beam	Lighting switch in the flash-to-pass (C) position or headlamp ON (2ND) position and high beam (A) position	12
			With parking brake released, engine running and lighting switch in OFF or parking and tail lamp ON (1ST) positions <b>CAUTION:</b> <b>Block wheels and ensure selector lever is in P or N position.</b>	12
			All other conditions	0
7	B/W	Headlamp LH control (ground)	Lighting switch in the flash-to-pass (C) position or headlamp ON (2ND) position	0
			All other conditions	6
8	R/W	Lighting switch headlamp RH high beam output	Lighting switch in the flash-to-pass (C) position or headlamp ON (2ND) position and high beam (A) position	12
			With parking brake released, engine running and lighting switch in OFF or parking and tail lamp ON (1ST) positions <b>CAUTION:</b> <b>Block wheels and ensure selector lever is in P or N position.</b>	6
			All other conditions	0
9	B	Ground	—	—
10	Y	Parking brake switch	Parking brake released	12
			Parking brake applied	0
11	Y/B	Generator (L terminal)	When engine is running	12
			All other conditions	0
12	G/W	Ignition switch ON signal	Ignition switch OFF, ACC positions	0
			Ignition switch ON, START positions	12

### Bulb Replacement

EKS006VH

Refer to [LT-8, "Bulb Replacement"](#) .

### Aiming Adjustment

EKS006VI

Refer to [LT-8, "Aiming Adjustment"](#) .



# PARKING, LICENSE AND TAIL LAMPS

## PARKING, LICENSE AND TAIL LAMPS

PFP:26550

### Wiring Diagram — TAIL/L —

EKS006VJ

### LT-TAIL/L-01

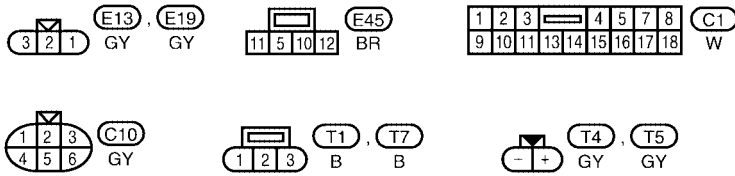
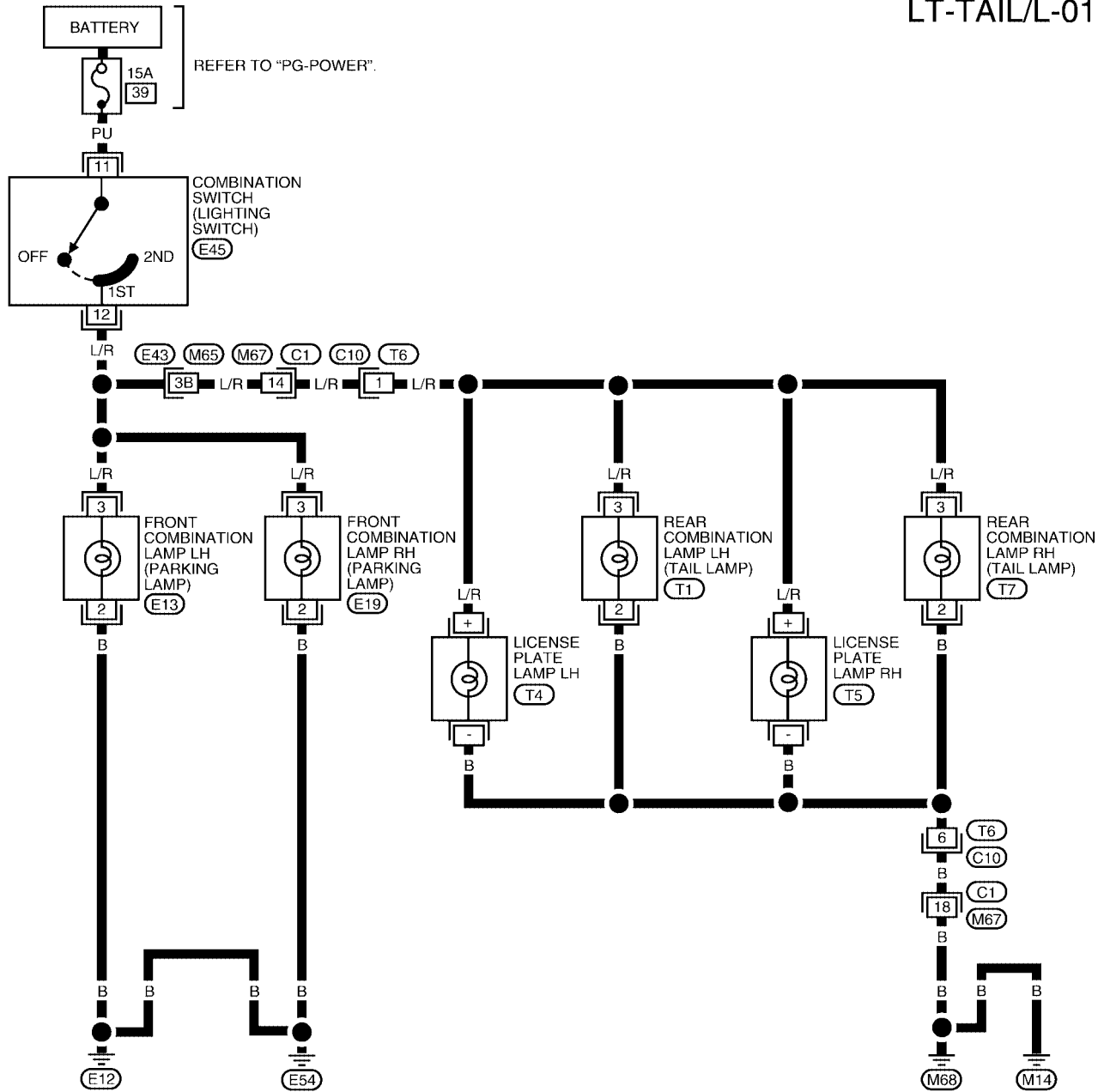

REFER TO THE FOLLOWING.  
 (E43) - SUPER  
 MULTIPLE JUNCTION (SMJ)

WKWA0831E

# STOP LAMP

PFP:26550

## STOP LAMP

### Wiring Diagram — STOP/L —

EKS006VK

## LT-STOP/L-01

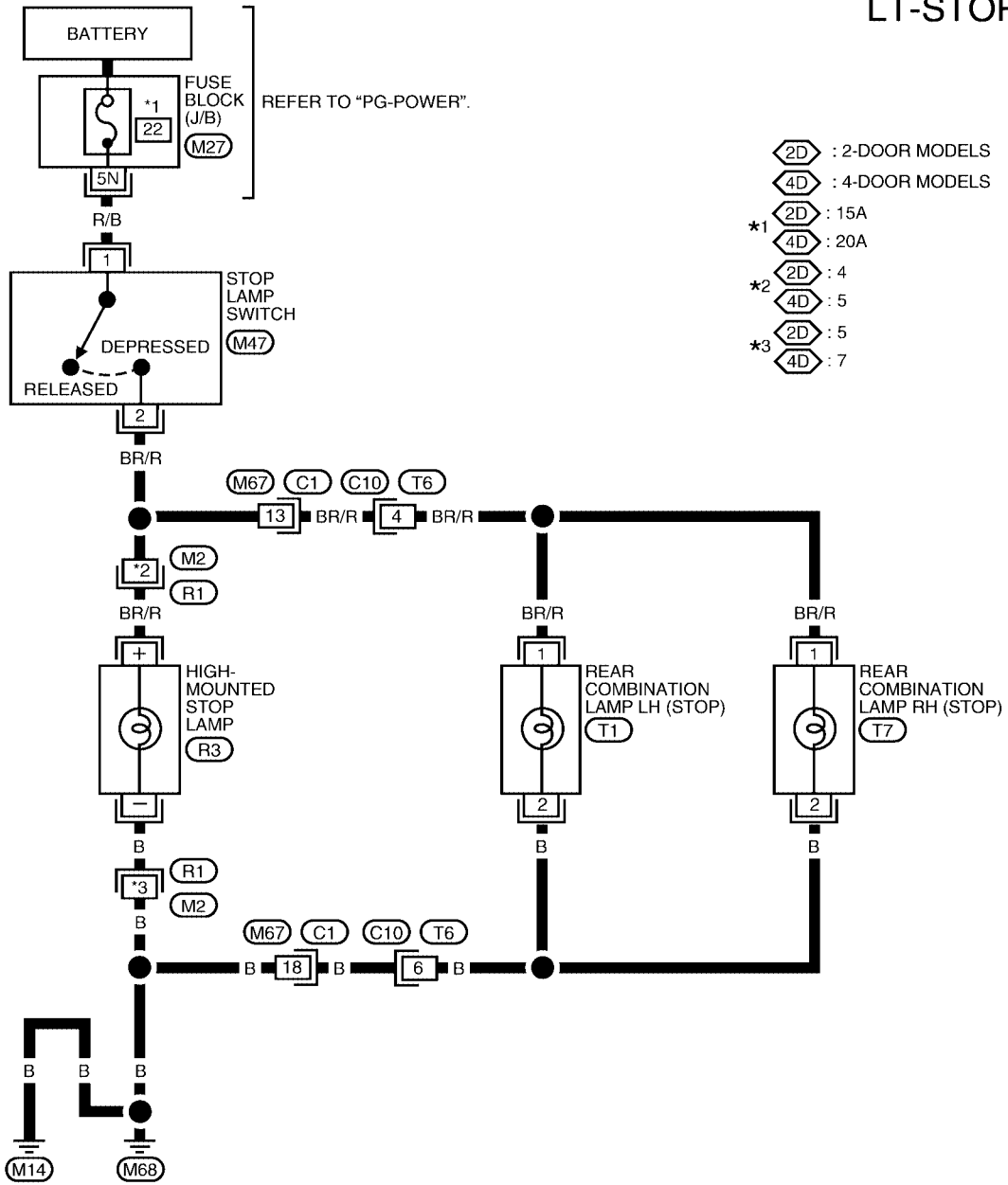

- 2D : 2-DOOR MODELS
- 4D : 4-DOOR MODELS
- \*1 2D : 15A
- 4D : 20A
- \*2 2D : 4
- 4D : 5
- \*3 2D : 5
- 4D : 7

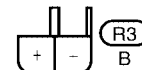
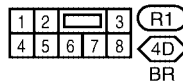
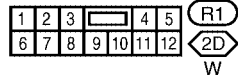
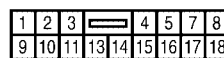
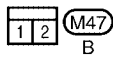
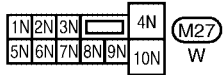

WKWA0832E

# BACK-UP LAMP

PF:26550

EKS006VL

## BACK-UP LAMP

### Wiring Diagram — BACK/L —

## LT-BACK/L-01

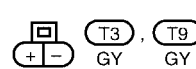
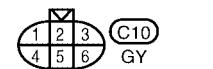
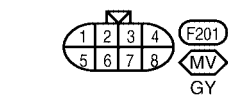
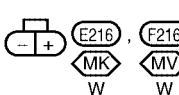
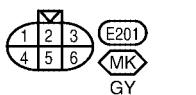
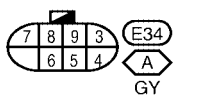
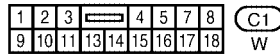
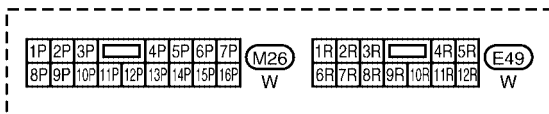
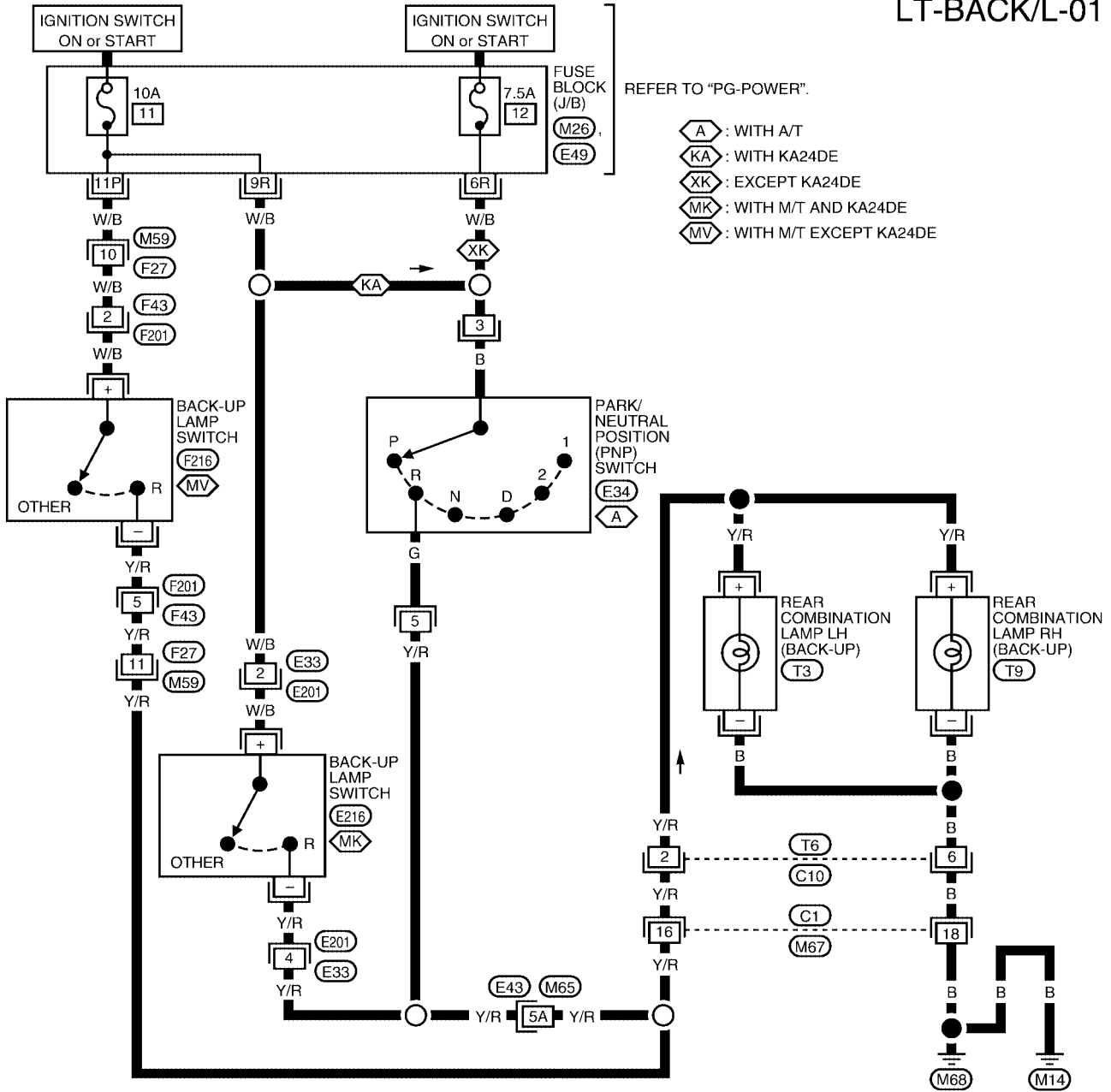

REFER TO THE FOLLOWING.

E43 - SUPER MULTIPLE JUNCTION (SMJ)

# FRONT FOG LAMP

---

## FRONT FOG LAMP

PF2:26150

### System Description

EKS006VM

Power is supplied at all times

- through 15A fuse (No. 40, located in the fuse and fusible link box)
- to front fog lamp relay terminal 5 and
- through 15A fuse (No. 37, located in the fuse and fusible link box)
- to lighting switch terminal 5.

With the lighting switch in the headlamp ON (2ND) position and low beam (B) position, power is supplied

- through lighting switch terminal 7
- to front fog lamp switch terminal 31.

### FRONT FOG LAMP OPERATION

The front fog lamp switch is built into the combination switch. The lighting switch must be in the headlamp ON (2ND) position and low beam (B) position for front fog lamp operation.

With the front fog lamp switch in the ON position:

- power is supplied to front fog lamp relay terminal 2
- through front fog lamp switch terminal 32
- through front fog lamp switch terminal 31.

The front fog lamp relay is energized and power is supplied

- through front fog lamp relay terminal 3
- to front fog lamp LH/RH terminal 1.

Ground is supplied to front fog lamp LH/RH terminal 2 and front fog lamp relay terminal 1 through body grounds E12 and E54.

With power and ground supplied, the front fog lamps illuminate.

# FRONT FOG LAMP

## Wiring Diagram — F/FOG —

EKS006VN

LT-F/FOG-01

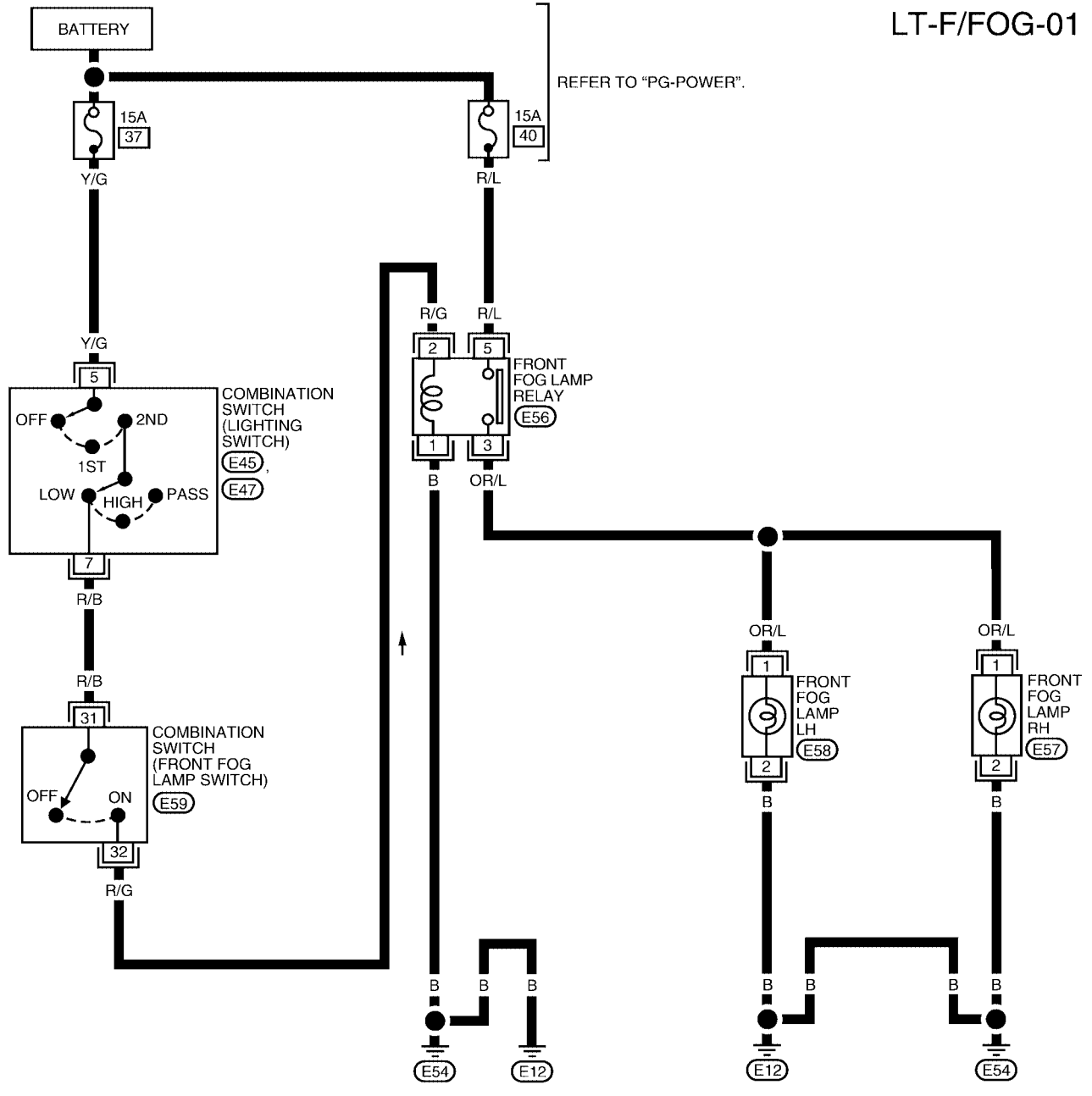

A  
B  
C  
D  
E  
F  
G  
H  
I  
J  
LT  
L  
M

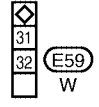
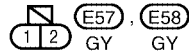
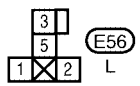
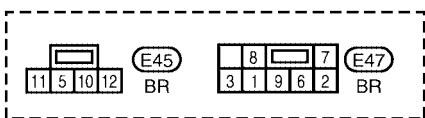

WKWA0834E

# FRONT FOG LAMP

EKS0076Y

## Aiming Adjustment

Before performing aiming adjustment, make sure of the following.

1. Keep all tires inflated to correct pressure.
2. Place vehicle on level ground.
3. See that vehicle is unloaded (except for full levels of coolant, engine oil and fuel, and spare tire, jack, and tools). Have the driver or equivalent weight placed in driver's seat.

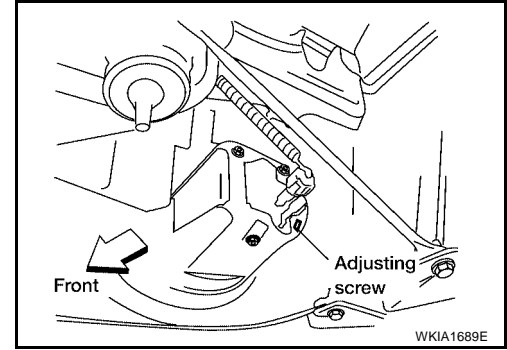

1. Set the distance between the screen and the center of the front fog lamp lens.
2. Turn front fog lamps ON.

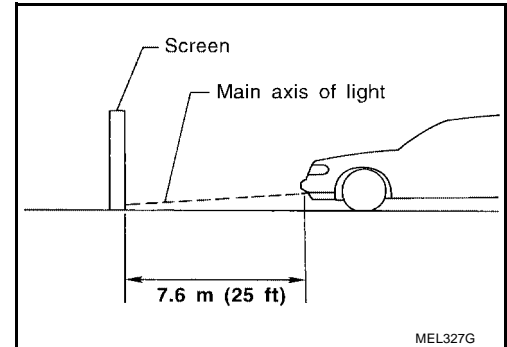

3. Using adjusting screw, adjust front fog lamps so that the top edge of the high intensity zone is 100 mm (4 in) below the height of the fog lamp centers.
  - When performing adjustment, if necessary, cover the headlamps and opposite fog lamp.

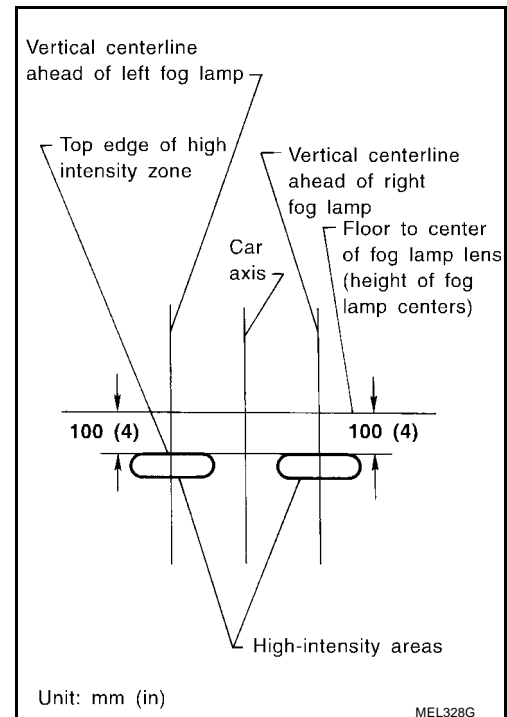

# FRONT FOG LAMP

## Removal and Installation

EKS0076Z

1. Disconnect front fog lamp harness connector.
2. Remove mounting bolt and remove lens and housing assembly from front bumper cover.
3. Install in reverse order of removal. Ensure top of lens faces up.
4. Tighten mounting bolt.

 : 5 – 6 N·m (0.51 – 0.61 kg-m, 44.3 – 53.1 in-lb)

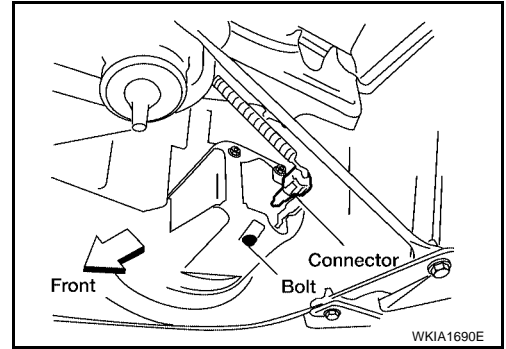

## Bulb Replacement

EKS00770

1. Disconnect fog lamp bulb connector.
2. Turn bulb counterclockwise and remove fog lamp bulb.
3. Install in reverse order of removal. **DO NOT TOUCH BULB.**

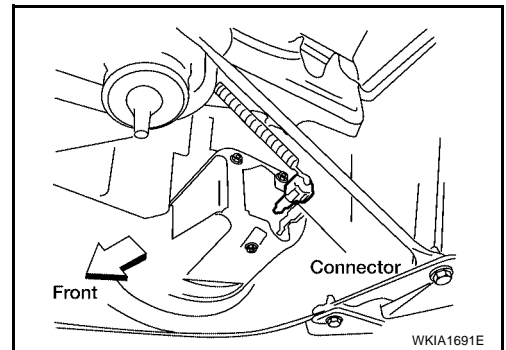

A  
B  
C  
D  
E  
F  
G  
H  
I  
J  
LT  
L  
M

# TURN SIGNAL AND HAZARD WARNING LAMPS

## TURN SIGNAL AND HAZARD WARNING LAMPS

PFP:26120

### System Description

EKS006VR

#### TURN SIGNAL OPERATION

With the hazard switch in the OFF position and the ignition switch in the ON or START position, power is supplied

- through 7.5A fuse [No. 2, located in the fuse block (J/B)]
- to hazard switch terminal 2
- through hazard switch terminal 1
- to combination flasher unit terminal B
- through combination flasher unit terminal L
- to turn signal switch terminal 1.

Ground is supplied to combination flasher unit terminal E through body grounds M14 and M68.

#### LH Turn

With the turn signal switch in the LH position, power is supplied from turn signal switch terminal 3 to

- front combination lamp LH terminal 1
- combination meter terminal 12 and
- rear combination lamp LH terminal +.

Ground is supplied to front combination lamp LH terminal 2 through body grounds E12 and E54.  
Ground is supplied

- to rear combination lamp LH terminal - and
- to combination meter terminal 13
- through body grounds M14 and M68.

With power and ground supplied, the combination flasher unit controls the flashing of the LH turn signal lamps.

#### RH Turn

With the turn signal switch in the RH position, power is supplied from turn signal switch terminal 2 to

- front combination lamp RH terminal 1
- combination meter terminal 14 and
- rear combination lamp RH terminal +.

Ground is supplied to the front combination lamp RH terminal 2 through body grounds E12 and E54.  
Ground is supplied

- to rear combination lamp RH terminal - and
- to combination meter terminal 13
- through body grounds M14 and M68.

With power and ground supplied, the combination flasher unit controls the flashing of the RH turn signal lamps.

#### HAZARD LAMP OPERATION

Power is supplied at all times to hazard switch terminal 3 through:

- 10A fuse [No. 17, located in the fuse block (J/B)].

With the hazard switch in the ON position, power is supplied

- through hazard switch terminal 1
- to combination flasher unit terminal B
- through combination flasher unit terminal L
- to hazard switch terminal 4.

Ground is supplied to combination flasher unit terminal E through body grounds M14 and M68.

Power is supplied through hazard switch terminal 5 to

- front combination lamp LH terminal 1
- combination meter terminal 12 and
- rear combination lamp LH terminal +.

Power is supplied through hazard switch terminal 6 to



# TURN SIGNAL AND HAZARD WARNING LAMPS

- front combination lamp RH terminal 1
- combination meter terminal 14 and
- rear combination lamp RH terminal +.

Ground is supplied to each front combination lamp terminal 2 through body grounds E12 and E54.

Ground is supplied to combination meter terminal 13 and each rear combination lamp terminal - through body grounds M14 and M68.

With power and ground supplied, the combination flasher unit controls the flashing of the hazard warning lamps.

## REMOTE KEYLESS ENTRY SYSTEM OPERATION

Power is supplied at all times to smart entrance control unit terminal 49

- through 7.5A fuse [No. 28, located in the fuse block (J/B)].

Ground is supplied to smart entrance control unit terminals 43 and 64.

Refer to [BL-29, "System Description"](#).

When the smart entrance control unit receives LOCK or UNLOCK signal from keyfob with all doors closed, power is supplied through smart entrance control unit terminal 47

- to front combination lamp LH terminal 1
- to combination meter terminal 12
- to rear combination lamp LH terminal +.

Power is supplied through smart entrance control unit terminal 48

- to front combination lamp RH terminal 1
- to combination meter terminal 14
- to rear combination lamp RH terminal +.

Ground is supplied to terminal 2 of each front combination lamp through body grounds E12 and E54.

Ground is supplied to terminal - of each rear combination lamp through body grounds M68 and M14.

Ground is supplied to combination meter terminal 13 through body grounds M14 and M68.

With power and ground supplied, the smart entrance control unit controls the flashing of the hazard warning lamps.

A

B

C

D

E

F

G

H

I

J

LT

L

M



# TURN SIGNAL AND HAZARD WARNING LAMPS

LT-TURN-02

A  
B  
C  
D  
E  
F  
G  
H  
I  
J  
LT  
L  
M

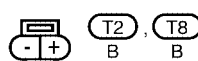
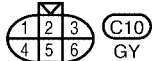
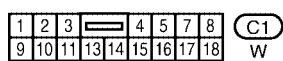
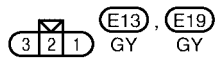
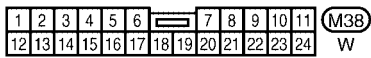
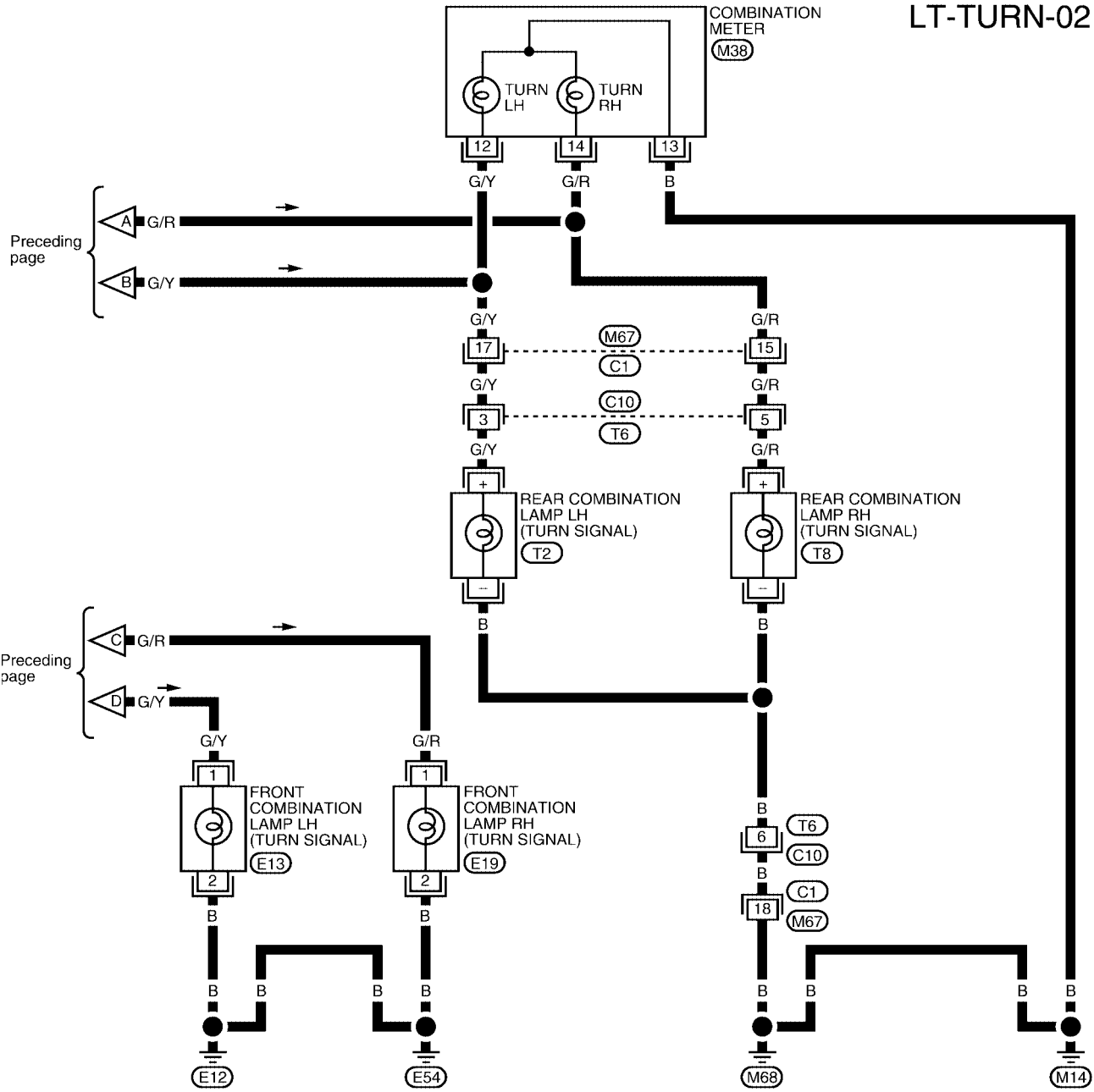

WKWA0375E

# TURN SIGNAL AND HAZARD WARNING LAMPS

## Trouble Diagnoses

EKS006VT

Symptom	Possible cause	Repair order
Turn signal and hazard warning lamps do not operate.	<ol style="list-style-type: none"> <li>1. 7.5A fuse</li> <li>2. 10A fuse</li> <li>3. Hazard switch</li> <li>4. Combination flasher unit</li> <li>5. Open in combination flasher unit circuit</li> </ol>	<ol style="list-style-type: none"> <li>1. Check 7.5A fuse [No. 2, located in fuse block (J/B)]. Turn ignition switch ON and verify battery positive voltage is present at terminal 2 of hazard switch.</li> <li>2. Check 10A fuse [No. 17, located in fuse block (J/B)]. Verify battery positive voltage is present at terminal 3 of hazard switch.</li> <li>3. Check hazard switch.</li> <li>4. Refer to combination flasher unit check.</li> <li>5. Check wiring to combination flasher unit for open circuit.</li> </ol>
Turn signal lamps do not operate but hazard warning lamps operate.	<ol style="list-style-type: none"> <li>1. 7.5A fuse</li> <li>2. Hazard switch</li> <li>3. Turn signal switch</li> <li>4. Open in turn signal switch circuit</li> </ol>	<ol style="list-style-type: none"> <li>1. Check 7.5A fuse [No. 2, located in fuse block (J/B)]. Turn ignition switch ON and verify battery positive voltage is present at terminal 2 of hazard switch.</li> <li>2. Check hazard switch.</li> <li>3. Check turn signal switch.</li> <li>4. Check G wire between combination flasher unit and turn signal switch for open circuit. Check the harness between turn signal switch and front combination lamp for open circuit.</li> </ol>
Hazard warning lamps do not operate but turn signal lamps operate.	<ol style="list-style-type: none"> <li>1. 10A fuse</li> <li>2. Hazard switch</li> <li>3. Open in hazard switch circuit</li> </ol>	<ol style="list-style-type: none"> <li>1. Check 10A fuse [No. 17, located in fuse block (J/B)]. Verify battery positive voltage is present at terminal 3 of hazard switch.</li> <li>2. Check hazard switch.</li> <li>3. Check G wire between combination flasher unit and hazard switch for open circuit.</li> </ol>
Front turn signal lamp LH or RH does not operate.	<ol style="list-style-type: none"> <li>1. Bulb</li> <li>2. Front turn signal lamp ground circuit</li> </ol>	<ol style="list-style-type: none"> <li>1. Check bulb.</li> <li>2. Check grounds E12 and E54 and continuity between front turn signal lamp and grounds E12 and E54.</li> </ol>
Rear turn signal lamp LH does not operate.	<ol style="list-style-type: none"> <li>1. Bulb</li> <li>2. Rear combination lamp LH ground circuit</li> </ol>	<ol style="list-style-type: none"> <li>1. Check bulb.</li> <li>2. Check grounds M14 and M68 and continuity between rear combination lamp LH and grounds M14 and M68.</li> </ol>
Rear turn signal lamp RH does not operate.	<ol style="list-style-type: none"> <li>1. Bulb</li> <li>2. Rear turn signal lamp RH ground circuit</li> </ol>	<ol style="list-style-type: none"> <li>1. Check bulb.</li> <li>2. Check grounds M14 and M68 and continuity between rear combination lamp RH and grounds M14 and M68.</li> </ol>
LH and RH turn indicators do not operate.	<ol style="list-style-type: none"> <li>1. Ground circuit</li> </ol>	<ol style="list-style-type: none"> <li>1. Check grounds M14 and M68 and continuity between combination meter terminal 13 and grounds M14 and M68.</li> </ol>
LH or RH turn indicator does not operate.	<ol style="list-style-type: none"> <li>1. Bulb</li> <li>2. Combination meter</li> <li>3. Turn indicator circuit</li> </ol>	<ol style="list-style-type: none"> <li>1. Check bulb in cluster lid A.</li> <li>2. Check continuity between combination meter terminal 12, 14 and 13.</li> <li>3. Check the wire between hazard switch and combination meter.</li> </ol>

# TURN SIGNAL AND HAZARD WARNING LAMPS

## Electrical Components Inspection COMBINATION FLASHER UNIT CHECK

EKS006VU

- Before checking, ensure that bulbs meet specifications.
- Connect a battery and test lamp to the combination flasher unit, as shown. Combination flasher unit is properly functioning if it blinks when power is supplied to the circuit.

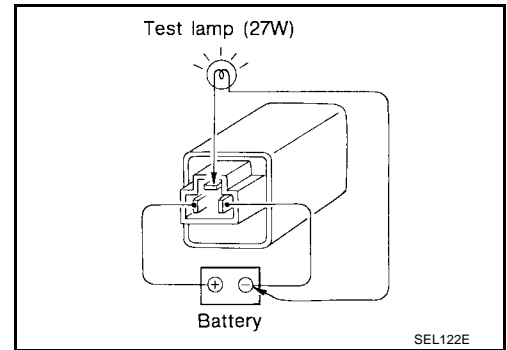

A  
B  
C  
D  
E  
F  
G  
H  
I  
J  
LT  
L  
M

# ILLUMINATION

PF2:27545

## ILLUMINATION

### System Description

EKS006VV

Power is supplied at all times

- through 15A fuse (No. 39, located in the fuse and fusible link box)
- to lighting switch terminal 11.

The lighting switch must be in the parking and tail lamps ON (1ST) or headlamps ON (2ND) position for illumination.

The illumination control switch controls the amount of current to the illumination system. As the amount of current increases, the illumination becomes brighter.

The following chart shows the power and ground connector terminals for the components included in the illumination system.

Component	Connector No.	Power terminal	Ground terminal
A/T device (With A/T and VG engine)	M35	4	3
Hazard switch	M53	7	8
Air control	M95	10	9
Audio unit	M51	8	7
Combination meter	M39	30, 32	42
Main power window and door lock/unlock switch	D7	3	8
A/T (With A/T and KA engine)	M127	1	2
Illumination control switch	M28	1	5

The ground for all of the components are controlled through terminals 4 and 5 of the illumination control switch and body grounds M14 and M68.

# ILLUMINATION

## Wiring Diagram — ILL —

EKS006VW

LT-ILL-01

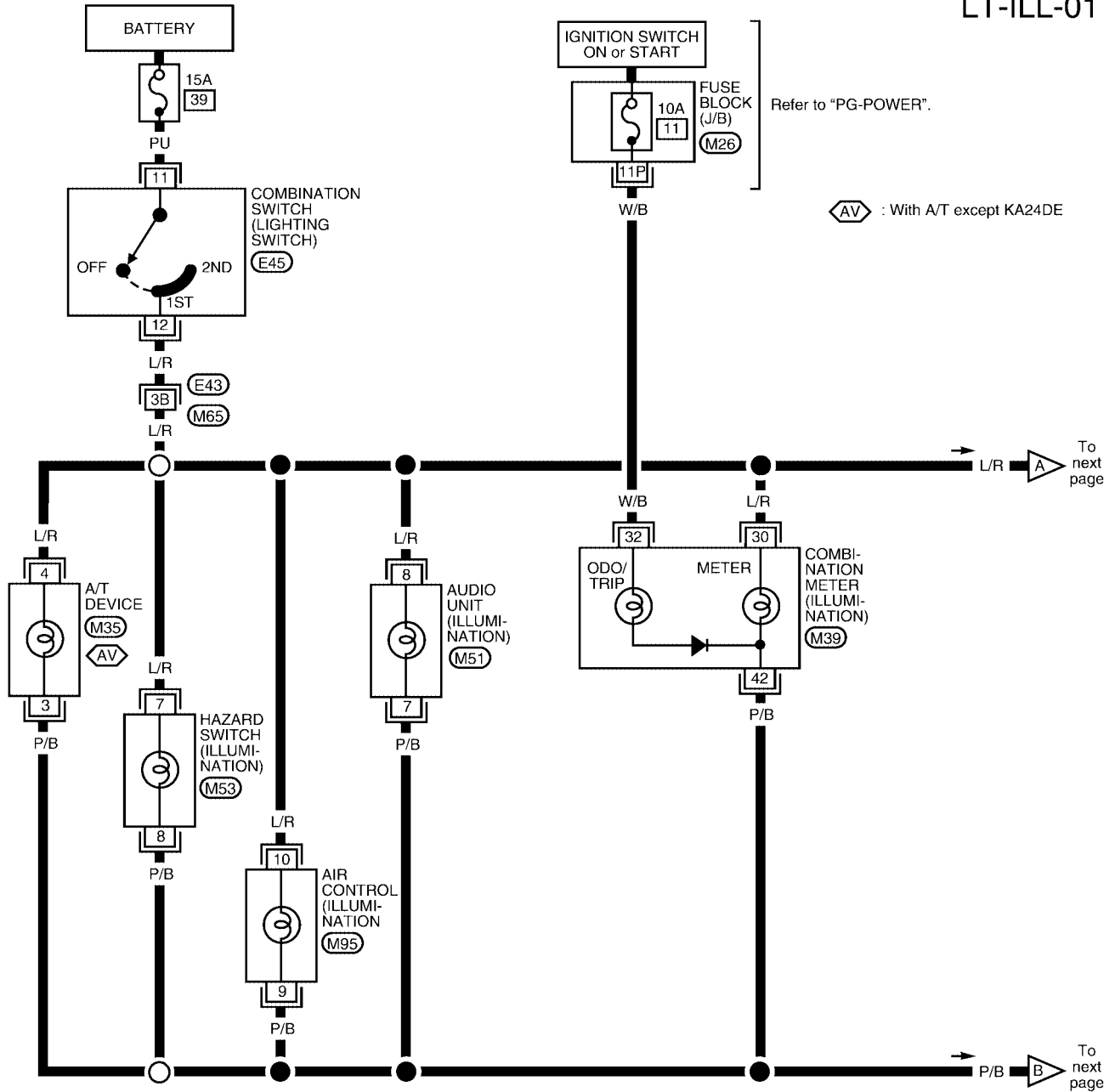

Refer to "PG-POWER".

AV : With A/T except KA24DE

A  
B  
C  
D  
E  
F  
G  
H  
I  
J  
LT  
L  
M

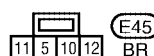
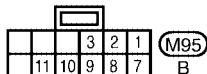
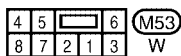
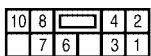
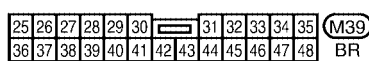
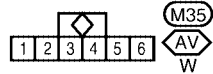
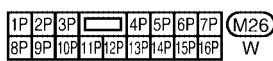





Refer to the following.

E43 - SUPER  
MULTIPLE JUNCTION (SMJ)

WKWA0376E

# ILLUMINATION

LT-ILL-02

-  : 2 door models
-  : 4 door models
-  : With A/T and KA engine
-  : With power door locks

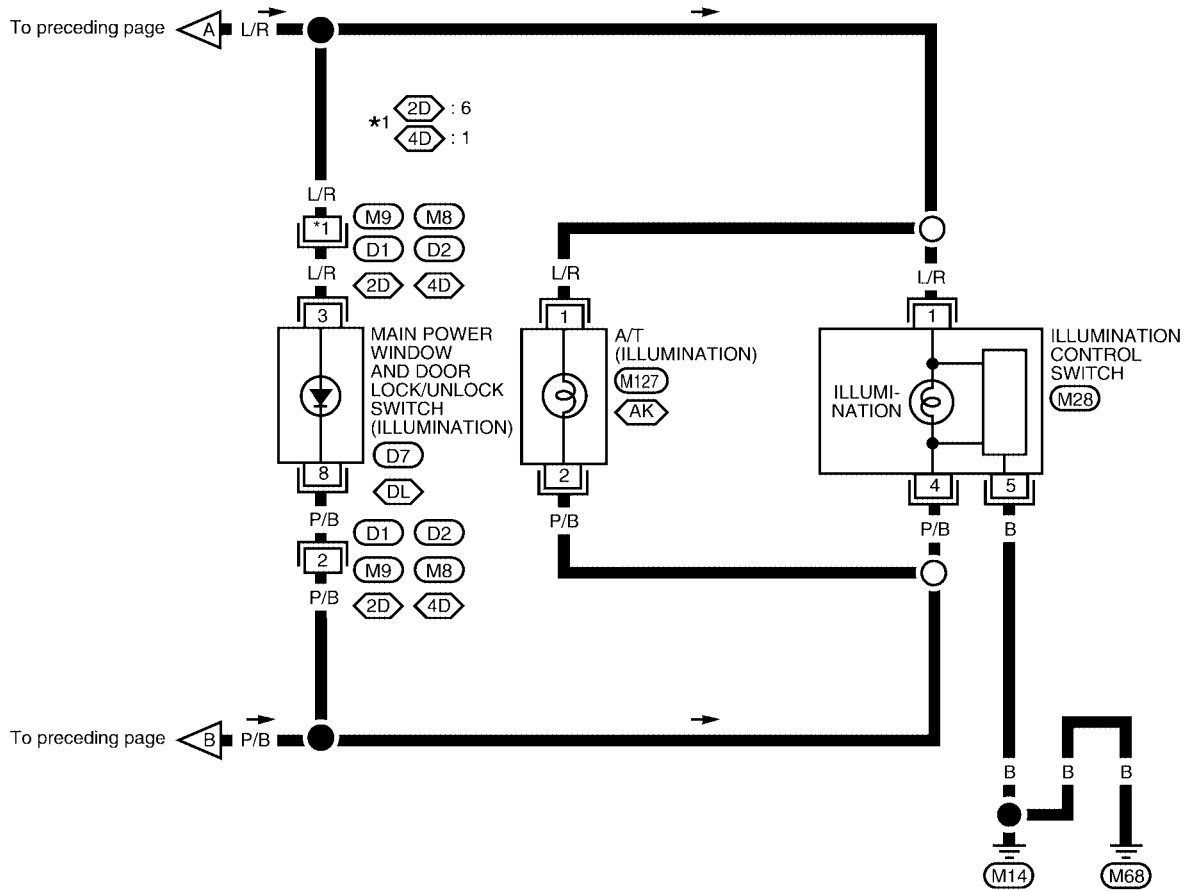



# INTERIOR ROOM LAMP

## INTERIOR ROOM LAMP

### Component Parts and Harness Connector Location

PF2:26410

EKS006VX

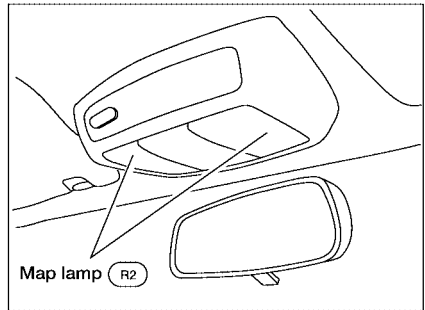
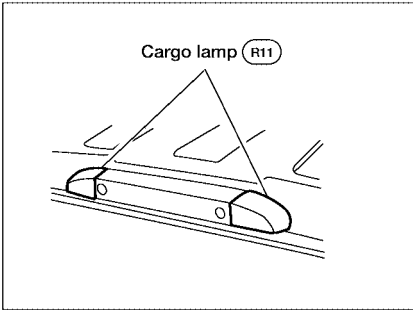
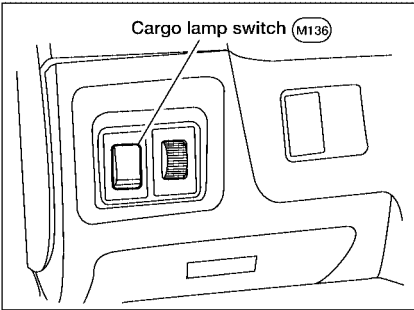
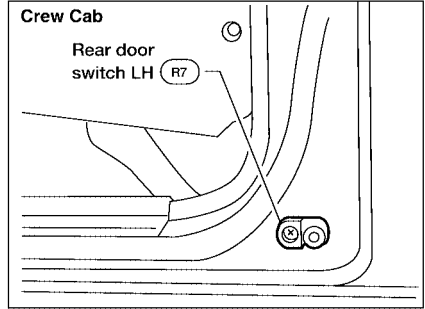
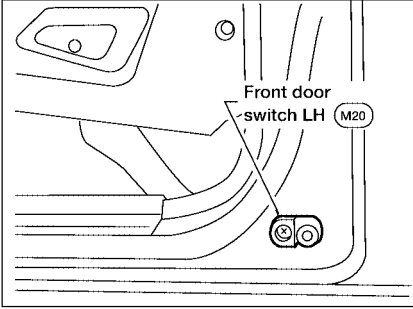
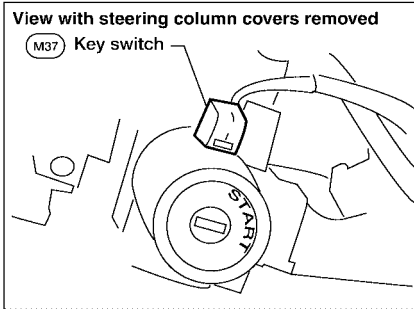
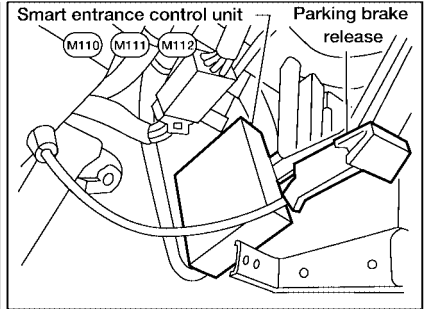
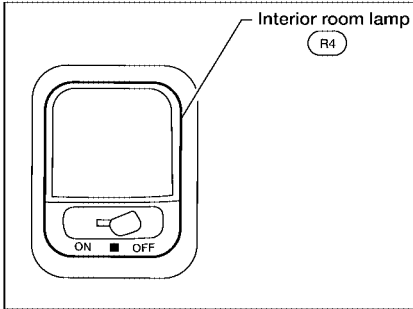
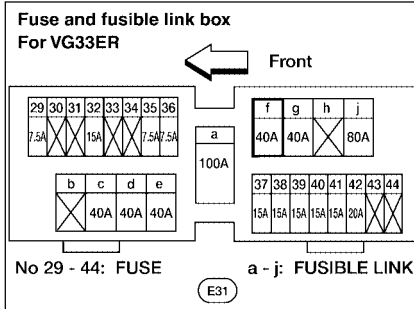
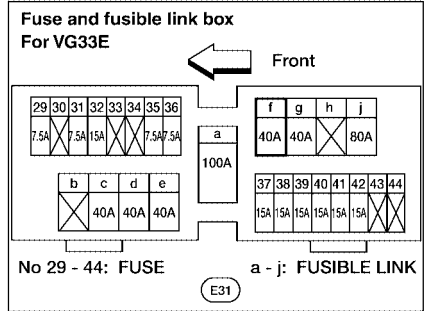
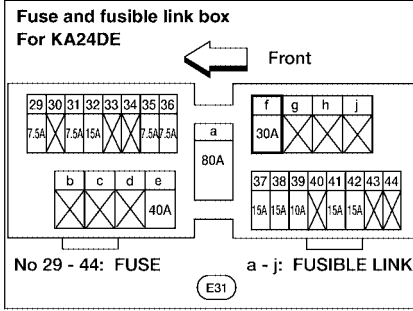
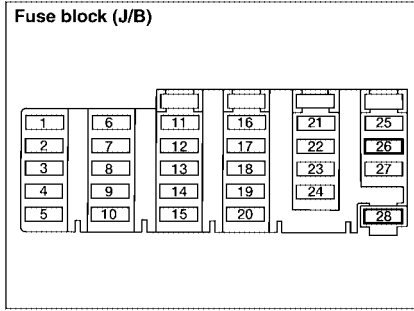

A  
B  
C  
D  
E  
F  
G  
H  
I  
J  
LT  
L  
M

# INTERIOR ROOM LAMP

EKS006VY

## System Description

### MODELS WITHOUT POWER DOOR LOCKS

#### Room Lamp

Power is supplied at all times

- through 7.5A fuse [No. 26, located in the fuse block (J/B)]
- to room lamp terminal +.

On 2 door models, with the room lamp switch in the ON position, ground is supplied

- to room lamp terminal -
- through body grounds M14 and M68.

On 4 door models, with the room lamp switch in the ON position, ground is supplied through the case of the room lamp.

With one or more doors open, with the room lamp switch in the DOOR position, ground is supplied

- to room lamp terminal SW
- through front door switch LH terminal 1 and/or
- through front door switch RH and/or rear door switch LH/RH terminal +.

#### Cargo Lamp

With the ignition switch in ACC or ON position, power is supplied

- through 15A fuse [No. 23, located in fuse block (J/B)]
- to cargo lamp switch terminal 2.

When cargo lamp switch is ON, power is supplied

- through cargo lamp switch terminal 3
- to cargo lamp terminal +, and
- to cargo lamp switch terminal 4.

Ground is supplied

- to cargo lamp terminal -, and
- to cargo lamp switch terminal 5
- through body grounds M14 and M68.

#### Map Lamp

Power is supplied at all times

- through 7.5A fuse [No. 26, located in fuse block (J/B)]
- to map lamp terminal +.

With the map lamp switch in the ON position, ground is supplied

- to map lamp terminal -
- through body grounds M14 and M68.

### MODELS WITH POWER DOOR LOCKS

#### Room Lamp

Power is supplied at all times

- through 7.5A fuse [No. 28, located in the fuse block (J/B)]
- to smart entrance control unit terminal 49.
- through smart entrance control unit terminal 50
- to room lamp terminal +.

Ground is supplied at all times to smart entrance control unit terminals 43 and 64 through body grounds M14 and M68.

On 2 door models, with the room lamp switch in the ON position, ground is supplied

- to room lamp terminal -
- through body grounds M14 and M68.

On 4 door models, with the room lamp switch in the ON position, ground is supplied through the case of the room lamp.

With the front door LH open and the room lamp switch in the DOOR position, ground is supplied

# INTERIOR ROOM LAMP

- to smart entrance control unit terminal 1
- through front door switch LH terminal 2
- through front door switch LH terminal 3
- through body grounds M14 and M68 and
- to room lamp terminal SW
- through smart entrance control unit terminal 31.

A

B

With the front door RH open and the room lamp switch in the DOOR position, ground is supplied

C

- to smart entrance control unit terminal 2
- through front door switch RH terminal + and
- to room lamp terminal SW
- through smart entrance control unit terminal 31.

D

On 4 door models, with rear door LH/RH open and the room lamp switch in the DOOR position, ground is supplied

E

- to smart entrance control unit terminal 3 (with vehicle security system), or
- to smart entrance control unit terminal 2 (without vehicle security system)
- through rear door switch LH/RH terminal + and
- to room lamp terminal SW
- through smart entrance control unit terminal 31.

F

G

## Room Lamp Timer Operation

When the room lamp switch is in the DOOR position, the smart entrance control unit keeps the room lamp illuminated for about 30 seconds when

H

- unlock signal is supplied from door lock/unlock switch while all doors are closed and key is out of ignition key cylinder
- unlock signal is supplied from keyfob or door key cylinder while all doors are closed
- key is removed from ignition key cylinder while driver door is closed
- driver door is opened and then closed while key is out of the ignition key cylinder. (However, if the driver door is closed with the key inserted in the ignition key cylinder after the front door LH is opened with the key removed, the timer operates.)

I

J

The timer is canceled and room lamp turns off when

- front door LH is locked with keyfob, or
- front door LH is opened, or
- ignition switch is turned ON.

LT

The smart entrance control unit turns off the room lamp if it is left on for 30 minutes.

L

## Cargo Lamp

With the ignition switch in ACC or ON, power is supplied

M

- through 15A fuse [No. 23, located in the fuse block (J/B)]
- to cargo lamp switch terminal 2.

When cargo lamp switch is ON, power is supplied

- through cargo lamp switch terminal 3
- to cargo lamp terminal +, and
- to cargo lamp switch terminal 4.

Ground is supplied

- to cargo lamp terminal -, and
- to cargo lamp switch terminal 5
- through body grounds M14 and M68.

## Map Lamp

Power is supplied at all times

- through 7.5A fuse [No. 28, located in the fuse block (J/B)]
- to smart entrance control unit terminal 49

## INTERIOR ROOM LAMP

---

- through smart entrance control unit terminal 50
- to map lamp terminal +.

With the map lamp switch in the ON position, ground is supplied to map lamp terminal - through body grounds M14 and M68.

### **ON-OFF CONTROL**

When the front door LH, front door RH, rear LH or rear RH door is opened, the interior room lamp turns on while the room lamp switch is in the DOOR position.

### **BATTERY SAVER**

On models with smart entrance control unit, the lamp turns off automatically when room lamp, map lamp and/or spot lamp is illuminated with the ignition key in OFF position, if the lamp remains lit by the door switch open signal or if the lamp switch in ON position for more than 30 minutes.

# INTERIOR ROOM LAMP

EKS006VZ

## Wiring Diagram — ROOM/L — MODELS WITHOUT POWER DOOR LOCKS

### LT-ROOM/L-01

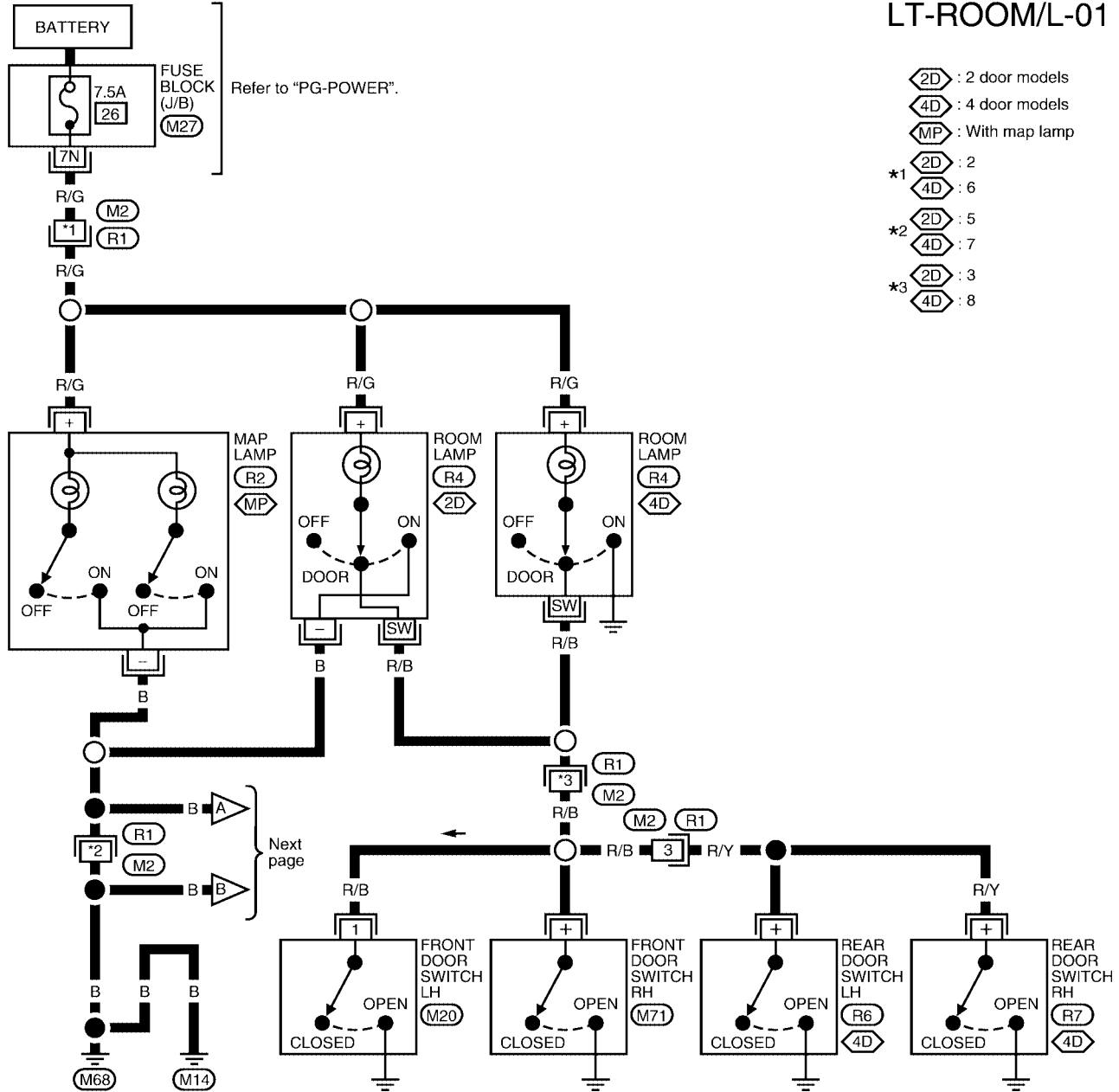

- ⬡2D : 2 door models
- ⬡4D : 4 door models
- ⬡MP : With map lamp
- \*1 ⬡2D : 2
- ⬡4D : 6
- \*2 ⬡2D : 5
- ⬡4D : 7
- \*3 ⬡2D : 3
- ⬡4D : 8

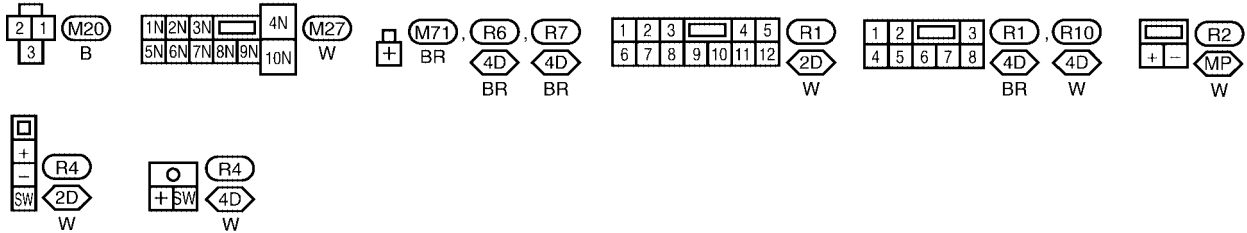

A  
B  
C  
D  
E  
F  
G  
H  
I  
J  
LT  
L  
M

# INTERIOR ROOM LAMP

LT-ROOM/L-02

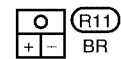
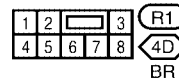
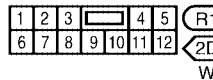
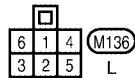
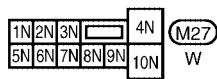
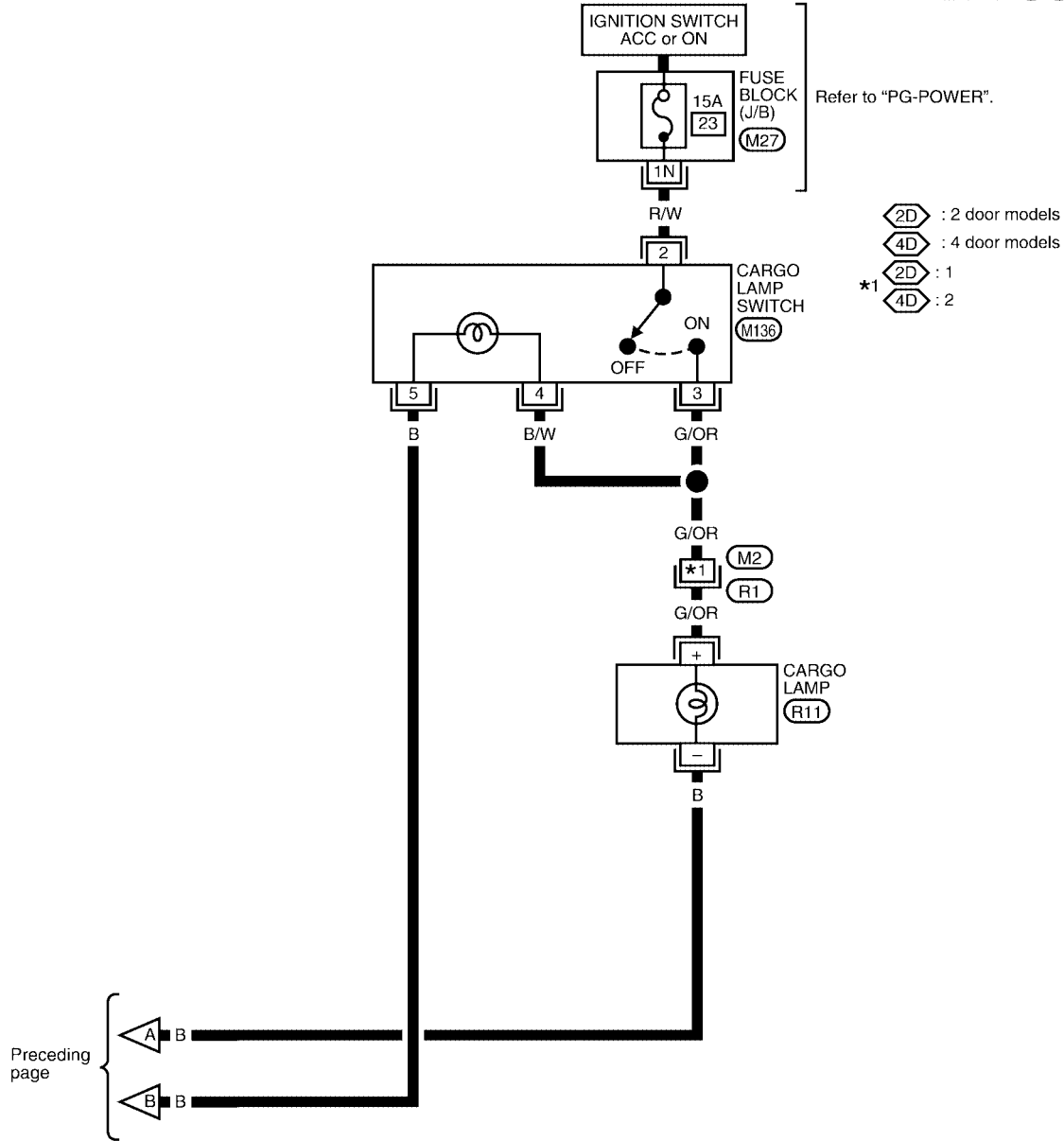

WKWA0650E

# INTERIOR ROOM LAMP

## MODELS WITH POWER DOOR LOCKS

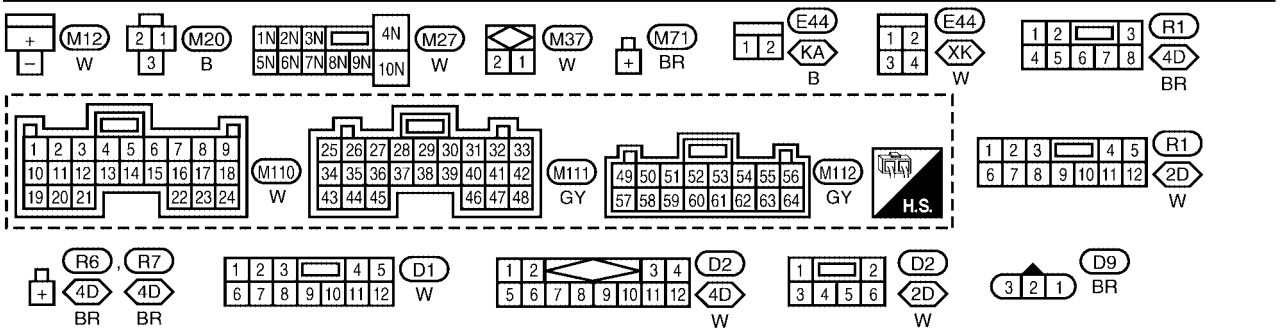
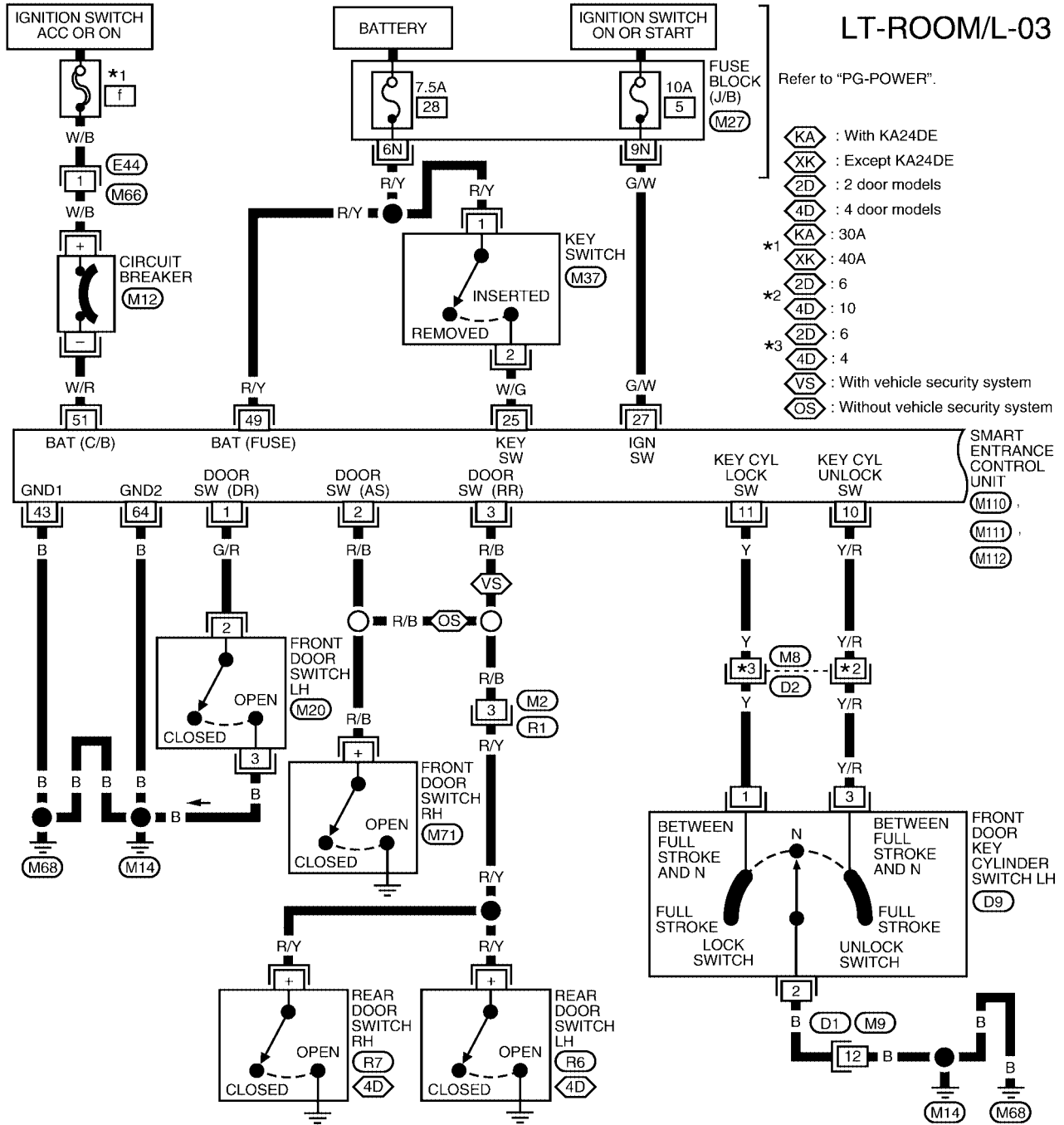

# INTERIOR ROOM LAMP

LT-ROOM/L-04

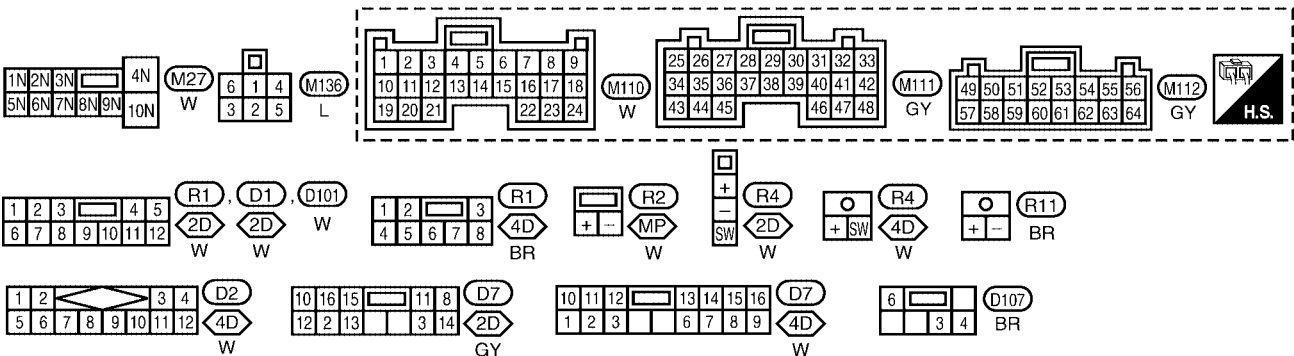
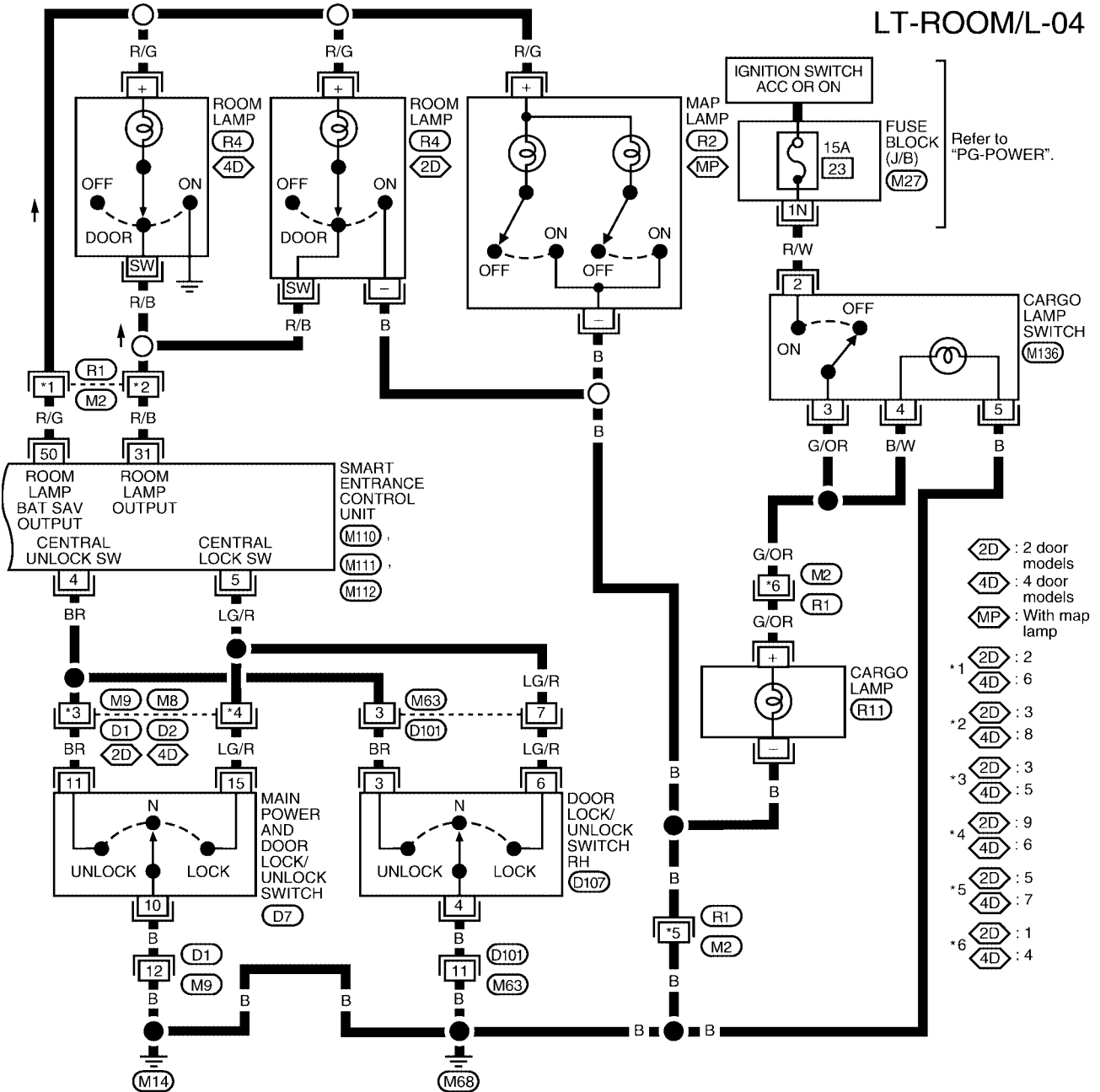

WKWA0651E



# INTERIOR ROOM LAMP

EKS006W0

## Trouble Diagnosis

**SYMPTOM:** Room lamp does not turn on or off properly.

### 1. CHECK ROOM LAMP FUSE

Check 7.5A fuse [No. 26 (without power door locks), 28 (with power door locks), located in fuse block (J/B)].

OK or NG

OK >> GO TO 2.

NG >> Replace fuse and check harness for short between fuse and room lamp.

### 2. CHECK ROOM LAMP SWITCH SIGNALS

1. Close all doors, turn ON room lamp switch.

**Room lamps should turn on.**

2. Turn off room lamp switch.

**Room lamps should turn off.**

OK or NG

OK >> GO TO 3.

NG >> Check the following.

- Room lamp switch
- Room lamp switch ground circuit
- Harness for open or short between room lamp switch and smart entrance control unit (models with power door locks)

### 3. CHECK ROOM LAMP POWER SUPPLY

Check voltage between room lamp connector R4 terminal + (R/G) and ground.

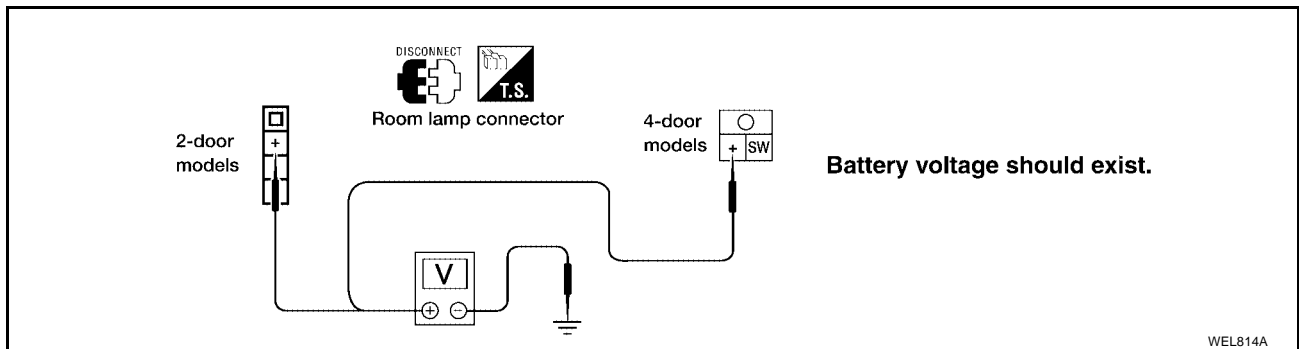

OK or NG

OK >> GO TO 4.

NG >> Check harness for open between fuse and room lamp.

### 4. CHECK INTERIOR ROOM LAMP BULB

Check interior room lamp bulb.

OK or NG

OK >> ● For models without power door locks, inspection end.

- For models with power door locks, GO TO 5.

NG >> Replace bulb.

## INTERIOR ROOM LAMP

---

### 5. CHECK KEY SWITCH (INSERTED) AND IGNITION ON SIGNAL

---

1. Insert key into ignition key cylinder.
2. Open front door LH.

**Warning chime should sound.**

3. Turn ignition key to ON position.

**Warning chime should stop sounding.**

OK or NG

OK >> GO TO 6.

NG >> Refer to [DI-35, "WARNING CHIME"](#) .

### 6. CHECK DOOR SWITCH INPUT SIGNAL

---

Unlock doors using LH door key cylinder.

**The doors should unlock.**

OK or NG

OK >> Replace smart entrance control unit.

NG >> Refer to [BL-24, "DOOR KEY CYLINDER SWITCH CHECK"](#) .

# BULB SPECIFICATIONS

PDF:26297

## BULB SPECIFICATIONS

### Bulb Specifications HEADLAMP

EKS006W1

	Wattage (W)	Bulb No.*
High/Low (Semi-sealed beam)	65/55	9007 (HB5)

\*: Always check with the Parts Department for the latest parts information.

### EXTERIOR LAMP

		Wattage (W)	Bulb No.*
Front combination lamp	Turn signal	28.5	3456K
	Parking	5	168
	Side marker	5	168
Fog lamp		37.5	899
Rear combination lamp	Turn signal	27	3157NAK
	Stop/Tail	27/7	3157K
	Back-up	27	3156K
Cargo lamp		10	*
High-mounted stop lamp		*	*
License plate lamp		3.8	194

\*: Always check with the Parts Department for the latest parts information.

### INTERIOR LAMP

	Wattage (W)	Bulb No.*
Room lamp (Dome lamp)	8	*
Map lamp (without compass and thermometer)	5	168
Map lamp (with compass and thermometer)	5	168

\*: Always check with the Parts Department for the latest parts information.

A  
B  
C  
D  
E  
F  
G  
H  
I  
J  
L  
M

LT

**BULB SPECIFICATIONS**

---