

A
B
MT
D
E
F
G
H
I
J
K
L
M

SECTION **MT**

MANUAL TRANSMISSION

CONTENTS

FS5W71C		
PREPARATION	3	
Special Service Tools	3	
Commercial Service Tools	5	
NOISE, VIBRATION, AND HARSHNESS (NVH)		
TROUBLESHOOTING	6	
NVH Troubleshooting Chart	6	
DESCRIPTION	7	
CROSS-SECTIONAL VIEW	7	
ON-VEHICLE SERVICE	9	
Replacing Rear Oil Seal	9	
REMOVAL	9	
INSTALLATION	9	
Position Switch Check	9	
TRANSMISSION ASSEMBLY	10	
Removal and Installation	10	
REMOVAL	10	
INSTALLATION	11	
Overhaul	12	
CASE COMPONENTS	12	
GEAR COMPONENTS	14	
SHIFT CONTROL COMPONENTS	16	
CASE COMPONENTS	18	
Disassembly	18	
Assembly	19	
SHIFT CONTROL COMPONENTS	22	
Disassembly	22	
Inspection	22	
Assembly	23	
GEAR COMPONENTS	24	
Disassembly	24	
Inspection	26	
GEARS AND SHAFTS	26	
SYNCHRONIZERS	27	
BEARINGS	27	
Assembly	27	
SERVICE DATA AND SPECIFICATIONS (SDS)	35	
General Specifications	35	
Gear End Play	35	
Clearance Between Baulk Ring and Gear	36	
		2ND & 3RD BAULK RING
		Available Snap Rings
		MAIN DRIVE GEAR BALL BEARING SNAP RING
		MAINSHAFT FRONT SNAP RING
		COUNTER DRIVE GEAR SNAP RING
		OD MAINSHAFT BEARING SNAP RING
		Available Shims
		COUNTERSHAFT FRONT BEARING SHIM
		FS5R30A
		PREPARATION
		Special Service Tools
		Commercial Service Tool
		NOISE, VIBRATION, AND HARSHNESS (NVH)
		TROUBLESHOOTING
		NVH Troubleshooting Chart
		DESCRIPTION
		Description
		CROSS-SECTIONAL VIEW — 2WD MODEL
		CROSS-SECTIONAL VIEW — 4WD MODEL
		ON-VEHICLE SERVICE
		Replacing Rear Oil Seal — 2WD Model
		REMOVAL
		INSTALLATION
		Position Switch Check
		TRANSMISSION ASSEMBLY
		Removal and Installation
		REMOVAL
		INSTALLATION
		Overhaul
		CASE COMPONENTS
		GEAR COMPONENTS
		SHIFT CONTROL COMPONENTS (2/4WD MODELS)
		CASE COMPONENTS
		Disassembly
		Assembly

SHIFT CONTROL COMPONENTS	63	Clearance Between Single Baulk Ring and Gear ...	81
Disassembly	63	DOUBLE BAULK RING	82
Inspection	63	Distance Between Rear Surface of Reverse Cone	
Assembly	63	and Reverse Baulk Ring	82
GEAR COMPONENTS	65	Available Snap Ring	82
Disassembly	65	MAIN DRIVE GEAR SNAP RING	82
Inspection	69	MAINSHAFT FRONT BEARING SNAP RING	82
GEARS AND SHAFTS	69	COUNTER GEAR REAR SNAP RING	83
SYNCHRONIZERS	69	Available C-ring	83
BEARINGS	70	MAINSHAFT C-RING	83
Assembly	70	Available Shim and Washer	83
SERVICE DATA AND SPECIFICATIONS (SDS)	81	TABLE FOR SELECTING PROPER COUNTER	
General Specifications	81	GEAR FRONT BEARING SHIM	83
Gear End Play	81	REVERSE IDLER REAR THRUST WASHER	83

PREPARATION

[FS5W71C]

PFP:00002

ECS007H9

PREPARATION

Special Service Tools

The actual shapes of Kent-Moore tools may differ from those of special service tools illustrated here.

Tool number (Kent-Moore No.) Tool name	Description
ST23810001 (—) Adapter setting plate	Fixing adapter plate with gear assembly a: 166 mm (6.54 in) b: 270 mm (10.63 in)
KV32101330 (See J34286) Puller	Removing overdrive mainshaft bearing a: 447 mm (17.60 in) b: 100 mm (3.94 in)
KV31100401 (—) Transmission press stand	Pressing counter gear, mainshaft, counter drive gear and main drive gear
ST22520000 (J26348) Wrench	Tightening mainshaft lock nut a: 100 mm (3.94 in) b: 41 mm (1.61 in)
ST23540000 (J25689-A) Pin punch	Removing and installing fork rod retaining pin a: 2.3 mm (0.091 in) dia. b: 4 mm (0.16 in) dia.
ST30031000 (J22912-01) Puller	Removing and installing 1st gear bushing Removing main drive gear ball bearing a: 90 mm (3.54 in) dia. b: 50 mm (1.97 in) dia.
ST23860000 (—) Drift	Installing counter drive gear a: 38 mm (1.50 in) dia. b: 33 mm (1.30 in) dia.

A
B
MT
D
E
F
G
H
I
J
K
L
M

PREPARATION

[FS5W71C]

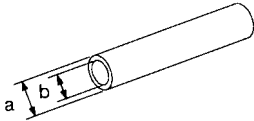
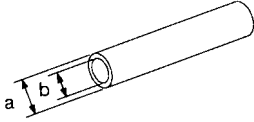
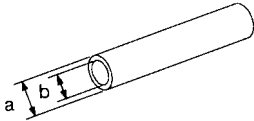
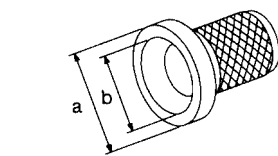
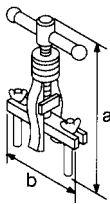
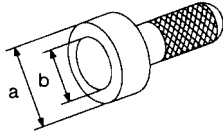
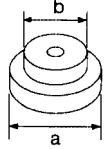
Tool number (Kent-Moore No.) Tool name	Description
ST22360002 (J25679-01) Drift	 <p style="text-align: center;">NT065</p> Installing counter gear front and rear end bearings a: 29 mm (1.14 in) dia. b: 23 mm (0.91 in) dia.
ST22350000 (J25678-01) Drift	 <p style="text-align: center;">NT065</p> Installing OD gear bushing a: 34 mm (1.34 in) dia. b: 28 mm (1.10 in) dia.
ST23800000 (J25691-01) Drift	 <p style="text-align: center;">NT065</p> Installing front cover oil seal a: 44 mm (1.73 in) dia. b: 31 mm (1.22 in) dia.
ST33400001 (J26082) Drift	 <p style="text-align: center;">NT086</p> Installing rear oil seal a: 60 mm (2.36 in) dia. b: 47 mm (1.85 in) dia.
ST33290001 (J34286) Puller	 <p style="text-align: center;">NT414</p> Removing rear oil seal a: 250 mm (9.84 in) b: 160 mm (6.30 in)
ST30720000 (J25405) Drift	 <p style="text-align: center;">NT115</p> Installing mainshaft ball bearing a: 77 mm (3.03 in) dia. b: 55.5 mm (2.185 in) dia.
ST30613000 (J25742-3) Drift	 <p style="text-align: center;">NT073</p> Installing main drive gear ball bearing a: 71.5 mm (2.815 in) dia. b: 47.5 mm (1.870 in) dia.

PREPARATION

[FS5W71C]

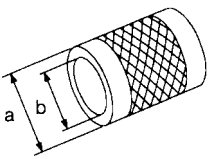
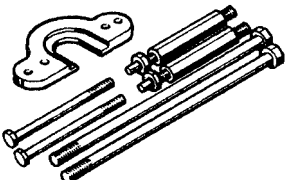
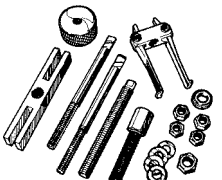
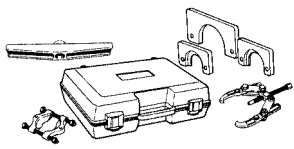
Tool number (Kent-Moore No.) Tool name	Description
ST33200000 (J26082) Drift  <p style="text-align: right;">NT091</p>	Installing counter rear bearing and counter gear assembly a: 60 mm (2.36 in) dia. b: 44.5 mm (1.752 in) dia.
(J-26349-A) Bearing Remover and Installer Set  <p style="text-align: right;">WMT065</p>	Removing and installing mainshaft bearing (Use with J-25726-B)
(J-34286) Rear Race Puller  <p style="text-align: right;">WMT066</p>	Removing races
(J-39856) Gear and Bearing Removal Kit  <p style="text-align: right;">WMT067</p>	Removing gears and bearings

A
B
MT

D
E
F
G
H
I
J

Commercial Service Tools

ECS007HA

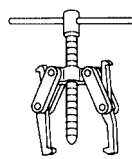
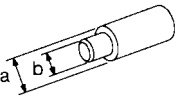
Tool name	Description
Puller  <p style="text-align: right;">NT077</p>	Removing counter bearings, counter drive and OD gears
Drift  <p style="text-align: right;">NT074</p>	Installing countershaft rear end bearing a: 40 mm (1.57 in) dia. b: 30 mm (1.18 in) dia.

K
L
M

NOISE, VIBRATION, AND HARSHNESS (NVH) TROUBLESHOOTING

[FS5W71C]

NOISE, VIBRATION, AND HARSHNESS (NVH) TROUBLESHOOTING

PFP:00003

NVH Troubleshooting Chart

ECS007HB

Use the chart below to help you find the cause of the symptom. The numbers indicate the order of the inspection. If necessary, repair or replace these parts.

Reference page		MA-36			MT-18		MT-22		MT-24			
SUSPECTED PARTS (Possible cause)		OIL (Oil level is low.)	OIL (Wrong oil.)	OIL (Oil level is high.)	GASKET (Damaged)	OIL SEAL (Worn or damaged)	CHECK PLUG RETURN SPRING AND CHECK BALL (Worn or damaged)	SHIFT FORK (Worn)	GEAR (Worn or damaged)	BEARING (Worn or damaged)	BAULK RING (Worn or damaged)	INSERT SPRING (Damaged)
Symptom	Noise	1	2						3	3		
	Oil leakage		3	1	2	2						
	Hard to shift or will not shift		1	1							2	2
	Jumps out of gear						1	2	2			

DESCRIPTION

[FS5W71C]

DESCRIPTION

PF0:0000

CROSS-SECTIONAL VIEW

ECS007HC

A

B

MT

D

E

F

G

H

I

J

K

L

M

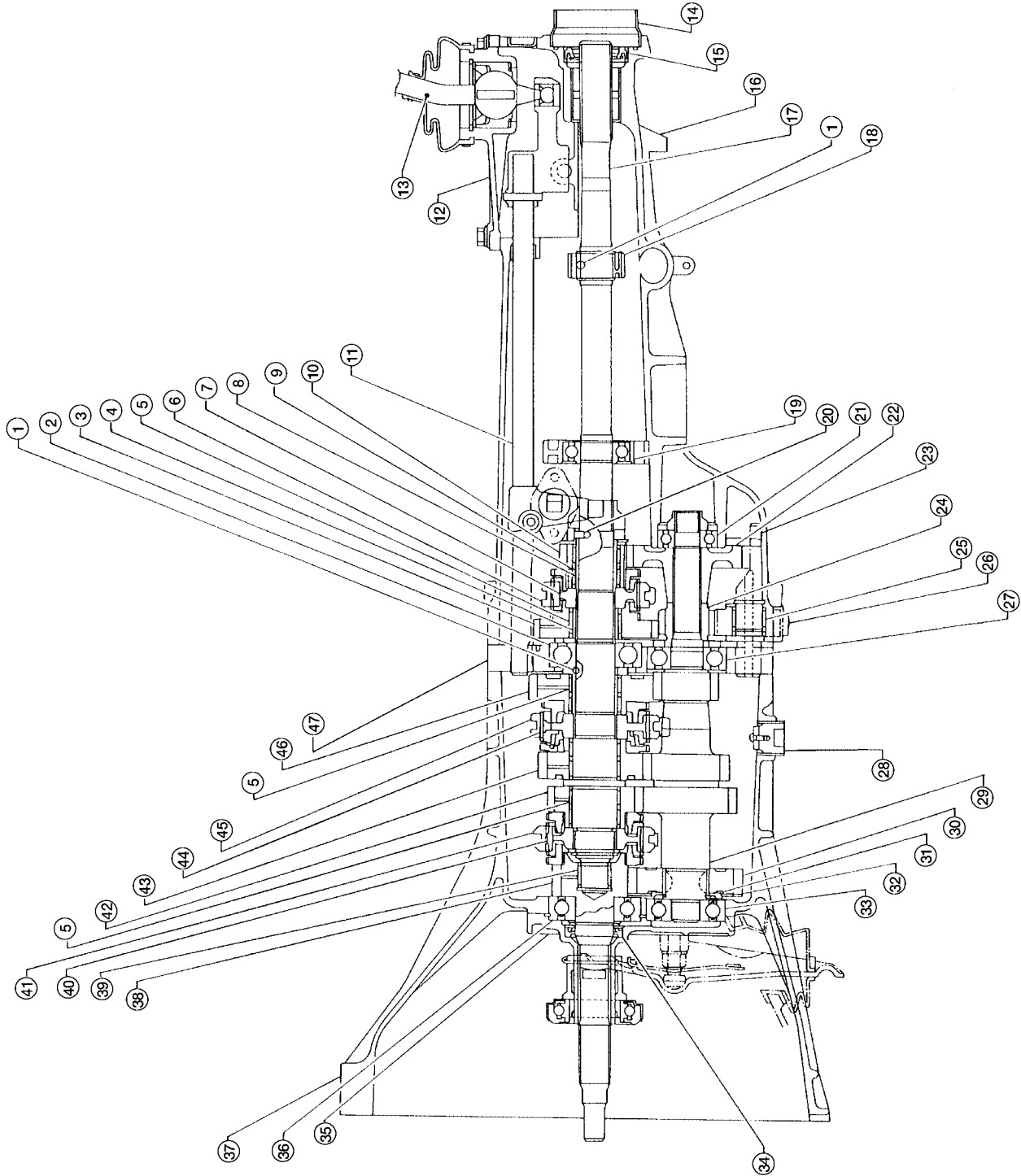

WCIA0175E

MT-7

DESCRIPTION

[FS5W71C]

-
- | | | |
|----------------------------------|--------------------------------|-----------------------------------|
| 1. Steel ball | 2. Mainshaft front bearing | 3. Reverse main gear |
| 4. Bushing | 5. Needle bearing | 6. OD & Reverse coupling sleeve |
| 7. OD & Reverse synchronizer hub | 8. OD gear bushing | 9. Needle bearing |
| 10. OD main gear | 11. Striking rod | 12. Control housing |
| 13. Shift lever | 14. Dust cover | 15. Oil seal |
| 16. Rear extension | 17. Mainshaft | 18. Speedometer drive gear |
| 19. OD mainshaft bearing | 20. Steel roller | 21. Counter gear rear end bearing |
| 22. OD counter gear | 23. Reverse idler shaft | 24. Reverse counter gear |
| 25. Reverse idler gear bushing | 26. Reverse idler gear | 27. Counter gear rear bearing |
| 28. Drain plug | 29. Counter gear | 30. Counter drive gear |
| 31. Sub gear bracket | 32. Sub gear | 33. counter gear front bearing |
| 34. Oil seal | 35. Front cover | 36. Main drive gear ball bearing |
| 37. Transmission case | 38. Main drive gear | 39. Pilot bearing |
| 40. 3rd & 4th synchronizer hub | 41. 3rd & 4th coupling sleeve | 42. 3rd main gear |
| 43. 2nd main gear | 44. 1st & 2nd synchronizer hub | 45. 1st & 2nd coupling sleeve |
| 46. 1st main gear | 47. Adapter plate | |

ON-VEHICLE SERVICE

Replacing Rear Oil Seal
REMOVAL

1. Remove the propeller shaft. Refer to [PR-8, "Removal and Installation"](#) .
2. Remove rear oil seal using Tool.
 - Always replace with a new seal once it has been removed.

Tool number : ST33290001 (J34286)

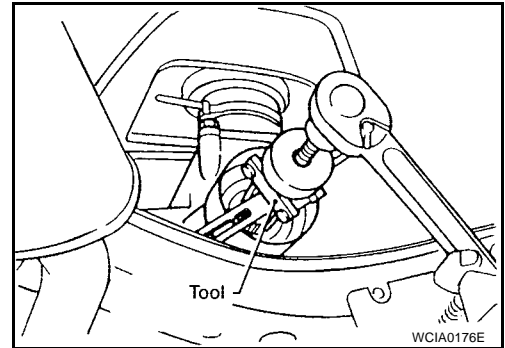

INSTALLATION

1. Install new rear oil seal using Tool until it stops.
 - Apply multi-purpose grease to seal lip of oil seal before installing.

Tool number : ST33400001 (J26082)

2. Installation is in the reverse order of removal.

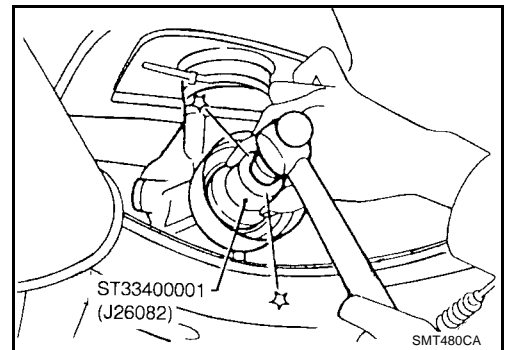

Position Switch Check

- Check continuity.

Switch	Gear position	Continuity
Back-up lamp switch	Reverse	Yes
	Except reverse	No
Park/neutral position (PNP) switch	Neutral	Yes
	Except neutral	No

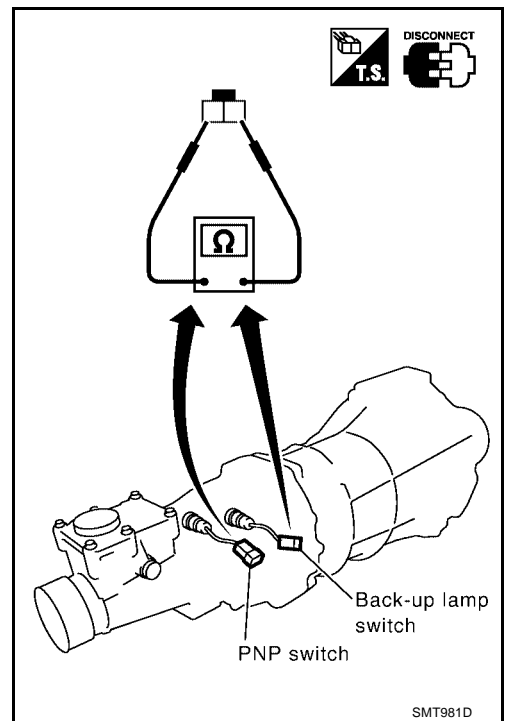

TRANSMISSION ASSEMBLY

PF3:32010

Removal and Installation REMOVAL

ECS007HF

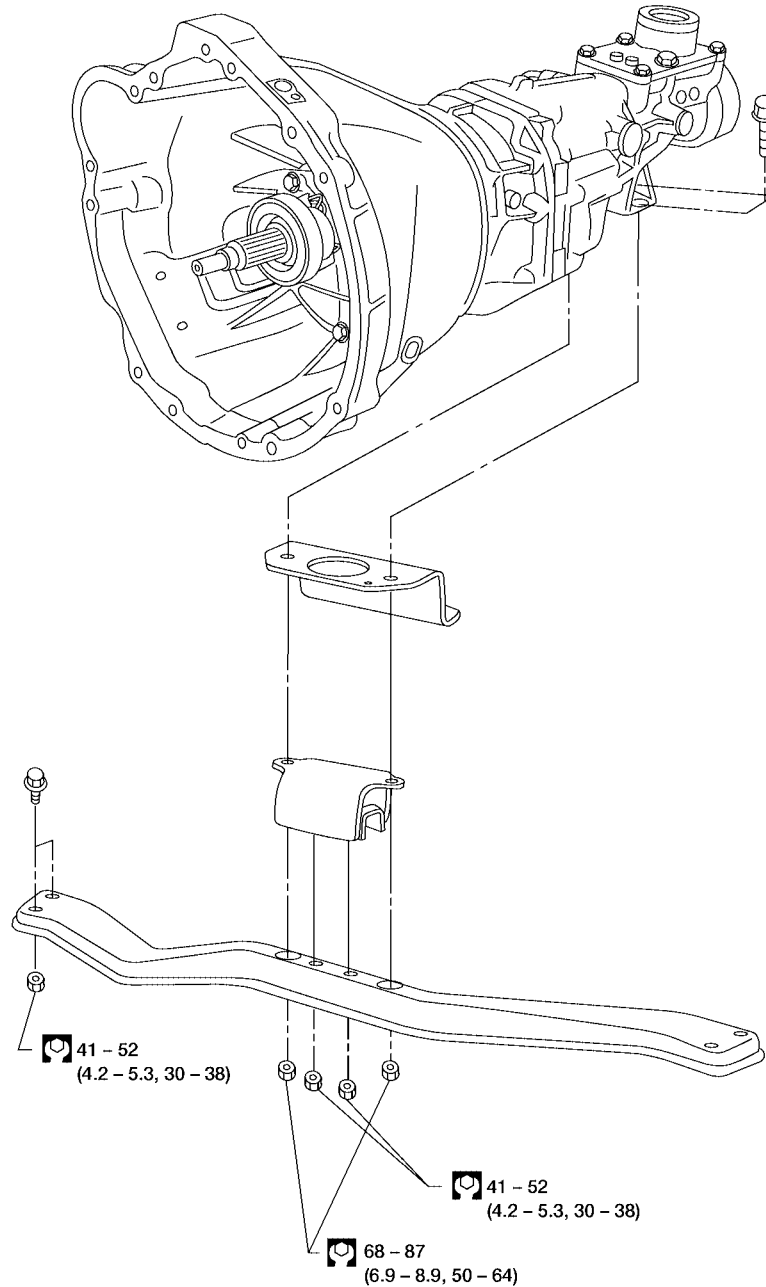

: N·m (kg·m, ft·lb)

WMT030

CAUTION:

Before separating the transmission from the engine, remove the crankshaft position sensor (OBD) from the transmission. Be careful not to damage sensor edge or ring gear teeth.

TRANSMISSION ASSEMBLY

[FS5W71C]

NOTE:

To prevent oil spills, drain transmission oil before removing transmission or insert plug into rear oil seal after removing propeller shaft.

- Be careful not to damage spline, sleeve yoke, and rear oil seal when removing propeller shaft.
1. Remove battery negative terminal.
 2. Remove the crankshaft position sensor (OBD) from transmission upper side.
 3. Remove the clutch operating cylinder from transmission. Refer to [CL-9, "OPERATING CYLINDER"](#) .
 4. Disconnect the vehicle speed sensor, back-up switch, and park/neutral position (PNP) switch harness connectors.
 5. Remove the starter motor. Refer to [SC-25, "Removal"](#) .
 6. Disconnect the exhaust hanger. Refer to [EX-3, "Removal and Installation"](#) .
 7. Remove the propeller shaft. Refer to [PR-8, "Removal and Installation"](#) .
 8. Remove the shift lever.
 9. Support the engine by placing a jack under the oil pan.
 - Do not place jack under oil pan drain plug.
 10. Remove the transmission crossmember.
 11. Separate the transmission from the engine.

WARNING:

Support manual transmission while removing it.

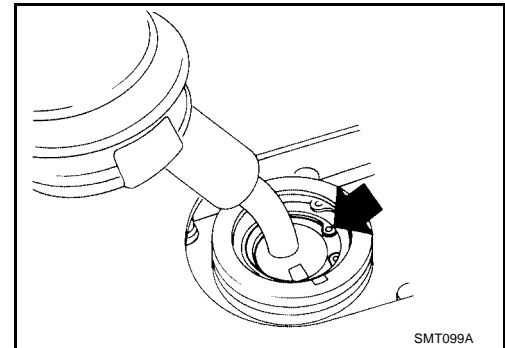

INSTALLATION

1. Tighten transmission bolts.

Bolt No.	Tightening torque N·m (kg·m, ft·lb)	ℓ mm (in)
1	40 - 49 (4.0 - 5.0, 29 - 36)	65 (2.56)
2	40 - 49 (4.0 - 5.0, 29 - 36)	58 (2.28)
3*	16 - 21 (1.6 - 2.2, 12 - 15)	25 (0.98)
4	16 - 21 (1.6 - 2.2, 12 - 15)	16 (0.63)

*: With nut

2. Installation is in the reverse order of removal.

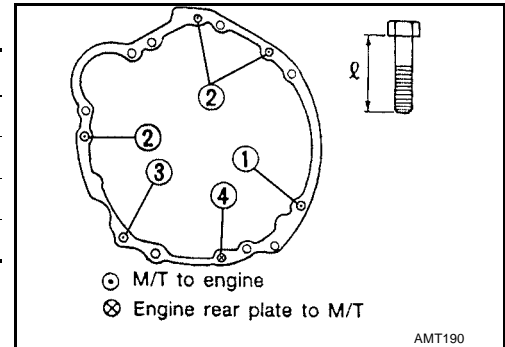

Overhaul CASE COMPONENTS

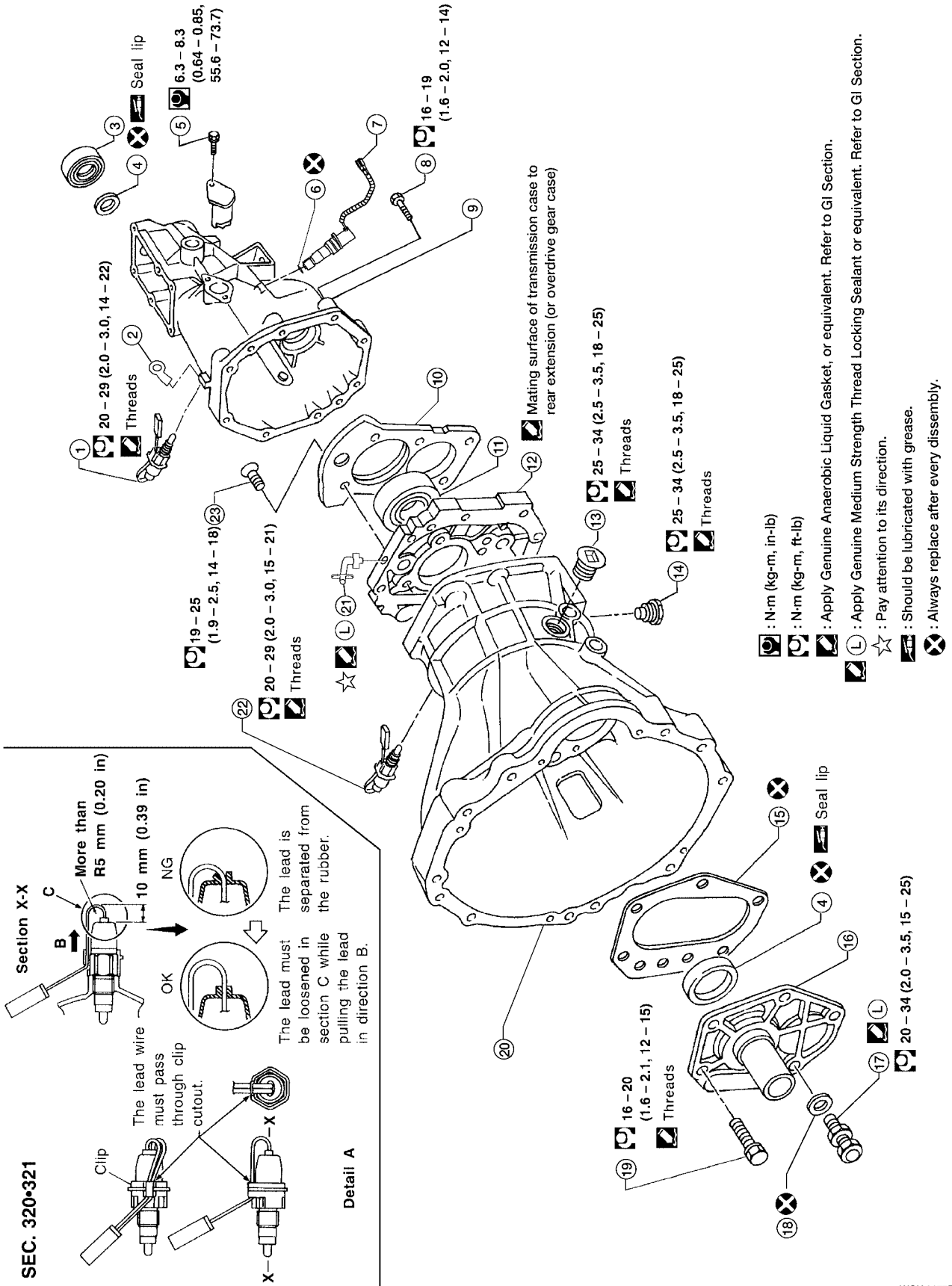

TRANSMISSION ASSEMBLY

[FS5W71C]

-
- | | | |
|---------------------------------------|------------------------------|-------------------|
| 1. Park/neutral position (PNP) switch | 2. Clip | 3. Dust cover |
| 4. Oil Seal | 5. Reverse check sleeve bolt | 6. O-ring |
| 7. Vehicle speed sensor | 8. Rear extension bolts | 9. Rear extension |
| 10. Bearing retainer | 11. Bearing | 12. Adapter plate |
| 13. Filler plug | 14. Drain plug | 15. Gasket |
| 16. Front cover | 17. Ball pin | 18. Washer |
| 19. Front cover bolt | 20. Transmission case | 21. Air breather |
| 22. Back-up lamp switch | | |

A

B

MT

D

E

F

G

H

I

J

K

L

M

TRANSMISSION ASSEMBLY

[FS5W71C]

GEAR COMPONENTS

SEC. 322

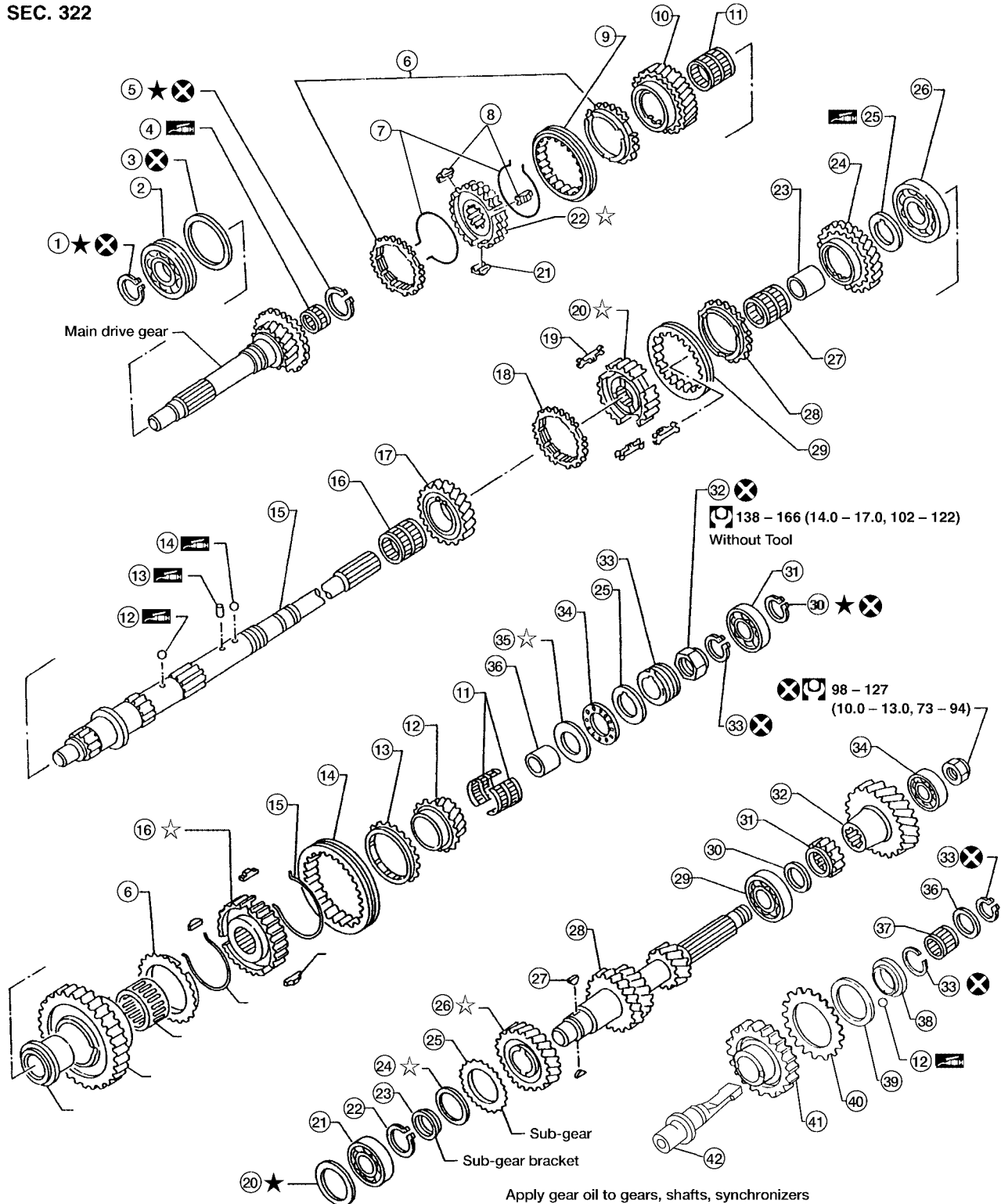

Apply gear oil to gears, shafts, synchronizers and bearings when assembling.

★ : Select proper thickness.

☆ : Pay attention to its direction.

☐ : N-m (kg-m, ft-lb)

☑ : Should be lubricated with grease.

⊗ : Always replace after every disassembly.

WCIA0178E

TRANSMISSION ASSEMBLY

[FS5W71C]

1. Main drive gear ball bearing snap ring	2. Main drive gear ball bearing	3. Snap ring	A
4. Pilot bearing	5. Mainshaft front snap ring	6. Baulk ring	
7. Spread spring	8. Shifting insert	9. 3rd and 4th coupling sleeve	
10. 3rd main gear	11. Needle bearing	12. Steel ball	B
13. Steel roller	14. Steel ball	15. Mainshaft	
16. 2nd main gear needle bearing	17. 2nd main gear	18. 2nd baulk ring	
19. Insert spring	20. 1st and 2nd synchronizer hub	21. Shifting insert	MT
22. 3rd and 4th synchronizer hub	23. 1st gear bushing	24. 1st main gear	
25. 1st gear thrust washer	26. Mainshaft ball bearing	27. Needle bearing	
28. Baulk ring	29. 1st and 2nd coupling sleeve	30. Overdrive mainshaft bearing snap ring	D
31. Overdrive mainshaft bearing	32. Mainshaft lock nut	33. Speedometer drive gear	
34. Counter gear rear end bearing	35. Counter gear lock nut	36. Reverse idler thrust washer	
37. Reverse idler gear bearing	38. Sub-gear bracket	39. Sub-gear spring	E
40. Sub-gear	41. Reverse idler gear	42. Reverse idler shaft	

F

G

H

I

J

K

L

M

TRANSMISSION ASSEMBLY

[FS5W71C]

SHIFT CONTROL COMPONENTS

CAUTION:

To avoid damage when replacing shift knob, remove shift lever with knob, as assembled.

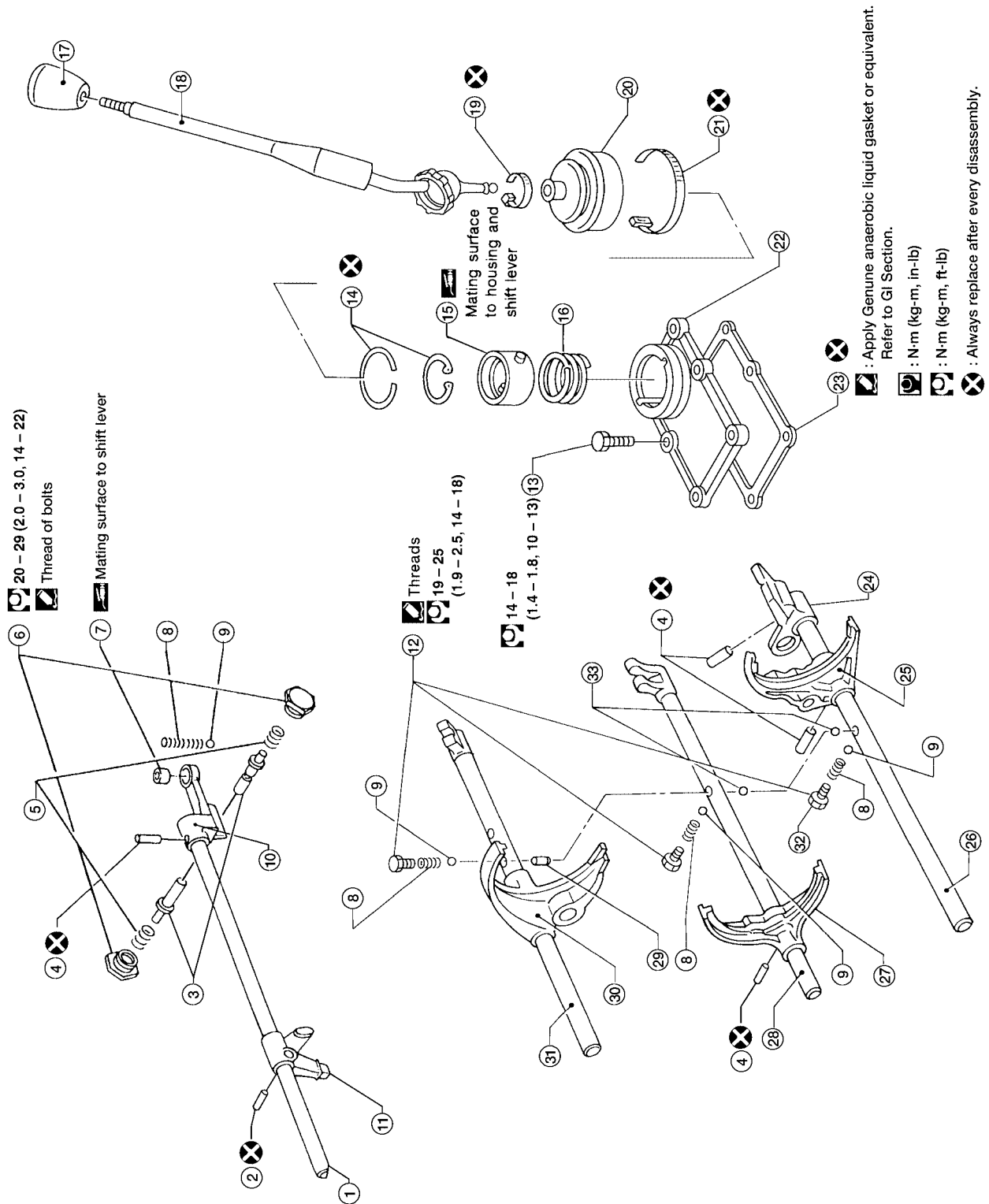

- | | | |
|------------------|---------------------------------|-------------------------|
| 1. Striking rod | 2. Striking lever retaining pin | 3. Select check plunger |
| 4. Retainer pin | 5. Return spring | 6. Select check plug |
| 7. Bushing | 8. Check spring | 9. Check ball |
| 10. Striking arm | 11. Striking lever | 12. Check ball plug |

TRANSMISSION ASSEMBLY

[FS5W71C]

-
- | | | |
|-------------------------------|-----------------------------|----------------------------|
| 13. Control housing bolt | 14. Snap ring | 15. Socket |
| 16. Spring | 17. Shift knob | 18. Shift lever |
| 19. Upper boot retainer | 20. Boot | 21. Lower boot retainer |
| 22. Control housing | 23. Gasket | 24. OD and reverse bracket |
| 25. OD and reverse shift fork | 26. OD and reverse fork rod | 27. 3rd and 4th shift fork |
| 28. 3rd and 4th fork rod | 29. Interlock plunger | 30. 1st and 2nd shift fork |
| 31. 1st and 2nd fork rod | 32. Reverse check plug | 33. Interlock ball |

A

B

MT

D

E

F

G

H

I

J

K

L

M

CASE COMPONENTS

Disassembly

1. Remove rear extension.
 - a. Remove control housing, check spring, check ball, select check plugs, return springs and select check plungers. Also remove reverse check plug, check spring and check ball.
 - **Be careful not to lose check balls.**

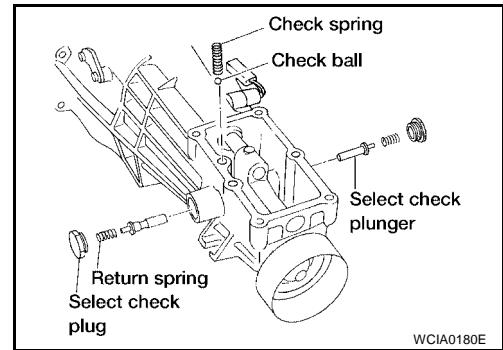

- b. Drive out striking lever retaining pin.
 - c. Remove striking lever from striking rod.
 - d. Remove rear extension by lightly tapping on it.

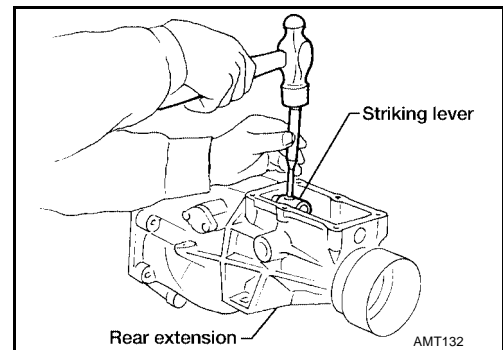

2. Remove front cover, gasket, counter gear front bearing shim and main drive gear ball bearing snap ring.
3. Separate transmission case from adapter plate by lightly tapping on it.

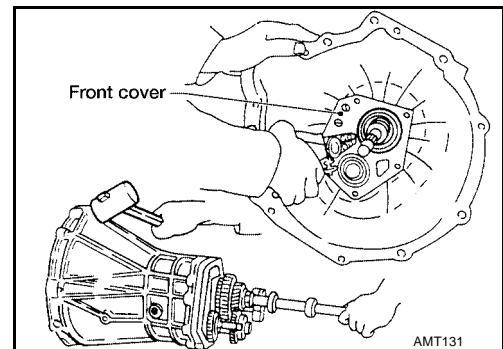

4. Remove oil seal from front cover using a screwdriver.
 - **Be careful not to damage mating surface of front cover.**

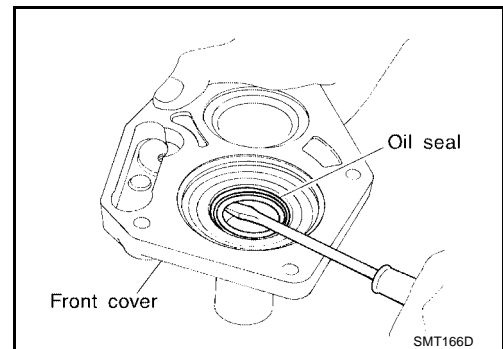

Assembly

1. Install front cover oil seal using Tool.
 - Apply multi-purpose grease to seal lip.

Tool number : ST23800000 (J25691-01)

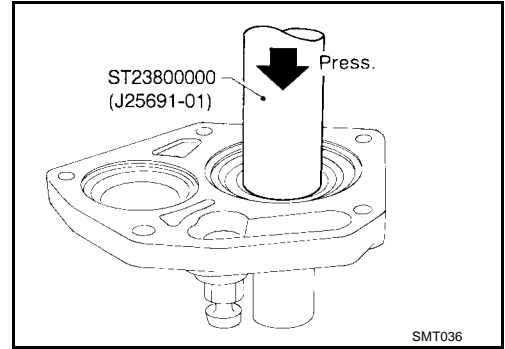

2. Apply sealant to mating surface of transmission case as shown in the figure.

- Use Genuine Anaerobic Liquid Gasket, or equivalent. Refer to [MA-12, "RECOMMENDED FLUIDS AND LUBRICANTS"](#).

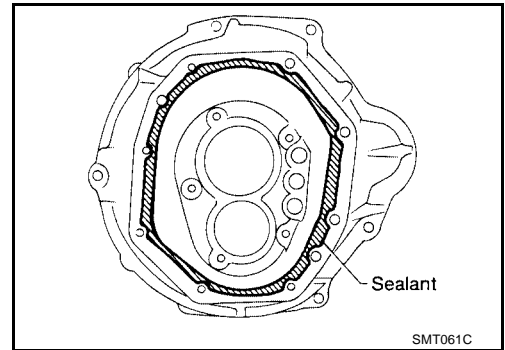

3. Install adapter plate into transmission case by lightly tapping it using a soft hammer.

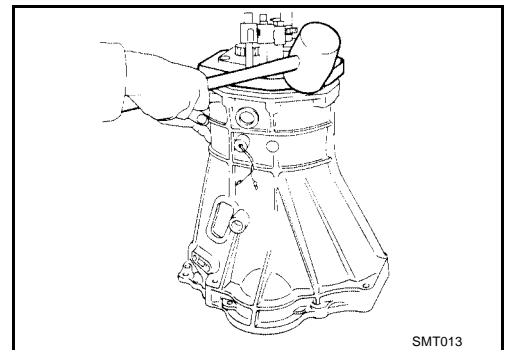

4. Install main drive gear ball bearing snap ring.

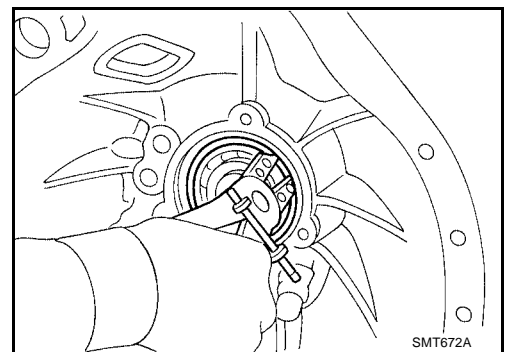

A
B
MT
D
E
F
G
H
I
J
K
L
M

CASE COMPONENTS

[FS5W71C]

5. Apply sealant to mating surface of adapter plate as shown.
- Use Genuine Anaerobic Liquid Gasket, or equivalent. Refer to [MA-12, "RECOMMENDED FLUIDS AND LUBRICANTS"](#).

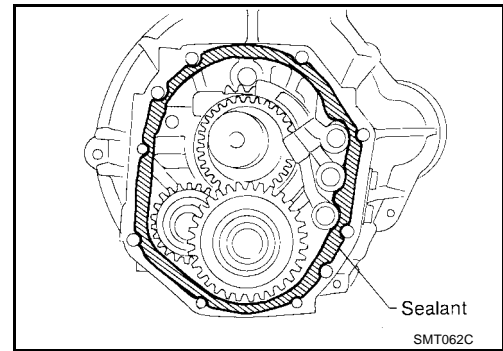

6. Place shift forks in neutral position.
7. Install striking lever and striking rod onto adapter plate and align striking lever with shift brackets.

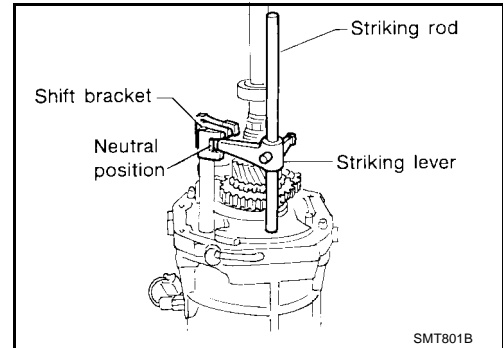

8. Install rear extension.
- Tighten rear extension bolts equally in a crisscross pattern.

Rear extension bolts : 16 - 19 N·m (1.6 - 2.0 kg·m, 12 - 14 ft·lb)

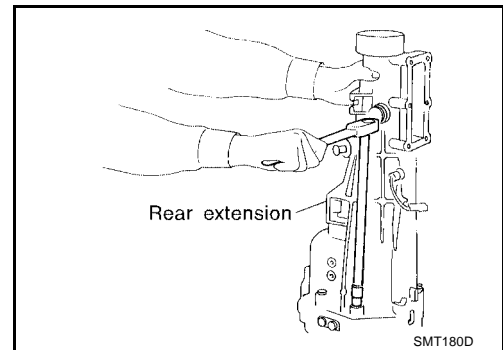

9. Install striking lever retaining pin.

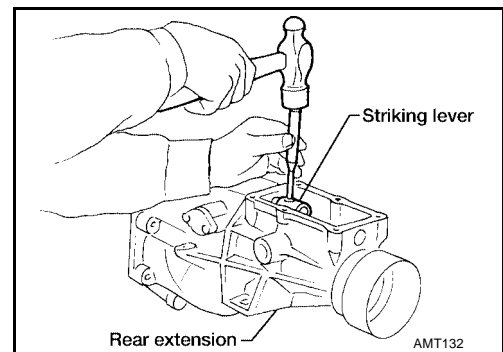

10. Select counter gear front bearing shim. Refer to [MT-37, "COUNTERSHAFT FRONT BEARING SHIM"](#).

Allowable clearance (A) : 0 - 0.16 mm (0 - 0.0063 in) from bearing surface to transmission case

11. Install new gasket and front cover.

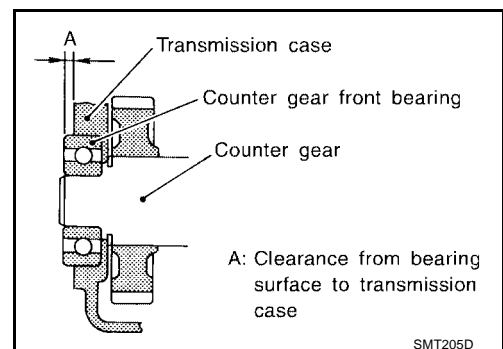

CASE COMPONENTS

[FS5W71C]

12. Apply sealant to front cover bolts. Tighten front cover bolts.

- Use Genuine Anaerobic Liquid Gasket, or equivalent. Refer to [MA-12, "RECOMMENDED FLUIDS AND LUBRICANTS"](#).

Front cover bolts : 16 - 20 N·m (1.6 - 2.1 kg-m, 12 - 15 ft-lb)

13. Install check ball, check spring, select check plungers and return springs.

14. Apply sealant to select check plugs. Tighten select check plugs.

- Use Genuine Anaerobic Liquid Gasket, or equivalent. Refer to [MA-12, "RECOMMENDED FLUIDS AND LUBRICANTS"](#).

Select check plugs : 20 - 29 N·m (2.0 - 3.0 kg-m, 14 - 22 ft-lb)

15. Install control housing and new gasket.

Control housing bolts : 14 - 18 N·m (1.4 - 1.8 kg-m, 10 - 13 ft-lb)

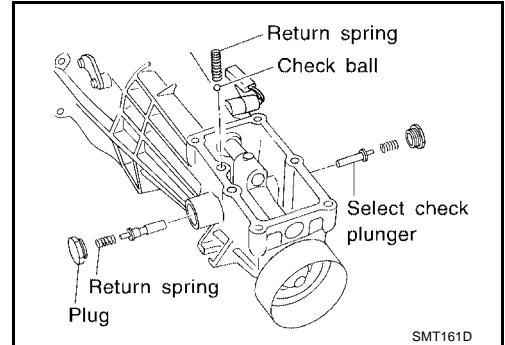

A

B

MT

D

E

F

G

H

I

J

K

L

M

SHIFT CONTROL COMPONENTS

Disassembly

1. Set up Tool on adapter plate.

Tool number : ST23810001 (—)

2. Remove striking rod from adapter plate.
3. Remove check ball plugs, check springs, and check balls.

NOTE:

Mark locations of interlock balls to ensure proper installation.

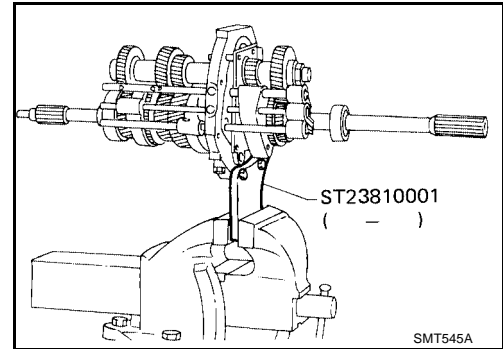

4. Drive out retaining pins. Then drive out fork rods and remove interlock balls.

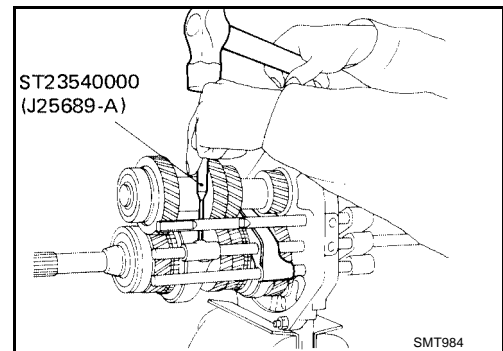

Inspection

- Check contact and sliding surfaces of fork rods for wear, scratches, projections and other damage.

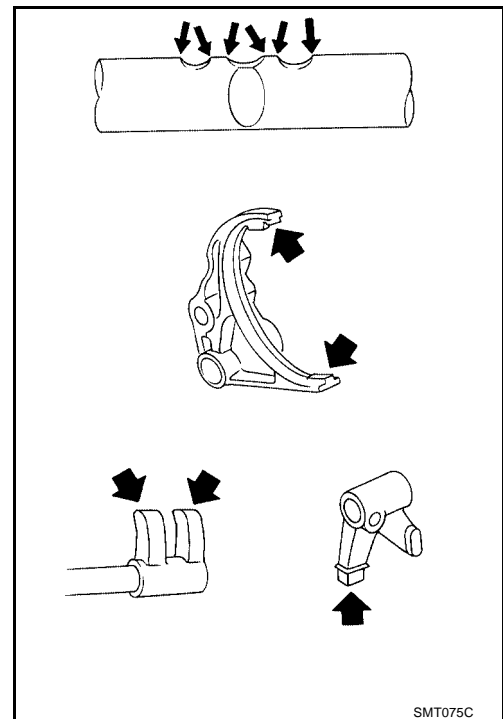

SHIFT CONTROL COMPONENTS

[FS5W71C]

ECS007HL

Assembly

1. Install fork rods, interlock plunger, interlock balls and check balls.

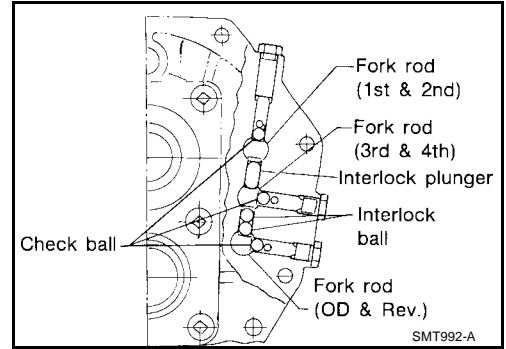

2. Install 1st and 2nd shift fork, then drive in retaining pin.

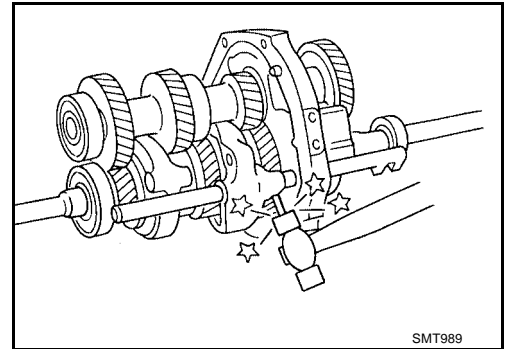

3. Install 3rd and 4th shift fork, then drive in retaining pin.

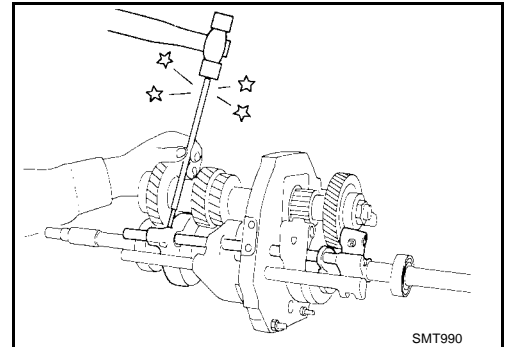

4. Install overdrive and reverse shift fork, then drive in retaining pin.

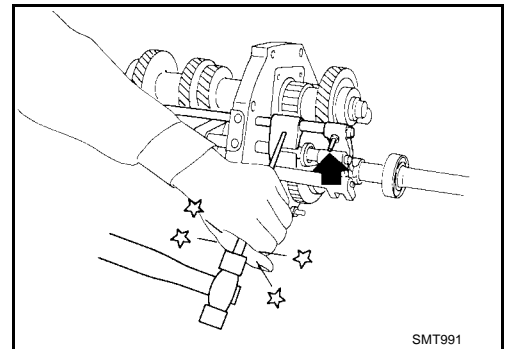

A
B
MT
D
E
F
G
H
I
J
K
L
M

GEAR COMPONENTS

Disassembly

1. Before disassembly, measure the end play of each gear.
 - If end play is not within the specified limit, disassemble and inspect the parts.
 - Replace any part which is worn or damaged. Refer to [MT-35](#). "[Gear End Play](#)".

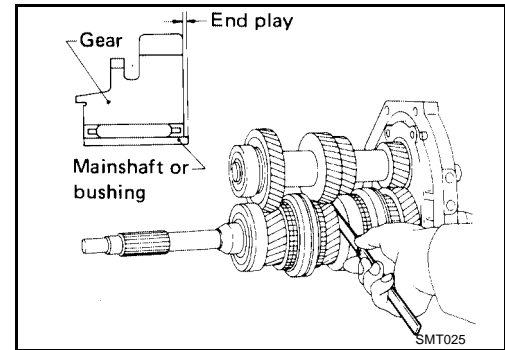

2. Mesh 2nd and reverse gear, then remove counter gear front bearing using a suitable puller.
3. Remove counter gear snap ring, then remove sub-gear bracket, sub-gear spring and sub-gear.

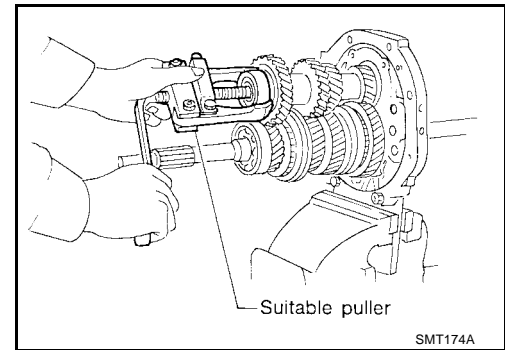

4. Remove counter drive gear together with main drive gear assembly using a suitable puller. Remove woodruff keys and pilot bearing.
 - When removing main drive gear assembly, be careful not to drop pilot bearing or baulk ring.
5. Remove mainshaft front snap ring, then remove 3rd and 4th synchronizer assembly, 3rd main gear and needle bearing using suitable puller.

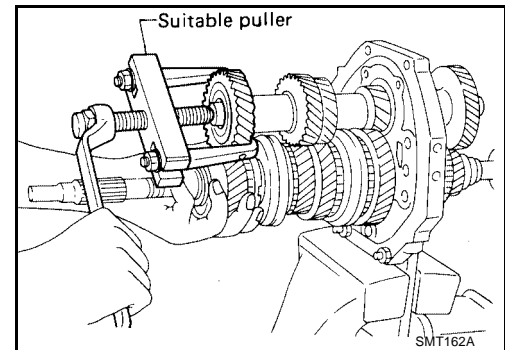

6. Disassemble parts at rear of adapter plate as follows:
 - a. Release staking on both counter gear and mainshaft lock nuts, then loosen both nuts.

Mainshaft lock nut : Left-hand thread

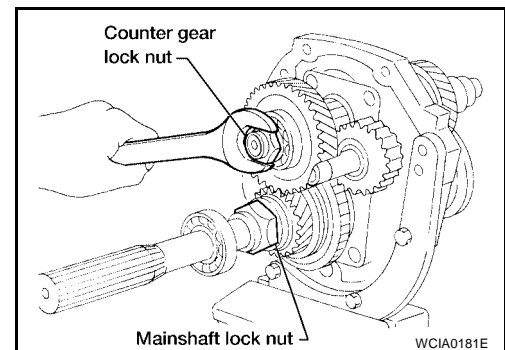

GEAR COMPONENTS

[FS5W71C]

- b. Remove overdrive counter gear together with counter gear rear end bearing using a suitable puller.
- c. Remove reverse counter gear and reverse counter gear spacer.
- d. Remove snap rings from reverse idler shaft, then remove reverse idler gear, sub-gear, sub-gear spring, sub-gear bracket, steel ball, reverse idler thrust washer and reverse idler gear bearing.

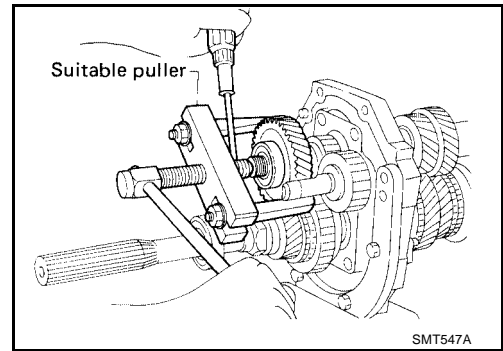

- e. Remove overdrive mainshaft bearing snap ring and pull out overdrive mainshaft bearing using Tool, then remove snap ring.

Tool number : (J-26349-A), (J-25726-B)

- f. Remove mainshaft lock nut.
- g. Remove speedometer drive gear and steel ball.
- h. Remove thrust washer, steel roller, roller bearing and washer.
- i. Remove overdrive main gear, needle bearing and overdrive baulk ring.
- j. Remove counter gear by tapping on rear end of counter gear.
- k. Press out overdrive gear bushing and overdrive & reverse synchronizer assembly.
- l. Remove reverse main gear and needle bearing.
- m. Press out reverse main gear bushing.

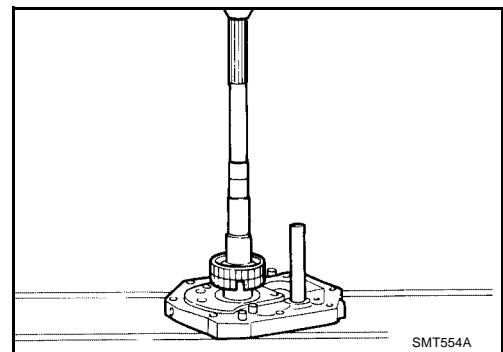

- n. Remove mainshaft by tapping on rear end of mainshaft.
- 7. Remove 1st gear thrust washer, steel ball, 1st main gear and needle bearing and 1st and 2nd synchronizer assembly.
 - Be careful not to lose steel ball.

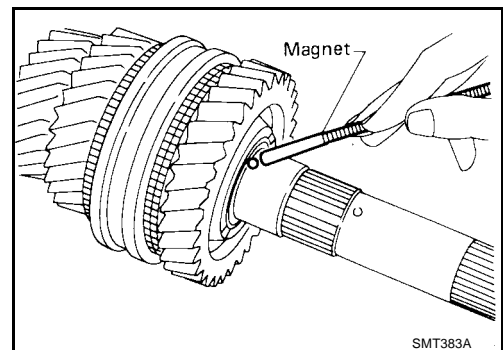

A
B
MT
D
E
F
G
H
I
J
K
L
M

GEAR COMPONENTS

[FS5W71C]

8. Press out 1st gear bushing together with 2nd main gear using Tool.

Tool number : ST30031000 (J22912-01)

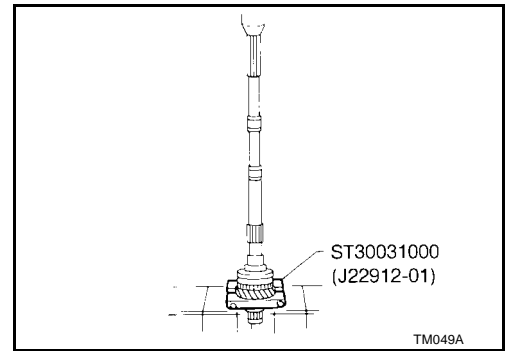

9. Remove 2nd gear needle bearing.
10. Remove main drive gear ball bearing.
a. Remove main drive gear ball bearing snap ring.
b. Remove main drive gear ball bearing using Tool.

Tool number : ST30031000 (J22912-01)

11. Disassemble adapter plate components.
a. Remove bearing retainer.
b. Remove oil gutter
c. Remove reverse idler shaft.
d. Remove mainshaft ball bearing and counter rear bearing using suitable tool.

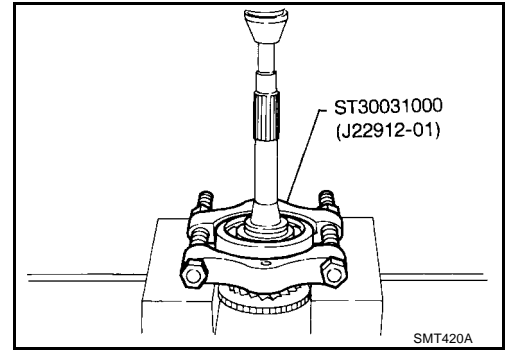

Inspection GEARS AND SHAFTS

- Check shafts for cracks, wear and bending.

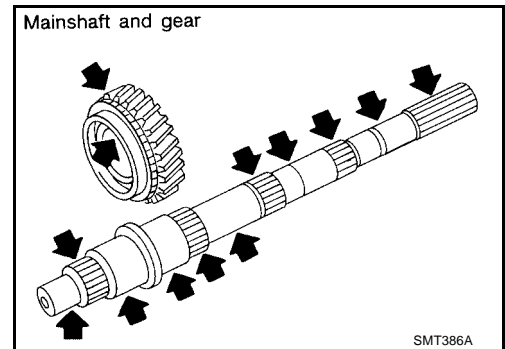

- Check gears for excessive wear, chips and cracks.

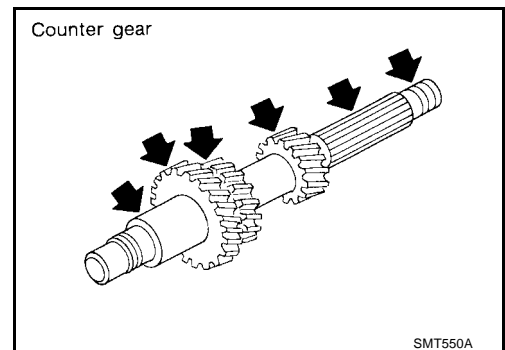

SYNCHRONIZERS

- Check spline portion of coupling sleeves, synchronizer hubs, and gears for wear, chips, and cracks.
- Check baulk rings for cracks and deformation.
- Check shifting inserts for wear and deformation.

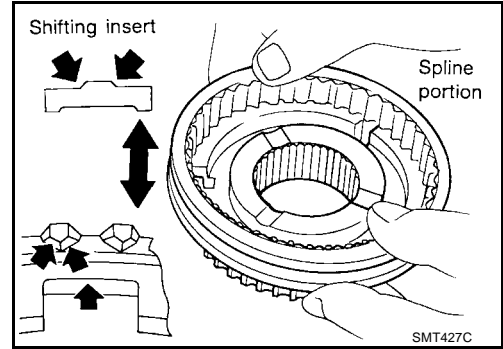

- Check insert spread springs for deformation.
 - Measure baulk ring wear.
1. Measure clearance between baulk ring and gear. Refer to [MT-36, "Clearance Between Baulk Ring and Gear"](#).
 - If the clearance is less than the wear limit, replace baulk ring.

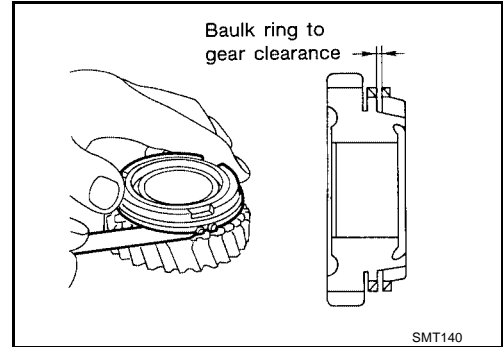

BEARINGS

- Make sure all bearings roll freely and are free from noise, cracks, pitting or wear.

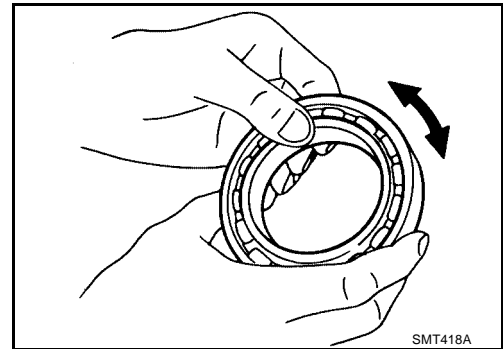

Assembly

1. Install bearings into case components.

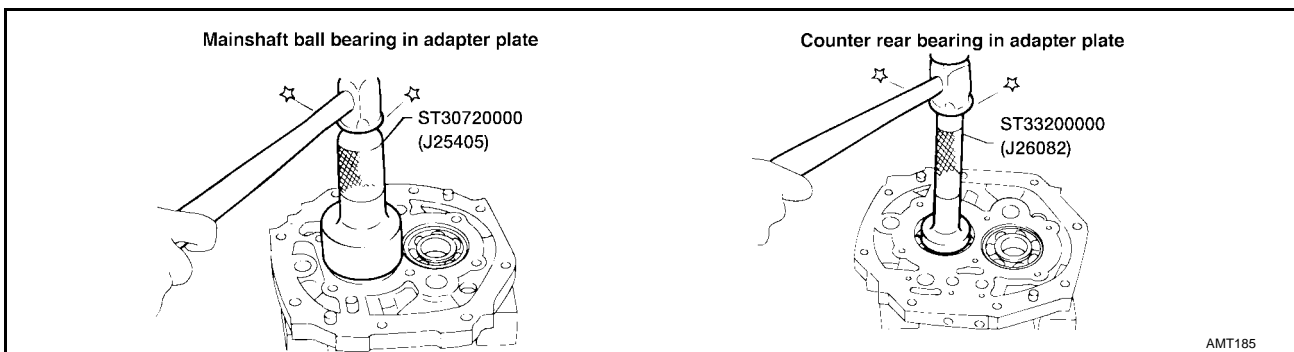

Tool numbers

Mainshaft ball bearing : ST30720000 (J25405)

Counter rear bearing : ST33200000 (J26082)

A
B
MT
D
E
F
G
H
I
J
K
L
M

GEAR COMPONENTS

[FS5W71C]

2. Assemble adapter plate parts.
 - a. Install oil gutter on adapter plate and expand on rear side.
 - b. Insert reverse idler shaft, then install bearing retainer.

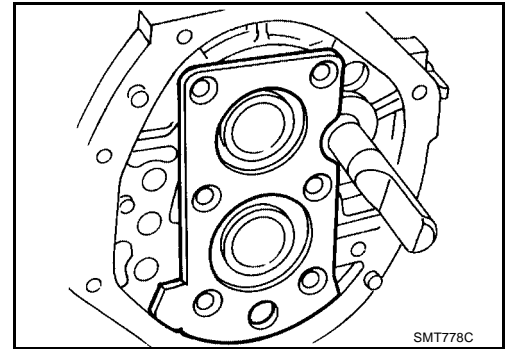

- c. Tighten bearing retainer screws, then stake each one at two points.

Bearing retainer screws : 19 - 25 (1.9 - 2.5 kg-m, 14 - 18 lb-ft)

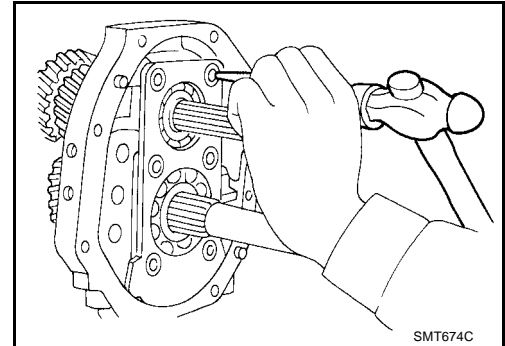

3. Install main drive gear ball bearing.
 - a. Press main drive gear ball bearing using Tool.

Tool number : ST30613000 (J25742-3)

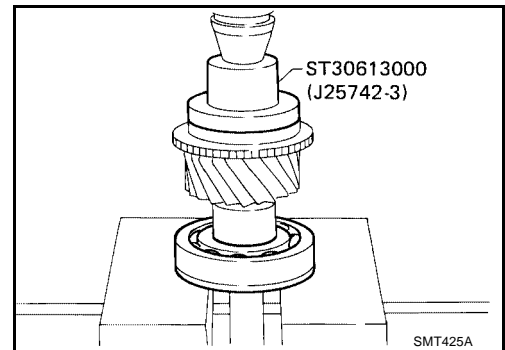

- b. Select and install proper main drive ball bearing gear snap ring to achieve proper clearance of groove. Refer to [MT-36, "MAIN DRIVE GEAR BALL BEARING SNAP RING"](#).

Main drive ball bearing gear snap ring groove allowable clearance : 0 - 0.13 mm (0 - 0.0051 in)

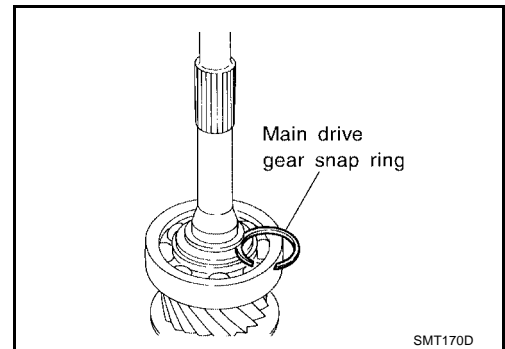

4. Assemble synchronizers.
 - Assemble the 1st and 2nd synchronizer.

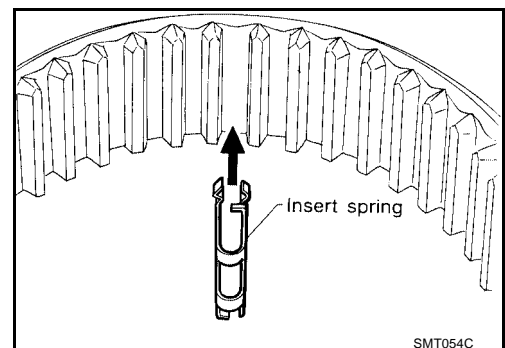

GEAR COMPONENTS

[FS5W71C]

- Check coupling sleeve and synchronizer hub orientation.

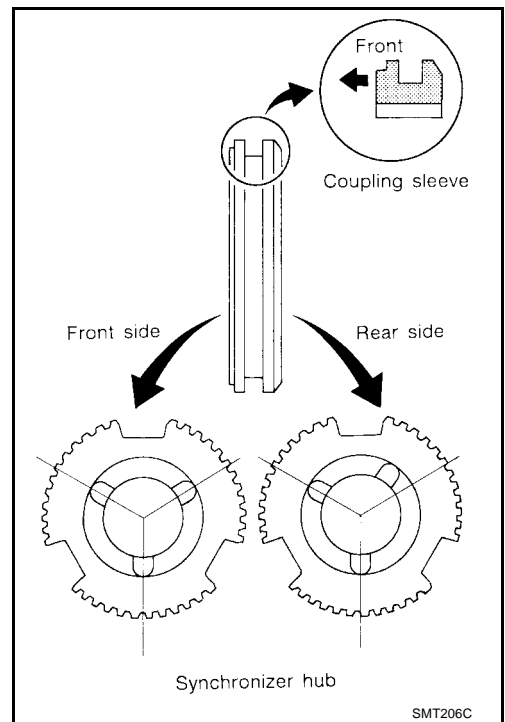

- Assemble the 3rd and 4th synchronizer.

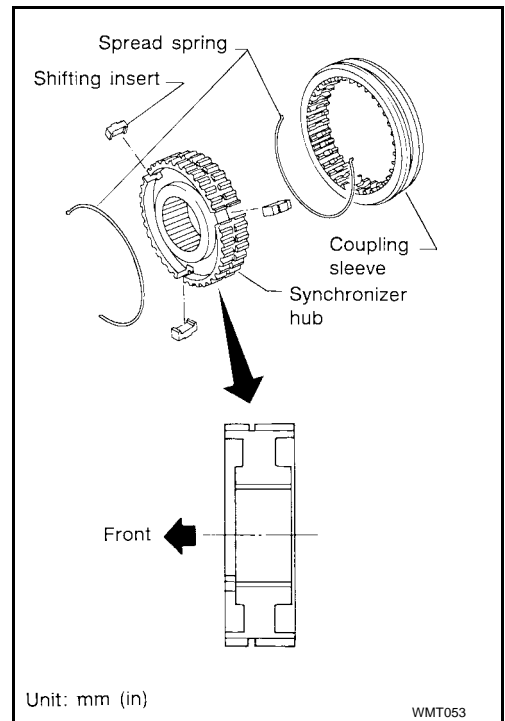

A
B
MT
D
E
F
G
H
I
J
K
L
M

GEAR COMPONENTS

[FS5W71C]

- Assemble the overdrive and reverse synchronizer.

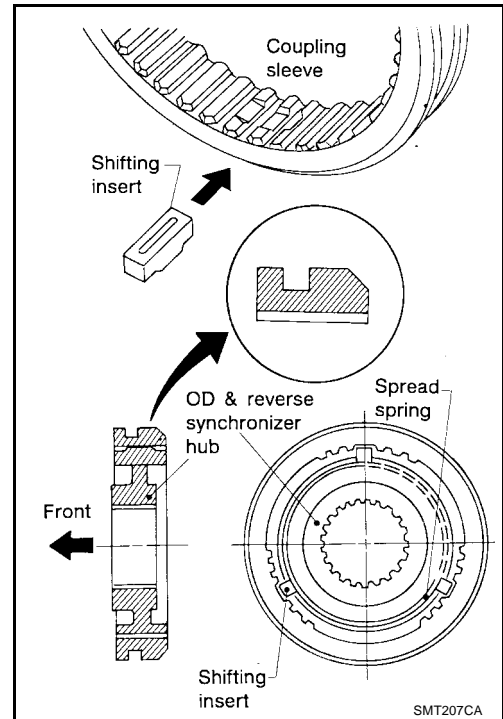

5. Assemble front side components to mainshaft.

- Install 2nd main gear, 2nd main gear needle bearing and 1st and 2nd synchronizer assembly; then press 1st gear bushing onto the mainshaft.
- Install 1st main gear.

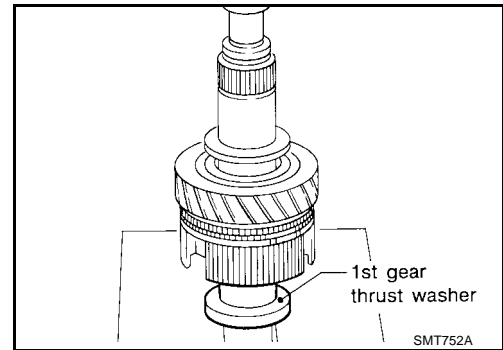

- c. Install steel ball and 1st gear thrust washer.

- Before installation, apply multi-purpose grease to steel ball and to both sides of the 1st gear thrust washer.

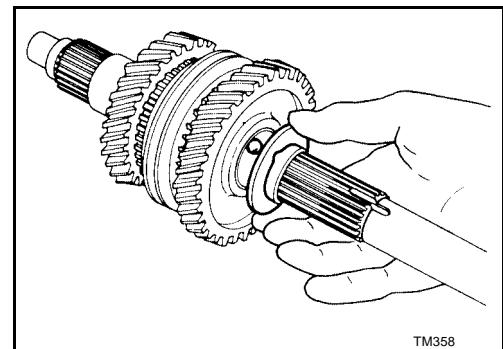

6. Install mainshaft and counter gear on adapter plate and main drive gear on mainshaft as follows:

- Press mainshaft assembly into adapter plate using Tool.

Tool number : KV31100401 (—)

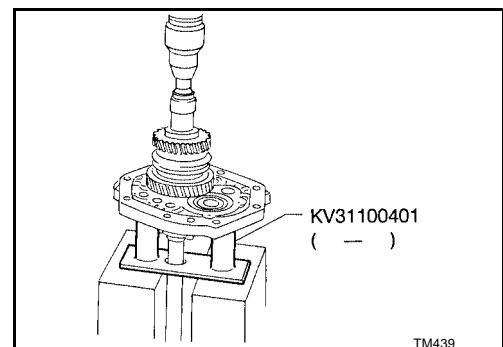

GEAR COMPONENTS

[FS5W71C]

b. Press counter gear into adapter plate using Tool.

Tool number : ST33200000 (J26082), KV31100401 (—)

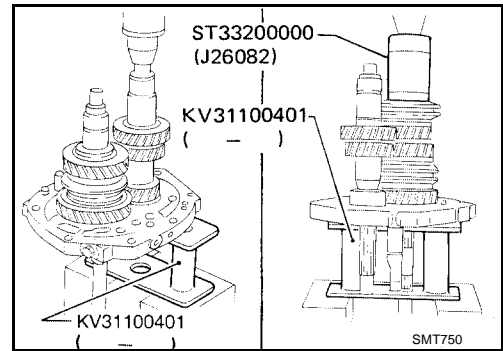

c. Install 3rd main gear and needle bearing, then press 3rd and 4th synchronizer assembly onto mainshaft.

- Pay attention to the direction of 3rd and 4th synchronizer.

d. Install mainshaft front snap ring.

Select proper front mainshaft snap ring to achieve proper clearance of groove. Refer to [MT-36, "MAINSHAFT FRONT SNAP RING"](#).

Mainshaft front snap ring groove allowable clearance : 0 - 0.13 mm (0 - 0.0051 in)

e. Apply gear oil to mainshaft pilot bearing and install it on mainshaft.

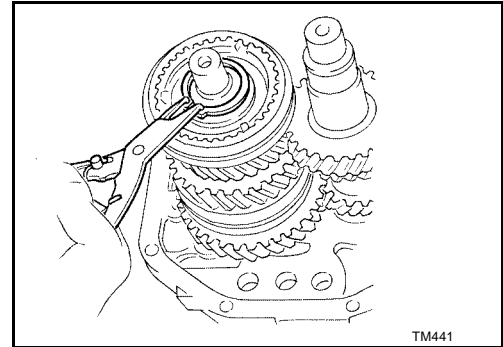

f. Press counter drive gear together with main drive gear using Tool.

- Pay attention to the direction of counter drive gear.

Tool numbers : ST23860000 (—), KV31100401 (—)

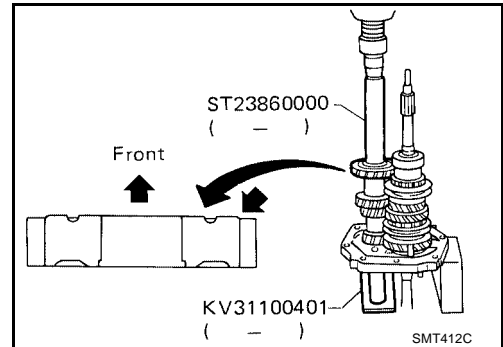

g. Install sub-gear and sub-gear bracket on counter drive gear and then select proper counter gear snap ring that will minimize clearance of groove in counter gear.

- Do not install sub-gear spring at this time. Refer to [MT-36, "COUNTER DRIVE GEAR SNAP RING"](#).

Counter gear snap ring groove allowable clearance : 0 - 0.13 mm (0 - 0.0051 in)

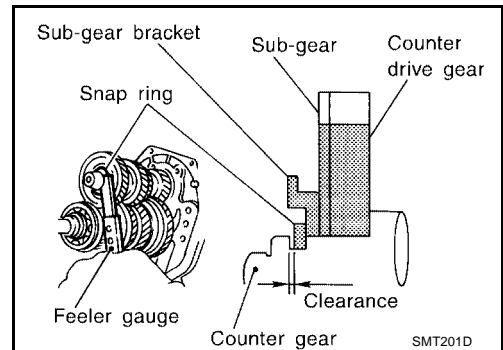

GEAR COMPONENTS

[FS5W71C]

- h. Remove snap ring, sub-gear bracket and sub-gear from counter gear.
- i. Reinstall sub-gear, sub-gear spring, sub-gear bracket and selected counter gear snap ring.

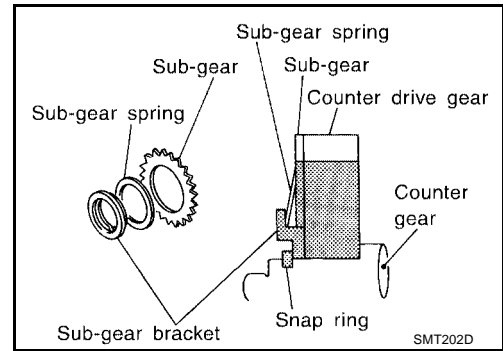

- j. Press counter gear front bearing onto counter gear using Tool.

**Tool number : ST22360002 (J25679-01),
KV31100401 (—)**

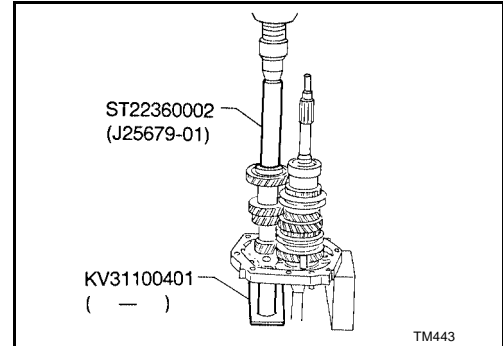

- 7. Install rear side components on mainshaft and counter gear as follows:

- a. Install sub-gear, sub-gear spring, sub-gear bracket, steel ball and snap ring on the reverse idler gear.
- b. Install reverse idler gear assembly, reverse idler thrust washer, snap ring and reverse idler gear bearing on the reverse idler shaft.

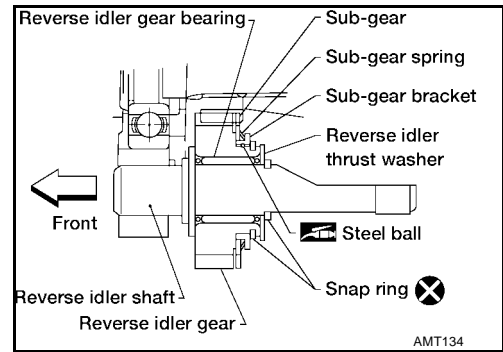

- c. Install reverse main gear bushing, needle bearing, reverse main gear and overdrive and reverse synchronizer to mainshaft.

● **Pay attention to the direction of synchronizer hub.**

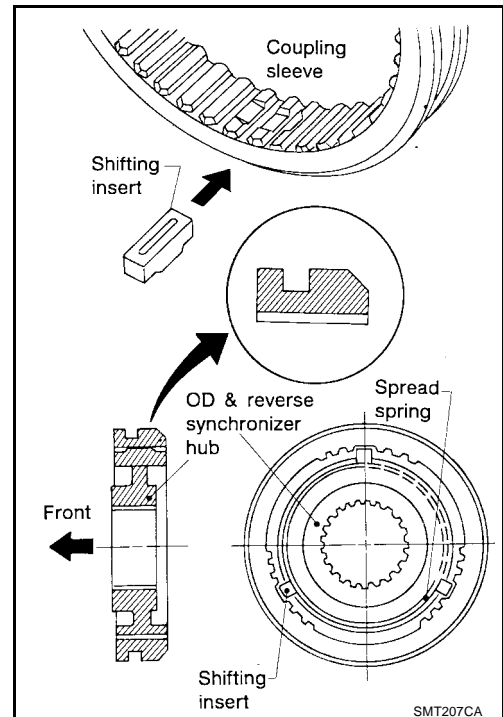

GEAR COMPONENTS

[FS5W71C]

d. Install overdrive gear bushing to mainshaft using Tool.

Tool number : ST22350000 (J25678-01)

- e. Install overdrive main gear and needle bearing to mainshaft.
- f. Install reverse counter gear spacer, reverse counter gear and overdrive counter gear to counter gear.
 - OD main gear and OD counter gear should be handled as a matched set.
- g. Install washer, roller bearing, steel roller and thrust washer.
- h. Install steel ball and speedometer drive gear.
- i. Tighten mainshaft lock nut temporarily.
 - Always use new mainshaft lock nut.

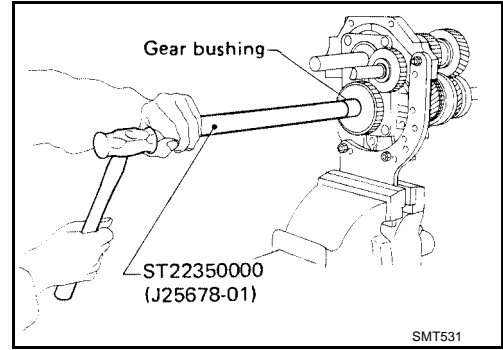

j. Install counter gear rear end bearing using Tool.

Tool number : ST22360002 (J25679-01)

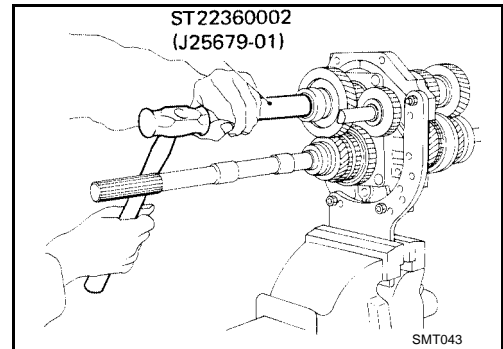

8. Mesh 2nd and reverse gears, then tighten mainshaft lock nut using Tool.

- Always use new mainshaft lock nut.

Mainshaft lock nut : 138 - 166 N-m (14.0 - 17.0 kg-m, 102 - 122 ft-lb)

Tool number : ST22520000 (J26348)

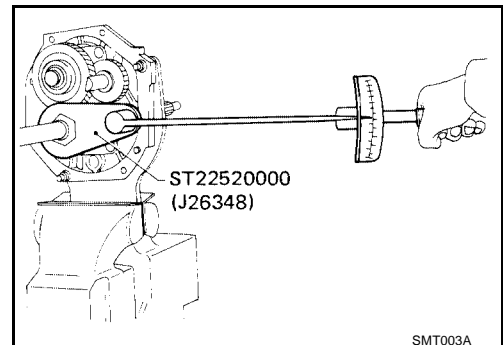

- Use the chart shown to determine the proper reading torque. (Length of torque wrench vs. setting or reading torque)
Reference: Formula to convert torque wrench indication to the true torque value:
 $T = (0.1 \text{ m (0.33 ft)} + L) / L \times C$
If the specified torque is T kg-m (ft-lb), the torque wrench scale indication C is determined using the following formula.
 $C = (T \times L) / (0.1 \text{ m (0.33 ft)} + L)$

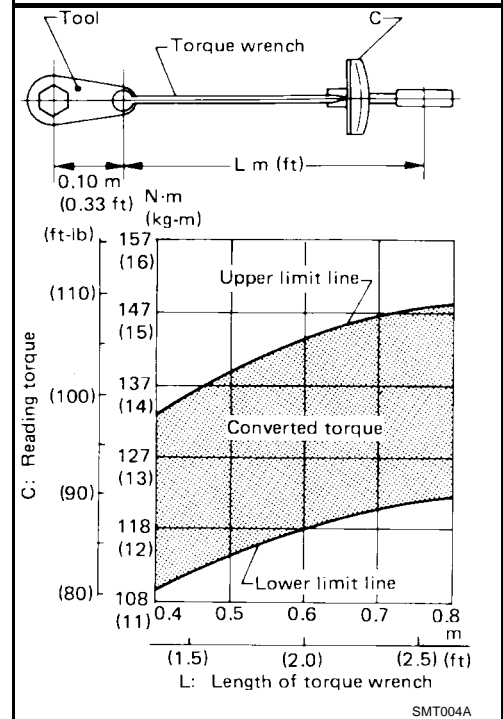

9. Tighten counter gear lock nut.
 - Always use new lock nut.

Counter gear lock nut : 98 - 127 N·m (10.0 - 13.0 kg-m, 73 - 94 ft-lb)

10. Stake mainshaft lock nut and counter gear lock nut using a punch.

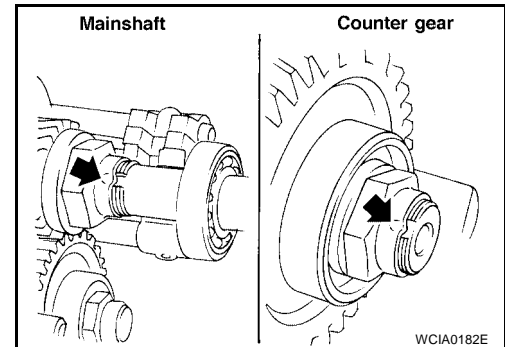

11. Measure the end play of each gear.
12. Install snap ring and press on OD mainshaft bearing using Tool, then install snap ring. Refer to [MT-37, "OD MAINSHAFT BEARING SNAP RING"](#).

OD mainshaft bearing snap ring groove allowable clearance : 0 - 0.14 mm (0 - 0.0055 in)

Tool number : (J-26349-A), (J-25726-B)

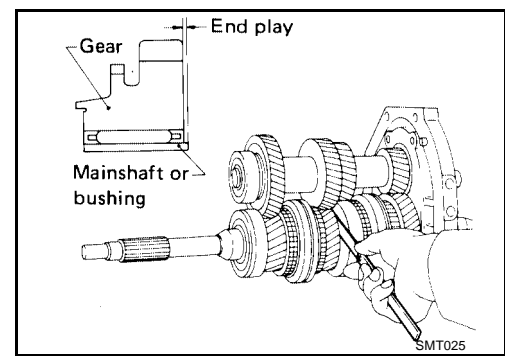

SERVICE DATA AND SPECIFICATIONS (SDS)

[FS5W71C]

SERVICE DATA AND SPECIFICATIONS (SDS)

PF0:00030

General Specifications

ECS007HP

Applied model	KA24DE
	2WD
Transmission	FS5W71C
Number of speed	5

Shift pattern

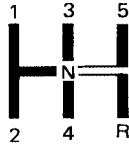

MT-SDS-2

Synchromesh type		Warner
Gear ratio	1st	3.321
	2nd	1.902
	3rd	1.308
	4th	1.000
	OD	0.838
	Reverse	3.382
Mainshaft (Number of teeth)	Drive	22
	1st	33
	2nd	27
	3rd	26
	OD	22
	Reverse	36
Countershaft gear (Number of teeth)	Drive	31
	1st	14
	2nd	20
	3rd	28
	OD	37
	Reverse	15
Reverse idler gear (Number of teeth)		21
Oil capacity ℓ (US pt, Imp pt)		2.0 (4-1/4, 3-1/2)
Remarks	Reverse synchronizer	Installed
	Sub gear	Counter drive gear and reverse idler gear

Gear End Play

ECS007HQ

Unit: mm (in)

1st gear	0.31 - 0.41 (0.0122 - 0.0161)
2nd gear	0.11 - 0.21 (0.0044 - 0.0083)
3rd gear	0.11 - 0.21 (0.0044 - 0.0083)
Overdrive gear	0.24 - 0.41 (0.0095 - 0.0161)

SERVICE DATA AND SPECIFICATIONS (SDS)

[FS5W71C]

Clearance Between Baulk Ring and Gear

ECS007HR

Unit: mm (in)

Standard	1st & 2nd	1.20 - 1.60 (0.0473 - 0.0629)
	3rd & main drive	1.20 - 1.60 (0.0473 - 0.0629)
	Overdrive	1.20 - 1.60 (0.0473 - 0.0629)
	Reverse	1.10 - 1.55 (0.0433 - 0.0610)
Wear limit	1st & 2nd	0.80 (0.0315)
	3rd & main drive	0.80 (0.0315)
	Overdrive	0.80 (0.0315)
	Reverse	0.70 (0.0276)

2ND & 3RD BAULK RING

Unit: mm (in)

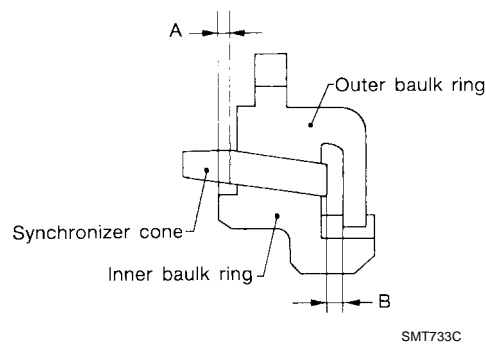

Dimension	Standard	Wear limit
A	0.7 - 0.9 (0.028 - 0.035)	0.2 (0.008)
B	0.6 - 1.1 (0.024 - 0.043)	

Available Snap Rings MAIN DRIVE GEAR BALL BEARING SNAP RING

ECS007HS

Unit: mm (in)

Main drive gear ball bearing snap ring groove allowable clearance 0 - 0.13 (0 - 0.0051)	
Thickness	Part number*
1.87 (0.0736)	32204-78001
1.94 (0.0764)	32204-78002
2.01 (0.0791)	32204-78003

*Always check with the Parts Department for the latest parts information.

MAINSHAFT FRONT SNAP RING

Unit: mm (in)

Mainshaft front snap ring groove allowable clearance 0 - 0.18 (0 - 0.0071)	
Thickness	Part number*
2.4 (0.094)	32263-V5200
2.5 (0.098)	32263-V5201

*Always check with the Parts Department for the latest parts information.

COUNTER DRIVE GEAR SNAP RING

Unit: mm (in)

Counter gear snap ring groove allowable clearance 0 - 0.13 (0 - 0.0051)	
Thickness	Part number*
1.4 (0.055)	32215-E9000

SERVICE DATA AND SPECIFICATIONS (SDS)

[FS5W71C]

1.5 (0.059)	32215-E9001
1.6 (0.063)	32215-E9002

*Always check with the Parts Department for the latest parts information.

OD MAINSHAFT BEARING SNAP RING

Unit: mm (in)

OD mainshaft bearing snap ring groove allowable clearance 0 - 0.14 (0 - 0.0055)	
Thickness	Part number*
1.1 (0.043)	32228-20100
1.2 (0.047)	32228-20101
1.3 (0.051)	32228-20102
1.4 (0.055)	32228-20103

*Always check with the Parts Department for the latest parts information.

Available Shims COUNTERSHAFT FRONT BEARING SHIM

ECS007HT

Unit: mm (in)

Allowable clearance "A" from bearing surface to transmission case 0 - 0.16 (0 - 0.0063)

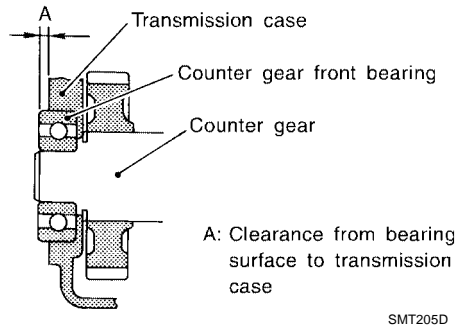

"A"	Thickness of shim	Part number*
4.52 - 4.71 (0.1780 - 0.1854)	Not necessary	
4.42 - 4.51 (0.1741 - 0.1775)	0.1 (0.004)	32218-V5000
4.32 - 4.41 (0.1701 - 0.1736)	0.2 (0.008)	32218-V5001
4.22 - 4.31 (0.1662 - 0.1691)	0.3 (0.012)	32218-V5002
4.12 - 4.21 (0.1622 - 0.1657)	0.4 (0.016)	32218-V5003
4.02 - 4.11 (0.1583 - 0.1618)	0.5 (0.020)	32218-V5004
3.92 - 4.01 (0.1544 - 0.1578)	0.6 (0.024)	32218-V5005

*Always check with the Parts Department for the latest parts information.

PREPARATION

[FS5R30A]

PREPARATION

PFP:00002

Special Service Tools

ECS007HU

The actual shapes of Kent-Moore tools may differ from those of special service tools illustrated here.

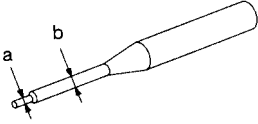
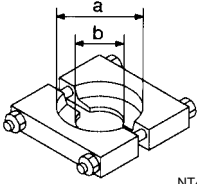
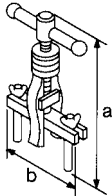
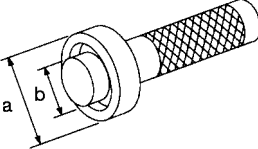
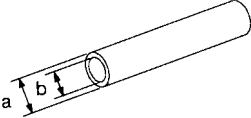
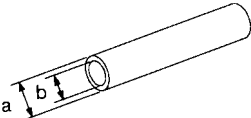
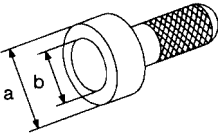
Tool number (Kent-Moore No.) Tool name	Description
ST23540000 (J25689-A) Pin punch	Removing and installing retaining pin a: 2.3 mm (0.091 in) dia. b: 4 mm (0.16 in) dia.
 <p style="text-align: center;">NT442</p>	
ST30031000 (J22912-01) Puller	Removing 1st & 2nd synchronizer assembly Removing counter gear rear thrust bearing Removing main drive bearing Inspecting baulk ring wear a: 90 mm (3.54 in) dia. b: 50 mm (1.97 in) dia.
 <p style="text-align: center;">NT411</p>	
ST33290001 (J34286) Puller	Removing rear oil seal a: 250 mm (9.84 in) b: 160 mm (6.30 in)
 <p style="text-align: center;">NT414</p>	
ST33230000 (—) Drift	Removing mainshaft and counter gear a: 51 mm (2.01 in) dia. b: 28.5 mm (1.122 in) dia.
 <p style="text-align: center;">NT084</p>	
ST22350000 (J25678-01) Drift	Removing counter gear front bearing (Use with KV38100300) a: 34 mm (1.34 in) dia. b: 28 mm (1.10 in) dia.
 <p style="text-align: center;">NT065</p>	
KV38100300 (J25523) Drift	Removing counter gear front bearing (Use with ST22350000) Installing counter gear rear bearing a: 54 mm (2.13 in) dia. b: 32 mm (1.26 in) dia.
 <p style="text-align: center;">NT065</p>	
ST30720000 1 (J34286) 2 (J34331) Drift	1 Removing mainshaft front bearing 2 Installing mainshaft front bearing a: 77 mm (3.03 in) dia. b: 55.5 mm (2.185 in) dia.
 <p style="text-align: center;">NT115</p>	

PREPARATION

[FS5R30A]

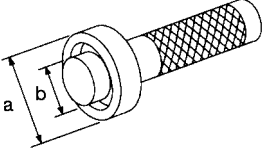
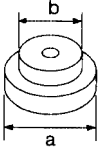
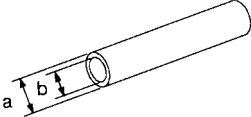
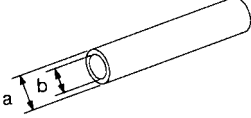
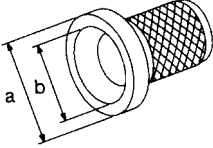
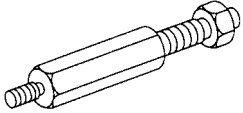
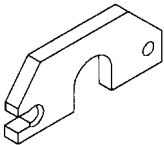
Tool number (Kent-Moore No.) Tool name	Description	
ST33210000 1 (J25523) 2 (J25803-01) Drift	 <p>1 Installing counter gear front bearing 2 Installing front cover oil seal a: 44 mm (1.73 in) dia. b: 24.5 mm (0.965 in) dia.</p>	A B MT
ST30613000 (J25742-3) Drift	 <p>Installing main drive gear bearing a: 72 mm (2.83 in) dia. b: 48 mm (1.89 in) dia.</p>	D E
ST37750000 1 (J34286) 2 (J34332) 3 (J34334) 4 (J25679-01) Drift	 <p>1 Removing counter gear rear bearing 2 Installing OD gear bushing 2 Removing and installing mainshaft rear bearing (4WD model) 2 Installing reverse cone 3 Installing reverse counter gear 4 Installing counter gear rear end bearing a: 40 mm (1.57 in) dia. b: 31 mm (1.22 in) dia.</p>	F G H
ST22452000 (J34337) Drift	 <p>Installing reverse synchronizer hub Installing mainshaft rear bearing (2WD model) a: 45 mm (1.77 in) dia. b: 36 mm (1.42 in) dia.</p>	I J
ST33400001 (J26082) Drift	 <p>Installing rear oil seal a: 60 mm (2.36 in) dia. b: 47 mm (1.85 in) dia.</p>	K L
(J26349-3) Puller leg	 <p>Installing mainshaft and counter gear (Use with J34328)</p>	M
(J34328) Puller	 <p>Installing mainshaft and counter gear (Use with J26349-3)</p>	

PREPARATION

[FS5R30A]

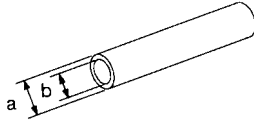
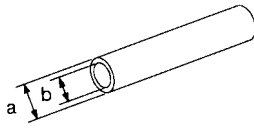
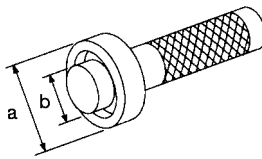
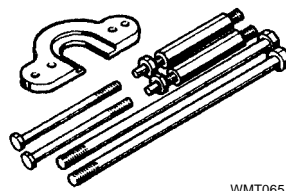
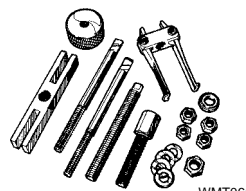
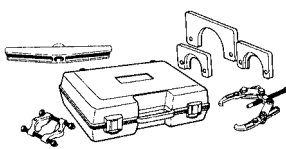
Tool number (Kent-Moore No.) Tool name		Description
(J26092) Drift		Installing sub-gear snap ring a: 44.5 mm (1.752 in) dia. b: 38.5 mm (1.516 in) dia.
(J34342) Drift		Installing OD main gear Installing reverse gear bushing a: 44.5 mm (1.752 in) dia. b: 40.5 mm (1.594 in) dia.
ST33220000 (J25804-01) Drift		Installing mainshaft rear bearing a: 37 mm (1.46 in) dia. b: 22 mm (0.87 in) dia.
(J-26349-A) Bearing Remover and Installer Set		Removing and installing mainshaft bearing (Use with J-25726-B)
(J-34286) Rear Race Puller		Removing races
(J-39856) Gear and Bearing Removal Kit		Removing gears and bearings

Commercial Service Tool

ECS007HV

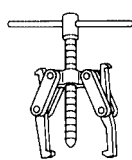
Tool name		Description
Puller		Removing counter gear rear end bearing Removing mainshaft rear bearing (2WD model) Removing reverse synchronizer hub Removing reverse counter gear

NOISE, VIBRATION, AND HARSHNESS (NVH) TROUBLESHOOTING

[FS5R30A]

NOISE, VIBRATION, AND HARSHNESS (NVH) TROUBLESHOOTING

PFP:00003

NVH Troubleshooting Chart

ECS007HW

Use the chart below to help you find the cause of the problem. The numbers indicate the order of the inspection. If necessary, repair or replace these parts.

Reference page	<u>MA-36</u>			<u>MT-59</u>			<u>MT-63</u>			<u>MT-65</u>		
SUSPECTED PARTS (Possible cause)	OIL (Level low)	OIL (Wrong)	OIL (Level too high)	GASKET (Damaged)	OIL SEAL (Worn or damaged)	O-RING (Worn or damaged)	CHECK PLUG RETURN SPRING AND CHECK BALL (Worn or damaged)	SHIFT FORK (Worn)	GEAR (Worn or damaged)	BEARING (Worn or damaged)	BAULK RING (Worn or damaged)	INSERT SPRING (Damaged)
Symptom	Noise	1	2						3	3		
	Oil leakage		3	1	2	2						
	Hard to shift or will not shift		1	1							2	2
	Jumps out of gear							1	2	2		

A
B
C
D
E
F
G
H
I
J
K
L
M

MT

DESCRIPTION

[FS5R30A]

DESCRIPTION

PFP:00000

Description CROSS-SECTIONAL VIEW — 2WD MODEL

ECS007HX

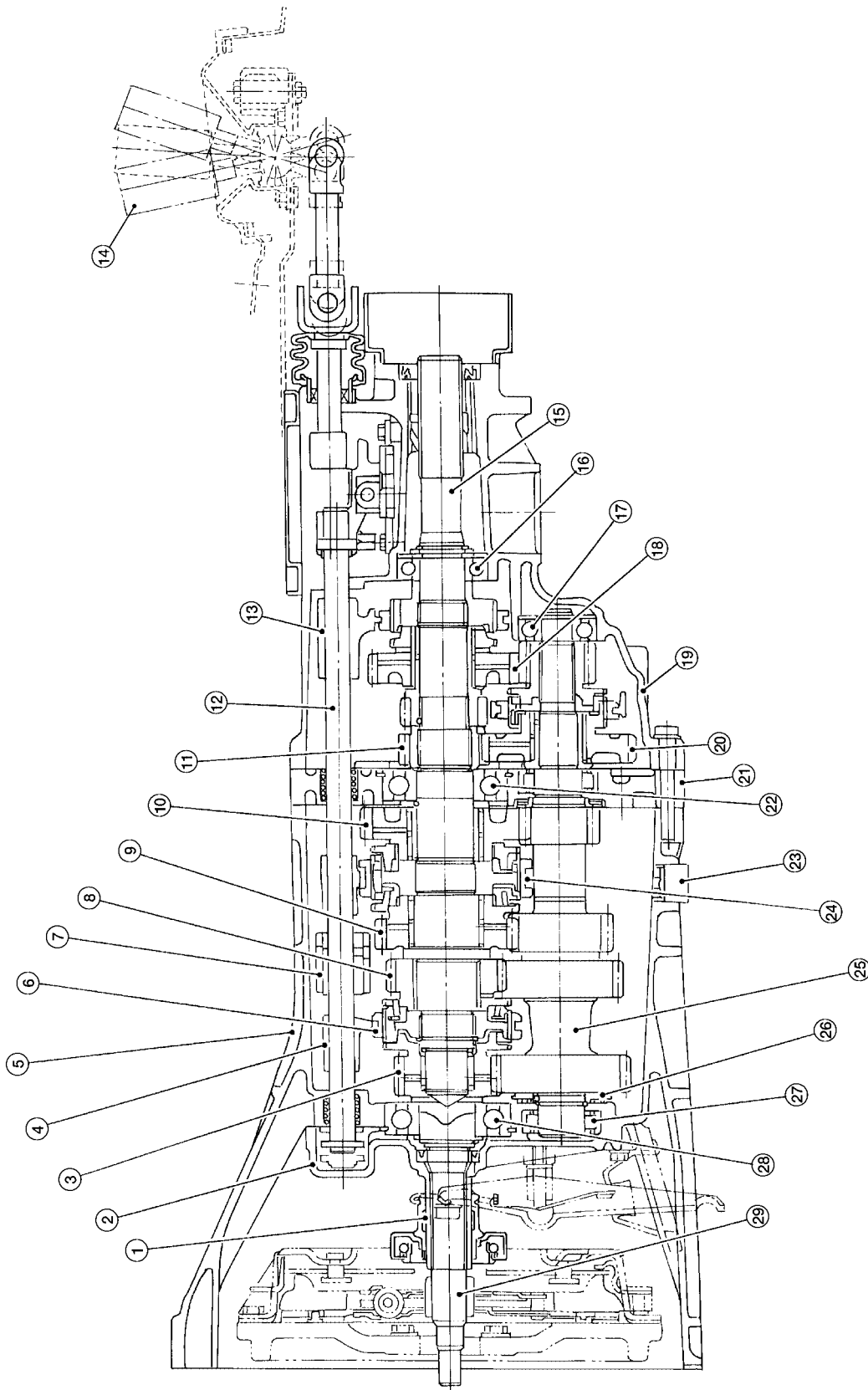

MT-42

WCIA0183E

DESCRIPTION

[FS5R30A]

- | | | |
|-----------------------------|-----------------------------------|---------------------------------|
| 1. Release bearing sleeve | 2. Front cover | 3. Main drive gear |
| 4. 3rd and 4th shift fork | 5. Transmission case | 6. 3rd and 4th coupling sleeve |
| 7. Striking interlock | 8. 3rd main gear | 9. 2nd main gear |
| 10. 1st main gear | 11. OD main gear | 12. Striking rod |
| 13. Reverse shift fork | 14. Shift lever | 15. Mainshaft |
| 16. Mainshaft rear bearing | 17. Counter gear rear end bearing | 18. Reverse main gear |
| 19. Rear extension | 20. OD counter gear | 21. Adapter plate |
| 22. Mainshaft front bearing | 23. Drain plug | 24. 1st and 2nd coupling sleeve |
| 25. Counter gear | 26. Sub-gear | 27. Counter gear front bearing |
| 28. Main drive gear bearing | 29. Main drive gear | |

A

B

MT

D

E

F

G

H

I

J

K

L

M

DESCRIPTION

[FS5R30A]

CROSS-SECTIONAL VIEW — 4WD MODEL

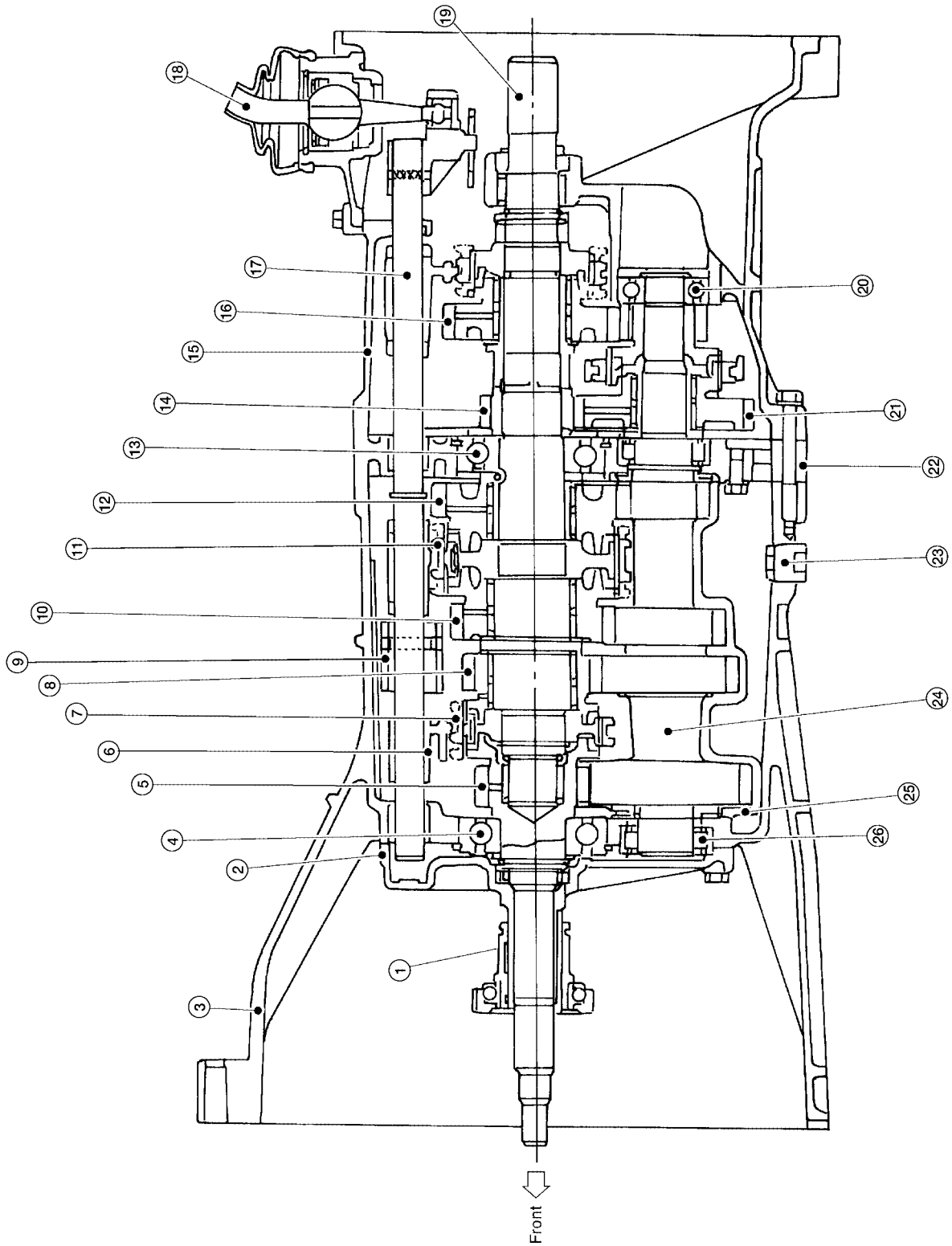

WCIA0184E

DESCRIPTION

[FS5R30A]

- | | | |
|--------------------------------|-----------------------------------|---------------------------|
| 1. Release bearing sleeve | 2. Front cover | 3. Transmission case |
| 4. Main drive gear bearing | 5. Main drive gear | 6. 3rd and 4th shift fork |
| 7. 3rd and 4th coupling sleeve | 8. 3rd main gear | 9. Striking interlock |
| 10. 2nd main gear | 11. 1st and 2nd coupling sleeve | 12. 1st main gear |
| 13. Mainshaft front bearing | 14. OD main gear | 15. Rear extension |
| 16. Reverse main gear | 17. Striking rod | 18. Shift lever |
| 19. Mainshaft | 20. Counter gear rear end bearing | 21. OD counter gear |
| 22. Adapter plate | 23. Drain plug | 24. Counter gear |
| 25. Sub-gear | 26. Counter gear front bearing | |

A

B

MT

D

E

F

G

H

I

J

K

L

M

ON-VEHICLE SERVICE

**Replacing Rear Oil Seal — 2WD Model
REMOVAL**

1. Remove the propeller shaft. Refer to [PR-8, "Removal and Installation"](#).
2. Remove rear oil seal using Tool.
 - Always replace with a new rear oil seal once it has been removed.

Tool number : ST33290001 (J25810-A)

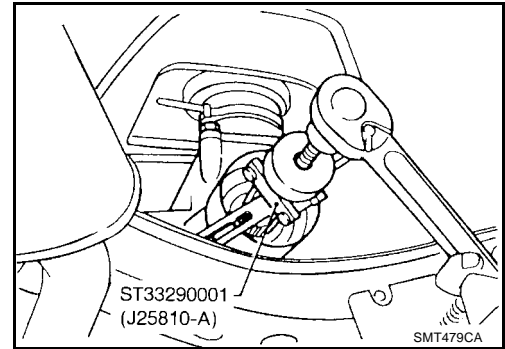

INSTALLATION

1. Install new rear oil seal until it stops.
 - Apply multi-purpose grease to seal lip of oil seal before installing.

Tool number : ST33400001 (J26082)

2. Installation is in the reverse order of removal.

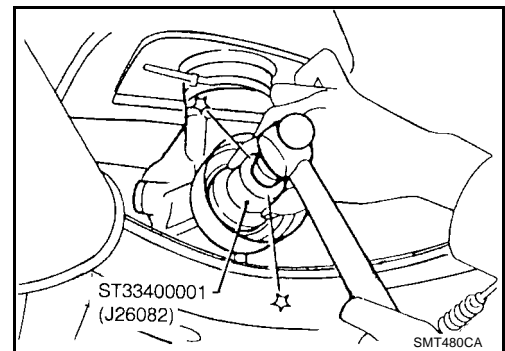

Position Switch Check

Switch	Gear position	Continuity
Back-up lamp switch	Reverse	Yes
	Except reverse	No
Park/neutral position (PNP) switch	Neutral	Yes
	Except neutral	No

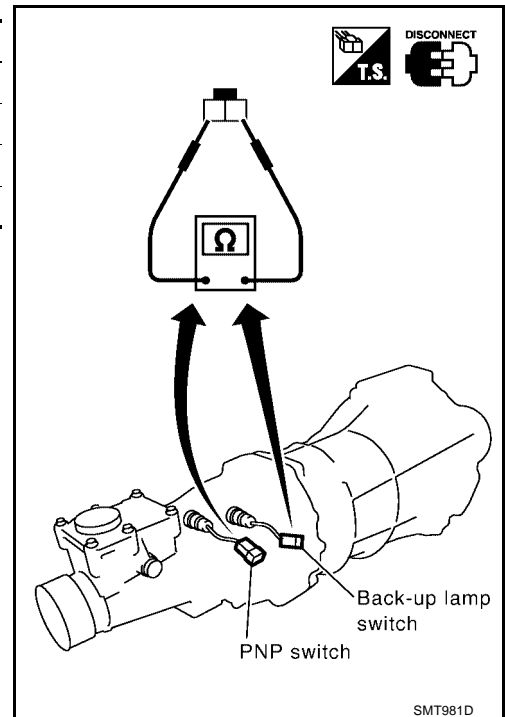

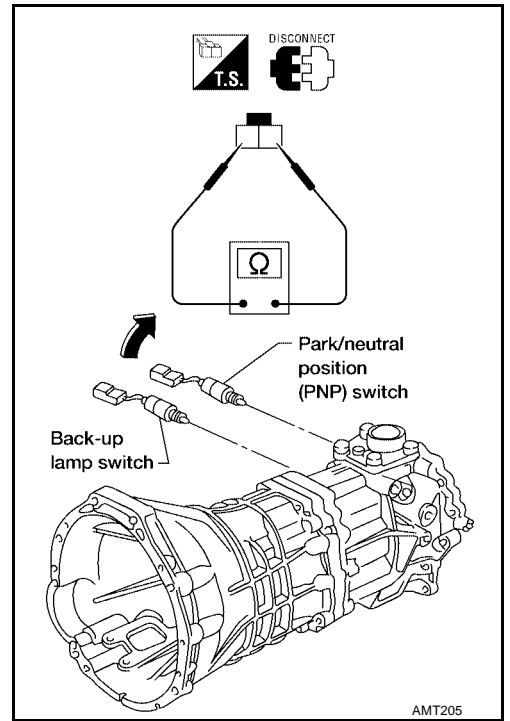

A
B
MT
D
E
F
G
H
I
J
K
L
M

TRANSMISSION ASSEMBLY

PFP:32010

Removal and Installation REMOVAL

ECS00710

CAUTION:

When removing the M/T assembly from engine, first remove the crankshaft position sensor (OBD) from the M/T assembly. Be careful not to damage sensor edge.

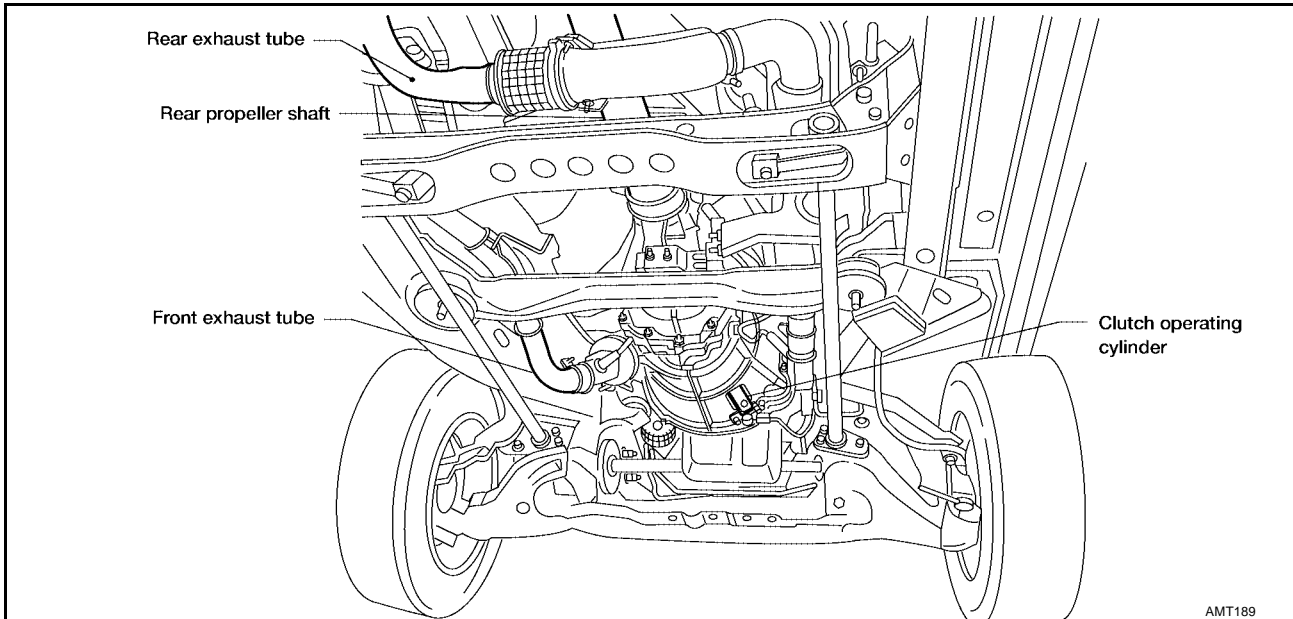

AMT189

2WD Model

1. Remove battery negative terminal.
2. Remove shift lever.
3. Remove crankshaft position sensor (OBD) from upper side of transmission case.
4. Remove operating cylinder from transmission. Refer to [CL-5, "Components"](#) .
5. Disconnect vehicle speed sensor, back-up lamp switch, heated oxygen sensor (rear) and park/neutral position (PNP) switch harness connectors.
6. Remove starter motor. Refer to [SC-25, "VG33E AND VG33ER MODELS"](#) .
7. Remove propeller shaft. Refer to [PR-8, "Removal and Installation"](#) .
 - Insert plug into rear oil seal after removing propeller shaft.
 - Be careful not to damage spline, sleeve yoke and rear oil seal when removing propeller shaft.
8. Remove gussets from transmission or engine.
9. Remove exhaust tube mounting bracket from transmission. Refer to [EX-3, "EXHAUST SYSTEM"](#) .
10. Support manual transmission with a jack.
11. Remove rear mounting member. Refer to [EM-128, "Removal and Installation"](#) .
12. Lower manual transmission.

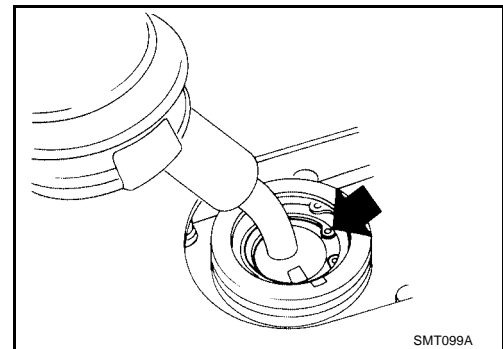

SMT099A

WARNING:

Support manual transmission together with transfer while removing it.

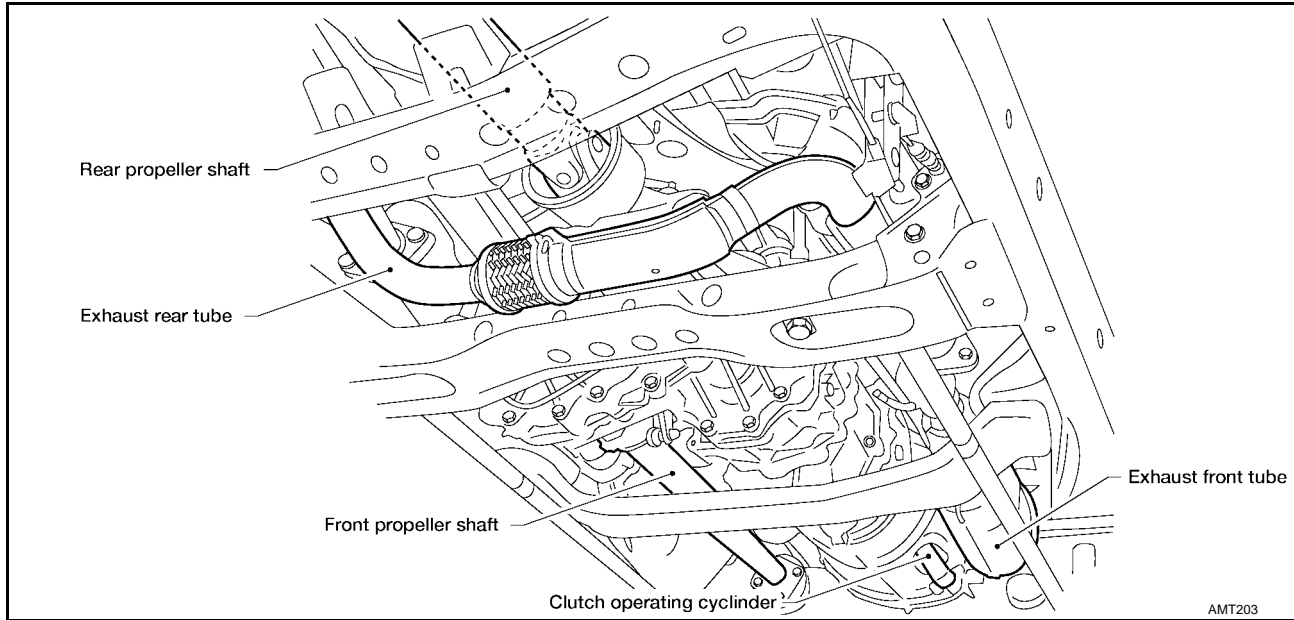

4WD Model

1. Disconnect the battery negative terminal.
2. Remove shift lever from transmission and control lever from transfer.
3. Remove clutch operating cylinder from transmission. Refer to [CL-5, "Components"](#).
4. Disconnect the vehicle speed sensor, back-up lamp switch, heated oxygen sensor (rear) and Park/neutral position (PNP) switch harness connectors.
5. Remove the starter motor. Refer to [SC-25, "VG33E AND VG33ER MODELS"](#).
6. Remove front and rear propeller shafts. Refer to [PR-8, "Removal and Installation"](#).

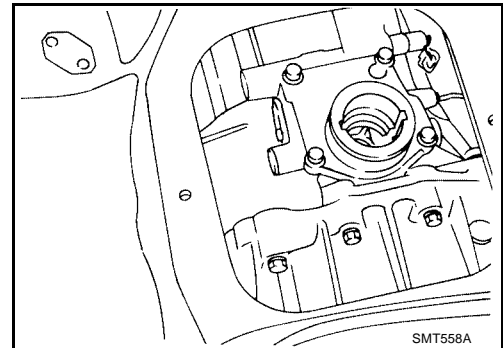

- Insert plug into rear oil seal after removing propeller shaft.
 - Be careful not to damage spline, sleeve yoke and rear oil seal when removing propeller shaft.
7. Remove exhaust tube mounting bracket from transmission. Refer to [EX-3, "EXHAUST SYSTEM"](#).
 8. Remove front exhaust tubes and center pipe.
 9. Remove the torsion bars and mounts. Refer to [FSU-17, "TORSION BAR SPRING"](#).
 10. Remove the rear torsion bar cross member.
 11. Remove the gussets from the transmission or engine.
 12. Support the manual transmission with a jack.
 13. Remove rear mounting member. Refer to [EM-128, "Removal and Installation"](#).
 14. Lower manual transmission.

WARNING:

Support manual transmission together with transfer while removing it.

15. Remove crankshaft position sensor (OBD) from upper side of transmission case.
16. Remove transmission bolts.

WARNING:

Support manual transmission together with transfer while removing it.

TRANSMISSION ASSEMBLY

[FS5R30A]

INSTALLATION

- Tighten the bolts securing the transmission to the specified torques in the chart below.

Bolt No.	Tightening torque N·m (kg·m, ft·lb)	ℓ mm (in)
1	39 - 49 (4.0 - 5.0, 29 - 36)	65 (2.56)
2	39 - 49 (4.0 - 5.0, 29 - 36)	58 (2.28)
3	29 - 39 (3.0 - 4.0, 22 - 29)	20 (0.79)
4 (Starter spacer and cover plate)	29 - 39 (3.0 - 4.0, 22 - 29)	25 (0.98)

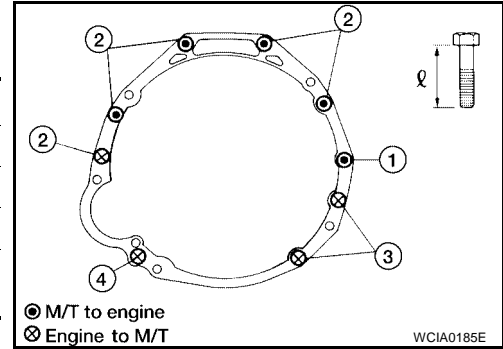

- Installation is in the reverse order of removal.

Overhaul CASE COMPONENTS

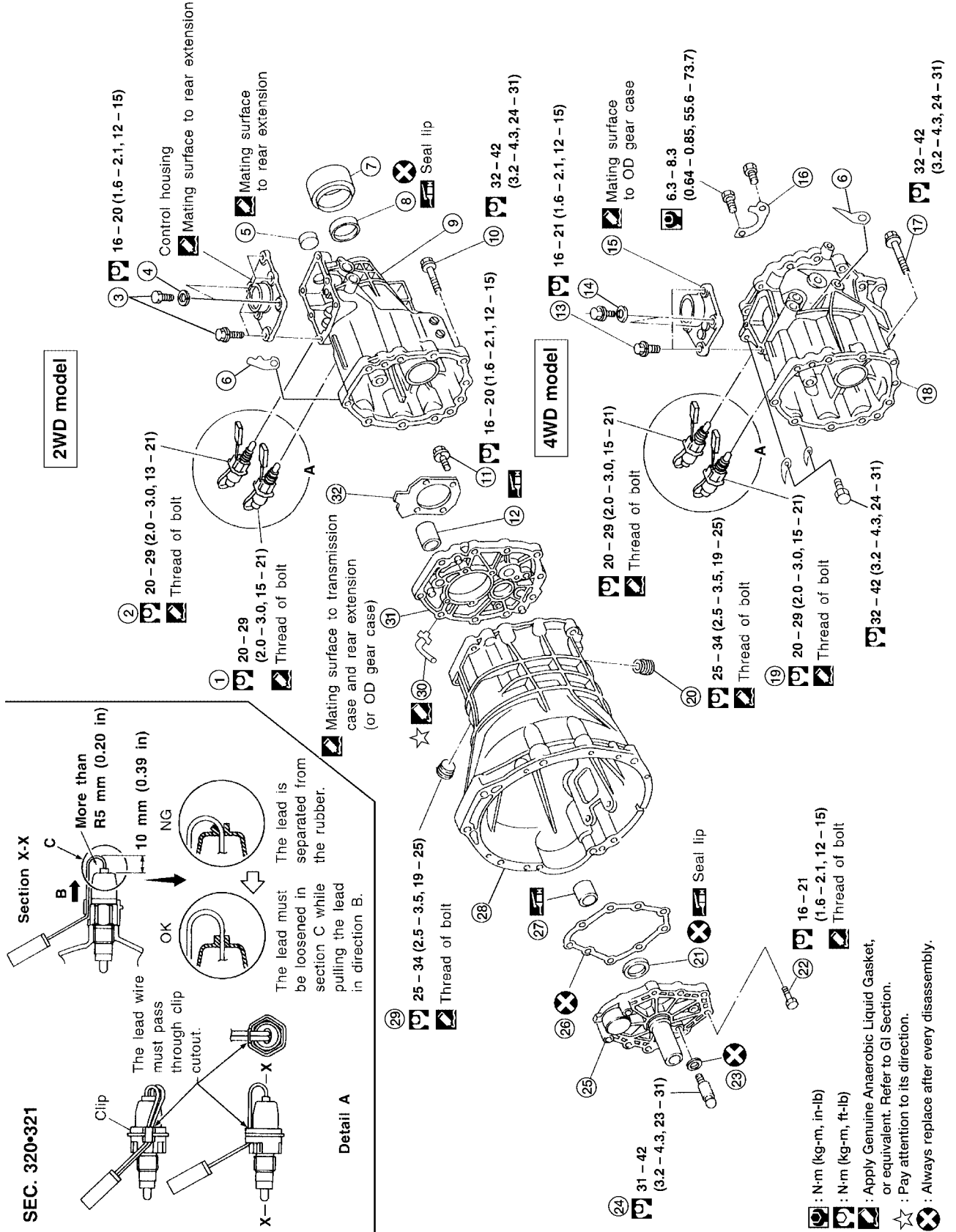

A
B
C
D
E
F
G
H
I
J
K
L
M

MT

TRANSMISSION ASSEMBLY

[FS5R30A]

-
- | | | |
|--------------------------|---------------------------------------|--------------------------|
| 1. Back-up lamp switch | 2. Park/neutral position (PNP) switch | 3. Control housing bolts |
| 4. Control housing | 5. Plug | 6. Clip |
| 7. Dust cover | 8. Rear oil seal | 9. Rear extension |
| 10. Rear extension bolt | 11. Bearing retainer bolt | 12. Slide ball bearing |
| 13. Control housing bolt | 14. Washer | 15. Control housing |
| 16. Baffle plate | 17. OD gear case bolt | 18. OD gear case |
| 19. Back-up lamp switch | 20. Drain plug | 21. Front cover oil seal |
| 22. Front cover bolt | 23. Washer | 24. Ball pin |
| 25. Front cover | 26. Gasket | 27. Slide ball bearing |
| 28. Transmission case | 29. Filler plug | 30. Air breather |
| 31. Adapter plate | 32. Bearing retainer | |

TRANSMISSION ASSEMBLY

[FS5R30A]

GEAR COMPONENTS

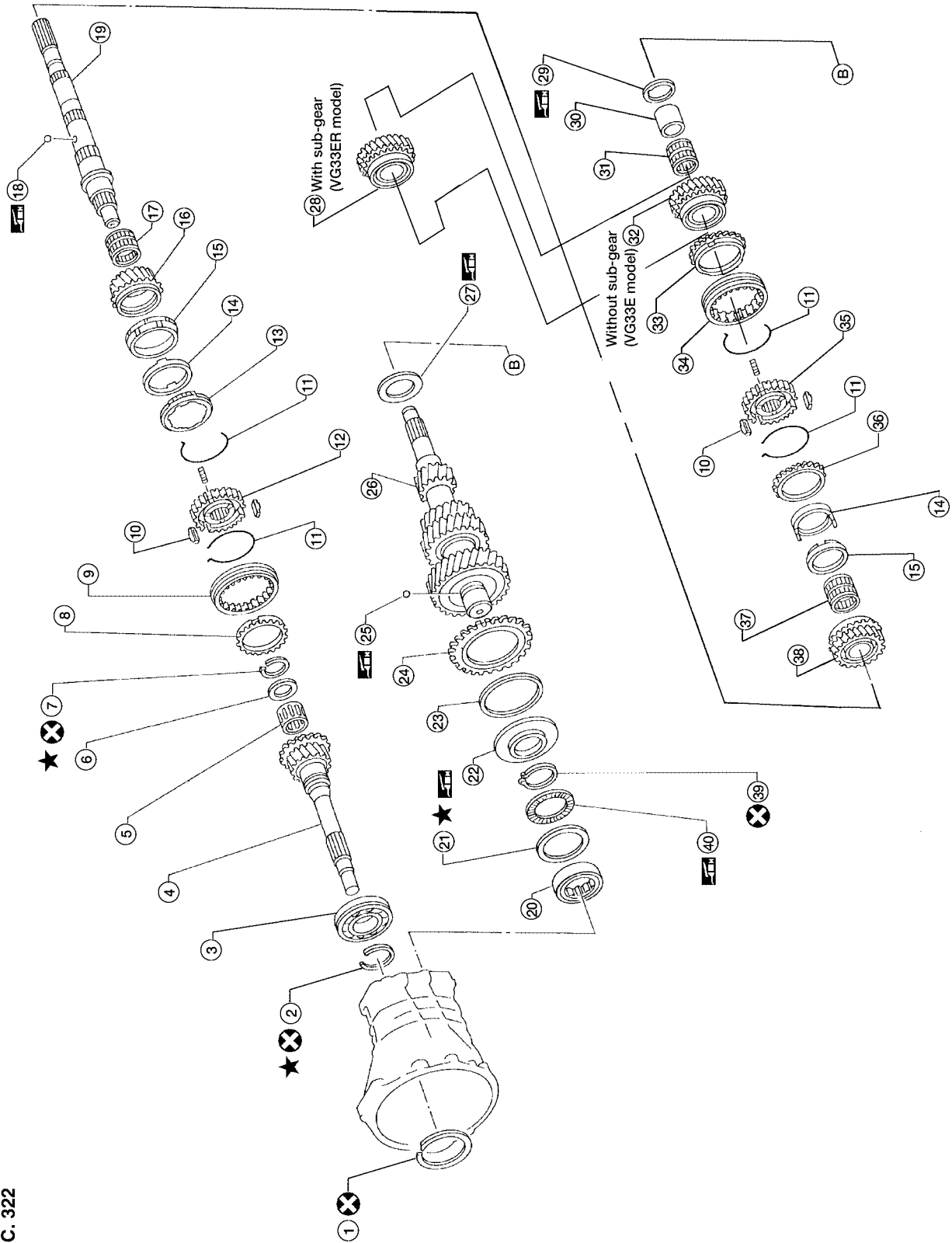

SEC. 322

MT-53

WCIA0188E

A
B
MT
D
E
F
G
H
I
J
K
L
M

TRANSMISSION ASSEMBLY

[FS5R30A]

-
- | | | |
|---|---|--------------------------------------|
| 1. Main drive bearing snap ring | 2. Main drive gear bearing snap ring | 3. Main drive gear bearing |
| 4. Main drive gear | 5. Pilot bearing | 6. Spacer |
| 7. Mainshaft front snap ring | 8. 4th baulk ring | 9. 3rd and 4th coupling sleeve |
| 10. Shifting insert | 11. Spread spring | 12. 3rd and 4th synchronizer hub |
| 13. 3rd outer baulk ring | 14. Synchronizer cone | 15. 3rd inner baulk ring |
| 16. 3rd main gear | 17. 3rd gear needle bearing | 18. Steel ball (For 1st gear washer) |
| 19. Mainshaft | 20. Counter gear front bearing | 21. Counter gear front bearing shim |
| 22. Sub-gear bracket | 23. Sub-gear spring | 24. Sub-gear |
| 25. Steel ball | 26. Counter gear | 27. Counter gear rear thrust bearing |
| 28. 1st main gear with sub-gear
(VG33ER) | 29. 1st gear washer | 30. 1st gear bushing |
| 31. 1st gear needle bearing | 32. 1st main gear without sub-gear
(VG33E) | 33. 1st baulk ring |
| 34. 1st and 2nd coupling sleeve | 35. 1st and 2nd synchronizer hub | 36. 2nd outer baulk ring |
| 37. 2nd inner baulk ring | 38. 2nd main gear | 39. Sub-gear snap ring |
| 40. Counter gear front bearing | | |

TRANSMISSION ASSEMBLY

[FS5R30A]

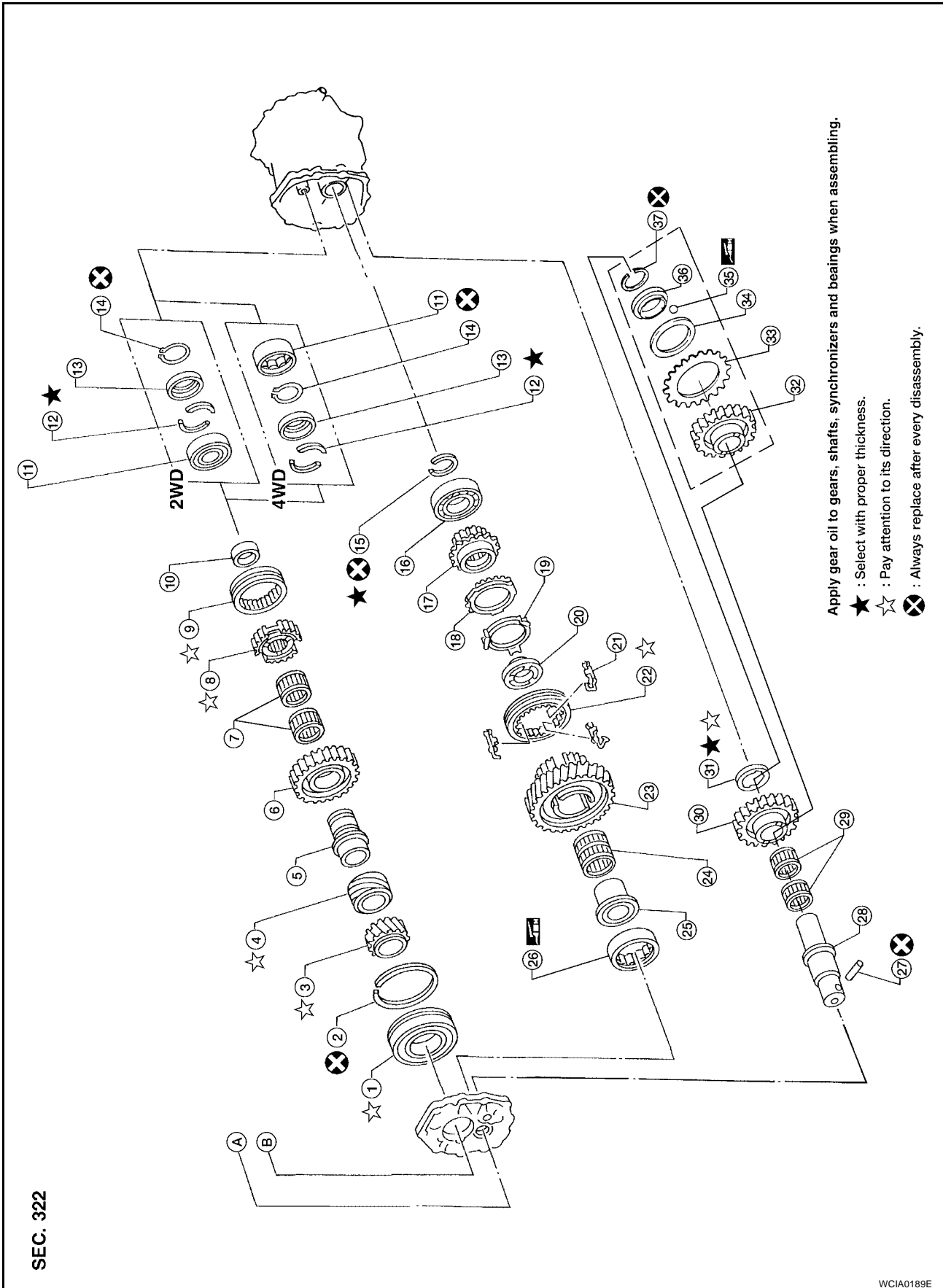

A
B
MT
D
E
F
G
H
I
J
K
L
M

TRANSMISSION ASSEMBLY

[FS5R30A]

-
- | | | |
|---------------------------------------|---|---|
| 1. Mainshaft front bearing | 2. Mainshaft front bearing snap ring | 3. OD main gear |
| 4. Speedometer drive gear (2WD model) | 5. Reverse gear bushing | 6. Reverse main gear |
| 7. Reverse gear needle bearings | 8. Reverse synchronizer hub | 9. Reverse coupling sleeve |
| 10. Mainshaft spacer | 11. Mainshaft rear bearing | 12. Mainshaft C-ring |
| 13. C-ring holder | 14. Mainshaft rear snap ring | 15. Counter gear rear snap ring |
| 16. Counter gear rear end bearing | 17. Reverse counter gear | 18. OD baulk ring |
| 19. Reverse baulk ring | 20. Reverse cone | 21. Spring insert |
| 22. OD coupling sleeve | 23. OD counter gear | 24. OD gear needle bearing |
| 25. OD gear bushing | 26. Counter gear rear bearing | 27. Retaining pin |
| 28. Reverse idler shaft | 29. Reverse idler needle bearings | 30. Reverse idler gear (without sub-gear) (VG33E model) |
| 31. Reverse idler rear thrust washer | 32. Reverse idler gear (with sub-gear) (VG33ER model) | 33. Sub-gear |
| 34. Sub-gear spring | 35. Steel ball | 36. Sub-gear bracket |
| 37. Snap ring | | |

TRANSMISSION ASSEMBLY

[FS5R30A]

-
- | | | |
|---------------------------------|---------------------------------|----------------------------|
| 1. Snap ring | 2. Socket | 3. Spring |
| 4. Shift knob | 5. Shift lever | 6. Upper boot retainer |
| 7. Boot | 8. Lower boot retainer | 9. Control housing bolt |
| 10. Washer | 11. Control housing | 12. Bushing |
| 13. Return spring | 14. Check ball | 15. Select check plunger |
| 16. Select check spring (small) | 17. Select check spring (large) | 18. Select check plug |
| 19. Select check spring | 20. Retaining pin | 21. Guide plate bolt |
| 22. Guide plate | 23. Striking arm | 24. O-ring |
| 25. Reverse check sleeve | 26. Reverse check sleeve bolt | 27. OD rod bracket |
| 28. OD shift fork | 29. OD fork rod | 30. 1st and 2nd shift fork |
| 31. Striking interlock | 32. Striking lever | 33. 3rd and 4th shift fork |
| 34. Stopper ring | 35. Interlock stopper bolt | 36. Interlock stopper |
| 37. Striking rod | 38. OD and reverse fork rod | 39. Reverse shift fork |
| 40. Check ball | 41. Check spring | 42. Check ball plug |

CASE COMPONENTS

Disassembly

1. Remove check ball plug, check spring and check ball. Then remove interlock stopper.
 - If interlock assembly is removed as a unit, the check ball can fall into transmission case.
 - Be careful not to lose check ball.

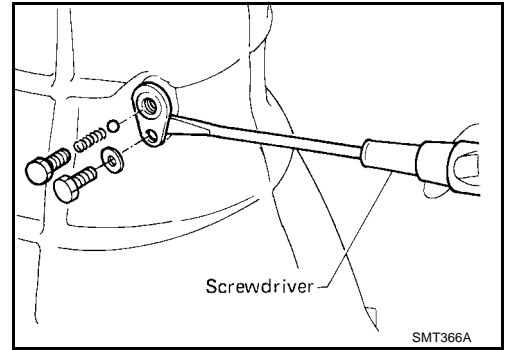

2. Remove control housing, return spring and check ball.
 - Be careful not to lose check ball.

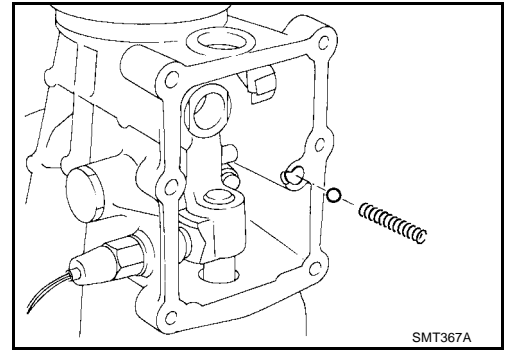

3. Drive out retaining pin from striking arm using Tool.

Tool number : ST23540000 (J25689-A)

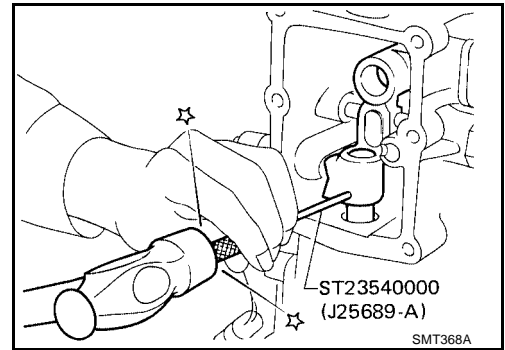

4. Remove rear extension (or OD gear case) together with striking arm by tapping lightly.

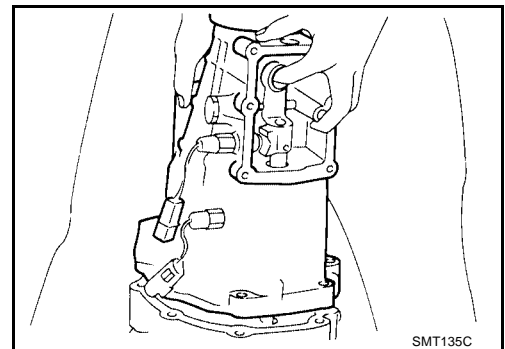

A
B
MT
D
E
F
G
H
I
J
K
L
M

CASE COMPONENTS

[FS5R30A]

5. Remove front cover and gasket.

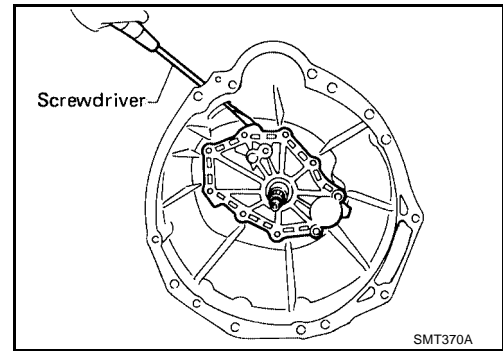

6. Remove stopper ring and main drive bearing snap ring.

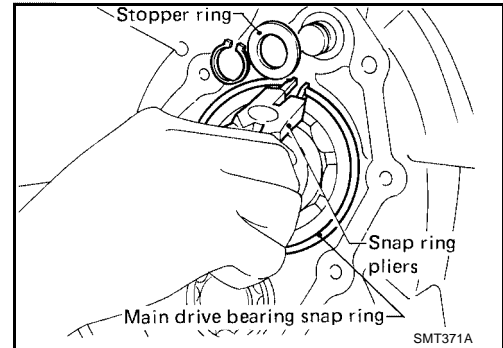

7. Remove transmission case by tapping lightly.

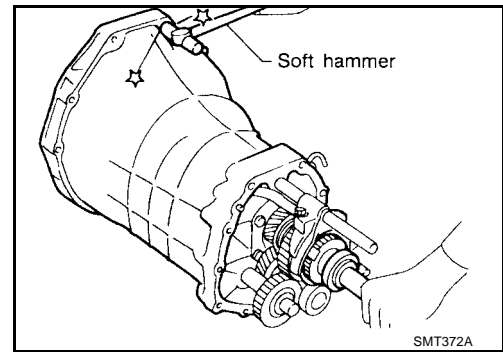

8. Remove counter gear front bearing shim and counter gear front thrust washer.
9. Remove spacer from between main drive gear and mainshaft.
10. Remove front cover oil seal using a screwdriver.

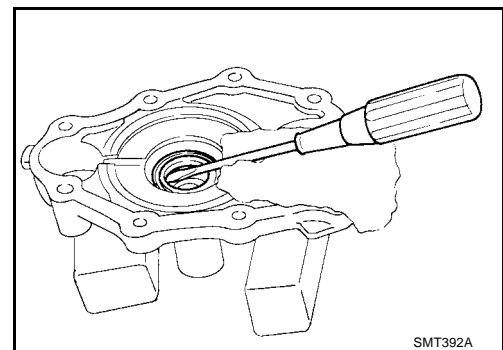

Assembly

1. Install front cover oil seal using Tool.
 - Apply multi-purpose grease to seal lip.

Tool number : ST33210000 (J25803-01)
2. Install selected counter gear front bearing shim onto transmission case.
 - Apply multi-purpose grease to counter gear front bearing shim.
3. Apply sealant to mating surface of transmission case.
 - Use Genuine Anaerobic Liquid Gasket or equivalent. Refer to [MA-12. "RECOMMENDED FLUIDS AND LUBRICANTS"](#).
4. Install gear assembly onto transmission case.
5. Install check ball and check spring into interlock stopper.
 - Apply multi-purpose grease to check ball.

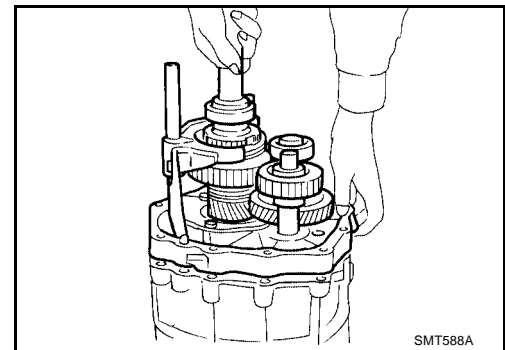
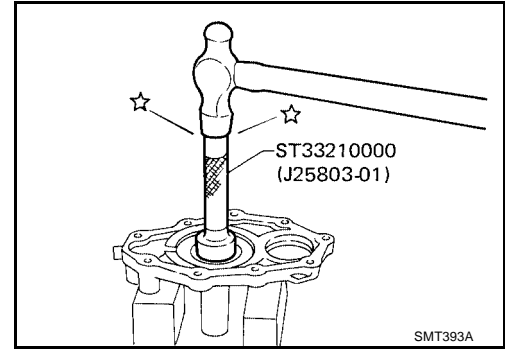

6. Install interlock stopper assembly and then tighten check ball plug.
 - Apply sealant to thread of check ball plug.
 - Use Genuine Anaerobic Liquid Gasket or equivalent. Refer to [MA-12. "RECOMMENDED FLUIDS AND LUBRICANTS"](#).

Interlock stopper bolt : 32 - 42 N·m (3.2 - 4.3 kg·m, 24 - 31 lb·ft)

Check ball plug : 32 - 42 N·m (3.2 - 4.3 kg·m, 24 - 31 lb·ft)

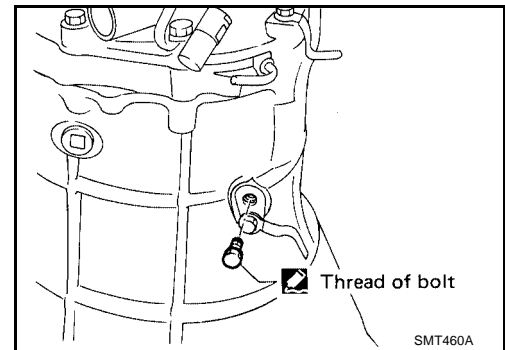

7. Install stopper ring and main drive bearing snap ring.

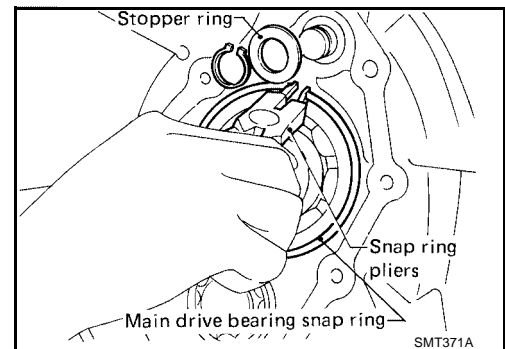

A
B
MT
D
E
F
G
H
I
J
K
L
M

CASE COMPONENTS

[FS5R30A]

8. Install front cover and gasket.

- Apply sealant to thread of 3 bolts shown.
- Use Genuine Anaerobic Liquid Gasket or equivalent. Refer to [MA-12, "RECOMMENDED FLUIDS AND LUBRICANTS"](#).

Front cover bolts : 16 - 21 N·m (1.6 - 2.1 kg·m, 12 - 15 lb·ft)

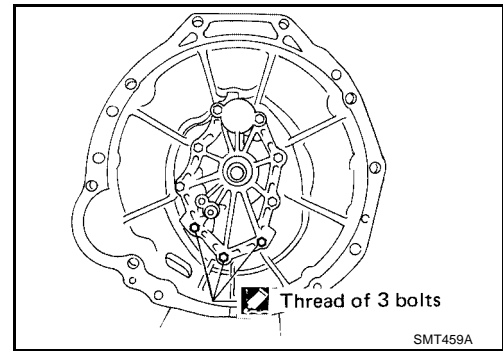

9. Apply sealant to mating surface of adapter plate.

- Use Genuine Anaerobic Liquid Gasket or equivalent. Refer to [MA-12, "RECOMMENDED FLUIDS AND LUBRICANTS"](#).

10. Install rear extension or (OD gear case) together with striking arm.

Rear extension bolts : 32 - 42 N·m (3.2 - 4.3 kg·m, 24 - 31 lb·ft)
(OD gear case bolts)

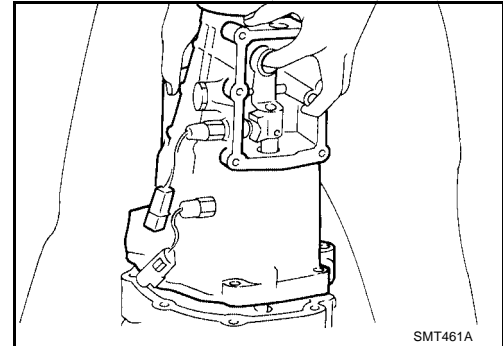

11. Install retaining pin into striking arm using Tool.

Tool number ST23540000 (J25689-A)

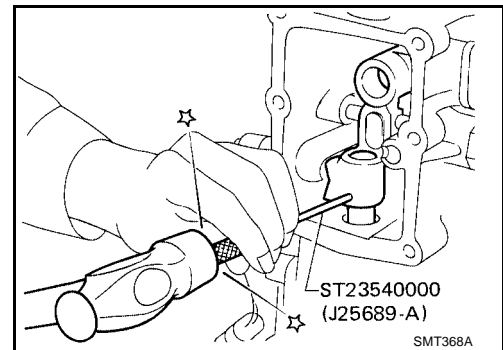

12. Install check ball and return spring and then apply sealant and install control housing.

- Use Genuine Anaerobic Liquid Gasket or equivalent. Refer to [MA-12, "RECOMMENDED FLUIDS AND LUBRICANTS"](#).

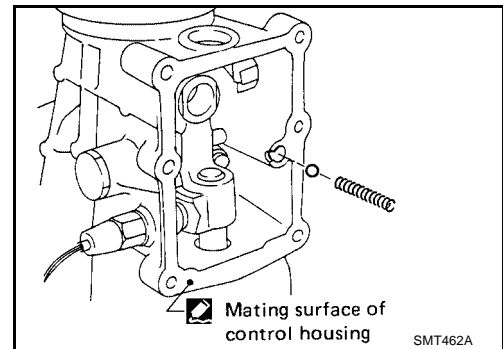

13. Tighten control housing bolts.

Bolt head size

A bolts : 12 mm (0.47 in)

B bolts : 13 mm (0.51 in)

Control housing bolts : 16 - 20 N·m (1.6 - 2.1 kg·m, 12 - 15 lb·ft)

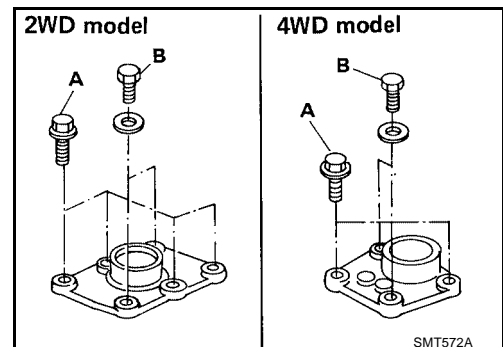

SHIFT CONTROL COMPONENTS

PFP:32982

ECS00714

Disassembly

1. Mount adapter plate on vise using copper plates to protect adapter plate.
2. Remove OD and reverse fork rod.

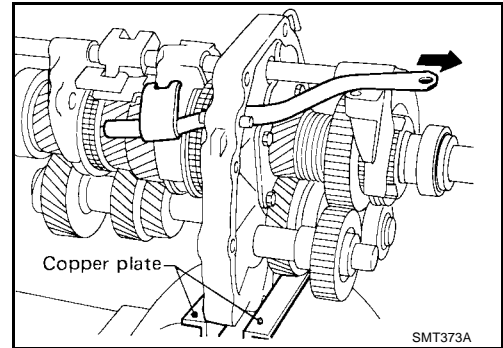

3. Drive out retaining pin from striking lever using Tool.

Tool number : ST23540000 (J25689-A)

4. While pulling out striking rod, remove striking lever and striking interlock. Then remove 1st and 2nd, 3rd and 4th, and reverse shift forks.

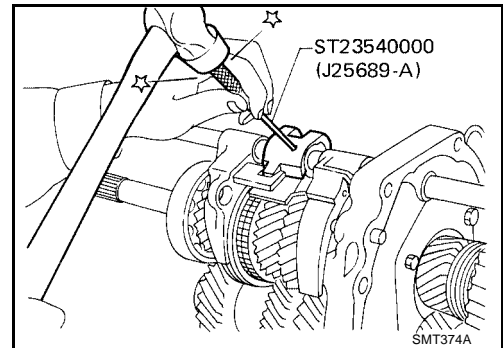

5. Drive out retaining pin from OD shift fork using Tool.

Tool number : ST23540000 (J25689-A)

6. Pull out OD fork rod and then remove OD shift fork.

Inspection

- Check contact surface and sliding surface for wear, scratches, projections or other damage.

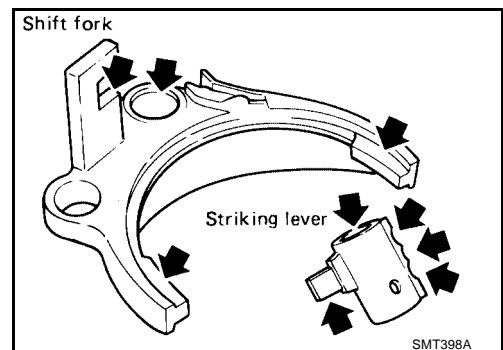

Assembly

1. Install OD fork rod and OD shift fork. Then install retaining pin into OD shift fork.

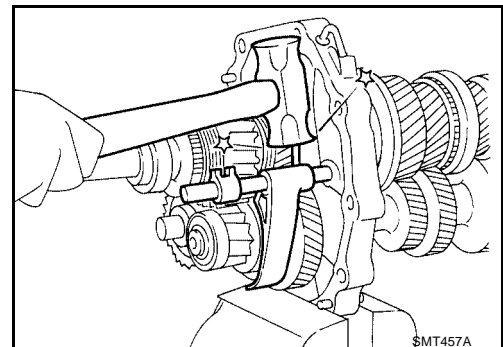

2. Install 1st and 2nd, 3rd and 4th, and reverse shift forks onto coupling sleeve.

A
B
MT
D
E
F
G
H
I
J
K
L
M

SHIFT CONTROL COMPONENTS

[FS5R30A]

3. Install striking rod into hole of shift forks, striking lever and interlock and then install retaining pin into striking lever using Tool.
 - **Make sure that striking rod moves smoothly.**

Tool number : ST23540000 (J25689-A)

4. Install OD and reverse fork rod.
 - Apply sealant to thread of OD and reverse fork rod bolt.

OD and reverse fork rod bolt : 25 - 29 N-m (2.5 - 3.0 kg-m, 19 - 21 lb-ft)

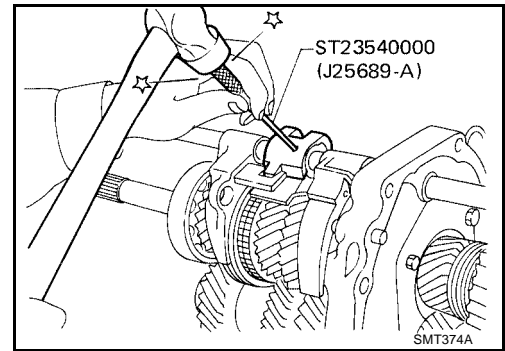

GEAR COMPONENTS

Disassembly

1. Before removing gears and shafts, measure each gear end play. Refer to [MT-81, "Gear End Play"](#).

- If not within specification, disassemble and check contact surface of gear to hub, washer, bushing, needle bearing and shaft.

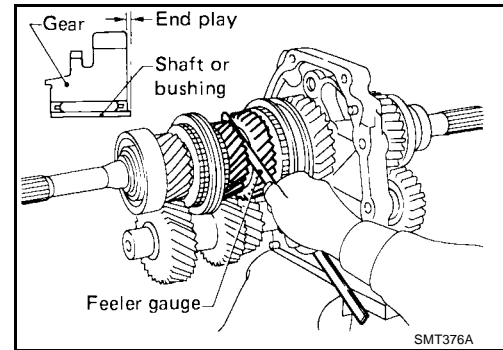

2. Remove rear side components on mainshaft and counter gear.

a. Remove reverse coupling sleeve.

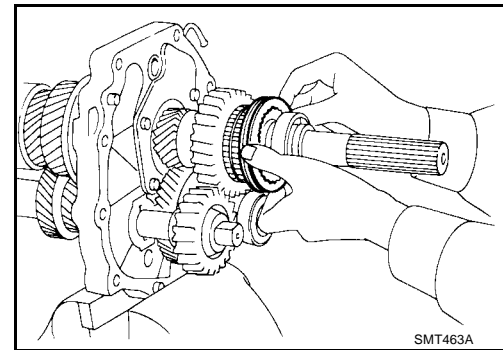

b. Remove mainshaft rear snap ring and counter gear rear snap ring.

c. Remove C-ring holder and mainshaft C-rings from mainshaft. Use punch and hammer to remove C-rings.

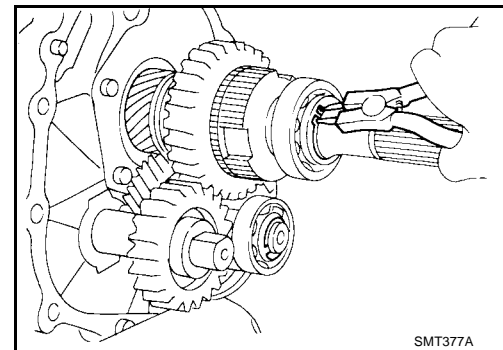

d. Remove counter gear rear end bearing using a puller.

e. Remove reverse idler thrust washer and reverse idler gear (VG33E model) or snap ring, sub-gear bracket, steel ball, sub-gear spring, sub-gear and reverse idler (VG33ER model) and reverse idler needle bearings.

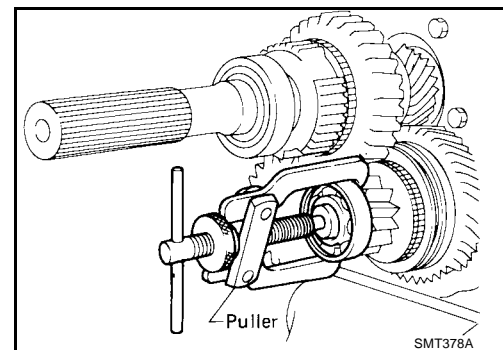

f. Remove mainshaft rear bearing (2WD model) using Tools.

Tool number : J-26349-A, J-25726-B

g. Remove mainshaft spacer.

A
B
MT
D
E
F
G
H
I
J
K
L
M

GEAR COMPONENTS

[FS5R30A]

- h. Remove reverse main gear together with mainshaft spacer and reverse synchronizer hub using a puller. Then remove reverse gear needle bearings.

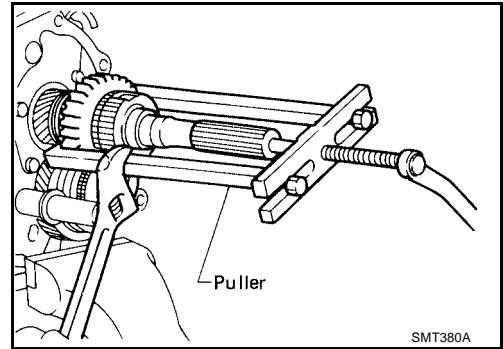

- i. Remove reverse counter gear using a puller.
- j. Remove OD coupling sleeve together with OD baulk ring, reverse baulk ring and spring inserts.

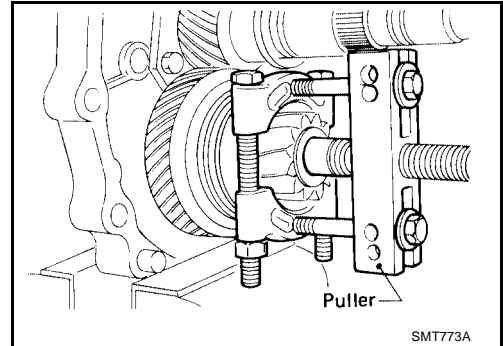

- k. Remove reverse gear bushing using a puller.

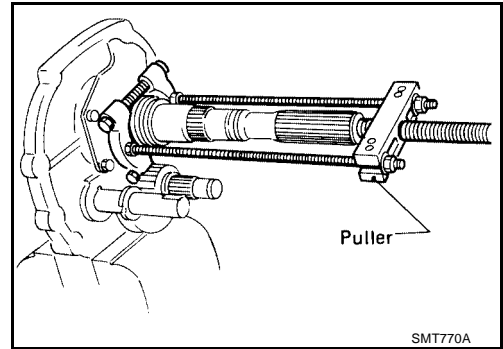

- l. Remove speedometer drive gear (2WD model).
- m. Remove OD gear bushing, OD gear needle bearing, OD counter gear and reverse cone using puller.

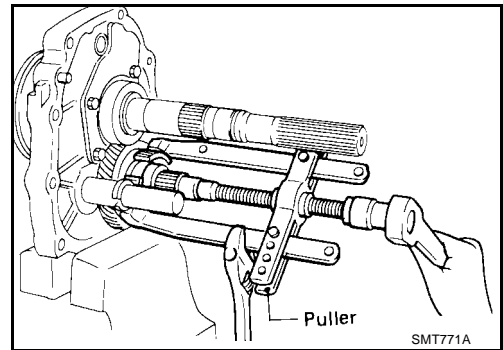

3. Press out mainshaft and counter gear alternately using Tool.

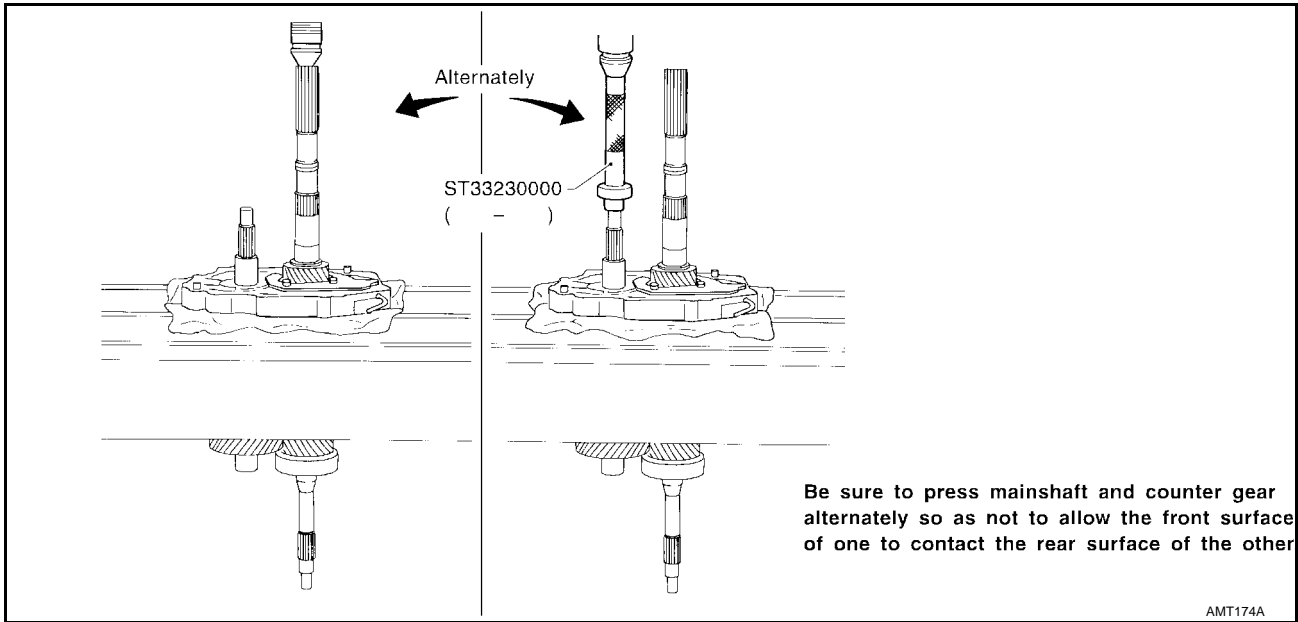

Tool number : ST33230000 (—)

4. Remove front side components on mainshaft.

- a. Remove 1st gear washer and steel ball.
 - Be careful not to lose steel ball.
- b. Remove 1st main gear and 1st gear needle bearing.

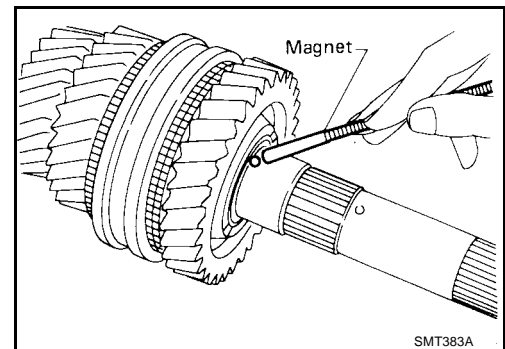

- c. Press out 2nd main gear together with 1st gear bushing, 2nd gear needle bearing and 1st and 2nd synchronizer assembly using Tool.

Tool number : ST30031000 (J22912-01)

- d. Remove mainshaft front bearing snap ring.

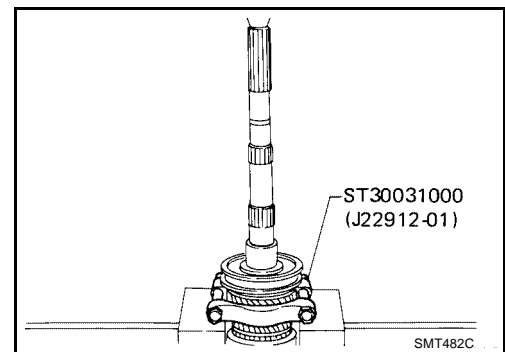

- e. Press out 3rd main gear together with 3rd and 4th synchronizer assembly and 3rd gear needle bearing.

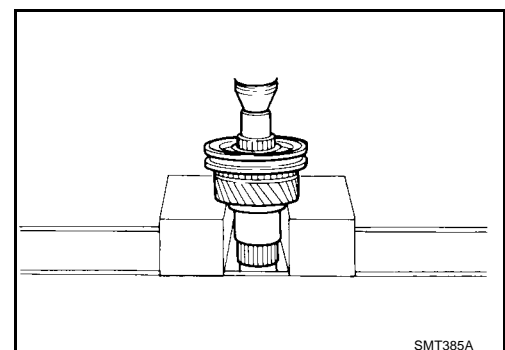

A
B
MT
D
E
F
G
H
I
J
K
L
M

GEAR COMPONENTS

[FS5R30A]

5. Remove front side components on counter gear.
 - a. Remove counter gear rear thrust bearing using Tool.

Tool number : ST30031000 (J22912-01)

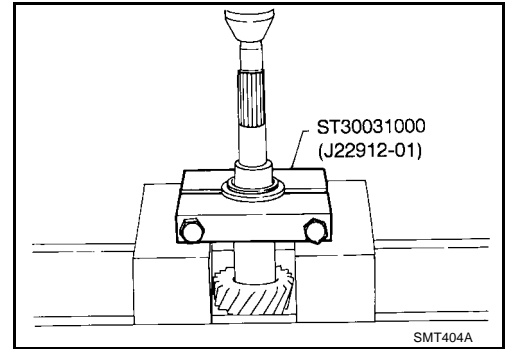

- b. Remove sub-gear snap ring, sub-gear bracket, sub-gear spring, sub-gear and steel ball.

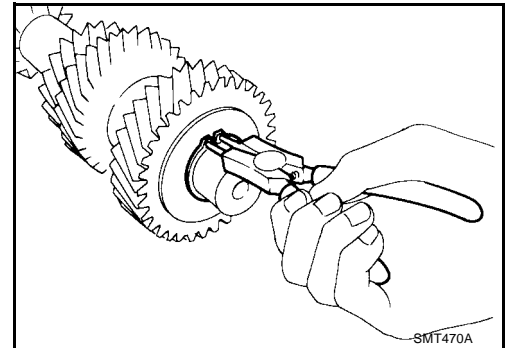

6. Remove main drive gear bearing.
 - a. Remove main drive gear snap ring.
 - b. Press out main drive gear bearing using Tool.

Tool number : ST30031000 (J22912-01)

- c. Remove pilot bearing.

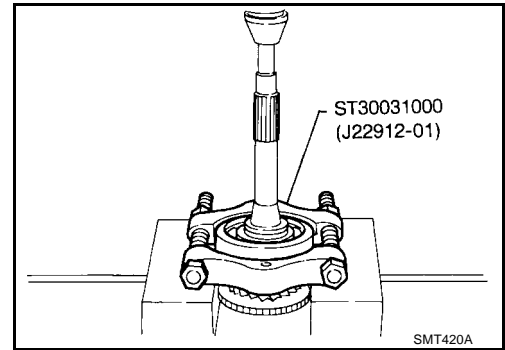

7. Remove front bearing snap ring from adapter plate.
8. Remove bearings from case components using Tool.

<p>Counter gear front bearing in transmission case</p> <p>ST22350000 (J25678-01) KV38100300 (J25523)</p>	<p>Mainshaft front bearing in adapter plate</p> <p>ST30720000 (J34331)</p>
<p>Mainshaft rear bearing in OD gear case</p> <p>ST37750000 (J34332)</p>	<p>Counter gear rear bearing in adapter plate</p> <p>ST37750000 (J34286)</p>

AMT173

Tool numbers

Counter gear front bearing : ST22350000 (J25678-01),
KV38100300 (J25523)

Mainshaft front bearing : ST30720000 (J34331)

Mainshaft rear bearing : ST37750000 (J34332)

Counter gear rear bearing : ST37750000 (J34286)

**Inspection
GEARS AND SHAFTS**

ECS00718

- Check shafts for cracks, wear or bending.

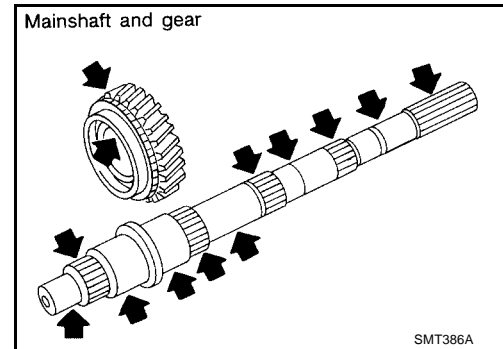

- Check gears for excessive wear, chips or cracks.

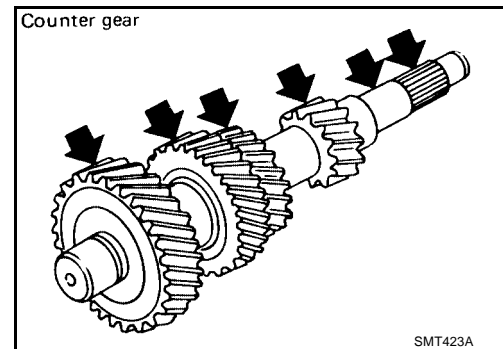

SYNCHRONIZERS

- Check spline portion of coupling sleeves, hubs, and gears for wear or cracks.
- Check baulk rings for cracks or deformation.
- Check shifting inserts for wear or deformation.
- Check insert springs for deformation.

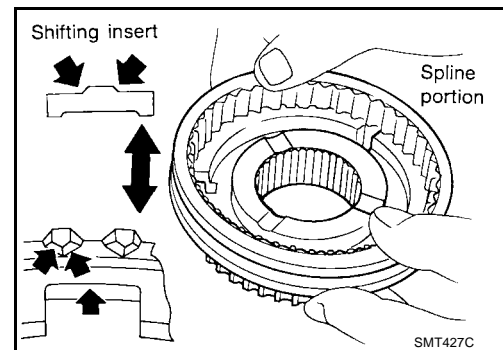

- Measure wear of main drive, 1st (VG33E model) and OD baulk rings. Refer to [MT-81, "Clearance Between Single Baulk Ring and Gear"](#) .
- If the clearance is smaller than the wear limit, replace baulk ring.

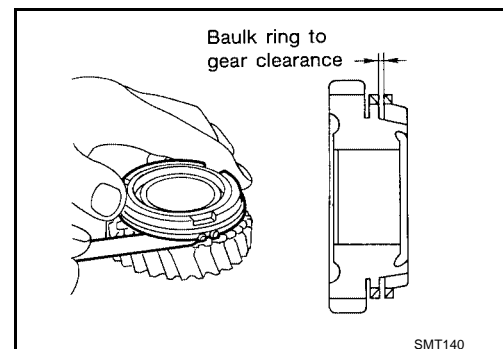

A
B
MT

D
E
F
G
H
I
J
K
L
M

- Measure wear of 1st, 2nd and 3rd double baulk rings.

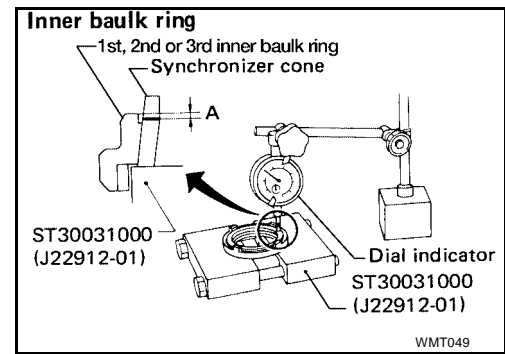

- 1st, 2nd and 3rd double baulk rings: VG33ER model.
2nd and 3rd double baulk rings: VG33E model.
- Place baulk rings in position on synchronizer cone.
- While holding baulk rings against synchronizer cone as far as it will go, measure dimensions "A" and "B".

Standard

Dimension "A" : 0.7 - 0.9 mm (0.028 - 0.035 in)

Dimension "B" : 0.6 - 1.1 mm (0.024 - 0.043 in)

Wear limit : 0.2 mm (0.008 in)

- If dimension "A" or "B" is smaller than the wear limit, replace outer baulk ring, inner baulk ring and synchronizer cone as a set.
- Measure wear of reverse baulk ring.
- Place baulk ring in position on reverse cone.
- While holding baulk ring against reverse cone as far as it will go, measure dimension "A" with dial indicator.

Standard

Dimension "A" : Standard 0.35 to 0.95 mm (0.0119 to 0.0295 in)

Wear limit : 1.1 mm (0.043 in)

- If dimension "A" is larger than the wear limit, replace baulk ring.

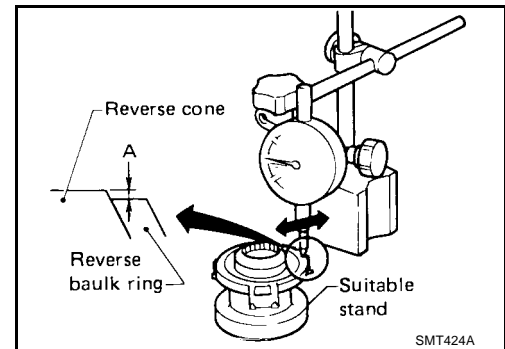
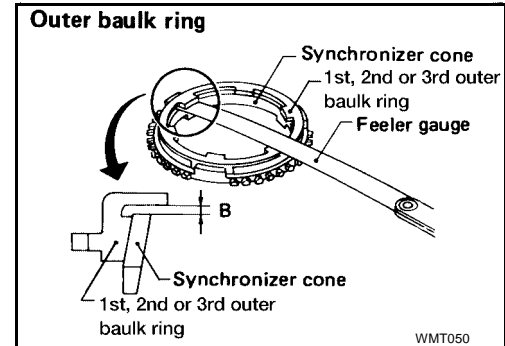

BEARINGS

- Make sure bearings roll freely and are free from noise, crack, pitting or wear.

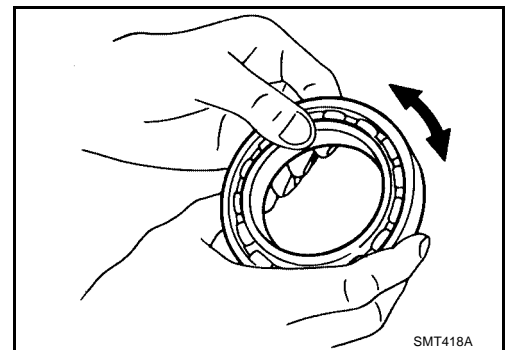

Assembly

ECS00719

1. Install bearings into case components.

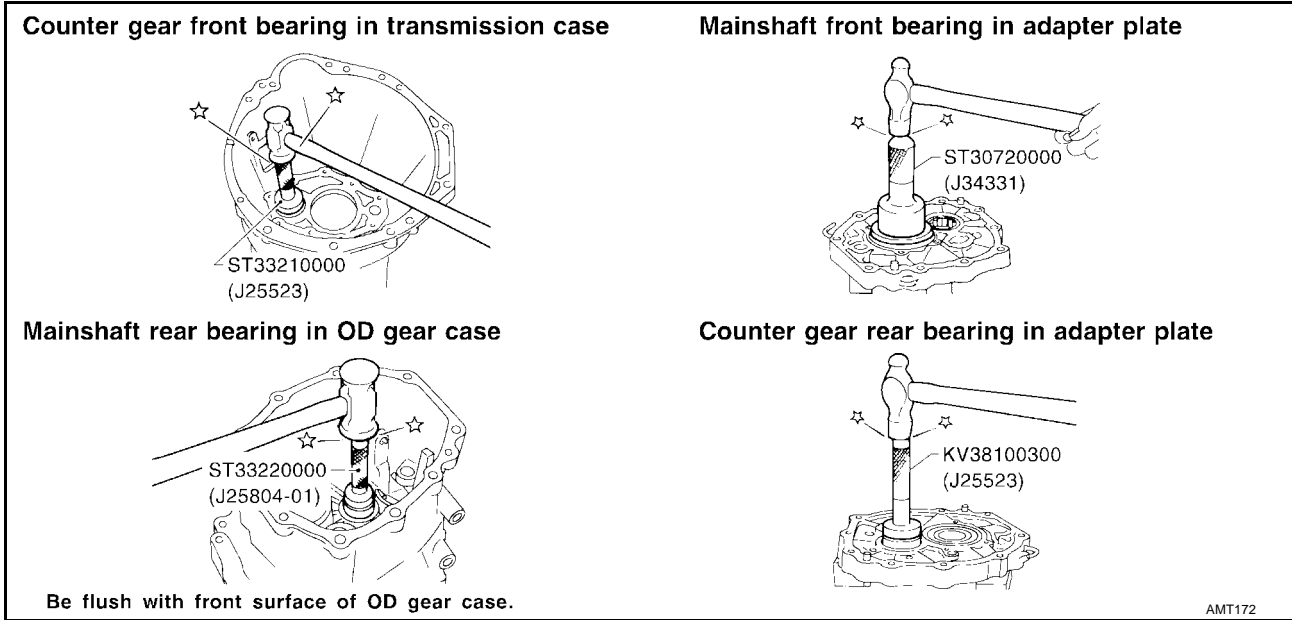

Tool numbers

- Counter gear front bearing : ST33210000 (J25523)**
- Mainshaft front bearing : ST30720000 (J34331)**
- Mainshaft rear bearing : ST33220000 (J25804-01)**
- Counter gear rear bearing : KV38100300 (J25523)**

2. Install mainshaft front bearing snap ring into adapter plate.
3. Install bearing retainer.

Bearing retainer bolt : 16 - 20 N·m (1.6 - 2.1 kg·m, 12 - 15 lb·ft)

4. Install main drive gear bearing.
- a. Press main drive gear bearing using Tool.

Tool number : ST30613000 (J25742-3)

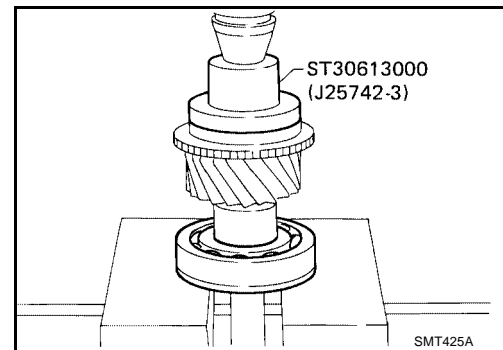

- b. Install pilot bearing.
- c. Select proper main drive gear snap ring to minimize clearance of groove. Refer to [MT-82, "MAIN DRIVE GEAR SNAP RING"](#).

Main drive gear snap ring allowable clearance : 0 - 0.1 mm (0 - 0.003 in)

- d. Install selected main drive gear snap ring on main drive gear.

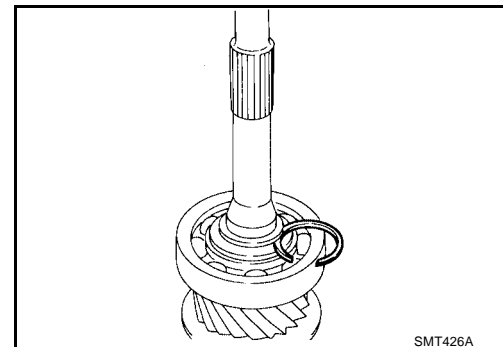

A
B
MT
D
E
F
G
H
I
J
K
L
M

GEAR COMPONENTS

[FS5R30A]

5. Install components on counter gear.

- a. Install sub-gear, sub-gear spring, sub-gear bracket and sub-gear snap ring.
- When installing sub-gear snap ring, tap sub-gear snap ring into position on counter gear using Tool.

Tool number : (J26092)

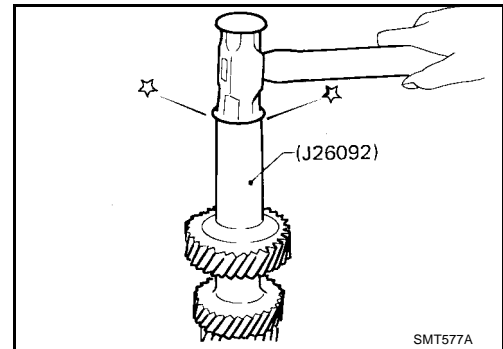

b. Install counter gear rear thrust bearing using a brass drift.

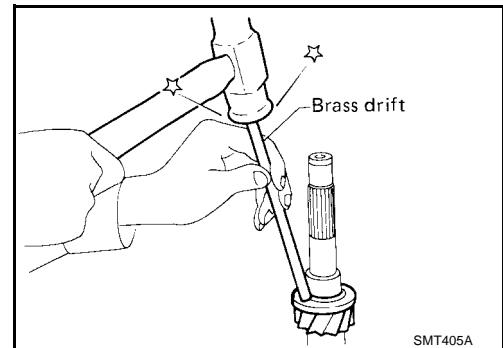

6. Install front side components on mainshaft.

a. Assemble 1st and 2nd synchronizer.

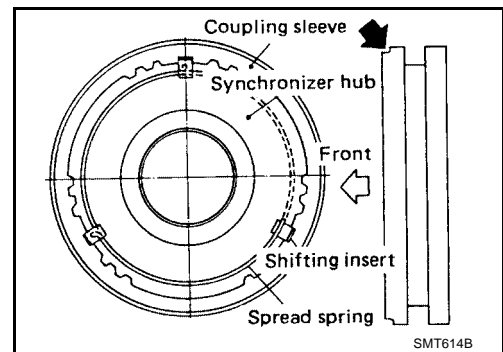

b. Assemble 3rd and 4th synchronizer.

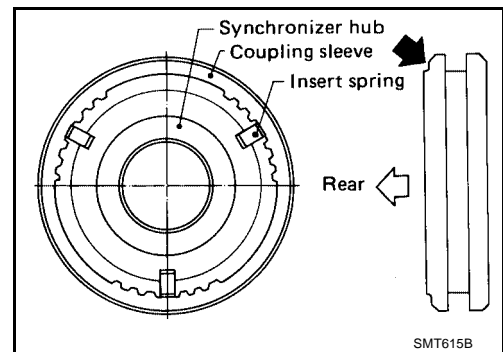

c. Press on 3rd and 4th synchronizer assembly together with 3rd main gear and 3rd gear needle bearing.

- Pay attention to direction of synchronizer assembly.

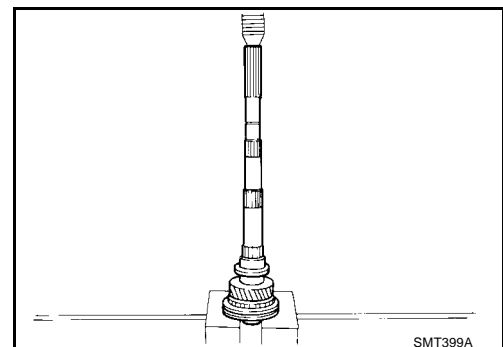

GEAR COMPONENTS

[FS5R30A]

- d. Select proper mainshaft front bearing snap ring to minimize clearance of groove. Refer to [MT-82, "MAINSHAFT FRONT BEARING SNAP RING"](#).

Mainshaft front bearing snap ring groove allowable clearance : 0 - 0.1 mm (0 - 0.003 in)

- e. Install selected mainshaft front bearing snap ring on mainshaft.

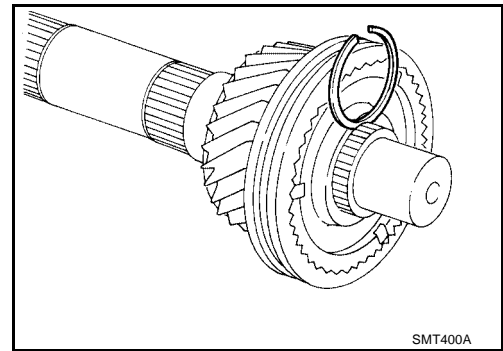

- f. Press on 1st and 2nd synchronizer assembly together with 2nd main gear and 2nd gear needle bearing.

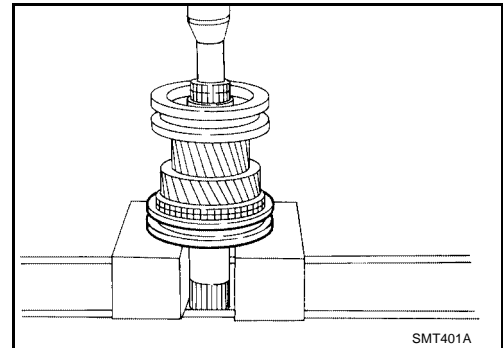

- g. Press on 1st gear bushing using 1st gear washer.

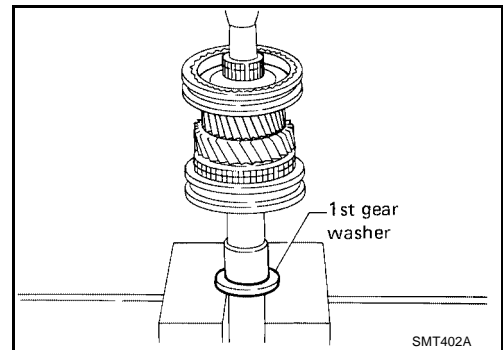

- h. Install 1st main gear and 1st gear needle bearing.

- i. Install steel ball and 1st gear washer.

- Apply multi-purpose grease to steel ball and 1st gear washer before installing.

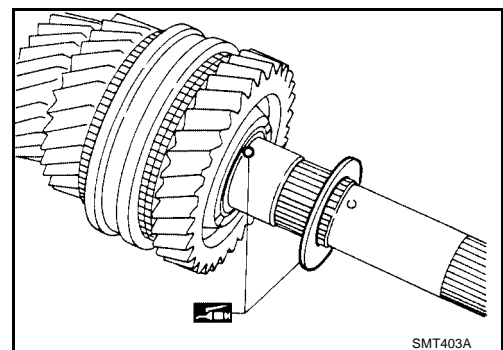

A
B
MT
D
E
F
G
H
I
J
K
L
M

GEAR COMPONENTS

[FS5R30A]

7. Select proper counter gear front bearing shim when replacing transmission case, counter gear, counter gear rear thrust bearing or sub-gear components.
 - a. Install counter gear with sub-gear components, counter gear front thrust washer and counter gear rear thrust washer on adapter plate.
 - b. Remove counter gear front bearing shim from transmission case.
 - c. Place adapter plate and counter gear assembly in transmission case (case inverted).

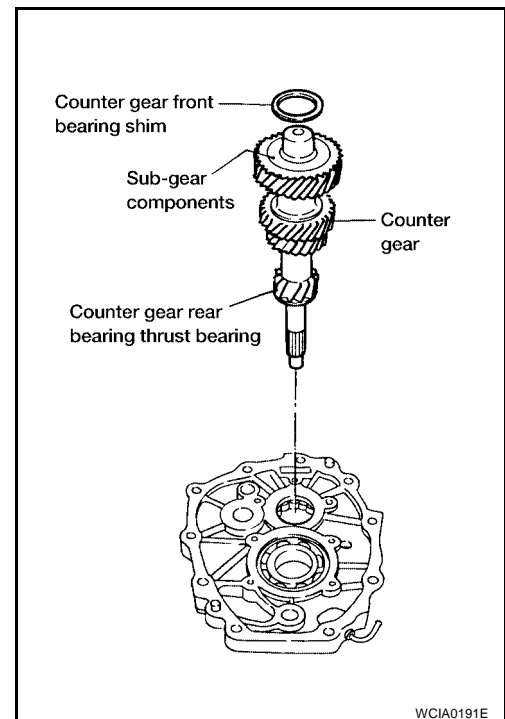

- d. Tighten adapter plate to transmission case using 2 bolts.
 - e. Place dial indicator on rear end of counter gear.
 - f. Move counter gear up and down and measure dial indicator deflection.
 - g. Select proper thrust washer using the table as a guide. Refer to [MT-83, "TABLE FOR SELECTING PROPER COUNTER GEAR FRONT BEARING SHIM"](#).

Counter gear end play : 0.10 - 0.26 mm (0.0040 - 0.0102 in)

- h. Separate adapter plate and transmission case.
 - i. Remove counter gear assembly.

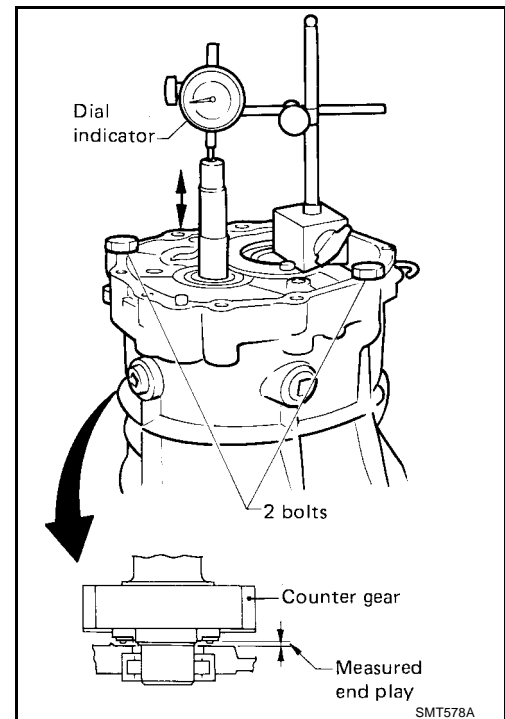

GEAR COMPONENTS

[FS5R30A]

8. Select proper reverse idler rear thrust washer when replacing rear extension (or OD gear case), reverse idler gear, reverse idler shaft or reverse idler front thrust washer.

a. Install reverse idler gear, reverse idler needle bearings, reverse idler rear thrust washer and reverse idler shaft into rear extension (or OD gear case).

● **When replacing reverse idler rear thrust washer, install either A or B. Refer to [MT-83, "REVERSE IDLER REAR THRUST WASHER"](#).**

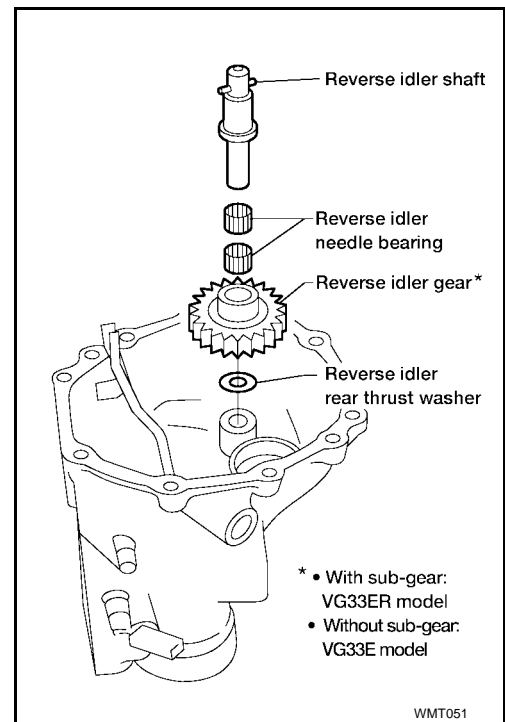

b. Place dial indicator on front end of reverse idler shaft.

c. Put straightedge on front surface of rear extension (or O/D gear case) as a stopper of reverse idler shaft.

d. Move reverse idler shaft up and down and measure reverse idler gear end play.

Reverse idler gear : 0.30 - 0.53 mm (0.0119 - 0.0208 in) end play

e. If not within specification, replace reverse idler rear thrust washer with the other (A or B) and check again.

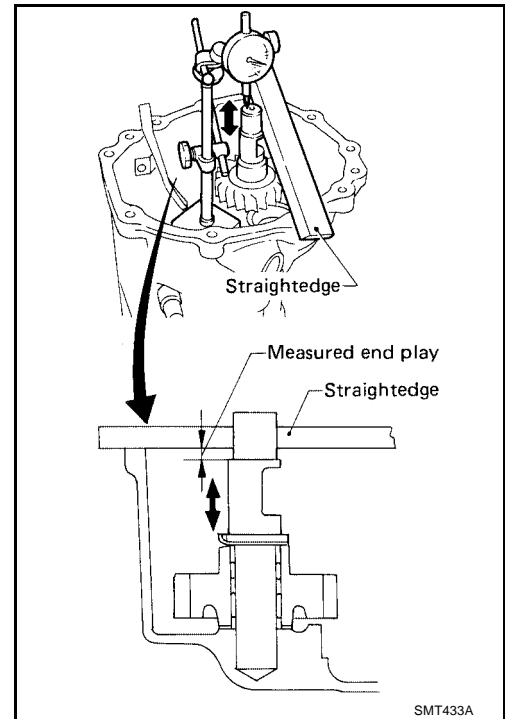

9. Install mainshaft and counter gear on adapter plate and main drive gear on mainshaft.

a. Mount adapter plate on vise and apply multi-purpose grease to counter gear rear bearing.

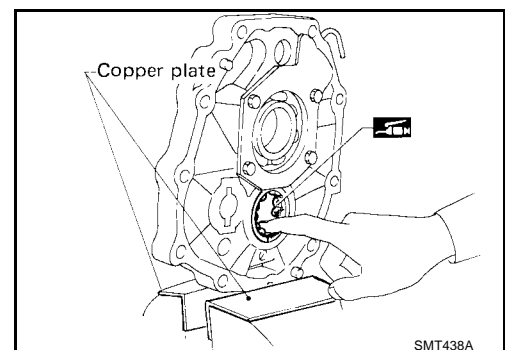

A
B
MT
D
E
F
G
H
I
J
K
L
M

GEAR COMPONENTS

[FS5R30A]

- b. Partially install mainshaft on mainshaft front bearing.
- To allow for installation of counter gear, do not install mainshaft completely.

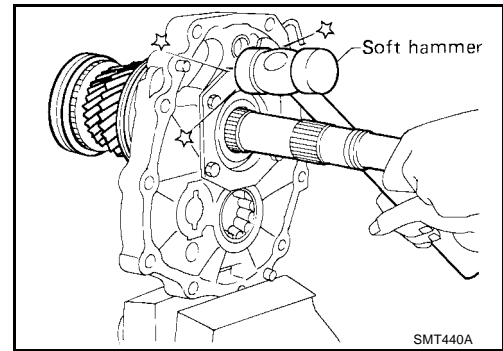

- c. Install counter gear in counter gear rear bearing and install main drive gear, pilot bearing and spacer on mainshaft.

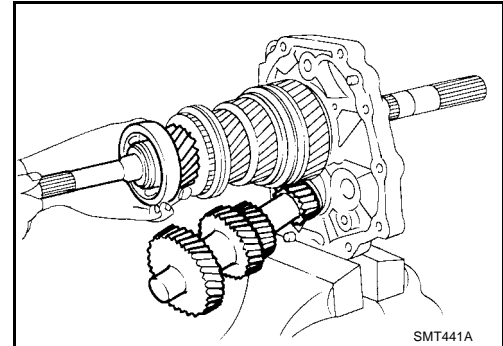

- When installing counter gear into counter gear rear bearing, push up on upper roller of counter gear rear bearing with screwdriver.

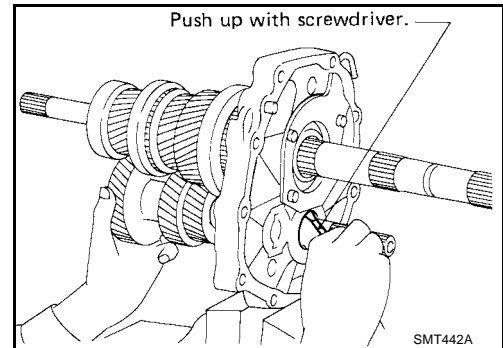

- d. Install Tools (J26349-3) onto adapter plate and C-ring and C-ring holder on mainshaft.
- e. Install Tool (J34328) on mainshaft.

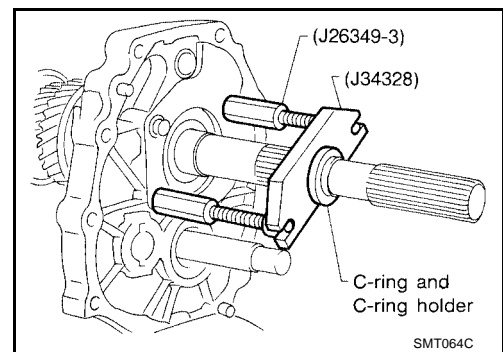

- f. Install mainshaft and counter gear completely by extending length of Tool (J26349-3).

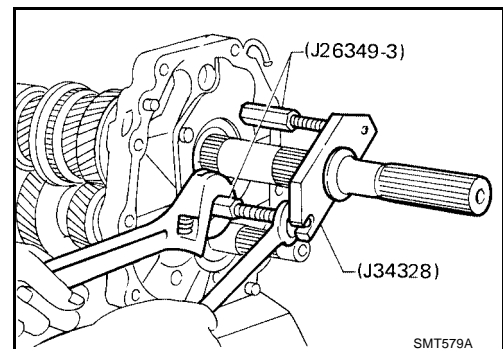

GEAR COMPONENTS

[FS5R30A]

10. Install rear side components on mainshaft and counter gear.

a. Install OD gear bushing using Tool while pushing on the front of counter gear.

Tool number : ST37750000 (J34332)

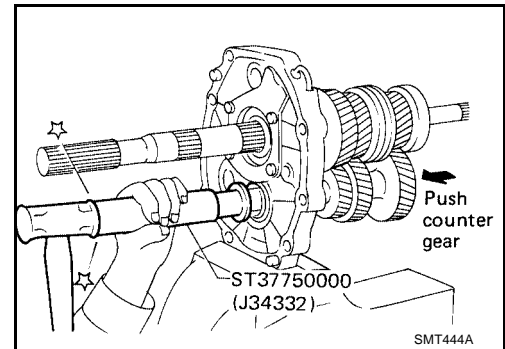

b. Install OD main gear using Tool.

- Pay attention to direction of OD main gear. (B is wider than A as shown.)

Tool number : (J34342)

c. Install adapter plate with gear assembly onto transmission case.

d. Install OD gear needle bearing and then install OD counter gear and reverse idler shaft.

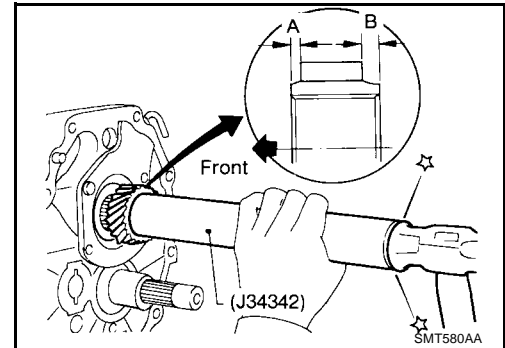

e. Install reverse gear bushing with speedometer drive gear (2WD model) using Tool.

Tool number : (J34342)

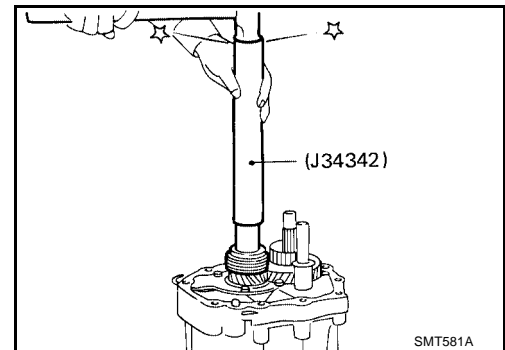

f. Install reverse cone using Tool.

Tool number : ST37750000 (J34332)

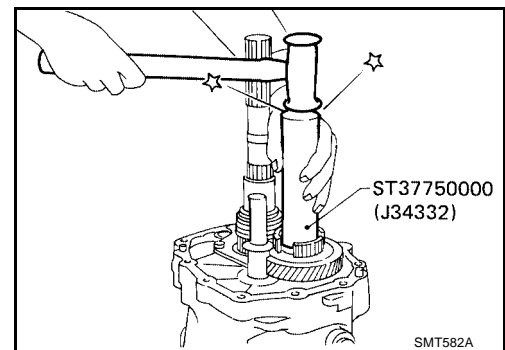

g. Install insert springs and reverse baulk ring on OD coupling sleeve. Then install them and OD baulk ring on OD counter gear.

- Pay attention to direction of OD coupling sleeve.

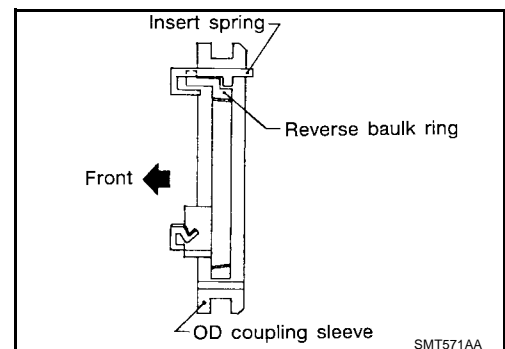

A
B
MT
D
E
F
G
H
I
J
K
L
M

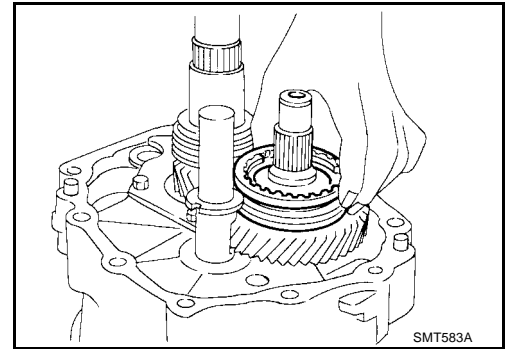

h. Install reverse counter gear using Tool.

Tool number : ST37750000 (J34332)

i. Install reverse gear needle bearing and then install reverse main gear, reverse idler gear and reverse idler rear thrust washer.

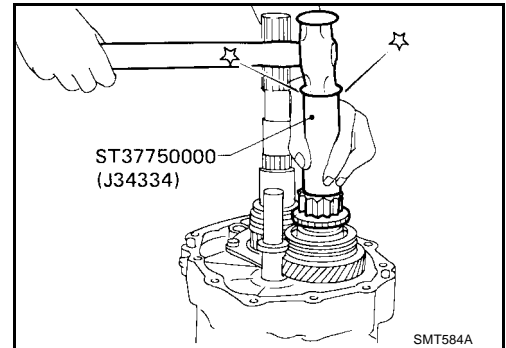

j. Install reverse synchronizer hub using Tool.

- Pay attention to its direction.

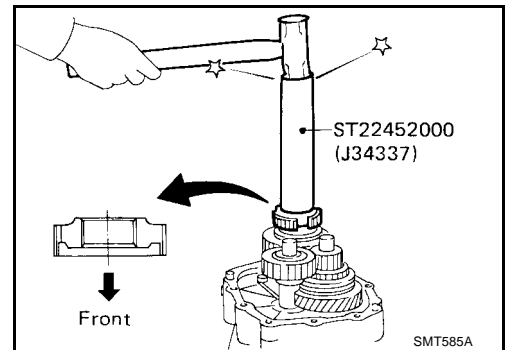

k. Install mainshaft spacer and mainshaft rear bearing (2WD model) using Tool.

Tool number : J-26349-A, J-25726-B

l. Install counter gear rear end bearing using Tool.

Tool number : ST37750000 (J25679-01)

m. Separate adapter plate from transmission case and mount adapter plate on vise again.

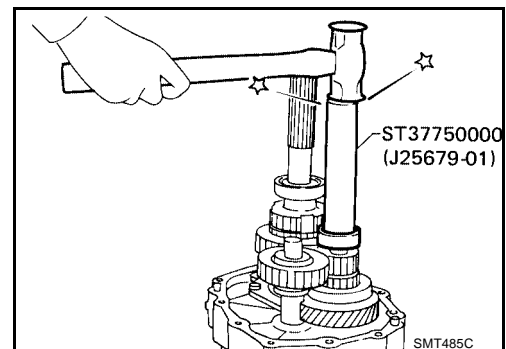

GEAR COMPONENTS

[FS5R30A]

- n. Select proper mainshaft C-ring to minimize clearance of groove. Refer to [MT-83, "MAINSHAFT C-RING"](#).

Mainshaft C-ring groove allowable clearance : 0 - 0.1 mm (0 - 0.003 in)

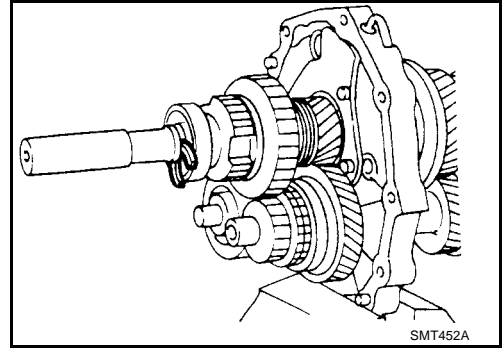

- o. Install selected mainshaft C-ring, C-ring holder and mainshaft rear snap ring.

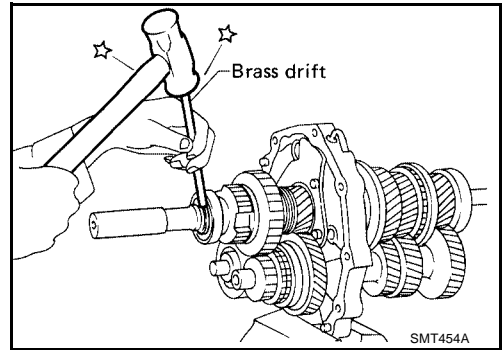

- p. Select proper counter gear rear snap ring to minimize clearance of groove. Refer to [MT-83, "COUNTER GEAR REAR SNAP RING"](#).

Counter gear rear snap ring groove allowable clearance 0 - 0.1 mm (0 - 0.003 in)

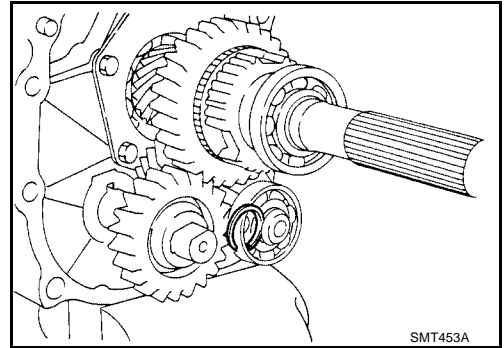

- q. Install selected counter gear rear snap ring.

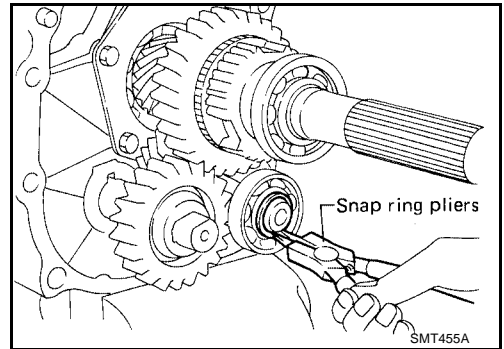

- r. Install reverse coupling sleeve.
● Pay attention to its direction.

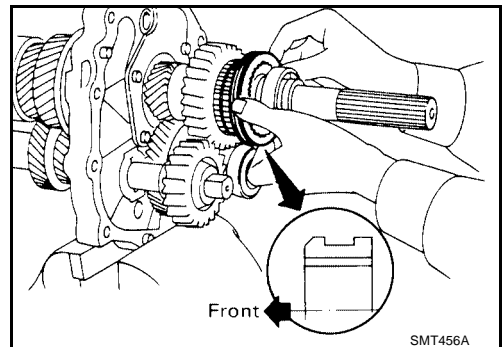

A
B
MT
D
E
F
G
H
I
J
K
L
M

GEAR COMPONENTS

[FS5R30A]

- s. Measure each gear end play as a final check. Refer to [MT-81](#), "[Gear End Play](#)".

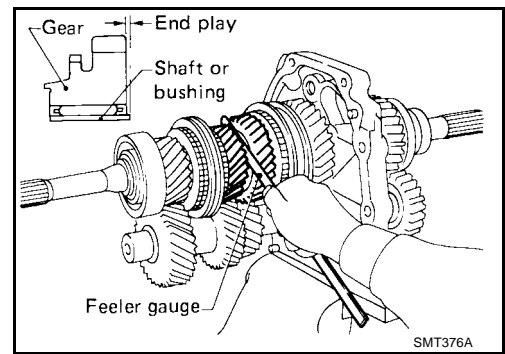

SERVICE DATA AND SPECIFICATIONS (SDS)

[FS5R30A]

SERVICE DATA AND SPECIFICATIONS (SDS)

PF0:00030

General Specifications

ECS0071A

	VG33E/VG33ER		
Transmission	FS5R30A		
	2WD	4WD	
Number of speed	5		
Shift pattern			
Synchromesh type	Warner		
	Gear ratio	Number of teeth	
		Mainshaft	Countershaft
Drive	—	22	32
1st	3.580	32	13
2nd	2.077	30	21
3rd	1.360	29	31
4th	1.000	—	—
OD	0.811	24	43
Reverse	3.636	30	12
Reverse idler gear	22		
Oil capacity ℓ (US pt, Imp pt)	2.8 (5-7/8, 4-7/8) — 2WD model		5.1 (10-3/4, 9) — 4WD model
Remarks	2nd & 3rd double baulk ring type synchronizer		

Gear End Play

ECS0071B

Unit: mm (in)

Gear	End play
1st main gear	0.23 - 0.33 (0.0091 - 0.0130)
2nd main gear	0.23 - 0.33 (0.0091 - 0.0130)
3rd main gear	0.06 - 0.16 (0.0024 - 0.0063)
OD counter gear	0.23 - 0.33 (0.0091 - 0.0130)
Reverse main gear	0.33 - 0.43 (0.0130 - 0.0169)
Counter gear	0.10 - 0.26 (0.0039 - 0.0102)
Reverse idler gear	0.30 - 0.53 (0.0119 - 0.0208)

Clearance Between Single Baulk Ring and Gear

ECS0071C

Unit: mm (in)

	Standard	Wear limit
1st (VG33E model)	1.05 - 1.3 (0.0414 - 0.0511)	0.7 (0.028)
Main drive	1.05 - 1.3 (0.0414 - 0.0511)	
OD	1.05 - 1.3 (0.0414 - 0.0511)	

SERVICE DATA AND SPECIFICATIONS (SDS)

[FS5R30A]

DOUBLE BAULK RING

Unit: mm (in)

VG33E model	2nd & 3rd baulk rings
VG33ER model	1st, 2nd & 3rd baulk rings

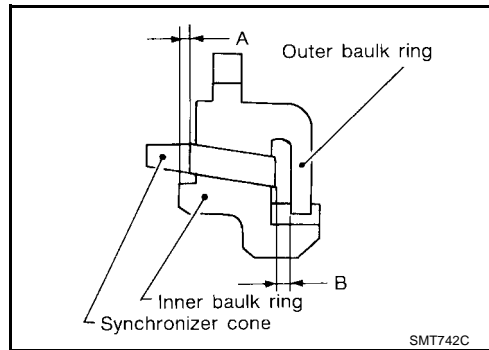

Dimension	Standard	Wear limit
A	0.7 - 0.9 (0.028 - 0.035)	0.2 (0.008)
B	0.6 - 1.1 (0.024 - 0.043)	

Distance Between Rear Surface of Reverse Cone and Reverse Baulk Ring

ECS0071D

Unit: mm (in)

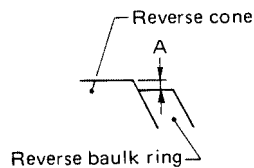

Dimension	Standard	Wear limit
A	0.35 to 0.95 (0.0119 to 0.0295)	1.1 (0.043)

Available Snap Ring MAIN DRIVE GEAR SNAP RING

ECS0071E

Unit: mm (in)

Main drive gear snap ring groove allowable clearance 0 - 0.1 (0 - 0.003)

Thickness	Part number*	Thickness	Part number*
1.89 (0.0744)	32204-01G60	2.03 (0.0799)	32204-01G63
1.95 (0.0768)	32204-01G61	2.07 (0.0815)	32204-01G64
1.99 (0.0783)	32204-01G62	2.11 (0.0831)	32204-01G65

*Always check with the Parts Department for the latest parts information.

MAINSHAFT FRONT BEARING SNAP RING

Unit: mm (in)

Mainshaft front bearing snap ring groove allowable clearance 0 - 0.1 (0 - 0.003)

Thickness	Part number*	Thickness	Part number*
1.99 (0.0783)	32204-01G62	2.11 (0.0831)	32204-01G65
2.03 (0.0799)	32204-01G63	2.15 (0.0846)	32204-01G66
2.07 (0.0815)	32204-01G64	2.19 (0.0862)	32204-01G67

*Always check with the Parts Department for the latest parts information.

SERVICE DATA AND SPECIFICATIONS (SDS)

[FS5R30A]

COUNTER GEAR REAR SNAP RING

Unit: mm (in)

Counter gear rear snap ring groove allowable clearance		0 - 0.1 (0 - 0.003)	
Thickness	Part number*	Thickness	Part number*
1.32 (0.0520)	32236-01G00	1.56 (0.0614)	32236-01G04
1.38 (0.0543)	32236-01G01	1.62 (0.0638)	32236-01G05
1.44 (0.0567)	32236-01G02	1.68 (0.0661)	32236-01G06
1.50 (0.0591)	32236-01G03	1.74 (0.0685)	32236-01G07

*Always check with the Parts Department for the latest parts information.

Available C-ring MAINSHAFT C-RING

ECS0071F

Unit: mm (in)

Mainshaft C-ring groove allowable clearance		0 - 0.1 (0 - 0.003)	
Thickness	Part number*	Thickness	Part number*
2.63 (0.1035)	32348-01G15	3.19 (0.1256)	32348-01G07
2.70 (0.1063)	32348-01G00	3.26 (0.1283)	32348-01G08
2.77 (0.1091)	32348-01G01	3.33 (0.1311)	32348-01G09
2.84 (0.1118)	32348-01G02	3.40 (0.1339)	32348-01G10
2.91 (0.1146)	32348-01G03	3.47 (0.1366)	32348-01G11
2.98 (0.1173)	32348-01G04	3.54 (0.1394)	32348-01G12
3.05 (0.1201)	32348-01G05	3.61 (0.1421)	32348-01G13
3.12 (0.1228)	32348-01G06	3.68 (0.1449)	32348-01G14

*Always check with the Parts Department for the latest parts information.

Available Shim and Washer TABLE FOR SELECTING PROPER COUNTER GEAR FRONT BEARING SHIM

ECS0071G

Unit: mm (in)

Counter gear end play		0.10 - 0.26 (0.0040 - 0.0102)	
Dial indicator deflection	Thickness of proper shim	Part number*	
0.93 - 1.02 (0.0367 - 0.0401)	0.80 (0.0315)	32218-01G00	
1.01 - 1.10 (0.0398 - 0.0433)	0.88 (0.0346)	32218-01G11	
1.09 - 1.18 (0.0430 - 0.0464)	0.96 (0.0378)	32218-01G12	
1.17 - 1.26 (0.0461 - 0.0496)	1.04 (0.0409)	32218-01G13	
1.25 - 1.34 (0.0493 - 0.0527)	1.12 (0.0441)	32218-01G14	
1.33 - 1.42 (0.0524 - 0.0559)	1.20 (0.0472)	32218-01G04	
1.41 - 1.50 (0.0556 - 0.0590)	1.28 (0.0504)	32218-01G15	
1.49 - 1.58 (0.0587 - 0.0622)	1.36 (0.0535)	32218-01G16	
1.57 - 1.66 (0.0619 - 0.0653)	1.44 (0.0567)	32218-01G17	

*Always check with the Parts Department for the latest parts information.

REVERSE IDLER REAR THRUST WASHER

Unit: mm (in)

Reverse idler gear end play		0.30 - 0.53 (0.0119 - 0.0208)	
Thickness	Part number*		
A	1.97 (0.0776)	32284-01G10	
B	2.07 (0.0815)	32284-01G11	

*Always check with the Parts Department for the latest parts information.

