

TF
SECTION
TRANSFER

A
 B
 C
TF

CONTENTS

PREPARATION	2	DISASSEMBLY	32	
Special Service Tools	2	INSPECTION	33	
Commercial Service Tools	4	ASSEMBLY	33	
NOISE, VIBRATION, AND HARSHNESS (NVH)		Main Gear	33	G
TROUBLESHOOTING	5	DISASSEMBLY	33	
NVH Troubleshooting Chart	5	INSPECTION	34	
DESCRIPTION	7	ASSEMBLY	34	H
Cross-sectional View	7	Front Case	35	
ON-VEHICLE SERVICE	8	SHIFT SHAFT OIL SEAL	35	
Replacing Oil Seal	8	Front Case Cover	36	
CENTER CASE OIL SEAL	8	COVER OIL SEAL	36	I
SHIFT SHAFT OIL SEAL	9	Bearing Retainer	36	
REAR OIL SEAL	9	OIL CATCHER	36	
Position Switch Check	10	Center Case	37	J
REMOVAL AND INSTALLATION	11	CENTER CASE OIL SEAL	37	
Removal	11	Rear Case	37	
Installation	11	REAR OIL SEAL	37	K
OVERHAUL	12	AIR BREATHER	38	
Transfer Gear Control	12	Shift Control Components	38	
Case Components	13	INSPECTION	38	L
Gear Components	14	SERVICE DATA AND SPECIFICATIONS (SDS)	40	
Shift Control Components	15	General Specifications	40	
TRANSFER ASSEMBLY	16	Inspection and Adjustment	40	M
Disassembly	16	CLEARANCE BETWEEN FRONT DRIVE		
Assembly	21	SPROCKET AND 2-4 COUPLING SLEEVE	40	
REPAIR FOR COMPONENT PARTS	29	GEAR END PLAY	40	
Mainshaft	29	CLEARANCE BETWEEN BAULK RING AND		
DISASSEMBLY	29	CLUTCH GEAR	40	
INSPECTION	30	Available Shim	40	
ASSEMBLY	31	COUNTER GEAR REAR BEARING	40	
Front Drive Shaft	32	Available Snap Ring	40	
DISASSEMBLY	32	MAINSHAFT FRONT BEARING	40	
INSPECTION	32	MAIN GEAR BEARING	40	
ASSEMBLY	32	MAINSHAFT REAR BEARING	41	
Counter Gear	32			

PREPARATION

PFP:00002

EDS00117

PREPARATION

Special Service Tools

The actual shapes of Kent-Moore tools may differ from those of special service tools illustrated here.

Tool number (Kent-Moore No.) Tool name	Description
KV38108300 (—) Companion flange wrench	Removing companion flange nut Installing companion flange nut
ST30021000 (J22912-01) Puller	Removing counter gear front bearing (Use with ST36710010) Removing L & H hub a: 110 mm (4.33 in) dia. b: 68 mm (2.68 in) dia.
ST30031000 (J22912-01) Puller	Removing counter gear rear bearing (Use with ST36710010) a: 90 mm (3.54 in) dia. b: 50 mm (1.97 in) dia.
ST33290001 (J34286) Puller	Removing center case oil seal Removing rear oil seal a: 250 mm (9.84 in) b: 160 mm (6.30 in)
ST33051001 (J22888) Puller	Removing companion flange a: 135 mm (5.31 in) b: 100 mm (3.94 in) c: 130 mm (5.12 in)
ST30720000 1 (J25273) 2 (J25405) Drift	1 Installing center case oil seal 2 Installing rear oil seal a: 77 mm (3.03 in) dia. b: 55.5 mm (2.185 in) dia.
ST36710010 (—) Drift	Removing counter gear front bearing (Use with ST30021000) Removing counter gear rear bearing (Use with ST30031000) a: 34.5 mm (1.358 in) dia.

PREPARATION

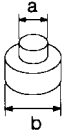
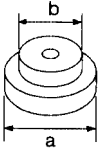
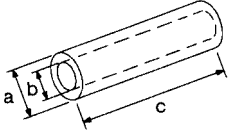
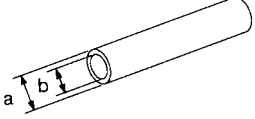
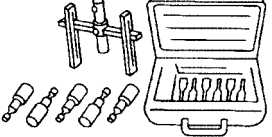
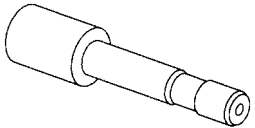
Tool number (Kent-Moore No.) Tool name	Description	
ST33061000 (J8107-2) Drift <div style="text-align: center;">  </div> <p style="text-align: right; margin-right: 50px;">NT116</p>	Removing main gear bearing a: 28.5 mm (1.122 in) dia. b: 38 mm (1.50 in) dia.	A B C
ST30613000 1 (J25742-3) 2 (J34339) Drift <div style="text-align: center;">  </div> <p style="text-align: right; margin-right: 50px;">NT073</p>	1 Installing main gear bearing 2 Installing front case cover oil seal a: 72 mm (2.83 in) dia. b: 48 mm (1.89 in) dia.	TF E
(J35864) Drift <div style="text-align: center;">  </div> <p style="text-align: right; margin-right: 50px;">NT117</p>	Installing shift shaft oil seal a: 26 mm (1.02 in) dia. b: 20 mm (0.79 in) dia. c: 150 mm (5.91 in)	F G H
(J26092) Drift <div style="text-align: center;">  </div> <p style="text-align: right; margin-right: 50px;">NT065</p>	Seating counter gear assembly a: 44.5 mm (1.752 in) dia. b: 38.5 mm (1.516 in) dia.	I J
(J34291) Shim setting gauge set <div style="text-align: center;">  </div> <p style="text-align: right; margin-right: 50px;">NT101</p>	Selecting counter gear rear bearing shim	K L
(J34291-20) Plunger-shim setting gauge <div style="text-align: center;">  </div> <p style="text-align: right; margin-right: 50px;">NT118</p>	Selecting counter gear rear bearing shim	M

PREPARATION

Commercial Service Tools

EDS00118

The actual shapes of Kent-Moore tools may differ from those of special service tools illustrated here.

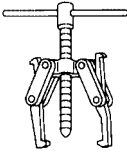
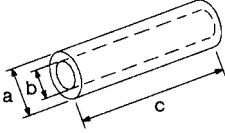
Tool name	Description
<p>Puller</p>  <p>NT077</p>	<p>Removing front drive shaft front bearing Removing front drive shaft rear bearing Removing main gear bearing</p>
<p>Drift</p>  <p>NT117</p>	<p>1 Installing mainshaft rear bearing 2 Installing L & H hub 1 a: 50 mm (1.97 in) dia. b: 42 mm (1.65 in) dia. c: 180 mm (7.09 in) 2 a: 60 mm (2.36 in) dia. b: 50 mm (1.97 in) dia. c: 60 mm (2.36 in)</p>

NOISE, VIBRATION, AND HARSHNESS (NVH) TROUBLESHOOTING

NOISE, VIBRATION, AND HARSHNESS (NVH) TROUBLESHOOTING

PFP:00003

NVH Troubleshooting Chart

EDS00119

Use the chart below to help you find the cause of the symptom. The numbers indicate the order of inspection. If necessary, repair or replace these parts.

Reference page		MA-38, "Checking Transfer Fluid"		IF-13	IF-13, IF-8	IF-13, IF-15	IF-15, IF-38		IF-14, IF-29		
SUSPECTED PARTS (Possible cause)	FLUID (Level low)	FLUID (Wrong)	FLUID (Level too high)	LIQUID GASKET (Damaged)	OIL SEAL (Worn or damaged)	CHECK SPRING AND CHECK BALL (Worn damaged)	SHIFT FORK (Worn)	GEAR (Worn or damaged)	Bearing (Worn or damaged)	BAULK RING (Worn or damaged)	SHIFTING INSERT (Damaged)
Symptom	Noise	1	2					3	3		
	Fluid leakage		3	1	2	2					
	Hard to shift or will not shift		1	1						2	2
	Jumps out of gear					1	2	2			

Transfer Case Diagnostic Table

Symptom	Possible cause	Service Information
Dark oil and/or small debris in the oil.	When checking or changing the oil; oil level may be okay, but the oil color is dark and small metallic debris are on the drain plug.	<p>No repair needed.</p> <p>The transfer case oil (Nissan-Matic-D) may turn dark in color after the vehicle accumulates miles or after operating at high temperatures.</p> <p>Small metal debris are residual material from the transfer case components. This is normal.</p>
Difficult, or no shift from 4H into 2H.	Differences in the front and rear ties size (circumference); caused by tire wear or excessive load on the rear of the vehicle.	<p>Inspect the tires for different sizes.</p> <p>All tires must be the same "height" and "distance around" (circumference).</p> <p>If there are differences in the size, or if one or more tires are excessively worn when compared to the other tires, make corrections as needed so all of the tires are the same size (circumference) before evaluating the transfer case operation.</p> <p>*Size = tire height and circumference (distance "around").</p>

A
B
C
TF
E
F
G
H
I
J
K
L
M

NOISE, VIBRATION, AND HARSHNESS (NVH) TROUBLESHOOTING

Symptom	Possible cause	Service Information
Difficult to shift from 2H into 4H and/or clunk noise when the vehicle is moving.	When engaging 4H, the 2-4 coupling sleeve has resistance when engaging the clutch gear. This resistance is caused by rotating parts attempting to bring stationary parts (parts that are not moving) "up to speed" (transfer case chain, front propshaft and differential).	<p>If difficulty in shifting/clunk noise is gone when the vehicle is stationary (not moving), inform the customer this is a normal characteristic of the transfer case.</p> <p>If shifting to 4H is normally louder the faster the vehicle is moving; CAUTION: never attempt shifting to 4H above 25 mph (50 mph for Pathfinder).</p> <p>If difficulty in shifting/clunk noise can be duplicated when the vehicle is stopped, refer to TF-5, "NVH Troubleshooting Chart".</p>
"Whine" noise while driving in 4H on dry, hard surface (i.e. dry paved road).	Additional torque is applied to the transfer case components.	<p>This is a normal characteristic when there is more than usual torque applied to the transfer case.</p> <p>When the vehicle is driven in 4H on a dry hard surface, above normal torque is applied to the mainshaft, front driveshaft, and transfer case chain. With this extra torque, the transfer case chain will have a "whine" noise.</p> <p>Instruct the customer not to drive the vehicle in 4H on a dry, hard surface.</p>
"Clunk" noise, seems to come from the transfer case.	Excessive friction of the prop shaft u-joint (transfer case end), causing the prop shaft sleeve yoke to stick against the transfer case output shaft.	<p>Inspect the rear prop shaft u-joint (transfer case end) to determine if there is excessive friction of the u-joint (u-joint feels "notchy").</p> <p>Refer to PR-3, "NVH Troubleshooting Chart".</p>
"Grind" noise when slowly shifting the transfer case from 4H to the Neutral and then into 4L, or from 4L to Neutral and then into 4H.	Gear clashing occurs as the Low/High (L/H) coupling sleeve "engages" the main or low gear.	<p>This is a normal characteristic of the transfer case due to all of the gears "spooling up" in Neutral.</p> <p>Instruct the customer to depress the transfer case lever, and then quickly and smoothly shift from 4H to 4L or 4L to 4H, without stopping in Neutral.</p>
"Ratcheting" noise from the front hub.	One of the automatic hubs may be stuck in the "Lock" position, causing the other hub to make a "ratcheting" noise.	<p>Determine which hub is "ratcheting" and inspect the opposite hub for possible damage. Check to see if it is unlocking. The ratcheting hub is likely okay.</p> <p>To check Automatic Hub operation, place the vehicle on a lift with the transfer case in 2H (engine off).</p> <ul style="list-style-type: none"> ● Hand turn the front propshaft to observe both wheels "lock-in". ● Reversing direction of the propshaft should first "un-lock" the wheels and then "lock" them again. ● This action should repeat each time the propshaft is reversed. <p>Refer to FFD-5, "NVH Troubleshooting Chart", and RAX-5, "NVH Troubleshooting Chart".</p>

DESCRIPTION

DESCRIPTION

Cross-sectional View

PFP:00000

EDS0011A

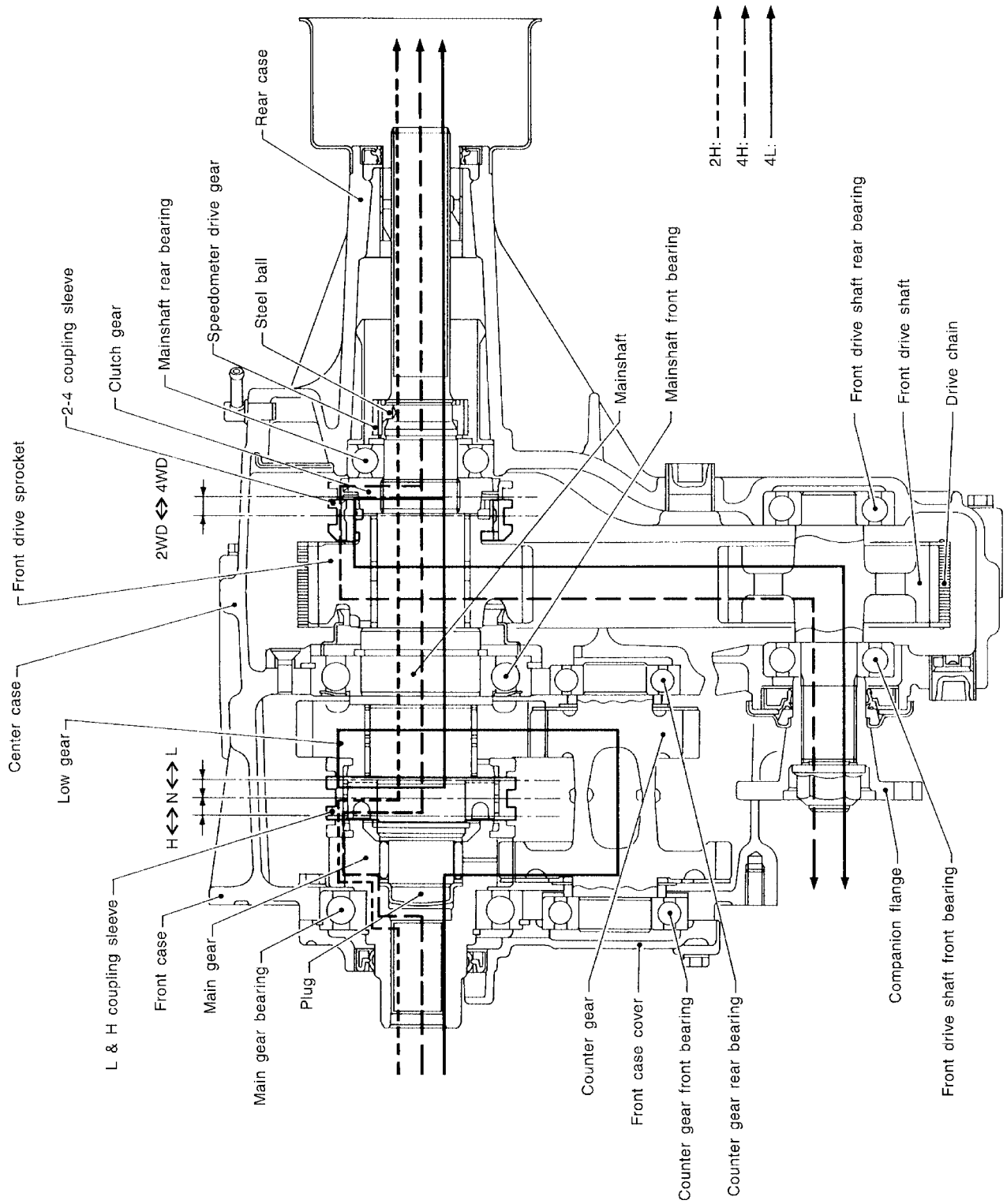

A
B
C
TF
E
F
G
H
I
J
K
L
M

ON-VEHICLE SERVICE

ON-VEHICLE SERVICE

PFP:00000

Replacing Oil Seal CENTER CASE OIL SEAL

EDS0011B

1. Remove front propeller shaft. Refer to [PR-8, "Removal and Installation"](#).
2. Remove companion flange nut using Tool, as shown.

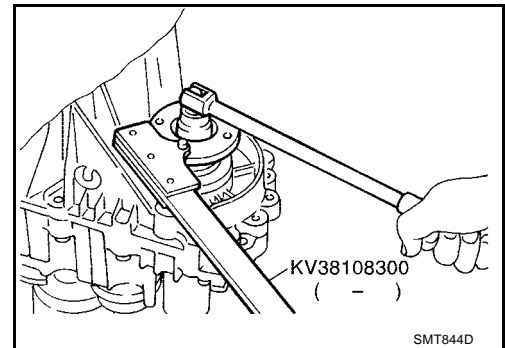

3. Remove companion flange using Tool, as shown.

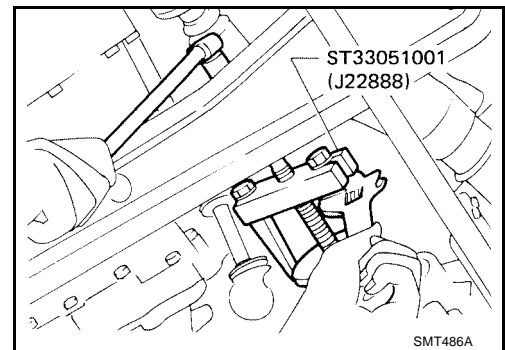

4. Remove center case oil seal using Tool, as shown.

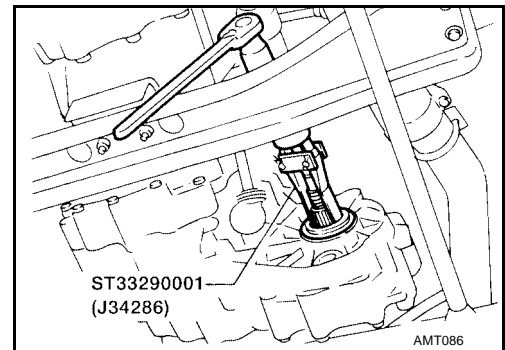

5. Install center case oil seal.
 - **Before installing, apply multi-purpose grease to seal lip.**
6. Install companion flange.
7. Tighten companion flange nut using Tool, as shown.

Companion flange nut : 226 - 324 N·m (23 - 33 kg·m, 166 - 239 ft·lb)

8. Install front propeller shaft. Refer to [PR-8, "Removal and Installation"](#).

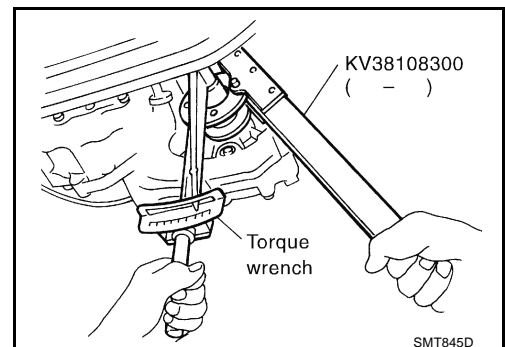

ON-VEHICLE SERVICE

SHIFT SHAFT OIL SEAL

1. Remove front propeller shaft. Refer to [PR-8, "Removal and Installation"](#) .
2. Remove companion flange. Refer to [TF-8, "CENTER CASE OIL SEAL"](#) .
3. Remove transfer control lever from transfer outer shift lever, then remove outer shift lever.

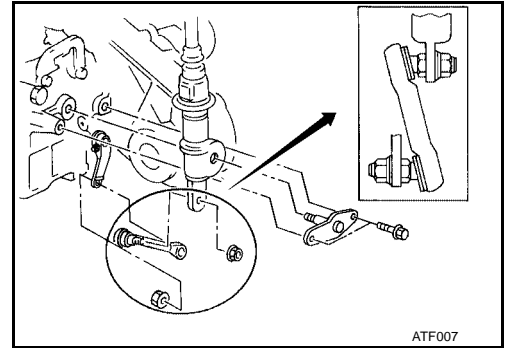

4. Remove shift shaft oil seal using a screwdriver or suitable tool.
 - **Be careful not to damage cross shaft.**

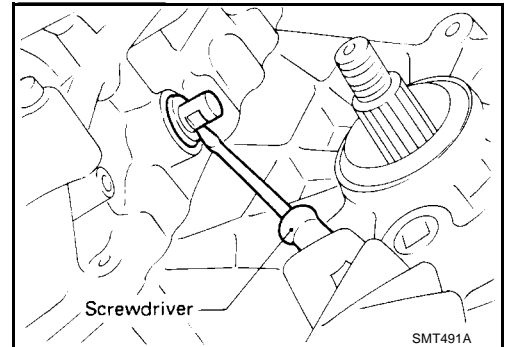

5. Install shift shaft oil seal.
 - **Before installing, apply multi-purpose grease to seal lip.**
6. Install transfer control linkage.
7. Install companion flange. Refer to [TF-8, "CENTER CASE OIL SEAL"](#) .
8. Install front propeller shaft. Refer to [PR-8, "Removal and Installation"](#) .

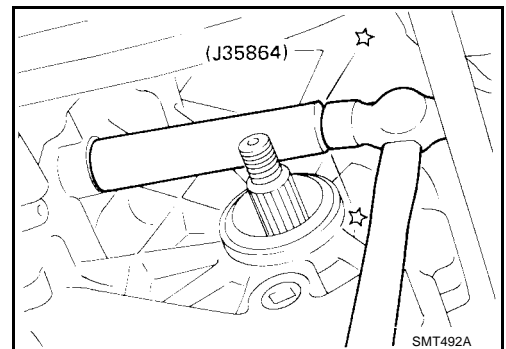

REAR OIL SEAL

1. Remove rear propeller shaft. Refer to [PR-8, "Removal and Installation"](#) .
2. Remove rear oil seal using Tool, as shown.

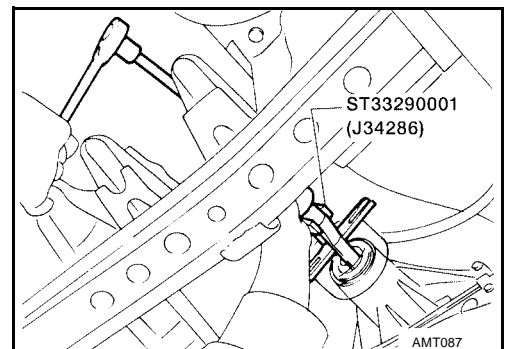

A
B
C
TF
E
F
G
H
I
J
K
L
M

ON-VEHICLE SERVICE

3. Install rear oil seal using Tool, as shown.
 - **Before installing apply multi-purpose grease to seal lip.**
4. Install rear propeller shaft. Refer to [PR-8, "Removal and Installation"](#).

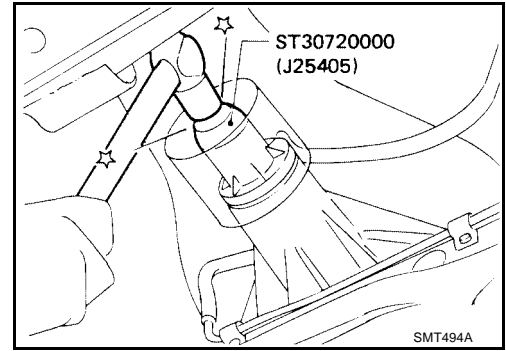

Position Switch Check

EDS0011C

Switch	Gear Position	Continuity
4WD Switch	4WD	Yes
	Except 4WD	No
Neutral Position Switch	Neutral	No
	Except Neutral	Yes

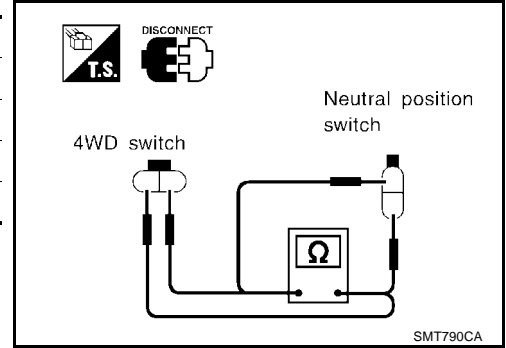

REMOVAL AND INSTALLATION

PFP:00000

EDS0011D

REMOVAL AND INSTALLATION

Removal

1. Drain fluid from transfer. Refer to [MA-38, "Changing Transfer Fluid"](#) .
2. Drain fluid from transmission. Refer to [MA-36, "Changing M/T Oil"](#) or [MA-38, "Changing A/T Fluid"](#) .
3. Remove front and rear propeller shaft. Refer to [PR-8, "Removal and Installation"](#) .
 - Insert plug into rear oil seal after removing propeller shaft.

CAUTION:

Be careful not to damage spline, sleeve yoke and rear oil seal, when removing propeller shaft.

4. Remove torsion bar spring. Refer to [FSU-17, "TORSION BAR SPRING"](#) .
5. Remove second crossmember.
6. Remove exhaust front and rear tubes. Refer to [EX-3, "EXHAUST SYSTEM"](#) .
7. Disconnect vehicle speed sensor, transfer neutral position switch and 4WD switch harness connectors.
8. Remove air breather hose.
9. Remove transfer control lever from transfer outer shift lever.
10. Separate transfer from transmission.

WARNING:

Support transfer while removing it.

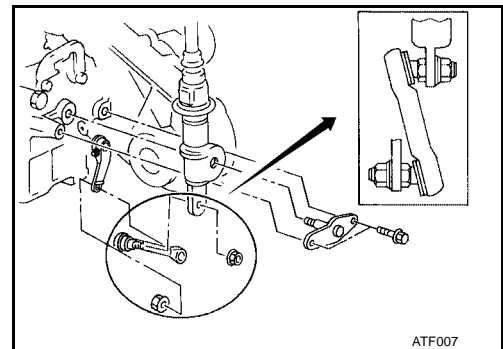

ATF007

EDS0011E

Installation

1. Installation is in the reverse order of removal, noting the following:
 - a. Apply sealant to mating surface to transmission. (M/T model only)
 - Use **Genuine Anaerobic Liquid Gasket or equivalent.** Refer to [GI-42, "RECOMMENDED CHEMICAL PRODUCTS AND SEALANTS"](#) .

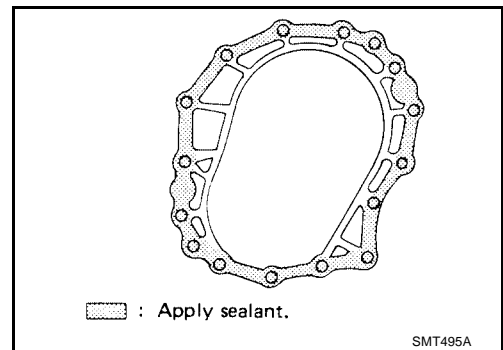

☐ : Apply sealant.

SMT495A

- b. Tighten bolts securing transfer.

M/T MODEL

Bolt No.	Tightening torque N-m (kg-m, ft-lb)	Length "ℓ" mm (in)
1	31 - 42 (3.2 - 4.3, 23 - 31)	60 (2.36)
2	31 - 42 (3.2 - 4.3, 23 - 31)	45 (1.77)

A/T MODEL

Bolt No.	Tightening torque N-m (kg-m, ft-lb)	Length "ℓ" mm (in)
1	31 - 42 (3.2 - 4.3, 23 - 31)	45 (1.77)
2	31 - 42 (3.2 - 4.3, 23 - 31)	45 (1.77)

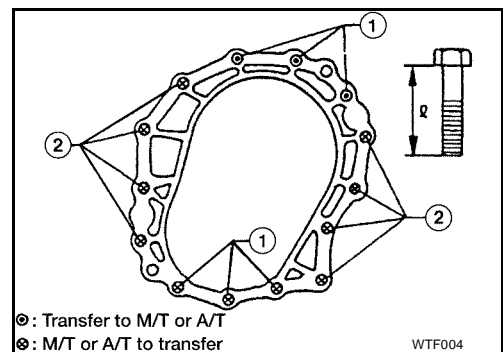

①: Transfer to M/T or A/T
②: M/T or A/T to transfer

WTF004

- c. Adjust the torsion bars for the correct vehicle height. Refer to [FSU-18, "Installation and Adjustment"](#) .
- d. When installing transfer control lever, refer to [TF-12, "Transfer Gear Control"](#) .

OVERHAUL

OVERHAUL

PFP:00000

Transfer Gear Control

EDS0011F

SEC. 333

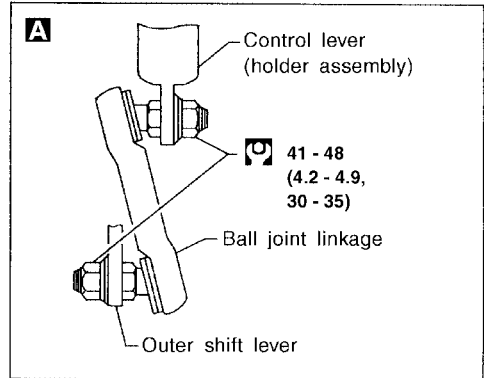
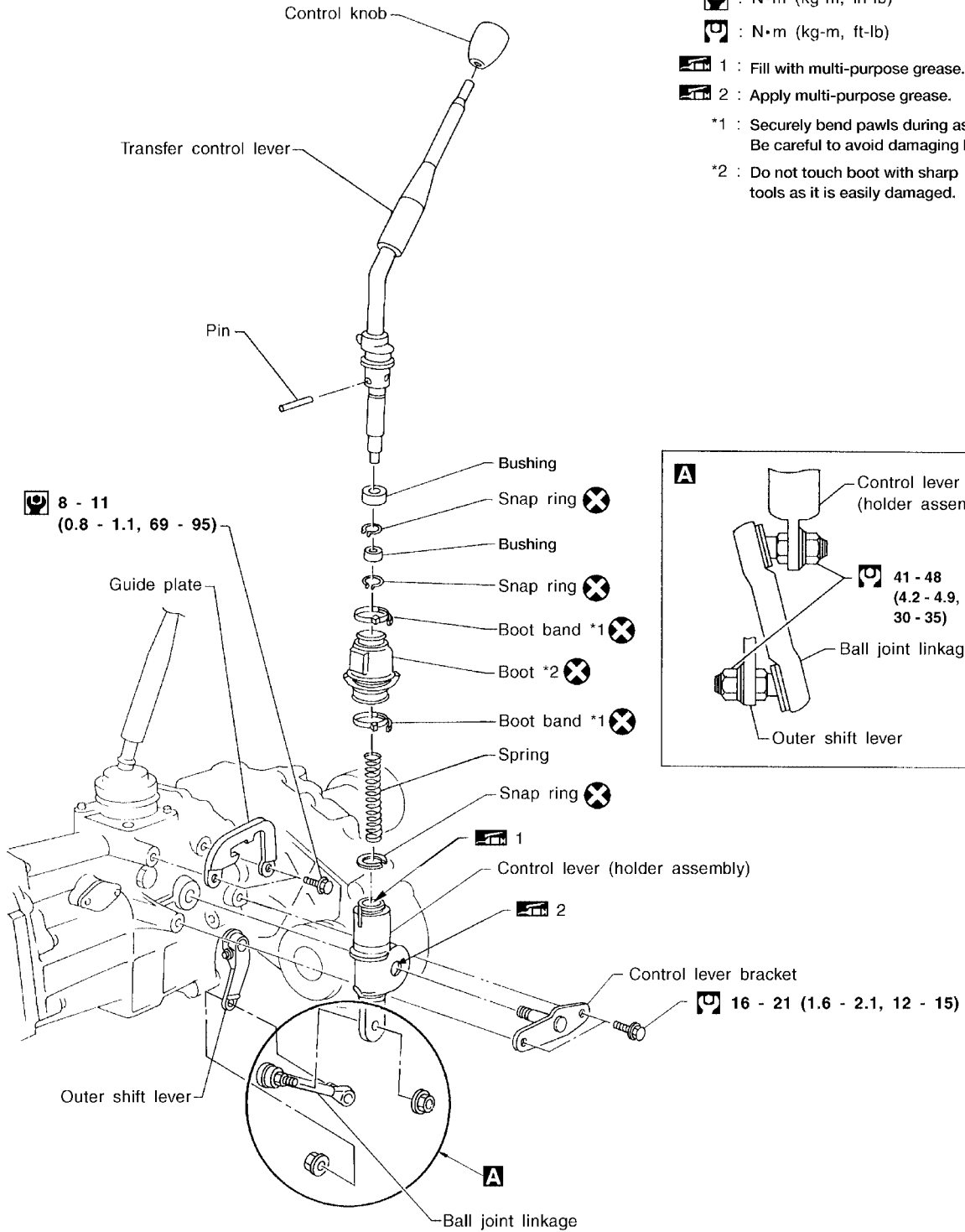

OVERHAUL

Case Components

EDS0011G

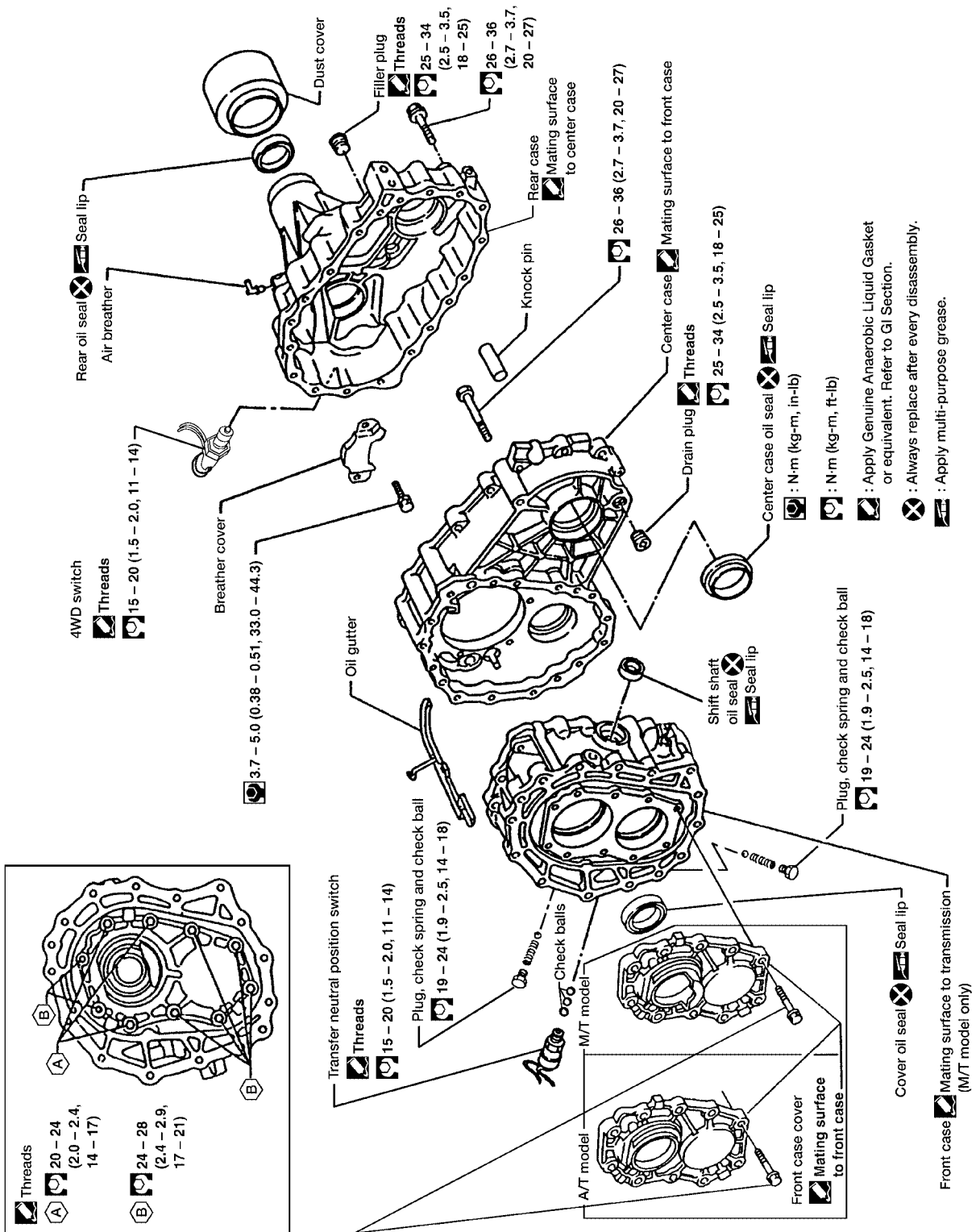

A
B
C
TF
E
F
G
H
I
J
K
L
M

Gear Components

SEC. 332

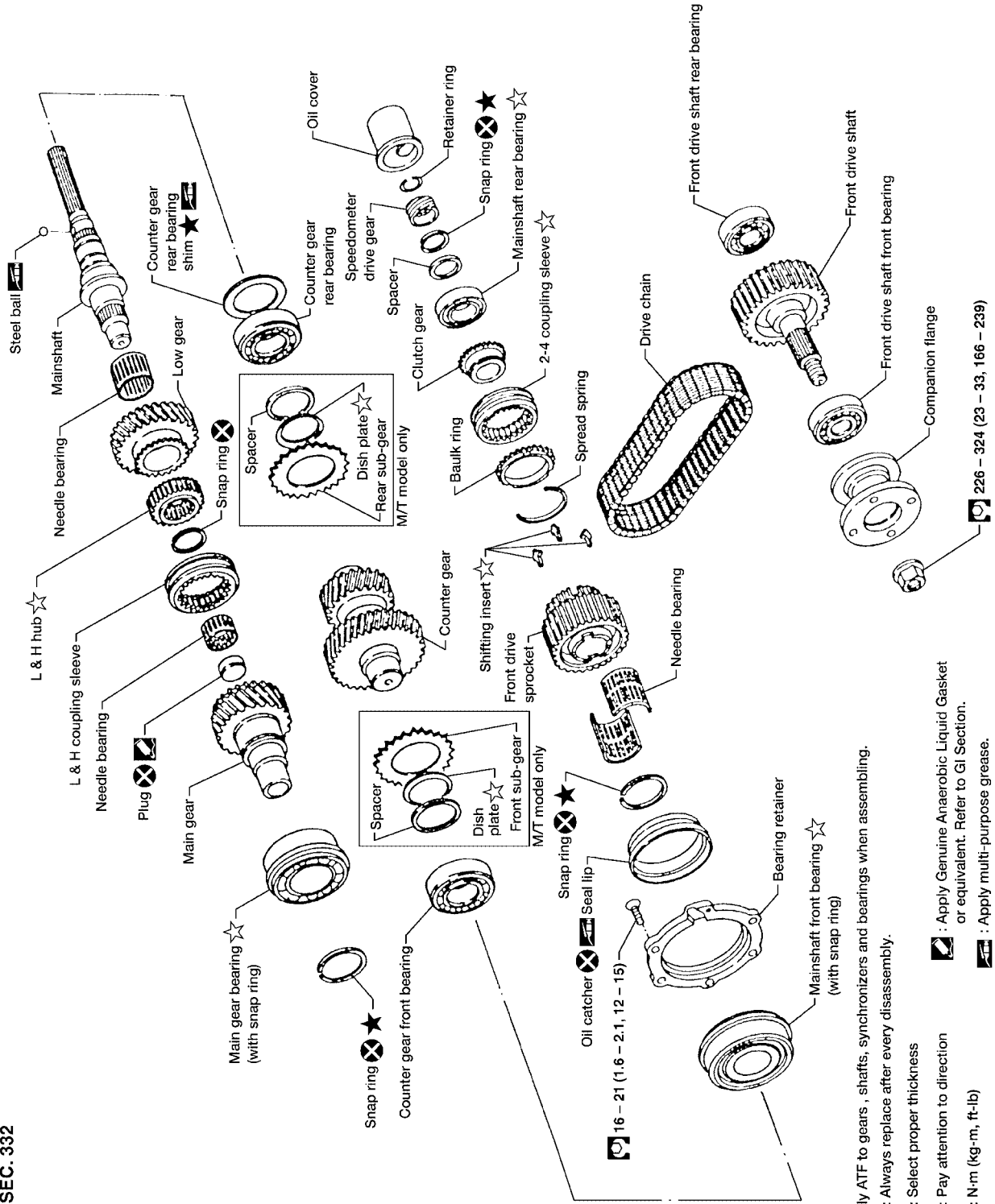

Apply ATF to gears, shafts, synchronizers and bearings when assembling.

Always replace after every disassembly.

Select proper thickness

Pay attention to direction

N:m (kg-m, ft-lb)

Apply Genuine Anaerobic Liquid Gasket or equivalent. Refer to GI Section.

Apply multi-purpose grease.

OVERHAUL

Shift Control Components

EDS00111

A
B
C
TF
E
F
G
H
I
J
K
L
M

SEC. 333

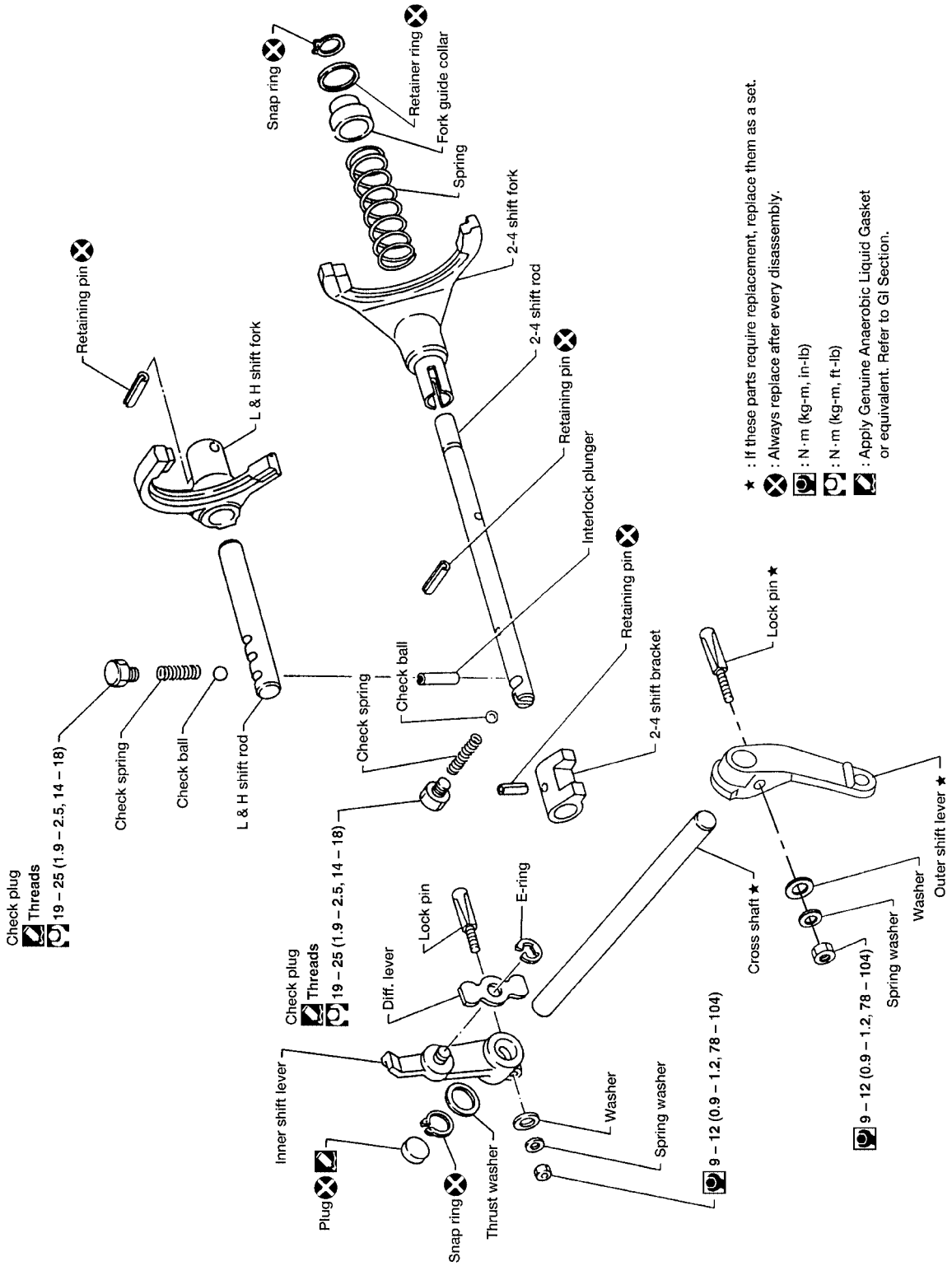

TRANSFER ASSEMBLY

TRANSFER ASSEMBLY

PFP:33100

Disassembly

EDS0011J

1. Remove companion flange nut and companion flange using Tool, as shown.

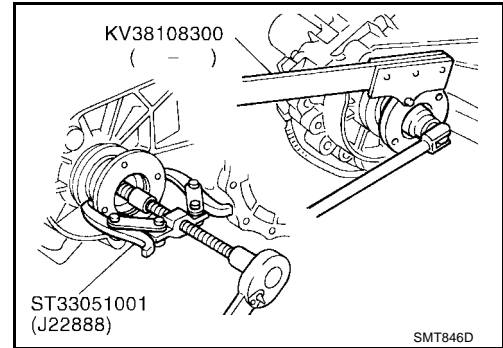

2. Remove 4WD switch.
3. Remove rear case using screwdriver or suitable tool, as shown.
 - Be careful not to damage the mating surface.

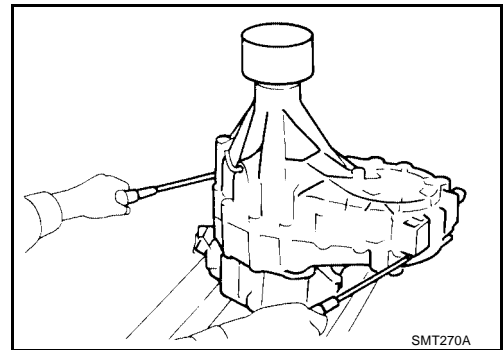

4. Remove oil cover and oil gutter.
5. Remove snap ring and retainer ring from 2-4 shift rod.

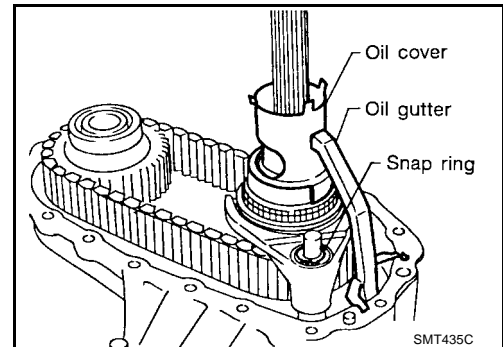

TRANSFER ASSEMBLY

6. Using calipers, measure the difference between front drive sprocket and 2-4 coupling sleeve as outlined under measuring method below. If it is outside specifications, check front drive sprocket, 2-4 coupling sleeve, clutch gear, 2-4 shift fork and 2-4 fork rod for abnormalities. Replace faulty part(s) as required.

Measuring method:

- Move Coupling sleeve until it is in contact with sprocket, then measure dimension A. Move coupling sleeve until it is in contact with clutch gear, then measure dimension B. Obtain dimension difference C between two measurements A and B.
- $A - B = C$
- To determine dimension A, measure at 3 or 4 different points by rotating sprocket and obtain average value of 3 or 4 measurements.
- Specification C: refer to [TF-40, "CLEARANCE BETWEEN FRONT DRIVE SPROCKET AND 2-4 COUPLING SLEEVE"](#).

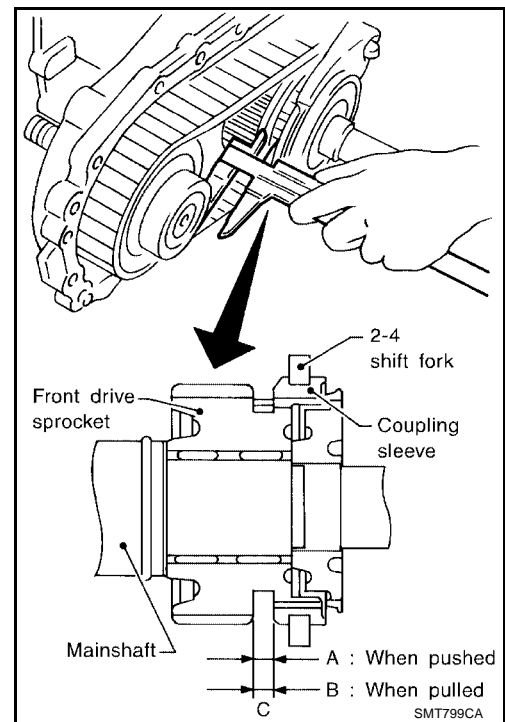

7. Remove bolts securing bearing retainer.
- **This step is necessary to remove mainshaft from center case.**

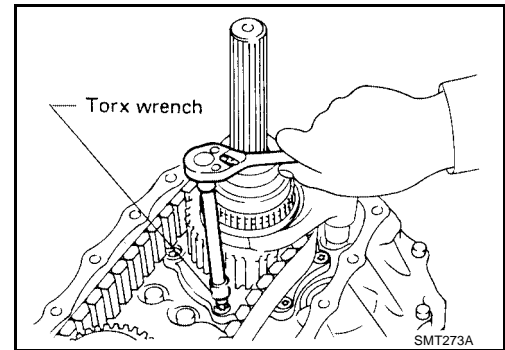

8. Remove bolts securing center case to front case and then separate center case and front case using screwdriver or suitable tool, as shown.
- **Be careful not to damage the mating surface.**

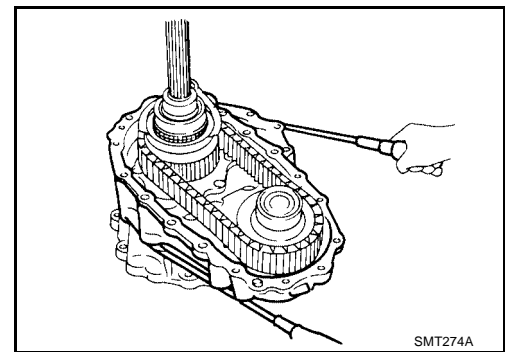

9. Measure low gear end play.
- Low gear end play : 0.2 - 0.35 mm (0.0079 - 0.0138 in)**
- **If end play is beyond the maximum value, check low gear and L & H hub for wear.**

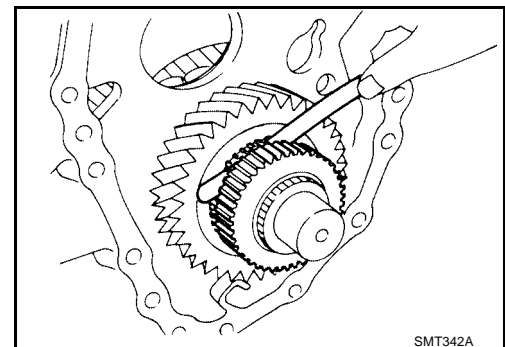

A
B
C
TF
E
F
G
H
I
J
K
L
M

TRANSFER ASSEMBLY

10. Disassemble center case assembly.

a. Remove snap ring from mainshaft.

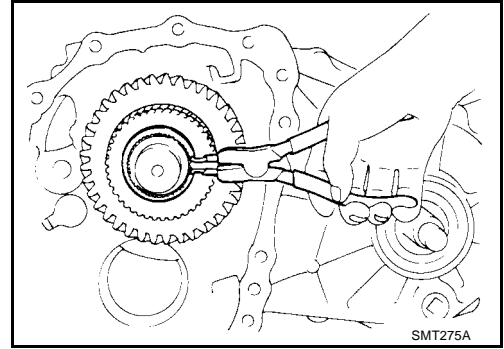

b. Pull out low gear with L & H hub using Tool, as shown.

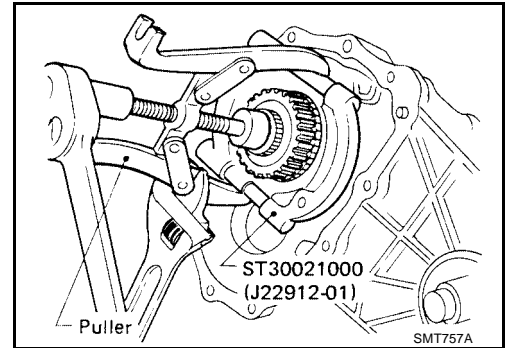

c. Remove needle bearing from mainshaft.

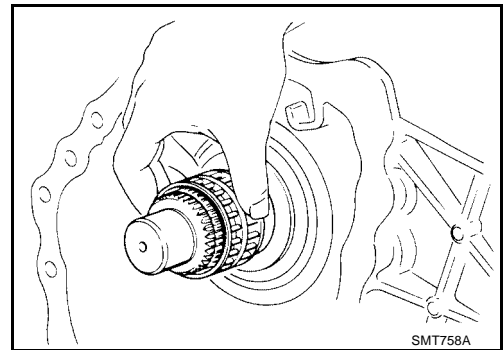

d. Make sure of the direction of the drive chain before removing it.
It must be reinstalled in the same direction.

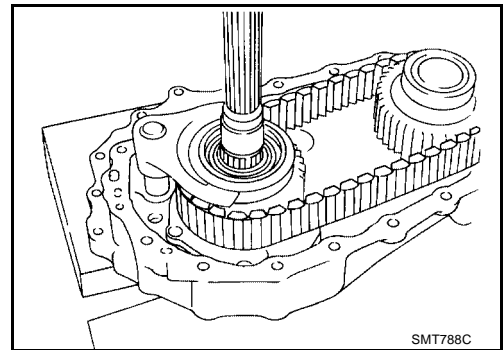

TRANSFER ASSEMBLY

- e. Remove mainshaft, front drive and drive chain as a set by tapping front end of mainshaft and front drive shaft alternately using a soft hammer, as shown.

CAUTION:

Be careful not to bend drive chain.

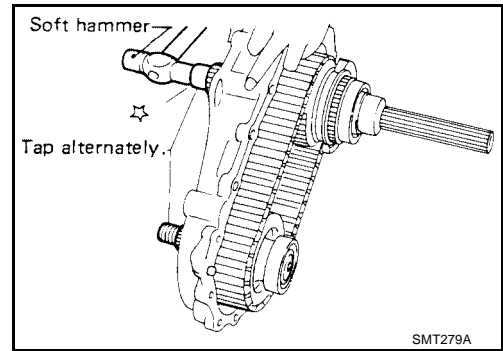

11. Disassemble front case assembly.

- a. Remove transfer neutral position switch, plugs, check springs and check balls.

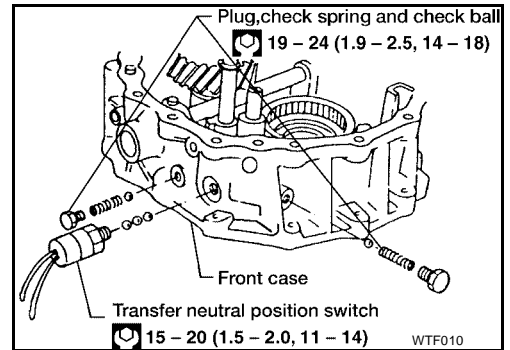

- b. Remove lock pin from outer shift lever using a drift or suitable tool, as shown. Then remove outer shift lever.

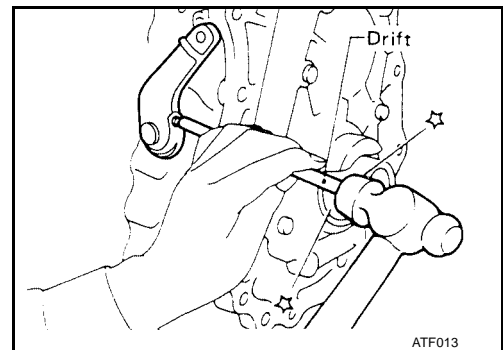

- c. Remove lock pin of inner shift lever and drive out cross shaft with plug using a soft hammer, as shown.

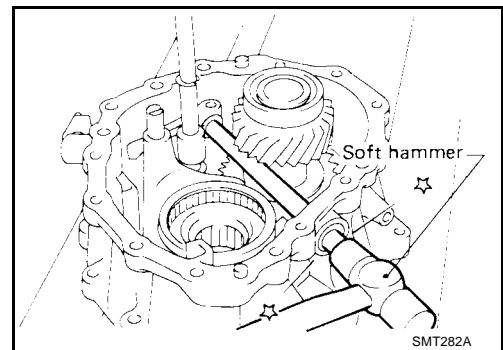

A
B
C
TF

E
F
G
H
I
J
K
L
M

TRANSFER ASSEMBLY

d. Remove 2-4 shift rod.

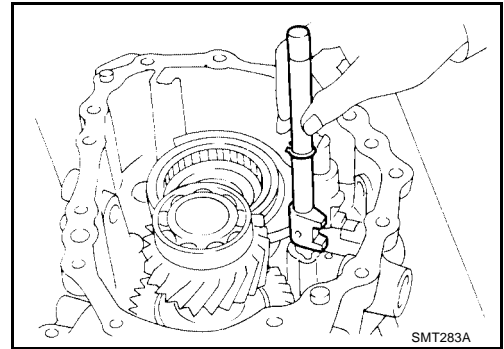

e. Remove L & H shift rod and fork assembly with coupling sleeve.

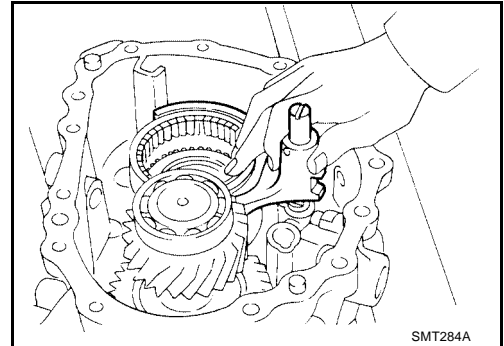

f. Remove needle bearing from main gear.

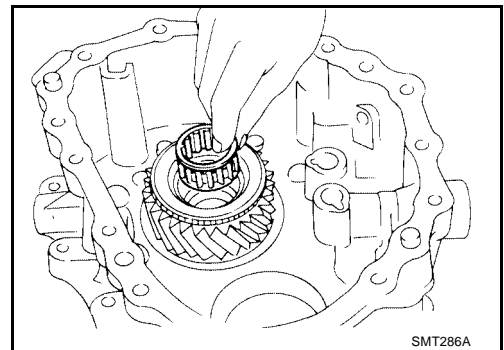

g. Remove bolts securing front case cover and then remove case using screwdriver or suitable tool.

- Be careful not to damage the mating surface.

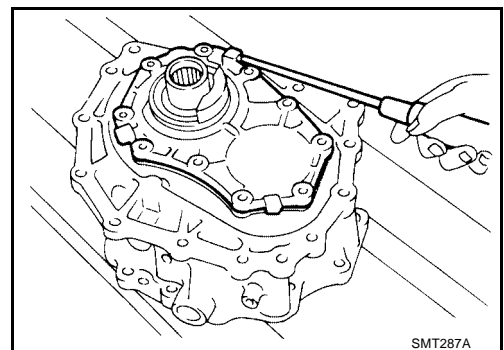

h. Remove counter gear by tapping lightly using a soft hammer, as shown.

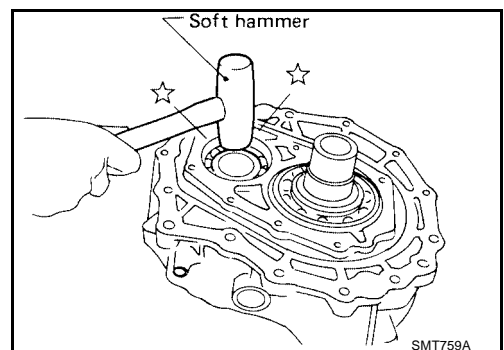

TRANSFER ASSEMBLY

- i. Remove main gear by tapping lightly using a soft hammer, as shown.

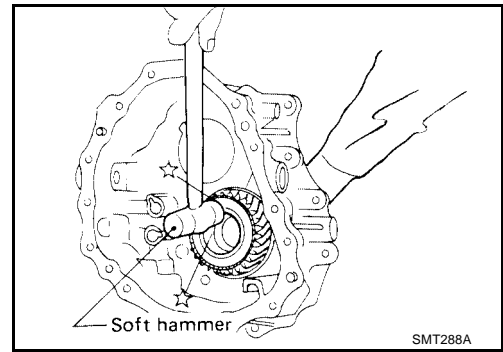

Assembly

1. Assemble front case.
a. Install main gear assembly by tapping lightly using a soft hammer, as shown.

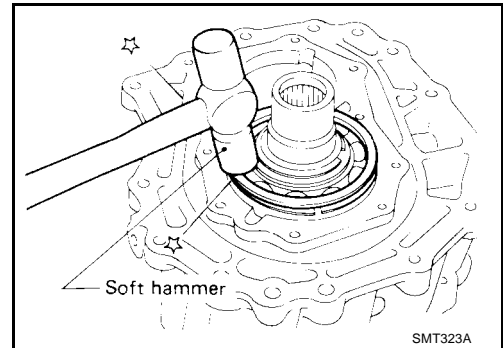

- b. Apply sealant to the mating surface and bolts of front case cover, then attach it to the front case.

- Use **Genuine Anaerobic Liquid Gasket or equivalent**. Refer to [GI-42, "RECOMMENDED CHEMICAL PRODUCTS AND SEALANTS"](#).

- These ten bolts should be coated with sealant.

Bolts A : 20 - 24 N·m (2.0 - 2.4 kg·m, 14 - 17 ft·lb)

Bolts B : 24 - 28 N·m (2.4 - 2.9 kg·m, 17 - 21 ft·lb)

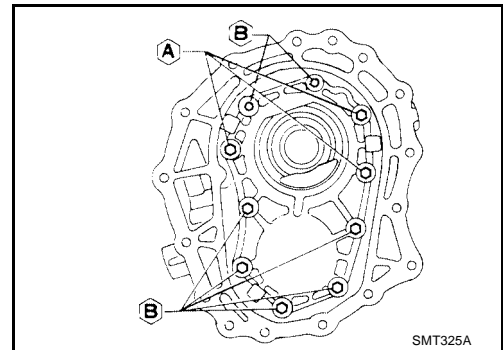

- c. Apply ATF to needle bearing and install it into main gear.

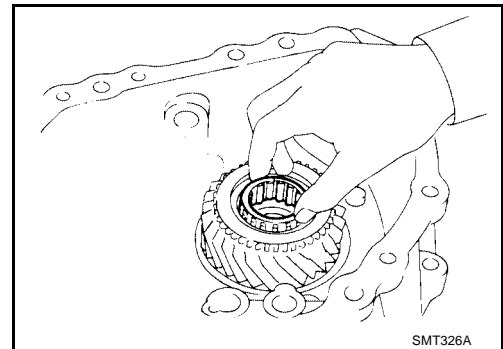

A
B
C
TF

E
F
G
H

I
J
K
L

M

TRANSFER ASSEMBLY

- d. Install counter gear assembly by tapping lightly using a soft hammer, as shown.

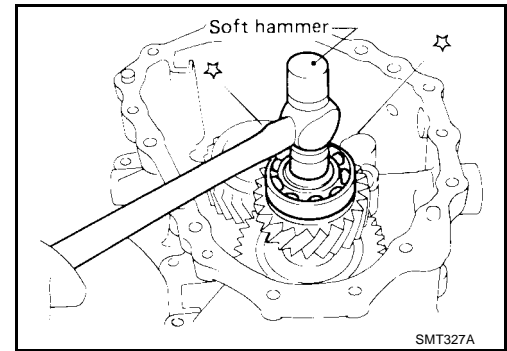

- e. Install cross shaft and inner shift lever.
- When replacing cross shaft, outer shift lever or outer shift lever lock pin, replace them as a set.

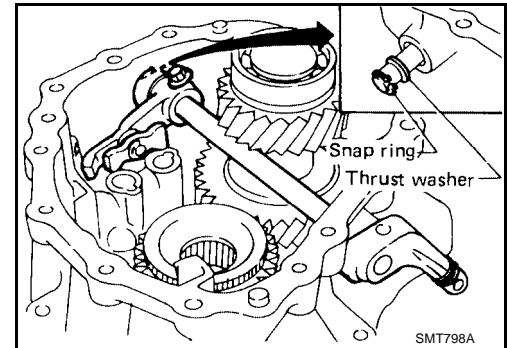

- f. Apply sealant to plug and install it into front case using a soft hammer, as shown.
Use Genuine Anaerobic Liquid Gasket or equivalent. Refer to [GI-42, "RECOMMENDED CHEMICAL PRODUCTS AND SEALANTS"](#).

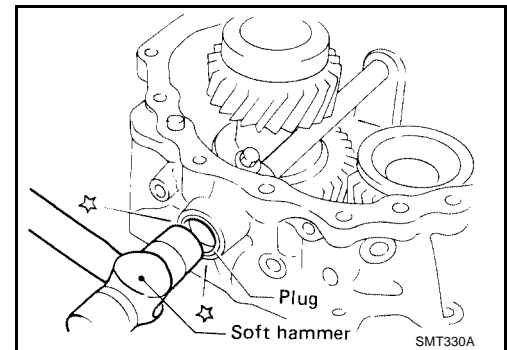

- g. Insert interlock plunger into front case.

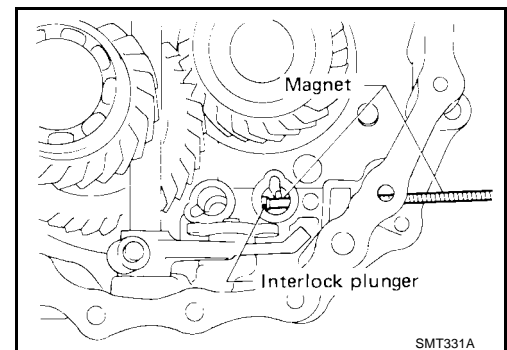

- h. Install L & H shift rod and fork assembly with coupling sleeve.

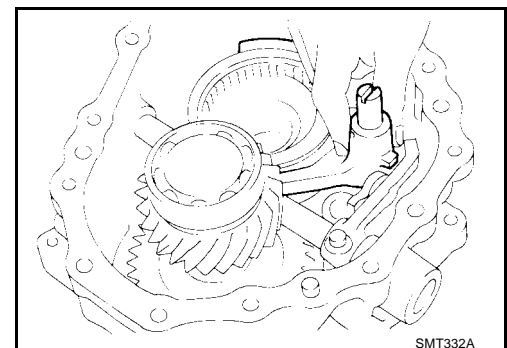

TRANSFER ASSEMBLY

- i. Install 2-4 shift rod.

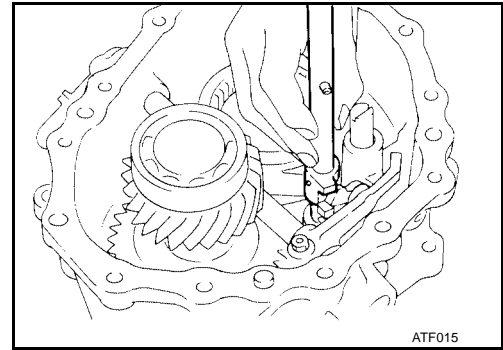

- j. Install transfer neutral position switch, check balls, check springs and plugs.

- Apply sealant to switches and plugs.
- Use Genuine Anaerobic Liquid Gasket or equivalent. Refer to [GI-42, "RECOMMENDED CHEMICAL PRODUCTS AND SEALANTS"](#).

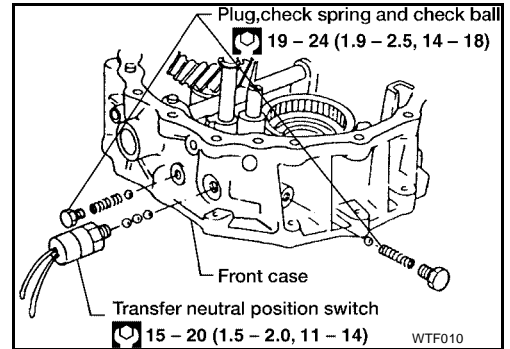

2. Select counter gear rear bearing shim.
a. Seat counter gear assembly using Tool, as shown.

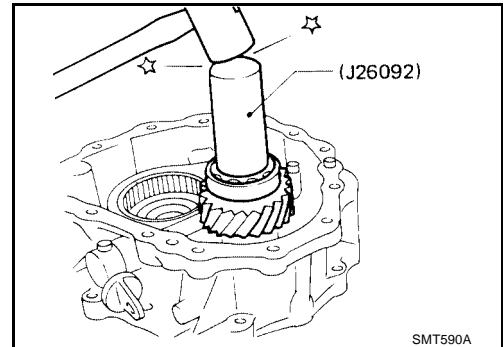

- b. Place J34291-1 (bridge), J34291-2 (legs) and J34291-5 (gauging cylinder) on machined surface of center case, allowing J34291-5 (gauging cylinder) to rest on top outer portion of counter gear rear bearing. Lock J34291-5 (gauging cylinder) in place.

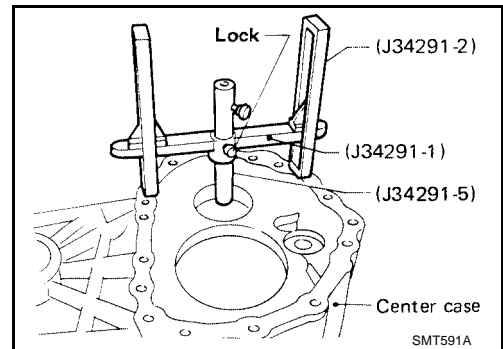

A
B
C
TF
E
F
G
H
I
J
K
L
M

TRANSFER ASSEMBLY

- c. Insert J34291-20 (gauging plunger) into J34291-5 (gauging cylinder).

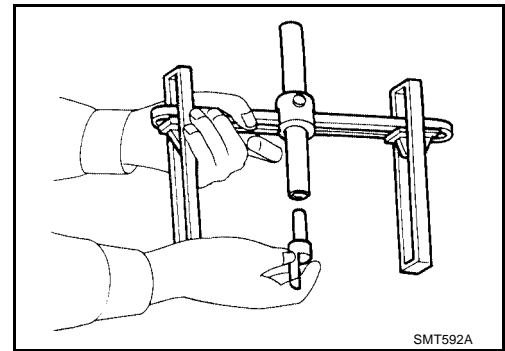

- d. Place J34291-1 (bridge), J34291-2 (legs), J34291-5 (gauging cylinder) and J34291-20 (gauging plunger) onto machined surface of front case assembly, allowing gauging plunger to drop until it contacts counter gear rear bearing mating surface.

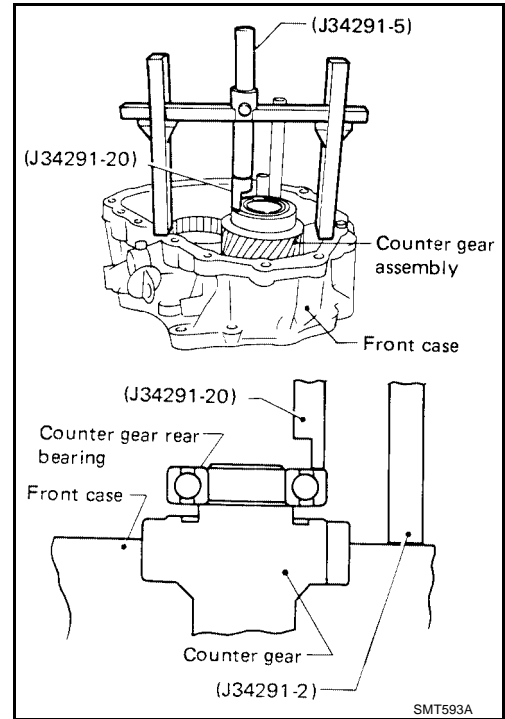

- e. Lock J34291-20 (gauging plunger) in place and use feeler gauge to measure end play between J34291-5 (gauging cylinder) and J34291-20 (gauging plunger).

- f. Use measured distance to select correct counter gear rear bearing shim.

Allowable counter gear end play : 0 - 0.2 mm (0 - 0.0079 in)

Allowable counter gear rear bearing shim : Refer to [TF-40, "COUNTER GEAR REAR BEARING"](#) .

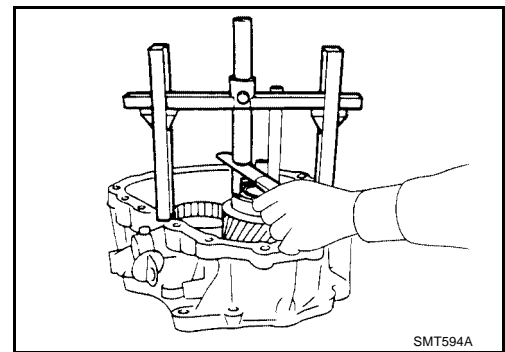

3. Place suitable shim with grease on counter gear rear bearing.
4. Apply ATF to each part in front case.

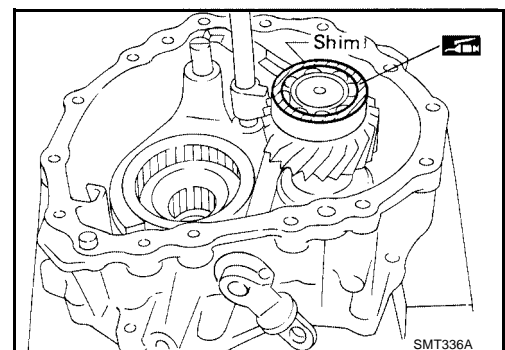

TRANSFER ASSEMBLY

5. Assemble center case assembly as follows:

a. Install mainshaft on center case by tapping lightly using a soft hammer, as shown.

- Apply ATF to mainshaft front bearing.

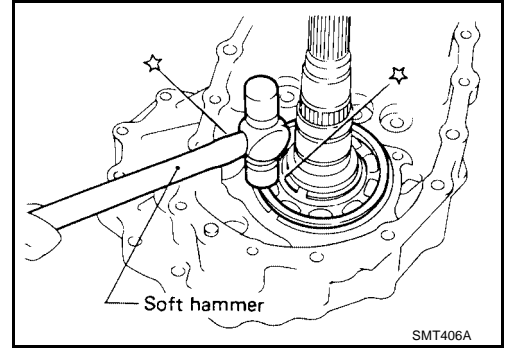

b. Install bearing retainer.

Bearing retainer : 16 - 21 N·m (1.6 - 2.1 kg-m, 12 - 15 ft-lb)

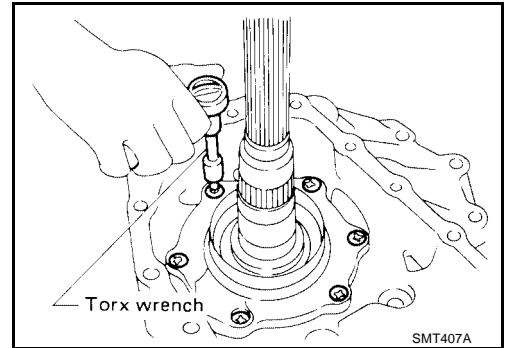

c. Put drive chain onto the front drive sprocket and front drive shaft, and then put them in center case.

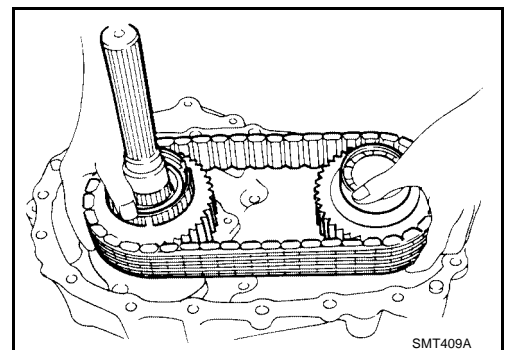
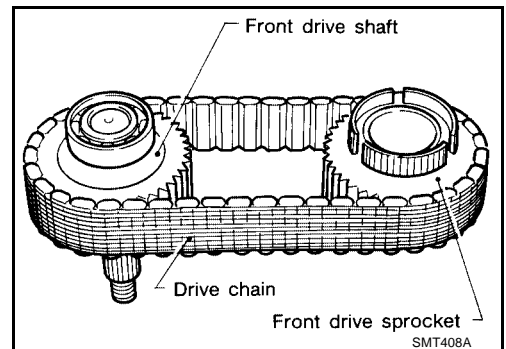

A
B
C
TF

E
F
G
H
I
J
K
L
M

TRANSFER ASSEMBLY

- d. Install front drive shaft by tapping lightly using a soft hammer, as shown.

- **Make sure shafts are aligned in the case.**

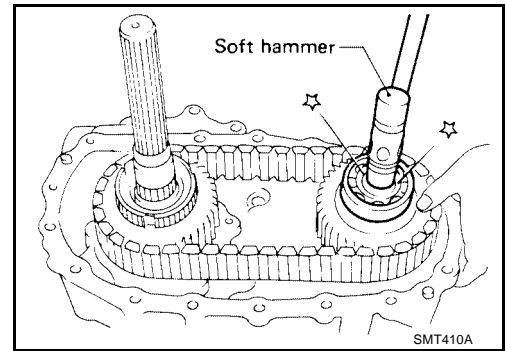

- e. Apply ATF to needle bearings and install them into front drive sprocket.

- **These needle bearings can be installed more easily if front drive sprocket is rotated while installing them.**

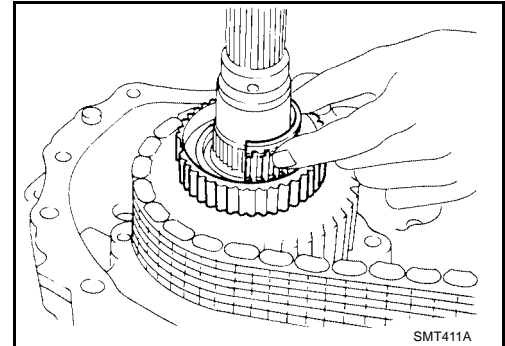

- f. Install 2-4 coupling sleeve with 2-4 shift fork.

- **Pay special attention to direction of coupling sleeve.**

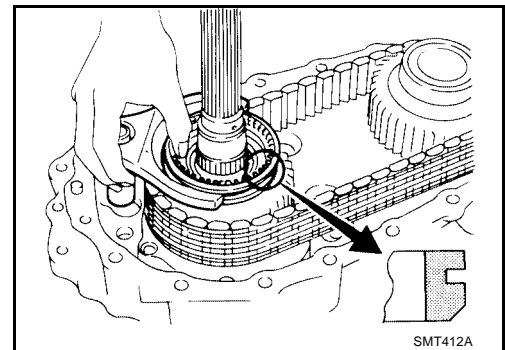

- g. Install shifting inserts and spread spring.

- **Pay attention to the direction of shifting inserts.**

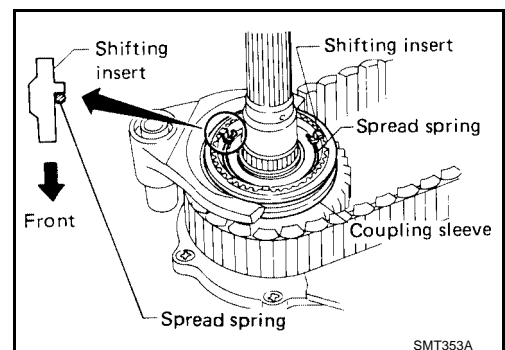

- h. Install baulk ring, then install clutch gear and mainshaft rear bearing using a drift, as shown.

- **Place wooden block under mainshaft in order to protect mainshaft front bearing.**

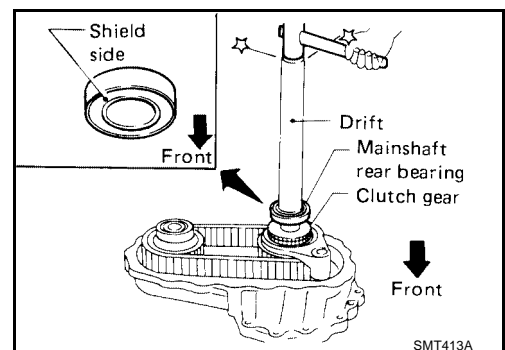

TRANSFER ASSEMBLY

- i. Install spacer.
- j. Select and install snap ring with proper thickness.

Allowable clearance between snap ring and groove : 0 - 0.15 mm (0 - 0.0059 in)

Available snap ring for mainshaft rear bearing : Refer to [TF-41, "MAIN-SHAFT REAR BEARING"](#) .

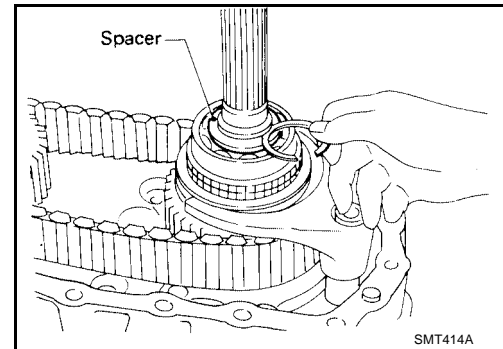

- k. Install steel ball, speedometer drive gear and retainer ring.
 - **Steel ball is the smallest of check balls for this unit.**

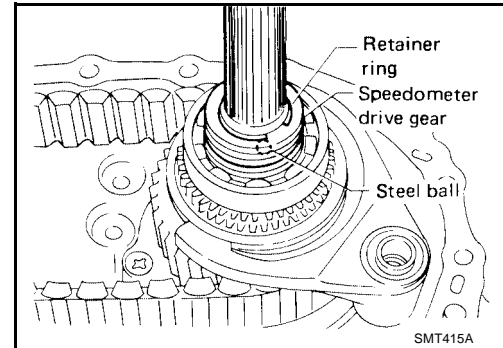

- l. Install low gear and its bearing onto mainshaft.
 - **Apply ATF to needle bearing.**

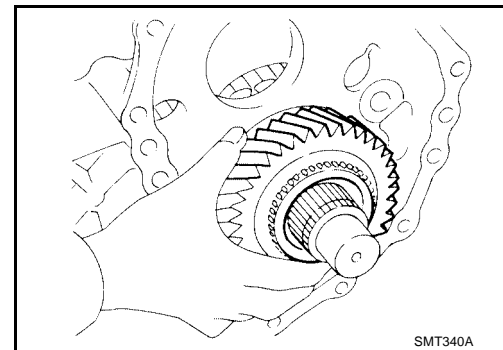

- m. Install L & H hub and snap ring to mainshaft using a drift, as shown.
 - **Pay attention to direction of L & H hub.**

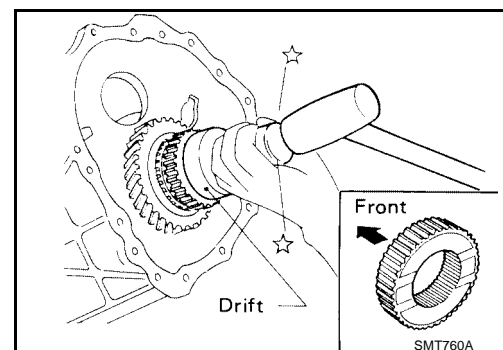

- n. Measure low gear end play.

Low gear end play : 0.2 - 0.35 mm (0.0079 - 0.0138 in)

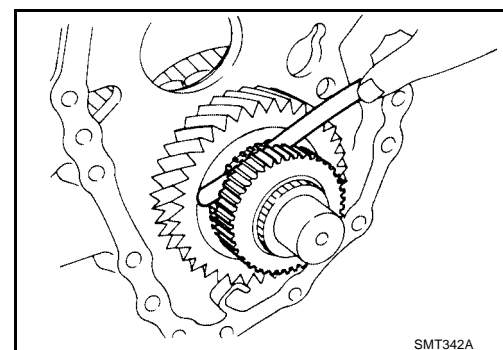

A
B
C
TF
E
F
G
H
I
J
K
L
M

TRANSFER ASSEMBLY

6. Apply sealant to mating surface of center case then attach to front case and tighten bolts. Refer to [TF-13, "Case Components"](#).

- Use Genuine Anaerobic Liquid Gasket or equivalent. Refer to [GI-42, "RECOMMENDED CHEMICAL PRODUCTS AND SEALANTS"](#).

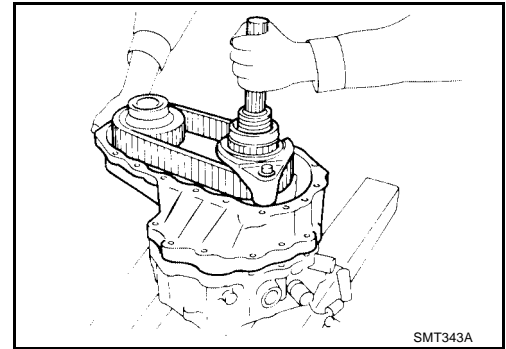

7. Install snap ring to 2-4 shift rod using snap ring pliers, as shown.

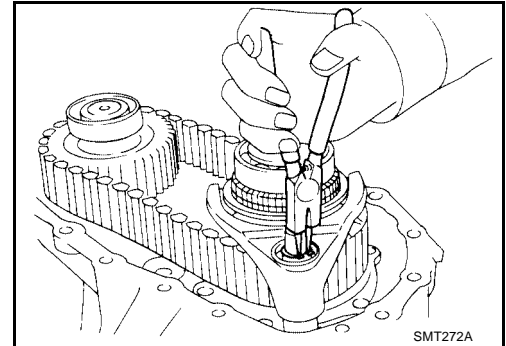

8. Install oil gutter and oil cover.
9. Apply ATF to each part in center case.

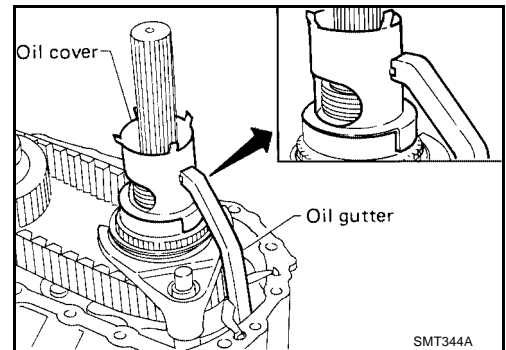

10. Apply sealant to mating surface of rear case then attach it to center case and tighten bolts. Refer to [TF-13, "Case Components"](#).

- Use Genuine Anaerobic Liquid Gasket or equivalent. Refer to [GI-42, "RECOMMENDED CHEMICAL PRODUCTS AND SEALANTS"](#).

11. Install 4WD switch.

- Apply sealant to switch threads.
- Use Genuine Anaerobic Liquid Gasket or equivalent. Refer to [GI-42, "RECOMMENDED CHEMICAL PRODUCTS AND SEALANTS"](#).

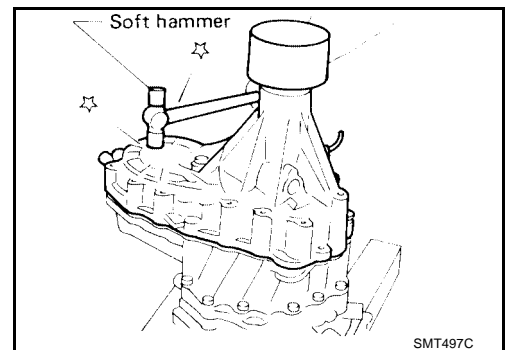

12. Install the companion flange and the companion flange nut using Tool, as shown.

- Tighten the companion flange to specification. Refer to [TF-14, "Gear Components"](#).

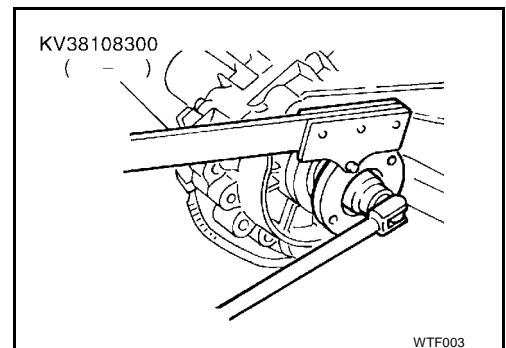

REPAIR FOR COMPONENT PARTS

REPAIR FOR COMPONENT PARTS

PFP:00000

EDS0011L

Mainshaft DISASSEMBLY

1. Check front drive sprocket end play using a dial gauge, as shown.

Standard : 0.2 - 0.35 mm (0.0079 - 0.0138 in)

- If end play is not within specification, check front drive sprocket and clutch gear for wear.

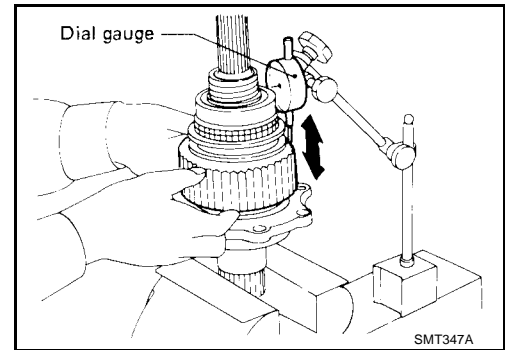

2. Remove retainer ring, speedometer drive gear and steel ball.

- Be careful not to lose the steel ball.

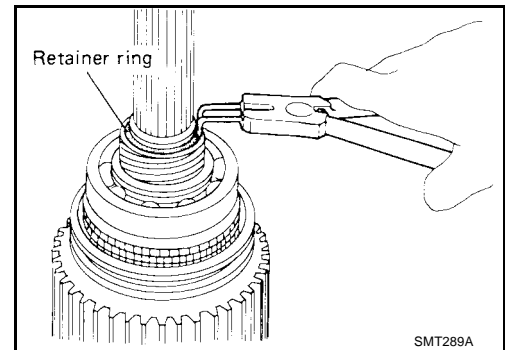

3. Remove snap ring and spacer.

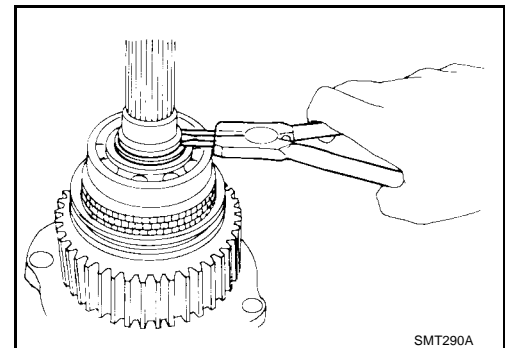

4. Use a press to remove front drive sprocket with mainshaft rear bearing and clutch gear together.
5. Remove needle bearing.

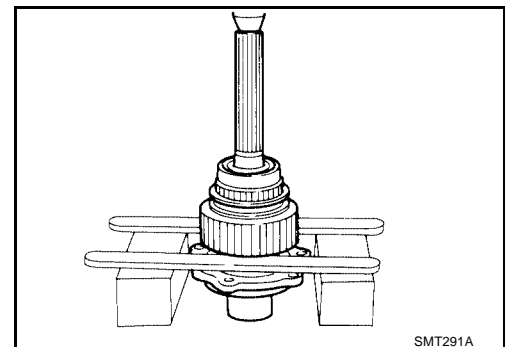

A
B
C
TF
E
F
G
H
I
J
K
L
M

REPAIR FOR COMPONENT PARTS

6. Remove bearing retainer and then remove snap ring.

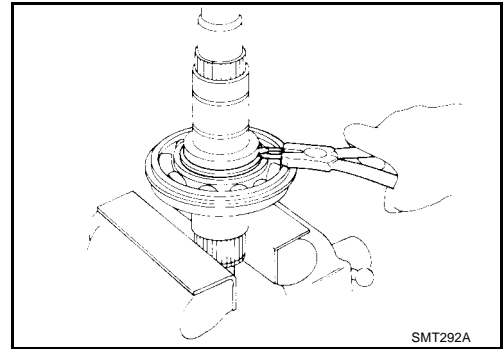

7. Use a press to remove mainshaft front bearing from mainshaft.

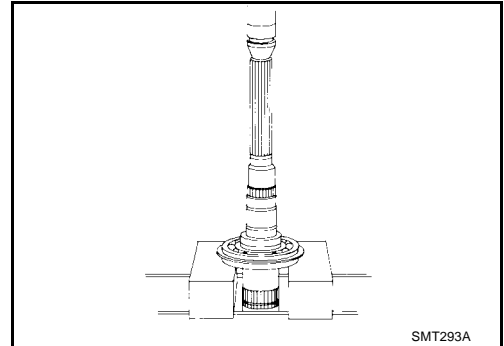

INSPECTION

Gear and Shaft

- Check gears for excessive wear, chips or cracks.
- Check shaft for cracks, wear or bending.
- Check coupling sleeve for wear or damage.

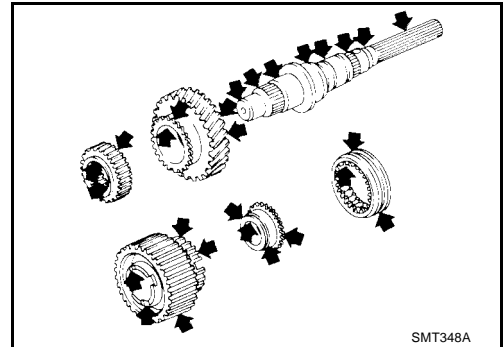

Baulk Ring

- Check baulk ring for cracks or deformation.

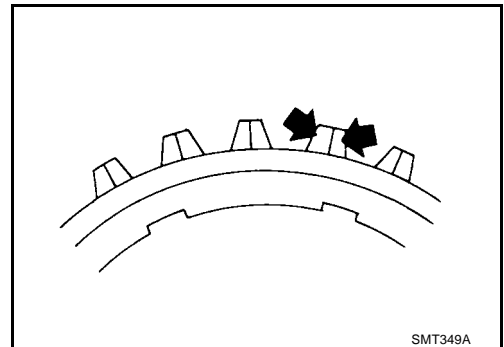

REPAIR FOR COMPONENT PARTS

- Measure clearance between baulk ring and clutch gear.

Baulk ring to clutch gear clearance : Refer to [TF-40, "CLEARANCE BETWEEN BAULK RING AND CLUTCH GEAR"](#) .

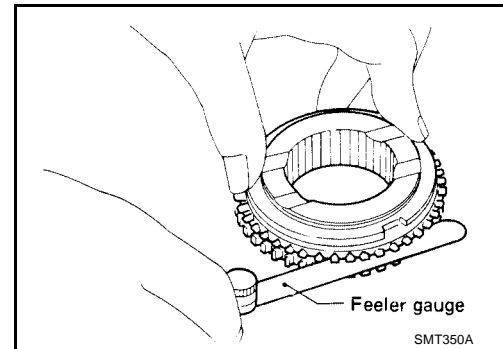

Bearing

Make sure bearings roll freely and are free from noise, cracks, pitting or wear.

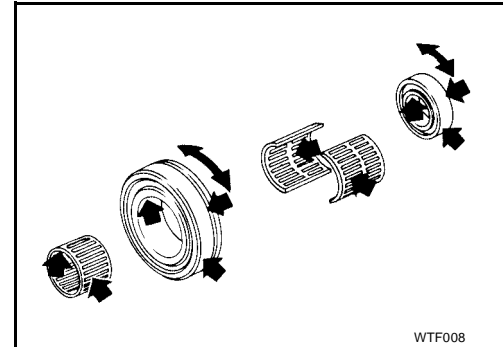

ASSEMBLY

1. Press mainshaft front bearing onto mainshaft.
 - Pay special attention to its direction.

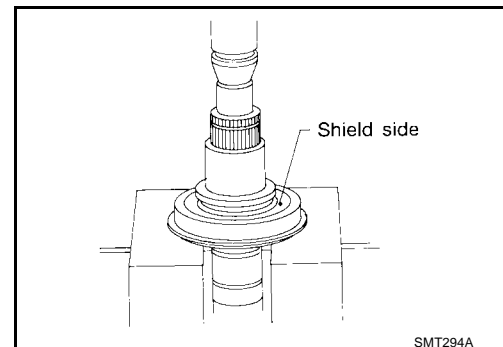

2. Select snap ring for the mainshaft front bearing with proper thickness.

Allowable clearance between snap ring and groove : 0 - 0.15 mm (0 - 0.0059 in)

Available snap ring for mainshaft front bearing : Refer to [TF-40, "MAIN-SHAFT FRONT BEARING"](#) .

3. For further procedures, refer to [TF-21, "Assembly"](#) .

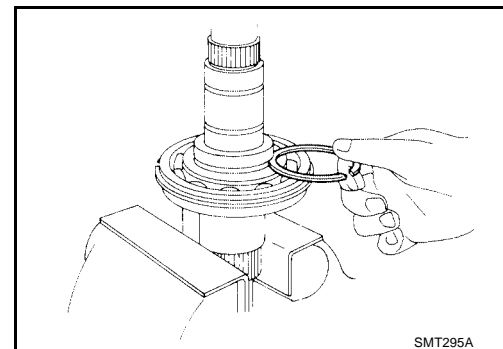

A
B
C
TF

E
F
G

H
I

J
K

L
M

REPAIR FOR COMPONENT PARTS

Front Drive Shaft DISASSEMBLY

EDS0011M

- Remove front drive shaft front and rear bearings using puller, as shown.

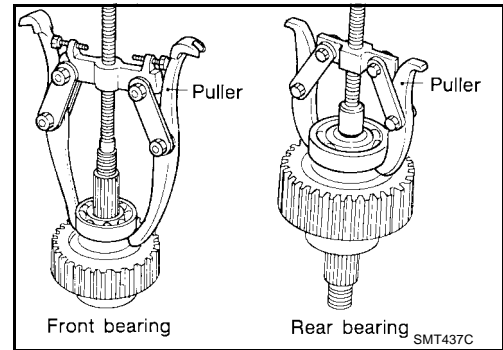

INSPECTION

Sprocket, Shaft and Bearing

- Check sprocket for excessive wear, chips or cracks.
- Check shaft for cracks or wear.
- Make sure bearings roll freely and are free from noise, cracks, pitting or wear.

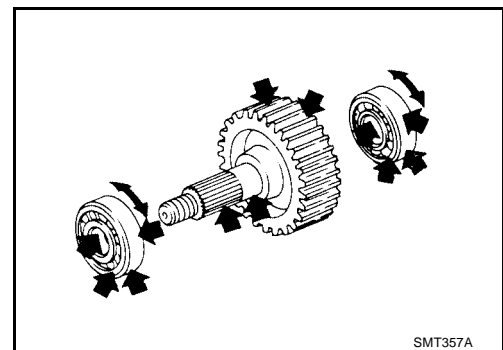

ASSEMBLY

Press front drive shaft front and rear bearings onto front drive shaft.

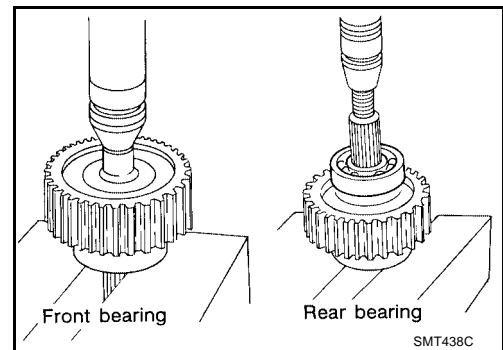

Counter Gear DISASSEMBLY

EDS0011N

1. Press out counter gear front bearing using Tool, as shown.
 - Remove front sub-gear, dish plate and spacer (M/T model only).

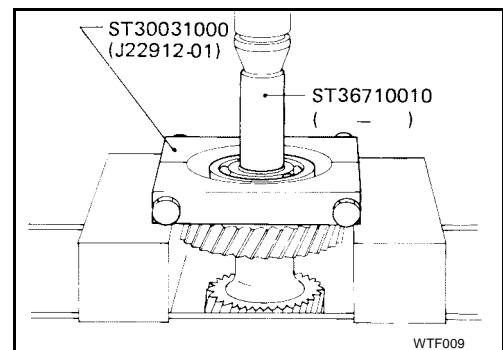

REPAIR FOR COMPONENT PARTS

2. Press out counter gear rear bearing using Tool, as shown.
 - Remove rear sub-gear, dish plate and spacer (M/T model only).

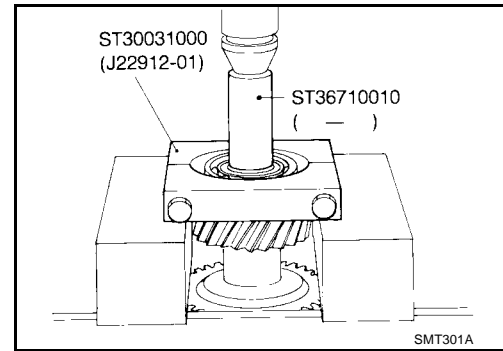

INSPECTION

Gear, Shaft and Bearing

- Check gears for excessive wear, chips or cracks.
- Check shaft for cracks or wear.
- Make sure bearings roll freely and are free from noise, cracks, pitting or wear.

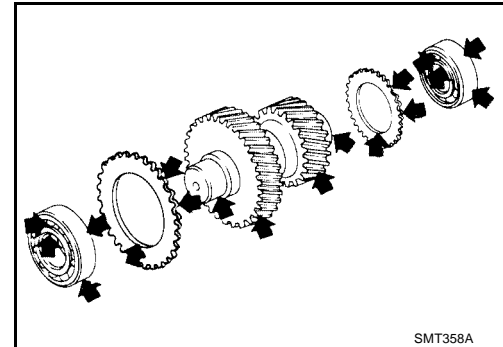

ASSEMBLY

1. Install front sub-gear, dish plate and spacer (M/T model only).
2. Press on counter gear front bearing.
3. Install rear sub-gear, dish plate and spacer (M/T model only).
4. Press on counter gear rear bearing.

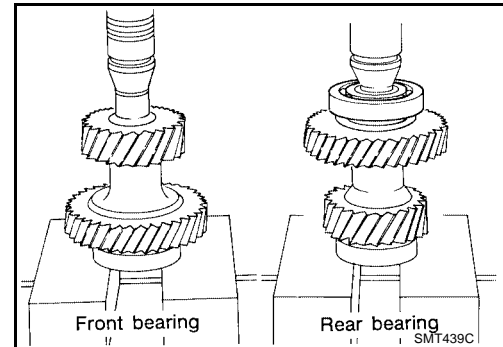

Main Gear DISASSEMBLY

Main Gear Bearing

1. Remove snap ring.

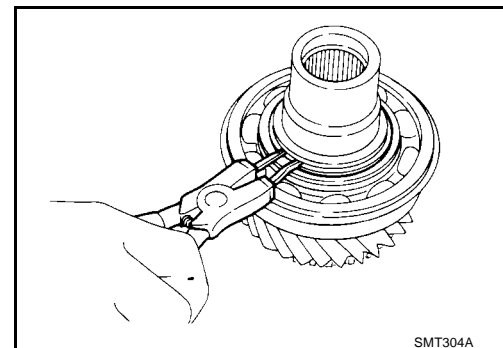

A
B
C
TF

E
F
G
H

I
J
K
L

M

REPAIR FOR COMPONENT PARTS

2. Remove main gear bearing using puller and Tool, as shown.

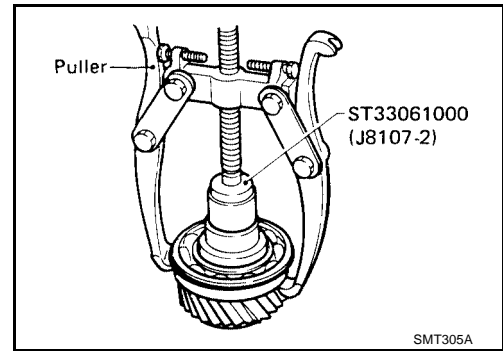

Plug

Remove plug using a drift or suitable tool, as shown.

- Always replace plug with a new one whenever it has been removed.

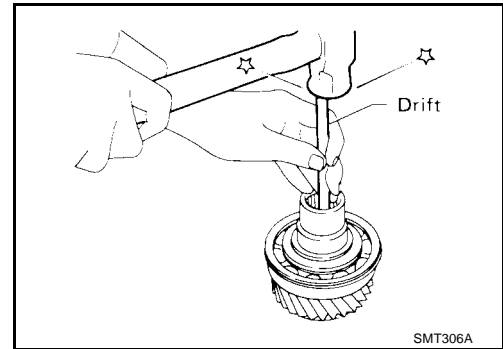

INSPECTION

Gear, Shaft and Bearing

- Check gears for excessive wear, chips or cracks.
- Check shaft for cracks or wear.
- Make sure bearings roll freely and are free from noise, cracks, pitting or wear.

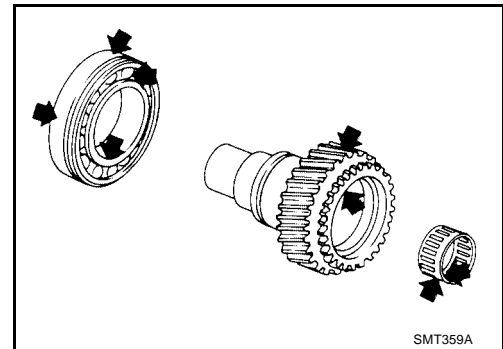

ASSEMBLY

Main Gear Bearing

1. Press on main gear bearing.

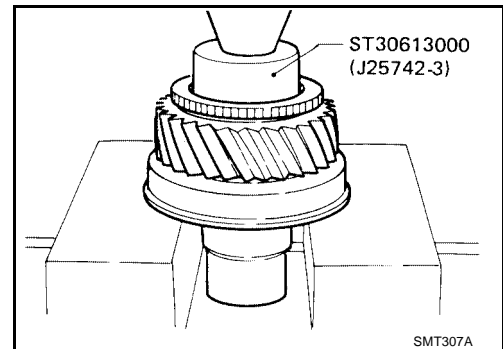

REPAIR FOR COMPONENT PARTS

2. Select and install snap ring with proper thickness.

Allowable clearance between snap ring and groove : 0 - 0.15 mm (0 - 0.0059 in)

Available snap ring for main gear bearing : Refer to [TF-40, "MAIN GEAR BEARING"](#) .

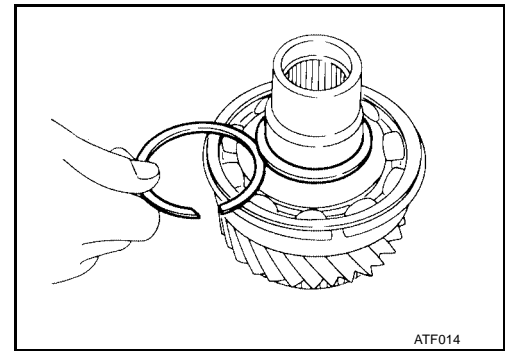

Plug

- Apply sealant to plug, then install using a drift or suitable tool, as shown.
- Use **Genuine Anaerobic Liquid Gasket or equivalent**. Refer to [GI-42, "RECOMMENDED CHEMICAL PRODUCTS AND SEALANTS"](#)

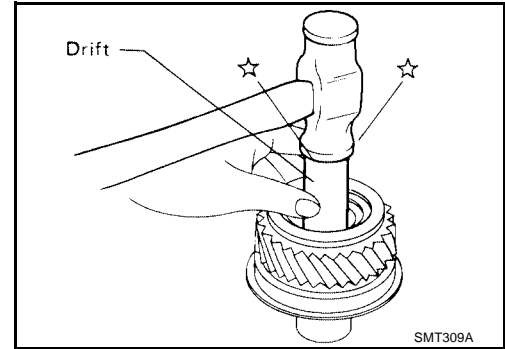

Front Case SHIFT SHAFT OIL SEAL

Removal

Use a screwdriver to pry out old seal.

- Be careful not to damage case.
- Always replace seal with a new one whenever it has been removed.

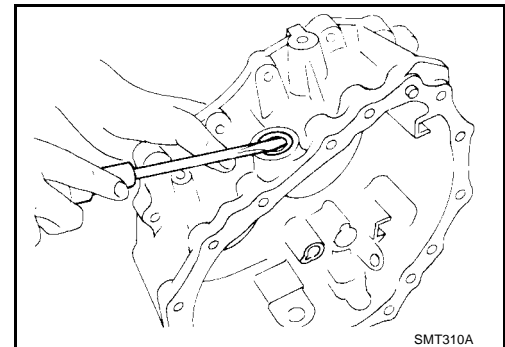

Installation

Install new shift shaft oil seal until flush with case.

- Before installing, apply multi-purpose grease to seal lip.

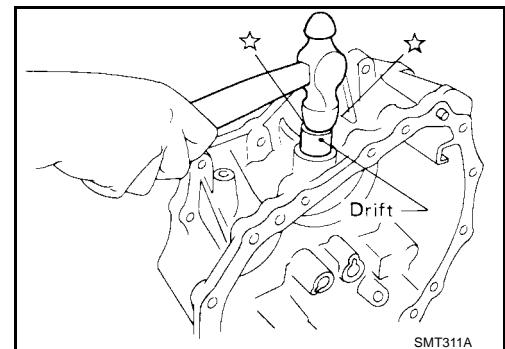

A
B
C
TF

E
F
G
H

I
J
K
L

M

REPAIR FOR COMPONENT PARTS

Front Case Cover COVER OIL SEAL

EDS0011Q

Removal

Drive out old seal from inside of front case cover using a drift or suitable tool, as shown.

- Be careful not to damage front case cover.

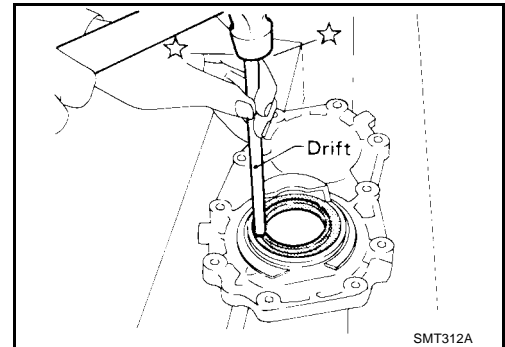

Installation

Install new front case cover oil seal until it stops using Tool, as shown.

- Before installing, apply multi-purpose grease to seal lip.

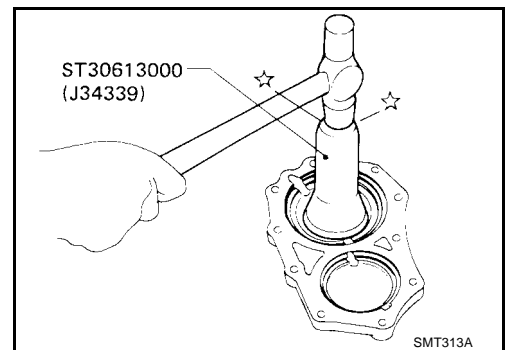

Bearing Retainer OIL CATCHER

EDS0011R

Removal

Drive out oil catcher from inside of bearing retainer using a drift or suitable tool, as shown.

- Be careful not to damage bearing retainer.

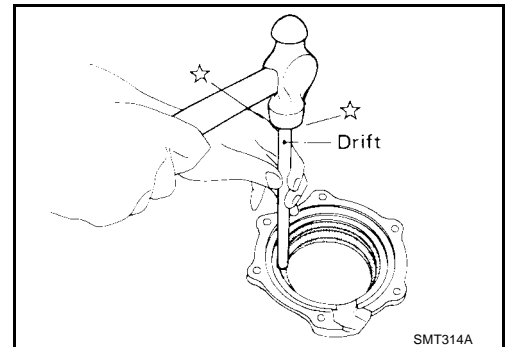

Installation

Install oil catcher until it stops using a drift or suitable tool, as shown.

- Be careful not to damage or distort oil catcher or bearing retainer.
- Before installing, apply multi-purpose grease to seal lip.

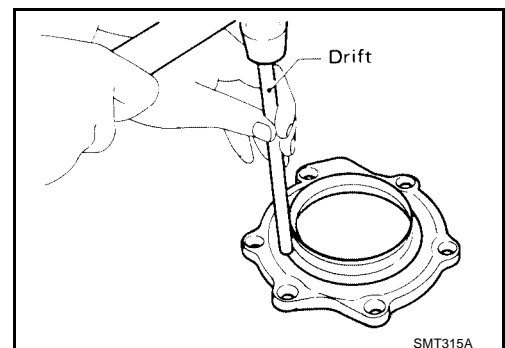

REPAIR FOR COMPONENT PARTS

Center Case CENTER CASE OIL SEAL

EDS0011S

Removal

Remove center case oil seal using Tool, as shown.

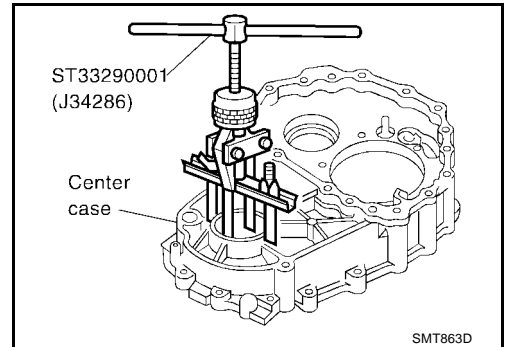

Installation

Install center case oil seal using Tool, as shown.

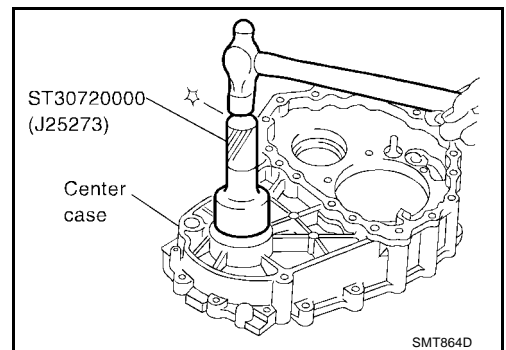

Rear Case REAR OIL SEAL

EDS0011T

Removal

Pull out rear oil seal using Tool, as shown.

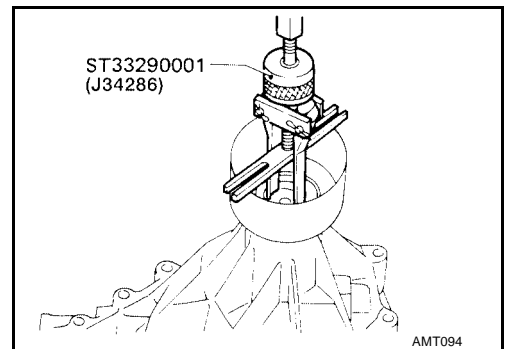

Installation

Install new rear oil seal until it stops using Tool, as shown.

- Before installing, apply multi-purpose grease to seal lip.

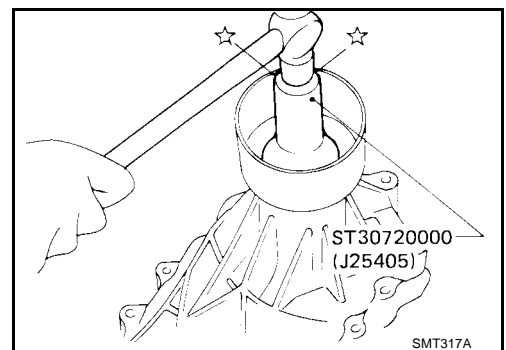

A
B
C
TF
E
F
G
H
I
J
K
L
M

REPAIR FOR COMPONENT PARTS

AIR BREATHER

Removal and Installation

Remove air breather by pulling straight out and install at specified angle, as shown.

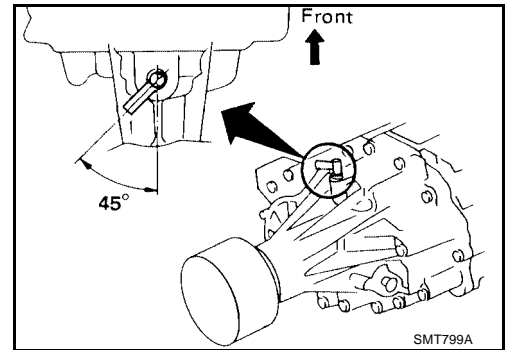

EDS0011U

Shift Control Components INSPECTION

Check contact surface and sliding surface for wear, scratches, projections or other faulty conditions, as shown.

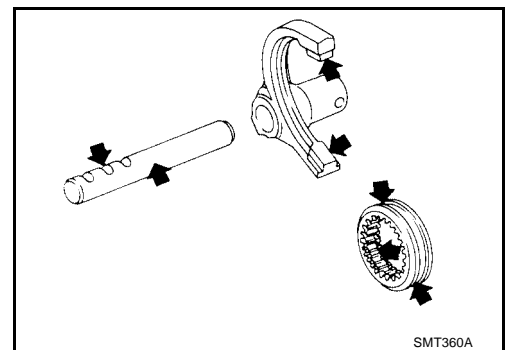

L & H Shift Rod & Fork

Assemble as shown.

- * Retaining pin is the same size as the one for 2-4 shift rod.

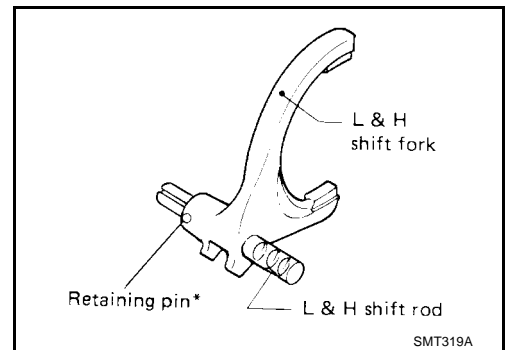

2-4 Shift Rod & Fork

Assemble as shown in illustration.

- * Retaining pins are the same size.

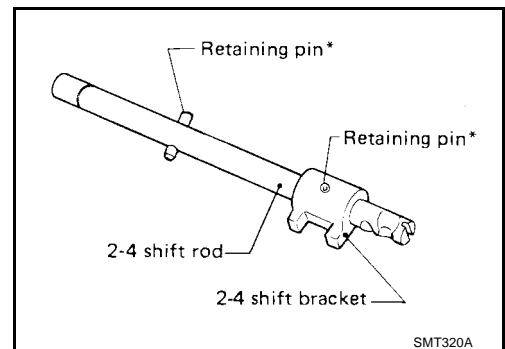

REPAIR FOR COMPONENT PARTS

- Pay special attention to the direction of fork guide collar.

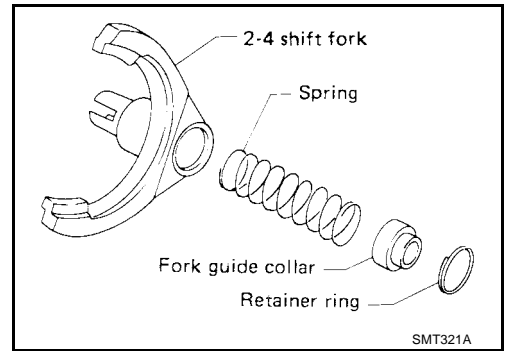

A
B
C
TF

E
F
G
H
I
J
K
L
M

SERVICE DATA AND SPECIFICATIONS (SDS)

SERVICE DATA AND SPECIFICATIONS (SDS)

PF0:00030

General Specifications

EDS0011V

Transfer model		TX10A	
Gear ratio	High	1.000	
	Low	2.020	
Number of teeth	Main gear	29	
	Low gear	37	
	Counter gear	High	38
		Low	24
	Front drive sprocket		41
	Front drive shaft		41
Fluid capacity ℓ (US qt, Imp qt)		2.2 (2-3/8, 2)	

Inspection and Adjustment

EDS0011W

CLEARANCE BETWEEN FRONT DRIVE SPROCKET AND 2-4 COUPLING SLEEVE

Unit: mm (in)

Allowable clearance "C"	0.2 - 0.54 (0.0079 - 0.0213)
-------------------------	------------------------------

GEAR END PLAY

Unit: mm (in)

Front drive sprocket	0.2 - 0.35 (0.0079 - 0.0138)
Low gear	0.2 - 0.35 (0.0079 - 0.0138)
Counter gear	0 - 0.2 (0 - 0.0079)

CLEARANCE BETWEEN BAULK RING AND CLUTCH GEAR

Unit: mm (in)

Standard	Wear limit
1.0 - 1.5 (0.039 - 0.059)	0.5 (0.020)

Available Shim

EDS0011X

COUNTER GEAR REAR BEARING

Allowable clearance	0 - 0.2 mm (0 - 0.0079 in)
Thickness mm (in)	Part No.*
0.1 (0.004)	33112-C6900
0.2 (0.008)	33112-C6901
0.3 (0.012)	33112-C6902
0.4 (0.016)	33112-C6903
0.5 (0.020)	33112-33G00
0.6 (0.024)	33112-33G01

*: Always check with the Parts Department for the latest parts information.

Available Snap Ring

EDS0011Y

MAINSHAFT FRONT BEARING

Allowable clearance	0 - 0.15 mm (0 - 0.0059 in)
Thickness mm (in)	Part No.*
3.10 (0.1220)	33138-73P10
3.19 (0.1256)	33138-73P11
3.28 (0.1291)	33138-73P12

*: Always check with the Parts Department for the latest parts information.

MAIN GEAR BEARING

Allowable clearance	0 - 0.15 mm (0 - 0.0059 in)
---------------------	-----------------------------

SERVICE DATA AND SPECIFICATIONS (SDS)

Thickness mm (in)	Part No.*
2.60 (0.1024)	33114-73P00
2.69 (0.1059)	33114-73P01
2.78 (0.1094)	33114-73P02

*: Always check with the Parts Department for the latest parts information.

MAINSHAFT REAR BEARING

Allowable clearance	0 - 0.15 mm (0 - 0.0059 in)
Thickness mm (in)	Part No.*
1.80 (0.0709)	33138-73P20
1.89 (0.0744)	33138-73P21
1.98 (0.0780)	33138-73P22
2.07 (0.0815)	33138-73P23
2.16 (0.0850)	33138-73P24

*: Always check with the Parts Department for the latest parts information.

A
B
C
TF
E
F
G
H
I
J
K
L
M

SERVICE DATA AND SPECIFICATIONS (SDS)
