

A

CO

CO

SECTION

ENGINE COOLING SYSTEM

C

CONTENTS

D

E

QR		
PRECAUTIONS	3	
Precautions for Supplemental Restraint System (SRS) "AIR BAG" and "SEAT BELT PRE-TENSIONER"	3	
Precautions for Liquid Gasket	3	
REMOVAL OF LIQUID GASKET SEALING	3	
LIQUID GASKET APPLICATION PROCEDURE.....	3	
PREPARATION	5	
Special Service Tools	5	
Commercial Service Tools	5	
OVERHEATING CAUSE ANALYSIS	6	
Troubleshooting Chart	6	
COOLING SYSTEM	8	
Cooling Circuit	8	
System Chart	9	
ENGINE COOLANT	10	
System Check	10	
CHECKING COOLING SYSTEM HOSES	10	
CHECKING RESERVOIR LEVEL	10	
CHECKING COOLING SYSTEM FOR LEAKS... ..	10	
CHECKING RESERVOIR CAP	10	
CHECKING RADIATOR	11	
Changing Engine Coolant	11	
DRAINING ENGINE COOLANT	11	
REFILLING ENGINE COOLANT	12	
FLUSHING COOLING SYSTEM	13	
RADIATOR	15	
Removal and Installation	15	
REMOVAL	15	
INSTALLATION	17	
INSPECTION AFTER INSTALLATION	17	
COOLING FAN	18	
Removal and Installation (Crankshaft driven type)..	18	
REMOVAL	18	
INSPECTION AFTER REMOVAL	18	
INSTALLATION	18	
INSPECTION AFTER INSTALLATION	18	
WATER PUMP	19	F
Removal and Installation	19	
REMOVAL	19	
INSPECTION AFTER REMOVAL	20	G
INSTALLATION	20	
INSPECTION AFTER INSTALLATION	20	
THERMOSTAT AND THERMOSTAT HOUSING	21	H
Removal and Installation Thermostat	21	
REMOVAL	21	
INSPECTION AFTER REMOVAL	21	
INSTALLATION	22	I
INSPECTION AFTER INSTALLATION	22	
Removal and Installation Water Pump and Thermostat Housing	23	J
REMOVAL	23	
INSTALLATION	23	
INSPECTION AFTER INSTALLATION	23	K
WATER CONTROL VALVE	25	
Removal and Installation	25	
REMOVAL	25	
INSPECTION AFTER REMOVAL	26	L
INSTALLATION	26	
WATER OUTLET AND WATER PIPING	27	M
Removal and Installation	27	
REMOVAL	27	
INSTALLATION	27	
INSPECTION AFTER INSTALLATION	28	
SERVICE DATA AND SPECIFICATIONS (SDS)	29	
Standard and Limit	29	
ENGINE COOLANT CAPACITY (APPROXIMATE)	29	
RESERVOIR CAP	29	
THERMOSTAT	29	
VQ		
PRECAUTIONS	30	
Precautions for Supplemental Restraint System (SRS) "AIR BAG" and "SEAT BELT PRE-TEN-		

SIONER”	30	REMOVAL	47
Precautions for Liquid Gasket	30	INSPECTION AFTER REMOVAL	47
REMOVAL OF LIQUID GASKET SEALING	30	INSTALLATION	47
LIQUID GASKET APPLICATION PROCEDURE..	30	INSPECTION AFTER INSTALLATION	47
PREPARATION	32	Removal and Installation (Motor driven type)	48
Special Service Tools	32	REMOVAL	48
Commercial Service Tools	33	INSTALLATION	48
OVERHEATING CAUSE ANALYSIS	34	WATER PUMP	49
Troubleshooting Chart	34	Removal and Installation	49
COOLING SYSTEM	36	REMOVAL	49
Cooling Circuit	36	INSPECTION AFTER REMOVAL	51
System Chart	37	INSTALLATION	51
ENGINE COOLANT	38	INSPECTION AFTER INSTALLATION	52
System Check	38	WATER INLET AND THERMOSTAT ASSEMBLY ...	54
CHECKING COOLING SYSTEM HOSES	38	Removal and Installation	54
CHECKING RESERVOIR LEVEL	38	REMOVAL	54
CHECKING COOLING SYSTEM FOR LEAKS ...	38	INSPECTION AFTER REMOVAL	54
CHECKING RESERVOIR CAP	38	INSTALLATION	55
CHECKING RADIATOR	39	INSPECTION AFTER INSTALLATION	55
Changing Engine Coolant	39	WATER OUTLET AND WATER PIPING	56
DRAINING ENGINE COOLANT	39	Removal and Installation	56
REFILLING ENGINE COOLANT	41	REMOVAL	56
FLUSHING COOLING SYSTEM	42	INSTALLATION	56
RADIATOR	44	INSPECTION AFTER INSTALLATION	56
Removal and Installation	44	SERVICE DATA AND SPECIFICATIONS (SDS)	58
REMOVAL	44	Standard and Limit	58
INSTALLATION	46	ENGINE COOLANT CAPACITY (APPROXI-	
INSPECTION AFTER INSTALLATION	46	MATE)	58
ENGINE COOLING FAN	47	RADIATOR	58
Removal and Installation (Crankshaft driven type)..	47	THERMOSTAT	58

PRECAUTIONS

Precautions for Supplemental Restraint System (SRS) “AIR BAG” and “SEAT BELT PRE-TENSIONER”

EBS00T38

The Supplemental Restraint System such as “AIR BAG” and “SEAT BELT PRE-TENSIONER”, used along with a front seat belt, helps to reduce the risk or severity of injury to the driver and front passenger for certain types of collision. Information necessary to service the system safely is included in the SRS and SB section of this Service Manual.

WARNING:

- To avoid rendering the SRS inoperative, which could increase the risk of personal injury or death in the event of a collision which would result in air bag inflation, all maintenance must be performed by an authorized NISSAN/INFINITI dealer.
- Improper maintenance, including incorrect removal and installation of the SRS, can lead to personal injury caused by unintentional activation of the system. For removal of Spiral Cable and Air Bag Module, see the SRS section.
- Do not use electrical test equipment on any circuit related to the SRS unless instructed to in this Service Manual. SRS wiring harnesses can be identified by yellow and/or orange harnesses or harness connectors.

**Precautions for Liquid Gasket
REMOVAL OF LIQUID GASKET SEALING**

EBS00NHD

- After removing nuts and bolts, separate the mating surface, using Tool and remove old liquid gasket sealing.

Tool number : KV1011100 (J-37228)

CAUTION:

Be careful not to damage the mating surfaces.

- Tap Tool to insert it, and then slide it by tapping on the side as shown.
- In areas where Tool is difficult to use, use plastic hammer to lightly tap the parts, to remove it.

CAUTION:

If for some unavoidable reason suitable tool such as screwdriver is used, be careful not to damage the mating surfaces.

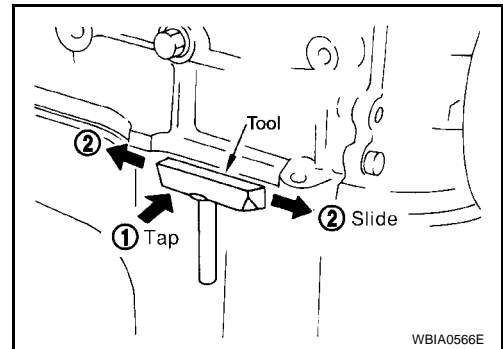

LIQUID GASKET APPLICATION PROCEDURE

1. Remove old liquid gasket adhering to the liquid gasket application surface and the mating surface, Using scraper.
 - Remove liquid gasket completely from the groove of the liquid gasket application surface, bolts, and bolt holes.
2. Thoroughly clean the mating surfaces and remove adhering moisture, grease and foreign materials.

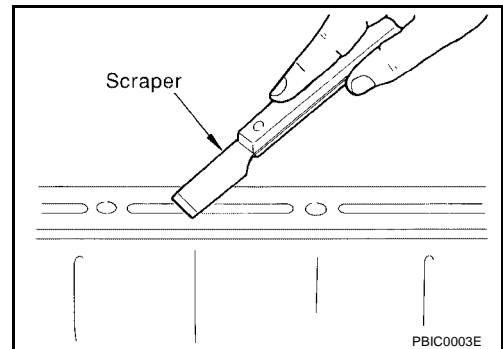

3. Attach liquid gasket tube to Tool.

PRECAUTIONS

[QR]

Tool number : WS39930000 (—)

Use Genuine RTV Silicone Sealant or equivalent. Refer to [GI-48, "Recommended Chemical Products and Sealants"](#) .

4. Apply liquid gasket without breaks to the specified location with the specified dimensions.
 - If there is a groove for the liquid gasket application, apply liquid gasket to the groove.

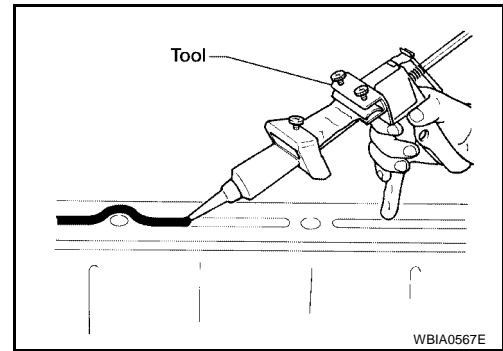

- As for the bolt holes, normally apply liquid gasket inside the holes. Occasionally, it should be applied outside the holes. Make sure to read the text of service manual.
- Within five minutes of liquid gasket application, install the mating component.
- If liquid gasket protrudes, wipe it off immediately.
- Do not retighten nuts or bolts after the installation.
- After 30 minutes or more have passed from the installation, fill engine oil and engine coolant.

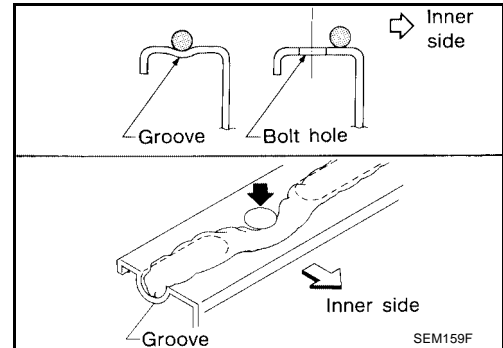

CAUTION:

If there are specific instructions in this manual, observe them.

PREPARATION

[QR]

PF0:00002

EBS00NHE

PREPARATION

Special Service Tools

The actual shapes of Kent-Moore tools may differ from those of special service tools illustrated here.

Tool number (Kent-Moore No.) Tool name	Description
EG17650301 (J-33984-A) Radiator cap tester adapter	Adapting radiator cap tester to radiator cap and radiator filler neck a: 28 (1.10) dia. b: 31.4 (1.236) dia. c: 41.3 (1.626) dia. Unit: mm (in)
KV10111100 (J-37228) Seal cutter	Removing chain tensioner cover and water pump cover
WS39930000 (—) Tube presser	Pressing the tube of liquid gasket
— (J-23688) Engine coolant refractometer	Checking concentration of ethylene glycol in engine coolant

Commercial Service Tools

EBS00NGN

Tool name	Description
Power tool	Loosening nuts and bolts
Radiator cap tester	Checking radiator and radiator cap

OVERHEATING CAUSE ANALYSIS

[QR]

OVERHEATING CAUSE ANALYSIS

PFP:00012

Troubleshooting Chart

EBS00NGO

		Symptom	Check items		
Cooling system parts malfunction	Poor heat transfer	Water pump malfunction	Worn or loose drive belt	—	
		Thermostat and water control valve stuck closed	—		
		Damaged fins	Dust contamination or paper clogging		
			Physical damage		
		Clogged radiator cooling tube	Excess foreign material (rust, dirt, sand, etc.)		
	Reduced air flow	Cooling fan does not operate	Fan assembly	—	
		High resistance to fan rotation			
		Damaged fan blades			
		Damaged radiator shroud	—	—	
		Improper engine coolant mixture ratio	—	—	
		Poor engine coolant quality	—	Engine coolant viscosity	—
	Insufficient engine coolant	Engine coolant leaks	Cooling hose	Loose clamp	
				Cracked hose	
			Water pump	Poor sealing	
			Radiator cap	Loose	
Poor sealing					
Radiator		O-ring for damage, deterioration or improper fitting			
		Cracked radiator tank			
	Cracked radiator core				
	Reservoir tank	Cracked reservoir tank			
Overflowing reservoir tank	Exhaust gas leaks into cooling system	Cylinder head deterioration			
		Cylinder head gasket deterioration			

OVERHEATING CAUSE ANALYSIS

[QR]

	Symptom		Check items				
Except cooling system parts malfunction	—	Overload on engine	Abusive driving	High engine rpm under no load	A		
				Driving in low gear for extended time	CO		
				Driving at extremely high speed	C		
					Power train system malfunction	—	D
					Installed improper size wheels and tires		D
					Dragging brakes		E
			Improper ignition timing	E			
	Blocked or restricted air flow	Blocked bumper	—	—	F		
		Blocked radiator grille	Installed car brassiere		F		
			Mud contamination or paper clogging		F		
		Blocked radiator	—		G		
		Blocked condenser	Blocked air flow		G		
Installed large fog lamp	G						

COOLING SYSTEM

[QR]

COOLING SYSTEM

PFP:21020

Cooling Circuit

EBS00NGP

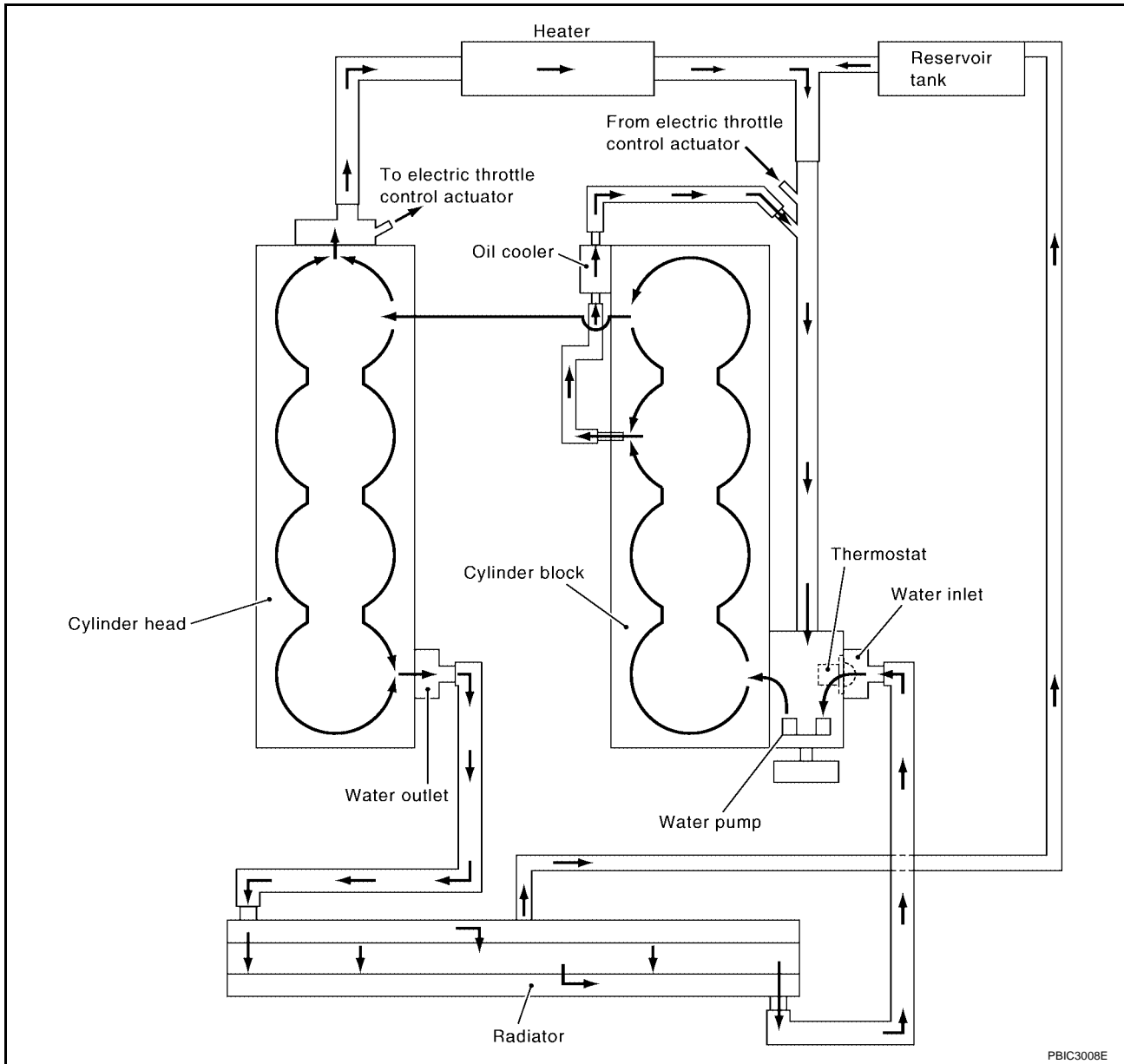

COOLING SYSTEM

[QR]

System Chart

EBS00NG0

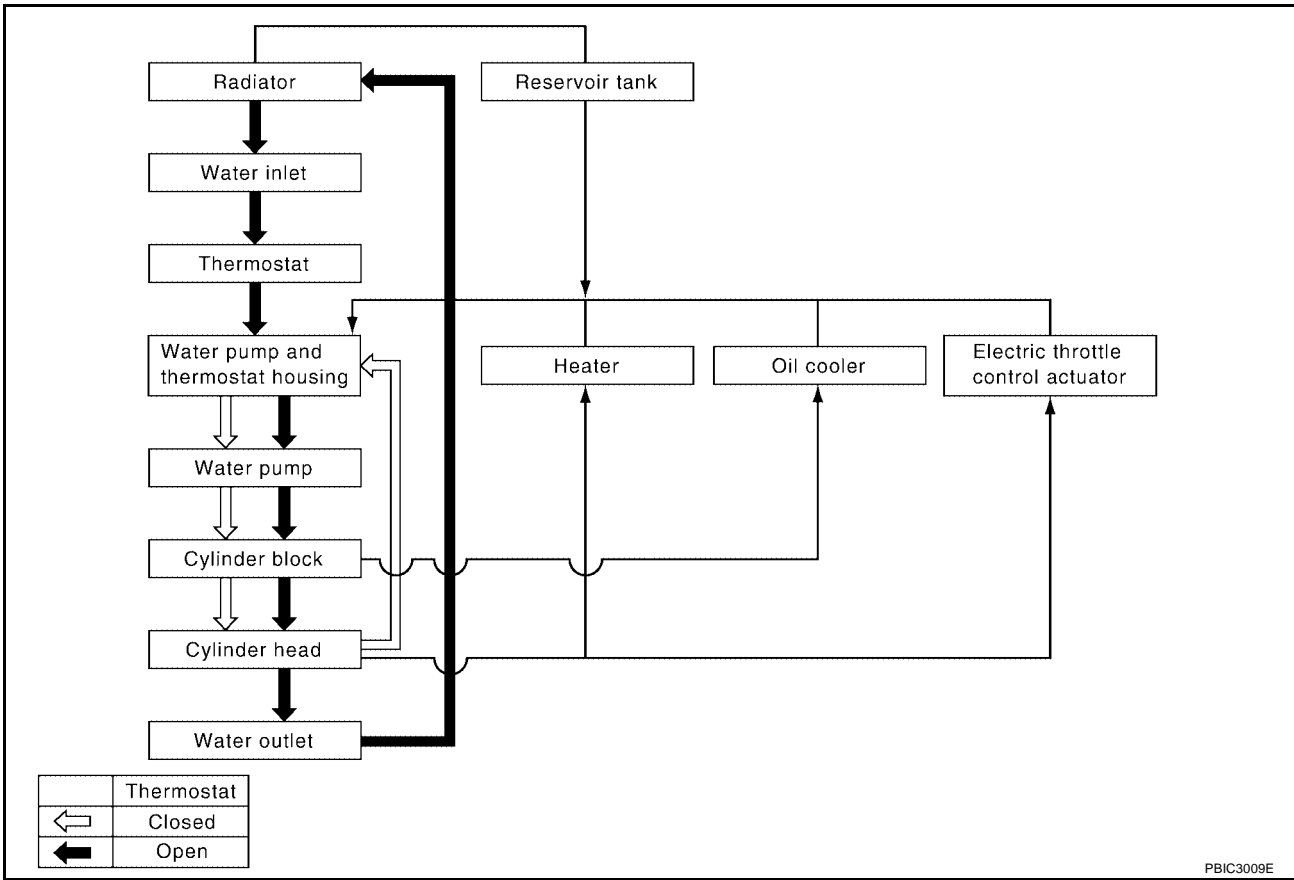

A
CO
C
D
E
F
G
H
I
J
K
L
M

ENGINE COOLANT

System Check

WARNING:

- Never remove the radiator cap or reservoir tank cap when the engine is hot. Serious burns could occur from high pressure fluid escaping from the radiator.
- Wrap a thick cloth around the cap. Slowly push down and turn it a quarter turn to allow built-up pressure to escape. Carefully remove the cap by pushing down and turning it all the way.

CHECKING COOLING SYSTEM HOSES

Check hoses for the following:

- Improper attachment
- Leaks
- Cracks
- Damage
- Loose connections
- Chafing
- Deterioration

CHECKING RESERVOIR LEVEL

- Check if the reservoir tank coolant level is within MIN to MAX when the engine is cool.
- Adjust engine coolant level as necessary.

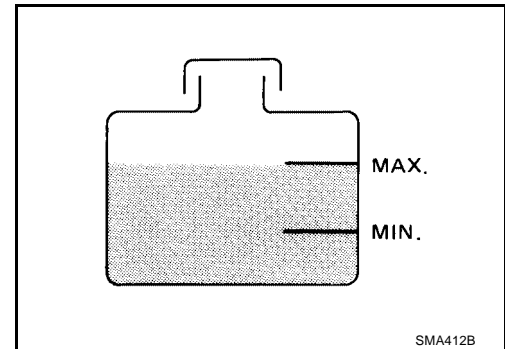

CHECKING COOLING SYSTEM FOR LEAKS

To check for leakage, apply pressure to the cooling system using Tool.

Tool number : EG17650301 (J-33984-A)

Testing pressure : 137 kPa (1.4 kg/cm² , 20 psi)

WARNING:

Never remove the radiator cap when the engine is hot. Serious burns could occur from high pressure coolant escaping from the radiator.

CAUTION:

Higher pressure than specified may cause radiator damage.

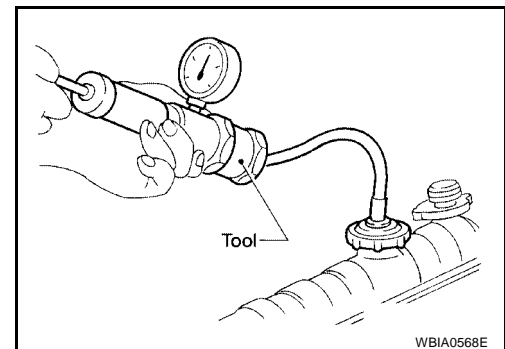

CHECKING RESERVOIR CAP

1. Inspect the reservoir cap.
 - Replace the cap if the metal plunger cannot be seen around the edge of the black rubber gasket.
 - Replace the cap if deposits of waxy residue or other foreign material are on the black rubber gasket or the metal retainer.

NOTE:

Thoroughly wipe out the reservoir filler neck to remove any waxy residue or foreign material.

ENGINE COOLANT

[QR]

2. Pull the negative-pressure valve to open it and check that it closes completely when released.
 - Check that there is no dirt or damage on the valve seat of the reservoir cap negative-pressure valve.
 - Check that there are no abnormalities in the opening and closing conditions of the negative-pressure valve.

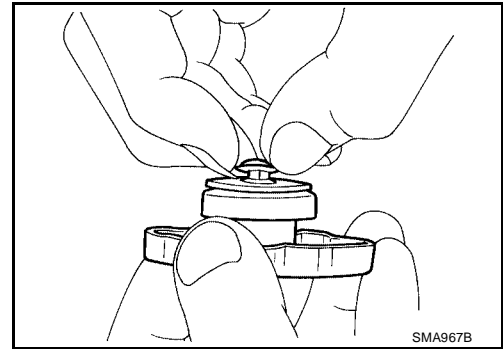

3. Check reservoir cap relief pressure using Tool.

Tool number : EG17650301 (J-33984-A)

Standard: 98 – 118 kPa (0.99 – 1.20 kg/cm² , 14 – 17 psi)

- When connecting the reservoir cap to the tester, apply water or coolant to the cap seal surface.
- Replace the reservoir cap if there is an abnormality in the negative-pressure valve, or if the open-valve pressure is outside of the standard values.

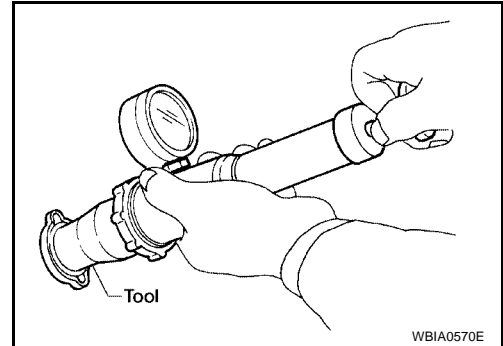

CHECKING RADIATOR

Check radiator for mud or clogging. If necessary, clean radiator as follows.

CAUTION:

- **Be careful not to bend or damage the radiator fins.**
 - **When radiator is cleaned without removal, remove all surrounding parts such as cooling fan shroud and horns. Then tape the harness and electrical connectors to prevent water from entering.**
1. Apply water by hose to the back side of the radiator core, with the hose pointed vertically downward.
 2. Apply water again to all radiator core surfaces once per minute.
 3. Stop washing if any stains no longer flow out from the radiator.
 4. Blow air into the back side of radiator core, with the air hose pointed vertically downward.
 - Use compressed air lower than 490 kPa (5 kg/cm² , 71 psi) and keep distance more than 30 cm (11.8 in).
 5. Blow air again into all the radiator core surfaces once per minute until no water sprays out.
 6. Check for leaks.

Changing Engine Coolant

EBS00T30

WARNING:

- **To avoid being scalded, never change the coolant when the engine is hot.**
- **Wrap a thick cloth around cap and carefully remove the cap. First, turn the cap a quarter of a turn to release built-up pressure. Then push down and turn the cap all the way to remove.**

DRAINING ENGINE COOLANT

1. Remove the engine undercover using power tool.

ENGINE COOLANT

[QR]

2. Open the radiator drain plug at the bottom of the radiator, and remove the radiator filler cap. This is the only step required when partially draining the cooling system (radiator only).
 - Do not to allow the coolant to contact the drive belts.

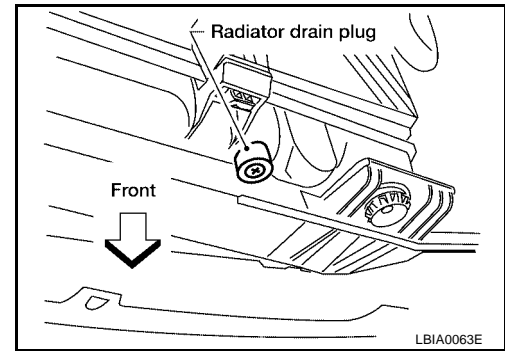

3. Follow this step for heater core removal/replacement only. Disconnect the upper heater hose at the engine side and apply moderate air pressure [103.46 kPa (15 psi, 1.055 kg/cm²) maximum air pressure] into the hose for 30 seconds to blow the excess coolant out of the heater core.
4. When draining all of the coolant in the system, remove the reservoir tank and drain the coolant, then clean the reservoir tank before installation.
5. When draining all of the coolant in the system for engine removal or repair, open the drain plug on the cylinder block.

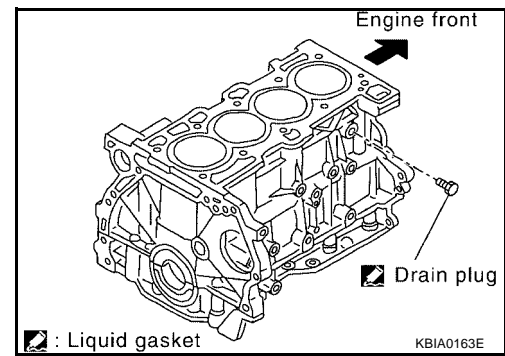

6. Check the drained coolant for contaminants such as rust, corrosion or discoloration. If the coolant is contaminated, flush the engine cooling system. Refer to [CO-13, "FLUSHING COOLING SYSTEM"](#).

REFILLING ENGINE COOLANT

1. Install the radiator drain plug. Install the reservoir tank and cylinder block drain plug, if removed for a total system drain or for engine removal or repair.
 - The radiator must be completely empty of coolant and water.
 - Apply sealant to the threads of the cylinder block drain plugs. Use Genuine High Performance Thread Sealant or equivalent. Refer to [GI-48, "Recommended Chemical Products and Sealants"](#).
Radiator drain plug : Refer to [CO-15, "RADIATOR"](#).
Cylinder block drain plug : Refer to [EM-75, "CYLINDER BLOCK"](#).
2. If disconnected, reattach the upper radiator hose at the engine side.
3. Set the vehicle heater controls to the full HOT and heater ON position. Turn the vehicle ignition ON with the engine OFF as necessary to activate the heater mode.

ENGINE COOLANT

[QR]

4. Install the Tool by installing the radiator cap adapter onto the radiator neck opening. Then attach the gauge body assembly with the refill tube and the venturi assembly to the radiator cap adapter.

Tool number : KV991J0070 (J-45695)

5. Insert the refill hose into the coolant mixture container that is placed at floor level. Make sure the ball valve is in the closed position.

- Use Genuine NISSAN Long Life Anti-freeze coolant or equivalent, mixed 50/50 with distilled water or demineralized water. Refer to [MA-13. "ANTI-FREEZE COOLANT MIXTURE RATIO"](#).

Engine coolant capacity (with reservoir tank) : Refer to [MA-11, "Fluids and Lubricants"](#).

6. Install an air hose to the venturi assembly, the air pressure must be within specification.

Compressed air supply pressure : 5.7 - 8.5 kPa (5.6 - 8.4 kg/cm², 80 - 120 psi)

CAUTION:

The compressed air supply must be equipped with an air dryer.

7. The vacuum gauge will begin to rise and there will be an audible hissing noise. During this process open the ball valve on the refill hose slightly. Coolant will be visible rising in the refill hose. Once the refill hose is full of coolant, close the ball valve. This will purge any air trapped in the refill hose.

8. Continue to draw the vacuum until the gauge reaches 28 inches of vacuum. The gauge may not reach 28 inches in high altitude locations, refer to the vacuum specifications based on the altitude above sea level.

Altitude above sea level	Vacuum gauge reading
0 - 100 m (328 ft)	: 28 inches of vacuum
300 m (984 ft)	: 27 inches of vacuum
500 m (1,641 ft)	: 26 inches of vacuum
1,000 m (3,281 ft)	: 24 - 25 inches of vacuum

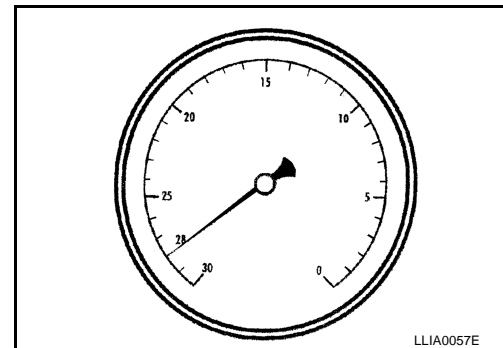
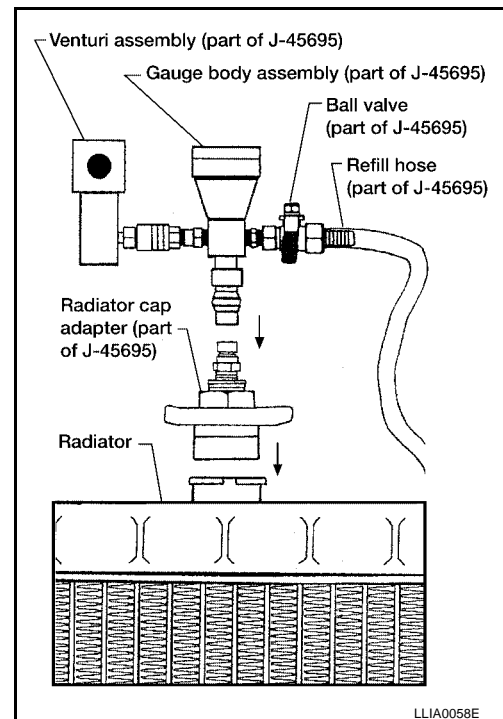

9. When the vacuum gauge has reached the specified amount, disconnect the air hose and wait 20 seconds to see if the system loses any vacuum. If the vacuum level drops, perform any necessary repairs to the system and repeat steps 6 - 8 to bring the vacuum to the specified amount. Recheck for any leaks.
10. Place the coolant container (with the refill hose inserted) at the same level as the top of the radiator. Then open the ball valve on the refill hose so the coolant will be drawn up to fill the cooling system. The cooling system is full when the vacuum gauge reads zero.

CAUTION:

Do not allow the coolant container to get too low when filling, to avoid air from being drawn into the cooling system.

11. Remove the Tool from the radiator neck opening.
12. Fill the cooling system reservoir tank to the specified level and install the radiator cap. Run the engine to warm up the cooling system and top up the system as necessary.

FLUSHING COOLING SYSTEM

1. Fill the radiator from the filler cap above the radiator upper hose and reservoir tank, with water and reinstall the filler cap above the radiator upper hose.
2. Run the engine until it reaches normal operating temperature.
3. Press the engine accelerator two or three times under no-load.

ENGINE COOLANT

[QR]

4. Stop the engine and wait until it cools down.
5. Drain the water.
6. Repeat steps 1 through 5 until clear water begins to drain from the radiator.

RADIATOR

Removal and Installation

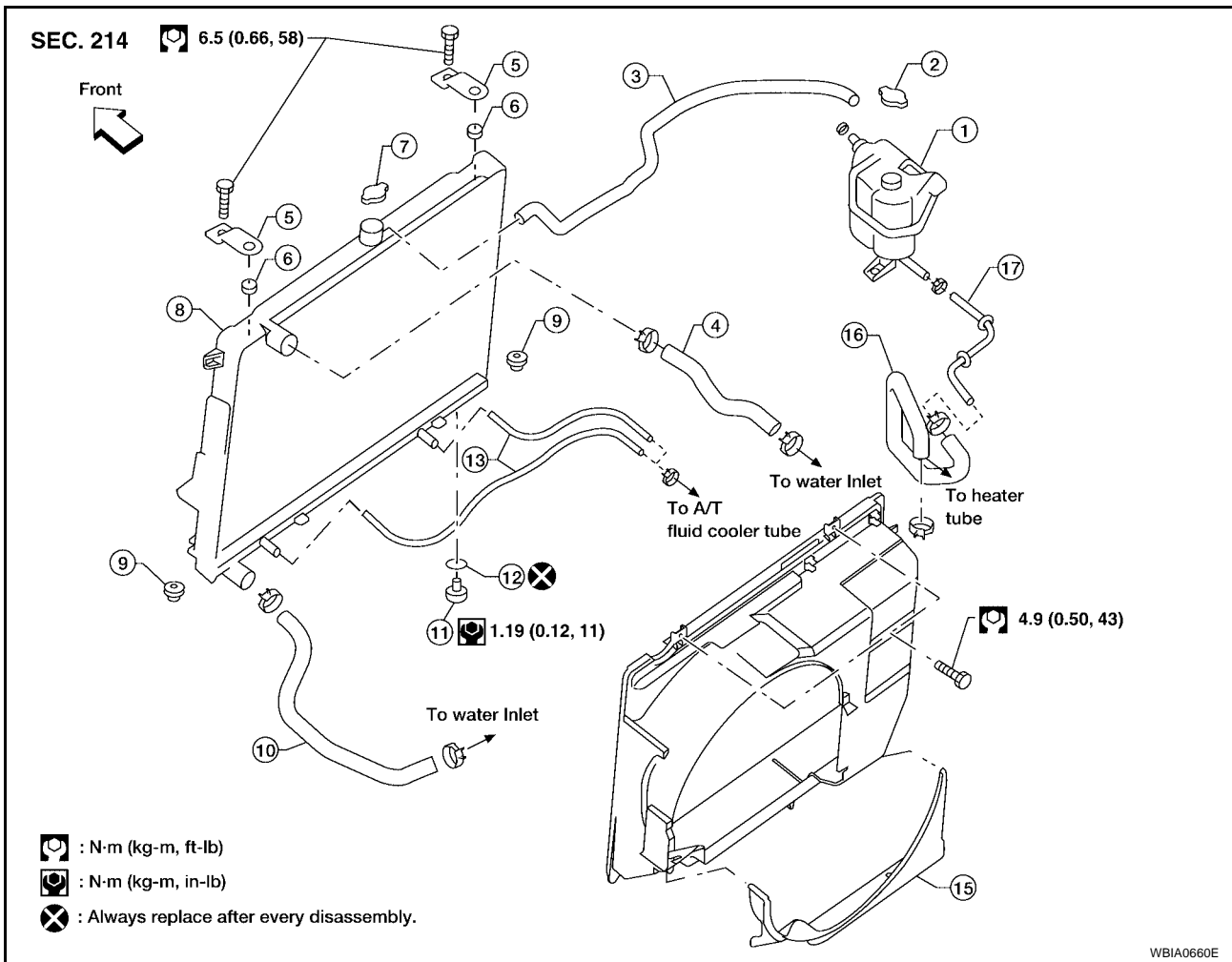

- | | | |
|---------------------------|-------------------------|----------------------------|
| 1. Reservoir tank | 2. Reservoir tank cap | 3. Reservoir tank hose |
| 4. Radiator hose (upper) | 5. Upper mount bracket | 6. Mounting rubber (upper) |
| 7. Radiator cap | 8. Radiator | 9. Mounting rubber (lower) |
| 10. Radiator hose (lower) | 11. Radiator drain plug | 12. O-ring |
| 13. A/T fluid cooler hose | 14. Upper shroud | 15. Lower shroud |
| 16. Heater bypass hose | 17. Heater bypass tube | |

WARNING:

Do not remove radiator cap when engine is hot. Serious burns could occur from high-pressure engine coolant escaping from radiator. Wrap a thick cloth around the cap. Slowly turn it a quarter of a turn to release built-up pressure. Carefully remove radiator cap by turning it all the way.

REMOVAL

1. Drain engine coolant from radiator. Refer to [CO-39, "DRAINING ENGINE COOLANT"](#).

CAUTION:

- Perform this step when engine is cold.
- Do not spill engine coolant on drive belts.

2. Remove air duct, air duct brackets and air cleaner case assembly. Refer to [EM-126, "REMOVAL"](#).
3. Remove reservoir tank hose.
4. Removal (upper and lower) radiator hoses.

CAUTION:

Be careful not to allow engine coolant to contact drive belts.

5. Remove radiator cooling fan assembly. Refer to [CO-18, "COOLING FAN"](#).

RADIATOR

[QR]

6. Disconnect A/T fluid cooler hoses. (A/T models)
 - Install blind plug to avoid leakage of A/T fluid.
7. Remove the upper mount bracket bolts.

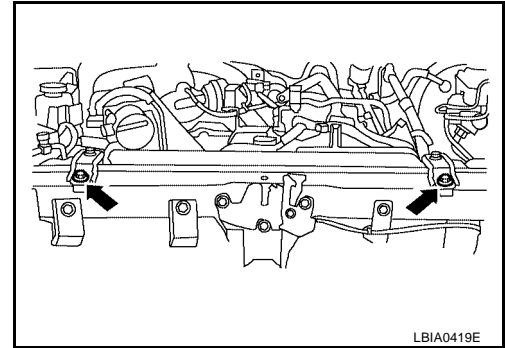

8. Remove the two A/C condenser bolts. (if equipped)

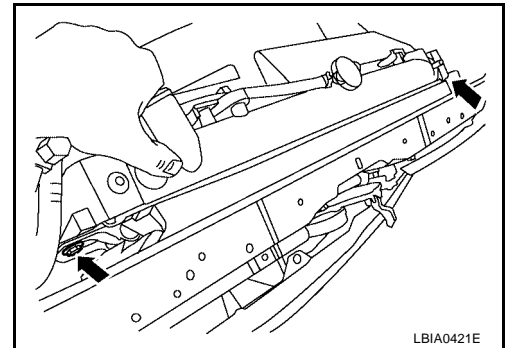

9. Remove radiator as follows:

CAUTION:

Do not damage or scratch A/C condenser and radiator core when removing.

- a. With lifting and pulling radiator in a rear direction, disassemble lower mount from radiator core support center.

CAUTION:

Because A/C condenser is onto the front-lower portion of radiator, moving to rear direction should be at minimum.

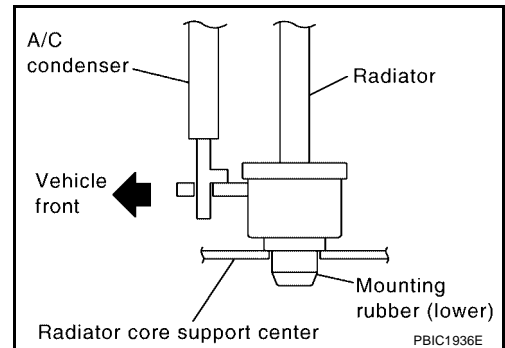

- b. Lift A/C condenser up and remove radiator after disengaging the fitting as front-bottom surface.

CAUTION:

Lifting A/C condenser should be minimum to prevent a load to A/C piping.

- c. After removing radiator, put A/C condenser on radiator core support center to prevent a load to A/C piping, and temporarily secure it with rope or by similar means.

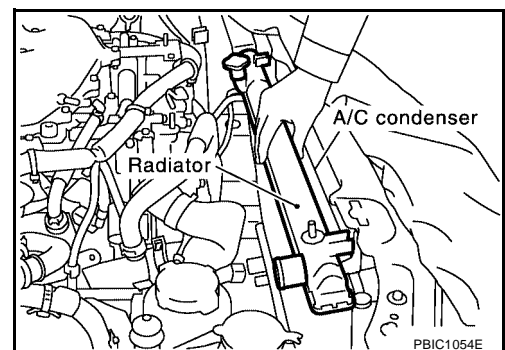

INSTALLATION

Installation is in the reverse order of removal.

INSPECTION AFTER INSTALLATION

- Check for leaks of engine coolant using tool. Refer to [CO-10, "CHECKING COOLING SYSTEM FOR LEAKS"](#).
- Start and warm up engine. Visually check there are no leaks of engine coolant and A/T fluid.

A

CO

C

D

E

F

G

H

I

J

K

L

M

COOLING FAN

Removal and Installation (Crankshaft driven type)

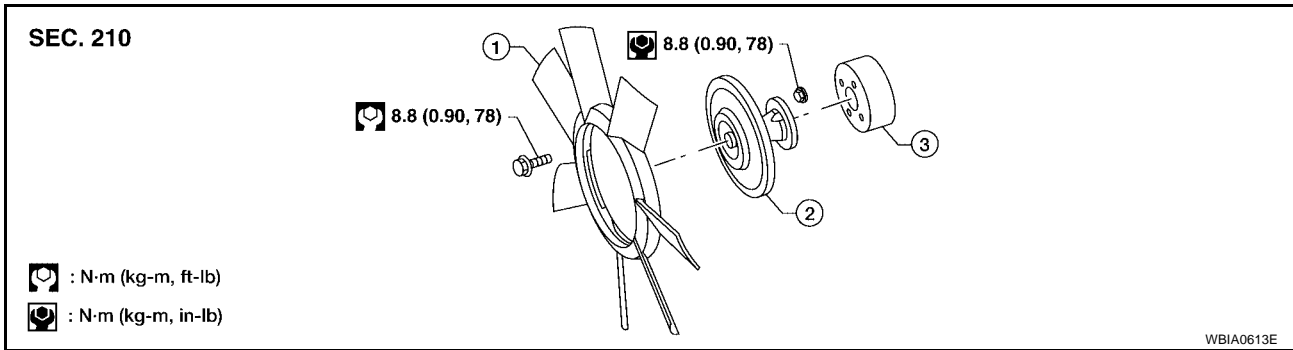

1. Cooling fan
2. Fan coupling
3. Fan bracket
4. Cooling fan pulley

REMOVAL

1. Remove air duct. Refer to [EM-126, "REMOVAL"](#).
2. Remove the engine front undercover.
3. Remove the upper and lower radiator shrouds. Refer to [CO-15, "REMOVAL"](#).
4. Remove drive belts. Refer to [EM-124, "Removal"](#).
5. Remove cooling fan.

INSPECTION AFTER REMOVAL

Fan Coupling

Inspect fan coupling for oil leakage and bimetal conditions.

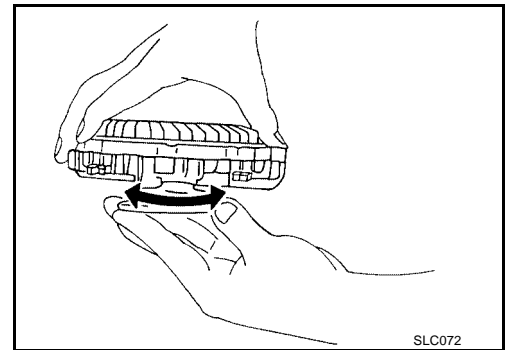

Cooling Fan

Inspect cooling fan for crack or unusual bend.

- If anything is found, replace cooling fan.

INSTALLATION

Installation is in the reverse order of removal.

- Install cooling fan with its front mark "F" facing front of engine. Refer to [CO-18, "INSTALLATION"](#).

INSPECTION AFTER INSTALLATION

- Check for leaks of the engine coolant using tool. Refer to [CO-10, "CHECKING COOLING SYSTEM FOR LEAKS"](#).
- Start and warm up the engine. Visually make sure that there are no leaks of the engine coolant.

WATER PUMP

[QR]

PF2:21020

EBS00NGZ

WATER PUMP

Removal and Installation

SEC. 210•211

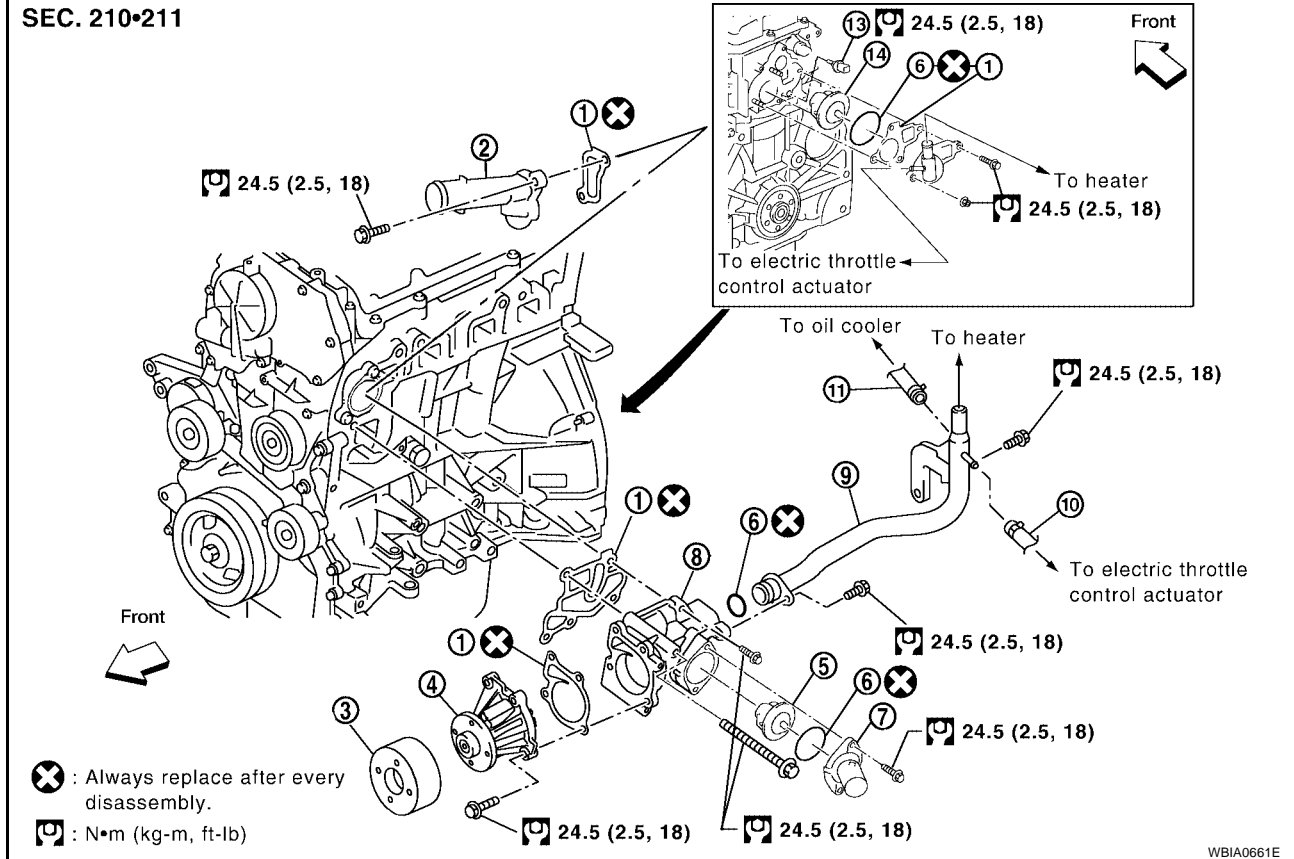

- | | | |
|---------------------------------------|--------------------------------------|----------------------|
| 1. Gasket | 2. Water outlet | 3. Water pump pulley |
| 4. Water pump | 5. Thermostat | 6. O-ring |
| 7. Water inlet | 8. Water pump and thermostat housing | 9. Heater pipe |
| 10. Water hose | 11. Water hose | 12. Heater outlet |
| 13. Engine coolant temperature sensor | 14. Water control Valve | |

REMOVAL

1. Drain engine coolant from radiator drain plug at the bottom of radiator and from water drain plug on cylinder block. Refer to [CO-11, "DRAINING ENGINE COOLANT"](#) and [EM-75, "CYLINDER BLOCK"](#).

CAUTION:

- Perform this step when the engine is cold.
- Do not spill engine coolant on drive belt.

2. Remove air duct; Refer to [EM-16, "AIR CLEANER AND AIR DUCT"](#).
3. Remove drive belt; Refer to [EM-14, "DRIVE BELTS"](#).
4. Remove radiator hose (upper and lower). Refer to [CO-15, "RADIATOR"](#).
5. Remove cooling fan and water pump pulley. Refer to [CO-18, "REMOVAL"](#).
6. Remove water pump with power tool.

CAUTION:

- Handle water pump vane so that it does not contact any other parts.
- Water pump cannot be disassembled and should be replaced as a unit.

NOTE:

- Engine coolant will leak from cylinder block, so have a receptacle ready below.

INSPECTION AFTER REMOVAL

- Visually check if there is no significant dirt or rusting on water pump body and vane.
- Make sure that there is no looseness in vane shaft, and that it turns smoothly when rotated by hand.
- Replace water pump, if necessary.

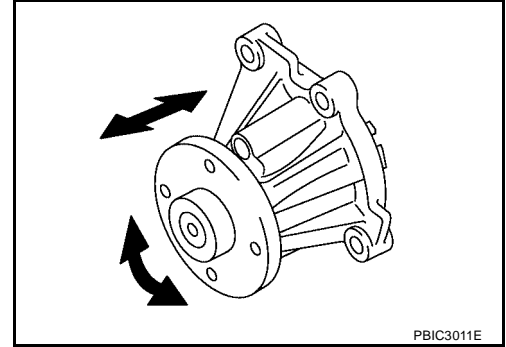

INSTALLATION

Installation is in the reverse order of removal.

- When inserting heater pipe end into water pump and thermostat housing, apply a neutral detergent to O-ring. Then insert it immediately.

INSPECTION AFTER INSTALLATION

- Check for leaks of engine coolant. Refer to [CO-10, "CHECKING COOLING SYSTEM FOR LEAKS"](#) .
- Start and warm up the engine. Visually check if there is no leaks of engine coolant.

THERMOSTAT AND THERMOSTAT HOUSING

PFP:21200

Removal and Installation Thermostat

EBS00NH0

SEC. 210•211

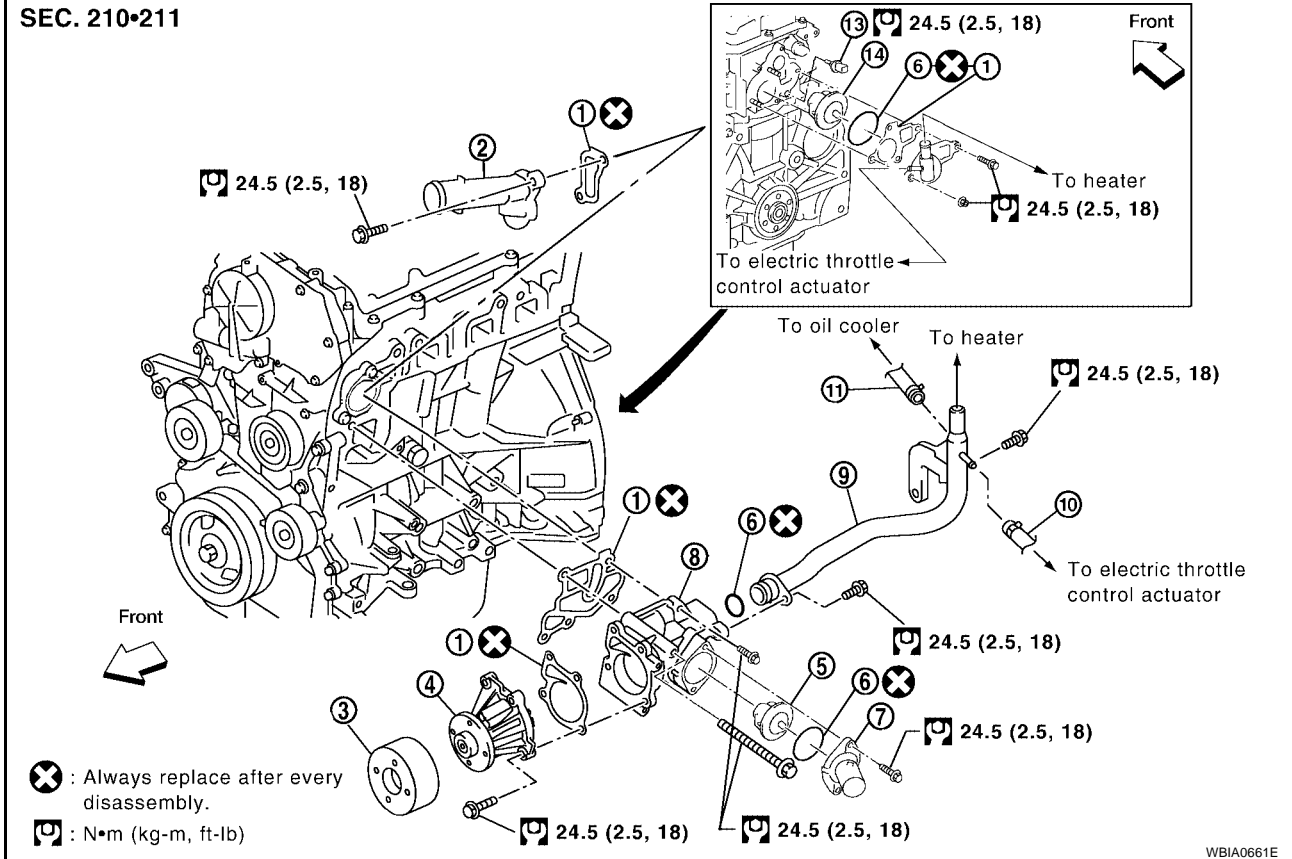

- | | | |
|---------------------------------------|--------------------------------------|----------------------|
| 1. Gasket | 2. Water outlet | 3. Water pump pulley |
| 4. Water pump | 5. Thermostat | 6. O-ring |
| 7. Water inlet | 8. Water pump and thermostat housing | 9. Heater pipe |
| 10. Water hose | 11. Water hose | 12. Heater outlet |
| 13. Engine coolant temperature sensor | 14. Water control valve | |

REMOVAL

1. Drain engine coolant. Refer to [CO-39, "DRAINING ENGINE COOLANT"](#) and [EM-75, "CYLINDER BLOCK"](#).

CAUTION:

- Perform this step when the engine is cold.
- Do not spill engine coolant on drive belt.

2. Disconnect radiator hose (lower) at water inlet side. Refer to [CO-15, "REMOVAL"](#).
3. Remove water inlet and thermostat.

INSPECTION AFTER REMOVAL

- Place a thread so that it is caught in the valves of thermostat. Immerse fully in a container filled with water. Heat while stirring.
- The valve opening temperature is the temperature at which the valve opens and falls from the thread.
- Continue heating. Check the maximum valve lift amount.

NOTE:

The maximum valve lift amount standard temperature for water control valve is the reference value.

- After checking the maximum valve lift amount, lower the water temperature and check the valve closing temperature.

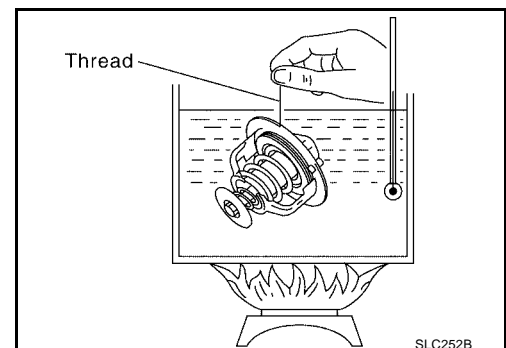

THERMOSTAT AND THERMOSTAT HOUSING

[QR]

Standard:

Items	Thermostat
Valve opening temperature	80.5 - 83.5°C (177 - 182°F)
Maximum valve lift	8 mm/ 95°C (0.315 in/ 203°F)
Valve closing temperature	77°C (171°F)

- If out of the standard, replace thermostat.

INSTALLATION

Installation is in the reverse order of removal.

Thermostat

- Install thermostat with making rubber ring groove fit to thermostat flange with the whole circumference.

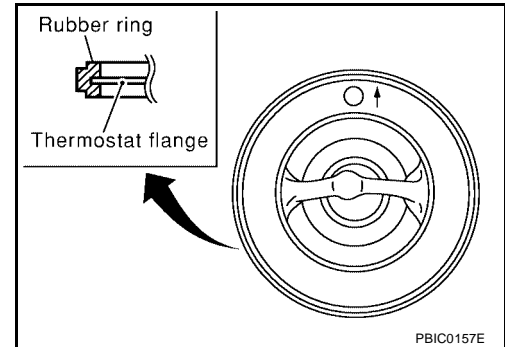

- Install thermostat with jiggle valve facing upwards. (The position deviation may be within the range of 20° as shown.)

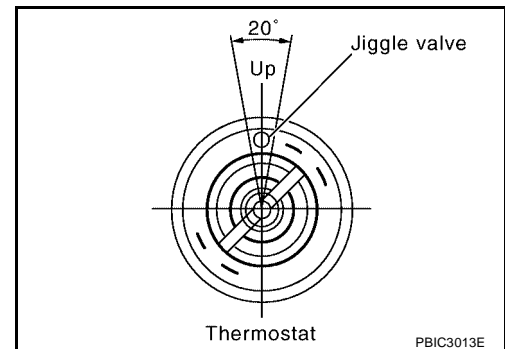

INSPECTION AFTER INSTALLATION

- Check for leaks of engine coolant. Refer to [CO-10, "System Check"](#).
- Start and warm up the engine. Visually check if there is no leaks of engine coolant.

THERMOSTAT AND THERMOSTAT HOUSING

[QR]

Removal and Installation Water Pump and Thermostat Housing

EBS00NHQ

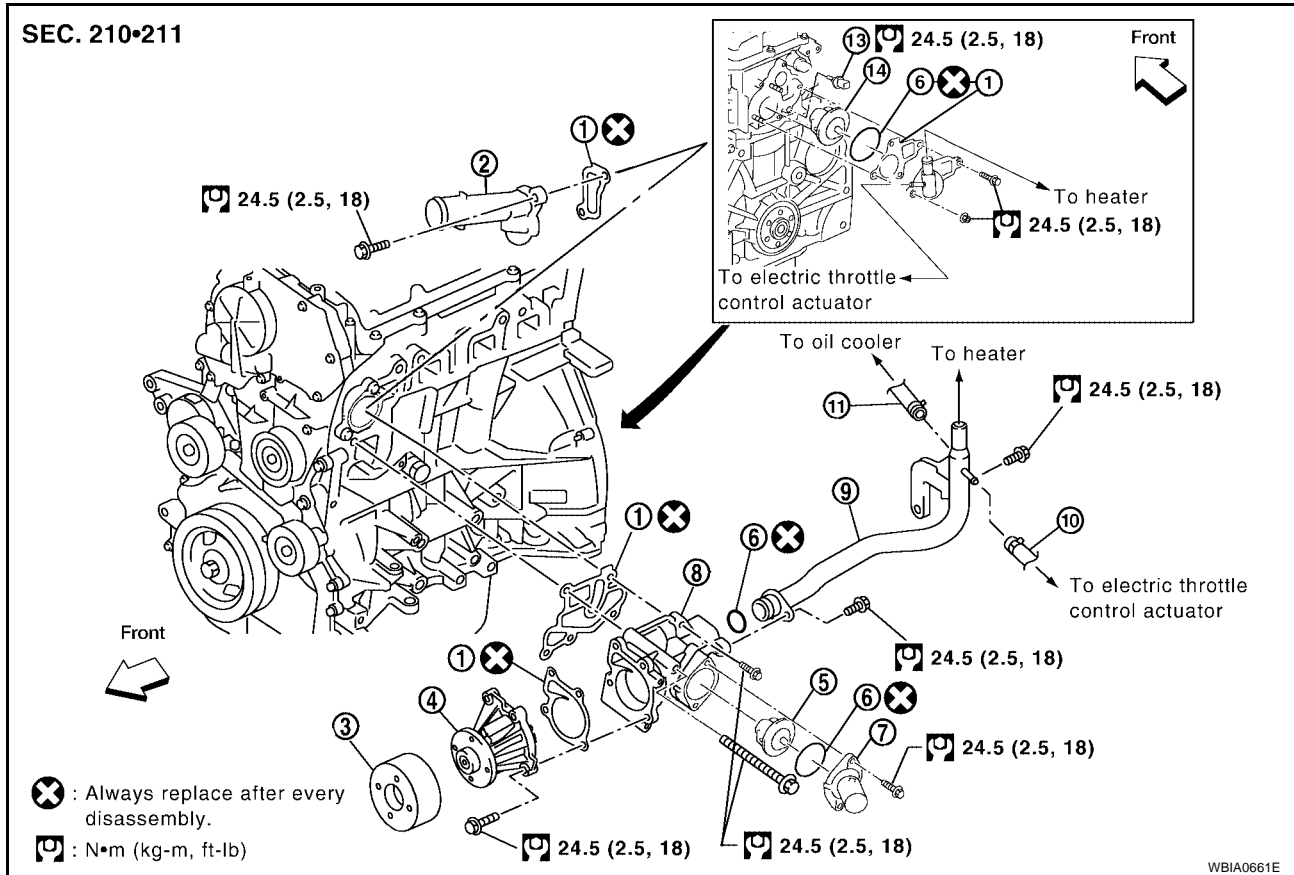

- | | | |
|---------------------------------------|--------------------------------------|----------------------|
| 1. Gasket | 2. Water outlet | 3. Water pump pulley |
| 4. Water pump | 5. Thermostat | 6. O-ring |
| 7. Water inlet | 8. Water pump and thermostat housing | 9. Heater pipe |
| 10. Water hose | 11. Water hose | 12. Heater outlet |
| 13. Engine coolant temperature sensor | 14. Water control valve | |

REMOVAL

1. Drain engine coolant. Refer to [CO-39, "DRAINING ENGINE COOLANT"](#) .
2. Remove air cleaner and air duct assembly. Refer to [EM-16, "REMOVAL"](#) .
3. Remove water pump. Refer to [CO-19, "WATER PUMP"](#) .
4. Remove exhaust manifold cover. Refer to [EM-21, "EXHAUST MANIFOLD AND THREE WAY CATALYST"](#) .
5. Remove oil level gauge and oil level gauge guide. Refer to [EM-75, "CYLINDER BLOCK"](#) .

CAUTION:

Plug the oil level gauge guide opening to prevent oil pan from entering foreign materials.

6. Remove A/C compressor and position aside. Refer to [MTC-102, "Removal and Installation for Compressor"](#) .
7. Remove bolt for heater pipe at water pump and thermostat housing.
8. Disconnect heater pipe from water pump and thermostat housing.
9. Remove water pump and thermostat housing.

INSTALLATION

Installation is in the reverse order of removal.

- When inserting heater pipe end into water pump and thermostat housing, apply a neutral detergent to O-ring. Then insert it immediately.

INSPECTION AFTER INSTALLATION

- Check for leaks of engine coolant. Refer to [CO-10, "CHECKING COOLING SYSTEM FOR LEAKS"](#) .

THERMOSTAT AND THERMOSTAT HOUSING

[QR]

- Start and warm up the engine. Visually check if there is no leaks of engine coolant.

WATER CONTROL VALVE

Removal and Installation

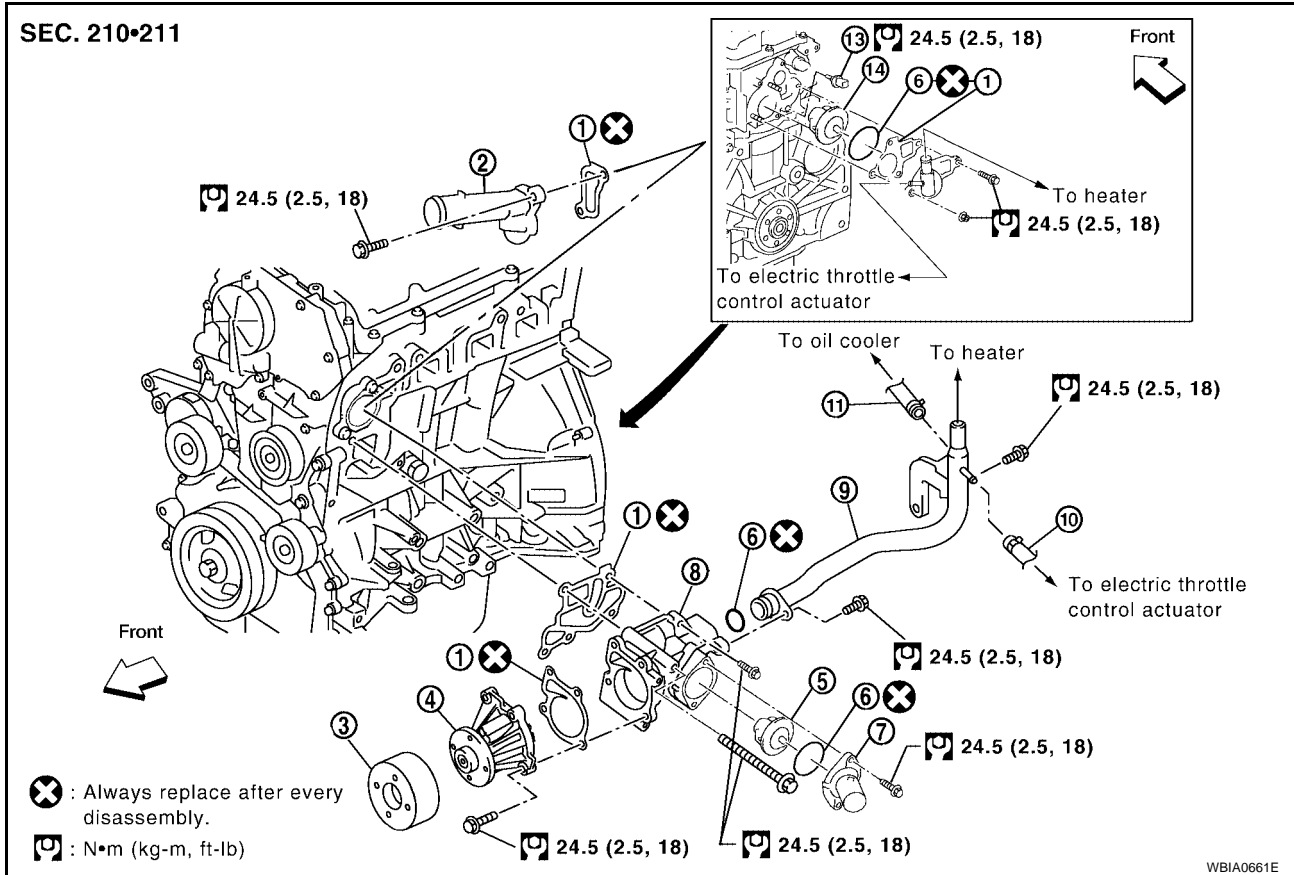

- | | | |
|---------------------------------------|--------------------------------------|----------------------|
| 1. Gasket | 2. Water outlet | 3. Water pump pulley |
| 4. Water pump | 5. Thermostat | 6. O-ring |
| 7. Water inlet | 8. Water pump and thermostat housing | 9. Heater pipe |
| 10. Water hose | 11. Water hose | 12. Heater outlet |
| 13. Engine coolant temperature sensor | 14. Water control valve | |

WARNING:

Never remove the radiator cap when the engine is hot. Serious burns could occur from high pressure coolant escaping from the radiator.

REMOVAL

CAUTION:

Perform when the engine cold.

1. Drain the engine coolant. Refer to [CO-11, "Changing Engine Coolant"](#) .
2. Remove the heater pipe, heater hose and water hoses.
3. Remove the heater outlet.
4. Remove the water control valve.

WATER CONTROL VALVE

[QR]

INSPECTION AFTER REMOVAL

- Place a thread so that it is caught in the valve of the water control valve. Immerse fully in a container filled with water. Heat while stirring.
- The valve opening temperature is the temperature at which the valve opens and the falls from the thread.
- Continue heating. Check the full-open lift amount.

NOTE:

The full-open lift amount standard temperature for the water control valve is the reference value.

- After checking the full-open lift amount, lower the water temperature and check the valve closing temperature.

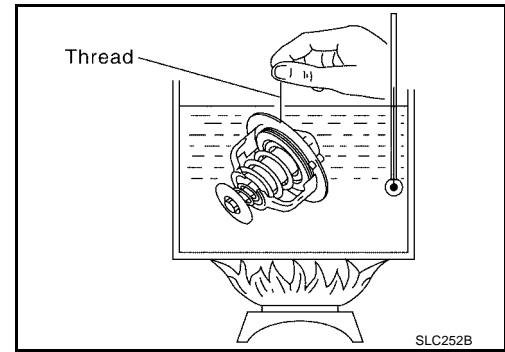

Standard values

Water Control Valve	Standard Value
Valve opening temperature	93.5° - 96.5°C (200° - 206°F)
Full-open lift amount	More than 8 mm / 108°C (0.315 in / 226° F)
Valve closing temperature	90°C (194° F) or higher

INSTALLATION

Installation is in the reverse order of removal.

- Install the engine coolant temperature sensor if removed.
Use Genuine RTV Silicone Sealant or equivalent. Refer to [GI-48, "RECOMMENDED CHEMICAL PRODUCTS AND SEALANTS"](#).
- Install the water control valve with the whole circumference of the flange part fitting securely inside the rubber ring.
- Install the water control valve with the up-mark facing up and the frame center part facing upwards. The position deviation may be within the range of $\pm 10^\circ$.

WATER OUTLET AND WATER PIPING

PFP:11060

Removal and Installation

EBS00NH1

SEC. 210•211

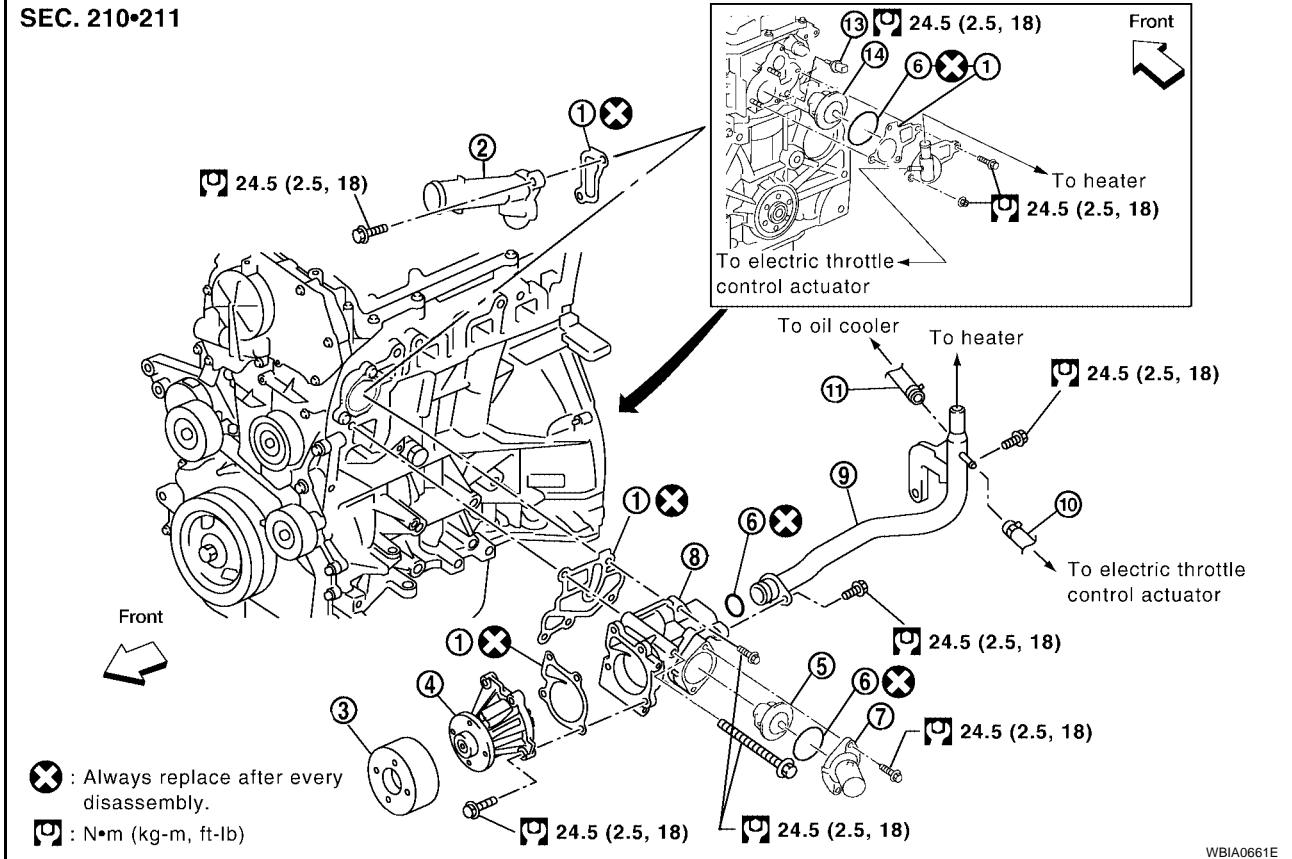

- | | | |
|---------------------------------------|--------------------------------------|----------------------|
| 1. Gasket | 2. Water outlet | 3. Water pump pulley |
| 4. Water pump | 5. Thermostat | 6. O-ring |
| 7. Water inlet | 8. Water pump and thermostat housing | 9. Heater pipe |
| 10. Water hose | 11. Water hose | 12. Heater outlet |
| 13. Engine coolant temperature sensor | 14. Water control valve | |

REMOVAL

1. Drain engine coolant from radiator drain plug at the bottom of radiator, and from water drain plug on the cylinder block. Refer to [CO-11, "DRAINING ENGINE COOLANT"](#) and [EM-75, "CYLINDER BLOCK"](#).

CAUTION:

- Perform this step when engine is cold.
- Do not spill engine coolant on drive belts.

2. Disconnect radiator hose (upper) at water outlet side. Refer to [CO-15, "RADIATOR"](#).
3. Remove water outlet.
4. Disconnect heater hoses and water hoses.
5. Remove heater outlet and water control valve.
6. Remove engine coolant temperature sensor as necessary.

CAUTION:

Be careful not to damage engine coolant temperature sensor.

INSTALLATION

Note the following, and install in the reverse order of removal.

- Securely insert each hose, and install clamp at a position where it does not interfere with the pipe bulge.

INSPECTION AFTER INSTALLATION

- Check for leaks of engine coolant using Tool and radiator cap tester (commercial service tool). Refer to [CO-10, "CHECKING COOLING SYSTEM FOR LEAKS"](#) .
- Start and warm up engine. Visually make sure that there is no leaks of engine coolant.

SERVICE DATA AND SPECIFICATIONS (SDS)

[QR]

SERVICE DATA AND SPECIFICATIONS (SDS)

PFP:00030

Standard and Limit

EBS00NH2

ENGINE COOLANT CAPACITY (APPROXIMATE)

Unit: ℓ (US gal, Imp gal)

Engine coolant capacity (With reservoir tank at "MAX" level)	9.4 (2 1/2, 2 1/8)
--	--------------------

RESERVOIR CAP

Unit: kPa (kg/cm², psi)

Cap relief pressure	Standard	98 - 118 (0.99 - 1.20, 14- 17)
Leakage test pressure		137 (1.4, 20)

THERMOSTAT

Valve opening temperature	80.5 - 83.5°C (177 - 182°F)
Maximum valve lift	8 mm/ 95°C (0.315 in/ 203°F)
Valve closing temperature	77°C (171°F)

A
CO
C
D
E
F
G
H
I
J
K
L
M

PRECAUTIONS

Precautions for Supplemental Restraint System (SRS) “AIR BAG” and “SEAT BELT PRE-TENSIONER”

EBS00T39

The Supplemental Restraint System such as “AIR BAG” and “SEAT BELT PRE-TENSIONER”, used along with a front seat belt, helps to reduce the risk or severity of injury to the driver and front passenger for certain types of collision. Information necessary to service the system safely is included in the SRS and SB section of this Service Manual.

WARNING:

- To avoid rendering the SRS inoperative, which could increase the risk of personal injury or death in the event of a collision which would result in air bag inflation, all maintenance must be performed by an authorized NISSAN/INFINITI dealer.
- Improper maintenance, including incorrect removal and installation of the SRS, can lead to personal injury caused by unintentional activation of the system. For removal of Spiral Cable and Air Bag Module, see the SRS section.
- Do not use electrical test equipment on any circuit related to the SRS unless instructed to in this Service Manual. SRS wiring harnesses can be identified by yellow and/or orange harnesses or harness connectors.

**Precautions for Liquid Gasket
REMOVAL OF LIQUID GASKET SEALING**

EBS00M62

- After removing nuts and bolts, separate the mating surface, using Tool and remove old liquid gasket sealing.

Tool number : KV10111100 (J-37228)

CAUTION:

Be careful not to damage the mating surfaces.

- Tap Tool to insert it, and then slide it by tapping on the side as shown.
- In areas where Tool is difficult to use, use plastic hammer to lightly tap the parts, to remove it.

CAUTION:

If for some unavoidable reason suitable tool such as screwdriver is used, be careful not to damage the mating surfaces.

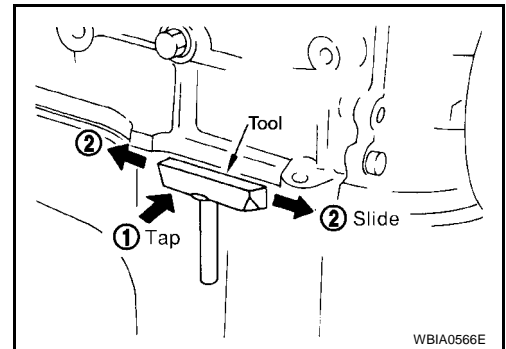

LIQUID GASKET APPLICATION PROCEDURE

1. Remove old liquid gasket adhering to the liquid gasket application surface and the mating surface, Using scraper.
 - Remove liquid gasket completely from the groove of the liquid gasket application surface, bolts, and bolt holes.
2. Thoroughly clean the mating surfaces and remove adhering moisture, grease and foreign materials.

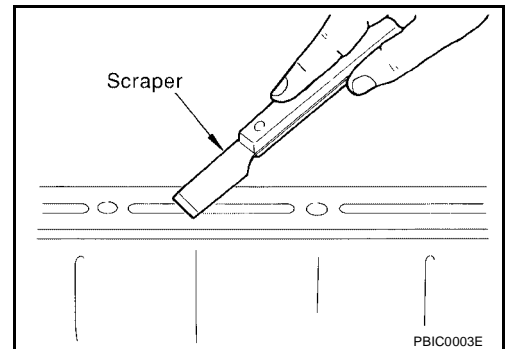

3. Attach liquid gasket tube to Tool.

PRECAUTIONS

[VQ]

Tool number : WS39930000 (—)

Use Genuine RTV Silicone Sealant or equivalent. Refer to [GI-48, "Recommended Chemical Products and Sealants"](#).

4. Apply liquid gasket without breaks to the specified location with the specified dimensions.
 - If there is a groove for the liquid gasket application, apply liquid gasket to the groove.
 - As for the bolt holes, normally apply liquid gasket inside the holes. Occasionally, it should be applied outside the holes. Make sure to read the text of service manual.
 - Within five minutes of liquid gasket application, install the mating component.
 - If liquid gasket protrudes, wipe it off immediately.
 - Do not retighten nuts or bolts after the installation.
 - After 30 minutes or more have passed from the installation, fill engine oil and engine coolant.

CAUTION:

If there are specific instructions in this manual, observe them.

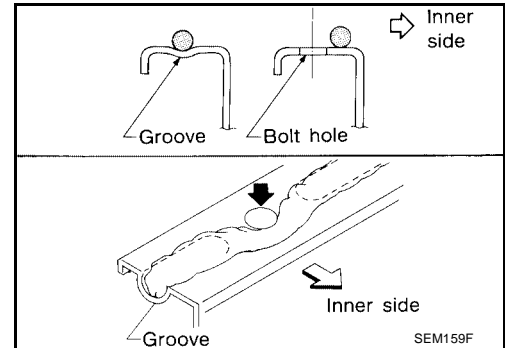
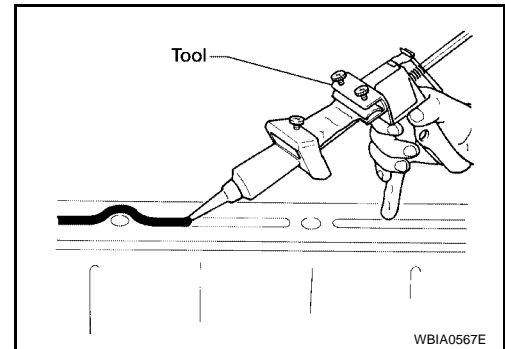

A
CO
C
D
E
F
G
H
I
J
K
L
M

PREPARATION

[VQ]

PFP:00002

EBS00M63

PREPARATION

Special Service Tools

The actual shapes of Kent-Moore tools may differ from those of special service tools illustrated here.

Tool number (Kent-Moore No.) Tool name	Description
EG17650301 (J-33984-A) Radiator cap tester adapter	Adapting radiator cap tester to radiator cap and radiator filler neck a: 28 (1.10) dia. b: 31.4 (1.236) dia. c: 41.3 (1.626) dia. Unit: mm (in)
KV10111100 (J-37228) Seal cutter	Removing chain tensioner cover and water pump cover
WS39930000 (—) Tube presser	Pressing the tube of liquid gasket
— (J-23688) Engine coolant refractometer	Checking concentration of ethylene glycol in engine coolant

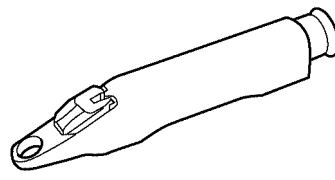
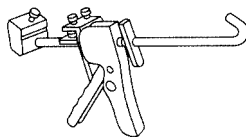
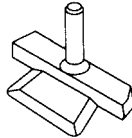
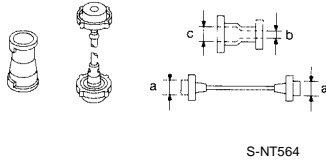

PREPARATION

[VQ]

Commercial Service Tools

EBS00M64

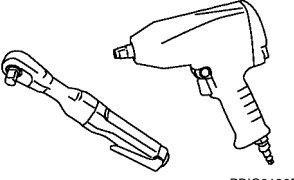
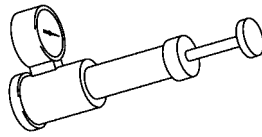
Tool name	Description
Power tool  <p>PBIC0190E</p>	Loosening nuts and bolts
Radiator cap tester  <p>PBIC1982E</p>	Checking radiator and radiator cap

A
CO
C
D
E
F
G
H
I
J
K
L
M

OVERHEATING CAUSE ANALYSIS

[VQ]

OVERHEATING CAUSE ANALYSIS

PFP:00012

Troubleshooting Chart

EBS00M65

		Symptom	Check items	
Cooling system parts malfunction	Poor heat transfer	Water pump malfunction	Worn or loose drive belt	—
		Thermostat stuck closed	—	
		Damaged fins	Dust contamination or paper clogging	
		Heater pump	Physical damage	
		Clogged radiator cooling tube	Excess foreign material (rust, dirt, sand, etc.)	
	Reduced air flow	Cooling fan does not operate	Fan assembly	—
		High resistance to fan rotation		
		Damaged fan blades		
	Damaged radiator shroud	—	—	—
	Improper engine coolant mixture ratio	—	—	—
	Poor engine coolant quality	—	Engine coolant viscosity	—
	Insufficient engine coolant	Engine coolant leaks	Cooling hose	Loose clamp
				Cracked hose
			Water pump	Poor sealing
			Radiator cap	Loose
Poor sealing				
Radiator		O-ring for damage, deterioration or improper fitting		
		Cracked radiator tank		
	Cracked radiator core			
Reservoir tank	Cracked reservoir tank			
Overflowing reservoir tank	Exhaust gas leaks into cooling system	Cylinder head deterioration		
		Cylinder head gasket deterioration		

OVERHEATING CAUSE ANALYSIS

[VQ]

	Symptom		Check items				
Except cooling system parts malfunction	—	Overload on engine	Abusive driving	High engine rpm under no load	A		
				Driving in low gear for extended time	CO		
				Driving at extremely high speed	C		
					Powertrain system malfunction	—	D
					Installed improper size wheels and tires		D
					Dragging brakes		E
			Improper ignition timing	E			
	Blocked or restricted air flow	Blocked bumper	—	—	F		
		Blocked radiator grille	Installed car brassiere		F		
			Mud contamination or paper clogging		F		
		Blocked radiator	—		G		
		Blocked condenser	Blocked air flow		G		
Installed large fog lamp	G						

COOLING SYSTEM

[VQ]

COOLING SYSTEM

PFP:21020

Cooling Circuit

EBS00M66

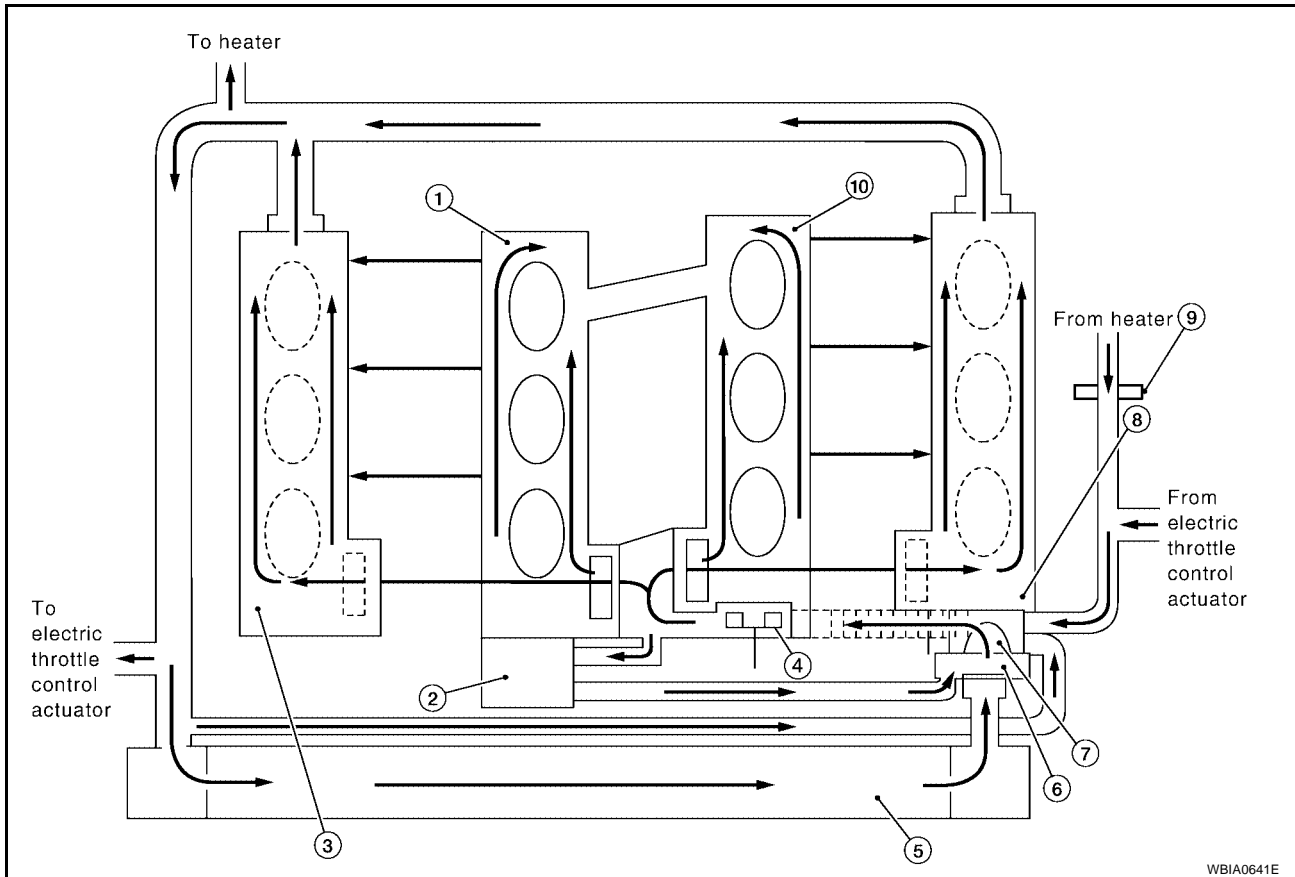

- | | | |
|-------------------------|-----------------------|-----------------------|
| 1. Cylinder block (RH) | 2. Oil cooler | 3. Cylinder head (RH) |
| 4. Water pump | 5. Radiator | 6. Water inlet |
| 7. Thermostat | 8. Cylinder head (LH) | 9. Heater pump |
| 10. Cylinder block (LH) | | |

COOLING SYSTEM

[VQ]

System Chart

EBS00M67

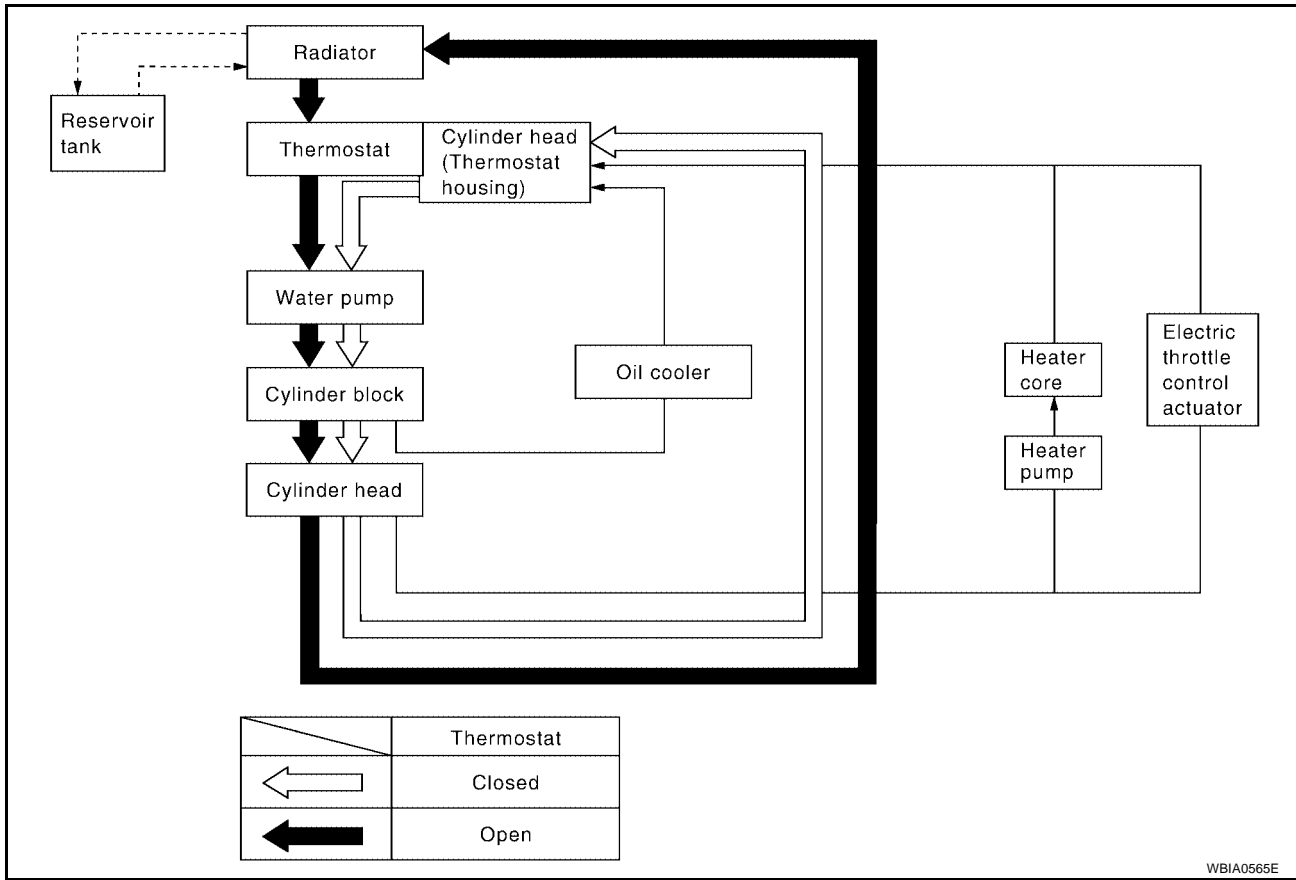

A
CO
C
D
E
F
G
H
I
J
K
L
M

ENGINE COOLANT

System Check

WARNING:

- Never remove the radiator cap or reservoir tank cap when the engine is hot. Serious burns could occur from high pressure fluid escaping from the radiator.
- Wrap a thick cloth around the cap. Slowly push down and turn it a quarter turn to allow built-up pressure to escape. Carefully remove the cap by pushing down and turning it all the way.

CHECKING COOLING SYSTEM HOSES

Check hoses for the following:

- Improper attachment
- Leaks
- Cracks
- Damage
- Loose connections
- Chafing
- Deterioration

CHECKING RESERVOIR LEVEL

- Check if the reservoir tank coolant level is within MIN to MAX when the engine is cool.
- Adjust engine coolant level as necessary.

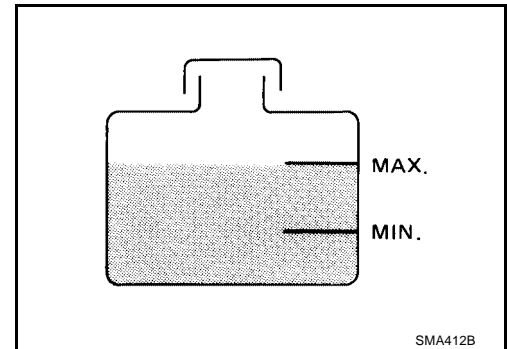

CHECKING COOLING SYSTEM FOR LEAKS

To check for leakage, apply pressure to the cooling system using Tool.

Tool number : EG17650301 (J-33984-A)

Testing pressure : 137 kPa (1.4 kg/cm² , 20 psi)

WARNING:

Never remove the radiator cap or reservoir tank cap when the engine is hot. Serious burns could occur from high pressure coolant escaping from the radiator.

CAUTION:

Higher pressure than specified may cause radiator damage.

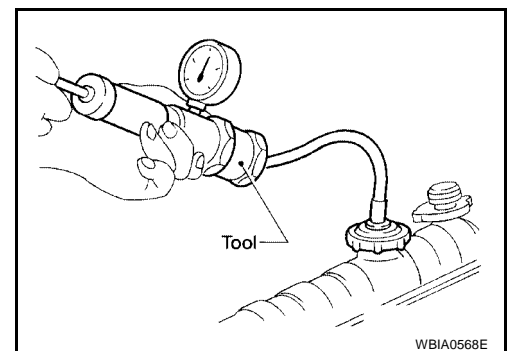

CHECKING RESERVOIR CAP

1. Inspect the reservoir cap.
 - Replace the cap if the metal plunger cannot be seen around the edge of the black rubber gasket.
 - Replace the cap if deposits of waxy residue or other foreign material are on the black rubber gasket or the metal retainer.

NOTE:

Thoroughly wipe out the reservoir filler neck to remove any waxy residue or foreign material.

ENGINE COOLANT

[VQ]

2. Pull the negative-pressure valve to open it and check that it closes completely when released.
 - Check that there is no dirt or damage on the valve seat of the radiator cap negative-pressure valve.
 - Check that there are no abnormalities in the opening and closing conditions of the negative-pressure valve.

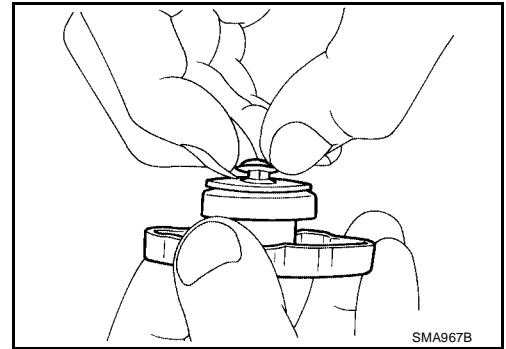

3. Check reservoir cap relief pressure using Tool.

Tool number : EG17650301 (J-33984-A)

Standard: 98 – 118 kPa (0.99 – 1.20 kg/cm² , 14 – 17 psi)

- When connecting the reservoir cap to the tester, apply water or coolant to the cap seal surface.
- Replace the reservoir cap if there is an abnormality in the negative-pressure valve, or if the open-valve pressure is outside of the standard values.

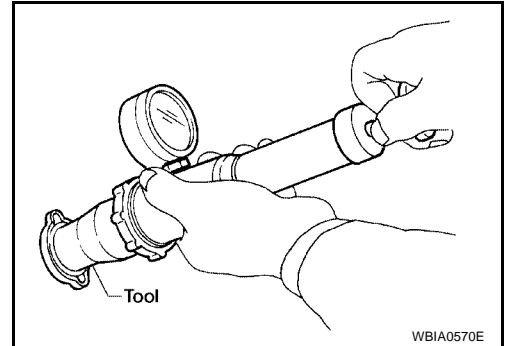

CHECKING RADIATOR

Check radiator for mud or clogging. If necessary, clean radiator as follows.

CAUTION:

- **Be careful not to bend or damage the radiator fins.**
 - **When radiator is cleaned without removal, remove all surrounding parts such as cooling fan shroud and horns. Then tape the harness and electrical connectors to prevent water from entering.**
1. Apply water by hose to the back side of the radiator core, with the hose pointed vertically downward.
 2. Apply water again to all radiator core surfaces once per minute.
 3. Stop washing if any stains no longer flow out from the radiator.
 4. Blow air into the back side of radiator core, with the air hose pointed vertically downward.
 - Use compressed air lower than 490 kPa (5 kg/cm² , 71 psi) and keep distance more than 30 cm (11.8 in).
 5. Blow air again into all the radiator core surfaces once per minute until no water sprays out.
 6. Check for leaks.

Changing Engine Coolant

EBS00T31

WARNING:

- **To avoid being scalded, never change the coolant when the engine is hot.**
- **Wrap a thick cloth around the cap to carefully remove the cap. First, turn the cap a quarter of a turn to release any built-up pressure, then push down and turn the cap all the way to remove it.**

DRAINING ENGINE COOLANT

1. Turn ignition switch ON and set temperature control lever all the way to HOT position or the highest temperature position. Wait 10 seconds and turn ignition switch OFF.
2. Remove the engine front undercover using power tool.

ENGINE COOLANT

[VQ]

3. Open the radiator drain plug at the bottom of the radiator, and remove the reservoir cap. This is the only step required when partially draining the cooling system (radiator only).

CAUTION:

Do not to allow the coolant to contaminate the drive belts.

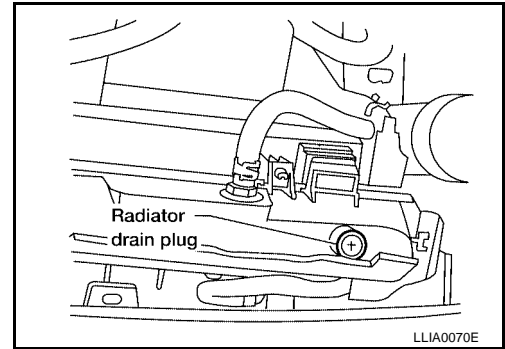

4. When draining all of the coolant in the system for engine removal or repair, it is necessary to drain the cylinder block. Remove the cylinder block drain plugs, and block heater if equipped, to drain the cylinder block as shown.

NOTE:

For Canada, the "D" cylinder block drain plug as shown, is not a cylinder block drain plug but a block heater.

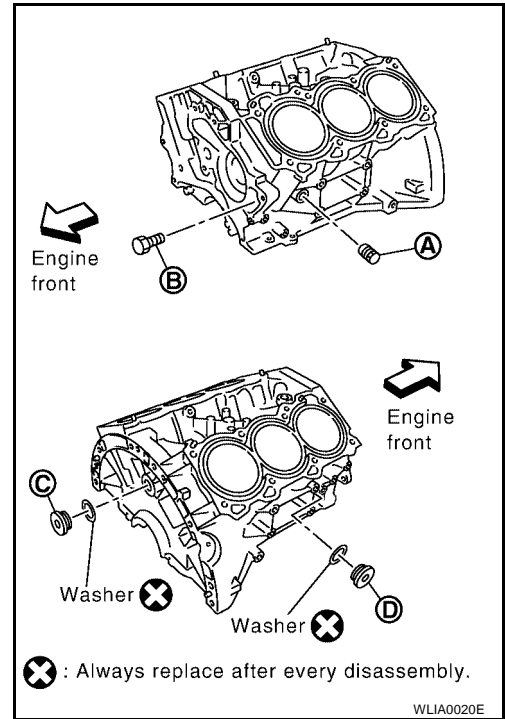

5. Remove the reservoir tank to drain the engine coolant, then clean the reservoir tank before installing it.
6. Check the drained coolant for contaminants such as rust, corrosion or discoloration. If the coolant is contaminated, flush the engine cooling system. Refer to [CO-42. "FLUSHING COOLING SYSTEM"](#).

REFILLING ENGINE COOLANT

- Close the radiator drain plug. Install the reservoir tank, cylinder block drain plugs, and block heater if equipped, if removed for a total system drain or for engine removal or repair.
 - The radiator must be completely empty of coolant and water.
 - Apply sealant to the threads of the cylinder block drain plug. Use Genuine High Performance Thread Sealant or equivalent. Refer to [GI-48, "Recommended Chemical Products and Sealants"](#).

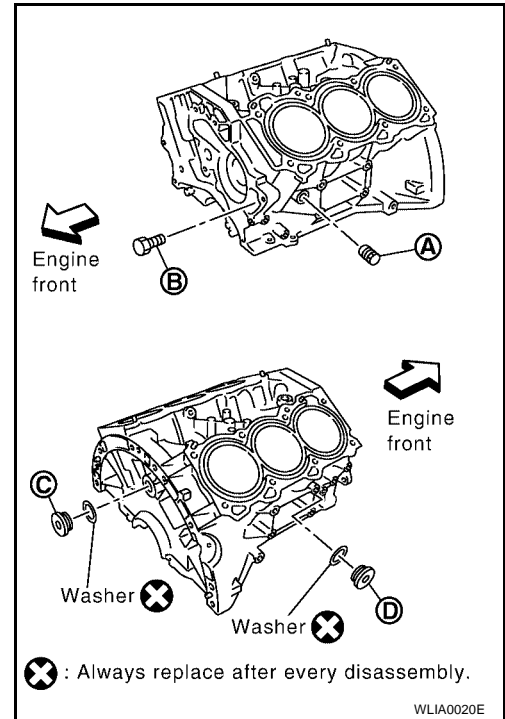

Block Plug and Block Heater Installation

Part	Washer	Tightening Torque
A	No	19.6 N·m (2.0 kg-m, 14 ft-lb)
B	Reuse	9.8 N·m (1.0 kg-m, 87 in-lb)
	New	6.0 N·m (0.61 kg-m, 53 in-lb)
C	Yes	62 N·m (6.3 kg-m, 46 ft-lb)
D	Plug	62 N·m (6.3 kg-m, 46 ft-lb)
	Block heater	73.5 N·m (7.5 kg-m, 54 ft-lb)

- Set the vehicle heater controls to the full H^OT and heater ON position. Turn the vehicle ignition ON with the engine OFF as necessary to activate the heater mode.
- Remove the vented reservoir cap and replace it with a non-vented reservoir cap before filling the cooling system.

- Install the Tool by installing the radiator cap adapter onto the radiator neck opening. Then attach the gauge body assembly with the refill tube and the venturi assembly to the radiator cap adapter.

Tool number : KV991J0070 (J-45695)

- Insert the refill hose into the coolant mixture container that is placed at floor level. Make sure the ball valve is in the closed position.

- Use Genuine NISSAN Long Life Anti-freeze coolant or equivalent, mixed 50/50 with distilled water or demineralized water. Refer to [MA-13, "ANTI-FREEZE COOLANT MIXTURE RATIO"](#).

Cooling system capacity (with reservoir) : Refer to [MA-11, "Fluids and Lubricants"](#).

- Install an air hose to the venturi assembly, the air pressure must be within specification.

Compressed air supply pressure : 5.7 - 8.5 kPa (5.6 - 8.4 kg/cm², 80 - 120 psi)

CAUTION:

The compressed air supply must be equipped with an air dryer.

- The vacuum gauge will begin to rise and there will be an audible hissing noise. During this process open the ball valve on the refill hose slightly. Coolant will be visible rising in the refill hose. Once the refill hose is full of coolant, close the ball valve. This will purge any air trapped in the refill hose.

- Continue to draw the vacuum until the gauge reaches 28 inches of vacuum. The gauge may not reach 28 inches in high altitude locations, refer to the vacuum specifications based on the altitude above sea level.

Altitude above sea level	Vacuum gauge reading
0 - 100 m (328 ft)	: 28 inches of vacuum
300 m (984 ft)	: 27 inches of vacuum
500 m (1,641 ft)	: 26 inches of vacuum
1,000 m (3,281 ft)	: 24 - 25 inches of vacuum

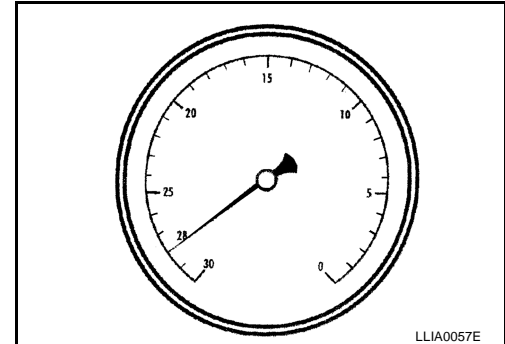
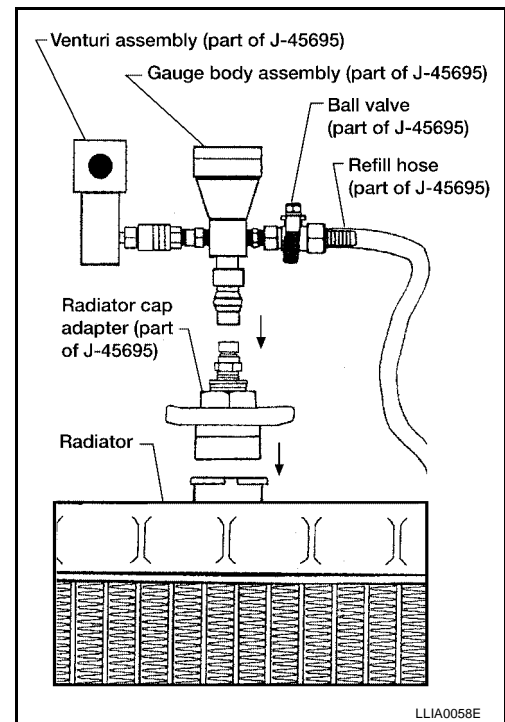

- When the vacuum gauge has reached the specified amount, disconnect the air hose and wait 20 seconds to see if the system loses any vacuum. If the vacuum level drops, perform any necessary repairs to the system and repeat steps 6 - 8 to bring the vacuum to the specified amount. Recheck for any leaks.

- Place the coolant container (with the refill hose inserted) at the same level as the top of the radiator. Then open the ball valve on the refill hose so the coolant will be drawn up to fill the cooling system. The cooling system is full when the vacuum gauge reads zero.

CAUTION:

Do not allow the coolant container to get too low when filling, to avoid air from being drawn into the cooling system.

- Remove the Tool from the radiator neck opening and install the radiator cap.
- Remove the reservoir cap.
- Fill the cooling system reservoir tank to the specified level. Run the engine to warm up the cooling system and top up the system as necessary before installing the reservoir cap.

FLUSHING COOLING SYSTEM

- Drain the water from the engine cooling system. Refer to [CO-39, "DRAINING ENGINE COOLANT"](#).
- Fill the radiator and the reservoir tank (to the "MAX" line), with water. Reinstall the radiator cap and leave the vented reservoir cap off.

ENGINE COOLANT

[VQ]

3. Run the engine until it reaches normal operating temperature.
4. Press the engine accelerator two or three times under no-load.
5. Stop the engine and wait until it cools down.
6. Drain the water from the engine cooling system. Refer to [CO-39, "DRAINING ENGINE COOLANT"](#) .
7. Repeat steps 2 through 6 until clear water begins to drain from the radiator.

A

CO

C

D

E

F

G

H

I

J

K

L

M

RADIATOR

Removal and Installation

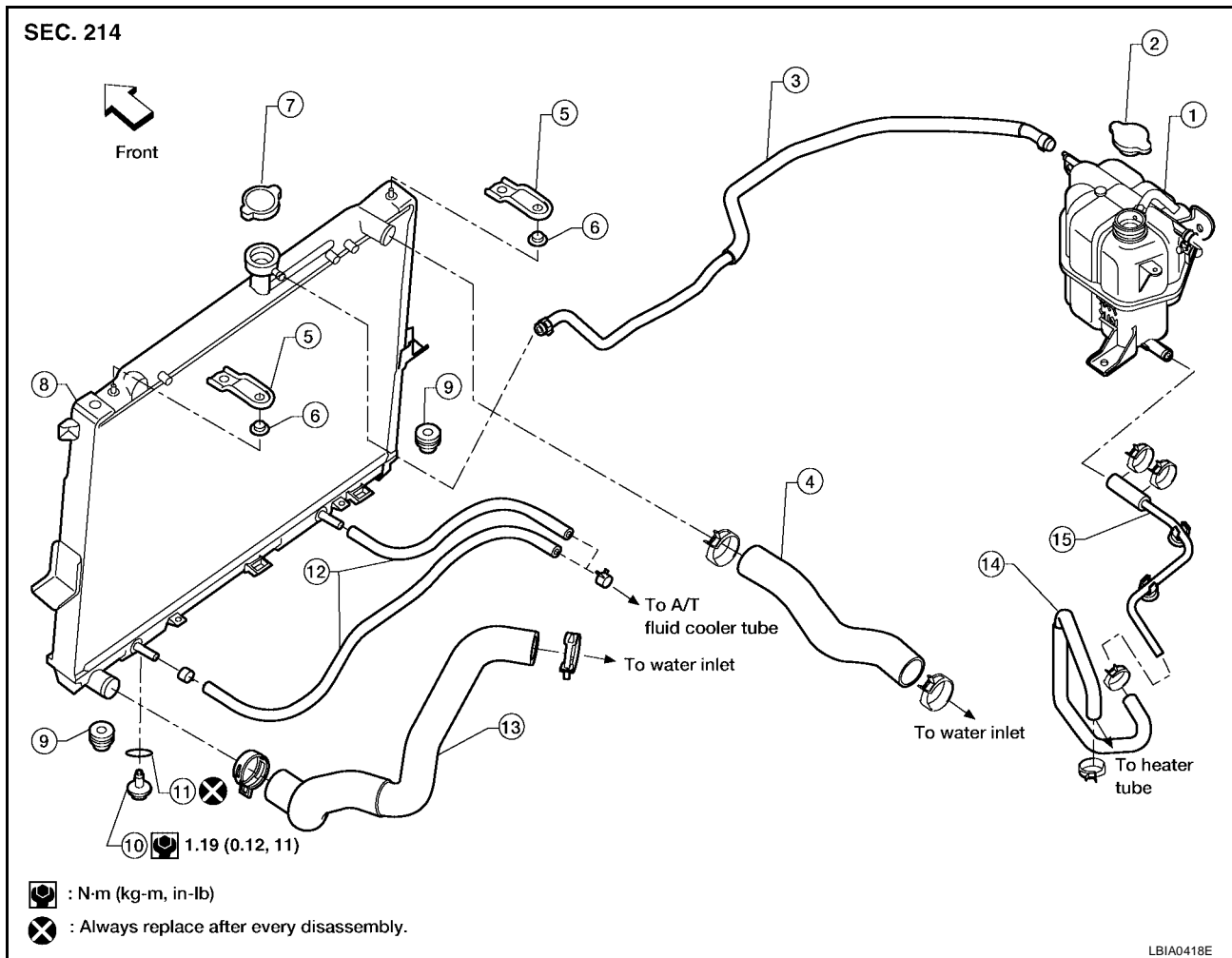

- | | | |
|---------------------------|------------------------|----------------------------|
| 1. Reservoir tank | 2. Reservoir tank cap | 3. Reservoir tank hose |
| 4. Radiator hose (upper) | 5. Upper mount bracket | 6. Mounting rubber (upper) |
| 7. Radiator cap | 8. Radiator | 9. Mounting rubber (lower) |
| 10. Radiator drain plug | 11. O-ring | 12. A/T fluid cooler hose |
| 13. Radiator hose (lower) | 14. Heater bypass tube | 15. Heater bypass hose |

WARNING:

Do not remove radiator cap when engine is hot. Serious burns could occur from high-pressure engine coolant escaping from radiator. Wrap a thick cloth around the cap. Slowly turn it a quarter of a turn to release built-up pressure. Carefully remove radiator cap by turning it all the way.

REMOVAL

- Remove engine cover with power tool. Refer to [EM-123, "REMOVAL"](#).
- Drain engine coolant from radiator. Refer to [CO-39, "DRAINING ENGINE COOLANT"](#).

CAUTION:

- Perform this step when engine is cold.
- Do not spill engine coolant on drive belts.

- Remove air duct and air cleaner case assembly. Refer to [EM-126, "REMOVAL"](#).
- Remove reservoir tank hose.
- Removal (upper and lower) radiator hoses.

CAUTION:

Be careful not to allow engine coolant to contact drive belts.

- Remove radiator cooling fan assembly. Refer to [CO-18, "REMOVAL"](#).

RADIATOR

[VQ]

7. Disconnect A/T fluid cooler hoses. (A/T models)
 - Install blind plug to avoid leakage of A/T fluid.
8. Remove the upper mount bracket bolts.

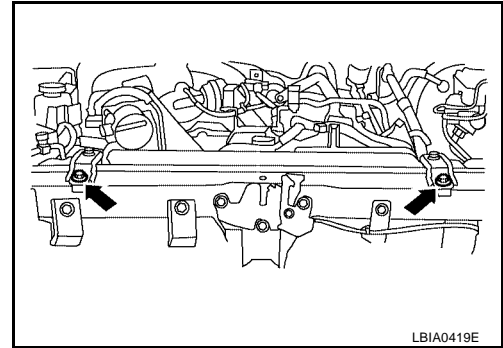

9. Remove the two A/C condenser bolts.

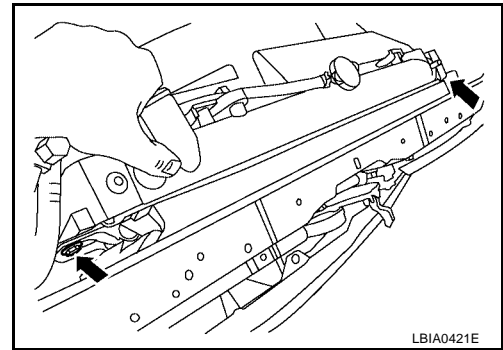

10. Remove radiator as follows:

CAUTION:

Do not damage or scratch A/C condenser and radiator core when removing.

- a. With lifting and pulling radiator in a rear direction, disassemble lower mount from radiator core support center.

CAUTION:

Because A/C condenser is onto the front-lower portion of radiator, moving to rear direction should be at minimum.

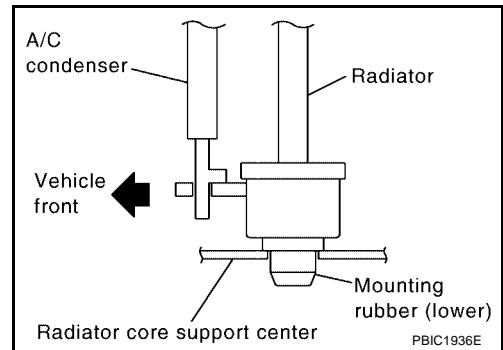

- b. Lift A/C condenser up and remove radiator after disengaging the fitting as front-bottom surface.

CAUTION:

Lifting A/C condenser should be minimum to prevent a load to A/C piping.

- c. After removing radiator, put A/C condenser on radiator core support center to prevent a load to A/C piping, and temporarily fix it with rope or similar means.

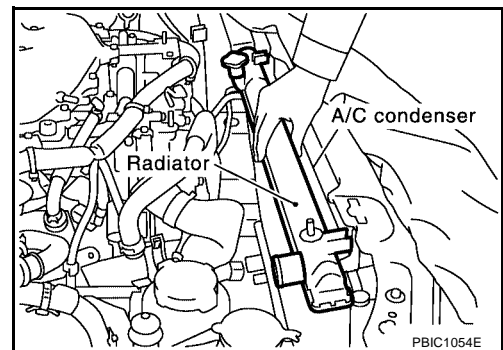

A
CO
C
D
E
F
G
H
I
J
K
L
M

INSTALLATION

Installation is in the reverse order of removal.

INSPECTION AFTER INSTALLATION

- Check for leaks of engine coolant using tool. Refer to [CO-10, "CHECKING COOLING SYSTEM FOR LEAKS"](#).
- Start and warm up engine. Visually check there are no leaks of engine coolant and A/T fluid.

ENGINE COOLING FAN

PF21140

Removal and Installation (Crankshaft driven type)

EBS00M6B

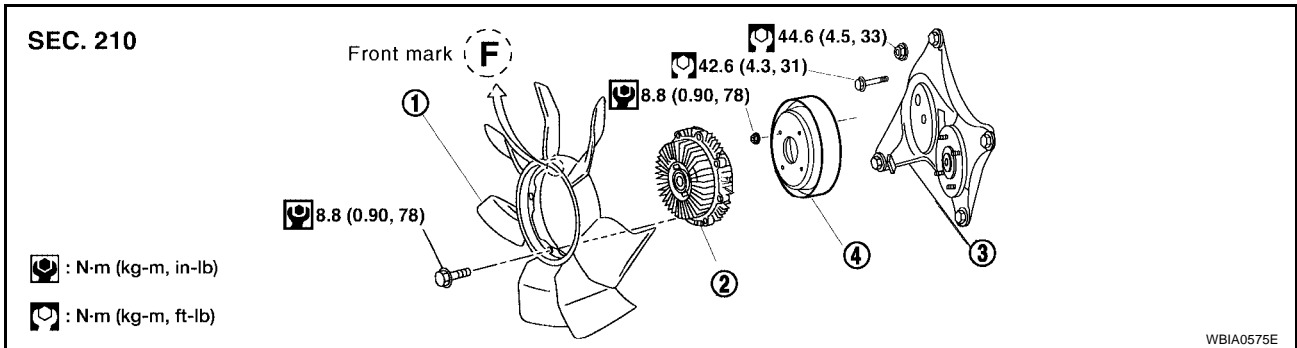

1. Cooling fan
2. Fan coupling
3. Fan bracket
4. Cooling fan pulley

REMOVAL

1. Remove air duct. Refer to [EM-126, "REMOVAL"](#) .
2. Remove the engine front undercover.
3. Remove the upper and lower radiator shrouds. Refer to [CO-44, "REMOVAL"](#) .
4. Remove drive belts. Refer to [EM-126, "REMOVAL"](#) .
5. Remove cooling fan.

INSPECTION AFTER REMOVAL

Fan Coupling

Inspect fan coupling for oil leakage and bimetal conditions.

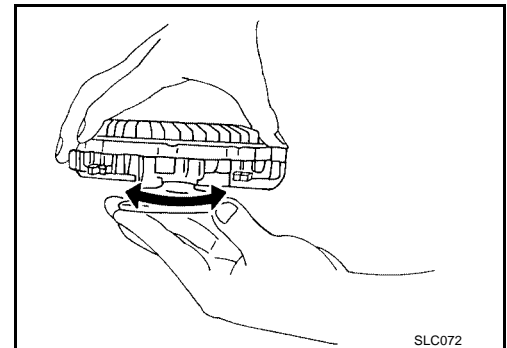

Fan Bracket

- Visually check that there is no significant looseness in the fan bracket shaft, and that it turns smoothly by hand.
- If there are any unusual concerns, replace the fan bracket assembly.

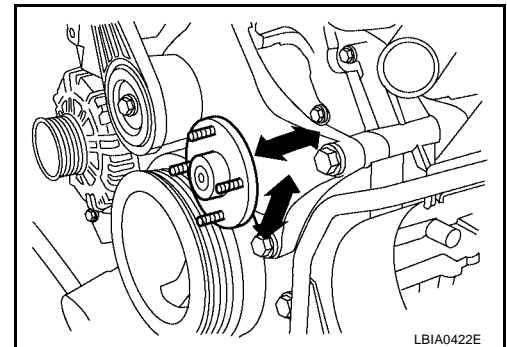

INSTALLATION

Installation is in the reverse order of removal.

- Install cooling fan with its front mark "F" facing front of engine.

INSPECTION AFTER INSTALLATION

- Check for leaks of the engine coolant using tool. Refer to [CO-38, "CHECKING COOLING SYSTEM FOR LEAKS"](#) .

ENGINE COOLING FAN

[VQ]

- Start and warm up the engine. Visually make sure that there are no leaks of the engine coolant.

Removal and Installation (Motor driven type)

EBS00M6C

REMOVAL

1. Remove radiator upper and lower shroud. Refer to [CO-44, "REMOVAL"](#).
2. Disconnect harness connector from fan motor.
3. Remove the bolt and remove the fan grille and motor assembly.

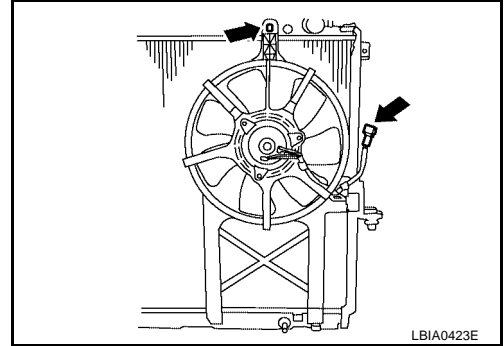

INSTALLATION

Installation is in the reverse order of removal.

Engine coolant fan bolt : 4.9 N·m (0.50 kg·m, 43 in·lb)

- Cooling fan is controlled by ECM. For details, refer to [EC-1104, "DTC P1217 ENGINE OVER TEMPERATURE"](#).

WATER PUMP

PFP:21020

Removal and Installation

EBS00M6D

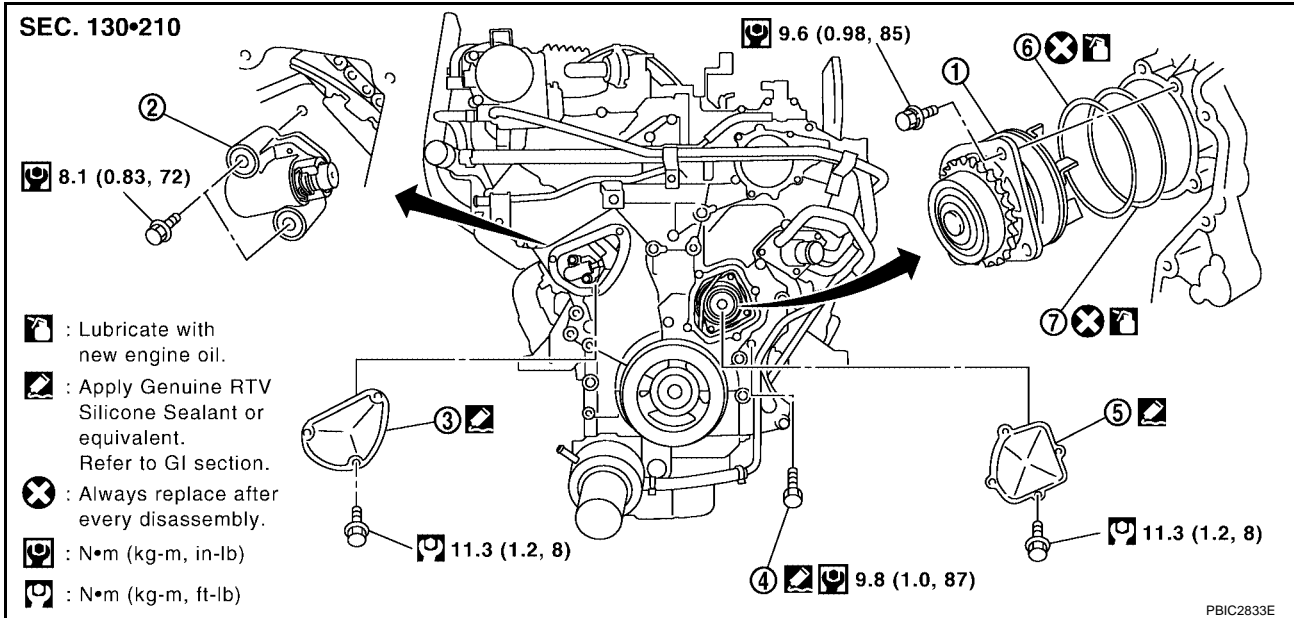

- | | | |
|-----------------------------|-------------------------------------|--------------------------|
| 1. Water pump | 2. Timing chain tensioner (primary) | 3. Chain tensioner cover |
| 4. Water drain plug (front) | 5. Water pump cover | 6. O-ring |
| 7. O-ring | | |

CAUTION:

- When removing water pump assembly, be careful not to get engine coolant on drive belts.
- Water pump cannot be disassembled and should be replaced as a unit.
- After installing water pump, connect hose and clamp securely, then check for leaks using tool.

REMOVAL

1. Remove undercover with power tool.
2. Remove drive belts. Refer to [EM-124, "Removal"](#).
3. Drain engine coolant. Refer to [CO-39, "DRAINING ENGINE COOLANT"](#).

CAUTION:

- Perform this step when engine is cold.
 - Do not spill engine coolant on drive belts.
4. Remove radiator hoses (upper and lower) and cooling fan assembly. Refer to [CO-44, "REMOVAL"](#).
 5. Remove chain tensioner cover and water pump cover from front timing chain case, using Tool.

Tool number : KV10111100 (J-37228)

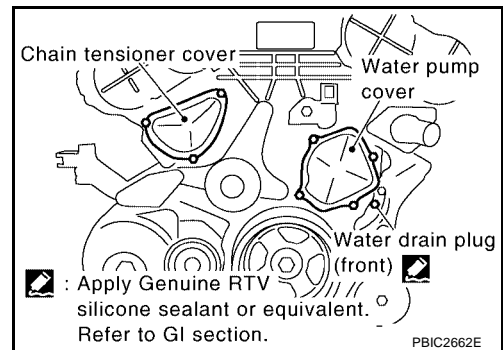

WATER PUMP

[VQ]

6. Remove timing chain tensioner (primary) as follows:

- a. Loosen clip of timing chain tensioner (primary), and release plunger stopper. (1)
- b. Insert plunger into tensioner body by pressing slack guide. (2)
- c. Keep slack guide pressed and hold plunger in by pushing stopper pin through the tensioner body hole and plunger groove. (3)

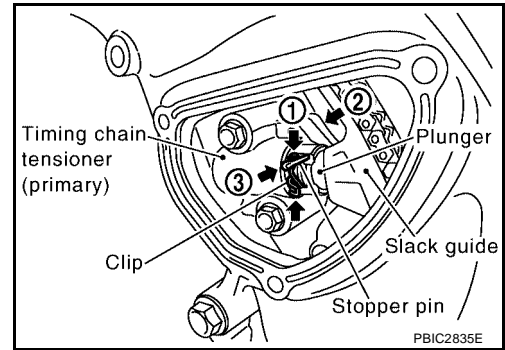

- d. Turn crankshaft pulley clockwise so that timing chain on the timing chain tensioner (primary) side is loose.

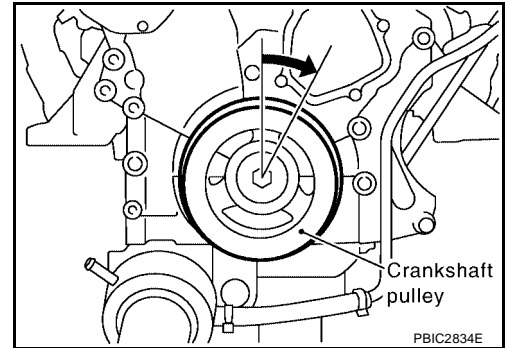

- e. Remove bolts and remove timing chain tensioner (primary).

CAUTION:

Be careful not to drop bolts inside timing chain case.

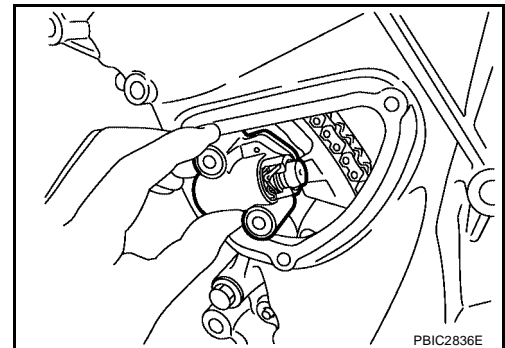

7. Remove water pump as follows:

- a. Remove three water pump bolts. Secure a gap between water pump gear and timing chain, by turning crankshaft pulley counterclockwise until timing chain looseness on water pump sprocket becomes maximum.

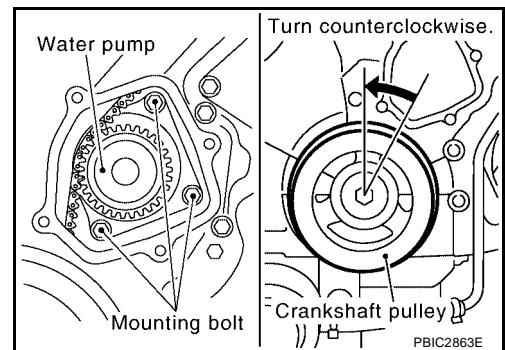

WATER PUMP

[VQ]

- b. Screw M8 bolts [pitch: 1.25 mm (0.049 in) length: approx. 50 mm (1.97 in)] into water pumps upper and lower bolt holes until they reach timing chain case. Then, alternately tighten each bolt for a half turn, and pull out water pump.

CAUTION:

- Pull straight out while preventing vane from contacting socket in installation area.
- Remove water pump without causing sprocket to contact timing chain.

- c. Remove M8 bolts and O-rings from water pump.

CAUTION:

Do not disassemble water pump.

NOTE:

Do not reuse O-rings.

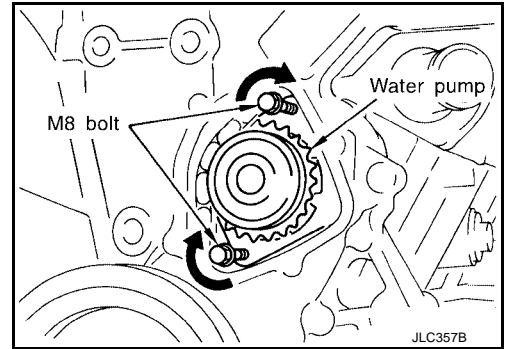

INSPECTION AFTER REMOVAL

- Check for badly rusted or corroded water pump body assembly.
- Check for rough operation due to excessive end play.
- Replace water pump, if necessary.

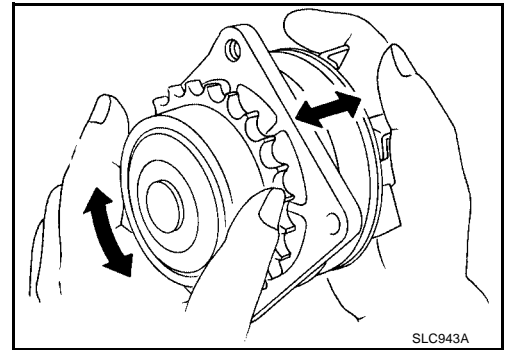

INSTALLATION

1. Install new O-rings to water pump.

NOTE:

- Apply engine oil to new O-rings.
- Locate new O-ring with white paint mark to engine front side.

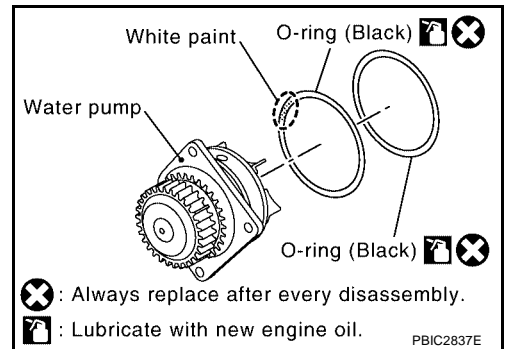

2. Install water pump.

CAUTION:

Do not allow timing chain case to nip O-rings when install water pump.

- Make sure that timing chain and water pump sprocket are engaged.
- Insert water pump by tightening bolts alternately and evenly.

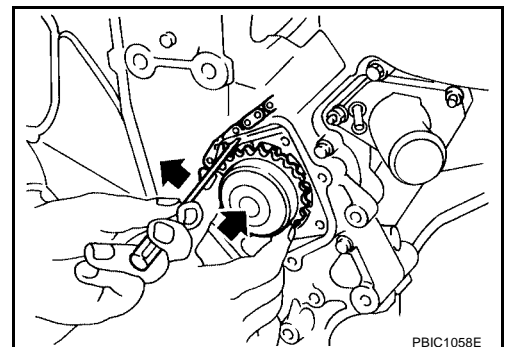

3. Install timing chain tensioner (primary) as follows:

WATER PUMP

[VQ]

- a. Remove dust and foreign material completely from backside of timing chain tensioner (primary) and from installation area of rear timing chain case.
- b. Turn crankshaft pulley clockwise so that timing chain on the timing chain tensioner (primary) side is loose.
- c. Install timing chain tensioner (primary) with its stopper pin attached.

CAUTION:

Be careful not to drop bolts inside timing chain case.

- d. Remove stopper pin.

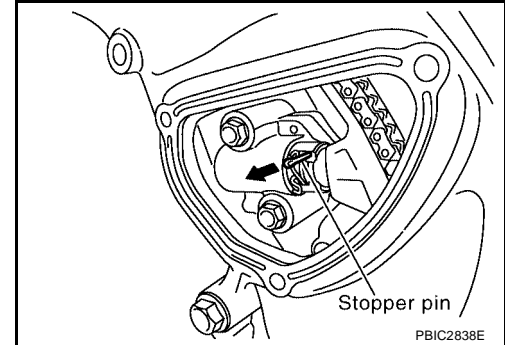

- e. Make sure again that timing chain and water pump sprocket are engaged.

4. Install chain tensioner cover and water pump cover as follows:

- a. Before installing, remove all traces of old liquid gasket from mating surface of water pump cover and chain tensioner cover using scraper. Also remove traces of old liquid gasket from the mating surface of front timing chain case.

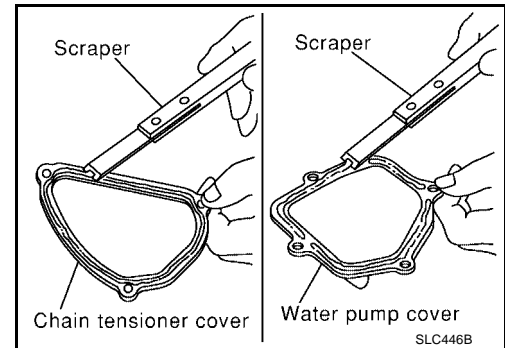

- b. Apply a continuous bead of liquid gasket, to mating surface of chain tensioner and water pump cover, Using Tool.

Tool number : WS39930000 (—)

Use Genuine RTV Silicone Sealant or equivalent. Refer to [GI-48, "Recommended Chemical Products and Sealants"](#) .

CAUTION:

Attaching should be done within 5 minutes after coating.

- c. Tighten bolts to specified torque. Refer to [CO-49, "Removal and Installation"](#) .

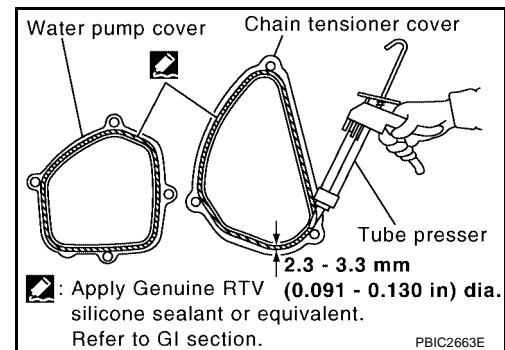

5. Refill engine coolant system. Refer to [CO-41, "REFILLING ENGINE COOLANT"](#) .

- Apply liquid gasket to the thread of water drain plug (front).

Use Genuine RTV Silicone Sealant or equivalent. Refer to [GI-48, "Recommended Chemical Products and Sealants"](#) .

6. Installation of the remaining components is in the reverse order of removal after this step.

- **After starting engine, let idle for three minutes, then rev engine up to 3,000 rpm under no load to purge air from the high-pressure chamber of chain tensioner. Engine may produce a rattling noise. This indicates that air still remains in the chamber and is not a matter of concern.**

INSPECTION AFTER INSTALLATION

- Check for leaks of engine coolant using tool. Refer to [CO-38, "CHECKING COOLING SYSTEM FOR LEAKS"](#) .

WATER PUMP

[VQ]

- Start and warm up engine. Visually check there are no leaks of engine coolant.

A

CO

C

D

E

F

G

H

I

J

K

L

M

WATER INLET AND THERMOSTAT ASSEMBLY

PFP:21200

Removal and Installation

EBS00M6E

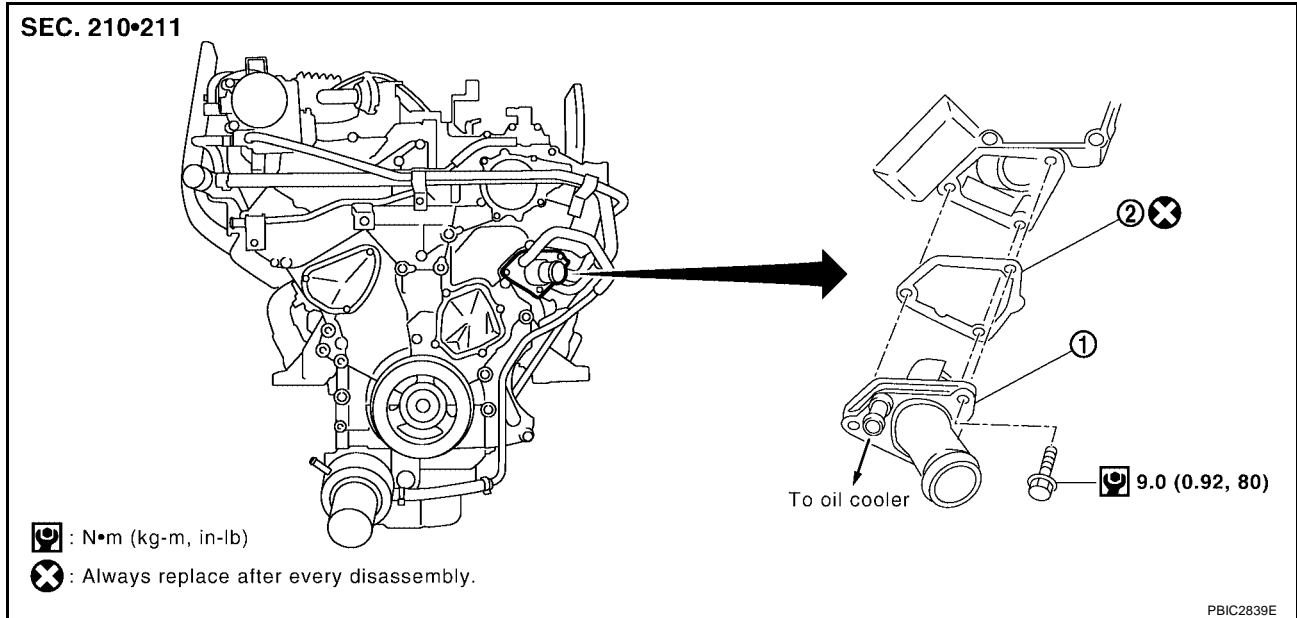

1. Water inlet and thermostat assembly 2. Gasket

REMOVAL

1. Completely drain engine coolant. Refer to [CO-39, "DRAINING ENGINE COOLANT"](#).

CAUTION:

- Perform this step when engine is cold.
- Do not spill engine coolant on drive belts.

2. Remove air duct and air cleaner case. Refer to [EM-126, "REMOVAL"](#).
3. Disconnect radiator hose (lower) and oil cooler hose from water inlet and thermostat assembly.
4. Remove water inlet and thermostat assembly.

CAUTION:

Do not disassemble water inlet and thermostat assembly. Replace them as a unit, if necessary.

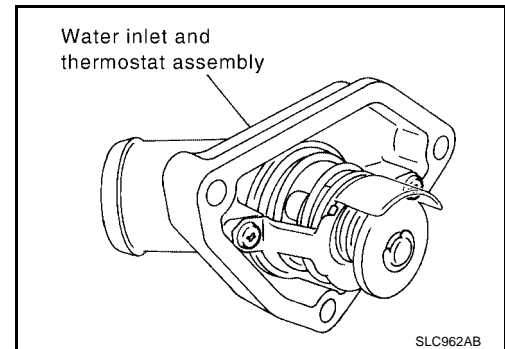

INSPECTION AFTER REMOVAL

1. Check valve seating condition at ordinary room temperatures. It should seat tightly.
2. Check valve operation.

Thermostat	Standard
Valve opening temperature	80.5 - 83.5°C (177 - 182°F)
Maximum valve lift	8.6 mm / 95°C (0.339 in / 203°F)
Valve closing temperature	77°C (171°F)

- If the malfunctioning condition, when valve seating at ordinary room temperature, or measured values are out of the standard, replace water inlet and thermostat assembly.

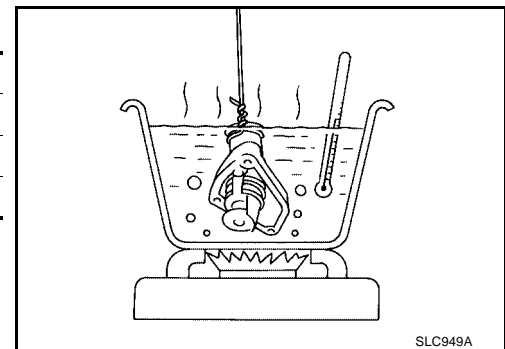

INSTALLATION

Installation is in the reverse order of removal, paying attention to the following.

- **Be careful not to spill engine coolant over engine room. Use rag to absorb engine coolant.**

INSPECTION AFTER INSTALLATION

- Check for leaks of engine coolant using tool. Refer to [CO-38, "CHECKING COOLING SYSTEM FOR LEAKS"](#).
- Start and warm up engine. Visually check there are no leaks of engine coolant.

A

CO

C

D

E

F

G

H

I

J

K

L

M

WATER OUTLET AND WATER PIPING

PFP:11060

Removal and Installation

EBS00M6F

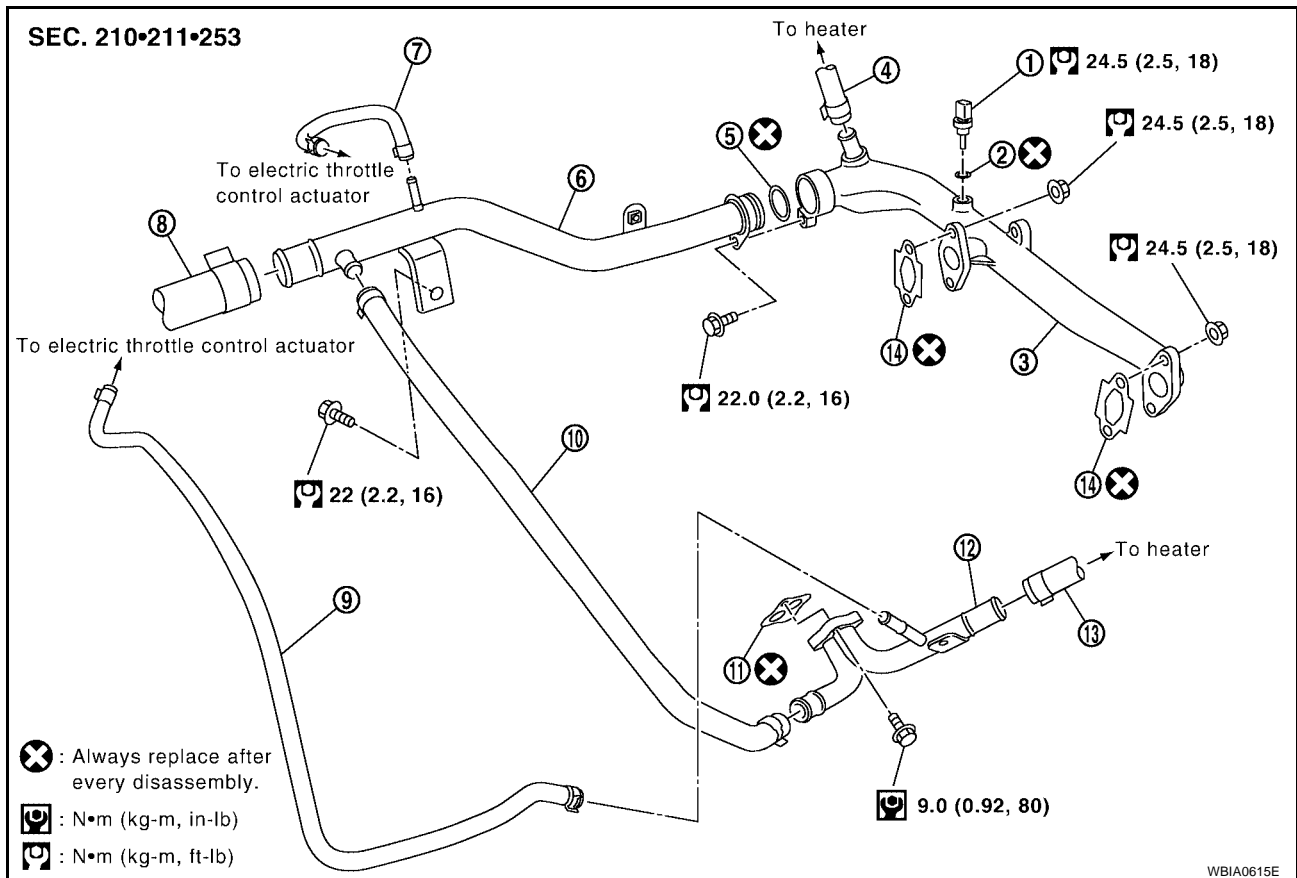

- | | | |
|--------------------------------------|--------------------------|-----------------|
| 1. Engine coolant temperature sensor | 2. Washer | 3. Water outlet |
| 4. Heater hose | 5. O-ring | 6. Water pipe |
| 7. Water hose | 8. Radiator hose (upper) | 9. Water hose |
| 10. Water hose | 11. Gasket | 12. Heater pipe |
| 13. Heater hose | 14. Gasket | |

REMOVAL

1. Completely drain engine coolant. Refer to [CO-39, "DRAINING ENGINE COOLANT"](#).

CAUTION:

- Perform this step when engine is cold.
- Do not spill engine coolant on drive belts.

2. Remove A/T fluid charging pipe. Refer to [AT-252, "REMOVAL"](#) (4X2) or [AT-254, "REMOVAL"](#) (4X4)
3. Remove the rocker cover (right bank). Refer to [EM-153, "REMOVAL \(Right bank\)"](#).
4. Remove engine coolant temperature sensor as necessary.

CAUTION:

Be careful not to damage engine coolant temperature sensor.

5. Remove water outlet, heater pipe, water bypass hoses and water pipe.

INSTALLATION

Installation is in the reverse order of removal, paying attention to the following.

- Securely insert each hose, and install clamp at a position where it does not interfere with the pipe bulge.
- When inserting water pipe into water outlet, apply neutral detergent to O-ring.

INSPECTION AFTER INSTALLATION

- Check for leaks of engine coolant using tool. Refer to [CO-38, "CHECKING COOLING SYSTEM FOR LEAKS"](#).

WATER OUTLET AND WATER PIPING

[VQ]

- Start and warm up engine. Visually check there are no leaks of engine coolant.

A

CO

C

D

E

F

G

H

I

J

K

L

M

SERVICE DATA AND SPECIFICATIONS (SDS)

[VQ]

SERVICE DATA AND SPECIFICATIONS (SDS)

PFP:00100

Standard and Limit

EBS00M6G

ENGINE COOLANT CAPACITY (APPROXIMATE)

Unit: ℓ (US gal, Imp gal)

Engine coolant capacity (With reservoir tank at "MAX" level)	10.2 (2-3/4, 2-1/4)
--	---------------------

RADIATOR

Unit: kPa (kg/cm², psi)

Cap relief pressure	Standard	98 - 118 (0.99 - 1.20, 14 - 17)
Leakage testing pressure		137 (1.4, 20)

THERMOSTAT

Valve opening temperature	80.5 - 83.5°C (177 - 182°F)
Maximum valve lift	8.6 mm / 95°C (0.339 in / 203°F)
valve closing temperature	77°C (171°F)