

A
B
C

SECTION PS

POWER STEERING SYSTEM

CONTENTS

<p>PRECAUTIONS 2</p> <p style="padding-left: 20px;">Precautions for Supplemental Restraint System (SRS) "AIR BAG" and "SEAT BELT PRE-TENSIONER" 2</p> <p style="padding-left: 20px;">Precautions for Steering System 2</p> <p>PREPARATION 3</p> <p style="padding-left: 20px;">Special Service Tools (SST) 3</p> <p style="padding-left: 20px;">Commercial Service Tools 4</p> <p>NOISE, VIBRATION, AND HARSHNESS (NVH)</p> <p>TROUBLESHOOTING 5</p> <p style="padding-left: 20px;">NVH Troubleshooting Chart 5</p> <p>POWER STEERING FLUID 6</p> <p style="padding-left: 20px;">Checking Fluid Level 6</p> <p style="padding-left: 20px;">Checking Fluid Leakage 6</p> <p style="padding-left: 20px;">Air Bleeding Hydraulic System 6</p> <p>STEERING WHEEL 8</p> <p style="padding-left: 20px;">On-Vehicle Inspection and Service 8</p> <p style="padding-left: 40px;">CHECKING CONDITION OF INSTALLATION 8</p> <p style="padding-left: 40px;">CHECKING STEERING WHEEL PLAY 8</p> <p style="padding-left: 40px;">CHECKING NEUTRAL POSITION ON STEERING WHEEL 8</p> <p style="padding-left: 40px;">CHECKING STEERING WHEEL TURNING FORCE 8</p> <p style="padding-left: 40px;">CHECKING FRONT WHEEL TURNING ANGLE... 9</p> <p style="padding-left: 20px;">Removal and Installation 9</p> <p style="padding-left: 40px;">REMOVAL 9</p> <p style="padding-left: 40px;">INSTALLATION 9</p> <p>STEERING COLUMN 10</p> <p style="padding-left: 20px;">Removal and Installation 10</p> <p style="padding-left: 40px;">REMOVAL 10</p> <p style="padding-left: 40px;">INSPECTION AFTER REMOVAL 11</p> <p style="padding-left: 40px;">INSTALLATION 11</p>	<p style="padding-left: 20px;">INSPECTION AFTER INSTALLATION 12</p> <p style="padding-left: 20px;">Disassembly and Assembly 13</p> <p style="padding-left: 40px;">DISASSEMBLY 13</p> <p style="padding-left: 40px;">ASSEMBLY 14</p> <p style="padding-left: 40px;">INSPECTION AFTER ASSEMBLY 14</p> <p>POWER STEERING GEAR AND LINKAGE 15</p> <p style="padding-left: 20px;">Removal and Installation 15</p> <p style="padding-left: 40px;">REMOVAL 15</p> <p style="padding-left: 40px;">INSTALLATION 16</p> <p style="padding-left: 40px;">INSPECTION AFTER INSTALLATION 16</p> <p style="padding-left: 20px;">Disassembly and Assembly 17</p> <p style="padding-left: 40px;">DISASSEMBLY 17</p> <p style="padding-left: 40px;">INSPECTION AFTER DISASSEMBLY 18</p> <p style="padding-left: 40px;">ASSEMBLY 18</p> <p>POWER STEERING OIL PUMP 20</p> <p style="padding-left: 20px;">On-Vehicle Inspection and Service 20</p> <p style="padding-left: 40px;">CHECKING RELIEF OIL PRESSURE 20</p> <p style="padding-left: 20px;">Components 21</p> <p style="padding-left: 20px;">Removal and Installation 22</p> <p style="padding-left: 40px;">REMOVAL 22</p> <p style="padding-left: 40px;">INSTALLATION 22</p> <p style="padding-left: 20px;">Disassembly and Assembly 23</p> <p style="padding-left: 40px;">INSPECTION BEFORE DISASSEMBLY 24</p> <p style="padding-left: 40px;">DISASSEMBLY 24</p> <p style="padding-left: 40px;">INSPECTION AFTER DISASSEMBLY 24</p> <p style="padding-left: 40px;">ASSEMBLY 24</p> <p>HYDRAULIC LINE 26</p> <p style="padding-left: 20px;">Removal and Installation 26</p> <p>SERVICE DATA AND SPECIFICATIONS (SDS) 28</p> <p style="padding-left: 20px;">Steering Wheel 28</p> <p style="padding-left: 20px;">Steering Column 28</p> <p style="padding-left: 20px;">Steering Gear Outer and Inner Socket 29</p> <p style="padding-left: 20px;">Tie-rod 29</p> <p style="padding-left: 20px;">Oil Pump 29</p> <p style="padding-left: 20px;">Steering Fluid 29</p>
---	---

F
PS
H
I
J
K
L
M

PRECAUTIONS

PRECAUTIONS

PF0:00001

Precautions for Supplemental Restraint System (SRS) “AIR BAG” and “SEAT BELT PRE-TENSIONER”

EGS000UT

The Supplemental Restraint System such as “AIR BAG” and “SEAT BELT PRE-TENSIONER”, used along with a front seat belt, helps to reduce the risk or severity of injury to the driver and front passenger for certain types of collision. This system includes seat belt switch inputs and dual stage front air bag modules. The SRS system uses the seat belt switches to determine the front air bag deployment, and may only deploy one front air bag, depending on the severity of a collision and whether the front occupants are belted or unbelted. Information necessary to service the system safely is included in the SRS and SB section of this Service Manual.

WARNING:

- To avoid rendering the SRS inoperative, which could increase the risk of personal injury or death in the event of a collision which would result in air bag inflation, all maintenance must be performed by an authorized NISSAN/INFINITI dealer.
- Improper maintenance, including incorrect removal and installation of the SRS, can lead to personal injury caused by unintentional activation of the system. For removal of Spiral Cable and Air Bag Module, see the SRS section.
- Do not use electrical test equipment on any circuit related to the SRS unless instructed to in this Service Manual. SRS wiring harnesses can be identified by yellow and/or orange harnesses or harness connectors.

Precautions for Steering System

EGS000UU

- Before disassembly, thoroughly clean the outside of the unit.
- Disassembly should be done in a clean work area. It is important to prevent the internal parts from becoming contaminated by dirt or other foreign matter.
- For easier and proper assembly, place disassembled parts in order on a parts rack.
- Use nylon cloth or paper towels to clean the parts; common shop rags can leave lint that might interfere with their operation.
- Before inspection or reassembly, carefully clean all parts with a general purpose, non-flammable solvent.
- Before assembly, apply a coat of recommended Genuine NISSAN PSF or equivalent to hydraulic parts. Petroleum jelly may be applied to O-rings and seals. Do not use any grease.
- Replace all gaskets, seals and O-rings. Avoid damaging O-rings, seals and gaskets during installation. Perform functional tests whenever designated.

PREPARATION

PFP:00002

EGS000UV

PREPARATION

Special Service Tools (SST)

The actual shapes of Kent-Moore tools may differ from those of special service tools illustrated here.

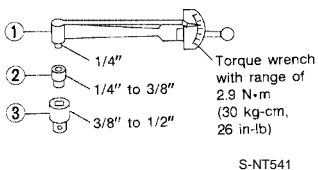
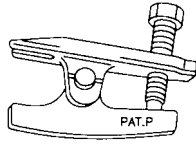
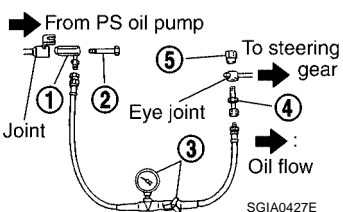
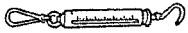
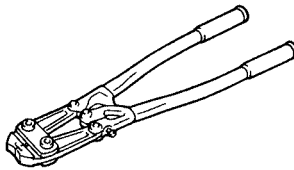
Tool number (Kent-Moore No.) Tool name	Description
ST3127 S000 (See J-25765-A) Preload gauge 1. GG9103000 (J-25765-A) Torque wrench 2. HT62940000 (—) Socket adapter 3. HT62900000 (—) Socket adapter	Inspecting of pinion rotating torque and rotational torque for ball joint 
HT72520000 (J-25730-A) Ball joint remover	Removing steering outer socket 
1. KV48105300-4 and 5295262U10 (—) Connector A and O-ring 2. KV48105300-3 and 5295262U00 (—) Eye-bolt and O-ring 3. KV48103500 (J-26357 and J-26357-10) Pressure gauge and shut-off valve 4. KV48105300-1 and 5295262U00 (—) Connector B and O-ring 5. KV48105300-2 (—) Nut	Measuring oil pump relief pressure 
— (J-44372) Spring gauge	Measuring steering wheel turning force 
KV40107300 (—) Band Crimper	Crimping boot bands 

A
B
C
D
E
F
PS
H
I
J
K
L
M

PREPARATION

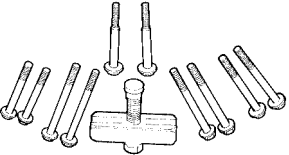
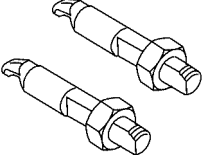
Tool number (Kent-Moore No.) Tool name	Description
KV481J0010 (J-1859A) Steering wheel puller <div style="text-align: center;">  <p>LHIA0043E</p> </div>	Removing steering wheel
KV481J0020 (J-42578) Steering wheel puller legs <div style="text-align: center;">  <p>LHIA0044E</p> </div>	Removing steering wheel

Commercial Service Tools

EGS000UW

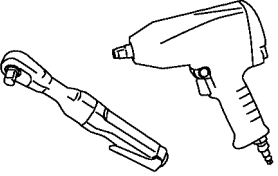
Tool name	Description
Power tool <div style="text-align: center;">  <p>PBIC0190E</p> </div>	Removing nuts and bolts

NOISE, VIBRATION, AND HARSHNESS (NVH) TROUBLESHOOTING

NOISE, VIBRATION, AND HARSHNESS (NVH) TROUBLESHOOTING

PF0:0003

NVH Troubleshooting Chart

EGS000UX

Use chart below to help you find the cause of the symptom. If necessary, repair or replace these parts.

Symptom	Possible cause and suspected parts		Reference page
	Noise	Shake	
			PS-6
		Fluid level	PS-6
		Air in hydraulic system	PS-6
		Outer socket ball joint swinging force	PS-18
		Outer socket ball joint rotating torque	PS-18
		Outer socket ball joint end play	PS-18
		Steering fluid leakage	PS-6
		Steering wheel play	PS-8
		Steering gear rack sliding force	PS-8
		Drive belt looseness	EM-14, "Checking Drive Belt" (QR25DE), EM-124, "Checking Drive Belts" (VQ40DE)
		Improper steering wheel	PS-8
		Improper installation or looseness of tilt lock lever	PS-10
		Mounting rubber deterioration	PS-15
		Steering column deformation or damage	PS-10
		Improper installation or looseness of steering column	PS-10
		Steering linkage looseness	PS-15
		PROPELLER SHAFT	PR-3, "NVH Troubleshooting Chart"
		DIFFERENTIAL	FFD-6, "NVH Troubleshooting Chart"
		AXLE	FAX-4, "NVH Troubleshooting Chart"
		SUSPENSION	FSU-4, "NVH Troubleshooting Chart"
		TIRES	WT-4, "NVH Troubleshooting Chart"
		ROAD WHEEL	WT-4, "NVH Troubleshooting Chart"
		DRIVE SHAFT	FAX-4, "NVH Troubleshooting Chart"
		BRAKES	BR-5, "NVH Troubleshooting Chart"

x: Applicable

A
B
C
D
E
F
PS
H
I
J
K
L
M

POWER STEERING FLUID

PPF:KLF20

POWER STEERING FLUID

Checking Fluid Level

EGS000UY

Check fluid level, referring to the scale on the reservoir tank.
Use HOT range for fluid temperatures of 50° – 80°C (122° – 176°F).
Use COLD range for fluid temperatures of 0° – 30°C (32° – 86°F).

CAUTION:

- Do not overfill.
- Do not reuse any power steering fluid.
- Recommended fluid is Genuine NISSAN PSF or equivalent. Refer to [MA-11, "RECOMMENDED FLUIDS AND LUBRICANTS"](#).

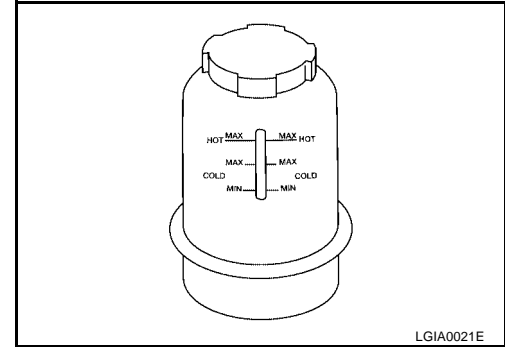

Checking Fluid Leakage

EGS000UZ

Check the hydraulic piping lines for improper attachment, leaks, cracks, damage, loose connections, chafing and deterioration.

CAUTION:

Do not reuse copper washers.

1. Run the engine until the fluid temperature reaches 50° – 80°C (122° – 176°F) in the reservoir tank. Keep engine speed idle.

CAUTION:

Do not allow steering fluid reservoir tank to go below the MIN level line. Check tank frequently and add fluid as needed.

2. Turn the steering wheel to the right and left several times.
3. Hold the steering wheel at each "locked" position for five seconds to check for fluid leakage.

CAUTION:

Do not hold steering wheel in the locked position for more than 10 seconds. (There is the possibility that the oil pump may be damaged.)

4. If fluid leakage at a connection is noticed, loosen the connection and then retighten. Do not over-tighten connector as this can damage O-ring, washer and connector. Refer to [PS-20, "POWER STEERING OIL PUMP"](#) and [PS-26, "HYDRAULIC LINE"](#).
5. If fluid leakage from the oil pump is noticed, check the oil pump. Refer to [PS-20, "POWER STEERING OIL PUMP"](#).
6. Check steering gear boots for accumulation of fluid, indicating a leak from the steering gear.

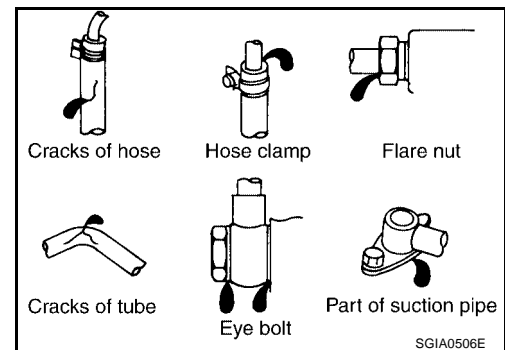

Air Bleeding Hydraulic System

EGS000V0

Incomplete air bleeding causes the following:

- Air bubbles in reservoir tank
- Clicking noise in oil pump
- Excessive buzzing in oil pump

When this happens bleed the air again.

NOTE:

When the vehicle is stationary or while the steering wheel is being turned slowly, some noise may be heard from the oil pump or gear. This noise is normal and does not affect any system.

1. Check for fluid leakage. Refer to [PS-6, "Checking Fluid Leakage"](#).
2. Start the engine and turn the steering wheel fully to the right and left several times.

CAUTION:

Do not allow steering fluid reservoir tank to go below the MIN level line. Check tank frequently and add fluid as needed.

3. Run the engine at idle speed. Hold the steering wheel at each "locked" position for three seconds.

POWER STEERING FLUID

CAUTION:

Do not hold steering wheel in the locked position for more than 10 seconds. (There is the possibility that oil pump may be damaged.)

4. Repeat step 3 several times at about three second intervals. A
5. Check for air bubbles, cloudy fluid and fluid leakage. B
6. If air bubbles or cloudiness exists, perform steps 3 and 4 again until air bubbles and cloudiness do not exist. C
7. Stop the engine and check fluid level. D

E

F

G

PS

H

I

J

K

L

M

STEERING WHEEL

STEERING WHEEL

PFP:48430

On-Vehicle Inspection and Service CHECKING CONDITION OF INSTALLATION

EGS0014D

- Check the installation condition of the steering gear assembly, front suspension, axle and steering column.
- Check if movement exists when the steering wheel is pushed up and down, left and right and in the axial direction.

End play of the axle direction for steering wheel : 0 mm (0 in)

- Check if the mounting nuts for the steering gear assembly are loose. Refer to [PS-15, "POWER STEERING GEAR AND LINK-AGE"](#) .

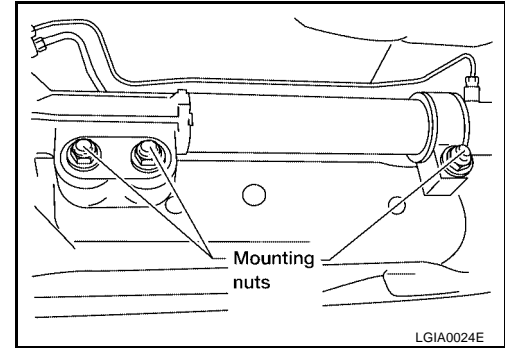

CHECKING STEERING WHEEL PLAY

1. Turn the tires straight ahead and start the engine. Lightly turn the steering wheel left and right to the point where the tires start moving, and measure the distance that the outer circumference of the steering wheel travels.

Steering wheel play on the outer circumference : 0 – 35 mm (0 – 1.38 in)

CHECKING NEUTRAL POSITION ON STEERING WHEEL

- Check the neutral position on the steering wheel after confirming the front wheel alignment is correct. Refer to [FSU-6, "Front Wheel Alignment"](#) .
1. Turn the tires straight ahead, check if the steering wheel is in the neutral position.
 2. If it is not in the neutral position, remove the steering wheel and reinstall it correctly on the steering stem, within two teeth of the original position.
 3. If the neutral position cannot be attained by repositioning the steering wheel within two teeth on the steering stem, loosen the tie-rod lock nuts of the steering outer sockets, then adjust the tie-rods by the same amount in the opposite direction of the steering wheel.

CHECKING STEERING WHEEL TURNING FORCE

1. Park vehicle on a level, dry surface and set parking brake.
2. Start engine.
3. Bring the power steering fluid up to adequate operating temperature. Make sure the fluid temperature is approximately 50° – 80°C (122° – 176°F).
4. Tires need to be inflated to specified pressure. Refer to [WT-35, "Tire"](#) .
5. Check steering wheel turning force using Tool when steering wheel has been turned 360° from the neutral position.

Tool number : — (J-44372)

**Steering wheel : 39 N (4 kg-f, 9 lb-f) or less
turning force**

6. If steering wheel turning force is out of specification, inspect the following:
 - Steering column. Refer to [PS-11, "INSPECTION AFTER REMOVAL"](#) .
 - Power steering oil pump. Refer to [PS-20, "CHECKING RELIEF OIL PRESSURE"](#) .

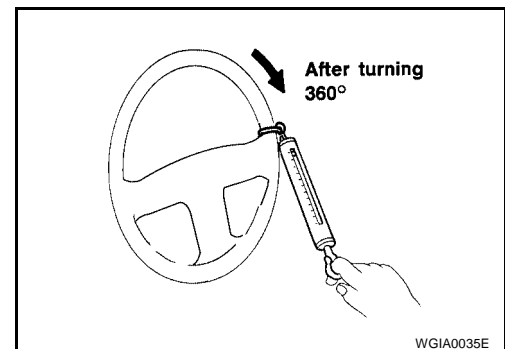

STEERING WHEEL

7. If steering column and power steering oil pump meet specifications, replace steering gear. Refer to [PS-15, "Removal and Installation"](#).

CHECKING FRONT WHEEL TURNING ANGLE

When checking the front wheel turning angle, refer to [FSU-9, "FRONT WHEEL TURNING ANGLE"](#).

Removal and Installation

EGS0014E

REMOVAL

1. Set the front wheels in the straight-ahead position.
2. Remove the driver air bag module. Refer to [SRS-43, "Removal and Installation"](#).
3. Disconnect the steering wheel switches.
4. Remove the steering wheel center nut.
5. Remove the steering wheel, using Tools.

Tool number **A: KV481J0010 (J-1859A)**
 B: KV481J0020 (J-42578)

6. Inspect the steering wheel near the puller holes for damage. If damage is found, replace the steering wheel.
 - Remove the steering wheel rear cover and steering wheel switches, if required.

CAUTION:

Place a piece of tape across the spiral cable so it will not be rotated out of position.

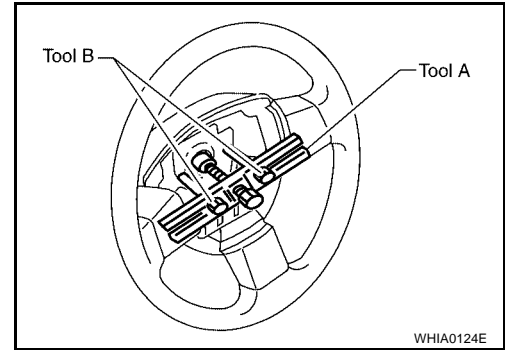

INSTALLATION

Installation is in the reverse order of removal.

- Align spiral cable correctly when installing steering wheel. Make sure that the spiral cable is in the neutral position. The neutral position is detected by turning left 2.6 revolutions from the right end position and ending with the locating pin at the top.
- If equipped with VDC, refer to [BRC-148, "Adjustment of Steering Angle Sensor Neutral Position"](#) for steering angle sensor adjustment.
- After the work is completed, perform self-diagnosis to make sure no malfunction is detected. Refer to [SRS-21, "SRS Operation Check"](#).
- Tighten steering wheel center nut to specification. Refer to [PS-10, "Removal and Installation"](#).

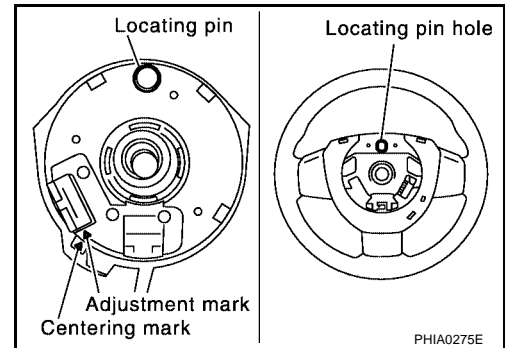

CAUTION:

- The spiral cable may snap due to steering operation if the cable is not installed in the correct position.
- With the steering linkage disconnected, the cable may snap by turning the steering wheel beyond the limited number of turns. The spiral cable can be turned counterclockwise about 2.5 turns from the neutral position.

STEERING COLUMN

PF:48810

STEERING COLUMN

Removal and Installation

EGS0014F

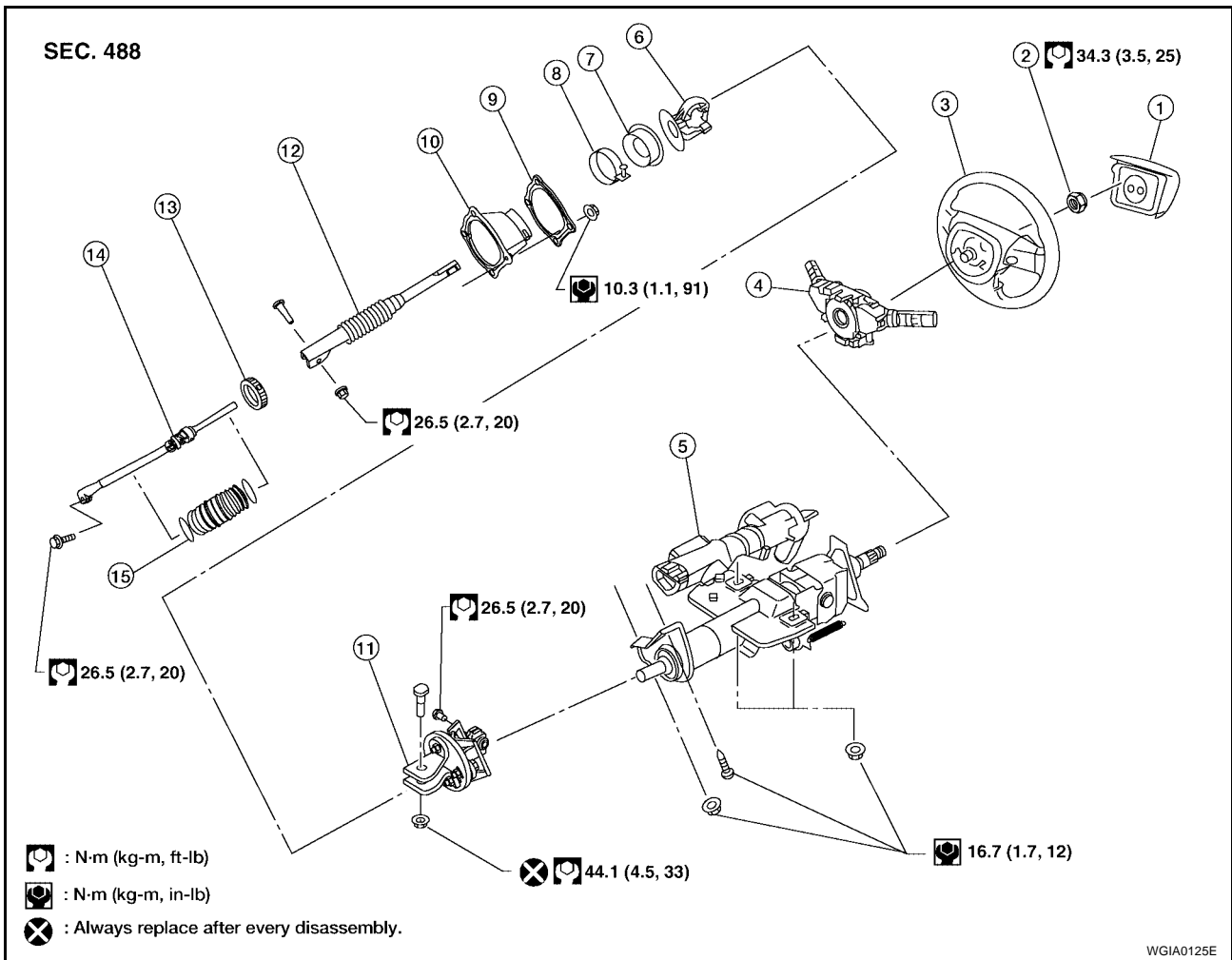

WGIA0125E

- | | | |
|--|---|------------------------------|
| 1. Driver air bag module | 2. Steering wheel center nut | 3. Steering wheel |
| 4. Combination switch and spiral cable | 5. Steering column assembly and ignition switch | 6. Collar |
| 7. Hole cover seal | 8. Clamp | 9. Hole cover mounting plate |
| 10. Hole cover | 11. Upper joint | 12. Upper shaft |
| 13. Boot clamp | 14. Lower joint shaft | 15. Boot and clips (plastic) |

CAUTION:

- Do not exert any axial load or impact to the steering column.
- Do not move the steering gear while the steering column assembly is removed.

REMOVAL

1. Remove the spiral cable with the combination switches attached from the steering column assembly. Refer to [SRS-45, "Removal and Installation"](#).
2. Remove the lower instrument panel LH. Refer to [IP-12, "LOWER INSTRUMENT PANEL LH"](#).
3. Remove the steering column cover and ignition key finisher. Refer to [IP-10, "INSTRUMENT PANEL"](#).
4. Remove the lower knee protector. Refer to [IP-10, "INSTRUMENT PANEL"](#).

STEERING COLUMN

- Remove the lock nut and bolt from the upper joint, then separate the upper joint from the upper shaft.

CAUTION:

- Do not reuse the lock nut.

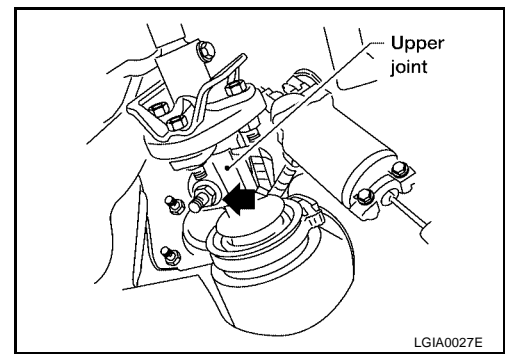

- Remove the three nuts and bolt from the steering column assembly, then remove the steering column assembly from the steering member.
- Remove the hole cover seal and clamp.
- Remove the hole cover nuts, then remove the hole cover from the dash panel.

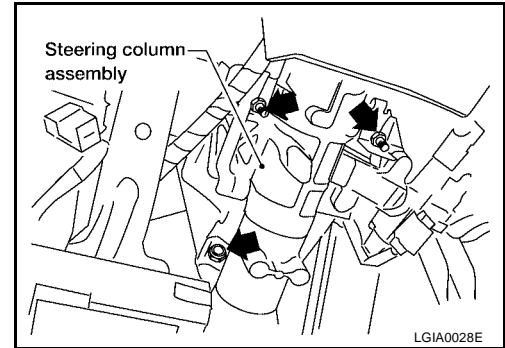

- Remove the bolt from the lower joint of the lower joint shaft, then remove the lower joint shaft from the vehicle.

CAUTION:

- Do not damage the lower joint.

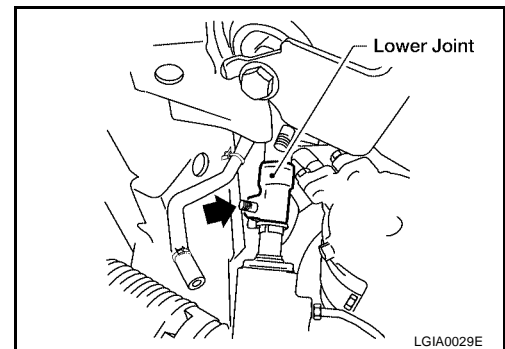

INSPECTION AFTER REMOVAL

- Check for damage to the steering column jacket tube. If damage is found, replace the steering column with a new one.

CAUTION:

- Do not exert any axial load or impact to the steering column.
- Replace the column if it is depleted of grease, worn, damaged, or if any scratches or coating separation is present on the shaft seal area.
- If the vehicle has been in a collision, or if noises are heard coming from the steering column, check column length "L1" and "L2" as shown. If out of specification, replace the steering column as an assembly.

Steering column length

L1 : 165.1 mm (6.500 in)

L2 : 258.0 mm (10.16 in)

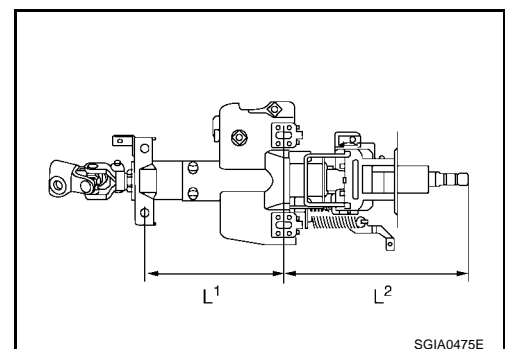

INSTALLATION

Installation is in the reverse order of removal.

STEERING COLUMN

CAUTION:

When installing the steering column, finger-tighten all of the lower bracket and joint bolts; then tighten them to specification. Do not apply undue stress to the steering column.

NOTE:

- With the wheels in the straight ahead position, align the slit of the lower joint with the projection on the dust cover. Insert the joint until surface "A" contacts surface "B".
- After installation, inspect the steering column for proper operation. Refer to [PS-12, "INSPECTION AFTER INSTALLATION"](#) .

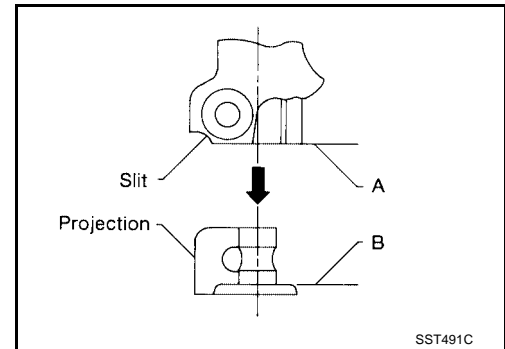

INSPECTION AFTER INSTALLATION

- Check the tilt device for proper tilt range.
Tilt range "A" : 73.8 mm (2.906 in)
- Check that the steering wheel turns smoothly to the left and right locks.
- Check that the number of turns are the same from the straight-forward position to the left and right locks.
- Check that the steering wheel is in the neutral position when driving straight ahead.

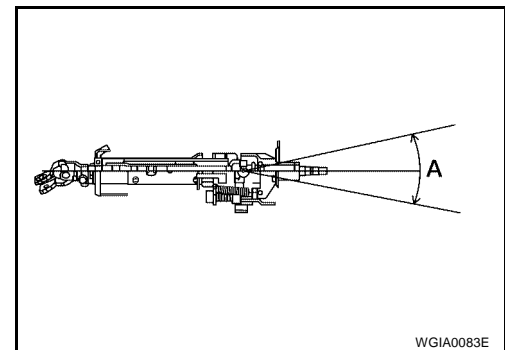

STEERING COLUMN

Disassembly and Assembly

EGS0014G

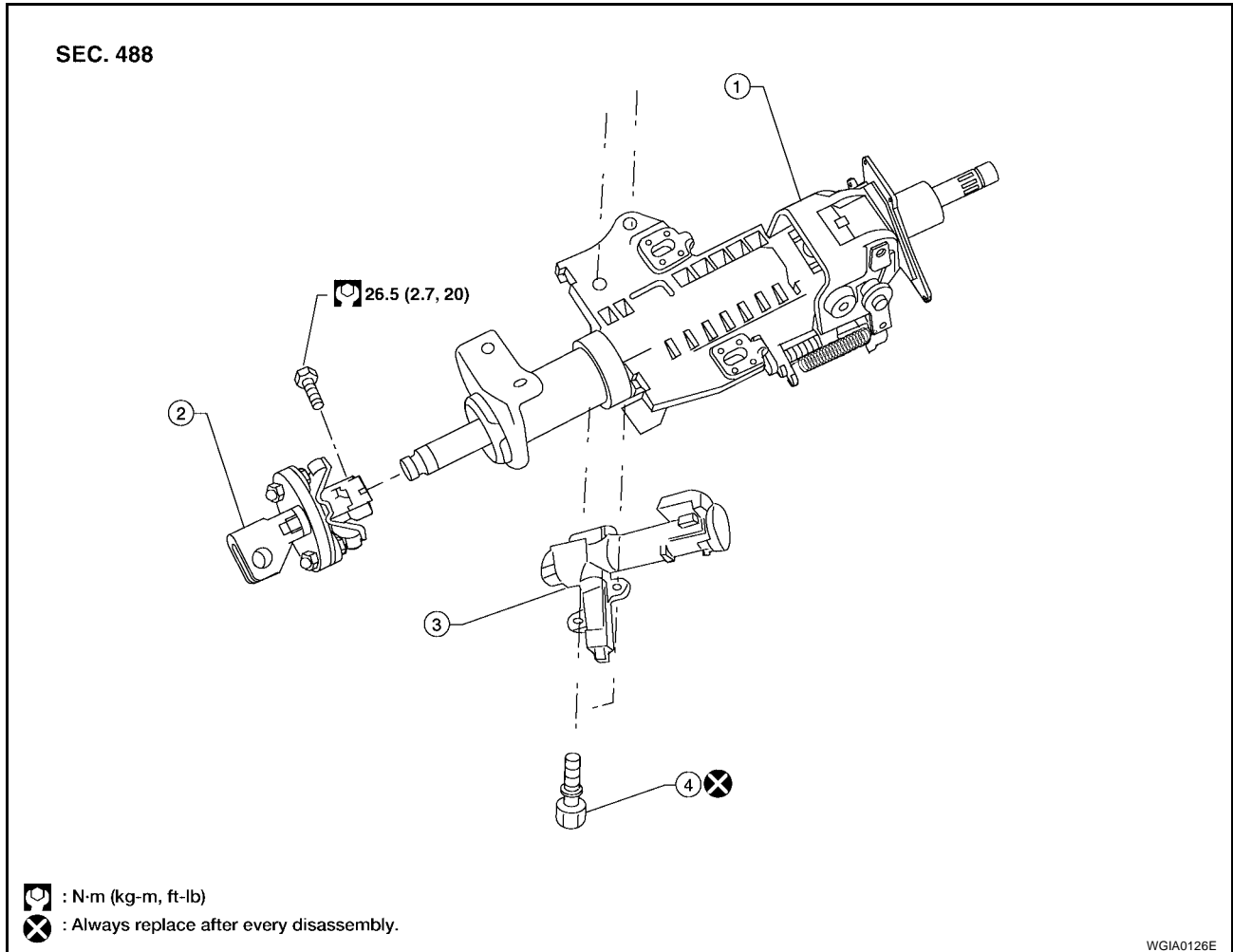

1. Steering column assembly
2. Upper joint
3. Ignition switch
4. Self-shear screw

DISASSEMBLY

1. Remove the bolt from the upper joint, then remove the upper joint from the steering column assembly.
2. Remove the ignition switch tamper resistant self-shear screws, using a drill.
3. Remove the ignition switch from the steering column.

A
B
C
D
E
F
PS
H
I
J
K
L
M

STEERING COLUMN

ASSEMBLY

Assembly is in the reverse order of disassembly.

NOTE:

Install new tamper resistant self-shear screws.

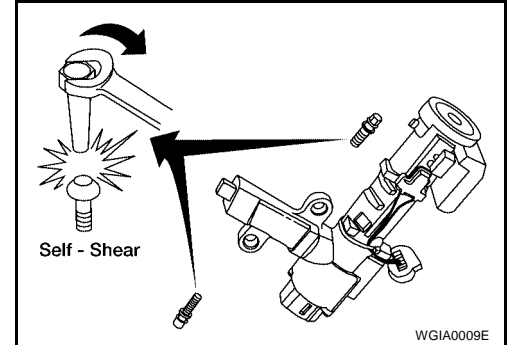

INSPECTION AFTER ASSEMBLY

When the steering wheel does not turn smoothly, check as follows:

1. Check the steering column for the following:

- Damage to the column tube or bearings
- Wear around the seal edges
- Corrosion or pitting around the seal sliding area

Replace the steering column as an assembly, if necessary.

CAUTION:

- Do not exert any axial load or impact to the steering column.
 - Replace the column if it is depleted of grease, worn, damaged, or if any scratches or coating separation is present on the shaft seal area.
2. If the vehicle has been in a collision, or if noises are heard coming from the steering column, check column length "L1" and "L2" as shown. If out of specification, replace the steering column as an assembly.

Steering column length

L1 : 165.1 mm (6.500 in)

L2 : 258.0 mm (10.16 in)

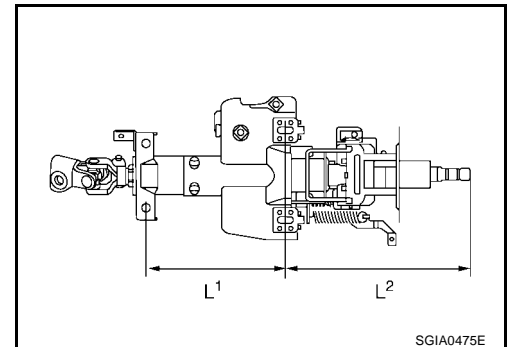

3. Check the tilt device for proper operation range.

Range "A" : 73.8 mm (2.906 in)

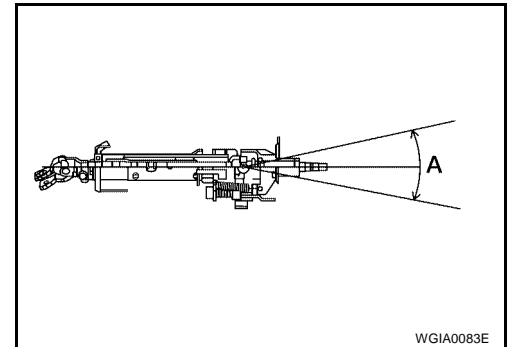

POWER STEERING GEAR AND LINKAGE

POWER STEERING GEAR AND LINKAGE

PF:49001

Removal and Installation

EGS0014H

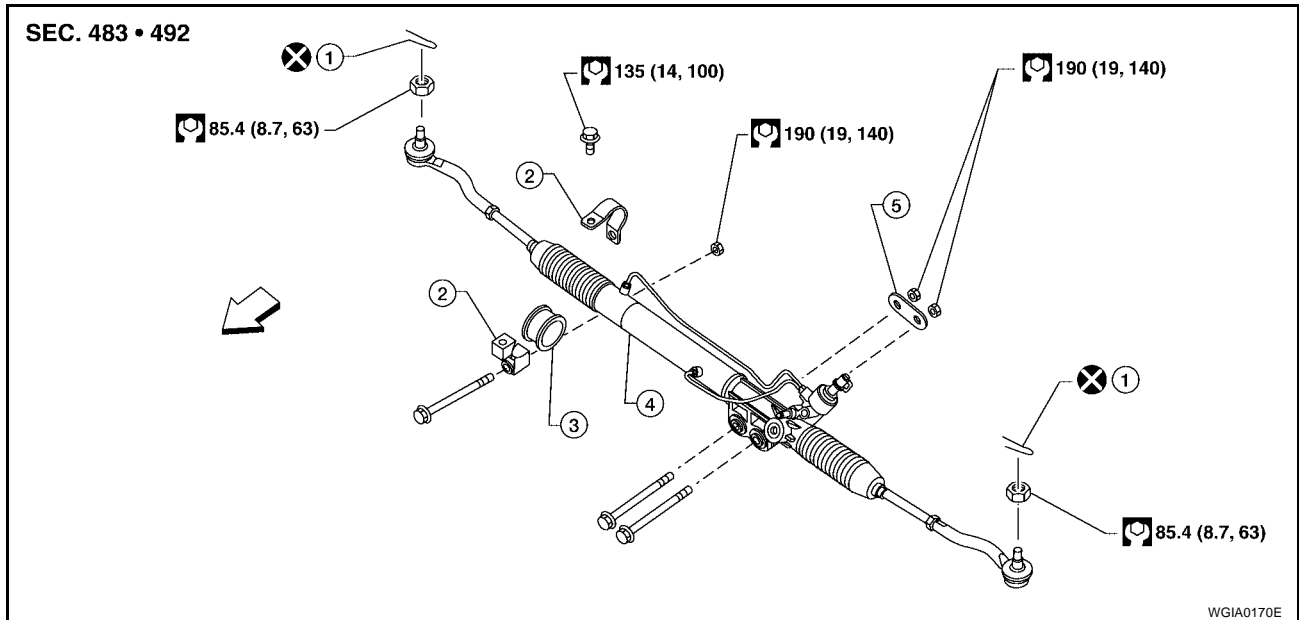

- | | | |
|---------------------------|---------------------|-----------------------|
| 1. Cotter pin | 2. Mounting bracket | 3. Mounting insulator |
| 4. Steering gear assembly | 5. Washer | ← Front |

CAUTION:

Spiral cable may snap due to steering operation if the steering column is separated from the steering gear assembly. Therefore secure the steering wheel to avoid turning.

REMOVAL

1. Set front wheels in the straight-ahead position.
2. Remove the front tires from the vehicle, using power tool.
3. Remove the undercover, using power tool.
4. On 4WD models, remove the front final drive, then support the drive shafts, using suitable wire. Refer to [FFD-14, "Removal and Installation"](#).
5. Remove the stabilizer bar brackets and reposition the stabilizer bar. Refer to [FSU-12, "Removal and Installation"](#).
6. Remove the cotter pins at the steering outer sockets.

CAUTION:

Do not reuse the cotter pins.

7. Loosen the outer socket nuts.
8. Remove the steering outer sockets from the steering knuckles, using Tool, then remove the nuts.

Tool number : HT72520000 (J-25730-A)

CAUTION:

- Do not damage the outer socket boots.
- Do not damage the outer socket threads. Thread the ball joint nut onto the end of the outer socket during removal.

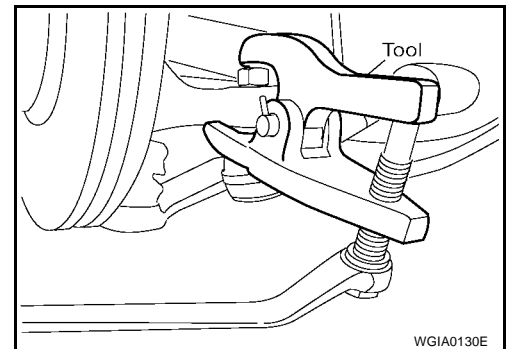

POWER STEERING GEAR AND LINKAGE

9. Remove the high-pressure and low-pressure piping from the steering gear assembly, then drain the fluid from the piping.

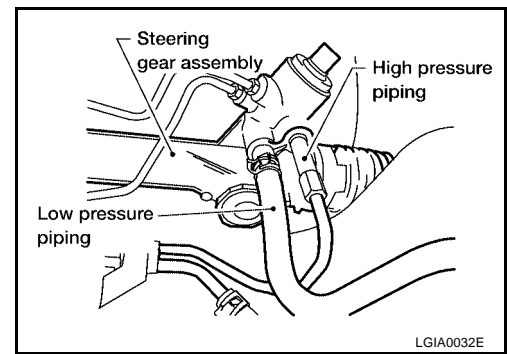

10. Remove the bolt from the lower joint of the lower joint shaft, then separate the lower joint from the steering gear assembly.

CAUTION:

- Do not damage the lower joint.

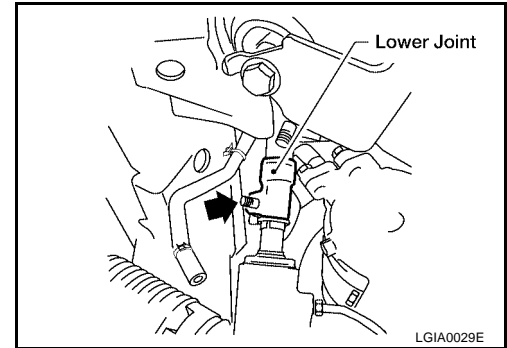

11. Remove the nuts and bolts of the steering gear assembly, using power tool, then remove the steering gear assembly from the vehicle.

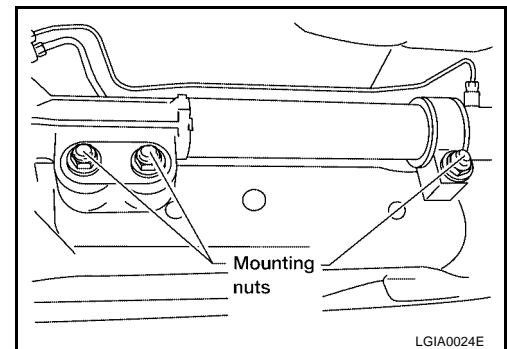

INSTALLATION

Installation is in the reverse order of removal.

- With the steering wheel in the straight ahead position, align the slit of the lower joint with the projection on the dust cover. Insert the joint until surface "A" contacts surface "B".
- After removing/installing or replacing steering components, check wheel alignment. Refer to [FSU-6, "Front Wheel Alignment"](#).
- After adjusting wheel alignment, adjust neutral position of the steering angle sensor. Refer to [BRC-148, "Adjustment of Steering Angle Sensor Neutral Position"](#).
- Bleed the air from the steering hydraulic system. Refer to [PS-6, "Air Bleeding Hydraulic System"](#).

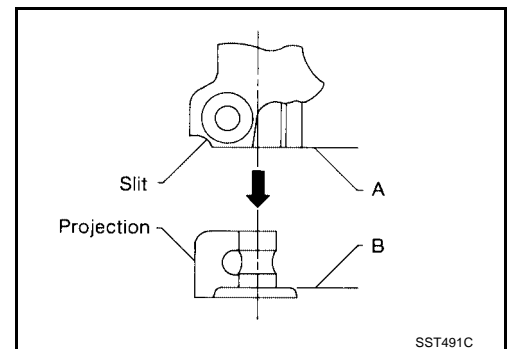

INSPECTION AFTER INSTALLATION

- Check that the steering wheel turns smoothly to the left and right locks.
- Check that the number of turns are the same from the straight-forward position to the left and right locks.
- Check that the steering wheel is in the neutral position when driving straight ahead.

POWER STEERING GEAR AND LINKAGE

EGS0014I

Disassembly and Assembly

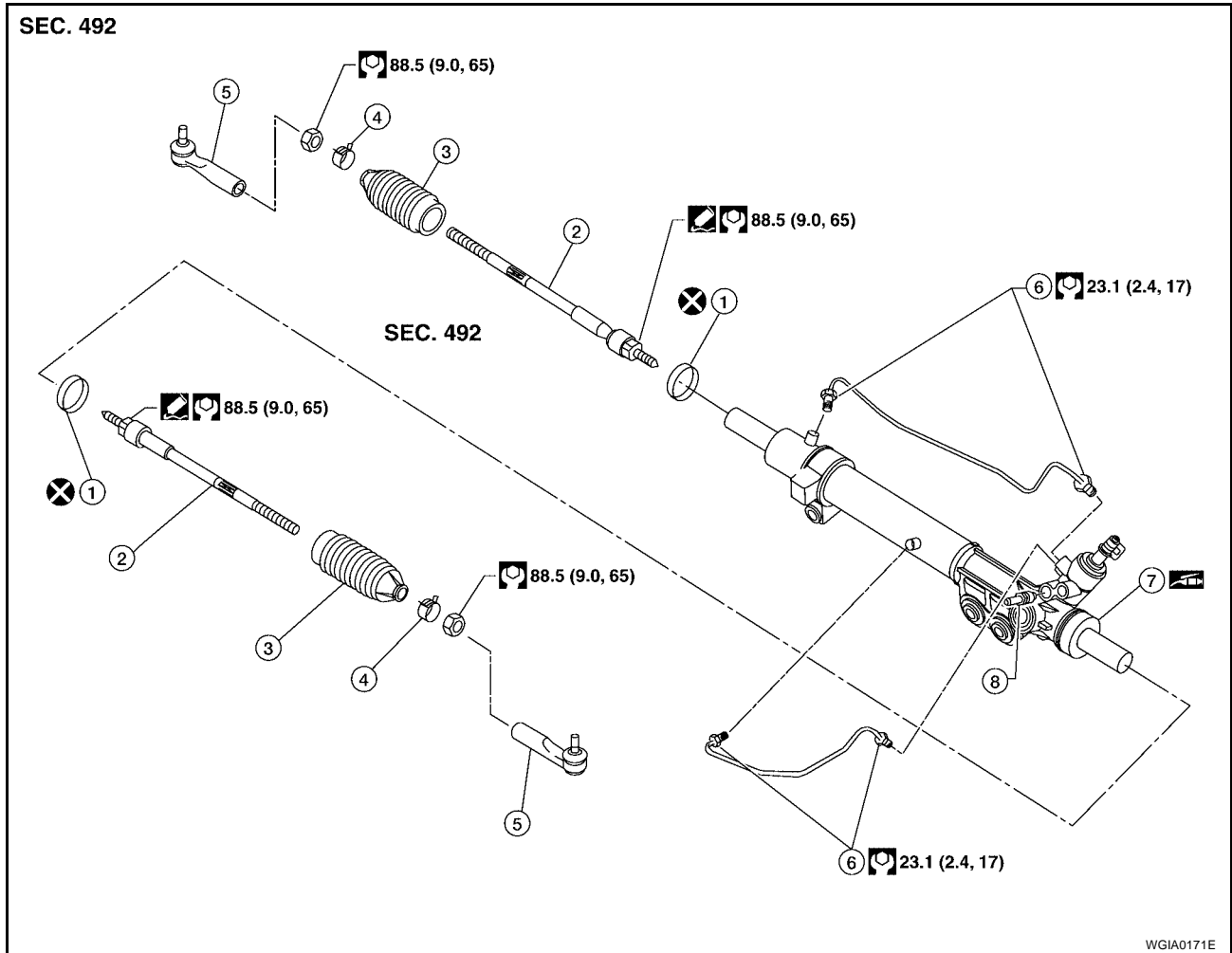

- | | | |
|--------------------------|-----------------|-------------------|
| 1. Boot clamp | 2. Inner socket | 3. Boot |
| 4. Boot clamp | 5. Outer socket | 6. Cylinder tubes |
| 7. Gear housing assembly | 8. Connector | |

CAUTION:

- Secure the gear housing assembly with a vise. Use copper plates or equivalent to prevent it from being damaged. Do not grip the cylinder with a vise.
- Before performing disassembly, clean the gear housing assembly. Be careful not to allow any cleaner to contact the discharge and return port connectors.

DISASSEMBLY

1. Remove the cylinder tubes from the gear housing assembly.
2. Loosen the lock nuts of the outer sockets, then remove the outer sockets from the inner sockets.
3. Remove the boot clamps from the boots, then remove the boots from the inner sockets and gear housing assembly.

CAUTION:

- Do not reuse the large-diameter boot clamps.
 - Do not damage the boots, inner socket or gear housing assembly. If they are damaged, replace them.
4. Remove the inner sockets.

POWER STEERING GEAR AND LINKAGE

INSPECTION AFTER DISASSEMBLY

Boot

Check boot for tears, cracks and deformation. Replace if necessary.

Gear Housing Assembly

Check gear housing assembly for dents, cracks or damage. Replace as an assembly if necessary.

Outer Socket and Inner Socket

SWING TORQUE

- Measure the swing torque, using Tool. When ball stud and inner socket start moving the measured value must be within the specification. If the reading is outside the specification, replace the socket.

Tool number : — (J-44372)

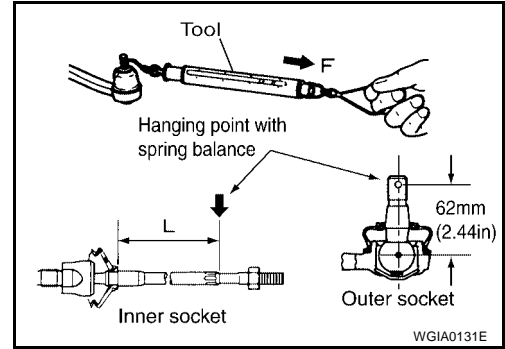

Item	Outer socket	Inner socket
Measuring point	Cotter pin hole of stud	Shown as L: 83.2 mm (3.276 in)
Swing torque	0.3 – 2.9 N·m (0.03 – 0.29 kg·m, 3 – 25 in·lb)	1.0 – 7.8 N·m (0.11 – 0.79 kg·m, 9 – 69 in·lb)
Measuring value	4.84 – 46.7 N (0.50 – 4.7 kg·f, 4 – 34 lb·f)	12.1 – 93.7 N (1.3 – 9.5 kg·f, 9 – 69 lb·f)

ROTATING TORQUE

- Measure the rotating torque, using Tool. If the value is outside the specification, replace the outer sockets.

Tool number : ST3127S000 (J-25765-A)

Outer socket rotating torque : 0.3 – 2.9 N·m (0.03 – 0.29 kg·m, 3 – 25 in·lb)

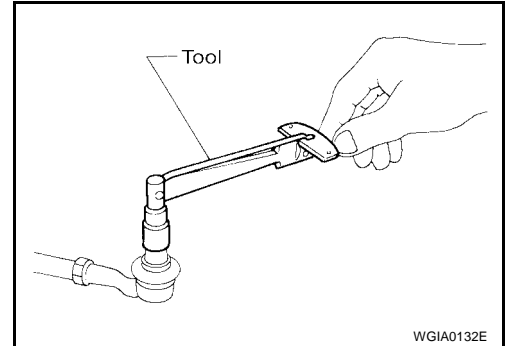

AXIAL END PLAY

- Apply a load of 490 N (50 kg·f, 110 lb·f) to the ball stud axially. Use a dial gauge to measure the amount of the movement that the stud makes. If the value is outside the specification, replace the sockets.

Outer socket : 0.5 mm (0.020 in) or less

Inner socket : 0.2 mm (0.08 in) or less

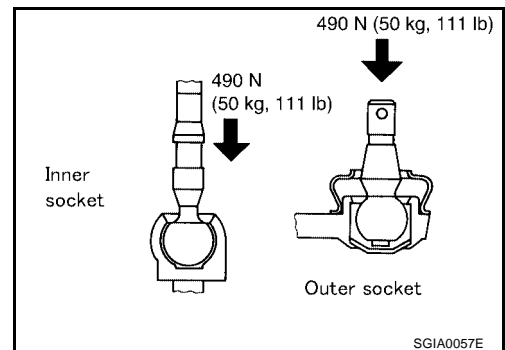

ASSEMBLY

1. Install the inner sockets.

POWER STEERING GEAR AND LINKAGE

2. Install the large-diameter side of the boots to the gear housing assembly.
3. Install the small-diameter side of the boots to the groove of the inner sockets.

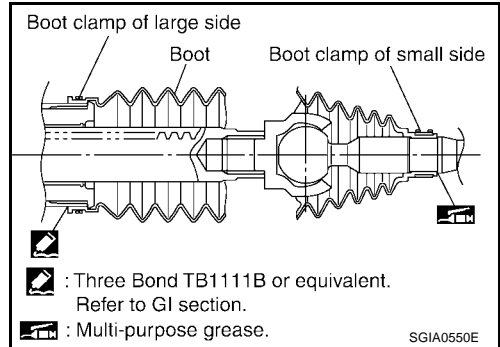

4. Install the boot clamps to the boots, as shown.

CAUTION:

Do not reuse the large boot clamps.

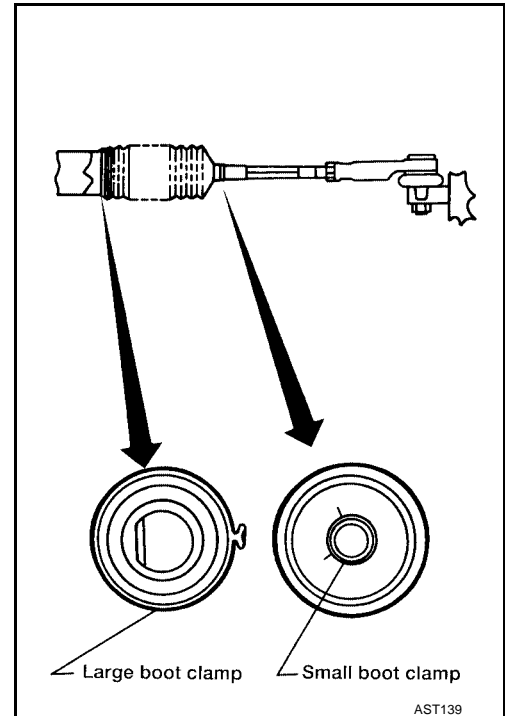

5. Crimp the large boot clamps, using Tool.

Tool number : KV40107300 (—)

6. Install the cylinder tubes to the gear housing assembly.
7. Install the lock nuts and outer sockets to the inner sockets.

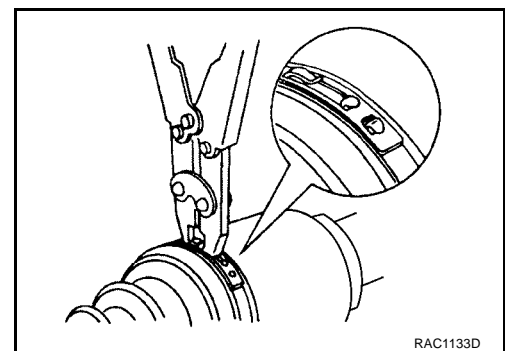

8. Thread the outer sockets onto the inner sockets to the specified length "L", then tighten the lock nuts to the specified torque. Refer to [PS-17, "Disassembly and Assembly"](#). Reconfirm that the tie-rod length "L" is within specification.

Maximum inner socket length "L" : 84.0 mm (3.31 in)

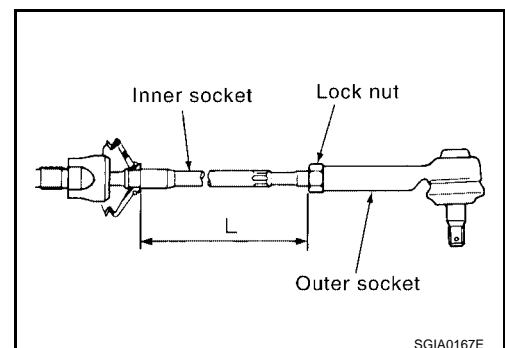

A
B
C
D
E
F
PS
H
I
J
K
L
M

POWER STEERING OIL PUMP

PF:49110

EGS000V7

POWER STEERING OIL PUMP

On-Vehicle Inspection and Service CHECKING RELIEF OIL PRESSURE

CAUTION:

Before starting work, confirm that the belt tension is within specification. Refer to [EM-14, "Tension Adjustment"](#) (QR25DE), [EM-124, "Tension Adjustment"](#) (VQ40DE).

1. Connect the Tool between the power steering oil pump discharge connector and the high pressure hose, then bleed the air from the hydraulic circuit. Refer to [PS-6, "Air Bleeding Hydraulic System"](#).

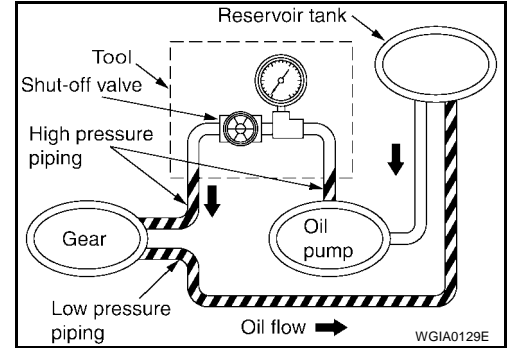

Tool number:		
Pressure gauge and shut-off valve		KV48103500 (J-26357 and J-26357-10)
Oil pump side	Connector A and O-ring	KV48105300-4 and 5295262U10 (—)
	Eye-bolt and O-ring	KV48105300-3 and 5295262U00 (—)
High pressure piping side	Connector B and O-ring	KV48105300-1 and 5295262U00 (—)
	Nut	KV48105300-2 (—)

2. Start the engine. Run the engine until the power steering fluid temperature reaches 50 – 80°C (122 – 176°F).

CAUTION:

- Warm up the engine with the shut-off valve fully opened. If the engine is started with the shut-off valve closed, fluid pressure in the power steering oil pump increases to maximum pressure. This will raise fluid temperature excessively.
- Do not contact the belt with the hose while the engine is running.

3. With the engine at idle, close the shut-off valve and read the relief oil pressure.

Relief oil pressure : 8.0 – 8.8 mPa (81.60 – 89.76 kg/cm² , 1160 – 1276 psi)

CAUTION:

Do not close the shut-off valve of the pressure gauge for more than 10 seconds.

4. After measurement, open the shut-off valve slowly.
 - If relief oil pressure is outside the specification, replace the power steering oil pump. Refer to [PS-22, "Removal and Installation"](#).
5. After inspection, disconnect the oil pressure gauge and oil pressure gauge adapter from the hydraulic circuit, then connect the power steering oil pump discharge connector. Add fluid and bleed the air from the hydraulic circuit thoroughly. Refer to [PS-6, "Air Bleeding Hydraulic System"](#).

POWER STEERING OIL PUMP

Components

EGS0014J

QR25DE

SEC.490

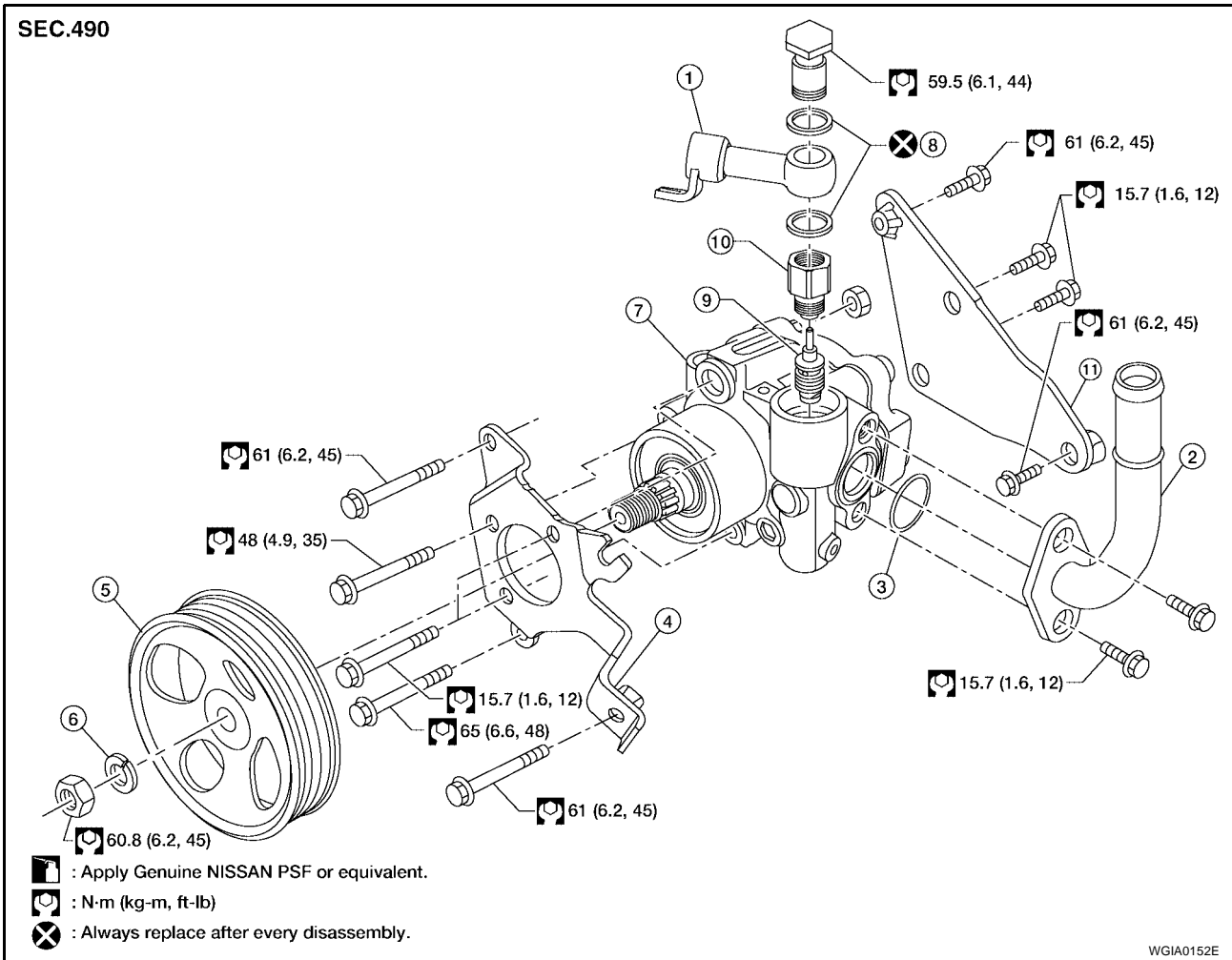

- | | | |
|------------------|-------------------|----------------------------------|
| 1. Joint | 2. Suction pipe | 3. O-ring |
| 4. Front bracket | 5. Pulley | 6. Lock washer |
| 7. Body assembly | 8. Copper washers | 9. Flow control valve and spring |
| 10. Connector | 11. Rear bracket | |

WGIA0152E

POWER STEERING OIL PUMP

VQ40DE

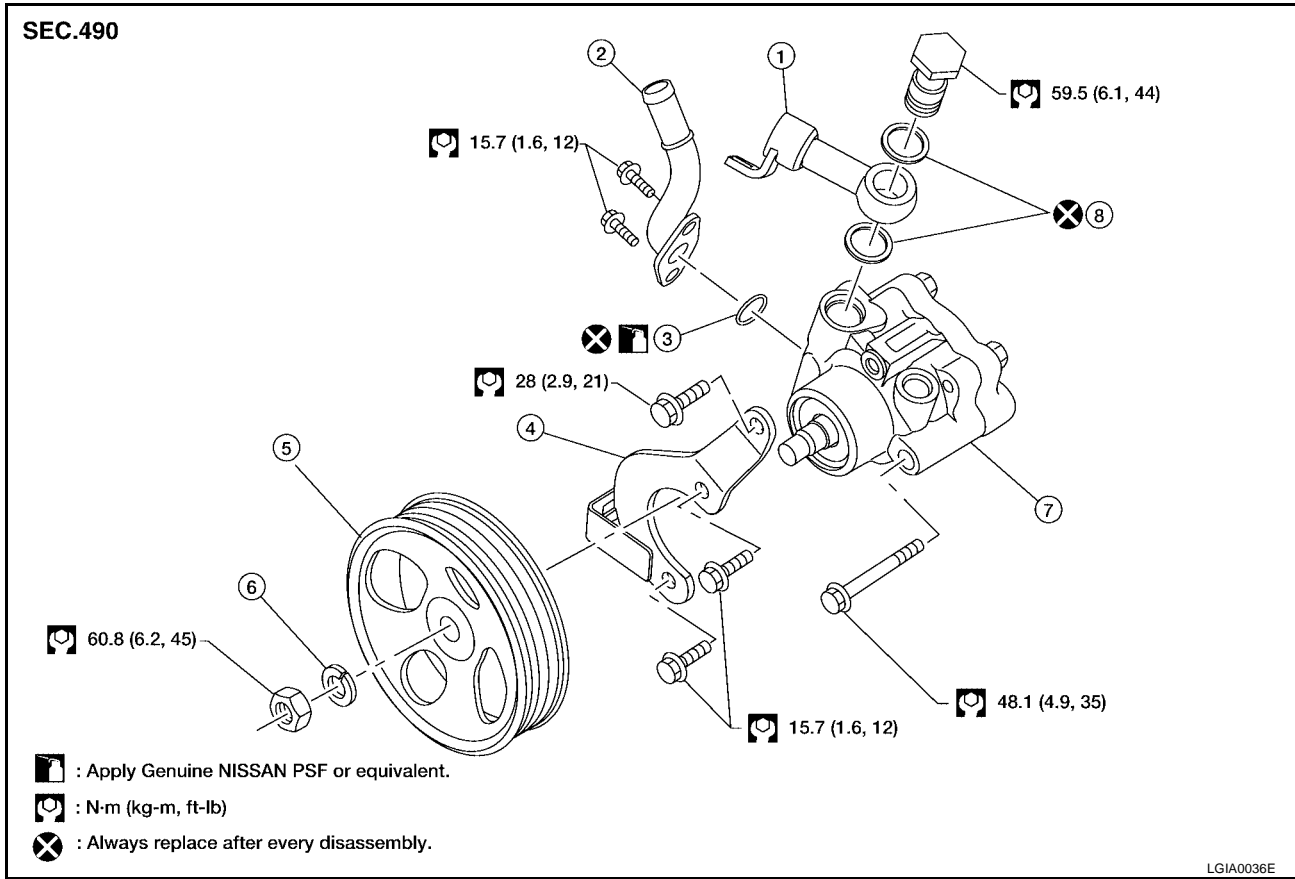

- | | | |
|------------------|-------------------|----------------|
| 1. Joint | 2. Suction pipe | 3. O-ring |
| 4. Front bracket | 5. Pulley | 6. Lock washer |
| 7. Body assembly | 8. Copper washers | |

Removal and Installation

REMOVAL

EGS000V8

1. Drain the power steering fluid from the reservoir tank.
2. On VQ40DE model, remove the engine room cover. Refer to [EM-123, "Removal and Installation"](#).
3. Remove the air duct assembly. Refer to [EM-16, "Removal and Installation"](#) (QR25DE), [EM-126, "Removal and Installation"](#) (VQ40DE).
4. Remove the serpentine drive belt from the auto tensioner and power steering oil pump. Refer to [EM-14, "Removal and Installation"](#) (QR25DE), [EM-124, "Removal and Installation"](#) (VQ40DE).
5. Disconnect the pressure sensor electrical connector.
6. Remove the high pressure and low pressure piping from the power steering oil pump. Refer to [PS-26, "Removal and Installation"](#).
7. Remove the power steering oil pump bolts, then remove the power steering pump.

INSTALLATION

Installation is in the reverse order of removal. Refer to [PS-26, "Removal and Installation"](#) for tightening torque.

- After installation, bleed the air from the hydraulic circuit thoroughly. Refer to [PS-6, "Air Bleeding Hydraulic System"](#).

NOTE:

Belt tension is automatic and requires no adjustment.

POWER STEERING OIL PUMP

Disassembly and Assembly

EGS000V9

QR25DE

SEC.490

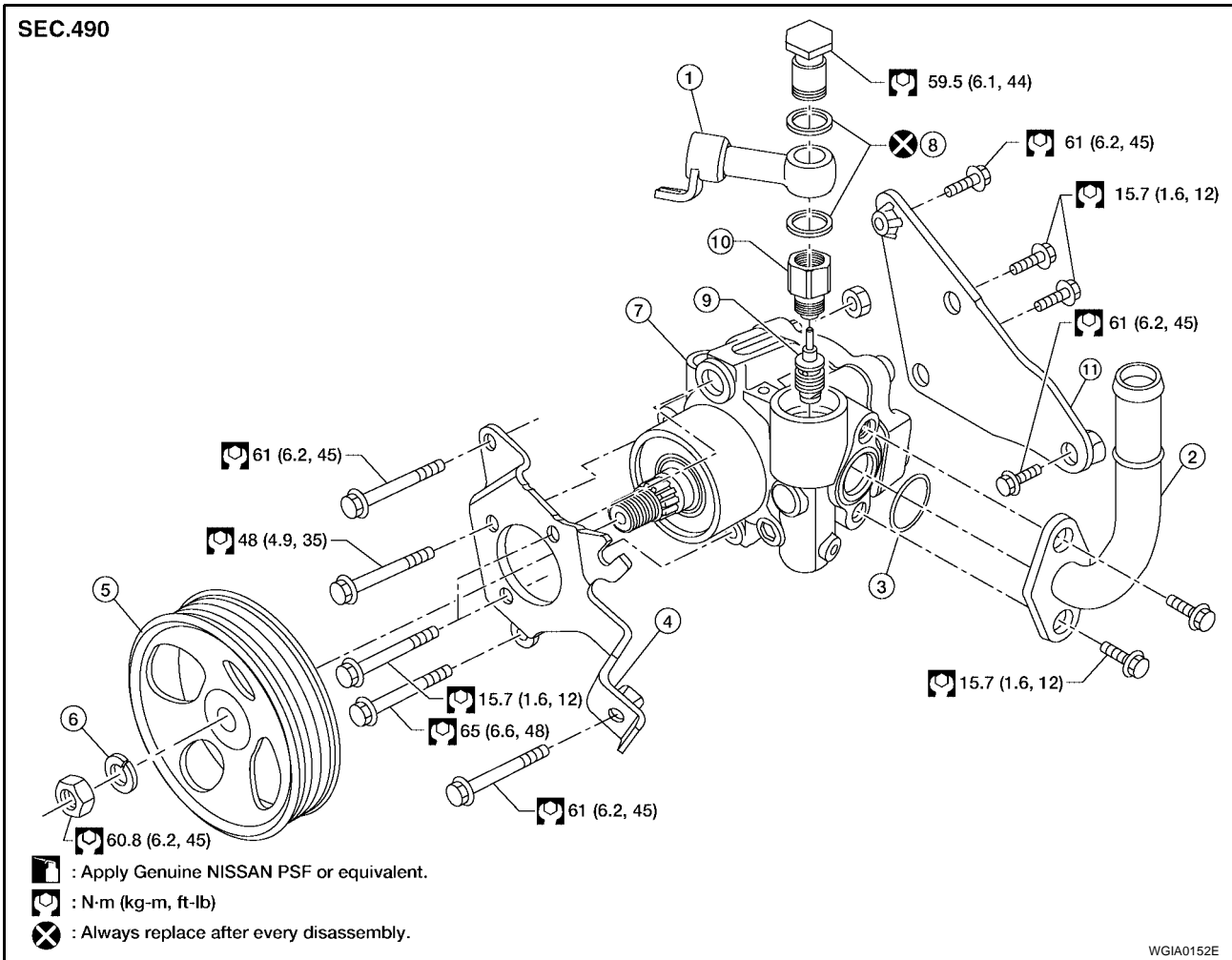

- | | | |
|------------------|-------------------|----------------------------------|
| 1. Joint | 2. Suction pipe | 3. O-ring |
| 4. Front bracket | 5. Pulley | 6. Lock washer |
| 7. Body assembly | 8. Copper washers | 9. Flow control valve and spring |
| 10. Connector | 11. Rear bracket | |

WGIA0152E

POWER STEERING OIL PUMP

VQ40DE

SEC.490

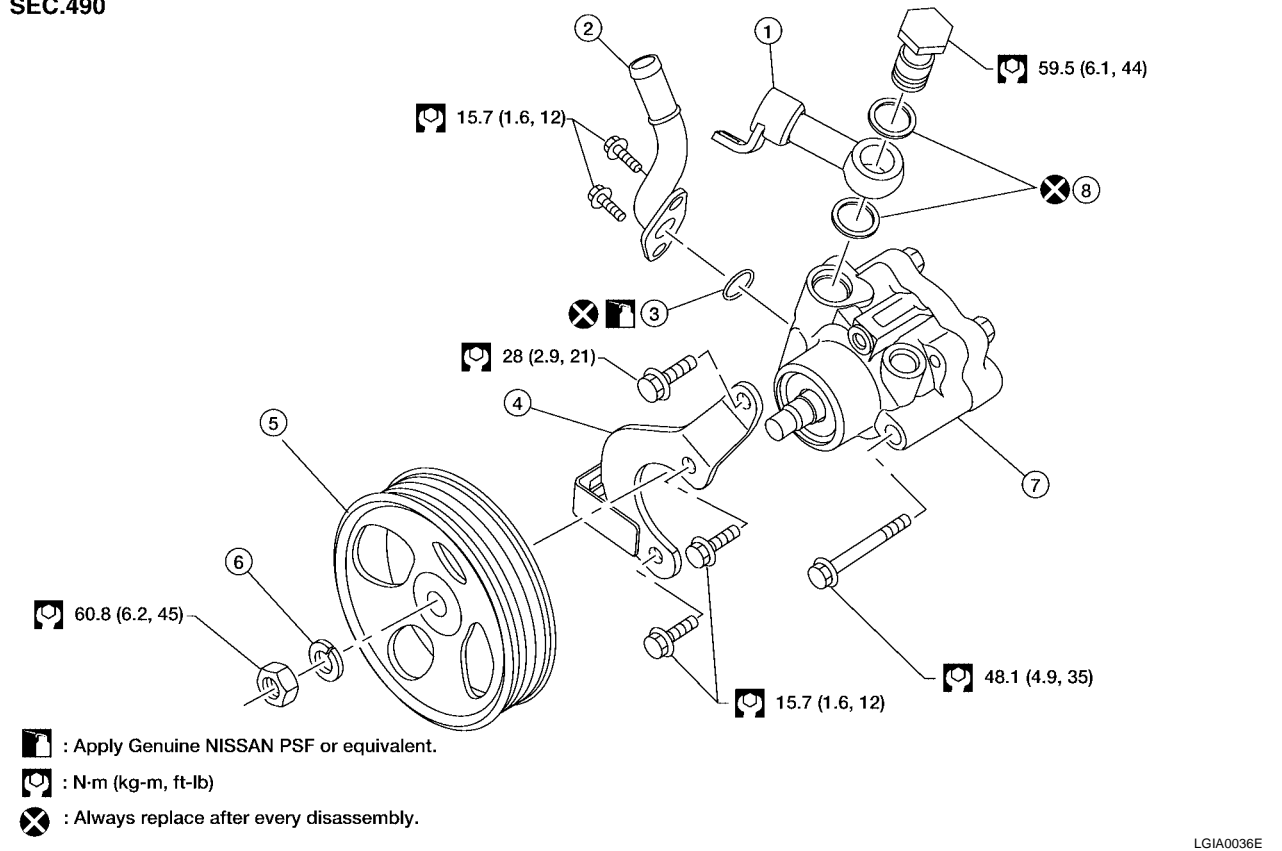

LGIA0036E

- | | | |
|------------------|-------------------|----------------|
| 1. Joint | 2. Suction pipe | 3. O-ring |
| 4. Front bracket | 5. Pulley | 6. Lock washer |
| 7. Body assembly | 8. Copper washers | |

INSPECTION BEFORE DISASSEMBLY

Disassemble the power steering oil pump only if the following items are found.

- Deformed or damaged pulley, bracket, connector or suction pipe
- Oil leakage from the suction pipe or connector.

DISASSEMBLY

NOTE:

Mount the power steering oil pump in a vise as needed.

1. Remove the joint bolt, joint and copper washers.

CAUTION:

Do not reuse the copper washers.

2. On QR25DE model, remove connector and flow control valve with spring.
3. Remove the suction pipe and O-ring.

CAUTION:

Do not reuse the O-ring.

4. Remove the pulley nut and pulley.
5. Remove the bracket bolts and bracket(s).

INSPECTION AFTER DISASSEMBLY

Body Assembly Inspection

Check the power steering oil pump body assembly for damage. If any damage is found, replace with a new power steering oil pump assembly.

ASSEMBLY

Assembly is in the reverse order of disassembly.

POWER STEERING OIL PUMP

CAUTION:

- Do not reuse the copper gaskets
- Do not reuse the O-ring. Apply a coat of Genuine NISSAN PSF or equivalent to the O-ring.

A

B

C

D

E

F

PS

H

I

J

K

L

M

HYDRAULIC LINE

PF:49721

EGS000VA

HYDRAULIC LINE

Removal and Installation

Refer to the following illustration for hydraulic line removal and installation.

SEC. 490 • 492 • 497

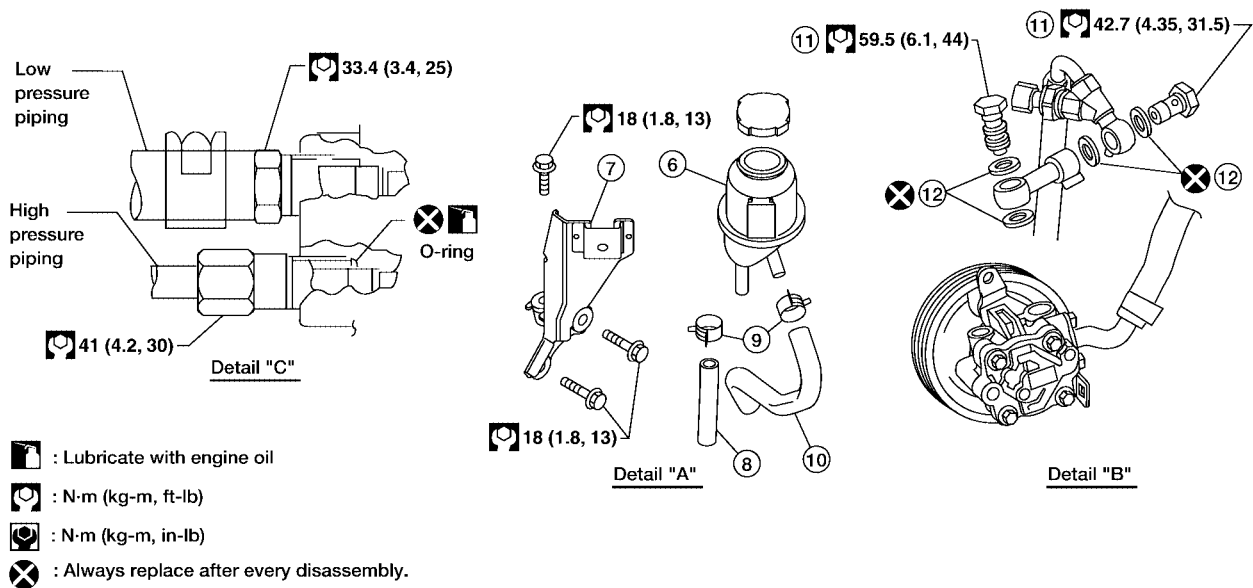
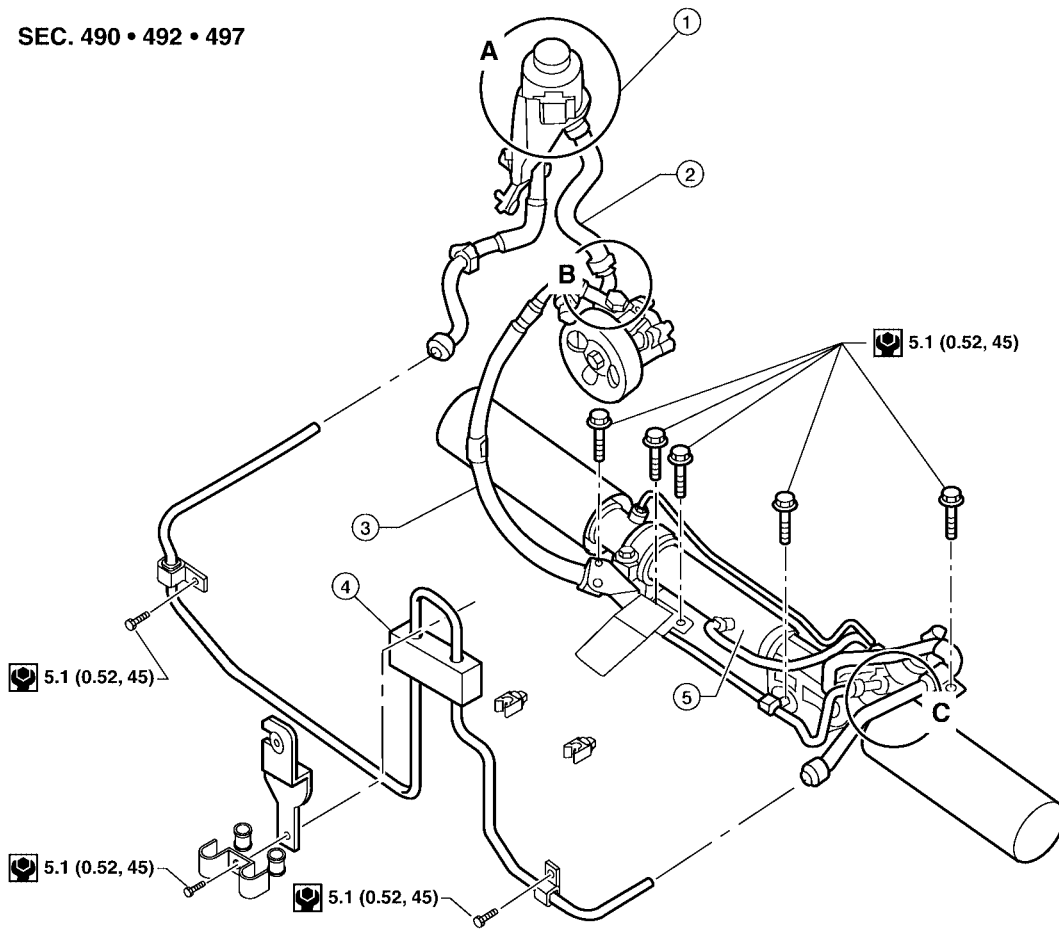

LGIA0035E

1. Reservoir tank
4. Oil cooler

2. Suction hose
5. Steering gear assembly

3. High pressure hose
6. Reservoir tank

HYDRAULIC LINE

7. Reservoir tank bracket
10. Suction hose

8. Return hose
11. Connector bolts

9. Hose clamps
12. Copper washers

A

B

C

D

E

F

PS

H

I

J

K

L

M

SERVICE DATA AND SPECIFICATIONS (SDS)

SERVICE DATA AND SPECIFICATIONS (SDS)

PFP:00030

Steering Wheel

EGS000VB

End play of the axle direction for steering wheel	0 mm (0 in)
Steering wheel turning force	39 N (4 kg-f, 9 lb-f) or less
Steering wheel play on the outer circumference	0 – 35 mm (0 – 1.38 in)

Steering Column

EGS000VC

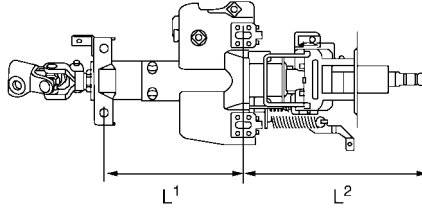

SGIA0475E

Steering column length "L1"	165.1 mm (6.500 in)
Steering column length "L2"	258.0 mm (10.16 in)

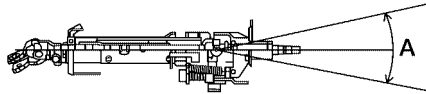

WGIA0083E

Tilt range "A"	73.8 mm (2.906 in)
----------------	--------------------

SERVICE DATA AND SPECIFICATIONS (SDS)

Steering Gear Outer and Inner Socket

EGS000VD

Steering gear type	PR26AM
--------------------	--------

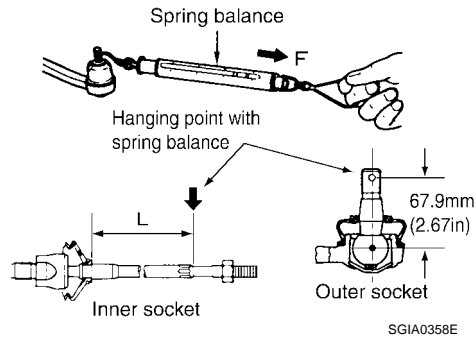

Outer socket	Swinging torque	0.3 – 2.9 N·m (0.03 – 0.29 kg-m, 3 – 25 in-lb)
	Measurement on spring balance ● Measuring point: cotter pin hole of stud	4.84 – 46.7 N (0.50 – 4.7 kg-f, 4 – 34 lb-f)
	Rotating torque	0.3 – 2.9 N·m (0.03 – 0.29 kg-m, 3 – 25 in-lb)
	Axial end play	0.5 mm (0.020 in) or less
Inner socket	Swinging torque	1.0 – 7.8 N·m (0.11 – 0.79 kg-m, 9 – 69 in-lb)
	Measurement on spring balance ● Measuring point: L mark see above, L=83.2 mm (3.276 in).	12.1 – 93.7 N (1.3 – 9.5 kg-f, 9 – 69 lb-f)
	Axial end play	0.2 mm (0.08 in) or less

Tie-rod

EGS00116

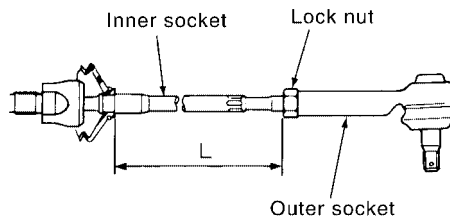

Tie-rod maximum length "L"	84 mm (3.31 in)
----------------------------	-----------------

Oil Pump

EGS000VF

Oil pump relief hydraulic pressure	8.0 – 8.8 mPa (81.60 – 89.76 kg/cm ² , 1160 – 1276 psi)
------------------------------------	--

Steering Fluid

EGS000VG

Fluid capacity	Approx. 1.0 ℓ (2 1/8 US pt, 1 3/4 Imp pt)
----------------	---

SERVICE DATA AND SPECIFICATIONS (SDS)
