

SECTION **EXL**

EXTERIOR LIGHTING SYSTEM

A
B
C
D
E
F
G
H
I
J
K
EXL
M
N
O
P

CONTENTS

<p>BASIC INSPECTION 4</p> <p>DIAGNOSIS AND REPAIR WORKFLOW 4</p> <p style="padding-left: 20px;">Work Flow4</p> <p>FUNCTION DIAGNOSIS 7</p> <p>HEADLAMP 7</p> <p style="padding-left: 20px;">System Diagram7</p> <p style="padding-left: 20px;">System Description7</p> <p style="padding-left: 20px;">Component Parts Location7</p> <p style="padding-left: 20px;">Component Description8</p> <p>DAYTIME RUNNING LIGHT SYSTEM 9</p> <p style="padding-left: 20px;">System Diagram9</p> <p style="padding-left: 20px;">System Description9</p> <p style="padding-left: 20px;">Component Parts Location10</p> <p style="padding-left: 20px;">Component Description10</p> <p>AUTO LIGHT SYSTEM12</p> <p style="padding-left: 20px;">System Diagram12</p> <p style="padding-left: 20px;">System Description12</p> <p style="padding-left: 20px;">Component Parts Location13</p> <p style="padding-left: 20px;">Component Description13</p> <p>FRONT FOG LAMP14</p> <p style="padding-left: 20px;">System Diagram14</p> <p style="padding-left: 20px;">System Description14</p> <p style="padding-left: 20px;">Component Parts Location14</p> <p style="padding-left: 20px;">Component Description15</p> <p>TURN SIGNAL AND HAZARD WARNING LAMPS16</p> <p style="padding-left: 20px;">System Diagram16</p> <p style="padding-left: 20px;">System Description16</p> <p style="padding-left: 20px;">Component Parts Location16</p> <p style="padding-left: 20px;">Component Description17</p> <p>PARKING, LICENSE PLATE AND TAIL LAMPS18</p> <p style="padding-left: 20px;">System Diagram18</p>	<p>System Description18</p> <p>Component Parts Location18</p> <p>Component Description19</p> <p>COMBINATION SWITCH READING SYSTEM20</p> <p style="padding-left: 20px;">System Diagram20</p> <p style="padding-left: 20px;">System Description20</p> <p style="padding-left: 20px;">Component Parts Location23</p> <p>DIAGNOSIS SYSTEM (BCM)25</p> <p>HEADLAMP25</p> <p style="padding-left: 20px;">HEADLAMP : CONSULT-III Function (BCM - HEAD LAMP)25</p> <p>FLASHER26</p> <p style="padding-left: 20px;">FLASHER : CONSULT-III Function (BCM - FLASHER)26</p> <p>COMB SW26</p> <p style="padding-left: 20px;">COMB SW : CONSULT-III Function (BCM - COMB SW)26</p> <p>BATTERY SAVER27</p> <p style="padding-left: 20px;">BATTERY SAVER : CONSULT-III Function (BCM - BATTERY SAVER)27</p> <p>DIAGNOSIS SYSTEM (IPDM E/R)29</p> <p style="padding-left: 20px;">Diagnosis Description29</p> <p style="padding-left: 20px;">CONSULT - III Function (IPDM E/R)31</p> <p>COMPONENT DIAGNOSIS34</p> <p>POWER SUPPLY AND GROUND CIRCUIT34</p> <p>BCM (BODY CONTROL MODULE)34</p> <p style="padding-left: 20px;">BCM (BODY CONTROL MODULE) : Diagnosis Procedure34</p> <p>IPDM E/R (INTELLIGENT POWER DISTRIBUTION MODULE ENGINE ROOM)35</p>
--	--

IPDM E/R (INTELLIGENT POWER DISTRIBUTION MODULE ENGINE ROOM) : Diagnosis Procedure	35	Terminal Layout	103
HEADLAMP (HI) CIRCUIT	36	Physical Values	104
Description	36	Wiring Diagram	109
Component Function Check	36	Fail Safe	112
Diagnosis Procedure	36	DTC Inspection Priority Chart	113
HEADLAMP (LO) CIRCUIT	38	DTC Index	113
Description	38	IPDM E/R (INTELLIGENT POWER DISTRIBUTION MODULE ENGINE ROOM)	115
Component Function Check	38	Reference Value	115
Diagnosis Procedure	38	Terminal Layout	117
FRONT FOG LAMP CIRCUIT	40	Physical Values	117
Description	40	Wiring Diagram	121
Component Function Check	40	Fail Safe	125
Diagnosis Procedure	40	DTC Index	127
PARKING LAMP CIRCUIT	42	SYMPTOM DIAGNOSIS	128
Description	42	EXTERIOR LIGHTING SYSTEM SYMPTOMS	128
Component Function Check	42	Symptom Table	128
Diagnosis Procedure	42	NORMAL OPERATING CONDITION	130
TURN SIGNAL LAMP CIRCUIT	47	Description	130
Description	47	BOTH SIDE HEADLAMPS DO NOT SWITCH TO HIGH BEAM	131
Component Function Check	47	Description	131
Diagnosis Procedure	47	Diagnosis Procedure	131
HEADLAMP	50	BOTH SIDE HEADLAMPS (LO) ARE NOT TURNED ON	132
Wiring Diagram	50	Description	132
DAYTIME LIGHT SYSTEM	54	Diagnosis Procedure	132
Wiring Diagram	54	PARKING, LICENSE PLATE AND TAIL LAMPS ARE NOT TURNED ON	133
AUTO LIGHT SYSTEM	63	Description	133
Wiring Diagram	63	Diagnosis Procedure	133
FRONT FOG LAMP SYSTEM	68	BOTH SIDE FRONT FOG LAMPS ARE NOT TURNED ON	134
Wiring Diagram	68	Description	134
TURN SIGNAL AND HAZARD WARNING LAMP SYSTEM	72	Diagnosis Procedure	134
Wiring Diagram	72	PRECAUTION	135
PARKING, LICENSE PLATE AND TAIL LAMPS SYSTEM	77	PRECAUTIONS	135
Wiring Diagram	77	Precaution for Supplemental Restraint System (SRS) "AIR BAG" and "SEAT BELT PRE-TENSIONER"	135
STOP LAMP	83	General precautions for service operations	135
Wiring Diagram	83	ON-VEHICLE MAINTENANCE	136
BACK-UP LAMP	88	HEADLAMP	136
Wiring Diagram	88	Aiming Adjustment	136
TRAILER TOW	92	FRONT FOG LAMP	138
Wiring Diagram	92	Aiming Adjustment	138
ECU DIAGNOSIS	100	ON-VEHICLE REPAIR	140
BCM (BODY CONTROL MODULE)	100		
Reference Value	100		

HEADLAMP	140	REAR COMBINATION LAMP	145	
Bulb Replacement	140	Bulb Replacement	145	A
Removal and Installation	140	Removal and Installation	145	
Disassembly and Assembly	141			
FRONT FOG LAMP	142	LIGHTING & TURN SIGNAL SWITCH	146	B
Bulb Replacement	142	Removal and Installation	146	
Removal and Installation	142			
STOP LAMP	143	HAZARD SWITCH	147	C
Bulb Replacement	143	Removal and Installation	147	
Removal and Installation	143			
LICENSE PLATE LAMP	144	SERVICE DATA AND SPECIFICATIONS		
Bulb Replacement	144	(SDS)	148	D
Removal and Installation	144			
		SERVICE DATA AND SPECIFICATIONS		
		(SDS)	148	E
		Headlamp	148	
		Exterior Lamp	148	
				F
				G
				H
				I
				J
				K
				EXL
				M
				N
				O
				P

DIAGNOSIS AND REPAIR WORKFLOW

< BASIC INSPECTION >

BASIC INSPECTION

DIAGNOSIS AND REPAIR WORKFLOW

Work Flow

INFOID:000000004056429

OVERALL SEQUENCE

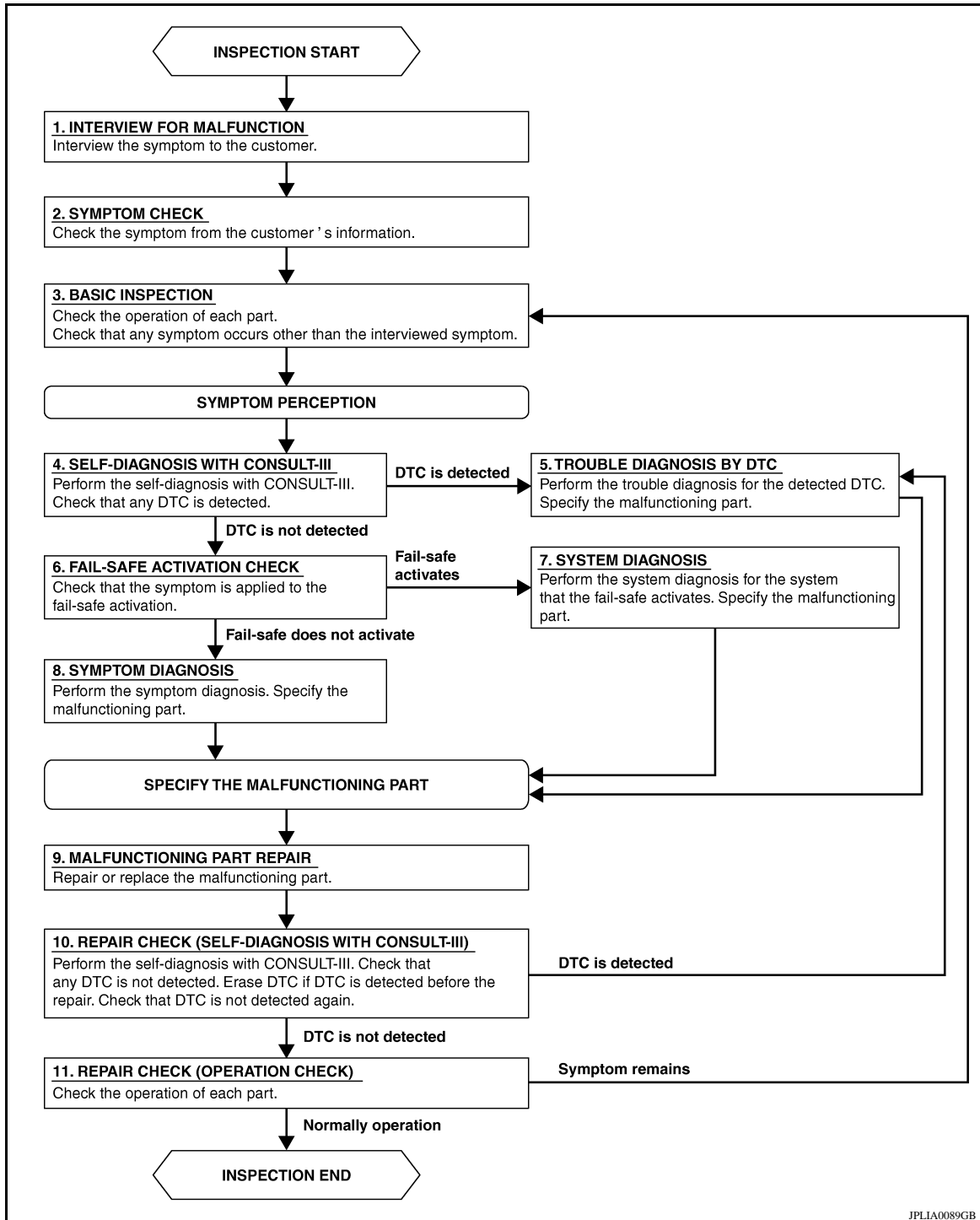

JPLIA0089GB

DIAGNOSIS AND REPAIR WORKFLOW

< BASIC INSPECTION >

DETAILED FLOW

1. INTERVIEW FOR MALFUNCTION

Find out what the customer's concerns are.

>> GO TO 2

2. SYMPTOM CHECK

Verify the symptom from the customer's information.

>> GO TO 3

3. BASIC INSPECTION

Check the operation of each part. Check that any concerns occur other than those mentioned in the customer interview.

>> GO TO 4

4. SELF-DIAGNOSIS WITH CONSULT-III

Perform the self diagnosis with CONSULT-III. Check that any DTC is detected.

Is any DTC detected?

YES >> GO TO 5

NO >> GO TO 6

5. TROUBLE DIAGNOSIS BY DTC

Perform the trouble diagnosis for the detected DTC. Specify the malfunctioning part.

>> GO TO 9

6. FAIL-SAFE ACTIVATION CHECK

Determine if the customer's concern is related to fail-safe activation.

Does the fail-safe activate?

YES >> GO TO 7

NO >> GO TO 8

7. SYSTEM DIAGNOSIS

Perform the system diagnosis for the system in which the fail-safe activates. Specify the malfunctioning part.

>> GO TO 9

8. SYMPTOM DIAGNOSIS

Perform the symptom diagnosis. Specify the malfunctioning part.

>> GO TO 9

9. MALFUNCTION PART REPAIR

Repair or replace the malfunctioning part.

>> GO TO 11

10. REPAIR CHECK (SELF-DIAGNOSIS WITH CONSULT-III)

Perform the self diagnosis with CONSULT-III. Verified that no DTCs are detected. Erase all DTCs detected prior to the repair. Verify that DTC is not detected again.

Is any DTC detected?

A

B

C

D

E

F

G

H

I

J

K

EXL

M

N

O

P

DIAGNOSIS AND REPAIR WORKFLOW

< BASIC INSPECTION >

YES >> GO TO 5

NO >> GO TO 11

11. REPAIR CHECK (OPERATION CHECK)

Check the operation of each part.

Does it operate normally?

YES >> Inspection End.

NO >> GO TO 3

HEADLAMP

< FUNCTION DIAGNOSIS >

FUNCTION DIAGNOSIS

HEADLAMP

System Diagram

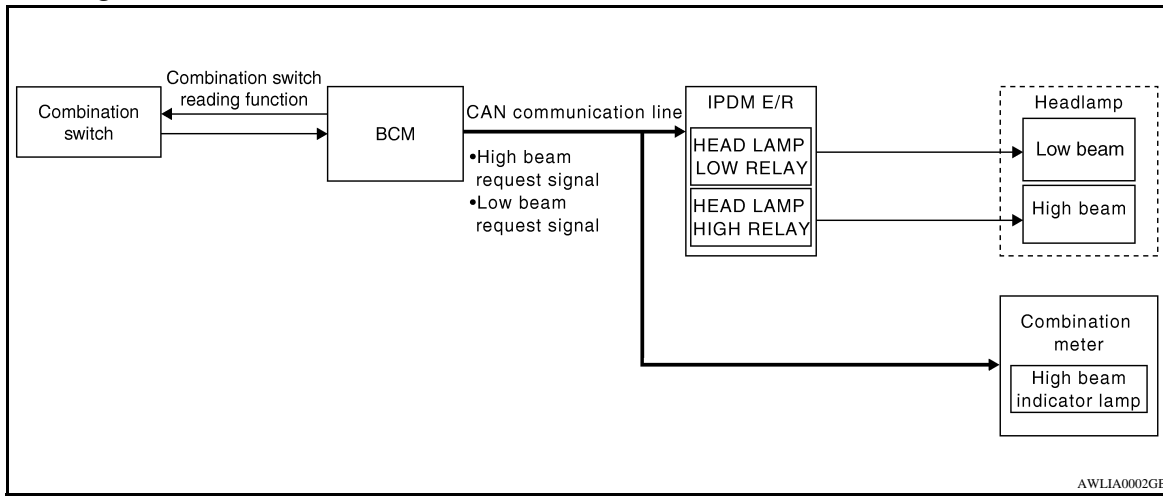

System Description

INFOID:000000004056431

Control of the headlamp system operation is dependent upon the position of the lighting switch (combination switch). When the lighting switch is placed in the 2nd position, the BCM (body control module) receives input requesting the headlamps and park lamps to illuminate. This input is communicated to the IPDM E/R (intelligent power distribution module engine room) via the CAN communication lines. The CPU (central processing unit) of the IPDM E/R controls the headlamp high and headlamp low relay coils. When energized, these relays direct power to the respective headlamps, which then illuminate.

HIGH BEAM OPERATION/FLASH-TO-PASS OPERATION

With the lighting switch in the 2ND position and placed in HIGH position, the BCM receives input requesting the headlamp high beams to illuminate. The flash to pass feature can be used any time and also sends a signal to the BCM. This input is communicated to the IPDM E/R via the CAN communication lines. The CPU of the combination meter controls the ON/OFF status of the HIGH BEAM indicator. The CPU of the IPDM E/R controls the headlamp high relay coil which supplies power to the high beam headlamps.

The combination meter receives a high beam request signal (ON) via the CAN communication lines and turns the high beam indicator lamp ON.

Component Parts Location

INFOID:000000004056432

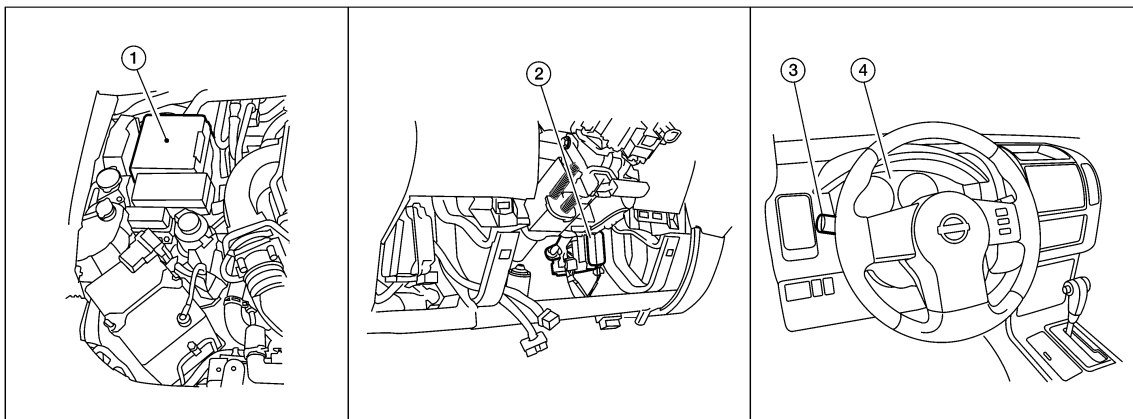

WKIA4957E

HEADLAMP

< FUNCTION DIAGNOSIS >

1. IPDM E/R E122, E123, E124
2. BCM M18, M20 (view with lower instrument panel LH removed)
3. Combination switch (lighting and turn signal switch) M28
4. Combination meter M24

Component Description

INFOID:000000004056433

Part name	Description
BCM	<ul style="list-style-type: none">• Receives lighting switch requests via BCM combination switch reading function.• Sends headlamp high/low request signal to the IPDM E/R.
IPDM E/R	Activates the headlamp high and headlamp low relays upon request from the BCM.
Combination switch (lighting and turn signal switch)	Outputs lighting requests to the BCM.

DAYTIME RUNNING LIGHT SYSTEM

< FUNCTION DIAGNOSIS >

DAYTIME RUNNING LIGHT SYSTEM

System Diagram

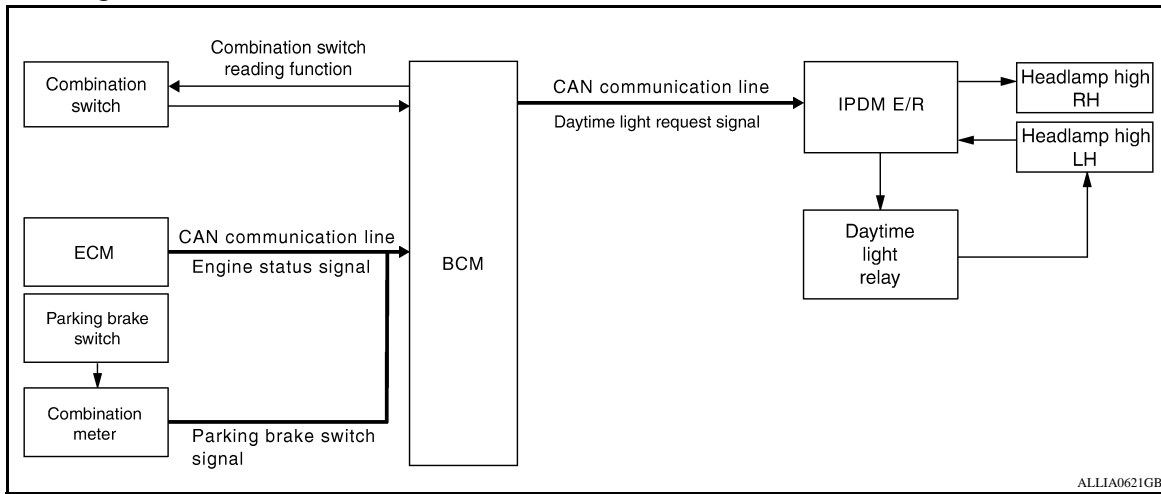

System Description

INFOID:000000004056435

The headlamp system for Canada vehicles is equipped with a daytime light control that activates the high beam headlamps at approximately half illumination whenever the engine is operating. If the parking brake is applied before the engine is started the daytime lights will not be illuminated. The daytime lights will illuminate once the parking brake is released. Thereafter, the daytime lights will continue to operate when the parking brake is applied.

OPERATION

The BCM monitors inputs from the parking brake switch and the combination switch to determine when to activate the daytime light system. The BCM sends a daytime light request to the IPDM E/R via the CAN communication lines. The IPDM E/R grounds the daytime light relay which in turn, provides power to the ground side of the LH high beam lamp. Power flows backward through the LH high beam lamp to the IPDM E/R, through the high beam fuses, through the RH high beam lamp circuit to the RH high beam lamp and on to ground. The high beam lamps are wired in series which causes them to illuminate at a reduced intensity.

A
B
C
D
E
F
G
H
I
J
K

EXL

M
N
O
P

DAYTIME RUNNING LIGHT SYSTEM

< FUNCTION DIAGNOSIS >

Component Parts Location

INFOID:000000004056436

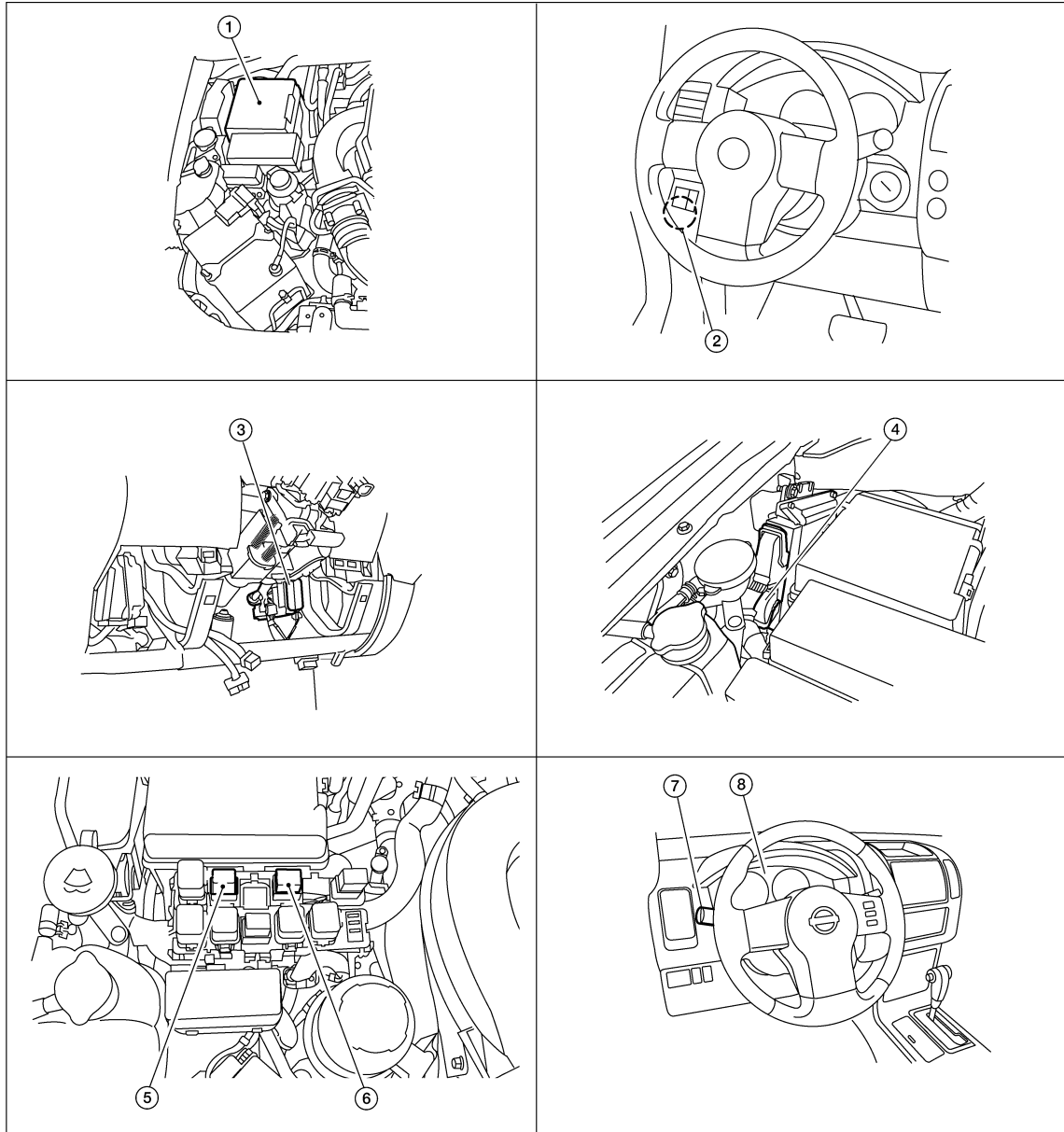

AWNIA0928ZZ

- | | | |
|---|-------------------------------|---|
| 1. IPDM E/R E119, E122, E123, E124 | 2. Parking brake switch B84 | 3. BCM M18, M20 (view with lower instrument panel LH removed) |
| 4. ECM E16 (view with ECM cover removed) | 5. Daytime light relay 1 E103 | 6. Daytime light relay 2 E104 |
| 7. Combination switch (lighting and turn signal switch) M28 | 8. Combination meter M24 | |

Component Description

INFOID:000000004056437

Part name	Description
BCM	<ul style="list-style-type: none"> Receives combination switch inputs via BCM combination switch reading function. Receives park brake applied input from the park brake switch. Receives engine running status from the ECM via CAN communication.

DAYTIME RUNNING LIGHT SYSTEM

< FUNCTION DIAGNOSIS >

IPDM E/R	Receives daytime light request from the BCM and activates the daytime light relay.
Combination switch (lighting and turn signal switch)	Outputs lighting requests to the BCM.
Parking brake switch	Outputs parking brake status to the combination meter which forwards that information to the BCM via CAN communication.
ECM	Outputs engine running status to the BCM.

A

B

C

D

E

F

G

H

I

J

K

EXL

M

N

O

P

AUTO LIGHT SYSTEM

< FUNCTION DIAGNOSIS >

AUTO LIGHT SYSTEM

System Diagram

INFOID:000000004056438

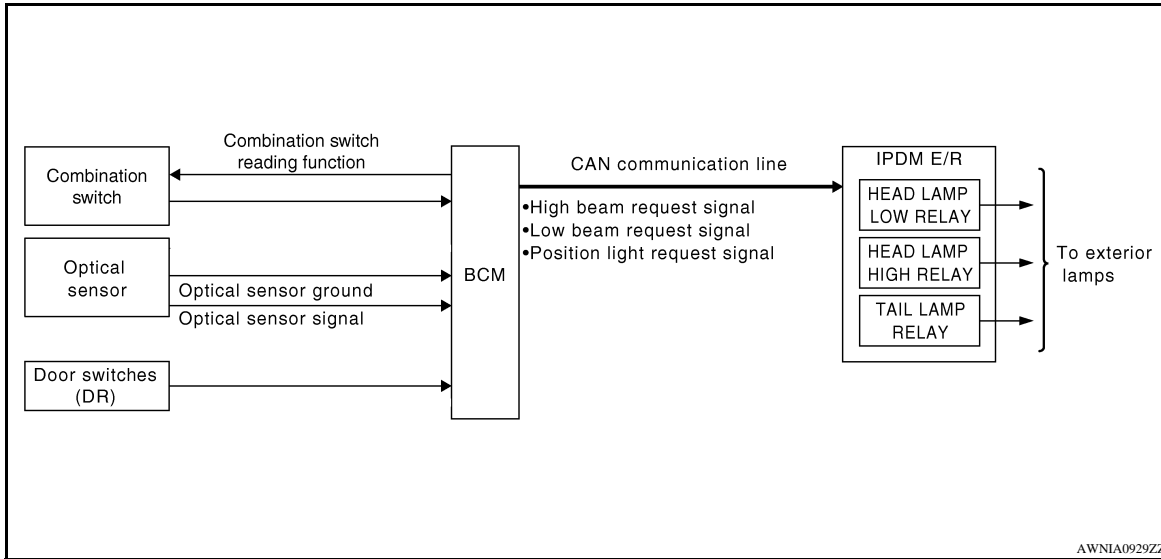

System Description

INFOID:000000004056439

The auto light control system has an optical sensor that detects outside brightness.

When the lighting switch is in AUTO position, it automatically turns ON/OFF the parking, license plate, tail and headlamps in accordance with the ambient light. Sensitivity can be adjusted in four steps. For the details, refer to [EXL-25, "HEADLAMP : CONSULT-III Function \(BCM - HEAD LAMP\)"](#).

AUTO LIGHT OPERATION

The auto light system operates the low beam and high beam headlamps, parking lamps, tail lamps and license plate lamps. The BCM monitors the lighting switch (combination switch) position as a part of the BCM combination switch reading function. When the lighting switch is in the AUTO position, the BCM automatically turns the lamps ON/OFF according to ambient light brightness. When the key is turned OFF and all doors are closed, the auto light system keeps the headlamps ON for 45 seconds.

NOTE:

Timing for when lamps turn ON/OFF can be changed by the function setting of CONSULT-III. Refer to [EXL-25, "HEADLAMP : CONSULT-III Function \(BCM - HEAD LAMP\)"](#).

AUTO LIGHT SYSTEM

< FUNCTION DIAGNOSIS >

Component Parts Location

INFOID:000000004056440

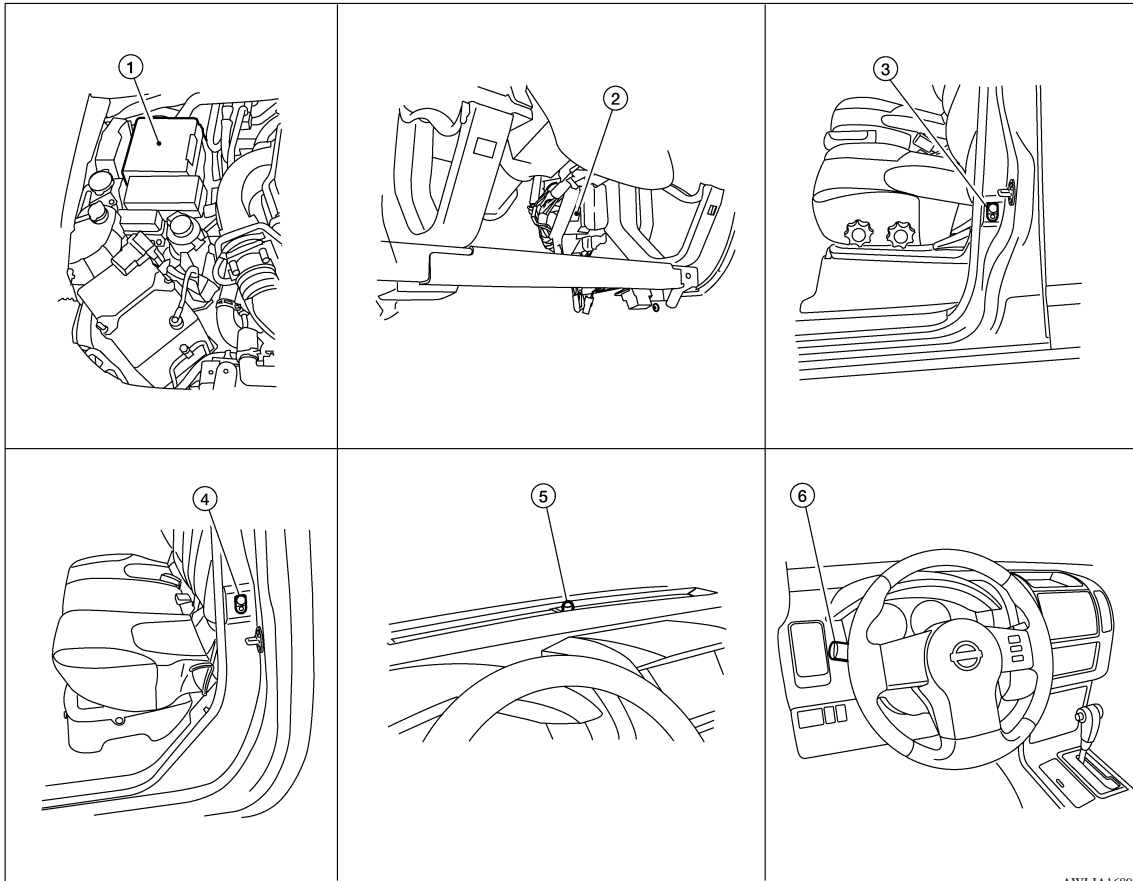

- | | | |
|--|--|---|
| 1. IPDM E/R E122, E123, E124 | 2. BCM M18, M19, M20 (view with lower instrument panel LH removed) | 3. Front door switch
LH B8
RH B108 |
| 4. Rear door switch
LH B18
RH B116 | 5. Optical sensor M14 | 6. Combination switch (lighting and turn signal switch) M28 |

Component Description

INFOID:000000004056441

Part name	Description
BCM	BCM (Body Control Module) controls auto light operation according to signals from optical sensor, lighting switch and ignition switch.
IPDM E/R	IPDM E/R (Intelligent Power Distribution Module Engine Room) operates parking, license plate, tail and headlamps according to CAN communication signals from BCM.
Combination switch (lighting and turn signal switch)	The lighting switch outputs lighting requests to the BCM.
Optical sensor	Optical sensor detects ambient brightness and converts light (lux) to voltage, then sends the optical sensor signal to BCM.
Door switches	Detects door open/closed status and forwards that status to the BCM.

FRONT FOG LAMP

< FUNCTION DIAGNOSIS >

FRONT FOG LAMP

System Diagram

INFOID:000000004056442

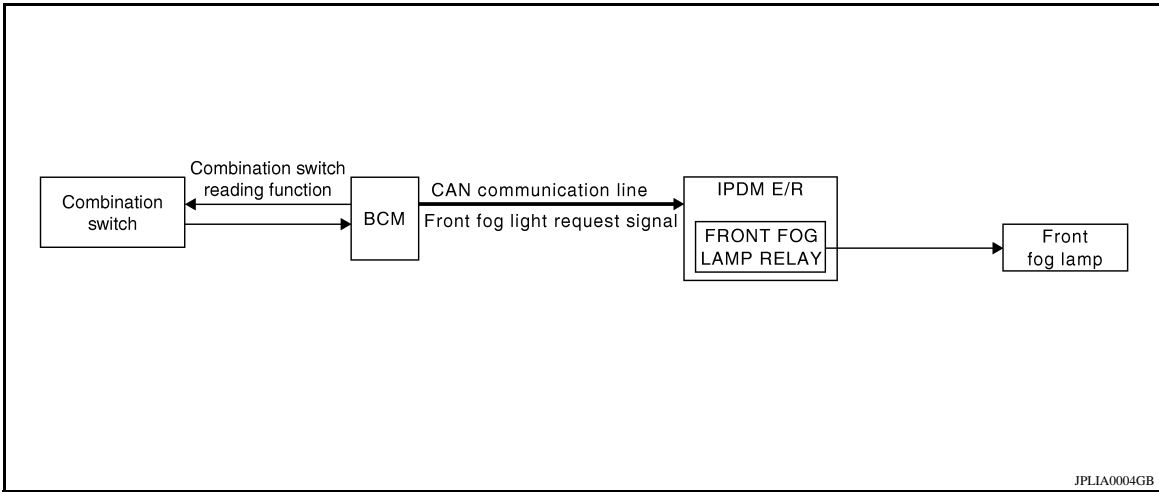

JPLIA0004GB

System Description

INFOID:000000004056443

The front fog lamps are activated with the lighting switch (combination switch). The lighting switch signal to the BCM is monitored with the BCM combination switch reading function. When the fog lamps are turned ON with the lighting switch, the BCM sends a front fog lamp request signal via CAN communication lines to the IPDM E/R. The IPDM E/R grounds the front fog lamp relay coil to activate the front fog lamps.

FRONT FOG LAMP OPERATION

When the lighting switch is in front fog lamp ON position and also in 1ST or 2ND position or AUTO (if equipped) position (headlamp is ON), the BCM detects FR FOG ON and the HEAD LAMP1 or 2 ON. The BCM sends a front fog lamp request ON signal via the CAN communication lines to the IPDM E/R. The IPDM E/R then turns ON the front fog lamp relay sending power to the front fog lamps.

Component Parts Location

INFOID:000000004056444

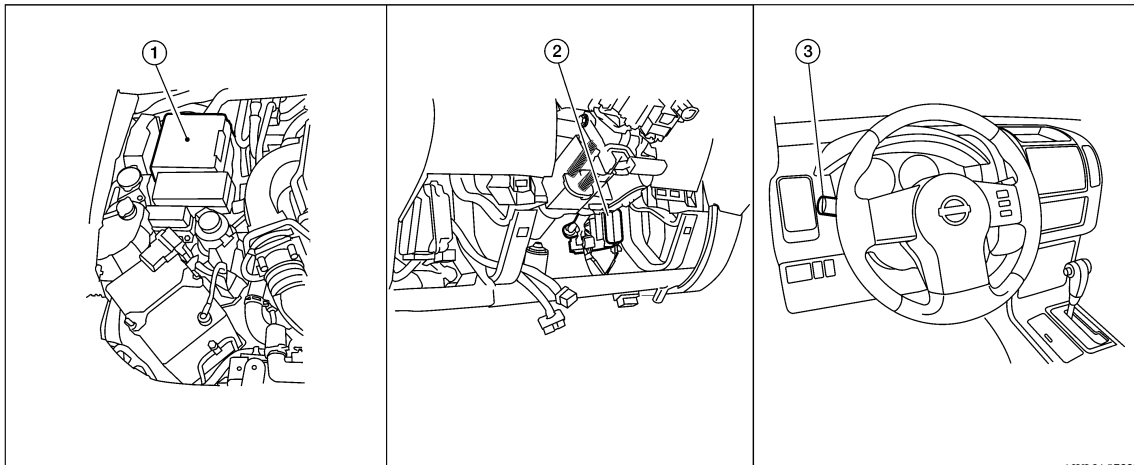

AWLIA0732ZZ

1. IPDM E/R E122, E123, E124

2. BCM M18, M20 (view with lower instrument panel LH removed)

3. Combination switch (lighting and turn signal switch) M28

FRONT FOG LAMP

< FUNCTION DIAGNOSIS >

Component Description

INFOID:000000004056445

Part name	Description
BCM	<ul style="list-style-type: none">• Receives lighting switch requests via BCM combination switch reading function.• Sends headlamp high/low request signal to the IPDM E/R.
IPDM E/R	Activates the front fog lamp relay upon request from the BCM.
Combination switch (lighting and turn signal switch)	Outputs lighting requests to the BCM.

A

B

C

D

E

F

G

H

I

J

K

EXL

M

N

O

P

TURN SIGNAL AND HAZARD WARNING LAMPS

< FUNCTION DIAGNOSIS >

TURN SIGNAL AND HAZARD WARNING LAMPS

System Diagram

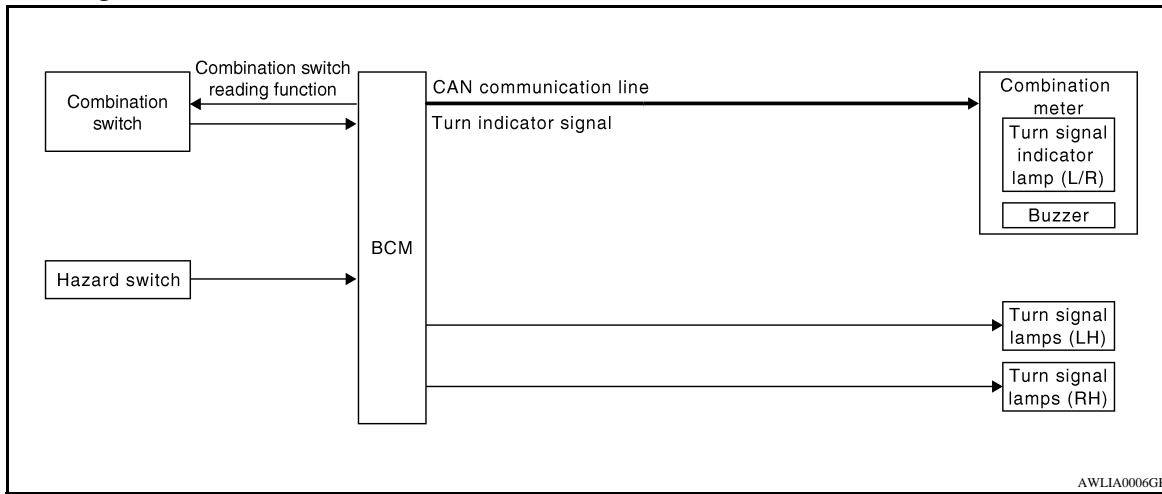

System Description

INFOID:000000004056447

TURN SIGNAL OPERATION

When the turn signal switch is in LH or RH position with the ignition switch in ON position, the BCM detects the TURN RH or TURN LH ON request. The BCM outputs the flasher signal to the respective turn signal lamp. The BCM also sends a turn indicator signal ON request via the CAN communication lines to the combination meter. The combination meter then activates the appropriate turn signal indicator and audible buzzer.

HAZARD LAMP OPERATION

When the hazard switch is in ON position, the BCM detects the hazard switch signal ON. The BCM outputs the flasher signal (right and left). The BCM sends a hazard indicator signal ON request via the CAN communication lines to the combination meter. The combination meter then activates the hazard indicator and audible buzzer.

Component Parts Location

INFOID:000000004056448

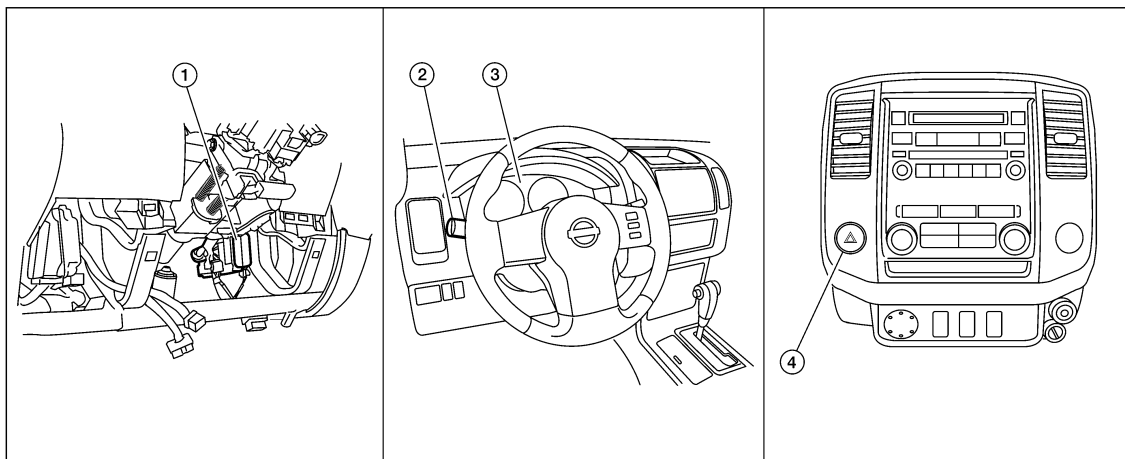

AWLIA1683ZZ

1. BCM M18, M20 (view with lower instrument panel LH removed)
2. Combination switch (lighting and turn signal switch) M28
3. Combination meter M24
4. Hazard switch M55

TURN SIGNAL AND HAZARD WARNING LAMPS

< FUNCTION DIAGNOSIS >

Component Description

INFOID:000000004056449

Part name	Description
BCM	Controls turn signal and hazard flasher operation.
Combination switch (lighting and turn signal switch)	Lighting and turn signal switch requests are output to the BCM.
Hazard switch	Hazard flasher request signal is output to the BCM.
Combination meter	Outputs turn and hazard indicator as requested by the BCM.

A

B

C

D

E

F

G

H

I

J

K

EXL

M

N

O

P

PARKING, LICENSE PLATE AND TAIL LAMPS

< FUNCTION DIAGNOSIS >

PARKING, LICENSE PLATE AND TAIL LAMPS

System Diagram

INFOID:000000004056450

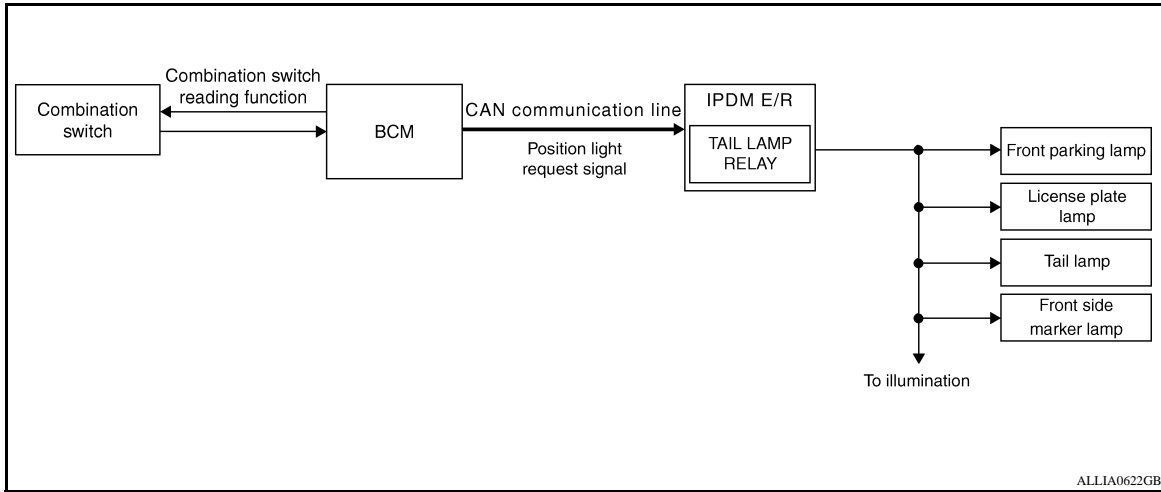

ALLIA0622GB

System Description

INFOID:000000004056451

PARKING, LICENSE PLATE AND TAIL LAMPS OPERATION

When the lighting switch is in 1ST position, BCM detects the LIGHTING SWITCH 1ST POSITION ON. The BCM sends a parking light ON request via the CAN communication lines to the IPDM E/R. The IPDM E/R then activates the tail lamp relay which sends power to the parking and instrument illumination circuits.

EXTERIOR LAMP BATTERY SAVER CONTROL

With the lighting switch (combination switch) in the 2nd position and the ignition switch is turned from ON or ACC to OFF, the battery saver feature is activated.

Under this condition, the headlamps remain illuminated for 5 minutes unless the lighting switch position is changed. If the lighting switch position is changed, then the headlamps are turned OFF.

This setting can be changed by CONSULT-III. Refer to [EXL-27, "BATTERY SAVER : CONSULT-III Function \(BCM - BATTERY SAVER\)"](#).

Component Parts Location

INFOID:000000004056452

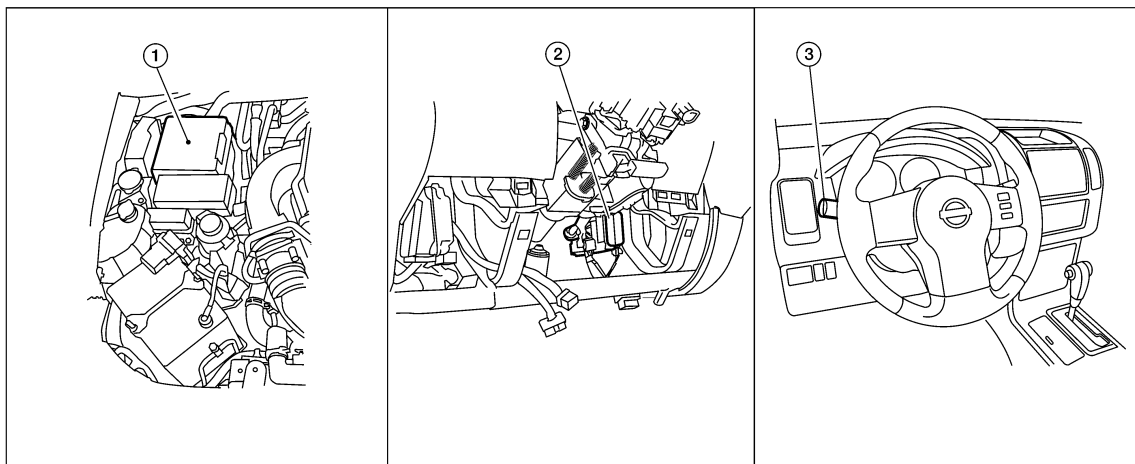

AWLIA0732ZZ

1. IPDM E/R E121, E122, E123, E124
2. BCM M18, M20 (view with lower instrument panel LH removed)
3. Combination switch (lighting and turn signal switch) M28

PARKING, LICENSE PLATE AND TAIL LAMPS

< FUNCTION DIAGNOSIS >

Component Description

INFOID:000000004056453

Part name	Description
BCM	<ul style="list-style-type: none">• Recieves lighting switch requests via BCM combination switch reading function.• Sends parking light request signal to the IPDM E/R.
IPDM E/R	Activates the tail lamp relay upon request of the BCM.
Combination switch (lighting switch)	Outputs lighting requests to the BCM.

A

B

C

D

E

F

G

H

I

J

K

EXL

M

N

O

P

COMBINATION SWITCH READING SYSTEM

< FUNCTION DIAGNOSIS >

COMBINATION SWITCH READING SYSTEM

System Diagram

INFOID:000000004454813

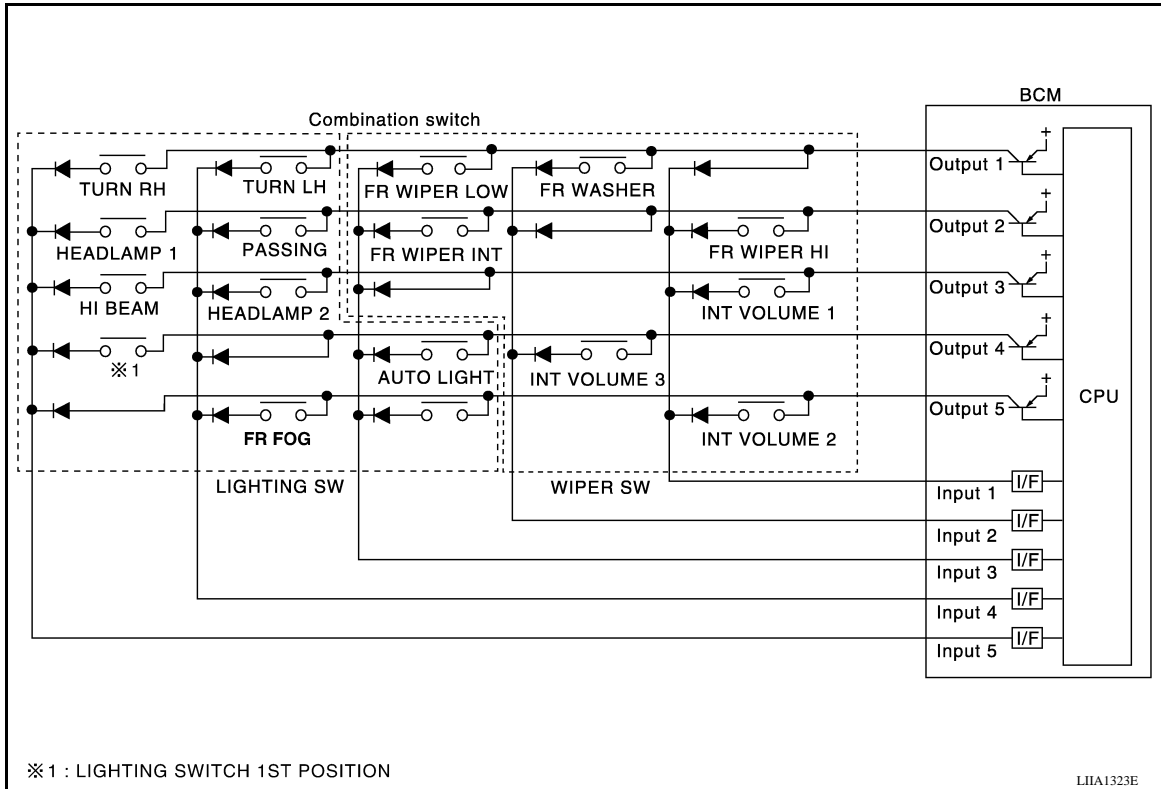

System Description

INFOID:000000004454814

OUTLINE

- BCM reads the status of the combination switch (light, turn signal, wiper and washer) and recognizes the status of each switch.
- BCM is a combination of 5 output terminals (OUTPUT 1 - 5) and 5 input terminals (INPUT 1 - 5). It reads a maximum of 20 switch status.

COMBINATION SWITCH MATRIX

COMBINATION SWITCH READING SYSTEM

< FUNCTION DIAGNOSIS >

Combination switch circuit

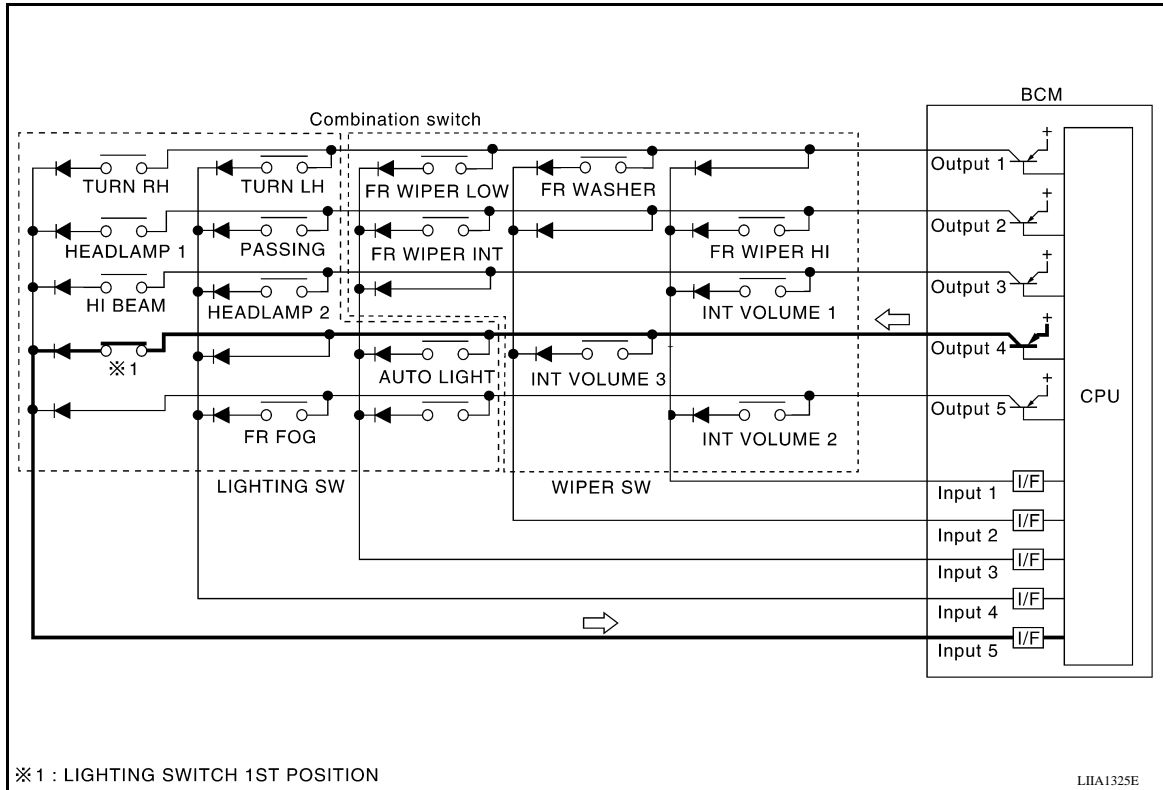

Combination switch INPUT-OUTPUT system list

System	OUTPUT 1	OUTPUT 2	OUTPUT 3	OUTPUT 4	OUTPUT 5
INPUT 1	—	FR WASHER	FR WIPER LOW	TURN LH	TURN RH
INPUT 2	FR WIPER HI	—	FR WIPER INT	PASSING	HEADLAMP 1
INPUT 3	INT VOLUME 1	—	—	HEADLAMP 2	HI BEAM
INPUT 4	—	INT VOLUME 3	AUTO LIGHT	—	TAIL LAMP
INPUT 5	INT VOLUME 2	—	—	FR FOG	—

NOTE:

Headlamp has a dual system switch.

COMBINATION SWITCH READING FUNCTION

Description

- BCM reads the status of the combination switch at 10ms interval normally.

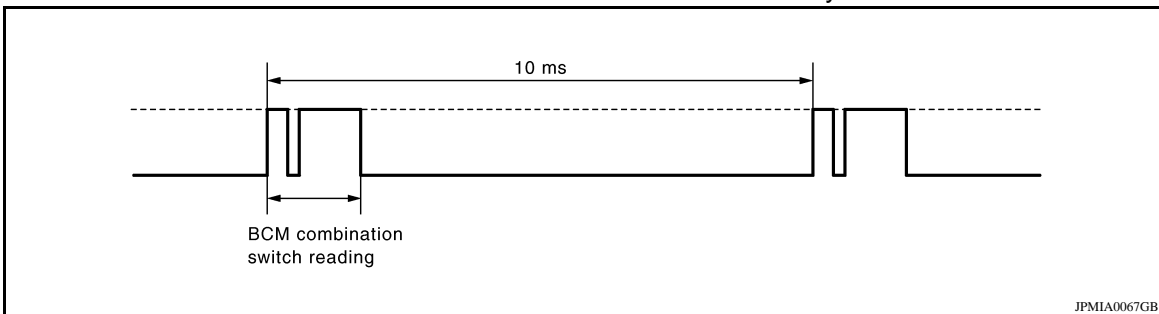

NOTE:

BCM reads the status of the combination switch at 20ms interval when BCM is controlled at low power consumption control mode.

- BCM operates as follows and judges the status of the combination switch.
 - INPUT 1 - 5 outputs the voltage waveforms of 5 systems simultaneously.
 - It operates the transistor on OUTPUT side in the following order: OUTPUT 5 → 4 → 3 → 2 → 1.

COMBINATION SWITCH READING SYSTEM

< FUNCTION DIAGNOSIS >

- The voltage waveform of INPUT corresponding to the formed circuit changes according to the operation of the transistor on OUTPUT side if any (1 or more) switches are ON.
- It reads this change of the voltage as the status signal of the combination switch.

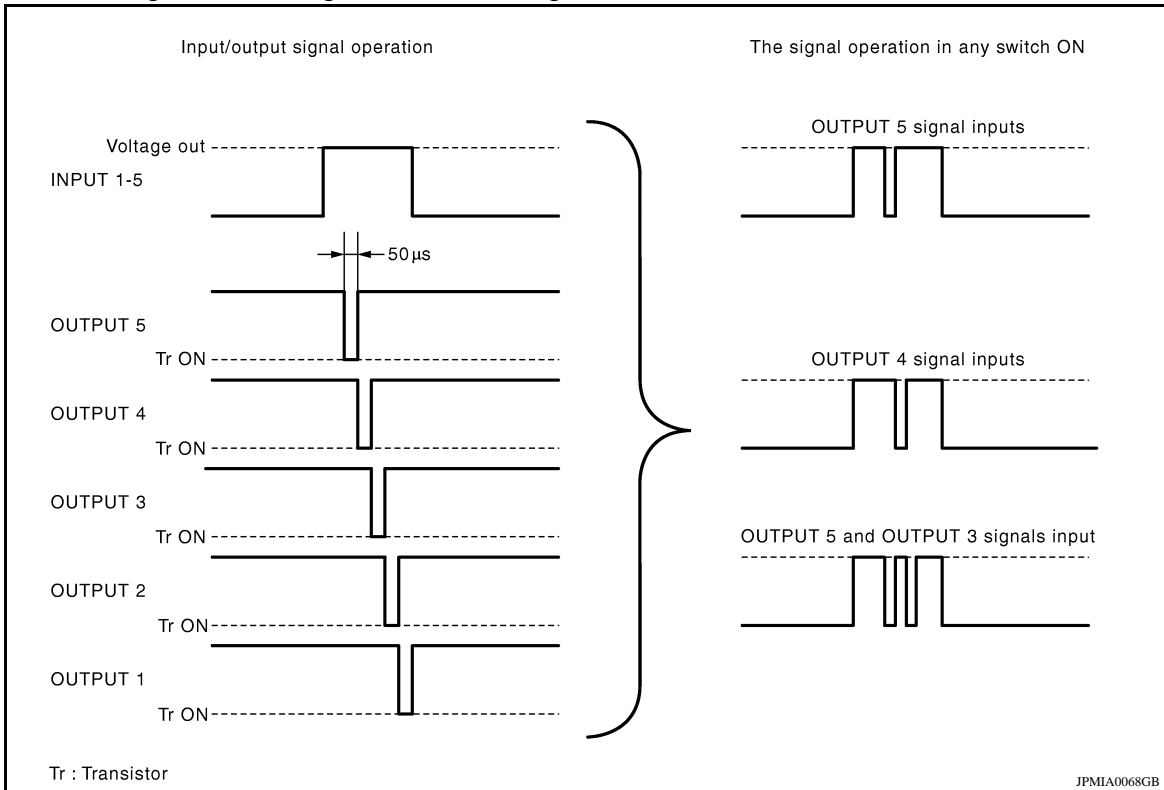

Operation Example

In the following operation example, the combination of the status signals of the combination switch is replaced as follows: INPUT 1 - 5 to "1 - 5" and OUTPUT 1 - 5 to "A - E".

Example 1: When a switch (TURN RH switch) is turned ON

- The circuit between INPUT 1 and OUTPUT 5 is formed when the TURN RH switch is turned ON.

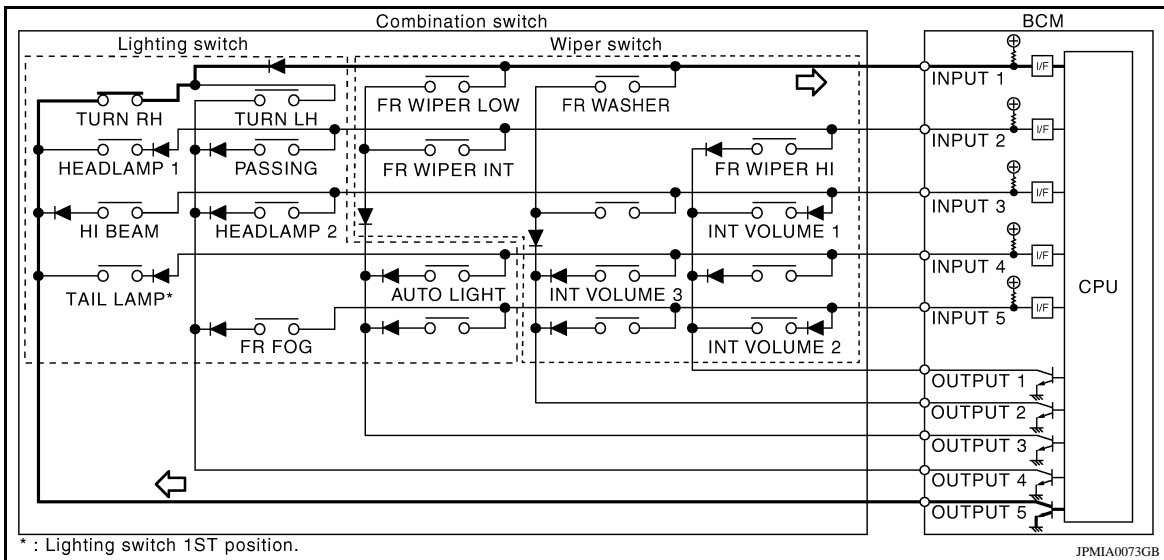

- BCM detects the combination switch status signal "1E" when the signal of OUTPUT 5 is input to INPUT 1.
- BCM judges that the TURN RH switch is ON when the signal "1E" is detected.

Example 2: When some switches (turn RH switch, front wiper LO switch) are turned ON

COMBINATION SWITCH READING SYSTEM

< FUNCTION DIAGNOSIS >

- The circuits between INPUT 1 and OUTPUT 5 and between INPUT 1 and OUTPUT 3 are formed when the TURN RH switch and FR WIPER LOW switch are turned ON.

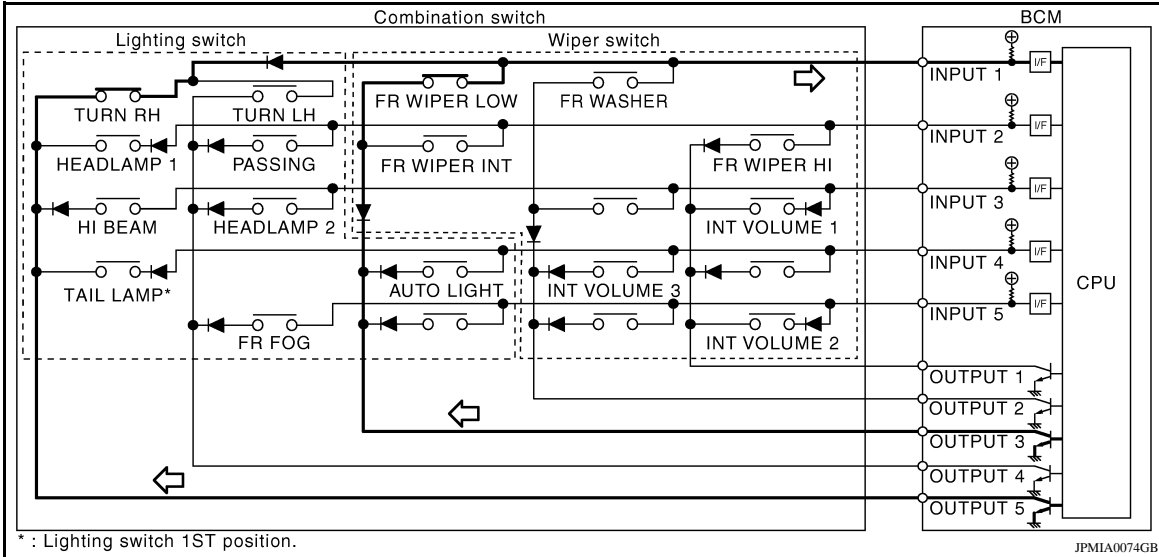

- BCM detects the combination switch status signal "1CE" when the signals of OUTPUT 3 and OUTPUT 5 are input to INPUT 1.
- BCM judges that the TURN RH switch and FR WIPER LOW switch are ON when the signal "1CE" is detected.

WIPER INTERMITTENT DIAL POSITION SETTING (FRONT WIPER INTERMITTENT OPERATION)

BCM judges the wiper intermittent dial 1 - 7 by the status of INT VOLUME 1, 2 and 3 switches.

Wiper intermittent dial position	Intermittent operation delay interval	INT VOLUME switch ON/OFF status		
		INT VOLUME 1 switch	INT VOLUME 2 switch	INT VOLUME 3 switch
1	Short ↑	ON	ON	ON
2		ON	ON	OFF
3		ON	OFF	OFF
4		OFF	OFF	OFF
5	↓ Long	OFF	OFF	ON
6		OFF	ON	ON
7		OFF	ON	OFF

Component Parts Location

INFOID:000000004454815

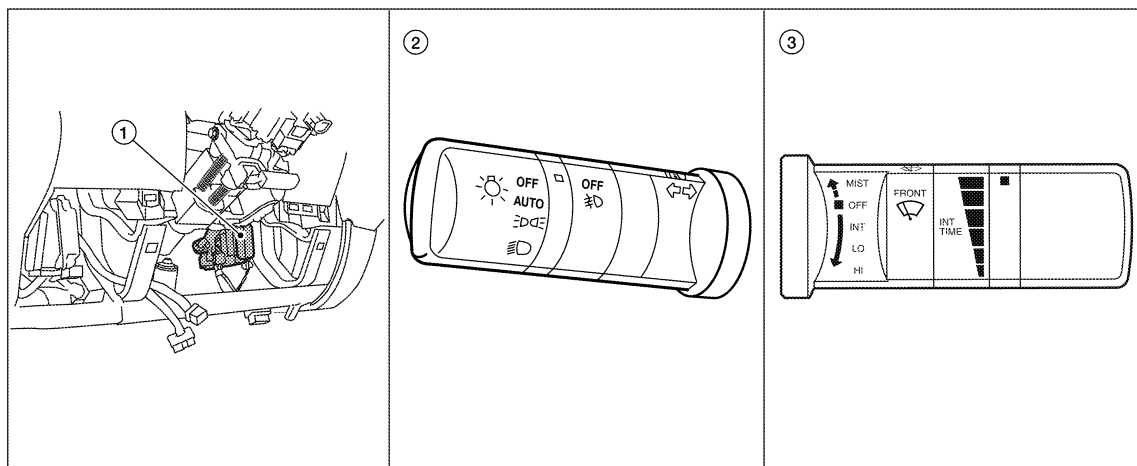

AL-MIA0416ZZ

COMBINATION SWITCH READING SYSTEM

< FUNCTION DIAGNOSIS >

1. BCM M18, M19, M20 (view with lower instrument panel LH removed)
2. Combination switch (lighting and turn signal switch) M28
3. Combination switch (wiper and washer switch) M28

DIAGNOSIS SYSTEM (BCM)

< FUNCTION DIAGNOSIS >

DIAGNOSIS SYSTEM (BCM)

HEADLAMP

HEADLAMP : CONSULT-III Function (BCM - HEAD LAMP)

INFOID:000000004454816

WORK SUPPORT

Work Item	Setting item	Setting
BATTERY SAVER SET	ON*	With the exterior lamp battery saver function
	OFF	Without the exterior lamp battery saver function

*: Initial setting

DATA MONITOR

Monitor Item [Unit]	Description
IGN ON SW [ON/OFF]	Ignition switch (ON) status judged from IGN signal (ignition power supply)
ACC ON SW [ON/OFF]	Ignition switch (ACC) status judged from ACC signal (accessory power supply)
HI BEAM SW [ON/OFF]	Each switch status that BCM judges from the combination switch reading function
HEAD LAMP SW 1 [ON/OFF]	
HEAD LAMP SW 2 [ON/OFF]	
LIGHT SW 1ST [ON/OFF]	
AUTO LIGHT SW [ON/OFF]	
PASSING SW [ON/OFF]	
FR FOG SW [ON/OFF]	
RR FOG SW [ON/OFF]*	
TURN SIGNAL R [ON/OFF]	
TURN SIGNAL L [ON/OFF]	
DOOR SW-DR [ON/OFF]	The switch status input from front door switch LH
DOOR SW-AS [ON/OFF]	The switch status input from front door switch RH
DOOR SW-RR [ON/OFF]	The switch status input from rear door switch RH
DOOR SW-RL [ON/OFF]	The switch status input from rear door switch LH
BACK DOOR SW [ON/OFF]	The switch status input from back door switch
CARGO LAMP SW [ON/OFF]	Cargo lamp status that BCM judges from the vehicle condition
OPTICAL SENSOR [ON/OFF]	The value of exterior brightness voltage input from the optical sensor

*: The item is indicated, not monitored.

ACTIVE TEST

Test Item	Operation	Description
TAIL LAMP	ON	Transmits the position light request signal to IPDM E/R with CAN communication to turn the tail lamp ON.
	OFF	Stops the tail lamp request signal transmission.
HEAD LAMP	HI	Transmits the high beam request signal with CAN communication to turn the headlamp (HI).
	LO	Transmits the low beam request signal with CAN communication to turn the headlamp (LO).
	OFF	Stops the high & low beam request signal transmission.

DIAGNOSIS SYSTEM (BCM)

< FUNCTION DIAGNOSIS >

Test Item	Operation	Description
FR FOG LAMP	ON	Transmits the front fog lights request signal to IPDM E/R with CAN communication to turn the front fog lamp ON.
	OFF	Stops the front fog lights request signal transmission.
CARGO LAMP	ON	Transmits the cargo lamp request signal to IPDM E/R with CAN communication to turn the each lamp ON.
	OFF	Stops the day time running light request signal transmission.
CORNERING LAMP*	RH	—
	LH	
	OFF	

*: The item is indicated, not monitored.

FLASHER

FLASHER : CONSULT-III Function (BCM - FLASHER)

INFOID:000000004454817

DATA MONITOR

Monitor Item [Unit]	Description
IGN ON SW [ON/OFF]	Ignition switch (ON) status judged from IGN signal (ignition power supply)
HAZARD SW [ON/OFF]	The switch status input from the hazard switch
TURN SIGNAL R [ON/OFF]	Each switch condition that BCM judges from the combination switch reading function
TURN SIGNAL L [ON/OFF]	
BRAKE SW [ON/OFF]	The switch status input from the brake switch

ACTIVE TEST

Test Item	Operation	Description
FLASHER	RH	Outputs the voltage to turn the right side turn signal lamps ON.
	LH	Outputs the voltage to turn the left side turn signal lamps ON.
	OFF	Stops the voltage to turn the turn signal lamps OFF.

COMB SW

COMB SW : CONSULT-III Function (BCM - COMB SW)

INFOID:000000004454818

DATA MONITOR

Monitor Item [Unit]	Description
TURN SIGNAL R [OFF/ON]	Displays the status of the TURN RH switch in combination switch judged by BCM with the combination switch reading function
TURN SIGNAL L [OFF/ON]	Displays the status of the TURN LH switch in combination switch judged by BCM with the combination switch reading function
HI BEAM SW [OFF/ON]	Displays the status of the HI BEAM switch in combination switch judged by BCM with the combination switch reading function
HEADLAMP SW1 [OFF/ON]	Displays the status of the HEADLAMP switch in combination switch judged by BCM with the combination switch reading function
HEADLAMP SW2 [OFF/ON]	Displays the status of the HEADLAMP switch in combination switch judged by BCM with the combination switch reading function
LIGHT SW 1ST [OFF/ON]	Displays the status of the HEADLAMP switch in combination switch judged by BCM with the combination switch reading function

DIAGNOSIS SYSTEM (BCM)

< FUNCTION DIAGNOSIS >

Monitor Item [Unit]	Description
PASSING SW [OFF/ON]	Displays the status of the PASSING switch in combination switch judged by BCM with the combination switch reading function
AUTO LIGHT SW [OFF/ON]	Displays the status of the AUTO LIGHT switch in combination switch judged by BCM with the combination switch reading function
FR FOG SW [OFF/ON]	Displays the status of the FR FOG switch in combination switch judged by BCM with the combination switch reading function
RR FOG SW* [OFF/ON]	—
FR WIPER HI [OFF/ON]	Displays the status of the FR WIPER HI switch in combination switch judged by BCM with the combination switch reading function
FR WIPER LOW [OFF/ON]	Displays the status of the FR WIPER LOW switch in combination switch judged by BCM with the combination switch reading function
FR WIPER INT [OFF/ON]	Displays the status of the FR WIPER INT switch in combination switch judged by BCM with the combination switch reading function
FR WASHER SW [OFF/ON]	Displays the status of the FR WASHER switch in combination switch judged by BCM with the combination switch reading function
INT VOLUME [1 - 7]	Displays the status of wiper intermittent dial position judged by BCM with the combination switch reading function
RR WIPER ON* [OFF/ON]	—
RR WIPER INT* [OFF/ON]	—
RR WASHER SW* [OFF/ON]	—

*: The item is indicated, not monitored.

BATTERY SAVER

BATTERY SAVER : CONSULT-III Function (BCM - BATTERY SAVER)

INFOID:000000004454819

WORK SUPPORT

Work Item	Setting Item	Setting	
ROOM LAMP TIMER SET	MODE 1*	15 min.	Sets the interior room lamp battery saver timer operating time.
	MODE 2	30 min.	

*: Initial setting

DATA MONITOR

Monitor Item [Unit]	Description
IGN ON SW [ON/OFF]	Ignition switch (ON) status judges from IGN signal (ignition power supply)
KEY ON SW [ON/OFF]	The switch status input from key switch
DOOR SW-DR [ON/OFF]	The switch status input from front door switch (driver side)
DOOR SW-AS [ON/OFF]	The switch status input from front door switch (passenger side)
DOOR SW-RR [ON/OFF]	The switch status input from rear door switch RH
DOOR SW- RL [ON/OFF]	The switch status input from rear door switch LH
BACK DOOR SW	NOTE: This is displayed even when it is not equipped
KEY CYL LK-SW [ON/OFF]	Lock switch status input from door key cylinder switch
KEY CYL UN-SW [ON/OFF]	Unlock switch status input from door key cylinder switch

DIAGNOSIS SYSTEM (BCM)

< FUNCTION DIAGNOSIS >

Monitor Item [Unit]	Description
CDL LOCK SW [ON/OFF]	Lock switch status input from door lock and unlock switch
CDL UNLOCK SW [ON/OFF]	Unlock switch status input from door lock and unlock switch
KEYLESS LOCK [ON/OFF]	Lock signal status received from remote keyless entry receiver (integrated in the BCM)
KEYLESS UNLOCK [ON/OFF]	Unlock signal status received from remote keyless entry receiver (integrated in the BCM)

ACTIVE TEST

Test Item	Operation	Description
BATTERY SAVER	OFF	Cuts the interior room lamp power supply to turn interior room lamps OFF.
	ON	Outputs the interior room lamp power supply to turn interior room lamps ON.*

*: Each lamp switch is in ON position.

DIAGNOSIS SYSTEM (IPDM E/R)

< FUNCTION DIAGNOSIS >

DIAGNOSIS SYSTEM (IPDM E/R)

Diagnosis Description

INFOID:000000004454820

AUTO ACTIVE TEST

Description

In auto active test mode, the IPDM E/R sends a drive signal to the following systems to check their operation.

- Oil pressure low warning indicator
- Oil pressure gauge (if equipped)
- Rear window defogger
- Front wipers
- Tail, license and parking lamps
- Front fog lamps (if equipped)
- Headlamps (Hi, Lo)
- A/C compressor (magnetic clutch) (if equipped)
- Cooling fan

Operation Procedure

1. Close the hood and front door RH, and lift the wiper arms from the windshield (to prevent windshield damage due to wiper operation).
NOTE:
When auto active test is performed with hood opened, sprinkle water on windshield before hand.
2. Turn ignition switch OFF.
3. Turn the ignition switch ON and, within 20 seconds, press the front door switch LH 10 times. Then turn the ignition switch OFF.
4. Turn the ignition switch ON within 10 seconds. After that the horn sounds once and the auto active test starts.
5. After a series of the following operations is repeated 3 times, auto active test is completed.

NOTE:

When auto active test mode has to be cancelled halfway through test, turn ignition switch OFF.

CAUTION:

- If auto active test mode cannot be actuated, check door switch system. Refer to [DLK-27, "KING CAB : Description"](#) or [DLK-29, "CREW CAB : Description"](#).
- Do not start the engine.

Inspection in Auto Active Test Mode

When auto active test mode is actuated, the following 7 steps are repeated 3 times.

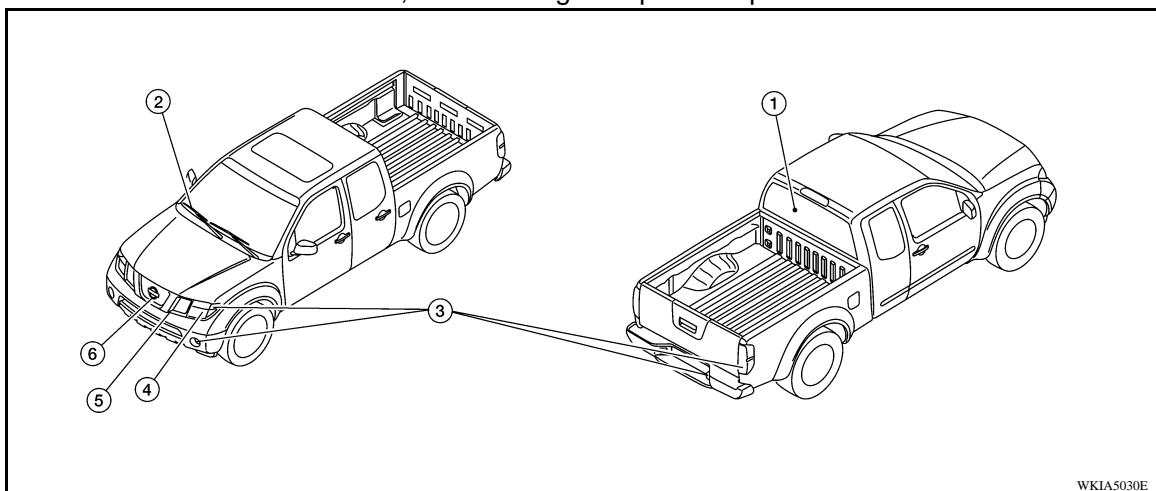

Item Number	Test Item	Operation Time/Frequency
1	Rear window defogger (Crew cab only)	10 seconds
2	Front wipers	LOW 5 seconds then HIGH 5 seconds
3	Tail, license plate, front fog and parking lamps	10 seconds

A
B
C
D
E
F
G
H
I
J
K
EXL
M
N
O
P

DIAGNOSIS SYSTEM (IPDM E/R)

< FUNCTION DIAGNOSIS >

Item Number	Test Item	Operation Time/Frequency
4	Headlamps	Low ON for 10 seconds, then High ON-OFF five times.
5	A/C compressor (magnet clutch) (if equipped)	ON-OFF 5 times
6	Cooling fan	LOW 5 seconds then HIGH 5 seconds

Concept of auto active test

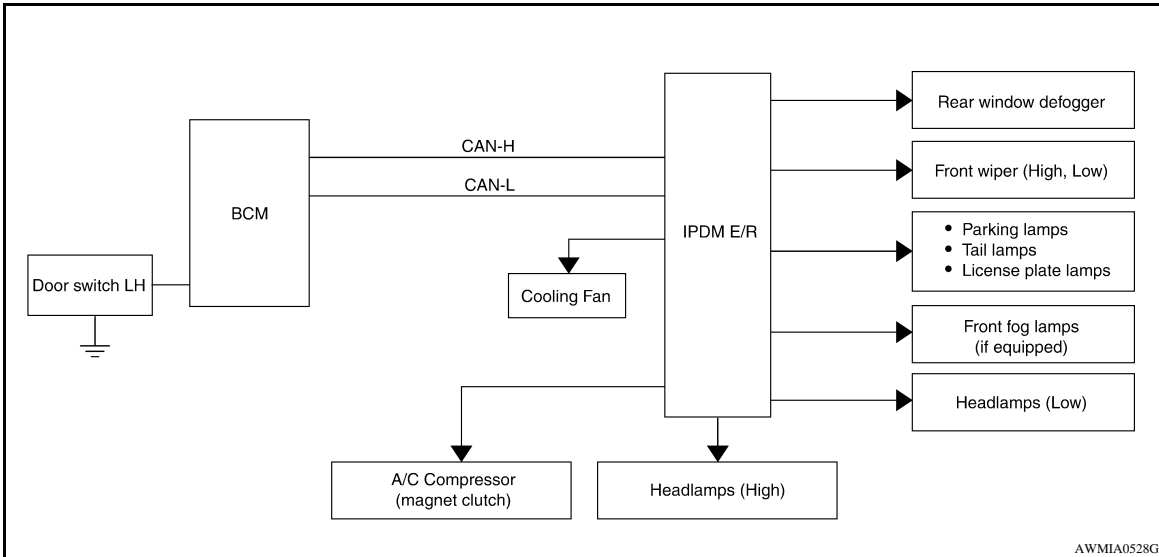

- IPDM E/R starts the auto active test with the door switch signals transmitted by BCM via CAN communication. Therefore, the CAN communication line between IPDM E/R and BCM is considered normal if the auto active test starts successfully.
- The auto active test facilitates troubleshooting if any systems controlled by IPDM E/R cannot be operated.

Diagnosis chart in auto active test mode

Symptom	Inspection contents	Possible cause
Oil pressure low warning indicator does not operate	Perform auto active test. Does the oil pressure low warning indicator operate?	YES • IPDM E/R signal input circuit • ECM signal input circuit • CAN communication signal between ECM and combination meter
		NO • CAN communication signal between IPDM E/R, BCM and combination meter
Oil pressure gauge does not operate	Perform auto active test. Does the oil pressure gauge operate?	YES IPDM E/R signal input circuit
		NO • CAN communication signal between IPDM E/R, BCM and combination meter
Rear window defogger does not operate	Perform auto active test. Does the rear window defogger operate?	YES BCM signal input circuit
		NO • Harness or connector between A/C and AV switch assembly and AV control unit • CAN communication signal between BCM and IPDM E/R

DIAGNOSIS SYSTEM (IPDM E/R)

< FUNCTION DIAGNOSIS >

Symptom	Inspection contents	Possible cause	
Any of the following components do not operate <ul style="list-style-type: none"> • Front wipers • Tail lamps • License plate lamps • Parking lamps • Front fog lamps (if equipped) • Headlamps (Hi, Lo) 	Perform auto active test. Does the applicable system operate?	YES	BCM signal input system
		NO	<ul style="list-style-type: none"> • Lamp or front wiper motor malfunction • Lamp or front wiper motor ground circuit • Harness or connector between IPDM E/R and applicable system • IPDM E/R (integrated relay malfunction)
A/C compressor does not operate	Perform auto active test. Does the A/C compressor operate?	YES	<ul style="list-style-type: none"> • BCM signal input circuit • CAN communication signal between BCM and ECM • CAN communication signal between ECM and IPDM E/R
		NO	<ul style="list-style-type: none"> • Magnetic clutch malfunction • Harness or connector between IPDM E/R and magnetic clutch • IPDM E/R (integrated relay malfunction)
Cooling fan does not operate	Perform auto active test. Does the cooling fan operate?	YES	<ul style="list-style-type: none"> • ECM signal input circuit • CAN communication signal between ECM and IPDM E/R
		NO	<ul style="list-style-type: none"> • Cooling fan motor malfunction • Harness or connector between IPDM E/R and cooling fan • IPDM E/R (integrated relay malfunction)

CONSULT - III Function (IPDM E/R)

INFOID:000000004454821

APPLICATION ITEM

CONSULT-III performs the following functions via CAN communication with IPDM E/R.

Diagnosis mode	Description
ECU Identification	Allows confirmation of IPDM E/R part number.
Self Diagnostic Result	Displays the diagnosis results judged by IPDM E/R.
Data Monitor	Displays the real-time input/output data from IPDM E/R input/output data.
Active Test	IPDM E/R can provide a drive signal to electronic components to check their operations.
CAN Diag Support Monitor	The results of transmit/receive diagnosis of CAN communication can be read.

SELF DIAGNOSTIC

Refer to [PCS-32, "DTC Index"](#).

DATA MONITOR

Monitor item

DIAGNOSIS SYSTEM (IPDM E/R)

< FUNCTION DIAGNOSIS >

Monitor Item [Unit]	MAIN SIG- NALS	Description
MOTOR FAN REQ [1/2/3/4]	×	Displays the status of the cooling fan speed request signal received from ECM via CAN communication.
A/C COMP REQ [OFF/ON]	×	Displays the status of the A/C request signal received from BCM via CAN communication.
TAIL&CLR REQ [OFF/ON]	×	Displays the status of the position light request signal received from BCM via CAN communication.
HL LO REQ [OFF/ON]	×	Displays the status of the low beam request signal received from BCM via CAN communication.
HL HI REQ [OFF/ON]	×	Displays the status of the high beam request signal received from BCM via CAN communication.
FR FOG REQ [OFF/ON]	×	Displays the status of the front fog lamp request signal received from BCM via CAN communication.
HL WASHER REQ [OFF/ON]		NOTE: This item is displayed, but cannot be monitored.
FR WIP REQ [STOP/1LOW/LOW/HI]	×	Displays the status of the front wiper request signal received from BCM via CAN communication.
WIP AUTO STOP [STOP P/ACT P]	×	Displays the status of the front wiper auto stop signal judged by IPDM E/R.
WIP PROT [OFF/Block]	×	Displays the status of the front wiper fail-safe operation judged by IPDM E/R.
ST RLY REQ [OFF/ON]		Displays the status of the starter request signal received from ECM via CAN communication.
IGN RLY [OFF/ON]	×	Displays the status of the ignition relay judged by IPDM E/R.
RR DEF REQ [OFF/ON]	×	Displays the status of the rear defogger request signal received from AV control unit via CAN communication.
OIL P SW [OPEN/CLOSE]		Displays the status of the oil pressure switch judged by IPDM E/R.
DTRL REQ [OFF]		NOTE: This item is displayed, but cannot be monitored.
HOOD SW [OPEN/CLOSE]		NOTE: This item is displayed, but cannot be monitored.
THFT HRN REQ [OFF/ON]		Displays the status of the theft warning horn request signal received from BCM via CAN communication.
HORN CHIRP [OFF/ON]		Displays the status of the horn reminder signal received from BCM via CAN communication.

ACTIVE TEST

Test item

Test item	Operation	Description
REAR DEFOGGER	OFF	OFF
	ON	Operates rear window defogger relay.
FRONT WIPER	OFF	OFF
	LO	Operates the front wiper relay.
	HI	Operates the front wiper relay and front wiper high relay.
HEAD LAMP WASHER	ON	—

DIAGNOSIS SYSTEM (IPDM E/R)

< FUNCTION DIAGNOSIS >

Test item	Operation	Description	
MOTOR FAN	1	OFF	A
	2	OFF	
	3	Operates the cooling fan relay.	B
	4	Operates the cooling fan relay.	
EXTERNAL LAMPS	OFF	OFF	C
	TAIL	Operates the tail lamp relay.	
	LO	Operates the headlamp low relay.	D
	HI	Operates the headlamp low relay and the headlamp (LH/RH) high relays alternately at 1 second intervals.	
	FOG	Operates the front fog lamp relay	E
HORN	ON	Operates horn relay for 20 ms.	

A
B
C
D
E
F
G
H
I
J
K
L
M
N
O
P

EXL

POWER SUPPLY AND GROUND CIRCUIT

< COMPONENT DIAGNOSIS >

COMPONENT DIAGNOSIS

POWER SUPPLY AND GROUND CIRCUIT

BCM (BODY CONTROL MODULE)

BCM (BODY CONTROL MODULE) : Diagnosis Procedure

INFOID:000000004454823

1. CHECK FUSES AND FUSIBLE LINK

Check that the following fuses and fusible link are not blown.

Terminal No.	Signal name	Fuses and fusible link No.
57	Battery power supply	18 (10A)
70		G (50A)
11	Ignition ACC or ON	4 (10A)
38	Ignition ON or START	1 (10A)

Is the fuse blown?

YES >> Replace the blown fuse or fusible link after repairing the affected circuit.

NO >> GO TO 2

2. CHECK POWER SUPPLY CIRCUIT

- Turn ignition switch OFF.
- Disconnect BCM.
- Check voltage between BCM harness connector and ground.

Connector	Terminals		Power source	Condition	Voltage (V) (Approx.)
	(+)	(-)			
M18	11	Ground	ACC power supply	Ignition switch ACC or ON	Battery voltage
	38	Ground	Ignition power supply	Ignition switch ON or START	Battery voltage
M20	57	Ground	Battery power supply	Ignition switch OFF	Battery voltage
	70	Ground	Battery power supply	Ignition switch OFF	Battery voltage

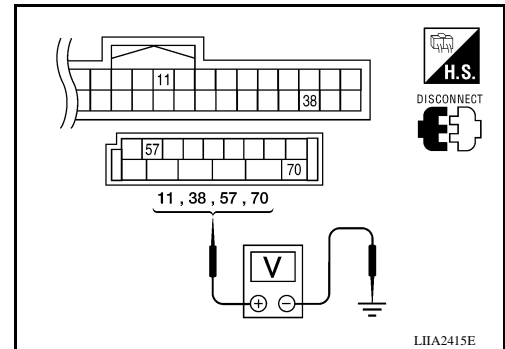

Is the measurement value normal?

YES >> GO TO 3

NO >> Repair or replace harness.

3. CHECK GROUND CIRCUIT

Check continuity between BCM harness connector and ground.

BCM		Ground	Continuity
Connector	Terminal		
M20	67		Yes

Does continuity exist?

YES >> Inspection End.

NO >> Repair or replace harness.

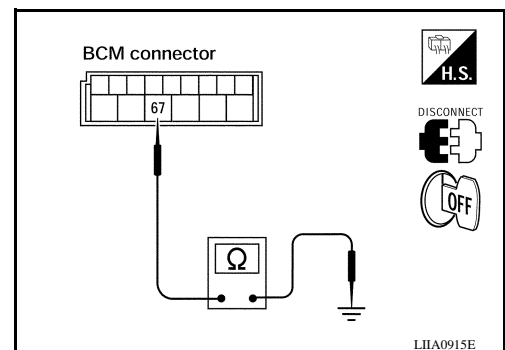

POWER SUPPLY AND GROUND CIRCUIT

< COMPONENT DIAGNOSIS >

IPDM E/R (INTELLIGENT POWER DISTRIBUTION MODULE ENGINE ROOM)

IPDM E/R (INTELLIGENT POWER DISTRIBUTION MODULE ENGINE ROOM) : Diagnosis Procedure

INFOID:000000004454822

1. CHECK FUSIBLE LINKS

Check that the following IPDM E/R fusible links are not blown.

Terminal No.	Signal name	Fusible link No.
1	Battery	A, D
2		C
22		I

Is the fusible link blown?

YES >> Replace the blown fusible link after repairing the affected circuit.

NO >> GO TO 2

2. CHECK BATTERY POWER SUPPLY CIRCUIT

1. Turn ignition switch OFF.
2. Disconnect IPDM E/R.
3. Check voltage between IPDM E/R harness connectors and ground.

Terminals		Ignition switch position	Voltage (V) (Approx.)
(+)			
Connector	Terminal		
E118 (A)	1	Ground	Battery voltage
	2		
E120 (B)	22	OFF	

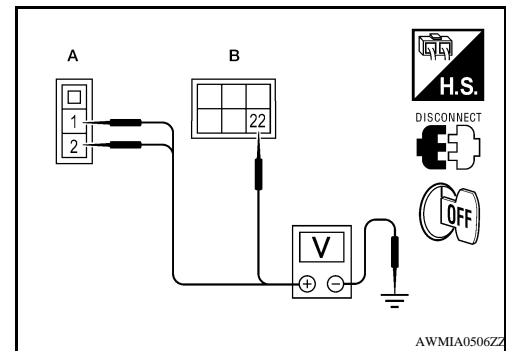

Is there voltage on all pins?

YES >> GO TO 3

NO >> Repair or replace harness.

3. CHECK GROUND CIRCUIT

1. Turn ignition switch OFF.
2. Check continuity between IPDM E/R harness connectors and ground.

IPDM E/R		Ground	Continuity
Connector	Terminal		
E122 (A)	38	Ground	Yes
E124 (B)	59		

Does continuity exist?

YES >> Inspection End.

NO >> Repair or replace harness.

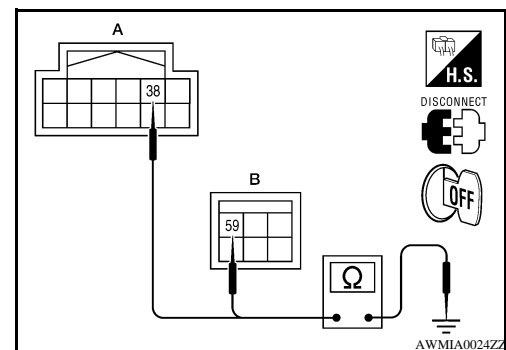

HEADLAMP (HI) CIRCUIT

< COMPONENT DIAGNOSIS >

HEADLAMP (HI) CIRCUIT

Description

INFOID:000000004056468

The IPDM E/R (intelligent power distribution module engine room) controls the headlamp high relay based on inputs from the BCM via the CAN communication lines. When the headlamp high relay is energized, power flows through fuses 34 and 35, located in the IPDM E/R. Power then flows to the front combination lamps to the headlamp high beam.

Component Function Check

INFOID:000000004056469

1. CHECK HEADLAMP (HI) OPERATION

⊗ WITHOUT CONSULT-III

1. Start IPDM E/R auto active test. Refer to [PCS-13, "Diagnosis Description"](#).

2. Check that the headlamp switches to the high beam.

NOTE:

HI/LO is repeated 1 second each when using the IPDM E/R auto active test.

ⓑ CONSULT-III

1. Select "EXTERNAL LAMP" of IPDM E/R active test item.

2. With the test item operating, check that the headlamp switches to high beam.

HI : Headlamp switches to the high beam.

OFF : Headlamp OFF

Does the headlamp switch to high beam?

YES >> Headlamp (HI) circuit is normal.

NO >> Refer to [EXL-36, "Diagnosis Procedure"](#).

Diagnosis Procedure

INFOID:000000004056470

1. CHECK HEADLAMP (HI) FUSES

1. Turn the ignition switch OFF.

2. Check that the following fuses are not open.

Unit	Location	Fuse No.	Capacity
Headlamp HI (LH)	IPDM E/R	34	10A
Headlamp HI (RH)	IPDM E/R	35	10A

Is the fuse open?

YES >> Repair the harness and replace the fuse.

NO >> GO TO 2

2. CHECK HEADLAMP (HI) OUTPUT VOLTAGE

1. Turn the ignition switch OFF.

2. Disconnect the front combination lamp connector E11 or E107.

3. Turn the ignition switch ON.

4. Turn the high beam headlamps ON.

5. With the high beam headlamps ON, check the voltage between the combination lamp connector and ground.

(+) Connector		Terminal	(-)	Voltage
LH	E11	1	Ground	Battery voltage
RH	E107	1		

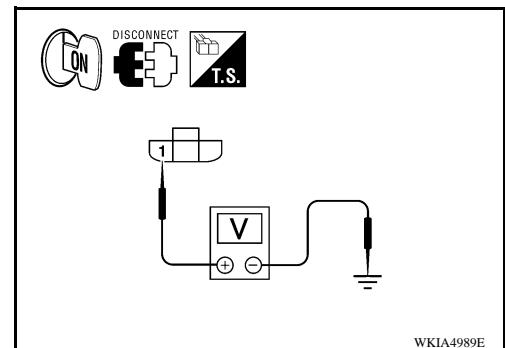

Is battery voltage present?

YES >> GO TO 4

NO >> GO TO 3

HEADLAMP (HI) CIRCUIT

< COMPONENT DIAGNOSIS >

3. CHECK HEADLAMP (HI) CIRCUIT FOR OPEN

1. Turn the ignition switch OFF.
2. Disconnect IPDM E/R connector E123.
3. Check continuity between the IPDM E/R harness connector (A) and the front combination lamp harness connector (B).

A		Terminal	B		Continuity
Connector			Connector	Terminal	
LH	E123	55	E11	1	Yes
RH		56	E107	1	

Does continuity exist?

YES >> GO TO 4

NO >> Repair the harnesses or connectors.

4. CHECK FRONT COMBINATION LAMP (HI) GROUND CIRCUIT

Check continuity between the front combination lamp harness connector terminal and ground.

Connector	Terminal	—	Continuity
LH	E11	Ground	Yes
RH	E107		

Does continuity exist?

YES >> Inspect the headlamp bulb.

NO >> Repair the harness.

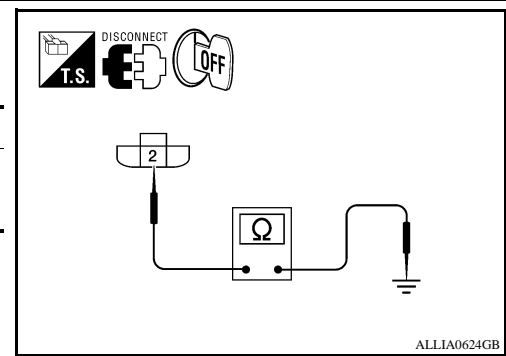
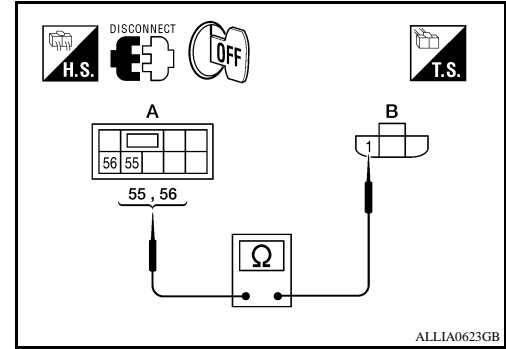

A
B
C
D
E
F
G
H
I
J
K
L
M
N
O
P

EXL

HEADLAMP (LO) CIRCUIT

< COMPONENT DIAGNOSIS >

HEADLAMP (LO) CIRCUIT

Description

INFOID:000000004056471

The IPDM E/R (intelligent power distribution module engine room) controls the headlamp low relay based on inputs from the BCM via the CAN communication lines. When the headlamp low relay is energized, power flows through fuses 40 and 41, located in the IPDM E/R. Power then flows to the front combination lamps to the headlamp low beam.

Component Function Check

INFOID:000000004056472

1. CHECK HEADLAMP (LO) OPERATION

⊗ WITHOUT CONSULT-III

1. Start IPDM E/R auto active test. Refer to [PCS-13, "Diagnosis Description"](#).
2. Check that the headlamp is turned ON.

NOTE:

HI/LO is repeated 1 second each when using the IPDM E/R auto active test.

Ⓢ CONSULT-III

1. Select "EXTERNAL LAMP" of IPDM E/R active test item.
2. With the test items operating, check that the headlamp is turned ON.

LO : Headlamp ON
OFF : Headlamp OFF

Is the headlamp turned ON?

- YES >> Headlamp (LO) is normal.
 NO >> Refer to [EXL-38, "Diagnosis Procedure"](#).

Diagnosis Procedure

INFOID:000000004056473

1. CHECK HEADLAMP (LO) FUSES

1. Turn the ignition switch OFF.
2. Check that the following fuses are not open.

Unit	Location	Fuse No.	Capacity
Headlamp LO (LH)	IPDM E/R	40	15A
Headlamp LO (RH)	IPDM E/R	41	15A

Is the fuse open?

- YES >> Repair the harness and replace the fuse.
 NO >> GO TO 2

2. CHECK HEADLAMP (LO) OUTPUT VOLTAGE

1. Turn the ignition switch OFF.
2. Disconnect the front combination lamp connector.
3. Turn the ignition switch ON.
4. Turn the low beam headlamps ON.
5. With the low beam headlamps ON, check the voltage between the combination lamp connector and ground.

(+) Connector		Terminal	(-)	Voltage
LH	E11	3	Ground	Battery voltage
RH	E107	3		

Is battery voltage present?

- YES >> GO TO 4
 NO >> GO TO 3

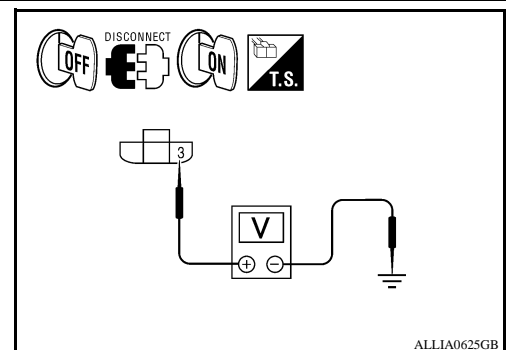

HEADLAMP (LO) CIRCUIT

< COMPONENT DIAGNOSIS >

3. CHECK HEADLAMP (LO) CIRCUIT FOR OPEN

1. Turn the ignition switch OFF.
2. Disconnect IPDM E/R connector.
3. Check continuity between the IPDM E/R harness connector and the front combination lamp harness connector.

A		B		Continuity
Connector	Terminal	Connector	Terminal	
LH	E123	52	E11	Yes
RH		54	E107	

Does continuity exist?

YES >> GO TO 4

NO >> Repair the harnesses or connectors.

4. CHECK FRONT COMBINATION LAMP (LO) GROUND CIRCUIT

Check continuity between the front combination lamp harness connector terminal and ground.

Connector	Terminal	—	Continuity
LH	E11	Ground	Yes
RH	E107		

Does continuity exist?

YES >> Inspect the headlamp bulb.

NO >> Repair the harness.

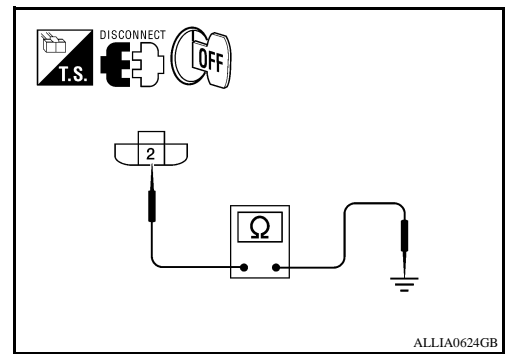
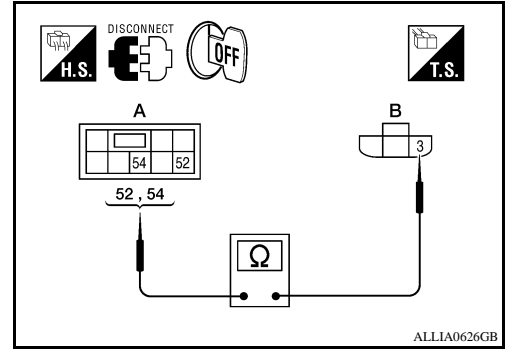

A
B
C
D
E
F
G
H
I
J
K
L
M
N
O
P

EXL

FRONT FOG LAMP CIRCUIT

< COMPONENT DIAGNOSIS >

FRONT FOG LAMP CIRCUIT

Description

INFOID:000000004056474

The IPDM E/R (intelligent power distribution module engine room) controls the front fog lamp relay based on inputs from the BCM via the CAN communication lines. When the front fog lamp relay is energized, power flows from the front fog lamp relay in the IPDM E/R to the front fog lamps.

Component Function Check

INFOID:000000004056475

1.CHECK FRONT FOG LAMP OPERATION

⊗WITHOUT CONSULT-III

1. Activate IPDM E/R auto active test. Refer to [PCS-13, "Diagnosis Description"](#).
2. Check that the front fog lamp is turned ON.

ⓅCONSULT-III

1. Select "EXTERNAL LAMP" of IPDM E/R active test item.
2. With operating the test items, Check that the front fog lamp is turned ON.

FOG : Front fog lamp ON
OFF : Front fog lamp OFF

Is the front fog lamp turned ON?

- YES >> Front fog lamp circuit is normal.
 NO >> Refer to [EXL-40, "Diagnosis Procedure"](#).

Diagnosis Procedure

INFOID:000000004056476

1.CHECK FRONT FOG LAMP FUSE

1. Turn the ignition switch OFF.
2. Check that the following fuses are not open.

Unit	Location	Fuse No.	Capacity
Front fog lamp	IPDM E/R	56	20A

Is the fuse open?

- YES >> Repair the harness and replace the fuse.
 NO >> GO TO 2

2.CHECK FRONT FOG LAMP OUTPUT VOLTAGE

1. Turn the ignition switch OFF.
2. Disconnect the front fog lamp connector.
3. Turn the ignition switch ON.
4. Turn the front fog lamps ON.
5. Check the voltage between the fog lamp connector and ground.

(+) Connector		Terminal	(-)	Voltage
LH	E101	1	Ground	Battery voltage
RH	E102	1		

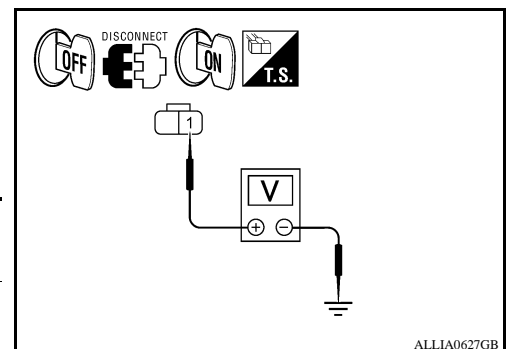

Is battery voltage present?

- YES >> GO TO 4
 NO >> GO TO 3

3.CHECK FRONT FOG LAMP OPEN CIRCUIT

FRONT FOG LAMP CIRCUIT

< COMPONENT DIAGNOSIS >

1. Turn the ignition switch OFF.
2. Disconnect IPDM E/R connector.
3. Check continuity between the IPDM E/R harness connector and the front fog lamp harness connector.

A		B		Continuity
Connector	Terminal	Connector	Terminal	
LH	E123	50	E101	Yes
RH		51	E102	

Does continuity exist?

YES >> GO TO 4

NO >> Repair the harnesses or connectors.

4. CHECK FRONT FOG LAMP GROUND CIRCUIT

1. Disconnect the front fog lamp connector.
2. Check continuity between the front fog lamp harness connector terminal and ground.

Connector	Terminal	—	Continuity
LH	E101	Ground	Yes
RH	E102		

Does continuity exist?

YES >> Inspect the fog lamp bulb.

NO >> Repair the harness.

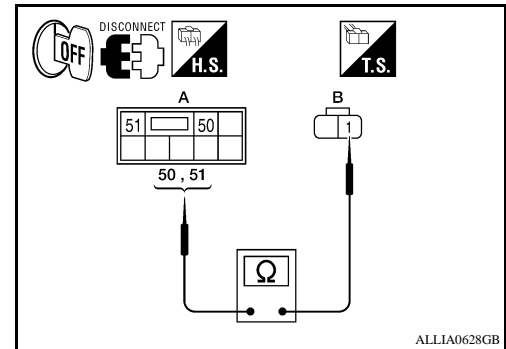

ALLIA0628GB

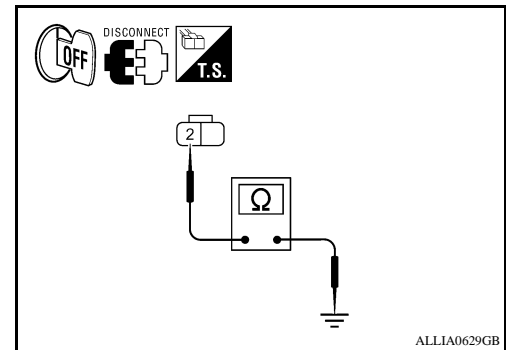

ALLIA0629GB

A
B
C
D
E
F
G
H
I
J
K
EXL
M
N
O
P

PARKING LAMP CIRCUIT

< COMPONENT DIAGNOSIS >

PARKING LAMP CIRCUIT

Description

INFOID:000000004056477

The IPDM E/R (intelligent power distribution module engine room) controls the tail lamp relay based on inputs from the BCM via the CAN communication lines. When the tail lamp relay is energized, power flows through fuse 37, located in the IPDM E/R. Power then flows to the front and rear combination lamps.

Component Function Check

INFOID:000000004056478

1. CHECK PARKING LAMP OPERATION

⊗ WITHOUT CONSULT-III

1. Activate IPDM E/R auto active test. Refer to [PCS-13, "Diagnosis Description"](#).
2. Check that the parking lamp is turned ON.

Ⓟ CONSULT-III

1. Select "EXTERNAL LAMP" of IPDM E/R active test item.
2. With operating the test items, check that the parking lamp is turned ON.

TAIL : Parking lamp ON
OFF : Parking lamp OFF

Is the parking lamp turned ON?

- YES >> Parking lamp circuit is normal.
 NO >> Refer to [EXL-42, "Diagnosis Procedure"](#).

Diagnosis Procedure

INFOID:000000004056479

1. CHECK PARKING LAMP FUSES

1. Turn the ignition switch OFF.
2. Check that the following fuses are not open.

Unit	Location	Fuse No.	Capacity
Parking lamps	IPDM E/R	36	10A
		37	10A

Is the fuse open?

- YES >> Repair the harness and replace the fuse.
 NO >> GO TO 2

2. CHECK TAIL LAMP RELAY OUTPUT (VOLTAGE)

1. Turn the ignition switch OFF.
2. Disconnect the front combination lamp connectors, front side marker lamp connectors, rear combination lamp connectors and license plate lamp connectors.
3. Turn the ignition switch ON.
4. Turn the parking lamps ON.
5. With the parking lamps ON, check voltage between the front combination lamp connectors and ground.

(+)		Terminal	(-)	Voltage
Connector				
LH	E27	2	Ground	Battery voltage
RH	E111			

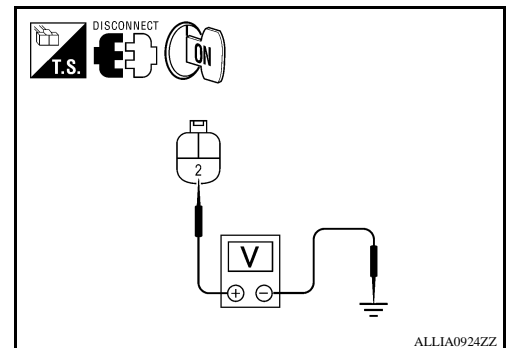

PARKING LAMP CIRCUIT

< COMPONENT DIAGNOSIS >

6. With the parking lamps ON, check voltage between the front side marker lamp connectors and ground.

(+)		Terminal	(-)	Voltage
Connector				
LH	E17	7	Ground	Battery voltage
RH	E108			

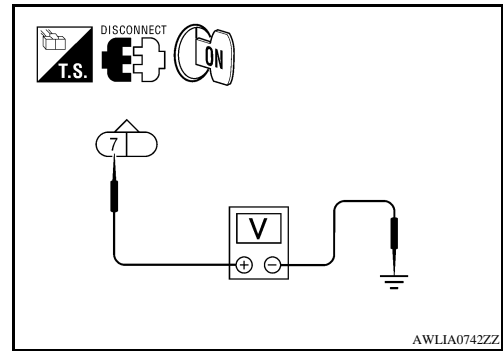

7. With the parking lamps ON, check voltage between the rear combination lamp connectors and ground.

(+)		Terminal	(-)	Voltage
Connector				
LH	C201	3	Ground	Battery voltage
RH	C202			

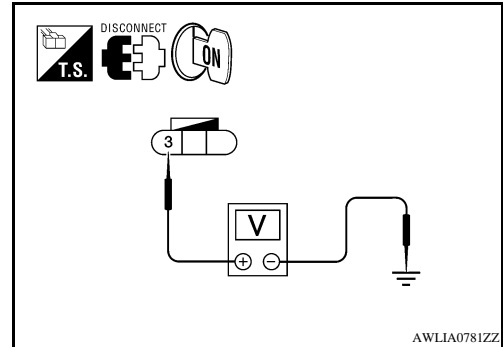

8. With the parking lamps ON, check voltage between the license plate lamp connector and ground.

(+)		Terminal	(-)	Voltage
Connector				
LH	C203	1	Ground	Battery voltage
RH	C204			

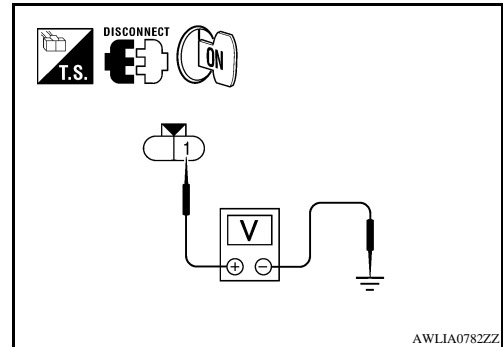

Are voltage readings as specified?

- YES >> GO TO 4
NO >> GO TO 3

3. CHECK PARKING, LICENSE PLATE AND TAIL LAMP CIRCUIT (OPEN)

1. Turn the ignition switch OFF.
2. Disconnect IPDM E/R connector.

A
B
C
D
E
F
G
H
I
J
K
EXL
M
N
O
P

PARKING LAMP CIRCUIT

< COMPONENT DIAGNOSIS >

3. Check continuity between the IPDM E/R harness connector (A)(B) and the front combination lamp harness connector (C).

Connector		Terminal	Connector	Terminal	Continuity
LH	A: E121	28	C: E27	2	Yes
RH	B: E123	49	C: E111		

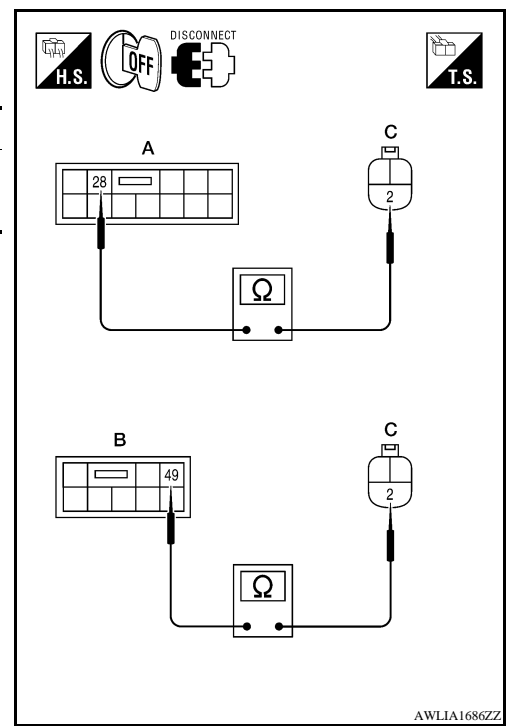

4. Check continuity between the IPDM E/R harness connector (A)(B) and the front side marker lamp harness connector (C).

Connector		Terminal	Connector	Terminal	Continuity
LH	A: E121	28	C: E17	7	Yes
RH	B: E123	49	C: E108		

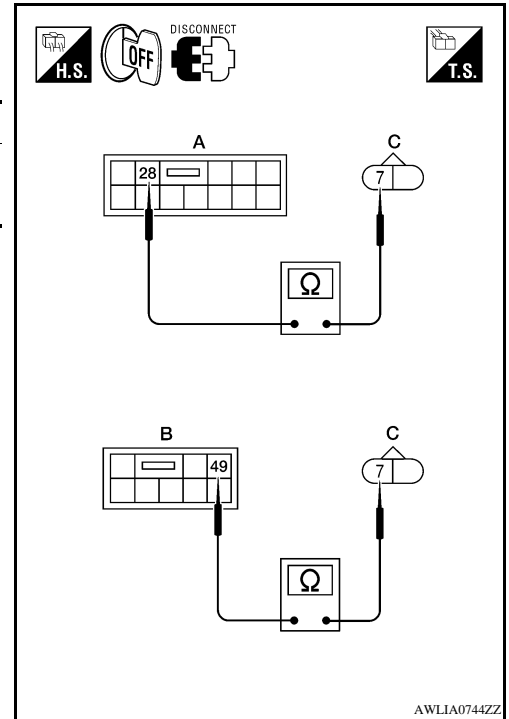

5. Check continuity between the IPDM E/R harness connector (A) and the rear combination lamp harness connector (B).

A		B		Continuity
Connector	Terminal	Connector	Terminal	
LH	E124	C201	3	Yes
RH		C202		

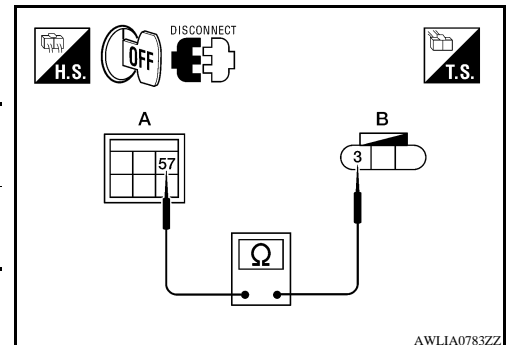

PARKING LAMP CIRCUIT

< COMPONENT DIAGNOSIS >

6. Check continuity between the IPDM E/R harness connector (A) and license plate lamp connector (B).

A			B		Continuity
Connector	Terminal	Connector	Terminal		
LH	E124	57	C203	1	Yes
RH			C204		

Are continuity results as specified?

YES >> GO TO 4

NO >> Repair the harnesses or connectors.

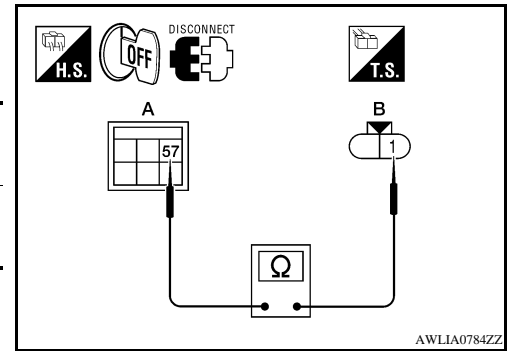

4. CHECK PARKING, LICENSE AND TAIL LAMP GROUND CIRCUITS

1. Check continuity between the front combination lamp harness connectors and ground.

Connector	Terminal	—	Continuity
LH	E27	Ground	Yes
RH	E111		

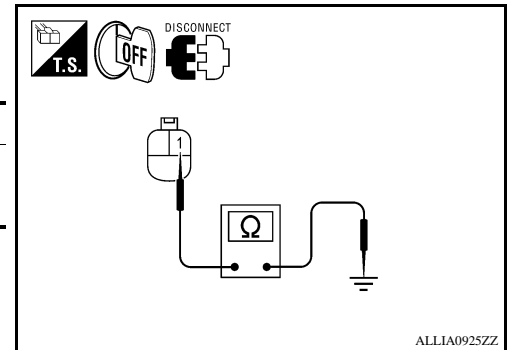

2. Check continuity between the front side marker lamp harness connectors and ground.

Connector	Terminal	—	Continuity
LH	E17	Ground	Yes
RH	E108		

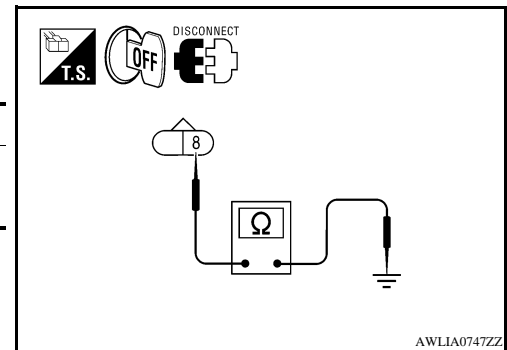

3. Check continuity between the rear combination lamp harness connectors and ground.

Connector	Terminal	—	Continuity
LH	C201	Ground	Yes
RH	C202		

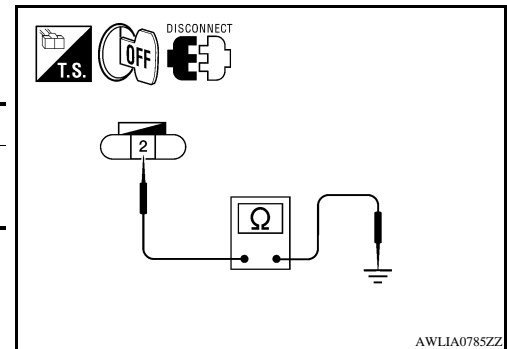

A
B
C
D
E
F
G
H
I
J
K
EXL
M
N
O
P

PARKING LAMP CIRCUIT

< COMPONENT DIAGNOSIS >

4. Check continuity between the license plate lamp harness connector and ground.

Connector		Terminal	—	Continuity
LH	C203	2	Ground	Yes
RH	C204			

Are continuity results as specified?

- YES >> Inspect the parking lamp bulb.
NO >> Repair the harness.

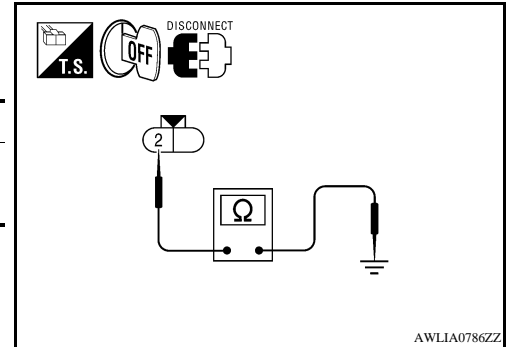

TURN SIGNAL LAMP CIRCUIT

< COMPONENT DIAGNOSIS >

TURN SIGNAL LAMP CIRCUIT

Description

INFOID:000000004056480

The BCM monitors inputs from the combination switch to determine when to activate the turn signals. The BCM outputs voltage direction to the left and right turn signals during turn signal operation or both during hazard warning operation. The BCM sends a turn signal indicator request to the combination meter via the CAN communication lines.

The BCM performs the fast flasher operation (fail-safe) if any bulb or harness of the turn signal lamp circuit is open.

NOTE:

Turn signal lamp blinks at normal speed when using the hazard warning lamp.

Component Function Check

INFOID:000000004056481

1. CHECK TURN SIGNAL LAMP

CONSULT-III

1. Select "FLASHER" of BCM (FLASHER) active test item.
2. With operating the test items, check that the turn signal lamp blinks.

- LH** : Turn signal lamp LH blinking
- RH** : Turn signal lamp RH blinking
- OFF** : The turn signal lamp OFF

Does the turn signal lamp blink?

- YES >> Turn signal lamp circuit is normal.
- NO >> Refer to [EXL-47, "Diagnosis Procedure"](#).

Diagnosis Procedure

INFOID:000000004056482

1. CHECK TURN SIGNAL LAMP BULB

Check the applicable lamp bulb to be sure the proper bulb standard is in use and the bulb is not open.

Is the bulb OK?

- YES >> GO TO 2
- NO >> Replace the bulb.

2. CHECK TURN SIGNAL LAMP OUTPUT VOLTAGE

1. Turn the ignition switch OFF.
2. Disconnect the front combination lamp connectors and the rear combination lamp connector.
3. Turn the ignition switch ON.
4. With turn signal switch operating, check the voltage between the BCM harness connector M20 and ground.

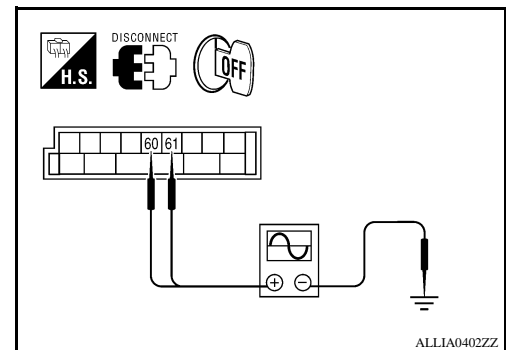

(+)		(-)	Voltage
Connector	Terminal		
M20	LH 60	Ground	
	RH 61		

PKID0926E

Is voltage reading as specified?

- YES >> GO TO 3

TURN SIGNAL LAMP CIRCUIT

< COMPONENT DIAGNOSIS >

NO >> Replace BCM. Refer to [BCS-56. "Removal and Installation"](#).

3. CHECK TURN SIGNAL LAMP CIRCUIT FOR OPEN

1. Turn the ignition switch OFF.
2. Disconnect BCM connector M20.
3. Check continuity between the BCM harness connector M20 and the front combination lamps.

A		B		Continuity
Connector	Terminal	Connector	Terminal	
Front LH	M20	60	E27	Yes
Front RH		61	E111	

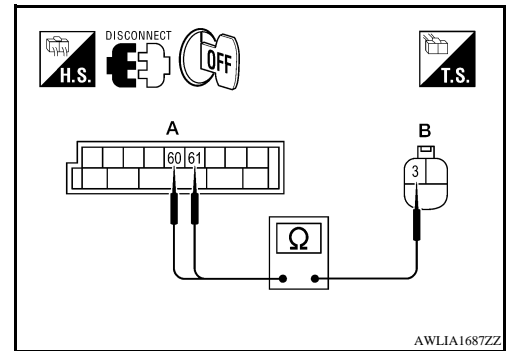

4. Check continuity between the BCM harness connector M20 and the rear combination lamp connectors.

A		B		Continuity
Connector	Terminal	Connector	Terminal	
Rear LH	M20	60	C207	Yes
Rear RH		61	C208	

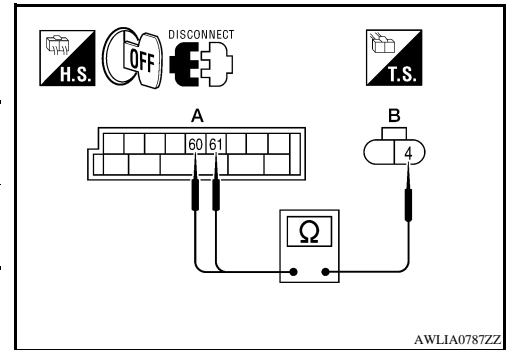

Are continuity results as specified?

YES >> GO TO 4

NO >> Repair the harnesses or connectors.

4. CHECK TURN SIGNAL LAMP SHORT CIRCUIT

Check continuity between the BCM harness connector M20 and ground.

Connector	Terminal	—	Continuity
LH	M20	60	No
RH		61	

Does continuity exist?

YES >> Repair the harnesses or connectors.

NO >> GO TO 5

5. CHECK TURN SIGNAL LAMP GROUND CIRCUIT

1. Check continuity between the front combination lamp harness connectors and ground.

Connector	Terminal	—	Continuity
Front LH	E27	1	Yes
Front RH	E111		

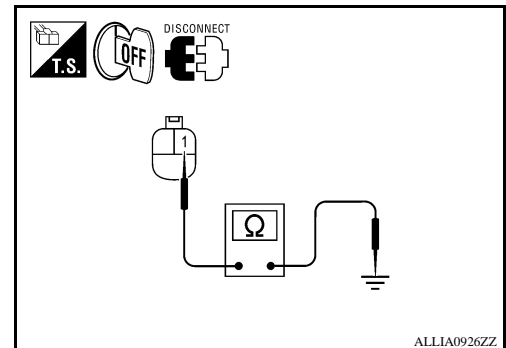

TURN SIGNAL LAMP CIRCUIT

< COMPONENT DIAGNOSIS >

- Check continuity between the rear combination lamp harness connectors and ground.

Connector		Terminal	—	Continuity
Rear LH	C207	5	Ground	Yes
Rear RH	C208			

Are continuity results as specified?

- YES >> Replace the malfunctioning lamp.
 NO >> Repair the harnesses or connectors.

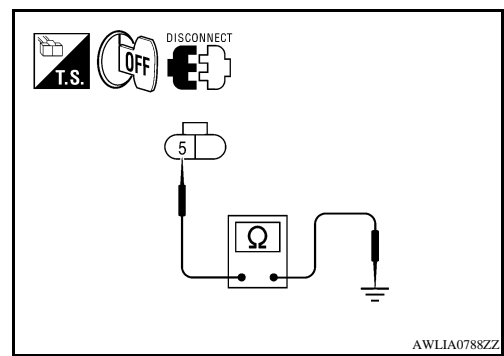

A
B
C
D
E
F
G
H
I
J
K
EXL
M
N
O
P

HEADLAMP

< COMPONENT DIAGNOSIS >

HEADLAMP

Wiring Diagram

INFOID:000000004056483

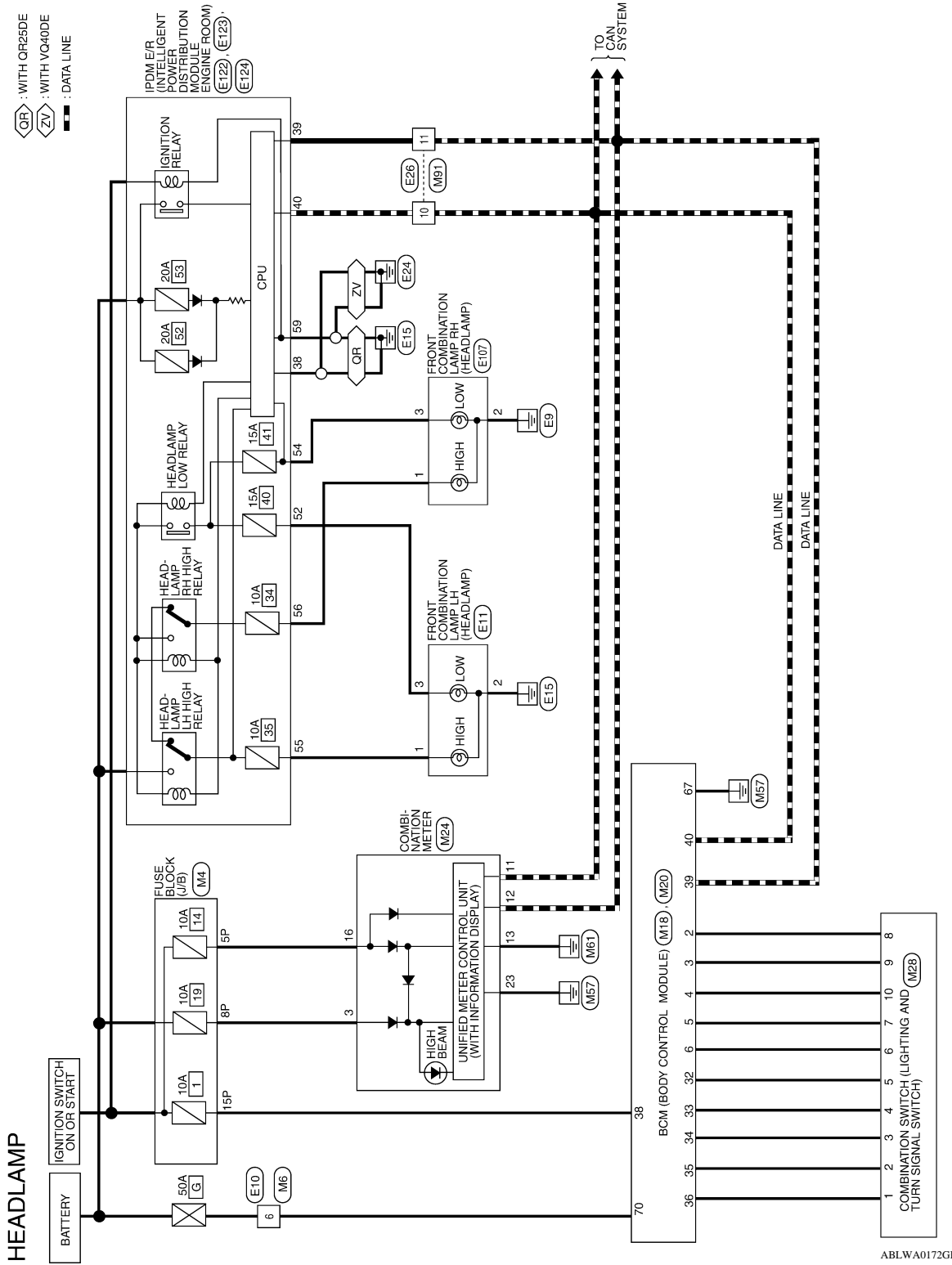

ABLWA0172GB

HEADLAMP

< COMPONENT DIAGNOSIS >

HEADLAMP CONNECTORS

Connector No.	M4
Connector Name	FUSE BLOCK (J/B)
Connector Color	WHITE



Terminal No.	Color of Wire	Signal Name
5P	W/G	-
8P	R/Y	-
15P	W/R	-

Connector No.	M6
Connector Name	WIRE TO WIRE
Connector Color	WHITE



Terminal No.	Color of Wire	Signal Name
6	W	-

Connector No.	M18
Connector Name	BCM (BODY CONTROL MODULE)
Connector Color	WHITE

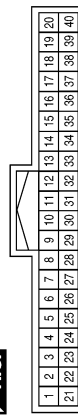

Terminal No.	Color of Wire	Signal Name
2	P	INPUT 5
3	SB	INPUT 4
4	V	INPUT 3

Terminal No.	Color of Wire	Signal Name
5	L	INPUT 2
6	R	INPUT 1
32	O	OUTPUT 5
33	GR	OUTPUT 4
34	G	OUTPUT 3
35	BR	OUTPUT 2
36	LG	OUTPUT 1
38	W/R	IGN SW
39	L	CAN-H
40	P	CAN-L

Connector No.	M20
Connector Name	BCM (BODY CONTROL MODULE)
Connector Color	BLACK

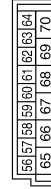

Terminal No.	Color of Wire	Signal Name
67	B	GND (POWER)
70	W	BAT (FL)

ABLIA0591GB

A
B
C
D
E
F
G
H
I
J
K
EXL
M
N
O
P

HEADLAMP

< COMPONENT DIAGNOSIS >

Connector No.	M24
Connector Name	COMBINATION METER
Connector Color	WHITE

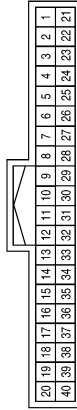

Terminal No.	Color of Wire	Signal Name
3	R/Y	BATTERY
11	P	CAN-L
12	L	CAN-H
13	GR	GROUND
16	W/G	RUN START
23	B	POWER GND

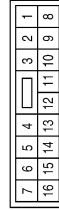

Connector No.	M91
Connector Name	WIRE TO WIRE
Connector Color	WHITE

Terminal No.	Color of Wire	Signal Name
10	P	--
11	L	--

Connector No.	M28
Connector Name	COMBINATION SWITCH
Connector Color	WHITE

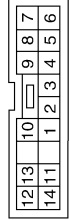

Terminal No.	Color of Wire	Signal Name
1	LG	INPUT 1
2	BR	INPUT 2
3	G	INPUT 3



Connector No.	E10
Connector Name	WIRE TO WIRE
Connector Color	WHITE

Terminal No.	Color of Wire	Signal Name
6	W	--

Terminal No.	Color of Wire	Signal Name
4	GR	INPUT 4
5	O	INPUT 5
6	R	OUTPUT 1
7	L	OUTPUT 2
8	P	OUTPUT 5
9	SB	OUTPUT 4
10	V	OUTPUT 3

Connector No.	E11
Connector Name	FRONT COMBINATION LAMP LH (WITHOUT DAYTIME LIGHT SYSTEM)
Connector Color	BLACK



Terminal No.	Color of Wire	Signal Name
1	G	--
2	B	--
3	P	--

HEADLAMP

< COMPONENT DIAGNOSIS >

Connector No.	E26
Connector Name	WIRE TO WIRE
Connector Color	WHITE

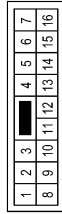

Terminal No.	Color of Wire	Signal Name
10	P	-
11	L	-

Connector No.	E107
Connector Name	FRONT COMBINATION LAMP RH
Connector Color	BLACK



Terminal No.	Color of Wire	Signal Name
1	L	-
2	B	-
3	R	-

Connector No.	E122
Connector Name	IPDM E/R (INTELLIGENT POWER DISTRIBUTION MODULE ENGINE ROOM)
Connector Color	WHITE

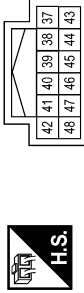

Terminal No.	Color of Wire	Signal Name
38	B	GND (SIGNAL)
39	L	CAN-H
40	P	CAN-L

Connector No.	E123
Connector Name	IPDM E/R (INTELLIGENT POWER DISTRIBUTION MODULE ENGINE ROOM)
Connector Color	BROWN



Terminal No.	Color of Wire	Signal Name
52	P	H/LAMP LO LH
54	R	H/LAMP LO RH
55	G	H/LAMP HI LH
56	L	H/LAMP HI RH

Connector No.	E124
Connector Name	IPDM E/R (INTELLIGENT POWER DISTRIBUTION MODULE ENGINE ROOM)
Connector Color	BLACK



Terminal No.	Color of Wire	Signal Name
59	B	GND (POWER)

AALIA0125GB

DAYTIME LIGHT SYSTEM

< COMPONENT DIAGNOSIS >

DAYTIME LIGHT SYSTEM

Wiring Diagram

INFOID:000000004056484

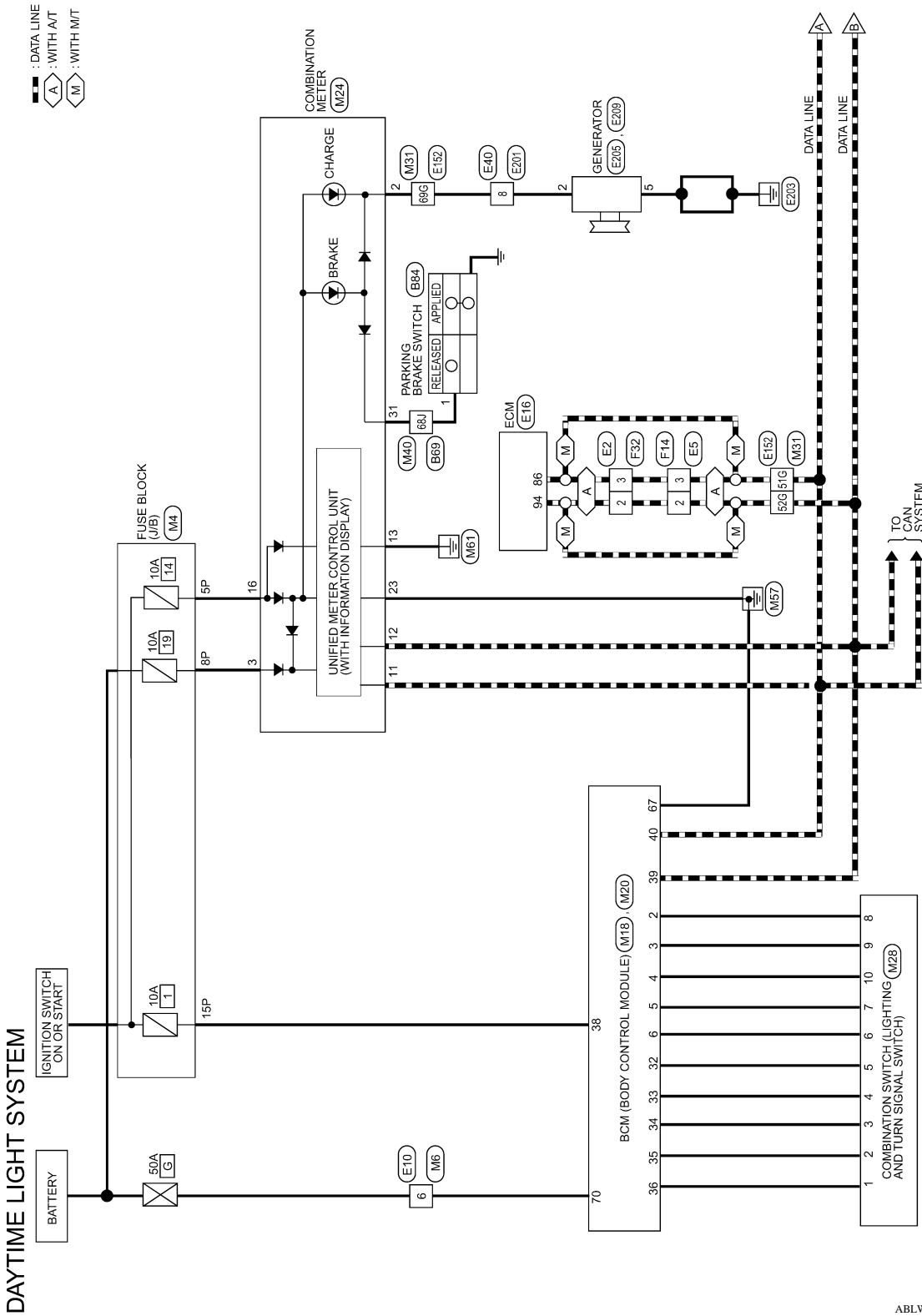

ABLWA0173GB

DAYTIME LIGHT SYSTEM

< COMPONENT DIAGNOSIS >

■ : DATA LINE
 OR : WITH QR25DE
 ZV : WITH VQ40DE

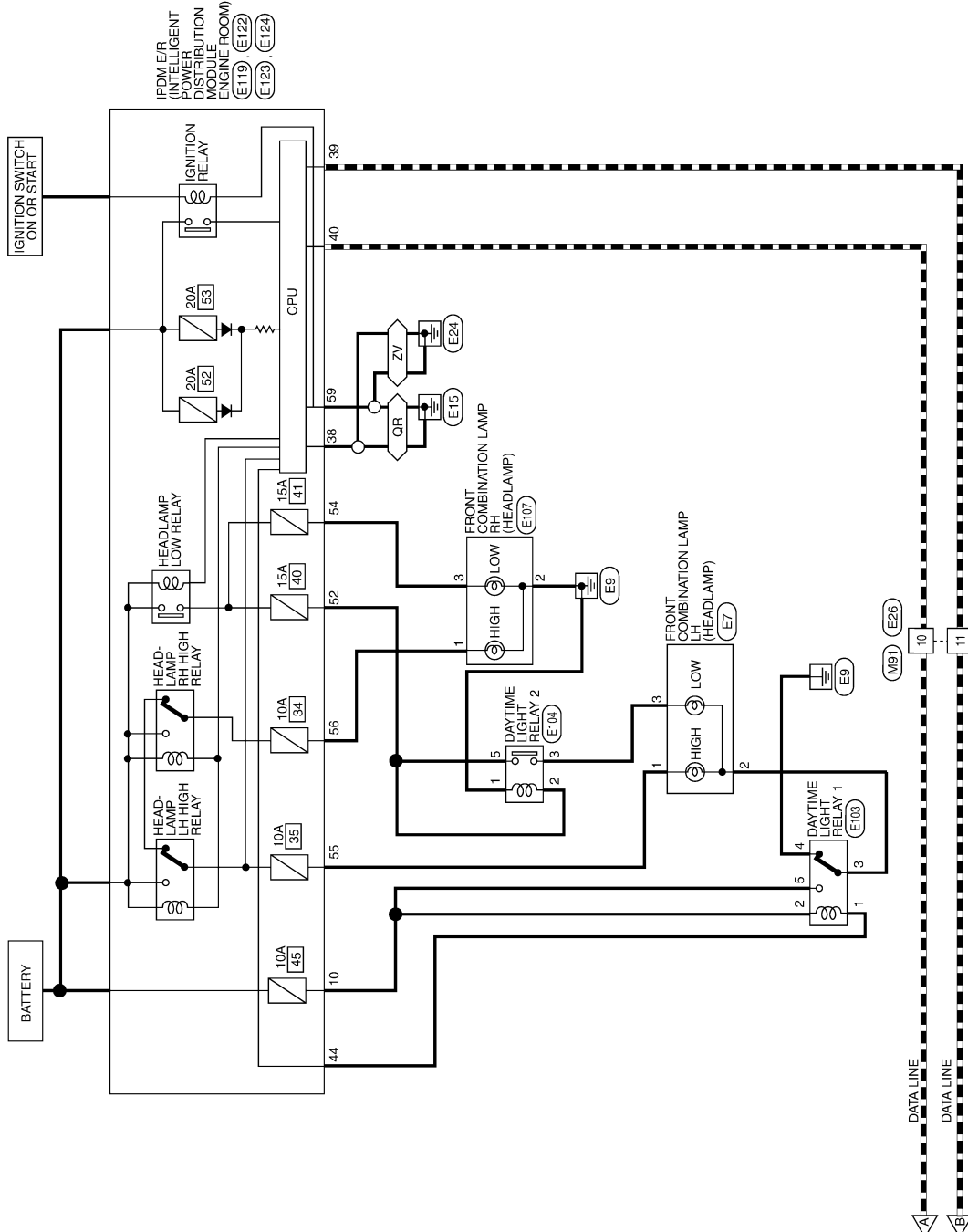

ABLWA0174GB

A
B
C
D
E
F
G
H
I
J
K
EXL
M
N
O
P

DAYTIME LIGHT SYSTEM

< COMPONENT DIAGNOSIS >

DAYTIME LIGHT SYSTEM CONNECTORS

Connector No.	M4
Connector Name	FUSE BLOCK (J/B)
Connector Color	WHITE



Terminal No.	Color of Wire	Signal Name
5P	W/G	-
8P	R/Y	-
15P	W/R	-

Connector No.	M6
Connector Name	WIRE TO WIRE
Connector Color	WHITE



Terminal No.	Color of Wire	Signal Name
6	W	-

Connector No.	M18
Connector Name	BCM (BODY CONTROL MODULE)
Connector Color	WHITE

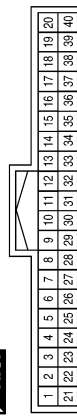

Terminal No.	Color of Wire	Signal Name
2	P	INPUT 5
3	SB	INPUT 4
4	V	INPUT 3

Terminal No.	Color of Wire	Signal Name
5	L	INPUT 2
6	R	INPUT 1
32	O	OUTPUT 5
33	GR	OUTPUT 4
34	G	OUTPUT 3
35	BR	OUTPUT 2
36	LG	OUTPUT 1
38	W/R	IGN SW
39	L	CAN-H
40	P	CAN-L

Connector No.	M20
Connector Name	BCM (BODY CONTROL MODULE)
Connector Color	BLACK

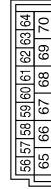

Terminal No.	Color of Wire	Signal Name
67	B	GND (POWER)
70	W	BAT (F/L)

ABLIA0593GB

DAYTIME LIGHT SYSTEM

< COMPONENT DIAGNOSIS >

Connector No.	M31
Connector Name	WIRE TO WIRE
Connector Color	WHITE

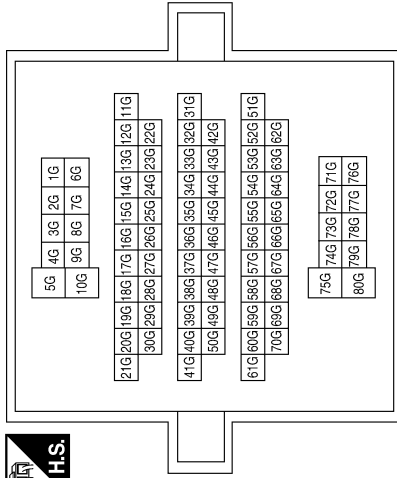

Terminal No.	Color of Wire	Signal Name
51G	P	-
52G	L	-
69G	P	-

Connector No.	M28
Connector Name	COMBINATION SWITCH
Connector Color	WHITE

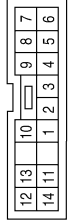

Terminal No.	Color of Wire	Signal Name
1	LG	INPUT 1
2	BR	INPUT 2
3	G	INPUT 3
4	GR	INPUT 4
5	O	INPUT 5
6	R	OUTPUT 1
7	L	OUTPUT 2
8	P	OUTPUT 5
9	SB	OUTPUT 4
10	V	OUTPUT 3

Connector No.	M24
Connector Name	COMBINATION METER
Connector Color	WHITE

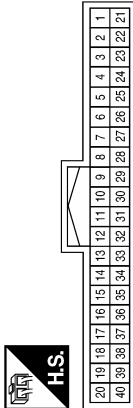

Terminal No.	Color of Wire	Signal Name
2	P	CHARGE (ALT) INPUT
3	R/Y	BATTERY
11	P	CAN-L
12	L	CAN-H
13	GR	GROUND
16	W/G	RUN START
23	B	POWER GND
31	G	PARK BRAKE SW

ABLIA0594GB

A
B
C
D
E
F
G
H
I
J
K
L
M
N
O
P

EXL

DAYTIME LIGHT SYSTEM

< COMPONENT DIAGNOSIS >

Connector No.	M40
Connector Name	WIRE TO WIRE
Connector Color	WHITE

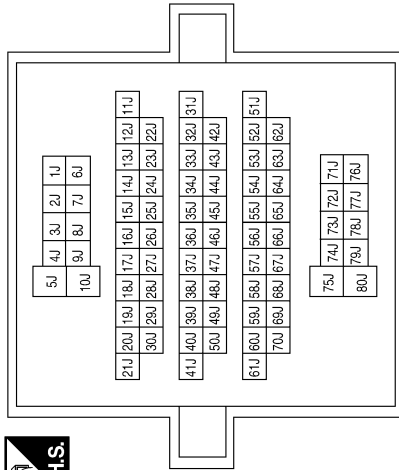

Terminal No.	Color of Wire	Signal Name
68J	G	-

Connector No.	M91
Connector Name	WIRE TO WIRE
Connector Color	WHITE

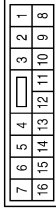

Terminal No.	Color of Wire	Signal Name
10	P	-
11	L	-

Connector No.	E2
Connector Name	WIRE TO WIRE
Connector Color	WHITE

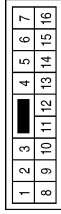

Terminal No.	Color of Wire	Signal Name
2	L	-
3	P	-

Connector No.	E5
Connector Name	WIRE TO WIRE
Connector Color	WHITE

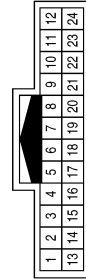

Terminal No.	Color of Wire	Signal Name
2	L	-
3	P	-

Connector No.	E7
Connector Name	FRONT COMBINATION LAMP LH (WITH DAYTIME LIGHT SYSTEM)
Connector Color	BLACK



Terminal No.	Color of Wire	Signal Name
1	G	-
2	B	-
3	SB	-

Connector No.	E10
Connector Name	WIRE TO WIRE
Connector Color	WHITE



Terminal No.	Color of Wire	Signal Name
6	W	-

ABLIA0595GB

DAYTIME LIGHT SYSTEM

< COMPONENT DIAGNOSIS >

Connector No.	E40
Connector Name	WIRE TO WIRE
Connector Color	GRAY

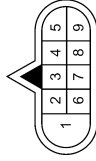

Terminal No.	Color of Wire	Signal Name
8	P	-

Connector No.	E26
Connector Name	WIRE TO WIRE
Connector Color	WHITE

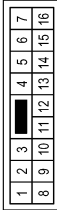

Terminal No.	Color of Wire	Signal Name
10	P	-
11	L	-

Connector No.	E16
Connector Name	ECM
Connector Color	BLACK

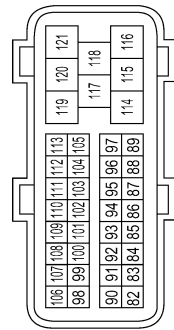

Terminal No.	Color of Wire	Signal Name
86	P	CAN-L
94	L	CAN-H

Connector No.	E107
Connector Name	FRONT COMBINATION LAMP RH
Connector Color	BLACK



Terminal No.	Color of Wire	Signal Name
1	L	-
2	B	-
3	R	-

Connector No.	E104
Connector Name	DAYTIME LIGHT RELAY 2
Connector Color	BLUE



Terminal No.	Color of Wire	Signal Name
1	B	-
2	G	-
3	SB	-
5	P	-

Connector No.	E103
Connector Name	DAYTIME LIGHT RELAY 1
Connector Color	BLACK



Terminal No.	Color of Wire	Signal Name
1	R	-
2	R/B	-
3	B	-
4	GR	-
5	R/B	-

ABLIA0596GB

DAYTIME LIGHT SYSTEM

< COMPONENT DIAGNOSIS >

Connector No.	E119
Connector Name	IPDM E/R (INTELLIGENT POWER DISTRIBUTION MODULE ENGINE ROOM)
Connector Color	WHITE



Terminal No.	Color of Wire	Signal Name
10	R/B	DTRL RLY SUPPLY

Connector No.	E122
Connector Name	IPDM E/R (INTELLIGENT POWER DISTRIBUTION MODULE ENGINE ROOM)
Connector Color	WHITE

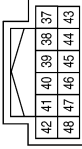

Terminal No.	Color of Wire	Signal Name
38	B	GND (SIGNAL)
39	L	CAN-H
40	P	CAN-L
44	R	DTRL RLY CONT

Connector No.	E123
Connector Name	IPDM E/R (INTELLIGENT POWER DISTRIBUTION MODULE ENGINE ROOM)
Connector Color	BROWN

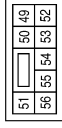

Terminal No.	Color of Wire	Signal Name
52	P	H/LAMP LO LH
54	R	H/LAMP LO RH
55	G	H/LAMP HI LH
56	L	H/LAMP HI RH

Connector No.	E124
Connector Name	IPDM E/R (INTELLIGENT POWER DISTRIBUTION MODULE ENGINE ROOM)
Connector Color	BLACK



Terminal No.	Color of Wire	Signal Name
59	B	GND (POWER)

Connector No.	E152
Connector Name	WIRE TO WIRE
Connector Color	WHITE

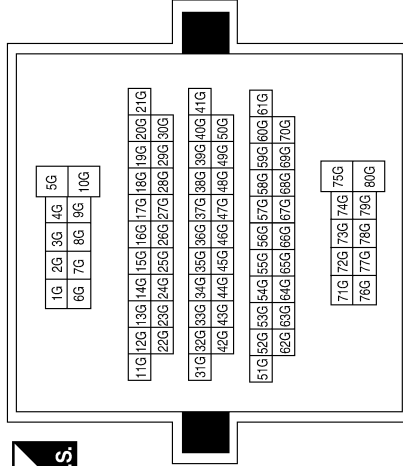

Terminal No.	Color of Wire	Signal Name
51G	P	-
52G	L	-
69G	P	-

DAYTIME LIGHT SYSTEM

< COMPONENT DIAGNOSIS >

Connector No.	E201
Connector Name	WIRE TO WIRE
Connector Color	GRAY



Terminal No.	8	Color of Wire	P	Signal Name	-
--------------	---	---------------	---	-------------	---

Connector No.	E205
Connector Name	GENERATOR
Connector Color	BLACK

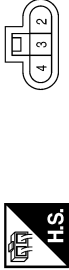

Terminal No.	2	Color of Wire	P	Signal Name	L
--------------	---	---------------	---	-------------	---

Connector No.	E209
Connector Name	GENERATOR
Connector Color	-



Terminal No.	5	Color of Wire	B	Signal Name	E
--------------	---	---------------	---	-------------	---

Connector No.	F14
Connector Name	WIRE TO WIRE
Connector Color	WHITE

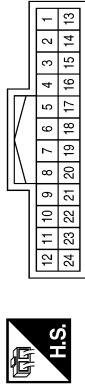

Terminal No.	2	Color of Wire	L	Signal Name	-
Terminal No.	3	Color of Wire	P	Signal Name	-

Connector No.	F32
Connector Name	WIRE TO WIRE
Connector Color	WHITE

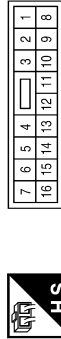

Terminal No.	2	Color of Wire	L	Signal Name	-
Terminal No.	3	Color of Wire	P	Signal Name	-

Connector No.	B69
Connector Name	WIRE TO WIRE
Connector Color	WHITE

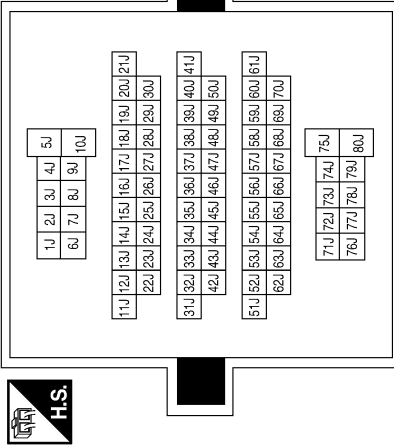

Terminal No.	68J	Color of Wire	G	Signal Name	-
--------------	-----	---------------	---	-------------	---

ABLIA0598GB

A
B
C
D
E
F
G
H
I
J
K
EXL
M
N
O
P

DAYTIME LIGHT SYSTEM

< COMPONENT DIAGNOSIS >

Connector No.	B84
Connector Name	PARKING BRAKE SWITCH
Connector Color	BLACK



Terminal No.	Color of Wire	Signal Name
1	G	-

ABLIA0805GB

AUTO LIGHT SYSTEM

< COMPONENT DIAGNOSIS >

AUTO LIGHT SYSTEM

Wiring Diagram

INFOID:000000004056485

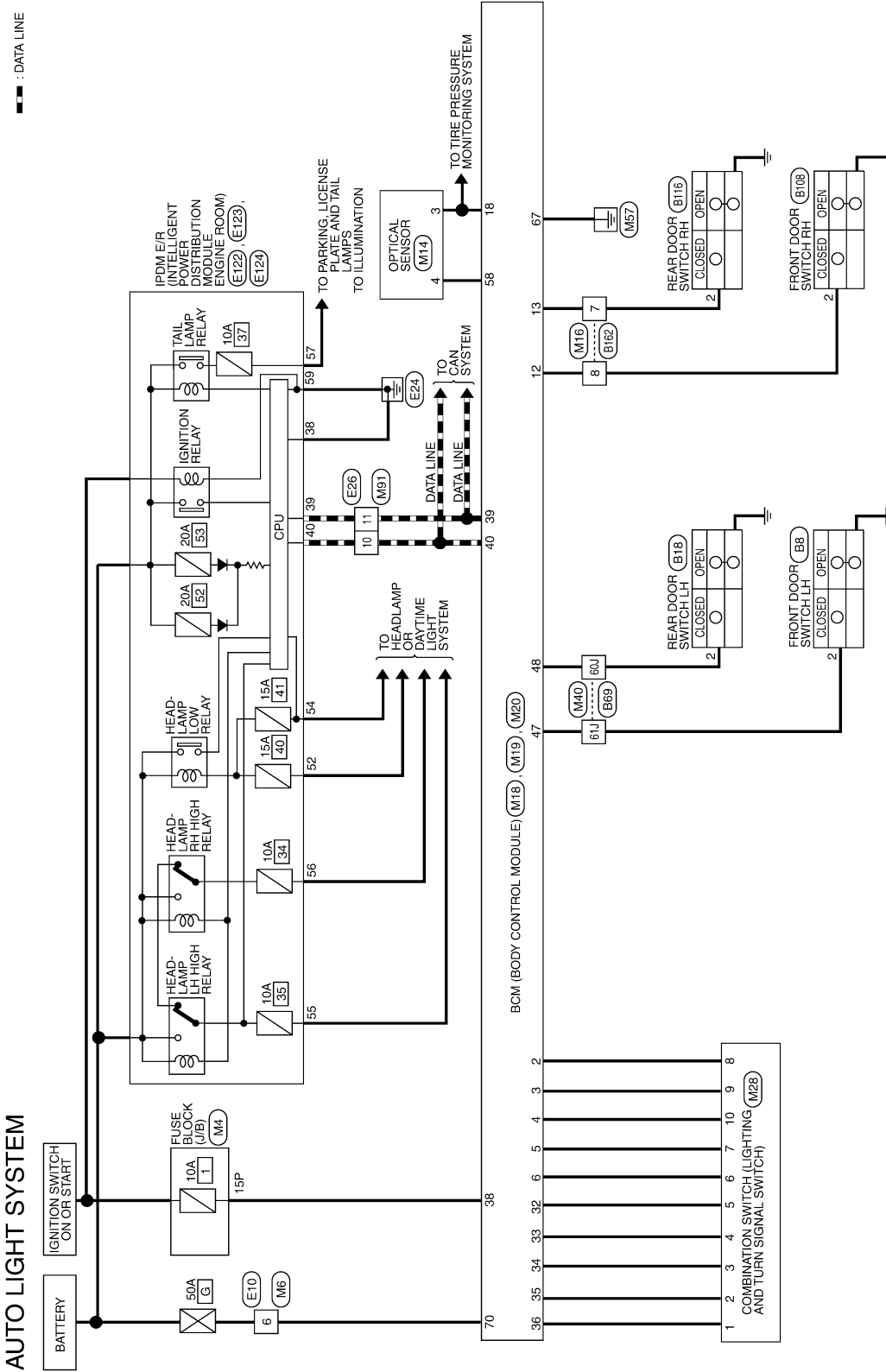

A
B
C
D
E
F
G
H
I
J
K
EXL
M
N
O
P

ABLWA0175GB

AUTO LIGHT SYSTEM

< COMPONENT DIAGNOSIS >

AUTO LIGHT SYSTEM CONNECTORS

Connector No.	M4
Connector Name	FUSE BLOCK (J/B)
Connector Color	WHITE



Terminal No.	Color of Wire	Signal Name
15P	W/R	-

Connector No.	M6
Connector Name	WIRE TO WIRE
Connector Color	WHITE



Terminal No.	Color of Wire	Signal Name
6	W	-

Connector No.	M14
Connector Name	OPTICAL-SENSOR
Connector Color	BLACK



Terminal No.	Color of Wire	Signal Name
3	P	SIGNAL_GND
4	W	SIGNAL

Connector No.	M16
Connector Name	WIRE TO WIRE
Connector Color	WHITE

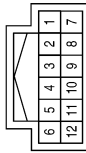

Terminal No.	Color of Wire	Signal Name
7	L	-
8	LG	-

Connector No.	M18
Connector Name	BCM (BODY CONTROL MODULE)
Connector Color	WHITE

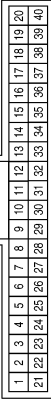

Terminal No.	Color of Wire	Signal Name
2	P	INPUT 5
3	SB	INPUT 4
4	V	INPUT 3

Terminal No.	Color of Wire	Signal Name
5	L	INPUT 2
6	R	INPUT 1
12	LG	DOOR SW (AS)
13	L	DOOR SW (RR)
18	BR	KEYLESS&AUTO LIGHT SENSOR GND
32	O	OUTPUT 5
33	GR	OUTPUT 4
34	G	OUTPUT 3
35	BR	OUTPUT 2
36	LG	OUTPUT 1
38	W/R	IGN SW
39	L	CAN-H
40	P	CAN-L

ABLIA0599GB

AUTO LIGHT SYSTEM

< COMPONENT DIAGNOSIS >

Connector No.	M19
Connector Name	BCM (BODY CONTROL MODULE)
Connector Color	WHITE



Terminal No.	Color of Wire	Signal Name
47	GR	DOOR SW (DR)
48	P	DOOR SW (RL)

Connector No.	M20
Connector Name	BCM (BODY CONTROL MODULE)
Connector Color	BLACK



Terminal No.	Color of Wire	Signal Name
58	W	AUTO LIGHT SENSOR INPUT 2
67	B	GND (POWER)
70	W	BAT (F/L)

Connector No.	M28
Connector Name	COMBINATION SWITCH
Connector Color	WHITE

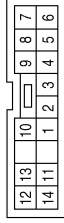

Terminal No.	Color of Wire	Signal Name
1	LG	INPUT 1
2	BR	INPUT 2
3	G	INPUT 3
4	GR	INPUT 4
5	O	INPUT 5
6	R	OUTPUT 1
7	L	OUTPUT 2
8	P	OUTPUT 5
9	SB	OUTPUT 4
10	V	OUTPUT 3

Connector No.	M40
Connector Name	WIRE TO WIRE
Connector Color	WHITE

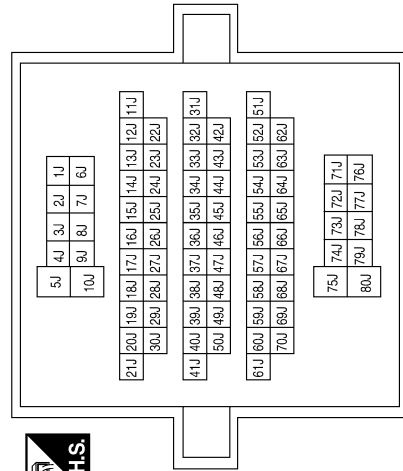
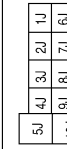

Terminal No.	Color of Wire	Signal Name
60J	P	-
61J	GR	-

Connector No.	M91
Connector Name	WIRE TO WIRE
Connector Color	WHITE

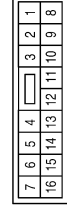

Terminal No.	Color of Wire	Signal Name
10	P	-
11	L	-

ABLIA0600GB

A B C D E F G H I J K EXL M N O P

AUTO LIGHT SYSTEM

< COMPONENT DIAGNOSIS >

Connector No.	E10
Connector Name	WIRE TO WIRE
Connector Color	WHITE



Terminal No.	Color of Wire	Signal Name
6	W	-

Connector No.	E26
Connector Name	WIRE TO WIRE
Connector Color	WHITE

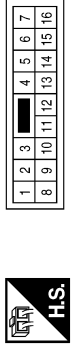

Terminal No.	Color of Wire	Signal Name
10	P	-
11	L	-

Connector No.	E122
Connector Name	IPDM E/R (INTELLIGENT POWER DISTRIBUTION MODULE ENGINE ROOM)
Connector Color	WHITE

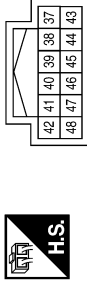

Terminal No.	Color of Wire	Signal Name
38	B	GND (SIGNAL)
39	L	CAN-H
40	P	CAN-L

Connector No.	E123
Connector Name	IPDM E/R (INTELLIGENT POWER DISTRIBUTION MODULE ENGINE ROOM)
Connector Color	BROWN

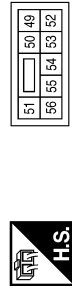

Terminal No.	Color of Wire	Signal Name
52	P	H/LAMP LO LH
54	R	H/LAMP LO RH
55	G	H/LAMP HI LH
56	L	H/LAMP HI RH

Connector No.	E124
Connector Name	IPDM E/R (INTELLIGENT POWER DISTRIBUTION MODULE ENGINE ROOM)
Connector Color	BLACK



Terminal No.	Color of Wire	Signal Name
57	GR	TAIL LAMPS
59	B	GND (POWER)

Connector No.	B8
Connector Name	FRONT DOOR SWITCH LH (CREW CAB)
Connector Color	WHITE



Terminal No.	Color of Wire	Signal Name
2	GR	-

ABLIA0601GB

AUTO LIGHT SYSTEM

< COMPONENT DIAGNOSIS >

Connector No.	B18	REAR DOOR SWITCH LH	
Connector Name	REAR DOOR SWITCH LH		
Connector Color	WHITE		

◇	1	2	3
---	---	---	---

Terminal No.	2	Color of Wire	P	Signal Name	-
--------------	---	---------------	---	-------------	---

Connector No.	B69	WIRE TO WIRE	
Connector Name	WIRE TO WIRE		
Connector Color	WHITE		

◇	1	2	3
---	---	---	---

1J	2J	3J	4J	5J
6J	7J	8J	9J	10J

11J	12J	13J	14J	15J	16J	17J	18J	19J	20J	21J
22J	23J	24J	25J	26J	27J	28J	29J	30J		

31J	32J	33J	34J	35J	36J	37J	38J	39J	40J	41J
42J	43J	44J	45J	46J	47J	48J	49J	50J		

51J	52J	53J	54J	55J	56J	57J	58J	59J	60J	61J
62J	63J	64J	65J	66J	67J	68J	69J	70J		

71J	72J	73J	74J	75J
76J	77J	78J	79J	80J

Terminal No.	2	Color of Wire	LG	Signal Name	-
--------------	---	---------------	----	-------------	---

Connector No.	B116	REAR DOOR SWITCH RH	
Connector Name	REAR DOOR SWITCH RH		
Connector Color	WHITE		

◇	1	2	3
---	---	---	---

Terminal No.	2	Color of Wire	L	Signal Name	-
--------------	---	---------------	---	-------------	---

Connector No.	B162	WIRE TO WIRE	
Connector Name	WIRE TO WIRE		
Connector Color	WHITE		

◇	1	2	3	4	5	6
7	8	9	10	11	12	

Terminal No.	7	Color of Wire	L	Signal Name	-
	8	LG			

ABLIA0602GB

A
B
C
D
E
F
G
H
I
J
K
EXL
M
N
O
P

FRONT FOG LAMP SYSTEM

< COMPONENT DIAGNOSIS >

FRONT FOG LAMP SYSTEM

Wiring Diagram

INFOID:000000004056486

FRONT FOG LAMP

--- : DATA LINE

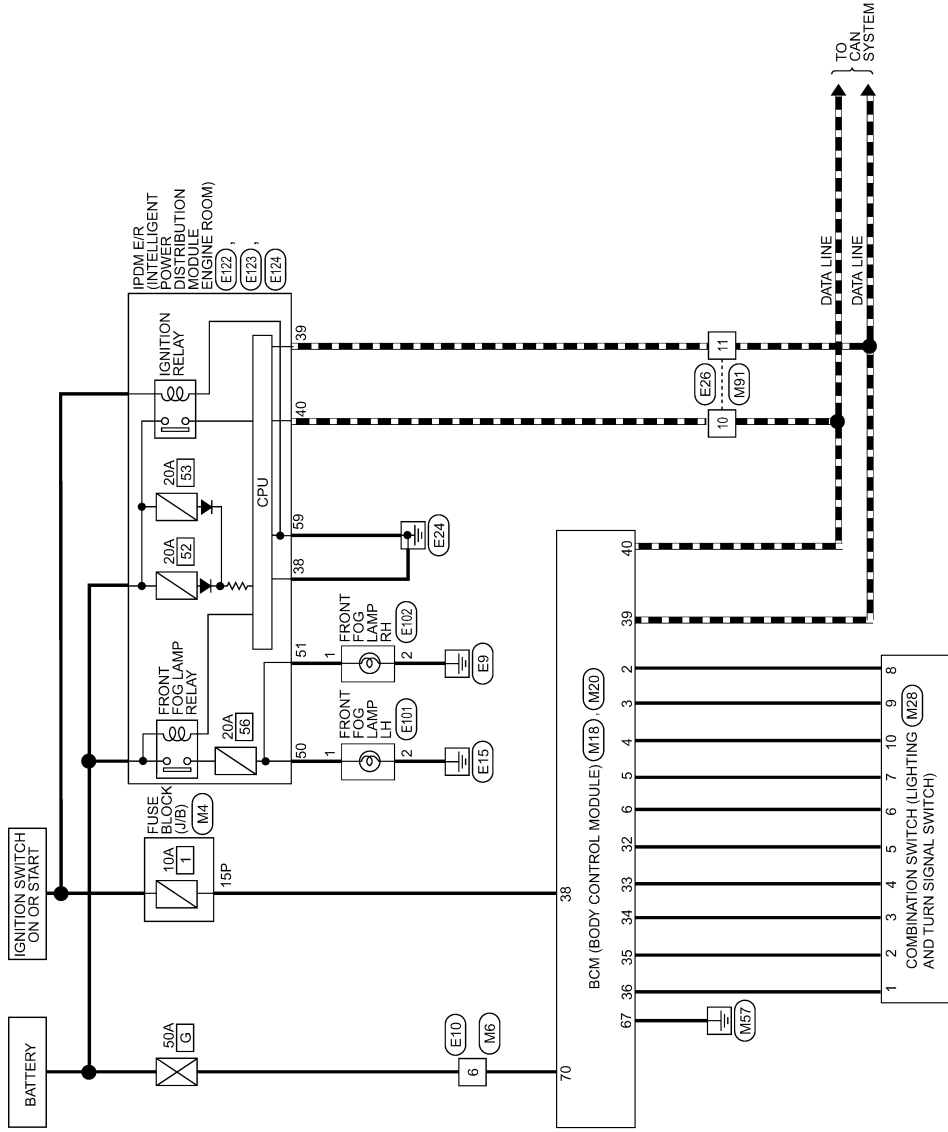

ABLWA0176GB

FRONT FOG LAMP SYSTEM

< COMPONENT DIAGNOSIS >

FRONT FOG LAMP CONNECTORS

Connector No.	M4
Connector Name	FUSE BLOCK (J/B)
Connector Color	WHITE



Terminal No.	15P	Color of Wire	W/R	Signal Name	-
--------------	-----	---------------	-----	-------------	---

Connector No.	M6
Connector Name	WIRE TO WIRE
Connector Color	WHITE



Terminal No.	6	Color of Wire	W	Signal Name	-
--------------	---	---------------	---	-------------	---

Connector No.	M18
Connector Name	BCM (BODY CONTROL MODULE)
Connector Color	WHITE

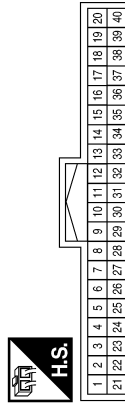

Terminal No.	Color of Wire	Signal Name
2	P	INPUT 5
3	SB	INPUT 4
4	V	INPUT 3
5	L	INPUT 2
6	R	INPUT 1

Terminal No.	Color of Wire	Signal Name
32	O	OUTPUT 5
33	GR	OUTPUT 4
34	G	OUTPUT 3
35	BR	OUTPUT 2
36	LG	OUTPUT 1
38	W/R	IGN SW
39	L	CAN-H
40	P	CAN-L

Connector No.	M20
Connector Name	BCM (BODY CONTROL MODULE)
Connector Color	BLACK

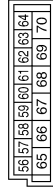

Terminal No.	Color of Wire	Signal Name
67	B	GND (POWER)
70	W	BAT (F/L)

A
B
C
D
E
F
G
H
I
J
K
EXL
M
N
O
P

FRONT FOG LAMP SYSTEM

< COMPONENT DIAGNOSIS >

Connector No.	M28
Connector Name	COMBINATION SWITCH
Connector Color	WHITE

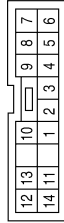

Terminal No.	Color of Wire	Signal Name
1	LG	INPUT 1
2	BR	INPUT 2
3	G	INPUT 3
4	GR	INPUT 4
5	O	INPUT 5
6	R	OUTPUT 1
7	L	OUTPUT 2
8	P	OUTPUT 5

Terminal No.	Color of Wire	Signal Name
9	SB	OUTPUT 4
10	V	OUTPUT 3

Connector No.	M91
Connector Name	WIRE TO WIRE
Connector Color	WHITE

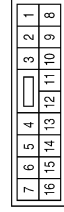

Terminal No.	Color of Wire	Signal Name
10	P	-
11	L	-

Connector No.	E10
Connector Name	WIRE TO WIRE
Connector Color	WHITE



Terminal No.	Color of Wire	Signal Name
6	W	-

Connector No.	E26
Connector Name	WIRE TO WIRE
Connector Color	WHITE



Terminal No.	Color of Wire	Signal Name
10	P	-
11	L	-

Connector No.	E101
Connector Name	FRONT FOG LAMP LH
Connector Color	BLACK



Terminal No.	Color of Wire	Signal Name
1	W	-
2	B	-

FRONT FOG LAMP SYSTEM

< COMPONENT DIAGNOSIS >

Connector No.	E102
Connector Name	FRONT FOG LAMP RH
Connector Color	BLACK



Terminal No.	Color of Wire	Signal Name
1	V	-
2	B	-

Connector No.	E122
Connector Name	IPDM E/R (INTELLIGENT POWER DISTRIBUTION MODULE ENGINE ROOM)
Connector Color	WHITE

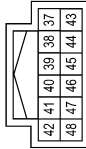

Terminal No.	Color of Wire	Signal Name
38	B	GND (SIGNAL)
39	L	CAN-H
40	P	CAN-L

Connector No.	E123
Connector Name	IPDM E/R (INTELLIGENT POWER DISTRIBUTION MODULE ENGINE ROOM)
Connector Color	BROWN

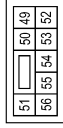

Terminal No.	Color of Wire	Signal Name
50	W	FR FOG LAMP LH
51	V	FR FOG LAMP RH

Connector No.	E124
Connector Name	IPDM E/R (INTELLIGENT POWER DISTRIBUTION MODULE ENGINE ROOM)
Connector Color	BLACK



Terminal No.	Color of Wire	Signal Name
59	B	GND (POWER)

A
B
C
D
E
F
G
H
I
J
K
EXL
M
N
O
P

AALIA0126GB

TURN SIGNAL AND HAZARD WARNING LAMP SYSTEM

< COMPONENT DIAGNOSIS >

TURN SIGNAL AND HAZARD WARNING LAMP SYSTEM

Wiring Diagram

INFOID:000000004056487

— : DATA LINE

TURN SIGNAL AND HAZARD WARNING LAMPS

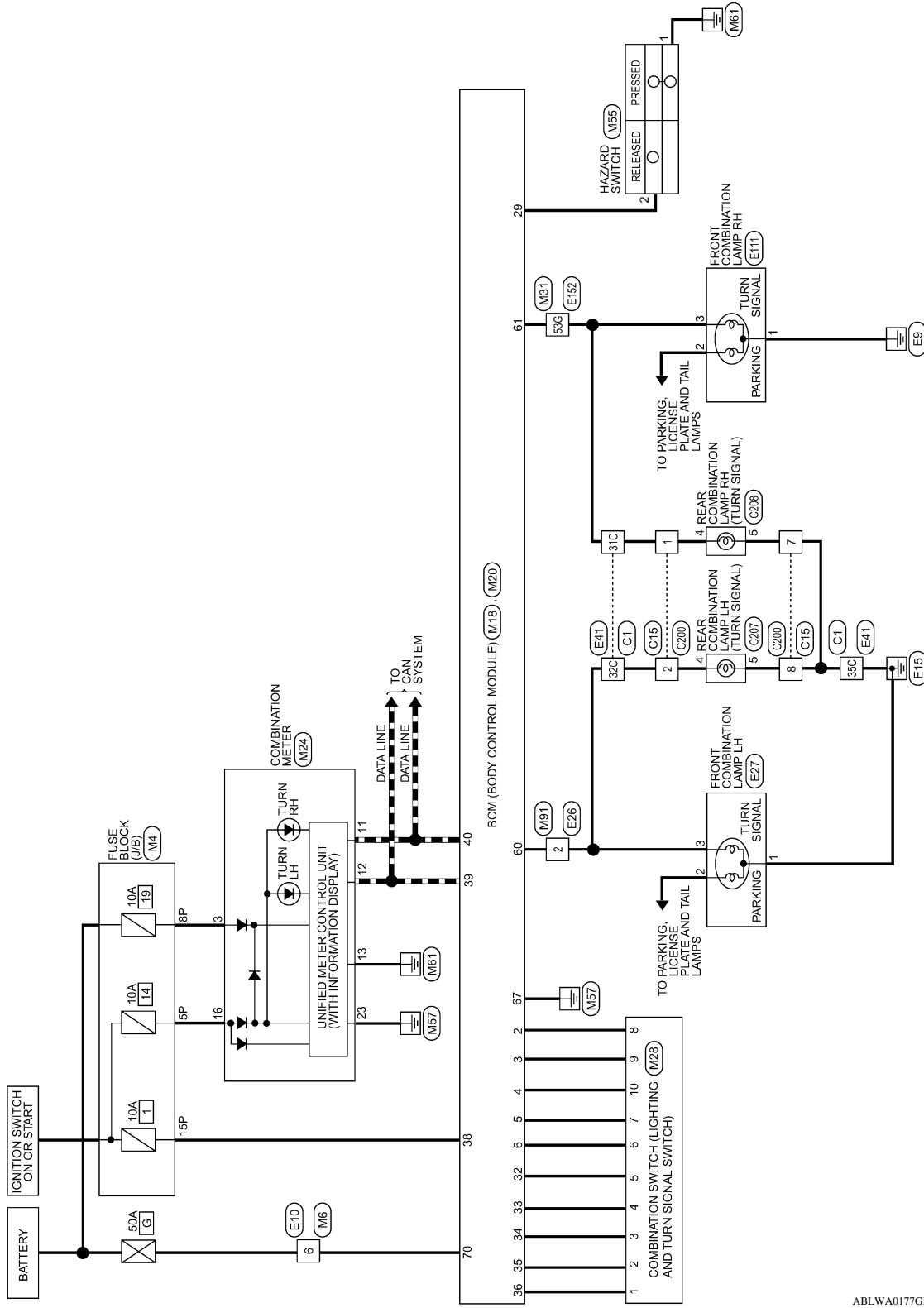

ABLWA0177GB

TURN SIGNAL AND HAZARD WARNING LAMP SYSTEM

< COMPONENT DIAGNOSIS >

TURN SIGNAL AND HAZARD WARNING LAMPS CONNECTORS

Connector No.	M4
Connector Name	FUSE BLOCK (J/B)
Connector Color	WHITE



Terminal No.	Color of Wire	Signal Name
5P	W/G	-
8P	R/Y	-
15P	W/R	-

Connector No.	M6
Connector Name	WIRE TO WIRE
Connector Color	WHITE



Terminal No.	Color of Wire	Signal Name
6	W	-

Connector No.	M18
Connector Name	BCM (BODY CONTROL MODULE)
Connector Color	WHITE

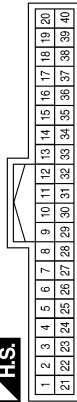

Terminal No.	Color of Wire	Signal Name
2	P	INPUT 5
3	SB	INPUT 4
4	V	INPUT 3
5	L	INPUT 2
6	R	INPUT 1
29	G	HAZARD SW

Terminal No.	Color of Wire	Signal Name
32	O	OUTPUT 5
33	GR	OUTPUT 4
34	G	OUTPUT 3
35	BR	OUTPUT 2
36	LG	OUTPUT 1
38	W/R	IGN SW
39	L	CAN-H
40	P	CAN-L

Connector No.	M20
Connector Name	BCM (BODY CONTROL MODULE)
Connector Color	WHITE



Terminal No.	Color of Wire	Signal Name
60	LG	FLASHER OUTPUT (LEFT)
61	G	FLASHER OUTPUT (RIGHT)
67	B	GND (POWER)
70	W	BAT (F/L)

ABLIA0604GB

A
B
C
D
E
F
G
H
I
J
K
L
M
N
O
P

EXL

TURN SIGNAL AND HAZARD WARNING LAMP SYSTEM

< COMPONENT DIAGNOSIS >

Connector No.	M24
Connector Name	COMBINATION METER
Connector Color	WHITE

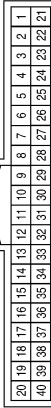

Terminal No.	Color of Wire	Signal Name
3	R/Y	BATTERY
11	P	CAN-L
12	L	CAN-H
13	GR	GROUND
16	W/G	RUN START
23	B	POWER GND

Connector No.	M28
Connector Name	COMBINATION SWITCH
Connector Color	WHITE

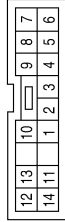

Terminal No.	Color of Wire	Signal Name
1	LG	INPUT 1
2	BR	INPUT 2
3	G	INPUT 3
4	GR	INPUT 4
5	O	INPUT 5
6	R	OUTPUT 1
7	L	OUTPUT 2
8	P	OUTPUT 5

Terminal No.	Color of Wire	Signal Name
9	SB	OUTPUT 4
10	V	OUTPUT 3

Connector No.	M31
Connector Name	WIRE TO WIRE
Connector Color	WHITE

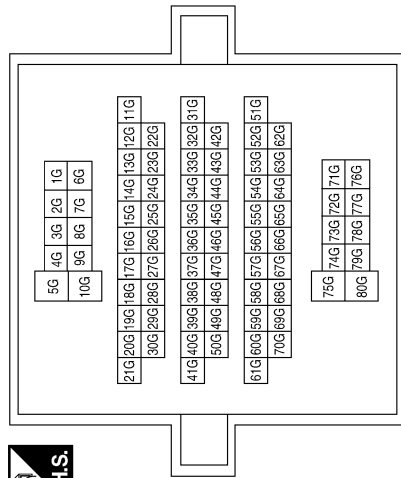

Terminal No.	Color of Wire	Signal Name
53G	G	-

Connector No.	M55
Connector Name	HAZARD SWITCH
Connector Color	WHITE

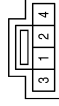



Terminal No.	Color of Wire	Signal Name
1	B	-
2	G	-

ABLIA0605GB

TURN SIGNAL AND HAZARD WARNING LAMP SYSTEM



< COMPONENT DIAGNOSIS >

Connector No.	M91
Connector Name	WIRE TO WIRE
Connector Color	WHITE



Terminal No.	2	LG	Signal Name	-
--------------	---	----	-------------	---

Connector No.	E10
Connector Name	WIRE TO WIRE
Connector Color	WHITE



Terminal No.	6	W	Signal Name	-
--------------	---	---	-------------	---

Connector No.	E26
Connector Name	WIRE TO WIRE
Connector Color	WHITE

Terminal No.	2	LG	Signal Name	-
--------------	---	----	-------------	---

Connector No.	E27
Connector Name	FRONT COMBINATION LAMP LH
Connector Color	GRAY



Terminal No.	Color of Wire	Signal Name
1	B	-
2	R	-
3	LG	-

Connector No.	E41
Connector Name	WIRE TO WIRE
Connector Color	BLACK

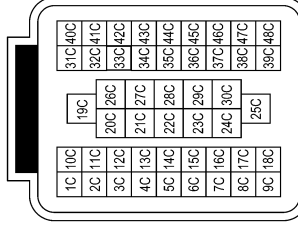
Terminal No.	Color of Wire	Signal Name
31C	L	-
32C	G	-
35C	B	-

Connector No.	E111
Connector Name	FRONT COMBINATION LAMP RH
Connector Color	GRAY

Terminal No.	Color of Wire	Signal Name
1	B	-
2	GR	-
3	G	-

ABLIA0606GB

TURN SIGNAL AND HAZARD WARNING LAMP SYSTEM

< COMPONENT DIAGNOSIS >

Connector No.	E152
Connector Name	WIRE TO WIRE
Connector Color	WHITE

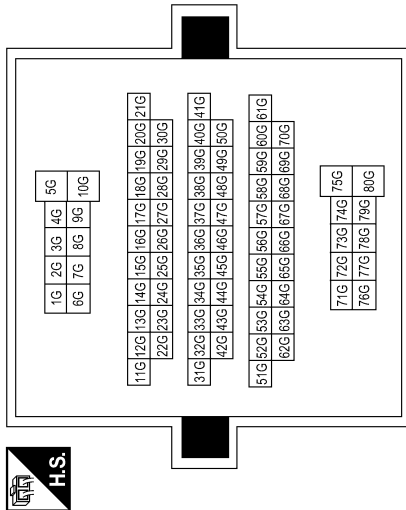

Connector No.	C1
Connector Name	WIRE TO WIRE
Connector Color	BLACK

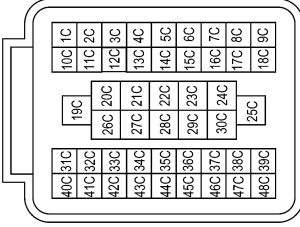

Connector No.	C15
Connector Name	WIRE TO WIRE
Connector Color	GRAY

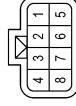

Terminal No.	Color of Wire	Signal Name
1	L	-
2	G	-
7	BR	-
8	B/Y	-

Terminal No.	Color of Wire	Signal Name
31C	L	-
32C	G	-
35C	B	-

Terminal No.	Color of Wire	Signal Name
53G	G	-

Connector No.	C200
Connector Name	WIRE TO WIRE
Connector Color	GRAY

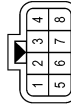

Connector No.	C207
Connector Name	REAR COMBINATION LAMP LH
Connector Color	GRAY

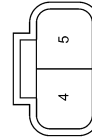

Terminal No.	Color of Wire	Signal Name
1	L	-
2	G	-
7	BR	-
8	B/Y	-

Connector No.	C208
Connector Name	REAR COMBINATION LAMP RH
Connector Color	GRAY

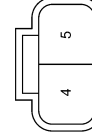

Terminal No.	Color of Wire	Signal Name
4	L	-
5	BR	-

PARKING, LICENSE PLATE AND TAIL LAMPS SYSTEM

< COMPONENT DIAGNOSIS >

PARKING, LICENSE PLATE AND TAIL LAMPS SYSTEM

Wiring Diagram

INFOID:000000004056488

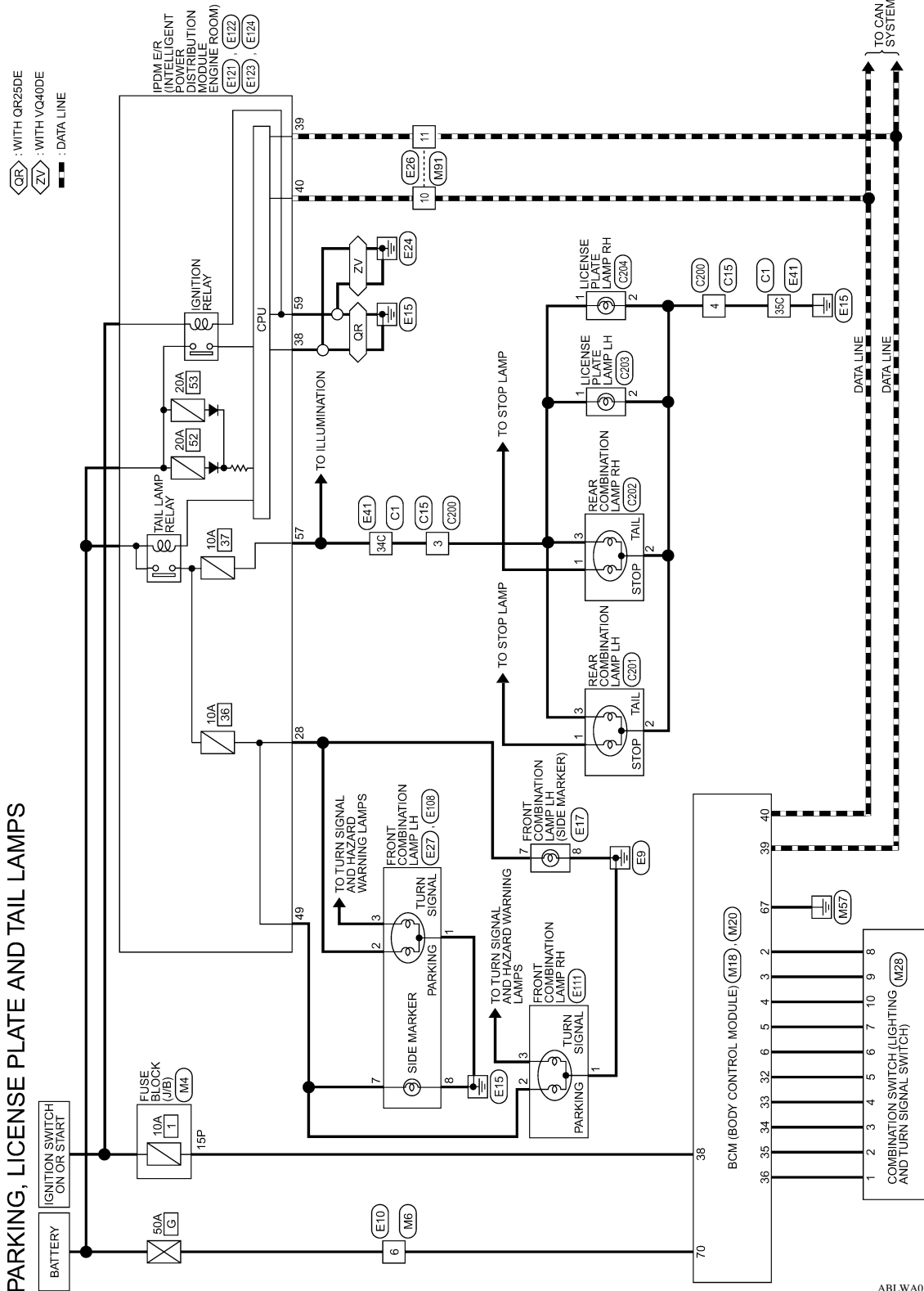

ABLWA0178GB

A
B
C
D
E
F
G
H
I
J
K
L
M
N
O
P

EXL

PARKING, LICENSE PLATE AND TAIL LAMPS SYSTEM

< COMPONENT DIAGNOSIS >

PARKING, LICENSE PLATE AND TAIL LAMPS CONNECTORS

Connector No.	M4
Connector Name	FUSE BLOCK (J/B)
Connector Color	WHITE



7P	8P	9P	4P	5P	2P	1P
10P	13P	12P	11P	10P	9P	8P

Terminal No.	Color of Wire	Signal Name
5P	W/G	-
8P	R/Y	-
15P	W/R	-

Connector No.	M6
Connector Name	WIRE TO WIRE
Connector Color	WHITE



3	2	1
6	5	4

Terminal No.	Color of Wire	Signal Name
6	W	-

Connector No.	M18
Connector Name	BCM (BODY CONTROL MODULE)
Connector Color	WHITE



1	2	3	4	5	6	7	8	9	10	11	12	13	14	15	16	17	18	19	20
21	22	23	24	25	26	27	28	29	30	31	32	33	34	35	36	37	38	39	40

Terminal No.	Color of Wire	Signal Name
2	P	INPUT 5
3	SB	INPUT 4
4	V	INPUT 3
5	L	INPUT 2
6	R	INPUT 1

Terminal No.	Color of Wire	Signal Name
32	O	OUTPUT 5
33	GR	OUTPUT 4
34	G	OUTPUT 3
35	BR	OUTPUT 2
36	LG	OUTPUT 1
38	W/R	IGN SW
39	L	CAN-H
40	P	CAN-L

Connector No.	M20
Connector Name	BCM (BODY CONTROL MODULE)
Connector Color	BLACK



56	57	58	59	60	61	62	63	64
65	66	67	68	69	70			

Terminal No.	Color of Wire	Signal Name
67	B	GND (POWER)
70	W	BAT (F/L)

ABLIA0608GB

PARKING, LICENSE PLATE AND TAIL LAMPS SYSTEM

< COMPONENT DIAGNOSIS >

Connector No.	M91
Connector Name	WIRE TO WIRE
Connector Color	WHITE

7	6	5	4	3	2	1
16	15	14	13	12	11	10



Terminal No.	Color of Wire	Signal Name
10	P	-
11	L	-

Terminal No.	Color of Wire	Signal Name
9	SB	OUTPUT 4
10	V	OUTPUT 3

Connector No.	M28
Connector Name	COMBINATION SWITCH
Connector Color	WHITE

12	13	10	9	8	7
14	11	1	2	3	4



Terminal No.	Color of Wire	Signal Name
1	LG	INPUT 1
2	BR	INPUT 2
3	G	INPUT 3
4	GR	INPUT 4
5	O	INPUT 5
6	R	OUTPUT 1
7	L	OUTPUT 2
8	P	OUTPUT 5

Connector No.	E26
Connector Name	WIRE TO WIRE
Connector Color	WHITE

1	2	3	4	5	6	7
8	9	10	11	12	13	14



Connector No.	E17
Connector Name	FRONT COMBINATION LAMP LH
Connector Color	GRAY



Terminal No.	Color of Wire	Signal Name
10	P	-
11	L	-

Terminal No.	Color of Wire	Signal Name
7	R	-
8	B	-

Connector No.	E10
Connector Name	WIRE TO WIRE
Connector Color	WHITE

1	2	3
4	5	6



Terminal No.	Color of Wire	Signal Name
6	W	-

AALIA0127GB

PARKING, LICENSE PLATE AND TAIL LAMPS SYSTEM

< COMPONENT DIAGNOSIS >

Connector No.	E108
Connector Name	FRONT COMBINATION LAMP RH
Connector Color	GRAY



Terminal No.	Color of Wire	Signal Name
7	R	-
8	B	-

Connector No.	E41
Connector Name	WIRE TO WIRE
Connector Color	BLACK

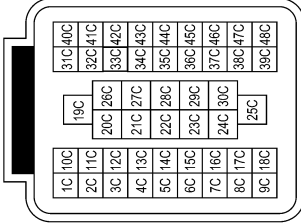

Terminal No.	Color of Wire	Signal Name
34C	GR	-
35C	B	-

Connector No.	E27
Connector Name	FRONT COMBINATION LAMP LH
Connector Color	GRAY



Terminal No.	Color of Wire	Signal Name
1	B	-
2	R	-
3	LG	-

Connector No.	E122
Connector Name	IPDM E/R (INTELLIGENT POWER DISTRIBUTION MODULE ENGINE ROOM)
Connector Color	WHITE

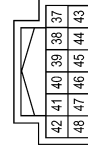

Terminal No.	Color of Wire	Signal Name
38	B	GND (SIGNAL)
39	L	CAN-H
40	P	CAN-L

Connector No.	E121
Connector Name	IPDM E/R (INTELLIGENT POWER DISTRIBUTION MODULE ENGINE ROOM)
Connector Color	BROWN

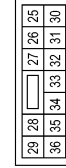

Terminal No.	Color of Wire	Signal Name
28	R	ILLUMINATION

Connector No.	E111
Connector Name	FRONT COMBINATION LAMP RH
Connector Color	GRAY



Terminal No.	Color of Wire	Signal Name
1	B	-
2	GR	-
3	G	-

ABLIA0609GB

PARKING, LICENSE PLATE AND TAIL LAMPS SYSTEM

< COMPONENT DIAGNOSIS >

Connector No.	C1
Connector Name	WIRE TO WIRE
Connector Color	BLACK

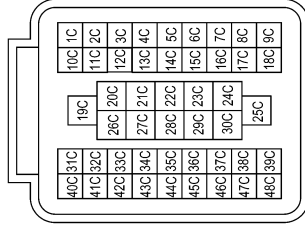

Terminal No.	Color of Wire	Signal Name
34C	GR	-
35C	B	-

Connector No.	E124
Connector Name	IPDM E/R (INTELLIGENT POWER DISTRIBUTION MODULE ENGINE ROOM)
Connector Color	BLACK



Terminal No.	Color of Wire	Signal Name
57	GR	TAIL LAMP
59	B	GND (POWER)

Connector No.	E123
Connector Name	IPDM E/R (INTELLIGENT POWER DISTRIBUTION MODULE ENGINE ROOM)
Connector Color	BROWN

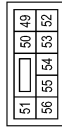

Terminal No.	Color of Wire	Signal Name
49	GR	ILLUMINATION

Connector No.	C201
Connector Name	REAR COMBINATION LAMP LH
Connector Color	BROWN



Terminal No.	Color of Wire	Signal Name
1	Y	-
2	B	-
3	GR	-

Connector No.	C200
Connector Name	WIRE TO WIRE
Connector Color	GRAY

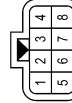

Terminal No.	Color of Wire	Signal Name
3	GR	-
4	B	-

Connector No.	C15
Connector Name	WIRE TO WIRE
Connector Color	GRAY

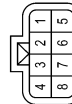

Terminal No.	Color of Wire	Signal Name
3	GR	-
4	B	-

ABLIA0610GB

PARKING, LICENSE PLATE AND TAIL LAMPS SYSTEM

< COMPONENT DIAGNOSIS >

Connector No.	C202
Connector Name	REAR COMBINATION LAMP RH
Connector Color	BROWN



Terminal No.	Color of Wire	Signal Name
1	R	-
2	B	-
3	V	-

Connector No.	C203
Connector Name	LICENSE PLATE LAMP LH
Connector Color	GRAY



Terminal No.	Color of Wire	Signal Name
1	V	-
2	B	-

Connector No.	C204
Connector Name	LICENSE PLATE LAMP RH
Connector Color	GRAY



Terminal No.	Color of Wire	Signal Name
1	V	-
2	B	-

AWLIA0632GB

STOP LAMP

< COMPONENT DIAGNOSIS >

STOP LAMP

Wiring Diagram

INFOID:000000004056489

◊ A : WITH A/T
 ◊ M : WITH M/T
 ◊ WV : WITH VDC

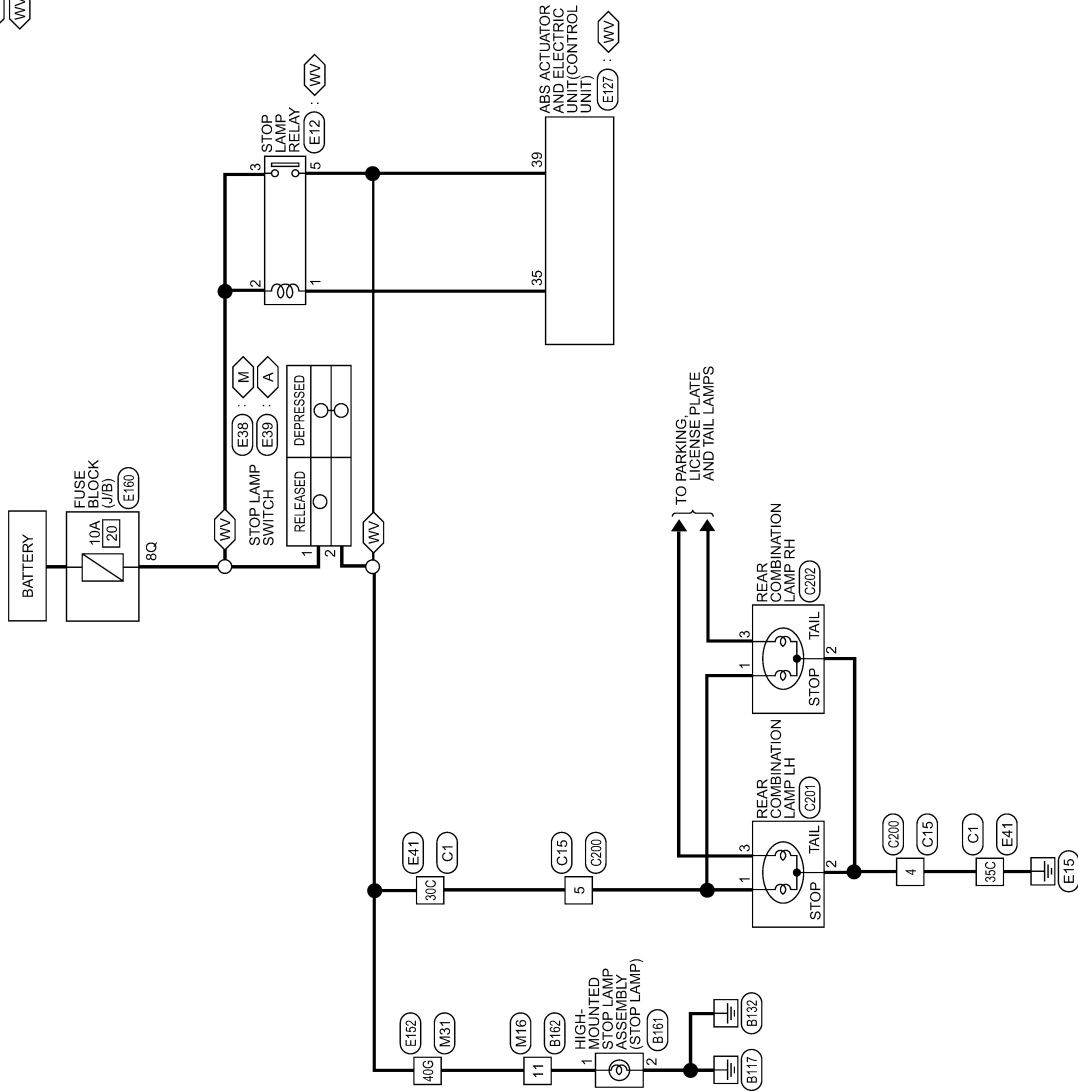

STOP LAMP

ABLWA0179GB

A
B
C
D
E
F
G
H
I
J
K
EXL
M
N
O
P

STOP LAMP

< COMPONENT DIAGNOSIS >

STOP LAMP CONNECTORS

Connector No.	M16
Connector Name	WIRE TO WIRE
Connector Color	WHITE

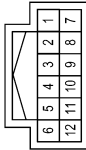

Terminal No.	Color of Wire	Signal Name
11	L	-

Connector No.	M31
Connector Name	WIRE TO WIRE
Connector Color	WHITE

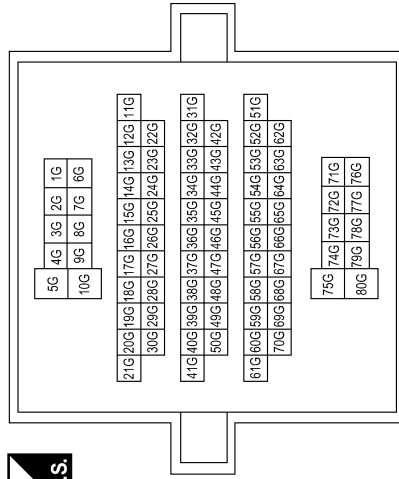

Terminal No.	Color of Wire	Signal Name
40G	L	-

Connector No.	E12
Connector Name	STOP LAMP RELAY
Connector Color	BLUE



Terminal No.	Color of Wire	Signal Name
1	V	-
2	R/B	-
3	R/B	-
5	G	-

Connector No.	E38
Connector Name	STOP LAMP SWITCH (WITH M/T)
Connector Color	BLACK



Terminal No.	Color of Wire	Signal Name
1	R/B	-
2	Y	-

Connector No.	E39
Connector Name	STOP LAMP SWITCH (WITH A/T)
Connector Color	WHITE



Terminal No.	Color of Wire	Signal Name
1	R/B	-
2	Y	-

ABLIA0611GB

STOP LAMP

< COMPONENT DIAGNOSIS >

Connector No.	E41
Connector Name	WIRE TO WIRE
Connector Color	BLACK

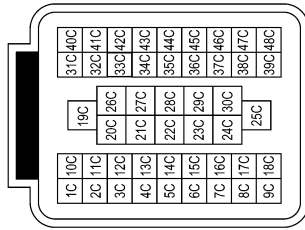

Terminal No.	Color of Wire	Signal Name
30C	Y	-
35C	B	-

Connector No.	E127
Connector Name	ABS ACTUATOR AND ELECTRIC UNIT (CONTROL UNIT) (WITH VDC)
Connector Color	BLACK

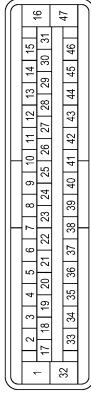

Terminal No.	Color of Wire	Signal Name
35	V	STOP LAMP SW ON
39	SB	STOP LAMP SW

Connector No.	E152
Connector Name	WIRE TO WIRE
Connector Color	WHITE

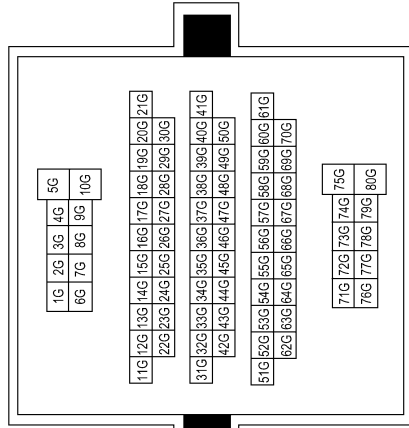

Terminal No.	Color of Wire	Signal Name
40G	L	-

Connector No.	E160
Connector Name	FUSE BLOCK (J/B)
Connector Color	WHITE



Terminal No.	Color of Wire	Signal Name
8Q	R/B	-

ABLIA0612GB

A B C D E F G H I J K L M N O P

EXL

STOP LAMP

< COMPONENT DIAGNOSIS >

Connector No.	C1
Connector Name	WIRE TO WIRE
Connector Color	BLACK

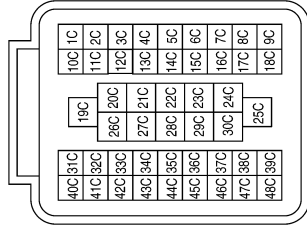

Terminal No.	Color of Wire	Signal Name
30C	Y	-
35C	B	-

Connector No.	B162
Connector Name	WIRE TO WIRE
Connector Color	WHITE

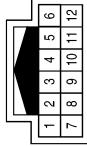

Terminal No.	Color of Wire	Signal Name
11	L	-

Connector No.	B161
Connector Name	HIGH MOUNTED STOP LAMP ASSEMBLY
Connector Color	WHITE

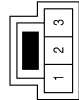

Terminal No.	Color of Wire	Signal Name
1	L	-
2	B	-

Connector No.	C201
Connector Name	REAR COMBINATION LAMP LH
Connector Color	BROWN



Terminal No.	Color of Wire	Signal Name
1	Y	-
2	B	-
3	GR	-

Connector No.	C200
Connector Name	WIRE TO WIRE
Connector Color	GRAY

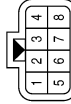

Terminal No.	Color of Wire	Signal Name
4	B	-
5	Y	-

Connector No.	C15
Connector Name	WIRE TO WIRE
Connector Color	GRAY

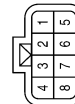

Terminal No.	Color of Wire	Signal Name
4	B	-
5	Y	-

ABLIA0613GB

STOP LAMP

< COMPONENT DIAGNOSIS >

A

B

C

D

E

F

G

H

I

J

K

EXL

M

N

O

P

Connector No.	C202
Connector Name	REAR COMBINATION LAMP RH
Connector Color	BROWN



Terminal No.	Color of Wire	Signal Name
1	R	-
2	B	-
3	V	-

ABLIA0625GB

BACK-UP LAMP

< COMPONENT DIAGNOSIS >

BACK-UP LAMP

Wiring Diagram

INFOID:000000004056490

BACK-UP LAMP

- (A) : WITH A/T
- (M) : WITH M/T
- (T7) : TRAILER TOW 7 PIN

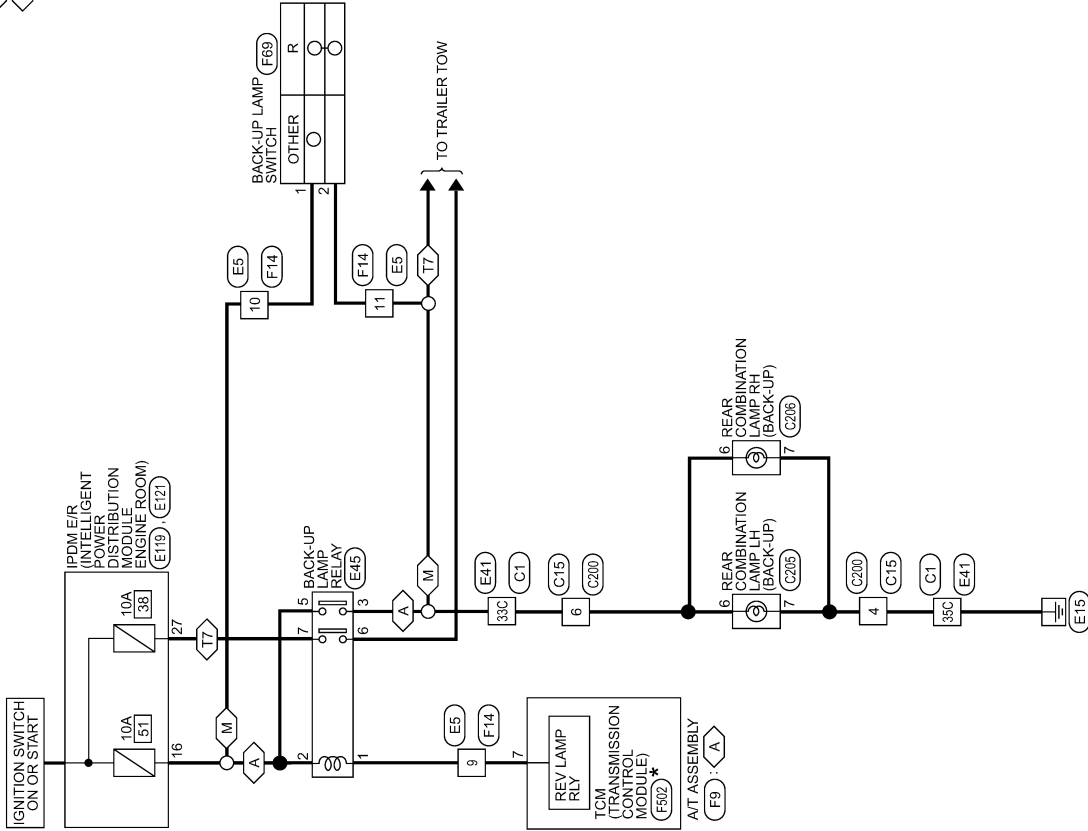

* : THIS CONNECTOR IS NOT SHOWN IN "HARNES LAYOUT" OF PG SECTION

ABLWA0180GB

BACK-UP LAMP

< COMPONENT DIAGNOSIS >

BACK-UP LAMP CONNECTORS

Connector No.	E5
Connector Name	WIRE TO WIRE
Connector Color	WHITE

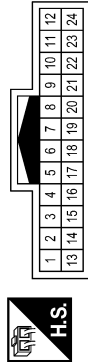

Terminal No.	Color of Wire	Signal Name
9	LG	-
10	W/G	-
11	SB	-

Connector No.	E41
Connector Name	WIRE TO WIRE
Connector Color	BLACK

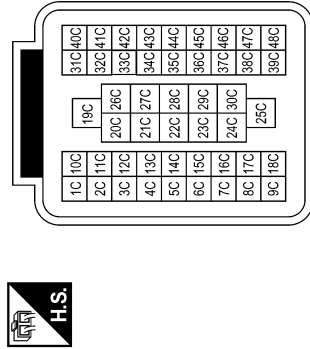

Terminal No.	Color of Wire	Signal Name
33C	SB	-
35C	B	-

Connector No.	E45
Connector Name	BACK-UP LAMP RELAY (WITH A/T)
Connector Color	BROWN



Terminal No.	Color of Wire	Signal Name
1	LG	-
2	W/G	-
3	SB	-
5	W/G	-
6	Y	-
7	W	-

Connector No.	E119
Connector Name	IPDM E/R (INTELLIGENT POWER DISTRIBUTION MODULE ENGINE ROOM)
Connector Color	WHITE

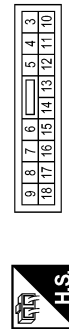

Terminal No.	Color of Wire	Signal Name
16	W/G	REVERSE LAMP

Connector No.	E121
Connector Name	IPDM E/R (INTELLIGENT POWER DISTRIBUTION MODULE ENGINE ROOM)
Connector Color	BROWN

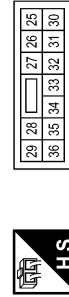

Terminal No.	Color of Wire	Signal Name
27	W	T TOW REV LAMP

Connector No.	F9
Connector Name	A/T ASSEMBLY
Connector Color	GREEN



Terminal No.	Color of Wire	Signal Name
7	LG	-

ABLIA0614GB

A
B
C
D
E
F
G
H
I
J
K
L
M
N
O
P

EXL

BACK-UP LAMP

< COMPONENT DIAGNOSIS >

Connector No.	F502
Connector Name	TCM (TRANSMISSION CONTROL MODULE)
Connector Color	GRAY

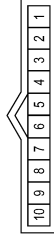

Terminal No.	Color of Wire	Signal Name
7	O	REV LAMP RLY

Connector No.	F69
Connector Name	BACK-UP LAMP SWITCH
Connector Color	WHITE



Terminal No.	Color of Wire	Signal Name
1	W/G	-
2	SB	-

Connector No.	F14
Connector Name	WIRE TO WIRE
Connector Color	WHITE

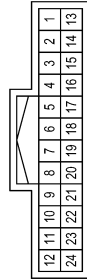

Terminal No.	Color of Wire	Signal Name
9	LG	-
10	W/G	-
11	SB	-

Connector No.	C200
Connector Name	WIRE TO WIRE
Connector Color	GRAY

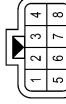

Terminal No.	Color of Wire	Signal Name
4	B	-
6	SB	-

Connector No.	C15
Connector Name	WIRE TO WIRE
Connector Color	GRAY



Terminal No.	Color of Wire	Signal Name
4	B	-
6	SB	-

Connector No.	C1
Connector Name	WIRE TO WIRE
Connector Color	BLACK

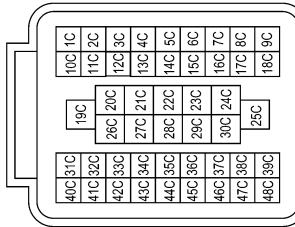

Terminal No.	Color of Wire	Signal Name
33C	SB	-
35C	B	-

ABLIA0615GB

BACK-UP LAMP

< COMPONENT DIAGNOSIS >

Connector No.	C206
Connector Name	REAR COMBINATION LAMP RH
Connector Color	GRAY



Terminal No.	Color of Wire	Signal Name
6	O	-
7	B	-

Connector No.	C205
Connector Name	REAR COMBINATION LAMP LH
Connector Color	GRAY



Terminal No.	Color of Wire	Signal Name
6	SB	-
7	B	-

A

B

C

D

E

F

G

H

I

J

K

EXL

M

N

O

P

ABLIA0682GB

TRAILER TOW

< COMPONENT DIAGNOSIS >

TRAILER TOW

Wiring Diagram

INFOID:000000004056491

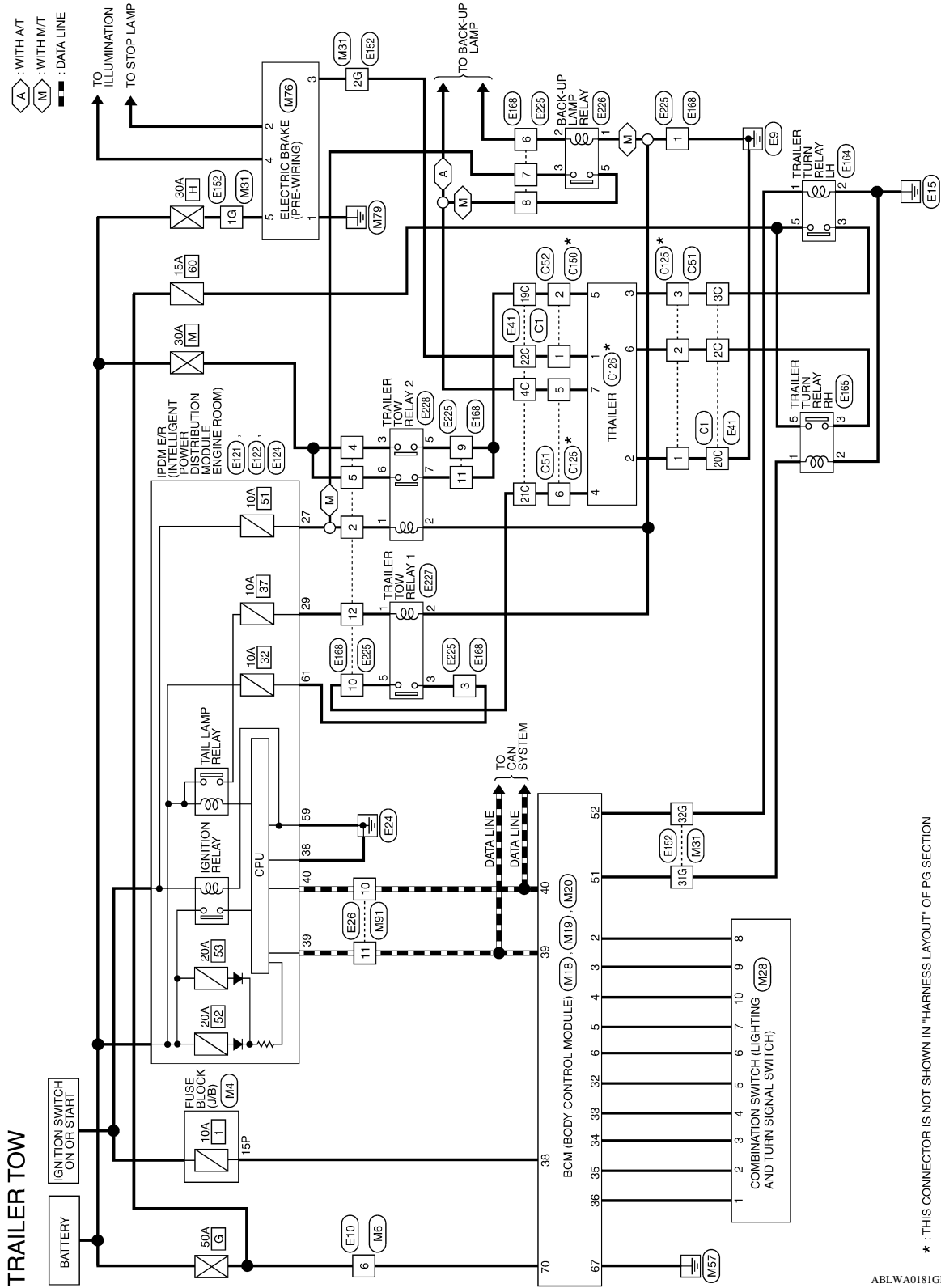

ABLWA0181GB

TRAILER TOW CONNECTORS

Connector No.	M4
Connector Name	FUSE BLOCK (J/B)
Connector Color	WHITE



Terminal No.	Color of Wire	Signal Name
15P	W/R	-

Connector No.	M6
Connector Name	WIRE TO WIRE
Connector Color	WHITE



Terminal No.	Color of Wire	Signal Name
6	W	-

Connector No.	M18
Connector Name	BCM (BODY CONTROL MODULE)
Connector Color	WHITE



Terminal No.	Color of Wire	Signal Name
2	P	INPUT 5
3	SB	INPUT 4
4	V	INPUT 3
5	L	INPUT 2
6	R	INPUT 1

Terminal No.	Color of Wire	Signal Name
32	O	OUTPUT 5
33	GR	OUTPUT 4
34	G	OUTPUT 3
35	BR	OUTPUT 2
36	LG	OUTPUT 1
38	W/R	IGN SW
39	L	CAN-H
40	P	CAN-L

Connector No.	M19
Connector Name	BCM (BODY CONTROL MODULE)
Connector Color	WHITE

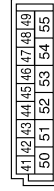

Terminal No.	Color of Wire	Signal Name
51	G	TRAILER FLASHER OUTPUT(RIGHT)
52	V	TRAILER FLASHER OUTPUT(LEFT)

ABLIA0616GB

TRAILER TOW

< COMPONENT DIAGNOSIS >

Connector No.	M20
Connector Name	BCM (BODY CONTROL MODULE)
Connector Color	BLACK



Terminal No.	Color of Wire	Signal Name
67	B	GND (POWER)
70	W	BAT (F/L)

Connector No.	M28
Connector Name	COMBINATION SWITCH
Connector Color	WHITE

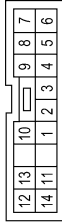

Terminal No.	Color of Wire	Signal Name
1	LG	INPUT 1
2	BR	INPUT 2
3	G	INPUT 3
4	GR	INPUT 4
5	O	INPUT 5
6	R	OUTPUT 1
7	L	OUTPUT 2
8	P	OUTPUT 5
9	SB	OUTPUT 4
10	V	OUTPUT 3

Connector No.	M31
Connector Name	WIRE TO WIRE
Connector Color	WHITE

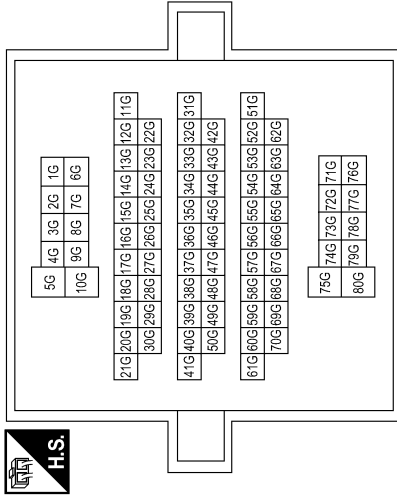

Terminal No.	Color of Wire	Signal Name
1G	O	-
2G	BR	-
31G	O	-
32G	LG	-

Connector No.	M76
Connector Name	ELECTRIC BRAKE (PRE-WIRING)
Connector Color	WHITE



Terminal No.	Color of Wire	Signal Name
1	B	GROUND
2	LG	STOP
3	BR	-
4	R	ILL (TAIL)
5	O	+B

Connector No.	M91
Connector Name	WIRE TO WIRE
Connector Color	WHITE

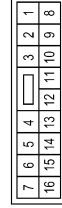

Terminal No.	Color of Wire	Signal Name
10	P	-
11	L	-

ABLIA0617GB

TRAILER TOW

< COMPONENT DIAGNOSIS >

Connector No.	E10
Connector Name	WIRE TO WIRE
Connector Color	WHITE



1	2	3
4	5	6

Terminal No.	Color of Wire	Signal Name
6	W	-

Connector No.	E26
Connector Name	WIRE TO WIRE
Connector Color	WHITE



1	2	3	4	5	6	7
8	9	10	11	12	13	14
15	16					

Terminal No.	Color of Wire	Signal Name
10	P	-
11	L	-

Connector No.	E41
Connector Name	WIRE TO WIRE
Connector Color	BLACK

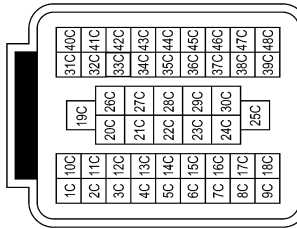

Terminal No.	Color of Wire	Signal Name
2C	G	-
3C	V	-
4C	Y	-
19C	V	-
20C	B	-
21C	R	-
22C	BR	-

Connector No.	E121
Connector Name	IPDM E/R (INTELLIGENT POWER DISTRIBUTION MODULE ENGINE ROOM)
Connector Color	BROWN



29	28	27	26	25
36	35	34	33	32
31	30			

Terminal No.	Color of Wire	Signal Name
27	W	T TOW REV LAMP
29	G	TRAILER RLY CONT

ABLIA0618GB

A
B
C
D
E
F
G
H
I
J
K
EXL
M
N
O
P

TRAILER TOW

< COMPONENT DIAGNOSIS >

Connector No.	E122
Connector Name	IPDM E/R (INTELLIGENT POWER DISTRIBUTION MODULE ENGINE ROOM)
Connector Color	WHITE

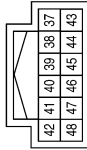

Terminal No.	Color of Wire	Signal Name
38	B	GND (SIGNAL)
39	L	CAN-H
40	P	CAN-L

Connector No.	E124
Connector Name	IPDM E/R (INTELLIGENT POWER DISTRIBUTION MODULE ENGINE ROOM)
Connector Color	BLACK



Terminal No.	Color of Wire	Signal Name
59	B	GND (POWER)
61	R/B	TRAILER RLY SUPPLY

Connector No.	E152
Connector Name	WIRE TO WIRE
Connector Color	WHITE

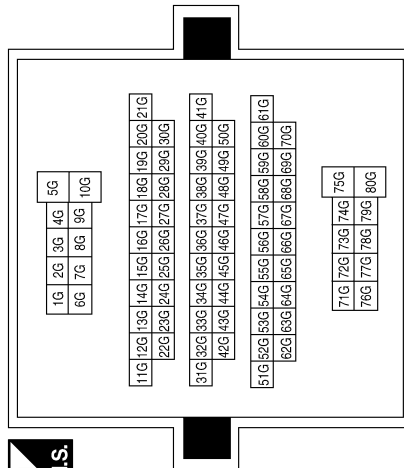

Terminal No.	Color of Wire	Signal Name
1G	O	-
2G	BR	-
31G	O	-
32G	LG	-

Connector No.	E164
Connector Name	TRAILER TURN RELAY LH
Connector Color	BLUE



Terminal No.	Color of Wire	Signal Name
1	LG	-
2	B	-
3	V	-
5	L	-

TRAILER TOW

< COMPONENT DIAGNOSIS >

Terminal No.	Color of Wire	Signal Name
4	GR	-
5	Y	-
6	P	-
7	W/G	-
8	Y	-
9	V	-
10	R	-
11	V	-
12	G	-

Connector No.	E168
Connector Name	WIRE TO WIRE
Connector Color	WHITE

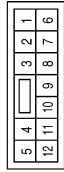

Terminal No.	Color of Wire	Signal Name
1	B	-
2	W/G	-
3	R/B	-

Connector No.	E165
Connector Name	TRAILER TURN RELAY RH
Connector Color	BLUE



Terminal No.	Color of Wire	Signal Name
1	O	-
2	B	-
3	G	-
5	L	-

Connector No.	E226
Connector Name	BACK-UP LAMP RELAY (WITH W/T)
Connector Color	BLUE



Terminal No.	Color of Wire	Signal Name
6	BR	-
7	W/G	-
8	SB	-
9	L	-
10	R	-
11	O	-
12	G	-

Connector No.	E225
Connector Name	WIRE TO WIRE
Connector Color	WHITE



Terminal No.	Color of Wire	Signal Name
1	B	-
2	W/G	-
3	R/B	-
4	GR	-
5	W	-

Terminal No.	Color of Wire	Signal Name
1	B	-
2	BR	-
3	W/G	-
5	SB	-

ABLIA0620GB

TRAILER TOW

< COMPONENT DIAGNOSIS >

Connector No.	E227
Connector Name	TRAILER TOW RELAY 1
Connector Color	BLUE



Terminal No.	Color of Wire	Signal Name
1	G	-
2	B	-
3	R/B	-
5	R	-

Connector No.	E228
Connector Name	TRAILER TOW RELAY 2
Connector Color	BROWN



Terminal No.	Color of Wire	Signal Name
1	W/G	-
2	B	-
3	GR	-
5	L	-
6	W	-
7	O	-

Connector No.	C1
Connector Name	WIRE TO WIRE
Connector Color	BLACK

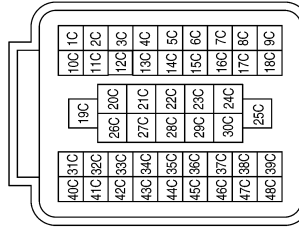

Terminal No.	Color of Wire	Signal Name
2C	G	-
3C	V	-
4C	Y	-
19C	V	-
20C	B	-
21C	R	-
22C	BR	-

Connector No.	C51
Connector Name	WIRE TO WIRE
Connector Color	GRAY

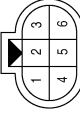

Terminal No.	Color of Wire	Signal Name
1	B	-
2	G	-
3	V	-
5	Y	-
6	R	-

ABLIA0681GB

TRAILER TOW

< COMPONENT DIAGNOSIS >

Connector No.	C52
Connector Name	WIRE TO WIRE
Connector Color	BLACK



Terminal No.	Color of Wire	Signal Name
1	BR	-
2	V	-

Connector No.	C125
Connector Name	WIRE TO WIRE (TRAILER TOW 7PIN)
Connector Color	GRAY

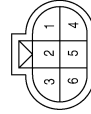

Terminal No.	Color of Wire	Signal Name
1	W	-
2	G	-
3	V	-
5	B	-
6	BR	-

Connector No.	C126
Connector Name	TRAILER
Connector Color	BLACK

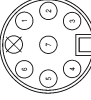

Terminal No.	Color of Wire	Signal Name
1	R	-
2	W	-
3	V	-
4	BR	-
5	L	-
6	G	-
7	B	-

Connector No.	C150
Connector Name	WIRE TO WIRE
Connector Color	BLACK



Terminal No.	Color of Wire	Signal Name
1	R	-
2	L	-

ABLIA0809GB

A
B
C
D
E
F
G
H
I
J
K
EXL
M
N
O
P

BCM (BODY CONTROL MODULE)

< ECU DIAGNOSIS >

ECU DIAGNOSIS

BCM (BODY CONTROL MODULE)

Reference Value

INFOID:000000004454837

VALUES ON THE DIAGNOSIS TOOL

Monitor Item	Condition	Value/Status
IGN ON SW	Ignition switch OFF or ACC	OFF
	Ignition switch ON	ON
KEY ON SW	Mechanical key is removed from key cylinder	OFF
	Mechanical key is inserted to key cylinder	ON
CDL LOCK SW	Door lock/unlock switch does not operate	OFF
	Press door lock/unlock switch to the lock side	ON
CDL UNLOCK SW	Door lock/unlock switch does not operate	OFF
	Press door lock/unlock switch to the unlock side	ON
DOOR SW-DR	Driver's door closed	OFF
	Driver's door opened	ON
DOOR SW-AS	Passenger door closed	OFF
	Passenger door opened	ON
DOOR SW-RR	Rear RH door closed	OFF
	Rear RH door opened	ON
DOOR SW-RL	Rear LH door closed	OFF
	Rear LH door opened	ON
BACK DOOR SW	NOTE: The item is indicated, but not monitored.	—
KEY CYL LK-SW	Other than driver door key cylinder LOCK position	OFF
	Driver door key cylinder LOCK position	ON
KEY CYL UN-SW	Other than driver door key cylinder UNLOCK position	OFF
	Driver door key cylinder UNLOCK position	ON
KEYLESS LOCK	"LOCK" button of key fob is not pressed	OFF
	"LOCK" button of key fob is pressed	ON
KEYLESS UNLOCK	"UNLOCK" button of key fob is not pressed	OFF
	"UNLOCK" button of key fob is pressed	ON
ACC ON SW	Ignition switch OFF	OFF
	Ignition switch ACC or ON	ON
REAR DEF SW	Rear window defogger switch OFF	OFF
	Rear window defogger switch ON	ON
LIGHT SW 1ST	Lighting switch OFF	OFF
	Lighting switch 1ST	ON
BUCKLE SW	The seat belt (driver side) is unfastened. [Seat belt switch (driver side) OFF]	OFF
	The seat belt (driver side) is fastened. [Seat belt switch (driver side) ON]	ON
KEYLESS PANIC	PANIC button of key fob is not pressed	OFF
	PANIC button of key fob is pressed	ON

BCM (BODY CONTROL MODULE)

< ECU DIAGNOSIS >

Monitor Item	Condition	Value/Status	
KEYLESS TRUNK	NOTE: The item is indicated, but not monitored.	OFF	A
TRNK OPN MNTR	NOTE: The item is indicated, but not monitored.	OFF	B
RKE LCK-UNLCK	LOCK/UNLOCK button of key fob is not pressed and held simultaneously	OFF	C
	LOCK/UNLOCK button of key fob is pressed and held simultaneously	ON	
RKE KEEP UNLK	UNLOCK button of key fob is not pressed	OFF	D
	UNLOCK button of key fob is pressed and held	ON	
HI BEAM SW	Lighting switch OFF	OFF	E
	Lighting switch HI	ON	
HEAD LAMP SW 1	Lighting switch OFF	OFF	F
	Lighting switch 2ND	ON	
HEAD LAMP SW 2	Lighting switch OFF	OFF	F
	Lighting switch 2ND	ON	
AUTO LIGHT SW	Lighting switch OFF	OFF	G
	Lighting switch AUTO	ON	
PASSING SW	Other than lighting switch PASS	OFF	H
	Lighting switch PASS	ON	
FR FOG SW	Front fog lamp switch OFF	OFF	I
	Front fog lamp switch ON	ON	
RR FOG SW	NOTE: The item is indicated, but not monitored.	OFF	I
TURN SIGNAL R	Turn signal switch OFF	OFF	J
	Turn signal switch RH	ON	
TURN SIGNAL L	Turn signal switch OFF	OFF	K
	Turn signal switch LH	ON	
CARGO LAMP SW	Cargo lamp switch OFF	OFF	EXL
	Cargo lamp switch ON	ON	
OPTICAL SENSOR	Bright outside vehicle	5V	EXL
	Dark outside vehicle	0V	
IGN SW CAN	Ignition switch OFF or ACC	OFF	M
	Ignition switch ON	ON	
FR WIPER HI	Front wiper switch OFF	OFF	N
	Front wiper switch HI	ON	
FR WIPER LOW	Front wiper switch OFF	OFF	O
	Front wiper switch LO	ON	
FR WIPER INT	Front wiper switch OFF	OFF	P
	Front wiper switch INT	ON	
FR WASHER SW	Front washer switch OFF	OFF	P
	Front washer switch ON	ON	
INT VOLUME	Wiper intermittent dial is in a dial position 1 - 7	1 - 7	
FR WIPER STOP	Any position other than front wiper stop position	OFF	
	Front wiper stop position	ON	
VEHICLE SPEED	While driving	Equivalent to speedometer reading	

BCM (BODY CONTROL MODULE)

< ECU DIAGNOSIS >

Monitor Item	Condition	Value/Status
RR WIPER ON	NOTE: The item is indicated, but not monitored.	OFF
RR WIPER INT	NOTE: The item is indicated, but not monitored.	OFF
RR WASHER SW	NOTE: The item is indicated, but not monitored.	OFF
RR WIPER STOP	NOTE: The item is indicated, but not monitored.	OFF
RR WIPER STP2	NOTE: The item is indicated, but not monitored.	OFF
H/L WASH SW	NOTE: The item is indicated, but not monitored.	OFF
HAZARD SW	Hazard switch OFF	OFF
	Hazard switch ON	ON
BRAKE SW	Brake pedal is not depressed	OFF
	Brake pedal is depressed	ON
FAN ON SIG	Blower fan motor switch OFF	OFF
	Blower fan motor switch ON (other than OFF)	ON
AIR COND SW	Compressor ON is not requested from auto amp. (A/C indicator OFF, blower fan motor switch OFF or etc.)	OFF
	Compressor ON is requested from auto amp. (A/C indicator ON and blower fan motor switch ON).	ON
TRNK OPNR SW	NOTE: The item is indicated, but not monitored.	OFF
TRUNK CYL SW	NOTE: The item is indicated, but not monitored.	OFF
HOOD SW	NOTE: The item is indicated, but not monitored.	OFF
OIL PRESS SW	<ul style="list-style-type: none"> • Ignition switch OFF or ACC • Engine running 	OFF
	Ignition switch ON	ON
AIR PRESS FL	Ignition switch ON (Only when the signal from the transmitter is received)	Air pressure of front LH tire
AIR PRESS FR	Ignition switch ON (Only when the signal from the transmitter is received)	Air pressure of front RH tire
AIR PRESS RR	Ignition switch ON (Only when the signal from the transmitter is received)	Air pressure of rear RH tire
AIR PRESS RL	Ignition switch ON (Only when the signal from the transmitter is received)	Air pressure of rear LH tire
ID REGST FL1	ID of front LH tire transmitter is registered	DONE
	ID of front LH tire transmitter is not registered	YET
ID REGST FR1	ID of front RH tire transmitter is registered	DONE
	ID of front RH tire transmitter is not registered	YET
ID REGST RR1	ID of rear RH tire transmitter is registered	DONE
	ID of rear RH tire transmitter is not registered	YET
ID REGST RL1	ID of rear LH tire transmitter is registered	DONE
	ID of rear LH tire transmitter is not registered	YET
WARNING LAMP	Tire pressure indicator OFF	OFF
	Tire pressure indicator ON	ON

BCM (BODY CONTROL MODULE)

< ECU DIAGNOSIS >

Monitor Item	Condition	Value/Status
BUZZER	Tire pressure warning alarm is not sounding	OFF
	Tire pressure warning alarm is sounding	ON

Terminal Layout

INFOID:000000004454838

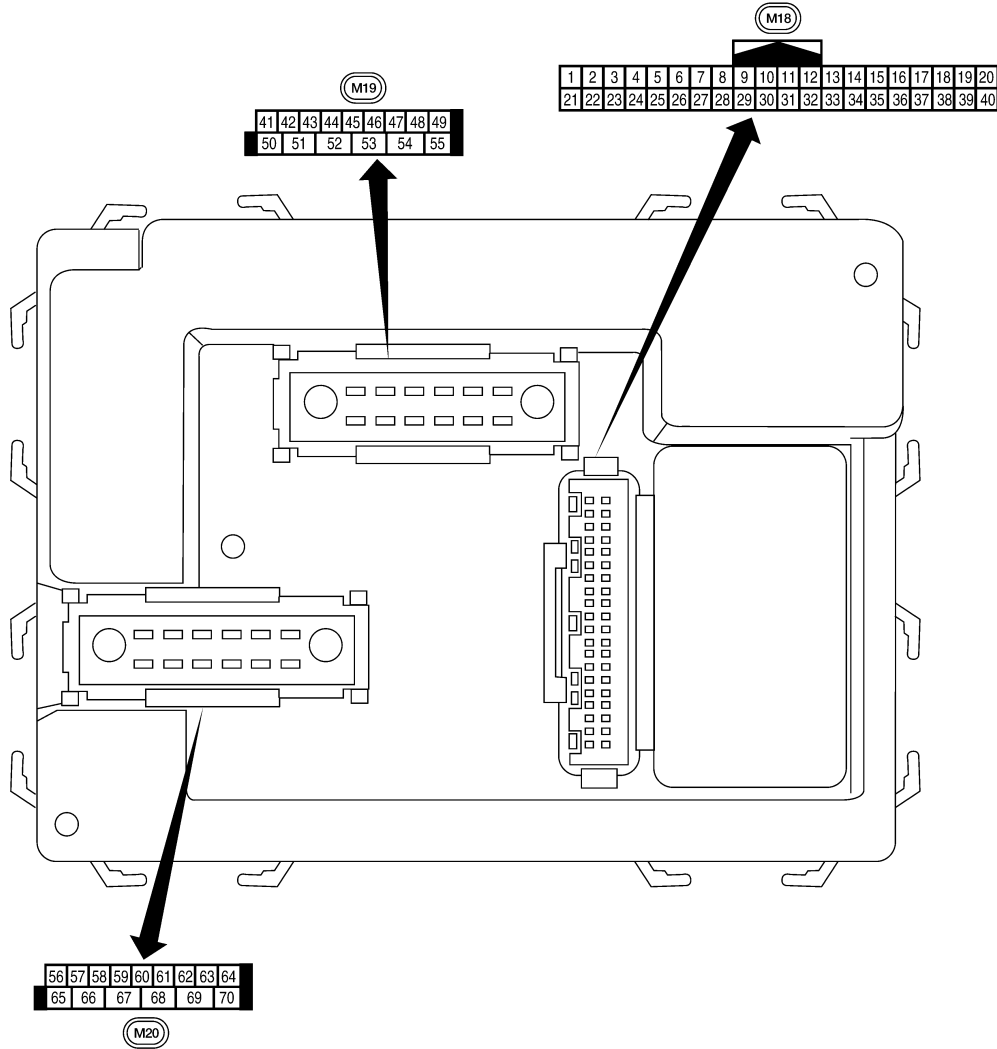

A
B
C
D
E
F
G
H
I
J
K
M
N
O
P

EXL

BCM (BODY CONTROL MODULE)

< ECU DIAGNOSIS >

Physical Values

INFOID:000000004454839

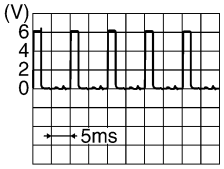
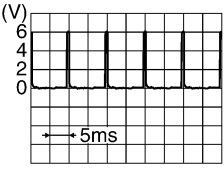
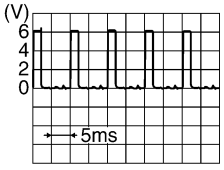
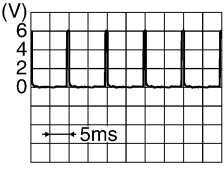
Terminal	Wire color	Item	Signal input/output	Measuring condition		Reference value or waveform (Approx.)
				Ignition switch	Operation or condition	
1	BR	Ignition keyhole illumination	Output	OFF	Door is locked (SW OFF)	Battery voltage
					Door is unlocked (SW ON)	0V
2	P	Combination switch input 5	Input	ON	Lighting, turn, wiper OFF Wiper dial position 4	 <p style="text-align: right;">SKIA5291E</p>
3	SB	Combination switch input 4	Input	ON	Lighting, turn, wiper OFF Wiper dial position 4	 <p style="text-align: right;">SKIA5292E</p>
4	V	Combination switch input 3	Input	ON	Lighting, turn, wiper OFF Wiper dial position 4	 <p style="text-align: right;">SKIA5291E</p>
5	L	Combination switch input 2	Input	ON	Lighting, turn, wiper OFF Wiper dial position 4	 <p style="text-align: right;">SKIA5292E</p>
6	R	Combination switch input 1				
7	GR	Front door lock assembly LH (key cylinder switch) unlock	Input	OFF	ON (open, 2nd turn)	Momentary 1.5V
8	SB	Front door lock assembly LH (key cylinder switch) lock			On (open)	Momentary 1.5V
			OFF (closed)	0V		
9	Y	Rear window defogger switch	Input	ON	Rear window defogger switch ON	0V
					Rear window defogger switch OFF	5V
11	G/B	Ignition switch (ACC or ON)	Input	ACC or ON	Ignition switch ACC or ON	Battery voltage

BCM (BODY CONTROL MODULE)

< ECU DIAGNOSIS >

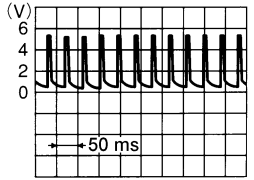
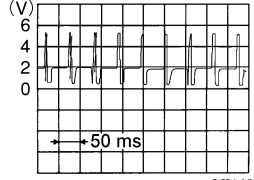
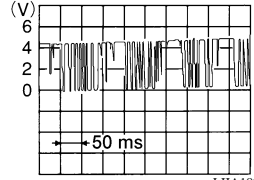
Terminal	Wire color	Item	Signal input/output	Measuring condition		Reference value or waveform (Approx.)
				Ignition switch	Operation or condition	
12	LG	Front door switch RH (All)	Input	OFF	ON (open)	0V
		Rear door switch upper RH (King Cab)			OFF (closed)	Battery voltage
		Rear door switch lower RH (King Cab)				
13	L	Rear door switch RH (Crew Cab)	Input	OFF	ON (open)	0V
					OFF (closed)	Battery voltage
15	W	Tire pressure warning check connector	Input	OFF	—	5V
18	BR	Remote keyless entry receiver (Ground)	Output	OFF	—	0V
19	V	Remote keyless entry receiver (power supply)	Output	OFF	Ignition switch OFF	
20	G	Remote keyless entry receiver signal (Signal)	Input	OFF	Stand-by (keyfob buttons released)	
					When remote keyless entry receiver receives signal from keyfob (keyfob buttons pressed)	
21	GR	NATS antenna amp.	Input	OFF → ON	Ignition switch (OFF → ON)	Just after turning ignition switch ON: Pointer of tester should move.
23	G	Security indicator lamp	Output	OFF	Goes OFF → illuminates (Every 2.4 seconds)	Battery voltage → 0V
25	BR	NATS antenna amp.	Input	OFF → ON	Ignition switch (OFF → ON)	Just after turning ignition switch ON: Pointer of tester should move.
27	W	Compressor ON signal	Input	ON	A/C switch OFF	5V
					A/C switch ON	0V
28	R	Front blower monitor	Input	ON	Front blower motor OFF	Battery voltage
					Front blower motor ON	0V
29	G	Hazard switch	Input	OFF	ON	0V
					OFF	5V

A
B
C
D
E
F
G
H
I
J
K
M
N
O
P

EXL

BCM (BODY CONTROL MODULE)

< ECU DIAGNOSIS >

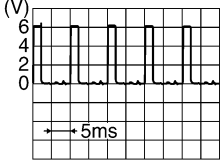
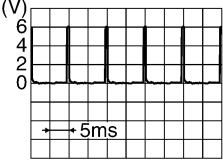
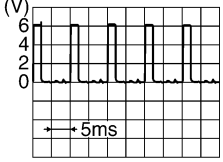
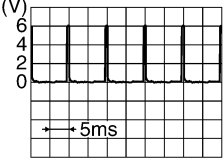
Terminal	Wire color	Item	Signal input/output	Measuring condition		Reference value or waveform (Approx.)
				Ignition switch	Operation or condition	
31	GR	Cargo lamp switch	Input	OFF	ON	0V
				OFF	OFF	Battery voltage
32	O	Combination switch output 5	Output	ON	Lighting, turn, wiper OFF Wiper dial position 4	 SKIA5291E
33	GR	Combination switch output 4	Output	ON	Lighting, turn, wiper OFF Wiper dial position 4	 SKIA5292E
34	G	Combination switch output 3	Output	ON	Lighting, turn, wiper OFF Wiper dial position 4	 SKIA5291E
35	BR	Combination switch output 2	Output	ON	Lighting, turn, wiper OFF Wiper dial position 4	 SKIA5292E
36	LG	Combination switch output 1				
37	B	Key switch	Input	OFF	Key inserted	Battery voltage
				OFF	Key removed	0V
38	W/R	Ignition switch (ON)	Input	ON	—	Battery voltage
39	L	CAN-H	—	—	—	—
40	P	CAN-L	—	—	—	—
45	V	Lock switch	Input	OFF	ON (lock)	0V
				OFF	OFF	Battery voltage
46	LG	Unlock switch	Input	OFF	ON (unlock)	0V
				OFF	OFF	Battery voltage
47	GR	Front door switch LH (All)	Input	OFF	ON (open)	0V
		Rear door switch upper LH (King Cab)			OFF (closed)	Battery voltage
		Rear door switch lower LH (King Cab)				
48	P	Rear door switch LH (Crew Cab)	Input	OFF	ON (open)	0V
				OFF	OFF (closed)	Battery voltage

BCM (BODY CONTROL MODULE)

< ECU DIAGNOSIS >

Terminal	Wire color	Item	Signal input/output	Measuring condition		Reference value or waveform (Approx.)	
				Ignition switch	Operation or condition		
50	P	Cargo lamp	Output	OFF	Any door open (ON)	0V	
					All doors closed (OFF)	Battery voltage	
51	G	Trailer turn signal (right)	Output	ON	Turn right ON	<p style="text-align: right; font-size: small;">SKIA3009J</p>	
52	V	Trailer turn signal (left)	Output	ON	Turn left ON	<p style="text-align: right; font-size: small;">SKIA3009J</p>	
56	V	Battery saver output	Output	OFF	30 minutes after ignition switch is turned OFF	0V	
				ON	—	Battery voltage	
57	R/Y	Battery power supply	Input	—	—	Battery voltage	
58	W	Optical sensor	Input	ON	When optical sensor is illuminated	3.1V or more	
					When optical sensor is not illuminated	0.6V or less	
59	GR	Front door lock assembly LH (unlock)	Output	OFF	OFF (neutral)	0V	
					ON (unlock)	Battery voltage	
60	LG	Turn signal (left)	Output	ON	Turn left ON	<p style="text-align: right; font-size: small;">SKIA3009J</p>	
61	G	Turn signal (right)	Output	ON	Turn right ON	<p style="text-align: right; font-size: small;">SKIA3009J</p>	
63	BR	Interior room/map lamp	Output	OFF	Any door switch	ON (open)	0V
					OFF (closed)	Battery voltage	
65	V	All door lock actuators (lock)	Output	OFF	OFF (neutral)	0V	
					ON (lock)	Battery voltage	
66	L	Front door lock actuator RH, rear door lock actuators LH/RH (unlock)	Output	OFF	OFF (neutral)	0V	
					ON (unlock)	Battery voltage	

A
B
C
D
E
F
G
H
I
J
K
L
M
N
O
P

EXL

BCM (BODY CONTROL MODULE)

< ECU DIAGNOSIS >

Terminal	Wire color	Item	Signal input/output	Measuring condition		Reference value or waveform (Approx.)
				Ignition switch	Operation or condition	
67	B	Ground	Input	ON	—	0V
68	O	Power window power supply (RAP)	Output	—	Ignition switch ON	Battery voltage
					Within 45 seconds after ignition switch OFF	Battery voltage
					More than 45 seconds after ignition switch OFF	0V
					When front door LH or RH is open or power window timer operates	0V
69	P	Power window power supply (BAT)	Output	OFF	—	Battery voltage
70	W	Battery power supply	Input	OFF	—	Battery voltage

BCM (BODY CONTROL MODULE)

< ECU DIAGNOSIS >

Wiring Diagram

INFOID:000000004454840

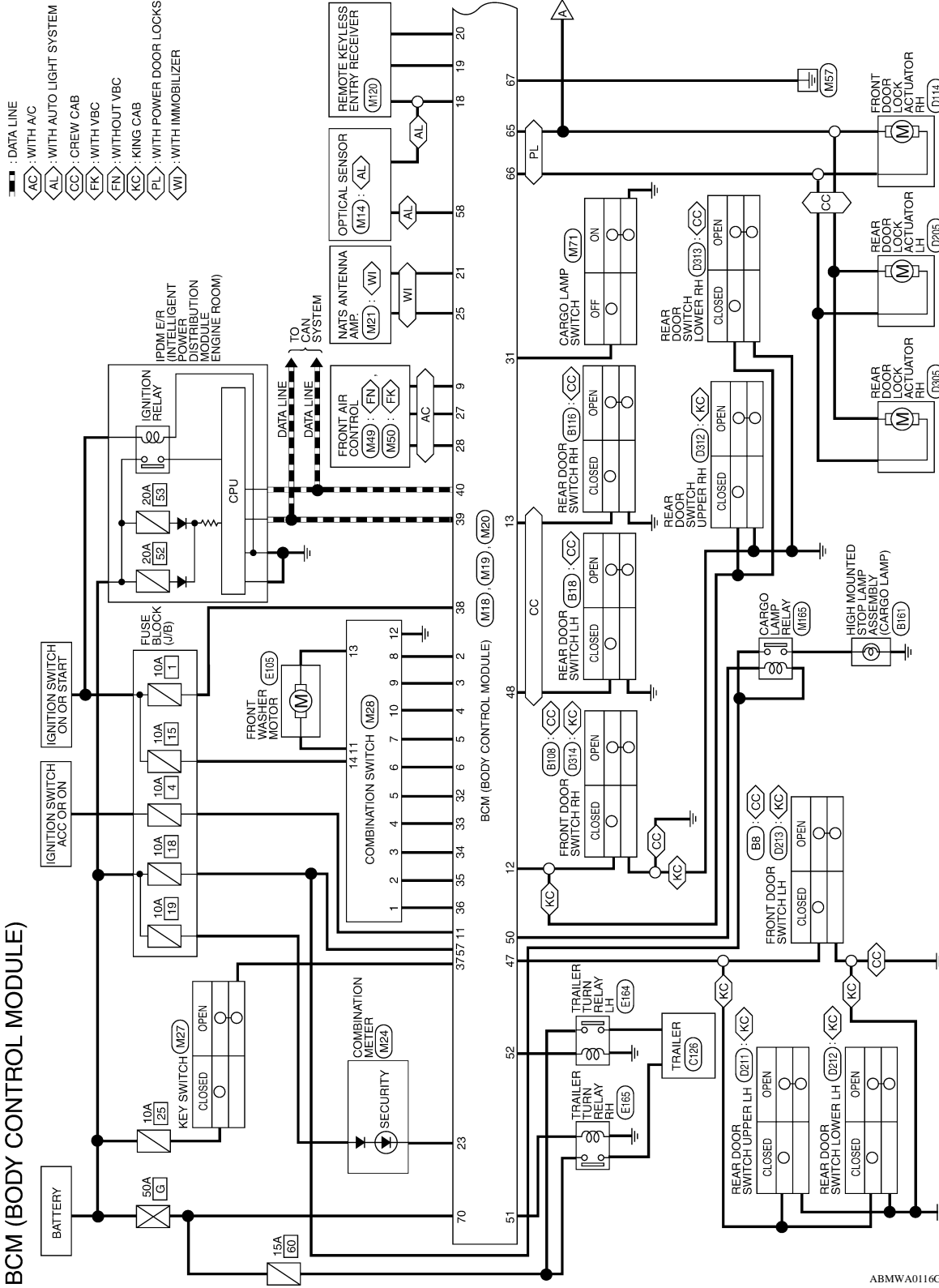

ABMWA0116GI

A
B
C
D
E
F
G
H
I
J
K
L
M
N
O
P

EXL

BCM (BODY CONTROL MODULE)

< ECU DIAGNOSIS >

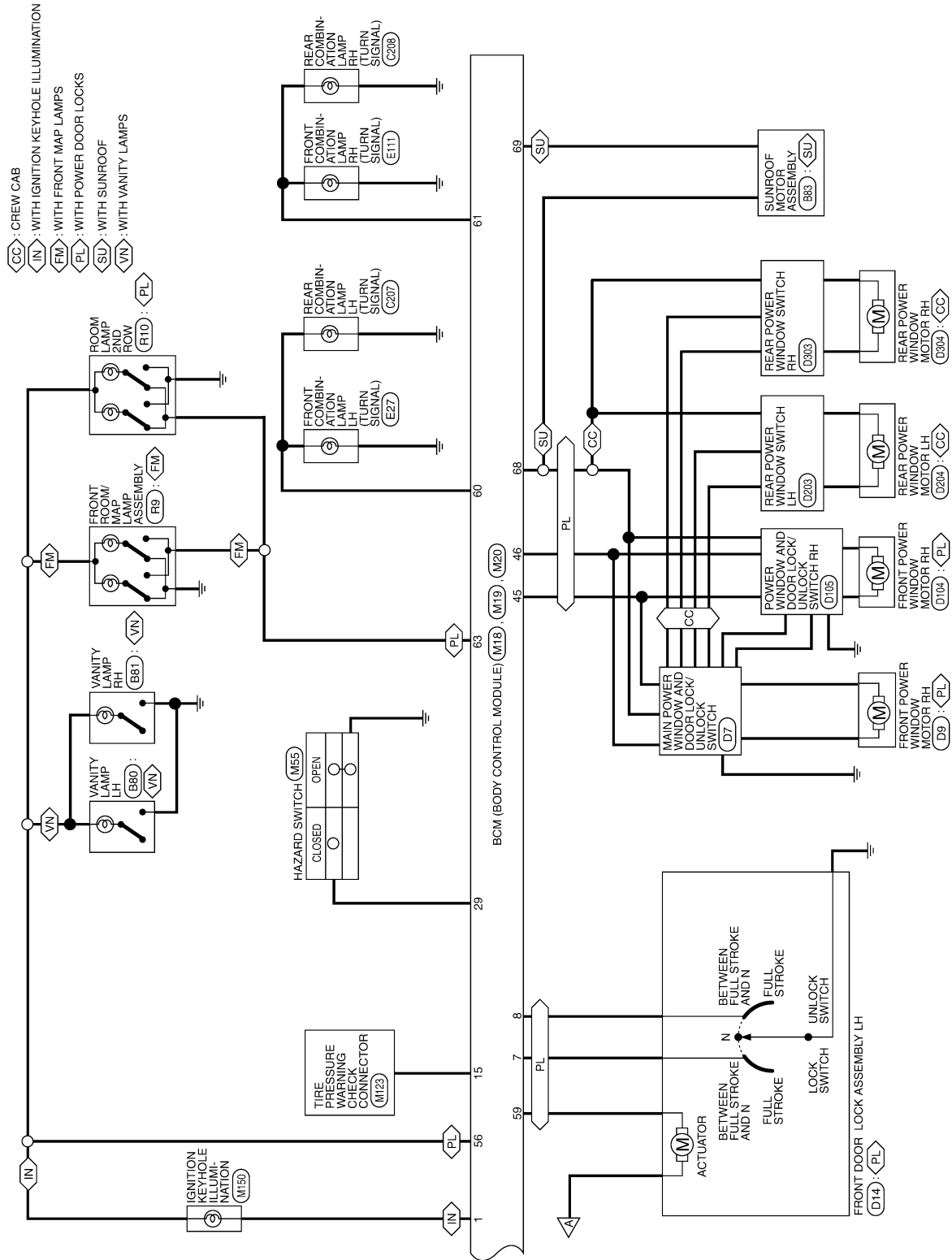

ABMWA0117GI

BCM (BODY CONTROL MODULE)

< ECU DIAGNOSIS >

BCM (BODY CONTROL MODULE) CONNECTORS

Connector No.	M18
Connector Name	BCM (BODY CONTROL MODULE)
Connector Color	WHITE



1	2	3	4	5	6	7	8	9	10	11	12	13	14	15	16	17	18	19	20
21	22	23	24	25	26	27	28	29	30	31	32	33	34	35	36	37	38	39	40

Terminal No.	Color of Wire	Signal Name
1	BR	KEY RING OUTPUT
2	P	INPUT 5
3	SB	INPUT 4
4	V	INPUT 3
5	L	INPUT 2
6	R	INPUT 1
7	GR	KEY CYLINDER UNLOCK SW
8	SB	KEY CYLINDER LOCK SW
9	Y	RR DEFOGGER SW
10	-	-
11	G/B	ACC_SW
12	LG	DOOR SW (AS)
13	L	DOOR SW (RR)
14	-	-
15	W	TPMS MODE TRIGGER SW
16	-	-
17	-	-
18	BR	KEYLESS & AUTO LIGHT SENSOR GND
19	V	KEYLESS TUNER POWER SUPPLY OUTPUT

Terminal No.	Color of Wire	Signal Name
20	G	KEYLESS TUNER SIGNAL
21	GR	IMMOBILIZER ANTENNA SIGNAL (CLOCK)
22	-	-
23	G	SECURITY INDICATOR OUTPUT
24	-	-
25	BR	IMMOBILIZER ANTENNA SIGNAL (RX, TX)
26	-	-
27	W	AIRCON SW
28	R	BLOWER FAN SW
29	G	HAZARD SW
30	-	-
31	GR	CARGO LAMP SW
32	O	OUTPUT 5
33	GR	OUTPUT 4
34	G	OUTPUT 3
35	BR	OUTPUT 2
36	LG	OUTPUT 1
37	B	KEY SW
38	W/R	IGN SW
39	L	CAN-H
40	P	CAN-L

Connector No.	M19
Connector Name	BCM (BODY CONTROL MODULE)
Connector Color	WHITE



41	42	43	44	45	46	47	48	49
50	51	52	53	54	55			

Terminal No.	Color of Wire	Signal Name
41	-	-
42	-	-
43	-	-
44	-	-
45	V	CDL LOCK SW
46	LG	CDL UNLOCK SW
47	GR	DOOR SW (DR)
48	P	DOOR SW (RL)
49	-	-
50	P	CARGO LAMP OUTPUT
51	G	TRAILER FLASHER OUTPUT (RIGHT)
52	V	TRAILER FLASHER OUTPUT (LEFT)
53	-	-
54	-	-
55	-	-

ABMIA0315GB

A B C D E F G H I J K L M N O P

EXL

BCM (BODY CONTROL MODULE)

< ECU DIAGNOSIS >

Connector No.	M28
Connector Name	COMBINATION SWITCH
Connector Color	WHITE

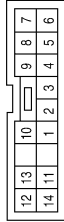

Terminal No.	Color of Wire	Signal Name
1	LG	INPUT 1
2	BR	INPUT 2
3	G	INPUT 3
4	GR	INPUT 4
5	O	INPUT 5
6	R	OUTPUT 1
7	L	OUTPUT 2
8	P	OUTPUT 5
9	SB	OUTPUT 4
10	V	OUTPUT 3
11	O	WASH FR (-) RR (+)
12	B	GND
13	L	WASH FR (-) RR (-)
14	W	IGN

Connector No.	M20
Connector Name	BCM (BODY CONTROL MODULE)
Connector Color	BLACK



Terminal No.	Color of Wire	Signal Name
56	V	BATTERY SAVER OUTPUT
57	R/Y	BAT (FUSE)
58	W	AUTO LIGHT SENSOR INPUT 2
59	GR	DOOR UNLOCK OUTPUT (DR)
60	LG	FLASHER OUTPUT (LEFT)
61	G	FLASHER OUTPUT (RIGHT)
62	-	-
63	BR	ROOM LAMP OUTPUT
64	-	-
65	V	DOOR LOCK OUTPUT (ALL)
66	L	DOOR UNLOCK OUTPUT (OTHER)
67	B	GND (POWER)
68	O	POWER WINDOW POWER SUPPLY OUTPUT (LINKED TO RAP)
69	P	POWER WINDOW POWER SUPPLY OUTPUT (BAT)
70	W	BAT (F/L)

ABMIA0316GB

INFOID:000000004454841

Fail Safe

Fail-safe index

BCM performs fail-safe control when any DTC listed below is detected.

BCM (BODY CONTROL MODULE)

< ECU DIAGNOSIS >

Display contents of CONSULT	Fail-safe	Cancellation
U1000: CAN COMM CIRCUIT	Inhibit engine cranking	When the BCM re-establishes communication with the other modules.
U1010: CONTROL UNIT (CAN)	Inhibit engine cranking	When the BCM re-start communicating with the other modules.

DTC Inspection Priority Chart

INFOID:000000004454842

If some DTCs are displayed at the same time, perform inspections one by one based on the following priority chart.

Priority	DTC
1	<ul style="list-style-type: none"> • U1000: CAN COMM CIRCUIT • U1010: CONTROL UNIT (CAN)
2	<ul style="list-style-type: none"> • B2190: NATS ANTENNA AMP • B2191: DIFFERENCE OF KEY • B2192: ID DISCORD BCM-ECM • B2193: CHAIN OF BCM-ECM
3	<ul style="list-style-type: none"> • C1729: VHCL SPEED SIG ERR • C1735: IGNITION SIGNAL
4	<ul style="list-style-type: none"> • C1704: LOW PRESSURE FL • C1705: LOW PRESSURE FR • C1706: LOW PRESSURE RR • C1707: LOW PRESSURE RL • C1708: [NO DATA] FL • C1709: [NO DATA] FR • C1710: [NO DATA] RR • C1711: [NO DATA] RL • C1712: [CHECKSUM ERR] FL • C1713: [CHECKSUM ERR] FR • C1714: [CHECKSUM ERR] RR • C1715: [CHECKSUM ERR] RL • C1716: [PRESSDATA ERR] FL • C1717: [PRESSDATA ERR] FR • C1718: [PRESSDATA ERR] RR • C1719: [PRESSDATA ERR] RL • C1720: [CODE ERR] FL • C1721: [CODE ERR] FR • C1722: [CODE ERR] RR • C1723: [CODE ERR] RL • C1724: [BATT VOLT LOW] FL • C1725: [BATT VOLT LOW] FR • C1726: [BATT VOLT LOW] RR • C1727: [BATT VOLT LOW] RL

DTC Index

INFOID:000000004454843

NOTE:

- Details of time display
- CRNT: Displays when there is a malfunction now or after returning to the normal condition until turning ignition switch OFF → ON again.
- 1 - 39: Displayed if any previous malfunction is present when current condition is normal. It increases like 1 → 2 → 3...38 → 39 after returning to the normal condition whenever ignition switch OFF → ON. The counter remains at 39 even if the number of cycles exceeds it. It is counted from 1 again when turning ignition switch OFF → ON after returning to the normal condition if the malfunction is detected again.

BCM (BODY CONTROL MODULE)

< ECU DIAGNOSIS >

CONSULT display	Fail-safe	Tire pressure monitor warning lamp ON	Reference page
No DTC is detected. further testing may be required.	—	—	—
U1000: CAN COMM CIRCUIT	—	—	BCS-30
U1010: CONTROL UNIT (CAN)	—	—	BCS-31
B2190: NATS ANTENA AMP	—	—	SEC-18
B2191: DIFFERENCE OF KEY	—	—	SEC-21
B2192: ID DISCORD BCM-ECM	—	—	SEC-22
B2193: CHAIN OF BCM-ECM	—	—	SEC-24
C1708: [NO DATA] FL	—	—	WT-14
C1709: [NO DATA] FR	—	—	WT-14
C1710: [NO DATA] RR	—	—	WT-14
C1711: [NO DATA] RL	—	—	WT-14
C1712: [CHECKSUM ERR] FL	—	—	WT-16
C1713: [CHECKSUM ERR] FR	—	—	WT-16
C1714: [CHECKSUM ERR] RR	—	—	WT-16
C1715: [CHECKSUM ERR] RL	—	—	WT-16
C1716: [PRESSDATA ERR] FL	—	—	WT-18
C1717: [PRESSDATA ERR] FR	—	—	WT-18
C1718: [PRESSDATA ERR] RR	—	—	WT-18
C1719: [PRESSDATA ERR] RL	—	—	WT-18
C1720: [CODE ERR] FL	—	—	WT-16
C1721: [CODE ERR] FR	—	—	WT-16
C1722: [CODE ERR] RR	—	—	WT-16
C1723: [CODE ERR] RL	—	—	WT-16
C1724: [BATT VOLT LOW] FL	—	—	WT-16
C1725: [BATT VOLT LOW] FR	—	—	WT-16
C1726: [BATT VOLT LOW] RR	—	—	WT-16
C1727: [BATT VOLT LOW] RL	—	—	WT-16
C1729: VHCL SPEED SIG ERR	—	—	WT-19
C1735: IGNITION SIGNAL	—	—	—

IPDM E/R (INTELLIGENT POWER DISTRIBUTION MODULE ENGINE ROOM)

< ECU DIAGNOSIS >

IPDM E/R (INTELLIGENT POWER DISTRIBUTION MODULE ENGINE ROOM)

Reference Value

INFOID:000000004454844

VALUES ON THE DIAGNOSIS TOOL

Monitor Item	Condition		Value/Status
MOTOR FAN REQ	Engine idle speed	Changes depending on engine coolant temperature, air conditioner operation status, vehicle speed, etc.	0 - 100 %
A/C COMP REQ	A/C switch OFF		OFF
	A/C switch ON		ON
TAIL&CLR REQ	Lighting switch OFF		OFF
	Lighting switch 1ST, 2ND, HI or AUTO (Light is illuminated)		ON
HL LO REQ	Lighting switch OFF		OFF
	Lighting switch 2ND HI or AUTO (Light is illuminated)		ON
HL HI REQ	Lighting switch OFF		OFF
	Lighting switch HI		ON
FR FOG REQ	Lighting switch 2ND	Front fog lamp switch OFF	OFF
		Front fog lamp switch ON	ON
H L WASHER REQ	NOTE: This item is displayed, but cannot be monitored.		OFF
FR WIP REQ	Ignition switch ON	Front wiper switch OFF	STOP
		Front wiper switch INT	1LOW
		Front wiper switch LO	LOW
		Front wiper switch HI	HI
WIP AUTO STOP	Ignition switch ON	Front wiper stop position	STOP P
		Any position other than front wiper stop position	ACT P
WIP PROT	Ignition switch ON	Front wiper operates normally	OFF
		Front wiper stops at fail-safe operation	BLOCK
ST RLY REQ	Ignition switch OFF or ACC		OFF
	Ignition switch START		ON
IGN RLY	Ignition switch OFF or ACC		OFF
	Ignition switch ON		ON
RR DEF REQ	Rear defogger switch OFF		OFF
	Rear defogger switch ON		ON
OIL P SW	Ignition switch OFF, ACC or engine running		OPEN
	Ignition switch ON		CLOSE
DTRL REQ	NOTE: This item is displayed, but cannot be monitored.		OFF
HOOD SW	NOTE: This item is displayed, but cannot be monitored.		OFF

IPDM E/R (INTELLIGENT POWER DISTRIBUTION MODULE ENGINE ROOM)

< ECU DIAGNOSIS >

Monitor Item	Condition	Value/Status
THFT HRN REQ	Not operated	OFF
	<ul style="list-style-type: none">• Panic alarm is activated• Horn is activated with VEHICLE SECURITY (THEFT WARNING) SYSTEM	ON
HORN CHIRP	Not operated	OFF
	Door locking with keyfob (horn chirp mode)	ON

IPDM E/R (INTELLIGENT POWER DISTRIBUTION MODULE ENGINE ROOM)

< ECU DIAGNOSIS >

Terminal Layout

INFOID:000000004454845

TERMINAL LAYOUT

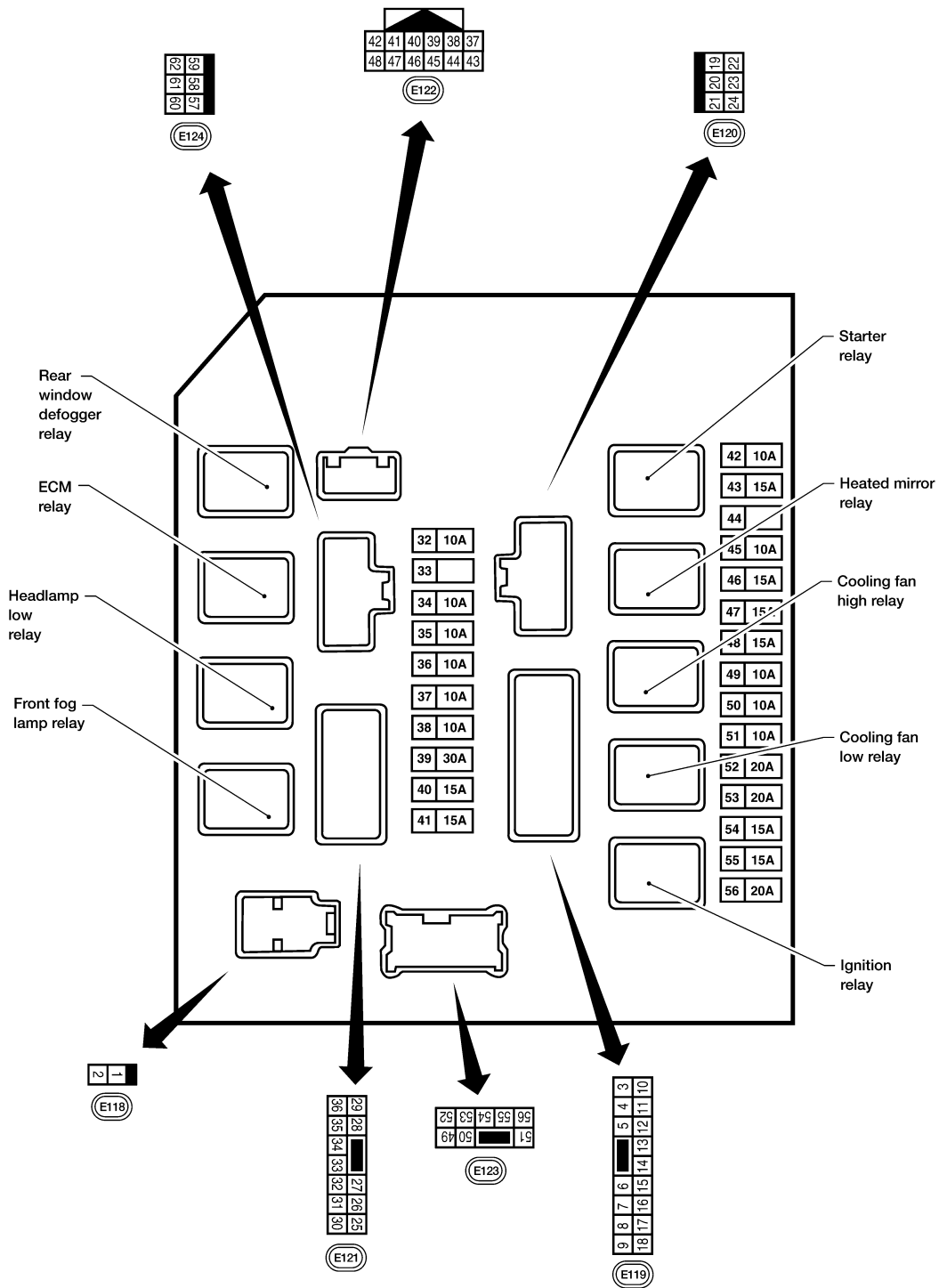

A
B
C
D
E
F
G
H
I
J
K
L
M
N
O
P

EXL

Physical Values

PHYSICAL VALUES

WKIA5883E

INFOID:000000004454846

IPDM E/R (INTELLIGENT POWER DISTRIBUTION MODULE ENGINE ROOM)

< ECU DIAGNOSIS >

Terminal	Wire color	Signal name	Signal input/output	Measuring condition		Reference value (Approx.)
				Ignition switch	Operation or condition	
1	W	Battery power supply	Input	OFF	—	Battery voltage
2	R	Battery power supply	Input	OFF	—	Battery voltage
3	G	ECM relay	Output	—	Ignition switch ON or START	Battery voltage
					Ignition switch OFF or ACC	0V
4	P	ECM relay	Output	—	Ignition switch ON or START	Battery voltage
					Ignition switch OFF or ACC	0V
6	V	Throttle control motor relay	Output	—	Ignition switch ON or START	Battery voltage
					Ignition switch OFF or ACC	0V
7	BR	ECM relay control	Input	—	Ignition switch ON or START	0V
					Ignition switch OFF or ACC	Battery voltage
8	W/R	Fuse 54	Output	—	Ignition switch ON or START	Battery voltage
					Ignition switch OFF or ACC	0V
10	R/B	Fuse 45	Output	ON	Daytime light system active	0V
					Daytime light system inactive	Battery voltage
11	Y	A/C compressor	Output	ON or START	A/C switch ON or defrost A/C switch	Battery voltage
					A/C switch OFF or defrost A/C switch	0V
12	W/G	Ignition switch supplied power	Input	—	OFF or ACC	0V
					ON or START	Battery voltage
13	R	Fuel pump relay	Output	—	Ignition switch ON or START	Battery voltage
					Ignition switch OFF or ACC	0V
14	W/G	Fuse 49	Output	—	Ignition switch ON or START	Battery voltage
					Ignition switch OFF or ACC	0V
15	W/R	Fuse 50 (ABS)	Output	—	Ignition switch ON or START	Battery voltage
					Ignition switch OFF or ACC	0V
16	W/G	Fuse 51	Output	—	Ignition switch ON or START	Battery voltage
					Ignition switch OFF or ACC	0V
17	W/G	Fuse 55	Output	—	Ignition switch ON or START	Battery voltage
					Ignition switch OFF or ACC	0V
19	W	Starter motor	Output	START	—	Battery voltage
20	BR	Cooling fan motor (low)	Output	ON or START	—	Battery voltage
21	GR	Ignition switch supplied power	Input	—	OFF or ACC	0V
					START	Battery voltage
22	G	Battery power supply	Output	OFF	—	Battery voltage
23	LG	Door mirror defogger output signal	Output	—	When rear defogger switch is ON	Battery voltage
					When raker defogger switch is OFF	0V

IPDM E/R (INTELLIGENT POWER DISTRIBUTION MODULE ENGINE ROOM)

< ECU DIAGNOSIS >

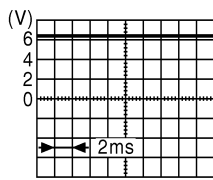
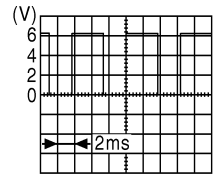
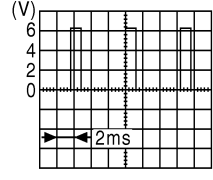
Terminal	Wire color	Signal name	Signal input/output	Measuring condition		Reference value (Approx.)
				Ignition switch	Operation or condition	
24	P	Cooling fan motor (high)	Output	—	Conditions correct for cooling fan operation	Battery voltage
					Conditions not correct for cooling fan operation	0V
27	W	Fuse 38	Output	—	Ignition switch ON or START	Battery voltage
					Ignition switch OFF or ACC	0V
28	R	LH front parking and front side marker lamp	Output	OFF	Lighting switch 1st position OFF	0V
					Lighting switch 1st position ON	Battery voltage
29	G	Trailer tow relay	Output	ON	Lighting switch 1st position OFF	0V
					Lighting switch 1st position ON	Battery voltage
30	R/B	Fuse 53	Output	—	Ignition switch ON or START	Battery voltage
					Ignition switch OFF or ACC	0V
32	GR	Wiper low speed signal	Output	ON or START	Wiper switch OFF	Battery voltage
					Wiper switch LO or INT	0V
35	L	Wiper high speed signal	Output	ON or START	Wiper switch OFF, LO, INT	Battery voltage
					Wiper switch HI	0V
37	Y	Power generation command signal	Output	—	Ignition switch ON	 <p>6.3 V</p>
					40% is set on "Active test," "ALTERNATOR DUTY" of "ENGINE"	 <p>3.8 V</p>
					40% is set on "Active test," "ALTERNATOR DUTY" of "ENGINE"	 <p>1.4 V</p>
38	B	Ground	Input	—	—	0V
39	L	CAN-H	—	ON	—	—
40	P	CAN-L	—	ON	—	—
42	GR	Oil pressure switch	Input	—	Engine running	Battery voltage
					Engine stopped	0V

A
B
C
D
E
F
G
H
I
J
K
L
M
N
O
P

EXL

IPDM E/R (INTELLIGENT POWER DISTRIBUTION MODULE ENGINE ROOM)

< ECU DIAGNOSIS >

Terminal	Wire color	Signal name	Signal input/output	Measuring condition		Reference value (Approx.)
				Ignition switch	Operation or condition	
43	G	Wiper auto stop signal	Input	ON or START	Wiper switch OFF, LO, INT	Battery voltage
44	R	Daytime light relay control (Canada only)	Input	ON	Daytime light system active	0V
					Daytime light system inactive	Battery voltage
45	LG	Horn relay control	Input	ON	When door locks are operated using keyfob (OFF → ON)*	Battery voltage → 0V
46	V	Fuel pump relay control	Input	—	Ignition switch ON or START	0V
					Ignition switch OFF or ACC	Battery voltage
47	O	Throttle control motor relay control	Input	—	Ignition switch ON or START	0V
					Ignition switch OFF or ACC	Battery voltage
48	R	Starter relay (inhibit switch)	Input	ON or START	Selector lever in "P" or "N"	0V
					Selector lever any other position	Battery voltage
49	GR	Front RH parking and front side marker lamp	Output	OFF	Lighting switch 1st position	OFF 0V
					ON	Battery voltage
50	W	Front fog lamp (LH)	Output	ON or START	Lighting switch must be in the 2nd position (LOW beam is ON) and the front fog lamp switch	OFF 0V
					ON	Battery voltage
51	V	Front fog lamp (RH)	Output	ON or START	Lighting switch must be in the 2nd position (LOW beam is ON) and the front fog lamp switch	OFF 0V
					ON	Battery voltage
52	P	LH low beam head-lamp	Output	—	Lighting switch in 2nd position	Battery voltage
54	R	RH low beam head-lamp	Output	—	Lighting switch in 2nd position	Battery voltage
55	G	LH high beam head-lamp	Output	—	Lighting switch in 2nd position and placed in HIGH or PASS position	Battery voltage
56	L	RH high beam head-lamp	Output	—	Lighting switch in 2nd position and placed in HIGH or PASS position	Battery voltage
57	GR	Parking, license, and tail lamp	Output	ON	Lighting switch 1st position	OFF 0V
					ON	Battery voltage
59	B	Ground	Input	—	—	0V
60	GR	Rear window defogger relay	Output	ON or START	Rear defogger switch ON	Battery voltage
					Rear defogger switch OFF	0V
61	R/B	Fuse 32	Output	OFF	—	Battery voltage

*: When horn reminder is ON

IPDM E/R (INTELLIGENT POWER DISTRIBUTION MODULE ENGINE ROOM)

< ECU DIAGNOSIS >

Wiring Diagram

INFOID:000000004454847

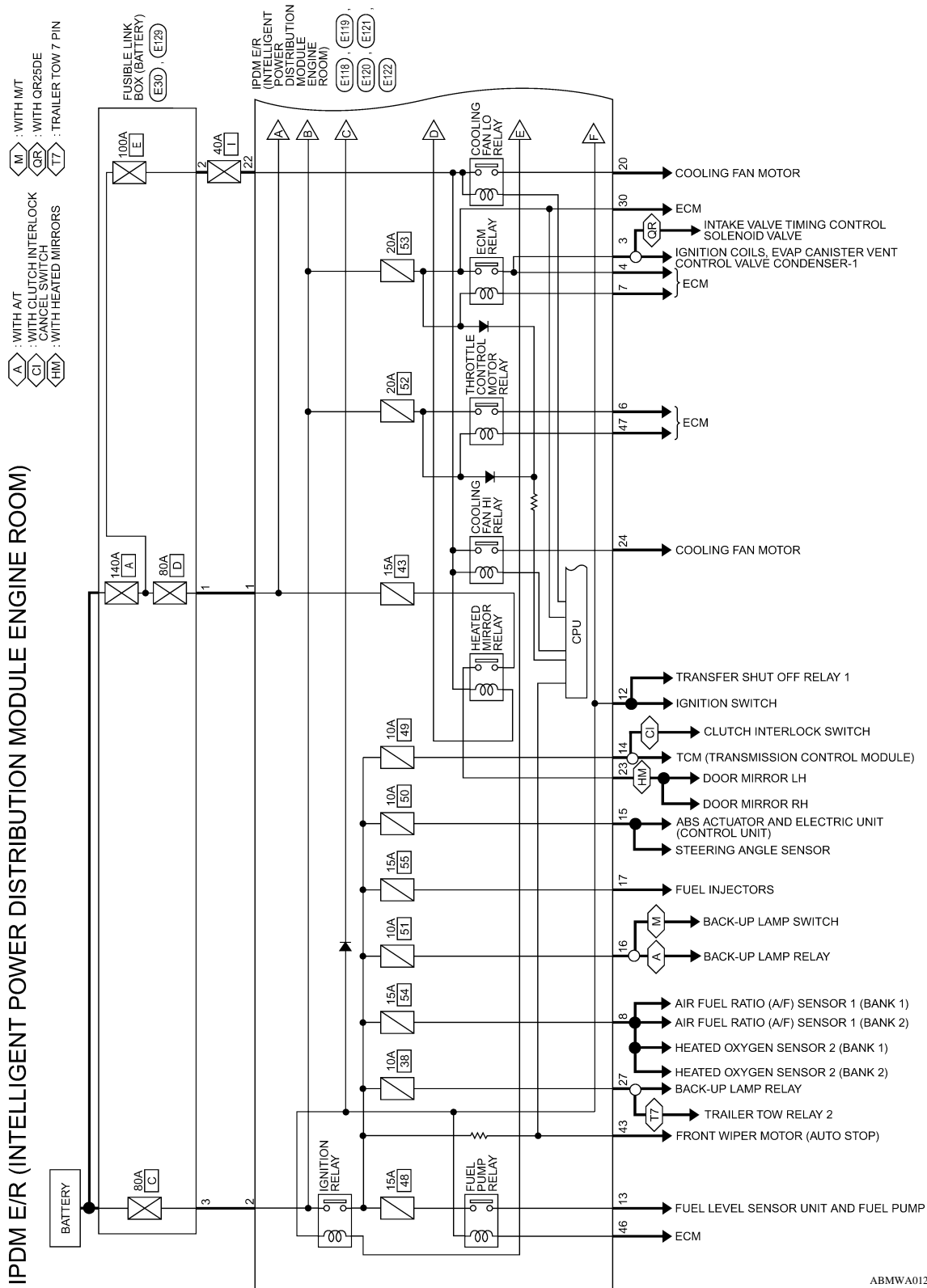

ABMWA0126GI

A
B
C
D
E
F
G
H
I
J
K
L
M
N
O
P

EXL

IPDM E/R (INTELLIGENT POWER DISTRIBUTION MODULE ENGINE ROOM)

< ECU DIAGNOSIS >

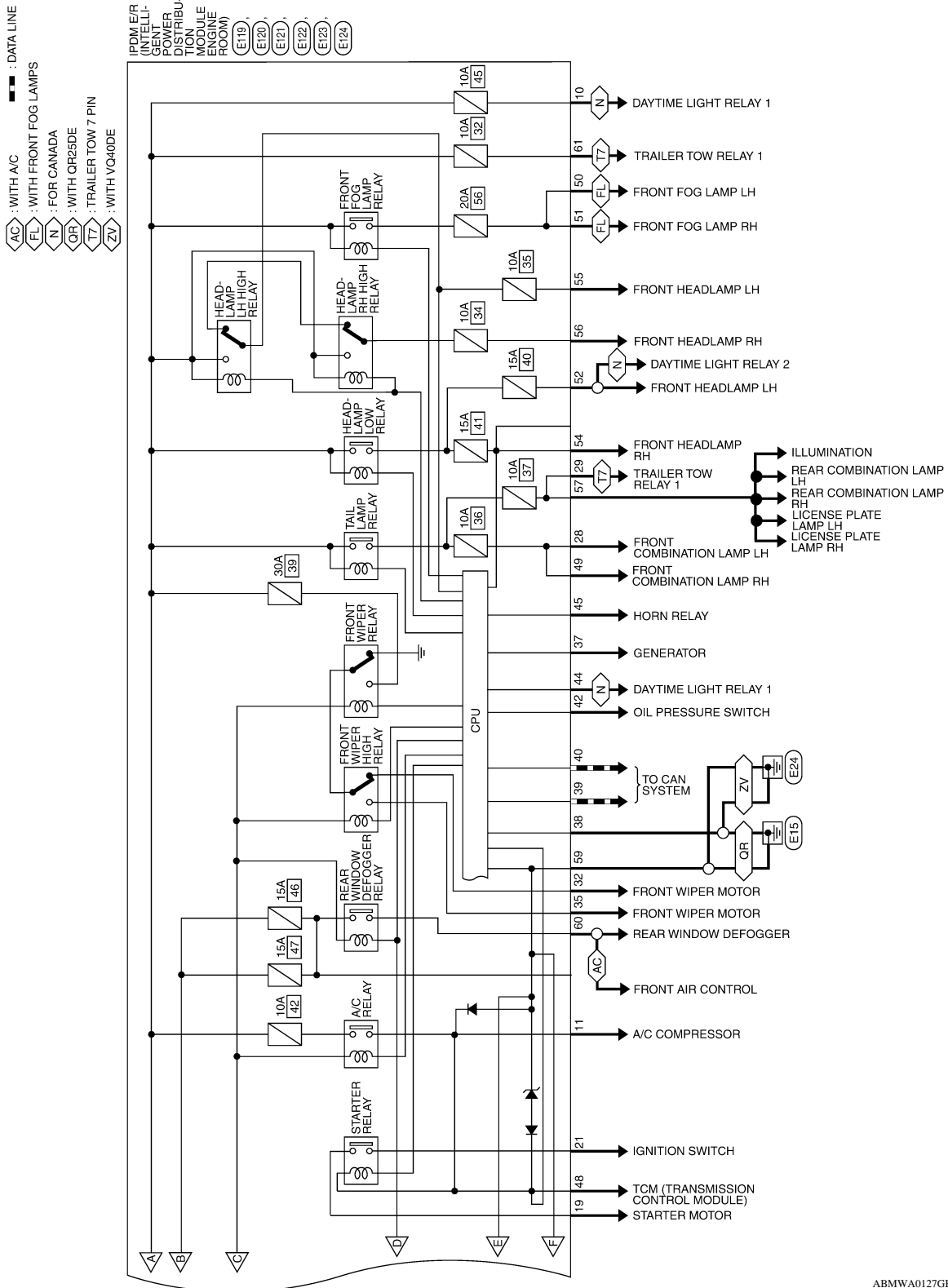

ABMWA0127GI

IPDM E/R (INTELLIGENT POWER DISTRIBUTION MODULE ENGINE ROOM)

< ECU DIAGNOSIS >

IPDM E/R (INTELLIGENT POWER DISTRIBUTION MODULE ENGINE ROOM) CONNECTORS

Connector No.	E30
Connector Name	FUSIBLE LINK BOX (BATTERY)
Connector Color	-



Terminal No.	Color of Wire	Signal Name
3	R	-

Connector No.	E118
Connector Name	IPDM E/R (INTELLIGENT POWER DISTRIBUTION MODULE ENGINE ROOM)
Connector Color	BLACK



Terminal No.	Color of Wire	Signal Name
1	W	F/L USM
2	R	F/L MAIN

Connector No.	E119
Connector Name	IPDM E/R (INTELLIGENT POWER DISTRIBUTION MODULE ENGINE ROOM)
Connector Color	WHITE



Terminal No.	Color of Wire	Signal Name
3	G	IGN COIL
4	P	ECM
5	-	-
6	V	ETC

Terminal No.	Color of Wire	Signal Name
7	BR	ECM RLY CONT
8	W/R	O2 SENSOR
9	-	-
10	R/B	DTRL RLY SUPPLY
11	Y	A/C COMPRESSOR
12	W/G	IGN SW (IG1)
13	R	FUEL PUMP
14	W/G	A/T ECU IGN SUPPLY
15	W/R	ABS IGN SUPPLY
16	W/G	REVERSE LAMP
17	W/G	INJECTOR
18	-	-

Connector No.	E120
Connector Name	IPDM E/R (INTELLIGENT POWER DISTRIBUTION MODULE ENGINE ROOM)
Connector Color	WHITE

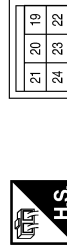

Terminal No.	Color of Wire	Signal Name
19	W	STARTER MTR
20	BR	MOTOR FAN 1
21	GR	IGN SW (ST)
22	G	F/L M/FAN
23	LG	HEATED MIRROR
24	P	MOTOR FAN 2

ABMLA0339GB

IPDM E/R (INTELLIGENT POWER DISTRIBUTION MODULE ENGINE ROOM)

< ECU DIAGNOSIS >

Connector No.	E123
Connector Name	IPDM E/R (INTELLIGENT POWER DISTRIBUTION MODULE ENGINE ROOM)
Connector Color	BROWN

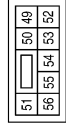

Terminal No.	Color of Wire	Signal Name
49	GR	ILLUMINATION
50	W	FR FOG LAMP LH
51	V	FR FOG LAMP RH
52	P	H/LAMP LO LH
53	-	-
54	R	H/LAMP LO RH
55	G	H/LAMP HI LH
56	L	H/LAMP HI RH

Connector No.	E122
Connector Name	IPDM E/R (INTELLIGENT POWER DISTRIBUTION MODULE ENGINE ROOM)
Connector Color	WHITE

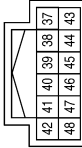

Terminal No.	Color of Wire	Signal Name
37	Y	ALT-C CONT
38	B	GND (SIGNAL)
39	L	CAN-H
40	P	CAN-L
41	-	-
42	GR	OIL PRESSURE SW
43	G	AUTO STOP SW
44	R	DTRL RLY CONT
45	LG	ANT THEFT HORN
46	V	FUEL PUMP RLY CONT
47	O	ETC RLY CONT
48	R	INHIBIT SW

Connector No.	E121
Connector Name	IPDM E/R (INTELLIGENT POWER DISTRIBUTION MODULE ENGINE ROOM)
Connector Color	BROWN

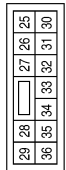

Terminal No.	Color of Wire	Signal Name
25	-	-
26	-	-
27	W	T TOW REV LAMP
28	R	ILLUMINATION
29	G	TRAILER RLY CONT
30	R/B	ECM BATT
31	-	-
32	GR	FR WIPER LO
33	-	-
34	-	-
35	L	FR WIPER HI
36	-	-



ABMIA0340GB

IPDM E/R (INTELLIGENT POWER DISTRIBUTION MODULE ENGINE ROOM)

< ECU DIAGNOSIS >



A
B
C
D
E
F
G
H
I
J
K
EXL
M
N
O
P

Connector No.	E129
Connector Name	FUSIBLE LINK BOX (BATTERY)
Connector Color	BROWN

Terminal No.	Color of Wire	Signal Name
1	W	-
2	R	-

Connector No.	E124
Connector Name	IPDM E/R (INTELLIGENT POWER DISTRIBUTION MODULE ENGINE ROOM)
Connector Color	BLACK

Terminal No.	Color of Wire	Signal Name
57	GR	TAIL LAMP
58	-	-
59	B	GND (POWER)
60	GR	RR DEF
61	R/B	TRAIL_RLY SUPPLY
62	-	-

ABMLA0341GB

Fail Safe

INFOID:0000000004454848

CAN COMMUNICATION CONTROL

When CAN communication with ECM and BCM is impossible, IPDM E/R performs fail-safe control. After CAN communication recovers normally, it also returns to normal control.

If No CAN Communication Is Available With ECM

IPDM E/R (INTELLIGENT POWER DISTRIBUTION MODULE ENGINE ROOM)

< ECU DIAGNOSIS >

Control part	Fail-safe in operation
Cooling fan	<ul style="list-style-type: none"> • Turns ON the cooling fan relay when the ignition switch is turned ON • Turns OFF the cooling fan relay when the ignition switch is turned OFF

If No CAN Communication Is Available With BCM

Control part	Fail-safe in operation
Headlamp	<ul style="list-style-type: none"> • Turns ON the headlamp low relay when the ignition switch is turned ON • Turns OFF the headlamp low relay when the ignition switch is turned OFF • Headlamp (LH/RH) high relays OFF
<ul style="list-style-type: none"> • Parking lamps • License plate lamps • Tail lamps 	<ul style="list-style-type: none"> • Turns ON the tail lamp relay when the ignition switch is turned ON • Turns OFF the tail lamp relay when the ignition switch is turned OFF
Front wiper	<ul style="list-style-type: none"> • The status just before activation of fail-safe control is maintained until the ignition switch is turned OFF while the front wiper is operating at LO or HI speed. • The wiper is operated at LO speed until the ignition switch is turned OFF if the fail-safe control is activated while the front wiper is set in the INT mode and the front wiper motor is operating.
Rear window defogger	Rear window defogger relay OFF
A/C compressor (if equipped)	A/C relay OFF
Front fog lamps (if equipped)	Front fog lamp relay OFF

IGNITION RELAY MALFUNCTION DETECTION FUNCTION

- IPDM E/R monitors the voltage at the contact circuit and excitation coil circuit of the ignition relay inside it.
- IPDM E/R judges the ignition relay error if the voltage differs between the contact circuit and the excitation coil circuit.
- If the ignition relay cannot turn OFF due to contact seizure, it activates the tail lamp relay for 10 minutes to alert the user to the ignition relay malfunction when the ignition switch is turned OFF.

Ignition switch	Ignition relay	Tail lamp relay
ON	ON	—
OFF	OFF	—

NOTE:

The tail lamp turns OFF when the ignition switch is turned ON.

FRONT WIPER CONTROL

IPDM E/R detects front wiper stop position by a front wiper auto stop signal.

When a front wiper auto stop signal is in the conditions listed below, IPDM E/R stops power supply to wiper after repeating a front wiper 10 second activation and 20 second stop five times.

Ignition switch	Front wiper switch	Auto stop signal
ON	OFF	Front wiper stop position signal cannot be input 10 seconds.
	ON	The signal does not change for 10 seconds.

NOTE:

This operation status can be confirmed on the IPDM E/R “DATA MONITOR” that displays “Block” for the item “WIP PROT” while the wiper is stopped.

STARTER MOTOR PROTECTION FUNCTION

IPDM E/R turns OFF the starter control relay to protect the starter motor when the starter control relay remains active for 90 seconds.

IPDM E/R (INTELLIGENT POWER DISTRIBUTION MODULE ENGINE ROOM)

< ECU DIAGNOSIS >

DTC Index

INFOID:000000004454849

CONSULT-III display	Fail-safe	TIME ^{NOTE}		Refer to
No DTC is detected. further testing may be required.	—	—	—	—
U1000: CAN COMM CIRCUIT	×	CRNT	1 – 39	PCS-18

NOTE:

The details of TIME display are as follows.

- CRNT: The malfunctions that are detected now
- 1 - 39: The number is indicated when it is normal at present and a malfunction was detected in the past. It increases like 0 → 1 → 2 ... 38 → 39 after returning to the normal condition whenever IGN OFF → ON. It is fixed to 39 until the self-diagnosis results are erased if it is over 39. It returns to 0 when a malfunction is detected again in the process.

A
B
C
D
E
F
G
H
I
J
K
EXL
M
N
O
P

EXTERIOR LIGHTING SYSTEM SYMPTOMS

< SYMPTOM DIAGNOSIS >

SYMPTOM DIAGNOSIS

EXTERIOR LIGHTING SYSTEM SYMPTOMS

Symptom Table

INFOID:000000004056504

CAUTION:

Perform the self-diagnosis with CONSULT-III before the symptom diagnosis. Perform the trouble diagnosis if any DTC is detected.

Symptom		Possible cause	Inspection item	
Headlamp does not switch to the high beam.	One side	<ul style="list-style-type: none"> • Fuse • Harness between IPDM E/R and the front combination lamp • Front combination lamp (High beam relay) • IPDM E/R 	Headlamp (HI) circuit Refer to EXL-36 .	
	Both sides	Symptom diagnosis "BOTH SIDE HEADLAMPS DO NOT SWITCH TO HIGH BEAM" Refer to EXL-131 .		
High beam indicator lamp is not turned ON. (Headlamp switches to the high beam.)		<ul style="list-style-type: none"> • Combination meter • BCM 	<ul style="list-style-type: none"> • Combination meter. Data monitor "HI-BEAM IND" • BCM (HEAD LAMP) Active test "HEADLAMP" 	
Headlamp does not switch to the low beam.	One side	Front combination lamp (Low beam relay)	—	
	Both sides	<ul style="list-style-type: none"> • Combination switch • Harness between the combination switch and BCM • BCM 	Combination switch Refer to BCS-37 .	
		High beam request signal	IPDM E/R	Data monitor "HL HI REQ"
		IPDM E/R	—	
Headlamp does not turn ON.	One side	<ul style="list-style-type: none"> • Fuse • Bulb • Harness between IPDM E/R and the front combination lamp • Front combination lamp • IPDM E/R 	Headlamp (LO) circuit Refer to EXL-38 .	
	Both sides	Symptom diagnosis "BOTH SIDE HEADLAMPS (LO) ARE NOT TURNED ON" Refer to EXL-132 , " Description ".		
Headlamp does not turn OFF.	When the ignition switch is turned ON	<ul style="list-style-type: none"> • BCM • Combination switch 	Combination switch Refer to BCS-37 .	
	The ignition switch is turned OFF (After activating the battery saver).	IPDM E/R	—	
Daytime light system does not activate.		<ul style="list-style-type: none"> • Either high beam bulb • Parking brake switch • Combination switch • BCM • IPDM E/R • Daytime light relay • Harness between IPDM E/R and daytime light relay. 	Daytime light system description. Refer to EXL-9 , " System Description ".	

EXTERIOR LIGHTING SYSTEM SYMPTOMS

< SYMPTOM DIAGNOSIS >

Symptom		Possible cause	Inspection item
Front fog lamp is not turned ON.	One side	<ul style="list-style-type: none"> • Front fog lamp bulb • Harness between IPDM E/R and the front combination lamp • Front combination lamp • IPDM E/R 	Front fog lamp circuit Refer to EXL-40 .
	Both side	Symptom diagnosis "BOTH SIDE FRONT FOG LAMPS ARE NOT TURNED ON" Refer to EXL-134 .	
Parking lamp is not turned ON.	One side	<ul style="list-style-type: none"> • Fuse • Parking lamp bulb • Harness between IPDM E/R and the front/rear combination lamp • Front/rear combination lamp • IPDM E/R 	Parking lamp circuit Refer to EXL-42 .
	Both sides	Symptom diagnosis "PARKING, LICENSE PLATE AND TAIL LAMPS ARE NOT TURNED ON" Refer to EXL-133 .	
Turn signal lamp does not blink.	Indicator lamp is normal. (The applicable side performs the high flasher activation).	<ul style="list-style-type: none"> • Harness between BCM and each turn signal lamp • Turn signal lamp bulb • Door mirror (if equipped with turn signals in the door mirrors) 	Turn signal lamp circuit Refer to EXL-47 .
Turn signal indicator lamp does not blink.	One side	Combination meter	—
	Both sides (Always)	<ul style="list-style-type: none"> • Turn signal indicator lamp signal • Combination meter • BCM 	<ul style="list-style-type: none"> • Combination meter. • Data monitor "TURN IND" • BCM (FLASHER) • Active test "FLASHER"
	Both sides (Does blink when activating the hazard warning lamp with the ignition switch OFF)	<ul style="list-style-type: none"> • The combination meter power supply and the ground circuit • Combination meter 	Power supply and the ground circuit Refer to MWI-29 .

A
B
C
D
E
F
G
H
I
J
K

EXL

M
N
O
P

NORMAL OPERATING CONDITION

< SYMPTOM DIAGNOSIS >

NORMAL OPERATING CONDITION

Description

INFOID:000000004056505

AUTO LIGHT SYSTEM

The auto light system may not turn the headlamp ON/OFF immediately after passing a dark area or a bright area (short tunnel, sky bridge, shadowed area etc.). This is normal.

BOTH SIDE HEADLAMPS DO NOT SWITCH TO HIGH BEAM

< SYMPTOM DIAGNOSIS >

BOTH SIDE HEADLAMPS DO NOT SWITCH TO HIGH BEAM

Description

INFOID:000000004056506

The headlamps (both sides) do not switch to high beam when the lighting switch is in the HI or PASS setting.

Diagnosis Procedure

INFOID:000000004056507

1.COMBINATION SWITCH INSPECTION

Check the combination switch. Refer to [BCS-37, "Diagnosis Procedure"](#).

Is the combination switch normal?

YES >> GO TO 2

NO >> Repair or replace the malfunctioning part.

2.CHECK HEADLAMP (HI) REQUEST SIGNAL INPUT

 CONSULT-III DATA MONITOR

1. Select "HL HI REQ" of IPDM E/R DATA MONITOR item.

2. With operating the lighting switch, check the monitor status.

Monitor item	Condition		Monitor status
HL HI REQ	Lighting switch (2ND)	HI or PASS	ON
		Except for HI or PASS	OFF

Is the monitor item status normal?

YES >> GO TO 3

NO >> Replace BCM. Refer to [BCS-56, "Removal and Installation"](#).

3.HEADLAMP (HI) CIRCUIT INSPECTION

Check the headlamp (HI) circuit. Refer to [EXL-36, "Description"](#).

Is the headlamp (HI) circuit normal?

YES >> Replace IPDM E/R. Refer to [PCS-34, "Removal and Installation of IPDM E/R"](#).

NO >> Repair or replace the malfunctioning part.

A
B
C
D
E
F
G
H
I
J
K

EXL

BOTH SIDE HEADLAMPS (LO) ARE NOT TURNED ON

< SYMPTOM DIAGNOSIS >

BOTH SIDE HEADLAMPS (LO) ARE NOT TURNED ON

Description

INFOID:000000004056508

The headlamps (both sides) do not turn ON in any lighting switch setting.

Diagnosis Procedure

INFOID:000000004056509

1. CHECK COMBINATION SWITCH

Check the combination switch. Refer to [BCS-6, "System Description"](#).

Is the combination switch normal?

YES >> GO TO 2

NO >> Repair or replace the malfunctioning part.

2. CHECK HEADLAMP (LO) REQUEST SIGNAL INPUT

ⓂCONSULT-III DATA MONITOR

1. Select "HL LO REQ" of IPDM E/R DATA MONITOR item.
2. With operating the lighting switch, check the monitor status.

Monitor item	Condition	Monitor status	
HL LO REQ	Lighting switch	2ND	ON
		OFF	OFF

Is the monitor item status normal?

YES >> GO TO 3

NO >> Replace BCM. Refer to [BCS-56, "Removal and Installation"](#).

3. HEADLAMP (LO) CIRCUIT INSPECTION

Check the headlamp (LO) circuit. Refer to [EXL-38, "Description"](#).

Is the headlamp (LO) circuit normal?

YES >> Replace IPDM E/R. Refer to [PCS-34, "Removal and Installation of IPDM E/R"](#).

NO >> Repair or replace the malfunctioning part.

PARKING, LICENSE PLATE AND TAIL LAMPS ARE NOT TURNED ON

< SYMPTOM DIAGNOSIS >

PARKING, LICENSE PLATE AND TAIL LAMPS ARE NOT TURNED ON

Description

INFOID:000000004056510

The parking, license plate and tail lamps do not turn ON in with any lighting switch setting.

Diagnosis Procedure

INFOID:000000004056511

1.COMBINATION SWITCH INSPECTION

Check the combination switch. Refer to [BCS-37, "Diagnosis Procedure"](#).

Is the combination switch normal?

YES >> GO TO 2

NO >> Repair or replace the malfunctioning part.

2.CHECK TAIL LAMP RELAY REQUEST SIGNAL INPUT

 CONSULT-III DATA MONITOR

1. Select "TAIL & CLR REQ" of IPDM E/R DATA MONITOR item.
2. With operating the lighting switch, check the monitor status.

Monitor item	Condition	Monitor status	
TAIL & CLR REQ	Lighting switch	1ST	ON
		OFF	OFF

Is the monitor item status normal?

YES >> GO TO 3

NO >> Replace BCM. Refer to [BCS-56, "Removal and Installation"](#).

3.PARK LAMP CIRCUIT INSPECTION

Check the parking lamp circuit. Refer to [EXL-42, "Description"](#).

Is the tail lamp circuit normal?

YES >> Replace IPDM E/R. Refer to [PCS-34, "Removal and Installation of IPDM E/R"](#).

NO >> Repair or replace the malfunctioning part.

A
B
C
D
E
F
G
H
I
J
K

EXL

M
N
O
P

BOTH SIDE FRONT FOG LAMPS ARE NOT TURNED ON

< SYMPTOM DIAGNOSIS >

BOTH SIDE FRONT FOG LAMPS ARE NOT TURNED ON

Description

INFOID:000000004056512

The front fog lamps do not turn ON in any setting.

Diagnosis Procedure

INFOID:000000004056513

1.COMBINATION SWITCH INSPECTION

Check the combination switch. Refer to [BCS-37, "Diagnosis Procedure"](#).

Is the combination switch normal?

- YES >> GO TO 2
- NO >> Repair or replace the malfunctioning part.

2.CHECK FRONT FOG LAMP REQUEST SIGNAL INPUT

ⓂCONSULT-III DATA MONITOR

1. Select "FR FOG REQ" of IPDM E/R DATA MONITOR item.
2. With operating the front fog lamp switch, check the monitor status.

Monitor item	Condition	Monitor status	
FR FOG REQ	Front fog lamp switch (Lighting switch 2ND)	ON	ON
		OFF	OFF

Is the monitor item status normal?

- YES >> GO TO 3
- NO >> Replace BCM. Refer to [BCS-56, "Removal and Installation"](#).

3.FRONT FOG LAMP CIRCUIT INSPECTION

Check the front fog lamp circuit. Refer to [EXL-40, "Description"](#).

Is the front fog lamp circuit normal?

- YES >> Replace IPDM E/R. Refer to [PCS-34, "Removal and Installation of IPDM E/R"](#).
- NO >> Repair or replace the malfunctioning part.

PRECAUTIONS

< PRECAUTION >

PRECAUTION

PRECAUTIONS

Precaution for Supplemental Restraint System (SRS) "AIR BAG" and "SEAT BELT PRE-TENSIONER"

INFOID:000000004056514

The Supplemental Restraint System such as "AIR BAG" and "SEAT BELT PRE-TENSIONER", used along with a front seat belt, helps to reduce the risk or severity of injury to the driver and front passenger for certain types of collision. This system includes seat belt switch inputs and dual stage front air bag modules. The SRS system uses the seat belt switches to determine the front air bag deployment, and may only deploy one front air bag, depending on the severity of a collision and whether the front occupants are belted or unbelted. Information necessary to service the system safely is included in the SR and SB section of this Service Manual.

WARNING:

- To avoid rendering the SRS inoperative, which could increase the risk of personal injury or death in the event of a collision which would result in air bag inflation, all maintenance must be performed by an authorized NISSAN/INFINITI dealer.
- Improper maintenance, including incorrect removal and installation of the SRS, can lead to personal injury caused by unintentional activation of the system. For removal of Spiral Cable and Air Bag Module, see the SR section.
- Do not use electrical test equipment on any circuit related to the SRS unless instructed to in this Service Manual. SRS wiring harnesses can be identified by yellow and/or orange harnesses or harness connectors.

General precautions for service operations

INFOID:000000004056515

- Never work with wet hands.
- Turn the lighting switch OFF before disconnecting and connecting the connector.
- When checking the headlamp on/off operation, check it on vehicle and with the power connected to the vehicle-side connector.
- Do not touch the headlamp bulb glass surface with bare hands or allow oil or grease to get on it. Do not touch the headlamp bulb just after the headlamp is turned off, because it is very hot.
- When the bulb has burned out, wrap it in a thick vinyl bag and discard. Do not break the bulb.
- Leaving the bulb removed from the headlamp housing for a long period of time can deteriorate the performance of the lens and reflector (dirt, clouding). Always prepare a new bulb and have it on hand when replacing the bulb.
- Do not use organic solvent (paint thinner or gasoline) to clean lamps and to remove old sealant.

A
B
C
D
E
F
G
H
I
J
K
P

EXL

HEADLAMP

< ON-VEHICLE MAINTENANCE >

ON-VEHICLE MAINTENANCE

HEADLAMP

Aiming Adjustment

INFOID:000000004056516

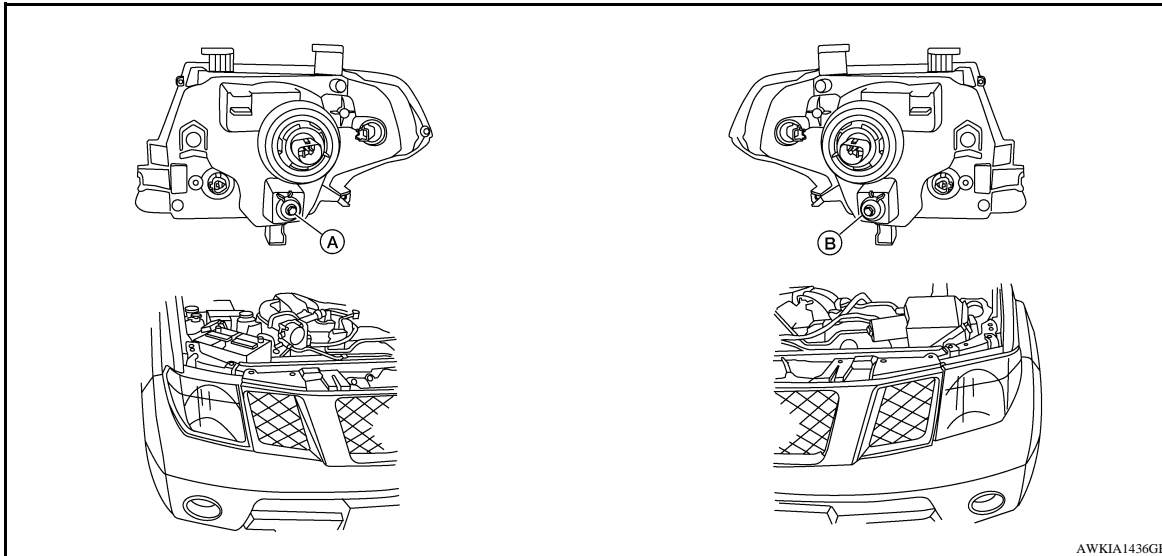

A. Headlamp RH adjustment screw

B. Headlamp LH adjustment screw

NOTE:

- For headlamp aiming details, refer to the regulations in your area.
- If vehicle front body has been repaired or the headlamp assembly has been replaced, check headlamp aiming.
- Before performing aiming adjustment, check the following:
 - Confirm headlamp aiming switch is set to "0" (zero) position.
 - Ensure all tires are inflated to correct pressure.
 - Place vehicle and screen on level surface.
 - Ensure there is no load in vehicle other than the driver (or equivalent weight placed in driver's position). Coolant and engine oil filled to correct level, and fuel tank full.
 - Confirm spare tire, jack and tools are properly stowed.
 - Aim each headlamp individually and ensure other headlamp beam pattern is blocked from screen.
 - Use adjusting screw to perform aiming adjustment

LOW BEAM AND HIGH BEAM

CAUTION:

Do not tighten adjustment screw beyond a torque of 1.67 N·m (17 kg·cm, 14.8 in·lb) or damage may occur.

NOTE:

By regulation, no means for horizontal aim adjustment is provided from the factory; only vertical aim is adjustable.

1. Turn headlamp low beam on.
2. Use adjustment screw to perform aiming adjustment.
3. Adjust beam pattern until cut-off line (top edge of illumination area) is positioned at same height off ground as bulb center (on H-line). Measure cut-off line within distance A on H-line. See aiming chart below.
 - Basic illuminating area for adjustment should be within the range shown on the aiming chart. Adjust headlamps accordingly.

Headlamp Aiming

HEADLAMP

< ON-VEHICLE MAINTENANCE >

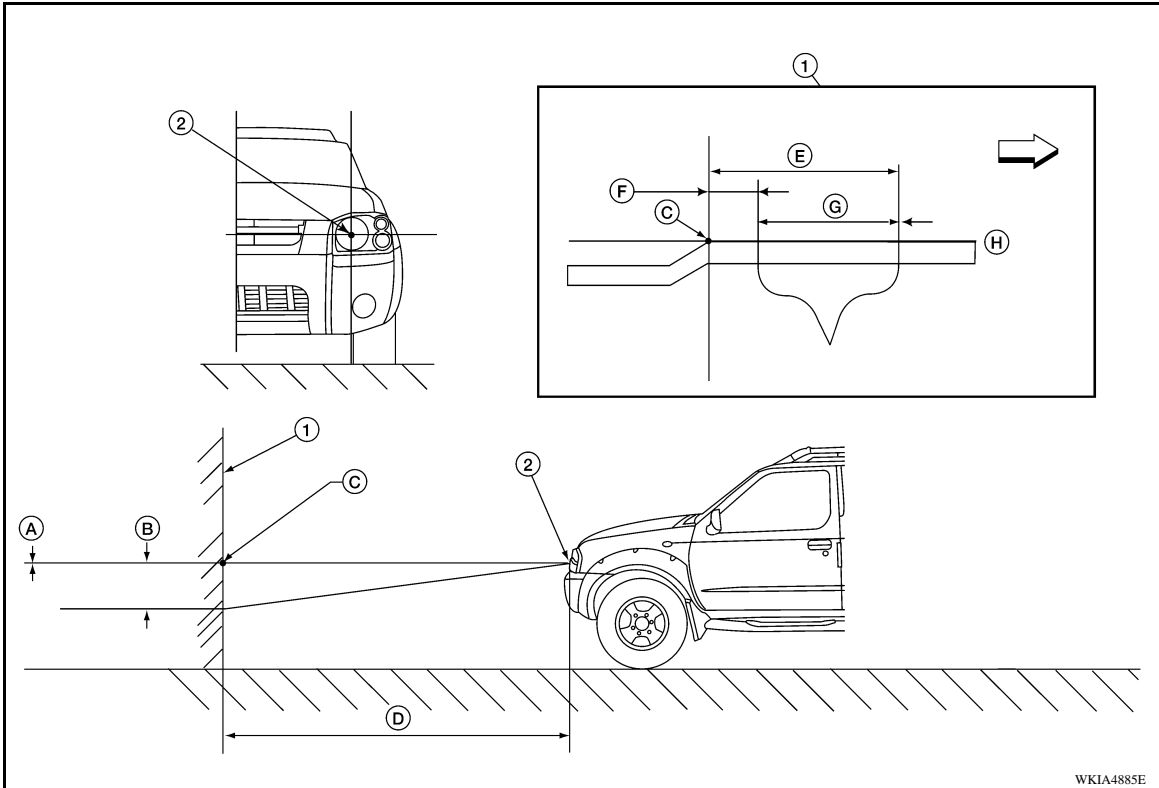

- | | | | | | |
|---|---|---|--|---|---|
| 1 | Adjustment screen | 2 | Headlamp bulb center (HV point) | A | Minimum acceptable vertical aim dimension (see aiming chart) |
| B | Maximum acceptable vertical aim dimension (see aiming chart) | C | H-V point | D | Distance of headlamp aiming screen from vehicle 7.62 m (25 ft.) |
| E | Maximum aim evaluation distance from vertical center on aiming screen 399mm (3° R). | F | Minimum aim evaluation distance from vertical center on aiming screen 133 mm (1°R) | G | Aim evaluation area |
| H | Horizontal aiming evaluation line. | ← | Right | | |

Aiming Chart

A (Minimum acceptable vertical aim dimension)	-3.3 mm (0.13 in)	0.025° up
B (Maximum acceptable vertical aim dimension)	36.6 mm (1.44 in)	0.275° down

A
B
C
D
E
F
G
H
I
J
K
L
M
N
O
P

EXL

FRONT FOG LAMP

< ON-VEHICLE MAINTENANCE >

FRONT FOG LAMP

Aiming Adjustment

INFOID:000000004056517

The fog lamp is a semi-sealed beam type which uses a replaceable halogen bulb. Before performing aiming adjustment, make sure of the following.

- Keep all tires inflated to correct pressure.
- Place vehicle on level ground.
- See that vehicle is unloaded (except for full levels of coolant, engine oil and fuel, and spare tire, jack, and tools). Have the driver or equivalent weight placed in driver seat.

Adjust aiming in the vertical direction by turning the adjustment screw.

NOTE:

Use a Phillips screwdriver to adjust. Turn screw clockwise to raise pattern and counterclockwise to lower pattern.

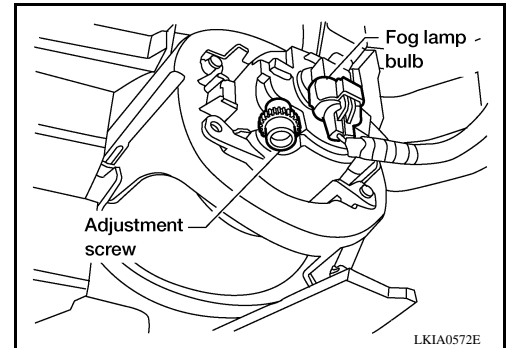

1. Set the distance between the screen and the center of the fog lamp lens as shown.

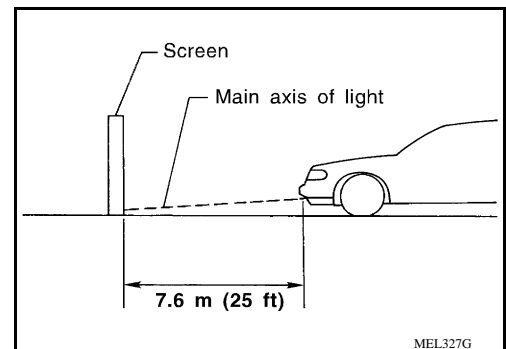

2. Turn front fog lamps ON.
3. Remove front portion of fender protector(s) for adjustment screw access. Refer to [EXT-20. "Removal and Installation"](#).

FRONT FOG LAMP

< ON-VEHICLE MAINTENANCE >

4. Adjust front fog lamps using adjustment screw so that the top edge of the high intensity zone is 100 mm (4 in) below the height of the fog lamp centers as shown.
 - When performing adjustment, if necessary, cover the headlamps and opposite fog lamp.

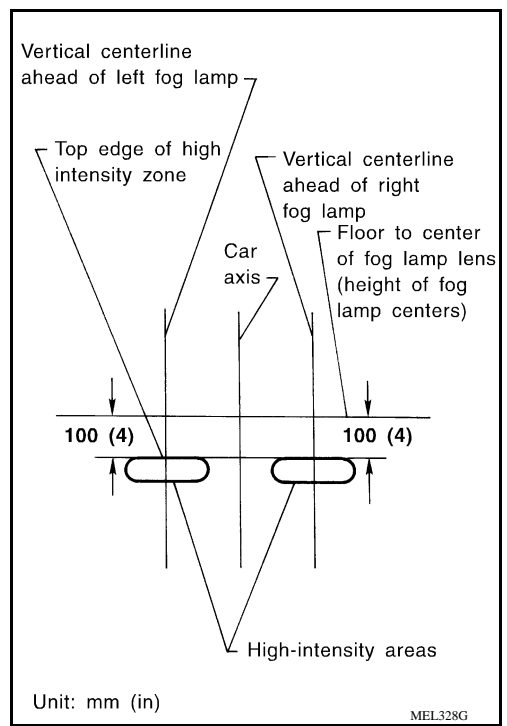

A
B
C
D
E
F
G
H
I
J
K
L
M
N
O
P

EXL

HEADLAMP

< ON-VEHICLE REPAIR >

ON-VEHICLE REPAIR

HEADLAMP

Bulb Replacement

INFOID:000000004056518

CAUTION:

Leaving bulb removed from the headlamp housing for a long period of time can deteriorate the performance of the lens and reflector (dirt, clouding). Always prepare a new bulb and have it on hand when replacing a bulb.

HEADLAMP

Removal

1. Turn front headlamp switch OFF.
2. Disconnect the electrical connector.
3. Rotate the headlamp bulb retaining ring counterclockwise and remove.
4. Pull the headlamp bulb straight out from the headlamp assembly.

CAUTION:

Grasp only the plastic base when handling headlamp bulb. Never touch the glass envelope.

Installation

Installation is in the reverse order of removal.

CAUTION:

After installing bulb, be sure to install the bulb socket and plastic cap securely to ensure watertightness.

FRONT TURN SIGNAL/PARKING LAMP

Removal

1. Turn the bulb socket counterclockwise to unlock it.
2. Pull the bulb to remove it from the socket.

Installation

Installation is in the reverse order of removal.

CAUTION:

After installing bulb, be sure to install the bulb socket and plastic cap securely to ensure watertightness.

FRONT SIDE MARKER LAMP

Removal

1. Turn the bulb socket counterclockwise to unlock it.
2. Pull the bulb to remove it from the socket.

Installation

Installation is in the reverse order of removal.

CAUTION:

After installing bulb, be sure to install the bulb socket securely for watertightness.

Removal and Installation

INFOID:000000004056519

FRONT COMBINATION LAMP

Removal

1. Position front fender protector aside. Refer to [EXT-22. "Removal and Installation of Front Fender Protector"](#).
2. Remove the front bumper upper valance. Refer to [EXT-13. "Removal and Installation"](#).
3. Remove the front combination lamp bolts.
4. Disconnect the front combination lamp connector and remove front combination lamp.

Installation

HEADLAMP

< ON-VEHICLE REPAIR >

Installation is in the reverse order of removal.

: 6.0 N-m (0.61 kg-m, 53 in-lb)

Disassembly and Assembly

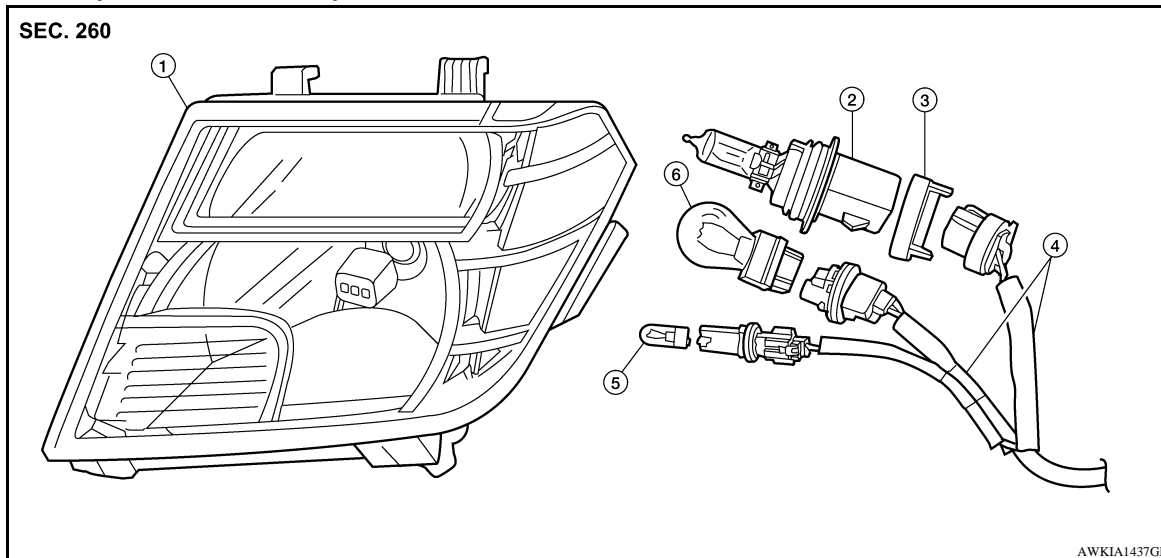

- | | | |
|----------------------------|--------------------------------|--|
| 1. Headlamp assembly | 2. Headlamp bulb | 3. Headlamp bulb retaining ring |
| 4. Wiring harness assembly | 5. Front side marker lamp bulb | 6. Front turn signal/parking lamp bulb |

DISASSEMBLY

CAUTION:

Leaving bulb removed from the headlamp housing for a long period of time can deteriorate the performance of the lens and reflector (dirt, clouding). Always prepare a new bulb and have it on hand when replacing a bulb.

1. Rotate headlamp bulb retaining ring counterclockwise and remove.

CAUTION:

Grasp only the plastic base when handling headlamp bulb. Never touch the glass envelope.

2. Turn front turn signal/parking lamp bulb socket counterclockwise to unlock and remove socket.
3. Turn front side marker lamp bulb socket counterclockwise to unlock and remove socket.

ASSEMBLY

Installation is in the reverse order of removal.

CAUTION:

After installing bulb, be sure to install the bulb socket and plastic cap securely to ensure watertightness.

FRONT FOG LAMP

< ON-VEHICLE REPAIR >

FRONT FOG LAMP

Bulb Replacement

INFOID:000000004056521

REMOVAL

1. Position front fender protector aside. Refer to [EXT-22. "Removal and Installation of Front Fender Protector"](#).
2. Disconnect fog lamp connector.
3. Turn the bulb counterclockwise to remove it.

CAUTION:

- Do not touch the glass of bulb directly by hand. Keep grease and other oily substances away from it. Do not touch bulb by hand while it is lit or right after being turned off. Burning may result.
- Do not leave bulb out of fog lamp reflector for a long time because dust, moisture smoke, etc. may affect the performance of fog lamp. When replacing bulb, be sure to replace it with new one.

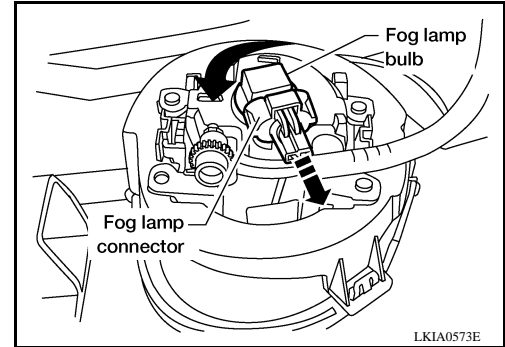

INSTALLATION

Installation is in the reverse order of removal.

Removal and Installation

INFOID:000000004056522

FOG LAMP

Removal

Note:

The fog lamp is a semi-sealed beam type which uses a replaceable halogen bulb.

1. Position front fender protector aside. Refer to [EXT-22. "Removal and Installation of Front Fender Protector"](#)
2. Disconnect fog lamp connector.
3. Remove fog lamp screws and pull fog lamp rearward out of front bumper.

CAUTION:

- Do not leave fog lamp assembly without bulb for a long period of time. Dust, moisture, smoke, etc. entering the fog lamp body may affect the performance. Remove the bulb from the headlamp assembly just before replacement bulb is installed.
- Grasp only the plastic base when handling the bulb. Never touch the glass envelope. Touching the glass could significantly affect the bulb life and/or fog lamp performance.

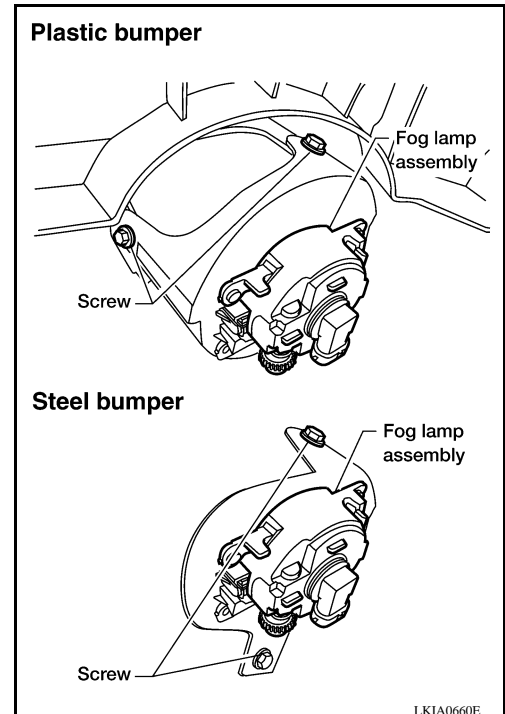

Installation

Installation is in the reverse order of removal.

STOP LAMP

< ON-VEHICLE REPAIR >

STOP LAMP

Bulb Replacement

INFOID:000000004056523

HIGH-MOUNTED STOP LAMP

Removal

1. Remove high-mounted stop lamp. Refer to [EXL-143, "Removal and Installation"](#).
2. Rotate the center bulb socket counterclockwise to release from high-mounted stop lamp assembly.
3. Pull bulb straight out from bulb socket.

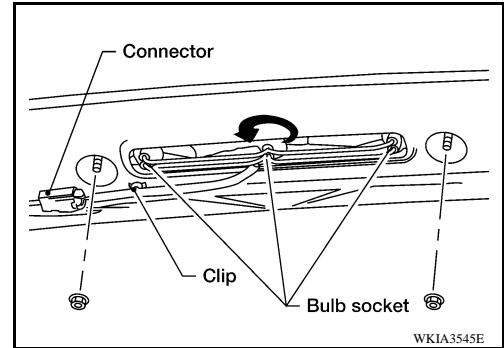

Installation

Installation is in the reverse order of removal.

Removal and Installation

INFOID:000000004056524

HIGH-MOUNTED STOP LAMP

Removal

1. Remove plugs on headlining.
2. Remove the nuts and remove high-mounted stop lamp from outside of roof outer panel.
3. Rotate the bulb sockets counterclockwise and remove the high-mounted stop lamp assembly.

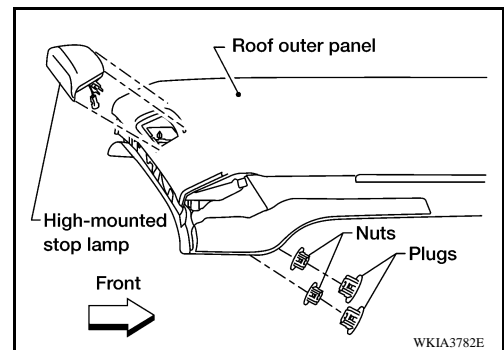

Installation

Installation is in the reverse order of removal.

High-mounted stop lamp nuts : 3.38 N-m (0.34 kg-m, 30 in-lb)

A
B
C
D
E
F
G
H
I
J
K
EXL
M
N
O
P

LICENSE PLATE LAMP

< ON-VEHICLE REPAIR >

LICENSE PLATE LAMP

Bulb Replacement

INFOID:000000004056525

REMOVAL

1. Turn bulb socket counterclockwise to unlock bulb socket.
2. Pull bulb to remove from bulb socket.

INSTALLATION

Installation is in the reverse order of removal.

Removal and Installation

INFOID:000000004056526

REMOVAL

1. Disconnect license plate lamp harness.
2. Depress tab to remove license plate lamp from rear bumper.

INSTALLATION

Installation is in the reverse order of removal.

REAR COMBINATION LAMP

< ON-VEHICLE REPAIR >

REAR COMBINATION LAMP

Bulb Replacement

INFOID:000000004056527

REMOVAL

1. Remove rear combination lamp. Refer to [EXL-145. "Removal and Installation"](#).
2. Turn bulb counterclockwise to remove bulb socket.
3. Pull bulb straight out away from socket to release.

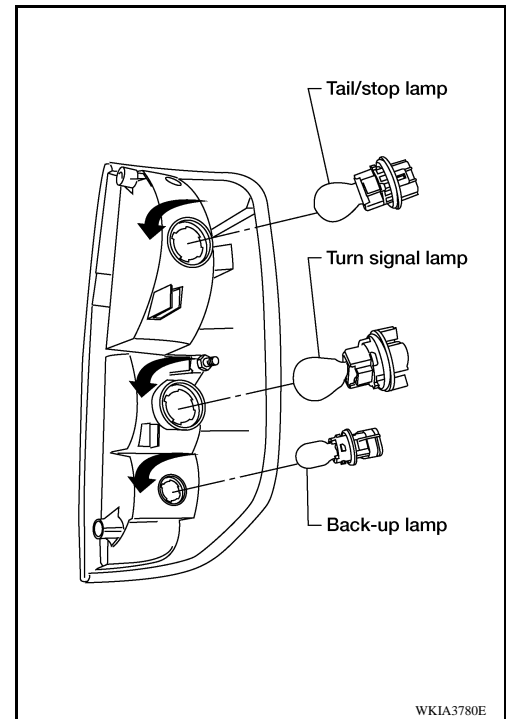

INSTALLATION

Installation is in the reverse order of removal.

Removal and Installation

INFOID:000000004056528

REMOVAL

1. Open tailgate and remove rear combination lamp bolts.
2. Pull combination lamp housing rearward to release locating snap.
3. Rotate each bulb socket counterclockwise to unlock it from lamp housing and remove from vehicle.

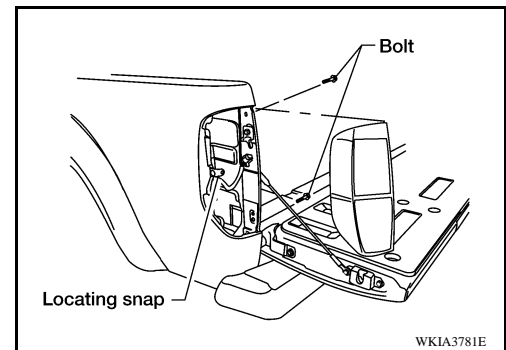

INSTALLATION

Installation is in the reverse order of removal.

NOTE:

During installation, align locating snap on body prior to installing bolts.

Rear combination lamp bolts : 2.4 Nm (0.24 kg-m, 21 in-lb)

A
B
C
D
E
F
G
H
I
J
K
EXL
M
N
O
P

LIGHTING & TURN SIGNAL SWITCH

< ON-VEHICLE REPAIR >

LIGHTING & TURN SIGNAL SWITCH

Removal and Installation

INFOID:000000004056529

REMOVAL

1. Remove lower instrument panel LH. Refer to [IP-10. "Exploded View"](#).
2. Remove knee protector brace.
3. Remove steering column cover.
4. Disconnect the lighting and turn signal switch connector.
5. While pressing tabs, pull lighting and turn signal switch toward driver door and release from the steering column.

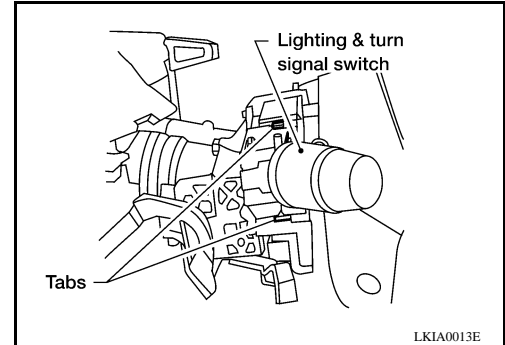

INSTALLATION

Installation is in the reverse order of removal.

HAZARD SWITCH

< ON-VEHICLE REPAIR >

HAZARD SWITCH

Removal and Installation

INFOID:000000004056530

REMOVAL

1. Remove cluster lid C. Refer to [IP-10. "Exploded View"](#).
2. Disconnect the hazard switch connector.
3. Remove the screws and remove the hazard switch.

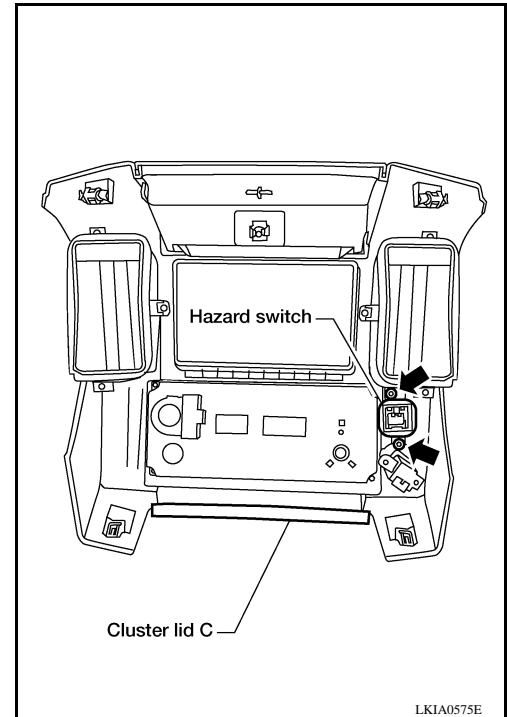

INSTALLATION

Installation is in the reverse order of removal.

A
B
C
D
E
F
G
H
I
J
K
L
M
N
O
P

EXL

SERVICE DATA AND SPECIFICATIONS (SDS)

< SERVICE DATA AND SPECIFICATIONS (SDS)

SERVICE DATA AND SPECIFICATIONS (SDS)

SERVICE DATA AND SPECIFICATIONS (SDS)

Headlamp

INFOID:000000004056531

Item	Wattage (W)*
Low/High	65/55 (HB5)

*: Always check with the Parts Department for the latest parts information.

Exterior Lamp

INFOID:000000004056532

Item	Wattage (W)*	
Front combination lamp	Turn signal lamp/parking lamp	28/8
	Side marker	3.8
Rear combination lamp	Stop/Tail lamp	27/8
	Turn signal lamp	27
	Back-up lamp	18
Fog lamp	55	
License plate lamp	5	
High-mounted stop lamp	16	
Cargo lamp (in high-mounted stop lamp)	16	

*: Always check with the Parts Department for the latest parts information.