

# AUTOMATIC TRANSAXLE

# SECTION AT

GI  
MA  
EM  
LG  
EC  
FE  
CL  
MT  
**AT**  
AX  
SU  
BR  
ST  
RS  
BT  
HA  
SC  
EL  
IDX

## CONTENTS

<p><b>TROUBLE DIAGNOSIS - INDEX</b> .....5</p> <p style="padding-left: 20px;">Alphabetical &amp; P No. Index for DTC .....5</p> <p><b>PRECAUTIONS</b> .....7</p> <p style="padding-left: 20px;">Supplemental Restraint System (SRS) "AIR BAG" and "SEAT BELT PRE-TENSIONER" .....7</p> <p style="padding-left: 20px;">Precautions for On Board Diagnostic (OBD) System of A/T and Engine.....7</p> <p style="padding-left: 20px;">Precautions .....7</p> <p style="padding-left: 20px;">Service Notice or Precautions.....9</p> <p style="padding-left: 20px;">Wiring Diagrams and Trouble Diagnosis.....10</p> <p><b>PREPARATION</b> .....11</p> <p style="padding-left: 20px;">Special Service Tools .....11</p> <p style="padding-left: 20px;">Commercial Service Tools .....14</p> <p><b>OVERALL SYSTEM</b> .....15</p> <p style="padding-left: 20px;">A/T Electrical Parts Location .....15</p> <p style="padding-left: 20px;">Circuit Diagram .....16</p> <p style="padding-left: 20px;">Cross-sectional View .....17</p> <p style="padding-left: 20px;">Hydraulic Control Circuit.....18</p> <p style="padding-left: 20px;">Shift Mechanism .....19</p> <p style="padding-left: 20px;">Control System .....28</p> <p style="padding-left: 20px;">Control Mechanism.....30</p> <p style="padding-left: 20px;">Control Valve .....34</p> <p><b>ON BOARD DIAGNOSTIC SYSTEM</b></p> <p><b>DESCRIPTION</b> .....36</p> <p style="padding-left: 20px;">Introduction .....36</p> <p style="padding-left: 20px;">OBD-II Function for A/T System.....36</p> <p style="padding-left: 20px;">One or Two Trip Detection Logic of OBD-II .....36</p> <p style="padding-left: 20px;">OBD-II Diagnostic Trouble Code (DTC).....36</p> <p style="padding-left: 20px;">Malfunction Indicator Lamp (MIL).....40</p> <p style="padding-left: 20px;">CONSULT-II .....40</p> <p style="padding-left: 20px;">Diagnostic Procedure Without CONSULT-II .....49</p> <p><b>TROUBLE DIAGNOSIS - INTRODUCTION</b>.....55</p> <p style="padding-left: 20px;">Introduction .....55</p> <p style="padding-left: 20px;">Work Flow.....59</p> <p><b>TROUBLE DIAGNOSIS - BASIC INSPECTION</b>.....61</p> <p style="padding-left: 20px;">A/T Fluid Check .....61</p> <p style="padding-left: 20px;">Stall Test .....61</p> <p style="padding-left: 20px;">Line Pressure Test.....65</p> <p style="padding-left: 20px;">Road Test.....66</p>	<p><b>TROUBLE DIAGNOSIS - GENERAL</b></p> <p><b>DESCRIPTION</b> .....84</p> <p style="padding-left: 20px;">Symptom Chart.....84</p> <p style="padding-left: 20px;">TCM Terminals and Reference Value.....95</p> <p><b>TROUBLE DIAGNOSIS FOR POWER SUPPLY</b>.....99</p> <p style="padding-left: 20px;">Wiring Diagram - AT - MAIN.....99</p> <p style="padding-left: 20px;">Diagnostic Procedure .....100</p> <p><b>DTC P0705 PARK/NEUTRAL POSITION SWITCH</b> ...102</p> <p style="padding-left: 20px;">Description .....102</p> <p style="padding-left: 20px;">On Board Diagnosis Logic.....102</p> <p style="padding-left: 20px;">Possible Cause.....103</p> <p style="padding-left: 20px;">Diagnostic Trouble Code (DTC) Confirmation Procedure .....103</p> <p style="padding-left: 20px;">Wiring Diagram - AT - PNP/SW.....104</p> <p style="padding-left: 20px;">Diagnostic Procedure .....105</p> <p><b>DTC P0710 A/T FLUID TEMPERATURE SENSOR CIRCUIT</b> .....108</p> <p style="padding-left: 20px;">Description .....108</p> <p style="padding-left: 20px;">On Board Diagnosis Logic.....108</p> <p style="padding-left: 20px;">Possible Cause.....109</p> <p style="padding-left: 20px;">Diagnostic Trouble Code (DTC) Confirmation Procedure .....109</p> <p style="padding-left: 20px;">Wiring Diagram - AT - FTS.....110</p> <p style="padding-left: 20px;">Diagnostic Procedure .....111</p> <p><b>DTC P0720 VEHICLE SPEED SENSOR.A/T (REVOLUTION SENSOR)</b> .....114</p> <p style="padding-left: 20px;">Description .....114</p> <p style="padding-left: 20px;">On Board Diagnosis Logic.....114</p> <p style="padding-left: 20px;">Possible Cause.....114</p> <p style="padding-left: 20px;">Diagnostic Trouble Code (DTC) Confirmation Procedure .....115</p> <p style="padding-left: 20px;">Wiring Diagram - AT - VSSA/T .....116</p> <p style="padding-left: 20px;">Diagnostic Procedure .....117</p> <p><b>DTC P0725 ENGINE SPEED SIGNAL</b> .....119</p> <p style="padding-left: 20px;">Description .....119</p> <p style="padding-left: 20px;">On Board Diagnosis Logic.....119</p> <p style="padding-left: 20px;">Possible Cause.....119</p> <p style="padding-left: 20px;">Diagnostic Trouble Code (DTC) Confirmation Procedure .....120</p>
---	---

# CONTENTS (Cont'd)

Wiring Diagram - AT - ENGSS .....	121	Description .....	166
Diagnostic Procedure .....	122	On Board Diagnosis Logic.....	166
<b>DTC P0731 A/T 1ST GEAR FUNCTION</b> .....	124	Possible Cause.....	167
Description .....	124	Diagnostic Trouble Code (DTC) Confirmation	
On Board Diagnosis Logic.....	124	Procedure .....	167
Possible Cause.....	125	Wiring Diagram - AT - LPSV.....	168
Diagnostic Trouble Code (DTC) Confirmation		Diagnostic Procedure .....	169
Procedure .....	125	<b>DTC P0750 SHIFT SOLENOID VALVE A</b> .....	172
Wiring Diagram - AT - 1ST .....	127	Description .....	172
Diagnostic Procedure .....	128	On Board Diagnosis Logic.....	172
<b>DTC P0732 A/T 2ND GEAR FUNCTION</b> .....	130	Possible Cause.....	172
Description .....	130	Diagnostic Trouble Code (DTC) Confirmation	
On Board Diagnosis Logic.....	130	Procedure .....	173
Possible Cause.....	131	Wiring Diagram - AT - SSV/A .....	174
Diagnostic Trouble Code (DTC) Confirmation		Diagnostic Procedure .....	175
Procedure .....	131	<b>DTC P0755 SHIFT SOLENOID VALVE B</b> .....	177
Wiring Diagram - AT - 2ND.....	133	Description .....	177
Diagnostic Procedure .....	134	On Board Diagnosis Logic.....	177
<b>DTC P0733 A/T 3RD GEAR FUNCTION</b> .....	136	Possible Cause.....	177
Description .....	136	Diagnostic Trouble Code (DTC) Confirmation	
On Board Diagnosis Logic.....	136	Procedure .....	178
Possible Cause.....	137	Wiring Diagram - AT - SSV/B .....	179
Diagnostic Trouble Code (DTC) Confirmation		Diagnostic Procedure .....	180
Procedure .....	137	<b>DTC P1705 THROTTLE POSITION SENSOR</b> .....	182
Wiring Diagram - AT - 3RD.....	139	Description .....	182
Diagnostic Procedure .....	140	On Board Diagnosis Logic.....	183
<b>DTC P0734 A/T 4TH GEAR FUNCTION</b> .....	142	Possible Cause.....	183
Description .....	142	Diagnostic Trouble Code (DTC) Confirmation	
On Board Diagnosis Logic.....	143	Procedure .....	184
Possible Cause.....	143	Wiring Diagram - AT - TPS.....	185
Diagnostic Trouble Code (DTC) Confirmation		Diagnostic Procedure .....	186
Procedure .....	144	<b>DTC P1760 OVERRUN CLUTCH SOLENOID</b>	
Wiring Diagram - AT - 4TH.....	145	<b>VALVE</b> .....	191
Diagnostic Procedure .....	146	Description .....	191
<b>DTC P0740 TORQUE CONVERTER CLUTCH</b>		On Board Diagnosis Logic.....	191
<b>SOLENOID VALVE</b> .....	151	Possible Cause.....	191
Description .....	151	Diagnostic Trouble Code (DTC) Confirmation	
On Board Diagnosis Logic.....	151	Procedure .....	192
Possible Cause.....	151	Wiring Diagram - AT - OVRCSV.....	193
Diagnostic Trouble Code (DTC) Confirmation		Diagnostic Procedure .....	194
Procedure .....	152	<b>DTC BATT/FLUID TEMP SEN (A/T FLUID TEMP</b>	
Wiring Diagram - AT - TCV.....	153	<b>SENSOR CIRCUIT AND TCM POWER SOURCE)</b> ....	196
Diagnostic Procedure .....	154	Description .....	196
<b>DTC P0744 A/T TCC S/V FUNCTION (LOCK-UP)</b> ....	156	On Board Diagnosis Logic.....	197
Description .....	156	Possible Cause.....	197
On Board Diagnosis Logic.....	156	Diagnostic Trouble Code (DTC) Confirmation	
Possible Cause.....	157	Procedure .....	197
Diagnostic Trouble Code (DTC) Confirmation		Wiring Diagram - AT - BA/FTS .....	198
Procedure .....	157	Diagnostic Procedure .....	199
Wiring Diagram - AT - TCCSIG .....	159	<b>DTC VEHICLE SPEED SENSOR.MTR</b> .....	203
Diagnostic Procedure .....	160	Description .....	203
<b>DTC P0745 LINE PRESSURE SOLENOID VALVE</b> ...	166	On Board Diagnosis Logic.....	203

# CONTENTS (Cont'd)

Possible Cause.....	203	
Diagnostic Trouble Code (DTC) Confirmation Procedure .....	204	
Wiring Diagram - AT - VSSMTR.....	205	
Diagnostic Procedure .....	206	
<b>DTC A/T COMM LINE</b> .....	208	
Description.....	208	
On Board Diagnosis Logic.....	208	
Possible Cause.....	208	
Diagnostic Trouble Code (DTC) Confirmation Procedure .....	209	
Wiring Diagram - AT - LAN.....	210	
Diagnostic Procedure .....	211	
<b>DTC CONTROL UNIT (RAM), CONTROL UNIT (ROM)</b> .....	212	
Description.....	212	
On Board Diagnosis Logic.....	212	
Possible Cause.....	212	
Diagnostic Trouble Code (DTC) Confirmation Procedure .....	212	
Diagnostic Procedure .....	213	
<b>DTC CONTROL UNIT (EEP ROM)</b> .....	214	
Description.....	214	
On Board Diagnosis Logic.....	214	
Possible Cause.....	214	
Diagnostic Trouble Code (DTC) Confirmation Procedure .....	214	
Diagnostic Procedure .....	215	
<b>TROUBLE DIAGNOSES FOR SYMPTOMS</b> .....	216	
Wiring Diagram - AT - NONDTC .....	216	
1. O/D OFF Indicator Lamp Does Not Come On.....	219	
2. Engine Cannot Be Started In P and N Position.....	222	
3. In P Position, Vehicle Moves Forward or Backward When Pushed .....	223	
4. In N Position, Vehicle Moves .....	224	
5. Large Shock. N -> R Position .....	227	
6. Vehicle Does Not Creep Backward In R Position .....	229	
7. Vehicle Does Not Creep Forward in D, 2 or 1 Position .....	233	
8. Vehicle Cannot Be Started From D <sub>1</sub> .....	236	
9. A/T Does Not Shift: D <sub>1</sub> -> D <sub>2</sub> or Does Not Kickdown: D <sub>4</sub> -> D <sub>2</sub> .....	239	
10. A/T Does Not Shift: D <sub>2</sub> -> D <sub>3</sub> .....	242	
11. A/T Does Not Shift: D <sub>3</sub> -> D <sub>4</sub> .....	245	
12. A/T Does Not Perform Lock-up .....	248	
13. A/T Does Not Hold Lock-up Condition .....	250	
14. Lock-up Is Not Released.....	252	
15. Engine Speed Does Not Return To Idle (Light Braking D <sub>4</sub> -> D <sub>3</sub> ).....	253	
16. Vehicle Does Not Start From D <sub>1</sub> .....	256	
17. A/T Does Not Shift: D <sub>4</sub> -> D <sub>3</sub> , When Overdrive Control Switch ON -> OFF .....	257	GI
18. A/T Does Not Shift: D <sub>3</sub> -> D <sub>2</sub> , When Selector Lever D -> 2 Position .....	258	MA
19. A/T Does Not Shift: D <sub>2</sub> -> D <sub>1</sub> , When Selector Lever 2 -> 1 Position .....	259	EM
20. Vehicle Does Not Decelerate By Engine Brake.....	260	LC
21. TCM Self-diagnosis Does Not Activate (PNP, Overdrive Control and Throttle Position Switches Circuit Checks) .....	260	EC
<b>A/T SHIFT LOCK SYSTEM</b> .....	270	FE
Description.....	270	
Wiring Diagram - SHIFT -.....	271	
Shift Lock System Electrical Parts Location.....	272	
Diagnostic Procedure .....	272	
Key Interlock Cable .....	276	CL
<b>SHIFT CONTROL SYSTEM</b> .....	278	MT
Control Device .....	278	
Control Cable.....	279	
<b>ON-VEHICLE SERVICE</b> .....	280	
Control Valve Assembly and Accumulators.....	280	
Revolution Sensor Replacement.....	281	AT
Park/Neutral Position (PNP) Switch Adjustment .....	281	
Control Cable Adjustment.....	282	AX
Differential Side Oil Seal Replacement .....	282	
<b>REMOVAL AND INSTALLATION</b> .....	283	
Removal.....	283	SU
Installation.....	284	
<b>OVERHAUL</b> .....	286	BR
Components.....	286	
Oil Channel.....	289	
Locations of Adjusting Shims, Needle Bearings, Thrust Washers and Snap Rings .....	290	ST
<b>DISASSEMBLY</b> .....	291	
<b>REPAIR FOR COMPONENT PARTS</b> .....	305	RS
Manual Shaft.....	305	
Oil Pump .....	308	
Control Valve Assembly.....	312	BT
Control Valve Upper Body .....	320	
Control Valve Lower Body .....	324	HA
Reverse Clutch .....	326	
High Clutch .....	329	SC
Forward and Overrun Clutches .....	334	
Low & Reverse Brake.....	339	
Rear Internal Gear, Forward Clutch Hub and Overrun Clutch Hub.....	342	EL
Output Shaft, Idler Gear, Reduction Pinion Gear and Bearing Retainer.....	346	IDX
Band Servo Piston Assembly .....	351	
Final Drive.....	356	
<b>ASSEMBLY</b> .....	362	

# CONTENTS (Cont'd)

Assembly (1).....	362	Planetary Carrier and Oil Pump .....	388
Adjustment (1) .....	362	Input Shaft .....	388
Assembly (2).....	367	Reduction Pinion Gear .....	388
Adjustment (2) .....	373	Band Servo .....	389
Assembly (3).....	375	Output Shaft.....	389
<b>SERVICE DATA AND SPECIFICATIONS (SDS) .....</b>	<b>382</b>	Bearing Retainer.....	390
General Specifications.....	382	Total End Play.....	390
Shift Schedule.....	382	Reverse Clutch End Play .....	390
Stall Revolution.....	382	Removal and Installation .....	391
Line Pressure.....	382	Shift Solenoid Valves.....	391
Control Valves.....	383	Solenoid Valves .....	391
Accumulator .....	383	A/T Fluid Temperature Sensor.....	391
Clutch and Brakes .....	384	Revolution Sensor .....	391
Final Drive.....	386	Dropping Resistor .....	391

## Alphabetical & P No. Index for DTC

NFAT0001

NFAT0001S01

### ALPHABETICAL INDEX FOR DTC

Items (CONSULT-II screen terms)	DTC	Reference page
	CONSULT-II GST*1	
A/T 1ST GR FNCTN	P0731	AT-124
A/T 2ND GR FNCTN	P0732	AT-130
A/T 3RD GR FNCTN	P0733	AT-136
A/T 4TH GR FNCTN	P0734	AT-142
A/T TCC S/V FNCTN	P0744	AT-156
ATF TEMP SEN/CIRC	P0710	AT-108
ENGINE SPEED SIG	P0725	AT-119
L/PRESS SOL/CIRC	P0745	AT-166
O/R CLTCH SOL/CIRC	P1760	AT-191
PNP SW/CIRC	P0705	AT-102
SFT SOL A/CIRC*2	P0750	AT-172
SFT SOL B/CIRC*2	P0755	AT-177
TCC SOLENOID/CIRC	P0740	AT-151
TP SEN/CIRC A/T*2	P1705	AT-182
VEH SPD SEN/CIR AT*3	P0720	AT-114

\*1: These numbers are prescribed by SAE J2012.

\*2: When the fail-safe operation occurs, the MIL illuminates.

\*3: The MIL illuminates when both the "Revolution sensor signal" and the "Vehicle speed sensor signal" meet the fail-safe condition at the same time.

GI

MA

EM

LG

EC

FE

CL

MT

**AT**

AX

SU

BR

ST

RS

BT

HA

SC

EL

IDX

# TROUBLE DIAGNOSIS — INDEX

Alphabetical & P No. Index for DTC (Cont'd)

## P NO. INDEX FOR DTC

=NFAT0001S02

DTC CONSULT-II GST*1	Items (CONSULT-II screen terms)	Reference page
P0705	PNP SW/CIRC	AT-102
P0710	ATF TEMP SEN/CIRC	AT-108
P0720	VEH SPD SEN/CIR AT*3	AT-114
P0725	ENGINE SPEED SIG	AT-119
P0731	A/T 1ST GR FNCTN	AT-124
P0732	A/T 2ND GR FNCTN	AT-130
P0733	A/T 3RD GR FNCTN	AT-136
P0734	A/T 4TH GR FNCTN	AT-142
P0740	TCC SOLENOID/CIRC	AT-151
P0744	A/T TCC S/V FNCTN	AT-156
P0745	L/PRESS SOL/CIRC	AT-166
P0750	SFT SOL A/CIRC*2	AT-172
P0755	SFT SOL B/CIRC*2	AT-177
P1705	TP SEN/CIRC A/T*2	AT-182
P1760	O/R CLTCH SOL/CIRC	AT-191

\*1: These numbers are prescribed by SAE J2012.

\*2: When the fail-safe operation occurs, the MIL illuminates.

\*3: The MIL illuminates when both the "Revolution sensor signal" and the "Vehicle speed sensor signal" meet the fail-safe condition at the same time.

# PRECAUTIONS

Supplemental Restraint System (SRS) "AIR BAG" and "SEAT BELT PRE-TENSIONER"

## Supplemental Restraint System (SRS) "AIR BAG" and "SEAT BELT PRE-TENSIONER"

NFAT0002

The Supplemental Restraint System such as "AIR BAG" and "SEAT BELT PRE-TENSIONER" used along with a seat belt, helps to reduce the risk or severity of injury to the driver and front passenger for certain types of collision. The SRS system composition which is available to NISSAN MODEL A33 is as follows (The composition varies according to optional equipment.):

- For a frontal collision  
The Supplemental Restraint System consists of driver air bag module (located in the center of the steering wheel), front passenger air bag module (located on the instrument panel on passenger side), seat belt pre-tensioners, a diagnosis sensor unit, warning lamp, wiring harness and spiral cable.
- For a side collision  
The Supplemental Restraint System consists of front side air bag module (located in the outer side of front seat), satellite sensor, diagnosis sensor unit (one of components of air bags for a frontal collision), wiring harness, warning lamp (one of components of air bags for a frontal collision).

Information necessary to service the system safely is included in the **RS section** of this Service Manual.

### WARNING:

- To avoid rendering the SRS inoperative, which could increase the risk of personal injury or death in the event of a collision which would result in air bag inflation, all maintenance should be performed by an authorized NISSAN dealer.
- Improper maintenance, including incorrect removal and installation of the SRS, can lead to personal injury caused by intentional activation of the system. For removal of Spiral Cable and Air Bag Module, see the RS section.
- Do not use electrical test equipment on any circuit related to the SRS unless instructed to in this Service Manual. Spiral cable and wiring harnesses covered with yellow insulation or tape either just before the harness connectors or for the complete harness are related to the SRS.

## Precautions for On Board Diagnostic (OBD) System of A/T and Engine

NFAT0003

The ECM has an on board diagnostic system. It will light up the malfunction indicator lamp (MIL) to warn the driver of a malfunction causing emission deterioration.

### CAUTION:

- Be sure to turn the ignition switch OFF and disconnect the negative battery terminal before any repair or inspection work. The open/short circuit of related switches, sensors, solenoid valves, etc. will cause the MIL to light up.
- Be sure to connect and lock the connectors securely after work. A loose (unlocked) connector will cause the MIL to light up due to an open circuit. (Be sure the connector is free from water, grease, dirt, bent terminals, etc.)
- Be sure to route and secure the harnesses properly after work. Interference of the harness with a bracket, etc. may cause the MIL to light up due to a short circuit.
- Be sure to connect rubber tubes properly after work. A misconnected or disconnected rubber tube may cause the MIL to light up due to a malfunction of the EGR system or fuel injection system, etc.
- Be sure to erase the unnecessary malfunction information (repairs completed) from the TCM or ECM before returning the vehicle to the customer.

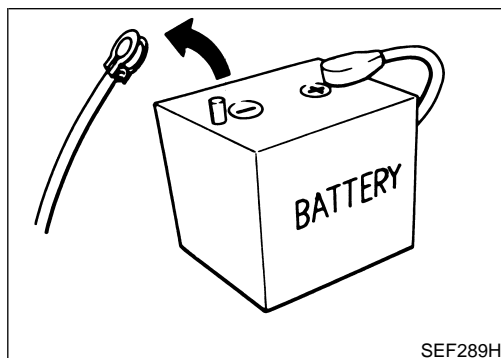

### Precautions

NFAT0004

- Before connecting or disconnecting the TCM harness connector, turn ignition switch OFF and disconnect negative battery terminal. Failure to do so may damage the TCM. Because battery voltage is applied to TCM even if ignition switch is turned off.



# PRECAUTIONS

Precautions (Cont'd)

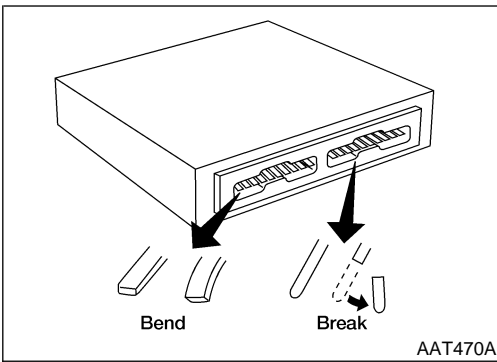

- When connecting or disconnecting pin connectors into or from TCM, take care not to damage pin terminals (bend or break).  
Make sure that there are not any bends or breaks on TCM pin terminal, when connecting pin connectors.

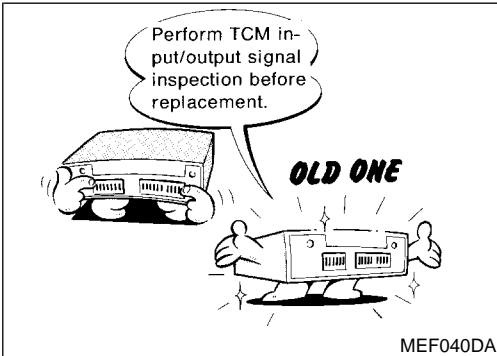

- Before replacing TCM, perform TCM input/output signal inspection and make sure whether TCM functions properly or not. (See page AT-95.)

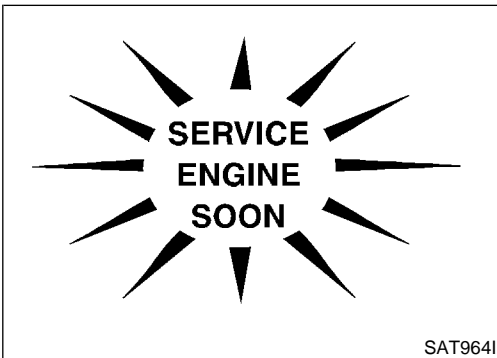

- After performing each TROUBLE DIAGNOSIS, perform "DTC (Diagnostic Trouble Code) CONFIRMATION PROCEDURE".  
The DTC should not be displayed in the "DTC CONFIRMATION PROCEDURE" if the repair is completed.

- Before proceeding with disassembly, thoroughly clean the outside of the transaxle. It is important to prevent the internal parts from becoming contaminated by dirt or other foreign matter.
- Disassembly should be done in a clean work area.
- Use lint-free cloth or towels for wiping parts clean. Common shop rags can leave fibers that could interfere with the operation of the transaxle.
- Place disassembled parts in order for easier and proper assembly.
- All parts should be carefully cleaned with a general purpose, non-flammable solvent before inspection or reassembly.
- Gaskets, seals and O-rings should be replaced any time the transaxle is disassembled.
- It is very important to perform functional tests whenever they are indicated.
- The valve body contains precision parts and requires extreme care when parts are removed and serviced. Place disassembled valve body parts in order for easier and proper assembly. Care will also prevent springs and small parts from becoming scattered or lost.
- Properly installed valves, sleeves, plugs, etc. will slide along bores in valve body under their own weight.
- Before assembly, apply a coat of recommended ATF to all



# PRECAUTIONS

Precautions (Cont'd)

parts. Apply petroleum jelly to protect O-rings and seals, or hold bearings and washers in place during assembly. Do not use grease.

- Extreme care should be taken to avoid damage to O-rings, seals and gaskets when assembling.
- Replace ATF cooler if excessive foreign material is found in oil pan or clogging strainer. Refer to “ATF COOLER SERVICE” (Refer to AT-10).
- After overhaul, refill the transaxle with new ATF.
- When the A/T drain plug is removed, only some of the fluid is drained. Old A/T fluid will remain in torque converter and ATF cooling system.  
Always follow the procedures under “Changing A/T Fluid” in the MA section when changing A/T fluid.

GI

MA

EM

LC

EC

FE

CL

MT

## Service Notice or Precautions

NFAT0005

NFAT0005S01

### FAIL-SAFE

The TCM has an electronic Fail-Safe (limp home mode). This allows the vehicle to be driven even if a major electrical input/output device circuit is damaged.

Under Fail-Safe, the vehicle always runs in third gear, even with a shift lever position of 1, 2 or D. The customer may complain of sluggish or poor acceleration.

When the ignition key is turned ON following Fail-Safe operation, O/D OFF indicator lamp blinks for about 8 seconds. (For “TCM Self-diagnostic Procedure (No Tools)”, refer to AT-49.)

Fail-Safe may occur without electrical circuit damage if the vehicle is driven under extreme conditions (such as excessive wheel spin followed by sudden braking). To recover normal shift pattern, turn the ignition key OFF for 5 seconds, then ON.

The blinking of the O/D OFF indicator lamp for about 8 seconds will appear only once and be cleared. The customer may resume normal driving conditions.

Always follow the “Work Flow” (Refer to AT-59).

The SELF-DIAGNOSIS results will be as follows:

The first SELF-DIAGNOSIS will indicate damage to the vehicle speed sensor or the revolution sensor.

During the next SELF-DIAGNOSIS, performed after checking the sensor, no damages will be indicated.

### TORQUE CONVERTER SERVICE

NFAT0005S02

The torque converter should be replaced under any of the following conditions:

- External leaks in the hub weld area.
- Converter hub is scored or damaged.
- Converter pilot is broken, damaged or fits poorly into crankshaft.
- Steel particles are found after flushing the cooler and cooler lines.
- Pump is damaged or steel particles are found in the converter.
- Vehicle has TCC shudder and/or no TCC apply. Replace only after all hydraulic and electrical diagnoses have been made. (Converter clutch material may be glazed.)
- Converter is contaminated with engine coolant containing antifreeze.
- Internal failure of stator roller clutch.
- Heavy clutch debris due to overheating (blue converter).
- Steel particles or clutch lining material found in fluid filter or on magnet when no internal parts in unit are worn or damaged — indicates that lining material came from converter.  
The torque converter should not be replaced if:
- The fluid has an odor, is discolored, and there is no evidence of metal or clutch facing particles.

AT

AX

SU

BR

ST

RS

BT

HA

SC

EL

IDX

## PRECAUTIONS

*Service Notice or Precautions (Cont'd)*

---

- The threads in one or more of the converter bolt holes are damaged.
- Transaxle failure did not display evidence of damaged or worn internal parts, steel particles or clutch plate lining material in unit and inside the fluid filter.
- Vehicle has been exposed to high mileage (only). The exception may be where the torque converter clutch dampener plate lining has seen excess wear by vehicles operated in heavy and/or constant traffic, such as taxi, delivery or police use.

### ATF COOLER SERVICE

NFAT0005S03

If A/T fluid contains frictional material (clutches, bands, etc.), replace radiator and flush cooler line using cleaning solvent and compressed air after repair of A/T. Refer to LC-16, "Radiator".

### OBD-II SELF-DIAGNOSIS

NFAT0005S04

- A/T self-diagnosis is performed by the TCM in combination with the ECM. The results can be read through the blinking pattern of the O/D OFF indicator or the malfunction indicator lamp (MIL). Refer to the table on AT-45 for the indicator used to display each self-diagnostic result.
- The self-diagnostic results indicated by the MIL are automatically stored in both the ECM and TCM memories.  
**Always perform the procedure "HOW TO ERASE DTC" on AT-41 to complete the repair and avoid unnecessary blinking of the MIL.**
- The following self-diagnostic items can be detected using ECM self-diagnostic results mode\* only when the O/D OFF indicator lamp does not indicate any malfunctions.
  - park/neutral position (PNP) switch
  - A/T 1st, 2nd, 3rd, or 4th gear function
  - A/T TCC S/V function (lock-up).

\*: For details of OBD-II, refer to EC-72, "ON BOARD DIAGNOSTIC SYSTEM DESCRIPTION".
- **Certain systems and components, especially those related to OBD, may use a new style slide-locking type harness connector.**  
**For description and how to disconnect, refer to EL-5, "Description".**

## Wiring Diagrams and Trouble Diagnosis

NFAT0006

When you read wiring diagrams, refer to the followings:

- GI-11, "HOW TO READ WIRING DIAGRAMS"
- EL-9, "POWER SUPPLY ROUTING" for power distribution circuit

When you perform trouble diagnosis, refer to the followings:

- GI-36, "HOW TO FOLLOW TEST GROUP IN TROUBLE DIAGNOSIS"
- GI-25, "HOW TO PERFORM EFFICIENT DIAGNOSIS FOR AN ELECTRICAL INCIDENT"

# PREPARATION

Special Service Tools

## Special Service Tools

NFAT0007

The actual shapes of Kent-Moore tools may differ from those of special service tools illustrated here.

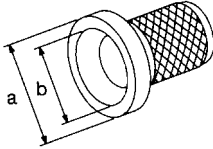
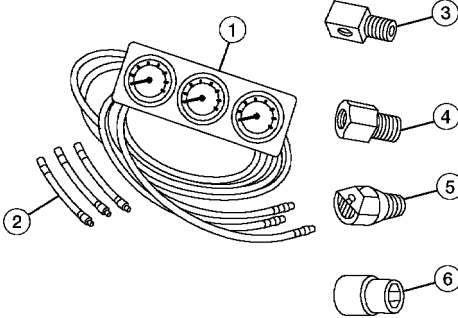
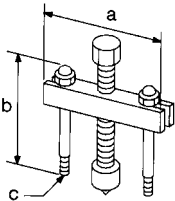
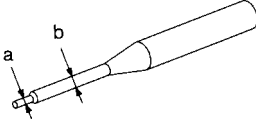
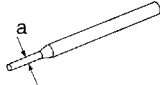
Tool number (Kent-Moore No.) Tool name	Description		
KV381054S0 (J34286) Puller		<ul style="list-style-type: none"> <li>● Removing differential side oil seals</li> <li>● Removing differential side bearing outer race</li> <li>● Removing idler gear bearing outer race</li> </ul> <p><b>a: 250 mm (9.84 in)</b> <b>b: 160 mm (6.30 in)</b></p>	GI MA EM LC
ST33400001 (J26082) Drift		<ul style="list-style-type: none"> <li>● Installing differential side oil seal F04B and F04W (RH side)</li> <li>● Installing oil seal on oil pump housing</li> </ul> <p><b>a: 60 mm (2.36 in) dia.</b> <b>b: 47 mm (1.85 in) dia.</b></p>	EC FE CL
(J34301-C) Oil pressure gauge set 1 (J34301-1) Oil pressure gauge 2 (J34301-2) Hoses 3 (J34298) Adapter 4 (J34282-2) Adapter 5 (790-301-1230-A) 60° Adapter 6 (J34301-15) Square socket		<ul style="list-style-type: none"> <li>● Measuring line pressure</li> </ul>	MT <b>AT</b> AX SU
ST27180001 (J25726-A) Puller		<ul style="list-style-type: none"> <li>● Removing idler gear</li> </ul> <p><b>a: 100 mm (3.94 in)</b> <b>b: 110 mm (4.33 in)</b> <b>c: M8 x 1.25P</b></p>	BR ST RS
ST23540000 (J25689-A) Pin punch		<ul style="list-style-type: none"> <li>● Removing and installing parking rod plate and manual plate pins</li> </ul> <p><b>a: 2.3 mm (0.091 in) dia.</b> <b>b: 4 mm (0.16 in) dia.</b></p>	BT HA
ST25710000 (J25689-A) Pin punch		<ul style="list-style-type: none"> <li>● Aligning groove of manual shaft and hole of transmission case</li> </ul> <p><b>a: 2 mm (0.08 in) dia.</b></p>	SC EL IDX

# PREPARATION

## Special Service Tools (Cont'd)

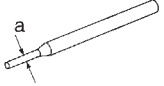
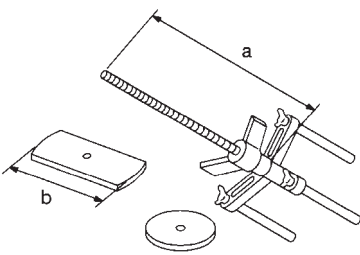
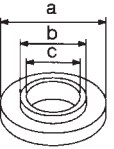
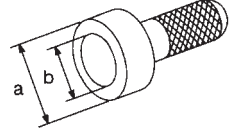
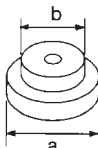
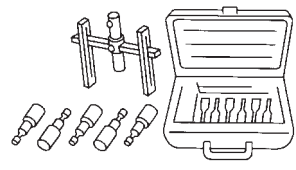
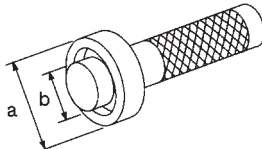
Tool number (Kent-Moore No.) Tool name	Description
KV32101000 (J25689-A) Pin punch	 <ul style="list-style-type: none"> <li>● Removing and installing manual shaft retaining pin</li> <li>● Removing and installing pinion mate shaft lock pin</li> </ul> <p><b>a: 4 mm (0.16 in) dia.</b></p> <p>NT410</p>
KV31102400 (J34285 and J34285-87) Clutch spring compressor	 <ul style="list-style-type: none"> <li>● Removing and installing clutch return springs</li> <li>● Installing low and reverse brake piston</li> </ul> <p><b>a: 320 mm (12.60 in)</b> <b>b: 174 mm (6.85 in)</b></p> <p>NT423</p>
KV40100630 (J26092) Drift	 <ul style="list-style-type: none"> <li>● Installing reduction gear bearing inner race</li> <li>● Installing idler gear bearing inner race</li> </ul> <p><b>a: 67.5 mm (2.657 in) dia.</b> <b>b: 44 mm (1.73 in) dia.</b> <b>c: 38.5 mm (1.516 in) dia.</b></p> <p>NT107</p>
ST30720000 (J25405 and J34331) Bearing installer	 <ul style="list-style-type: none"> <li>● Installing idler gear bearing outer race</li> </ul> <p><b>a: 77 mm (3.03 in) dia.</b> <b>b: 55.5 mm (2.185 in) dia.</b></p> <p>NT115</p>
ST35321000 ( — ) Drift	 <ul style="list-style-type: none"> <li>● Installing output shaft bearing</li> </ul> <p><b>a: 49 mm (1.93 in) dia.</b> <b>b: 41 mm (1.61 in) dia.</b></p> <p>NT073</p>
(J34291-A) Shim setting gauge set	 <ul style="list-style-type: none"> <li>● Selecting oil pump cover bearing race and oil pump thrust washer</li> <li>● Selecting side gear thrust washer</li> </ul> <p>NT101</p>
ST33230000 (J25805-01) Drift	 <ul style="list-style-type: none"> <li>● Installing differential side bearing inner race F04B and F04W (RH side)</li> </ul> <p><b>a: 51 mm (2.01 in) dia.</b> <b>b: 28.5 mm (1.122 in) dia.</b></p> <p>NT084</p>

# PREPARATION

Special Service Tools (Cont'd)

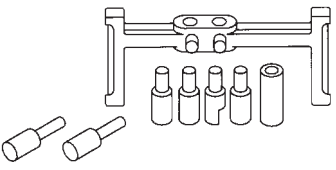
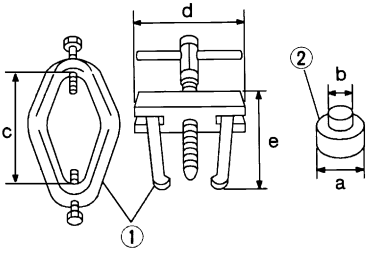
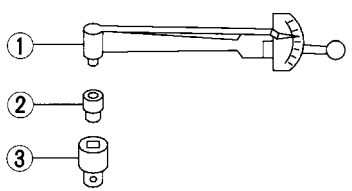
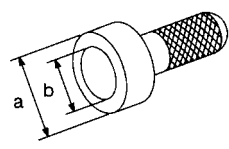
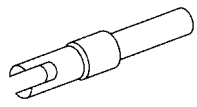
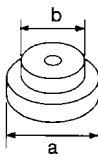
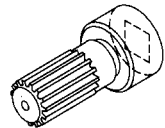
Tool number (Kent-Moore No.) Tool name	Description		
(J34290) Shim selecting tool set		<ul style="list-style-type: none"> <li>Selecting differential side bearing adjusting shim</li> </ul>	GI MA EM
ST3306S001 (J22888-D) Differential side bearing puller set 1 ST33051001 (J22888-D) Puller 2 ST33061000 (J8107-2) Adapter		<ul style="list-style-type: none"> <li>Removing differential side bearing inner race</li> </ul> <p><b>a: 38 mm (1.50 in) dia.</b>  <b>b: 28.5 mm (1.122 in) dia.</b>  <b>c: 130 mm (5.12 in)</b>  <b>d: 135 mm (5.31 in)</b>  <b>e: 100 mm (3.94 in)</b></p>	LC EC FE CL
ST3127S000 (J25765-A) Preload gauge 1 GG91030000 (J25765-A) Torque wrench 2 HT62940000 ( — ) Socket adapter 3 HT62900000 ( — ) Socket adapter		<ul style="list-style-type: none"> <li>Checking differential side bearing preload</li> </ul>	MT <b>AT</b> AX SU
ST35271000 (J26091) Drift		<ul style="list-style-type: none"> <li>Installing idler gear</li> <li>Installing differential side bearing inner race F04W (LH side)</li> </ul> <p><b>a: 72 mm (2.83 in) dia.</b>  <b>b: 63 mm (2.48 in) dia.</b></p>	BR ST
(J39713) Preload adapter		<ul style="list-style-type: none"> <li>Selecting differential side bearing adjusting shim (F04B)</li> <li>Checking differential side bearing preload (F04B)</li> </ul>	RS BT
ST30613000 (J25742-3) Drift		<ul style="list-style-type: none"> <li>Installing differential side bearing inner race F04W (LH side)</li> </ul> <p><b>a: 72 mm (2.83 in) dia.</b>  <b>b: 48 mm (1.89 in) dia.</b></p>	HA SC
KV38105210 (J39883) Preload adapter		<ul style="list-style-type: none"> <li>Selecting differential side bearing adjusting shim (F04W)</li> <li>Checking differential side bearing preload (F04W)</li> </ul>	EL IDX

# PREPARATION

Commercial Service Tools

## Commercial Service Tools

NFAT0008

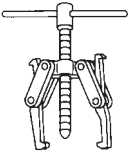
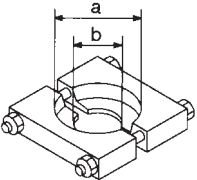
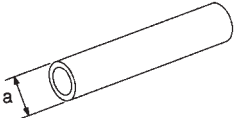
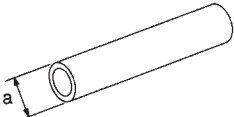
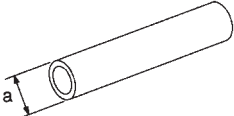
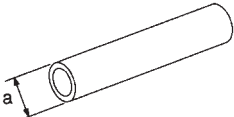
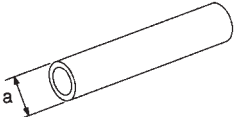
Tool name	Description
Puller	 <ul style="list-style-type: none"> <li>● Removing idler gear bearing inner race</li> <li>● Removing and installing band servo piston snap ring</li> </ul> <p>NT077</p>
Puller	 <ul style="list-style-type: none"> <li>● Removing reduction gear bearing inner race</li> <li><b>a: 60 mm (2.36 in) dia.</b></li> <li><b>b: 35 mm (1.38 in) dia.</b></li> </ul> <p>NT411</p>
Drift	 <ul style="list-style-type: none"> <li>● Installing differential side oil seal F04W (LH side)</li> <li><b>a: 90 mm (3.54 in) dia.</b></li> </ul> <p>NT083</p>
Drift	 <ul style="list-style-type: none"> <li>● Installing needle bearing on bearing retainer</li> <li><b>a: 36 mm (1.42 in) dia.</b></li> </ul> <p>NT083</p>
Drift	 <ul style="list-style-type: none"> <li>● Removing needle bearing from bearing retainer</li> <li><b>a: 33.5 mm (1.319 in) dia.</b></li> </ul> <p>NT083</p>
Drift	 <ul style="list-style-type: none"> <li>● Installing differential side bearing outer race F04B and F04W (RH side)</li> <li><b>a: 75 mm (2.95 in) dia.</b></li> </ul> <p>NT083</p>
Drift	 <ul style="list-style-type: none"> <li>● Installing differential side bearing outer race F04W (LH side)</li> <li><b>a: 100 mm (3.94 in) dia.</b></li> </ul> <p>NT083</p>

# OVERALL SYSTEM

A/T Electrical Parts Location

## A/T Electrical Parts Location

NFAT0009

- GI
- MA
- EM
- LC
- EC
- FE
- CL
- MT
- AT**
- AX
- SU
- BR
- ST
- RS
- BT
- HA
- SC
- EL
- IDX

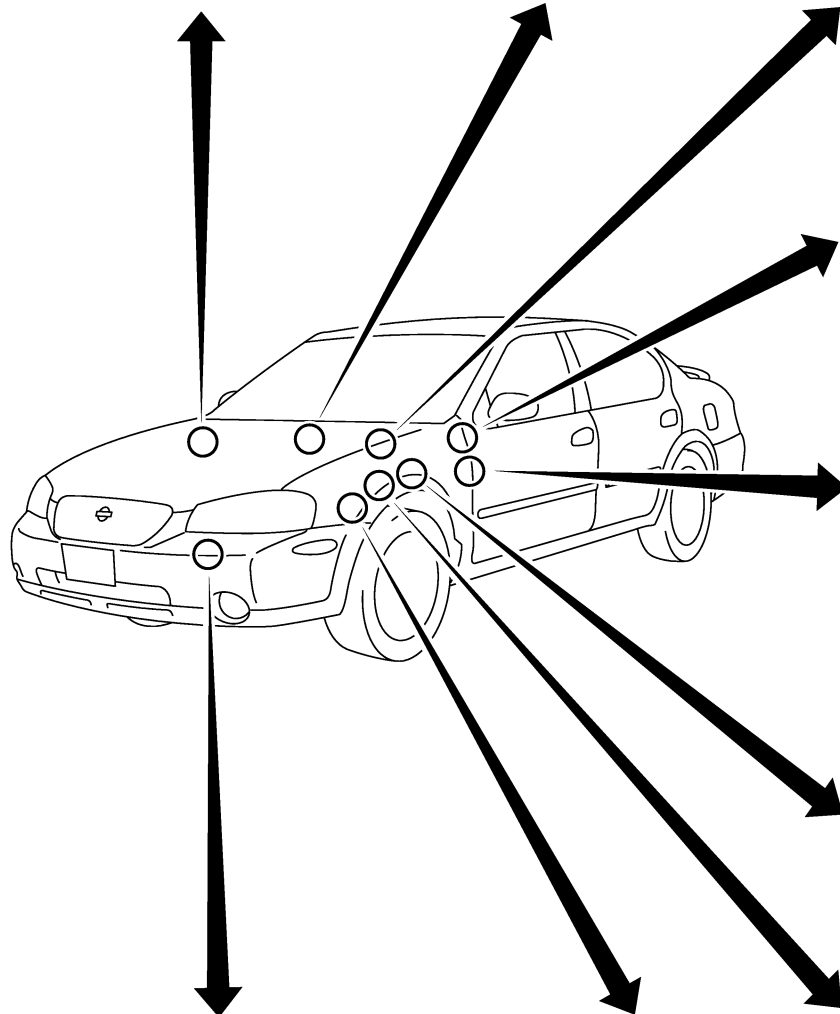
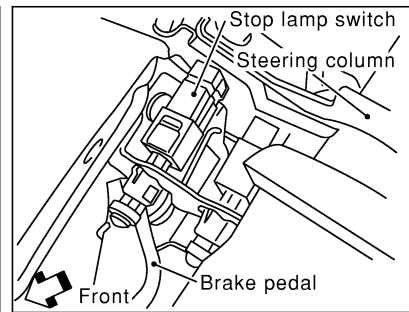
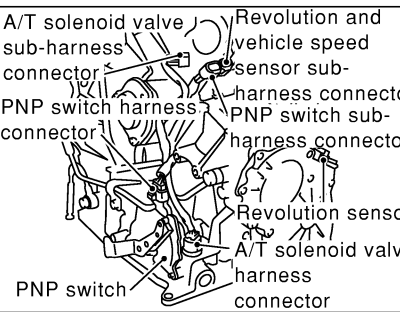
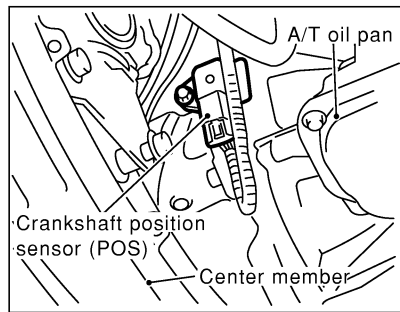
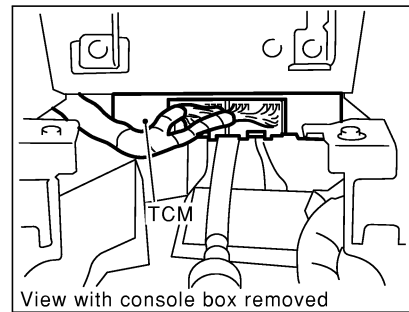
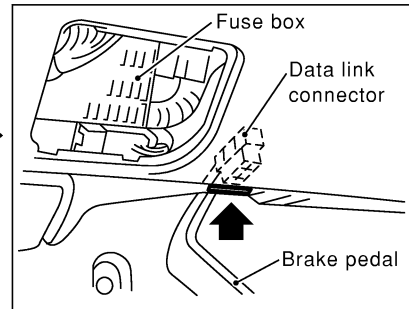
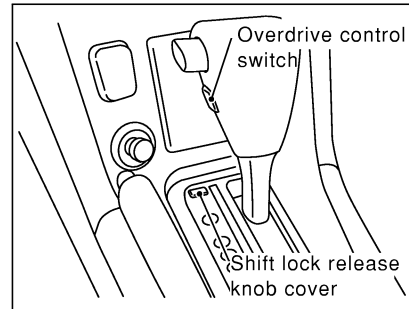
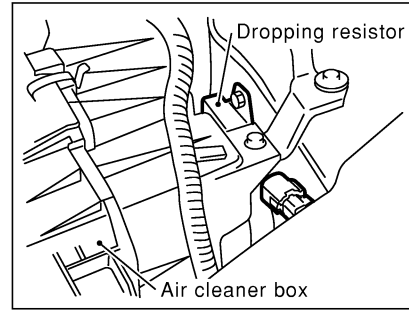
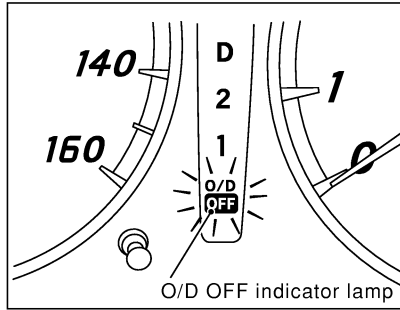
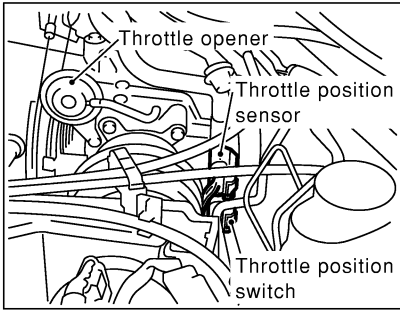



# OVERALL SYSTEM

Circuit Diagram

## Circuit Diagram

NFAT0010

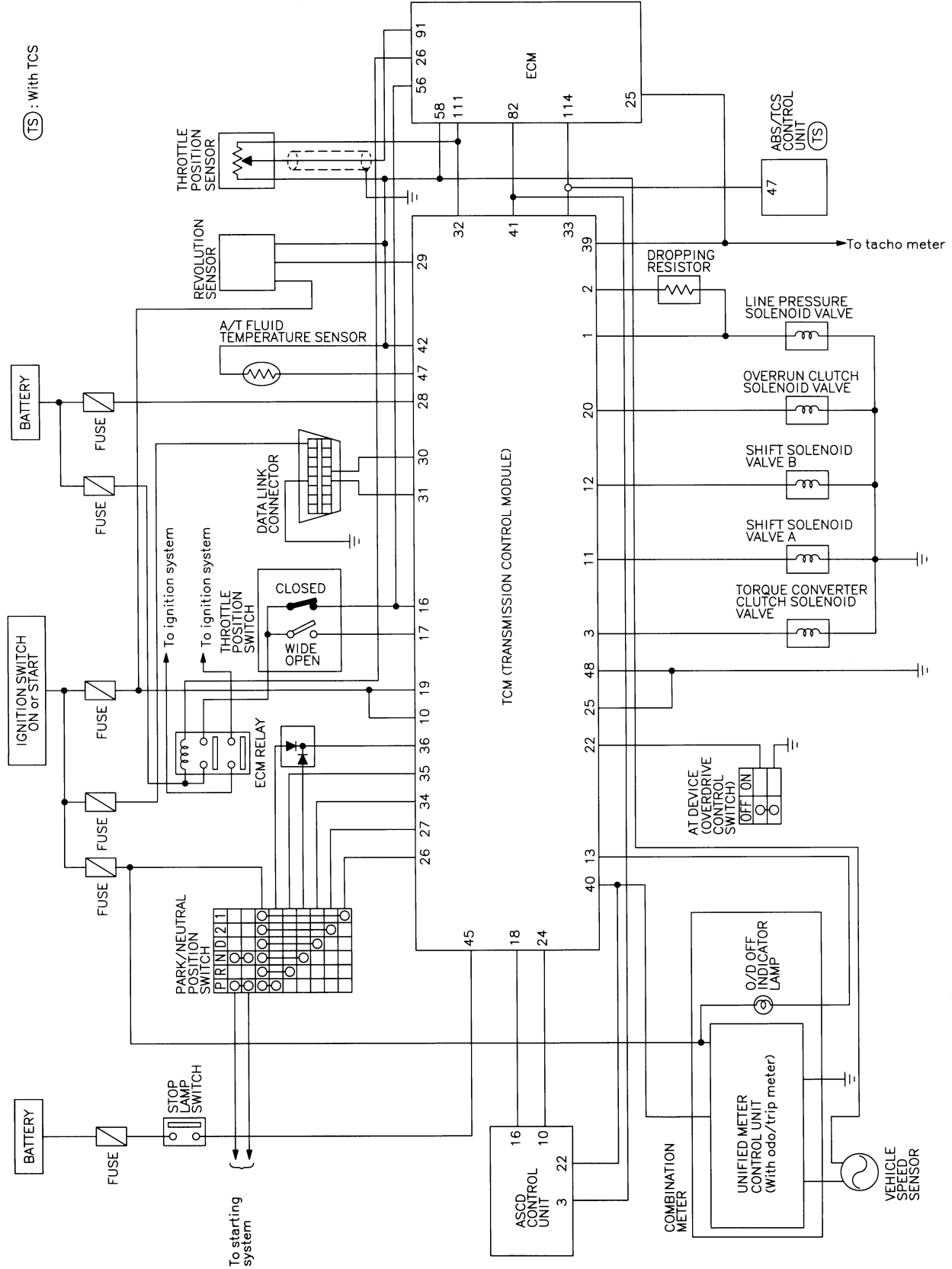

MAT802A

# OVERALL SYSTEM

Cross-sectional View

## Cross-sectional View

NFAT0011

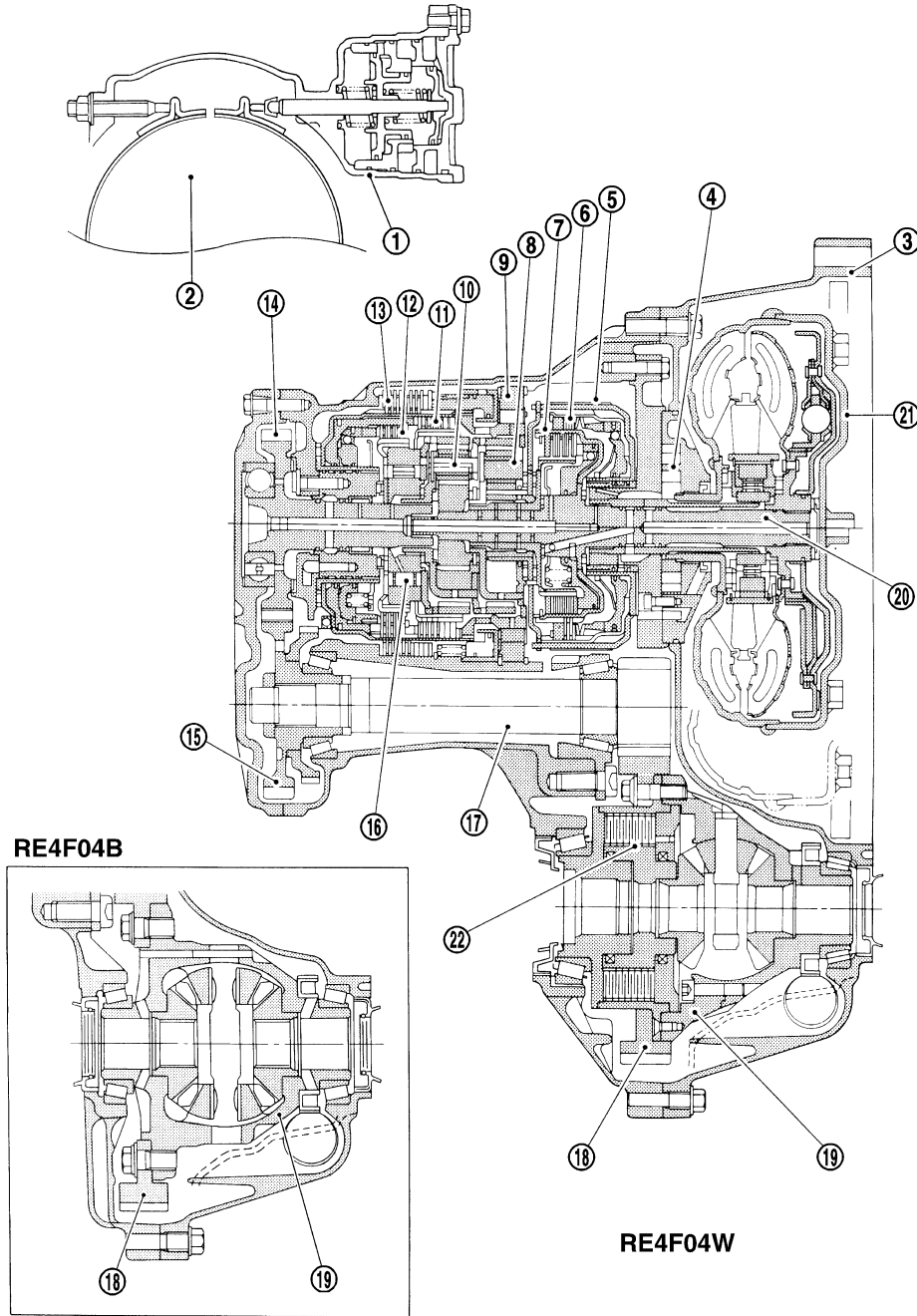

- |                        |                         |                            |
|------------------------|-------------------------|----------------------------|
| 1. Band servo piston   | 8. Front planetary gear | 15. Idler gear             |
| 2. Reverse clutch drum | 9. Low one-way clutch   | 16. Forward one-way clutch |
| 3. Converter housing   | 10. Rear planetary gear | 17. Pinion reduction gear  |
| 4. Oil pump            | 11. Forward clutch      | 18. Final gear             |
| 5. Brake band          | 12. Overrun clutch      | 19. Differential case      |
| 6. Reverse clutch      | 13. Low & reverse brake | 20. Input shaft            |
| 7. High clutch         | 14. Output gear         | 21. Torque converter       |

GI

MA

EM

LC

EC

FE

CL

MT

**AT**

AX

SU

BR

ST

RS

BT

SAT577J

HA

SC

EL

IDX

# OVERALL SYSTEM

Hydraulic Control Circuit

## Hydraulic Control Circuit

NFAT0012

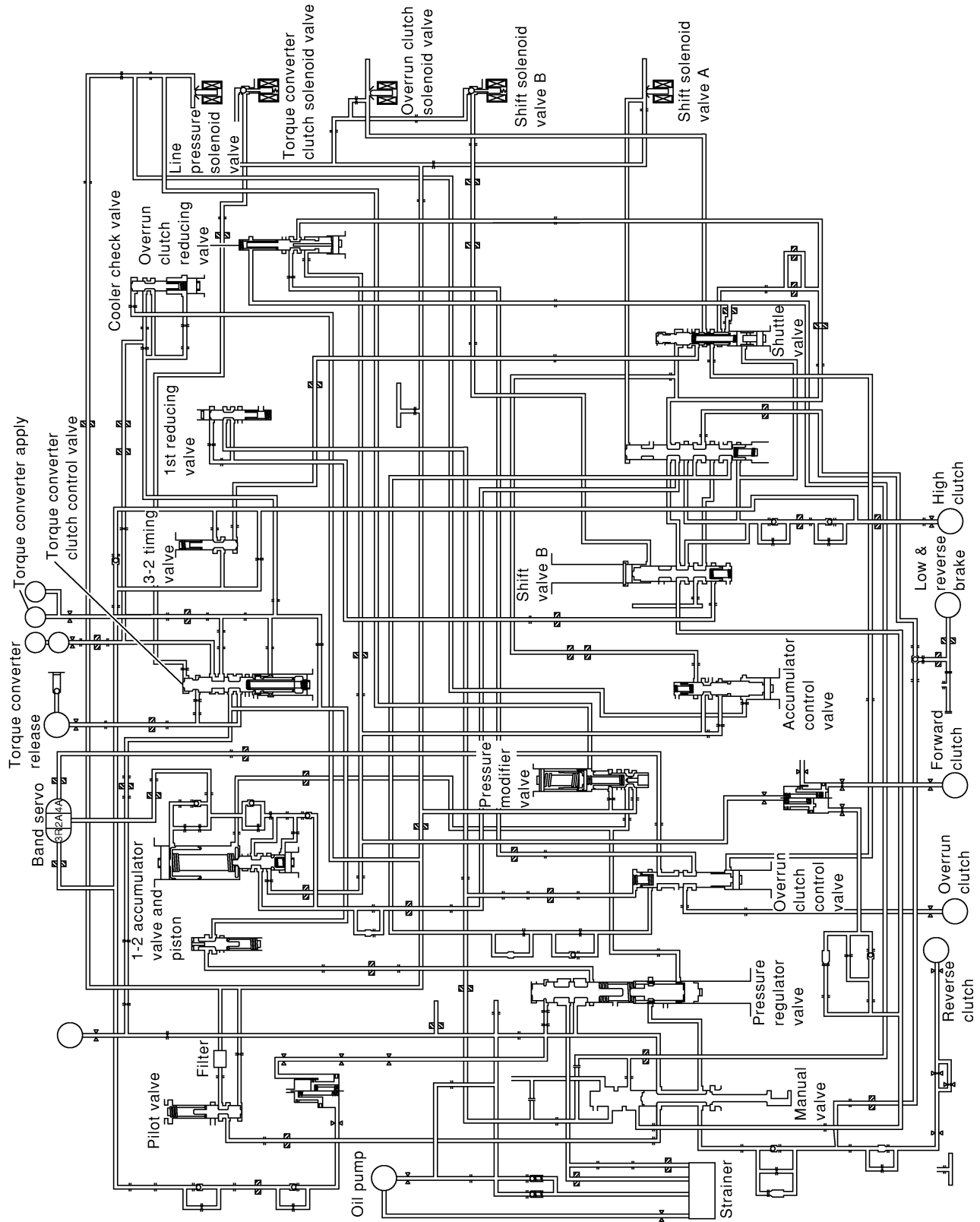

SAT578J

## Shift Mechanism

NFAT0013

NFAT0013S01

### CONSTRUCTION

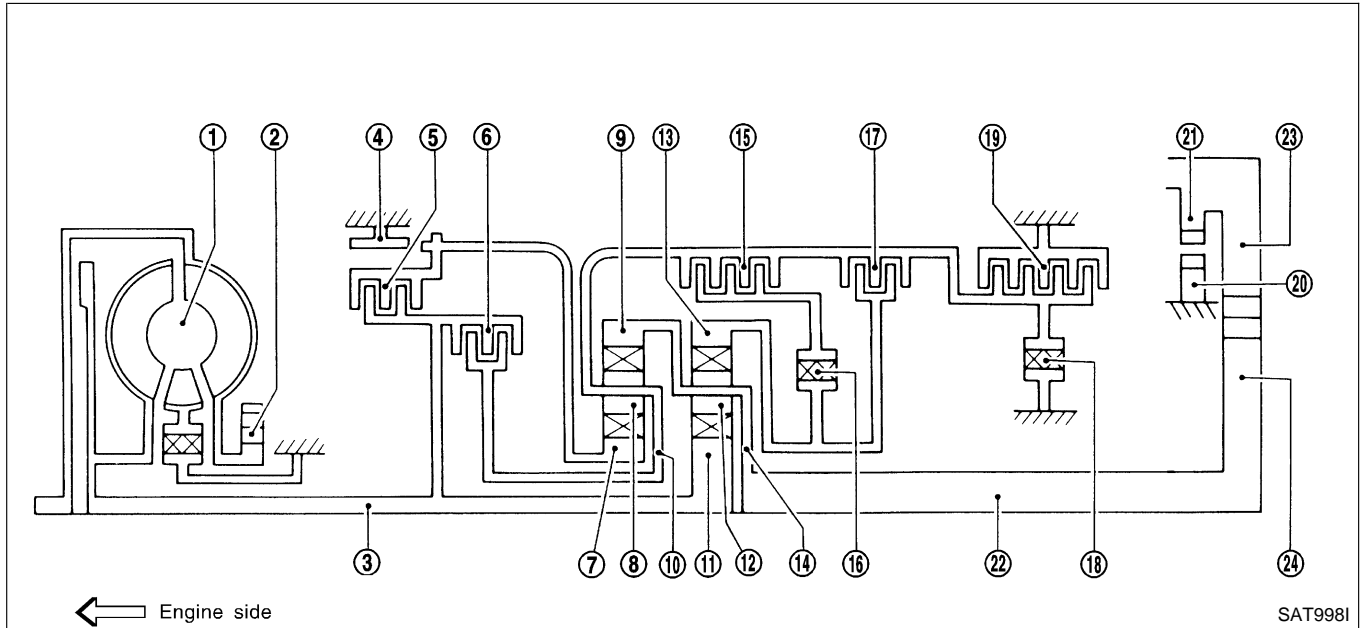

- |                      |                             |                         |
|----------------------|-----------------------------|-------------------------|
| 1. Torque converter  | 9. Front internal gear      | 17. Overrun clutch      |
| 2. Oil pump          | 10. Front planetary carrier | 18. Low one-way clutch  |
| 3. Input shaft       | 11. Rear sun gear           | 19. Low & reverse brake |
| 4. Brake band        | 12. Rear pinion gear        | 20. Parking pawl        |
| 5. Reverse clutch    | 13. Rear internal gear      | 21. Parking gear        |
| 6. High clutch       | 14. Rear planetary carrier  | 22. Output shaft        |
| 7. Front sun gear    | 15. Forward clutch          | 23. Idle gear           |
| 8. Front pinion gear | 16. Forward one-way clutch  | 24. Output gear         |

### FUNCTION OF CLUTCH AND BRAKE

NFAT0013S02

Clutch and brake components	Abbr.	Function
Reverse clutch <b>5</b>	R/C	To transmit input power to front sun gear <b>7</b> .
High clutch <b>6</b>	H/C	To transmit input power to front planetary carrier <b>10</b> .
Forward clutch <b>15</b>	F/C	To connect front planetary carrier <b>10</b> with forward one-way clutch <b>16</b> .
Overrun clutch <b>17</b>	O/C	To connect front planetary carrier <b>10</b> with rear internal gear <b>13</b> .
Brake band <b>4</b>	B/B	To lock front sun gear <b>7</b> .
Forward one-way clutch <b>16</b>	F/O.C	When forward clutch <b>15</b> is engaged, to stop rear internal gear <b>13</b> from rotating in opposite direction against engine revolution.
Low one-way clutch <b>18</b>	L/O.C	To stop front planetary carrier <b>10</b> from rotating in opposite direction against engine revolution.
Low & reverse brake <b>19</b>	L & R/B	To lock front planetary carrier <b>10</b> .

# OVERALL SYSTEM

Shift Mechanism (Cont'd)

## CLUTCH AND BAND CHART

NFAT0013S03

Shift position	Reverse clutch 5	High clutch 6	Forward clutch 15	Over-run clutch 17	Band servo			Forward one-way clutch 16	Low one-way clutch 18	Low & reverse brake 19	Lock-up	Remarks
					2nd apply	3rd release	4th apply					
P												PARK POSITION
R	○									○		REVERSE POSITION
N												NEUTRAL POSITION
D*4	1st		○	*1D				B	B			Automatic shift 1 ⇔ 2 ⇔ 3 ⇔ 4
	2nd		○	*1 A	○			B				
	3rd		○	○	*1 A	*2C	C	B			*5○	
	4th		○	C		*3C	C	○			○	
2	1st		○	D				B	B			Automatic shift 1 ⇔ 2 ⇔ 3
	2nd		○	A	○			B				
1	1st		○	○				B		○		Locks (held stationary) in 1st speed 1 ⇔ 2 ⇔ 3
	2nd		○	○	○			B				

\*1: Operates when overdrive control switch is set in OFF position.

\*2: Oil pressure is applied to both 2nd "apply" side and 3rd "release" side of band servo piston. However, brake band does not contract because oil pressure area on the "release" side is greater than that on the "apply" side.

\*3: Oil pressure is applied to 4th "apply" side in condition \*2 above, and brake band contracts.

\*4: A/T will not shift to 4th when overdrive control switch is set in OFF position.

\*5: Operates when overdrive control switch is OFF.

○: Operates

A: Operates when throttle opening is less than 3/16, activating engine brake.

B: Operates during "progressive" acceleration.

C: Operates but does not affect power transmission.

D: Operates when throttle opening is less than 3/16, but does not affect engine brake.

## POWER TRANSMISSION

### P and N Positions

=NFAT0013S04

NFAT0013S0401

- P position  
Similar to the N position, the clutches do not operate. The parking pawl engages with the parking gear to mechanically hold the output shaft so that the power train is locked.
- N position  
Power from the input shaft is not transmitted to the output shaft because the clutches do not operate.

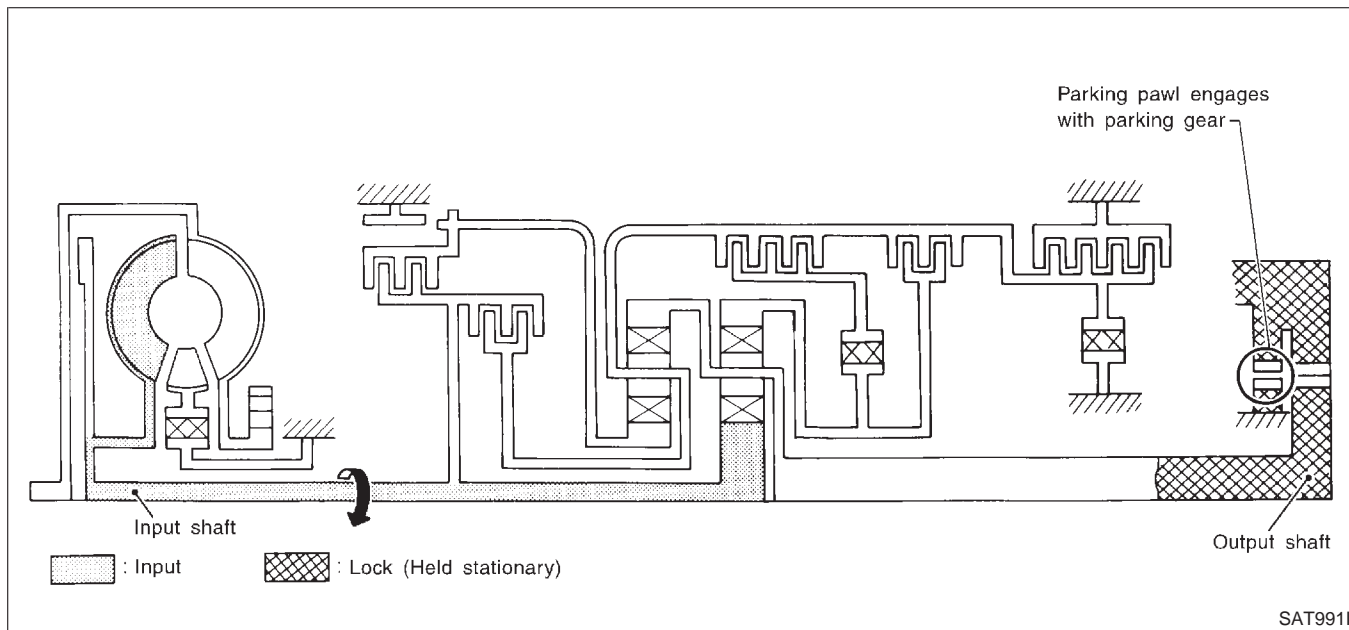

GI

MA

EM

LC

EC

FE

CL

MT

**AT**

AX

SU

BR

ST

RS

BT

HA

SC

EL

IDX

# OVERALL SYSTEM

Shift Mechanism (Cont'd)

## 1<sub>1</sub> Position

=NFAT0013S0402

<ul style="list-style-type: none"> <li>● Forward clutch</li> <li>● Forward one-way clutch</li> <li>● Overrun clutch</li> <li>● Low and reverse brake</li> </ul>	<p>As overrun clutch engages, rear internal gear is locked by the operation of low and reverse brake. This is different from that of D<sub>1</sub> and 2<sub>1</sub>.</p>
<p>Engine brake</p>	<p>Overrun clutch always engages, therefore engine brake can be obtained when decelerating.</p>

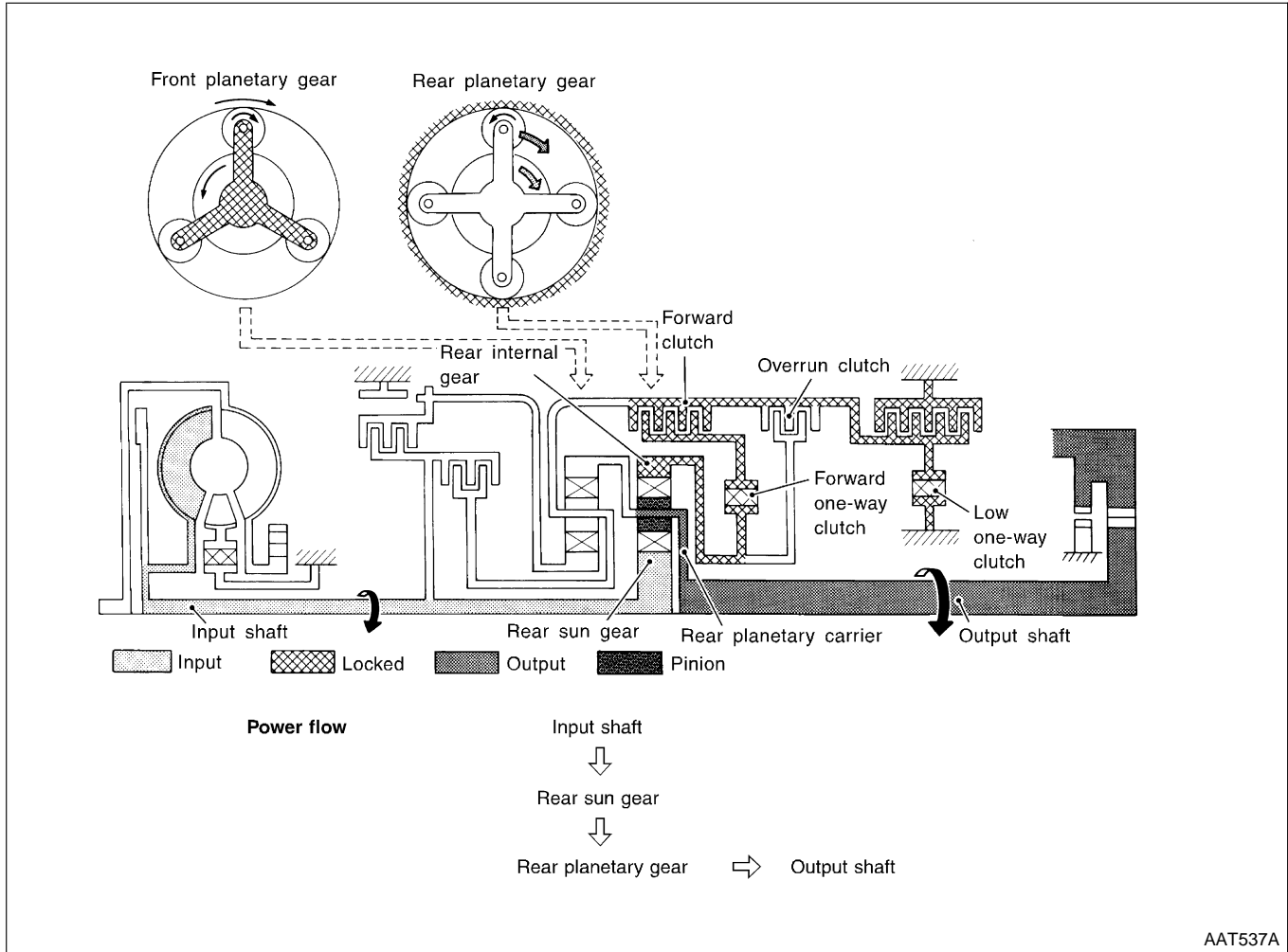

AAT537A



# OVERALL SYSTEM

Shift Mechanism (Cont'd)

## D<sub>1</sub> and 2<sub>1</sub> Positions

=NFAT0013S0403

<ul style="list-style-type: none"> <li>● Forward one-way clutch</li> <li>● Forward clutch</li> <li>● Low one-way clutch</li> </ul>	Rear internal gear is locked to rotate counterclockwise because of the functioning of these three clutches.
<b>Overrun clutch</b> engagement conditions (Engine brake)	D <sub>1</sub> : Overdrive control switch OFF and throttle opening is less than 3/16 2 <sub>1</sub> : Always engaged At D <sub>1</sub> and 2 <sub>1</sub> positions, engine brake is not activated due to free turning of low one-way clutch.

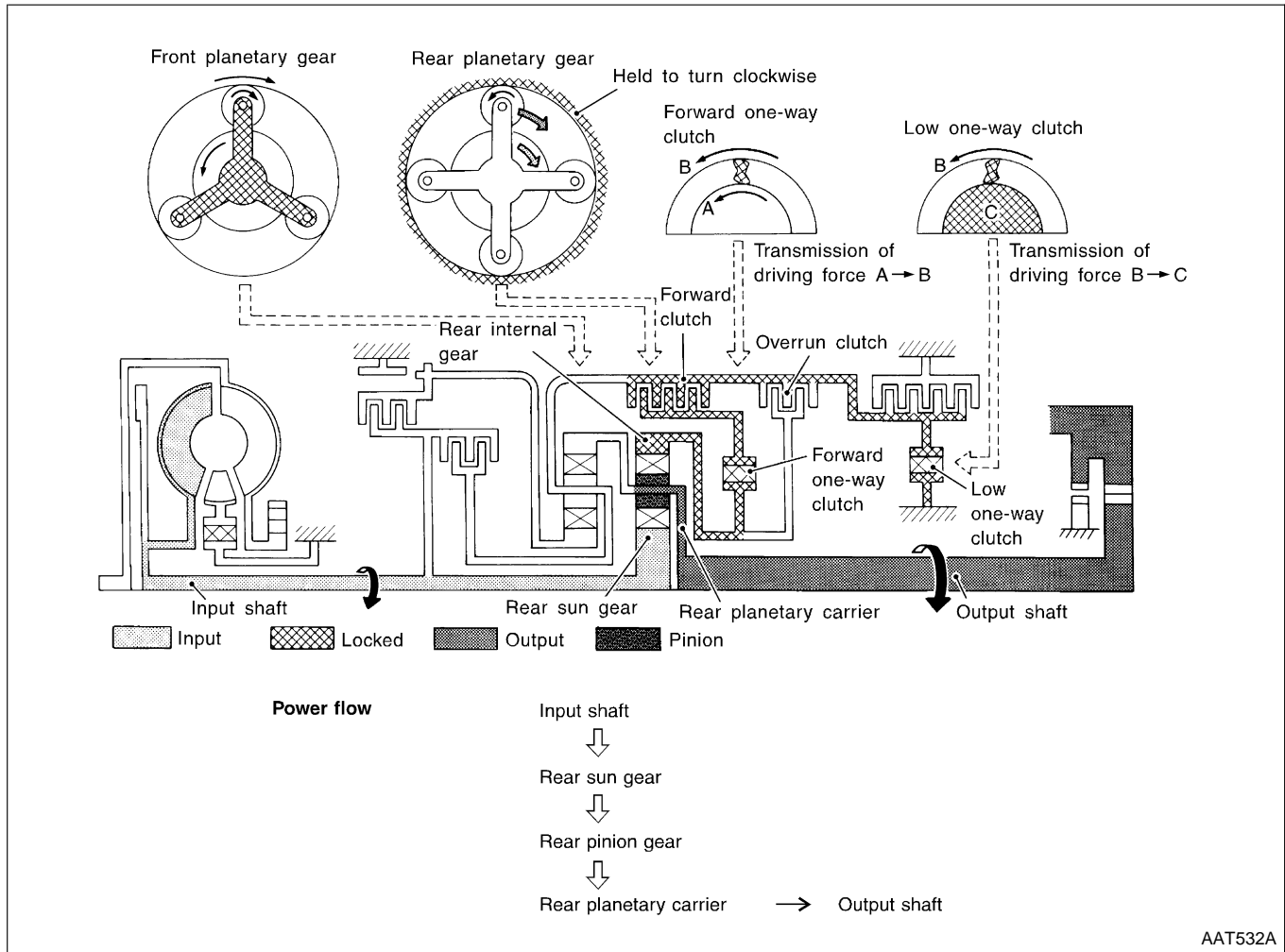

AAT532A

GI  
MA  
EM  
LC  
EC  
FE  
CL  
MT  
AT  
AX  
SU  
BR  
ST  
RS  
BT  
HA  
SC  
EL  
IDX

# OVERALL SYSTEM

Shift Mechanism (Cont'd)

## D<sub>2</sub>, 2<sub>2</sub> and 1<sub>2</sub> Positions

=NFAT0013S0404

<ul style="list-style-type: none"> <li>• Forward clutch</li> <li>• Forward one-way clutch</li> <li>• Brake band</li> </ul>	<p>Rear sun gear drives rear planetary carrier and combined front internal gear. Front internal gear now rotates around front sun gear accompanying front planetary carrier. As front planetary carrier transfers the power to rear internal gear through forward clutch and forward one-way clutch, this rotation of rear internal gear increases the speed of rear planetary carrier compared with that of the 1st speed.</p>
<p><b>Overrun clutch</b> engagement conditions</p>	<p>D<sub>2</sub>: Overdrive control switch OFF and throttle opening is less than 3/16 2<sub>2</sub> and 1<sub>2</sub>: Always engaged</p>

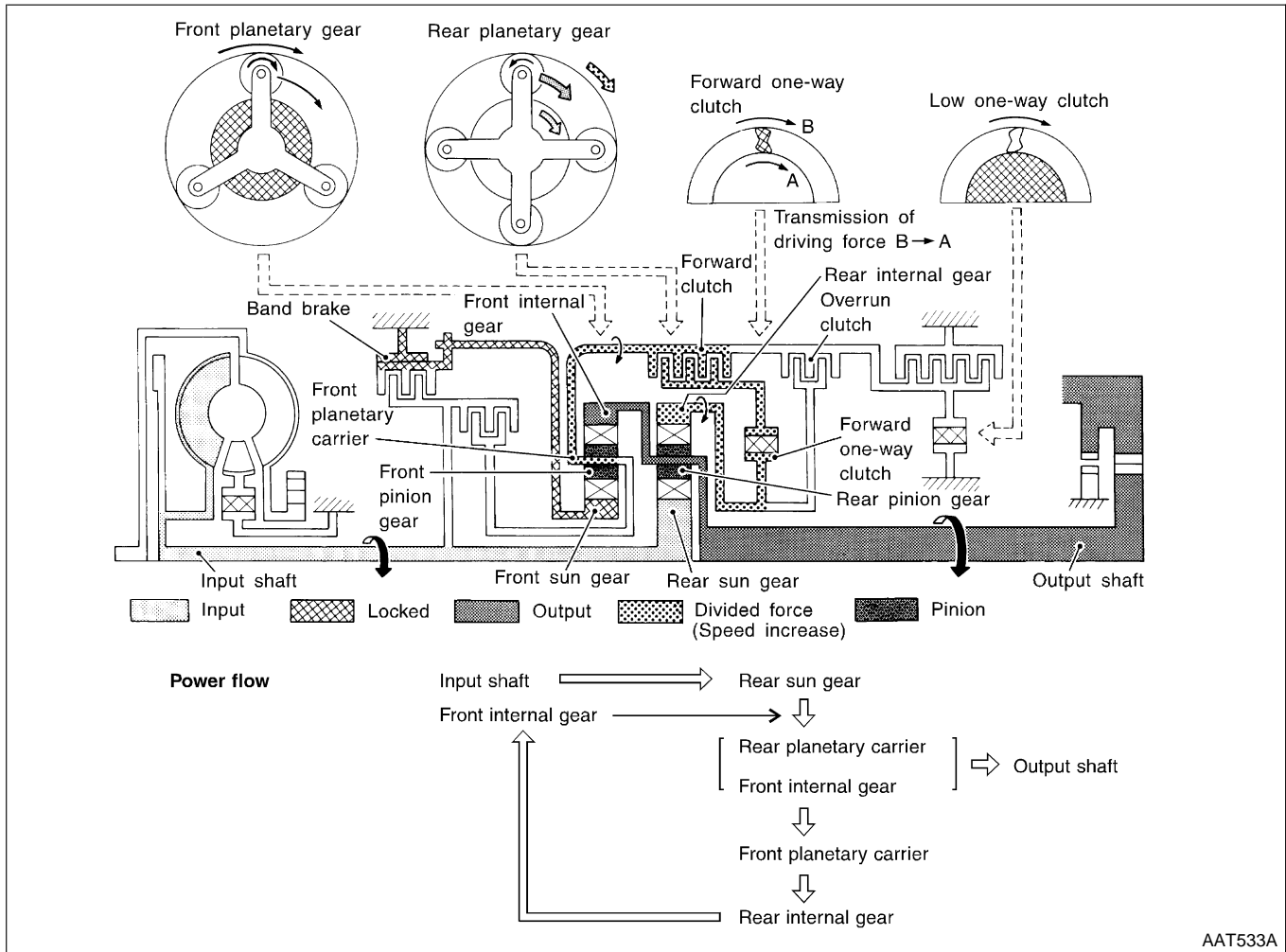

AAT533A

# OVERALL SYSTEM

Shift Mechanism (Cont'd)

## D<sub>3</sub> Position

=NFAT0013S0405

<ul style="list-style-type: none"> <li>● High clutch</li> <li>● Forward clutch</li> <li>● Forward one-way clutch</li> </ul>	<p>Input power is transmitted to front planetary carrier through high clutch. And front planetary carrier is connected to rear internal gear by operation of forward clutch and forward one-way clutch.</p> <p>This rear internal gear rotation and another input (the rear sun gear) accompany rear planetary carrier to turn at the same speed.</p>	<p>GI MA</p>
<p><b>Overrun clutch</b> engagement conditions</p>	<p>D<sub>3</sub>: Overdrive control switch "OFF" and throttle opening is less than 3/16</p>	<p>EM</p>

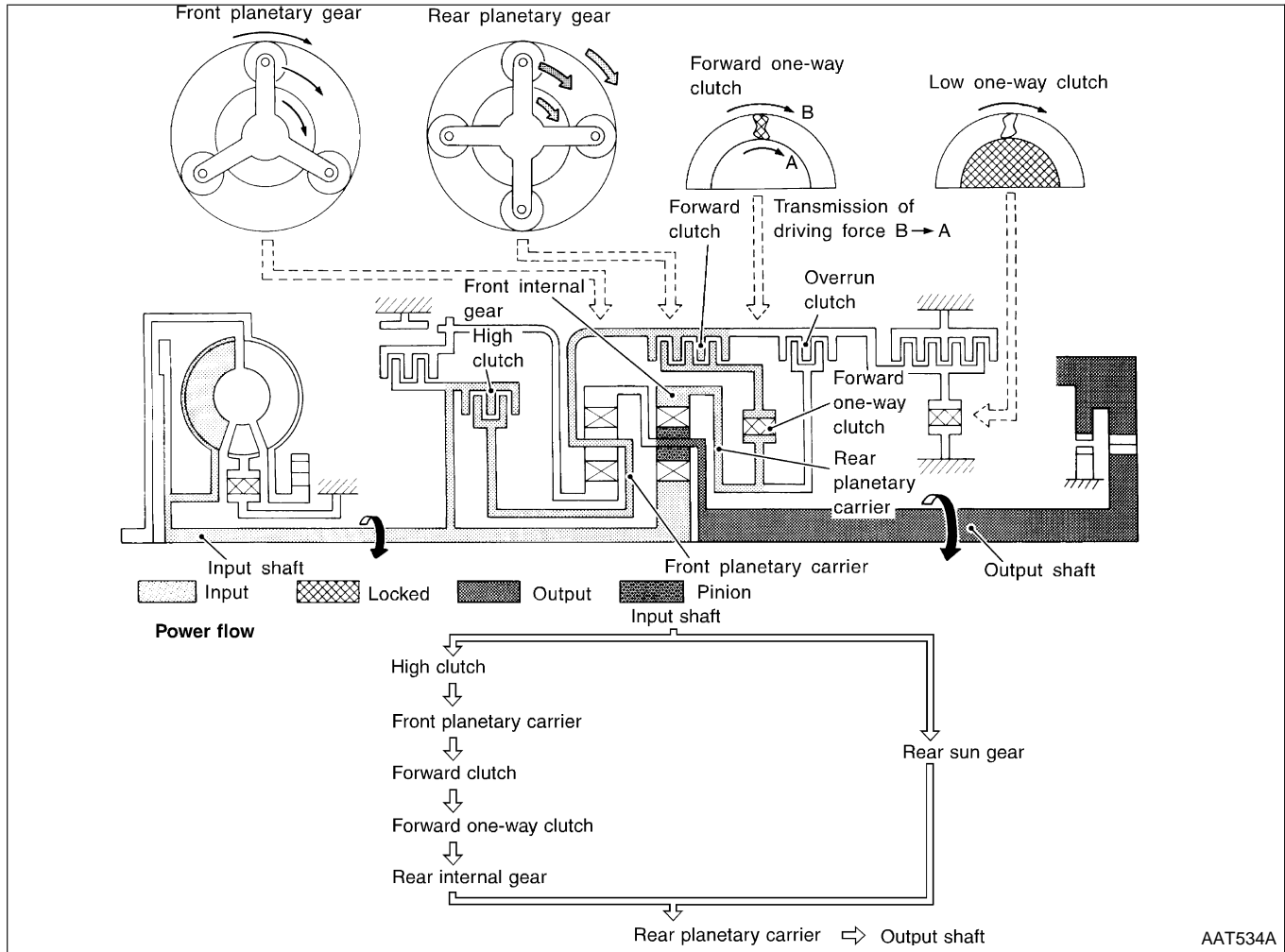

GI  
MA  
EM  
LC  
EC  
FE  
CL  
MT  
AT  
AX  
SU  
BR  
ST  
RS  
BT  
HA  
SC  
EL  
IDX

AAT534A

# OVERALL SYSTEM

Shift Mechanism (Cont'd)

## D<sub>4</sub> (O/D) Position

=NFAT0013S0406

<ul style="list-style-type: none"> <li>● High clutch</li> <li>● Brake band</li> <li>● Forward clutch (Does not affect power transmission)</li> </ul>	<p>Input power is transmitted to front carrier through high clutch. This front carrier turns around the sun gear which is fixed by brake band and makes front internal gear (output) turn faster.</p>
<p>Engine brake</p>	<p>At D<sub>4</sub> position, there is no one-way clutch in the power transmission line and engine brake can be obtained when decelerating.</p>

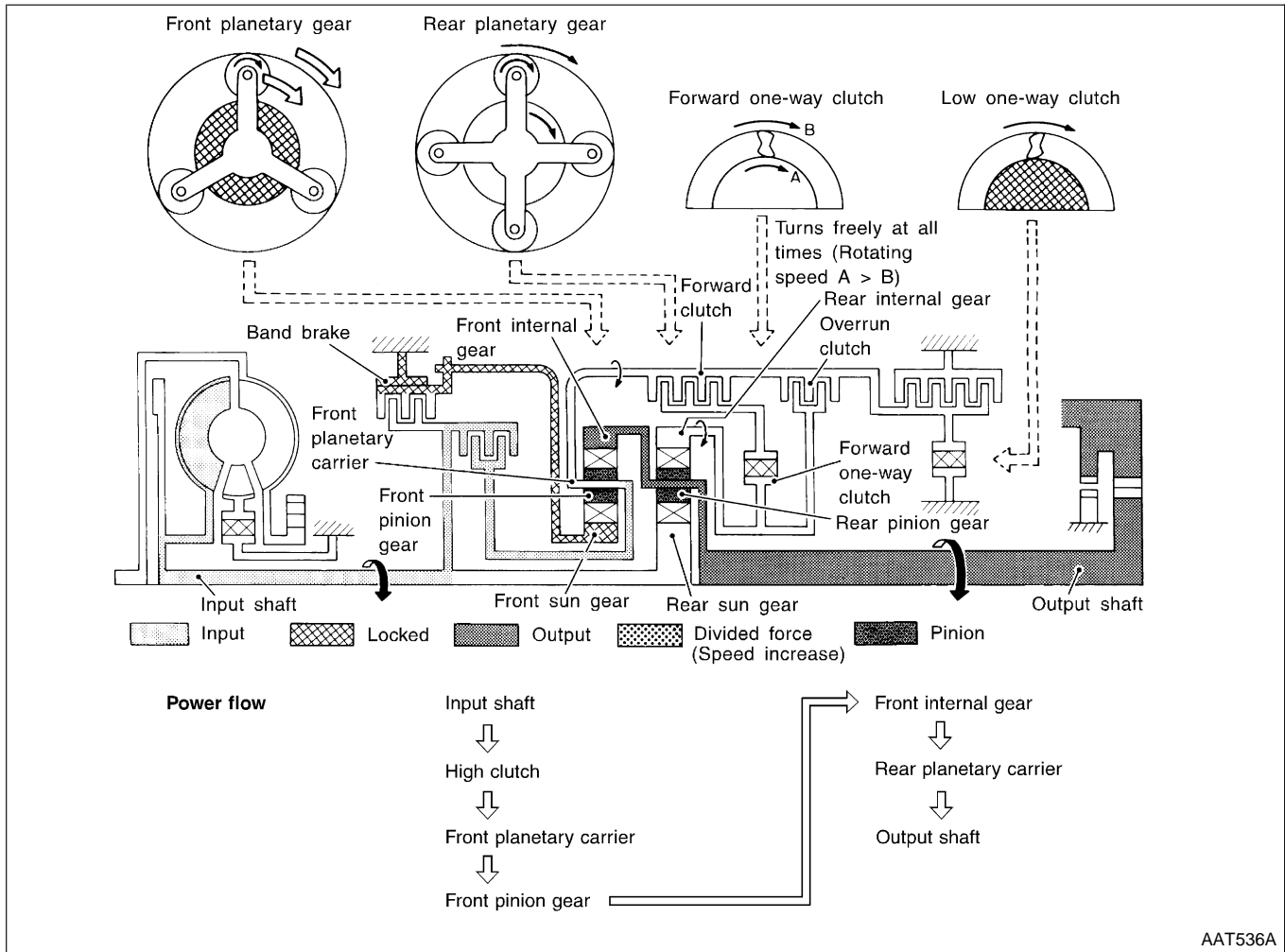

AAT536A

# OVERALL SYSTEM

Shift Mechanism (Cont'd)

## R Position

=NFAT0013S0407

<ul style="list-style-type: none"> <li>● Reverse clutch</li> <li>● Low and reverse brake</li> </ul>	<p>Front planetary carrier is stationary because of the operation of low and reverse brake. Input power is transmitted to front sun gear through reverse clutch, which drives front internal gear in the opposite direction.</p>	<p>GI</p>
<p>Engine brake</p>	<p>As there is no one-way clutch in the power transmission line, engine brake can be obtained when decelerating.</p>	<p>MA</p>

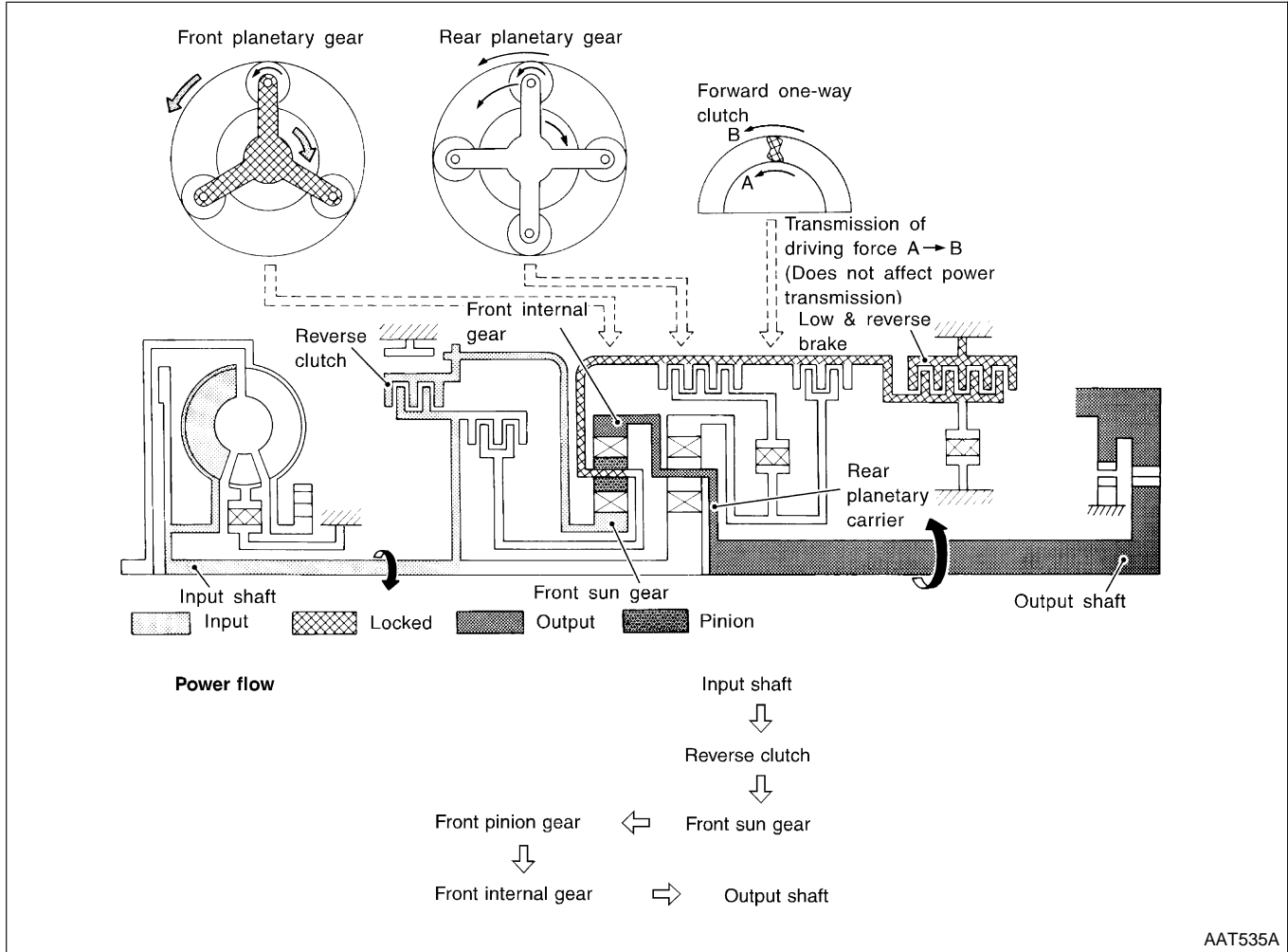

AAT535A

EM  
LC  
EC  
FE  
CL  
MT  
AT  
AX  
SU  
BR  
ST  
RS  
BT  
HA  
SC  
EL  
IDX

# OVERALL SYSTEM

Control System

## Control System

=NFAT0014

### OUTLINE

NFAT0014S01

The automatic transaxle senses vehicle operating conditions through various sensors. It always controls the optimum shift position and reduces shifting and lock-up shocks.

SENSORS		TCM		ACTUATORS
Park/neutral position (PNP) switch Throttle position sensor Closed throttle position switch Wide open throttle position switch Engine speed signal A/T fluid temperature sensor Revolution sensor Vehicle speed sensor Overdrive control switch ASCD control unit Stop lamp switch	▶	Shift control Line pressure control Lock-up control Overrun clutch control Timing control Fail-safe control Self-diagnosis CONSULT-II communication line control Duet-EA control	▶	Shift solenoid valve A Shift solenoid valve B Overrun clutch solenoid valve Torque converter clutch solenoid valve Line pressure solenoid valve O/D OFF indicator lamp

### CONTROL SYSTEM

NFAT0014S02

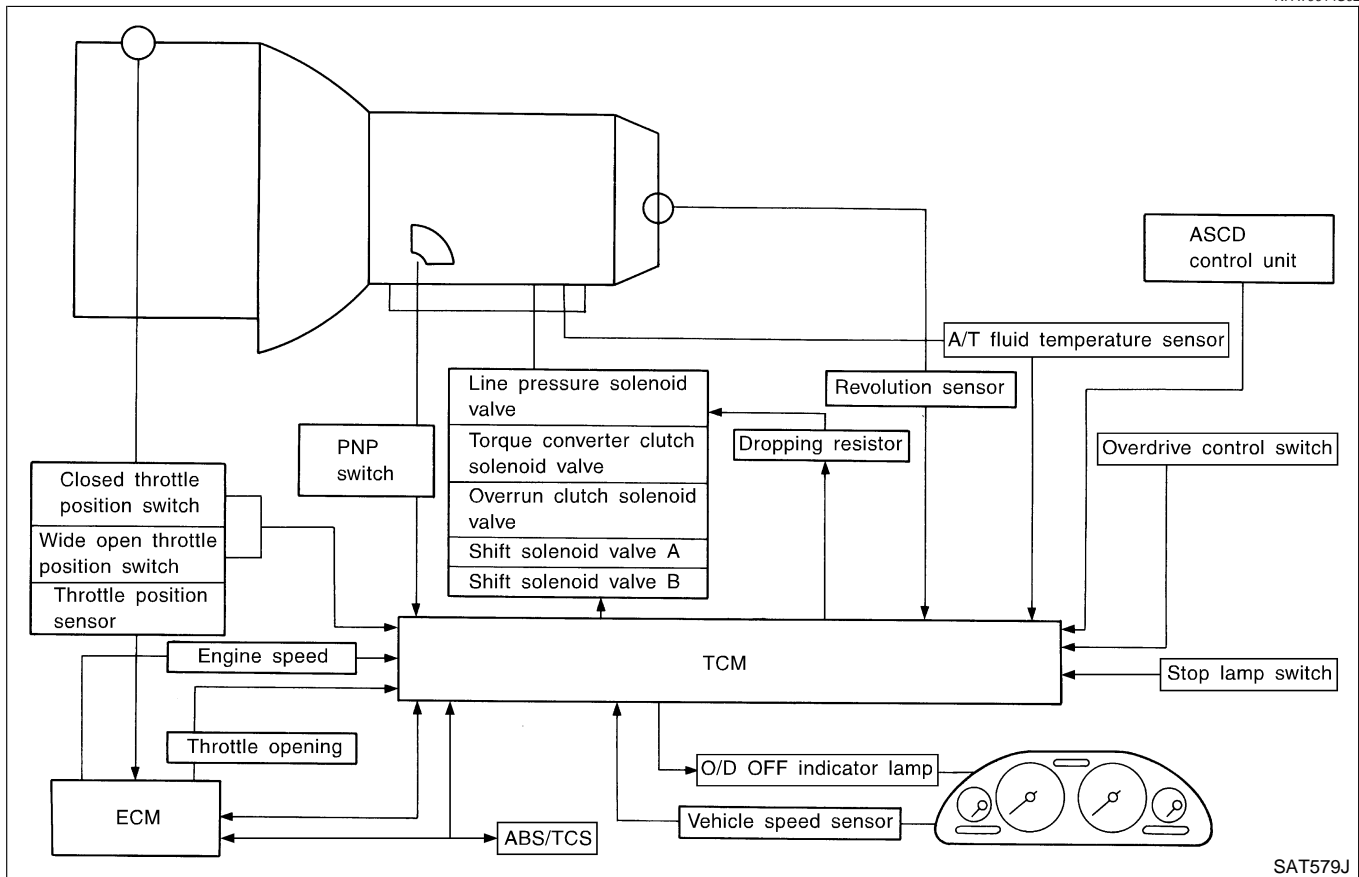

SAT579J

## TCM FUNCTION

=NFAT0014S03

The function of the TCM is to:

- Receive input signals sent from various switches and sensors.
- Determine required line pressure, shifting point, lock-up operation, and engine brake operation.
- Send required output signals to the respective solenoids.

GI

MA

## INPUT/OUTPUT SIGNAL OF TCM

NFAT0014S04

	Sensors and solenoid valves	Function	
Input	Park/neutral position (PNP) switch	Detects select lever position and sends a signal to TCM.	EM
	Throttle position sensor	Detects throttle valve position and sends a signal to TCM.	LC
	Closed throttle position switch	Detects throttle valve's fully-closed position and sends a signal to TCM.	EC
	Wide open throttle position switch	Detects a throttle valve position of greater than 1/2 of full throttle and sends a signal to TCM.	FE
	Engine speed signal	From ECM.	FE
	A/T fluid temperature sensor	Detects transmission fluid temperature and sends a signal to TCM.	CL
	Revolution sensor	Detects output shaft rpm and sends a signal to TCM.	CL
	Vehicle speed sensor	Used as an auxiliary vehicle speed sensor. Sends a signal when revolution sensor (installed on transmission) malfunctions.	MT
	Overdrive control switch	Sends a signal, which prohibits a shift to D <sub>4</sub> (overdrive) position, to the TCM.	AT
	ASCD control unit	Sends the cruise signal and D <sub>4</sub> (overdrive) cancellation signal from ASCD control unit to TCM.	AX
	Stop lamp switch	Send the lock-up release signal to the TCM at time of D <sub>4</sub> (lock-up).	AX
Output	Shift solenoid valve A/B	Selects shifting point suited to driving conditions in relation to a signal sent from TCM.	SU
	Line pressure solenoid valve	Regulates (or decreases) line pressure suited to driving conditions in relation to a signal sent from TCM.	BR
	Torque converter clutch solenoid valve	Regulates (or decreases) lock-up pressure suited to driving conditions in relation to a signal sent from TCM.	ST
	Overrun clutch solenoid valve	Controls an "engine brake" effect suited to driving conditions in relation to a signal sent from TCM.	ST
	O/D OFF indicator lamp	Shows TCM faults, when A/T control components malfunction.	RS

EM

LC

EC

FE

CL

MT

AT

AX

SU

BR

ST

RS

BT

HA

SC

EL

IDX



## Control Mechanism

=NFAT0015

### LINE PRESSURE CONTROL

NFAT0015S01

TCM has various line pressure control characteristics to meet the driving conditions.

An ON-OFF duty signal is sent to the line pressure solenoid valve based on TCM characteristics.

Hydraulic pressure on the clutch and brake is electronically controlled through the line pressure solenoid valve to accommodate engine torque. This results in smooth shift operation.

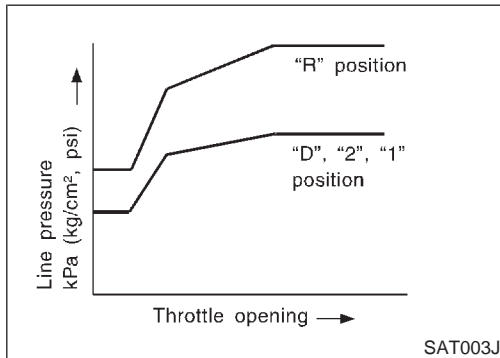

### Normal Control

NFAT0015S0101

The line pressure to throttle opening characteristics is set for suitable clutch operation.

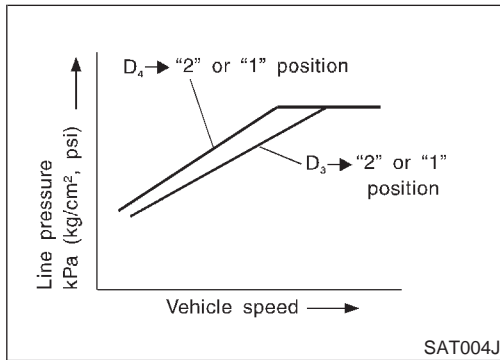

### Back-up Control (Engine brake)

NFAT0015S0102

If the selector lever is shifted to 2 position while driving in D<sub>4</sub> (O/D) or D<sub>3</sub>, great driving force is applied to the clutch inside the transmission. Clutch operating pressure (line pressure) must be increased to deal with this driving force.

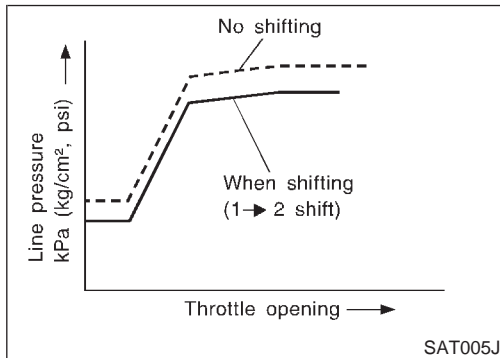

### During Shift Change

NFAT0015S0103

The line pressure is temporarily reduced corresponding to a change in engine torque when shifting gears (that is, when the shift solenoid valve is switched for clutch operation) to reduce shifting shock.

### At Low Fluid Temperature

NFAT0015S0104

- Fluid viscosity and frictional characteristics of the clutch facing change with fluid temperature. Clutch engaging or band-contacting pressure is compensated for, according to fluid temperature, to stabilize shifting quality.

# OVERALL SYSTEM

Control Mechanism (Cont'd)

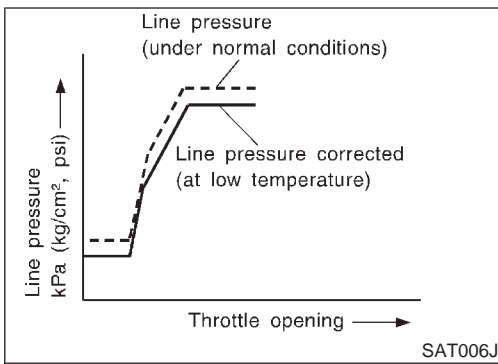

- The line pressure is reduced below 60°C (140°F) to prevent shifting shock due to low viscosity of automatic transmission fluid when temperature is low.

GI

MA

EM

LC

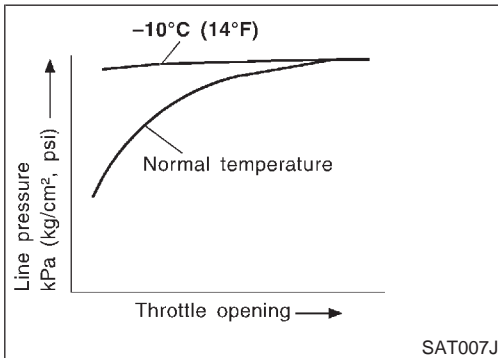

- Line pressure is increased to a maximum irrespective of the throttle opening when fluid temperature drops to -10°C (14°F). This pressure rise is adopted to prevent a delay in clutch and brake operation due to extreme drop of fluid viscosity at low temperature.

EC

FE

CL

MT

## SHIFT CONTROL

NFAT0015S02

The shift is regulated entirely by electronic control to accommodate vehicle speed and varying engine operations. This is accomplished by electrical signals transmitted by the revolution sensor and throttle position sensor. This results in improved acceleration performance and fuel economy.

AT

AX

SU

BR

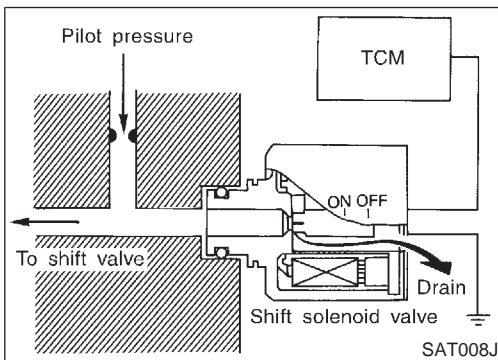

## Control of Shift Solenoid Valves A and B

NFAT0015S0201

The TCM activates shift solenoid valves A and B according to signals from the throttle position sensor and revolution sensor to select the optimum gear position on the basis of the shift schedule memorized in the TCM.

The shift solenoid valve performs simple ON-OFF operation. When set to ON, the drain circuit closes and pilot pressure is applied to the shift valve.

ST

RS

BT

HA

SC

## Relation between shift solenoid valves A and B and gear positions

Shift solenoid valve	Gear position				
	D <sub>1</sub> , 2 <sub>1</sub> , 1 <sub>1</sub>	D <sub>2</sub> , 2 <sub>2</sub> , 1 <sub>2</sub>	D <sub>3</sub>	D <sub>4</sub> (O/D)	N-P
A	ON (Closed)	OFF (Open)	OFF (Open)	ON (Closed)	ON (Closed)
B	ON (Closed)	ON (Closed)	OFF (Open)	OFF (Open)	ON (Closed)

EL

IDX

# OVERALL SYSTEM

Control Mechanism (Cont'd)

## Control of Shift Valves A and B

NFAT0015S0202

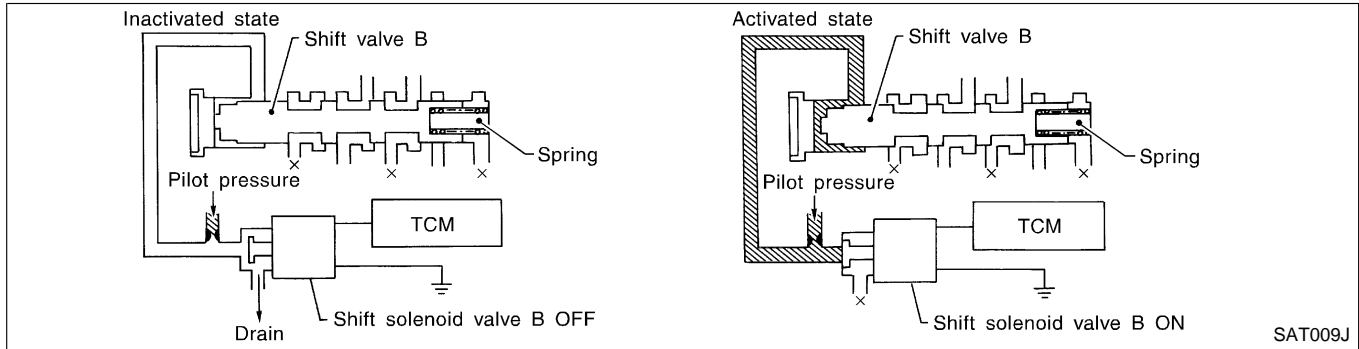

Pilot pressure generated by the operation of shift solenoid valves A and B is applied to the end face of shift valves A and B. The drawing above shows the operation of shift valve B. When the shift solenoid valve is ON, pilot pressure applied to the end face of the shift valve overcomes spring force, moving the valve upward.

### LOCK-UP CONTROL

NFAT0015S03

The torque converter clutch piston in the torque converter is locked to eliminate torque converter slip to increase power transmission efficiency. The solenoid valve is controlled by an ON-OFF duty signal sent from the TCM. The signal is converted to an oil pressure signal which controls the lock-up piston.

### Conditions for Lock-up Operation

NFAT0015S0301

When vehicle is driven in 4th gear position, vehicle speed and throttle opening are detected. If the detected values fall within the lock-up zone memorized in the TCM, lock-up is performed.

Overdrive control switch	ON	OFF
Selector lever	D position	
Gear position	D <sub>4</sub>	D <sub>3</sub>
Vehicle speed sensor	More than set value	
Throttle position sensor	Less than set opening	
Closed throttle position switch	OFF	
A/T fluid temperature sensor	More than 40°C (104°F)	

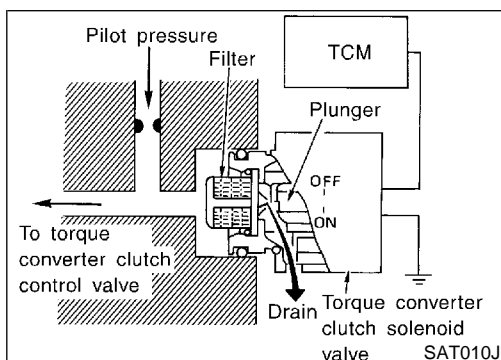

### Torque Converter Clutch Solenoid Valve Control

NFAT0015S0302

The torque converter clutch solenoid valve is controlled by the TCM. The plunger closes the drain circuit during the OFF period, and opens the circuit during the ON period. If the percentage of OFF-time increases in one cycle, the pilot pressure drain time is reduced and pilot pressure remains high.

The torque converter clutch piston is designed to slip to adjust the ratio of ON-OFF, thereby reducing lock-up shock.

# OVERALL SYSTEM

Control Mechanism (Cont'd)

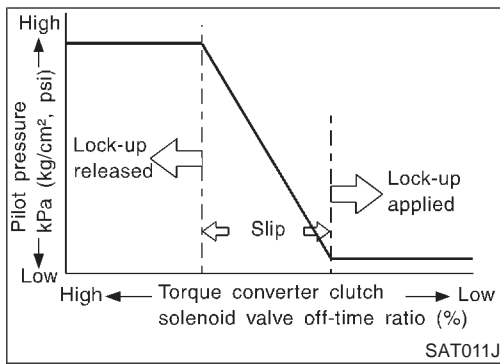

OFF-time INCREASING  
 ↓  
 Amount of drain DECREASING  
 ↓  
 Pilot pressure HIGH  
 ↓  
 Lock-up RELEASING

GI  
 MA  
 EM  
 LC

## Torque Converter Clutch Control Valve Operation

NFAT0015S0303

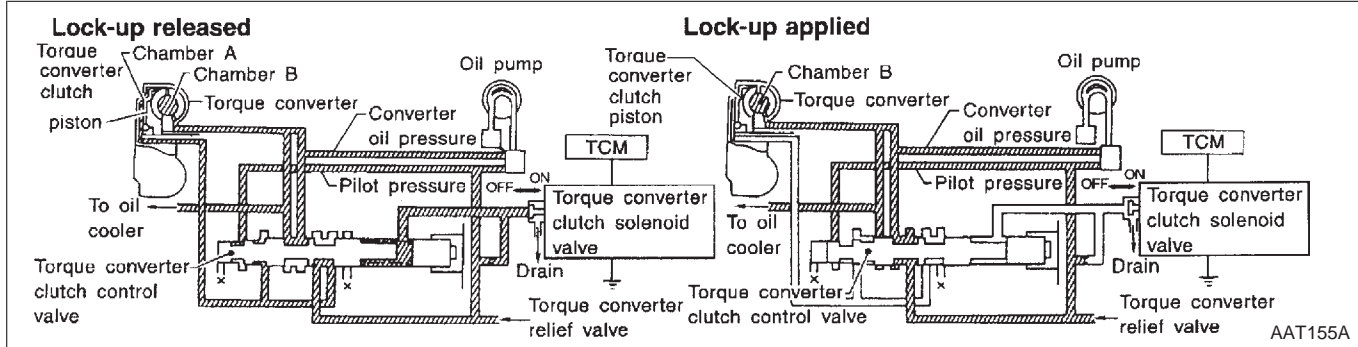

EC  
 FE  
 CL  
 MT

### Lock-up released

The OFF-duration of the torque converter clutch solenoid valve is long, and pilot pressure is high. The pilot pressure pushes the end face of the torque converter clutch control valve in combination with spring force to move the valve to the left. As a result, converter pressure is applied to chamber A (torque converter clutch piston release side). Accordingly, the torque converter clutch piston remains unlocked.

### Lock-up applied

When the OFF-duration of the torque converter clutch solenoid valve is short, pilot pressure drains and becomes low. Accordingly, the control valve moves to the right by the pilot pressure of the other circuit and converter pressure. As a result, converter pressure is applied to chamber B, keeping the torque converter clutch piston applied.

Also smooth lock-up is provided by transient application and release of the lock-up.

AT

AX

SU

BR

ST

RS

## OVERRUN CLUTCH CONTROL (ENGINE BRAKE CONTROL)

NFAT0015S04

Forward one-way clutch is used to reduce shifting shocks in downshifting operations. This clutch transmits engine torque to the wheels. However, drive force from the wheels is not transmitted to the engine because the one-way clutch rotates idle. This means the engine brake is not effective.

The overrun clutch operates when the engine brake is needed.

BT

HA

SC

EL

### Overrun Clutch Operating Conditions

NFAT0015S0401

	Gear position	Throttle opening
D position	D <sub>1</sub> , D <sub>2</sub> , D <sub>3</sub> gear position	Less than 3/16
2 position	2 <sub>1</sub> , 2 <sub>2</sub> gear position	
1 position	1 <sub>1</sub> , 1 <sub>2</sub> gear position	At any position

IDX

# OVERALL SYSTEM

## Control Mechanism (Cont'd)

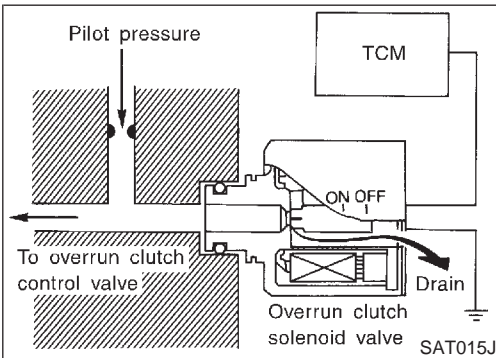
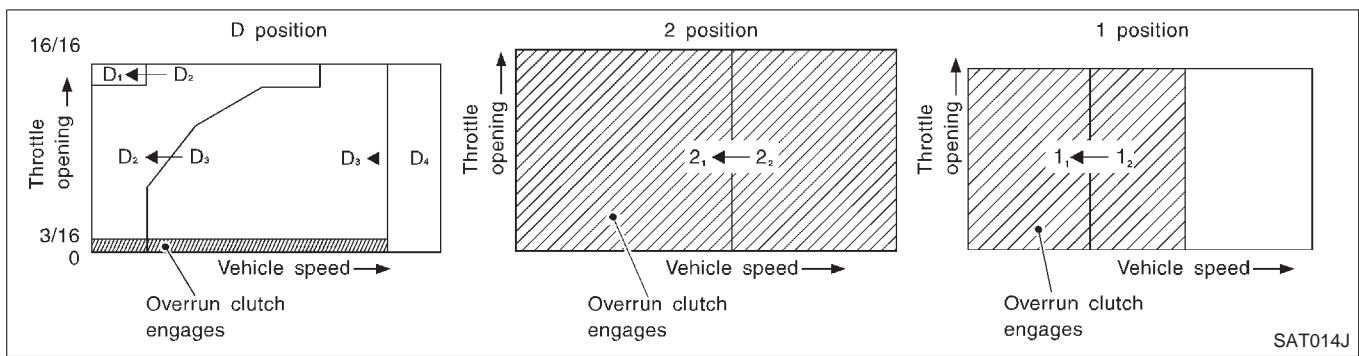

### Overrun Clutch Solenoid Valve Control

The overrun clutch solenoid valve is operated by an ON-OFF signal transmitted by the TCM to provide overrun clutch control (engine brake control).

When this solenoid valve is ON, the pilot pressure drain port closes. When it is OFF, the drain port opens.

During the solenoid valve ON pilot pressure is applied to the end face of the overrun clutch control valve.

NFAT0015S0402

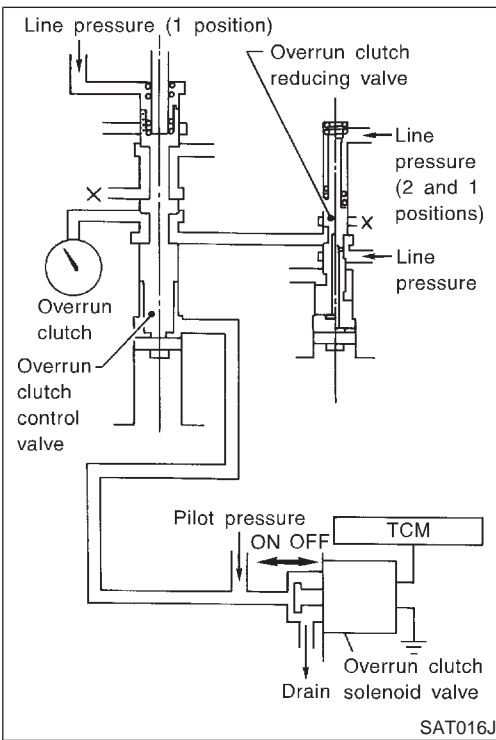

### Overrun Clutch Control Valve Operation

When the solenoid valve is ON, pilot pressure is applied to the overrun clutch control valve. This pushes up the overrun clutch control valve. The line pressure is then shut off so that the clutch does not engage.

When the solenoid valve is OFF, pilot pressure is not generated. At this point, the overrun clutch control valve moves downward by spring force. As a result, overrun clutch operation pressure is provided by the overrun clutch reducing valve. This causes the overrun clutch to engage.

In the 1 position, the overrun clutch control valve remains pushed down so that the overrun clutch is engaged at all times.

NFAT0015S0403

## Control Valve

### FUNCTION OF CONTROL VALVES

NFAT0016

Valve name	Function
Pressure regulator valve, plug and sleeve plug	Regulates oil discharged from the oil pump to provide optimum line pressure for all driving conditions.
Pressure modifier valve and sleeve	Used as a signal supplementary valve to the pressure regulator valve. Regulates pressure-modifier pressure (signal pressure) which controls optimum line pressure for all driving conditions.

NFAT0016S01

# OVERALL SYSTEM

Control Valve (Cont'd)

Valve name	Function	
Pilot valve	Regulates line pressure to maintain a constant pilot pressure level which controls lock-up mechanism, overrun clutch, shift timing.	GI
Accumulator control valve	Regulates accumulator backpressure to pressure suited to driving conditions.	MA
Manual valve	Directs line pressure to oil circuits corresponding to select positions. Hydraulic pressure drains when the shift lever is in Neutral.	EM
Shift valve A	Simultaneously switches three oil circuits using output pressure of shift solenoid valve A to meet driving conditions (vehicle speed, throttle opening, etc.). Provides automatic downshifting and up-shifting (1st → 2nd → 3rd → 4th gears/4th → 3rd → 2nd → 1st gears) in combination with shift valve B.	LC
Shift valve B	Simultaneously switches two oil circuits using output pressure of shift solenoid valve B in relation to driving conditions (vehicle speed, throttle opening, etc.). Provides automatic downshifting and up-shifting (1st → 2nd → 3rd → 4th gears/4th → 3rd → 2nd → 1st gears) in combination with shift valve A.	EC
Overrun clutch control valve	Switches hydraulic circuits to prevent engagement of the overrun clutch simultaneously with application of the brake band in D <sub>4</sub> . (Interlocking occurs if the overrun clutch engages during D <sub>4</sub> .)	FE
"1" reducing valve	Reduces low & reverse brake pressure to dampen engine-brake shock when downshifting from the 1 position 1 <sub>2</sub> to 1 <sub>1</sub> .	CL
Overrun clutch reducing valve	Reduces oil pressure directed to the overrun clutch and prevents engine-brake shock. In 1 and 2 positions, line pressure acts on the overrun clutch reducing valve to increase the pressure-regulating point, with resultant engine brake capability.	MT
Torque converter relief valve	Prevents an excessive rise in torque converter pressure.	<b>AT</b>
Torque converter clutch control valve, plug and sleeve	Activates or inactivates the lock-up function. Also provides smooth lock-up through transient application and release of the lock-up system.	AX
1-2 accumulator valve and piston	Dampens the shock encountered when 2nd gear band servo contracts, and provides smooth shifting.	SU
3-2 timing valve	Switches the pace that oil pressure is released depending on vehicle speed; maximizes the high clutch release timing, and allows for soft down shifting.	BR
Shuttle valve	Determines if the overrun clutch solenoid valve should control the 3-2 timing valve or the overrun clutch control valve and switches between the two.	ST
Cooler check valve	At low speeds and with a small load when little heat is generated, saves the volume of cooler flow, and stores the oil pressure for lock up.	RS

RS

BT

HA

SC

EL

IDX

## Introduction

NFAT0017

The A/T system has two self-diagnostic systems.

The first is the emission-related on board diagnostic system (OBD-II) performed by the TCM (transmission control module) in combination with the ECM. The malfunction is indicated by the MIL (malfunction indicator lamp) and is stored as a DTC in the ECM memory but not the TCM memory.

The second is the TCM original self-diagnosis indicated by the O/D OFF indicator lamp. The malfunction is stored in the TCM memory. The detected items are overlapped with OBD-II self-diagnostic items. For detail, refer to AT-52.

## OBD-II Function for A/T System

NFAT0018

The ECM provides emission-related on board diagnostic (OBD-II) functions for the A/T system. One function is to receive a signal from the TCM used with OBD-related parts of the A/T system. The signal is sent to the ECM when a malfunction occurs in the corresponding OBD-related part. The other function is to indicate a diagnostic result by means of the MIL (malfunction indicator lamp) on the instrument panel. Sensors, switches and solenoid valves are used as sensing elements.

The MIL automatically illuminates in One or Two Trip Detection Logic when a malfunction is sensed in relation to A/T system parts.

## One or Two Trip Detection Logic of OBD-II

NFAT0019

### ONE TRIP DETECTION LOGIC

NFAT0019S01

If a malfunction is sensed during the first test drive, the MIL will illuminate and the malfunction will be stored in the ECM memory as a DTC. The TCM is not provided with such a memory function.

### TWO TRIP DETECTION LOGIC

NFAT0019S02

When a malfunction is sensed during the first test drive, it is stored in the ECM memory as a 1st trip DTC (diagnostic trouble code) or 1st trip freeze frame data. At this point, the MIL will not illuminate. — First Trip  
If the same malfunction as that experienced during the first test drive is sensed during the second test drive, the MIL will illuminate. — Second Trip

A/T-related parts for which the MIL illuminates during the first or second test drive are listed below.

Items	MIL	
	One trip detection	Two trip detection
Shift solenoid valve A — DTC: P0750 (0750)	X	
Shift solenoid valve B — DTC: P0755 (0755)	X	
Throttle position sensor or switch — DTC: P1705 (1705)	X	
Except above		X

The “trip” in the “One or Two Trip Detection Logic” means a driving mode in which self-diagnosis is performed during vehicle operation.

## OBD-II Diagnostic Trouble Code (DTC)

NFAT0020

### HOW TO READ DTC AND 1ST TRIP DTC

NFAT0020S01

DTC and 1st trip DTC can be read by the following methods.

**(CONSULT-II or GST) CONSULT-II or GST (Generic Scan Tool)** Examples: P0705, P0710, P0720, P0725, etc.

These DTCs are prescribed by SAE J2012.

(CONSULT-II also displays the malfunctioning component or system.)

- **1st trip DTC No. is the same as DTC No.**
- **Output of the diagnostic trouble code indicates that the indicated circuit has a malfunction. However, in case of the Mode II and GST they do not indicate whether the malfunction is still occurring or occurred in the past and returned to normal. CONSULT-II can identify them as shown below. Therefore, using CONSULT-II (if available) is recommended.**

A sample of CONSULT-II display for DTC is shown at left. DTC or 1st trip DTC of a malfunction is displayed in “SELF DIAGNOSIS” mode for “ENGINE” with CONSULT-II. Time data indicates how many times the vehicle was driven after the last detection of a DTC.



SELECT SYSTEM
A/T
ENGINE

SAT014K

GI  
MA  
EM  
LC

If the DTC is being detected currently, the time data will be "0".

SELF-DIAG RESULTS	
DTC RESULTS	TIME
PNP SW/CIRC [P0705]	0

SAT015K

EC  
FE  
CL  
MT

If a 1st trip DTC is stored in the ECM, the time data will be "245".

SELF-DIAG RESULTS	
DTC RESULTS	TIME
PNP SW/CIRC [P0705]	1 t

SAT016K

**AT**  
AX  
SU  
BR  
ST  
RS

### Freeze Frame Data and 1st Trip Freeze Frame Data

The ECM has a memory function, which stores the driving condition such as fuel system status, calculated load value, engine coolant temperature, short term fuel trim, long term fuel trim, engine speed and vehicle speed at the moment the ECM detects a malfunction.

Data which are stored in the ECM memory, along with the 1st trip DTC, are called 1st trip freeze frame data, and the data, stored together with the DTC data, are called freeze frame data and displayed on CONSULT-II or GST. The 1st trip freeze frame data can only be displayed on the CONSULT-II screen, not on the GST. For detail, refer to EC-94, "CONSULT-II".

Only one set of freeze frame data (either 1st trip freeze frame data of freeze frame data) can be stored in the ECM. 1st trip freeze frame data is stored in the ECM memory along with the 1st trip DTC. There is no priority for 1st trip freeze frame data and it is updated each time a different 1st trip DTC is detected. However, once freeze frame data (2nd trip detection/MIL on) is stored in the ECM memory, 1st trip freeze frame data is no longer stored. Remember, only one set of freeze frame data can be stored in the ECM. The ECM has the following priorities to update the data.

NFAT0020S0101  
BT  
HA  
SC  
EL  
IDX

# ON BOARD DIAGNOSTIC SYSTEM DESCRIPTION

OBD-II Diagnostic Trouble Code (DTC) (Cont'd)

Priority	Items	
1	Freeze frame data	Misfire — DTC: P0300 - P0306 Fuel Injection System Function — DTC: P0171, P0172, P0174, P0175
2		Except the above items (Includes A/T related items)
3	1st trip freeze frame data	

Both 1st trip freeze frame data and freeze frame data (along with the DTCs) are cleared when the ECM memory is erased.

## HOW TO ERASE DTC

The diagnostic trouble code can be erased by CONSULT-II, GST or ECM DIAGNOSTIC TEST MODE as described following. NFAT0020S02

- **If the battery terminal is disconnected, the diagnostic trouble code will be lost within 24 hours.**
- **When you erase the DTC, using CONSULT-II or GST is easier and quicker than switching the mode selector on the ECM.**

The following emission-related diagnostic information is cleared from the ECM memory when erasing DTC related to OBD-II. For details, refer to EC-73, "Emission-related Diagnostic Information".

- **Diagnostic trouble codes (DTC)**
- **1st trip diagnostic trouble codes (1st trip DTC)**
- **Freeze frame data**
- **1st trip freeze frame data**
- **System readiness test (SRT) codes**
- **Test values**

## ⓑ HOW TO ERASE DTC (WITH CONSULT-II)

- **If a DTC is displayed for both ECM and TCM, it needs to be erased for both ECM and TCM.** NFAT0020S03
1. If the ignition switch stays ON after repair work, be sure to turn ignition switch OFF once. Wait at least 5 seconds and then turn it ON (engine stopped) again.
  2. Turn CONSULT-II "ON" and touch "A/T".
  3. Touch "SELF-DIAG RESULTS".
  4. Touch "ERASE". (The DTC in the TCM will be erased.) Then touch "BACK" twice.
  5. Touch "ENGINE".
  6. Touch "SELF DIAGNOSIS".
  7. Touch "ERASE". (The DTC in the ECM will be erased.)

## How to erase DTC (With CONSULT-II)

1. If the ignition switch stays "ON" after repair work, be sure to turn ignition switch "OFF" once. Wait at least 5 seconds and then turn it "ON" (engine stopped) again.

SELECT SYSTEM	
A/T	
ENGINE	



SELECT DIAG MODE	
SELF-DIAG RESULTS	
DATA MONITOR	
DTC WORK SUPPORT	
TCM PART NUMBER	



SELF-DIAG RESULTS	
DTC RESULTS	
T/C CLUTCH SOL/V	

2. Turn CONSULT-II "ON", and touch "A/T".

3. Turn "SELF-DIAG RESULTS".

4. Touch "ERASE". (The DTC in the TCM will be erased.)

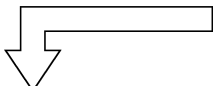

Touch "BACK".

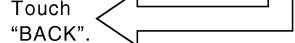

Touch "BACK".

SELECT SYSTEM	
A/T	
ENGINE	

SELECT DIAG MODE	
WORK SUPPORT	
SELF-DIAG RESULTS	
DATA MONITOR	
ACTIVE TEST	
DTC & SRT CONFIRMATION	
ECM PART NUMBER	

SELF-DIAG RESULTS	
DTC RESULTS	TIME
TCC SOLENOID/CIRC [P0740]	0

5. Touch "ENGINE".

6. Touch "SELF-DIAG RESULTS".

7. Touch "ERASE". (The DTC in the ECM will be erased.)

SAT017K

GI  
MA  
EM  
LC  
EC  
FE  
CL  
MT  
**AT**  
AX  
SU  
BR  
ST  
RS  
BT  
HA  
SC  
EL  
IDX

### HOW TO ERASE DTC (WITH GST)

NFAT0020S04

1. If the ignition switch stays ON after repair work, be sure to turn ignition switch OFF once. Wait at least 5 seconds and then turn it ON (engine stopped) again.
2. Perform "OBD-II SELF-DIAGNOSTIC PROCEDURE (No Tools)". Refer to AT-49. (The engine warm-up step can be skipped when performing the diagnosis only to erase the DTC.)
3. Select Mode 4 with Generic Scan Tool (GST). For details, refer to EC-107, "Generic Scan Tool (GST)".

### HOW TO ERASE DTC (NO TOOLS)

NFAT0020S05

1. If the ignition switch stays ON after repair work, be sure to turn ignition switch OFF once. Wait at least 5 seconds and then turn it ON (engine stopped) again.
2. Perform "TCM SELF-DIAGNOSTIC PROCEDURE (NO TOOLS)". Refer to AT-49. (The engine warm-up step can be skipped when performing the diagnosis only to erase the DTC.)

# ON BOARD DIAGNOSTIC SYSTEM DESCRIPTION

## Malfunction Indicator Lamp (MIL)

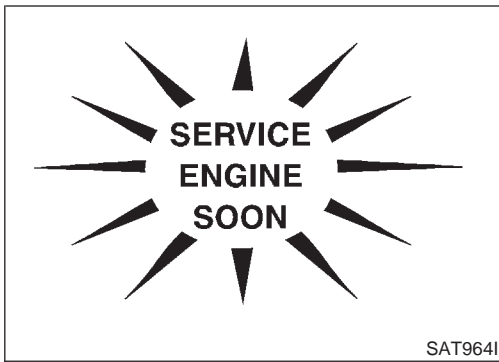

## Malfunction Indicator Lamp (MIL)

=NFAT0021

1. The malfunction indicator lamp will light up when the ignition switch is turned ON without the engine running. This is for checking the lamp.
  - If the malfunction indicator lamp does not light up, refer to EL-121, "WARNING LAMPS". (Or see MIL & Data Link Connectors in EC section.)
2. When the engine is started, the malfunction indicator lamp should go off. If the lamp remains on, the on board diagnostic system has detected an emission-related (OBD-II) malfunction. For detail, refer to EC-72, "ON BOARD DIAGNOSTIC SYSTEM DESCRIPTION".

## CONSULT-II

NFAT0022

After performing "SELF-DIAGNOSTIC PROCEDURE (WITH CONSULT-II)" (AT-41), place check marks for results on the "Diagnostic Worksheet", AT-57. Reference pages are provide following the items.

### NOTICE:

- 1) The CONSULT-II electrically displays shift timing and lock-up timing (that is, operation timing of each solenoid). Check for time difference between actual shift timing and the CONSULT-II display. If the difference is noticeable, mechanical parts (except solenoids, sensors, etc.) may be malfunctioning. Check mechanical parts using applicable diagnostic procedures.
- 2) Shift schedule (which implies gear position) displayed on CONSULT-II and that indicated in Service Manual may differ slightly. This occurs because of the following reasons:
  - Actual shift schedule has more or less tolerance or allowance,
  - Shift schedule indicated in Service Manual refers to the point where shifts start, and
  - Gear position displayed on CONSULT-II indicates the point where shifts are completed.
- 3) Shift solenoid valve "A" or "B" is displayed on CONSULT-II at the start of shifting. Gear position is displayed upon completion of shifting (which is computed by TCM).
- 4) Additional CONSULT-II information can be found in the Operation Manual supplied with the CONSULT-II unit.

SELECT SYSTEM
A/T
ENGINE

SAT014K

SELF-DIAG RESULTS
DTC RESULTS
T/C CLUTCH SOL/V

SAT970J

## Ⓜ SELF-DIAGNOSTIC PROCEDURE (WITH CONSULT-II) NFAT0022S01

1. Turn on CONSULT-II and touch "ENGINE" for OBD-II detected items or touch "A/T" for TCM self-diagnosis.  
If A/T is not displayed, check TCM power supply and ground circuit. Refer to AT-95. If result is NG, refer to EL-9, "POWER SUPPLY ROUTING".
  
2. Touch "SELF DIAGNOSIS".  
Display shows malfunction experienced since the last erasing operation.  
CONSULT-II performs "Real Time Diagnosis".  
Also, any malfunction detected while in this mode will be displayed at real time.

GI  
MA  
EM  
LC  
EC  
FE  
CL  
MT

## SELF-DIAGNOSTIC RESULT TEST MODE

NFAT0022S02



Detected items (Screen terms for CONSULT-II, "SELF DIAGNOSIS" test mode)		Malfunction is detected when ...	TCM self-diagnosis	OBD-II (DTC)
"A/T"	"ENGINE"		 Available by O/D OFF indicator lamp or "A/T" on CONSULT-II	 Available by malfunction indicator lamp*2, "ENGINE" on CON- SULT-II or GST
—	PNP SW/CIRC	● TCM does not receive the correct voltage signal (based on the gear position) from the switch.	—	P0705
Revolution sensor		● TCM does not receive the proper voltage signal from the sensor.	X	P0720
VHCL SPEED SEN-A/T	VEH SPD SEN/ CIR AT			
Vehicle speed sensor (Meter)		● TCM does not receive the proper voltage signal from the sensor.	X	—
VHCL SPEED SEN-MTR	—			
A/T 1st gear function		● A/T cannot be shifted to the 1st gear position even if electrical circuit is good.	—	P0731*1
—	A/T 1ST GR FNCTN			
A/T 2nd gear function		● A/T cannot be shifted to the 2nd gear position even if electrical circuit is good.	—	P0732*1
—	A/T 2ND GR FNCTN			
A/T 3rd gear function		● A/T cannot be shifted to the 3rd gear position even if electrical circuit is good.	—	P0733*1
—	A/T 3RD GR FNCTN			

AT  
AX  
SU  
BR  
ST  
RS  
BT  
HA  
SC  
EL  
IDX

# ON BOARD DIAGNOSTIC SYSTEM DESCRIPTION





CONSULT-II (Cont'd)

Detected items (Screen terms for CONSULT-II, "SELF DIAGNOSIS" test mode)		Malfunction is detected when ...	TCM self-diagnosis	OBD-II (DTC)
"A/T"	"ENGINE"		 Available by O/D OFF indicator lamp or "A/T" on CONSULT-II	 Available by malfunction indicator lamp*2, "ENGINE" on CON- SULT-II or GST
A/T 4th gear function		● A/T cannot be shifted to the 4th gear position even if electrical circuit is good.	—	P0734*1
—	A/T 4TH GR FNCTN			
A/T TCC S/V function (lock-up)		● A/T cannot perform lock-up even if electrical circuit is good.	—	P0744*1
—	A/T TCC S/V FNCTN			
Shift solenoid valve A		● TCM detects an improper voltage drop when it tries to operate the solenoid valve.	X	P0750
SHIFT SOLENOID/V A	SFT SOL A/CIRC			
Shift solenoid valve B		● TCM detects an improper voltage drop when it tries to operate the solenoid valve.	X	P0755
SHIFT SOLENOID/V B	SFT SOL B/CIRC			
Overrun clutch solenoid valve		● TCM detects an improper voltage drop when it tries to operate the solenoid valve.	X	P1760
OVERRUN CLUTCH S/V	O/R CLUCH SOL/ CIRC			
T/C clutch solenoid valve		● TCM detects an improper voltage drop when it tries to operate the solenoid valve.	X	P0740
T/C CLUTCH SOL/V	TCC SOLENOID/ CIRC			
Line pressure solenoid valve		● TCM detects an improper voltage drop when it tries to operate the solenoid valve.	X	P0745
LINE PRESSURE S/V	L/PRESS SOL/ CIRC			
Throttle position sensor Throttle position switch		● TCM receives an excessively low or high voltage from the sensor.	X	P1705
THROTTLE POSI SEN	TP SEN/CIRC A/T			
Engine speed signal		● TCM does not receive the proper voltage signal from the ECM.	X	P0725
ENGINE SPEED SIG				
A/T fluid temperature sensor		● TCM receives an excessively low or high voltage from the sensor.	X	P0710
BATT/FLUID TEMP SEN	ATF TEMP SEN/ CIRC			
Engine control		● The ECM-A/T communication line is open or shorted.	X	EC-517, EC-691
A/T COMM LINE	—			
TCM (RAM)		● TCM memory (RAM) is malfunctioning	—	—
CONTROL UNIT (RAM)	—			
TCM (ROM)		● TCM memory (ROM) is malfunctioning	—	—
CONTROL UNIT (ROM)	—			

# ON BOARD DIAGNOSTIC SYSTEM DESCRIPTION



CONSULT-II (Cont'd)

Detected items (Screen terms for CONSULT-II, "SELF DIAGNOSIS" test mode)		Malfunction is detected when ...	TCM self-diagnosis	OBD-II (DTC)	GI
"A/T"	"ENGINE"			 Available by O/D OFF indicator lamp or "A/T" on CONSULT-II	 Available by malfunction indicator lamp*2, "ENGINE" on CONSULT-II or GST
TCM (EEP ROM)		<ul style="list-style-type: none"> <li>TCM memory (EEP ROM) is malfunctioning.</li> </ul>	—	—	EM
CONT UNIT (EEP ROM)	—				LC
Initial start		<ul style="list-style-type: none"> <li>This is not a malfunction message (Whenever shutting off a power supply to the TCM, this message appears on the screen.)</li> </ul>	X	—	EC
INITIAL START	—				FE
No failure (NO SELF DIAGNOSTIC FAILURE INDICATED FURTHER TESTING MAY BE REQUIRED**)		<ul style="list-style-type: none"> <li>No failure has been detected.</li> </ul>	X	X	CL

X: Applicable

—: Not applicable

\*1: These malfunctions cannot be displayed by MIL  if another malfunction is assigned to MIL.

\*2: Refer to EC-87, "Malfunction Indicator Lamp (MIL)".

## DATA MONITOR MODE (A/T)

NFAT0022S03

Item	Display	Monitor item		Description	Remarks	AX
		ECU Input signals	Main signals			SU
Vehicle speed sensor 1 (A/T) (Revolution sensor)	VHCL/S SE-A/T [km/h] or [mph]	X	—	<ul style="list-style-type: none"> <li>Vehicle speed computed from signal of revolution sensor is displayed.</li> </ul>	When racing engine in N or P with vehicle stationary, CONSULT-II data may not indicate 0 km/h (0 mph).	BR
Vehicle speed sensor 2 (Meter)	VHCL/S SE-MTR [km/h] or [mph]	X	—	<ul style="list-style-type: none"> <li>Vehicle speed computed from signal of vehicle speed sensor is displayed.</li> </ul>	Vehicle speed display may not be accurate under approx. 10 km/h (6 mph). It may not indicate 0 km/h (0 mph) when vehicle is stationary.	ST
Throttle position sensor	THRTL POS SEN [V]	X	—	<ul style="list-style-type: none"> <li>Throttle position sensor signal voltage is displayed.</li> </ul>		RS
A/T fluid temperature sensor	FLUID TEMP SE [V]	X	—	<ul style="list-style-type: none"> <li>A/T fluid temperature sensor signal voltage is displayed.</li> <li>Signal voltage lowers as fluid temperature rises.</li> </ul>		BT
Battery voltage	BATTERY VOLT [V]	X	—	<ul style="list-style-type: none"> <li>Source voltage of TCM is displayed.</li> </ul>		HA
Engine speed	ENGINE SPEED [rpm]	X	X	<ul style="list-style-type: none"> <li>Engine speed, computed from engine speed signal, is displayed.</li> </ul>	Engine speed display may not be accurate under approx. 800 rpm. It may not indicate 0 rpm even when engine is not running.	SC



# ON BOARD DIAGNOSTIC SYSTEM DESCRIPTION

CONSULT-II (Cont'd)

Item	Display	Monitor item		Description	Remarks
		ECU Input signals	Main signals		
Overdrive control switch	OVERDRIVE SW [ON/OFF]	X	—	<ul style="list-style-type: none"> <li>ON/OFF state computed from signal of overdrive control SW is displayed.</li> </ul>	
Park/neutral position (PNP) switch	P/N POSI SW [ON/OFF]	X	—	<ul style="list-style-type: none"> <li>ON/OFF state computed from signal of P/N position SW is displayed.</li> </ul>	
R position switch	R POSITION SW [ON/OFF]	X	—	<ul style="list-style-type: none"> <li>ON/OFF state computed from signal of R position SW is displayed.</li> </ul>	
D position switch	D POSITION SW [ON/OFF]	X	—	<ul style="list-style-type: none"> <li>ON/OFF state computed from signal of D position SW is displayed.</li> </ul>	
2 position switch	2 POSITION SW [ON/OFF]	X	—	<ul style="list-style-type: none"> <li>ON/OFF status, computed from signal of 2 position SW, is displayed.</li> </ul>	
1 position switch	1 POSITION SW [ON/OFF]	X	—	<ul style="list-style-type: none"> <li>ON/OFF status, computed from signal of 1 position SW, is displayed.</li> </ul>	
ASCD cruise signal	ASCD-CRUISE [ON/OFF]	X	—	<ul style="list-style-type: none"> <li>Status of ASCD cruise signal is displayed. ON ... Cruising state OFF ... Normal running state</li> </ul>	<ul style="list-style-type: none"> <li>This is displayed even when no ASCD is mounted.</li> </ul>
ASCD OD cut signal	ASCD-OD CUT [ON/OFF]	X	—	<ul style="list-style-type: none"> <li>Status of ASCD OD release signal is displayed. ON ... OD released OFF ... OD not released</li> </ul>	<ul style="list-style-type: none"> <li>This is displayed even when no ASCD is mounted.</li> </ul>
Kickdown switch	KICKDOWN SW [ON/OFF]	X	—	<ul style="list-style-type: none"> <li>ON/OFF status, computed from signal of kickdown SW, is displayed.</li> </ul>	<ul style="list-style-type: none"> <li>This is displayed even when no kickdown switch is equipped.</li> </ul>
Closed throttle position switch	CLOSED THL/SW [ON/OFF]	X	—	<ul style="list-style-type: none"> <li>ON/OFF status, computed from signal of closed throttle position SW, is displayed.</li> </ul>	
Wide open throttle position switch	W/O THRL/P-SW [ON/OFF]	X	—	<ul style="list-style-type: none"> <li>ON/OFF status, computed from signal of wide open throttle position SW, is displayed.</li> </ul>	
Gear position	GEAR	—	X	<ul style="list-style-type: none"> <li>Gear position data used for computation by TCM, is displayed.</li> </ul>	
Selector lever position	SLCT LVR POSI	—	X	<ul style="list-style-type: none"> <li>Selector lever position data, used for computation by TCM, is displayed.</li> </ul>	<ul style="list-style-type: none"> <li>A specific value used for control is displayed if fail-safe is activated due to error.</li> </ul>
Vehicle speed	VEHICLE SPEED [km/h] or [mph]	—	X	<ul style="list-style-type: none"> <li>Vehicle speed data, used for computation by TCM, is displayed.</li> </ul>	

# ON BOARD DIAGNOSTIC SYSTEM DESCRIPTION



CONSULT-II (Cont'd)

Item	Display	Monitor item		Description	Remarks
		ECU Input signals	Main signals		
Throttle position	THROTTLE POSI [8]	—	X	<ul style="list-style-type: none"> <li>Throttle position data, used for computation by TCM, is displayed.</li> </ul>	<ul style="list-style-type: none"> <li>A specific value used for control is displayed if fail-safe is activated due to error.</li> </ul>
Stop lamp switch	BRAKE SW [ON/OFF]	X	—	<ul style="list-style-type: none"> <li>ON/OFF status is displayed.</li> <li>ON ... Brake pedal is depressed.</li> <li>OFF ... Brake pedal is released.</li> </ul>	
Line pressure duty	LINE PRES DTY [%]	—	X	<ul style="list-style-type: none"> <li>Control value of line pressure solenoid valve, computed by TCM from each input signal, is displayed.</li> </ul>	
Torque converter clutch solenoid valve duty	TCC S/V DUTY [%]	—	X	<ul style="list-style-type: none"> <li>Control value of torque converter clutch solenoid valve, computed by TCM from each input signal, is displayed.</li> </ul>	
Shift solenoid valve A	SHIFT S/V A [ON/OFF]	—	X	<ul style="list-style-type: none"> <li>Control value of shift solenoid valve A, computed by TCM from each input signal, is displayed.</li> </ul>	Control value of solenoid is displayed even if solenoid circuit is disconnected. The OFF signal is displayed if solenoid circuit is shorted.
Shift solenoid valve B	SHIFT S/V B [ON/OFF]	—	X	<ul style="list-style-type: none"> <li>Control value of shift solenoid valve B, computed by TCM from each input signal, is displayed.</li> </ul>	
Overrun clutch solenoid valve	OVERRUN/C S/V [ON/OFF]	—	X	<ul style="list-style-type: none"> <li>Control value of overrun clutch solenoid valve computed by TCM from each input signal is displayed.</li> </ul>	
Self-diagnosis display lamp (O/D OFF indicator lamp)	SELF-D DP LMP [ON/OFF]	—	X	<ul style="list-style-type: none"> <li>Control status of O/D OFF indicator lamp is displayed.</li> </ul>	

X: Applicable

—: Not applicable

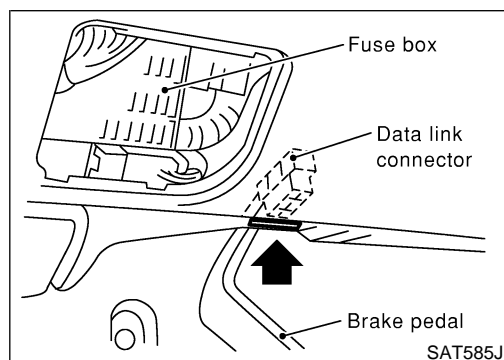

## DTC WORK SUPPORT MODE WITH CONSULT-II CONSULT-II Setting Procedure

NFAT0022S04

NFAT0022S0401

1. Turn ignition switch OFF.
2. Connect CONSULT-II to Data link connector, which is located in left side dash panel.

GI

MA

EM

LC

EC

FE

CL

MT

AT

AX

SU

BR

ST

RS

BT

HA

SC

EL

IDX

# ON BOARD DIAGNOSTIC SYSTEM DESCRIPTION

CONSULT-II (Cont'd)

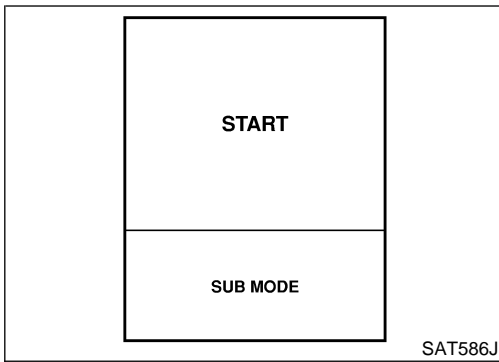

SAT586J

3. Turn ignition switch ON.
4. Touch "START".

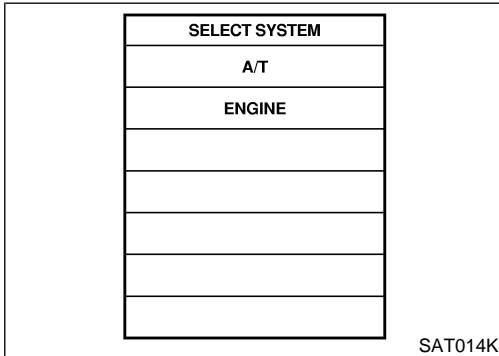

SAT014K

5. Touch "A/T".

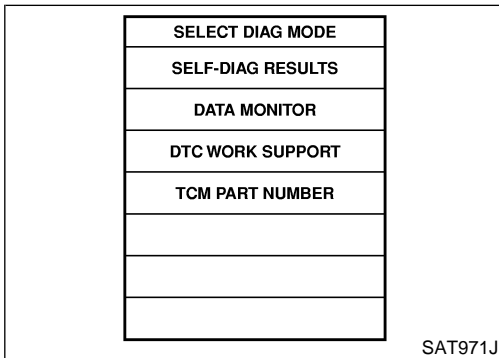

SAT971J

6. Touch "DTC WORK SUPPORT".

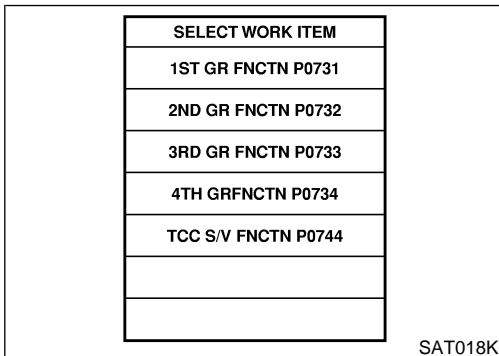

SAT018K

7. Touch select item menu (1ST, 2ND, etc.).

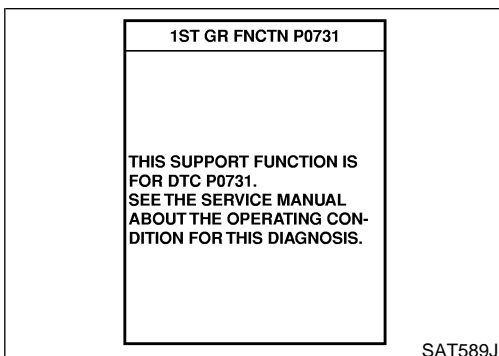

SAT589J

8. Touch "START".

# ON BOARD DIAGNOSTIC SYSTEM DESCRIPTION

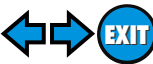

CONSULT-II (Cont'd)

1ST GR FNCTN P0731	
OUT OF CONDITON	
MONITOR	
GEAR	XXX
VEHICLE SPEED	XXXkm/h
THROTTLE POSI	XXX
TCC S/V DUTY	XXX %

SAT019K

1ST GR FNCTN P0731	
TESTING	
MONITOR	
GEAR	XXX
VEHICLE SPEED	XXXkm/h
THROTTLE POSI	XXX
TCC S/V DUTY	XXX %

SAT591J

1ST GR FNCTN P0731	
STOP VEHICLE	

SAT592J

1ST GR FNCTN P0731	
NG	

SAT593J

1ST GR FNCTN P0731	
DRIVE VHCL IN D RANGE SHIFTING 1→2→3→4 UNDER NORMAL ACCELERATION. DOES A/T SHFT NORMAL CHECK FOR PROPER SHF TIMING AND SHFT SHOCK	

SAT594J

9. Perform driving test according to "DTC CONFIRMATION PROCEDURE" in "TROUBLE DIAGNOSIS FOR DTC".

- When testing conditions are satisfied, CONSULT-II screen changes from "OUT OF CONDITION" to "TESTING".

10. Stop vehicle. If "NG" appears on the screen, malfunction may exist. Go to "DIAGNOSTIC PROCEDURE".

11. Perform test drive to check gear shift feeling in accordance with instructions displayed.

GI

MA

EM

LC

EC

FE

CL

MT

AT

AX

SU

BR

ST

RS

BT

HA

SC

EL

IDX

# ON BOARD DIAGNOSTIC SYSTEM DESCRIPTION

CONSULT-II (Cont'd)

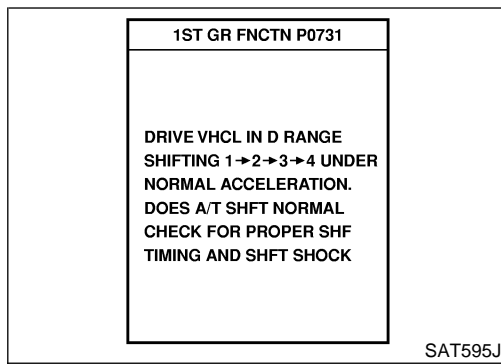

12. Touch "YES" or "NO".

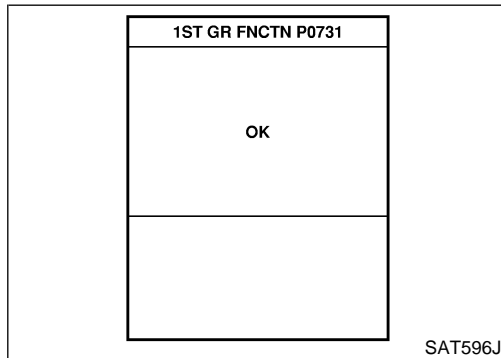

13. CONSULT-II procedure ended. If "NG" appears on the screen, a malfunction may exist. Go to "DIAGNOSTIC PROCEDURE".

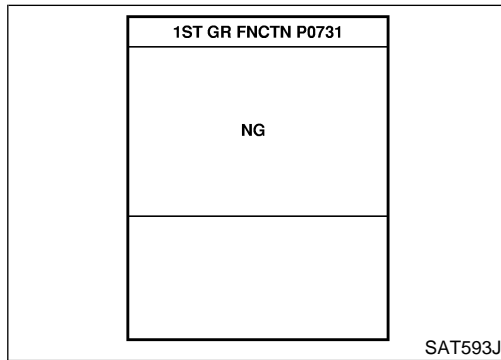

## DTC WORK SUPPORT MODE

NFAT0022S05

DTC work support item	Description	Check item
1ST GR FNCTN P0731	Following items for "A/T 1st gear function (P0731)" can be confirmed. <ul style="list-style-type: none"> <li>Self-diagnosis status (whether the diagnosis is being conducted or not)</li> <li>Self-diagnosis result (OK or NG)</li> </ul>	<ul style="list-style-type: none"> <li>Shift solenoid valve A</li> <li>Shift solenoid valve B</li> <li>Each clutch</li> <li>Hydraulic control circuit</li> </ul>
2ND GR FNCTN P0732	Following items for "A/T 2nd gear function (P0732)" can be confirmed. <ul style="list-style-type: none"> <li>Self-diagnosis status (whether the diagnosis is being conducted or not)</li> <li>Self-diagnosis result (OK or NG)</li> </ul>	<ul style="list-style-type: none"> <li>Shift solenoid valve B</li> <li>Each clutch</li> <li>Hydraulic control circuit</li> </ul>
3RD GR FNCTN P0733	Following items for "A/T 3rd gear function (P0733)" can be confirmed. <ul style="list-style-type: none"> <li>Self-diagnosis status (whether the diagnosis is being conducted or not)</li> <li>Self-diagnosis result (OK or NG)</li> </ul>	<ul style="list-style-type: none"> <li>Shift solenoid valve A</li> <li>Each clutch</li> <li>Hydraulic control circuit</li> </ul>

DTC work support item	Description	Check item
4TH GR FNCTN P0734	Following items for "A/T 4th gear function (P0734)" can be confirmed. ● Self-diagnosis status (whether the diagnosis is being conducted or not) ● Self-diagnosis result (OK or NG)	<ul style="list-style-type: none"> <li>● Shift solenoid valve A</li> <li>● Shift solenoid valve B</li> <li>● Overrun clutch solenoid valve</li> <li>● Line pressure solenoid valve</li> <li>● Each clutch</li> <li>● Hydraulic control circuit</li> </ul>
TCC S/V FNCTN P0744	Following items for "A/T TCC S/V function (lock-up) (P0744)" can be confirmed. ● Self-diagnosis status (whether the diagnosis is being conducted or not) ● Self-diagnosis result (OK or NG)	<ul style="list-style-type: none"> <li>● Torque converter clutch solenoid valve</li> <li>● Each clutch</li> <li>● Hydraulic control circuit</li> </ul>

GI  
 MA  
 EM  
 LC  
 EC  
 FE  
 CL  
 MT  
 AT  
 AX  
 SU  
 BR  
 ST  
 RS  
 BT  
 HA  
 SC  
 EL  
 IDX

## Diagnostic Procedure Without CONSULT-II

### GST OBD-II SELF-DIAGNOSTIC PROCEDURE (WITH GST) NFAT0023 NFAT0023S01

Refer to EC-107, "Generic Scan Tool (GST)".

### NO TOOLS OBD-II SELF-DIAGNOSTIC PROCEDURE (NO TOOLS)

Refer to EC-87, "Malfunction Indicator Lamp (MIL)".

### NO TOOLS TCM SELF-DIAGNOSTIC PROCEDURE (NO TOOLS) NFAT0023S03

#### Preparation

1. Turn ignition switch to "OFF" position.
2. Connect the handy type vacuum pump to the throttle opener and apply vacuum -25.3 kPa (-190 mmHg, -7.48 inHg).
3. Disconnect the throttle position switch harness connector.
4. Turn ignition switch to "ON" position.
5. Check continuity of the closed throttle position switch.  
**Continuity should exist.**  
**(If continuity does not exist, check throttle opener and closed throttle position switch. Then increase vacuum until closed throttle position switch shows continuity.)**
6. Go to "DIAGNOSIS START" on next page.

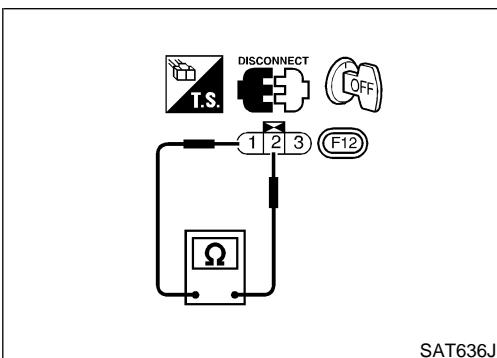
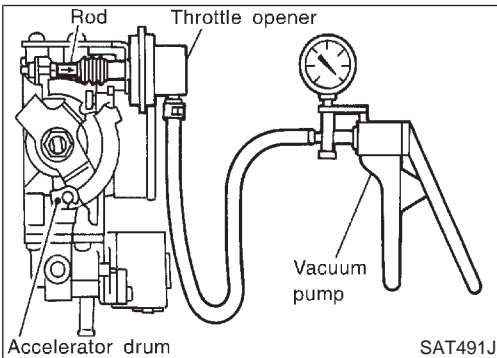

# ON BOARD DIAGNOSTIC SYSTEM DESCRIPTION

Diagnostic Procedure Without CONSULT-II (Cont'd)

<b>1</b>	<b>CHECK O/D OFF INDICATOR LAMP</b>	
	<p>1. Move selector lever to P position. Start engine and warm it up to normal engine operating temperature.</p> <p>2. Turn ignition switch to OFF position.</p> <p>3. Wait 5 seconds.</p> <p>4. Turn ignition switch to ON position. (Do not start engine.)</p>	
		SAT967I
	<p>5. Does O/D OFF indicator lamp come on for about 2 seconds?</p>	
		SAT598J
	<b>Yes or No</b>	
Yes	▶	GO TO 2.
No	▶	Stop procedure. Perform "1. O/D OFF Indicator Lamp Does Not Come On", AT-219 before proceeding.



# ON BOARD DIAGNOSTIC SYSTEM DESCRIPTION

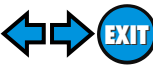

Diagnostic Procedure Without CONSULT-II (Cont'd)

## 2 JUDGEMENT PROCEDURE STEP 1

1. Turn ignition switch to OFF position.
2. Turn ignition switch to ACC position.
3. Move selector lever from P to D position.
4. Turn ignition switch to ON position.  
(Do not start engine.)
5. Depress and hold overdrive control switch in OFF position (the O/D OFF indicator lamp will be ON) until directed to release the switch. (If O/D OFF indicator lamp does not come on, refer to "Step 3 and 4" on AT-261).
6. Turn ignition switch to OFF position.

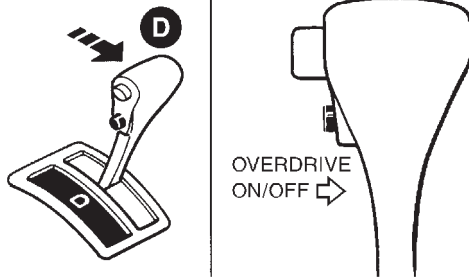

SAT968I

7. Turn ignition switch to ON position (Do not start engine.)
8. Release the overdrive control switch (the O/D OFF indicator lamp will be OFF).
9. Wait 2 seconds.
10. Move selector lever to 2 position.
11. Depress and release overdrive control switch in ON position until next step is completed (the O/D OFF indicator lamp will be ON).
12. Depress and hold the overdrive control switch (the O/D OFF indicator lamp will be OFF) until directed to release the switch.

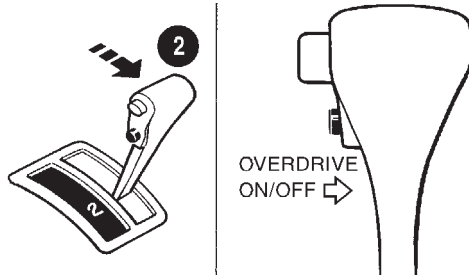

SAT969I

▶ GO TO 3.

GI  
MA  
EM  
LC  
EC  
FE  
CL  
MT  
AT  
AX  
SU  
BR  
ST  
RS  
BT  
HA  
SC  
EL  
IDX

# ON BOARD DIAGNOSTIC SYSTEM DESCRIPTION

Diagnostic Procedure Without CONSULT-II (Cont'd)

<b>3</b>	<b>JUDGEMENT PROCEDURE STEP 2</b>
<ol style="list-style-type: none"> <li>1. Move selector lever to 1 position.</li> <li>2. Release the overdrive control switch.</li> <li>3. Depress and release the overdrive control switch (the O/D OFF indicator lamp will be ON).</li> <li>4. Depress and release the overdrive control switch (the O/D OFF indicator lamp will be OFF).</li> <li>5. Depress and hold the overdrive control switch (the O/D OFF indicator lamp will be ON) until directed to release the switch.</li> <li>6. Depress accelerator pedal fully and release it.</li> <li>7. Release the overdrive control switch (the O/D OFF indicator lamp will begin to flash ON and OFF).</li> </ol>	
<div style="display: flex; justify-content: space-around; align-items: center;"> <div style="text-align: center;"> <p>1</p> </div> <div style="text-align: center;"> <p>OVERDRIVE ON/OFF →</p> </div> </div>	
SAT970I	
▶ GO TO 4.	

<b>4</b>	<b>CHECK SELF-DIAGNOSTIC CODE</b>
<p>Check O/D OFF indicator lamp. Refer to JUDGEMENT OF SELF-DIAGNOSIS CODE, AT-52.</p>	
<p>O/D OFF indicator lamp</p>	
SAT598J	
▶ <b>DIAGNOSIS END</b>	

## JUDGEMENT OF SELF-DIAGNOSIS CODE

NFAT0023S04

O/D OFF indicator lamp:

All judgement flickers are the same.

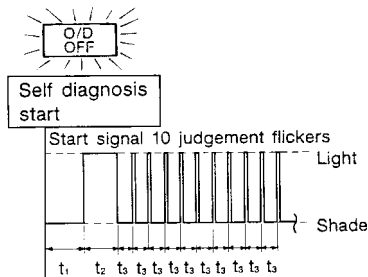

SAT436F

All circuits that can be confirmed by self-diagnosis are OK.

1st judgement flicker is longer than others.

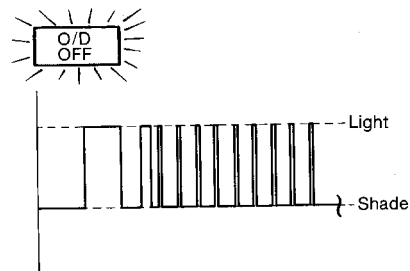

SAT437F

Revolution sensor circuit is short-circuited or disconnected.  
 ⇒ Go to **VEHICLE SPEED SENSOR-A/T (REVOLUTION SENSOR)**, AT-114.

# ON BOARD DIAGNOSTIC SYSTEM DESCRIPTION

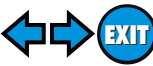

Diagnostic Procedure Without CONSULT-II (Cont'd)

O/D OFF indicator lamp:

2nd judgement flicker is longer than others.

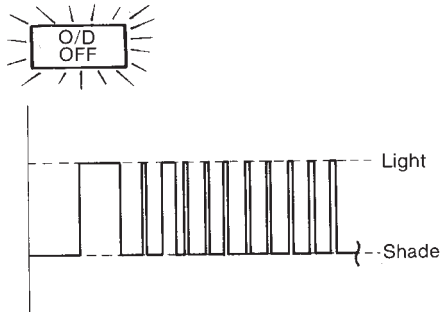

SAT439F

Vehicle speed sensor circuit is short-circuited or disconnected.  
⇒ Go to **VEHICLE SPEED SENSOR-MTR, AT-203.**

3rd judgement flicker is longer than others.

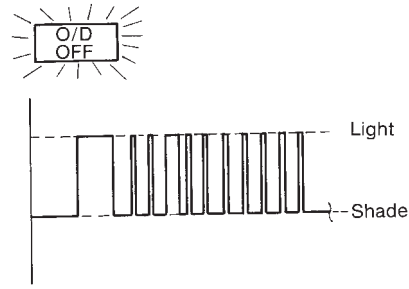

SAT441F

Throttle position sensor circuit is short-circuited or disconnected.  
⇒ Go to **THROTTLE POSITION SENSOR, AT-182.**

4th judgement flicker is longer than others.

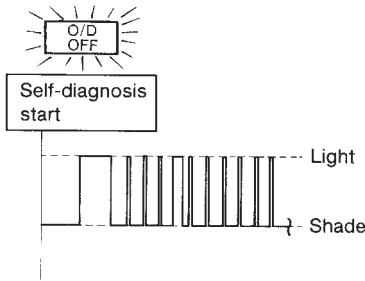

SAT443F

Shift solenoid valve A circuit is short-circuited or disconnected.  
⇒ Go to **SHIFT SOLENOID VALVE A, AT-172.**

5th judgement flicker is longer than others.

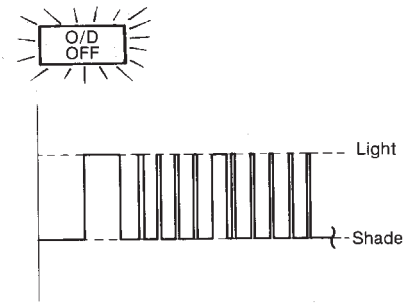

SAT445F

Shift solenoid valve B circuit is short-circuited or disconnected.  
⇒ Go to **SHIFT SOLENOID VALVE B, AT-177.**

6th judgement flicker is longer than others.

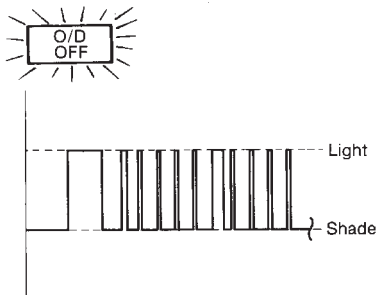

SAT447F

Overrun clutch solenoid valve circuit is short-circuited or disconnected.  
⇒ Go to **OVERRUN CLUTCH SOLENOID VALVE, AT-191.**

7th judgement flicker is longer than others.

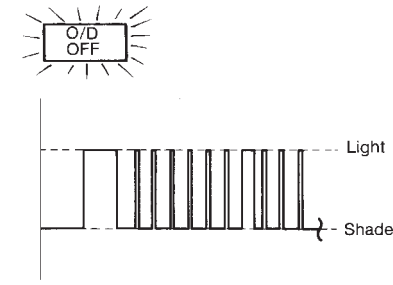

SAT449F

Torque converter clutch solenoid valve circuit is short-circuited or disconnected.  
⇒ Go to **TORQUE CONVERTER CLUTCH SOLENOID VALVE, AT-151.**

GI

MA

EM

LC

EC

FE

CL

MT

**AT**

AX

SU

BR

ST

RS

BT

HA

SC

EL

IDX

# ON BOARD DIAGNOSTIC SYSTEM DESCRIPTION

Diagnostic Procedure Without CONSULT-II (Cont'd)

O/D OFF indicator lamp:

8th judgement flicker is longer than others.

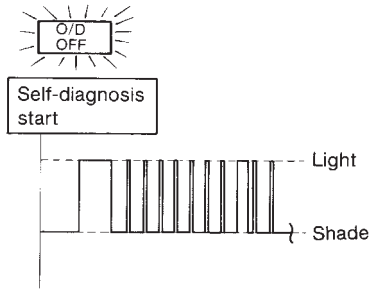

SAT451F

A/T fluid temperature sensor is disconnected or TCM power source circuit is damaged.  
 ⇒ Go to **A/T FLUID TEMPERATURE SENSOR AND TCM POWER SOURCE, AT-196.**

9th judgement flicker is longer than others.

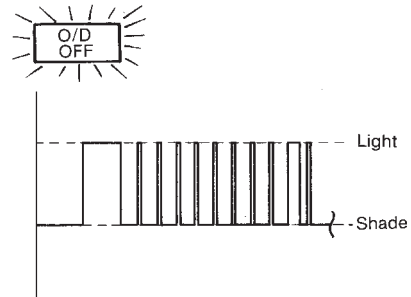

SAT453F

Engine speed signal circuit is short-circuited or disconnected.  
 ⇒ Go to **ENGINE SPEED SIGNAL, AT-119.**

10th judgement flicker is longer than others.

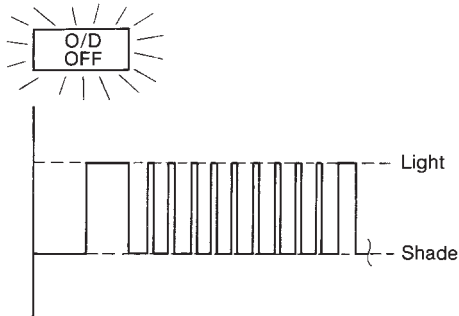

SAT455F

Line pressure solenoid valve circuit is short-circuited or disconnected.  
 ⇒ Go to **LINE PRESSURE SOLENOID VALVE, AT-166.**

11th judgement flicker is longer than others.

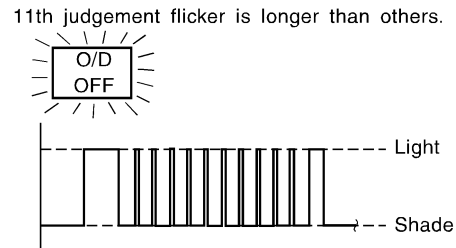

SAT599J

The ECM-A/T communication line is open or shorted.  
 ⇒ Go to **A/T COMMUNICATION LINE, AT-208.**

Lamp comes on.

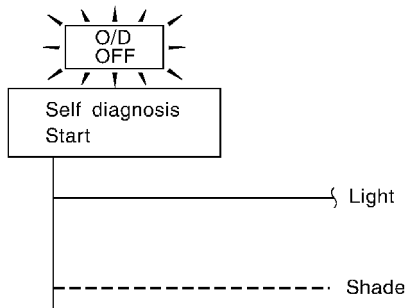

SAT367J

Park/neutral position (PNP) switch, overdrive control switch or throttle position switch circuit is disconnected or TCM is damaged.  
 ⇒ Go to **21. TCM Self-diagnosis Does Not Activate (Park/neutral position (PNP), Overdrive Control and Throttle Position Switch Circuit Checks), AT-260.**

Flickers as shown below.

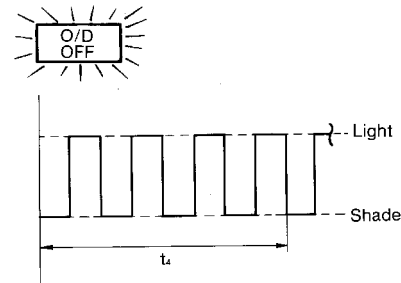

SAT457F

Battery power is low.  
 Battery has been disconnected for a long time.  
 Battery is connected conversely.  
 (When reconnecting TCM connectors. — This is not a problem.)

$t_1 = 2.5$  seconds  $t_2 = 2.0$  seconds  $t_3 = 1.0$  second  $t_4 = 1.0$  second

NFAT0024

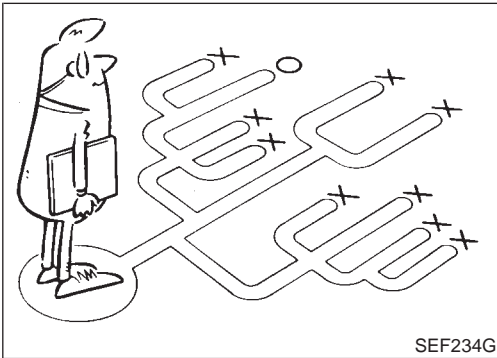
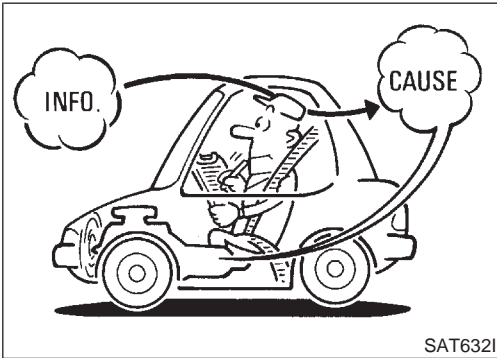
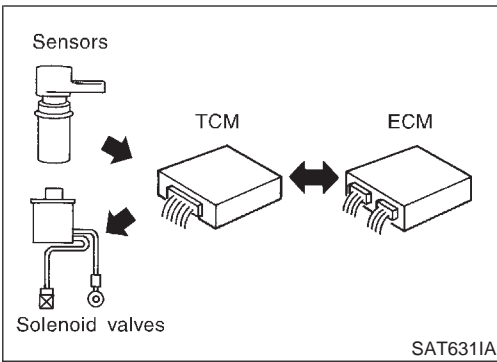

## Introduction

The TCM receives a signal from the vehicle speed sensor, throttle position sensor or park/neutral position (PNP) switch and provides shift control or lock-up control via A/T solenoid valves.

The TCM also communicates with the ECM by means of a signal sent from sensing elements used with the OBD-related parts of the A/T system for malfunction-diagnostic purposes. The TCM is capable of diagnosing malfunctioning parts while the ECM can store malfunctions in its memory.

Input and output signals must always be correct and stable in the operation of the A/T system. The A/T system must be in good operating condition and be free of valve seizure, solenoid valve malfunction, etc.

It is much more difficult to diagnose a problem that occurs intermittently rather than continuously. Most intermittent problems are caused by poor electric connections or improper wiring. In this case, careful checking of suspected circuits may help prevent the replacement of good parts.

A visual check only, may not find the cause of the problems. A road test with CONSULT-II (or GST) or a circuit tester connected should be performed. Follow the "Work Flow". Refer to AT-59.

Before undertaking actual checks, take a few minutes to talk with a customer who approaches with a driveability complaint. The customer can supply good information about such problems, especially intermittent ones. Find out what symptoms are present and under what conditions they occur. A "DIAGNOSTIC WORKSHEET" like the example (AT-56) should be used.

Start your diagnosis by looking for "conventional" problems first. This will help troubleshoot driveability problems on an electronically controlled engine vehicle.

**Also check related Service bulletins for information.**

GI

MA

EM

LC

EC

FE

CL

MT

AT

AX

SU

BR

ST

RS

BT

HA

SC

EL

IDX

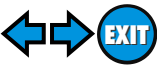

# TROUBLE DIAGNOSIS — INTRODUCTION

Introduction (Cont'd)

## DIAGNOSTIC WORKSHEET

### Information from Customer

=NFAT0024S01

#### KEY POINTS

**WHAT** ..... Vehicle & A/T model

**WHEN** ..... Date, Frequencies

**WHERE** ..... Road conditions

**HOW** ..... Operating conditions, Symptoms

NFAT0024S0101

Customer name MR/MS	Model & Year	VIN
Trans. model	Engine	Mileage
Incident Date	Manuf. Date	In Service Date
Frequency	<input type="checkbox"/> Continuous <input type="checkbox"/> Intermittent ( times a day)	
Symptoms	<input type="checkbox"/> Vehicle does not move. ( <input type="checkbox"/> Any position <input type="checkbox"/> Particular position)	
	<input type="checkbox"/> No up-shift ( <input type="checkbox"/> 1st → 2nd <input type="checkbox"/> 2nd → 3rd <input type="checkbox"/> 3rd → O/D)	
	<input type="checkbox"/> No down-shift ( <input type="checkbox"/> O/D → 3rd <input type="checkbox"/> 3rd → 2nd <input type="checkbox"/> 2nd → 1st)	
	<input type="checkbox"/> Lockup malfunction	
	<input type="checkbox"/> Shift point too high or too low.	
	<input type="checkbox"/> Shift shock or slip ( <input type="checkbox"/> N → D <input type="checkbox"/> Lockup <input type="checkbox"/> Any drive position)	
	<input type="checkbox"/> Noise or vibration	
	<input type="checkbox"/> No kickdown	
	<input type="checkbox"/> No pattern select	
O/D OFF indicator lamp	<input type="checkbox"/> Others ( )	
	Blinks for about 8 seconds.	
Malfunction indicator lamp (MIL)	<input type="checkbox"/> Continuously lit	<input type="checkbox"/> Not lit
	<input type="checkbox"/> Continuously lit	<input type="checkbox"/> Not lit

## Diagnostic Worksheet

=NFAT0024S0102

1.	<input type="checkbox"/> Read the Fail-safe and listen to customer complaints.	AT-9	GI
2.	<input type="checkbox"/> CHECK A/T FLUID <input type="checkbox"/> Leakage (Follow specified procedure) <input type="checkbox"/> Fluid condition <input type="checkbox"/> Fluid level	AT-61	MA
3.	<input type="checkbox"/> Perform STALL TEST and PRESSURE TEST. <input type="checkbox"/> Stall test — Mark possible damaged components/others. <div style="display: flex; justify-content: space-between;"> <div style="width: 45%;"> <input type="checkbox"/> Torque converter one-way clutch  <input type="checkbox"/> Reverse clutch  <input type="checkbox"/> Forward clutch  <input type="checkbox"/> Overrun clutch  <input type="checkbox"/> Forward one-way clutch                 </div> <div style="width: 45%;"> <input type="checkbox"/> Low &amp; reverse brake  <input type="checkbox"/> Low one-way clutch  <input type="checkbox"/> Engine  <input type="checkbox"/> Line pressure is low  <input type="checkbox"/> Clutches and brakes except high clutch and brake band are OK                 </div> </div> <input type="checkbox"/> Pressure test — Suspected parts:	AT-61, 65	EM LC EC FE
4.	<input type="checkbox"/> Perform all ROAD TEST and mark required procedures.	AT-66	CL
4-1.	Check before engine is started. <input type="checkbox"/> SELF-DIAGNOSTIC PROCEDURE - Mark detected items. <input type="checkbox"/> Park/neutral position (PNP) switch, AT-102. <input type="checkbox"/> A/T fluid temperature sensor, AT-108. <input type="checkbox"/> Vehicle speed sensor-A/T (Revolution sensor), AT-114. <input type="checkbox"/> Engine speed signal, AT-119. <input type="checkbox"/> Torque converter clutch solenoid valve, AT-156. <input type="checkbox"/> Line pressure solenoid valve, AT-166. <input type="checkbox"/> Shift solenoid valve A, AT-172. <input type="checkbox"/> Shift solenoid valve B, AT-177. <input type="checkbox"/> Throttle position sensor, AT-182. <input type="checkbox"/> Overrun clutch solenoid valve, AT-191. <input type="checkbox"/> Park/neutral position (PNP), overdrive control and throttle position switches, AT-260. <input type="checkbox"/> A/T fluid temperature sensor and TCM power source, AT-196. <input type="checkbox"/> Vehicle speed sensor-MTR, AT-203. <input type="checkbox"/> A/T communication line, AT-208. <input type="checkbox"/> Control unit (RAM), Control unit (ROM), AT-212. <input type="checkbox"/> Control unit (EEP ROM), AT-214. <input type="checkbox"/> Battery <input type="checkbox"/> Others	AT-67	MT <b>AT</b> AX SU BR ST
4-2.	Check at idle <input type="checkbox"/> 1. O/D OFF Indicator Lamp Does Not Come On, AT-219. <input type="checkbox"/> 2. Engine Cannot Be Started In P and N Position, AT-222. <input type="checkbox"/> 3. In P Position, Vehicle Moves Forward or Backward When Pushed, AT-223. <input type="checkbox"/> 4. In N Position, Vehicle Moves, AT-224. <input type="checkbox"/> 5. Large Shock. N → R Position, AT-227. <input type="checkbox"/> 6. Vehicle Does Not Creep Backward In R Position, AT-229. <input type="checkbox"/> 7. Vehicle Does Not Creep Forward In D, 2 or 1 Position, AT-233.	AT-68	RS BT HA SC EL IDX



# TROUBLE DIAGNOSIS — INTRODUCTION

Introduction (Cont'd)

4.	4-3. Cruise test	AT-71 AT-74
	Part-1	
	<input type="checkbox"/> 8. Vehicle Cannot Be Started From D <sub>1</sub> , AT-236. <input type="checkbox"/> 9. A/T Does Not Shift: D <sub>1</sub> → D <sub>2</sub> or Does Not Kickdown: D <sub>4</sub> → D <sub>2</sub> , AT-239. <input type="checkbox"/> 10. A/T Does Not Shift: D <sub>2</sub> →D <sub>3</sub> , AT-242. <input type="checkbox"/> 11. A/T Does Not Shift: D <sub>3</sub> →D <sub>4</sub> , AT-245. <input type="checkbox"/> 12. A/T Does Not Perform Lock-up, AT-248. <input type="checkbox"/> 13. A/T Does Not Hold Lock-up Condition, AT-250. <input type="checkbox"/> 14. Lock-up Is Not Released, AT-252. <input type="checkbox"/> 15. Engine Speed Does Not Return To Idle (Light Braking D <sub>4</sub> → D <sub>3</sub> ), AT-253.	
	Part-2	AT-78
	<input type="checkbox"/> 16. Vehicle Does Not Start From D <sub>1</sub> , AT-256. <input type="checkbox"/> 9. A/T Does Not Shift: D <sub>1</sub> → D <sub>2</sub> or Does Not Kickdown: D <sub>4</sub> → D <sub>2</sub> , AT-239. <input type="checkbox"/> 10. A/T Does Not Shift: D <sub>2</sub> →D <sub>3</sub> , AT-242. <input type="checkbox"/> 11. A/T Does Not Shift: D <sub>3</sub> →D <sub>4</sub> , AT-245.	
	Part-3	AT-80
	<input type="checkbox"/> 17. A/T Does Not Shift: D <sub>4</sub> →D <sub>3</sub> When Overdrive Control Switch ON → OFF, AT-257. <input type="checkbox"/> 15. Engine Speed Does Not Return To Idle (Engine Brake In D <sub>3</sub> ), AT-253. <input type="checkbox"/> 18. A/T Does Not Shift: D <sub>3</sub> →2 <sub>2</sub> , When Selector Lever D → 2 Position, AT-258. <input type="checkbox"/> 15. Engine Speed Does Not Return To Idle (Engine Brake In 2 <sub>2</sub> ), AT-253. <input type="checkbox"/> 19. A/T Does Not Shift: 2 <sub>2</sub> →1 <sub>1</sub> , When Selector Lever 2 → 1 Position, AT-259. <input type="checkbox"/> 20. Vehicle Does Not Decelerate By Engine Brake, AT-260. <input type="checkbox"/> SELF-DIAGNOSTIC PROCEDURE — Mark detected items.	
	<input type="checkbox"/> Park/neutral position (PNP) switch, AT-102. <input type="checkbox"/> A/T fluid temperature sensor, AT-108. <input type="checkbox"/> Vehicle speed sensor-A/T (Revolution sensor), AT-114. <input type="checkbox"/> Engine speed signal, AT-119. <input type="checkbox"/> Torque converter clutch solenoid valve, AT-151. <input type="checkbox"/> Line pressure solenoid valve, AT-166. <input type="checkbox"/> Shift solenoid valve A, AT-175. <input type="checkbox"/> Shift solenoid valve B, AT-177. <input type="checkbox"/> Throttle position sensor, AT-182. <input type="checkbox"/> Overrun clutch solenoid valve, AT-191. <input type="checkbox"/> Park/neutral position (PNP), overdrive control and throttle position switches, AT-260. <input type="checkbox"/> A/T fluid temperature sensor and TCM power source, AT-196. <input type="checkbox"/> Vehicle speed sensor-MTR, AT-203. <input type="checkbox"/> A/T communication line, AT-208. <input type="checkbox"/> Control unit (RAM), Control unit (ROM), AT-212. <input type="checkbox"/> Control unit (EEP ROM), AT-214. <input type="checkbox"/> Battery <input type="checkbox"/> Others	
5.	<input type="checkbox"/> For self-diagnosis NG items, inspect each component. Repair or replace the damaged parts.	AT-41
6.	<input type="checkbox"/> Perform all ROAD TEST and re-mark required procedures.	AT-66
7.	<input type="checkbox"/> Perform DTC CONFIRMATION PROCEDURE for following MIL indicating items and check out NG items. Refer to EC-73, "Emission-related Diagnostic Information".	EC-73
	<input type="checkbox"/> DTC (P0731) A/T 1st gear function, AT-124. <input type="checkbox"/> DTC (P0732) A/T 2nd gear function, AT-130. <input type="checkbox"/> DTC (P0733) A/T 3rd gear function, AT-136. <input type="checkbox"/> DTC (P0734) A/T 4th gear function, AT-142. <input type="checkbox"/> DTC (P0744) A/T TCC S/V function (lock-up), AT-156.	
8.	<input type="checkbox"/> Perform the Diagnostic Procedures for all remaining items marked NG. Repair or replace the damaged parts. Refer to the Symptom Chart when you perform the procedures. (The chart also shows some other possible symptoms and the component inspection orders.)	AT-84 AT-95
9.	<input type="checkbox"/> Erase DTC from TCM and ECM memories.	AT-38

## Work Flow

### HOW TO PERFORM TROUBLE DIAGNOSES FOR QUICK AND ACCURATE REPAIR

NFAT0025

NFAT0025S01

A good understanding of the malfunction conditions can make troubleshooting faster and more accurate. In general, each customer feels differently about a problem. It is important to fully understand the symptoms or conditions for a customer complaint.

Make good use of the two sheets provided, “Information from Customer” (AT-56) and “Diagnostic Worksheet” (AT-57), to perform the best troubleshooting possible.

GI

MA

EM

LC

EC

FE

CL

MT

**AT**

AX

SU

BR

ST

RS

BT

HA

SC

EL

IDX

# TROUBLE DIAGNOSIS — INTRODUCTION

Work Flow (Cont'd)

## WORK FLOW CHART

=NFAT0025S02

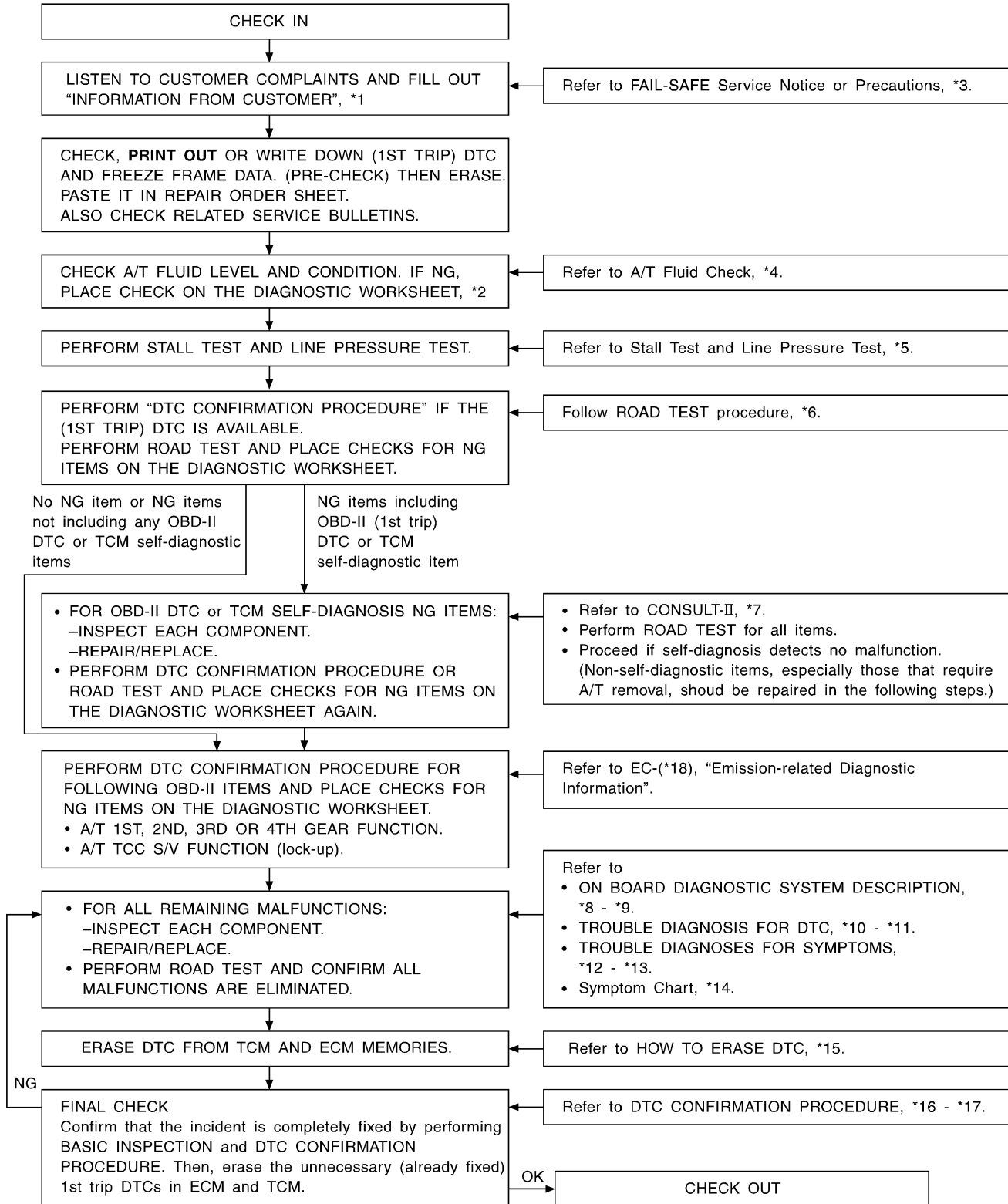

SAT086JD

\*1: AT-56

\*2: AT-57

\*3: AT-9

\*4: AT-61

\*5: AT-61, 65

\*6: AT-66

\*7: AT-40

\*8: AT-36

\*9: AT-52

\*10: AT-102

\*11: AT-203

\*12: AT-216

\*13: AT-260

\*14: AT-84

\*15: AT-38

\*16: AT-103

\*17: AT-212

\*18: EC-73

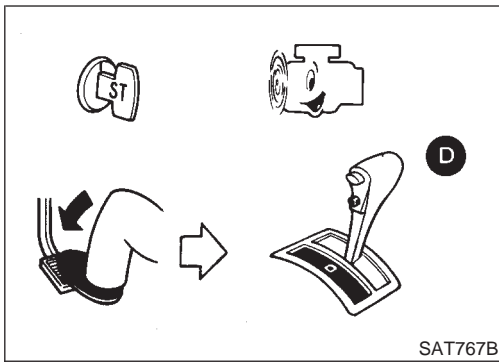

SAT767B

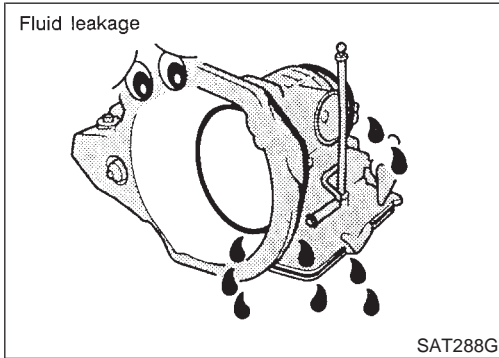

SAT288G

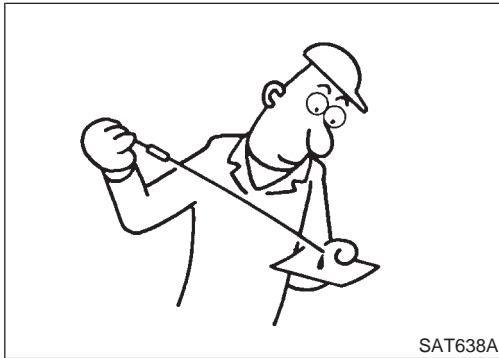

SAT638A

## A/T Fluid Check

NFAT0026

### FLUID LEAKAGE CHECK

NFAT0026S01

1. Clean area suspected of leaking. — for example, mating surface of converter housing and transmission case.
2. Start engine, apply foot brake, place selector lever in D position and wait a few minutes.
3. Stop engine.

GI

MA

EM

LC

4. Check for fresh leakage.

EC

FE

CL

MT

### FLUID CONDITION CHECK

NFAT0026S02

Fluid color	Suspected problem
Dark or black with burned odor	Wear of frictional material
Milky pink	Water contamination — Road water entering through filler tube or breather
Varnished fluid, light to dark brown and tacky	Oxidation — Over or under filling, — Overheating

AT

AX

SU

BR

### FLUID LEVEL CHECK

NFAT0026S03

Refer to MA-22, "Checking A/T Fluid".

ST

RS

BT

HA

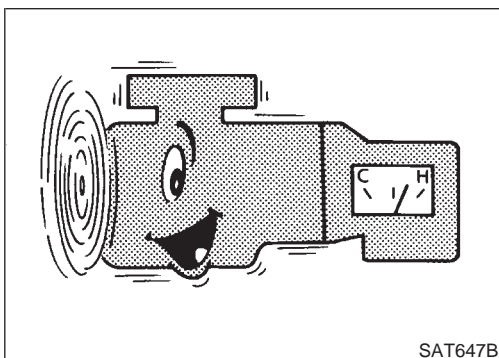

SAT647B

## Stall Test

NFAT0027

### STALL TEST PROCEDURE

NFAT0027S01

1. Check A/T fluid and engine oil levels. If necessary, add fluid and oil.
2. Drive vehicle for approx. 10 minutes or until fluid and oil reach operating temperature.

EL

IDX

**ATF operating temperature:**  
50 - 80°C (122 - 176°F)

# TROUBLE DIAGNOSIS — BASIC INSPECTION

## Stall Test (Cont'd)

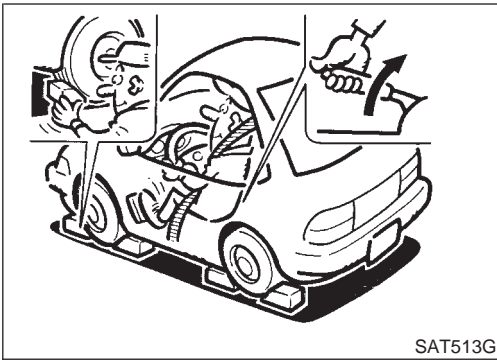

SAT513G

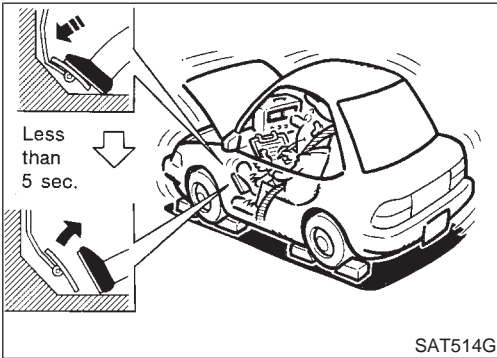

SAT514G

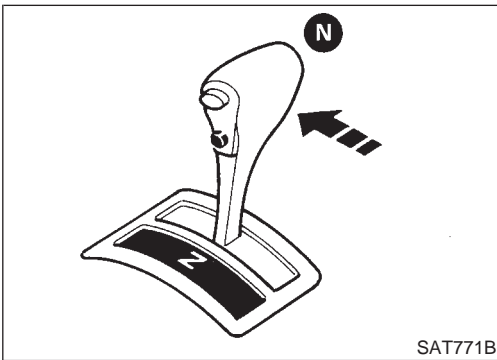

SAT771B

3. Set parking brake and block wheels.
  4. Install a tachometer where it can be seen by driver during test.
    - **It is good practice to mark the point of specified engine rpm on indicator.**
  5. Start engine, apply foot brake, and place selector lever in D position.
  6. Accelerate to wide open throttle gradually while applying foot brake.
  7. Quickly note the engine stall revolution and immediately release throttle.
    - **During test, never hold throttle wide open for less than 5 seconds.**
- Stall revolution:**  
**2,150 - 2,450 rpm**
8. Move selector lever to N position.
  9. Cool off ATF.
    - **Run engine at idle for at least one minute.**
  10. Repeat steps 5 through 9 with selector lever in 2, 1 and R positions.

### JUDGEMENT OF STALL TEST

NFAT0027S02

The test result and possible damaged components relating to each result are shown in the illustrations on next page. In order to pinpoint the possible damaged components, follow the "WORK FLOW CHART" shown in AT-60.

#### NOTE:

Stall revolution is too high in D, 2 or 1 position:

- Slippage occurs in 1st gear but not in 2nd and 3rd gears. .... Low one-way clutch slippage
- Slippage occurs in the following gears:  
1st through 3rd gears in D position and engine brake functions with overdrive control switch set to OFF.  
1st and 2nd gears in 2 position and engine brake functions with accelerator pedal released (fully closed throttle). .... Forward clutch or forward one-way clutch slippage

#### Stall revolution is too high in R position:

- Engine brake does not function in 1 position. .... Low & reverse brake slippage
- Engine brake functions in 1 position. .... Reverse clutch slippage

#### Stall revolution within specifications:

- Vehicle does not achieve speed of more than 80 km/h (50

MPH). ..... One-way clutch seizure in torque converter housing

**CAUTION:**

**Be careful since automatic fluid temperature increases abnormally.**

- Slippage occurs in 3rd and 4th gears in D position. .... High clutch slippage
- Slippage occurs in 2nd and 4th gear in D position. .... Brake band slippage
- Engine brake does not function in 2nd and 3rd gears in D position, 2nd gear in 2 position, and 1st gear in 1 position with overdrive control switch set to OFF.

**Stall revolution less than specifications:**

- Poor acceleration during starts. .... One-way clutch seizure in torque converter

GI

MA

EM

LC

EC

FE

CL

MT

**AT**

AX

SU

BR

ST

RS

BT

HA

SC

EL

IDX

# TROUBLE DIAGNOSIS — BASIC INSPECTION

Stall Test (Cont'd)

Selector lever position	Judgement		
	H	O	L
D	H	O	L
2	H	O	L
1	H	O	L
R	O	H	L

O : Stall revolution is normal.  
 H : Stall revolution is higher than specified.  
 L : Stall revolution is lower than specified.

Damaged components

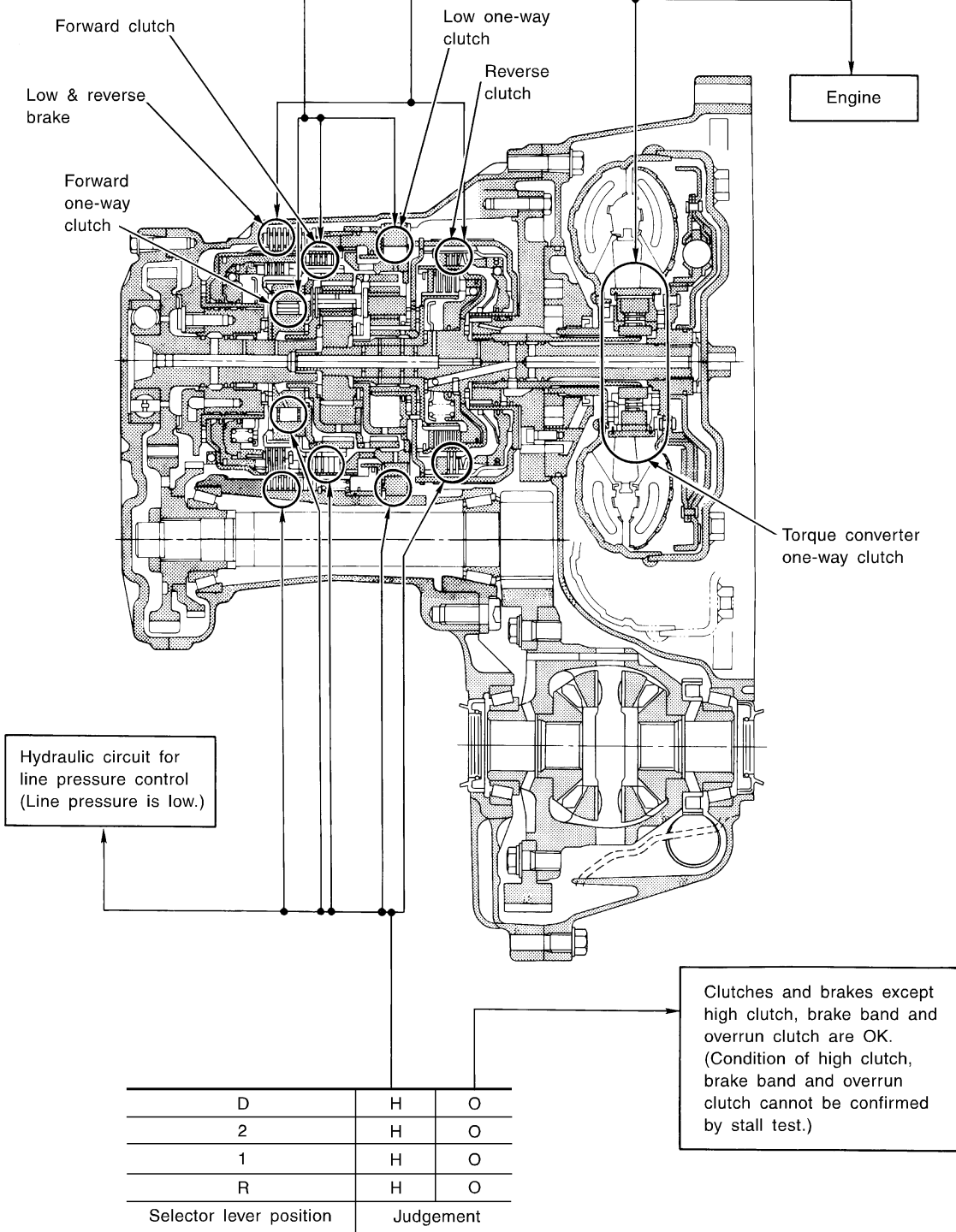

SAT600J

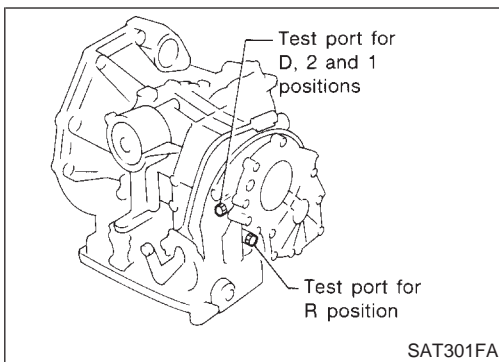

## Line Pressure Test

### LINE PRESSURE TEST PORTS

NFAT0028

NFAT0028S01

Location of line pressure test ports are shown in the illustration.

- **Always replace pressure plugs as they are self-sealing bolts.**

GI

MA

EM

LC

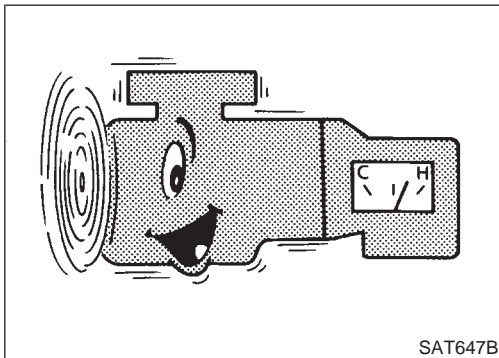

### LINE PRESSURE TEST PROCEDURE

NFAT0028S02

1. Check A/T fluid and engine oil levels. If necessary, add fluid and oil.
2. Drive vehicle for approx. 10 minutes or until fluid and oil reach operating temperature.

**ATF operating temperature:  
50 - 80°C (122 - 176°F)**

EC

FE

CL

MT

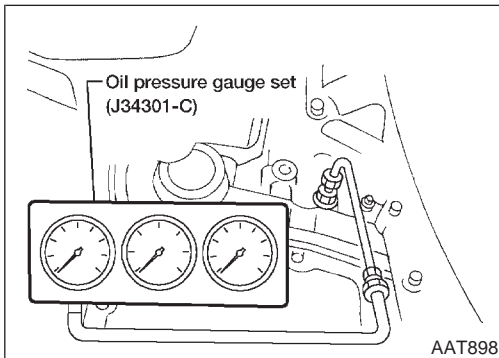

3. Install pressure gauge to corresponding line pressure port.

AT

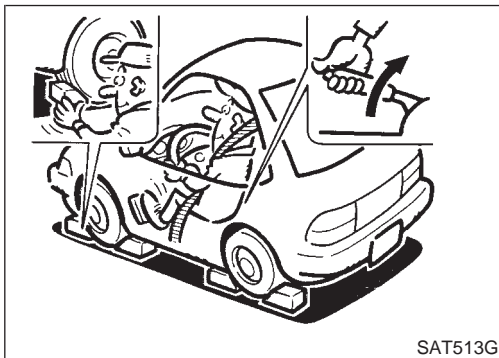

4. Set parking brake and block wheels.
  - **Continue to depress brake pedal fully while line pressure test is being performed at stall speed.**

AX

SU

BR

ST

RS

BT

HA

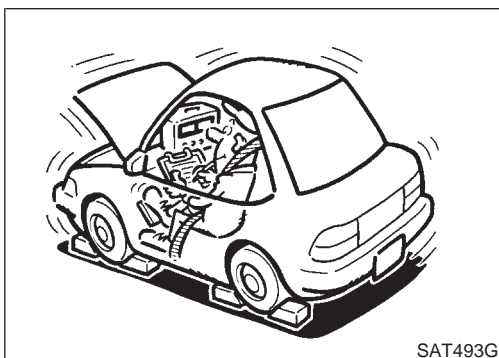

5. Start engine and measure line pressure at idle and stall speed.
  - **When measuring line pressure at stall speed, follow the stall test procedure.**

**Line pressure: Refer to SDS, AT-382.**

SC

EL

IDX



# TROUBLE DIAGNOSIS — BASIC INSPECTION

Line Pressure Test (Cont'd)

## JUDGEMENT OF LINE PRESSURE TEST

NFAT0028S03

Judgement		Suspected parts
At idle	Line pressure is low in all positions.	<ul style="list-style-type: none"> <li>Oil pump wear</li> <li>Control piston damage</li> <li>Pressure regulator valve or plug sticking</li> <li>Spring for pressure regulator valve damaged</li> <li>Fluid pressure leakage between oil strainer and pressure regulator valve</li> <li>Clogged strainer</li> </ul>
	Line pressure is low in particular position.	<ul style="list-style-type: none"> <li>Fluid pressure leakage between manual valve and particular clutch</li> <li>For example, line pressure is:                             <ul style="list-style-type: none"> <li>– Low in R and 1 positions, but</li> <li>– Normal in D and 2 positions.</li> </ul>                             Therefore, fluid leakage exists at or around low and reverse brake circuit. Refer to “CLUTCH AND BAND CHART”, AT-19.                         </li> </ul>
	Line pressure is high.	<ul style="list-style-type: none"> <li>Maladjustment of throttle position sensor</li> <li>A/T fluid temperature sensor damaged</li> <li>Line pressure solenoid valve sticking</li> <li>Short circuit of line pressure solenoid valve circuit</li> <li>Pressure modifier valve sticking</li> <li>Pressure regulator valve or plug sticking</li> <li>Open in dropping resistor circuit</li> </ul>
At stall speed	Line pressure is low.	<ul style="list-style-type: none"> <li>Maladjustment of throttle position sensor</li> <li>Line pressure solenoid valve sticking</li> <li>Short circuit of line pressure solenoid valve circuit</li> <li>Pressure regulator valve or plug sticking</li> <li>Pressure modifier valve sticking</li> <li>Pilot valve sticking</li> </ul>

### ROAD TEST PROCEDURE

1. Check before engine is started.



2. Check at idle.



3. Cruise test.

SAT786A

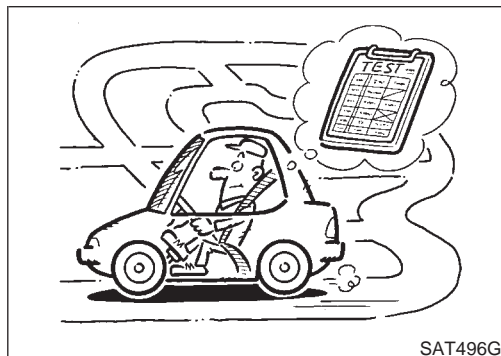

SAT496G

### Road Test

#### DESCRIPTION

NFAT0029

NFAT0029S01

- The purpose of the test is to determine overall performance of A/T and analyze causes of problems.
- The road test consists of the following three parts:
  - Check before engine is started
  - Check at idle
  - Cruise test
- Before road test, familiarize yourself with all test procedures and items to check.
- Conduct tests on all items until specified symptom is found. Troubleshoot items which check out No Good after road test. Refer to “ON BOARD DIAGNOSTIC SYSTEM DESCRIPTION” and “TROUBLE DIAGNOSES FOR SYMPTOMS”, AT-36 to AT-52 and AT-216 to AT-260.

## 1. CHECK BEFORE ENGINE IS STARTED

=NFAT0029S02

<b>1</b>	<b>CHECK O/D OFF INDICATOR LAMP</b>	
<p>1. Park vehicle on flat surface. 2. Move selector lever to P position.</p> <div style="text-align: center;"> <p>The diagram shows two views of the vehicle's controls. On the left, a close-up of the 'OVERDRIVE ON/OFF' switch with an arrow pointing to the right. On the right, a gear selector lever with an arrow pointing to the 'P' (Park) position.</p> </div> <p>3. Turn ignition switch to OFF position. Wait at least 5 seconds. 4. Turn ignition switch to ON position. (Do not start engine.) 5. Does O/D OFF indicator lamp come on for about 2 seconds?</p> <p style="text-align: right;">SAT967I</p>		
<b>Yes or No</b>		
Yes	▶	GO TO 2.
No	▶	Stop ROAD TEST. Go to "1. O/D OFF Indicator Lamp Does Not Come On", AT-219.

GI  
MA  
EM  
LC  
EC  
FE  
CL  
MT

<b>2</b>	<b>CHECK O/D OFF INDICATOR LAMP</b>	
<p>Does O/D OFF indicator lamp flicker for about 8 seconds?</p> <div style="text-align: center;"> <p>The diagram shows the O/D OFF indicator lamp with a scale from 1 to 160. A 'D' is marked above the scale. A '1' is marked on the right side. The lamp is shown with a flicker pattern. Below the diagram is the label 'O/D OFF indicator lamp'.</p> </div> <p style="text-align: right;">SAT598J</p>		
<b>Yes or No</b>		
Yes	▶	Perform self-diagnosis and check NG items on the DIAGNOSTIC WORKSHEET, AT-56. Refer to TCM SELF-DIAGNOSTIC PROCEDURE (NO TOOLS), AT-49.
No	▶	1. Turn ignition switch to OFF position. 2. Perform self-diagnosis and note NG items. Refer to TCM SELF-DIAGNOSTIC PROCEDURE (NO TOOLS), AT-49. 3. Go to "2. CHECK AT IDLE", AT-68.

AT  
AX  
SU  
BR  
ST  
RS  
BT  
HA  
SC  
EL  
IDX

## 2. CHECK AT IDLE

NFAT0029S03

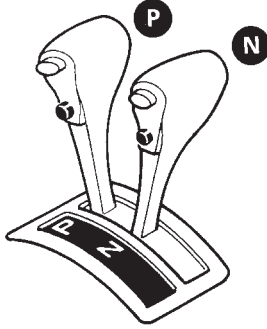
<b>1</b>	<b>CHECK ENGINE START</b>	
<p>1. Park vehicle on flat surface. 2. Move selector lever to P position.</p> <div style="text-align: center;">  </div> <p style="text-align: right;">SAT769B</p> <p>3. Turn ignition switch to OFF position. 4. Turn ignition switch to START position. 5. Is engine started?</p> <p style="text-align: center;"><b>Yes or No</b></p>		
Yes	▶	GO TO 2.
No	▶	Mark the box on the DIAGNOSTIC WORKSHEET. Go to "2. Engine Cannot Be Started In P and N Position", AT-222. Continue ROAD TEST.

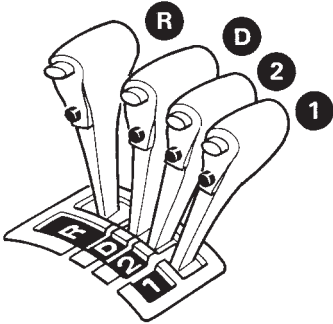
<b>2</b>	<b>CHECK ENGINE START</b>	
<p>1. Turn ignition switch to ACC position. 2. Move selector lever to D, 1, 2 or R position.</p> <div style="text-align: center;">  </div> <p style="text-align: right;">SAT770B</p> <p>3. Turn ignition switch to START position. 4. Is engine started?</p> <p style="text-align: center;"><b>Yes or No</b></p>		
Yes	▶	Mark the box on the DIAGNOSTIC WORKSHEET. Mark the box on the DIAGNOSTIC WORKSHEET. Go to "2. Engine Cannot Be Started In P and N Position", AT-222. Continue ROAD TEST.
No	▶	GO TO 3.

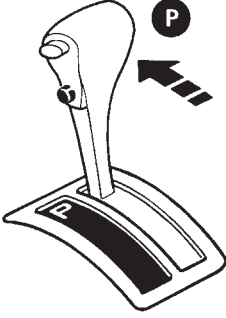
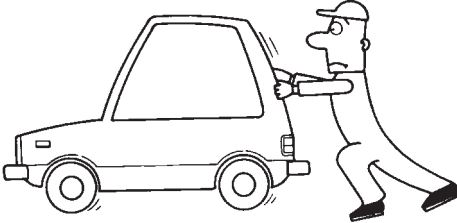
<b>3</b>	<b>CHECK VEHICLE MOVE</b>	
<p>1. Move selector lever to P position.</p> <div style="text-align: center;">  </div> <p style="text-align: right;">SAT768B</p> <p>2. Turn ignition switch to OFF position. 3. Release parking brake. 4. Push vehicle forward or backward.</p> <div style="text-align: center;">  </div> <p style="text-align: right;">SAT796A</p> <p>5. Does vehicle move when it is pushed forward or backward? 6. Apply parking brake.</p>		
<b>Yes or No</b>		
Yes	▶	Mark the box on the DIAGNOSTIC WORKSHEET. Go to "3. In P Position, Vehicle Moves Forward Or Backward When Pushed", AT-223. Continue ROAD TEST.
No	▶	GO TO 4.

GI  
 MA  
 EM  
 LC  
 EC  
 FE  
 CL  
 MT  
**AT**

AX  
 SU  
 BR

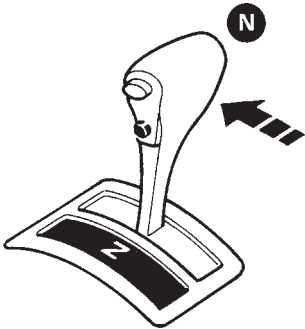
<b>4</b>	<b>CHECK VEHICLE MOVE</b>	
<p>1. Start engine. 2. Move selector lever to N position.</p> <div style="text-align: center;">  </div> <p style="text-align: right;">SAT771B</p> <p>3. Release parking brake. 4. Does vehicle move forward or backward?</p>		
<b>Yes or No</b>		
Yes	▶	Mark the box on the DIAGNOSTIC WORKSHEET. Go to "4. In N Position, Vehicle Moves", AT-224. Continue ROAD TEST.
No	▶	GO TO 5.

ST  
 RS  
 BT  
 HA  
 SC  
 EL  
 IDX

Road Test (Cont'd)

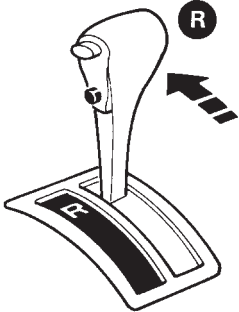
<b>5</b>	<b>CHECK SHIFT LOCK</b>	
1. Apply foot brake.		
		
2. Move selector lever to R position.		
		
3. Is there large shock when changing from N to R position?		
<b>Yes or No</b>		
Yes	▶	Mark the box on the DIAGNOSTIC WORKSHEET. Go to "5. Large Shock N → R Position", AT-227. Continue ROAD TEST.
No	▶	GO TO 6.

SAT797A

SAT772B

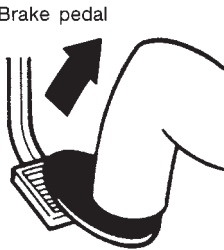
<b>6</b>	<b>CHECK VEHICLE MOVE</b>	
1. Release foot brake for several seconds.		
		
For several seconds		
2. Does vehicle creep backward when foot brake is released?		
<b>Yes or No</b>		
Yes	▶	GO TO 7.
No	▶	Mark the box on the DIAGNOSTIC WORKSHEET. Go to "6. Vehicle Does Not Creep Backward In R Position", AT-229. Continue ROAD TEST.

SAT799A

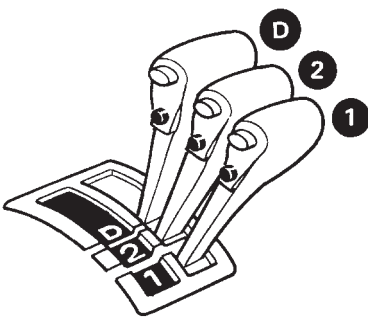
<b>7</b>	<b>CHECK VEHICLE MOVE</b>	
<p>1. Move selector lever to D, 2 and 1 positions and check if vehicle creeps forward.</p> <div style="text-align: center;">  </div>		
SAT773B		
<p>2. Does vehicle creep forward in all three positions?</p> <p style="text-align: center;"><b>Yes or No</b></p>		
Yes	▶	Go to 3. CRUISE TEST, AT-71.
No	▶	Mark the box on the DIAGNOSTIC WORKSHEET. Go to "7. Vehicle Does Not Creep Forward In D, 2 Or 1 Position", AT-233. Continue ROAD TEST.

GI  
MA  
EM  
LC  
EC  
FE  
CL

MT

AT

AX

SU

BR

ST

RS

BT

HA

SC

EL

IDX

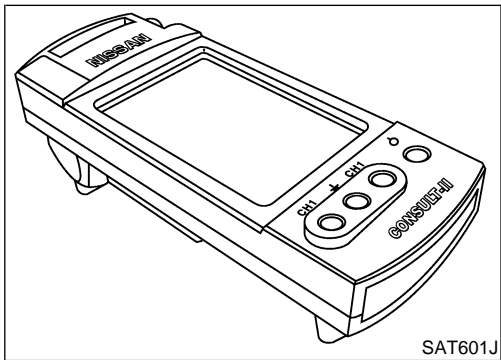

### 3. CRUISE TEST

NFAT0029S04

- Check all items listed in Parts 1 through 3.

#### With CONSULT-II

NFAT0029S0401

- Using CONSULT-II, conduct a cruise test and record the result.
- Print the result and ensure that shifts and lock-ups take place as per Shift Schedule.

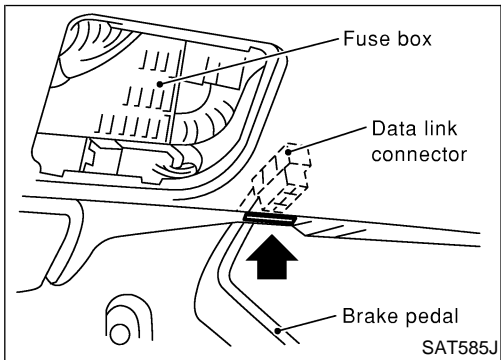

### CONSULT-II Setting Procedure

NFAT0029S0402

1. Turn ignition switch OFF.
2. Connect CONSULT-II to data link connector, which is located in left side dash panel.

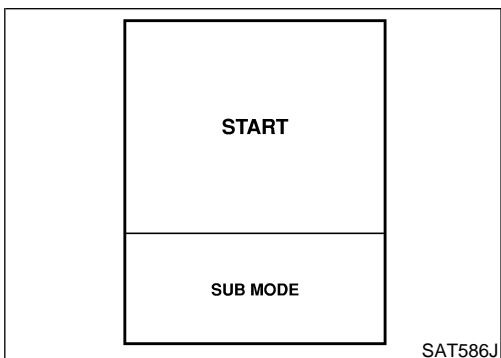

3. Turn ignition switch ON.
4. Touch "START".

# TROUBLE DIAGNOSIS — BASIC INSPECTION

Road Test (Cont'd)

SELECT SYSTEM
A/T
ENGINE

SAT014K

5. Touch "A/T".

SELECT DIAG MODE
SELF-DIAG RESULTS
DATA MONITOR
DTC WORK SUPPORT
TCM PART NUMBER

SAT971J

6. Touch "DATA MONITOR".

DATA MONITOR
SELECT MONITOR ITEM
ECU INPUT SIGNALS
<b>MAIN SIGNAL</b>
SELECTION FROM MENU

SAT972J

7. Touch "MAIN SIGNALS" or "ECU INPUT SIGNALS" to set recording condition.

8. See "Numerical Display", "Barchart Display" or "Line Graph Display".

SET RECORDING CONDITION
<b>AUTO TRIG</b>
MANU TRIG
TRIGGER POINT
<< [Slider] >>
0% 20% 40% 60% 80% 100%
Recording Speed
MIN [Slider] MAX
/64 /32 /16 /8 /4 /2 FULL

SAT973J

9. Touch "SETTING" to set recording condition ("AUTO TRIG" or "MAIN TRIG") and touch "BACK".

10. Touch "Start".

DATA MONITOR	
MONITOR	NO DTC
ENGINE SPEED	XXX rpm
GEAR	XXX
SLCT LVR POSI	N/P
VEHICLE SPEED	XXX km/h
THROTTLE POSI	XXX

SAT985J

11. When performing cruise test, touch "RECORD".







<b>2</b>	<b>CHECK SHIFT UP (D<sub>1</sub> TO D<sub>2</sub>)</b>	
Does A/T shift from D <sub>1</sub> to D <sub>2</sub> at the specified speed? <input type="checkbox"/> <b>Read gear position, throttle opening and vehicle speed.</b> Specified speed when shifting from D <sub>1</sub> to D <sub>2</sub> : Refer to Shift schedule, AT-382.		
<p style="text-align: center;">Accelerator pedal Halfway</p> <p style="text-align: center;"><b>Yes or No</b></p>		
SAT954I		
Yes	▶	GO TO 3.
No	▶	Go to "9. A/T Does Not Shift: D <sub>1</sub> → D <sub>2</sub> Or Does Not Kickdown: D <sub>4</sub> → D <sub>2</sub> ", AT-239. Continue ROAD TEST.

GI  
MA  
EM  
LC  
EC  
FE  
CL

<b>3</b>	<b>CHECK SHIFT UP (D<sub>2</sub> TO D<sub>3</sub>)</b>	
Does A/T shift from D <sub>2</sub> to D <sub>3</sub> at the specified speed? <input type="checkbox"/> <b>Read gear position, throttle position and vehicle speed.</b> Specified speed when shifting from D <sub>2</sub> to D <sub>3</sub> : Refer to Shift schedule, AT-382.		
<p style="text-align: center;">Accelerator pedal Halfway</p> <p style="text-align: center;"><b>Yes or No</b></p>		
SAT955I		
Yes	▶	GO TO 4.
No	▶	Go to "10. A/T Does Not Shift: D <sub>2</sub> → D <sub>3</sub> ", AT-242. Continue ROAD TEST.

MT  
**AT**  
AX  
SU  
BR  
ST

RS  
BT  
HA  
SC  
EL  
IDX

Road Test (Cont'd)

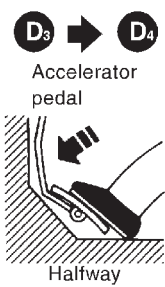
<b>4</b>	<b>CHECK SHIFT UP (D<sub>3</sub> TO D<sub>4</sub>)</b>	
Does A/T shift from D <sub>3</sub> to D <sub>4</sub> at the specified speed? (i) <b>Read gear position, throttle position and vehicle speed.</b> Specified speed when shifting from D <sub>3</sub> to D <sub>4</sub> : Refer to shift schedule, AT-382.		
		
Yes or No		
Yes	▶	GO TO 5.
No	▶	Go to "11. A/T Does Not Shift: D <sub>3</sub> → D <sub>4</sub> ", AT-245. Continue ROAD TEST.

SAT956I

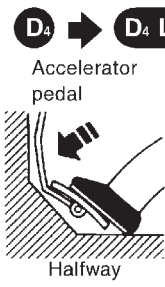
<b>5</b>	<b>CHECK LOCK-UP (D<sub>4</sub> TO D<sub>4</sub>L/U)</b>	
Does A/T perform lock-up at the specified speed? (i) <b>Read vehicle speed, throttle position when lock-up duty becomes 94%.</b> Specified speed when lock-up occurs: Refer to Shift schedule, AT-382.		
		
Yes or No		
Yes	▶	GO TO 6.
No	▶	Go to "12. A/T Does Not Perform Lock-up", AT-248. Continue ROAD TEST.

SAT957I

<b>6</b>	<b>CHECK HOLD LOCK-UP</b>	
Does A/T hold lock-up condition for more than 30 seconds? <p style="text-align: center;">Yes or No</p>		
Yes	▶	GO TO 7.
No	▶	Go to "13. A/T Does Not Hold Lock-up Condition", AT-250.

<b>7</b>	<b>CHECK SHIFT DOWN (D<sub>4</sub>L/U TO D<sub>4</sub>)</b>	
<p>1. Release accelerator pedal.</p> <div style="text-align: center;"> </div> <p style="text-align: right;">SAT958I</p>		
2. Is lock-up released when accelerator pedal is released?		
<b>Yes or No</b>		
Yes	▶	GO TO 8.
No	▶	Go to "14. Lock-up Is Not Released", AT-252. Continue ROAD TEST.

GI

MA

EM

LC

EC

FE

<b>8</b>	<b>CHECK SHIFT DOWN (D<sub>4</sub> TO D<sub>3</sub>)</b>	
<p>1. Decelerate vehicle by applying foot brake lightly.</p> <div style="text-align: center;"> </div> <p style="text-align: right;">SAT959I</p>		
2. Does engine speed return to idle smoothly when A/T is shifted from D <sub>4</sub> to D <sub>3</sub> ?		
<input type="checkbox"/> <b>Read gear position and engine speed.</b>		
<b>Yes or No</b>		
Yes	▶	1. Stop vehicle. 2. Go to "Cruise Test — Part 2", AT-78.
No	▶	Go to "15. Engine Speed Does Not Return To Idle (Light Braking D <sub>4</sub> → D <sub>3</sub> )", AT-253. Continue ROAD TEST.

CL

MT

AT

AX

SU

BR

ST

RS

BT

HA

SC

EL

IDX

## Cruise Test — Part 2

=NFAT0029S0405

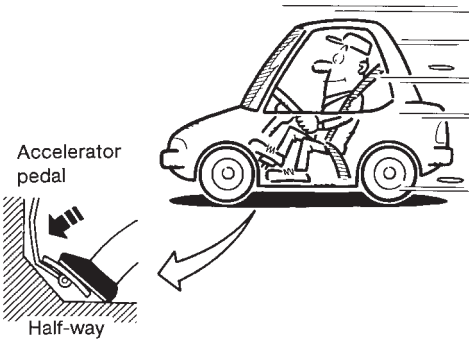
<b>1</b>	<b>CHECK STARTING GEAR (D<sub>1</sub>) POSITION</b>	<p>1. Confirm overdrive control switch is in ON position.                  2. Confirm selector lever is in D position.                  3. Accelerate vehicle by half throttle again.</p> <div style="text-align: center;">  </div> <p>4. Does vehicle start from D<sub>1</sub>?  <input type="checkbox"/> <b>Read gear position.</b></p> <p style="text-align: center;"><b>Yes or No</b></p>	SAT495G
Yes	▶	GO TO 2.	
No	▶	Go to "16. Vehicle Does Not Start From D <sub>1</sub> ", AT-256. Continue ROAD TEST.	

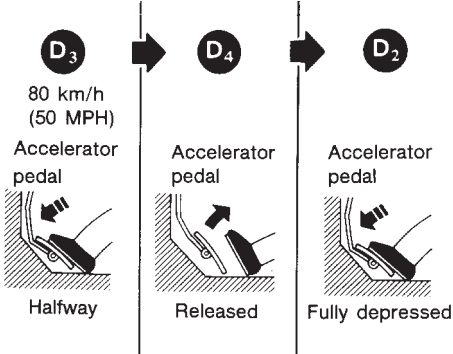
<b>2</b>	<b>CHECK SHIFT UP AND SHIFT DOWN (D<sub>3</sub> TO D<sub>4</sub> TO D<sub>2</sub>)</b>	<p>1. Accelerate vehicle to 80 km/h (50 MPH) as shown in illustration.                  2. Release accelerator pedal and then quickly depress it fully.</p> <div style="text-align: center;">  </div> <p>3. Does A/T shift from D<sub>4</sub> to D<sub>2</sub> as soon as accelerator pedal is depressed fully?  <input type="checkbox"/> <b>Read gear position and throttle position.</b></p> <p style="text-align: center;"><b>Yes or No</b></p>	SAT404H
Yes	▶	GO TO 3.	
No	▶	Go to "9. A/T Does Not Shift: D <sub>1</sub> → D <sub>2</sub> Or Does Not Kickdown: D <sub>4</sub> → D <sub>2</sub> ", AT-239. Continue ROAD TEST.	

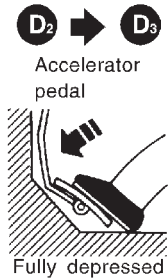
<b>3</b>	<b>CHECK SHIFT UP (D<sub>2</sub> TO D<sub>3</sub>)</b>	
Does A/T shift from D <sub>2</sub> to D <sub>3</sub> at the specified speed? <input type="checkbox"/> <b>Read gear position, throttle position and vehicle speed.</b> Specified speed when shifting from D <sub>2</sub> to D <sub>3</sub> : Refer to Shift schedule, AT-382.		
 <p style="text-align: center;">Fully depressed</p>		
<b>Yes or No</b>		
Yes	▶	GO TO 4.
No	▶	Go to "10. A/T Does Not Shift: D <sub>2</sub> → D <sub>3</sub> ", AT-242. Continue ROAD TEST.

GI  
MA  
EM  
LC  
EC  
FE  
CL

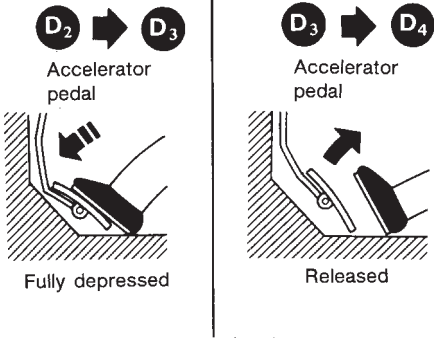
<b>4</b>	<b>CHECK SHIFT UP (D<sub>3</sub> TO D<sub>4</sub>) AND ENGINE BRAKE</b>	
Release accelerator pedal after shifting from D <sub>2</sub> to D <sub>3</sub> . Does A/T shift from D <sub>3</sub> to D <sub>4</sub> and does vehicle decelerate by engine brake? <input type="checkbox"/> <b>Read gear position, throttle position and vehicle speed.</b>		
		
<b>Yes or No</b>		
Yes	▶	1. Stop vehicle. 2. Go to "CRUISE TEST — Part 3", AT-80.
No	▶	Go to "11. A/T Does Not Shift: D <sub>3</sub> → D <sub>4</sub> ", AT-245. Continue ROAD TEST.

MT  
**AT**  
AX  
SU  
BR  
ST

RS  
BT  
HA  
SC  
EL  
IDX

## Cruise Test — Part 3

=NFAT0029S0406

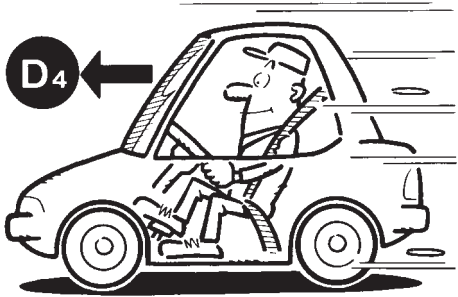
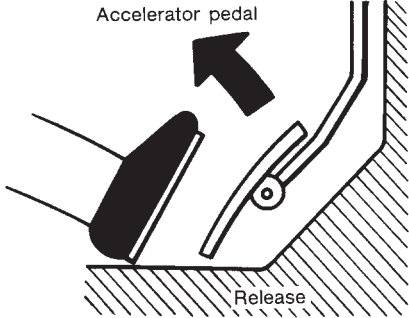
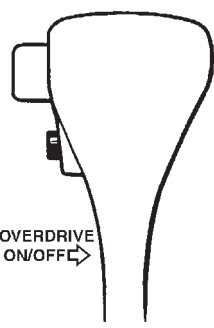
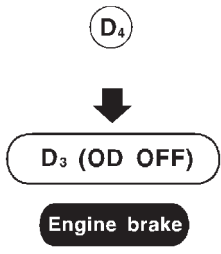
<b>1</b>	<b>VEHICLE SPEED (D<sub>4</sub>) POSITION</b>	<p>1. Confirm overdrive control switch is in ON position.                  2. Confirm selector lever is in D position.                  3. Accelerate vehicle using half-throttle to D<sub>4</sub>.</p> <div style="text-align: center;">  </div> <p>4. Release accelerator pedal.</p> <div style="text-align: center;">  </div> <p>5. Set overdrive control switch to OFF position while driving in D<sub>4</sub>.                  6. Does A/T shift from D<sub>4</sub> to D<sub>3</sub> (O/D OFF)?</p> <p><input type="checkbox"/> <b>Read gear position and vehicle speed.</b></p> <div style="display: flex; justify-content: center; align-items: center;"> <div style="text-align: center; margin-right: 20px;">  </div> <div style="text-align: center;">  </div> </div> <p style="text-align: center;">Yes or No</p>	<p>SAT812A</p> <p>SAT813A</p> <p>SAT999I</p>
Yes	▶	GO TO 2.	
No	▶	Go to "17. A/T Does Not Shift: D <sub>4</sub> → D <sub>3</sub> , When Overdrive Control Switch ON → OFF, AT-257. Continue ROAD TEST.	

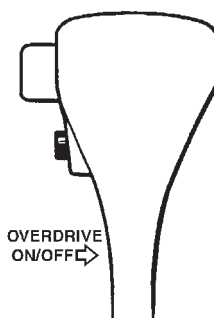
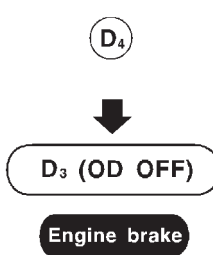
<b>2</b>	<b>CHECK ENGINE BRAKE</b>		
Does vehicle decelerate by engine brake?			
			SAT999I
Yes or No			
Yes	▶	GO TO 3.	
No	▶	Go to "15. Engine Speed Does Not Return To Idle (Light Braking D <sub>4</sub> → D <sub>3</sub> )", AT-253. Continue ROAD TEST.	

GI  
 MA  
 EM  
 LC  
 EC  
 FE  
 CL

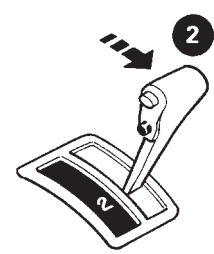
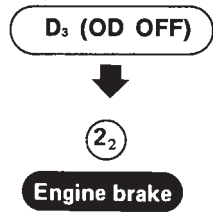
<b>3</b>	<b>CHECK SHIFT DOWN (D<sub>3</sub> TO D<sub>2</sub>)</b>		
1. Move selector lever from D to 2 position while driving in D <sub>3</sub> (O/D OFF). 2. Does A/T shift from D <sub>3</sub> (O/D OFF) to 2 <sub>2</sub> ? ⓘ Read gear position.			
			SAT791GA
Yes or No			
Yes	▶	GO TO 4.	
No	▶	Go to "18. A/T Does Not Shift: D <sub>3</sub> → D <sub>2</sub> , When Selector Lever D → 2 Position", AT-258. Continue ROAD TEST.	

MT  
**AT**  
 AX  
 SU  
 BR  
 ST  
 RS  
 BT  
 HA  
 SC  
 EL  
 IDX



# TROUBLE DIAGNOSIS — BASIC INSPECTION

Road Test (Cont'd)

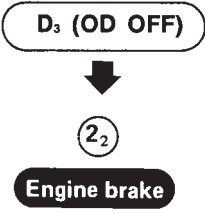
<b>4</b>	<b>CHECK ENGINE BRAKE</b>		
Does vehicle decelerate by engine brake?			
			
Yes or No			
Yes	▶	GO TO 5.	
No	▶	Go to "15. Engine Speed Does Not Return To Idle (Light Braking D <sub>4</sub> → D <sub>3</sub> )", AT-253. Continue ROAD TEST.	

SAT791GA

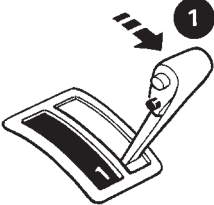
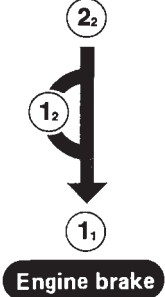
<b>5</b>	<b>CHECK SHIFT DOWN (2<sub>2</sub> TO 1<sub>1</sub>)</b>		
1. Move selector lever from 2 to 1 position while driving in 2 <sub>2</sub> . 2. Does A/T shift from 2 <sub>2</sub> to 1 <sub>1</sub> position? <input type="checkbox"/> Read gear position.			
			
Yes or No			
Yes	▶	GO TO 6.	
No	▶	Go to "19. A/T Does Not Shift: 2 <sub>2</sub> → 1 <sub>1</sub> , When Selector Lever 2 → 1 Position", AT-259. Continue ROAD TEST.	

SAT778B

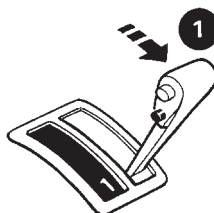
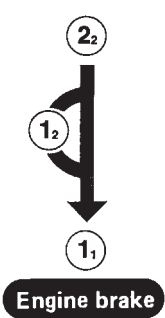
<b>6</b>	<b>CHECK ENGINE BRAKE</b>	
Does vehicle decelerate by engine brake?		
<div style="display: flex; justify-content: space-around; align-items: center;">   </div> <p style="text-align: center; margin-top: 10px;">Yes or No</p> <p style="text-align: right; margin-top: 10px;">SAT778B</p>		
Yes	▶	<ol style="list-style-type: none"> <li>1. Stop vehicle.</li> <li>2. Perform self-diagnosis. Refer to TCM Self-diagnostic Procedure (No Tools), AT-49.</li> </ol>
No	▶	Go to “20. Vehicle Does Not Decelerate By Engine Brake”, AT-260. Continue ROAD TEST.

GI

MA

EM

LC

EC

FE

CL

MT

**AT**

AX

SU

BR

ST

RS

BT

HA

SC

EL

IDX

# TROUBLE DIAGNOSIS — GENERAL DESCRIPTION

Symptom Chart

## Symptom Chart

NFAT0030

Numbers are arranged in order of inspection.

Perform inspections starting with number one and work up.

Symptom	Condition	Diagnostic Item	Reference Page
Engine cannot be started in P and N positions. AT-222	ON vehicle	1. Ignition switch and starter	EL-14, and SC-6
		2. Control cable adjustment	AT-282
		3. Park/neutral position (PNP) switch adjustment	AT-281
Engine starts in positions other than P and N. AT-222	ON vehicle	1. Control cable adjustment	AT-282
		2. Park/neutral position (PNP) switch adjustment	AT-281
Transaxle noise in P and N positions.	ON vehicle	1. Fluid level	AT-61
		2. Line pressure test	AT-65
		3. Throttle position sensor (Adjustment)	EC-60
		4. Vehicle speed sensor-A/T (Revolution sensor) and vehicle speed sensor-MTR	AT-114, 203
		5. Engine speed signal	AT-119
	OFF vehicle	6. Oil pump	AT-308
		7. Torque converter	AT-291
Vehicle moves when changing into P position or parking gear does not disengage when shifted out of P position. AT-223	ON vehicle	1. Control cable adjustment	AT-282
	OFF vehicle	2. Parking components	AT-362
Vehicle runs in N position. AT-224	ON vehicle	1. Control cable adjustment	AT-282
	OFF vehicle	2. Forward clutch	AT-334
		3. Reverse clutch	AT-326
		4. Overrun clutch	AT-334
Vehicle will not run in R position (but runs in D, 2 and 1 positions). Clutch slips. Very poor acceleration. AT-229	ON vehicle	1. Control cable adjustment	AT-282
		2. Line pressure test	AT-65
		3. Line pressure solenoid valve	AT-166
		4. Control valve assembly	AT-280
	OFF vehicle	5. Reverse clutch	AT-326
		6. High clutch	AT-329
		7. Forward clutch	AT-334
		8. Overrun clutch	AT-334
		9. Low & reverse brake	AT-339

# TROUBLE DIAGNOSIS — GENERAL DESCRIPTION



*Symptom Chart (Cont'd)*

Symptom	Condition	Diagnostic Item	Reference Page	
Vehicle braked when shifting into R position.	ON vehicle	1. Fluid level	AT-61	GI
		2. Control cable adjustment	AT-282	
		3. Line pressure test	AT-65	MA
		4. Line pressure solenoid valve	AT-166	
		5. Control valve assembly	AT-280	EM
	OFF vehicle	6. High clutch	AT-329	
		7. Brake band	AT-351	LC
		8. Forward clutch	AT-334	
		9. Overrun clutch	AT-334	EC
Sharp shock in shifting from N to D position.	ON vehicle	1. Engine idling rpm	AT-68	FE
		2. Throttle position sensor (Adjustment)	EC-60	
		3. Line pressure test	AT-65	CL
		4. A/T fluid temperature sensor	AT-108	
		5. Engine speed signal	AT-119	MT
		6. Line pressure solenoid valve	AT-166	
		7. Control valve assembly	AT-280	<b>AT</b>
		8. Accumulator N-D	AT-280	
	OFF vehicle	9. Forward clutch	AT-334	AX
Vehicle will not run in D and 2 positions (but runs in 1 and R positions).	ON vehicle	1. Control cable adjustment	AT-282	
	OFF vehicle	2. Low one-way clutch	AT-286	SU
Vehicle will not run in D, 1, 2 positions (but runs in R position). Clutch slips. Very poor acceleration. AT-233	ON vehicle	1. Fluid level	AT-61	
		2. Line pressure test	AT-65	BR
		3. Line pressure solenoid valve	AT-166	
		4. Control valve assembly	AT-280	ST
		5. Accumulator N-D	AT-280	
	OFF vehicle	6. Reverse clutch	AT-326	RS
		7. High clutch	AT-329	
		8. Forward clutch	AT-334	BT
		9. Forward one-way clutch	AT-342	
		10. Low one-way clutch	AT-286	HA

SC

EL

IDX

# TROUBLE DIAGNOSIS — GENERAL DESCRIPTION

Symptom Chart (Cont'd)

Symptom	Condition	Diagnostic Item	Reference Page
Clutches or brakes slip somewhat in starting.	ON vehicle	1. Fluid level	AT-61
		2. Control cable adjustment	AT-282
		3. Throttle position sensor (Adjustment)	EC-60
		4. Line pressure test	AT-65
		5. Line pressure solenoid valve	AT-166
		6. Control valve assembly	AT-280
		7. Accumulator N-D	AT-280
	OFF vehicle	8. Forward clutch	AT-334
		9. Reverse clutch	AT-326
		10. Low & reverse brake	AT-339
		11. Oil pump	AT-308
		12. Torque converter	AT-291
Excessive creep.	ON vehicle	1. Engine idling rpm	AT-68
No creep at all. AT-229, 233	ON vehicle	1. Fluid level	AT-61
		2. Line pressure test	AT-65
		3. Control valve assembly	AT-280
	OFF vehicle	4. Forward clutch	AT-334
		5. Oil pump	AT-308
		6. Torque converter	AT-291
Failure to change gear from D <sub>1</sub> to D <sub>2</sub> .	ON vehicle	1. Park/neutral position (PNP) switch adjustment	AT-281
		2. Control cable adjustment	AT-282
		3. Shift solenoid valve A	AT-172
		4. Control valve assembly	AT-280
		5. Vehicle speed sensor-A/T (Revolution sensor) and vehicle speed sensor-MTR	AT-114, 203
	OFF vehicle	6. Brake band	AT-351
Failure to change gear from D <sub>2</sub> to D <sub>3</sub> .	ON vehicle	1. Park/neutral position (PNP) switch adjustment	AT-281
		2. Control cable adjustment	AT-282
		3. Shift solenoid valve B	AT-177
		4. Control valve assembly	AT-280
		5. Vehicle speed sensor-A/T (Revolution sensor) and vehicle speed sensor-MTR	AT-114, 203
	OFF vehicle	6. High clutch	AT-329
		7. Brake band	AT-351

# TROUBLE DIAGNOSIS — GENERAL DESCRIPTION



*Symptom Chart (Cont'd)*

Symptom	Condition	Diagnostic Item	Reference Page	
Failure to change gear from D <sub>3</sub> to D <sub>4</sub> .	ON vehicle	1. Park/neutral position (PNP) switch adjustment	AT-281	GI
		2. Control cable adjustment	AT-282	MA
		3. Shift solenoid valve A	AT-172	
		4. Vehicle speed sensor-A/T (Revolution sensor) and vehicle speed sensor-MTR	AT-114, 203	EM
		5. A/T fluid temperature sensor	AT-108	LC
	OFF vehicle	6. Brake band	AT-351	
Too high a gear change point from D <sub>1</sub> to D <sub>2</sub> , from D <sub>2</sub> to D <sub>3</sub> , from D <sub>3</sub> to D <sub>4</sub> . AT-239, 242, 245	ON vehicle	1. Throttle position sensor (Adjustment)	EC-60	EC
		2. Vehicle speed sensor-A/T (Revolution sensor) and vehicle speed sensor-MTR	AT-114, 203	
		3. Shift solenoid valve A	AT-172	FE
		4. Shift solenoid valve B	AT-177	
Gear change directly from D <sub>1</sub> to D <sub>3</sub> occurs.	ON vehicle	1. Fluid level	AT-61	CL
		2. Accumulator servo release	AT-280	
	OFF vehicle	3. Brake band	AT-351	MT
Engine stops when shifting lever into R, D, 2 and 1.	ON vehicle	1. Engine idling rpm	AT-68	<b>AT</b>
		2. Torque converter clutch solenoid valve	AT-151	
		3. Control valve assembly	AT-280	AX
	OFF vehicle	4. Torque converter	AT-291	
Too sharp a shock in change from D <sub>1</sub> to D <sub>2</sub> .	ON vehicle	1. Throttle position sensor (Adjustment)	EC-60	SU
		2. Line pressure test	AT-65	
		3. Accumulator servo release	AT-280	BR
		4. Control valve assembly	AT-280	
		5. A/T fluid temperature sensor	AT-108	ST
	OFF vehicle	6. Brake band	AT-351	
Too sharp a shock in change from D <sub>2</sub> to D <sub>3</sub> .	ON vehicle	1. Throttle position sensor (Adjustment)	EC-60	RS
		2. Line pressure test	AT-65	
		3. Control valve assembly	AT-280	BT
	OFF vehicle	4. High clutch	AT-329	
		5. Brake band	AT-351	HA
Too sharp a shock in change from D <sub>3</sub> to D <sub>4</sub> .	ON vehicle	1. Throttle position sensor (Adjustment)	EC-60	SC
		2. Line pressure test	AT-65	
		3. Control valve assembly	AT-280	EL
	OFF vehicle	4. Brake band	AT-351	
		5. Overrun clutch	AT-334	IDX

## TROUBLE DIAGNOSIS — GENERAL DESCRIPTION

### Symptom Chart (Cont'd)

Symptom	Condition	Diagnostic Item	Reference Page
Almost no shock or clutches slipping in change from D <sub>1</sub> to D <sub>2</sub> .	ON vehicle	1. Fluid level	AT-61
		2. Throttle position sensor (Adjustment)	EC-60
		3. Line pressure test	AT-65
		4. Accumulator servo release	AT-280
		5. Control valve assembly	AT-280
	OFF vehicle	6. Brake band	AT-351
Almost no shock or slipping in change from D <sub>2</sub> to D <sub>3</sub> .	ON vehicle	1. Fluid level	AT-61
		2. Throttle position sensor (Adjustment)	EC-60
		3. Line pressure test	AT-65
		4. Control valve assembly	AT-280
	OFF vehicle	5. High clutch	AT-329
		6. Forward clutch	AT-334
Almost no shock or slipping in change from D <sub>3</sub> to D <sub>4</sub> .	ON vehicle	1. Fluid level	AT-61
		2. Throttle position sensor (Adjustment)	EC-60
		3. Line pressure test	AT-65
		4. Control valve assembly	AT-280
	OFF vehicle	5. High clutch	AT-329
		6. Brake band	AT-351
Vehicle braked by gear change from D <sub>1</sub> to D <sub>2</sub> .	ON vehicle	1. Fluid level	AT-61
	OFF vehicle	2. Reverse clutch	AT-326
		3. Low & reverse brake	AT-339
		4. High clutch	AT-329
		5. Low one-way clutch	AT-286
Vehicle braked by gear change from D <sub>2</sub> to D <sub>3</sub> .	ON vehicle	1. Fluid level	AT-61
	OFF vehicle	2. Brake band	AT-351
Vehicle braked by gear change from D <sub>3</sub> to D <sub>4</sub> .	ON vehicle	1. Fluid level	AT-61
	OFF vehicle	2. Overrun clutch	AT-334
		3. Forward one-way clutch	AT-342
		4. Reverse clutch	AT-326

# TROUBLE DIAGNOSIS — GENERAL DESCRIPTION

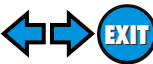

*Symptom Chart (Cont'd)*

Symptom	Condition	Diagnostic Item	Reference Page	
Maximum speed not attained. Acceleration poor.	ON vehicle	1. Fluid level	AT-61	GI
		2. Park/neutral position (PNP) switch adjustment	AT-281	MA
		3. Shift solenoid valve A	AT-172	
		4. Shift solenoid valve B	AT-177	EM
		5. Control valve assembly	AT-280	
	OFF vehicle	6. Reverse clutch	AT-326	LC
		7. High clutch	AT-329	
		8. Brake band	AT-351	EC
		9. Low & reverse brake	AT-339	
		10. Oil pump	AT-308	FE
		11. Torque converter	AT-291	
Failure to change gear from D <sub>4</sub> to D <sub>3</sub> .	ON vehicle	1. Fluid level	AT-61	CL
		2. Throttle position sensor (Adjustment)	EC-60	
		3. Overrun clutch solenoid valve	AT-191	MT
		4. Shift solenoid valve A	AT-172	
		5. Line pressure solenoid valve	AT-166	<b>AT</b>
		6. Control valve assembly	AT-280	
	OFF vehicle	7. Low & reverse brake	AT-339	AX
		8. Overrun clutch	AT-334	SU
Failure to change gear from D <sub>3</sub> to D <sub>2</sub> or from D <sub>4</sub> to D <sub>2</sub> .	ON vehicle	1. Fluid level	AT-61	
		2. Throttle position sensor (Adjustment)	EC-60	BR
		3. Shift solenoid valve A	AT-172	
		4. Shift solenoid valve B	AT-177	ST
		5. Control valve assembly	AT-280	
	OFF vehicle	6. High clutch	AT-329	RS
		7. Brake band	AT-351	
Failure to change gear from D <sub>2</sub> to D <sub>1</sub> or from D <sub>3</sub> to D <sub>1</sub> .	ON vehicle	1. Fluid level	AT-61	BT
		2. Throttle position sensor (Adjustment)	EC-60	
		3. Shift solenoid valve A	AT-172	HA
		4. Shift solenoid valve B	AT-177	
		5. Control valve assembly	AT-280	SC
	OFF vehicle	6. Low one-way clutch	AT-286	
		7. High clutch	AT-329	EL
		8. Brake band	AT-351	IDX



# TROUBLE DIAGNOSIS — GENERAL DESCRIPTION

## Symptom Chart (Cont'd)

Symptom	Condition	Diagnostic Item	Reference Page
Gear change shock felt during deceleration by releasing accelerator pedal.	ON vehicle	1. Throttle position sensor (Adjustment)	EC-60
		2. Line pressure test	AT-65
		3. Overrun clutch solenoid valve	AT-191
		4. Control valve assembly	AT-280
Too high a change point from D <sub>4</sub> to D <sub>3</sub> , from D <sub>3</sub> to D <sub>2</sub> , from D <sub>2</sub> to D <sub>1</sub> .	ON vehicle	1. Throttle position sensor (Adjustment)	EC-60
		2. Vehicle speed sensor-A/T (Revolution sensor) and vehicle speed sensor-MTR	AT-114, 203
Kickdown does not operate when depressing pedal in D <sub>4</sub> within kickdown vehicle speed.	ON vehicle	1. Throttle position sensor (Adjustment)	EC-60
		2. Vehicle speed sensor-A/T (Revolution sensor) and vehicle speed sensor-MTR	AT-114, 203
		3. Shift solenoid valve A	AT-172
		4. Shift solenoid valve B	AT-177
Kickdown operates or engine overruns when depressing pedal in D <sub>4</sub> beyond kickdown vehicle speed limit.	ON vehicle	1. Vehicle speed sensor-A/T (Revolution sensor) and vehicle speed sensor-MTR	AT-114, 203
		2. Throttle position sensor (Adjustment)	EC-60
		3. Shift solenoid valve A	AT-172
		4. Shift solenoid valve B	AT-177
Races extremely fast or slips in changing from D <sub>4</sub> to D <sub>3</sub> when depressing pedal.	ON vehicle	1. Fluid level	AT-61
		2. Throttle position sensor (Adjustment)	EC-60
		3. Line pressure test	AT-65
		4. Line pressure solenoid valve	AT-166
		5. Control valve assembly	AT-280
	OFF vehicle	6. High clutch	AT-329
		7. Forward clutch	AT-334
Races extremely fast or slips in changing from D <sub>4</sub> to D <sub>2</sub> when depressing pedal.	ON vehicle	1. Fluid level	AT-61
		2. Throttle position sensor (Adjustment)	EC-60
		3. Line pressure test	AT-65
		4. Line pressure solenoid valve	AT-166
		5. Shift solenoid valve A	AT-172
		6. Control valve assembly	AT-280
	OFF vehicle	7. Brake band	AT-351
		8. Forward clutch	AT-334

# TROUBLE DIAGNOSIS — GENERAL DESCRIPTION



*Symptom Chart (Cont'd)*

Symptom	Condition	Diagnostic Item	Reference Page	
Races extremely fast or slips in changing from D <sub>3</sub> to D <sub>2</sub> when depressing pedal.	ON vehicle	1. Fluid level	AT-61	GI
		2. Throttle position sensor (Adjustment)	EC-60	
		3. Line pressure test	AT-65	MA
		4. Line pressure solenoid valve	AT-166	
		5. Control valve assembly	AT-280	EM
		6. A/T fluid temperature sensor	AT-108	
	OFF vehicle	7. Brake band	AT-351	LC
		8. Forward clutch	AT-334	
		9. High clutch	AT-329	EC
Races extremely fast or slips in changing from D <sub>4</sub> or D <sub>3</sub> to D <sub>1</sub> when depressing pedal.	ON vehicle	1. Fluid level	AT-61	FE
		2. Throttle position sensor (Adjustment)	EC-60	
		3. Line pressure test	AT-65	CL
		4. Line pressure solenoid valve	AT-166	
		5. Control valve assembly	AT-280	MT
	OFF vehicle	6. Forward clutch	AT-334	
		7. Forward one-way clutch	AT-342	<b>AT</b>
		8. Low one-way clutch	AT-286	
Vehicle will not run in any position.	ON vehicle	1. Fluid level	AT-61	AX
		2. Control cable adjustment	AT-282	
		3. Line pressure test	AT-65	SU
		4. Line pressure solenoid valve	AT-166	
	OFF vehicle	5. Oil pump	AT-308	BR
		6. High clutch	AT-329	
		7. Brake band	AT-351	ST
		8. Low & reverse brake	AT-339	
		9. Torque converter	AT-291	RS
		10. Parking components	AT-362	
Transaxle noise in D, 2, 1 and R positions.	ON vehicle	1. Fluid level	AT-61	BT
	ON vehicle	2. Torque converter	AT-291	HA

SC

EL

IDX

# TROUBLE DIAGNOSIS — GENERAL DESCRIPTION

## Symptom Chart (Cont'd)

Symptom	Condition	Diagnostic Item	Reference Page
Failure to change from D <sub>3</sub> to 2 <sub>2</sub> when changing lever into 2 position. AT-253	ON vehicle	1. Park/neutral position (PNP) switch adjustment	AT-281
		2. Throttle position sensor (Adjustment)	EC-60
		3. Overrun clutch solenoid valve	AT-191
		4. Shift solenoid valve B	AT-177
		5. Shift solenoid valve A	AT-172
		6. Control valve assembly	AT-280
		7. Control cable adjustment	AT-282
	OFF vehicle	8. Brake band	AT-351
		9. Overrun clutch	AT-334
Gear change from 2 <sub>2</sub> to 2 <sub>3</sub> in 2 position.	ON vehicle	1. Park/neutral position (PNP) switch adjustment	AT-281
Engine brake does not operate in "1" position. AT-256	ON vehicle	1. Park/neutral position (PNP) switch adjustment	AT-281
		2. Control cable adjustment	AT-282
		3. Throttle position sensor (Adjustment)	EC-60
		4. Vehicle speed sensor-A/T (Revolution sensor) and vehicle speed sensor-MTR	AT-114, 203
		5. Shift solenoid valve A	AT-172
		6. Control valve assembly	AT-280
		7. Overrun clutch solenoid valve	AT-191
	OFF vehicle	8. Overrun clutch	AT-334
		9. Low & reverse brake	AT-339
Gear change from 1 <sub>1</sub> to 1 <sub>2</sub> in 1 position.	ON vehicle	1. Park/neutral position (PNP) switch adjustment	AT-281
		2. Control cable adjustment	AT-282
Does not change from 1 <sub>2</sub> to 1 <sub>1</sub> in 1 position.	ON vehicle	1. Park/neutral position (PNP) switch adjustment	AT-281
		2. Vehicle speed sensor-A/T (Revolution sensor) and vehicle speed sensor-MTR	AT-114, 203
		3. Shift solenoid valve A	AT-172
		4. Control valve assembly	AT-280
		5. Overrun clutch solenoid valve	AT-191
	OFF vehicle	6. Overrun clutch	AT-334
		7. Low & reverse brake	AT-339
Large shock changing from 1 <sub>2</sub> to 1 <sub>1</sub> in 1 position.	ON vehicle	1. Control valve assembly	AT-280
	ON vehicle	2. Low & reverse brake	AT-339

# TROUBLE DIAGNOSIS — GENERAL DESCRIPTION

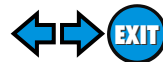

*Symptom Chart (Cont'd)*

Symptom	Condition	Diagnostic Item	Reference Page	
Transaxle overheats.	ON vehicle	1. Fluid level	AT-61	GI
		2. Engine idling rpm	AT-68	
		3. Throttle position sensor (Adjustment)	EC-60	MA
		4. Line pressure test	AT-65	
		5. Line pressure solenoid valve	AT-166	EM
		6. Control valve assembly	AT-280	
	OFF vehicle	7. Oil pump	AT-308	LC
		8. Reverse clutch	AT-326	
		9. High clutch	AT-329	EC
		10. Brake band	AT-351	
		11. Forward clutch	AT-334	FE
		12. Overrun clutch	AT-334	
		13. Low & reverse brake	AT-339	CL
		14. Torque converter	AT-291	MT
ATF shoots out during operation. White smoke emitted from exhaust pipe during operation.	ON vehicle	1. Fluid level	AT-61	
	OFF vehicle	2. Reverse clutch	AT-326	<b>AT</b>
		3. High clutch	AT-329	
		4. Brake band	AT-351	AX
		5. Forward clutch	AT-334	
		6. Overrun clutch	AT-334	SU
		7. Low & reverse brake	AT-339	
Offensive smell at fluid charging pipe.	ON vehicle	1. Fluid level	AT-61	BR
	OFF vehicle	2. Torque converter	AT-291	
		3. Oil pump	AT-308	ST
		4. Reverse clutch	AT-326	
		5. High clutch	AT-329	RS
		6. Brake band	AT-351	
		7. Forward clutch	AT-334	BT
		8. Overrun clutch	AT-334	
		9. Low & reverse brake	AT-339	HA

SC

EL

IDX

# TROUBLE DIAGNOSIS — GENERAL DESCRIPTION

## Symptom Chart (Cont'd)

Symptom	Condition	Diagnostic Item	Reference Page
Torque converter is not locked up.	ON vehicle	1. Throttle position sensor (Adjustment)	EC-60
		2. Vehicle speed sensor-A/T (Revolution sensor) and vehicle speed sensor-MTR	AT-114, 203
		3. Park/neutral position (PNP) switch adjustment	AT-281
		4. Engine speed signal	AT-119
		5. A/T fluid temperature sensor	AT-108
		6. Line pressure test	AT-65
		7. Torque converter clutch solenoid valve	AT-151
		8. Control valve assembly	AT-280
	OFF vehicle	9. Torque converter	AT-291
Torque converter clutch piston slip.	ON vehicle	1. Fluid level	AT-61
		2. Throttle position sensor (Adjustment)	EC-60
		3. Line pressure test	AT-65
		4. Torque converter clutch solenoid valve	AT-151
		5. Line pressure solenoid valve	AT-166
		6. Control valve assembly	AT-280
	OFF vehicle	7. Torque converter	AT-291
Lock-up point is extremely high or low. AT-248	ON vehicle	1. Throttle position sensor (Adjustment)	EC-60
		2. Vehicle speed sensor-A/T (Revolution sensor) and vehicle speed sensor-MTR	AT-114, 203
		3. Torque converter clutch solenoid valve	AT-151
		4. Control valve assembly	AT-280
A/T does not shift to D <sub>4</sub> when driving with overdrive control switch ON.	ON vehicle	1. Throttle position sensor (Adjustment)	EC-60
		2. Park/neutral position (PNP) switch adjustment	AT-281
		3. Vehicle speed sensor-A/T (Revolution sensor) and vehicle speed sensor-MTR	AT-114, 203
		4. Shift solenoid valve A	AT-172
		5. Overrun clutch solenoid valve	AT-191
		6. Control valve assembly	AT-280
		7. A/T fluid temperature sensor	AT-108
		8. Line pressure solenoid valve	AT-166
	OFF vehicle	9. Brake band	AT-351
		10. Overrun clutch	AT-334
Engine is stopped at R, D, 2 and 1 positions.	ON vehicle	1. Fluid level	AT-61
		2. Torque converter clutch solenoid valve	AT-151
		3. Shift solenoid valve B	AT-177
		4. Shift solenoid valve A	AT-172
		5. Control valve assembly	AT-280

# TROUBLE DIAGNOSIS — GENERAL DESCRIPTION

TCM Terminals and Reference Value

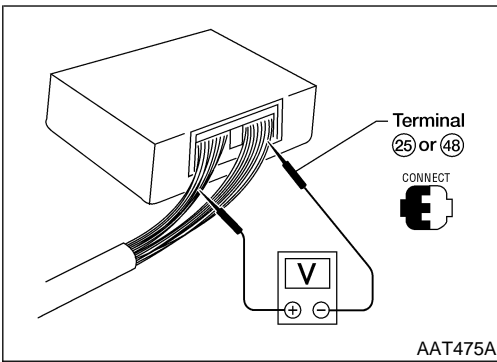

## TCM Terminals and Reference Value

NFAT0031

### PREPARATION

- Measure voltage between each terminal and terminal 25 or 48 by following "TCM INSPECTION TABLE".

NFAT0031S01

## TCM HARNESS CONNECTOR TERMINAL LAYOUT

NFAT0031S02

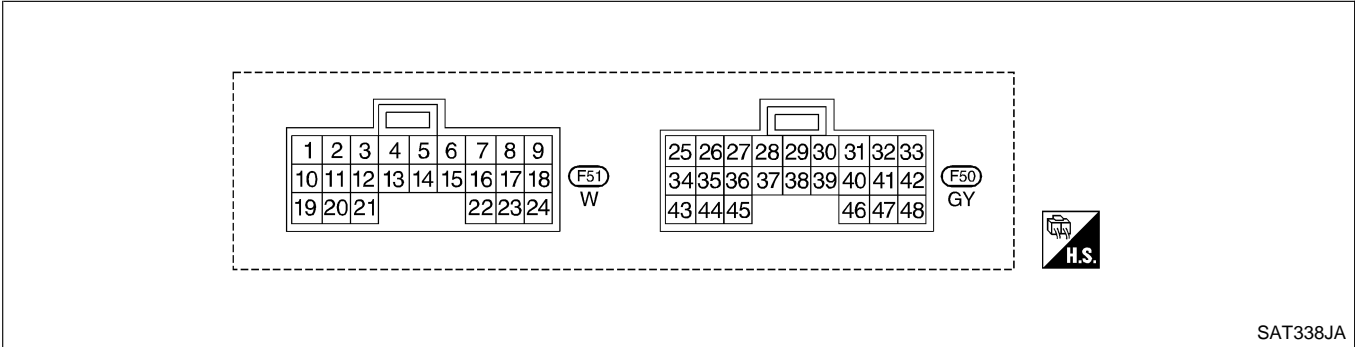

## TCM INSPECTION TABLE















(Data are reference values.)

NFAT0031S03

Terminal No.	Wire color	Item	Condition	Judgement standard
1	G/R	Line pressure solenoid valve	When releasing accelerator pedal after warming up engine.	1.5 - 3.0V
			When depressing accelerator pedal fully after warming up engine.	0.5V or less
2	W/B	Line pressure solenoid valve (with dropping resistor)	When releasing accelerator pedal after warming up engine.	4 - 14V
			When depressing accelerator pedal fully after warming up engine.	0.5V or less
3	G/B	Torque converter clutch solenoid valve	When A/T performs lock-up.	8 - 15V
			When A/T does not perform lock-up.	1V or less
10	R/Y	Power source	When turning ignition switch to ON.	Battery voltage
			When turning ignition switch to OFF.	1V or less
11	R/Y	Shift solenoid valve A	When shift solenoid valve A operates. (When driving in D <sub>1</sub> or D <sub>4</sub> .)	Battery voltage
			When shift solenoid valve A does not operate. (When driving in D <sub>2</sub> or D <sub>3</sub> .)	1V or less
12	LG/B	Shift solenoid valve B	When shift solenoid valve B operates. (When driving in D <sub>1</sub> or D <sub>2</sub> .)	Battery voltage
			When shift solenoid valve B does not operate. (When driving in D <sub>3</sub> or D <sub>4</sub> .)	1V or less

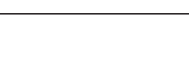







# TROUBLE DIAGNOSIS — GENERAL DESCRIPTION

TCM Terminals and Reference Value (Cont'd)

Terminal No.	Wire color	Item	Condition	Judgement standard
13	G/Y	O/D OFF indicator lamp	 When setting overdrive control switch in OFF position.	1V or less
			When setting overdrive control switch in ON position.	Battery voltage
16	GY/L	Closed throttle position switch (in throttle position switch)	 When releasing accelerator pedal after warming up engine.	Battery voltage
			 When depressing accelerator pedal after warming up engine.	1V or less
17	P	Wide open throttle position switch (in throttle position switch)	 When depressing accelerator pedal more than half-way after warming up engine.	Battery voltage
			 When releasing accelerator pedal after warming up engine.	1V or less
18	Y	ASCD cruise switch	 When ASCD cruise is being performed. ("CRUISE" lamp comes on.)	Battery voltage
			When ASCD cruise is not being performed. ("CRUISE" lamp does not comes on.)	1V or less
19	R/Y	Power source	Same as No. 10	
20	BR/Y	Overrun clutch solenoid valve	 When overrun clutch solenoid valve operates.	Battery voltage
			When overrun clutch solenoid valve does not operate.	1V or less
22	G/Y	Overdrive control switch	 When setting overdrive control switch in ON position	Battery voltage
			 When setting overdrive control switch in OFF position	1V or less
24	L	ASCD OD cut signal	 When "ACCEL" set switch on ASCD cruise is in D <sub>4</sub> position.	5 - 10V
			When "ACCEL" set switch on ASCD cruise is in D <sub>3</sub> position.	Less than 2V
25	B	Ground	—	—
26	PU/W	PNP switch 1 position	 When setting selector lever to 1 position.	Battery voltage
			When setting selector lever to other positions.	1V or less
27	P/B	PNP switch 2 position	 When setting selector lever to 2 position.	Battery voltage
			When setting selector lever to other positions.	1V or less
28	Y/R	Power source (Memory back-up)	 When turning ignition switch to OFF.	Battery voltage
			 or  When turning ignition switch to ON.	Battery voltage

# TROUBLE DIAGNOSIS — GENERAL DESCRIPTION

*TCM Terminals and Reference Value (Cont'd)*

Terminal No.	Wire color	Item	Condition		Judgement standard	
29	W	Revolution sensor		When moving at 20 km/h (12 MPH), use the CONSULT-II pulse frequency measuring function.*1 <b>CAUTION:</b> Connect the diagnosis data link cable to the vehicle diagnosis connector. *1: A circuit tester cannot be used to test this item.	450Hz (Approx.)	GI MA EM
				When vehicle parks.	Under 1.3V or over 4.5V	LC
30**	BR/Y	Data link connector		—	—	EC
31**	P	Data link connector		—	—	
32	R	Throttle position sensor (Power source)		Ignition switch ON.	4.5 - 5.5V	FE
33*	Y/B	LAN		Ignition switch OFF.	0.5V or less	
				—	—	CL
34	Y/PU	PNP switch D position		When setting selector lever to D position.	Battery voltage	MT
				When setting selector lever to other positions.	1V or less	
35	G/W	PNP switch R position	 	When setting selector lever to R position.	Battery voltage	AT
				When setting selector lever to other positions.	1V or less	AX
36	R/G	PNP switch P or N position		When setting selector lever to P or N position.	Battery voltage	SU
				When setting selector lever to other positions.	1V or less	BR
39	W/G	Engine speed signal	 	Refer to EC-148, "ECM INSPECTION TABLE".		ST
40	PU/R	Vehicle speed sensor		When moving vehicle at 2 to 3 km/h (1 to 2 MPH) for 1 m (3 ft) or more.	Voltage varies between less than 1V and more than 4.5V	RS BT
41	W	Throttle position sensor		When depressing accelerator pedal slowly after warming up engine. (Voltage rises gradually in response to throttle position.)	Fully-closed throttle: Approximately 0.5V Fully-open throttle: Approximately 4V	HA SC
42	B	Throttle position sensor (Ground)	—	—	—	EL IDX



# TROUBLE DIAGNOSIS — GENERAL DESCRIPTION

TCM Terminals and Reference Value (Cont'd)

Terminal No.	Wire color	Item	Condition		Judgement standard
45	R/G	Stop lamp switch		When depressing brake pedal	Battery voltage
				When releasing brake pedal	1V or less
47	G	A/T fluid temperature sensor		When ATF temperature is 20°C (68°F).	Approximately 1.5V
				When ATF temperature is 80°C (176°F).	Approximately 0.5V
48	B	Ground	—	—	—

\*: These terminals are connected to the ECM.

\*\* : These terminals are connected to the Data link connector.

# TROUBLE DIAGNOSIS FOR POWER SUPPLY

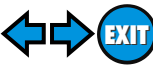

Wiring Diagram — AT — MAIN

## Wiring Diagram — AT — MAIN

NFAT0032

### AT-MAIN-01

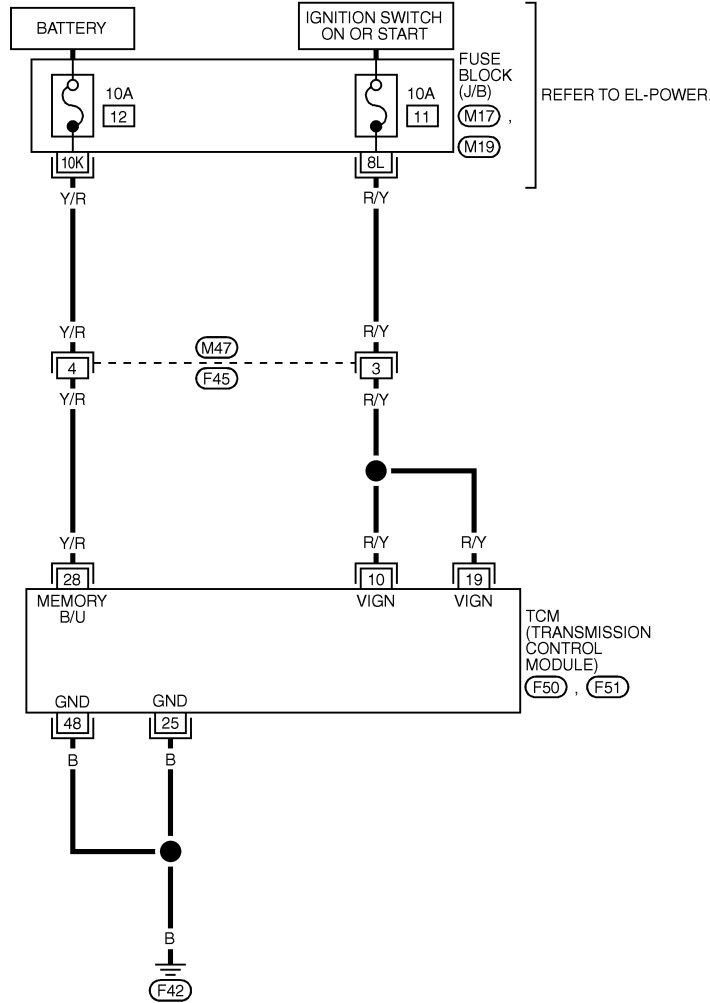

— : DETECTABLE LINE FOR DTC  
 — : NON-DETECTABLE LINE FOR DTC

- GI
- MA
- EM
- LC
- EC
- FE
- CL
- MT
- AT**
- AX
- SU
- BR
- ST
- RS
- BT
- HA
- SC
- EL
- IDX

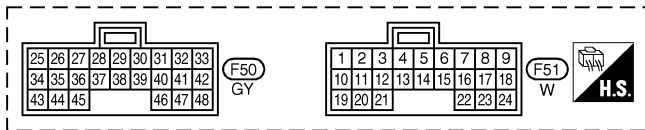
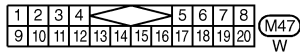

REFER TO THE FOLLOWING.

- (M17) - FUSE BLOCK - JUNCTION BOX (J/B)
- (M19) - FUSE BLOCK - JUNCTION BOX (J/B)

MAT803A

TCM TERMINALS AND REFERENCE VALUE (MEASURED BETWEEN EACH TERMINALS AND 25 OR 48 (TCM GROUND))

TERMINAL	WIRE COLOR	ITEM	CONDITION	DATA (DC)
10	R/Y	POWER SOURCE	WHEN IGN ON	BATTERY VOLTAGE
			WHEN IGN OFF	1V OR LESS
19	R/Y	POWER SOURCE	SAME AS NO. 10	
25	B	GROUND	—	
28	Y/R	POWER SOURCE (MEMOLY BACK-UP)	WHEN IGN ON	BATTERY VOLTAGE
			WHEN IGN OFF	BATTERY VOLTAGE
48	B	GROUND	—	

SAT709J

# TROUBLE DIAGNOSIS FOR POWER SUPPLY

Wiring Diagram — AT — MAIN (Cont'd)

## TCM TERMINALS AND REFERENCE VALUE

=NFAT0032S01

Terminal No.	Wire color	Item	Condition	Judgement standard	
10	R/Y	Power source		When turning ignition switch to ON.	Battery voltage
			or 	When turning ignition switch to OFF.	1V or less
19	R/Y	Power source	Same as No. 10		
25	B	Ground	—	—	
28	Y/R	Power source (Memory back-up)		When turning ignition switch to OFF.	Battery voltage
			or 	When turning ignition switch to ON.	Battery voltage
48	B	Ground	—	—	

## Diagnostic Procedure

NFAT0033

<b>1</b>	<b>CHECK TCM POWER SOURCE STEP 1</b>	
<p>1. Turn ignition switch to ON position. (Do not start engine.)</p> <p>2. Check voltage between TCM terminals 10, 19, 28 and ground.</p> <div style="text-align: center;"> <p><b>Voltage:</b> <b>Battery voltage</b></p> </div> <p style="text-align: right;">SAT611J</p>		
<b>OK or NG</b>		
OK	▶	GO TO 2.
NG	▶	GO TO 3.

# TROUBLE DIAGNOSIS FOR POWER SUPPLY

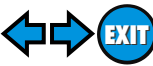

Diagnostic Procedure (Cont'd)

<b>2</b>	<b>CHECK TCM POWER SOURCE STEP 2</b>	
<p>1. Turn ignition switch to OFF position. 2. Check voltage between TCM terminal 28 and ground.</p> <div style="text-align: center;"> </div> <p style="text-align: right;">SAT612J</p>		GI MA EM LC EC FE CL
OK	▶	GO TO 4.
NG	▶	GO TO 3.

<b>3</b>	<b>DETECT MALFUNCTIONING ITEM</b>	
<p>Check the following items:</p> <ul style="list-style-type: none"> <li>● Harness for short or open between ignition switch and TCM terminals 10, 19 and 28 (Main harness)</li> <li>● Fuse</li> <li>● Ignition switch</li> </ul> <p style="padding-left: 20px;">Refer to EL section ("POWER SUPPLY ROUTING").</p> <p style="text-align: center;"><b>OK or NG</b></p>		MT <b>AT</b> AX SU
OK	▶	GO TO 4.
NG	▶	Repair or replace damaged parts.

<b>4</b>	<b>CHECK TCM GROUND CIRCUIT</b>	
<p>1. Turn ignition switch to OFF position. 2. Disconnect TCM harness connector. 3. Check continuity between TCM terminals 25, 48 and ground. Refer to wiring diagram — AT — MAIN. <b>Continuity should exist.</b> If OK, check harness for short to ground and short to power.</p> <p style="text-align: center;"><b>OK or NG</b></p>		BR ST RS BT HA SC EL IDX
OK	▶	<b>INSPECTION END</b>
NG	▶	Repair open circuit or short to ground or short to power in harness or connectors.

# DTC P0705 PARK/NEUTRAL POSITION SWITCH

## Description

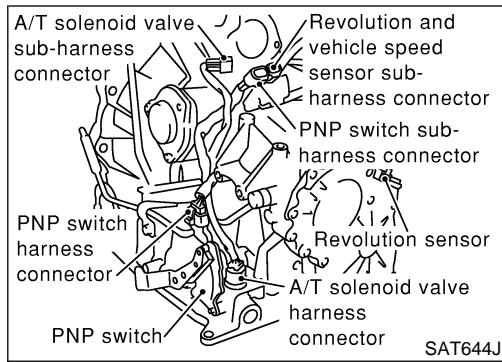

## Description

NFAT0034

- The park/neutral position (PNP) switch includes a transmission range switch.
- The transmission range switch detects the selector lever position and sends a signal to the TCM.

## TCM TERMINALS AND REFERENCE VALUE

NFAT0034S01

Remarks: Specification data are reference values.

Terminal No.	Wire color	Item	Condition	Judgement standard
26	PU/W	PNP switch 1 position	When setting selector lever to 1 position.	Battery voltage
			When setting selector lever to other positions.	1V or less
27	P/B	PNP switch 2 position	When setting selector lever to 2 position.	Battery voltage
			When setting selector lever to other positions.	1V or less
34	Y/PU	PNP switch D position	When setting selector lever to D position.	Battery voltage
			When setting selector lever to other positions.	1V or less
35	G/W	PNP switch R position	When setting selector lever to R position.	Battery voltage
			When setting selector lever to other positions.	1V or less
36	R/G	PNP switch P or N position	When setting selector lever to P or N position.	Battery voltage
			When setting selector lever to other positions.	1V or less



## On Board Diagnosis Logic

NFAT0201

Diagnostic trouble code PNP SW/CIRC with CONSULT-II or P0705 without CONSULT-II is detected when TCM does not receive the correct voltage signal from the switch based on the gear position.

## Possible Cause

NFAT0202

Check the following items.

- Harness or connectors  
(The park/neutral position (PNP) switch circuit is open or shorted.)
- Park/neutral position (PNP) switch

GI

MA

EM

LC

SELECT SYSTEM
A/T
ENGINE

SAT014K

## Diagnostic Trouble Code (DTC) Confirmation Procedure

NFAT0203

### CAUTION:

Always drive vehicle at a safe speed.

### NOTE:

If "DTC Confirmation Procedure" has been previously conducted, always turn ignition switch OFF and wait at least 5 seconds before conducting the next test.

After the repair, perform the following procedure to confirm the malfunction is eliminated.

EC

FE

CL

MT

SELECT DIAG MODE
WORK SUPPORT
SELF-DIAG RESULTS
DATA MONITOR
ACTIVE TEST
DTC & SRT CONFIRMATION
ECM PART NUMBER

SAT020K

## WITH CONSULT-II

NFAT0203S01

- 1) Turn ignition switch ON.
- 2) Select "DATA MONITOR" mode for "ENGINE" with CONSULT-II.
- 3) Start engine and maintain the following conditions for at least 5 consecutive seconds.  
**VHCL SPEED SE: 10 km/h (6 MPH) or more**  
**THRTL POS SEN: More than 1.3V**  
**Selector lever: D position (O/D ON or OFF)**

AT

AX

SU

BR

## WITH GST

NFAT0203S02

Follow the procedure "With CONSULT-II".

ST

RS

BT

HA

SC

EL

IDX

# DTC P0705 PARK/NEUTRAL POSITION SWITCH

Wiring Diagram — AT — PNP/SW

## Wiring Diagram — AT — PNP/SW

NFAT0035

AT-PNP/SW-01

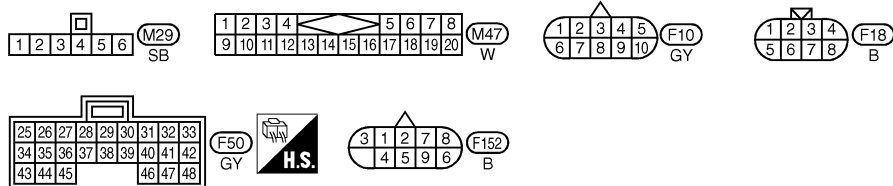
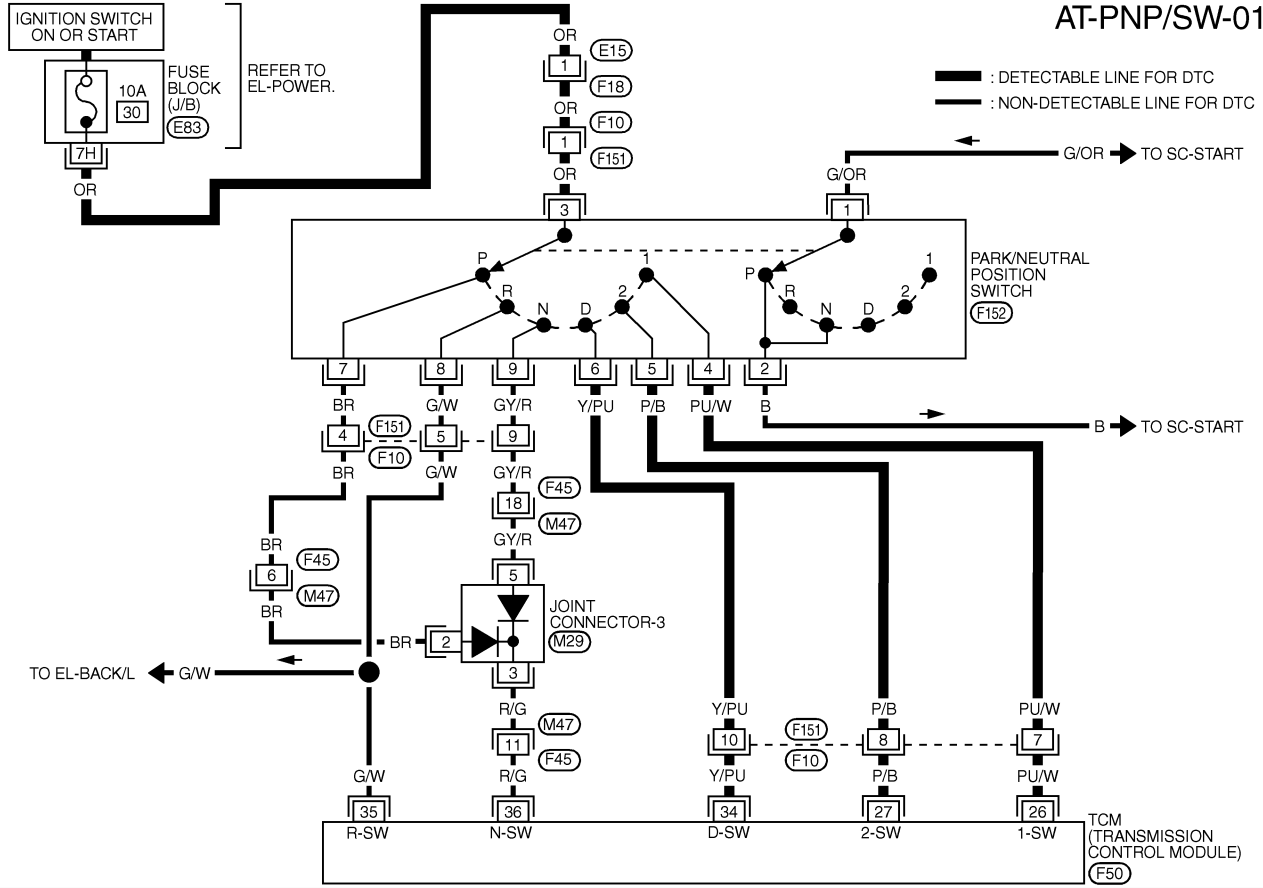

REFER TO THE FOLLOWING.  
 (E83) - FUSE BLOCK-JUNCTION BOX (J/B)

MAT843A

TCM TERMINALS AND REFERENCE VALUE (MEASURED BETWEEN EACH TERMINALS AND 25 OR 48 (TCM GROUND))

TERMINAL	WIRE COLOR	ITEM	CONDITION	DATA (DC)
26	PU/W	PNP SWITCH 1 POSITION	WHEN IGN ON AND SELECTOR LEVER 1 POSITION	BATTERY VOLTAGE
			WHEN IGN ON AND SELECTOR LEVER OTHER POSITIONS	1V OR LESS
27	P/B	PNP SWITCH 2 POSITION	WHEN IGN ON AND SELECTOR LEVER 2 POSITION	BATTERY VOLTAGE
			WHEN IGN ON AND SELECTOR LEVER OTHER POSITIONS	1V OR LESS
34	Y/PU	PNP SWITCH D POSITION	WHEN IGN ON AND SELECTOR LEVER D POSITION	BATTERY VOLTAGE
			WHEN IGN ON AND SELECTOR LEVER OTHER POSITIONS	1V OR LESS
35	G/W	PNP SWITCH R POSITION	WHEN IGN ON AND SELECTOR LEVER R POSITION	BATTERY VOLTAGE
			WHEN IGN ON AND SELECTOR LEVER OTHER POSITIONS	1V OR LESS
36	R/G	PNP SWITCH P OR N POSITION	WHEN IGN ON AND SELECTOR LEVER P POSITION	BATTERY VOLTAGE
			WHEN IGN ON AND SELECTOR LEVER OTHER POSITIONS	1V OR LESS

SAT710J

## Diagnostic Procedure

NFAT0036

<b>1</b>	<b>INSPECTION START</b>	
Do you have CONSULT-II?		
Yes or No		
Yes	▶	GO TO 2.
No	▶	GO TO 6.

GI  
MA  
EM

<b>2</b>	<b>CHECK PARK/NEUTRAL POSITION (PNP) SWITCH CIRCUIT (With CONSULT-II)</b>															
<p> <b>With CONSULT-II</b></p> <ol style="list-style-type: none"> <li>1. Turn ignition switch to ON position. (Do not start engine.)</li> <li>2. Select "ECU INPUT SIGNALS" in "DATA MONITOR" mode for "A/T" with CONSULT-II.</li> <li>3. Read out P, R, N, D, 2 and 1 position switches moving selector lever to each position. Check the signal of the selector lever position is indicated properly.</li> </ol>																
<table border="1" style="margin: auto; border-collapse: collapse;"> <thead> <tr> <th colspan="2">DATA MONITOR</th> </tr> <tr> <th>MONITORING</th> <th></th> </tr> </thead> <tbody> <tr> <td>PN POSI SW</td> <td style="text-align: center;">OFF</td> </tr> <tr> <td>R POSITION SW</td> <td style="text-align: center;">OFF</td> </tr> <tr> <td>D POSITION SW</td> <td style="text-align: center;">OFF</td> </tr> <tr> <td>2 POSITION SW</td> <td style="text-align: center;">ON</td> </tr> <tr> <td>1 POSITION SW</td> <td style="text-align: center;">OFF</td> </tr> </tbody> </table>			DATA MONITOR		MONITORING		PN POSI SW	OFF	R POSITION SW	OFF	D POSITION SW	OFF	2 POSITION SW	ON	1 POSITION SW	OFF
DATA MONITOR																
MONITORING																
PN POSI SW	OFF															
R POSITION SW	OFF															
D POSITION SW	OFF															
2 POSITION SW	ON															
1 POSITION SW	OFF															
OK or NG																
OK	▶	GO TO 7.														
NG	▶	GO TO 3.														

LC  
EC  
FE  
CL  
MT

AT

AX

SU

<b>3</b>	<b>DETECT MALFUNCTIONING ITEM</b>																						
<p>Check the following item:</p> <ul style="list-style-type: none"> <li>● Park/neutral position (PNP) switch Check continuity between terminals 1 and 2 and between terminals 3 and 4, 5, 6, 7, 8, 9 while moving manual shaft through each position.</li> </ul>																							
<div style="display: flex; align-items: flex-start;"> <div style="flex: 1;"> <p style="font-size: small;">View with air cleaner box removed</p> </div> <div style="flex: 1; text-align: center;"> </div> <div style="flex: 1;"> <table border="1" style="margin: auto; border-collapse: collapse; font-size: x-small;"> <thead> <tr> <th>Lever position</th> <th colspan="2">Terminal No.</th> </tr> </thead> <tbody> <tr> <td>P</td> <td style="text-align: center;">3 - 7</td> <td style="text-align: center;">1 - 2</td> </tr> <tr> <td>R</td> <td style="text-align: center;">3 - 8</td> <td></td> </tr> <tr> <td>N</td> <td style="text-align: center;">3 - 9</td> <td style="text-align: center;">1 - 2</td> </tr> <tr> <td>D</td> <td style="text-align: center;">3 - 6</td> <td></td> </tr> <tr> <td>2</td> <td style="text-align: center;">3 - 5</td> <td></td> </tr> <tr> <td>1</td> <td style="text-align: center;">3 - 4</td> <td></td> </tr> </tbody> </table> </div> </div>			Lever position	Terminal No.		P	3 - 7	1 - 2	R	3 - 8		N	3 - 9	1 - 2	D	3 - 6		2	3 - 5		1	3 - 4	
Lever position	Terminal No.																						
P	3 - 7	1 - 2																					
R	3 - 8																						
N	3 - 9	1 - 2																					
D	3 - 6																						
2	3 - 5																						
1	3 - 4																						
OK or NG																							
OK	▶	GO TO 5.																					
NG	▶	GO TO 4.																					

BR

ST

RS

BT

HA

SC

EL

IDX



# DTC P0705 PARK/NEUTRAL POSITION SWITCH

Diagnostic Procedure (Cont'd)

<b>4</b>	<b>CHECK MANUAL CONTROL CABLE ADJUSTMENT</b>	
Check PNP switch again with manual control cable disconnected from manual shaft of A/T assembly. Refer to test group 1.		
<b>OK or NG</b>		
OK	▶	Adjust manual control cable. Refer to AT-282.
NG	▶	Repair or replace PNP switch.

<b>5</b>	<b>DETECT MALFUNCTIONING ITEM</b>	
Check the following items:		
<ul style="list-style-type: none"> <li>● Harness for short or open between ignition switch and park/neutral position (PNP) switch (Main harness)</li> <li>● Harness for short or open between park/neutral position (PNP) switch and TCM (Main harness)</li> <li>● Fuse</li> <li>● Joint connector-3 M29</li> <li>● Ignition switch</li> </ul> Refer to EC-17, "POWER SUPPLY ROUTING".		
<b>OK or NG</b>		
OK	▶	GO TO 7.
NG	▶	Repair or replace damaged parts.

<b>6</b>	<b>CHECK PARK/NEUTRAL POSITION (PNP) SWITCH CIRCUIT (Without CONSULT-II)</b>																																										
<p> <b>Without CONSULT-II</b></p> <ol style="list-style-type: none"> <li>Turn ignition switch to ON position. (Do not start engine.)</li> <li>Check voltage between TCM terminals 26, 27, 34, 35, 36 and ground while moving selector lever through each position.</li> </ol>																																											
<div style="display: flex; align-items: center;"> <div style="flex: 1;"> </div> <div style="flex: 1;"> <p><b>Voltage:</b>  <b>B: Battery voltage</b>  <b>0: 0V</b></p> </div> <div style="flex: 2;"> <table border="1" style="width: 100%; text-align: center;"> <thead> <tr> <th rowspan="2">Lever position</th> <th colspan="5">Terminal No.</th> </tr> <tr> <th>36</th> <th>35</th> <th>34</th> <th>27</th> <th>26</th> </tr> </thead> <tbody> <tr> <td>P, N</td> <td><b>B</b></td> <td>0</td> <td>0</td> <td>0</td> <td>0</td> </tr> <tr> <td>R</td> <td>0</td> <td><b>B</b></td> <td>0</td> <td>0</td> <td>0</td> </tr> <tr> <td>D</td> <td>0</td> <td>0</td> <td><b>B</b></td> <td>0</td> <td>0</td> </tr> <tr> <td>2</td> <td>0</td> <td>0</td> <td>0</td> <td><b>B</b></td> <td>0</td> </tr> <tr> <td>1</td> <td>0</td> <td>0</td> <td>0</td> <td>0</td> <td><b>B</b></td> </tr> </tbody> </table> </div> </div>			Lever position	Terminal No.					36	35	34	27	26	P, N	<b>B</b>	0	0	0	0	R	0	<b>B</b>	0	0	0	D	0	0	<b>B</b>	0	0	2	0	0	0	<b>B</b>	0	1	0	0	0	0	<b>B</b>
Lever position	Terminal No.																																										
	36	35	34	27	26																																						
P, N	<b>B</b>	0	0	0	0																																						
R	0	<b>B</b>	0	0	0																																						
D	0	0	<b>B</b>	0	0																																						
2	0	0	0	<b>B</b>	0																																						
1	0	0	0	0	<b>B</b>																																						
SAT840J																																											
<b>OK or NG</b>																																											
OK	▶	GO TO 7.																																									
NG	▶	GO TO 5.																																									

<b>7</b>	<b>CHECK DTC</b>	
Perform Diagnostic Trouble Code (DTC) confirmation procedure, AT-103.		
<b>OK or NG</b>		
OK	▶	<b>INSPECTION END</b>
NG	▶	GO TO 8.

# DTC P0705 PARK/NEUTRAL POSITION SWITCH

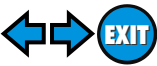

Diagnostic Procedure (Cont'd)

<b>8</b>	<b>CHECK TCM INSPECTION</b>	
1. Perform TCM input/output signal inspection. 2. If NG, recheck TCM pin terminals for damage or loose connection with harness connector.		GI
<b>OK or NG</b>		MA
OK	▶	<b>INSPECTION END</b>
NG	▶	Repair or replace damaged parts.

GI

MA

EM

LC

EC

FE

CL

MT

**AT**

AX

SU

BR

ST

RS

BT

HA

SC

EL

IDX

# DTC P0710 A/T FLUID TEMPERATURE SENSOR CIRCUIT

## Description

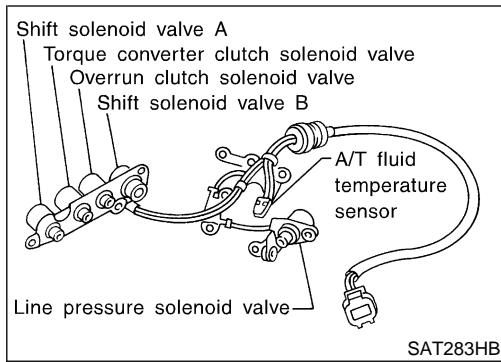

## Description

NFAT0037

The A/T fluid temperature sensor detects the A/T fluid temperature and sends a signal to the TCM.

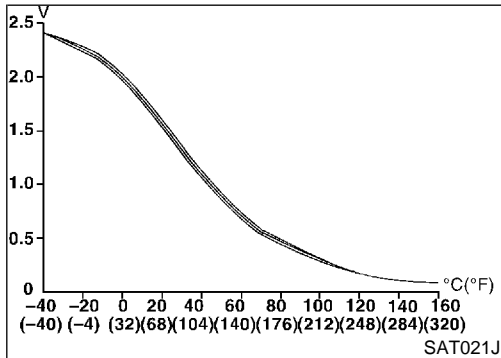

## CONSULT-II REFERENCE VALUE IN DATA MONITOR MODE

NFAT0037S01

Remarks: Specification data are reference values.

Monitor item	Condition	Specification
A/T fluid temperature sensor	Cold [20°C (68°F)]	Approximately 1.5V
	Hot [80°C (176°F)]	Approximately 0.5V

## TCM TERMINALS AND REFERENCE VALUE

NFAT0037S02

Remarks: Specification data are reference values.

Terminal No.	Wire color	Item	Condition	Judgement standard
42	B	Throttle position sensor (Ground)	—	—
47	G	A/T fluid temperature sensor	 When ATF temperature is 20°C (68°F).	Approximately 1.5V
			 When ATF temperature is 80°C (176°F).	Approximately 0.5V

## On Board Diagnosis Logic

NFAT0204

Diagnostic trouble code ATF TEMP SEN/CIRC with CONSULT-II or P0710 without CONSULT-II is detected when TCM receives an excessively low or high voltage from the sensor.

## Possible Cause

Check the following items.

- Harness or connectors  
(The sensor circuit is open or shorted.)
- A/T fluid temperature sensor

NFAT0205

GI

MA

EM

LC

EC

NFAT0206

FE

CL

MT

SELECT SYSTEM
A/T
ENGINE

SAT014K

## Diagnostic Trouble Code (DTC) Confirmation Procedure

### CAUTION:

Always drive vehicle at a safe speed.

### NOTE:

If "DTC Confirmation Procedure" has been previously conducted, always turn ignition switch OFF and wait at least 5 seconds before conducting the next test.

After the repair, perform the following procedure to confirm the malfunction is eliminated.

### WITH CONSULT-II

NFAT0206S01

- 1) Turn ignition switch ON and select "DATA MONITOR" mode for "ENGINE" with CONSULT-II.
- 2) Start engine and maintain the following conditions for at least 10 minutes (Total). (It is not necessary to maintain continuously.)

**CMPS-RPM (REF): 450 rpm or more**

**VHCL SPEED SE: 10 km/h (6 MPH) or more**

**THRTL POS SEN: More than 1.2V**

**Selector lever: D position (O/D ON)**

SELECT DIAG MODE
WORK SUPPORT
SELF-DIAG RESULTS
DATA MONITOR
ACTIVE TEST
DTC & SRT CONFIRMATION
ECM PART NUMBER

SAT020K

### WITH GST

NFAT0206S02

Follow the procedure "With CONSULT-II".

**AT**

AX

SU

BR

ST

RS

BT

HA

SC

EL

IDX

# DTC P0710 AT FLUID TEMPERATURE SENSOR CIRCUIT

Wiring Diagram — AT — FTS

## Wiring Diagram — AT — FTS

NFAT0038

AT-FTS-01

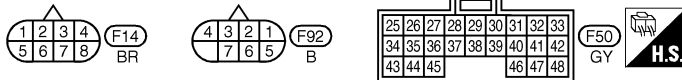
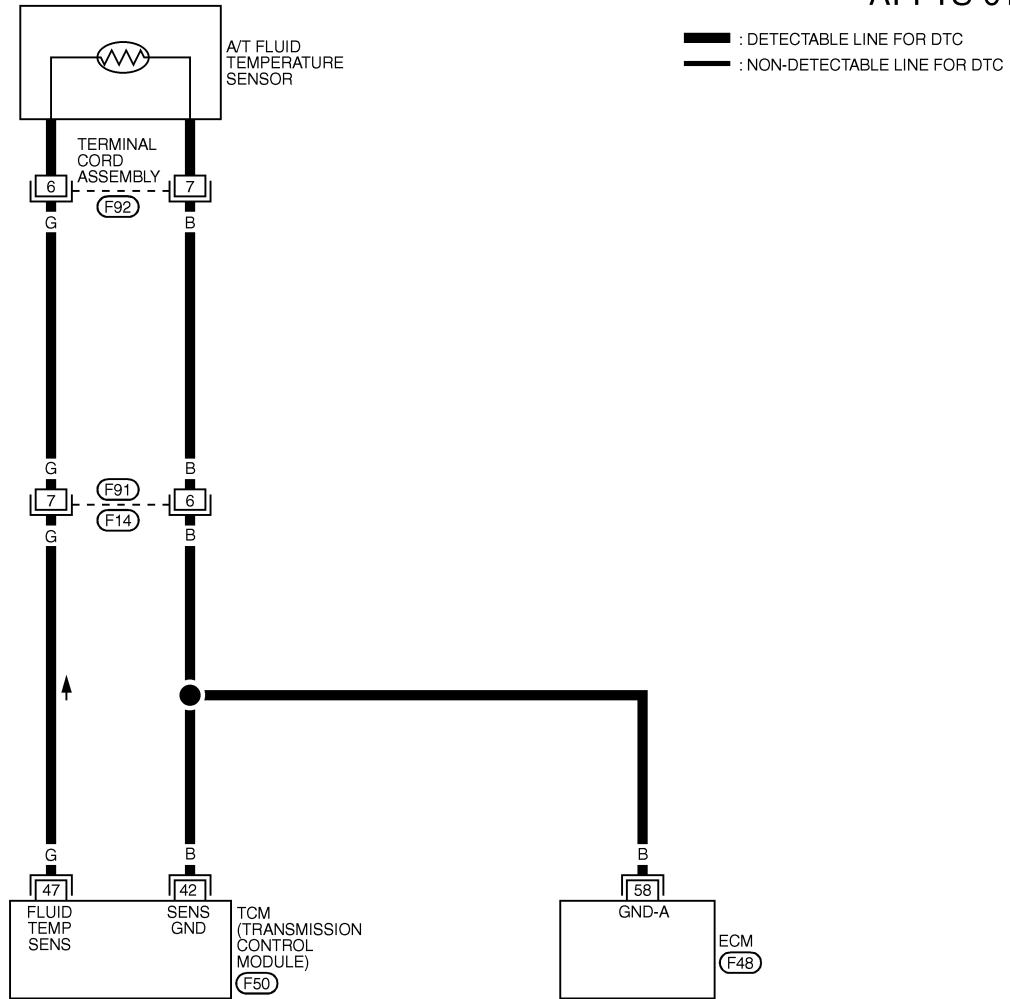

REFER TO THE FOLLOWING.  
 (F48) - ELECTRICAL UNITS

MAT805A

TCM TERMINALS AND REFERENCE VALUE (MEASURED BETWEEN EACH TERMINALS AND 25 OR 48 (TCM GROUND))

TERMINAL	WIRE COLOR	ITEM	CONDITION	DATA (DC)
42	B	THROTTLE POSITION SENSOR (GROUND)	—	—
47	G	A/T FLUID TEMPERATURE SENSOR	WHEN IGN ON AND ATF TEMPERATURE IS 20°C (68°F) WHEN IGN ON AND ATF TEMPERATURE IS 80°C (176°F)	APPROXIMATELY 1.5V APPROXIMATELY 0.5V

SAT711J

## Diagnostic Procedure

=NFAT0039

<b>1</b>	<b>INSPECTION START</b>	
Do you have CONSULT-II?		
Yes or No		
Yes	▶	GO TO 2.
No	▶	GO TO 6.

GI  
MA  
EM

<b>2</b>	<b>CHECK INPUT SIGNAL OF A/T FLUID TEMPERATURE SENSOR (With CONSULT-II)</b>															
<p> <b>With CONSULT-II</b></p> <ol style="list-style-type: none"> <li>Start engine.</li> <li>Select "ECU INPUT SIGNALS" in "DATA MONITOR" mode for "A/T" with CONSULT-II.</li> <li>Read out the value of "FLUID TEMP SE".</li> </ol>																
<table border="1" style="margin: auto;"> <thead> <tr> <th colspan="2">DATA MONITOR</th> </tr> <tr> <th>MONITORING</th> <th></th> </tr> </thead> <tbody> <tr> <td>VHCL/S SE-A/T</td> <td>XXX km/h</td> </tr> <tr> <td>VHCL/S SE-MTR</td> <td>XXX km/h</td> </tr> <tr> <td>THRTL POS SEN</td> <td>XXX V</td> </tr> <tr> <td>FLUID TEMP SE</td> <td>XXX V</td> </tr> <tr> <td>BATTERY VOLT</td> <td>XXX V</td> </tr> </tbody> </table>			DATA MONITOR		MONITORING		VHCL/S SE-A/T	XXX km/h	VHCL/S SE-MTR	XXX km/h	THRTL POS SEN	XXX V	FLUID TEMP SE	XXX V	BATTERY VOLT	XXX V
DATA MONITOR																
MONITORING																
VHCL/S SE-A/T	XXX km/h															
VHCL/S SE-MTR	XXX km/h															
THRTL POS SEN	XXX V															
FLUID TEMP SE	XXX V															
BATTERY VOLT	XXX V															
<p><b>Voltage:</b> Cold [20°C (68°F)] → Hot [80°C (176°F)]: Approximately 1.5V → 0.5V</p>																
OK or NG																
OK	▶	GO TO 7.														
NG	▶	GO TO 3.														

LC  
EC  
FE  
CL  
MT

SAT614J

**AT**

AX

SU

BR

<b>3</b>	<b>CHECK A/T FLUID TEMPERATURE SENSOR WITH TERMINAL CORD ASSEMBLY</b>	
<ol style="list-style-type: none"> <li>Turn ignition switch to OFF position.</li> <li>Disconnect terminal cord assembly connector in engine compartment.</li> <li>Check resistance between terminals 6 and 7 when A/T is cold.</li> </ol>		
<p><b>Resistance:</b> Cold [20°C (68°F)] Approximately 2.5 kΩ</p>		
<p>4. Reinstall any part removed.</p>		
OK or NG		
OK	▶	GO TO 4.
NG	▶	GO TO 5.

ST

RS

BT

HA

SC

EL

IDX

SAT616J

# DTC P0710 A/T FLUID TEMPERATURE SENSOR CIRCUIT

Diagnostic Procedure (Cont'd)

<b>4</b>	<b>DETECT MALFUNCTIONING ITEM</b>	
<p>Check the following items:</p> <ul style="list-style-type: none"> <li>● Harness for short to ground or short to power or open between TCM, ECM and terminal cord assembly (Main harness)</li> <li>● Ground circuit for ECM</li> </ul> <p>Refer to EC-157, "TROUBLE DIAGNOSIS FOR POWER SUPPLY".</p> <p style="text-align: center;"><b>OK or NG</b></p>		
OK	▶	GO TO 7.
NG	▶	Repair or replace damaged parts.

<b>5</b>	<b>DETECT MALFUNCTIONING ITEM</b>							
<p>1. Remove oil pan, refer to AT-280.</p> <p>2. Check the following items:</p> <ul style="list-style-type: none"> <li>● A/T fluid temperature sensor</li> </ul> <p>Check resistance between two terminals while changing temperature as shown at below.</p>								
SAT298F								
<table border="1" style="margin-left: auto; margin-right: auto;"> <thead> <tr> <th style="text-align: center;">Temperature °C (°F)</th> <th style="text-align: center;">Resistance</th> </tr> </thead> <tbody> <tr> <td style="text-align: center;">20 (68)</td> <td style="text-align: center;">Approximately 2.5 kΩ</td> </tr> <tr> <td style="text-align: center;">80 (176)</td> <td style="text-align: center;">Approximately 0.3 kΩ</td> </tr> </tbody> </table>			Temperature °C (°F)	Resistance	20 (68)	Approximately 2.5 kΩ	80 (176)	Approximately 0.3 kΩ
Temperature °C (°F)	Resistance							
20 (68)	Approximately 2.5 kΩ							
80 (176)	Approximately 0.3 kΩ							
MTBL0210								
<ul style="list-style-type: none"> <li>● Harness of terminal cord assembly for short or open</li> </ul> <p style="text-align: center;"><b>OK or NG</b></p>								
OK	▶	GO TO 7.						
NG	▶	Repair or replace damaged parts.						

# DTC P0710 A/T FLUID TEMPERATURE SENSOR CIRCUIT

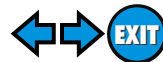

Diagnostic Procedure (Cont'd)

6	CHECK INPUT SIGNAL OF A/T FLUID TEMPERATURE SENSOR (Without CONSULT-II)
	<p>⊗ Without CONSULT-II</p> <ol style="list-style-type: none"> <li>Start engine.</li> <li>Check voltage between TCM terminal 47 and ground while warming up A/T.</li> </ol> <div style="text-align: center;"> </div> <p><b>Voltage:</b>            Cold [20°C (68°F)] → Hot [80°C (176°F)]:            Approximately 1.5V → 0.5V</p> <p style="text-align: right;">SAT335J</p> <p style="text-align: center;"><b>OK or NG</b></p>
OK	▶ GO TO 7.
NG	▶ GO TO 3.

GI  
MA  
EM  
LC  
EC  
FE  
CL  
MT

7	CHECK DTC
	<p>Perform Diagnostic Trouble Code (DTC) confirmation procedure, AT-109.</p> <p style="text-align: center;"><b>OK or NG</b></p>
OK	▶ <b>INSPECTION END</b>
NG	▶ GO TO 8.

AT  
AX  
SU

8	CHECK TCM INSPECTION
	<ol style="list-style-type: none"> <li>Perform TCM input/output signal inspection.</li> <li>If NG, recheck TCM pin terminals for damage or loose connection with harness connector.</li> </ol> <p style="text-align: center;"><b>OK or NG</b></p>
OK	▶ <b>INSPECTION END</b>
NG	▶ Repair or replace damaged parts.

BR  
ST  
RS  
BT  
HA  
SC  
EL  
IDX



# DTC P0720 VEHICLE SPEED SENSOR-A/T (REVOLUTION SENSOR)

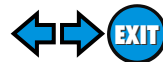

## Description

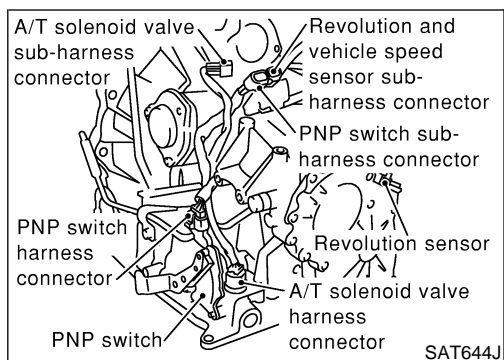

## Description

The revolution sensor detects the revolution of the idler gear parking pawl lock gear and emits a pulse signal. The pulse signal is sent to the TCM which converts it into vehicle speed.

NFAT0040

## TCM TERMINALS AND REFERENCE VALUE

NFAT0040S01

Remarks: Specification data are reference values.

Terminal No.	Wire color	Item	Condition		Judgement standard
29	W	Revolution sensor		When moving at 20 km/h (12 MPH), use the CONSULT-II pulse frequency measuring function.*1 <b>CAUTION:</b> Connect the diagnosis data link cable to the vehicle diagnosis connector. *1: A circuit tester cannot be used to test this item.	450Hz (Approx.)
				When vehicle parks.	Under 1.3V or over 4.5V
42	B	Throttle position sensor (Ground)	—	—	—

## On Board Diagnosis Logic

Diagnostic trouble code VEH SPD SEN/CIR AT with CONSULT-II or P0720 without CONSULT-II is detected when TCM does not receive the proper voltage signal from the sensor.

NFAT0207

## Possible Cause

Check the following items.

- Harness or connectors (The sensor circuit is open or shorted.)
- Revolution sensor

NFAT0208

SELECT SYSTEM
A/T
ENGINE

SAT014K

SELECT DIAG MODE
SELF-DIAG RESULTS
DATA MONITOR
DTC WORK SUPPORT
TCM PART NUMBER

SAT971J

SELECT SYSTEM
A/T
ENGINE

SAT014K

SELECT DIAG MODE
WORK SUPPORT
SELF-DIAG RESULTS
DATA MONITOR
ACTIVE TEST
DTC & SRT CONFIRMATION
ECM PART NUMBER

SAT020K

## Diagnostic Trouble Code (DTC) Confirmation Procedure

NFAT0209

### CAUTION:

- Always drive vehicle at a safe speed.
- Be careful not to rev engine into the red zone on the tachometer.

### NOTE:

If "DTC Confirmation Procedure" has been previously conducted, always turn ignition switch OFF and wait at least 5 seconds before conducting the next test.

After the repair, perform the following procedure to confirm the malfunction is eliminated.

### WITH CONSULT-II

NFAT0209S01

- Turn ignition switch ON and select "DATA MONITOR" mode for "A/T" with CONSULT-II.
- Drive vehicle and check for an increase of "VHCL/S SE-MTR" value.  
If the check result is NG, go to "DIAGNOSTIC PROCEDURE", AT-204.  
If the check result is OK, go to following step.
- Select "DATA MONITOR" mode for "ENGINE" with CONSULT-II.
- Start engine and maintain the following conditions for at least 5 consecutive seconds.  
**VHCL SPEED SE: 30 km/h (19 MPH) or more**  
**THRTL POS SEN: More than 1.2V**  
**Selector lever: D position (O/D ON)**  
**Driving location: Driving the vehicle uphill (increased engine load) will help maintain the driving conditions required for this test.**  
If the check result is NG, go to "DIAGNOSTIC PROCEDURE", AT-117.  
If the check result is OK, go to following step.
- Maintain the following conditions for at least 5 consecutive seconds.  
**CMPS-RPM (REF): 3,500 rpm or more**  
**THRTL POS SEN: More than 1.2V**  
**Selector lever: D position (O/D ON)**  
**Driving location: Driving the vehicle uphill (increased engine load) will help maintain the driving conditions required for this test.**

### WITH GST

NFAT0209S02

Follow the procedure "With CONSULT-II".

GI  
MA  
EM  
LC  
EC  
FE  
CL  
MT  
AT  
AX  
SU  
BR  
ST  
RS  
BT  
HA  
SC  
EL  
IDX

# DTC P0720 VEHICLE SPEED SENSOR-A/T (REVOLUTION SENSOR)

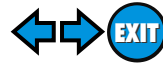

Wiring Diagram — AT — VSSA/T

## Wiring Diagram — AT — VSSA/T

NFAT0041

AT-VSSA/T-01

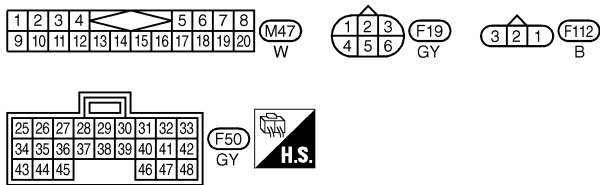
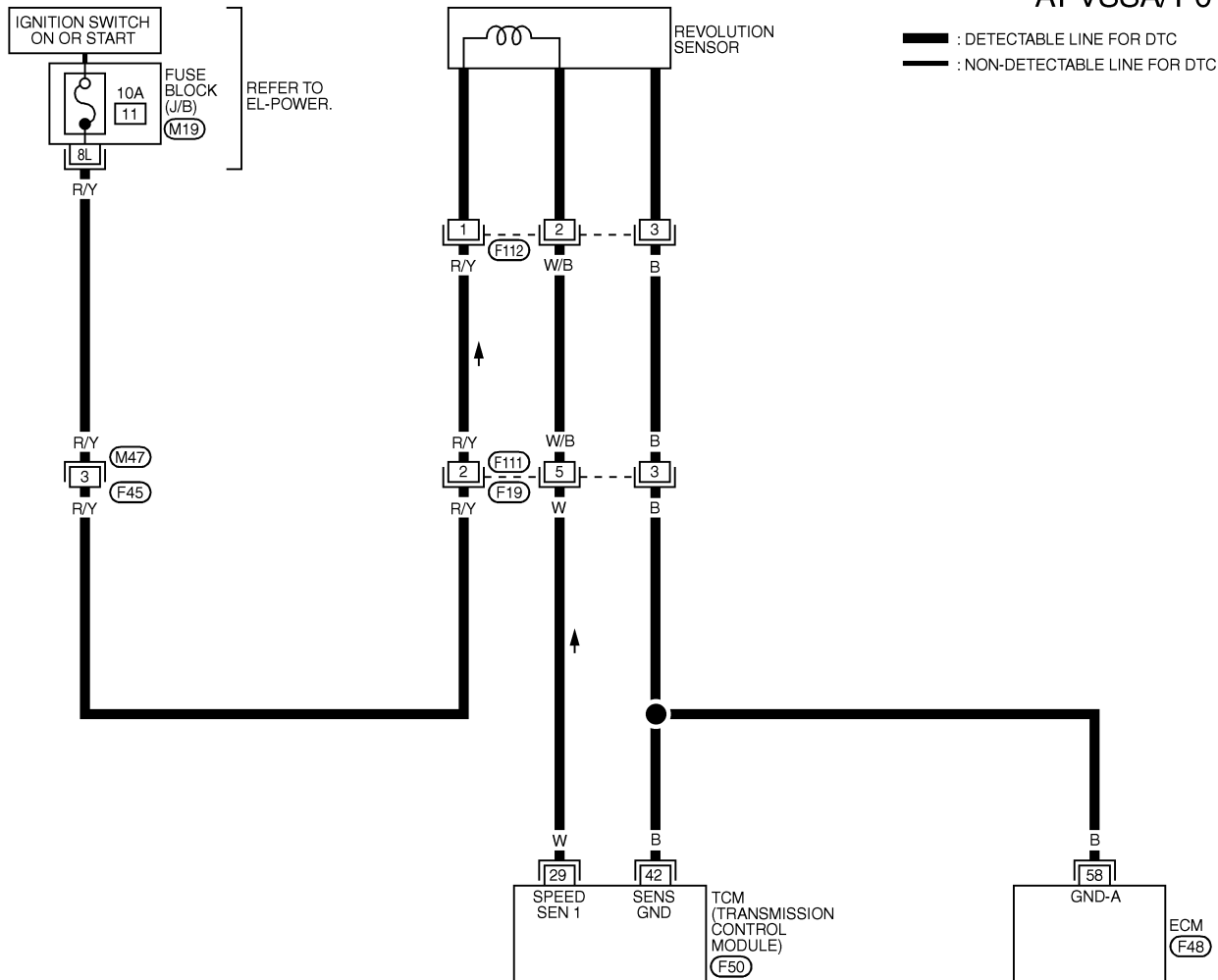

REFER TO THE FOLLOWING.  
 (M19) - FUSE BLOCK - JUNCTION BOX (J/B)  
 (F48) - ELECTRICAL UNITS

MAT806A

TCM TERMINALS AND REFERENCE VALUE (MEASURED BETWEEN EACH TERMINALS AND 25 OR 48 (TCM GROUND))

TERMINAL	WIRE COLOR	ITEM	CONDITION	DATA (DC)
29	W	REVOLUTION SENSOR	WHEN MOVING AT 20 km/h (12 MPH), USE THE CONSULT-II PULSE FREQUENCY MEASURING FUNCTION. *1 CAUTION: CONNECT THE DIAGNOSIS DATA LINK CABLE TO THE VEHICLE DIAGNOSIS CONNECTOR. *1: A CIRCUIT TESTER CANNOT BE USED TO TEST THIS ITEM.	450 Hz (Approx.)
			WHEN VEHICLE PARKS.	UNDER 1.3V OR OVER 4.5V
42	B	THROTTLE POSITION SENSOR (GROUND)	—	—

SAT712JB

## Diagnostic Procedure

NFAT0042

<b>1</b>	<b>CHECK INPUT SIGNAL (With CONSULT-II)</b>															
<p> <b>With CONSULT-II</b></p> <p>1. Start engine.</p> <p>2. Select "ECU INPUT SIGNALS" in "DATA MONITOR" mode for "A/T" with CONSULT-II.</p> <p>3. Read out the value of "VHCL/S SE-A/T" while driving. Check the value changes according to driving speed.</p>																
<table border="1" style="margin: auto; border-collapse: collapse;"> <thead> <tr> <th colspan="2">DATA MONITOR</th> </tr> <tr> <th>MONITORING</th> <th></th> </tr> </thead> <tbody> <tr> <td>VHCL/S SE-A/T</td> <td>XXX km/h</td> </tr> <tr> <td>VHCL/S SE-MTR</td> <td>XXX km/h</td> </tr> <tr> <td>THRTL POS SEN</td> <td>XXX V</td> </tr> <tr> <td>FLUID TEMP SE</td> <td>XXX V</td> </tr> <tr> <td>BATTERY VOLT</td> <td>XXX V</td> </tr> </tbody> </table>			DATA MONITOR		MONITORING		VHCL/S SE-A/T	XXX km/h	VHCL/S SE-MTR	XXX km/h	THRTL POS SEN	XXX V	FLUID TEMP SE	XXX V	BATTERY VOLT	XXX V
DATA MONITOR																
MONITORING																
VHCL/S SE-A/T	XXX km/h															
VHCL/S SE-MTR	XXX km/h															
THRTL POS SEN	XXX V															
FLUID TEMP SE	XXX V															
BATTERY VOLT	XXX V															
SAT614J																
<b>OK or NG</b>																
OK	▶	GO TO 3.														
NG	▶	GO TO 2.														

GI  
MA  
EM  
LC  
EC  
FE  
CL  
MT

<b>2</b>	<b>CHECK REVOLUTION SENSOR (With CONSULT-II)</b>							
<p> <b>With CONSULT-II</b></p> <p>1. Start engine.</p>								
<table border="1" style="margin: auto; border-collapse: collapse;"> <thead> <tr> <th>Condition</th> <th>Judgement standard</th> </tr> </thead> <tbody> <tr> <td>When moving at 20 km/h (12 MPH), use the CONSULT-II pulse frequency measuring function. *1 <b>CAUTION:</b> Connect the diagnosis data link cable to the vehicle diagnosis connector. *1: A circuit tester cannot be used to test this item.</td> <td>450 Hz (Approx.)</td> </tr> <tr> <td>When vehicle parks.</td> <td>Under 1.3V or over 4.5V</td> </tr> </tbody> </table>			Condition	Judgement standard	When moving at 20 km/h (12 MPH), use the CONSULT-II pulse frequency measuring function. *1 <b>CAUTION:</b> Connect the diagnosis data link cable to the vehicle diagnosis connector. *1: A circuit tester cannot be used to test this item.	450 Hz (Approx.)	When vehicle parks.	Under 1.3V or over 4.5V
Condition	Judgement standard							
When moving at 20 km/h (12 MPH), use the CONSULT-II pulse frequency measuring function. *1 <b>CAUTION:</b> Connect the diagnosis data link cable to the vehicle diagnosis connector. *1: A circuit tester cannot be used to test this item.	450 Hz (Approx.)							
When vehicle parks.	Under 1.3V or over 4.5V							
MTBL0451								
<ul style="list-style-type: none"> <li>● Harness for short or open between TCM, ECM and revolution sensor (Main harness)</li> </ul>								
<b>OK or NG</b>								
OK	▶	GO TO 3.						
NG	▶	Repair or replace damaged parts.						

AT  
AX  
SU  
BR  
ST  
RS  
BT

<b>3</b>	<b>CHECK DTC</b>	
Perform Diagnostic Trouble Code (DTC) confirmation procedure, AT-115.		
<b>OK or NG</b>		
OK	▶	<b>INSPECTION END</b>
NG	▶	GO TO 4.

HA  
SC  
EL  
IDX

# DTC P0720 VEHICLE SPEED SENSOR-A/T (REVOLUTION SENSOR)

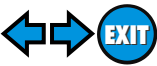

Diagnostic Procedure (Cont'd)

<b>4</b>	<b>CHECK TCM INSPECTION</b>
1. Perform TCM input/output signal inspection. 2. If NG, recheck TCM pin terminals for damage or loose connection with harness connector.	
<b>OK or NG</b>	
OK	▶ <b>INSPECTION END</b>
NG	▶ Repair or replace damaged parts.

# DTC P0725 ENGINE SPEED SIGNAL

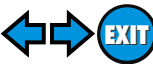

Description



## Description

The engine speed signal is sent from the ECM to the TCM. NFAT0043

## TCM TERMINALS AND REFERENCE VALUE

NFAT0043S01

Remarks: Specification data are reference values.

Terminal No.	Wire color	Item	Condition	Judgement standard
39	W/G	Engine speed signal	 When engine runs at idle speed.	Approximately 0.6V
			 When engine runs at 3,000 rpm.	Approximately 2.2V

GI  
MA  
EM  
LC  
EC  
FE  
CL  
MT

## On Board Diagnosis Logic

Diagnostic trouble code ENGINE SPEED SIG with CONSULT-II or P0725 without CONSULT-II is detected when TCM does not receive the proper voltage signal from ECM. NFAT0210

AT

AX

SU

BR

## Possible Cause

Check harness or connectors. (The sensor circuit is open or shorted.) NFAT0211

ST

RS

BT

HA

SC

EL

IDX

# DTC P0725 ENGINE SPEED SIGNAL

Diagnostic Trouble Code (DTC) Confirmation Procedure

SELECT SYSTEM
A/T
ENGINE

SAT014K

SELECT DIAG MODE
WORK SUPPORT
SELF-DIAG RESULTS
DATA MONITOR
ACTIVE TEST
DTC & SRT CONFIRMATION
ECM PART NUMBER

SAT020K

## Diagnostic Trouble Code (DTC) Confirmation Procedure

NFAT0212

### CAUTION:

Always drive vehicle at a safe speed.

### NOTE:

If "DTC Confirmation Procedure" has been previously conducted, always turn ignition switch OFF and wait at least 5 seconds before conducting the next test.

After the repair, perform the following procedure to confirm the malfunction is eliminated.

### WITH CONSULT-II

NFAT0212S01

- 1) Turn ignition switch ON and select "DATA MONITOR" mode for "ENGINE" with CONSULT-II.
- 2) Start engine and maintain the following conditions for at least 10 consecutive seconds.

**VHCL SPEED SE: 10 km/h (6 MPH) or more**

**THRTL POS SEN: More than 1.2V**

**Selector lever: D position (O/D ON)**

### WITH GST

NFAT0212S02

Follow the procedure "With CONSULT-II".

# DTC P0725 ENGINE SPEED SIGNAL

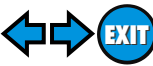

Wiring Diagram — AT — ENGSS

## Wiring Diagram — AT — ENGSS

NFAT0044

### AT-ENGSS-01

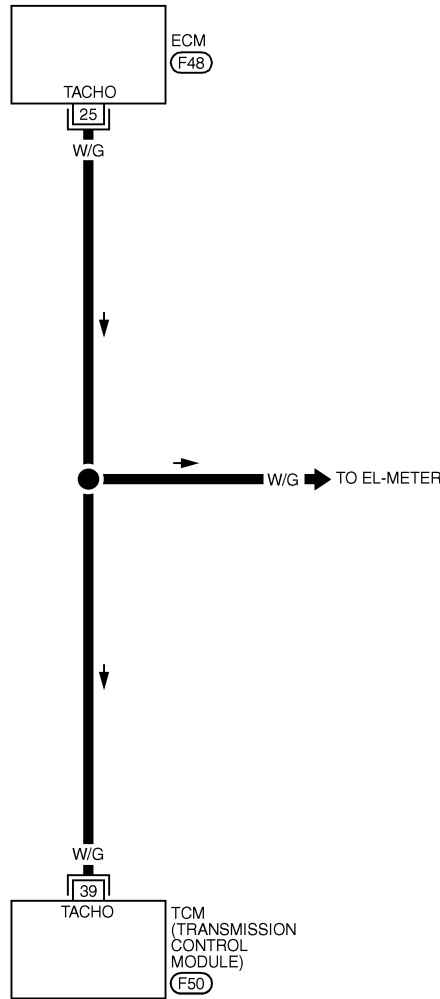

— : DETECTABLE LINE FOR DTC  
 — : NON-DETECTABLE LINE FOR DTC

- GI
- MA
- EM
- LC
- EC
- FE
- CL
- MT
- AT**
- AX
- SU
- BR
- ST
- RS
- BT
- HA
- SC
- EL
- IDX

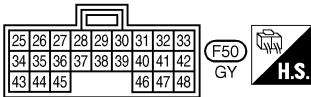

REFER TO THE FOLLOWING.  
 (F48) - ELECTRICAL UNITS

MAT807A

TCM TERMINALS AND REFERENCE VALUE (MEASURED BETWEEN EACH TERMINALS AND 25 OR 48 (TCM GROUND))

TERMINAL	WIRE COLOR	ITEM	CONDITION	DATA (DC)
39	W/G	ENGINE SPEED SIGNAL.	WHEN ENGINE RUNS AT IDLE SPEED	APPROXIMATELY 0.6 V
			WHEN ENGINE RUNS AT 3,000 RPM	APPROXIMATELY 0.5 V

SAT713J



# DTC P0725 ENGINE SPEED SIGNAL

Diagnostic Procedure

## Diagnostic Procedure

NFAT0045

<b>1</b>	<b>CHECK DTC WITH ECM</b>	
<ul style="list-style-type: none"> <li>Check P code with CONSULT-II "ENGINE". Turn ignition switch ON and select "SELF-DIAGNOSTIC RESULTS" mode for "ENGINE" with CONSULT-II. Refer to EC-87, "MALFUNCTION Indicator Lamp (MIL)".</li> </ul> <p style="text-align: center;"><b>OK or NG</b></p>		
OK (with CONSULT-II)	▶	GO TO 2.
OK (without CONSULT-II)	▶	GO TO 4.
NG	▶	Check ignition signal circuit for engine control. Refer to EC-585, "DTC P1320 Ignition Signal".

<b>2</b>	<b>CHECK INPUT SIGNAL (With CONSULT-II)</b>															
<p> <b>With CONSULT-II</b></p> <ol style="list-style-type: none"> <li>Start engine.</li> <li>Select "ECU INPUT SIGNALS" in "DATA MONITOR" mode for "A/T" with CONSULT-II.</li> <li>Read out the value of "ENGINE SPEED". Check engine speed changes according to throttle position.</li> </ol>																
<table border="1"> <thead> <tr> <th colspan="2">DATA MONITOR</th> </tr> <tr> <th>MONITORING</th> <th></th> </tr> </thead> <tbody> <tr> <td>ENGINE SPEED</td> <td>XXX rpm</td> </tr> <tr> <td>TURBINE REV</td> <td>XXX rpm</td> </tr> <tr> <td>OVERDRIVE SW</td> <td>ON</td> </tr> <tr> <td>PN POSI SW</td> <td>OFF</td> </tr> <tr> <td>R POSITION SW</td> <td>OFF</td> </tr> </tbody> </table>			DATA MONITOR		MONITORING		ENGINE SPEED	XXX rpm	TURBINE REV	XXX rpm	OVERDRIVE SW	ON	PN POSI SW	OFF	R POSITION SW	OFF
DATA MONITOR																
MONITORING																
ENGINE SPEED	XXX rpm															
TURBINE REV	XXX rpm															
OVERDRIVE SW	ON															
PN POSI SW	OFF															
R POSITION SW	OFF															
<b>OK or NG</b>																
OK	▶	GO TO 6.														
NG	▶	GO TO 3.														

SAT645J

<b>3</b>	<b>DETECT MALFUNCTIONING ITEM</b>	
<p>Check the following items:</p> <ul style="list-style-type: none"> <li>Harness for short or open between TCM and ECM</li> <li>Resistor and ignition coil Refer to EC-585, "DTC P1320 Ignition Signal".</li> </ul> <p style="text-align: center;"><b>OK or NG</b></p>		
OK	▶	GO TO 6.
NG	▶	Repair or replace damaged parts.

# DTC P0725 ENGINE SPEED SIGNAL

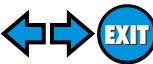

Diagnostic Procedure (Cont'd)

<b>4</b>	<b>CHECK INPUT SIGNAL (Without CONSULT-II)</b>		
		<p>⊗ <b>Without CONSULT-II</b></p> <ol style="list-style-type: none"> <li>Start engine.</li> <li>Check voltage between TCM terminal 39 and ground.</li> </ol>	<p>GI</p> <p>MA</p> <p>EM</p> <p>LC</p> <p>EC</p> <p>FE</p> <p>CL</p>
			<p>SAT520JA</p>
		<b>OK or NG</b>	
OK	▶	GO TO 6.	
NG	▶	GO TO 5.	

<b>5</b>	<b>DETECT MALFUNCTIONING ITEM</b>		
		<p>Check the following items:</p> <ul style="list-style-type: none"> <li>Harness for short or open between TCM and ECM</li> <li>Resistor and ignition coil Refer to EC-585, "DTC P1320 Ignition Signal".</li> </ul>	<p>MT</p> <p style="background-color: black; color: white; text-align: center;">AT</p> <p>AX</p> <p>SU</p>
		<b>OK or NG</b>	
OK	▶	GO TO 6.	
NG	▶	Repair or replace damaged parts.	

<b>6</b>	<b>CHECK DTC</b>		
		<p>Perform Diagnostic Trouble Code (DTC) confirmation procedure, AT-120.</p>	<p>BR</p> <p>ST</p> <p>RS</p>
		<b>OK or NG</b>	
OK	▶	<b>INSPECTION END</b>	
NG	▶	GO TO 7.	

<b>7</b>	<b>CHECK TCM INSPECTION</b>		
		<ol style="list-style-type: none"> <li>Perform TCM input/output signal inspection.</li> <li>If NG, recheck TCM pin terminals for damage or loose connection with harness connector.</li> </ol>	<p>BT</p> <p>HA</p> <p>SC</p> <p>EL</p> <p>IDX</p>
		<b>OK or NG</b>	
OK	▶	<b>INSPECTION END</b>	
NG	▶	Repair or replace damaged parts.	

# DTC P0731 A/T 1ST GEAR FUNCTION

Description

## Description

NFAT0046

- This is an OBD-II self-diagnostic item and not available in TCM self-diagnosis.
- This malfunction will not be detected while the O/D OFF indicator lamp is indicating another self-diagnosis malfunction.
- This malfunction is detected when the A/T does not shift into first gear position as instructed by the TCM. This is not caused by electrical malfunction (circuits open or shorted) but by mechanical malfunction such as control valve sticking, improper solenoid valve operation, etc.

Gear position	1	2	3	4
Shift solenoid valve A	ON (Closed)	OFF (Open)	OFF (Open)	ON (Closed)
Shift solenoid valve B	ON (Closed)	ON (Closed)	OFF (Open)	OFF (Open)

## TCM TERMINALS AND REFERENCE VALUE

NFAT0046S01

Remarks: Specification data are reference values.

Terminal No.	Wire color	Item	Condition	Judgement standard
11	R/Y	Shift solenoid valve A	When shift solenoid valve A operates. (When driving in D <sub>1</sub> or D <sub>4</sub> .)	Battery voltage
			When shift solenoid valve A does not operate. (When driving in D <sub>2</sub> or D <sub>3</sub> .)	1V or less
12	LG/B	Shift solenoid valve B	When shift solenoid valve B operates. (When driving in D <sub>1</sub> or D <sub>2</sub> .)	Battery voltage
			When shift solenoid valve B does not operate. (When driving in D <sub>3</sub> or D <sub>4</sub> .)	1V or less



## On Board Diagnosis Logic

NFAT0213

This diagnosis monitors actual gear position by checking the torque converter slip ratio calculated by TCM as follows:

Torque converter slip ratio = A x C/B

A: Output shaft revolution signal from revolution sensor

B: Engine speed signal from ECM

C: Gear ratio determined as gear position which TCM supposes  
 If the actual gear position is higher than the position (1st) supposed by TCM, the slip ratio will be more than normal. In case the ratio exceeds the specified value, TCM judges this diagnosis malfunction.

This malfunction will be caused when either shift solenoid valve A is stuck open or shift solenoid valve B is stuck open.

Gear positions supposed by TCM are as follows.

In case of gear position with no malfunctions: 1, 2, 3 and 4 positions

In case of gear position with shift solenoid valve A stuck open: 2\*, 2, 3 and 3 positions

In case of gear position with shift solenoid valve B stuck open: 4\*, 3, 3 and 4 positions to each gear position above

\*: P0731 is detected.

Diagnostic trouble code A/T 1ST GR FNCTN with CONSULT-II or P0731 without CONSULT-II is detected when A/T cannot be shifted to the 1st gear position even if electrical circuit is good.

## Possible Cause

NFAT0214

Check the following items.

- Shift solenoid valve A
- Shift solenoid valve B
- Each clutch
- Hydraulic control circuit

GI

MA

EM

LC

EC

NFAT0215

## Diagnostic Trouble Code (DTC) Confirmation Procedure

### CAUTION:

- Always drive vehicle at a safe speed.
- Be careful not to rev engine into the red zone on the tachometer.

FE

### NOTE:

If "DTC Confirmation Procedure" has been previously conducted, always turn ignition switch OFF and wait at least 5 seconds before conducting the next test.

CL

### TESTING CONDITION:

Always drive vehicle on a level road to improve the accuracy of test.

MT

After the repair, perform the following procedure to confirm the malfunction is eliminated.

AT

### WITH CONSULT-II

- 1) Start engine and select "DATA MONITOR" mode for "A/T" with CONSULT-II.
- 2) Make sure that output voltage of A/T fluid temperature sensor is within the range below.

#### FLUID TEMP SEN: 0.4 - 1.5V

If out of range, drive the vehicle to decrease the voltage (warm up the fluid) or stop engine to increase the voltage (cool down the fluid).

AX

- 3) Select "1ST GR FNCTN P0731" of "DTC WORK SUPPORT" mode for "A/T" with CONSULT-II and touch "START".

SU

- 4) Accelerate vehicle to 20 to 25 km/h (12 to 16 MPH) under the following condition and release the accelerator pedal completely.

BR

#### THROTTLE POSI: Less than 1.0/8 (at all times during step 4)

#### Selector lever: D position (O/D ON)

- Check that "GEAR" shows "2" after releasing pedal.
- 5) Depress accelerator pedal to WOT (more than 7.0/8 of "THROTTLE POSI") quickly from a speed of 20 to 25 km/h (12 to 16 MPH) until "TESTING" changes to "STOP VEHICLE" or "COMPLETED". (It will take approximately 3 seconds.)  
If the check result NG appears on CONSULT-II screen, go to "DIAGNOSTIC PROCEDURE", AT-128.  
If "STOP VEHICLE" appears on CONSULT-II screen, go to the following step.

ST

RS

BT

HA

SC

EL

IDX

- Check that "GEAR" shows "1" when depressing accelerator pedal to WOT.
- If "TESTING" does not appear on CONSULT-II for a long time, select "SELF-DIAG RESULTS" for "ENGINE". In case

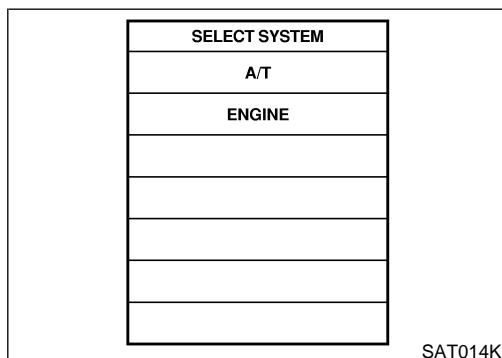

SAT014K

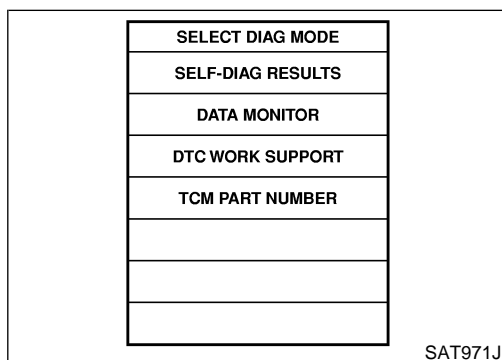

SAT971J

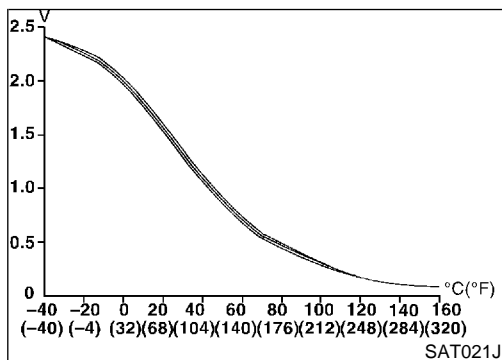

SAT021J

## DTC P0731 A/T 1ST GEAR FUNCTION

Diagnostic Trouble Code (DTC) Confirmation Procedure (Cont'd)

**a 1st trip DTC other than P0731 is shown, refer to applicable "TROUBLE DIAGNOSIS FOR DTC".**

- 6) Stop vehicle.
- 7) Follow the instruction displayed. (Check for normal shifting referring to the table below.)

Vehicle condition	Gear on actual transmission shift pattern when screen is changed to 1 → 2 → 3 → 4
No malfunction exists.	1 → 2 → 3 → 4
Malfunction for P0731 exists.	2 → 2 → 3 → 3
	4 → 3 → 3 → 4

- 8) Make sure that "OK" is displayed. (If "NG" is displayed, refer to "DIAGNOSTIC PROCEDURE".)  
 Refer to "DIAGNOSTIC PROCEDURE", AT-128.  
 Refer to shift schedule, AT-382.

### WITH GST

Follow the procedure "With CONSULT-II".

NFAT0215S02

# DTC P0731 A/T 1ST GEAR FUNCTION

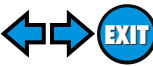

Wiring Diagram — AT — 1ST

## Wiring Diagram — AT — 1ST

NFAT0047

### AT-1STSIG-01

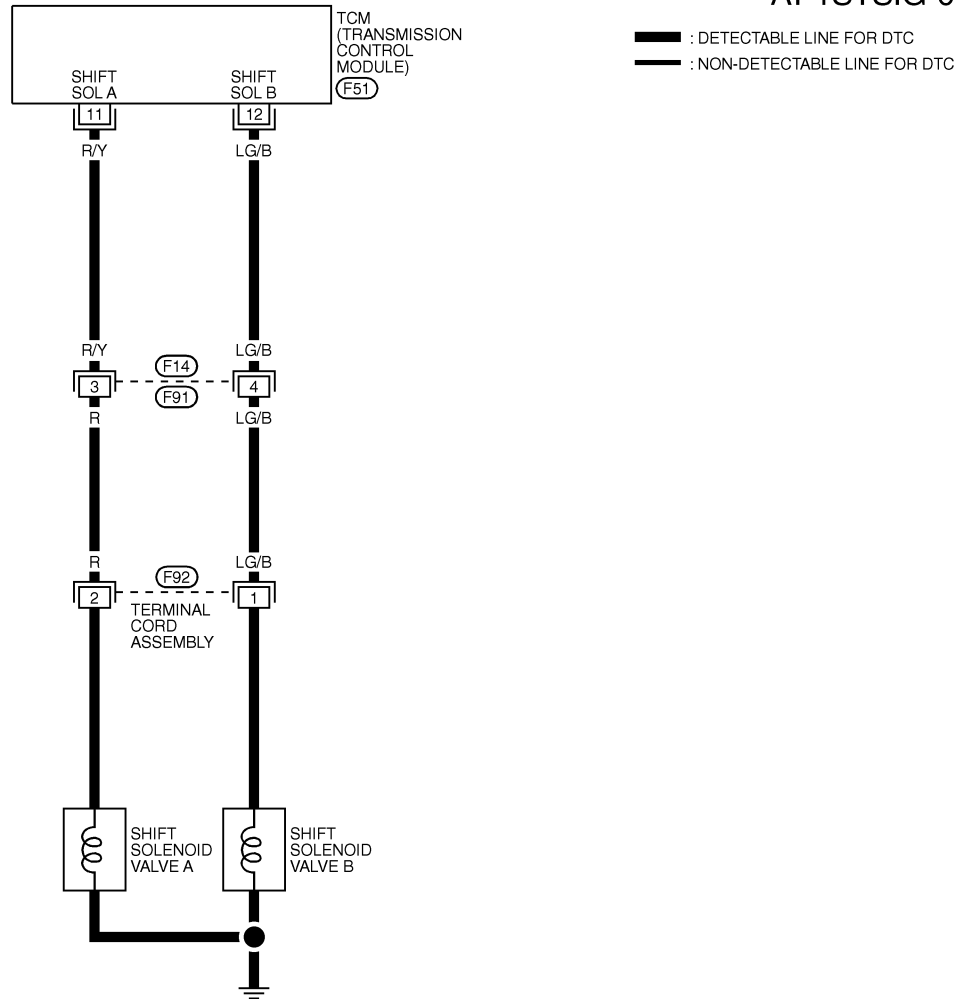

- GI
- MA
- EM
- LC
- EC
- FE
- CL
- MT

**AT**

- AX
- SU
- BR

- ST
- RS
- BT

MAT808A

- HA
- SC
- EL
- IDX

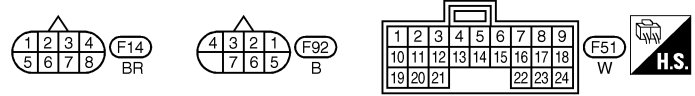

TCM TERMINALS AND REFERENCE VALUE (MEASURED BETWEEN EACH TERMINALS AND 25 OR 48 (TCM GROUND))

TERMINAL	WIRE COLOR	ITEM	CONDITION	DATA (DC)
11	R/Y	SHIFT SOLENOID VALVE A	WHEN VEHICLE STARTS AND SHIFT SOLENOID VALVE A OPERATES (WHEN DRIVING IN D1 OR D4)	BATTERY VOLTAGE
			WHEN VEHICLE STARTS AND SHIFT SOLENOID VALVE A DOES NOT OPERATE (WHEN DRIVING IN D2 OR D3)	1V OR LESS
12	LG/B	SHIFT SOLENOID VALVE B	WHEN VEHICLE STARTS AND SHIFT SOLENOID VALVE B OPERATES (WHEN DRIVING IN D1 OR D2)	BATTERY VOLTAGE
			WHEN VEHICLE STARTS AND SHIFT SOLENOID VALVE B DOES NOT OPERATE (WHEN DRIVING IN D3 OR D4)	1V OR LESS

SAT714J

# DTC P0731 A/T 1ST GEAR FUNCTION

Diagnostic Procedure

## Diagnostic Procedure

NFAT0048

<b>1</b>	<b>CHECK VALVE RESISTANCE</b>														
<p>1. Remove control valve assembly. Refer to AT-280.</p> <ul style="list-style-type: none"> <li>● Shift solenoid valve A</li> <li>● Shift solenoid valve B</li> </ul> <p>2. Check resistance between two terminals.</p>															
<div style="display: flex; align-items: center;"> <div style="flex: 1;"> <p>Shift solenoid valve A Shift solenoid valve B</p> </div> <div style="flex: 1; text-align: center;"> <p>Solenoid valve harness connector (F92)</p> </div> <div style="flex: 1;"> <table border="1" style="width: 100%; border-collapse: collapse;"> <thead> <tr> <th>Solenoid valve</th> <th>Terminal No.</th> <th>Ground</th> <th>Resistance (Approx.)</th> </tr> </thead> <tbody> <tr> <td>Shift solenoid valve A</td> <td>2</td> <td rowspan="2" style="text-align: center;">Ground</td> <td>20 - 30 Ω</td> </tr> <tr> <td>Shift solenoid valve B</td> <td>1</td> <td>5 - 20 Ω</td> </tr> </tbody> </table> </div> </div>					Solenoid valve	Terminal No.	Ground	Resistance (Approx.)	Shift solenoid valve A	2	Ground	20 - 30 Ω	Shift solenoid valve B	1	5 - 20 Ω
Solenoid valve	Terminal No.	Ground	Resistance (Approx.)												
Shift solenoid valve A	2	Ground	20 - 30 Ω												
Shift solenoid valve B	1		5 - 20 Ω												
SAT043KA															
<b>OK or NG</b>															
OK		▶	GO TO 2.												
NG		▶	Repair or replace damaged parts.												

<b>2</b>	<b>CHECK VALVE OPERATION</b>			
<p>1. Remove control valve assembly. Refer to AT-280.</p> <ul style="list-style-type: none"> <li>● Shift solenoid valve A</li> <li>● Shift solenoid valve B</li> </ul> <p>2. Check solenoid valve by listening for its operating sound while applying battery voltage to the terminal and ground.</p>				
<div style="display: flex; align-items: center;"> <div style="flex: 1;"> <p>Shift solenoid valve B Shift solenoid valve A</p> </div> <div style="flex: 1; text-align: center;"> <p>Solenoid valve harness connector (F92)</p> </div> </div>				
SAT044K				
<b>OK or NG</b>				
OK		▶	GO TO 3.	
NG		▶	Repair or replace shift solenoid valve assembly.	

# DTC P0731 A/T 1ST GEAR FUNCTION

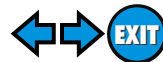

Diagnostic Procedure (Cont'd)

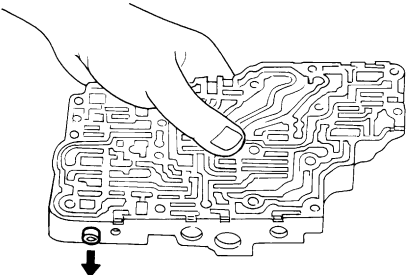
<b>3</b>	<b>CHECK CONTROL VALVE</b>	
<p>1. Disassemble control valve assembly. Refer to "Control Valve Assembly", AT-312.</p> <p>2. Check to ensure that:</p> <ul style="list-style-type: none"> <li>● Valve, sleeve and plug slide along valve bore under their own weight.</li> <li>● Valve, sleeve and plug are free from burrs, dents and scratches.</li> <li>● Control valve springs are free from damage, deformation and fatigue.</li> <li>● Hydraulic line is free from obstacles.</li> </ul>		
		
SAT367H		
<b>OK or NG</b>		
OK	▶	GO TO 4.
NG	▶	Repair control valve assembly.

GI

MA

EM

LC

EC

FE

CL

MT

<b>4</b>	<b>CHECK DTC</b>	
Perform Diagnostic Trouble Code (DTC) confirmation procedure, AT-125.		
<b>OK or NG</b>		
OK	▶	<b>INSPECTION END</b>
NG	▶	Check control valve again. Repair or replace control valve assembly.

**AT**

AX

SU

BR

ST

RS

BT

HA

SC

EL

IDX



# DTC P0732 A/T 2ND GEAR FUNCTION

Description

## Description

NFAT0049

- This is an OBD-II self-diagnostic item and not available in TCM self-diagnosis.
- This malfunction will not be detected while the O/D OFF indicator lamp is indicating another self-diagnosis malfunction.
- This malfunction is detected when the A/T does not shift into second gear position as instructed by the TCM. This is not caused by electrical malfunction (circuits open or shorted) but by mechanical malfunction such as control valve sticking, improper solenoid valve operation, etc.

Gear position	1	2	3	4
Shift solenoid valve A	ON (Closed)	OFF (Open)	OFF (Open)	ON (Closed)
Shift solenoid valve B	ON (Closed)	ON (Closed)	OFF (Open)	OFF (Open)

## TCM TERMINALS AND REFERENCE VALUE

NFAT0049S01

Remarks: Specification data are reference values.

Terminal No.	Wire color	Item	Condition	Judgement standard
12	LG/B	Shift solenoid valve B	 When shift solenoid valve B operates. (When driving in D <sub>1</sub> or D <sub>2</sub> .)	Battery voltage
			When shift solenoid valve B does not operate. (When driving in D <sub>3</sub> or D <sub>4</sub> .)	1V or less

## On Board Diagnosis Logic

NFAT0216

This diagnosis monitors actual gear position by checking the torque converter slip ratio calculated by TCM as follows:

Torque converter slip ratio = A x C/B

A: Output shaft revolution signal from revolution sensor

B: Engine speed signal from ECM

C: Gear ratio determined as gear position which TCM supposes  
If the actual gear position is higher than the position (2nd) supposed by TCM, the slip ratio will be more than normal. In case the ratio exceeds the specified value, TCM judges this diagnosis malfunction.

This malfunction will be caused when shift solenoid valve B is stuck open.

Gear positions supposed by TCM are as follows.

In case of gear position with no malfunctions: 1, 2, 3 and 4 positions

In case of gear position with shift solenoid valve B stuck open: 4, 3\*, 3 and 4 positions to each gear position above

\*: P0732 is detected.

Diagnostic trouble code A/T 2ND GR FNCTN with CONSULT-II or P0732 without CONSULT-II is detected when A/T cannot be shifted to the 2nd gear position even if electrical circuit is good.

## Possible Cause

NFAT0217

Check the following items.

- Shift solenoid valve B
- Each clutch
- Hydraulic control circuit

GI

MA

EM

LC

EC

NFAT0218

## Diagnostic Trouble Code (DTC) Confirmation Procedure

### CAUTION:

- Always drive vehicle at a safe speed.
- Be careful not to rev engine into the red zone on the tachometer.

FE

### NOTE:

If "DTC Confirmation Procedure" has been previously conducted, always turn ignition switch OFF and wait at least 5 seconds before conducting the next test.

CL

MT

### TESTING CONDITION:

**Always drive vehicle on a level road to improve the accuracy of test.**

After the repair, perform the following procedure to confirm the malfunction is eliminated.

### WITH CONSULT-II

- 1) Start engine and select "DATA MONITOR" mode for "A/T" with CONSULT-II.
- 2) Make sure that output voltage of A/T fluid temperature sensor is within the range below.

**FLUID TEMP SEN: 0.4 - 1.5V**

If out of range, drive the vehicle to decrease the voltage (warm up the fluid) or stop engine to increase the voltage (cool down the fluid).

- 3) Select "2ND GR FNCTN P0732" of "DTC WORK SUPPORT" mode for "A/T" with CONSULT-II and touch "START".

- 4) Accelerate vehicle to 63 to 68 km/h (39 to 42 MPH) under the following condition and release the accelerator pedal completely.

**THROTTLE POSI: Less than 1.0/8**

**Selector lever: D position (O/D ON)**

- Check that "GEAR" shows "3" or "4" after releasing pedal.
- 5) Depress accelerator pedal to WOT (more than 7.0/8 of "THROTTLE POSI") quickly from a speed of 63 to 68 km/h (39 to 42 MPH) until "TESTING" changes to "STOP VEHICLE" or "COMPLETE". (It will take approximately 3 seconds.)

If the check result NG appears on CONSULT-II screen, go to "DIAGNOSTIC PROCEDURE", AT-134.

If "STOP VEHICLE" appears on CONSULT-II screen, go to following step.

- Check that "GEAR" shows "2" when depressing accelerator pedal to WOT.
- If "TESTING" does not appear on CONSULT-II for a long time, select "SELF-DIAG RESULTS" for "ENGINE". In case

AT

AX

SU

BR

ST

RS

BT

HA

SC

EL

IDX

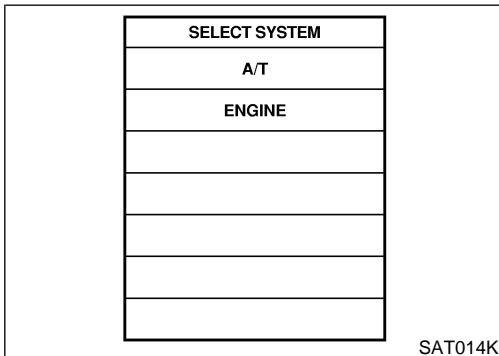

SAT014K

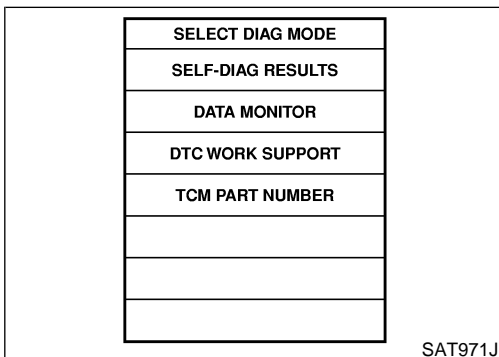

SAT971J

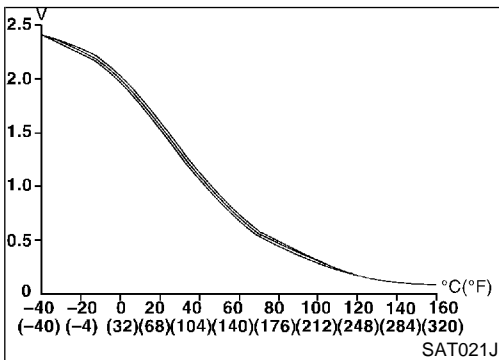

SAT021J

## DTC P0732 A/T 2ND GEAR FUNCTION

*Diagnostic Trouble Code (DTC) Confirmation Procedure (Cont'd)*

**a 1st trip DTC other than P0732 is shown, refer to applicable “TROUBLE DIAGNOSIS FOR DTC”.**

- 6) Stop vehicle.
- 7) Follow the instruction displayed. (Check for normal shifting referring to the table below.)

Vehicle condition	Gear on actual transmission shift pattern when screen is changed to 1 → 2 → 3 → 4
No malfunction exists	1 → 2 → 3 → 4
Malfunction for P0732 exists.	4 → 3 → 3 → 4

- 8) Make sure that “OK” is displayed. (If “NG” is displayed, refer to “DIAGNOSTIC PROCEDURE”.)  
 Refer to “DIAGNOSTIC PROCEDURE”, AT-134.  
 Refer to shift schedule, AT-382.

### WITH GST

Follow the procedure “With CONSULT-II”.

NFAT0218S02

# DTC P0732 A/T 2ND GEAR FUNCTION

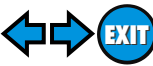

Wiring Diagram — AT — 2ND

## Wiring Diagram — AT — 2ND

NFAT0050

AT-2NDSIG-01

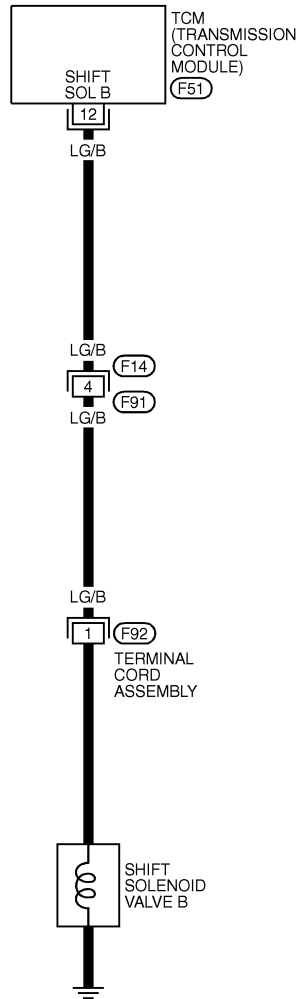

— : DETECTABLE LINE FOR DTC  
 — : NON-DETECTABLE LINE FOR DTC

- GI
- MA
- EM
- LC
- EC
- FE
- CL
- MT

**AT**

- AX
- SU
- BR

- ST
- RS
- BT

MAT809A HA

- SC
- EL
- IDX

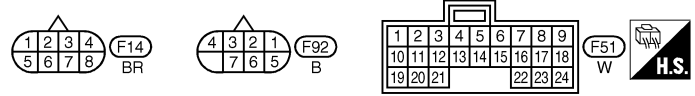

TCM TERMINALS AND REFERENCE VALUE (MEASURED BETWEEN EACH TERMINALS AND 25 OR 48 (TCM GROUND))

TERMINAL	WIRE COLOR	ITEM	CONDITION	DATA (DC)
12	LG/B	SHIFT SOLENOID VALVE B	WHEN VEHICLE STARTS AND SHIFT SOLENOID VALVE B OPERATES (WHEN DRIVING IN D1 OR D2)	BATTERY VOLTAGE
			WHEN VEHICLE STARTS AND SHIFT SOLENOID VALVE B DOES NOT OPERATE (WHEN DRIVING IN D3 OR D4)	1V OR LESS

SAT715J

# DTC P0732 A/T 2ND GEAR FUNCTION

Diagnostic Procedure

## Diagnostic Procedure

NFAT0051

**1 CHECK VALVE RESISTANCE**

1. Remove control valve assembly. Refer to AT-280.  
 ● Shift solenoid valve B  
 2. Check resistance to the terminal and ground.

Solenoid valve	Terminal No.		Resistance (Approx.)
Shift solenoid valve B	1	Ground	5 - 20Ω

SAT045KA

**OK or NG**

OK	▶	GO TO 2.
NG	▶	Repair or replace shift solenoid valve assembly.

**2 CHECK VALVE OPERATION**

1. Remove control valve assembly. Refer to AT-280.  
 ● Shift solenoid valve B  
 2. Check solenoid valve by listening for its operating sound while applying battery voltage to the terminal and ground.

SAT036K

**OK or NG**

OK	▶	GO TO 3.
NG	▶	Repair or replace shift solenoid valve assembly.

# DTC P0732 A/T 2ND GEAR FUNCTION

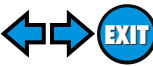

Diagnostic Procedure (Cont'd)

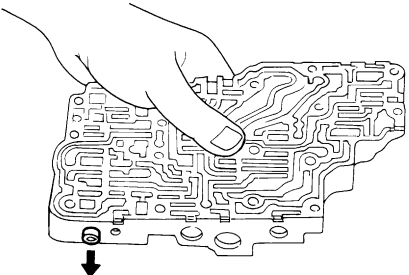
<b>3</b>	<b>CHECK CONTROL VALVE</b>	<p>1. Disassemble control valve assembly. Refer to "Control Valve Assembly", AT-312.</p> <p>2. Check to ensure that:</p> <ul style="list-style-type: none"> <li>● Valve, sleeve and plug slide along valve bore under their own weight.</li> <li>● Valve, sleeve and plug are free from burrs, dents and scratches.</li> <li>● Control valve springs are free from damage, deformation and fatigue.</li> <li>● Hydraulic line is free from obstacles.</li> </ul>	GI  MA  EM  LC  EC  FE  CL  MT
			
		<b>OK or NG</b>	SAT367H
OK	▶	GO TO 4.	
NG	▶	Repair control valve assembly.	

<b>4</b>	<b>CHECK DTC</b>	<p>Perform Diagnostic Trouble Code (DTC) confirmation procedure, AT-131.</p>	AT  AX  SU  BR  ST  RS  BT  HA  SC  EL  IDX
		<b>OK or NG</b>	
OK	▶	<b>INSPECTION END</b>	
NG	▶	Check control valve again. Repair or replace control valve assembly.	

*Description*

## Description

- This is an OBD-II self-diagnostic item and not available in TCM self-diagnosis. NFAT0052
- This malfunction will not be detected while the O/D OFF indicator lamp is indicating another self-diagnosis malfunction.
- This malfunction is detected when the A/T does not shift into third gear position as instructed by the TCM. This is not caused by electrical malfunction (circuits open or shorted) but by mechanical malfunction such as control valve sticking, improper solenoid valve operation, malfunctioning servo piston or brake band, etc.

Gear position	1	2	3	4
Shift solenoid valve A	ON (Closed)	OFF (Open)	OFF (Open)	ON (Closed)
Shift solenoid valve B	ON (Closed)	ON (Closed)	OFF (Open)	OFF (Open)

## TCM TERMINALS AND REFERENCE VALUE

Remarks: Specification data are reference values.

NFAT0052S01

Terminal No.	Wire color	Item	Condition	Judgement standard	
11	R/Y	Shift solenoid valve A		When shift solenoid valve A operates. (When driving in D <sub>1</sub> or D <sub>4</sub> .)	Battery voltage
				When shift solenoid valve A does not operate. (When driving in D <sub>2</sub> or D <sub>3</sub> .)	1V or less

## On Board Diagnosis Logic

NFAT0219

This diagnosis monitors actual gear position by checking the torque converter slip ratio calculated by TCM as follows:

Torque converter slip ratio = A x C/B

A: Output shaft revolution signal from revolution sensor

B: Engine speed signal from ECM

C: Gear ratio determined as gear position which TCM supposes  
If the actual gear position is higher than the position (3rd) supposed by TCM, the slip ratio will be more than normal. In case the ratio exceeds the specified value, TCM judges this diagnosis malfunction.

This malfunction will be caused when shift solenoid valve A is stuck closed.

Gear positions supposed by TCM are as follows.

In case of gear position with no malfunctions: 1, 2, 3 and 4 positions

In case of gear position with shift solenoid valve A stuck closed: 1, 1, 4\* and 4 positions to each gear position above

\*: P0733 is detected.

Diagnostic trouble code A/T 3RD GR FNCTN with CONSULT-II or P0733 without CONSULT-II is detected when A/T cannot be shifted to the 3rd gear position even if electrical circuit is good.

## Possible Cause

Check the following items.

- Shift solenoid valve A
- Each clutch
- Hydraulic control circuit

NFAT0220

GI

MA

EM

LC

EC

NFAT0221

FE

CL

MT

AT

AX

SU

BR

ST

RS

BT

HA

SC

EL

IDX

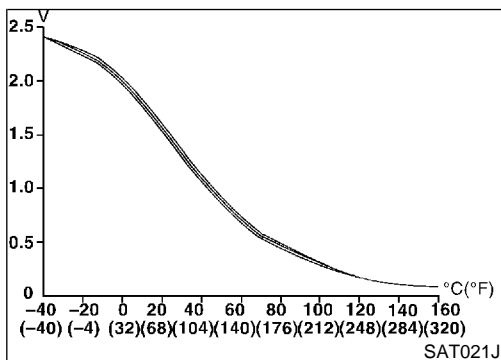
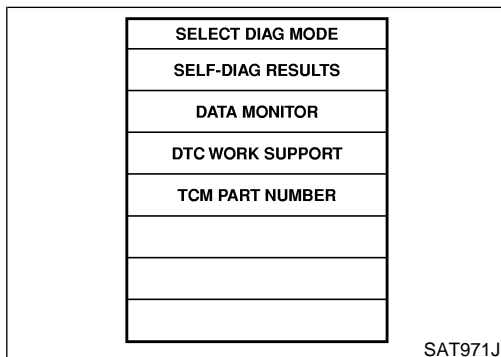
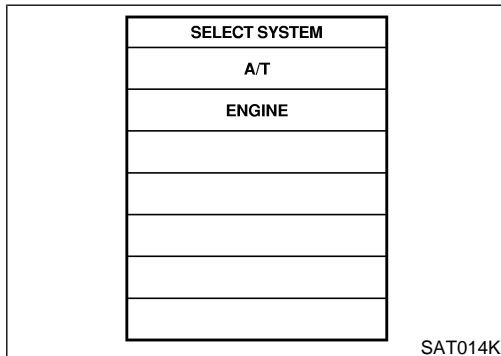

## Diagnostic Trouble Code (DTC) Confirmation Procedure

### CAUTION:

- Always drive vehicle at a safe speed.
- Be careful not to rev engine into the red zone on the tachometer.

### NOTE:

If "DTC Confirmation Procedure" has been previously conducted, always turn ignition switch "OFF" and wait at least 5 seconds before conducting the next test.

### TESTING CONDITION:

Always drive vehicle on a level road to improve the accuracy of test.

After the repair, perform the following procedure to confirm the malfunction is eliminated.

### WITH CONSULT-II

- 1) Start engine and select "DATA MONITOR" mode for "A/T" with CONSULT-II.
- 2) Make sure that output voltage of A/T fluid temperature sensor is within the range below.

**FLUID TEMP SEN: 0.4 - 1.5V**

If out of range, drive the vehicle to decrease the voltage (warm up the fluid) or stop engine to increase the voltage (cool down the fluid).

- 3) Select "3RD GR FNCTN P0733" of "DTC WORK SUPPORT" mode for "A/T" with CONSULT-II and touch "START".

- 4) Accelerate vehicle to 80 to 95 km/h (50 to 59 MPH) under the following condition and release the accelerator pedal completely.

**THROTTLE POSI: Less than 1.0/8 (at all times during step 4)**

**Selector lever: D position (OD "ON")**

- Check that "GEAR" shows "4" after releasing pedal.
- 5) Depress accelerator pedal steadily with 3.5/8 - 4.5/8 of "THROTTLE POSI" from a speed of 80 to 95 km/h (50 to 59 MPH) until "TESTING" changes to "STOP VEHICLE" or "COMPLETED". (It will take approximately 3 seconds.)  
If the check result NG appears on CONSULT-II screen, go to "DIAGNOSTIC PROCEDURE", AT-140.  
If "STOP VEHICLE" appears on CONSULT-II screen, go to following step.

- Check that "GEAR" shows "3" when depressing accelerator pedal with 3.5/8 - 4.5/8 of "THROTTLE POSI".
- If "TESTING" does not appear on CONSULT-II for a long time, select "SELF-DIAG RESULTS" for "ENGINE". In case



## DTC P0733 A/T 3RD GEAR FUNCTION

Diagnostic Trouble Code (DTC) Confirmation Procedure (Cont'd)

**a 1st trip DTC other than P0733 is shown, refer to applicable “TROUBLE DIAGNOSIS FOR DTC”.**

- 6) Stop vehicle.
- 7) Follow the instruction displayed. (Check for normal shifting referring to the table below.)

Vehicle condition	Gear on actual transmission shift pattern when screen is changed to 1 → 2 → 3 → 4
No malfunction exists.	1 → 2 → 3 → 4
Malfunction for P0733 exists.	1 → 1 → 4 → 4

- 8) Make sure that “OK” is displayed. (If “NG” is displayed, refer to “DIAGNOSTIC PROCEDURE”.)  
Refer to “DIAGNOSTIC PROCEDURE”, AT-140.  
Refer to shift schedule, AT-382.

### WITH GST

Follow the procedure “With CONSULT-II”.

NFAT0221S02

# DTC P0733 A/T 3RD GEAR FUNCTION

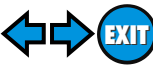

Wiring Diagram — AT — 3RD

## Wiring Diagram — AT — 3RD

NFAT0053

AT-3RDSIG-01

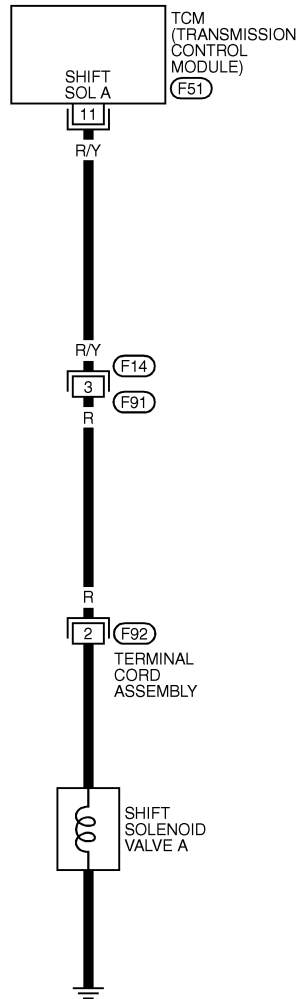

— : DETECTABLE LINE FOR DTC  
 — : NON-DETECTABLE LINE FOR DTC

- GI
- MA
- EM
- LC
- EC
- FE
- CL
- MT

**AT**

- AX
- SU
- BR

- ST
- RS
- BT

MAT810A HA

- SC
- EL
- IDX

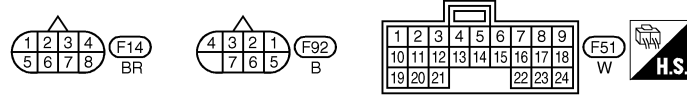

TCM TERMINALS AND REFERENCE VALUE (MEASURED BETWEEN EACH TERMINALS AND 25 OR 48 (TCM GROUND))

TERMINAL	WIRE COLOR	ITEM	CONDITION	DATA (DC)
11	R/Y	SHIFT SOLENOID VALVE A	WHEN VEHICLE STARTS AND SHIFT SOLENOID VALVE A OPERATES (WHEN DRIVING IN D1 OR D4)	BATTERY VOLTAGE
			WHEN VEHICLE STARTS AND SHIFT SOLENOID VALVE A DOES NOT OPERATE (WHEN DRIVING IN D2 OR D3)	1V OR LESS

SAT716J

# DTC P0733 A/T 3RD GEAR FUNCTION

Diagnostic Procedure

## Diagnostic Procedure

NFAT0054

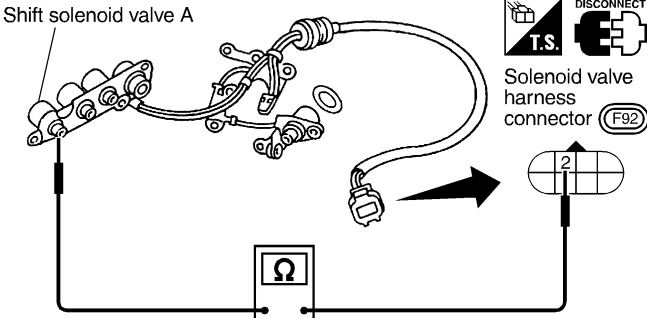
<b>1</b>	<b>CHECK VALVE RESISTANCE</b>											
<p>1. Remove control valve assembly. Refer to AT-280.</p> <ul style="list-style-type: none"> <li>● Shift solenoid valve A</li> </ul> <p>2. Check resistance to the terminal and ground.</p>												
<div style="display: flex; align-items: center;">  <div style="margin-left: 20px;"> <p><b>DISCONNECT</b></p> <p>Solenoid valve harness connector (F92)</p> </div> <table border="1" style="margin-left: 20px; border-collapse: collapse;"> <thead> <tr> <th style="width: 30%;">Solenoid valve</th> <th style="width: 20%;">Terminal No.</th> <th style="width: 20%;"></th> <th style="width: 30%;">Resistance (Approx.)</th> </tr> </thead> <tbody> <tr> <td>Shift solenoid valve A</td> <td>2</td> <td>Ground</td> <td>20 - 30Ω</td> </tr> </tbody> </table> </div>					Solenoid valve	Terminal No.		Resistance (Approx.)	Shift solenoid valve A	2	Ground	20 - 30Ω
Solenoid valve	Terminal No.		Resistance (Approx.)									
Shift solenoid valve A	2	Ground	20 - 30Ω									
SAT046KA												
<b>OK or NG</b>												
OK	▶	GO TO 2.										
NG	▶	Repair or replace shift solenoid valve assembly.										

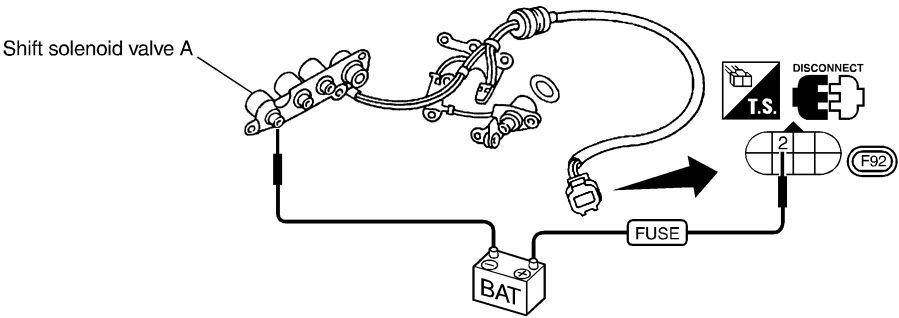
<b>2</b>	<b>CHECK VALVE OPERATION</b>			
<p>1. Remove control valve assembly. Refer to AT-280.</p> <ul style="list-style-type: none"> <li>● Shift solenoid valve A</li> </ul> <p>2. Check solenoid valve by listening for its operating sound while applying battery voltage to the terminal and ground.</p>				
<div style="display: flex; align-items: center;">  <div style="margin-left: 20px;"> <p><b>DISCONNECT</b></p> <p>Solenoid valve harness connector (F92)</p> </div> </div>				
SAT035K				
<b>OK or NG</b>				
OK	▶	GO TO 3.		
NG	▶	Repair or replace shift solenoid valve assembly.		

# DTC P0733 A/T 3RD GEAR FUNCTION

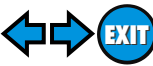

Diagnostic Procedure (Cont'd)

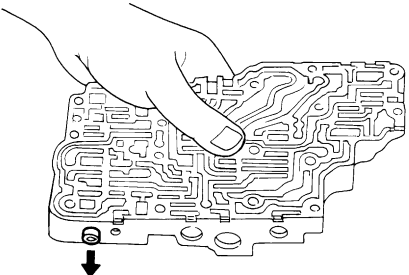
<b>3</b>	<b>CHECK CONTROL VALVE</b>	<p>1. Disassemble control valve assembly. Refer to "Control Valve Assembly", AT-312.</p> <p>2. Check to ensure that:</p> <ul style="list-style-type: none"> <li>● Valve, sleeve and plug slide along valve bore under their own weight.</li> <li>● Valve, sleeve and plug are free from burrs, dents and scratches.</li> <li>● Control valve springs are free from damage, deformation and fatigue.</li> <li>● Hydraulic line is free from obstacles.</li> </ul>	GI  MA  EM  LC  EC  FE  CL  MT
			
		<b>OK or NG</b>	SAT367H
OK	▶	GO TO 4.	
NG	▶	Repair control valve assembly.	

<b>4</b>	<b>CHECK DTC</b>	<p>Perform Diagnostic Trouble Code (DTC) confirmation procedure, AT-137.</p>	AT  AX  SU  BR  ST  RS  BT  HA  SC  EL  IDX
		<b>OK or NG</b>	
OK	▶	<b>INSPECTION END</b>	
NG	▶	Check control valve again. Repair or replace control valve assembly.	

# DTC P0734 A/T 4TH GEAR FUNCTION

Description

## Description

- This is an OBD-II self-diagnostic item and not available in TCM self-diagnosis. NFAT0055
- This malfunction will not be detected while the O/D OFF indicator lamp is indicating another self-diagnosis malfunction.
- This malfunction is detected when the A/T does not shift into fourth gear position or the torque converter clutch does not lock up as instructed by the TCM. This is not caused by electrical malfunction (circuits open or shorted) but by mechanical malfunction such as control valve sticking, improper solenoid valve operation, malfunctioning oil pump or torque converter clutch, etc.

Gear position	1	2	3	4
Shift solenoid valve A	ON (Closed)	OFF (Open)	OFF (Open)	ON (Closed)
Shift solenoid valve B	ON (Closed)	ON (Closed)	OFF (Open)	OFF (Open)

## CONSULT-II REFERENCE VALUE IN DATA MONITOR MODE

NFAT0055S01





Remarks: Specification data are reference values.

Monitor item	Condition	Specification
Torque converter clutch solenoid valve duty	Lock-up OFF	Approximately 4%
	↓	↓
	Lock-up ON	Approximately 94%
Line pressure solenoid valve duty	Small throttle opening (Low line pressure)	Approximately 24%
	↓	↓
	Large throttle opening (High line pressure)	Approximately 95%

## TCM TERMINALS AND REFERENCE VALUE

NFAT0055S02

Remarks: Specification data are reference values.

Terminal No.	Wire color	Item	Condition	Judgement standard	
1	G/R	Line pressure solenoid valve		When releasing accelerator pedal after warming up engine.	1.5 - 3.0V
				When depressing accelerator pedal fully after warming up engine.	0.5V or less
2	W/B	Line pressure solenoid valve (with dropping resistor)		When releasing accelerator pedal after warming up engine.	4 - 14V
				When depressing accelerator pedal fully after warming up engine.	0.5V or less
11	R/Y	Shift solenoid valve A		When shift solenoid valve A operates. (When driving in D <sub>1</sub> or D <sub>4</sub> .)	Battery voltage
				When shift solenoid valve A does not operate. (When driving in D <sub>2</sub> or D <sub>3</sub> .)	1V or less
12	LG/B	Shift solenoid valve B		When shift solenoid valve B operates. (When driving in D <sub>1</sub> or D <sub>2</sub> .)	Battery voltage
				When shift solenoid valve B does not operate. (When driving in D <sub>3</sub> or D <sub>4</sub> .)	1V or less

## On Board Diagnosis Logic

NFAT0222

This diagnosis monitors actual gear position by checking the torque converter slip ratio calculated by TCM as follows:

Torque converter slip ratio =  $A \times C/B$

A: Output shaft revolution signal from revolution sensor

B: Engine speed signal from ECM

C: Gear ratio determined as gear position which TCM supposes  
If the actual gear position is much lower than the position (4th) supposed by TCM, the slip ratio will be much less than normal. In case the ratio does not reach the specified value, TCM judges this diagnosis malfunction.

This malfunction will be caused when shift solenoid valve B is stuck closed.

Gear positions supposed by TCM are as follows.

In case of gear position with no malfunctions: 1, 2, 3 and 4 positions

In case of gear position with shift solenoid valve B stuck closed: 1, 2, 2 and 1\* positions to each gear position above

\*: P0734 is detected.

Diagnostic trouble code A/T 4TH GR FNCTN with CONSULT-II or P0734 without CONSULT-II is detected when A/T cannot be shifted to the 4th gear position even if electrical circuit is good.

GI

MA

EM

LC

EC

FE

CL

MT

## Possible Cause

NFAT0223

Check the following items.

- Shift solenoid valve A
- Shift solenoid valve B
- Line pressure solenoid valve
- Each clutch
- Hydraulic control circuit

AT

AX

SU

BR

ST

RS

BT

HA

SC

EL

IDX

# DTC P0734 A/T 4TH GEAR FUNCTION

Diagnostic Trouble Code (DTC) Confirmation Procedure

SELECT SYSTEM
A/T
ENGINE

SAT014K

SELECT DIAG MODE
SELF-DIAG RESULTS
DATA MONITOR
DTC WORK SUPPORT
TCM PART NUMBER

SAT971J

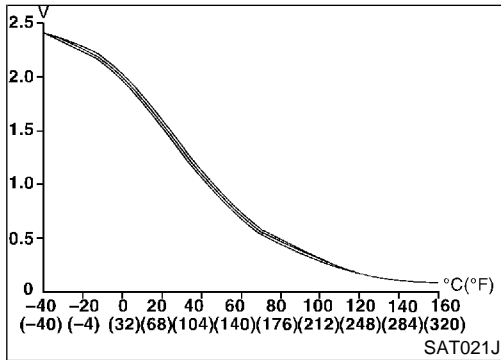

## Diagnostic Trouble Code (DTC) Confirmation Procedure

NFAT0224

### CAUTION:

- Always drive vehicle at a safe speed.
- If conducting this “DTC CONFIRMATION PROCEDURE” again, always turn ignition switch OFF and wait at least 5 seconds before continuing.
- Be careful not to rev engine into the red zone on the tachometer.

### NOTE:

If “DTC Confirmation Procedure” has been previously conducted, always turn ignition switch OFF and wait at least 5 seconds before conducting the next test.

### TESTING CONDITION:

Always drive vehicle on a level road to improve the accuracy of test.

After the repair, perform the following procedure to confirm the malfunction is eliminated.

### WITH CONSULT-II

NFAT0224S01

- 1) Start engine and select “DATA MONITOR” mode for “A/T” with CONSULT-II.
- 2) Make sure that output voltage of A/T fluid temperature sensor is within the range below.

#### FLUID TEMP SEN: 0.4 - 1.5V

If out of range, drive the vehicle to decrease the voltage (warm up the fluid) or stop engine to increase the voltage (cool down the fluid).

- 3) Select “4TH GR FNCTN P0734” of “DTC WORK SUPPORT” mode for “A/T” with CONSULT-II and touch “START”.
- 4) Accelerate vehicle to 60 to 70 km/h (37 to 43 MPH) under the following condition and release the accelerator pedal completely.

**THROTTLE POSI: Less than 5.5/8 (at all times during step 4)**

**Selector lever: D position (O/D ON)**

- Check that “GEAR” shows “3” after releasing pedal.
- 5) Depress accelerator pedal steadily with 1.0/8 - 2.0/8 of “THROTTLE POSI” from a speed of 60 to 70 km/h (37 to 43 MPH) until “TESTING” has turned to “STOP VEHICLE” or “COMPLETED”. (It will take approximately 3 seconds.)  
If the check result NG appears on CONSULT-II screen, go to “DIAGNOSTIC PROCEDURE”, AT-146.  
If “STOP VEHICLE” appears on CONSULT-II screen, go to following step.
  - Check that “GEAR” shows “4” when depressing accelerator pedal with 1.0/8 - 2.0/8 of “THROTTLE POSI”.
  - If “TESTING” does not appear on CONSULT-II for a long time, select “SELF-DIAG RESULTS” for “ENGINE”. In case a 1st trip DTC other than P0734 is shown, refer to applicable “TROUBLE DIAGNOSIS FOR DTC”.
  - 6) Stop vehicle.
  - 7) Follow the instruction displayed. (Check for normal shifting referring to the table below.)

Vehicle condition	Gear on actual transmission shift pattern when screen is changed to 1 → 2 → 3 → 4
No malfunction exists	1 → 2 → 3 → 4

# DTC P0734 A/T 4TH GEAR FUNCTION

Diagnostic Trouble Code (DTC) Confirmation Procedure (Cont'd)

Vehicle condition	Gear on actual transmission shift pattern when screen is changed to 1 → 2 → 3 → 4
Malfunction for P0734 exists.	1 → 2 → 2 → 1

- 8) Make sure that "OK" is displayed. (If "NG" is displayed, refer to "DIAGNOSTIC PROCEDURE".)  
 Refer to "DIAGNOSTIC PROCEDURE", AT-146.  
 Refer to shift schedule, AT-382.

## WITH GST

Follow the procedure "With CONSULT-II".

## Wiring Diagram — AT — 4TH

AT-4THSIG-01

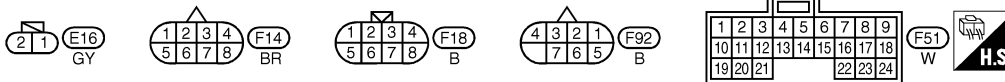
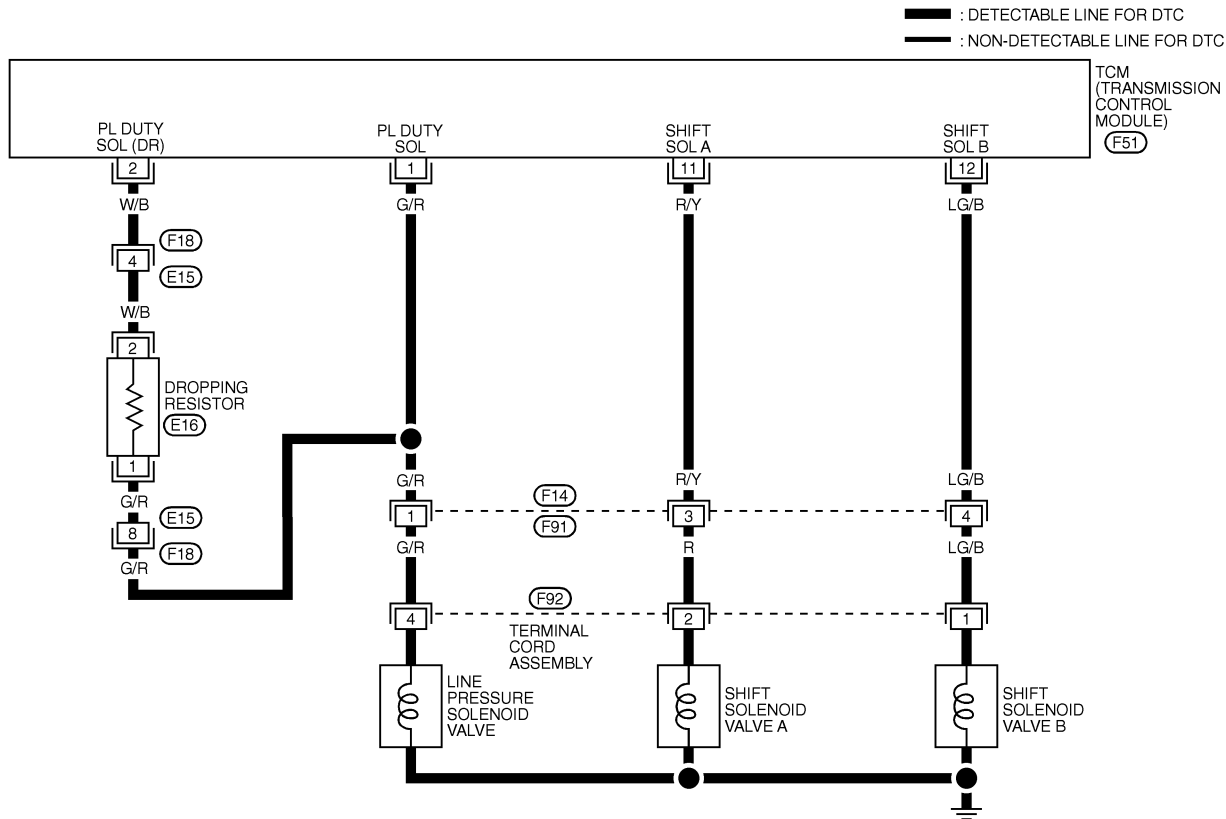

MAT811A



# DTC P0734 A/T 4TH GEAR FUNCTION

Wiring Diagram — AT — 4TH (Cont'd)

TCM TERMINALS AND REFERENCE VALUE (MEASURED BETWEEN EACH TERMINALS AND 25 OR 48 (TCM GROUND))

TERMINAL	WIRE COLOR	ITEM	CONDITION	DATA (DC)
1	G/R	LINE PRESSURE SOLENOID VALVE	WHEN VEHICLE STARTS AND ACCELERATOR PEDAL IS RELEASED	1.5 - 3.0V
			WHEN VEHICLE STARTS AND ACCELERATOR PEDAL IS DEPRESSED	0.5V OR LESS
2	W/B	LINE PRESSURE SOLENOID VALVE (DROPPING RESISTOR)	WHEN VEHICLE STARTS AND ACCELERATOR PEDAL IS RELEASED	4 - 14V
			WHEN VEHICLE STARTS AND ACCELERATOR PEDAL IS DEPRESSED	1V OR LESS
11	R/Y	SHIFT SOLENOID VALVE A	WHEN VEHICLE STARTS AND SHIFT SOLENOID VALVE A OPERATES (WHEN DRIVING IN D1 OR D4)	BATTERY VOLTAGE
			WHEN VEHICLE STARTS AND SHIFT SOLENOID VALVE A DOES NOT OPERATE (WHEN DRIVING IN D2 OR D3)	1V OR LESS
12	LG/B	SHIFT SOLENOID VALVE B	WHEN VEHICLE STARTS AND SHIFT SOLENOID VALVE B OPERATES (WHEN DRIVING IN D1 OR D2)	BATTERY VOLTAGE
			WHEN VEHICLE STARTS AND SHIFT SOLENOID VALVE B DOES NOT OPERATE (WHEN DRIVING IN D3 OR D4)	1V OR LESS

SAT717J

## Diagnostic Procedure

NFAT0057

<b>1</b>	<b>CHECK SHIFT UP (D<sub>3</sub> TO D<sub>4</sub>)</b>	
<p>During "Cruise test – Part 1" (AT-74), does A/T shift from D<sub>3</sub> to D<sub>4</sub> at the specified speed?</p> <div style="text-align: center;"> <p>Accelerator pedal</p> <p>Halfway</p> </div>		
<b>Yes or No</b>		
Yes	▶	GO TO 11.
No	▶	GO TO 2.

SAT988H

<b>2</b>	<b>CHECK LINE PRESSURE</b>													
Perform line pressure test. Refer to AT-65.														
		<table border="1" style="margin: auto; border-collapse: collapse;"> <thead> <tr> <th rowspan="2">Engine speed rpm</th> <th colspan="2">Line pressure kPa (kg/cm<sup>2</sup>, psi)</th> </tr> <tr> <th>D, 2 and 1 positions</th> <th>R position</th> </tr> </thead> <tbody> <tr> <td>Idle</td> <td>500 (5.1, 73)</td> <td>775 (7.9, 112)</td> </tr> <tr> <td>Stall</td> <td>1,225 (12.5, 178)</td> <td>1,912 (19.5, 277)</td> </tr> </tbody> </table>		Engine speed rpm	Line pressure kPa (kg/cm <sup>2</sup> , psi)		D, 2 and 1 positions	R position	Idle	500 (5.1, 73)	775 (7.9, 112)	Stall	1,225 (12.5, 178)	1,912 (19.5, 277)
Engine speed rpm	Line pressure kPa (kg/cm <sup>2</sup> , psi)													
	D, 2 and 1 positions	R position												
Idle	500 (5.1, 73)	775 (7.9, 112)												
Stall	1,225 (12.5, 178)	1,912 (19.5, 277)												
MTBL0308														
<b>OK or NG</b>														
OK	▶	GO TO 3.												
NG	▶	GO TO 7.												

GI  
MA  
EM  
LC  
EC

<b>3</b>	<b>CHECK VALVE RESISTANCE</b>												
1. Remove control valve assembly. Refer to AT-280. ● Shift solenoid valve A ● Shift solenoid valve B 2. Check resistance between two terminals.													
		<table border="1" style="margin: auto; border-collapse: collapse;"> <thead> <tr> <th>Solenoid valve</th> <th>Terminal No.</th> <th>Resistance (Approx.)</th> </tr> </thead> <tbody> <tr> <td>Shift solenoid valve A</td> <td>2</td> <td rowspan="2">Ground</td> <td>20 - 30 Ω</td> </tr> <tr> <td>Shift solenoid valve B</td> <td>1</td> <td>5 - 20 Ω</td> </tr> </tbody> </table>		Solenoid valve	Terminal No.	Resistance (Approx.)	Shift solenoid valve A	2	Ground	20 - 30 Ω	Shift solenoid valve B	1	5 - 20 Ω
Solenoid valve	Terminal No.	Resistance (Approx.)											
Shift solenoid valve A	2	Ground	20 - 30 Ω										
Shift solenoid valve B	1		5 - 20 Ω										
SAT043KA													
<b>OK or NG</b>													
OK	▶	GO TO 5.											
NG	▶	Replace solenoid valve assembly.											

FE  
CL  
MT  
**AT**

<b>4</b>	<b>CHECK VALVE OPERATION</b>												
1. Remove control valve assembly. Refer to AT-280. ● Shift solenoid valve A ● Shift solenoid valve B 2. Check solenoid valve by listening for its operating sound while applying battery voltage to the terminal and ground.													
		<table border="1" style="margin: auto; border-collapse: collapse;"> <thead> <tr> <th>Solenoid valve</th> <th>Terminal No.</th> <th>Resistance (Approx.)</th> </tr> </thead> <tbody> <tr> <td>Shift solenoid valve A</td> <td>2</td> <td rowspan="2">Ground</td> <td>20 - 30 Ω</td> </tr> <tr> <td>Shift solenoid valve B</td> <td>1</td> <td>5 - 20 Ω</td> </tr> </tbody> </table>		Solenoid valve	Terminal No.	Resistance (Approx.)	Shift solenoid valve A	2	Ground	20 - 30 Ω	Shift solenoid valve B	1	5 - 20 Ω
Solenoid valve	Terminal No.	Resistance (Approx.)											
Shift solenoid valve A	2	Ground	20 - 30 Ω										
Shift solenoid valve B	1		5 - 20 Ω										
SAT044K													
<b>OK or NG</b>													
OK	▶	GO TO 5.											
NG	▶	Replace solenoid valve assembly.											

AX  
SU  
BR  
ST  
RS  
BT  
HA  
SC  
EL  
IDX

# DTC P0734 A/T 4TH GEAR FUNCTION

Diagnostic Procedure (Cont'd)

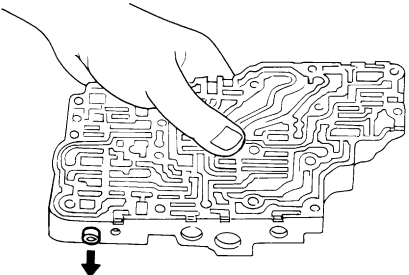
<b>5</b>	<b>CHECK CONTROL VALVE</b>		
<p>1. Disassemble control valve assembly. Refer to AT-312.</p> <p>2. Check to ensure that:</p> <ul style="list-style-type: none"> <li>● Valve, sleeve and plug slide along valve bore under their own weight.</li> <li>● Valve, sleeve and plug are free from burrs, dents and scratches.</li> <li>● Control valve springs are free from damage, deformation and fatigue.</li> <li>● Hydraulic line is free from obstacles.</li> </ul>			
			
SAT367H			
<b>OK or NG</b>			
OK	▶	GO TO 6.	
NG	▶	Repair control valve.	

<b>6</b>	<b>CHECK SHIFT UP (D<sub>3</sub> TO D<sub>4</sub>)</b>		
Does A/T shift from D <sub>3</sub> to D <sub>4</sub> at the specified speed?			
<b>OK or NG</b>			
OK	▶	GO TO 11.	
NG	▶	Check control valve again. Repair or replace control valve assembly.	

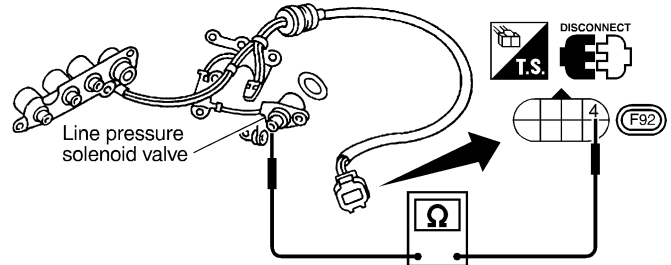
<b>7</b>	<b>CHECK VALVE RESISTANCE</b>		
<p>1. Remove control valve assembly. Refer to AT-280.</p> <ul style="list-style-type: none"> <li>● Line pressure solenoid valves</li> </ul> <p>2. Check resistance to the terminal and ground.</p>			
			
SAT625J			
<b>OK or NG</b>			
OK	▶	GO TO 9.	
NG	▶	Replace solenoid valve assembly.	

Solenoid valve	Terminal No.		Resistance (Approx.)
Line pressure solenoid valve	4	Ground	2.5 - 5Ω

<b>8</b>	<b>CHECK VALVE OPERATION</b>	<p>1. Remove control valve assembly. Refer to AT-280.</p> <ul style="list-style-type: none"> <li>● Line pressure solenoid valves</li> </ul> <p>2. Check solenoid valve by listening for its operating sound while applying battery voltage to the terminal and ground.</p>	GI MA EM LC EC FE CL
		<p style="text-align: center;"><b>OK or NG</b></p> <p style="text-align: right;">SAT626J</p>	
OK	▶	GO TO 9.	
NG	▶	Replace solenoid valve assembly.	

<b>9</b>	<b>CHECK CONTROL VALVE</b>	<p>1. Disassemble control valve assembly. Refer to AT-312.</p> <p>2. Check line pressure circuit valves for sticking.</p> <ul style="list-style-type: none"> <li>● Pressure regulator valve</li> <li>● Pilot valve</li> <li>● Pressure modifier valve</li> </ul>	MT <b>AT</b> AX SU BR ST RS BT
		<p style="text-align: center;"><b>OK or NG</b></p> <p style="text-align: right;">SAT367H</p>	
OK	▶	GO TO 10.	
NG	▶	Repair control valve.	

<b>10</b>	<b>CHECK SHIFT UP (D<sub>3</sub> TO D<sub>4</sub>)</b>	<p>Does A/T shift from D<sub>3</sub> to D<sub>4</sub> at the specified speed?</p> <p style="text-align: center;"><b>OK or NG</b></p>	HA SC EL IDX
OK	▶	GO TO 11.	
NG	▶	Check control valve again. Repair or replace control valve assembly.	

# DTC P0734 A/T 4TH GEAR FUNCTION

Diagnostic Procedure (Cont'd)

<b>11</b>	<b>CHECK DTC</b>
Perform Diagnostic Trouble Code (DTC) confirmation procedure, AT-144.	
<b>OK or NG</b>	
OK	▶ <b>INSPECTION END</b>
NG	▶ Perform "Cruise test — Part 1" again and return to the start point of this test group.

# DTC P0740 TORQUE CONVERTER CLUTCH SOLENOID VALVE

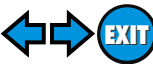

Description

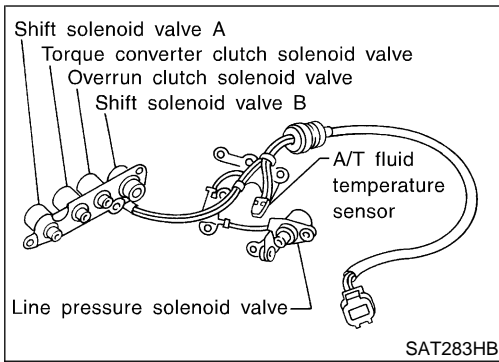

## Description

NFAT0058

The torque converter clutch solenoid valve is activated, with the gear in D<sub>4</sub>, by the TCM in response to signals sent from the vehicle speed and throttle position sensors. Lock-up piston operation will then be controlled.

Lock-up operation, however, is prohibited when A/T fluid temperature is too low.

When the accelerator pedal is depressed (less than 2/8) in lock-up condition, the engine speed should not change abruptly. If there is a big jump in engine speed, there is no lock-up.

## CONSULT-II REFERENCE VALUE IN DATA MONITOR MODE

NFAT0058S01

Remarks: Specification data are reference values.

Monitor item	Condition	Specification
Torque converter clutch solenoid valve duty	Lock-up OFF	Approximately 4%
	↓ Lock-up ON	↓ Approximately 94%

## TCM TERMINALS AND REFERENCE VALUE

NFAT0058S02

Remarks: Specification data are reference values.

Terminal No.	Wire color	Item	Condition	Judgement standard
3	G/B	Torque converter clutch solenoid valve	 When A/T performs lock-up.	8 - 15V
			When A/T does not perform lock-up.	1V or less

## On Board Diagnosis Logic

NFAT0225

Diagnostic trouble code TCC SOLENOID/CIRC with CONSULT-II or P0740 without CONSULT-II is detected when TCM detects an improper voltage drop when it tries to operate the solenoid valve.

## Possible Cause

NFAT0226

Check the following items.

- Torque converter clutch solenoid valve
- Harness or connectors  
(The solenoid circuit is open or shorted.)

# DTC P0740 TORQUE CONVERTER CLUTCH SOLENOID VALVE

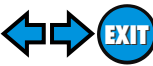

Diagnostic Trouble Code (DTC) Confirmation Procedure

SELECT SYSTEM
A/T
ENGINE

SAT014K

SELECT DIAG MODE
WORK SUPPORT
SELF-DIAG RESULTS
DATA MONITOR
ACTIVE TEST
DTC & SRT CONFIRMATION
ECM PART NUMBER

SAT020K

## Diagnostic Trouble Code (DTC) Confirmation Procedure

NFAT0227

### NOTE:

If "DTC Confirmation Procedure" has been previously conducted, always turn ignition switch OFF and wait at least 5 seconds before conducting the next test.

After the repair, perform the following procedure to confirm the malfunction is eliminated.

### WITH CONSULT-II

NFAT0227S01

- 1) Turn ignition switch ON.
- 2) Select "DATA MONITOR" mode for "ENGINE" with CONSULT-II and wait at least 1 second.

### WITH GST

NFAT0227S02

Follow the procedure "With CONSULT-II".

# DTC P0740 TORQUE CONVERTER CLUTCH SOLENOID VALVE

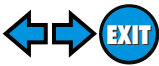

Wiring Diagram — AT — TCV

## Wiring Diagram — AT — TCV

NFAT0059

AT-TCV-01

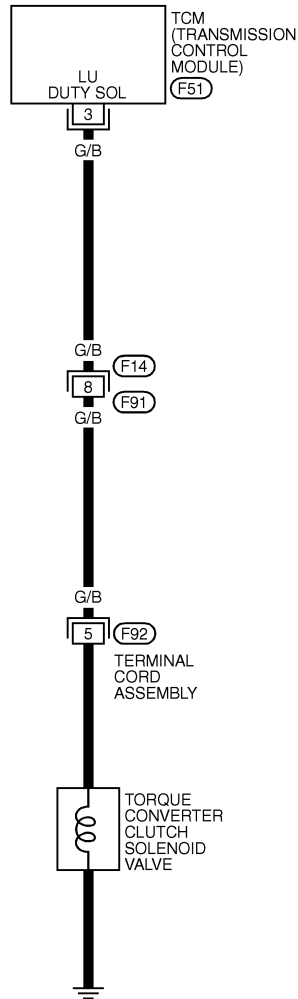

— : DETECTABLE LINE FOR DTC  
 — : NON-DETECTABLE LINE FOR DTC

- GI
- MA
- EM
- LC
- EC
- FE
- CL
- MT
- AT**
- AX
- SU
- BR
- ST
- RS
- BT
- HA
- SC
- EL
- IDX

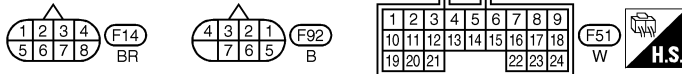

MAT812A

TCM TERMINALS AND REFERENCE VALUE (MEASURED BETWEEN EACH TERMINALS AND 25 OR 48 (TCM GROUND))

TERMINAL	WIRE COLOR	ITEM	CONDITION	DATA (DC)
3	G/B	TORQUE CONVERTER CLUTCH SOLENOID VALVE	VEHICLE STARTS AND A/T PERFORMS LOCK-UP	8 - 15V
			VEHICLE STARTS AND A/T DOES NOT PERFORM LOCK-UP	1V OR LESS

SAT718J



# DTC P0740 TORQUE CONVERTER CLUTCH SOLENOID VALVE

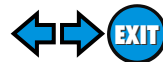

Diagnostic Procedure

## Diagnostic Procedure

NFAT0060

<b>1</b>	<b>CHECK VALVE RESISTANCE</b>
<p>1. Turn ignition switch to OFF position.                  2. Disconnect terminal cord assembly connector in engine compartment.                  3. Check resistance between terminal 5 and ground.</p> <div style="text-align: center;"> <p>Sub-harness connector (F92)</p> <p><b>Resistance: 5 - 20Ω (Approx.)</b></p> </div> <p style="text-align: right;">SAT627JB</p> <p style="text-align: center;"><b>OK or NG</b></p>	
OK	▶ GO TO 3.
NG	▶ GO TO 2.

<b>2</b>	<b>CHECK VALVE OPERATION</b>
<p>1. Remove oil pan. Refer to AT-280.                  2. Check the following items:                  ● Torque converter clutch solenoid valve                  i. Check solenoid valve by listening for its operating sound while applying battery voltage to the terminal and ground.</p> <div style="text-align: center;"> <p>Torque converter clutch solenoid valve</p> <p>Solenoid valve harness connector (F92)</p> <p>BAT</p> <p>FUSE</p> </div> <p style="text-align: right;">SAT037K</p> <p style="text-align: center;"><b>OK or NG</b></p>	
OK	▶ GO TO 3.
NG	▶ Repair or replace damaged parts.

<b>3</b>	<b>CHECK POWER SOURCE CIRCUIT</b>
<p>1. Turn ignition switch to OFF position.                  2. Disconnect TCM harness connector.                  3. Check continuity between sub-harness connector terminal 5 and TCM harness connector terminal 3. Refer to wiring diagram — AT — TCV.  <b>Continuity should exist.</b>                  If OK, check harness for short to ground and short to power.                  4. Reinstall any part removed.</p> <p style="text-align: center;"><b>OK or NG</b></p>	
OK	▶ GO TO 4.
NG	▶ Repair open circuit or short to ground or short to power in harness or connectors.

# DTC P0740 TORQUE CONVERTER CLUTCH SOLENOID VALVE

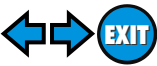

Diagnostic Procedure (Cont'd)

<b>4</b>	<b>CHECK DTC</b>
Perform Diagnostic Trouble Code (DTC) confirmation procedure, AT-152.	
<b>OK or NG</b>	
OK	▶ <b>INSPECTION END</b>
NG	▶ GO TO 5.

GI

MA

EM

<b>5</b>	<b>CHECK TCM INSPECTION</b>
1. Perform TCM input/output signal inspection. 2. If NG, recheck TCM pin terminals for damage or loose connection with harness connector.	
<b>OK or NG</b>	
OK	▶ <b>INSPECTION END</b>
NG	▶ Repair or replace damaged parts.

LC

EC

FE

CL

MT

**AT**

AX

SU

BR

ST

RS

BT

HA

SC

EL

IDX

# DTC P0744 A/T TCC S/V FUNCTION (LOCK-UP)

Description

## Description

- This is an OBD-II self-diagnostic item and not available in TCM self-diagnosis. NFAT0061
- This malfunction will not be detected while the O/D OFF indicator lamp is indicating another self-diagnosis malfunction.
- This malfunction is detected when the A/T does not shift into fourth gear position or the torque converter clutch does not lock up as instructed by the TCM. This is not caused by electrical malfunction (circuits open or shorted) but by mechanical malfunction such as control valve sticking, improper solenoid valve operation, malfunctioning oil pump or torque converter clutch, etc.

## CONSULT-II REFERENCE VALUE IN DATA MONITOR MODE

NFAT0061S01



Remarks: Specification data are reference values.

Monitor item	Condition	Specification
Torque converter clutch solenoid valve duty	Lock-up OFF	Approximately 4%
	↓	↓
	Lock-up ON	Approximately 94%

## TCM TERMINALS AND REFERENCE VALUE

NFAT0061S02

Remarks: Specification data are reference values.

Terminal No.	Wire color	Item	Condition	Judgement standard	
1	G/R	Line pressure solenoid valve		When releasing accelerator pedal after warming up engine.	1.5 - 3.0V
				When depressing accelerator pedal fully after warming up engine.	0.5V or less
2	W/B	Line pressure solenoid valve (with dropping resistor)		When releasing accelerator pedal after warming up engine.	4 - 14V
				When depressing accelerator pedal fully after warming up engine.	0.5V or less
3	G/B	Torque converter clutch solenoid valve		When A/T performs lock-up.	8 - 15V
				When A/T does not perform lock-up.	1V or less

## On Board Diagnosis Logic

NFAT0228

This diagnosis monitors actual gear position by checking the torque converter slip ratio calculated by TCM as follows:

Torque converter slip ratio = A x C/B

A: Output shaft revolution signal from revolution sensor

B: Engine speed signal from ECM

C: Gear ratio determined as gear position which TCM supposes  
 If the actual gear position is much lower than the position (4th) supposed by TCM, the slip ratio will be much less than normal. In case the ratio does not reach the specified value, TCM judges this diagnosis malfunction.

# DTC P0744 A/T TCC S/V FUNCTION (LOCK-UP)

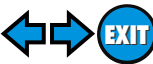

On Board Diagnosis Logic (Cont'd)

This malfunction will be caused when shift solenoid valve B is stuck closed.

Gear positions supposed by TCM are as follows.

In case of gear position with no malfunctions: 1, 2, 3 and 4 positions

In case of gear position with shift solenoid valve B stuck closed: 1, 2, 2 and 1\* positions to each gear position above

\*: P0744 is detected.

Diagnostic trouble code A/T TCC S/V FNCTN with CONSULT-II or P0744 without CONSULT-II is detected when A/T cannot perform lock-up even if electrical circuit is good.

GI

MA

EM

LC

## Possible Cause

Check the following items.

- Line pressure solenoid valve
- Torque converter clutch solenoid valve
- Each clutch
- Hydraulic control circuit

NFAT0229

EC

FE

CL

MT

SELECT SYSTEM
A/T
ENGINE

SAT014K

## Diagnostic Trouble Code (DTC) Confirmation Procedure

### CAUTION:

Always drive vehicle at a safe speed.

### NOTE:

If "DTC Confirmation Procedure" has been previously conducted, always turn ignition switch OFF and wait at least 5 seconds before conducting the next test.

After the repair, perform the following procedure to confirm the malfunction is eliminated.

NFAT0230

AT

AX

SELECT DIAG MODE
SELF-DIAG RESULTS
DATA MONITOR
DTC WORK SUPPORT
TCM PART NUMBER

SAT971J

### WITH CONSULT-II

1) Start engine and select "DATA MONITOR" mode for "A/T" with CONSULT-II.

2) Make sure that output voltage of A/T fluid temperature sensor is within the range below.

**FLUID TEMP SEN: 0.4 - 1.5V**

If out of range, drive vehicle to decrease voltage (warm up the fluid) or stop engine to increase voltage (cool down the fluid).

3) Select "TCC S/V FNCTN P0744" of "DTC WORK SUPPORT" mode for "A/T" with CONSULT-II and touch "START".

4) Accelerate vehicle to more than 70 km/h (43 MPH) and maintain the following condition continuously until "TESTING" has turned to "COMPLETE". (It will take approximately 30 seconds after "TESTING" shows.)

**THROTTLE POSI: 1.0/8 - 2.0/8 (at all times during step 4)**

**Selector lever: D position (O/D ON)**

**TCC S/V DUTY: More than 94%**

**VHCL/S SE-A/T: Constant speed of more than 70 km/h (43 MPH)**

- Check that "GEAR" shows "4".
- For shift schedule, refer to SDS, AT-382.
- If "TESTING" does not appear on CONSULT-II for a long time, select "SELF-DIAG RESULTS". In case a 1st trip DTC

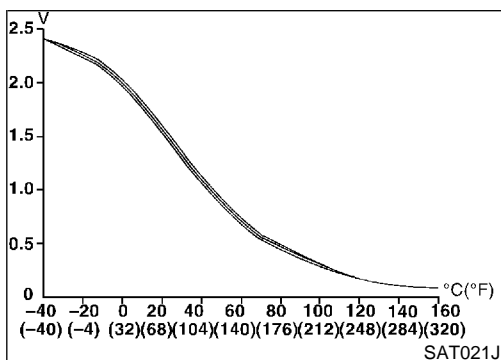

ST

RS

BT

HA

SC

EL

IDX

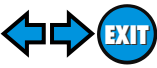

## DTC P0744 A/T TCC S/V FUNCTION (LOCK-UP)

*Diagnostic Trouble Code (DTC) Confirmation Procedure (Cont'd)*

---

**other than P0744 is shown, refer to applicable “TROUBLE DIAGNOSIS FOR DTC”.**

- 5) Make sure that “OK” is displayed. (If “NG” is displayed, refer to “DIAGNOSTIC PROCEDURE”.)  
Refer to “DIAGNOSTIC PROCEDURE”, AT-160.  
Refer to shift schedule, AT-382.

### **WITH GST**

Follow the procedure “With CONSULT-II”.

NFAT0230S02

# DTC P0744 A/T TCC S/V FUNCTION (LOCK-UP)

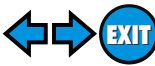

Wiring Diagram — AT — TCCSIG

## Wiring Diagram — AT — TCCSIG

=NFAT0062

### AT-TCCSIG-01

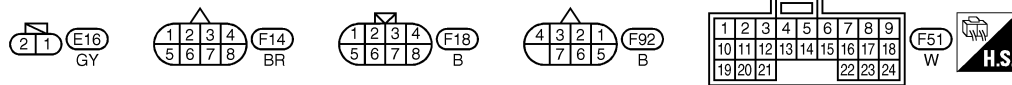
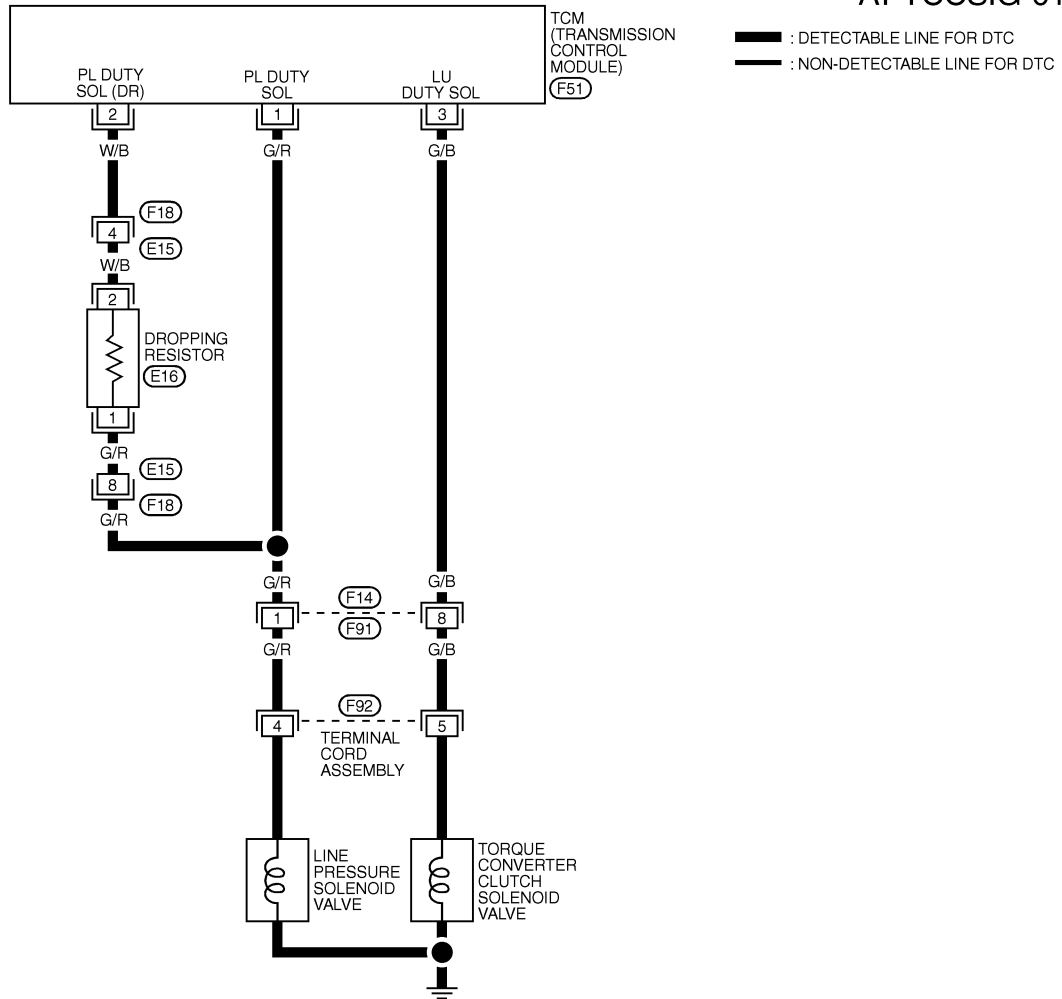

MAT813A

TCM TERMINALS AND REFERENCE VALUE (MEASURED BETWEEN EACH TERMINALS AND 25 OR 48 (TCM GROUND))

TERMINAL	WIRE COLOR	ITEM	CONDITION	DATA (DC)
1	G/R	LINE PRESSURE SOLENOID VALVE	WHEN VEHICLE STARTS AND ACCELERATOR PEDAL IS RELEASED	1.5 - 3.0V
			WHEN VEHICLE STARTS AND ACCELERATOR PEDAL IS DEPRESSED	0.5V OR LESS
2	W/B	LINE PRESSURE SOLENOID VALVE (DROPPING RESISTOR)	WHEN VEHICLE STARTS AND ACCELERATOR PEDAL IS RELEASED	4 - 14V
			WHEN VEHICLE STARTS AND ACCELERATOR PEDAL IS DEPRESSED	1V OR LESS
3	G/B	TORQUE CONVERTER CLUTCH SOLENOID VALVE	WHEN VEHICLE STARTS AND A/T PERFORMS LOCK-UP	8 - 15V
			WHEN VEHICLE STARTS AND A/T DOES NOT PERFORM LOCK-UP	1V OR LESS

SAT719J

# DTC P0744 A/T TCC S/V FUNCTION (LOCK-UP)

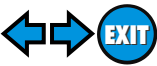

Diagnostic Procedure

## Diagnostic Procedure

NFAT0063

<b>1</b>	<b>CHECK SHIFT UP (D<sub>3</sub> TO D<sub>4</sub>)</b>	
During "Cruise test – Part 1" (AT-74), does A/T shift from D <sub>3</sub> to D <sub>4</sub> at the specified speed?		
<p style="text-align: center;">Accelerator pedal</p> <p style="text-align: center;">Halfway</p>		
<b>Yes or No</b>		
Yes	▶	GO TO 11.
No	▶	GO TO 2.

SAT988H

<b>2</b>	<b>CHECK LINE PRESSURE</b>												
Perform line pressure test. Refer to AT-65.													
<table border="1" style="margin: auto; border-collapse: collapse;"> <thead> <tr> <th rowspan="2" style="text-align: left;">Engine speed rpm</th> <th colspan="2" style="text-align: center;">Line pressure kPa (kg/cm<sup>2</sup>, psi)</th> </tr> <tr> <th style="text-align: center;">D, 2 and 1 positions</th> <th style="text-align: center;">R position</th> </tr> </thead> <tbody> <tr> <td style="text-align: center;">Idle</td> <td style="text-align: center;">500 (5.1, 73)</td> <td style="text-align: center;">775 (7.9, 112)</td> </tr> <tr> <td style="text-align: center;">Stall</td> <td style="text-align: center;">1,225 (12.5, 178)</td> <td style="text-align: center;">1,912 (19.5, 277)</td> </tr> </tbody> </table>			Engine speed rpm	Line pressure kPa (kg/cm <sup>2</sup> , psi)		D, 2 and 1 positions	R position	Idle	500 (5.1, 73)	775 (7.9, 112)	Stall	1,225 (12.5, 178)	1,912 (19.5, 277)
Engine speed rpm	Line pressure kPa (kg/cm <sup>2</sup> , psi)												
	D, 2 and 1 positions	R position											
Idle	500 (5.1, 73)	775 (7.9, 112)											
Stall	1,225 (12.5, 178)	1,912 (19.5, 277)											
<b>OK or NG</b>													
OK	▶	GO TO 3.											
NG	▶	GO TO 6.											

MTBL0308

# DTC P0744 A/T TCC S/V FUNCTION (LOCK-UP)

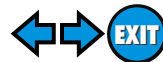

Diagnostic Procedure (Cont'd)

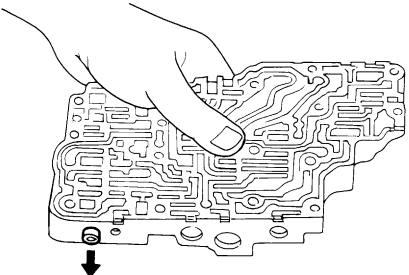
<b>3</b>	<b>CHECK CONTROL VALVE</b>			
		<p>1. Disassemble control valve assembly. Refer to AT-312.</p> <p>2. Check to ensure that:</p> <ul style="list-style-type: none"> <li>● Valve, sleeve and plug slide along valve bore under their own weight.</li> <li>● Valve, sleeve and plug are free from burrs, dents and scratches.</li> <li>● Control valve springs are free from damage, deformation and fatigue.</li> <li>● Hydraulic line is free from obstacles.</li> </ul>	GI  MA  EM  LC  EC  FE  CL	
			SAT367H	
		<b>OK or NG</b>		
	OK	▶	GO TO 4.	MT
	NG	▶	Repair control valve.	

<b>4</b>	<b>CHECK SHIFT UP (D<sub>3</sub> TO D<sub>4</sub>)</b>			
		Does A/T shift from D <sub>3</sub> to D <sub>4</sub> at the specified speed?		
		<b>OK or NG</b>		
	OK	▶	GO TO 5.	AX
	NG	▶	Check control valve again. Repair or replace control valve assembly.	SU

<b>5</b>	<b>CHECK DTC</b>			
		Perform Diagnostic Trouble Code (DTC) confirmation procedure, AT-157.		
		<b>OK or NG</b>		
	OK	▶	<b>INSPECTION END</b>	BR  ST
	NG	▶	GO TO 11. Check for proper lock-up.	RS  BT  HA  SC  EL  IDX



# DTC P0744 A/T TCC S/V FUNCTION (LOCK-UP)

Diagnostic Procedure (Cont'd)

**6 CHECK VALVE RESISTANCE**

- Remove control valve assembly. Refer to AT-280.
  - Line pressure solenoid valve
- Check resistance to the terminal and ground.

Solenoid valve	Terminal No.		Resistance (Approx.)
Line pressure solenoid valve	4	Ground	2.5 - 5Ω

SAT625J

**OK or NG**

OK	▶	GO TO 8.
NG	▶	Replace solenoid valve assembly.

**7 CHECK VALVE OPERATION**

- Remove control valve assembly. Refer to AT-280.
  - Line pressure solenoid valve
- Check solenoid valve by listening for its operating sound while applying battery voltage to the terminal and ground.

SAT626J

**OK or NG**

OK	▶	GO TO 8.
NG	▶	Replace solenoid valve assembly.

# DTC P0744 A/T TCC S/V FUNCTION (LOCK-UP)

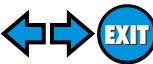

Diagnostic Procedure (Cont'd)

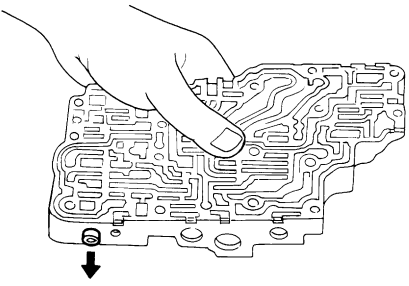
<b>8</b>	<b>CHECK CONTROL VALVE</b>	
		<p>1. Disassemble control valve assembly. Refer to AT-312.</p> <p>2. Check line pressure circuit valves for sticking.</p> <ul style="list-style-type: none"> <li>● Pressure regulator valve</li> <li>● Pilot valve</li> <li>● Pressure modifier valve</li> </ul>
		
		SAT367H
		<b>OK or NG</b>
	OK	▶ GO TO 9.
	NG	▶ Repair control valve.

GI  
MA  
EM  
LC  
EC  
FE  
CL  
MT

<b>9</b>	<b>CHECK SHIFT UP (D<sub>3</sub> TO D<sub>4</sub>)</b>	
		Does A/T shift from D <sub>3</sub> to D <sub>4</sub> at the specified speed?
		<b>OK or NG</b>
	OK	▶ GO TO 10.
	NG	▶ Check control valve again. Repair or replace control valve assembly.

AT  
AX  
SU

<b>10</b>	<b>CHECK DTC</b>	
		Perform Diagnostic Trouble Code (DTC) confirmation procedure, AT-157.
		<b>OK or NG</b>
	OK	▶ <b>INSPECTION END</b>
	NG	▶ GO TO 11. Check for proper lock-up.

BR  
ST  
RS

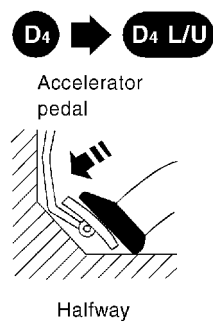
<b>11</b>	<b>CHECK LOCK-UP</b>	
		During "Cruise test – Part 1" (AT-74), does A/T perform lock-up at the specified speed?
		
		SAT989H
		<b>Yes or No</b>
	Yes	▶ Perform "Cruise test – Part 1" again and return to the start point of this test group.
	No	▶ GO TO 12.

BT  
HA  
SC  
EL  
IDX

# DTC P0744 A/T TCC S/V FUNCTION (LOCK-UP)

Diagnostic Procedure (Cont'd)

12	<b>CHECK VALVE RESISTANCE</b>								
<p>1. Remove control valve assembly. Refer to AT-280.</p> <ul style="list-style-type: none"> <li>● Torque converter clutch solenoid valve</li> </ul> <p>2. Check resistance to the terminal and ground.</p>									
<div style="display: flex; align-items: flex-start;"> <div style="flex: 1;"> <p>Torque converter clutch solenoid valve</p> </div> <div style="flex: 1; margin-left: 20px;"> <table border="1" style="width: 100%; border-collapse: collapse;"> <thead> <tr> <th style="width: 30%;">Solenoid valve</th> <th colspan="2" style="width: 30%;">Terminal No.</th> <th style="width: 40%;">Resistance (Approx.)</th> </tr> </thead> <tbody> <tr> <td>Torque converter clutch solenoid valve</td> <td style="text-align: center;">5</td> <td style="text-align: center;">Ground</td> <td style="text-align: center;">5 - 20Ω</td> </tr> </tbody> </table> </div> </div>		Solenoid valve	Terminal No.		Resistance (Approx.)	Torque converter clutch solenoid valve	5	Ground	5 - 20Ω
Solenoid valve	Terminal No.		Resistance (Approx.)						
Torque converter clutch solenoid valve	5	Ground	5 - 20Ω						
SAT047KA									
<b>OK or NG</b>									
OK	▶	GO TO 14.							
NG	▶	Replace solenoid valve assembly.							

13	<b>CHECK VALVE OPERATION</b>	
<p>1. Remove control valve assembly. Refer to AT-280.</p> <ul style="list-style-type: none"> <li>● Torque converter clutch solenoid valve</li> </ul> <p>2. Check solenoid valve by listening for its operating sound while applying battery voltage to the terminal and ground.</p>		
<div style="display: flex; align-items: flex-start;"> <div style="flex: 1;"> <p>Torque converter clutch solenoid valve</p> </div> <div style="flex: 1; margin-left: 20px;"> <p>Solenoid valve harness connector (F92)</p> </div> </div>		
SAT037K		
<b>OK or NG</b>		
OK	▶	GO TO 14.
NG	▶	Replace solenoid valve assembly.

# DTC P0744 A/T TCC S/V FUNCTION (LOCK-UP)

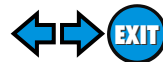

Diagnostic Procedure (Cont'd)

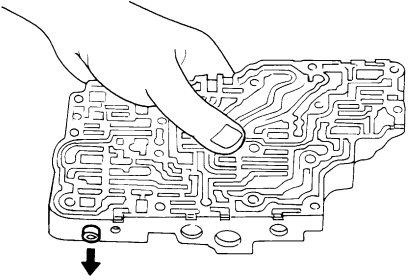
<b>14</b>	<b>CHECK CONTROL VALVE</b>	
<p>1. Disassemble control valve assembly. Refer to AT-312.                  2. Check control valves for sticking.</p> <ul style="list-style-type: none"> <li>● Torque converter clutch control valve</li> <li>● Torque converter clutch relief valve</li> </ul>		
		
SAT367H		
<b>OK or NG</b>		
OK	▶	GO TO 15.
NG	▶	Repair control valve.

GI

MA

EM

LC

EC

FE

CL

MT

<b>15</b>	<b>CHECK LOCK-UP</b>	
Does A/T perform lock-up at the specified speed?		
<b>Yes or No</b>		
Yes	▶	GO TO 16.
No	▶	Check control valve again. Repair or replace control valve assembly.

**AT**

AX

<b>16</b>	<b>CHECK DTC</b>	
Perform Diagnostic Trouble Code (DTC) confirmation procedure, AT-157.		
<b>OK or NG</b>		
OK	▶	<b>INSPECTION END</b>
NG	▶	Perform "Cruise test — Part 1" again and return to the start point of this test group.

SU

BR

ST

RS

BT

HA

SC

EL

IDX

# DTC P0745 LINE PRESSURE SOLENOID VALVE

## Description

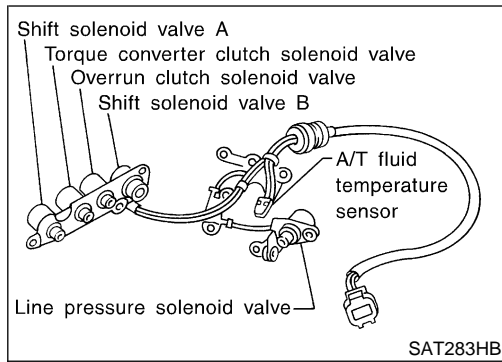

## Description

NFAT0064

The line pressure solenoid valve regulates the oil pump discharge pressure to suit the driving condition in response to a signal sent from the TCM.

**The line pressure duty cycle value is not consistent when the closed throttle position switch is ON. To confirm the line pressure duty cycle at low pressure, the accelerator (throttle) should be open until the closed throttle position switch is OFF.**

## CONSULT-II REFERENCE VALUE IN DATA MONITOR MODE

NFAT0064S01

Remarks: Specification data are reference values.

Monitor item	Condition	Specification
Line pressure solenoid valve duty	Small throttle opening (Low line pressure)	Approximately 24%
	↓ Large throttle opening (High line pressure)	↓ Approximately 95%

### NOTE:

The line pressure duty cycle value is not consistent when the closed throttle position switch is ON. To confirm the line pressure duty cycle at low pressure, the accelerator (throttle) should be open until the closed throttle position switch is OFF.

## TCM TERMINALS AND REFERENCE VALUE

NFAT0064S02

Remarks: Specification data are reference values.

Terminal No.	Wire color	Item	Condition	Judgement standard
1	G/R	Line pressure solenoid valve	When releasing accelerator pedal after warming up engine.	1.5 - 3.0V
			When depressing accelerator pedal fully after warming up engine.	0.5V or less
2	W/B	Line pressure solenoid valve (with dropping resistor)	When releasing accelerator pedal after warming up engine.	4 - 14V
			When depressing accelerator pedal fully after warming up engine.	0.5V or less

## On Board Diagnosis Logic

NFAT0231

Diagnostic trouble code L/PRESS SOL/CIRC with CONSULT-II or P0745 without CONSULT-II is detected when TCM detects an improper voltage drop when it tries to operate the solenoid valve.

## Possible Cause

Check the following items.

- Harness or connectors  
(The solenoid circuit is open or shorted.)
- Line pressure solenoid valve

NFAT0232

GI

MA

EM

LC

## Diagnostic Trouble Code (DTC) Confirmation Procedure

NFAT0233

EC

### NOTE:

If "DTC Confirmation Procedure" has been previously conducted, always turn ignition switch OFF and wait at least 5 seconds before conducting the next test.

FE

After the repair, perform the following procedure to confirm the malfunction is eliminated.

CL

### WITH CONSULT-II

NFAT0233S01

MT

- 1) Turn ignition switch ON and select "DATA MONITOR" mode for "ENGINE" with CONSULT-II.
- 2) Depress accelerator pedal completely and wait at least 1 second.

AT

### WITH GST

NFAT0233S02

AX

Follow the procedure "With CONSULT-II".

SU

BR

ST

RS

BT

HA

SC

EL

IDX

SELECT SYSTEM
A/T
ENGINE

SAT014K

SELECT DIAG MODE
WORK SUPPORT
SELF-DIAG RESULTS
DATA MONITOR
ACTIVE TEST
DTC & SRT CONFIRMATION
ECM PART NUMBER

SAT020K

# DTC P0745 LINE PRESSURE SOLENOID VALVE

Wiring Diagram — AT — LPSV

## Wiring Diagram — AT — LPSV

NFAT0065

AT-LPSV-01

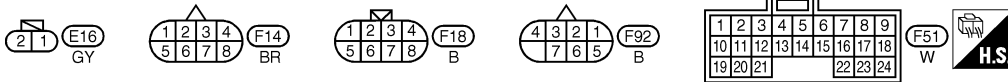
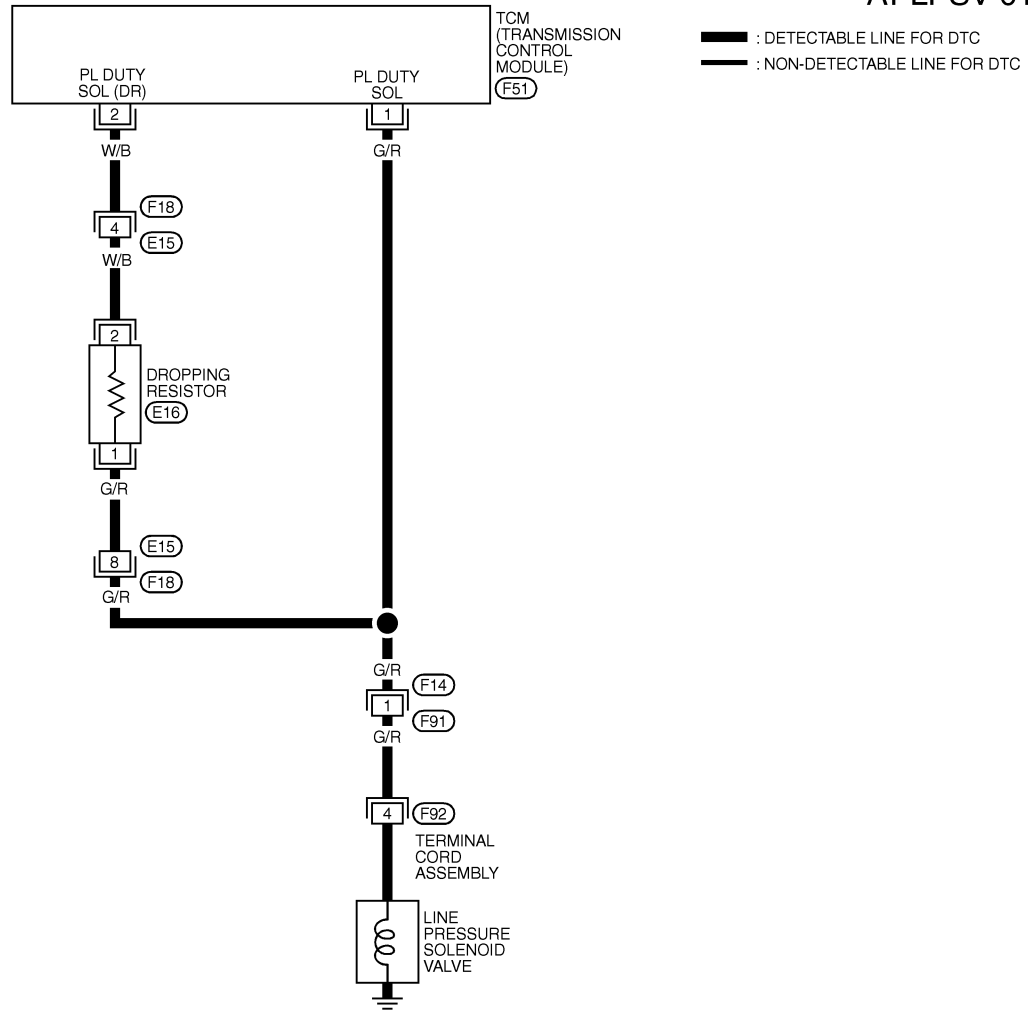

MAT814A

TCM TERMINALS AND REFERENCE VALUE (MEASURED BETWEEN EACH TERMINALS AND 25 OR 48 (TCM GROUND))

TERMINAL	WIRE COLOR	ITEM	CONDITION	DATA (DC)
1	G/R	LINE PRESSURE SOLENOID VALVE	WHEN VEHICLE STARTS AND ACCELERATOR PEDAL IS RELEASED	1.5 - 3.0V
			WHEN VEHICLE STARTS AND ACCELERATOR PEDAL IS DEPRESSED	0.5V OR LESS
2	W/B	LINE PRESSURE SOLENOID VALVE (DROPPING RESISTOR)	WHEN VEHICLE STARTS AND ACCELERATOR PEDAL IS RELEASED	4 - 14V
			WHEN VEHICLE STARTS AND ACCELERATOR PEDAL IS DEPRESSED	1V OR LESS

SAT720J

## Diagnostic Procedure

NFAT0066

<b>1</b>	<b>CHECK VALVE RESISTANCE</b>	
<p>1. Turn ignition switch to OFF position.                  2. Disconnect terminal cord assembly connector in engine compartment.                  3. Check resistance between terminal 4 and ground.</p>		
<p style="text-align: center;"><b>Resistance: 2.5 - 5 Ω</b></p>		
SAT630J		
<b>OK or NG</b>		
OK	▶	GO TO 3.
NG	▶	GO TO 2.

GI  
MA  
EM  
LC  
EC  
FE  
CL  
MT

<b>2</b>	<b>CHECK VALVE OPERATION</b>	
<p>1. Remove control valve assembly. Refer to AT-280.                  2. Check the following items:                  ● Line pressure solenoid valve                  i. Check solenoid valve by listening for its operating sound while applying battery voltage to the terminal and ground.</p>		
SAT038K		
<b>OK or NG</b>		
<p>● Harness of terminal cord assembly for short or open</p>		
OK	▶	GO TO 3.
NG	▶	Repair or replace damaged parts.

AT  
AX  
SU  
BR  
ST  
RS  
BT  
HA  
SC  
EL  
IDX



# DTC P0745 LINE PRESSURE SOLENOID VALVE

Diagnostic Procedure (Cont'd)

<b>3</b>	<b>CHECK POWER SOURCE AND DROPPING RESISTOR CIRCUIT</b>
<p>1. Turn ignition switch to OFF position.                  2. Disconnect TCM harness connector.                  3. Check resistance between terminal 4 and TCM harness connector terminal 2.</p>	
<b>Resistance: 10 - 15 Ω</b>	
SAT631JB	
<b>OK or NG</b>	
OK	▶ GO TO 5.
NG	▶ GO TO 4.

<b>4</b>	<b>DETECT MALFUNCTIONING ITEM</b>
<p>Check the following items:</p> <ul style="list-style-type: none"> <li>● Dropping resistor</li> <li>● Check resistance between two terminals.</li> </ul>	
<b>Resistance: 10 - 15 Ω</b>	
SAT9331B	
<b>OK or NG</b>	
<ul style="list-style-type: none"> <li>● Harness for short or open between TCM terminal 2 and terminal cord assembly (Main harness)</li> </ul>	
OK	▶ GO TO 5.
NG	▶ Repair or replace damaged parts.

<b>5</b>	<b>CHECK POWER SOURCE CIRCUIT</b>
<p>1. Turn ignition switch to OFF position.                  2. Check continuity between sub-harness connector terminal 4 and TCM harness connector terminal 1. Refer to wiring diagram — AT — LPSV.  <b>Continuity should exist.</b>                  If OK, check harness for short to ground and short to power.                  3. Reinstall any part removed.</p>	
<b>OK or NG</b>	
OK	▶ GO TO 6.
NG	▶ Repair open circuit or short to ground or short to power in harness or connectors.

# DTC P0745 LINE PRESSURE SOLENOID VALVE

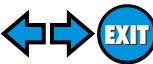

Diagnostic Procedure (Cont'd)

<b>6</b>	<b>CHECK DTC</b>
Perform Diagnostic Trouble Code (DTC) confirmation procedure, AT-167.	
<b>OK or NG</b>	
OK	▶ <b>INSPECTION END</b>
NG	▶ GO TO 7.

GI

MA

EM

<b>7</b>	<b>CHECK TCM INSPECTION</b>
1. Perform TCM input/output signal inspection. 2. If NG, recheck TCM pin terminals for damage or loose connection with harness connector.	
<b>OK or NG</b>	
OK	▶ <b>INSPECTION END</b>
NG	▶ Repair or replace damaged parts.

LC

EC

FE

CL

MT

**AT**

AX

SU

BR

ST

RS

BT

HA

SC

EL

IDX

# DTC P0750 SHIFT SOLENOID VALVE A

## Description

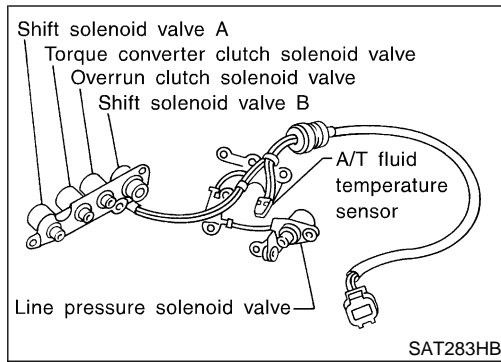

## Description

Shift solenoid valves A and B are turned ON or OFF by the TCM in response to signals sent from the park/neutral position (PNP) switch, vehicle speed and throttle position sensors. Gears will then be shifted to the optimum position.

NFAT0067

Gear position	1	2	3	4
Shift solenoid valve A	ON (Closed)	OFF (Open)	OFF (Open)	ON (Closed)
Shift solenoid valve B	ON (Closed)	ON (Closed)	OFF (Open)	OFF (Open)

## TCM TERMINALS AND REFERENCE VALUE

NFAT0067S01

Remarks: Specification data are reference values.

Terminal No.	Wire color	Item	Condition	Judgement standard
11	R/Y	Shift solenoid valve A	 When shift solenoid valve A operates. (When driving in D <sub>1</sub> or D <sub>4</sub> .)	Battery voltage
			When shift solenoid valve A does not operate. (When driving in D <sub>2</sub> or D <sub>3</sub> .)	1V or less

## On Board Diagnosis Logic

Diagnostic trouble code SFT SOL A/CIRC with CONSULT-II or P0750 without CONSULT-II is detected when TCM detects an improper voltage drop when it tries to operate the solenoid valve.

NFAT0234

## Possible Cause

Check the following items.

- Harness or connectors (The solenoid circuit is open or shorted.)
- Shift solenoid valve A

NFAT0235

# DTC P0750 SHIFT SOLENOID VALVE A

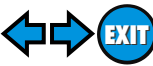

Diagnostic Trouble Code (DTC) Confirmation Procedure

SELECT SYSTEM
A/T
ENGINE

SAT014K

SELECT DIAG MODE
WORK SUPPORT
SELF-DIAG RESULTS
DATA MONITOR
ACTIVE TEST
DTC & SRT CONFIRMATION
ECM PART NUMBER

SAT020K

## Diagnostic Trouble Code (DTC) Confirmation Procedure

NFAT0236

### CAUTION:

Always drive vehicle at a safe speed.

### NOTE:

If "DTC Confirmation Procedure" has been previously conducted, always turn ignition switch OFF and wait at least 5 seconds before conducting the next test.

After the repair, perform the following procedure to confirm the malfunction is eliminated.

### WITH CONSULT-II

NFAT0236S01

- 1) Turn ignition switch ON and select "DATA MONITOR" mode for "ENGINE" with CONSULT-II.
- 2) Start engine.
- 3) Drive vehicle in D position and allow the transmission to shift 1 → 2 ("GEAR").

### WITH GST

NFAT0236S02

Follow the procedure "With CONSULT-II".

- GI
- MA
- EM
- LC
- EC
- FE
- CL
- MT
- AT**
- AX
- SU
- BR
- ST
- RS
- BT
- HA
- SC
- EL
- IDX

# DTC P0750 SHIFT SOLENOID VALVE A

Wiring Diagram — AT — SSV/A

## Wiring Diagram — AT — SSV/A

NFAT0068

AT-SSV/A-01

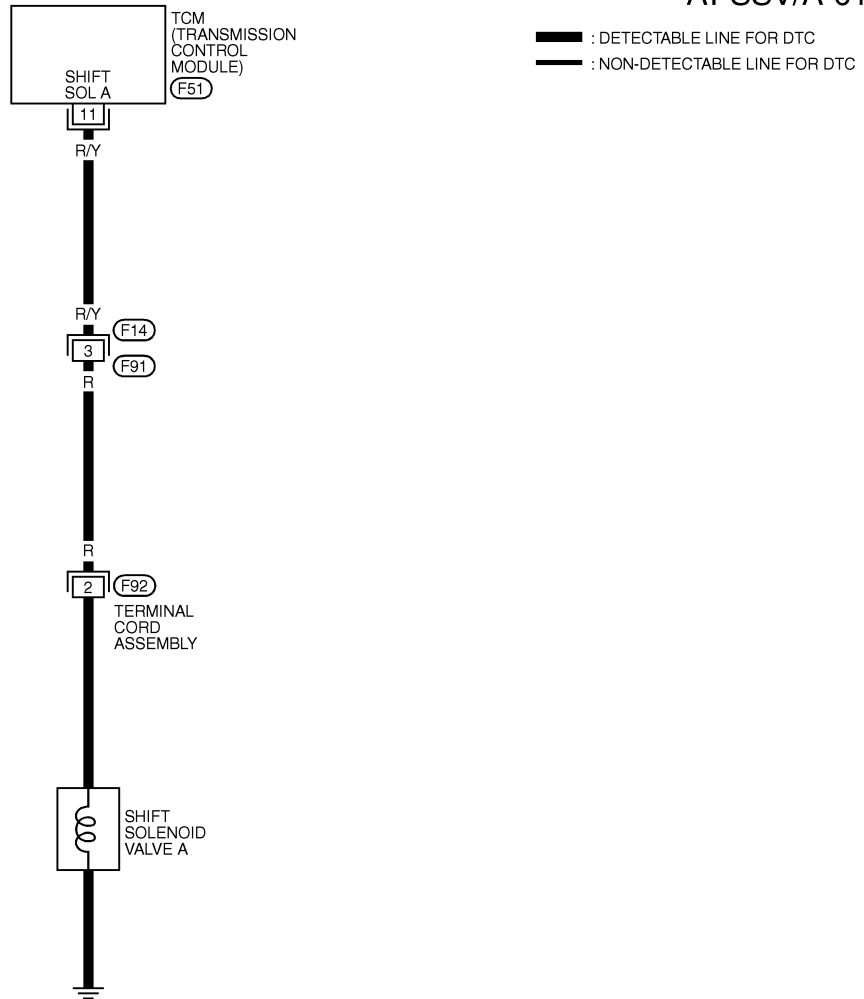

MAT815A

TCM TERMINALS AND REFERENCE VALUE (MEASURED BETWEEN EACH TERMINALS AND 25 OR 48 (TCM GROUND))

TERMINAL	WIRE COLOR	ITEM	CONDITION	DATA (DC)
11	R/Y	SHIFT SOLENOID VALVE A	WHEN VEHICLE STARTS AND SHIFT SOLENOID VALVE A OPERATES (WHEN DRIVING IN D1 OR D4)	BATTERY VOTAGE
			WHEN VEHICLE STARTS AND SHIFT SOLENOID VALVE A DOES NOT OPERATE (WHEN DRIVING IN D2 OR D3)	1V OR LESS

SAT721J

## Diagnostic Procedure

NFAT0069

<b>1</b>	<b>CHECK VALVE RESISTANCE</b>	<p>1. Turn ignition switch to OFF position.                  2. Disconnect terminal cord assembly connector in engine compartment.                  3. Check resistance between terminal 2 and ground.</p> <div style="text-align: center;"> <p><b>Resistance: 20 - 30 Ω</b></p> </div> <p style="text-align: right;">SAT632JB</p> <p style="text-align: center;"><b>OK or NG</b></p>	GI MA EM LC EC FE CL MT
OK	▶	GO TO 3.	
NG	▶	GO TO 2.	

<b>2</b>	<b>CHECK VALVE OPERATION</b>	<p>1. Remove control valve assembly. Refer to AT-280.                  2. Check the following items:</p> <ul style="list-style-type: none"> <li>● Shift solenoid valve A</li> <li>● Operation check</li> </ul> <p>i. Check solenoid valve by listening for its operating sound while applying battery voltage to the terminal and ground.</p> <div style="text-align: center;"> </div> <p style="text-align: right;">SAT035K</p> <p style="text-align: center;"><b>OK or NG</b></p>	AT AX SU BR ST RS BT HA
OK	▶	GO TO 3.	
NG	▶	Repair or replace damaged parts.	

<b>3</b>	<b>CHECK POWER SOURCE CIRCUIT</b>	<p>1. Turn ignition switch to OFF position.                  2. Disconnect TCM harness connector.                  3. Check continuity between sub-harness connector terminal 2 and TCM harness connector terminal 11. Refer to wiring diagram — AT — SSV/A.  <b>Continuity should exist.</b>                  If OK, check harness for short to ground and short to power.                  4. Reinstall any part removed.</p> <p style="text-align: center;"><b>OK or NG</b></p>	SC EL IDX
OK	▶	GO TO 4.	
NG	▶	Repair open circuit or short to ground or short to power in harness or connectors.	

## DTC P0750 SHIFT SOLENOID VALVE A

Diagnostic Procedure (Cont'd)

<b>4</b>	<b>CHECK DTC</b>
Perform Diagnostic Trouble Code (DTC) confirmation procedure, AT-173.	
<b>OK or NG</b>	
OK	▶ <b>INSPECTION END</b>
NG	▶ GO TO 5.

<b>5</b>	<b>CHECK TCM INSPECTION</b>
1. Perform TCM input/output signal inspection. 2. If NG, recheck TCM pin terminals for damage or loose connection with harness connector.	
<b>OK or NG</b>	
OK	▶ <b>INSPECTION END</b>
NG	▶ Repair or replace damaged parts.

# DTC P0755 SHIFT SOLENOID VALVE B

Description

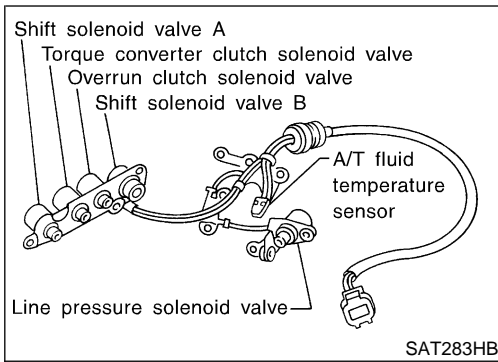

## Description

Shift solenoid valves A and B are turned ON or OFF by the TCM in response to signals sent from the park/neutral position (PNP) switch, vehicle speed and throttle position sensors. Gears will then be shifted to the optimum position.

NFAT0070

Gear position	1	2	3	4
Shift solenoid valve A	ON (Closed)	OFF (Open)	OFF (Open)	ON (Closed)
Shift solenoid valve B	ON (Closed)	ON (Closed)	OFF (Open)	OFF (Open)

## TCM TERMINALS AND REFERENCE VALUE

NFAT0070S01

Remarks: Specification data are reference values.

Terminal No.	Wire color	Item	Condition	Judgement standard
12	LG/B	Shift solenoid valve B	 When shift solenoid valve B operates. (When driving in D <sub>1</sub> or D <sub>2</sub> .)	Battery voltage
			When shift solenoid valve B does not operate. (When driving in D <sub>3</sub> or D <sub>4</sub> .)	1V or less

## On Board Diagnosis Logic

Diagnostic trouble code SFT SOL B/CIRC with CONSULT-II or P0755 without CONSULT-II is detected when TCM detects an improper voltage drop when it tries to operate the solenoid valve.

NFAT0237

## Possible Cause

Check the following items.

- Harness or connectors (The solenoid circuit is open or shorted.)
- Shift solenoid valve B

NFAT0239



# DTC P0755 SHIFT SOLENOID VALVE B

Diagnostic Trouble Code (DTC) Confirmation Procedure

SELECT SYSTEM
A/T
ENGINE

SAT014K

SELECT DIAG MODE
WORK SUPPORT
SELF-DIAG RESULTS
DATA MONITOR
ACTIVE TEST
DTC & SRT CONFIRMATION
ECM PART NUMBER

SAT020K

## Diagnostic Trouble Code (DTC) Confirmation Procedure

NFAT0238

### CAUTION:

Always drive vehicle at a safe speed.

### NOTE:

If "DTC Confirmation Procedure" has been previously conducted, always turn ignition switch OFF and wait at least 5 seconds before conducting the next test.

After the repair, perform the following procedure to confirm the malfunction is eliminated.

### WITH CONSULT-II

NFAT0238S01

- 1) Turn ignition switch ON and select "DATA MONITOR" mode for "ENGINE" with CONSULT-II.
- 2) Start engine.
- 3) Drive vehicle in D position and allow the transmission to shift 1 → 2 → 3 ("GEAR").

### WITH GST

NFAT0238S02

Follow the procedure "With CONSULT-II".

# DTC P0755 SHIFT SOLENOID VALVE B

Wiring Diagram — AT — SSV/B

## Wiring Diagram — AT — SSV/B

NFAT0071

AT-SSV/B-01

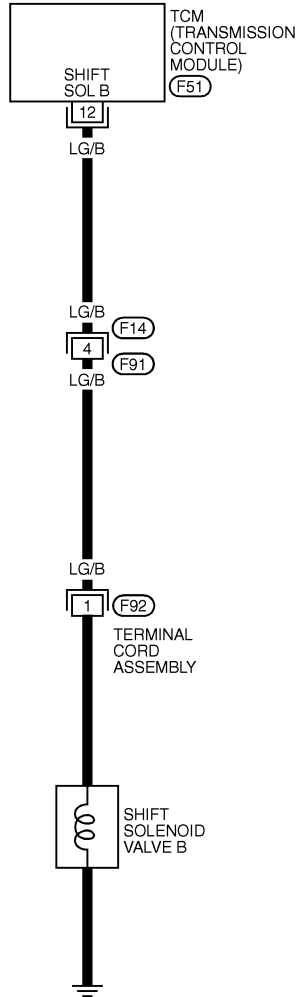

: DETECTABLE LINE FOR DTC  
 : NON-DETECTABLE LINE FOR DTC

- GI
- MA
- EM
- LC
- EC
- FE
- CL
- MT

**AT**

- AX
- SU
- BR

- ST
- RS
- BT

MAT816A HA

- SC
- EL
- IDX

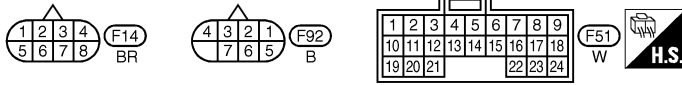

TCM TERMINALS AND REFERENCE VALUE (MEASURED BETWEEN EACH TERMINALS AND 25 OR 48 (TCM GROUND))

TERMINAL	WIRE COLOR	ITEM	CONDITION	DATA (DC)
12	LG/B	SHIFT SOLENOID VALVE B	WHEN VEHICLE STARTS AND SHIFT SOLENOID VALVE B OPERATES (WHEN DRIVING IN D1 OR D2)	BATTERY VOTAGE
			WHEN VEHICLE STARTS AND SHIFT SOLENOID VALVE B DOES NOT OPERATE (WHEN DRIVING IN D3 OR D4)	1V OR LESS

SAT722J

# DTC P0755 SHIFT SOLENOID VALVE B

Diagnostic Procedure

## Diagnostic Procedure

NFAT0072

<b>1</b>	<b>CHECK VALVE RESISTANCE</b>
<p>1. Turn ignition switch to OFF position.                  2. Disconnect terminal cord assembly connector in engine compartment.                  3. Check resistance between terminal 1 and ground.</p> <div style="text-align: center;"> <p>Sub-harness connector (F92)</p> <p>Resistance: 5 - 20 <math>\Omega</math></p> <p>OK or NG</p> </div>	
OK	▶ GO TO 3.
NG	▶ GO TO 2.

SAT633JC

<b>2</b>	<b>CHECK VALVE OPERATION</b>
<p>1. Remove control valve assembly. Refer to AT-280.                  2. Check the following items:</p> <ul style="list-style-type: none"> <li>● Shift solenoid valve B</li> <li>● Operation check</li> </ul> <p>i. Check solenoid valve by listening for its operating sound while applying battery voltage to the terminal and ground.</p> <div style="text-align: center;"> <p>Shift solenoid valve B</p> <p>BAT</p> <p>FUSE</p> <p>F92</p> </div>	
<ul style="list-style-type: none"> <li>● Harness of terminal cord assembly for short or open</li> </ul> <p>OK or NG</p>	
OK	▶ GO TO 3.
NG	▶ Repair or replace damaged parts.

SAT036K

<b>3</b>	<b>CHECK POWER SOURCE CIRCUIT</b>
<p>1. Turn ignition switch to OFF position.                  2. Disconnect TCM harness connector.                  3. Check continuity between sub-harness connector terminal 1 and TCM harness connector terminal 12. Refer to wiring diagram — AT — SSV/B.  <b>Continuity should exist.</b>                  If OK, check harness for short to ground and short to power.                  4. Reinstall any part removed.</p> <p>OK or NG</p>	
OK	▶ GO TO 4.
NG	▶ Repair open circuit or short to ground or short to power in harness or connectors.

# DTC P0755 SHIFT SOLENOID VALVE B

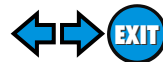

Diagnostic Procedure (Cont'd)

<b>4</b>	<b>CHECK DTC</b>
Perform Diagnostic Trouble Code (DTC) confirmation procedure, AT-178.	
<b>OK or NG</b>	
OK	▶ <b>INSPECTION END</b>
NG	▶ GO TO 5.

GI

MA

EM

<b>5</b>	<b>CHECK TCM INSPECTION</b>
1. Perform TCM input/output signal inspection. 2. If NG, recheck TCM pin terminals for damage or loose connection with harness connector.	
<b>OK or NG</b>	
OK	▶ <b>INSPECTION END</b>
NG	▶ Repair or replace damaged parts.

LC

EC

FE

CL

MT

**AT**

AX

SU

BR

ST

RS

BT

HA

SC

EL

IDX

# DTC P1705 THROTTLE POSITION SENSOR

## Description

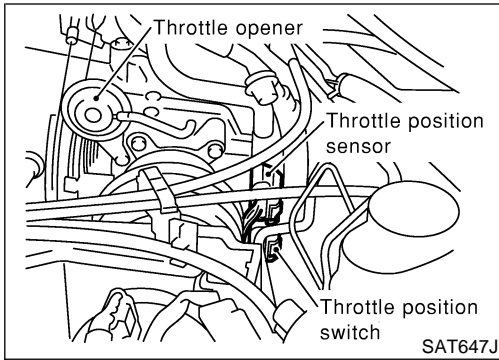

## Description

NFAT0073

- Throttle position sensor  
The throttle position sensor detects the throttle valve position and sends a signal to the TCM.
- Throttle position switch  
Consists of a wide open throttle position switch and a closed throttle position switch.  
The wide open throttle position switch sends a signal to the TCM when the throttle valve is open at least 1/2 of the full throttle position. The closed throttle position switch sends a signal to the TCM when the throttle valve is fully closed.

## CONSULT-II REFERENCE VALUE IN DATA MONITOR MODE

NFAT0073S01

Remarks: Specification data are reference values.

Monitor item	Condition	Specification
Throttle position sensor	Fully-closed throttle	Approximately 0.5V
	Fully-open throttle	Approximately 4V

## TCM TERMINALS AND REFERENCE VALUE

NFAT0073S02

Remarks: Specification data are reference values.

Terminal No.	Wire color	Item	Condition	Judgement standard
16	GY/L	Closed throttle position switch (in throttle position switch)	When releasing accelerator pedal after warming up engine.	Battery voltage
			When depressing accelerator pedal after warming up engine.	1V or less
17	P	Wide open throttle position switch (in throttle position switch)	When depressing accelerator pedal more than half-way after warming up engine.	Battery voltage
			When releasing accelerator pedal after warming up engine.	1V or less
32	R	Throttle position sensor (Power source)	Ignition switch ON.	4.5 - 5.5V
			Ignition switch OFF.	0.5V or less
41	W	Throttle position sensor	When depressing accelerator pedal slowly after warming up engine. (Voltage rises gradually in response to throttle position.)	Fully-closed throttle: Approximately 0.5V Fully-open throttle: Approximately 4V
42	B	Throttle position sensor (Ground)	—	—

## On Board Diagnosis Logic

Diagnostic trouble code TP SEN/CIRC A/T with CONSULT-II or P1705 without CONSULT-II is detected when TCM receives an excessively low or high voltage from the sensor.

NFAT0240

GI

MA

EM

LC

## Possible Cause

Check the following items.

NFAT0241

- Harness or connectors (The sensor circuit is open or shorted.)
- Throttle position sensor
- Throttle position switch

EC

FE

CL

MT

**AT**

AX

SU

BR

ST

RS

BT

HA

SC

EL

IDX

# DTC P1705 THROTTLE POSITION SENSOR

Diagnostic Trouble Code (DTC) Confirmation Procedure

SELECT SYSTEM
A/T
ENGINE

SAT014K

## Diagnostic Trouble Code (DTC) Confirmation Procedure

NFAT0242

### CAUTION:

Always drive vehicle at a safe speed.

### NOTE:

If "DTC Confirmation Procedure" has been previously conducted, always turn ignition switch OFF and wait at least 5 seconds before conducting the next test.

After the repair, perform the following procedure to confirm the malfunction is eliminated.

SELECT DIAG MODE
SELF-DIAG RESULTS
DATA MONITOR
DTC WORK SUPPORT
TCM PART NUMBER

SAT971J

### WITH CONSULT-II

NFAT0242S01

- 1) Turn ignition switch ON and select "DATA MONITOR" mode for "A/T" with CONSULT-II.
- 2) Apply vacuum to the throttle opener, then check the following. Refer to steps 1 and 2 of "Preparation", "TCM SELF-DIAGNOSTIC PROCEDURE (No Tools)", AT-49.

Accelerator pedal condition	THRTL POS SEN	CLOSED THL/SW	W/O THRL/P-SW
Fully released	Less than 4.7V	ON	OFF
Partially depressed	0.1 - 4.6V	OFF	OFF
Fully depressed	1.9 - 4.6V	OFF	ON

If the check result is NG, go to "DIAGNOSTIC PROCEDURE", AT-186.

If the check result is OK, go to following step.

- 3) Turn ignition switch ON and select "DATA MONITOR" mode for "ENGINE" with CONSULT-II.
- 4) Start engine and maintain the following conditions for at least 3 consecutive seconds. Then release accelerator pedal completely.

**VHCL SPEED SE: 10 km/h (6 MPH) or more**

**THRTL POS SEN: Approximately 3V or less**

**Selector lever: D position (O/D ON)**

If the check result is NG, go to "DIAGNOSTIC PROCEDURE", AT-186.

If the check result is OK, go to following step.

- 5) Maintain the following conditions for at least 3 consecutive seconds. Then release accelerator pedal completely.

**VHCL SPEED SE: 10 km/h (6 MPH) or more**

**Accelerator pedal: Wide open throttle**

**Selector lever: D position (O/D ON)**

SELECT SYSTEM
A/T
ENGINE

SAT014K

SELECT DIAG MODE
WORK SUPPORT
SELF-DIAG RESULTS
DATA MONITOR
ACTIVE TEST
DTC & SRT CONFIRMATION
ECM PART NUMBER

SAT020K

### WITH GST

NFAT0242S02

Follow the procedure "With CONSULT-II".

# DTC P1705 THROTTLE POSITION SENSOR

Wiring Diagram — AT — TPS

## Wiring Diagram — AT — TPS

NFAT0074

AT-TPS-01

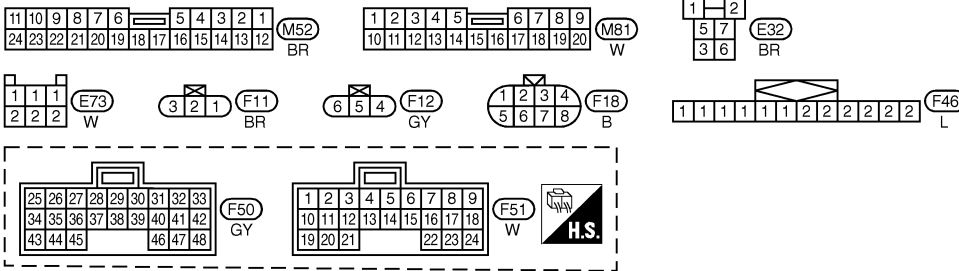
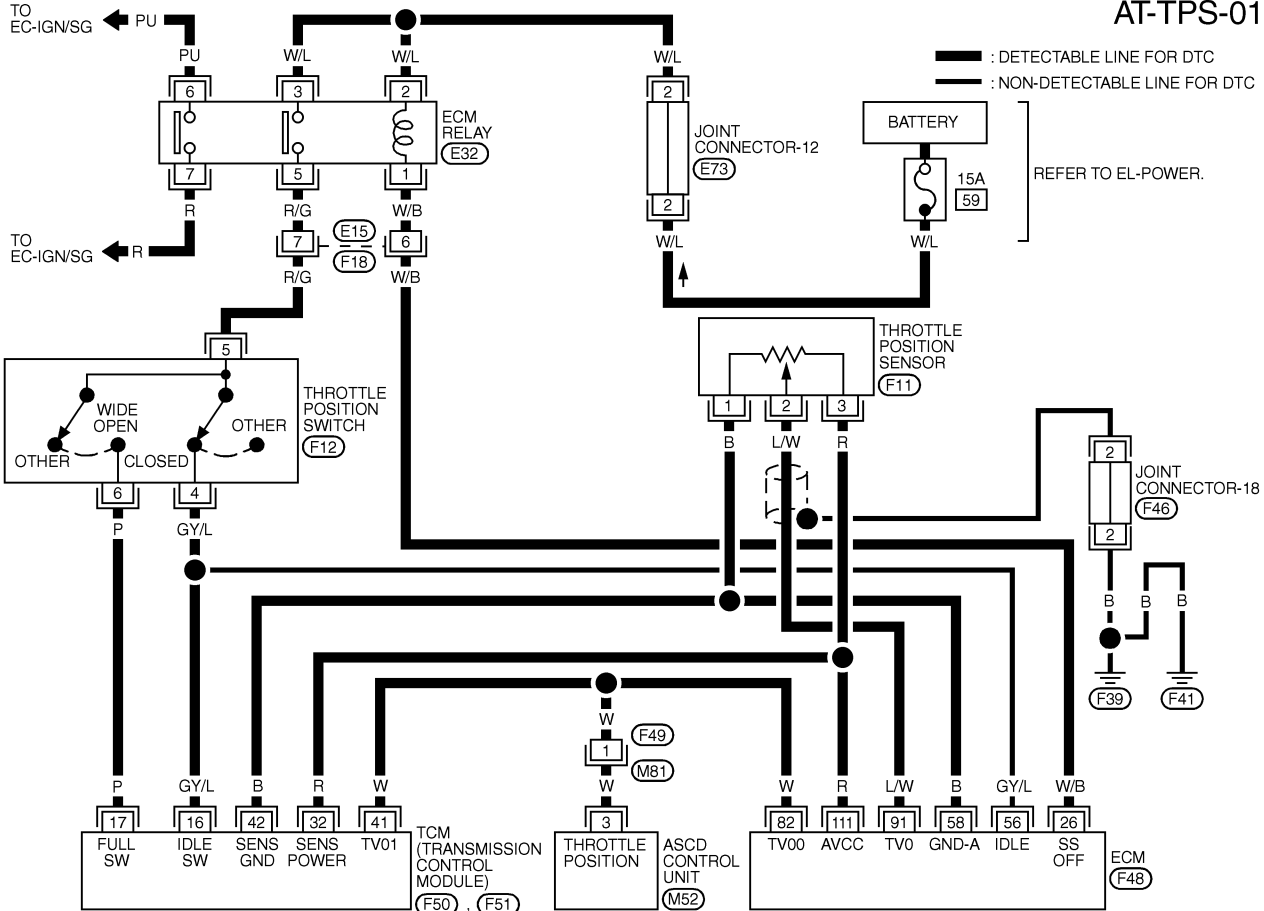

MAT885A

TCM TERMINALS AND REFERENCE VALUE (MEASURED BETWEEN EACH TERMINALS AND 25 OR 48 (TCM GROUND))

TERMINAL	WIRE COLOR	ITEM	CONDITION	DATA (DC)
16	GY/L	CLOSED THROTTLE POSITION SWITCH	WHEN IGN ON AND ACCELERATOR PEDAL IS RELEASED	BATTERY VOLTAGE
			WHEN IGN ON AND ACCELERATOR PEDAL IS DEPRESSED	1V OR LESS
17	P	WIDE OPEN THROTTLE POSITION SWITCH	WHEN IGN ON AND ACCELERATOR PEDAL IS RELEASED	1V OR LESS
			WHEN IGN ON AND ACCELERATOR PEDAL IS DEPRESSED	BATTERY VOLTAGE
32	R	THROTTLE POSITION SENSOR (POWER SOURCE)	WHEN IGN ON	4.5 - 5.5V
			WHEN IGN OFF	0.5V OR LESS
41	W	THROTTLE POSITION SENSOR	WHEN IGN ON AND ACCELERATOR PEDAL IS DEPRESSED SLOWLY AFTER WARMING UP ENGINE (VOLTAGE RISES GRADUALLY IN RESPONSE TO THROTTLE POSITION.)	FULLY-CLOSED THROTTLE: APPROXIMATELY 0.5V FULLY-OPEN THROTTLE: APPROXIMATELY 4V
42	B	THROTTLE POSITION SENSOR (GROUND)	—	—

SAT723J



# DTC P1705 THROTTLE POSITION SENSOR

Diagnostic Procedure

## Diagnostic Procedure

NFAT0075

<b>1</b>	<b>CHECK DTC WITH ECM</b>	
<ul style="list-style-type: none"> <li>Check P code with CONSULT-II "ENGINE". Turn ignition switch ON and select "SELF DIAGNOSTIC RESULTS" mode for "ENGINE" with CONSULT-II. Refer to EC-87, "Malfunction Indicator Lamp (MIL)".</li> </ul> <p style="text-align: center;"><b>OK or NG</b></p>		
OK (with CONSULT-II)	▶	GO TO 2.
OK (without CONSULT-II)	▶	GO TO 3.
NG	▶	Check throttle position sensor circuit for engine control. Refer to EC-188, "DTC P0120 Throttle Position Sensor".

<b>2</b>	<b>CHECK INPUT SIGNAL (With CONSULT-II)</b>															
<p> <b>With CONSULT-II</b></p> <ol style="list-style-type: none"> <li>Turn ignition switch to ON position. (Do not start engine.)</li> <li>Select "ECU INPUT SIGNALS" in "DATA MONITOR" mode for "A/T" with CONSULT-II.</li> <li>Read out the value of "THRTL POS SEN".</li> </ol> <p><b>Voltage:</b>  <b>Fully-closed throttle:</b>              <b>Approximately 0.5V</b>  <b>Fully-open throttle:</b>              <b>Approximately 4V</b></p> <table border="1" style="margin-left: auto; margin-right: auto;"> <thead> <tr> <th colspan="2">DATA MONITOR</th> </tr> <tr> <th>MONITORING</th> <th></th> </tr> </thead> <tbody> <tr> <td>VHCL/S SE-A/T</td> <td>XXX km/h</td> </tr> <tr> <td>VHCL/S SE-MTR</td> <td>XXX km/h</td> </tr> <tr> <td>THRTL POS SEN</td> <td>XXX V</td> </tr> <tr> <td>FLUID TEMP SE</td> <td>XXX V</td> </tr> <tr> <td>BATTERY VOLT</td> <td>XXX V</td> </tr> </tbody> </table> <p style="text-align: right;">SAT614J</p> <p style="text-align: center;"><b>OK or NG</b></p>			DATA MONITOR		MONITORING		VHCL/S SE-A/T	XXX km/h	VHCL/S SE-MTR	XXX km/h	THRTL POS SEN	XXX V	FLUID TEMP SE	XXX V	BATTERY VOLT	XXX V
DATA MONITOR																
MONITORING																
VHCL/S SE-A/T	XXX km/h															
VHCL/S SE-MTR	XXX km/h															
THRTL POS SEN	XXX V															
FLUID TEMP SE	XXX V															
BATTERY VOLT	XXX V															
OK	▶	GO TO 4.														
NG	▶	Check harness for short or open between ECM and TCM regarding throttle position sensor circuit. (Main harness)														

# DTC P1705 THROTTLE POSITION SENSOR

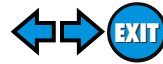

Diagnostic Procedure (Cont'd)

**3 CHECK INPUT SIGNAL (Without CONSULT-II)**

**⊗ Without CONSULT-II**

- Turn ignition switch to ON position. (Do not start engine.)
- Check voltage between TCM terminals 41 and 42 while accelerator pedal is depressed slowly.

SAT349JA

**Voltage:**  
**Fully-closed throttle valve:**  
 Approximately 0.5V  
**Fully-open throttle valve:**  
 Approximately 4V  
 (Voltage rises gradually in response to throttle position.)

**OK or NG**

OK	▶	GO TO 6.
NG	▶	Check harness for short or open between ECM and TCM regarding throttle position sensor circuit. (Main harness)

GI  
MA  
EM  
LC  
EC  
FE  
CL  
MT

**AT**

**4 CHECK THROTTLE POSITION SWITCH CIRCUIT (With CONSULT-II)**

**Ⓟ With CONSULT-II**

- Turn ignition switch to ON position. (Do not start engine.)
- Select "ECU INPUT SIGNALS" in "DATA MONITOR" mode for "A/T" with CONSULT-II.
- Apply vacuum to the throttle opener, then check the following. Refer to steps 1 and 2 of "Preparation", "TCM SELF-DIAGNOSTIC PROCEDURE (No Tools)", AT-49.
- Read out "CLOSED THL/SW" and "W/O THRL/P-SW" depressing and releasing accelerator pedal. Check the signal of throttle position switch is indicated properly.

Accelerator pedal condition	Data monitor	
	CLOSED THL/SW	W/O THRL/P-SW
Released	ON	OFF
Fully depressed	OFF	ON

DATA MONITOR	
MONITORING	
POWERSHIFT SW	OFF
CLOSED THL/SW	OFF
W/O THRL/P-SW	OFF
HOLD SW	OFF
BRAKE SW	ON

MTBL0011

**OK or NG**

OK	▶	GO TO 8.
NG	▶	GO TO 5.

AX  
SU  
BR  
ST  
RS  
BT  
HA  
SC  
EL  
IDX

SAT646J

# DTC P1705 THROTTLE POSITION SENSOR

Diagnostic Procedure (Cont'd)

## 5 DETECT MALFUNCTIONING ITEM

Check the following items:

- Throttle position switch.
- a. Closed throttle position switch (idle position)
  - i. Check continuity between terminals 4 and 5.

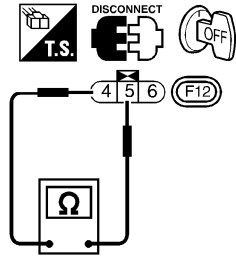

Accelerator pedal condition	Continuity
Released	Yes
Depressed	No

SAT634J

- ii. To adjust closed throttle position switch, refer to EC-113, "Basic Inspection".
- b. Wide open throttle position switch
  - i. Check continuity between terminals 5 and 6.

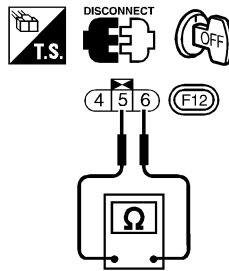

Accelerator pedal condition	Continuity
Released	No
Depressed	Yes

SAT635J

- Harness for short or open between ignition switch and throttle position switch (Main harness)
- Harness for short or open between throttle position switch and TCM (Main harness)

**OK or NG**

OK	▶	GO TO 8.
NG	▶	Repair or replace damaged parts.

# DTC P1705 THROTTLE POSITION SENSOR

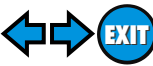

Diagnostic Procedure (Cont'd)

## 6 CHECK THROTTLE POSITION SWITCH CIRCUIT (Without CONSULT-II)

### ⊗ Without CONSULT-II

1. Turn ignition switch to ON position.  
(Do not start engine.)
2. Check voltage between TCM terminals 16, 17 and ground while depressing, and releasing accelerator pedal slowly.  
(After warming up engine)  
[Refer to "Preparation", "TCM SELF-DIAGNOSTIC PROCEDURE (No Tools)", AT-49].

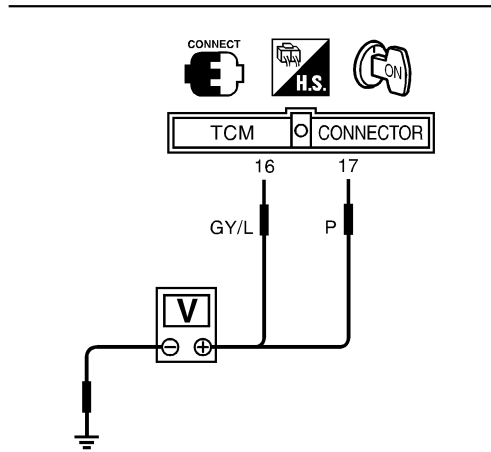

Accelerator pedal condition	Voltage	
	Terminal No. 16	Terminal No. 17
Released	Battery voltage	1V or less
Fully depressed	1V or less	Battery voltage

SAT350JA

MTBL0120

**OK or NG**

OK	▶	GO TO 8.
NG	▶	GO TO 7.

GI  
MA  
EM  
LC  
EC  
FE  
CL  
MT  
AT  
AX  
SU  
BR  
ST  
RS  
BT  
HA  
SC  
EL  
IDX

# DTC P1705 THROTTLE POSITION SENSOR

Diagnostic Procedure (Cont'd)

<b>7</b>	<b>DETECT MALFUNCTIONING ITEM</b>						
<p>Check the following items:</p> <ul style="list-style-type: none"> <li>● Throttle position switch.</li> <li>a. Closed throttle position switch (idle position)             <ul style="list-style-type: none"> <li>i. Check continuity between terminals 4 and 5.</li> </ul> </li> </ul>							
<table border="1" style="width: 100%; border-collapse: collapse;"> <thead> <tr> <th style="width: 50%;">Accelerator pedal condition</th> <th style="width: 50%;">Continuity</th> </tr> </thead> <tbody> <tr> <td style="text-align: center;">Released</td> <td style="text-align: center;">Yes</td> </tr> <tr> <td style="text-align: center;">Depressed</td> <td style="text-align: center;">No</td> </tr> </tbody> </table>		Accelerator pedal condition	Continuity	Released	Yes	Depressed	No
Accelerator pedal condition	Continuity						
Released	Yes						
Depressed	No						
SAT634J							
<ul style="list-style-type: none"> <li>ii. To adjust closed throttle position switch, refer to EC-113, "Basic Inspection".</li> <li>b. Wide open throttle position switch             <ul style="list-style-type: none"> <li>i. Check continuity between terminals 5 and 6.</li> </ul> </li> </ul>							
<table border="1" style="width: 100%; border-collapse: collapse;"> <thead> <tr> <th style="width: 50%;">Accelerator pedal condition</th> <th style="width: 50%;">Continuity</th> </tr> </thead> <tbody> <tr> <td style="text-align: center;">Released</td> <td style="text-align: center;">No</td> </tr> <tr> <td style="text-align: center;">Depressed</td> <td style="text-align: center;">Yes</td> </tr> </tbody> </table>		Accelerator pedal condition	Continuity	Released	No	Depressed	Yes
Accelerator pedal condition	Continuity						
Released	No						
Depressed	Yes						
SAT635J							
<ul style="list-style-type: none"> <li>● Harness for short or open between ignition switch and throttle position switch (Main harness)</li> <li>● Harness for short or open between throttle position switch and TCM (Main harness)</li> </ul>							
<b>OK or NG</b>							
OK	▶ GO TO 8.						
NG	▶ Repair or replace damaged parts.						

<b>8</b>	<b>CHECK DTC</b>
Perform Diagnostic Trouble Code (DTC) confirmation procedure, AT-184.	
<b>OK or NG</b>	
OK	▶ <b>INSPECTION END</b>
NG	▶ GO TO 9.

<b>9</b>	<b>CHECK TCM INSPECTION</b>
<ol style="list-style-type: none"> <li>1. Perform TCM input/output signal inspection.</li> <li>2. If NG, recheck TCM pin terminals for damage or loose connection with harness connector.</li> </ol>	
<b>OK or NG</b>	
OK	▶ <b>INSPECTION END</b>
NG	▶ Repair or replace damaged parts.

# DTC P1760 OVERRUN CLUTCH SOLENOID VALVE

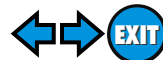

Description

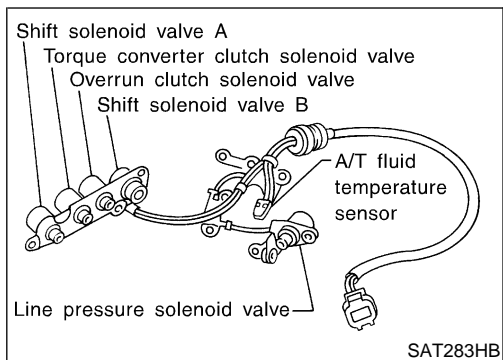

## Description

The overrun clutch solenoid valve is activated by the TCM in response to signals sent from the park/neutral position (PNP) switch, overdrive control switch, vehicle speed and throttle position sensors. The overrun clutch operation will then be controlled.

NFAT0076

GI

MA

EM

LC

## TCM TERMINALS AND REFERENCE VALUE

NFAT0076S01

Remarks: Specification data are reference values.

Terminal No.	Wire color	Item	Condition	Judgement standard	
20	BR/Y	Overrun clutch solenoid valve		When overrun clutch solenoid valve operates.	Battery voltage
				When overrun clutch solenoid valve does not operate.	1V or less

EC

FE

CL

MT

## On Board Diagnosis Logic

Diagnostic trouble code O/R CLTCH SOL/CIRC with CONSULT-II or P1760 without CONSULT-II is detected when TCM detects an improper voltage drop when it tries to operate the solenoid valve.

NFAT0243

AT

AX

SU

BR

## Possible Cause

Check the following items.

- Harness or connectors (The solenoid circuit is open or shorted.)
- Overrun clutch solenoid valve

NFAT0244

ST

RS

BT

HA

SC

EL

IDX

# DTC P1760 OVERRUN CLUTCH SOLENOID VALVE

Diagnostic Trouble Code (DTC) Confirmation Procedure

SELECT SYSTEM
A/T
ENGINE

SAT014K

SELECT DIAG MODE
WORK SUPPORT
SELF-DIAG RESULTS
DATA MONITOR
ACTIVE TEST
DTC & SRT CONFIRMATION
ECM PART NUMBER

SAT020K

## Diagnostic Trouble Code (DTC) Confirmation Procedure

NFAT0245

### CAUTION:

Always drive vehicle at a safe speed.

### NOTE:

If "DIAGNOSTIC TROUBLE CODE CONFIRMATION PROCEDURE" has been previously conducted, always turn ignition switch OFF and wait at least 5 seconds before conducting the next test.

### TESTING CONDITION:

Always drive vehicle on a level road to improve accuracy of test.

After the repair, perform the following procedure to confirm the malfunction is eliminated.

### WITH CONSULT-II

NFAT0245S01

- 1) Turn ignition switch ON and select "DATA MONITOR" mode for "ENGINE" with CONSULT-II.
- 2) Start engine.
- 3) Accelerate vehicle to a speed of more than 10 km/h (6 MPH) with D position (O/D ON).
- 4) Release accelerator pedal completely with D position (O/D OFF).

### WITH GST

NFAT0245S02

Follow the procedure "With CONSULT-II".

# DTC P1760 OVERRUN CLUTCH SOLENOID VALVE

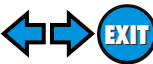

Wiring Diagram — AT — OVRCSV

## Wiring Diagram — AT — OVRCSV

NFAT0077

### AT-OVRCSV-01

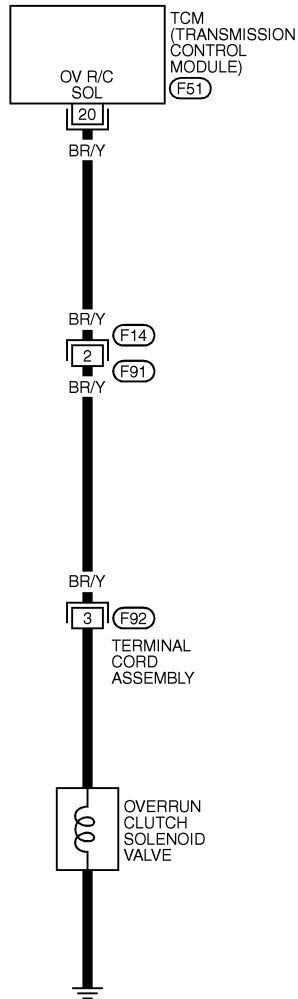

— : DETECTABLE LINE FOR DTC  
 — : NON-DETECTABLE LINE FOR DTC

GI

MA

EM

LC

EC

FE

CL

MT

**AT**

AX

SU

BR

ST

RS

BT

MAT818A

HA

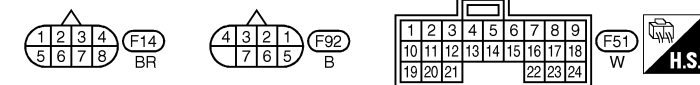

TCM TERMINALS AND REFERENCE VALUE (MEASURED BETWEEN EACH TERMINALS AND 25 OR 48 (TCM GROUND))

TERMINAL	WIRE COLOR	ITEM	CONDITION	DATA (DC)
20	BR/Y	OVERRUN CLUTCH SOLENOID VALVE	WHEN VEHICLE STARTS AND OVERRUN CLUTCH S/V OPERATES	BATTERY VOTAGE
			WHEN VEHICLE STARTS AND OVERRUN CLUTCH S/V DOES NOT OPERATE	1V OR LESS

SC

EL

IDX

SAT724J



# DTC P1760 OVERRUN CLUTCH SOLENOID VALVE

Diagnostic Procedure

## Diagnostic Procedure

NFAT0078

<b>1</b>	<b>CHECK VLAVE RESISTANCE</b>		
<p>1. Turn ignition switch to OFF position.                  2. Disconnect terminal cord assembly connector in engine compartment.                  3. Check resistance between terminal 3 and ground.</p>			
<p style="text-align: center;">Resistance: 20 - 30 Ω</p>			
SAT637JB			
<b>OK or NG</b>			
OK	▶	GO TO 3.	
NG	▶	GO TO 2.	

<b>2</b>	<b>CHECK VALVE OPERATION</b>		
<p>1. Remove control valve assembly. Refer to AT-280.                  2. Check the following items:</p> <ul style="list-style-type: none"> <li>● Overrun clutch solenoid valve</li> <li>● Operation check</li> </ul> <p>i. Check solenoid valve by listening for its operating sound while applying battey voltage to the terminal and ground.</p>			
SAT638J			
<b>OK or NG</b>			
<ul style="list-style-type: none"> <li>● Harness of terminal cord assembly for short or open</li> </ul>			
OK	▶	GO TO 3.	
NG	▶	Repair or replace damaged parts.	

<b>3</b>	<b>CHECK POWER SOURCE CIRCUIT</b>		
<p>1. Turn ignition switch to OFF position.                  2. Disconnect TCM harness connector.                  3. Check continuity between sub-harness connector terminal 3 and TCM harness connector terminal 20. Refer to wiring diagram — AT — OVRCVS.  <b>Continuity should exist.</b>                  If OK, check harness for short to ground and short to power.                  4. Reinstall any part removed.</p>			
<b>OK or NG</b>			
OK	▶	GO TO 4.	
NG	▶	Repair open circuit or short to ground or short to power in harness or connectors.	

# DTC P1760 OVERRUN CLUTCH SOLENOID VALVE

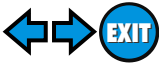

Diagnostic Procedure (Cont'd)

<b>4</b>	<b>CHECK DTC</b>
Perform Diagnostic Trouble Code (DTC) confirmation procedure, AT-192.	
<b>OK or NG</b>	
OK	▶ <b>INSPECTION END</b>
NG	▶ GO TO 5.

GI

MA

EM

<b>5</b>	<b>CHECK TCM INSPECTION</b>
1. Perform TCM input/output signal inspection. 2. If NG, recheck TCM pin terminals for damage or loose connection with harness connector.	
<b>OK or NG</b>	
OK	▶ <b>INSPECTION END</b>
NG	▶ Repair or replace damaged parts.

LC

EC

FE

CL

MT

**AT**

AX

SU

BR

ST

RS

BT

HA

SC

EL

IDX

# DTC BATT/FLUID TEMP SEN (A/T FLUID TEMP SENSOR CIRCUIT AND TCM POWER SOURCE)

## Description

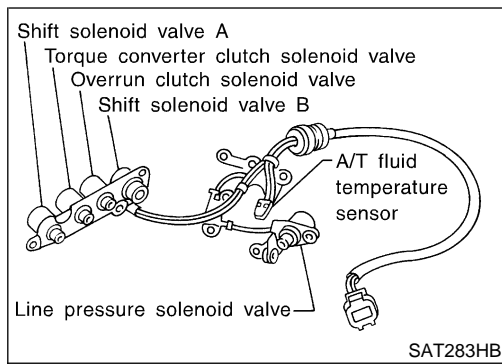

## Description

The A/T fluid temperature sensor detects the A/T fluid temperature and sends a signal to the TCM. NFAT0079

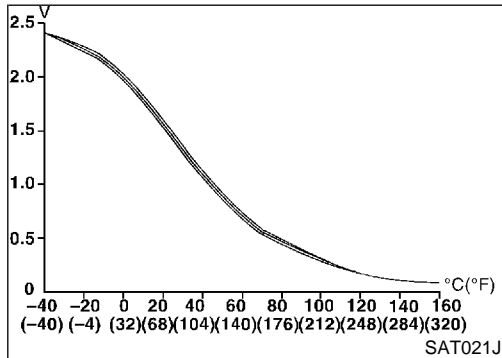







## CONSULT-II REFERENCE VALUE IN DATA MONITOR MODE

Remarks: Specification data are reference values. NFAT0079S01

Monitor item	Condition	Specification
A/T fluid temperature sensor	Cold [20°C (68°F)]	Approximately 1.5V
	↓	↓
	Hot [80°C (176°F)]	Approximately 0.5V

## TCM TERMINALS AND REFERENCE VALUE

Remarks: Specification data are reference values. NFAT0079S02

Terminal No.	Wire color	Item	Condition	Judgement standard
10	R/Y	Power source		Battery voltage
				1V or less
19	R/Y	Power source	Same as No. 10	
28	Y/R	Power source (Memory back-up)		Battery voltage
				Battery voltage
42	B	Throttle position sensor (Ground)	—	—
47	G	A/T fluid temperature sensor		Approximately 1.5V
				Approximately 0.5V

## On Board Diagnosis Logic

Diagnostic trouble code BATT/FLUID TEMP SEN with CONSULT-II or 8th judgement flicker without CONSULT-II is detected when TCM receives an excessively low or high voltage from the sensor. NFAT0246

GI

MA

EM

LC

## Possible Cause

Check the following items. NFAT0247

- Harness or connectors  
(The sensor circuit is open or shorted.)
- A/T fluid temperature sensor

EC

FE

CL

MT

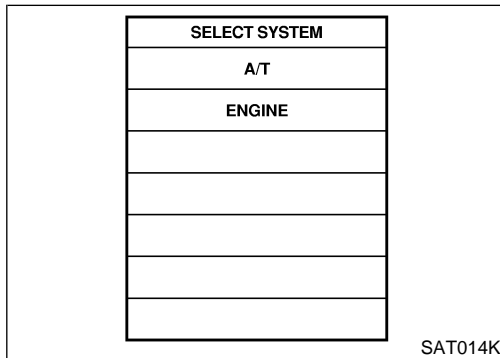

## Diagnostic Trouble Code (DTC) Confirmation Procedure

After the repair, perform the following procedure to confirm the malfunction is eliminated. NFAT0248

AT

### WITH CONSULT-II

- 1) Start engine. NFAT0248S01
- 2) Select "DATA MONITOR" mode for "A/T" with CONSULT-II.
- 3) Drive vehicle under the following conditions:  
Selector lever in D, vehicle speed higher than 20 km/h (12 MPH).

AX

SU

BR

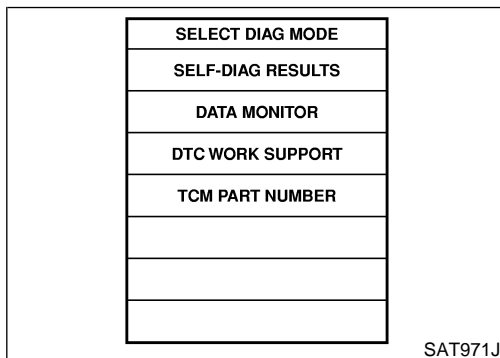

### WITHOUT CONSULT-II

- 1) Start engine. NFAT0248S02
- 2) Drive vehicle under the following conditions:  
Selector lever in D, vehicle speed higher than 20 km/h (12 MPH).
- 3) Perform self-diagnosis.  
Refer to TCM SELF-DIAGNOSTIC PROCEDURE (NO TOOLS), AT-49.

ST

RS

BT

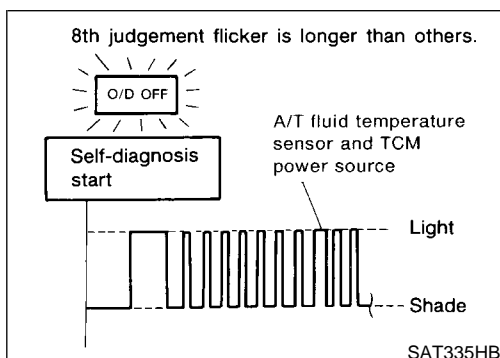

HA

SC

EL

IDX

# DTC BATT/FLUID TEMP SEN (A/T FLUID TEMP SENSOR CIRCUIT AND TCM POWER SOURCE) EXIT

Wiring Diagram — AT — BA/FTS

## Wiring Diagram — AT — BA/FTS

NFAT0080

### AT-BA/FTS-01

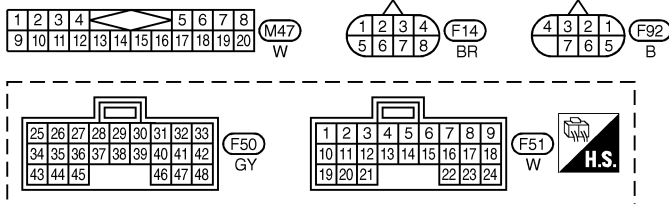
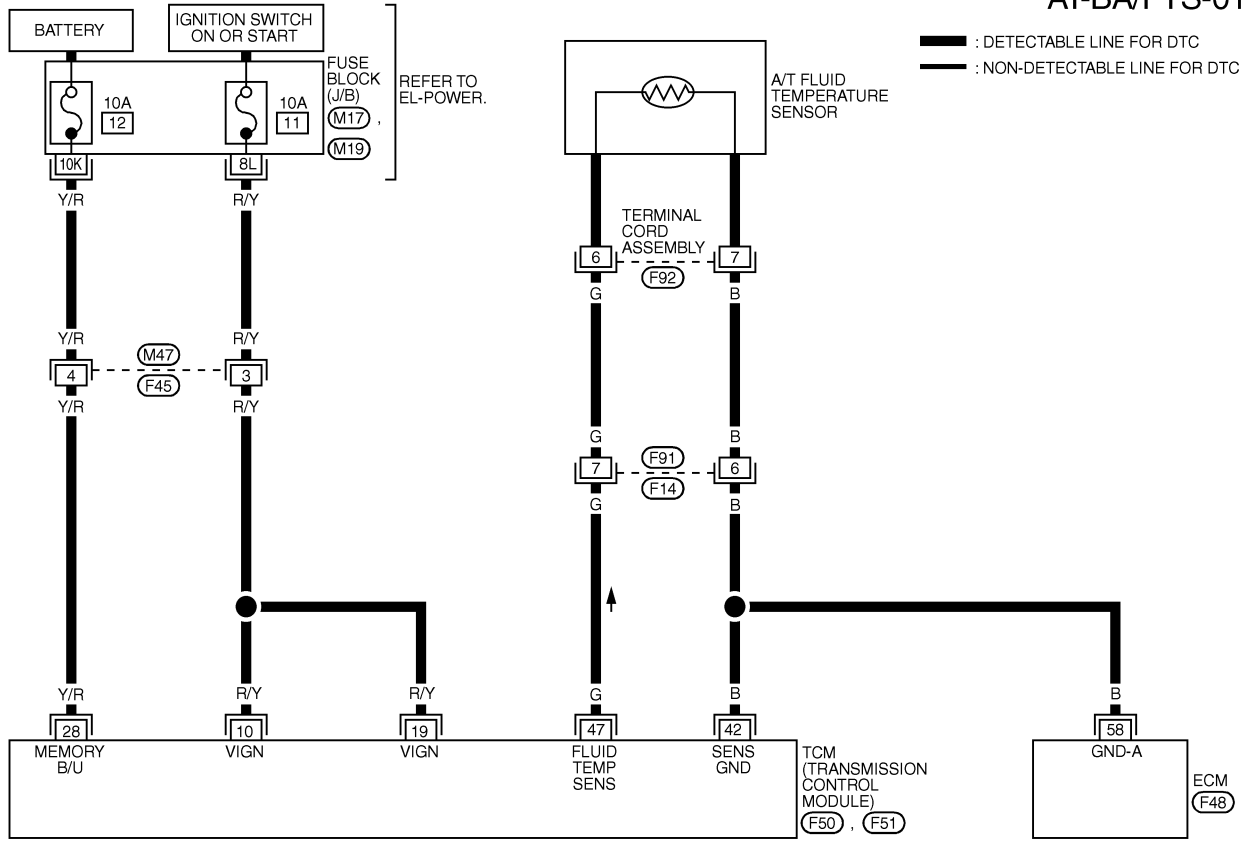

REFER TO THE FOLLOWING.

- (M17) - FUSE BLOCK - JUNCTION BOX (J/B)
- (M19) - FUSE BLOCK - JUNCTION BOX (J/B)
- (F48) - ELECTRICAL UNITS

MAT819A

TCM TERMINALS AND REFERENCE VALUE (MEASURED BETWEEN EACH TERMINALS AND 25 OR 48 (TCM GROUND))

TERMINAL	WIRE COLOR	ITEM	CONDITION	DATA (DC)
10	R/Y	POWER SOURCE	WHEN IGN ON WHEN IGN OFF	BATTERY VOLTAGE 1V OR LESS
19	R/Y	POWER SOURCE	SAME AS NO. 10	
28	Y/R	POWER SOURCE (MEMORY BACK-UP)	WHEN IGN ON WHEN IGN OFF	BATTERY VOLTAGE BATTERY VOLTAGE
42	B	THROTTLE POSITION SENSOR (GROUND)	—	—
47	G	A/T FLUID TEMPERATURE SENSOR	WHEN IGN ON AND ATF TEMPERATURE IS 20°C (68°F) WHEN IGN ON AND ATF TEMPERATURE IS 80°C (176°F)	APPROXIMATELY 1.5V APPROXIMATELY 0.5V

SAT725J

## Diagnostic Procedure

NFAT0081

<b>1</b>	<b>CHECK INPUT SIGNAL OF A/T FLUID TEMPERATURE SENSOR (With CONSULT-II)</b>	GI MA EM LC EC FE CL MT														
<p><b>With CONSULT-II</b></p> <ol style="list-style-type: none"> <li>1. Start engine.</li> <li>2. Select "ECU INPUT SIGNALS" in "DATA MONITOR" mode for "A/T" with CONSULT-II.</li> <li>3. Read out the value of "FLUID TEMP SE".</li> </ol>																
<table border="1" style="margin: auto; border-collapse: collapse;"> <thead> <tr> <th colspan="2">DATA MONITOR</th> </tr> <tr> <th>MONITORING</th> <th></th> </tr> </thead> <tbody> <tr> <td>VHCL/S SE-A/T</td> <td>XXX km/h</td> </tr> <tr> <td>VHCL/S SE-MTR</td> <td>XXX km/h</td> </tr> <tr> <td>THRTL POS SEN</td> <td>XXX V</td> </tr> <tr> <td>FLUID TEMP SE</td> <td>XXX V</td> </tr> <tr> <td>BATTERY VOLT</td> <td>XXX V</td> </tr> </tbody> </table>		DATA MONITOR		MONITORING		VHCL/S SE-A/T	XXX km/h	VHCL/S SE-MTR	XXX km/h	THRTL POS SEN	XXX V	FLUID TEMP SE	XXX V	BATTERY VOLT	XXX V	SAT614J
DATA MONITOR																
MONITORING																
VHCL/S SE-A/T	XXX km/h															
VHCL/S SE-MTR	XXX km/h															
THRTL POS SEN	XXX V															
FLUID TEMP SE	XXX V															
BATTERY VOLT	XXX V															
<p><b>Voltage:</b> Cold [20°C (68°F)] → Hot [80°C (176°F)]: Approximately 1.5V → 0.5V</p> <p style="text-align: center;"><b>OK or NG</b></p>																
OK	▶ GO TO 9.															
NG	▶ GO TO 2.															

<b>2</b>	<b>DETECT MALFUNCTIONING ITEM</b>	AX SU BR ST
<p>Check the following items:</p> <ul style="list-style-type: none"> <li>● Harness for short or open between TCM, ECM and terminal cord assembly (Main harness)</li> <li>● Ground circuit for ECM</li> </ul> <p>Refer to EC-157, "TROUBLE DIAGNOSIS FOR POWER SUPPLY".</p> <p style="text-align: center;"><b>OK or NG</b></p>		
OK	▶ GO TO 9.	
NG	▶ Repair or replace damaged parts.	

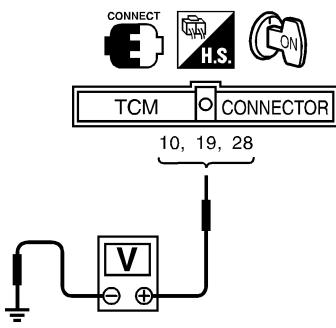
<b>3</b>	<b>CHECK TCM POWER SOURCE STEP 1</b>	RS BT HA SC EL IDX
<ol style="list-style-type: none"> <li>1. Turn ignition switch to ON position. (Do not start engine.)</li> <li>2. Check voltage between TCM terminals 10, 19, 28 and ground.</li> </ol>		
 <p style="text-align: right;"><b>Voltage:</b> <b>Battery voltage</b></p>		SAT611J
<b>OK or NG</b>		
OK	▶ GO TO 4.	
NG	▶ GO TO 5.	

# DTC BATT/FLUID TEMP SEN (A/T FLUID TEMP SENSOR CIRCUIT AND TCM POWER SOURCE) ←→ EXIT

Diagnostic Procedure (Cont'd)

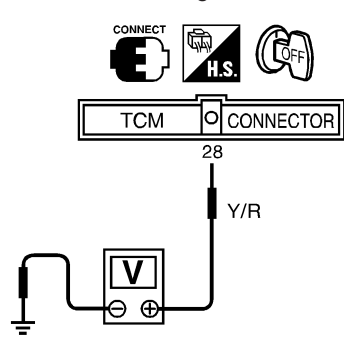
<b>4</b>	<b>CHECK TCM POWER SOURCE STEP 2</b>	
<p>1. Turn ignition switch to OFF position.                  2. Check voltage between TCM terminal 28 and ground.</p>		
		
		<p><b>Voltage:</b>  <b>Battery voltage</b></p>
SAT612J		
<b>OK or NG</b>		
OK	▶	GO TO 6.
NG	▶	GO TO 5.

<b>5</b>	<b>DETECT MALFUNCTIONING ITEM</b>	
<p>Check the following items:</p> <ul style="list-style-type: none"> <li>● Harness for short or open between ignition switch and TCM (Main harness)</li> <li>● Ignition switch and fuse</li> </ul> <p>Refer to EL-119, "POWER SUPPLY ROUTING".</p>		
<b>OK or NG</b>		
OK	▶	GO TO 6.
NG	▶	Repair or replace damaged parts.

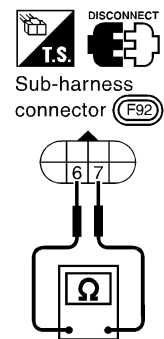
<b>6</b>	<b>CHECK A/T FLUID TEMPERATURE SENSOR WITH TERMINAL CORD ASSEMBLY</b>	
<p>1. Turn ignition switch to OFF position.                  2. Disconnect terminal cord assembly connector in engine compartment.                  3. Check resistance between terminals 6 and 7 when A/T is cold.</p>		
		
		<p><b>Resistance:</b>  <b>Cold [20°C (68°F)]</b>  <b>Approximately 2.5 kΩ</b></p>
SAT616J		
<p>4. Reinstall any part removed.</p>		
<b>OK or NG</b>		
OK (without CONSULT-II)	▶	GO TO 8.
NG	▶	GO TO 7.

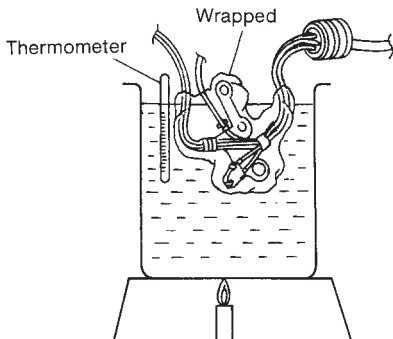
<b>7</b>	<b>DETECT MALFUNCTIONING ITEM</b>	<p>1. Remove oil pan. Refer to AT-280.</p> <p>2. Check the following items:</p> <ul style="list-style-type: none"> <li>● A/T fluid temperature sensor</li> </ul> <p>i. Check resistance between two terminals while changing temperature as shown below.</p> <div style="text-align: center;">  </div> <table border="1" style="margin: 10px auto; border-collapse: collapse;"> <thead> <tr> <th style="text-align: center;">Temperature °C (°F)</th> <th style="text-align: center;">Resistance</th> </tr> </thead> <tbody> <tr> <td style="text-align: center;">20 (68)</td> <td style="text-align: center;">Approximately 2.5 kΩ</td> </tr> <tr> <td style="text-align: center;">80 (176)</td> <td style="text-align: center;">Approximately 0.3 kΩ</td> </tr> </tbody> </table> <p>● Harness of terminal cord assembly for short or open</p> <p style="text-align: center;"><b>OK or NG</b></p>	Temperature °C (°F)	Resistance	20 (68)	Approximately 2.5 kΩ	80 (176)	Approximately 0.3 kΩ	GI MA EM LC EC SAT298F FE CL MTBL0210 MT
Temperature °C (°F)	Resistance								
20 (68)	Approximately 2.5 kΩ								
80 (176)	Approximately 0.3 kΩ								
OK (without CONSULT-II) ► GO TO 8.			<b>AT</b>						
NG ► Repair or replace damaged parts.			AX						

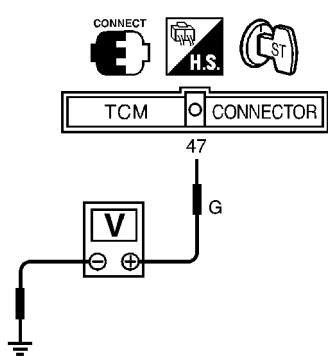
<b>8</b>	<b>CHECK INPUT SIGNAL OF A/T FLUID TEMPERATURE SENSOR (Without CONSULT-II)</b>	<p><input checked="" type="checkbox"/> <b>Without CONSULT-II</b></p> <p>1. Start engine.</p> <p>2. Check voltage between TCM terminal 47 and ground while warming up A/T.</p> <div style="text-align: center;">  </div> <p><b>Voltage:</b>  <span style="color: blue;">Cold [20°C (68°F)] → Hot [80°C (176°F)]:</span>  <span style="color: blue;">Approximately 1.5V → 0.5V</span></p> <p>3. Turn ignition switch to OFF position.</p> <p>4. Disconnect TCM harness connector.</p> <p>5. Check resistance between terminal 42 and ground. Refer to wiring diagram — AT — BA/FTS.  <span style="color: blue;"><b>Continuity should exist.</b></span></p> <p style="text-align: center;"><b>OK or NG</b></p>	SU BR ST RS BT SAT354J HA SC EL IDX
OK ► GO TO 10.			
NG ► GO TO 9.			



# DTC BATT/FLUID TEMP SEN (A/T FLUID TEMP SENSOR CIRCUIT AND TCM POWER SOURCE)

Diagnostic Procedure (Cont'd)

<b>9</b>	<b>DETECT MALFUNCTIONING ITEM</b>
Check the following items: <ul style="list-style-type: none"><li>● Harness for short or open between TCM, ECM and terminal cord assembly (Main harness)</li><li>● Ground circuit for ECM</li></ul> Refer to EC-157, "TROUBLE DIAGNOSIS FOR POWER SUPPLY".	
<b>OK or NG</b>	
OK	▶ GO TO 10.
NG	▶ Repair or replace damaged parts.

<b>10</b>	<b>CHECK DTC</b>
Perform Diagnostic Trouble Code (DTC) confirmation procedure, AT-197.	
<b>OK or NG</b>	
OK	▶ <b>INSPECTION END</b>
NG	▶ GO TO 11.

<b>11</b>	<b>CHECK TCM INSPECTION</b>
1. Perform TCM input/output signal inspection. 2. If NG, recheck TCM pin terminals for damage or loose connection with harness connector.	
<b>OK or NG</b>	
OK	▶ <b>INSPECTION END</b>
NG	▶ Repair or replace damaged parts.

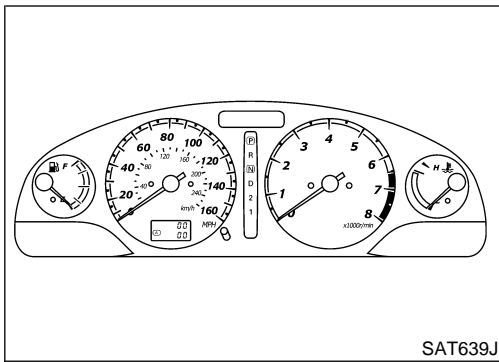

## Description

The vehicle speed sensor-MTR is built into the speedometer assembly. The sensor functions as an auxiliary device to the revolution sensor when it is malfunctioning. The TCM will then use a signal sent from the vehicle speed sensor-MTR.

NFAT0082

GI  
MA  
EM  
LC

## TCM TERMINALS AND REFERENCE VALUE

NFAT0082S01

Remarks: Specification data are reference values.

Terminal No.	Wire color	Item	Condition		Judgement standard
40	PU/R	Vehicle speed sensor		When moving vehicle at 2 to 3 km/h (1 to 2 MPH) for 1 m (3 ft) or more.	Voltage varies between less than 1V and more than 4.5V
42	B	Throttle position sensor (Ground)	—	—	—

EC  
FE  
CL  
MT

**AT**

AX

SU

BR

## On Board Diagnosis Logic

Diagnostic trouble code VHCL SPEED SEN-MTR with CONSULT-II or 2nd judgement flicker without CONSULT-II is detected when TCM does not receive the proper voltage signal from the sensor.

NFAT0249

ST  
RS

BT

HA

## Possible Cause

Check the following items.

- Harness or connectors (The sensor circuit is open or shorted.)
- Vehicle speed sensor

NFAT0250

SC  
EL  
IDX

# DTC VEHICLE SPEED SENSOR-MTR

Diagnostic Trouble Code (DTC) Confirmation Procedure

SELECT SYSTEM
A/T
ENGINE

SAT014K

SELECT DIAG MODE
SELF-DIAG RESULTS
DATA MONITOR
DTC WORK SUPPORT
TCM PART NUMBER

SAT971J

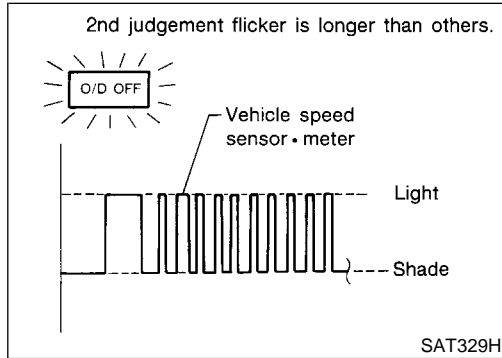

## Diagnostic Trouble Code (DTC) Confirmation Procedure

NFAT0251

### CAUTION:

- Always drive vehicle at a safe speed.
- If conducting this “DTC Confirmation Procedure” again, always turn ignition switch OFF and wait at least 5 seconds before continuing.

After the repair, perform the following procedure to confirm the malfunction is eliminated.

### WITH CONSULT-II

NFAT0251S01

- 1) Turn ignition switch ON and select “DATA MONITOR” mode for “A/T” with CONSULT-II.
- 2) Start engine and accelerate vehicle from 0 to 25 km/h (0 to 16 MPH).

### WITHOUT CONSULT-II

NFAT0251S02

- 1) Start engine.
- 2) Drive vehicle under the following conditions:  
Selector lever in D and vehicle speed higher than 25 km/h (16 MPH).
- 3) Perform self-diagnosis.  
Refer to TCM SELF-DIAGNOSTIC PROCEDURE (NO TOOLS), AT-49.

# DTC VEHICLE SPEED SENSOR-MTR

Wiring Diagram — AT — VSSMTR

## Wiring Diagram — AT — VSSMTR

NFAT0083

### AT-VSSMTR-01

— : DETECTABLE LINE FOR DTC  
 — : NON-DETECTABLE LINE FOR DTC

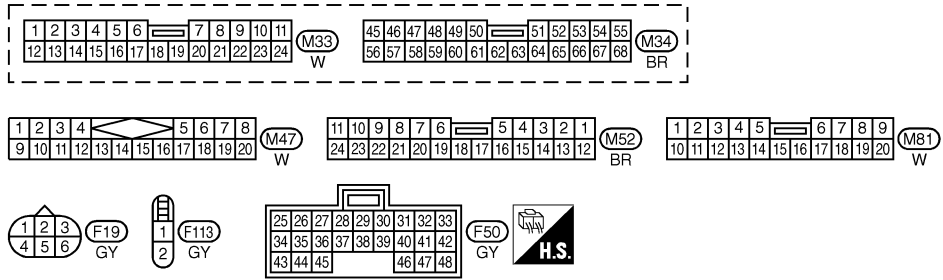
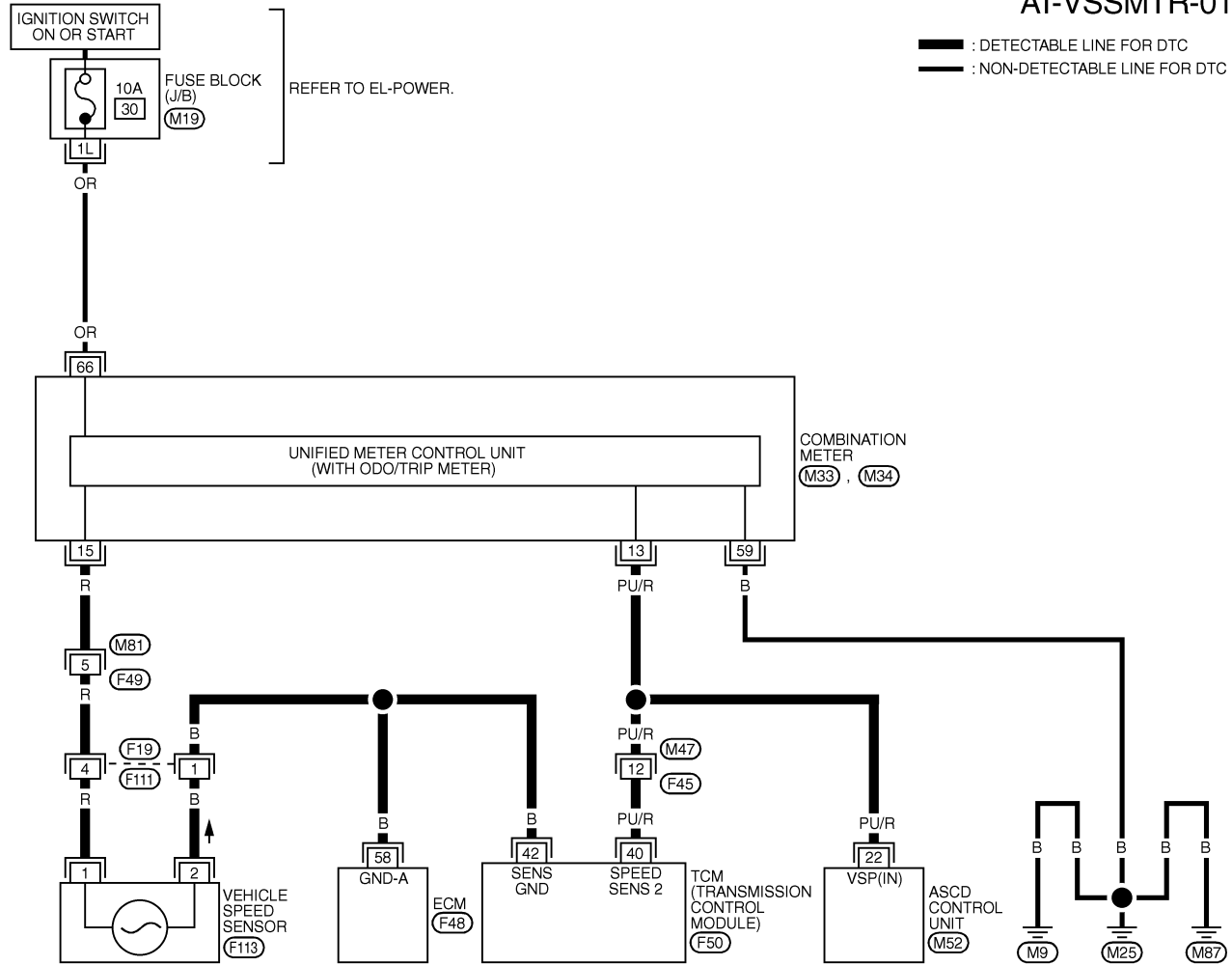

REFER TO THE FOLLOWING.  
 (M19) - FUSE BLOCK-JUNCTION BOX (J/B)  
 (F48) - ELECTRICAL UNITS

MAT820A

TCM TERMINALS AND REFERENCE VALUE (MEASURED BETWEEN EACH TERMINALS AND 25 OR 48 (TCM GROUND))

TERMINAL	WIRE COLOR	ITEM	CONDITION	DATA (DC)
40	PU/R	VEHICLE SPEED SENSOR	WHEN MOVING VEHICLE AT 2 TO 3 KM/H (1 TO 2 MPH) FOR 1 M (3 FT)	VOLTAGE VARIES BETWEEN LESS THAN 1V AND MORE THAN 4.5 V

GI  
 MA  
 EM  
 LC  
 EC  
 FE  
 CL  
 MT  
**AT**  
 AX  
 SU  
 BR  
 ST  
 RS  
 BT  
 HA  
 SC  
 EL  
 IDX

# DTC VEHICLE SPEED SENSOR-MTR

Diagnostic Procedure

## Diagnostic Procedure

NFAT0084

<b>1</b>	<b>CHECK INPUT SIGNAL</b>														
<p> <b>With CONSULT-II</b></p> <ol style="list-style-type: none"> <li>1. Start engine.</li> <li>2. Select "ECU INPUT SIGNALS" in "DATA MONITOR" mode for "A/T" with CONSULT-II.</li> <li>3. Read out the value of "VHCL/S SE-MTR" while driving. Check the value changes according to driving speed.</li> </ol>															
<table border="1" style="margin: auto; border-collapse: collapse;"> <thead> <tr> <th colspan="2">DATA MONITOR</th> </tr> <tr> <th>MONITORING</th> <th></th> </tr> </thead> <tbody> <tr> <td>VHCL/S SE-A/T</td> <td>XXX km/h</td> </tr> <tr> <td>VHCL/S SE-MTR</td> <td>XXX km/h</td> </tr> <tr> <td>THRTL POS SEN</td> <td>XXX V</td> </tr> <tr> <td>FLUID TEMP SE</td> <td>XXX V</td> </tr> <tr> <td>BATTERY VOLT</td> <td>XXX V</td> </tr> </tbody> </table>		DATA MONITOR		MONITORING		VHCL/S SE-A/T	XXX km/h	VHCL/S SE-MTR	XXX km/h	THRTL POS SEN	XXX V	FLUID TEMP SE	XXX V	BATTERY VOLT	XXX V
DATA MONITOR															
MONITORING															
VHCL/S SE-A/T	XXX km/h														
VHCL/S SE-MTR	XXX km/h														
THRTL POS SEN	XXX V														
FLUID TEMP SE	XXX V														
BATTERY VOLT	XXX V														
SAT614J															
<p> <b>Without CONSULT-II</b></p> <ol style="list-style-type: none"> <li>1. Start engine.</li> <li>2. Check voltage between TCM terminal 40 and ground while driving at 2 to 3 km/h (1 to 2 MPH) for 1 m (3 ft) or more.</li> </ol>															
SAT356JA															
<p><b>Voltage:</b> Voltage varies between less than 1V and more than 4.5V.</p> <p style="text-align: center;"><b>OK or NG</b></p>															
OK	▶ GO TO 3.														
NG	▶ GO TO 2.														

<b>2</b>	<b>DETECT MALFUNCTIONING ITEM</b>
<p>Check the following items:</p> <ul style="list-style-type: none"> <li>● Vehicle speed sensor and ground circuit for vehicle speed sensor Refer to EL-105, "METERS AND GAUGES".</li> <li>● Harness for short or open between TCM and vehicle speed sensor (Main harness)</li> </ul>	
<b>OK or NG</b>	
OK	▶ GO TO 3.
NG	▶ Repair or replace damaged parts.

# DTC VEHICLE SPEED SENSOR-MTR

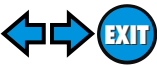

Diagnostic Procedure (Cont'd)

<b>3</b>	<b>CHECK DTC</b>
Perform Diagnostic Trouble Code (DTC) confirmation procedure, AT-204.	
<b>OK or NG</b>	
OK	▶ <b>INSPECTION END</b>
NG	▶ GO TO 4.

GI

MA

EM

<b>4</b>	<b>CHECK TCM INSPECTION</b>
1. Perform TCM input/output signal inspection. 2. If NG, recheck TCM pin terminals for damage or loose connection with harness connector.	
<b>OK or NG</b>	
OK	▶ <b>INSPECTION END</b>
NG	▶ Repair or replace damaged parts.

LC

EC

FE

CL

MT

**AT**

AX

SU

BR

ST

RS

BT

HA

SC

EL

IDX

# DTC A/T COMM LINE

Description

## Description

The ECM and TCM provide mutual communication in relation to engine output control signal (ignition timing retard signal) during rapid standing starts/acceleration. With this consistent real-time control, the shifting feel is substantially improved. NFAT0252

## TCM TERMINALS AND REFERENCE VALUE

NFAT0252S01

Remarks: Specification data are reference values.

Terminal No.	Wire color	Item	Condition	Judgement standard
33	Y/B	LAN		—

\*: This terminal is connected to the ECM.

## On Board Diagnosis Logic

Diagnostic trouble code A/T COMM LINE with CONSULT-II or 11th judgement flicker without CONSULT-II is detected when the ECM-A/T communication line is open or shorted. NFAT0253

## Possible Cause

Check harness or connector.

NFAT0254

# DTC A/T COMM LINE

Diagnostic Trouble Code (DTC) Confirmation Procedure

SELECT SYSTEM
A/T
ENGINE

SAT014K

SELECT DIAG MODE
SELF-DIAG RESULTS
DATA MONITOR
DTC WORK SUPPORT
TCM PART NUMBER

SAT971J

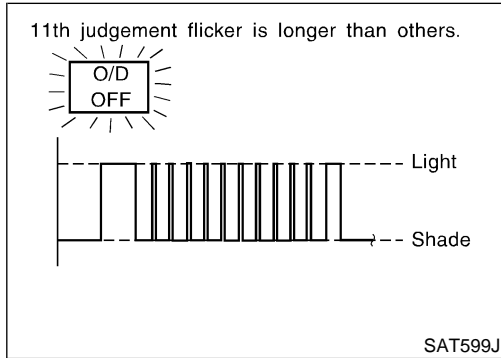

## Diagnostic Trouble Code (DTC) Confirmation Procedure

NFAT0255

After the repair, perform the following procedure to confirm the malfunction is eliminated.

### WITH CONSULT-II

NFAT0255S01

- 1) Turn ignition switch "ON".
- 2) Select "DATA MONITOR" mode for "A/T" with CONSULT-II.
- 3) Wait at least 6 seconds or start engine and wait for at least 6 seconds.

### WITHOUT CONSULT-II

NFAT0255S02

- 1) Turn ignition switch "ON".
- 2) Wait at least 6 seconds or start engine and wait at least 6 seconds.
- 3) Perform self-diagnosis.  
Refer to TCM SELF-DIAGNOSTIC PROCEDURE (NO TOOLS), AT-49.

- GI
- MA
- EM
- LC
- EC
- FE
- CL
- MT
- AT**
- AX
- SU
- BR
- ST
- RS
- BT
- HA
- SC
- EL
- IDX



# DTC A/T COMM LINE

Wiring Diagram — AT — LAN

## Wiring Diagram — AT — LAN

NFAT0256

### AT-LAN-01

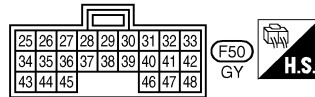
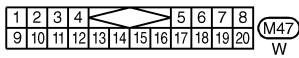
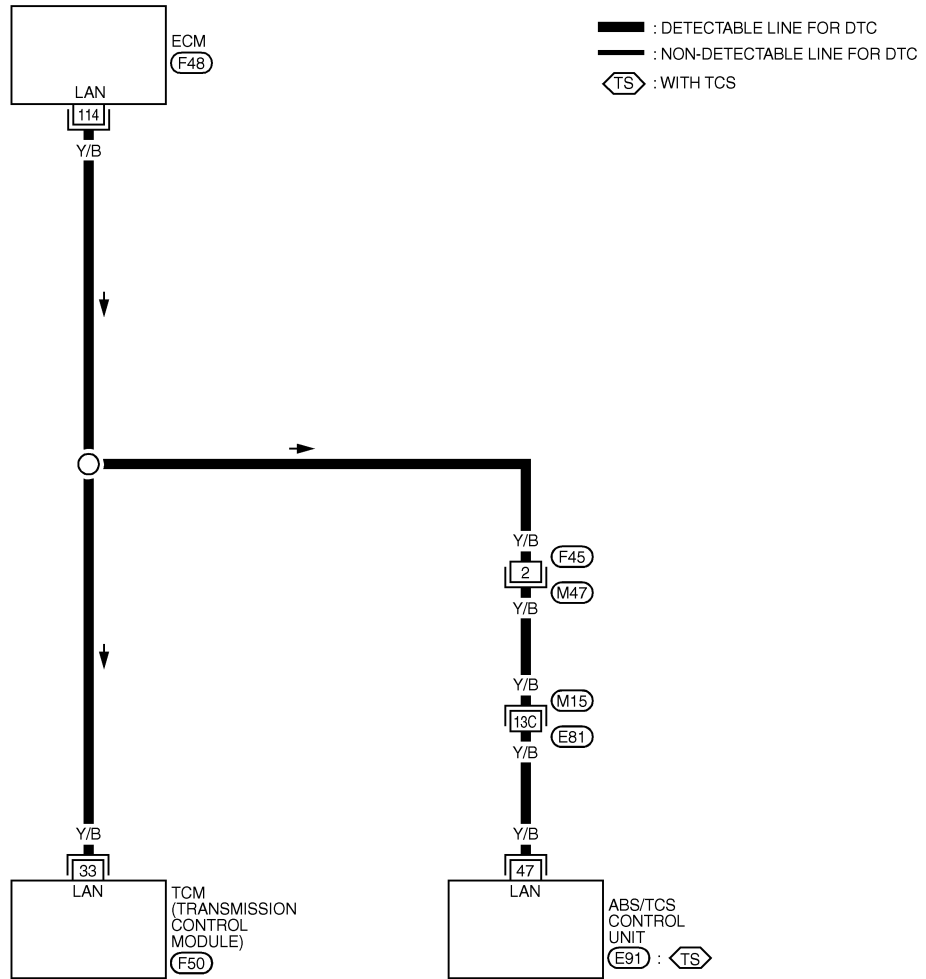

REFER TO THE FOLLOWING.

- (M15), (E81) - SUPER
- MULTIPLE JUNCTION (SMJ)
- (E91) - ELECTRICAL UNITS
- (F48) - ELECTRICAL UNITS

MAT821A

TCM TERMINALS AND REFERENCE VALUE (MEASURED BETWEEN EACH TERMINALS AND 25 OR 48 (TCM GROUND))

TERMINAL	WIRE COLOR	ITEM	CONDITION	DATA (DC)
33	Y/B	LAN	—	—

SAT727J

## Diagnostic Procedure

NFAT0257

<b>1</b>	<b>CHECK CIRCUIT BETWEEN TCM AND ECM</b>								
		<p>1. Turn ignition switch to OFF position. 2. Check continuity between TCM terminal 33 and ECM terminal 114.</p> <div style="display: flex; justify-content: space-around; align-items: center;"> <div style="text-align: center;"> <p>ECM 114 Y/B</p> </div> <div style="text-align: center;"> <p>TCM 33 Y/B</p> </div> <div style="text-align: center;"> <p><b>Continuity should exist.</b></p> </div> </div> <p style="text-align: right;">SAT640J</p> <p style="text-align: center;"><b>OK or NG</b></p>	<p>GI</p> <p>MA</p> <p>EM</p> <p>LC</p> <p>EC</p> <p>FE</p> <p>CL</p>						
		<table style="width: 100%; border-collapse: collapse;"> <tr> <td style="width: 20%;">OK</td> <td style="width: 10%; text-align: center;">▶</td> <td>GO TO 2.</td> </tr> <tr> <td>NG</td> <td style="text-align: center;">▶</td> <td>Repair or replace harness and connector between TCM and ECM.</td> </tr> </table>	OK	▶	GO TO 2.	NG	▶	Repair or replace harness and connector between TCM and ECM.	
OK	▶	GO TO 2.							
NG	▶	Repair or replace harness and connector between TCM and ECM.							

<b>2</b>	<b>CHECK DTC WITH ECM STEP 1</b>								
		<p>Perform self-diagnosis for engine control. Refer to EC-87, "Malfunction Indicator Lamp (MIL)".</p> <p style="text-align: center;"><b>OK or NG</b></p>	<p>MT</p> <p style="background-color: black; color: white; text-align: center; padding: 5px;"><b>AT</b></p> <p>AX</p>						
		<table style="width: 100%; border-collapse: collapse;"> <tr> <td style="width: 20%;">OK</td> <td style="width: 10%; text-align: center;">▶</td> <td>GO TO 4.</td> </tr> <tr> <td>NG</td> <td style="text-align: center;">▶</td> <td>GO TO 3.</td> </tr> </table>	OK	▶	GO TO 4.	NG	▶	GO TO 3.	
OK	▶	GO TO 4.							
NG	▶	GO TO 3.							

<b>3</b>	<b>CHECK DTC WITH ECM STEP 2</b>								
		<p>Check ECM. Refer to EC-517 and EC-691, "DTC P0600 A/T Communication Line" and "DTC P1605 A/T Diagnosis Communication Line".</p> <p style="text-align: center;"><b>OK or NG</b></p>	<p>SU</p> <p>BR</p> <p>ST</p>						
		<table style="width: 100%; border-collapse: collapse;"> <tr> <td style="width: 20%;">OK</td> <td style="width: 10%; text-align: center;">▶</td> <td>GO TO 4.</td> </tr> <tr> <td>NG</td> <td style="text-align: center;">▶</td> <td>Repair or replace damaged parts.</td> </tr> </table>	OK	▶	GO TO 4.	NG	▶	Repair or replace damaged parts.	
OK	▶	GO TO 4.							
NG	▶	Repair or replace damaged parts.							

<b>4</b>	<b>CHECK DTC</b>								
		<p>Perform Diagnostic Trouble Code (DTC) confirmation procedure, AT-209.</p> <p style="text-align: center;"><b>OK or NG</b></p>	<p>RS</p> <p>BT</p> <p>HA</p>						
		<table style="width: 100%; border-collapse: collapse;"> <tr> <td style="width: 20%;">OK</td> <td style="width: 10%; text-align: center;">▶</td> <td><b>INSPECTION END</b></td> </tr> <tr> <td>NG</td> <td style="text-align: center;">▶</td> <td>GO TO 5.</td> </tr> </table>	OK	▶	<b>INSPECTION END</b>	NG	▶	GO TO 5.	
OK	▶	<b>INSPECTION END</b>							
NG	▶	GO TO 5.							

<b>5</b>	<b>CHECK TCM INSPECTION</b>								
		<p>If NG, recheck TCM pin terminals for damage or loose connection with harness connector.</p> <p style="text-align: center;"><b>OK or NG</b></p>	<p>SC</p> <p>EL</p> <p>IDX</p>						
		<table style="width: 100%; border-collapse: collapse;"> <tr> <td style="width: 20%;">OK</td> <td style="width: 10%; text-align: center;">▶</td> <td><b>INSPECTION END</b></td> </tr> <tr> <td>NG</td> <td style="text-align: center;">▶</td> <td>Repair or replace damaged parts.</td> </tr> </table>	OK	▶	<b>INSPECTION END</b>	NG	▶	Repair or replace damaged parts.	
OK	▶	<b>INSPECTION END</b>							
NG	▶	Repair or replace damaged parts.							

# DTC CONTROL UNIT (RAM), CONTROL UNIT (ROM)

## Description

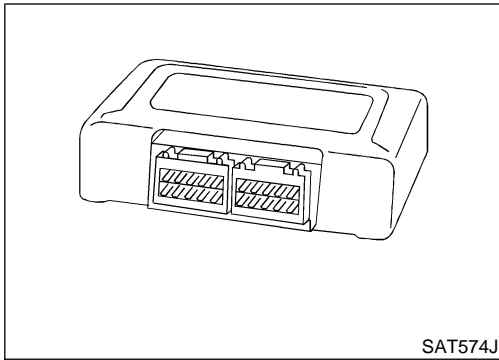

### Description

The TCM consists of a microcomputer and connectors for signal input and output and for power supply. The unit controls the A/T. NFAT0085

### On Board Diagnosis Logic

Diagnostic trouble code CONTROL UNIT (RAM), CONTROL UNIT (ROM) with CONSULT-II is detected when TCM memory (RAM) or (ROM). NFAT0258

### Possible Cause

Check TCM. NFAT0269

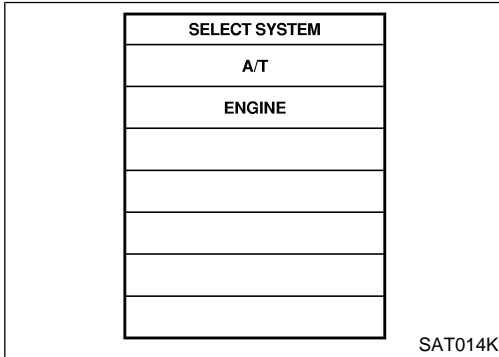

### Diagnostic Trouble Code (DTC) Confirmation Procedure

#### NOTE:

If "DTC Confirmation Procedure" has been previously conducted, always turn ignition switch OFF and wait at least 5 seconds before conducting the next test. NFAT0259

#### WITH CONSULT-II

- 1) Turn ignition switch ON and select "DATA MONITOR" mode for A/T with CONSULT-II. NFAT0259S01
- 2) Start engine.
- 3) Run engine for at least 2 seconds at idle speed.

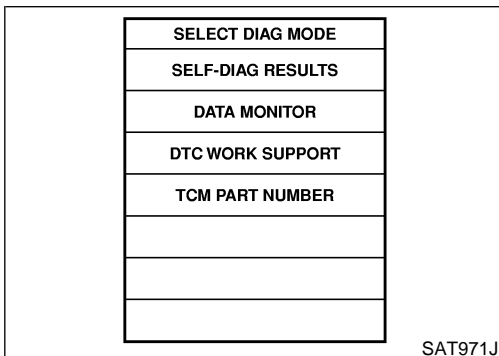

## Diagnostic Procedure

NFAT0086

<b>1</b>	<b>INSPECTION START</b>	
<p> <b>With CONSULT-II</b></p> <ol style="list-style-type: none"> <li>1. Turn ignition switch ON and select "SELF DIAGNOSIS" mode for A/T with CONSULT-II.</li> <li>2. Touch "ERASE".</li> <li>3. Perform "Diagnostic Trouble Code (DTC) Confirmation Procedure", AT-212.</li> <li>4. Is the "CONTROL UNIT (RAM)" or "CONTROL UNIT (ROM)" displayed again?</li> </ol> <p style="text-align: center;"><b>Yes or No</b></p>		
Yes	▶	Replace TCM.
No	▶	<b>INSPECTION END</b>

GI

MA

EM

LC

EC

FE

CL

MT

**AT**

AX

SU

BR

ST

RS

BT

HA

SC

EL

IDX

# DTC CONTROL UNIT (EEP ROM)

## Description

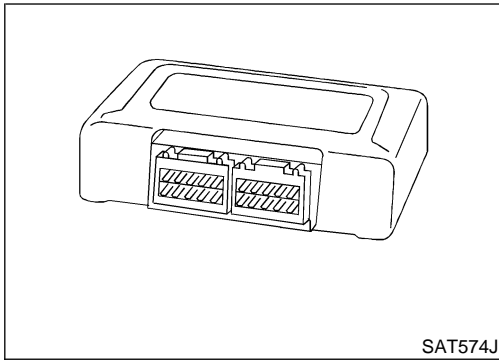

### Description

The TCM consists of a microcomputer and connectors for signal input and output and for power supply. The unit controls the A/T. NFAT0199

### On Board Diagnosis Logic

Diagnostic trouble code CONTROL UNIT (EEP ROM) with CONSULT-II is detected when TCM memory (EEP ROM) is malfunctioning. NFAT0260

### Possible Cause

Check TCM. NFAT0270

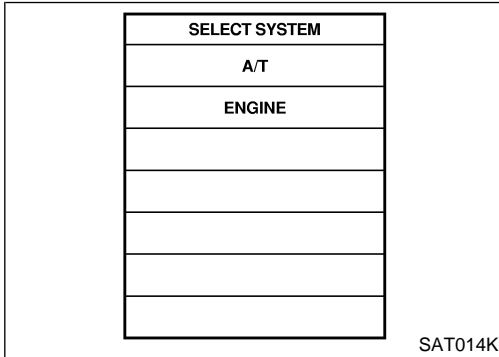

### Diagnostic Trouble Code (DTC) Confirmation Procedure

#### NOTE:

If "DTC Confirmation Procedure" has been previously conducted, always turn ignition switch "OFF" and wait at least 5 seconds before conducting the next test. NFAT0261

#### WITH CONSULT-II

- 1) Turn ignition switch "ON" and select "DATA MONITOR" mode for A/T with CONSULT-II. NFAT0261S01
- 2) Start engine.
- 3) Run engine for at least 2 seconds at idle speed.

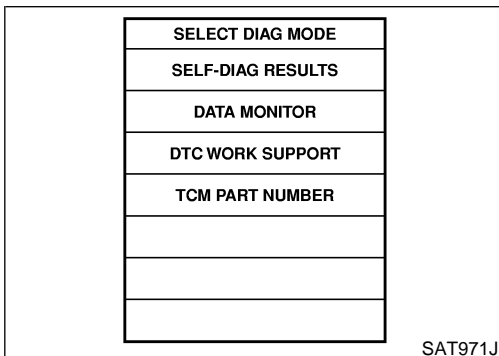

## Diagnostic Procedure

=NFAT0200

<b>1</b>	<b>CHECK DTC</b>	
<p> <b>With CONSULT-II</b></p> <ol style="list-style-type: none"> <li>1. Turn ignition switch "ON" and select "SELF DIAGNOSIS" mode for A/T with CONSULT-II.</li> <li>2. Move selector lever to "R" position.</li> <li>3. Depress accelerator pedal (Full throttle position).</li> <li>4. Touch "ERASE".</li> <li>5. Turn ignition switch to "OFF" position for 10 seconds.</li> <li>6. Perform "Diagnostic Trouble Code (DTC) Confirmation Procedure", AT-214.</li> </ol> <p style="text-align: center;"><b>Is the "CONT UNIT (EEP ROM)" displayed again?</b></p>		
Yes	▶	Replace TCM.
No	▶	<b>INSPECTION END</b>

GI

MA

EM

LC

EC

FE

CL

MT

**AT**

AX

SU

BR

ST

RS

BT

HA

SC

EL

IDX

# TROUBLE DIAGNOSES FOR SYMPTOMS

Wiring Diagram — AT — NONDTC

## Wiring Diagram — AT — NONDTC

NFAT0087

### AT-NONDTC-01

: DETECTABLE LINE FOR DTC  
 : NON-DETECTABLE LINE FOR DTC

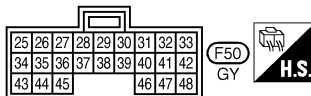
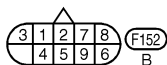
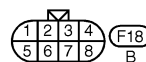
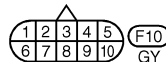
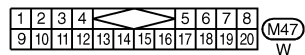
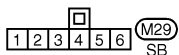
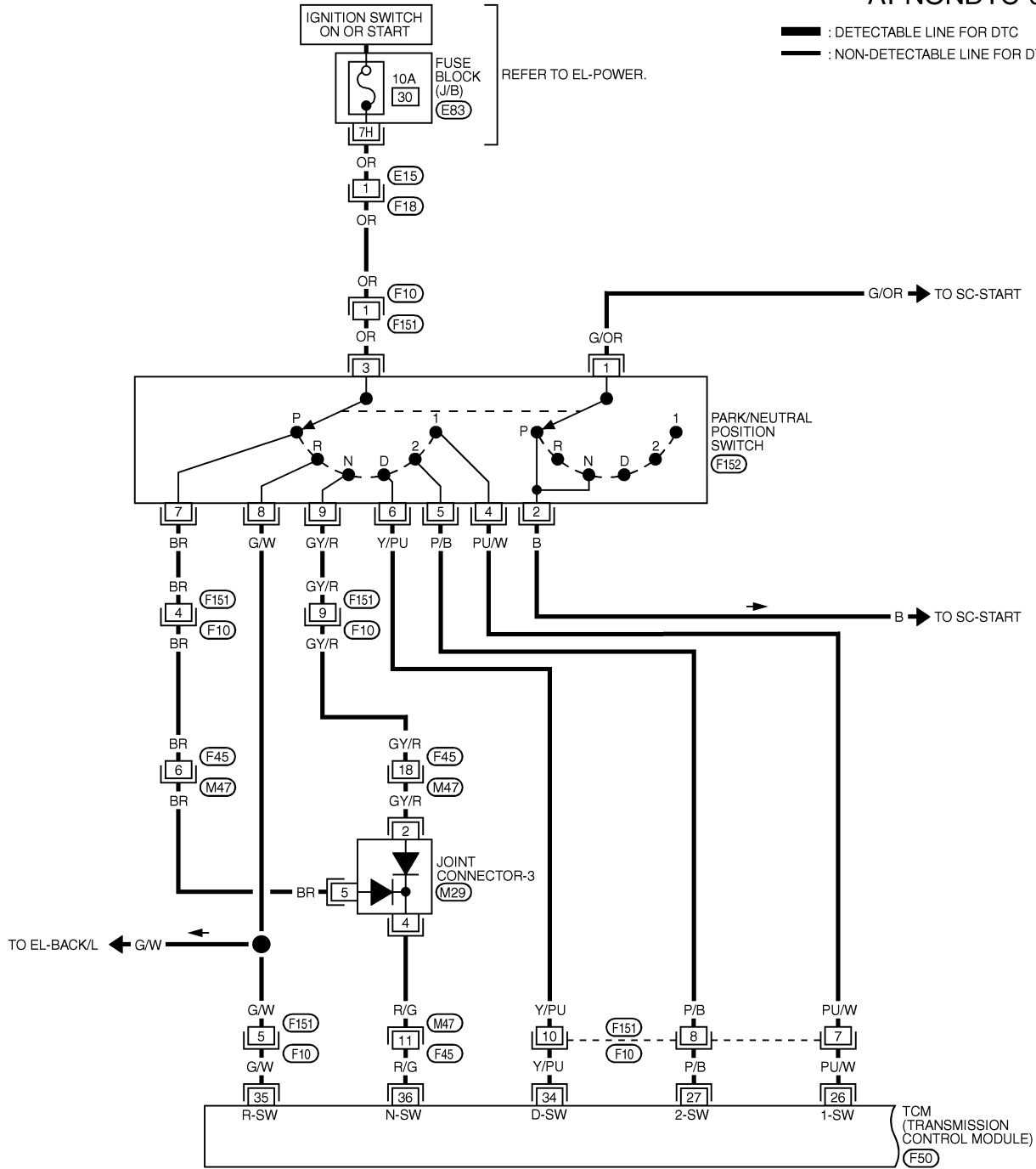

REFER TO THE FOLLOWING.

(E83) - FUSE BLOCK - JUNCTION BOX (J/B)

# TROUBLE DIAGNOSES FOR SYMPTOMS

Wiring Diagram — AT — NONDTC (Cont'd)

## AT-NONDTC-02

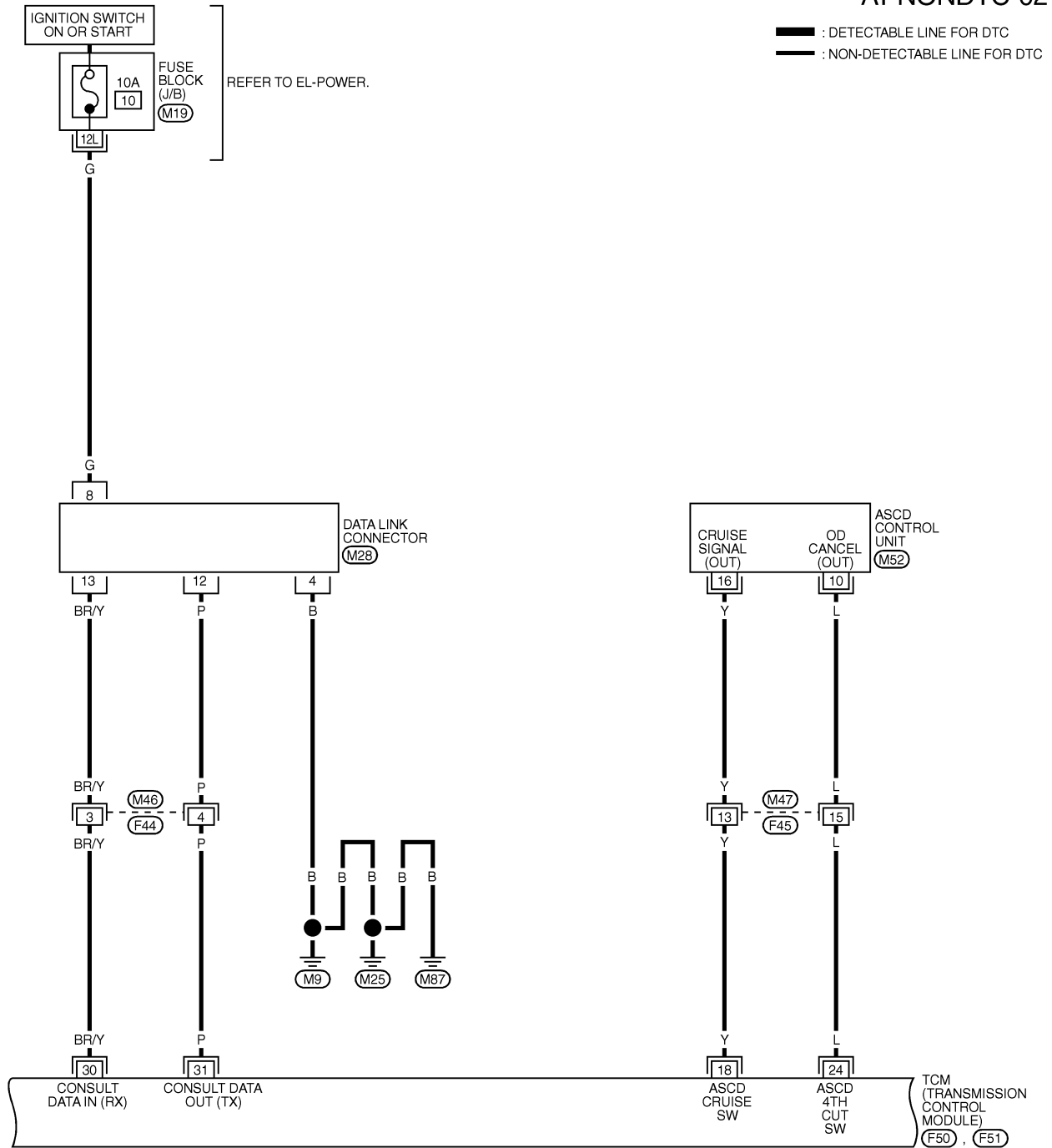

- GI
- MA
- EM
- LC
- EC
- FE
- CL
- MT
- AT**
- AX
- SU
- BR
- ST
- RS
- BT
- HA
- SC
- EL
- IDX

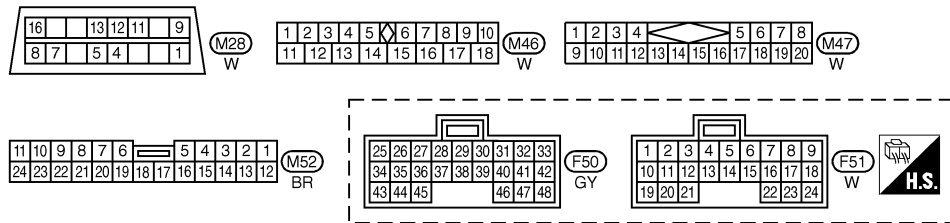

REFER TO THE FOLLOWING.  
 (M19) - FUSE BLOCK -  
 JUNCTION BOX (J/B)

MAT823A



# TRUBLE DIAGNOSES FOR SYMPTOMS

Wiring Diagram — AT — NONDTC (Cont'd)

AT-NONDTC-03

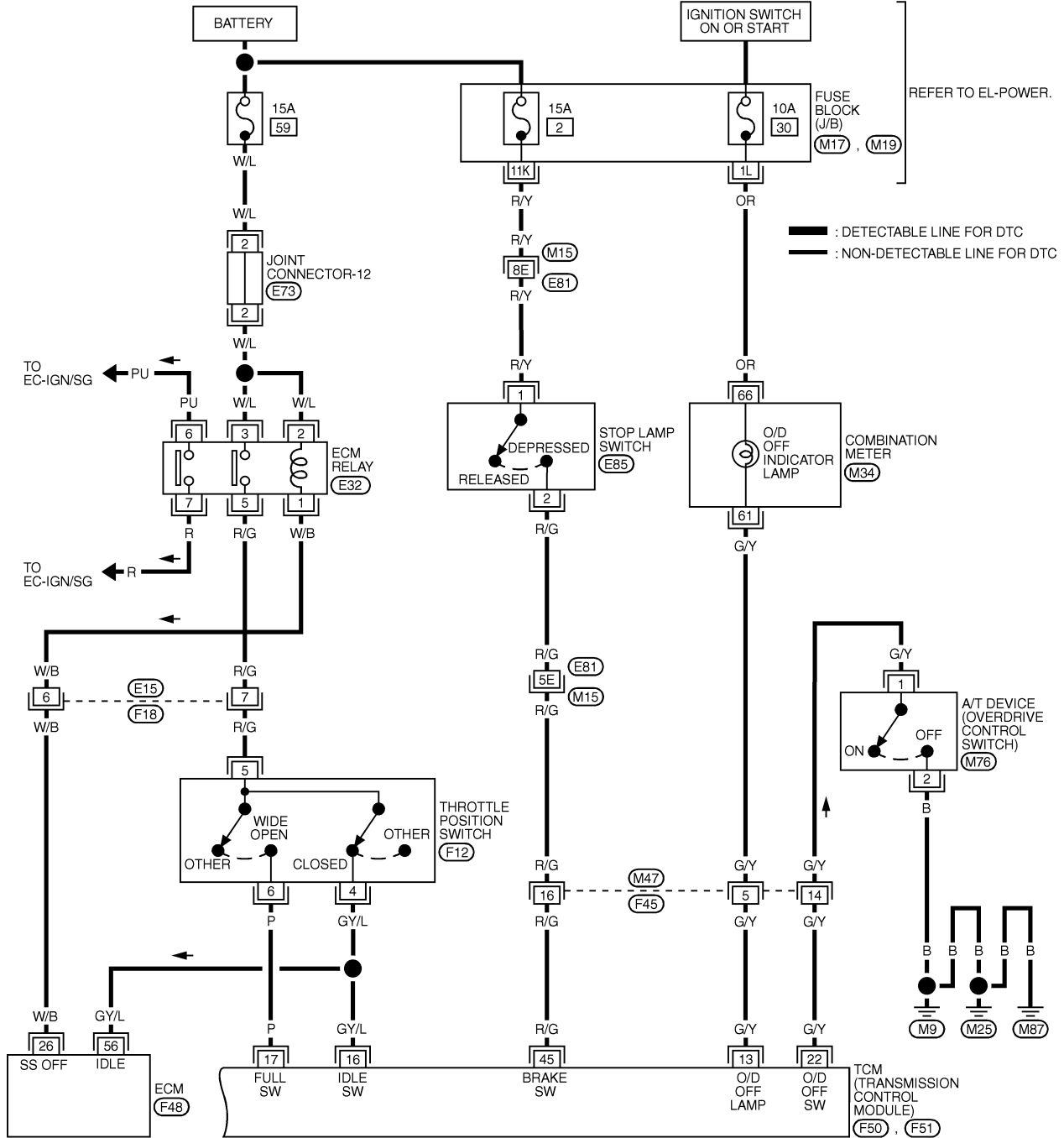

REFER TO EL-POWER.

— : DETECTABLE LINE FOR DTC  
 — : NON-DETECTABLE LINE FOR DTC

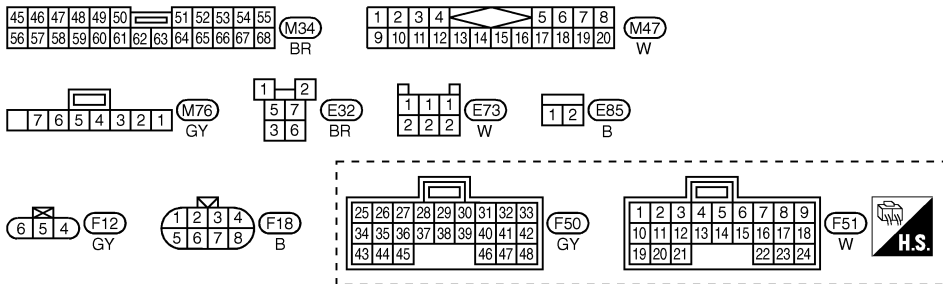

REFER TO THE FOLLOWING.

- (M15), (E81) - SUPER
- MULTIPLE JUNCTION (SMJ)
- (M17) - FUSE BLOCK -
- JUNCTION BOX (J/B)
- (M19) - FUSE BLOCK -
- JUNCTION BOX (J/B)
- (F48) - ELECTRICAL UNITS

MAT887A

# TROUBLE DIAGNOSES FOR SYMPTOMS

1. O/D OFF Indicator Lamp Does Not Come On

## 1. O/D OFF Indicator Lamp Does Not Come On

NFAT0088

### SYMPTOM:

O/D OFF indicator lamp does not come on for about 2 seconds when turning ignition switch to ON.

GI

MA

EM

LC

EC

FE

CL

MT

AT

AX

SU

BR

ST

RS

BT

HA

SC

EL

IDX

1 CHECK TCM POWER SOURCE	
1. Turn ignition switch to ON position. (Do not start engine.) 2. Check voltage between TCM terminals 10, 19, 28 and ground.	
<p style="text-align: right;"><b>Voltage:</b> Battery voltage</p> <p style="text-align: right;">SAT611J</p>	
OK or NG	
OK	▶ GO TO 2.
NG	▶ GO TO 3.

2 CHECK POWER SOURCE STEP 2	
1. Turn ignition switch to OFF position. 2. Check voltage between TCM terminal 28 and ground.	
<p style="text-align: right;"><b>Voltage:</b> Battery voltage</p> <p style="text-align: right;">SAT612J</p>	
OK or NG	
OK	▶ GO TO 4.
NG	▶ GO TO 3.

3 DETECT MALFUNCTIONING ITEM	
Check the following items: <ul style="list-style-type: none"> <li>● Harness for short or open between ignition switch and TCM (Main harness) Refer to "Wiring Diagram — AT — MAIN" in AT-99.</li> <li>● Ignition switch and fuse Refer to EL-9, "POWER SUPPLY ROUTING".</li> </ul>	
OK or NG	
OK	▶ GO TO 4.
NG	▶ Repair or replace damaged parts.

# TROUBLE DIAGNOSES FOR SYMPTOMS

## 1. O/D OFF Indicator Lamp Does Not Come On (Cont'd)

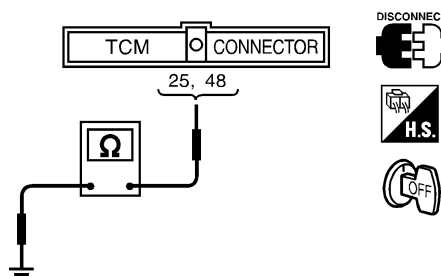
<b>4</b>	<b>CHECK TCM GROUND CIRCUIT</b>		
<ol style="list-style-type: none"> <li>1. Turn ignition switch to OFF position.</li> <li>2. Disconnect TCM harness connector.</li> <li>3. Check continuity between TCM terminals 25, 48 and ground.</li> </ol>			
			
SAT515J			
<p><b>Continuity should exist.</b></p> <p>If OK, check harness for short to ground and short to power.</p> <p style="text-align: center;"><b>OK or NG</b></p>			
OK	▶	GO TO 5.	
NG	▶	Repair open circuit or short to ground or short to power in harness or connectors. Refer to "Wiring Diagram — AT — MAIN" in AT-99.	

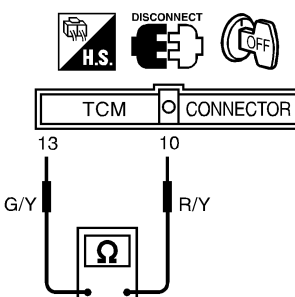
<b>5</b>	<b>CHECK LAMP CIRCUIT</b>		
<ol style="list-style-type: none"> <li>1. Turn ignition switch to OFF position.</li> <li>2. Check resistance between TCM terminals 10 and 13.</li> </ol>			
			
SAT360JA			
<p><b>Resistance:</b></p> <p style="text-align: center;"><b>50 - 100Ω</b></p> <p>3. Reinstall any part removed.</p> <p style="text-align: center;"><b>OK or NG</b></p>			
OK	▶	GO TO 7.	
NG	▶	GO TO 6.	

<b>6</b>	<b>DETECT MALFUNCTIONING ITEM</b>		
<p>Check the following items:</p> <ul style="list-style-type: none"> <li>● Harness and fuse for short or open between ignition switch and O/D OFF indicator lamp (Main harness) Refer to EL-9, "POWER SUPPLY ROUTING".</li> <li>● Harness for short or open between O/D OFF indicator lamp and TCM</li> </ul> <p style="text-align: center;"><b>OK or NG</b></p>			
OK	▶	GO TO 7.	
NG	▶	Repair or replace damaged parts.	

# TROUBLE DIAGNOSES FOR SYMPTOMS

1. O/D OFF Indicator Lamp Does Not Come On (Cont'd)

<b>7</b>	<b>CHECK SYMPTOM</b>	
Check again.		
OK or NG		
OK	▶	<b>INSPECTION END</b>
NG	▶	GO TO 8.

GI

MA

EM

<b>8</b>	<b>CHECK TCM INSPECTION</b>	
1. Perform TCM input/output signal inspection.		
2. If NG, recheck TCM pin terminals for damage or loose connection with harness connector.		
OK or NG		
OK	▶	<b>INSPECTION END</b>
NG	▶	Repair or replace damaged parts.

LC

EC

FE

CL

MT

**AT**

AX

SU

BR

ST

RS

BT

HA

SC

EL

IDX

# TROUBLE DIAGNOSES FOR SYMPTOMS

## 2. Engine Cannot Be Started In P and N Position

### 2. Engine Cannot Be Started In P and N Position

=NFAT0089

#### SYMPTOM:

- Engine cannot be started with selector lever in P or N position.
- Engine can be started with selector lever in D, 2, 1 or R position.

<b>1</b>	<b>CHECK PARK/NEUTRAL POSITION (PNP) SWITCH CIRCUIT</b>
<p> <b>With CONSULT-II</b> Does "ECU INPUT SIGNALS" in "DATA MONITOR" show damage to park/neutral position (PNP) switch circuit?</p>	
<p> <b>Without CONSULT-II</b> Does self-diagnosis show damage to park/neutral position (PNP) switch circuit?</p>	
<p>The diagram shows a box labeled "O/D OFF" with radiating lines above it. Below it is a box labeled "Self diagnosis Start". A solid line connects the "Self diagnosis Start" box to a bracket labeled "Light". A dashed line connects the "Self diagnosis Start" box to a bracket labeled "Shade".</p>	
SAT367J	
<b>Yes or No</b>	
Yes	▶ Check park/neutral position (PNP) switch circuit. Refer to "DTC P0705", AT-102.
No	▶ GO TO 2.

<b>2</b>	<b>CHECK PARK/NEUTRAL POSITION (PNP) SWITCH</b>
Check for short or open of park/neutral position (PNP) switch harness connector terminals 1 and 2. Refer to AT-105.	
<b>OK or NG</b>	
OK	▶ GO TO 3.
NG	▶ Repair or replace park/neutral position (PNP) switch.

<b>3</b>	<b>CHECK STARTING SYSTEM</b>
Check starting system. Refer to EL-7, "System Description".	
<b>OK or NG</b>	
OK	▶ <b>INSPECTION END</b>
NG	▶ Repair or replace damaged parts.

# TROUBLE DIAGNOSES FOR SYMPTOMS

3. In P Position, Vehicle Moves Forward or Backward When Pushed

## 3. In P Position, Vehicle Moves Forward or Backward When Pushed

=NFAT0090

### SYMPTOM:

Vehicle moves when it is pushed forward or backward with selector lever in P position.

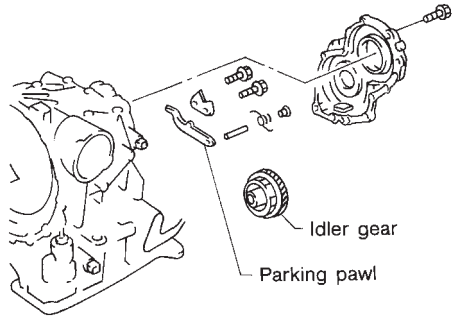
<b>1</b>	<b>CHECK PARKING COMPONENTS</b>	
<p>Check parking components. Refer to "Overhaul" and "Assembly", AT-286, 362.</p> <div style="text-align: center;">  <p style="margin-left: 100px;">Idler gear</p> <p style="margin-left: 100px;">Parking pawl</p> </div> <p style="text-align: right;">SAT282F</p>		
<b>OK or NG</b>		
OK	▶	<b>INSPECTION END</b>
NG	▶	Repair or replace damaged parts.

- GI
- MA
- EM
- LC
- EC
- FE
- CL
- MT
- AT
- AX
- SU
- BR
- ST
- RS
- BT
- HA
- SC
- EL
- IDX

# TROUBLE DIAGNOSES FOR SYMPTOMS

4. In N Position, Vehicle Moves

## 4. In N Position, Vehicle Moves

=NFAT0091

### SYMPTOM:

Vehicle moves forward or backward when selecting N position.

<b>1</b>	<b>CHECK PARK/NEUTRAL POSITION (PNP) SWITCH CIRCUIT</b>	
<p> <b>With CONSULT-II</b> Does "ECU INPUT SIGNALS" in "DATA MONITOR" show damage to park/neutral position (PNP) switch circuit?</p>		
<p> <b>Without CONSULT-II</b> Does self-diagnosis show damage to park/neutral position (PNP) switch circuit?</p>		
SAT367J		
<b>Yes or No</b>		
Yes	▶	Check park/neutral position (PNP) switch circuit. Refer to "DTC P0705", AT-102.
No	▶	GO TO 2.

<b>2</b>	<b>CHECK CONTROL LINKAGE</b>	
Check control cable. Refer to AT-282.		
<b>OK or NG</b>		
OK	▶	GO TO 4.
NG	▶	GO TO 3.

<b>3</b>	<b>ADJUST CONTROL CABLE</b>	
Adjust control cable.		
SAT023JA		
▶		Refer to AT-282.

# TROUBLE DIAGNOSES FOR SYMPTOMS

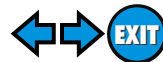

4. In N Position, Vehicle Moves (Cont'd)

<b>4</b>	<b>CHECK A/T FLUID LEVEL</b>
Check A/T fluid level again.	
	
SAT638A	
<b>OK or NG</b>	
OK	▶ GO TO 5.
NG	▶ Refill ATF.

GI  
MA  
EM  
LC  
EC  
FE

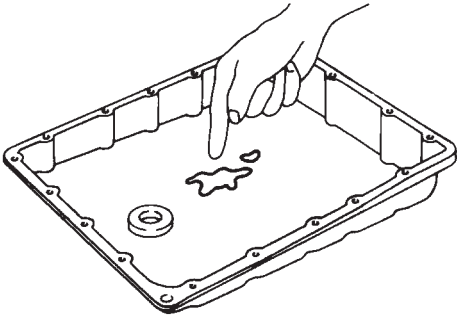
<b>5</b>	<b>CHECK A/T FLUID CONDITION</b>
1. Remove oil pan. 2. Check A/T fluid condition.	
	
SAT171B	
<b>OK or NG</b>	
OK	▶ GO TO 7.
NG	▶ GO TO 6.

CL  
MT

**AT**

AX  
SU  
BR

<b>6</b>	<b>DETECT MALFUNCTIONING ITEM</b>
1. Disassemble A/T. 2. Check the following items: <ul style="list-style-type: none"> <li>● Forward clutch assembly</li> <li>● Overrun clutch assembly</li> <li>● Reverse clutch assembly</li> </ul>	
<b>OK or NG</b>	
OK	▶ GO TO 7.
NG	▶ Repair or replace damaged parts.

ST  
RS

BT  
HA

SC  
EL

<b>7</b>	<b>CHECK SYMPTOM</b>
Check again.	
<b>OK or NG</b>	
OK	▶ <b>INSPECTION END</b>
NG	▶ GO TO 8.

IDX



## TROUBLE DIAGNOSES FOR SYMPTOMS

### 4. In N Position, Vehicle Moves (Cont'd)

<b>8</b>	<b>CHECK TCM INSPECTION</b>
1. Perform TCM input/output signal inspection. 2. If NG, recheck TCM pin terminals for damage or loose connection with harness connector.	
<b>OK or NG</b>	
OK	▶ <b>INSPECTION END</b>
NG	▶ Repair or replace damaged parts.

## 5. Large Shock. N → R Position

=NFAT0092

### SYMPTOM:

There is large shock when changing from N to R position.

<b>1</b>	<b>CHECK SELF-DIAGNOSTIC RESULTS</b>	
Does self-diagnosis show damage to A/T fluid temperature sensor, line pressure solenoid valve or throttle position sensor circuit?		
SAT345HA		
<b>Yes or No</b>		
Yes	▶	GO TO 2.
No	▶	GO TO 3.

<b>2</b>	<b>CHECK DAMAGED CIRCUIT</b>	
Check damaged circuit.		
▶ Refer to "DTC P0710, P0745 or P1705", AT-108, 166 or 182.		

<b>3</b>	<b>CHECK THROTTLE POSITION SENSOR</b>	
Check throttle position sensor. Refer to EC-188, "DTC P0120 Throttle Position Sensor".		
SAT641J		
<b>OK or NG</b>		
OK	▶	GO TO 4.
NG	▶	Repair or replace throttle position sensor.

GI  
 MA  
 EM  
 LC  
 EC  
 FE  
 CL  
 MT  
 AT  
 AX  
 SU  
 BR  
 ST  
 RS  
 BT  
 HA  
 SC  
 EL  
 IDX

# TROUBLE DIAGNOSES FOR SYMPTOMS

5. Large Shock. N → R Position (Cont'd)

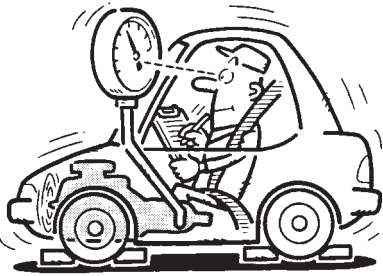
<b>4</b>	<b>CHECK LINE PRESSURE</b>	
<p>Check line pressure at idle with selector lever in D position. Refer to "LINE PRESSURE TEST", AT-65.</p>		
		
SAT494G		
<b>OK or NG</b>		
OK	▶	GO TO 6.
NG	▶	GO TO 5.

<b>5</b>	<b>DETECT MALFUNCTIONING ITEM</b>	
<p>1. Remove control valve assembly. Refer to AT-280.                  2. Check the following items:</p> <ul style="list-style-type: none"> <li>● Valves to control line pressure (Pressure regulator valve, pressure modifier valve, pilot valve and pilot filter)</li> <li>● Line pressure solenoid valve</li> </ul>		
<b>OK or NG</b>		
OK	▶	GO TO 6.
NG	▶	Repair or replace damaged parts.

<b>6</b>	<b>CHECK SYMPTOM</b>	
<p>Check again.</p>		
<b>OK or NG</b>		
OK	▶	<b>INSPECTION END</b>
NG	▶	GO TO 7.

<b>7</b>	<b>CHECK TCM INSPECTION</b>	
<p>1. Perform TCM input/output signal inspection.                  2. If NG, recheck TCM pin terminals for damage or loose connection with harness connector.</p>		
<b>OK or NG</b>		
OK	▶	<b>INSPECTION END</b>
NG	▶	Repair or replace damaged parts.

# TROUBLE DIAGNOSES FOR SYMPTOMS

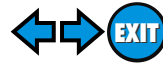

6. Vehicle Does Not Creep Backward In R Position

## 6. Vehicle Does Not Creep Backward In R Position

=NFAT0093

**SYMPTOM:**

Vehicle does not creep backward when selecting R position.

<b>1</b>	<b>CHECK A/T FLUID LEVEL</b>	
Check A/T fluid level again.		
		
SAT638A		
<b>OK or NG</b>		
OK	▶	GO TO 2.
NG	▶	Refill ATF.

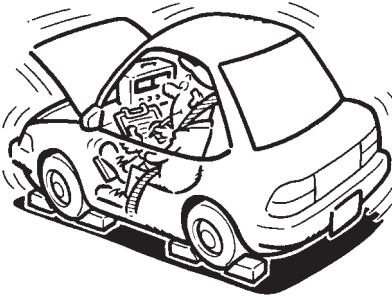
<b>2</b>	<b>CHECK STALL REVOLUTION</b>	
Check stall revolution with selector lever in 1 and R positions.		
		
SAT493G		
<b>OK or NG</b>		
OK	▶	GO TO 5.
OK in 1 position, NG in R position	▶	GO TO 3.
NG in both 1 and R positions	▶	GO TO 4.

GI  
MA  
EM  
LC  
EC  
FE  
CL  
MT  
AT  
AX  
SU  
BR  
ST  
RS  
BT  
HA  
SC  
EL  
IDX

## TROUBLE DIAGNOSES FOR SYMPTOMS

### 6. Vehicle Does Not Creep Backward In R Position (Cont'd)

<b>3</b>	<b>DETECT MALFUNCTIONING ITEM</b>	
<p>1. Remove control valve assembly. Refer to "ON-VEHICLE SERVICE", AT-280.</p> <p>2. Check the following items:</p> <ul style="list-style-type: none"> <li>● Valves to control line pressure (Pressure regulator valve, pressure modifier valve, pilot valve and pilot filter)</li> <li>● Line pressure solenoid valve</li> </ul> <p>3. Disassemble A/T.</p> <p>4. Check the following items:</p> <ul style="list-style-type: none"> <li>● Oil pump assembly</li> <li>● Torque converter</li> <li>● Reverse clutch assembly</li> <li>● High clutch assembly</li> </ul>		
<b>OK or NG</b>		
OK	▶	GO TO 5.
NG	▶	Repair or replace damaged parts.

<b>4</b>	<b>DETECT MALFUNCTIONING ITEM</b>	
<p>1. Remove control valve assembly. Refer to "ON-VEHICLE SERVICE", AT-280.</p> <p>2. Check the following items:</p> <ul style="list-style-type: none"> <li>● Valves to control line pressure (Pressure regulator valve, pressure modifier valve, pilot valve and pilot filter)</li> <li>● Line pressure solenoid valve</li> </ul> <p>3. Disassemble A/T.</p> <p>4. Check the following items:</p> <ul style="list-style-type: none"> <li>● Oil pump assembly</li> <li>● Torque converter</li> <li>● Reverse clutch assembly</li> <li>● High clutch assembly</li> <li>● Low &amp; reverse brake assembly</li> <li>● Low one-way clutch</li> </ul>		
<b>OK or NG</b>		
OK	▶	GO TO 5.
NG	▶	Repair or replace damaged parts.

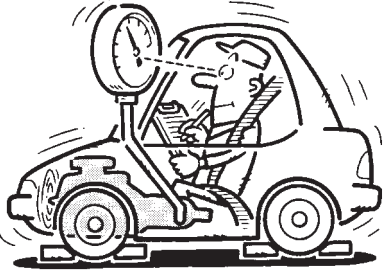
<b>5</b>	<b>CHECK LINE PRESSURE</b>	
<p>Check line pressure at idle with selector lever in R position. Refer to "LINE PRESSURE TEST", AT-65.</p>		
		
<b>OK or NG</b>		
OK	▶	GO TO 7.
NG	▶	GO TO 6.

SAT494G

# TROUBLE DIAGNOSES FOR SYMPTOMS

6. Vehicle Does Not Creep Backward In R Position (Cont'd)

<b>6</b>	<b>DETECT MALFUNCTIONING ITEM</b>	
1. Remove control valve assembly. Refer to "ON-VEHICLE SERVICE", AT-280. 2. Check the following items: <ul style="list-style-type: none"> <li>● Valves to control line pressure (Pressure regulator valve, pressure modifier valve, pilot valve and pilot filter)</li> <li>● Line pressure solenoid valve</li> </ul> 3. Disassemble A/T. 4. Check the following item: <ul style="list-style-type: none"> <li>● Oil pump assembly</li> </ul>		
<b>OK or NG</b>		
OK	▶	GO TO 7.
NG	▶	Repair or replace damaged parts.

GI  
MA  
EM  
LC

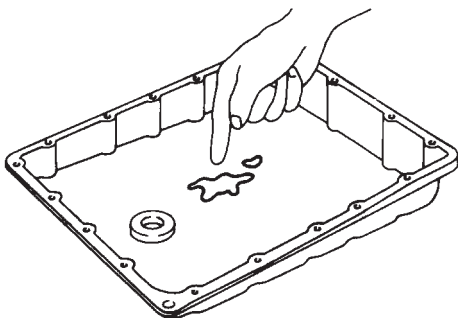
<b>7</b>	<b>CHECK A/T FLUID CONDITION</b>	
1. Remove oil pan. 2. Check A/T fluid condition.		
		
SAT171B		
<b>OK or NG</b>		
OK	▶	GO TO 9.
NG	▶	GO TO 8.

EC  
FE  
CL  
MT  
**AT**

<b>8</b>	<b>DETECT MALFUNCTIONING ITEM</b>	
1. Remove control valve assembly. Refer to "ON-VEHICLE SERVICE", AT-280. 2. Check the following items: <ul style="list-style-type: none"> <li>● Valves to control line pressure (Pressure regulator valve, pressure modifier valve, pilot valve and pilot filter)</li> <li>● Line pressure solenoid valve</li> </ul> 3. Disassemble A/T. 4. Check the following items: <ul style="list-style-type: none"> <li>● Oil pump assembly</li> <li>● Torque converter</li> <li>● Reverse clutch assembly</li> <li>● High clutch assembly</li> <li>● Low &amp; reverse brake assembly</li> <li>● Low one-way clutch</li> </ul>		
<b>OK or NG</b>		
OK	▶	GO TO 9.
NG	▶	Repair or replace damaged parts.

AX  
SU  
BR  
ST  
RS  
BT  
HA  
SC  
EL

IDX

## TROUBLE DIAGNOSES FOR SYMPTOMS

### 6. Vehicle Does Not Creep Backward In R Position (Cont'd)

<b>9</b>	<b>CHECK SYMPTOM</b>
Check again.	
<b>OK or NG</b>	
OK	▶ <b>INSPECTION END</b>
NG	▶ GO TO 10.

<b>10</b>	<b>CHECK TCM INSPECTION</b>
1. Perform TCM input/output signal inspection. 2. If NG, recheck TCM pin terminals for damage or loose connection with harness connector.	
<b>OK or NG</b>	
OK	▶ <b>INSPECTION END</b>
NG	▶ Repair or replace damaged parts.

# TROUBLE DIAGNOSES FOR SYMPTOMS

7. Vehicle Does Not Creep Forward in D, 2 or 1 Position

## 7. Vehicle Does Not Creep Forward in D, 2 or 1 Position

=NFAT0094

### SYMPTOM:

Vehicle does not creep forward when selecting D, 2 or 1 position.

<b>1</b>	<b>CHECK A/T FLUID LEVEL</b>	Check A/T fluid level again.	
		SAT638A	
OK or NG			
OK	▶	GO TO 2.	
NG	▶	Refill ATF.	

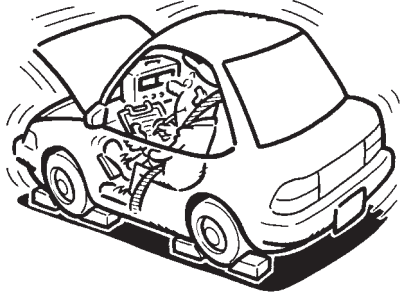
<b>2</b>	<b>CHECK STALL REVOLUTION</b>	Check stall revolution with selector lever in D position. Refer to "STALL TEST", AT-61.	
		SAT493G	
OK or NG			
OK	▶	GO TO 4.	
NG	▶	GO TO 3.	

GI  
MA  
EM  
LC  
EC  
FE  
CL  
MT  
AT  
AX  
SU  
BR  
ST  
RS  
BT  
HA  
SC  
EL  
IDX



## TROUBLE DIAGNOSES FOR SYMPTOMS

### 7. Vehicle Does Not Creep Forward in D, 2 or 1 Position (Cont'd)

<b>3</b>	<b>DETECT MALFUNCTIONING ITEM</b>	
<p>1. Remove control valve assembly. Refer to AT-280.</p> <p>2. Check the following items:</p> <ul style="list-style-type: none"> <li>● Valves to control line pressure (Pressure regulator valve, pressure modifier valve, pilot valve and pilot filter)</li> <li>● Line pressure solenoid valve</li> </ul> <p>3. Disassemble A/T.</p> <p>4. Check the following items:</p> <ul style="list-style-type: none"> <li>● Oil pump assembly</li> <li>● Forward clutch assembly</li> <li>● Forward one-way clutch</li> <li>● Low one-way clutch</li> <li>● Low &amp; reverse brake assembly</li> <li>● Torque converter</li> </ul>		
<b>OK or NG</b>		
OK	▶	GO TO 4.
NG	▶	Repair or replace damaged parts.

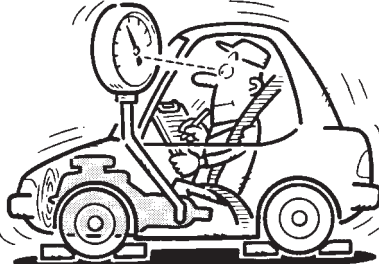
<b>4</b>	<b>CHECK LINE PRESSURE</b>	
<p>Check line pressure at idle with selector lever in D position. Refer to "LINE PRESSURE TEST", AT-65.</p>		
		
SAT494G		
<b>OK or NG</b>		
OK	▶	GO TO 6.
NG	▶	GO TO 5.

<b>5</b>	<b>DETECT MALFUNCTIONING ITEM</b>	
<p>1. Remove control valve assembly. Refer to AT-280.</p> <p>2. Check the following items:</p> <ul style="list-style-type: none"> <li>● Valves to control line pressure (Pressure regulator valve, pressure modifier valve, pilot valve and pilot filter)</li> <li>● Line pressure solenoid valve</li> </ul> <p>3. Disassemble A/T.</p> <p>4. Check the following item:</p> <ul style="list-style-type: none"> <li>● Oil pump assembly</li> </ul>		
<b>OK or NG</b>		
OK	▶	GO TO 6.
NG	▶	Repair or replace damaged parts.

# TROUBLE DIAGNOSES FOR SYMPTOMS

7. Vehicle Does Not Creep Forward in D, 2 or 1 Position (Cont'd)

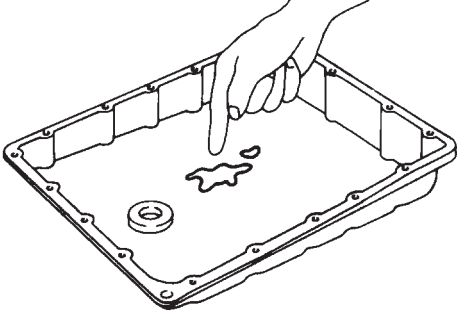
<b>6</b>	<b>CHECK A/T FLUID CONDITION</b>	
1. Remove oil pan. 2. Check A/T fluid condition.		
		
SAT171B		
<b>OK or NG</b>		
OK	▶	GO TO 8.
NG	▶	GO TO 7.

GI  
MA  
EM  
LC  
EC  
FE  
CL

<b>7</b>	<b>DETECT MALFUNCTIONING ITEM</b>	
1. Remove control valve assembly. Refer to AT-280. 2. Check the following items: <ul style="list-style-type: none"> <li>● Valves to control line pressure (Pressure regulator valve, pressure modifier valve, pilot valve and pilot filter)</li> <li>● Line pressure solenoid valve</li> </ul> 3. Disassemble A/T. 4. Check the following items: <ul style="list-style-type: none"> <li>● Oil pump assembly</li> <li>● Forward clutch assembly</li> <li>● Forward one-way clutch</li> <li>● Low one-way clutch</li> <li>● Low &amp; reverse brake assembly</li> <li>● Torque converter</li> </ul>		
<b>OK or NG</b>		
OK	▶	GO TO 8.
NG	▶	Repair or replace damaged parts.

MT  
**AT**

AX  
SU  
BR

<b>8</b>	<b>CHECK SYMPTOM</b>	
Check again.		
<b>OK or NG</b>		
OK	▶	<b>INSPECTION END</b>
NG	▶	GO TO 9.

RS  
BT  
HA

<b>9</b>	<b>CHECK TCM INSPECTION</b>	
1. Perform TCM input/output signal inspection. 2. If NG, recheck TCM pin terminals for damage or loose connection with harness connector.		
<b>OK or NG</b>		
OK	▶	<b>INSPECTION END</b>
NG	▶	Repair or replace damaged parts.

SC  
EL  
IDX

# TROUBLE DIAGNOSES FOR SYMPTOMS

8. Vehicle Cannot Be Started From D<sub>1</sub>

## 8. Vehicle Cannot Be Started From D<sub>1</sub>

=NFAT0095

### SYMPTOM:

Vehicle cannot be started from D<sub>1</sub> on Cruise test — Part 1.

<b>1</b>	<b>CHECK SYMPTOM</b>	
Is "6. Vehicle Does Not Creep Backward In R Position" OK?		
<b>Yes or No</b>		
Yes	▶	GO TO 2.
No	▶	Go to "6. Vehicle Does Not Creep Backward In R Position", AT-229.

<b>2</b>	<b>CHECK SELF-DIAGNOSTIC RESULTS</b>	
Does self-diagnosis show damage to vehicle speed sensor-A/T (revolution sensor), shift solenoid valve A, B or vehicle speed sensor-MTR after cruise test?		
<p style="text-align: right;">SAT934FB</p>		
<b>Yes or No</b>		
Yes	▶	Check damaged circuit. Refer to "DTC P0720, P0750, P0755 or VHCL SPEED SEN-MTR", AT-114, 172, 177 or 203.
No	▶	GO TO 3.

<b>3</b>	<b>CHECK THROTTLE POSITION SENSOR</b>	
Check throttle position sensor. Refer to EC-188, "DTC P0120 Throttle Position Sensor".		
<p style="text-align: right;">SAT641J</p>		
<b>OK or NG</b>		
OK	▶	GO TO 4.
NG	▶	Repair or replace throttle position sensor.

# TROUBLE DIAGNOSES FOR SYMPTOMS

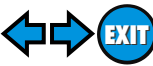

8. Vehicle Cannot Be Started From D<sub>1</sub> (Cont'd)

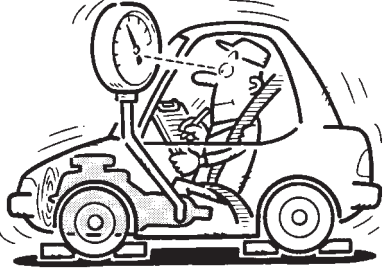
<b>4</b>	<b>CHECK LINE PRESSURE</b>	
<p>Check line pressure at stall point with selector lever in D position. Refer to "LINE PRESSURE TEST", AT-65.</p> <div style="text-align: center;">  </div> <p style="text-align: right;">SAT494G</p> <p style="text-align: center;"><b>OK or NG</b></p>		
OK	▶	GO TO 6.
NG	▶	GO TO 5.

GI  
MA  
EM  
LC  
EC  
FE  
CL  
MT  
AT  
AX  
SU  
BR  
ST  
RS  
BT  
HA  
SC  
EL  
IDX

<b>5</b>	<b>DETECT MALFUNCTIONING ITEM</b>	
<p>1. Remove control valve assembly. Refer to AT-280.                  2. Check the following items:</p> <ul style="list-style-type: none"> <li>● Shift valve A</li> <li>● Shift valve B</li> <li>● Shift solenoid valve A</li> <li>● Shift solenoid valve B</li> <li>● Pilot valve</li> <li>● Pilot filter</li> </ul> <p>3. Disassemble A/T.                  4. Check the following items:</p> <ul style="list-style-type: none"> <li>● Forward clutch assembly</li> <li>● Forward one-way clutch</li> <li>● Low one-way clutch</li> <li>● High clutch assembly</li> <li>● Torque converter</li> <li>● Oil pump assembly</li> </ul> <p style="text-align: center;"><b>OK or NG</b></p>		
OK	▶	GO TO 8.
NG	▶	Repair or replace damaged parts.

# TROUBLE DIAGNOSES FOR SYMPTOMS

## 8. Vehicle Cannot Be Started From D<sub>1</sub> (Cont'd)

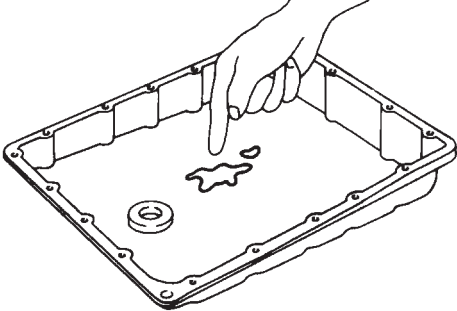
<b>6</b>	<b>CHECK A/T FLUID CONDITION</b>	
<p>1. Remove oil pan. 2. Check A/T fluid condition.</p>		
		
SAT171B		
<b>OK or NG</b>		
OK	▶	GO TO 7.
NG	▶	GO TO 5.

<b>7</b>	<b>DETECT MALFUNCTIONING ITEM</b>	
<p>1. Remove control valve assembly. Refer to AT-280. 2. Check the following items:</p> <ul style="list-style-type: none"> <li>● Shift valve A</li> <li>● Shift valve B</li> <li>● Shift solenoid valve A</li> <li>● Shift solenoid valve B</li> <li>● Pilot valve</li> <li>● Pilot filter</li> </ul>		
<b>OK or NG</b>		
OK	▶	GO TO 8.
NG	▶	Repair or replace damage parts.

<b>8</b>	<b>CHECK SYMPTOM</b>	
Check again.		
<b>OK or NG</b>		
OK	▶	<b>INSPECTION END</b>
NG	▶	GO TO 9.

<b>9</b>	<b>CHECK TCM INSPECTION</b>	
<p>1. Perform TCM input/output signal inspection. 2. If NG, recheck TCM pin terminals for damage or loose connection with harness connector.</p>		
<b>OK or NG</b>		
OK	▶	<b>INSPECTION END</b>
NG	▶	Repair or replace damaged parts.

# TROUBLE DIAGNOSES FOR SYMPTOMS

9. A/T Does Not Shift:  $D_1 \rightarrow D_2$  or Does Not Kickdown:  $D_4 \rightarrow D_2$

## 9. A/T Does Not Shift: $D_1 \rightarrow D_2$ or Does Not Kickdown: $D_4 \rightarrow D_2$

=NFAT0096

### SYMPTOM:

A/T does not shift from  $D_1$  to  $D_2$  at the specified speed.

A/T does not shift from  $D_4$  to  $D_2$  when depressing accelerator pedal fully at the specified speed.

<b>1</b>	<b>CHECK SYMPTOM</b>	
Are "7. Vehicle Does Not Creep Forward In D, 2 Or 1 Position" and "8. Vehicle Cannot Be Started From $D_1$ " OK?		
<b>Yes or No</b>		
Yes	▶	GO TO 2.
No	▶	Go to "7. Vehicle Does Not Creep Forward In D, 2 Or 1 Position" and "8. Vehicle Cannot Be Started From $D_1$ ", AT-233, AT-236.

<b>2</b>	<b>CHECK SELF-DIAGNOSTIC RESULTS</b>	
<input type="checkbox"/> <b>With CONSULT-II</b> Does "ECU INPUT SIGNALS" in "DATA MONITOR" show damage to park/neutral position (PNP) switch circuit?		
<input checked="" type="checkbox"/> <b>Without CONSULT-II</b> Does self-diagnosis show damage to park/neutral position (PNP) switch circuit?		
SAT367J		
<b>Yes or No</b>		
Yes	▶	Check park/neutral position (PNP) switch circuit. Refer to "DTC P0705", AT-102.
No	▶	GO TO 3.

<b>3</b>	<b>CHECK VEHICLE SPEED SENSOR-A/T AND VEHICLE SPEED SENSOR-MTR CIRCUIT</b>	
Check vehicle speed sensor-A/T (revolution sensor) and vehicle speed sensor-MTR circuit. Refer to "DTC P0720 and VHCL SPEED SEN-MTR", AT-114, AT-203.		
<b>OK or NG</b>		
OK	▶	GO TO 4.
NG	▶	Repair or replace vehicle speed sensor-A/T (revolution sensor) and vehicle speed sensor-MTR circuits.

# TROUBLE DIAGNOSES FOR SYMPTOMS

9. A/T Does Not Shift:  $D_1 \rightarrow D_2$  or Does Not Kickdown:  $D_4 \rightarrow D_2$  (Cont'd)

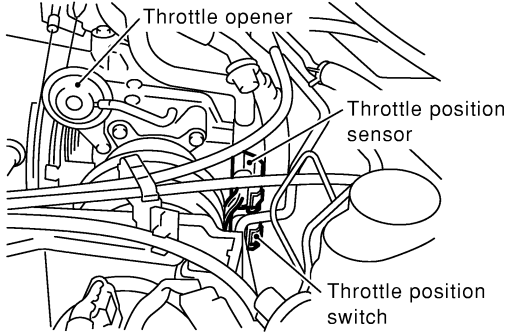
<b>4</b>	<b>CHECK THROTTLE POSITION SENSOR</b>	
<p>Check throttle position sensor. Refer to EC-188, "DTC P0120 Throttle Position Sensor".</p> <div style="text-align: center;">  </div> <p style="text-align: right;">SAT641J</p>		
<b>OK or NG</b>		
OK	▶	GO TO 5.
NG	▶	Repair or replace throttle position sensor.

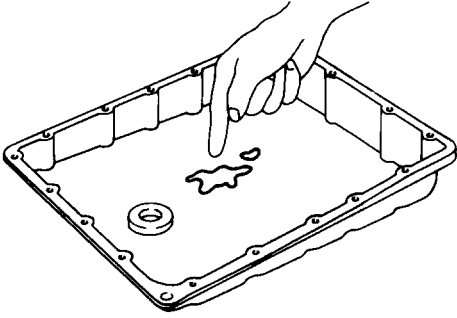
<b>5</b>	<b>CHECK A/T FLUID CONDITION</b>	
<p>1. Remove oil pan. 2. Check A/T fluid condition.</p> <div style="text-align: center;">  </div> <p style="text-align: right;">SAT171B</p>		
<b>OK or NG</b>		
OK	▶	GO TO 7.
NG	▶	GO TO 6.

<b>6</b>	<b>DETECT MALFUNCTIONING ITEM</b>	
<p>1. Remove control valve. Refer to AT-280. 2. Check the following items:</p> <ul style="list-style-type: none"> <li>● Shift valve A</li> <li>● Shift solenoid valve A</li> <li>● Pilot valve</li> <li>● Pilot filter</li> </ul> <p>3. Disassemble A/T. 4. Check the following items:</p> <ul style="list-style-type: none"> <li>● Servo piston assembly</li> <li>● Brake band</li> <li>● Oil pump assembly</li> </ul>		
<b>OK or NG</b>		
OK	▶	GO TO 8.
NG	▶	Repair or replace damaged parts.

# TROUBLE DIAGNOSES FOR SYMPTOMS

9. A/T Does Not Shift: D<sub>1</sub> → D<sub>2</sub> or Does Not Kickdown: D<sub>4</sub> → D<sub>2</sub> (Cont'd)

<b>7</b>	<b>DETECT MALFUNCTIONING ITEM</b>	
1. Remove control valve. Refer to AT-280. 2. Check the following items: <ul style="list-style-type: none"> <li>● Shift valve A</li> <li>● Shift solenoid valve A</li> <li>● Pilot valve</li> <li>● Pilot filter</li> </ul>		
<b>OK or NG</b>		
OK	▶	GO TO 8.
NG	▶	Repair or replace damaged parts.

GI

MA

EM

LC

<b>8</b>	<b>CHECK SYMPTOM</b>	
Check again.		
<b>OK or NG</b>		
OK	▶	<b>INSPECTION END</b>
NG	▶	GO TO 9.

EC

FE

CL

<b>9</b>	<b>CHECK TCM INSPECTION</b>	
1. Perform TCM input/output signal inspection. 2. If NG, recheck TCM pin terminals for damage or loose connection with harness connector.		
<b>OK or NG</b>		
OK	▶	<b>INSPECTION END</b>
NG	▶	Repair or replace damaged parts.

MT

**AT**

AX

SU

BR

ST

RS

BT

HA

SC

EL

IDX



# TROUBLE DIAGNOSES FOR SYMPTOMS

10. A/T Does Not Shift:  $D_2 \rightarrow D_3$

## 10. A/T Does Not Shift: $D_2 \rightarrow D_3$

=NFAT0097

### SYMPTOM:

A/T does not shift from  $D_2$  to  $D_3$  at the specified speed.

<b>1</b>	<b>CHECK SYMPTOM</b>	
Are 7. Vehicle Does Not Creep Forward In D, 2 Or 1 Position and 8. Vehicle Cannot Be Started From $D_1$ OK?		
<b>Yes or No</b>		
Yes	▶	GO TO 2.
No	▶	Go to 7. Vehicle Does Not Creep Forward In D, 2 Or 1 Position and 8. Vehicle Cannot Be Started From $D_1$ , AT-233, AT-236.

<b>2</b>	<b>CHECK PARK/NEUTRAL POSITION (PNP) SWITCH CIRCUIT</b>	
<input type="checkbox"/> <b>With CONSULT-II</b> Does "ECU INPUT SIGNALS" in "DATA MONITOR" show damage to park/neutral position (PNP) switch circuit?		
<input checked="" type="checkbox"/> <b>Without CONSULT-II</b> Does self-diagnosis show damage to park/neutral position (PNP) switch circuit?		
SAT367J		
<b>Yes or No</b>		
Yes	▶	Check park/neutral position (PNP) switch circuit. Refer to "DTC P0705", AT-102.
No	▶	GO TO 3.

<b>3</b>	<b>CHECK THROTTLE POSITION SENSOR</b>	
Check throttle position sensor. Refer to EC-188, "DTC P0120 Throttle Position Sensor".		
SAT641J		
<b>OK or NG</b>		
OK	▶	GO TO 4.
NG	▶	Repair or replace throttle position sensor.

# TROUBLE DIAGNOSES FOR SYMPTOMS

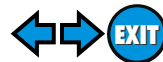

10. A/T Does Not Shift: D<sub>2</sub> → D<sub>3</sub> (Cont'd)

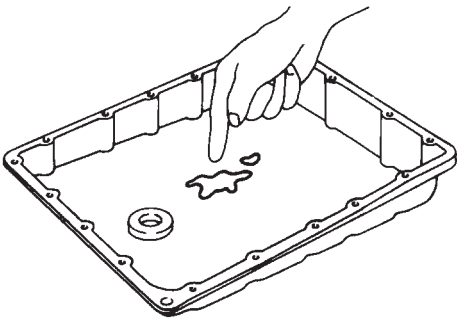
<b>4</b>	<b>CHECK A/T FLUID CONDITION</b>	
<p>1. Remove oil pan. 2. Check A/T fluid condition.</p> <div style="text-align: center;">  <p>SAT171B</p> </div> <p style="text-align: center;"><b>OK or NG</b></p>		
OK	▶	GO TO 6.
NG	▶	GO TO 5.

GI  
MA  
EM  
LC  
EC  
FE  
CL

<b>5</b>	<b>DETECT MALFUNCTIONING ITEM</b>	
<p>1. Remove control valve assembly. Refer to AT-280. 2. Check the following items:</p> <ul style="list-style-type: none"> <li>● Shift valve B</li> <li>● Shift solenoid valve B</li> <li>● Pilot valve</li> <li>● Pilot filter</li> </ul> <p>3. Disassemble A/T. 4. Check the following items:</p> <ul style="list-style-type: none"> <li>● Servo piston assembly</li> <li>● High clutch assembly</li> <li>● Oil pump assembly</li> </ul> <p style="text-align: center;"><b>OK or NG</b></p>		
OK	▶	GO TO 7.
NG	▶	Repair or replace damaged parts.

MT  
**AT**

AX  
SU  
BR

<b>6</b>	<b>DETECT MALFUNCTIONING ITEM</b>	
<p>1. Remove control valve assembly. Refer to AT-280. 2. Check the following items:</p> <ul style="list-style-type: none"> <li>● Shift valve B</li> <li>● Shift solenoid valve B</li> <li>● Pilot valve</li> <li>● Pilot filter</li> </ul> <p style="text-align: center;"><b>OK or NG</b></p>		
OK	▶	GO TO 7.
NG	▶	Repair or replace damaged parts.

ST

RS  
BT  
HA

<b>7</b>	<b>CHECK SYMPTOM</b>	
<p>Check again.</p> <p style="text-align: center;"><b>OK or NG</b></p>		
OK	▶	<b>INSPECTION END</b>
NG	▶	GO TO 8.

SC  
EL  
IDX

## TROUBLE DIAGNOSES FOR SYMPTOMS

10. A/T Does Not Shift:  $D_2 \rightarrow D_3$  (Cont'd)

<b>8</b>	<b>CHECK TCM INSPECTION</b>
1. Perform TCM input/output signal inspection. 2. If NG, recheck TCM pin terminals for damage or loose connection with harness connector.	
<b>OK or NG</b>	
OK	▶ <b>INSPECTION END</b>
NG	▶ Repair or replace damaged parts.

# TROUBLE DIAGNOSES FOR SYMPTOMS

11. A/T Does Not Shift: D<sub>3</sub> → D<sub>4</sub>

## 11. A/T Does Not Shift: D<sub>3</sub> → D<sub>4</sub>

=NFAT0098

### SYMPTOM:

- A/T does not shift from D<sub>3</sub> to D<sub>4</sub> at the specified speed.
- A/T must be warm before D<sub>3</sub> to D<sub>4</sub> shift will occur.

<b>1</b>	<b>CHECK SYMPTOM</b>	
Are "7. Vehicle Does Not Creep Forward In D, 2 Or 1 Position" and "8. Vehicle Cannot Be Started From D <sub>1</sub> " OK?		
<b>Yes or No</b>		
Yes	▶	GO TO 2.
No	▶	Go to "7. Vehicle Does Not Creep Forward In D, 2 Or 1 Position" and "8. Vehicle Cannot Be Started From D <sub>1</sub> ", AT-233, AT-236.

<b>2</b>	<b>CHECK SELF-DIAGNOSTIC RESULTS</b>	
<p> <b>With CONSULT-II</b> Does self-diagnosis, after cruise test, show damage to any of the following circuits?</p> <ul style="list-style-type: none"> <li>● Park/neutral position (PNP) switch</li> <li>● Overdrive control switch</li> <li>● A/T fluid temperature sensor</li> <li>● Vehicle speed sensor-A/T (revolution sensor)</li> <li>● Shift solenoid valve A or B</li> <li>● Vehicle speed sensor-MTR</li> </ul>		
SAT363HC		
<b>Yes or No</b>		
Yes	▶	Check damaged circuit. Refer to "DTC P0705, P0710, P0720, P0750, P0755 or VHCL SPEED SEN-MTR", AT-102, AT-108, AT-114, AT-172, AT-177 or AT-203.
No	▶	GO TO 3.

# TROUBLE DIAGNOSES FOR SYMPTOMS

11. A/T Does Not Shift:  $D_3 \rightarrow D_4$  (Cont'd)

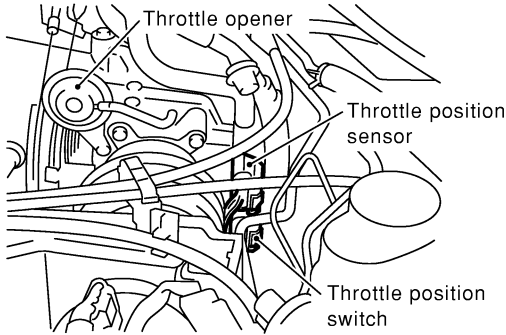
<b>3</b>	<b>CHECK THROTTLE POSITION SENSOR</b>	
<p>Check throttle position sensor. Refer to EC-188, "DTC P0120 Throttle Position Sensor."</p> <div style="text-align: center;">  </div> <p style="text-align: right;">SAT641J</p>		
<b>OK or NG</b>		
OK	▶	GO TO 4.
NG	▶	Repair or replace throttle position sensor.

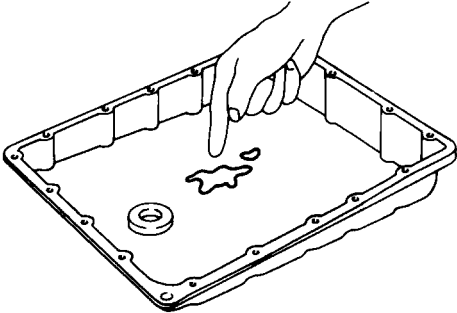
<b>4</b>	<b>CHECK A/T FLUID CONDITION</b>	
<p>1. Remove oil pan. 2. Check A/T fluid condition.</p> <div style="text-align: center;">  </div> <p style="text-align: right;">SAT171B</p>		
<b>OK or NG</b>		
OK	▶	GO TO 6.
NG	▶	GO TO 5.

<b>5</b>	<b>DETECT MALFUNCTIONING ITEM</b>	
<p>1. Remove control valve assembly. Refer to AT-280. 2. Check the following items:</p> <ul style="list-style-type: none"> <li>● Shift valve B</li> <li>● Overrun clutch control valve</li> <li>● Shift solenoid valve B</li> <li>● Pilot valve</li> <li>● Pilot filter</li> </ul> <p>3. Disassemble A/T. 4. Check the following items:</p> <ul style="list-style-type: none"> <li>● Servo piston assembly</li> <li>● Brake band</li> <li>● Torque converter</li> <li>● Oil pump assembly</li> </ul>		
<b>OK or NG</b>		
OK	▶	GO TO 7.
NG	▶	Repair or replace damaged parts.

# TROUBLE DIAGNOSES FOR SYMPTOMS

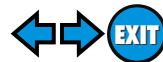

11. A/T Does Not Shift: D<sub>3</sub> → D<sub>4</sub> (Cont'd)

<b>6</b>	<b>DETECT MALFUNCTIONING ITEM</b>	
1. Remove control valve assembly. Refer to AT-280. 2. Check the following items: <ul style="list-style-type: none"> <li>● Shift valve B</li> <li>● Overrun clutch control valve</li> <li>● Shift solenoid valve B</li> <li>● Pilot valve</li> <li>● Pilot filter</li> </ul>		
<b>OK or NG</b>		
OK	▶	GO TO 7.
NG	▶	Repair or replace damaged parts.

GI

MA

EM

LC

EC

<b>7</b>	<b>CHECK SYMPTOM</b>	
Check again.		
<b>OK or NG</b>		
OK	▶	<b>INSPECTION END</b>
NG	▶	GO TO 8.

FE

CL

<b>8</b>	<b>CHECK TCM INSPECTION</b>	
1. Perform TCM input/output signal inspection. 2. If NG, recheck TCM pin terminals for damage or loose connection with harness connector.		
<b>OK or NG</b>		
OK	▶	<b>INSPECTION END</b>
NG	▶	Repair or replace damaged parts.

MT

**AT**

AX

SU

BR

ST

RS

BT

HA

SC

EL

IDX

# TROUBLE DIAGNOSES FOR SYMPTOMS

12. A/T Does Not Perform Lock-up

## 12. A/T Does Not Perform Lock-up

=NFAT0099

**SYMPTOM:**

A/T does not perform lock-up at the specified speed.

<b>1</b>	<b>CHECK SELF-DIAGNOSTIC RESULTS</b>	
Does self-diagnosis show damage to torque converter clutch solenoid valve circuit after cruise test?		
SAT346H		
<b>Yes or No</b>		
Yes	▶	Check torque converter clutch solenoid valve circuit. Refer to "DTC P0740", AT-151.
No	▶	GO TO 2.

<b>2</b>	<b>CHECK THROTTLE POSITION SENSOR</b>	
Check throttle position sensor. Refer to EC-188, "DTC P0120 Throttle Position Sensor".		
SAT641J		
<b>OK or NG</b>		
OK	▶	GO TO 3.
NG	▶	Repair or replace throttle position sensor.

<b>3</b>	<b>DETECT MALFUNCTIONING ITEM</b>	
1. Remove control valve. Refer to AT-280. 2. Check following items: <ul style="list-style-type: none"> <li>● Torque converter clutch control valve</li> <li>● Torque converter relief valve</li> <li>● Torque converter clutch solenoid valve</li> <li>● Pilot valve</li> <li>● Pilot filter</li> </ul>		
<b>OK or NG</b>		
OK	▶	GO TO 4.
NG	▶	Repair or replace damaged parts.

# TROUBLE DIAGNOSES FOR SYMPTOMS

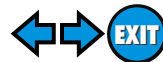

12. A/T Does Not Perform Lock-up (Cont'd)

<b>4</b>	<b>CHECK SYMPTOM</b>	
Check again.		
OK or NG		
OK	▶	<b>INSPECTION END</b>
NG	▶	GO TO 5.

GI

MA

EM

<b>5</b>	<b>CHECK TCM INSPECTION</b>	
1. Perform TCM input/output signal inspection.		
2. If NG, recheck TCM pin terminals for damage or loose connection with harness connector.		
OK or NG		
OK	▶	<b>INSPECTION END</b>
NG	▶	Repair or replace damaged parts.

LC

EC

FE

CL

MT

**AT**

AX

SU

BR

ST

RS

BT

HA

SC

EL

IDX



# TROUBLE DIAGNOSES FOR SYMPTOMS

13. A/T Does Not Hold Lock-up Condition

## 13. A/T Does Not Hold Lock-up Condition

=NFAT0100

**SYMPTOM:**

A/T does not hold lock-up condition for more than 30 seconds.

<b>1</b>	<b>CHECK SELF-DIAGNOSTIC RESULTS</b>	
Does self-diagnosis show damage to engine speed signal circuit after cruise test?		
<p>The diagram shows a sequence of events: 'O/D OFF' light is on, 'Self-diagnosis start' begins, 'Engine speed signal' is shown as a pulse, 'Light' is shown as a pulse, and 'Shade' is shown as a pulse.</p>		
SAT347H		
<b>Yes or No</b>		
Yes	▶	Check engine speed signal circuit. Refer to "DTC P0725", AT-119.
No	▶	GO TO 2.

<b>2</b>	<b>CHECK A/T FLUID CONDITION</b>	
<ol style="list-style-type: none"> <li>1. Remove oil pan.</li> <li>2. Check A/T fluid condition.</li> </ol>		
<p>The diagram shows a hand pointing to a puddle of fluid in an oil pan.</p>		
SAT171B		
<b>OK or NG</b>		
OK	▶	GO TO 4.
NG	▶	GO TO 3.

<b>3</b>	<b>DETECT MALFUNCTIONING ITEM</b>	
<ol style="list-style-type: none"> <li>1. Remove control valve assembly. Refer to AT-280.</li> <li>2. Check the following items: <ul style="list-style-type: none"> <li>● Torque converter clutch control valve</li> <li>● Pilot valve</li> <li>● Pilot filter</li> </ul> </li> <li>3. Disassemble A/T.</li> <li>4. Check torque converter and oil pump assembly.</li> </ol>		
<b>OK or NG</b>		
OK	▶	GO TO 5.
NG	▶	Repair or replace damaged parts.

# TROUBLE DIAGNOSES FOR SYMPTOMS

13. A/T Does Not Hold Lock-up Condition (Cont'd)

<b>4</b>	<b>DETECT MALFUNCTIONING ITEM</b>	
1. Remove control valve assembly. Refer to AT-280. 2. Check the following items: <ul style="list-style-type: none"> <li>● Torque converter clutch control valve</li> <li>● Pilot valve</li> <li>● Pilot filter</li> </ul>		
<b>OK or NG</b>		
OK	▶	GO TO 5.
NG	▶	Repair or replace damaged parts.

GI

MA

EM

LC

<b>5</b>	<b>CHECK SYMPTOM</b>	
Check again.		
<b>OK or NG</b>		
OK	▶	<b>INSPECTION END</b>
NG	▶	GO TO 6.

EC

FE

CL

<b>6</b>	<b>CHECK TCM INSPECTION</b>	
1. Perform TCM input/output signal inspection. 2. If NG, recheck TCM pin terminals for damage or loose connection with harness connector.		
<b>OK or NG</b>		
OK	▶	<b>INSPECTION END</b>
NG	▶	Repair or replace damaged parts.

MT

AT

AX

SU

BR

ST

RS

BT

HA

SC

EL

IDX

# TROUBLE DIAGNOSES FOR SYMPTOMS

14. Lock-up Is Not Released

## 14. Lock-up Is Not Released

=NFAT0101

**SYMPTOM:**

Lock-up is not released when accelerator pedal is released.

<b>1</b>	<b>CHECK THROTTLE POSITION SWITCH CIRCUIT</b>	
<p> <b>With CONSULT-II</b> Does "ECU INPUT SIGNALS" in "DATA MONITOR" show damage to closed throttle position switch circuit?</p>		
<p> <b>Without CONSULT-II</b> Does self-diagnosis show damage to closed throttle position switch circuit?</p>		
SAT367J		
<b>Yes or No</b>		
Yes	▶	Check closed throttle position switch circuit. Refer to "DTC P0705", AT-102.
No	▶	GO TO 2.

<b>2</b>	<b>CHECK SYMPTOM</b>	
Check again.		
<b>OK or NG</b>		
OK	▶	<b>INSPECTION END</b>
NG	▶	GO TO 3.

<b>3</b>	<b>CHECK TCM INSPECTION</b>	
<p>1. Perform TCM input/output signal inspection. 2. If NG, recheck TCM pin terminals for damage or loose connection with harness connector.</p>		
<b>OK or NG</b>		
OK	▶	<b>INSPECTION END</b>
NG	▶	Repair or replace damaged parts.

# TROUBLE DIAGNOSES FOR SYMPTOMS

15. Engine Speed Does Not Return To Idle (Light Braking D<sub>4</sub> → D<sub>3</sub>)

## 15. Engine Speed Does Not Return To Idle (Light Braking D<sub>4</sub> → D<sub>3</sub>)

=NFAT0102

### SYMPTOM:

- Engine speed does not smoothly return to idle when A/T shifts from D<sub>4</sub> to D<sub>3</sub>.
- Vehicle does not decelerate by engine brake when turning overdrive control switch OFF.
- Vehicle does not decelerate by engine brake when shifting A/T from D to 2 position.

GI

MA

EM

LC

EC

FE

CL

MT

AT

AX

SU

BR

ST

RS

BT

HA

SC

EL

IDX

<b>1</b>	<b>CHECK SELF-DIAGNOSTIC RESULTS</b>	
Does self-diagnosis show damage to overrun clutch solenoid valve circuit after cruise test?		
SAT348H		
<b>Yes or No</b>		
Yes	▶	Check overrun clutch solenoid valve circuit. Refer to "DTC P1760", AT-191.
No	▶	GO TO 2.

<b>2</b>	<b>CHECK THROTTLE POSITION SENSOR</b>	
Check throttle position sensor. Refer to EC-188, "DTC P0120 Throttle Position Sensor".		
SAT641J		
<b>OK or NG</b>		
OK	▶	GO TO 3.
NG	▶	Repair or replace throttle position sensor.

## TROUBLE DIAGNOSES FOR SYMPTOMS

### 15. Engine Speed Does Not Return To Idle (Light Braking $D_4 \rightarrow D_3$ ) (Cont'd)

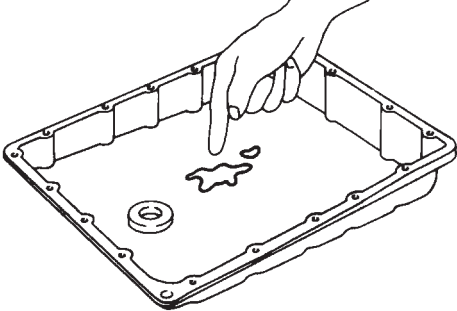
<b>3</b>	<b>CHECK A/T FLUID CONDITION</b>		
<p>1. Remove oil pan. 2. Check A/T fluid condition.</p> <div style="text-align: center;">  </div> <p style="text-align: right;">SAT171B</p>			
<b>OK or NG</b>			
OK	▶	GO TO 5.	
NG	▶	GO TO 4.	

<b>4</b>	<b>DETECT MALFUNCTIONING ITEM</b>		
<p>1. Remove control valve assembly. Refer to AT-280. 2. Check the following items:</p> <ul style="list-style-type: none"> <li>● Overrun clutch control valve</li> <li>● Overrun clutch reducing valve</li> <li>● Overrun clutch solenoid valve</li> </ul> <p>3. Disassemble A/T. 4. Check the following items:</p> <ul style="list-style-type: none"> <li>● Overrun clutch assembly</li> <li>● Oil pump assembly</li> </ul>			
<b>OK or NG</b>			
OK	▶	GO TO 6.	
NG	▶	Repair or replace damaged parts.	

<b>5</b>	<b>DETECT MALFUNCTIONING ITEM</b>		
<p>1. Remove control valve assembly. Refer to AT-280. 2. Check the following items:</p> <ul style="list-style-type: none"> <li>● Overrun clutch control valve</li> <li>● Overrun clutch reducing valve</li> <li>● Overrun clutch solenoid valve</li> </ul>			
<b>OK or NG</b>			
OK	▶	GO TO 6.	
NG	▶	Repair or replace damaged parts.	

<b>6</b>	<b>CHECK SYMPTOM</b>		
Check again.			
<b>OK or NG</b>			
OK	▶	<b>INSPECTION END</b>	
NG	▶	GO TO 7.	

# TROUBLE DIAGNOSES FOR SYMPTOMS

15. Engine Speed Does Not Return To Idle (Light Braking  $D_4 \rightarrow D_3$ ) (Cont'd)

<b>7</b>	<b>CHECK TCM INSPECTION</b>	
	1. Perform TCM input/output signal inspection. 2. If NG, recheck TCM pin terminals for damage or loose connection with harness connector.	
	<b>OK or NG</b>	
OK	▶	<b>INSPECTION END</b>
NG	▶	Repair or replace damaged parts.

GI

MA

EM

LC

EC

FE

CL

MT

**AT**

AX

SU

BR

ST

RS

BT

HA

SC

EL

IDX

# TROUBLE DIAGNOSES FOR SYMPTOMS

16. Vehicle Does Not Start From D<sub>1</sub>

## 16. Vehicle Does Not Start From D<sub>1</sub>

=NFAT0103

### SYMPTOM:

**Vehicle does not start from D<sub>1</sub> on Cruise test — Part 2.**

<b>1</b>	<b>CHECK SELF-DIAGNOSTIC RESULTS</b>	
Does self-diagnosis show damage to vehicle speed sensor-A/T (revolution sensor), shift solenoid valve A, B or vehicle speed sensor-MTR after cruise test?		
SAT934FA		
<b>Yes or No</b>		
Yes	▶	Check damaged circuit. Refer to “DTC P0720, P0750, P0755 or VHCL SPEED SEN-MTR”, AT-114, 172, 177 or 203.
No	▶	GO TO 2.

<b>2</b>	<b>CHECK SYMPTOM</b>	
Check again.		
<b>OK or NG</b>		
OK	▶	Go to 8. Vehicle Cannot Be Started From D <sub>1</sub> , AT-236.
NG	▶	GO TO 3.

<b>3</b>	<b>CHECK TCM INSPECTION</b>	
1. Perform TCM input/output signal inspection. 2. If NG, recheck TCM pin terminals for damage or loose connection with harness connector.		
<b>OK or NG</b>		
OK	▶	<b>INSPECTION END</b>
NG	▶	Repair or replace damaged parts.

# TROUBLE DIAGNOSES FOR SYMPTOMS

17. A/T Does Not Shift: D<sub>4</sub> → D<sub>3</sub>, When Overdrive Control Switch ON → OFF

## 17. A/T Does Not Shift: D<sub>4</sub> → D<sub>3</sub>, When Overdrive Control Switch ON → OFF

=NFAT0104

### SYMPTOM:

A/T does not shift from D<sub>4</sub> to D<sub>3</sub> when changing overdrive control switch to OFF position.

<b>1</b>	<b>CHECK OVERDRIVE SWITCH CIRCUIT</b>	
<p><input type="checkbox"/> <b>With CONSULT-II</b> Does "ECU INPUT SIGNALS" in "DATA MONITOR" show damage to overdrive control switch circuit?</p>		
<p><input checked="" type="checkbox"/> <b>Without CONSULT-II</b> Does self-diagnosis show damage to overdrive control switch circuit?</p>		
SAT344H		
<b>Yes or No</b>		
Yes	▶	Check overdrive control switch circuit. Refer to "DTC P0705", AT-102.
No	▶	Go to 10. A/T Does Not Shift: D <sub>2</sub> → D <sub>3</sub> , AT-242.

GI  
MA  
EM  
LC  
EC  
FE  
CL  
MT  
AT  
AX  
SU  
BR  
ST  
RS  
BT  
HA  
SC  
EL  
IDX



## TROUBLE DIAGNOSES FOR SYMPTOMS

18. A/T Does Not Shift:  $D_3 \rightarrow 2_2$ , When Selector Lever  $D \rightarrow 2$  Position

### 18. A/T Does Not Shift: $D_3 \rightarrow 2_2$ , When Selector Lever $D \rightarrow 2$ Position

=NFAT0105

**SYMPTOM:**

A/T does not shift from  $D_3$  to  $2_2$  when changing selector lever from  $D$  to  $2$  position.

<b>1</b>	<b>CHECK PARK/NEUTRAL POSITION (PNP) SWITCH CIRCUIT</b>
<p><input type="checkbox"/> <b>With CONSULT-II</b> Does "ECU INPUT SIGNALS" in "DATA MONITOR" show damage to park/neutral position (PNP) switch circuit?</p>	
<p><input checked="" type="checkbox"/> <b>Without CONSULT-II</b> Does self-diagnosis show damage to park/neutral position (PNP) switch circuit?</p> <div style="text-align: center; margin: 20px 0;"> </div> <p style="text-align: right; margin-right: 50px;">SAT367J</p>	
<b>Yes or No</b>	
Yes	▶ Check park/neutral position (PNP) switch circuit. Refer to "DTC P0705", AT-102.
No	▶ Go to 9. A/T Does Not Shift: $D_1 \rightarrow D_2$ Or Does Not Kickdown: $D_4 \rightarrow D_2$ , AT-239.

# TROUBLE DIAGNOSES FOR SYMPTOMS

19. A/T Does Not Shift: 2<sub>2</sub> → 1<sub>1</sub>, When Selector Lever 2 → 1 Position

## 19. A/T Does Not Shift: 2<sub>2</sub> → 1<sub>1</sub>, When Selector Lever 2 → 1 Position

=NFAT0106

### SYMPTOM:

A/T does not shift from 2<sub>2</sub> to 1<sub>1</sub> when changing selector lever from 2 to 1 position.

<b>1</b>	<b>CHECK PARK/NEUTRAL POSITION (PNP) SWITCH CIRCUIT</b>
<p> <b>With CONSULT-II</b> Does "ECU INPUT SIGNALS" in "DATA MONITOR" show damage to park/neutral position (PNP) switch circuit?</p>	
<p> <b>Without CONSULT-II</b> Does self-diagnosis show damage to park/neutral position (PNP) switch circuit?</p>	
SAT367J	
<b>Yes or No</b>	
Yes	▶ Check park/neutral position (PNP) switch circuit. Refer to "DTC P0705", AT-102.
No	▶ GO TO 2.

<b>2</b>	<b>CHECK SYMPTOM</b>
Check again.	
SAT778B	
<b>OK or NG</b>	
OK	▶ <b>INSPECTION END</b>
NG	▶ GO TO 3.

<b>3</b>	<b>CHECK TCM INSPECTION</b>
<p>1. Perform TCM input/output signal inspection. 2. If NG, recheck TCM pin terminals for damage or loose connection with harness connector.</p>	
<b>OK or NG</b>	
OK	▶ <b>INSPECTION END</b>
NG	▶ Repair or replace damaged parts.

# TROUBLE DIAGNOSES FOR SYMPTOMS

20. Vehicle Does Not Decelerate By Engine Brake

## 20. Vehicle Does Not Decelerate By Engine Brake

=NFAT0107

### SYMPTOM:

Vehicle does not decelerate by engine brake when shifting from 2<sub>2</sub> (1<sub>2</sub>) to 1<sub>1</sub>.

<b>1</b>	<b>CHECK SYMPTOM</b>	
Is "6. Vehicle Does Not Creep Backward In R Position" OK?		
Yes or No		
Yes	▶	Go to "15. Engine Speed Does Not Return To Idle (Light Braking D <sub>4</sub> → D <sub>3</sub> )", AT-253.
No	▶	Go to "6. Vehicle Does Not Creep Backward In R Position", AT-229.

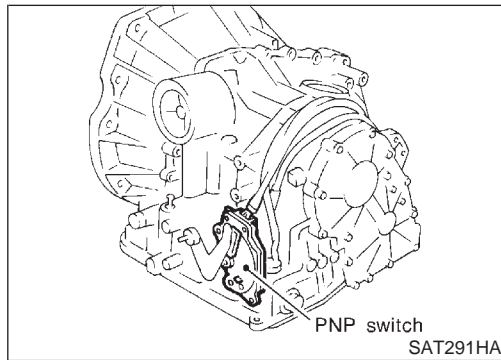

## 21. TCM Self-diagnosis Does Not Activate (PNP, Overdrive Control and Throttle Position Switches Circuit Checks)

NFAT0108

### SYMPTOM:

O/D OFF indicator lamp does not come on in TCM self-diagnostic procedure even if the lamp circuit is good.

### DESCRIPTION

NFAT0108S01

- Park/neutral position (PNP) switch  
The park/neutral (PNP) switch assembly includes a transmission range switch. The transmission range switch detects the selector lever position and sends a signal to the TCM.
- Overdrive control switch  
Detects the overdrive control switch position (ON or OFF) and sends a signal to the TCM.
- Throttle position switch  
Consists of a wide open throttle position switch and a closed throttle position switch.  
The wide open throttle position switch sends a signal to the TCM when the throttle valve is open at least 1/2 of the full throttle position. The closed throttle position switch sends a signal to the TCM when the throttle valve is fully closed.

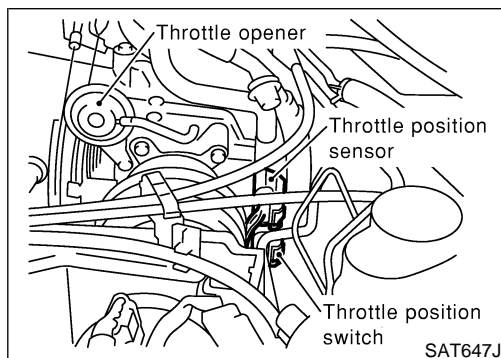
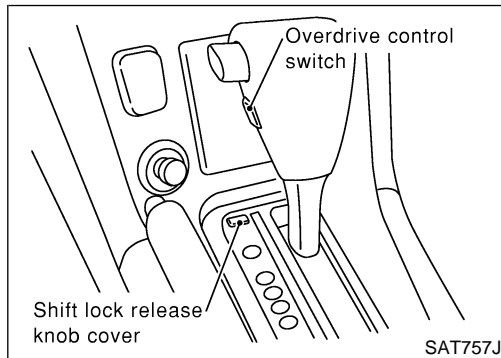

# TROUBLE DIAGNOSES FOR SYMPTOMS

21. TCM Self-diagnosis Does Not Activate (PNP, Overdrive Control and Throttle Position Switches Circuit Checks) (Cont'd)

## DIAGNOSTIC PROCEDURE

=NFAT0108S02

### NOTE:

The diagnostic procedure includes inspections for the overdrive control and throttle position switch circuits.

<b>1</b>	<b>CHECK PARK/NEUTRAL POSITION (PNP) SWITCH CIRCUIT (With CONSULT-II)</b>																
<p><b>With CONSULT-II</b></p> <ol style="list-style-type: none"> <li>1. Turn ignition switch to "ON" position. (Do not start engine.)</li> <li>2. Select "ECU INPUT SIGNALS" in "DATA MONITOR" mode for "A/T" with CONSULT-II.</li> <li>3. Read out P/N, R, D, 2 and 1 position switches moving selector lever to each position. Check that the signal of the selector lever position is indicated properly.</li> </ol>																	
<table border="1" style="margin: auto; border-collapse: collapse;"> <thead> <tr> <th colspan="2">DATA MONITOR</th> </tr> <tr> <th>MONITORING</th> <th></th> </tr> </thead> <tbody> <tr> <td>PN POSI SW</td> <td>OFF</td> </tr> <tr> <td>R POSITION SW</td> <td>OFF</td> </tr> <tr> <td>D POSITION SW</td> <td>OFF</td> </tr> <tr> <td>2 POSITION SW</td> <td>ON</td> </tr> <tr> <td>1 POSITION SW</td> <td>OFF</td> </tr> </tbody> </table>				DATA MONITOR		MONITORING		PN POSI SW	OFF	R POSITION SW	OFF	D POSITION SW	OFF	2 POSITION SW	ON	1 POSITION SW	OFF
DATA MONITOR																	
MONITORING																	
PN POSI SW	OFF																
R POSITION SW	OFF																
D POSITION SW	OFF																
2 POSITION SW	ON																
1 POSITION SW	OFF																
SAT643J																	
<b>OK or NG</b>																	
OK	▶	GO TO 5.															
NG	▶	GO TO 2.															

<b>2</b>	<b>DETECT MALFUNCTIONING ITEM</b>																							
<p>Check the following items:</p> <ul style="list-style-type: none"> <li>● Park/neutral position (PNP) switch</li> </ul> <p>a. Check continuity between terminals 1 and 2 and between terminals 3 and 4, 5, 6, 7, 8, 9 while moving manual shaft through each position.</p>																								
<p style="text-align: center;">View with air cleaner box removed</p>		<table border="1" style="margin: auto; border-collapse: collapse;"> <thead> <tr> <th>Lever position</th> <th colspan="2">Terminal No.</th> </tr> </thead> <tbody> <tr> <td>P</td> <td>3 - 7</td> <td>1 - 2</td> </tr> <tr> <td>R</td> <td>3 - 8</td> <td></td> </tr> <tr> <td>N</td> <td>3 - 9</td> <td>1 - 2</td> </tr> <tr> <td>D</td> <td>3 - 6</td> <td></td> </tr> <tr> <td>2</td> <td>3 - 5</td> <td></td> </tr> <tr> <td>1</td> <td>3 - 4</td> <td></td> </tr> </tbody> </table>	Lever position	Terminal No.		P	3 - 7	1 - 2	R	3 - 8		N	3 - 9	1 - 2	D	3 - 6		2	3 - 5		1	3 - 4		SAT615J
Lever position	Terminal No.																							
P	3 - 7	1 - 2																						
R	3 - 8																							
N	3 - 9	1 - 2																						
D	3 - 6																							
2	3 - 5																							
1	3 - 4																							
<p>b. If NG, check again with manual control cable disconnected from manual shaft of A/T assembly. Refer to step a.  c. If OK on step b, adjust manual control cable. Refer to AT-282.  d. If NG on step b, remove park/neutral position (PNP) switch from A/T and check continuity of park/neutral position (PNP) switch terminals. Refer to step a.  e. If OK on step d, adjust park/neutral position (PNP) switch. Refer to AT-281.  f. If NG on step d, replace park/neutral position (PNP) switch.</p> <ul style="list-style-type: none"> <li>● Harness for short or open between ignition switch and park/neutral position (PNP) switch (Main harness)</li> <li>● Harness for short or open between park/neutral position (PNP) switch and TCM (Main harness)</li> </ul>																								
<b>OK or NG</b>																								
OK	▶	GO TO 5.																						
NG	▶	Repair or replace damaged parts.																						

# TROUBLE DIAGNOSES FOR SYMPTOMS

21. TCM Self-diagnosis Does Not Activate (PNP, Overdrive Control and Throttle Position Switches Circuit Checks) (Cont'd)

## 3 CHECK PARK/NEUTRAL POSITION (PNP) SWITCH CIRCUIT (Without CONSULT-II)

⊗ Without CONSULT-II

1. Turn ignition switch to ON position. (Do not start engine.)
2. Check voltage between TCM terminals 26, 27, 34, 35, 36 and ground while moving selector lever through each position.

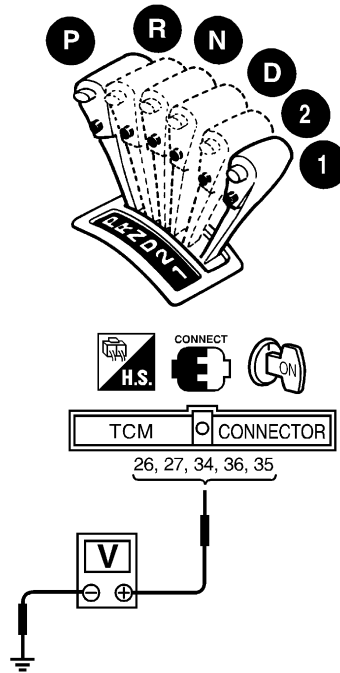

**Voltage:**  
**B: Battery voltage**  
**0: 0V**

SAT361J

Lever position	Terminal No.				
	36	35	34	27	26
P, N	B	0	0	0	0
R	0	B	0	0	0
D	0	0	B	0	0
2	0	0	0	B	0
1	0	0	0	0	B

MTBL0119

OK or NG

OK	▶	GO TO 7.
NG	▶	GO TO 4.

# TROUBLE DIAGNOSES FOR SYMPTOMS

## 21. TCM Self-diagnosis Does Not Activate (PNP, Overdrive Control and Throttle Position Switches Circuit Checks) (Cont'd)

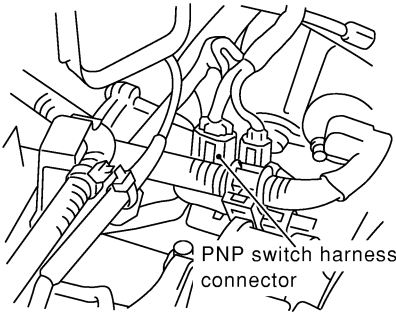
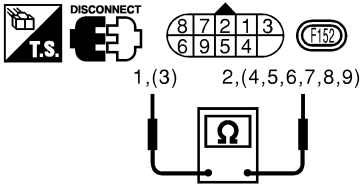
<b>4</b>	<b>DETECT MALFUNCTIONING ITEM</b>	<p>Check the following items:</p> <ul style="list-style-type: none"> <li>● Park/neutral position (PNP) switch</li> <li>a. Check continuity between terminals 1 and 2 and between terminals 3 and 4, 5, 6, 7, 8, 9 while moving manual shaft through each position.</li> </ul> <div style="display: flex; justify-content: space-between; align-items: flex-start;"> <div style="width: 30%;">  <p style="font-size: small;">View with air cleaner box removed</p> </div> <div style="width: 20%; text-align: center;">  </div> <div style="width: 40%;"> <table border="1" style="width: 100%; border-collapse: collapse; font-size: x-small;"> <thead> <tr> <th style="text-align: left;">Lever position</th> <th colspan="2" style="text-align: center;">Terminal No.</th> </tr> </thead> <tbody> <tr> <td>P</td> <td style="text-align: center;">3 - 7</td> <td style="text-align: center;">1 - 2</td> </tr> <tr> <td>R</td> <td style="text-align: center;">3 - 8</td> <td></td> </tr> <tr> <td>N</td> <td style="text-align: center;">3 - 9</td> <td style="text-align: center;">1 - 2</td> </tr> <tr> <td>D</td> <td style="text-align: center;">3 - 6</td> <td></td> </tr> <tr> <td>2</td> <td style="text-align: center;">3 - 5</td> <td></td> </tr> <tr> <td>1</td> <td style="text-align: center;">3 - 4</td> <td></td> </tr> </tbody> </table> <p style="text-align: right; font-size: x-small;">SAT615J</p> </div> </div> <p>b. If NG, check again with manual control cable disconnected from manual shaft of A/T assembly. Refer to step a.  c. If OK on step b, adjust manual control cable. Refer to AT-282.  d. If NG on step b, remove park/neutral position (PNP) switch from A/T and check continuity of park/neutral position (PNP) switch terminals. Refer to step a.  e. If OK on step d, adjust park/neutral position (PNP) switch. Refer to AT-281.  f. If NG on step d, replace park/neutral position (PNP) switch.</p> <ul style="list-style-type: none"> <li>● Harness for short or open between ignition switch and park/neutral position (PNP) switch (Main harness)</li> <li>● Harness for short or open between park/neutral position (PNP) switch and TCM (Main harness)</li> </ul> <p style="text-align: center; font-weight: bold; font-size: small;">OK or NG</p>	Lever position	Terminal No.		P	3 - 7	1 - 2	R	3 - 8		N	3 - 9	1 - 2	D	3 - 6		2	3 - 5		1	3 - 4		
Lever position	Terminal No.																							
P	3 - 7	1 - 2																						
R	3 - 8																							
N	3 - 9	1 - 2																						
D	3 - 6																							
2	3 - 5																							
1	3 - 4																							
OK	▶	GO TO 7.																						
NG	▶	Repair or replace damaged parts.																						

<b>5</b>	<b>CHECK OVERDRIVE CONTROL SWITCH CIRCUIT (With CONSULT-II)</b>	<p> <b>With CONSULT-II</b></p> <ol style="list-style-type: none"> <li>1. Turn ignition switch to "ON" position. (Do not start engine.)</li> <li>2. Select "ECU INPUT SIGNALS" in "DATA MONITOR" mode for "A/T" with CONSULT-II.</li> <li>3. Read out "OVERDRIVE SW".</li> </ol> <p>Check the signal of the overdrive control switch is indicated properly. (Overdrive control switch "ON" displayed on CONSULT-II means overdrive "OFF".)</p> <div style="text-align: center; margin: 10px 0;"> <table border="1" style="border-collapse: collapse; font-size: x-small;"> <thead> <tr> <th colspan="2" style="text-align: center;">DATA MONITOR</th> </tr> <tr> <th style="text-align: left;">MONITORING</th> <th></th> </tr> </thead> <tbody> <tr> <td>ENGINE SPEED</td> <td style="text-align: center;">XXX rpm</td> </tr> <tr> <td>TURBINE REV</td> <td style="text-align: center;">XXX rpm</td> </tr> <tr> <td>OVERDRIVE SW</td> <td style="text-align: center;">ON</td> </tr> <tr> <td>PN POSI SW</td> <td style="text-align: center;">OFF</td> </tr> <tr> <td>R POSITION SW</td> <td style="text-align: center;">OFF</td> </tr> </tbody> </table> <p style="text-align: right; font-size: x-small;">SAT645J</p> </div> <p style="text-align: center; font-weight: bold; font-size: small;">OK or NG</p>	DATA MONITOR		MONITORING		ENGINE SPEED	XXX rpm	TURBINE REV	XXX rpm	OVERDRIVE SW	ON	PN POSI SW	OFF	R POSITION SW	OFF	
DATA MONITOR																	
MONITORING																	
ENGINE SPEED	XXX rpm																
TURBINE REV	XXX rpm																
OVERDRIVE SW	ON																
PN POSI SW	OFF																
R POSITION SW	OFF																
OK	▶	GO TO 9.															
NG	▶	GO TO 6.															

# TROUBLE DIAGNOSES FOR SYMPTOMS

21. TCM Self-diagnosis Does Not Activate (PNP, Overdrive Control and Throttle Position Switches Circuit Checks) (Cont'd)

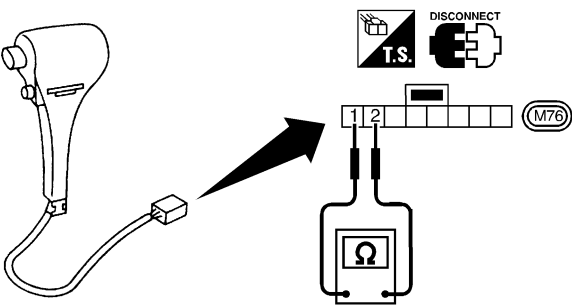
<b>6</b>	<b>DETECT MALFUNCTIONING ITEM</b>							
<p>Check the following items:</p> <ul style="list-style-type: none"> <li>● Overdrive control switch.</li> </ul> <p>a. Check continuity between two terminals.</p>								
								
<table border="1" style="border-collapse: collapse;"> <thead> <tr> <th style="width: 50%;">Switch position</th> <th style="width: 50%;">Continuity</th> </tr> </thead> <tbody> <tr> <td style="text-align: center;">ON</td> <td style="text-align: center;">No</td> </tr> <tr> <td style="text-align: center;">OFF</td> <td style="text-align: center;">Yes</td> </tr> </tbody> </table>			Switch position	Continuity	ON	No	OFF	Yes
Switch position	Continuity							
ON	No							
OFF	Yes							
<p>SAT642J</p> <ul style="list-style-type: none"> <li>● Harness for short or open between TCM and overdrive control switch (Main harness)</li> <li>● Harness of ground circuit for overdrive control switch (Main harness) for short or open</li> </ul> <p style="text-align: center;"><b>OK or NG</b></p>								
OK	▶	GO TO 9.						
NG	▶	Repair or replace damaged parts.						

# TROUBLE DIAGNOSES FOR SYMPTOMS

21. TCM Self-diagnosis Does Not Activate (PNP, Overdrive Control and Throttle Position Switches Circuit Checks) (Cont'd)

<b>7</b>	<b>CHECK OVERDRIVE CONTROL SWITCH CIRCUIT (Without CONSULT-II)</b>							
<p>⊗ <b>Without CONSULT-II</b></p> <p>1. Turn ignition switch to ON position. (Do not start engine.)</p> <p>2. Check voltage between TCM terminal 22 and ground when overdrive control switch is ON and OFF.</p>								
<table border="1" style="margin-left: auto; margin-right: auto;"> <thead> <tr> <th>Switch position</th> <th>Voltage</th> </tr> </thead> <tbody> <tr> <td>ON</td> <td>Battery voltage</td> </tr> <tr> <td>OFF</td> <td>1V or less</td> </tr> </tbody> </table>			Switch position	Voltage	ON	Battery voltage	OFF	1V or less
Switch position	Voltage							
ON	Battery voltage							
OFF	1V or less							
<b>OK or NG</b>								
OK	▶	GO TO 11.						
NG	▶	GO TO 8.						

GI  
MA  
EM  
LC  
EC  
FE  
CL  
MT  
**AT**  
AX  
SU  
BR  
ST  
RS  
BT  
HA  
SC  
EL  
IDX

SAT362J  
MTBL0106



# TROUBLE DIAGNOSES FOR SYMPTOMS

## 21. TCM Self-diagnosis Does Not Activate (PNP, Overdrive Control and Throttle Position Switches Circuit Checks) (Cont'd)

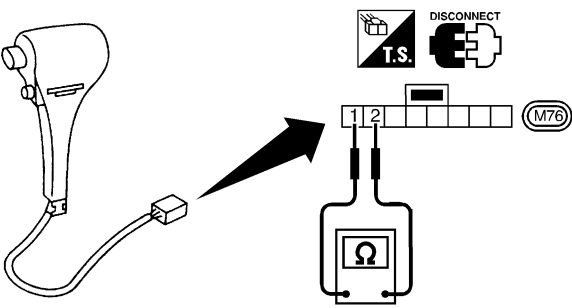
<b>8</b>	<b>DETECT MALFUNCTIONING ITEM</b>						
<p>Check the following items:</p> <ul style="list-style-type: none"> <li>● Overdrive control switch.</li> <li>a. Check continuity between two terminals.</li> </ul>							
 <table border="1" style="margin-left: auto; margin-right: auto;"> <thead> <tr> <th>Switch position</th> <th>Continuity</th> </tr> </thead> <tbody> <tr> <td style="text-align: center;">ON</td> <td style="text-align: center;">No</td> </tr> <tr> <td style="text-align: center;">OFF</td> <td style="text-align: center;">Yes</td> </tr> </tbody> </table>		Switch position	Continuity	ON	No	OFF	Yes
Switch position	Continuity						
ON	No						
OFF	Yes						
SAT642J							
<ul style="list-style-type: none"> <li>● Harness for short or open between TCM and overdrive control switch (Main harness)</li> <li>● Harness of ground circuit for overdrive control switch (Main harness) for short or open</li> </ul> <p style="text-align: center;"><b>OK or NG</b></p>							
OK	▶	GO TO 11.					
NG	▶	Repair or replace damaged parts.					

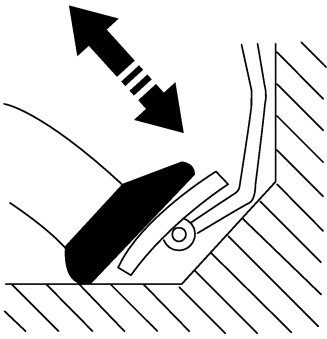
<b>9</b>	<b>CHECK THROTTLE POSITION SWITCH CIRCUIT (With CONSULT-II)</b>														
<p> <b>With CONSULT-II</b></p> <ol style="list-style-type: none"> <li>1. Turn ignition switch to ON position. (Do not start engine.)</li> <li>2. Select "ECU INPUT SIGNALS" in "DATA MONITOR" mode for "A/T" with CONSULT-II.</li> <li>3. Apply vacuum to the throttle opener, then check the following. Refer to steps 1 and 2 of "Preparation", "TCM SELF-DIAGNOSTIC PROCEDURE (No Tools)", AT-49.</li> <li>4. Read out "CLOSED THL/SW" and "W/O THRL/P-SW" depressing and releasing accelerator pedal. Check the signal of throttle position switch is indicated properly.</li> </ol>															
<table border="1" style="margin-left: auto; margin-right: auto;"> <thead> <tr> <th rowspan="2">Accelerator pedal condition</th> <th colspan="2">Data monitor</th> </tr> <tr> <th>CLOSED THL/SW</th> <th>W/O THRL/P-SW</th> </tr> </thead> <tbody> <tr> <td style="text-align: center;">Released</td> <td style="text-align: center;">ON</td> <td style="text-align: center;">OFF</td> </tr> <tr> <td style="text-align: center;">Fully depressed</td> <td style="text-align: center;">OFF</td> <td style="text-align: center;">ON</td> </tr> </tbody> </table>		Accelerator pedal condition	Data monitor		CLOSED THL/SW	W/O THRL/P-SW	Released	ON	OFF	Fully depressed	OFF	ON			
Accelerator pedal condition	Data monitor														
	CLOSED THL/SW	W/O THRL/P-SW													
Released	ON	OFF													
Fully depressed	OFF	ON													
MTBL0011															
 <table border="1" style="margin-left: auto; margin-right: auto;"> <thead> <tr> <th colspan="2">DATA MONITOR</th> </tr> <tr> <th>MONITORING</th> <th></th> </tr> </thead> <tbody> <tr> <td>POWERSHIFT SW</td> <td style="text-align: center;">OFF</td> </tr> <tr> <td>CLOSED THL/SW</td> <td style="text-align: center;">OFF</td> </tr> <tr> <td>W/OTHRL/P-SW</td> <td style="text-align: center;">OFF</td> </tr> <tr> <td>HOLD SW</td> <td style="text-align: center;">OFF</td> </tr> <tr> <td>BRAKE SW</td> <td style="text-align: center;">ON</td> </tr> </tbody> </table>		DATA MONITOR		MONITORING		POWERSHIFT SW	OFF	CLOSED THL/SW	OFF	W/OTHRL/P-SW	OFF	HOLD SW	OFF	BRAKE SW	ON
DATA MONITOR															
MONITORING															
POWERSHIFT SW	OFF														
CLOSED THL/SW	OFF														
W/OTHRL/P-SW	OFF														
HOLD SW	OFF														
BRAKE SW	ON														
SAT646J															
<b>OK or NG</b>															
OK	▶	GO TO 13.													
NG	▶	GO TO 10.													

# TROUBLE DIAGNOSES FOR SYMPTOMS

## 21. TCM Self-diagnosis Does Not Activate (PNP, Overdrive Control and Throttle Position Switches Circuit Checks) (Cont'd)

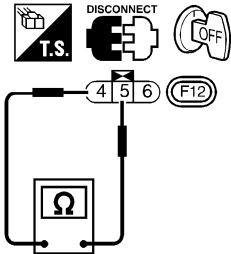
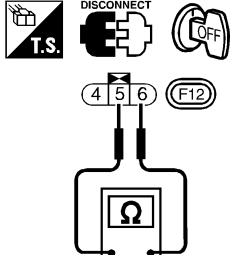
10	DETECT MALFUNCTIONING ITEM							
	<p>Check the following items:</p> <ul style="list-style-type: none"> <li>● Throttle position switch</li> <li>● Closed throttle position switch (idle position)</li> </ul> <p>a. Check continuity between terminals 4 and 5.</p> <div style="display: flex; align-items: center;">  <table border="1" style="margin-left: 20px;"> <thead> <tr> <th>Accelerator pedal condition</th> <th>Continuity</th> </tr> </thead> <tbody> <tr> <td>Released</td> <td>Yes</td> </tr> <tr> <td>Depressed</td> <td>No</td> </tr> </tbody> </table> </div>	Accelerator pedal condition	Continuity	Released	Yes	Depressed	No	GI MA EM LC EC SAT634J FE
Accelerator pedal condition	Continuity							
Released	Yes							
Depressed	No							
	<p>b. To adjust closed throttle position switch, refer to EC-113, "Basic Inspection".</p> <ul style="list-style-type: none"> <li>● Wide open throttle position switch</li> </ul> <p>a. Check continuity between terminals 5 and 6.</p> <div style="display: flex; align-items: center;">  <table border="1" style="margin-left: 20px;"> <thead> <tr> <th>Accelerator pedal condition</th> <th>Continuity</th> </tr> </thead> <tbody> <tr> <td>Released</td> <td>No</td> </tr> <tr> <td>Depressed</td> <td>Yes</td> </tr> </tbody> </table> </div>	Accelerator pedal condition	Continuity	Released	No	Depressed	Yes	CL MT AT
Accelerator pedal condition	Continuity							
Released	No							
Depressed	Yes							
	<ul style="list-style-type: none"> <li>● Harness for short or open between ignition switch and throttle position switch (Main harness)</li> <li>● Harness for short or open between throttle position switch and TCM (Main harness)</li> </ul> <p style="text-align: center;"><b>OK or NG</b></p>	SAT635J SU BR						
OK	▶ GO TO 13.							
NG	▶ Repair or replace damaged parts.							

GI  
MA  
EM  
LC  
EC  
SAT634J  
FE  
CL  
MT  
AT  
AX  
SU  
BR  
ST  
RS  
BT  
HA  
SC  
EL  
IDX

# TROUBLE DIAGNOSES FOR SYMPTOMS

21. TCM Self-diagnosis Does Not Activate (PNP, Overdrive Control and Throttle Position Switches Circuit Checks) (Cont'd)

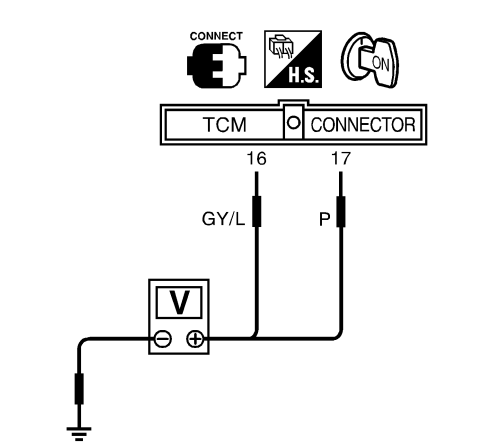
<b>11</b>	<b>CHECK THROTTLE POSITION SWITCH CIRCUIT (Without CONSULT-II)</b>											
<p>⊗ <b>Without CONSULT-II</b></p> <ol style="list-style-type: none"> <li>1. Turn ignition switch to ON position. (Do not start engine.)</li> <li>2. Check voltage between TCM terminals 16, 17 and ground while depressing, and releasing accelerator pedal slowly. (After warming up engine) [Refer to "Preparation", "TCM SELF-DIAGNOSTIC PROCEDURE (No Tools)", AT-49].</li> </ol>												
												
												
SAT363JA												
<table border="1" style="margin: auto; border-collapse: collapse;"> <thead> <tr> <th rowspan="2" style="text-align: left;">Accelerator pedal condition</th> <th colspan="2" style="text-align: center;">Voltage</th> </tr> <tr> <th style="text-align: center;">Terminal No. 16</th> <th style="text-align: center;">Terminal No. 17</th> </tr> </thead> <tbody> <tr> <td style="text-align: center;">Released</td> <td style="text-align: center;">Battery voltage</td> <td style="text-align: center;">1V or less</td> </tr> <tr> <td style="text-align: center;">Fully depressed</td> <td style="text-align: center;">1V or less</td> <td style="text-align: center;">Battery voltage</td> </tr> </tbody> </table>		Accelerator pedal condition	Voltage		Terminal No. 16	Terminal No. 17	Released	Battery voltage	1V or less	Fully depressed	1V or less	Battery voltage
Accelerator pedal condition	Voltage											
	Terminal No. 16	Terminal No. 17										
Released	Battery voltage	1V or less										
Fully depressed	1V or less	Battery voltage										
MTBL0120												
<b>OK or NG</b>												
OK	▶ GO TO 13.											
NG	▶ GO TO 12.											

# TROUBLE DIAGNOSES FOR SYMPTOMS

## 21. TCM Self-diagnosis Does Not Activate (PNP, Overdrive Control and Throttle Position Switches Circuit Checks) (Cont'd)

<b>12</b>	<b>DETECT MALFUNCTIONING ITEM</b>	<p>Check the following items:</p> <ul style="list-style-type: none"> <li>● Throttle position switch</li> <li>a. Closed throttle position switch (idle position)             <ul style="list-style-type: none"> <li>i. Check continuity between terminals 4 and 5.</li> </ul> </li> </ul> <div style="display: flex; justify-content: space-around; align-items: flex-start; margin-top: 10px;"> <div style="text-align: center;"> </div> <table border="1" style="border-collapse: collapse; text-align: center;"> <thead> <tr> <th style="width: 50%;">Accelerator pedal condition</th> <th style="width: 50%;">Continuity</th> </tr> </thead> <tbody> <tr> <td>Released</td> <td>Yes</td> </tr> <tr> <td>Depressed</td> <td>No</td> </tr> </tbody> </table> </div> <p style="text-align: right; margin-top: 10px;">SAT634J</p> <ul style="list-style-type: none"> <li>ii. To adjust closed throttle position switch, refer to EC-113, "Basic Inspection".</li> <li>b. Wide open throttle position switch             <ul style="list-style-type: none"> <li>i. Check continuity between terminals 5 and 6.</li> </ul> </li> </ul> <div style="display: flex; justify-content: space-around; align-items: flex-start; margin-top: 10px;"> <div style="text-align: center;"> </div> <table border="1" style="border-collapse: collapse; text-align: center;"> <thead> <tr> <th style="width: 50%;">Accelerator pedal condition</th> <th style="width: 50%;">Continuity</th> </tr> </thead> <tbody> <tr> <td>Released</td> <td>No</td> </tr> <tr> <td>Depressed</td> <td>Yes</td> </tr> </tbody> </table> </div> <p style="text-align: right; margin-top: 10px;">SAT635J</p> <ul style="list-style-type: none"> <li>● Harness for short or open between ignition switch and throttle position switch (Main harness)</li> <li>● Harness for short or open between throttle position switch and TCM (Main harness)</li> </ul> <p style="text-align: center; margin-top: 10px;"><b>OK or NG</b></p> <table border="1" style="width: 100%; border-collapse: collapse;"> <tr> <td style="width: 15%;">OK</td> <td style="width: 10%; text-align: center;">▶</td> <td>GO TO 13.</td> </tr> <tr> <td>NG</td> <td style="text-align: center;">▶</td> <td>Repair or replace damaged parts.</td> </tr> </table>	Accelerator pedal condition	Continuity	Released	Yes	Depressed	No	Accelerator pedal condition	Continuity	Released	No	Depressed	Yes	OK	▶	GO TO 13.	NG	▶	Repair or replace damaged parts.	GI MA EM LC EC FE CL MT <b>AT</b> AX SU BR ST
Accelerator pedal condition	Continuity																				
Released	Yes																				
Depressed	No																				
Accelerator pedal condition	Continuity																				
Released	No																				
Depressed	Yes																				
OK	▶	GO TO 13.																			
NG	▶	Repair or replace damaged parts.																			

<b>13</b>	<b>CHECK DTC</b>	<p>Perform Diagnostic procedure, AT-261.</p> <p style="text-align: center; margin-top: 10px;"><b>OK or NG</b></p> <table border="1" style="width: 100%; border-collapse: collapse;"> <tr> <td style="width: 15%;">OK</td> <td style="width: 10%; text-align: center;">▶</td> <td><b>INSPECTION END</b></td> </tr> <tr> <td>NG</td> <td style="text-align: center;">▶</td> <td>GO TO 14.</td> </tr> </table>	OK	▶	<b>INSPECTION END</b>	NG	▶	GO TO 14.	RS BT HA
OK	▶	<b>INSPECTION END</b>							
NG	▶	GO TO 14.							

<b>14</b>	<b>CHECK TCM INSPECTION</b>	<p>1. Perform TCM input/output signal inspection.</p> <p>2. If NG, recheck TCM pin terminals for damage or loose connection with harness connector.</p> <p style="text-align: center; margin-top: 10px;"><b>OK or NG</b></p> <table border="1" style="width: 100%; border-collapse: collapse;"> <tr> <td style="width: 15%;">OK</td> <td style="width: 10%; text-align: center;">▶</td> <td><b>INSPECTION END</b></td> </tr> <tr> <td>NG</td> <td style="text-align: center;">▶</td> <td>Repair or replace damaged parts.</td> </tr> </table>	OK	▶	<b>INSPECTION END</b>	NG	▶	Repair or replace damaged parts.	SC EL IDX
OK	▶	<b>INSPECTION END</b>							
NG	▶	Repair or replace damaged parts.							

## Description

NFAT0109

- The mechanical key interlock mechanism also operates as a shift lock:  
With the key switch turned to ON, the selector lever cannot be shifted from P (parking) to any other position unless the brake pedal is depressed.  
With the key removed, the selector lever cannot be shifted from P to any other position.  
The key cannot be removed unless the selector lever is placed in P.
- The shift lock and key interlock mechanisms are controlled by the ON-OFF operation of the shift lock solenoid and by the operation of the rotator and slider located inside the key cylinder, respectively.

# A/T SHIFT LOCK SYSTEM

Wiring Diagram — SHIFT —

## Wiring Diagram — SHIFT —

NFAT0110

AT-SHIFT-01

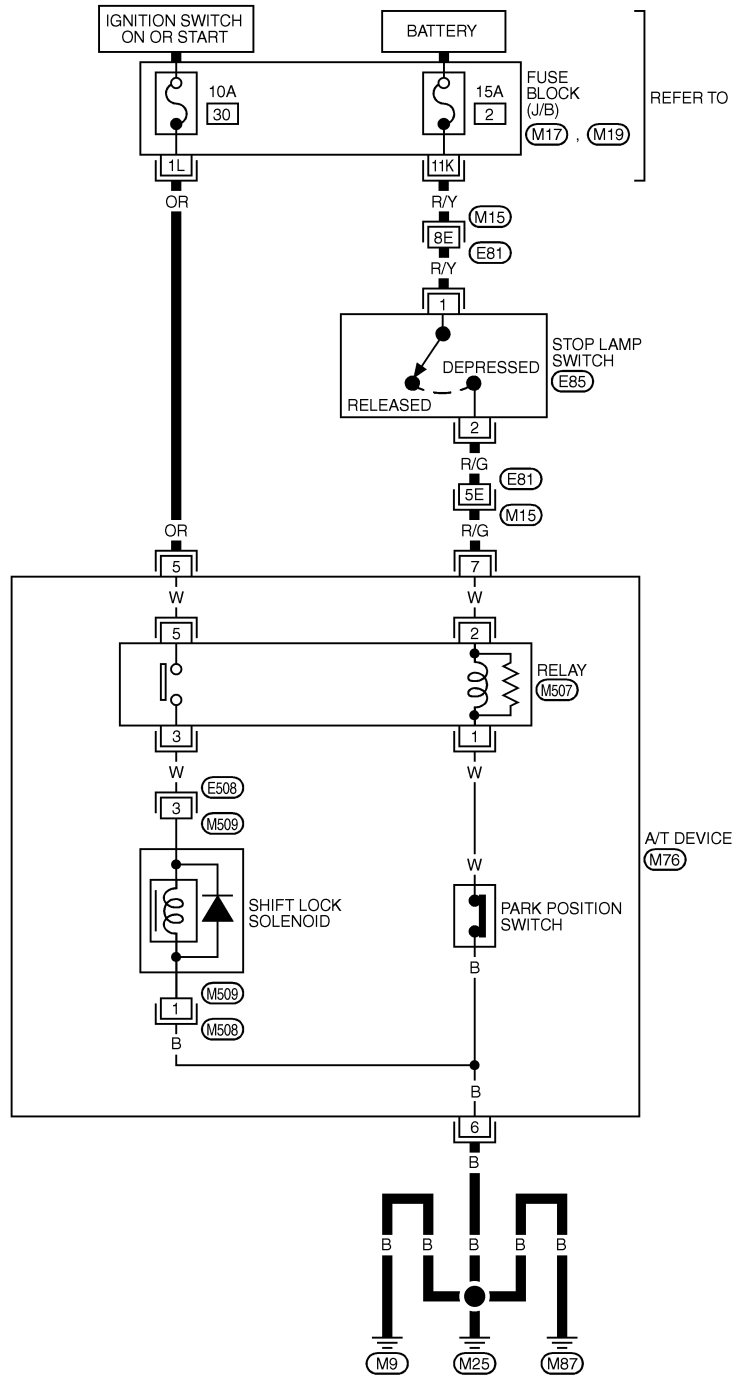

REFER TO EL-POWER.

AT DEVICE  
(M76)

- GI
- MA
- EM
- LC
- EC
- FE
- CL
- MT
- AT**
- AX
- SU
- BR
- ST
- RS
- BT
- HA
- SC
- EL
- IDX

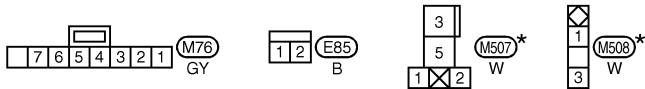

REFER TO THE FOLLOWING.  
 (M15), (E81) - SUPER  
 MULTIPLE JUNCTION (SMJ)  
 (M17) - FUSE BLOCK -  
 JUNCTION BOX (J/B)  
 (M19) - FUSE BLOCK -  
 JUNCTION BOX (J/B)

\* THIS CONNECTOR IS NOT SHOWN IN "HARNESS LAYOUT", EL SECTION.

# A/T SHIFT LOCK SYSTEM

Shift Lock System Electrical Parts Location

## Shift Lock System Electrical Parts Location

NFAT0111

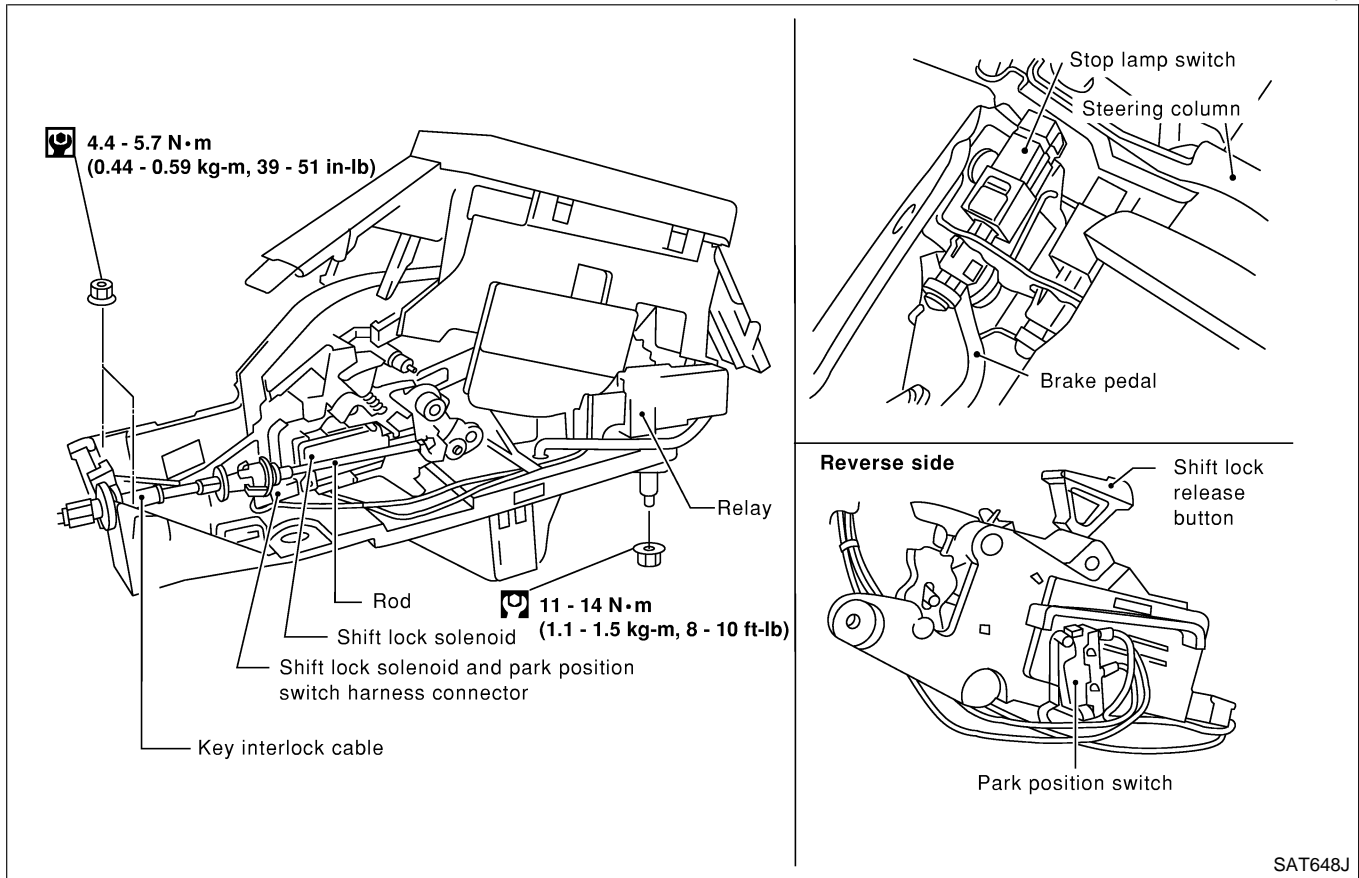

## Diagnostic Procedure

NFAT0112

### SYMPTOM 1:

- Selector lever cannot be moved from P position with key in ON position and brake pedal applied.
- Selector lever can be moved from P position with key in ON position and brake pedal released.
- Selector lever can be moved from P position when key is removed from key cylinder.

### SYMPTOM 2:

Ignition key cannot be removed when selector lever is set to P position. It can be removed when selector lever is set to any position except P.

<b>1</b>	<b>CHECK KEY INTERLOCK CABLE</b>	
Check key interlock cable for damaged.		
<b>OK or NG</b>		
OK	▶	GO TO 2.
NG	▶	Repair key interlock cable. Refer to "Key Interlock Cable", AT-276.

# A/T SHIFT LOCK SYSTEM

Diagnostic Procedure (Cont'd)

<b>2</b>	<b>CHECK SELECTOR LEVER POSITION</b>
Check selector lever position for damage.	
<b>OK or NG</b>	
OK	▶ GO TO 3.
NG	▶ Check selector lever. Refer to "ON-VEHICLE SERVICE — Park/Neutral Position (PNP) Switch and Control Cable Adjustment", AT-281, AT-282.

GI  
MA  
EM

<b>3</b>	<b>CHECK POWER SOURCE</b>
<p>1. Turn ignition switch to ON position. (Do not start engine.)</p> <p>2. Check voltage between A/T device harness terminal 5 and ground.</p>	
<p>A/T device harness terminal (M76)</p> <p><b>Voltage:</b> <b>Battery voltage</b></p> <p>OR</p> <p>SAT758J</p>	
<b>OK or NG</b>	
OK	▶ GO TO 5.
NG	▶ GO TO 4.

LC  
EC  
FE  
CL  
MT  
**AT**

<b>4</b>	<b>DETECT MALFUNCTIONING ITEM</b>
<p>Check the following items:</p> <ol style="list-style-type: none"> <li>1. Harness for short or open between ignition switch and A/T device harness terminal 5</li> <li>2. Fuse</li> <li>3. Ignition switch (Refer to EL-14, "POWER SUPPLY ROUTING".)</li> </ol>	
<b>OK or NG</b>	
OK	▶ GO TO 5.
NG	▶ Repair or replace damaged parts.

AX  
SU  
BR  
ST  
RS  
BT  
HA  
SC  
EL  
IDX



# A/T SHIFT LOCK SYSTEM

Diagnostic Procedure (Cont'd)

<b>5</b>	<b>CHECK INPUT SIGNAL A/T DEVICE</b>								
<p>Turn ignition switch to OFF position.</p> <ul style="list-style-type: none"> <li>Check voltage between A/T device harness terminal 7 and ground.</li> </ul>									
<p>A/T device harness terminal (M76)</p>		<table border="1" style="width: 100%; border-collapse: collapse;"> <tr> <td style="width: 50%;">Brake pedal</td> <td style="width: 50%;">Voltage</td> </tr> <tr> <td>Depressed</td> <td>0V</td> </tr> <tr> <td>Released</td> <td>Battery voltage</td> </tr> </table>		Brake pedal	Voltage	Depressed	0V	Released	Battery voltage
Brake pedal	Voltage								
Depressed	0V								
Released	Battery voltage								
SAT759J									
<b>OK or NG</b>									
OK	▶	GO TO 7.							
NG	▶	GO TO 6.							

<b>6</b>	<b>DETECT MALFUNCTIONING ITEM</b>								
<p>Check the following items:</p> <ol style="list-style-type: none"> <li>Harness for short or open between battery and stop lamp switch harness connector 2</li> <li>Harness for short or open between stop lamp switch harness connector 1 and A/T device harness connector 7</li> <li>Fuse</li> <li>Stop lamp switch             <ol style="list-style-type: none"> <li>Check continuity between terminals 1 and 2.</li> </ol> </li> </ol>									
<p>Stop lamp switch harness connector</p>		<table border="1" style="width: 100%; border-collapse: collapse;"> <tr> <td style="width: 50%;">Condition</td> <td style="width: 50%;">Continuity</td> </tr> <tr> <td>When brake pedal is depressed</td> <td>Yes</td> </tr> <tr> <td>When brake pedal is released</td> <td>No</td> </tr> </table>		Condition	Continuity	When brake pedal is depressed	Yes	When brake pedal is released	No
Condition	Continuity								
When brake pedal is depressed	Yes								
When brake pedal is released	No								
SAT060K									
<b>Check stop lamp switch after adjusting brake pedal — refer to BR-13, “Adjustment”.</b>									
<b>OK or NG</b>									
OK	▶	GO TO 7.							
NG	▶	Repair or replace damaged parts.							

<b>7</b>	<b>CHECK GROUND CIRCUIT</b>		
<ol style="list-style-type: none"> <li>Turn ignition switch to OFF position.</li> <li>Disconnect A/T device harness connector.</li> <li>Check continuity between A/T device harness terminal 6 and ground. Refer to wiring diagram — SHIFT —.</li> </ol> <p style="color: blue;"><b>Continuity should exist.</b></p> <p>If OK, check harness for short to ground and short to power.</p>			
<b>OK or NG</b>			
OK	▶	GO TO 8.	
NG	▶	Repair open circuit or short to ground or short to power in harness or connectors.	

<b>8</b>	<b>CHECK RELAY CIRCUIT</b>																
<p>1. Turn ignition switch to ON and OFF position.</p> <ul style="list-style-type: none"> <li>Check continuity between terminals 1, 2, 3 and 5.</li> </ul>																	
<div style="display: flex; justify-content: space-between; align-items: flex-start;"> <div style="width: 45%;"> </div> <div style="width: 50%;"> <table border="1" style="width: 100%; border-collapse: collapse;"> <thead> <tr> <th style="width: 30%;">Condition</th> <th style="width: 15%;">Terminal No.</th> <th style="width: 15%;">Ignition SW</th> <th style="width: 30%;">Continuity</th> </tr> </thead> <tbody> <tr> <td rowspan="2">When selector lever is set in "P" position and breake pedal depressed</td> <td rowspan="2">1 - 2</td> <td>ON or OFF</td> <td>Approx. 100±25Ω</td> </tr> <tr> <td>3 - 5</td> <td>ON</td> <td>Yes</td> </tr> <tr> <td></td> <td></td> <td>OFF</td> <td>No</td> </tr> </tbody> </table> </div> </div>			Condition	Terminal No.	Ignition SW	Continuity	When selector lever is set in "P" position and breake pedal depressed	1 - 2	ON or OFF	Approx. 100±25Ω	3 - 5	ON	Yes			OFF	No
Condition	Terminal No.	Ignition SW	Continuity														
When selector lever is set in "P" position and breake pedal depressed	1 - 2	ON or OFF	Approx. 100±25Ω														
		3 - 5	ON	Yes													
		OFF	No														
SAT775J																	
<b>Yes or No</b>																	
Yes	▶	GO TO 9.															
No	▶	Replace relay.															

GI  
MA  
EM  
LC  
EC  
FE  
CL

<b>9</b>	<b>CHECK PARK POSITION SWITCH</b>							
<p>• Check continuity between A/T device harness terminal 6 and relay (park position switch) harness terminal 1.</p>								
<div style="display: flex; justify-content: space-between; align-items: flex-start;"> <div style="width: 45%;"> </div> <div style="width: 50%;"> <table border="1" style="width: 100%; border-collapse: collapse;"> <thead> <tr> <th style="width: 70%;">Condition</th> <th style="width: 30%;">Continuity</th> </tr> </thead> <tbody> <tr> <td>When selector lever is set in "P" position and selector lever button is released</td> <td>Yes</td> </tr> <tr> <td>Except above</td> <td>No</td> </tr> </tbody> </table> </div> </div>			Condition	Continuity	When selector lever is set in "P" position and selector lever button is released	Yes	Except above	No
Condition	Continuity							
When selector lever is set in "P" position and selector lever button is released	Yes							
Except above	No							
SAT761J								
<b>OK or NG</b>								
OK	▶	GO TO 10.						
NG	▶	Replace park position switch.						

MT  
**AT**  
AX  
SU  
BR  
ST

<b>10</b>	<b>CHECK SHIFT LOCK SOLENOID</b>	
<p>• Check operation by applying battery voltage shift lock solenoid harness terminals 1 and 3.</p>		
<div style="display: flex; justify-content: center; align-items: center;"> </div>		
SAT762J		
<b>OK or NG</b>		
OK	▶	GO TO 11.
NG	▶	Replace shift lock solenoid.

RS  
BT  
HA  
SC  
EL  
IDX

# A/T SHIFT LOCK SYSTEM

Diagnostic Procedure (Cont'd)

<b>11</b>	<b>CHECK SHIFT LOCK OPERATION</b>	
1. Reconnect shift lock harness connector. 2. Turn ignition switch from OFF to ON position. (Do not start engine.) 3. Recheck shift lock operation.		
<b>OK or NG</b>		
OK	▶	<b>INSPECTION END</b>
NG	▶	GO TO 12.

<b>12</b>	<b>CHECK A/T DEVICE INSPECTION</b>	
1. Perform A/T device input/output signal inspection test. 2. If NG, recheck harness connector connection.		
<b>OK or NG</b>		
OK	▶	<b>INSPECTION END</b>
NG	▶	Repair or replace damaged parts.

## Key Interlock Cable

NFAT0113

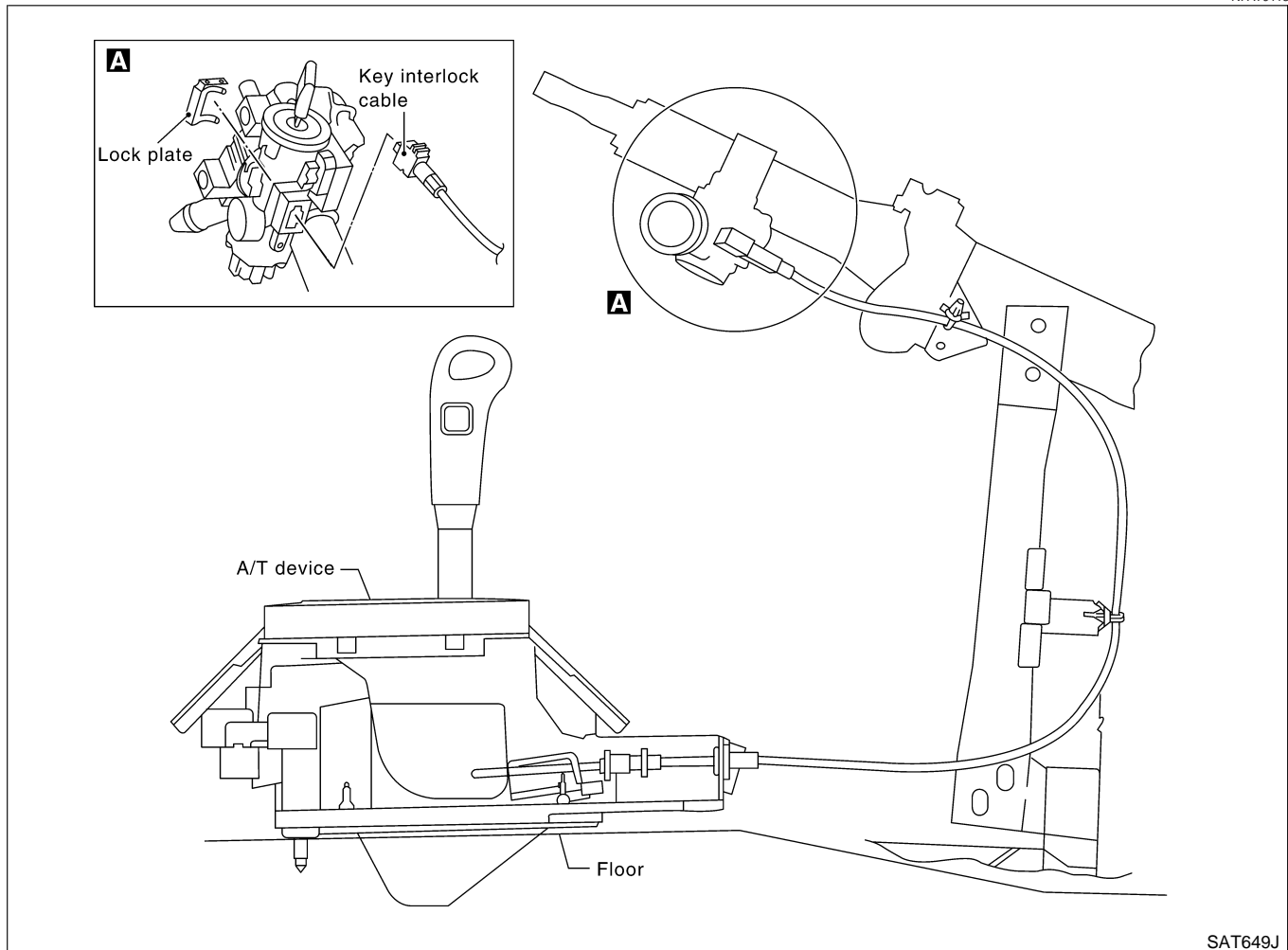

SAT649J

## CAUTION:

- Install key interlock cable in such a way that it will not be damaged by sharp bends, twists or interference with adjacent parts.
- After installing key interlock cable to control device, make sure that casing cap and bracket are firmly secured in their positions. If casing cap can be removed with an external load of less than 39.2 N (4.0 kg, 8.8 lb), replace key interlock cable with new one.

GI

MA

EM

LC

## REMOVAL

Unlock slider from adjuster holder and remove rod from cable.

NFAT0113S01

EC

FE

CL

MT

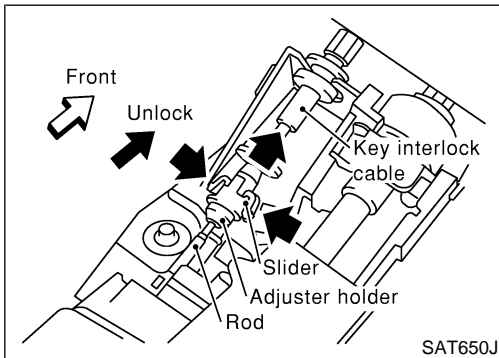

SAT650J

## INSTALLATION

1. Set key interlock cable to steering lock assembly and install lock plate.
2. Clamp cable to steering column and fix to control cable with band.
3. Set control lever to P position.

NFAT0113S02

AT

AX

SU

BR

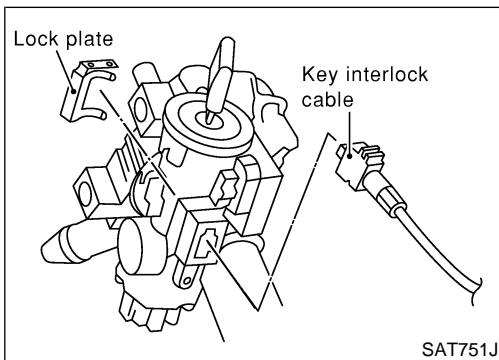

SAT751J

4. Insert rod into adjuster holder.
5. Install casing cap to bracket.
6. Move slider in order to fix adjuster holder to rod.

ST

RS

BT

HA

SC

EL

IDX

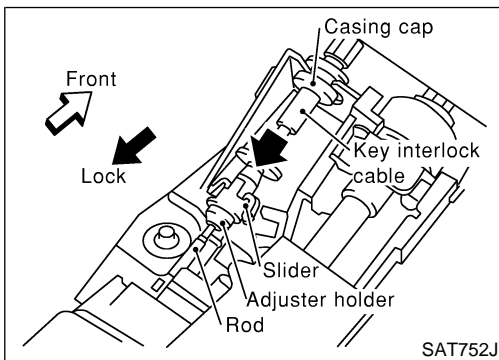

SAT752J

# SHIFT CONTROL SYSTEM

Control Device

## Control Device

NFAT0262

### SEC. 349

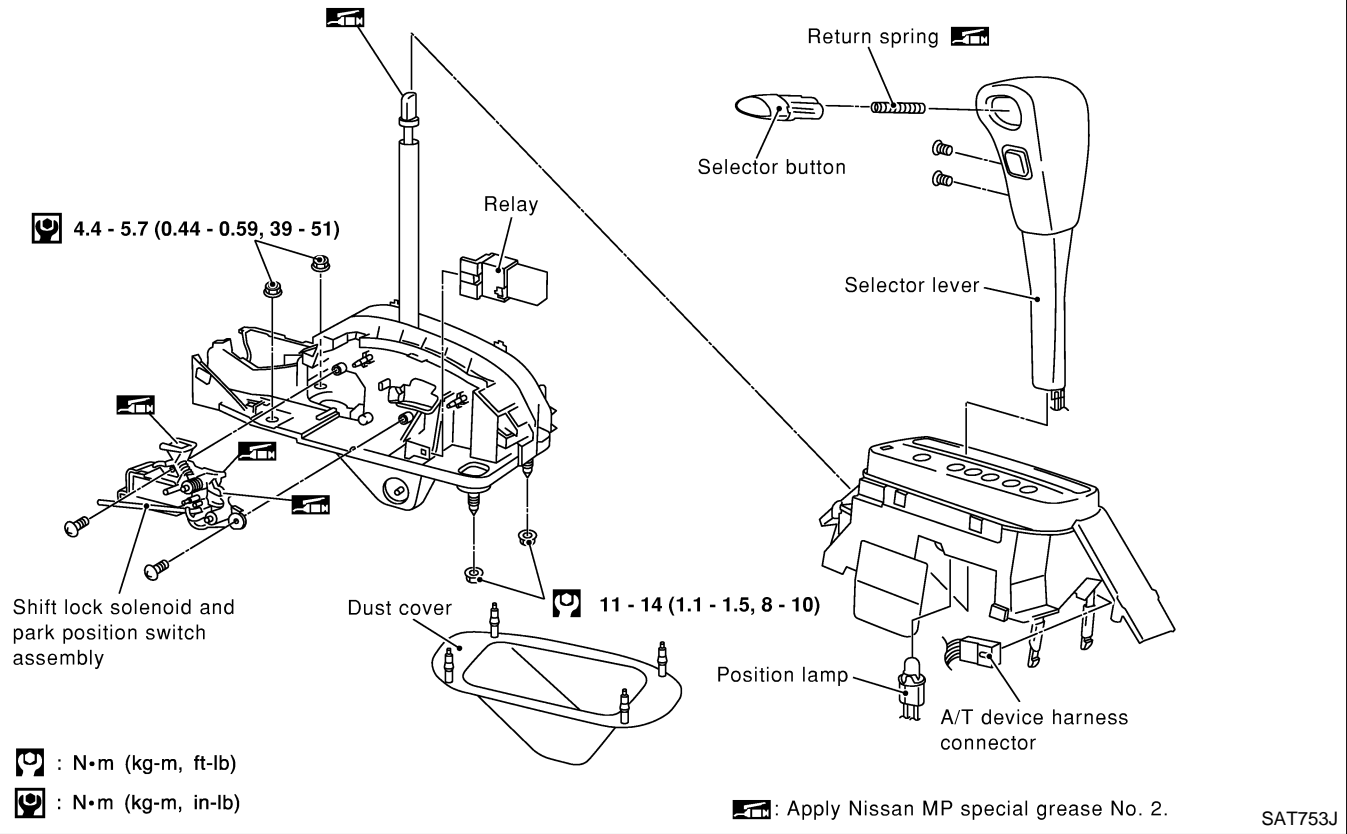

SAT753J

# SHIFT CONTROL SYSTEM

Control Cable

## Control Cable

NFAT0263

SEC. 349

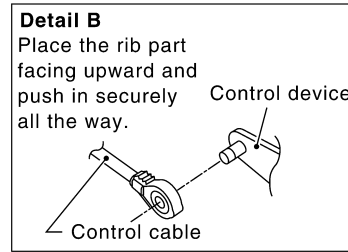
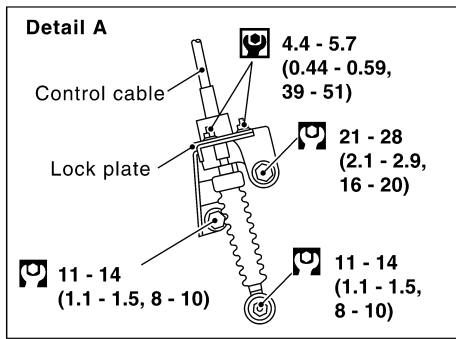
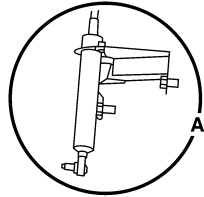
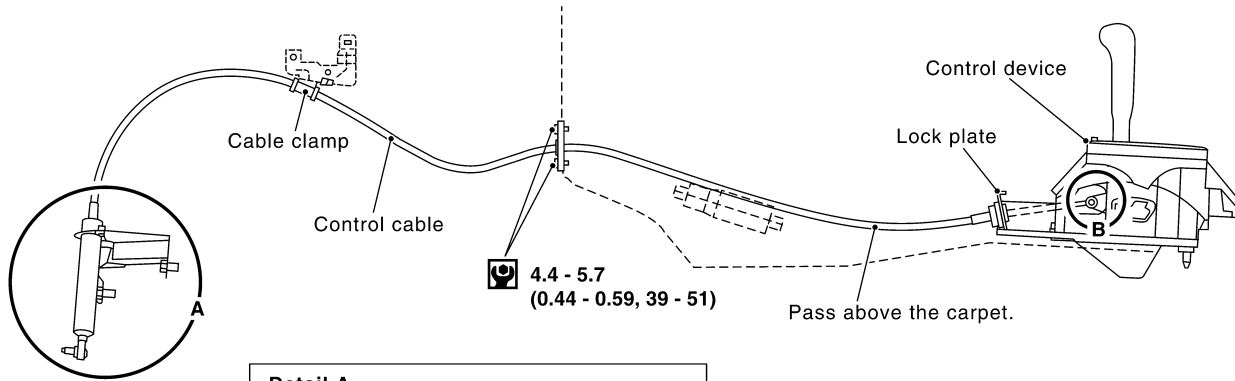

: N•m (kg-m, in-lb)  
 : N•m (kg-m, ft-lb)

SAT754J

GI  
 MA  
 EM  
 LC  
 EC  
 FE  
 CL  
 MT  
**AT**  
 AX  
 SU  
 BR  
 ST  
 RS  
 BT  
 HA  
 SC  
 EL  
 IDX

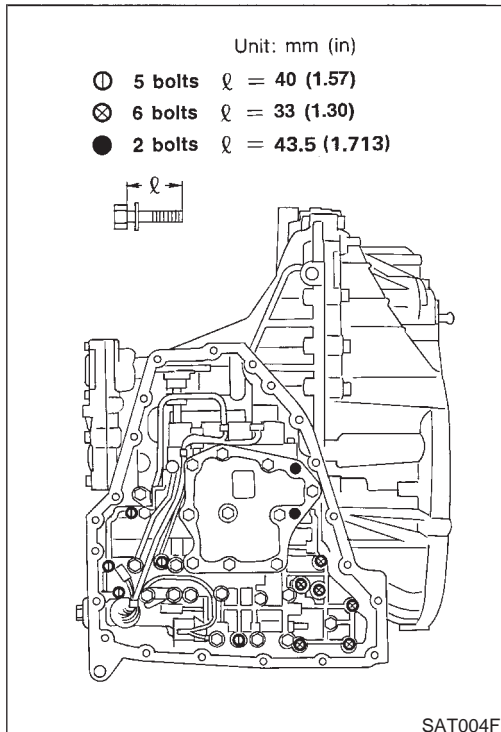
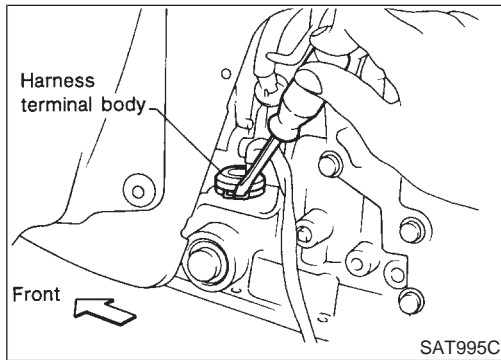
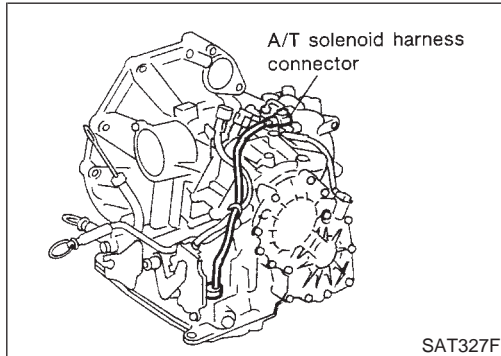
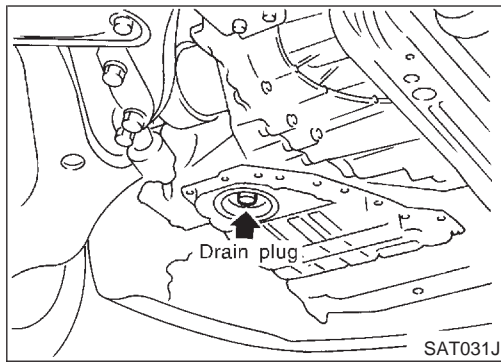

### Control Valve Assembly and Accumulators

NFAT0114

#### REMOVAL

NFAT0114S01

1. Drain ATF from transaxle.
  2. Remove oil pan and gasket.
  3. Disconnect A/T solenoid harness connector.
  4. Remove stopper ring from terminal cord assembly harness terminal body.
  5. Remove terminal cord assembly harness from transmission case by pushing on terminal body.
  6. Remove control valve assembly by removing fixing bolts I, X and ●.
- Bolt length, number and location are shown in the illustration.
- **Be careful not to drop manual valve and servo release accumulator return spring.**
7. Disassemble and inspect control valve assembly if necessary. Refer to AT-312.

# ON-VEHICLE SERVICE

Control Valve Assembly and Accumulators (Cont'd)

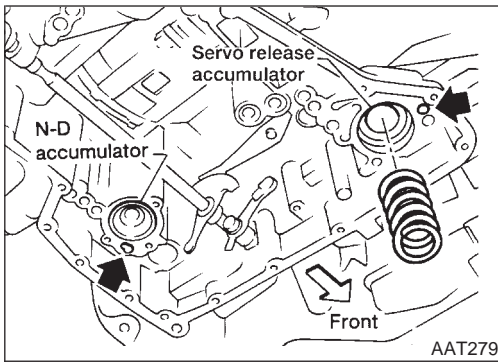

8. Remove servo release and N-D accumulators by applying compressed air if necessary.
  - Hold each piston with a rag.

GI

MA

EM

LC

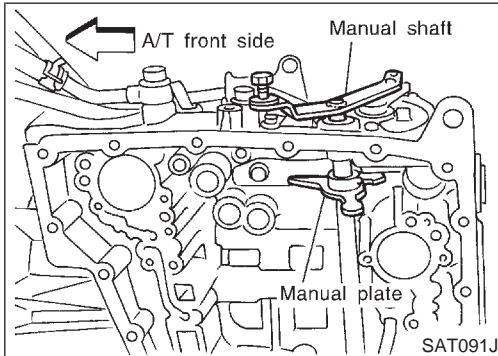

## INSTALLATION

- Set manual shaft in Neutral, then align manual plate with groove in manual valve. NFAT0114S02
- After installing control valve assembly, make sure that selector lever can be moved to all positions.

EC

FE

CL

MT

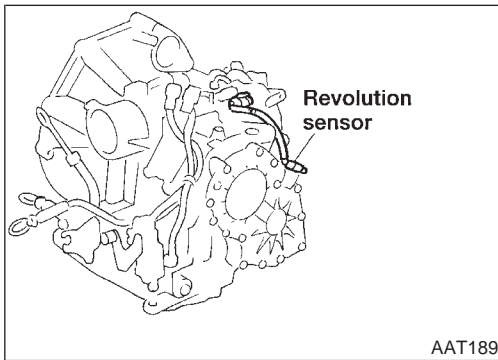

## Revolution Sensor Replacement

1. Remove under cover.
2. Remove revolution sensor from A/T.
3. Reinstall any part removed.
- Always use new sealing parts.

NFAT0115

AT

AX

SU

BR

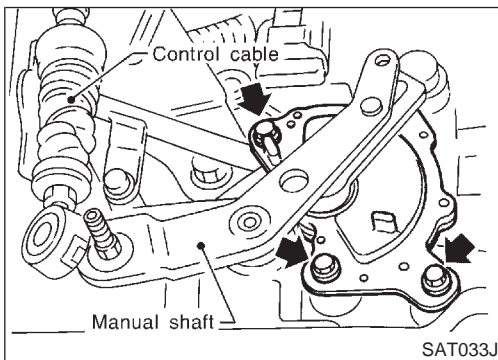

## Park/Neutral Position (PNP) Switch Adjustment

1. Remove control cable from manual shaft. NFAT0116
2. Set manual shaft in N position.
3. Loosen park/neutral position (PNP) switch fixing bolts.

ST

RS

BT

HA

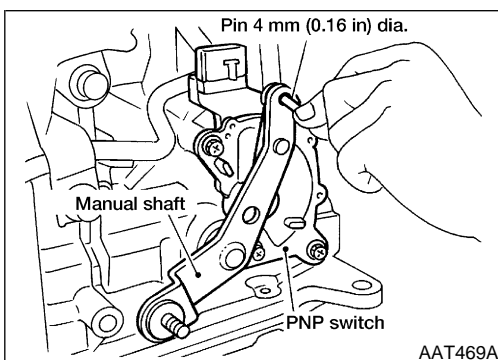

4. Insert pin into adjustment holes in both park/neutral position (PNP) switch and manual shaft as near vertical as possible. SC
5. Reinstall any part removed.
6. Check continuity of park/neutral position (PNP) switch. Refer to AT-108. EL

IDX



## Control Cable Adjustment

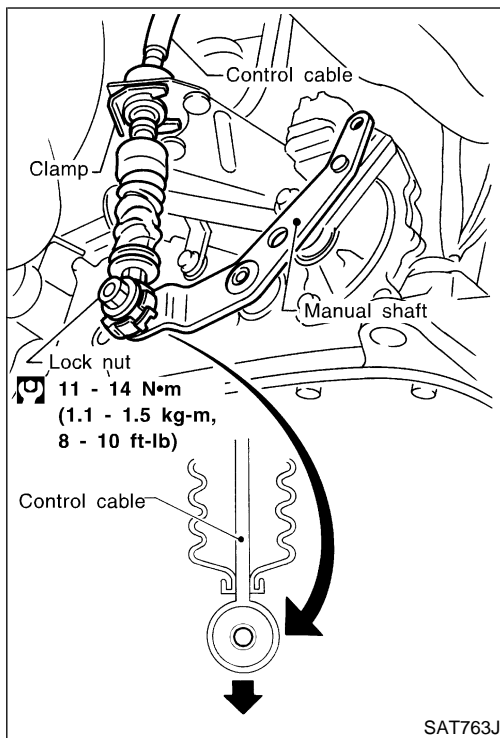

## Control Cable Adjustment

NFAT0117

Move selector lever from the P position to the 1 position. You should be able to feel the detents in each position. If the detents cannot be felt or the pointer indicating the position is improperly aligned, the control cable needs adjustment.

1. Place selector lever in P position.
2. Loosen control cable lock nut and place manual shaft in P position.

### CAUTION:

**Turn wheels more than 1/4 rotations and apply the park lock.**

3. Push control cable in the direction of the arrow shown in the illustration by specified force.

**Specified force: 4.9 - 9.8 N (0.5 - 1.0 kg, 1.1 - 2.2 lb)**

4. Tighten control cable lock nut.
  5. Move selector lever from P to 1 position again. Make sure that selector lever moves smoothly.
- Make sure that the starter operates when the selector lever is placed in the N or P position.
  - Make sure that the transmission is locked properly when the selector lever is placed in the P position.

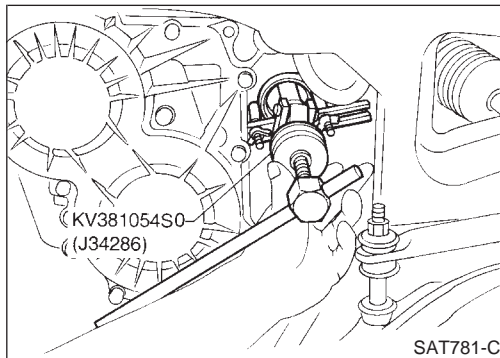

## Differential Side Oil Seal Replacement

NFAT0118

1. Remove drive shaft assembly. Refer to AX-4, "Drive Shaft".
2. Remove oil seal.

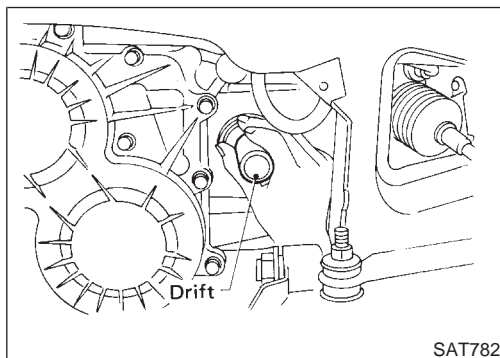

3. Install oil seal.
- Apply ATF before installing.

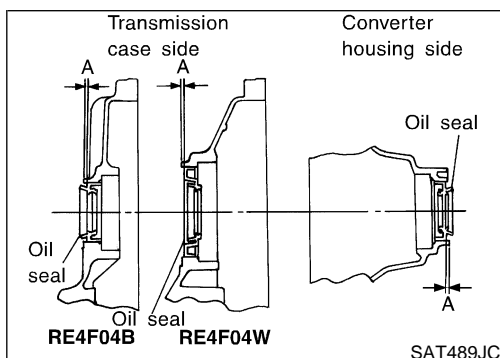

- Install oil seals so dimension A is within specification  
**A: -0.5 mm (-0.02 in) to 0.5 (0.02 in)**
4. Reinstall any part removed.

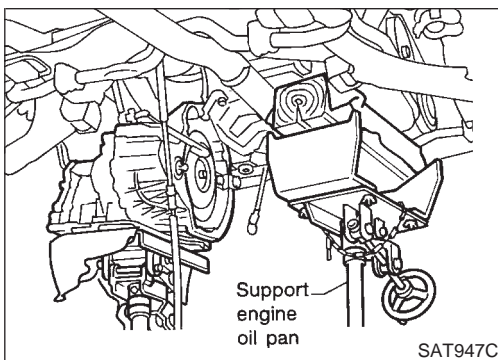
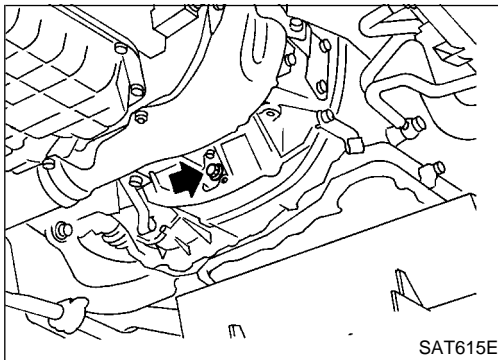
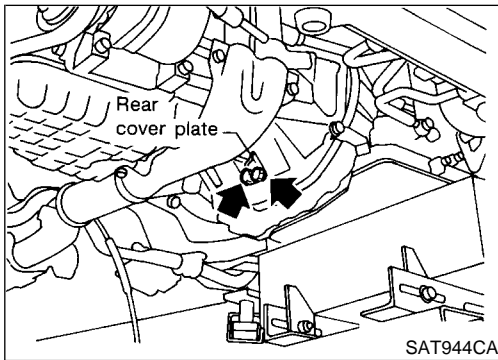
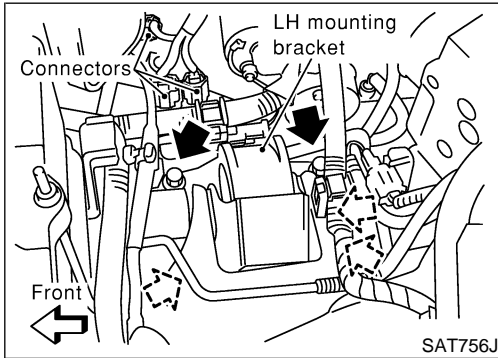
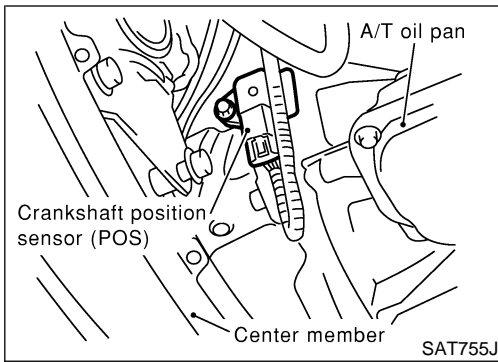

## Removal

### CAUTION:

When removing the transaxle assembly from engine, first remove the crankshaft position sensor (OBD) from the assembly.

Be careful not to damage sensor edge.

1. Remove battery and bracket.
2. Remove air cleaner and resonator.
3. Disconnect terminal cord assembly harness connector and park/neutral position (PNP) switch harness connectors.
4. Disconnect harness connectors of revolution sensor, ground and vehicle speed sensor.
5. Remove crankshaft position sensor (POS) from transaxle.
6. Remove LH mounting bracket from transaxle and body.
7. Disconnect control cable at transaxle side.
8. Drain ATF.
9. Remove drive shafts. Refer to AX-4, "Drive Shaft".
10. Disconnect fluid cooler piping.
11. Remove starter motor from transaxle.
12. Support engine by placing a jack under oil pan.
- **Do not place jack under oil pan drain plug.**
13. Remove center member.
14. Remove rear cover plate and bolts securing torque converter to drive plate.
- **Rotate crankshaft for access to securing bolts.**

15. Support transaxle with a jack.
16. Remove bolts fixing A/T to engine.
17. Lower transaxle while supporting it with a jack.

GI

MA

EM

LC

EC

FE

CL

MT

AT

AX

SU

BR

ST

RS

BT

HA

SC

EL

IDX

# REMOVAL AND INSTALLATION

## Installation

NFAT0120

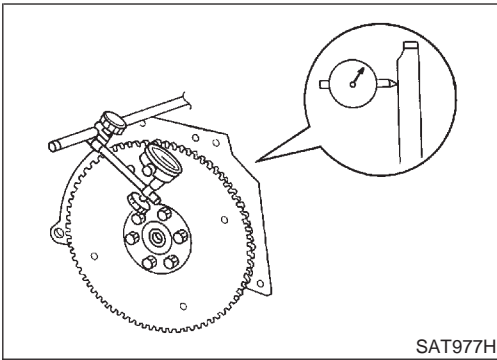

SAT977H

## Installation

- Drive plate runout

### CAUTION:

Do not allow any magnetic materials to contact the ring gear teeth.

### Maximum allowable runout:

Refer to EM-68, "Flywheel/Drive Plate Runout".

- If this runout is out of allowance, replace drive plate and ring gear.

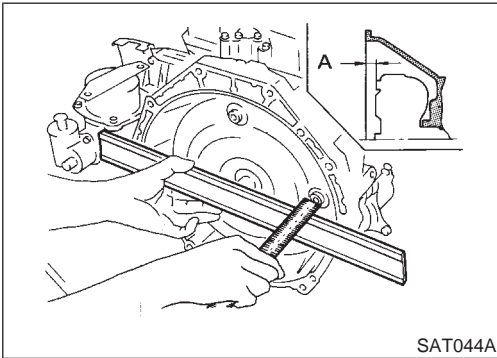

SAT044A

- When connecting torque converter to transaxle, measure distance "A" to be certain that they are correctly assembled.

### Distance "A":

14 mm (0.55 in) or more

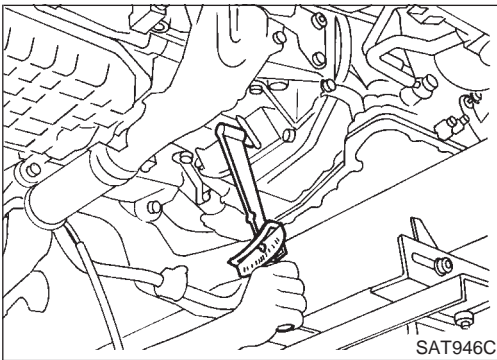

SAT946C

- Install bolts fixing converter to drive plate.
- **With converter installed, rotate crankshaft several turns to check that transaxle rotates freely without binding.**

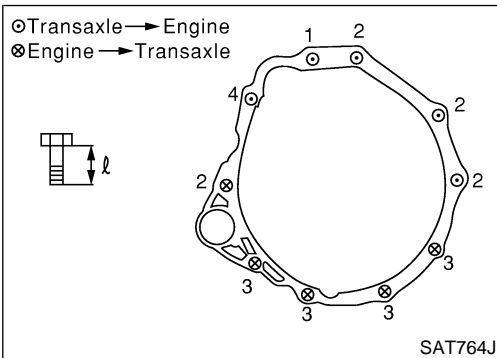

SAT764J

- Tighten bolts securing transaxle.
- Tighten LH mounting bracket bolts to the specified torque. Refer to EM-57, "Removal and Installation".
- Tighten center member bolts to the specified torque. Refer to EM-57, "Removal and Installation".
- Tighten rear plate cover bolts to the specified torque. Refer to EM-13, "OIL PAN".

Bolt No.	Tightening torque N-m (kg-m, ft-lb)	ℓ mm (in)
1	70 - 79 (7.1 - 8.1, 52 - 58)	65 (2.56)
2	70 - 79 (7.1 - 8.1, 52 - 58)	52 (2.05)
3	70 - 79 (7.1 - 8.1, 52 - 58)	40 (1.57)
4	78 - 98 (7.9 - 10.0, 58 - 72)	124 (4.88)

- Reinstall any part removed.

# REMOVAL AND INSTALLATION

Installation (Cont'd)



- Check fluid level in transaxle.
- Move selector lever through all positions to be sure that transaxle operates correctly.  
With parking brake applied, rotate engine at idling. Move selector lever through N to D, to 2, to 1 and to R position. A slight shock should be felt by hand gripping selector each time transaxle is shifted.
- Perform road test. Refer to AT-66.

GI

MA

EM

LC

EC

FE

CL

MT

**AT**

AX

SU

BR

ST

RS

BT

HA

SC

EL

IDX









## Oil Channel

NFAT0122

GI  
MA  
EM  
LC  
EC  
FE  
CL  
MT  
AT  
AX  
SU  
BR  
ST  
RS  
BT  
HA  
SC  
EL  
IDX

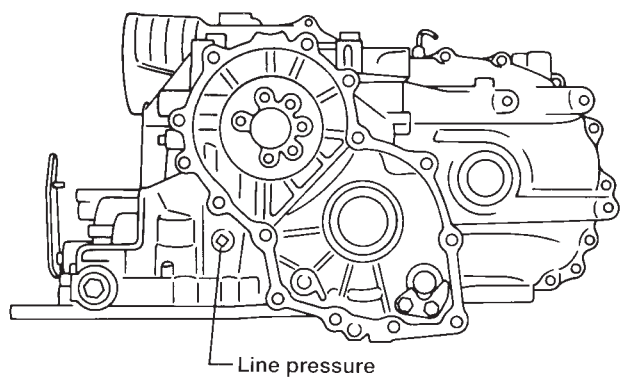
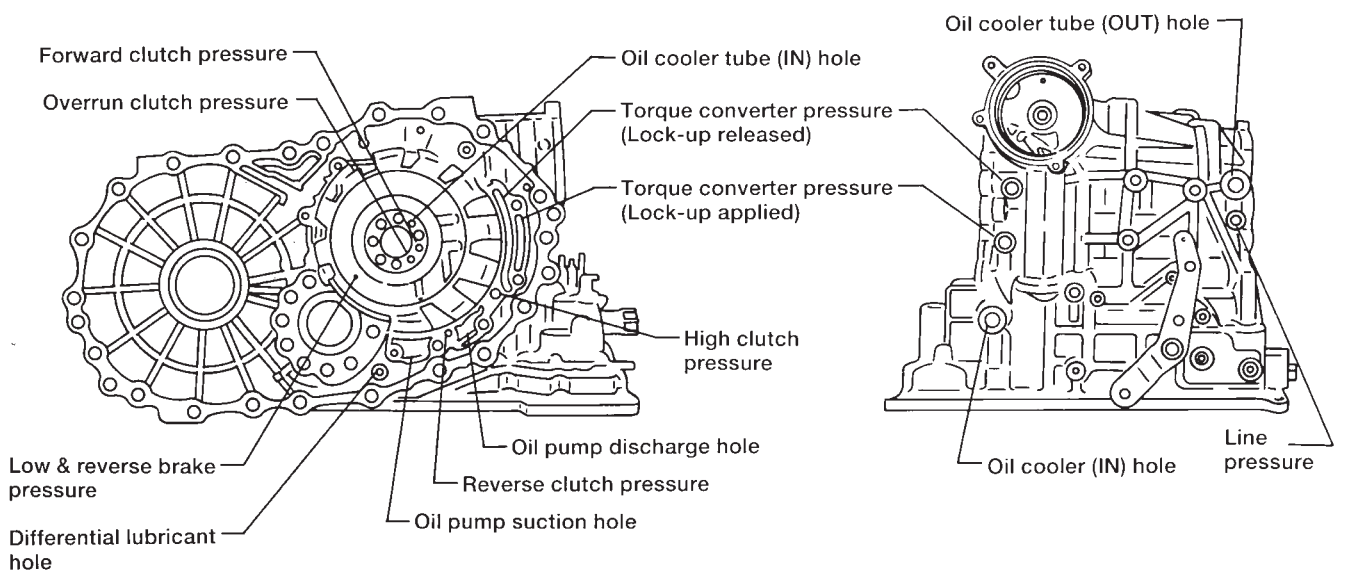
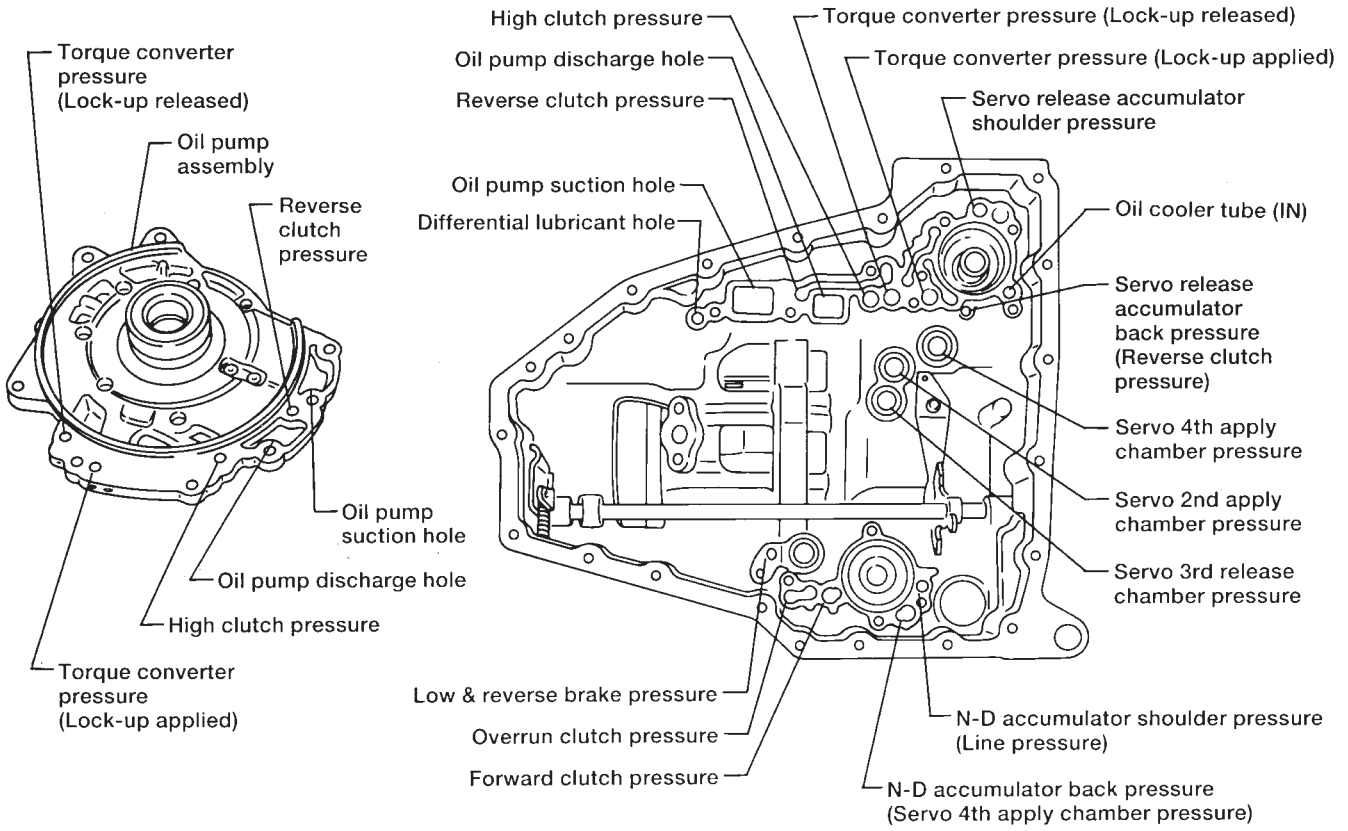



# OVERHAUL

Locations of Adjusting Shims, Needle Bearings, Thrust Washers and Snap Rings

## Locations of Adjusting Shims, Needle Bearings, Thrust Washers and Snap Rings

NFAT0123

Outer diameter of thrust washers

Item number	Outer diameter mm (in)
<b>J</b> ★	76.0 (2.992)
<b>K</b> ★	80.0 (3.150)

★ : Select proper thickness.

Outer and inner diameter of needle bearings

Item number	Outer diameter mm (in)	Inner diameter mm (in)
<b>A</b>	49.1 (1.933)	35.2 (1.386)
<b>B</b>	42.0 (1.654)	23.1 (0.909)
<b>C</b>	70.0 (2.756)	50.0 (1.969)
<b>D</b>	50.9 (2.004)	33.1 (1.303)
<b>E</b>	48.0 (1.890)	30.0 (1.181)
<b>F</b>	49.8 (1.961)	35.2 (1.386)
<b>G</b>	56.5 (2.224)	38.5 (1.516)
<b>H</b>	87.0 (3.425)	69.0 (2.717)
<b>I</b>	108.0 (4.252)	85.15 (3.3524)

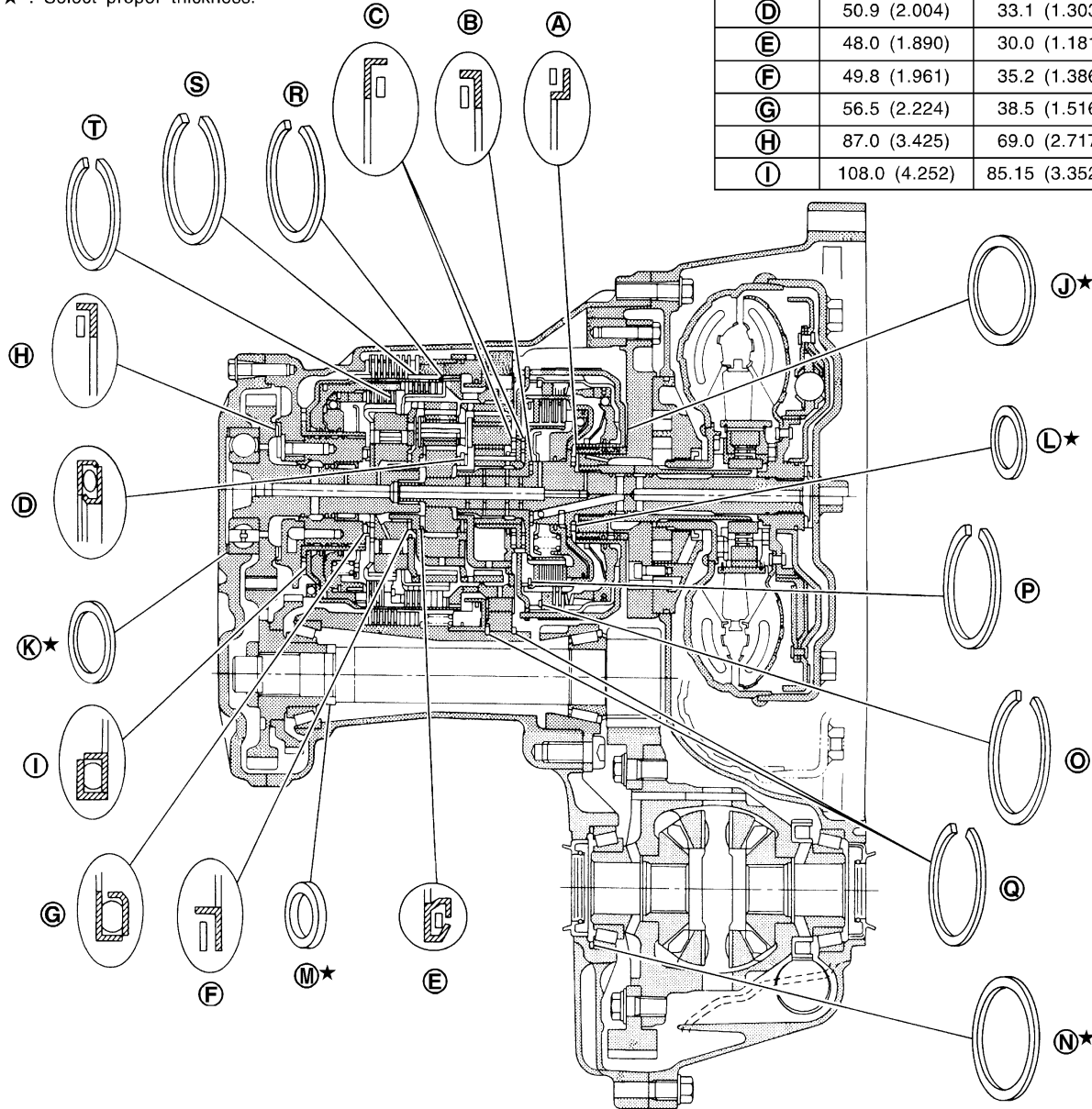

Outer & inner diameter of bearing races, adjusting shims and adjusting spacer

Item number	Outer diameter mm (in)	Inner diameter mm (in)
<b>L</b> ★	51.0 (2.008)	36.0 (1.417)
<b>M</b> ★	38.0 (1.496)	28.1 (1.106)
<b>N</b> ★	75.0 (2.953)	68.0 (2.677)
	98.0 (3.858)	91.0 (3.583)

★ : Select proper thickness.

Outer diameter of snap rings

Item number	Outer diameter mm (in)
<b>O</b>	150 (5.91)
<b>P</b>	119.1 (4.689)
<b>Q</b>	182.8 (7.197)
<b>R</b>	144.8 (5.701)
<b>S</b>	173.8 (6.843)
<b>T</b>	133.9 (5.272)

SAT767J

# DISASSEMBLY

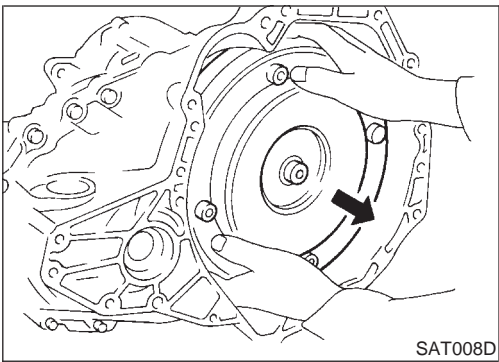

1. Drain ATF through drain plug.
2. Remove torque converter.

GI

MA

EM

LC

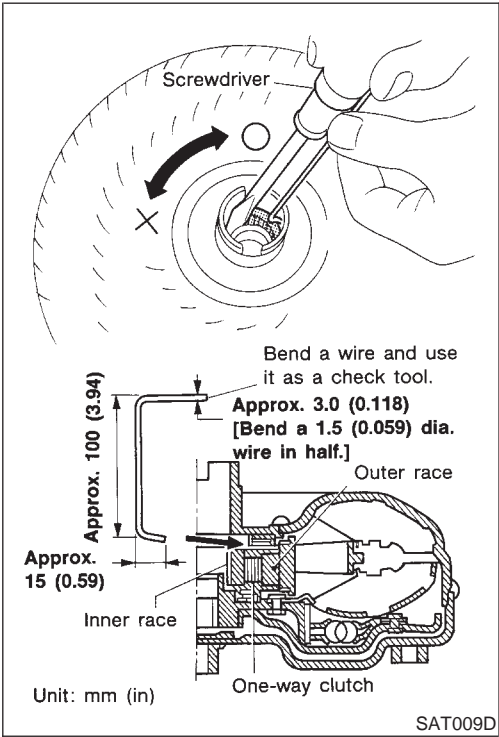

3. Check torque converter one-way clutch using check tool as shown at left.
  - a. Insert check tool into the groove of bearing support built into one-way clutch outer race.
  - b. When fixing bearing support with check tool, rotate one-way clutch spline using screwdriver.
  - c. Check that inner race rotates clockwise only. If not, replace torque converter assembly.

EC

FE

CL

MT

**AT**

AX

SU

BR

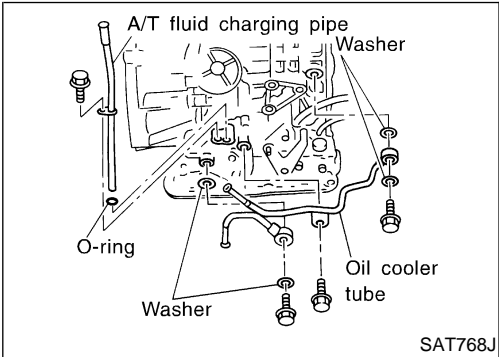

4. Remove A/T fluid charging pipe and fluid cooler tube.

ST

RS

BT

HA

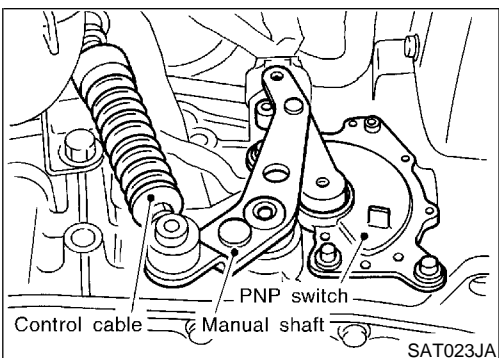

5. Set manual shaft to position P.
6. Remove park/neutral position (PNP) switch.

SC

EL

IDX

# DISASSEMBLY

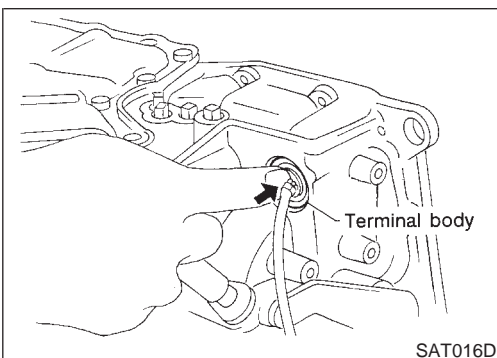
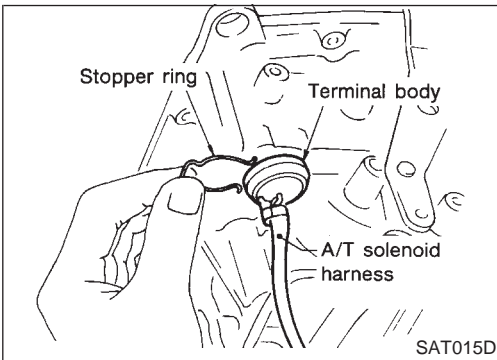
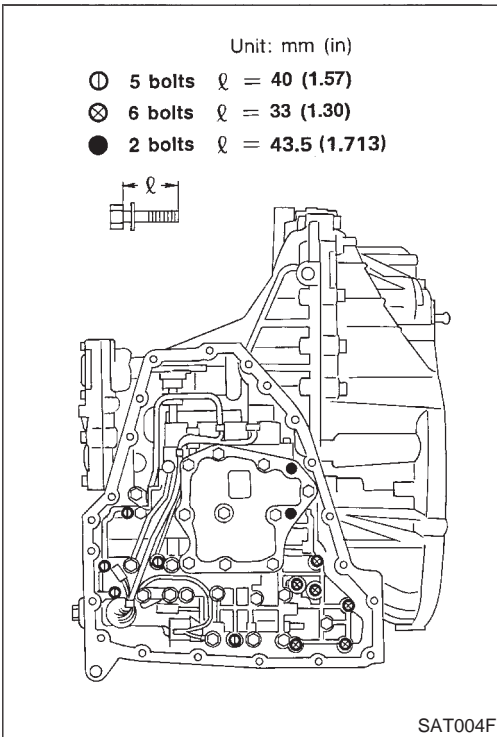
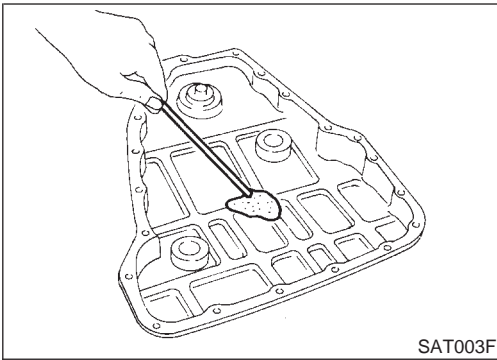

7. Remove oil pan and oil pan gasket.
  - **Do not reuse oil pan bolts.**
8. Check foreign materials in oil pan to help determine causes of malfunction. If the fluid is very dark, smells burned, or contains foreign particles, the frictional material (clutches, band) may need replacement. A tacky film that will not wipe clean indicates varnish build up. Varnish can cause valves, servo, and clutches to stick and can inhibit pump pressure.
  - **If frictional material is detected, replace radiator after repair of A/T. Refer to LC-16, "Radiator".**
9. Remove control valve assembly according to the following procedures.
  - a. Remove control valve assembly mounting bolts I, X and ●.
  - b. Remove stopper ring from terminal body.
  - c. Push terminal body into transmission case and draw out solenoid harness.

# DISASSEMBLY

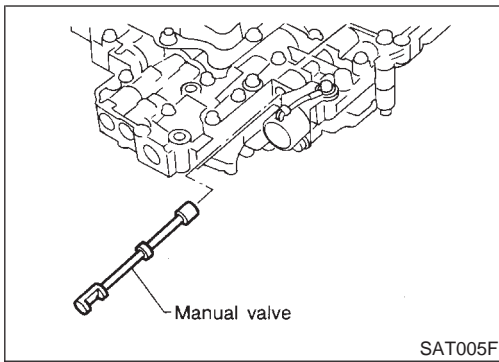

10. Remove manual valve from control valve assembly.

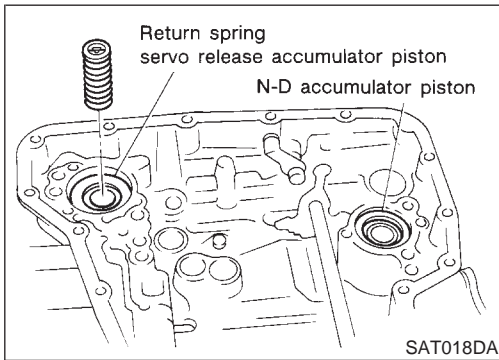

11. Remove return spring from servo release accumulator piston.

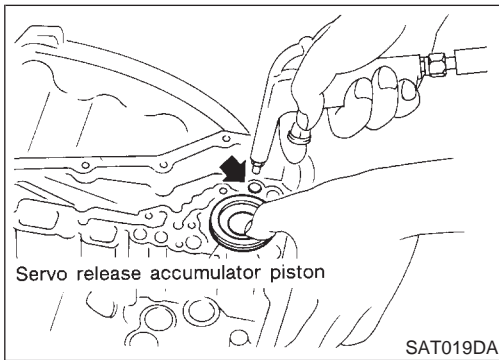

12. Remove servo release accumulator piston with compressed air.

13. Remove O-rings from servo release accumulator piston.

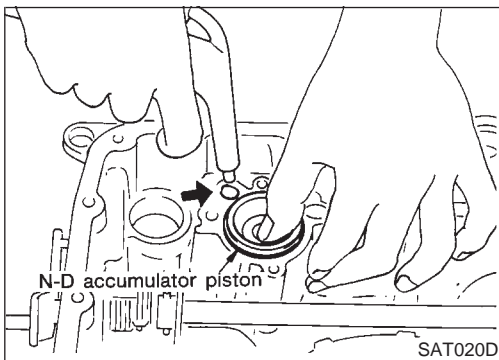

14. Remove N-D accumulator piston and return spring with compressed air.

15. Remove O-rings from N-D accumulator piston.

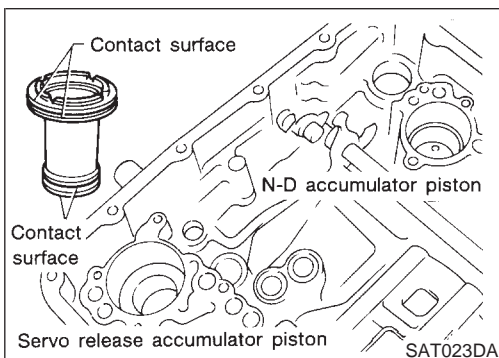

16. Check accumulator pistons and contact surface of transmission case for damage.

17. Check accumulator return springs for damage and free length.

GI

MA

EM

LC

EC

FE

CL

MT

AT

AX

SU

BR

ST

RS

BT

HA

SC

EL

IDX

# DISASSEMBLY

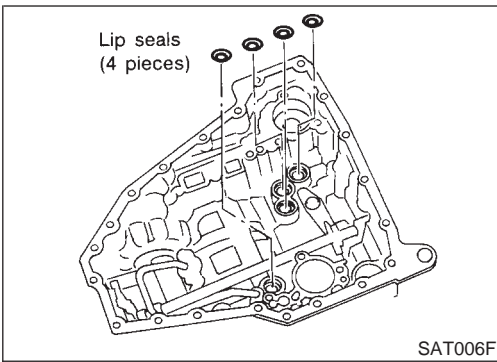

18. Remove lip seals.

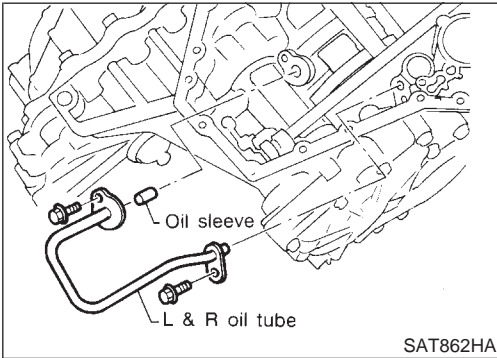

19. Remove L & R oil tube and oil sleeve.

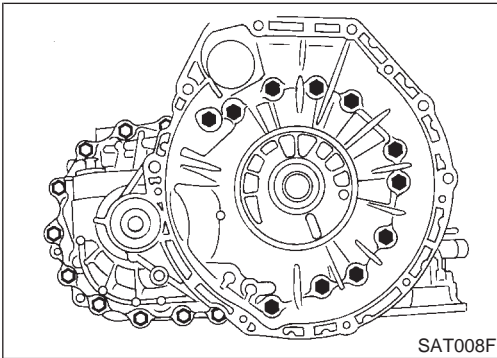

20. Remove converter housing according to the following procedures.

- Remove converter housing mounting bolts.
- Remove converter housing by tapping it lightly.

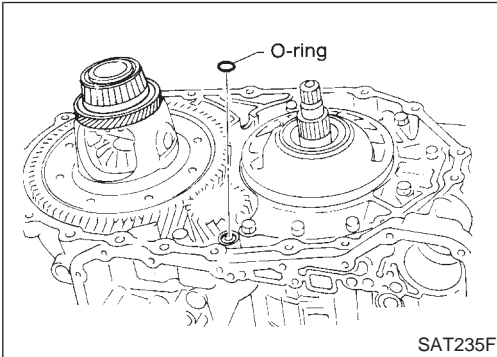

c. Remove O-ring from differential oil port.

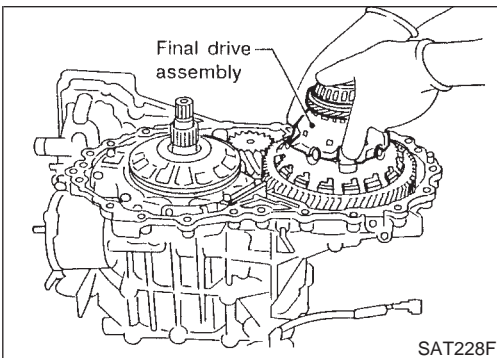

21. Remove final drive assembly from transmission case.

# DISASSEMBLY

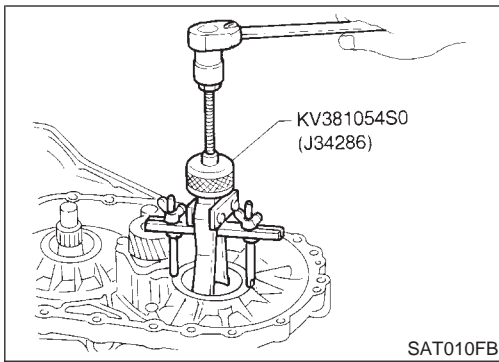

22. Remove differential side bearing outer race and side bearing adjusting shim from transmission case.

GI

MA

EM

LC

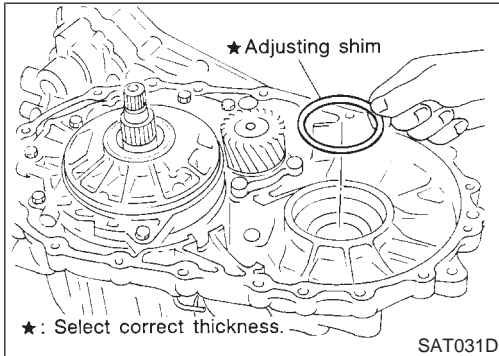

23. Remove differential side bearing adjusting shim from transmission case.

EC

FE

CL

MT

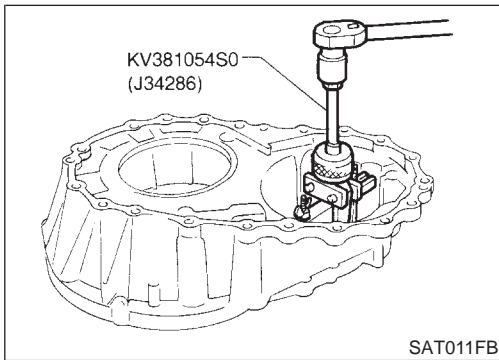

24. Remove differential side bearing outer race from converter housing.

AT

AX

SU

BR

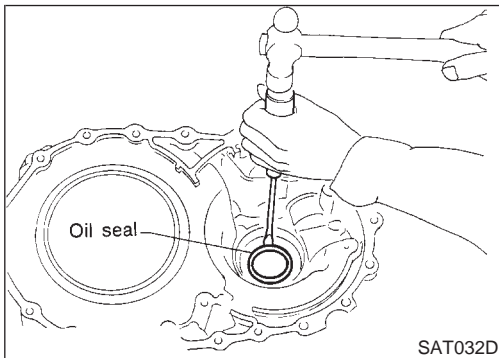

25. Remove oil seal with screwdriver from converter housing.  
 ● **Be careful not to damage case.**

ST

RS

BT

HA

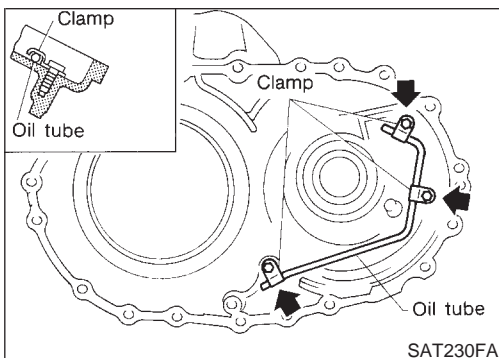

26. Remove oil tube from converter housing.

SC

EL

IDX



# DISASSEMBLY

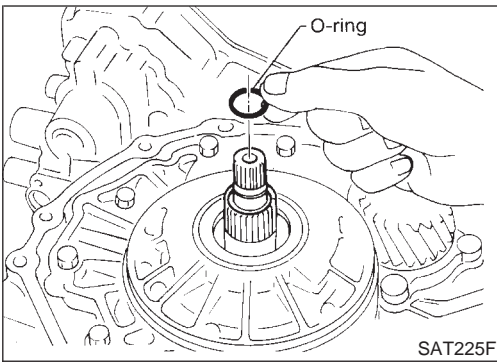

27. Remove oil pump according to the following procedures.
- a. Remove O-ring from input shaft.

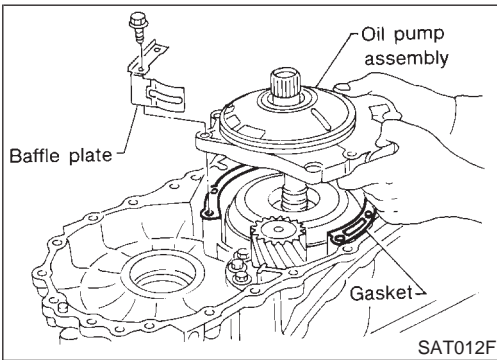

- b. Remove oil pump assembly, baffle plate and gasket from transmission case.

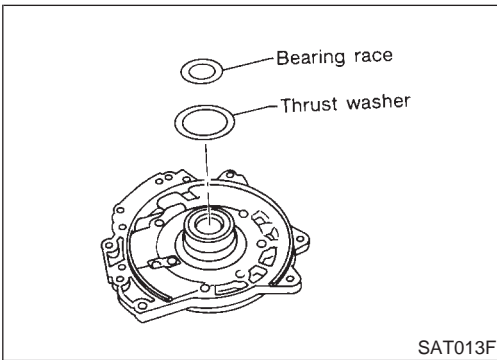

- c. Remove thrust washer and bearing race from oil pump assembly.

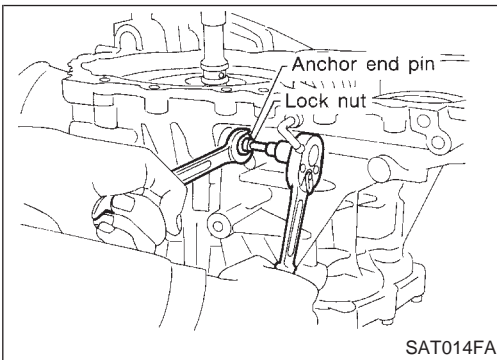

28. Remove brake band according to the following procedures.
- a. Loosen lock nut, then back off anchor end pin.
    - **Do not reuse anchor end pin.**

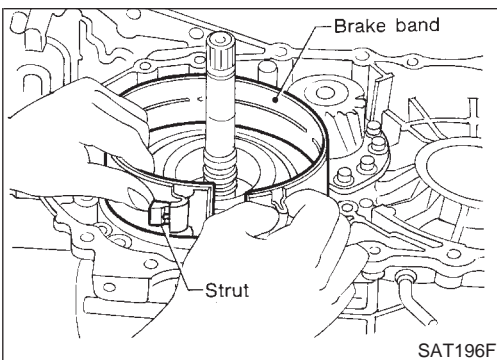

- b. Remove brake band and strut from transmission case.

# DISASSEMBLY

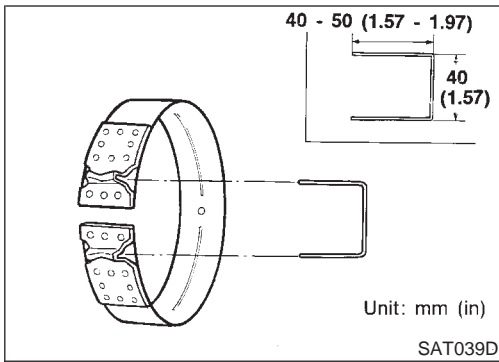

- To prevent brake linings from cracking or peeling, do not stretch the flexible band unnecessarily. When removing the brake band, always secure it with a clip as shown in the figure at left. Leave the clip in position after removing the brake band.

GI

MA

EM

LC

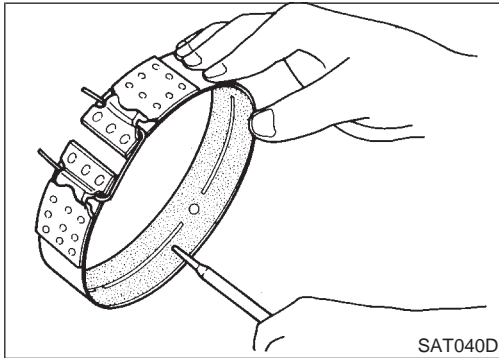

- Check brake band facing for damage, cracks, wear or burns.

EC

FE

CL

MT

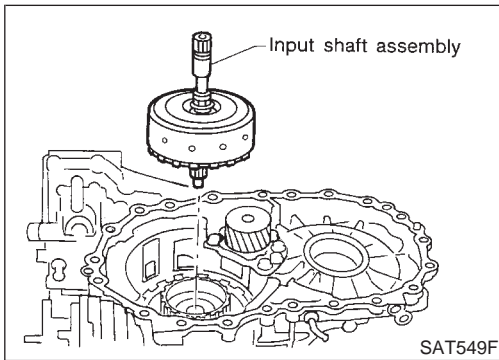

- Remove input shaft assembly (high clutch) and reverse clutch according to the following procedures.

- Remove input shaft assembly (high clutch) with reverse clutch.

AT

AX

SU

BR

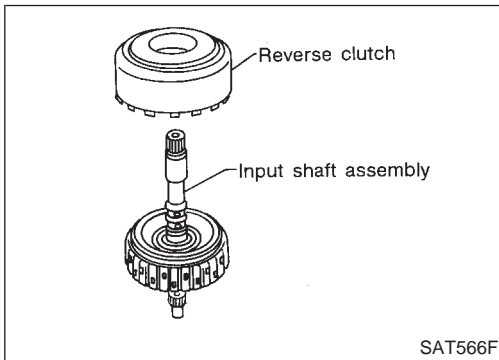

- Remove input shaft assembly (high clutch) from reverse clutch.

ST

RS

BT

HA

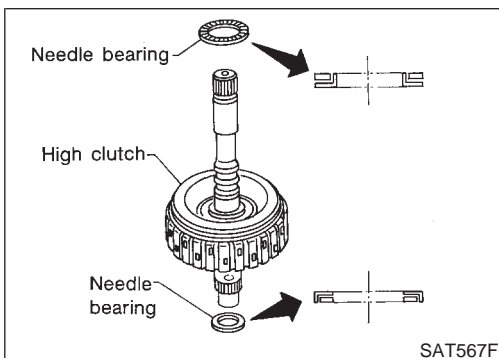

- Remove needle bearings from high clutch drum and check for damage or wear.

SC

EL

IDX



# DISASSEMBLY

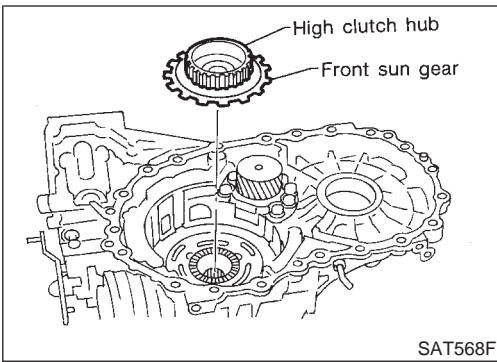

d. Remove high clutch hub and front sun gear from transmission case.

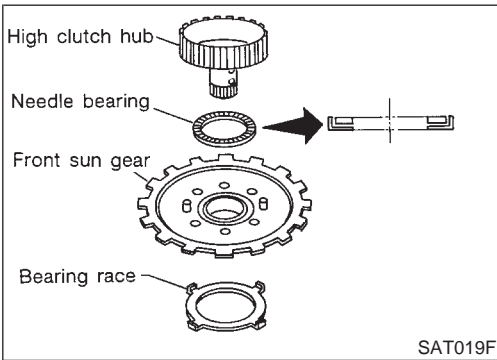

e. Remove front sun gear and needle bearing from high clutch hub and check for damage or wear.

f. Remove bearing race from front sun gear and check for damage or wear.

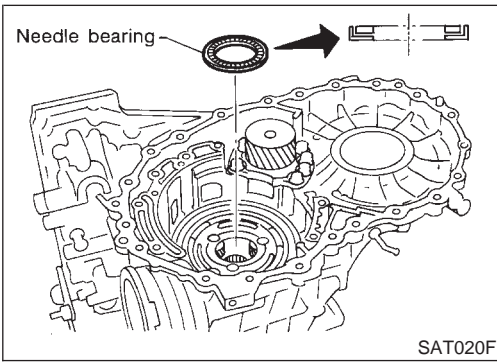

30. Remove needle bearing from transmission case and check for damage or wear.

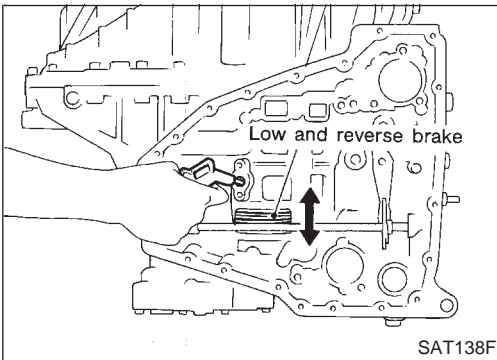

31. Apply compressed air and check to see that low and reverse brake operates.

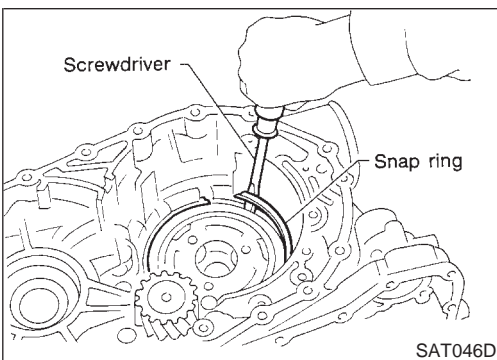

32. Remove low one-way clutch and front planetary carrier assembly according to the following procedures.

a. Remove snap ring with flat-bladed screwdriver.

# DISASSEMBLY

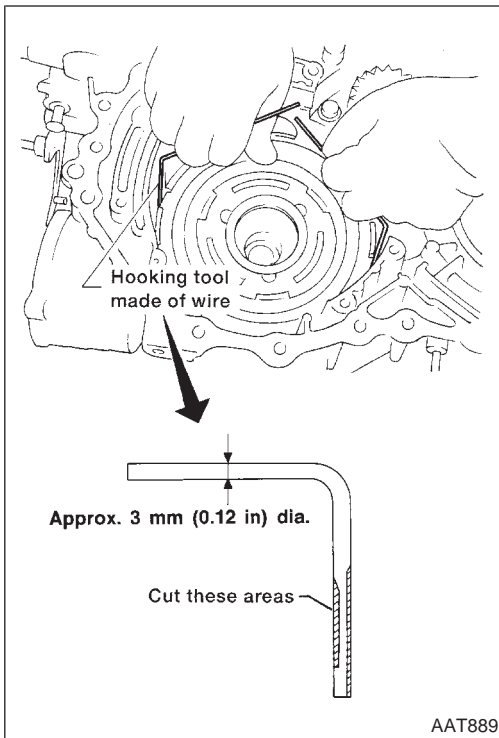

b. Remove low one-way clutch with a hook made of wire.

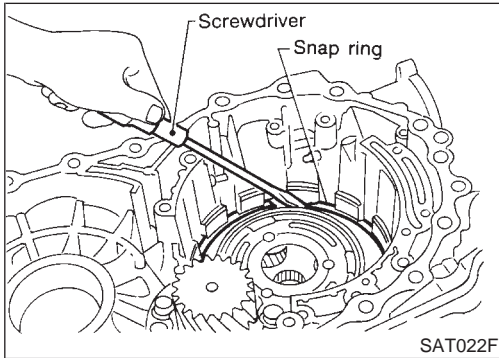

c. Remove snap ring with flat-bladed screwdriver.

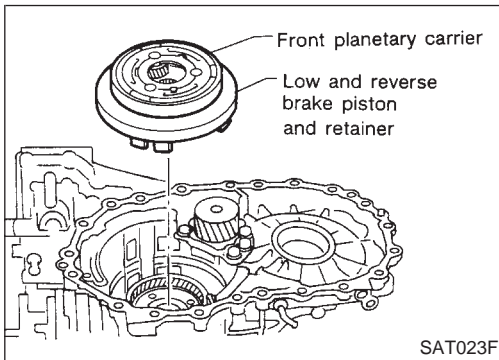

d. Remove front planetary carrier with low and reverse brake piston and retainer.

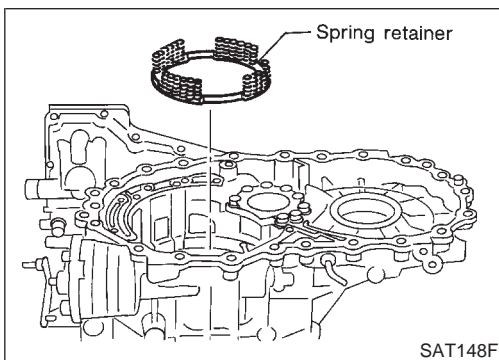

e. Remove low and reverse brake spring retainer.  
 ● Do not remove return springs from spring retainer.

GI

MA

EM

LC

EC

FE

CL

MT

**AT**

AX

SU

BR

ST

RS

BT

HA

SC

EL

IDX

# DISASSEMBLY

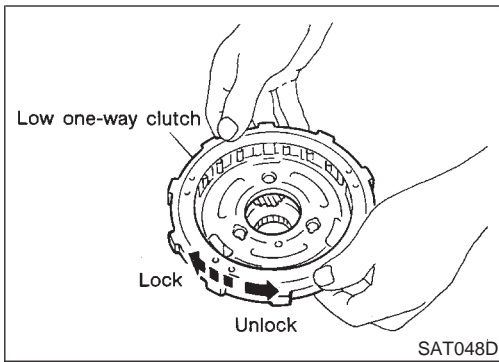

- f. Check that low one-way clutch rotates in the direction of the arrow and locks in the opposite direction.

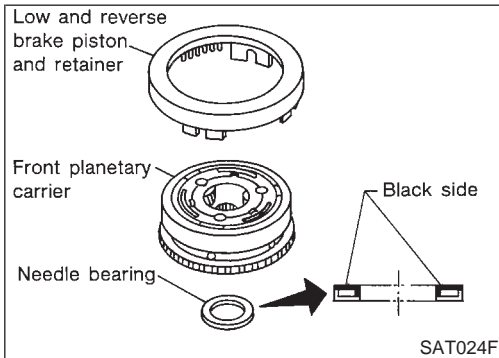

- g. Remove needle bearing, low and reverse brake piston and retainer from front planetary carrier.

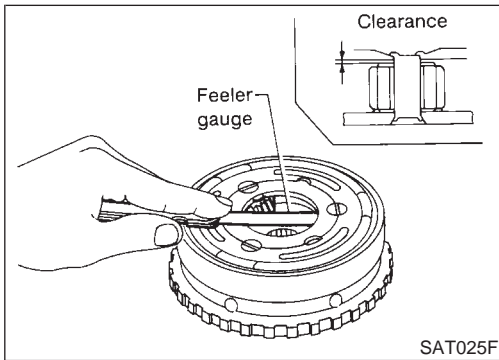

- h. Check front planetary carrier, low one-way clutch and needle bearing for damage or wear.
- i. Check clearance between planetary gears and planetary carrier with feeler gauge.

**Standard clearance:**

**0.20 - 0.70 mm (0.0079 - 0.0276 in)**

**Allowable limit:**

**0.80 mm (0.0315 in)**

Replace front planetary carrier if the clearance exceeds allowable limit.

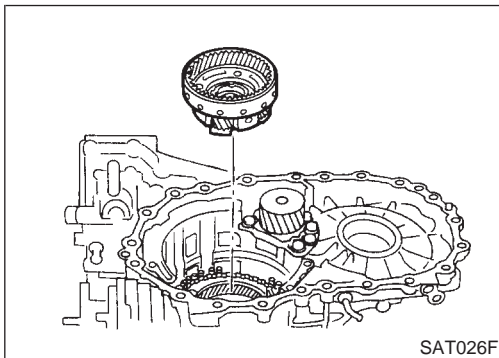

33. Remove rear planetary carrier assembly and rear sun gear according to the following procedures.

- a. Remove rear planetary carrier assembly from transmission case.

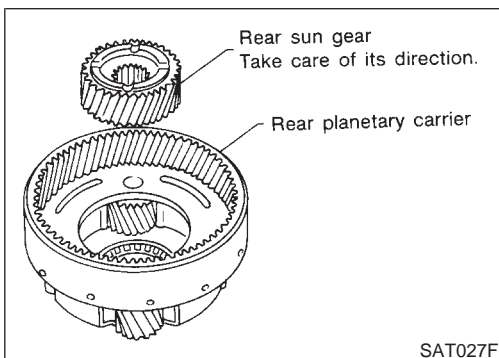

- b. Remove rear sun gear from rear planetary carrier.

# DISASSEMBLY

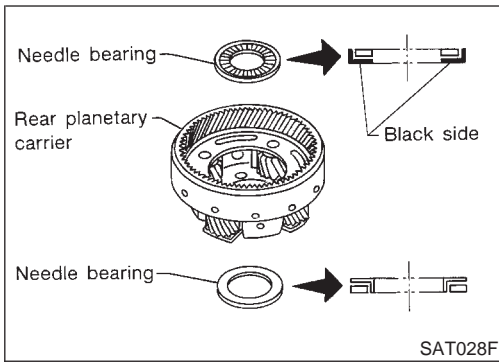

c. Remove needle bearings from rear planetary carrier assembly.

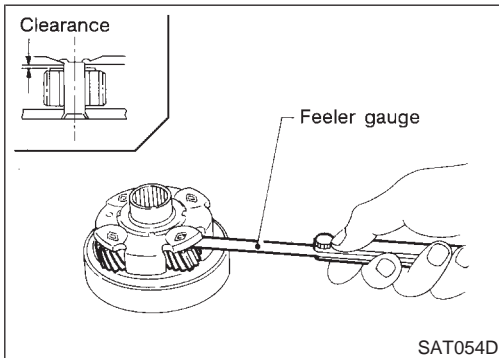

d. Check rear planetary carrier, rear sun gear and needle bearings for damage or wear.

e. Check clearance between pinion washer and rear planetary carrier with feeler gauge.

**Standard clearance:**

**0.20 - 0.70 mm (0.0079 - 0.0276 in)**

**Allowable limit:**

**0.80 mm (0.0315 in)**

Replace rear planetary carrier if the clearance exceeds allowable limit.

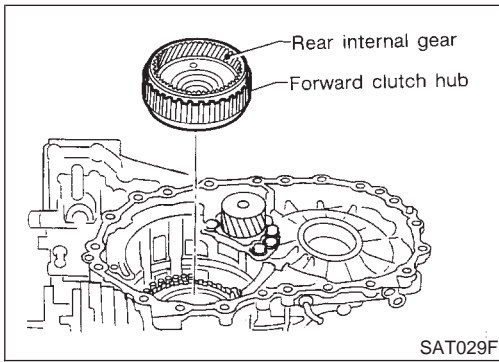

34. Remove rear internal gear and forward clutch hub from transmission case.

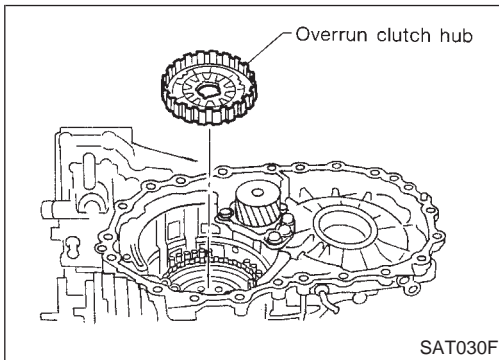

35. Remove overrun clutch hub from transmission case.

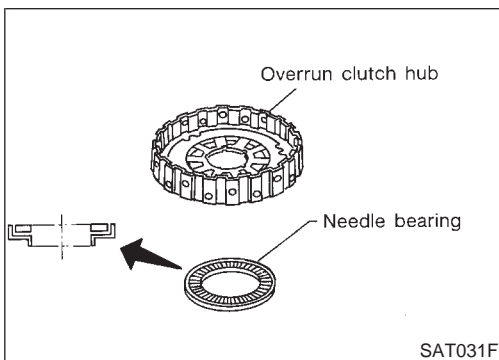

36. Remove needle bearing from overrun clutch hub and check for damage or wear.

GI

MA

EM

LC

EC

FE

CL

MT

AT

AX

SU

BR

ST

RS

BT

HA

SC

EL

IDX

# DISASSEMBLY

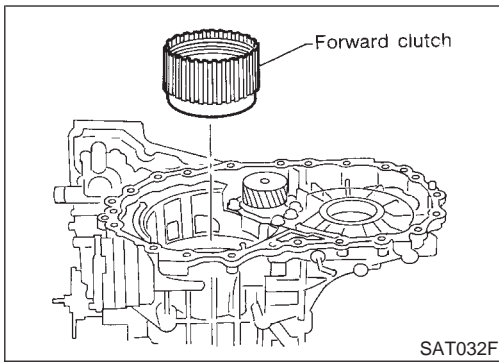

37. Remove forward clutch assembly from transmission case.

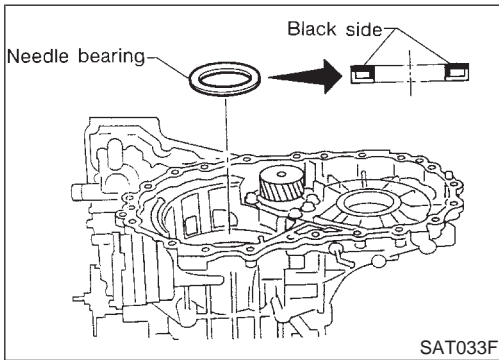

38. Remove needle bearing from transmission case.

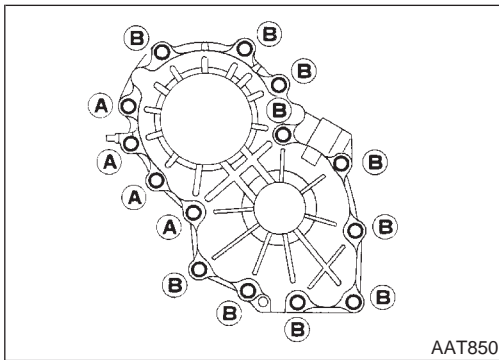

39. Remove output shaft assembly according to the following procedures.

a. Remove side cover bolts.

- Do not mix bolts A and B.
- Always replace bolts A as they are self-sealing bolts.

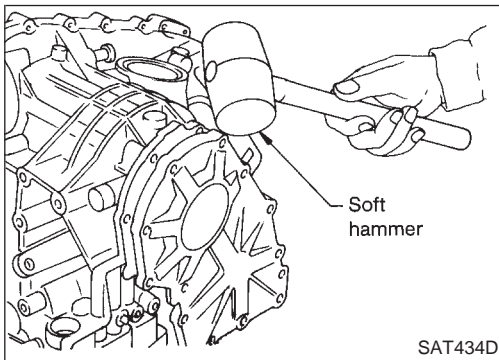

b. Remove side cover by lightly tapping it with a soft hammer.

- Be careful not to drop output shaft assembly. It might come out when removing side cover.

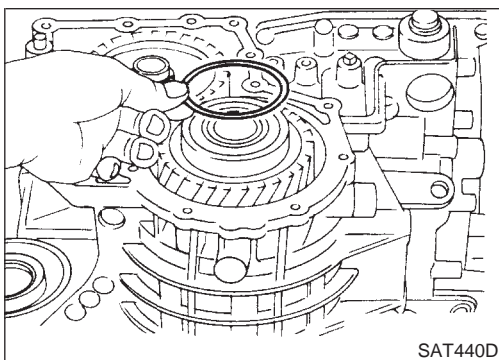

c. Remove adjusting shim.

# DISASSEMBLY

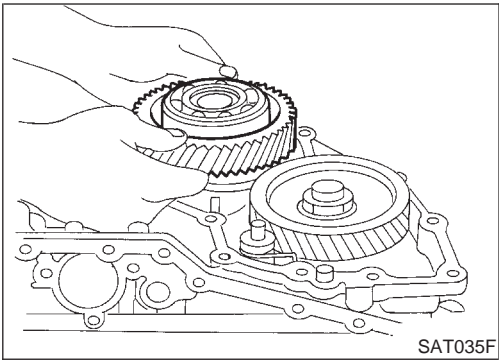

d. Remove output shaft assembly.

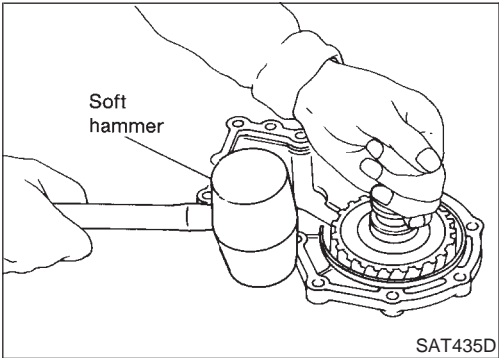

- If output shaft assembly came off with side cover, tap cover with a soft hammer to separate.

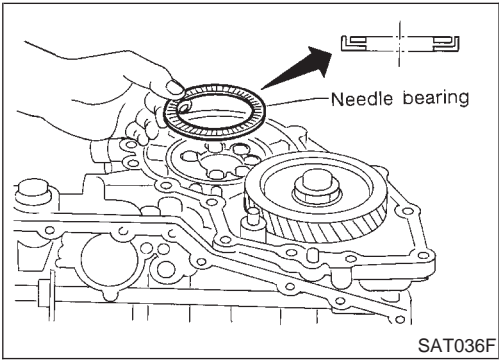

e. Remove needle bearing.

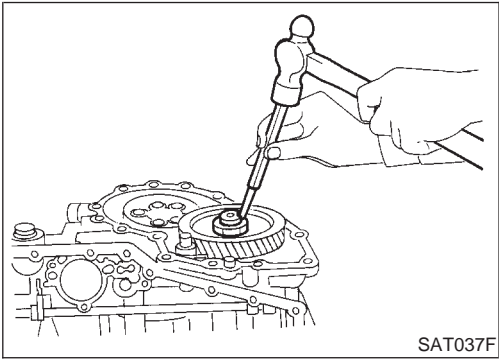

40. Disassemble reduction pinion gear according to the following procedures.

- Set manual shaft to position P to fix idler gear.
- Unlock idler gear lock nut using a pin punch.

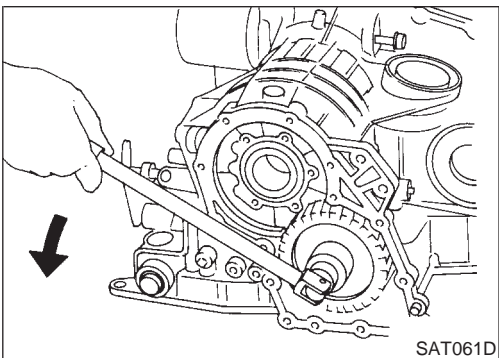

c. Remove idler gear lock nut.

- **Do not reuse idler gear lock nut.**

GI

MA

EM

LC

EC

FE

CL

MT

**AT**

AX

SU

BR

ST

RS

BT

HA

SC

EL

IDX

# DISASSEMBLY

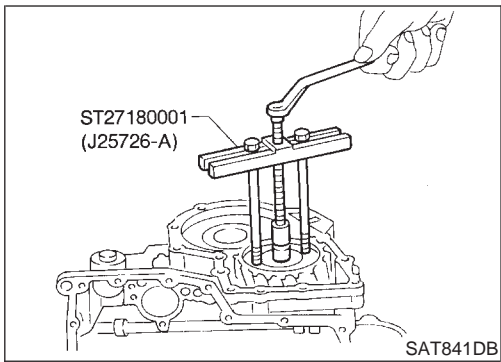

d. Remove idler gear with puller.

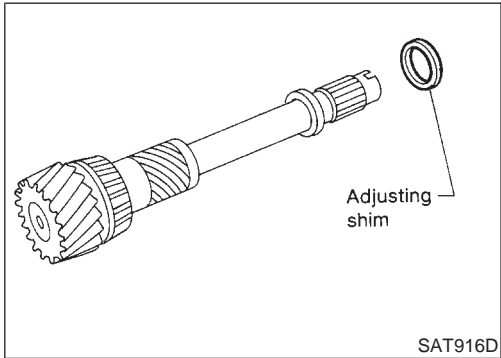

e. Remove reduction pinion gear.

f. Remove adjusting shim from reduction pinion gear.

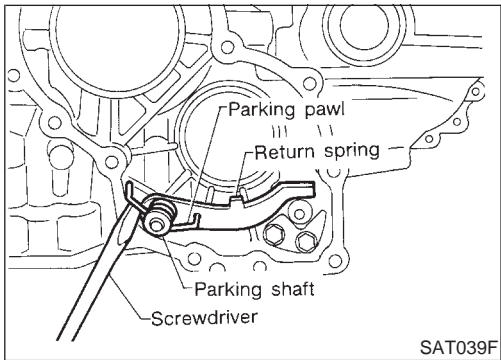

41. Remove return spring from parking shaft with screwdriver.

42. Draw out parking shaft and remove parking pawl from transmission case.

43. Check parking pawl and shaft for damage or wear.

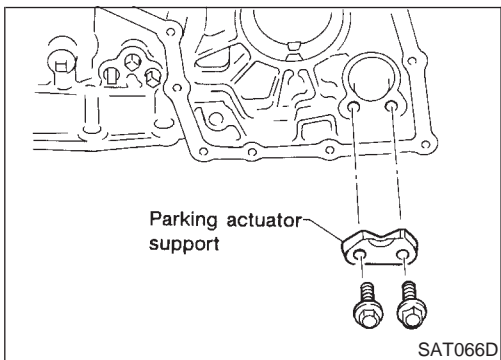

44. Remove parking actuator support from transmission case.

45. Check parking actuator support for damage or wear.

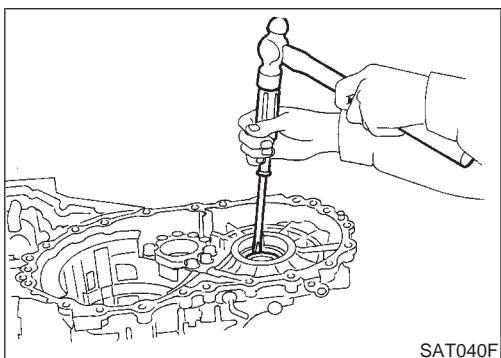

46. Remove side oil seal with screwdriver from transmission case.



## Manual Shaft COMPONENTS

NFAT0125

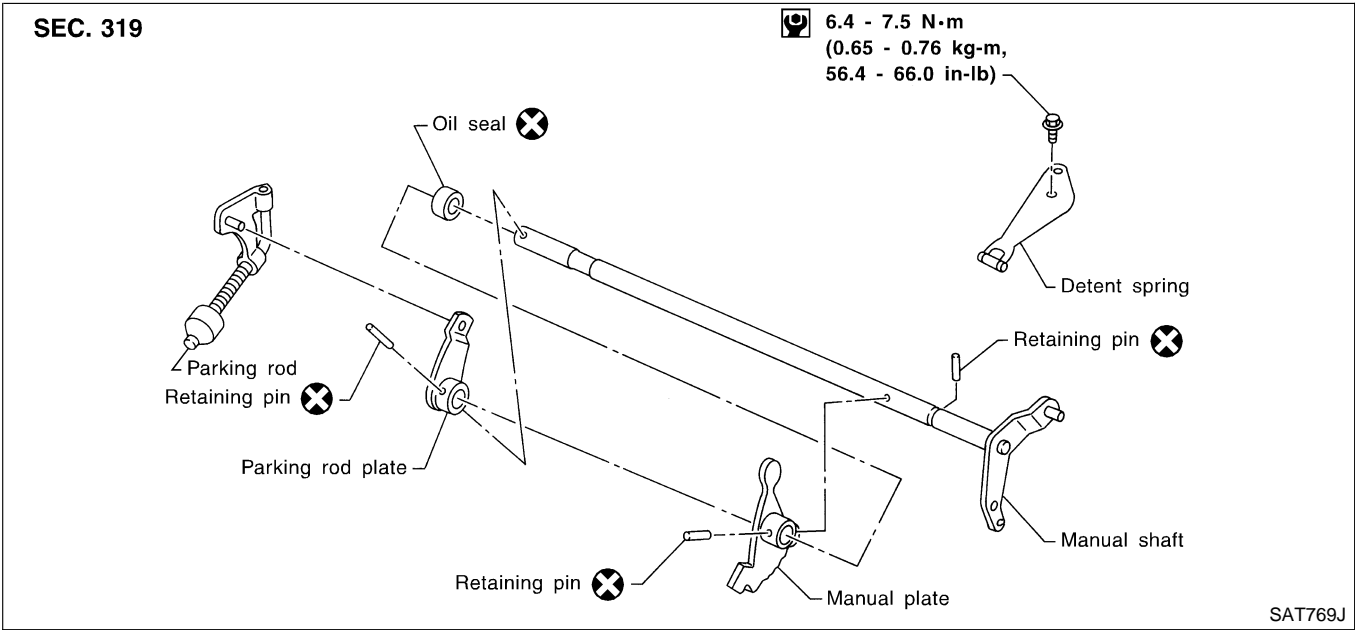

GI  
MA  
EM  
LC  
EC  
FE  
CL  
MT

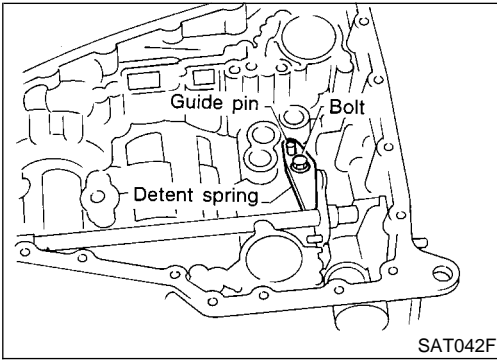

### REMOVAL

NFAT0126

1. Remove detent spring from transmission case.

AT

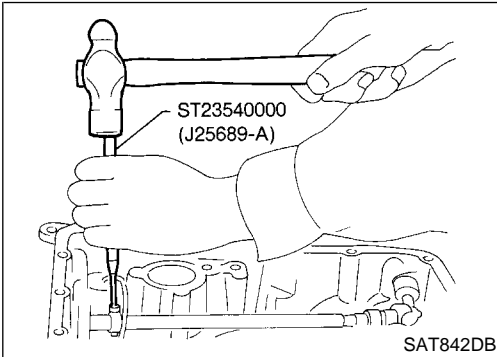

2. Drive out manual plate retaining pin.

AX

SU

BR

ST

RS

BT

HA

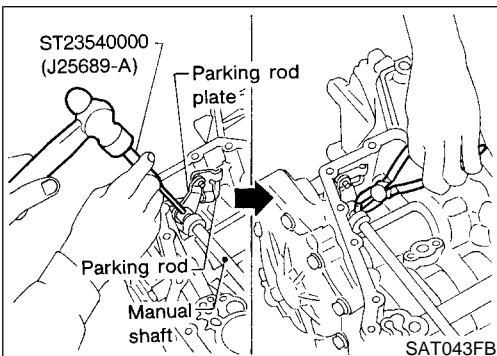

3. Drive and pull out parking rod plate retaining pin.
4. Remove parking rod plate from manual shaft.
5. Draw out parking rod from transmission case.

SC

EL

IDX



# REPAIR FOR COMPONENT PARTS

## Manual Shaft (Cont'd)

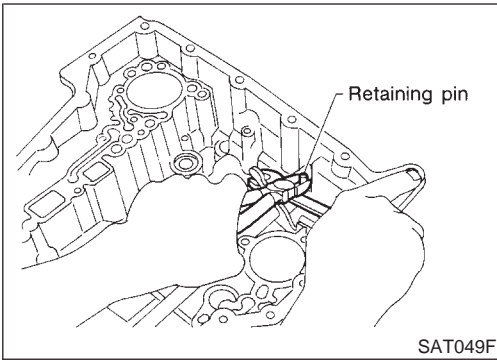

6. Pull out manual shaft retaining pin.
7. Remove manual shaft and manual plate from transmission case.

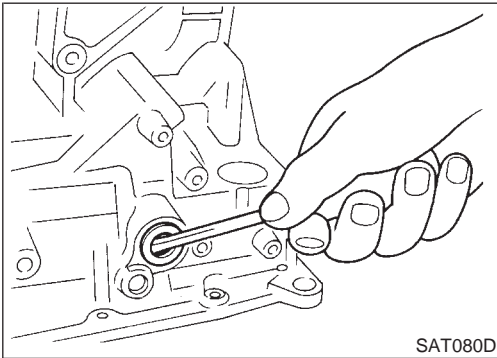

8. Remove manual shaft oil seal.

### INSPECTION

- Check component parts for wear or damage. Replace if necessary. NFAT0127

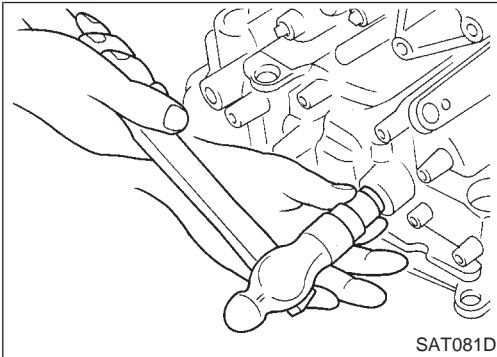

### INSTALLATION

1. Install manual shaft oil seal. NFAT0128
  - Apply ATF to outer surface of oil seal.

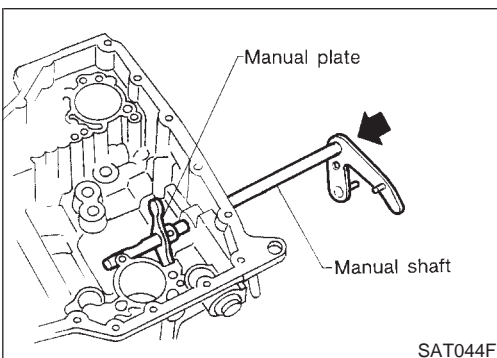

2. Install manual shaft and manual plate.

# REPAIR FOR COMPONENT PARTS

Manual Shaft (Cont'd)

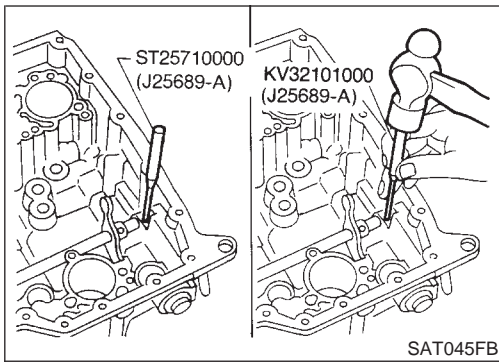

3. Align groove of manual shaft and hole of transmission case.
4. Install manual shaft retaining pin up to bottom of hole.

GI

MA

EM

LC

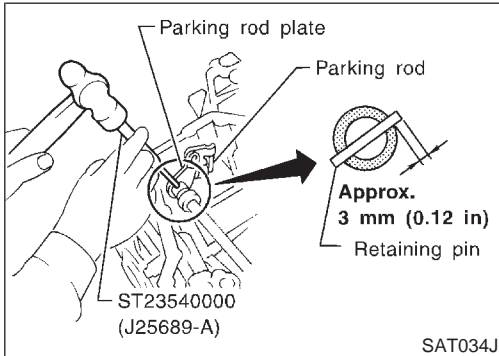

5. Install parking rod to parking rod plate.
6. Set parking rod assembly onto manual shaft and drive retaining pin.
  - Both ends of pin should protrude.

EC

FE

CL

MT

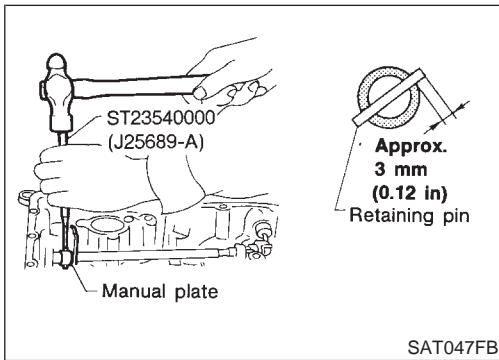

7. Drive manual plate retaining pin.
  - Both ends of pin should protrude.

**AT**

AX

SU

BR

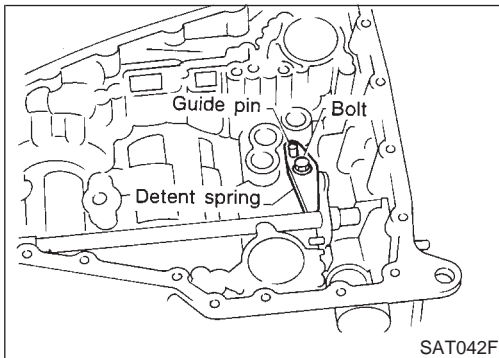

8. Install detent spring. Tighten detent spring bolts to the specified torque. Refer to AT-305.

ST

RS

BT

HA

SC

EL

IDX

# REPAIR FOR COMPONENT PARTS

Oil Pump

## Oil Pump COMPONENTS

NFAT0129

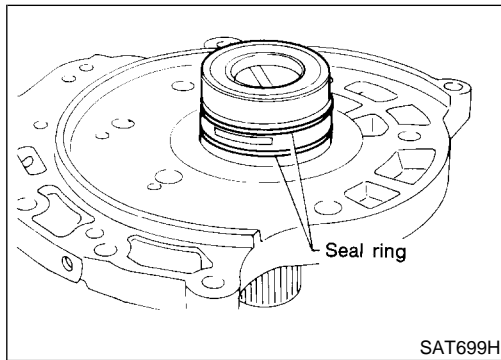
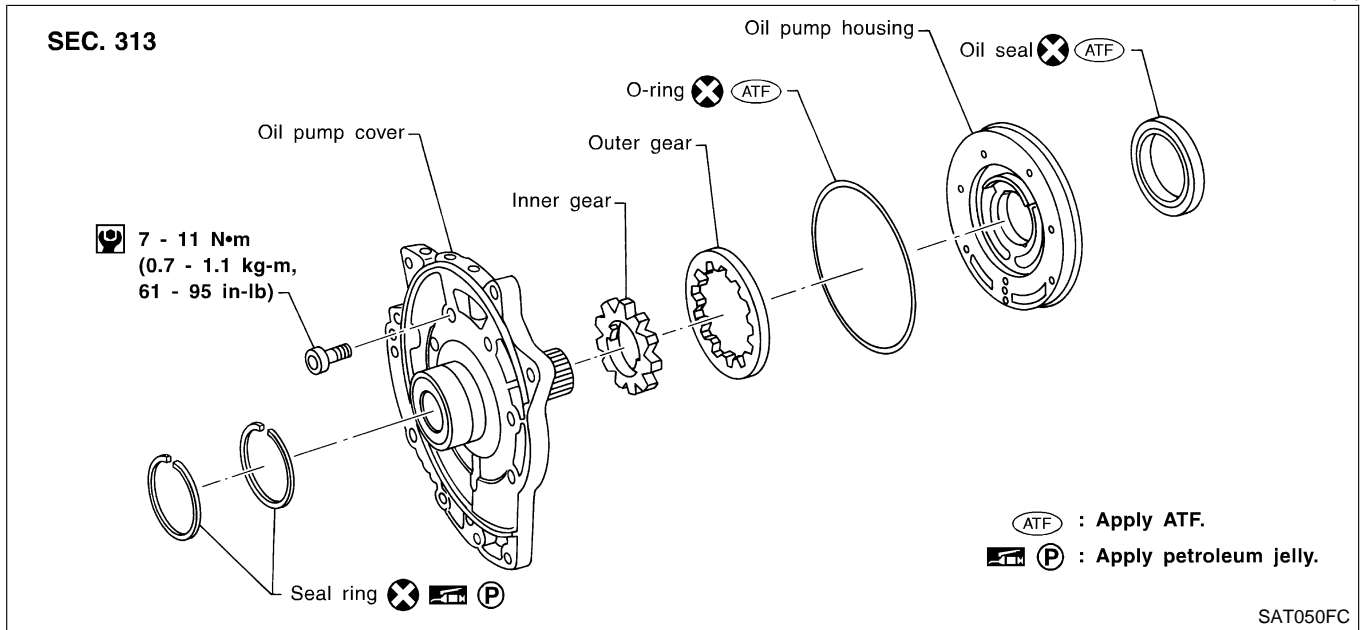

### DISASSEMBLY

NFAT0130

1. Remove seal rings.

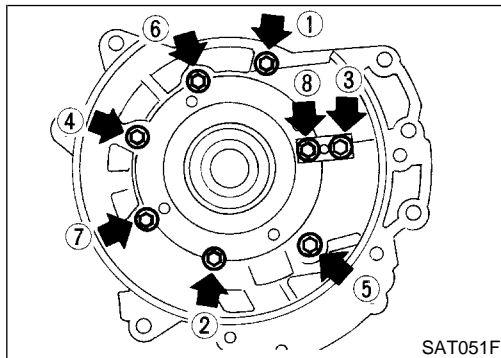

2. Loosen bolts in a crisscross pattern and remove oil pump cover.

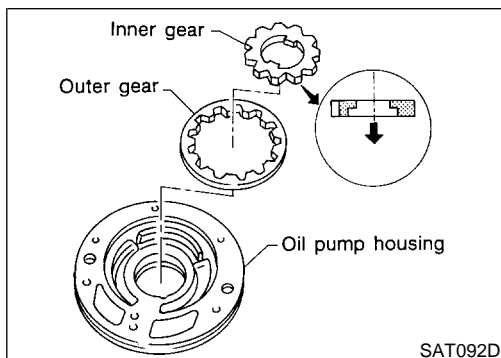

3. Remove inner and outer gear from oil pump housing.

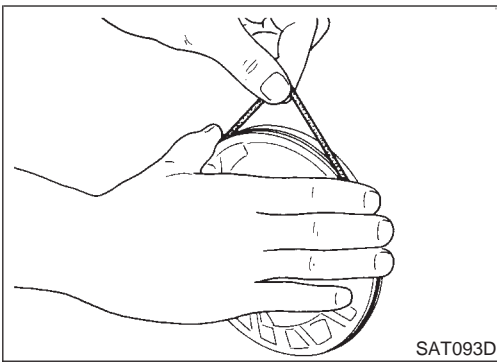

4. Remove O-ring from oil pump housing.

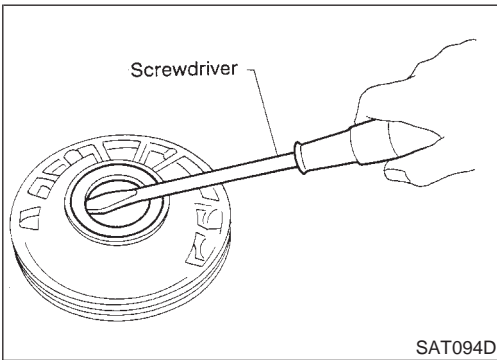

5. Remove oil pump housing oil seal.

GI  
MA  
EM  
LC  
EC  
FE  
CL  
MT

## INSPECTION

### Oil Pump Housing, Oil Pump Cover, Inner Gear and Outer Gear

NFAT0131

AT

NFAT0131S01

- Check for wear or damage.

AX

SU

BR

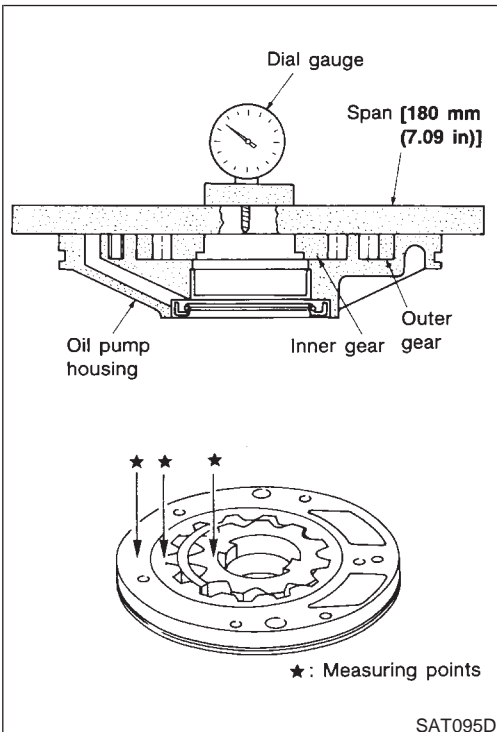

## Side Clearances

NFAT0131S02

ST

- Measure side clearance of inner and outer gears in at least four places around each outside edge. Maximum measured values should be within specified positions.

### Standard clearance:

**0.030 - 0.050 mm (0.0012 - 0.0020 in)**

RS

- If clearance is less than standard, select inner and outer gear as a set so that clearance is within specifications.

### Inner and outer gear:

**Refer to SDS, AT-388.**

BT

HA

- If clearance is more than standard, replace whole oil pump assembly except oil pump cover.

SC

EL

IDX

# REPAIR FOR COMPONENT PARTS

## Oil Pump (Cont'd)

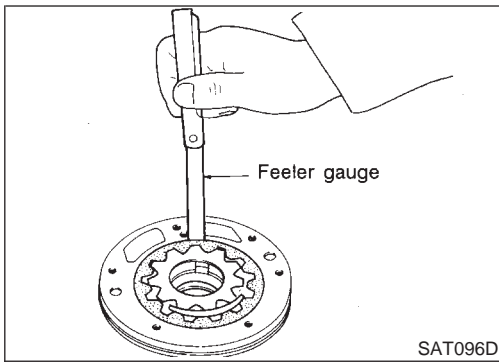

- Measure clearance between outer gear and oil pump housing.
  - Standard clearance:**  
0.111 - 0.181 mm (0.0044 - 0.0071 in)
  - Allowable limit:**  
0.181 mm (0.0071 in)
- If not within allowable limit, replace whole oil pump assembly except oil pump cover.

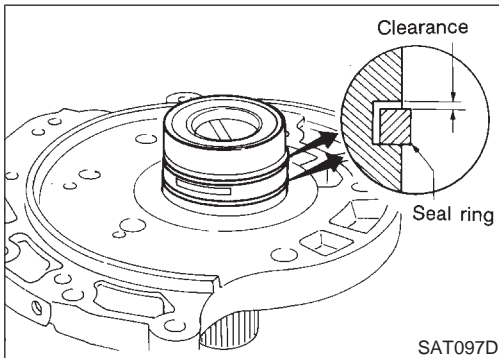

### Seal Ring Clearance

- Measure clearance between seal ring and ring groove. NFAT0131S03
  - Standard clearance:**  
0.1 - 0.25 mm (0.0039 - 0.0098 in)
  - Allowable limit:**  
0.25 mm (0.0098 in)
- If not within allowable limit, replace oil pump cover assembly.

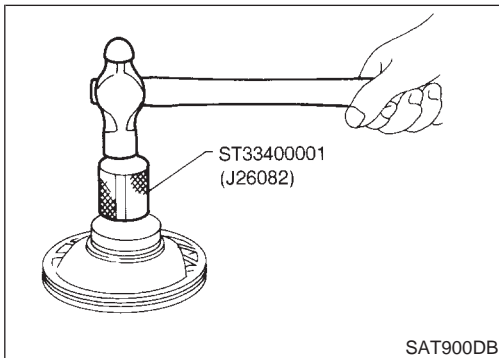

### ASSEMBLY

1. Install oil seal on oil pump housing. NFAT0132

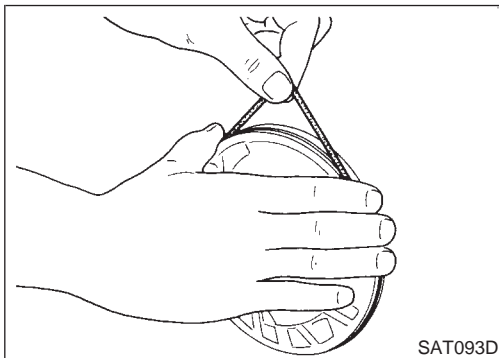

2. Install O-ring on oil pump housing.
  - **Apply ATF to O-ring.**

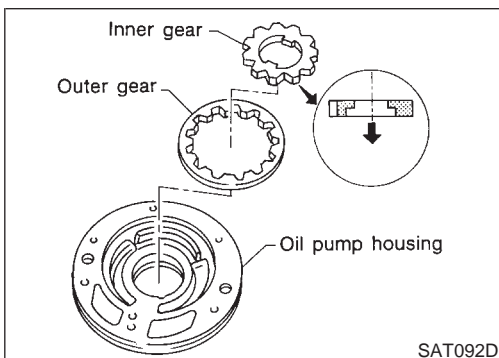

3. Install inner and outer gears on oil pump housing.
  - **Be careful of direction of inner gear.**

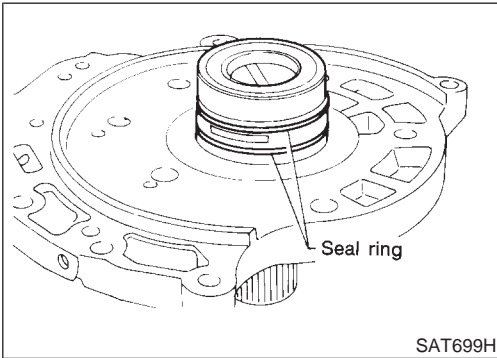
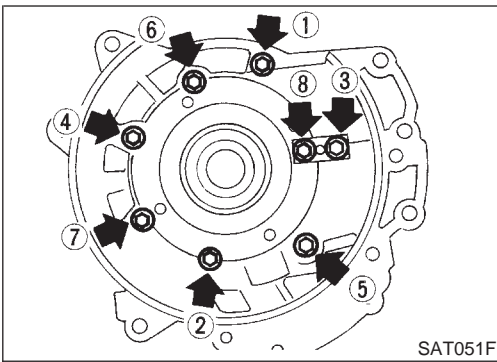

4. Install oil pump cover on oil pump housing.
  - a. Wrap masking tape around splines of oil pump cover assembly to protect seal. Position oil pump cover assembly on oil pump housing assembly, then remove masking tape.
  - b. Tighten bolts in a crisscross pattern. Tighten oil pump cover bolts to the specified torque. Refer to AT-308.
  
5. Install new seal rings carefully after packing ring groove with petroleum jelly.
  - **Do not spread gap of seal ring excessively while installing. The ring may be deformed.**

GI

MA

EM

LC

EC

FE

CL

MT

**AT**

AX

SU

BR

ST

RS

BT

HA

SC

EL

IDX

# REPAIR FOR COMPONENT PARTS

Control Valve Assembly

## Control Valve Assembly COMPONENTS

=NFAT0133

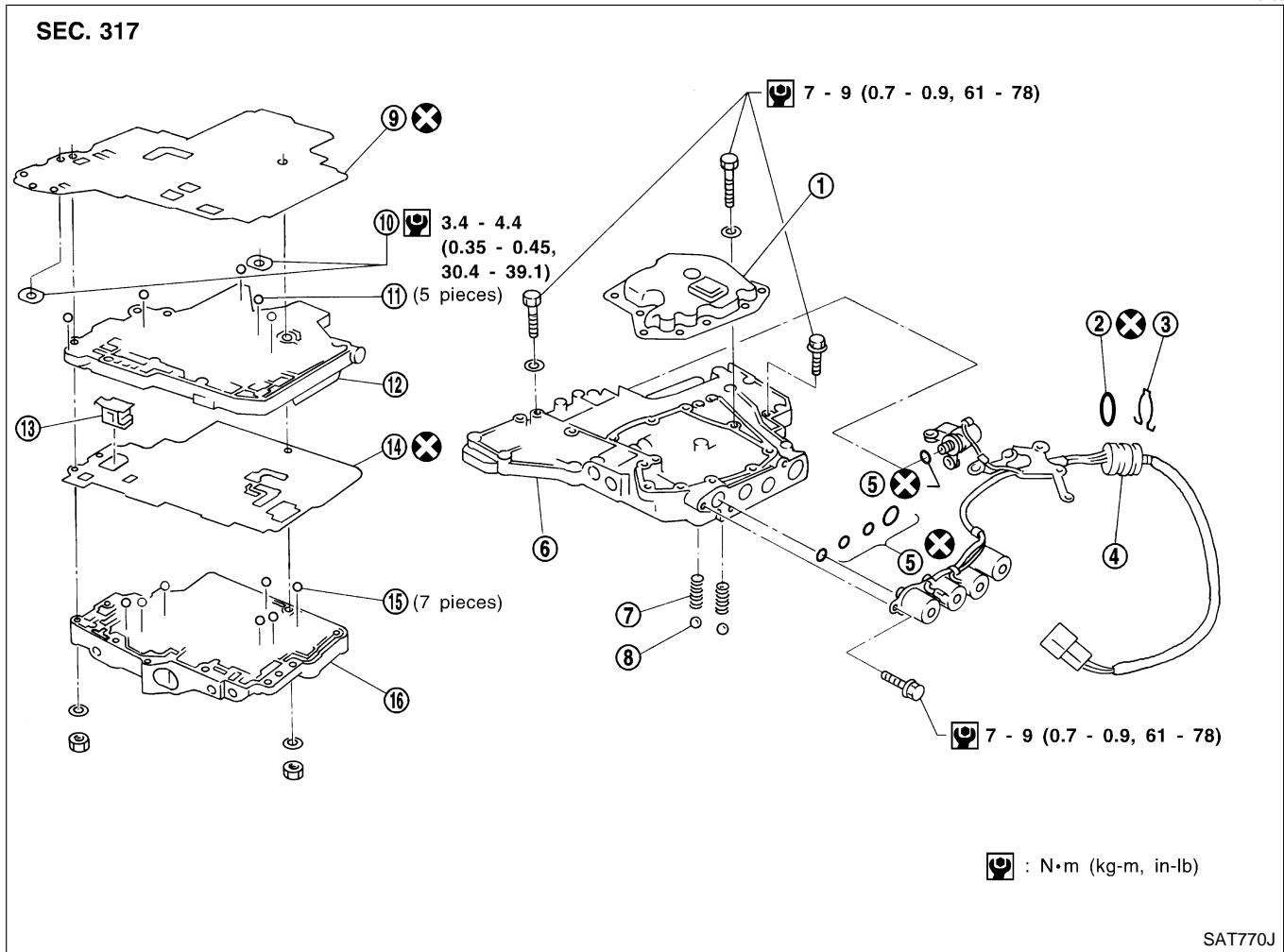

- |                             |                                   |                              |
|-----------------------------|-----------------------------------|------------------------------|
| 1. Oil strainer             | 7. Oil cooler relief valve spring | 12. Control valve inter body |
| 2. O-ring                   | 8. Check ball                     | 13. Pilot filter             |
| 3. Stopper ring             | 9. Separating plate               | 14. Separating plate         |
| 4. Terminal body            | 10. Support plate                 | 15. Steel ball               |
| 5. O-rings                  | 11. Steel ball                    | 16. Control valve upper body |
| 6. Control valve lower body |                                   |                              |

### DISASSEMBLY

Disassemble upper, inter and lower bodies.

NFAT0134

#### Bolt length, number and location:

Bolt symbol	a	b	c	d	e	f	g
Bolt length "ℓ" mm (in)	13.5 (0.531)	58.0 (2.283)	40.0 (1.575)	66.0 (2.598)	33.0 (1.299)	78.0 (3.071)	18.0 (0.709)
ℓ							
Number of bolts	6	3	6	11	2	2	1

f: Reamer bolt and nut.

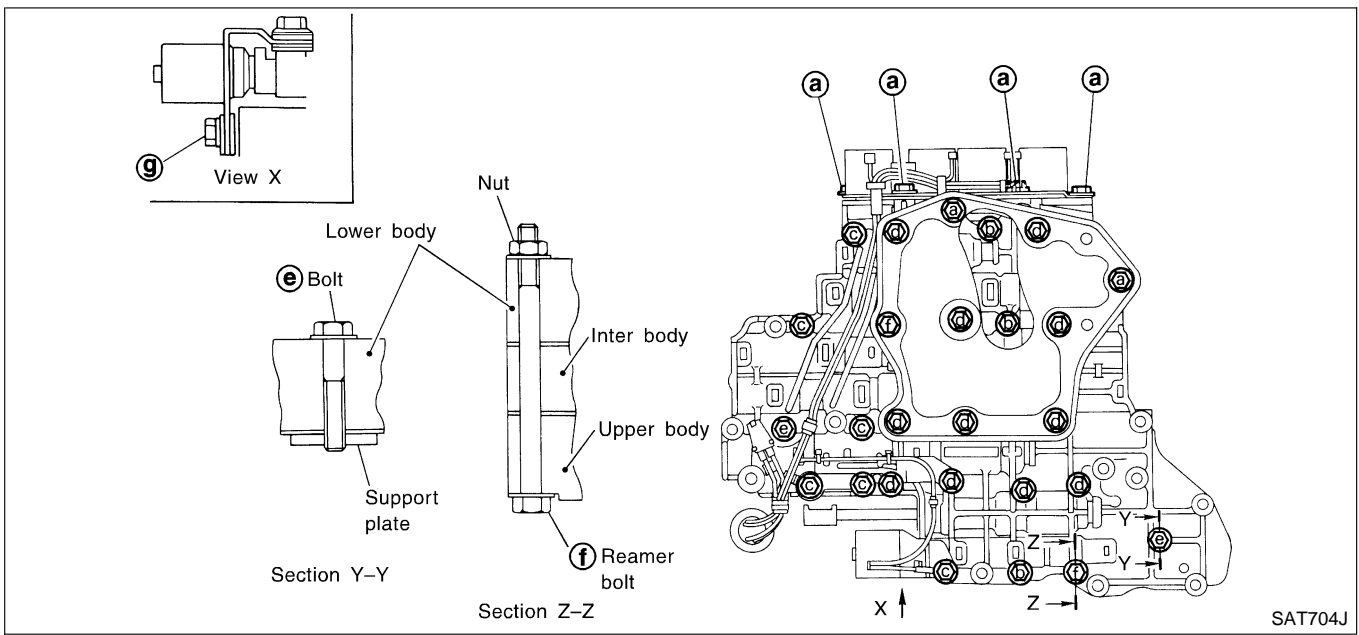

GI

MA

EM

LC

EC

FE

CL

MT

AT

AX

SU

BR

ST

RS

BT

HA

SC

EL

IDX

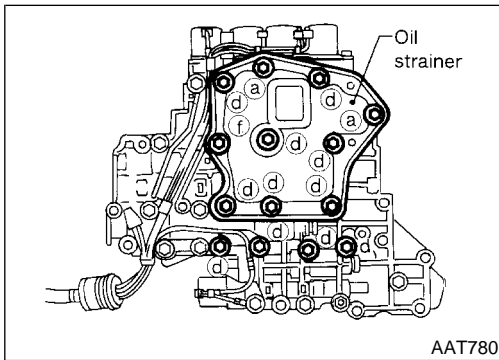

1. Remove bolts **a**, **d** and nut **f** and remove oil strainer from control valve assembly.

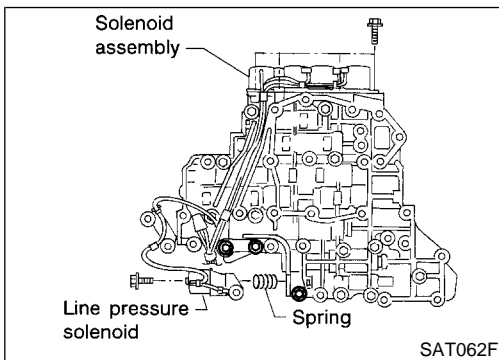

2. Remove solenoid valve assembly and line pressure solenoid valve from control valve assembly.

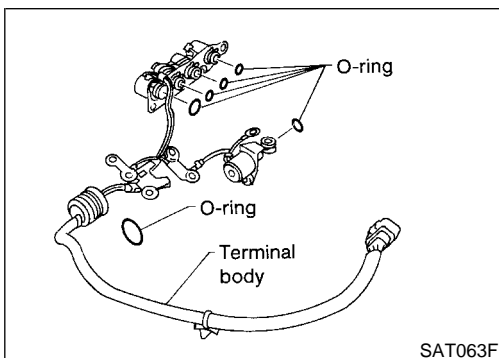

3. Remove O-rings from solenoid valves and terminal body.



# REPAIR FOR COMPONENT PARTS

## Control Valve Assembly (Cont'd)

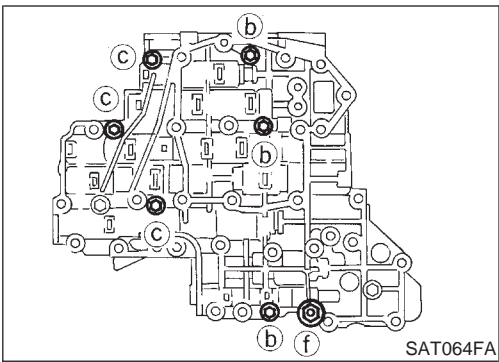

4. Place upper body facedown, and remove bolts **b**, **c** and nut **f**.

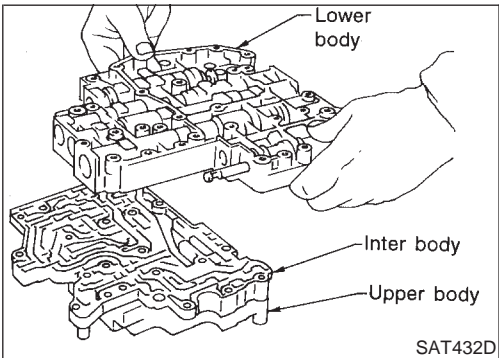

5. Remove inter body from lower body.

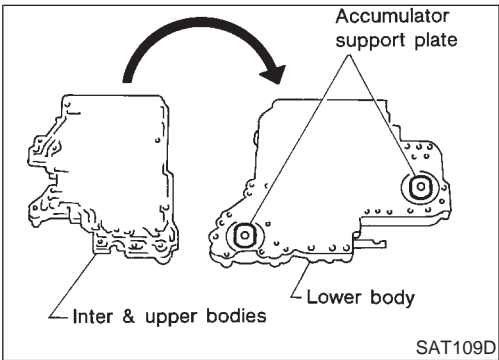

6. Turn over lower body, and remove accumulator support plate.

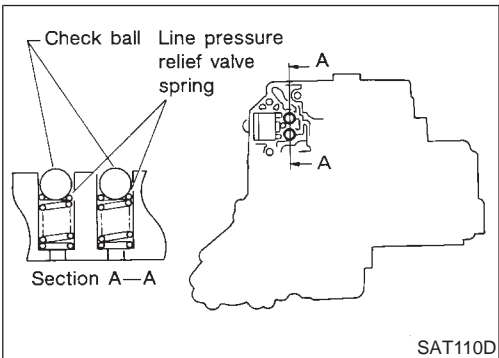

7. Remove bolts **e**, separating plate and separating gasket from lower body.

8. Remove steel balls and relief valve springs from lower body.

● **Be careful not to lose steel balls and relief valve springs.**

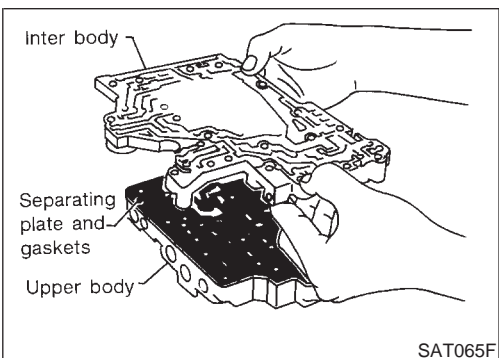

9. Remove inter body from upper body.

# REPAIR FOR COMPONENT PARTS

Control Valve Assembly (Cont'd)

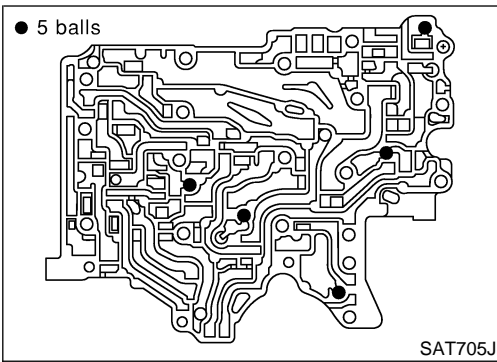

10. Check to see that steel balls are properly positioned in inter body and then remove them.

- **Be careful not to lose steel balls.**

GI

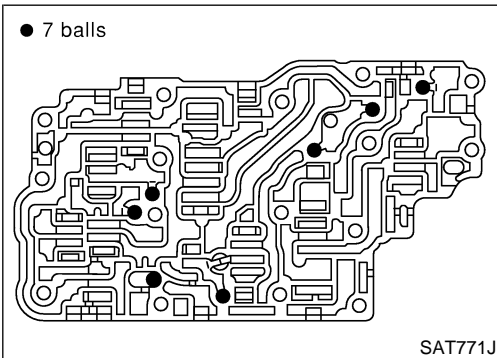

11. Check to see that steel balls are properly positioned in upper body and then remove them.

- **Be careful not to lose steel balls.**

MA

EM

LC

EC

FE

CL

MT

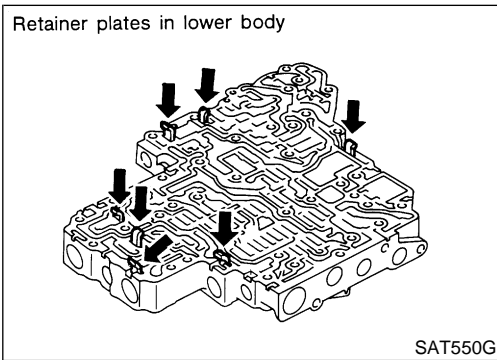

## INSPECTION

### Lower and Upper Bodies

- Check to see that retainer plates are properly positioned in lower body.

NFAT0135

NFAT0135S01

AT

AX

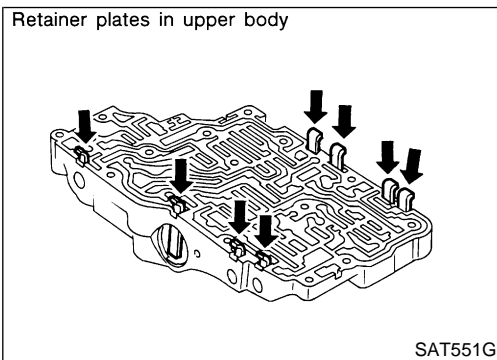

- Check to see that retainer plates are properly positioned in upper body.

- **Be careful not to lose these parts.**

SU

BR

ST

### Oil Strainer

- Check wire netting of oil strainer for damage.

NFAT0135S02

RS

BT

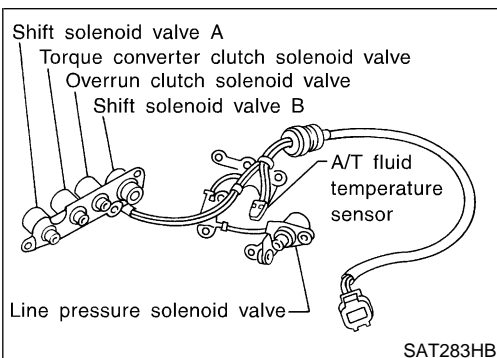

### Shift Solenoid Valves "A" and "B", Line Pressure Solenoid Valve, Torque Converter Clutch Solenoid Valve and Overrun Clutch Solenoid Valve

- Measure resistance.
- For shift solenoid valve A, refer to AT-175.
- For shift solenoid valve B, refer to AT-180.
- For line pressure solenoid valve, refer to AT-169.
- For torque converter clutch solenoid valve, refer to AT-154.
- For overrun clutch solenoid valve, refer to AT-194.

NFAT0135S03

SC

EL

IDX

# REPAIR FOR COMPONENT PARTS

Control Valve Assembly (Cont'd)

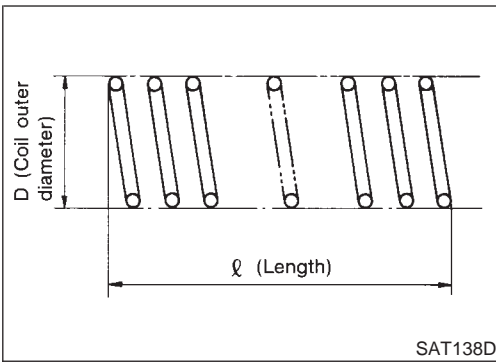

## Oil Cooler Relief Valve Spring

NFAT0135S04

- Check springs for damage or deformation.
- Measure free length and outer diameter.

**Inspection standard:**  
Refer to SDS, AT-383.

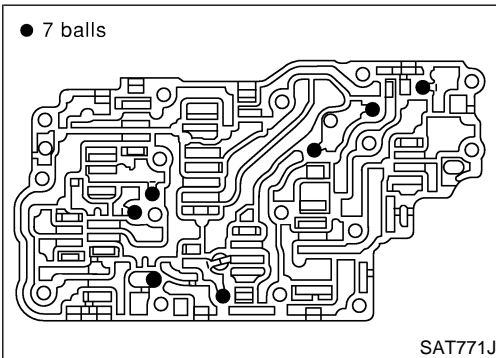

## ASSEMBLY

NFAT0136

1. Install upper, inter and lower body.
  - a. Place oil circuit of upper body face up. Install steel balls in their proper positions.

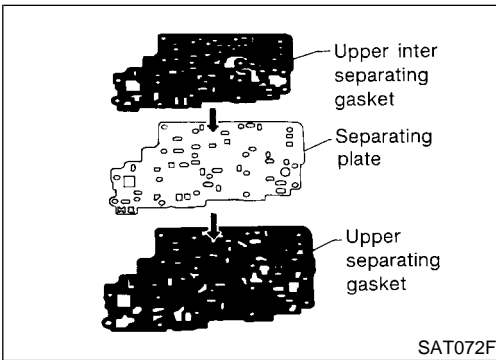

- b. Install upper separating gasket, upper inter separating gasket and upper separating plate in order shown in illustration.

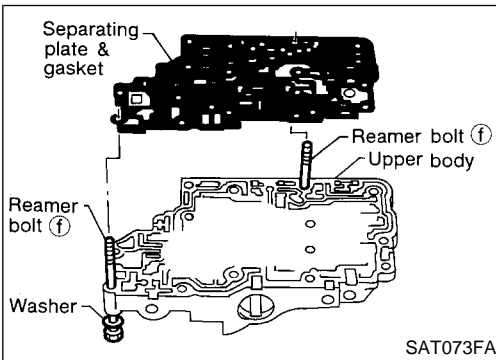

- c. Install reamer bolts **f** from bottom of upper body. Using reamer bolts as guides, install separating plate and gaskets as a set.

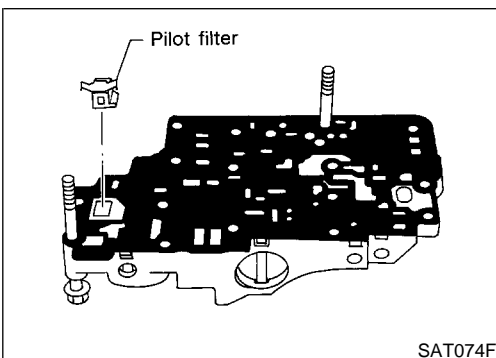

- d. Install pilot filter.

# REPAIR FOR COMPONENT PARTS

Control Valve Assembly (Cont'd)

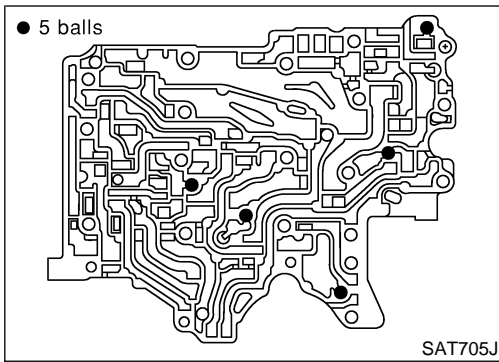

e. Place lower body as shown in illustration (side of inter body face up). Install steel balls in their proper positions.

GI

MA

EM

LC

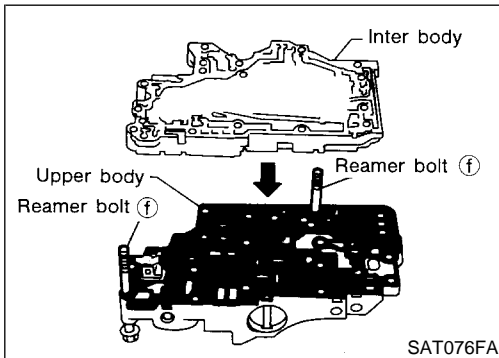

f. Install inter body on upper body using reamer bolts **f** as guides.

● **Be careful not to dislocate or drop steel balls.**

EC

FE

CL

MT

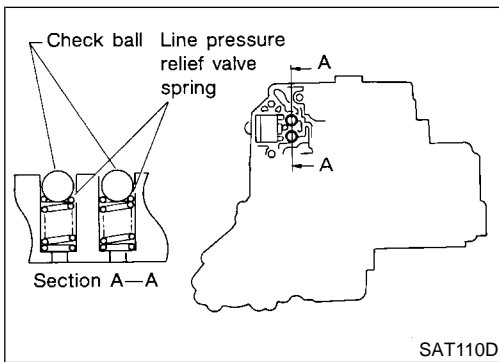

g. Install steel balls and relief valve springs in their proper positions in lower body.

AT

AX

SU

BR

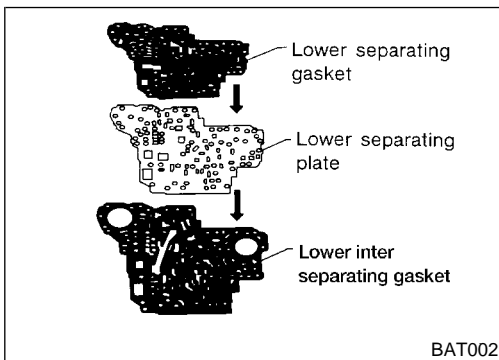

h. Install lower separating gasket, lower inter separating gasket and lower separating plate in order shown in illustration.

ST

RS

BT

HA

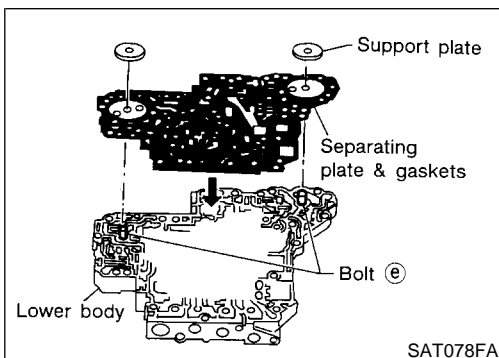

i. Install bolts **e** from bottom of lower body. Using bolts **e** as guides, install separating plate and gaskets as a set.

SC

j. Temporarily install support plates on lower body.

EL

IDX

# REPAIR FOR COMPONENT PARTS

## Control Valve Assembly (Cont'd)

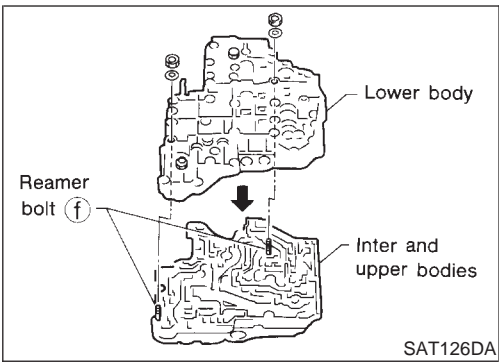

- k. Install lower body on inter body using reamer bolts f as guides and tighten reamer bolts f slightly.

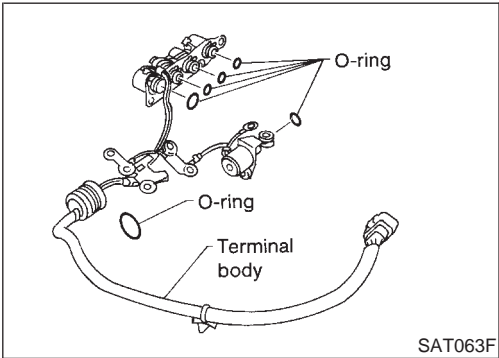

2. Install O-rings to solenoid valves and terminal body.
- Apply ATF to O-rings.

3. Install and tighten bolts.

### Bolt length, number and location:

Bolt symbol	a	b	c	d	e	f	g
Bolt length "ℓ" mm (in)	13.5 (0.531)	58.0 (2.283)	40.0 (1.575)	66.0 (2.598)	33.0 (1.299)	78.0 (3.071)	18.0 (0.709)
							
Number of bolts	6	3	6	11	2	2	1

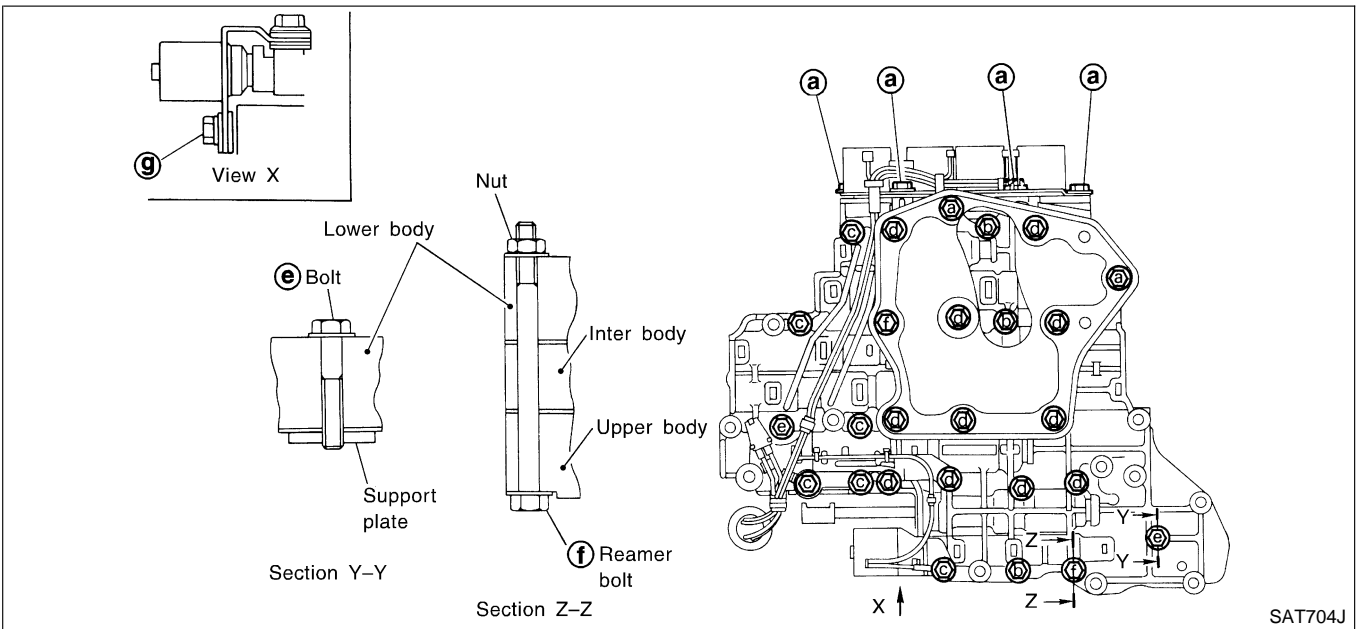

# REPAIR FOR COMPONENT PARTS

Control Valve Assembly (Cont'd)

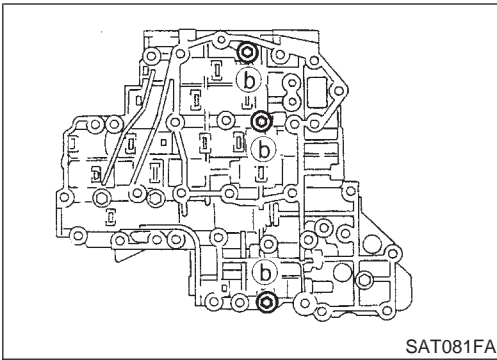

- a. Install and tighten bolts **b** to specified torque.  
 : 7 - 9 N·m (0.7 - 0.9 kg-m, 61 - 78 in-lb)

GI

MA

EM

LC

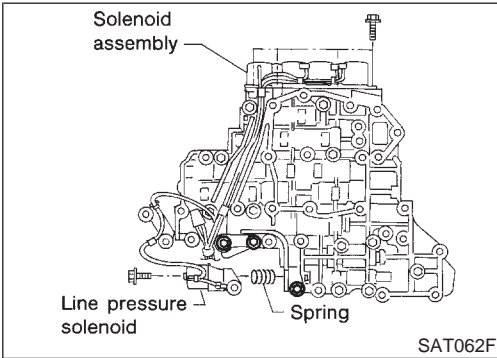

- b. Install solenoid valve assembly and line pressure solenoid valve to lower body.

EC

FE

CL

MT

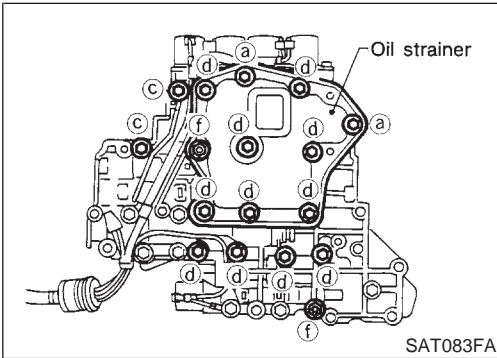

- c. Set oil strainer, then tighten bolts **a**, **c**, **d** and nuts **f** to specified torque.  
 : 7 - 9 N·m (0.7 - 0.9 kg-m, 61 - 78 in-lb)

AT

AX

SU

BR

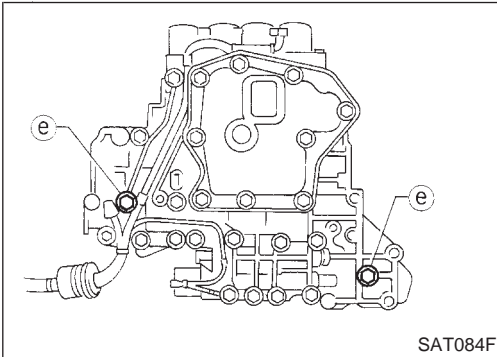

- d. Tighten bolts **e** to specified torque.  
 : 3.4 - 4.4 N·m (0.35 - 0.45 kg-m, 30.4 - 39.1 in-lb)

ST

RS

BT

HA

SC

EL

IDX

# REPAIR FOR COMPONENT PARTS

Control Valve Upper Body

## Control Valve Upper Body COMPONENTS

Apply ATF to all components before installation.

=NFAT0137

### SEC. 317

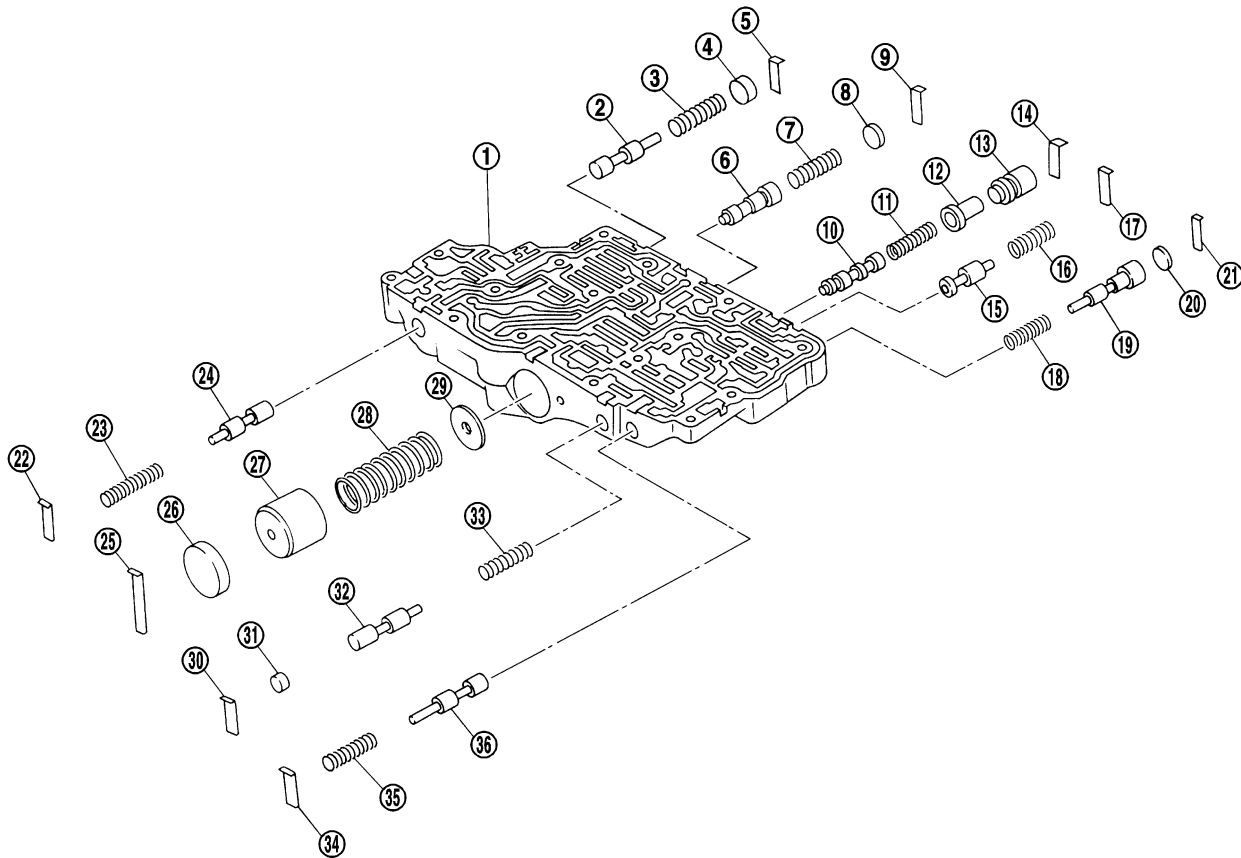

SAT772J

- |   |  |                                    |
|---|--|------------------------------------|
| 1. Upper body                             | 13. Torque converter clutch control sleeve | 25. Retainer plate                 |
| 2. Cooler check valve                     | 14. Retainer plate                         | 26. Plug                           |
| 3. Return spring                          | 15. Torque converter relief valve          | 27. 1-2 accumulator piston         |
| 4. Plug                                   | 16. Return spring                          | 28. Return spring                  |
| 5. Retainer plate                         | 17. Retainer plate                         | 29. 1-2 accumulator retainer plate |
| 6. 1-2 accumulator valve                  | 18. Return spring                          | 30. Retainer plate                 |
| 7. Return spring                          | 19. Overrun clutch reducing valve          | 31. Plug                           |
| 8. Plug                                   | 20. Plug                                   | 32. 1st reducing valve             |
| 9. Retainer plate                         | 21. Retainer plate                         | 33. Return spring                  |
| 10. Torque converter clutch control valve | 22. Retainer plate                         | 34. Retainer plate                 |
| 11. Return spring                         | 23. Return spring                          | 35. Return spring                  |
| 12. Torque converter clutch control plug  | 24. Pilot valve                            | 36. 3-2 timing valve               |

# REPAIR FOR COMPONENT PARTS

Control Valve Upper Body (Cont'd)

NFAT0138

Retainer plates in upper body

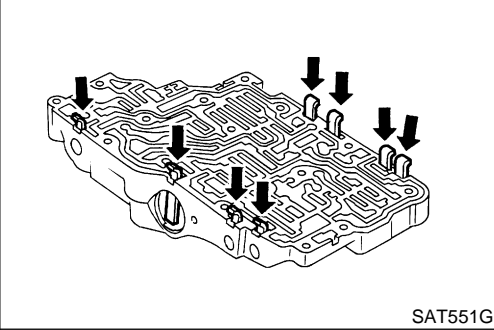

SAT551G

## DISASSEMBLY

1. Remove valves at retainer plates.
  - Do not use a magnetic pick-up tool.

GI

MA

EM

LC

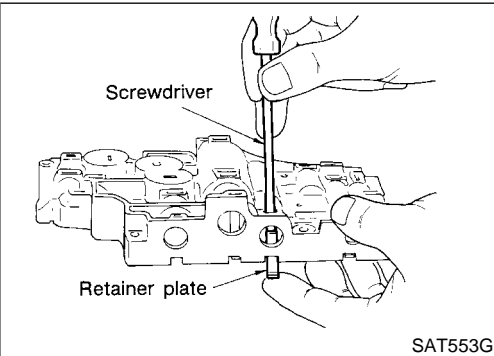

SAT553G

- a. Use a screwdriver to remove retainer plates.

EC

FE

CL

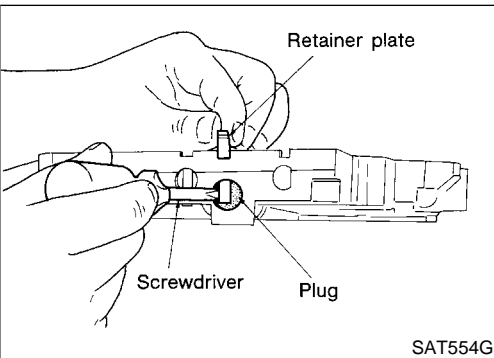

SAT554G

- b. Remove retainer plates while holding spring, plugs or sleeves.
  - Remove plugs slowly to prevent internal parts from jumping out.

AT

AX

SU

BR

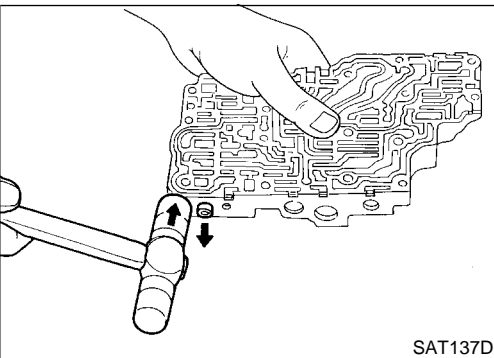

SAT137D

- c. Place mating surface of valve body face down, and remove internal parts.
  - If a valve is hard to remove, place valve body face down and lightly tap it with a soft hammer.
  - Be careful not to drop or damage valves and sleeves.

ST

RS

BT

HA

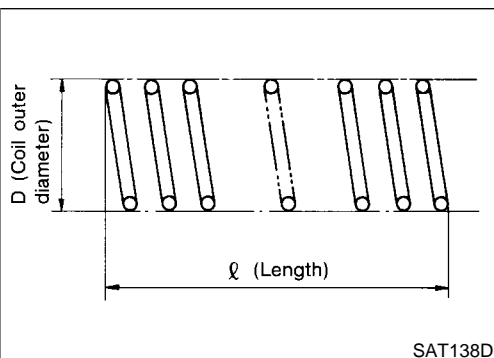

SAT138D

## INSPECTION

### Valve Spring

NFAT0139

NFAT0139S01

- Measure free length and outer diameter of each valve spring. Also check for damage or deformation.

**Inspection standard:**

**Refer to SDS, AT-383.**

SC

EL

- Replace valve springs if deformed or fatigued.

IDX

### Control Valves

NFAT0139S02

- Check sliding surfaces of valves, sleeves and plugs.



# REPAIR FOR COMPONENT PARTS

Control Valve Upper Body (Cont'd)

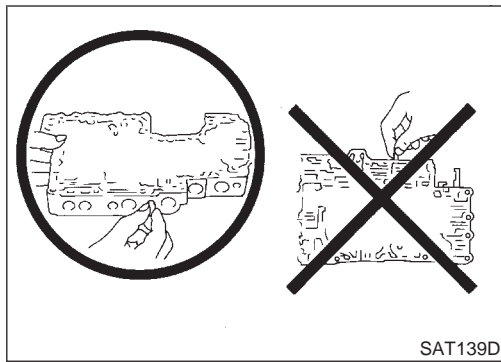

## ASSEMBLY

NFAT0140

- Lay control valve body down when installing valves. Do not stand the control valve body upright.

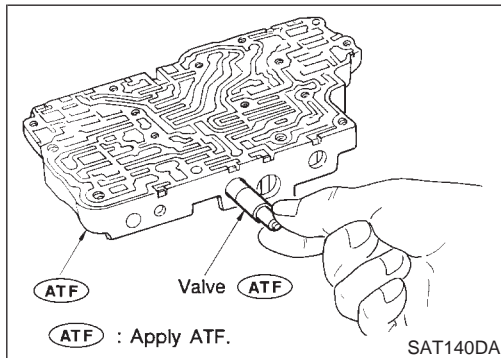

1. Lubricate the control valve body and all valves with ATF. Install control valves by sliding them carefully into their bores.
- Be careful not to scratch or damage valve body.

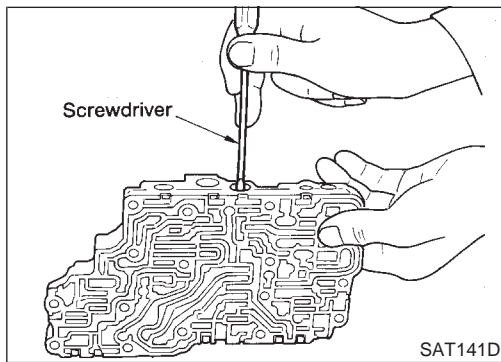

- Wrap a small screwdriver with vinyl tape and use it to insert the valves into their proper positions.

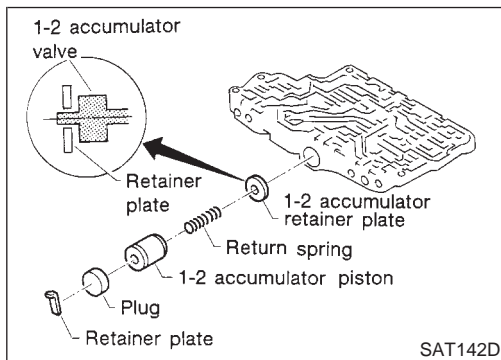

## 1-2 Accumulator Valve

NFAT0140S01

- Install 1-2 accumulator valve. Align 1-2 accumulator retainer plate from opposite side of control valve body.
- Install return spring, 1-2 accumulator piston and plug.

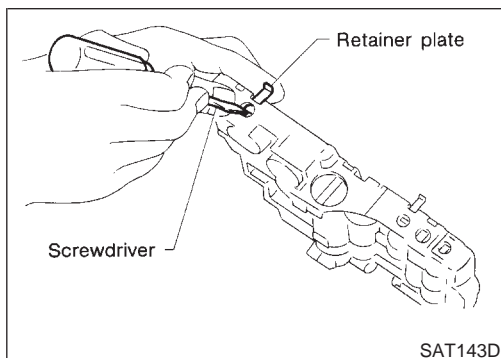

1. Install retainer plates
- While pushing plug or return spring, install retainer plate.

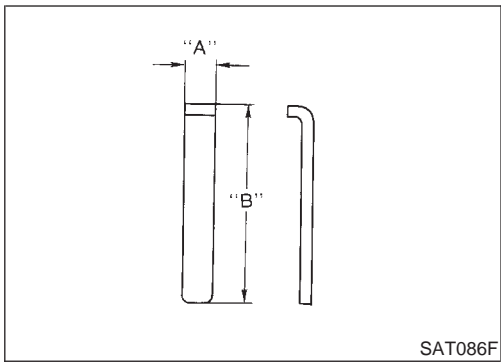

## Retainer Plate (Upper body)

NFAT0140S02  
Unit: mm (in)

No.	Name of control valve	Length A	Length B	
22	Pilot valve	6.0 (0.236)	21.5 (0.846)	GI
30	1st reducing valve			MA
34	3-2 timing valve			EM
17	Torque converter relief valve		38.5 (1.516)	LC
9	1-2 accumulator valve			EC
25	1-2 accumulator piston valve			FE
21	Overrun clutch reducing valve			
5	Cooler check valve		24.0 (0.945)	
14	Torque converter clutch control valve		28.0 (1.102)	

- Install proper retainer plates.  
Refer to "Control Valve Upper Body", AT-102.

CL

MT

**AT**

AX

SU

BR

ST

RS

BT

HA

SC

EL

IDX

# REPAIR FOR COMPONENT PARTS

Control Valve Lower Body

## Control Valve Lower Body COMPONENTS

Apply ATF to all components before installation.

=NFAT0141

SEC. 317

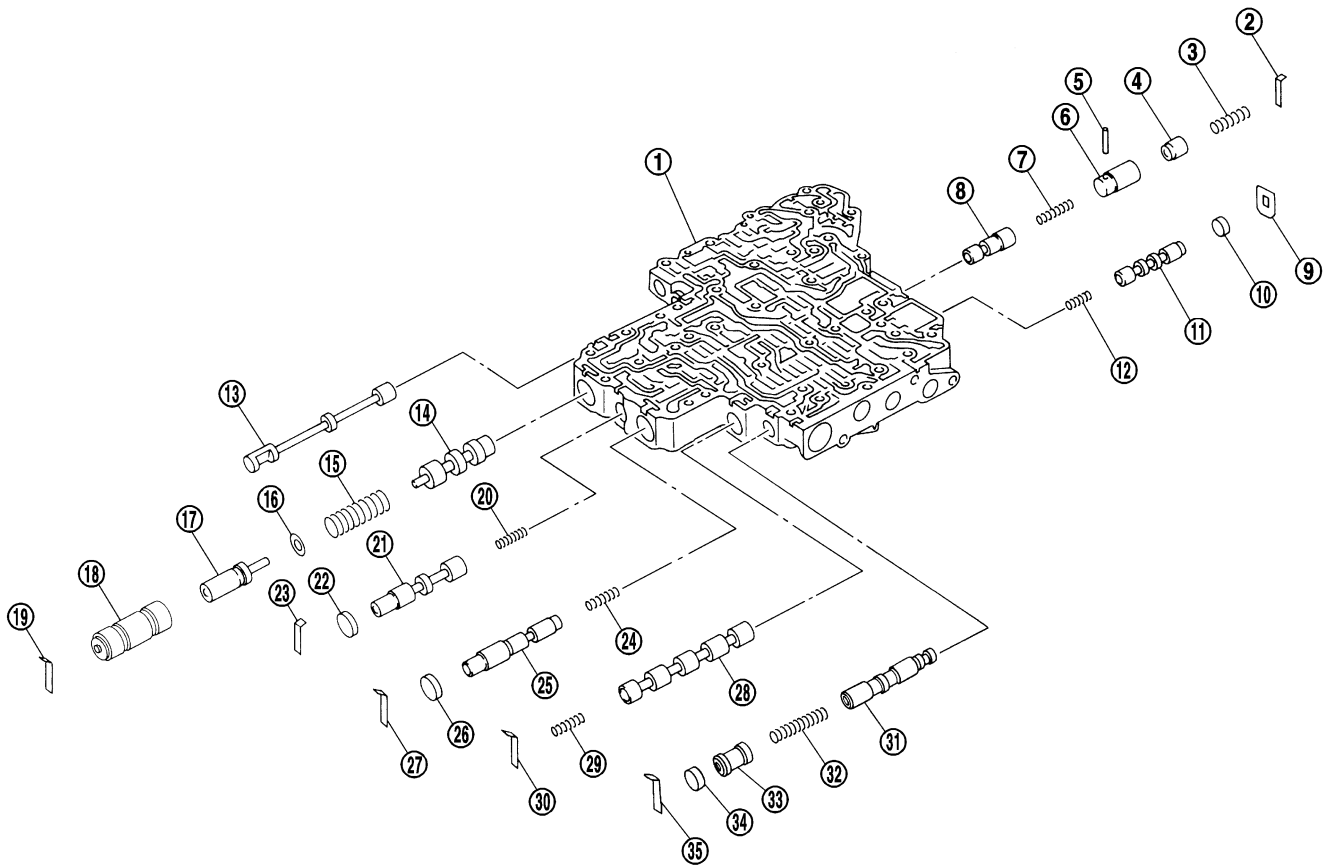

SAT773J

- |                            |                                  |                               |
|----------------------------|----------------------------------|-------------------------------|
| 1. Lower body              | 13. Manual valve                 | 25. Accumulator control valve |
| 2. Retainer plate          | 14. Pressure regulator valve     | 26. Plug                      |
| 3. Return spring           | 15. Return spring                | 27. Retainer plate            |
| 4. Piston                  | 16. Spring seat                  | 28. Shift valve A             |
| 5. Parallel pin            | 17. Plug                         | 29. Return spring             |
| 6. Sleeve                  | 18. Sleeve                       | 30. Retainer plate            |
| 7. Return spring           | 19. Retainer plate               | 31. Shuttle valve             |
| 8. Pressure modifier valve | 20. Return spring                | 32. Return spring             |
| 9. Retainer plate          | 21. Overrun clutch control valve | 33. Plug                      |
| 10. Plug                   | 22. Plug                         | 34. Plug                      |
| 11. Shift valve B          | 23. Retainer plate               | 35. Retainer plate            |
| 12. Return spring          | 24. Return spring                |                               |

# REPAIR FOR COMPONENT PARTS

Control Valve Lower Body (Cont'd)

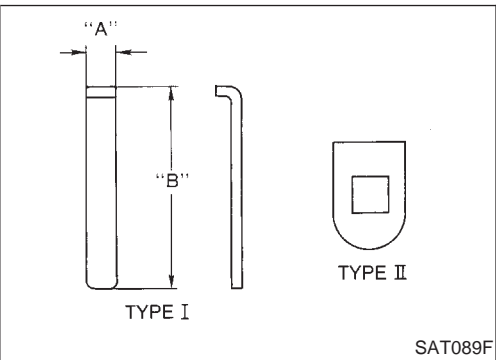
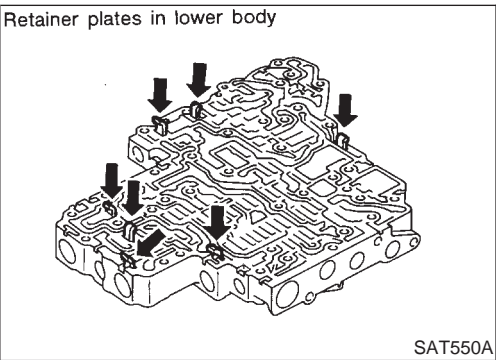
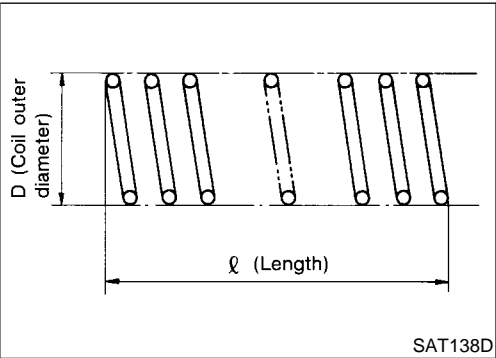
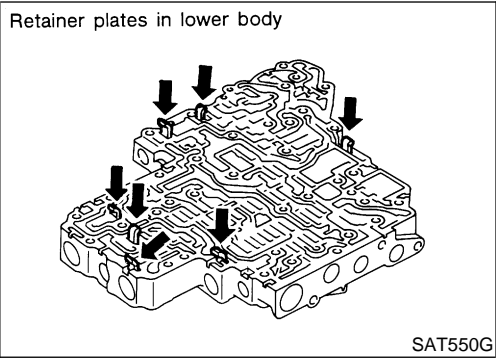

## DISASSEMBLY

NFAT0142

- Remove valves at retainer plate. For removal procedures, refer to "DISASSEMBLY", "Control Valve Upper Body", AT-321.

GI

MA

EM

LC

## INSPECTION

NFAT0143

### Valve Springs

NFAT0143S01

- Check each valve spring for damage or deformation. Also measure free length and outer diameter.

**Inspection standard:**

**Refer to SDS, AT-383.**

- Replace valve springs if deformed or fatigued.

EC

FE

CL

### Control Valves

NFAT0143S02

- Check sliding surfaces of control valves, sleeves and plugs for damage.

MT

## ASSEMBLY

NFAT0144

- Install control valves. For installation procedures, refer to "ASSEMBLY", "Control Valve Upper Body", AT-322.

AT

AX

SU

BR

## Retainer Plate (Lower body)

NFAT0144S01  
Unit: mm (in)

No.	Name of control valve and plug	Length A	Length B	Type
19	Pressure regulator valve	6.0 (0.236)	28.0 (1.102)	I
27	Accumulator control valve			
36	Shift valve A			
23	Overrun clutch control valve			
2	Pressure modifier valve			
35	Shuttle valve	—	—	II
9	Shift valve B			

ST

RS

BT

HA

SC

- Install proper retainer plates. Refer to "Control Valve Lower Body", AT-324.

EL

IDX

# REPAIR FOR COMPONENT PARTS

Reverse Clutch

## Reverse Clutch COMPONENTS

NFAT0145

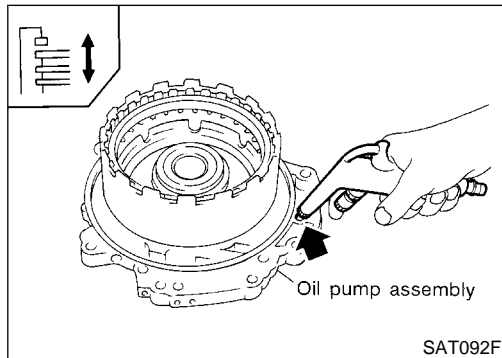
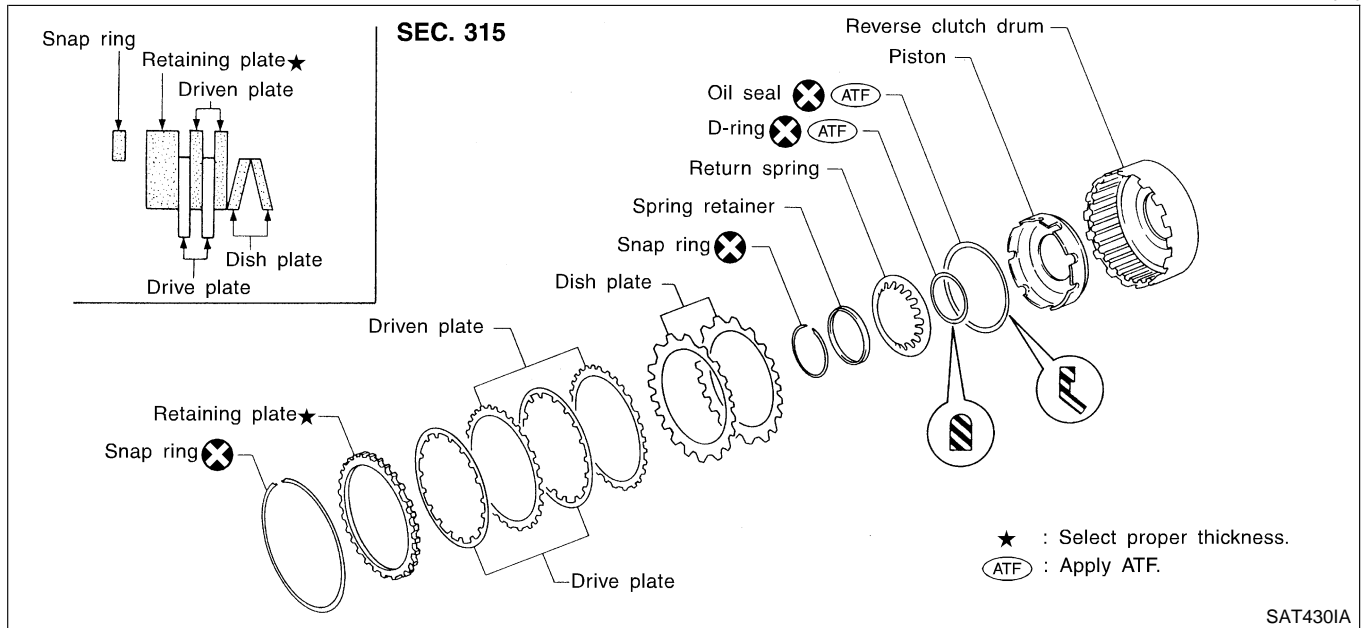

### DISASSEMBLY

NFAT0146

1. Check operation of reverse clutch
  - a. Install seal ring onto drum support of oil pump cover and install reverse clutch assembly. Apply compressed air to oil hole.
  - b. Check to see that retaining plate moves to snap ring.
  - c. If retaining plate does not contact snap ring:
    - D-ring might be damaged.
    - Oil seal might be damaged.
    - Fluid might be leaking past piston check ball.
2. Remove snap ring.
3. Remove drive plates, driven plates, retaining plate, and dish plates.

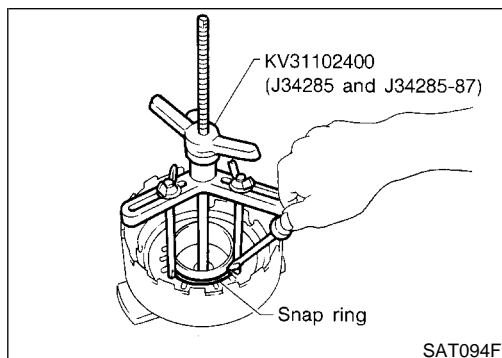
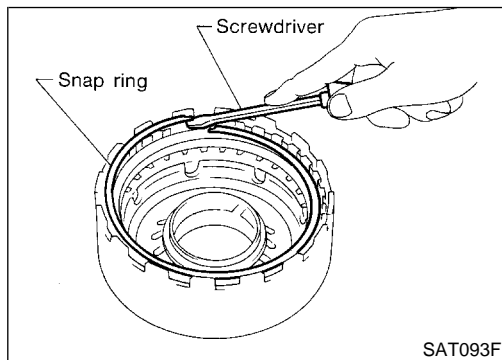

4. Set Tool on spring retainer and remove snap ring from reverse clutch drum while compressing return springs.
  - **Set Tool directly over springs.**
  - **Do not expand snap ring excessively.**
5. Remove spring retainer and return springs.

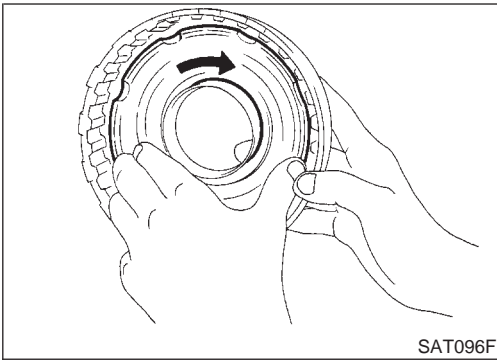

6. Remove piston from reverse clutch drum by turning it.
7. Remove D-ring and oil seal from piston.

GI  
MA  
EM  
LC

## INSPECTION

### Reverse Clutch Snap Ring, Spring Retainer and Return Springs NFAT0147

- Check for deformation, fatigue or damage. If necessary, replace. NFAT0147S01

EC  
FE

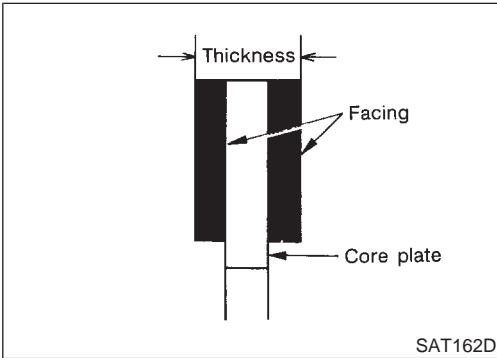

### Reverse Clutch Drive Plates NFAT0147S02

- Check facing for burns, cracks or damage.
- Measure thickness of facing.
  - Thickness of drive plate:**
  - Standard value: 1.6 mm (0.063 in)**
  - Wear limit: 1.4 mm (0.055 in)**
- If not within wear limit, replace.

AT  
AX  
SU  
BR

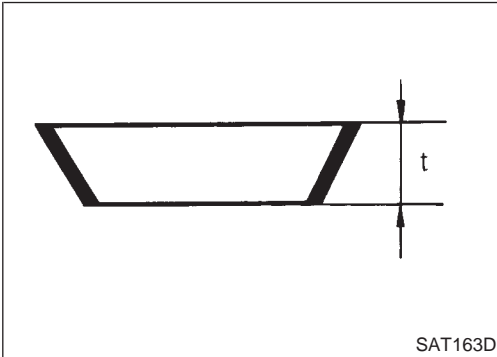

### Reverse Clutch Dish Plates NFAT0147S03

- Check for deformation or damage.
- Measure thickness of dish plate.
  - Thickness of dish plate: 3.08 mm (0.1213 in)**
- If deformed or fatigued, replace.

ST  
RS

### Reverse Clutch Piston NFAT0147S04

- Make sure that check balls are not fixed.
- Apply compressed air to check ball oil hole opposite the return spring. Make sure there is no air leakage.
- Apply compressed air to oil hole on return spring side to make sure that air leaks past ball.

BT  
HA  
SC

EL  
IDX

# REPAIR FOR COMPONENT PARTS

Reverse Clutch (Cont'd)

NFAT0148

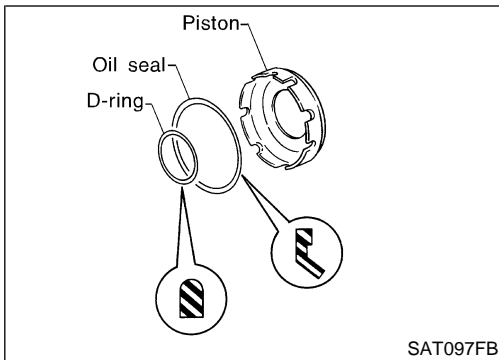

## ASSEMBLY

1. Install D-ring and oil seal on piston.
  - Take care with the direction of oil seal.
  - Apply ATF to both parts.

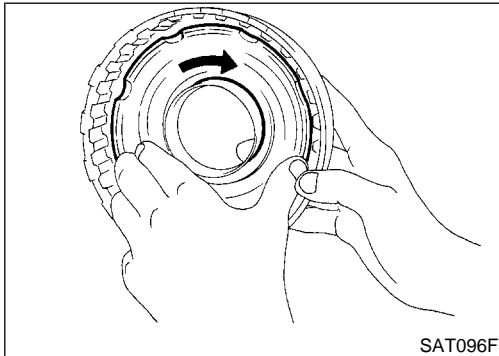

2. Install piston assembly by turning it slowly.
  - Apply ATF to inner surface of drum.

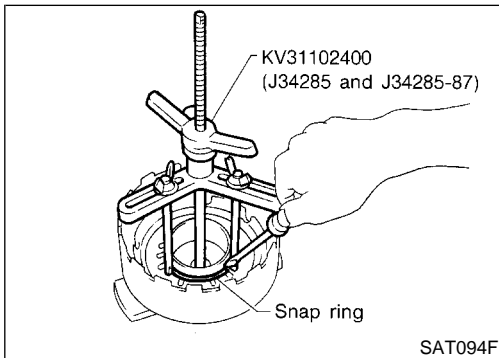

3. Install return springs and spring retainer on piston.
4. Set Tool on spring retainer and install snap ring while compressing return springs.
  - Set Tool directly over return springs.

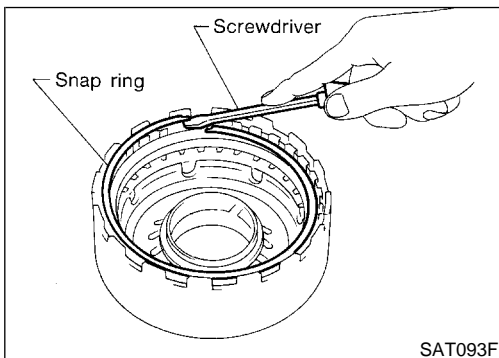

5. Install drive plates, driven plates, retaining plate and dish plates.
  - Take care with order of plates.
6. Install snap ring.

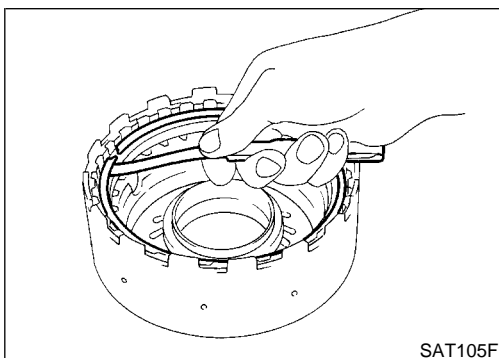

7. Measure clearance between retaining plate and snap ring. If not within allowable limit, select proper retaining plate.

**Specified clearance:**

**Standard 0.5 - 0.8 mm (0.020 - 0.031 in)**

**Allowable limit 1.2 mm (0.047 in)**

**Retaining plate:**

**Refer to SDS, AT-384.**

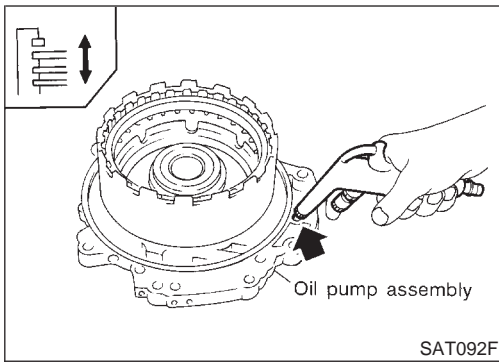

8. Check operation of reverse clutch.  
Refer to "DISASSEMBLY", "Reverse Clutch", AT-326.

GI  
MA  
EM  
LC  
EC

## High Clutch COMPONENTS

NFAT0149

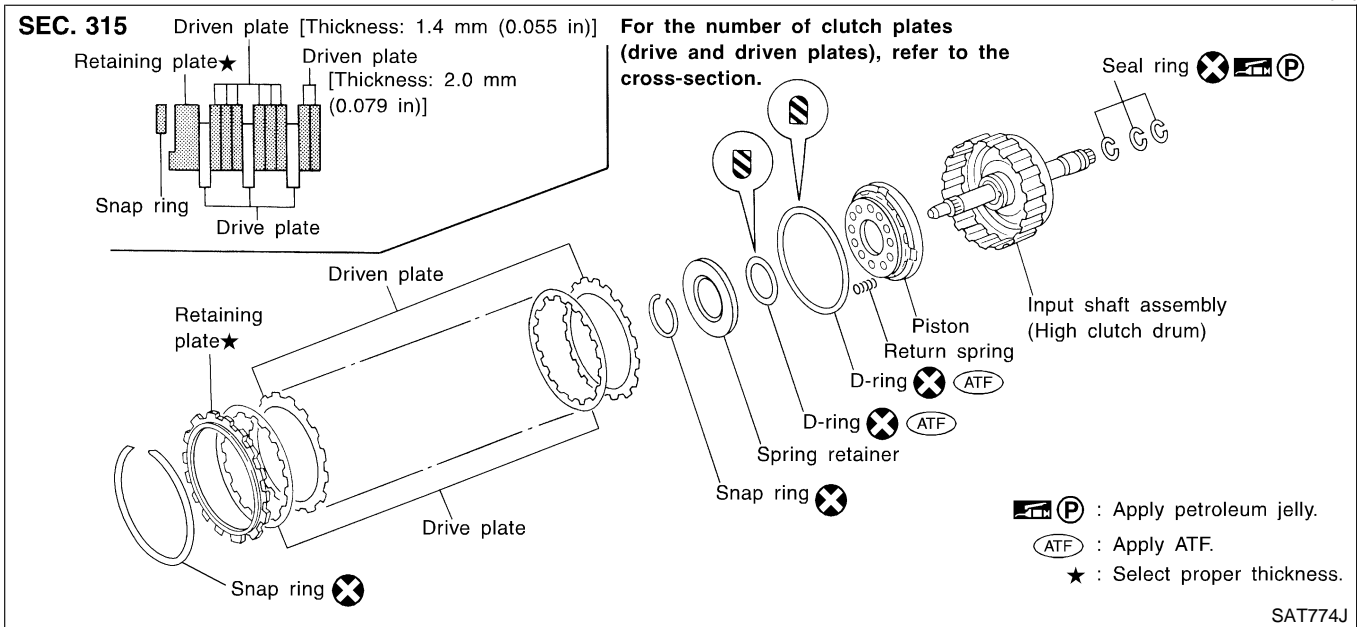

FE  
CL  
MT  
AT  
AX  
SU  
BR

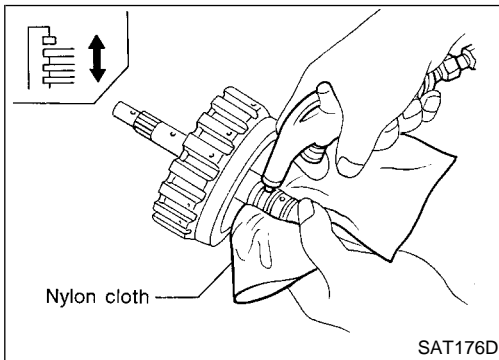

## DISASSEMBLY

NFAT0150

1. Check operation of high clutch.
  - a. Apply compressed air to oil hole of input shaft with nylon cloth.
    - **Stop up hole on opposite side of input shaft with nylon cloth.**
  - b. Check to see that retaining plate moves to snap ring.
  - c. If retaining plate does not contact snap ring:
    - D-ring might be damaged.
    - Oil seal might be damaged.
    - Fluid might be leaking past piston check ball.
2. Remove seal rings from input shaft.
  - **Always replace when removed.**

ST  
RS  
BT  
HA  
SC  
EL  
IDX

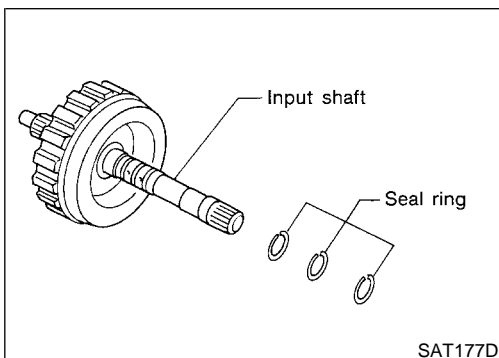



# REPAIR FOR COMPONENT PARTS

## High Clutch (Cont'd)

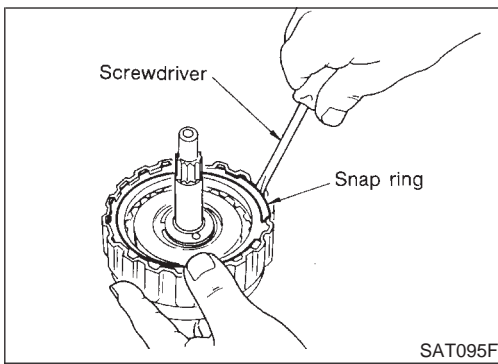

3. Remove snap ring.
4. Remove drive plates, driven plates and retaining plate.

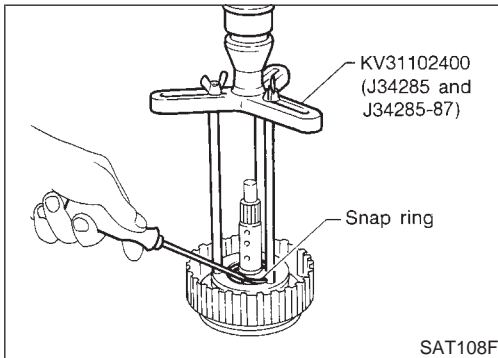

5. Set Tool on spring retainer and remove snap ring from high clutch drum while compressing return springs.
  - **Set Tool directly over springs.**
  - **Do not expand snap ring excessively.**
6. Remove spring retainer and return springs.

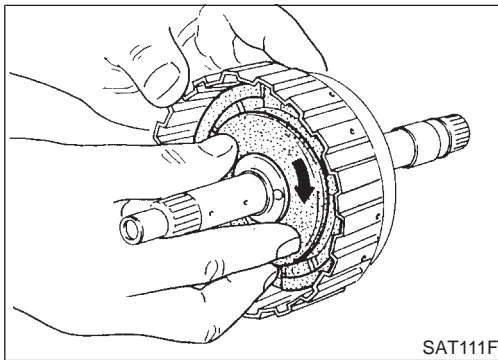

7. Remove piston from high clutch drum by turning it.

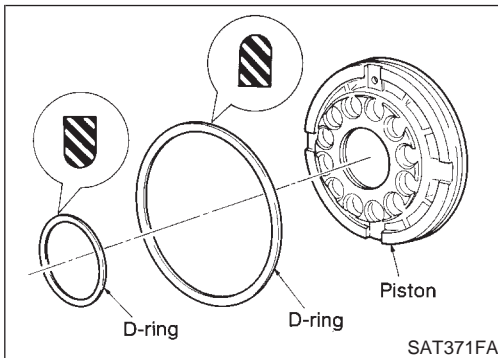

8. Remove D-rings from piston.

### INSPECTION

#### High Clutch Snap Ring, Spring Retainer and Return Springs

NFAT0151

NFAT0151S01

- Check for deformation, fatigue or damage. If necessary, replace.
- **When replacing spring retainer and return springs, replace them as a set.**

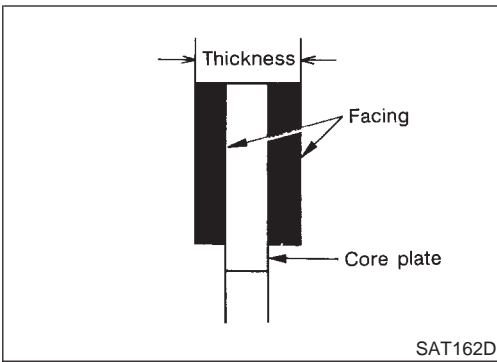

## High Clutch Drive Plates

NFAT0151S02

- Check facing for burns, cracks or damage.
- Measure thickness of facing.
  - Thickness of drive plate:**
  - Standard value 1.6 mm (0.063 in)**
  - Wear limit 1.4 mm (0.055 in)**
- If not within wear limit, replace.

GI

MA

EM

LC

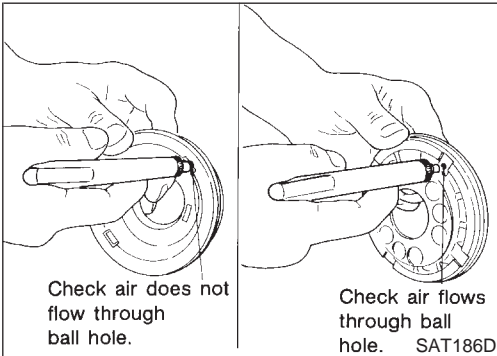

## High Clutch Piston

NFAT0151S03

- Make sure that check balls are not fixed.
- Apply compressed air to check ball oil hole opposite the return spring. Make sure there is no air leakage.
- Apply compressed air to oil hole on return spring side to make sure that air leaks past ball.

EC

FE

CL

MT

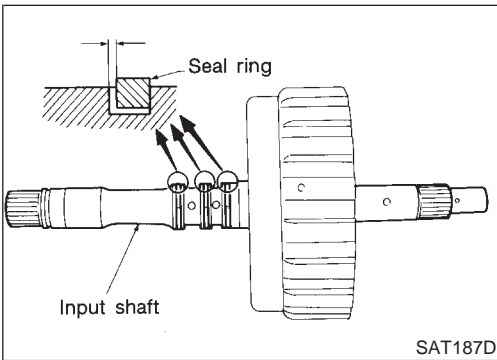

## Seal Ring Clearance

NFAT0151S04

- Install new seal rings onto input shaft.
- Measure clearance between seal ring and ring groove.
  - Standard clearance:**
  - 0.08 - 0.23 mm (0.0031 - 0.0091 in)**
  - Allowable limit:**
  - 0.23 mm (0.0091 in)**
- If not within allowable limit, replace input shaft assembly.

AT

AX

SU

BR

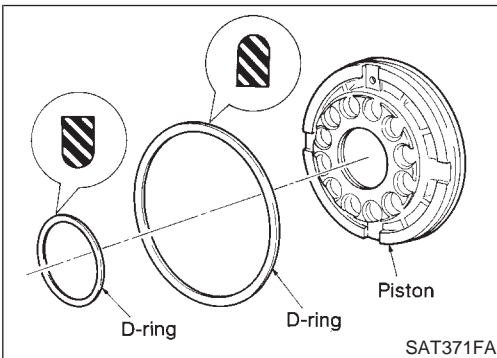

## ASSEMBLY

NFAT0152

1. Install D-rings on piston.
- **Apply ATF to both parts.**

ST

RS

BT

HA

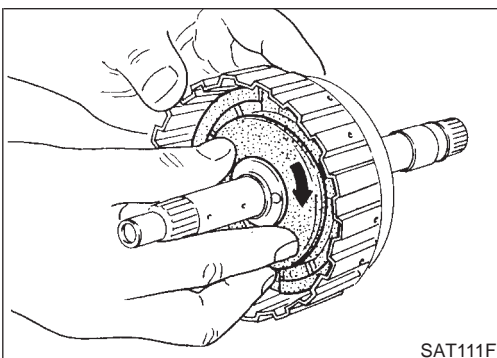

2. Install piston assembly by turning it slowly.
- **Apply ATF to inner surface of drum.**

SC

EL

IDX

# REPAIR FOR COMPONENT PARTS

## High Clutch (Cont'd)

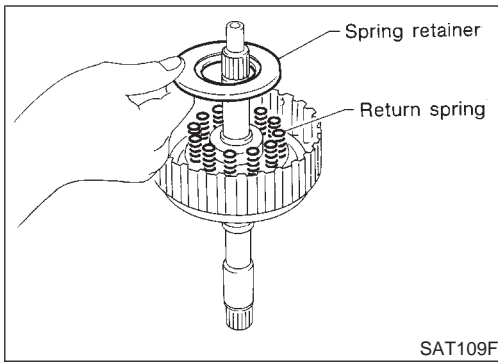

3. Install return springs and spring retainer on piston.

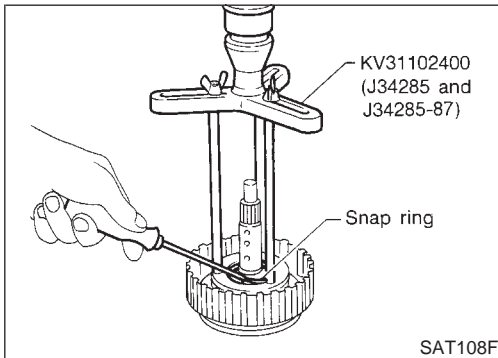

4. Set Tool on spring retainer and install snap ring while compressing return springs.

- **Set Tool directly over return springs.**

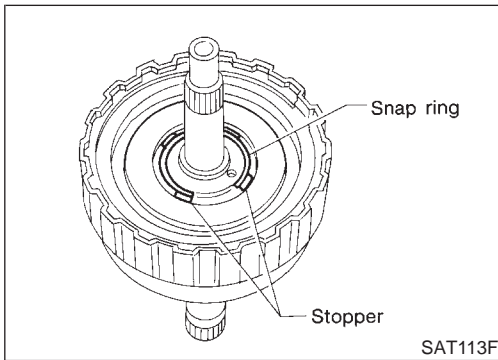

- **Do not align snap ring gap with spring retainer stopper.**

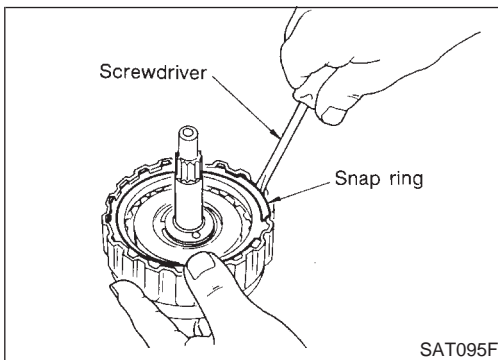

5. Install drive plates, driven plates and retaining plate.

- **Take care with the order and direction of plates.**

6. Install snap ring.

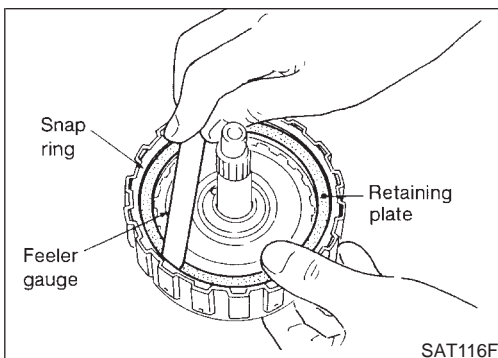

7. Measure clearance between retaining plate and snap ring. If not within allowable limit, select proper retaining plate.

**Specified clearance:**

**Standard 1.8 - 2.2 mm (0.071 - 0.087 in)**

**Allowable limit 2.8 mm (0.110 in)**

**Retaining plate:**

**Refer to SDS, AT-384.**

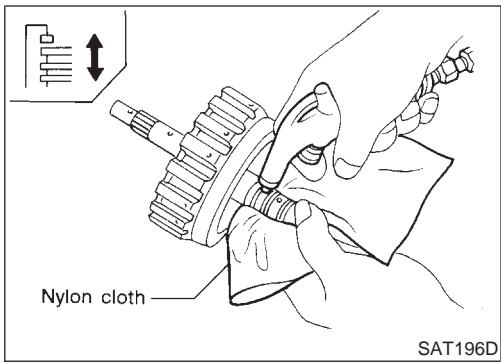

8. Check operation of high clutch.  
Refer to "DISASSEMBLY", "High Clutch", AT-329.

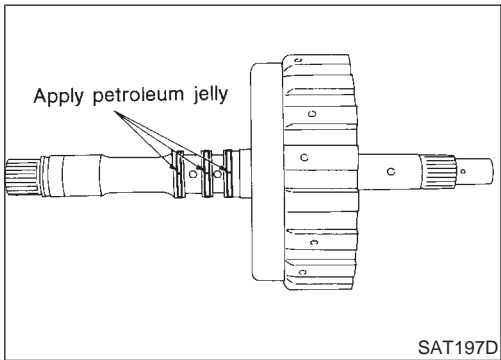

9. Install seal rings to input shaft.
- Apply petroleum jelly to seal rings.
  - Always replace when removed.

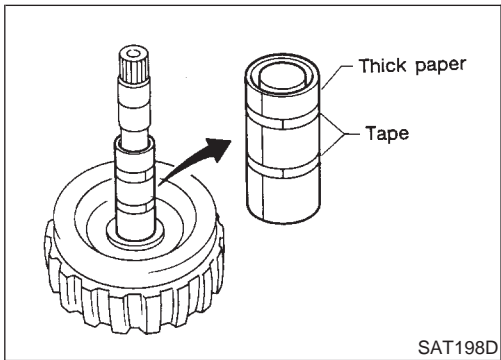

- Roll paper around seal rings to prevent seal rings from spreading.

GI

MA

EM

LC

EC

FE

CL

MT

**AT**

AX

SU

BR

ST

RS

BT

HA

SC

EL

IDX

# REPAIR FOR COMPONENT PARTS

Forward and Overrun Clutches

## Forward and Overrun Clutches COMPONENTS

NFAT0153

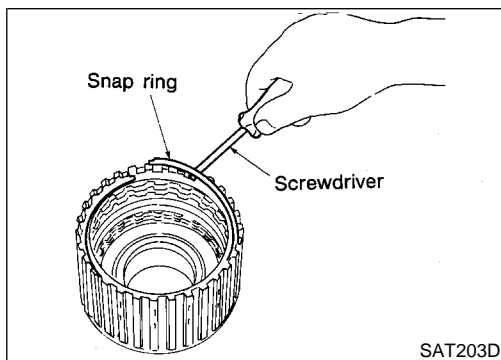
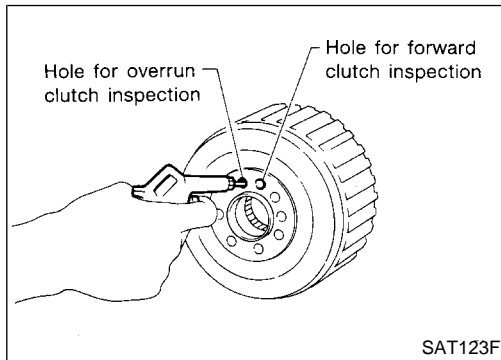
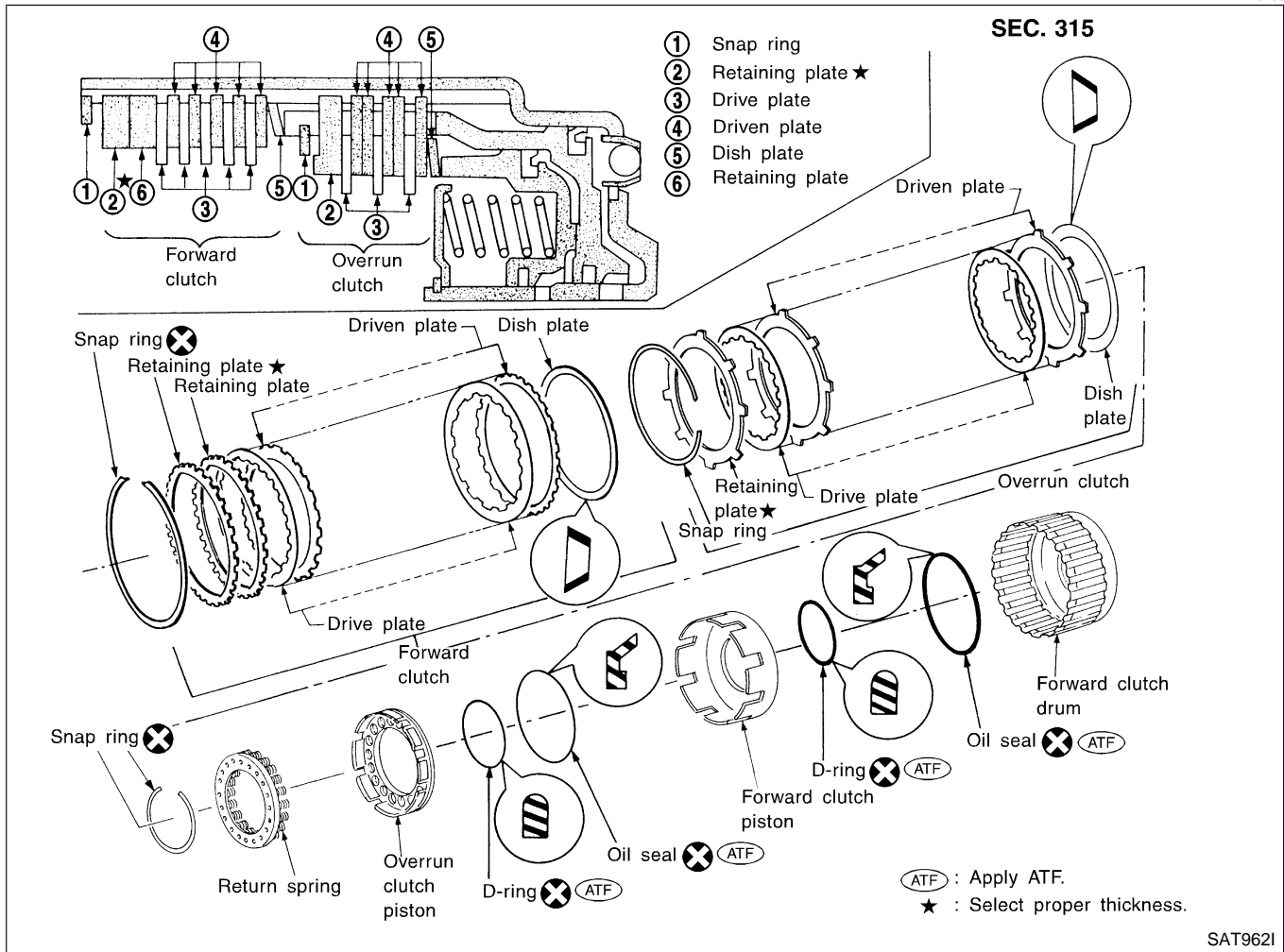

### DISASSEMBLY

NFAT0154

1. Check operation of forward clutch and overrun clutch.
  - a. Install bearing retainer on forward clutch drum.
  - b. Apply compressed air to oil hole of forward clutch drum.
  - c. Check to see that retaining plate moves to snap ring.
  - d. If retaining plate does not contact snap ring:
    - D-ring might be damaged.
    - Oil seal might be damaged.
    - Fluid might be leaking past piston check ball.
2. Remove snap ring for forward clutch.
3. Remove drive plates, driven plates, retaining plate and dish plate for forward clutch.

# REPAIR FOR COMPONENT PARTS

Forward and Overrun Clutches (Cont'd)

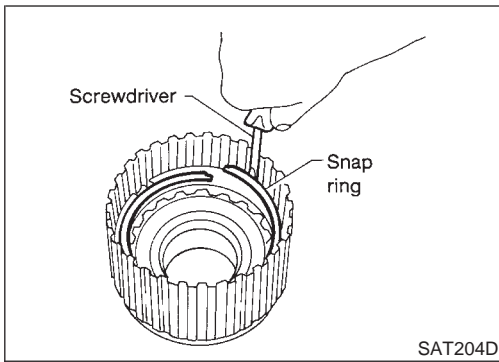

4. Remove snap ring for overrun clutch.
5. Remove drive plates, driven plates, retaining plate and dish plate for overrun clutch.

GI

MA

EM

LC

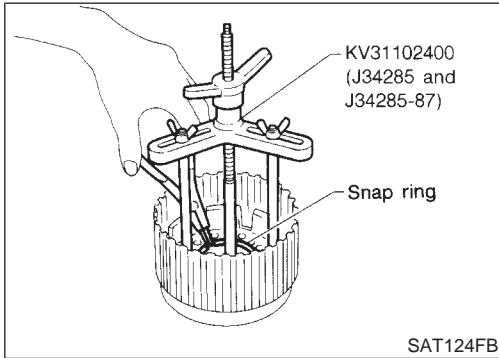

6. Set Tool on spring retainer and remove snap ring from forward clutch drum while compressing return springs.

EC

- **Set Tool directly over return springs.**
  - **Do not expand snap ring excessively.**
7. Remove spring retainer and return springs.
- **Do not remove return springs from spring retainer.**

FE

CL

MT

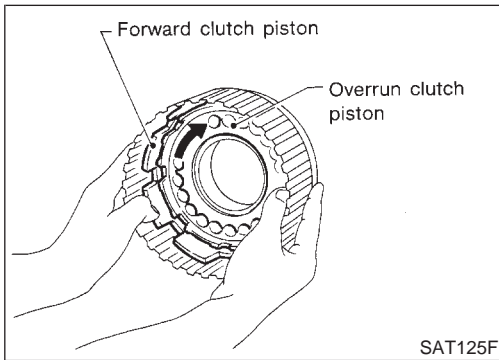

8. Remove forward clutch piston with overrun clutch piston from forward clutch drum by turning it.

AT

AX

SU

BR

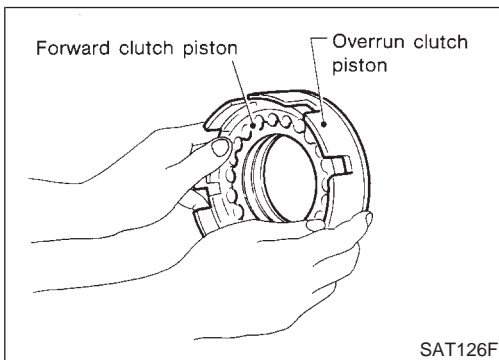

9. Remove overrun clutch piston from forward clutch piston by turning it.

ST

RS

BT

HA

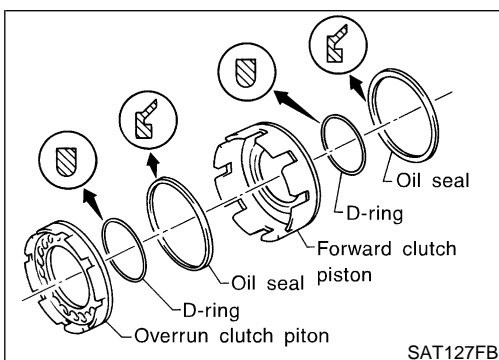

10. Remove D-rings and oil seals from forward clutch piston and overrun clutch piston.

SC

EL

IDX

# REPAIR FOR COMPONENT PARTS

Forward and Overrun Clutches (Cont'd)

## INSPECTION

### Snap Rings, Spring Retainer and Return Springs

NFAT0155

NFAT0155S01

- Check for deformation, fatigue or damage.
- Replace if necessary.
- **When replacing spring retainer and return springs, replace them as a set.**

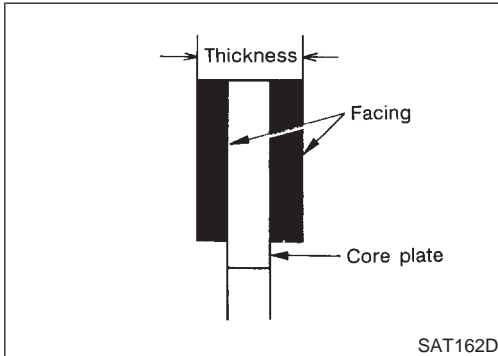

### Forward Clutch and Overrun Clutch Drive Plates

NFAT0155S02

- Check facing for burns, cracks or damage.
- Measure thickness of facing.

#### Thickness of drive plate:

##### Forward clutch

**Standard value: 1.6 mm (0.063 in)**

**Wear limit: 1.4 mm (0.055 in)**

##### Overrun clutch

**Standard value: 1.6 mm (0.063 in)**

**Wear limit: 1.4 mm (0.055 in)**

- If not within wear limit, replace.

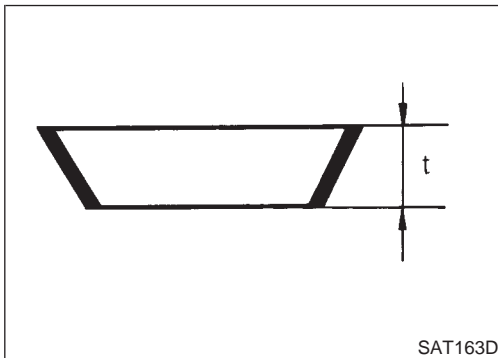

### Forward Clutch and Overrun Clutch Dish Plates

NFAT0155S03

- Check for deformation or damage.
- Measure thickness of dish plate.

#### Thickness of dish plate:

**Forward clutch 2.7 mm (0.106 in)**

**Overrun clutch 2.7 mm (0.106 in)**

- If deformed or fatigued, replace.

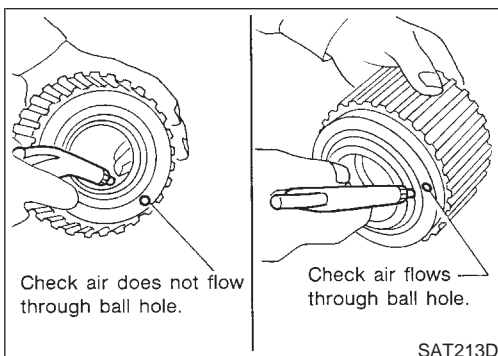

### Forward Clutch Drum

NFAT0155S04

- Make sure that check balls are not fixed.
- Apply compressed air to check ball oil hole from outside of forward clutch drum. Make sure air leaks past ball.
- Apply compressed air to oil hole from inside of forward clutch drum. Make sure there is no air leakage.

# REPAIR FOR COMPONENT PARTS

Forward and Overrun Clutches (Cont'd)

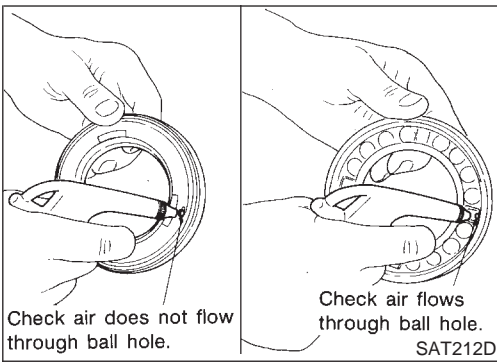

## Overrun Clutch Piston

NFAT0155S05

- Make sure that check balls are not fixed.
- Apply compressed air to check ball oil hole opposite the return spring. Make sure there is no air leakage.
- Apply compressed air to oil hole on return spring side. Make sure that air leaks past ball.

GI

MA

EM

LC

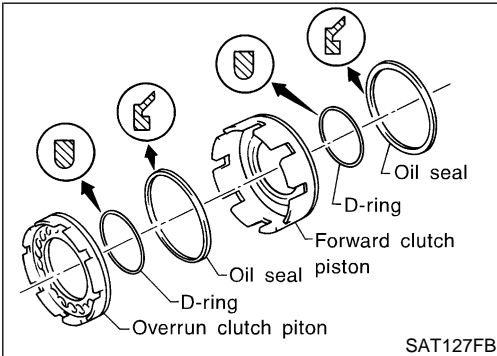

## ASSEMBLY

NFAT0156

1. Install D-rings and oil seals on forward clutch piston and overrun clutch piston.
  - Take care with direction of oil seal.
  - Apply ATF to both parts.

EC

FE

CL

MT

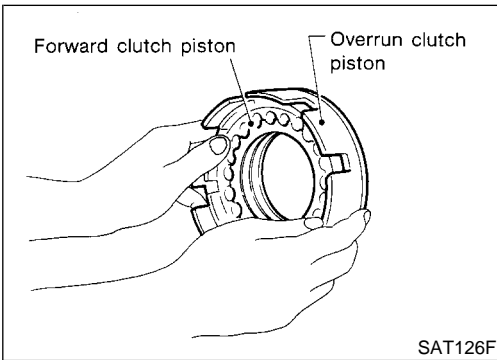

2. Install overrun clutch piston assembly on forward clutch piston by turning it slowly.
  - Apply ATF to inner surface of forward clutch piston.

AT

AX

SU

BR

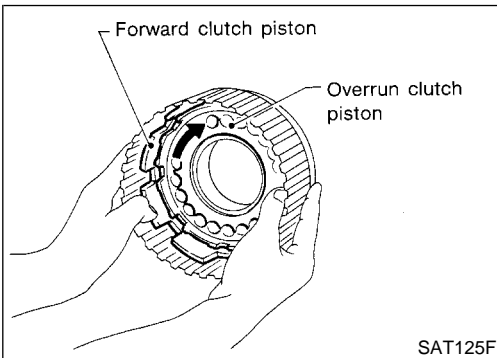

3. Install forward clutch piston assembly on forward clutch drum by turning it slowly.
  - Apply ATF to inner surface of drum.

ST

RS

BT

HA

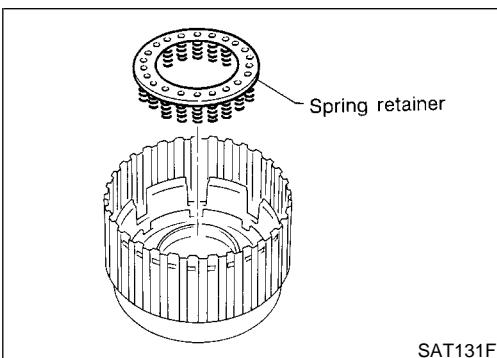

4. Install return spring on overrun clutch piston.

SC

EL

IDX



# REPAIR FOR COMPONENT PARTS

## Forward and Overrun Clutches (Cont'd)

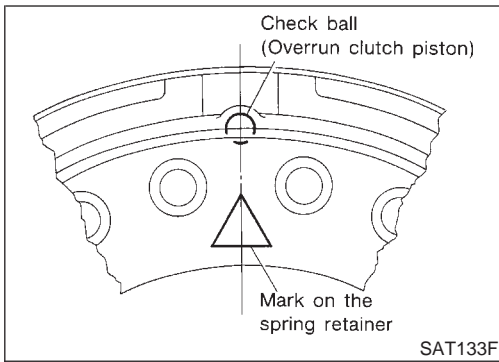

- Align the mark on spring retainer with check ball in overrun clutch piston.

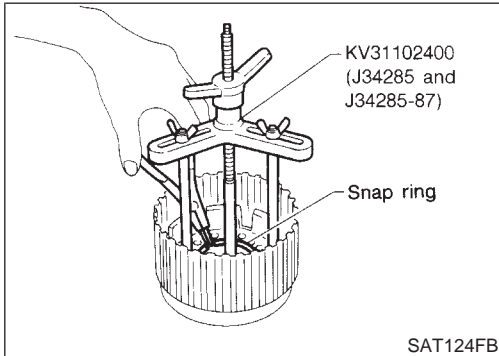

5. Set Tool on spring retainer and install snap ring while compressing return springs.

- **Set Tool directly over return springs.**

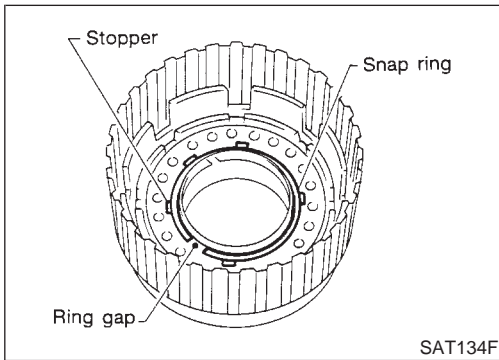

- **Do not align snap ring gap with spring retainer stopper.**

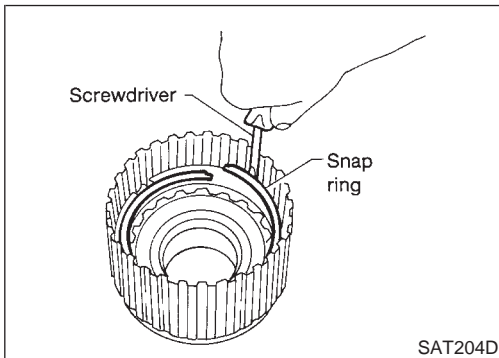

6. Install drive plates, driven plates, retaining plate and dish plate for overrun clutch.

- **Take care with order of plates.**

7. Install snap ring for overrun clutch.

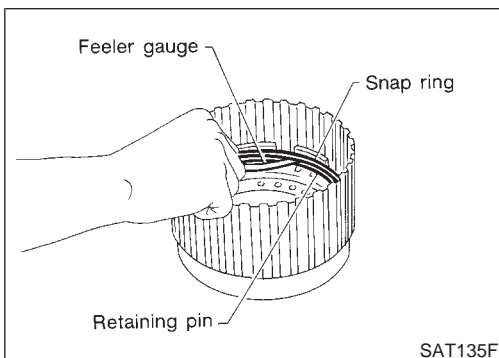

8. Measure clearance between overrun clutch retaining plate and snap ring.

If not within allowable limit, select proper retaining plate.

**Specified clearance:**

**Standard 0.7 - 1.1 mm (0.028 - 0.043 in)**

**Allowable limit 1.7 mm (0.067 in)**

**Overrun clutch retaining plate:**

**Refer to SDS, AT-385.**

# REPAIR FOR COMPONENT PARTS

Forward and Overrun Clutches (Cont'd)

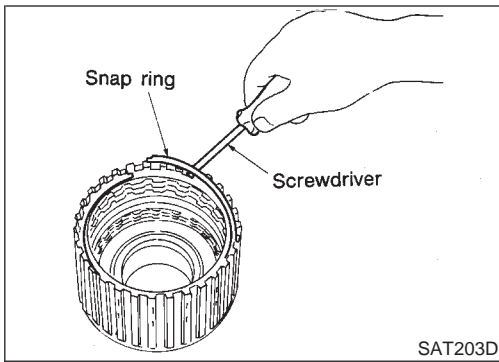

9. Install drive plates, driven plates, retaining plate and dish plate for forward clutch.
  - **Take care with order of plates.**
10. Install snap ring for forward clutch.

GI

MA

EM

LC

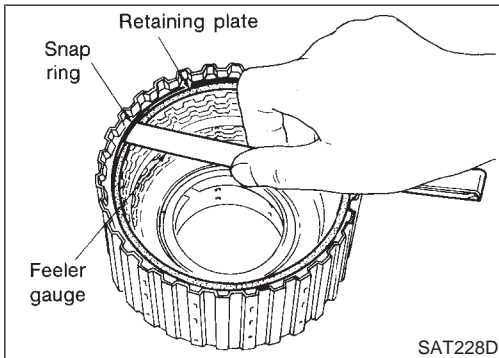

11. Measure clearance between forward clutch retaining plate and snap ring.  
If not within allowable limit, select proper retaining plate.

**Specified clearance:**

**Standard 0.45 - 0.85 mm (0.0177 - 0.0335 in)**

**Allowable limit 1.85 mm (0.0728 in)**

**Forward clutch retaining plate:**

**Refer to SDS, AT-385.**

EC

FE

CL

MT

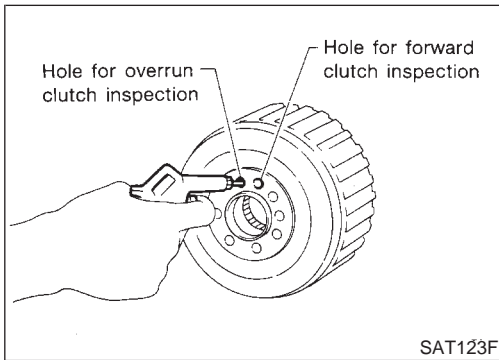

12. Check operation of forward clutch.  
Refer to "DISASSEMBLY", "Forward Clutch and Overrun Clutch", AT-334.
13. Check operation of overrun clutch.  
Refer to "DISASSEMBLY", "Forward Clutch and Overrun Clutch", AT-334.

AT

AX

SU

BR

## Low & Reverse Brake COMPONENTS

NFAT0157

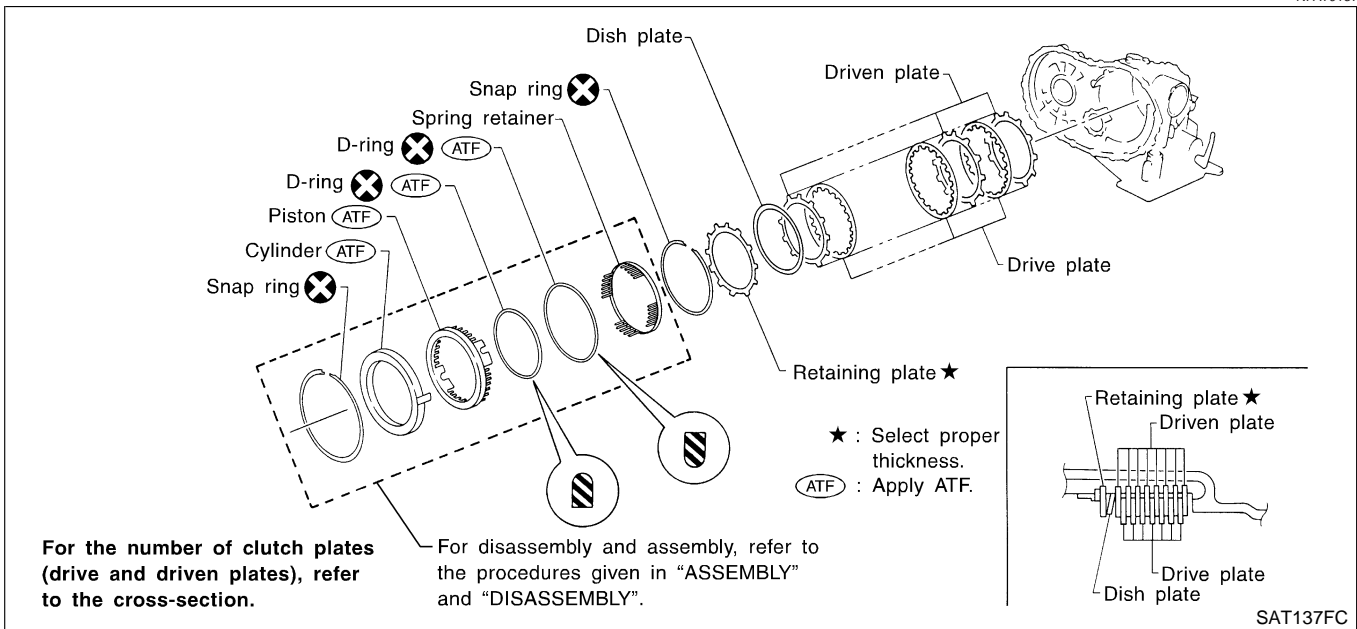

RS

BT

HA

SC

EL

IDX

# REPAIR FOR COMPONENT PARTS

## Low & Reverse Brake (Cont'd)

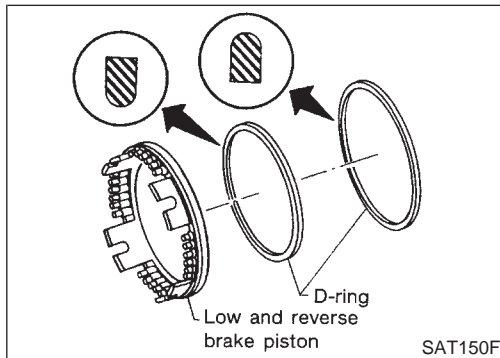
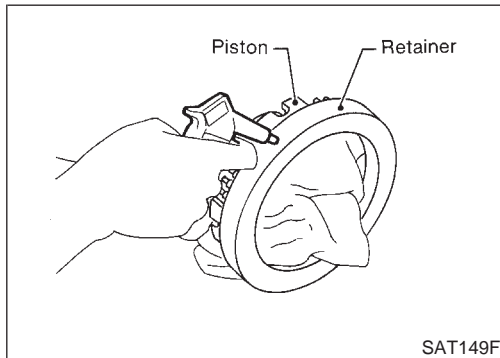
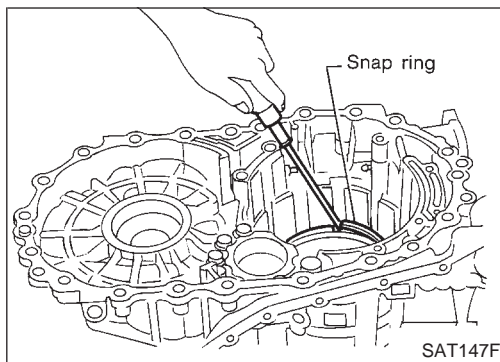

### DISASSEMBLY

NFAT0158

1. Check operation of low & reverse brake.
  - a. Apply compressed air to oil hole of transmission case.
  - b. Check to see that retaining plate moves to snap ring.
  - c. If retaining plate does not contact snap ring:
    - D-ring might be damaged.
    - Fluid might be leaking past piston check ball.
2. In order to remove piston, apply compressed air to oil hole of retainer while holding piston.
  - **Apply air gradually and allow piston to come out evenly.**
3. Remove D-rings from piston.

### INSPECTION

NFAT0159

#### Low and Reverse Brake Snap Ring, Spring Retainer and Return Springs

NFAT0159S01

- Check for deformation, fatigue or damage. If necessary, replace.
- **When replacing spring retainer and return springs, replace them as a set.**

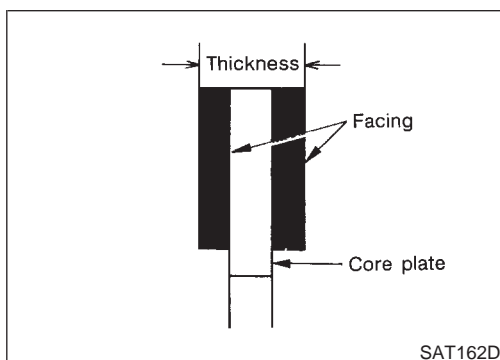

#### Low and Reverse Brake Drive Plate

NFAT0159S02

- Check facing for burns, cracks or damage.
- Measure thickness of facing.
  - Thickness of drive plate:**
  - Standard value 1.8 mm (0.071 in)**
  - Wear limit 1.6 mm (0.063 in)**
- If not within wear limit, replace.

NFAT0160

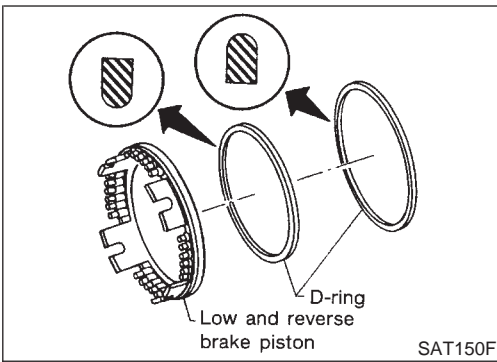

## ASSEMBLY

1. Install D-rings on piston.
  - Apply ATF to both parts.

GI

MA

EM

LC

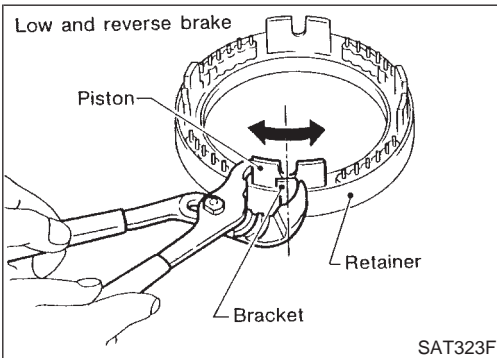

2. Set and align piston with retainer.
  - This operation is required in order to engage the protrusions of piston to return springs correctly. Further procedures are given in "ASSEMBLY".

EC

FE

CL

MT

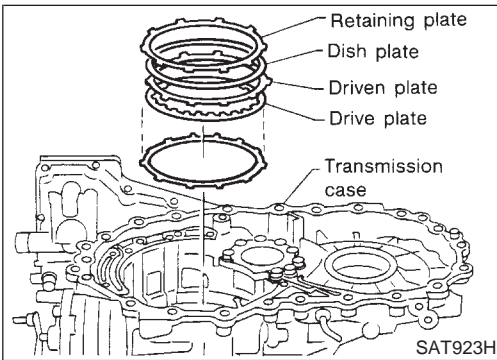

3. Install driven plates, drive plates, retaining plate and dish plate on transmission case.
  - Take care with order of plates and direction of dish plate.

AT

AX

SU

BR

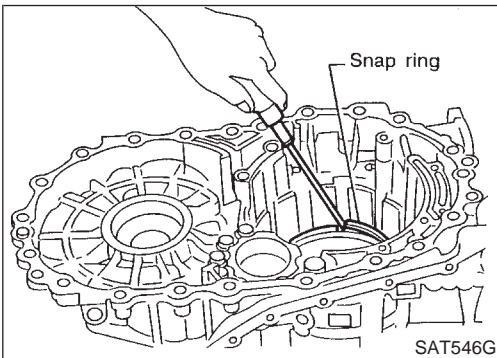

4. Install snap ring.

ST

RS

BT

HA

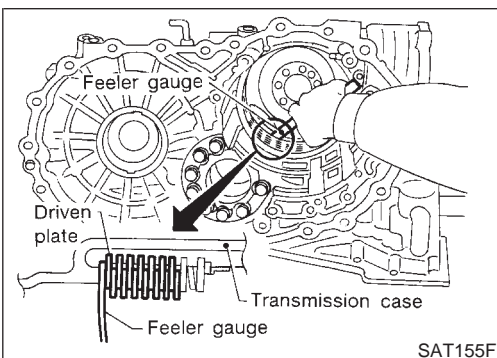

5. Measure clearance between driven plate and transmission case. If not within allowable limit, select proper retaining plate. (front side)

SC

EL

IDX

**Specified clearance:**

**Standard 1.7 - 2.1 mm (0.067 - 0.083 in)**

**Allowable limit 3.3 mm (0.130 in)**

**Retaining plate:**

**Refer to SDS, AT-386.**

# REPAIR FOR COMPONENT PARTS

Rear Internal Gear, Forward Clutch Hub and Overrun Clutch Hub

## Rear Internal Gear, Forward Clutch Hub and Overrun Clutch Hub COMPONENTS

NFAT0161

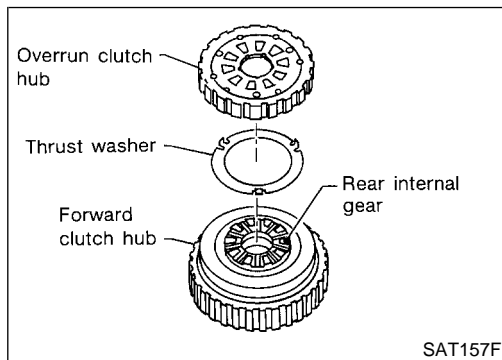
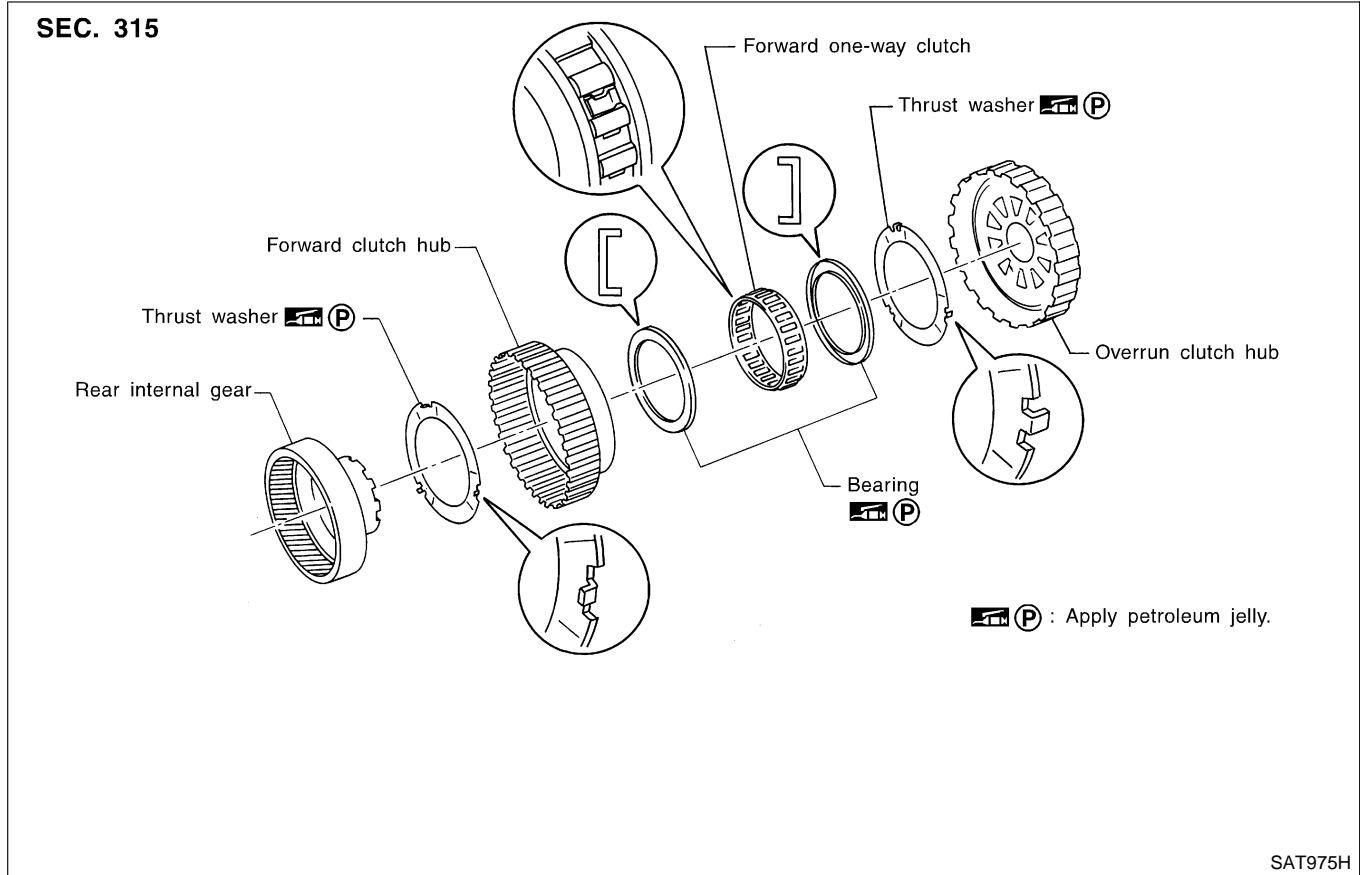

### DISASSEMBLY

NFAT0162

1. Remove overrun clutch hub and thrust washer from forward clutch hub.
2. Remove forward clutch hub from rear internal gear.

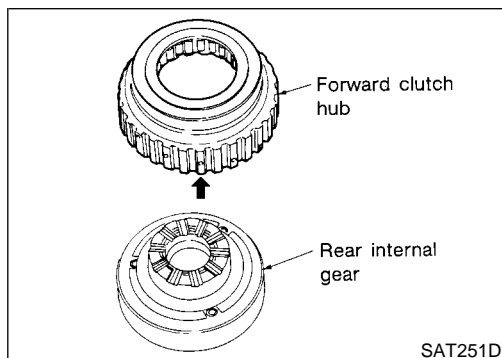

# REPAIR FOR COMPONENT PARTS

Rear Internal Gear, Forward Clutch Hub and Overrun Clutch Hub (Cont'd)

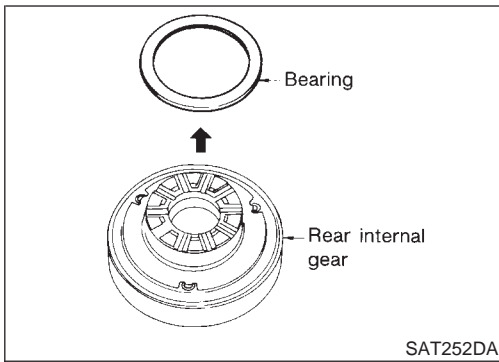

3. Remove bearing from rear internal gear.

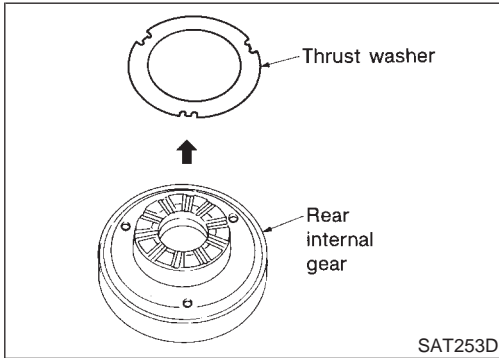

4. Remove thrust washer from rear internal gear.

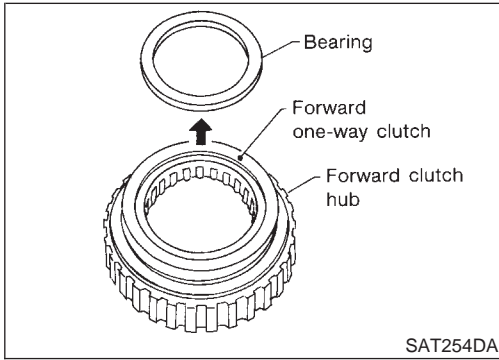

5. Remove bearing from forward one-way clutch.

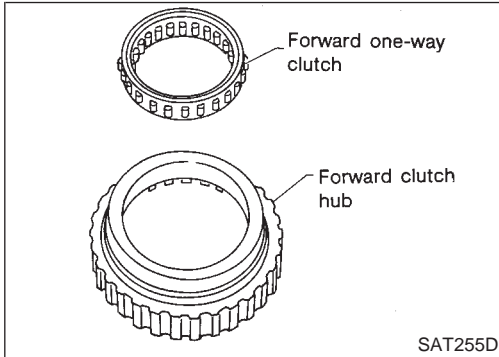

6. Remove forward one-way clutch from forward clutch hub.

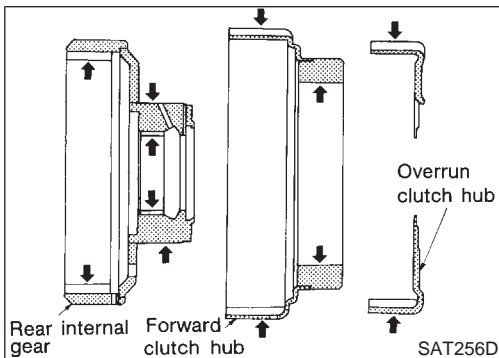

## INSPECTION

Rear Internal Gear, Forward Clutch Hub and Overrun Clutch Hub

NFAT0163

- Check rubbing surfaces for wear or damage.

NFAT0163S01

GI

MA

EM

LC

EC

FE

CL

MT

**AT**

AX

SU

BR

ST

RS

BT

HA

SC

EL

IDX

# REPAIR FOR COMPONENT PARTS

Rear Internal Gear, Forward Clutch Hub and Overrun Clutch Hub (Cont'd)

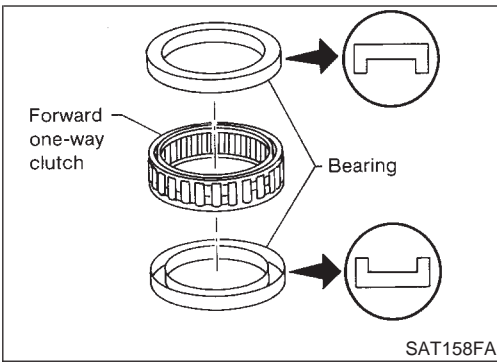

## Bearings and Forward One-way Clutch

NFAT0163S02

- Check bearings for deformation and damage.
- Check forward one-way clutch for wear and damage.

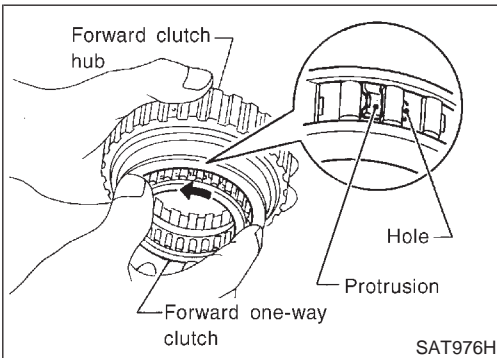

## ASSEMBLY

NFAT0164

1. Install forward one-way clutch on forward clutch.
  - **Take care with the direction of forward one-way clutch.**

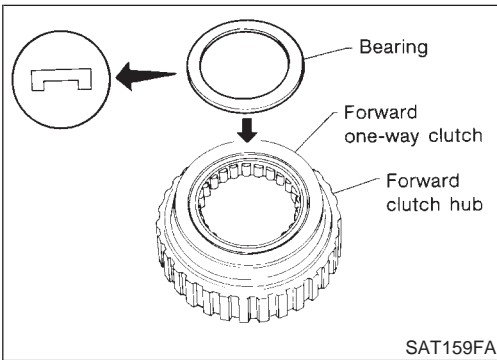

2. Install bearing on forward one-way clutch.
  - **Apply petroleum jelly to bearing.**

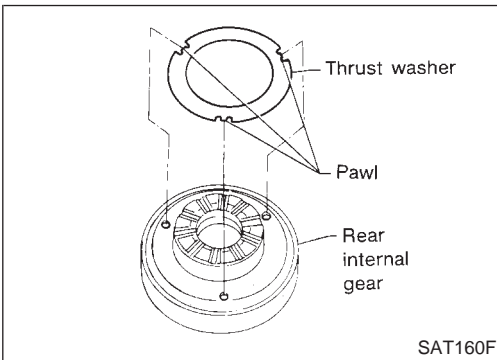

3. Install thrust washer on rear internal gear.
  - **Apply petroleum jelly to thrust washer.**
  - **Align hooks of thrust washer with holes of rear internal gear.**

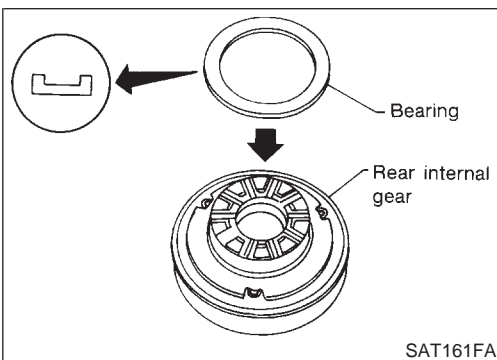

4. Install bearing on rear internal gear.
  - **Apply petroleum jelly to bearing.**

# REPAIR FOR COMPONENT PARTS

Rear Internal Gear, Forward Clutch Hub and Overrun Clutch Hub (Cont'd)

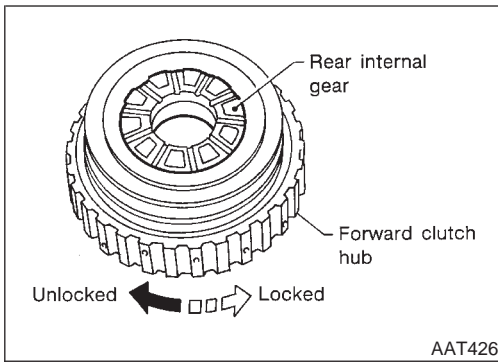

5. Install forward clutch hub on rear internal gear.
  - **Check operation of forward one-way clutch. Hold rear internal gear and turn forward clutch hub. Check forward clutch hub for correct locking and unlocking directions.**
  - **If not as shown in illustration, check installation direction of forward one-way clutch.**

GI

MA

EM

LC

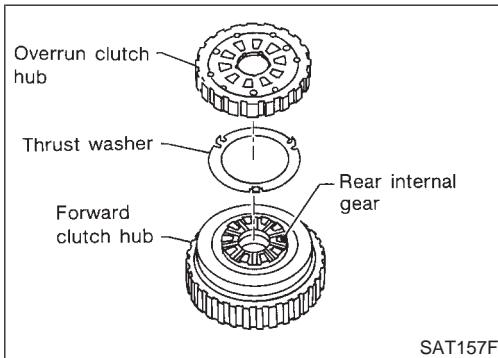

6. Install thrust washer and overrun clutch hub.
  - **Apply petroleum jelly to thrust washer.**
  - **Align hooks of thrust washer with holes of overrun clutch hub.**
  - **Align projections of rear internal gear with holes of overrun clutch hub.**

EC

FE

CL

MT

AT

AX

SU

BR

ST

RS

BT

HA

SC

EL

IDX



# REPAIR FOR COMPONENT PARTS

Output Shaft, Idler Gear, Reduction Pinion Gear and Bearing Retainer

## Output Shaft, Idler Gear, Reduction Pinion Gear and Bearing Retainer COMPONENTS

NFAT0165

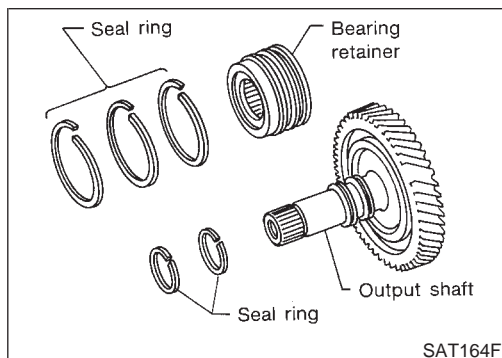
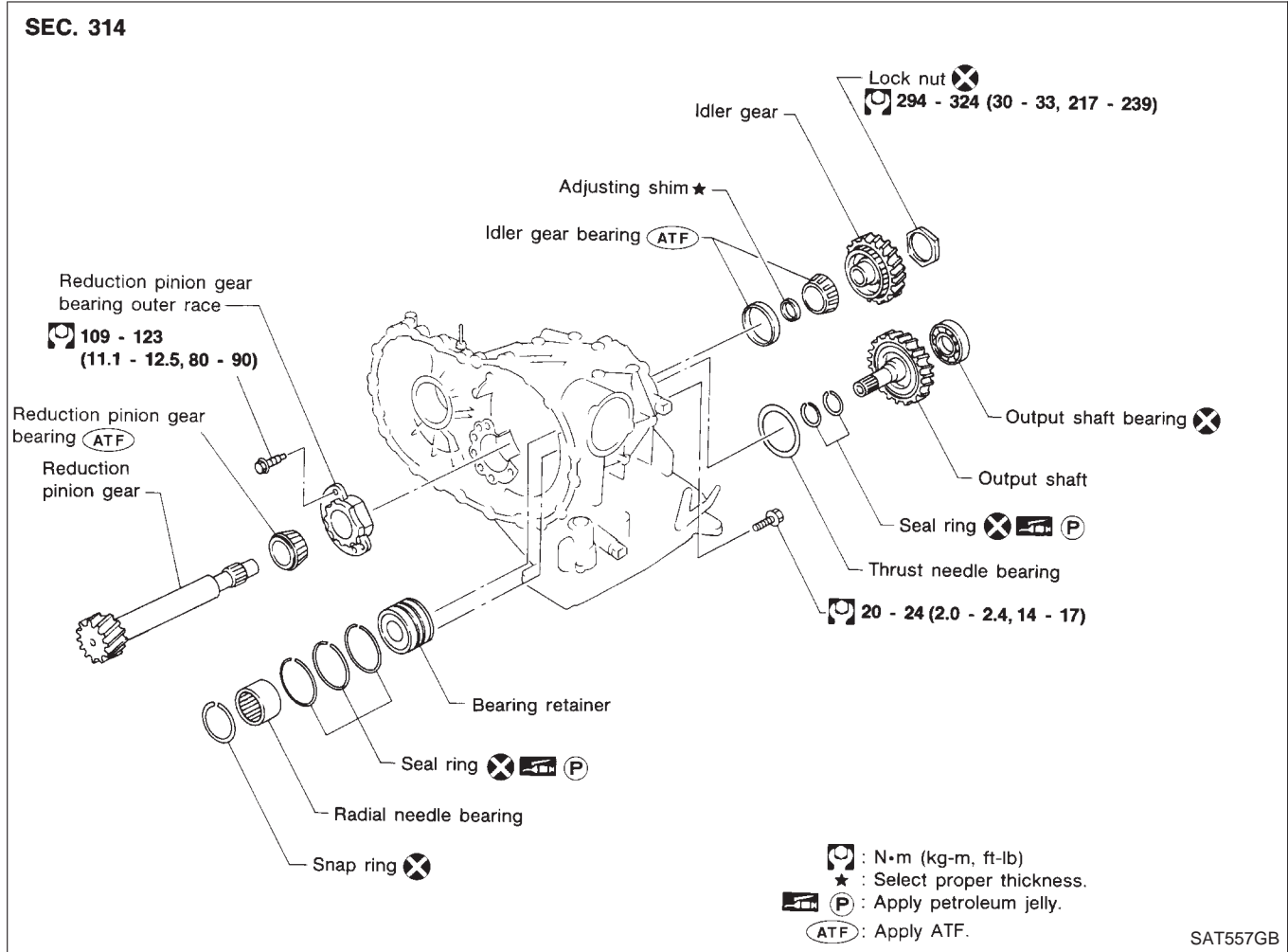

### DISASSEMBLY

1. Remove seal rings from output shaft and bearing retainer.

NFAT0166

# REPAIR FOR COMPONENT PARTS

Output Shaft, Idler Gear, Reduction Pinion Gear and Bearing Retainer (Cont'd)

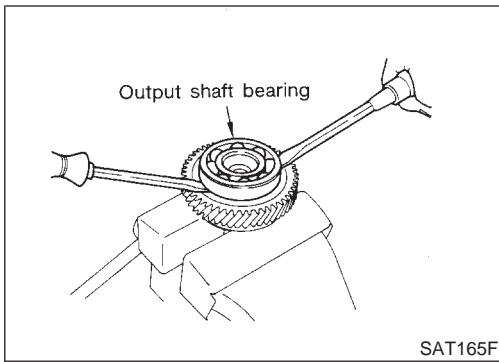

2. Remove output shaft bearing with screwdrivers.
  - Always replace bearing with a new one when removed.
  - Do not damage output shaft.

GI

MA

EM

LC

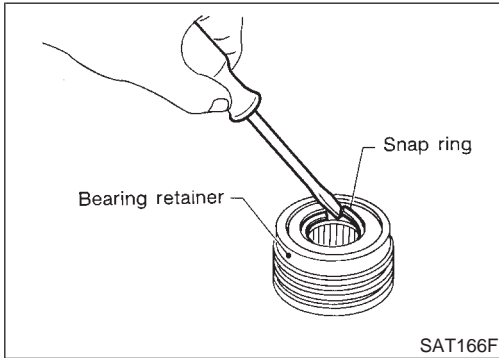

3. Remove snap ring from bearing retainer.

EC

FE

CL

MT

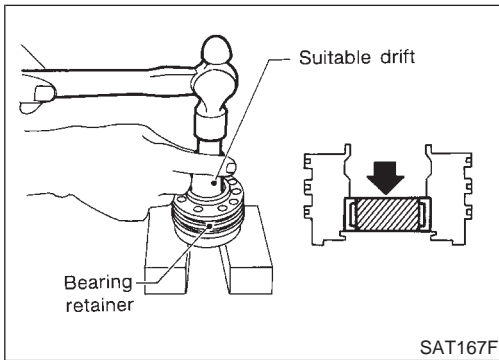

4. Remove needle bearing from bearing retainer.

AT

AX

SU

BR

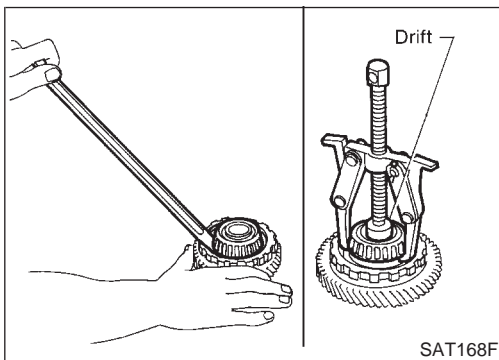

5. Remove idler gear bearing inner race from idler gear.

ST

RS

BT

HA

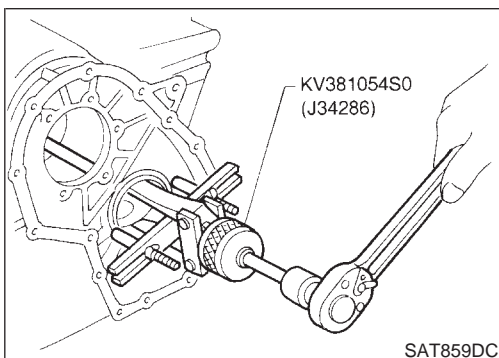

6. Remove idler gear bearing outer race from transmission case.

SC

EL

IDX

# REPAIR FOR COMPONENT PARTS

Output Shaft, Idler Gear, Reduction Pinion Gear and Bearing Retainer (Cont'd)

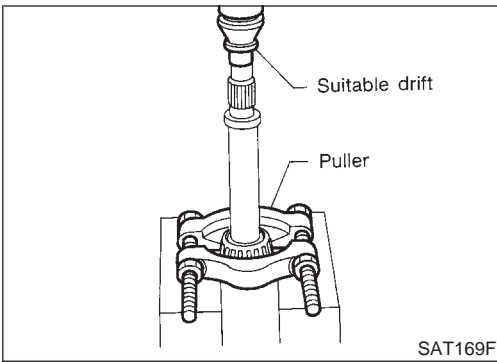

- Press out reduction pinion gear bearing inner race from reduction pinion gear.

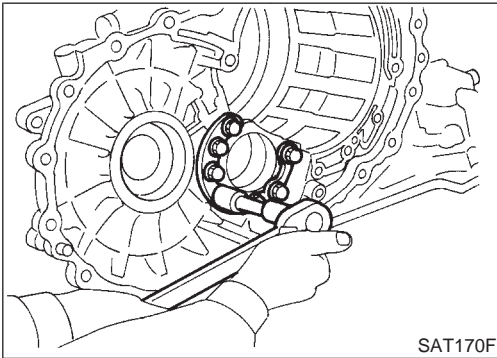

- Remove reduction pinion gear bearing outer race from transmission case.

## INSPECTION

### Output Shaft, Idler Gear and Reduction Pinion Gear

NFAT0167

NFAT0167S01

- Check shafts for cracks, wear or bending.
- Check gears for wear, chips and cracks.

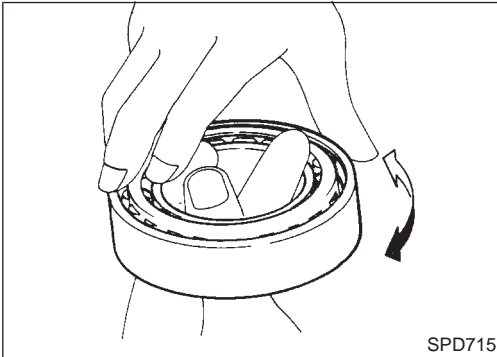

## Bearing

NFAT0167S02

- Make sure bearings roll freely and are free from noise, cracks, pitting or wear.
- When replacing taper roller bearing, replace outer and inner race as a set.**

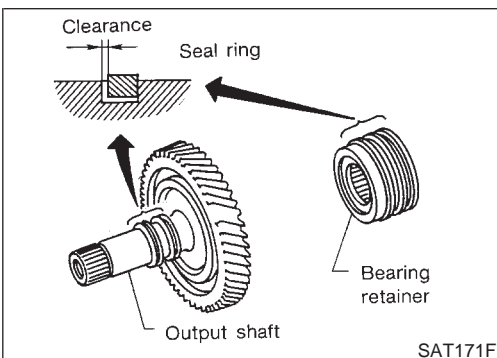

## Seal Ring Clearance

NFAT0167S03

- Install new seal rings to output shaft.
- Measure clearance between seal ring and ring groove of output shaft.

### Standard clearance:

**0.10 - 0.25 mm (0.0039 - 0.0098 in)**

### Allowable limit:

**0.25 mm (0.0098 in)**

- If not within allowable limit, replace output shaft.
- Install new seal rings to bearing retainer.

# REPAIR FOR COMPONENT PARTS

Output Shaft, Idler Gear, Reduction Pinion Gear and Bearing Retainer (Cont'd)

- Measure clearance between seal ring and ring groove of bearing retainer.
  - Standard clearance:**  
0.10 - 0.30 mm (0.0039 - 0.0118 in)
  - Allowable limit:**  
0.30 mm (0.0118 in)
- If not within allowable limit, replace bearing retainer.

GI

MA

EM

LC

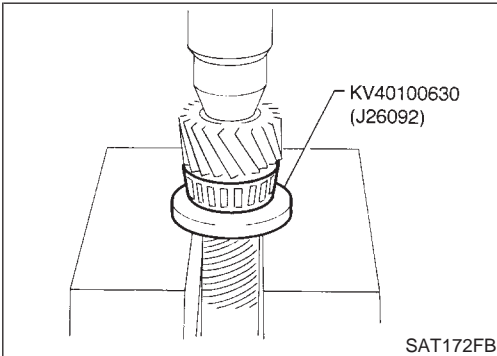

## ASSEMBLY

1. Press reduction pinion gear bearing inner race on reduction pinion gear. NFAT0168

EC

FE

CL

MT

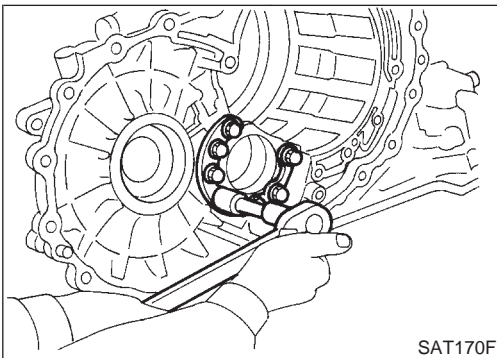

2. Install reduction pinion gear bearing outer race on transmission case.

: 109 - 123 N·m (11.1 - 12.5 kg·m, 80 - 90 ft·lb)

AT

AX

SU

BR

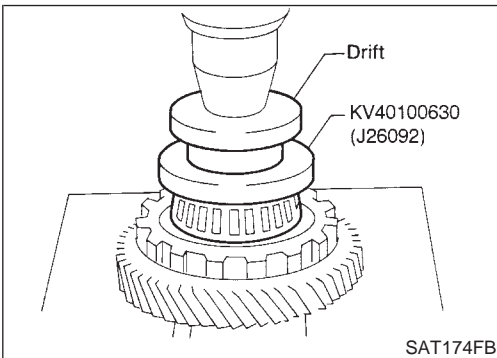

3. Press idler gear bearing inner race on idler gear.

ST

RS

BT

HA

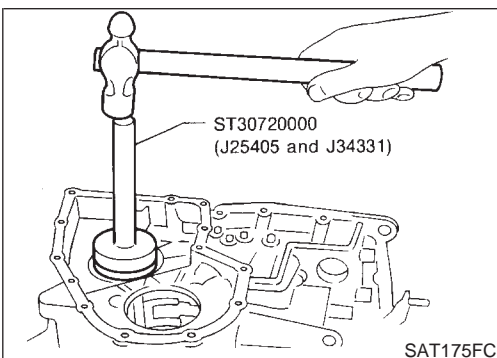

4. Install idler gear bearing outer race on transmission case.

SC

EL

IDX

# REPAIR FOR COMPONENT PARTS

Output Shaft, Idler Gear, Reduction Pinion Gear and Bearing Retainer (Cont'd)

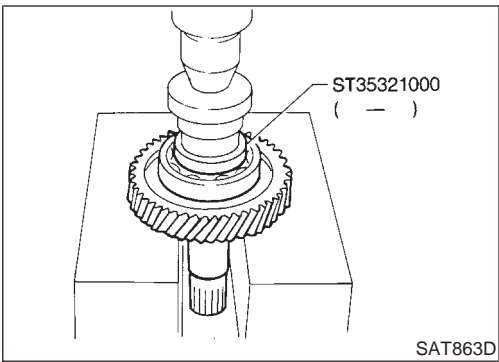

5. Press output shaft bearing on output shaft.

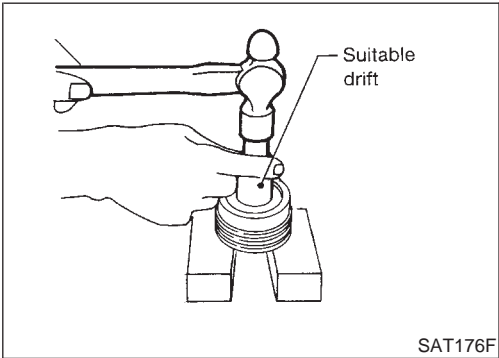

6. Press needle bearing on bearing retainer.

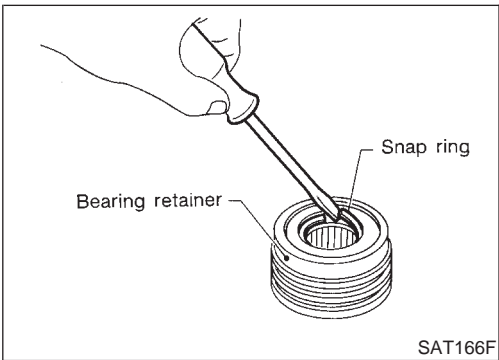

7. Install snap ring to bearing retainer.

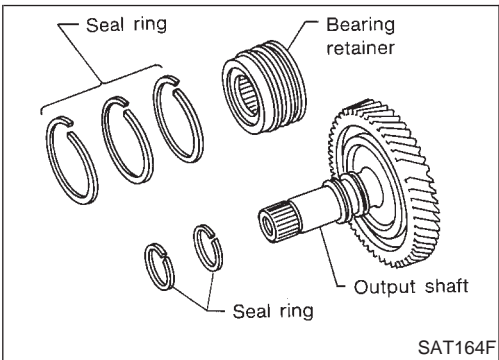

8. After packing ring grooves with petroleum jelly, carefully install new seal rings on output shaft and bearing retainer.

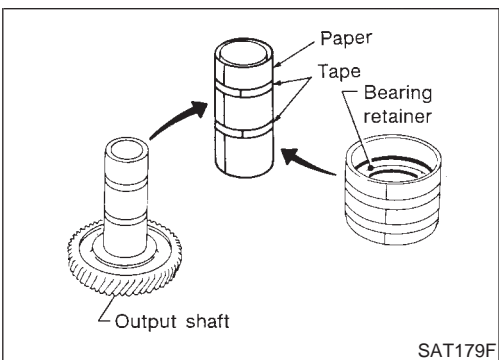

- Roll paper around seal rings to prevent seal rings from spreading.

## Band Servo Piston Assembly COMPONENTS

NFAT0169

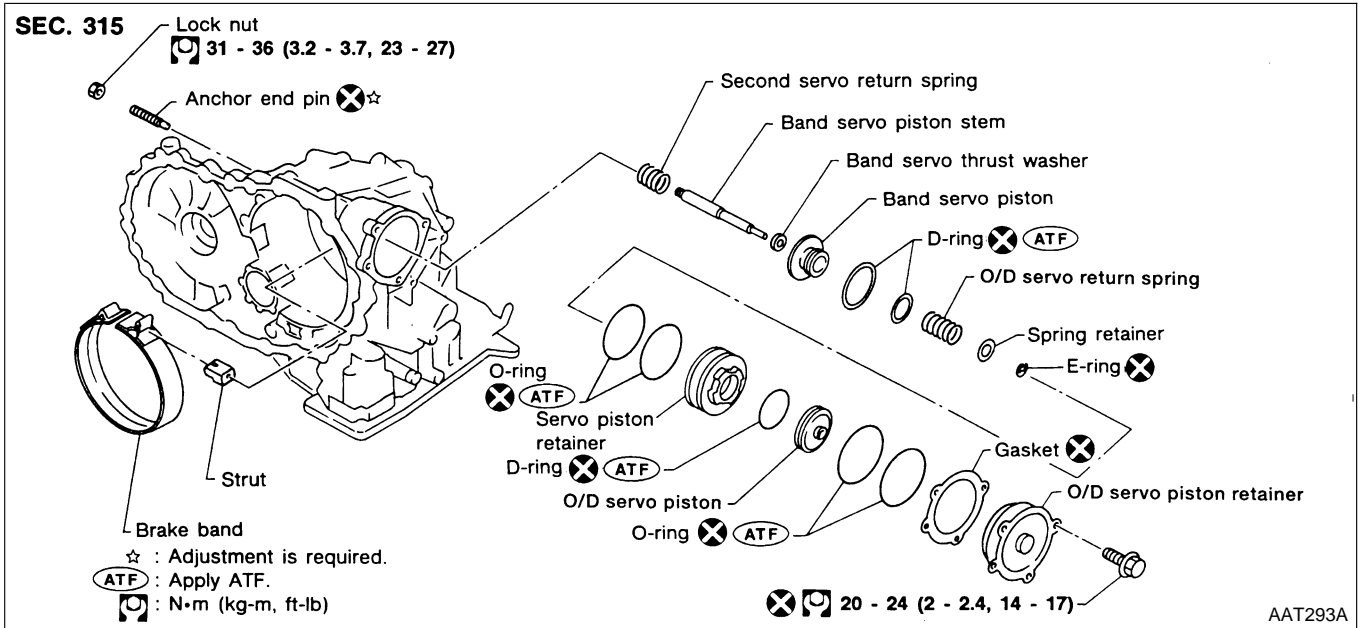

GI  
MA  
EM  
LC  
EC  
FE  
CL  
MT

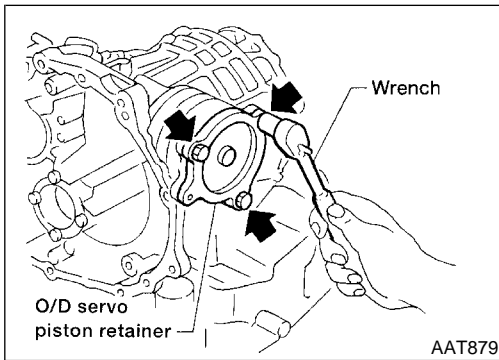

### DISASSEMBLY

NFAT0170

1. Remove band servo piston fixing bolts.

AT

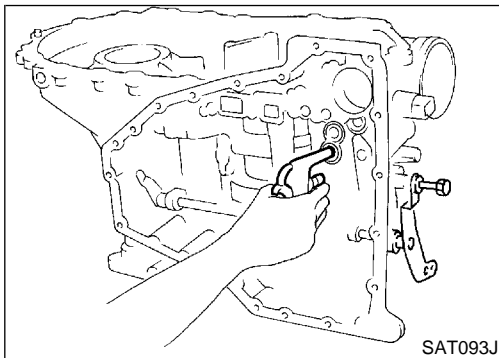

2. Apply compressed air to oil hole in transmission case to remove O/D servo piston retainer and band servo piston assembly.

ST

- Hold band servo piston assembly with a rag or nylon waste.

RS

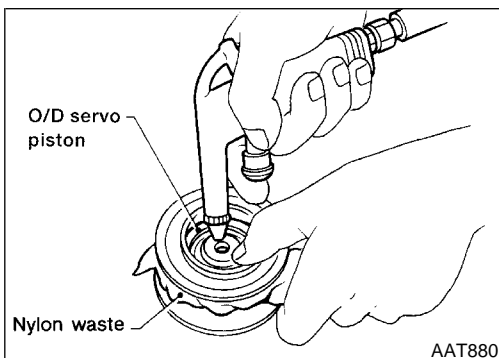

3. Apply compressed air to oil hole in O/D servo piston retainer to remove O/D servo piston from retainer.

SC

- Hold O/D band servo piston while applying compressed air.

EL

IDX

# REPAIR FOR COMPONENT PARTS

## Band Servo Piston Assembly (Cont'd)

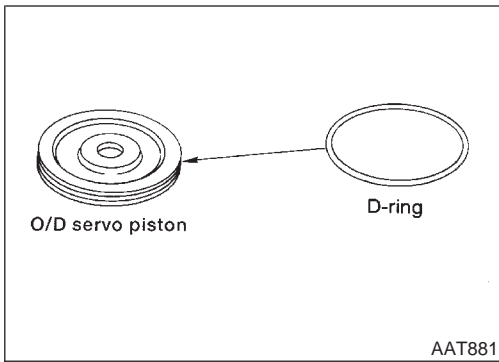

4. Remove D-ring from O/D servo piston.

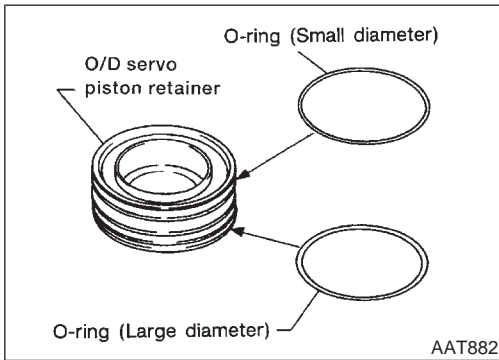

5. Remove O-rings from O/D servo piston retainer.

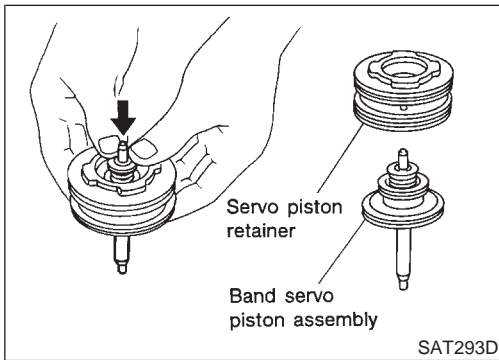

6. Remove band servo piston assembly from servo piston retainer by pushing it forward.

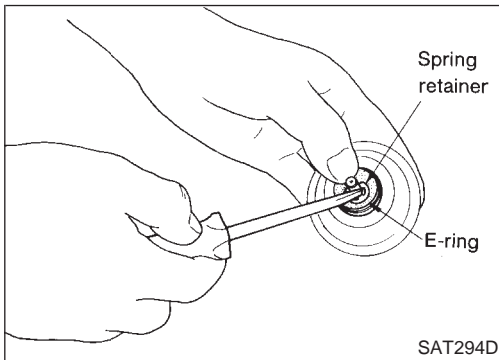

7. Place piston stem end on a wooden block. While pushing servo piston spring retainer down, remove E-ring.

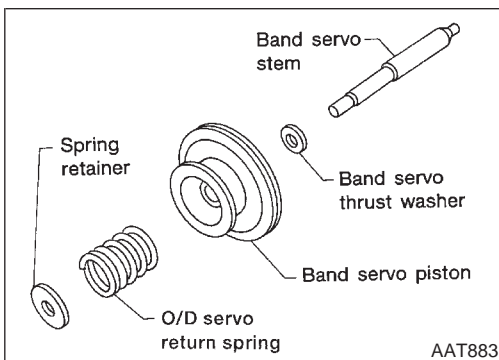

8. Remove O/D servo return spring, band servo thrust washer and band servo piston stem from band servo piston.

# REPAIR FOR COMPONENT PARTS

Band Servo Piston Assembly (Cont'd)

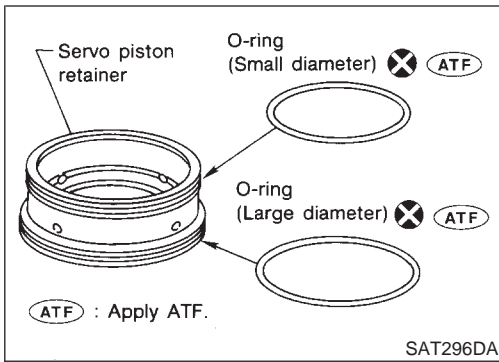

9. Remove O-rings from servo piston retainer.

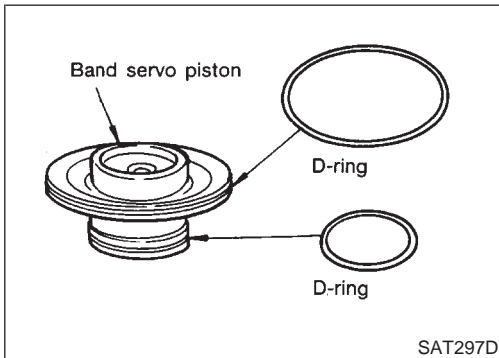

10. Remove D-rings from band servo piston.

## INSPECTION

### Pistons, Retainers and Piston Stem

- Check frictional surfaces for abnormal wear or damage.

NFAT0171

AT

NFAT0171S01

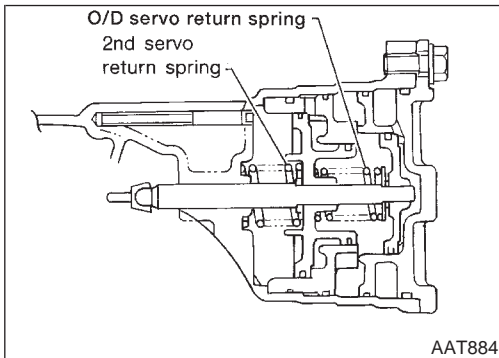

## Return Springs

- Check for deformation or damage.
- Measure free length and outer diameter.

**Inspection standard:**  
Refer to SDS, AT-389.

NFAT0171S02

ST

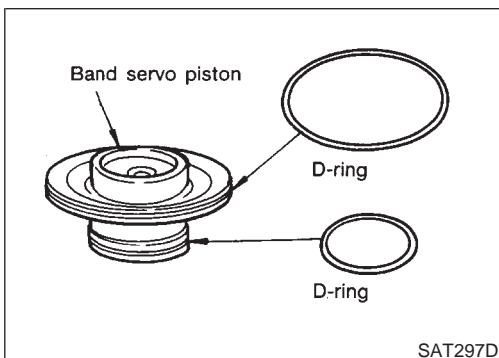

## ASSEMBLY

1. Install D-rings to servo piston retainer.
- Apply ATF to D-rings.
  - Pay attention to position of each O-ring.

NFAT0172

SC

EL

IDX



# REPAIR FOR COMPONENT PARTS

## Band Servo Piston Assembly (Cont'd)

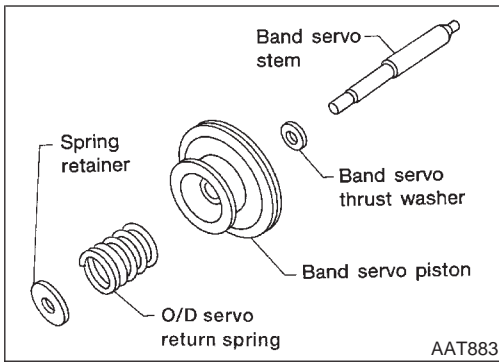

2. Install band servo piston stem, band servo thrust washer, O/D servo return spring and spring retainer to band servo piston.

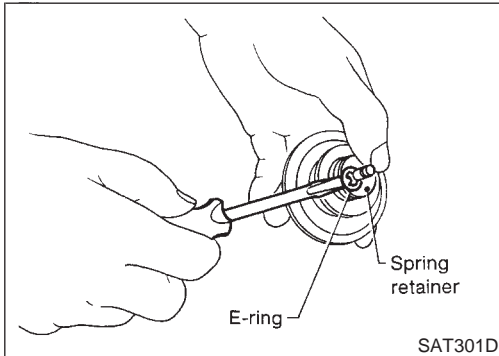

3. Place piston stem end on a wooden block. While pushing servo piston spring retainer down, install E-ring.

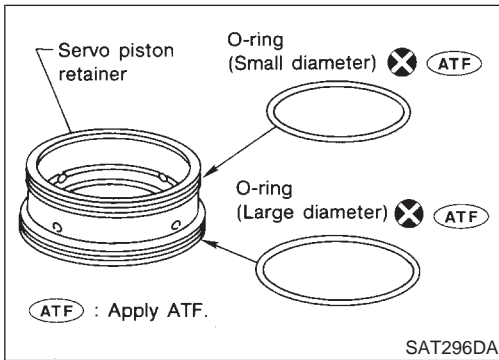

4. Install O-rings to servo piston retainer.
  - **Apply ATF to O-rings.**
  - **Pay attention to position of each O-ring.**

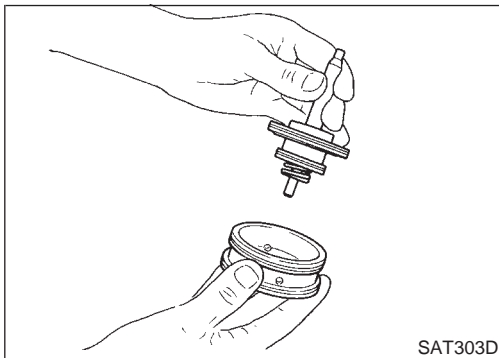

5. Install band servo piston assembly to servo piston retainer by pushing it inward.

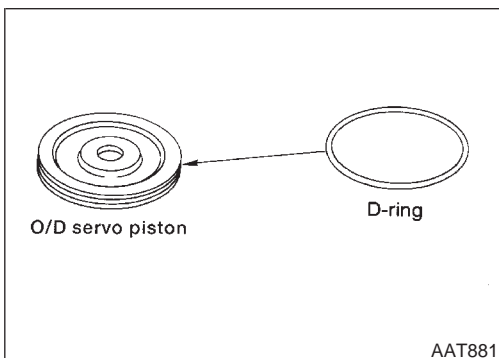

6. Install D-ring to O/D servo piston.
  - **Apply ATF to D-ring.**

# REPAIR FOR COMPONENT PARTS

Band Servo Piston Assembly (Cont'd)

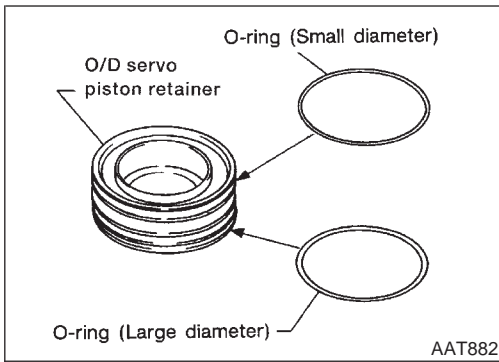

7. Install O-rings to O/D servo piston retainer.
  - Apply ATF to O-rings.
  - Pay attention to position of each O-ring.

GI

MA

EM

LC

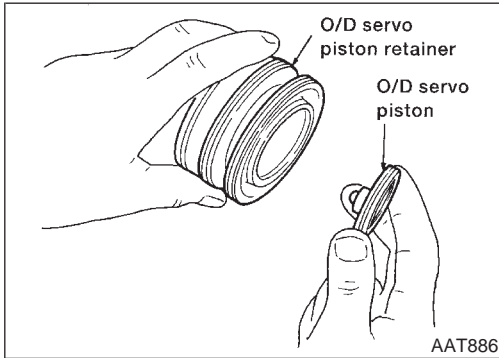

8. Install O/D servo piston to O/D servo piston retainer.

EC

FE

CL

MT

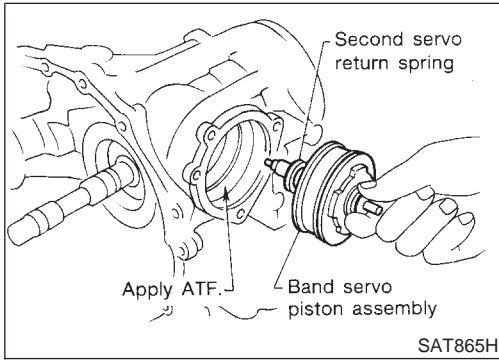

9. Install band servo piston assembly and 2nd servo return spring to transmission case.
  - Apply ATF to O-ring of band servo piston and transmission case.

AT

AX

SU

BR

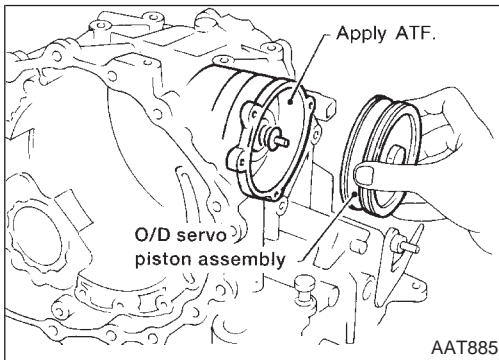

10. Install O/D servo piston assembly to transmission case.
  - Apply ATF to O-ring of band servo piston and transmission case.

ST

RS

BT

HA

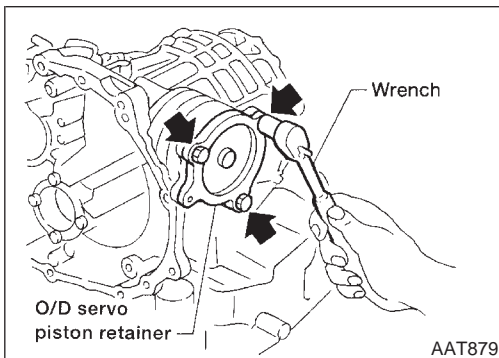

11. Install O/D servo piston retainer to transmission case. Refer to AT-351.

SC

EL

IDX

# REPAIR FOR COMPONENT PARTS

Final Drive

## Final Drive COMPONENTS

NFAT0173

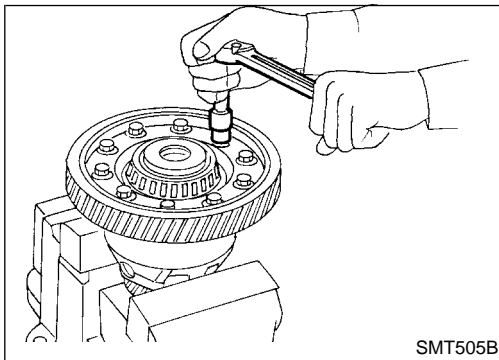
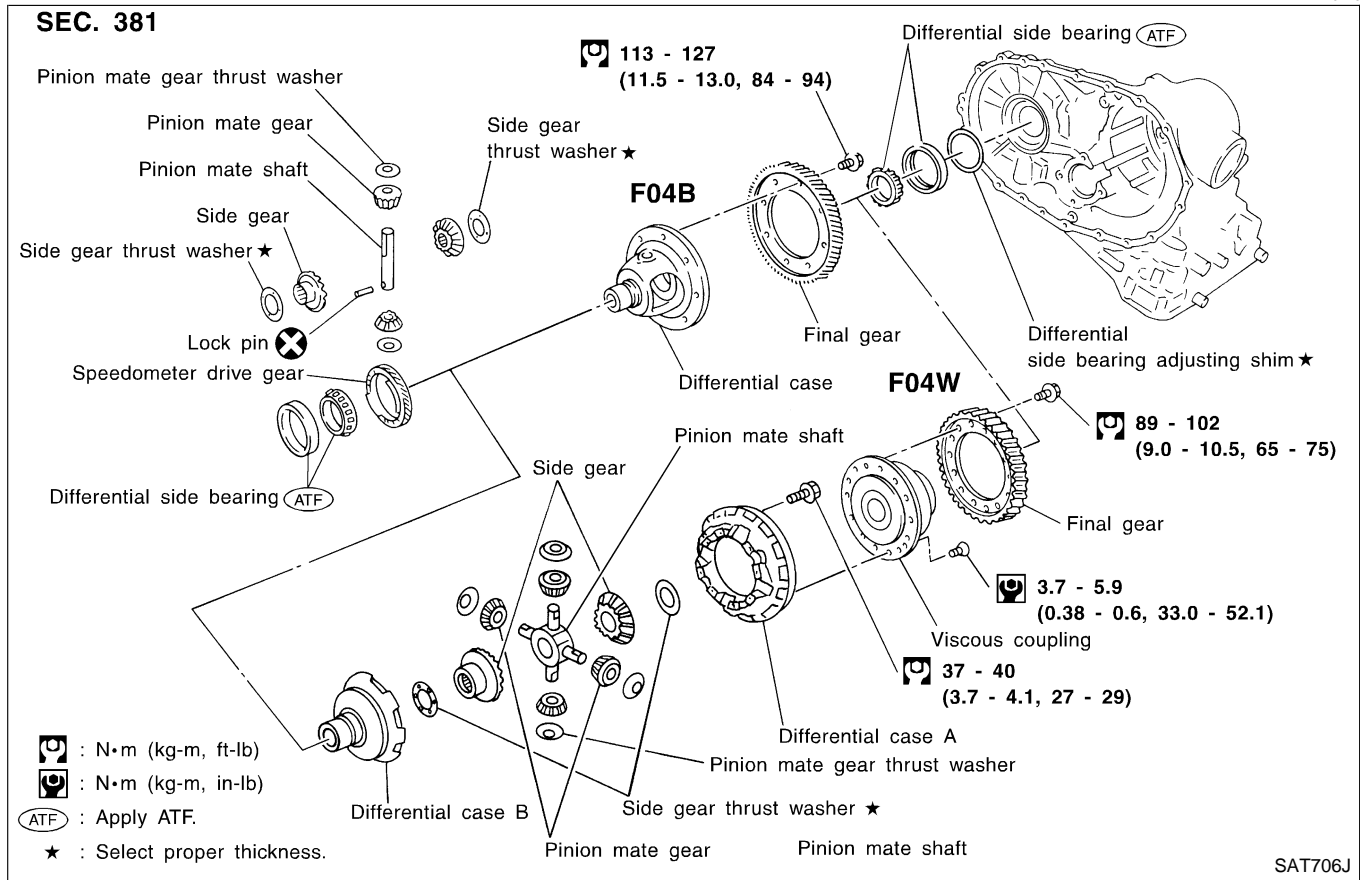

### DISASSEMBLY

NFAT0174

1. Remove final gear.

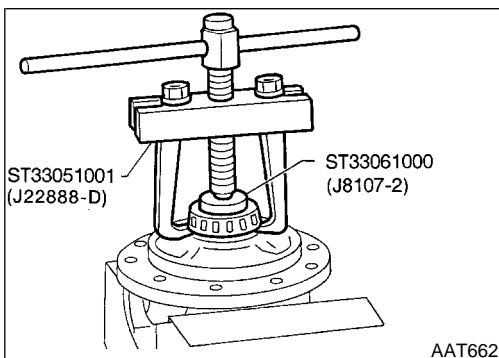

2. Press out differential side bearings.

- Be careful not to mix up the right and left bearings.

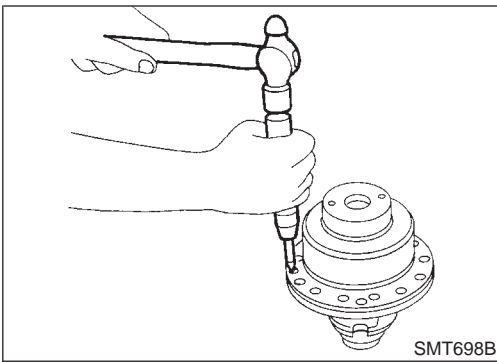

3. Remove viscous coupling — RE4F04W.
  - a. Remove viscous coupling.

GI

MA

EM

LC

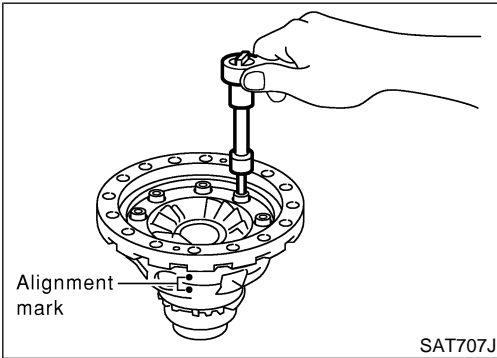

- b. Make alignment marks with paint on differential cases A and B.
  - c. Remove the bolts holding the differential cases, and remove the pinion mate gears and side gears.

EC

FE

CL

MT

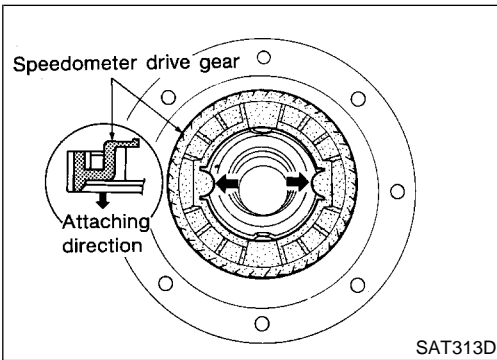

4. Remove speedometer drive gear.

**AT**

AX

SU

BR

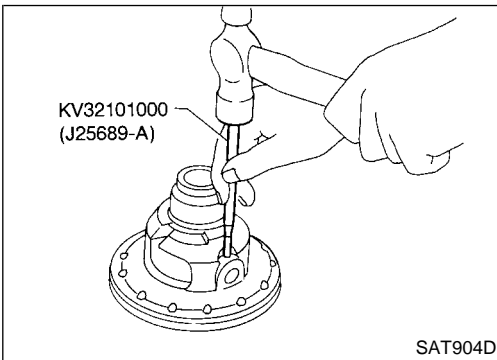

5. Drive out pinion mate shaft lock pin.

ST

RS

BT

HA

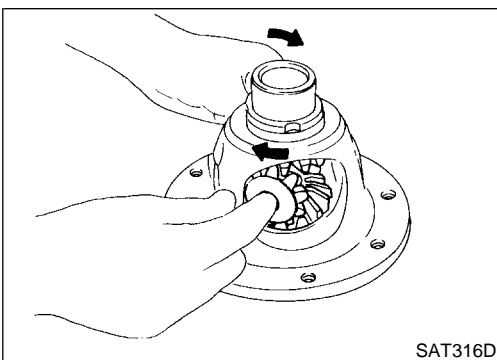

6. Draw out pinion mate shaft lock pin.
7. Remove pinion mate gears and side gears.

SC

EL

IDX

# REPAIR FOR COMPONENT PARTS

Final Drive (Cont'd)

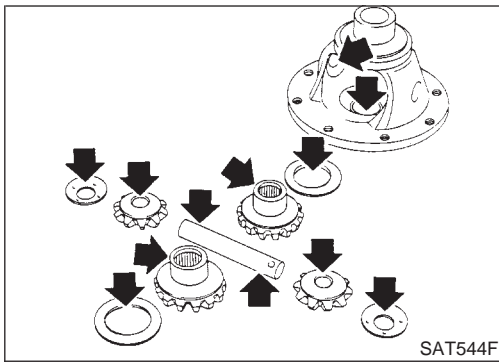

## INSPECTION

### Gear, Washer, Shaft and Case

NFAT0175

NFAT0175S01

- Check mating surfaces of differential case, side gears and pinion mate gears.
- Check washers for wear.

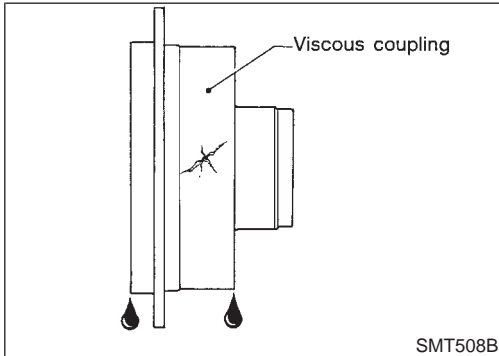

### Viscous Coupling — RE4F04W

NFAT0175S02

- Check case for cracks.
- Check silicone oil for leakage.

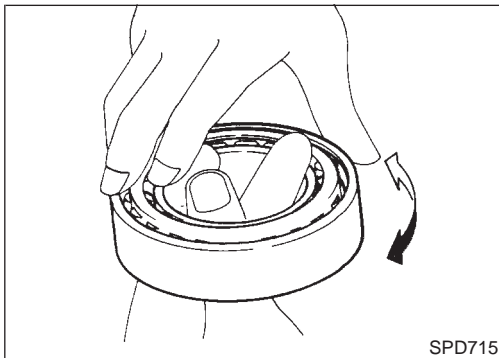

## Bearings

NFAT0175S03

- Make sure bearings roll freely and are free from noise, cracks, pitting or wear.
- **When replacing taper roller bearing, replace outer and inner race as a set.**

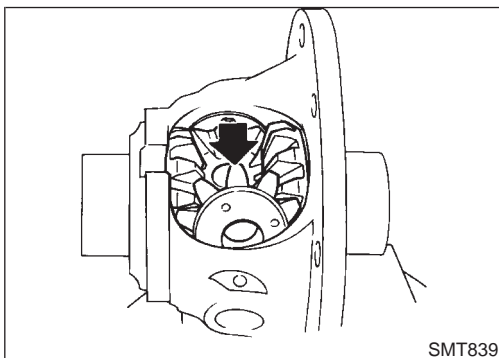

## ASSEMBLY

NFAT0176

1. Attach side gear thrust washers to side gears, then install pinion mate thrust washers and pinion mate gears in place.
- **Apply ATF to any parts.**

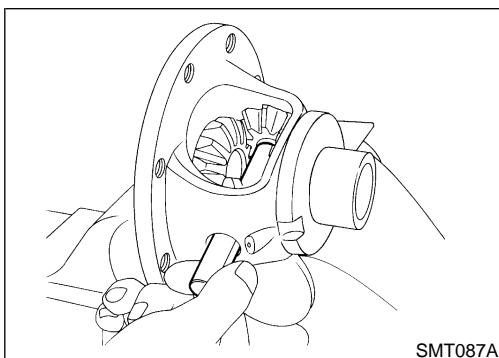

2. Insert pinion mate shaft.
- **When inserting, be careful not to damage pinion mate thrust washers.**

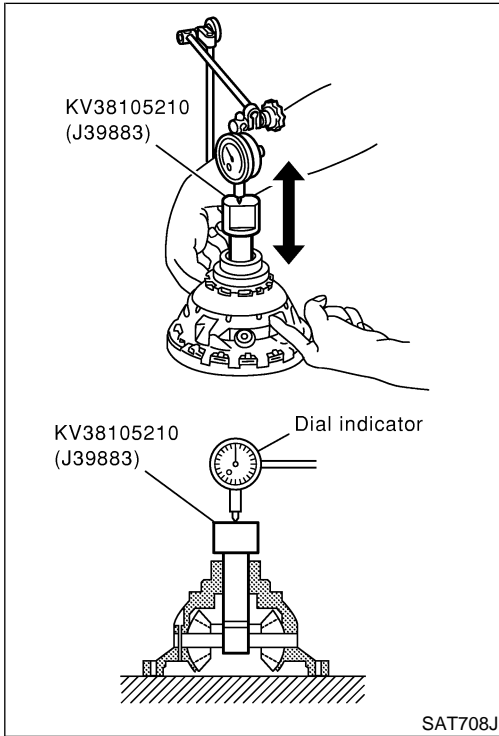
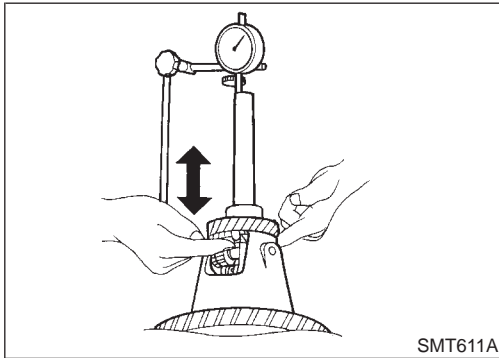
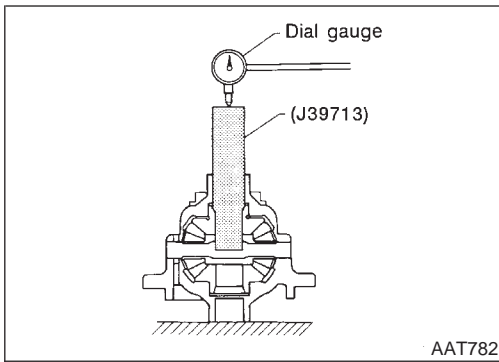

## — RE4F04B —

NFAT0176S01

1. Measure clearance between side gear and differential case with washers following the procedure below:
  - a. Set Tool and dial indicator on side gear.

GI

MA

EM

LC

- b. Move side gear up and down to measure dial indicator deflection. Always measure indicator deflection on both side gears.

EC

**Clearance between side gear and differential case with washer:**

**0.1 - 0.2 mm (0.004 - 0.008 in)**

FE

- c. If not within specification, adjust clearance by changing thickness of differential side gear thrust washers.

**Differential side gear thrust washers:**

**Refer to SDS, AT-386.**

CL

MT

## — RE4F04W —

NFAT0176S02

### Differential Case Side

NFAT0176S0201

1. Measure clearance between side gear and differential case & viscous coupling with washers using the following procedure:
  - a. Set Tool and dial indicator on side gear.
  - b. Move side gear up and down to measure dial indicator deflection.

AT

AX

SU

**Clearance between side gear and differential case with washers:**

**0.1 - 0.2 mm (0.004 - 0.008 in)**

BR

- c. If not within specification adjust clearance by changing thickness of side gear thrust washer.

**Differential side gear thrust washers for differential case side:**

**Refer to SDS, AT-386.**

ST

RS

BT

HA

SC

EL

IDX

# REPAIR FOR COMPONENT PARTS

Final Drive (Cont'd)

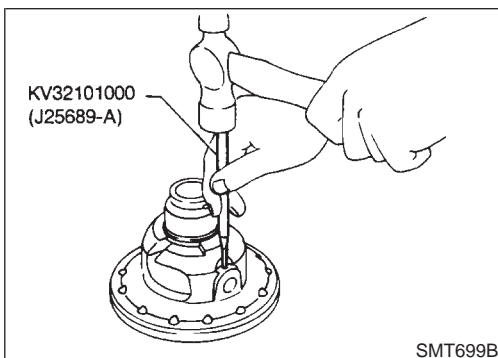
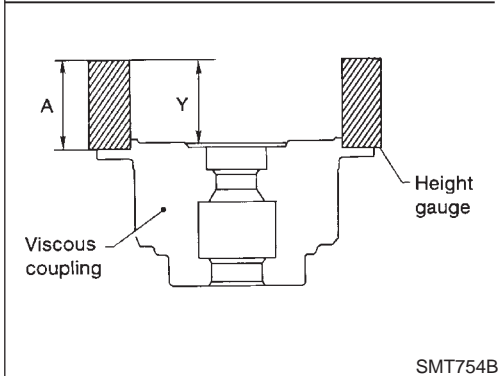
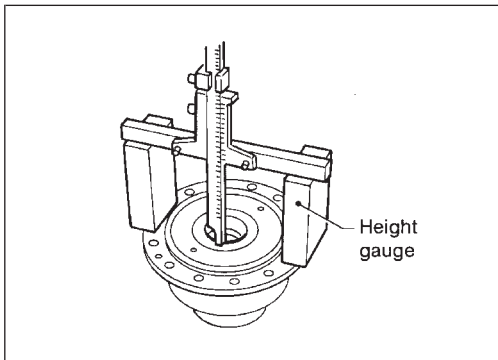
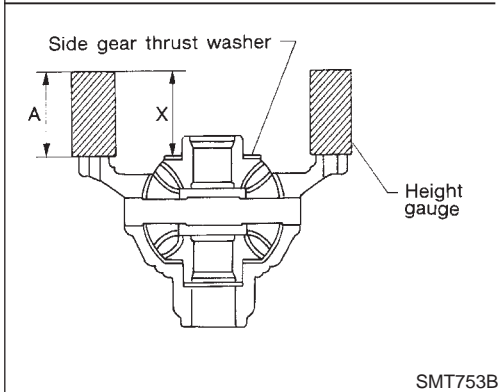
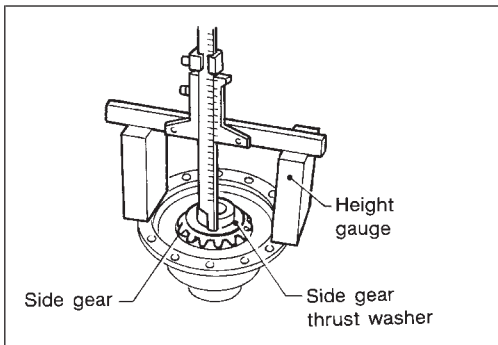

## Viscous Coupling Side

NFAT0176S0202

1. Measure clearance between side gear and differential case & viscous coupling with washers using the following procedure:
  - a. Place side gear and thrust washer on pinion mate gears installed on differential case.
  - b. Measure dimension X.
    - **Measure dimension X in at least two places.**

- c. Measure dimension Y.
  - **Measure dimension Y in at least two places.**

**Clearance between side gear and viscous coupling =  $X + Y - 2A$ : 0.1 - 0.2 mm (0.004 - 0.008 in)**

**A: Height of gauge**
- d. If not within specification, adjust clearance by changing thickness of side gear thrust washer.
 

**Differential side gear thrust washers for viscous coupling side:**

**Refer to SDS, AT-386.**

3. Install lock pin.
  - **Make sure that lock pin is flush with case.**

# REPAIR FOR COMPONENT PARTS

Final Drive (Cont'd)

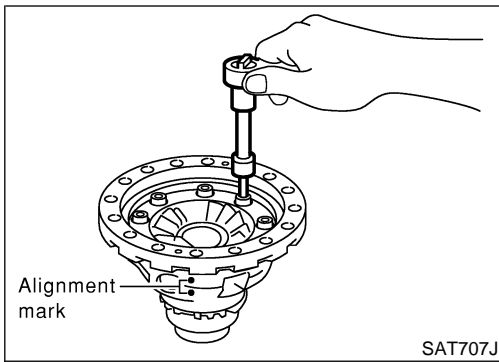

4. Install viscous coupling — RE4F04W.
  - a. After choosing the side gear washer, tighten down differential cases A and B. Tighten bolts to the specified torque. Refer to AT-356.

**CAUTION:**  
Make sure that A and B alignment marks are positioned correctly.

- b. Install viscous coupling.

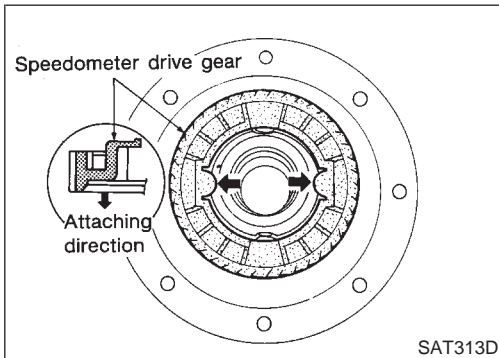

5. Install speedometer drive gear on differential case.
  - Align the projection of speedometer drive gear with the groove of differential case.

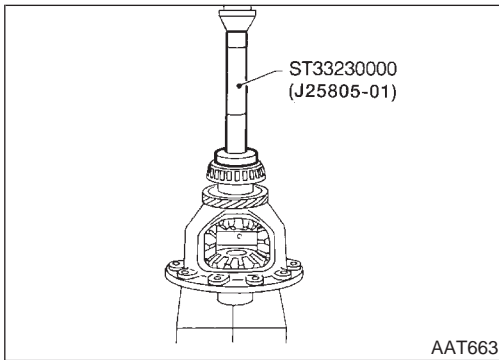

6. Press on differential side bearings.

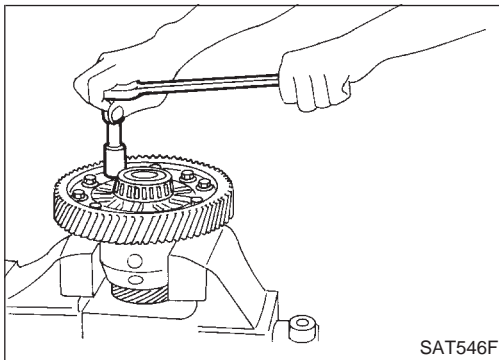

7. Install final gear and tighten fixing bolts in a crisscross pattern. Tighten final gear bolts to the specified torque. Refer to AT-356.

GI  
MA  
EM  
LC  
EC  
FE  
CL  
MT  
**AT**  
AX  
SU  
BR  
ST  
RS  
BT  
HA  
SC  
EL  
IDX



# ASSEMBLY

## Assembly (1)

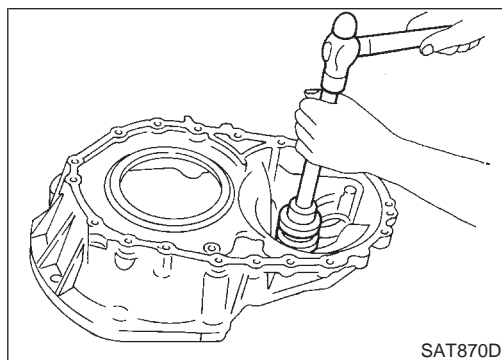
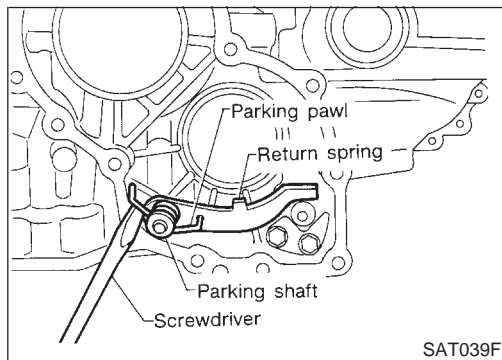
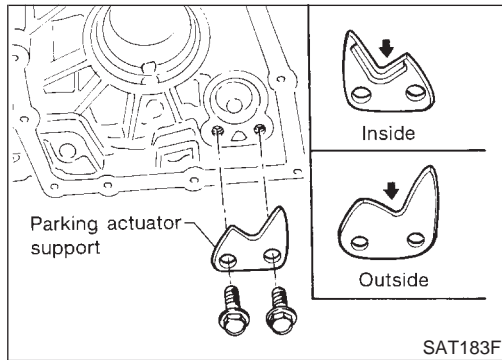
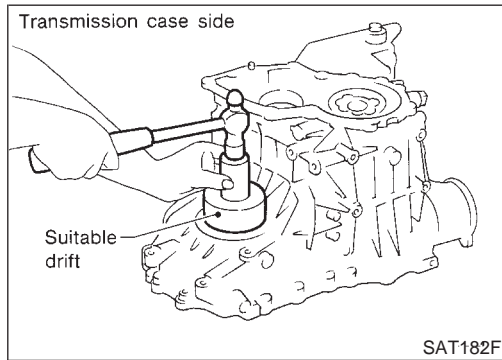
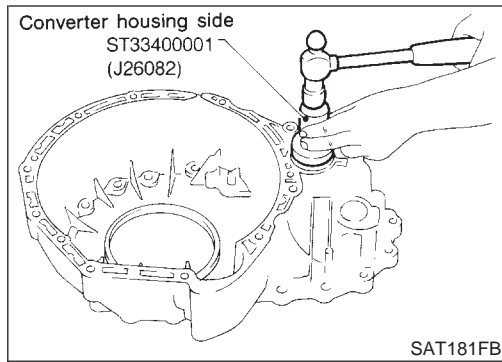

## Assembly (1)

NFAT0177

1. Install differential side oil seals on transmission case and converter housing.

2. Install parking actuator support to transmission case. Tighten parking actuator support bolts to the specified torque. Refer to AT-286.

- Pay attention to direction of parking actuator support.

3. Install parking pawl on transmission case and fix it with parking shaft.
4. Install return spring.

## Adjustment (1)

NFAT0178

### DIFFERENTIAL SIDE BEARING PRELOAD

NFAT0178S01

1. Install differential side bearing outer race without adjusting shim on transmission case.
2. Install differential side bearing outer race on converter housing.

# ASSEMBLY

Adjustment (1) (Cont'd)

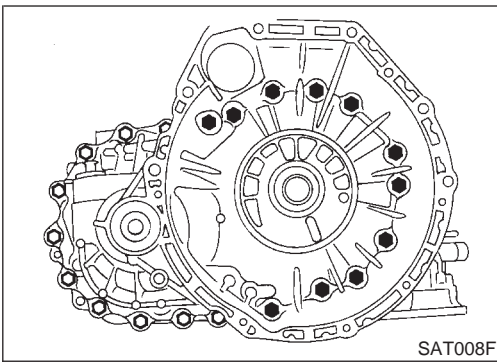

3. Place final drive assembly on transmission case.
4. Install transmission case on converter housing. Tighten transmission case fixing bolts to the specified torque. Refer to AT-286.

GI

MA

EM

LC

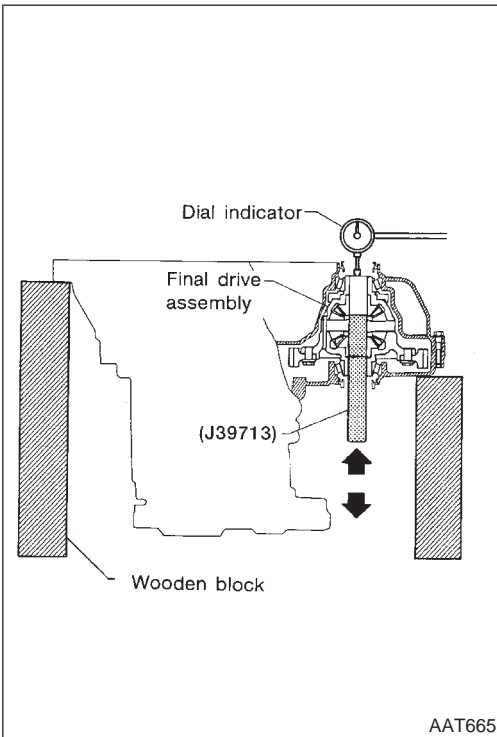

5. Attach dial indicator on differential case at converter housing side.
6. Insert Tool into differential side gear from transmission case side.
7. Move Tool up and down and measure dial indicator deflection.
8. Select proper thickness of differential side bearing adjusting shim(s).

EC

FE

**Suitable shim thickness = Dial indicator deflection + Specified bearing preload**

CL

**Differential side bearing preload adjusting shim:  
Refer to SDS, AT-387.**

MT

**Bearing preload:**

**0.05 - 0.09 mm (0.0020 - 0.0035 in)**

AT

AX

SU

BR

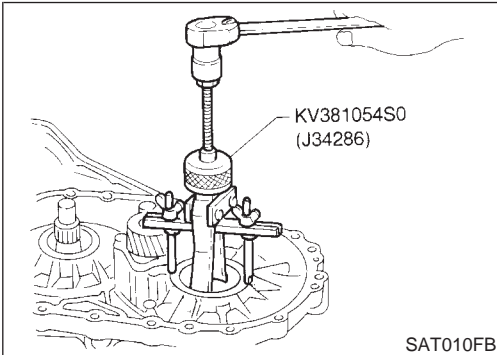

9. Remove converter housing from transmission case.
10. Remove final drive assembly from transmission case.
11. Remove differential side bearing outer race from transmission case.
12. Reinstall differential side bearing outer race and shim(s) selected from SDS table on transmission case.
13. Reinstall converter housing on transmission case and tighten transmission case fixing bolts to the specified torque. Refer to AT-286.

ST

RS

BT

HA

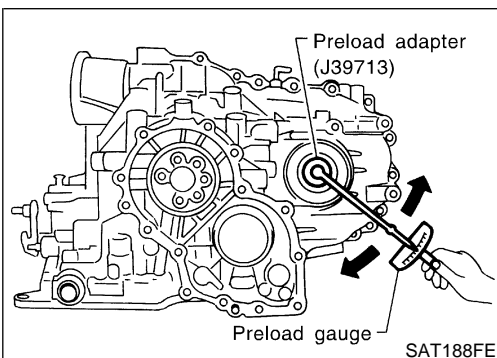

14. Insert Tool and measure turning torque of final drive assembly.
- Turn final drive assembly in both directions several times to seat bearing rollers correctly.

SC

**Turning torque of final drive assembly (New bearing):  
0.78 - 1.37 N-m (8.0 - 14.0 kg-cm, 6.9 - 12.2 in-lb)**

EL

- When old bearing is used again, turning torque will be slightly less than the above.

IDX

- Make sure torque is close to the specified range.

**Preload adapter:**

**RE4F04B-(J39713)**

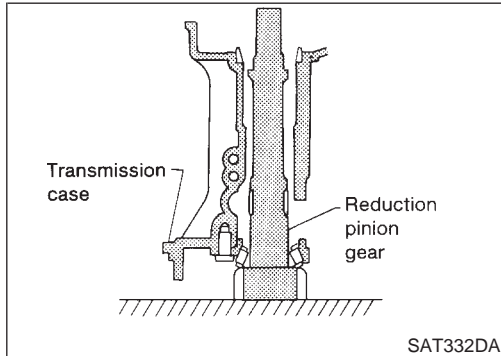

## REDUCTION PINION GEAR BEARING PRELOAD

NFAT0178S02

1. Remove transmission case and final drive assembly from converter housing.
2. Select proper thickness of reduction pinion gear bearing adjusting shim using the following procedures.
  - a. Place reduction pinion gear on transmission case as shown.

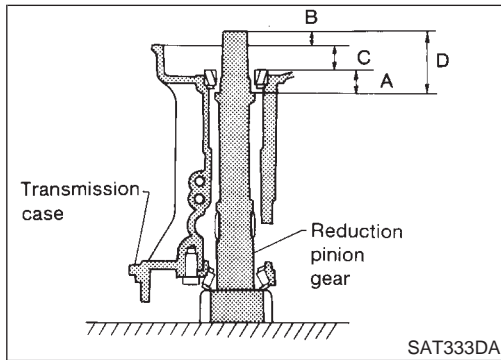

- b. Place idler gear bearing on transmission case.
  - c. Measure dimensions "B" "C" and "D" and calculate dimension "A".

$$A = D - (B + C)$$

**"A": Distance between the surface of idler gear bearing inner race and the adjusting shim mating surface of reduction pinion gear.**

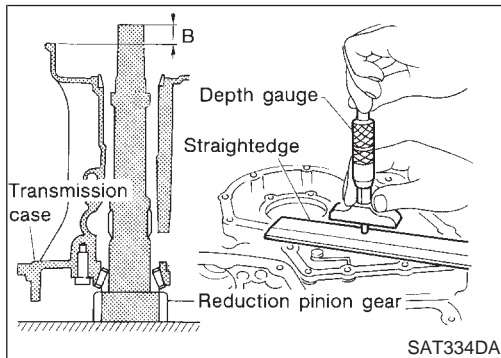

- Measure dimension "B" between the end of reduction pinion gear and the surface of transmission case.
- **Measure dimension "B" in at least two places.**

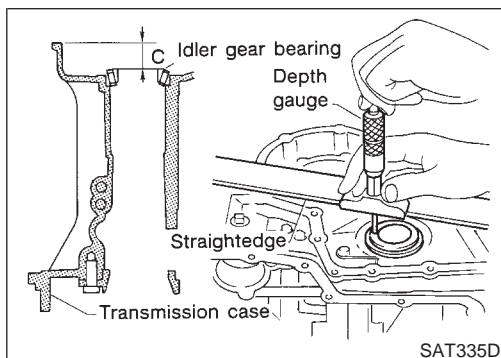

- Measure dimension "C" between the surface of idler gear bearing inner race and the surface of transmission case.
- **Measure dimension "C" in at least two places.**

# ASSEMBLY

Adjustment (1) (Cont'd)

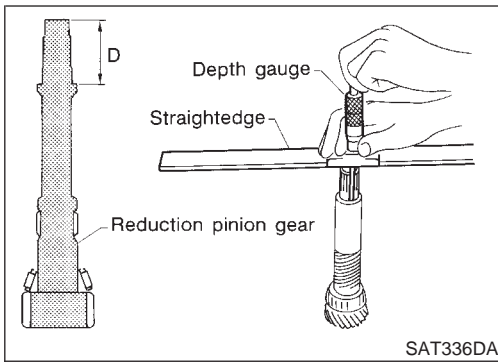

- Measure dimension “D” between the end of reduction pinion gear and the adjusting shim mating surface of reduction pinion gear.
- **Measure dimension “D” in at least two places.**
- Calculate dimension “A”.

$$A = D - (B + C)$$

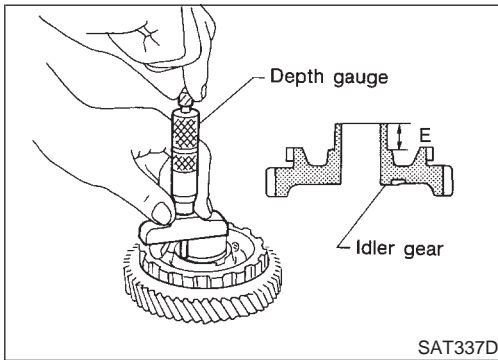

- d. Measure dimension “E” between the end of idler gear and the idler gear bearing inner race mating surface of idler gear.
- **Measure dimension “E” in at least two places.**

- e. Select proper thickness of reduction pinion gear bearing adjusting shim.

**Proper shim thickness = A – E – 0.05 mm (0.0020 in)\***  
 (\* ... Bearing preload)

**Reduction pinion gear bearing adjusting shim:  
 Refer to SDS, AT-388.**

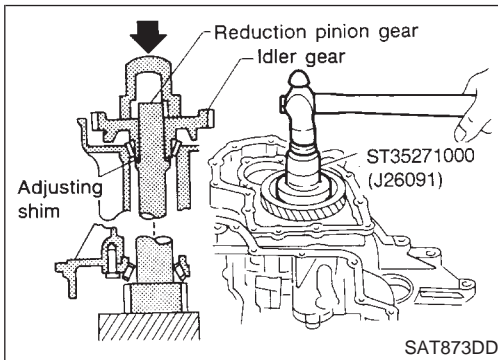

3. Install reduction gear and reduction gear bearing adjusting shim selected in step 2-e on transmission case.
  4. Press idler gear bearing inner race on idler gear.
  5. Press idler gear on reduction gear.
- **Press idler gear until idler gear fully contacts adjusting shim.**

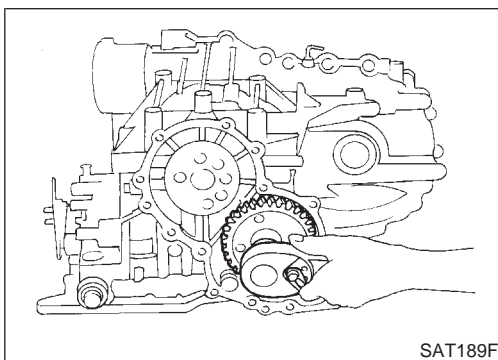

6. Tighten idler gear lock nut to the specified torque. Refer to AT-346.
- **Lock idler gear with parking pawl when tightening lock nut.**

GI  
 MA  
 EM  
 LC  
 EC  
 FE  
 CL  
 MT  
 AT  
 AX  
 SU  
 BR  
 ST  
 RS  
 BT  
 HA  
 SC  
 EL  
 IDX

# ASSEMBLY

## Adjustment (1) (Cont'd)

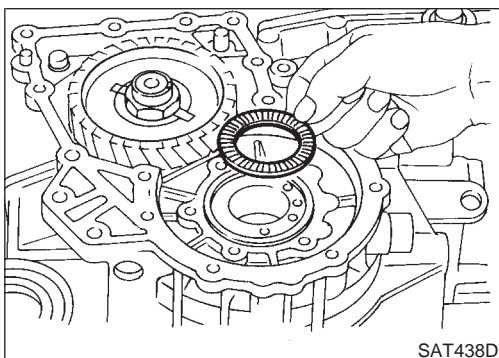
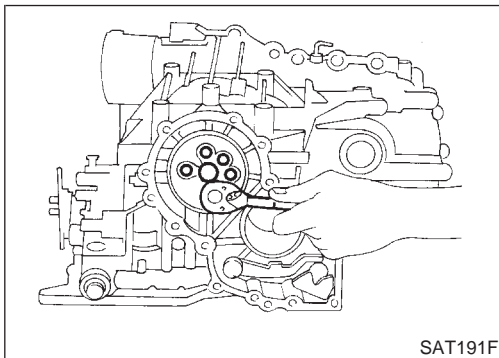
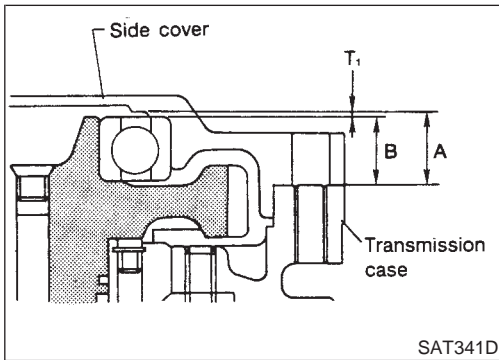
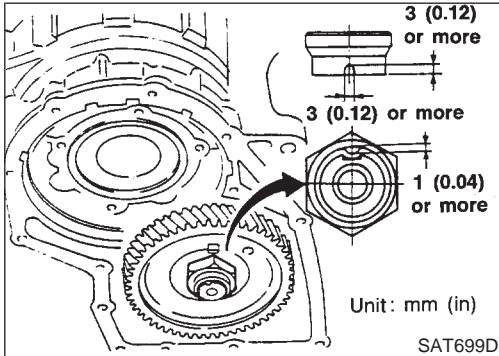
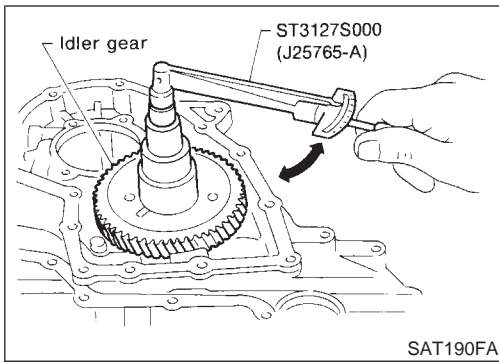

7. Measure turning torque of reduction pinion gear.
  - When measuring turning torque, turn reduction pinion gear in both directions several times to seat bearing rollers correctly.
 

**Turning torque of reduction pinion gear:**  
**0.05 - 0.39 N·m (0.5 - 4.0 kg-cm, 0.43 - 3.47 in-lb)**
  - If turning torque is out of specification, decrease or increase thickness of reduction pinion gear bearing adjusting shim.
8. After properly adjusting turning torque, clinch idler gear lock nut as shown.

## OUTPUT SHAFT END PLAY

NFAT0178S03

- Measure clearance between side cover and the end of the output shaft bearing.
  - Select proper thickness of adjusting shim so that clearance is within specifications.
1. Install bearing retainer for output shaft.
  2. Install output shaft thrust needle bearing on bearing retainer.

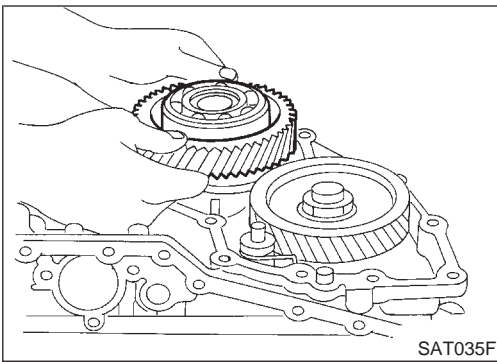

3. Install output shaft on transmission case.

GI

MA

EM

LC

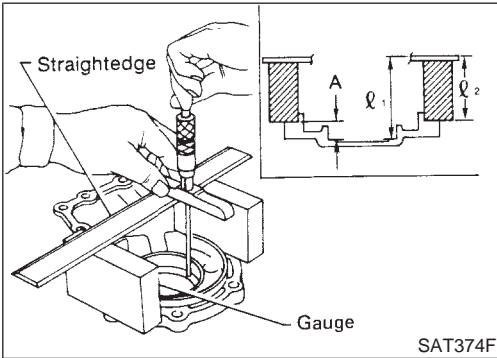

4. Measure dimensions " $l_1$ " and " $l_2$ " at side cover and then calculate dimension "A".

EC

- Measure dimension " $l_1$ " and " $l_2$ " in at least two places.  
**"A": Distance between transmission case fitting surface and adjusting shim mating surface.**

FE

$$A = l_1 - l_2$$

$l_2$ : Height of gauge

CL

MT

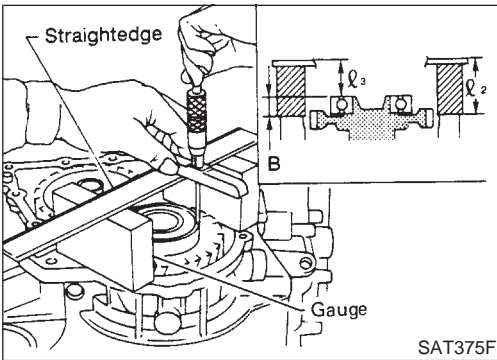

5. Measure dimensions " $l_2$ " and " $l_3$ " and then calculate dimension "B".

AT

- Measure " $l_2$ " and " $l_3$ " in at least two places.  
**"B": Distance between the end of output shaft bearing outer race and the side cover fitting surface of transmission case.**

AX

$$B = l_2 - l_3$$

$l_2$ : Height of gauge

SU

BR

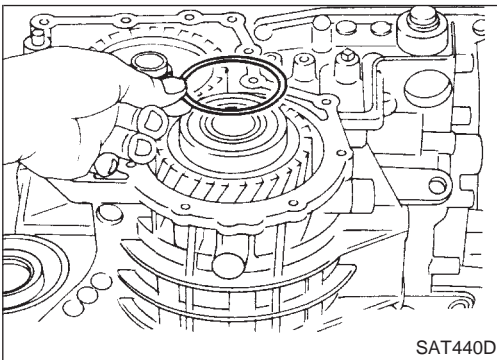

6. Select proper thickness of adjusting shim so that output shaft end play (clearance between side cover and output shaft bearing) is within specifications.

ST

**Output shaft end play (A - B):**

**0 - 0.15 mm (0 - 0.0059 in)**

RS

**Output shaft end play adjusting shims:**

**Refer to SDS, AT-390.**

BT

7. Install adjusting shim on output shaft bearing.

HA

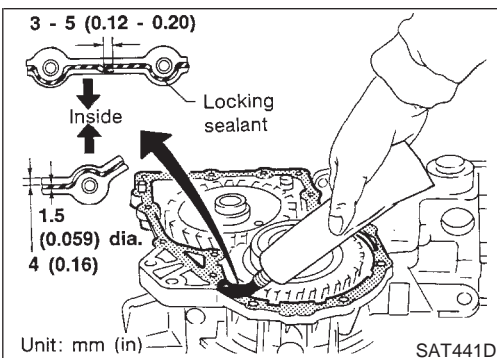

## Assembly (2)

NFAT0179

1. Apply locking sealant (Loctite #518) to transmission case as shown in illustration.

SC

EL

IDX



# ASSEMBLY

## Assembly (2) (Cont'd)

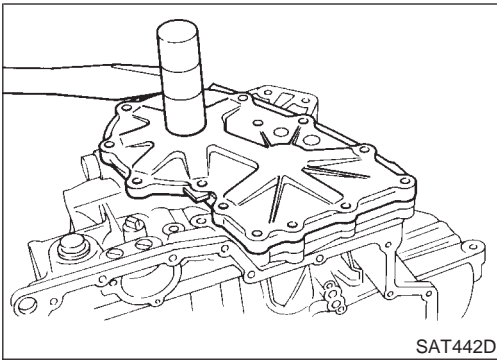

2. Set side cover on transmission case.
  - Apply locking sealant to the mating surface of transmission case.

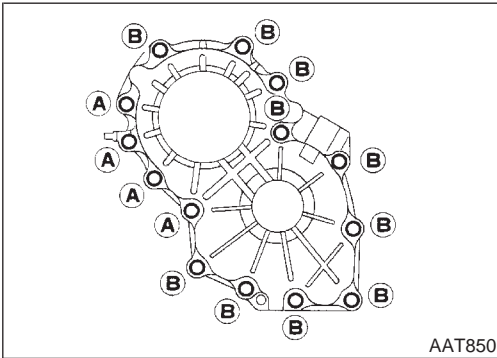

3. Tighten side cover fixing bolts to specified torque. Refer to AT-286.
  - Do not mix bolts A and B.
  - Always replace bolts A as they are self-sealing bolts.

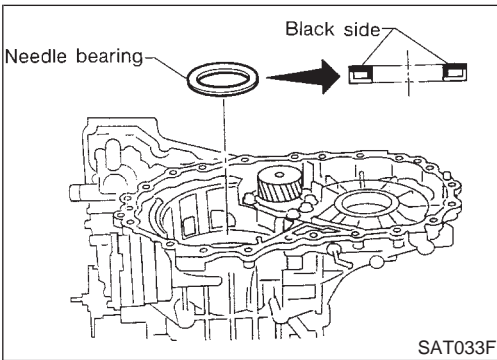

4. Remove paper rolled around bearing retainer.
5. Install thrust washer on bearing retainer.
  - Apply petroleum jelly to thrust washer.

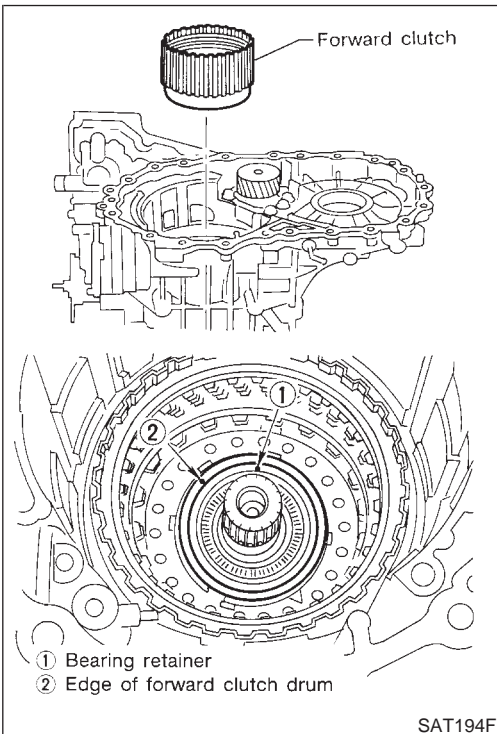

6. Install forward clutch assembly.
  - Align teeth of low & reverse brake drive plates before installing.
  - Make sure that bearing retainer seal rings are not spread.
  - If forward clutch assembly is correctly seated, points 1 and 2 are at almost same level.

# ASSEMBLY

Assembly (2) (Cont'd)

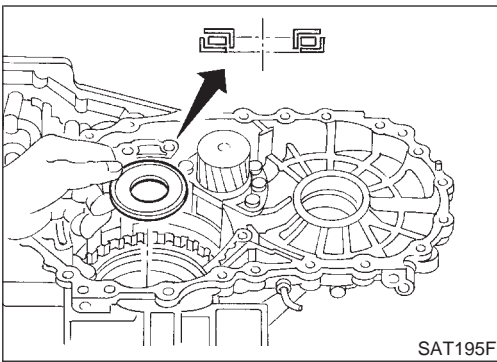

7. Install thrust needle bearing on bearing retainer.
  - Apply petroleum jelly to thrust needle bearing.
  - Pay attention to direction of thrust needle bearing.

GI

MA

EM

LC

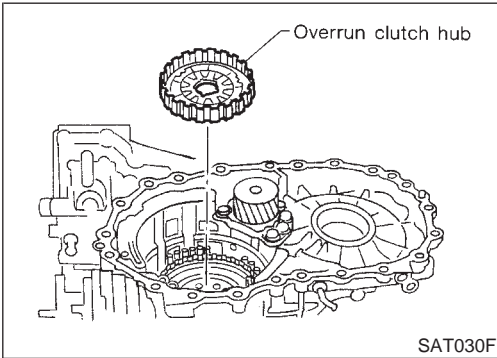

8. Install overrun clutch hub.
  - Apply petroleum jelly to thrust washers.
  - Align teeth of overrun clutch drive plates before installing.

EC

FE

CL

MT

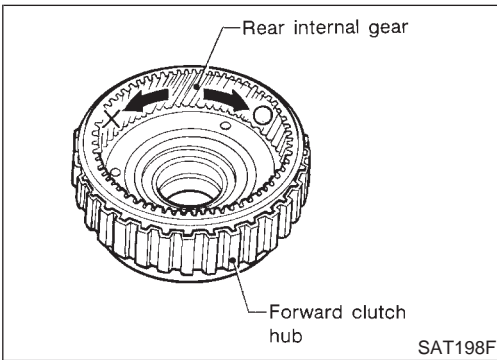

9. Hold forward clutch hub and turn rear internal gear. Check overrun clutch hub for correct directions of lock and unlock.
  - If not shown as illustrated, check installed direction of forward one-way clutch.

AT

AX

SU

BR

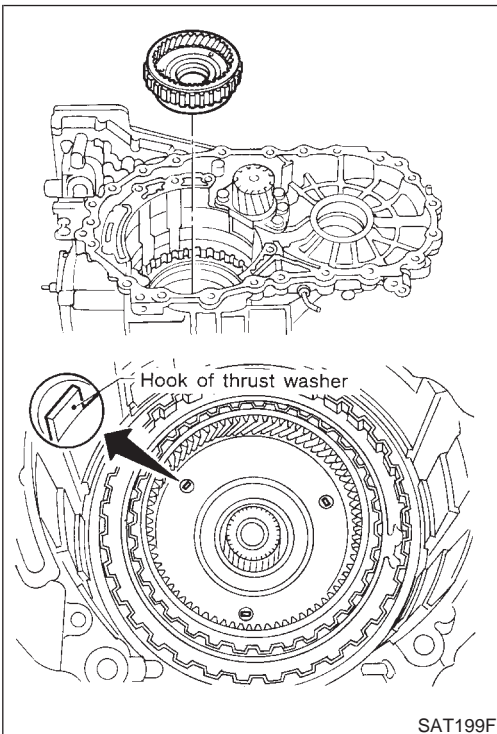

10. Install forward clutch hub and rear internal gear assembly.
  - Align teeth of forward clutch drive plates before installing.
  - Check that three hooks of thrust washer are correctly aligned after installing.

ST

RS

BT

HA

SC

EL

IDX



# ASSEMBLY

## Assembly (2) (Cont'd)

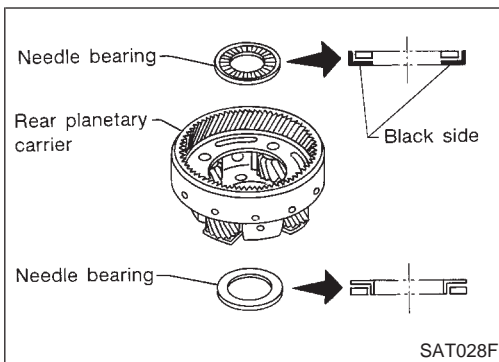

11. Install rear planetary carrier assembly and rear sun gear according to the following procedures.

- a. Install needle bearings on rear planetary carrier.
  - **Apply petroleum jelly to needle bearings.**
  - **Pay attention to direction of needle bearings.**

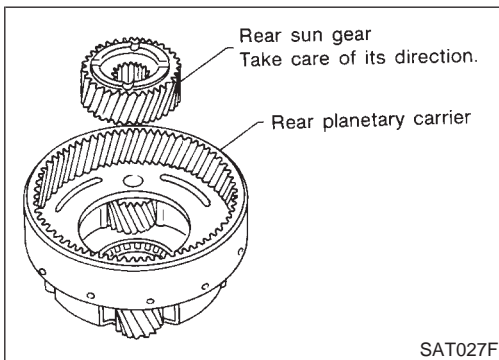

- b. Install rear sun gear on rear planetary carrier.
  - **Pay attention to direction of rear sun gear.**

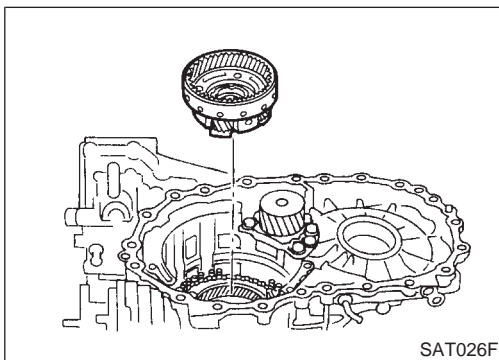

- c. Install rear planetary carrier on transmission case.

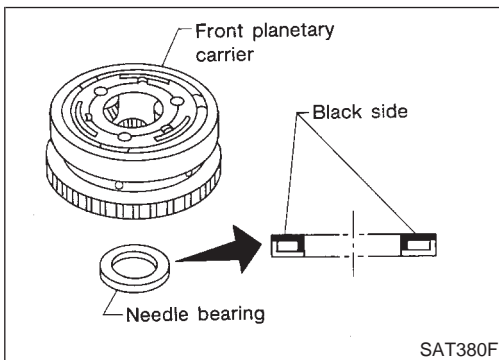

12. Install thrust needle bearing on front planetary carrier, then install them together on transmission case.

- **Apply petroleum jelly to thrust needle bearing.**
- **Pay attention to direction of thrust needle bearing.**

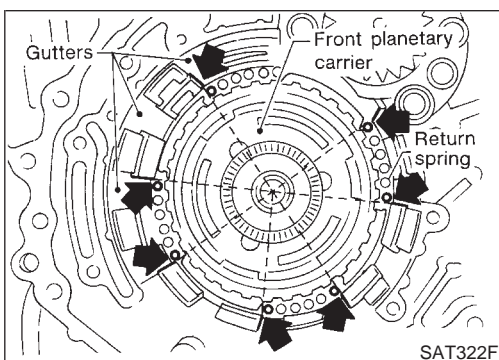

13. Install low and reverse brake piston according to the following procedures.

- a. Set and align return springs to transmission case gutters as shown in illustration.

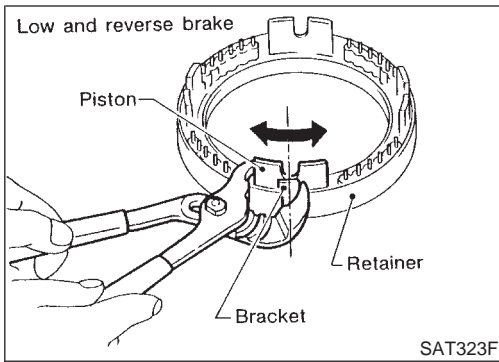

b. Set and align piston with retainer.

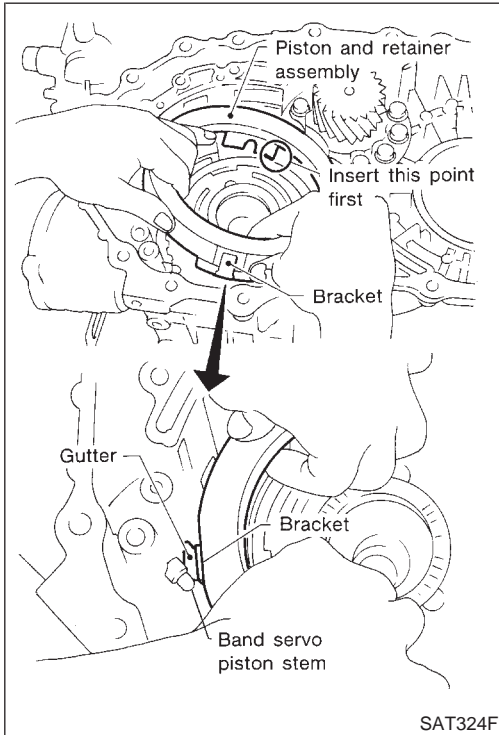

c. Install piston and retainer assembly on the transmission case.

- **Align bracket to specified gutter as indicated in illustration.**

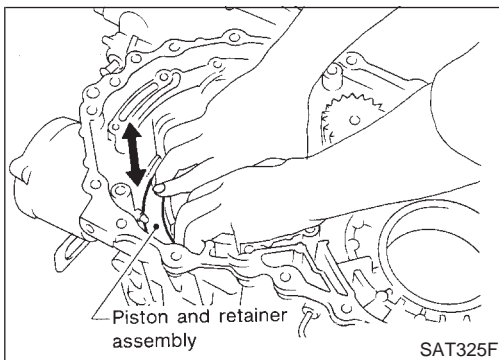

d. Check that each protrusion of piston is correctly set to corresponding return spring as follows.

- **Push piston and retainer assembly evenly and confirm they move smoothly.**
- **If they can not move smoothly, remove piston and retainer assembly and align return spring correctly as instructed in step "a".**

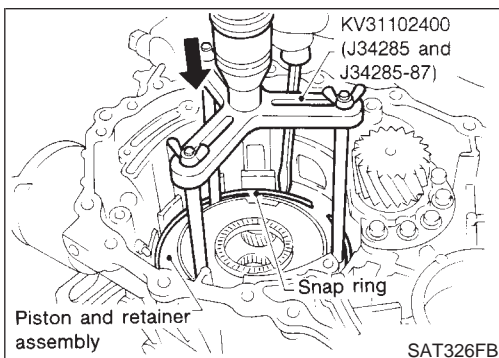

e. Push down piston and retainer assembly and install snap ring.

GI  
MA  
EM  
LC  
EC  
FE  
CL  
MT  
AT  
AX  
SU  
BR  
ST  
RS  
BT  
HA  
SC  
EL  
IDX

# ASSEMBLY

## Assembly (2) (Cont'd)

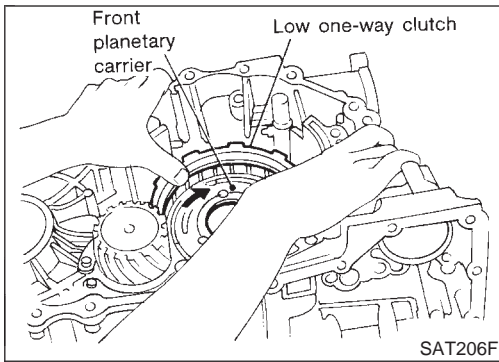

14. Install low one-way clutch to front planetary carrier by turning carrier in the direction of the arrow shown.

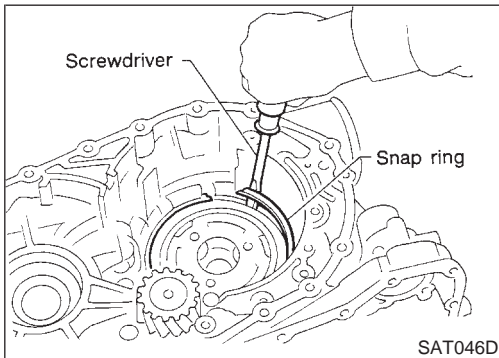

15. Install snap ring with screwdriver.
- **Forward clutch and bearing must be correctly installed for snap ring to fit into groove of transmission case.**

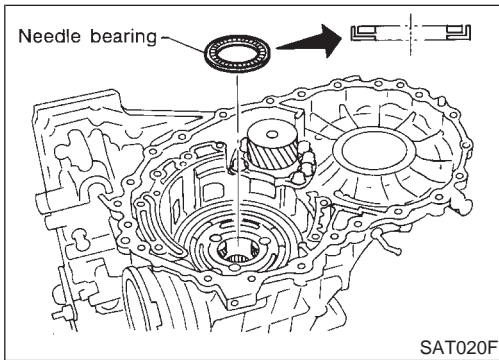

16. Install needle bearing on transmission case.
- **Apply petroleum jelly to needle bearing.**
  - **Pay attention to direction of needle bearing.**

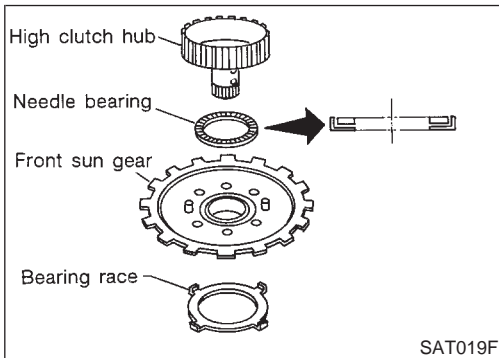

17. Install bearing race, needle bearing and high clutch hub on front sun gear.
- **Apply petroleum jelly to needle bearing.**
  - **Pay attention to direction of needle bearing.**

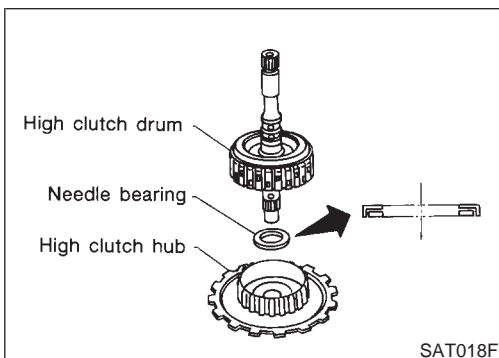

18. Install needle bearing and high clutch drum on high clutch hub.

# ASSEMBLY

Assembly (2) (Cont'd)

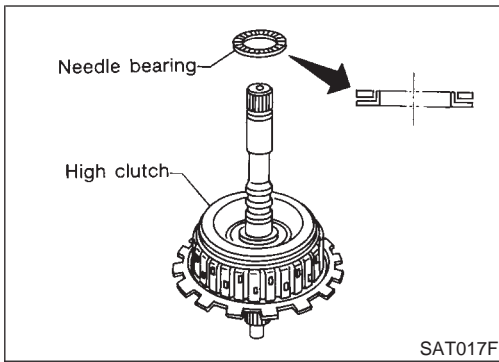

19. Install needle bearing on high clutch drum.
- Apply petroleum jelly to needle bearing.
  - Pay attention to direction of needle bearing.

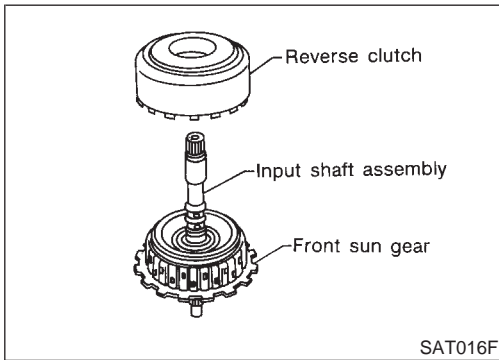

20. Remove paper rolled around input shaft.
21. Install input shaft assembly in reverse clutch.
- Align teeth of reverse clutch drive plates before installing.

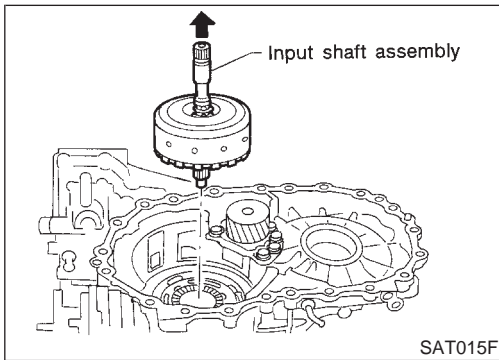

22. Install reverse clutch assembly on transmission case.
- Align teeth of high clutch drive plates before installing.

## Adjustment (2)

NFAT0180

When any parts listed below are replaced, adjust total end play and reverse clutch end play.

Part name	Total end play	Reverse clutch end play
Transmission case	●	●
Overrun clutch hub	●	●
Rear internal gear	●	●
Rear planetary carrier	●	●
Rear sun gear	●	●
Front planetary carrier	●	●
Front sun gear	●	●
High clutch hub	●	●
High clutch drum	●	●
Oil pump cover	●	●
Reverse clutch drum	—	●

GI

MA

EM

LC

EC

FE

CL

MT

AT

AX

SU

BR

ST

RS

BT

HA

SC

EL

IDX

# ASSEMBLY

## Adjustment (2) (Cont'd)

NFAT0180S01

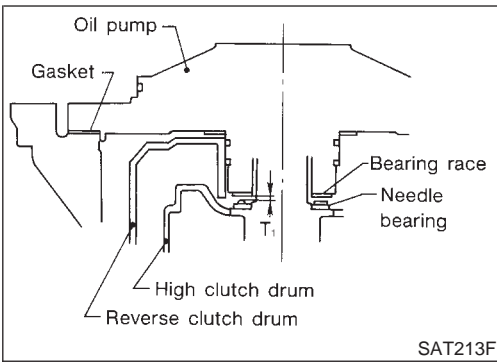

### TOTAL END PLAY

1. Adjust total end play "T<sub>1</sub>".

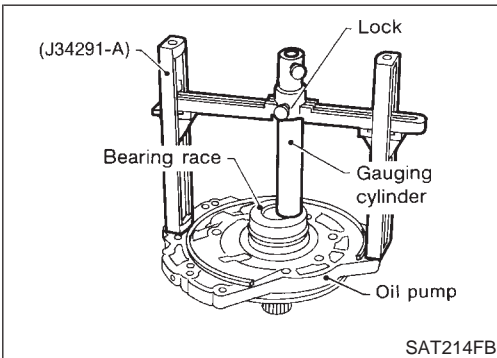

- a. With original bearing race installed, place Tool onto oil pump. The long ends of legs should be placed firmly on machined surface of oil pump assembly. The gauging cylinder should rest on top of bearing race. Lock gauging cylinder in place with set screw.

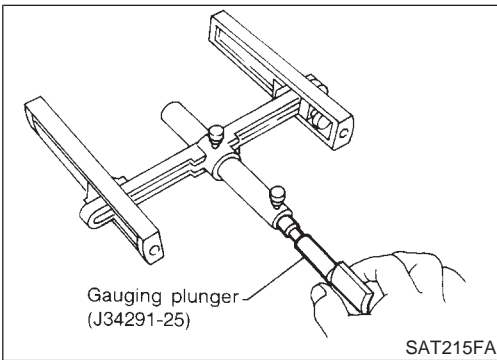

- b. Install gauging plunger into cylinder.

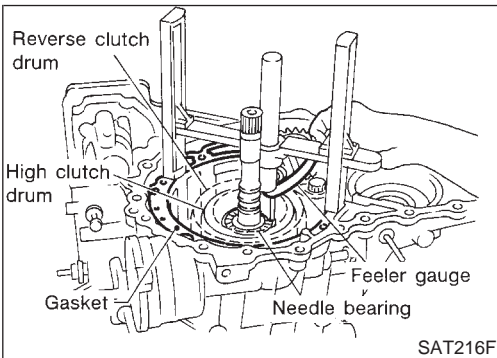

- c. With needle bearing installed on high clutch drum, place Tool legs on machined surface of transmission case (with gasket). Then allow plunger to rest on needle bearing.
- d. Measure gap between cylinder and plunger. This measurement should give exact total end play.

**Total end play "T<sub>1</sub>":**

**0.25 - 0.55 mm (0.0098 - 0.0217 in)**

- If end play is out of specification, decrease or increase thickness of bearing race as necessary.

**Available bearing race for adjusting total end play:**

**Refer to SDS, AT-390.**

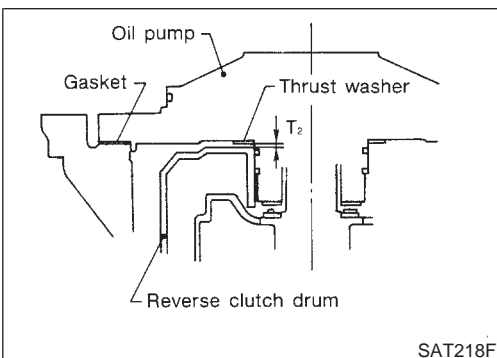

2. Adjust reverse clutch drum end play "T<sub>2</sub>".

# ASSEMBLY

Adjustment (2) (Cont'd)

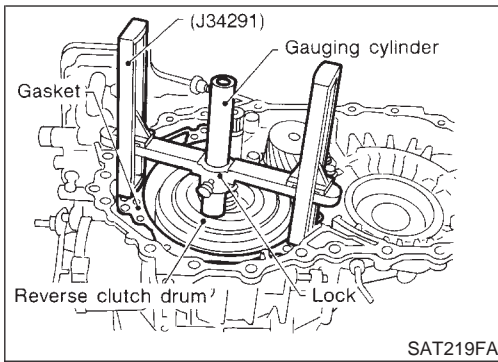

- a. Place Tool on machined surface of transmission case (with gasket). Then allow gauging cylinder to rest on reverse clutch drum. Lock cylinder in place with set screw.

GI

MA

EM

LC

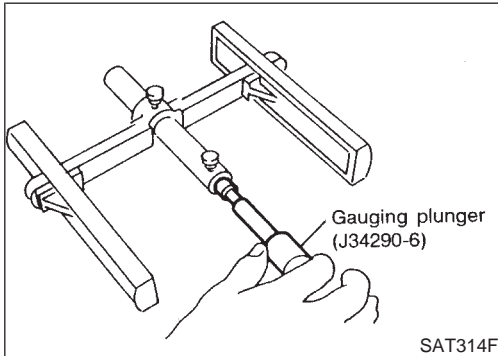

- b. Install gauging plunger into cylinder.
- c. With original thrust washer installed on oil pump, place Tool legs onto machined surface of oil pump assembly. Then allow plunger to rest on thrust washer.
- d. Measure gap between cylinder and plunger with feeler gauge. This measurement should give exact reverse clutch drum end play.

EC

FE

CL

**Reverse clutch drum end play "T<sub>2</sub>":**  
**0.55 - 0.90 mm (0.0217 - 0.0354 in)**

- If end play is out of specification, decrease or increase thickness of thrust washer as necessary.

MT

**Available thrust washer for adjusting reverse clutch drum end play:**

**Refer to SDS, AT-390.**

AT

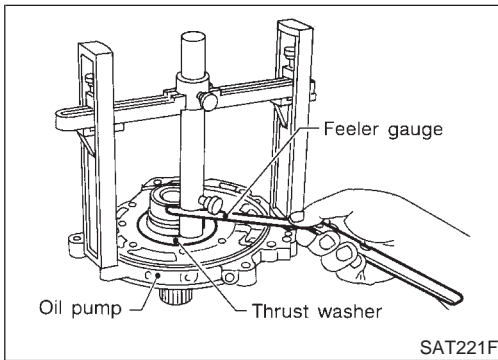

AX

SU

BR

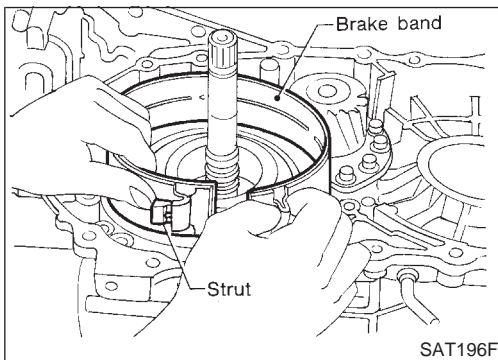

## Assembly (3)

NFAT0181

1. Install anchor end pin and lock nut on transmission case.
2. Place brake band on outside of reverse clutch drum. Tighten anchor end pin just enough so that brake band is evenly fitted on reverse clutch drum.

ST

RS

BT

HA

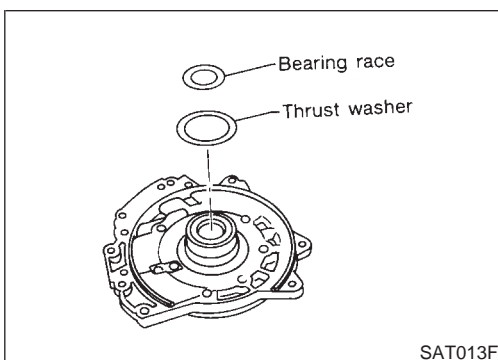

3. Place bearing race selected in total end play adjustment step on oil pump cover.

SC

- **Apply petroleum jelly to bearing race.**
- 4. Place thrust washer selected in reverse clutch end play step on reverse clutch drum.

EL

- **Apply petroleum jelly to thrust washer.**

IDX

# ASSEMBLY

## Assembly (3) (Cont'd)

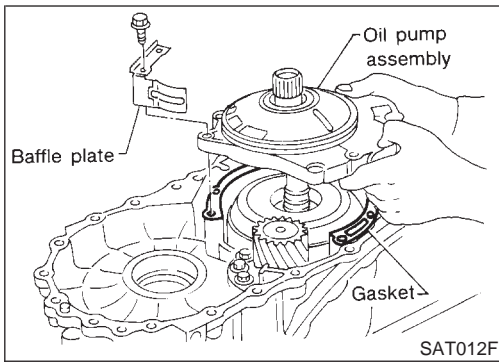

5. Install oil pump assembly, baffle plate and gasket on transmission case.
6. Tighten oil pump fixing bolts to the specified torque.

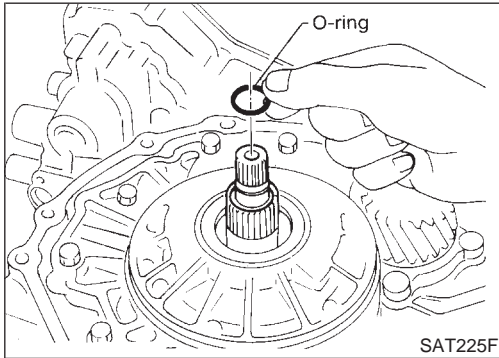

7. Install O-ring to input shaft.
  - **Apply ATF to O-ring.**

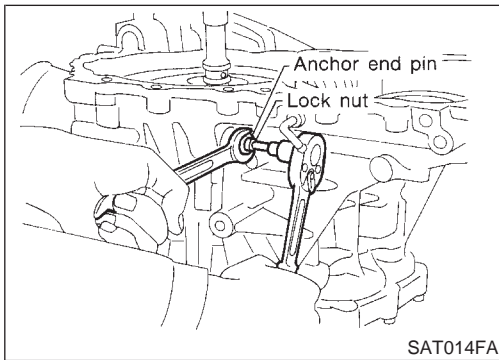

8. Adjust brake band.
  - a. Tighten anchor end pin to the specified torque.
    - Anchor end pin:**  
**Refer to SDS, AT-386.**
  - b. Back off anchor end pin two and a half turns.
  - c. While holding anchor end pin, tighten lock nut.
    - Lock nut:**  
**Refer to SDS, AT-386.**

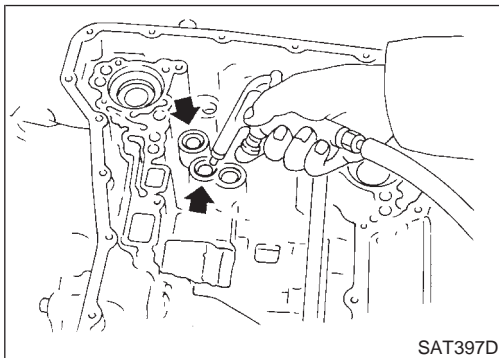

9. Apply compressed air to oil holes of transmission case and check operation of brake band.

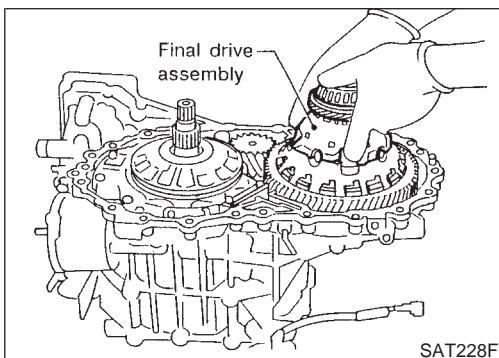

10. Install final drive assembly on transmission case.



# ASSEMBLY

Assembly (3) (Cont'd)

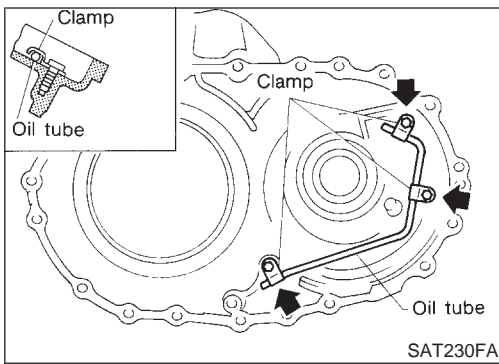

11. Install differential lubricant tube on converter housing. Tighten differential lubricant tube bolts to the specified torque. Refer to AT-286.

GI

MA

EM

LC

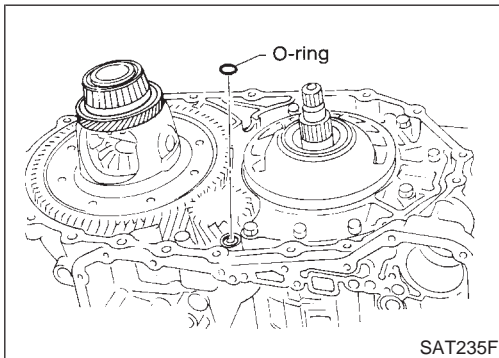

12. Install O-ring on differential oil port of transmission case.

EC

FE

CL

MT

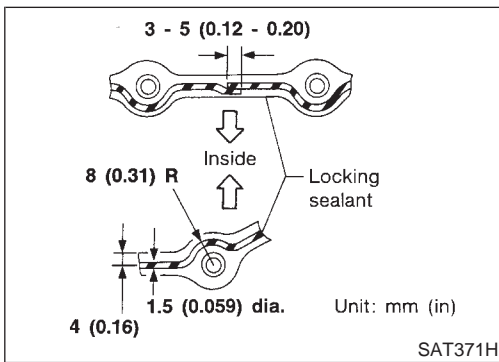

13. Install converter housing on transmission case.

- Apply locking sealant (Loctite #518) to mating surface of converter housing.

AT

AX

SU

BR

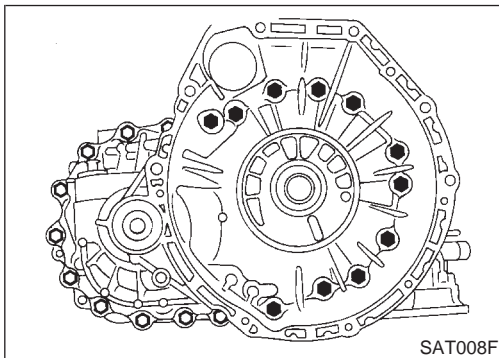

- Tighten converter housing bolts to the specified torque. Refer to AT-286.

ST

RS

BT

HA

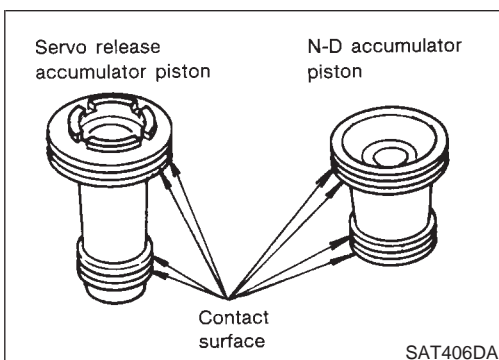

14. Install accumulator piston.

- a. Check contact surface of accumulator piston for damage.

SC

EL

IDX



# ASSEMBLY

## Assembly (3) (Cont'd)

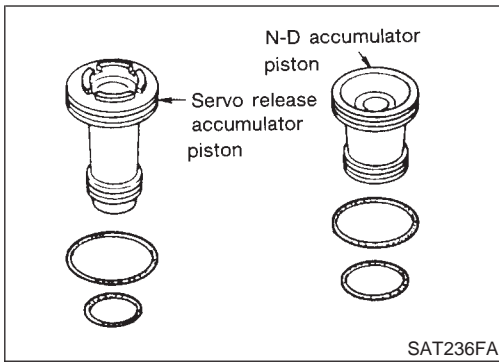

- b. Install O-rings on accumulator piston.
- **Apply ATF to O-rings.**  
**Accumulator piston O-rings:**  
**Refer to SDS, AT-383.**

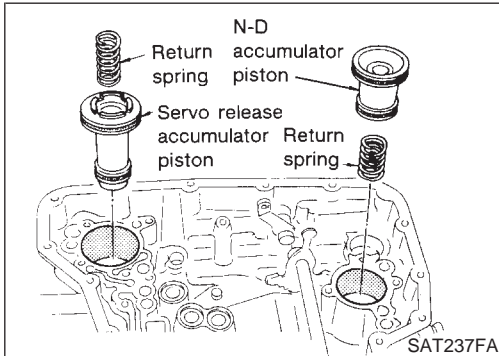

- c. Install accumulator pistons and return springs on transmission case.
- **Apply ATF to inner surface of transmission case.**  
**Return springs:**  
**Refer to SDS, AT-384.**

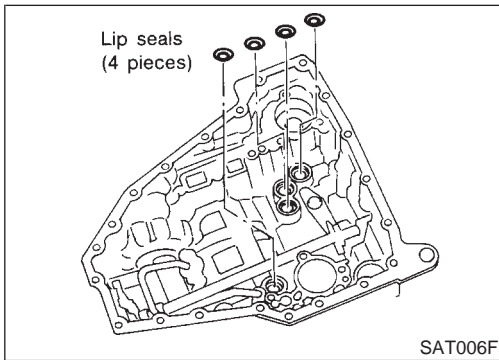

15. Install lip seals for band servo oil holes on transmission case.
- **Apply petroleum jelly to lip seals.**

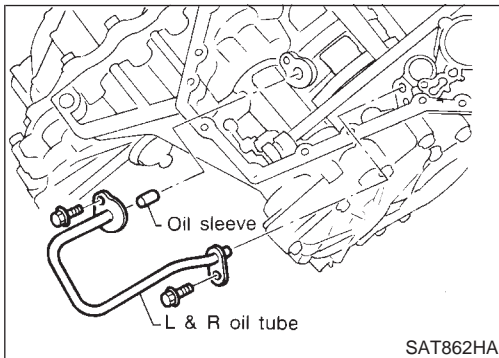

16. Install L & R oil tube and oil sleeve. Tighten L & R oil tube bolts to the specified torque. Refer to AT-286.

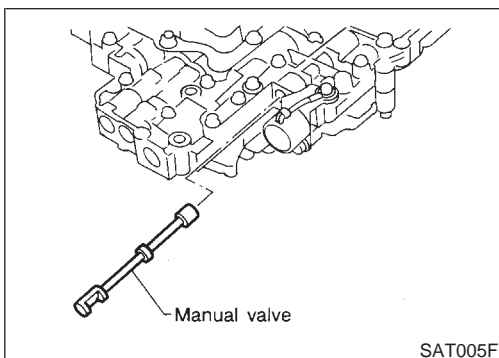

17. Install control valve assembly.
- a. Insert manual valve into control valve assembly.
- **Apply ATF to manual valve.**

# ASSEMBLY

Assembly (3) (Cont'd)

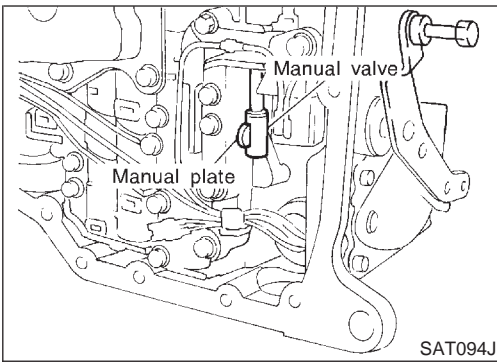

- b. Set manual shaft in Neutral position.
- c. Install control valve assembly on transmission case while aligning manual valve with manual plate.

GI

MA

EM

LC

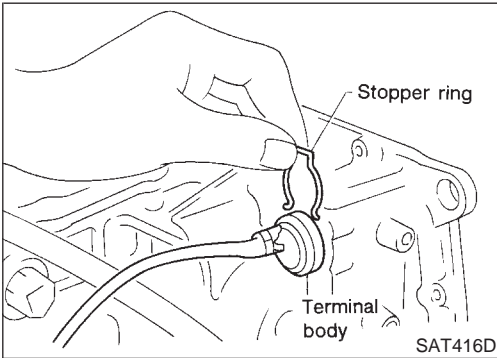

- d. Pass solenoid harness through transmission case and install terminal body on transmission case by pushing it.
- e. Install stopper ring to terminal body.

EC

FE

CL

MT

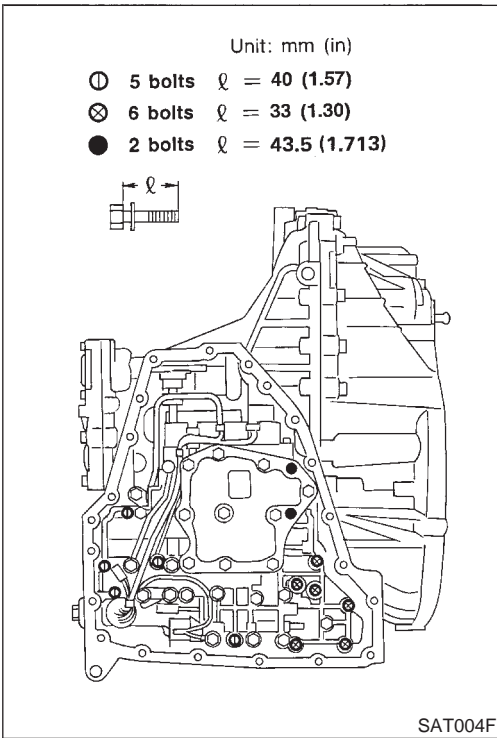

- f. Tighten bolts I, X and ●.

### Bolt length, number and location:

Bolt	I	X	●
Bolt length "ℓ"  ℓ mm (in)	40 (1.57)	33 (1.30)	43.5 (1.713)
Number of bolts	5	6	2

AT

AX

SU

BR

ST

RS

BT

HA

SC

EL

IDX

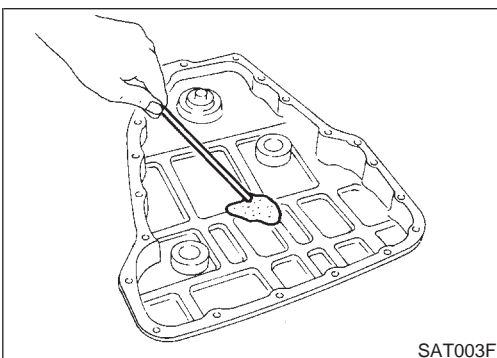

- 18. Install oil pan.
  - a. Attach a magnet to oil pan.
  - b. Install new oil pan gasket on transmission case.
  - c. Install oil pan on transmission case.
    - **Always replace oil pan bolts as they are self-sealing bolts.**
    - **Tighten four bolts in a criss-cross pattern to prevent dislocation of gasket.**
  - d. Tighten oil pan bolts and drain plug to the specified torque. Refer to AT-286.

# ASSEMBLY

## Assembly (3) (Cont'd)

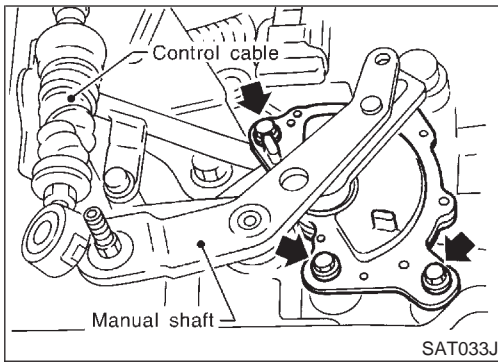

19. Install park/neutral position (PNP) switch.
  - a. Set manual shaft in P position.
  - b. Temporarily install park/neutral position (PNP) switch on manual shaft.
  - c. Move selector lever to N position.

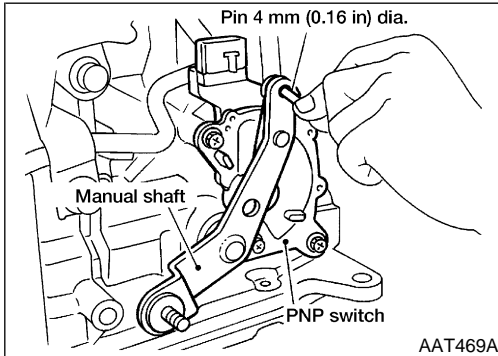

- d. Use a 4 mm (0.16 in) pin for this adjustment.
  - i. Insert the pin straight into the manual shaft adjustment hole.
  - ii. Rotate park/neutral position (PNP) switch until the pin can also be inserted straight into hole in park/neutral position (PNP) switch.
- e. Tighten park/neutral position (PNP) switch fixing bolts. Refer to AT-286.
- f. Remove pin from adjustment hole after adjusting park/neutral position (PNP) switch.

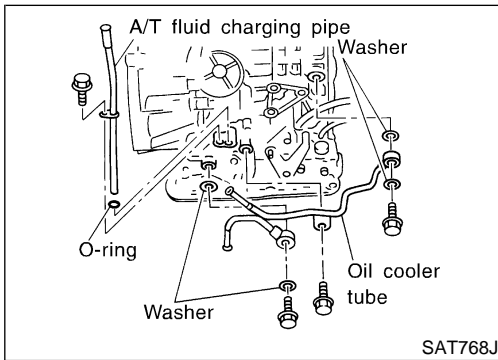

20. Install A/T fluid charging pipe and fluid cooler tube to transmission case. Tighten A/T fluid charging pipe and fluid cooler tube bolts to the specified torque. Refer to AT-286.

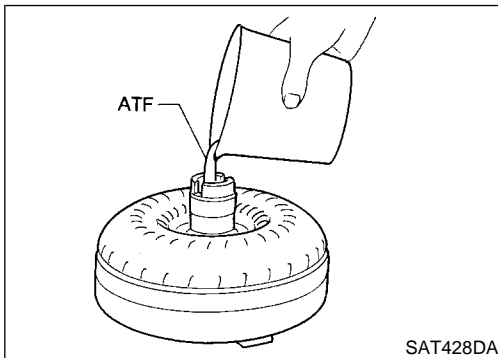

21. Install torque converter.
  - a. Pour ATF into torque converter.
    - **Approximately 1 liter (1-1/8 US qt, 7/8 Imp qt) of fluid is required for a new torque converter.**
    - **When reusing old torque converter, add the same amount of fluid as was drained.**

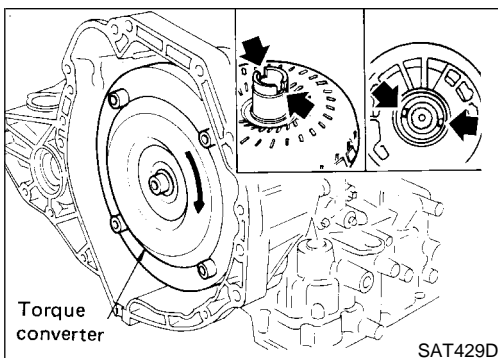

- b. Install torque converter while aligning notches of torque converter with notches of oil pump.

# ASSEMBLY

Assembly (3) (Cont'd)

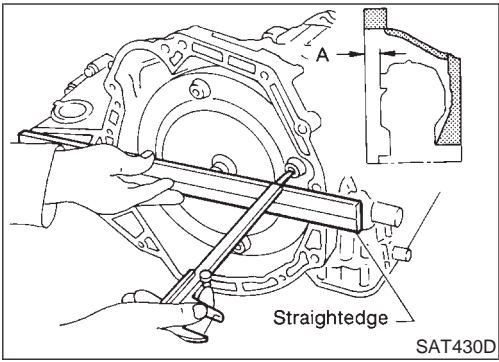

- c. Measure distance "A" to check that torque converter is in proper position.

**Distance A:**  
Refer to SDS, AT-391.

GI

MA

EM

LC

EC

FE

CL

MT

**AT**

AX

SU

BR

ST

RS

BT

HA

SC

EL

IDX

# SERVICE DATA AND SPECIFICATIONS (SDS)



General Specifications

## General Specifications

NFAT0182

Engine	VQ30DE		
Automatic transaxle model	RE4F04B		RE4F04W
Automatic transaxle assembly	Model code number	85X05	85X06
Transaxle gear ratio	1st	2.785	
	2nd	1.545	
	3rd	1.000	
	4th	0.694	
	Reverse	2.272	
	Final drive	3.789	
Recommended fluid	Nissan Matic "D" (Continental U.S. and Alaska) or Genuine Nissan Automatic Transmission Fluid (Canada)*1		
Fluid capacity ℓ (US qt, Imp qt)	9.4 (10, 8-1/4)		

\*1: Refer to MA-11, "Fluids and Lubricants".

## Shift Schedule

NFAT0183

### VEHICLE SPEED WHEN SHIFTING GEARS THROTTLE POSITION

NFAT0183S01

Throttle position	Shift pattern	Vehicle speed km/h (MPH)					
		D <sub>1</sub> → D <sub>2</sub>	D <sub>2</sub> → D <sub>3</sub>	D <sub>3</sub> → D <sub>4</sub>	D <sub>4</sub> → D <sub>3</sub>	D <sub>3</sub> → D <sub>2</sub>	D <sub>2</sub> → D <sub>1</sub>
Full throttle	Comfort	58 - 66 (36 - 41)	108 - 116 (67 - 72)	169 - 177 (105 - 110)	165 - 173 (103 - 108)	98 - 106 (61 - 66)	41 - 49 (25 - 30)
	Auto power	58 - 66 (36 - 41)	108 - 116 (67 - 72)	169 - 177 (105 - 110)	165 - 173 (103 - 108)	98 - 106 (61 - 66)	41 - 49 (25 - 30)
Half throttle	Comfort	38 - 46 (24 - 29)	70 - 78 (43 - 48)	132 - 140 (82 - 87)	85 - 93 (53 - 58)	32 - 40 (20 - 25)	5 - 13 (3 - 8)
	Auto power	41 - 49 (25 - 30)	78 - 86 (48 - 53)	132 - 140 (82 - 87)	85 - 93 (53 - 58)	45 - 53 (28 - 33)	5 - 13 (3 - 8)

### VEHICLE SPEED WHEN PERFORMING AND RELEASING LOCK-UP

NFAT0183S02  
Unit: km/h (MPH)

Model code No.	85X05	85X06
Vehicle speed	Throttle position 1/8	50 - 58 (31 - 36)

#### NOTE:

- Lock-up vehicle speed indicates the speed in D<sub>4</sub> position.
- Perform lock-up inspection after warming up engine.
- Lock-up vehicle speed may vary depending on the driving conditions and circumstances.

## Stall Revolution

NFAT0184

Engine	Stall revolution rpm
VQ30DE	2,150 - 2,450

## Line Pressure

NFAT0185

Engine speed rpm	Line pressure kPa (kg/cm <sup>2</sup> , psi)	
	D, 2 and 1 positions	R position
Idle	500 (5.1, 73)	775 (7.9, 112)
Stall	1,225 (12.5, 178)	1,912 (19.5, 277)

## Control Valves

NFAT0186

### CONTROL VALVE AND PLUG RETURN SPRINGS

NFAT0186S01  
Unit: mm (in)

	Parts		Item		
			Part No.*	Free length	Outer diameter
Upper body	23	Pilot valve spring	31742-3AX03	38.98 (1.5346)	8.9 (0.350)
	7	1-2 accumulator valve spring	31742-3AX00	20.5 (0.807)	6.95 (0.274)
	28	1-2 accumulator piston spring	31742-3AX08	55.26 (2.176)	19.6 (0.772)
	33	1st reducing valve spring	31742-80X05	27.0 (1.063)	7.0 (0.276)
	35	3-2 timing valve spring	31736-01X00	23.0 (0.906)	6.65 (0.262)
	18	Overrun clutch reducing valve spring	31742-80X15	37.5 (1.476)	6.9 (0.272)
	16	Torque converter relief valve spring	31742-80X07	31.0 (1.220)	9.0 (0.354)
	11	Torque converter clutch control valve	31742-85X00	56.98 (2.243)	6.5 (0.256)
	3	Cooler check valve spring	31742-85X01	29.4 (1.157)	6.0 (0.236)
Lower body	15	Pressure regulator valve spring	31742-80X13	45.0 (1.772)	15.0 (0.591)
	20	Overrun clutch control valve spring	31762-80X00	21.7 (0.854)	7.0 (0.276)
	24	Accumulator control valve spring	31742-80X02	22.0 (0.866)	6.5 (0.256)
	29	Shift valve A spring	31762-80X00	21.7 (0.854)	7.0 (0.276)
	32	Shuttle valve spring	31762-41X04	51.0 (2.008)	5.65 (0.222)
	12	Shift valve B spring	31762-80X00	21.7 (0.854)	7.0 (0.276)
	7	Pressure modifier valve spring	31742-41X15	30.5 (1.201)	9.8 (0.386)
	3		31742-80X16	32.0 (1.260)	6.9 (0.272)
	—	Oil cooler relief valve spring	31872-31X00	17.02 (0.670)	8.0 (0.315)

\*: Always check with the Parts Department for the latest parts information.

## Accumulator

NFAT0187

### O-RING

NFAT0187S01  
Unit: mm (in)

Accumulator	Inner diameter (Small)	Inner diameter (Large)
Servo release accumulator	26.9 (1.059)	44.2 (1.740)
N-D accumulator	34.6 (1.362)	39.4 (1.551)

# SERVICE DATA AND SPECIFICATIONS (SDS)



Accumulator (Cont'd)

## RETURN SPRING

<sup>=NFAT0187S02</sup>  
Unit: mm (in)

Accumulator	Part number*	Free length	Outer diameter
Servo release accumulator	31605-80X00	52.5 (2.067)	20.1 (0.791)
N-D accumulator	31605-31X15	43.5 (1.713)	28.0 (1.102)

\*: Always check with the Parts Department for the latest parts information.

## Clutch and Brakes

NFAT0188

### REVERSE CLUTCH

NFAT0188S01

Model code number		85X05	85X06
Number of drive plates		2	
Number of driven plates		2	
Drive plate thickness mm (in)	Standard	1.6 (0.063)	
	Allowable limit	1.4 (0.055)	
Clearance mm (in)	Standard	0.5 - 0.8 (0.020 - 0.031)	
	Allowable limit	1.2 (0.047)	
Thickness of retaining plates	Thickness mm (in)	Part number*	
		6.6 (0.260)	31537-80X05
		6.8 (0.268)	31537-80X06
		7.0 (0.276)	31537-80X07
		7.2 (0.283)	31537-80X08
		7.4 (0.291)	31537-80X09
		7.6 (0.299)	31537-80X20
	7.8 (0.307)	31537-80X21	

\*: Always check with the Parts Department for the latest parts information.

### HIGH CLUTCH

NFAT0188S02

Model code number		85X05	85X06
Number of drive plates		3	
Number of driven plates		7 + 1	
Drive plate thickness mm (in)	Standard	1.6 (0.063)	
	Allowable limit	1.4 (0.055)	
Clearance mm (in)	Standard	1.8 - 2.2 (0.071 - 0.087)	
	Allowable limit	2.8 (0.110)	
Thickness of retaining plates	Thickness mm (in)	Part number*	
		3.2 (0.126)	31537-81X11
		3.4 (0.134)	31537-81X12
		3.6 (0.142)	31537-81X13
		3.8 (0.150)	31537-81X14
	4.0 (0.157)	31537-81X15	

\*: Always check with the Parts Department for the latest parts information.

# SERVICE DATA AND SPECIFICATIONS (SDS)

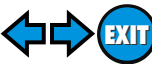

Clutch and Brakes (Cont'd)

## FORWARD CLUTCH

NFAT0188S03

Model code number		85X05	85X06	GI	
Number of drive plates		5			
Number of driven plates		5		MA	
Drive plate thickness mm (in)	Standard	1.6 (0.063)			
	Allowable limit	1.4 (0.055)		EM	
Clearance mm (in)	Standard	0.45 - 0.85 (0.0177 - 0.0335)			
	Allowable limit	1.85 (0.0728)		LC	
Thickness of retaining plates		Thickness mm (in)			
		Part number*			
		3.2 (0.126)		31537-80X76	EC
		3.4 (0.134)		31537-80X75	
		3.6 (0.142)		31537-80X70	
		3.8 (0.150)		31537-80X71	FE
		4.0 (0.157)		31537-80X72	
4.2 (0.165)		31537-80X73			
4.4 (0.173)		31537-80X74	CL		

\*: Always check with the Parts Department for the latest parts information.

## OVERRUN CLUTCH

NFAT0188S04

Model code number		85X05	85X06	MT	
Number of drive plates		3			
Number of driven plates		5		AT	
Drive plate thickness mm (in)	Standard	1.6 (0.063)		AX	
	Allowable limit	1.4 (0.055)			
Clearance mm (in)	Standard	0.7 - 1.1 (0.028 - 0.043)		SU	
	Allowable limit	1.7 (0.067)			
Thickness of retaining plates		Thickness mm (in)			
		Part number*			
		3.0 (0.118)		31537-80X65	BR
		3.2 (0.126)		31537-80X66	
		3.4 (0.134)		31537-80X67	ST
		3.6 (0.142)		31537-80X68	
3.8 (0.150)		31537-80X69			

\*: Always check with the Parts Department for the latest parts information.

RS  
BT  
HA  
SC  
EL  
IDX



# SERVICE DATA AND SPECIFICATIONS (SDS)

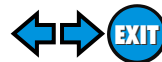

Clutch and Brakes (Cont'd)

## LOW & REVERSE BRAKE

NFAT0188S05

Model code number		85X05	85X06
Number of drive plates		7	
Number of driven plates		8	
Drive plate thickness mm (in)	Standard	1.8 (0.071)	
	Allowable limit	1.6 (0.063)	
Clearance mm (in)	Standard	1.7 - 2.1 (0.067 - 0.083)	
	Allowable limit	3.3 (0.130)	
Thickness of retaining plates		Thickness mm (in)	Part number*
		2.0 (0.079) 2.2 (0.087) 2.4 (0.094) 2.6 (0.102) 2.8 (0.110) 3.0 (0.118) 3.2 (0.126) 3.4 (0.134)	31667-80X00 31667-80X01 31667-80X02 31667-80X03 31667-80X04 31667-80X05 31667-80X06 31667-80X07

\*: Always check with the Parts Department for the latest parts information.

## BRAKE BAND

NFAT0188S06

Anchor end pin tightening torque N-m (kg-m, in-lb)	3.9 - 5.9 (0.4 - 0.6, 35 - 52)
Number of returning revolutions for anchor end pin	2.5
Lock nut tightening torque N-m (kg-m, ft-lb)	31 - 36 (3.2 - 3.7, 23 - 27)

## Final Drive

### DIFFERENTIAL SIDE GEAR CLEARANCE

NFAT0189

NFAT0189S01

Clearance between side gear and differential case with washer mm (in)	0.1 - 0.2 (0.004 - 0.008)
---	---------------------------

### DIFFERENTIAL SIDE GEAR THRUST WASHERS RE4F04B

NFAT0189S02

NFAT0189S0201

Thickness mm (in)	Part number*
0.75 (0.0295)	38424-81X00
0.80 (0.0315)	38424-81X01
0.85 (0.0335)	38424-81X02
0.90 (0.0354)	38424-81X03
0.95 (0.0374)	38424-81X04

\*: Always check with the Parts Department for the latest parts information.

### RE4F04W

NFAT0189S0202

	Thickness mm (in)	Part number*
Viscous coupling side	0.43 - 0.45 (0.0169 - 0.0177)	38424-51E10
	0.52 - 0.54 (0.0205 - 0.0213)	38424-51E11
	0.61 - 0.63 (0.0240 - 0.0248)	38424-51E12
	0.70 - 0.72 (0.0276 - 0.0283)	38424-51E13
	0.79 - 0.81 (0.0311 - 0.0319)	38424-51E14
Differential case side	0.75 - 0.80 (0.0295 - 0.0315)	38424-E3000
	0.80 - 0.85 (0.0315 - 0.0335)	38424-E3001
	0.85 - 0.90 (0.0335 - 0.0354)	38424-E3002
	0.90 - 0.95 (0.0354 - 0.0374)	38424-E3003

\*: Always check with the Parts Department for the latest parts information.

# SERVICE DATA AND SPECIFICATIONS (SDS)

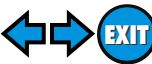

Final Drive (Cont'd)

## DIFFERENTIAL SIDE BEARING PRELOAD ADJUSTING SHIMS RE4F04B

NFAT0189S03

NFAT0189S0301

Thickness mm (in)	Part number*
0.48 (0.0189)	31438-80X00
0.52 (0.0205)	31438-80X01
0.56 (0.0220)	31438-80X02
0.60 (0.0236)	31438-80X03
0.64 (0.0252)	31438-80X04
0.68 (0.0268)	31438-80X05
0.72 (0.0283)	31438-80X06
0.76 (0.0299)	31438-80X07
0.80 (0.0315)	31438-80X08
0.84 (0.0331)	31438-80X09
0.88 (0.0346)	31438-80X10
0.92 (0.0362)	31438-80X11

\*: Always check with the Parts Department for the latest parts information.

## RE4F04W

NFAT0189S0302

Thickness mm (in)	Part number*
0.36 (0.0142)	38753-56E00
0.40 (0.0157)	38753-56E01
0.44 (0.0173)	38753-56E02
0.48 (0.0189)	38753-56E03
0.52 (0.0205)	38753-56E04
0.56 (0.0220)	38753-56E05
0.60 (0.0236)	38753-56E06
0.64 (0.0252)	38753-56E07
0.68 (0.0268)	38753-56E08
0.72 (0.0283)	38753-56E09
0.76 (0.0299)	38753-56E10
0.80 (0.0315)	38753-56E11
0.84 (0.0331)	38753-56E12
0.88 (0.0346)	38753-56E13
0.92 (0.0362)	38753-56E14
0.12 (0.0047)	38753-56E15
0.16 (0.0063)	38753-56E16
0.20 (0.0079)	38753-56E17
0.24 (0.0094)	38753-56E18
0.28 (0.0110)	38753-56E19
0.32 (0.0126)	38753-56E20

\*: Always check with the Parts Department for the latest parts information.

## BEARING PRELOAD

NFAT0189S04

Differential side bearing preload mm (in)	0.05 - 0.09 (0.0020 - 0.0035)
---	-------------------------------

## TURNING TORQUE

NFAT0189S05

Turning torque of final drive assembly N-m (kg-cm, in-lb)	0.78 - 1.37 (8.0 - 14.0, 6.9 - 12.2)
---	--------------------------------------

## CLUTCH AND BRAKE RETURN SPRINGS

NFAT0189S06  
Unit: mm (in)

Parts	Part number*	Free length	Outer diameter
Forward clutch (Overrun clutch) (22 pcs)	31505-80X02	21.4 (0.843)	10.3 (0.406)
High clutch (12 pcs)	31505-80X05	22.5 (0.886)	10.8 (0.425)
Low & reverse brake (24 pcs)	31505-80X07	24.1 (0.949)	6.6 (0.260)

\*: Always check with the Parts Department for the latest parts information.

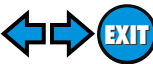

# SERVICE DATA AND SPECIFICATIONS (SDS)

Planetary Carrier and Oil Pump

## Planetary Carrier and Oil Pump

NFAT0190

### PLANETARY CARRIER

NFAT0190S01

Clearance between planetary carrier and pinion washer mm (in)	Standard	0.20 - 0.70 (0.0079 - 0.0276)
	Allowable limit	0.80 (0.0315)

### OIL PUMP

NFAT0190S02

Oil pump side clearance mm (in)	0.030 - 0.050 (0.0012 - 0.0020)	
Thickness of inner gears and outer gears	Inner gear	
	Thickness mm (in)	Part number*
	11.99 - 12.0 (0.4720 - 0.4724)	31346-80X00
	11.98 - 11.99 (0.4717 - 0.4720)	31346-80X01
	11.97 - 11.98 (0.4713 - 0.4717)	31346-80X02
	Outer gear	
Thickness mm (in)	Part number*	
11.99 - 12.0 (0.4720 - 0.4724)	31347-80X00	
11.98 - 11.99 (0.4717 - 0.4720)	31347-80X01	
11.97 - 11.98 (0.4713 - 0.4717)	31347-80X02	
Clearance between oil pump housing and outer gear mm (in)	Standard	0.111 - 0.181 (0.0044 - 0.0071)
	Allowable limit	0.181 (0.0071)
Oil pump cover seal ring clearance mm (in)	Standard	0.1 - 0.25 (0.0039 - 0.0098)
	Allowable limit	0.25 (0.0098)

\*: Always check with the Parts Department for the latest parts information.

### Input Shaft

NFAT0191

Input shaft seal ring clearance mm (in)	Standard	0.08 - 0.23 (0.0031 - 0.0091)
	Allowable limit	0.23 (0.0091)

### Reduction Pinion Gear

NFAT0192

### TURNING TORQUE

NFAT0192S01

Turning torque of reduction pinion gear N-m (kg-cm, in-lb)	0.05 - 0.39 (0.5 - 4.0, 0.43 - 3.47)
--	--------------------------------------

### REDUCTION PINION GEAR BEARING ADJUSTING SHIMS

NFAT0192S02

NO.	Thickness mm (in)	Part number	NO.	Thickness mm (in)	Part number*
1	5.00 (0.1969)	31439-81X00	39	5.76 (0.2268)	31439-81X69
2	5.02 (0.1976)	31439-81X01	40	5.78 (0.2276)	31439-81X70
3	5.04 (0.1984)	31439-81X02	41	5.80 (0.2283)	31439-81X71
4	5.06 (0.1992)	31439-81X03	42	5.82 (0.2291)	31439-81X72
5	5.08 (0.2000)	31439-81X04	43	5.84 (0.2299)	31439-81X73
6	5.10 (0.2008)	31439-81X05	44	5.86 (0.2307)	31439-81X74
7	5.12 (0.2016)	31439-81X06	45	5.88 (0.2315)	31439-81X75
8	5.14 (0.2024)	31439-81X07	46	5.90 (0.2323)	31439-81X76
9	5.16 (0.2031)	31439-81X08	47	5.92 (0.2331)	31439-81X77
10	5.18 (0.2039)	31439-81X09	48	5.94 (0.2339)	31439-81X78
11	5.20 (0.2047)	31439-81X10	49	5.96 (0.2346)	31439-81X79

# SERVICE DATA AND SPECIFICATIONS (SDS)

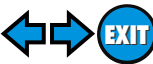

Reduction Pinion Gear (Cont'd)

NO.	Thickness mm (in)	Part number	NO.	Thickness mm (in)	Part number*	
12	5.22 (0.2055)	31439-81X11	50	5.98 (0.2354)	31439-81X80	GI
13	5.24 (0.2063)	31439-81X12	51	6.00 (0.2362)	31439-81X81	
14	5.26 (0.2071)	31439-81X13	52	4.50 (0.1772)	31439-83X00	MA
15	5.28 (0.2079)	31439-81X14	53	4.52 (0.1780)	31439-83X01	
16	5.30 (0.2087)	31439-81X15	54	4.54 (0.1787)	31439-83X02	EM
17	5.32 (0.2094)	31439-81X16	55	4.56 (0.1795)	31439-83X03	
18	5.34 (0.2102)	31439-81X17	56	4.58 (0.1803)	31439-83X04	LC
19	5.36 (0.2110)	31439-81X18	57	4.60 (0.1811)	31439-83X05	
20	5.38 (0.2118)	31439-81X19	58	4.62 (0.1819)	31439-83X06	EC
21	5.40 (0.2126)	31439-81X20	59	4.64 (0.1827)	31439-83X07	
22	5.42 (0.2134)	31439-81X21	60	4.66 (0.1835)	31439-83X08	FE
23	5.44 (0.2142)	31439-81X22	61	4.68 (0.1843)	31439 83X09	
24	5.46 (0.2150)	31439-81X23	62	4.70 (0.1850)	31439 83X10	CL
25	5.48 (0.2157)	31439-81X24	63	4.72 (0.1858)	31439 83X11	
26	5.50 (0.2165)	31439-81X46	64	4.74 (0.1866)	31439 83X12	MT
27	5.52 (0.2173)	31439-81X47	65	4.76 (0.1874)	31439 83X13	
28	5.54 (0.2181)	31439-81X48	66	4.78 (0.1882)	31439 83X14	AT
29	5.56 (0.2189)	31439-81X49	67	4.80 (0.1890)	31439 83X15	
30	5.58 (0.2197)	31439-81X60	68	4.82 (0.1898)	31439 83X16	AX
31	5.60 (0.2205)	31439-81X61	69	4.84 (0.1906)	31439 83X17	
32	5.62 (0.2213)	31439-81X62	70	4.86 (0.1913)	31439 83X18	SU
33	5.64 (0.2220)	31439-81X63	71	4.88 (0.1921)	31439 83X19	
34	5.66 (0.2228)	31439-81X64	72	4.90 (0.1929)	31439 83X20	BR
35	5.68 (0.2236)	31439-81X65	73	4.92 (0.1937)	31439 83X21	
36	5.70 (0.2244)	31439-81X66	74	4.94 (0.1945)	31439 83X22	ST
37	5.72 (0.2252)	31439-81X67	75	4.96 (0.1953)	31439 83X23	
38	5.74 (0.2260)	31439-81X68	76	4.98 (0.1961)	31439 83X24	RS

\*: Always check with the Parts Department for the latest parts information.

## Band Servo

NFAT0193

### RETURN SPRING

NFAT0193S01  
Unit: mm (in)

Return spring	Part number*	Free length	Outer diameter
2nd servo return spring	31605-31X20	32.5 (1.280)	25.9 (1.020)
OD servo return spring	31605-80X07	31.0 (1.220)	62.6 (2.465)

\*: Always check with the Parts Department for the latest parts information.

## Output Shaft

NFAT0194

### SEAL RING CLEARANCE

NFAT0194S01

Output shaft seal ring clearance mm (in)	Standard	0.10 - 0.25 (0.0039 - 0.0098)
	Allowable limit	0.25 (0.0098)

# SERVICE DATA AND SPECIFICATIONS (SDS)



Output Shaft (Cont'd)

## END PLAY

NFAT0194S02

Output shaft end play mm (in)	0 - 0.15 (0 - 0.0059)
-------------------------------	-----------------------

## OUTPUT SHAFT ADJUSTING SHIMS

NFAT0194S03

Thickness mm (in)	Part number*
0.80 (0.0315)	31438-80X60
0.84 (0.0331)	31438-80X61
0.88 (0.0346)	31438-80X62
0.92 (0.0362)	31438-80X63
0.96 (0.0378)	31438-80X64
1.00 (0.0394)	31438-80X65
1.04 (0.0409)	31438-80X66
1.08 (0.0425)	31438-80X67
1.12 (0.0441)	31438-80X68
1.16 (0.0457)	31438-80X69
1.20 (0.0472)	31438-80X70

\*: Always check with the Parts Department for the latest parts information.

## Bearing Retainer

NFAT0195

### SEAL RING CLEARANCE

NFAT0195S01

Bearing retainer seal ring clearance mm (in)	Standard	0.10 - 0.30 (0.0039 - 0.0118)
	Allowable limit	0.30 (0.0118)

## Total End Play

NFAT0196

Total end play mm (in)	0.25 - 0.55 (0.0098 - 0.0217)
------------------------	-------------------------------

## BEARING RACE FOR ADJUSTING TOTAL END PLAY

NFAT0196S01

Thickness mm (in)	Part number*
0.8 (0.031)	31435-80X00
1.0 (0.039)	31435-80X01
1.2 (0.047)	31435-80X02
1.4 (0.055)	31435-80X03
1.6 (0.063)	31435-80X04
1.8 (0.071)	31435-80X05
2.0 (0.079)	31435-80X06
0.9 (0.035)	31435-80X09
1.1 (0.043)	31435-80X10
1.3 (0.051)	31435-80X11
1.5 (0.059)	31435-80X12
1.7 (0.067)	31435-80X13
1.9 (0.075)	31435-80X14

\*: Always check with the Parts Department for the latest parts information.

## Reverse Clutch End Play

NFAT0197

Reverse clutch end play mm (in)	0.55 - 0.90 (0.0217 - 0.0354)
---------------------------------	-------------------------------

## THRUST WASHERS FOR ADJUSTING REVERSE CLUTCH DRUM END PLAY

NFAT0197S01

Thickness mm (in)	Part number*
0.80 (0.0315)	31508-80X13
0.95 (0.0374)	31508-80X14
1.10 (0.0433)	31508-80X15
1.25 (0.0492)	31508-80X16
1.40 (0.0551)	31508-80X17
1.55 (0.0610)	31508-80X18
1.70 (0.0669)	31508-80X19
1.85 (0.0728)	31508-80X20

\*: Always check with the Parts Department for the latest parts information.

# SERVICE DATA AND SPECIFICATIONS (SDS)

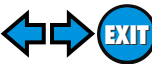

Removal and Installation

## Removal and Installation

NFAT0198  
Unit: mm (in)

Distance between end of converter housing and torque converter	14 (0.55)
--	-----------

## Shift Solenoid Valves

NFAT0264

Gear position	1	2	3	4
Shift solenoid valve A	ON (Closed)	OFF (Open)	OFF (Open)	ON (Closed)
Shift solenoid valve B	ON (Closed)	ON (Closed)	OFF (Open)	OFF (Open)

## Solenoid Valves

NFAT0265

Solenoid valves	Resistance (Approx.) $\Omega$	Terminal No.
Shift solenoid valve A	20 - 30	2
Shift solenoid valve B	5 - 20	1
Overrun clutch solenoid valve	20 - 30	3
Line pressure solenoid valve	2.5 - 5	4
Torque converter clutch solenoid valve	5 - 20	5

## A/T Fluid Temperature Sensor

NFAT0266

Remarks: Specification data are reference values.

Monitor item	Condition	Specification
A/T fluid temperature sensor	Cold [20°C (68°F)]	Approximately 1.5V
	↓	↓
	Hot [80°C (176°F)]	Approximately 0.5V

## Revolution Sensor

NFAT0267

Condition	Judgement standard
When moving at 20 km/h (12 MPH), use the CONSULT-II pulse frequency measuring function.*1 <b>CAUTION:</b> Connect the diagnosis data link cable to the vehicle diagnosis connector. *1: A circuit tester cannot be used to test this item.	450 Hz (Approx.)
When vehicle parks.	Under 1.3V or over 4.5V

## Dropping Resistor

NFAT0268

Resistance	10 - 15 $\Omega$
------------	------------------

## NOTES