

A
CO
C
D
E
F
G
H
I
J
K
L
M
N
O
P

SECTION CO

ENGINE COOLING SYSTEM

CONTENTS

SERVICE INFORMATION	RADIATOR	2	13
	Removal and Installation		13
PRECAUTIONS	COOLING FAN	2	15
Precaution for Supplemental Restraint System (SRS) "AIR BAG" and "SEAT BELT PRE-TENSIONER"	Removal and Installation	2	15
Precaution for Liquid Gasket	Disassembly and Assembly of Radiator Fan	2	15
PREPARATION	WATER PUMP	4	16
Special Service Tool	Removal and Installation	4	16
Commercial Service Tool	THERMOSTAT AND THERMOSTAT HOUSING	4	21
OVERHEATING CAUSE ANALYSIS	Removal and Installation	6	21
Troubleshooting Chart	WATER OUTLET AND WATER PIPING	6	23
COOLING SYSTEM	Removal and Installation	8	23
Cooling Circuit	SERVICE DATA AND SPECIFICATIONS (SDS)	8	25
Schematic	Capacity	8	25
ENGINE COOLANT	Thermostat	9	25
System Inspection	Radiator	9	25
Changing Engine Coolant		10	

PRECAUTIONS

< SERVICE INFORMATION >

SERVICE INFORMATION

PRECAUTIONS

Precaution for Supplemental Restraint System (SRS) "AIR BAG" and "SEAT BELT PRE-TENSIONER"

INFOID:000000001720719

The Supplemental Restraint System such as "AIR BAG" and "SEAT BELT PRE-TENSIONER", used along with a front seat belt, helps to reduce the risk or severity of injury to the driver and front passenger for certain types of collision. This system includes seat belt switch inputs and dual stage front air bag modules. The SRS system uses the seat belt switches to determine the front air bag deployment, and may only deploy one front air bag, depending on the severity of a collision and whether the front occupants are belted or unbelted. Information necessary to service the system safely is included in the SRS and SB section of this Service Manual.

WARNING:

- To avoid rendering the SRS inoperative, which could increase the risk of personal injury or death in the event of a collision which would result in air bag inflation, all maintenance must be performed by an authorized NISSAN/INFINITI dealer.
- Improper maintenance, including incorrect removal and installation of the SRS, can lead to personal injury caused by unintentional activation of the system. For removal of Spiral Cable and Air Bag Module, see the SRS section.
- Do not use electrical test equipment on any circuit related to the SRS unless instructed to in this Service Manual. SRS wiring harnesses can be identified by yellow and/or orange harnesses or harness connectors.

Precaution for Liquid Gasket

INFOID:000000001720720

REMOVAL OF LIQUID GASKET SEALING

- After removing nuts and bolts, separate the mating surface, using Tool and remove old liquid gasket sealing.

Tool number : KV10111100 (J-37228)

CAUTION:

Be careful not to damage the mating surfaces.

- Tap Tool to insert it (1), and then slide it by tapping on the side (2) as shown.
- In areas where Tool is difficult to use, use plastic hammer to lightly tap the parts, to remove it.

CAUTION:

If for some unavoidable reason suitable tool such as screwdriver is used, be careful not to damage the mating surfaces.

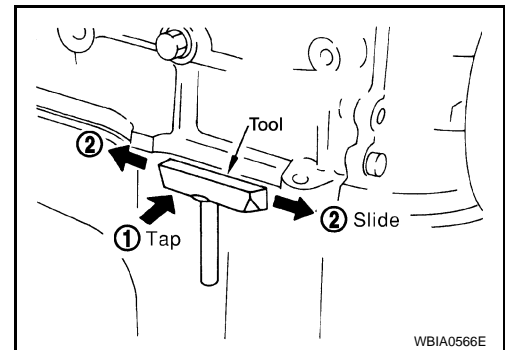

LIQUID GASKET APPLICATION PROCEDURE

1. Remove old liquid gasket adhering to the liquid gasket application surface and the mating surface, using scraper.
 - Remove liquid gasket completely from the groove of the liquid gasket application surface, bolts, and bolt holes.
2. Thoroughly clean the mating surfaces and remove adhering moisture, grease and foreign materials.

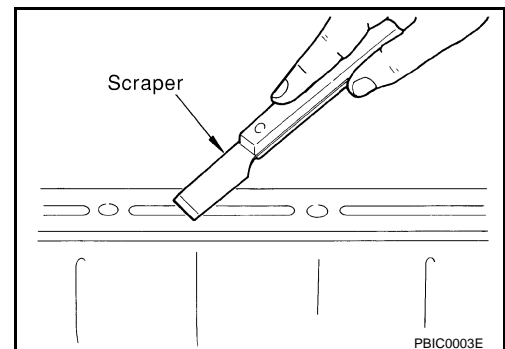

PRECAUTIONS

< SERVICE INFORMATION >

3. Attach liquid gasket tube to Tool.

Tool number : WS39930000 (—)

Use Genuine RTV Silicone Sealant or equivalent. Refer to GI-42, "Recommended Chemical Product and Sealant".

4. Apply liquid gasket without breaks to the specified location with the specified dimensions.
- If there is a groove for the liquid gasket application, apply liquid gasket to the groove.

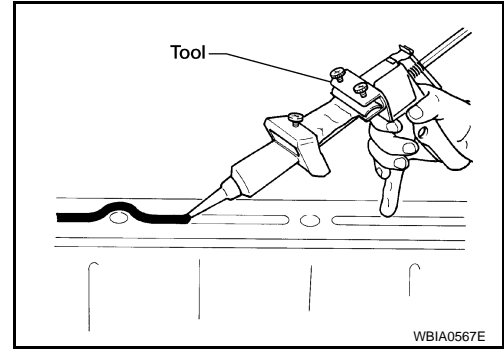

- As for the bolt holes, normally apply liquid gasket inside the holes. Occasionally, it should be applied outside the holes. Make sure to read the text of service manual.
- Within five minutes of liquid gasket application, install the mating component.
- If liquid gasket protrudes, wipe it off immediately.
- Do not retighten nuts or bolts after the installation.
- After 30 minutes or more have passed from the installation, fill engine oil and engine coolant.

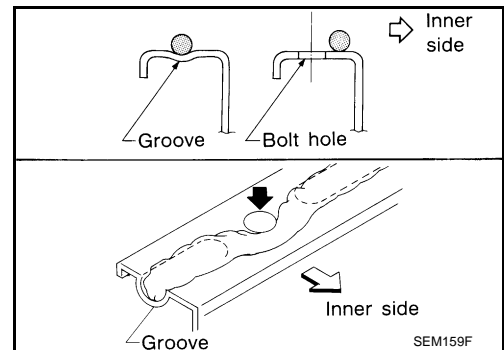

CAUTION:

If there are specific instructions in this manual, observe them.

A
CO
C
D
E
F
G
H
I
J
K
L
M
N
O
P

PREPARATION

< SERVICE INFORMATION >

PREPARATION

Special Service Tool

INFOID:000000001720721

The actual shapes of Kent-Moore tools may from those of special service tools illustrated here.

Tool number (Kent-Moore No.) Tool name	Description
WS39930000 (—) Tube pressure	Pressing the tube of liquid gasket
EG17650301 (J-33984-A) Radiator cap tester adapter	Adapting radiator cap tester to radiator cap and radiator filler neck a: 28 (1.10) dia. b: 31.4 (1.236) dia. c: 41.3 (1.626) dia. Unit: mm (in)
KV10111100 (J-37228) Seal cutter	Removing chain tensioner cover and water pump cover
KV991J0070 (J-45695) Coolant Refill Tool	Refilling engine cooling system
— (J-23688) Engine coolant refractometer	Checking concentration of ethylene glycol in engine coolant

Commercial Service Tool

INFOID:000000001720722

PREPARATION

< SERVICE INFORMATION >

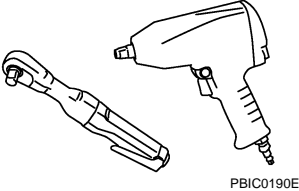
Tool name	Description
<p data-bbox="164 199 272 226">Power tool</p>  <p data-bbox="852 415 922 436">FBIC0190E</p>	<p data-bbox="1013 199 1263 226">Loosening bolts and nuts</p>

A

CO

C

D

E

F

G

H

I

J

K

L

M

N

O

P

OVERHEATING CAUSE ANALYSIS

< SERVICE INFORMATION >

OVERHEATING CAUSE ANALYSIS

Troubleshooting Chart

INFOID:000000001720723

		Symptom	Check items		
Cooling system parts malfunction	Poor heat transfer	Water pump malfunction	Worn or loose drive belt	—	
		Thermostat stuck closed	—		
		Damaged fins	Dust contamination or paper clogging		
			Physical damage		
		Clogged radiator cooling tube	Excess foreign material (rust, dirt, sand, etc.)		
	Reduced air flow	Cooling fan does not operate	Fan assembly	—	
		High resistance to fan rotation			
		Damaged fan blades			
		Damaged radiator shroud	—	—	
		Improper coolant mixture ratio	—	—	
		Poor coolant quality	—	Coolant viscosity	—
	Insufficient coolant	Coolant leaks	Cooling hose	Loose clamp	
				Cracked hose	
			Water pump	Poor sealing	
Radiator cap			Loose		
			Poor sealing		
Radiator			O-ring for damage, deterioration or improper fitting		
		Cracked radiator tank			
		Cracked radiator core			
	Reservoir tank	Cracked reservoir tank			
Overflowing reservoir tank	Exhaust gas leaks into cooling system	Cylinder head deterioration			
		Cylinder head gasket deterioration			

OVERHEATING CAUSE ANALYSIS

< SERVICE INFORMATION >

	Symptom		Check items			
Except cooling system parts malfunction	—	Overload on engine	Abusive driving	High engine rpm under no load	A	
				Driving in low gear for extended time	CO	
				Driving at extremely high speed		
					Powertrain system malfunction	C
					Installed improper size wheels and tires	D
					Dragging brakes	
			Improper ignition timing	E		
	Blocked or restricted air flow	Blocked bumper	—		E	
		Blocked radiator grille	Installed car brassiere		F	
			Mud contamination or paper clogging	—		
		Blocked radiator	—			
		Blocked condenser	Blocked air flow		G	
Installed large fog lamp						

A
CO
C
D
E
F
G
H
I
J
K
L
M
N
O
P

COOLING SYSTEM

< SERVICE INFORMATION >

COOLING SYSTEM

Cooling Circuit

INFOID:000000001720724

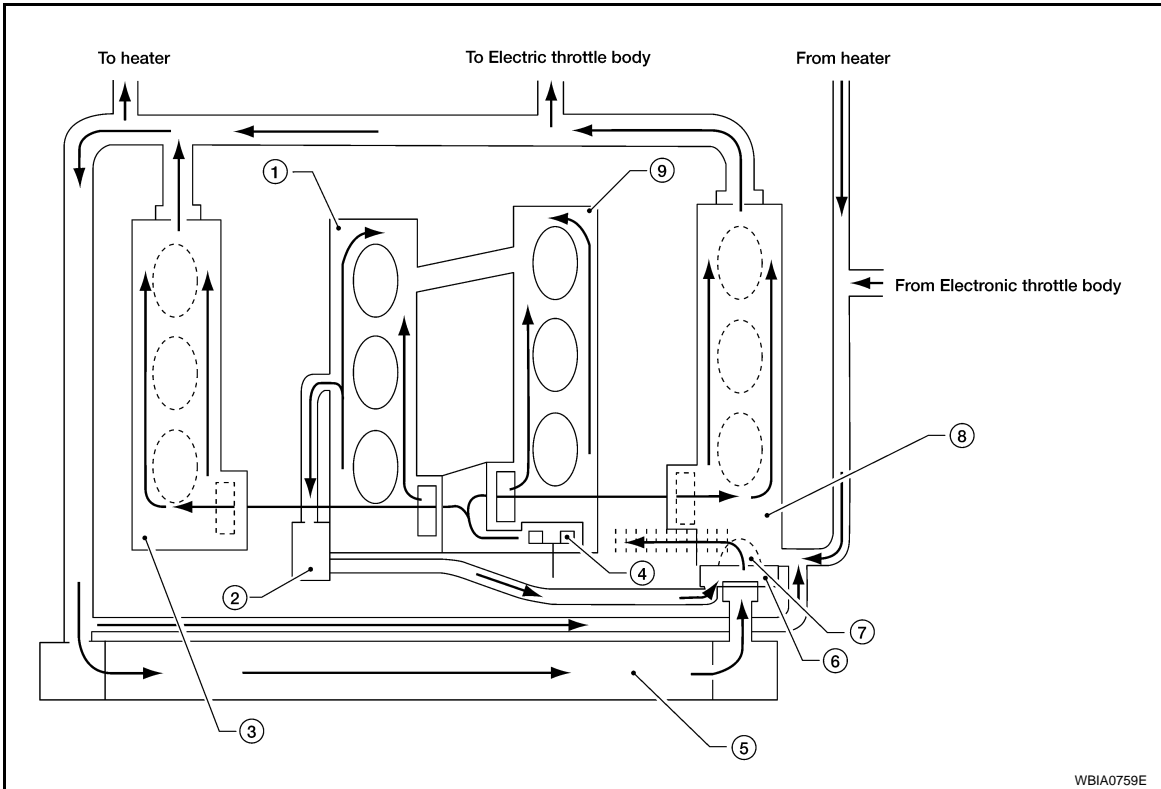

WBIA0759E

- | | | |
|------------------------|-----------------------|------------------------|
| 1. Cylinder block (RH) | 2. Oil cooler | 3. Cylinder head (RH) |
| 4. Water pump | 5. Radiator | 6. Water inlet |
| 7. Thermostat | 8. Cylinder head (LH) | 9. Cylinder block (LH) |

Schematic

INFOID:000000001720725

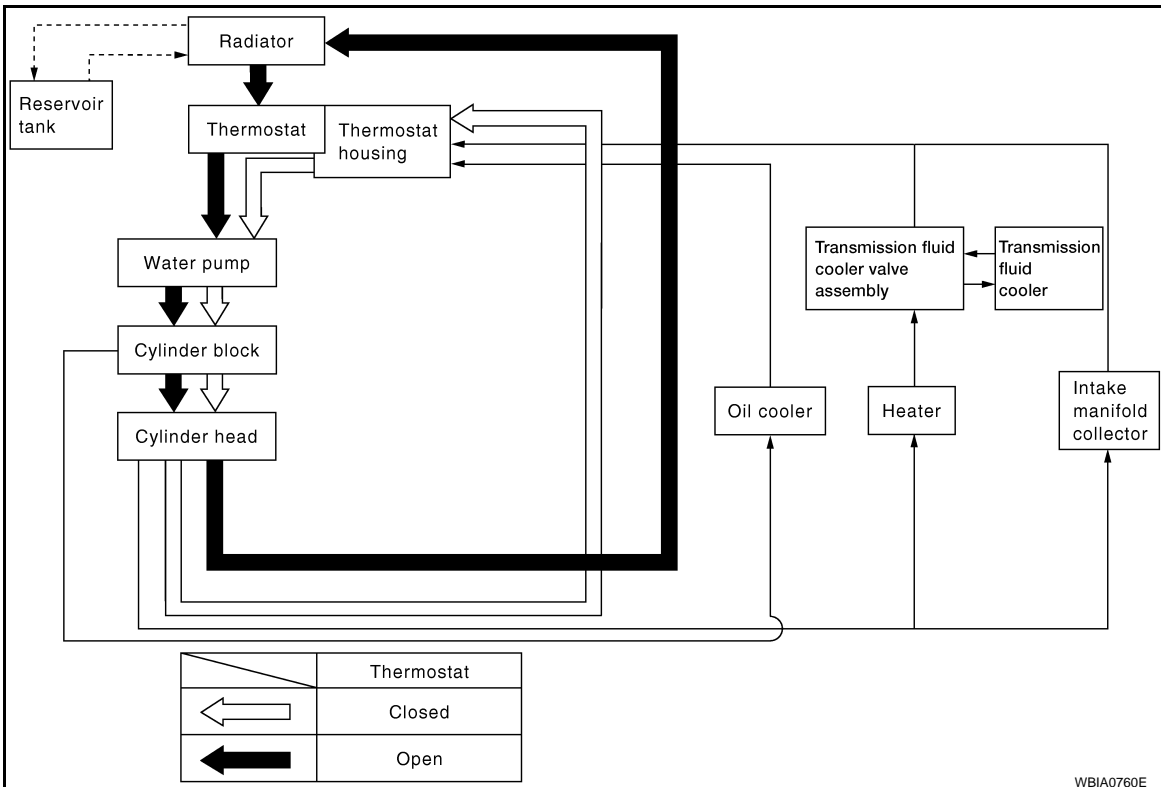

WBIA0760E

ENGINE COOLANT

< SERVICE INFORMATION >

ENGINE COOLANT

System Inspection

INFOID:000000001720726

WARNING:

- **Never remove the radiator cap when the engine is hot. Serious burns could occur from high pressure coolant escaping from the radiator.**
- **Wrap a thick cloth around the cap. Slowly push down and turn it a quarter turn to allow built-up pressure to escape. Carefully remove the cap by pushing down and turning it all the way.**

CHECKING COOLING SYSTEM HOSES

Check hoses for the following:

- Improper attachment
- Leaks
- Cracks
- Damage
- Loose connections
- Chafing
- Deterioration

CHECKING RESERVOIR LEVEL

- Check if the reservoir tank coolant level is within MIN to MAX range when the engine is cool.
- Adjust coolant level if it is too much or too little.

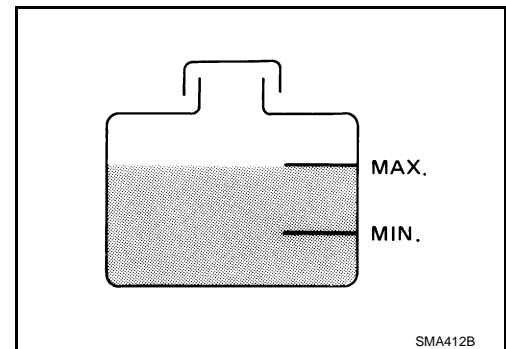

CHECKING COOLING SYSTEM FOR LEAKS

To check for leaks, apply pressure to the cooling system using Tool.

Tool number : EG17650301 (J-33984-A)

Testing pressure : 157 kPa (1.6 kg/cm², 23 psi)

WARNING:

Never remove the radiator cap when the engine is hot. Serious burns could occur from high pressure coolant escaping from the radiator.

CAUTION:

Higher pressure than specified may cause radiator damage.

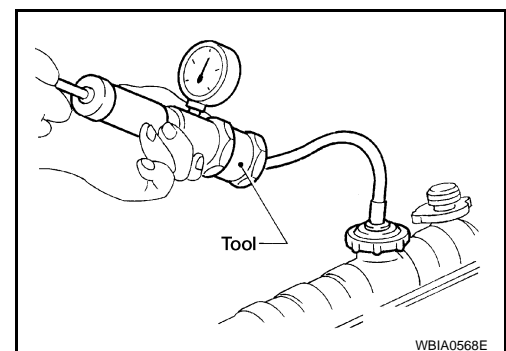

CHECKING RADIATOR CAP

1. Inspect the radiator cap.
 - Replace the cap if the metal plunger cannot be seen around the edge of the black rubber gasket.
 - Replace the cap if deposits of waxy residue or other foreign material are on the black rubber gasket or the metal retainer.

NOTE:

Thoroughly wipe out the radiator filler neck to remove any waxy residue or foreign material.

ENGINE COOLANT

< SERVICE INFORMATION >

2. Pull the negative-pressure valve to open it and check that it closes completely when released.
 - Check that there is no dirt or damage on the valve seat of the radiator cap negative-pressure valve.
 - Check that there are no abnormalities in the opening and closing conditions of the negative-pressure valve.

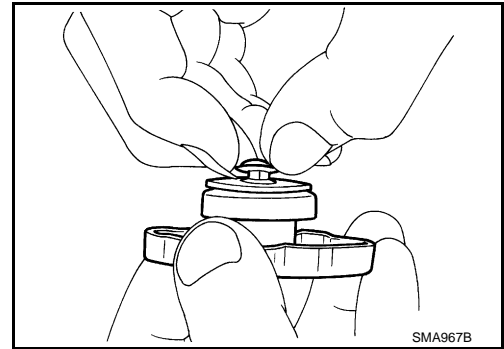

3. Check radiator cap relief pressure using Tool.

Tool number : EG17650301 (J-33984-A)

Standard: 78 – 98 kPa (0.8 – 1.0 kg/cm², 11 – 14 psi)

Limit: 59 kPa (0.6 kg/cm², 9 psi)

- When connecting the radiator cap to the tester, apply water or coolant to the cap seal surface.
- Replace the radiator cap if there is an abnormality in the negative-pressure valve, or if the open-valve pressure is outside of the standard values.

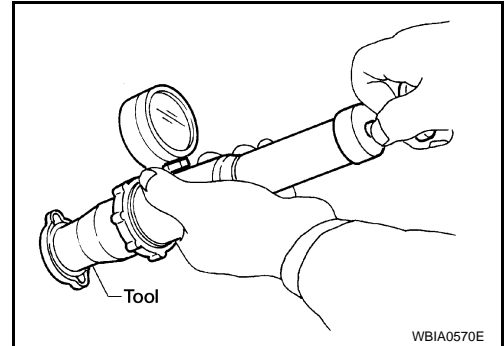

CHECKING RADIATOR

Check radiator for sludge or clogging. If necessary, clean radiator as follows:

- Be careful not to bend or damage the radiator fins.
 - When radiator is cleaned without removing, remove all surrounding parts such as cooling fan shroud and horns. Then tape the harness and electrical connectors to prevent water from entering.
1. Apply water by hose to the back side of the radiator core, with the hose pointed vertically downward.
 2. Apply water again to all radiator core surfaces once per minute.
 3. Stop washing if any dirt no longer rinse out from the radiator.
 4. Blow air into the back side of radiator core, with the air hose pointed vertically downward.
 - Use compressed air lower than 490 kPa (5 kg/cm², 71 psi) and keep distance more than 30 cm (11.8 in).
 5. Blow air again into all the radiator core surfaces once per minute until no water sprays out.
 6. Check for leaks.

Changing Engine Coolant

INFOID:000000001720727

WARNING:

- To avoid being scalded, never change the coolant when the engine is hot.
- Wrap a thick cloth around cap and carefully remove the cap. First, turn the cap a quarter of a turn to release built-up pressure. Then turn the cap all the way.

DRAINING ENGINE COOLANT

1. Remove engine undercover, using power tools.
2. Open radiator drain plug at the bottom of radiator and remove the radiator filler cap. This is the only step required for a partial cooling system drain.
3. If removing the heater core, remove the upper heater hose from the engine coolant outlet and apply moderate air pressure of 15 psi (103.46 kPa, 1.055 kg-cm²) maximum for 30 seconds into the hose to blow out excess coolant from the core.
4. For a complete cooling system drain, remove the reservoir tank and drain the coolant, and then clean the reservoir tank before installation.

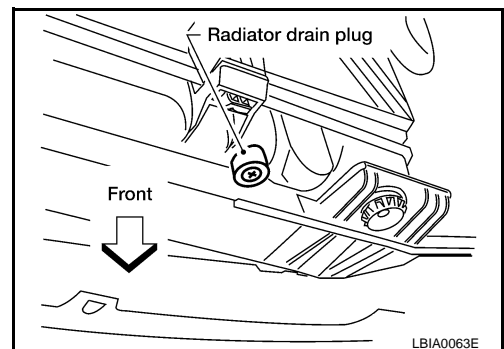

ENGINE COOLANT

< SERVICE INFORMATION >

- Do not allow coolant to spill on the drive belts.
5. When performing a complete cooling system drain (to remove the engine or for engine repair), remove the cylinder block front drain plug and the cylinder block RH drain plug.
 6. Check the drained coolant for contaminants such as rust, corrosion or discoloration.
 - If contaminated, flush the engine cooling system. Follow the "FLUSHING COOLING SYSTEM" procedure.

REFILLING ENGINE COOLANT

1. Install the radiator drain plug. If the cooling system was drained completely, install the reservoir tank and the cylinder block drain plugs.
 - The radiator must be completely empty of coolant and water.
 - Apply sealant to the threads of the cylinder block drain plugs. Use Genuine High Performance Thread Sealant or equivalent. Refer to [GI-42, "Recommended Chemical Product and Sealant"](#).

Radiator drain plug : Refer to [CO-13, "Removal and Installation"](#).

Cylinder block front drain plug : Refer to [EM-113, "Disassembly and Assembly"](#).

Cylinder block RH drain plug : Refer to [EM-113, "Disassembly and Assembly"](#).

2. If disconnected, reattach the upper radiator hose at the engine side.
3. Set the vehicle heater controls to the full HOT and heater ON position. Turn the vehicle ignition ON with the engine OFF as necessary to activate the heater mode.
4. Install the Tool by installing the radiator cap adapter onto the radiator neck opening. Then attach the gauge body assembly with the refill tube and the venturi assembly to the radiator cap adapter.

Tool number : KV991J0070 (J-45695)

5. Insert the refill hose into the coolant mixture container that is placed at floor level. Make sure the ball valve is in the closed position.
 - Use Genuine NISSAN Long Life Anti-freeze coolant or equivalent, mixed 50/50 with distilled water or demineralized water. Refer to [MA-11, "Engine Oil Recommendation"](#).

Engine coolant capacity (with reservoir at MAX level) : Refer to [MA-11, "Fluids and Lubricants"](#).

6. Install an air hose to the venturi assembly, the air pressure must be within specification.

Compressed air supply pressure : 5.7 - 8.5 kPa (5.6 - 8.4 kg/cm², 80 - 120 psi)

CAUTION:

The compressed air supply must be equipped with an air dryer.

7. The vacuum gauge will begin to rise and there will be an audible hissing noise. During this process open the ball valve on the refill hose slightly. Coolant will be visible rising in the refill hose. Once the refill hose is full of coolant, close the ball valve. This will purge any air trapped in the refill hose.

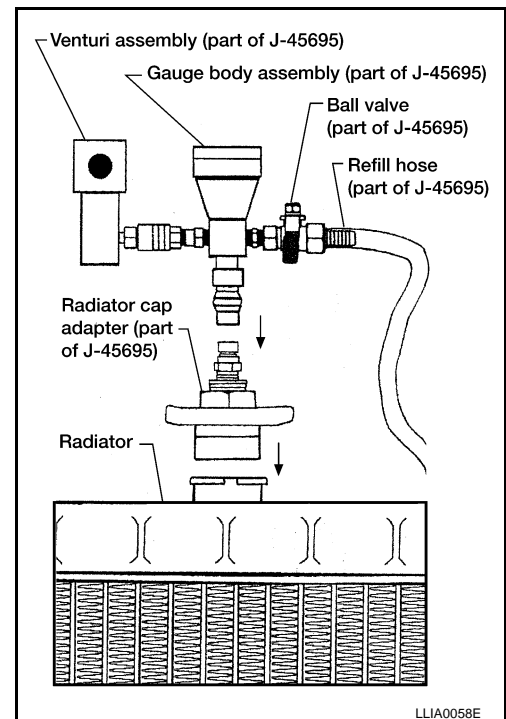

ENGINE COOLANT

< SERVICE INFORMATION >

8. Continue to draw the vacuum until the gauge reaches 28 inches of vacuum. The gauge may not reach 28 inches in high altitude locations, use the vacuum specifications below based on the altitude above sea level.

Altitude above sea level	Vacuum gauge reading
0 - 100 m (328 ft)	: 28 inches of vacuum
300 m (984 ft)	: 27 inches of vacuum
500 m (1,641 ft)	: 26 inches of vacuum
1,000 m (3,281 ft)	: 24 - 25 inches of vacuum

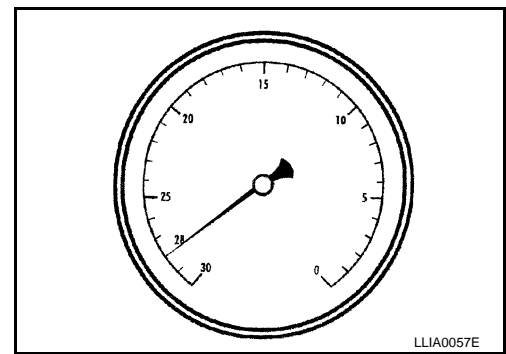

9. When the vacuum gauge has reached the specified amount, disconnect the air hose and wait 20 seconds to see if the system loses any vacuum. If the vacuum level drops, perform any necessary repairs to the system and repeat steps 6 - 8 to bring the vacuum to the specified amount. Recheck for any leaks.
10. Place the coolant container (with the refill hose inserted) at the same level as the top of the radiator. Then open the ball valve on the refill hose so the coolant will be drawn up to fill the cooling system. The cooling system is full when the vacuum gauge reads zero.

CAUTION:

Do not allow the coolant container to get too low when filling, to avoid air from being drawn into the cooling system.

11. Remove the Tool from the radiator neck opening.
12. Fill the cooling system reservoir tank to the specified level and install the radiator cap. Run the engine to warm up the cooling system and top up the system as necessary.

FLUSHING COOLING SYSTEM

1. Fill the radiator from the filler neck above the radiator upper hose and reservoir tank with clean water and reinstall radiator filler cap.
2. Run the engine and warm it up to normal operating temperature.
3. Rev the engine two or three times under no-load.
4. Stop the engine and wait until it cools down.
5. Drain the water from the system. Refer to [MA-15. "Changing Engine Coolant"](#).
6. Repeat steps 1 through 5 until clear water begins to drain from the radiator.

RADIATOR

< SERVICE INFORMATION >

RADIATOR

Removal and Installation

INFOID:000000001720728

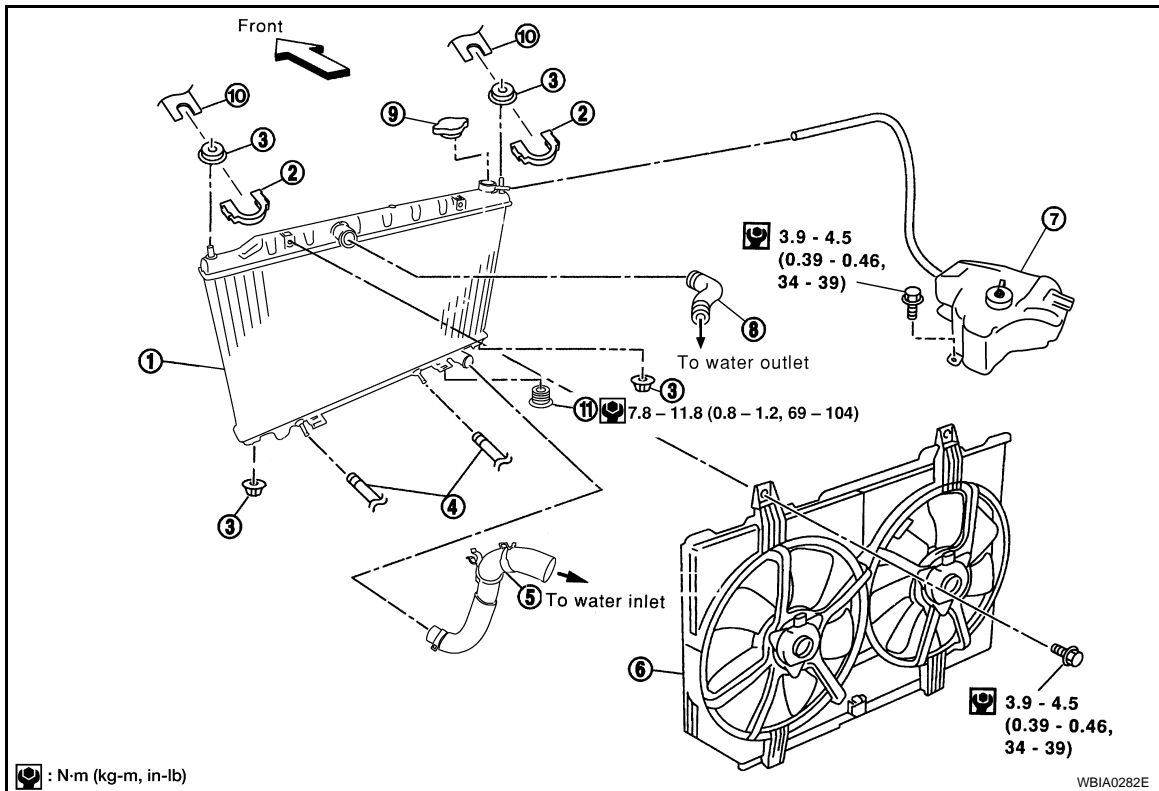

- | | | |
|--|--------------------------|--------------------------|
| 1. Radiator | 2. Radiator upper clip | 3. Mounting rubber |
| 4. CVT fluid cooler hose (if equipped) | 5. Radiator hose (lower) | 6. Radiator fan assembly |
| 7. Reservoir tank | 8. Radiator hose (upper) | 9. Radiator filler cap |
| 10. Radiator core connection | 11. Radiator drain plug | |

WARNING:

Never remove the radiator cap when the engine is hot. Serious burns could occur from high pressure coolant escaping from the radiator.

REMOVAL

1. Drain the coolant from the radiator. Refer to [MA-15. "Changing Engine Coolant"](#).

CAUTION:

Perform when engine is cold.

2. Remove fresh air duct. Refer to [EM-16. "Removal and Installation"](#).
3. Disconnect radiator upper and lower hoses.
4. Remove the CVT fluid cooler hoses, if equipped.
 - Plug hoses to avoid leakage of CVT fluid.
5. Disconnect the reservoir tank hose.

RADIATOR

< SERVICE INFORMATION >

6. Remove the radiator upper clips by pulling the tabs outside to release the lock, as shown.

CAUTION:

To prevent damage, do not pull lock tabs excessively.

7. Remove cooling fan assembly to radiator bolts.
8. Remove the radiator assembly.

CAUTION:

Do not damage or scratch air conditioner condenser and radiator core when removing.

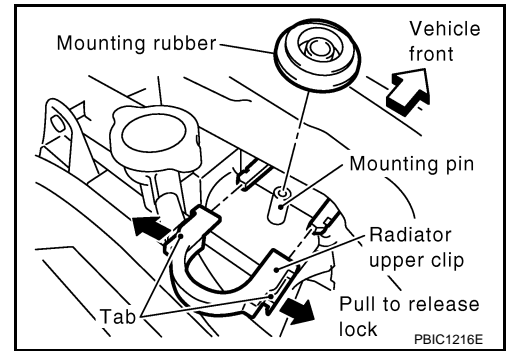

INSTALLATION

Installation is in the reverse order of removal, paying attention to the following.

- Fill the radiator with coolant. Refer to [MA-15. "Changing Engine Coolant"](#).

Installation of Radiator Upper Clip

- Install radiator upper clip on radiator core connection with the following procedure:

1. Install the rubber on mounting pin of radiator core.
2. Align the radiator upper clip with the radiator core connector, then insert the radiator upper clip straight into the radiator core connections until a click is heard.
3. After connecting the radiator upper clip, use the following method to make sure it is fully connected.
 - Visually confirm that the two radiator upper clips are connected to the radiator core connections.
 - Move the radiator upper clip and the radiator core forward and backward to make sure they are securely connected.

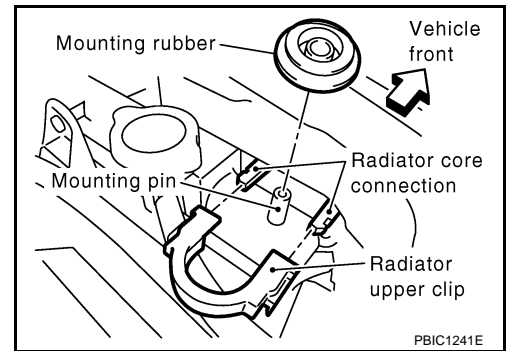

COOLING FAN

< SERVICE INFORMATION >

COOLING FAN

Removal and Installation

INFOID:000000001720729

REMOVAL

WARNING:

Never remove the radiator cap when the engine is hot. Serious burns could occur from high pressure coolant escaping from the radiator

1. Drain engine coolant from radiator. Refer to [CO-10. "Changing Engine Coolant"](#).

CAUTION:

Perform when engine is cold.

2. Remove air cleaner duct assembly. Refer to [EM-16. "Removal and Installation"](#).
3. Disconnect radiator upper hose.
4. Disconnect fan motor connectors.
5. Remove radiator cooling fan assembly.

INSTALLATION

Install in the reverse order of removal.

- Cooling fan is controlled by ECM. For details, refer to [EC-433](#).

Disassembly and Assembly of Radiator Fan

INFOID:000000001720730

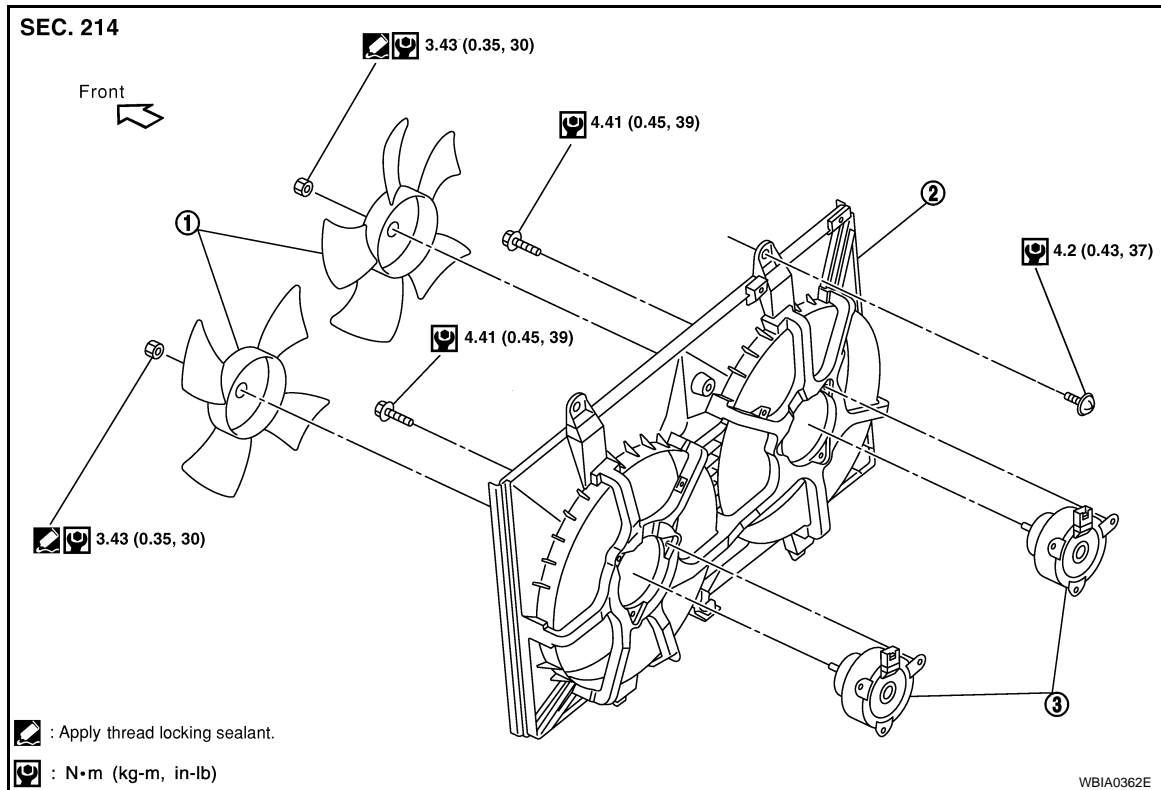

1. Fan blade

2. Fan shroud

3. Fan motor

DISASSEMBLY

1. Remove fan blade.
2. Remove fan motor from fan shroud.

ASSEMBLY

Assembly is in the reverse order of disassembly.

WATER PUMP

< SERVICE INFORMATION >

WATER PUMP

Removal and Installation

INFOID:000000001720731

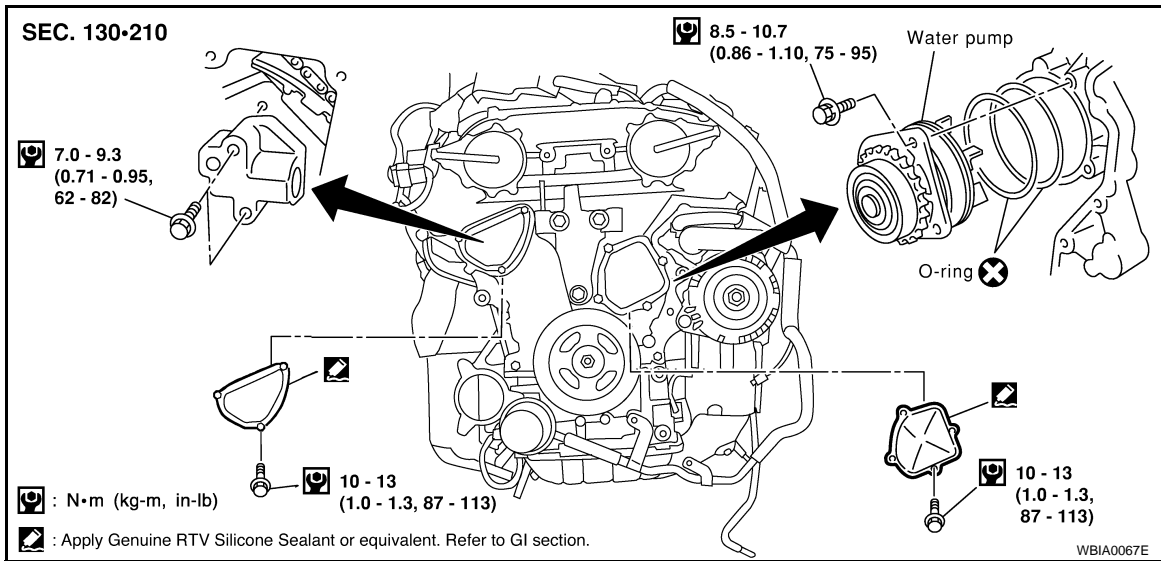

CAUTION:

- When removing water pump assembly, be careful not to get coolant on drive belt.
- Water pump cannot be disassembled and should be replaced as a unit.
- After installing water pump, connect hose and clamp securely, then check for leaks using radiator cap tester.

REMOVAL

1. Drain coolant from radiator. Refer to [CO-10. "Changing Engine Coolant"](#).

CAUTION:

Perform when the engine is cold.

2. Remove engine coolant reservoir tank. Refer to [CO-13. "Removal and Installation"](#).
3. Reposition IPDM/ER aside. Refer to [PG-29. "Removal and Installation of IPDM E/R"](#).
4. Remove RH wheel and tire and the splash shield.
5. Remove drive belts.
6. Remove idler pulley, then the power steering and generator adjusting bars.
7. Support engine and remove the front engine insulator and bracket. Refer to [EM-109. "Removal and Installation"](#).
8. Remove water drain plug on water pump side of cylinder block.
9. Remove chain tensioner cover and water pump cover.
10. Remove the timing chain tensioner assembly.
 - a. Pull the lever down and release the plunger stopper tab.

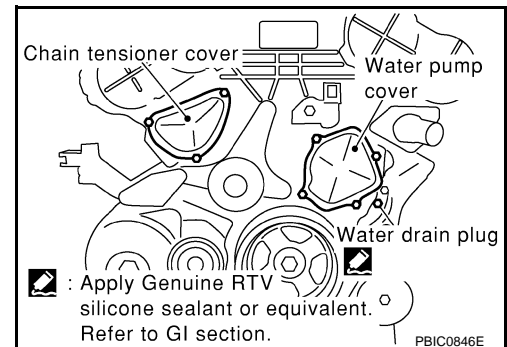

WATER PUMP

< SERVICE INFORMATION >

- b. Insert the stopper pin into the tensioner body hole to hold the lever and keep the stopper tab released.

NOTE:

An allen wrench [(2.5 mm (0.98 in))] is used for a stopper pin as an example.

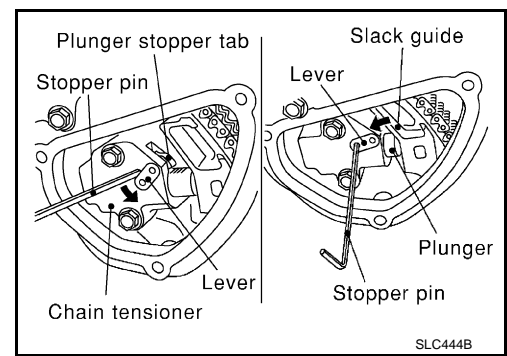

- c. Insert the plunger into the tensioner body by pressing the timing chain slack guide.
d. Keep the slack guide pressed and hold the plunger in by pushing the stopper pin deeper through the lever and into the tensioner body hole
e. Make a gap between water pump gear and timing chain, by turning the crankshaft pulley approximately 20° clockwise.

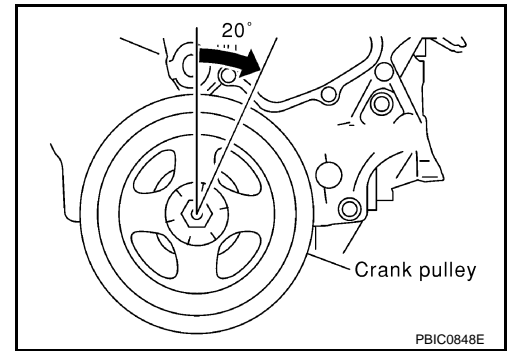

11. Remove timing chain tensioner.

CAUTION:

Be careful not to drop bolts inside chain case.

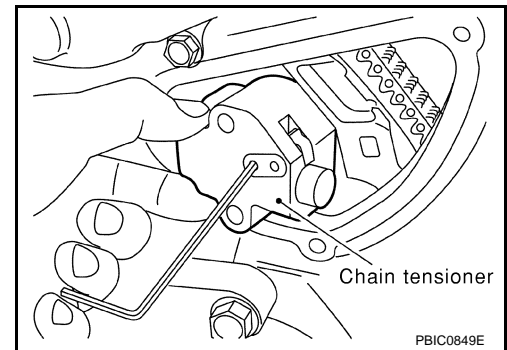

12. Remove the three water pump bolts. Make a gap between water pump gear and timing chain, by turning crankshaft pulley counterclockwise until timing chain loosens on water pump sprocket.

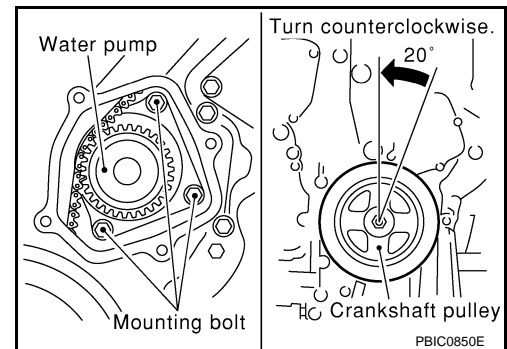

A
CO
C
D
E
F
G
H
I
J
K
L
M
N
O
P

WATER PUMP

< SERVICE INFORMATION >

13. Screw M8 bolts [pitch: 1.25 mm (0.49 in) length: approx. 50 mm (1.97 in)] into water pumps upper and lower bolt holes until they reach the timing chain case. Then, alternately tighten each bolt for a half turn, and pull out the water pump.
 - Pull straight out while preventing vane from contacting socket in installation area.
 - Remove water pump without causing sprocket to contact timing chain.
14. Remove M8 bolts and O-rings from water pump.

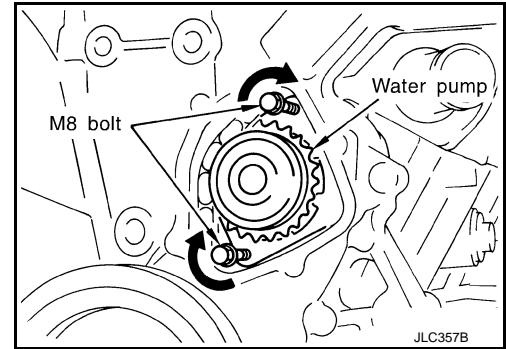

INSPECTION AFTER REMOVAL

1. Check for badly rusted or corroded water pump body assembly.
2. Check for rough operation due to excessive end play.

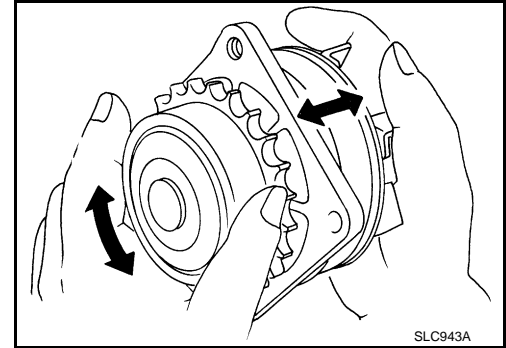

INSTALLATION

1. Install new O-rings to water pump.
2. Apply engine oil and coolant to the O-rings as shown.
 - Locate the O-ring with white paint mark to engine front side.

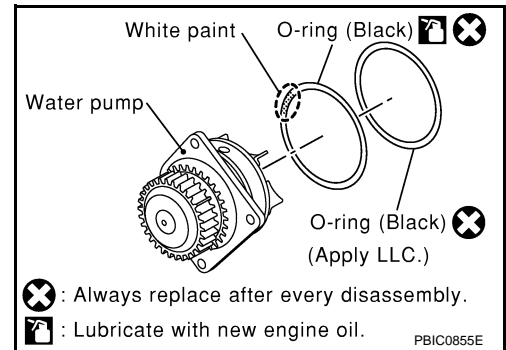

3. Install the water pump.

CAUTION:
Do not allow cylinder block to interfere with the O-rings when installing the water pump.

 - Check that timing chain and water pump sprocket are engaged.
 - Insert water pump by tightening bolts alternately and evenly.

Water pump bolts **8.5 – 10.7 N·m (0.86 – 1.10 kg·m, 75 – 95 in-lb)**

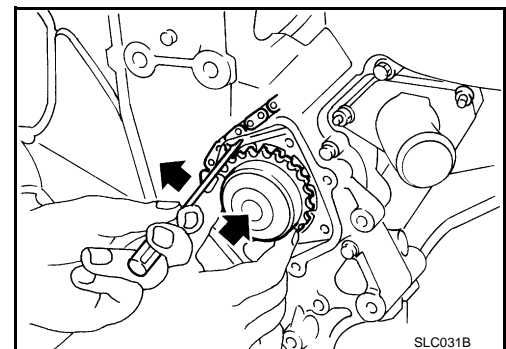

4. Remove dust and foreign material completely from backside of chain tensioner and from installation area of rear timing chain case.

WATER PUMP

< SERVICE INFORMATION >

- Turn the crankshaft pulley approximately 20° clockwise so that the timing chain on the timing chain tensioner side is loose.

NOTE:

When installing the timing chain tensioner, engine oil should be applied to the oil hole and tensioner.

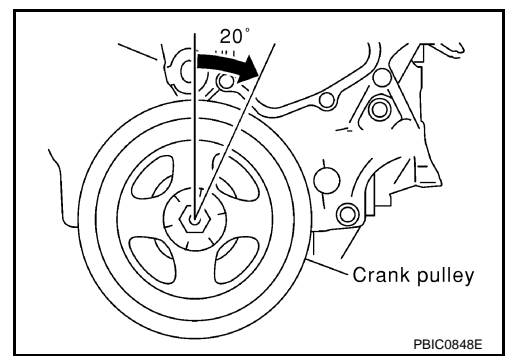

- Install the timing chain tensioner.

Timing chain tensioner bolts 7.0 – 9.3 N·m (0.71 – 0.95 kg·m, 62 – 82 in·lb)

- Remove the stopper pin.

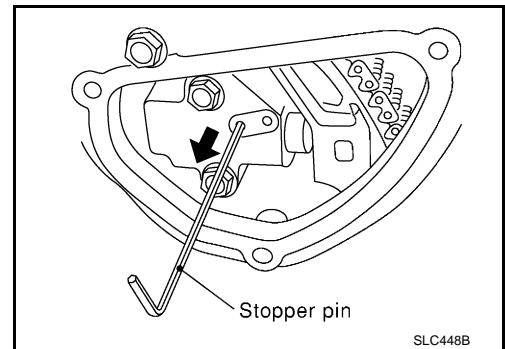

- Install chain tensioner cover and water pump cover.

- Before installing, remove all traces of sealant from mating surface of water pump cover and chain tensioner cover using a scraper. Also remove traces of sealant from the mating surface of the front cover.

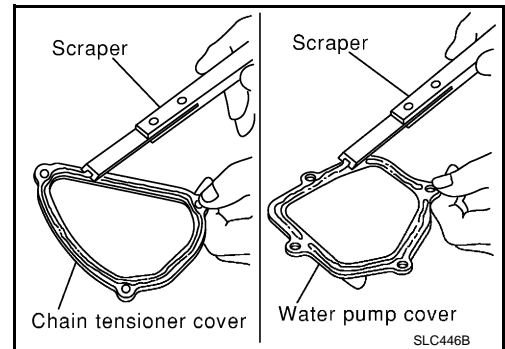

- Apply a continuous bead of RTV Silicone Sealant or equivalent, to mating surface of chain tensioner cover and water pump cover. Refer to [GI-42. "Recommended Chemical Product and Sealant"](#).

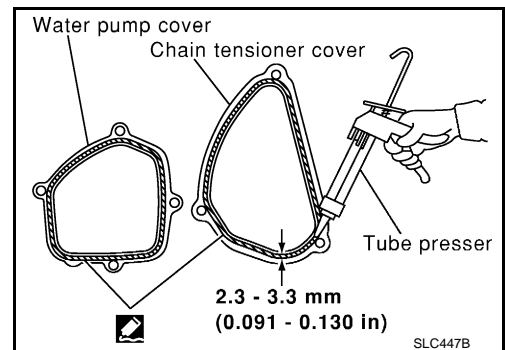

- Install water drain plug on water pump side of cylinder block. Refer to [CO-10. "Changing Engine Coolant"](#).
- Install idler pulley.

Idler pulley bolts : 28.4 N·m (2.9 kg·m, 21 ft·lb)

WATER PUMP

< SERVICE INFORMATION >

11. Installation of remaining components is in the reverse order of removal.
 - Refill engine coolant. Refer to [CO-10, "Changing Engine Coolant"](#).
 - After starting engine, let idle for three minutes, then rev engine up to 3,000 rpm under no load to purge air from the high-pressure chamber of the chain tensioner. The engine may produce a rattling noise. This indicates that air still remains in the chamber and is not a matter of concern.

THERMOSTAT AND THERMOSTAT HOUSING

< SERVICE INFORMATION >

THERMOSTAT AND THERMOSTAT HOUSING

Removal and Installation

INFOID:000000001720732

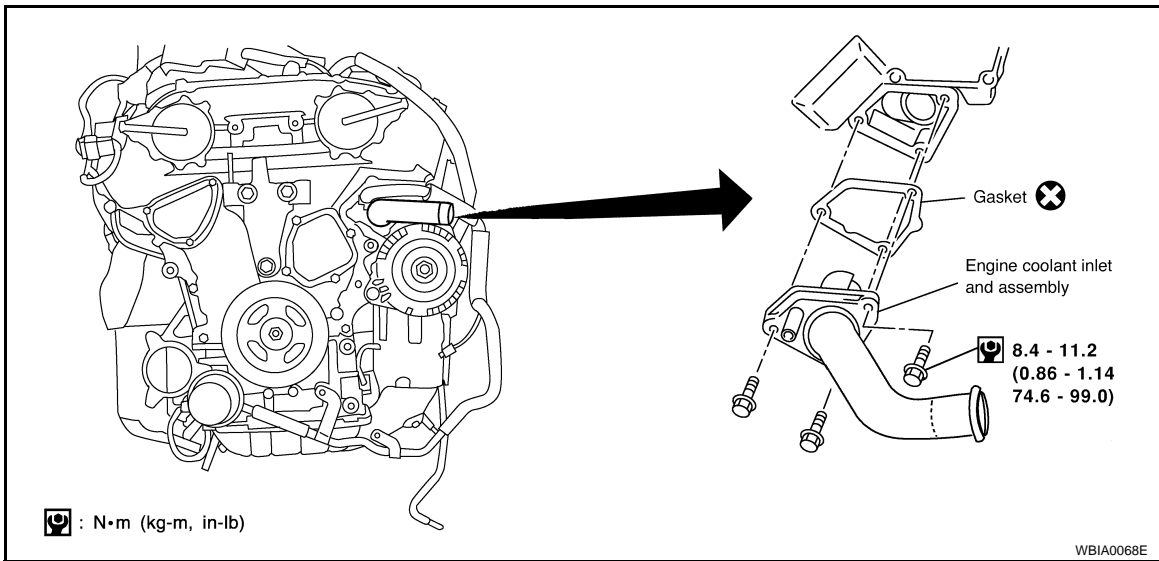

REMOVAL

1. Remove engine undercover using power tool.
2. Drain coolant from radiator. Refer to [CO-10, "Changing Engine Coolant"](#).
CAUTION:
Perform when engine is cool.
3. Remove drive belts. Refer to [EM-13](#).
4. Remove water drain plug on water pump side of the engine. Refer to [CO-10, "Changing Engine Coolant"](#).
5. Disconnect lower radiator hose.
6. Remove engine coolant inlet and thermostat assembly.
 - **Do not disassemble engine coolant inlet and thermostat. Replace them as a unit, if necessary.**

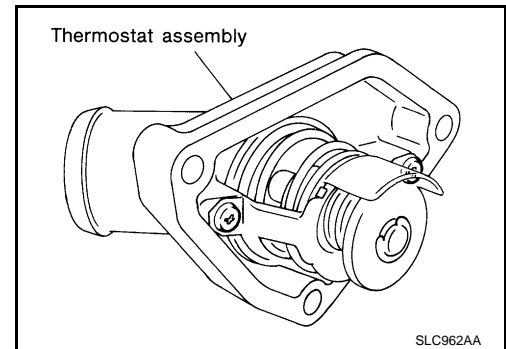

INSPECTION AFTER REMOVAL

1. Check valve seating condition at ordinary room temperatures. It should seat tightly.
2. Check valve opening temperature and maximum valve lift.

Thermostat	Standard Values
Valve opening temperature	82°C (180°F)
Valve lift	8.6 mm / 95°C (0.339 in / 203°F)

3. Then check if valve closes at 5°C (9°F) below valve opening temperature.

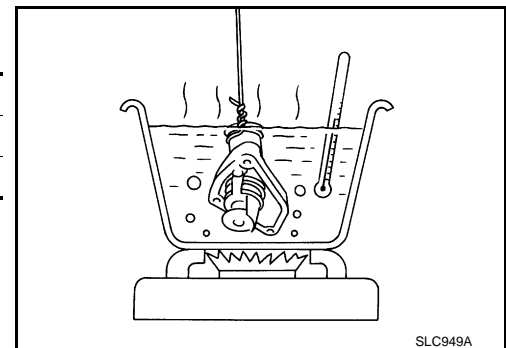

INSTALLATION

THERMOSTAT AND THERMOSTAT HOUSING

< SERVICE INFORMATION >

1. Install thermostat with jiggle valve facing upward.
 - **After installation, run engine for a few minutes, and check for leaks.**
 - **Be careful not to spill coolant over engine compartment. Use a rag to absorb coolant.**
2. Installation of the remaining components is in the reverse order of removal.

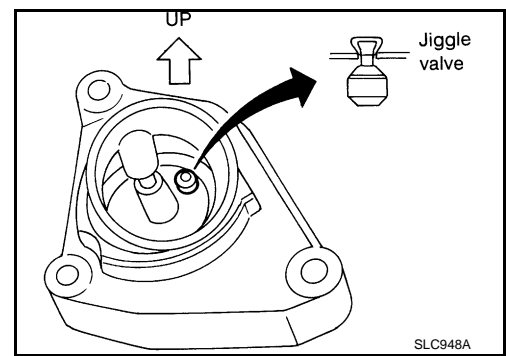

WATER OUTLET AND WATER PIPING

< SERVICE INFORMATION >

WATER OUTLET AND WATER PIPING

Removal and Installation

INFOID:000000001720733

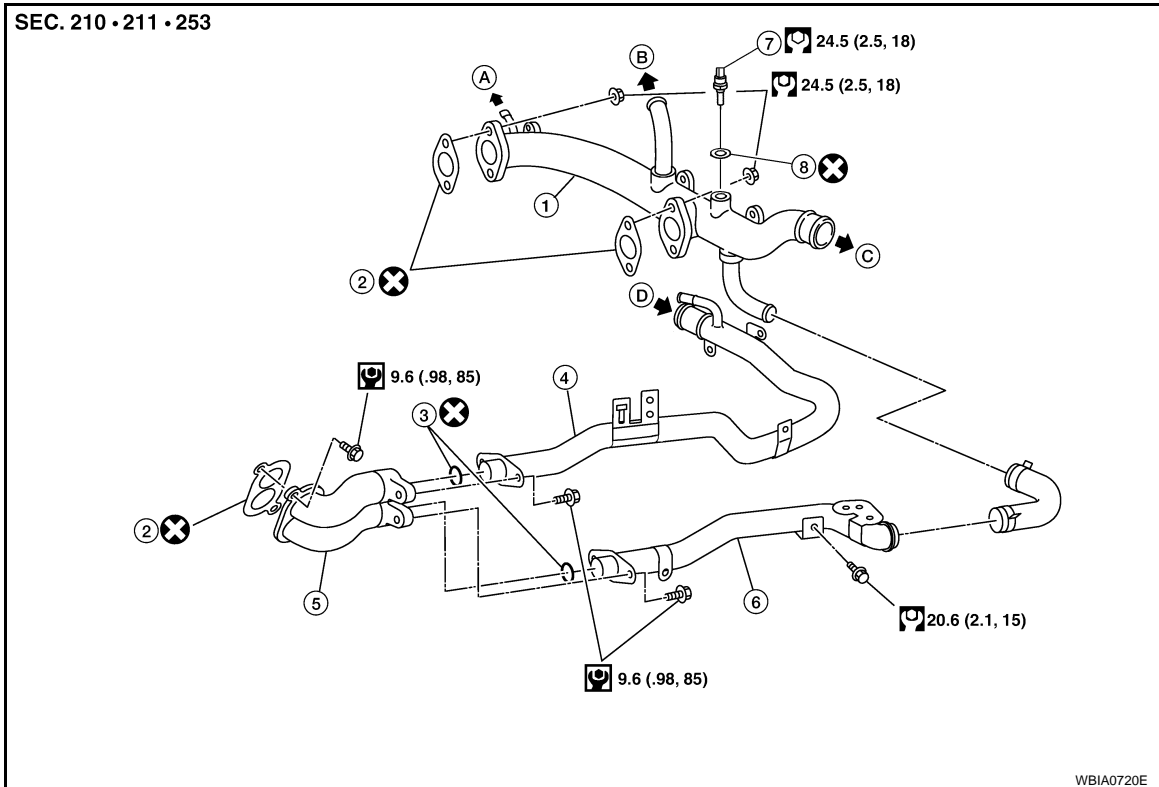

- | | | |
|--------------------------------------|--------------------|---|
| 1. Water outlet | 2. Gasket | 3. O-ring |
| 4. Heater pipe | 5. Water connector | 6. Water bypass pipe |
| 7. Engine coolant temperature sensor | 8. Washer | A. To electric throttle control actuator |
| B. To heater | C. To radiator | D. From heater or transmission oil cooler (if equipped) |

REMOVAL

1. Drain coolant from drain plugs on radiator and both sides of cylinder block. Refer to [CO-10. "Changing Engine Coolant"](#).
CAUTION:
Perform when the engine is cold.
2. Remove engine cover using power tool.
3. Remove air duct and air cleaner case assembly. Refer to [EM-16. "Removal and Installation"](#).
4. Remove radiator upper hose and heater hose.
5. Remove connector(s) from heater pipe.
6. Disconnect engine coolant temperature sensor electrical connector on water outlet.
7. Remove water outlet, heater pipe, water connector, and water bypass pipe nuts and bolts.

INSTALLATION

1. Installation is in the reverse order of removal.
 - Securely insert each hose, and install a clamp at a position where it does not interfere with the pipe bulge.
CAUTION:
Use new gasket for installation
 - When inserting heater pipe and water bypass pipe into water connector, apply neutral detergent to new O-rings.
CAUTION:
Use new O-rings for installation

WATER OUTLET AND WATER PIPING

< SERVICE INFORMATION >

- Refill engine coolant. Refer to [CO-10. "Changing Engine Coolant"](#).

SERVICE DATA AND SPECIFICATIONS (SDS)

< SERVICE INFORMATION >

SERVICE DATA AND SPECIFICATIONS (SDS)

Capacity

INFOID:000000001720734

ℓ (US gal, Imp gal)

Coolant capacity (With reservoir tank at MAX level)	8.5 (2 1/4, 1 7/8)
---	--------------------

Thermostat

INFOID:000000001720735

Valve opening temperature	82°C (180°F)
Valve lift	8.6 mm / 95°C (0.339 in / 203°F)

Radiator

INFOID:000000001720736

Unit: kPa (kg/cm², psi)

Cap relief pressure	Standard	78 – 98 (0.8 – 1.0, 11 – 14)
	Limit	59 (0.6, 9)
Radiator leak test pressure		157 (1.6, 23)

A
CO
C
D
E
F
G
H
I
J
K
L
M
N
O
P