

SECTION **ST**
STEERING SYSTEM

A
 B
 C
 D
 E
 F
ST
 H
 I
 J
 K
 L
 M
 N
 O
 P

CONTENTS

SYSTEM DESCRIPTION	3	POWER STEERING OIL PUMP	16
HEATED STEERING WHEEL	3	Inspection	16
System Diagram	3	REMOVAL AND INSTALLATION	17
System Description	3	STEERING WHEEL	17
Component Parts Location	3	Removal and Installation	17
Component Description	4	TILT MOTOR	18
WIRING DIAGRAM	5	Exploded View	18
HEATED STEERING WHEEL	5	Removal and Installation	18
Wiring Diagram	5	TELESCOPIC MOTOR	20
SYMPTOM DIAGNOSIS	8	Exploded View	20
NOISE, VIBRATION AND HARSHNESS		Removal and Installation	20
(NVH) TROUBLESHOOTING	8	STEERING COLUMN	22
NVH Troubleshooting Chart	8	Exploded View	22
PRECAUTION	9	Removal and Installation	23
PRECAUTIONS	9	STEERING GEAR AND LINKAGE	26
Precaution for Supplemental Restraint System		Exploded View	26
(SRS) "AIR BAG" and "SEAT BELT PRE-TEN-		Removal and Installation	26
SIONER"	9	POWER STEERING OIL PUMP	28
Service Notice or Precautions	9	Exploded View	28
PREPARATION	10	Removal and Installation	28
PREPARATION	10	HYDRAULIC LINE	29
Special Service Tool	10	Exploded View	29
Commercial Service Tool	11	Removal and Installation	30
PERIODIC MAINTENANCE	12	UNIT DISASSEMBLY AND ASSEMBLY ...	31
POWER STEERING FLUID	12	STEERING COLUMN	31
Inspection	12	Disassembly and Assembly	31
Draining	12	STEERING GEAR AND LINKAGE	33
Refilling	12	Exploded View	33
STEERING WHEEL	14	Disassembly	33
Inspection	14	Inspection	33
		Assembly	34

POWER STEERING OIL PUMP	36	Steering Wheel	37
Disassembly and Assembly	36	Steering Angle	37
SERVICE DATA AND SPECIFICATIONS		Steering Column	37
(SDS)	37	Steering Gear	38
SERVICE DATA AND SPECIFICATIONS		Oil Pump	39
(SDS)	37	Steering Fluid	39

HEATED STEERING WHEEL

< SYSTEM DESCRIPTION >

SYSTEM DESCRIPTION

HEATED STEERING WHEEL

System Diagram

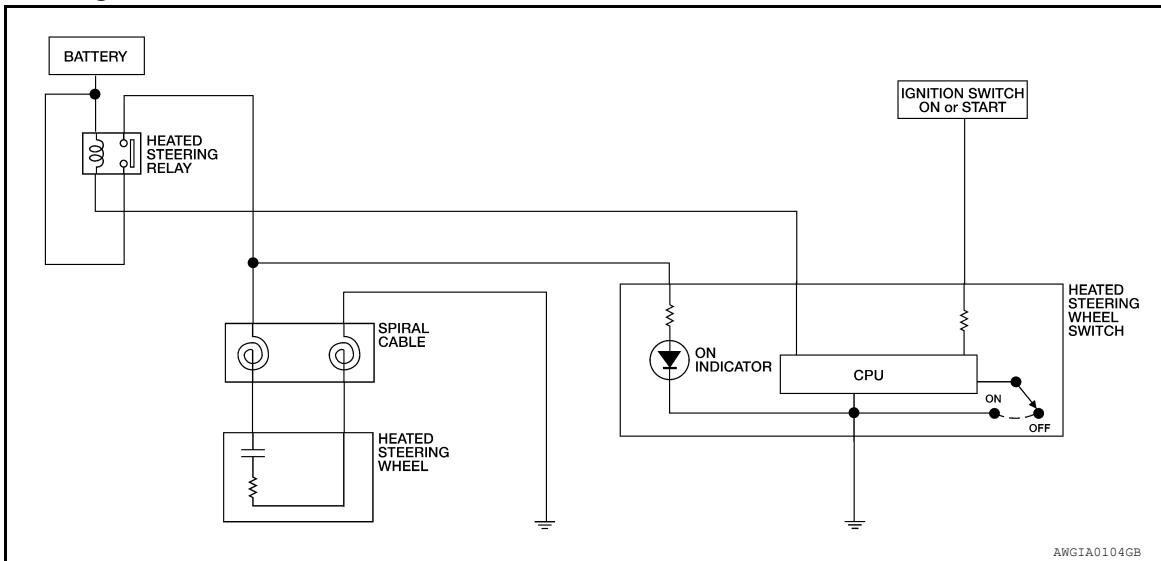

System Description

INFOID:000000006236452

The heated steering wheel switch controls the heated steering relay. When the switch is turned on, the relay is energized and the heated steering system will operate. The heated steering system will turn off when the steering wheel temperature reaches approximately 86° F (30° C). Heated steering system operation can also be canceled by pressing the heated steering wheel switch again.

NOTE:

If the surface temperature of the steering wheel is below 68° F (20° C), the system will heat the steering wheel and cycle off and on to maintain a temperature above 68° F (20° C). The indicator light will remain on as long as the system is on. Push the switch again to turn the heated steering wheel system off manually. The indicator light will go off.

Component Parts Location

INFOID:000000006236453

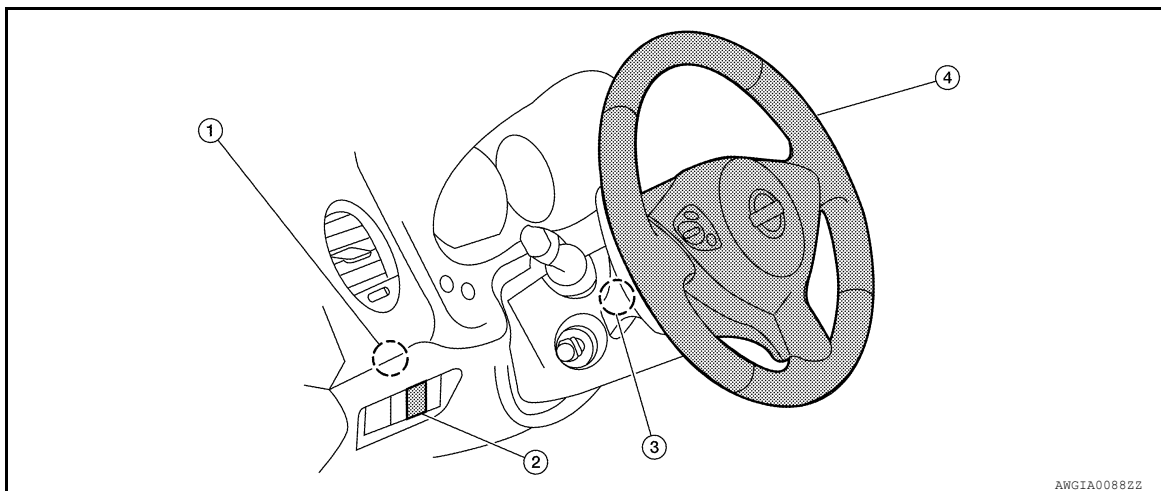

1. Heated steering relay M97
2. Heated steering wheel switch M96
3. Spiral cable M26
4. Heated steering wheel M114

HEATED STEERING WHEEL

< SYSTEM DESCRIPTION >

Component Description

INFOID:000000006236454

Heated steering wheel switch	<ul style="list-style-type: none">• Controls the heated steering relay and operates the heated steering wheel system.• Turns the indicator lamp ON when the system is activated.
Heated steering relay	<ul style="list-style-type: none">• Operates the heated steering system with the control signal from the heated steering wheel switch.
Heated steering wheel	<ul style="list-style-type: none">• Heats the heating element with the power supplied from the heated steering relay.

HEATED STEERING WHEEL

< WIRING DIAGRAM >

WIRING DIAGRAM

HEATED STEERING WHEEL

Wiring Diagram

INFOID:000000006236455

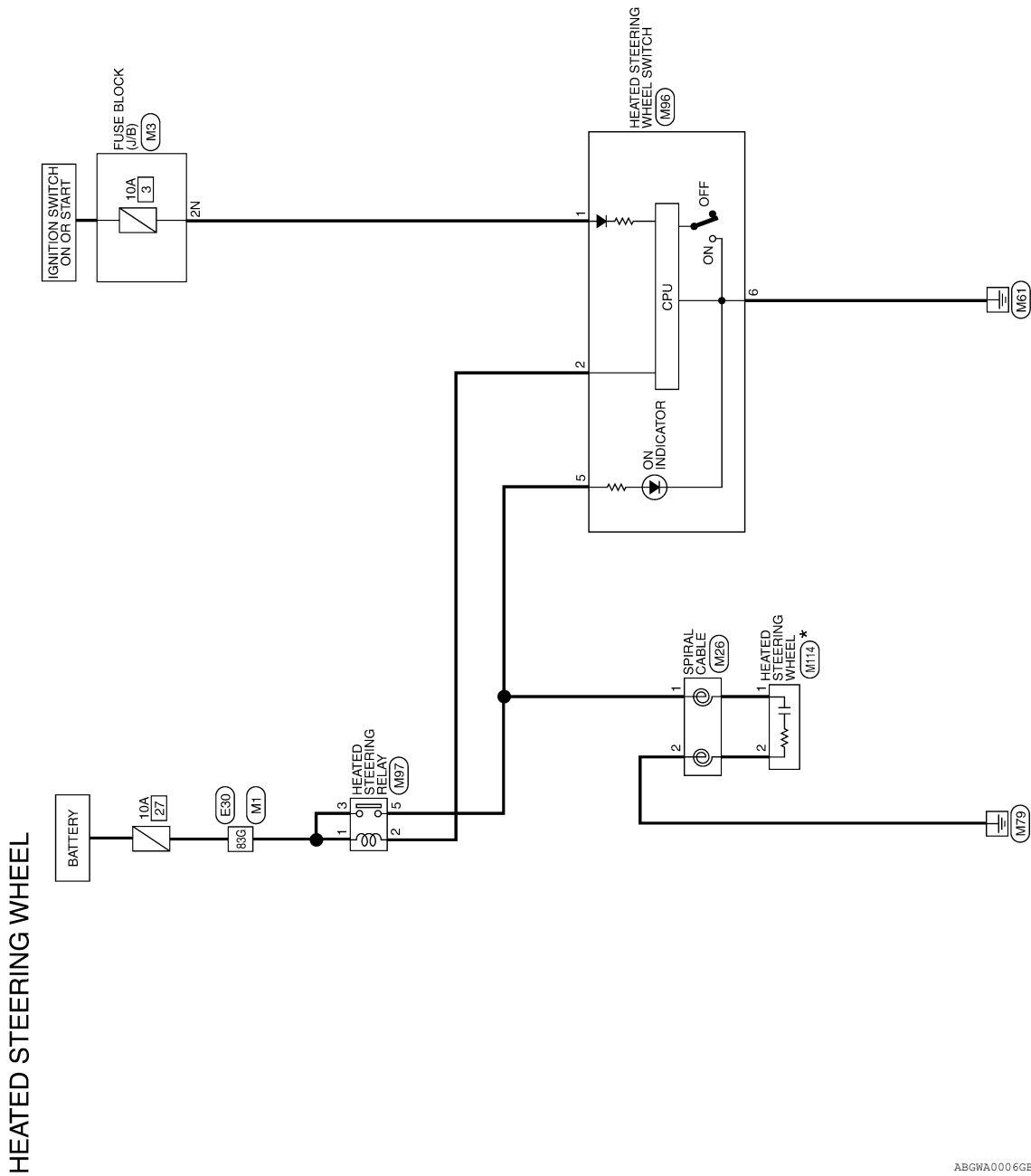

A
B
C
D
E
F
ST
H
I
J
K
L
M
N
O
P

HEATED STEERING WHEEL

< WIRING DIAGRAM >

HEATED STEERING WHEEL CONNECTORS

Connector No.	M1
Connector Name	WIRE TO WIRE
Connector Color	WHITE

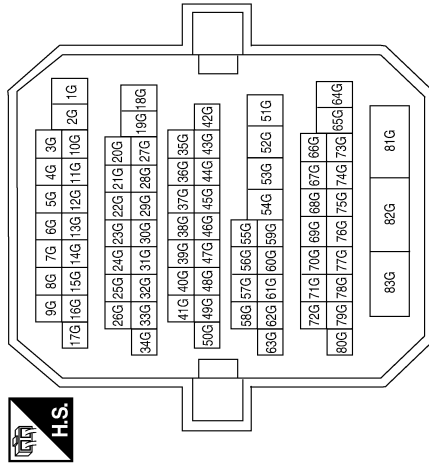

Terminal No.	Color of Wire	Signal Name
83G	B/W	-

Connector No.	M3
Connector Name	FUSE BLOCK (J/B)
Connector Color	WHITE

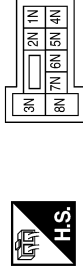

Terminal No.	Color of Wire	Signal Name
2N	G	-

Connector No.	M26
Connector Name	SPIRAL CABLE
Connector Color	WHITE



Terminal No.	Color of Wire	Signal Name
1	BR	-
2	B	-

Connector No.	M96
Connector Name	HEATED STEERING WHEEL SWITCH
Connector Color	WHITE



Terminal No.	Color of Wire	Signal Name
1	G	-
2	B/R	-
5	BR	-
6	B	-

Connector No.	M97
Connector Name	HEATED STEERING RELAY
Connector Color	BLUE



Terminal No.	Color of Wire	Signal Name
1	B/W	-
2	B/R	-
3	B/W	-
5	BR	-

HEATED STEERING WHEEL

< WIRING DIAGRAM >

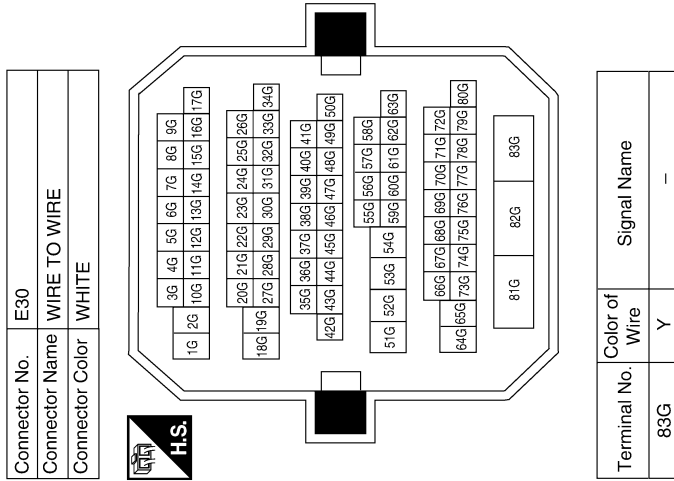

A
B
C
D
E
F
ST

H
I
J
K
L
M
N
O
P

PRECAUTIONS

< PRECAUTION >

PRECAUTION

PRECAUTIONS

Precaution for Supplemental Restraint System (SRS) "AIR BAG" and "SEAT BELT PRE-TENSIONER"

INFOID:000000006236457

The Supplemental Restraint System such as "AIR BAG" and "SEAT BELT PRE-TENSIONER", used along with a front seat belt, helps to reduce the risk or severity of injury to the driver and front passenger for certain types of collision. This system includes seat belt switch inputs and dual stage front air bag modules. The SRS system uses the seat belt switches to determine the front air bag deployment, and may only deploy one front air bag, depending on the severity of a collision and whether the front occupants are belted or unbelted. Information necessary to service the system safely is included in the SR and SB section of this Service Manual.

WARNING:

- To avoid rendering the SRS inoperative, which could increase the risk of personal injury or death in the event of a collision which would result in air bag inflation, all maintenance must be performed by an authorized NISSAN/INFINITI dealer.
- Improper maintenance, including incorrect removal and installation of the SRS, can lead to personal injury caused by unintentional activation of the system. For removal of Spiral Cable and Air Bag Module, see the SR section.
- Do not use electrical test equipment on any circuit related to the SRS unless instructed to in this Service Manual. SRS wiring harnesses can be identified by yellow and/or orange harnesses or harness connectors.

PRECAUTIONS WHEN USING POWER TOOLS (AIR OR ELECTRIC) AND HAMMERS

WARNING:

- When working near the Airbag Diagnosis Sensor Unit or other Airbag System sensors with the Ignition ON or engine running, DO NOT use air or electric power tools or strike near the sensor(s) with a hammer. Heavy vibration could activate the sensor(s) and deploy the air bag(s), possibly causing serious injury.
- When using air or electric power tools or hammers, always switch the Ignition OFF, disconnect the battery, and wait at least 3 minutes before performing any service.

Service Notice or Precautions

INFOID:000000006236459

- In case of removing steering gear assembly, make the final tightening with grounded and unloaded vehicle condition, and then check wheel alignment.
- Observe the following precautions when disassembling.
 - Before disassembly, thoroughly clean the outside of the unit.
 - Disassembly should be done in a clean work area. It is important to prevent the internal parts from becoming contaminated by dirt or other foreign matter.
 - For easier and proper assembly, place disassembled parts in order on a parts rack.
 - Use nylon cloth or paper towels to clean the parts; common shop rags can leave lint that might interfere with their operation.
 - Do not reuse non-reusable parts.
 - Before assembling, apply the specified grease to the directed parts.

PREPARATION

< PREPARATION >

PREPARATION

PREPARATION

Special Service Tool

INFOID:000000006236460

The actual shapes of Kent-Moore tools may differ from those of special service tools illustrated here.

Tool number (Kent-Moore No.) Tool name	Description
ST27180001 (J-25726-A) Steering wheel puller	Removing steering wheel
ST3127S000 (J-25765-A) Preload gauge 1. GG9103000 (J-25765-A) Torque wrench 2. HT62940000 (-) Socket adapter 3. HT62900000 (-) Socket adapter	Inspecting of rotating torque for ball joint and steering column
KV48103500 (J-26357) Pressure gauge	Measuring oil pump relief pressure
KV40107300 (-) Boot clamp crimping tool	Installing boot clamps
KV48102500 (J-33914) Pressure gauge adapter	Measuring oil pump relief pressure

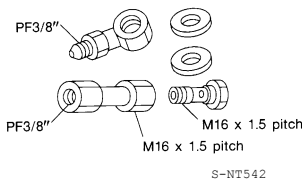
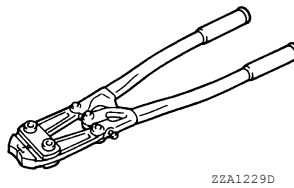
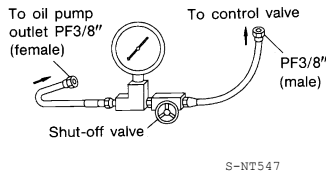
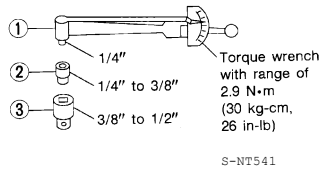
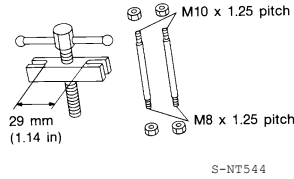

PREPARATION

< PREPARATION >

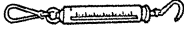
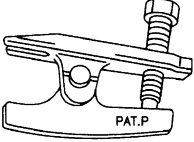
Tool number (Kent-Moore No.) Tool name	Description	A
— (J-44372) Spring gauge  LST024	Measuring steering wheel turning force, rack sliding force and ball joint swinging force	B
HT72520000 (J-25730-A) Ball joint remover  NT146	Removing ball joint	C
		D
		E
		F

Commercial Service Tool

INFOID:000000008107996

ST

Tool name	Description	H
Power tool  PIIB1407E	Loosening bolts, screws and nuts.	I
		J
		K
		L
		M
		N
		O
		P

POWER STEERING FLUID

< PERIODIC MAINTENANCE >

PERIODIC MAINTENANCE

POWER STEERING FLUID

Inspection

INFOID:000000006236462

FLUID LEVEL

- Check fluid level with engine stopped.
- Make sure that fluid level is between MIN and MAX.
- Fluid levels at HOT (A) and COLD (B) are different. Do not confuse them.

HOT (A) : Fluid temperature 50° - 80 °C (122° - 176°F)

COLD (B) : Fluid temperature 0° - 30°C (32° - 86°F)

CAUTION:

- The fluid level should not exceed the MAX line. Excessive fluid will cause fluid leakage from the cap.
- Do not reuse drained power steering fluid.
- Recommended fluid is Genuine Nissan PSF or equivalent.

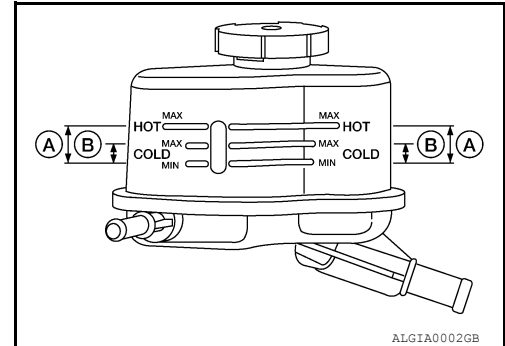

FLUID LEAKAGE

Check hydraulic connections for fluid leakage, cracks, damage, looseness, or wear.

1. Run engine until the fluid temperature reaches 50° to 80° C (122° to 176°F) in reservoir tank, and keep engine speed idle.
2. Turn steering wheel several times from full left stop to full right stop.
3. Hold steering wheel at each lock position for five seconds and carefully, check for fluid leakage.

CAUTION:

Do not hold the steering wheel in a locked position for more than 10 seconds. (There is the possibility that oil pump may be damaged.)

4. If fluid leakage at connections is noticed, then loosen flare nut and then retighten. Do not overtighten connector as this can damage O-ring, washer and connector.
5. If fluid leakage from oil pump is noticed, check oil pump. Refer to [ST-28. "Removal and Installation"](#).
6. Check steering gear boots for accumulation of fluid indicating leakage from steering gear.

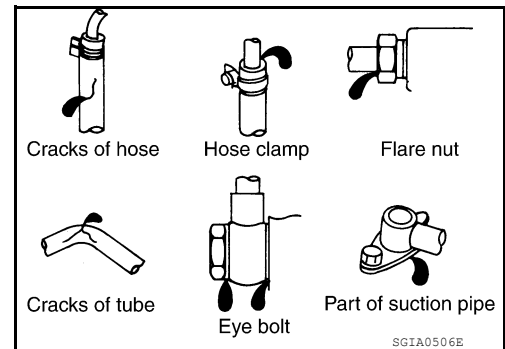

Draining

INFOID:000000006236463

1. Disconnect both high and low pressure lines from power steering gear.
2. Drain into a suitable container.

Refilling

INFOID:000000006236464

FILLING HYDRAULIC SYSTEM

1. Fill power steering reservoir while checking fluid level.
2. Bleed air from hydraulic system.
3. Check for fluid leaks.

AIR BLEEDING HYDRAULIC SYSTEM

If air bleeding is not complete, the following symptoms can be observed.

- Bubbles are created in reservoir tank.
- Clicking noise can be heard from oil pump.
- Excessive buzzing in the oil pump.

NOTE:

POWER STEERING FLUID

< PERIODIC MAINTENANCE >

Fluid noise may occur in the steering gear or oil pump. This does not affect performance or durability of the system.

1. Turn steering wheel several times from full left stop to full right stop with engine off.

CAUTION:

Turn steering wheel while filling reservoir tank with fluid so as not to lower fluid level below the MIN line.

2. Start engine and hold steering wheel at each lock position for 3 seconds at idle to check for fluid leakage.
3. Repeat step 2 above several times at approximately 3-second intervals.

CAUTION:

Do not hold the steering wheel in a locked position for more than 10 seconds. (There is the possibility that oil pump may be damaged.)

4. Check fluid for bubbles and white contamination.
5. Stop engine if bubbles and white contamination do not drain out. Perform step 2 and 3 above after waiting until bubbles and white contamination drain out.
6. Stop the engine, and then check fluid level.

A

B

C

D

E

F

ST

H

I

J

K

L

M

N

O

P

STEERING WHEEL

< PERIODIC MAINTENANCE >

STEERING WHEEL

Inspection

INFOID:000000006236465

INSTALLATION CONDITION

- Check installation conditions of steering gear assembly, front suspension assembly, axle and steering column assembly.
- Check if movement exists when steering wheel is moved up and down, to the left and right and to the axial direction.

Steering wheel axial end play : Refer to [ST-37, "Steering Wheel"](#)

- Check steering gear assembly bolts and nut for looseness. Refer to [ST-26, "Exploded View"](#).

STEERING WHEEL PLAY

- Turn steering wheel so that front wheels come to the straight-ahead position. Start engine and lightly turn steering wheel to the left and right until front wheels start to move. Measure steering wheel movement on the outer circumference.

Steering wheel play : Refer to [ST-37, "Steering Wheel"](#)

- When the measurement value is outside the standard value, check backlash for each joint of steering column assembly and installation condition of steering gear assembly.

NEUTRAL POSITION OF STEERING WHEEL

- Make sure that steering gear assembly, steering column assembly and steering wheel are installed in the correct position.
- Perform neutral position inspection after wheel alignment. Refer to [FSU-6, "Inspection and Adjustment"](#).
- Set vehicle to the straight-ahead position and confirm steering wheel is in the neutral position.
- Loosen outer socket lock nut and turn inner socket to left and right equally to make fine adjustments if steering wheel is not in the neutral position.

STEERING WHEEL TURNING FORCE

1. Park vehicle on a level, dry surface and set parking brake.
2. Start engine.
3. Bring power steering fluid up to adequate operating temperature. Make sure the fluid temperature is approximately 60 to 80°C (140 to 176°F).
Tires need to be inflated to normal pressure.
4. Check steering wheel turning force using Tool when steering wheel has been turned 360 degrees from the neutral position.

Tool number : — (J-44372)

Steering wheel turning force : Refer to [ST-37, "Steering Wheel"](#)

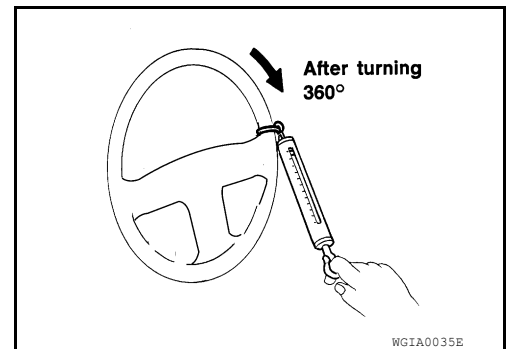

5. If steering wheel turning force is out of specification, check rack sliding force.

STEERING WHEEL

< PERIODIC MAINTENANCE >

- While pulling outer socket slowly in ± 11.5 mm (± 0.453 in) range from neutral position, make sure rack sliding force is within specification using Tool.

Tool number : — (J-44372)

Rack sliding force : Refer to [ST-38, "Steering Gear"](#)

- If rack sliding force is not within specification, replace steering gear assembly.
- If rack sliding force is OK, inspect steering column. Refer to [ST-23, "Removal and Installation"](#).

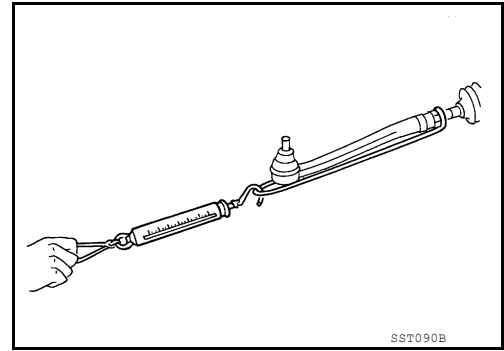

FRONT WHEEL TURNING ANGLE

- Check front wheel turning angle after toe-in inspection. Place front wheels on turning radius gauges and rear wheels on stands. Check the maximum inner and outer wheel turning angles for LH and RH road wheels.

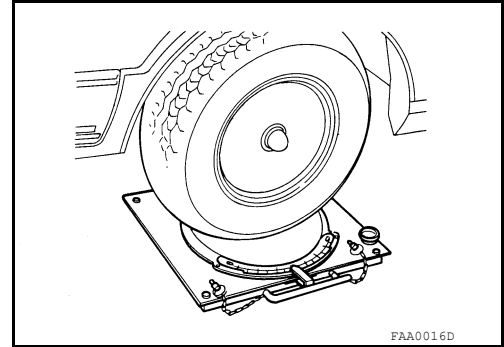

- With the engine at idle, turn steering wheel from full left stop to full right stop and measure the turning angles.

Inner wheel angle (A) : Refer to [ST-37, "Steering Angle"](#)

Outer wheel angle (B) : Refer to [ST-37, "Steering Angle"](#)

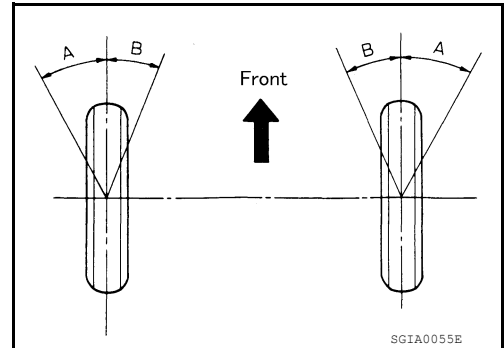

- Measure rack stroke in neutral position if angles are outside the specified value.

Rack stroke in neutral position (L) : Refer to [ST-38, "Steering Gear"](#)

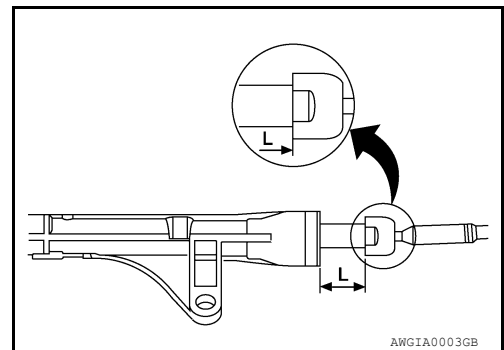

A
B
C
D
E
F
ST
H
I
J
K
L
M
N
O
P

POWER STEERING OIL PUMP

< PERIODIC MAINTENANCE >

POWER STEERING OIL PUMP

Inspection

INFOID:000000006236466

RELIEF OIL PRESSURE

CAUTION:

Make sure that belt tension is normal before starting the following procedure.

1. Connect the Tool between oil pump discharge connector and high-pressure hose. Bleed air from the hydraulic circuit while opening valve fully. Refer to [ST-12, "Inspection"](#).

Tool numbers : KV48103500 (J-26357)
: KV48102500 (J-33914)

2. Start engine. Run engine until power steering fluid temperature reaches 50° to 80°C (122° to 176°F).

CAUTION:

- Leave the valve of the hydraulic pressure gauge fully open while starting and running engine. If engine is started with the valve closed, the hydraulic pressure in oil pump goes up to the relief pressure along with unusual increase of oil temperature.
- Be sure to keep hose clear of belts and other parts when engine is started.

3. Fully close the Tool valve with engine at idle and measure the relief oil pressure.

Relief oil pressure : Refer to [ST-39, "Oil Pump"](#)

CAUTION:

Never keep valve closed for 10 seconds or longer.

4. Open the valve slowly after measuring. Replace oil pump if the relief oil pressure is outside the standard.
5. After inspection, disconnect the Tool from hydraulic circuit, then add fluid and bleed air. Refer to [ST-12, "Inspection"](#).

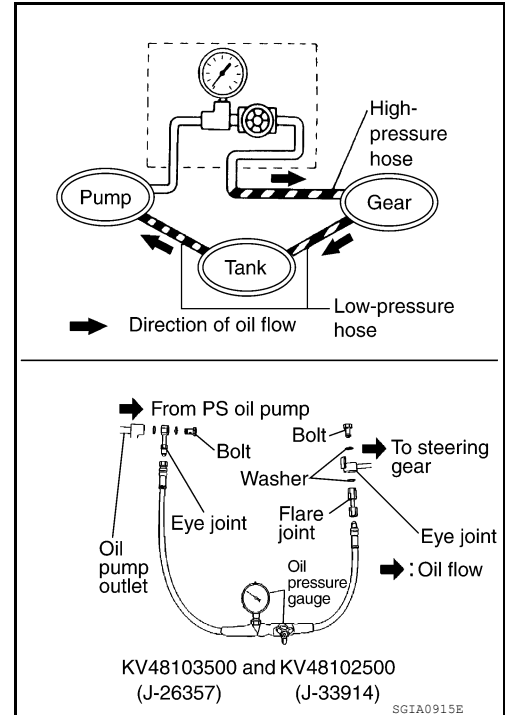

STEERING WHEEL

< REMOVAL AND INSTALLATION >

REMOVAL AND INSTALLATION

STEERING WHEEL

Removal and Installation

INFOID:000000006236467

REMOVAL

NOTE:

When reconnecting spiral cable, fix cable with a tape so that fixing case and rotating part keep aligned. This will omit neutral position alignment procedure during spiral cable installation.

1. Set vehicle to the straight-ahead position.
2. Remove driver air bag module. Refer to [SR-4, "Removal and Installation"](#).
3. Remove steering wheel lock nut after steering is locked.
4. Remove steering wheel using Tool (A).

Tool number (A) : ST27180001 (J-25726-A)

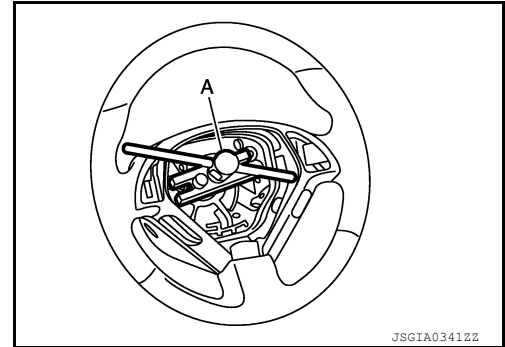

INSTALLATION

Installation is in the reverse order of removal.

CAUTION:

Never twist spiral cable freely or excessively after it becomes tight (doing so may cause the cable to tear off).

NOTE:

- Check the spiral cable neutral position after replacing or rotating spiral cable. Refer to [SR-7, "Removal and Installation"](#).
- Tighten the steering wheel lock nut to specification. Refer to [ST-22, "Exploded View"](#).

TILT MOTOR

< REMOVAL AND INSTALLATION >

TILT MOTOR

Exploded View

INFOID:000000006236468

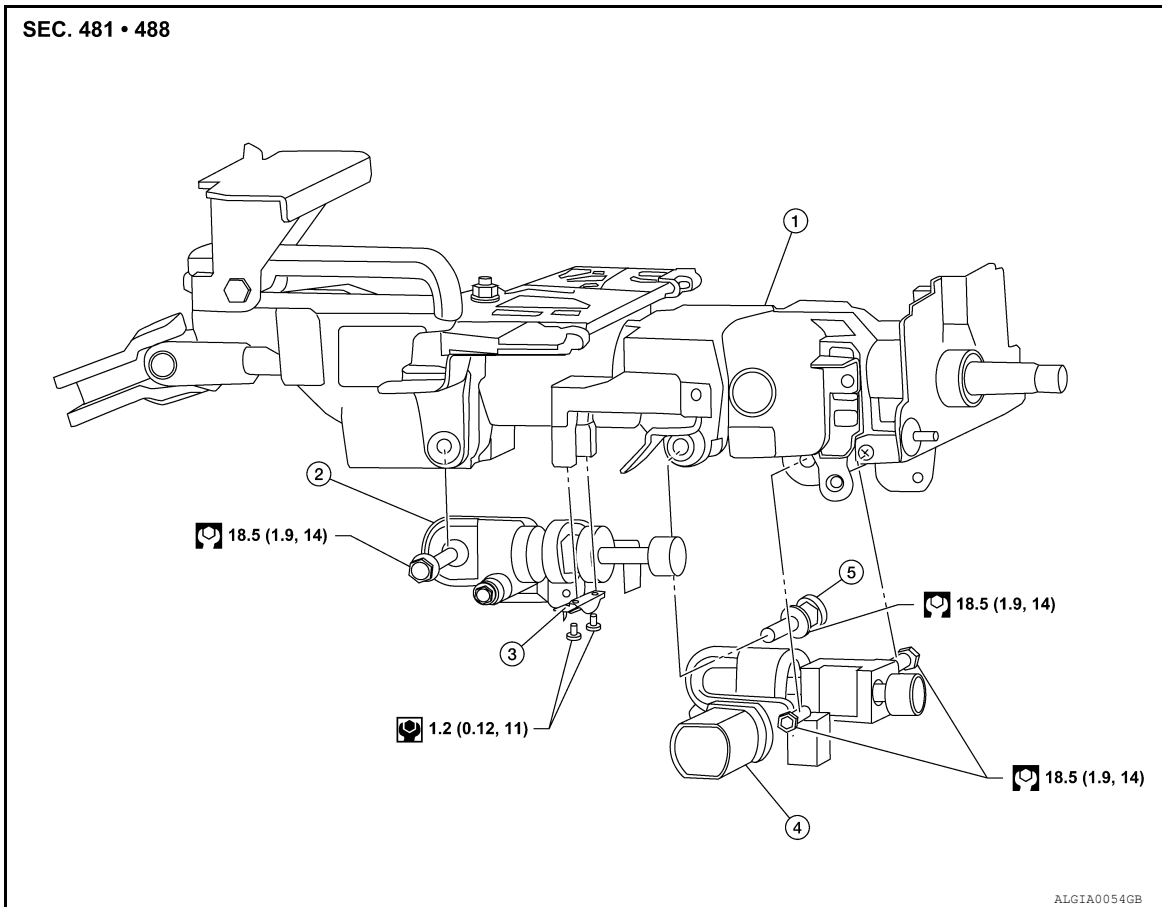

1. Steering column assembly
2. Telescope motor
3. Telescope motor link bracket
4. Tilt motor
5. Tilt motor bolt cap

Removal and Installation

INFOID:000000006236469

REMOVAL

1. Remove instrument lower cover LH. Refer to [IP-10, "Exploded View"](#).
2. Remove knee bolster bolts (A) and the knee bolster (B).

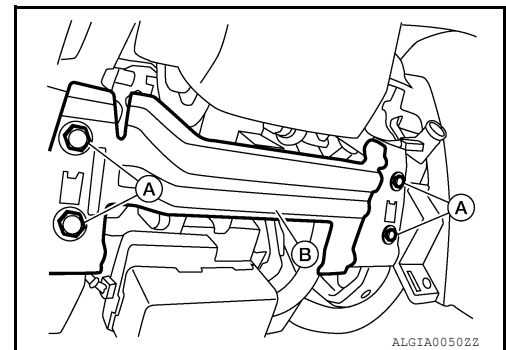

3. Telescope the steering wheel to the full out position and tilt to highest position.
NOTE:
If either function is inoperative you can do this manually prior to installation.
4. Remove the steering column covers. Refer to [IP-11, "Removal and Installation"](#).
NOTE:

TILT MOTOR

< REMOVAL AND INSTALLATION >

The tilt/telescope switch can remain attached to the side cover.

5. Remove the tilt motor. Refer to [ST-31, "Disassembly and Assembly"](#).

INSTALLATION

Installation is in the reverse order of removal

NOTE:

- Upon installation of the tilt motor link bolts manually move steering wheel up and down to align the bolts.
- Inform customer that they will need to rest their Automatic Drive Positioner (ADP) settings.

A
B
C
D
E
F
ST
H
I
J
K
L
M
N
O
P

TELESCOPIC MOTOR

< REMOVAL AND INSTALLATION >

TELESCOPIC MOTOR

Exploded View

INFOID:000000006236470

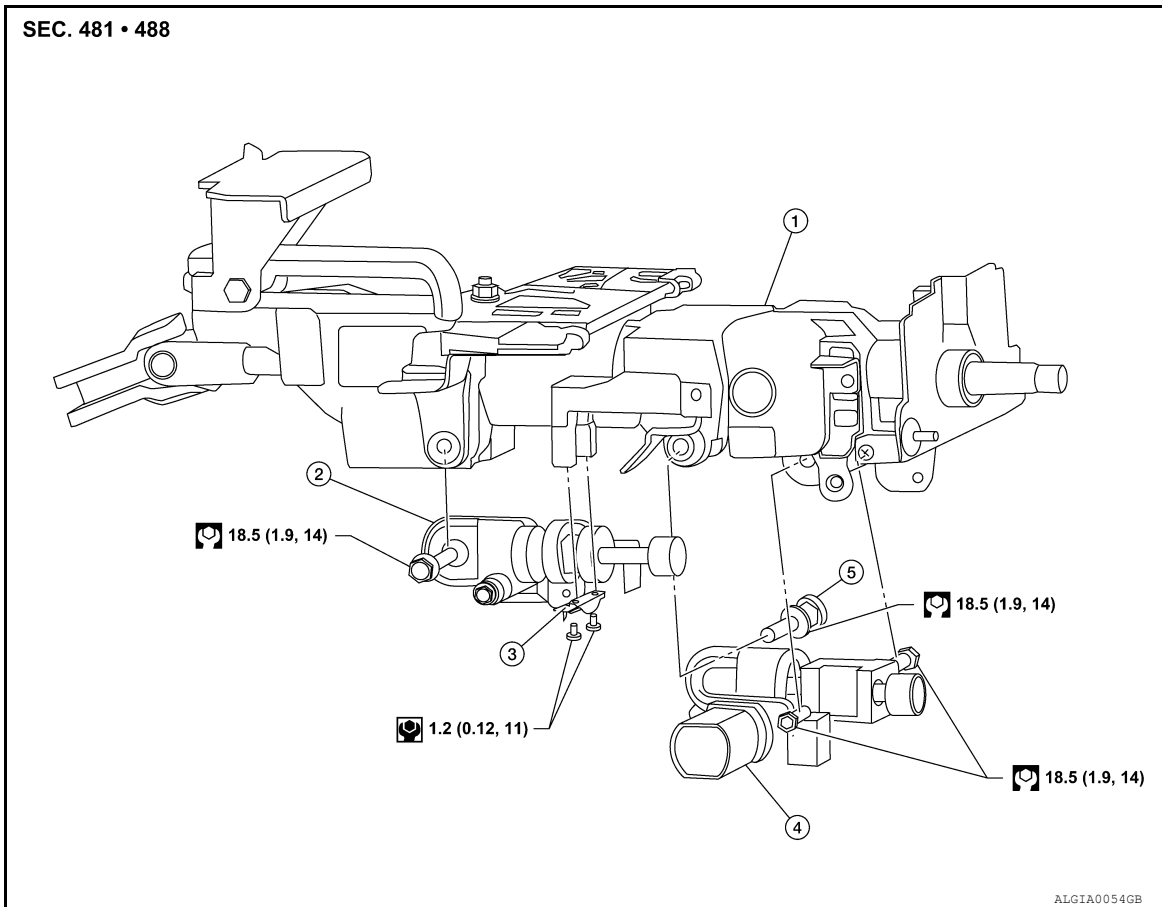

- | | | |
|-----------------------------|------------------------|---------------------------------|
| 1. Steering column assembly | 2. Telescope motor | 3. Telescope motor link bracket |
| 4. Tilt motor | 5. Tilt motor bolt cap | |

Removal and Installation

INFOID:000000006236471

REMOVAL

1. Remove instrument lower cover LH. Refer to [IP-10, "Exploded View"](#).
2. Remove knee bolster bolts (A) and the knee bolster (B).

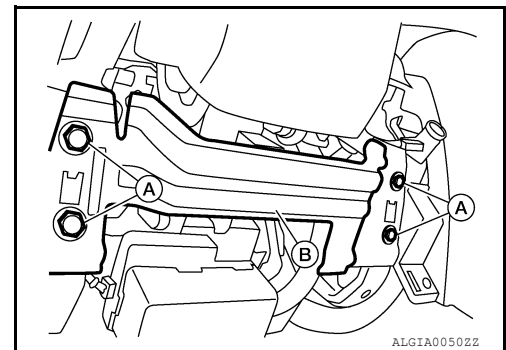

3. Telescope the steering wheel to the full out position and tilt to highest position.
NOTE:
If either function is inoperative you can do this manually prior to installation.
4. Remove the steering column covers. Refer to [IP-11, "Removal and Installation"](#).
NOTE:

TELESCOPIC MOTOR

< REMOVAL AND INSTALLATION >

The tilt/telescope switch can remain attached to the side cover.

5. Remove telescope motor. Refer to [ST-31, "Disassembly and Assembly"](#).

INSTALLATION

Installation is in the reverse order of removal.

NOTE:

- Adjust the telescope link to full out position and adjust as needed to fit into proper installed position.
- Inform customer that they will need to reset their Automatic Drive Positioner (ADP) settings.

A
B
C
D
E
F
ST
H
I
J
K
L
M
N
O
P

STEERING COLUMN

< REMOVAL AND INSTALLATION >

STEERING COLUMN

Exploded View

INFOID:000000006236472

Without Electric Motor

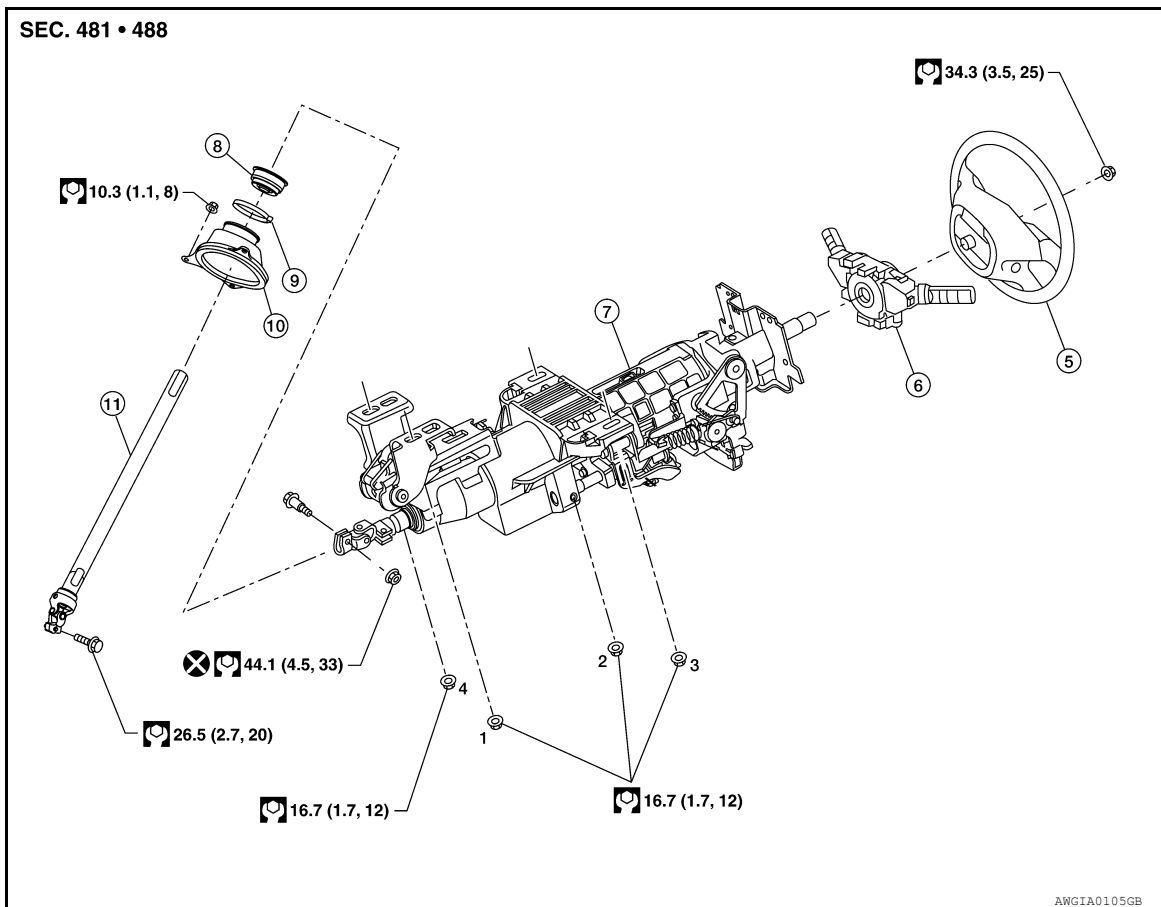

- | | | |
|--|--------------------------|--|
| 1-4. Steering column assembly nut tightening order | 5. Steering wheel | 6. Combination switch and spiral cable |
| 7. Steering column assembly | 8. Hole cover seal | 9. Herbie clip |
| 10. Hole cover | 11. Lower shaft assembly | |

STEERING COLUMN

< REMOVAL AND INSTALLATION >

3. Remove bolt (A) and nut (B) of column upper joint (2), then remove lower shaft assembly (1).
4. Loosen herbie clip, then remove hole cover seal from hole cover.
5. Remove nuts of hole cover, and then remove clamp and hole cover from dash panel.

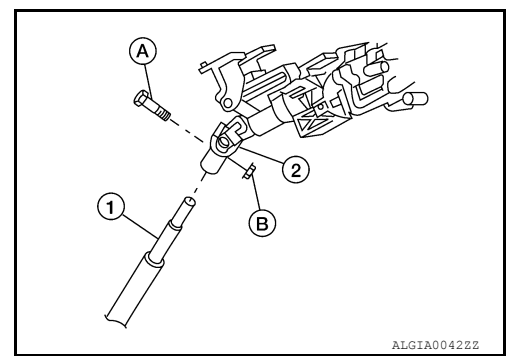

Steering Column Assembly

1. Set wheels to the straight-ahead position.
2. Remove instrument side mask LH. Refer to [IP-10. "Exploded View"](#).
3. Remove instrument lower cover LH. Refer to [IP-10. "Exploded View"](#).
4. Remove lower knee protector bolts, then remove knee protector (1). Refer to [IP-10. "Exploded View"](#).
5. Remove steering column cover upper and lower. Refer to [IP-10. "Exploded View"](#).
6. Remove combination switch and spiral cable. Refer to [SR-7. "Removal and Installation"](#).
7. Disconnect each switch connector installed to steering column assembly, and then disconnect harness from steering column assembly.

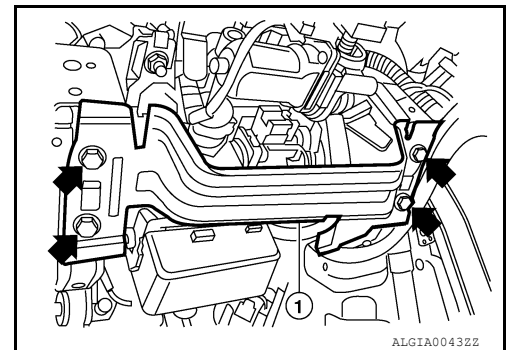

8. Remove bolt (A) and nut (B) of column upper joint (2).
 - Lower shaft assembly (1).
9. Remove steering column assembly and nuts, then remove steering column assembly.

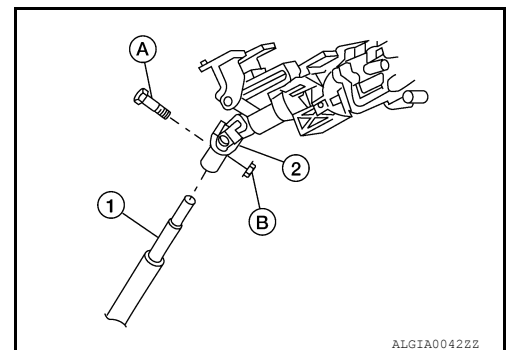

INSPECTION AFTER REMOVAL

Hole Cover Seal, Hole Cover and Lower Shaft Assembly

Check each part of hole cover seal, hole cover and steering column and lower shaft assembly for damage or other malfunctions. Replace if necessary.

Steering Column Assembly

- Check each part of steering column assembly for damage or other malfunctions. Replace entire steering column assembly if any parts are damaged.
- Measure the length (L) as shown if vehicle has been involved in a minor collision. Replace steering column assembly if outside the specifications.

Steering column length (L) : Refer to [ST-37. "Steering Column"](#)

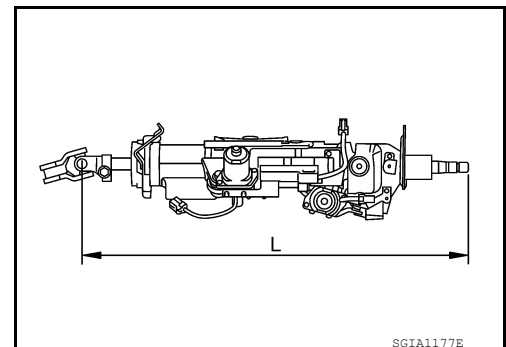

STEERING COLUMN

< REMOVAL AND INSTALLATION >

- Measure steering column rotating torque using Tool. Replace steering column assembly if outside the standard.

Tool number : ST3127S000 (J-25765-A)

Rotating torque : Refer to [ST-37, "Steering Column"](#)

- Check tilt and telescopic mechanism operating range (L^1), (L^2) as shown.

Tilt operating range (L^1) : Refer to [ST-37, "Steering Column"](#)

Telescopic operating range (L^2) : Refer to [ST-37, "Steering Column"](#)

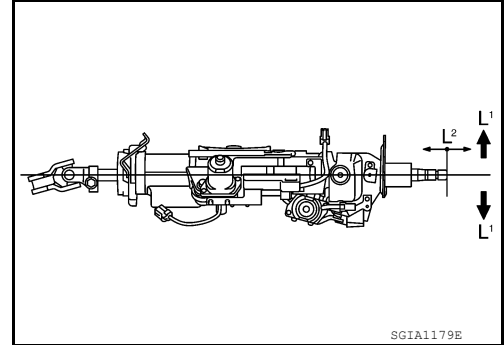

INSTALLATION

Steering Column Assembly

Installation is in the reverse order of removal.

Hole Cover Seal, Hole Cover and Lower Shaft Assembly

Installation is in the reverse order of removal.

- When installing lower shaft assembly to steering gear assembly, follow the procedure listed below.
- Set rack of steering gear in the neutral position.

NOTE:

To get the neutral position of rack, turn gear sub-assembly and measure the distance of inner socket, and then measure the intermediate position of the distance.

- Align rear cover cap projection (A) with the marking position (B) of gear housing assembly.
- Install slit part of lower shaft assembly (C) aligning with the projection (A) of rear cover cap (1). Make sure that the slit part of lower shaft assembly (C) is aligned with both the projection (A) of rear cover cap (1) and the marking position (B) of gear housing assembly.
- Perform final tightening of nuts and bolts on each part under unladen conditions with tires on level ground when removing steering gear assembly. Check wheel alignment. Refer to [FSU-6, "Inspection and Adjustment"](#).

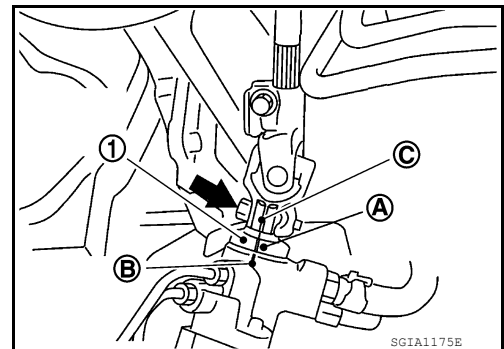

STEERING GEAR AND LINKAGE

< REMOVAL AND INSTALLATION >

STEERING GEAR AND LINKAGE

Exploded View

INFOID:000000006236474

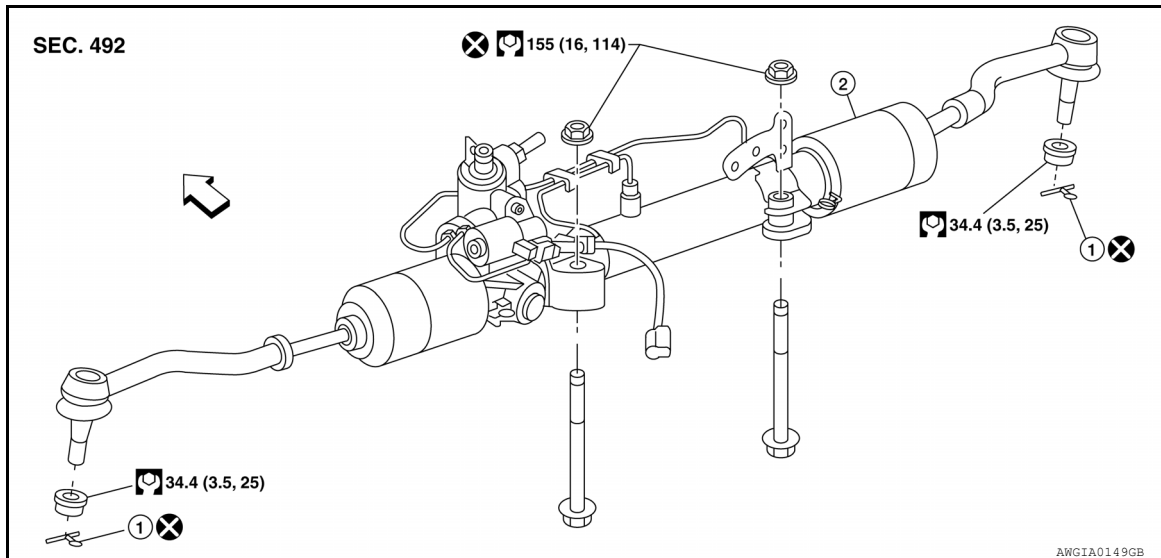

1. Cotter pin

2. Steering gear assembly

← Front

Removal and Installation

INFOID:000000006236475

REMOVAL

NOTE:

When removing components such as hoses, tubes/lines, etc., cap or plug openings to prevent fluid from spilling.

1. Remove front tires using power tool. Refer to [WT-60, "Adjustment"](#).
2. Drain power steering fluid. Refer to [ST-12, "Draining"](#).
3. Disconnect front stabilizer connecting rods from front stabilizer and reposition front stabilizer. Refer to [FSU-11, "Removal and Installation"](#).
4. Remove steering outer socket cotter pins (1), and then loosen the nuts.
5. Remove steering outer sockets (2) from steering knuckles (3) so as not to damage ball joint boots (4) using Tool.

CAUTION:

Temporarily tighten the nut to prevent damage to threads and to prevent the Tool from suddenly coming off.

Tool number : HT72520000 (J-25730-A)

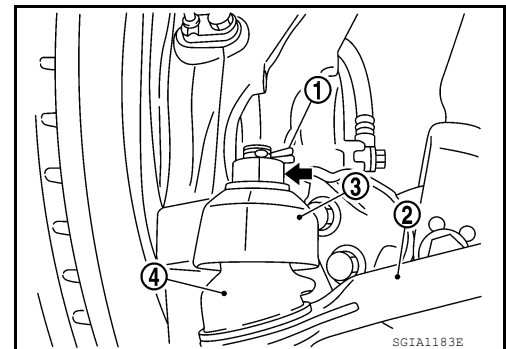

6. Remove side bolt (A) of lower shaft assembly (1) and disconnect lower shaft assembly.
 - Steering gear assembly (2)
7. Remove front exhaust tube. Refer to [EX-5, "Removal and Installation"](#).
8. Disconnect SSPS valve harness connector. Refer to [ST-33, "Exploded View"](#).
9. Disconnect high and low pressure piping from steering gear assembly. Refer to [ST-29, "Exploded View"](#).

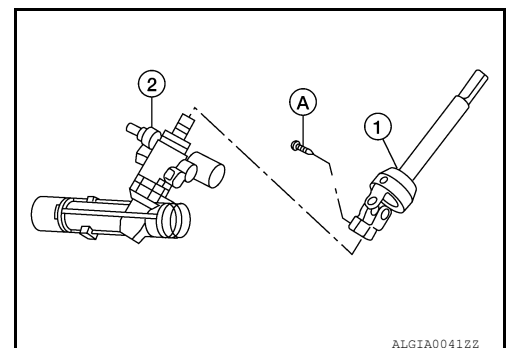

STEERING GEAR AND LINKAGE

< REMOVAL AND INSTALLATION >

10. Remove steering hydraulic piping bracket from front suspension member.
11. Remove bolts and nuts of steering gear assembly, and then remove steering gear assembly from vehicle.

INSPECTION AFTER REMOVAL

Check for fluid leaks or damage to steering gear assembly. If any exist, replace steering gear assembly.

INSTALLATION

Installation is in the reverse order of removal.

- When installing lower shaft assembly to steering gear assembly, follow the procedure listed below.
- Set rack of steering gear in the neutral position.

NOTE:

To get the neutral position of rack, turn gear sub-assembly and measure the distance of inner socket, and then measure the intermediate position of the distance.

- Align rear cover cap projection (A) with the marking position (B) of gear housing assembly.
- Install slit part of lower shaft assembly (C) aligning with the projection (A) of rear cover cap (1). Make sure that the slit part of lower shaft assembly (C) is aligned with both the projection (A) of rear cover cap (1) and the marking position (B) of gear housing assembly.
- Connect the high and low pressure piping to the steering gear. Tighten to specification. Refer to [ST-30, "Removal and Installation"](#).
- After installation, bleed air from the steering hydraulic system. Refer to [ST-12, "Inspection"](#).
- Perform final tightening of nuts and bolts on each part under unladen conditions with tires on level ground when removing steering gear assembly. Check wheel alignment. Refer to [FSU-6, "Inspection and Adjustment"](#).

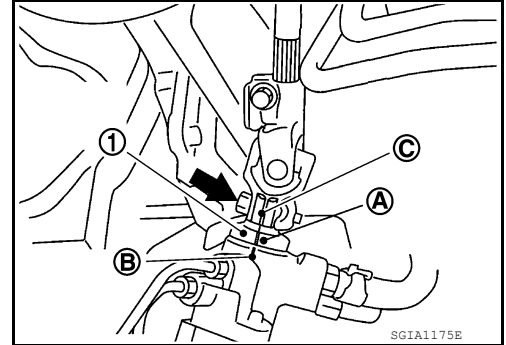

INSPECTION AFTER INSTALLATION

Make sure that steering wheel operates smoothly by turning several times from full left stop to full right stop.

POWER STEERING OIL PUMP

< REMOVAL AND INSTALLATION >

POWER STEERING OIL PUMP

Exploded View

INFOID:000000006236476

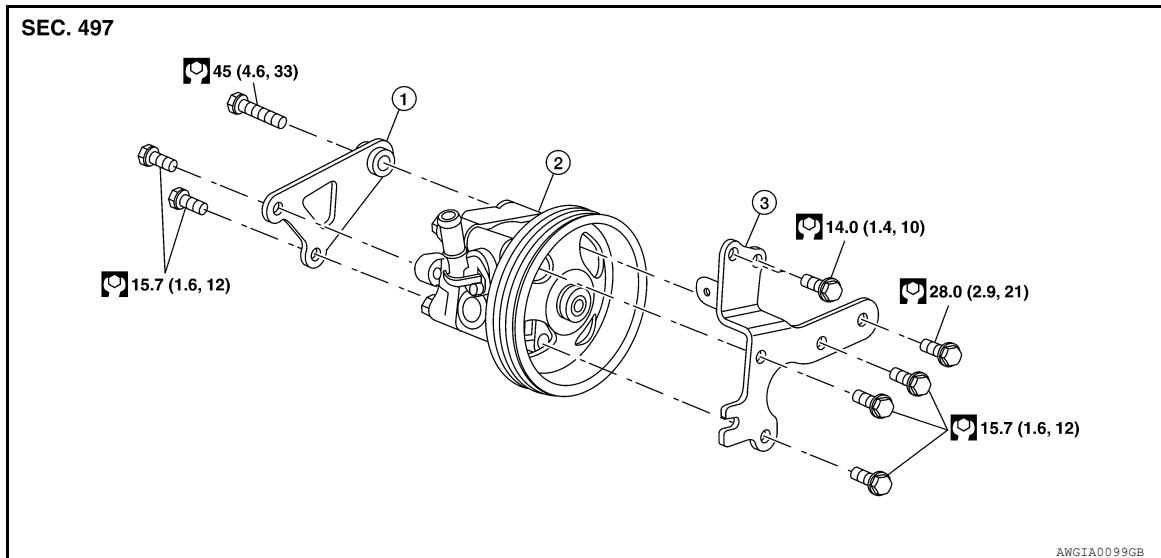

1. Rear bracket
2. Power steering oil pump assembly
3. Front bracket

Removal and Installation

INFOID:000000006236477

REMOVAL

1. Remove front tire (RH) using power tool. Refer to [WT-60. "Adjustment"](#).
2. Remove engine side undercover.
3. Remove hood ledge cover (RH).
4. Drain power steering fluid. Refer to [ST-12. "Draining"](#).
5. Disconnect the power steering pressure sensor electrical connector at the high pressure pipe. Refer to [ST-29. "Exploded View"](#).
6. Disconnect high pressure piping and suction hose from power steering oil pump. Refer to [ST-29. "Exploded View"](#).
7. Loosen drive belt. Refer to [EM-14. "Removal and Installation"](#).
8. Remove drive belt from power steering oil pump pulley.
9. Remove power steering oil pump bolts, and then remove power steering oil pump.

INSTALLATION

Installation is in the reverse order of removal.

- When installing power steering oil pump, install all bolts by hand initially, then tighten bolts to specification.
- Perform the following procedures after installing.
 - Check belt tension. Refer to [EM-14. "Checking Drive Belts"](#).
 - Bleed air from power steering system. Refer to [ST-12. "Refilling"](#).

HYDRAULIC LINE

< REMOVAL AND INSTALLATION >

HYDRAULIC LINE

Exploded View

INFOID:00000006236478

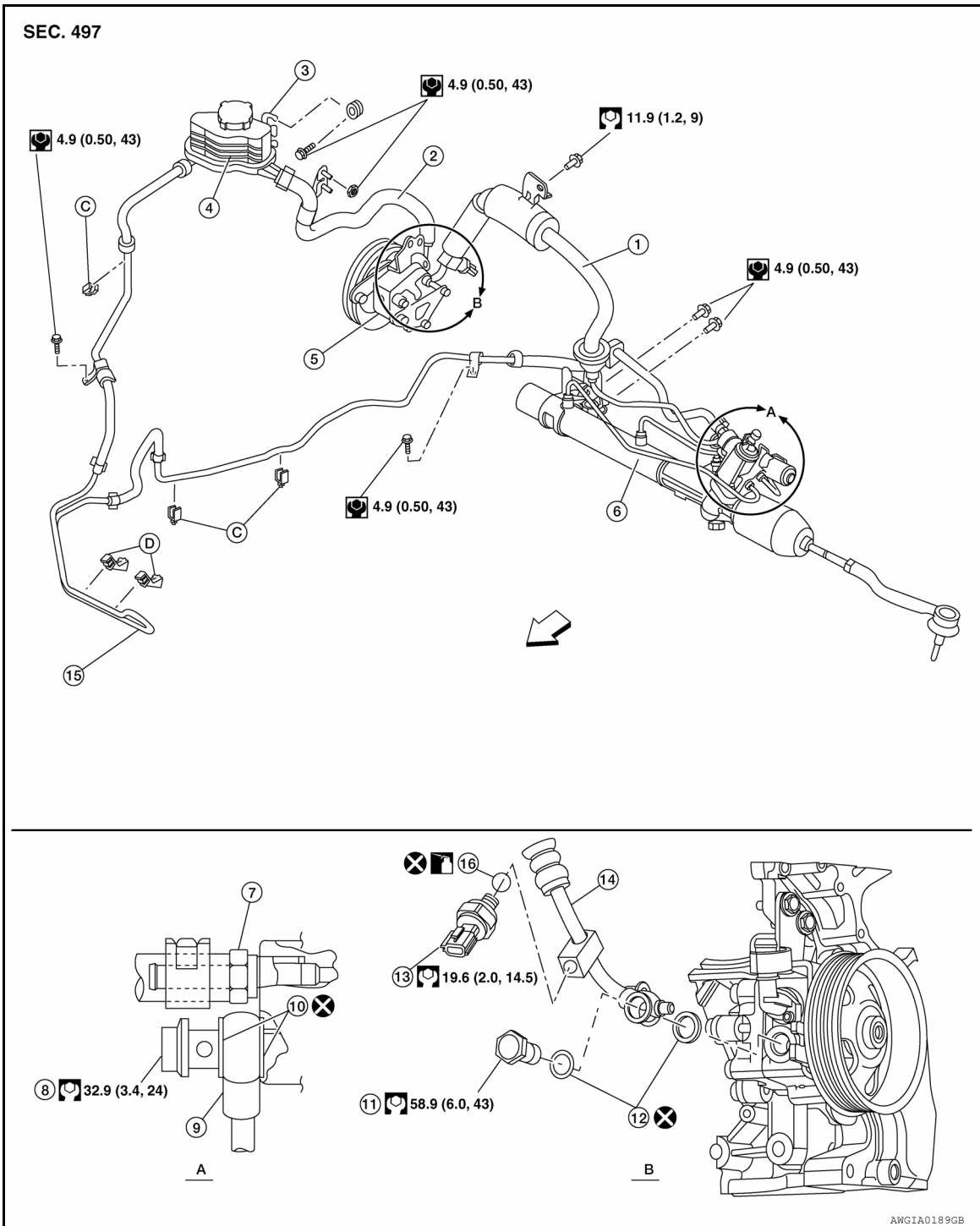

- | | | |
|------------------------------------|-------------------------------|---------------------------------|
| 1. High pressure hose | 2. Suction hose | 3. Reservoir tank bracket |
| 4. Reservoir tank | 5. Oil pump assembly | 6. Steering gear assembly |
| 7. Low pressure piping | 8. Eye bolt | 9. High pressure piping |
| 10. Copper sealing washers | 11. Eye bolt | 12. Copper sealing washers |
| 13. Power steering pressure sensor | 14. High pressure hose piping | 15. Power steering fluid cooler |
| 16. O-ring | ← Front | |

HYDRAULIC LINE

< REMOVAL AND INSTALLATION >

Removal and Installation

INFOID:000000006236479

CAUTION:

- Securely insert harness connector to pressure sensor.
- Do not reuse O-rings or copper sealing washers.

NOTE:

When removing components such as hoses, tubes/lines, etc., cap or plug openings to prevent fluid from spilling.

REMOVAL

Refer to [ST-29. "Exploded View"](#) for removal.

INSTALLATION

- Insert hose securely until it contacts tube spool.

CAUTION:

Do not apply fluid.

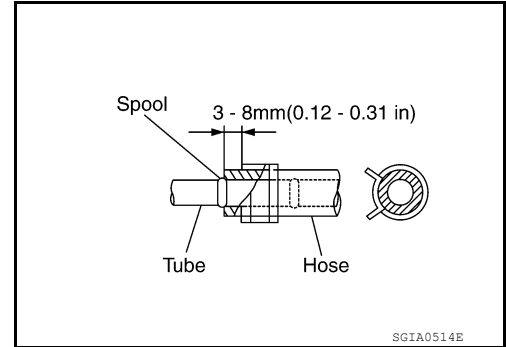

- Install eye-bolt (1), copper sealing washers (2) and eye-joint (assembled to high-pressure hose) (4) onto oil pump assembly (3), and then tighten it to the specified torque after tightening by hand.

CAUTION:

Do not reuse copper sealing washers.

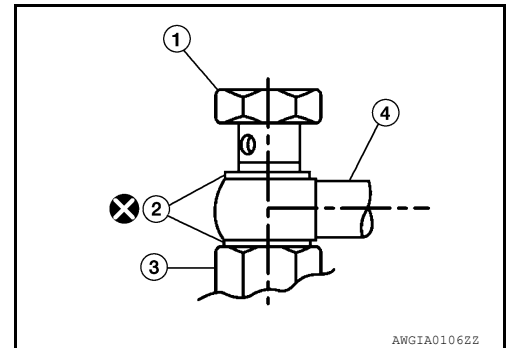

STEERING COLUMN

< UNIT DISASSEMBLY AND ASSEMBLY >

UNIT DISASSEMBLY AND ASSEMBLY

STEERING COLUMN

Disassembly and Assembly

INFOID:000000006236480

The steering column assembly without electric motor is not serviceable and must be replaced as an assembly.

With Electric Motor

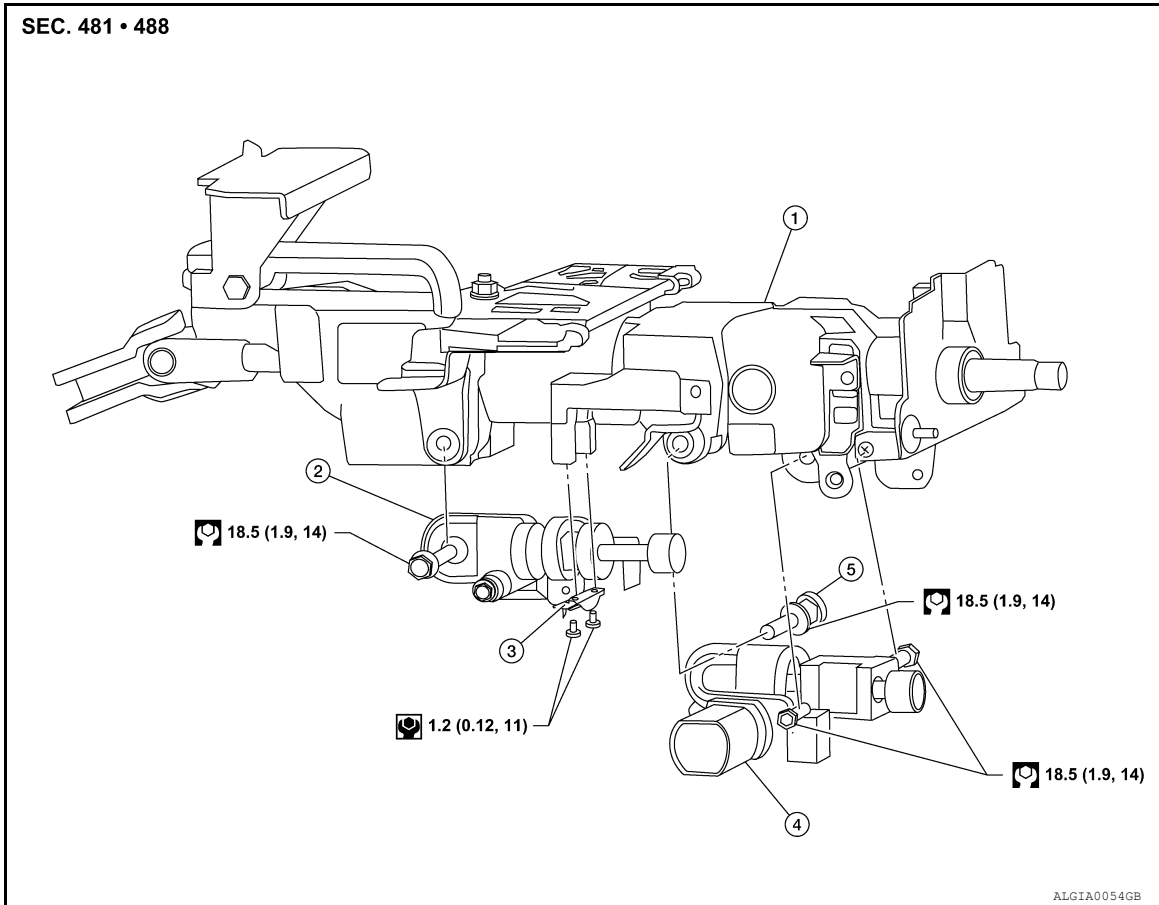

- | | | |
|-----------------------------|------------------------|---------------------------------|
| 1. Steering column assembly | 2. Telescope motor | 3. Telescope motor link bracket |
| 4. Tilt motor | 5. Tilt motor bolt cap | |

DISASSEMBLY

Tilt motor

1. Remove the steering wheel. Refer to [ST-17, "Removal and Installation"](#).
2. Disconnect the tilt motor electrical connector (A).
3. Remove the tilt motor link bolts (B).

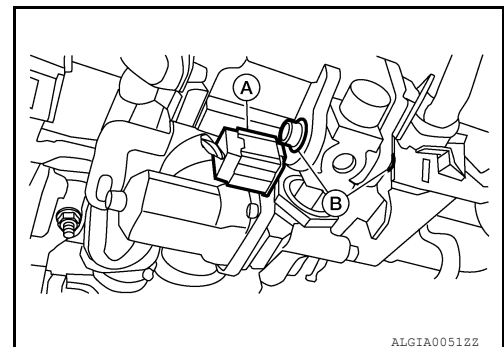

STEERING COLUMN

< UNIT DISASSEMBLY AND ASSEMBLY >

4. Remove the tilt motor bolt (A) from the RH side of column.
5. Remove the tilt motor (B).

NOTE:

If the steering wheel could not be tilted to the highest position, manually tilt steering wheel to the highest position.

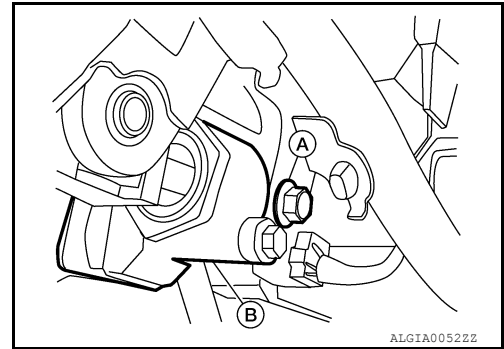

Telescope motor

1. Remove the steering wheel. Refer to [ST-17, "Removal and Installation"](#).
2. Disconnect telescope motor electrical connector (A).
3. Remove the two telescope link screws (B) and link bracket.
4. Remove telescope bolt (C).
5. Remove the telescope motor (D).

NOTE:

If the steering wheel could not be telescoped to full out position manually pull steering wheel to the full out position

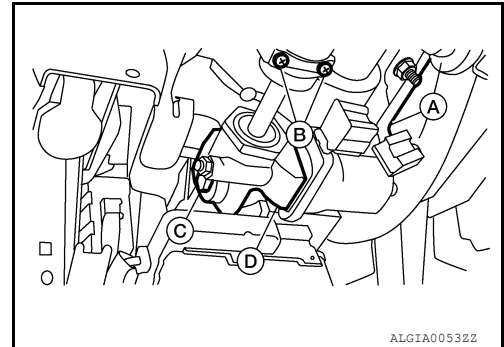

ASSEMBLY

Assembly is in the reverse order of removal

NOTE:

- Upon installation of the tilt motor link bolts manually move steering wheel up and down to align the bolts.
- Adjust the telescope link to full out position and adjust as needed to fit into proper installed position.
- Inform customer that they will need to rest their Automatic Drive Positioner (ADP) settings.

STEERING GEAR AND LINKAGE

< UNIT DISASSEMBLY AND ASSEMBLY >

STEERING GEAR AND LINKAGE

Exploded View

INFOID:000000006236481

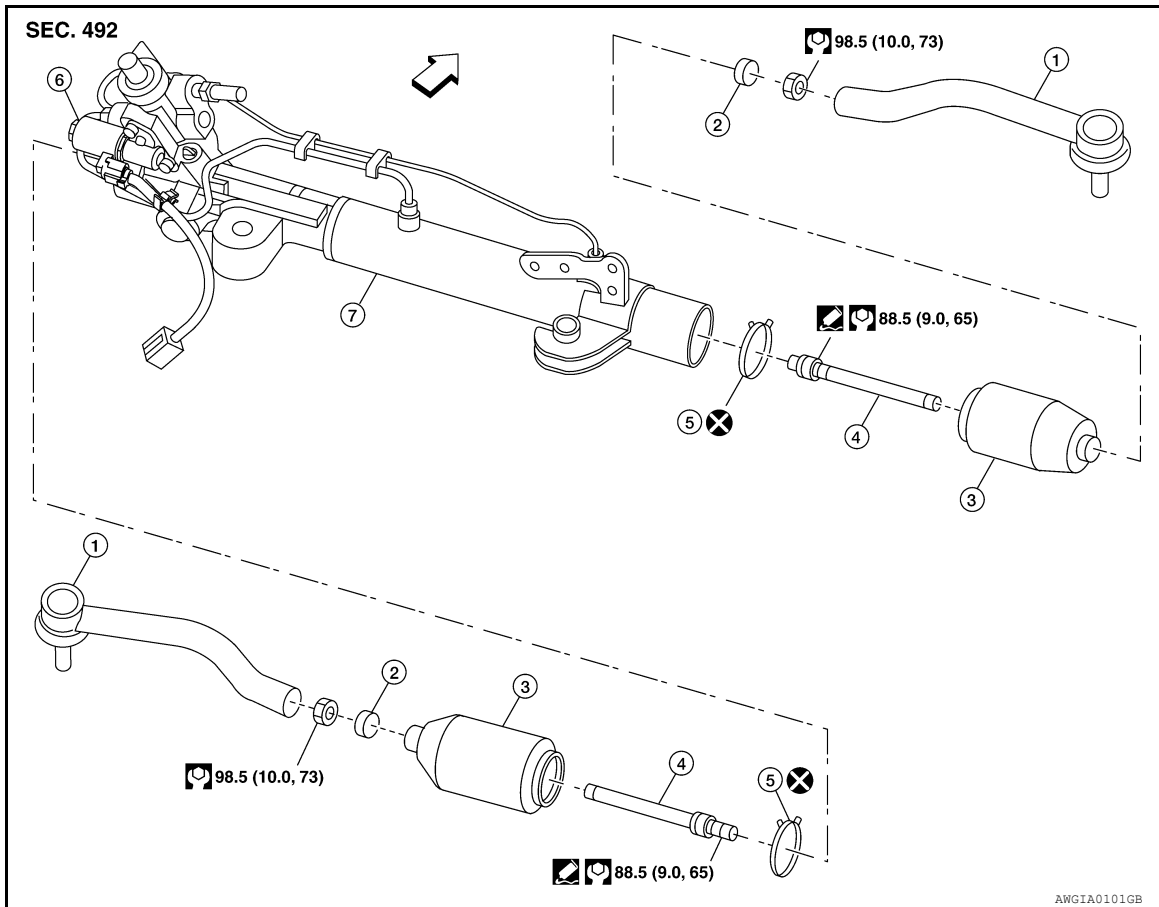

- | | | |
|------------------|---------------|---------------------------------------|
| 1. Outer socket | 2. Boot clamp | 3. Boot |
| 4. Inner socket | 5. Boot clamp | 6. SSPS valve (part of gear assembly) |
| 7. Gear assembly | ← Front | ▣ Three Bond 1111B or equivalent |

Disassembly

INFOID:000000006236482

1. Remove outer socket locknut and outer socket.
2. Remove boot clamps and boot.
3. Remove inner socket.

Inspection

INFOID:000000006236483

INSPECTION AFTER DISASSEMBLY

Boot

Check boot for cracks. Replace if any damage is found.

Outer Socket and Inner Socket

- Ball joint swinging torque

STEERING GEAR AND LINKAGE

< UNIT DISASSEMBLY AND ASSEMBLY >

- Hook a spring balance to the ball stud and inner socket measuring point (*) and pull the spring balance. Make sure that the spring balance reads the specified value when ball stud and inner socket start to move. Replace outer socket and steering gear assembly if they are outside the standard.

Tool number : — (J-44372)

Swinging torque : Refer to [ST-38, "Steering Gear"](#)

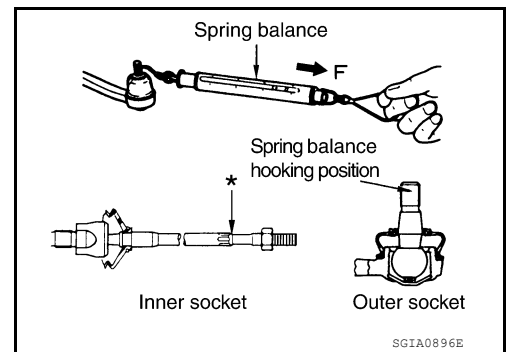

- Ball joint rotating torque
- Make sure that the reading is within the following specified range using Tool. Replace outer socket if the reading is outside the specified value.

Tool number : ST3127S000 (J-25765-A)

Rotating torque : Refer to [ST-38, "Steering Gear"](#)

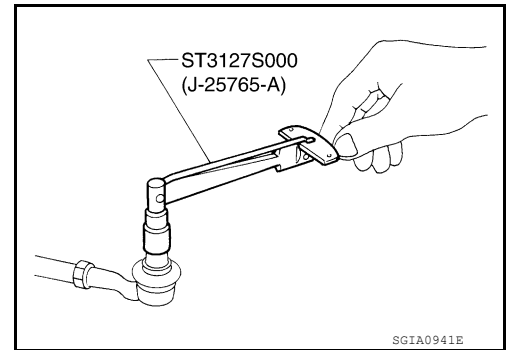

- Ball joint axial end play
- Apply an axial load of 490 N (50 kg, 111 lb) to ball stud. Measure amount of stud movement using a dial gauge and then make sure that the value is within the following specified range. Replace outer socket and inner socket if the measured value is outside the standard.

Axial end play : Refer to [ST-38, "Steering Gear"](#)

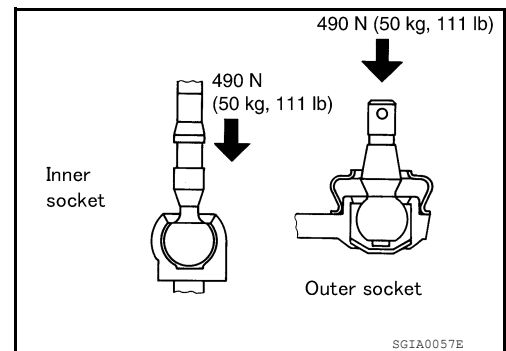

Assembly

1. Apply Three Bond 1111B or equivalent to inner socket and turn pinion fully to retract inner socket into gear housing assembly.
2. Install large end (1) of boot (2) to gear housing assembly.
3. Install small end (3) of boot (2) to inner socket boot mounting groove.

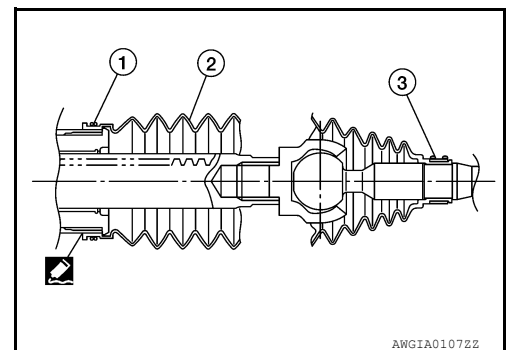

STEERING GEAR AND LINKAGE

< UNIT DISASSEMBLY AND ASSEMBLY >

4. Install boot clamp to boot small end.
5. Install boot clamp to boot large end using Tool.

CAUTION:

Do not reuse boot clamps.

Tool number : KV40107300 (—)

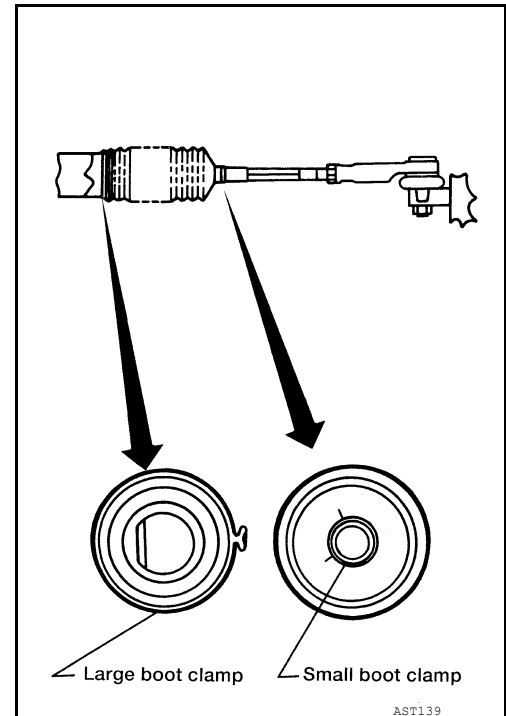

6. Adjust inner socket to standard length (L), and then tighten lock nut to the specified torque. Check length of inner socket (L) again after tightening lock nut. Make sure that the length is the standard.

Inner socket length (L) : Refer to [ST-38, "Steering Gear"](#)

CAUTION:

Adjust toe-in after this procedure. The length achieved after toe-in adjustment is not necessarily the above value.

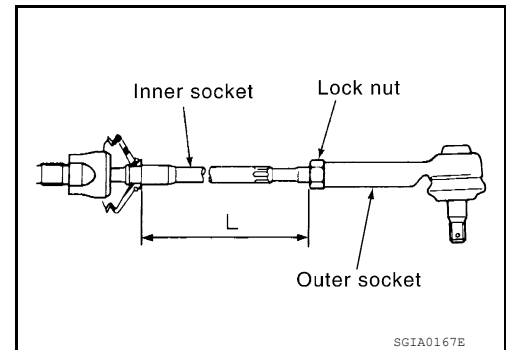

POWER STEERING OIL PUMP

< UNIT DISASSEMBLY AND ASSEMBLY >

POWER STEERING OIL PUMP

Disassembly and Assembly

INFOID:000000006236485

The power steering oil pump and pulley is not serviceable and should be replaced as an assembly. For front and rear bracket removal, refer to [ST-28, "Exploded View"](#).

SERVICE DATA AND SPECIFICATIONS (SDS)

< SERVICE DATA AND SPECIFICATIONS (SDS)

SERVICE DATA AND SPECIFICATIONS (SDS)

SERVICE DATA AND SPECIFICATIONS (SDS)

Steering Wheel

INFOID:000000006236486

Steering wheel axial end play	0 mm (0 in)
Steering wheel play	0 - 35 mm (0 - 1.38 in)
Steering wheel turning force	39 N (4 kg, 9 lb) or less

Steering Angle

INFOID:000000006236487

Unit: Degree minute (Decimal Degree)

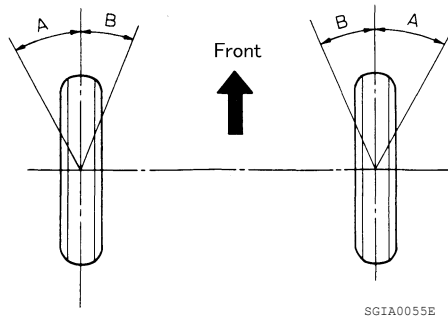

Tire size		P245/45R18	P245/40R19
Inner wheel angle (A)	Minimum	33° 30' (33.5°)	33° 30' (33.5°)
	Nominal	36° 30' (36.5°)	36° 30' (36.5°)
	Maximum	37° 30' (37.5°)	37° 30' (37.5°)
Outer wheel angle (B)	Nominal	31° 0' (31.0°)	31° 0' (31.0°)

Steering Column

INFOID:000000006236488

STEERING COLUMN LENGTH

Unit: mm (in)

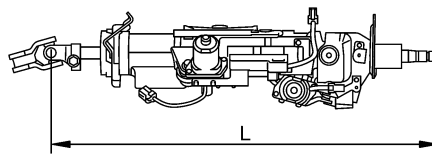

Steering column length (L)	Telescopic maximum	513 - 543 (20.20 - 21.38)
	Telescopic minimum	503 - 513 (19.80 - 20.20)

STEERING COLUMN ROTATING TORQUE

Unit: N·m (kg·m, in·lb)

Rotating torque	0 - 0.25 (0 - 0.03, 0 - 2)
-----------------	----------------------------

TILT MECHANISM OPERATING RANGE

SERVICE DATA AND SPECIFICATIONS (SDS)

< SERVICE DATA AND SPECIFICATIONS (SDS)

Unit: mm (in)

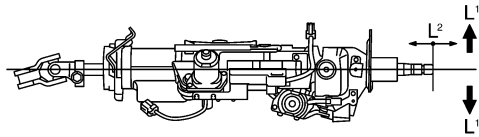

SGIA1179E

	Without electric motor	With electric motor
Tilt operating range (L ¹)	41 (1.61)	49.63 (1.95)
Telescopic operating range (L ²)	40 (1.57)	40 (1.57)

Steering Gear

INFOID:000000006236489

STEERING OUTER SOCKET AND INNER SOCKET

Steering gear type		PR26AF
Outer socket	Swinging torque	0.1 - 2.9 N·m (0.01 - 0.29 kg·m, 1.0 - 25 in·lb)
	<ul style="list-style-type: none"> • Measurement on spring balance • Measuring point: cotter pin hole of stud 	1.4 - 42.7 N (0.14 - 4.4 kg, 12 - 31 lb)
	Rotating torque	0.3 - 2.9 N·m (0.03 - 0.29 kg·m, 3.0 - 25 in·lb)
	Axial end play	0.5 mm (0.020 in) or less
Inner socket	Swinging torque	0.1 - 7.8 N·m (0.01 - 0.79 kg·m, 1.0 - 69 in·lb)
	<ul style="list-style-type: none"> • Measurement on spring balance • Measuring point at * mark shown 	0.8 - 64 N (0.082 - 6.5 kg, 0.18 - 14.4 lb)
	Axial end play	0.2 mm (0.008 in) or less
Inner socket length (L)		119.5 mm (4.705 in) or less

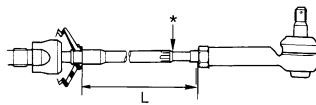

SGIA0950E

RACK STROKE

SERVICE DATA AND SPECIFICATIONS (SDS)

< SERVICE DATA AND SPECIFICATIONS (SDS)

Steering gear model	PR26AF	
Tire size	P245/45R18	P245/40R19
Rack stroke in neutral position (L)	69.5 ± 0.75 mm (2.735 ± 0.030 in)	

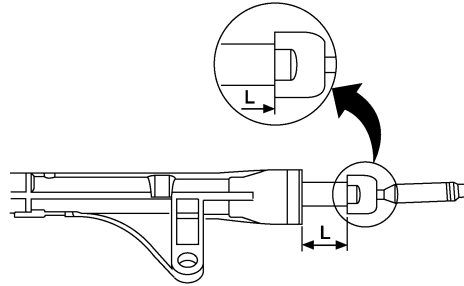

AWGIA0003GB

RACK SLIDING FORCE

Tire size	P245/45R18	P245/40R19
Rack sliding force	205 - 350 N (20.9 - 35.7 kg, 46.1 - 78.7 lb)	

Oil Pump

INFOID:000000006236490

Relief oil pressure - Maximum	10,300 kPa (105.03 kg/cm ² , 1,493.88 psi)
-------------------------------	---

Steering Fluid

INFOID:000000006236491

Fluid type	Refer to MA-19. "FOR USA AND CANADA : Fluids and Lubricants" (United States and Canada), MA-20. "FOR MEXICO : Fluids and Lubricants" (Mexico).
Fluid capacity	1.0 ℓ (1-1/8 US qt, 7/8 Imp qt)