

SECTION **MA**
 MAINTENANCE

A
B
C
D
E
F
G
H
I
J
K
L
M
N
O

MA

CONTENTS

PRECAUTION	3	FOR USA AND CANADA : Anti-Freeze Coolant Mixture Ratio	17
PRECAUTIONS	3	FOR MEXICO	17
Precaution for Supplemental Restraint System (SRS) "AIR BAG" and "SEAT BELT PRE-TENSIONER"	3	FOR MEXICO : Fluids and Lubricants	17
PREPARATION	4	FOR MEXICO : Engine Oil Recommendation	18
PREPARATION	4	FOR MEXICO : Engine Coolant Mixture Ratio	18
Special Service Tool	4	ENGINE MAINTENANCE (VQ35DE)	20
Commercial Service Tool	4	DRIVE BELTS	20
PERIODIC MAINTENANCE	5	DRIVE BELTS : Checking Drive Belts	20
GENERAL MAINTENANCE	5	DRIVE BELTS : Tension Adjustment	20
FOR USA AND CANADA	5	ENGINE COOLANT	20
FOR USA AND CANADA : Explanation of General Maintenance	5	ENGINE COOLANT : System Inspection	20
FOR MEXICO	6	ENGINE COOLANT : Changing Engine Coolant	21
FOR MEXICO : Explanation of General Maintenance	7	FUEL LINES	23
PERIODIC MAINTENANCE	9	FUEL LINES : Inspection	23
FOR USA AND CANADA	9	AIR CLEANER FILTER	23
FOR USA AND CANADA : Introduction of Periodic Maintenance	9	AIR CLEANER FILTER : Removal and Installation	23
FOR USA AND CANADA : Schedule 1	9	ENGINE OIL	24
FOR USA AND CANADA : Schedule 2	11	ENGINE OIL : Inspection	24
FOR MEXICO	12	ENGINE OIL : Changing Engine Oil	24
FOR MEXICO : Periodic Maintenance	12	OIL FILTER	24
RECOMMENDED FLUIDS AND LUBRICANTS	16	OIL FILTER : Removal and Installation	24
FOR USA AND CANADA	16	SPARK PLUG	25
FOR USA AND CANADA : Fluids and Lubricants... ..	16	SPARK PLUG : Exploded View	26
FOR USA AND CANADA : Engine Oil Recommendation	16	SPARK PLUG : Removal and Installation	26
		EVAP VAPOR LINES	27
		EVAP VAPOR LINES : Inspection	27
		CHASSIS AND BODY MAINTENANCE	28
		IN-CABIN MICROFILTER	28
		IN-CABIN MICROFILTER : Removal and Installation	28

EXHAUST SYSTEM	28	REAR BRAKE : Inspection of Pad	34
EXHAUST SYSTEM : Inspection	28	REAR BRAKE : Inspection of Rotor	34
CVT FLUID	28	STEERING GEAR AND LINKAGE	35
CVT FLUID : Inspection	28	STEERING GEAR AND LINKAGE : Inspection	35
CVT FLUID : Changing	29	POWER STEERING FLUID AND LINES	35
WHEELS	30	POWER STEERING FLUID AND LINES : Inspec-	35
WHEELS : Inspection	30	tion	35
WHEELS : Adjustment	30	AXLE AND SUSPENSION PARTS	36
BRAKE FLUID LEVEL AND LEAKS	32	AXLE AND SUSPENSION PARTS : Inspection	36
BRAKE FLUID LEVEL AND LEAKS : Inspection ...	32	DRIVE SHAFT	36
BRAKE LINES AND CABLES	32	DRIVE SHAFT : Inspection	37
BRAKE LINES AND CABLES : Inspection	32	LOCKS, HINGES AND HOOD LATCH	37
BRAKE FLUID	32	LOCKS, HINGES AND HOOD LATCH : Lubricat-	37
BRAKE FLUID : Drain and Refill	33	ing	37
FRONT BRAKE	33	SEAT BELT, BUCKLES, RETRACTORS, AN-	37
FRONT BRAKE : Inspection of Pad	33	CHORS AND ADJUSTERS	37
FRONT BRAKE : Inspection of Rotor	33	SEAT BELT, BUCKLES, RETRACTORS, AN-	37
REAR BRAKE	34	CHORS AND ADJUSTERS : Inspection	37

PRECAUTIONS

< PRECAUTION >

PRECAUTION

PRECAUTIONS

Precaution for Supplemental Restraint System (SRS) "AIR BAG" and "SEAT BELT PRE-TENSIONER"

INFOID:000000008633016

The Supplemental Restraint System such as "AIR BAG" and "SEAT BELT PRE-TENSIONER", used along with a front seat belt, helps to reduce the risk or severity of injury to the driver and front passenger for certain types of collision. This system includes seat belt switch inputs and dual stage front air bag modules. The SRS system uses the seat belt switches to determine the front air bag deployment, and may only deploy one front air bag, depending on the severity of a collision and whether the front occupants are belted or unbelted. Information necessary to service the system safely is included in the SR and SB section of this Service Manual.

WARNING:

- To avoid rendering the SRS inoperative, which could increase the risk of personal injury or death in the event of a collision which would result in air bag inflation, all maintenance must be performed by an authorized NISSAN/INFINITI dealer.
- Improper maintenance, including incorrect removal and installation of the SRS, can lead to personal injury caused by unintentional activation of the system. For removal of Spiral Cable and Air Bag Module, see the SR section.
- Do not use electrical test equipment on any circuit related to the SRS unless instructed to in this Service Manual. SRS wiring harnesses can be identified by yellow and/or orange harnesses or harness connectors.

PRECAUTIONS WHEN USING POWER TOOLS (AIR OR ELECTRIC) AND HAMMERS

WARNING:

- When working near the Airbag Diagnosis Sensor Unit or other Airbag System sensors with the Ignition ON or engine running, DO NOT use air or electric power tools or strike near the sensor(s) with a hammer. Heavy vibration could activate the sensor(s) and deploy the air bag(s), possibly causing serious injury.
- When using air or electric power tools or hammers, always switch the Ignition OFF, disconnect the battery, and wait at least 3 minutes before performing any service.

A
B
C
D
E
F
G
H
I
J
K
L
M
N
O

MA

PREPARATION

< PREPARATION >

PREPARATION

PREPARATION

Special Service Tool

INFOID:000000008633017

The actual shapes of Kent-Moore tools may differ from those of special service tools illustrated here.

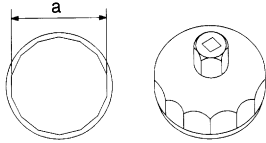
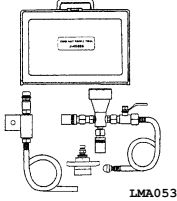
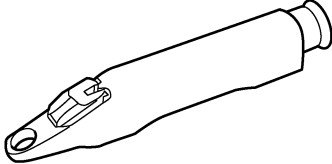
Tool number (Kent-Moore No.) Tool name	Description
KV10115801 (J-38956) Oil filter wrench  S-NT375	Removing and installing oil filter a: 64.3 mm (2.531 in)
KV991J0070 (J-45695) Coolant Refill Tool  LMA053	Refilling engine cooling system
— (J-23688) Engine coolant refractometer  WBIA0539E	Checking concentration of ethylene glycol in engine coolant

Commercial Service Tool

INFOID:000000008633018

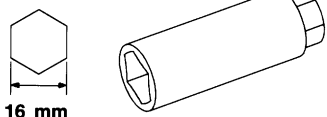
Tool name	Description
Power tool  PIIB1407E	Loosening nuts, screws and bolts
Spark plug wrench  16 mm (0.63 in) S-NT047	Removing and installing spark plug

GENERAL MAINTENANCE

< PERIODIC MAINTENANCE >

PERIODIC MAINTENANCE

GENERAL MAINTENANCE FOR USA AND CANADA

FOR USA AND CANADA : Explanation of General Maintenance

INFOID:000000008633022

General maintenance includes those items which should be checked during the normal day-to-day operation of the vehicle. They are essential if the vehicle is to continue operating properly. The owners can perform checks and inspections themselves or have their NISSAN dealers do them.

OUTSIDE THE VEHICLE

The maintenance items listed here should be performed from time to time, unless otherwise specified.

Item		Reference page
Tires	Check the pressure with a gauge often and always prior to long distance trips. Adjust the pressure in all tires, including the spare, to the pressure specified. Check carefully for damage, cuts or excessive wear.	WT-65
Wheel nuts	When checking the tires, make sure no nuts are missing, and check for any loose nuts. Tighten if necessary.	WT-60
Tire rotation	Tires should be rotated every 7,500 miles (12,000 km).	WT-60
Tire pressure monitoring system (TPMS) transmitter components	Replace the TPMS transmitter grommet seal, valve core and cap when the tires are replaced due to wear or age.	WT-10
Wheel alignment and balance	If the vehicle should pull to either side while driving on a straight and level road, or if you detect uneven or abnormal tire wear, there may be a need for wheel alignment. If the steering wheel or seat vibrates at normal highway speeds, wheel balancing may be needed. For additional information regarding tires, refer to "Important Tire Safety Information" (US) or "Tire Safety Information" (Canada) in the NISSAN Warranty Information Booklet.	FSU-18, WT-58
Windshield	Clean the windshield on a regular basis. Check the windshield at least every six months for cracks or other damage. Repair as necessary.	—
Windshield wiper blades	Check for cracks or wear if they do not wipe properly.	—
Doors and engine hood	Check that all doors and the engine hood operate properly. Also make sure that all latches lock securely. Lubricate if necessary. Make sure that the secondary latch keeps the hood from opening when the primary latch is released. When driving in areas using road salt or other corrosive materials, check for lubrication frequently.	MA-37
Lamps	Make sure that the headlamps, stop lamps, tail lamps, turn signal lamps, and other lamps are all operating properly and installed securely. Also check headlamp aim. Clean the headlamps on a regular basis.	EXL-151 (Xenon), EXL-315 (Halogen)

INSIDE THE VEHICLE

The maintenance items listed here should be checked on a regular basis, such as when performing periodic maintenance, cleaning the vehicle, etc.

Item		Reference page
Warning lamps and chimes	Make sure that all warning lamps and chimes are operating properly.	—
Windshield wiper and washer	Check that the wipers and washer operate properly and that the wipers do not streak.	—
Windshield defroster	Check that the air comes out of the defroster outlets properly and in sufficient quantity when operating the heater or air conditioner.	—
Steering wheel	Check that it has the specified play. Check for changes in the steering condition, such as excessive play, hard steering or strange noises. Free play: Less than 35 mm (1.38 in)	ST-14

GENERAL MAINTENANCE

< PERIODIC MAINTENANCE >

Item		Reference page
Seats	Check seat position controls such as seat adjusters, seatback recliner, etc. to make sure they operate smoothly and that all latches lock securely in every position. Check that the head restraints move up and down smoothly and that the locks (if equipped) hold securely in all latched positions. Check that the latches lock securely for folding-down rear seatbacks.	—
Seat belts	Check that all parts of the seat belt system (e.g., buckles, anchors, adjusters and retractors) operate properly and smoothly, and are installed securely. Check the belt webbing for cuts, fraying, wear or damage.	SB-3
Accelerator pedal	Check the pedal for smooth operation and make sure the pedal does not catch or require uneven effort. Keep the floor mats away from the pedal.	—
Brakes	Check that the brake does not pull the vehicle to one side when applied.	—
Brake pedal and booster	Check the pedal for smooth operation and make sure it has the proper distance under it when depressed fully. Check the brake booster function. Be sure to keep the floor mats away from the pedal.	BR-9 , BR-26
Parking brake	Check that the lever or pedal has the proper travel and make sure that the vehicle is held securely on a fairly steep hill when only the parking brake is applied.	PB-4
CVT P (Park) position mechanism	On a fairly steep hill check that the vehicle is held securely with the shift selector in the P (Park) position without applying any brakes.	—

UNDER THE HOOD AND VEHICLE

The maintenance items listed here should be checked periodically (e.g., each time you check the engine oil or refuel).

Item		Reference page
Windshield washer fluid	Check that there is adequate fluid in the tank.	—
Engine coolant level	Check the coolant level when the engine is cold.	CO-10
Radiator and hoses	Check the front of the radiator and clean off any dirt, insects, leaves, etc., that may have accumulated. Make sure the hoses have no cracks, deformation, deterioration or loose connections.	—
Brake fluid level	Make sure that the brake fluid level is between the “MAX” and “MIN” lines on the reservoir.	BR-16
Battery	Check the fluid level in each cell. It should be between the “MAX” and “MIN” lines. Vehicles operated in high temperatures or under severe conditions require frequent checks of the battery fluid level.	PG-2
Engine drive belts	Make sure that no belt is frayed, worn, cracked or oily.	MA-20
Engine oil level	Check the level on the oil level gauge after parking the vehicle on a level spot and turning off the engine.	MA-24
Power steering fluid level and lines	Check the level on the dipstick with the engine off. Check the lines for improper attachment, leaks, cracks, etc.	MA-35
Exhaust system	Make sure there are no loose supports, cracks or holes. If the sound of the exhaust seems unusual or there is a smell of exhaust fumes, immediately locate the trouble and correct it.	MA-28
Underbody	The underbody is frequently exposed to corrosive substances such as those used on icy roads or to control dust. It is very important to remove these substances, otherwise rust will form on the floor pan, frame, fuel lines and around the exhaust system. At the end of winter, the underbody should be thoroughly flushed with plain water, being careful to clean those areas where mud and dirt can easily accumulate.	—
Fluid leaks	Check under the vehicle for fuel, oil, water or other fluid leaks after the vehicle has been parked for a while. Water dripping from the air conditioner after use is normal. If you should notice any leaks or gasoline fumes are evident, check for the cause and correct it immediately.	—

FOR MEXICO

GENERAL MAINTENANCE

< PERIODIC MAINTENANCE >

FOR MEXICO : Explanation of General Maintenance

INFOID:000000008831160

General maintenance includes those items which should be checked during the normal day-to-day operation of the vehicle. They are essential if the vehicle is to continue operating properly. The owners can perform the checks and inspections themselves or they can have their **NISSAN** dealers do them.

OUTSIDE THE VEHICLE

The maintenance items listed here should be performed from time to time, unless otherwise specified.

Item	Reference page	
Doors and engine hood	Check that all doors and the engine hood operate smoothly as well as the back door, trunk lid and hatch. Also make sure that all latches lock securely. Lubricate if necessary. Make sure that the secondary latch keeps the hood from opening when the primary latch is released. When driving in areas using road salt or other corrosive materials, check lubrication frequently.	MA-37
Lamps	Clean the headlamps on a regular basis. Make sure that the headlamps, stop lamps, tail lamps, turn signal lamps, and other lamps are all operating properly installed securely. Also check the aim of the headlamps.	—
Tires	Check the pressure with a gauge often and always prior to long distance trips. Adjust the pressure in all tires, including the spare, to the pressure specified. Check carefully for damage, cuts or excessive wear.	WT-65
Tire rotation	In the case that Two-Wheel Drive (2WD) and front & rear tires are same size; Tires should be rotated every 10,000 km (6,000 miles). Tires marked with directional indicators can only be rotated between front and rear. Make sure that the directional indicators point in the direction of wheel rotation after the tire rotation is completed. In the case that Four-Wheel Drive (4WD) and front & rear tires are same size; Tires should be rotated every 5,000 km (3,000 miles). Tires marked with directional indicators can only be rotated between front and rear. Make sure that the directional indicators point in the direction of wheel rotation after the tire rotation is completed. In the case that front tires are different size from rear tires; Tires cannot be rotated. However, the timing for tire rotation may vary according to your driving habits and the road surface conditions.	WT-60
Tire Pressure Monitoring System (TPMS) transmitter components (if equipped)	Replace the TPMS transmitter grommet seal, valve core and cap when the tires are replaced due to wear or age.	WT-59
Wheel alignment and balance	If the vehicle should pull to either side while driving on a straight and level road, or if you detect uneven or abnormal tire wear, there may be a need for wheel alignment. If the steering wheel or seat vibrates at normal highway speeds, wheel balancing may be needed.	FSU-6 RSU-6 MA-30
Windshield	Clean the windshield on a regular basis. Check the windshield at least every six months for cracks or other damage. Repairs necessary.	—
Wiper blades	Check for cracks or wear if not functioning correctly.	—

INSIDE THE VEHICLE

The maintenance items listed here should be checked on a regular basis, such as when performing periodic maintenance, cleaning the vehicle, etc.

Item	Reference page	
Accelerator pedal	Check the pedal for smooth operation and make sure that the pedal does not catch or require uneven effort. Keep the floor mats away from the pedal.	—
Brake pedal	Check the pedal for smooth operation and make sure that it attains the proper distance from the floor mat when depressed fully. Check the brake booster function. Be sure to keep the floor mats away from the pedal.	BR-14 BR-46
Parking brake	Check the parking brake operation regularly. Check that the pedal has the proper travel. Also make sure that the vehicle is held securely on a fairly steep hill when only the parking brake is applied.	PB-4
Seat belts	Check that all parts of the seat belt system (for example, buckles, anchors, adjusters and retractors) operate properly and smoothly, and are installed securely. Check the belt webbing for cuts, fraying, wear or damage.	SB-3

GENERAL MAINTENANCE

< PERIODIC MAINTENANCE >

Item		Reference page
Steering wheel	Check for changes in the steering condition, such as excessive play, hard steering or strange noises. Check that it has the specified play. Free play: Less than 35 mm (1.38 in)	—
Warning lamps and chimes	Make sure that all warning lamps and chimes are operating properly.	—
Windshield defogger	Check that the air comes out of the defogger outlets properly and in good quantity when operating the heater or air conditioner.	—
Windshield wiper and washer	Check that the wipers and washer operate properly and that the wipers do not streak.	—

UNDER THE HOOD AND VEHICLE

The maintenance items listed here should be checked periodically (for example, each time you check the engine oil or refuel.)

Item		Reference page
Battery	Except for maintenance free battery; Check the fluid level in each cell. It should be between the "UPPER" and "LOWER" lines. Vehicles operated in high temperatures or under severe conditions require frequent checks of the battery fluid level.	PG-2 PG-69
Brake fluid level	Make sure that the brake fluid level is between the "MAX" and "MIN" lines on the reservoir.	MA-32
Engine coolant level	Check the coolant level when the engine is cold. Make sure that the coolant level is between the "MAX" and "MIN" lines on the reservoir.	MA-20
Engine drive belt(s)	Make sure that drive belt(s) is/are not frayed, worn, cracked or oily.	MA-20
Engine oil level	Check the level after parking the vehicle (on a level ground) and turning off the engine.	MA-24
Fluid leaks	Check under the vehicle for fuel, oil, water or other fluid leaks after the vehicle has been parked for a while. Water dripping from the air conditioner after use is normal. If you should notice any leaks or if fuel fumes are evident, check for cause and have it corrected immediately.	—
Power steering fluid level and lines	Check the level when the fluid is cold with the engine off. Check the lines for proper attachment, leaks, cracks, etc.	MA-35
Windshield washer fluid	Check that there is adequate fluid in the reservoir tank.	—

PERIODIC MAINTENANCE

< PERIODIC MAINTENANCE >

PERIODIC MAINTENANCE FOR USA AND CANADA

FOR USA AND CANADA : Introduction of Periodic Maintenance

INFOID:000000008633024

Two different maintenance schedules are provided, and should be used, depending upon the conditions in which the vehicle is mainly operated. **After 60,000 miles (96,000 km) or 48 months, continue the periodic maintenance at the same mileage/time intervals.**

Schedule 1	Follow Periodic Maintenance Schedule 1 if the driving habits frequently include one or more of the following driving conditions: <ul style="list-style-type: none"> • Repeated short trips of less than 5 miles (8 km). • Repeated short trips of less than 10 miles (16 km) with outside temperatures remaining below freezing. • Operating in hot weather in stop-and-go "rush hour" traffic. • Extensive idling and/or low speed driving for long distances, such as police, taxi or door-to-door delivery use. • Driving in dusty conditions. • Driving on rough, muddy, or salt spread roads. • Towing a trailer, a caravan or using a car-top carrier. 	Emission Control System Maintenance	MA-9
		Chassis and Body Maintenance	MA-9
Schedule 2	Follow Periodic Maintenance Schedule 2 if none of driving conditions shown in Schedule 1 apply to the driving habits.	Emission Control System Maintenance	MA-11
		Chassis and Body Maintenance	MA-11

FOR USA AND CANADA : Schedule 1

INFOID:000000008633025

EMISSION CONTROL SYSTEM

Abbreviations: R = Replace. I = Inspect. Correct or replace if necessary. []: At the mileage intervals only

MAINTENANCE OPERATION		MAINTENANCE INTERVAL								Reference Page
Perform at number of miles, kilometers or months, whichever comes first.	Miles x 1,000 (km x 1,000) Months	3.75 (6)	7.50 (12)	11.25 (18)	15 (24)	18.75 (30)	22.5 (36)	26.25 (42)	30 (48)	
Drive belts	NOTE (1)									MA-20
Air cleaner filter	NOTE (2)								[R]	MA-23
EVAP vapor lines									I*	MA-27
Fuel lines									I*	MA-23
Fuel filter	NOTE (3)									—
Engine coolant *	NOTE (4) (5)									MA-20
Engine oil		R	R	R	R	R	R	R	R	MA-24
Engine oil filter [Use genuine NISSAN engine oil filter or equivalent.]		R	R	R	R	R	R	R	R	MA-24
Spark plugs (Iridium-tipped type)		Replace every 105,000 miles (168,000 km).								MA-26
Intake & exhaust valve clearance *	NOTE (6)									EM-132

MAINTENANCE OPERATION		MAINTENANCE INTERVAL								Reference Page
Perform at number of miles, kilometers or months, whichever comes first.	Miles x 1,000 (km x 1,000) Months	33.75 (54)	37.5 (60)	41.25 (66)	45 (72)	48.75 (78)	52.5 (84)	56.25 (90)	60 (96)	
Drive belts	NOTE (1)								I*	MA-20
Air cleaner filter	NOTE (2)								[R]	MA-23

PERIODIC MAINTENANCE

< PERIODIC MAINTENANCE >

MAINTENANCE OPERATION		MAINTENANCE INTERVAL								Reference Page
Perform at number of miles, kilometers or months, whichever comes first.	Miles x 1,000 (km x 1,000) Months	33.75 (54) 27	37.5 (60) 30	41.25 (66) 33	45 (72) 36	48.75 (78) 39	52.5 (84) 42	56.25 (90) 45	60 (96) 48	
EVAP vapor lines									I*	MA-27
Fuel lines									I*	MA-23
Fuel filter	NOTE (3)									—
Engine coolant*	NOTE (4) (5)									MA-20
Engine oil		R	R	R	R	R	R	R	R	MA-24
Engine oil filter [Use genuine NISSAN engine oil filter or equivalent.]		R	R	R	R	R	R	R	R	MA-24
Spark plugs (Iridium-tipped type)		Replace every 105,000 miles (168,000 km).								MA-26
Intake & exhaust valve clearance*	NOTE (6)									EM-132

NOTE:

- (1) After 60,000 miles (96,000 km) or 48 months, inspect every 15,000 miles (24,000 km) or 12 months. Replace the drive belts if found damaged.
- (2) If operating mainly in dusty conditions, more frequent maintenance may be required.
- (3) Maintenance-free item. For service procedures, refer to FL section.
- (4) First replacement interval is 105,000 miles (168,000 km) or 84 months. After first replacement, replace every 75,000 miles (120,000 km) or 60 months.
- (5) When adding or replacing coolant, be sure to use only Genuine NISSAN Long Life Antifreeze/Coolant (blue) or equivalent. Genuine NISSAN Long Life Antifreeze/Coolant (blue) is pre-diluted to provide antifreeze protection to -34° F (-37° C). If additional freeze protection is needed due to weather where you operate your vehicle, add Genuine NISSAN Long Life antifreeze/Coolant (blue) concentrate following the directions on the container. If an equivalent coolant other than Genuine NISSAN Long Life Antifreeze/Coolant (blue) is used, follow the manufacturer's instructions to maintain minimum antifreeze protection to -34° F (-37° C). The use of other types or coolant solutions other than Genuine NISSAN Long Life Antifreeze/Coolant (blue) or equivalent may damage the engine cooling system.
- (6) Periodic maintenance is not required. However, if valve noise increases, inspect valve clearance.

: Maintenance items and intervals with "" are recommended by NISSAN for reliable vehicle operation. The owner need not perform such maintenance in order to maintain the emission warranty or manufacturer recall liability. Other maintenance items and intervals are required.

CHASSIS AND BODY

Abbreviations: R = Replace. I = Inspect. Correct or replace if necessary.

MAINTENANCE OPERATION		MAINTENANCE INTERVAL								Reference Page
Perform at number of miles, kilometers or months, whichever comes first.	Miles x 1,000 (km x 1,000) Months	3.75 (6) 3	7.50 (12) 6	11.25 (18) 9	15 (24) 12	18.75 (30) 15	22.5 (36) 18	26.25 (42) 21	30 (48) 24	
Brake lines & cables					I				I	MA-32
Brake fluid					R				R	MA-33
Brake pads & rotors			I		I		I		I	BR-7, BR-7 BR-8, BR-8
CVT fluid	NOTE (1)				I				I	MA-28
Steering gear and linkage, axle & suspension parts			I		I		I		I	MA-35
Tire rotation	NOTE (2)									MA-30
Exhaust system			I		I		I		I	MA-28
Front drive shaft boot			I		I		I		I	MA-36
In-cabin microfilter					R				R	MA-28

PERIODIC MAINTENANCE

< PERIODIC MAINTENANCE >

MAINTENANCE OPERATION		MAINTENANCE INTERVAL								Reference Page
		Miles x 1,000 (54) Months 27	37.5 (60) 30	41.25 (66) 33	45 (72) 36	48.75 (78) 39	52.5 (84) 42	56.25 (90) 45	60 (96) 48	
Perform at number of miles, kilometers or months, whichever comes first.	Miles x 1,000 (km x 1,000) Months	33.75 (54) 27	37.5 (60) 30	41.25 (66) 33	45 (72) 36	48.75 (78) 39	52.5 (84) 42	56.25 (90) 45	60 (96) 48	
Brake lines & cables					I				I	MA-32
Brake fluid					R				R	MA-33
Brake pads & rotors			I		I		I		I	BR-7, BR-7 BR-8, BR-8
CVT fluid	NOTE (1)				I				I	MA-28
Steering gear and linkage, axle & suspension parts			I		I		I		I	MA-35
Tire rotation	NOTE (2)									MA-30
Exhaust system			I		I		I		I	MA-28
Front drive shaft boot			I		I		I		I	MA-36
In-cabin microfilter					R				R	MA-28

NOTE:

(1) Use only Genuine NISSAN CVT fluid (NS-2). If towing a trailer, using a camper or a car-top carrier, or driving on rough or muddy roads, inspect CVT fluid deterioration at NISSAN dealer every 60,000 miles (96,000 km), then change the CVT fluid NS-2 if necessary. And if the inspection is not performed, change (not just inspect) CVT fluid NS-2 every 60,000 miles (96,000 km). **Using transmission fluid other than Genuine NISSAN CVT Fluid NS-2 will damage the CVT, which is not covered by the NISSAN new vehicle limited warranty.**

(2) Refer to "Tire rotation" under the "General maintenance" heading earlier in this section.

FOR USA AND CANADA : Schedule 2

INFOID:0000000008633026

EMISSION CONTROL SYSTEM

Abbreviations: R = Replace. I = Inspect. Correct or replace if necessary. []: At the mileage intervals only

MAINTENANCE OPERATION		MAINTENANCE INTERVAL								Reference Page
		Miles x 1,000 (12) Months 6	7.5 (24) 12	22.5 (36) 18	30 (48) 24	37.5 (60) 30	45 (72) 36	52.5 (84) 42	60 (96) 48	
Perform at number of miles, kilometers or months, whichever comes first.	Miles x 1,000 (km x 1,000) Months	7.5 (12) 6	15 (24) 12	22.5 (36) 18	30 (48) 24	37.5 (60) 30	45 (72) 36	52.5 (84) 42	60 (96) 48	
Drive belts	NOTE (1)								I*	MA-20
Air cleaner filter					[R]				[R]	MA-23
EVAP vapor lines					I*				I*	MA-27
Fuel lines					I*				I*	MA-23
Fuel filter	NOTE (2)									—
Engine coolant *	NOTE (3) (4)									MA-20
Engine oil		R	R	R	R	R	R	R	R	MA-24
Engine oil filter [Use genuine NISSAN engine oil filter or equivalent.]		R	R	R	R	R	R	R	R	MA-23
Spark plugs (Iridium-tipped type)		Replace every 105,000 miles (168,000 km).								MA-26
Intake & exhaust valve clearance *	NOTE (5)									EM-132

NOTE:

(1) After 60,000 miles (96,000 km) or 48 months, inspect every 15,000 miles (24,000 km) or 12 months. Replace the drive belt if found damaged or if the drive belt auto-tensioner reading reaches maximum limit.

(2) Maintenance-free item. For service procedures, refer to FL section.

PERIODIC MAINTENANCE

< PERIODIC MAINTENANCE >

(3) First replacement interval is 105,000 miles (168,000 km) or 84 months. After first replacement, replace every 75,000 miles (120,000 km) or 60 months.

(4) When adding or replacing coolant, be sure to use only Genuine NISSAN Long Life Antifreeze/Coolant (blue) or equivalent. Genuine NISSAN Long Life Antifreeze/Coolant (blue) is pre-diluted to provide antifreeze protection to -34° F (-37° C). If additional freeze protection is needed due to weather where you operate your vehicle, add Genuine NISSAN Long Life antifreeze/Coolant (blue) concentrate following the directions on the container. If an equivalent coolant other than Genuine NISSAN Long Life Antifreeze/Coolant (blue) is used, follow the manufacturer's instructions to maintain minimum antifreeze protection to -34° F (-37° C). The use of other types or coolant solutions other than Genuine NISSAN Long Life Antifreeze/Coolant (blue) or equivalent may damage the engine cooling system.

(5) Periodic maintenance is not required. However, if valve noise increases, inspect valve clearance.

: Maintenance items and intervals with "" are recommended by NISSAN for reliable vehicle operation. The owner need not perform such maintenance in order to maintain the emission warranty or manufacturer recall liability. Other maintenance items and intervals are required.

CHASSIS AND BODY

Abbreviations: R = Replace. I = Inspect. Correct or replace if necessary.

MAINTENANCE OPERATION		MAINTENANCE INTERVAL								Reference Page
Perform at number of miles, kilometers or months, whichever comes first.	Miles x 1,000 (km x 1,000) Months	7.5 (12) 6	15 (24) 12	22.5 (36) 18	30 (48) 24	37.5 (60) 30	45 (72) 36	52.5 (84) 42	60 (96) 48	
Brake lines and cables			I		I		I		I	MA-32
Brake fluid					R				R	MA-33
Brake pads & rotors			I		I		I		I	BR-7, BR-7 BR-8, BR-8
CVT fluid	NOTE (1)		I		I		I		I	MA-28
Steering gear and linkage, axle & suspension parts					I				I	MA-35
Tire rotation	NOTE (2)									MA-30
Exhaust system					I				I	MA-28
Front drive shaft boot			I		I		I		I	MA-36
In-cabin microfilter			R		R		R		R	MA-28

NOTE:

(1) Using transmission fluid other than Genuine NISSAN CVT Fluid NS-2 will damage the CVT, which is not covered by the NISSAN new vehicle limited warranty.

(2) Refer to "Tire rotation" under the "General maintenance" heading earlier in this section.

FOR MEXICO

FOR MEXICO : Periodic Maintenance

INFOID:000000008633027

The following tables show the normal maintenance schedule. Depending upon weather and atmospheric conditions, varying road surfaces, individual driving habits and vehicle usage, additional or more frequent maintenance may be required.

Periodic maintenance beyond the last period shown on the tables requires similar maintenance.

ENGINE AND EMISSION CONTROL MAINTENANCE

PERIODIC MAINTENANCE

< PERIODIC MAINTENANCE >

Abbreviations: I = Inspect and correct or replace as necessary, R = Replace, E = Check and correct the engine coolant mixture ratio.

MAINTENANCE OPERATION		MAINTENANCE INTERVAL								Reference page
	km x 1,000 (Miles x 1,000) Months	10 (6) 6	20 (12) 12	30 (18) 18	40 (24) 24	50 (30) 30	60 (36) 36	70 (42) 42	80 (48) 48	
Under hood and under vehicle										
Intake & exhaust valve clearance	NOTE (1)									EM-132
Drive belts	NOTE (2)				I				I	MA-20
Engine oil (Use recommended oil.)★		R	R	R	R	R	R	R	R	MA-24
Engine oil filter (Use genuine NISSAN engine oil filter or equivalent)★		R	R	R	R	R	R	R	R	MA-24
Engine coolant	NOTE (3)				E				E	MA-20
Cooling system					I				I	CO-10
Fuel lines					I				I	MA-23
Air cleaner filter (Viscous paper type)★					R				R	MA-23
Fuel filter (In-tank type)	NOTE (4)									—
Spark plugs (Iridium-tipped type)		Replace every 100,000 km (60,000 miles)								MA-26
EVAP vapor lines (With carbon canister)					I				I	MA-27

NOTE:

Maintenance items with “★” should be performed more frequently according to “Maintenance Under Severe Driving Conditions”.

- (1) Periodic maintenance is not required. However, if valve noise increases, check valve clearance.
- (2) Replace the drive belt if found damaged or if the drive belt auto-tensioner reading reaches the maximum limit.
- (3) Use Genuine NISSAN Engine Coolant (blue) or equivalent in its quality, in order to avoid possible aluminum corrosion within the engine cooling system caused by the use of non-genuine engine coolant. Check and correct the engine coolant mixture ratio every 40,000 km (24,000 miles) or 24 months. First replacement interval is 160,000 km (96,000 miles) or 96 months. After first replacement, replace every 80,000 km (48,000 miles) or 48 months.
- (4) Maintenance-free item. For service procedures, refer to FL section.

CHASSIS AND BODY MAINTENANCE

Abbreviations: I = Inspect and correct or replace as necessary, R = Replace.

MAINTENANCE OPERATION		MAINTENANCE INTERVAL								Reference page
	km x 1,000 (Miles x 1,000) Months	10 (6) 6	20 (12) 12	30 (18) 18	40 (24) 24	50 (30) 30	60 (36) 36	70 (42) 42	80 (48) 48	
Under hood and under vehicle										
Brake fluid (For level & leaks)				I		I		I		MA-32
Brake fluid ★					R				R	MA-33
Power steering fluid & lines (For level & leaks)				I		I		I		MA-32
Brake line & cables				I		I		I		MA-32 , MA-28
Exhaust system						I			I	MA-32 , MA-28

PERIODIC MAINTENANCE

< PERIODIC MAINTENANCE >

MAINTENANCE OPERATION		MAINTENANCE INTERVAL								Reference page
	km x 1,000 (Miles x 1,000) Months	10 (6) 6	20 (12) 12	30 (18) 18	40 (24) 24	50 (30) 30	60 (36) 36	70 (42) 42	80 (48) 48	
Perform either at number of kilometers (miles) or months, whichever comes first.										
CVT fluid (For level & leaks)	See NOTE (1)		I		I		I		I	MA-28
Steering gear & linkage, axle & suspension parts ★					I				I	MA-35 , MA-36 , MA-37
Drive shafts ★			I		I		I		I	MA-35 , MA-36 , MA-37
Outside and inside										
Wheel alignment (If necessary, rotate & balance wheels)			I		I		I		I	MA-30
Brake pads, rotors, drums & linings ★			I		I		I		I	BR-7 , BR-7 , MA-32
Foot brake & parking brake (For free play, stroke & operation)			I		I		I		I	BR-14 , PB-4
Air conditioner filter★			R		R		R		R	MA-28

NOTE:

- Maintenance items with “★” should be performed more frequently according to “Maintenance Under Severe Driving Conditions”.
- (1) Use only Genuine NISSAN CVT fluid (MNS-2). If towing a trailer, using a camper or a car-top carrier, or driving on rough or muddy roads, inspect CVT fluid deterioration at NISSAN dealer every 100,000 km (60,000 miles), then change CVT fluid NS-2 if necessary. And if the inspection is not performed, change (not just inspect) CVT fluid NS-2 every 100,000 km (60,000 miles). **Using transmission fluid other than Genuine NISSAN CVT Fluid NS-2 will damage the CVT, which is not covered by the warranty.**

MAINTENANCE UNDER SEVERE DRIVING CONDITIONS

The maintenance intervals shown on the preceding pages are for normal operating conditions. If the vehicle is mainly operated under severe driving conditions as shown below, more frequent maintenance must be performed on the following items as shown in the table.

Severe driving conditions

A — Driving under dusty conditions

B — Repeatedly driving short distances

C — Towing a trailer or caravan

D — Extensive idling

E — Driving in extremely adverse weather conditions or in areas where ambient temperatures are either extremely low or extremely high

F — Driving in high humidity or mountainous areas

G — Driving in areas using salt or other corrosive materials

H — Driving on rough and/or muddy roads or in the desert

I — Driving with frequent use of braking or in mountainous areas

J — Frequent driving in water

Maintenance operation: Inspect = Inspect and correct or replace as necessary.

Driving condition										Maintenance item		Maintenance operation	Maintenance interval	Reference page
A	Air cleaner filter	Viscous paper type	Replace	More frequently	MA-23
A	B	C	D	Engine oil & engine oil filter		Replace	Every 5,000 km (3,000 miles) or 3 months	MA-24 , MA-24
.	F	Brake fluid		Replace	Every 20,000 km (12,000 miles) or 12 months	MA-33
.	G	H	.	.	Steering gear & linkage, axle & suspension parts		Inspect	Every 20,000 km (12,000 miles) or 12 months	MA-35 , MA-36 , MA-37

PERIODIC MAINTENANCE

< PERIODIC MAINTENANCE >

.	G	H	.	.	Drive shafts	Inspect	Every 10,000 km (6,000 miles) or 6 months	MA-37
A	.	C	.	.	.	G	H	I	.	Brake pads, rotors, drums & linings	Inspect	Every 10,000 km (6,000 miles) or 6 months	BR-Z , BR-Z
A	Air conditioner filter	Replace	More frequently	MA-28

A
B
C
D
E
F
G
H
I
J
K
L
M
N
O

MA

RECOMMENDED FLUIDS AND LUBRICANTS

< PERIODIC MAINTENANCE >

RECOMMENDED FLUIDS AND LUBRICANTS FOR USA AND CANADA

FOR USA AND CANADA : Fluids and Lubricants

INFOID:000000008633028

Description		Capacity (Approximate)			Recommended Fluids/Lubricants
		Metric	US measure	Imp measure	
Fuel		75.6 ℓ	20 gal	16-5/8 gal	Unleaded gasoline with an octane rating of at least 91 AKI (RON 96)
Engine oil Drain and refill	With oil filter change	4.8 ℓ	5-1/8 qt	4-1/4 qt	<ul style="list-style-type: none"> • Engine oil with API Certification Mark *1*2 • Viscosity SAE 5W-30 *2
	Without oil filter change	4.5 ℓ	4-3/4 qt	4 qt	
	Dry engine (Overhaul)	5.3 ℓ	5-5/8 qt	4-5/8 qt	
Cooling system (with reservoir at MAX level)		9.0 ℓ	9-1/2 qt	7-7/8 qt	Pre-diluted Genuine NISSAN Long Life Antifreeze/ Coolant (blue) or equivalent
CVT fluid		10.2 ℓ	10-3/4 qt	9 qt	Genuine NISSAN CVT Fluid NS-2 *3
Power steering fluid (PSF)		1.0 ℓ	1-1/8 qt	7/8 qt	Genuine NISSAN PSF or equivalent *4
Brake fluid		—	—	—	Genuine NISSAN Super Heavy Duty Brake Fluid *5 or equivalent DOT 3 (US FMVSS No. 116)
Multi-purpose grease		—	—	—	NLGI No. 2 (Lithium soap base)
Windshield washer fluid		4.5 ℓ	4-3/4 qt	4 qt	Genuine NISSAN Windshield Washer Concentrate Cleaner & Antifreeze or equivalent
Air conditioning system refrigerant		0.55 ± 0.025 kg	1.21 ± 0.055 lb	1.21 ± 0.055 lb	HFC-134a (R-134a) *6
Air conditioning system oil		150 m ℓ	5.03 fl oz	5.03 fl oz	A/C System Oil Type S (DH-PS) *6

*1: For further details, see "Engine Oil Recommendation".

*2: NISSAN recommends Genuine NISSAN Ester Oil available at a NISSAN dealer.

***3: Use only Genuine NISSAN CVT Fluid NS-2. Using transmission fluid other than Genuine NISSAN CVT Fluid NS-2 will damage the CVT, which is not covered by the NISSAN new vehicle limited warranty.**

*4: DEXRON™ VI type ATF may also be used.

*5: Available in mainland USA through a NISSAN dealer.

*6: For further information, see "Air conditioning specification label".

FOR USA AND CANADA : Engine Oil Recommendation

INFOID:000000008633029

NISSAN recommends the use of an energy conserving oil in order to improve fuel economy. Select only engine oils that meet the American Petroleum Institute (API) certification and International Lubricant Standardization and Approval Committee (ILSAC) certification and SAE viscosity standard. These oils have the API certification mark on the front of the container. Oils which do not have the specified quality label should not be used as they could cause engine damage.

RECOMMENDED FLUIDS AND LUBRICANTS

< PERIODIC MAINTENANCE >

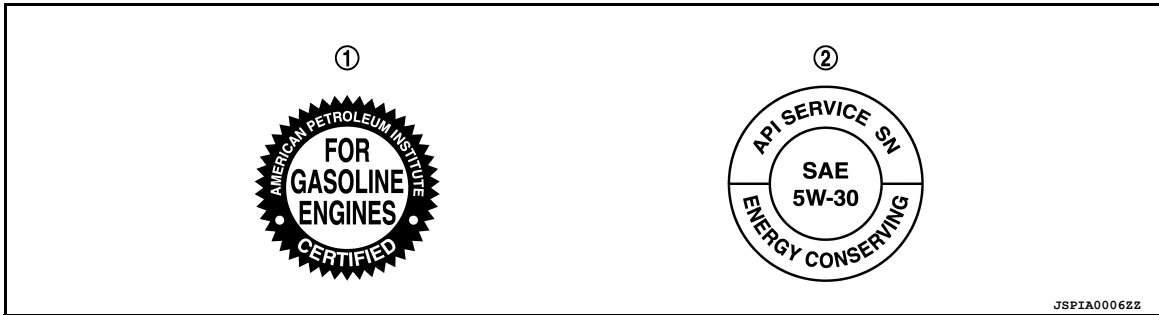

1. API certification mark
2. API service symbol

FOR USA AND CANADA : Anti-Freeze Coolant Mixture Ratio

INFOID:000000008831164

The engine cooling system is filled at the factory with a pre-diluted mixture of 50% Genuine NISSAN Long Life Antifreeze/Coolant (blue) and 50% water to provide year-round anti-freeze and coolant protection. The anti-freeze solution contains rust and corrosion inhibitors. Additional engine cooling system additives are not necessary.

WARNING:

- Do not remove the radiator or coolant reservoir cap when the engine is hot. Wait until the engine and radiator cool down. Serious burns could be caused by high pressure fluid escaping from the radiator.
- The radiator is equipped with a pressure type radiator cap. To prevent engine damage, use only a genuine NISSAN radiator cap.

CAUTION:

- When adding or replacing coolant, be sure to use only Genuine NISSAN Long Life Antifreeze/Coolant (blue) or equivalent. Genuine NISSAN Long Life Antifreeze/Coolant (blue) is pre-diluted to provide antifreeze protection to -34°F (-37°C). If additional freeze protection is needed due to weather where you operate your vehicle, add Genuine NISSAN Long Life Antifreeze/Coolant (blue) concentrate following the directions on the container. If an equivalent coolant other than Genuine NISSAN Long Life Antifreeze/Coolant (blue) is used, follow the coolant manufacturer's instructions to maintain minimum antifreeze protection to -34°F (-37°C). The use of other types of coolant solutions other than Genuine NISSAN Long Life Antifreeze/Coolant (blue) or equivalent may damage the engine cooling system.
- Mixing any other type of coolant other than Genuine NISSAN Long Life Antifreeze/Coolant (blue), including Genuine NISSAN Long Life Antifreeze/Coolant (green), or the use of non-distilled water will reduce the life expectancy of the factory-fill coolant.

FOR MEXICO

FOR MEXICO : Fluids and Lubricants

INFOID:000000008633031

Description		Capacity (Approximate)			Recommended Fluids/Lubricants
		Metric	US measure	Imp measure	
Fuel		75.6 ℓ	20 gal	16-5/8 gal	Unleaded gasoline with an octane rating of at least 91 AKI (RON 96)
Engine oil Drain and re-fill	With oil filter change	4.8 ℓ	5-1/8 qt	4-1/4 qt	<ul style="list-style-type: none"> • Genuine NISSAN engine oil *1 • API grade SL, SM or SN *1 • ILSAC grade GF-2, GF-3, GF-4 or GF-5 *1 • Viscosity SAE 10W-30 *1
	Without oil filter change	4.5 ℓ	4-3/4 qt	4 qt	
	Dry engine (engine overhaul)	5.3 ℓ	5-5/8 qt	4 5/8 qt	
Cooling system (with reservoir at MAX level)		9.0 ℓ	9-1/2 qt	7-7/8 qt	Genuine NISSAN Engine Coolant (blue) or equivalent *2
CVT fluid		10.2 ℓ	10-3/4 qt	9 qt	Genuine NISSAN CVT fluid NS-2 *3

A
B
C
D
E
F
G
H
I
J
K
L
M
N
O

MA

RECOMMENDED FLUIDS AND LUBRICANTS

< PERIODIC MAINTENANCE >

Description	Capacity (Approximate)			Recommended Fluids/Lubricants
	Metric	US measure	Imp measure	
Power steering fluid	1.0 ℓ	1-1/8 qt	7/8 qt	Genuine NISSAN PSF or equivalent *4
Brake fluid	—	—	—	Genuine NISSAN Super Heavy Duty Brake Fluid, or equivalent DOT 3 (FM-VSS No. 116)
Multi-purpose grease	—	—	—	NLGI No. 2 (Lithium soap base)
Air conditioning system refrigerant	0.55 ± 0.025 kg	1.21 ± 0.055 lb	1.21 ± 0.055 lb	HFC-134a (R-134a) *5
Air conditioning system oil	150 m ℓ	5.03 fl oz	5.03 fl oz	A/C System Oil Type S (DH-PS) *5
Windshield washer fluid	4.5 ℓ	4-3/4 qt	4 qt	Genuine NISSAN Windshield Washer Concentrate Cleaner & Antifreeze or equivalent

*1: For further details, see "Engine Oil Recommendation".

*2: Use Genuine NISSAN Engine Coolant (blue) or equivalent in its quality, in order to avoid possible aluminum corrosion within the engine cooling system caused by the use of non-genuine engine coolant.

Note that any repairs for the incidents within the engine cooling system while using non-genuine engine coolant may not be covered by the warranty even if such incidents occurred during the warranty period.

***3: Use only Genuine NISSAN CVT Fluid NS-2. Using transmission fluid other than Genuine NISSAN CVT fluid NS-2 will damage the CVT, which is not covered by the warranty.**

*4: DEXTRON™ VI type ATF may also be used.

*5: For further information, see "Air conditioning specification label".

FOR MEXICO : Engine Oil Recommendation

INFOID:000000008633032

GASOLINE ENGINE

- 10W-30 is preferable.
- 5W-30 is also preferable and will improve fuel economy.
- If 10W-30 or 5W-30 is not available, select the viscosity, from the chart, that is suitable for the outside temperature range.

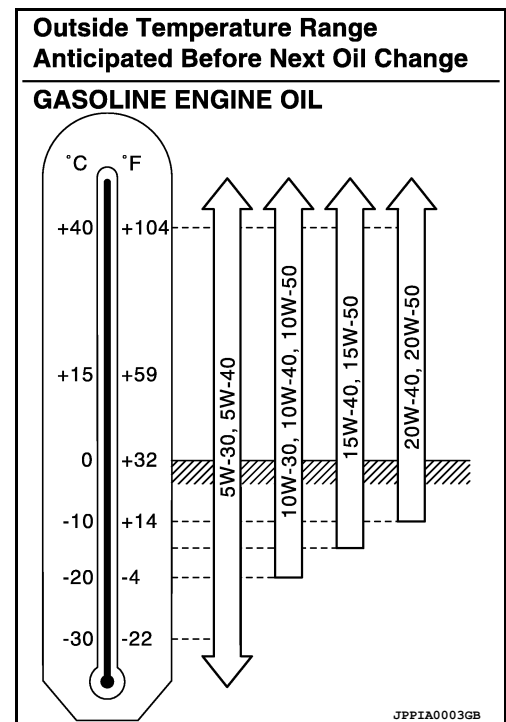

FOR MEXICO : Engine Coolant Mixture Ratio

INFOID:000000008633033

The engine cooling system is filled at the factory with a high-quality, year-round and extended life engine coolant. The high quality engine coolant contains the specific solutions effective for the anti-corrosion and the anti-freeze function. Therefore, additional cooling system additives are not necessary.

RECOMMENDED FLUIDS AND LUBRICANTS

< PERIODIC MAINTENANCE >

Coolant Mixture Ratios

For outside temperatures down to:		Anti-freeze coolant mixture ratio	
° C	° F	Genuine NISSAN Engine Coolant or equivalent	Demineralized water or distilled water
- 15°	5°	30 %	70 %
- 35°	- 30°	50 %	50 %

When checking the engine coolant mixture ratio by the coolant hydrometer, use the chart below to correct your hydrometer reading (specific gravity) according to coolant temperature.

Mixed Coolant Specific Gravity

Unit: specific gravity

Engine coolant mixture ratio	Coolant temperature °C (°F)			
	15° (59°)	25° (77°)	35° (95°)	45° (113°)
30%	1.046 - 1.050	1.042 - 1.046	1.038 - 1.042	1.033 - 1.038
50%	1.076 - 1.080	1.070 - 1.076	1.065 - 1.071	1.059 - 1.065

WARNING:

Do not remove the radiator cap when the engine is hot. Serious burns could be caused by high pressure fluid escaping from the radiator. Wait until the engine and radiator cool down.

CAUTION:

- When adding or replacing coolant, be sure to use only Genuine NISSAN Engine Coolant or equivalent in its quality with the proper mixture ratio.
- The use of other types of engine coolant may damage your cooling system.

A
B
C
D
E
F
G
H
I
J
K
L
M
N
O

MA

ENGINE MAINTENANCE (VQ35DE)

< PERIODIC MAINTENANCE >

ENGINE MAINTENANCE (VQ35DE)

DRIVE BELTS

DRIVE BELTS : Checking Drive Belts

INFOID:000000008633034

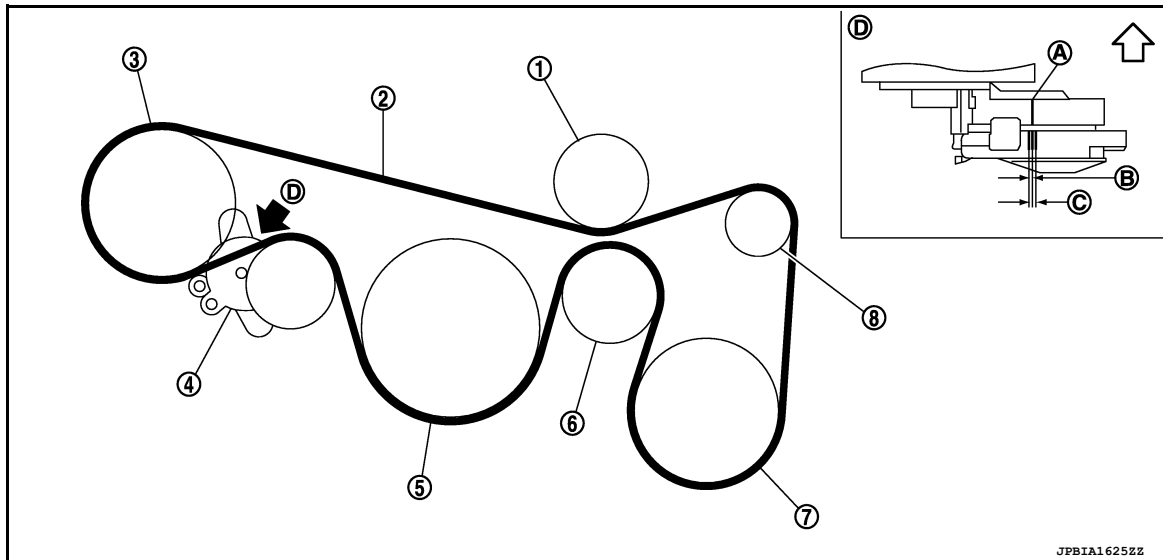

- | | | |
|------------------------------|-----------------------|----------------------------|
| 1. Idler pulley | 2. Drive belt | 3. Power steering oil pump |
| 4. Drive belt auto-tensioner | 5. Crankshaft pulley | 6. Idler pulley |
| 7. A/C compressor | 8. Generator | A. Indicator |
| B. New drive belt range | C. Possible use range | D. View D |
- ⇐ Engine front

WARNING:

Inspect and check the drive belts with the engine off.

- Check that the indicator of drive belt auto-tensioner is within the possible use range.

NOTE:

- Check the drive belt auto-tensioner indication when the engine is cold.
- When new drive belt is installed, the indicator should be within the new drive belt range.
- Visually check entire drive belt for wear, damage or cracks.
- If the indicator is out of the possible use range or the drive belt is damaged, replace the drive belt.

DRIVE BELTS : Tension Adjustment

INFOID:000000008633035

- Belt tension is not manually adjustable, it is automatically adjusted by the drive belt auto-tensioner.

ENGINE COOLANT

ENGINE COOLANT : System Inspection

INFOID:000000008633036

WARNING:

- **Do not remove the radiator cap when the engine is hot. Serious burns could occur from high pressure coolant escaping from the radiator.**
- **Wrap a thick cloth around the cap. Slowly push down and turn it a quarter turn to allow built-up pressure to escape. Carefully remove the cap by pushing down and turning it all the way.**

CHECKING COOLING SYSTEM HOSES

Check hoses for the following:

- Improper attachment
- Leaks
- Cracks
- Damage
- Loose connections

ENGINE MAINTENANCE (VQ35DE)

< PERIODIC MAINTENANCE >

- Chafing
- Deterioration

CHECKING RESERVOIR TANK LEVEL

- Check if the reservoir tank coolant level is within MIN to MAX range when the engine is cool.
- Adjust coolant level if it is too much or too little.

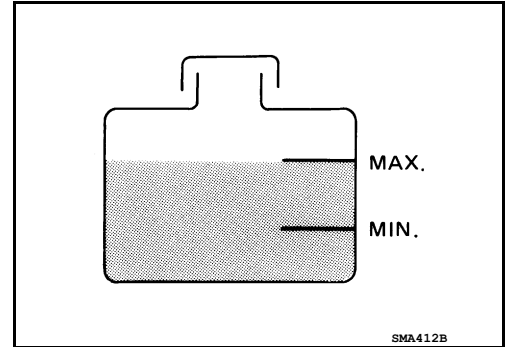

ENGINE COOLANT : Changing Engine Coolant

INFOID:000000008633037

WARNING:

- To avoid being scalded, do not change the coolant when the engine is hot.
- Wrap a thick cloth around cap and carefully remove the cap. First, turn the cap a quarter of a turn to release built-up pressure. Then turn the cap all the way.

DRAINING ENGINE COOLANT

1. Remove the engine under cover. Refer to [EM-23, "Removal and Installation"](#).
2. Open radiator drain plug at the bottom of radiator and remove the radiator filler cap. This is the only step required for a partial cooling system drain.

CAUTION:

Do not allow the coolant to contact drive belt.

3. If removing the heater core, remove the upper heater hose from the engine coolant outlet and apply moderate air pressure of 103.46 kPa (1.055 kg-cm², 15 psi) maximum for 30 seconds into the hose to blow out excess coolant from the core.
4. For a complete cooling system drain, remove the reservoir tank and drain the coolant, and then clean the reservoir tank before installation.

CAUTION:

Do not allow the coolant to contact drive belt.

5. When performing a complete cooling system drain remove the cylinder block front drain plug and the cylinder block RH drain plug.
6. Check the drained coolant for contaminants such as rust, corrosion or discoloration.
 - If contaminated, flush the engine cooling system.

REFILLING ENGINE COOLANT

1. Install the radiator drain plug. If the cooling system was drained completely, install the reservoir tank and the cylinder block drain plugs.
 - The radiator must be completely empty of coolant and water.
 - Apply sealant to the threads of the cylinder block drain plugs. Use Genuine High Performance Thread Sealant or equivalent. Refer to [GI-21, "Recommended Chemical Products and Sealants"](#).

Radiator drain plug : Refer to [CO-14, "Removal and Installation"](#).

Cylinder block front drain plug : 9.8 N·m (1.0 kg-m, 87 in-lb)

Cylinder block RH drain plug : 19.6 N·m (2.0 kg-m, 14 ft-lb)

2. If disconnected, reattach the upper radiator hose at the engine side.
3. Set the vehicle heater controls to the full HOT and heater ON position. Turn the vehicle ignition ON with the engine OFF as necessary to activate the heater mode.

ENGINE MAINTENANCE (VQ35DE)

< PERIODIC MAINTENANCE >

4. Install the Tool by installing the radiator cap adapter onto the radiator neck opening. Then attach the gauge body assembly with the refill tube and the venturi assembly to the radiator cap adapter.

Tool number : KV991J0070 (J-45695)

5. Insert the refill hose into the coolant mixture container that is placed at floor level. Make sure the ball valve is in the closed position.
 - Use recommended coolant or equivalent.
Refer to [MA-17, "FOR USA AND CANADA : Anti-Freeze Coolant Mixture Ratio"](#) (United States and Canada) or [MA-18, "FOR MEXICO : Engine Coolant Mixture Ratio"](#) (Mexico).

CAUTION:

Do not use any cooling system additives such as radiator sealer. Additives may clog the cooling system and cause damage to the engine, transmission and/or cooling system.

Engine coolant capacity (with reservoir tank) : Refer to [MA-16, "FOR USA AND CANADA : Fluids and Lubricants"](#) (United States and Canada) or [MA-17, "FOR MEXICO : Fluids and Lubricants"](#) (Mexico).

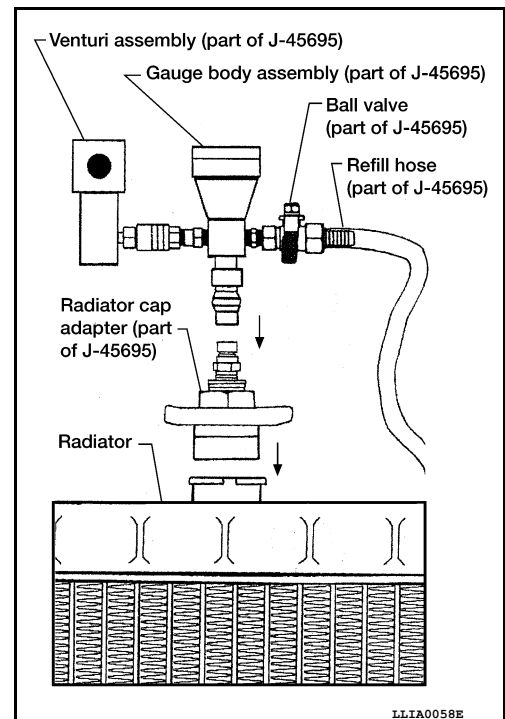

6. Install an air hose to the venturi assembly, the air pressure must be within specification.

Compressed air supply pressure : 549 - 824 kPa (5.6 - 8.4 kg/cm², 80 - 119 psi)

CAUTION:

The compressed air supply must be equipped with an air dryer.

7. The vacuum gauge will begin to rise and there will be an audible hissing noise. During this process open the ball valve on the refill hose slightly. Coolant will be visible rising in the refill hose. Once the refill hose is full of coolant, close the ball valve. This will purge any air trapped in the refill hose.
8. Continue to draw the vacuum until the gauge reaches 28 inches of vacuum. The gauge may not reach 28 inches in high altitude locations; use the vacuum specifications based on the altitude above sea level.

Altitude above sea level	Vacuum gauge reading
0 - 100 m (328 ft)	: 28 inches of vacuum
300 m (984 ft)	: 27 inches of vacuum
500 m (1,641 ft)	: 26 inches of vacuum
1,000 m (3,281 ft)	: 24 - 25 inches of vacuum

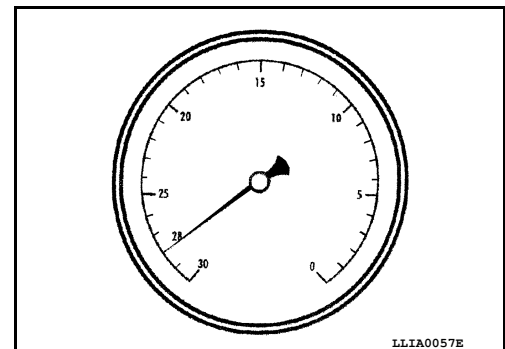

9. When the vacuum gauge has reached the specified amount, disconnect the air hose and wait 20 seconds to see if the system loses any vacuum. If the vacuum level drops, perform any necessary repairs to the system and repeat steps 6 - 8 to bring the vacuum to the specified amount. Recheck for any leaks.
10. Place the coolant container (with the refill hose inserted) at the same level as the top of the radiator. Then open the ball valve on the refill hose so the coolant will be drawn up to fill the cooling system. The cooling system is full when the vacuum gauge reads zero.

CAUTION:

Do not allow the coolant container to get too low when filling, to avoid air from being drawn into the cooling system.

11. Remove the Tool from the radiator neck opening.

ENGINE MAINTENANCE (VQ35DE)

< PERIODIC MAINTENANCE >

12. Fill the cooling system reservoir tank to the specified level and install the radiator cap. Run the engine to warm up the cooling system and top up the system as necessary.
13. Install the engine under cover. Refer to [EM-23. "Removal and Installation"](#).

FUEL LINES

FUEL LINES : Inspection

INFOID:000000008633038

Inspect fuel lines, filler cap and tank for improper attachment, leaks, cracks, damage, loose connections, chafing or deterioration. If necessary, repair or replace damaged parts.

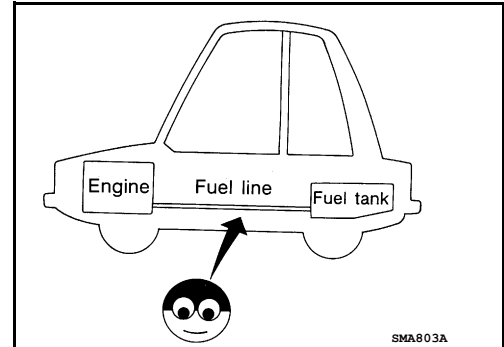

AIR CLEANER FILTER

AIR CLEANER FILTER : Removal and Installation

INFOID:000000008633039

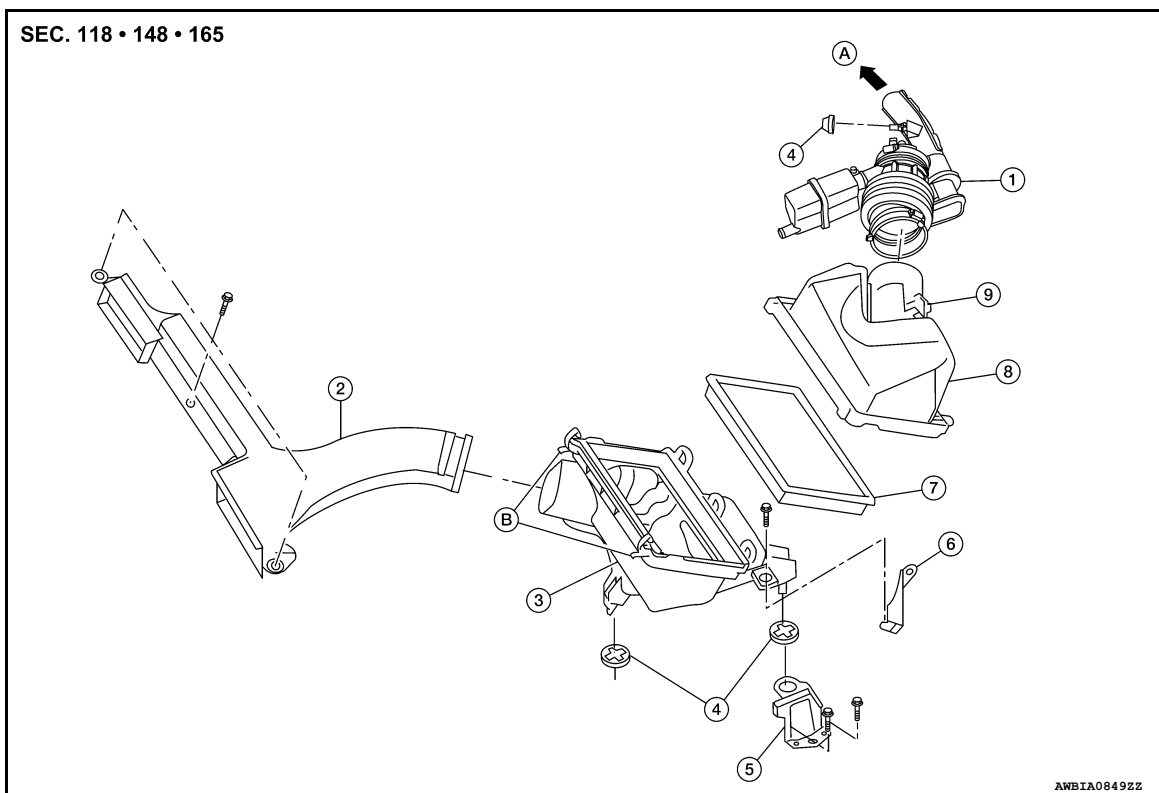

- | | | |
|--|--------------------------------------|-----------------------------|
| 1. Air duct hose and resonator assembly | 2. Front air duct | 3. Air cleaner case (lower) |
| 4. Grommets | 5. Air cleaner case mounting bracket | 6. Bracket |
| 7. Air cleaner filter | 8. Air cleaner case (upper) | 9. Mass air flow sensor |
| A. To electric throttle control actuator | B. Air cleaner case side clips | |

CHANGING THE AIR CLEANER FILTER

CAUTION:

It is not necessary to remove the front air duct to replace the air cleaner filter.

1. Unhook the air cleaner case side clips.

ENGINE MAINTENANCE (VQ35DE)

< PERIODIC MAINTENANCE >

2. Remove the air cleaner filter.
3. Install a new air cleaner filter.
4. Lock the air cleaner case side clips.

ENGINE OIL

ENGINE OIL : Inspection

INFOID:000000008633041

OIL LEVEL

NOTE:

- Before starting the engine, check the oil level. If the engine is already started, stop it and allow 10 minutes before checking.
- Check that the oil level is within the range as indicated on the dipstick.
- If it is out of range, add oil as necessary until the dipstick indicates the correct level.

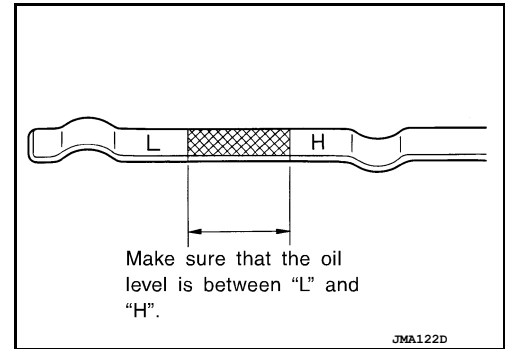

ENGINE OIL : Changing Engine Oil

INFOID:000000008633041

WARNING:

- **Be careful not to burn yourself, as the engine oil may be hot.**
 - **Prolonged and repeated contact with used engine oil may cause skin cancer; try to avoid direct skin contact with used oil. If skin contact is made, wash thoroughly with soap or hand cleaner as soon as possible.**
1. Position the vehicle so it is level on the hoist.
 2. Warm up the engine and check for oil leaks from the engine.
 3. Stop engine and wait for 10 minutes.
 4. Remove the oil pan drain plug and oil filler cap.
 5. Drain the engine oil.
 6. Install the oil pan drain plug with a new washer and refill the engine with new engine oil.

Oil specification and viscosity : Refer to [MA-16, "FOR USA AND CANADA : Engine Oil Recommendation" \(United States and Canada\)](#) or [MA-18, "FOR MEXICO : Engine Oil Recommendation" \(Mexico\)](#).

Oil pan drain plug : 34.3 N·m (3.5 kg-m, 25 ft-lb)

CAUTION:

- **Be sure to clean the oil pan drain plug and install with a new washer.**
 - **The refill capacity depends on the oil temperature and drain time. Use the specifications for reference only. Always use the dipstick to determine when the proper amount of oil is in the engine.**
7. Warm up the engine and check around the oil pan drain plug and oil filter for oil leaks.
 8. Stop engine and wait for 10 minutes.
 9. Check the engine oil level using the dipstick.

CAUTION:

Do not overfill the engine oil.

OIL FILTER

OIL FILTER : Removal and Installation

INFOID:000000008633042

REMOVAL

1. Drain engine oil. Refer to [MA-24, "ENGINE OIL : Changing Engine Oil"](#).

ENGINE MAINTENANCE (VQ35DE)

< PERIODIC MAINTENANCE >

- Remove front fender protector side cover. Refer to [EXT-15. "Exploded View"](#).
- Remove the oil filter using Tool (A) as shown.

Tool number : KV10115801 (J-38956)

WARNING:

Be careful not to get burned; the engine oil may be hot.

CAUTION:

- When removing, prepare a shop cloth to absorb any oil leakage or spillage.
- Do not allow engine oil to adhere to the drive belts.
- Completely wipe off any oil that adheres to the engine and the vehicle.

- The oil filter is provided with a relief valve. Use a genuine NISSAN oil filter or equivalent

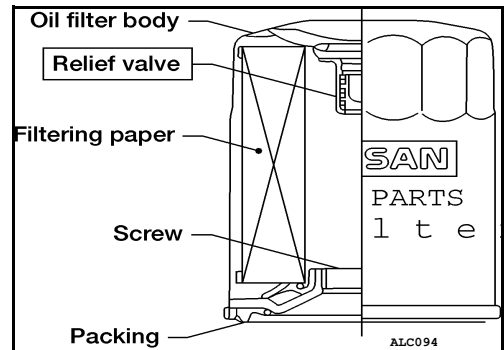
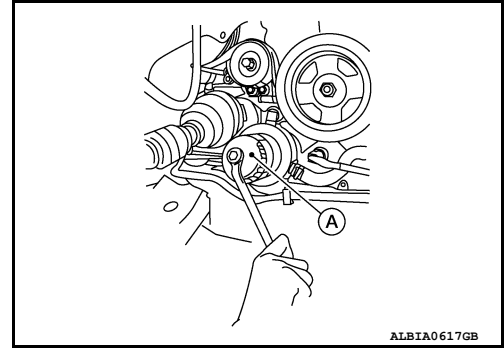

INSTALLATION

- Remove foreign materials adhering to the oil filter installation surface.
- Apply clean engine oil to the oil seal contact surface of the new oil filter.

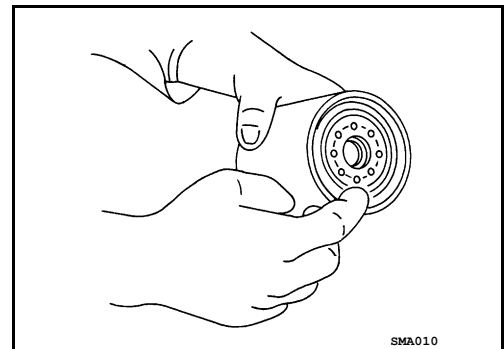

- Screw the oil filter manually until it touches the installation surface, then tighten it by turning another 2/3 turn, or tighten to specification using Tool.

Oil filter : 18.0 N·m (1.8 kg-m, 13 ft-lb)

Tool number : KV10115801 (J-38956)

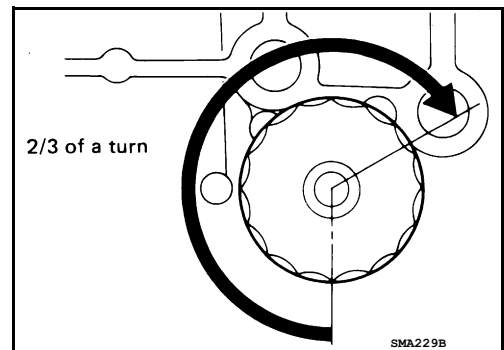

- Refill the engine with new engine oil. Refer to [MA-24. "ENGINE OIL : Changing Engine Oil"](#).
- Check the oil level and add engine oil as necessary. Refer to [MA-24. "ENGINE OIL : Inspection"](#).
- After warming up the engine, check for engine oil leaks.
- Install front fender protector side cover. Refer to [EXT-15. "Exploded View"](#).

SPARK PLUG

A
B
C
D
E
F
G
H
I
J
K
L
M
N
O

MA

ENGINE MAINTENANCE (VQ35DE)

< PERIODIC MAINTENANCE >

SPARK PLUG : Exploded View

INFOID:000000008633043

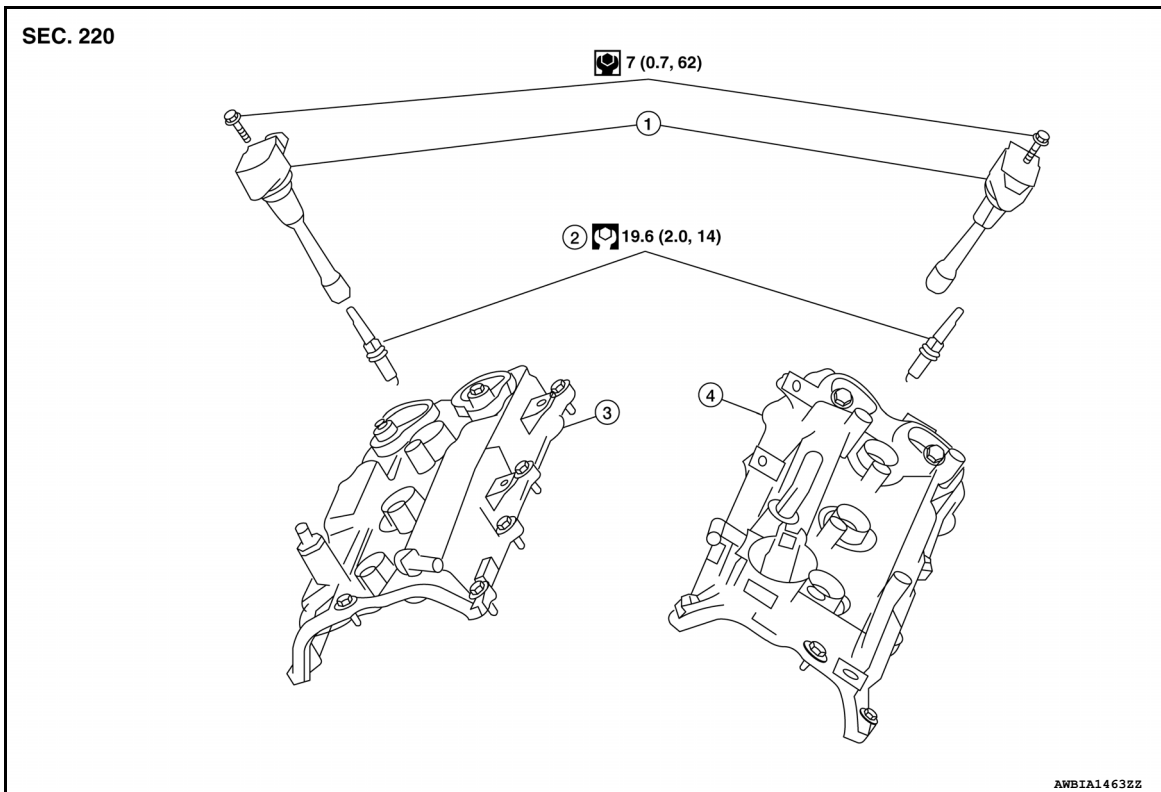

1. Ignition coil

2. Spark plug

3. Rocker cover RH

4. Rocker cover LH

SPARK PLUG : Removal and Installation

INFOID:000000008633044

REMOVAL

1. Remove the ignition coil. Refer to [EM-42. "Removal and Installation \(LH\)"](#) and [EM-42. "Removal and Installation \(RH\)"](#).
2. Remove the spark plug with a suitable spark plug wrench.

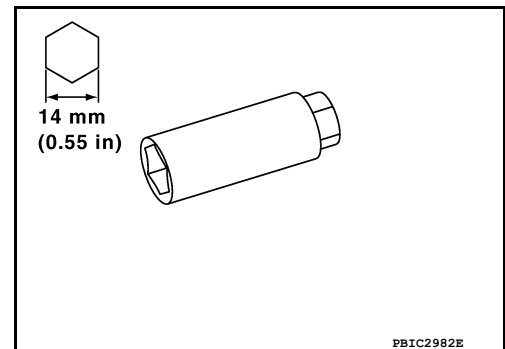

INSPECTION AFTER REMOVAL

ENGINE MAINTENANCE (VQ35DE)

< PERIODIC MAINTENANCE >

- Do not use a wire brush for cleaning the spark plugs. Replace as necessary.

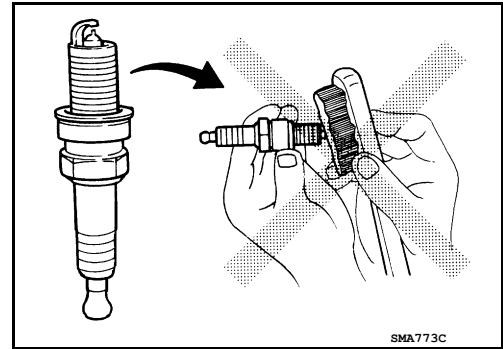

- If plug is covered with carbon, a spark plug cleaner may be used.

Cleaner air pressure : less than 588 kPa (6 kg/cm², 85 psi)

Cleaning time : less than 20 seconds

- Checking and adjusting plug gap is not required between change intervals. If the gap is out of specification, replace the spark plug.

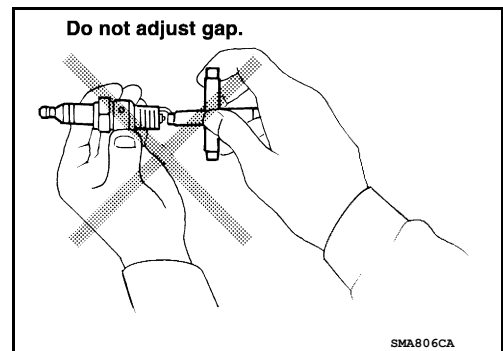

INSTALLATION

Installation is in the reverse order of removal.

Make	DENSO
Standard type*	FXE22HR11
Gap (nominal)	1.1 mm (0.043 in)

*: Always check with the Parts Department for the latest parts information.

EVAP VAPOR LINES

EVAP VAPOR LINES : Inspection

INFOID:000000008633045

1. Visually inspect EVAP vapor lines for improper attachment and for cracks, damage, loose connections, chafing and deterioration.
2. Inspect fuel tank filler cap vacuum relief valve for clogging, sticking, etc.

CHASSIS AND BODY MAINTENANCE

< PERIODIC MAINTENANCE >

CHASSIS AND BODY MAINTENANCE

IN-CABIN MICROFILTER

IN-CABIN MICROFILTER : Removal and Installation

INFOID:000000008633046

REMOVAL

1. Disengage the filter cover tab (1) by pushing up and pull out to remove the filter cover.
2. Remove the in-cabin microfilter from the blower unit.

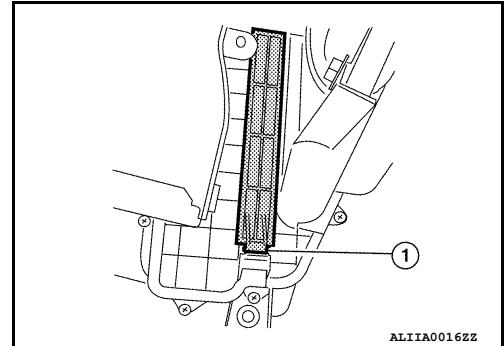

INSTALLATION

Installation is in the reverse order of removal.

EXHAUST SYSTEM

EXHAUST SYSTEM : Inspection

INFOID:000000008633047

Check exhaust pipes, muffler and mounting for improper attachment, leaks, cracks, damage, chafing or deterioration.

- If anything is found, repair or replace damaged parts.

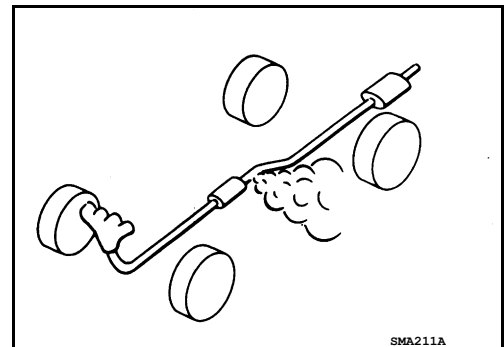

CVT FLUID

CVT FLUID : Inspection

INFOID:000000008633048

CHECKING CVT FLUID

The fluid level should be checked with the fluid warmed up to 50° to 80°C (122° to 176°F). The fluid level check procedure is as follows:

1. Check for fluid leakage.
2. With the engine warmed up, drive the vehicle in an urban area. When ambient temperature is 20°C (68°F), it takes about 10 minutes for the CVT fluid to warm up to 50° to 80°C (122° to 176°F).
3. Park the vehicle on a level surface.
4. Apply parking brake firmly.
5. With engine at idle, while depressing brake pedal, move shift selector throughout the entire shift range.

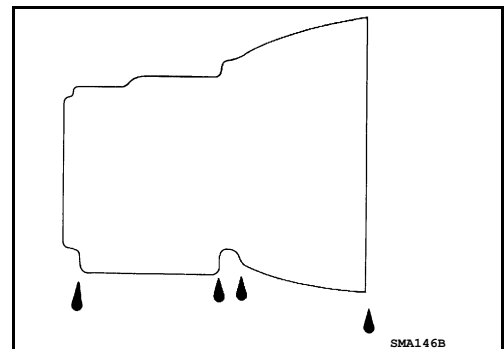

CHASSIS AND BODY MAINTENANCE

< PERIODIC MAINTENANCE >

6. Pull out the CVT fluid level gauge from the CVT fluid charging pipe after pressing the tab on the CVT fluid level gauge to release the lock.

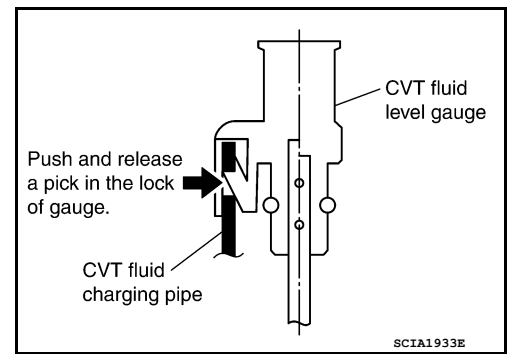

7. Wipe fluid off the CVT fluid level gauge. Insert the CVT fluid level gauge rotating 180° from the originally installed position, then securely push the CVT fluid level gauge until it meets the top end of the CVT fluid charging pipe.

CAUTION:

When wiping away the CVT fluid level gauge, always use lint-free paper, not a cloth rag.

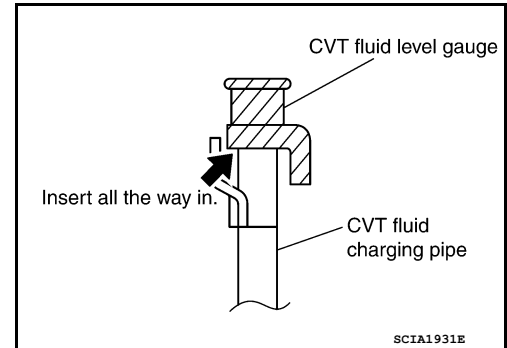

8. Place the shift selector in "P" or "N" position and check that the fluid level is within the specified range.

CAUTION:

When reinstalling CVT fluid level gauge, insert it into the CVT fluid charging pipe and rotate it to the original installation position until securely locked.

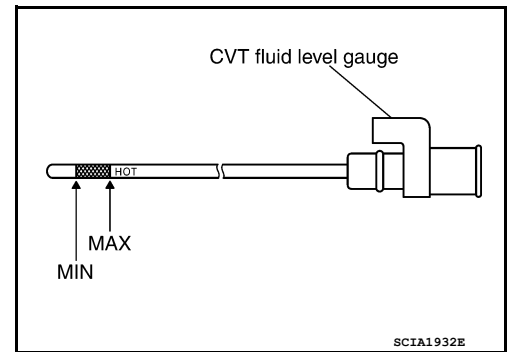

CVT FLUID CONDITION

Check CVT fluid condition.

- If CVT fluid is very dark or smells burned, check operation of CVT. Flush cooling system after repair of CVT.
- If CVT fluid contains frictional material (clutches, brakes, etc.), inspect and clean the CVT fluid cooler mounted in the radiator and flush cooler line using cleaning solvent and compressed air after repair of CVT. Refer to [TM-155, "Cleaning"](#).

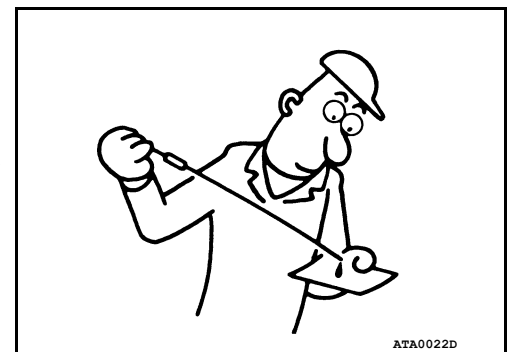

Fluid status	Conceivable cause	Required operation
Varnished (viscous varnish state)	CVT fluid becomes degraded due to high temperatures.	Replace the CVT fluid and check the CVT main unit and the vehicle for malfunctions (wire harnesses, cooler pipes, etc.)
Milky white or cloudy	Water in the fluid	Replace the CVT fluid and check for places where water is getting in.
Large amount of metal powder mixed in	Unusual wear of sliding parts within CVT	Replace the CVT fluid and check for improper operation of the CVT.

CVT FLUID : Changing

CAUTION:

A
B
C
D
E
F
G
H
I
J
K
L
M
N
O

CHASSIS AND BODY MAINTENANCE

< PERIODIC MAINTENANCE >

Replace a O-ring with new ones at the final stage of the operation when installing.

1. Remove drain plug from oil pan.
2. Remove O-ring from drain plug and discard the O-ring.
3. Install a new O-ring on drain plug.

CAUTION:

Never reuse O-ring.

4. Install drain plug in oil pan. Refer to [TM-175, "Exploded View"](#).
5. Fill CVT fluid from CVT fluid charging pipe to the specified level.

CVT fluid : Refer to [TM-192, "General Specification"](#).

Fluid capacity : Refer to [TM-192, "General Specification"](#).

CAUTION:

- Use only Genuine NISSAN CVT Fluid NS-2. Never mix with other fluid.
- Using CVT fluid other than Genuine NISSAN CVT Fluid NS-2 will deteriorate in driveability and CVT durability, and may damage the CVT, which is not covered by the warranty.
- When filling CVT fluid, take care not to scatter heat generating parts such as exhaust.
- Sufficiently shake the container of CVT fluid before using.
- Delete CVT fluid deterioration date with CONSULT after changing CVT fluid. Refer to [TM-37, "CONSULT Function"](#).

6. With the engine warmed up, drive the vehicle in an urban area.

NOTE:

When ambient temperature is 20°C (68°F), it takes about 10 minutes for the CVT fluid to warm up to 50° to 80°C (122° to 176°F).

7. Check CVT fluid level and condition.
8. Repeat steps 1 to 5 if CVT fluid has been contaminated.

WHEELS

WHEELS : Inspection

INFOID:000000008633050

ALUMINUM WHEEL

1. Check tires for wear and improper inflation.
2. Check wheels for deformation, cracks and other damage. If deformed, remove wheel and check wheel runout.
 - a. Remove tire from aluminum wheel and then mount the wheel on a tire balancer machine. Remove the transmitter, refer to [WT-62, "Removal and Installation"](#).
 - b. Set dial indicator as shown and rotate the wheel to check for runout.
 - Replace wheel if runout exceeds specification.

Wheel runout Refer to [WT-65, "Road Wheel"](#).

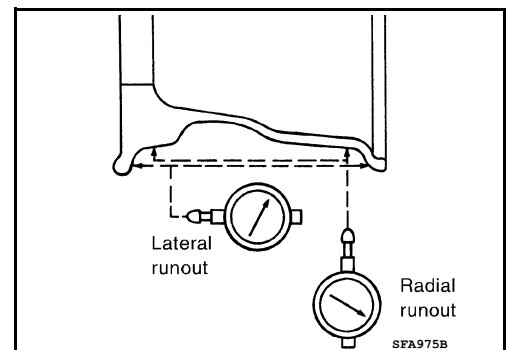

INFOID:000000008633051

WHEELS : Adjustment

BALANCING WHEELS (ADHESIVE WEIGHT TYPE)

Preparation Before Adjustment

Remove inner and outer balance weights from the road wheel using releasing agent, remove double-faced adhesive tape from the road wheel.

CAUTION:

- Be careful not to scratch the road wheel during removal.

CHASSIS AND BODY MAINTENANCE

< PERIODIC MAINTENANCE >

- After removing double-faced adhesive tape, wipe clean all traces of releasing agent from the road wheel.

Wheel Balance Adjustment

- If a balancer machine has an adhesive weight mode setting, select the adhesive weight mode setting and skip Step 2. below. If a balancer machine only has the clip-on (rim flange) weight mode setting, follow Step 2. to calculate the correct size adhesive weight.

1. Set road wheel on balancer machine using the center hole as a guide. Start the balancer machine.
2. For balancer machines that only have a clip-on (rim flange) weight mode setting, follow this step to calculate the correct size adhesive weight to use. When inner and outer imbalance values are shown on the balancer machine indicator, multiply outer imbalance value by 5/3 (1.67) to determine balance weight that should be used. Select the outer balance weight with a value closest to the calculated value above and install in to the designated outer position of, or at the designated angle in relation to the road wheel.

- a. Indicated imbalance value $\times 5/3 =$ balance weight to be installed

Calculation example:

23 g (0.81 oz) $\times 5/3$ (1.67) = 38.33 g (1.35 oz) \Rightarrow 40 g (1.41 oz)
balance weight (closer to calculated balance weight value)

NOTE:

Note that balance weight value must be closer to the calculated balance weight value.

Example:

37.4 \Rightarrow 35 g (1.23 oz)

37.5 \Rightarrow 40 g (1.41 oz)

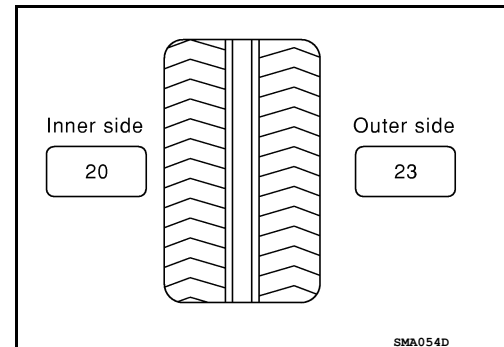

3. Install balance weight in the position shown.

CAUTION:

- Do not install the inner balance weight before installing the outer balance weight.
- Before installing the balance weight, be sure to clean the mating surface of the road wheel.
- When installing balance weight (1) to road wheel, set it into the grooved area (A) on the inner wall of the road wheel as shown so that the balance weight center (B) is aligned with the balancer machine indication position (angle) (C).

CAUTION:

- Always use genuine NISSAN adhesive balance weights.
- Balance weights are non-reusable; always replace with new ones.
- Do not install more than three sheets of balance weight.

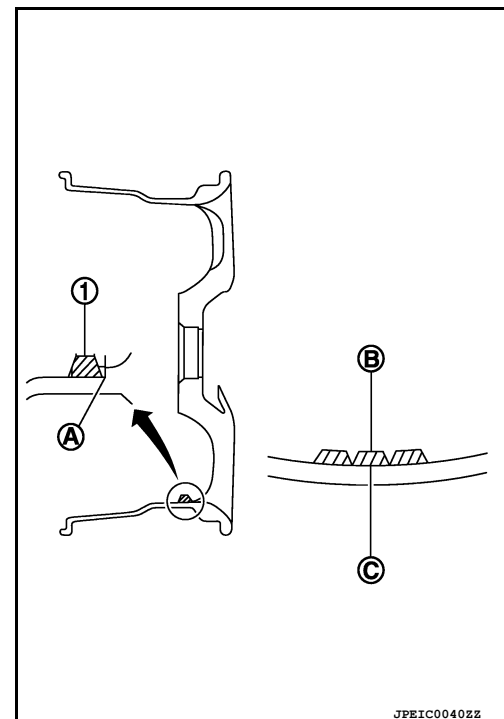

4. If calculated balance weight value exceeds 50 g (1.76 oz), install two balance weight sheets in line with each other as shown.

CAUTION:

Do not install one balance weight sheet on top another.

5. Start balancer machine again.

6. Install balance weight on inner side of road wheel in the balancer machine indication position (angle).

CAUTION:

Do not install more than two balance weights.

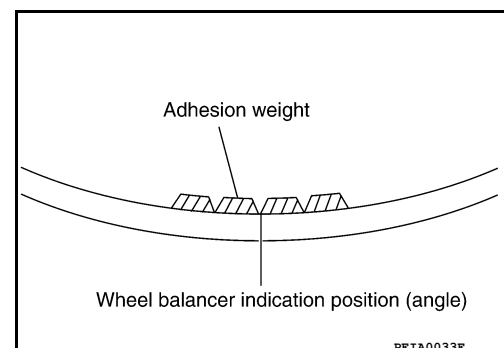

A
B
C
D
E
F
G
H
I
J
K
L
M
N
O

CHASSIS AND BODY MAINTENANCE

< PERIODIC MAINTENANCE >

7. Start balancer machine. Make sure that inner and outer residual imbalance values are 5 g (0.17 oz) each or below.
8. If either residual imbalance value exceeds 5 g (0.17 oz), repeat installation procedures.

Wheel balance	Dynamic (At flange)	Static (At flange)
Maximum allowable imbalance	Refer to WT-65, "Road Wheel" .	

TIRE ROTATION

- Use power tool to remove wheel and tire assembly.
- Follow the maintenance schedule for tire rotation service intervals. Refer to [MA-5, "FOR USA AND CANADA : Explanation of General Maintenance"](#) (United States and Canada) or [MA-7, "FOR MEXICO : Explanation of General Maintenance"](#) (Mexico).

CAUTION:

- Do not include the T-type spare tire when rotating the tires.
- When installing wheels, tighten them diagonally by dividing the work two to three times in order to prevent the wheels from developing any distortion.
- Be careful not to tighten wheel nut at torque exceeding the criteria for preventing strain of disc rotor.

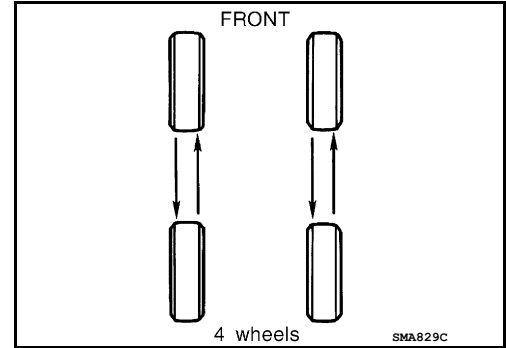

Wheel nut tightening torque : Refer to [WT-65, "Road Wheel"](#).

BRAKE FLUID LEVEL AND LEAKS

BRAKE FLUID LEVEL AND LEAKS : Inspection

INFOID:000000008633052

LEVEL CHECK

- Make sure that a brake fluid level in reservoir tank is between MAX and MIN lines as shown.
- Visually check around reservoir tank for fluid leakage.
- If the level is excessively low, check brake system for leaks.
- If brake warning lamp remains illuminated after parking brake pedal is released, check brake system for fluid leaks.

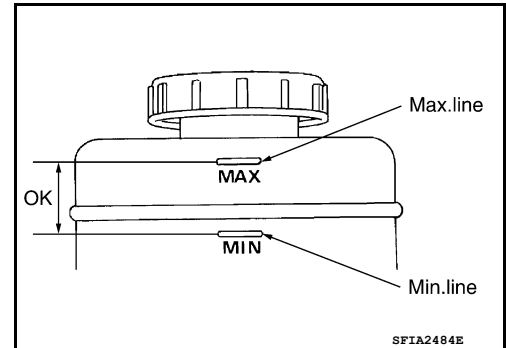

BRAKE LINES AND CABLES

BRAKE LINES AND CABLES : Inspection

INFOID:000000008633053

- Check brake fluid lines and parking brake cables for improper attachment, leaks, chafing, abrasions, deterioration, etc.

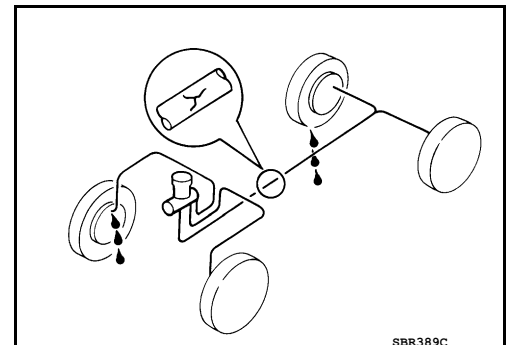

BRAKE FLUID

CHASSIS AND BODY MAINTENANCE

< PERIODIC MAINTENANCE >

BRAKE FLUID : Drain and Refill

INFOID:000000008633054

CAUTION:

- Refill with new brake fluid. Refer to [MA-16, "FOR USA AND CANADA : Fluids and Lubricants"](#) (for United States and Canada) or [MA-17, "FOR MEXICO : Fluids and Lubricants"](#) (for Mexico).
- Do not reuse drained brake fluid.
- Do not let brake fluid splash on the painted surfaces of the body. This might damage the paint. If brake fluid is splashed on painted areas, wash it away with water immediately.
- Before working, disconnect ABS actuator and electric unit (control unit) connector or battery negative terminal.

1. Turn ignition switch OFF and disconnect ABS actuator and electric unit (control unit) connector or battery negative terminal.
2. Connect a vinyl tube to bleed valve.
3. Depress brake pedal, loosen bleed valve, and gradually remove brake fluid.

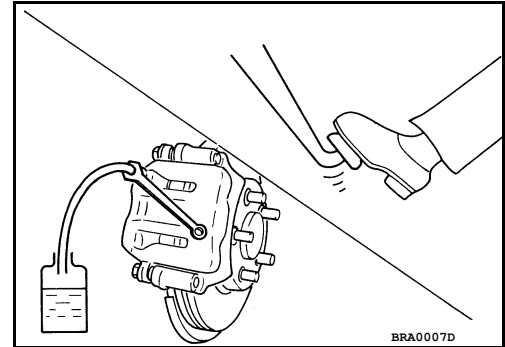

4. Make sure there is no foreign material in the reservoir tank, and refill with new brake fluid.
5. Rest foot on brake pedal. Loosen bleed valve. Slowly depress brake pedal until it stops. Tighten bleed valve. Release brake pedal. Repeat the process a few times, then pause to add new brake fluid to master cylinder. Continue until the new brake fluid flows out of bleed valve. Bleed the air out of the brake hydraulic system. Refer to [BR-16, "Bleeding Brake System"](#).

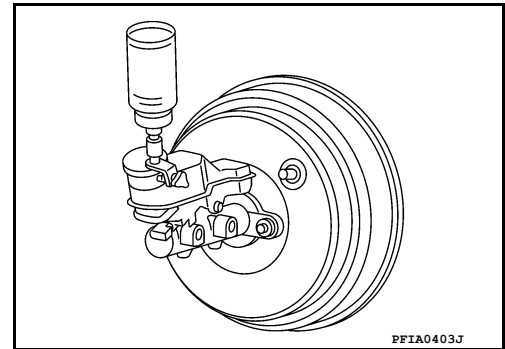

FRONT BRAKE

FRONT BRAKE : Inspection of Pad

INFOID:000000008832698

PAD WEAR

- Check pad thickness from the inspection hole on cylinder body. Check using a scale if necessary.

Standard thickness : Refer to [BR-46, "Front Disc Brake"](#).

Minimum thickness : Refer to [BR-46, "Front Disc Brake"](#).

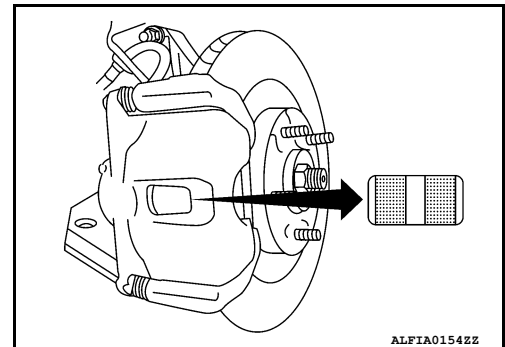

FRONT BRAKE : Inspection of Rotor

INFOID:000000008832699

VISUAL

Check surface of disc rotor for uneven wear, cracks, and serious damage. Replace as necessary.

RUNOUT

A
B
C
D
E
F
G
H
I
J
K
L
M
N
O
MA

CHASSIS AND BODY MAINTENANCE

< PERIODIC MAINTENANCE >

1. Attach disc rotor to wheel hub using wheel nuts (at two or more positions).
2. Inspect runout using a dial gauge placed at 10 mm (0.39 in) inside the disc edge.

Runout limit : Refer to [BR-46, "Front Disc Brake"](#).
(with it attached to the vehicle)

NOTE:

Before measuring, make sure that wheel bearing axial end play is within the specification. Refer to [FAX-5, "Inspection"](#).

3. When runout exceeds limit value, displace mounting positions of disc rotor by one hole. Then find a position of the minimum value for runout.
4. If runout is outside the specified value after performing the above operation, refinish disc rotor.

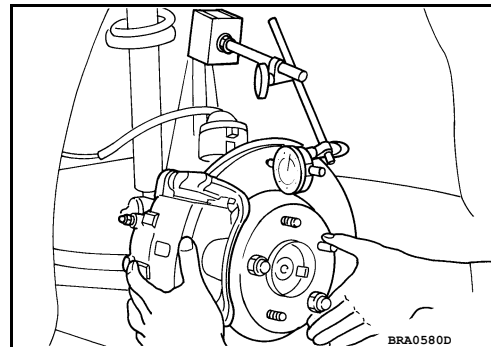

THICKNESS

Check thickness of the disc rotor using a micrometer. Replace disc rotor if thickness is under the wear limit.

Standard thickness : Refer to [BR-46, "Front Disc Brake"](#).

Minimum thickness : Refer to [BR-46, "Front Disc Brake"](#).

Thickness variation (Measured at 8 positions) : Refer to [BR-46, "Front Disc Brake"](#).

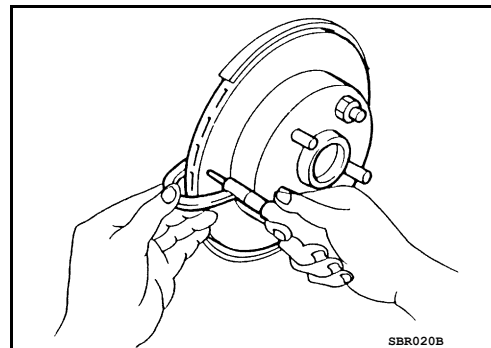

REAR BRAKE

REAR BRAKE : Inspection of Pad

INFOID:000000008832700

PAD WEAR

- Check pad thickness from the inspection hole on cylinder body. Check using a scale if necessary.

Standard thickness : Refer to [BR-46, "Rear Disc Brake"](#).

Minimum thickness : Refer to [BR-46, "Rear Disc Brake"](#).

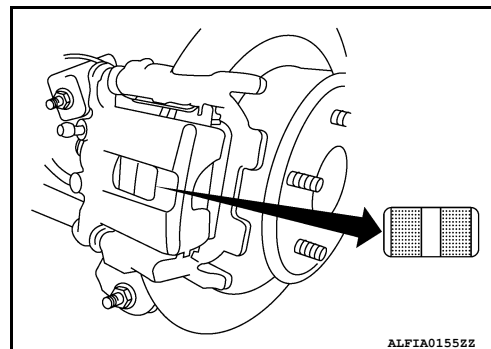

REAR BRAKE : Inspection of Rotor

INFOID:000000008832701

VISUAL

Check surface of disc rotor for uneven wear, cracks, and serious damage. Replace if necessary.

RUNOUT

CHASSIS AND BODY MAINTENANCE

< PERIODIC MAINTENANCE >

1. Attach disc rotor to wheel hub using wheel nuts (at two or more positions).
2. Inspect runout using dial gauge placed at 10 mm (0.39 in) inside disc edge.

Runout limit : Refer to [BR-46. "Rear Disc Brake"](#).

(With it attached to the vehicle)

NOTE:

Before measuring, make sure that wheel bearing axial end play is within the specification. Refer to [RAX-5. "Inspection"](#).

3. When runout exceeds limit value, displace mounting positions of disc rotor by one hole. Then find a position of the minimum value for runout.
4. If runout is outside the specified value after performing the above operation, refinish the disc rotor.

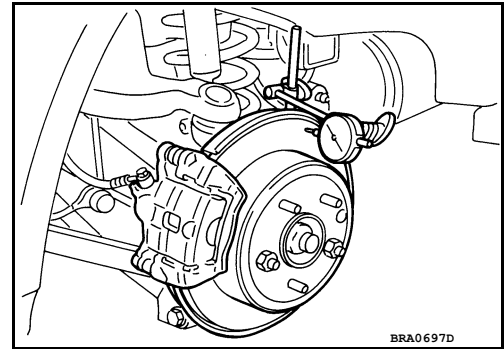

THICKNESS

Check the thickness of the disc rotor using a micrometer. Replace disc rotor if the thickness is less than the wear limit.

Standard thickness : Refer to [BR-46. "Rear Disc Brake"](#).

Minimum thickness : Refer to [BR-46. "Rear Disc Brake"](#).

Thickness variation (Measured at 8 positions) : Refer to [BR-46. "Rear Disc Brake"](#).

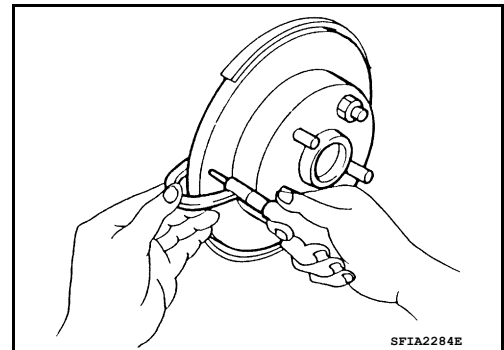

STEERING GEAR AND LINKAGE

STEERING GEAR AND LINKAGE : Inspection

INFOID:000000008633059

STEERING GEAR

- Check gear housing and boots for looseness, damage and grease leakage.
- Check connection with steering column for looseness.

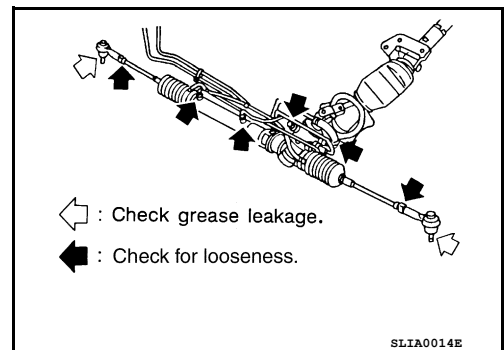

STEERING LINKAGE

Check ball joint, dust cover and other component parts for looseness, wear, damage and grease leakage.

POWER STEERING FLUID AND LINES

POWER STEERING FLUID AND LINES : Inspection

INFOID:000000008633060

FLUID LEVEL

- Check fluid level with engine stopped.

A
B
C
D
E
F
G
H
I
J
K
L
M
N
O
MA

CHASSIS AND BODY MAINTENANCE

< PERIODIC MAINTENANCE >

- Make sure that fluid level is between MIN and MAX.
- Fluid levels at HOT (A) and COLD (B) are different. Do not confuse them.

HOT (A) : Fluid temperature 50° - 80 °C (122° - 176°F)

COLD (B) : Fluid temperature 0° - 30°C (32° - 86°F)

CAUTION:

- The fluid level should not exceed the MAX line. Excessive fluid will cause fluid leakage from the cap.
- Do not reuse drained power steering fluid.
- Recommended fluid is Genuine Nissan PSF or equivalent.

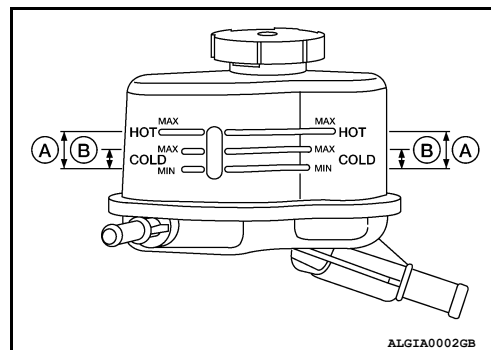

FLUID LEAKAGE

Check hydraulic connections for fluid leakage, cracks, damage, looseness, or wear.

1. Run engine until the fluid temperature reaches 50° to 80° C (122° to 176°F) in reservoir tank, and keep engine speed idle.
2. Turn steering wheel several times from full left stop to full right stop.
3. Hold steering wheel at each lock position for five seconds and carefully, check for fluid leakage.

CAUTION:

Do not hold the steering wheel in a locked position for more than 10 seconds. (There is the possibility that oil pump may be damaged.)

4. If fluid leakage at connections is noticed, then loosen flare nut and then retighten. Do not overtighten connector as this can damage O-ring, washer and connector.
5. If fluid leakage from oil pump is noticed, check oil pump. Refer to [ST-28. "Removal and Installation"](#).
6. Check steering gear boots for accumulation of fluid indicating leakage from steering gear.

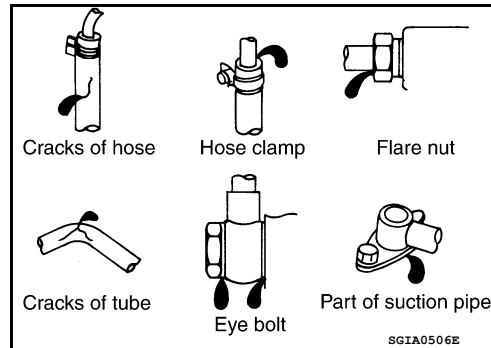

AXLE AND SUSPENSION PARTS

AXLE AND SUSPENSION PARTS : Inspection

INFOID:000000008633061

Check front and rear axle and suspension parts for excessive play, cracks, wear or other damage.

- Shake each wheel to check for excessive play.
- Check wheel bearings for smooth operation.
- Check axle and suspension nuts and bolts for looseness.
- Check strut (shock absorber) for oil leakage or other damage.
- Check suspension ball joint for grease leakage and ball joint dust cover for cracks or other damage.

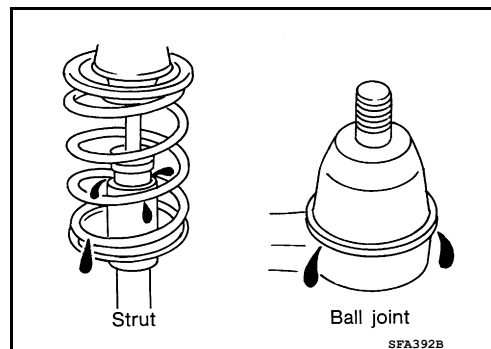
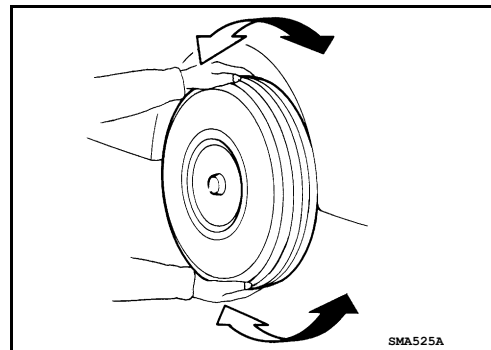

DRIVE SHAFT

CHASSIS AND BODY MAINTENANCE

< PERIODIC MAINTENANCE >

DRIVE SHAFT : Inspection

INFOID:000000008633062

Check boot and drive shaft for cracks, wear, damage and grease leakage.

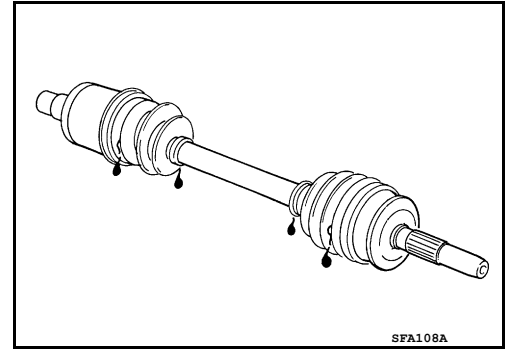

LOCKS, HINGES AND HOOD LATCH

LOCKS, HINGES AND HOOD LATCH : Lubricating

INFOID:000000008633063

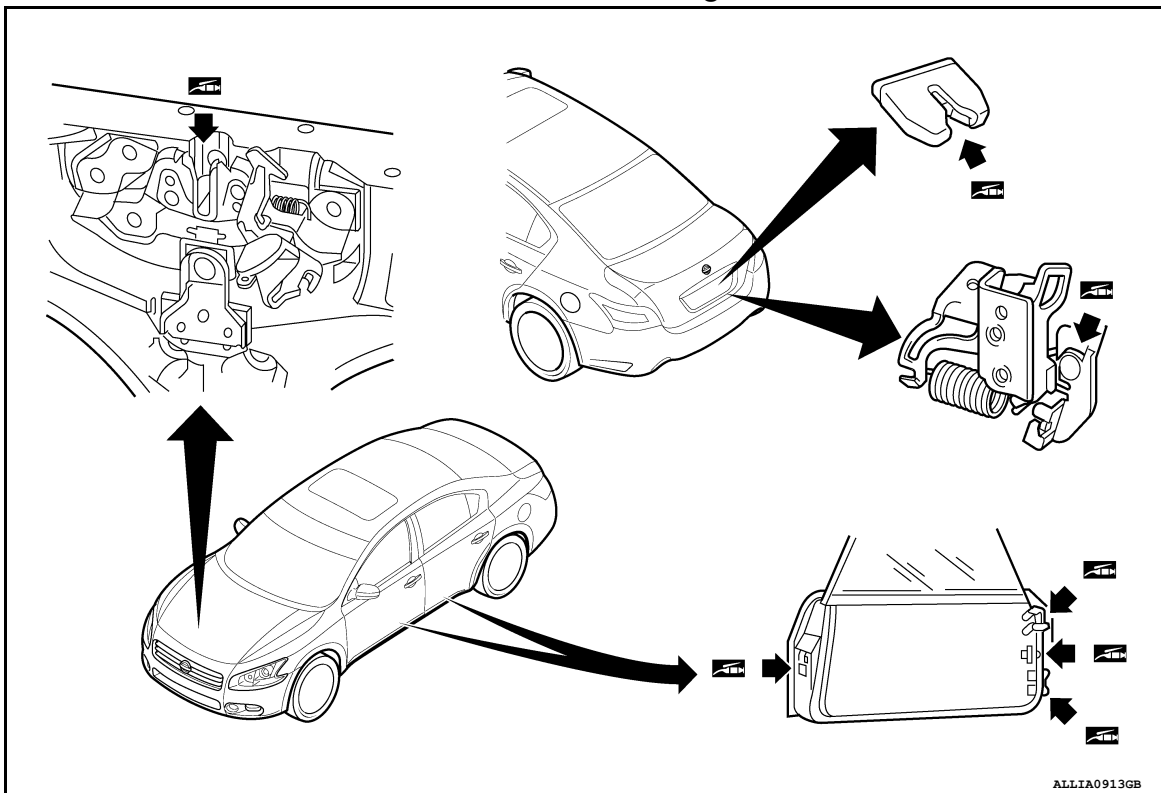

SEAT BELT, BUCKLES, RETRACTORS, ANCHORS AND ADJUSTERS

SEAT BELT, BUCKLES, RETRACTORS, ANCHORS AND ADJUSTERS : Inspection

INFOID:000000008633064

For details, refer to [SB-3. "Inspection"](#) in SB section.

- Check anchors for loose mounting
- Check belts for damage
- Check retractor for smooth operation
- Check function of buckles and tongues when buckled and released

CAUTION:

- **After any collision, inspect all seat belt assemblies, including retractors and other attached hardware (i.e., anchor bolt, guide rail set). Nissan recommends replacing all seat belt assemblies in use during a collision, unless not damaged and properly operating after minor collision. Also inspect seat belt assemblies not in use during a collision, and replace if damaged or improperly operating.**
- **Seat belt pre-tensioner should be replaced even if the seat belts are not in use during a frontal collision where the driver and passenger air bags are deployed.**

A
B
C
D
E
F
G
H
I
J
K
L
M
N
O

MA

CHASSIS AND BODY MAINTENANCE

< PERIODIC MAINTENANCE >

- If any component of seat belt assembly is questionable, do not repair, replace the entire seat belt assembly.
- If webbing is cut, frayed, or damaged, replace seat belt assembly.
- Do not oil tongue and buckle.
- Use a genuine NISSAN seat belt assembly.