

SECTION **AV**

**AUDIO, VISUAL, NAVIGATION & TELEPHONE SYSTEM**

**CONTENTS**

<b>PRECAUTIONS</b> .....	<b>5</b>	<b>FOR CD ONLY</b> .....	<b>36</b>
Precautions for Supplemental Restraint System (SRS) "AIR BAG" and "SEAT BELT PRE-TENSIONER" .....	5	Noise Inspection .....	37
Wiring Diagrams and Trouble Diagnosis .....	5	TYPE OF NOISE AND POSSIBLE CAUSE .....	37
<b>PREPARATION</b> .....	<b>6</b>	Power Supply Circuit Inspection .....	38
Commercial Service Tools .....	6	Steering Switch Check .....	39
<b>AUDIO</b> .....	<b>7</b>	A/C and AV Switch Check .....	40
Component Parts and Harness Connector Location...	7	Audio Communication Line Check (Without Navigation System) .....	40
System Description .....	7	Audio Communication Line Check (With Navigation System) .....	41
BASE SYSTEM .....	7	Front Door Speaker Check (Base System) .....	41
BOSE SYSTEM .....	8	Rear Door Speaker Check (Base System) .....	43
SPEED SENSITIVE VOLUME SYSTEM .....	8	Front Door Speaker Check (BOSE System) .....	45
Schematic .....	9	Rear Door Speaker Check (BOSE System) .....	49
BASE SYSTEM .....	9	Woofer Check (BOSE System) .....	53
BOSE SYSTEM WITH NAVIGATION SYSTEM..	10	Vehicle Speed Signal Check .....	54
BOSE SYSTEM WITHOUT NAVIGATION SYSTEM .....	11	Locking CD Auto-changer Mechanism .....	55
Wiring Diagram -AUDIO- .....	12	DAMPER LOCK PROCEDURE .....	55
BASE SYSTEM .....	12	Removal and Installation of Audio Unit .....	55
BOSE SYSTEM WITH NAVIGATION SYSTEM..	15	REMOVAL .....	55
BOSE SYSTEM WITHOUT NAVIGATION SYSTEM .....	23	INSTALLATION .....	57
Terminals and Reference Value for Audio Unit for Base System .....	30	Removal and Installation for A/C and AV Switch ...	57
Terminals and Reference Value for Audio Unit for BOSE System .....	31	REMOVAL .....	57
Terminals and Reference Value for BOSE Speaker Amp. ....	33	INSTALLATION .....	57
A/C and AV Switch Self-Diagnosis Function .....	34	Removal and Installation of Front Door Speaker (Base system) .....	58
STARTING THE SELF-DIAGNOSIS MODE .....	34	REMOVAL .....	58
EXITING THE SELF-DIAGNOSIS MODE .....	34	INSTALLATION .....	58
DIAGNOSIS FUNCTION .....	34	Removal and Installation of Front Door Speaker (BOSE system) .....	58
Trouble Diagnosis .....	35	REMOVAL .....	58
MALFUNCTION WITH RADIO AND CD (BASE SYSTEM) .....	35	INSTALLATION .....	58
MALFUNCTION WITH RADIO, TAPE AND CD (BOSE SYSTEM) .....	35	Removal and Installation of Rear Door Speaker (Base system) .....	58
FOR RADIO ONLY .....	36	REMOVAL .....	58
FOR CASSETTE PLAYER ONLY .....	36	INSTALLATION .....	58
		Removal and Installation of Rear Door Speaker (BOSE system) .....	59
		REMOVAL .....	59
		INSTALLATION .....	59

Removal and Installation of Tweeter .....	59	AV Switch .....	105
REMOVAL .....	59	Vehicle Speed Signal Check .....	106
INSTALLATION .....	59	Illumination Signal Check .....	107
Removal and Installation of Woofer .....	59	Ignition Signal Check .....	107
REMOVAL .....	59	Audio Communication Line Check .....	107
INSTALLATION .....	59	AV Communication Line Check .....	109
Removal and Installation of BOSE Speaker Amp... 60		CAN Communication Line Check .....	110
REMOVAL .....	60	Steering Wheel Audio Control Switch Check .....	111
INSTALLATION .....	60	Removal and Installation of Display Unit .....	112
<b>AUDIO ANTENNA .....</b>	<b>61</b>	REMOVAL .....	112
Location of Antenna .....	61	INSTALLATION .....	112
Removal and Installation of Roof Antenna .....	61	Removal and Installation of A/C and AV Switch ...	112
REMOVAL .....	61	<b>NAVIGATION SYSTEM .....</b>	<b>113</b>
INSTALLATION .....	61	System Description .....	113
<b>INTEGRATED DISPLAY SYSTEM .....</b>	<b>62</b>	TRAVEL DISTANCE .....	113
System Description .....	62	TRAVEL DIRECTION .....	113
A/C AND AV SWITCH SYSTEM .....	62	MAP-MATCHING .....	113
PRECAUTION OF LCD MONITOR .....	62	GPS (GLOBAL POSITIONING SYSTEM) .....	114
POWER SUPPLY AND GROUND .....	62	COMPONENT DESCRIPTION .....	115
DRIVE COMPUTER .....	63	BIRDVIEW™ .....	115
SETTING SCREEN .....	65	MAP DISPLAY .....	116
WARNING INDICATIONS .....	65	FUNCTION OF CENTER SWITCH .....	117
AV COMMUNICATION LINE .....	66	“VIEW” MODE .....	122
CAN Communication System Description .....	66	“HEADING” MODE .....	123
CAN Communication Unit For 2WD Models .....	66	“NEARBY DISPLAY ICONS” MODE .....	123
TYPE 1/TYPE 2/TYPE 3/TYPE 4/TYPE 5/TYPE		“SAVE CURRENT LOCATION” MODE .....	123
6/TYPE 7/TYPE 8 .....	67	“ADJUST CURRENT LOCATION” MODE .....	123
TYPE 9/TYPE10/TYPE 11/TYPE 12/TYPE 13/		“AUTO RE-ROUTE” MODE .....	124
TYPE 14/TYPE 15/TYPE 16 .....	72	“AVOID AREA SETTINGS” MODE .....	124
CAN Communication Unit For AWD Models .....	77	“CLEAR MEMORY” MODE .....	124
TYPE 17/TYPE 18/TYPE 19/TYPE 20/TYPE 21/		“EDIT ADDRESS BOOK” MODE .....	125
TYPE 22/TYPE 23/TYPE 24 .....	77	“GPS INFORMATION” MODE .....	125
TYPE 25/TYPE26/TYPE 27/TYPE 28/TYPE 29/		“QUICK STOP CUSTOMER SETTING” MODE .....	125
TYPE 30/TYPE 31/TYPE 32 .....	83	“SET AVERAGE SPEED” MODE .....	125
Component Parts and Harness Connector Location..	88	“TRACKING” MODE .....	126
Schematic .....	89	GUIDANCE VOLUME .....	126
Wiring Diagram — INF/D — .....	90	DISPLAY WITH PUSHED “TRIP” BUTTON .....	126
Wiring Diagram — COMM — .....	95	TRIP 1 OR TRIP 2 .....	127
Terminals and Reference Value for Display Unit ...	97	FUEL ECONOMY .....	127
Terminals and Reference Value for A/C and AV		MAINTENANCE .....	127
Switch .....	98	ENGINE OIL OR TIRE ROTATION .....	127
On Board Self-Diagnosis Function .....	100	TIRE PRESSURE .....	128
DESCRIPTION .....	100	WARNING INDICATIONS .....	128
DIAGNOSIS ITEM .....	100	CAN Communication System Description .....	129
Self-Diagnosis Mode .....	100	CAN Communication Unit For 2WD Models .....	129
OPERATION PROCEDURES .....	100	TYPE 1/TYPE 2/TYPE 3/TYPE 4/TYPE 5/TYPE	
NETWORK CHECK .....	101	6/TYPE 7/TYPE 8 .....	130
PARTS CHECK .....	101	TYPE 9/TYPE10/TYPE 11/TYPE 12/TYPE 13/	
HVAC DETAIL SCREEN .....	102	TYPE 14/TYPE 15/TYPE 16 .....	135
VERSION CHECK .....	102	CAN Communication Unit For AWD Models .....	140
CAN DIAG MNTR (CAN DIAG MONITOR) .....	102	TYPE 17/TYPE 18/TYPE 19/TYPE 20/TYPE 21/	
A/C and AV Switch Self-Diagnosis Function .....	102	TYPE 22/TYPE 23/TYPE 24 .....	140
STARTING THE SELF-DIAGNOSIS MODE .....	102	TYPE 25/TYPE26/TYPE 27/TYPE 28/TYPE 29/	
EXITING THE SELF-DIAGNOSIS MODE .....	102	TYPE 30/TYPE 31/TYPE 32 .....	146
DIAGNOSIS FUNCTION .....	102	Component Parts Location .....	151
Trouble Diagnosis Chart by Symptom .....	103	Schematic—NAVI— .....	152
Power Supply and Ground Circuit Check for Display		Wiring Diagram —NAVI— .....	153
Unit .....	104	Schematic— COMM — .....	160
Power Supply and Ground Circuit Check for A/C and		Wiring Diagram — COMM — .....	161

Terminals and Reference Value for NAVI Control unit .....	164	If NAVI Control Unit Detects That Inserted DVD-ROM Map Malfunctioning or If It Is Impossible to Load Data From DVD-ROM Map .....	203	A
Terminals and Reference Value for Display Control unit .....	166	If Connection Between NAVI Control Unit and GPS Antenna is Malfunctioning .....	204	B
Terminals and Reference Value for Display .....	170	RGB Screen is Not Shown .....	204	
Terminals and Reference Value for A/C and AV Switch .....	172	Color of RGB Image is Not Proper (NAVI Screen Looks Bluish) .....	205	C
On Board Self-Diagnosis Function .....	173	Color of RGB Image is Not Proper (NAVI Screen Looks Reddish) .....	206	
DESCRIPTION .....	173	Color of RGB Image is Not Proper (NAVI Screen Looks Yellowish) .....	207	D
DIAGNOSIS ITEM .....	173	Color of RGB Image is Not Proper (Excepting NAVI Screen Looks Bluish) .....	208	
Self-Diagnosis Mode (DCU) .....	174	Color of RGB Image is Not Proper (Excepting NAVI Screen Looks Reddish) .....	209	E
OPERATION PROCEDURE .....	174	Color of RGB Image is Not Proper (Excepting NAVI Screen Looks Yellowish) .....	210	
SELF-DIAGNOSIS RESULT .....	175	RGB Screen is Rolling (NAVI Screen) .....	212	F
Self-Diagnosis Mode (NAVI) .....	176	RGB Screen Is Rolling (Excepting NAVI Screen) .....	213	
OPERATION PROCEDURE .....	176	Guide Sound is Not Heard .....	214	G
SELF-DIAGNOSIS RESULT .....	177	Screen is Not Shown .....	215	
CONFIRMATION/ADJUSTMENT Mode .....	178	Audio Screen is Not Shown (NAVI Screen is Shown) .....	215	H
OPERATION PROCEDURE .....	178	A/C Screen is Not Shown (NAVI Screen is Shown) .....	215	
DISPLAY DIAGNOSIS .....	179	TRIP, FUEL ECON and MAINTENANCE Screens are Not Shown .....	215	I
VEHICLE SIGNALS .....	179	Average Fuel Economy Displayed is Not Shown ("is Shown) .....	216	
AUTO CLIMATE CONTROL .....	180	Distance to Empty Displayed is Not Shown ("is Shown) .....	216	J
NAVIGATION .....	180	Driving Distance or Average speed Displayed is Not Shown ("is Shown) .....	217	
DISPLAY DIAGNOSIS .....	180	WARNING DOOR OPEN Screen is Not Shown .....	217	
VEHICLE SIGNALS .....	181	Wheel Air Pressure is not Displayed .....	218	AV
HISTORY OF ERRORS .....	182	Unable to Operate All of A/C and AV Switches (Unable to Start Self-Diagnosis) .....	218	
DIAGNOSIS BY HISTORY OF ERRORS .....	182	Audio Does Not Work .....	219	L
NAVIGATION .....	184	A/C Does Not Work .....	219	
CAN DIAG SUPPORT MONITOR .....	186	Navigation System Does Not Activate .....	220	M
OPERATION PROCEDURE .....	186	Previous NAVI Conditions Are Not Stored. ....	220	
A/C and AV Switch Self-Diagnosis Function .....	187	Previous Vehicle Conditions Are Not Stored .....	220	
STARTING THE SELF-DIAGNOSIS MODE .....	187	Position of Current-Location Mark is Not Correct .....	220	
EXITING THE SELF-DIAGNOSIS MODE .....	187	Radio Wave From GPS Satellite is Not Received .....	220	
DIAGNOSIS FUNCTION .....	187	Driving Test .....	221	
Power Supply and Ground Circuit Check for NAVI Control Unit .....	188	Example of Symptoms Judged Not Malfunction .....	222	
Power Supply and Ground Circuit Check for Display Control Unit .....	189	BASIC OPERATION .....	222	
Power Supply and Ground Circuit Check for Display	190	VEHICLE MARK .....	222	
Power Supply and Ground Circuit Check for A/C and AV Switch .....	192	DESTINATION, PASSING POINTS, AND MENU ITEMS CANNOT BE SELECTED/SET. ....	222	
Vehicle Speed Signal Check for NAVI Control Unit	192	VOICE GUIDE .....	223	
Vehicle Speed Signal Check for Display Control Unit	193	ROUTE SEARCH .....	223	
Illumination Signal Check for NAVI Control Unit ..	195	EXAMPLES OF CURRENT-LOCATION MARK DISPLACEMENT .....	224	
Illumination Signal Check for Display Control Unit	195	CURRENT LOCATION MARK SHOWS A POSITION WHICH IS COMPLETELY WRONG .....	227	
Ignition Signal Check for NAVI Control Unit .....	195	CURRENT-LOCATION MARK JUMPS .....	227	
Ignition Signal Check for Display Control Unit .....	196	CURRENT LOCATION MARK IS IN A RIVER OR SEA .....	228	
Reverse Signal Check for NAVI Control Unit .....	196	WHEN DRIVING ON SAME ROAD, SOME-		
Reverse Signal Check for Display Control Unit .....	196			
AV Communication Line Check (Between Display Control Unit and NAVI Control Unit) .....	197			
Audio Communication Line Check (Between Display Control Unit and Audio Unit) .....	198			
Display Communication Line Check (Between Display Control Unit and Display) .....	200			
AV Communication Line Check (Between Display Control Unit and A/C and AV Switch) .....	202			
CAN Communication Line Check .....	203			
If NAVI Control Unit Detects That DVD-ROM Map is not Inserted .....	203			

---

TIMES CURRENT-LOCATION MARK IS IN RIGHT PLACE AND SOMETIMES IT IS WRONG PLACE .....	228	INSTALLATION .....	230
LOCATION CORRECTION BY MAP-MATCH- ING IS SLOW .....	228	Removal and Installation of GPS Antenna .....	231
ALTHOUGH GPS RECEIVING DISPLAY IS GREEN, VEHICLE MARK DOES NOT RETURN TO CORRECT LOCATION .....	228	REMOVAL .....	231
NAME OF CURRENT PLACE IS NOT DIS- PLAYED .....	228	INSTALLATION .....	231
CONTENTS OF DISPLAY DIFFER FOR BIRD- VIEW™ AND THE (FLAT) MAP SCREEN .....	228	Removal and Installation of Steering Wheel Switch	231
Program Loading of NAVI Control Unit .....	229	Removal and Installation of NAVI Switch .....	231
Removal and Installation of NAVI Control Unit ....	230	REMOVAL .....	231
REMOVAL .....	230	INSTALLATION .....	232
		Removal and Installation of Display .....	232
		REMOVAL .....	232
		INSTALLATION .....	232
		Removal and Installation of Display Control Unit .	232
		REMOVAL .....	232
		INSTALLATION .....	233

# PRECAUTIONS

## PRECAUTIONS

PFP:00001

### Precautions for Supplemental Restraint System (SRS) “AIR BAG” and “SEAT BELT PRE-TENSIONER”

AKS007WC

The Supplemental Restraint System such as “AIR BAG” and “SEAT BELT PRE-TENSIONER”, used along with a front seat belt, helps to reduce the risk or severity of injury to the driver and front passenger for certain types of collision. This system includes seat belt switch inputs and dual stage front air bag modules. The SRS system uses the seat belt switches to determine the front air bag deployment, and may only deploy one front air bag, depending on the severity of a collision and whether the front occupants are belted or unbelted. Information necessary to service the system safely is included in the SRS and SB section of this Service Manual.

#### **WARNING:**

- To avoid rendering the SRS inoperative, which could increase the risk of personal injury or death in the event of a collision which would result in air bag inflation, all maintenance must be performed by an authorized NISSAN/INFINITI dealer.
- Improper maintenance, including incorrect removal and installation of the SRS, can lead to personal injury caused by unintentional activation of the system. For removal of Spiral Cable and Air Bag Module, see the SRS section.
- Do not use electrical test equipment on any circuit related to the SRS unless instructed to in this Service Manual. SRS wiring harnesses can be identified by yellow and/or orange harnesses or harness connectors.

### Wiring Diagrams and Trouble Diagnosis

AKS007VO

When you read wiring diagrams, refer to the following:

- Refer to [GI-14, "How to Read Wiring Diagrams"](#) .  
Refer to [PG-3, "POWER SUPPLY ROUTING CIRCUIT"](#) .

When you perform trouble diagnosis, refer to the following:

- Refer to [GI-10, "HOW TO FOLLOW TEST GROUPS IN TROUBLE DIAGNOSES"](#) .  
Refer to [GI-26, "How to Perform Efficient Diagnosis for an Electrical Incident"](#) .

A  
B  
C  
D  
E  
F  
G  
H  
I  
J  
L  
M

AV

# PREPARATION

## PREPARATION

PFP:00002

### Commercial Service Tools

AKS007VM

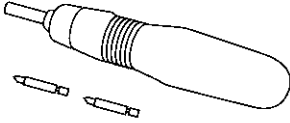
Tool name	Description
<p data-bbox="140 410 252 436">Power tool</p>  <p data-bbox="836 512 911 532">PBIC0191E</p>	<p data-bbox="999 312 1254 338">Loosening bolts and nuts</p>

## AUDIO

PPF:28111

### Component Parts and Harness Connector Location

AKS00712

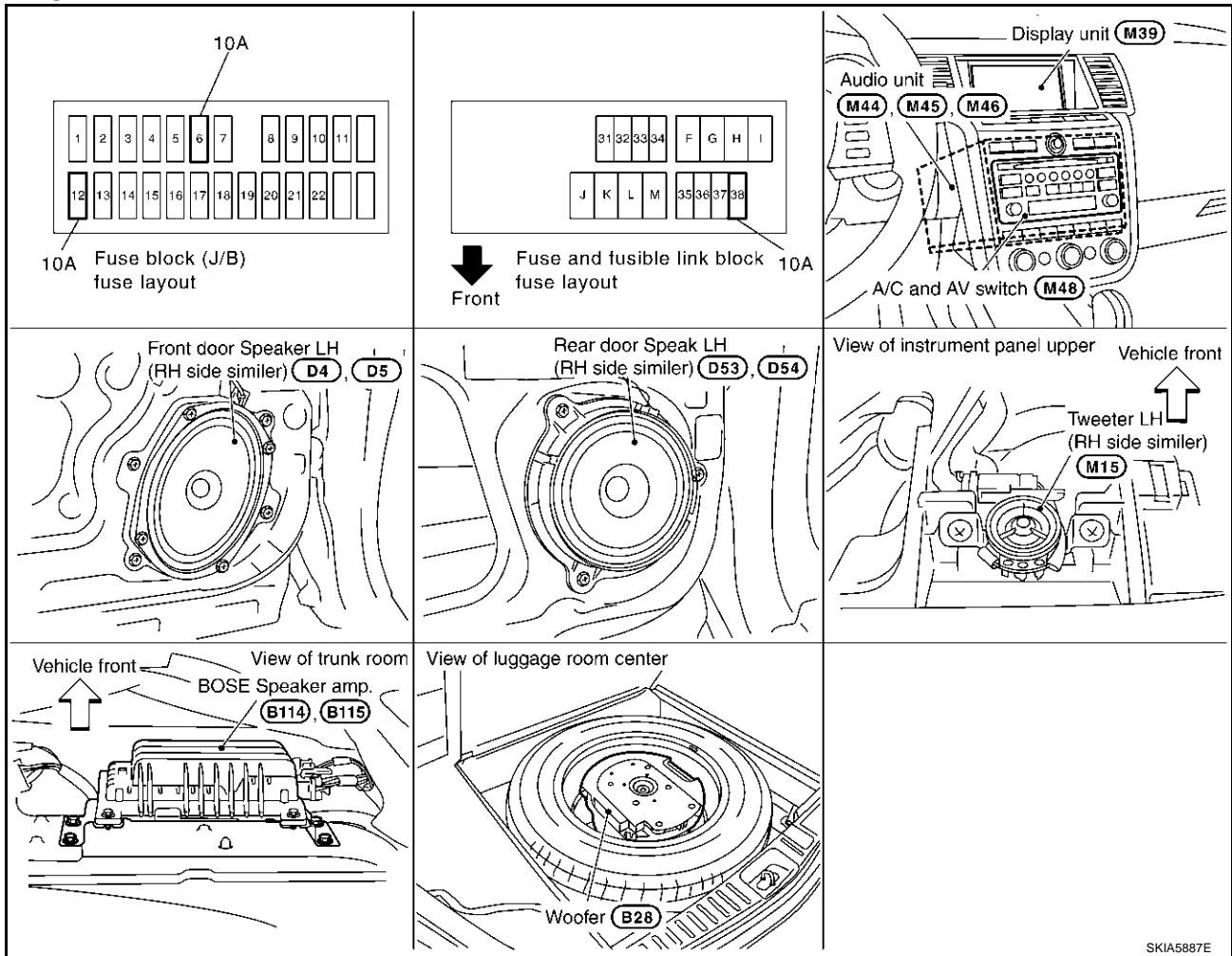

SKIA5887E

### System Description BASE SYSTEM

AKS005EV

Refer to Owner's Manual for audio system operating instructions.

Power is supplied at all times

- through 15A fuse [No. 38, located in the fuse and fusible link box]
- to audio unit terminal 6.

With the ignition switch in the ACC or ON position, power is supplied

- through 10A fuse [No. 6, located in the fuse block (J/B)]
- to audio unit terminal 10.

Ground is supplied through the case of the audio unit.

Audio unit and A/C and audio controller are connected by FPC (Flexible Print Circuit).

A/C and audio controller integrates A/C switches and audio switches.

When A/C and audio controller is pushed to audio switch, it sends audio signal to audio unit.

Then audio signals are supplied

- through audio unit terminals 1, 2, 3, 4, 13, 14, 15, and 16
- to terminals 1 and 2 of front door speaker LH and RH
- to terminals 1 and 2 of rear door speaker LH and RH
- to terminals 1 and 2 of tweeter LH and RH.

When one of steering wheel audio control switches is pushed to volume up, seek up, or mode ON, resistance in steering switch circuit changes depending on which button is pushed.

When one of steering wheel audio control switches is pushed to volume down, seek down, or power ON, resistance in steering switch circuit changes depending on which button is pushed.

A

B

C

D

E

F

G

H

I

J

AV

L

M

# AUDIO

---

## BOSE SYSTEM

Refer to Owner's Manual for audio system operating instructions.

Power is supplied at all times

- through 15A fuse [No. 38, located in the fuse and fusible link box]
- to audio unit terminal 6, and
- to BOSE speaker amp. terminal 1.

With the ignition switch in the ACC or ON position, power is supplied

- through 10A fuse [No. 6, located in the fuse block (J/B)]
- to audio unit terminal 10.

Ground is supplied through the case of the audio unit.

Ground is also supplied

- to BOSE speaker amp. terminal 17
- through body ground B105 and B116.

Audio unit and A/C and audio controller are connected by FPC (Flexible Print Circuit).

A/C and audio controller integrates A/C switches and audio switches.

When A/C and audio controller is pushed to audio switch, it send audio signal to audio unit.

Then audio signals are supplied

- through audio unit terminals 1, 2, 3, 4, 13, 14, 15, and 16
- to Bose speaker amp. terminals 23, 24, 25, 26, 27, 28, 29, and 30.

Audio signals are amplified by the BOSE speaker amp.

The amplified audio signals are supplied

- through BOSE speaker amp. terminals 2, 3, 9,10,11,12, 13, 14, 15, 16, 18, and 19
- to terminals 1 and 2 of front door speaker LH and RH
- to terminals 1 and 2 of rear door speaker LH and RH
- to terminals 1 and 2 of tweeter LH and RH.
- to terminals 2, 3, 4 and 6 of woofer.

When one of steering wheel audio control switches is pushed to volume up, seek up, or mode ON, resistance in steering switch circuit changes depending on which button is pushed.

When one of steering wheel audio control switches is pushed to volume down, seek down, or power ON, resistance in steering switch circuit changes depending on which button is pushed.

## SPEED SENSITIVE VOLUME SYSTEM

Volume level of this system gone up and down automatically in proportion to the vehicle speed. And the control level can be selected by the customer. This system is equipped for BOSE system.



# AUDIO

## Schematic BASE SYSTEM

AKS005EW

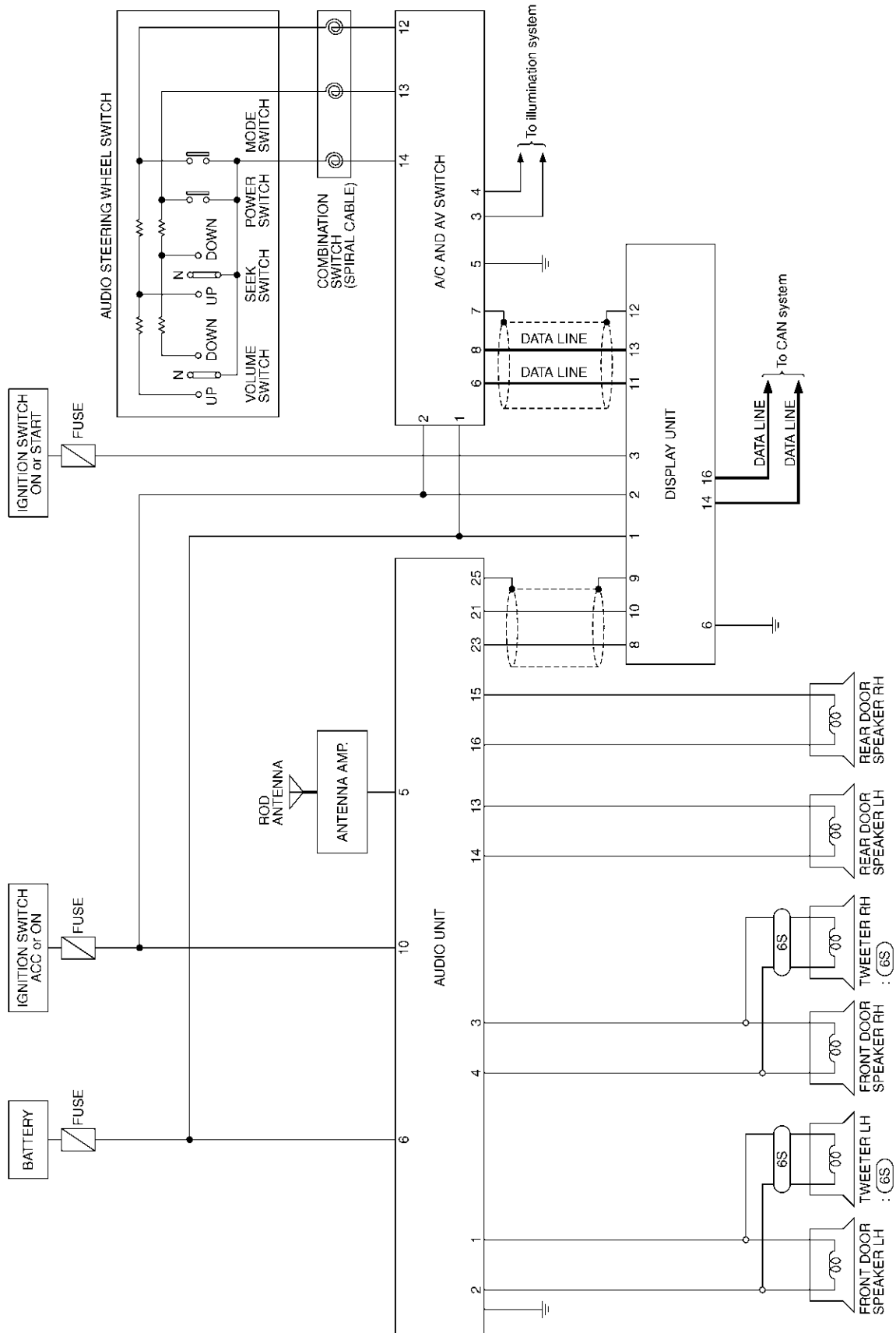

**6S** : With 6 speakers

TKWA0880E

A  
B  
C  
D  
E  
F  
G  
H  
I  
J  
AV  
L  
M

# AUDIO

## BOSE SYSTEM WITH NAVIGATION SYSTEM

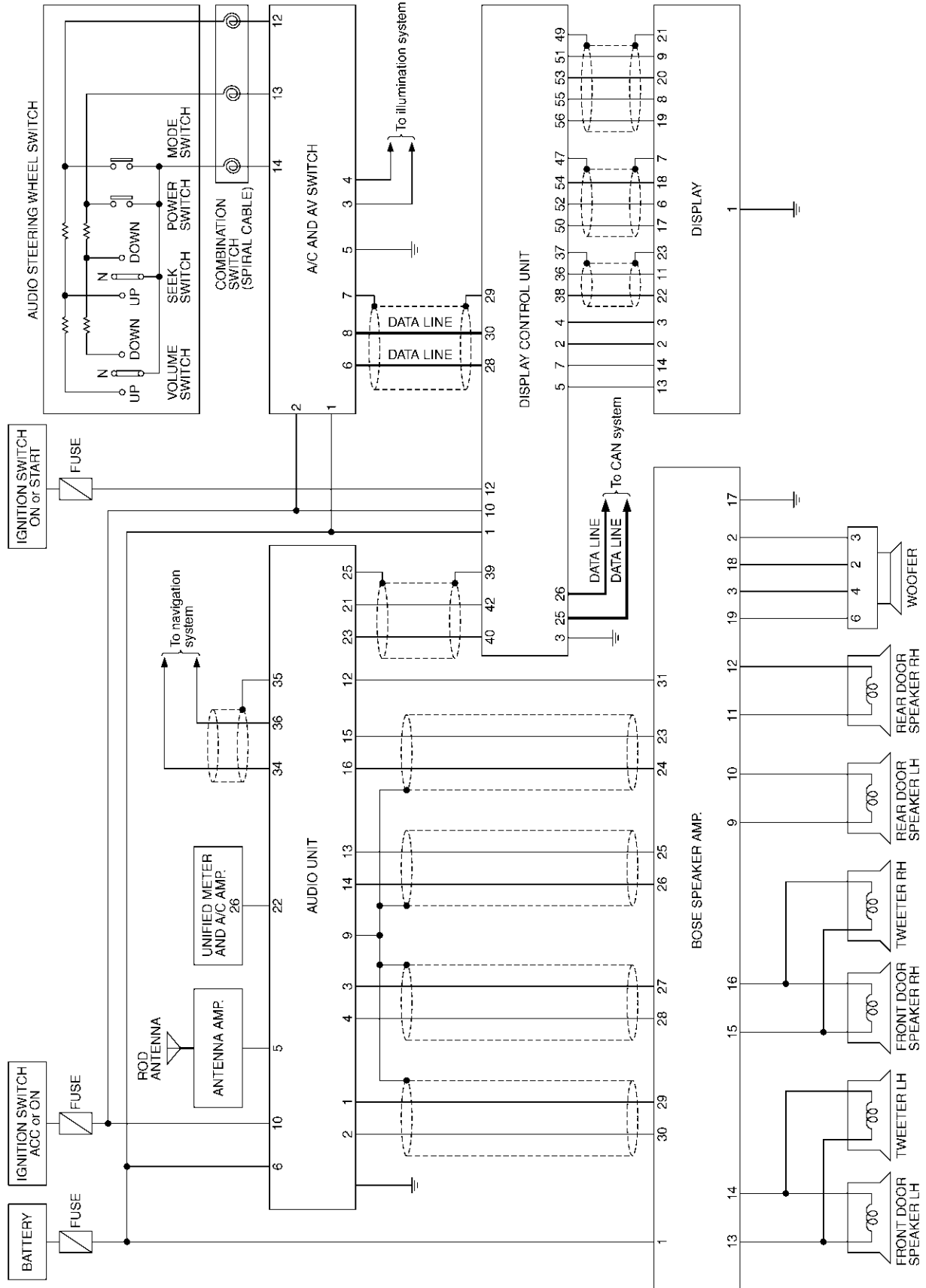

TKWA0884E

# AUDIO

## BOSE SYSTEM WITHOUT NAVIGATION SYSTEM

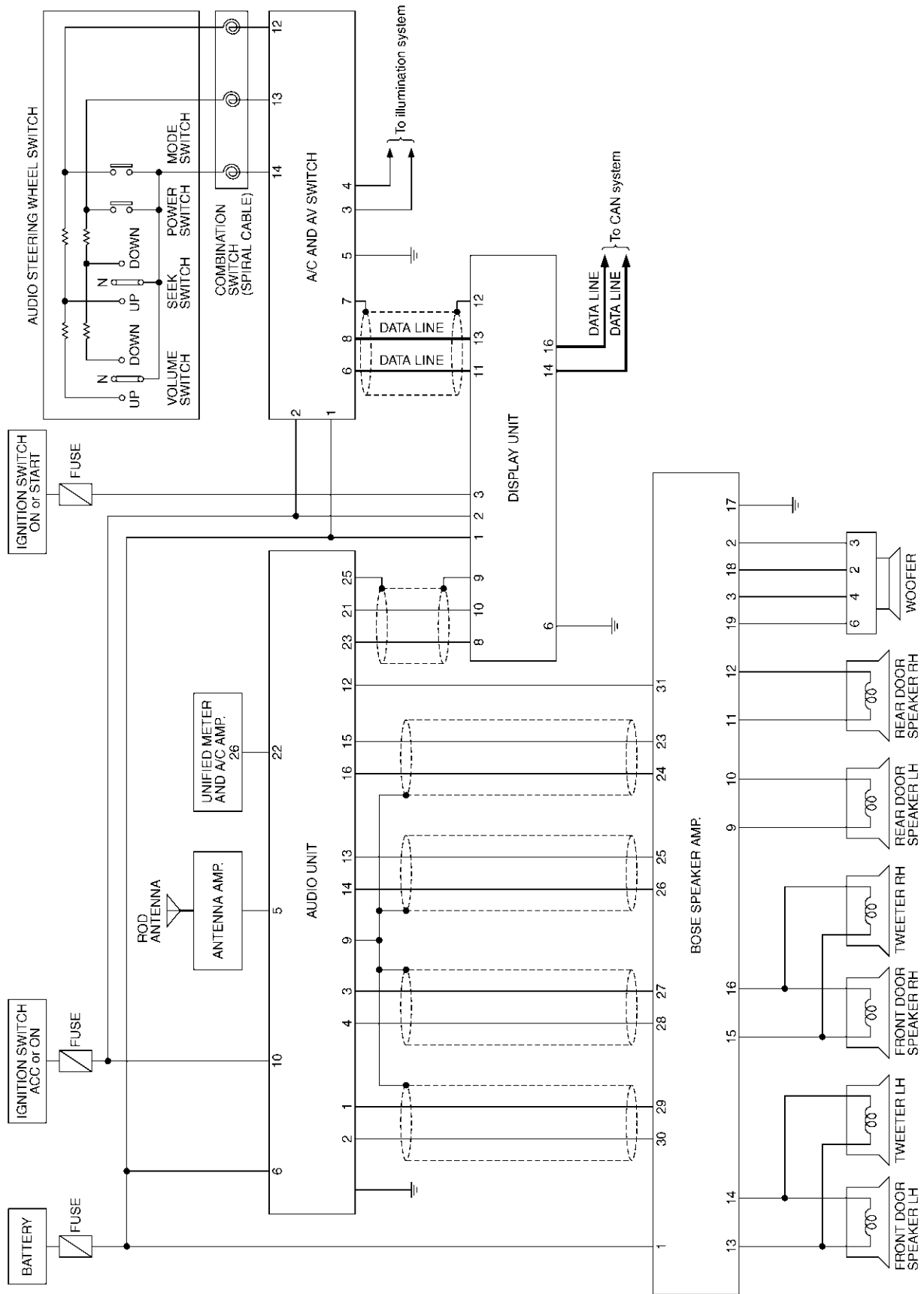

TKWA0904E

A  
B  
C  
D  
E  
F  
G  
H  
I  
J  
L  
M

AV

# AUDIO

AKS005EX

## Wiring Diagram -AUDIO- BASE SYSTEM

### AV-AUDIO-01

⬡6S : WITH 6 SPEAKERS

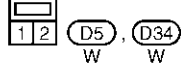
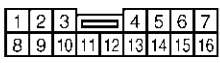
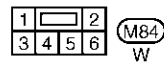
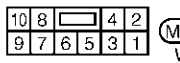
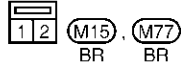
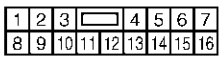
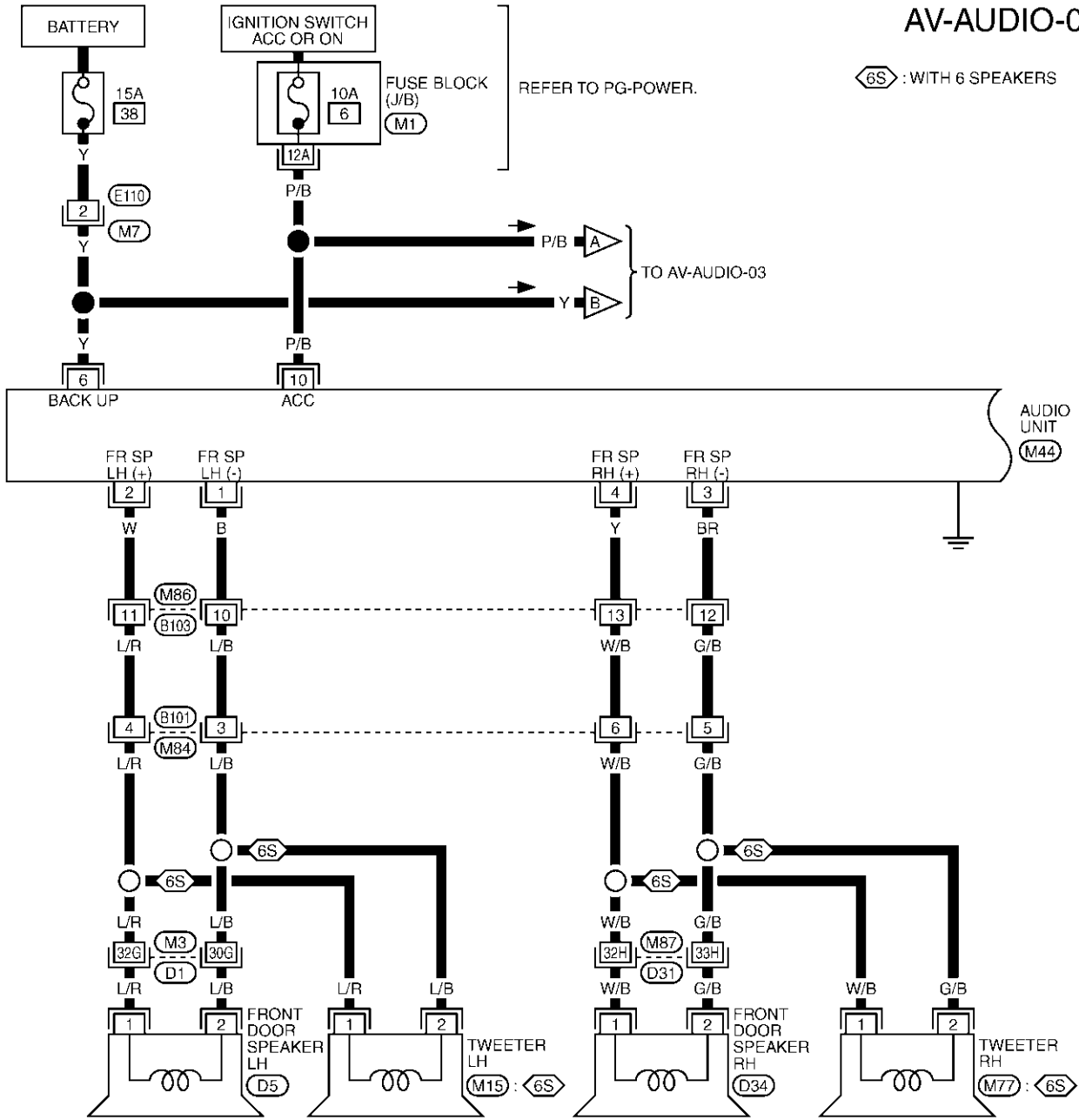

REFER TO THE FOLLOWING.  
 (D1), (D31) -SUPER MULTIPLE JUNCTION (SMJ)  
 (M1) -FUSE BLOCK-JUNCTION BOX (J/B)

TKWA0881E

# AUDIO

AV-AUDIO-02

A  
B  
C  
D  
E  
F  
G  
H  
I  
J  
AV  
L  
M

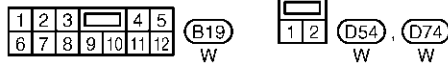
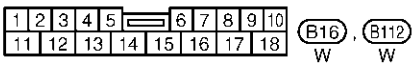
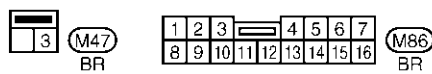
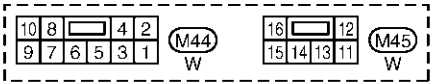
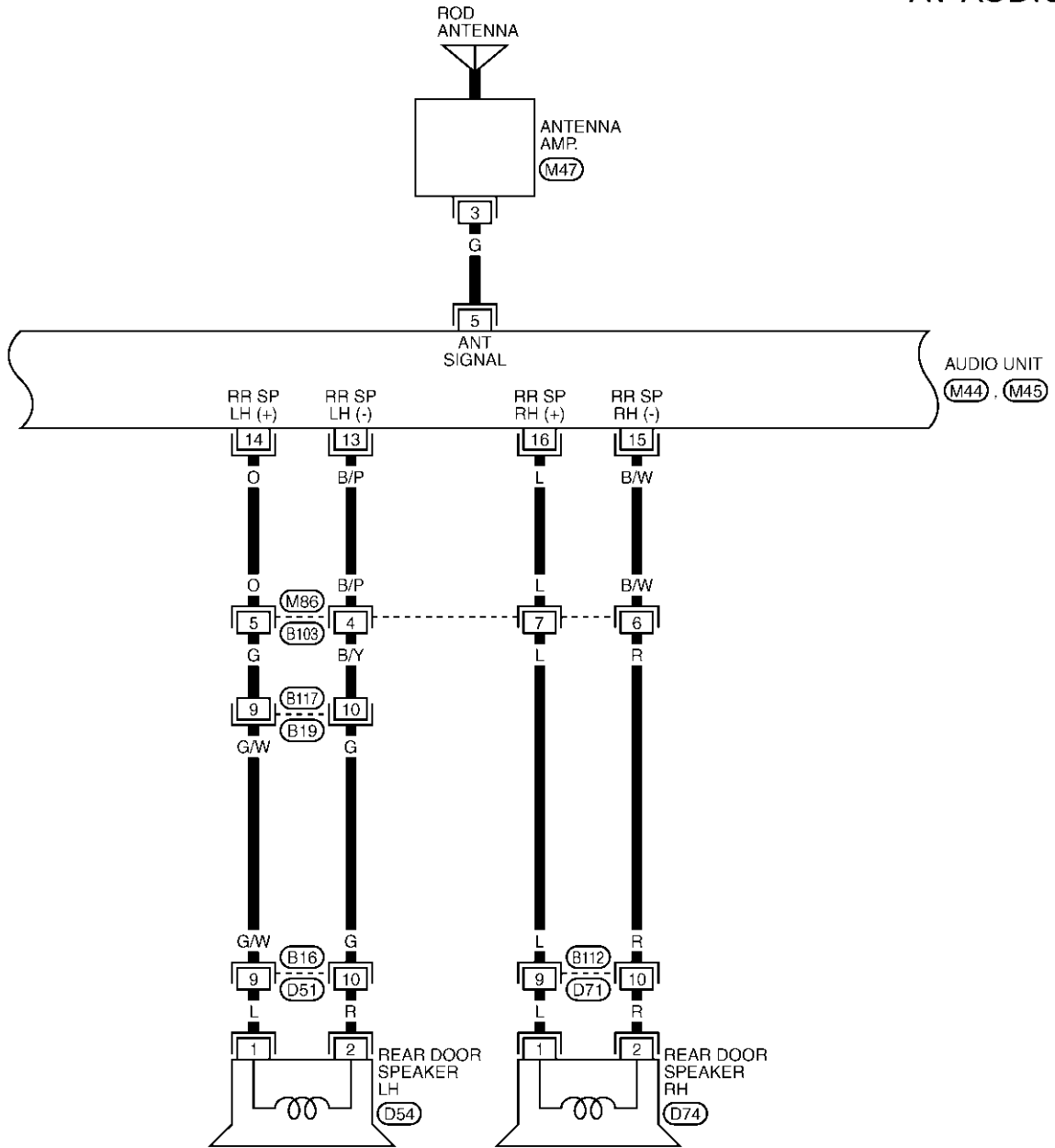

TKWA0882E

# AUDIO

AV-AUDIO-03

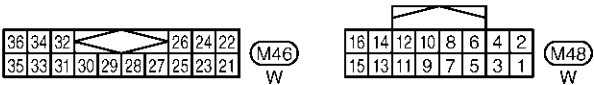
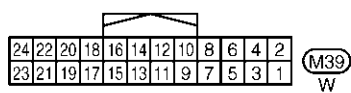
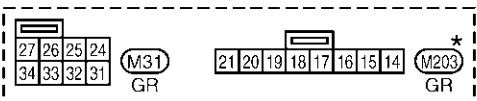
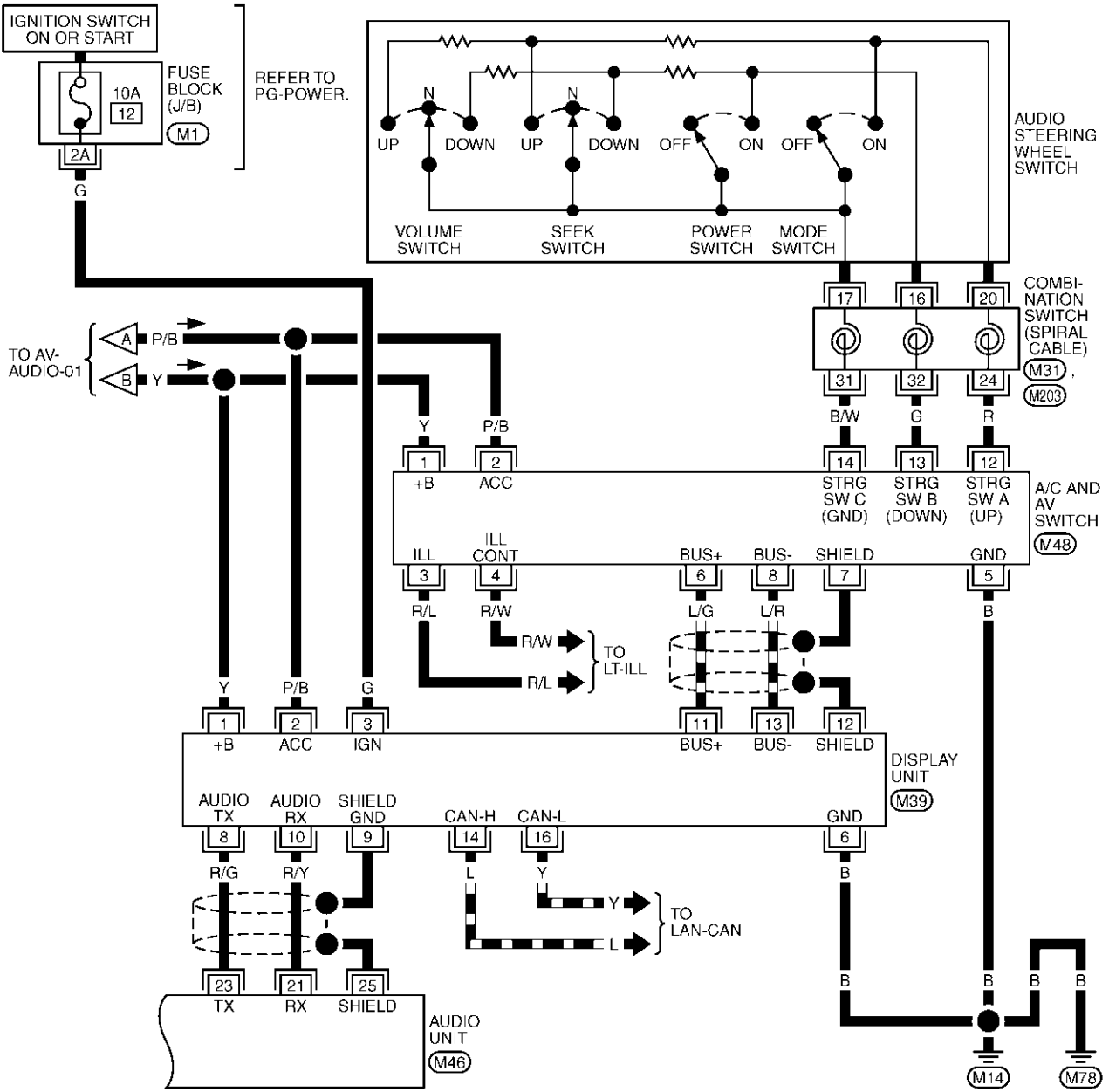

\*: THIS CONNECTOR IS NOT SHOWN IN "HARNESS LAYOUT", PG SECTION.

REFER TO THE FOLLOWING.  
 (M1) - FUSE BLOCK-JUNCTION BOX (J/B)

TKWA1181E

# AUDIO

## BOSE SYSTEM WITH NAVIGATION SYSTEM

AV-AUDIO-04

A  
B  
C  
D  
E  
F  
G  
H  
I  
J  
AV  
L  
M

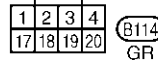
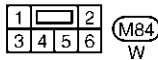
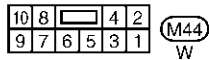
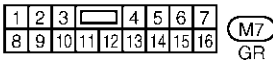
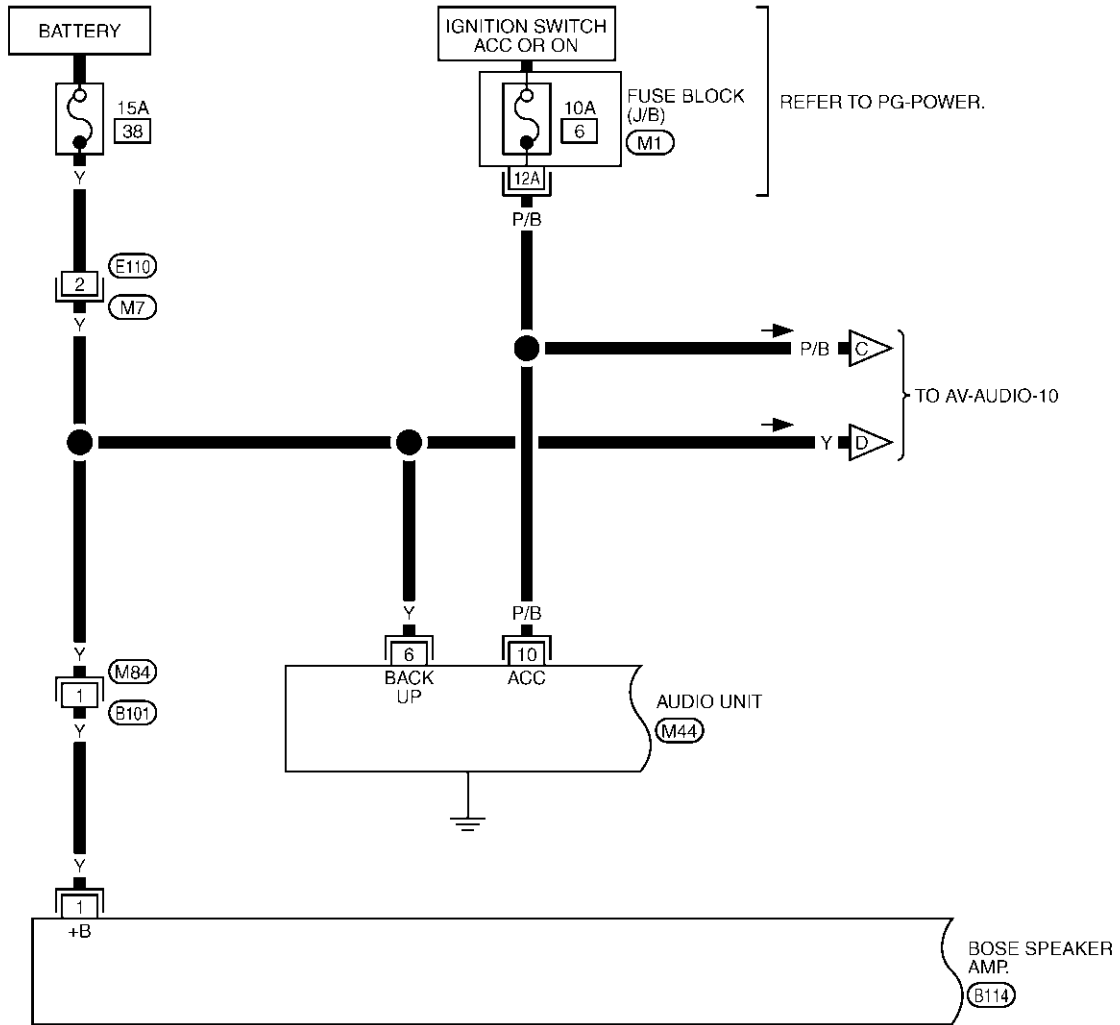

REFER TO THE FOLLOWING.  
(M1) -FUSE BLOCK-JUNCTION BOX (J/B)

TKWA0885E

# AUDIO

AV-AUDIO-05

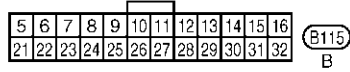
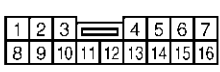
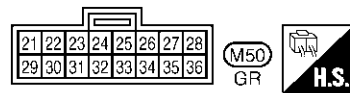
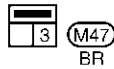
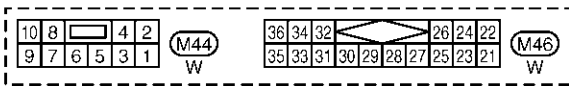
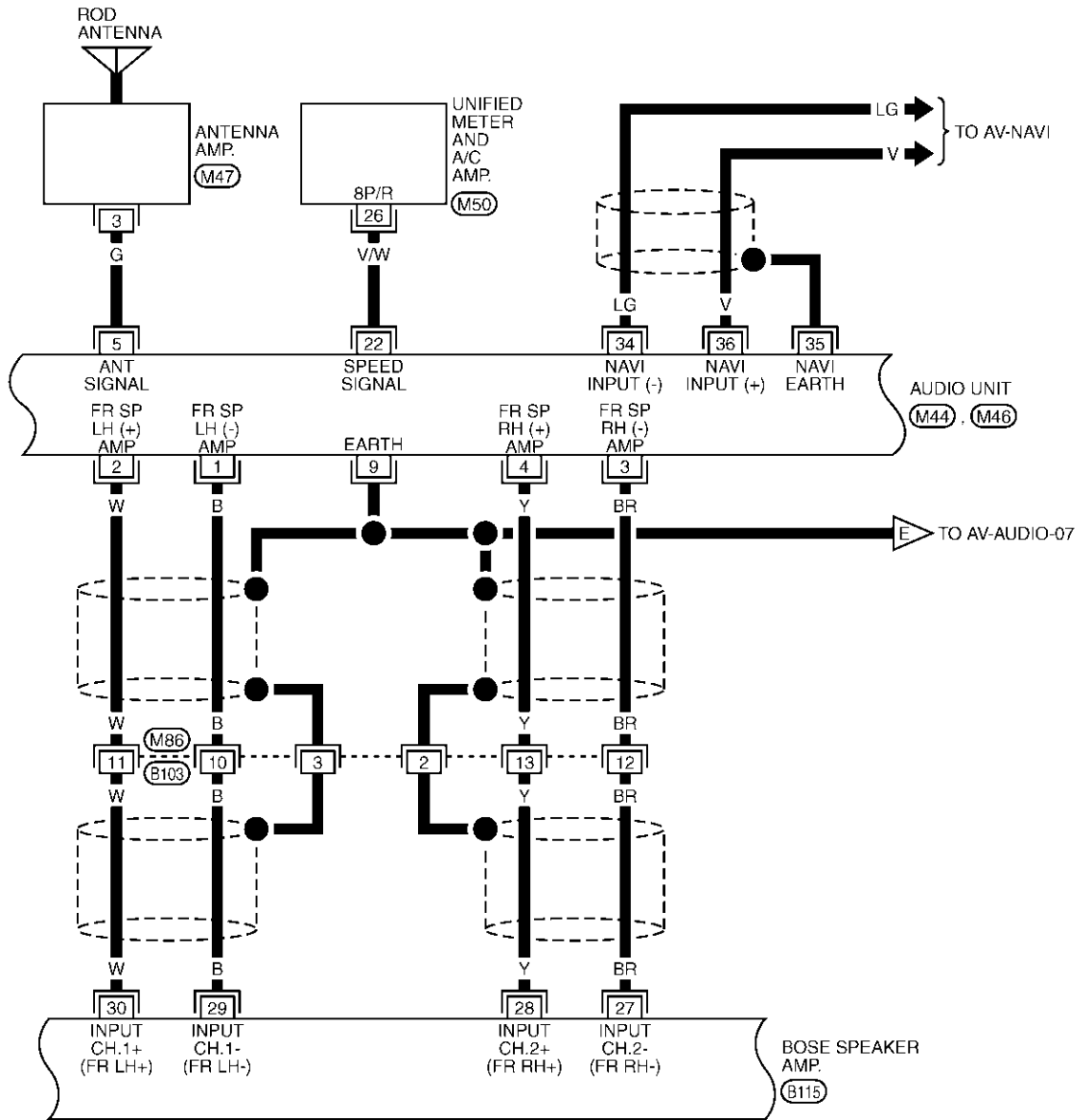

TKWA1253E



# AUDIO

## AV-AUDIO-06

A  
B  
C  
D  
E  
F  
G  
H  
I  
J  
AV  
L  
M

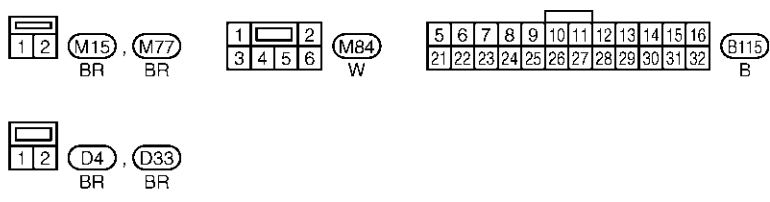
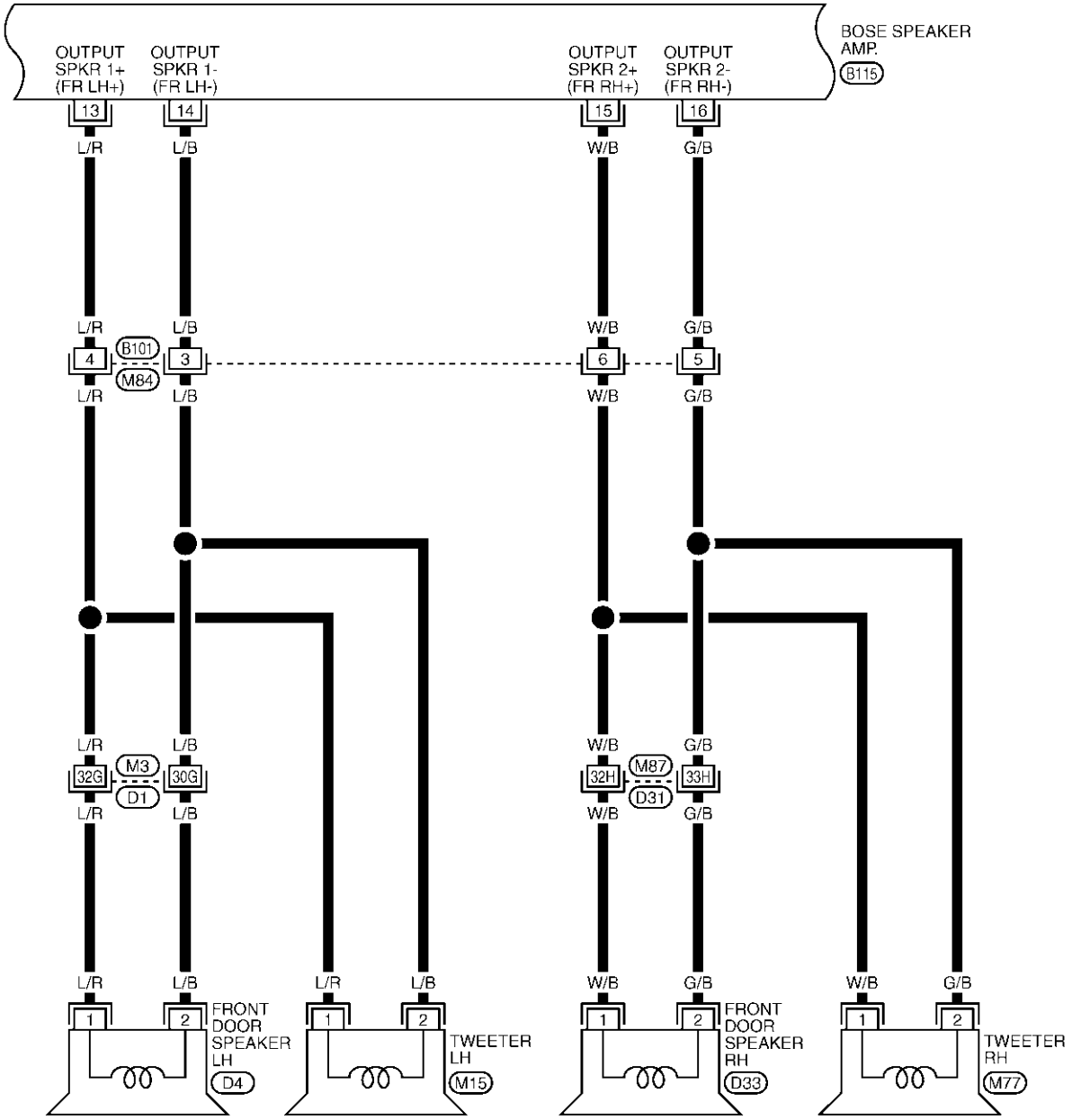

REFER TO THE FOLLOWING.  
 (D1), (D31) -SUPER MULTIPLE JUNCTION (SMJ)

TKWA0887E



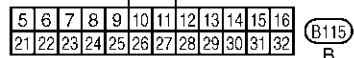
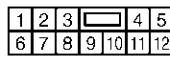
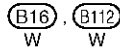
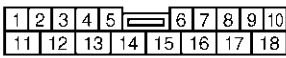
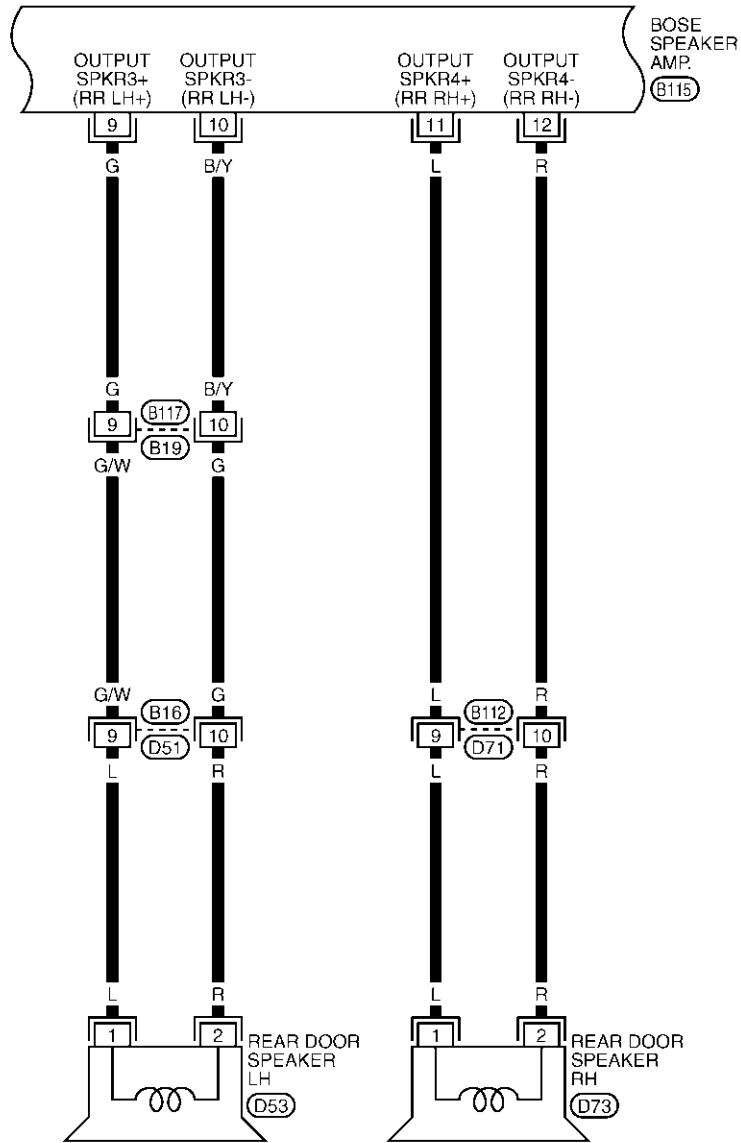

TKWA0889E

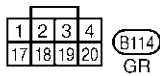
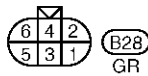
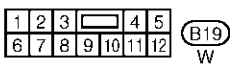
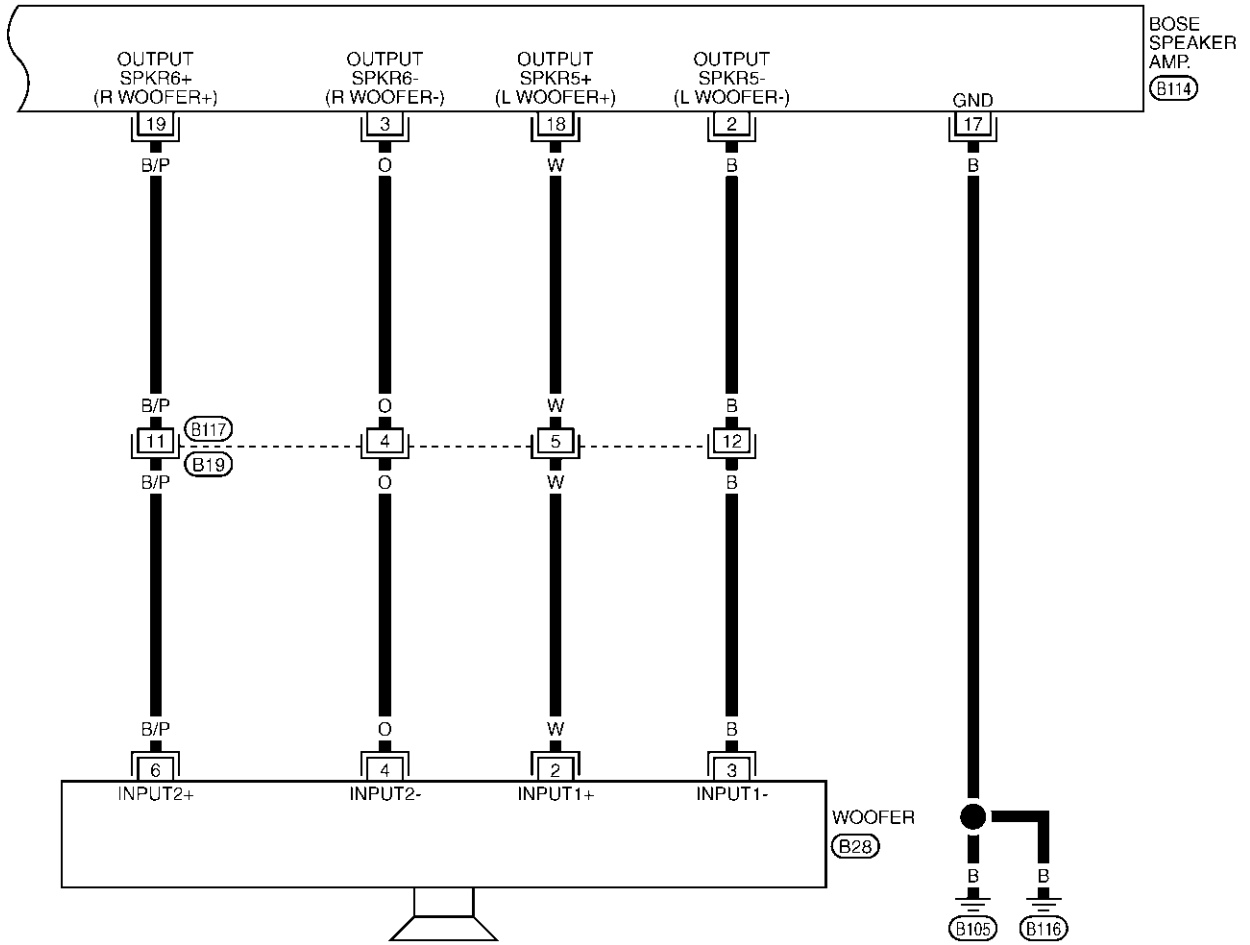

# AUDIO

## AV-AUDIO-10

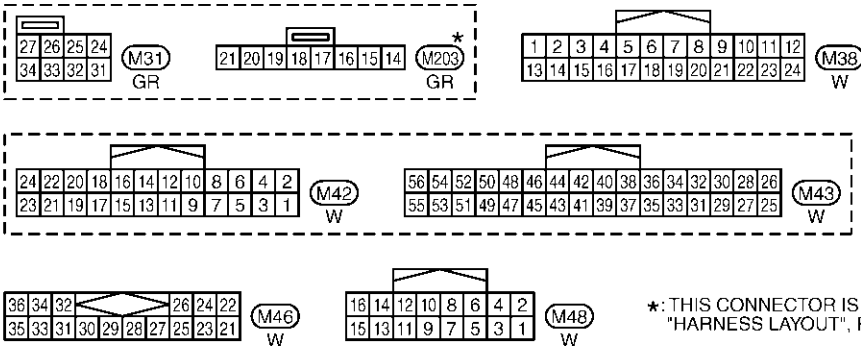
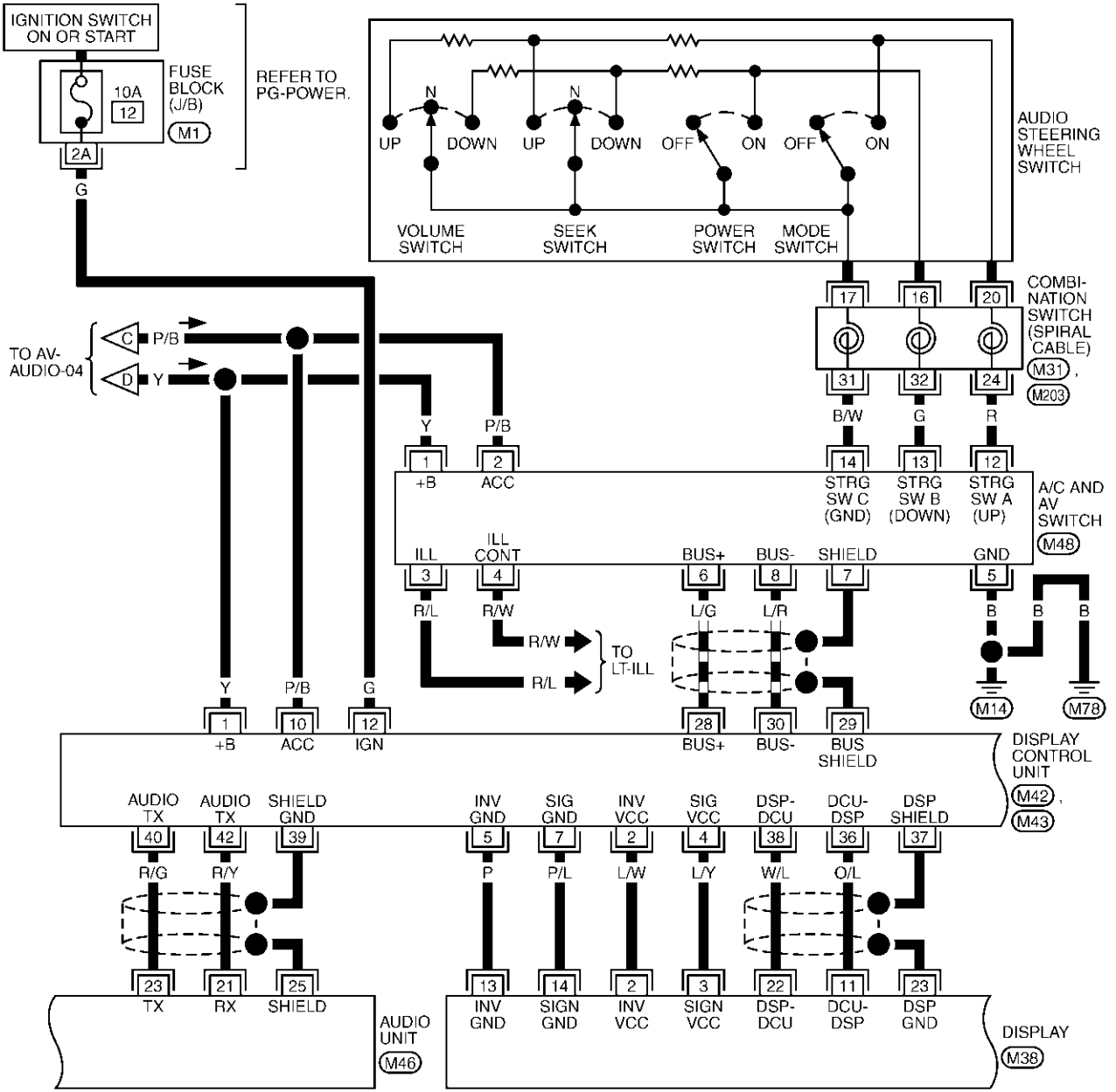

A  
B  
C  
D  
E  
F  
G  
H  
I  
J  
K  
L  
M

AV

# AUDIO

## AV-AUDIO-11

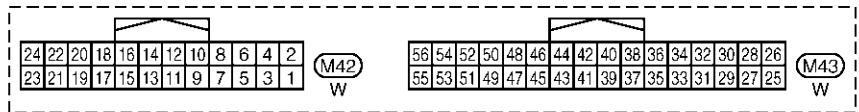
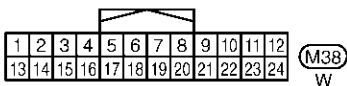
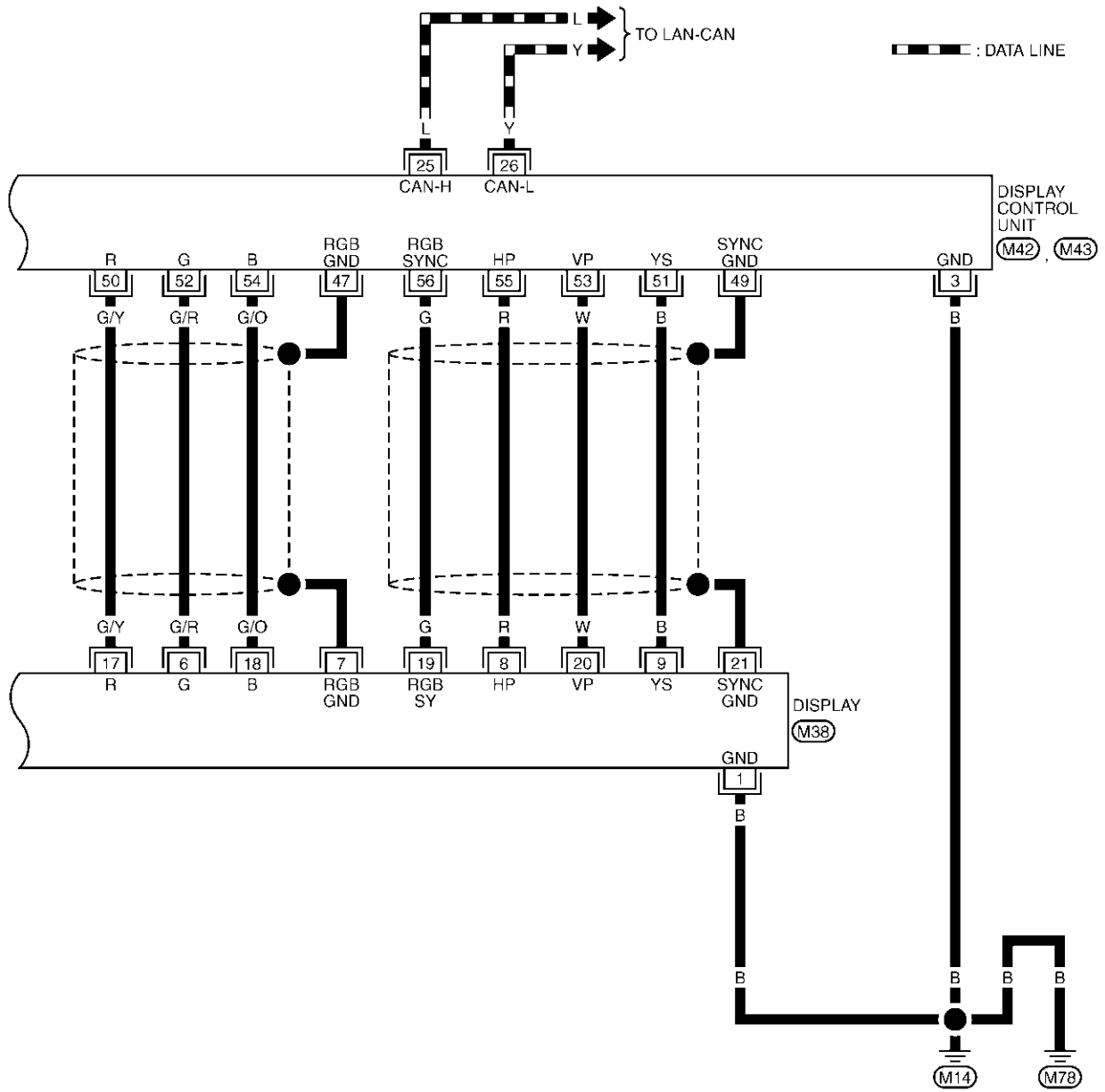

TKWA0892E

# AUDIO

## BOSE SYSTEM WITHOUT NAVIGATION SYSTEM

AV-AUDIO-12

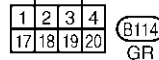
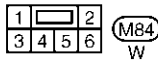
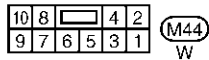
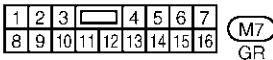
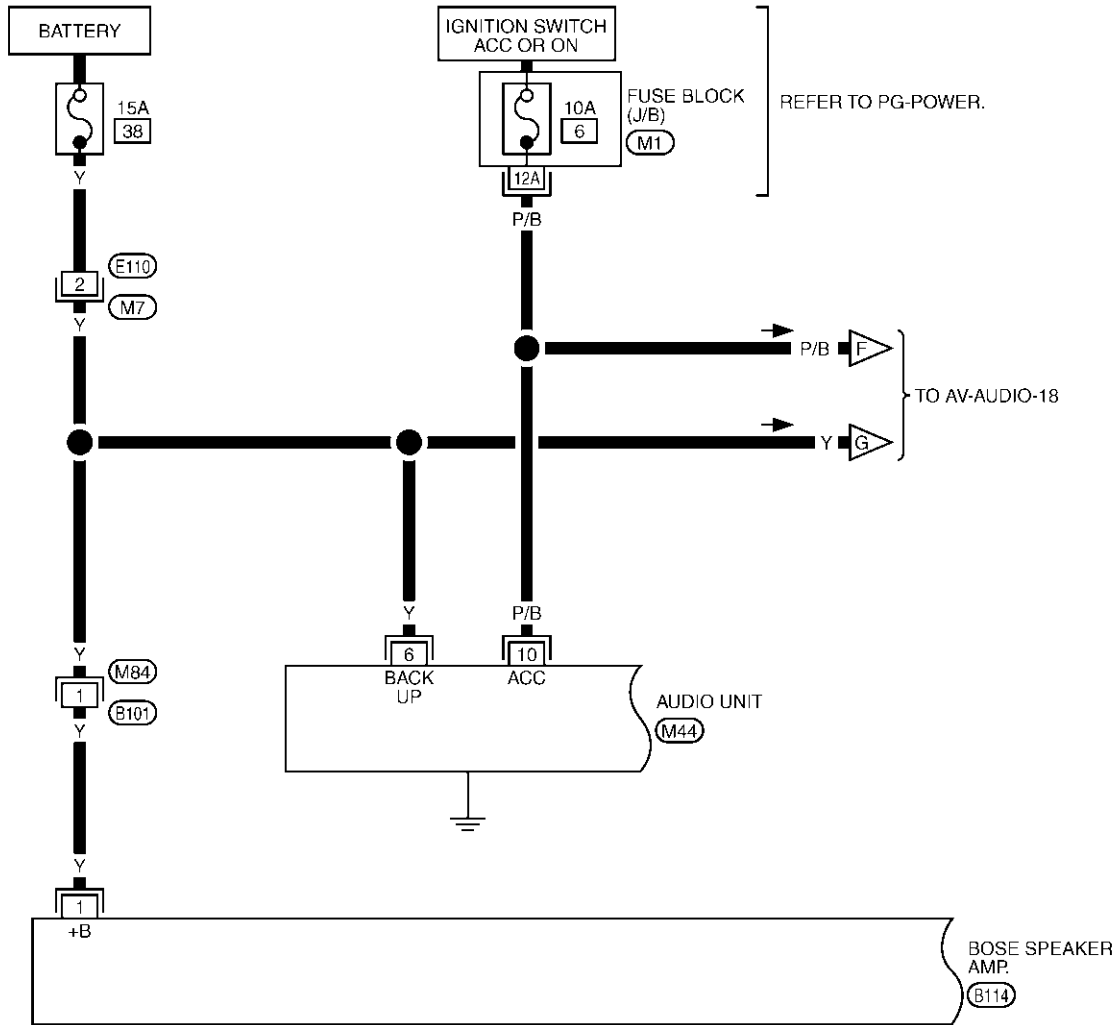

REFER TO THE FOLLOWING.  
 (M1) -FUSE BLOCK-JUNCTION BOX (J/B)

TKWA0905E

# AUDIO

AV-AUDIO-13

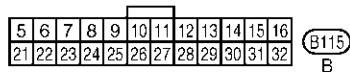
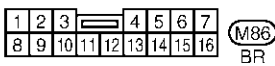
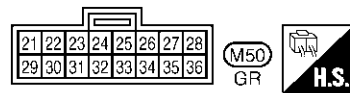
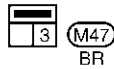
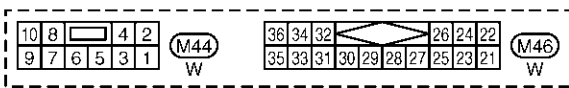
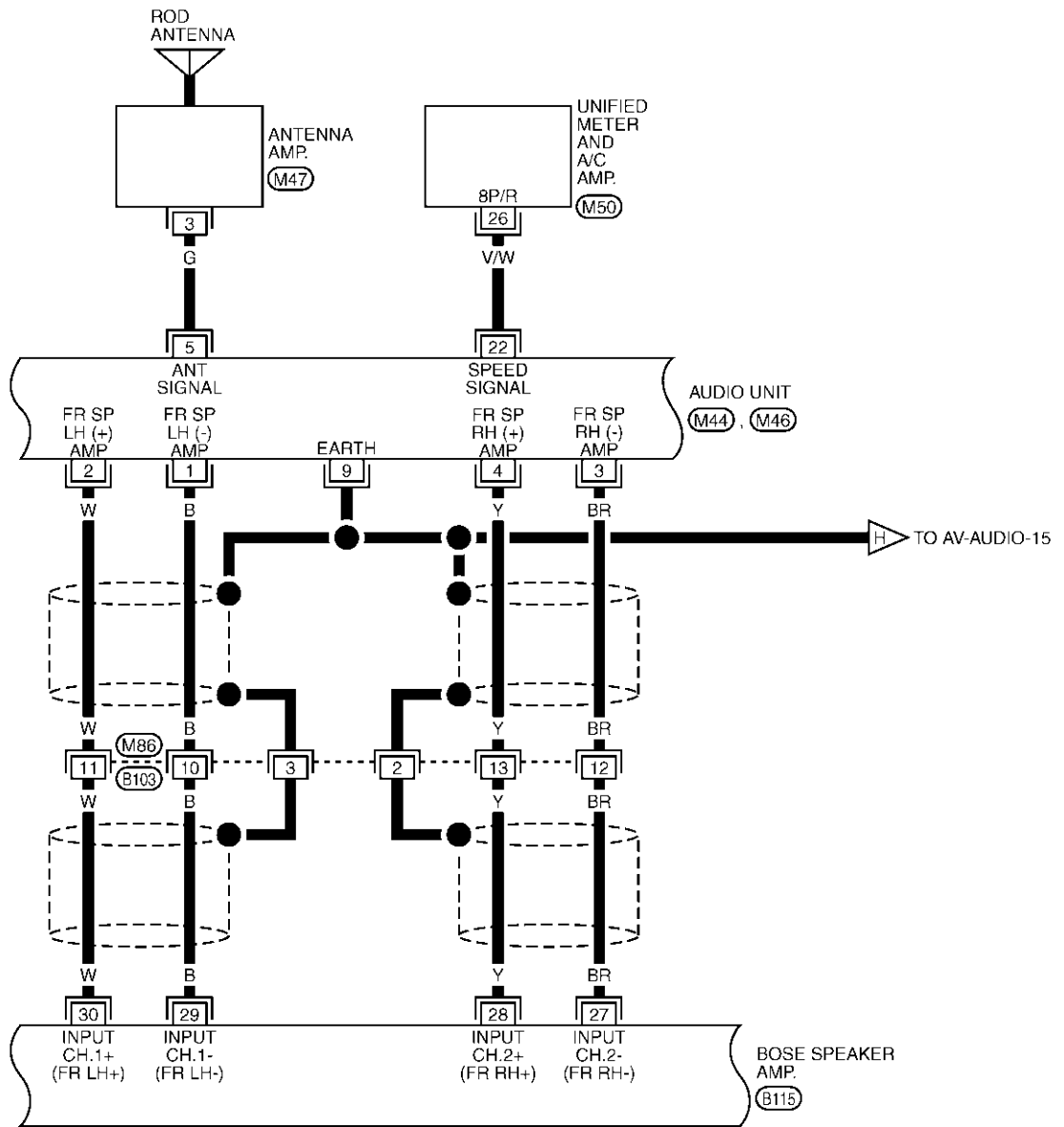

TKWA1254E



# AUDIO

## AV-AUDIO-14

A  
B  
C  
D  
E  
F  
G  
H  
I  
J  
AV  
L  
M

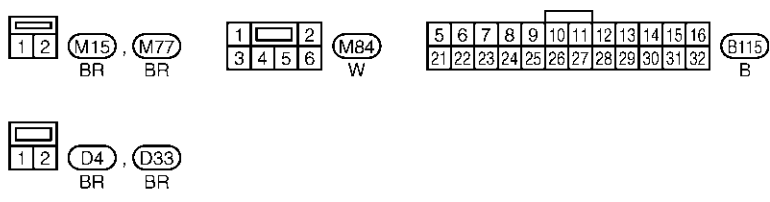
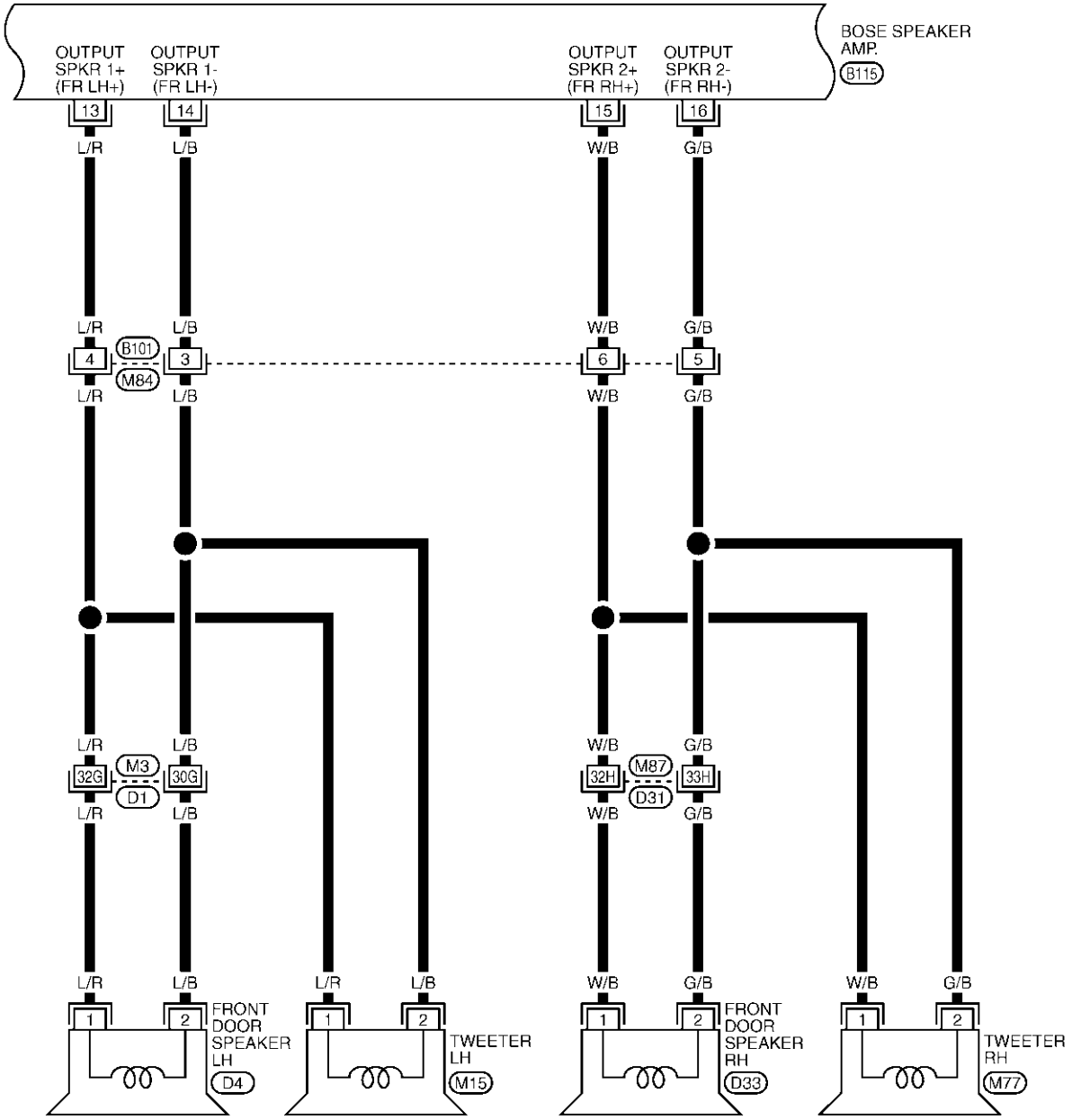

REFER TO THE FOLLOWING.  
 (D1), (D31) -SUPER MULTIPLE JUNCTION (SMJ)

TKWA0907E

# AUDIO

AV-AUDIO-15

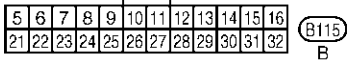
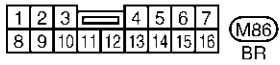
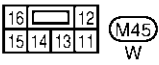
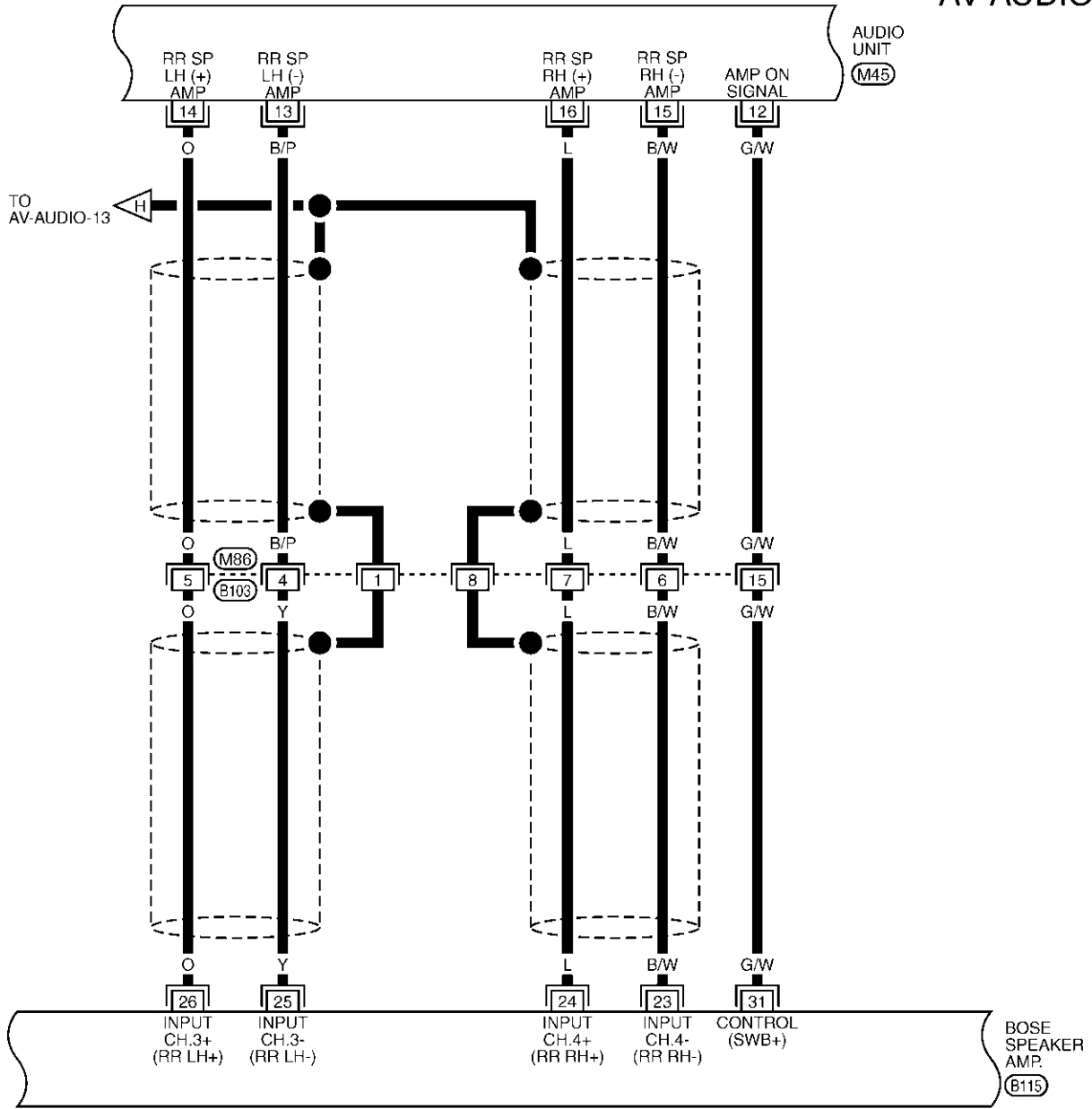

TKWA0908E

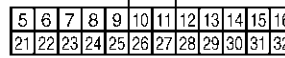
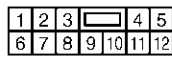
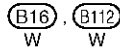
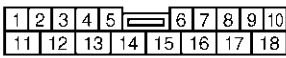
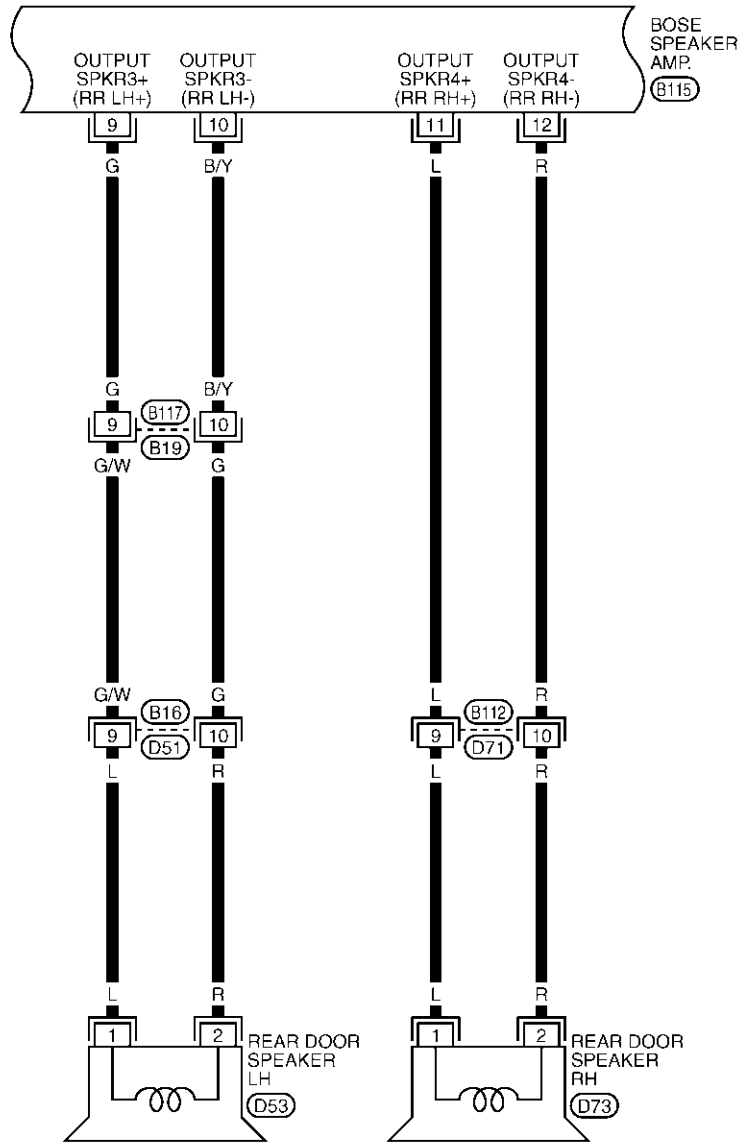

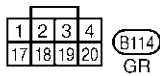
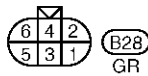
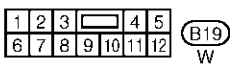
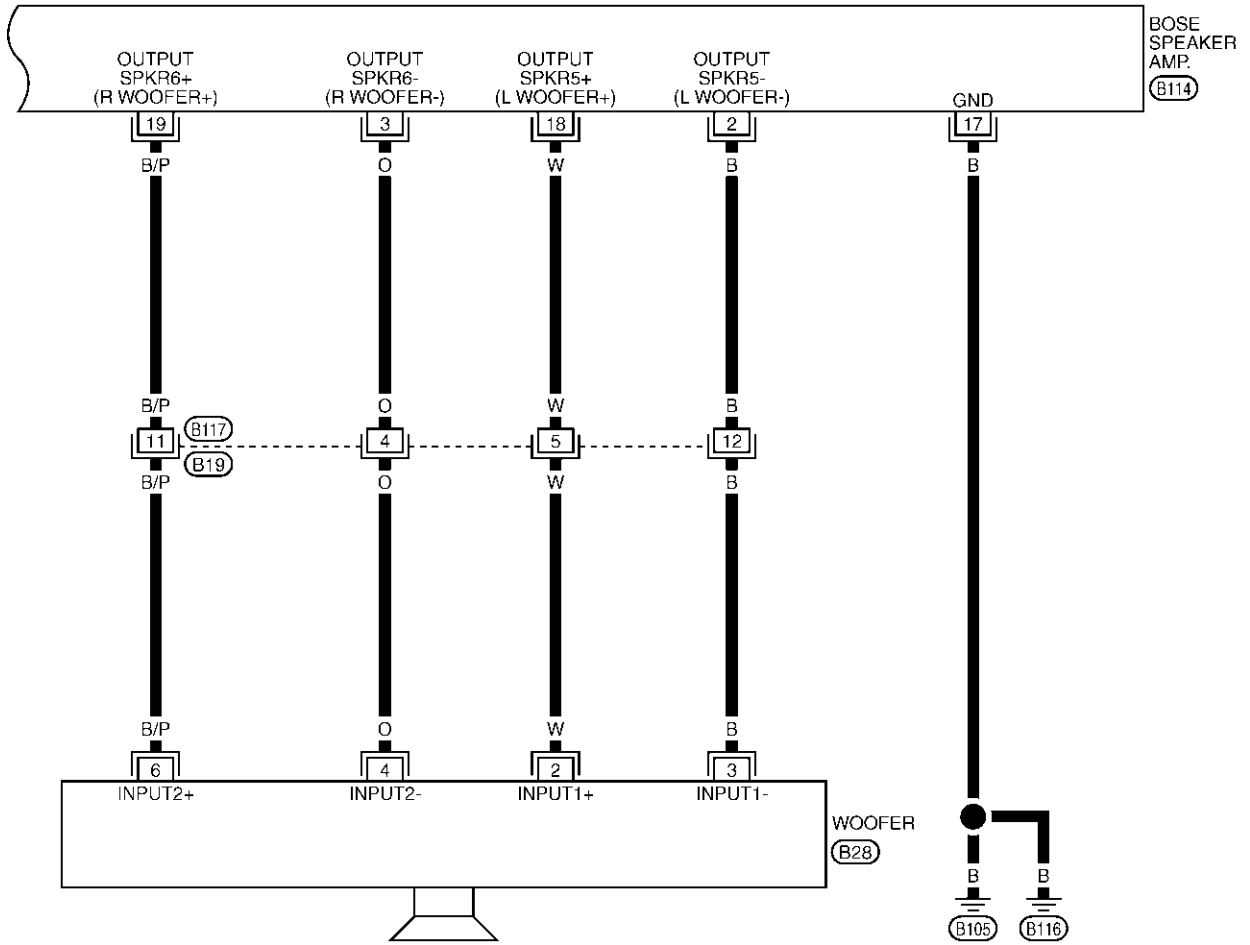

# AUDIO

## AV-AUDIO-18

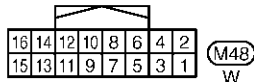
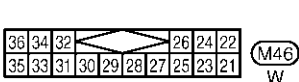
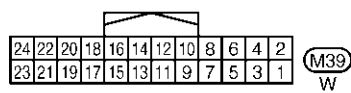
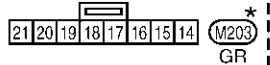
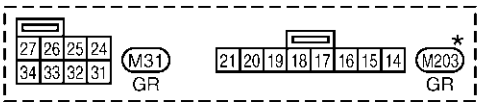
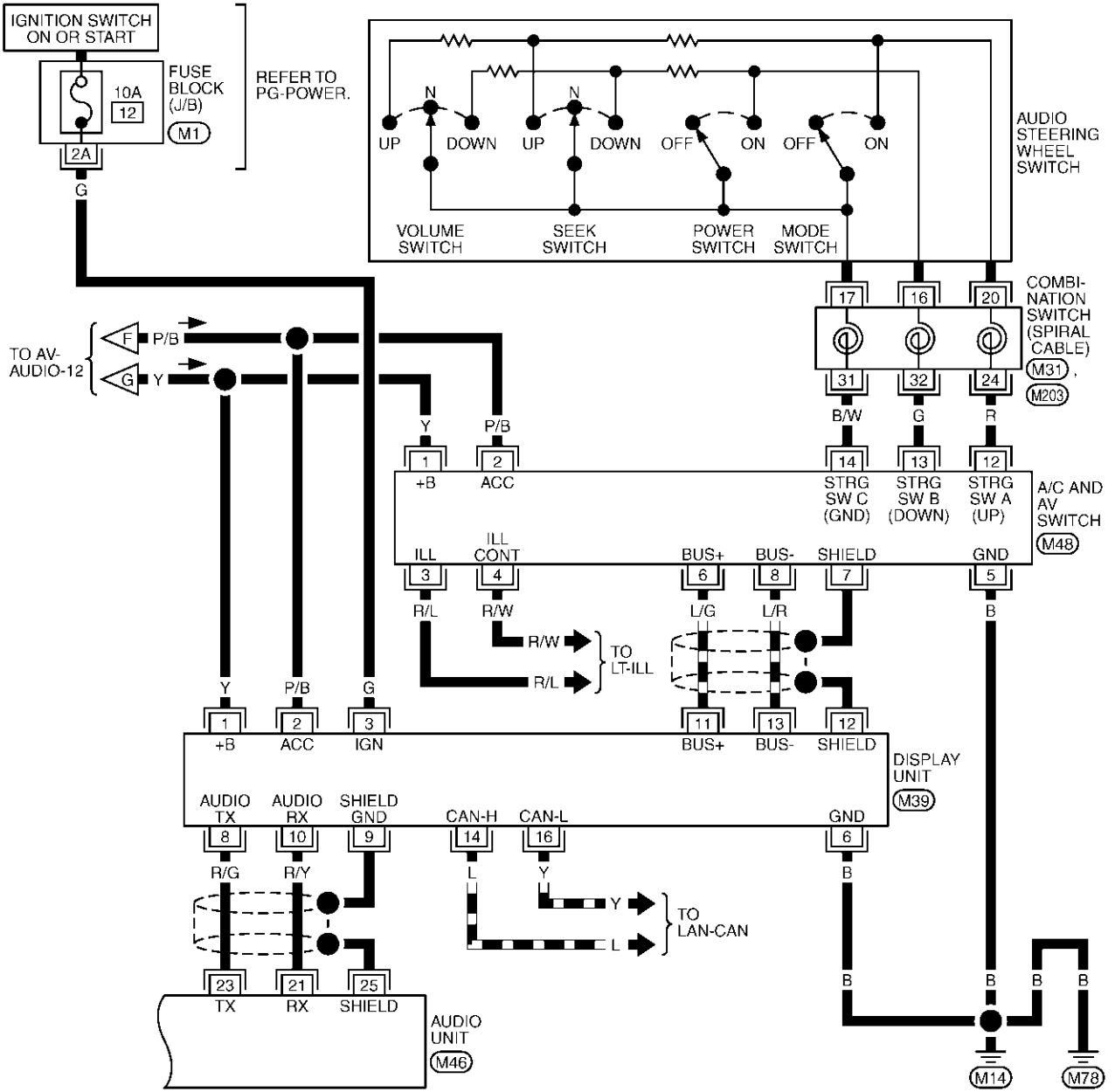

REFER TO THE FOLLOWING.  
 (M1) - FUSE BLOCK-JUNCTION BOX (J/B)

\*: THIS CONNECTOR IS NOT SHOWN IN "HARNESS LAYOUT", PG SECTION.

TKWA1255E

A  
B  
C  
D  
E  
F  
G  
H  
I  
J  
K  
L  
M

AV

# AUDIO

## Terminals and Reference Value for Audio Unit for Base System

AKS005EY

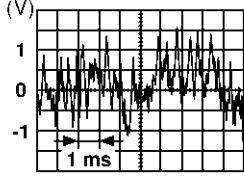
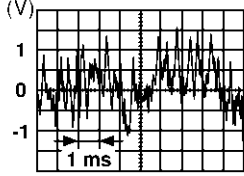
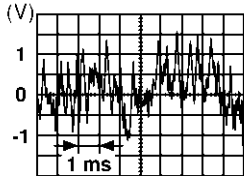
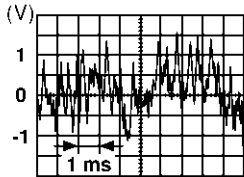
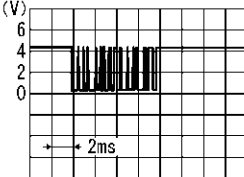
Terminal (Wire color)		Item	Signal input/ output	Condition		Reference value	Example of symp- tom
+	-			Ignition switch	Operation		
2 (W)	1(B)	Audio sound signal front LH	Output	ON	Receive audio signal	 <p style="text-align: right; font-size: small;">SKIA0177E</p>	No sound from front door speaker LH or tweeter LH
4 (Y)	3 (BR)	Audio sound signal front RH	Output	ON	Receive audio signal	 <p style="text-align: right; font-size: small;">SKIA0177E</p>	No sound from front door speaker RH or tweeter RH
5 (G)	Ground	Antenna signal	Output	ON	-	Approx. 12V	Antenna anp. does not work properly.
6 (Y)	Ground	Battery power sup- ply	Input	OFF	-	Battery voltage	System does not work properly.
10 (P/B)	Ground	ACC power supply	Input	ACC	-	Battery voltage	System does not work properly.
14 (O)	13 (B/P)	Audio sound signal rear LH	Output	ON	Receive audio signal	 <p style="text-align: right; font-size: small;">SKIA0177E</p>	No sound from rear speaker LH
16 (L)	15 (B/W)	Audio sound signal rear RH	Output	ON	Receive audio signal	 <p style="text-align: right; font-size: small;">SKIA0177E</p>	No sound from rear speaker RH
21(R/Y)	Ground	Audio RX	Output	ON	Operate audio volume	 <p style="text-align: right; font-size: small;">SKIA4402E</p>	Audio does not operate properly.

# AUDIO

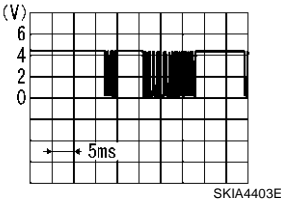
Terminal (Wire color)		Item	Signal input/ output	Condition		Reference value	Example of symp- tom
+	-			Ignition switch	Operation		
23 (R/G)	Ground	Audio TX	Input	ON	Operate audio volume		Audio does not operate properly.
25	Ground	Shield	-	ON	-	Approx. 0V	-

● \*1: Without VDC, navigation and adjust pedal system, manual mode switch and sun roof.

● \*2: Except \*1.

## Terminals and Reference Value for Audio Unit for BOSE System

AKS005EZ

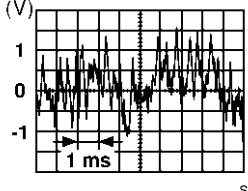
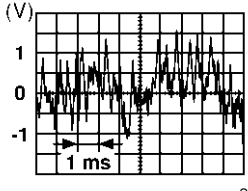
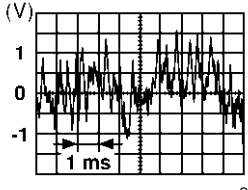
Terminal (Wire color)		Item	Signal input/ output	Condition		Reference value	Example of symp- tom
+	-			Ignition switch	Operation		
2 (W)	1 (B)	Audio sound signal front LH	Output	ON	Receive audio signal		No sound from front door speaker LH or tweeter LH
4 (Y)	3 (BR)	Audio sound signal front RH	Output	ON	Receive audio signal		No sound from front door speaker RH or tweeter RH
5 (G)	Ground	Antenna signal	Output	ON	-	Approx. 12V	Antenna amp. does not work properly.
6 (Y)	Ground	Battery power supply	Input	OFF	-	Battery voltage	System will not work properly.
9	Ground	Shield	-	ON	-	Approx. 0V	-
10 (P/B)	Ground	ACC power supply	Input	ACC	-	Battery voltage	System does not work properly.
12 (G/W)	Ground	Amp. ON sig- nal	Output	ON	-	Approx. 12V	Amp. does not work properly.
14 (O)	13 (B/P)	Audio sound signal rear LH	Output	ON	Receive audio signal		No sound from rear speaker LH

# AUDIO

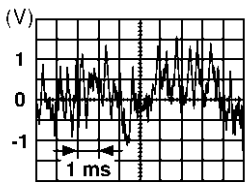
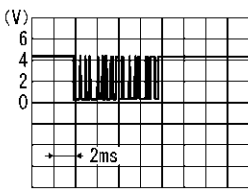
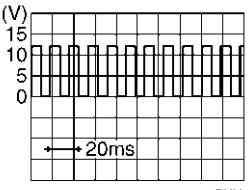
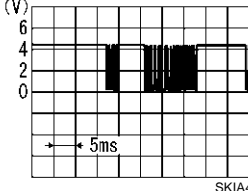
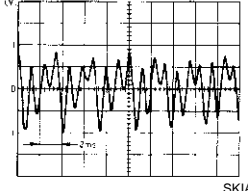
Terminal (Wire color)		Item	Signal input/ output	Condition		Reference value	Example of symp- tom
+	-			Ignition switch	Operation		
16 (L)	15 (B/W)	Audio sound signal rear RH	Output	ON	Receive audio signal	 SKIA0177E	No sound from rear speaker RH
21 (R/Y)	Ground	Audio RX	Output	ON	Operate audio volume	 SKIA4402E	Audio does not operate properly.
22 (V/W)	Ground	Vehicle speed signal (8- pulse)	Input	ON	When vehicle speed is approx.40 km/h (25MPH)	 PKIA1935E	Speed sensitive volume system dose not work properly.
23 (R/G)	Ground	Audio TX	Input	ON	Operate audio volume	 SKIA4403E	Audio does not operate properly.
25	Ground	Shield	-	ON	-	Approx. 0V	-
35	Ground	Shield	-	ON	-	Approx. 0V	-
36 (V)	34 (LG)	Voice guide signal	Input	ON	Press the "GUIDE/VOICE" button.	 SKIA0171E	Only route guide and operation guide are not heard.



# AUDIO

## Terminals and Reference Value for BOSE Speaker Amp.

AKS005F0

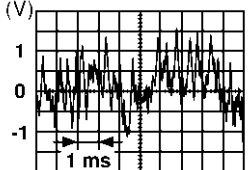
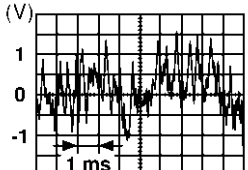
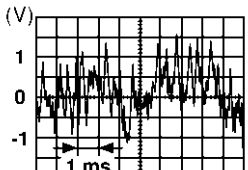
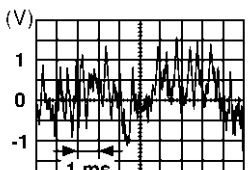
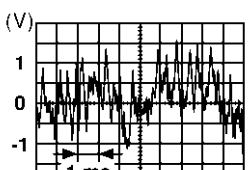
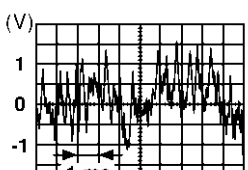
Terminal (Wire color)		Item	Signal input/ output	Condition		Reference value	Example of symptom
+	-			Ignition switch	Operation		
1 (Y)	Ground	Battery power supply	Input	OFF	-	Battery voltage	System does not work properly.
18 (W)	2 (B)	Woofer 1	Output	ON	Receive audio signal	 <small>SKIA0177E</small>	No sound from woofer
19 (B/P)	3 (O)	Woofer 2					
9 (G)	10 (B/Y)	Rear door speaker LH	Output	ON	Receive audio signal	 <small>SKIA0177E</small>	No sound from rear speaker LH
11 (L)	12 (R)	Rear door speaker RH	Output	ON	Receive audio signal	 <small>SKIA0177E</small>	No sound from rear speaker RH
13 (L/R)	14 (L/B)	Front door speaker LH and tweeter LH	Output	ON	Receive audio signal	 <small>SKIA0177E</small>	No sound from front door speaker LH or tweeter LH
15 (W/B)	16 (G/B)	Front door speaker RH and tweeter RH	Output	ON	Receive audio signal	 <small>SKIA0177E</small>	No sound from front door speaker RH or tweeter RH
17 (B)	Ground	Ground	-	ON	-	Approx. 0V	-
24 (L)	23 (B/W)	Audio sound signal rear RH	Input	ON	Receive audio signal	 <small>SKIA0177E</small>	No sound from rear speaker RH

A  
B  
C  
D  
E  
F  
G  
H  
I  
J  
L  
M

AV

# AUDIO

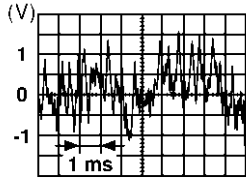
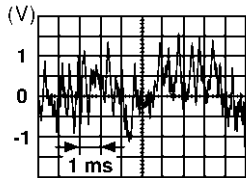
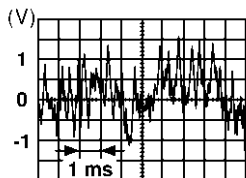
Terminal (Wire color)		Item	Signal input/ output	Condition		Reference value	Example of symptom
+	-			Ignition switch	Operation		
26 (O)	25 (Y)	Audio sound signal rear LH	Input	ON	Receive audio signal	 SKIA0177E	No sound from rear speaker LH
28 (Y)	27 (BR)	Audio sound signal front RH	Input	ON	Receive audio signal	 SKIA0177E	No sound from front door speaker RH or tweeter RH
30 (W)	29 (B)	Audio sound signal front LH	Input	ON	Receive audio signal	 SKIA0177E	No sound from front door speaker LH or tweeter LH
31 (G/W)	Ground	Control (sub+)	Input	ON	-	Approx. 12V	System does not work properly.

## A/C and AV Switch Self-Diagnosis Function

AKS005R1

It can check ON/OFF operation of each switch in the A/C and AV switch and diagnose the input signals to the steering switch.

### STARTING THE SELF-DIAGNOSIS MODE

1. Turn ignition switch from OFF to ACC.
2. Within 10 seconds press and hold the switches "PAUSE/MUTE" and "PREV" simultaneously for 3 seconds.

Then the self-diagnosis operates.

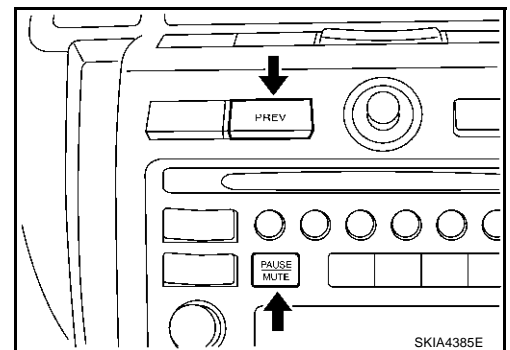

### EXITING THE SELF-DIAGNOSIS MODE

- Turn ignition switch OFF. Then the self-diagnosis ends.

### DIAGNOSIS FUNCTION

- It can illuminate all the indicators (LED) in the A/C and AV switch.
- It can check for continuity of the switches by sounding the buzzer when the A/C and AV switch is pressed.
- It can check for continuity of harness between A/C and AV switch and steering switch.

# AUDIO

AKS005F2

## Trouble Diagnosis

The majority of the audio malfunctions are the result of outside causes (bad CD/cassette, electromagnetic interference, etc.). Check the symptoms below to diagnose the malfunction.

### MALFUNCTION WITH RADIO AND CD (BASE SYSTEM)

Make sure that operation excepting audio system can be done with A/C and AV switch. If not, refer [AV-103, "Trouble Diagnosis Chart by Symptom"](#) to repair malfunctioning parts.

Symptom	Possible cause
Inoperative	<ul style="list-style-type: none"> <li>● Audio unit power supply circuit. Refer to <a href="#">AV-38, "Power Supply Circuit Inspection"</a> .</li> <li>● Audio communication line. Refer to <a href="#">AV-40, "Audio Communication Line Check (Without Navigation System)"</a> .</li> <li>● A/C and AV switch check. Refer to <a href="#">AV-40, "A/C and AV Switch Check"</a> .</li> </ul> <p>If above system is OK, replace audio unit.</p>
Steering switch dose not operate	<ul style="list-style-type: none"> <li>● Steering switch check. Refer to <a href="#">AV-39, "Steering Switch Check"</a> .</li> <li>● A/C and AV switch check. Refer to <a href="#">AV-40, "A/C and AV Switch Check"</a> .</li> </ul> <p>If above systems are OK, replace audio unit.</p>
All speaker do not sound	<p>Replace audio unit. Refer to <a href="#">AV-55, "Removal and Installation of Audio Unit"</a> .</p>
One or several speaker does not sound	<ul style="list-style-type: none"> <li>● Front door speaker check. Refer to <a href="#">AV-41, "Front Door Speaker Check (Base System)"</a> .</li> <li>● Rear door speaker check. Refer to <a href="#">AV-43, "Rear Door Speaker Check (Base System)"</a> .</li> </ul> <p>If above system is OK, replace door speaker.</p>
Poor sound	<ul style="list-style-type: none"> <li>● Audio unit</li> <li>● Speaker</li> </ul>
Noisy	<ul style="list-style-type: none"> <li>● Audio unit</li> <li>● Each electrical equipment</li> </ul>

### MALFUNCTION WITH RADIO, TAPE AND CD (BOSE SYSTEM)

Make sure that operation excepting audio system can be done with A/C and AV switch. If not, refer [AV-103, "Trouble Diagnosis Chart by Symptom"](#) (Without navigation system), [AV-218, "Unable to Operate All of A/C and AV Switches \(Unable to Start Self-Diagnosis\)"](#) (With navigation system) to repair malfunctioning parts.

Symptom	Possible cause
Inoperative	<ul style="list-style-type: none"> <li>● Audio unit power supply circuit. Refer to <a href="#">AV-38, "Power Supply Circuit Inspection"</a> .</li> <li>● Audio communication line (Without navigation system). Refer to <a href="#">AV-40, "Audio Communication Line Check (Without Navigation System)"</a> .</li> <li>● Audio communication line (With navigation system). Refer to <a href="#">AV-41, "Audio Communication Line Check (With Navigation System)"</a> .</li> <li>● A/C and AV switch check. Refer to <a href="#">AV-40, "A/C and AV Switch Check"</a> .</li> </ul> <p>If above system is OK, replace audio unit.</p>
Steering switch dose not operate	<ul style="list-style-type: none"> <li>● Steering switch check. Refer to <a href="#">AV-39, "Steering Switch Check"</a> .</li> <li>● A/C and AV switch check. Refer to <a href="#">AV-40, "A/C and AV Switch Check"</a> .</li> </ul> <p>If above systems are OK, replace audio unit.</p>
All speaker do not sound	<p>Replace audio unit. Refer to <a href="#">AV-55, "Removal and Installation of Audio Unit"</a> .</p>
One or several speaker does not sound	<ul style="list-style-type: none"> <li>● Front door speaker check. Refer to <a href="#">AV-45, "Front Door Speaker Check (BOSE System)"</a> .</li> <li>● Rear door speaker check. Refer to <a href="#">AV-49, "Rear Door Speaker Check (BOSE System)"</a> .</li> </ul> <p>If above system is OK, replace BOSE speaker amp.</p> <ul style="list-style-type: none"> <li>● Woofer check. Refer to <a href="#">AV-53, "Woofer Check (BOSE System)"</a></li> </ul> <p>If above system is OK, replace woofer.</p>

# AUDIO

Symptom	Possible cause
Speed sensitive volume system dose not work	<ul style="list-style-type: none"> <li>● Vehicle speed signal check. Refer to <a href="#">AV-54, "Vehicle Speed Signal Check"</a>.</li> <li>If above system is OK, replace audio unit.</li> </ul>
Poor sound	<ul style="list-style-type: none"> <li>● Audio unit</li> <li>● BOSE speaker amp.</li> <li>● Speaker</li> </ul>
Noisy	<ul style="list-style-type: none"> <li>● Audio unit</li> <li>● BOSE speaker amp.</li> <li>● Each electrical equipment</li> </ul>

## FOR RADIO ONLY

Symptom	Possible cause
No sound	<ul style="list-style-type: none"> <li>● Audio unit</li> <li>● Antenna feeder</li> <li>● Antenna amp.</li> </ul>
Noisy	<ul style="list-style-type: none"> <li>● Audio unit</li> <li>● Antenna feeder</li> <li>● Antenna amp.</li> <li>● Noise prevention parts</li> <li>● Each electrical equipment</li> <li>● Wire harness of each piece of electrical equipment</li> </ul>
Selected radio stations stored in memory are deleted	<ul style="list-style-type: none"> <li>● Audio unit</li> </ul>

### NOTE:

1. This is noise resulting from variations in field strength, such as fading noise and multi-path noise, or external noise from trains and other sources. It is not a malfunction.
  - Fading noise: This noise occurs because of variations in the field strength in a narrow range due to mountains or buildings blocking the signal.
  - Multi-path noise: This noise results from the waves sent directly from the broadcast station arriving at the antenna at a different time from the waves which reflect off of mountains or buildings.

## FOR CASSETTE PLAYER ONLY

Symptom	Possible cause
Cassette tape cannot be inserted	<ul style="list-style-type: none"> <li>● Cassette tape</li> <li>● Audio unit</li> </ul>
Cassette tape cannot be ejected	
Auto reverse does not work, or the tape direction changes in the middle of play	
There is much noise	
The sound is not clear	
Sound fluctuates/tape speed not correct	
No sound	

## FOR CD ONLY

Symptom	Possible cause
CD cannot be inserted	<ul style="list-style-type: none"> <li>● CD</li> <li>● Audio unit</li> </ul>
CD cannot be ejected	
The CD cannot be played	
The sound skips, stops suddenly, or is distorted	

# AUDIO

AKS005F3

## Noise Inspection

The vehicle itself can be a source of noise if noise prevention parts or electrical equipment is malfunction. Check if noise is caused and/or changed by engine speed, ignition switch turned to each position, and operation of each piece of electrical equipment, and determine the cause.

### NOTE:

The source of the noise can be found easily by listening to the noise while removing the fuses of electrical components, one by one.

### TYPE OF NOISE AND POSSIBLE CAUSE

Occurrence condition		Possible cause
Occurs only when engine is ON.	A continuous growling noise occurs. The speed of the noise varies with changes in the engine speed.	● Ignition condenser
	A whistling noise occurs while the engine speed is high. A booming noise occurs while the engine is running and the lighting switch is ON.	● Alternator
The occurrence of the noise is linked with the operation of the fuel pump.		● Fuel pump condenser
Noise only occurs when various electrical components are operating.	A cracking or snapping sound occurs with the operation of various switches.	● Relay malfunction, radio malfunction
	The noise occurs when various motors are operating.	● Motor case ground ● Motor
The noise occurs constantly, not just under certain conditions.		● Rear defogger coil malfunction ● Open circuit in printed heater ● Poor ground of antenna amplifier or antenna feeder line
A cracking or snapping sound occurs while the vehicle is being driven, especially when it is vibrating excessively.		● Ground wire of body parts ● Ground due to incorrect installation of parts ● Wiring connections or a short circuit

A  
B  
C  
D  
E  
F  
G  
H  
I  
J

AV

L  
M

# AUDIO

AKS005F4

## Power Supply Circuit Inspection

### 1. CHECK FUSE

Make sure that the following fuses of the BOSE speaker amp. and audio unit are not blown.

Unit	Terminals	Signal name	Fuse No.
Audio unit	6	Battery power	38
	10	Ignition switch ACC or ON	6
BOSE speaker amp.	1	Battery power	38

#### OK or NG

OK >> GO TO 2.

NG >> If fuse is blown, be sure to eliminate cause of malfunction before installing new fuse. Refer to [PG-3. "POWER SUPPLY ROUTING CIRCUIT"](#).

### 2. POWER SUPPLY CIRCUIT CHECK

#### 1. Check voltage between audio unit and ground.

Unit	Terminal No.			OFF	ACC	ON
	(+)		(-)			
	Connector	Terminal (wire color)				
Audio unit	M44	6 (Y)	Ground	Battery voltage	Battery voltage	Battery voltage
		10 (P/B)	Ground	0 V	Battery voltage	Battery voltage

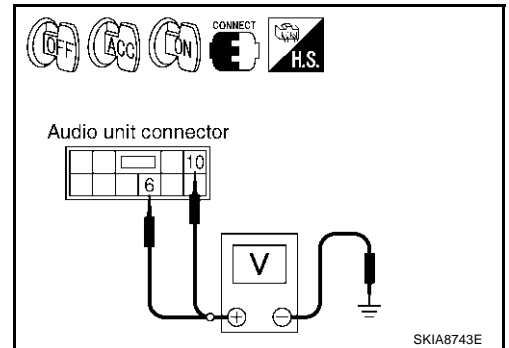

#### 2. Check voltage between BOSE speaker amp. and ground.

Unit	Terminal No.			OFF	ACC	ON
	(+)		(-)			
	Connector	Terminal (wire color)				
BOSE speaker amp.	B114	1(Y)	Ground	Battery voltage	Battery voltage	Battery voltage

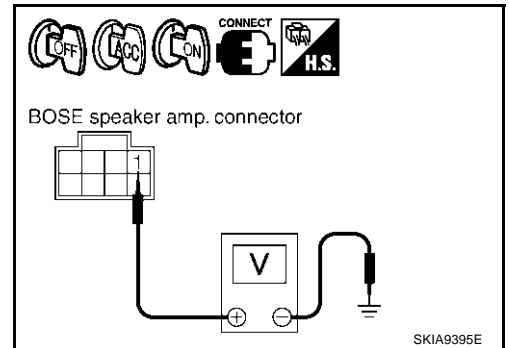

#### OK or NG

OK >> ● INSPECTION END (Base system)

- GO TO 3 (BOSE system).

NG >> ● Check connector housings for disconnected or loose terminals.

- Repair harness or connector.

## 3. GROUND CIRCUIT CHECK

1. Turn ignition switch OFF.
2. Disconnect BOSE speaker amp. connector.
3. Check continuity between BOSE speaker amp. harness connector B114 terminal 17 (B) and ground.

Continuity should exist.

OK or NG

OK >> INSPECTION END

NG >> ● Check connector housings for disconnected or loose terminals.

- Repair harness or connector.

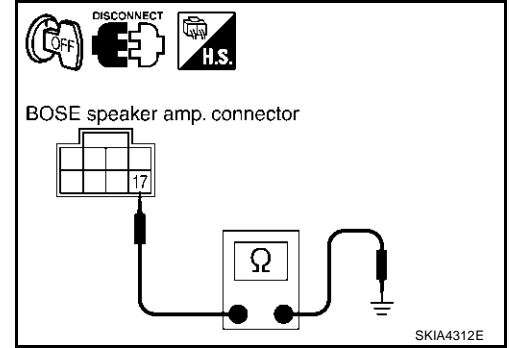

AKS0069B

## Steering Switch Check

### 1. A/C AND AV SWITCH SELF-DIAGNOSIS FUNCTION CHECK

1. Start A/C and AV switch self-diagnosis function. Refer to [AV-34, "A/C and AV Switch Self-Diagnosis Function"](#).
2. Operate steering switch.

Does steering switch operate normally?

YES >> INSPECTION END

NO >> GO TO 2.

## 2. CHECK HARNESS

1. Turn ignition switch OFF.
2. Disconnect A/C and AV switch connector and spiral cable connector.
3. Check continuity between spiral cable harness connector terminal and A/C and AV switch harness connector terminal.

Terminals				Continuity
Spiral cable		A/C and AV switch		
Connector	Terminal	Connector	Terminal (Wire color)	
M31	32 (G)	M48	13 (G)	Yes
	31 (B/W)		14 (B/W)	Yes
	24 (R)		12 (R)	Yes

4. Check continuity between A/C and AV switch and ground.

Terminals			Continuity
A/C and AV switch (+)		(-)	
Connector	Terminal (Wire color)		
M48	12 (R)	Ground	No
	13 (G)		
	14 (B/W)		

OK or NG

OK >> GO TO 3.

NG >> Repair harness.

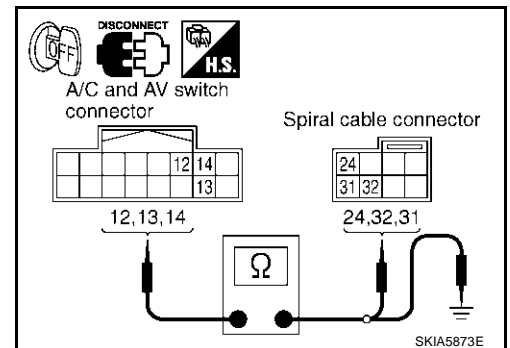

A  
B  
C  
D  
E  
F  
G  
H  
I  
J  
L  
M

AV

# AUDIO

## 3. SPIRAL CABLE CHECK

1. Disconnect spiral cable connector.
2. Check continuity between spiral cable terminals.

Terminals				Continuity
Spiral cable				
Connector	Terminal	Connector	Terminal	
M31	32	M203	16	Yes
	31		17	Yes
	24		20	Yes

OK or NG

- OK >> GO TO 4.  
 NG >> Replace spiral cable.

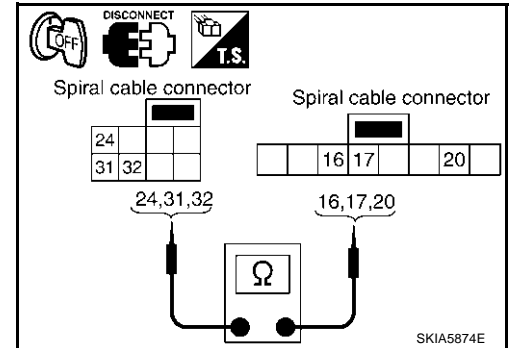

## 4. CHECK STEERING SWITCH RESISTANCE

Check resistance steering switch terminals.

Terminal	Signal name	Condition	Resistance (Ω)
16	Seek down	Depress (station) down switch.	Approx.165
	Power	Depress power switch.	Approx.0
17	Volume (down)	Depress volume down switch.	Approx.652
	Seek up	Depress (station) up switch.	Approx.165
20	Mode	Depress mode switch.	Approx.0
	Volume (up)	Depress volume up switch.	Approx.652

OK or NG

- OK >> INSPECTION END  
 NG >> Replace steering switch.

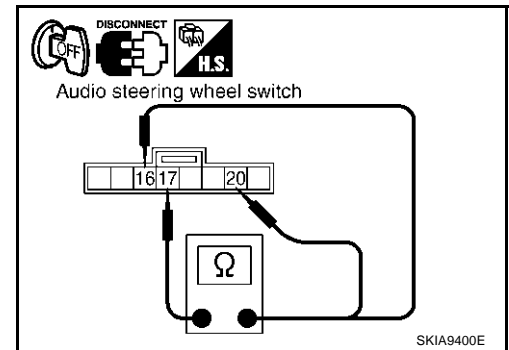

## A/C and AV Switch Check

AKS007H8

### 1. A/C AND AV SWITCH SELF-DIAGNOSIS FUNCTION CHECK

1. Start A/C and AV switch self-diagnosis function. Refer to [AV-34, "A/C and AV Switch Self-Diagnosis Function"](#).
2. Operate voluntary switch.

Does A/C and AV switch operate normally?

- YES >> INSPECTION END  
 NO >> Replace A/C and AV switch.

## Audio Communication Line Check (Without Navigation System)

AKS005RJ

### 1. CHECK AUDIO COMMUNICATION LINE

Start audio communication line check. Refer to [AV-40, "Audio Communication Line Check \(Without Navigation System\)"](#).

OK or NG

- OK >> INSPECTION END  
 NG >> Replace malfunctioning part.



# AUDIO

## Audio Communication Line Check (With Navigation System)

AKS005RK

### 1. CHECK AUDIO COMMUNICATION LINE

Start audio communication line check. Refer to [AV-41, "Audio Communication Line Check \(With Navigation System\)"](#).

OK or NG

- OK >> INSPECTION END
- NG >> Replace malfunctioning part.

## Front Door Speaker Check (Base System)

AKS005FT

### 1. HARNESS CHECK

1. Disconnect audio unit connector and front door speaker connector.
2. Check continuity between audio unit harness connector terminal and front door speaker harness connector terminal.

Terminals				Continuity
Audio unit		Speaker		
Connector	Terminal (Wire color)	Connector	Terminal (Wire color)	
M44	2 (W)	D5	1 (L/R)	Yes
	1 (B)		2 (L/B)	
	4 (Y)	D34	1 (W/B)	
	3 (BR)		2 (G/B)	

3. Check continuity between audio unit harness connector terminal and ground.

Terminals			Continuity
Audio unit		—	
Connector	Terminal (Wire color)		
M44	2 (W)	Ground	No
	1 (B)		
	4 (Y)		
	3 (BR)		

OK or NG

- OK >> GO TO 2.
- NG >>
  - Check connector housings for disconnected or loose terminals.
  - Repair harness or connector.

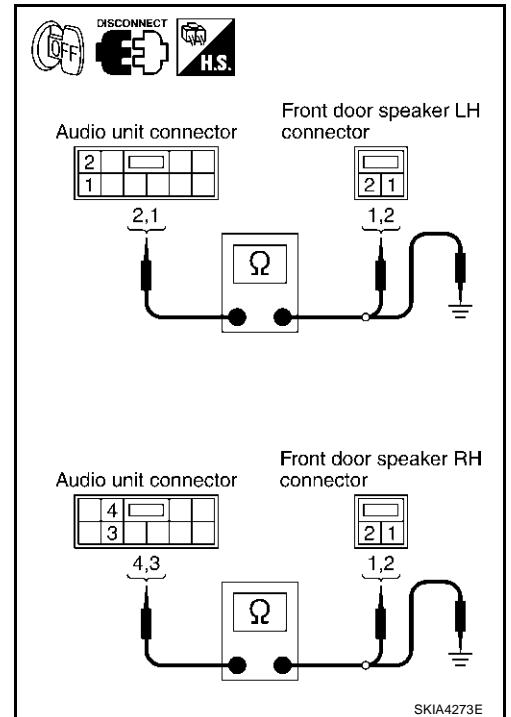

SKIA4273E

# AUDIO

## 2. FRONT SPEAKER SIGNAL CHECK

1. Connect audio unit connector and front speaker connector.
2. Turn ignition switch ON.
3. Push "POWER" switch.
4. Check signal between audio unit harness connector terminal and ground with CONSULT-II or oscilloscope.

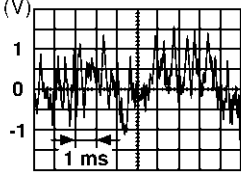
		Terminals		Condi- tion	Reference signal
		(+)	(-)		
Con- nec- tor	Termi- nal (Wire color)	Con- nec- tor	Termi- nal (Wire color)		
M44	2 (W)	M44	1 (B)	Receive audio signal	
	4 (Y)		3 (BR)		

SKIA0177E

### OK or NG

- OK >> INSPECTION END  
 NG >> Replace audio unit.

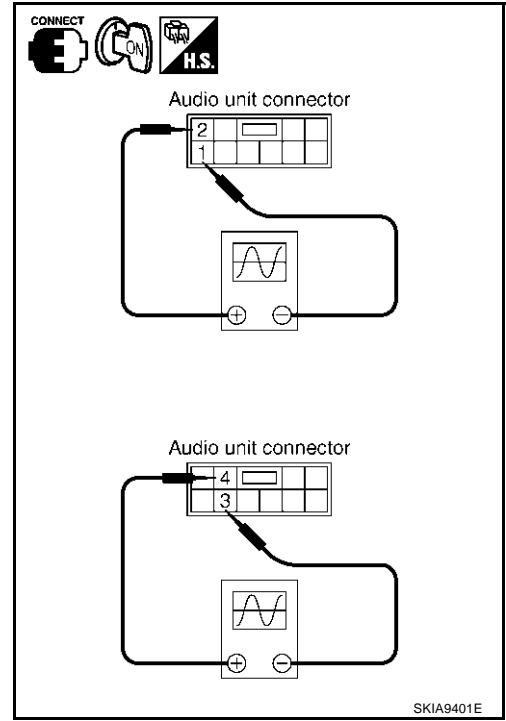

# AUDIO

AKS005FU

## Rear Door Speaker Check (Base System)

### 1. HARNESS CHECK

1. Disconnect audio unit connector and rear door speaker connector.
2. Check continuity between audio unit harness connector terminal and rear door speaker harness connector terminal.

Terminals				Continuity
Audio unit		Speaker		
Connector	Terminal (Wire color)	Connector	Terminal (Wire color)	
M45	13 (B/P)	D54	2 (R)	Yes
	14 (O)		1(L)	
	15 (B/W)	D74	2 (R)	
	16 (L)		1 (L)	

3. Check continuity between audio unit harness connector terminal and ground.

Terminals			Continuity
Audio unit		—	
Connector	Terminal (Wire color)		
M45	13 (B/P)	Ground	No
	14 (O)		
	15 (B/W)		
	16 (L)		

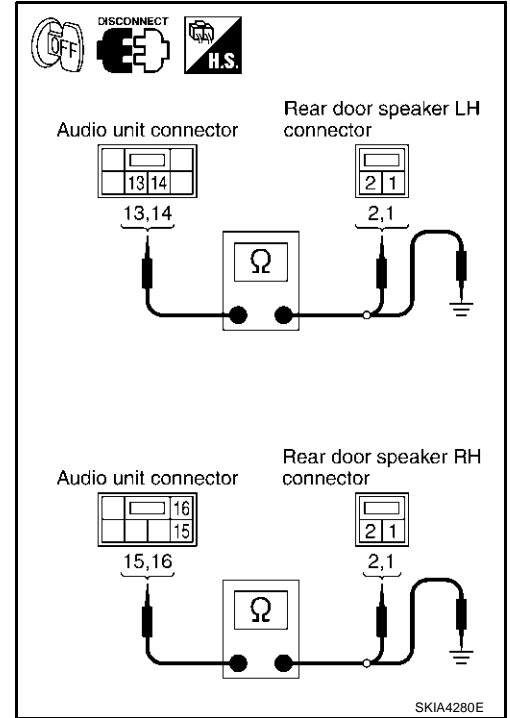

#### OK or NG

- OK >> GO TO 2.  
 NG >> ● Check connector housings for disconnected or loose terminals.  
 ● Repair harness or connector.

A  
B  
C  
D  
E  
F  
G  
H  
I  
J  
L  
M

AV

# AUDIO

## 2. REAR SPEAKER SIGNAL CHECK

1. Connect audio unit connector and rear speaker connector.
2. Turn ignition switch ON.
3. Push "POWER" switch.
4. Check signal audio unit harness connector terminal with CONSULT-II or oscilloscope.

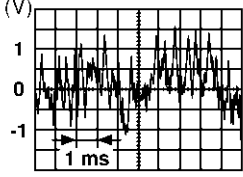
Terminals				Condi- tion	Reference signal
(+)		(-)			
Con- nector	Termi- nal (Wire color)	Con- nector	Termi- nal (Wire color)		
M45	14 (O)	M45	13 (B/P)	Receive audio signal	
	16 (L)		15 (B/W)		

SKIA0177E

OK or NG

- OK >> INSPECTION END  
 NG >> Replace audio unit.

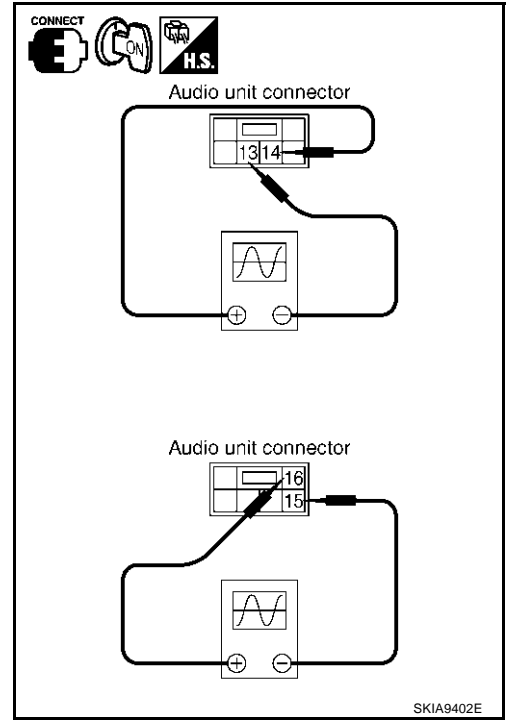

# AUDIO

AKS005FV

## Front Door Speaker Check (BOSE System)

### 1. HARNESS CHECK

1. Disconnect BOSE speaker amp. connector and front door speaker connector.
2. Check continuity between BOSE speaker amp. harness connector terminal and front door speaker harness connector terminal.

Terminals				Continuity
BOSE speaker amp.		Speaker		
Connector	Terminal (Wire color)	Connector	Terminal (Wire color)	
B115	13 (L/R)	D4	1 (L/R)	Yes
	14 (L/B)		2 (L/B)	
	15 (W/B)	D34	1 (W/B)	
	16 (G/B)		2 (G/B)	

3. Check continuity between BOSE speaker amp. harness connector terminal and ground.

Terminals			Continuity
BOSE speaker amp.		—	
Connector	Terminal (Wire color)		
B115	13 (L/R)	Ground	No
	14 (L/B)		
	15 (W/B)		
	16 (G/B)		

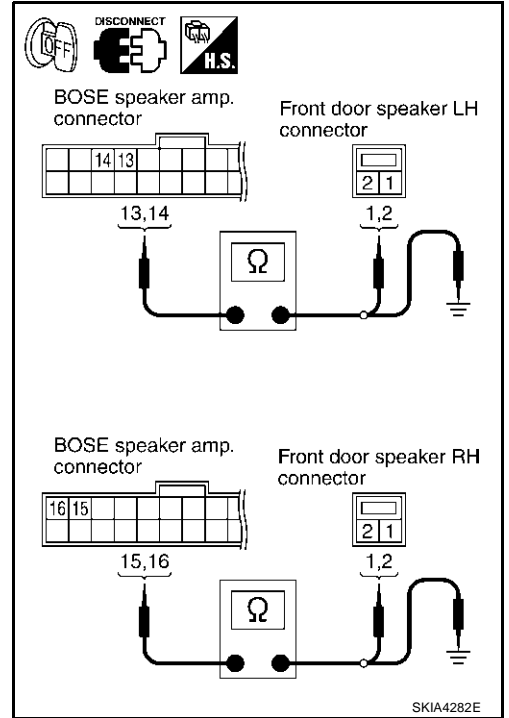

#### OK or NG

- OK >> GO TO 2.  
 NG >> ● Check connector housings for disconnected or loose terminals.  
 ● Repair harness or connector.

A  
B  
C  
D  
E  
F  
G  
H  
I  
J  
L  
M

AV

# AUDIO

## 2. FRONT SPEAKER SIGNAL CHECK

1. Connect BOSE speaker amp. connector and front door speaker connector.
2. Turn ignition switch ON.
3. Push "POWER" switch.
4. Check signal BOSE speaker amp. harness connector terminal with CONSULT-II or oscilloscope.

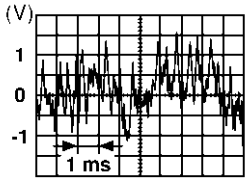
		Terminals		Condi- tion	Reference signal
		(+)	(-)		
Con- nector	Termi- nal (Wire color)	Con- nector	Termi- nal (Wire color)		
B115	13 (L/R)	B115	14 (L/B)	Receive audio signal	
	15 (W/B)		16 (G/B)		

SKIA0177E

### OK or NG

- OK >> Replace front door speaker.  
 NG >> GO TO 3.

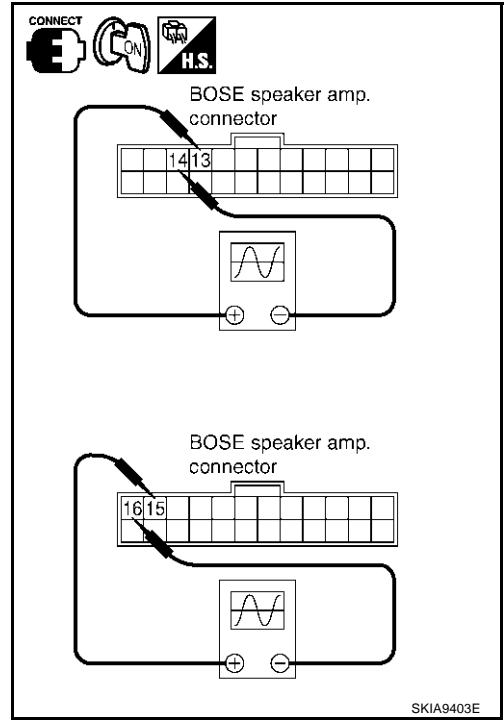

# AUDIO

## 3. HARNESS CHECK

1. Disconnect audio unit connector and BOSE speaker amp. connector.
2. Check continuity between audio unit harness connector terminal and BOSE speaker amp. harness connector terminal.

Terminals				Continuity
Audio unit		BOSE speaker amp.		
Connector	Terminal (Wire color)	Connector	Terminal (Wire color)	
M44	1 (B)	B115	29 (B)	Yes
	2 (W)		30 (W)	
	3 (BR)		27 (BR)	
	4 (Y)		28 (Y)	

3. Check continuity between audio unit harness connector terminal and ground.

Terminals				Continuity
Audio unit		—		
Connector	Terminal (Wire color)			
M44	1 (B)	Ground		No
	2 (W)			
	3 (BR)			
	4 (Y)			

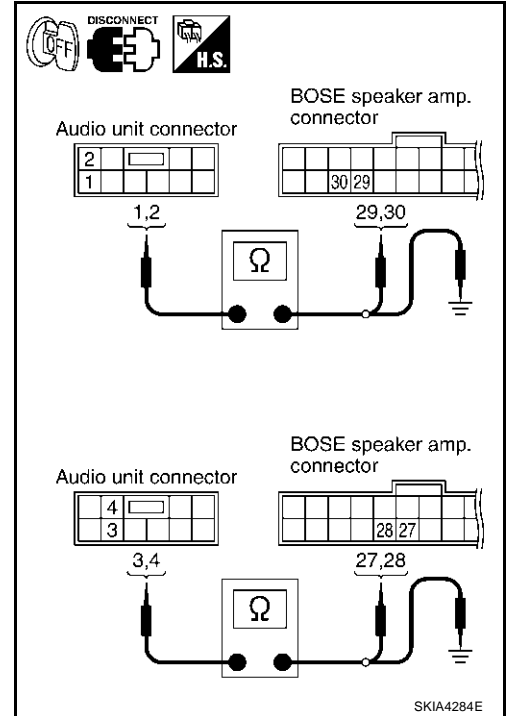

### OK or NG

- OK >> GO TO 4.  
 NG >> ● Check connector housings for disconnected or loose terminals.  
 ● Repair harness or connector.

A  
B  
C  
D  
E  
F  
G  
H  
I  
J  
L  
M

AV

# AUDIO

## 4. FRONT SPEAKER SIGNAL CHECK

1. Connect audio unit connector and BOSE speaker amp. connector.
2. Turn ignition switch ON.
3. Push "POWER" switch.
4. Check the signal audio unit harness connector terminal with CONSULT-II or oscilloscope.

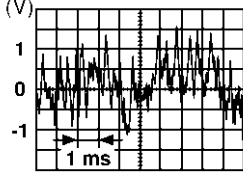
		Terminals		Condi- tion	Reference signal
		(+)	(-)		
Con- nector	Termi- nal (Wire color)	Con- nector	Termi- nal (Wire color)		
M44	2 (W)	M44	1 (B)	Receive audio signal	
	4 (Y)		3 (BR)		

SKIA0177E

OK or NG

- OK >> INSPECTION END  
 NG >> Replace audio unit.

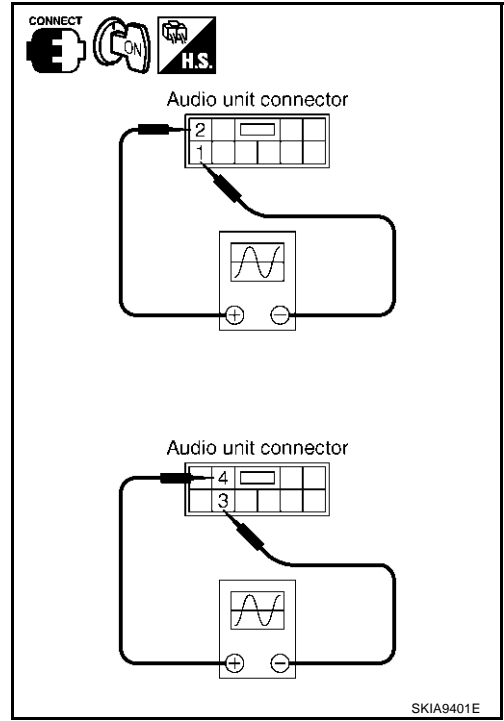



## Rear Door Speaker Check (BOSE System)

### 1. HARNESS CHECK

1. Disconnect BOSE speaker amp. connector and rear door speaker connector.
2. Check continuity between BOSE speaker amp. harness connector terminal and speaker harness connector terminal.

Terminals				Continuity
BOSE speaker amp.		Speaker		
Connector	Terminal (Wire color)	Connector	Terminal (Wire color)	
B115	9 (G)	D53	1 (L)	Yes
	10 (B/Y)		2 (R)	
	11 (L)	D73	1 (L)	
	12 (R)		2 (R)	

3. Check continuity between BOSE speaker amp. harness connector terminal and ground.

Terminals			Continuity
BOSE speaker amp.		—	
Connector	Terminal (Wire color)		
B115	9 (G)	Ground	No
	10 (B/Y)		
	11 (L)		
	12 (R)		

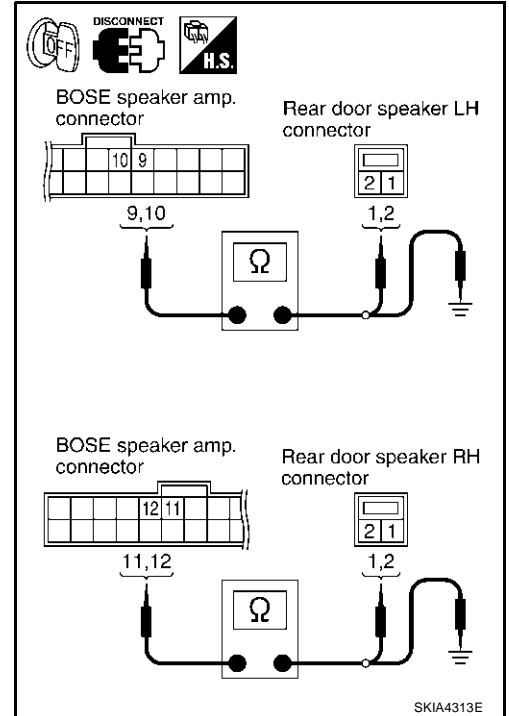

#### OK or NG

- OK >> GO TO 2.
- NG >> ● Check connector housings for disconnected or loose terminals.  
● Repair harness or connector.

A  
B  
C  
D  
E  
F  
G  
H  
I  
J  
L  
M

AV

# AUDIO

## 2. REAR SPEAKER SIGNAL CHECK

1. Connect BOSE speaker amp. connector and rear door speaker connector.
2. Turn ignition switch ON.
3. Push "POWER" switch.
4. Check signal BOSE speaker amp. harness connector terminal with CONSULT-II or oscilloscope.

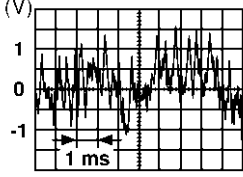
Terminals		Con- nec- tor	Terminal (Wire color)	Condi- tion	Reference signal
(+)	(-)				
Con- nec- tor	Termi- nal (Wire color)	Con- nec- tor	Terminal (Wire color)		
B115	9 (G)	B115	10 (B/Y)	Receive audio signal	
	11 (L)		12 (R)		

SKIA0177E

### OK or NG

- OK >> Replace rear door speaker.  
 NG >> GO TO 3.

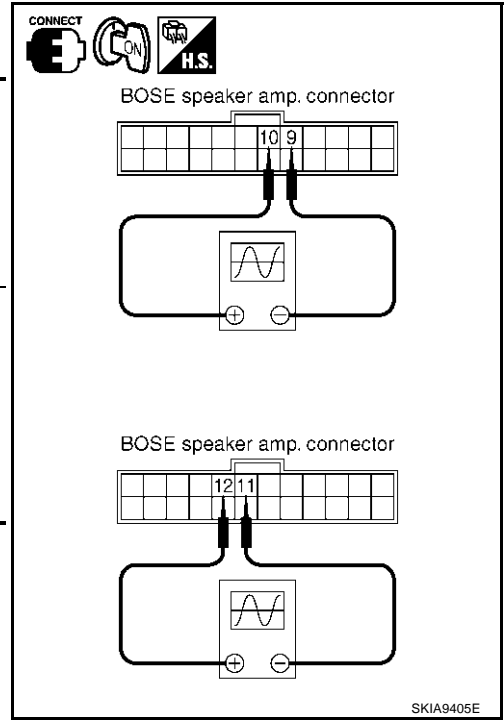

# AUDIO

## 3. HARNESS CHECK

1. Disconnect audio unit connector and BOSE speaker amp. connector.
2. Check continuity between audio unit harness connector terminal and BOSE speaker amp. harness connector terminal.

Terminals				Continuity
Audio unit		BOSE speaker amp.		
Connector	Terminal (Wire color)	Connector	Terminal (Wire color)	
M45	13 (B/P)	B115	25 (Y)	Yes
	14 (O)		26 (O)	
	15 (B/W)		23 (B/W)	
	16 (L)		24 (L)	

3. Check continuity between audio unit harness connector terminal and ground.

Terminals			Continuity
Audio unit		—	
Connector	Terminal (Wire color)		
M45	13 (B/P)	Ground	No
	14 (O)		
	15 (B/W)		
	16 (L)		

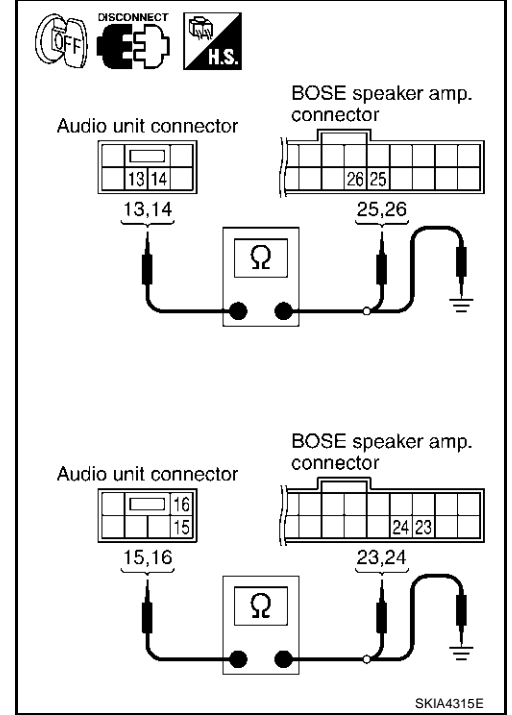

### OK or NG

- OK >> GO TO 4.
- NG >> ● Check connector housings for disconnected or loose terminals.  
● Repair harness or connector.

A  
B  
C  
D  
E  
F  
G  
H  
I  
J  
L  
M

AV

# AUDIO

## 4. REAR SPEAKER SIGNAL CHECK

1. Connect audio unit connector and BOSE speaker amp. connector.
2. Turn ignition switch ON.
3. Push "POWER" switch.
4. Check signal audio unit harness connector terminal with CONSULT-II or oscilloscope.

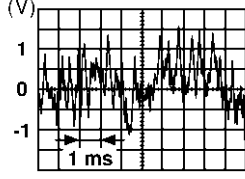
Terminals				Condition	Reference signal
(+)		(-)			
Con- nector	Termi- nal (Wire color)	Con- nector	Termi- nal (Wire color)		
M45	14 (O)	M45	13 (B/P)	Receiv e audio signal	
	16 (L)		15 (B/W)		

SKIA0177E

OK or NG

- OK >> INSPECTION END  
 NG >> Replace audio unit.

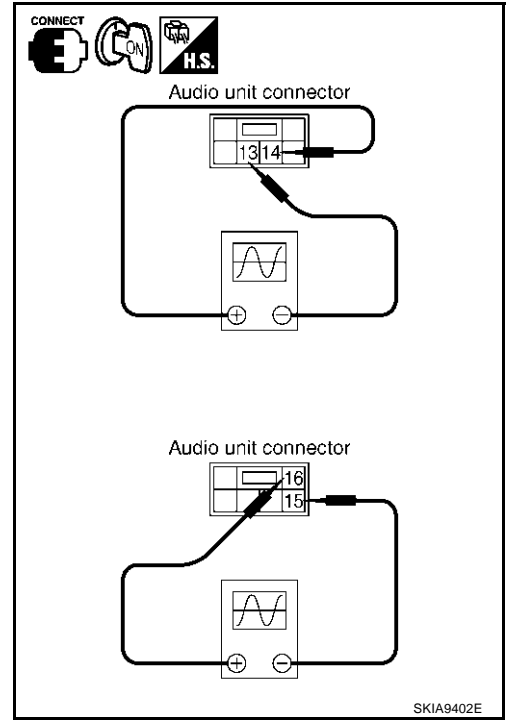

# AUDIO

AKS005FX

## Woofers Check (BOSE System)

### 1. HARNESS CHECK

1. Disconnect BOSE speaker amp. connector and woofer connector.
2. Check continuity between BOSE speaker amp. harness connector terminal and speaker harness connector harness connector terminal.

Terminals				Continuity
BOSE speaker amp.		Woofer		
Connector	Terminal (Wire color)	Connector	Terminal (Wire color)	
B114	2 (B)	B28	3 (B)	Yes
	3 (O)		4 (O)	
	18 (W)		2 (W)	
	19 (B/P)		6 (B/P)	

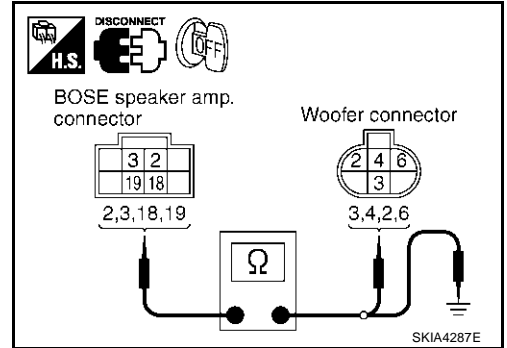

3. Check continuity between BOSE speaker amp. harness connector terminal and ground.

Terminals			Continuity
BOSE speaker amp.		—	
Connector	Terminal (Wire color)		
B114	2 (B)	Ground	No
	3 (O)		
	18 (W)		
	19 (B/P)		

#### OK or NG

- OK >> GO TO 2.
- NG >> ● Check connector housings for disconnected or loose terminals.  
● Repair harness or connector.

A  
B  
C  
D  
E  
F  
G  
H  
I  
J  
L  
M

AV

# AUDIO

## 2. WOOFER SIGNAL CHECK

1. Connect BOSE speaker amp. connector and woofer connector.
2. Turn ignition switch ON.
3. Push "POWER" switch.
4. Check signal BOSE speaker amp. harness connector terminal with CONSULT-II or oscilloscope.

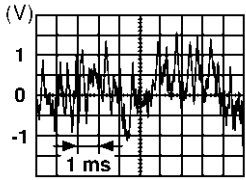
Terminals				Condi- tion	Reference signal
(+)		(-)			
Con- nec- tor	Ter- minal (Wire color)	Con- nec- tor	Ter- minal (Wire color)		
B114	18 (W)	B114	2 (B)	Receive audio signal	
	19 (B/P)		3 (O)		

OK or NG

- OK >> INSPECTION END  
 NG >> Replace BOSE speaker amp.

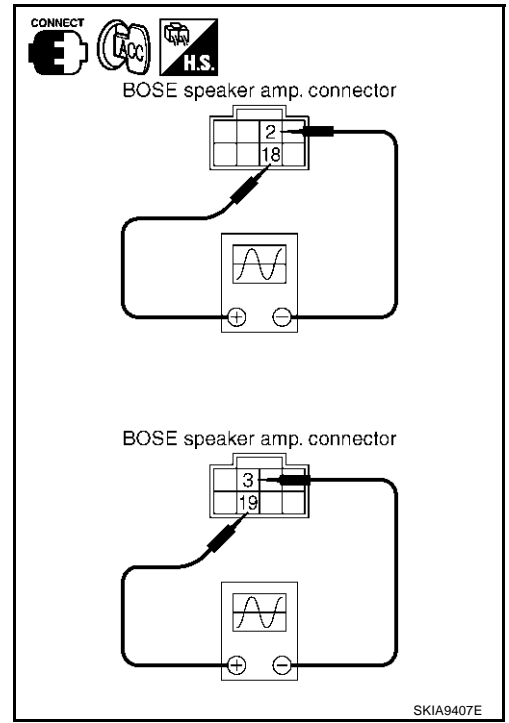

## Vehicle Speed Signal Check

### 1. VEHICLE SPEED OPERATION CHECK

Does speedometer is operated normally?

Yes or No

- Yes >> GO TO 2.  
 No >> Check combination meter trouble diagnosis. Refer to [DI-15, "Diagnosis Flow"](#).

### 2. HARNESS CHECK

1. Turn the ignition switch OFF.
2. Disconnect audio unit connector, unified meter and A/C amp. connector, combination meter connector, shift lock control unit connector, NAVI control unit connector (With navigation system) and display unit connector (Without navigation system) or display control unit connector (With navigation system).
3. Check continuity between audio unit harness connector M46 terminal 22 (V/W) and unified meter and A/C amp. harness connector M50 terminal 26 (V/W).

**Continuity should exist.**

4. Check continuity between audio unit harness connector M46 terminal 22 (V/W) and ground.

**Continuity should not exist.**

OK or NG

- OK >> GO TO 3.  
 NG >> ● Check connector housings for disconnected or loose terminals.  
 ● Repair harness or connector.

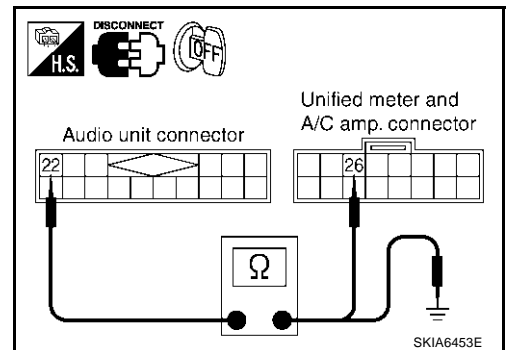

# AUDIO

## 3. VEHICLE SPEED SIGNAL CHECK

1. Connect audio unit connector, unified meter and A/C amp. connector, combination meter connector, shift lock control unit connector, NAVI control unit connector (With navigation system) and display unit connector (Without navigation system) or display control unit connector (With navigation system).
2. Start engine and drive vehicle at more than 40 km/h (25MPH).
3. Check signal between audio unit harness connector M46 terminal 22 (V/W) and ground with CONSULT-II or oscilloscope.

Terminals		(-)	Condition	Reference signal
(+)	Terminal (Wire color)			
M46	22 (V/W)	Ground	When vehicle speed is approx.40 km/h (25MPH)	<p>PKIA1935E</p>

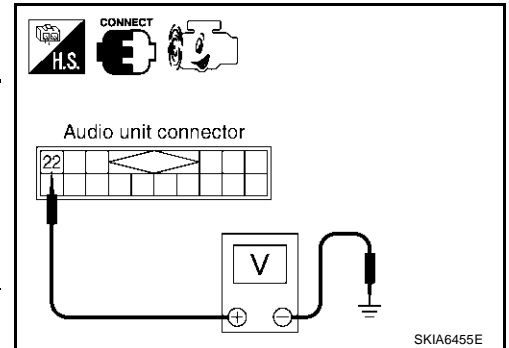

OK or NG

- OK >> INSPECTION END  
 NG >> Replace unified meter and A/C amp.

## Locking CD Auto-changer Mechanism

AKS004NR

### CAUTION:

- Prior to removing a malfunctioning CD auto-changer unit that will be shipped for repair, the changer mechanism **MUST BE LOCKED** to prevent the mechanism from being damaged during shipping.
- If a CD is jammed or unable to be removed from the unit, do **NOT** lock the changer mechanism. If the unit is to be shipped for repair, carefully package the unit to prevent vibration and shock.

## DAMPER LOCK PROCEDURE

1. Eject and remove any CDs from the CD auto-changer unit.
2. Turn ignition switch OFF. Wait until CD auto-changer unit display is off and mechanism stops moving (mechanism sound stops).
3. Press any one of the disc selection buttons once. When a display shows on the CD auto-changer unit, press the same disc selection button again within 5 seconds.
  - The changer mechanism will lock itself within 10 seconds.
4. After mechanism stops moving (mechanism sound stops), disconnect negative battery cable.

### NOTE:

After installing a new or remanufactured CD auto-changer unit, switching the CD auto-changer unit ON will automatically unlock the mechanism. A special unlocking procedure is not required.

## Removal and Installation of Audio Unit

AKS004NS

### REMOVAL

1. Perform damper lock operation. (BOSE system) Refer to [AV-55, "Locking CD Auto-changer Mechanism"](#).
2. Remove center ventilator. Refer to [IP-14, "\(K\) CENTER VENTILATOR"](#)
3. Remove instrument stay cover (LH/RH). Refer to [IP-14, "\(M\) INSTRUMENT STAY COVER \(LH/RH\)"](#)

# AUDIO

4. Remove screws (2).

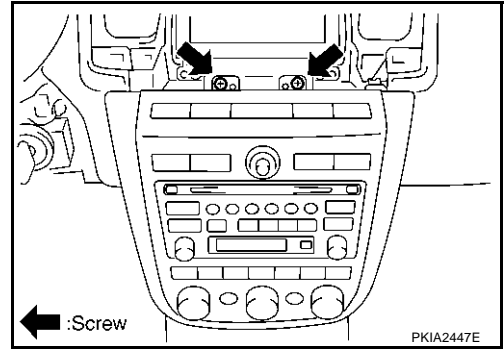

5. Remove screws (4).
6. Remove cluster lid C and audio unit.

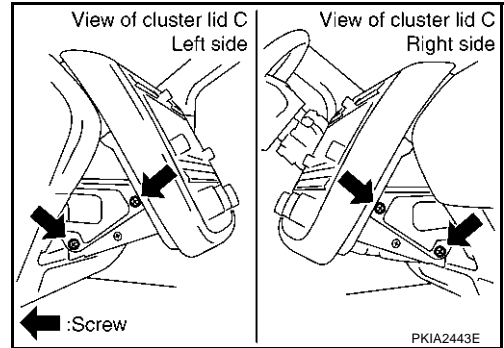

7. Unlock FPC (Flexible Print Circuit) connector lock on A/C and AV switch side.
8. Pull off flexible printed circuit from connector.

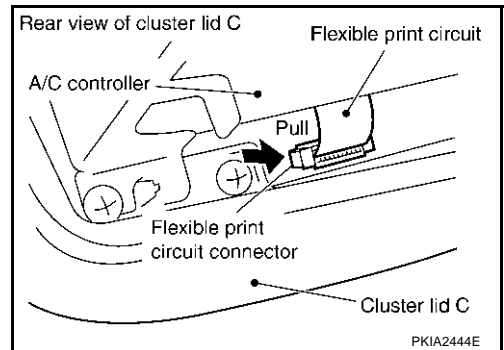

9. Remove screws (4) and clips (2). Then remove audio unit from cluster lid C.

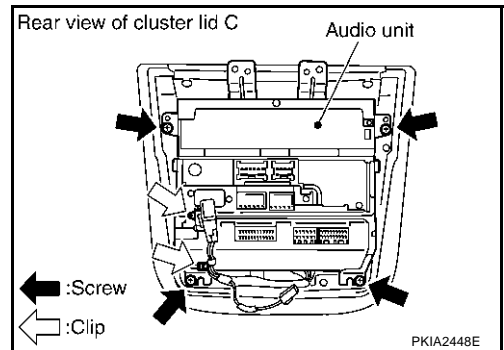



# AUDIO

- Remove audio unit screws (8), unified meter and A/C amp. screws (2) and remove bracket.

## CAUTION:

- When carrying audio unit body, do not touch internal mechanism access from cassette tape slot.
- Be careful not to allow foreign material to enter from cassette tape slot.
- Use appropriate screws for each, as screws for audio unit are different from that for unified meter and A/C amp.

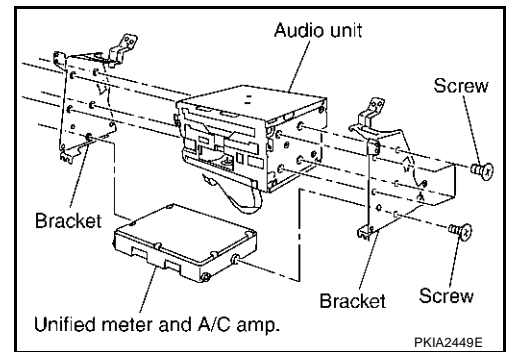

## INSTALLATION

Install in the reverse order of removal.

## Removal and Installation for A/C and AV Switch REMOVAL

AKS004NU

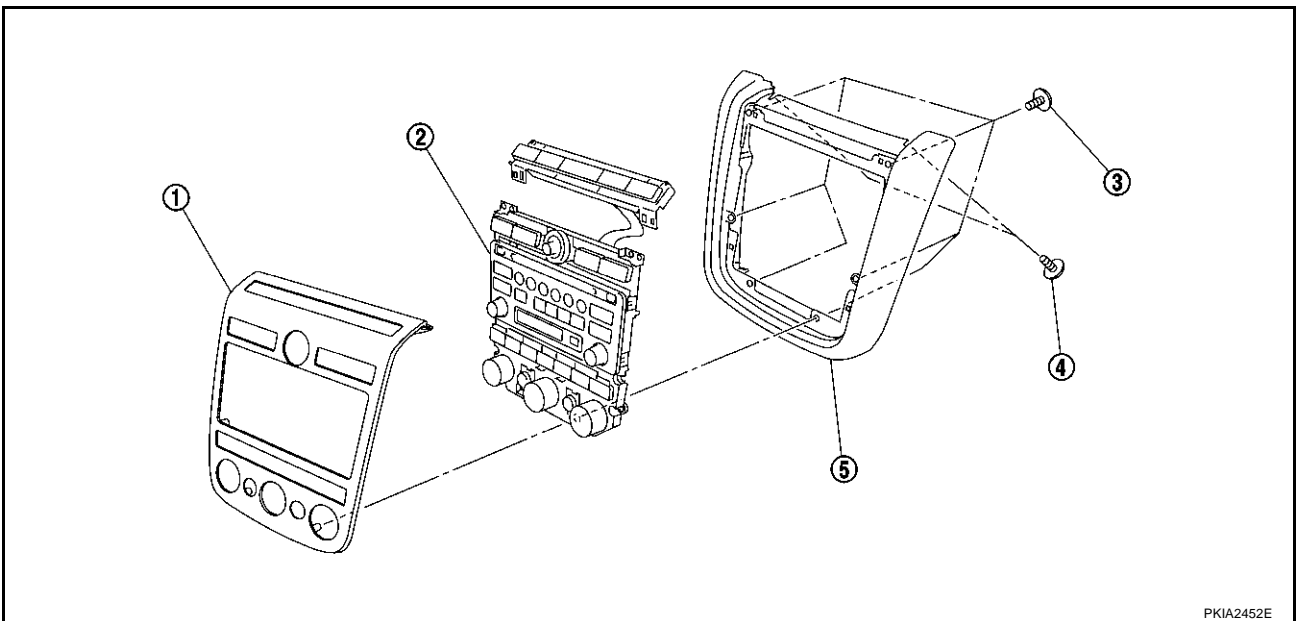

- Front finisher
- A/C and AV switch
- Screws
- Screws
- Cluster lid C

- Remove audio unit from cluster lid C. Refer to [AV-55, "Removal and Installation of Audio Unit"](#).
- Remove screws (8) and remove A/C and AV switch.

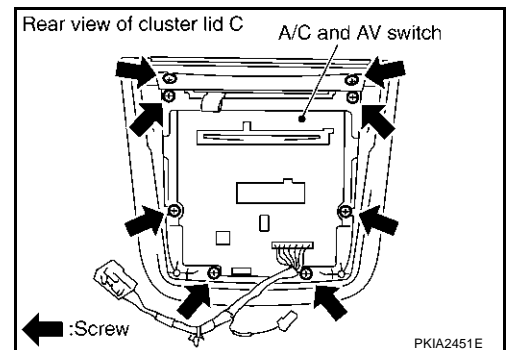

## INSTALLATION

Install in the reverse order of removal.

# AUDIO

## Removal and Installation of Front Door Speaker (Base system)

AKS004NV

### REMOVAL

1. Remove door finisher. Refer to [EI-30, "DOOR FINISHER"](#) .
2. Remove screws (4) and remove speaker.
3. Disconnect connector.
4. Remove screws (4) and remove bracket.

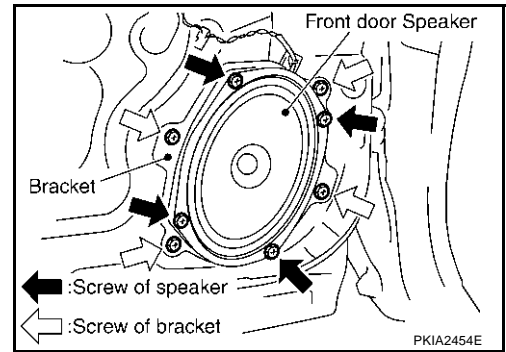

### INSTALLATION

Install in the reverse order of removal.

## Removal and Installation of Front Door Speaker (BOSE system)

AKS004NW

### REMOVAL

1. Remove door finisher. Refer to [EI-30, "DOOR FINISHER"](#) .
2. Remove screws (3) and remove speaker.
3. Disconnect connector.
4. Remove screws (3) and remove bracket.

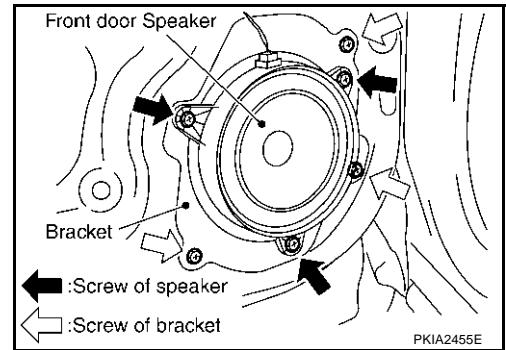

### INSTALLATION

Install in the reverse order of removal.

## Removal and Installation of Rear Door Speaker (Base system)

AKS004NX

### REMOVAL

1. Remove door finisher. Refer to [EI-30, "DOOR FINISHER"](#) .
2. Disconnect connector.
3. Remove screws (3) and remove speaker.

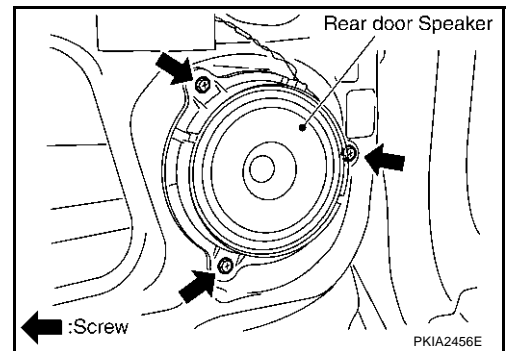

### INSTALLATION

Install in the reverse order of removal.

# AUDIO

## Removal and Installation of Rear Door Speaker (BOSE system)

AKS004NY

### REMOVAL

1. Remove door finisher. Refer to [EI-30, "DOOR FINISHER"](#) .
2. Remove screws (3) and remove speaker.
3. Disconnect connector.

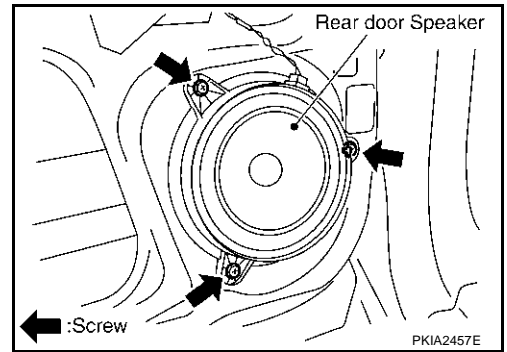

### INSTALLATION

Install in the reverse order of removal.

## Removal and Installation of Tweeter

### REMOVAL

1. Remove side ventilator assembly. Refer to [IP-13, "\(H\) SIDE VENTILATOR ASSEMBLY \(LH/RH\)"](#)
2. Remove instrument side finisher. Refer to [IP-13, "\(I\) INSTRUMENT SIDE FINISHER \(LH/RH\)"](#)
3. Remove screws (2) and remove tweeter.

AKS004NZ

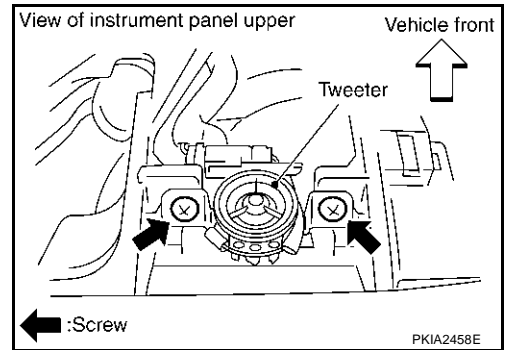

### INSTALLATION

Install in the reverse order of removal.

## Removal and Installation of Woofer

### REMOVAL

1. Open luggage floor finisher (center). Refer to [EI-38, "Removal and Installation"](#)
2. Remove woofer clamp and remove connector.
3. Remove woofer.

### CAUTION:

- Connectors must be placed in the left side, when installed.

AKS004O0

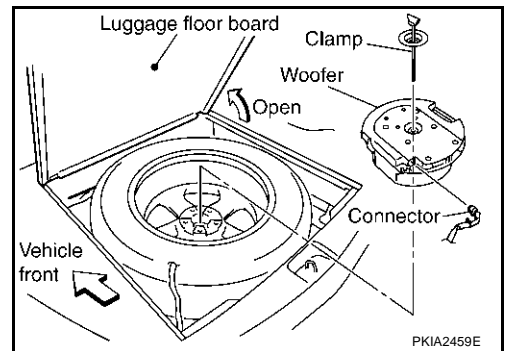

### INSTALLATION

Install in the reverse order of removal.

# AUDIO

## Removal and Installation of BOSE Speaker Amp.

AKS004R3

### REMOVAL

1. Remove luggage floor finisher (front). Refer to [EI-38, "Removal and Installation"](#)
2. Remove screws (4) and connectors (2) and remove BOSE speaker amp. from luggage floor.

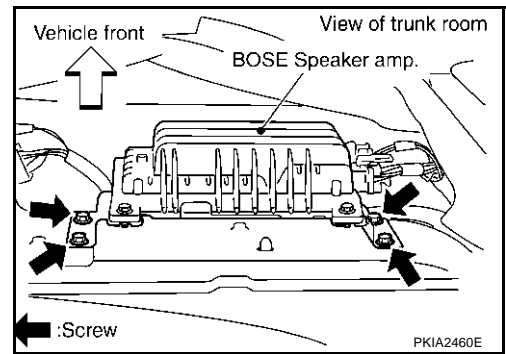

3. Remove screws (4) and remove bracket.

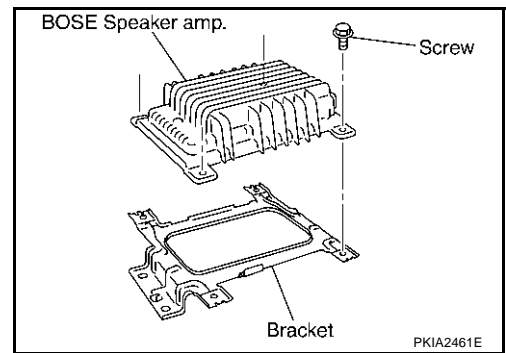

### INSTALLATION

Install in the reverse order of removal.

# AUDIO ANTENNA

## AUDIO ANTENNA

PFP:28200

### Location of Antenna

AKS00401

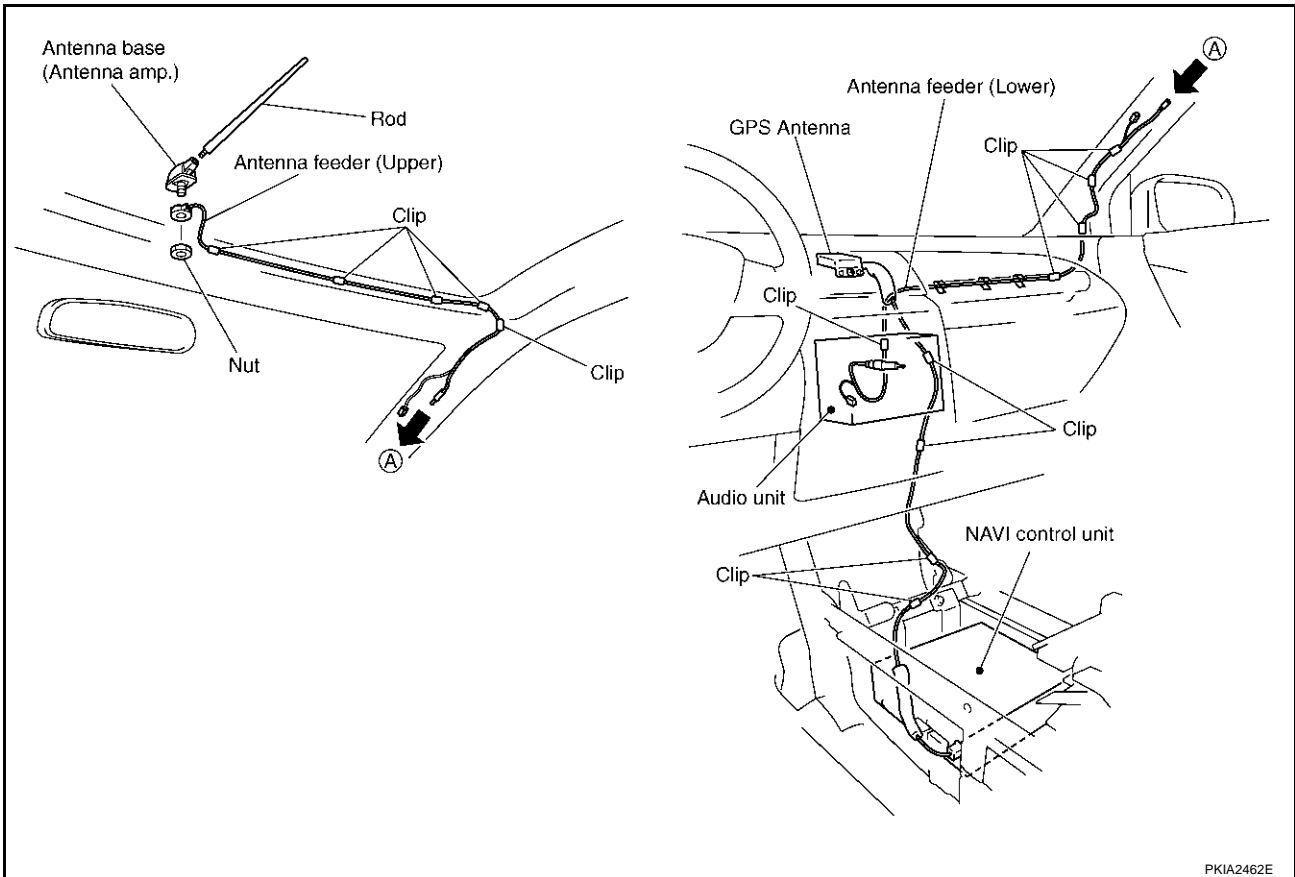

### Removal and Installation of Roof Antenna REMOVAL

AKS00403

1. Remove head lining. Refer to [EI-36, "HEADLINING"](#).
2. Remove nut and antenna base.

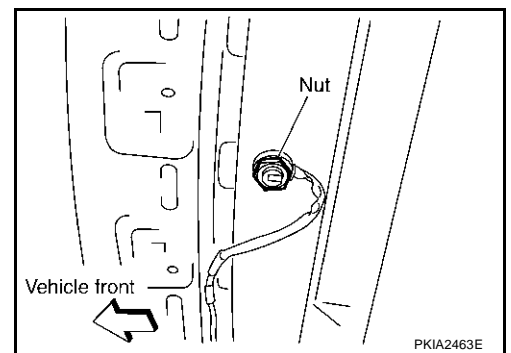

3. Remove instrument panel. Refer to [IP-15, "\(V\) INSTRUMENT PANEL"](#)
4. Disassembly antenna feeder (upper) and antenna feeder (lower).
5. Disengaged the clips (5) to separate antenna feeder (upper) from vehicle.
6. Pull off antenna feeder (lower) from audio unit.
7. Disengaged the clips (5) to separate antenna feeder (lower) from vehicle.

### INSTALLATION

Install in the reverse order of removal.

A  
B  
C  
D  
E  
F  
G  
H  
I  
J  
AV  
L  
M

## INTEGRATED DISPLAY SYSTEM

PFP:28090

### System Description A/C AND AV SWITCH SYSTEM

AKS004XS

Refer to Owner's Manual for A/C and AV switch operating instructions.

Using the A/C and AV switch at the center of the instrument panel, the controls of the following systems are centralized:

- Integrated display system (Drive computer, setting screen, clock, etc.)
- Auto A/C system
- Audio system

### PRECAUTION OF LCD MONITOR

- In order to use LED for backlight of a display, by in car temperature, brightness may change. In low temperature, the refreshing rate of the picture also becomes low because of the low response of the LCD monitor. When passenger room becomes warm, however, the LCD recovers the normal display.
- Backlight sometimes flickers or darkens according to the total consumption hours and the number of times switched ON and OFF. In this case, display unit should be replaced.(Exchange only of backlight is impossible.)

### POWER SUPPLY AND GROUND

#### Power is Supplied at All Times

- through 15A fuse (No. 38, located in fuse and fusible link box)
- to display unit terminal 1
- to A/C and AV switch terminal 1.

#### When Ignition Switch is in ACC or ON Position, Power is Supplied

- through 10A fuse [No. 6, located in fuse block (J/B)]
- to display unit terminal 2,
- to A/C and AV switch terminal 2.
- to unified meter and A/C amp terminal 35.

#### When Ignition Switch is in ON or START Position, Power is Supplied

- through 10A fuse [No. 12, located in fuse block (J/B)]
- to display unit terminal 3.

#### Ground is Supplied

- to display unit terminal 6
- to A/C and AV switch terminal 5 and
- through body grounds M14 and M78.

# INTEGRATED DISPLAY SYSTEM

## DRIVE COMPUTER

Refer to Owner's Manual for drive computer operating instructions.

### TRIP Switch

When "TRIP" switch is pressed, display TRIP screen. As TRIP information, it indicates journey time (TIME), trip odometer (DIST), and average vehicle speed (AVG).

Pressing "TRIP" switch once cycles display from TRIP 1→TRIP 2→Display OFF→TRIP 1.

#### "TIME"

- Journey time indication is conducted by reset or battery connection.
- When pushing "TRIP RESET" or "TRIP" switch more than approximately 1.5 seconds, journey time will be reset.
- If journey time is reset, journey distance and average speed will be reset at the same time.

#### "DIST"

- Trip odometer indication is conducted by vehicle speed signal.
- When pushing "TRIP RESET" or "TRIP" switch more than approximately 1.5 seconds, driving distance will be reset.
- If trip odometer is reset, journey time average speed will be reset at the same time.

#### "AVG"

- Average speed indication is conducted by running distance and running time.
- Indication will be renewed every 30 seconds.
- When pushing "TRIP RESET" or "TRIP" switch more than approximately 1.5 seconds, average speed will be reset.
- After reset operation, the displays shows "\*" for 30 seconds.

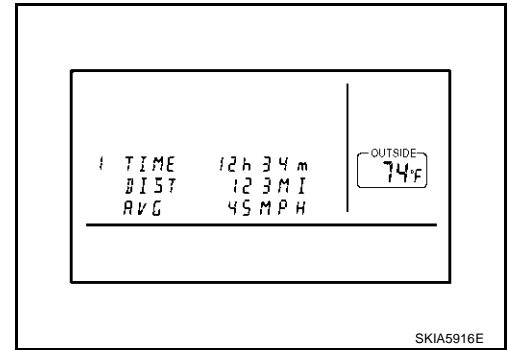

### FUEL ECON Switch

When "FUEL ECON" switch is pressed, display FUEL ECON screen. As FUEL ECON information, it indicates average fuel consumption (AVG), and distance to empty (DTE).

Pressing "FUEL ECON" switch once cycles display from FUEL ECON→Display OFF→FUEL ECON.

#### "AVG" (Average Fuel Consumption)

- Average fuel consumption indication is conducted by ECM pulse signal and vehicle speed signal after system is reset.
- Indication will be renewed every 30 seconds.
- When pushing "TRIP RESET" or "FUEL ECON" switch more than approximately 1.5 seconds, average fuel economy will be reset.
- After reset operation, the display shows "\*.\*" until the vehicle is driven 500 m (1,600 ft.) or 30 seconds has passed.

#### "DTE" (Distance to Empty)

- Distance to empty receives via CAN communication and indicates values calculated by meter.
- Display range is max 999 miles (max 999 km).
- If low-fuel WARNING is received from combination meter via CAN communication, distance to empty indication will be "\*".
- Indication will be renewed every 30 seconds.

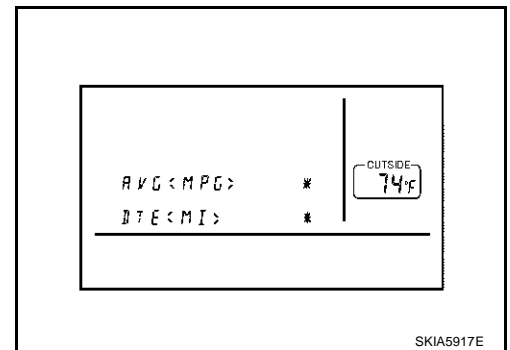

A  
B  
C  
D  
E  
F  
G  
H  
I  
J  
AV  
L  
M

# INTEGRATED DISPLAY SYSTEM

## MAINT Switch (Maintenance Switch)

- When "MAINT" switch is pressed, display vehicle information screen. As vehicle information, it indicates engine oil, tire rotation, and tire pressure.
- Pressing "MAINT" switch once cycles display from engine oil→tire rotation→tire pressure<sup>Note</sup> →engine oil.

### NOTE:

There is not low tire pressure warning system becomes display OFF.

### Engine Oil and Tire Rotation

- Operating the joystick left/right, replace distance can be set.
- When journey distance is the same as replace distance, alert is displayed. (SERVICE ALERT setting is ON.)
- Selected replace distance is 0 - 7,500 miles (0 - 12,000 km) in increments of 500 mile (800 km).
- Press and hold "TRIP RESET" or "MAINT" switch for 1.5 seconds or longer, reset present journey distance.
- During driving, cannot change settings.

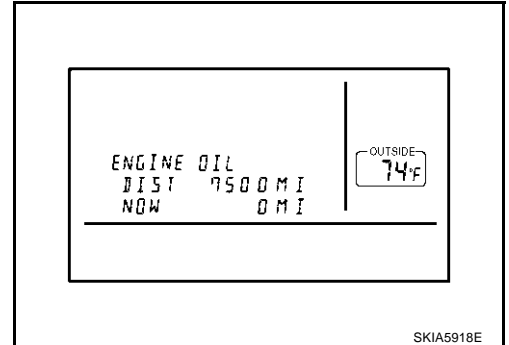

### Tire Pressure

- Tire pressure signal is received from low tire pressure warning control unit via CAN communication.
- Tire pressure is displayed.
- When FLAT TIRE signal is received from low tire pressure warning control unit, "FLAT TIRE" is displayed.

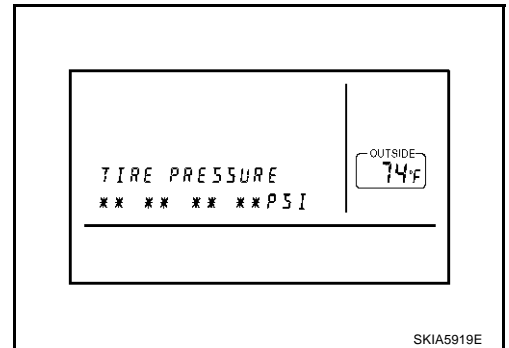

## H,M Switch

- When "H" or "M" switch is pressed and held for 1.5 seconds or more, mode is changed to clock mode.
- "hour" and "minute" are flashed.
- When "H" switch is pressed, "hour" is adjusted.
- When "M" switch is pressed, "minute" is adjusted.



# INTEGRATED DISPLAY SYSTEM

## SETTING SCREEN

- Setting of electric status can be changed by A/C and AV switch. The signal is sent to BCM through display unit to change vehicle electric system setting.
- Display unit is communicating with seat ECU.
- Pressing "SETTING" switch once cycles display from DISPLAY→LANGUAGE→BEEP SET→SERVICE ALERT→PERSONALIZED SETTINGS MENU→DISPLAY OFF→DISPLAY.
- Using the joystick, setting of each item will become possible.

## Adjustable Vehicle Status

Setting items		Setting variations	Initial setting	Operation
DISPLAY		ON/OFF	ON	It switches displayed/Non-displayed of the screen.
LANGUAGE		ENGLISH/ FRANCAIS	-	It switches displayed language.
BEEP SET		ON/OFF	ON	It selects beep sound ON/OFF during switch operation.
SERVICE ALERT		ON/OFF	OFF	It switches displayed/Non-displayed of alert indication. <ul style="list-style-type: none"> <li>● When the setting is ON, if engine oil or tire rotation will be replace distance, alert is displayed.</li> <li>● When the setting is OFF, alert is not displayed.</li> </ul>
PERSONALIZED SETTINGS MENU	SLIDE BACK DR SEAT ON EXIT	ON/OFF	OFF <sup>Note</sup>	The driver's seat automatically slides backward when the driver gets out, and returns to the original position when the driver gets on. Details; the same as above
	CONFIRM RESET SETTINGS	YES/NO	OFF	If YES is selected, all setting items are return to default.

### NOTE:

Setting in factory shipment is ON.

## D/N SCREEN

- When D/N switch is pressed, change screen of adjustment luminance.
- If press D/N again when display adjustment luminance, change DAY-NIGHT(NIGHT-DAY) mode (screen of adjustment luminance).  
As follows:

Now	Change display
DAY	DAY (adjustment)→NIGHT (adjustment)→DAY (adjustment)→.....
NIGHT	NIGHT (adjustment)→DAY (adjustment)→NIGHT (adjustment)→.....

- Press "PREV" or not operate for 10sec. when displayed screen of adjustment luminance, back to default screen (same mode).
- Can adjust luminance by joystick (R/L) in adjustment screen.
- Adjustment range is a 12 stage (MIN to MAX) and default set value is 10(DAY) and 4(NIGHT).

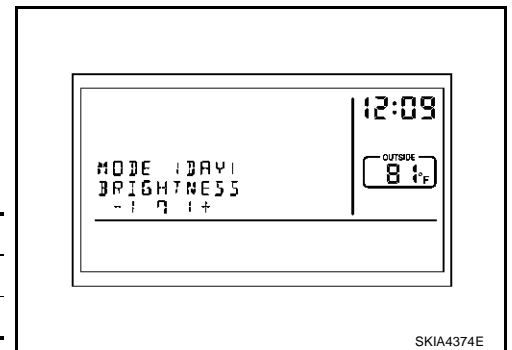

## WARNING INDICATIONS

When unified meter and A/C amp. receives warning signal from some control units or sensors, then combination meter warning lamp is illuminated.

Then unified meter and A/C amp. sends warning signal to display unit warning indications on the screen.

Warning indicators	Warning lamps in instrument panel	Warning detection and cancel conditions		Cases of malfunction
DOOR OPEN	Door	Detection condition	Vehicle is running [approx. 5 km/h (3 MPH) or faster] and door ajar of any of the doors is detected.	Door is open
		Cancel condition	Vehicle is stopped and all the doors lock.	

# INTEGRATED DISPLAY SYSTEM

## AV COMMUNICATION LINE

Display unit is controlled by the following unit with AV communication line.

- A/C and AV switch

## CAN Communication System Description

AKS007PU

CAN (Controller Area Network) is a serial communication line for real time application. It is an on-vehicle multiplex communication line with high data communication speed and excellent error detection ability. Modern vehicles are equipped with many electronic control units and each control unit shares information and links with other control units during operation (not independent). In CAN communication, control units are connected with 2 communication lines (CAN H line, CAN L line) allowing a high rate of information transmission with less wiring. Each control unit transmits/receives data but selectively reads required data only.

## CAN Communication Unit For 2WD Models

AKS007PV

Go to CAN system, when selecting your car model from the following table.

Body type	Wagon															
Axle	2WD															
Engine	VQ35DE															
Transmission	CVT															
Brake control	ABS								VDC							
Low tire pressure warning system		×			×	×		×		×			×	×		×
Navigation system			×		×		×	×			×		×		×	×
Automatic drive positioner				×		×	×	×				×		×	×	×
CAN communication unit																
ECM	×	×	×	×	×	×	×	×	×	×	×	×	×	×	×	×
TCM	×	×	×	×	×	×	×	×	×	×	×	×	×	×	×	×
Low tire pressure warning control unit		×			×	×		×		×			×	×		×
Display unit	×	×		×		×			×	×		×		×		
Display control unit			×		×		×	×			×		×		×	×
Data link connector	×	×	×	×	×	×	×	×	×	×	×	×	×	×	×	×
BCM	×	×	×	×	×	×	×	×	×	×	×	×	×	×	×	×
Unified meter and A/C amp.	×	×	×	×	×	×	×	×	×	×	×	×	×	×	×	×
Steering angle sensor									×	×	×	×	×	×	×	×
Driver seat control unit				×		×	×	×				×		×	×	×
ABS actuator and electric unit (control unit)	×	×	×	×	×	×	×	×	×	×	×	×	×	×	×	×
IPDM E/R	×	×	×	×	×	×	×	×	×	×	×	×	×	×	×	×
CAN communication type	<u>AV-67. "TYPE 1/TYPE 2/TYPE 3/TYPE 4/TYPE 5/TYPE 6/TYPE 7/TYPE 8"</u>								<u>AV-72. "TYPE 9/TYPE 10/TYPE 11/TYPE 12/TYPE 13/TYPE 14/TYPE 15/TYPE 16"</u>							

×: Applicable

# INTEGRATED DISPLAY SYSTEM

## TYPE 1/TYPER 2/TYPER 3/TYPER 4/TYPER 5/TYPER 6/TYPER 7/TYPER 8

### System Diagram

- Type1

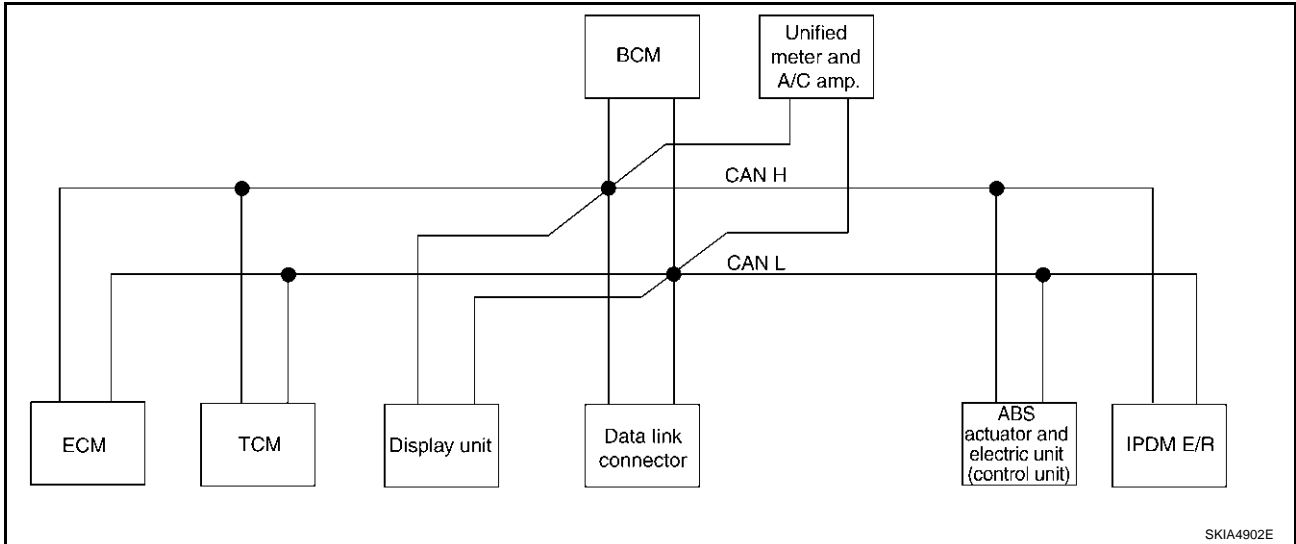

- Type2

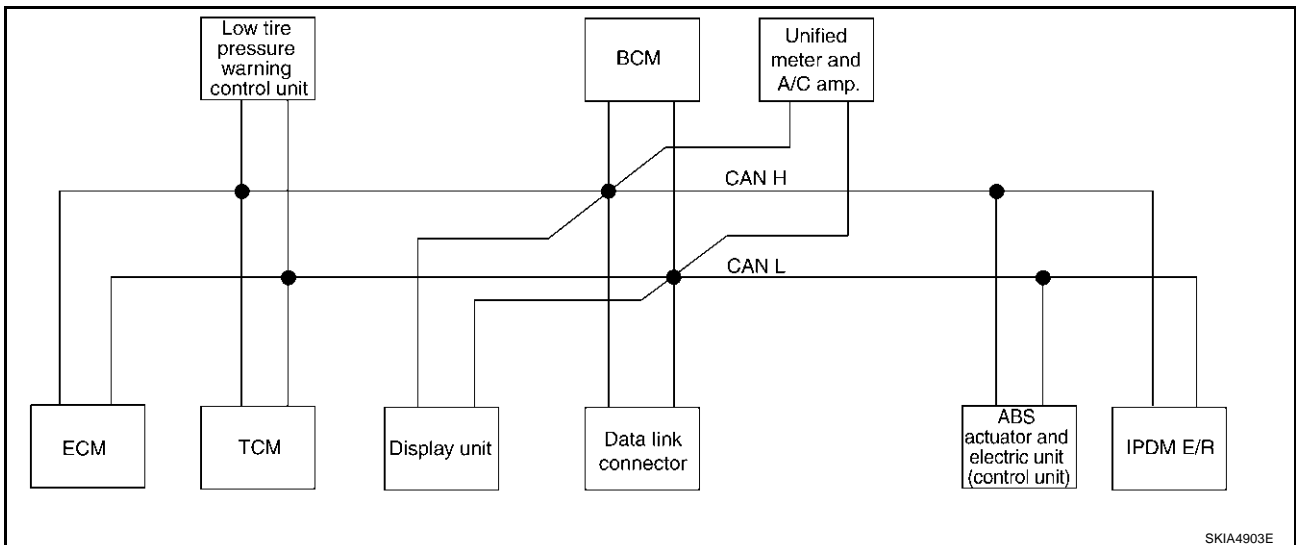

- Type3

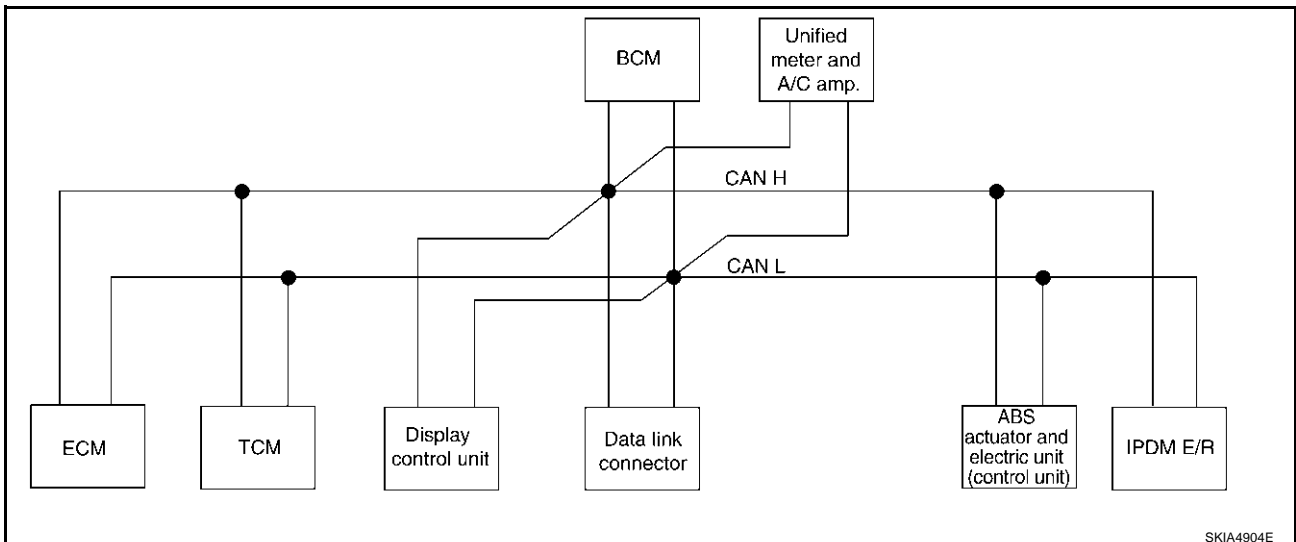

A  
B  
C  
D  
E  
F  
G  
H  
I  
J  
AV  
L  
M

# INTEGRATED DISPLAY SYSTEM

- Type4

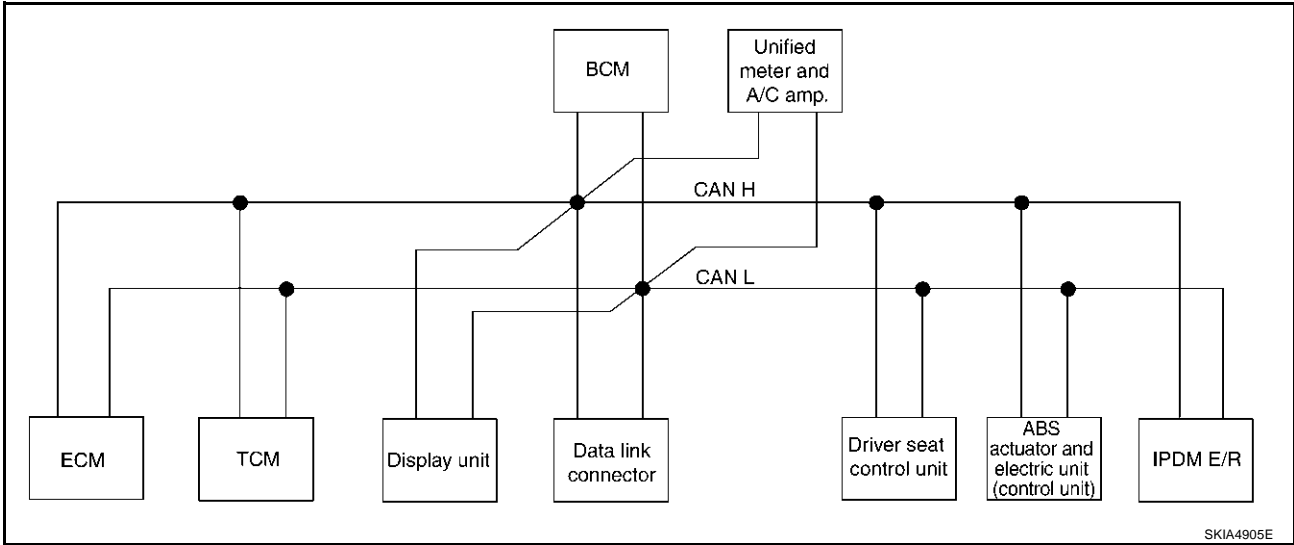

- Type5

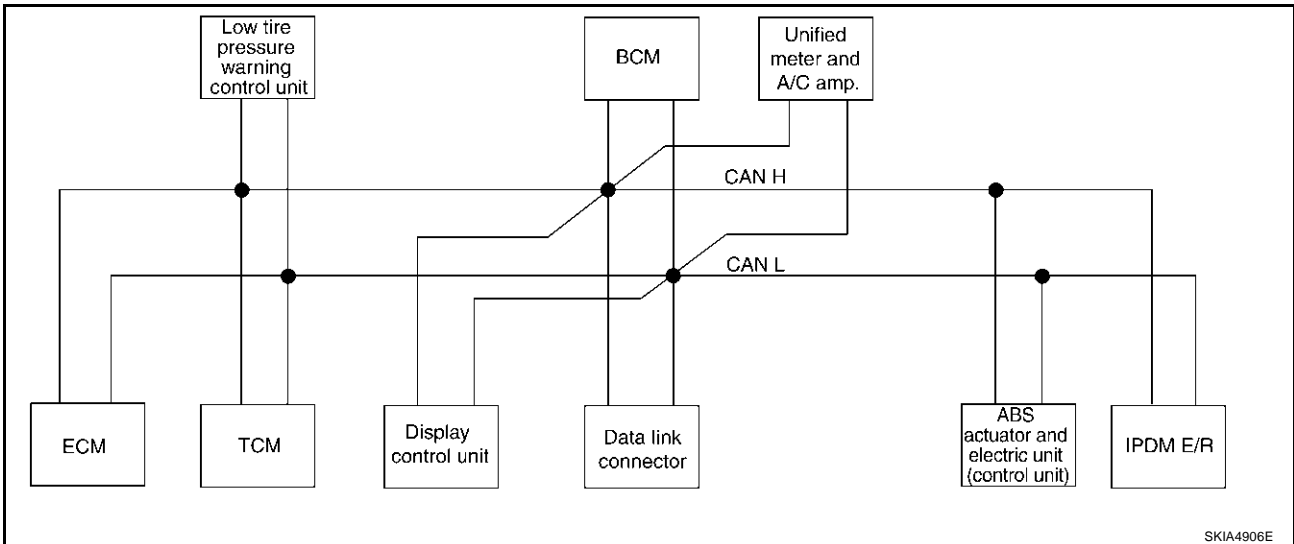

- Type6

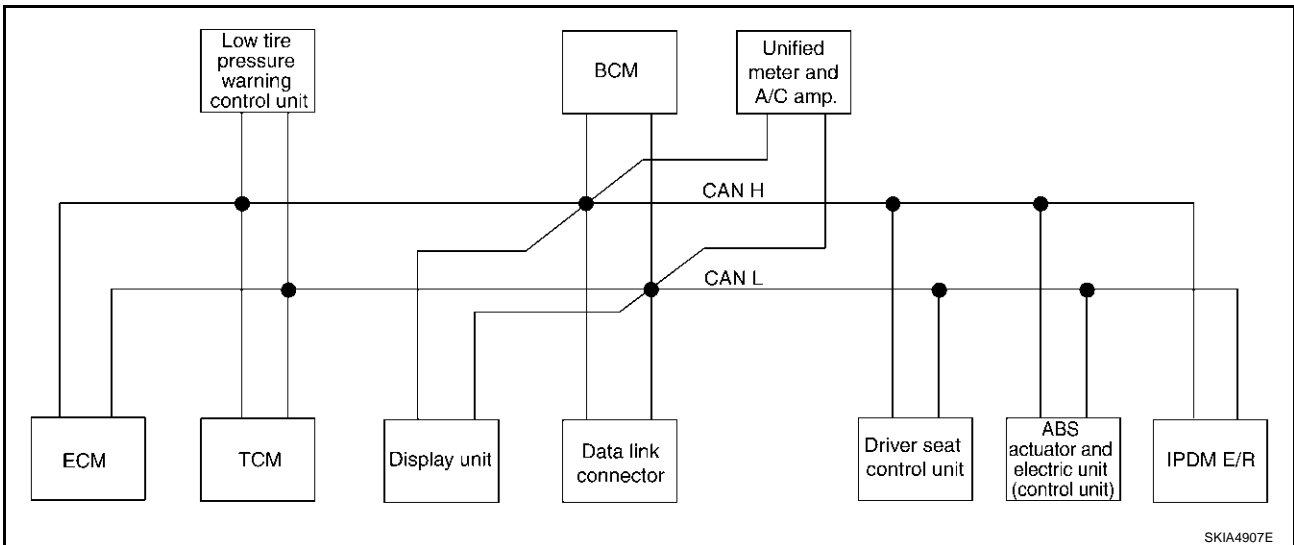

# INTEGRATED DISPLAY SYSTEM

- Type7

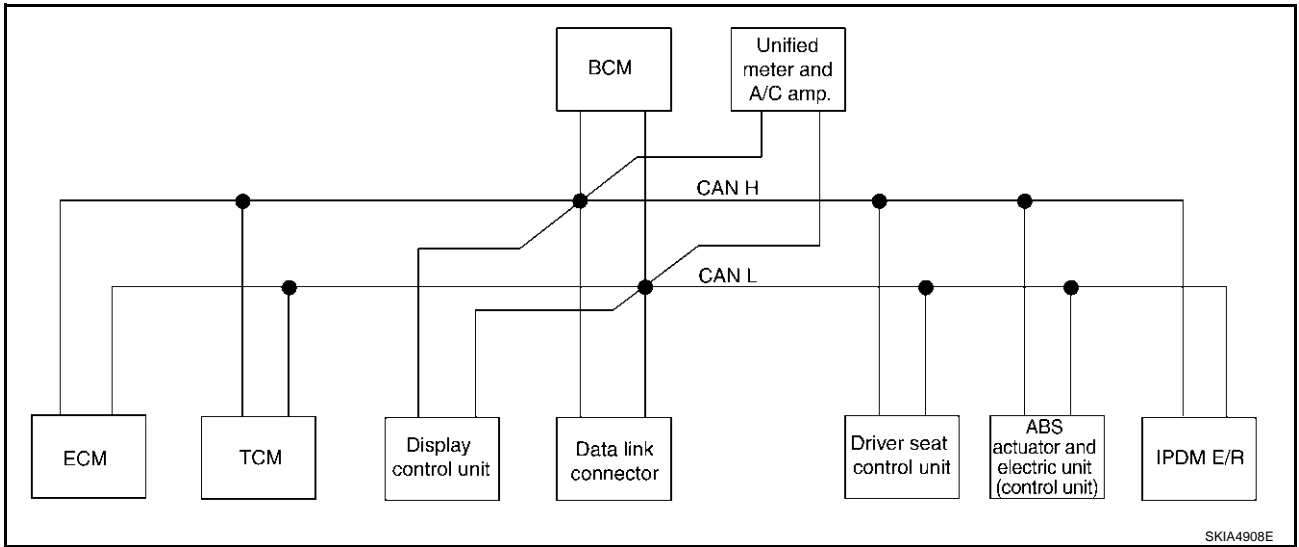

- Type8

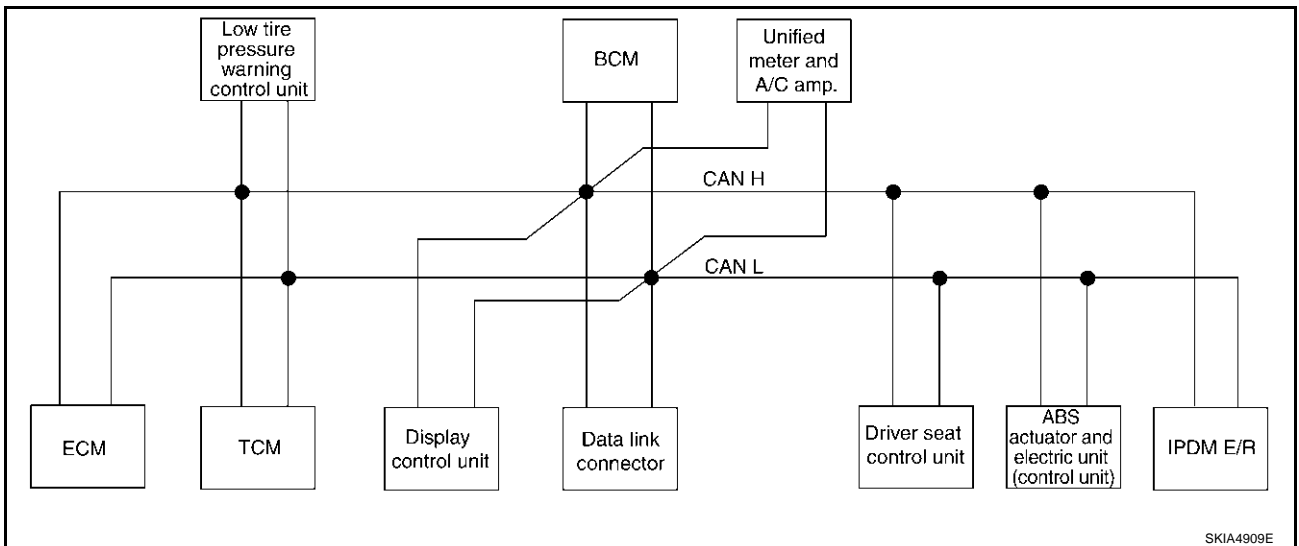

A  
B  
C  
D  
E  
F  
G  
H  
I  
J  
AV  
L  
M

# INTEGRATED DISPLAY SYSTEM

## Input/output Signal Chart

T: Transmit R: Receive

Signals	ECM	TCM	Low tire pressure warning control unit	Display unit	Display control unit	BCM	Unified meter and A/C amp.	Driver seat control unit	ABS actuator and electric unit (control unit)	IPDM E/R
Engine speed signal	T	R			R	R	R			
Engine status signal	T					R				
Engine coolant temperature signal	T						R			
CVT position indicator signal		T					R			
Second position signal		R					T			
Second position indicator signal		T					R			
Engine and CVT integrated control signal	T	R								
	R	T								
Accelerator pedal position signal	T	R								
Closed throttle position signal	T	R								
Wide open throttle position signal	T	R								
Key switch signal						T		R		
Ignition switch signal						T		R		R
P range signal		T						R		
Stop lamp switch signal		R					T			
Fuel consumption monitor signal	T						R			
CVT self-diagnosis signal	R	T								
ABS operation signal		R							T	
Air conditioner switch signal	R					T				
A/C compressor request signal	T									R
A/C compressor feedback signal	T						R			
Blower fan motor switch signal	R					T				
A/C control signal				T	T		R			
				R	R		T			
Cooling fan speed request signal	T									R
Position lights request signal						T	R			R
Low beam request signal						T				R
Low beam status signal	R									T
High beam request signal						T	R			R
High beam status signal	R									T
Front fog lights request signal						T				R
Vehicle speed signal		R					R		T	
	R		R		R	R	T	R		
Sleep request 1 signal						T	R			
Sleep request 2 signal						T				R
Door switch signal						R	T			
				R	R	T	R	R		R
Turn indicator signal						T	R			

# INTEGRATED DISPLAY SYSTEM

Signals	ECM	TCM	Low tire pres- sure warn- ing control unit	Dis- play unit	Dis- play control unit	BCM	Uni- fied meter and A/ C amp.	Driver seat control unit	ABS actua- tor and elec- tric unit (con- trol unit)	IPDM E/R
Key fob ID signal						T		R		
Key fob door unlock signal						T		R		
Seat belt buckle switch signal						R	T			
Oil pressure switch signal						R				T
						T	R			
Buzzer output signal						T	R			
Fuel level sensor signal	R						T			
Fuel level low warning signal				R	R		T			
Malfunction indicator lamp signal	T						R			
ASCD SET lamp signal	T						R			
ASCD CRUISE lamp signal	T						R			
Input shaft revolution signal	R	T								
Output shaft revolution signal	R	T								
Front wiper request signal						T				R
Front wiper stop position signal						R				T
Rear window defogger switch signal						T				R
Rear window defogger control signal	R			R	R					T
Hood switch signal						R				T
Theft warning horn request signal						T				R
Horn chirp signal						T				R
Tire pressure signal			T				R			
Tire pressure data signal			T	R	R					
ABS warning lamp signal							R		T	
Brake warning lamp signal							R		T	
System setting signal				T	T			R		
Parking brake switch signal						R	T			

A  
B  
C  
D  
E  
F  
G  
H  
I  
J  
AV  
L  
M

# INTEGRATED DISPLAY SYSTEM

TYPE 9/TYPER10/TYPER 11/TYPER 12/TYPER 13/TYPER 14/TYPER 15/TYPER 16

## System Diagram

- Type9

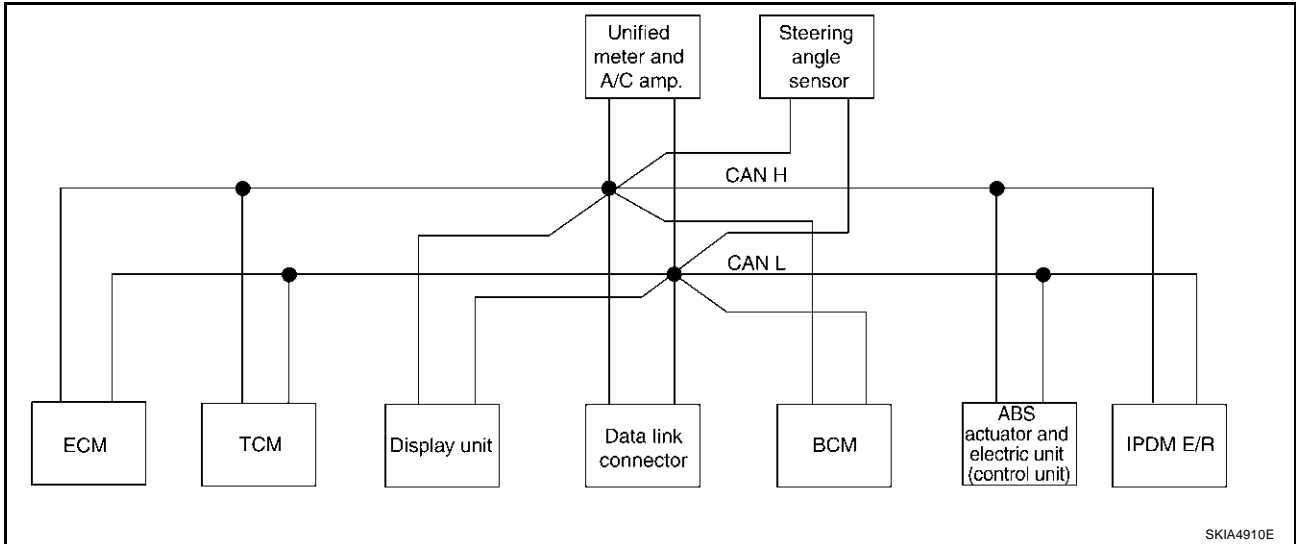

- Type10

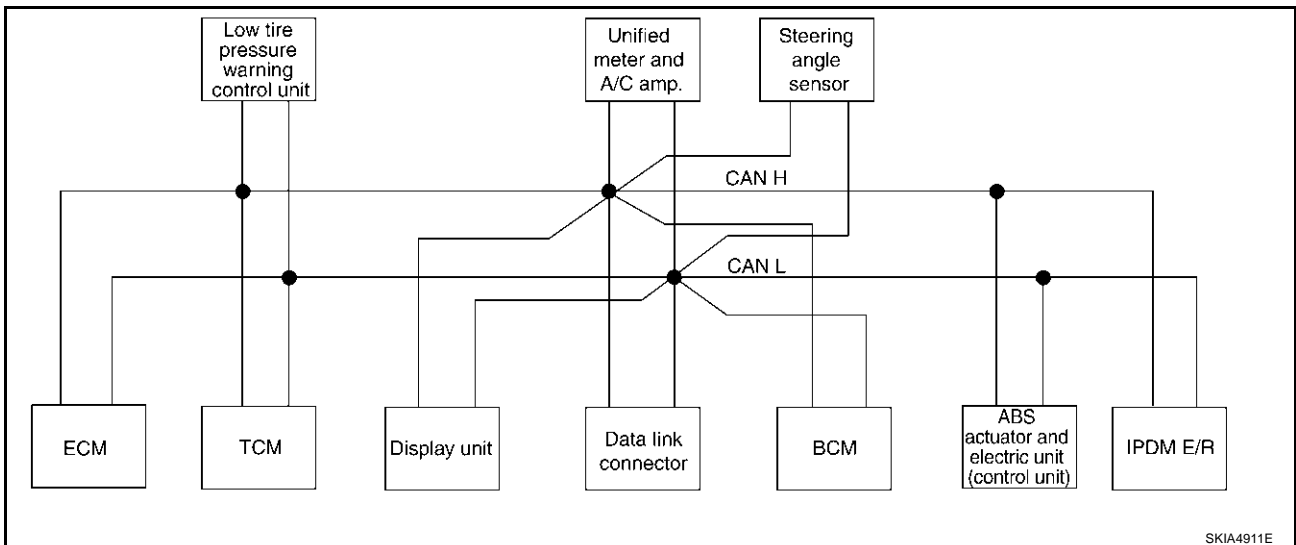

- Type11

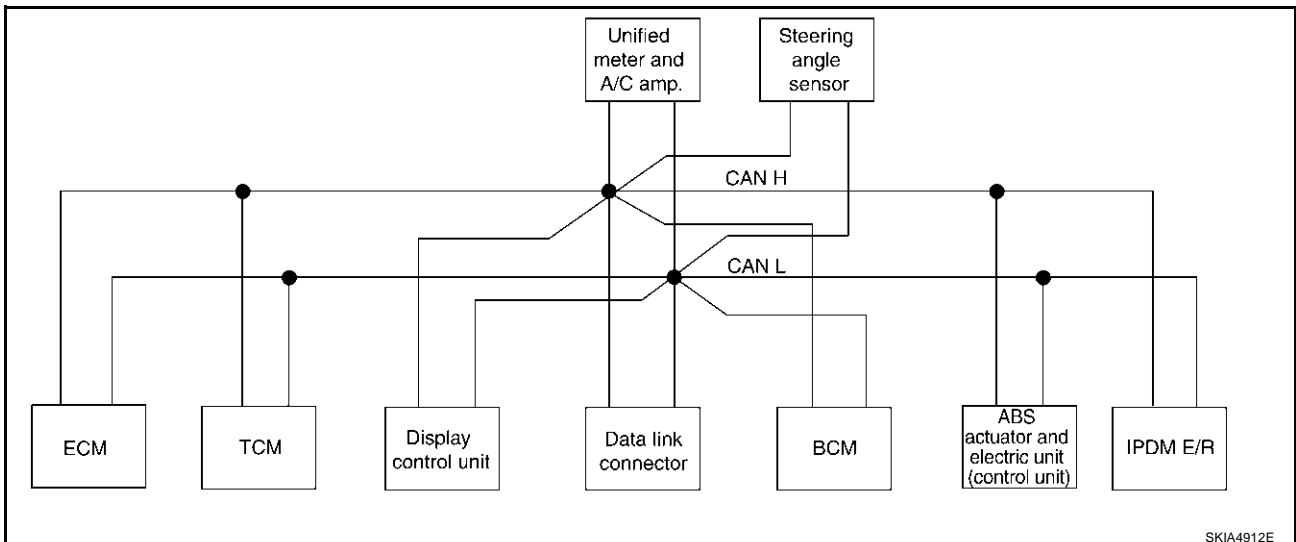



# INTEGRATED DISPLAY SYSTEM

- Type12

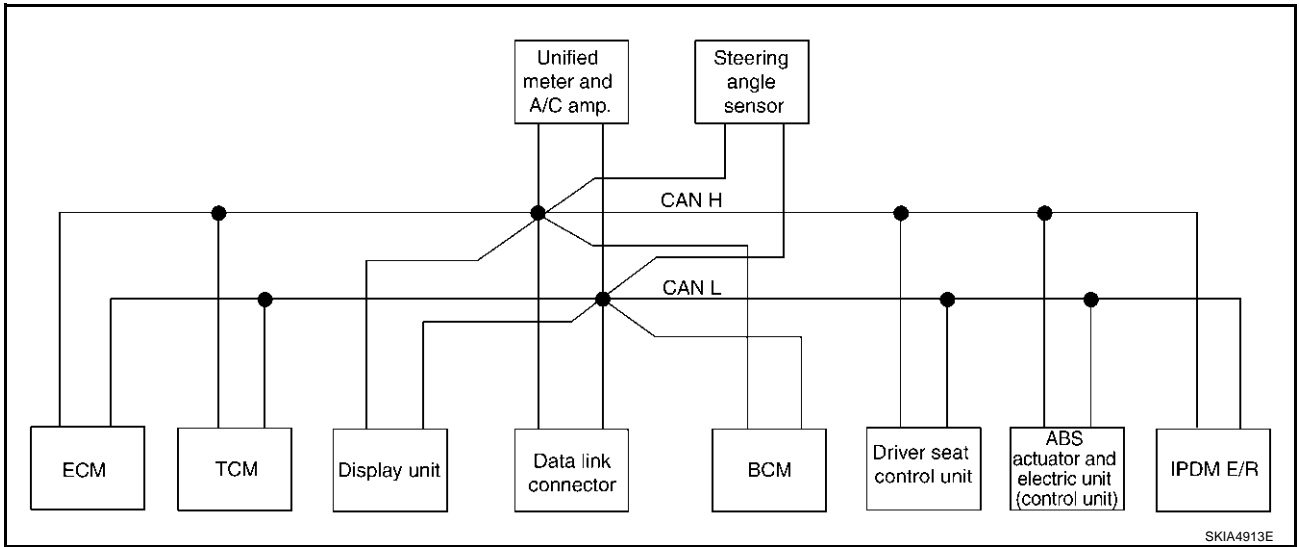

- Type13

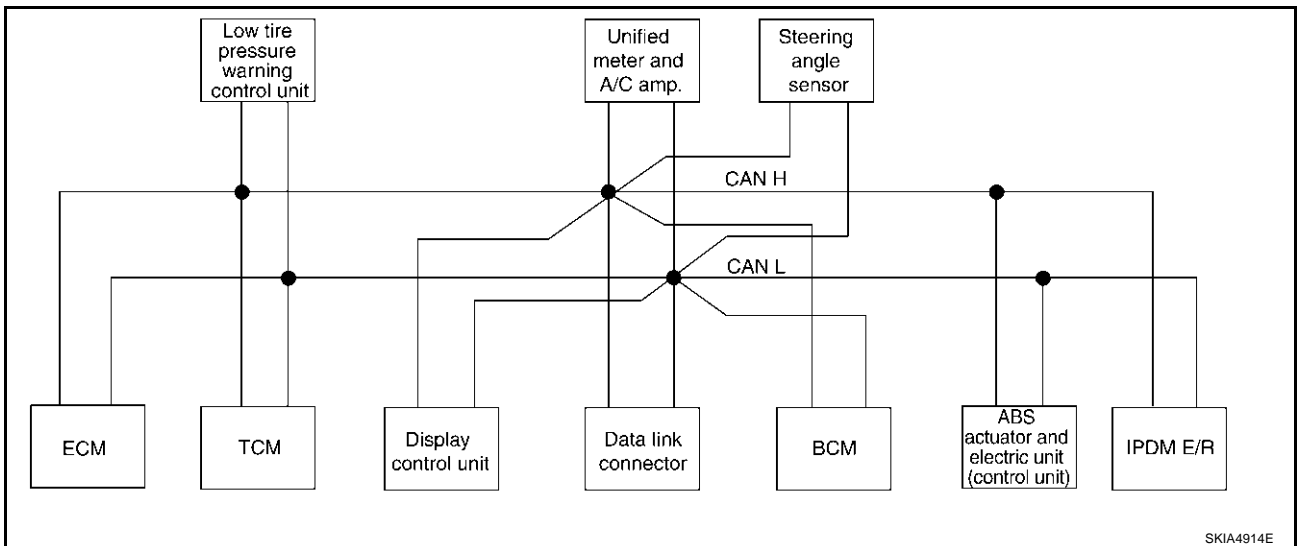

- Type14

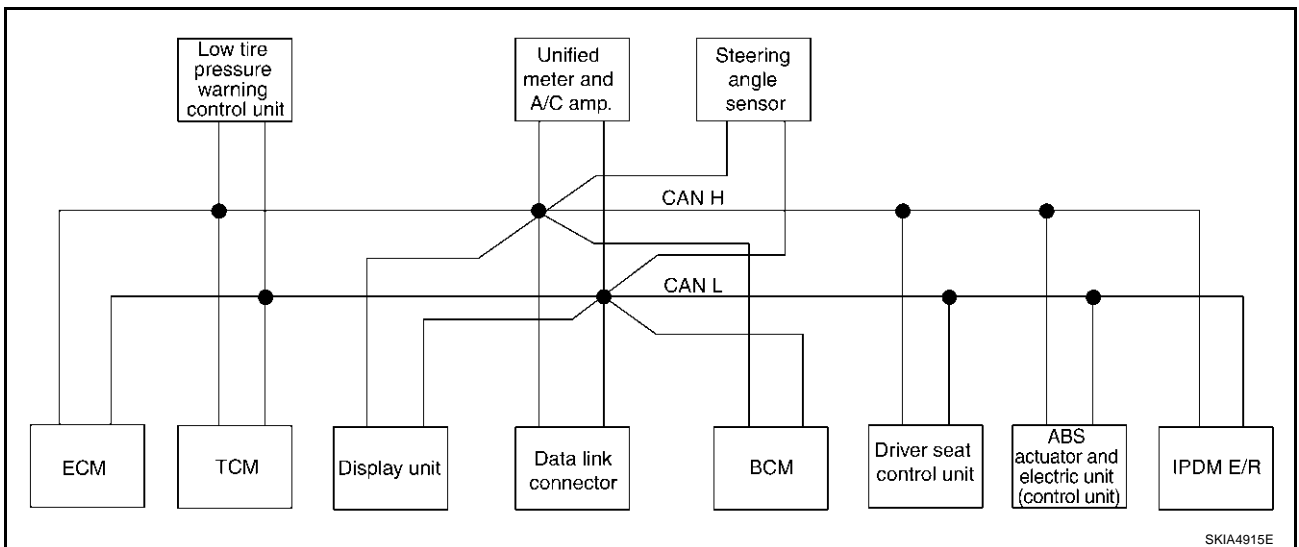

A  
B  
C  
D  
E  
F  
G  
H  
I  
J  
AV  
L  
M

# INTEGRATED DISPLAY SYSTEM

- Type15

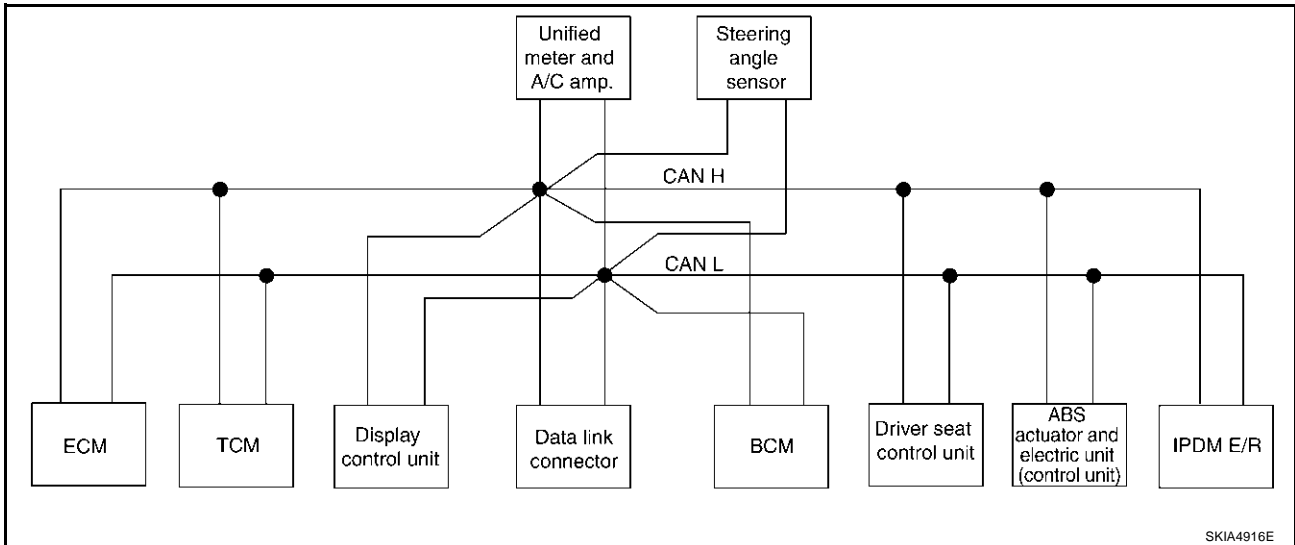

- Type16

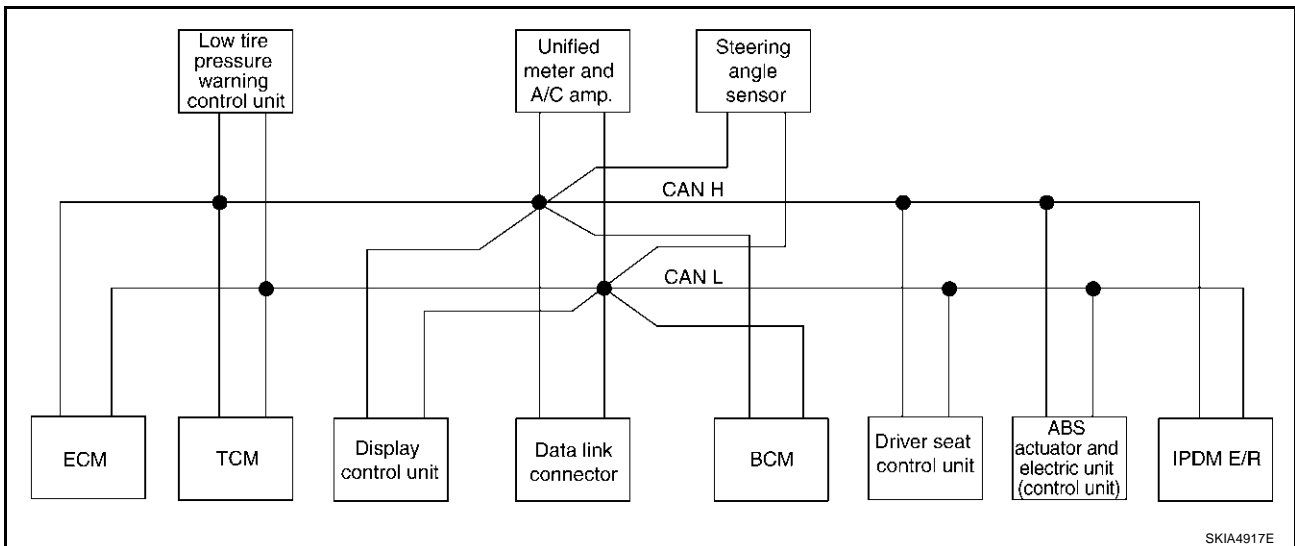

# INTEGRATED DISPLAY SYSTEM

## Input/output Signal Chart

T: Transmit R: Receive

Signals	ECM	TCM	Low tire pressure warning control unit	Display unit	Display control unit	BCM	Unified meter and A/C amp.	Steering angle sensor	Driver seat control unit	ABS actuator and electric unit (control unit)	IPDM E/R
Engine speed signal	T	R			R	R	R			R	
Engine status signal	T					R					
Engine coolant temperature signal	T						R				
Engine and CVT integrated control signal	T	R									
	R	T									
Accelerator pedal position signal	T	R								R	
Closed throttle position signal	T	R									
Wide open throttle position signal	T	R									
Key switch signal						T			R		
Ignition switch signal						T			R		R
P range signal		T							R	R	
Stop lamp switch signal		R					T				
VDC operation signal		R								T	
Second position indicator signal		T					R			R	
Second position signal		R					T				
Fuel consumption monitor signal	T						R				
CVT self-diagnosis signal	R	T									
Input shaft revolution signal	R	T								R	
Output shaft revolution signal	R	T								R	
Air conditioner switch signal	R					T					
A/C compressor request signal	T										R
A/C compressor feedback signal	T						R				
Blower fan motor switch signal	R					T					
A/C control signal				T	T		R				
				R	R		T				
Cooling fan speed request signal	T										R
Position lights request signal						T	R				R
Low beam request signal						T					R
Low beam status signal	R										T
High beam request signal						T	R				R
High beam status signal	R										T
Front fog lights request signal						T					R
Vehicle speed signal		R					R			T	
	R		R		R	R	T		R		
Sleep request 1 signal						T	R				
Sleep request 2 signal						T					R

A  
B  
C  
D  
E  
F  
G  
H  
I  
J  
AV  
L  
M

# INTEGRATED DISPLAY SYSTEM

Signals	ECM	TCM	Low tire pressure warning control unit	Display unit	Display control unit	BCM	Unified meter and A/C amp.	Steering angle sensor	Driver seat control unit	ABS actuator and electric unit (control unit)	IPDM E/R
Door switch signal						R	T				
Turn indicator signal				R	R	T	R		R		R
Key fob ID signal						T			R		
Key fob door unlock signal						T			R		
Seat belt buckle switch signal						R	T				
Oil pressure switch signal						R					T
Buzzer output signal						T	R				
Fuel level sensor signal	R						T				
Fuel level low warning signal				R	R		T				
Malfunction indicator signal	T						R				
ASCD SET lamp signal	T						R				
ASCD CRUISE lamp signal	T						R				
Front wiper request signal						T					R
Front wiper stop position signal						R					T
Rear window defogger switch signal						T					R
Rear window defogger control signal	R			R	R						T
Hood switch signal						R					T
Theft warning horn request signal						T					R
Horn chirp signal						T					R
Steering angle sensor signal								T		R	
Tire pressure signal			T				R				
Tire pressure data signal			T	R	R						
CVT position indicator signal		T					R			R	
ABS warning lamp signal							R			T	
VDC OFF indicator lamp signal							R			T	
SLIP indicator lamp signal							R			T	
Brake warning lamp signal							R			T	
System setting signal				T	T				R		
Parking brake switch signal						R	T				

# INTEGRATED DISPLAY SYSTEM

## CAN Communication Unit For AWD Models

AKS007PW

Go to CAN system, when selecting your car model from the following table.

Body type	Wagon															
Axle	AWD															
Engine	VQ35DE															
Transmission	CVT															
Brake control	ABS								VDC							
Low tire pressure warning system		×			×	×		×		×			×	×		×
Navigation system			×		×		×	×			×		×		×	×
Automatic drive positioner				×		×	×	×				×		×	×	×
CAN communication unit																
ECM	×	×	×	×	×	×	×	×	×	×	×	×	×	×	×	×
TCM	×	×	×	×	×	×	×	×	×	×	×	×	×	×	×	×
Low tire pressure warning control unit		×			×	×		×		×			×	×		×
Display unit	×	×		×		×			×	×		×		×		
Display control unit			×		×		×	×			×		×		×	×
Data link connector	×	×	×	×	×	×	×	×	×	×	×	×	×	×	×	×
BCM	×	×	×	×	×	×	×	×	×	×	×	×	×	×	×	×
Unified meter and A/C amp.	×	×	×	×	×	×	×	×	×	×	×	×	×	×	×	×
Steering angle sensor									×	×	×	×	×	×	×	×
Driver seat control unit				×		×	×	×				×		×	×	×
AWD control unit	×	×	×	×	×	×	×	×	×	×	×	×	×	×	×	×
ABS actuator and electric unit (control unit)	×	×	×	×	×	×	×	×	×	×	×	×	×	×	×	×
IPDM E/R	×	×	×	×	×	×	×	×	×	×	×	×	×	×	×	×
CAN communication type	<a href="#">AV-77. "TYPE 17/TYPE 18/TYPE 19/TYPE 20/TYPE 21/TYPE 22/TYPE 23/TYPE 24"</a>								<a href="#">AV-83. "TYPE 25/TYPE26/TYPE 27/TYPE 28/TYPE 29/TYPE 30/TYPE 31/TYPE 32"</a>							

×: Applicable

### TYPE 17/TYPE 18/TYPE 19/TYPE 20/TYPE 21/TYPE 22/TYPE 23/TYPE 24

#### System Diagram

- Type17

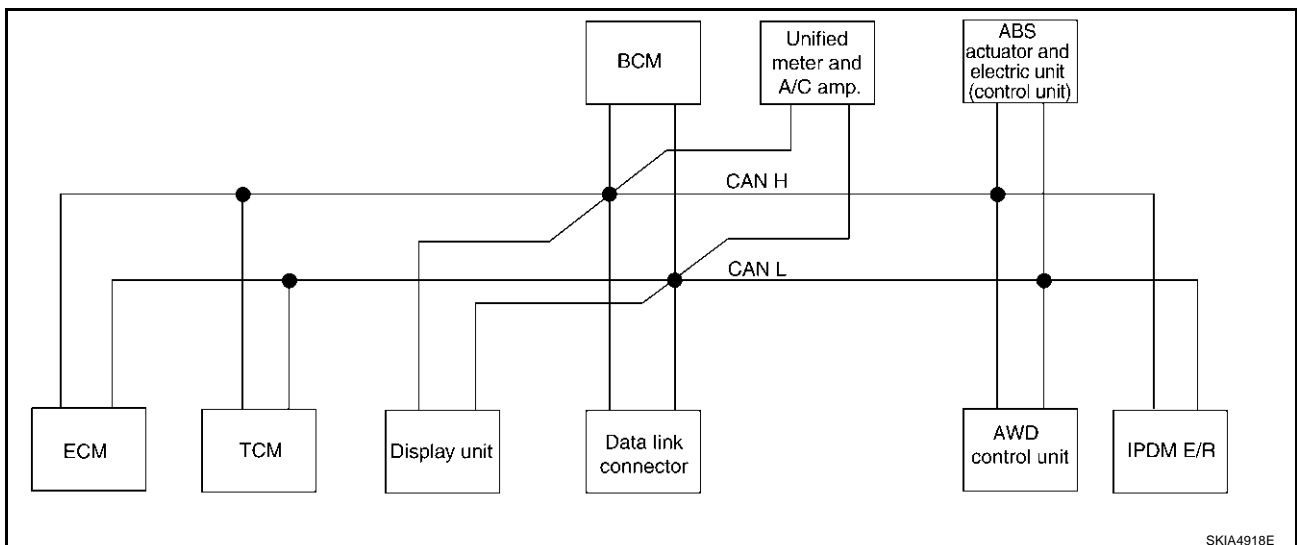

SKIA4918E

# INTEGRATED DISPLAY SYSTEM

- Type18

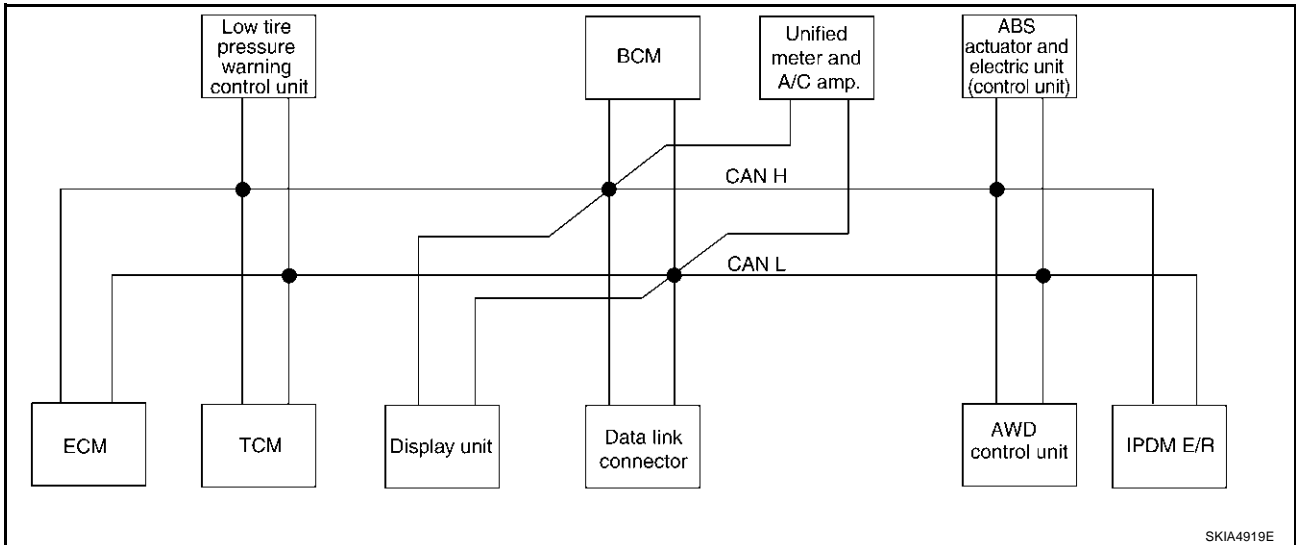

- Type19

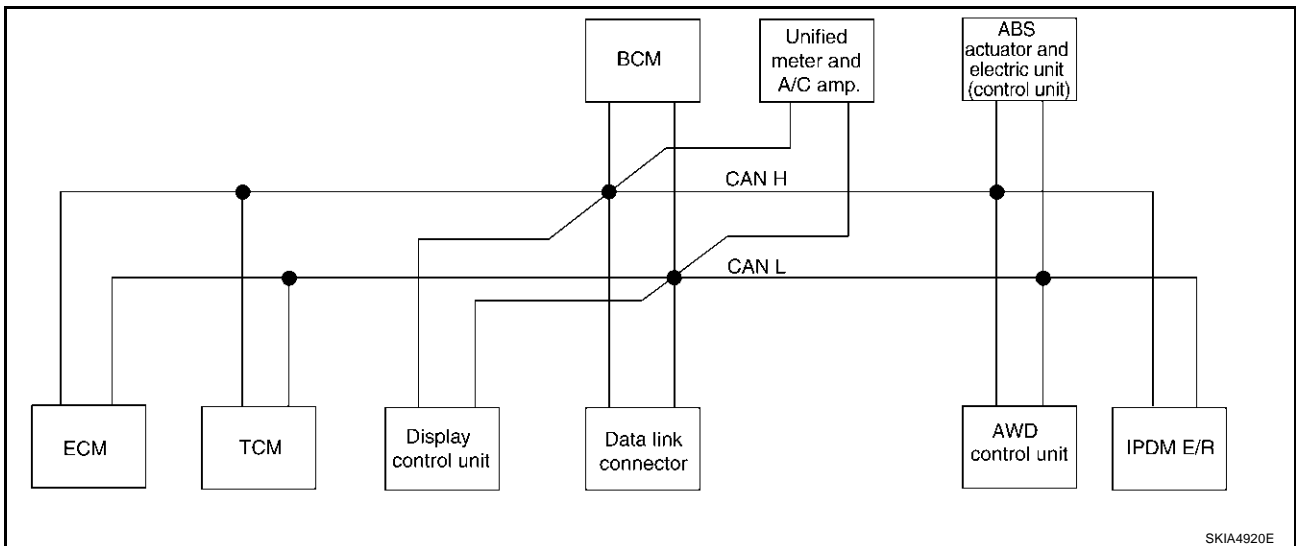

- Type20

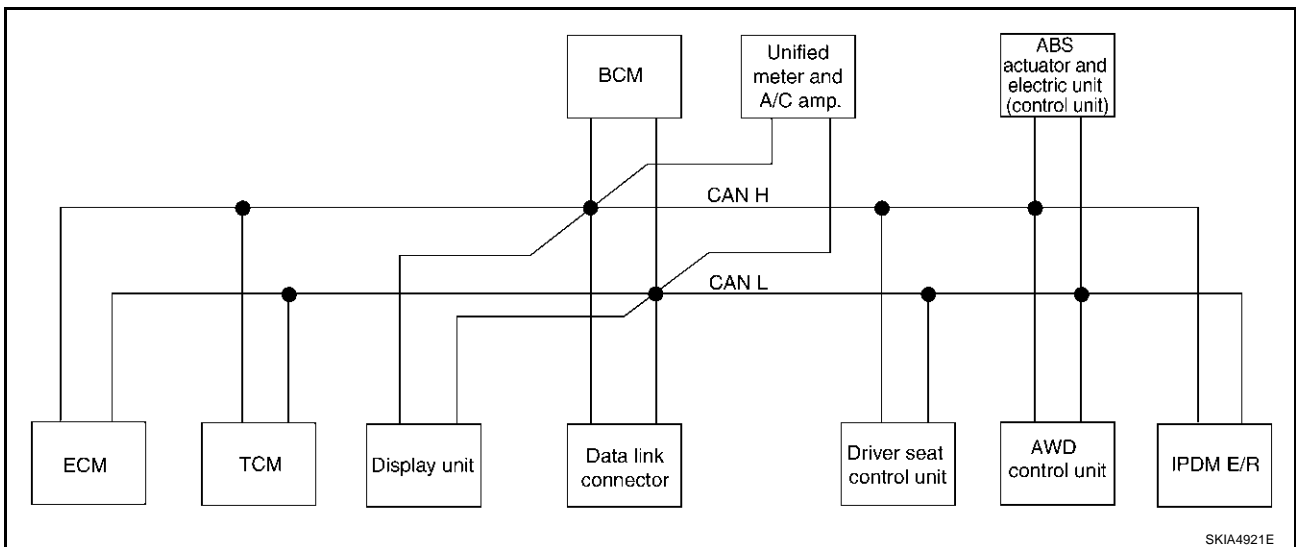

# INTEGRATED DISPLAY SYSTEM

- Type21

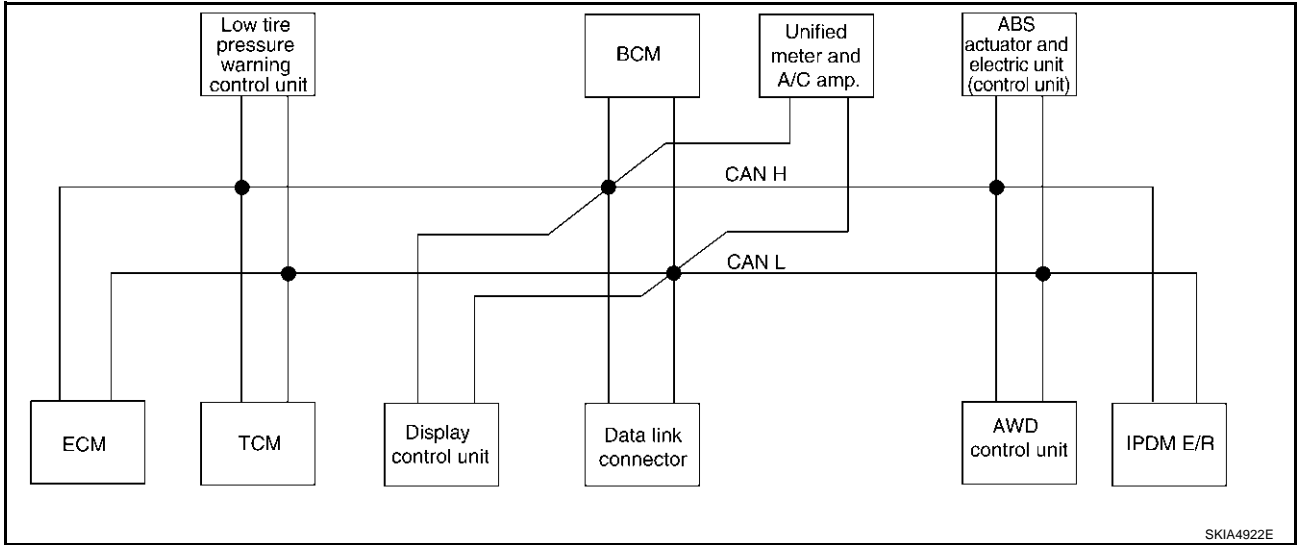

- Type22

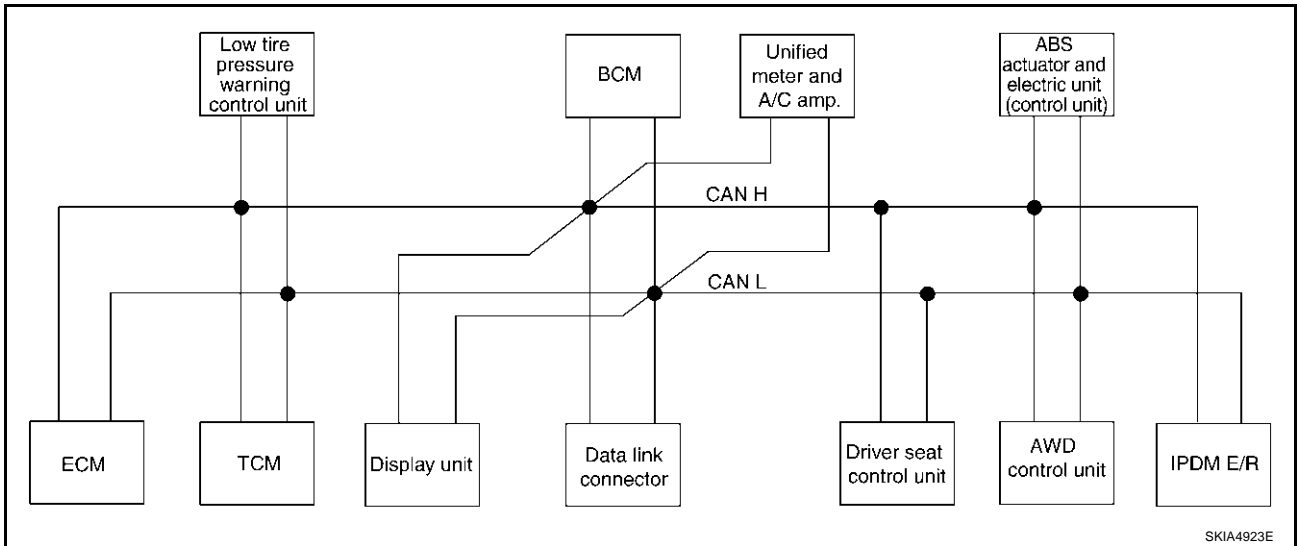

- Type23

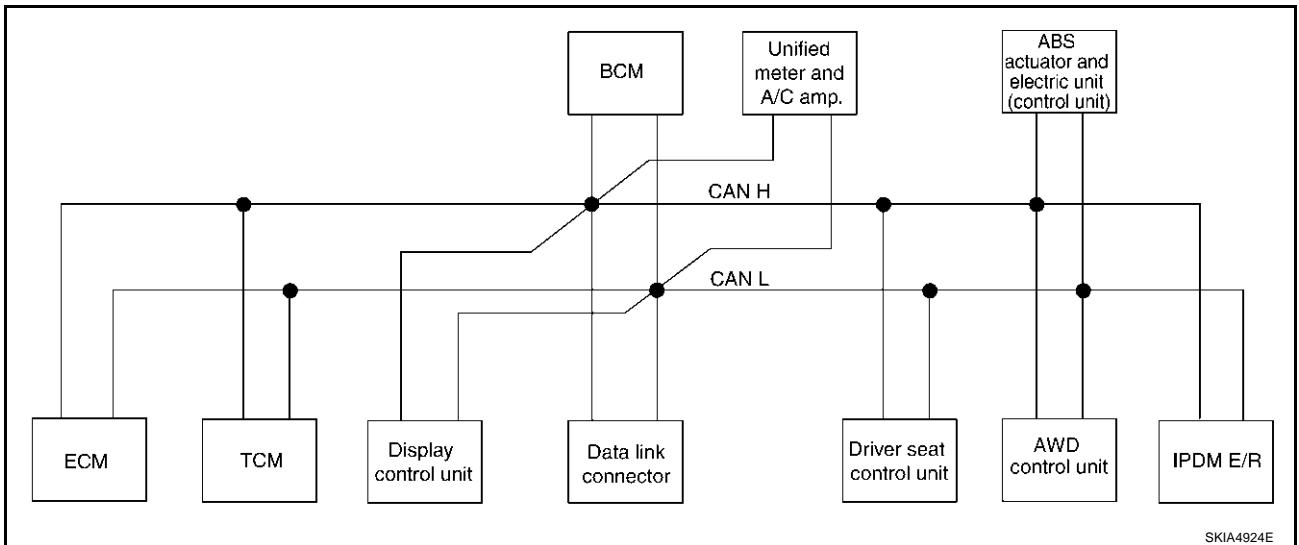

A  
B  
C  
D  
E  
F  
G  
H  
I  
J  
AV  
L  
M

# INTEGRATED DISPLAY SYSTEM

- Type24

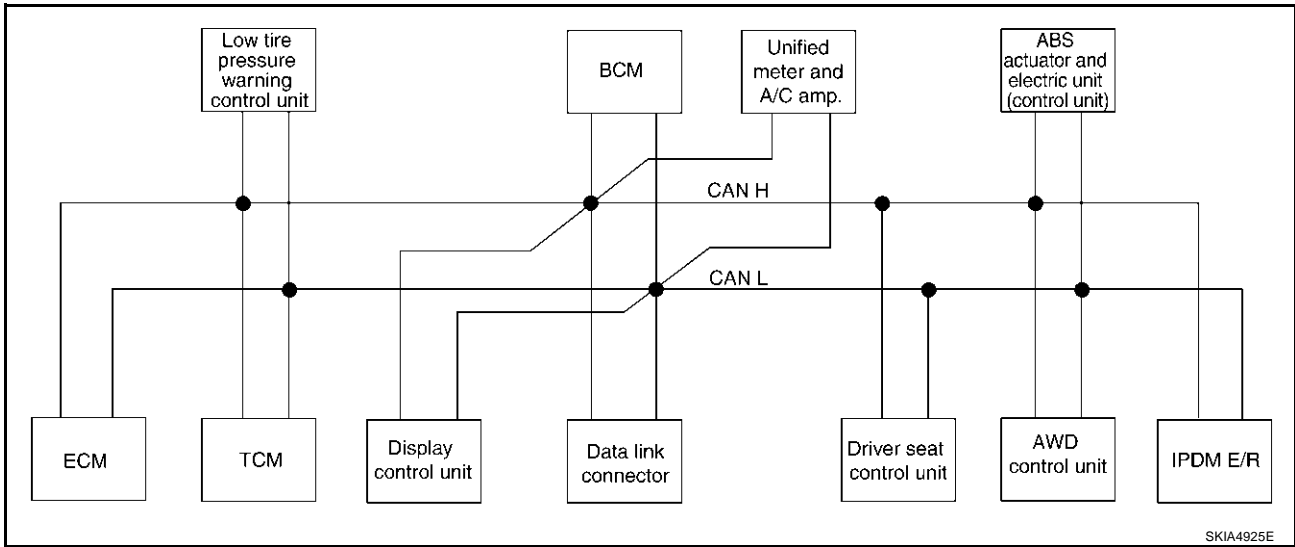



# INTEGRATED DISPLAY SYSTEM

## Input/output Signal Chart

T: Transmit R: Receive

Signals	ECM	TCM	Low tire pressure warning control unit	Display unit	Display control unit	BCM	Unified meter and A/C amp.	Driver seat control unit	AWD control unit	ABS actuator and electric unit (control unit)	IPDM E/R
CVT position indicator signal		T					R				
Second position signal		R					T				
Second position indicator signal		T					R				
Engine speed signal	T	R	R		R	R	R		R		
Engine status signal	T					R					
Engine coolant temperature signal	T						R				
Accelerator pedal position signal	T	R							R		
Closed throttle position signal	T	R									
Wide open throttle position signal	T	R									
Key switch signal						T		R			
Ignition switch signal						T		R			R
P range signal		T						R			
Stop lamp switch signal		R					T		R		
Fuel consumption monitor signal	T						R				
CVT self-diagnosis signal	R	T									
ABS operation signal		R							R	T	
Air conditioner switch signal	R					T					
A/C compressor request signal	T										R
A/C compressor feedback signal	T						R				
Blower fan motor switch signal	R					T					
A/C control signal				T	T		R				
				R	R		T				
Cooling fan speed request signal	T										R
Position lights request signal						T	R				R
Low beam request signal						T					R
Low beam status signal	R										T
High beam request signal						T	R				R
High beam status signal	R										T
Front fog lights request signal						T					R
Vehicle speed signal		R					R		R	T	
	R		R		R	R	T	R			
Sleep request 1 signal						T	R				
Sleep request 2 signal						T					R
Door switch signal						R	T				
				R	R	T	R	R			R
Key fob ID signal						T		R			
Key fob door unlock signal						T		R			

# INTEGRATED DISPLAY SYSTEM

Signals	ECM	TCM	Low tire pressure warning control unit	Display unit	Display control unit	BCM	Unified meter and A/C amp.	Driver seat control unit	AWD control unit	ABS actuator and electric unit (control unit)	IPDM E/R
Turn indicator signal						T	R				
Seat belt buckle switch signal						R	T				
Oil pressure switch signal						R					T
						T	R				
Buzzer output signal						T	R				
Fuel level sensor signal	R						T				
Fuel level low warning signal				R	R		T				
Malfunction indicator lamp signal	T						R				
ASCD SET lamp signal	T						R				
ASCD CRUISE lamp signal	T						R				
Input shaft revolution signal	R	T									
Output shaft revolution signal	R	T									
Front wiper request signal						T					R
Front wiper stop position signal						R					T
Rear window defogger switch signal						T					R
Rear window defogger control signal	R			R	R						T
Engine and CVT integrated control signal	T	R									
	R	T									
Hood switch signal						R					T
Theft warning horn request signal						T					R
Horn chirp signal						T					R
Tire pressure signal			T				R				
Tire pressure data signal			T	R	R						
ABS warning lamp signal							R			T	
Brake warning lamp signal							R			T	
System setting signal				T	T			R			
AWD warning lamp signal							R		T		
AWD lock indicator lamp signal							R		T		
AWD lock switch signal							T		R		
Parking brake switch signal						R	T		R		

# INTEGRATED DISPLAY SYSTEM

TYPE 25/TYPER26/TYPER 27/TYPER 28/TYPER 29/TYPER 30/TYPER 31/TYPER 32

## System Diagram

- Type25

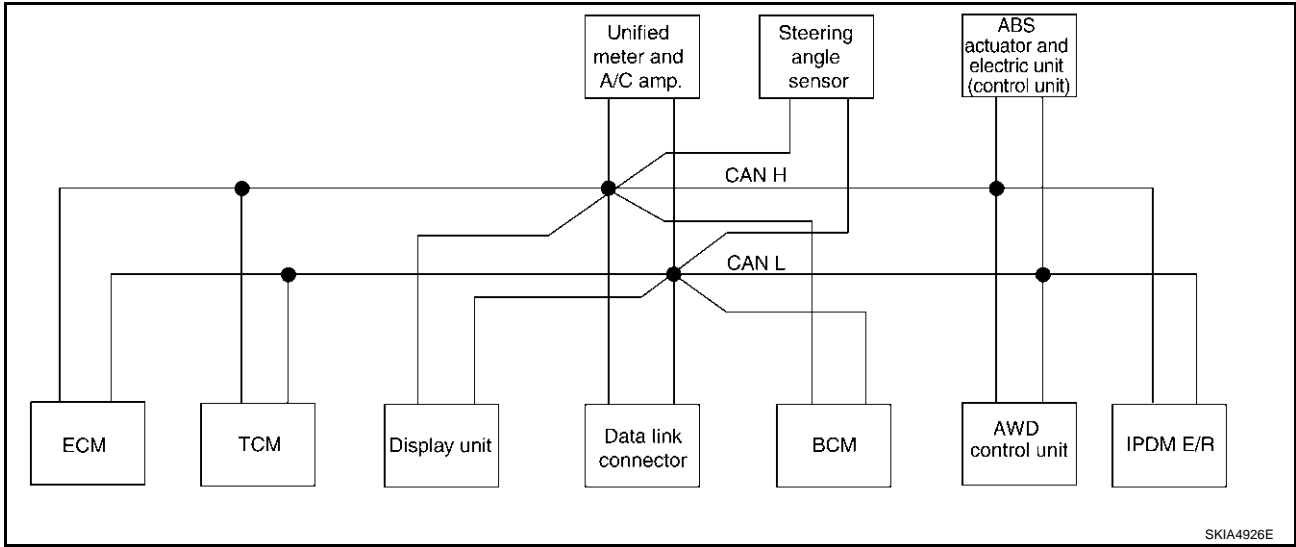

- Type26

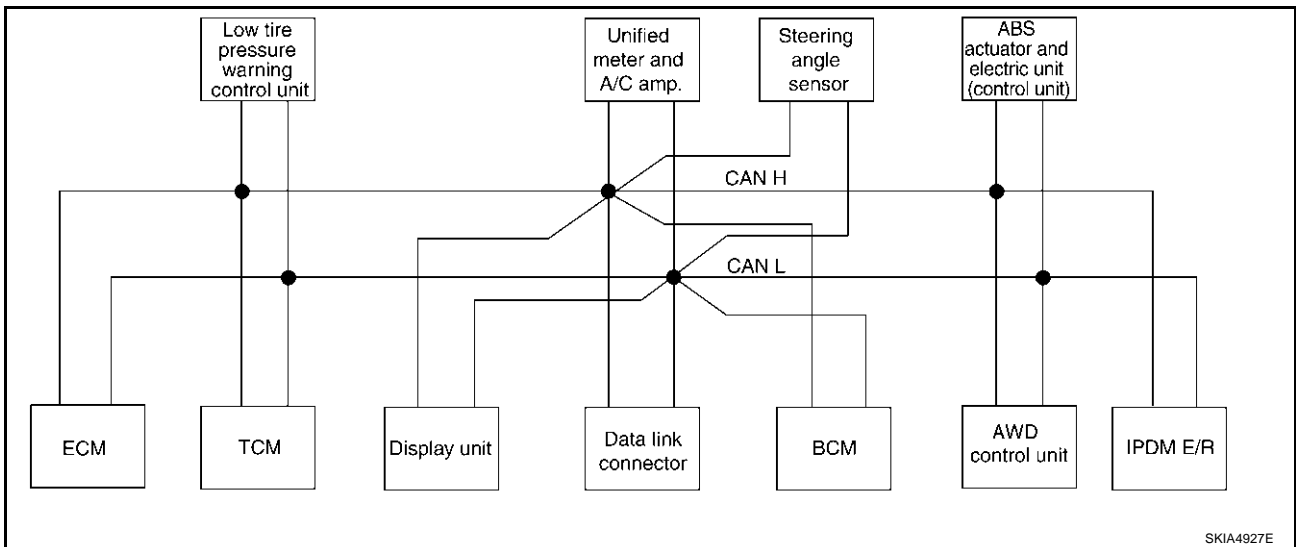

- Type27

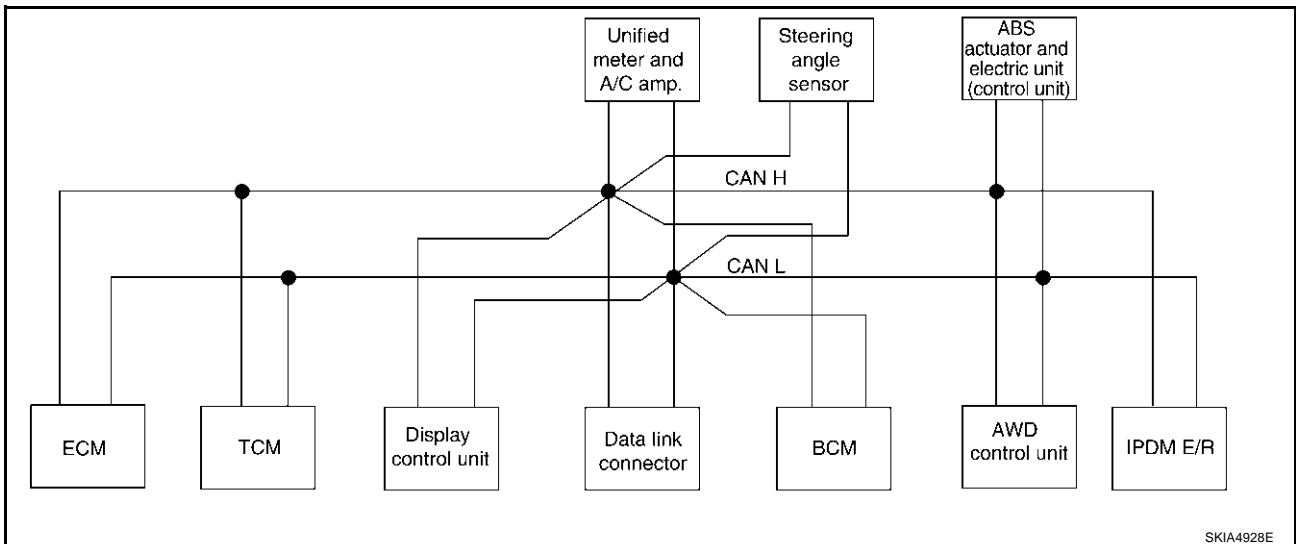

A  
B  
C  
D  
E  
F  
G  
H  
I  
J  
K  
L  
M

AV

# INTEGRATED DISPLAY SYSTEM

- Type28

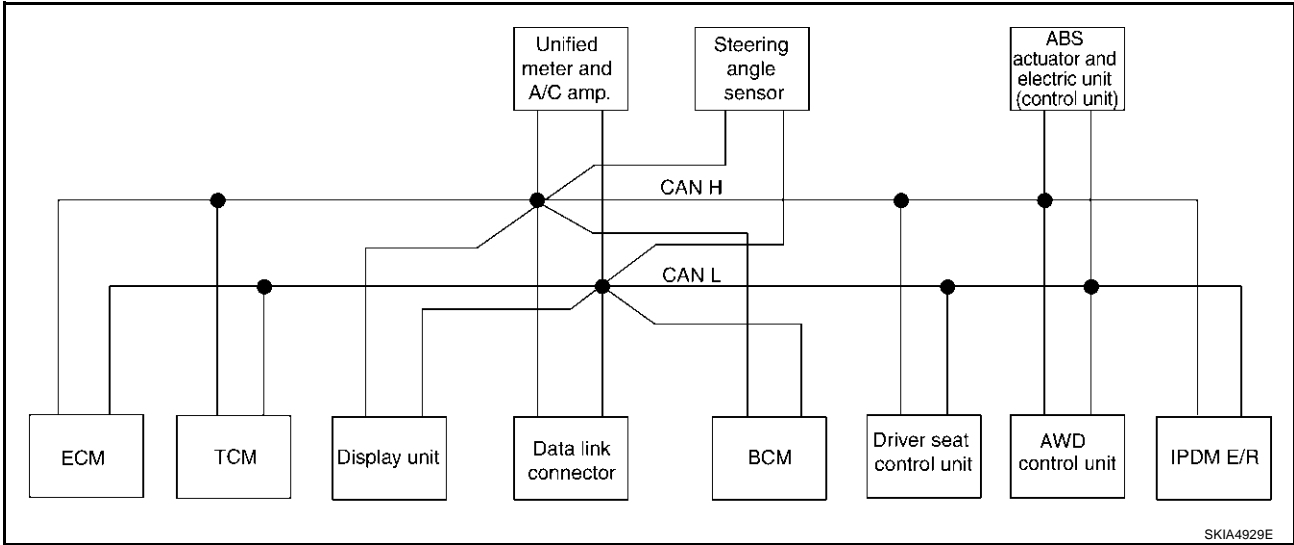

SKIA4929E

- Type29

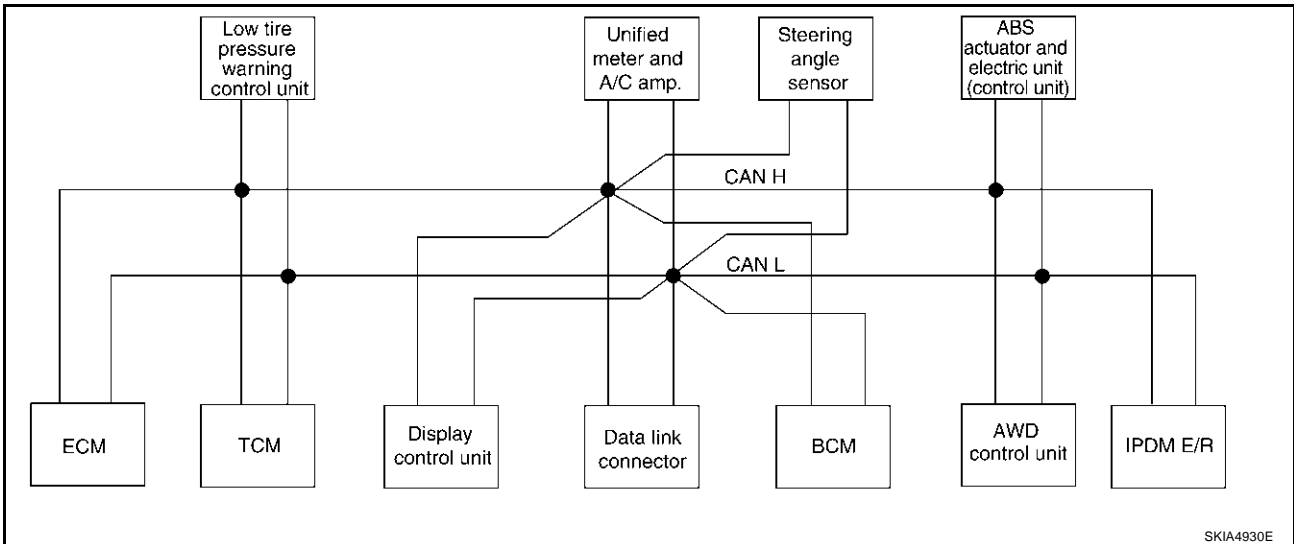

SKIA4930E

- Type30

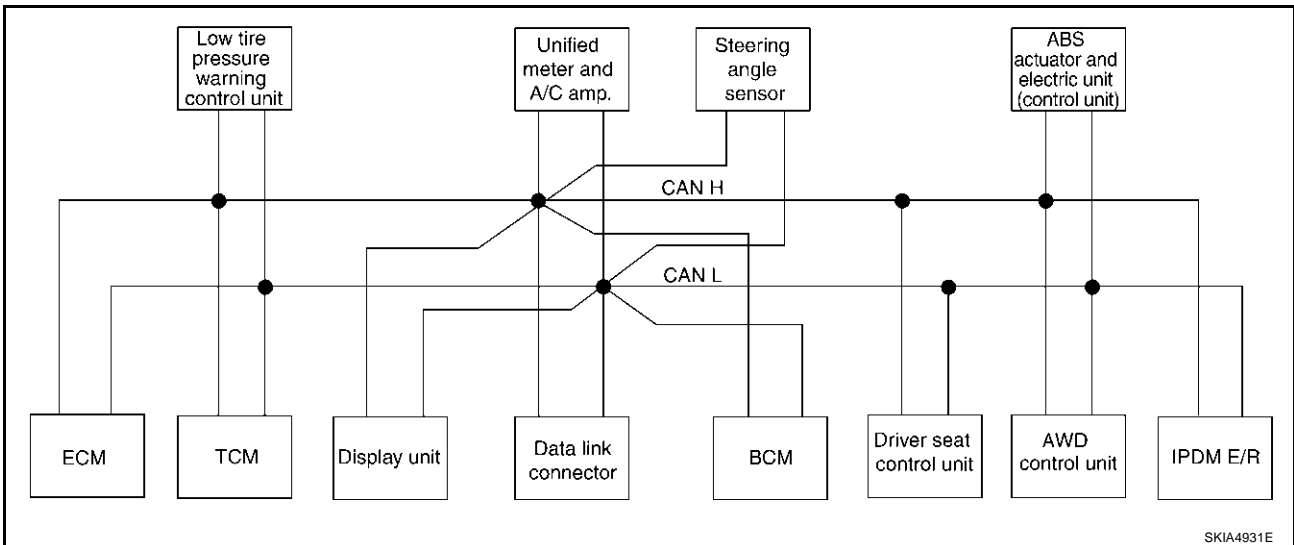

SKIA4931E

# INTEGRATED DISPLAY SYSTEM

- Type31

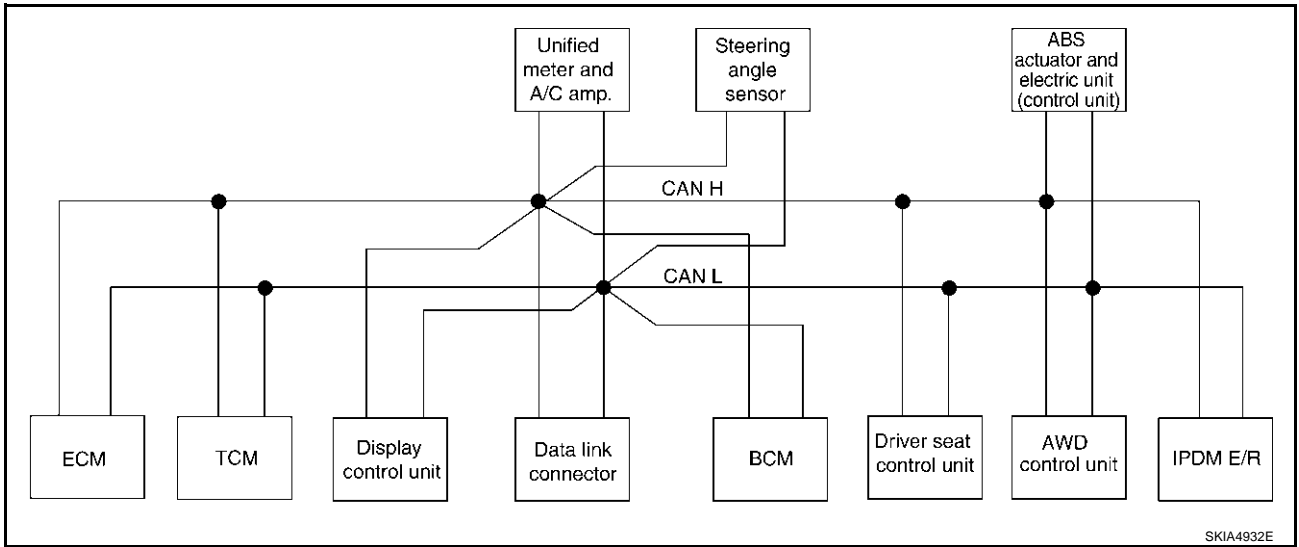

- Type32

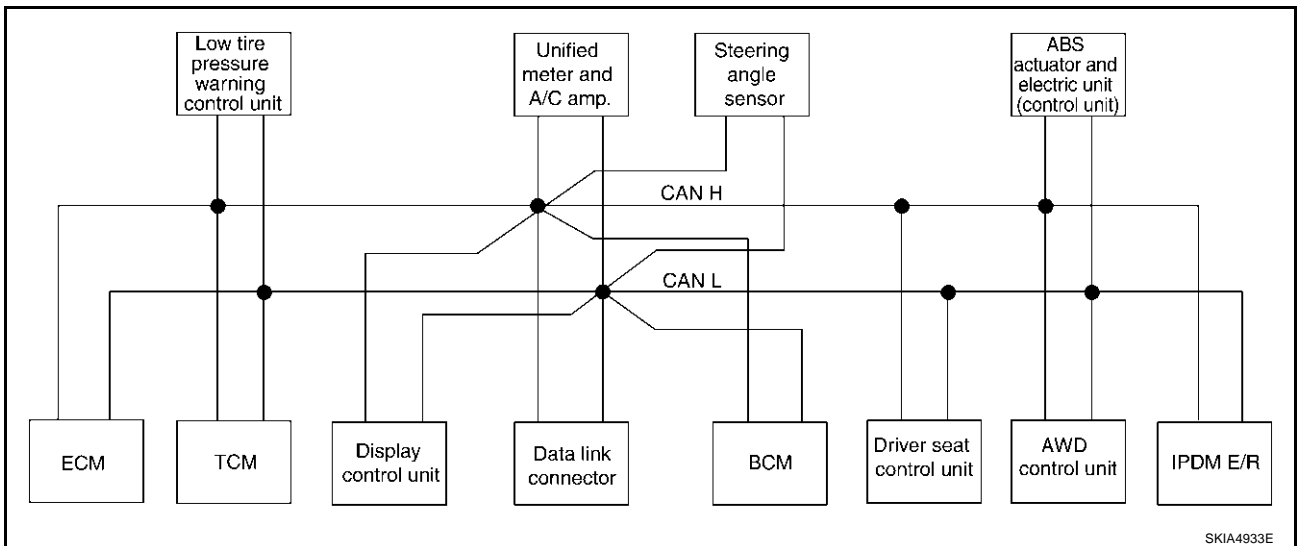

A  
B  
C  
D  
E  
F  
G  
H  
I  
J  
AV  
L  
M

# INTEGRATED DISPLAY SYSTEM

## Input/output Signal Chart

T: Transmit R: Receive

Signals	ECM	TCM	Low tire pressure warning control unit	Display unit	Display control unit	BCM	Unified meter and A/C amp.	Steering angle sensor	Driver seat control unit	AWD control unit	ABS actuator and electric unit (control unit)	IPDM E/R
Engine and CVT integrated control signal	T	R										
	R	T										
Second position signal		R					T					
VDC operation signal		R								R	T	
Stop lamp switch signal		R					T			R		
Key switch signal						T			R			
Ignition switch signal						T			R			R
P range signal		T							R		R	
Closed throttle position signal	T	R										
Wide open throttle position signal	T	R										
Second position indicator signal		T					R				R	
Engine speed signal	T	R			R	R	R			R	R	
Engine status signal	T					R						
Engine coolant temperature signal	T						R					
Accelerator pedal position signal	T	R								R	R	
Fuel consumption monitor signal	T						R					
CVT self-diagnosis signal	R	T										
Input shaft revolution signal	R	T									R	
Output shaft revolution signal	R	T									R	
Air conditioner switch signal	R					T						
A/C compressor request signal	T											R
A/C compressor feedback signal	T						R					T
Blower fan motor switch signal	R					T						
A/C control signal				T	T		R					
				R	R		T					
Cooling fan speed request signal	T											R
Position lights request signal						T	R					R
Low beam request signal						T						R
Low beam status signal	R											T
High beam request signal						T	R					R
High beam status signal	R											T
Front fog lights request signal						T						R
Vehicle speed signal		R					R			R	T	
	R		R		R	R	T		R			
Sleep request 1 signal						T	R					
Sleep request 2 signal						T						R

# INTEGRATED DISPLAY SYSTEM

Signals	ECM	TCM	Low tire pressure warning control unit	Display unit	Display control unit	BCM	Unified meter and A/C amp.	Steering angle sensor	Driver seat control unit	AWD control unit	ABS actuator and electric unit (control unit)	IPDM E/R
Door switch signal						R	T					
Turn indicator signal				R	R	T	R		R			R
Key fob ID signal						T			R			
Key fob door unlock signal						T			R			
Seat belt buckle switch signal						R	T					
Oil pressure switch signal						R						T
Buzzer output signal						T	R					
Fuel level sensor signal	R						T					
Fuel level low warning signal				R	R		T					
Malfunction indicator signal	T						R					
ASCD SET lamp signal	T						R					
ASCD CRUISE lamp signal	T						R					
Front wiper request signal						T						R
Front wiper stop position signal						R						T
Rear window defogger switch signal						T						R
Rear window defogger control signal	R			R	R							T
Hood switch signal						R						T
Theft warning horn request signal						T						R
Horn chirp signal						T						R
Steering angle sensor signal								T			R	
Tire pressure signal			T				R					
Tire pressure data signal			T	R	R							
CVT position indicator signal		T					R				R	
ABS warning lamp signal							R				T	
VDC OFF indicator lamp signal							R				T	
SLIP indicator lamp signal							R				T	
Brake warning lamp signal							R				T	
System setting signal				T	T				R			
AWD warning lamp signal							R			T		
AWD lock indicator lamp signal							R			T		
AWD lock switch signal							T			R		
Parking brake switch signal						R	T			R		

A  
B  
C  
D  
E  
F  
G  
H  
I  
J  
L  
M

AV

# INTEGRATED DISPLAY SYSTEM

## Component Parts and Harness Connector Location

AKS004XU

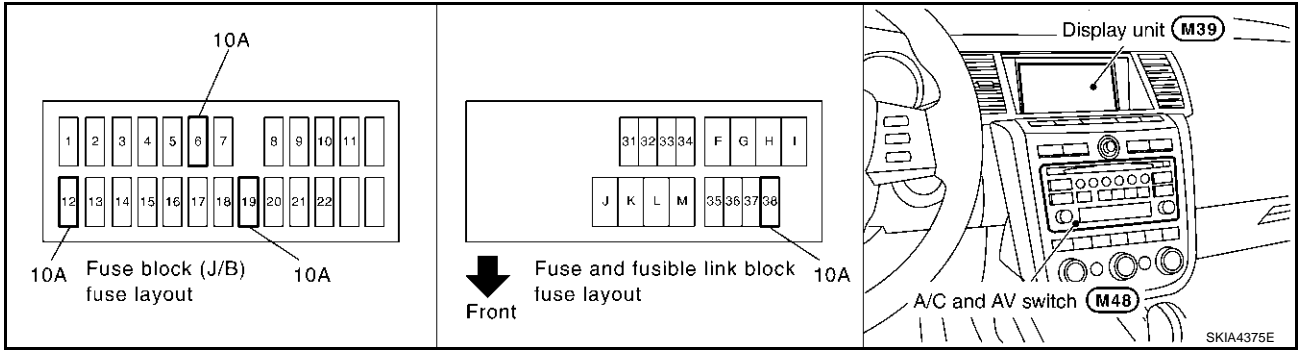



# INTEGRATED DISPLAY SYSTEM

## Schematic

AKS004YZ

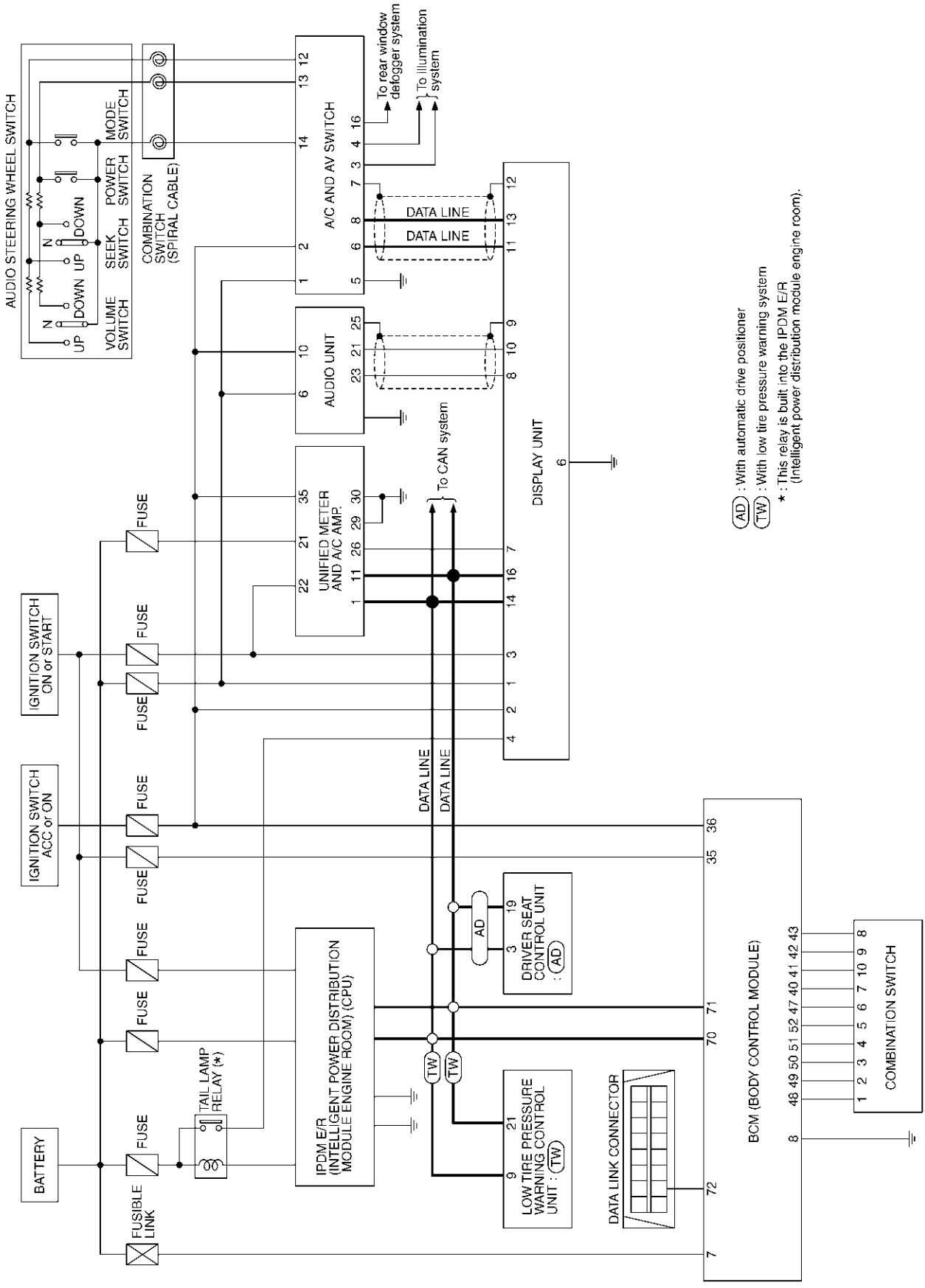

(AD) : With automatic drive positioner  
 (TW) : With low tire pressure warning system  
 \* : This relay is built into the IPDM E/R  
 (Intelligent power distribution module engine room).

A  
B  
C  
D  
E  
F  
G  
H  
I  
J  
AV  
L  
M

# INTEGRATED DISPLAY SYSTEM

## Wiring Diagram — INF/D —

AKS004Z0

### AV-INF/D-01

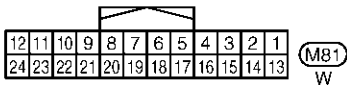
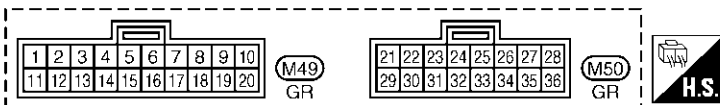
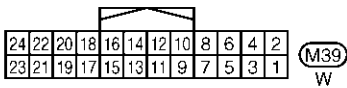
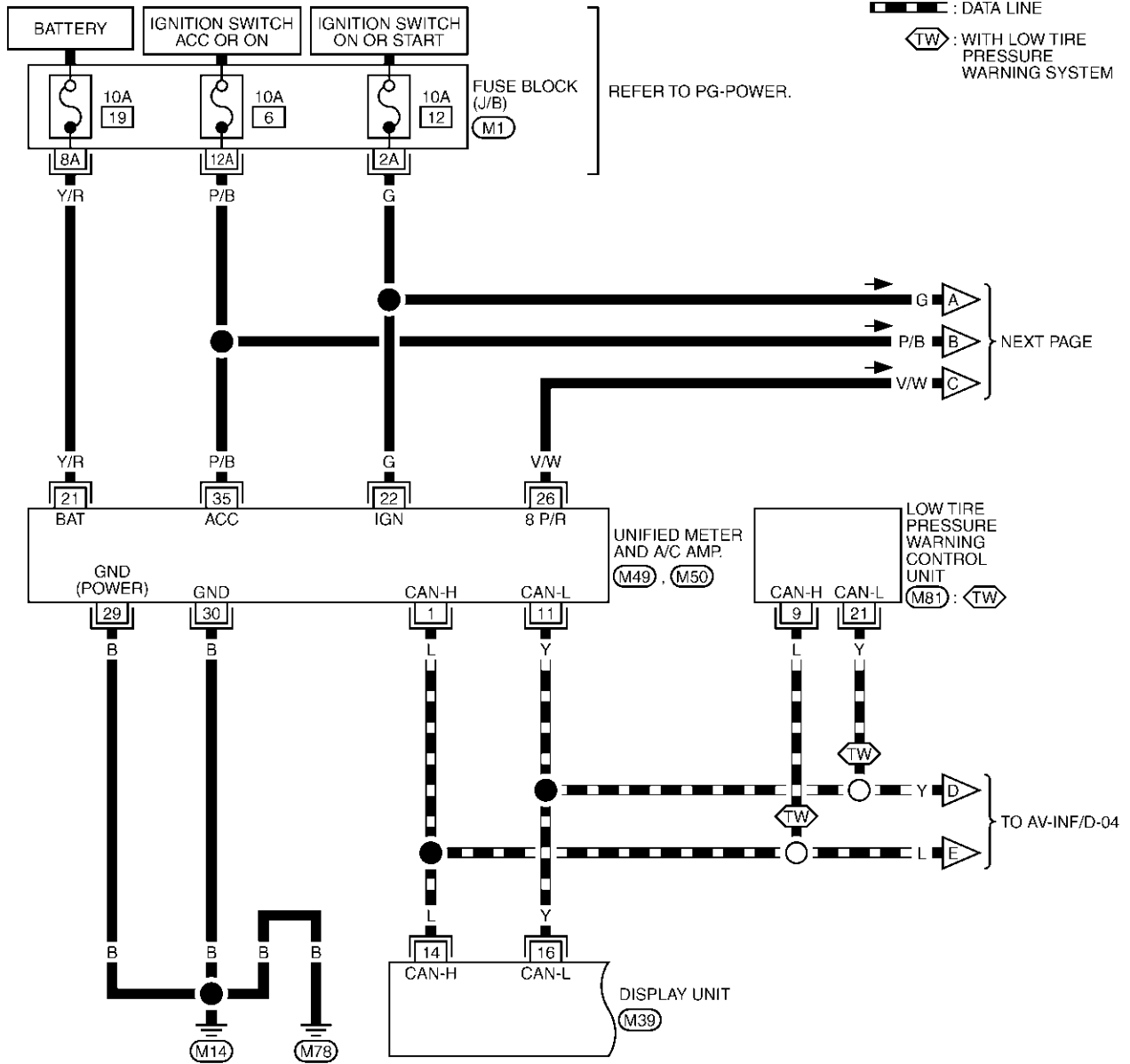

REFER TO THE FOLLOWING.

M1 - FUSE BLOCK-JUNCTION BOX (J/B)

TKWA0838E

# INTEGRATED DISPLAY SYSTEM

AV-INF/D-02

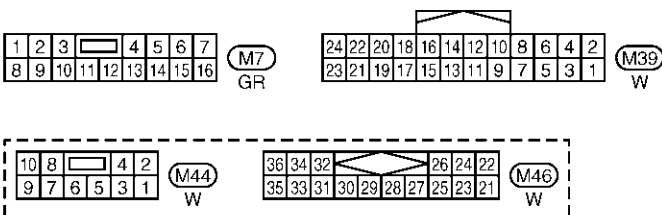
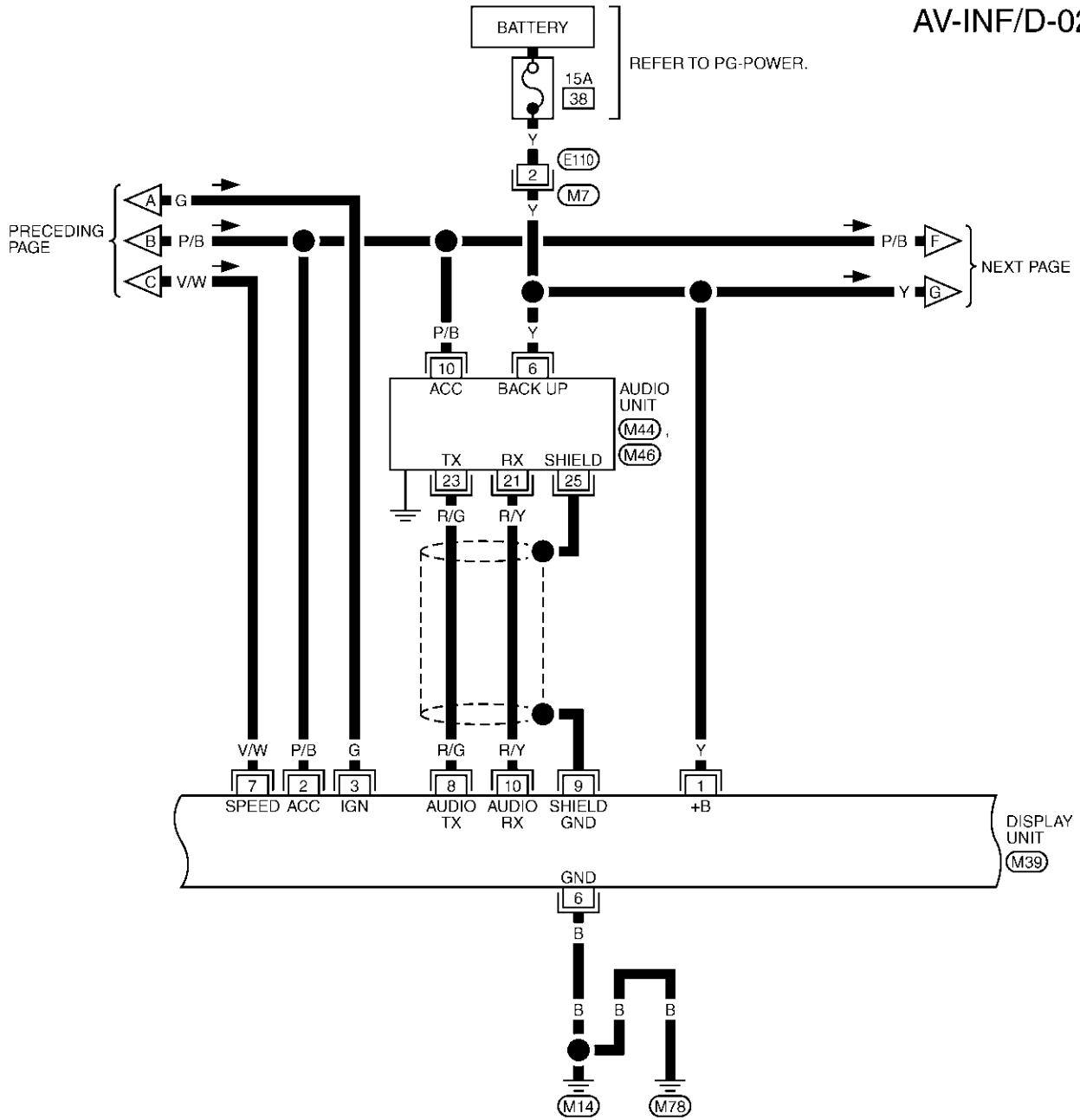

TKWA0839E

# INTEGRATED DISPLAY SYSTEM

AV-INF/D-03

▬ : DATA LINE

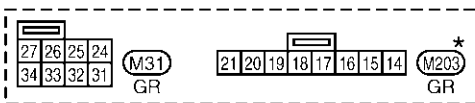
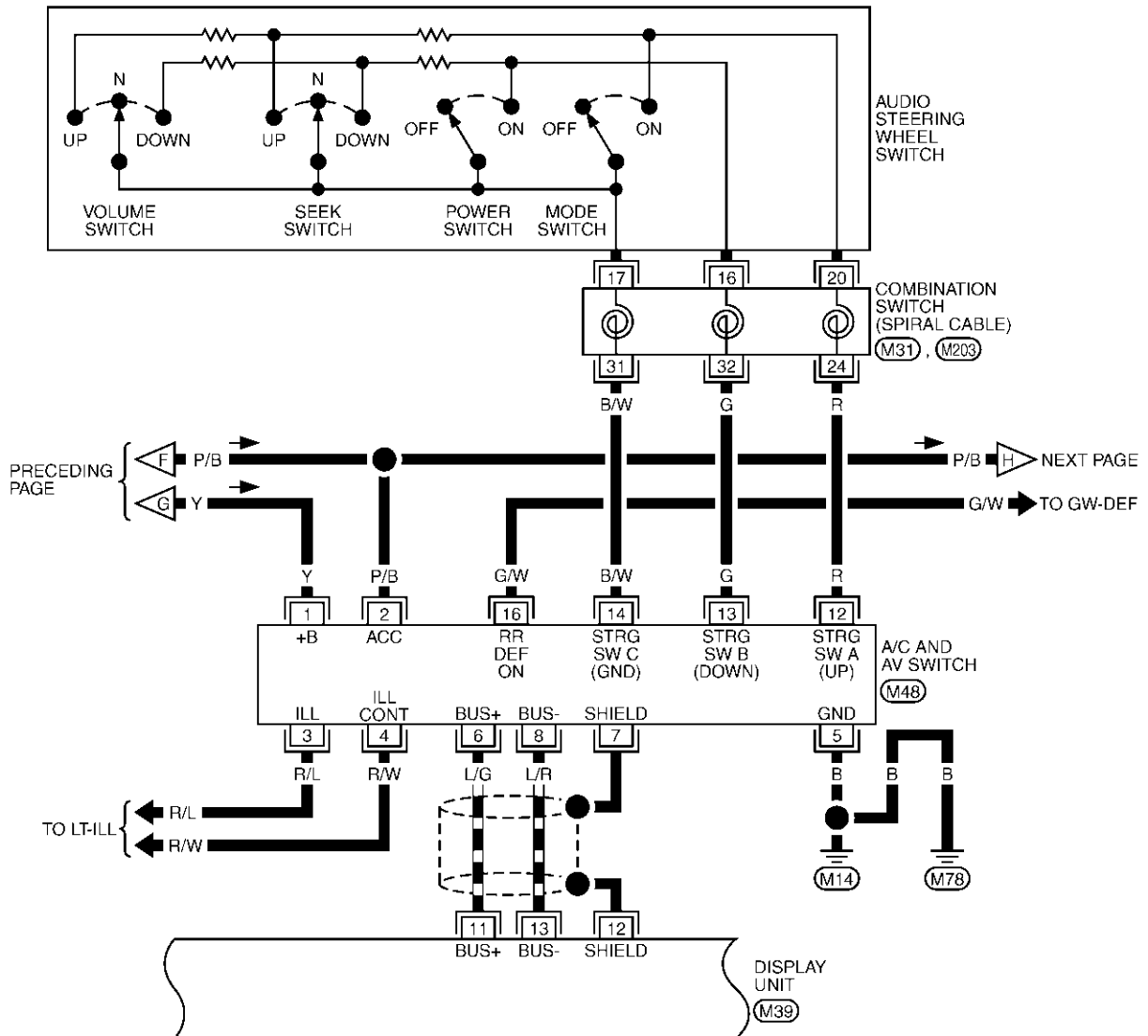

\*: THIS CONNECTOR IS NOT SHOWN IN "HARNESS LAYOUT", PG SECTION.

TKWA1056E

# INTEGRATED DISPLAY SYSTEM

AV-INF/D-04

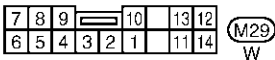
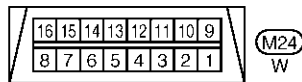
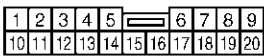
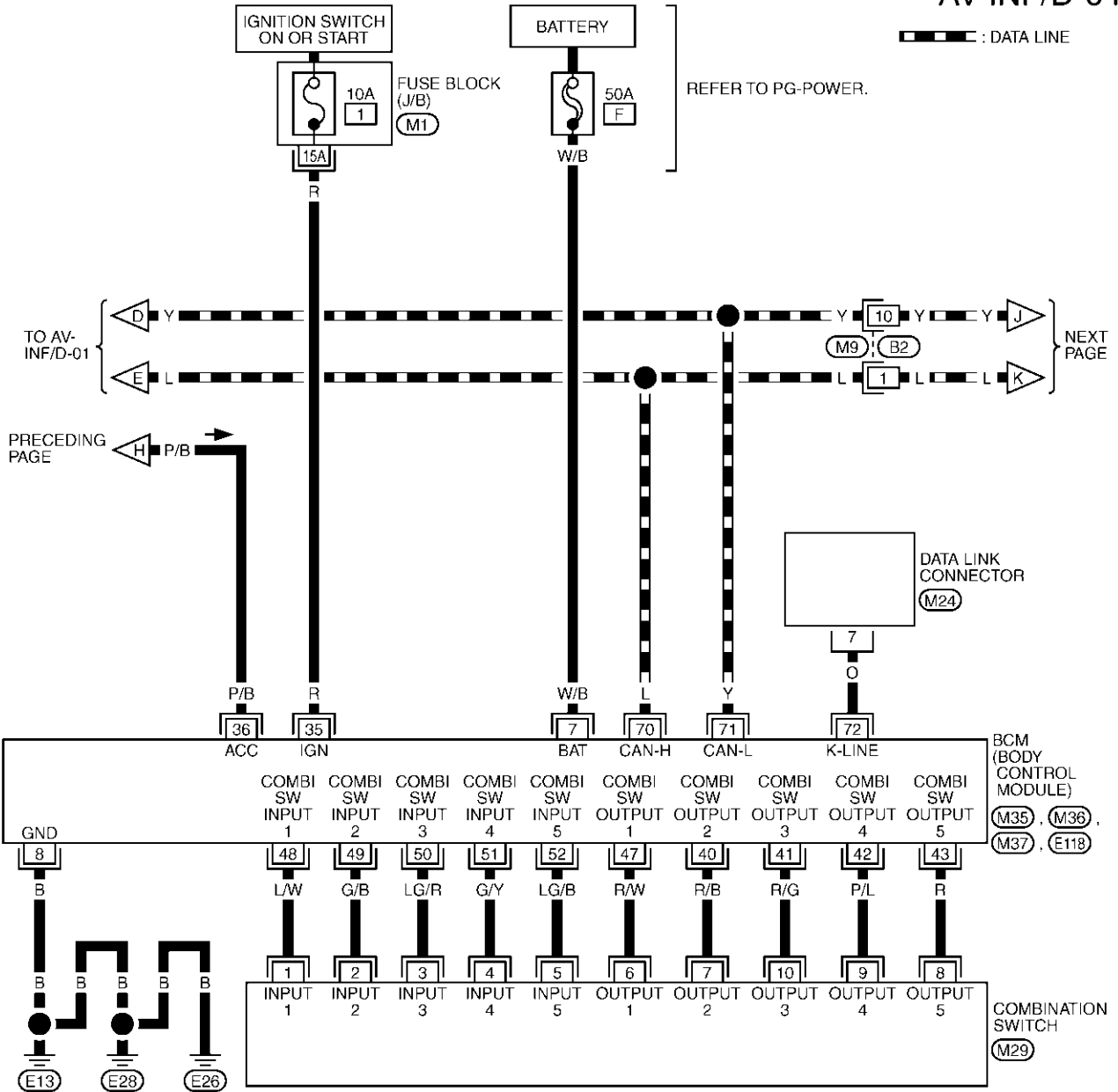

REFER TO THE FOLLOWING.  
 (M1) - FUSE BLOCK-JUNCTION BOX (J/B)  
 (M35), (M36), (M37), (E118) - ELECTRICAL UNITS

TKWA0840E

# INTEGRATED DISPLAY SYSTEM

AV-INF/D-05

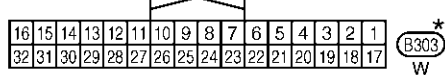
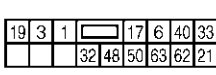
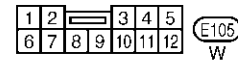
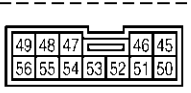
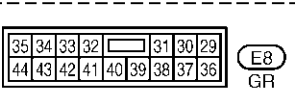
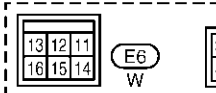
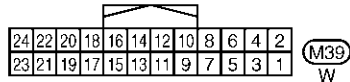
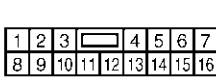
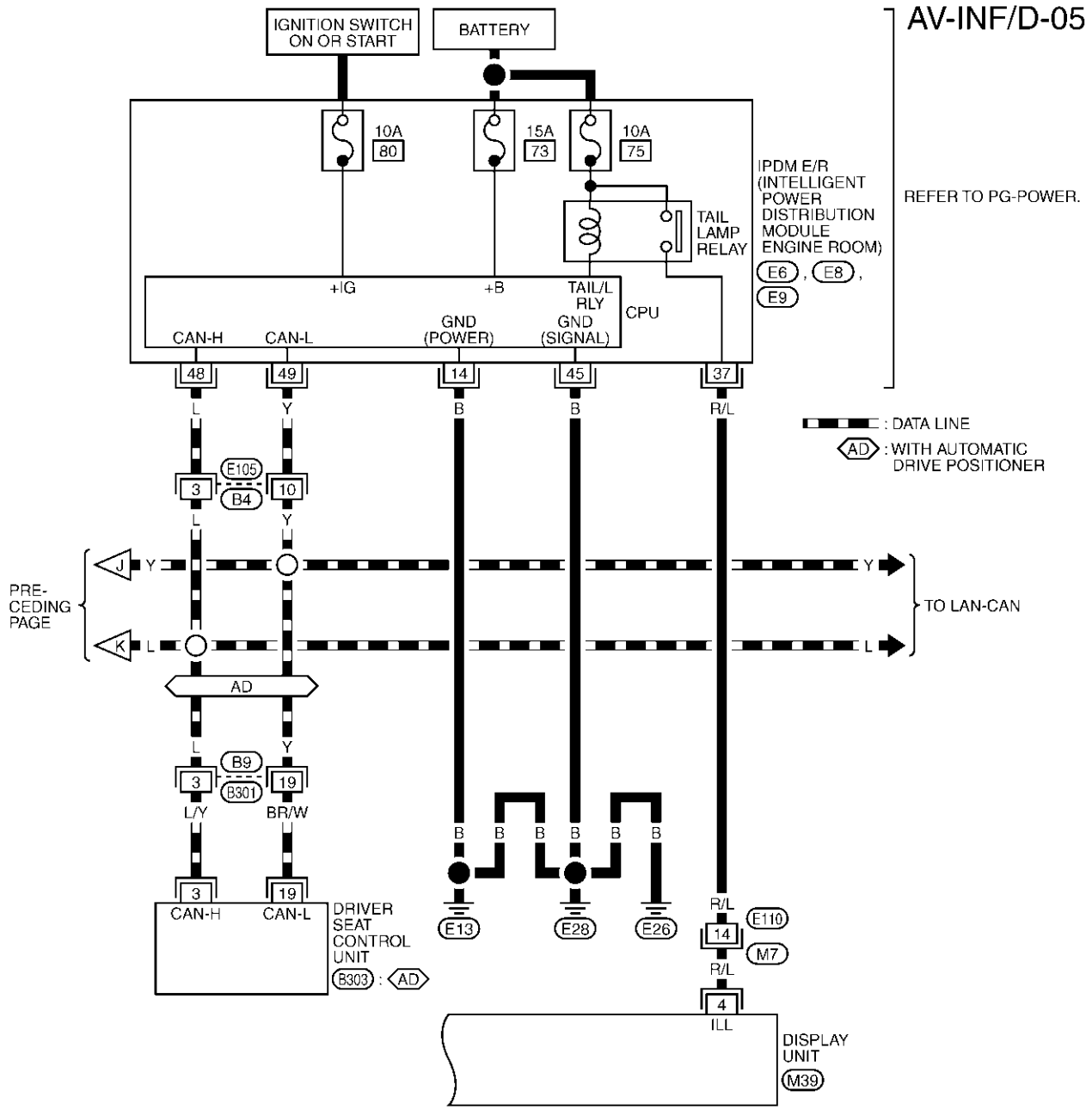

\*: THIS CONNECTOR IS NOT SHOWN IN "HARNESS LAYOUT", PG SECTION.

TKWA0841E

# INTEGRATED DISPLAY SYSTEM

## Wiring Diagram — COMM —

AKS004ZZ

### AV-COMM-04

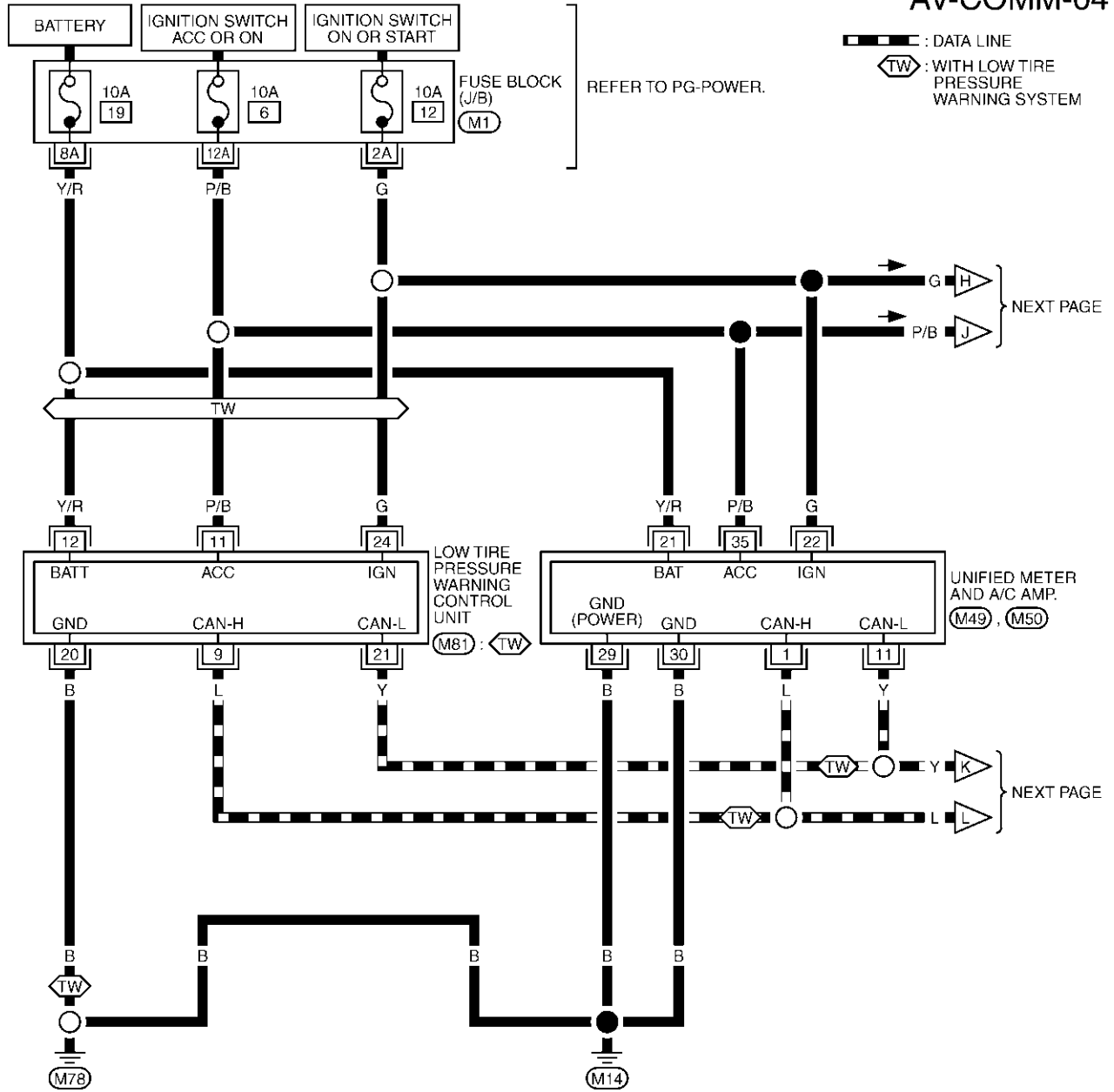

A  
B  
C  
D  
E  
F  
G  
H  
I  
J  
AV  
L  
M

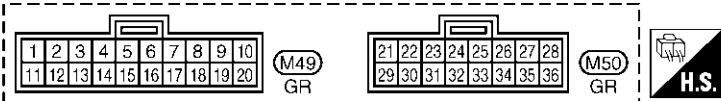

REFER TO THE FOLLOWING.

(M1) - FUSE BLOCK-JUNCTION BOX (J/B)

TKWA0846E

# INTEGRATED DISPLAY SYSTEM

AV-COMM-05

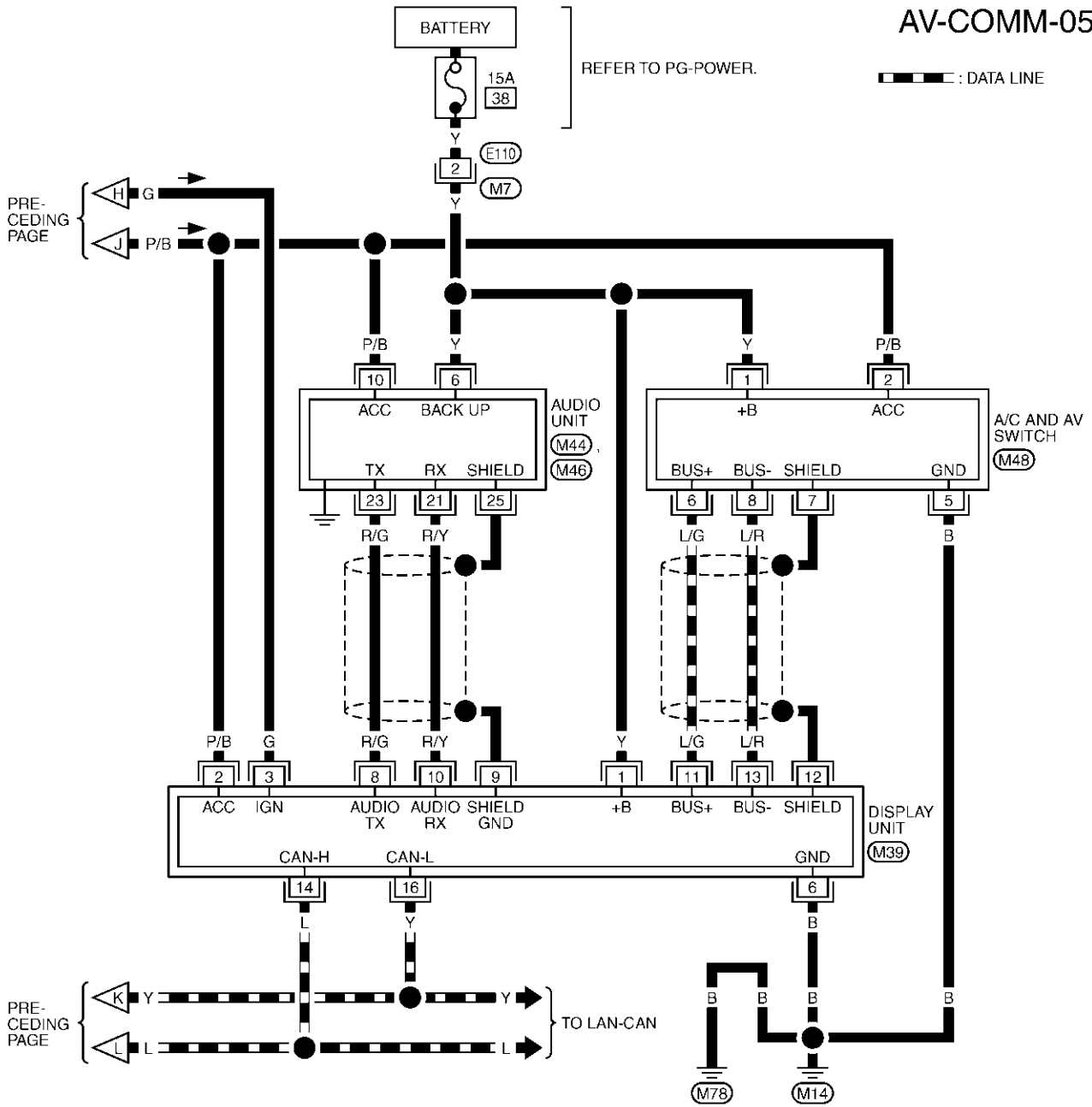

1	2	3	4	5	6	7		
8	9	10	11	12	13	14	15	16

(M7)  
GR

24	22	20	18	16	14	12	10	8	6	4	2
23	21	19	17	15	13	11	9	7	5	3	1

(M39)  
W

10	8	4	2		
9	7	6	5	3	1

(M44)  
W

36	34	32	26	24	22				
35	33	31	30	29	28	27	25	23	21

(M46)  
W

16	14	12	10	8	6	4	2
15	13	11	9	7	5	3	1

(M48)  
W

TKWA1256E



# INTEGRATED DISPLAY SYSTEM

## Terminals and Reference Value for Display Unit

AKS004XW

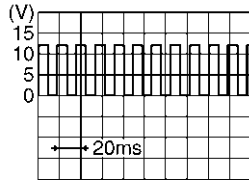
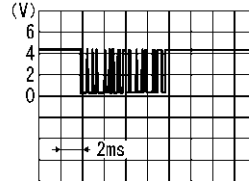
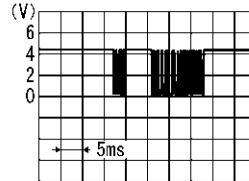
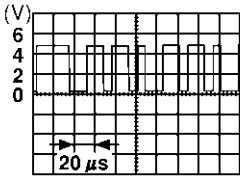
Terminal (Wire color)		Item	Signal input/ output	Condition		Reference value	Example of symptom
+	-			Ignition switch	Operation		
1 (Y)	Ground	Battery power supply	Input	OFF	-	Battery voltage	System does not work properly.
2 (P/B)	Ground	ACC power supply	Input	ACC	-	Battery voltage	System does not work properly.
3 (G)	Ground	Ignition signal	Input	ON	-	Battery voltage	A/C operation is not possible. Vehicle information setting is not possible.
4 (R/L)	Ground	Illumination signal	Input	OFF	Lighting switch is ON (position 1).	Approx. 12V	Screen does not switch between daytime mode and night-time mode.
					Turn lighting switch OFF.	Approx. 0V	
6 (B)	Ground	Ground	-	ON	-	Approx. 0V	-
7 (V/W)	Ground	Vehicle speed signal (8-pulse)	Input	ON	When vehicle speed is approx. 40 km/h (25 MPH)	 <p style="text-align: right; font-size: small;">PKIA1935E</p>	Drive computer item is not displayed correctly.
8 (R/G)	Ground	Audio TX	Output	ON	Operate audio volume.	 <p style="text-align: right; font-size: small;">SKIA4402E</p>	Audio does not operate properly.
9	Ground	Shield	-	ON	-	Approx. 0V	-
10 (R/Y)	Ground	Audio RX	Input	ON	Operate audio volume.	 <p style="text-align: right; font-size: small;">SKIA4403E</p>	Audio does not operate properly.
11 (L/G)	Ground	Communication signal (+)	Input/output	ON	-	 <p style="text-align: right; font-size: small;">SKIA0175E</p>	System does not work properly.
12	Ground	Shield	-	ON	-	Approx. 0V	-

A  
B  
C  
D  
E  
F  
G  
H  
I  
J  
L  
M

AV

# INTEGRATED DISPLAY SYSTEM

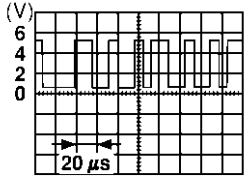
Terminal (Wire color)		Item	Signal input/ output	Condition		Reference value	Example of symptom
+	-			Ignition switch	Operation		
13 (L/R)	Ground	Communica- tion signal (-)	Input/ output	ON	-	 <small>SKIA0176E</small>	System does not work properly.
14 (L)	-	CAN-H	-	-	-	-	-
16 (Y)	-	CAN-L	-	-	-	-	-

## Terminals and Reference Value for A/C and AV Switch

AKS004XX

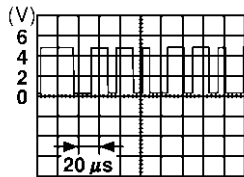
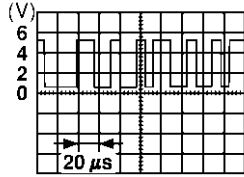
Terminal (Wire color)		Item	Signal input/ output	Condition		Reference value	Example of symptom
+	-			Ignition switch	Operation		
1 (Y)	Ground	Battery power supply	Input	OFF	-	Battery voltage	System does not work properly.
2 (P/B)	Ground	ACC power supply	Input	ACC	-	Battery voltage	System does not work properly.
3 (R/L)	Ground	Illumination signal	Input	OFF	Lighting switch is ON (position 1).	Approx. 12V	A/C and AV switch illumina- tion does not come on when lighting switch is ON (position 1).
					Turn lighting switch OFF.	Approx. 0V	
4 (R/W)	Ground	Illumination control signal	Input	ON	Illumination control switch is operated by lighting switch in 1st position.	Changes between approx. 0 and approx. 12V.	A/C and AV switch illumina- tion cannot be controlled.
5 (B)	Ground	Ground	-	ON	-	Approx. 0V	-
6 (L/G)	Ground	Communica- tion signal (+)	Input/ output	ON	-	 <small>SKIA0175E</small>	System does not work properly.
7	Ground	Shield	-	ON	-	Approx. 0V	-
8 (L/R)	Ground	Communica- tion signal (-)	Input/ output	ON	-	 <small>SKIA0176E</small>	System does not work properly.
12 (R)	Ground	Remote con- trol A	Input	ON	Press MODE switch	Approx. 0V	Steering wheel audio controls do not function.
					Press SEEK UP switch	Approx. 0.75V	
					Press VOL UP switch	Approx. 2V	
					Except for above	Approx. 5V	

# INTEGRATED DISPLAY SYSTEM

Terminal (Wire color)		Item	Signal input/ output	Condition		Reference value	Example of symptom
+	-			Ignition switch	Operation		
13 (G)	Ground	Remote control B	Input	ON	Press POWER switch	Approx. 0V	Steering wheel audio controls do not function.
					Press SEEK DOWN switch	Approx. 0.75V	
					Press VOL DOWN switch	Approx. 2V	
					Except for above	Approx. 5V	
14 (B/W)	Ground	Remote control ground	-	ON	-	Approx. 0V	Steering wheel audio controls do not function.
16 (G/W)	Ground	Rear window defogger switch signal	Output	ON	Press rear window defogger switch	Approx. 0V	Rear window defogger does not operate.
					-	Approx. 5V	

A  
B  
C  
D  
E  
F  
G  
H  
I  
J  
L  
M

AV

# INTEGRATED DISPLAY SYSTEM

AKS004XY

## On Board Self-Diagnosis Function DESCRIPTION

- Diagnosis function consists of the self-diagnosis mode performed automatically.
- Self-diagnosis mode checks for connections between the units constituting this system, analyzes each individual unit at the same time, and displays the results on the LCD screen.

## DIAGNOSIS ITEM

Mode	Item	Description	Reference page
Self-diagnosis	NETWORK CHECK	Check network between control unit and switch connected from display unit via communication line.	<a href="#">AV-101, "NETWORK CHECK"</a>
	PARTS CHECK	<ul style="list-style-type: none"> <li>● Perform diagnosis and setting of display unit.</li> <li>● Perform self-diagnosis for auto air conditioner system.</li> </ul>	<a href="#">AV-101, "PARTS CHECK"</a>
	VERSION CHECK	Displays version of each unit.	<a href="#">AV-102, "VERSION CHECK"</a>
	CAN DIAG MNTR	Display unit displays CAN communication status.	<a href="#">AV-102, "CAN DIAG MNTR (CAN DIAG MONITOR)"</a>

## Self-Diagnosis Mode OPERATION PROCEDURES

AKS004XZ

1. Start the engine.
2. Turn the audio system OFF.
3. While pressing the "PAUSE/MUTE" switch, turn the volume control dial clockwise or counterclockwise for 30 clicks or more. (When the self-diagnosis mode is started, a short beep will be heard.)

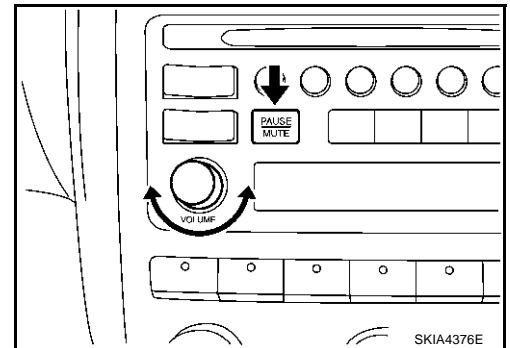

4. Display unit connection check screen.
5. Select each connecting unit (IVCS, CHANGER, SATELLITE RADIO).

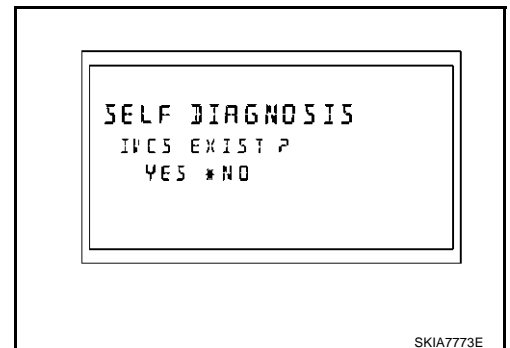

6. Self-diagnosis screen is displayed.
  - Using the joystick, select each item, and perform diagnosis.

**CAUTION:**

If self-diagnosis cannot be activated, refer to [AV-103, "Trouble Diagnosis Chart by Symptom"](#).

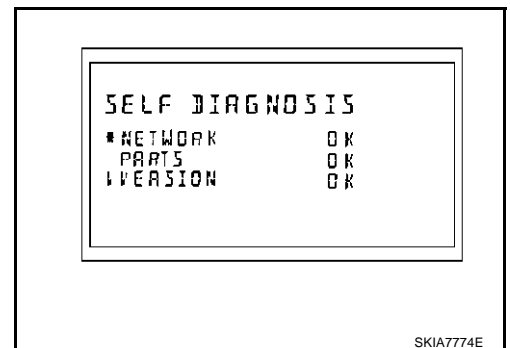

# INTEGRATED DISPLAY SYSTEM

## NETWORK CHECK

Selecting NETWORK CHECK on self-diagnosis screen, display self-diagnostic results.

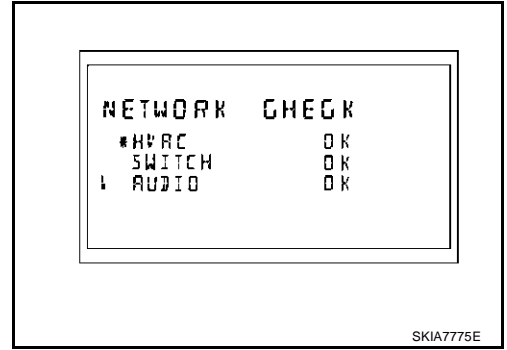

A  
B  
C  
D

Diagnosis item	Contents	DTC return condition	Reference at error
HVAC	OK/NG	Communication error between unified meter and A/C amp. and display unit.	<a href="#">AV-110, "CAN Communication Line Check"</a>
SWITCH	OK/NG	Communication error between A/C and AV switch and display unit.	<a href="#">AV-109, "AV Communication Line Check"</a>
AUDIO	OK/NG	Communication error between audio and display unit.	<a href="#">AV-107, "Audio Communication Line Check"</a>

E  
F  
G

## PARTS CHECK

- Selecting PARTS CHECK on self-diagnosis screen, display selection screen.
- Select DISPLAY, indicate DISPLAY DETAIL screen. Display diagnosis and setting can be performed.
- Select HVAC, Indicate HVAC DETAIL screen. Auto air conditioner system self-diagnosis can be performed.

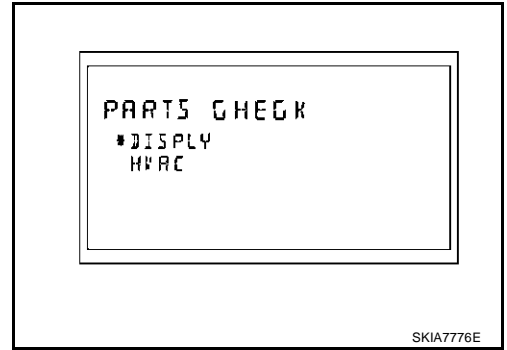

H  
I  
J

AV

## Display Detail Screen

Items	Description
FULL BLINK	All display unit segments turn ON.
BLANK-ADJ	Adjust the display timeout for 5 to 15 seconds. (Default is 10 seconds.) <sup>Note</sup>
WARNING	Select warning indication ON/OFF. (Default is ON.)

### NOTE:

Except an audio screen.

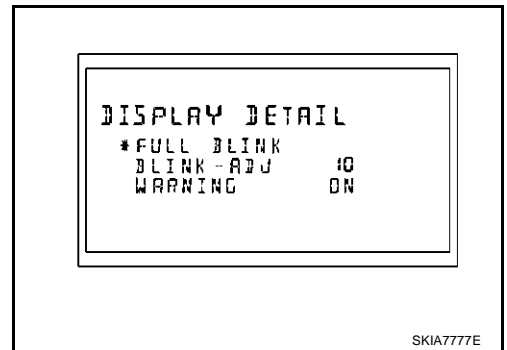

L  
M

# INTEGRATED DISPLAY SYSTEM

## HVAC DETAIL SCREEN

Press the joystick, start auto air conditioner system self-diagnosis. Refer to [ATC-68, "Self-diagnosis Function"](#) .

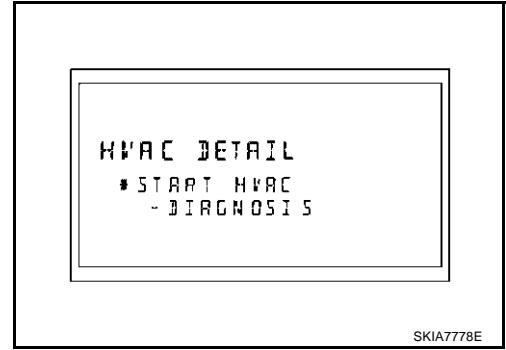

## VERSION CHECK

Check ID and version of display, A/C and AV switch, and audio.

## CAN DIAG MNTR (CAN DIAG MONITOR)

Display CAN communication status.

Items shown	Contents
CANCOMM	OK/NG
CAN1	OK/UNKWN
CAN2	OK/UNKWN
CAN3	OK/UNKWN
CAN4	OK/UNKWN
CAN5	OK/UNKWN
CAN6	OK/UNKWN
CAN7	OK/UNKWN
CAN8	OK/UNKWN
CAN9	OK/UNKWN

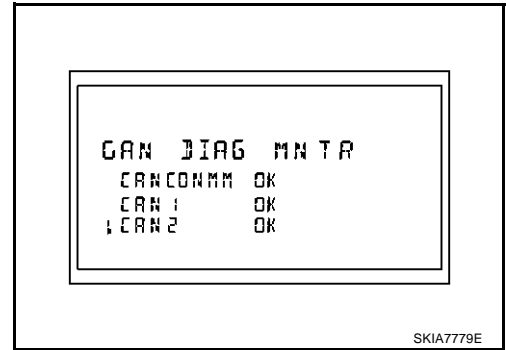

## A/C and AV Switch Self-Diagnosis Function

AKS005FY

It can check ON/OFF operation of each switch in the A/C and AV switch and diagnose the input signals to the steering switch (audio).

### STARTING THE SELF-DIAGNOSIS MODE

1. Turn ignition switch from OFF to ACC.
2. Within 10 seconds press and hold the witches "PAUSE/MUTE" and "PREV" simultaneously for 3 seconds.

Then the self-diagnosis operates.

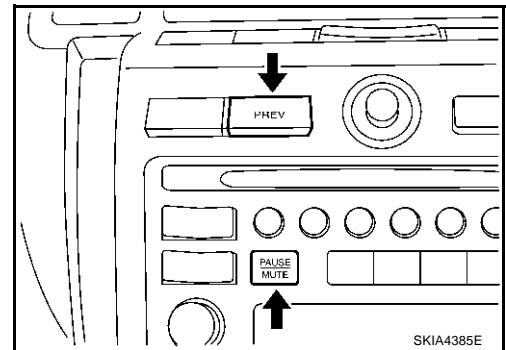

### EXITING THE SELF-DIAGNOSIS MODE

- Turn ignition switch OFF. Then the self-diagnosis ends.

### DIAGNOSIS FUNCTION

- It can illuminate all the indicators (LED) in the A/C and AV switch.
- It can check for continuity of the switches by sounding the buzzer when the A/C and AV switch is pressed.
- It can check for continuity of harness between A/C and AV switch and steering switch (audio).

# INTEGRATED DISPLAY SYSTEM

## Trouble Diagnosis Chart by Symptom

AKS005IF

Symptom	Suspect Systems and reference
No screen is shown.	Refer to <a href="#">AV-104, "Power Supply and Ground Circuit Check for Display Unit"</a> . If above is normal, replace display unit.
Screen does not switch to nighttime mode after the lighting switch is turned 1st.	Refer to <a href="#">AV-107, "Illumination Signal Check"</a> . If above is normal, replace display unit.
TRIP and FUEL ECON screen do not appear.	Refer to <a href="#">AV-107, "Ignition Signal Check"</a> . If above is normal, replace display unit.
<ul style="list-style-type: none"> <li>● Trip odometer (DIST) is not added up.</li> <li>● Average vehicle speed (AVG) is not displayed.</li> </ul>	Refer to <a href="#">DI-19, "Vehicle Speed Signal Inspection"</a> . If above is normal, replace display unit.
Average fuel consumption (AVG) is not displayed.	<ul style="list-style-type: none"> <li>● Refer to <a href="#">DI-19, "Vehicle Speed Signal Inspection"</a> .</li> <li>● Refer to <a href="#">AV-110, "CAN Communication Line Check"</a> .</li> </ul> If above is normal, replace display unit.
Distance to empty (DTE) is not displayed.	<ul style="list-style-type: none"> <li>● Check if speedometer operates. If it does not operate, go to <a href="#">DI-19, "Vehicle Speed Signal Inspection"</a> .</li> <li>● Check if fuel gauge operates. If it does not operate, go to <a href="#">DI-23, "Fuel Level Sensor Signal Inspection 1"</a> .</li> <li>● Refer to <a href="#">AV-110, "CAN Communication Line Check"</a> .</li> </ul> If above is normal, replace display unit.
Tire pressure is not displayed.	<ul style="list-style-type: none"> <li>● Check low tire pressure warning control unit. Refer to <a href="#">WT-38, "Self-Diagnosis"</a> .</li> <li>● Refer to <a href="#">AV-110, "CAN Communication Line Check"</a> .</li> </ul> If above is normal, replace display unit.
Door warning screen does not appear.	<ul style="list-style-type: none"> <li>● Refer to <a href="#">DI-19, "Vehicle Speed Signal Inspection"</a> .</li> <li>● Refer to <a href="#">AV-110, "CAN Communication Line Check"</a> .</li> </ul> If above is normal, replace display unit.
A/C and AV switch and all switch operation are not possible. (Do not start self-diagnosis.)	<ul style="list-style-type: none"> <li>● Refer to <a href="#">AV-105, "Power Supply and Ground Circuit Check for A/C and AV Switch"</a> .</li> <li>● Refer to <a href="#">AV-102, "A/C and AV Switch Self-Diagnosis Function"</a> .</li> <li>● Refer to <a href="#">AV-109, "AV Communication Line Check"</a> .</li> </ul> If above is normal, replace display unit.
Audio operation is not possible.	<ul style="list-style-type: none"> <li>● Refer to <a href="#">AV-102, "A/C and AV Switch Self-Diagnosis Function"</a> .</li> <li>● Refer to <a href="#">AV-107, "Audio Communication Line Check"</a> .</li> </ul>
Air conditioner operation is not possible.	<ul style="list-style-type: none"> <li>● Refer to <a href="#">AV-102, "A/C and AV Switch Self-Diagnosis Function"</a> .</li> <li>● Refer to <a href="#">AV-110, "CAN Communication Line Check"</a> .</li> </ul>

A  
B  
C  
D  
E  
F  
G  
H  
I  
J  
AV  
L  
M

# INTEGRATED DISPLAY SYSTEM

## Power Supply and Ground Circuit Check for Display Unit

AKS005FF

### 1. CHECK FUSE

Make sure that the following fuses in display are not blown.

Unit	Power source	Fuse No.
Display	Battery power	38
	Ignition switch ACC or ON	6

OK or NG

OK >> GO TO 2.

NG >> If fuse is blown, be sure to eliminate case of malfunction before installing new fuse. Refer to [PG-3](#), "[POWER SUPPLY ROUTING CIRCUIT](#)".

### 2. CHECK POWER SUPPLY CIRCUIT

Check voltage between display unit connector and ground.

Terminals		Ignition switch position			
(+)		(-)	OFF	ACC	ON
Connector	Terminal (Wire color)				
M39	1 (Y)	Ground	Battery voltage	Battery voltage	Battery voltage
	2 (P/B)	Ground	0V	Battery voltage	Battery voltage

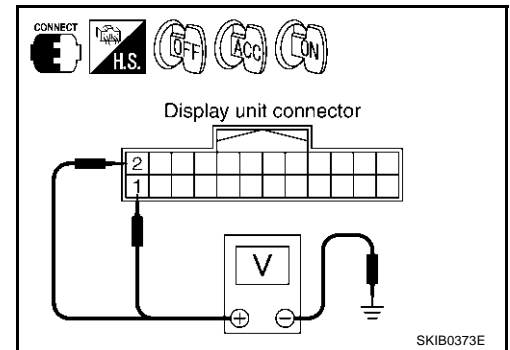

OK or NG

OK >> GO TO 3.

NG >> Check harness for open or short between display and fuse.

### 3. CHECK GROUND CIRCUIT

1. Turn ignition switch OFF.
2. Disconnect display unit connector.
3. Check continuity between Display unit harness connector M39 terminals 6 (B) and ground.

**Continuity should exist.**

OK or NG

OK >> INSPECTION END

NG >> Repair ground harness.

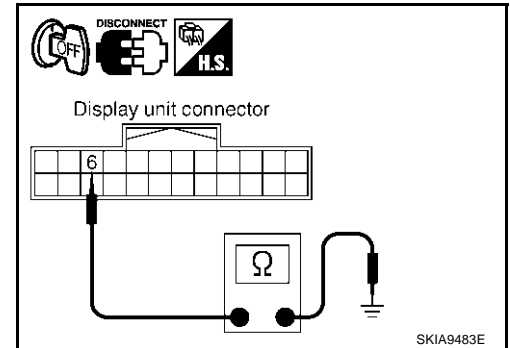



# INTEGRATED DISPLAY SYSTEM

## Power Supply and Ground Circuit Check for A/C and AV Switch

AKS005FG

### 1. CHECK FUSES

Make sure that the following fuses of the A/C and AV switch are not blown.

Unit	Power source	Fuse No.
A/C and AV switch	Battery power	38
	Ignition switch ACC or ON	6

OK or NG

OK >> GO TO 2.

NG >> If fuse is blown, be sure to eliminate cause of malfunction before installing new fuse. Refer to [PG-3](#), "[POWER SUPPLY ROUTING CIRCUIT](#)".

### 2. CHECK POWER SUPPLY CIRCUIT

Check voltage between A/C and AV switch and ground.

Terminals		(-)	Ignition switch position		
(+)	Terminal (Wire color)		OFF	ACC	ON
M48	1 (Y)	Ground	Battery voltage	Battery voltage	Battery voltage
	2 (P/B)	Ground	0V	Battery voltage	Battery voltage

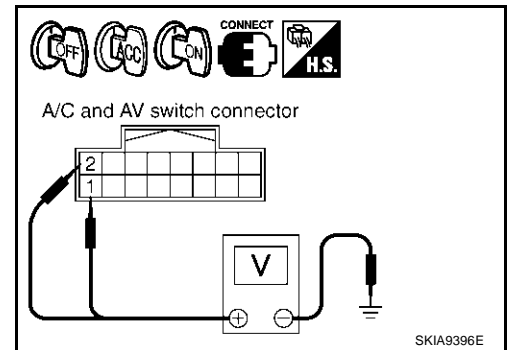

OK or NG

OK >> GO TO 3.

NG >> Check harness for open or short between A/C and AV switch and fuse.

### 3. CHECK GROUND CIRCUIT

1. Turn ignition switch OFF.
2. Disconnect A/C and AV switch connector.
3. Check continuity between A/C and AV switch harness connector M48 terminals 5 (B) and ground.

**Continuity should exist.**

OK or NG

OK >> INSPECTION END

NG >> Repair ground harness.

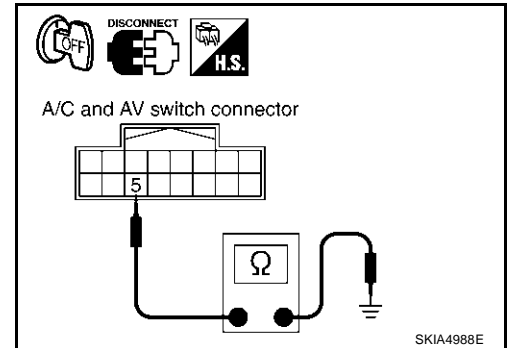

A  
B  
C  
D  
E  
F  
G  
H  
I  
J  
K  
L  
M

AV

# INTEGRATED DISPLAY SYSTEM

AKS005G9

## Vehicle Speed Signal Check

### 1. SPEEDOMETER FUNCTION CHECK

Does speedometer is operated normally?

Yes or No

Yes >> GO TO 2.

No >> Check combination meter trouble diagnosis. Refer to [DI-15, "Diagnosis Flow"](#).

### 2. CHECK HARNESS

1. Turn ignition switch OFF.
2. Disconnect display unit connector, unified meter and A/C amp. connector, audio unit connector, combination meter connector and shift lock control unit connector.
3. Check continuity between display unit harness connector M39 terminal 7 (V/W) and unified meter and A/C amp. harness connector M50 terminal 26 (V/W).

**Continuity should exist.**

4. Check continuity between display unit harness connector M39 terminal 7 (V/W) and ground.

**Continuity should not exist.**

OK or NG

OK >> GO TO 3.

NG >> Repair harness.

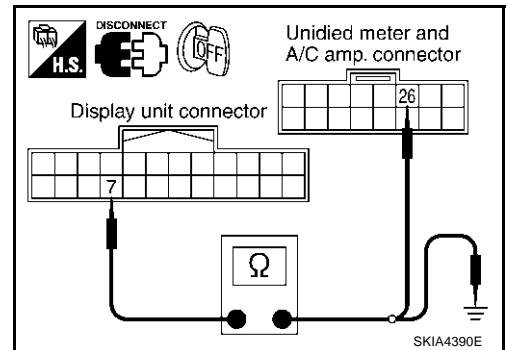

### 3. CHECK DISPLAY UNIT

1. Connect display unit connector..
2. Turn ignition switch ON.
3. Check voltage between display unit harness connector M39 terminal 7 (V/W) and ground.

**Approx. 5V**

OK or NG

OK >> GO TO 4.

NG >> Replace display unit.

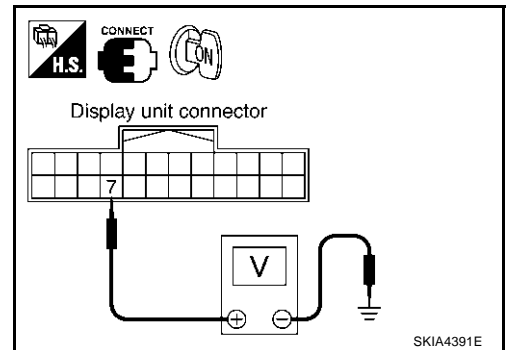

### 4. CHECK 2: VEHICLE SPEED SIGNAL

1. Connect unified meter and A/C amp. connector, audio unit connector, combination meter connector and shift lock control unit connector.
2. Drive vehicle at a constant speed.
3. Check signal between display unit harness connector M39 terminal 7 (V/W) and ground with CONSULT-II or oscilloscope.

**7 (V/W) - Ground** : Refer to [AV-97, "Terminals and Reference Value for Display Unit"](#).

OK or NG

OK >> INSPECTION END

NG >> Check unified meter and A/C amp. system, refer to [DI-19, "Vehicle Speed Signal Inspection"](#).

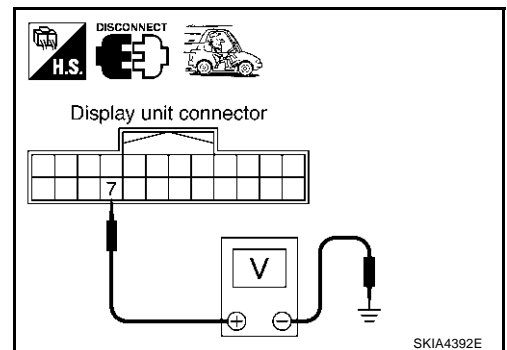

# INTEGRATED DISPLAY SYSTEM

AKS005GA

## Illumination Signal Check

### 1. CHECK ILLUMINATION SIGNAL

1. Turn ignition switch ON.
2. Check voltage between display unit and ground.

Terminals			Lighting switch position	
(+)		(-)	1st or 2nd position	OFF
Connector	Terminal (Wire color)			
M39	4 (R/L)	Ground	Approx. 12V	Approx. 0V

OK or NG

OK >> INSPECTION END

NG >> Check harness for open or short between display unit and IPDM E/R.

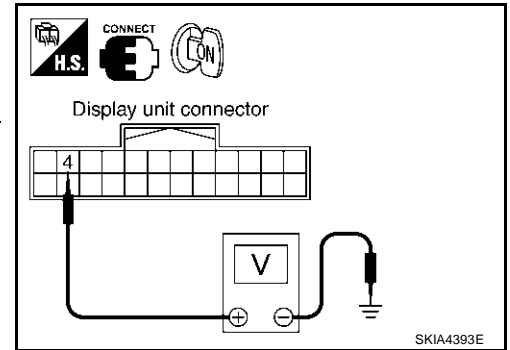

## Ignition Signal Check

### 1. CHECK IGNITION SIGNAL

1. Turn ignition switch ON.
2. Check voltage between display unit harness connector M39 terminal 3 (G) and ground.

**Battery voltage should exist.**

OK or NG

OK >> INSPECTION END

NG >> Check harness for open or short between display unit and fuse.

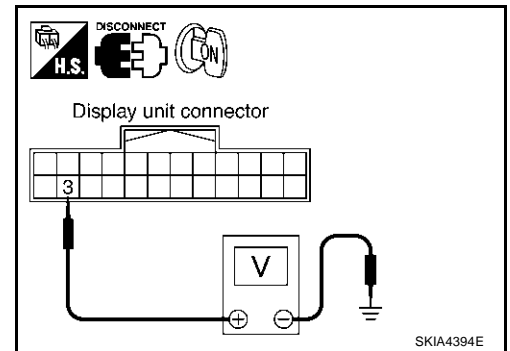

## Audio Communication Line Check

### 1. CHECK HARNESS

1. Turn ignition switch OFF.
2. Disconnect audio unit connector and display unit connector.
3. Check continuity between audio unit and display unit.

Terminals				Continuity
Display unit		Audio unit		
Connector	Terminal (Wire color)	Connector	Terminal (Wire color)	
M39	8 (R/G)	M46	23 (R/G)	Yes
	10 (R/Y)		21 (R/Y)	
	9		25	

4. Check continuity between display unit and ground.

Terminals			Continuity
Display unit		Ground	
Connector	Terminal (Wire color)		
M39	8 (R/G)	No	
	10 (R/Y)		

OK or NG

OK >> GO TO 2.

NG >> Repair harness.

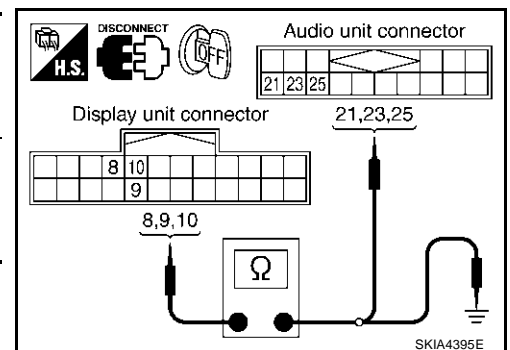

# INTEGRATED DISPLAY SYSTEM

## 2. CHECK AUDIO TX COMMUNICATION SIGNAL

1. Connect audio unit connector.
2. Turn ignition switch ON.
3. Check voltage between audio unit harness connector M46 terminal 23 (R/G) and ground.

**Approx. 4V**

OK or NG

- OK >> GO TO 3.  
NG >> Replace audio unit.

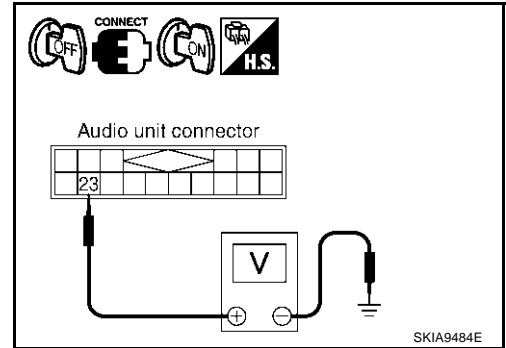

## 3. CHECK AUDIO RX COMMUNICATION SIGNAL

1. Turn ignition switch OFF.
2. Disconnect audio unit connector, and connect display unit connector.
3. Turn ignition switch ON.
4. Check voltage between display unit harness connector M39 terminal 10 (R/Y) and ground.

**Approx. 4V**

OK or NG

- OK >> GO TO 4.  
NG >> Replace display unit.

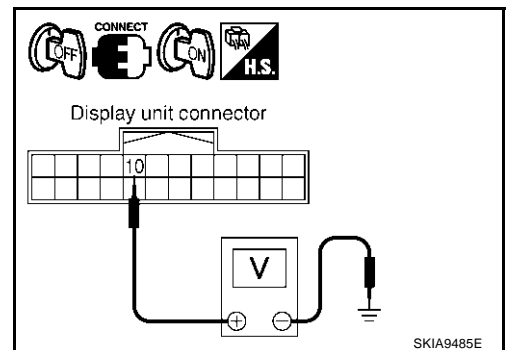

## 4. CHECK AUDIO TX COMMUNICATION SIGNAL

1. Turn ignition switch OFF.
2. Connect audio unit connector.
3. Turn ignition switch ON.
4. Check signal between display unit harness connector M39 terminal 8 (R/G) and ground with CONSULT-II or oscilloscope.

**8 (R/G) - Ground** : Refer to [AV-97, "Terminals and Reference Value for Display Unit"](#) .

OK or NG

- OK >> GO TO 5.  
NG >> Replace display unit.

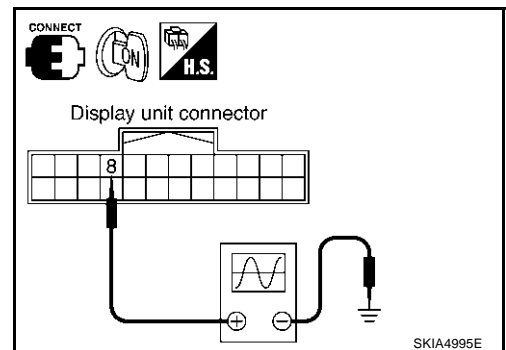

# INTEGRATED DISPLAY SYSTEM

## 5. CHECK AUDIO RX COMMUNICATION SIGNAL

1. Turn ignition switch ON.
2. Check signal between display unit harness connector M39 terminal 10 (R/Y) and ground with CONSULT-II or oscilloscope.

**10 (R/Y) - Ground** : Refer to [AV-97, "Terminals and Reference Value for Display Unit"](#) .

OK or NG

- OK >> INSPECTION END  
 NG >> Replace audio unit.

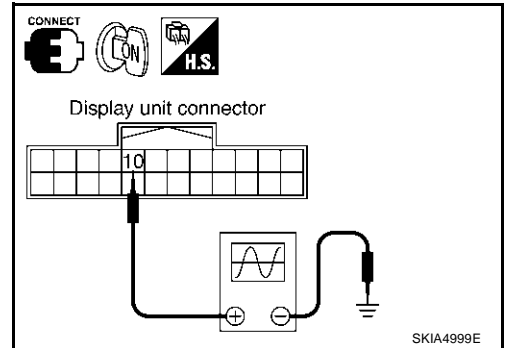

## AV Communication Line Check

### 1. CHECK A/C AND AV SWITCH CIRCUIT

1. Turn ignition switch OFF.
2. Disconnect display unit connector and A/C and AV switch connector.
3. Check continuity between display unit and A/C and AV switch.

Terminals				Continuity
Display unit		A/C and AV switch		
Connector	Terminal (Wire color)	Connector	Terminal (Wire color)	
M39	11 (L/G)	M48	6 (L/G)	Yes
	13 (L/R)		8 (L/R)	
	12		7	

4. Check continuity between display unit and ground.

Terminals			Continuity
Connector	Terminal (Wire color)	Terminal	
M39	11 (L/G)	Ground	No
	13 (L/R)		

OK or NG

- OK >> GO TO 2.  
 NG >> Replace harness.

### 2. CHECK AV COMMUNICATION SIGNAL

1. Connect display unit connector and A/C and AV switch connector.
2. Turn ignition switch ON.
3. Check the signal between display unit harness connector M39 terminals 11 (L/G), 13 (L/R) and ground with CONSULT-II or oscilloscope.

**11 (L/G), 13 (L/R) - Ground** : Refer to [AV-97, "Terminals and Reference Value for Display Unit"](#) .

OK or NG

- OK >> Replace A/C and AV switch.  
 NG >> Replace display unit.

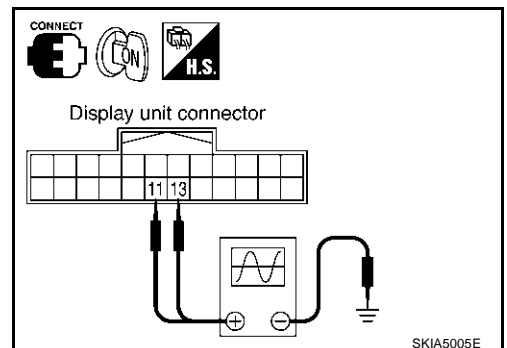
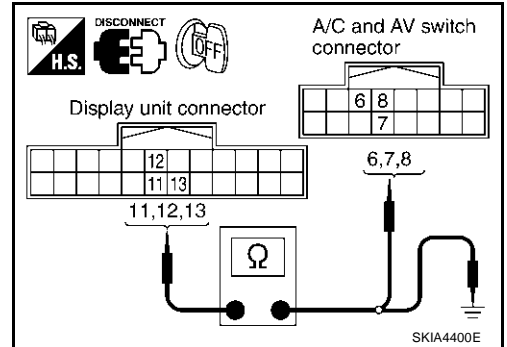

# INTEGRATED DISPLAY SYSTEM

AKS005H0

## CAN Communication Line Check

### 1. CHECK MONITOR DESCRIPTION

1. Start display unit self-diagnosis. [AV-100, "Self-Diagnosis Mode"](#)
2. Select "CAN DIAG MNTR". [AV-102, "CAN DIAG MNTR \(CAN DIAG MONITOR\)"](#)

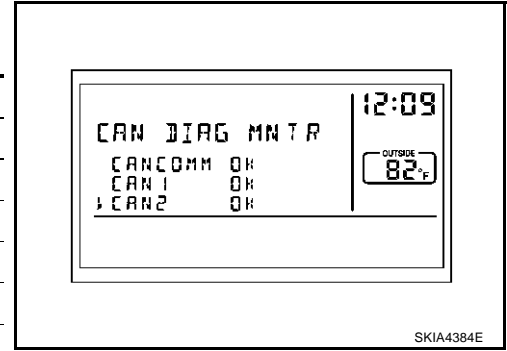

Diagnosis item	Data monitor display description	
	Normal condition	Error (example)
CANCOMM	OK	NG
CAN1	OK	UNKWN
CAN2	OK	UNKWN
CAN3	OK	UNKWN
CAN4	OK	UNKWN
CAN5	OK	UNKWN
CAN6	OK	UNKWN
CAN7	OK	UNKWN
CAN8	OK	UNKWN
CAN9	OK	UNKWN

3. Record each item display description (OK/NG/UNKWN) displayed on the following CAN DIAG MONITOR Check Sheet.

#### CAN DIAG MONITOR Check Sheet

Diagnosis item	Screen display		Diagnosis item	Screen display	
CANCOMM	OK	NG	CAN5	OK	UNKWN
CAN1	OK	UNKWN	CAN6	OK	UNKWN
CAN2	OK	UNKWN	CAN7	OK	UNKWN
CAN3	OK	UNKWN	CAN8	OK	UNKWN
CAN4	OK	UNKWN	CAN9	OK	UNKWN

>> After filling in CAN DIAG MONITOR Check Sheet, go to [LAN-10, "Precautions When Using CONSULT-II"](#) .

# INTEGRATED DISPLAY SYSTEM

AKS005FZ

## Steering Wheel Audio Control Switch Check

### 1. A/C AND AV SWITCH SELF-DIAGNOSIS FUNCTION CHECK

1. Start A/C and AV switch self-diagnosis function. Refer to [AV-102, "A/C and AV Switch Self-Diagnosis Function"](#) .
2. Operate steering wheel audio control switch.

Dose steering wheel audio control switch operate normally?

- OK >> Inspection end.  
 NG >> GO TO 2

### 2. CHECK HARNESS

1. Turn ignition switch OFF.
2. Disconnect A/C and AV switch connector and spiral cable connector.
3. Check continuity between spiral cable harness connector terminals and A/C and AV switch harness connector terminals .

Terminals				Continuity
spiral cable		A/C and AV switch		
Connector	Terminal	Connector	Terminal (Wire color)	
M31	32 (G)	M48	13 (G)	Yes
	31 (B/W)		14 (B/W)	
	24 (R)		12 (R)	

4. Check continuity between A/C and AV switch and ground.

Terminals			Continuity
A/C and AV switch (+)		(-)	
Connector	Terminal (Wire color)		
M48	12 (R)	Ground	No
	13 (G)		
	14 (B/W)		

OK or NG

- OK >> GO TO 2.  
 NG >> Repair harness.

### 3. SPIRAL CABLE CHECK

Check spiral cable harness.

OK or NG

- OK >> GO TO 4  
 NG >> Replace spiral cable.

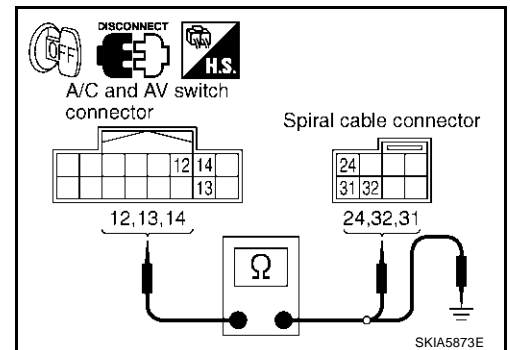

A  
B  
C  
D  
E  
F  
G  
H  
I  
J  
L  
M

AV

# INTEGRATED DISPLAY SYSTEM

## 4. CHECK AUDIO STEERING WHEEL SWITCH RESISTANCE

Check resistance audio steering wheel switch terminals.

Terminal		Signal name	Condition	Resistance (Ω)
(+)	(-)			
16	17	Seek down	Depress (station) down switch.	Approx. 165
		Power	Depress power switch.	Approx. 0
		Volume (down)	Depress volume down switch.	Approx. 652
20	17	Seek up	Depress (station) up switch.	Approx. 165
		Mode	Depress mode switch.	Approx. 0
		Volume (up)	Depress volume up switch.	Approx. 652

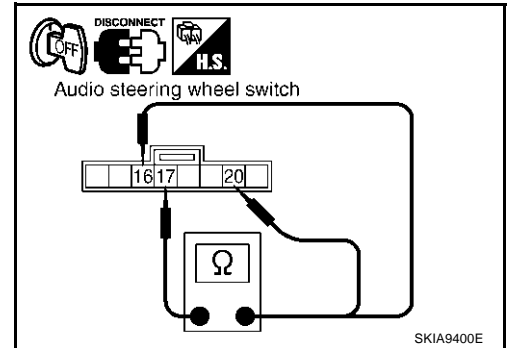

### OK or NG

- OK >> Replace AV and A/C switch.
- NG >> Replace steering wheel audio control switch.

## Removal and Installation of Display Unit REMOVAL

1. Remove center ventilator grille. Refer to [IP-11, "WORK STEP"](#).
2. Remove screws (4) and remove display unit.

AKS005R3

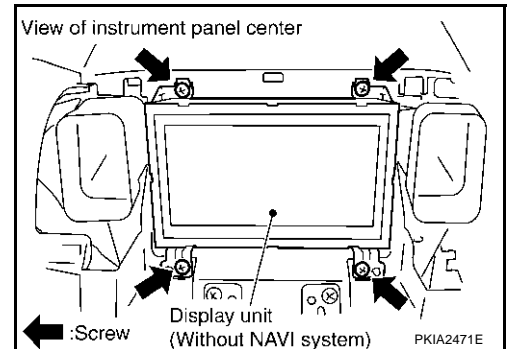

3. Remove screws (4) and remove bracket.

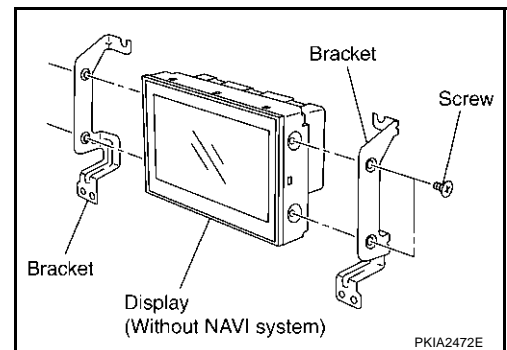

## INSTALLATION

Install in the reverse order of removal.

## Removal and Installation of A/C and AV Switch

Refer to [AV-57, "Removal and Installation for A/C and AV Switch"](#).

AKS005R2



## NAVIGATION SYSTEM

PFP:25915

### System Description

AKS004R4

The navigation system periodically calculates the vehicle's current position according to the following three signals: Travel distance of the vehicle as determined by the vehicle speed sensor, turning angle of the vehicle as determined by the gyroscope (angular velocity sensor), and the direction of vehicle travel as determined by the GPS antenna (GPS information).

The current position of the vehicle is then identified by comparing the calculated vehicle position with map data read from the map DVD-ROM, which is stored in the DVD-ROM drive (map-matching), and indicated on the screen with a current-location mark.

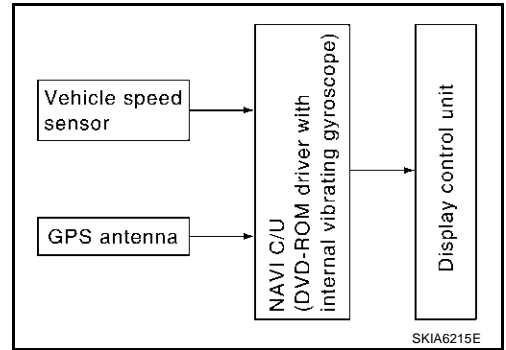

By comparing the vehicle position detection results found by the GPS and by map-matching, more accurate vehicle position data can be used.

The current vehicle position will be calculated by detecting the distance the vehicle moved from the previous calculation point and its direction.

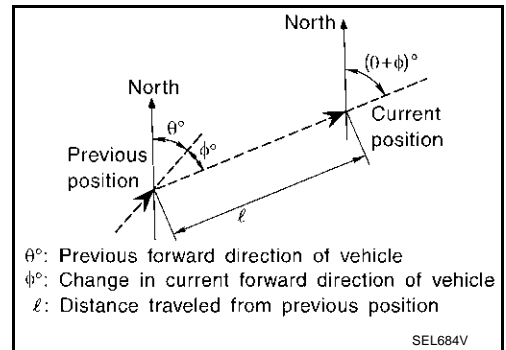

### TRAVEL DISTANCE

Travel distance calculations are based on the vehicle speed sensor input signal. Therefore, the calculation may become incorrect as the tires wear down. To prevent this, an automatic distance fine adjustment function has been adopted.

### TRAVEL DIRECTION

Change in the travel direction of the vehicle is calculated by a gyroscope (angular velocity sensor) and a GPS antenna (GPS information). As the gyroscope and GPS antenna have both merit and demerit, input signals from them are prioritized in each situation. However, this order of priority may change in accordance with more detailed travel conditions so that the travel direction is detected more accurately.

Type	Advantage	Disadvantage
Gyroscope (angular velocity sensor)	<ul style="list-style-type: none"> <li>Can detect the vehicle's turning angle quite accurately.</li> </ul>	<ul style="list-style-type: none"> <li>Direction errors may accumulate when the vehicle is driven for long distances without stopping.</li> </ul>
GPS antenna (GPS information)	<ul style="list-style-type: none"> <li>Can detect the vehicle's travel direction (North/South/East/West).</li> </ul>	<ul style="list-style-type: none"> <li>Correct direction cannot be detected when the vehicle speed is low.</li> </ul>

### MAP-MATCHING

Map-matching is a function that repositions the vehicle on the road map when a new location is judged to be the most accurate. This is done by comparing the current vehicle position, calculated by the method described in the position detection principle, with the road map data around the vehicle, read from the map DVD-ROM stored in the DVD-ROM drive.

Therefore, the vehicle position may not be corrected after the vehicle is driven over a certain distance or time in which GPS information is hard to receive. In this case, the current-location mark on the display must be corrected manually.

#### CAUTION:

The road map data is based on data stored in the map DVD-ROM.

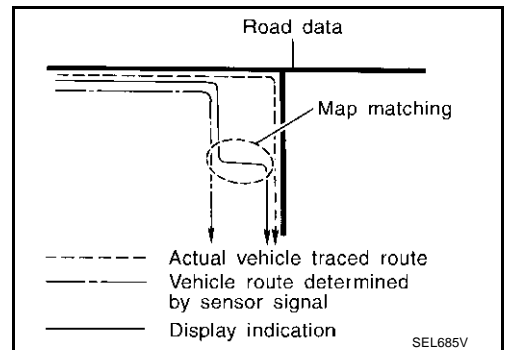

# NAVIGATION SYSTEM

- In map-matching, alternative routes to reach the destination will be shown and prioritized, after the road on which the vehicle is currently driven has been judged and the current-location mark has been repositioned.  
If there is an error in distance and/or direction, the alternative routes will be shown in different order of priority, and the wrong road can be avoided.  
If two roads are running in parallel, they are of the same priority. Therefore, the current-location mark may appear on either of them alternately, depending on maneuvering of the steering wheel and configuration of the road.

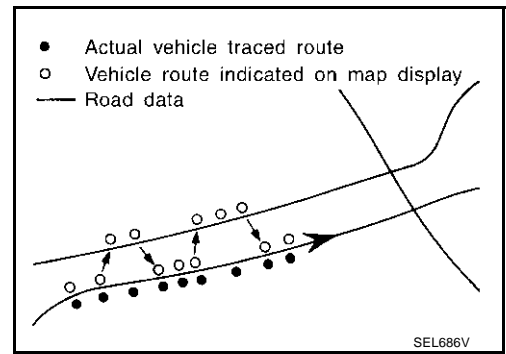

- Map-matching does not function correctly when the road on which the vehicle is driving is new and not recorded in the map DVD-ROM, or when the road pattern stored in the map data and the actual road pattern are different due to repair.  
When driving on a road not present in the map, the map-matching function may find another road and position the current-location mark on it. Then, when the correct road is detected, the current-location mark may leap to it.
- Effective range for comparing the vehicle position and travel direction calculated by the distance and direction with the road data read from the map DVD-ROM is limited. Therefore, when there is an excessive gap between the current vehicle position and the position on the map, correction by map-matching is not possible.

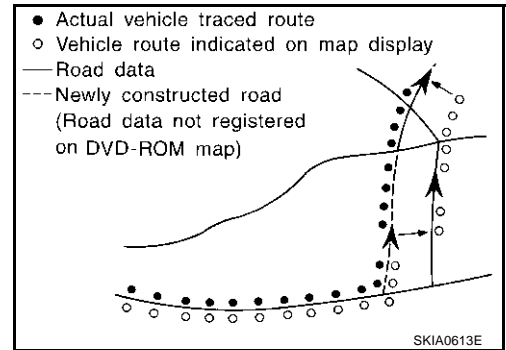

## GPS (GLOBAL POSITIONING SYSTEM)

GPS (Global Positioning System) has been developed and controlled by the US Department of Defense. The system utilizes GPS satellite (NAVSTAR), sending out radio waves while flying on an orbit around the earth at the height of approx. 21,000 km (13,000 miles). The GPS receiver calculates the vehicle's position in three dimensions (latitude/longitude/altitude) according to the time lag of the radio waves received from four or more GPS satellites (three-dimensional positioning). If radio waves were received only from three GPS satellites, the GPS receiver calculates the vehicle's position in two dimensions (latitude/longitude), utilizing the altitude data calculated previously by using radio waves from four or more GPS satellites (two-dimensional positioning).

Accuracy of the GPS will deteriorate under the following conditions.

- In two-dimensional positioning, the GPS accuracy will deteriorate when the altitude of the vehicle position changes.
- There may be an error of approximately 10 m (30 ft) in position detected by three-dimensional positioning, which is more accurate than two-dimensional positioning. The accuracy can be even lower depending on the arrangement of the GPS satellites utilized for the positioning.
- Position detection is not possible when the vehicle is in an area where radio waves from the GPS satellite do not reach, such as in a tunnel, parking lot in a building, and under an elevated highway. Radio waves from the GPS satellites may not be received when some object is located over the GPS antenna.
- Position correction by GPS is not available while the vehicle is stopped.

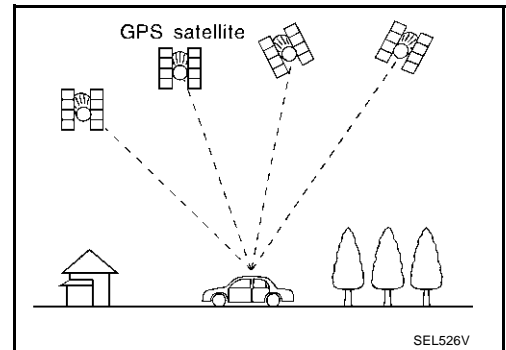

# NAVIGATION SYSTEM

## COMPONENT DESCRIPTION

### NAVI Control Unit

- The gyro (angular speed sensor) and the DVD-ROM drive are built-in units that control the navigation functions.
- Signals are received from the gyro, the vehicle speed sensor, and the GPS antenna. Vehicle location is determined by combining this data with the data contained in the DVD-ROM map. Locational information is shown on liquid crystal display panel.

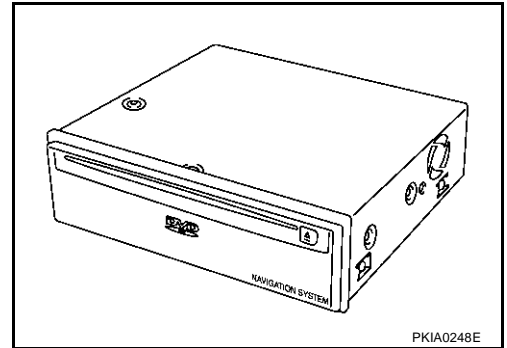

### DVD-ROM Drive

Maps, traffic control regulations, and other pertinent information can be easily read from the DVD-ROM disc.

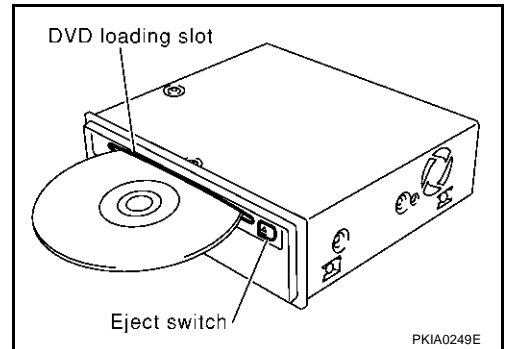

### Map DVD-ROM

- The map DVD-ROM has maps, traffic control regulations, and other pertinent information.
- To improve DVD-ROM map matching and route determination functions, the DVD-ROM uses an exclusive Nissan format. Therefore, the use of a DVD-ROM provided by other manufacturers cannot be used.

### Gyro (Angular Speed Sensor)

- The oscillator gyro sensor is used to detect changes in vehicle steering angle.
- The gyro is built into the navigation (NAVI) control unit.

### BIRDVIEW™

The BIRDVIEW™ provides a detailed and easily seen display of road conditions covering the vehicle's immediate to distant area.

- MAP DISPLAY

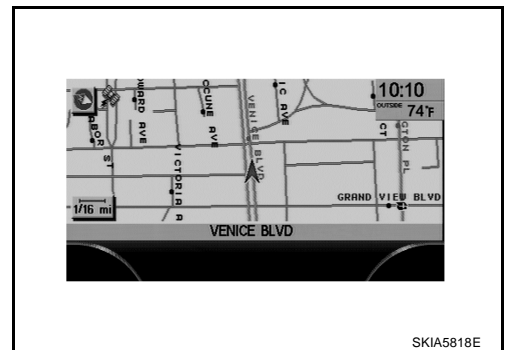

A  
B  
C  
D  
E  
F  
G  
H  
I  
J  
L  
M

AV

# NAVIGATION SYSTEM

- BIRDVIEW™

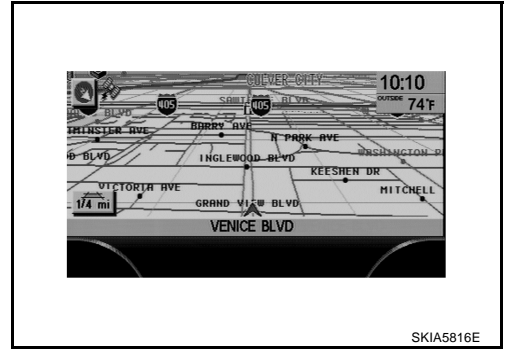

## Description

- Display area: Trapezoidal representation showing approximate distances ( $W_n$ ,  $D$ , and  $W_d$ ).
- Ten horizontal grid lines indicate display width while six vertical grid lines indicate display depth and direction.
- Pushing the “ZOOM IN” button during operation displays the scale change and the view point height on the left side of the screen.  
The height of the view point increases or decreases when “ZOOM” or “WIDE” is selected with the joystick.

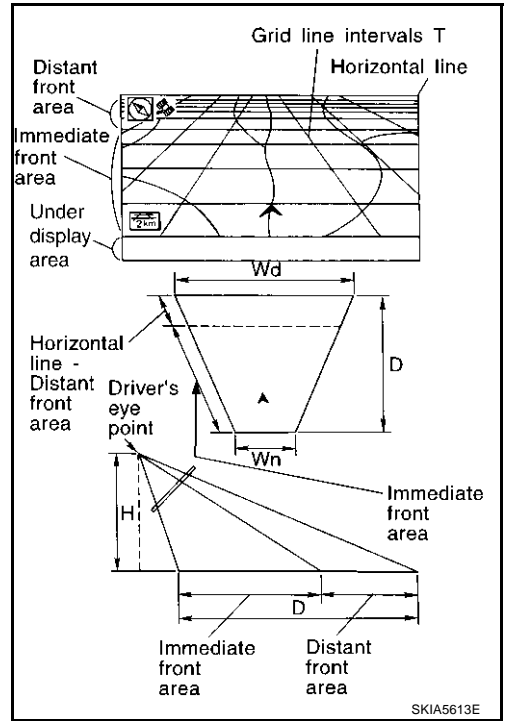

## MAP DISPLAY

Function of each icon is as follows:

1. Azimuth indication.
2. Position marker.
  - The tip of the arrow shows the current location. The shaft of the arrow indicates the direction in which the vehicle is traveling.
3. GPS reception signal (indicates current reception conditions).
4. Distance display (shows the distance in a reduced scale).

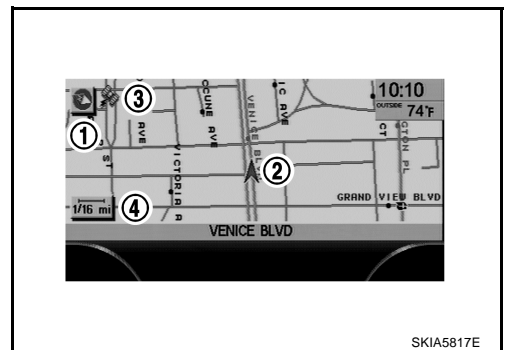

# NAVIGATION SYSTEM

## FUNCTION OF CENTER SWITCH

### Display with Pushed "DEST" Button

- Easy Mode



- Expert Mode



The function of each icon is as follows:

Icon	Mode		Description
	Easy	Expert	
Address Book		×	Favorite place can be saved to memory.
Address/Street	×	×	The destination can be searched from the address.
Point of Interest (POI)	×	×	The destination of favorite facility can be searched.
Previous Dest.		×	The previous ten destinations stored in memory are displayed.
Intersection		×	The destination can be searched from the intersection.
City		×	The destination can be searched from city name.
Map		×	The destination can be searched from the map.
Phone Number		×	When two or more countries are included in one DVD-ROM, the destination can be searched for under the country name.
Home	×		Sets the home as a destination.
Help	×		Explanation of navigational functions appear on the display.
Country	×	×	Select country (USA, CANADA)

# NAVIGATION SYSTEM

## Display with Pushed "ROUTE" Button

- Easy Mode

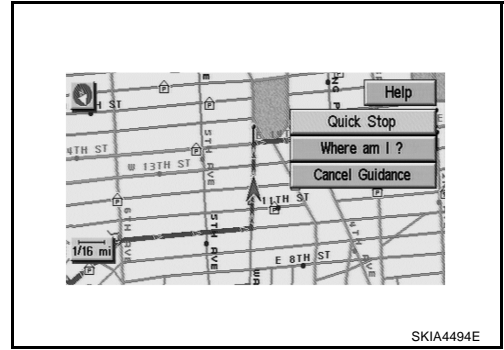

- Expert Mode

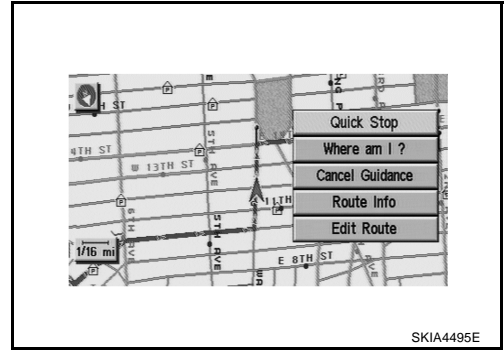

### The function of each icon is as follows:

Icon	Mode		Description
	Easy	Expert	
Quick Stop	×	×	The selected facility is set as the destination or waypoint. (Route guidance has been turned OFF or the destination has been reached.)
Where am I?	×	×	Next, current and previous street names can be displayed.
Cancel Guidance	×	×	The following items can be set. <ul style="list-style-type: none"> <li>● All Destinations</li> <li>● Way point</li> <li>● Not Cancel</li> </ul>
Route Info.*		×	The following items can be set. <ul style="list-style-type: none"> <li>● Complete Route</li> <li>● Turn List</li> <li>● Route Simulation</li> </ul> (Displayed only when the destination area has been set.)
Edit Route*		×	Change the destination or add the transit points of the route set in the route guide. (Displayed only when the automatic reroute function has been turned OFF and the recommended route is not followed.)
Help	×		Explanation of navigational functions appear on the display.

\*: When destinations have been entered, route guidance has been turned OFF or destination has been reached, "Route Info." and "Edit Route" are not displayed.

# NAVIGATION SYSTEM

## Display with Pushed “SETTING” Button

The function of each icon is as follows:

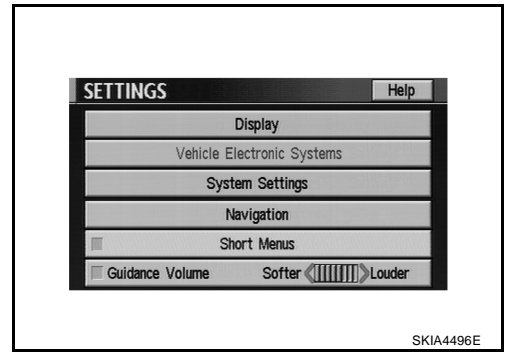

Icon	Description
Display	Settings of display can be performed.
Vehicle Electronic Systems	Settings of vehicle electrical equipment can be performed.
System Settings	Settings of linguistic select , time adjusting and beep sound can be performed.
Navigation	Settings and adjusting of navigation can be performed.
Short Menus	Easy Mode and Expert Easy Mode can be switched.
Guidance Volume	The volume and/or on/off of voice prompt can be controlled by the joystick.
Help (only easy mode)	Explanation of navigational functions appear on the display.

## Display Settings

How To Perform Display Settings.

1. Start the engine.
2. Push “SETTING” button.
3. Select “Display”.

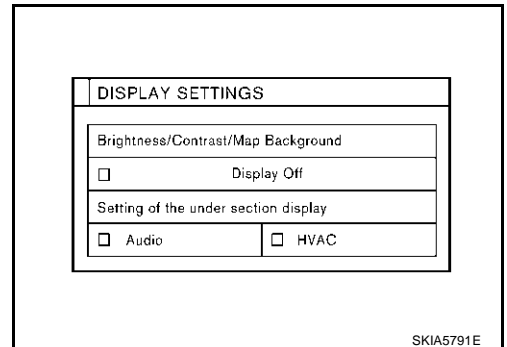

## Application Items

Icon	Description	Reference page
Brightness/Contrast/Map Background	Brightness, Contrast and Map Background can be set.	<a href="#">AV-119</a>
Display Off	Display sleep mode ON/OFF can be switched.	<a href="#">AV-119</a>
Setting of the under section display	The setting status of A/C or AV can be shown.	<a href="#">AV-119</a>

## Brightness/Contrast/Map Back Ground

Select “Brightness/Contrast/Map Background”.

- Brightness, Contrast and Back ground are shown at the lower part of the screen, and it can be set by pushing joystick.

## Display Off

Select “Display Off”.

- When setting is turned on (Indicator light ON), the display will be under sleep mode.

## Setting of the Under Section Display

Select “Setting of the under section display”.

- The setting status that is selected from A/C or AV is shown at the lower part of the screen.

# NAVIGATION SYSTEM

## Vehicle Electronic Systems

How To Perform Vehicle Electronic Systems.

1. Start the engine.
2. Push "SETTING" button.
3. Select "Vehicle Electronic Systems".

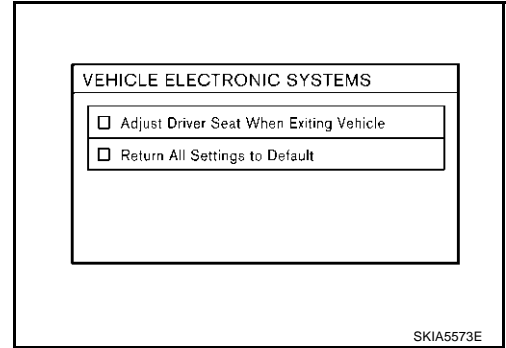

## Application Items

Icon	Description	Reference page
Adjust Driver Seat When Exiting Vehicle	The driver's seat automatically moves back and returns to the original position.	<a href="#">AV-120</a>
Return All Settings to Default	All settings will return to the initial conditions.	<a href="#">AV-120</a>

## Adjust Driver Seat When Exiting Vehicle

Select "Adjust Driver Seat When Exiting Vehicle".

- The driver's seat automatically moves back and returns to the original position when the switch is turned on.  
(Indicator light is illuminated-ON, Indicator light is not illuminated-OFF.)

## Return All Settings to Default

Select "Return All Settings to Default".

- All settings made by VEHICLE ELECTRONICS will return to the initial conditions when the switch is turned on.  
(Indicator light is illuminated-ON, Indicator light is not illuminated-OFF.)

## System Settings

How To Perform System Settings.

1. Start the engine.
2. Push "SETTING" button.
3. Select "System Settings".

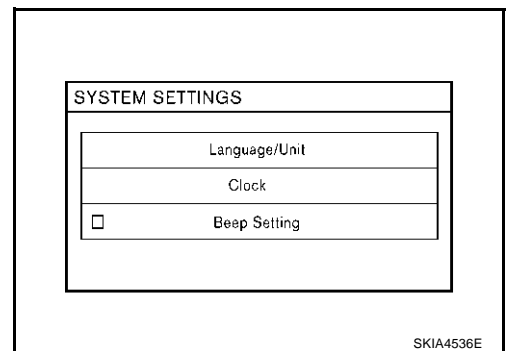



# NAVIGATION SYSTEM

## Application Items

Icon	Description	Reference page
Language/Unit	Settings of Language or unit can be performed.	<a href="#">AV-121</a>
Clock	Settings of clock can be performed.	<a href="#">AV-121</a>
Beep Setting	Settings of Beep sound can be performed.	<a href="#">AV-121</a>

### Language Setting

Select "Language/ Unit".

- Language setting can be switched.
- Unit setting can be changed.

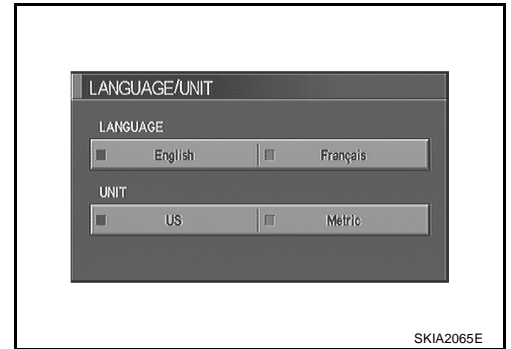

### Clock Settings

Select "Clock".

- Select the "Hours" or "Minutes" key and tilt the joystick to the right or left to adjust the time.
- Turn ON and OFF daylight saving time.
- Select the "Auto Adjust" key. The time will be reset to the GPS time.
- Select the "Select Time Zone" key. The [TIME ZONE] screen will appear.

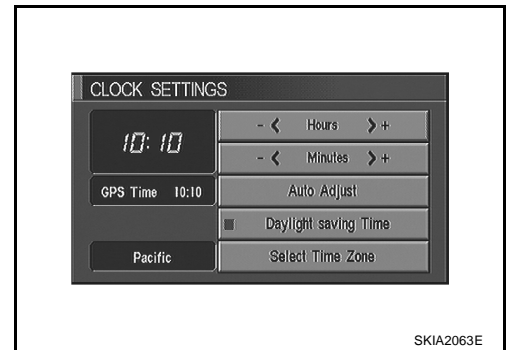

### Beep Setting

Select "Beep Setting".

- When Beep Setting is on (indicator light on), a beep will sound if the button is pushed.

#### NOTE:

Items in exception of Beep Setting ON/OFF.

- An error beep.
- An interrupted-screen beep.

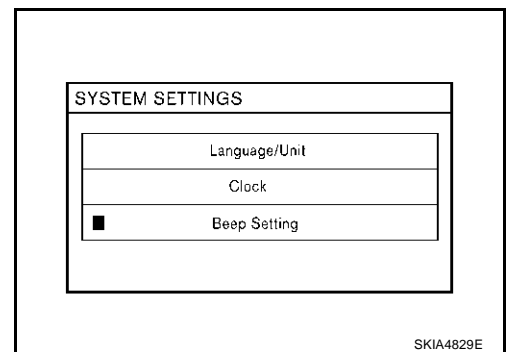

# NAVIGATION SYSTEM

## Navigation Settings

How To Perform Navigation Settings.

1. Start the engine.
2. Push "SETTING" button.
3. Select "Navigation".

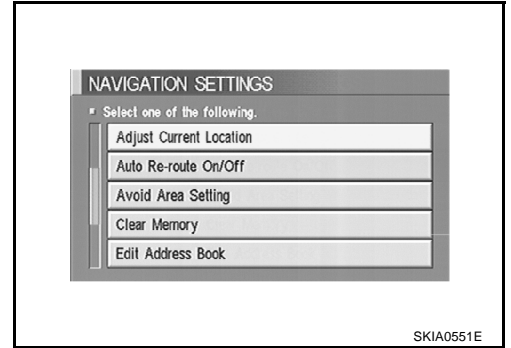

## Application Items

Icon	Description	Reference page
View	Map display mode can be switched.	<a href="#">AV-122</a>
Heading	Heading of the map display can be customized for either north heading or the actual driving direction of the vehicle.	<a href="#">AV-123</a>
Nearby Display Icons	Icons of facilities can be displayed. Facilities to be displayed can be selected from the variety selections.	<a href="#">AV-123</a>
Save Current Location	Current vehicle location can be registered in Address Book.	<a href="#">AV-123</a>
Adjust Current Location	Current location of position marker can be adjusted. Direction of position marker also can be calibrated when heading direction of the vehicle on the display is not matched with the actual direction.	<a href="#">AV-123</a>
Auto Re-route On/Off	ON/OFF of Auto Re-route can be switched.	<a href="#">AV-124</a>
Avoid Area Setting	A particular area can be avoided when routing.	<a href="#">AV-124</a>
Clear Memory	Address Book, Previous destination or Avoid area can be deleted.	<a href="#">AV-124</a>
Edit Address Book	Address Book can be edited.	<a href="#">AV-125</a>
GPS Information	The GPS data includes longitude, latitude and altitude (distance above sea level) of the present vehicle position, and current date and time for the area in which the vehicle is being driven. Also indicated are the GPS reception conditions and the GPS satellite position.	<a href="#">AV-125</a>
Quick Stop Customer Setting	One facility of your selection can be added to your Quick Stop.	<a href="#">AV-125</a>
Set Average Speed for Estimated Journey Time	Average vehicle speed can be set to calibrate estimated journey time for the destination.	<a href="#">AV-125</a>
Tracking On/Off	Tracking to the present vehicle position can be displayed.	<a href="#">AV-126</a>

## "VIEW" MODE

- To open the map screen display with Birdview™, select "Birdview™".
- To open the map screen display with Plan View, select "Plan View".

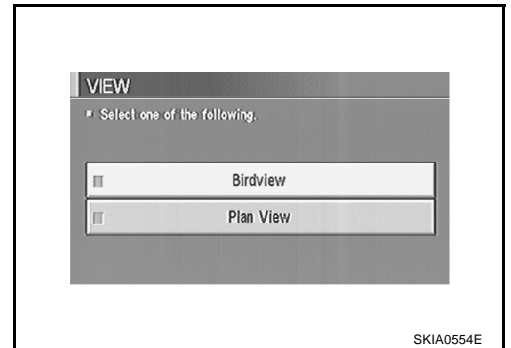

# NAVIGATION SYSTEM

## “HEADING” MODE

- To display North up, select “North up”.
- To display the car heading up, select “Heading up”.

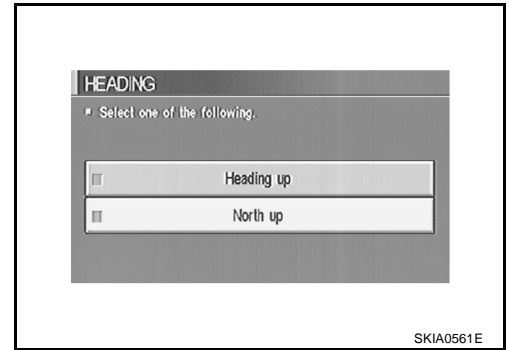

A  
B  
C  
D

## “NEARBY DISPLAY ICONS” MODE

- Select an icon to display on the map screen.

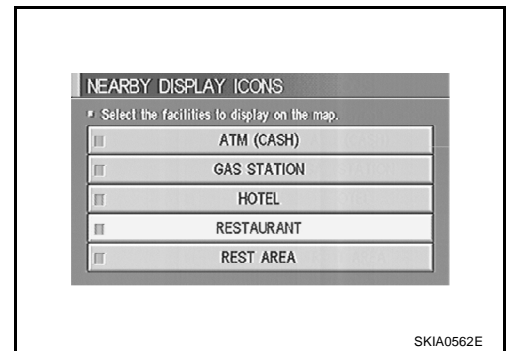

E  
F  
G  
H

## “SAVE CURRENT LOCATION” MODE

- The current vehicle location can be registered in “Address Book”.

### NOTE:

“Address Book” can store 50 items max.

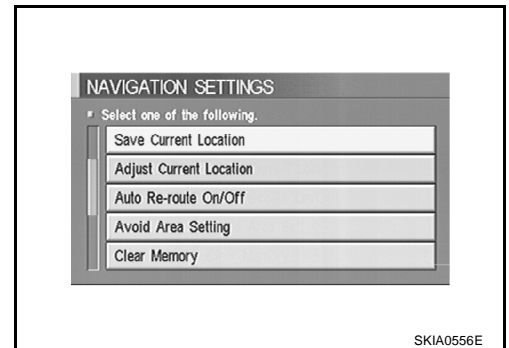

I  
J  
AV  
L

## “ADJUST CURRENT LOCATION” MODE

- Select an icon “right” or “left” to calibrate the heading direction. (Arrow marks will rotate corresponding to the calibration key.)

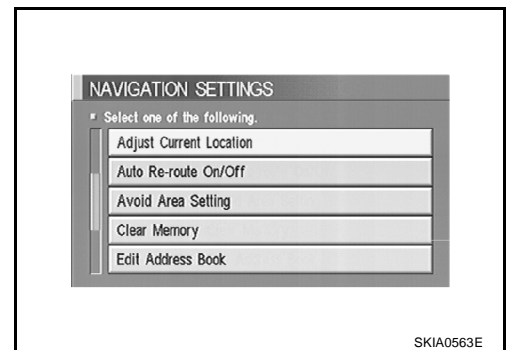

M

# NAVIGATION SYSTEM

- Select “Set”. Then the vehicle mark will be matched to the arrow mark.

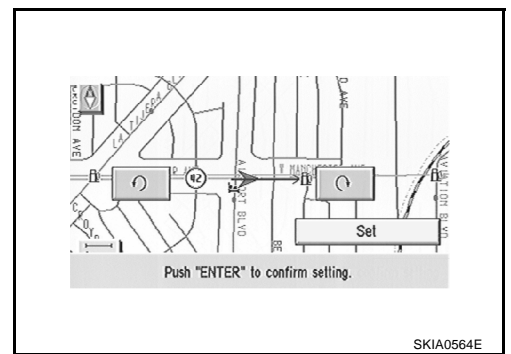

## “AUTO RE-ROUTE” MODE

- To activate “AUTO RE-ROUTE” mode, select “On”.
- To disactivate “AUTO RE-ROUTE” mode, select “Off”.

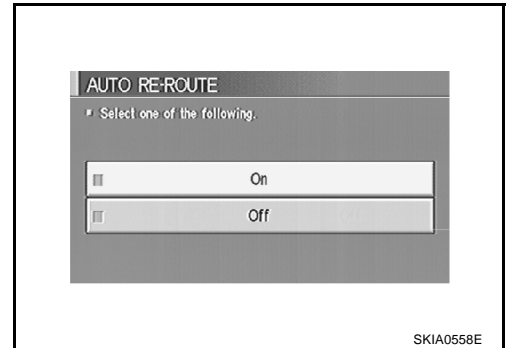

## “AVOID AREA SETTINGS” MODE

- Areas to avoid can be registered.

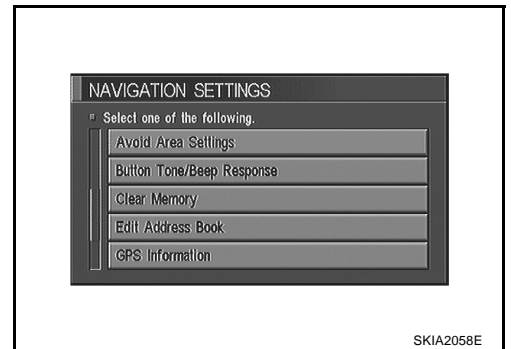

## “CLEAR MEMORY” MODE

- To delete all the stored places in “Address Book”, “Avoid Area” and “Previous Dest”, select “Yes”.

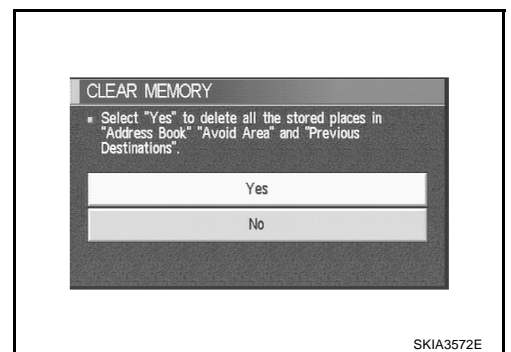

# NAVIGATION SYSTEM

## “EDIT ADDRESS BOOK” MODE

- Edit the items registered in Address Book.

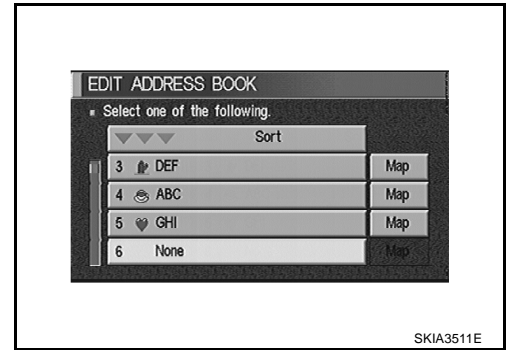

A  
B  
C  
D

## “GPS INFORMATION” MODE

- Latitude, longitude, altitude, astrometric state, and satellite location are displayed as GPS information.

### NOTE:

Altitude is displayed only in three-dimensional status.

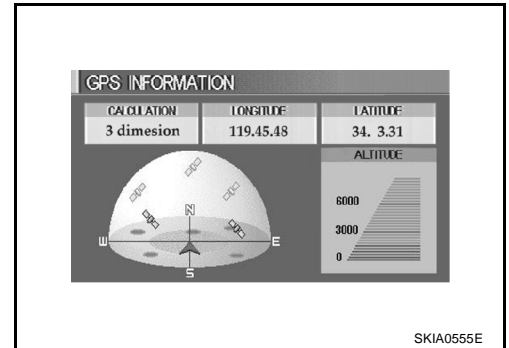

E  
F  
G  
H

## “QUICK STOP CUSTOMER SETTING” MODE

- Select a category for the “Quick Stop” menu.

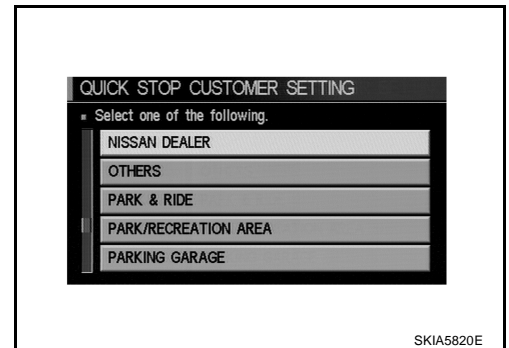

I  
J  
AV

## “SET AVERAGE SPEED” MODE

- Set the average vehicle speed to calibrate the estimated journey time for the destination.
- Set three items; “Freeway”, “Main Roads”, and “Ordinary Roads”.

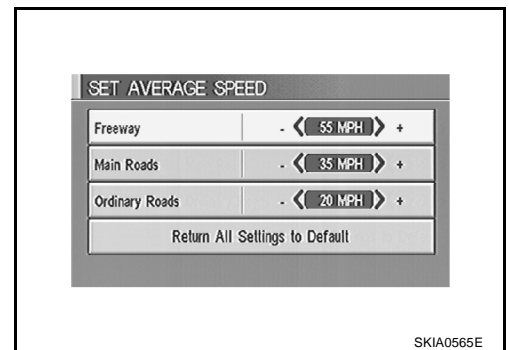

L  
M

# NAVIGATION SYSTEM

## “TRACKING” MODE

- To delete the tracking marks on the map, select “Off”.
- To leave the tracking marks on the map, select “On”.

### NOTE:

When a trail display is turned OFF, trail data is erased from the memory.

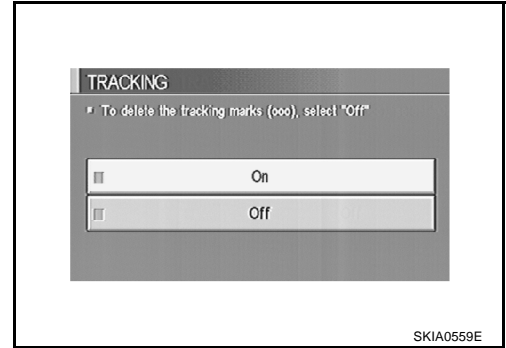

## GUIDANCE VOLUME

### Description

Following guidance volume setting can be changed.

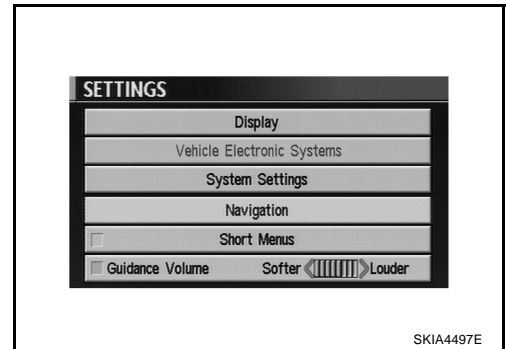

### Activation/Deactivation Setting

- The voice prompt can be turned on/off by pressing the “Guidance Volume” button.

### Voice Volume Setting

- Volume of the voice can be controlled by bending the joystick to left/right.

## DISPLAY WITH PUSHED “TRIP” BUTTON

- When the “TRIP” button is pushed , the following models will display on the screen.
- Warning message (if there are any) →TRIP1→TRIP2→FUEL ECONOMY→MAINTENANCE→OFF.

Display items	Display/Setting contents		Reference page
Trip1 or Trip2	Elapsed Time	Displays driving time with a range of 0000:00:00 to 9999:59:59.	<a href="#">AV-127.</a> <a href="#">"TRIP 1 OR TRIP 2"</a>
	Driving Distance [(km) or (miles)]	Displays driving distance with a range of 00000.0 to 99999.9.	
	Average speed [(km/h) or (MPH)]	Displays average speed with a range of 000.0 to 999.9.	
Fuel Economy	Average Fuel Economy [(MPG) or (l/100km)]	Displays fuel economy with ignition switch ON, average fuel economy each 30 minutes.	<a href="#">AV-127.</a> <a href="#">"FUEL ECONOMY"</a>
	Distance to Empty [(km) or (miles)] , [(MPG) or (l/100km)]	Displays possible driving distance with remaining fuel.	
	Fuel Economy (MPG)	Displays fuel economy each approx. 100 ms.	
Maintenance	Engine oil	Maintenance intervals of engine oil and setting of oil change cycle.	<a href="#">AV-127.</a> <a href="#">"MAINTENANCE"</a>
	Tire rotation	Maintenance intervals of tire and setting of tire replacement cycle.	
	Tire pressure	Tire pressure displayed as tire pressure information.	

# NAVIGATION SYSTEM

## TRIP 1 OR TRIP 2

- Elapsed time, Driving distance and Average speed are displayed as Trip 1 information or Trip 2 information.
- The way to reset is by pushing the “Reset” switch or by keeping pushing “TRIP” button more than 1.5 seconds.

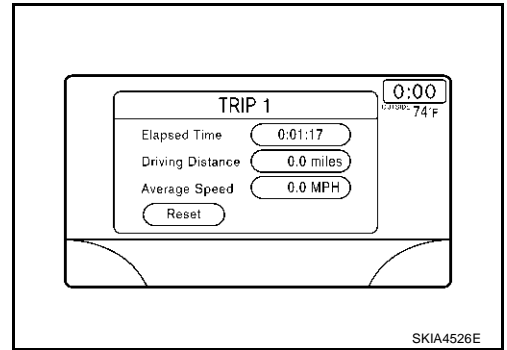

## FUEL ECONOMY

- Average Fuel Economy, Distance to Empty, Fuel Economy are displayed as Fuel Economy information.
- The way to reset is by pushing the “Reset” switch or by keeping pushing “TRIP” button more than 1.5 seconds.

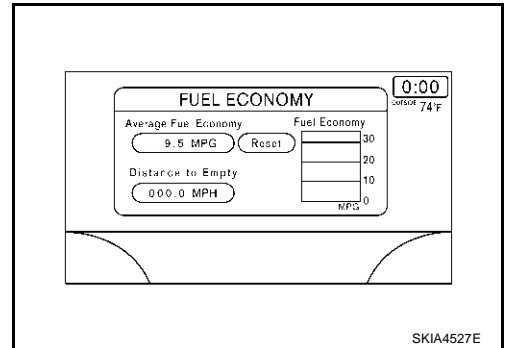

## MAINTENANCE

- Engine Oil, Tire Rotation and Tire pressure are displayed as Maintenance information.

### NOTE:

In a case of a vehicle with Low tire pressure warning control unit, “Tire Pressure” switch is displayed.

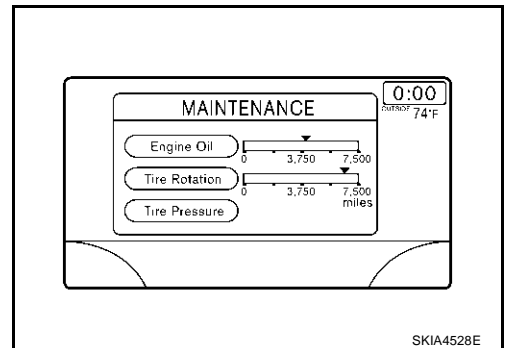

## ENGINE OIL OR TIRE ROTATION

- Possible to set up interval of engine oil and tire rotation by moving joystick right and left.

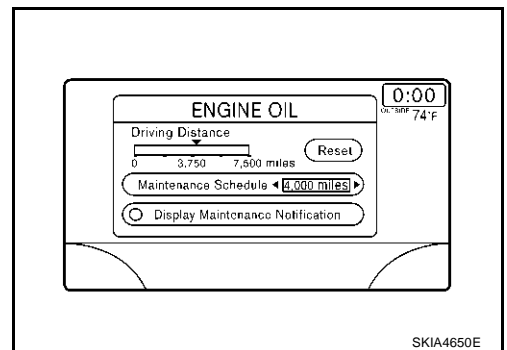

A  
B  
C  
D  
E  
F  
G  
H  
I  
J  
AV  
L  
M

# NAVIGATION SYSTEM

## TIRE PRESSURE

- Pressure indication in \*\* psi on the screen indicates that the pressure is being measured. After a few driving trips, the pressures for all four tires will be displayed.
- The order of tire pressure figures displayed on the screen does not correspond with the actual order of the tire position.
- Tire pressure rises and falls depending on the heat caused by the vehicle's traveling condition and the temperature.
- In case of low tire pressure, the low tire pressure warning light will come on and/or a warning is displayed on the screen.
- FLAT TIRE—very low tire air pressure.

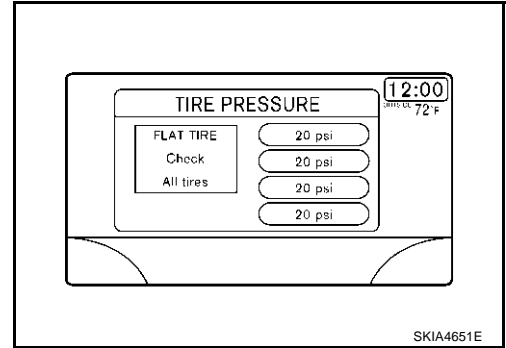

### NOTE:

- In a case of FLAT TIRE pressure, interrupt screen is not shown on the display.
- On the screen of TIRE PRESSURE, “FLAT TIRE”, “Check”, “All tire” is displayed.

## WARNING INDICATIONS

Warning signal (Door switch signal) is received from BCM through CAN communication line.

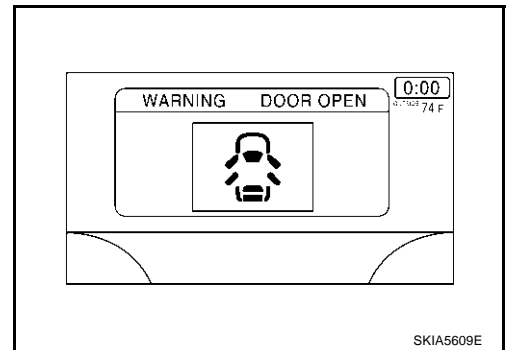

Warning indicators	Warning lamps in instrument panel	Warning detection and cancel conditions		Cases of malfunction
DOOR OPEN	Door	Detection condition	Vehicle is running [approx. 5 km/h (3 MPH) or faster] and door ajar of any of the doors is detected.	Door is open
		Cancel condition	Vehicle is stopped and all the doors lock.	



# NAVIGATION SYSTEM

## CAN Communication System Description

AKS007PX

CAN (Controller Area Network) is a serial communication line for real time application. It is an on-vehicle multiplex communication line with high data communication speed and excellent error detection ability. Modern vehicles are equipped with many electronic control units and each control unit shares information and links with other control units during operation (not independent). In CAN communication, control units are connected with 2 communication lines (CAN H line, CAN L line) allowing a high rate of information transmission with less wiring. Each control unit transmits/receives data but selectively reads required data only.

## CAN Communication Unit For 2WD Models

AKS007PY

Go to CAN system, when selecting your car model from the following table.

Body type	Wagon															
Axle	2WD															
Engine	VQ35DE															
Transmission	CVT															
Brake control	ABS								VDC							
Low tire pressure warning system		×			×	×		×		×			×	×		×
Navigation system			×		×		×	×			×		×		×	×
Automatic drive positioner				×		×	×	×				×		×	×	×
CAN communication unit																
ECM	×	×	×	×	×	×	×	×	×	×	×	×	×	×	×	×
TCM	×	×	×	×	×	×	×	×	×	×	×	×	×	×	×	×
Low tire pressure warning control unit		×			×	×		×		×			×	×		×
Display unit	×	×		×		×			×	×		×		×		
Display control unit			×		×		×	×			×		×		×	×
Data link connector	×	×	×	×	×	×	×	×	×	×	×	×	×	×	×	×
BCM	×	×	×	×	×	×	×	×	×	×	×	×	×	×	×	×
Unified meter and A/C amp.	×	×	×	×	×	×	×	×	×	×	×	×	×	×	×	×
Steering angle sensor									×	×	×	×	×	×	×	×
Driver seat control unit				×		×	×	×				×		×	×	×
ABS actuator and electric unit (control unit)	×	×	×	×	×	×	×	×	×	×	×	×	×	×	×	×
IPDM E/R	×	×	×	×	×	×	×	×	×	×	×	×	×	×	×	×
CAN communication type	<u>AV-130. "TYPE 1/TYPE 2/TYPE 3/TYPE 4/TYPE 5/TYPE 6/TYPE 7/TYPE 8"</u>								<u>AV-135. "TYPE 9/TYPE 10/TYPE 11/TYPE 12/TYPE 13/TYPE 14/TYPE 15/TYPE 16"</u>							

×: Applicable

A  
B  
C  
D  
E  
F  
G  
H  
I  
J  
AV  
L  
M

# NAVIGATION SYSTEM

## TYPE 1/TYPER 2/TYPER 3/TYPER 4/TYPER 5/TYPER 6/TYPER 7/TYPER 8

### System Diagram

- Type1

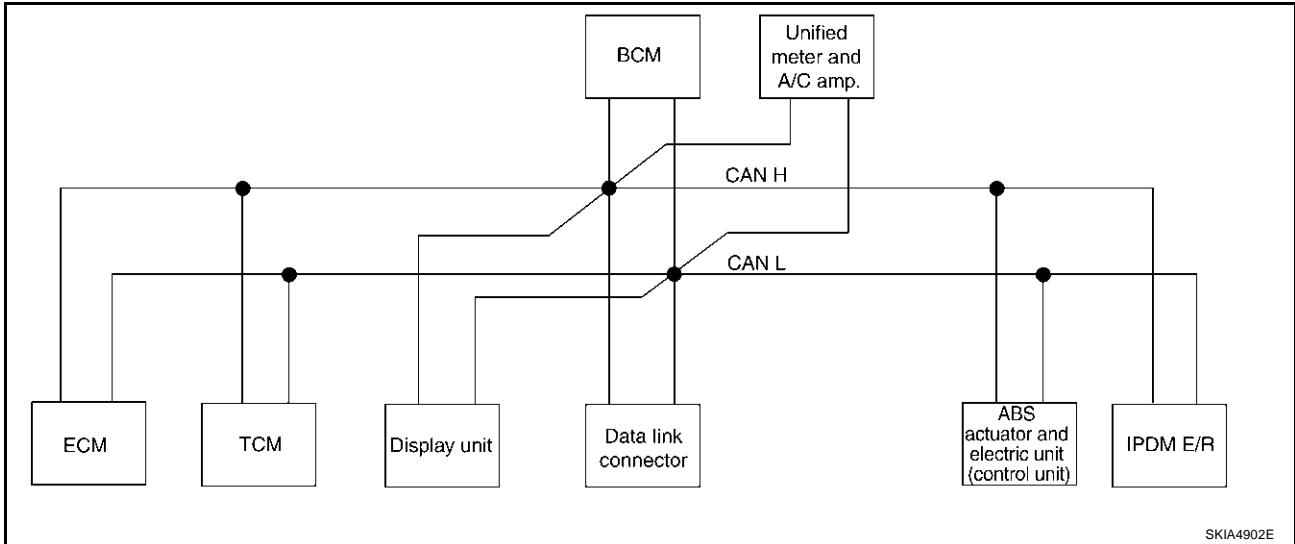

- Type2

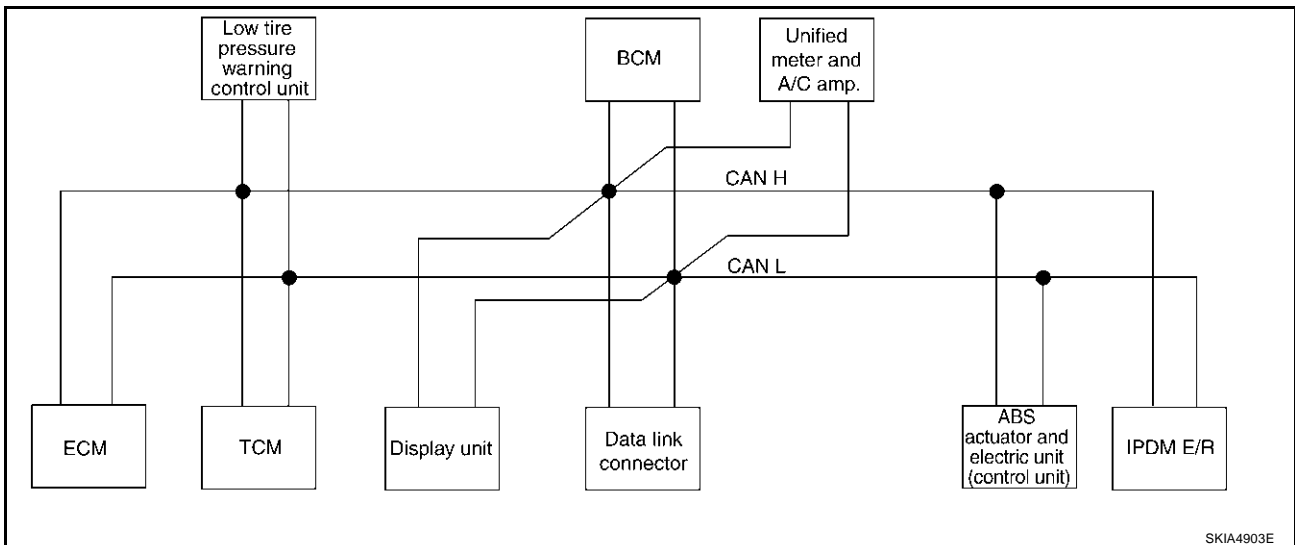

- Type3

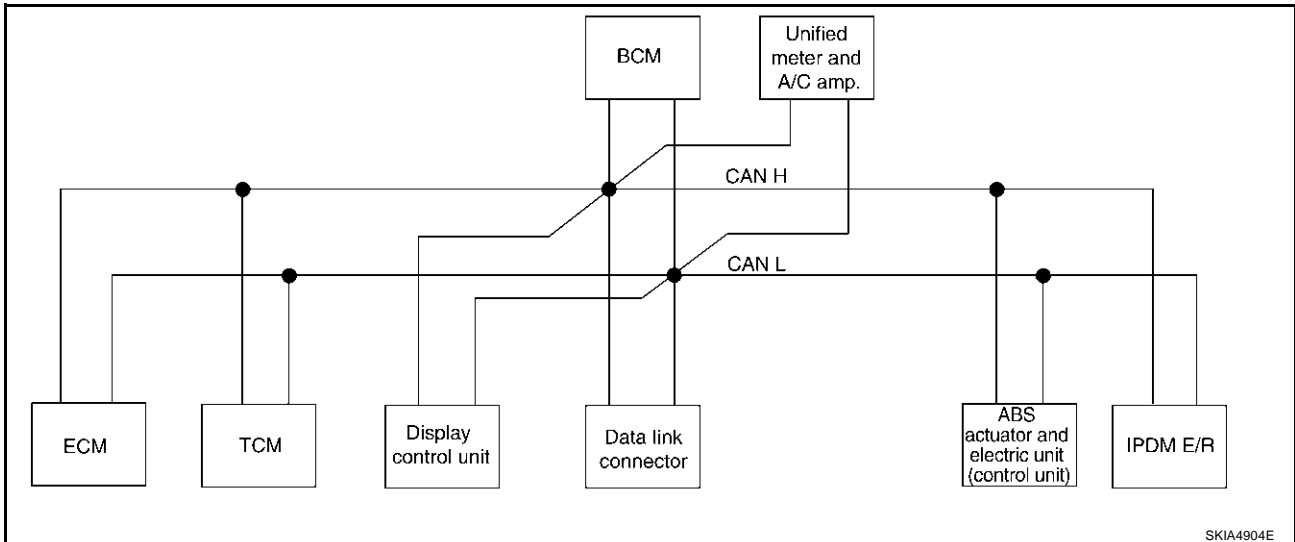

# NAVIGATION SYSTEM

- Type4

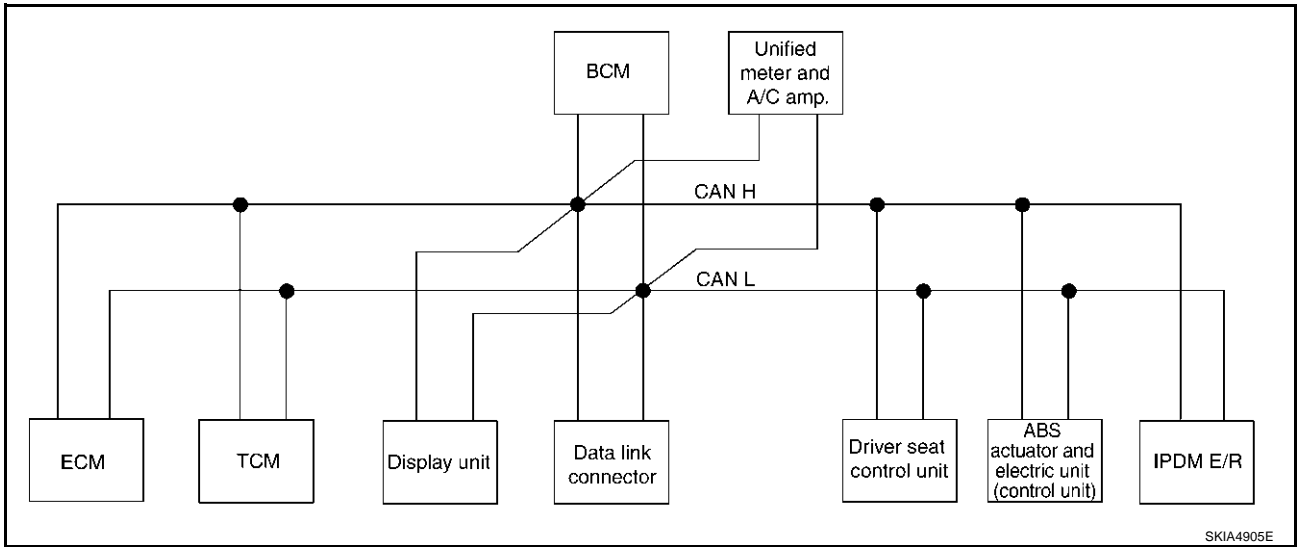

- Type5

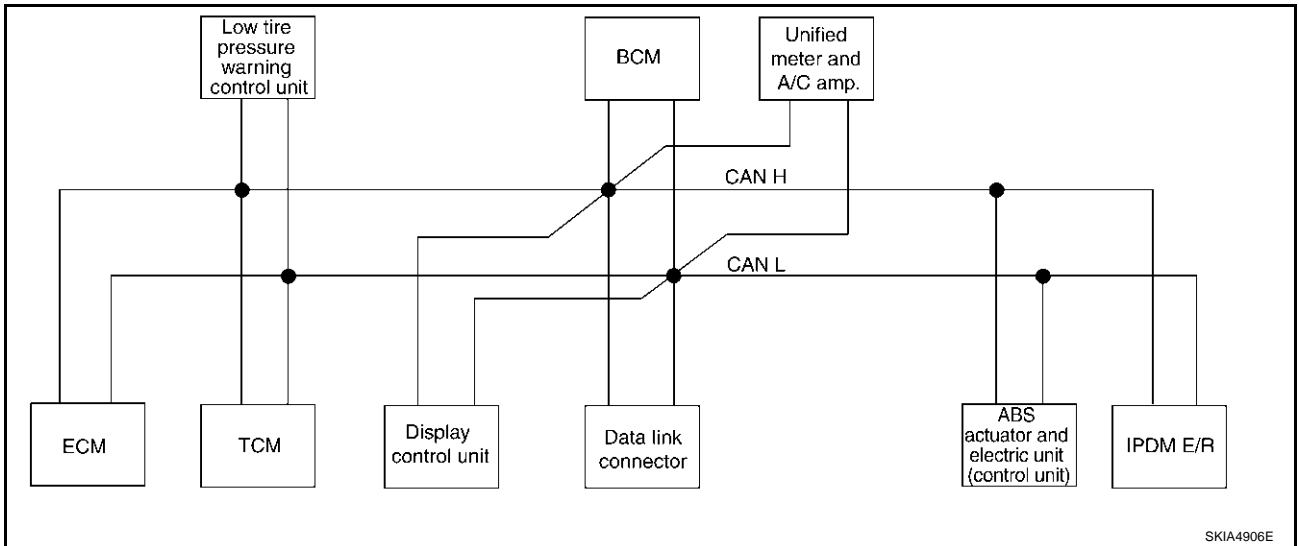

- Type6

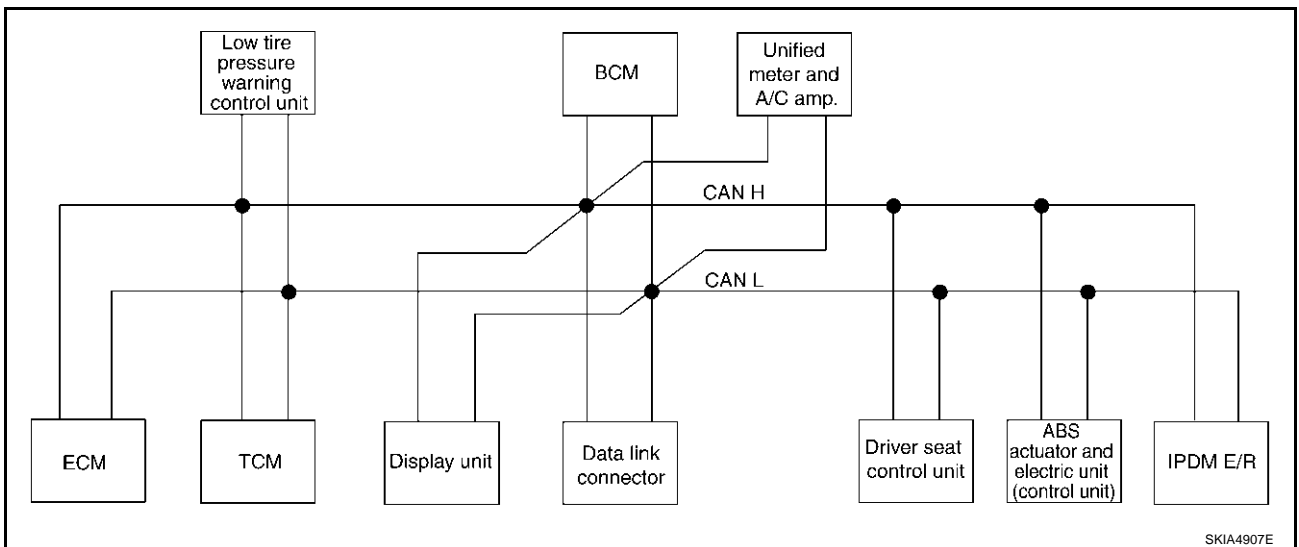

A  
B  
C  
D  
E  
F  
G  
H  
I  
J  
AV  
L  
M

AV

# NAVIGATION SYSTEM

- Type7

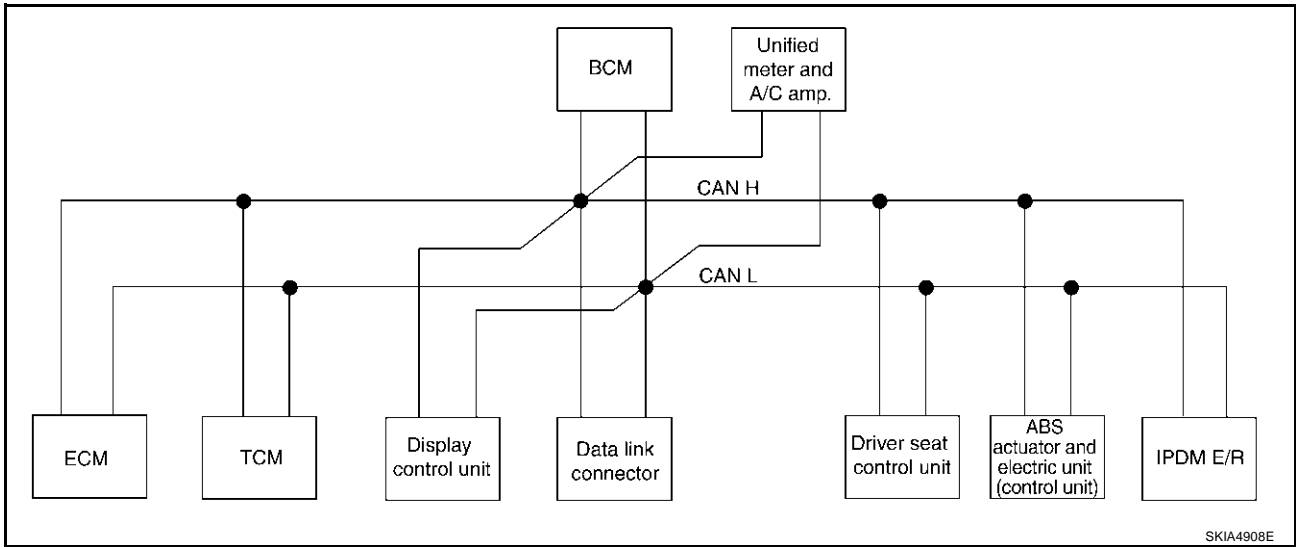

- Type8

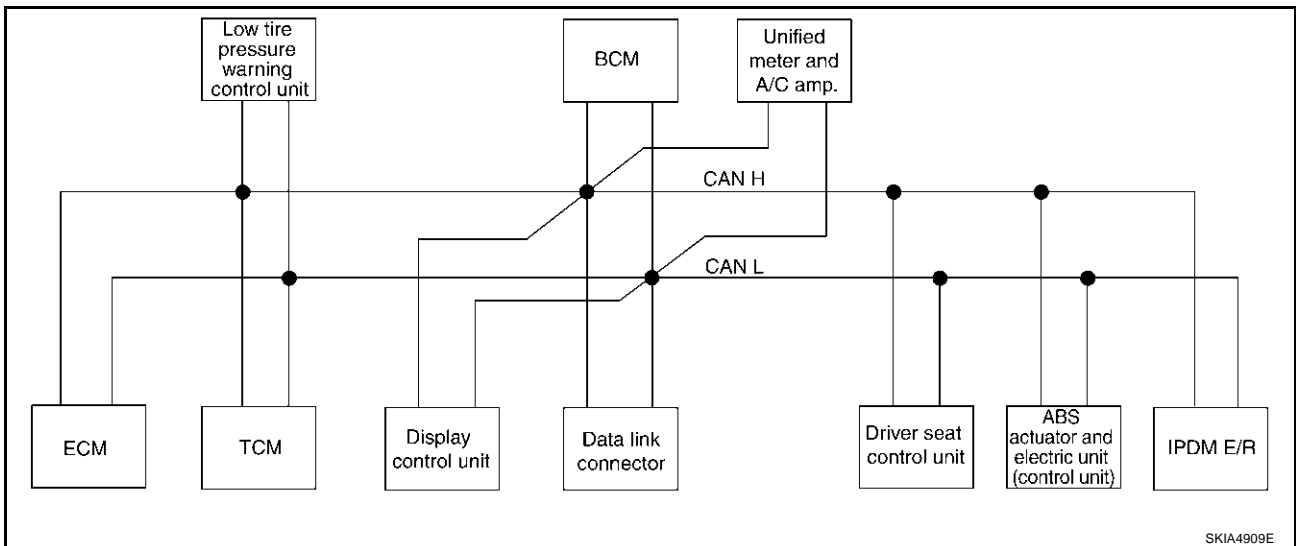

# NAVIGATION SYSTEM

## Input/output Signal Chart

T: Transmit R: Receive

Signals	ECM	TCM	Low tire pressure warning control unit	Display unit	Display control unit	BCM	Unified meter and A/C amp.	Driver seat control unit	ABS actuator and electric unit (control unit)	IPDM E/R
Engine speed signal	T	R			R	R	R			
Engine status signal	T					R				
Engine coolant temperature signal	T						R			
CVT position indicator signal		T					R			
Second position signal		R					T			
Second position indicator signal		T					R			
Engine and CVT integrated control signal	T	R								
	R	T								
Accelerator pedal position signal	T	R								
Closed throttle position signal	T	R								
Wide open throttle position signal	T	R								
Key switch signal						T		R		
Ignition switch signal						T		R		R
P range signal		T						R		
Stop lamp switch signal		R					T			
Fuel consumption monitor signal	T						R			
CVT self-diagnosis signal	R	T								
ABS operation signal		R							T	
Air conditioner switch signal	R					T				
A/C compressor request signal	T									R
A/C compressor feedback signal	T						R			
Blower fan motor switch signal	R					T				
A/C control signal				T	T		R			
				R	R		T			
Cooling fan speed request signal	T									R
Position lights request signal						T	R			R
Low beam request signal						T				R
Low beam status signal	R									T
High beam request signal						T	R			R
High beam status signal	R									T
Front fog lights request signal						T				R
Vehicle speed signal		R					R		T	
	R		R		R	R	T	R		
Sleep request 1 signal						T	R			
Sleep request 2 signal						T				R
Door switch signal						R	T			
				R	R	T	R	R		R
Turn indicator signal						T	R			

# NAVIGATION SYSTEM

Signals	ECM	TCM	Low tire pressure warning control unit	Display unit	Display control unit	BCM	Unified meter and A/C amp.	Driver seat control unit	ABS actuator and electric unit (control unit)	IPDM E/R
Key fob ID signal						T		R		
Key fob door unlock signal						T		R		
Seat belt buckle switch signal						R	T			
Oil pressure switch signal						R				T
						T	R			
Buzzer output signal						T	R			
Fuel level sensor signal	R						T			
Fuel level low warning signal				R	R		T			
Malfunction indicator lamp signal	T						R			
ASCD SET lamp signal	T						R			
ASCD CRUISE lamp signal	T						R			
Input shaft revolution signal	R	T								
Output shaft revolution signal	R	T								
Front wiper request signal						T				R
Front wiper stop position signal						R				T
Rear window defogger switch signal						T				R
Rear window defogger control signal	R			R	R					T
Hood switch signal						R				T
Theft warning horn request signal						T				R
Horn chirp signal						T				R
Tire pressure signal			T				R			
Tire pressure data signal			T	R	R					
ABS warning lamp signal							R		T	
Brake warning lamp signal							R		T	
System setting signal				T	T			R		
Parking brake switch signal						R	T			

# NAVIGATION SYSTEM

**TYPE 9/TYPER10/TYPER 11/TYPER 12/TYPER 13/TYPER 14/TYPER 15/TYPER 16**

## System Diagram

- Type9

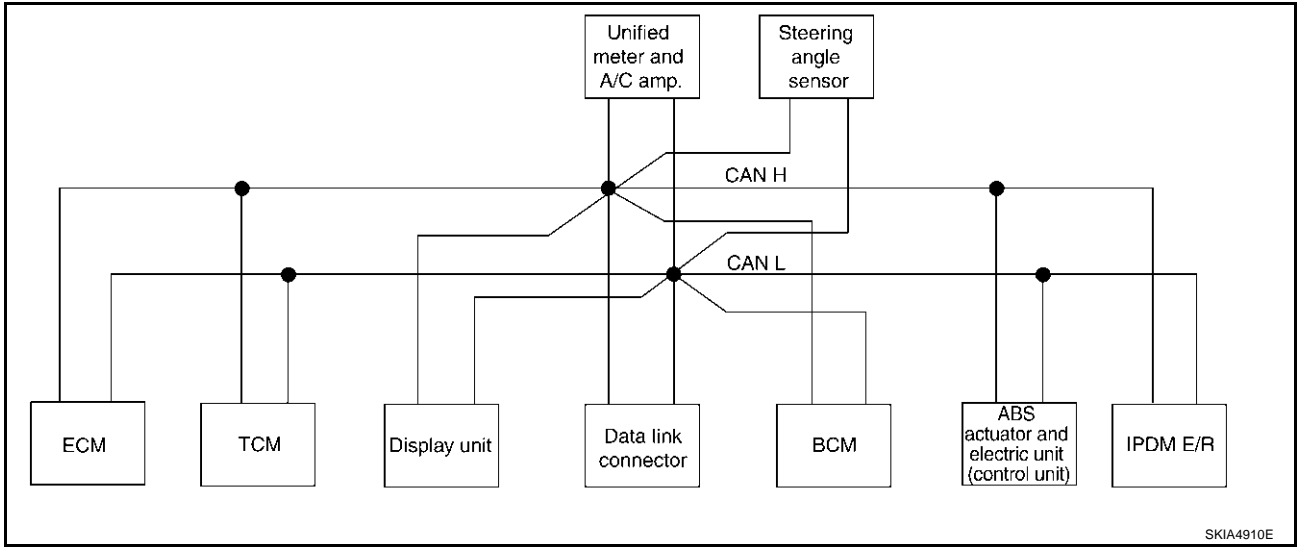

- Type10

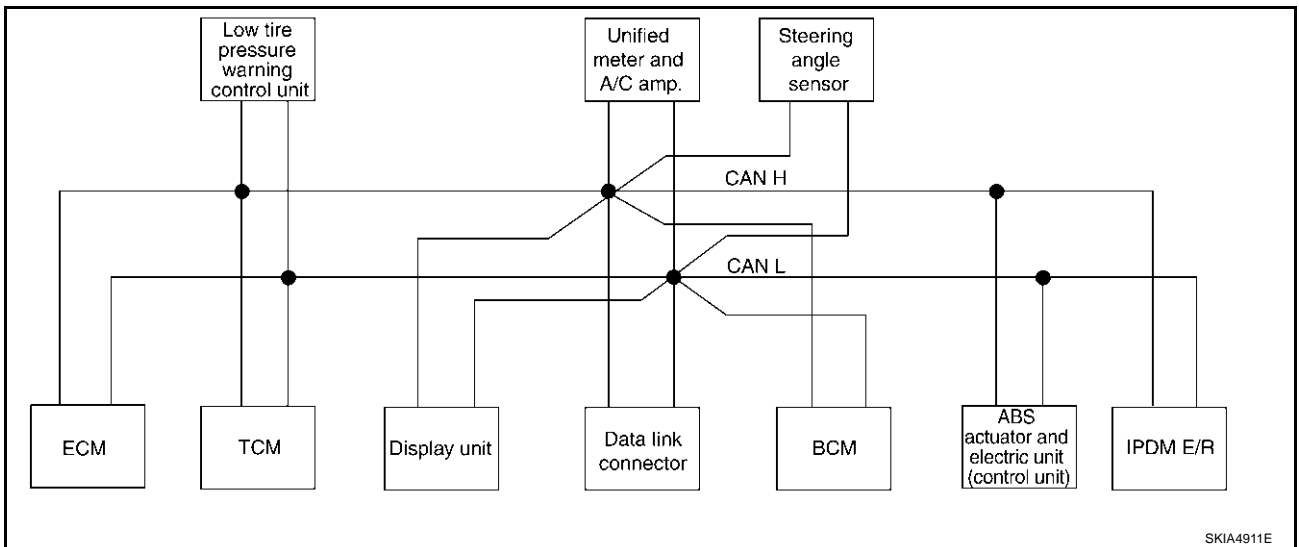

- Type11

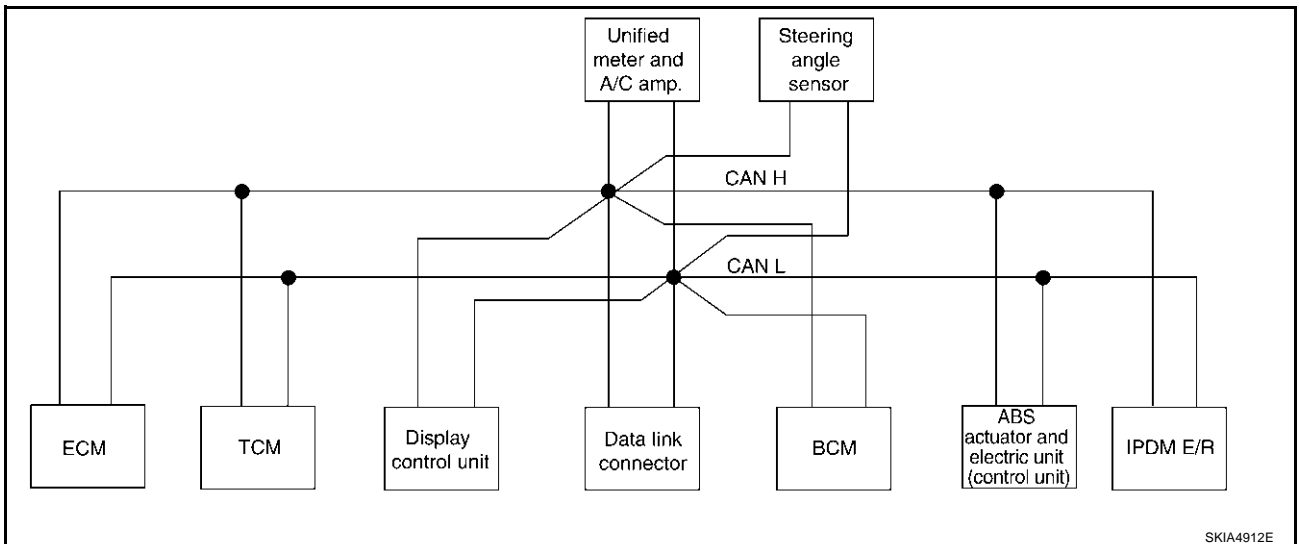

A  
B  
C  
D  
E  
F  
G  
H  
I  
J  
AV  
L  
M

# NAVIGATION SYSTEM

- Type12

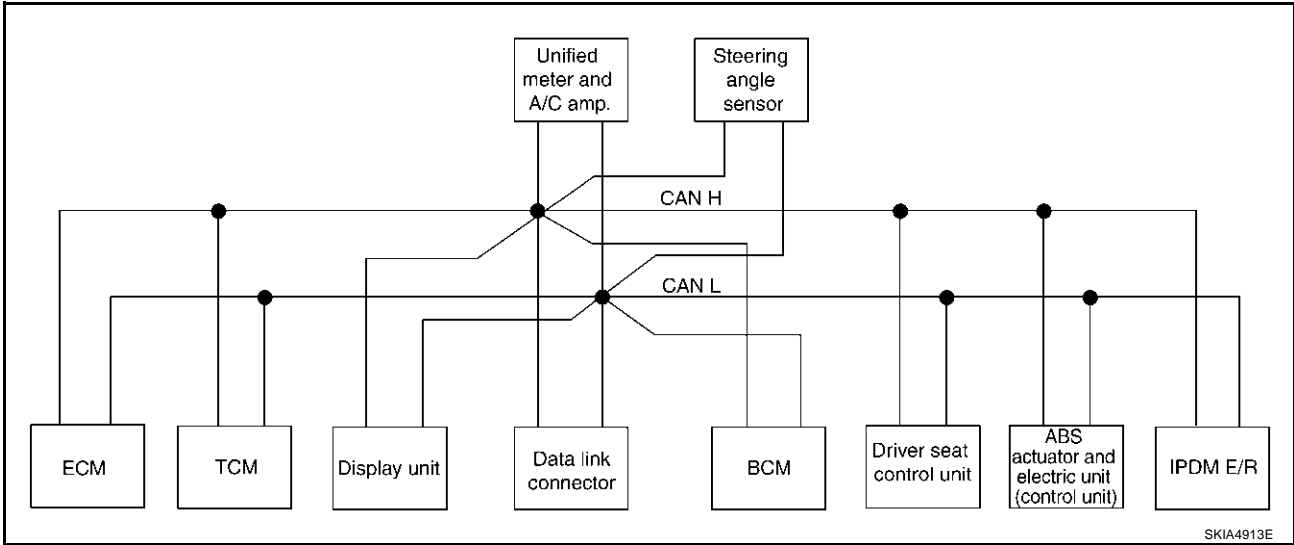

- Type13

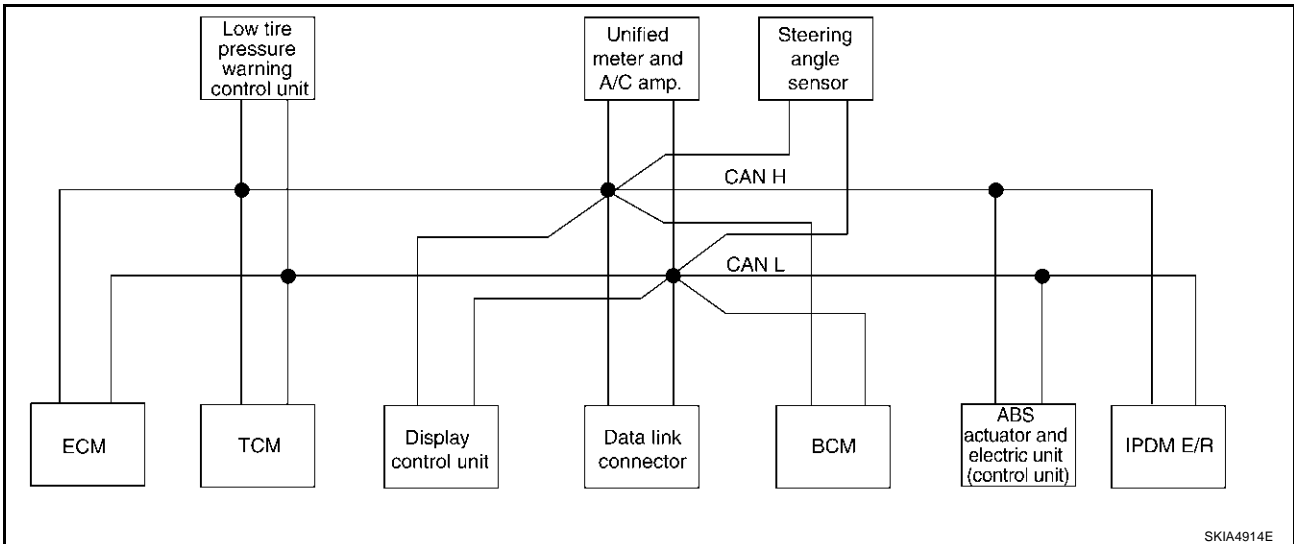

- Type14

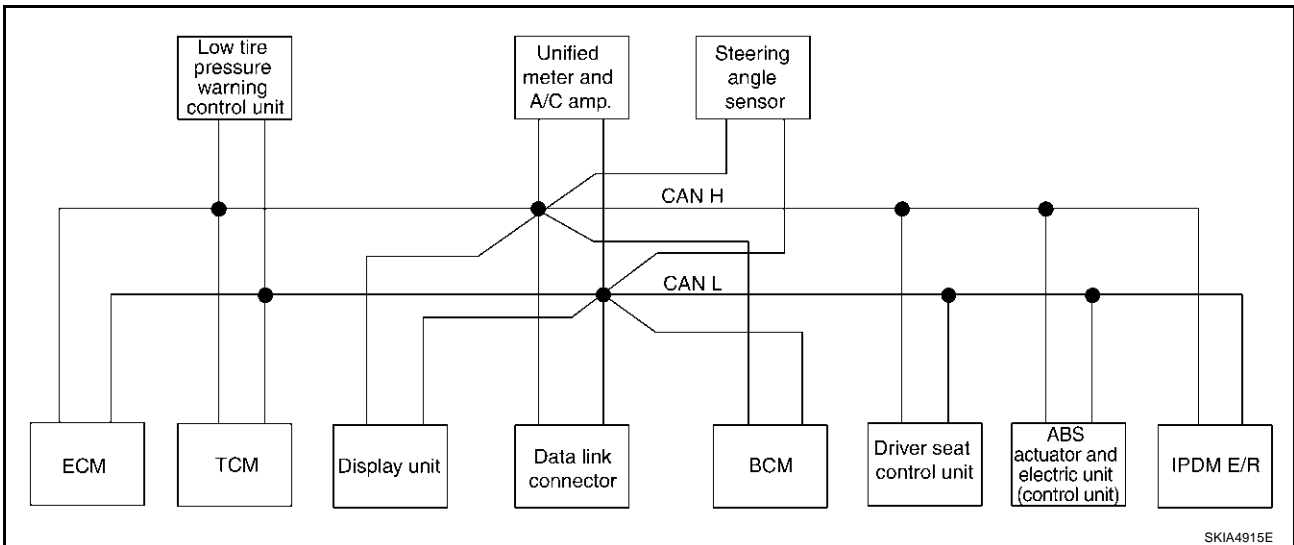



# NAVIGATION SYSTEM

- Type15

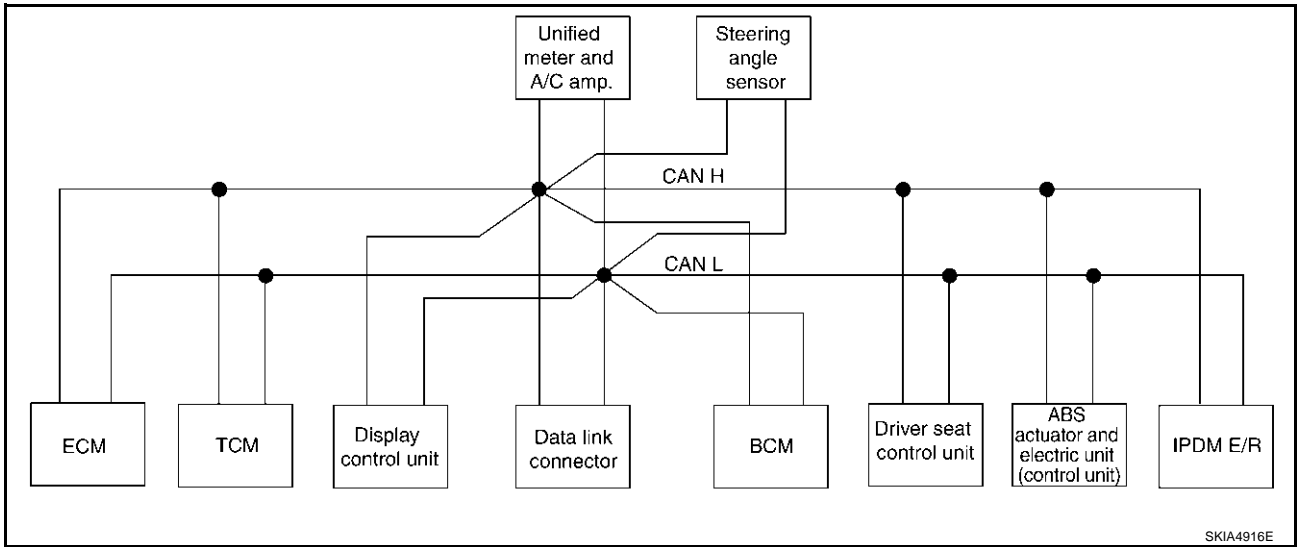

- Type16

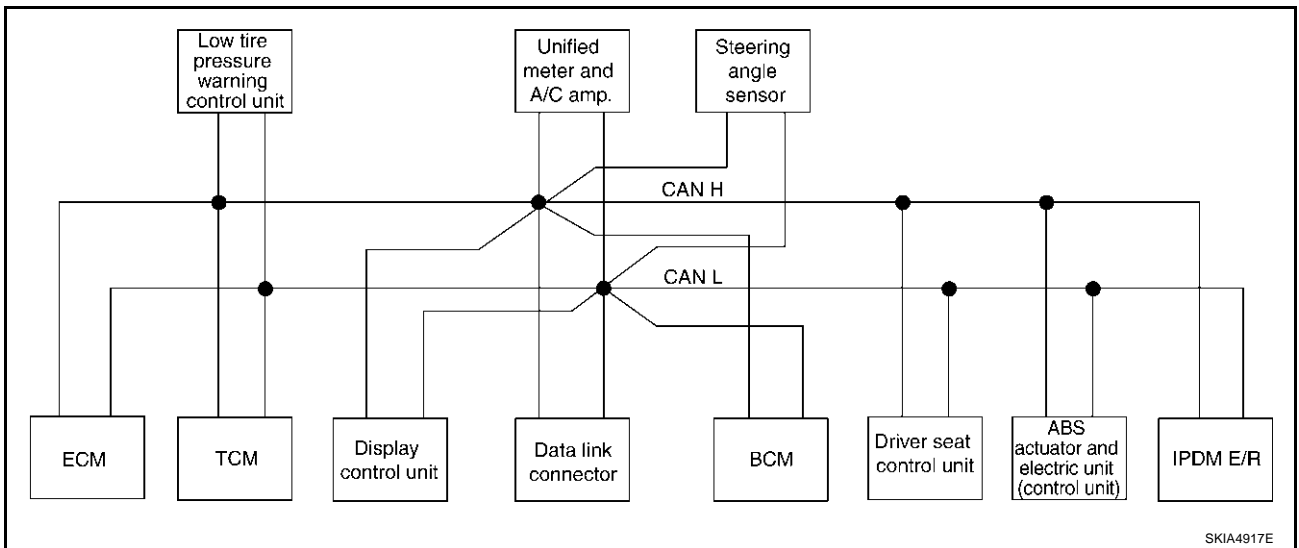

A  
B  
C  
D  
E  
F  
G  
H  
I  
J  
AV  
L  
M

# NAVIGATION SYSTEM

## Input/output Signal Chart

T: Transmit R: Receive

Signals	ECM	TCM	Low tire pressure warning control unit	Display unit	Display control unit	BCM	Unified meter and A/C amp.	Steering angle sensor	Driver seat control unit	ABS actuator and electric unit (control unit)	IPDM E/R
Engine speed signal	T	R			R	R	R			R	
Engine status signal	T					R					
Engine coolant temperature signal	T						R				
Engine and CVT integrated control signal	T	R									
	R	T									
Accelerator pedal position signal	T	R								R	
Closed throttle position signal	T	R									
Wide open throttle position signal	T	R									
Key switch signal						T			R		
Ignition switch signal						T			R		R
P range signal		T							R	R	
Stop lamp switch signal		R					T				
VDC operation signal		R								T	
Second position indicator signal		T					R			R	
Second position signal		R					T				
Fuel consumption monitor signal	T						R				
CVT self-diagnosis signal	R	T									
Input shaft revolution signal	R	T								R	
Output shaft revolution signal	R	T								R	
Air conditioner switch signal	R					T					
A/C compressor request signal	T										R
A/C compressor feedback signal	T						R				
Blower fan motor switch signal	R					T					
A/C control signal				T	T		R				
				R	R		T				
Cooling fan speed request signal	T										R
Position lights request signal						T	R				R
Low beam request signal						T					R
Low beam status signal	R										T
High beam request signal						T	R				R
High beam status signal	R										T
Front fog lights request signal						T					R
Vehicle speed signal		R					R			T	
	R		R		R	R	T		R		
Sleep request 1 signal						T	R				
Sleep request 2 signal						T					R

# NAVIGATION SYSTEM

Signals	ECM	TCM	Low tire pressure warning control unit	Display unit	Display control unit	BCM	Unified meter and A/C amp.	Steering angle sensor	Driver seat control unit	ABS actuator and electric unit (control unit)	IPDM E/R
Door switch signal						R	T				
Turn indicator signal				R	R	T	R		R		R
Key fob ID signal						T			R		
Key fob door unlock signal						T			R		
Seat belt buckle switch signal						R	T				
Oil pressure switch signal						R					T
Buzzer output signal						T	R				
Fuel level sensor signal	R						T				
Fuel level low warning signal				R	R		T				
Malfunction indicator signal	T						R				
ASCD SET lamp signal	T						R				
ASCD CRUISE lamp signal	T						R				
Front wiper request signal						T					R
Front wiper stop position signal						R					T
Rear window defogger switch signal						T					R
Rear window defogger control signal	R			R	R						T
Hood switch signal						R					T
Theft warning horn request signal						T					R
Horn chirp signal						T					R
Steering angle sensor signal								T		R	
Tire pressure signal			T				R				
Tire pressure data signal			T	R	R						
CVT position indicator signal		T					R			R	
ABS warning lamp signal							R			T	
VDC OFF indicator lamp signal							R			T	
SLIP indicator lamp signal							R			T	
Brake warning lamp signal							R			T	
System setting signal				T	T				R		
Parking brake switch signal						R	T				

A  
B  
C  
D  
E  
F  
G  
H  
I  
J  
L  
M

AV

# NAVIGATION SYSTEM

## CAN Communication Unit For AWD Models

AKS007PZ

Go to CAN system, when selecting your car model from the following table.

Body type	Wagon															
Axle	AWD															
Engine	VQ35DE															
Transmission	CVT															
Brake control	ABS								VDC							
Low tire pressure warning system		×			×	×		×		×			×	×		×
Navigation system			×		×		×	×			×		×		×	×
Automatic drive positioner				×		×	×	×				×		×	×	×
CAN communication unit																
ECM	×	×	×	×	×	×	×	×	×	×	×	×	×	×	×	×
TCM	×	×	×	×	×	×	×	×	×	×	×	×	×	×	×	×
Low tire pressure warning control unit		×			×	×		×		×			×	×		×
Display unit	×	×		×		×			×	×		×		×		
Display control unit			×		×		×	×			×		×		×	×
Data link connector	×	×	×	×	×	×	×	×	×	×	×	×	×	×	×	×
BCM	×	×	×	×	×	×	×	×	×	×	×	×	×	×	×	×
Unified meter and A/C amp.	×	×	×	×	×	×	×	×	×	×	×	×	×	×	×	×
Steering angle sensor									×	×	×	×	×	×	×	×
Driver seat control unit				×		×	×	×				×		×	×	×
AWD control unit	×	×	×	×	×	×	×	×	×	×	×	×	×	×	×	×
ABS actuator and electric unit (control unit)	×	×	×	×	×	×	×	×	×	×	×	×	×	×	×	×
IPDM E/R	×	×	×	×	×	×	×	×	×	×	×	×	×	×	×	×
CAN communication type	AV-140, "TYPE 17/TYPE 18/TYPE 19/TYPE 20/ TYPE 21/TYPE 22/TYPE 23/TYPE 24"								AV-146, "TYPE 25/TYPE 26/TYPE 27/TYPE 28/ TYPE 29/TYPE 30/TYPE 31/TYPE 32"							

×: Applicable

### TYPE 17/TYPE 18/TYPE 19/TYPE 20/TYPE 21/TYPE 22/TYPE 23/TYPE 24

#### System Diagram

- Type17

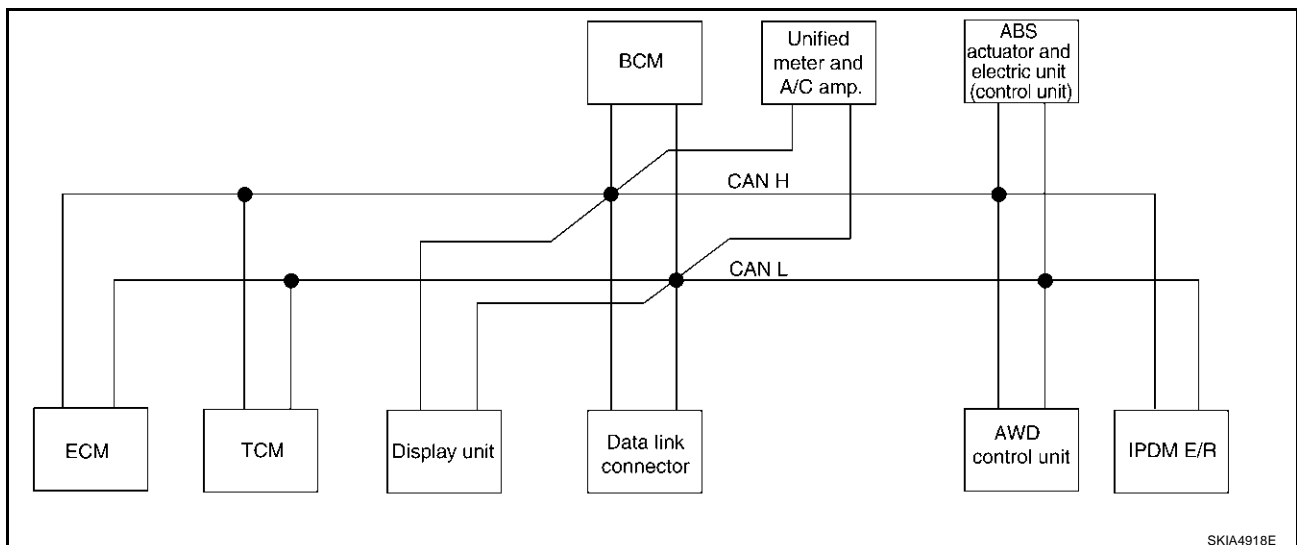

SKIA4918E

# NAVIGATION SYSTEM

- Type18

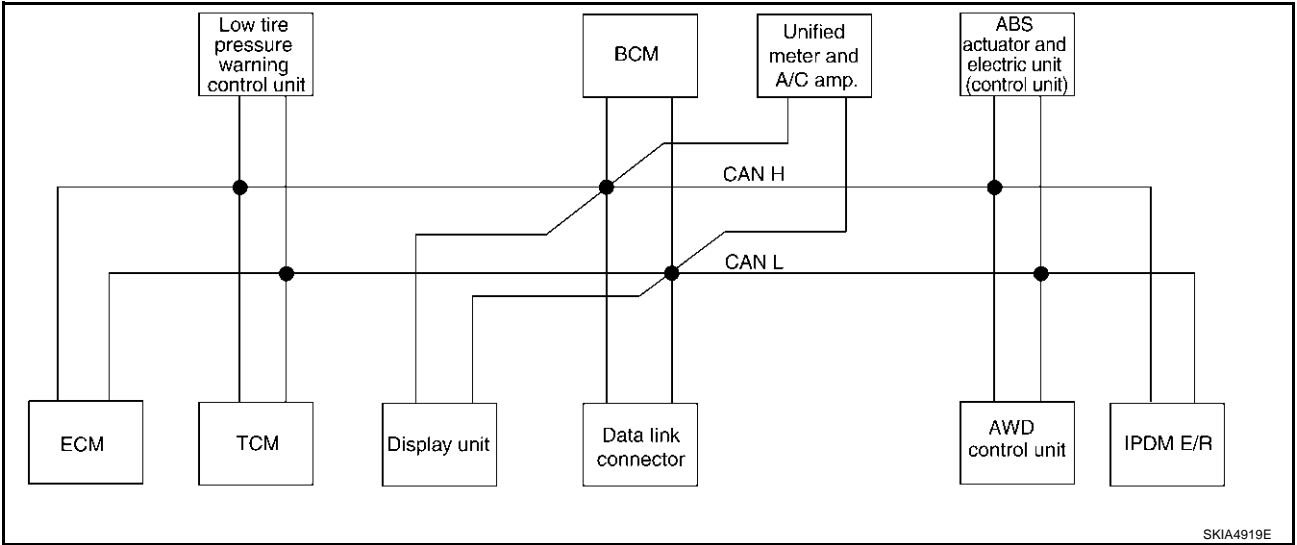

- Type19

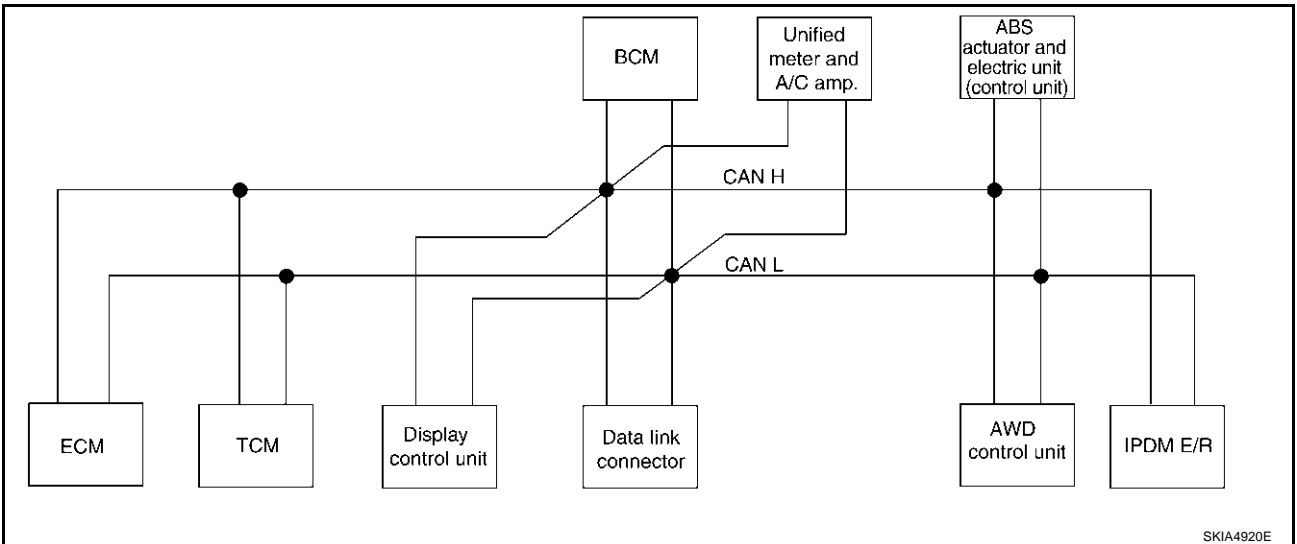

- Type20

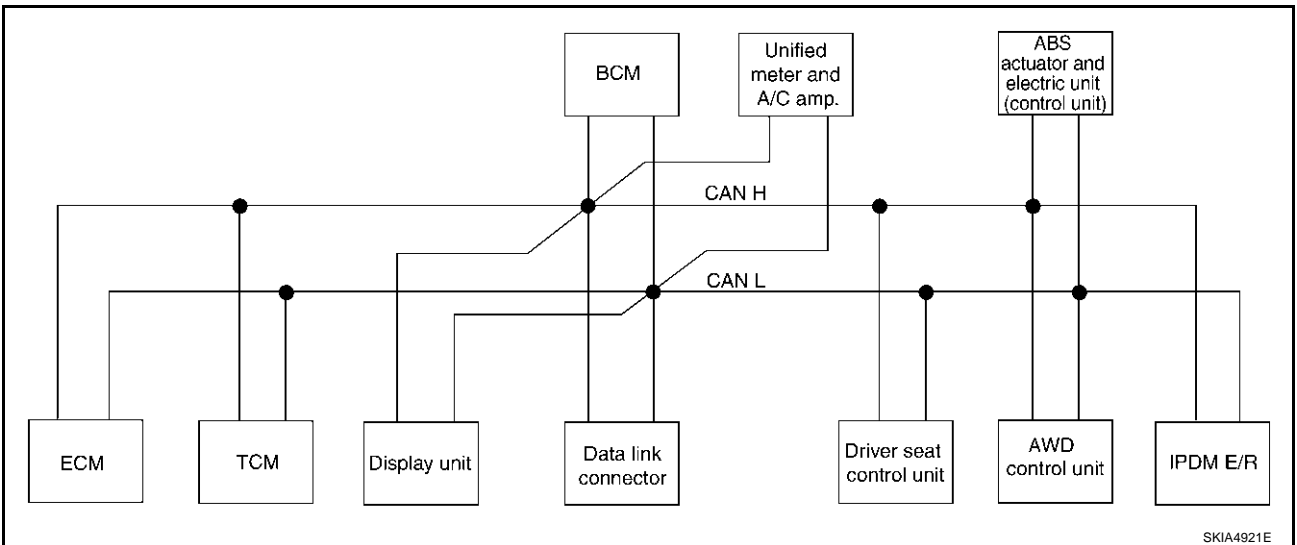

A  
B  
C  
D  
E  
F  
G  
H  
I  
J  
AV  
L  
M

# NAVIGATION SYSTEM

- Type21

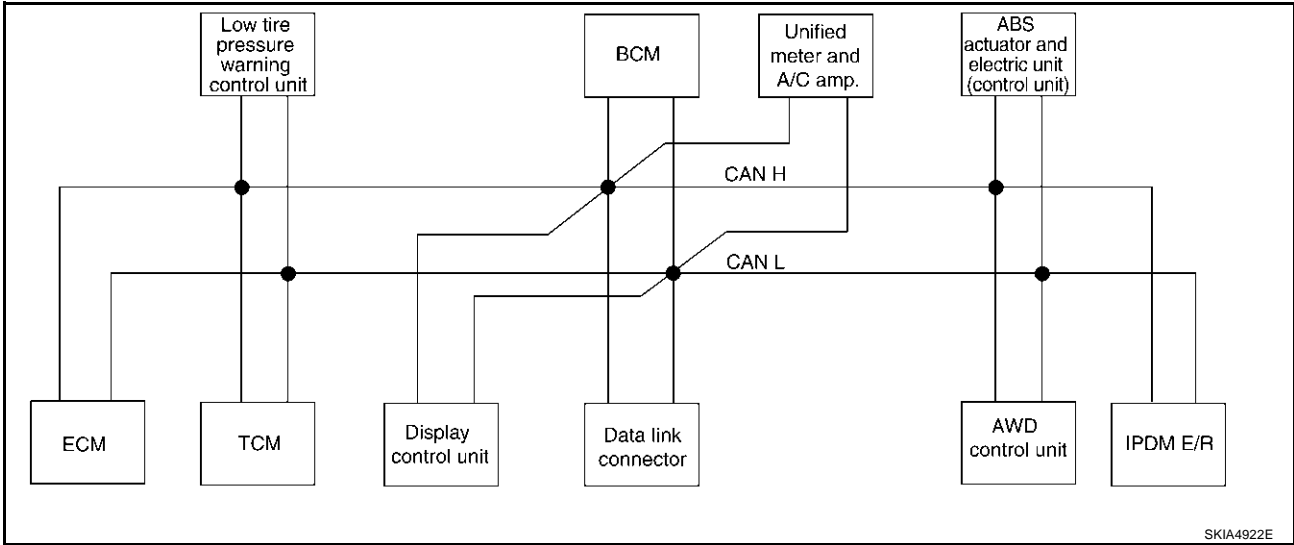

- Type22

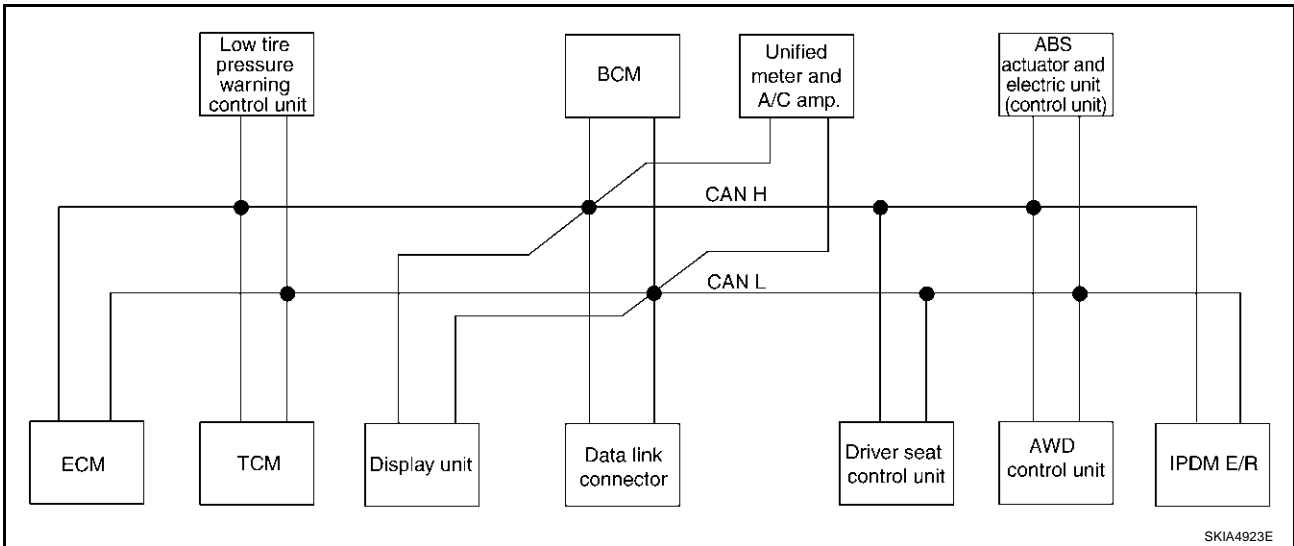

- Type23

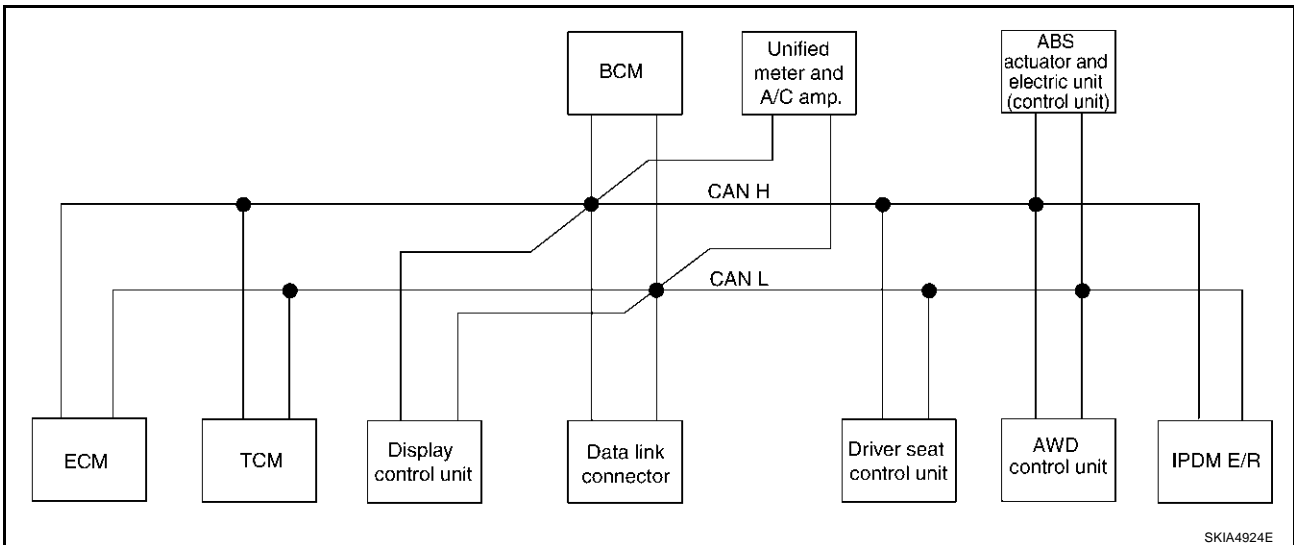

# NAVIGATION SYSTEM

- Type24

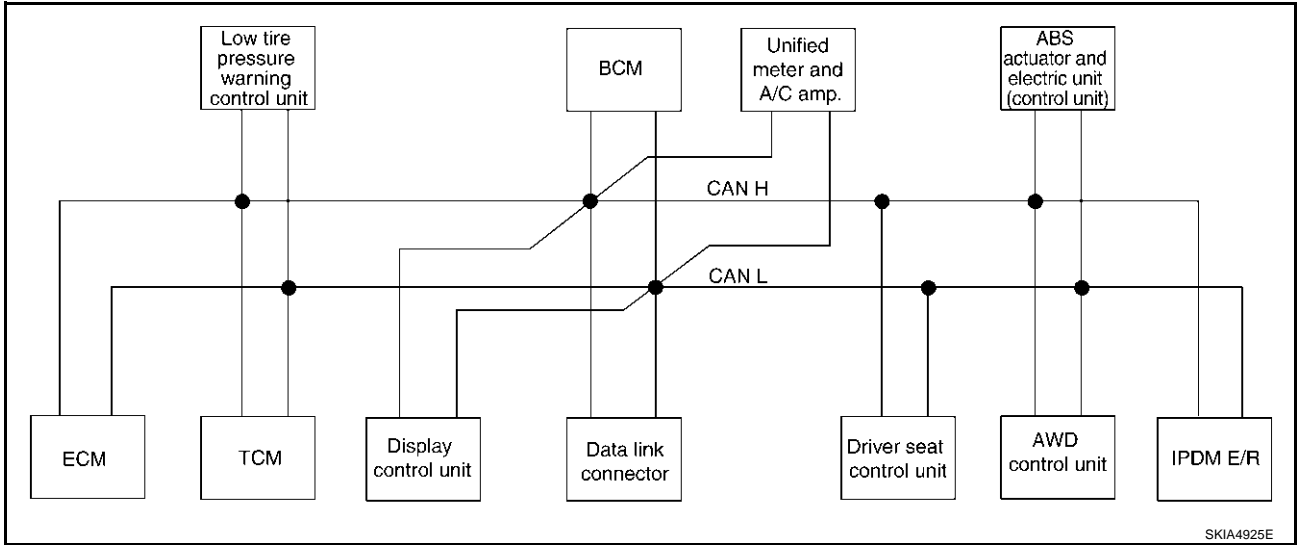

A  
B  
C  
D  
E  
F  
G  
H  
I  
J  
AV  
L  
M

# NAVIGATION SYSTEM

## Input/output Signal Chart

T: Transmit R: Receive

Signals	ECM	TCM	Low tire pressure warning control unit	Display unit	Display control unit	BCM	Unified meter and A/C amp.	Driver seat control unit	AWD control unit	ABS actuator and electric unit (control unit)	IPDM E/R
CVT position indicator signal		T					R				
Second position signal		R					T				
Second position indicator signal		T					R				
Engine speed signal	T	R	R		R	R	R		R		
Engine status signal	T					R					
Engine coolant temperature signal	T						R				
Accelerator pedal position signal	T	R							R		
Closed throttle position signal	T	R									
Wide open throttle position signal	T	R									
Key switch signal						T		R			
Ignition switch signal						T		R			R
P range signal		T						R			
Stop lamp switch signal		R					T		R		
Fuel consumption monitor signal	T						R				
CVT self-diagnosis signal	R	T									
ABS operation signal		R							R	T	
Air conditioner switch signal	R					T					
A/C compressor request signal	T										R
A/C compressor feedback signal	T						R				
Blower fan motor switch signal	R					T					
A/C control signal				T	T		R				
				R	R		T				
Cooling fan speed request signal	T										R
Position lights request signal						T	R				R
Low beam request signal						T					R
Low beam status signal	R										T
High beam request signal						T	R				R
High beam status signal	R										T
Front fog lights request signal						T					R
Vehicle speed signal		R					R		R	T	
	R		R		R	R	T	R			
Sleep request 1 signal						T	R				
Sleep request 2 signal						T					R
Door switch signal						R	T				
				R	R	T	R	R			R
Key fob ID signal						T		R			
Key fob door unlock signal						T		R			



# NAVIGATION SYSTEM

Signals	ECM	TCM	Low tire pressure warning control unit	Display unit	Display control unit	BCM	Unified meter and A/C amp.	Driver seat control unit	AWD control unit	ABS actuator and electric unit (control unit)	IPDM E/R
Turn indicator signal						T	R				
Seat belt buckle switch signal						R	T				
Oil pressure switch signal						R					T
						T	R				
Buzzer output signal						T	R				
Fuel level sensor signal	R						T				
Fuel level low warning signal				R	R		T				
Malfunction indicator lamp signal	T						R				
ASCD SET lamp signal	T						R				
ASCD CRUISE lamp signal	T						R				
Input shaft revolution signal	R	T									
Output shaft revolution signal	R	T									
Front wiper request signal						T					R
Front wiper stop position signal						R					T
Rear window defogger switch signal						T					R
Rear window defogger control signal	R			R	R						T
Engine and CVT integrated control signal	T	R									
	R	T									
Hood switch signal						R					T
Theft warning horn request signal						T					R
Horn chirp signal						T					R
Tire pressure signal			T				R				
Tire pressure data signal			T	R	R						
ABS warning lamp signal							R			T	
Brake warning lamp signal							R			T	
System setting signal				T	T			R			
AWD warning lamp signal							R		T		
AWD lock indicator lamp signal							R		T		
AWD lock switch signal							T		R		
Parking brake switch signal						R	T		R		

A  
B  
C  
D  
E  
F  
G  
H  
I  
J  
AV  
L  
M

# NAVIGATION SYSTEM

TYPE 25/TYPER26/TYPER 27/TYPER 28/TYPER 29/TYPER 30/TYPER 31/TYPER 32

## System Diagram

- Type25

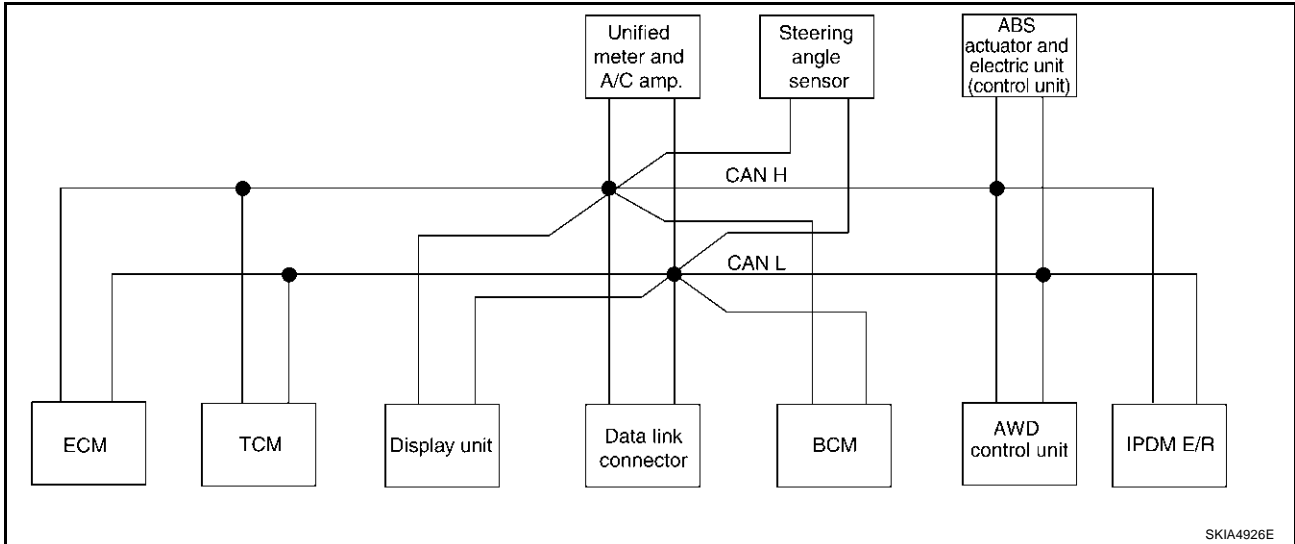

- Type26

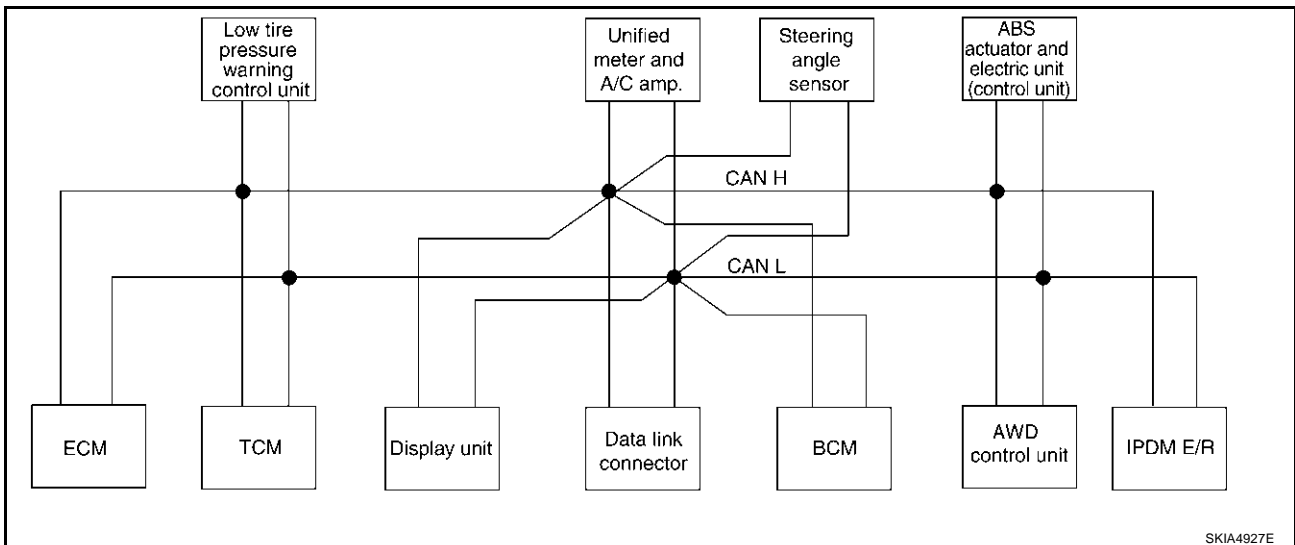

- Type27

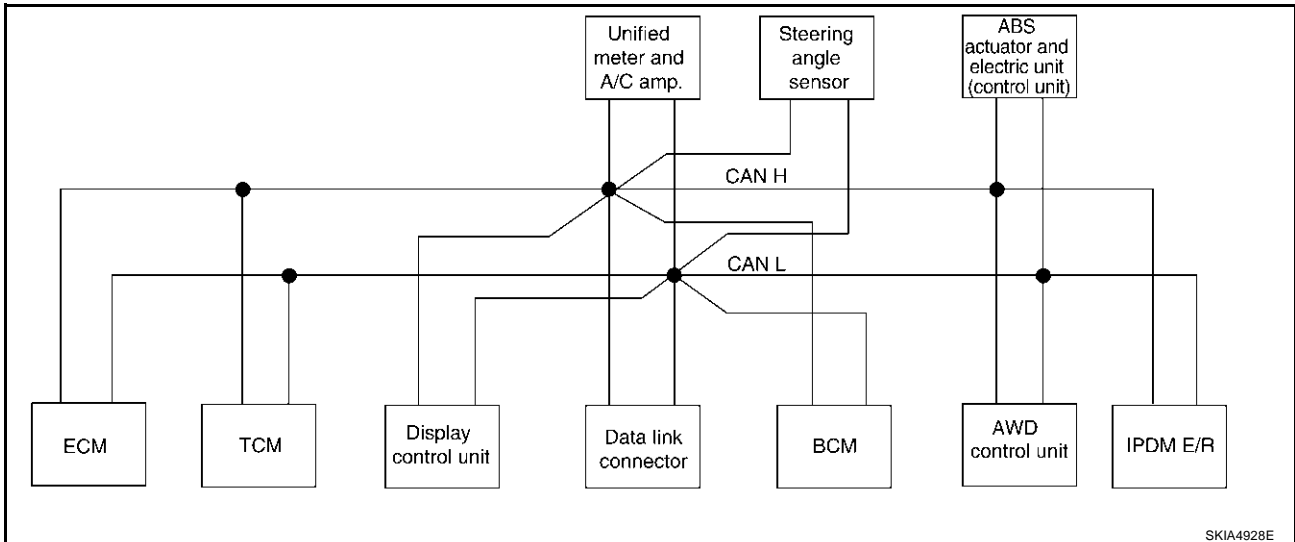

# NAVIGATION SYSTEM

- Type28

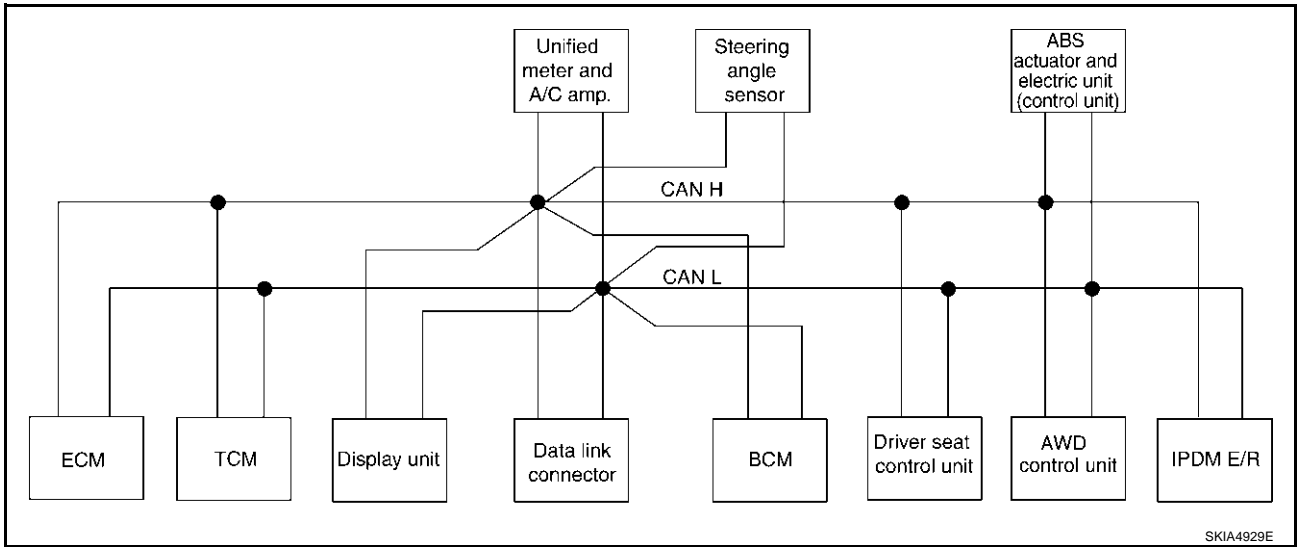

- Type29

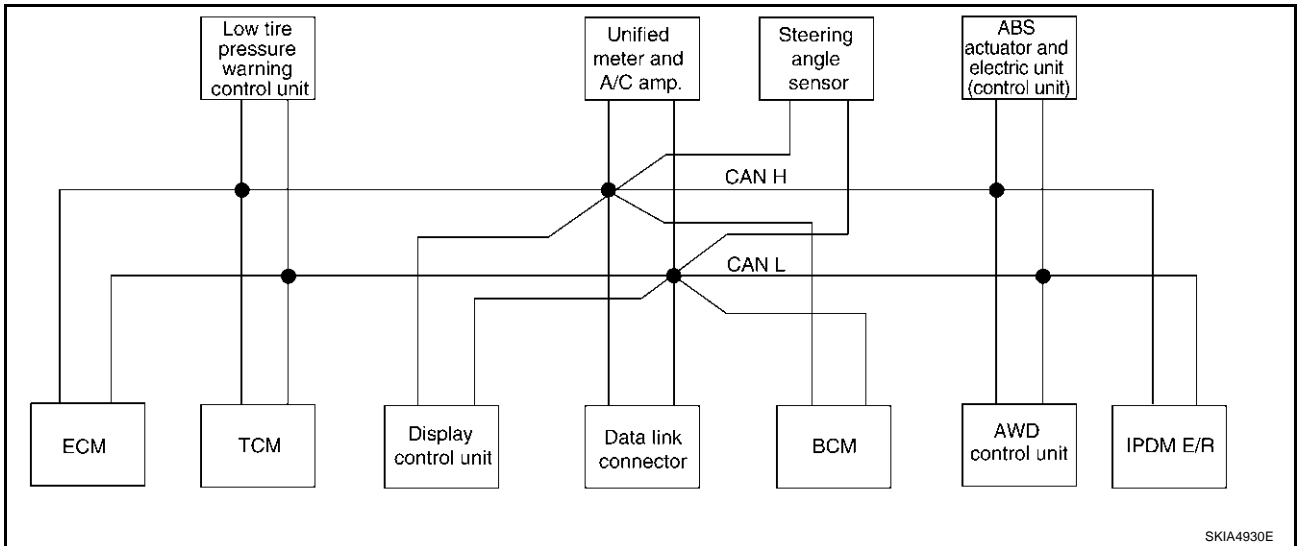

- Type30

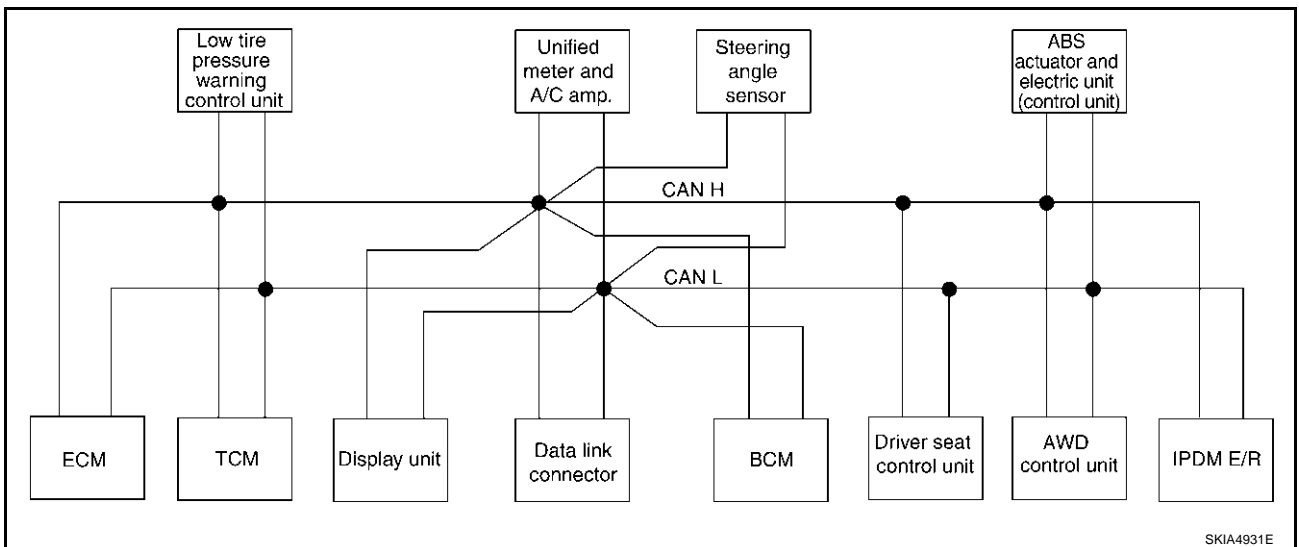

A  
B  
C  
D  
E  
F  
G  
H  
I  
J  
AV  
L  
M

# NAVIGATION SYSTEM

- Type31

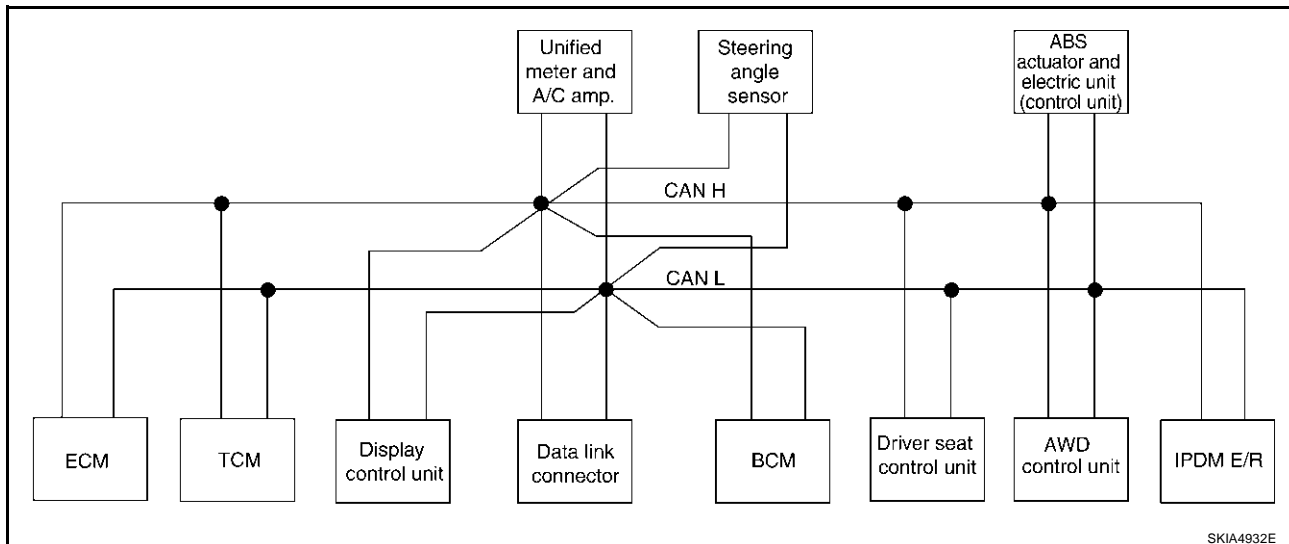

- Type32

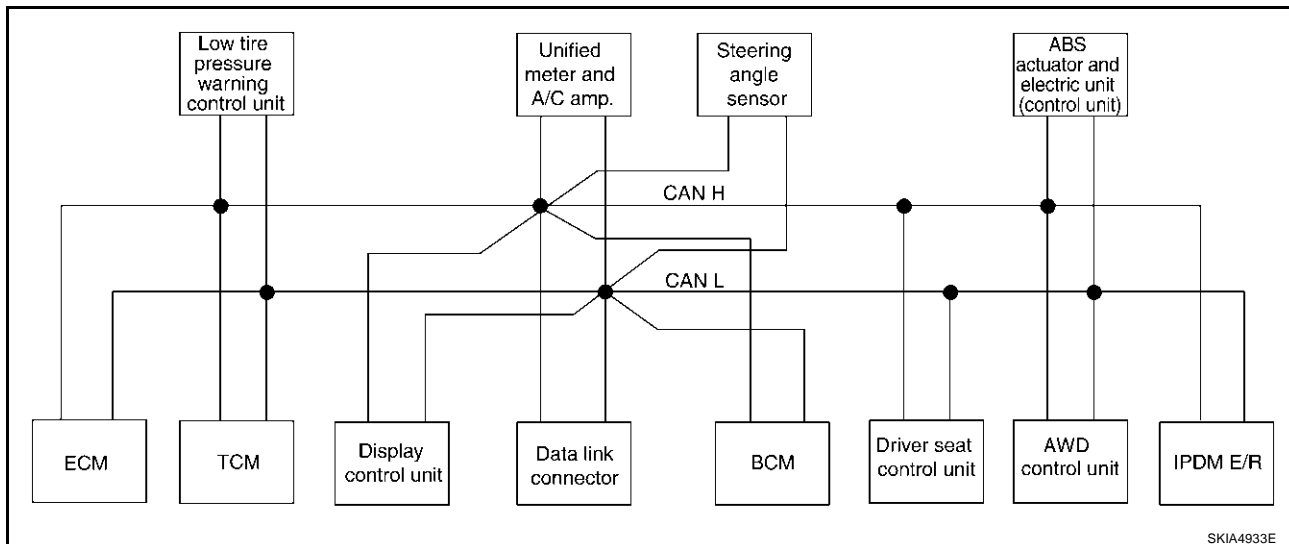

# NAVIGATION SYSTEM

## Input/output Signal Chart

T: Transmit R: Receive

Signals	ECM	TCM	Low tire pressure warning control unit	Display unit	Display control unit	BCM	Unified meter and A/C amp.	Steering angle sensor	Driver seat control unit	AWD control unit	ABS actuator and electric unit (control unit)	IPDM E/R
Engine and CVT integrated control signal	T	R										
	R	T										
Second position signal		R					T					
VDC operation signal		R								R	T	
Stop lamp switch signal		R					T			R		
Key switch signal						T			R			
Ignition switch signal						T			R			R
P range signal		T							R		R	
Closed throttle position signal	T	R										
Wide open throttle position signal	T	R										
Second position indicator signal		T					R				R	
Engine speed signal	T	R			R	R	R			R	R	
Engine status signal	T					R						
Engine coolant temperature signal	T						R					
Accelerator pedal position signal	T	R								R	R	
Fuel consumption monitor signal	T						R					
CVT self-diagnosis signal	R	T										
Input shaft revolution signal	R	T									R	
Output shaft revolution signal	R	T									R	
Air conditioner switch signal	R					T						
A/C compressor request signal	T											R
A/C compressor feedback signal	T						R					T
Blower fan motor switch signal	R					T						
A/C control signal				T	T		R					
				R	R		T					
Cooling fan speed request signal	T											R
Position lights request signal						T	R					R
Low beam request signal						T						R
Low beam status signal	R											T
High beam request signal						T	R					R
High beam status signal	R											T
Front fog lights request signal						T						R
Vehicle speed signal		R					R			R	T	
	R		R		R	R	T		R			
Sleep request 1 signal						T	R					
Sleep request 2 signal						T						R

A

B

C

D

E

F

G

H

I

J

AV

L

M

# NAVIGATION SYSTEM

Signals	ECM	TCM	Low tire pressure warning control unit	Display unit	Display control unit	BCM	Unified meter and A/C amp.	Steering angle sensor	Driver seat control unit	AWD control unit	ABS actuator and electric unit (control unit)	IPDM E/R
Door switch signal						R	T					
Turn indicator signal				R	R	T	R		R			R
Key fob ID signal						T			R			
Key fob door unlock signal						T			R			
Seat belt buckle switch signal						R	T					
Oil pressure switch signal						R						T
Buzzer output signal						T	R					
Fuel level sensor signal	R						T					
Fuel level low warning signal				R	R		T					
Malfunction indicator signal	T						R					
ASCD SET lamp signal	T						R					
ASCD CRUISE lamp signal	T						R					
Front wiper request signal						T						R
Front wiper stop position signal						R						T
Rear window defogger switch signal						T						R
Rear window defogger control signal	R			R	R							T
Hood switch signal						R						T
Theft warning horn request signal						T						R
Horn chirp signal						T						R
Steering angle sensor signal								T			R	
Tire pressure signal			T				R					
Tire pressure data signal			T	R	R							
CVT position indicator signal		T					R				R	
ABS warning lamp signal							R				T	
VDC OFF indicator lamp signal							R				T	
SLIP indicator lamp signal							R				T	
Brake warning lamp signal							R				T	
System setting signal				T	T				R			
AWD warning lamp signal							R			T		
AWD lock indicator lamp signal							R			T		
AWD lock switch signal							T			R		
Parking brake switch signal						R	T			R		

# NAVIGATION SYSTEM

## Component Parts Location

AKS004R6

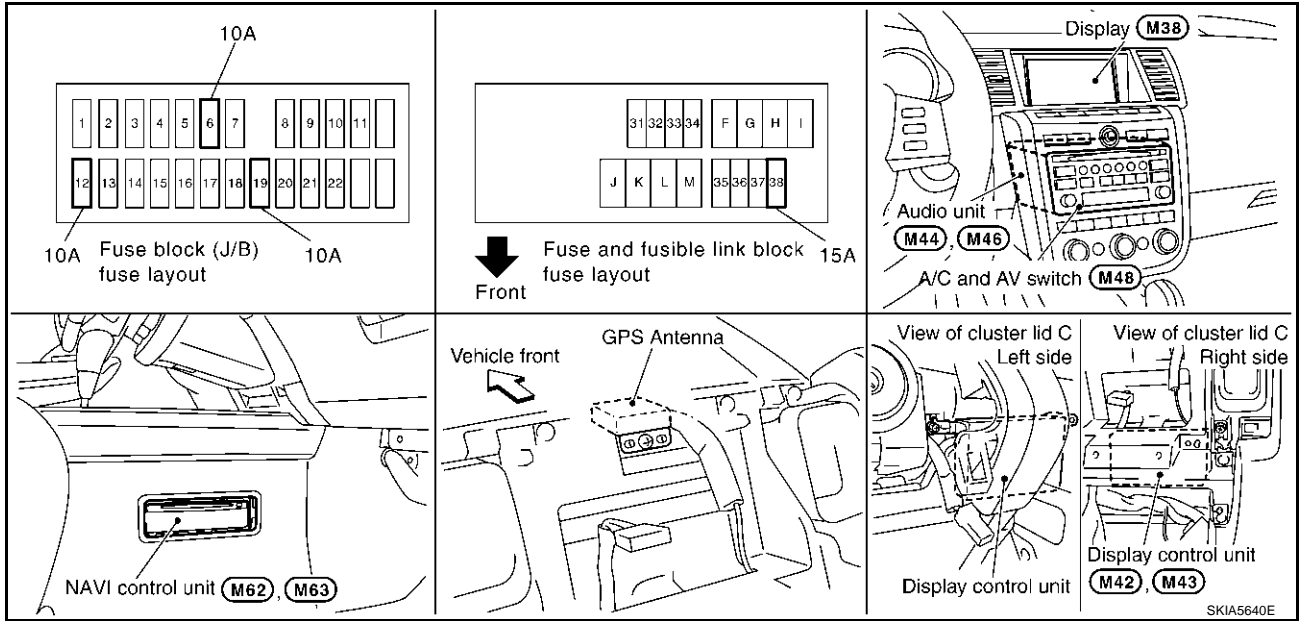

A  
B  
C  
D  
E  
F  
G  
H  
I  
J  
AV  
L  
M

# NAVIGATION SYSTEM

## Schematic—NAVI—

AKS004R8

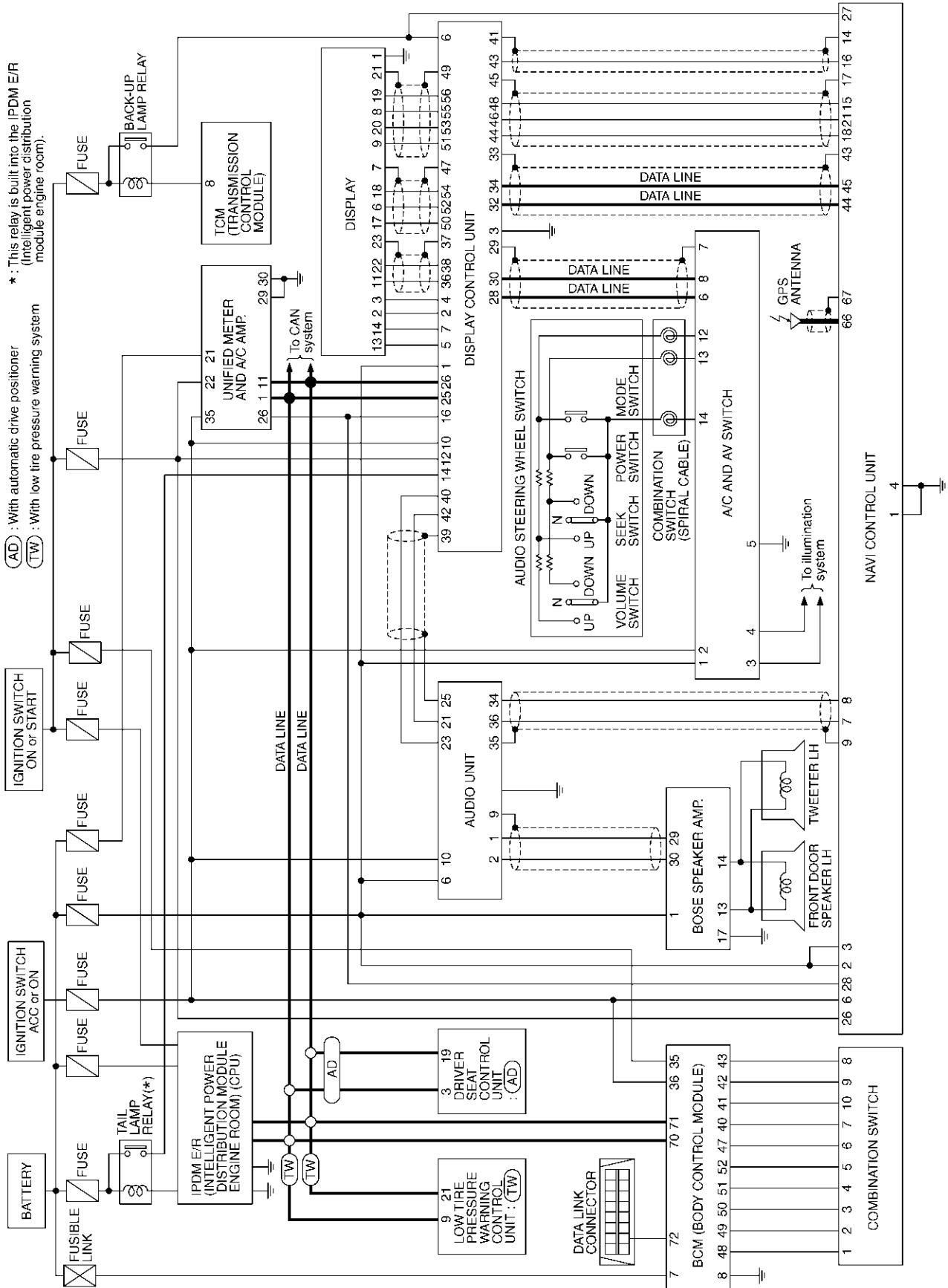

TKWA0894E



# NAVIGATION SYSTEM

## Wiring Diagram —NAVI—

AKS004R9

AV-NAVI-01

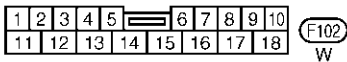
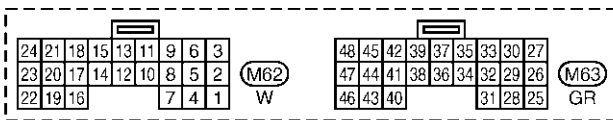
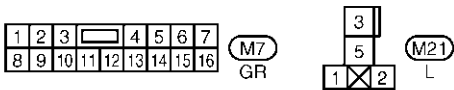
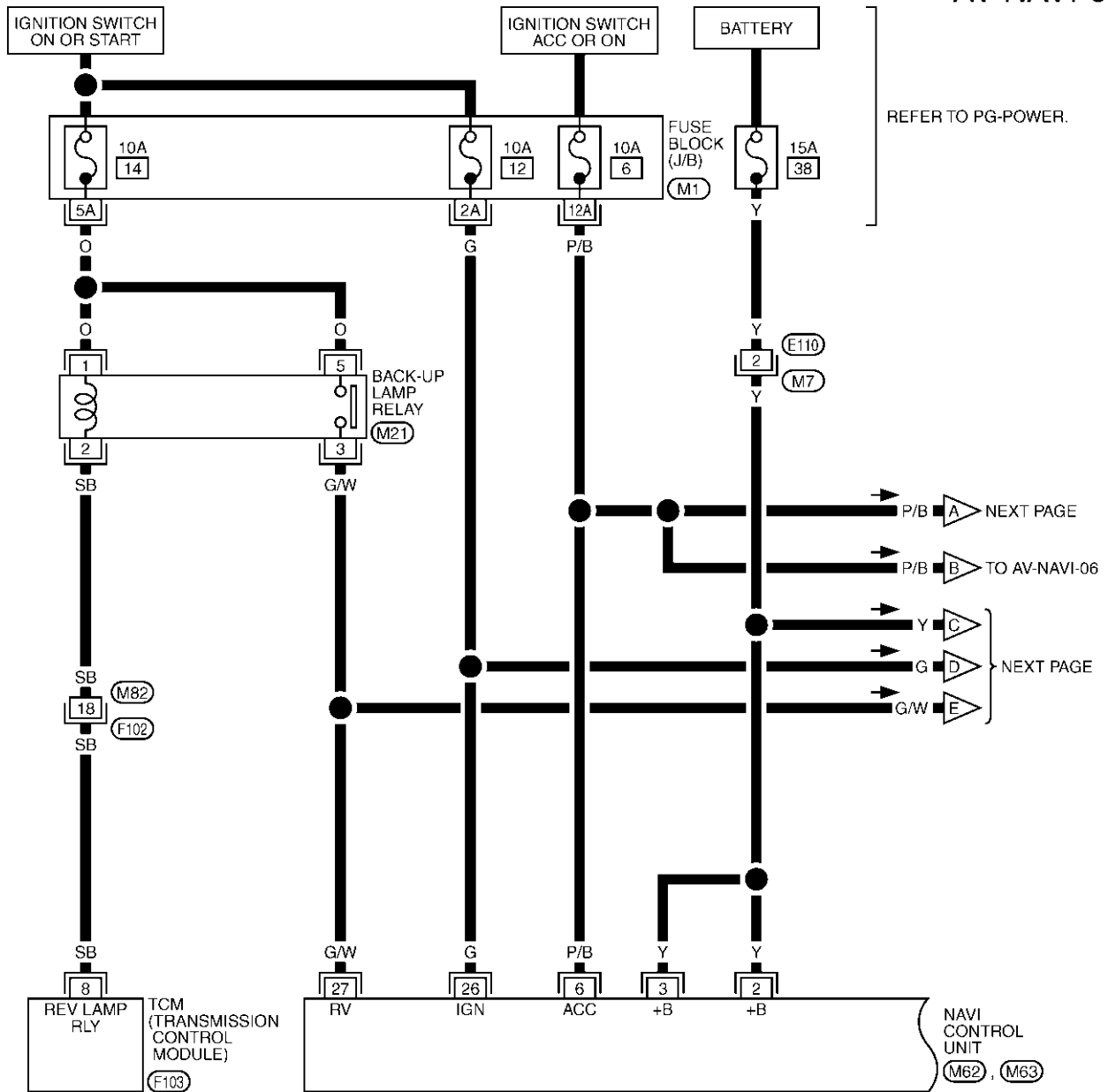

REFER TO THE FOLLOWING.

(M1) - FUSE BLOCK-JUNCTION BOX (J/B)

(F103) - ELECTRICAL UNITS

A  
B  
C  
D  
E  
F  
G  
H  
I  
J  
K  
L  
M

AV

# NAVIGATION SYSTEM

AV-NAVI-02

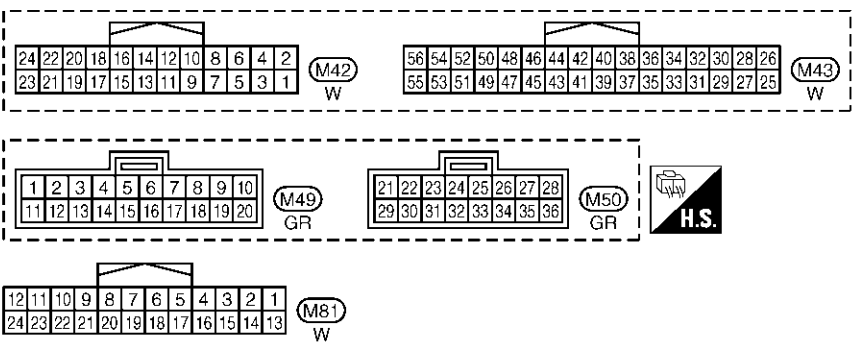
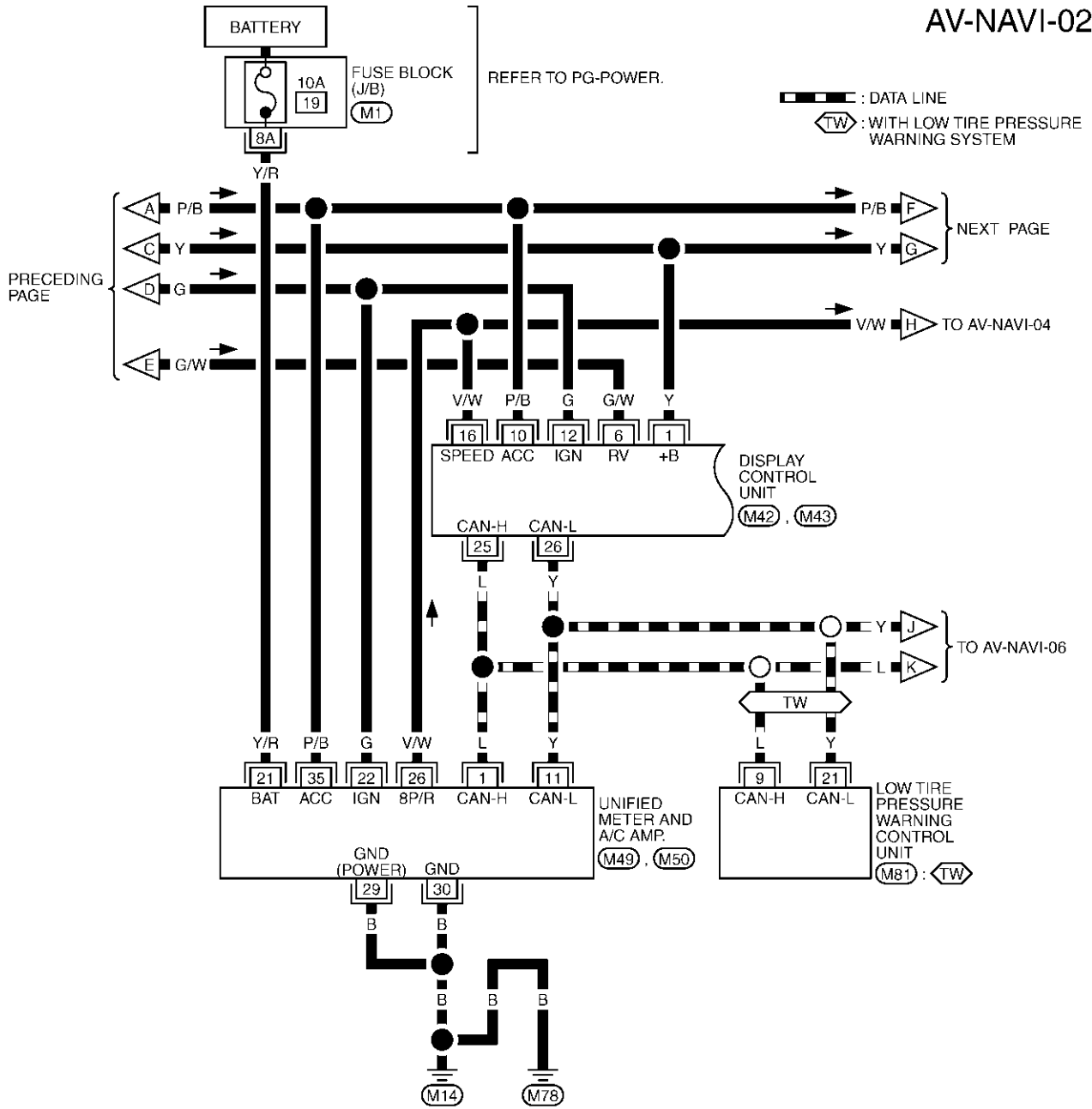

REFER TO THE FOLLOWING.  
 (M1) - FUSE BLOCK-JUNCTION BOX (J/B)

TKWA0896E

# NAVIGATION SYSTEM

AV-NAVI-03

DATA LINE

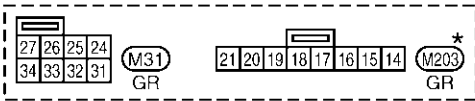
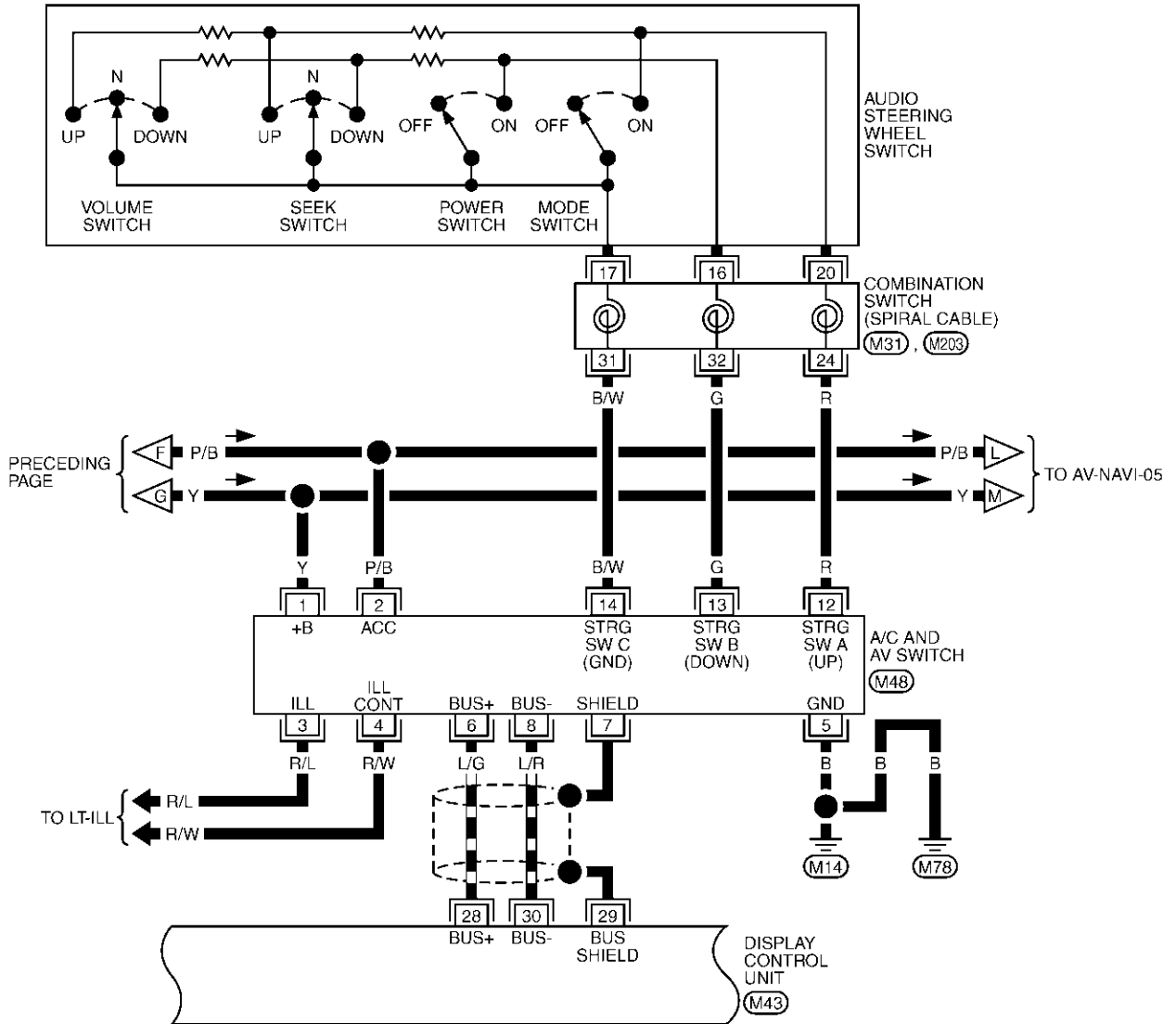

\*: THIS CONNECTOR IS NOT SHOWN IN "HARNESS LAYOUT", PG SECTION.

TKWA1055E

# NAVIGATION SYSTEM

AV-NAVI-04

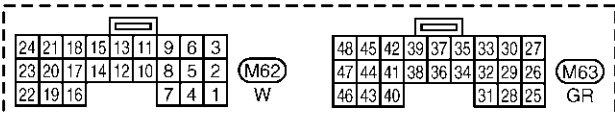
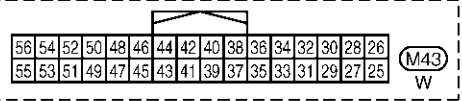
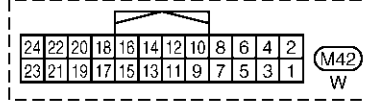
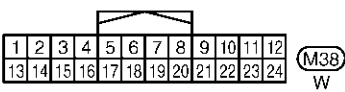
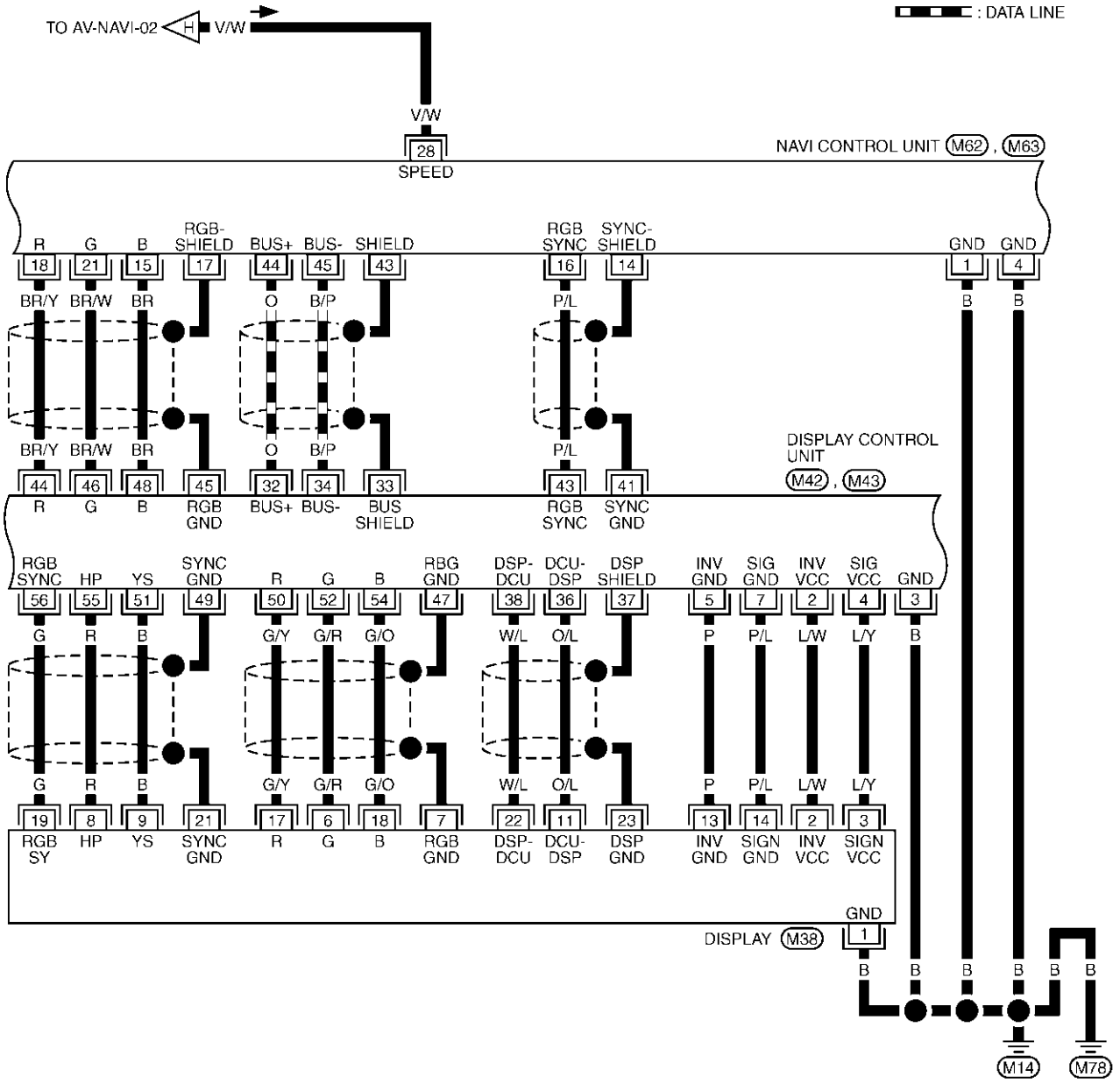

TKWA0897E

# NAVIGATION SYSTEM

AV-NAVI-05

A  
B  
C  
D  
E  
F  
G  
H  
I  
J  
AV  
L  
M

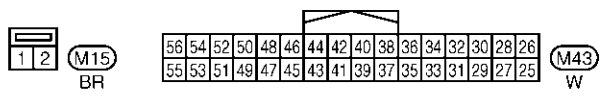
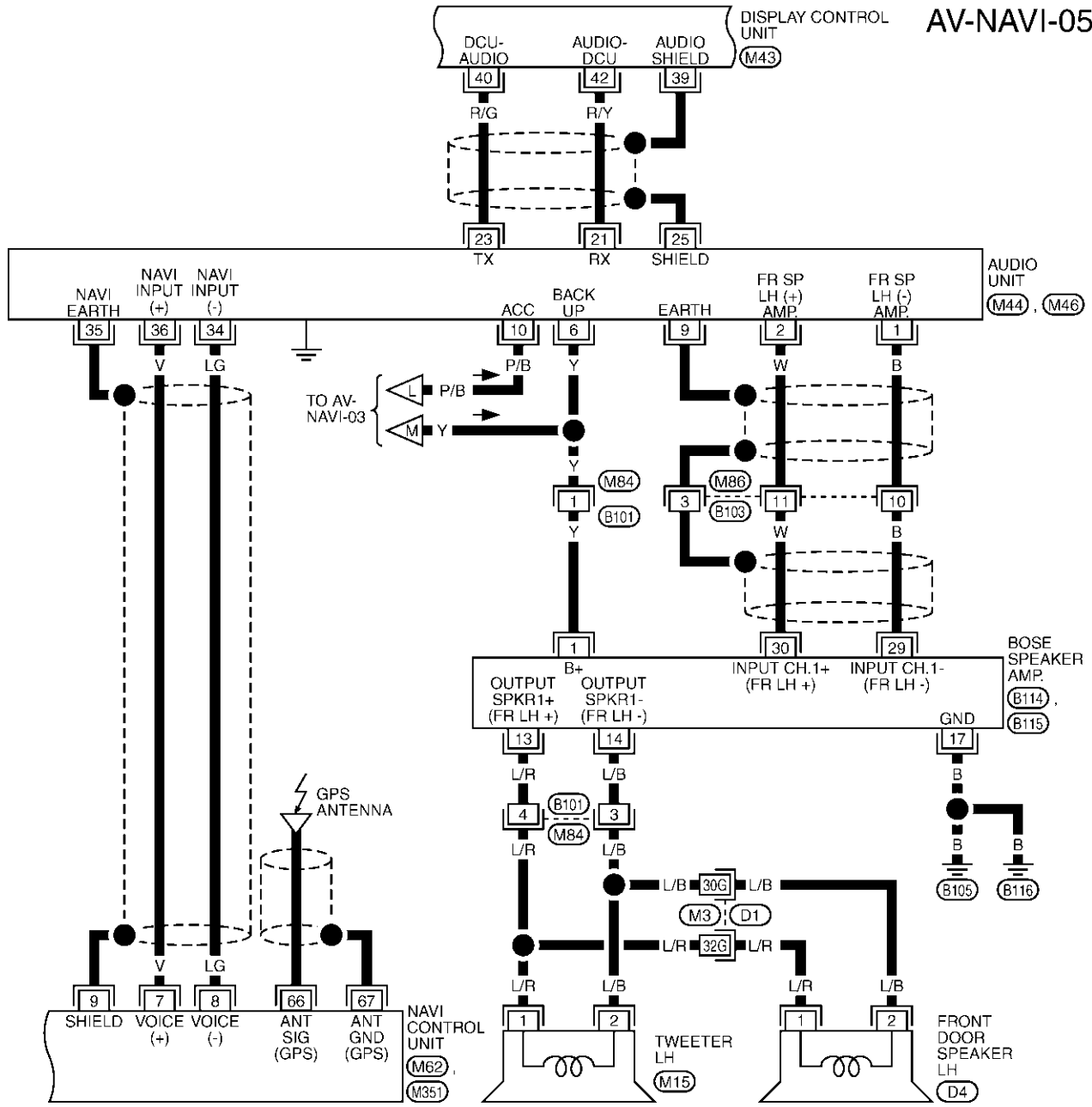

REFER TO THE FOLLOWING.  
(D1) -SUPER MULTIPLE JUNCTION (SMJ)

\*: THIS CONNECTOR IS NOT SHOWN IN "HARNES LAYOUT", PG SECTION.

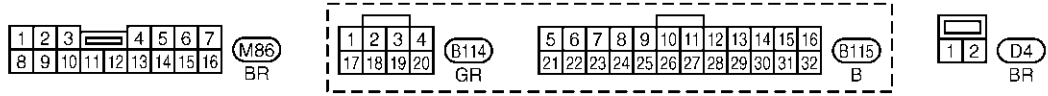
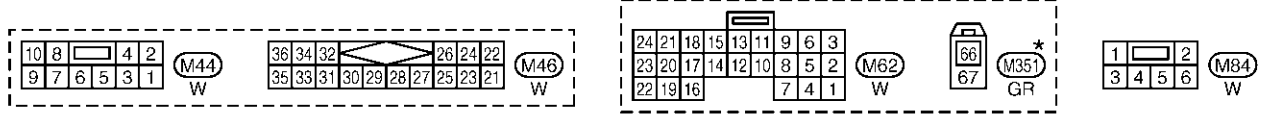

TKWA0898E

# NAVIGATION SYSTEM

AV-NAVI-06

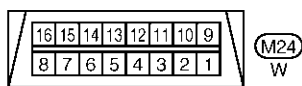
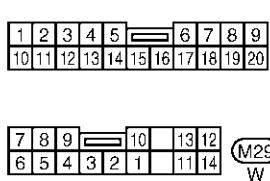
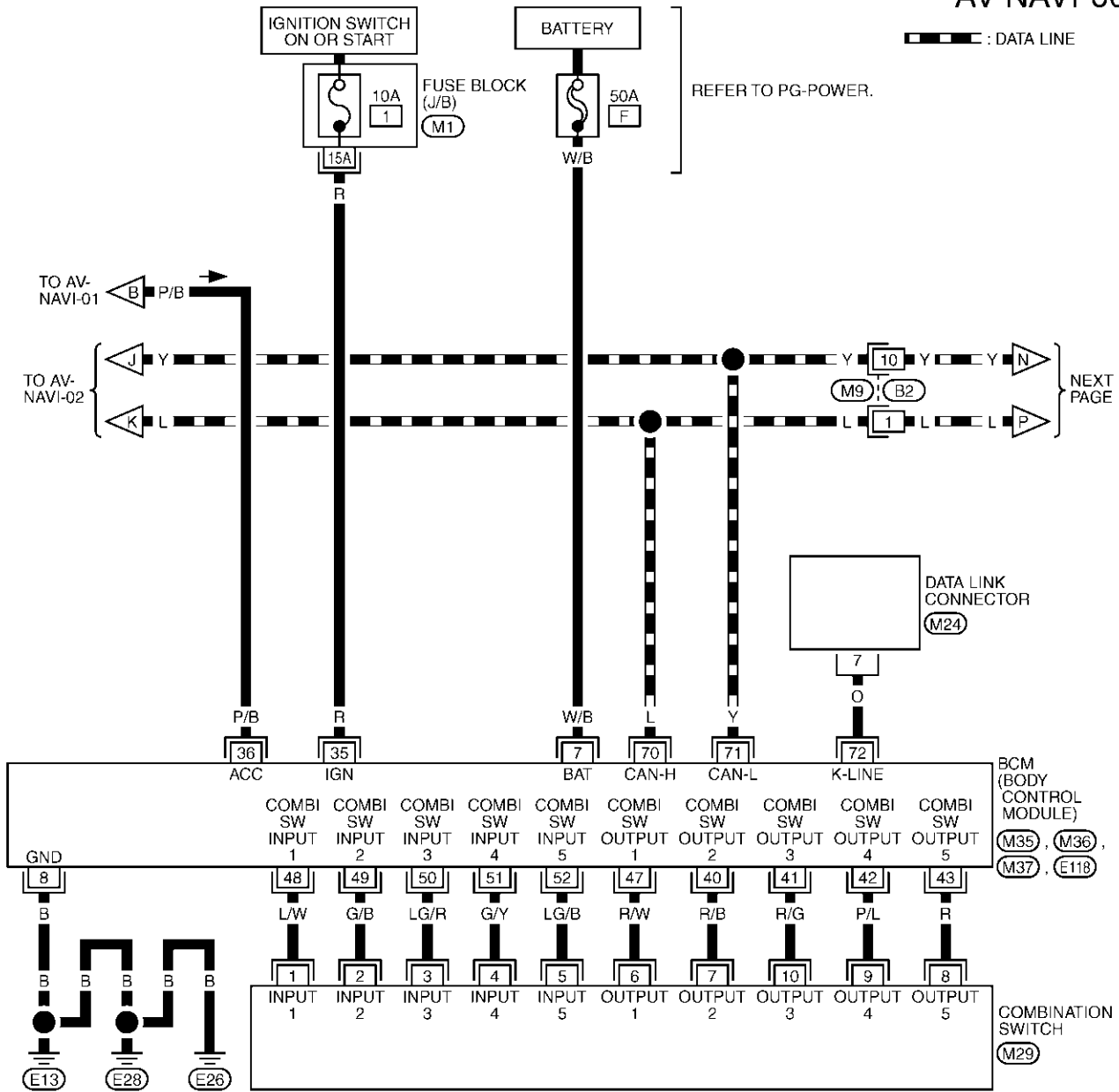

REFER TO THE FOLLOWING.

(M1) -FUSE BLOCK-JUNCTION BOX (J/B)

(M35, M36, M37, E118) -ELECTRICAL UNITS

TKWA0835E

# NAVIGATION SYSTEM

**AV-NAVI-07**

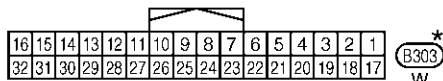
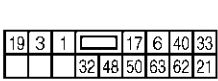
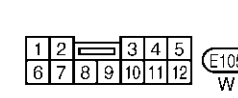
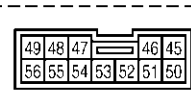
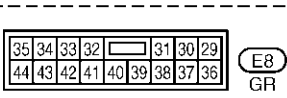
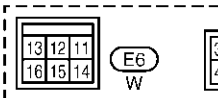
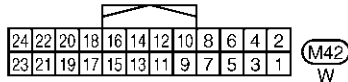
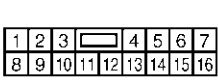
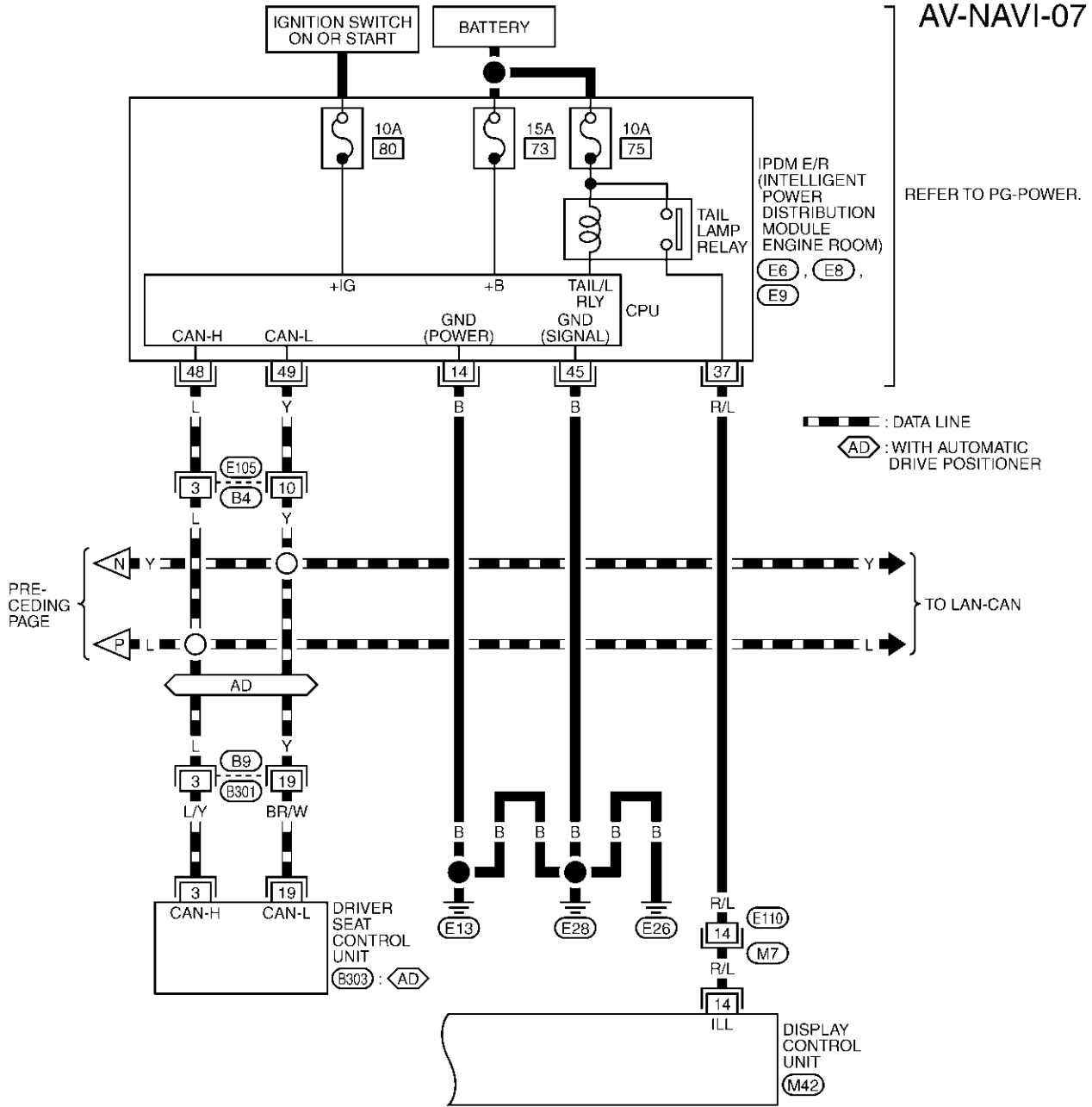

\*: THIS CONNECTOR IS NOT SHOWN IN "HARNES LAYOUT", PG SECTION.

# NAVIGATION SYSTEM

## Schematic— COMM —

AKS007WB

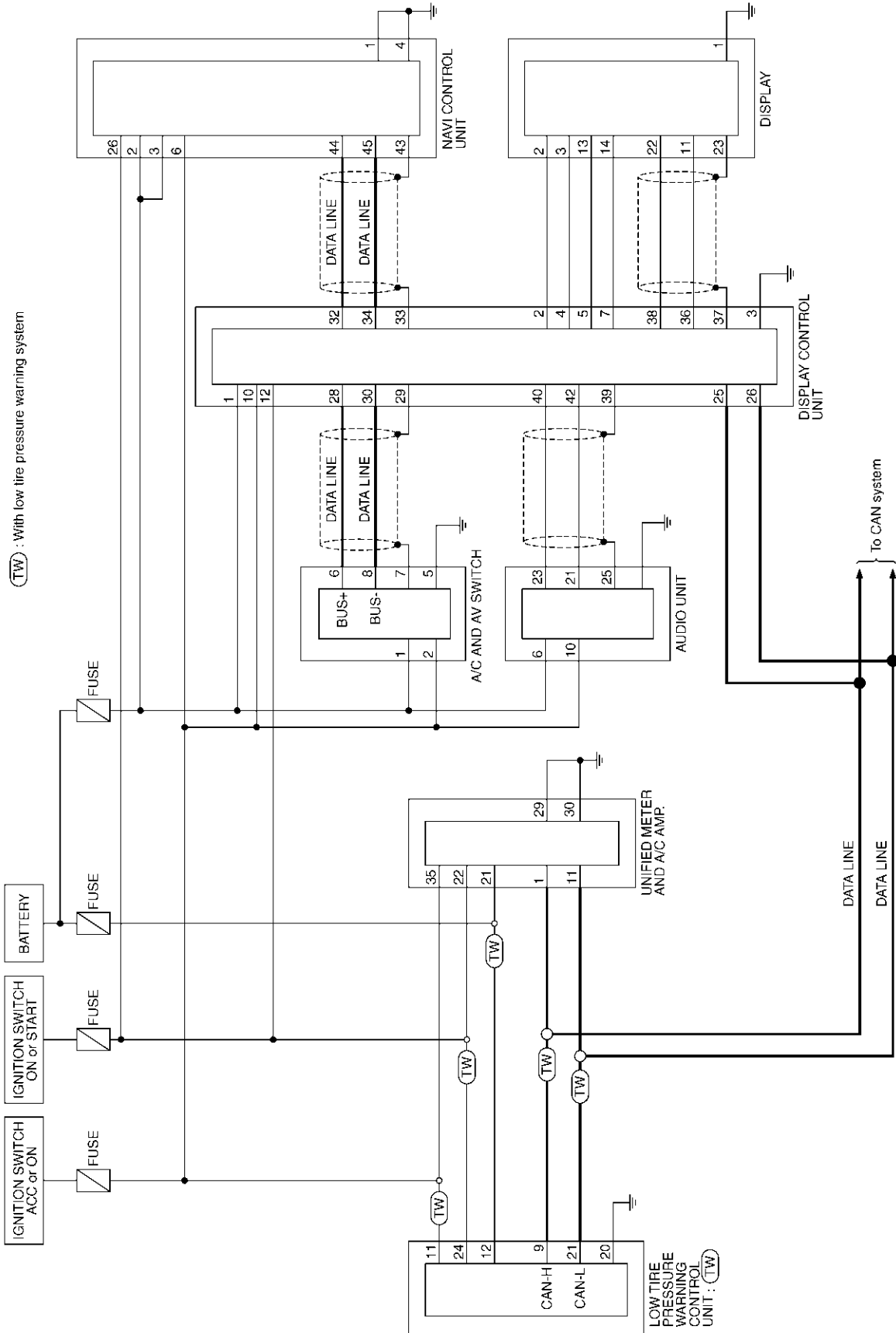

TKWA0842E



# NAVIGATION SYSTEM

## Wiring Diagram — COMM —

AKS004RB

### AV-COMM-01

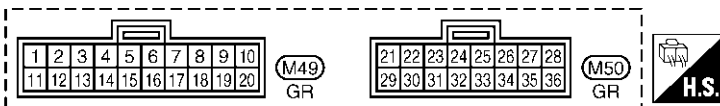
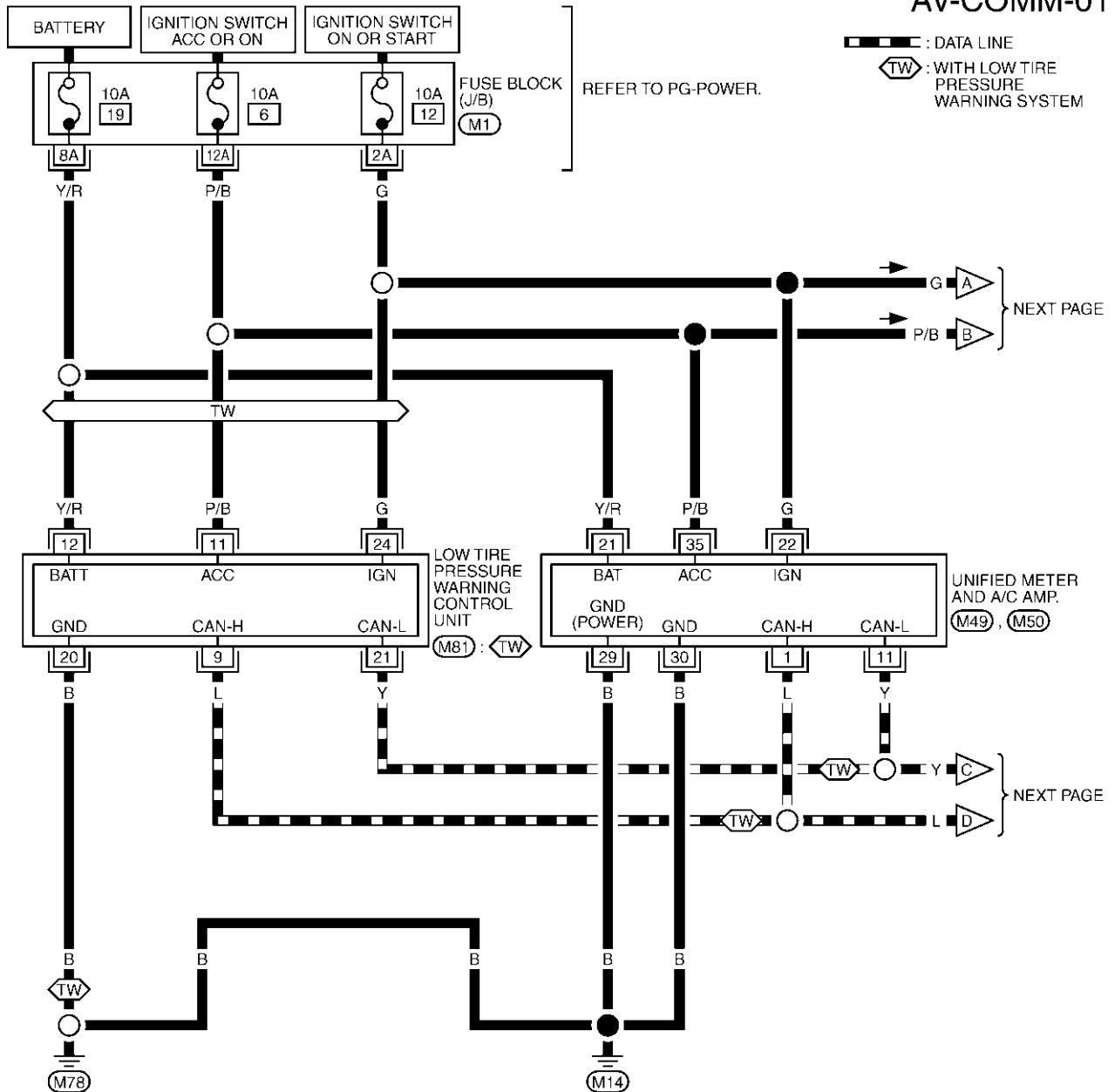

REFER TO THE FOLLOWING.

(M1) - FUSE BLOCK-JUNCTION BOX (J/B)

A  
B  
C  
D  
E  
F  
G  
H  
I  
J  
AV  
L  
M

# NAVIGATION SYSTEM

AV-COMM-02

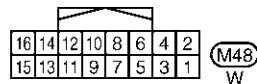
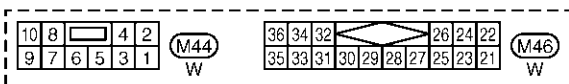
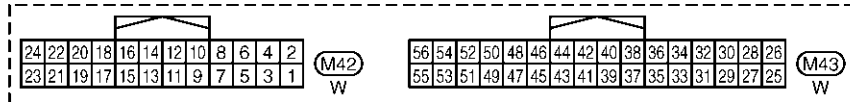
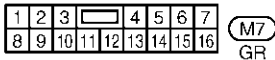
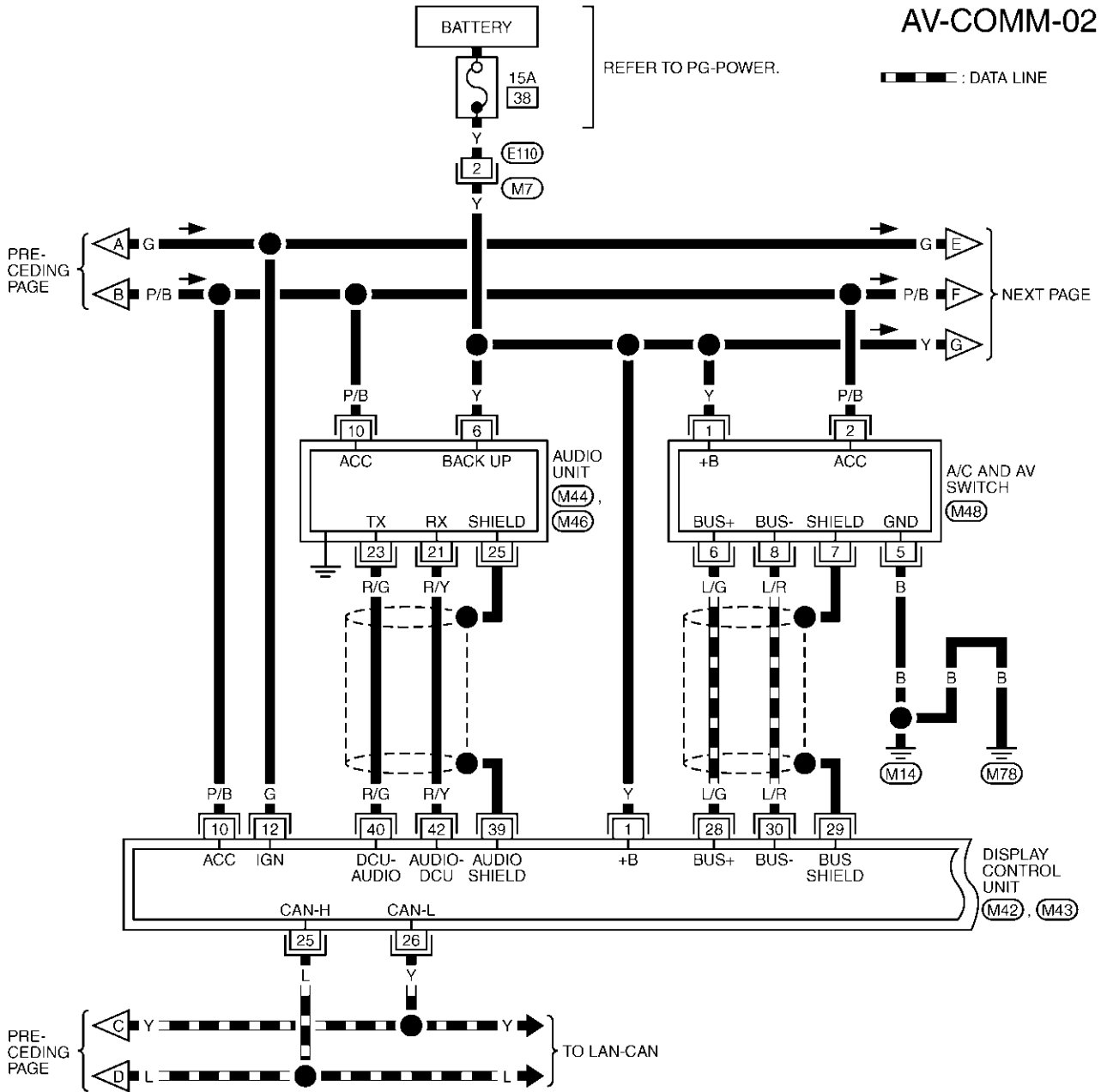

TKWA0844E

# NAVIGATION SYSTEM

AV-COMM-03

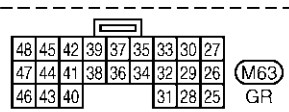
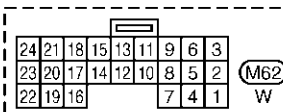
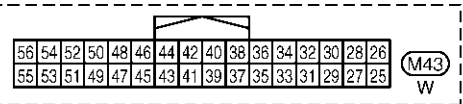
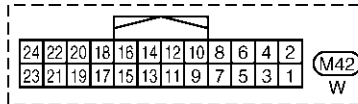
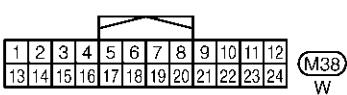
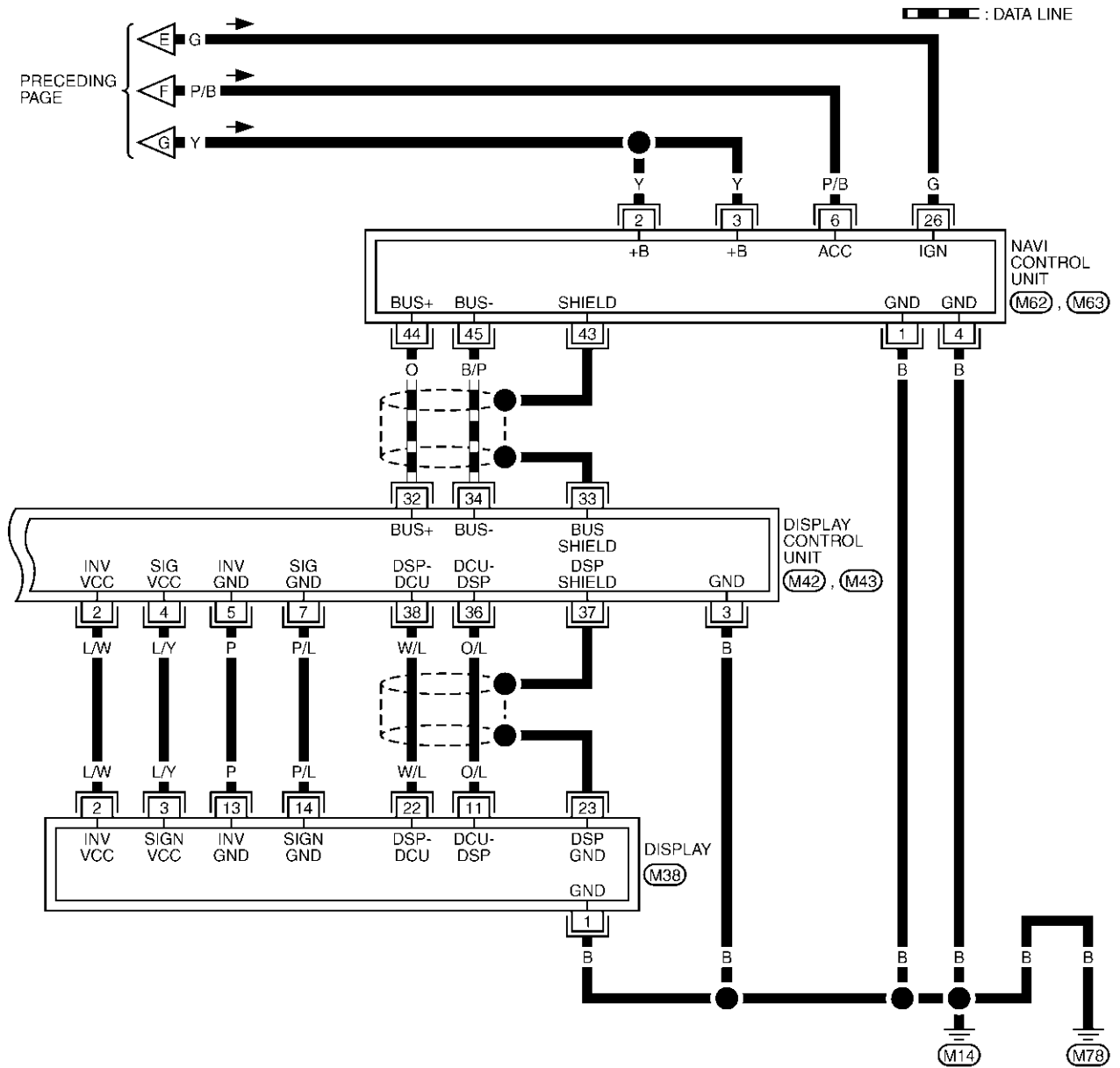

TKWA0845E

# NAVIGATION SYSTEM

## Terminals and Reference Value for NAVI Control unit

AKS004RC

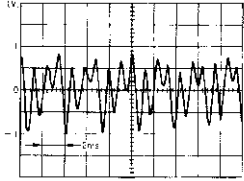
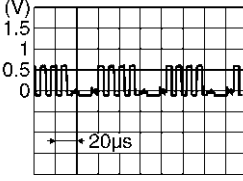
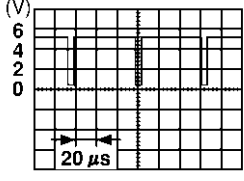
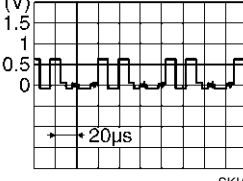
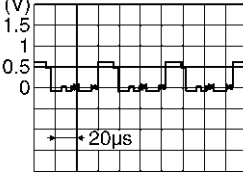
Terminal (Wire color)		Item	Signal input/ output	Condition		Reference value	Example of symptom
+	-			Igni- tion switch	Operation		
1 (B)	Ground	Ground	-	ON	-	Approx. 0 V	-
2 (Y)	Ground	Battery power supply	Input	OFF	-	Battery voltage	System does not work properly.
3 (Y)							
4 (B)	Ground	Ground	-	ON	-	Approx. 0 V	-
6 (P/B)	Ground	ACC power supply	Input	ACC	-	Battery voltage	System does not work properly.
7 (V)	8 (L/G)	Voice guide signal	Output	ON	Press the "GUIDE/ VOICE" button.	 SKIA0171J	Only route guide and operation guide are not heard.
9	Ground	Shield	-	ON	-	Approx. 0V	-
14	Ground	Shield	-	ON	-	Approx. 0V	-
15 (BR)	17	RGB signal (B: blue)	Output	ON	Select "Display Diagnosis (NAVI)" of CONFIRMATION/ ADJUSTMENT function.	 SKIA4979E	RGB screen looks yellowish.
16 (P/L)	14	RGB syn- chronizing signal	Output	ON	Press the "MAP" button.	 SKIA0164E	RGB screen is rolling.
17	Ground	Shield	-	ON	-	Approx. 0V	-
18 (BR/Y)	17	RGB signal (R: red)	Output	ON	Select "Display Diagnosis (NAVI)" of CONFIRMATION/ ADJUSTMENT function.	 SKIA4977E	RGB screen looks bluish.
21 (BR/W)	17	RGB signal (G: green)	Output	ON	Select "Display Diagnosis (NAVI)" of CONFIRMATION/ ADJUSTMENT function.	 SKIA4978E	RGB screen looks reddish.

# NAVIGATION SYSTEM

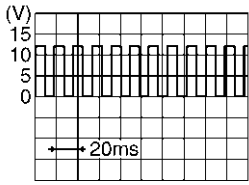
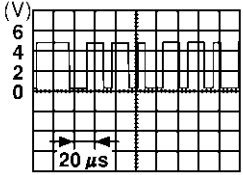
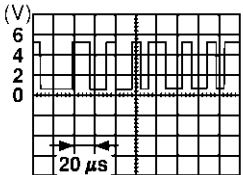
Terminal (Wire color)		Item	Signal input/ output	Condition		Reference value	Example of symptom
+	-			Igni- tion switch	Operation		
25 (R/L)	Ground	Illumination signal	Input	OFF	Lighting switch posi- tion 1st or 2nd	Approx. 12V	Night illumina- tion for switches does not illmi- nate.
					Lighting switch posi- tion OFF	Approx. 0V	
26 (G)	Ground	Ignition signal	Input	ON	-	Battery voltage	System does not work properly.
27 (G/W)	Ground	Reverse signal	Input	ON	Selector lever in R position	Approx. 12V	The navigation current-location mark moves strangely when the vehicle is moving back- wards.
					Selector lever not in R position	Approx. 0V	
28 (V/W)	Ground	Vehicle speed signal (8-pulse)	Input	ON	When vehicle speed is approx. 40 km/h (25 MPH)	 PKIA1935E	Navigation cur- rent-location mark does not indicate the cor- rect position.
43	Ground	Shield	-	ON	-	Approx. 0V	-
44 (O)	Ground	Communica- tion signal (+)	Input/ output	ON	-	 SKIA0175E	System does not work properly.
45 (B/P)	Ground	Communica- tion signal (-)	Input/ output	ON	-	 SKIA0176E	System does not work properly.
66	67	GPS signal	Input	ON	Connector is not connected.	Approx. 5 V	Navigation sys- tem GPS correc- tion is not possible.

A  
B  
C  
D  
E  
F  
G  
H  
I  
J  
AV  
L  
M

# NAVIGATION SYSTEM

## Terminals and Reference Value for Display Control unit

AKS004YU

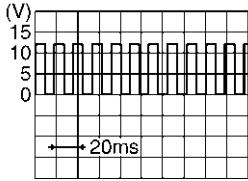
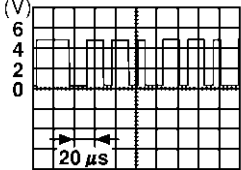
Terminal (Wire color)		Item	Signal input/ output	Condition		Reference value	Example of symptom
+	-			Igni- tion switch	Operation		
1 (Y)	Ground	Battery Power supply	Input	OFF	-	Battery voltage	System does not work properly.
2 (L/W)	Ground	Power Sup- ply (Inverter)	Output	ON	-	Approx. 9 V	Screen is not shown
3 (B)	Ground	Ground	-	ON	-	Approx. 0 V	-
4 (L/Y)	Ground	Power Sup- ply (Signal)	Output	ON	-	Approx. 9 V	Screen is not shown
5 (P)	Ground	(Inverter) Ground	-	ON	-	Approx. 0 V	-
6 (G/W)	Ground	Reverse signal	Input	ON	Selector lever in R position	Approx. 12V	Impossible to gain direction of vehicle.
					Selector lever not in R position	Approx. 0 V	
7 (P/L)	Ground	(Signal) Ground	-	ON	-	Approx. 0 V	-
10 (P/B)	Ground	ACC power supply	Input	ACC	-	Battery voltage	System does not work properly.
12 (G)	Ground	Ignition signal	Input	ON	-	Battery voltage	A/C operation is not possible. Vehicle informa- tion setting is not possible.
14 (R/L)	Ground	Illumination signal	Input	OFF	Lighting switch posi- tion 1st or 2nd	Approx. 12V	Screen does not switch between daytimemode and night-time mode.
					Lighting switch posi- tion OFF	Approx. 0 V	
16 (V/W)	Ground	Vehicle speed signal (8-pulse)	Input	ON	When vehicle speed is approx. 40 km/h (25 MPH)		Value of vehicle information is not accurately displayed.
<small>PKIA1935E</small>							
25 (L)	-	CAN H	-	-	-	-	-
26 (Y)	-	CAN L	-	-	-	-	-
28 (L/G)	Ground	Communica- tion signal (+)	Input/ Output	ON	-		System does not work properly.
<small>SKIA0175E</small>							
29	Ground	Shield	-	ON	-	Approx. 0V	-

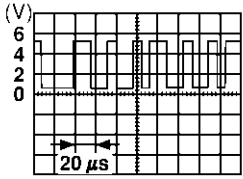
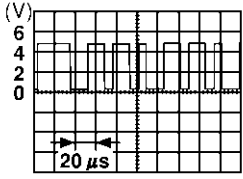
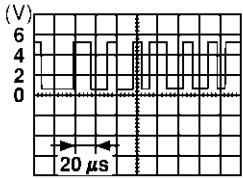
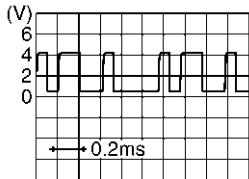
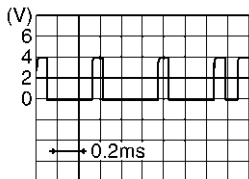
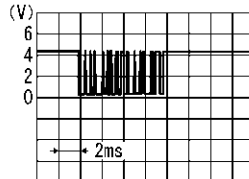

# NAVIGATION SYSTEM

Terminal (Wire color)		Item	Signal input/ output	Condition		Reference value	Example of symptom
+	-			Igni- tion switch	Operation		
30 (L/R)	Ground	Communica- tion signal (-)	Input/ output	ON	-	 <p style="text-align: right; font-size: small;">SKIA0176E</p>	System does not work properly.
32 (O)	Ground	Communica- tion signal (+)	Input/ output	ON	-	 <p style="text-align: right; font-size: small;">SKIA0175E</p>	System does not work properly.
33	Ground	Shield	-	ON	-	Approx. 0V	-
34 (B/P)	Ground	Communica- tion signal (-)	Input/ output	ON	-	 <p style="text-align: right; font-size: small;">SKIA0176E</p>	System does not work properly.
36 (O/L)	37	Display Com- munication signal (DCU-DSP)	Output	ON	Press the "TRIP" button.	 <p style="text-align: right; font-size: small;">SKIA4364E</p>	Though a screen is displayed, it is impossible to adjust bright- ness.
37	Ground	Shield	-	ON	-	Approx. 0V	-
38 (W/L)	Ground	Display Com- munication signal (DSP-DCU)	Input	ON	Press the "TRIP" button.	 <p style="text-align: right; font-size: small;">SKIA4363E</p>	Though a screen is displayed, it is impossible to adjust bright- ness.
39	Ground	Shield	-	ON	-	Approx. 0V	-
40 (R/G)	Ground	Audio TX Communica- tion signal	Output	ON	Operate audio volume.	 <p style="text-align: right; font-size: small;">SKIA4402E</p>	Audio dose not operate properly.
41	Ground	Shield	-	ON	-	Approx. 0V	-

A  
B  
C  
D  
E  
F  
G  
H  
I  
J  
M

AV

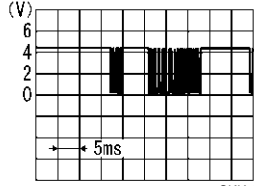
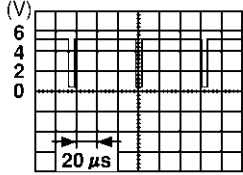
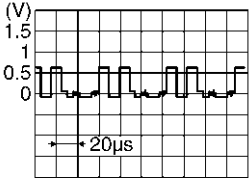
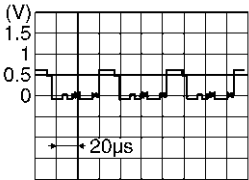
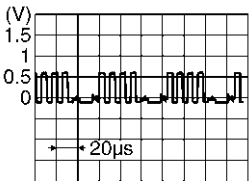
# NAVIGATION SYSTEM

Terminal (Wire color)		Item	Signal input/ output	Condition		Reference value	Example of symptom
+	-			Igni- tion switch	Operation		
42 (R/Y)	Ground	Audio RX communica- tion signal	Input	ON	Operate audio volume.	 SKIA4403E	Audio dose not operate properly.
43 (P/L)	41	RGB syn- chronizing signal	Input	ON	Press the "MAP" button.	 SKIA0164E	RGB screen is rolling.
44 (BR/Y)	45	RGB signal (R: red)	Input	ON	Select "Display Diagnosis (NAVI)" of CONFIRMATION/ ADJUSTMENT function.	 SKIA4977E	RGB screen looks bluish.
45	Ground	Shield	-	ON	-	Approx. 0V	-
46 (BR/W)	45	RGB signal (G: green)	Input	ON	Select "Display Diagnosis (NAVI)" of CONFIRMATION/ ADJUSTMENT function.	 SKIA4978E	RGB screen looks reddish.
47	Ground	Shield	-	ON	-	Approx. 0V	-
48 (BR)	45	RGB signal (B: blue)	Input	ON	Select "Display Diagnosis (NAVI)" of CONFIRMATION/ ADJUSTMENT function.	 SKIA4979E	RGB screen looks yellowish.
49	Ground	Shield	-	ON	-	Approx. 0V	-
50 (G/Y)	47	RGB signal (R: red)	Output	ON	Select "Display Diagnosis (DCU)" of CONFIRMATION/ ADJUSTMENT function.	 SKIA4980E	RGB screen looks bluish.

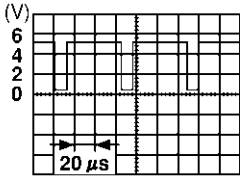
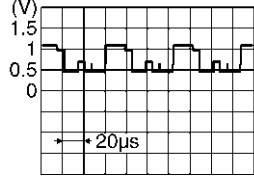
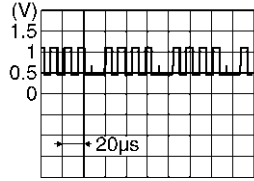
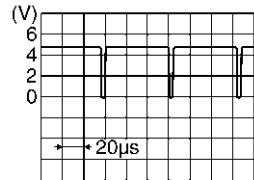
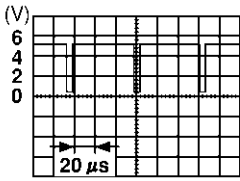

# NAVIGATION SYSTEM

Terminal (Wire color)		Item	Signal input/ output	Condition		Reference value	Example of symptom
+	-			Igni- tion switch	Operation		
51 (B)	49	RGB area (YS) signal	Output	ON	Press the "TRIP" button.	 <p style="text-align: right; font-size: small;">SKIA0162E</p>	RGB screen is not shown.
52 (G/R)	47	RGB signal (G: green)	Output	ON	Select "Display Diagnosis (DCU)" of CONFIRMATION/ ADJUSTMENT function.	 <p style="text-align: right; font-size: small;">SKIA4981E</p>	RGB screen looks reddish.
54 (G/O)	47	RGB signal (B: blue)	Output	ON	Select "Display Diagnosis (DCU)" of CONFIRMATION/ ADJUSTMENT function.	 <p style="text-align: right; font-size: small;">SKIA4982E</p>	RGB screen looks yellowish.
55 (R)	49	Horizontal synchroniz- ing (HP) sig- nal	Input	ON	-	 <p style="text-align: right; font-size: small;">SKIA4983E</p>	RGB screen is not shown.
56 (G)	49	RGB syn- chronizing signal	Output	ON	Press the "TRIP" button.	 <p style="text-align: right; font-size: small;">SKIA0164E</p>	RGB screen is rolling.

A  
B  
C  
D  
E  
F  
G  
H  
I  
J  
AV  
L  
M

# NAVIGATION SYSTEM

## Terminals and Reference Value for Display

AKS004YV

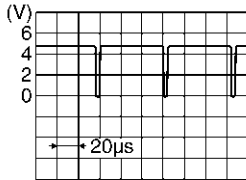
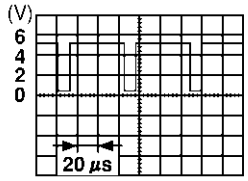
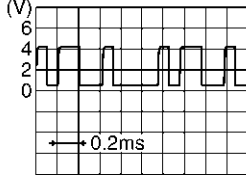
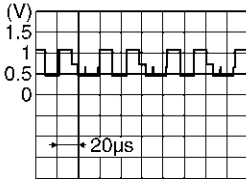
Terminal (Wire color)		Item	Signal input/ output	Condition		Reference value	Example of symptom
+	-			Igni- tion switch	Operation		
1 (B)	Ground	Ground	-	ON	-	Approx. 0 V	-
2 (L/W)	Ground	Power supply (Inverter)	Input	ON	-	Approx. 9 V	Screen is not shown.
3 (L/Y)	Ground	Power supply (Signal)	Input	ON	-	Approx. 9 V	Screen is not shown.
6 (G/R)	7	RGB signal (G: green)	Input	ON	Select "Display Diagnosis (DCU)" of CONFIRMATION/ADJUSTMENT function.	 <p style="text-align: right; font-size: small;">SKIA4981E</p>	RGB screen looks reddish.
7	Ground	Shield	-	ON	-	Approx. 0V	-
8 (R)	21	Horizontal synchronizing (HP) signal	Output	ON	-	 <p style="text-align: right; font-size: small;">SKIA4983E</p>	RGB screen is not shown.
9 (B)	21	RGB area (YS) signal	Input	ON	Press the "TRIP" button.	 <p style="text-align: right; font-size: small;">SKIA0162E</p>	RGB screen is not shown.
11 (O/L)	23	Display communication signal (DCU-DSP)	Input	ON	-	 <p style="text-align: right; font-size: small;">SKIA4364E</p>	Though a screen is displayed, it is impossible to adjust brightness.
13 (P)	Ground	(Inverter) Ground	-	ON	-	Approx. 0 V	-
14 (P/L)	Ground	(Signal) Ground	-	ON	-	Approx. 0 V	-
17 (G/Y)	7	RGB signal (R: red)	Input	ON	Select "Display Diagnosis (DCU)" of CONFIRMATION/ADJUSTMENT function.	 <p style="text-align: right; font-size: small;">SKIA4980E</p>	RGB screen looks bluish.

# NAVIGATION SYSTEM

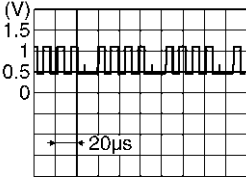
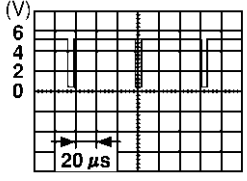
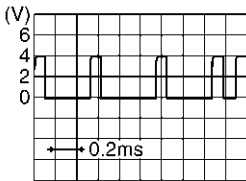
Terminal (Wire color)		Item	Signal input/ output	Condition		Reference value	Example of symptom
+	-			Igni- tion switch	Operation		
18(G/O)	7	RGB signal (B: blue)	Input	ON	Select "Display Diagnosis (DCU)" of CONFIRMATION/ ADJUSTMENT function.	 <p style="text-align: right; font-size: small;">SKIA4982E</p>	RGB screen looks yellowish.
19 (G)	21	RGB syn- chronizing signal	Input	ON	Press the "TRIP" button.	 <p style="text-align: right; font-size: small;">SKIA0164E</p>	RGB screen is rolling.
21	Ground	Shield	-	ON	-	Approx. 0V	-
22 (W/L)	Ground	Display com- munication signal (DSP-DCU)	Output	ON	-	 <p style="text-align: right; font-size: small;">SKIA4363E</p>	Though a screen is displayed, it is impossible to adjust bright- ness.
23	Ground	Shield	-	ON	-	Approx. 0V	-

A

B

C

D

E

F

G

H

I

J

AV

L

M

# NAVIGATION SYSTEM

## Terminals and Reference Value for A/C and AV Switch

AKS005LS

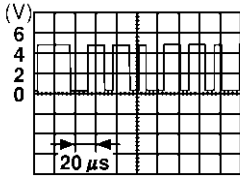
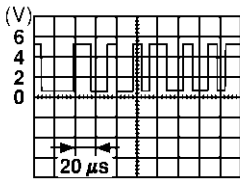
Terminal (Wire color)		Item	Signal input/ output	Condition		Reference value	Example of symptom
+	-			Igni- tion switch	Operation		
1 (Y)	Ground	Battery power supply	Input	OFF	-	Battery voltage	System does not work properly.
2 (P/B)	Ground	ACC power supply	Input	ACC	-	Battery voltage	System does not work properly.
3 (R/L)	Ground	Illumination signal	Input	OFF	Lighting switch is ON (position 1).	Approx. 12V	A/C and AV switch illumination does not come on when lighting switch is ON (position 1).
					Turn lighting switch OFF.	Approx. 0V	
4 (R/W)	Ground	Illumination ground	Output	ON	-	Approx. 0V	A/C and AV switch illumination does not come on when lighting switch is ON (position 1).
5 (B)	Ground	Ground	-	ON	-	Approx. 0V	-
6 (L/G)	Ground	Communication signal (+)	Input/output	ON	-	 <p style="text-align: right; font-size: small;">SKIA0175E</p>	System does not work properly.
7	Ground	Shield	-	ON	-	Approx. 0V	-
8 (L/R)	Ground	Communication signal (-)	Input/output	ON	-	 <p style="text-align: right; font-size: small;">SKIA0176E</p>	System does not work properly.
12 (R)	Ground	Remote control A	Input	ON	Press MODE switch	Approx. 0 V	Steering wheel audio controls do not function
					Press SEEK UP switch	Approx. 0.75 V	
					Press VOL UP switch	Approx. 2 V	
					Except for above	Approx. 5 V	
13 (G)	Ground	Remote control B	Input	ON	Press POWER switch	Approx. 0 V	Steering wheel audio controls do not function
					Press SEEK DOWN switch	Approx. 0.75 V	
					Press VOL DOWN switch	Approx. 2 V	
					Except for above	Approx. 5 V	
14 (B/W)	Ground	Remote control ground	-	ON	-	Approx. 0V	Steering wheel audio controls do not function.

# NAVIGATION SYSTEM

## On Board Self-Diagnosis Function DESCRIPTION

AKS004RD

- Diagnosis function consists of the self-diagnosis mode performed automatically and the CONFIRMATION/ADJUSTMENT mode operated manually.
- Self-diagnosis mode checks for connections between the units constituting this system, analyzes each individual unit at the same time, and displays the results on the LCD screen.
- CONFIRMATION/ADJUSTMENT mode is used to perform trouble diagnosis that require operation and judgment by an operator (trouble that cannot be automatically judged by the system), to check/change the set value, and to display the History of Errors of the navigation system.

## DIAGNOSIS ITEM

Mode		Description			
Self-diagnosis (DCU)		Display control unit diagnosis			
Self-diagnosis (NAVI)		<ul style="list-style-type: none"> <li>● NAVI Control unit diagnosis (DVD-ROM drive will not be diagnosed when no map DVD-ROM is in it)</li> <li>● Analyzes connection between the NAVI control unit and the GPS antenna connection between the NAVI control unit and each unit, and operation of each unit.</li> </ul>			
CONFIRMATION/ ADJUSTMENT	Display diagnosis		On display control unit mode, color tone and shading of the screen can be checked by the display of a color bar and a gray scale.		
	Vehicle signals		On display control unit mode, analyzes the following vehicle signals: Vehicle speed signal, light signal <sup>NOTE</sup> , ignition switch signal, and reverse signal.		
	Auto Climate Control		A/C self-diagnosis of A/C system.		
	Navigation	Display diagnosis		On NAVI C/U mode, color tone and shading of the screen can be checked by the display of a color bar and a gray scale.	
		Vehicle signals		On NAVI C/U mode, analyzes the following vehicle signals: Vehicle speed signal, light signal, ignition switch signal, and reverse signal.	
		History of Errors		Diagnosis results previously stored in the memory (before turning ignition switch ON) are displayed in this mode. Time and location when/where the errors occurred are also displayed.	
		Navigation	Display Longitude & Latitude		Display the map. Use the joystick to adjust position. Longitude and latitude will be displayed.
			Speed Calibration		Under ordinary conditions, the navigation system distance measuring function will automatically compensate for minute decreases in wheel and tire diameter caused by tire wear or low -pressure. Speed calibration immediately restores system accuracy in cases such as when distance calibration is needed because of the use of tire chains in inclement weather.
	Angle adjustment		Corrects difference between actual turning angle of a vehicle and turning angle of the car mark on the display.		
	Initialize Location		This mode is for initializing the current location. Use when the vehicle is transported a long distance on a trailer, etc.		
CAN DIAG SUPPORT MONITOR		Display status of CAN communication.			

### NOTE:

Make the status that is set by D/N function be shown.

# NAVIGATION SYSTEM

AKS004RE

## Self-Diagnosis Mode (DCU) OPERATION PROCEDURE

1. Start the engine.
2. Turn the audio system off.
3. While pressing the "PAUSE/MUTE" button, turn the volume control dial clockwise or counterclockwise for 30 clicks or more. (When the self-diagnosis mode is started, a short beep will be heard.)
  - Shifting from current screen to previous screen is performed by pressing "PREV" button.
4. The initial trouble diagnosis screen will be shown, and items "Self-Diagnosis (DCU)", "Self-Diagnosis (NAVI)", "Confirmation/Adjustment" and "CAN DIAG SUPPORT MONITOR" will become selective.
5. Perform self-diagnosis by selecting the "Self-diagnosis".
  - Self-diagnosis subdivision screen will be shown and the operation enters the self-diagnosis mode.
  - A bar graph shown below the self-diagnosis subdivision screen indicates progress of the diagnosis.
6. When the self-diagnosis completes, optional part confirmation screen will be shown.
  - When connection of an optional part is judged error, a screen to check if the optional part is actually fitted on the vehicle or not will be shown. When fitted, select the switch of the part on the screen and press "End". Then the "SELF DIAGNOSIS" screen will be shown.
  - When the optional part is connected normally, the switch for the part will not appear on the screen.

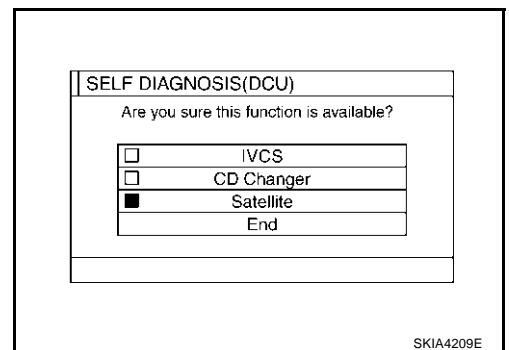
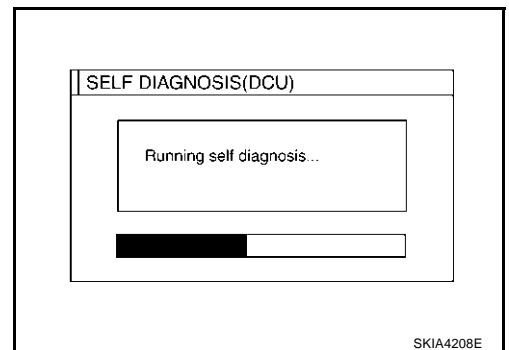
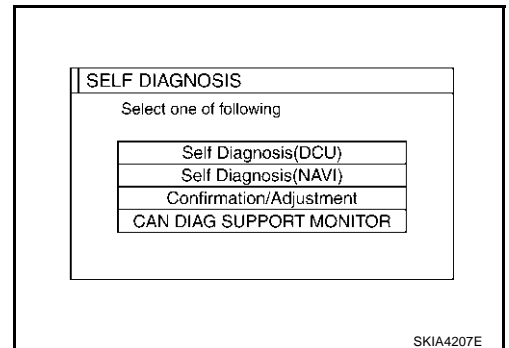
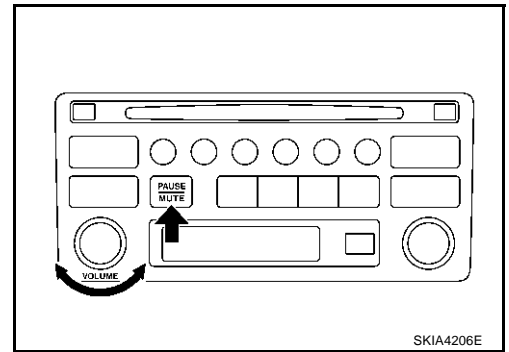

# NAVIGATION SYSTEM

7. On the "SELF DIAGNOSIS" screen, each unit name will be colored according to the diagnosis result, as follows.

**Green** : No malfunctioning.

**Yellow** : Cannot be judged by self-diagnosis results.

**Red** : Unit is malfunctioning.

- If several malfunctions are present in a unit, color of its switch on the screen will be either red, yellow, or gray, determined by the malfunction of the highest priority.

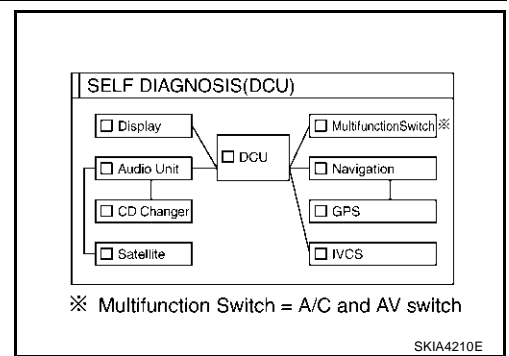

8. Select a switch on the "SELF DIAGNOSIS" screen and comments for the diagnosis results will be shown.

- When the switch is green, the following comment will be shown. "Self-diagnosis was successful. Further diagnosis and adjustments are recommended. Follow the "confirmation/adjustments" menu or refer to the service manual."
- When the switch is yellow, the following comment will be shown. "Connection to the following unit is abnormal. See the service manual for further details".
- When the switch is red, the following comment will be shown. "DCU is abnormal".

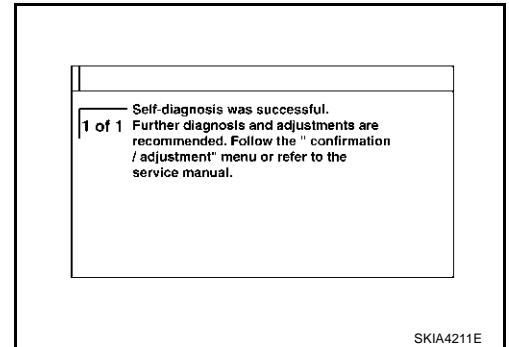

## SELF-DIAGNOSIS RESULT

### Quick Reference Table

1. Select an malfunctioning diagnosis No. in the diagnosis result quick reference table.
2. Find estimated malfunctioning system in the diagnosis No. table and perform check by referring to [AV-161, "Wiring Diagram — COMM —"](#).
3. Turn the ignition switch OFF and perform self-diagnosis again.

Switch color	Screen switch				Diagnosis No.
	DCU*	Audio unit	Navigation	GPS antenna	
Red	×				1
Yellow	×	×			2
	×		×	×	3

\*: DCU = Display control unit

### CAUTION:

- When A/C and AV switch has a malfunction, you cannot start.
- When display has a malfunction, you cannot start.
- Check the following when the self-diagnosis mode cannot be used.
  - AV communication line between display control unit and A/C and AV switch. Refer to [AV-202, "AV Communication Line Check \(Between Display Control Unit and A/C and AV Switch\)"](#).
  - A/C and AV switch power supply and ground circuit. Refer to [AV-192, "Power Supply and Ground Circuit Check for A/C and AV Switch"](#).
  - Display communication line between display control unit and display. Refer to [AV-200, "Display Communication Line Check \(Between Display Control Unit and Display\)"](#).
  - Display power supply and ground circuit. Refer to [AV-190, "Power Supply and Ground Circuit Check for Display"](#).

# NAVIGATION SYSTEM

## Self-Diagnosis Codes

Diagnosis No.	Possible cause	Reference page
1	Display control unit malfunction	Refer to <a href="#">AV-232</a>
2	Audio unit power supply and ground circuit. Audio communication line between display control unit and audio unit.	Refer to <a href="#">AV-198</a>
3	NAVI control unit power supply and ground circuit AV communication line between display control unit and NAVI control unit.	Refer to <a href="#">AV-197</a>

## Self-Diagnosis Mode (NAVI) OPERATION PROCEDURE

AKS005R4

1. Start the engine.
2. Turn the audio system off.
3. While pressing the "PAUSE/MUTE" button, turn the volume control dial clockwise or counterclockwise for 30 clicks or more. (When the self-diagnosis mode is started, a short beep will be heard.)
  - Shifting from current screen to previous screen is performed by pressing "PREV" button.

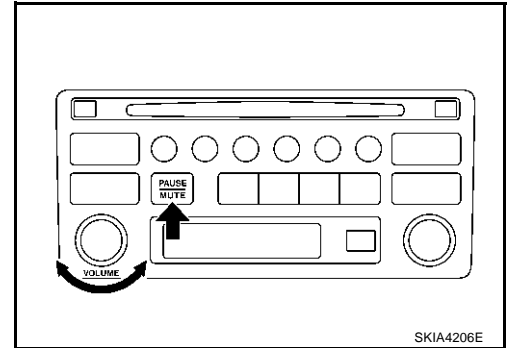

4. The initial trouble diagnosis screen will be shown, and items "Self-Diagnosis (DCU)", "Self-Diagnosis (NAVI)", "Confirmation/Adjustment" and "CAN DIAG SUPPORT MONITOR" will become selective.

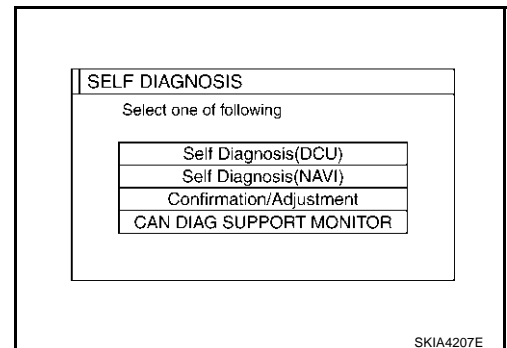

5. Perform self-diagnosis by selecting the "Self-diagnosis (NAVI)".
  - Self-diagnosis subdivision screen will be shown and the operation enters the self-diagnosis mode.
  - A bar graph shown below the self-diagnosis subdivision screen indicates progress of the diagnosis.

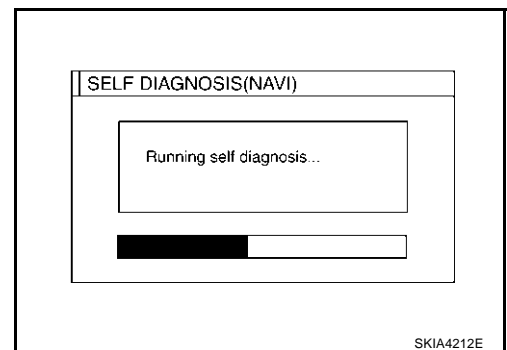



# NAVIGATION SYSTEM

6. On the "SELF DIAGNOSIS" screen, each unit name will be colored according to the diagnosis result, as follows.

- Green** : No malfunctioning.
- Yellow** : Cannot be judged by self-diagnosis results.
- Red** : Unit is malfunctioning.
- Gray** : Diagnosis has not been done.

- If several malfunctions are present in a unit, color of its switch on the screen will be either red, yellow, or gray, determined by the malfunction of the highest priority.

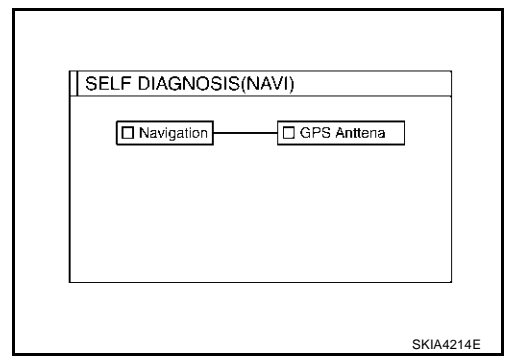

7. Select a switch on the "SELF DIAGNOSIS" screen and comments for the diagnosis results will be shown.

- When the switch is green, the following comment will be shown. "Self-diagnosis was successful. Further diagnosis and adjustments are recommended. Follow the "confirmation and adjustments" menu or refer to the service manual."
- When the switch is yellow, the following comment will be shown. "Connection to the following unit is abnormal. See the service manual for further details".
- When the switch is red, the following comment will be shown. "Center Control Unit is abnormal".
- When the switch is gray, the following comment will be shown. "Self-diagnosis for DVD-ROM DRIVER of NAVI was not conducted because no DVD-ROM was available."

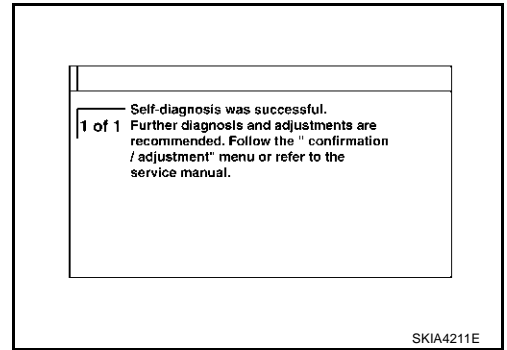

## SELF-DIAGNOSIS RESULT

### Quick Reference Table

1. Select an malfunctioning diagnosis No. in the diagnosis result quick reference table.
2. Find estimated malfunctioning system in the diagnosis No. table and perform check by referring to [AV-161, "Wiring Diagram — COMM —"](#).
3. Turn the ignition switch OFF and perform self-diagnosis again.

Switch color	Screen switch		Diagnosis No.
	Navigation*	GPS antenna	
Red	×		1
Gray	×		2
Yellow	×		3
	×		4
	×	×	5

\*: Navigation = NAVI control unit

### CAUTION:

- When A/C and AV switch has a malfunction, you cannot start.
- When display has a malfunction, you cannot start.
- Check the following when the self-diagnosis mode cannot be used.
  - AV communication line between display control unit and A/C and AV switch. Refer to [AV-202, "AV Communication Line Check \(Between Display Control Unit and A/C and AV Switch\)"](#).
  - A/C and AV switch power supply and ground circuit. Refer to [AV-192, "Power Supply and Ground Circuit Check for A/C and AV Switch"](#).
  - Display communication line between display control unit and display. Refer to [AV-200, "Display Communication Line Check \(Between Display Control Unit and Display\)"](#).
  - Display power supply and ground circuit. Refer to [AV-190, "Power Supply and Ground Circuit Check for Display"](#).

# NAVIGATION SYSTEM

## Self-diagnosis Codes

Diagnosis No.	Possible cause	Reference page
1	NAVI control unit malfunction	Refer to <a href="#">AV-230</a>
2	No map DVD-ROM is inserted in the NAVI control unit.	Refer to <a href="#">AV-203</a>
3	When "DVD-ROM error. Please check disc." is shown. 1. Eject map DVD-ROM and check if it is compatible with the system. 2. Check ejected DVD-ROM for dirt, damage, and warpage. 3. If no error is found, insert a known good map DVD-ROM of the same type and perform self-diagnosis again. If same result is shown, the NAVI control unit is malfunctioning. If result is normal, the map DVD-ROM is malfunctioning.	Refer to <a href="#">AV-203</a>
4	If "Error found in DVD-ROM or DVD-ROM driver in control unit. Please perform diagnosis in accordance with service manual" is shown, carry out same inspection as diagnosis No. 3.	Refer to <a href="#">AV-203</a>
5	GPS antenna system 1. Visually check for a broken wire in the GPS antenna coaxial cable. 2. Disconnect GPS antenna connector, and make sure approximately 5V is supplied from the NAVI control unit. If not, the NAVI control unit is malfunctioning. If 5V is supplied, replace the GPS antenna. If the connection is still malfunction after the replacement of the GPS antenna, the NAVI control unit is malfunctioning.	Refer to <a href="#">AV-204</a>

## CONFIRMATION/ADJUSTMENT Mode OPERATION PROCEDURE

AKS005R5

1. Start the engine.
2. Turn the audio system off.
3. While pressing the "PAUSE/MUTE" button, turn the volume control dial clockwise or counterclockwise for 30 clicks or more. (When the self-diagnosis mode is started, a short beep will be heard.)
  - Shifting from current screen to previous screen is performed by pressing "PREV" button.
4. The initial trouble diagnosis screen will be shown, and items "Self-Diagnosis (DCU)", "Self-Diagnosis (NAVI)", "Confirmation/Adjustment" and "CAN DIAG SUPPORT MONITOR" will become selective.

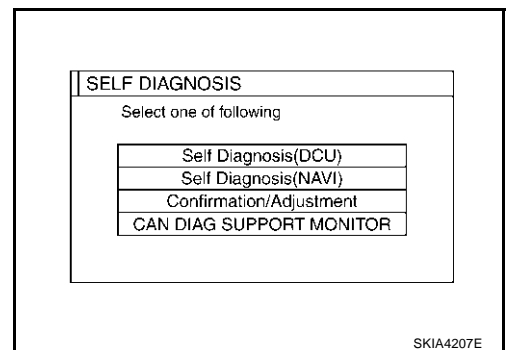
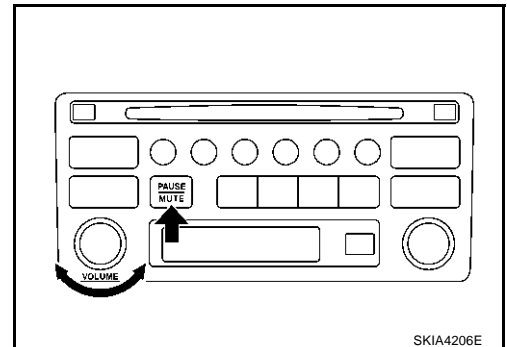

# NAVIGATION SYSTEM

5. When "Confirmation/Adjustment" is selected on the initial trouble diagnosis screen, the operation will enter the CONFIRMATION/ADJUSTMENT mode. In this mode, check and adjustment of each item will become possible.
6. The initial trouble diagnosis screen will be shown, and items "Display Diagnosis", "Vehicle Signals", "Auto Climate Control" and "Navigation" will become selective.
7. Select each switch on "CONFIRMATION/ADJUSTMENT" screen to display the relevant diagnosis screen.

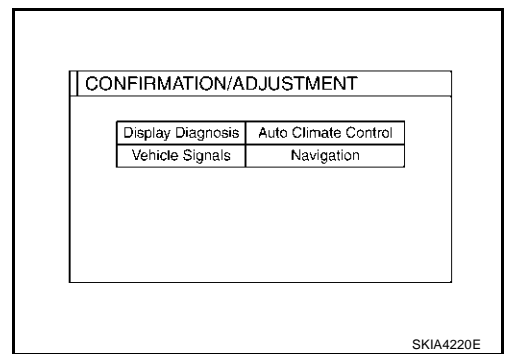

## DISPLAY DIAGNOSIS

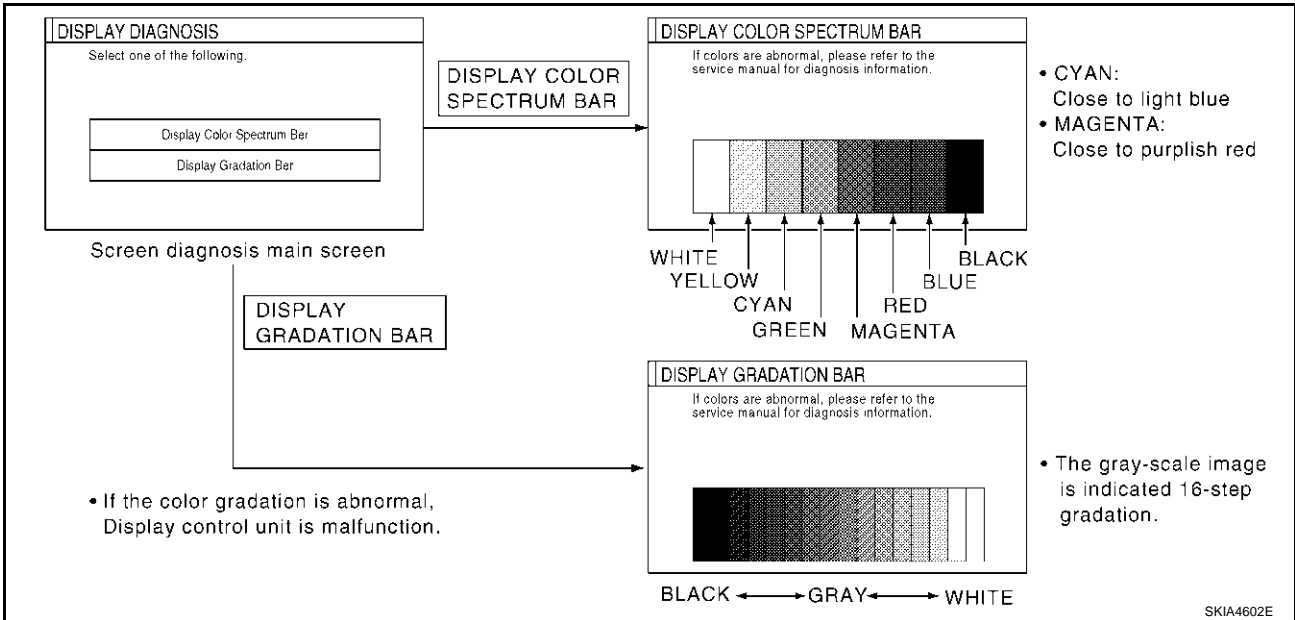

- When RGB signal error occurred in the RGB system, tone of the color bar will change as follows.
  - R (red) signal error : Screen looks bluish**
  - G (green) signal error : Screen looks reddish**
  - B (blue) signal error : Screen looks yellowish**
- When the color of the screen looks unusual, refer to [AV-208, "Color of RGB Image is Not Proper \(Excepting NAVI Screen Looks Bluish\)"](#), [AV-209, "Color of RGB Image is Not Proper \(Excepting NAVI Screen Looks Reddish\)"](#) and [AV-210, "Color of RGB Image is Not Proper \(Excepting NAVI Screen Looks Yellowish\)"](#).

## VEHICLE SIGNALS

- A comparison check can be made of each actual vehicle signal and the signals recognized by the system.

### CAUTION:

**In case of confirming light signal, set D/N mode to ON/OFF of lighting switch (normal setting).**

- OFF: D (Day mode)
- ON: N (Night mode)

**Unless above setting, light signal (ON/OFF) may not be accurately displayed.**

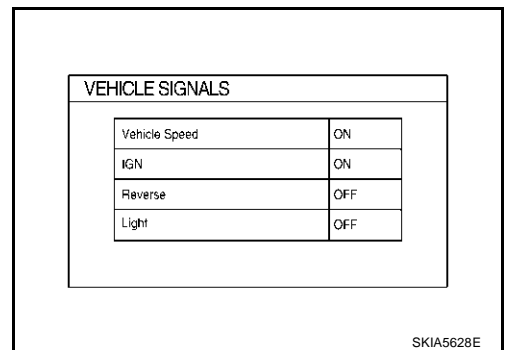

# NAVIGATION SYSTEM

Diagnosis item	Display	Condition	Remarks
Vehicle speed	ON	Vehicle speed > 0 km/h (0 MPH)	Changes in indication may be delayed by approx. 1.5 seconds. This is normal.
	OFF	Vehicle speed = 0 km/h (0 MPH)	
	–	Ignition switch in ACC position	
Light	ON	Lighting switch ON	–
	OFF	Lighting switch OFF	
IGN	ON	Ignition switch ON	–
	OFF	Ignition switch ACC or OFF	
Reverse	ON	Selector lever in R position	Changes in indication may be delayed by approx. 1.5 seconds. This is normal.
	OFF	Selector lever in other than R position	
	–	Ignition switch in ACC position	

- If vehicle speed is NG, refer to [AV-193, "Vehicle Speed Signal Check for Display Control Unit"](#) .
- If light is NG, refer to [AV-195, "Illumination Signal Check for Display Control Unit"](#) .
- If IGN is NG, refer to [AV-196, "Ignition Signal Check for Display Control Unit"](#) .
- If reverse is NG, refer to [AV-196, "Reverse Signal Check for Display Control Unit"](#) .

## AUTO CLIMATE CONTROL

- Refer to ATC Automatic Air Conditioner [ATC-68, "Self-diagnosis Function"](#) for details.

## NAVIGATION

1. The initial trouble diagnosis screen will be shown, and items "Display Diagnosis", "Vehicle Signals", "History of Errors" and "Navigation" will become selective.
2. Select each switch on "CONFIRMATION/ADJUSTMENT" screen to display the relevant diagnosis screen.

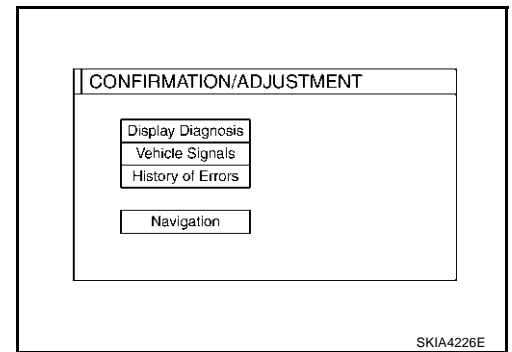

## DISPLAY DIAGNOSIS

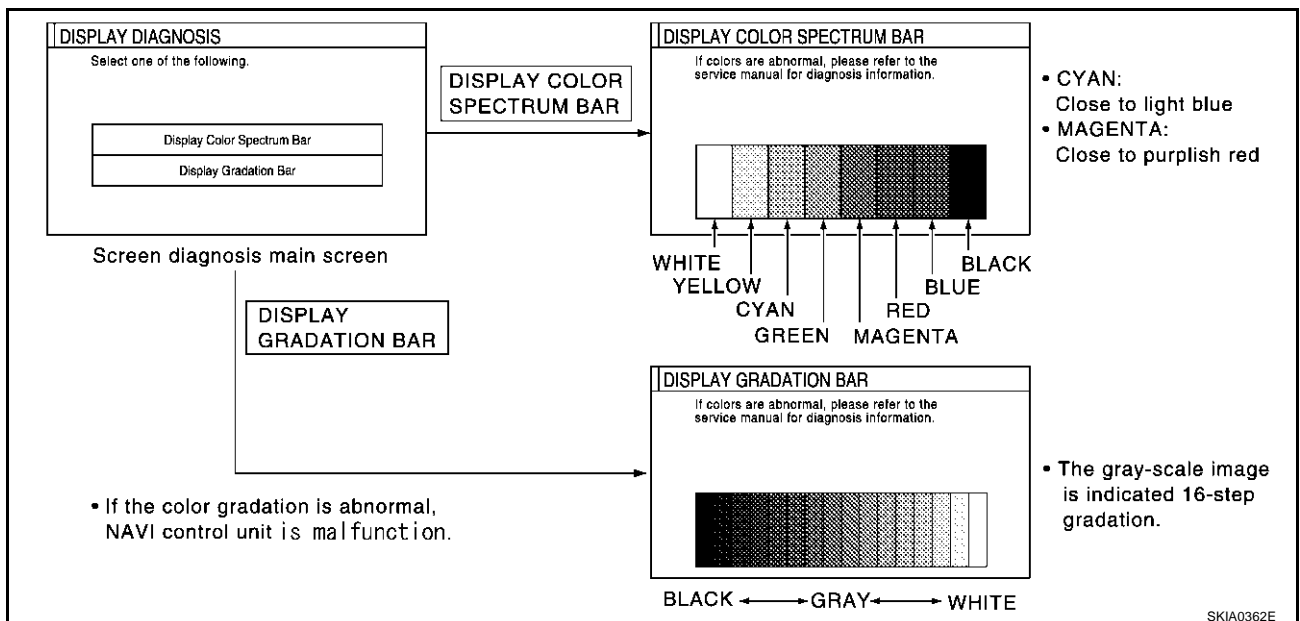

- When RGB signal error occurred in the RGB system, tone of the color bar will change as follows.

# NAVIGATION SYSTEM

- R (red) signal error** : Screen looks bluish
- G (green) signal error** : Screen looks reddish
- B (blue) signal error** : Screen looks yellowish

- When the color of the screen looks unusual, refer to [AV-205, "Color of RGB Image is Not Proper \(NAVI Screen Looks Bluish\)"](#), [AV-206, "Color of RGB Image is Not Proper \(NAVI Screen Looks Reddish\)"](#) and [AV-207, "Color of RGB Image is Not Proper \(NAVI Screen Looks Yellowish\)"](#).

## VEHICLE SIGNALS

- A comparison check can be made of each actual vehicle signal and the signals recognized by the system.

**CAUTION:**

**In case of confirming light signal, set D/N mode to ON/OFF of light switch (normal setting).**

- **OFF: D (Day mode)**
- **ON: N (Night mode)**

**Unless above setting, light signal (ON/OFF) may not be accurately displayed.**

VEHICLE SIGNALS	
Vehicle Speed	ON
IGN	ON
Reverse	OFF
Light	OFF

SKIA5628E

Diagnosis item	Display	Condition	Remarks
Vehicle speed	ON	Vehicle speed > 0 km/h (0 MPH)	Changes in indication may be delayed by approx. 1.5 seconds. This is normal.
	OFF	Vehicle speed = 0 km/h (0 MPH)	
	–	Ignition switch in ACC position	
Light	ON	Lighting switch ON	–
	OFF	Lighting switch OFF	
IGN	ON	Ignition switch ON	–
	OFF	Ignition switch ACC or OFF	
Reverse	ON	Selector lever in R position	Changes in indication may be delayed by approx. 1.5 seconds. This is normal.
	OFF	Selector lever in other than R position	
	–	Ignition switch in ACC position	

- If vehicle speed is NG, refer to [AV-192, "Vehicle Speed Signal Check for NAVI Control Unit"](#).
- If light is NG, refer to [AV-195, "Illumination Signal Check for NAVI Control Unit"](#).
- If IGN is NG, refer to [AV-195, "Ignition Signal Check for NAVI Control Unit"](#).
- If reverse is NG, refer to [AV-196, "Reverse Signal Check for NAVI Control Unit"](#).

# NAVIGATION SYSTEM

## HISTORY OF ERRORS

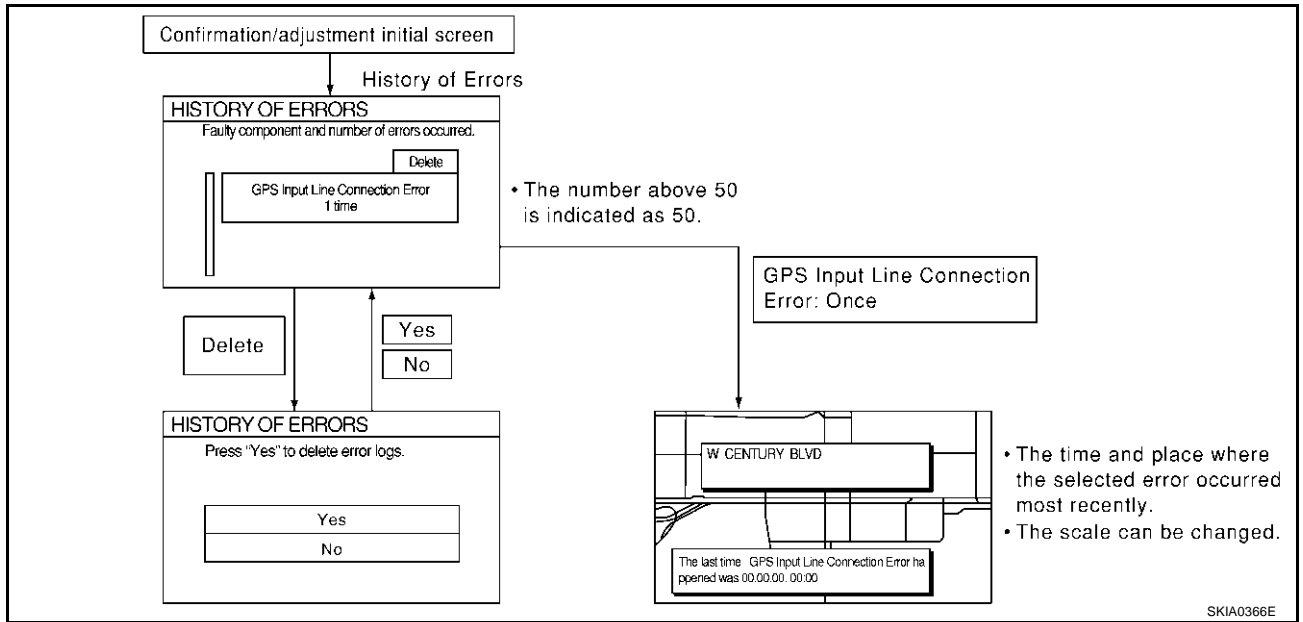

## DIAGNOSIS BY HISTORY OF ERRORS

The “Self-diagnosis” results indicate whether an error occurred during the period from when the ignition switch is turned to ON until “Self-diagnosis” is completed.

If an error occurred before the ignition switch was turned to ON and does not occur again until the “Self-diagnosis” is completed, the diagnosis result will be judged normal. Therefore, those errors in the past, which cannot be found by the “Self-diagnosis”, must be found by diagnosing the “History of Errors”.

The History of Errors displays the time and place of the most recent occurrence of that error. However, take note of the following points.

- Correct time of the error occurrence may not be displayed when the GPS antenna substrate within the NAVI control unit has malfunctioned.
- Place of the error occurrence is represented by the position of the current-location mark at the time when the error occurred. If the current-location mark has deviated from the correct position, then the place of the error occurrence may be located correctly.
- The maximum number of occurrences which can be stored is 50. For the 51st and later occurrences, the displayed number remains 50.

When a reproducible malfunction occurred but its cause cannot be identified because several errors are present, record the item, number and place (longitude/latitude) of error occurrence (or delete the History of Errors), then turn the ignition switch from OFF to ON to reproduce the malfunction. Check the History of Errors to find the items which show an increased number of occurrences, and diagnose the item.

Error item	Possible causes	Example of symptom
	Action/symptom	
Gyro sensor disconnected	Communications malfunction between NAVI control unit and internal gyro	<ul style="list-style-type: none"> <li>● Navigation location detection performance has deteriorated. (Angular velocity cannot be detected.)</li> </ul>
	<ul style="list-style-type: none"> <li>● Perform self-diagnosis.</li> <li>● When the NAVI control unit is judged normal by self-diagnosis, the symptom may be intermittent, caused by strong radio interference.</li> </ul>	
GPS disconnected	Communication error between NAVI control unit and internal GPS substrate	<ul style="list-style-type: none"> <li>● Navigation location detection performance has deteriorated. (Location correction using GPS is not performed.)</li> <li>● GPS receiving status remains gray.</li> </ul>
	<ul style="list-style-type: none"> <li>● Perform self-diagnosis.</li> <li>● When the NAVI control unit is judged normal by self-diagnosis, the symptom may be intermittent, caused by strong radio interference.</li> </ul>	

# NAVIGATION SYSTEM

Error item	Possible causes	Example of symptom	A
	Action/symptom		
GPS transmission cable malfunction	Malfunctioning transmission wires to NAVI control unit and internal GPS substrate	<ul style="list-style-type: none"> <li>● During self-diagnosis, GPS diagnosis is not performed.</li> </ul>	B
	<ul style="list-style-type: none"> <li>● Perform self-diagnosis.</li> <li>● When the NAVI control unit is judged normal by self-diagnosis, the symptom may be intermittent, caused by strong radio interference.</li> </ul>		
GPS input line connection error	Malfunctioning receiving wires to NAVI control unit and internal GPS substrate	<ul style="list-style-type: none"> <li>● Navigation location detection performance has deteriorated. (Location correction using GPS is not performed.)</li> <li>● GPS receiving status remains gray.</li> </ul>	D
	<ul style="list-style-type: none"> <li>● Perform self-diagnosis.</li> <li>● When the NAVI control unit is judged normal by self-diagnosis, the symptom may be intermittent, caused by strong radio interference.</li> </ul>		
GPS TCX0 over GPS TCX0 under	Oscillating frequency of the GPS substrate frequency synchronizing oscillation circuit exceeded (or below) the specification	<ul style="list-style-type: none"> <li>● Navigation location detection performance has deteriorated. (Location correction using GPS is not performed.)</li> <li>● GPS receiving status remains gray.</li> </ul>	F
	<ul style="list-style-type: none"> <li>● Perform self-diagnosis.</li> <li>● When the NAVI control unit is judged normal by self-diagnosis, the symptom may be intermittent, caused by strong radio interference, or the control unit may have been subjected to excessively high or low temperatures.</li> </ul>		
GPS ROM malfunction GPS RAM malfunction	Contents of ROM (or RAM) in GPS substrate are malfunctioning.	<ul style="list-style-type: none"> <li>● Location detection accuracy of the navigation system will deteriorate, depending on the error area in the memory, because GPS cannot make correct positioning. (Location correction using GPS is not performed.)</li> </ul>	H
	<ul style="list-style-type: none"> <li>● Perform self-diagnosis.</li> <li>● When the NAVI control unit is judged normal by self-diagnosis, the symptom may be intermittent, caused by strong radio interference.</li> </ul>		
GPS RTC malfunction	Clock IC in GPS substrate is malfunctioning.	<ul style="list-style-type: none"> <li>● Correct time may not be displayed.</li> <li>● After the power is turned on, the system always takes some time until GPS positioning becomes possible. (The GPS receiver starts positioning without re-collecting the whole satellite information when it judged the data stored in the receiver is correct.)</li> <li>● Correct time of error occurrence may not be stored in the "History of Errors".</li> </ul>	J
	<ul style="list-style-type: none"> <li>● Perform self-diagnosis.</li> <li>● When the NAVI control unit is judged normal by self-diagnosis, the symptom may be intermittent, caused by strong radio interference.</li> </ul>		
GPS antenna disconnected	Malfunctioning connection between GPS substrate in NAVI control unit and GPS antenna.	<ul style="list-style-type: none"> <li>● Navigation location detection performance has deteriorated. (Location correction using GPS is not performed.)</li> <li>● GPS receiving status remains gray.</li> </ul>	M
	<ul style="list-style-type: none"> <li>● Perform self-diagnosis.</li> <li>● When connection between NAVI control unit and GPS antenna is judged normal by self-diagnosis, the symptom may be intermittent, caused by impact or vibration.</li> </ul>		
Low voltage of GPS	The power voltage supplied to the GPS circuit board has decreased.	<ul style="list-style-type: none"> <li>● Navigation location detection performance has deteriorated. (Location correction using GPS is not performed.)</li> <li>● GPS receiving status remains gray.</li> </ul>	
	<ul style="list-style-type: none"> <li>● Perform self-diagnosis.</li> <li>● When connection between NAVI control unit and GPS antenna is judged normal by self-diagnosis, the symptom may be intermittent, caused by impact or vibration.</li> </ul>		

A  
B  
C  
D  
E  
F  
G  
H  
I  
J  
AV  
L  
M

# NAVIGATION SYSTEM

Error item	Possible causes	Example of symptom
	Action/symptom	
DVD-ROM Malfunction DVD-ROM Read error DVD-ROM Response Error	Malfunctioning NAVI control unit	-
	Dedicated map DVD-ROM is in the system, but the data cannot be read.	<ul style="list-style-type: none"> <li>● The map of a particular location cannot be displayed.</li> <li>● Specific guidance information cannot be displayed.</li> <li>● Map display is slow.</li> <li>● Guidance information display is slow.</li> <li>● System has been affected by vibration.</li> </ul>
	<ul style="list-style-type: none"> <li>● Is map DVD-ROM damaged, warped, or dirty?                             <ul style="list-style-type: none"> <li>- If damaged or warped, the map DVD-ROM is malfunctioning.</li> <li>- If dirty, wipe the DVD-ROM clean with a soft cloth.</li> </ul> </li> <li>● Perform self-diagnosis.</li> <li>● When NAVI control unit is judged normal by self-diagnosis, the symptom is judged intermittent, caused by vibration.</li> </ul>	

## NAVIGATION

1. The initial trouble diagnosis screen will be shown, and items "Display Longitude & Latitude", "Speed Calibration", "Angle Adjustment" and "Initialize Location" will become selective.
2. Select each switch on "NAVIGATION" screen to display the relevant diagnosis screen.

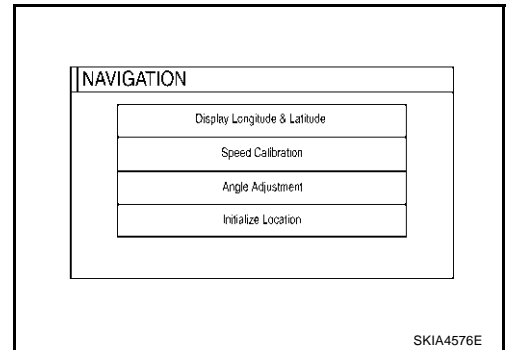

### Display Longitude & Latitude

- Able to confirm/adjust longitude and latitude.

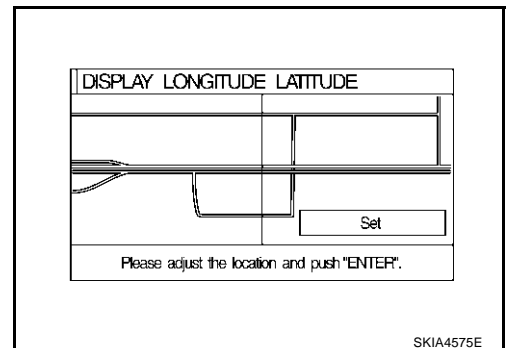

### Angle adjustment

- Adjusts turning angle output detected by the gyroscope.

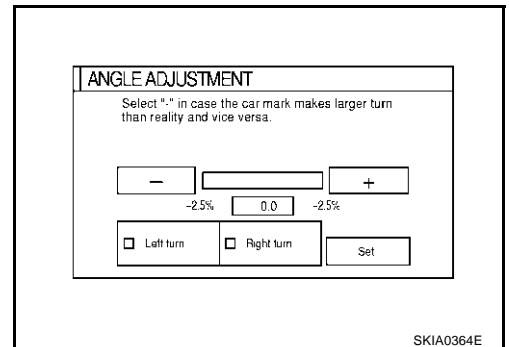



# NAVIGATION SYSTEM

## Speed Calibration

- During normal driving, distance error caused by tire wear and tire pressure change is automatically adjusted for by the automatic distance correction function. This function, on the other hand, is for immediate adjustment, in cases such as driving with tire chain fitted on tires.

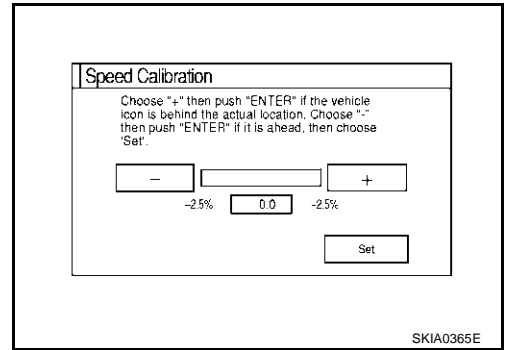

## Initialize Location

- This mode is for initializing the current location.

A  
B  
C  
D  
E  
F  
G  
H  
I  
J  
AV  
L  
M

# NAVIGATION SYSTEM

AKS005R6

## CAN DIAG SUPPORT MONITOR OPERATION PROCEDURE

1. Start the engine.
2. Turn the audio system off.
3. While pressing the "PAUSE/MUTE" button, turn the volume control dial clockwise or counterclockwise for 30 clicks or more. (When the self-diagnosis mode is started, a short beep will be heard.)
  - Shifting from current screen to previous screen is performed by pressing "PREV" button.

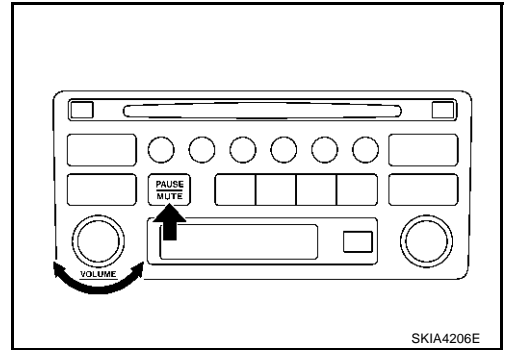

4. The initial trouble diagnosis screen will be shown, and items "Self-Diagnosis (DCU)", "Self-Diagnosis (NAVI)", "Confirmation/Adjustment" and "CAN DIAG SUPPORT MONITOR" will become selective.
5. Select "CAN DIAG SUPPORT MONITOR".

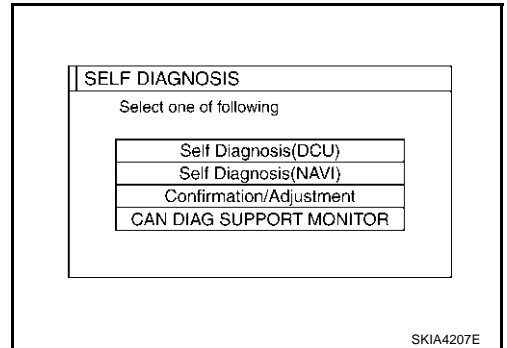

6. Display status of CAN communication.

Item	Content	Error counter (Reference value)
CANCOMM	OK/NG	0-50
CAN_CIRC_1	OK/UNKWN	0-50
CAN_CIRC_2	OK/UNKWN	0-50
CAN_CIRC_3	OK/UNKWN	0-50
CAN_CIRC_4	OK/UNKWN	0-50
CAN_CIRC_5	OK/UNKWN	0-50
CAN_CIRC_6	OK/UNKWN	0-50
CAN_CIRC_7	OK/UNKWN	0-50
CAN_CIRC_8	OK/UNKWN	0-50
CAN_CIRC_9	OK/UNKWN	0-50

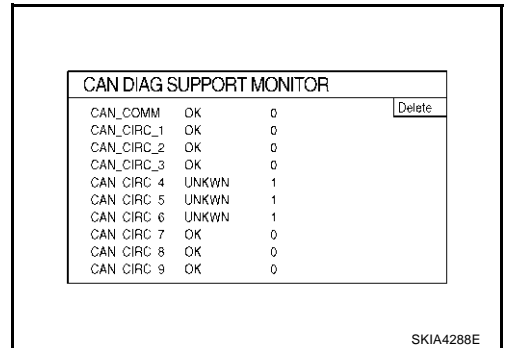

### NOTE:

Counter shows the status of CAN communication.

# NAVIGATION SYSTEM

## A/C and AV Switch Self-Diagnosis Function

AKS005R7

It can check ON/OFF operation of each switch in the A/C and AV Switch and diagnose the input signals to the steering switch (audio).

### STARTING THE SELF-DIAGNOSIS MODE

1. Turn ignition switch from OFF to ACC.
2. Within 10 seconds press and hold the witches "PAUSE/MUTE" and "PREV" simultaneously for 3 seconds.

Then the self-diagnosis operates.

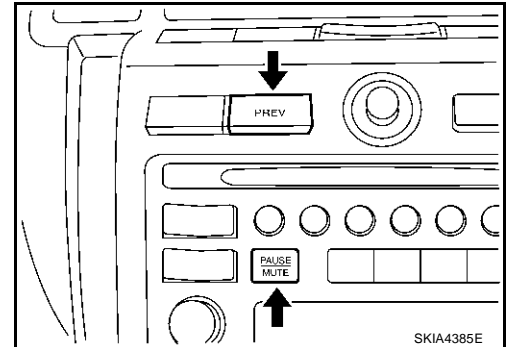

### EXITING THE SELF-DIAGNOSIS MODE

- Turn ignition switch OFF. Then the self-diagnosis ends.

### DIAGNOSIS FUNCTION

- It can illuminate all the indicators (LED) in the A/C and AV switch.
- It can check for continuity of the switches by sounding the buzzer when the A/C and AV switch is pressed.
- It can check for continuity of harness between A/C and AV switch and steering switch (audio).

A  
B  
C  
D  
E  
F  
G  
H  
I  
J

AV

L  
M

# NAVIGATION SYSTEM

## Power Supply and Ground Circuit Check for NAVI Control Unit

AKS004RH

### 1. CHECK FUSE

Make sure that the following fuses of the NAVI control unit are not blown.

Terminals		Power source	Fuse No.
Connector	Terminal (Wire color)		
M62	2 (Y), 3 (Y)	Battery power	38
	6 (P/B)	ACC power	6

OK or NG

OK >> GO TO 2.

NG >> If fuse is blown, be sure to eliminate case of malfunction before installing new fuse. Refer to [PG-3](#), "[POWER SUPPLY ROUTING CIRCUIT](#)".

### 2. CHECK POWER SUPPLY CIRCUIT

Check voltage between connector terminals and ground as follows.

Terminals			Ignition switch position		
(+)		(-)	OFF	ACC	ON
Connector	Terminal (Wire color)				
M62	2 (Y), 3 (Y)	Ground	Battery voltage	Battery voltage	Battery voltage
	6 (P/B)		0V	Battery voltage	Battery voltage

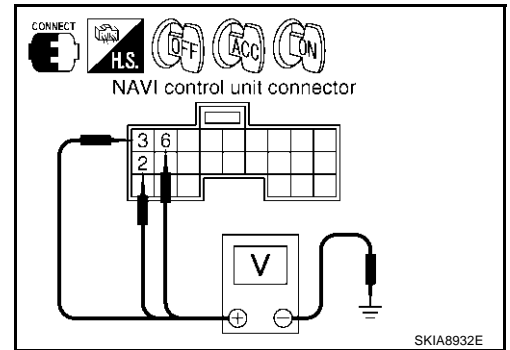

OK or NG

OK >> GO TO 3.

NG >> Check harness for open or short between NAVI control unit and fuse.

### 3. CHECK GROUND CIRCUIT

1. Turn ignition switch OFF.
2. Disconnect NAVI control unit connector.
3. Check continuity between the following NAVI control unit and ground.

Terminals			Ignition switch	Continuity
(+)		(-)		
Connector	Terminal (Wire color)			
M62	1 (B), 4 (B)	Ground	OFF	Yes

OK or NG

OK >> INSPECTION END

NG >> Repair or replace harness.

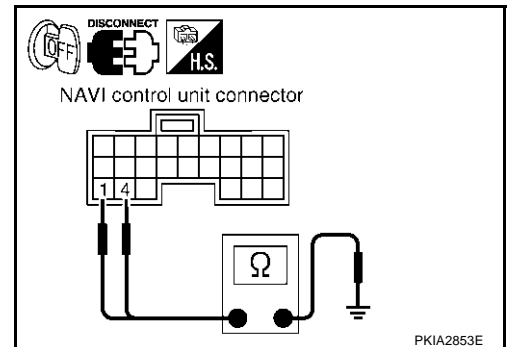

# NAVIGATION SYSTEM

## Power Supply and Ground Circuit Check for Display Control Unit

AKS005G3

### 1. CHECK FUSE

Make sure that the following fuses of the display control unit are not blown.

Terminals		Power source	Fuse No.
Connector	Terminal (Wire color)		
M42	1 (Y)	Battery power	38
	10 (P/B)	ACC power	6

OK or NG

OK >> GO TO 2.

NG >> If fuse is blown, be sure to eliminate case of malfunction before installing new fuse. Refer to [PG-3](#), "[POWER SUPPLY ROUTING CIRCUIT](#)".

### 2. CHECK POWER SUPPLY CIRCUIT

Check voltage between connector terminals and ground as follows.

Terminals		Ignition switch position			
(+)			OFF	ACC	ON
Connector	Terminal (Wire color)	(-)			
M42	1 (Y)	Ground	Battery voltage	Battery voltage	Battery voltage
	10 (P/B)		0V	Battery voltage	Battery voltage

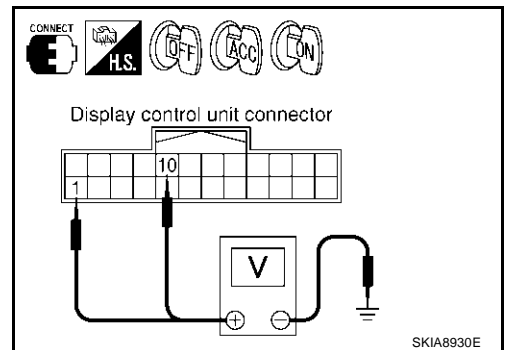

OK or NG

OK >> GO TO 3.

NG >> Check harness for open or short between display control unit and fuse.

### 3. CHECK GROUND CIRCUIT

1. Turn ignition switch OFF.
2. Disconnect display control unit connector.
3. Check continuity between the following display control unit and ground.

Terminals		Ignition switch	Continuity
(+)			
Connector	Terminal (Wire color)		
M42	3 (B)	OFF	Yes

OK or NG

OK >> INSPECTION END

NG >> Repair or replace harness.

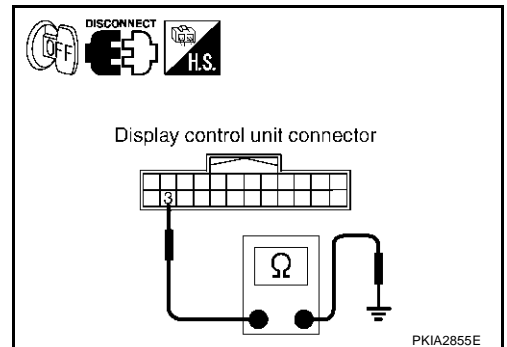

A  
B  
C  
D  
E  
F  
G  
H  
I  
J  
AV  
L  
M

# NAVIGATION SYSTEM

AKS005G4

## Power Supply and Ground Circuit Check for Display

### 1. CHECK POWER SUPPLY AND GROUND CIRCUIT FOR DISPLAY CONTROL UNIT

Check power supply and ground circuit for display control unit. Refer to [AV-189, "Power Supply and Ground Circuit Check for Display Control Unit"](#).

OK or NG

- OK >> GO TO 2.
- NG >> Repair malfunctioning parts.

### 2. CHECK1: POWER SUPPLY CIRCUIT

1. Turn ignition switch ON.
2. Check voltage between display unit harness connector M38 terminals 2 (L/W), 3 (L/Y) and ground.

**Approx. 9 V**

OK or NG

- OK >> GO TO 3.
- NG >> GO TO 4.

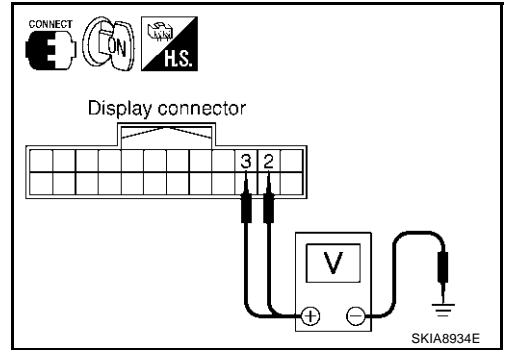

### 3. CHECK GROUND CIRCUIT

Check continuity between display and ground as follows.

Terminals		(-)	Ignition switch	Continuity
(+)				
Connector	Terminal (Wire color)			
M38	1 (B)	Ground	OFF	Yes

OK or NG

- OK >> INSPECTION END
- NG >> Repair harness.

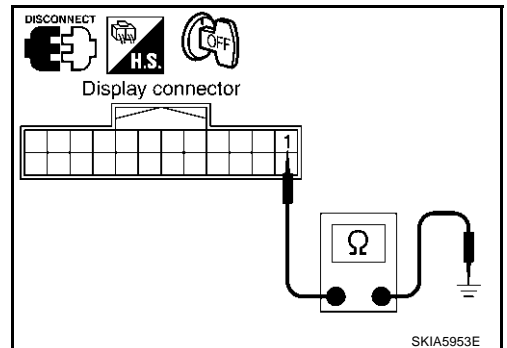

# NAVIGATION SYSTEM

## 4. CHECK HARNESS

1. Turn ignition switch OFF.
2. Disconnect display connector and display control unit connector.
3. Check continuity between display control unit harness connector M42 terminals 2(L/W), 4(L/Y) and display harness connector M38 terminals 2(L/W), 3(L/Y).

**Continuity should exist.**

4. Check continuity between display and ground.

Terminals		(-)	Continuity
display (+)			
Connector	Terminal (Wire color)		
M38	2 (L/W)	Ground	No
	3 (L/Y)		

### OK or NG

- OK >> Replace display control unit.  
 NG >> Repair harness.

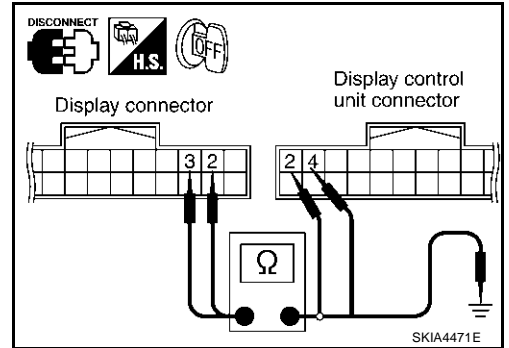

A  
B  
C  
D  
E  
F  
G  
H  
I  
J  
AV  
L  
M

# NAVIGATION SYSTEM

## Power Supply and Ground Circuit Check for A/C and AV Switch

AKS005LU

### 1. CHECK FUSE

Make sure that the following fuses of the A/C and AV switch are not blown.

Terminals		Power source	Fuse No.
Connector	Terminal (Wire color)		
M48	1 (Y)	Battery power	38
	2 (P/B)	ACC power	6

OK or NG

OK >> GO TO 2.

NG >> If fuse is blown, be sure to eliminate case of malfunction before installing new fuse. Refer to [PG-3](#), "[POWER SUPPLY ROUTING CIRCUIT](#)".

### 2. CHECK POWER SUPPLY CIRCUIT

Check voltage between connector terminals and ground as follows.

Terminals			Ignition switch position		
(+)		(-)	OFF	ACC	ON
Connector	Terminal (Wire color)		OFF	ACC	ON
M48	1 (Y)	Ground	Battery voltage	Battery voltage	Battery voltage
	2 (P/B)		0V	Battery voltage	Battery voltage

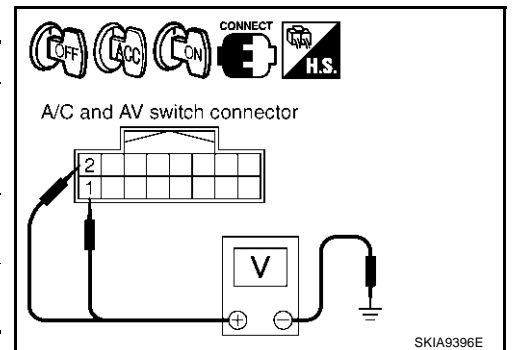

OK or NG

OK >> GO TO 3.

NG >> Check harness for open or short between A/C and AV switch and fuse.

### 3. CHECK GROUND CIRCUIT

1. Turn ignition switch OFF.
2. Disconnect A/C and AV switch connector.
3. Check continuity between A/C and AV switch and ground as follows.

Terminals			Ignition switch	Continuity
(+)		(-)		
Connector	Terminal (Wire color)			
M48	5 (B)	Ground	OFF	Yes

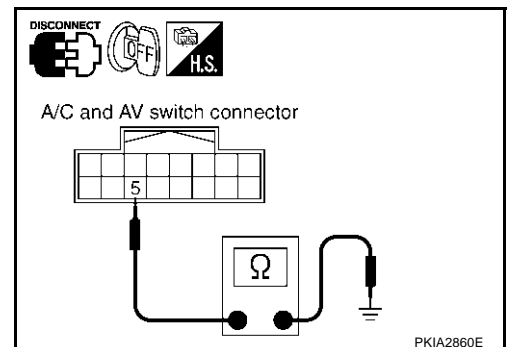

OK or NG

OK >> INSPECTION END

NG >> Repair or replace harness.

## Vehicle Speed Signal Check for NAVI Control Unit

AKS004RI

### 1. SPEEDOMETER FUNCTION CHECK

Does speedometer is operated normally?

Yes or No

Yes >> GO TO 2.

No >> Check combination meter trouble diagnosis. Refer to [DI-15](#), "[Diagnosis Flow](#)".



# NAVIGATION SYSTEM

## 2. CHECK HARNESS

1. Turn ignition switch OFF.
2. Disconnect NAVI control unit connector, unified meter and A/C amp. connector, combination meter connector, display control unit connector, audio unit connector and shift lock control unit connector.
3. Check continuity between NAVI control unit harness connector M63 terminal 28 (V/W) and unified meter and A/C amp. harness connector M50 terminal 26 (V/W).

**Continuity should exist.**

4. Check continuity between NAVI control unit harness connector M63 terminal 28 (V/W) and ground.

**Continuity should not exist.**

OK or NG

- OK >> GO TO 3.  
NG >> Repair harness.

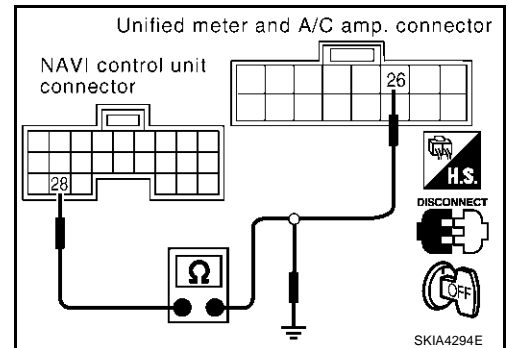

## 3. CHECK NAVI CONTROL UNIT

1. Connect NAVI control unit connector.
2. Turn ignition switch ON.
3. Check voltage between NAVI control unit harness connector M63 terminal 28 (V/W) and ground.

**Approx. 5V**

OK or NG

- OK >> GO TO 4.  
NG >> Replace NAVI control unit.

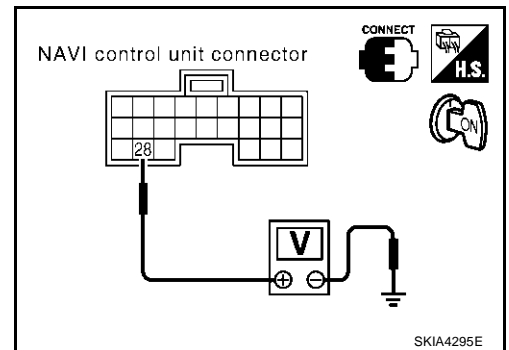

## 4. CHECK VEHICLE SPEED SIGNAL

1. Connect unified meter and A/C amp. connector, combination meter connector, display control unit connector, audio unit connector and shift lock control unit connector.
2. Drive vehicle at a constant speed.
3. Check signal between NAVI control unit harness connector M63 terminal 28 (V/W) and ground with CONSULT-II or oscilloscope.

**28 (V/W) – Ground : Refer to [AV-164, "Terminals and Reference Value for NAVI Control unit"](#) .**

OK or NG

- OK >> INSPECTION END  
NG >> Check combination meter system. Refer to [DI-15, "Diagnosis Flow"](#) .

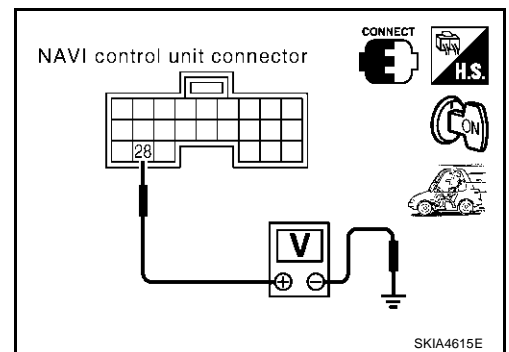

## Vehicle Speed Signal Check for Display Control Unit

### 1. SPEEDOMETER FUNCTION CHECK

Does speedometer is operated normally?

Yes or No

- Yes >> GO TO 2.  
No >> Check combination meter trouble diagnosis. Refer to [DI-15, "Diagnosis Flow"](#) .

A  
B  
C  
D  
E  
F  
G  
H  
I  
J  
AV  
L  
M

# NAVIGATION SYSTEM

## 2. HARNESS CHECK

1. Turn ignition switch OFF.
2. Disconnect display control unit connector, unified meter and A/C amp. connector, combination meter connector, NAVI control unit connector, audio unit connector and shift lock control unit connector.
3. Check continuity between display control unit harness connector M42 terminal 16 (V/W) and unified meter and A/C amp. harness connector M50 terminal 26 (V/W).

**Continuity should exist.**

4. Check continuity between display control unit harness connector M42 terminal 16 (V/W) and ground.

**Continuity should not exist.**

OK or NG

OK >> GO TO 3.

NG >> Repair harness.

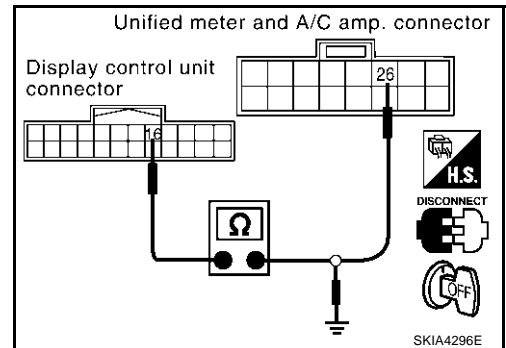

## 3. CHECK DISPLAY CONTROL UNIT

1. Connect display control unit connector.
2. Turn ignition switch ON.
3. Check voltage between display control unit harness connector M42 terminal 16 (V/W) and ground.

**Approx. 5V**

OK or NG

OK >> GO TO 4.

NG >> Replace display control unit.

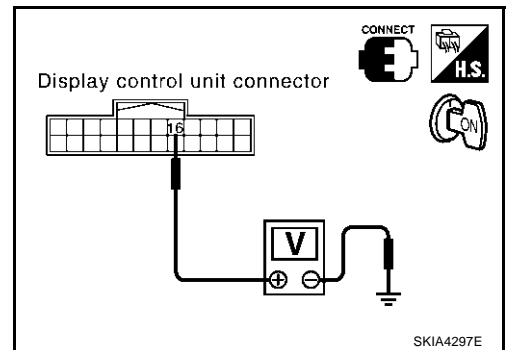

## 4. CHECK VEHICLE SPEED SIGNAL

1. Connect unified meter and A/C amp. connector, combination meter connector, NAVI control unit connector, audio unit connector and shift lock control unit connector.
2. Drive vehicle at a constant speed.
3. Check signal between display control unit harness connector M42 terminal 16 (V/W) and ground with CONSULT-II or oscilloscope.

**16 (V/W) – Ground : Refer to [AV-166, "Terminals and Reference Value for Display Control unit"](#) .**

OK or NG

OK >> INSPECTION END

NG >> Check unified meter and A/C amp. system. Refer to [DI-15, "Diagnosis Flow"](#) .

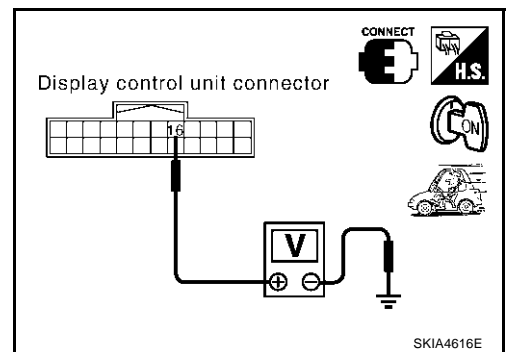

# NAVIGATION SYSTEM

## Illumination Signal Check for NAVI Control Unit

AKS004RJ

### 1. CHECK ILLUMINATION SIGNAL

1. Turn the ignition switch ON.
2. Check voltage between NAVI control unit and ground.

Terminals			Lighting switch position	
(+)		(-)	1st or 2nd position	OFF
Connector	Terminal (Wire color)			
M63	25 (R/L)	Ground	Approx. 12V	Approx. 0V

#### OK or NG

- OK >> INSPECTION END  
 NG >> Check harness for open or short between NAVI control unit and IPDM E/R.

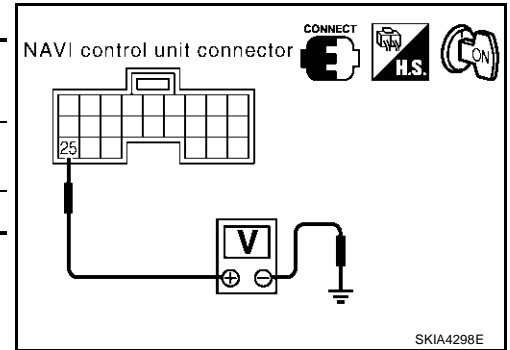

SKIA4298E

## Illumination Signal Check for Display Control Unit

AKS005G6

### 1. CHECK ILLUMINATION SIGNAL

1. Turn ignition switch ON.
2. Check voltage between display control unit and ground.

Terminals			Lighting switch position	
(+)		(-)	1st or 2nd position	OFF
Connector	Terminal (Wire color)			
M42	14 (R/L)	Ground	Approx. 12V	Approx. 0V

#### OK or NG

- OK >> INSPECTION END  
 NG >> Check harness for open or short between display control unit and IPDM E/R.

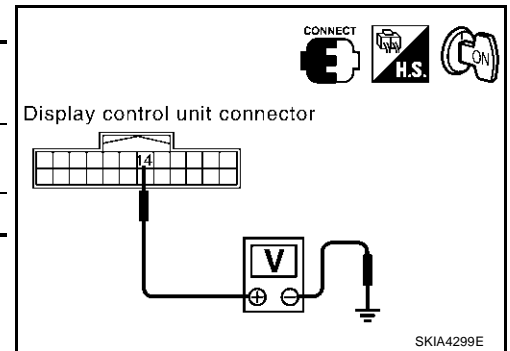

SKIA4299E

## Ignition Signal Check for NAVI Control Unit

AKS004RK

### 1. CHECK IGNITION SIGNAL

1. Turn ignition switch ON.
2. Check voltage between NAVI control unit harness connector M63 terminal 26 (G) and ground.

**Battery voltage should exist.**

#### OK or NG

- OK >> INSPECTION END  
 NG >> Check harness for open or short between NAVI control unit and fuse.

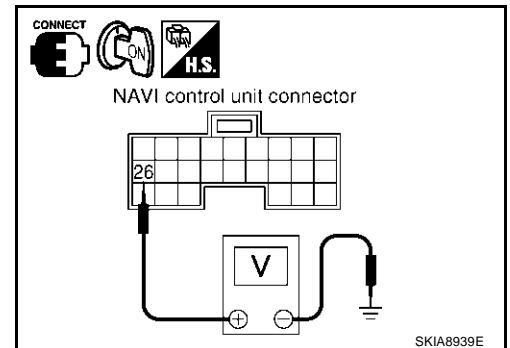

SKIA8939E

## Ignition Signal Check for Display Control Unit

AKS005G7

### 1. CHECK IGNITION SIGNAL

1. Turn ignition switch ON.
2. Check voltage between display control unit harness connector M42 terminal 12 (G) and ground.

**Battery voltage should exist.**

OK or NG

OK >> INSPECTION END

NG >> Check harness for open or short between display control unit and fuse.

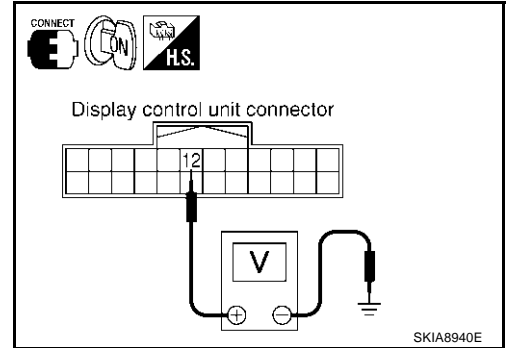

## Reverse Signal Check for NAVI Control Unit

AKS005G8

### 1. CHECK REVERSE LAMP

1. Turn ignition switch ON.
2. Selector lever into R-position. Does "R" in the shift position indicator come on?

YES or NO

YES >> GO TO 2.

NO >> Check back-up lamp system. Refer to [LT-268, "BACK-UP LAMP"](#) .

### 2. CHECK REVERSE SIGNAL

With the selector lever in R-position, Check voltage between NAVI control unit and ground.

Terminals		Selector lever position		
(+)				
Connector	Terminal (Wire color)	(-)	R-position	Other than R-position
M63	27 (G/W)	Ground	Approx. 12V	Approx. 0V

OK or NG

OK >> INSPECTION END

NG >> Check harness for open or short between NAVI control unit and back-up lamp position relay.

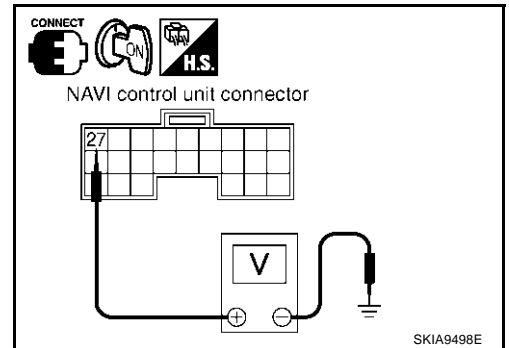

## Reverse Signal Check for Display Control Unit

AKS004RL

### 1. CHECK REVERSE LAMP

1. Turn ignition switch ON.
2. Selector lever into R-position. Does "R" in the shift position indicator come on?

YES or NO

YES >> GO TO 2.

NO >> Check back-up lamp system. Refer to [LT-268, "BACK-UP LAMP"](#) .

# NAVIGATION SYSTEM

## 2. CHECK REVERSE SIGNAL

With the selector lever in R-position, Check voltage between display control unit and ground.

Terminals			Selector lever position	
(+)		(-)	R-position	Other than R-position
Connector	Terminal (Wire color)			
M42	6 (G/W)	Ground	Approx. 12V	Approx. 0V

**OK or NG**

OK >> INSPECTION END

NG >> Check harness for open or short between display control unit and back-up lump position relay.

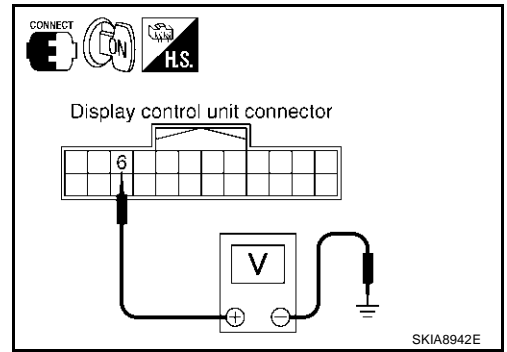

## AV Communication Line Check (Between Display Control Unit and NAVI Control Unit).

AKS005R8

### 1. CHECK POWER SUPPLY AND GROUND CIRCUIT

1. Check system of power supply and ground circuit NAVI control unit. Refer to [AV-188, "Power Supply and Ground Circuit Check for NAVI Control Unit"](#).

**OK or NG**

OK >> GO TO 2.

NG >> Check the malfunctioning parts.

### 2. CHECK HARNESS

1. Turn ignition switch OFF.
2. Disconnect NAVI control unit connector and display control unit connector.
3. Check continuity between NAVI control unit and display control unit.

Terminals				Continuity
NAVI control unit (+)		Display control unit (-)		
Connector	Terminal (Wire color)	Connector	Terminal (Wire color)	
M63	44 (O)	M43	32 (O)	Yes
	45 (B/P)		34 (B/P)	

4. Check continuity between NAVI control unit and ground.

Terminals			Continuity
NAVI control unit(+)		(-)	
Connector	Terminal (Wire color)		
M63	44 (O)	Ground	No
	45 (B/P)		

**OK or NG**

OK >> GO TO 3.

NG >> Repair harness or connector.

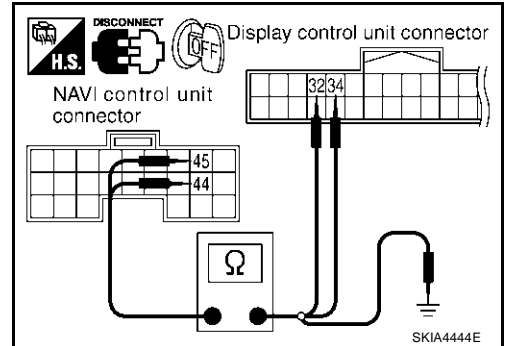

A  
B  
C  
D  
E  
F  
G  
H  
I  
J  
AV  
L  
M

# NAVIGATION SYSTEM

## 3. CHECK AV COMMUNICATION SIGNAL

1. Connect NAVI control unit connector and display control unit connector.
2. Turn ignition switch ON.
3. Check signal between NAVI control unit harness connector M63 terminal 44 (O) and 45 (B/P) with CONSULT-II or oscilloscope.

**44 (O), 45 (B/P)-Ground** : Refer to [AV-164](#), "[Terminals and Reference Value for NAVI Control unit](#)".

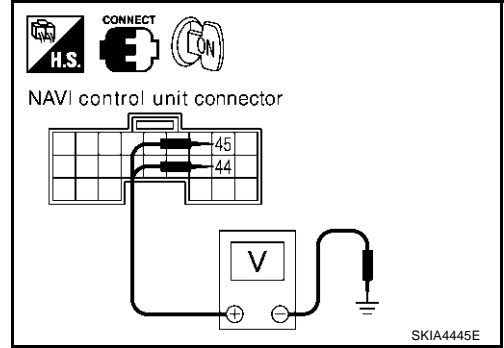

OK or NG

- OK >> Replace display control unit.
- NG >> Replace NAVI control unit.

## Audio Communication Line Check (Between Display Control Unit and Audio Unit)

AKS005R9

### 1. CHECK POWER SUPPLY AND GROUND CIRCUIT

1. Check system of power supply and ground circuit audio unit. Refer to [AV-38](#), "[Power Supply Circuit Inspection](#)".

OK or NG

- OK >> GO TO 2.
- NG >> Check the malfunctioning parts.

### 2. CHECK HARNESS

1. Turn ignition switch OFF.
2. Disconnect audio unit connector and display control unit connector.
3. Check continuity between audio unit and display control unit.

Terminals				Continuity
Display control unit (+)		Audio unit (-)		
Connector	Terminal (Wire color)	Connector	Terminal (Wire color)	
M43	40 (R/G)	M46	23 (R/G)	Yes
	42 (R/Y)		21 (R/Y)	

4. Check continuity between display control unit and ground.

Terminals			Continuity
Display control unit(+)		(-)	
Connector	Terminal (Wire color)		
M43	40 (R/G)	Ground	No
	42 (R/Y)		

OK or NG

- OK >> GO TO 3.
- NG >> Repair harness or connector.

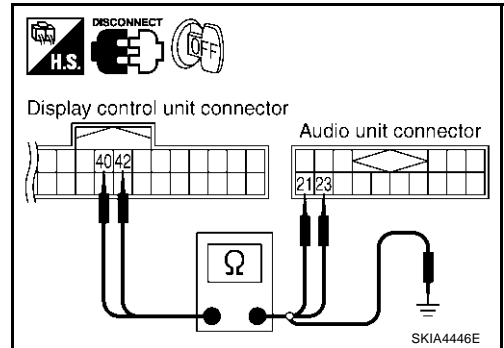

# NAVIGATION SYSTEM

## 3. CHECK1: AUDIO-TX COMMUNICATION SIGNAL

1. Connect audio unit connector.
2. Turn ignition switch ON.
3. Check voltage between audio unit harness connector M46 terminal 23 (R/G) and ground.

**Approx. 4V**

OK or NG

- OK >> GO TO 4.  
NG >> Replace audio unit.

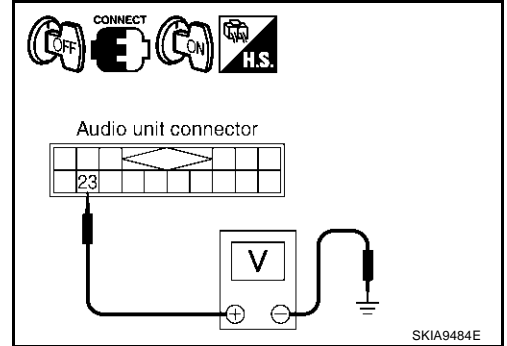

## 4. CHECK2: AUDIO-RX COMMUNICATION SIGNAL

1. Disconnect audio unit connector, and connect display control unit connector.
2. Turn ignition switch ON.
3. Check voltage between display control unit harness connector M43 terminal 42 (R/Y) and ground.

**Approx. 4V**

OK or NG

- OK >> GO TO 5.  
NG >> Replace display control unit.

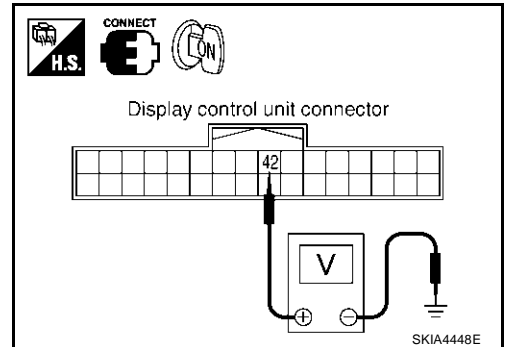

## 5. CHECK3: AUDIO-TX COMMUNICATION SIGNAL

1. Connect audio unit connector.
2. Turn ignition switch ON.
3. Check signal between display control unit harness connector M43 terminal 40 (R/G) and ground with CONSULT-II or oscilloscope.

**40 (R/G) - Ground**

**: Refer to [AV-166](#), "[Terminals and Reference Value for Display Control unit](#)".**

OK or NG

- OK >> GO TO 6.  
NG >> Replace display control unit.

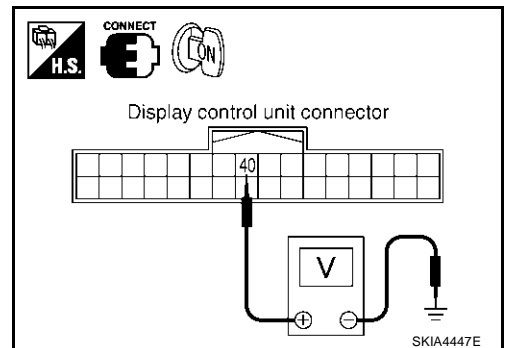

A  
B  
C  
D  
E  
F  
G  
H  
I  
J  
AV  
L  
M

# NAVIGATION SYSTEM

## 6. CHECK4: AUDIO-RX COMMUNICATION SIGNAL

1. Turn ignition switch ON.
2. Check signal between display control unit harness connector M43 terminal 42 (R/Y) and ground with CONSULT-II or oscilloscope.

**42 (R/Y) - Ground** : Refer to [AV-166](#), "[Terminals and Reference Value for Display Control unit](#)".

OK or NG

- OK >> Replace display control unit.  
 NG >> Replace audio unit.

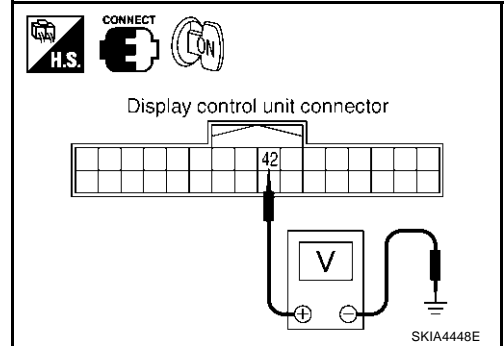

## Display Communication Line Check (Between Display Control Unit and Display)

AKS005RA

### 1. CHECK HARNESS

1. Turn ignition switch OFF.
2. Disconnect display connector and display control unit connector.
3. Check continuity between display control unit and Display.

Terminals				Continuity
Display control unit (+)		Display (-)		
Connector	Terminal (Wire color)	Connector	Terminal (Wire color)	
M43	36 (O/L)	M38	11 (O/L)	Yes
	38 (W/L)		22 (W/L)	

4. Check continuity between display control unit and ground.

Terminals			Continuity
Display control unit(+)		(-)	
Connector	Terminal (Wire color)		
M43	36 (O/L)	Ground	No
	38 (W/L)		

OK or NG

- OK >> GO TO 2.  
 NG >> Repair harness or connector.

### 2. CHECK1: COMMUNICATION SIGNAL (DCU-DSP)

1. Connect display connector.
2. Turn ignition switch ON.
3. Check voltage between display harness connector M38 terminal 11 (O/L) and ground.

**Approx. 4V**

OK or NG

- OK >> GO TO 3.  
 NG >> Replace display.

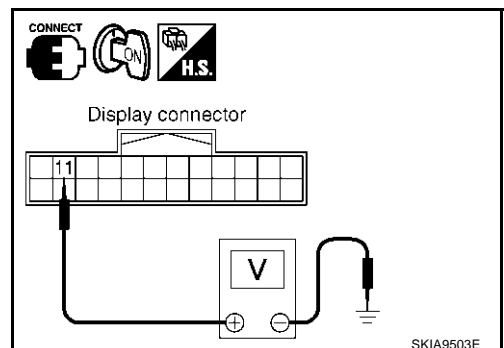



# NAVIGATION SYSTEM

## 3. CHECK2: COMMUNICATION SIGNAL (DSP-DCU)

1. Disconnect display connector, and connect display control unit connector.
2. Turn ignition switch ON.
3. Check voltage between display control unit harness connector M43 terminal 38 (W/L) and ground.

**Approx. 4V**

OK or NG

- OK >> GO TO 4.  
NG >> Replace display control unit.

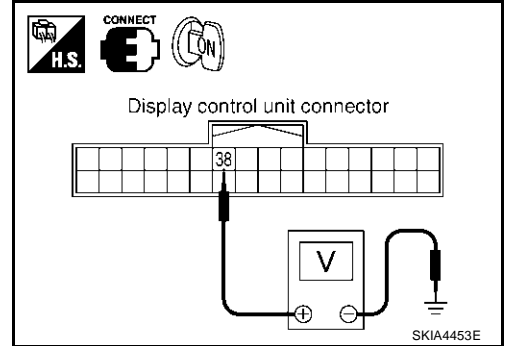

## 4. CHECK3: COMMUNICATION SIGNAL (DCU-DSP)

1. Connect display connector.
2. Turn ignition switch ON.
3. Check signal between display control unit harness connector M43 terminal 36 (O/L) and ground with CONSULT-II or oscilloscope.

**36 (O/L) - Ground** : Refer to [AV-166, "Terminals and Reference Value for Display Control unit"](#) .

OK or NG

- OK >> GO TO 5.  
NG >> Replace display control unit.

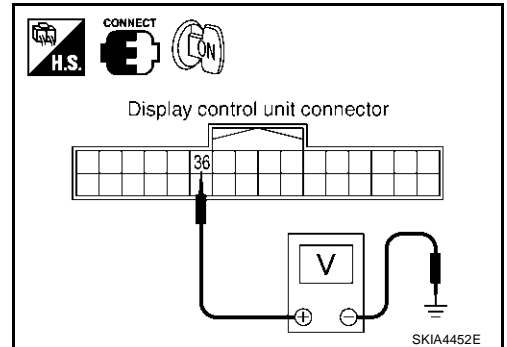

## 5. CHECK4: COMMUNICATION SIGNAL (DSP-DCU)

1. Turn ignition switch ON.
2. Check signal between display control unit harness connector M43 terminal 38 (W/L) and ground with CONSULT-II or oscilloscope.

**38 (W/L) - Ground** : Refer to [AV-166, "Terminals and Reference Value for Display Control unit"](#) .

OK or NG

- OK >> Replace display control unit.  
NG >> Replace display.

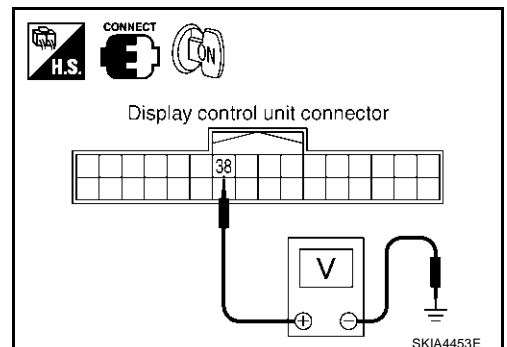

A  
B  
C  
D  
E  
F  
G  
H  
I  
J  
AV  
L  
M

# NAVIGATION SYSTEM

## AV Communication Line Check (Between Display Control Unit and A/C and AV Switch)

AKS005RB

### 1. CHECK A/C AND AV SWITCH CIRCUIT

1. Turn ignition switch OFF.
2. Disconnect display control unit connector and A/C and AV switch connector.
3. Check continuity between display control unit and A/C and AV switch.

Terminals				Continuity
Display control unit (+)		A/C and AV switch (-)		
Connector	Terminal (Wire color)	Connector	Terminal (Wire color)	
M43	28 (L/G)	M48	6 (L/G)	Yes
	30 (L/R)		8 (L/R)	

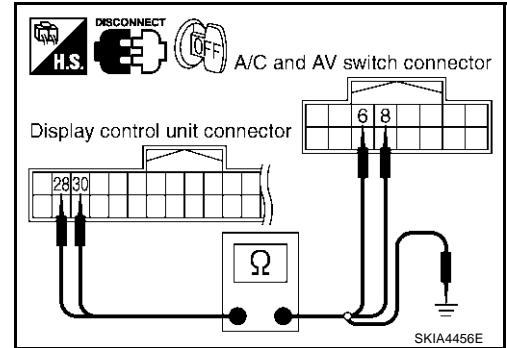

4. Check continuity between display control unit and ground.

Terminals				Continuity
Display control unit(+)		(-)		
Connector	Terminal (Wire color)			
M43	28 (L/G)	Ground		No
	30 (L/R)			

OK or NG

- OK    >> GO TO 2.  
 NG    >> Repair harness or connector.

### 2. CHECK AV COMMUNICATION SIGNAL

1. Connect display control unit connector and A/C and AV switch connector.
2. Turn ignition switch ON.
3. Check signal between display control unit harness connector M43 terminal 28 (L/G) and 30 (L/R) with CONSULT-II or oscilloscope.

**28 (L/G), 30 (L/R) - Ground** : Refer to [AV-166. "Terminals and Reference Value for Display Control unit"](#) .

OK or NG

- OK    >> Replace A/C and AV switch.  
 NG    >> Replace display control unit.

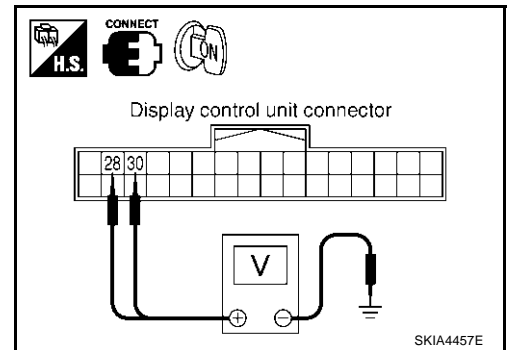

# NAVIGATION SYSTEM

## CAN Communication Line Check

AKS005RC

### 1. CHECK MONITOR DESCRIPTION

1. Start display control unit self-diagnosis. Refer to [AV-174, "Self-Diagnosis Mode \(DCU\)"](#)
2. Select "CAN DIAG SUPPORT MONITOR". Refer to [AV-186, "CAN DIAG SUPPORT MONITOR"](#).

Item	content		Error counter (Reference value)
	Normal condition	Error (Example)	
CANCOMM	OK	NG	0-50
CAN_CIRC_1	OK	UNKWN	0-50
CAN_CIRC_2	OK	UNKWN	0-50
CAN_CIRC_3	OK	UNKWN	0-50
CAN_CIRC_4	OK	UNKWN	0-50
CAN_CIRC_5	OK	UNKWN	0-50
CAN_CIRC_6	OK	UNKWN	0-50
CAN_CIRC_7	OK	UNKWN	0-50
CAN_CIRC_8	OK	UNKWN	0-50
CAN_CIRC_9	OK	UNKWN	0-50

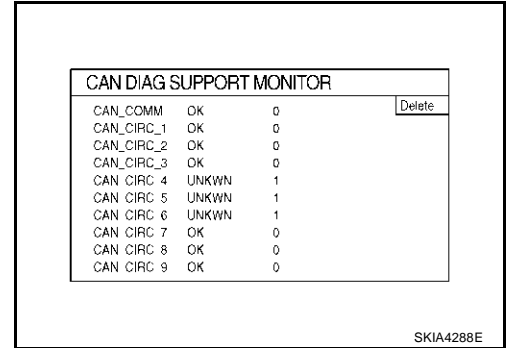

3. Record each item display description (OK/NG/UNKWN) displayed on the following CAN DIAG SUPPORT MONITOR Check Sheet.

#### CAN DIAG SUPPORT MONITOR Check Sheet

Diagnosis item	Screen display		Diagnosis item	Screen display	
CANCOMM	OK	NG	CAN_CIRC_5	OK	UNKWN
CAN_CIRC_1	OK	UNKWN	CAN_CIRC_6	OK	UNKWN
CAN_CIRC_2	OK	UNKWN	CAN_CIRC_7	OK	UNKWN
CAN_CIRC_3	OK	UNKWN	CAN_CIRC_8	OK	UNKWN
CAN_CIRC_4	OK	UNKWN	CAN_CIRC_9	OK	UNKWN

>> After filling in CAN DIAG SUPPORT MONITOR Check Sheet, GO TO [LAN-10, "Precautions When Using CONSULT-II"](#).

## If NAVI Control Unit Detects That DVD-ROM Map is not Inserted

AKS005RD

### 1. CHECK DVD-ROM

1. Make sure identified DVD-ROM map is inserted.

#### OK or NG

- OK >> Replace NAVI control unit.
- NG >> Insert identified DVD-ROM map.

## If NAVI Control Unit Detects That Inserted DVD-ROM Map Malfunctioning or If It Is Impossible to Load Data From DVD-ROM Map

AKS005RE

### 1. CHECK1: DVD-ROM

1. Remove inserted DVD-ROM map to check that it is identified.

#### OK or NG

- OK >> GO TO 2.
- NG >> Replace identified DVD-ROM map.

## 2. CHECK2: DVD-ROM

1. Check removed DVD-ROM that there are dirt, scratch and warp.

OK or NG

- OK >> GO TO 3.
- NG >> Replace DVD-ROM map.

## 3. CHECK3: DVD-ROM

1. Insert same DVD-ROM to make sure same diagnosis result is found as last self-diagnosis.

OK or NG

- OK >> Replace NAVI control unit.
- NG >> Replace DVD-ROM map.

## If Connection Between NAVI Control Unit and GPS Antenna is Malfunctioning

AKS005RF

### 1. CHECK GPS ANTENNA

1. Check cable for GPS antenna by watching out to see that cable is malfunctioning.

OK or NG

- OK >> GO TO 2.
- NG >> Replace GPS antenna.

### 2. CHECK BY REPLACEMENT OF GPS ANTENNA

1. Replace other functional GPS antenna to try self-diagnosis again.

Result of self-diagnosis; Found same result?

- Yes >> Replace NAVI control unit.
- No >> Replace GPS antenna.

## RGB Screen is Not Shown

AKS004RM

### 1. CHECK HARNESS

1. Turn ignition switch OFF.
2. Disconnect display control unit connector and display connector.
3. Check continuity between display control unit harness connector M43 terminal 51 (B) and display harness connector M38 terminal 9 (B).

**Continuity should exist.**

4. Check continuity between display control unit harness connector M43 terminal 55 (R) and display harness connector M38 terminal 8 (R).

**Continuity should exist.**

5. Check continuity between display control unit harness connector M43 terminal 51 (B), 55 (R) and ground.

**Continuity should not exist.**

OK or NG

- OK >> GO TO 2.
- NG >> Repair harness or connector.

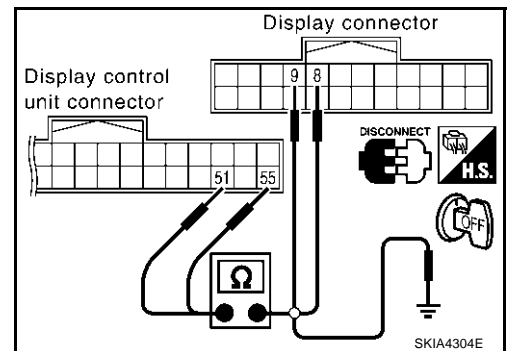

# NAVIGATION SYSTEM

## 2. CHECK HORIZONTAL SYNCHRONIZATION SIGNAL

1. Connect display control unit connector and display connector.
2. Turn ignition switch ON.
3. Check signal between display control unit connector M43 terminals 55 (R) and 49 with CONSULT-II or oscilloscope.

**55 (R) - 49** : Refer to [AV-166, "Terminals and Reference Value for Display Control unit"](#) .

OK or NG

- OK >> GO TO 3.  
 NG >> Replace display.

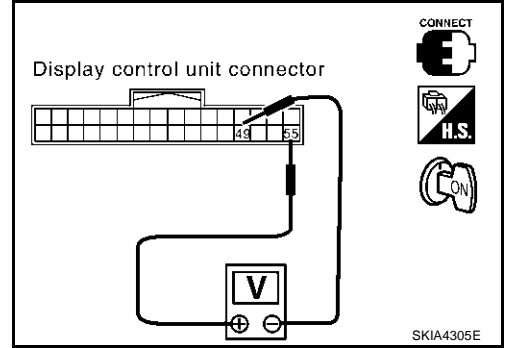

## 3. CHECK RGB AREA SIGNAL

1. Press the "TRIP" button.
2. Check signal between display control unit connector M43 terminals 51 (B) and 49 with CONSULT-II or oscilloscope.

**51 (B) -49** : Refer to [AV-166, "Terminals and Reference Value for Display Control unit"](#) .

OK or NG

- OK >> Replace display.  
 NG >> Replace display control unit.

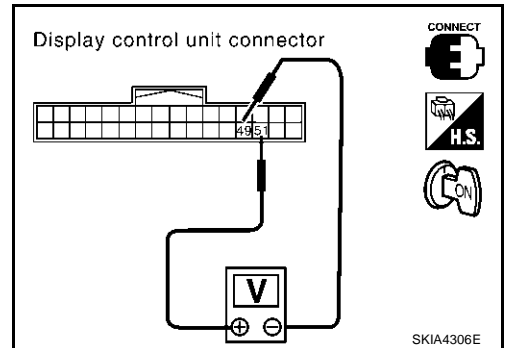

## Color of RGB Image is Not Proper (NAVI Screen Looks Bluish)

### 1. CHECK RGB HARNESS

1. Turn ignition switch OFF.
2. Disconnect NAVI control unit connector and display control unit connector.
3. Check continuity between NAVI control unit and display control unit.
4. Check continuity between NAVI control unit and ground.

#### ● When the screen looks bluish

Terminals				Continuity
NAVI control unit (+)		Display control unit (-)		
Connector	Terminal (Wire color)	Connector	Terminal (Wire color)	
M62	18 (BR/Y)	M43	44 (BR/Y)	Yes
	17		45	

Terminals			Continuity
NAVI control unit (+)		(-)	
Connector	Terminal (Wire color)		
M62	18 (BR/Y)	Ground	No
	17		

OK or NG

- OK >> GO TO 2.  
 NG >> Repair harness or connector.

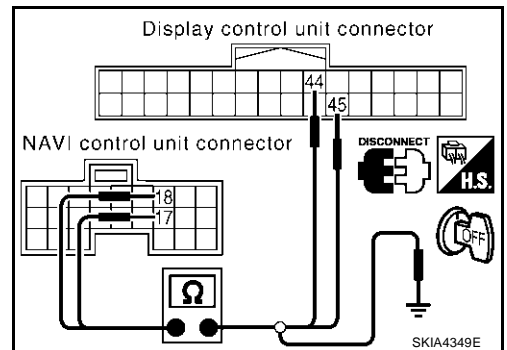

# NAVIGATION SYSTEM

## 2. CHECK RGB SIGNAL

1. Connect NAVI control unit connector and display control unit connector.
2. Turn ignition switch ON.
3. Display "Color bar" by "CONFIRMATION/ADJUSTMENT" mode.
4. Check signal between NAVI control unit terminal 18 (BR/Y) and 17 with CONSULT-II or oscilloscope.

- **When the screen looks bluish.**

Voltage signal between NAVI control unit connector M62 terminal 18 (BR/Y) and 17.

18 (BR/Y) – 17

: Refer to [AV-164, "Terminals and Reference Value for NAVI Control unit"](#) .

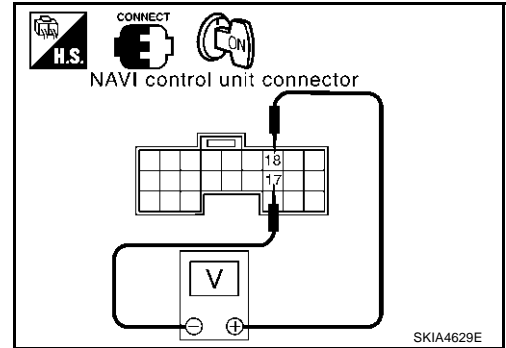

OK or NG

- OK >> Replace display control unit.
- NG >> Replace NAVI control unit.

## Color of RGB Image is Not Proper (NAVI Screen Looks Reddish)

AKS005SP

### 1. CHECK RGB HARNESS

1. Turn ignition switch OFF.
2. Disconnect NAVI control unit connector and display control unit connector.
3. Check continuity between NAVI control unit and display control unit.
4. Check continuity between NAVI control unit and ground.

- **When the screen looks reddish.**

Terminals				Continuity
NAVI control unit (+)		Display control unit (-)		
Connector	Terminal (Wire color)	Connector	Terminal (Wire color)	
M62	21 (BR/W)	M43	46 (BR/W)	Yes
	17		45	

Terminals				Continuity
NAVI control unit (+)		(-)		
Connector	Terminal (Wire color)			
M62	21 (BR/W)	Ground		No
	17			

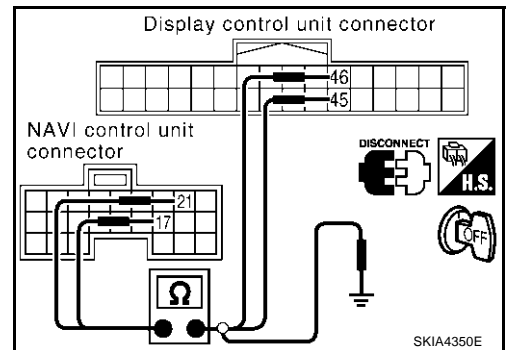

OK or NG

- OK >> GO TO 2.
- NG >> Repair harness or connector.

# NAVIGATION SYSTEM

## 2. CHECK RGB SIGNAL

1. Connect NAVI control unit connector and display control unit connector.
2. Turn ignition switch ON.
3. Display "Color bar" by "CONFIRMATION/ADJUSTMENT" mode.
4. Check signal between NAVI control unit terminal 21 (BR/W) and 17 with CONSULT-II or oscilloscope.

● **When the screen looks reddish.**

Voltage signal between NAVI control unit connector M62 terminal 21 (BR/W) and 17.

**21 (BR/W) – 17**

**: Refer to AV-164, "Terminals and Reference Value for NAVI Control unit" .**

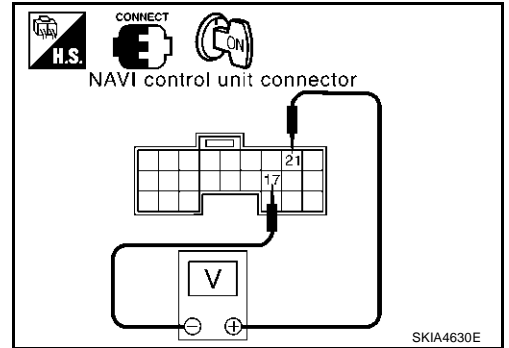

OK or NG

- OK >> Replace display control unit.
- NG >> Replace NAVI control unit.

## Color of RGB Image is Not Proper (NAVI Screen Looks Yellowish)

AKS005SQ

### 1. CHECK RGB HARNESS

1. Turn ignition switch OFF.
2. Disconnect NAVI control unit connector and display control unit connector.
3. Check continuity between NAVI control unit and display control unit.
4. Check continuity between NAVI control unit and ground.

● **When the screen looks yellowish.**

Terminals				Continuity
NAVI control unit (+)		Display control unit (-)		
Connector	Terminal (Wire color)	Connector	Terminal (Wire color)	
M62	15 (BR)	M43	48 (BR)	Yes
	17		45	

Terminals				Continuity
NAVI control unit(+)			(-)	
Connector	Terminal (Wire color)			
M62	15 (BR)		Ground	No
	17			

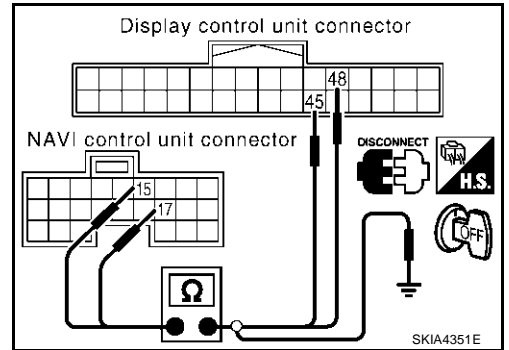

OK or NG

- OK >> GO TO 2.
- NG >> Repair harness or connector.

# NAVIGATION SYSTEM

## 2. CHECK RGB SIGNAL

1. Connect NAVI control unit connector and display control unit connector.
2. Turn ignition switch ON.
3. Display "Color bar" by "CONFIRMATION/ADJUSTMENT" mode.
4. Check signal between NAVI control unit terminal 15 (BR) and 17 with CONSULT-II or oscilloscope.

- **When the screen looks yellowish.**

Voltage signal between NAVI control unit connector M62 terminal 15 (BR) and 17.

**15 (BR) – 17**

**: Refer to AV-164, "Terminals and Reference Value for NAVI Control unit" .**

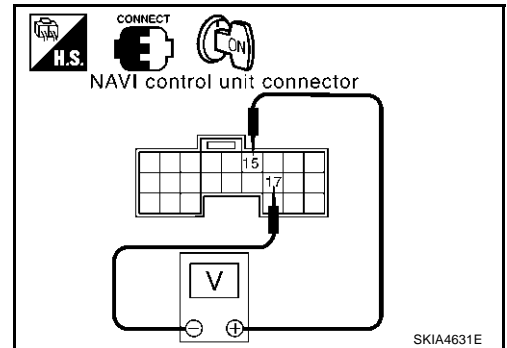

OK or NG

- OK >> Replace display control unit.
- NG >> Replace NAVI control unit.

## Color of RGB Image is Not Proper (Excepting NAVI Screen Looks Bluish)

AKS005SR

### 1. CHECK RGB HARNESS

1. Turn ignition switch OFF.
2. Disconnect display control unit connector and display connector.
3. Check continuity between display control unit and display.
4. Check continuity between display control unit and ground.

- **When the screen looks bluish**

Terminals				Continuity
Display control unit (+)		Display (-)		
Connector	Terminal (Wire color)	Connector	Terminal (Wire color)	
M43	50 (G/Y)	M38	17 (G/Y)	Yes
	47		7	

Terminals			Continuity
Display control unit (+)		(-)	
Connector	Terminal (Wire color)		
M43	50 (G/Y)	Ground	No
	47		

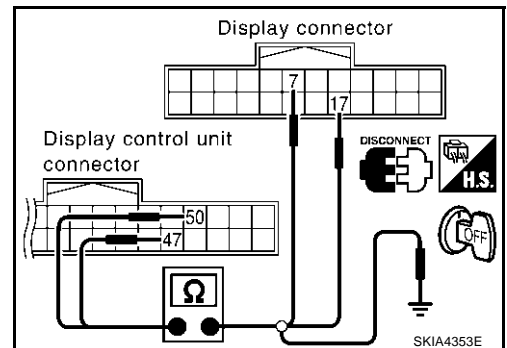

OK or NG

- OK >> GO TO 2.
- NG >> Repair harness or connector.



# NAVIGATION SYSTEM

## 2. CHECK RGB SIGNAL

1. Connect display control unit connector and display connector.
2. Turn ignition switch ON.
3. Display "Color bar" by "CONFIRMATION/ADJUSTMENT" mode.
4. Check the following with CONSULT-II or oscilloscope.

- **When the screen looks bluish.**

Voltage signal between display control unit connector M43 terminal 50 (G/Y) and 47.

**50 (G/Y) – 47**

**: Refer to AV-166, "Terminals and Reference Value for Display Control unit" .**

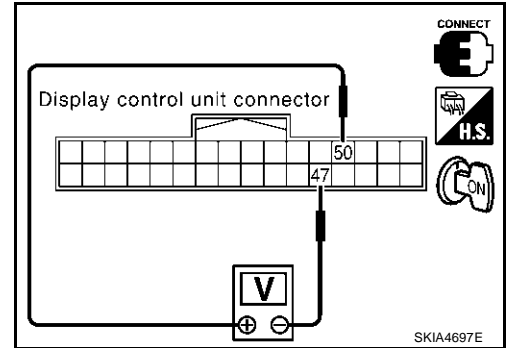

OK or NG

- OK >> Replace display.
- NG >> Replace display control unit.

## Color of RGB Image is Not Proper (Excepting NAVI Screen Looks Reddish) AKS005SS

### 1. CHECK RGB HARNESS

1. Turn ignition switch OFF.
2. Disconnect display control unit connector and display connector.
3. Check continuity between display control unit and display.
4. Check continuity between display control unit and ground.

- **When the screen looks reddish.**

Terminals				Continuity
Display control unit (+)		Display (-)		
Connector	Terminal (Wire color)	Connector	Terminal (Wire color)	
M43	52 (G/R)	M38	6 (G/R)	Yes
	47		7	

Terminals				Continuity
Display control unit (+)		(-)		
Connector	Terminal (Wire color)			
M43	52 (G/R)	Ground		No
	47			

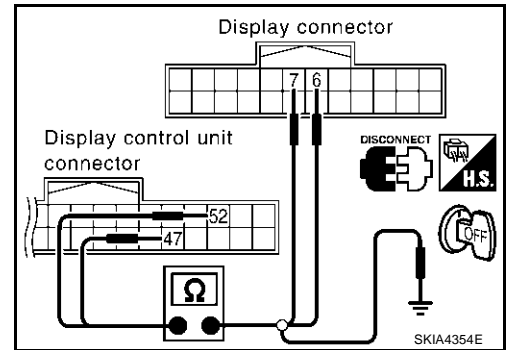

OK or NG

- OK >> GO TO 2.
- NG >> Repair harness or connector.

# NAVIGATION SYSTEM

## 2. CHECK RGB SIGNAL

1. Connect display control unit connector and display connector.
2. Turn ignition switch ON.
3. Display "Color bar" by "CONFIRMATION/ADJUSTMENT" mode.
4. Check the following with CONSULT-II or oscilloscope.

- **When the screen looks reddish.**

Voltage signal between display control unit connector M43 terminal 52 (G/R) and 47.

52 (G/R) – 47

: Refer to [AV-166, "Terminals and Reference Value for Display Control unit"](#) .

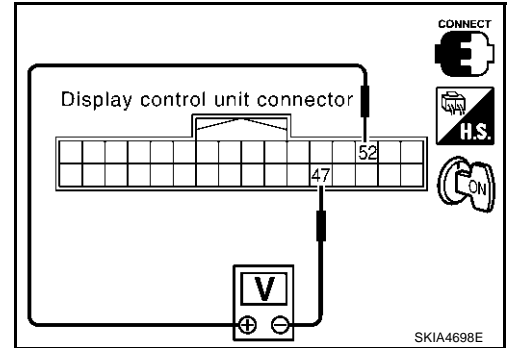

OK or NG

- OK >> Replace display.
- NG >> Replace display control unit.

## Color of RGB Image is Not Proper (Excepting NAVI Screen Looks Yellowish)

AKS005ST

### 1. CHECK RGB HARNESS

1. Turn ignition switch OFF.
2. Disconnect display control unit connector and display connector.
3. Check continuity between display control unit and display.
4. Check continuity between display control unit and ground.

- **When the screen looks yellowish.**

Terminals				Continuity
Display control unit (+)		Display (-)		
Connector	Terminal (Wire color)	Connector	Terminal (Wire color)	
M43	54 (G/O)	M38	18 (G/O)	Yes
	47		7	

Terminals				Continuity
Display control unit (+)		(-)		
Connector	Terminal (Wire color)			
M43	54 (G/O)	Ground		No
	47			

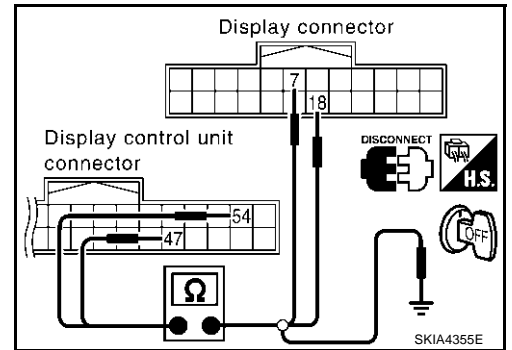

OK or NG

- OK >> GO TO 2.
- NG >> Repair harness or connector.

# NAVIGATION SYSTEM

## 2. CHECK RGB SIGNAL

1. Connect display control unit connector and display connector.
2. Turn ignition switch ON.
3. Display "Color bar" by "CONFIRMATION/ADJUSTMENT" mode.
4. Check the following with CONSULT-II or oscilloscope.

- **When the screen looks yellowish.**

Voltage signal between display control unit connector M43 terminal 54 (G/O) and 47.

54 (G/O) – 47

: Refer to [AV-166, "Terminals and Reference Value for Display Control unit"](#) .

### OK or NG

- OK >> Replace display.
- NG >> Replace display control unit.

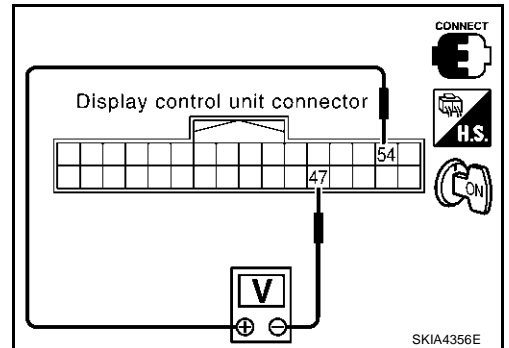

A  
B  
C  
D  
E  
F  
G  
H  
I  
J  
AV  
L  
M

# NAVIGATION SYSTEM

AKS005RH

## RGB Screen is Rolling (NAVI Screen)

### 1. CHECK HARNESS

1. Turn ignition switch OFF.
2. Disconnect NAVI control unit connector and display control unit connector.
3. Check continuity between NAVI control unit and display control unit.

Terminals				Continuity
NAVI control unit (+)		Display control unit (-)		
Connector	Terminal (Wire color)	Connector	Terminal (Wire color)	
M62	16 (P/L)	M43	43 (P/L)	Yes

4. Check continuity between NAVI control unit and ground.

Terminals			Continuity
NAVI control unit (+)		(-)	
Connector	Terminal (Wire color)		
M62	16 (P/L)	Ground	No

OK or NG

- OK >> GO TO 2.  
 NG >> Repair harness or connector.

### 2. CHECK RGB SYNCHRONIZING SIGNAL

1. Connect NAVI control unit connector and display control unit connector.
2. Turn ignition switch ON.
3. Check signal between NAVI control unit connector M43 terminals 16 (P/L) and 14 with CONSULT-II or oscilloscope.

**16 (P/L) – 14**

**: Refer to [AV-164](#), "[Terminals and Reference Value for NAVI Control unit](#)".**

OK or NG

- OK >> Replace display control unit.  
 NG >> Replace NAVI control unit.

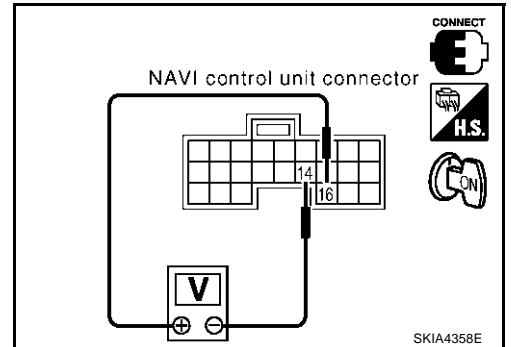
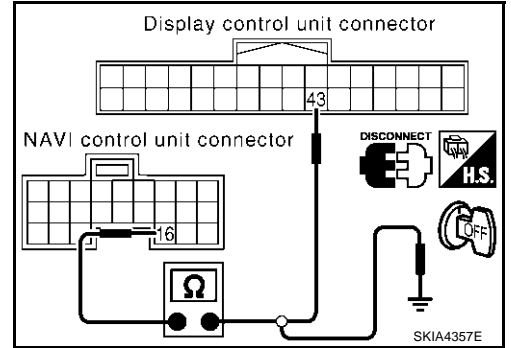

# NAVIGATION SYSTEM

AKS004RO

## RGB Screen Is Rolling (Excepting NAVI Screen)

### 1. CHECK HARNESS

1. Turn ignition switch OFF.
2. Disconnect display control unit connector and display connector.
3. Check continuity between display control unit and display.

Terminals				Continuity
Display control unit (+)		Display (-)		
Connector	Terminal (Wire color)	Connector	Terminal (Wire color)	
M43	56 (G)	M38	19 (G)	Yes

4. Check continuity between display control unit and ground.

Terminals			Continuity
Display control unit (+)		(-)	
Connector	Terminal (Wire color)		
M43	56 (G)	Ground	No

OK or NG

- OK >> GO TO 2.  
 NG >> Repair harness or connector.

### 2. CHECK RGB SYNCHRONIZING SIGNAL

1. Connect display control unit connector and display connector.
2. Turn ignition switch ON.
3. Check signal between display u connector M38 terminals 19 (G) and 21 with CONSULT-II or oscilloscope.

**19 (G) – 21**

**: Refer to [AV-170, "Terminals and Reference Value for Display"](#) .**

OK or NG

- OK >> Replace display.  
 NG >> Replace display control unit.

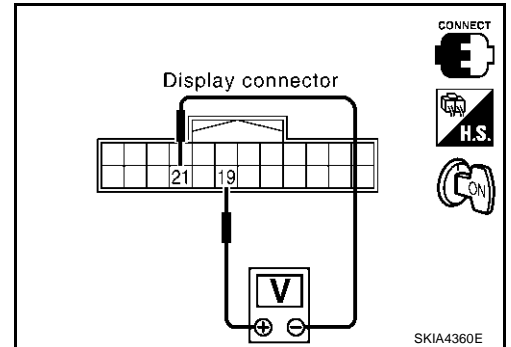
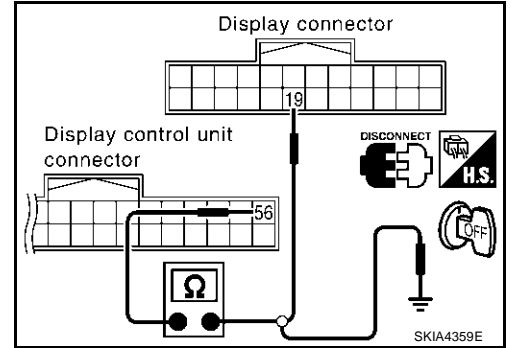

A  
B  
C  
D  
E  
F  
G  
H  
I  
J  
AV  
L  
M

# NAVIGATION SYSTEM

AKS004RP

## Guide Sound is Not Heard

### 1. CHECK VOICE GUIDE SETTING

- While driving in the dark pink route, voice guide does not operate. (note)
- Is volume setting not switched ON?

#### NOTE:

Voice guide is only available at intersections that satisfy certain conditions (indicated by ● on the map). Therefore, guidance may not be given even when the route on the map changes direction.

#### Yes or No

- Yes >> GO TO 2.  
No >> Switch the setting ON and turn the volume up.

### 2. CHECK HARNESS

1. Turn ignition switch OFF.
2. Disconnect NAVI control unit connector and audio unit connector.
3. Check continuity between NAVI control unit and audio unit.

Terminals				Continuity
NAVI control unit (+)		Audio unit (-)		
Connector	Terminal (Wire color)	Connector	Terminal (Wire color)	
M62	7 (V)	M46	36 (V)	Yes
	8 (LG)		34 (LG)	

4. Check continuity between NAVI control unit and ground.

Terminals				Continuity
NAVI control unit(+)		(-)		
Connector	Terminal (Wire color)			
M62	7 (V)	Ground		No
	8 (L/G)			

#### OK or NG

- OK >> GO TO 3.  
NG >> Repair harness or connector.

### 3. CHECK VOICE GUIDE

1. Connect NAVI control unit connector and audio unit connector.
2. Turn ignition switch ON.
3. Check signal between NAVI control unit harness connector M62 terminal 7 (V) and 8 (LG) with CONSULT-II or oscilloscope.

**7 (V) – 8 (LG)**

**: Refer to [AV-164, "Terminals and Reference Value for NAVI Control unit"](#) .**

#### OK or NG

- OK >> Replace audio unit.  
NG >> Replace NAVI control unit.

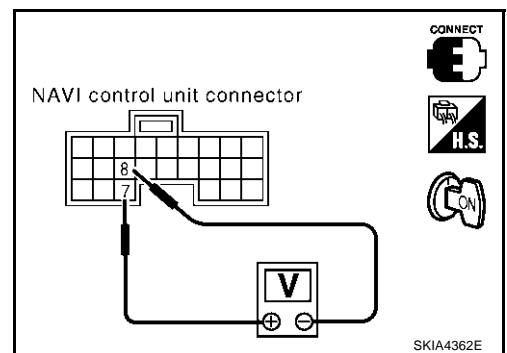
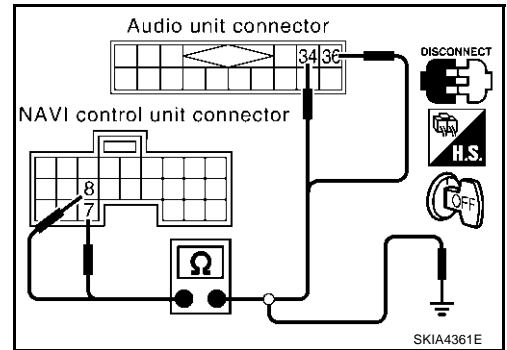

## Screen is Not Shown

AKS007IP

### 1. POWER SUPPLY AND GROUND CIRCUIT CHECK

Check power supply and ground circuit. Refer to [AV-190, "Power Supply and Ground Circuit Check for Display"](#) .

OK or NG

- OK >> Replace display.
- NG >> Check the malfunctioning parts.

## Audio Screen is Not Shown (NAVI Screen is Shown)

AKS005P9

### 1. CHECK1: COMMUNICATION LINE

1. Check audio communication line. Refer to [AV-198, "Audio Communication Line Check \(Between Display Control Unit and Audio Unit\)"](#) .

OK or NG

- OK >> GO TO 2.
- NG >> Check the malfunctioning parts.

### 2. CHECK2: COMMUNICATION LINE

1. Check display communication line. Refer to [AV-200, "Display Communication Line Check \(Between Display Control Unit and Display\)"](#) .

OK or NG

- OK >> Replace display.
- NG >> Check the malfunctioning parts.

## A/C Screen is Not Shown (NAVI Screen is Shown)

AKS005QW

### 1. CHECK CAN COMMUNICATION LINE

1. Check CAN communication line. Refer to [AV-203, "CAN Communication Line Check"](#) .

OK or NG

- OK >> GO TO 2.
- NG >> After filling out CAN DIAG SUPPORT MONITOR check sheet, GO TO [LAN-10, "Precautions When Using CONSULT-II"](#) .

### 2. CHECK COMMUNICATION LINE

1. Check display communication line. Refer to [AV-200, "Display Communication Line Check \(Between Display Control Unit and Display\)"](#) .

OK or NG

- OK >> Replace display.
- NG >> Check the malfunctioning parts.

## TRIP, FUEL ECON and MAINTENANCE Screens are Not Shown

AKS005QX

### 1. CHECK IGNITION SIGNAL

1. Check ignition signal. Refer to [AV-196, "Ignition Signal Check for Display Control Unit"](#) .

OK or NG

- OK >> GO TO 2.
- NG >> Check the malfunctioning parts.

### 2. CHECK POWER SUPPLY AND GROUND CIRCUIT

1. Check power supply circuit for display. Refer to [AV-190, "Power Supply and Ground Circuit Check for Display"](#) .

OK or NG

- OK >> GO TO 3.
- NG >> Check the malfunctioning parts.

A  
B  
C  
D  
E  
F  
G  
H  
I  
J  
L  
M

AV

# NAVIGATION SYSTEM

---

## 3. CHECK COMMUNICATION LINE

---

1. Check display communication line. Refer to [AV-200, "Display Communication Line Check \(Between Display Control Unit and Display\)"](#) .

OK or NG

- OK >> Replace display.  
NG >> Check the malfunctioning parts.

### \*Average Fuel Economy Displayed is Not Shown (" " is Shown)

AKS005L9

#### 1. CHECK VEHICLE SPEED SIGNAL

---

1. Check vehicle speed signal. Refer to [AV-193, "Vehicle Speed Signal Check for Display Control Unit"](#) .

OK or NG

- OK >> GO TO 2.  
NG >> Check the malfunctioning parts.

#### 2. CHECK CAN COMMUNICATION LINE

---

1. Check CAN communication line. Refer to [AV-203, "CAN Communication Line Check"](#) .

OK or NG

- OK >> GO TO 3.  
NG >> After filling out CAN DIAG SUPPORT MONITOR check sheet, GO TO [LAN-10, "Precautions When Using CONSULT-II"](#) .

#### 3. CHECK COMMUNICATION LINE

---

1. Check display communication line. Refer to [AV-200, "Display Communication Line Check \(Between Display Control Unit and Display\)"](#) .

OK or NG

- OK >> Replace display.  
NG >> Check the malfunctioning parts.

### \*Distance to Empty Displayed is Not Shown (" " is Shown)

AKS005PB

#### 1. CHECK SPEED METER

---

1. Confirm that speed meter is functioning.

Is speed meter functioning?

- YES >> GO TO 2.  
NO >> Refer to [DI-15, "Diagnosis Flow"](#) .

#### 2. CHECK FUEL METER

---

1. Confirm that fuel meter is functioning.

Is fuel meter functioning?

- YES >> GO TO 3.  
NO >> Refer to [DI-15, "Diagnosis Flow"](#) .

#### 3. CHECK CAN COMMUNICATION LINE

---

1. Check CAN communication line. Refer to [AV-203, "CAN Communication Line Check"](#) .

OK or NG

- OK >> GO TO 4.  
NG >> After filling out CAN DIAG SUPPORT MONITOR check sheet, GO TO [LAN-10, "Precautions When Using CONSULT-II"](#) .



# NAVIGATION SYSTEM

---

## 4. CHECK COMMUNICATION LINE

---

1. Check display communication line. Refer to [AV-200, "Display Communication Line Check \(Between Display Control Unit and Display\)"](#) .

OK or NG

- OK >> Replace display.  
NG >> Check the malfunctioning parts.

### \*Driving Distance or Average speed Displayed is Not Shown (" " is Shown) AKS005P4

#### 1. CHECK VEHICLE SPEED SIGNAL

---

1. Check vehicle speed signal. Refer to [AV-193, "Vehicle Speed Signal Check for Display Control Unit"](#) .

OK or NG

- OK >> GO TO 2.  
NG >> Check the malfunctioning parts.

#### 2. CHECK CAN COMMUNICATION LINE

---

1. Check CAN communication line. Refer to [AV-203, "CAN Communication Line Check"](#) .

OK or NG

- OK >> GO TO 3.  
NG >> After filling out CAN DIAG SUPPORT MONITOR check sheet, GO TO [LAN-10, "Precautions When Using CONSULT-II"](#) .

#### 3. CHECK COMMUNICATION LINE

---

1. Check display communication line. Refer to [AV-200, "Display Communication Line Check \(Between Display Control Unit and Display\)"](#) .

OK or NG

- OK >> Replace display.  
NG >> Check the malfunctioning parts.

### WARNING DOOR OPEN Screen is Not Shown AKS005P6

#### 1. CHECK VEHICLE SPEED SIGNAL

---

1. Check vehicle speed signal. Refer to [AV-193, "Vehicle Speed Signal Check for Display Control Unit"](#) .

OK or NG

- OK >> GO TO 2.  
NG >> Check the malfunctioning parts.

#### 2. CHECK CAN COMMUNICATION LINE

---

1. Check CAN communication line. Refer to [AV-203, "CAN Communication Line Check"](#) .

OK or NG

- OK >> GO TO 3.  
NG >> After filling out CAN DIAG SUPPORT MONITOR check sheet, GO TO [LAN-10, "Precautions When Using CONSULT-II"](#) .

#### 3. CHECK COMMUNICATION LINE

---

1. Check display communication line. Refer to [AV-200, "Display Communication Line Check \(Between Display Control Unit and Display\)"](#) .

OK or NG

- OK >> Replace display.  
NG >> Check the malfunctioning parts.

## Wheel Air Pressure is not Displayed

### 1. CHECK LOW TIRE PRESSURE WARNING CONTROL UNIT

1. Check low tire pressure warning control unit. Refer to [WT-38, "Self-Diagnosis"](#) .

OK or NG

- OK >> GO TO 2.
- NG >> Check the malfunctioning parts.

### 2. CHECK CAN COMMUNICATION LINE

1. Check CAN communication line. Refer to [AV-203, "CAN Communication Line Check"](#) .

OK or NG

- OK >> GO TO 3.
- NG >> After filling out CAN DIAG SUPPORT MONITOR check sheet, GO TO [LAN-10, "Precautions When Using CONSULT-II"](#) .

### 3. CHECK COMMUNICATION LINE

1. Check display communication line. Refer to [AV-200, "Display Communication Line Check \(Between Display Control Unit and Display\)"](#) .

OK or NG

- OK >> Replace display.
- NG >> Check the malfunctioning parts.

## Unable to Operate All of A/C and AV Switches (Unable to Start Self-Diagnosis)

### 1. CHECK POWER SUPPLY AND GROUND CIRCUIT

1. Check power supply and ground circuit. Refer to [AV-192, "Power Supply and Ground Circuit Check for A/C and AV Switch"](#) .

OK or NG

- OK >> GO TO 2.
- NG >> Check the malfunctioning parts.

### 2. A/C AND AV SWITCH SELF-DIAGNOSIS

1. A/C and AV switch self-diagnosis. Refer to [AV-187, "A/C and AV Switch Self-Diagnosis Function"](#) .

OK or NG

- OK >> GO TO 3.
- NG >> Check the malfunctioning parts.

### 3. CHECK A/C AND AV SWITCH CIRCUIT

1. Turn ignition switch OFF.
2. Disconnect display control unit connector and A/C and AV switch connector.
3. Check continuity between display control unit harness connector M43 terminals 28 (L/G), 30 (L/R) and A/C and AV switch harness connector M48 terminals 6 (L/G), 8 (L/R).

**Continuity should exist.**

4. Check continuity between display control unit harness connector M43 terminals 28 (L/G), 30 (L/R) and ground.

**Continuity should not exist.**

OK or NG

- OK >> GO TO 4.
- NG >> Repair harness or connector.

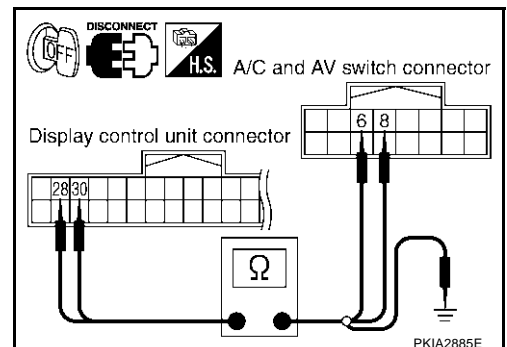

## 4. CHECK SELF-DIAGNOSIS OF DCU

1. Replace A/C and AV switch.
2. Connect display control unit connector and A/C and AV switch connector.
3. Turn ignition switch ON.
4. Start self-diagnosis of DCU, and check the self-diagnosis result. Refer to [AV-174, "Self-Diagnosis Mode \(DCU\)"](#) .

### OK or NG

- OK >> INSPECTION END  
NG >> Replace display control unit.

## Audio Does Not Work

AKS005QY

### 1. A/C AND AV SWITCH SELF-DIAGNOSIS

1. A/C and AV switch self-diagnosis. Refer to [AV-187, "A/C and AV Switch Self-Diagnosis Function"](#) .

### OK or NG

- OK >> GO TO 2.  
NG >> Check the malfunctioning parts.

### 2. CHECK COMMUNICATION LINE

1. Check audio communication line. Refer to [AV-198, "Audio Communication Line Check \(Between Display Control Unit and Audio Unit\)"](#) .

### OK or NG

- OK >> Replace audio unit.  
NG >> Check the malfunctioning parts.

## A/C Does Not Work

AKS005PC

### 1. A/C AND AV SWITCH SELF-DIAGNOSIS

1. A/C and AV switch self-diagnosis. Refer to [AV-187, "A/C and AV Switch Self-Diagnosis Function"](#) .

### OK or NG

- OK >> GO TO 2.  
NG >> Check the malfunctioning parts.

### 2. CHECK COMMUNICATION LINE

1. Check AV communication line. Refer to [AV-202, "AV Communication Line Check \(Between Display Control Unit and A/C and AV Switch\)"](#) .

### OK or NG

- OK >> GO TO 3.  
NG >> Check the malfunctioning parts.

### 3. CHECK CAN COMMUNICATION LINE

1. Check CAN communication line. Refer to [AV-203, "CAN Communication Line Check"](#) .

### OK or NG

- OK >> Replace display control unit.  
NG >> After filling out CAN DIAG SUPPORT MONITOR check sheet, GO TO [LAN-10, "Precautions When Using CONSULT-II"](#) .

# NAVIGATION SYSTEM

---

## Navigation System Does Not Activate

AKS007FZ

### 1. POWER SUPPLY AND GROUND CIRCUIT CHECK

---

Check power supply and ground circuit. Refer to [AV-188, "Power Supply and Ground Circuit Check for NAVI Control Unit"](#).

#### OK or NG

- OK >> Replace NAVI control unit.
- NG >> Check the malfunctioning parts.

## Previous NAVI Conditions Are Not Stored.

AKS004RU

### 1. CHECK BATTERY POWER

---

- Check NAVI control unit battery power.  
Refer to [AV-188, "Power Supply and Ground Circuit Check for NAVI Control Unit"](#).

#### OK or NG

- OK >> Replace NAVI control unit.
- NG >> Check NAVI control unit battery power system harness.

## Previous Vehicle Conditions Are Not Stored

AKS007GS

### 1. CHECK BATTERY POWER

---

- Check display control unit battery power.  
Refer to [AV-189, "Power Supply and Ground Circuit Check for Display Control Unit"](#).

#### OK or NG

- OK >> Replace display control unit.
- NG >> Check display control unit battery power system harness.

## Position of Current–Location Mark is Not Correct

AKS004RV

### 1. SELF-DIAGNOSIS

---

- "Self-diagnosis mode" of the self-diagnosis function. Refer to [AV-176, "Self-Diagnosis Mode \(NAVI\)"](#).

#### OK or NG

- OK >> GO TO 2.
- NG >> Check the malfunctioning parts.

### 2. HISTORY OF ERRORS DIAGNOSIS

---

- Was any error stored in [AV-182, "HISTORY OF ERRORS"](#) of the CONFIRMATION/ADJUSTMENT mode?

#### YES or NO

- YES >> [AV-182, "DIAGNOSIS BY HISTORY OF ERRORS"](#).
- NO >> [AV-221, "Driving Test"](#).

## Radio Wave From GPS Satellite is Not Received

AKS004RW

### 1. CHECK ENVIRONMENT

---

- Check if any metal object that intercepts radio waves or an object that emits radio waves (such as a portable phone) is located near the GPS antenna. Check if the vehicle is shielded by a building.

#### OK or NG

- OK >> ● System is not malfunction.  
The GPS antenna may not be able to receive radio waves from the GPS satellite if it is shielded by metal object or an object emitting radio waves is placed near it.
- NG >> GO TO 2.

# NAVIGATION SYSTEM

## 2. SELF-DIAGNOSIS

- "Self-diagnosis mode" of the self-diagnosis function. Refer to [AV-176, "Self-Diagnosis Mode \(NAVI\)"](#).

### OK or NG

- OK >> Replace GPS antenna.
- NG >> Check the malfunctioning parts.

## Driving Test

AKS004RX

### 1. DRIVING TEST 1

1. Scroll the map screen to display the area to make correction. Press "ENTER" and select "CURRENT LOCATION CORRECTION".
2. Correct direction of the vehicle mark.
3. Perform the distance correction of the CONFIRMATION/ADJUSTMENT mode.  
Note: Normally, adjustment is not necessary because this system has automatic distance correction function. However, when a tire chain is fitted, adjustment in accordance with the tire diameter ratio must be made.
4. Are symptoms malfunctioning to the [AV-222, "Example of Symptoms Judged Not Malfunction"](#) present after driving the vehicle?

### YES or NO

- YES >> Limit of the location detection capacity of the navigation system.
- NO >> GO TO 2.

### 2. DRIVING TEST 2

- Did any malfunction occur when the proper test in the following test patterns is performed?
- Test pattern  
Driving test finds the difference between the symptoms monitored with and without each sensor.
  - Test pattern 1: Test method with no GPS location correction  
Disconnect GPS antenna connector (GT5) connected to the NAVI control unit. Accurately adjust the current location and the direction, then drive the vehicle.
  - Test pattern 2: Test method with no map-matching  
Accurately adjust the current location and the direction. Eject the map DVD-ROM from the NAVI control unit with ignition switch turned to OFF, then drive the vehicle. After driving, insert the map DVD-ROM back in the unit, display the track of the vehicle on the map screen and compare it with the actual road configuration.
- Sample tests
  - <To determine if the current-location mark skips at the same position, if so, whether it is caused by map-matching or by GPS>  
Perform test pattern 1.
  - <To determine if the pattern of streets displayed is correct or not>  
Perform test pattern 1 & 2.  
Compare the track of the vehicle on the map screen and the actual road configuration. For fairly accurate tracking, plotting shall be made every several hundred meters.
  - <When the distance is adjusted accurately>  
Perform test pattern 1 & 2.  
Drive on a road of which distance is accurately known (by utilizing distance posts on a highway). Calculate the rate of change (increased/decreased) of the distance by comparing with the actual distance.  
Correction = A/B  
A: Distance shown on the screen  
B: Actual distance

### YES or NO

- YES >>
  - If adjustment is insufficient, perform adjustment again.
  - If any error is found in the map, please let us know.
  - Replace NAVI control unit.
- NO >> Limit of the location detection capacity of the navigation system.

# NAVIGATION SYSTEM

## Example of Symptoms Judged Not Malfunction BASIC OPERATION

AKS004RY

Symptom	Cause	Remedy
No image is shown.	Display brightness adjustment is set fully to DARK side.	Adjust the display brightness.
No guide sound is heard. Audio guide volume is too low or too high.	Volume control is set to OFF, MIN or MAX.	Adjust the audio guide volume.
	Audio guidance is not available while the vehicle is driving on a dark pink route.	System is not malfunction.
Screen is too dark. Motion of the image is too slow.	Temperature inside the vehicle is low.	Wait until the temperature inside the vehicle reaches the proper temperature.
Small black or bright spots appear on the screen.	Symptom peculiar to a liquid crystal display.	System is not malfunction.

## VEHICLE MARK

Symptom	Cause	Remedy
Map screen and BIRDVIEW™ Name of the place vary with the screen.	Some thinning of the character data is done to prevent the display becoming to complex. In some cases and in some locations, the display contents may differ. The same place name, street name, etc. may not be displayed every time on account of the data processing.	System is not malfunction.
Vehicle mark is not positioned correctly.	Vehicle is transferred by ferry or by towing after its ignition switch is turned to OFF.	Drive the vehicle for a while in the GPS satellite signal receiving condition.
Screen will not switch to nighttime mode after the lighting switch is turned ON.	The daytime screen is selected by the "SWITCH SCREENS" when the last time the screen dimming setting is done. Switching between daytime/nighttime screen may be inhibited by the automatic illumination adjustment function.	Perform screen dimming and select the nighttime screen by "SWITCH SCREENS".
Map screen will not scroll in accordance with the vehicle travel.	Current location is not displayed.	Press "MAP" button to display the current location.
Vehicle mark will not be shown.	Current location is not displayed.	Press "MAP" button to display the current location.
Accuracy indicator (GPS satellite mark) on the map screen stays gray.	GPS satellite signal is intercepted because the vehicle is in or behind a building.	Move the vehicle out to an open space.
	GPS satellite signal cannot be received because an obstacle is placed on top of the display.	Do not place anything in the center on top of the display.
	GPS satellites are located badly.	Wait until the location becomes better.
Vehicle location accuracy is low.	Accuracy indicator (GPS satellite mark) on the map screen stays gray.	Current location is not determined.
	Vehicle speed setting by the vehicle speed pulse has been deviated (advanced or retarded) from the actual vehicle speed because tire chain is fitted or the system has been used on another vehicle.	Drive the vehicle for a while [for approx. 30 minutes at approx. 30 km/h (19 MPH)] and the deviation will be automatically adjusted. If advancement or retard still occur, perform the distance adjustment by CONFIRMATION/ADJUSTMENT mode of diagnosis function.
	Map data has error or omission. (Vehicle mark is always deviated to the same position.)	As a rule, an updated map DVD-ROM will be released once a year.

## DESTINATION, PASSING POINTS, AND MENU ITEMS CANNOT BE SELECTED/SET.

Symptom	Cause	Remedy
Destination cannot be set.	Destination to be set is on an expressway.	Set the destination on an ordinary road.
Passing point is not searched when re-searching the route.	The vehicle has already passed the passing point, or the system judged so.	To include the passing points that have been passed into the route again, set the route again.

# NAVIGATION SYSTEM

Symptom	Cause	Remedy
Route information will not be displayed.	Route searching has not been done.	Set the destination and perform route searching.
	Vehicle mark is not on the recommended route.	Drive on the recommended route.
	Route guide is turned OFF.	Turn route guide ON.
	Route information is not available on the dark pink route.	System is not malfunction.
After the route searching, no guide sign will appear as the vehicle goes near the entrance/exit to the toll road.	Vehicle mark is not on the recommended route. (On the display, only guide signs related to the recommended route will be shown.)	Drive on the recommended route.
Automatic route searching is not possible.	Vehicle is driving on a highway (gray route), or no recommended route is available.	Drive on a road to be searched. Or re-search the route manually. In this case, however, the whole route will be searched.
Performed automatic detour search (or detour search). However, the result is the same as that of the previous search.	Performed search with every conditions considered. However, the result is the same as that of the previous search.	System is not malfunction.
Passing points cannot be set.	More than five passing points were set.	Passing points can be set up to five. To stop at more than five points, perform sharing in several steps.
When setting the route, the starting point cannot be selected.	The current vehicle location is always set as the starting point of a route.	System is not malfunction.
Some menu items cannot be selected.	The vehicle is being driven.	Stop the vehicle at a safe place and then operate the system.

## VOICE GUIDE

Symptom	Cause	Remedy
Voice guide will not operate.	Note: Voice guide is only available at intersections that satisfy certain conditions (indicated by ● on the map). Therefore, guidance may not be given even when the route on the map changes direction.	System is not malfunction.
	The vehicle is not on the recommended route.	Return to the recommended route or re-search the route.
	Voice guide is turned OFF.	Turn voice guide ON.
	Route guide is turned OFF.	Turn route guide ON.
Voice guide does not match the actual road pattern.	Voice guide may vary with the direction to which the vehicle is turn and the connection of the road to other roads.	Drive in conformity to the actual traffic rules.

## ROUTE SEARCH

Symptom	Cause	Remedy
No route is shown.	No road to be searched is found around the destination.	Find wider road (orange road or wider) nearby and reset the destination and passing points onto it. Take care of the traveling direction when there are separate up and down roads.
	Starting point and the destination are too close.	Set the destination at more distant point.
	Conditional traffic regulation (day of the week/ time of the day) is set at the area around the current location or the destination.	Turn the time-regulating search conditions OFF. Turn "Avoid regulation time" in the search conditions OFF.
Indicated route is intermittent.	In some areas, highways (gray routes) are not used for the search <sup>(Note)</sup> Therefore, the route to the current location or the passing points may be intermittent.	System is not malfunction.

# NAVIGATION SYSTEM

Symptom	Cause	Remedy
When the vehicle has passed the recommended route, it is deleted from the screen.	A recommended route is controlled by each section. When the vehicle has passed the passing point 1, then the map data from the starting point up to the passing point 1 will be deleted. (The data may remain undeleted in some area.)	System is not malfunction.
Detouring route is recommended.	In some areas, highways (gray routes) are not used for the search. (Note). Therefore, detour route may be recommended.	Set the route closer to the basic route (gray route).
	A detour route may be shown when some traffic regulation (one-way traffic, etc.) is set at the area around the starting point or the destination.	Slightly move the starting point or the destination, or set the passing point on the route of your choice.
	In the area where highways (gray routes) are used for the search, left turn has priority around the current location and the destination (passing points). For this reason, the recommended route may be detouring.	System is not malfunction.
Landmarks on the map do not match the actual ones.	This can be happen due to omission or error in the map data.	As a rule, an updated map DVD-ROM will be released once a year. Wait until the latest map has become available.
Recommended route is far from the starting point, passing points, and destination.	Starting point, passing points, and destination of the route guide were set far from the desired points because route searching data around these area were not stored.	Reset the destination onto the road nearby. If this road is one of the highways (gray routes), an ordinary road nearby may be displayed as the recommended route.

**NOTE:**

Except for the ordinance-designated cities and the prefectural capitals (Malfunctioning areas may be changed in the updated map disc.)

**EXAMPLES OF CURRENT-LOCATION MARK DISPLACEMENT**

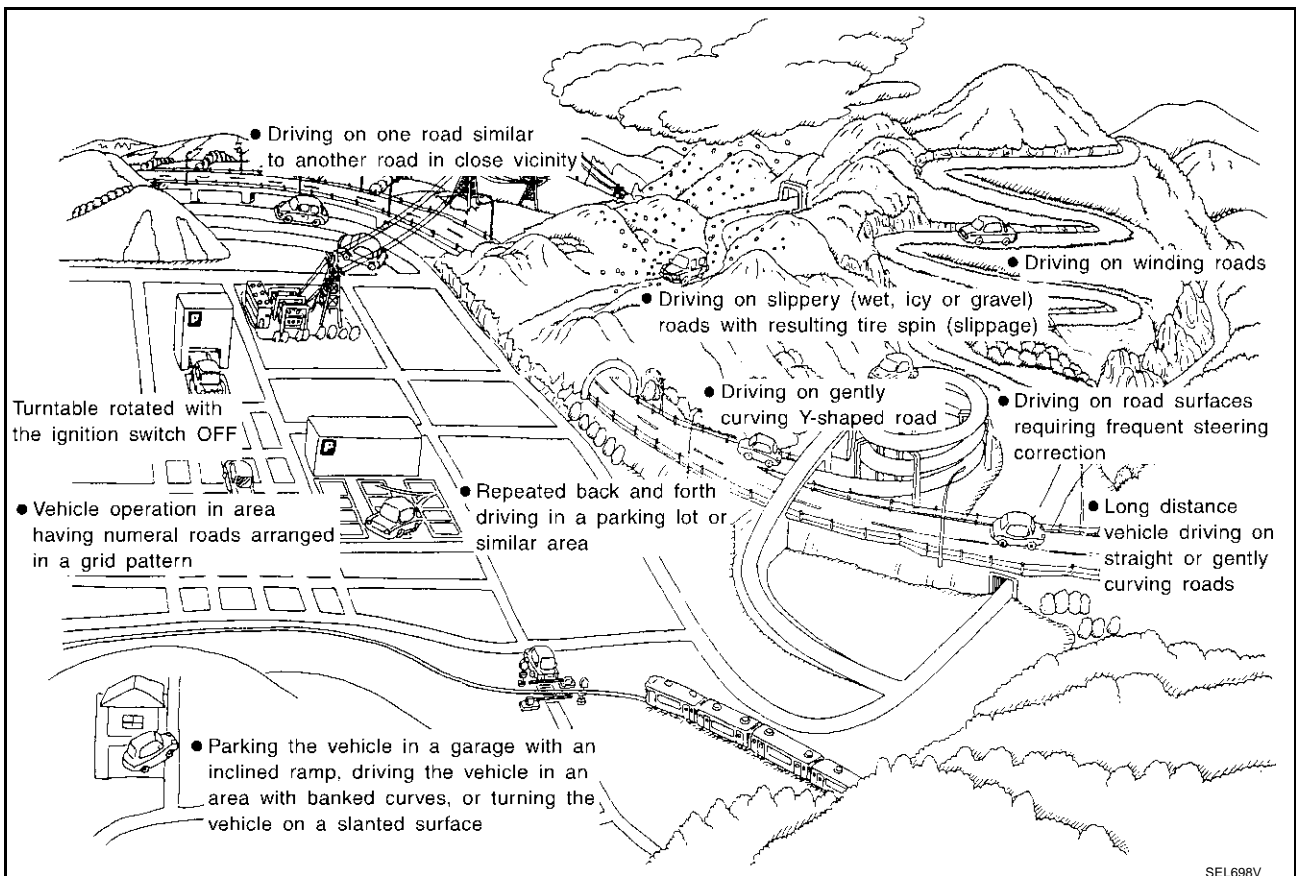

Vehicle's travel amount is calculated by reading its travel distance and turning angle. Therefore, if the vehicle is driven in the following manner, an error will occur in the vehicle's current location display. If correct location has not been restored after driving the vehicle for a while, perform location correction.



SEL698V



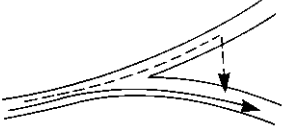
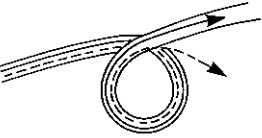
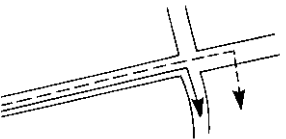
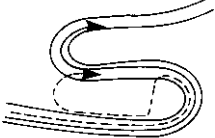
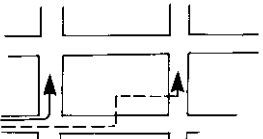

# NAVIGATION SYSTEM

Cause (condition)	—: While driving    ooo: Display	Driving condition	Remarks (correction, etc.)
Road configuration	<p>Y-intersections</p>  <p style="text-align: right; font-size: small;">ELK0192D</p>	<p>At a Y intersection or similar gradual division of roads, error the direction of travel deduced by the sensor may result in the current-location mark appearing on the wrong road.</p>	<p>If after travelling about 10 km (6 miles) the correct location has not been restored, perform location correction and, if necessary, direction correction.</p>
	<p>Spiral roads</p>  <p style="text-align: right; font-size: small;">ELK0193D</p>	<p>When driving on a large, continuous spiral road (such as loop bridge), turning angle error is accumulated and the vehicle mark may deviate from the correct location.</p>	
	<p>Straight roads</p>  <p style="text-align: right; font-size: small;">ELK0194D</p>	<p>When driving on a long, straight road and slow curve without stopping, map-matching does not work effectively enough and distance errors may accumulate. As a result, the vehicle mark may deviate from the correct location when the vehicle turned at a corner.</p>	
	<p>Zigzag roads</p>  <p style="text-align: right; font-size: small;">ELK0195D</p>	<p>When driving on a zigzag road, the map may be matched to other roads in the similar direction nearby at every turn, and the vehicle mark may deviate from the correct location.</p>	
	<p>Roads laid out in a grid pattern</p>  <p style="text-align: right; font-size: small;">ELK0196D</p>	<p>When driving at where roads are laid out in a grid pattern, where many roads are running in the similar direction nearby, the map may be matched to them by mistake and the vehicle mark may deviate from the correct location.</p>	
	<p>Parallel roads</p>  <p style="text-align: right; font-size: small;">ELK0197D</p>	<p>When two roads are running in parallel (such as highway and sideway), the map may be matched to the other road by mistake and the vehicle mark may deviate from the correct location.</p>	

A  
B  
C  
D  
E  
F  
G  
H  
I  
J  
AV  
L  
M

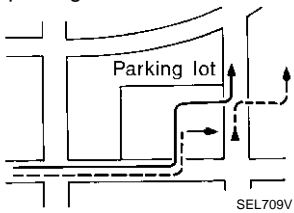
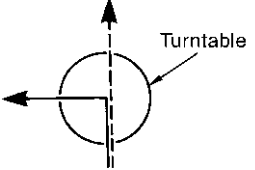
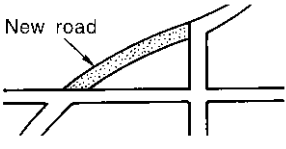
# NAVIGATION SYSTEM

	Cause (condition)    -: While driving    ooo: Display	Driving condition	Remarks (correction, etc.)
Place	In a parking lot  <small>SEL709V</small>	When driving in a parking lot, or other location where there are no roads on the map, matching may place the vehicle mark on a nearby road. When the vehicle returns to the road, the vehicle mark may have deviated from the correct location. When driving in circle or turning the steering wheel repeatedly, direction errors accumulate, and the vehicle mark may deviate from the correct location.	If after travelling about 10km (6miles) the correct location has not been restored, perform location correction and, if necessary, direction correction.
	Turn table  <small>SEL710V</small>	When the ignition switch is OFF, the navigation system cannot get the signal from the gyroscope (angular speed sensor). Therefore, the displayed direction may be wrong and the correct road may not be easily returned to after rotating the vehicle on a turn table with the ignition OFF.	
	Slippery roads	On snow, wet roads, gravel, or other roads where tires may slip easily, accumulated mileage errors may cause the vehicle mark to deviate from the correct road.	
	Slopes	When parking in sloped garages, when travelling on banked roads, or in other cases where the vehicle turns when tilted, an error in the turning angle will occur, and the vehicle mark may deviate from the road.	
Map data	Road not displayed on the map screen  <small>SEL699V</small>	When driving on new roads or other roads not displayed on the map screen, map matching does not function correctly and matches the location to a nearby road. When the vehicle returns to a road which is on the map, the vehicle mark may deviate from the correct road.	
	Different road pattern (Changed due to repair)  <small>ELK0201D</small>	If the road pattern stored in the map data and the actual road pattern are different, map matching does not function correctly and matches the location to a nearby road. The vehicle mark may deviate from the correct road.	
Vehicle	Use of tire chains	When tire chains are used, the mileage is not correctly detected, and the vehicle mark may deviate from the correct road.	Drive the vehicle for a while. If the distance is still deviated, adjust it by using the distance adjustment function. (If the tire chain is removed, recover the original value.)

# NAVIGATION SYSTEM

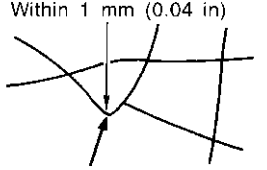
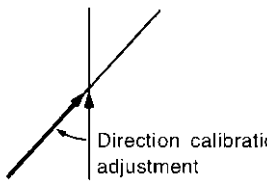
Cause (condition)    -: While driving    ooo: Display	Driving condition	Remarks (correction, etc.)
Precautions for driving	Just after the engine is started	If the vehicle is driven off just after the engine is started when the gyroscope (angular speed sensor) correction is not completed, the vehicle can lose its direction and may have deviated from the correct location.
	Continuous driving without stopping	When driving long distances without stopping, direction errors may accumulate, and the current-location mark may deviate from the correct road.
	Abusive driving	Spinning the wheels or engaging in other kinds of abusive driving may result in the system being unable perform correct detection, and may cause the vehicle mark to deviate from the correct road.
How to correct location	Position correction accuracy Within 1 mm (0.04 in)  <small>SEL701V</small>	If the accuracy of location settings is poor, accuracy may be reduced when the correct road cannot be found, particularly in places where there are many roads.  Enter in the road displayed on the screen with an accuracy of approx. 1mm. Caution: Whenever possible, use detailed map for the correction.
	Direction when location is corrected  <small>SEL702V</small>	If the accuracy of location settings during correction is poor, accuracy may be reduced afterwards.  Perform direction correction.

A  
B  
C  
D  
E  
F  
G  
H  
I  
J

## CURRENT LOCATION MARK SHOWS A POSITION WHICH IS COMPLETELY WRONG

In the following cases, the current-location mark may appear on completely different position in the map depending on the GPS satellite signal receiving conditions. In this case, perform location correction and direction correction.

- When location correction has not been done
  - If the receiving conditions of the GPS satellite signal is poor, if the current-location mark becomes out of place, it may move to a completely different location and not come back if location correction is not done. The position will be corrected if the GPS signal can be received.
- When the vehicle has traveled by ferry, or when the vehicle has been being towed
  - Because calculation of the current location cannot be done when travelling with the ignition OFF, for example when traveling by ferry or when being towed, the location before travel is displayed. If the precise location can be detected with GPS, the location will be corrected.

AV

L  
M

## CURRENT-LOCATION MARK JUMPS

In the following cases, the current-location mark may appear to jump as a result of automatic correction of the current location.

- When map matching has been done
  - If the current location and the current-location mark are different when map matching is done, the current-location mark may seem to jump. At this time, the location may be "corrected" to the wrong road or to a location which is not on a road.
- When GPS location correction has been done
  - If the current location and the current-location mark are different when the location is corrected using GPS measurements, the current-location mark may seem to jump. At this time, the location may be "corrected" to a location which is not on a road.

# NAVIGATION SYSTEM

---

## **CURRENT LOCATION MARK IS IN A RIVER OR SEA**

The navigation system moves the current-location mark with no distinction between land and rivers or sea. If the location mark is somehow out of place, it may appear that the vehicle is driving in a river or the sea.

## **WHEN DRIVING ON SAME ROAD, SOMETIMES CURRENT-LOCATION MARK IS IN RIGHT PLACE AND SOMETIMES IT IS WRONG PLACE**

The conditions of the GPS antenna (GPS data) and gyroscope (angular speed sensor) change gradually. Depending on the road traveled and the operation of the steering wheel, the location detection results will be different. Therefore, even on a road on which the location has never been wrong, conditions may cause the vehicle mark to deviate.

## **LOCATION CORRECTION BY MAP-MATCHING IS SLOW**

- The map matching function needs to refer to the data of the surrounding area. It is necessary to drive some distance for the function to work.
- Because map matching operates on this principle, when there are many roads running in similar directions in the surrounding area, no matching determination may be made. The location may not be corrected until some special feature is found.

## **ALTHOUGH GPS RECEIVING DISPLAY IS GREEN, VEHICLE MARK DOES NOT RETURN TO CORRECT LOCATION**

- The GPS accuracy has an error of approximately 10 m (30 ft). In some cases the current-location mark may not be on the correct street, even when GPS location-correction is done.
- The navigation system compares the results of GPS location detection with the results from map-matching location detection. The one which is determined to have higher accuracy is used.
- GPS location correction may not be performed when the vehicle is stopped.

## **NAME OF CURRENT PLACE IS NOT DISPLAYED**

The current place name may not be displayed if there are no place names displayed on the map screen.

## **CONTENTS OF DISPLAY DIFFER FOR BIRDVIEW™ AND THE (FLAT) MAP SCREEN**

**Difference of the BIRDVIEW™ screen from the flat map screen are as follows.**

- The current place name displays names which are primarily in the direction of vehicle travel.
- The amount of time before the vehicle travel or turn angle is updated on the screen is longer than for the (flat) map display.
- The conditions for display of place names, roads, and other data are different for nearby areas and for more distant areas.
- Some thinning of the character data is done to prevent the display becoming too complex. In some cases and in some locations, the display contents may differ.
- The same place name, street name, etc. may be displayed multiple times.

# NAVIGATION SYSTEM

## Program Loading of NAVI Control Unit

AKS004RZ

A  
B  
C  
D  
E  
F  
G  
H  
I  
J  
AV  
L  
M

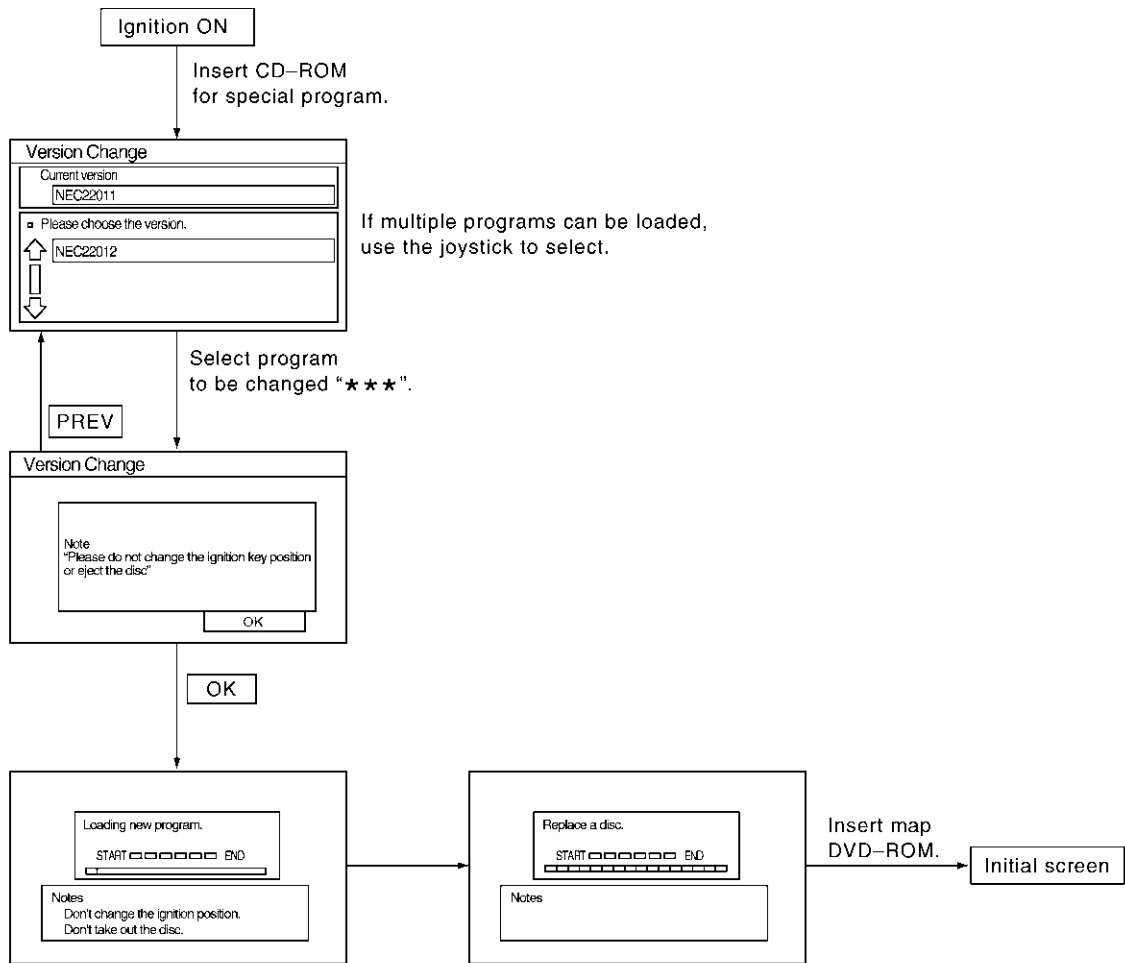

NOTE: Always load a program with the engine running.

SKIA0389E

# NAVIGATION SYSTEM

## Removal and Installation of NAVI Control Unit REMOVAL

AKS00684

1. Remove center console. Refer to [IP-18, "Removal and Installation"](#) .
2. Remove console cover (LH and RH). Refer to [IP-18, "Removal and Installation"](#) .
3. Remove control device assembly and remove NAVI control unit screws (2) and nut.
4. Disconnect NAVI control unit connector.

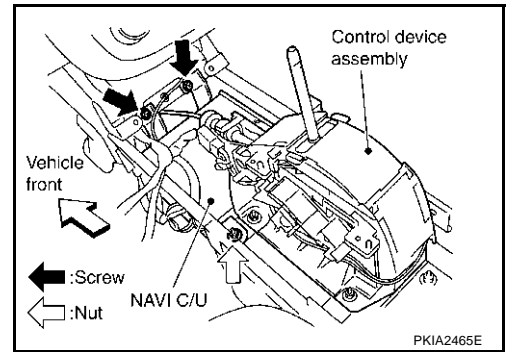

5. Pull NAVI control unit to a cock, then your side.

### **CAUTION:**

Cover unit with cloth avoid contact with console box bracket that may cause scratches or damages.

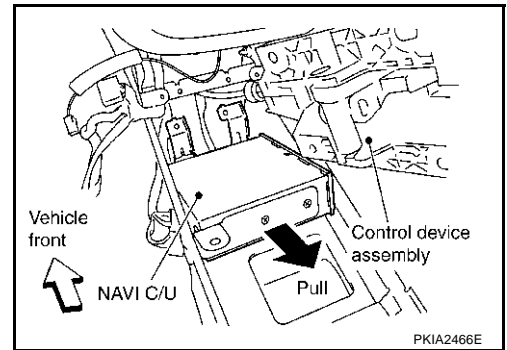

6. Remove screws (4) and remove bracket.

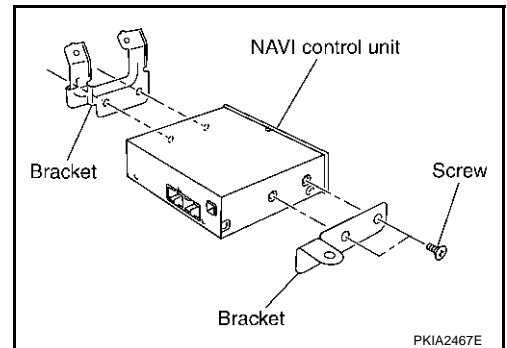

## INSTALLATION

Install in the reverse order of removal.

# NAVIGATION SYSTEM

## Removal and Installation of GPS Antenna

AKS00685

### REMOVAL

1. Remove cluster lid C. Refer to [IP-11, "Removal and Installation"](#) .
2. Remove center console. Refer to [IP-18, "Removal and Installation"](#) .
3. Remove console cover (LH). Refer to [IP-18, "Removal and Installation"](#) .
4. Remove display. Refer to [AV-232, "Removal and Installation of Display"](#) .
5. Disengaged the clips (4) to separate antenna feeder.

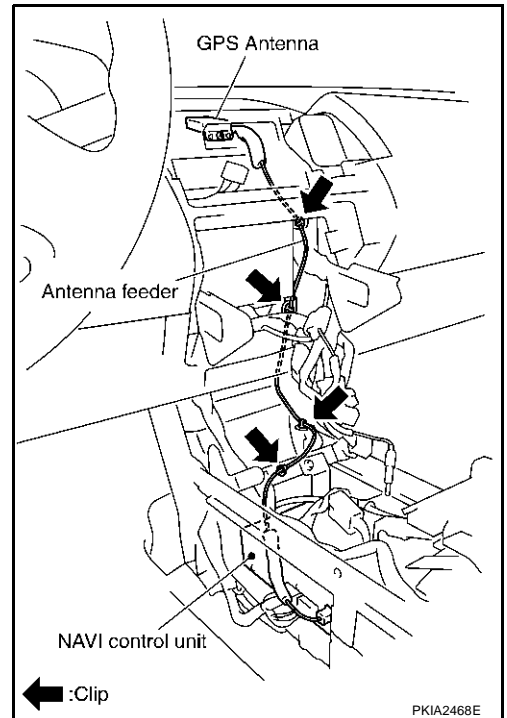

6. Remove screw and remove GPS antenna.

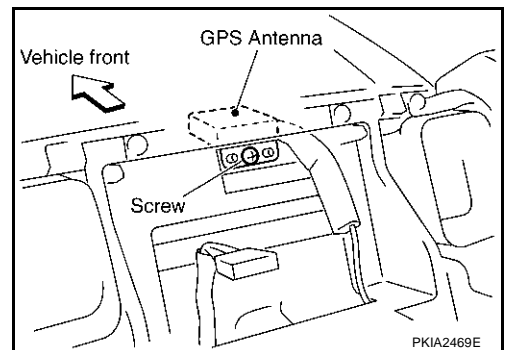

### INSTALLATION

Install in the reverse order of removal.

## Removal and Installation of Steering Wheel Switch

AKS00686

Refer to [SRS-36, "DRIVER AIR BAG MODULE"](#) .

## Removal and Installation of NAVI Switch

AKS00687

### REMOVAL

1. Remove audio unit from cluster lid C. Refer to [AV-55, "Removal and Installation of Audio Unit"](#) .
2. Remove screws (8) and remove NAVI switch with A/C and audio controller.

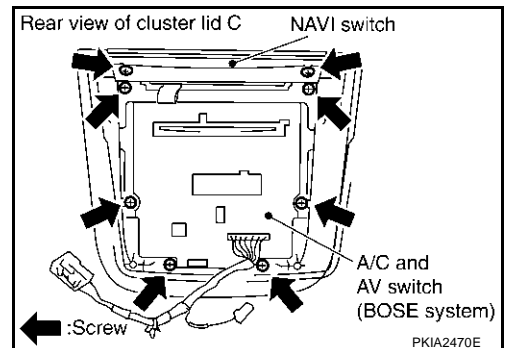

# NAVIGATION SYSTEM

## INSTALLATION

Install in the reverse order of removal.

### Removal and Installation of Display

#### REMOVAL

1. Remove center ventilator. Refer to [IP-11, "Removal and Installation"](#).
2. Remove screws (4) and remove display.

AKS00688

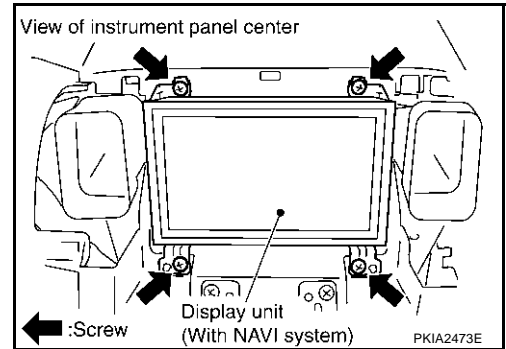

3. Remove screws (4) and remove bracket.

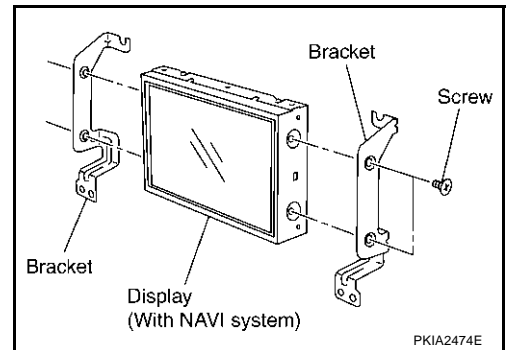

## INSTALLATION

Install in the reverse order of removal.

### Removal and Installation of Display Control Unit

#### REMOVAL

1. Remove cluster lid C. Refer to [IP-11, "Removal and Installation"](#).
2. Remove steering lock escutcheon. Refer to [IP-11, "Removal and Installation"](#).
3. Remove screws (2) and remove display control unit.

AKS00689

#### CAUTION:

See the illustration attached, when install or remove screws for display control unit.

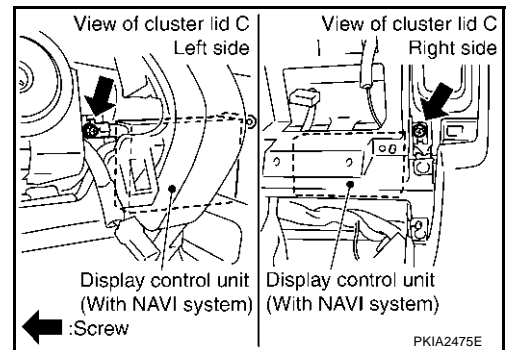

4. Remove screws (4) and remove bracket.

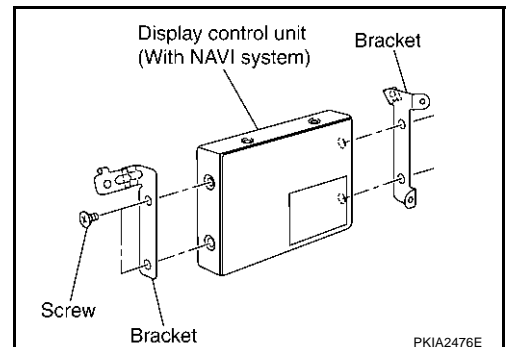



# NAVIGATION SYSTEM

---

## INSTALLATION

Install in the reverse order of removal.

A

B

C

D

E

F

G

H

I

J

**AV**

L

M

# NAVIGATION SYSTEM

---