

SECTION **AP**  
ADJUSTABLE PEDAL

A  
B  
C  
D  
E  
F  
G  
H  
J  
K  
L  
M

CONTENTS

<b>PRECAUTIONS</b> .....	<b>2</b>	<b>ADJUSTABLE PEDAL SYSTEM</b> .....	<b>3</b>
Precautions for Supplemental Restraint System (SRS) "AIR BAG" and "SEAT BELT PRE-TENSIONER" .....	2	Automatic Drive Positioner Interlocking Adjustable Pedal .....	3
Trouble Diagnosis Precaution .....	2	Adjustable Pedal (Only Manual Operation Model)....	3
		Removal and Installation .....	16

**AP**

# PRECAUTIONS

## PRECAUTIONS

PFP:00001

### Precautions for Supplemental Restraint System (SRS) “AIR BAG” and “SEAT BELT PRE-TENSIONER”

AI500316

The Supplemental Restraint System such as “AIR BAG” and “SEAT BELT PRE-TENSIONER”, used along with a front seat belt, helps to reduce the risk or severity of injury to the driver and front passenger for certain types of collision. This system includes seat belt switch inputs and dual stage front air bag modules. The SRS system uses the seat belt switches to determine the front air bag deployment, and may only deploy one front air bag, depending on the severity of a collision and whether the front occupants are belted or unbelted. Information necessary to service the system safely is included in the SRS and SB section of this Service Manual.

#### **WARNING:**

- To avoid rendering the SRS inoperative, which could increase the risk of personal injury or death in the event of a collision which would result in air bag inflation, all maintenance must be performed by an authorized NISSAN/INFINITI dealer.
- Improper maintenance, including incorrect removal and installation of the SRS, can lead to personal injury caused by unintentional activation of the system. For removal of Spiral Cable and Air Bag Module, see the SRS section.
- Do not use electrical test equipment on any circuit related to the SRS unless instructed to in this Service Manual. SRS wiring harnesses can be identified by yellow and/or orange harnesses or harness connectors.

### Trouble Diagnosis Precaution

AI500318

When you read wiring diagrams, refer to the following:

- [GI-14, "How to Read Wiring Diagrams"](#) in GI section
- [PG-3, "POWER SUPPLY ROUTING CIRCUIT"](#) in PG section

When you perform trouble diagnosis, refer to the following:

- [GI-10, "HOW TO FOLLOW TEST GROUPS IN TROUBLE DIAGNOSES"](#) in GI section
- [GI-26, "How to Perform Efficient Diagnosis for an Electrical Incident"](#) in GI section

Check for any service bulletins before servicing the vehicle.

# ADJUSTABLE PEDAL SYSTEM

## ADJUSTABLE PEDAL SYSTEM

PFP:98800

### Automatic Drive Positioner Interlocking Adjustable Pedal

AIS00314

Automatic drive positioner interlocking adjustable pedal. Refer to [SE-12, "AUTOMATIC DRIVE POSITIONER"](#)

### Adjustable Pedal (Only Manual Operation Model) SYSTEM DESCRIPTION

AIS0020E

The pedal adjustable system is power supply controlled by pedal adjusting control unit. Power is at all times supplied

- through 50A fusible link [Letter F, located in the fuse block (J/B)],
- to BCM (Body control module) terminal 55.
- through 10A fuse [No. 18, located in the fuse block (J/B)],
- through BCM terminal 42,
- through BCM terminal 54,
- to pedal adjusting control unit terminal 5.
- through 10A fuse [No. 21, located in the fuse block (J/B)],
- to Key switch and key lock solenoid terminal 3.

With ignition key inserted, power is supplied

- through Key switch and key lock solenoid terminal 4,
- to CVT device terminal 5.

With the ignition switch to ON position, power is supplied

- through 10A fuse [No. 12, located in the fuse block (J/B)],
- to pedal adjusting control unit terminal 4.

Ground is supplied

- to BCM terminal 49 and 52,
- through body grounds M14 and M78.
- to pedal adjusting control unit terminal 1,
- through body grounds M14 and M78.

When the ignition key inserted and CVT selector lever is shifted to a position other than P-position, power is supplied

- through CVT device terminal 6,
- to pedal adjusting terminal 3.

Then pedal adjusting control unit recognizes that CVT selector lever is shifted to a position other than P-position.

When ignition switch to OFF position or ON position and CVT selector lever is shifted to P-position, power is supplied

- through pedal adjusting control unit terminal 7,
- to pedal adjusting switch terminal 64.

With power supplied, pedal adjusting switch is energized.

When pedal adjusting switch forward, power is supplied

- through pedal adjusting switch terminal 30,
- to pedal adjusting motor terminal 2.

Then ground is supplied

- to pedal adjusting motor terminal 1,
- through pedal adjusting switch terminal 15,
- through pedal adjusting switch terminal 48C,
- through body grounds B20 and B7.

With power and ground are supplied, accelerator and brake pedal moves forward.

When pedal adjusting switch backward, power is supplied

- through pedal adjusting switch terminal 15,

A  
B  
C  
D  
E  
F  
G  
H  
AP  
J  
K  
L  
M

# ADJUSTABLE PEDAL SYSTEM

- to pedal adjusting motor terminal 1.
- Then ground is supplied
- to pedal adjusting motor terminal 2,
  - through pedal adjusting switch terminal 30,
  - through pedal adjusting switch terminal 48C,
  - through body grounds B20 and B7.

With power and ground are supplied, accelerator and brake pedal moves backward.

## COMPONENT PARTS AND HARNESS CONNECTOR LOCATION

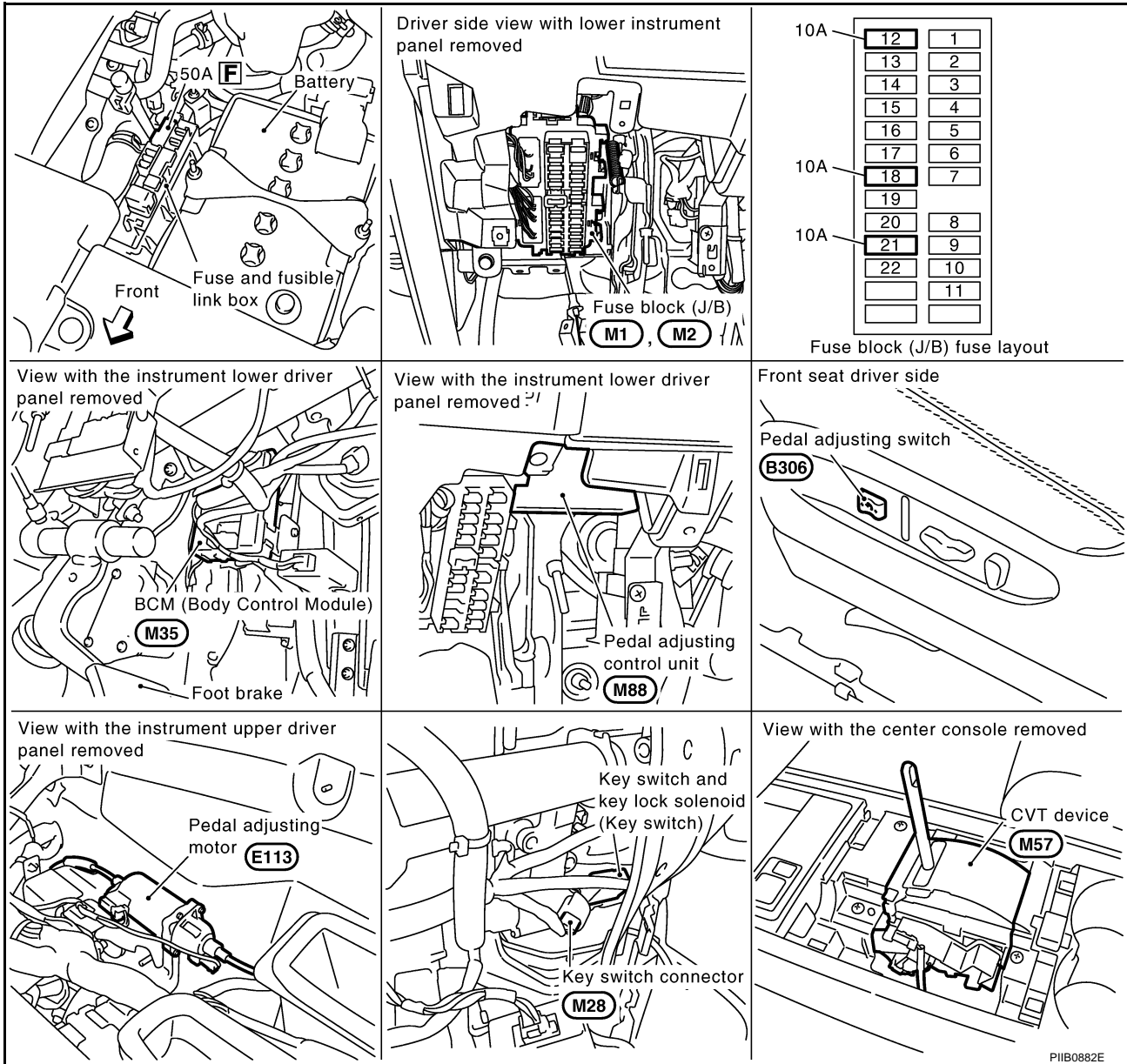

# ADJUSTABLE PEDAL SYSTEM

## WIRING DIAGRAM —PEDAL—

AP-PEDAL-01

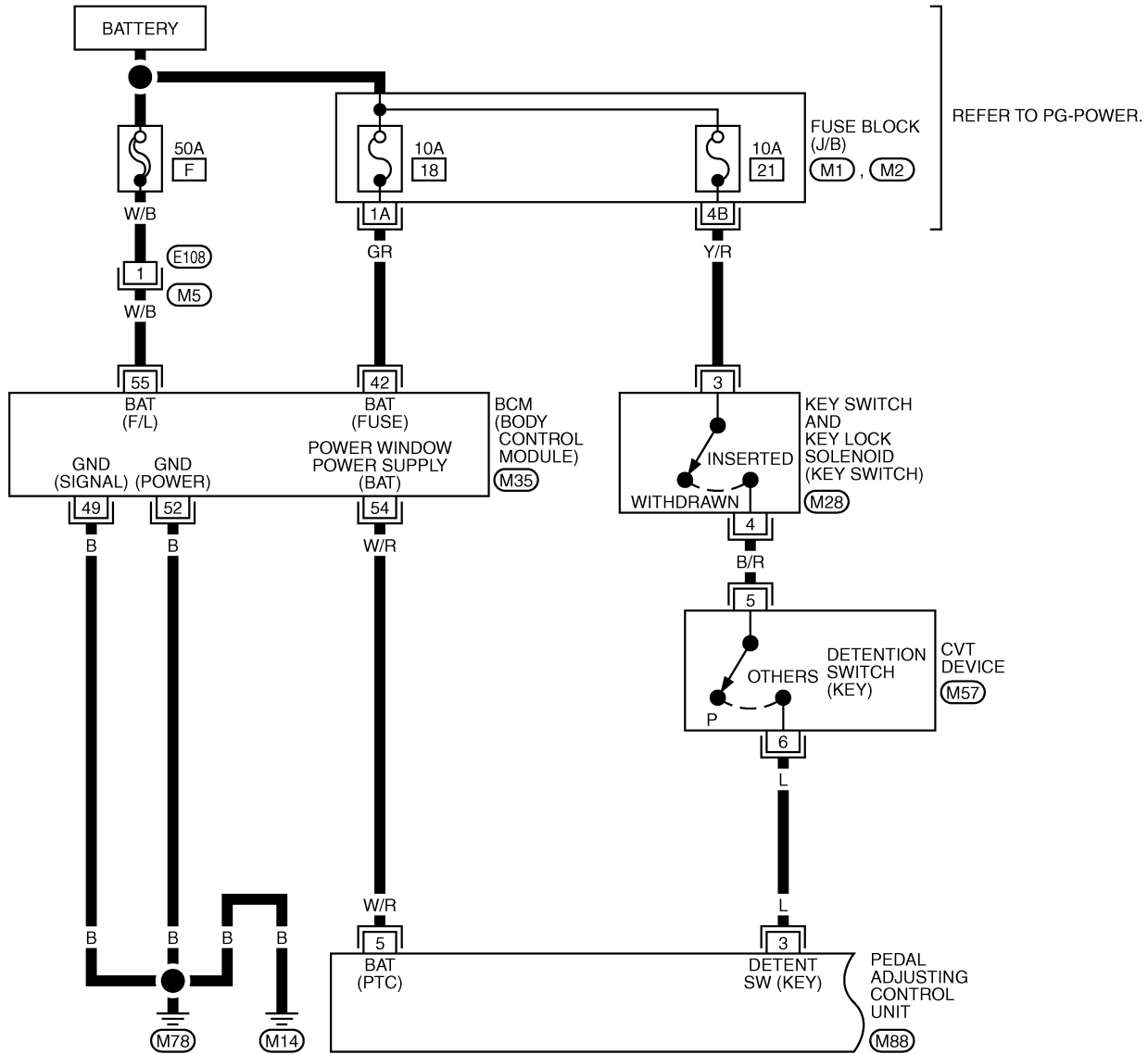

A  
B  
C  
D  
E  
F  
G  
H  
AP  
J  
K  
L  
M

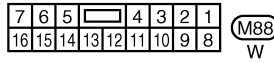
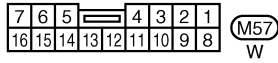
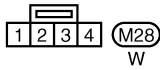
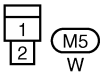

REFER TO THE FOLLOWING.  
 (M1), (M2) - FUSE BLOCK-JUNCTION BOX (J/B)  
 (M35) - ELECTRICAL UNITS

TWA0534E

# ADJUSTABLE PEDAL SYSTEM

AP-PEDAL-02

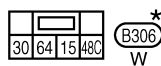
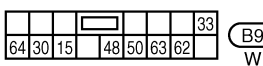
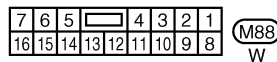
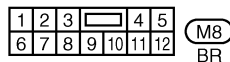
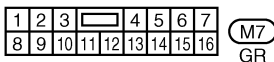
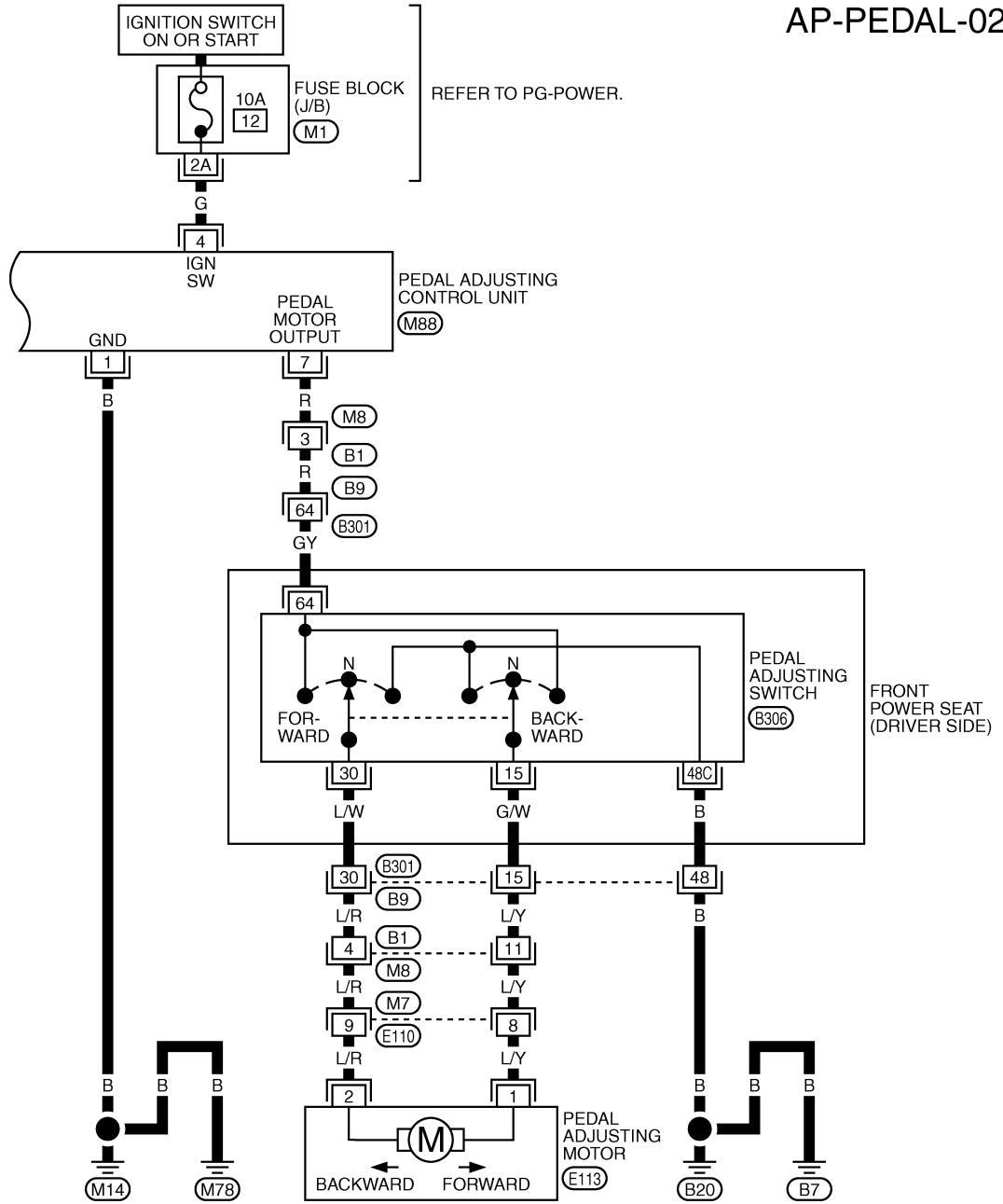

REFER TO THE FOLLOWING.  
 (M1) - FUSE BLOCK-JUNCTION BOX (J/B)

\*: THIS CONNECTOR IS NOT SHOWN IN "HARNESS LAYOUT", PG SECTION.

TIWA0327E

# ADJUSTABLE PEDAL SYSTEM

## TERMINAL AND REFERENCE VALUE FOR BCM

TERMINAL	WIRE COLOR	ITEM	CONDITION	VOLTAGE (V) (Approx)
42	GR	BAT power supply	Ignition switch OFF	Battery voltage
49, 52	B	Ground	Ignition switch ON	0
54	W/R	Adjustable pedal power supply	Ignition switch OFF	Battery voltage
55	W/B	BAT power supply	Ignition switch OFF	Battery voltage

## TERMINAL AND REFERENCE VALUE FOR PEDAL ADJUSTING CONTROL UNIT

TERMINAL	WIRE COLOR	ITEM	CONDITION	VOLTAGE (V) (Approx)
1	B	Ground	Ignition switch turn ON	0
3	L	Detention switch (key) signal	Key switch ON Selector lever in other than P-position	Battery voltage
			Except the above	0
4	G	Ignition power supply	Ignition switch ON	Battery voltage
5	W/R	Battery power supply	Ignition switch OFF	Battery voltage
7	R	Pedal adjusting switch power supply output	Ignition switch turn ON Selector lever in other than P-position	0
			Selector lever is shifted to P-position	Battery voltage

## WORK FLOW

1. Check the symptom and customer's requests.
2. Perform the preliminary check. Refer to [AP-7, "PRELIMINARY CHECK"](#) .
3. According to the trouble diagnosis chart, repair or replace the cause of the malfunction.  
Refer to [AP-8, "TROUBLE DIAGNOSIS CHART BY SYMPTOM"](#) .
4. Does adjustable pedal system operate normally?  
YES: GO TO 5.  
NO: GO TO 3.
5. INSPECTION END

## PRELIMINARY CHECK

### 1. CHECK ADJUSTABLE PEDAL MECHANISM

Check the following.

- Movable part of accelerator pedal or brake pedal is deformed, or there is foreign material in it.
- Accelerator pedal or brake pedal is deformed or broken.

OK or NG

- OK >> Preliminary check is OK.  
NG >> Repair the malfunctioning part and check again.

# ADJUSTABLE PEDAL SYSTEM

## TROUBLE DIAGNOSIS CHART BY SYMPTOM

### NOTE:

Always check the "Work Flow" before troubleshooting. Refer to [AP-7, "WORK FLOW"](#) .

Symptom	Diagnoses / service procedure	Refer to page
No adjustable pedal system operates.	1. BCM power supply and ground circuit inspection	<a href="#">AP-8</a>
	2. Pedal adjusting control unit supply and ground circuit inspection	<a href="#">AP-10</a>
	3. Pedal adjusting switch power supply and ground inspection	<a href="#">AP-14</a>
	4. Pedal adjusting motor circuit inspection	<a href="#">AP-15</a>
	5. Replace pedal adjusting motor	<a href="#">AP-4</a>
Adjustable pedal system does operate when ignition switch turned ON and CVT selector lever is other than P-position.	1. Key switch and CVT device circuit inspection	<a href="#">AP-11</a>
	2. Pedal adjusting control unit ignition signal inspection	<a href="#">AP-9</a>
	3. Replace pedal adjusting control unit	<a href="#">AP-4</a>
Adjustable pedal system does not operate when ignition switch turned ON and CVT selector lever is other than P-position.	CVT device circuit inspection	<a href="#">AP-16</a>

## BCM POWER SUPPLY AND GROUND CIRCUIT INSPECTION

### 1. CHECK FUSE

- Check 50A fusible link (letter **F** located in the fuse and fusible link box).
- Check 10A fuse [No. 18, located in the fuse block (J/B)],

### NOTE:

Refer to [AP-4, "COMPONENT PARTS AND HARNESS CONNECTOR LOCATION"](#) .

### OK or NG

OK >> GO TO 2.

NG >> If fuse is blown, be sure to eliminate cause of malfunction before installing new fuse. Refer to [PG-3, "POWER SUPPLY ROUTING CIRCUIT"](#)

### 2. CHECK BCM POWER SUPPLY

1. Turn ignition switch OFF.
2. Check voltage between BCM connector M35 terminal 42 (GR), 55 (W/B) and ground.

**42 (GR) - Ground : Battery voltage**

**55 (W/B) - Ground : Battery voltage**

### OK or NG

OK >> GO TO 3.

NG >> Repair or replace harness between fuse and BCM.

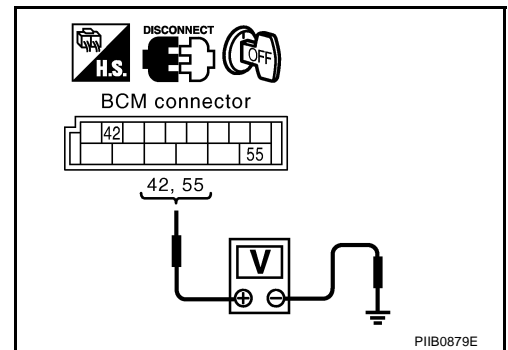

### 3. CHECK BCM GROUND CIRCUIT

Check continuity between BCM connector M35 terminal 49 (B), 52 (B) and ground.

**49 (B) - Ground : Continuity should exist.**

**52 (B) - Ground : Continuity should exist.**

### OK or NG

OK >> GO TO 4.

NG >> Repair or replace the harness between BCM and ground.

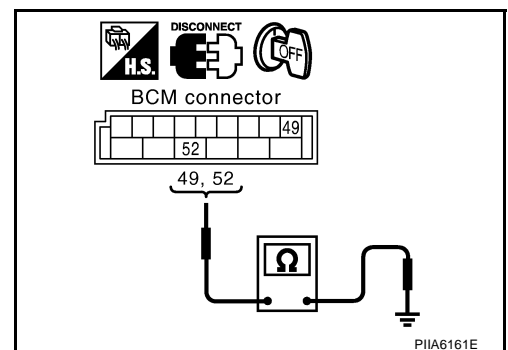



# ADJUSTABLE PEDAL SYSTEM

## 4. CHECK BCM OUTPUT POWER SUPPLY CIRCUIT

1. Disconnect BCM connector.
2. Check voltage between BCM connector M35 terminal 54 (W/R) and ground.

**54 (W/R) - Ground : Battery voltage**

OK or NG

- OK >> BCM power supply and ground circuit are OK.  
 NG >> Replace BCM.

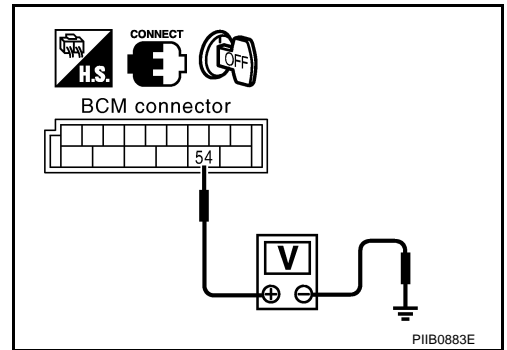

## PEDAL ADJUSTING CONTROL UNIT IGNITION SIGNAL INSPECTION

### 1. CHECK FUSE

1. Turn ignition switch OFF.
2. Check 10A fuse [No. 12, located in fuse block (J/B)]

**NOTE:**

Refer to [AP-4, "COMPONENT PARTS AND HARNESS CONNECTOR LOCATION"](#) .

OK or NG

- OK >> GO TO 2.  
 NG >> If fuse is blown, be sure to eliminate cause of malfunction before installing new fuse. Refer to [PG-3, "POWER SUPPLY ROUTING CIRCUIT"](#) .

### 2. CHECK PEDAL ADJUSTING CONTROL UNIT IGNITION POWER SUPPLY CIRCUIT

1. Disconnect pedal adjusting control unit connector.
2. Turn ignition switch ON.
3. Check voltage between pedal adjusting control unit connector and ground.

Connector	Terminal (Wire color)		Condition	Voltage (V) (Approx.)
	(+)	(-)		
M88	4(G)	Ground	Turn ignition switch ON	Battery voltage
			Turn ignition switch OFF	0

OK or NG

- OK >> Pedal adjusting control unit ignition signal is OK.  
 NG >> Repair or replace the harness between pedal adjusting control unit and fuse block (J/B).

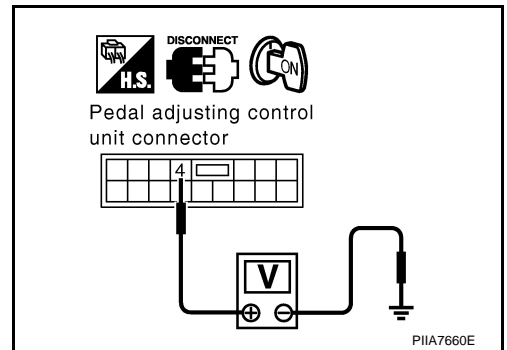

# ADJUSTABLE PEDAL SYSTEM

## PEDAL ADJUSTING CONTROL UNIT POWER SUPPLY AND GROUND INSPECTION

### 1. CHECK PEDAL ADJUSTING CONTROL UNIT POWER SUPPLY CIRCUIT

1. Turn ignition switch OFF.
2. Disconnect pedal adjusting control unit connector.
3. Check voltage between pedal adjusting control unit connector M88 terminal 5 (W/R) and ground.

**5 (W/R) - Ground : Battery voltage**

OK or NG

OK >> GO TO 2.

NG >> Repair or replace the harness between pedal adjusting control unit and BCM.

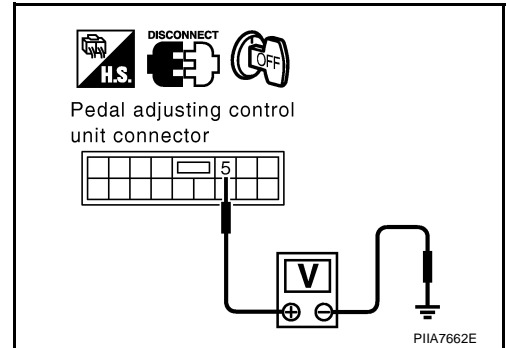

### 2. CHECK PEDAL ADJUSTING CONTROL UNIT GROUND CIRCUIT

Check continuity between pedal adjusting control unit connector M88 terminal 1 (B) and ground.

**1 (B) - Ground : Continuity should exist.**

OK or NG

OK >> GO TO 2.

NG >> Repair or replace harness between pedal adjusting control unit and ground.

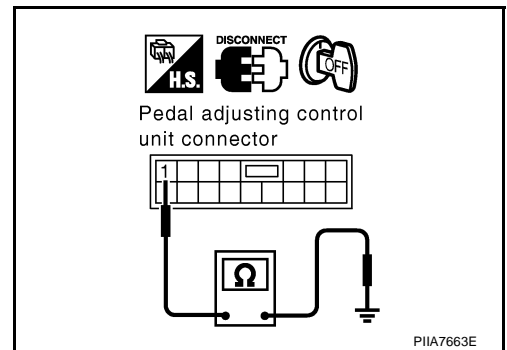

### 3. CHECK PEDAL ADJUSTING CONTROL UNIT OUTPUT POWER SUPPLY

1. Connect pedal adjusting control unit connector.
2. Check voltage between pedal adjusting control unit connector M88 terminal 7 (R) and ground.

**7 (R) - Ground : Battery voltage**

OK or NG

OK >> Pedal adjusting control unit power supply and ground is OK.

NG >> Replace pedal adjusting control unit.

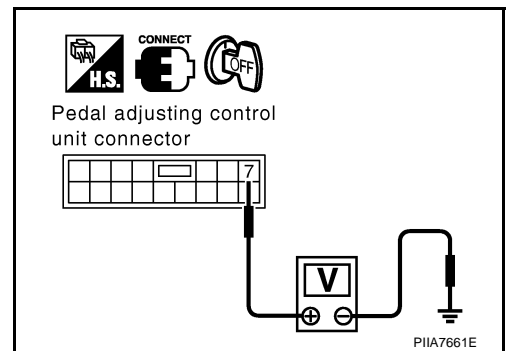

# ADJUSTABLE PEDAL SYSTEM

## KEY SWITCH AND CVT DEVICE CIRCUIT INSPECTION

### 1. CHECK FUSE

Check 10A fuse [No. 21, located in fuse block (J/B)]

**NOTE:**

Refer to [AP-4, "COMPONENT PARTS AND HARNESS CONNECTOR LOCATION"](#) .

OK or NG

OK >> GO TO 2.

NG >> If fuse is blown, be sure to eliminate cause of malfunction before installing new fuse. Refer to [PG-3, "POWER SUPPLY ROUTING CIRCUIT"](#) .

### 2. CHECK PEDAL ADJUSTING CONTROL UNIT INPUT SIGNAL

1. Disconnect pedal adjusting control unit connector.
2. Key is inserted in ignition key cylinder.
3. Check voltage between pedal adjusting control unit connector and ground.

Connector	Terminal (Wire color)		Condition	Voltage (V) (Approx.)
	(+)	(-)		
M88	3 (L)	Ground	P-position	0
			Other than P-position.	Battery voltage

OK or NG

OK >> Key switch and CVT device circuit is OK.

NG >> GO TO 3.

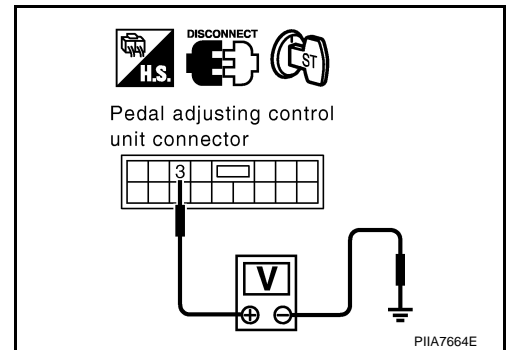

### 3. CHECK KEY SWITCH POWER SUPPLY CIRCUIT

1. Turn ignition switch OFF.
2. Key is removed from ignition key cylinder.
3. Check voltage between key switch and key lock solenoid connector M28 terminal 3 (Y/R) and ground.

**3 (Y/R) - Ground : Battery voltage.**

OK or NG

OK >> GO TO 4.

NG >> Repair or replace harness between key switch and key lock solenoid and fuse.

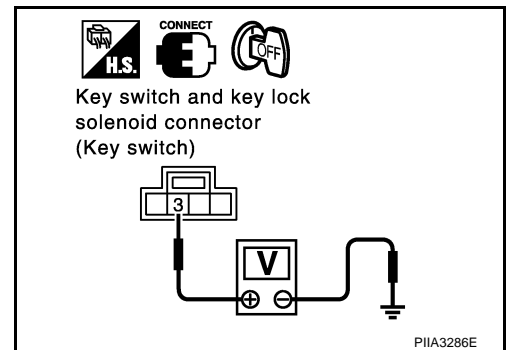

### 4. CHECK KEY SWITCH

Check continuity between key switch and key lock solenoid (key switch) as follows.

Terminals		Condition	Continuity
3	4	Key is inserted in ignition key cylinder.	Yes
		Key is removed from ignition key cylinder.	No

OK or NG

OK >> GO TO 5.

NG >> Replace key switch and key lock solenoid.

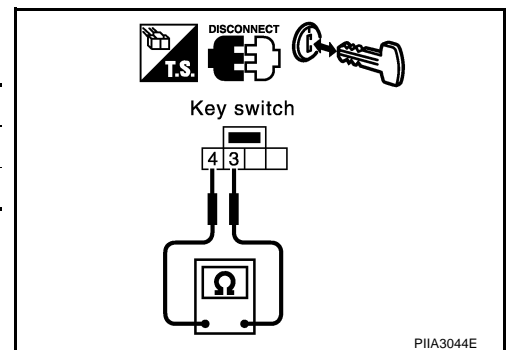

# ADJUSTABLE PEDAL SYSTEM

## 5. CHECK CVT DEVICE POWER SUPPLY CIRCUIT

1. Disconnect CVT device connector.
2. Connect key switch and key lock solenoid connector.
3. Key is inserted in ignition key cylinder.
4. Check voltage between CVT device connector M57 terminal 5 (B/R) and ground.

**5 (B/R) - Ground : Battery voltage.**

OK or NG

- OK >> GO TO 7.  
 NG >> GO TO 6.

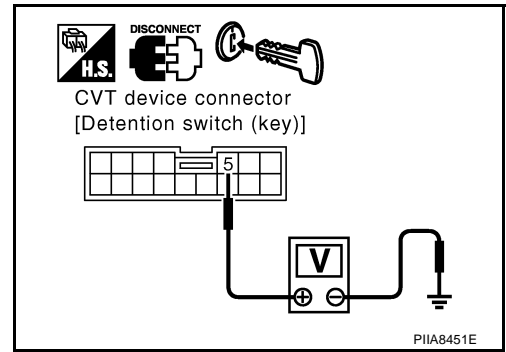

## 6. CHECK CVT DEVICE HARNESS

1. Key is removed from ignition key cylinder.
2. Disconnect key switch and key lock solenoid connector.
3. Check continuity between CVT device connector M57 terminal 5 (B/R) and key switch and key lock solenoid (key switch) connector M28 terminal 4 (B/R).

**5 (B/R) - 4 (B/R) : Continuity should exist.**

4. Check continuity between CVT device connector M57 terminal 5 (B/R) and ground.

**5 (B/R) - Ground : Continuity should not exist.**

OK or NG

- OK >> Check the condition the harness and connector.  
 NG >> Repair or replace harness between key switch and key lock solenoid and CVT device connector.

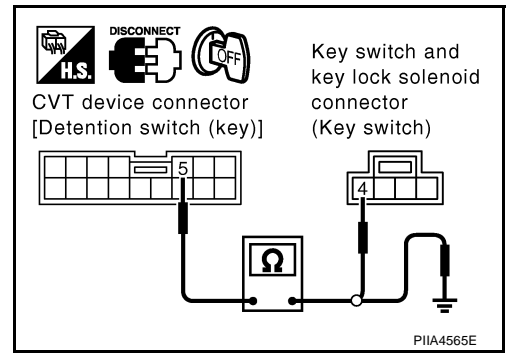

## 7. CHECK CVT DEVICE

Check continuity between CVT device as follows.

Terminals		Condition	Continuity
5	6	P-position.	Continuity should not exist.
		Other than P-position.	Continuity should exist.

OK or NG

- OK >> GO TO 8.  
 NG >> Replace CVT device.

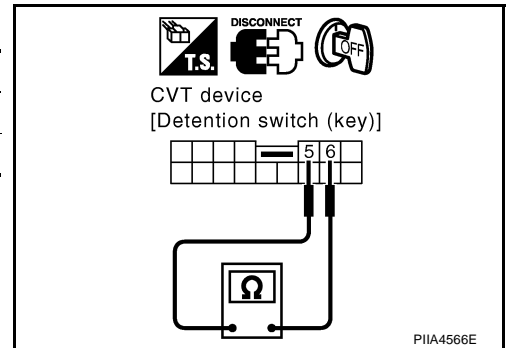

# ADJUSTABLE PEDAL SYSTEM

## 8. CHECK PEDAL ADJUSTING CONTROL UNIT HARNESS

1. Disconnect pedal adjusting control unit connector.
2. Connect key switch and key lock solenoid connector.
3. Check voltage between CVT device connector M57 terminal 6 (L) and pedal adjusting control unit connector M88 terminal 3 (L).

**6 (L) - 3 (L) : Continuity should exist.**

4. Check voltage between CVT device connector M57 terminal 6 (L) and ground.

**6 (L) - Ground : Continuity should not exist.**

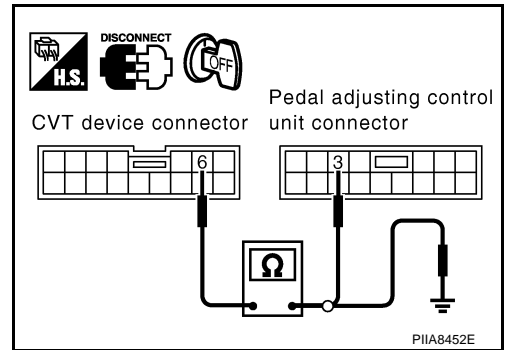

OK or NG

OK >> Check the condition of the harness and connector.

NG >> Repair or replace harness between CVT device and pedal adjusting control unit.

A  
B  
C  
D  
E  
F  
G  
H  
AP  
J  
K  
L  
M

# ADJUSTABLE PEDAL SYSTEM

## PEDAL ADJUSTING SWITCH POWER SUPPLY AND GROUND INSPECTION

### 1. CHECK PEDAL ADJUSTING SWITCH POWER SUPPLY

1. Turn ignition switch OFF.
2. Disconnect pedal adjusting switch connector.
3. Check voltage between pedal adjusting switch connector B306 terminal 64 (GY) and ground.

**64 (GY) - Ground : Battery voltage.**

OK >> GO TO 3.  
NG >> GO TO 2.

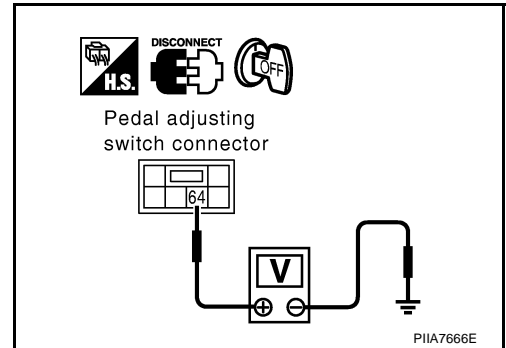

### 2. CHECK PEDAL ADJUSTING SWITCH HARNESS

1. Disconnect pedal adjusting control unit connector.
2. Check continuity between pedal adjusting control unit connector M88 terminal 7 (R) and pedal adjusting switch connector B306 terminal 64 (GY).

**7 (R) - 64 (GY) : Continuity should exist.**

3. Check continuity between pedal adjusting control unit connector M88 terminal 7 (R) and ground.

**7 (R) - Ground : Continuity should not exist.**

OK or NG

OK >> Check the condition of the harness and connector.  
NG >> Repair or replace harness between pedal adjusting control unit and pedal adjusting switch.

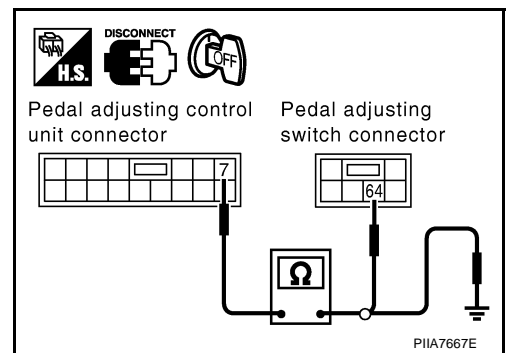

### 3. CHECK PEDAL ADJUSTING SWITCH GROUND CIRCUIT INSPECTION

Check continuity pedal adjusting switch connector B306 terminal 48C (B) and ground.

**48C (B) - Ground : Continuity should exist.**

OK or NG

OK >> Pedal adjusting switch power supply and ground circuit is OK.  
NG >> Repair or replace the harness between pedal adjusting switch and ground.

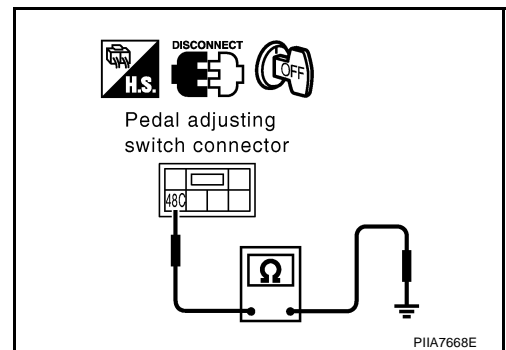

# ADJUSTABLE PEDAL SYSTEM

## PEDAL ADJUSTING MOTOR CIRCUIT INSPECTION

### 1. CHECK PEDAL ADJUSTING SWITCH

1. Turn ignition switch OFF.
2. Disconnect pedal adjusting switch connector.
3. Check continuity between pedal adjusting switch as follows.

Terminals	Condition	Continuity	
30	64	pedal adjusting switch forward.	Continuity should exist.
		pedal adjusting switch neutral.	Continuity should not exist.
	48C	pedal adjusting switch backward.	Continuity should exist.
		pedal adjusting switch neutral.	Continuity should not exist
15	64	pedal adjusting switch backward.	Continuity should exist.
		pedal adjusting switch neutral.	Continuity should not exist.
	48C	pedal adjusting switch forward.	Continuity should exist.
		pedal adjusting switch neutral.	Continuity should not exist.

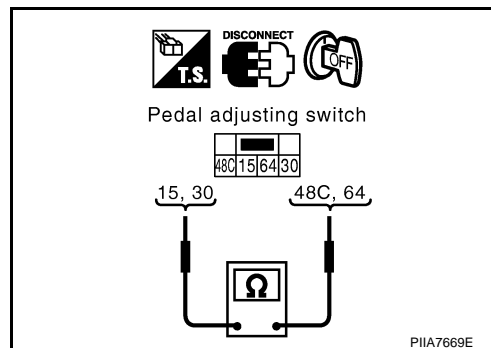

OK or NG

- OK >> GO TO 2.  
 NG >> Replace pedal adjusting switch.

### 2. CHECK PEDAL ADJUSTING MOTOR HARNESS

1. Disconnect pedal adjusting motor connector.
2. Check continuity between pedal adjusting switch connector B306 terminal 15 (G/W), 30 (L/W) and pedal adjusting motor connector E113 terminal 1 (L/Y), 2 (L/R).

**15 (G/W) - 1 (L/Y) : Continuity should exist.**

**30 (L/W) - 2 (L/R) : Continuity should exist.**

3. Check continuity between pedal adjusting switch connector B306 terminal 15 (G/W), 30 (L/W) and ground.

**15 (G/W) - Ground : Continuity should not exist.**

**30 (L/W) - Ground : Continuity should not exist.**

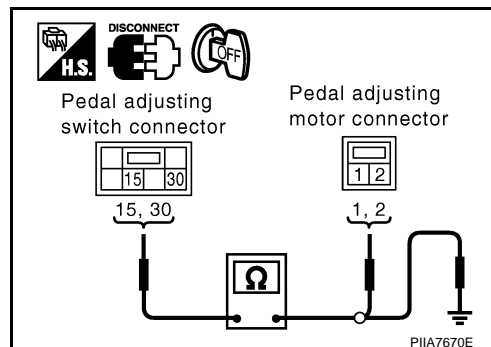

OK or NG

- OK >> Pedal adjusting motor circuit is OK.  
 NG >> Repair or replace harness between pedal adjusting switch and pedal adjusting motor.

# ADJUSTABLE PEDAL SYSTEM

## CVT DEVICE CIRCUIT INSPECTION

### 1. CHECK CVT DEVICE

1. Turn ignition switch OFF.
2. Disconnect CVT device connector.
3. Check continuity between CVT device as follows.

Terminals		Condition	Continuity
5	6	P-position.	Continuity should not exist.
		Other than P-position.	Continuity should exist.

#### OK or NG

- OK >> GO TO 2.  
 NG >> Replace CVT device.

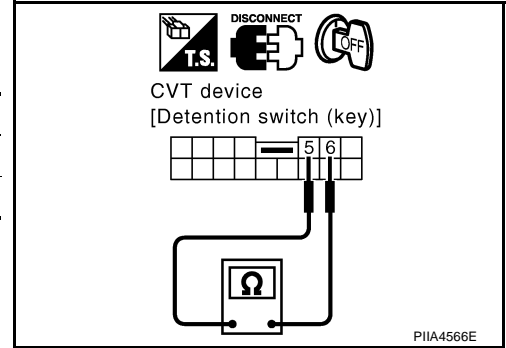

### 2. CHECK PEDAL ADJUSTING CONTROL UNIT HARNESS

1. Disconnect pedal adjusting control unit connector.
2. Connect key switch connector and key lock solenoid connector.
3. Check voltage between CVT device connector M57 terminal 6 (L) and ground.

**6 (L) - Ground : Continuity should not exist.**

#### OK or NG

- OK >> Replace pedal adjusting control unit.  
 NG >> Repair or replace harness between CVT device and pedal adjusting control unit.

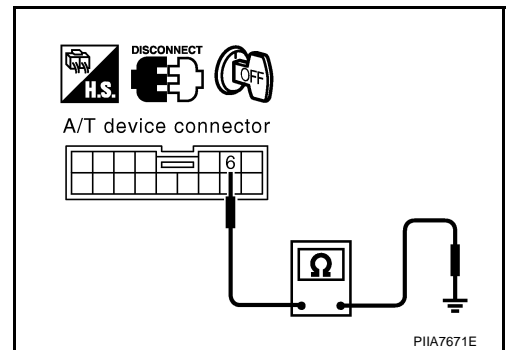

## Removal and Installation

Refer to [BR-8, "Removal and Installation"](#) .

AIS004VZ