

SECTION **FAX**
FRONT AXLE

A
B
C

FAX

CONTENTS

E

PRECAUTIONS	2	INSTALLATION	8	F
Caution	2	Removal and Installation (Right Side)	9	
PREPARATION	3	COMPONENTS	9	
Special Service Tools (SST)	3	REMOVAL	9	G
Commercial Service Tools	3	INSPECTION AFTER REMOVAL	10	
NOISE, VIBRATION AND HARSHNESS (NVH)		INSTALLATION	10	
TROUBLESHOOTING	4	Disassembly and Assembly (Left Side)	11	H
NVH Troubleshooting Chart	4	COMPONENTS	11	
FRONT WHEEL HUB AND KNUCKLE	5	DISASSEMBLY	11	
On-Vehicle Inspection	5	INSPECTION AFTER DISASSEMBLY	12	I
WHEEL BEARING INSPECTION	5	ASSEMBLY	13	
Removal and Installation	5	Disassembly and Assembly (Right Side)	16	
COMPONENTS	5	COMPONENTS	16	J
REMOVAL	5	DISASSEMBLY	16	
INSPECTION AFTER REMOVAL	6	INSPECTION AFTER DISASSEMBLY	18	
INSTALLATION	6	ASSEMBLY	19	
FRONT DRIVE SHAFT	7	SERVICE DATA AND SPECIFICATIONS (SDS)	22	K
Removal and Installation (Left Side)	7	Wheel Bearing	22	
COMPONENTS	7	Drive Shaft	22	L
REMOVAL	7	Dynamic Damper	22	
INSPECTION AFTER REMOVAL	8			M

PRECAUTIONS

PRECAUTIONS

PFP:00001

Caution

NDS0008P

Observe the following precautions when disassembling and servicing drive shaft.

- Perform work in a location which is as dust-free as possible.
- Before disassembling and servicing, clean the outside of parts.
- Prevention of the entry of foreign objects must be taken into account during disassembly of the service location.
- Disassembled parts must be carefully reassembled in the correct order. If work is interrupted, a clean cover must be placed over parts.
- Paper shop cloths must be used. Fabric shop cloths must not be used because of the danger of lint adhering to parts.
- Disassembled parts (except for rubber parts) should be cleaned with kerosene which shall be removed by blowing with air or wiping with paper shop cloths.

PREPARATION

PREPARATION

PPF:00002

Special Service Tools (SST)

NDS0008Q

The actual shapes of Kent-Moore tools may differ from those of special service tools illustrated here.

Tool number (Kent-Moore No.) Tool name	Description
HT72520000 (J-25730-A) Ball joint remover a: 33 mm (1.30 in) b: 50 mm (1.97 in) r: 11.5 mm (0.453 in)	Removing steering outer socket
KV40107500 (-) Drive shaft attachment	Removing drive shaft

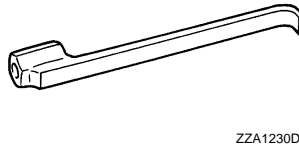
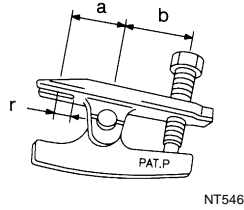

Commercial Service Tools

NDS0008R

Tool name	Description
Power tool	Loosening bolts and nuts

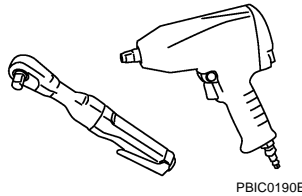

A
B
C
FAX
E
F
G
H
I
J
K
L
M

NOISE, VIBRATION AND HARSHNESS (NVH) TROUBLESHOOTING

NOISE, VIBRATION AND HARSHNESS (NVH) TROUBLESHOOTING

PFP:00003

NVH Troubleshooting Chart

NDS0008S

Use chart below to help you find the cause of the symptom. If necessary, repair or replace these parts.

Symptom			Possible cause and SUSPECTED PARTS										Reference page			
			Excessive joint angle	Joint sliding resistance	Imbalance	Improper installation, looseness	Parts interference	FRONT AXLE AND FRONT SUSPENSION	FRONT AXLE	TIRES	ROAD WHEEL	DRIVE SHAFT	BRAKES	STEERING		
DRIVE SHAFT	Noise	x	x				x	x	x	x			x	x	—	FAX-12, FAX-18
	Shake	x		x			x	x	x	x			x	x	—	FAX-5
FRONT AXLE	Noise				x	x	x		x	x	x		x	x	—	
	Shake				x	x	x		x	x	x		x	x	—	
	Vibration				x	x	x		x		x				—	
	Shimmy				x	x	x		x	x			x	x	—	
	Judder				x		x		x	x			x	x	—	
	Poor quality ride or handling				x	x	x		x	x					—	
															—	

x: Applicable

FRONT WHEEL HUB AND KNUCKLE

FRONT WHEEL HUB AND KNUCKLE

PFP:40202

On-Vehicle Inspection

NDS0008T

Make sure the mounting conditions (looseness, back lash) of each component and component status (wear, damage) are normal.

WHEEL BEARING INSPECTION

- Move wheel hub in the axial direction by hand. Make sure there is no looseness of wheel bearing.

Axial end play limit : 0.05 mm (0.002 in) or less

- Rotate wheel hub and make sure there is no unusual noise or other irregular conditions. If there are any irregular conditions, replace wheel hub and bearing assembly.

Removal and Installation COMPONENTS

NDS0008U

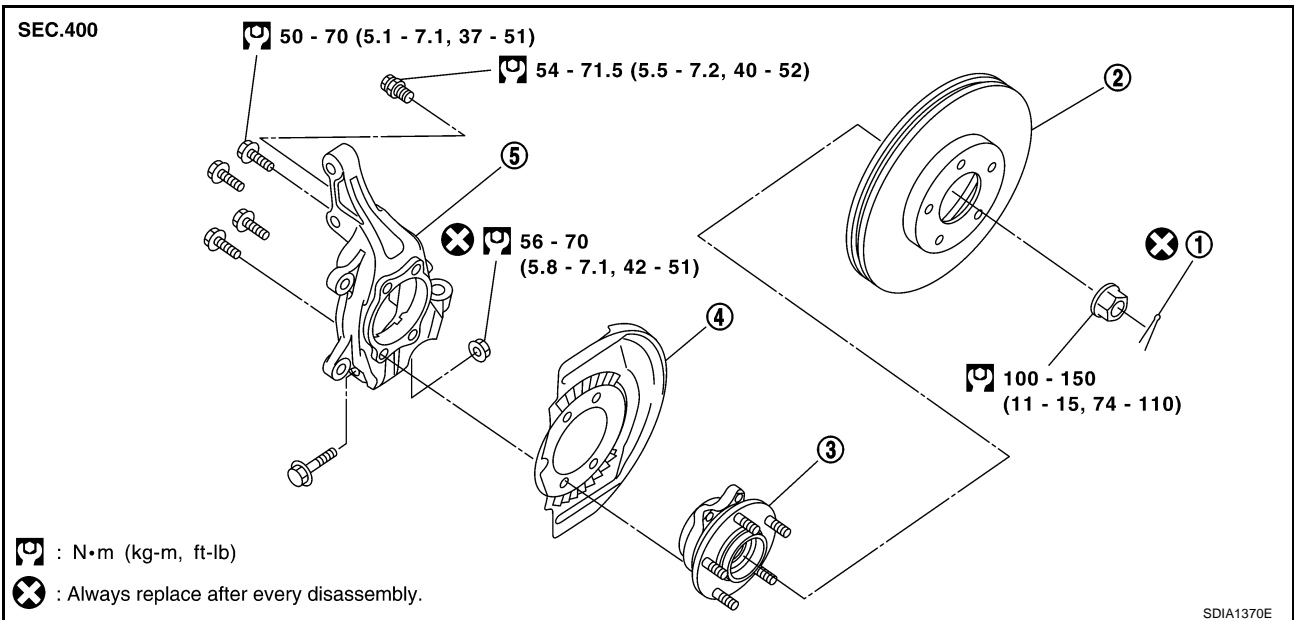

1. Cotter pin
2. Disc rotor
3. Wheel hub and bearing assembly
4. Splash guard
5. Steering knuckle

REMOVAL

1. Remove tire from vehicle with power tool.
2. Remove brake caliper with power tool. Hang it in a place where it will not interfere with work. Refer to [BR-27, "Removal and Installation of Brake Caliper Assembly"](#).

NOTE:

Avoid depressing brake pedal while brake caliper is removed.

3. Put alignment marks on disc rotor and wheel hub and bearing assembly, then remove disc rotor.
4. Remove wheel sensor from steering knuckle. Refer to [BRC-43, "WHEEL SENSORS"](#)

CAUTION:

Do not pull on wheel sensor harness.

5. Remove cotter pin, then remove lock nut from drive shaft.
6. Remove steering outer socket and cotter pin at steering knuckle, then loosen mounting nut.

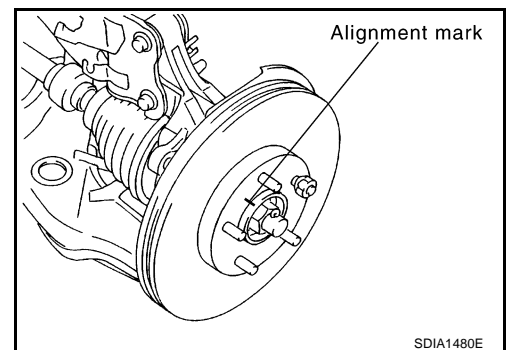

FRONT WHEEL HUB AND KNUCKLE

- Use a ball joint remover (SST) to remove steering outer socket from steering knuckle. Be careful not to damage ball joint boot.

CAUTION:

To prevent damage to threads and to prevent ball joint remover (SST) from coming off suddenly, temporarily tighten mounting nut.

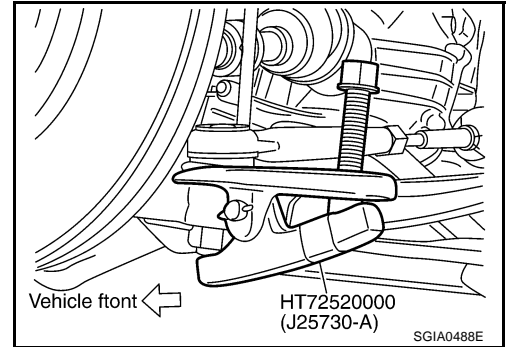

- Using a puller (suitable tool), remove wheel hub and bearing assembly from drive shaft.

NOTE:

- When removing wheel hub and bearing assembly, do not apply an excessive angle to drive shaft joint. Also be careful not to excessively extend slide joint.
 - Do not hang over drive shaft with out support.
- Remove wheel hub and bearing assembly fixing bolt.
 - Remove splash guard and wheel hub and bearing assembly from steering knuckle.
 - Remove strut assembly and steering knuckle fixing bolts and nuts.
 - Remove transverse link and steering knuckle fixing bolt and nut.
 - Remove steering knuckle from vehicle.

INSPECTION AFTER REMOVAL

Check for deformity, cracks and damage on each parts, replace if necessary.

Ball Joint Inspection

- Check for boot breakage, axial looseness, and torque of transverse link ball joint. Refer to [FSU-12, "INSPECTION AFTER REMOVAL"](#).

INSTALLATION

CAUTION:

Be sure to replace the new differential side oil seal every removal of drive shaft. Refer to [CVT-223, "DIFFERENTIAL SIDE OIL SEAL"](#).

- Refer to [FAX-5, "Removal and Installation"](#) for tightening torque. Install in the reverse order of removal.

NOTE:

Refer to component parts location and do not reuse non-reusable parts.

- To assemble disc rotor and wheel hub and bearing assembly, align the marks.
(When not using the alignment mark, refer to [BR-30, "DISC ROTOR INSPECTION"](#).)

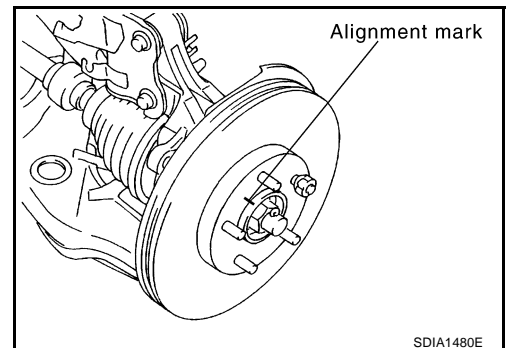

FRONT DRIVE SHAFT

FRONT DRIVE SHAFT

PFP:39100

Removal and Installation (Left Side) COMPONENTS

NDS0008V

SEC. 391

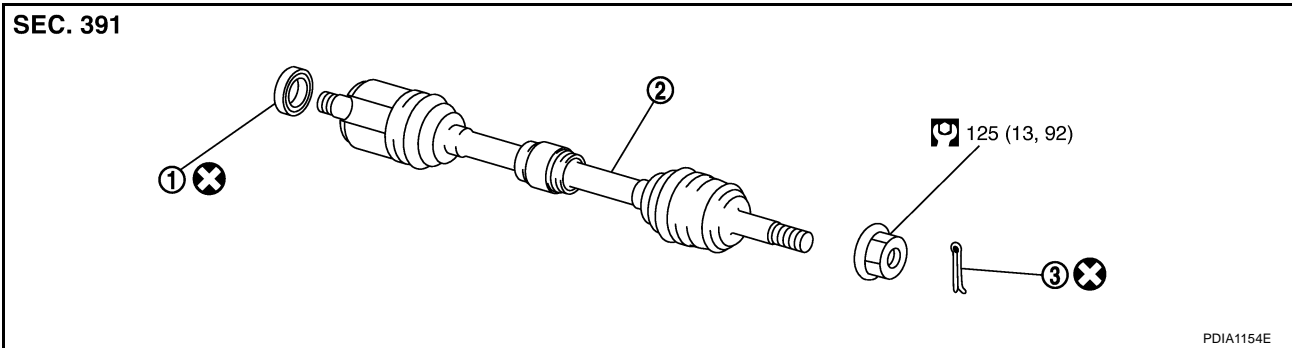

1. Dust shield

2. Drive shaft

3. Cotter pin

Refer to [GI-10, "Components"](#), for the symbols in the figure.

REMOVAL

1. Remove tire with power tool.
2. Remove wheel sensor from steering knuckle. Refer to [BRC-43, "WHEEL SENSORS"](#).
3. Remove cotter pin. Then remove lock nut from drive shaft.
4. Remove brake hose rock plate. Then remove brake hose from strut assembly.
5. Remove strut assembly and steering knuckle fixing bolt and nut. Refer to [FAX-5, "Removal and Installation"](#).
6. Using a puller (suitable tool), remove drive shaft from steering knuckle.

CAUTION:

When removing drive shaft, do not apply an excessive angle to drive shaft joint. Also be careful not to excessively extend slide joint.

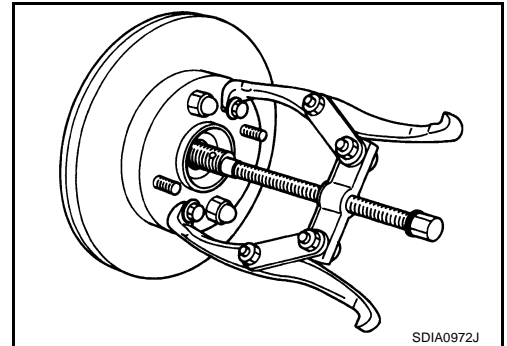

7. Remove drive shaft from transaxle.
 - Set an drive shaft attachment (SST) and a drive shaft puller (suitable tool) between drive shaft (slide joint side) and rear final drive as shown in the figure and remove drive shaft.

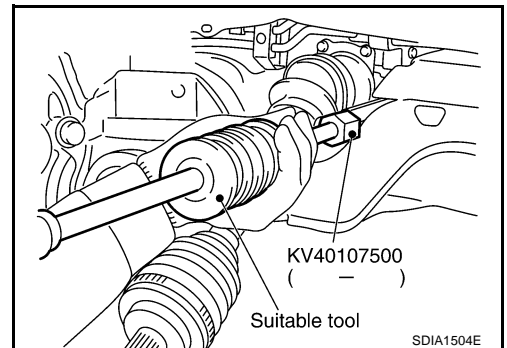

FRONT DRIVE SHAFT

INSPECTION AFTER REMOVAL

- Move joint up/down, left /right, and in axial direction. Check for any rough movement or significant looseness.
- Check boot for cracks or other damage, and also for grease leakage.
- If a trouble is found, disassemble drive shaft, and then replace with new one.

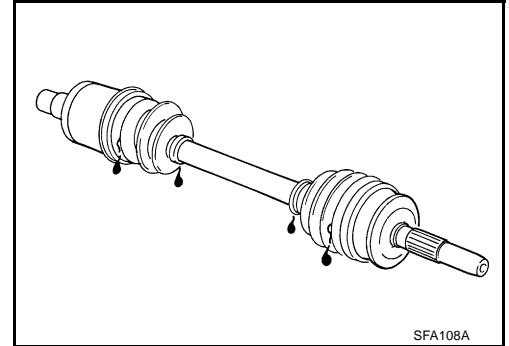

INSTALLATION

CAUTION:

Be sure to replace the new differential side oil seal every removal of drive shaft. Refer to [CVT-223, "DIFFERENTIAL SIDE OIL SEAL"](#) .

- Refer to [FAX-7, "Removal and Installation \(Left Side\)"](#) for tightening torque. Install in the reverse order of removal.

CAUTION:

Refer to component parts location and do not reuse non-reusable parts.

- In order to prevent damage to transaxle side oil seal, first fit a protector (suitable tool) onto oil seal before inserting drive shaft. Slide drive shaft into slide joint and tap with a hammer to install securely.

CAUTION:

Be sure to make sure circular clip is securely fastened.

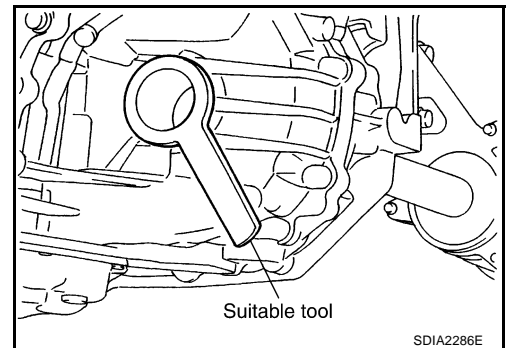

FRONT DRIVE SHAFT

Removal and Installation (Right Side) COMPONENTS

NDS0008W

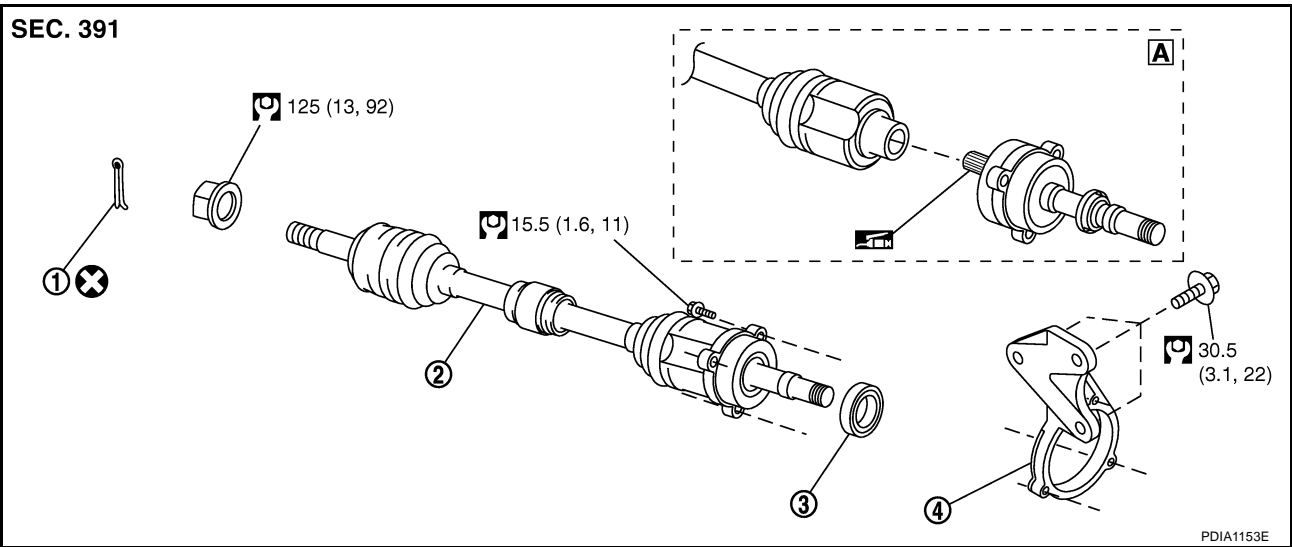

1. Cotter pin
2. Drive shaft
3. Dust shield
4. Support bearing bracket

A: AWD models

Refer to [GI-10. "Components"](#) and the followings for the symbols in the figure.

:Apply NISSAN genuine grease or equivalent.

REMOVAL

2WD Models

1. Remove tire with power tool.
2. Remove wheel sensor from steering knuckle. Refer to [BRC-43. "WHEEL SENSORS"](#) .
3. Remove cotter pin. Then remove lock nut from drive shaft.
4. Remove brake hose lock plate. Then remove brake hose from strut assembly.
5. Remove strut assembly and steering knuckle fixing bolt and nut. Refer to [FAX-5. "FRONT WHEEL HUB AND KNUCKLE"](#) .
6. Using a puller (suitable tool), remove drive shaft from axle.

CAUTION:

When removing drive shaft, do not apply an excessive angle to drive shaft joint. Also be careful not to excessively extend slide joint.

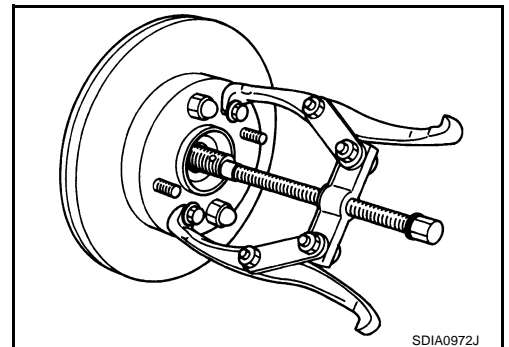

7. Remove support bearing bolts using power tool, and pull drive shaft from transaxle.
 - Pry off drive shaft from transaxle.

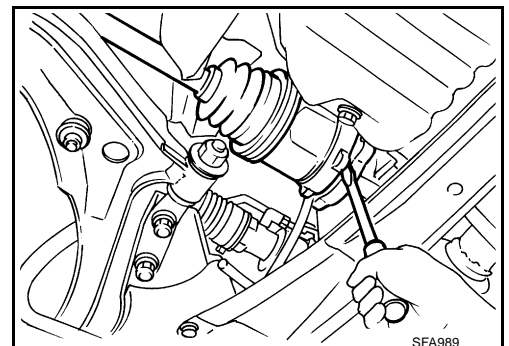

A
B
C
FAX
E
F
G
H
I
J
K
L
M

FRONT DRIVE SHAFT

AWD Models

1. Remove tire with power tool.
2. Remove wheel sensor from steering knuckle. Refer to [BRC-43, "WHEEL SENSORS"](#).
3. Remove brake hose lock plate. Then remove brake hose from strut assembly.
4. Remove cotter pin. Then remove rock nut from drive shaft.
5. Remove strut assembly and steering knuckle fixing bolt and nut. Refer to [FAX-5, "FRONT WHEEL HUB AND KNUCKLE"](#).
6. Using a puller (suitable tool), remove drive shaft from axle.

CAUTION:

When removing drive shaft, do not apply an excessive angle to drive shaft joint. Also be careful not to excessively extend slide joint.

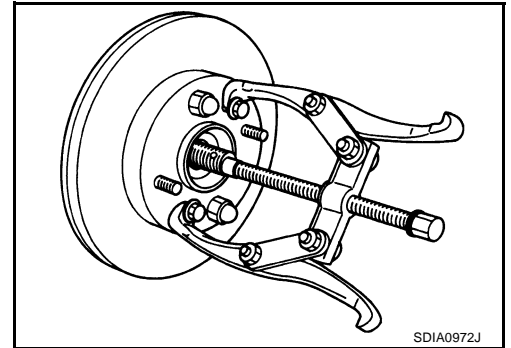

7. Remove drive shaft from transaxle.
 - Set an drive shaft attachment (SST) and a drive shaft puller (suitable tool) between drive shaft (slide joint side) and transaxle as shown in the figure and remove drive shaft.

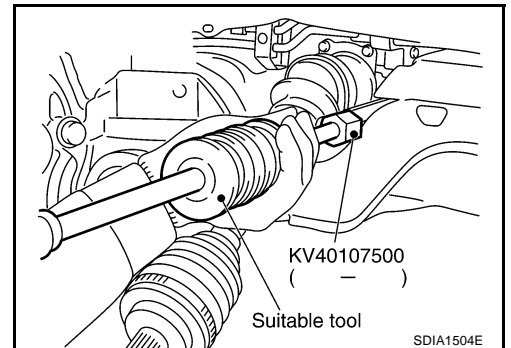

INSPECTION AFTER REMOVAL

- Move joint up/down, left/right, and in axial direction. Check for any rough movement or significant looseness.
- Check boot for cracks or other damage, and also for grease leakage.
- If a trouble is found, disassemble drive shaft, and then replace with new one.

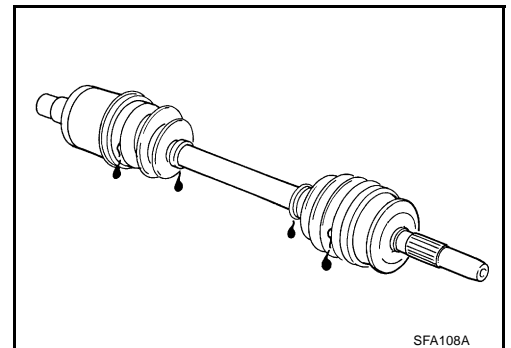

INSTALLATION

- Refer to [RAX-7, "Removal and Installation"](#) for tightening torque. Install in the reverse order of removal.

NOTE:

Refer to component parts location and do not reuse non-reusable parts.

- Push drive shaft, then press-fit circular clip on the drive shaft into circular clip groove of side gear.
- After its insertion, try to pull the flange out of the slide joint by hand. If it pulls out, the circular clip is not properly meshed with the side gear.

FRONT DRIVE SHAFT

Disassembly and Assembly (Left Side) COMPONENTS

NDS0008X

A
B
C
FAX
E
F
G
H
I
J
K
L
M

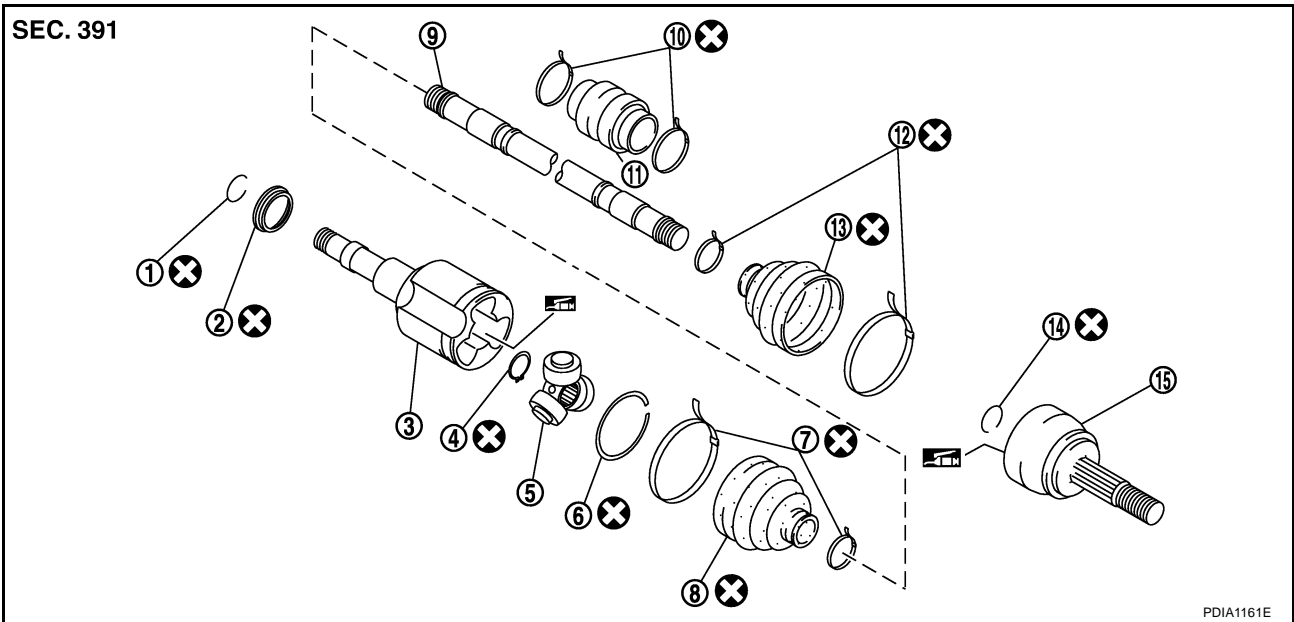

PDIA1161E

- | | | |
|------------------|--------------------|-------------------------|
| 1. Circular clip | 2. Dust shield | 3. Slide joint assembly |
| 4. Snap ring | 5. Spider assembly | 6. Stopper ring |
| 7. Boot band | 8. Boot | 9. Shaft |
| 10. Damper band | 11. Damper | 12. Boot band |
| 13. Boot | 14. Circular clip | 15. Joint sub-assembly |

Refer to [GI-10. "Components"](#) and the followings for the symbols in the figure.

 : Fill NISSAN genuine grease or equivalent.

DISASSEMBLY

Transaxle Side

- Press shaft in a vise.
 - CAUTION:**
When retaining shaft in a vise, always use copper or aluminum plates between vise and shaft.
- Remove boot bands.
- Put matching marks on slide joint assembly and shaft before separating joint assembly.
- Remove stopper ring with a flat-bladed screwdriver, and pull out slide joint housing.

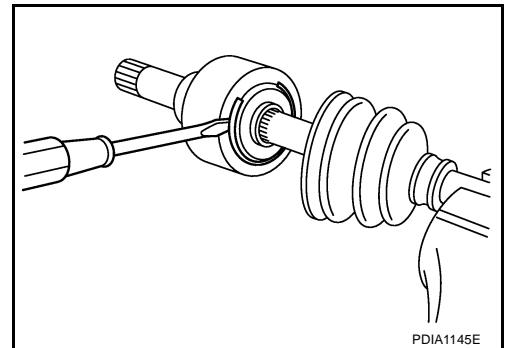

PDIA1145E

FRONT DRIVE SHAFT

5. Put matching marks on spider assembly and shaft.

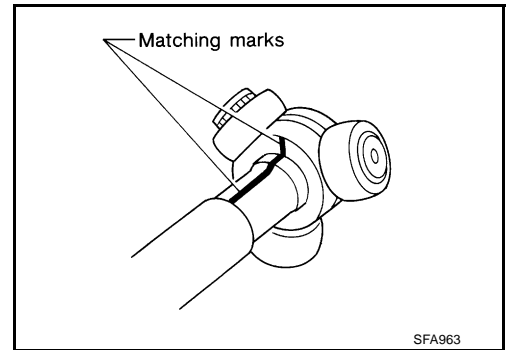

6. Remove snap ring, then remove spider assembly from shaft.
7. Remove boot from shaft.
8. Remove old grease on slide joint assembly with paper towels.

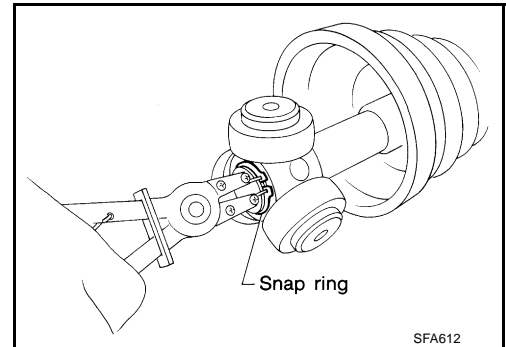

Wheel Side

1. Place shaft in a vise.

CAUTION:

When retaining shaft in a vise, always use copper or aluminum plates between vise and shaft.

2. Remove boot bands. Then remove boot from joint sub-assembly.
3. Screw a drive shaft puller (suitable tool) 30 mm (1.18 in) or more into threaded part of joint sub-assembly. Pull joint sub-assembly out of shaft.

CAUTION:

- If joint sub-assembly cannot be removed after five or more unsuccessful attempts, replace the entire drive shaft assembly.
- Align sliding hammer and drive shaft and remove them by pulling directly.

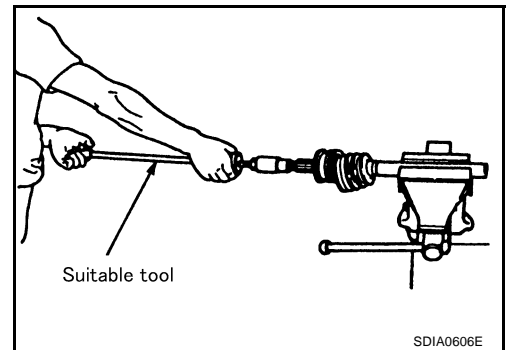

4. Remove boot from shaft.
5. Remove circular clip from shaft.
6. While rotating ball cage, remove old grease on joint sub-assembly with paper towels.

Damper

- Remove damper band, then remove damper from shaft.

INSPECTION AFTER DISASSEMBLY

Shaft

- Replace shaft if there is any runout, cracking, or other damage.

Joint Sub-Assembly

Check the followings, and then replace joint sub-assembly if a malfunction is detected.

- Make sure there is no rough rotation or unusual axial looseness.
- Make sure there is no foreign material inside joint sub-assembly.
- Check joint sub-assembly for compression scars, cracks or fractures.

FRONT DRIVE SHAFT

Slide Joint Side

Housing

- Make sure there are no compression scars, cracks or fractures or unusual wear of ball rolling surface.
- Make sure there is no damage to shaft screws.
- Make sure there is no deformation of boot installation parts.

Damper

- Check damper for cracks or wear. Replace damper with new damper bands.

ASSEMBLY

Transaxle Side

1. Install new boot and new small boot band on shaft.

CAUTION:

Cover drive shaft serration with tape to prevent damages to boot during installation.

2. Remove protective tape wound around serrated part of shaft.

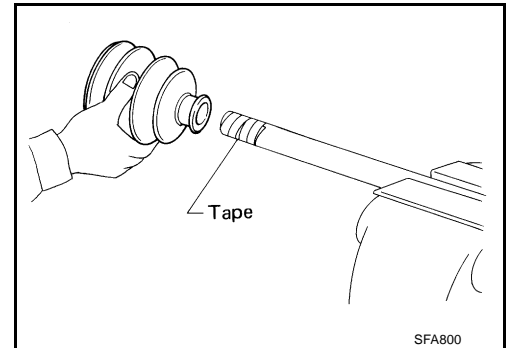

3. Install spider assembly securely, making sure the matching marks which were made during disassembly are properly aligned.

4. Install new snap ring.

5. Pack drive shaft with specified amount of new grease.

Grease amount : 265 – 285 g (9.35 – 10.05 oz)

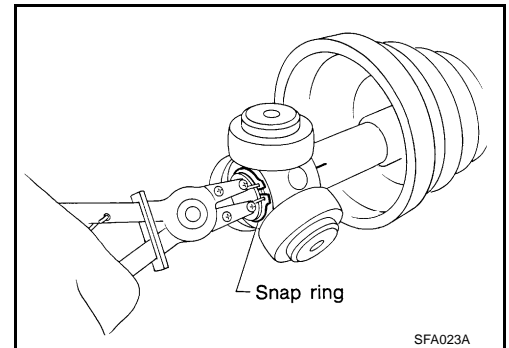

6. Install new stopper ring to housing of slide joint assembly.

7. After installed, pull shaft to check engagement between joint sub-assembly and stopper ring.

8. Install boot securely into grooves (indicated by * marks) shown in the figure.

CAUTION:

If there is grease on boot mounting surfaces (indicated by* marks) of shaft and housing, boot may come off. Remove all grease from surfaces.

9. Make sure boot installation length "L" is the length indicated below. Insert a flat-bladed screwdriver or similar tool into smaller side of boot. Bleed air from boot to prevent boot deformation.

Boot installation length "L" : 172.1 mm (6.78 in)

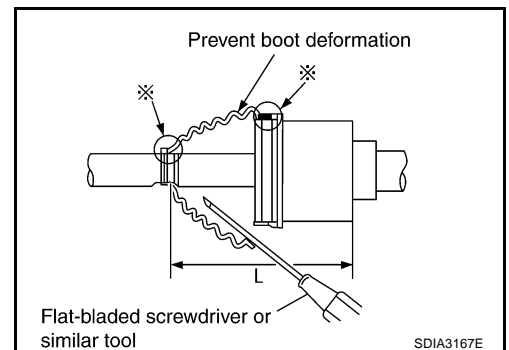

CAUTION:

- Boot may break if boot installation length is less than standard value.
- Take care not to touch the tip of screwdriver to inside of boot.

FRONT DRIVE SHAFT

- Secure big and small ends of boot with new boot bands as shown in the figure.

CAUTION:

Discard old boot band; replace with new ones.

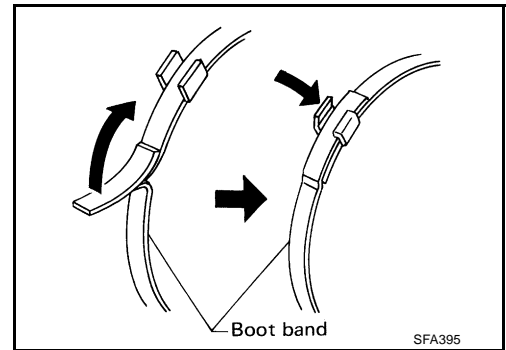

- After installing housing and shaft, rotate boot to check whether or not the actual position is correct. If boot position is not correct, secure boot with new boot bands again.

Wheel Side

- Insert the amount of grease (NISSAN genuine grease or equivalent) into joint sub-assembly serration hole until grease begins to ooze from ball groove and serration hole. After inserting grease, use a shop cloth to wipe off old grease that has oozed out.

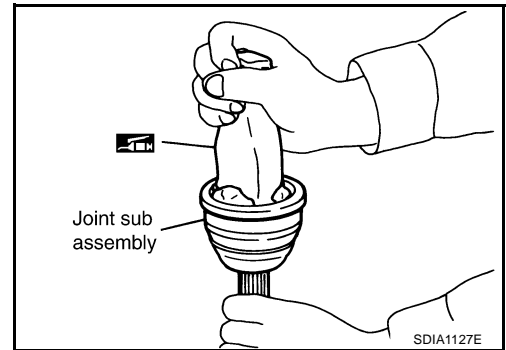

- Wind serrated part of shaft with tape. Install new boot band and boot to shaft. Be careful not to damage boot.

CAUTION:

Discard old boot band and boot; replace with new one.

- Remove protective tape wound around serrated part of shaft.

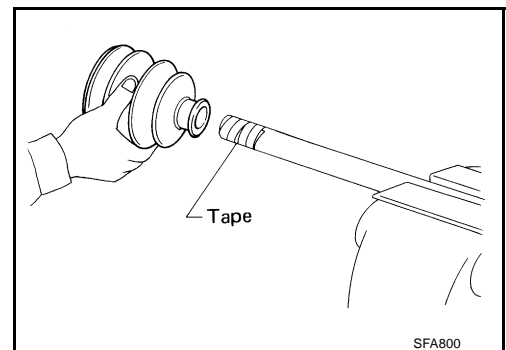

- Attach new circular clip to shaft. At this time, circular clip must fit securely into shaft groove. Attach nut to joint sub-assembly. Use a wooden hammer to press-fit.

CAUTION:

Discard old circular clip; replace with new one.

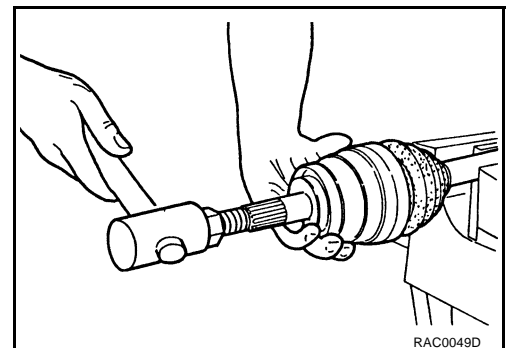

- Insert the amount of new grease (NISSAN genuine grease or equivalent) listed below into housing from large end of boot.

Grease amount : 145 – 165 g (5.11 – 5.82 oz)

FRONT DRIVE SHAFT

6. Install boot securely into grooves (indicated by * marks) shown in the figure.

CAUTION:

If there is grease on boot mounting surfaces (indicated by* marks) of shaft and housing, boot may come off. Remove all grease from surfaces.

7. Make sure boot installation length “L” is the length indicated below. Insert a flat-bladed screwdriver or similar tool into smaller side of boot. Bleed air from boot to prevent boot deformation.

Boot installation length “L” : 170.3 mm (6.70 in)

CAUTION:

- Boot may brake if boot installation length is less than standard value.
- Be careful that screwdriver tip does not contact inside surface of boot.

8. Install new larger and smaller boot bands securely with a suitable tool.

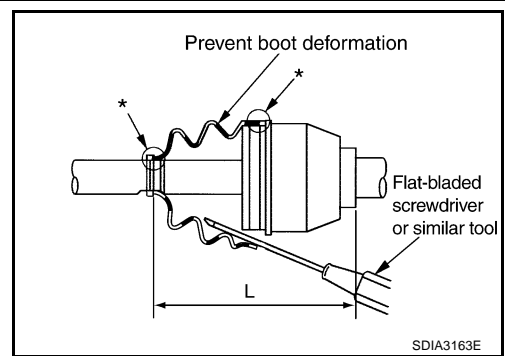

A
B
C

FAX

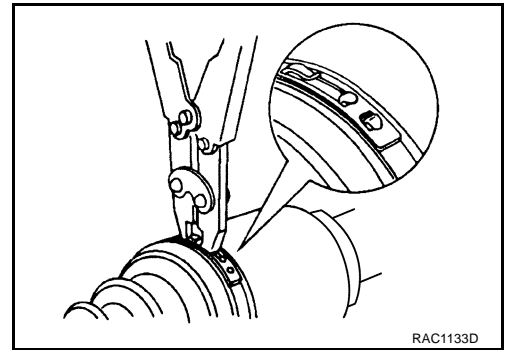

E
F
G
H

CAUTION:

- Secure boot band so that dimension “M” shown in the figure satisfies the following:

Dimension “M” : 1.0 – 4.0 mm (0.039 – 0.157 in)

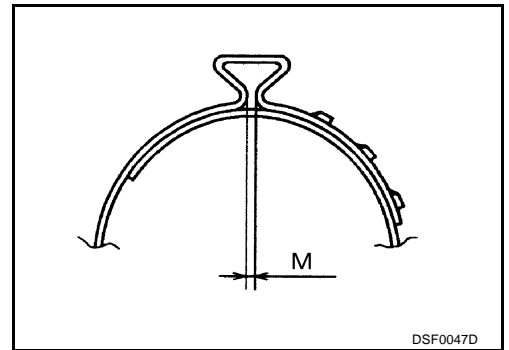

I
J
K
L

9. After installing housing and shaft, rotate boot to check whether or not the actual position is correct. If boot position is not correct, secure boot with new boot bands again.

M

Damper

1. Use new damper bands when installing.
2. Install damper from stationary-joint side while holding it securely.

“A” : 207 – 213 mm (8.15 – 8.39 in)

“B” : 70 mm (2.76 in)

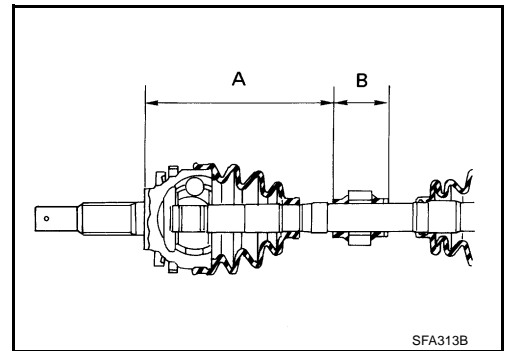

FRONT DRIVE SHAFT

NDS0008Y

Disassembly and Assembly (Right Side) COMPONENTS

SEC. 396

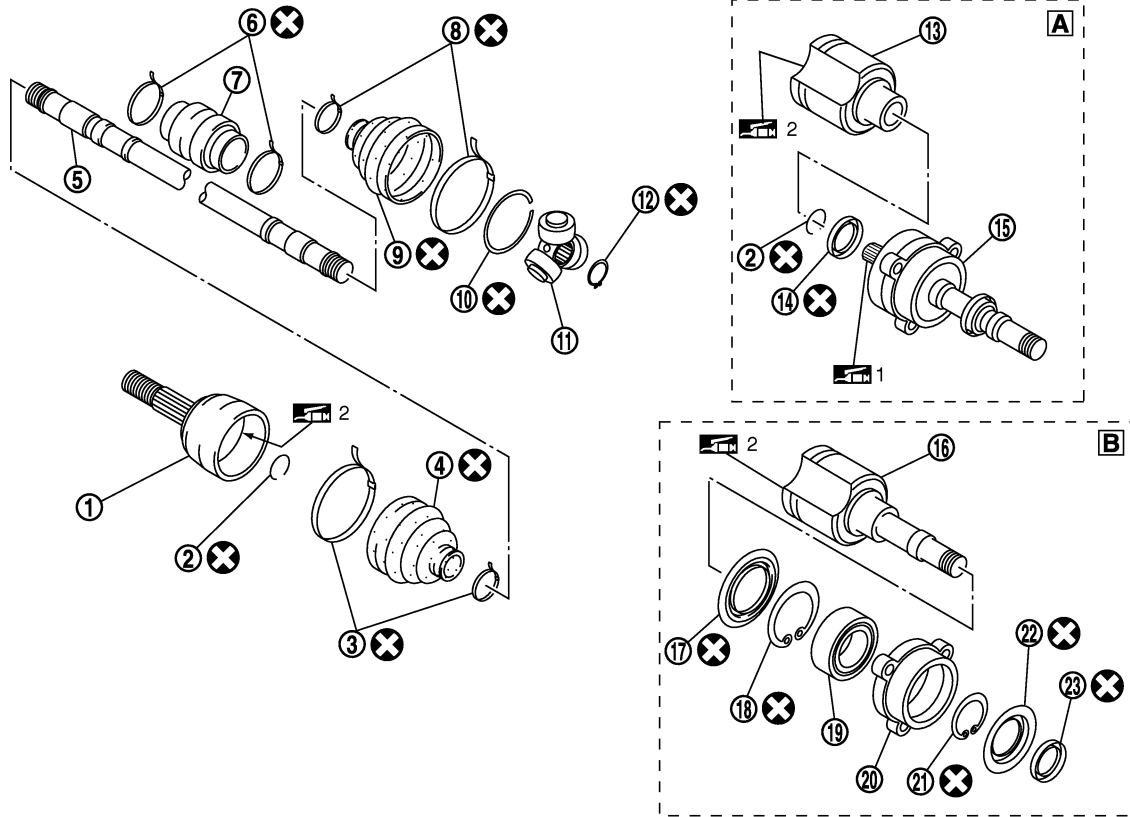

PDIA1162E

- | | | |
|--------------------------|---------------------|----------------|
| 1. Joint sub-assembly | 2. Circular clip | 3. Boot band |
| 4. Boot | 5. Shaft | 6. Damper band |
| 7. Damper | 8. Boot band | 9. Boot |
| 10. Stopper ring | 11. Spider assembly | 12. Snap ring |
| 13. Slide joint assembly | 14. Dust shield | 15. Side shaft |
| 16. Slide joint assembly | 17. Dust shield | 18. Snap ring |
| 19. Bearing | 20. Bracket | 21. Snap ring |
| 22. Dust shield | 23. Dust shield | |

A: AWD models

B: 2WD models

Refer to [GI-10, "Components"](#) and the followings for the symbols in the figure.

1: Apply MOLYLEX CS NO.1 or equivalent.

2: Fill NISSAN genuine grease or equivalent.

DISASSEMBLY

Transaxle Side

1. Press shaft in a vise.

CAUTION:

When retaining shaft in a vise, always use copper or aluminum plates between vise and shaft.

2. Remove boot bands.
3. Put matching marks on slide joint assembly and shaft before separating slide joint assembly.

FRONT DRIVE SHAFT

4. Remove stopper ring with a flat-bladed screwdriver, and pull out side joint assembly.

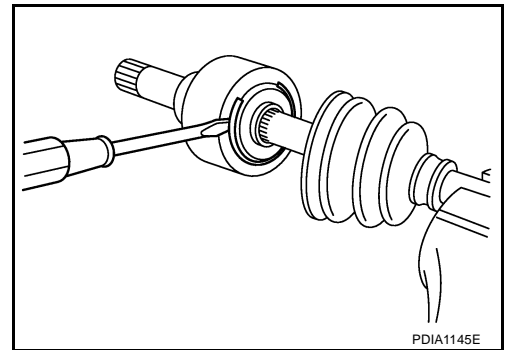

5. Put matching marks on spider assembly and shaft.

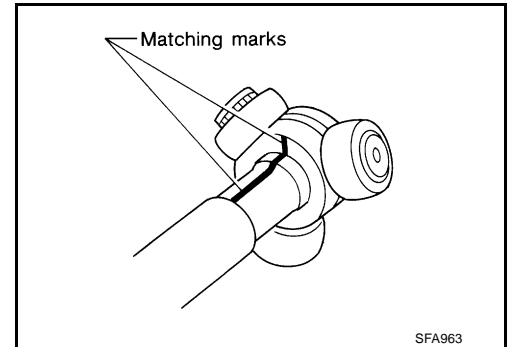

6. Remove snap ring, then remove spider assembly from shaft.
7. Remove boot from shaft.
8. Remove old grease on slide joint assembly with paper towels.

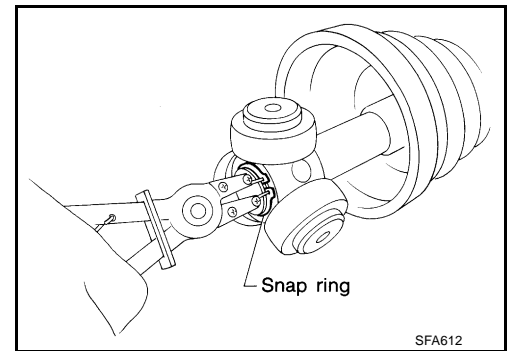

Wheel Side

1. Place shaft in a vise.

CAUTION:

When retaining shaft in a vise, always use copper or aluminum plates between vise and shaft.

2. Remove boot bands. Then remove boot from joint sub-assembly.
3. Screw a drive shaft puller (suitable tool) 30 mm (1.18 in) or more into threaded part of joint sub-assembly. Pull joint sub-assembly out of shaft.

CAUTION:

- If joint sub-assembly cannot be removed after five or more unsuccessful attempts, replace the entire drive shaft assembly.
- Align sliding hammer and drive shaft and remove them by pulling directly.

4. Remove boot from shaft.
5. Remove circular clip from shaft.
6. While rotating ball cage, remove old grease on joint sub-assembly with paper towels.

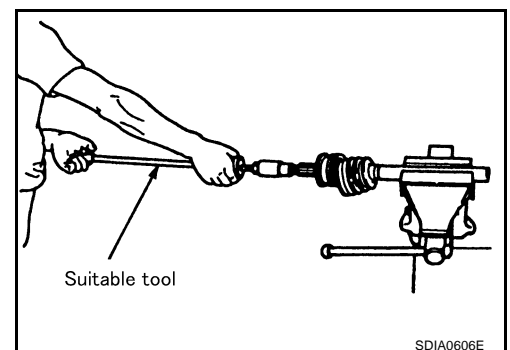

A
B
C

FAX

E
F
G

H
I
J

K
L
M

FRONT DRIVE SHAFT

Support Bearing (2WD Models)

1. Remove dust shield from slide joint assembly.

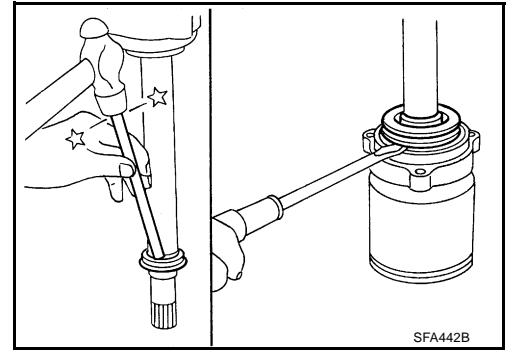

2. Remove snap ring.

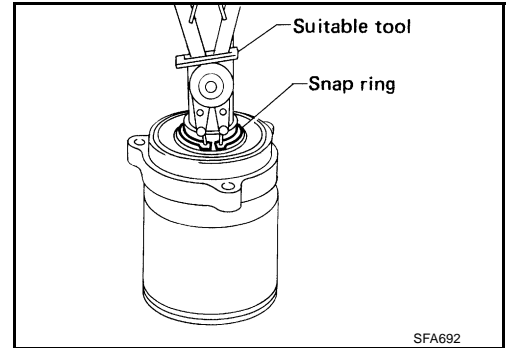

3. Press support bearing assembly off slide joint assembly.

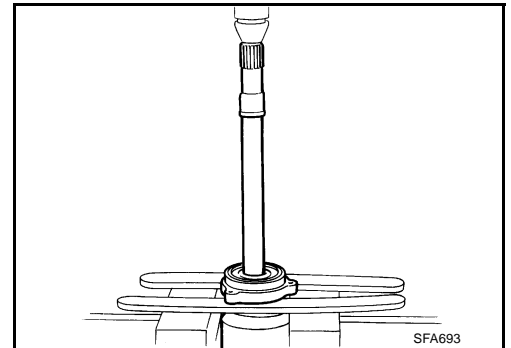

4. Separate support bearing from bracket.

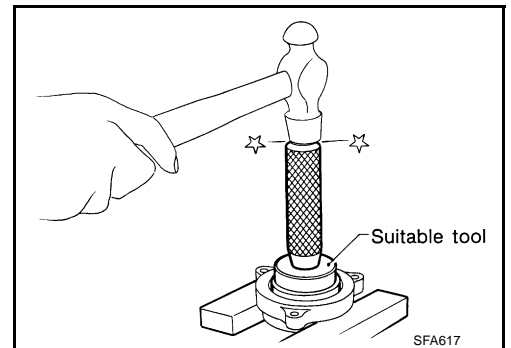

Damper

- Remove damper band, then remove damper from shaft.

INSPECTION AFTER DISASSEMBLY

Shaft

- Replace shaft if there is any runout, cracking, or other damage.

FRONT DRIVE SHAFT

Joint Sub-Assembly

Check the followings, and then replace joint sub-assembly if a malfunction is detected.

- Make sure there is no rough rotation or unusual axial looseness.
- Make sure there is no foreign material inside joint sub-assembly.
- Check joint sub-assembly for compression scars, crack or fractures.

Sliding Joint Side

Housing

- Make sure there are no compression scars, cracks, fractures or unusual wear of ball rolling surface.
- Make sure there is no damage to shaft screws.
- Make sure there is no deformation of boot installation parts.

Support Bearing

- Make sure wheel bearing rolls freely and is free from noise, cracks, pitting or wear.

Damper

- Check damper for cracks or wear. Replace damper with new damper bands.

ASSEMBLY

Transaxle Side

1. Install new boot and new small boot band on shaft.

CAUTION:

Cover shaft serration with tape to prevent damage to boot during installation.

2. Remove protective tape wound around serrated part of shaft.

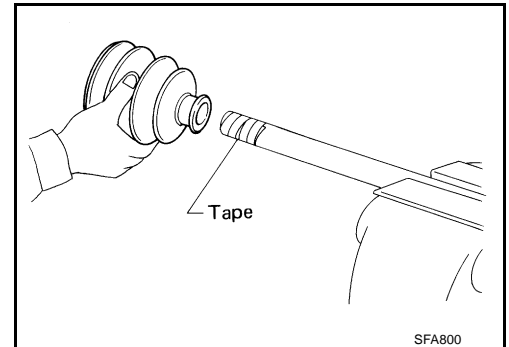

3. Install spider assembly securely, making sure the matching marks which were made during disassembly are properly aligned.

4. Install new snap ring.

5. Pack drive shaft with specified of grease.

Grease amount : 265 – 285 g (9.35 – 10.05 oz)

6. Install new stopper ring to slide joint assembly.

7. After installed, pull shaft to check engagement between joint sub-assembly and stopper ring.

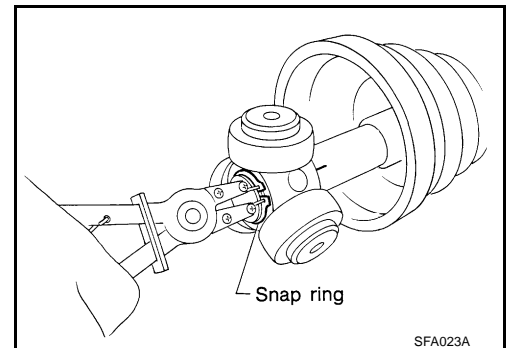

8. Install boot securely into grooves (indicated by * marks) shown in the figure.

CAUTION:

If there is grease on boot mounting surfaces (indicated by * marks) of shaft and housing, boot may come off. Remove all grease from surfaces.

9. Make sure boot installation length "L" is the length indicated below. Insert a flat-bladed screwdriver or similar tool into smaller side of boot. Bleed air from boot to prevent boot deformation.

Boot installation length "L"

2WD models: 172.1 mm (6.78 in)

AWD models: 171.1 mm (6.74 in)

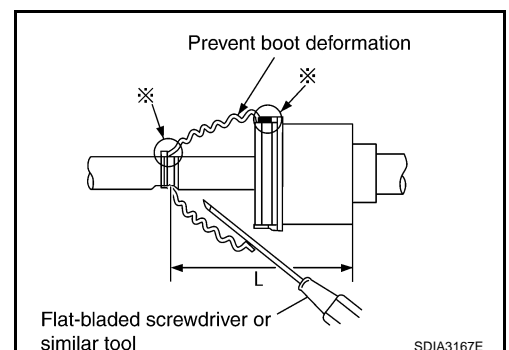

FRONT DRIVE SHAFT

CAUTION:

- Boot may break if boot installation length is less than standard value.
- Take care not to touch the tip of screwdriver to inside of boot.

10. Secure big and small ends of boot with new boot bands as shown in the figure.

CAUTION:

Discard old boot band; replace with new ones.

11. After installing housing and shaft, rotate boot to check whether or not the actual position is correct. If boot position is not correct, secure boot with new boot band again.

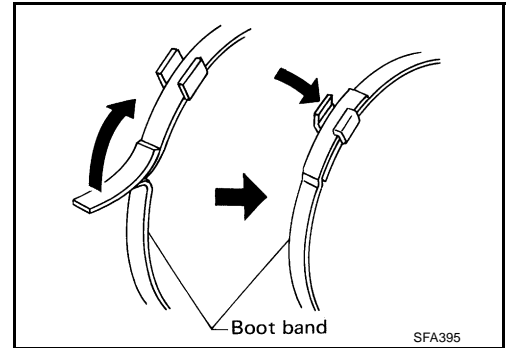

Wheel Side

1. Insert the amount of grease (NISSAN genuine grease or equivalent) into joint sub-assembly serration hole until grease begins to ooze from ball groove and serration hole. After inserting grease, use a shop cloth to wipe off old grease that has oozed out.

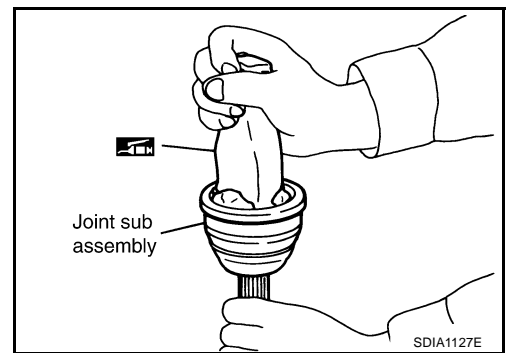

2. Wind serrated part of shaft with tape. Install new boot band and boot to shaft. Be careful not to damage boot.

CAUTION:

Discard old boot band and boot; replace with new ones.

3. Remove protective tape wound around serrated part of shaft.

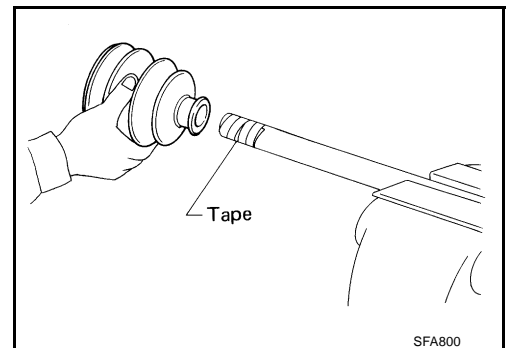

4. Attach new circular clip to shaft. At this time, circular clip must fit securely into shaft groove. Attach nut to joint sub-assembly. Use a wooden hammer to press-fit.

CAUTION:

Discard old circular clip; replace with new ones.

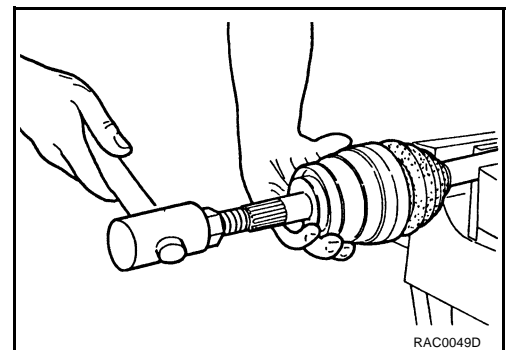

5. Insert the amount of new grease (NISSAN genuine grease or equivalent) listed below into housing from large end of boot.

Grease amount : 145 – 165 g (5.11 – 5.82 oz)

FRONT DRIVE SHAFT

6. Install boot securely into grooves (indicated by * marks) shown in the figure.

CAUTION:

If there is grease on boot mounting surfaces (indicated by* marks) of shaft and housing, boot may come off. Remove all grease from surfaces.

7. Make sure boot installation length “L” is the length indicated below. Insert a flat-bladed screwdriver or similar tool into smaller side of boot. Bleed air from boot to prevent boot deformation.

Boot installation length “L” : 170.3 mm (6.70 in)

CAUTION:

- Boot may brake if boot installation length is than standard value.
- Be careful that screwdriver tip does not contact inside surface of boot.

8. Install new larger and smaller boot bands securely with a suitable tool.

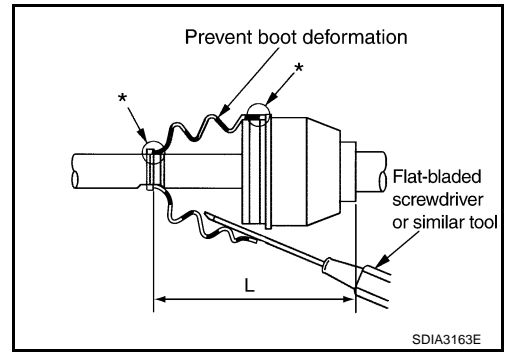

A
B
C

FAX

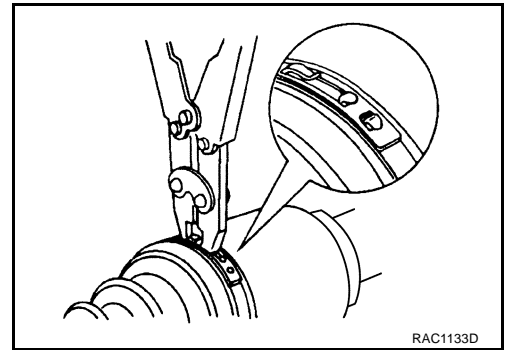

E
F
G
H

CAUTION:

- Secure boot band so that dimension “M” shown at right satisfies the following:

Dimension “M” : 1.0 – 4.0 mm (0.039 – 0.157 in)

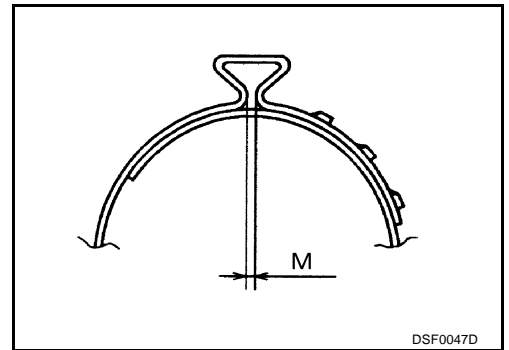

I
J
K
L

9. After installing housing and shaft, rotate boot to check whether or not the actual position is correct. If boot position is not correct, secure boot with new boot bands again.

Damper

1. Use new damper bands when installing.
2. Install damper from stationary-joint side while holding it securely.

“A” : 207 – 213 mm (8.15 – 8.39 in)

“B” : 70 mm (2.76 in)

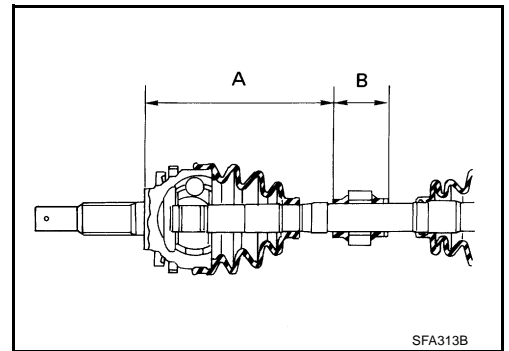

M

SERVICE DATA AND SPECIFICATIONS (SDS)

SERVICE DATA AND SPECIFICATIONS (SDS)

PFP:00030

Wheel Bearing

NDS0008Z

Axial end play limit	0.05 mm (0.002 in) or less
----------------------	----------------------------

Drive Shaft

NDS00090

Joint type	Wheel side	Transaxle side
Grease quantity	145 – 165 g (5.11 – 5.82 oz)	265 – 285 g (9.35 – 10.05 oz)
Boots installed length	170.3 mm (6.70 in)	2WD: 172.1 mm (6.78 in) AWD: 171.1 mm (6.74 in)

Dynamic Damper

NDS0009L

Dimension A	207 – 213 mm (8.15 – 8.39 in)
Dimension B	70 mm (2.76 in)

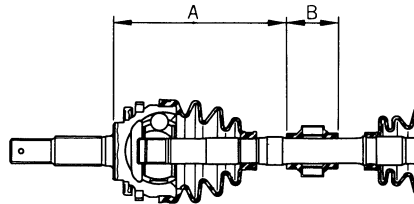

FAC0156D