

SECTION **PB**
PARKING BRAKE SYSTEM

A
B
C
D
E
PB
G
H
I
J
K
L
M

CONTENTS

PARKING BRAKE SYSTEM	2	PARKING BRAKE SHOE	5
On-Vehicle Inspection	2	Components	5
PEDAL STROKE	2	Removal and Installation	6
INSPECT COMPONENTS	2	REMOVAL	6
ADJUSTMENT	2	INSPECTION AFTER REMOVAL	6
PARKING BRAKE CONTROL	3	INSTALLATION	7
Components	3	SERVICE DATA AND SPECIFICATIONS (SDS)	8
Removal and Installation	3	Parking Drum Brake	8
REMOVAL	3	Parking Brake Control	8
INSTALLATION	4		

PARKING BRAKE SYSTEM

PARKING BRAKE SYSTEM

PFP:36010

On-Vehicle Inspection PEDAL STROKE

NFS000ET

- When parking brake pedal is operated with a force of 196 N (20 kg, 44 lb), make sure the stroke is within the specified number of notches. (Check it by listening and counting the ratchet clicks.)

Pedal stroke : 3 to 4 notches

INSPECT COMPONENTS

- Make sure the components are attached properly (check for looseness, backlash, etc.).
- Check parking brake pedal assembly for bend, damage and cracks, and replace if necessary.
- Check cable for wear and damage, and replace if necessary.
- Check parking brake switch for malfunction, and replace if necessary.

ADJUSTMENT

- To perform adjustment operations, remove tire from the vehicle with power tool.

1. Insert a deep socket wrench to rotate adjusting nut and loosen the cable sufficiently. Then, return the pedal to the free height.
2. Using wheel nuts, fix the disc to the hub and prevent it from tilting.

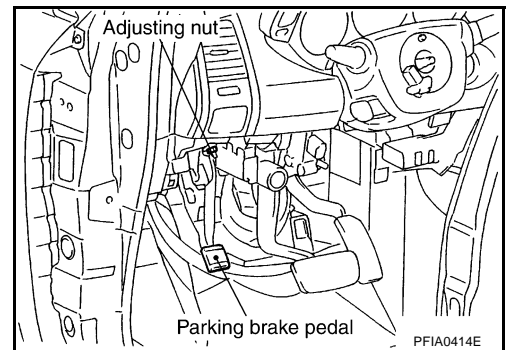

3. Remove adjusting hole plug installed on the disc rotor. Using a screwdriver, turn the adjuster as shown in the figure until the disc rotor is locked. After locking, turn the adjuster in the opposite direction by 5 or 6 notches.
4. Rotate the disc rotor to make sure there is no drag. Install the adjusting hole plug.
5. Adjust cable as follows:
 - a. Operate pedal 10 or more times with a force of 294 N (30 kg, 66 lb).
 - b. Rotate adjusting nut with deep socket to adjust pedal stroke.

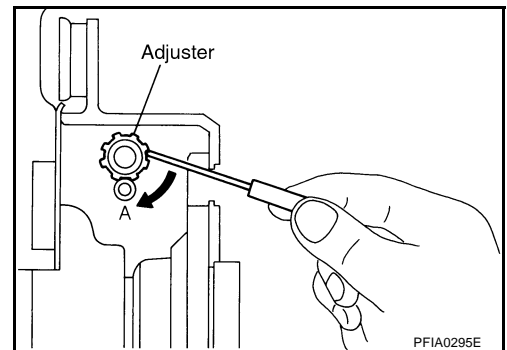

NOTE:

Do not reuse the adjusting nut after removing it.

- c. When parking brake pedal is operated with a force of 196 N (20 kg, 44 lb), make sure the stroke is within the specified number of notches. (Check it by listening and counting the ratchet clicks.)

Pedal stroke : 3 to 4 notches

- d. With the pedal completely returned, make sure there is no drag on the rear brake.

PARKING BRAKE CONTROL

PARKING BRAKE CONTROL

PFP:36010

Components

NFS000EU

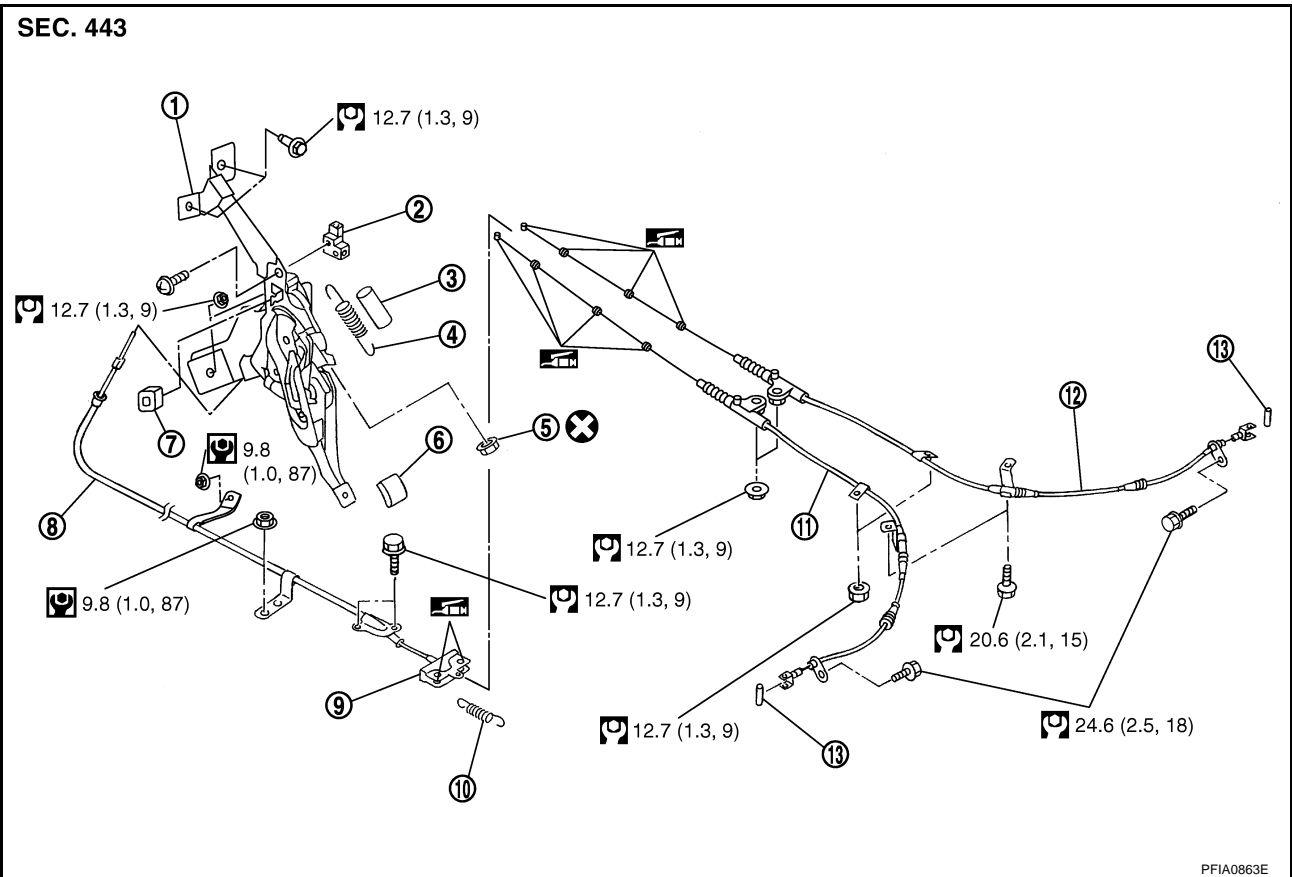

- | | | |
|--------------------|-------------------------|---------------------|
| 1. Device assembly | 2. Parking brake switch | 3. Spring insulator |
| 4. Return spring | 5. Adjusting nut | 6. Pedal cover |
| 7. Stopper rubber | 8. Front cable | 9. Equalizer |
| 10. Return spring | 11. Rear cable (LH) | 12. Rear cable (RH) |
| 13. Pin | | |

Refer to [GI-10, "Components"](#) and the followings for the symbols in the figure.

: Apply multi-purpose grease.

Removal and Installation

REMOVAL

1. Remove front kicking plate (driver side). Refer to [EI-32, "BODY SIDE TRIM"](#) .
2. Remove front body side welt (driver side). Refer to [EI-32, "BODY SIDE TRIM"](#) .
3. Remove lower instrument panel (driver side). Refer to [IP-10, "INSTRUMENT PANEL ASSEMBLY"](#) .
4. Remove dash side finisher (driver side). Refer to [EI-32, "BODY SIDE TRIM"](#) .
5. Remove side ventilator assembly (Left). Refer to [IP-10, "INSTRUMENT PANEL ASSEMBLY"](#) .
6. Remove relay box stay fixing screw.
7. Disconnect parking brake switch connector.
8. Remove adjusting nut.
9. Remove device assembly bolts, nuts and remove device assembly from the vehicle.
10. Remove center console. Refer to [IP-17, "CENTER CONSOLE ASSEMBLY"](#) .
11. Remove front cable mounting bolts, nuts and remove front cable from the vehicle.
12. Remove center muffler. Refer to [EX-3, "EXHAUST SYSTEM"](#) .
13. Remove propeller shaft with AWD model. Refer to [PR-4, "REAR PROPELLER SHAFT"](#) .
14. Remove disc rotors. Refer to [BR-32, "Removal and Installation of Brake Caliper Assembly"](#) .

NFS000EV

PARKING BRAKE CONTROL

15. Remove rear cable from the toggle lever.
16. Remove right and left rear cable mounting nuts, bolts, and remove right and left rear cable assembly from the vehicle.

INSTALLATION

1. Refer to "Component Parts Location" for tightening torque. Install in the reverse order of removal.

NOTE:

Do not reuse the adjusting nut.

2. Adjust the parking brake. Refer to [PB-2, "ADJUSTMENT"](#) .

PARKING BRAKE SHOE

PARKING BRAKE SHOE

PFP:44060

Components

NFS000EW

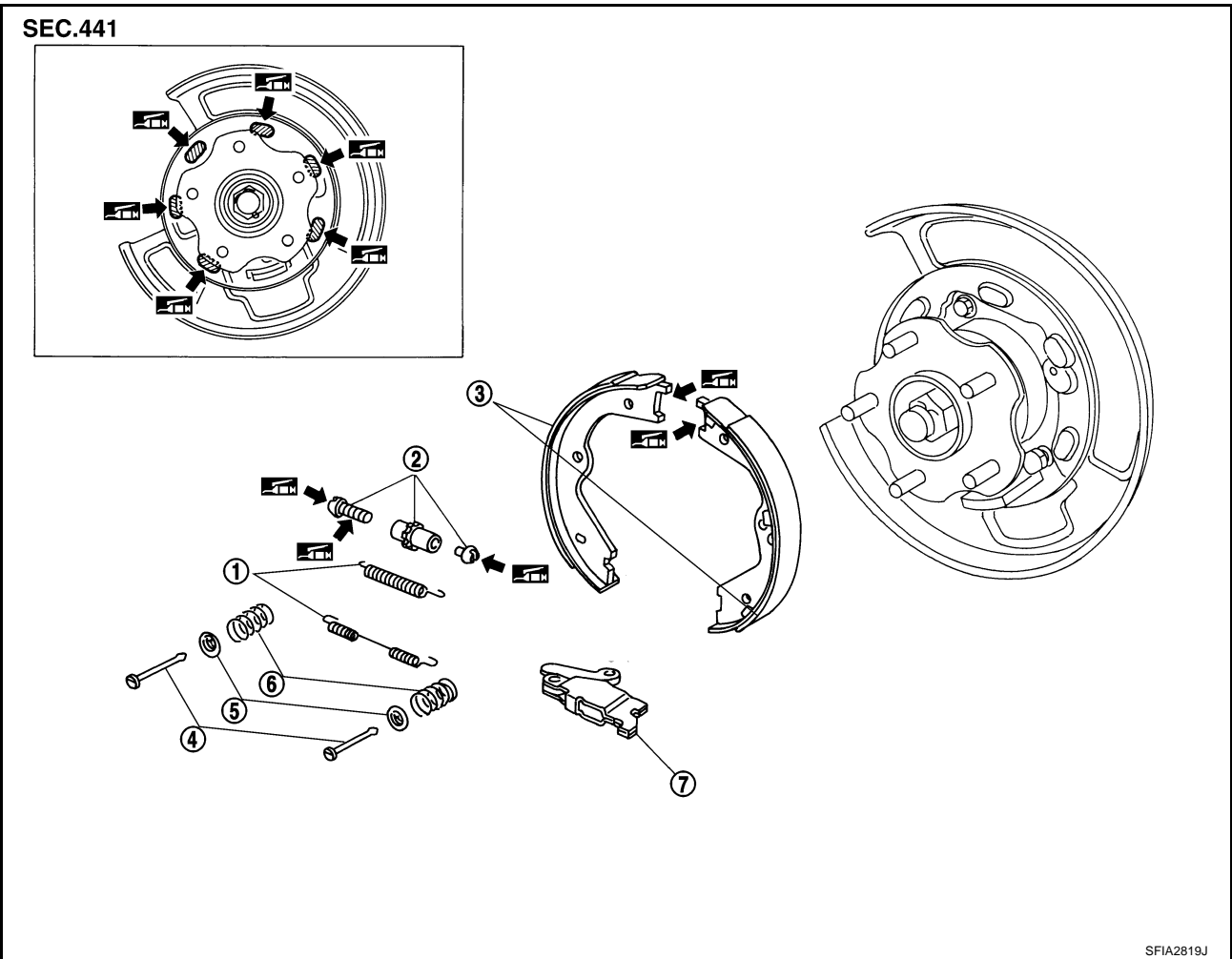

1. Return spring

2. Adjuster assembly

3. Brake shoe

4. Anti-rattle pin

5. Retainer

6. Anti-rattle spring

7. Toggle lever

 : Apply PBC (Poly Butyl Cuprysil) grease or silicone-based grease.

A
B
C
D
E
PB
G
H
I
J
K
L
M

PARKING BRAKE SHOE

NFS000EX

Removal and Installation

REMOVAL

WARNING:

Clean brakes with a vacuum dust collector to minimize the hazard of air borne particles or other materials.

CAUTION:

Clean dust on the disc and back plate with a vacuum dust collector. Do not blow with compressed air.

Be careful of the following:

- Remove the disc rotor only with the parking brake pedal completely in the returned position.
 - If disc rotor cannot be removed, remove as follows.
1. Fix the disc rotor in place with wheel nuts and remove disc rotor plug. Using a flat-bladed screwdriver, rotate adjuster wheel on the adjuster assembly in direction B to retract and loosen brake shoes.

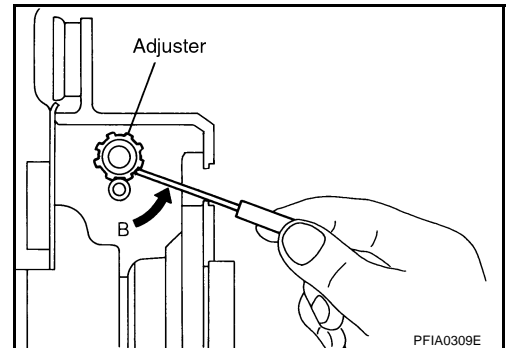

INSPECTION AFTER REMOVAL

Lining Thickness Inspection

- Check thickness of lining.

Standard

Standard thickness (A) : 3.2 mm (0.126 in) dia.

Repair limit thickness (A) : 1.5 mm (0.059 in) dia.

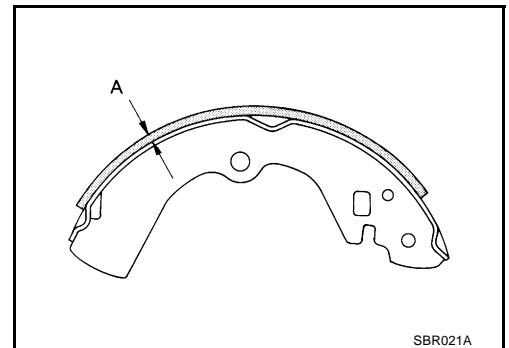

Drum Inner Diameter Inspection

- Check drum inner diameter.

Standard

Standard inner diameter : 190 mm (7.48 in)

Maximum inner diameter : 191 mm (7.52 in)

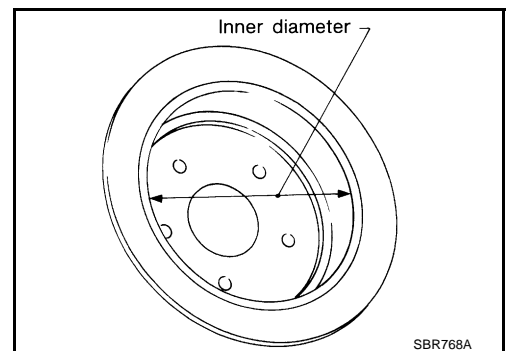

Other Inspections

- Check shoe sliding surface for excessive wear and damage.
- Check anti-rattle pin for excessive wear and corrosion.
- Check return spring for sagging.
- Does the adjuster move smoothly?
- Check either visually or with a vernier caliper to see if there is any excessive wear, cracks, or damage inside the drum.

PARKING BRAKE SHOE

INSTALLATION

Be careful of the following.

- Refer to “Component Parts Location” and apply brake grease to the specified points during assembly.
 - There is difference of the adjusters orientation difference between left and right. Assemble the adjuster so that threaded part expands when rotating it in the direction shown by the arrow.
 - Shorten adjuster by rotating it.
 - When disassembling the adjuster, apply PBC (Poly Butyl Cuprysil) grease or silicone based grease to the threads.
 - After replacing brake shoes or disc rotors, or if brakes do not function well, perform break-in operation as follows.
1. Adjust the parking brake pedal stroke to the specified stroke.
 2. Perform break-in (drag run) operation by driving the vehicle under the following conditions:

Drive forward

- **Vehicle speed approx. 40 km/h (25 MPH) set (forward)**
 - **Parking brake operating force approx. 147 N (15 kg, 33 lb) set**
 - **Distance approx. 100 m (328 ft)**
3. After break-in operation, check lever stroke of the parking brake. Readjust if it is no longer at the specified stroke.
 - To prevent the lining from getting too hot, allow a cool off period of approximately 5 minutes after every break-in operation.
 - Do not perform excessive break-in operations, because it may cause uneven or early wear of the lining.

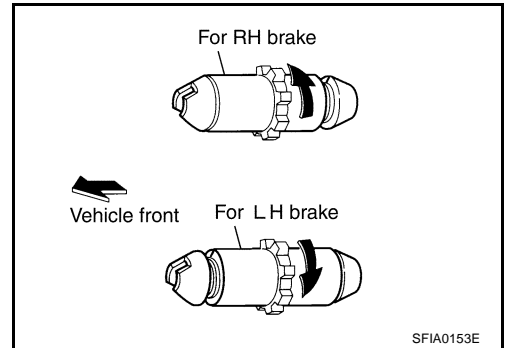

A
B
C
D
E
PB
G
H
I
J
K
L
M

SERVICE DATA AND SPECIFICATIONS (SDS)

SERVICE DATA AND SPECIFICATIONS (SDS)

PFP:00030

Parking Drum Brake

NFS000EY

Brake lining	Standard thickness	3.2 mm (0.126 in)
	Repair limit thickness	1.5 mm (0.059 in)
Drum (disc)	Standard inner diameter	190 mm (7.48 in) dia.
	Maximum inner diameter	191 mm (7.52 in) dia.

Parking Brake Control

NFS000EZ

Control type	Foot pedal type
Number of notches [under a force of 196 N (20 kg, 44 lb)]	3 to 4 notches
Number of notches when parking brake warning lamp comes on	1 notch