

# ENGINE LUBRICATION & COOLING SYSTEMS

## SECTION **LC**

CI  
MA  
EM  
**LC**

EC

FE

CL

MT

AT

TF

PD

FA

RA

BR

ST

RS

BT

HA

EL

IDX



## CONTENTS

<b>PREPARATION/PRECAUTION</b> .....2	Water Pump.....9
Special Service Tools .....2	Thermostat.....10
Liquid Gasket Application Procedure .....3	Radiator .....11
<b>ENGINE LUBRICATION SYSTEM</b> .....4	Cooling Fan (Crankshaft driven) .....12
Lubrication Circuit.....4	Refilling Engine Coolant .....13
Oil Pressure Check.....4	Radiator (Aluminum type).....13
Oil Pump.....5	Overheating Cause Analysis .....17
<b>ENGINE COOLING SYSTEM</b> .....8	<b>SERVICE DATA AND SPECIFICATIONS (SDS)</b> .....18
Cooling Circuit .....8	Engine Lubrication System.....18
System Check.....8	Engine Cooling System .....18

# PREPARATION/PRECAUTION

## Special Service Tools

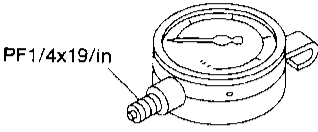
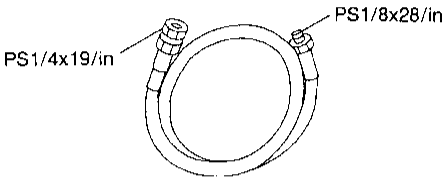
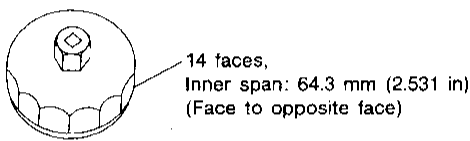
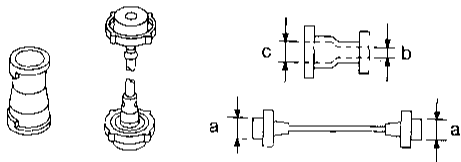
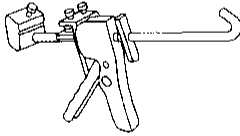
The actual shapes of Kent-Moore tools may differ from those of special service tools illustrated here.

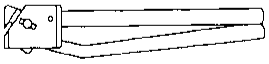
Tool number (Kent-Moore No.) Tool name	Description	
ST25051001 (J25695-1) Oil pressure gauge	 <p>PF1/4x19/in</p>	Measuring oil pressure  <b>Maximum measuring range:</b> <b>2,452 kPa (25 kg/cm<sup>2</sup>, 356 psi)</b>
ST25052000 (J25695-2) Hose	 <p>PS1/4x19/in      PS1/8x28/in</p>	Adapting oil pressure gauge to cylinder block
KV10115801 (J38956) Oil filter wrench	 <p>14 faces, Inner span: 64.3 mm (2.531 in) (Face to opposite face)</p>	Removing oil filter
EG17650301 (J33984-A) Radiator cap tester adapter	 <p>a      b      c</p>	Adapting radiator cap tester to radiator filler neck  <b>a: 28 (1.10) dia.</b> <b>b: 31.4 (1.236) dia.</b> <b>c: 41.3 (1.626) dia.</b> Unit: mm (in)
WS39930000 ( — ) Tube presser		Pressing the tube of liquid gasket
KV99103510 ( — ) Radiator plate pliers A		Installing radiator upper and lower tanks
KV99103520 ( — ) Radiator plate pliers B		Removing radiator upper and lower tanks

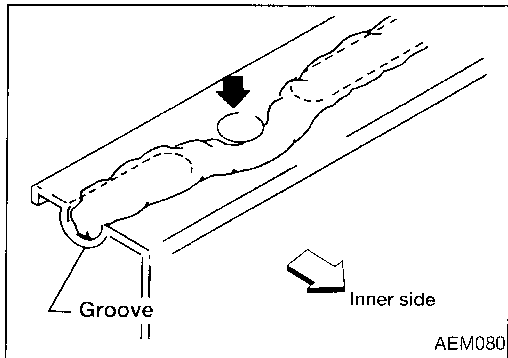
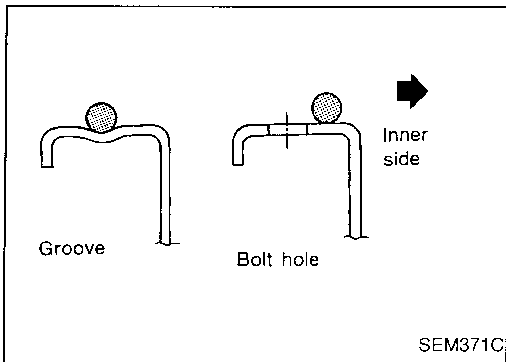

### Liquid Gasket Application Procedure

- a. Use a scraper to remove all traces of old liquid gasket from mating surface and grooves. Also, completely clean any oil from these areas.
- b. Apply a continuous bead of liquid gasket to mating surfaces. (Use Genuine Liquid Gasket or equivalent.)
  - Be sure liquid gasket is 3.5 to 4.5 mm (0.138 to 0.177 in) dia. (for oil pan).
  - Be sure liquid gasket is 2.0 to 3.0 mm (0.079 to 0.118 in) dia. (in areas except oil pan).
- c. Apply liquid gasket around the inner side of bolt holes (unless otherwise specified).
- d. Assembly should be done within 5 minutes after coating.
- e. Wait at least 30 minutes before refilling engine oil and engine coolant.

GI

MA

EM

LC

EC

FE

CL

MT

AT

TF

PD

FA

RA

BR

ST

RS

BT

HA

EL

IDX

## Lubrication Circuit

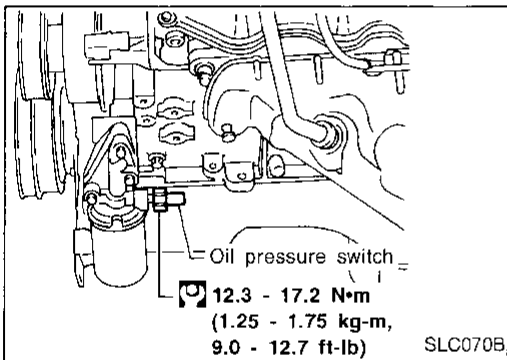
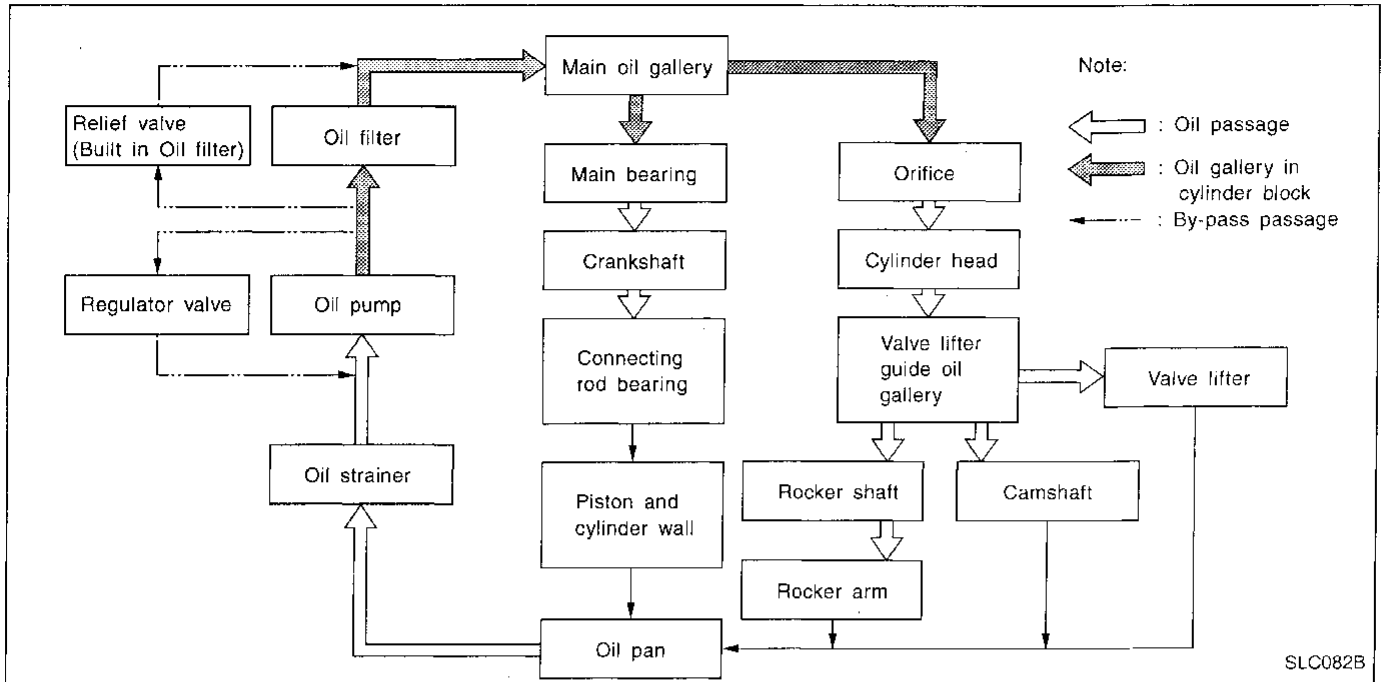

## Oil Pressure Check

### WARNING:

- Be careful not to burn yourself, as the engine and oil may be hot.
- Oil pressure check should be done in "Neutral position" (M/T) or "Parking position" (A/T).

1. Check oil level.
2. Remove oil pressure switch.

3. Install pressure gauge.
4. Start engine and warm it up to normal operating temperature.
5. Check oil pressure with engine running under no-load.

Engine speed rpm	Approximate discharge pressure kPa (kg/cm <sup>2</sup> , psi)
Idle speed	More than 59 (0.6, 9)
2,000	412 - 451 (4.2 - 4.6, 60 - 65)

**If difference is extreme, check oil passage and oil pump for oil leaks.**

6. Install oil pressure switch with sealant.

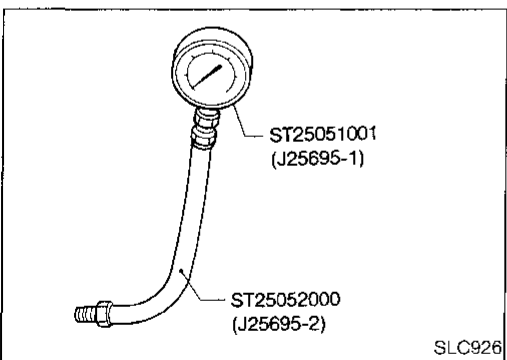

## Oil Pump

### REMOVAL AND INSTALLATION

1. Drain engine oil.
2. Drain engine coolant from drain plug on radiator.
3. Remove air duct (from mass air flow sensor to throttle body).
4. Remove cooling fan.
5. Remove radiator hoses (upper and lower) and fan shroud. Refer to "Radiator".
6. Remove drive belts. Refer to MA section ("Checking Drive Belts").
7. Remove crankshaft pulley and front upper and lower belt covers. Refer to EM section ("TIMING BELT").
8. Remove oil pan. Refer to EM section ("OIL PAN").
9. Remove oil strainer.
10. Remove oil pump assembly.

### DISASSEMBLY AND ASSEMBLY

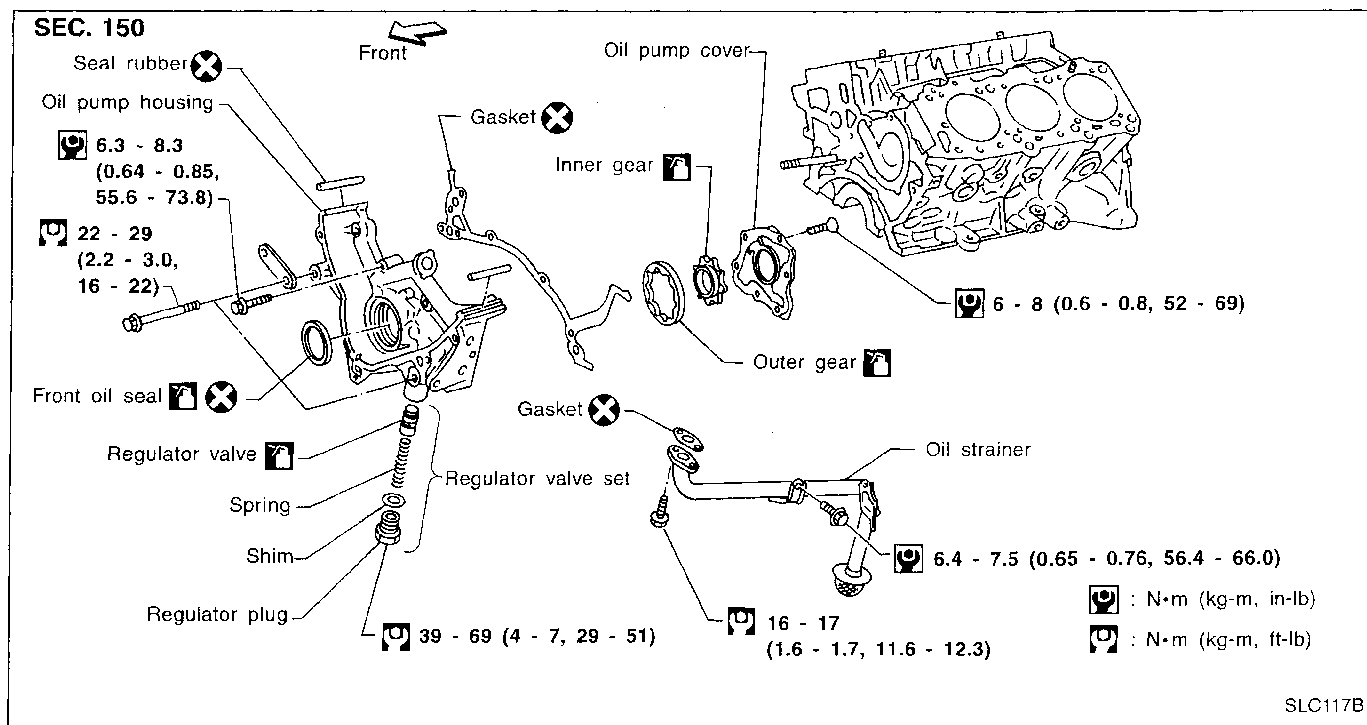

- Always replace with new oil seal and gasket.
- When installing oil pump, apply engine oil to inner and outer gears.
- Be sure that O-ring is properly installed.

# ENGINE LUBRICATION SYSTEM

## Oil Pump (Cont'd)

### INSPECTION

Using a feeler gauge, straightedge and micrometers, check the following clearances:

Unit: mm (in)

Body to outer gear radial clearance ①	0.114 - 0.200 (0.0045 - 0.0079)
Inner gear to outer gear tip clearance ②	Below 0.18 (0.0071)
Body to inner gear axial clearance ③	0.05 - 0.09 (0.0020 - 0.0035)
Body to outer gear axial clearance ④	0.050 - 0.110 (0.0020 - 0.0043)
Inner gear to brazed portion of housing clearance ⑤	0.045 - 0.091 (0.0018 - 0.0036)

- If the tip clearance (②) exceeds the limit, replace gear set.
- If body to gear clearances (①, ③, ④, ⑤) exceed the limit, replace oil pump body assembly.

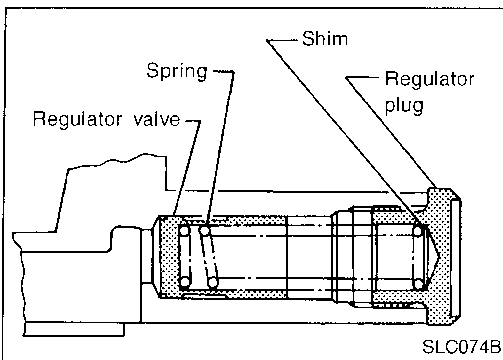
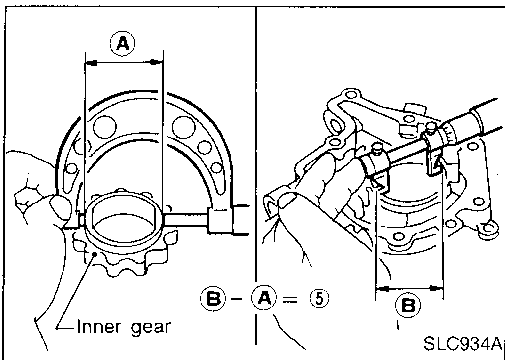
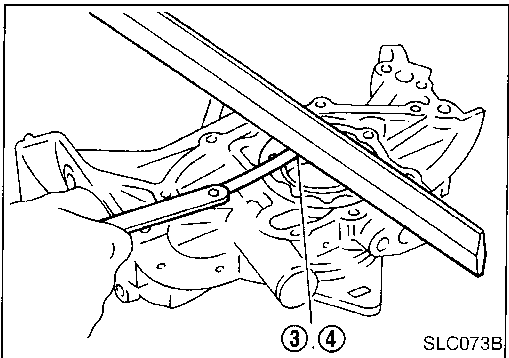
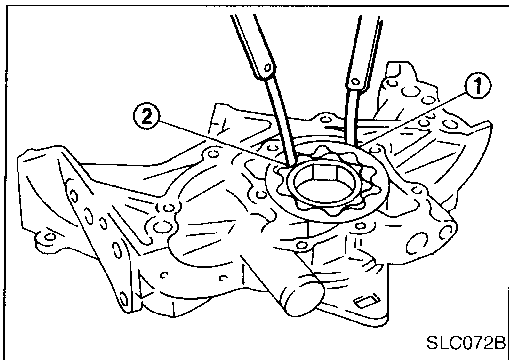

### REGULATOR VALVE INSPECTION

1. Visually inspect components for wear and damage.
2. Check oil pressure regulator valve sliding surface and valve spring.
3. Coat regulator valve with engine oil. Check that it falls smoothly into the valve hole by its own weight.

If damaged, replace regulator valve set or oil pump assembly.

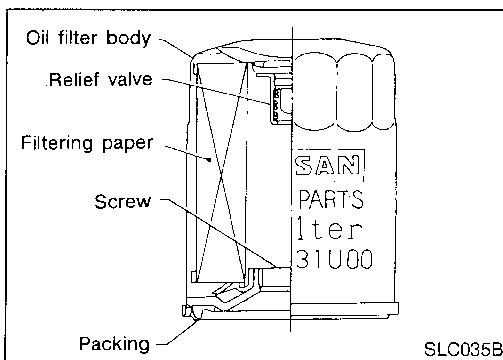

### OIL FILTER

The oil filter is a small, full-flow cartridge type and is provided with a relief valve.

- The new and previous oil filter designs differ from each other and are not interchangeable.
- Use Tool KV10115801 (J38956) for removing oil filter.

# ENGINE LUBRICATION SYSTEM

## Oil Pump (Cont'd)

### OIL FILTER BRACKET

1. Remove oil filter.
2. Disconnect oil pressure switch and connector.
3. Remove oil filter bracket.

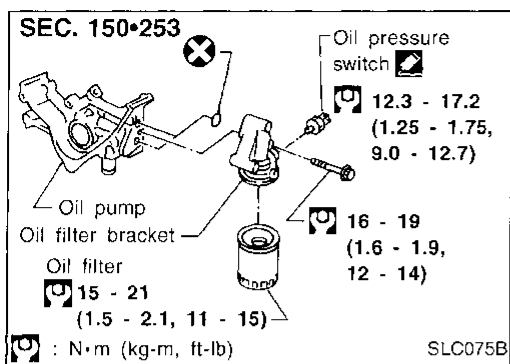

GI

MA

EM

**LC**

EC

FE

CL

MT

AT

TF

PD

FA

RA

BR

ST

RS

BT

HA

EL

IDX

# ENGINE COOLING SYSTEM

## Cooling Circuit

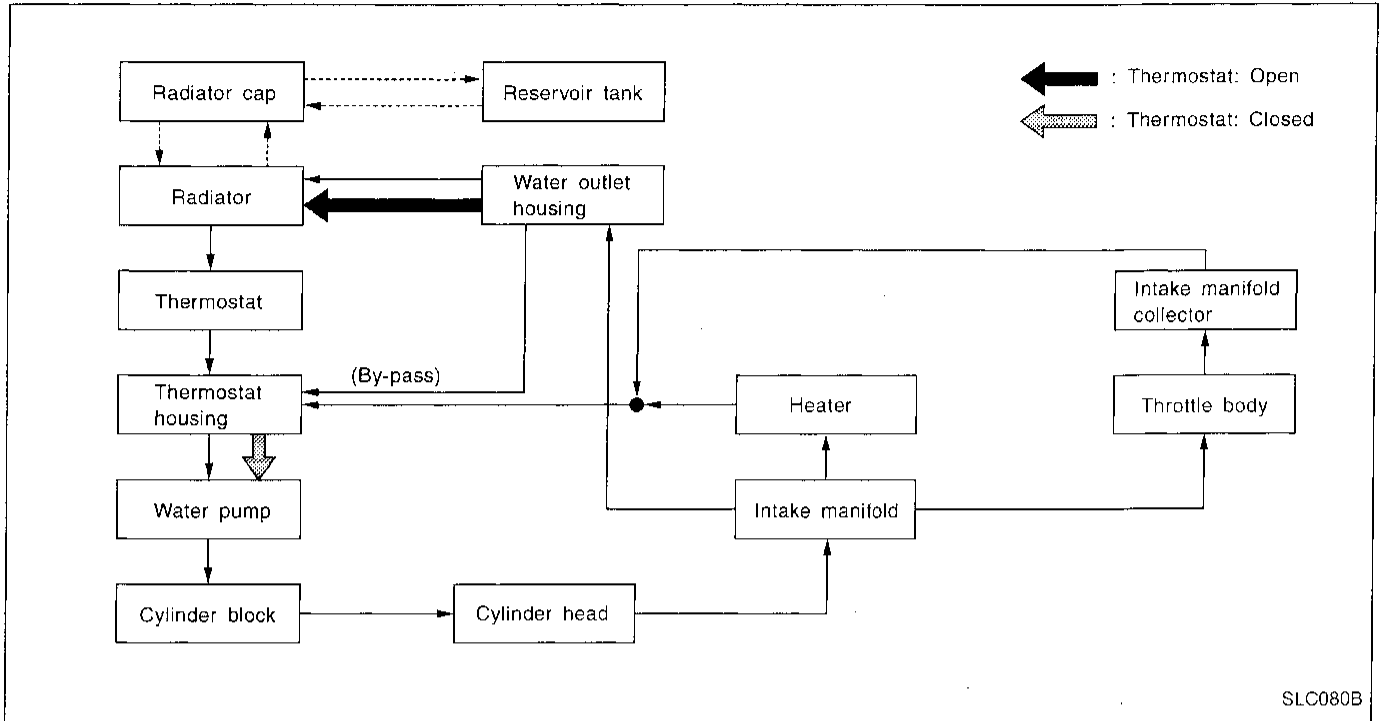

## System Check

### WARNING:

Never remove the radiator cap when the engine is hot. Serious burns could occur from high pressure coolant escaping from the radiator.

Wrap a thick cloth around the cap. Slowly turn it a quarter turn to allow built-up pressure to escape. Carefully remove the cap by turning it all the way.

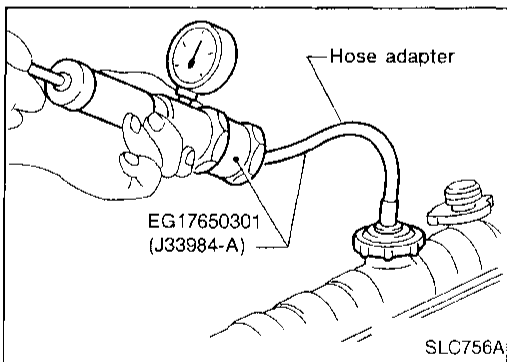

### CHECKING COOLING SYSTEM HOSES

Check hoses for improper attachment, leaks, cracks, damage, loose connections, chafing and deterioration.

### CHECKING COOLING SYSTEM FOR LEAKS

To check for leakage, apply pressure to the cooling system with a tester.

Testing pressure: 157 kPa (1.6 kg/cm<sup>2</sup>, 23 psi)

### CAUTION:

Higher pressure than specified may cause radiator damage.

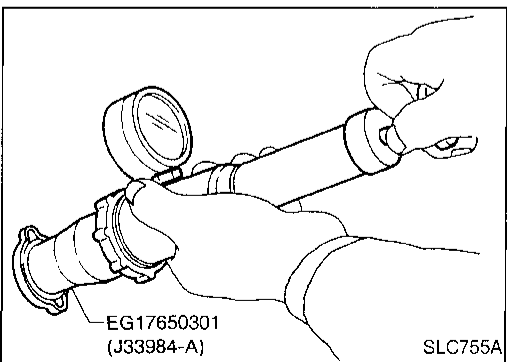

### CHECKING RADIATOR CAP

To check radiator cap, apply pressure to cap with a tester.

Radiator cap relief pressure:

Standard

78 - 98 kPa (0.8 - 1.0 kg/cm<sup>2</sup>, 11 - 14 psi)

Limit

59 - 98 kPa (0.6 - 1.0 kg/cm<sup>2</sup>, 9 - 14 psi)



# ENGINE COOLING SYSTEM

## Water Pump

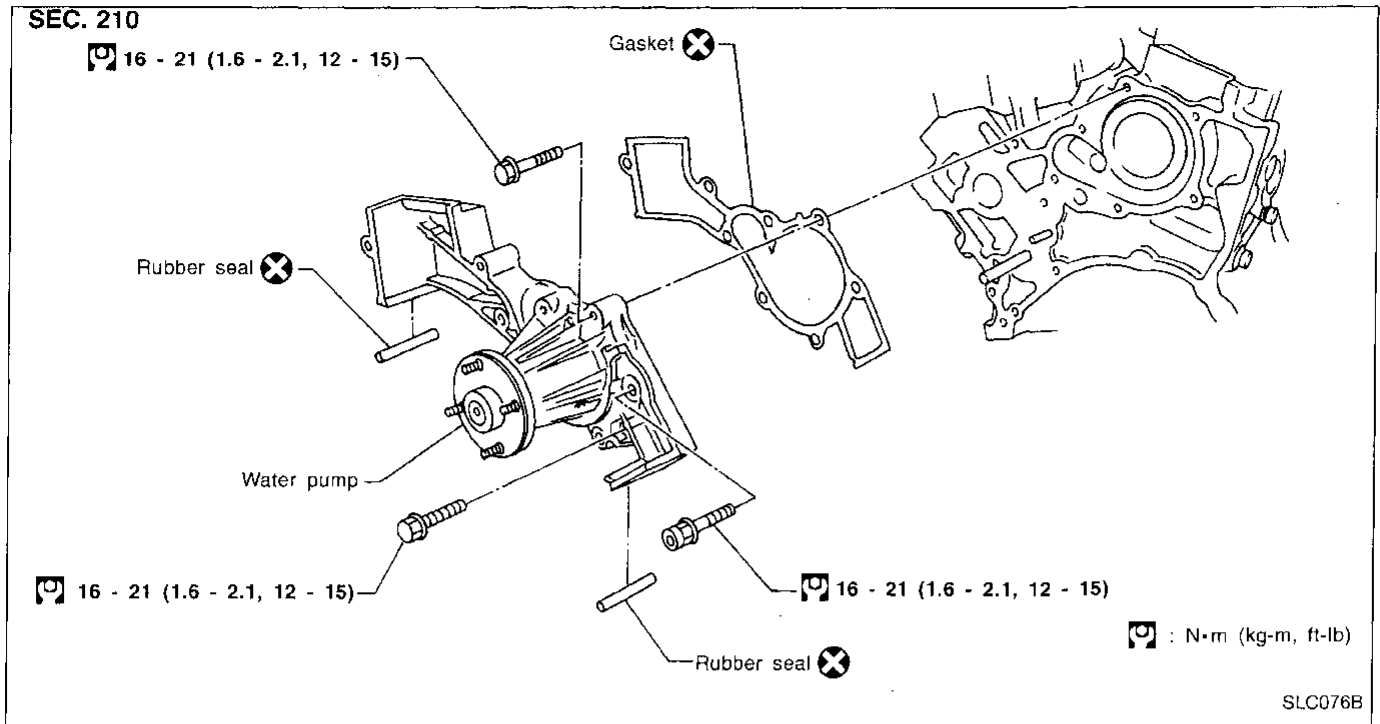

### CAUTION:

- When removing water pump assembly, be careful not to get coolant on timing belt.
- Water pump cannot be disassembled and should be replaced as a unit.
- After installing water pump, connect hose and clamp securely, then check for leaks using radiator cap tester.
- To avoid deforming timing cover, make sure there is adequate clearance between it and the hose clamp.

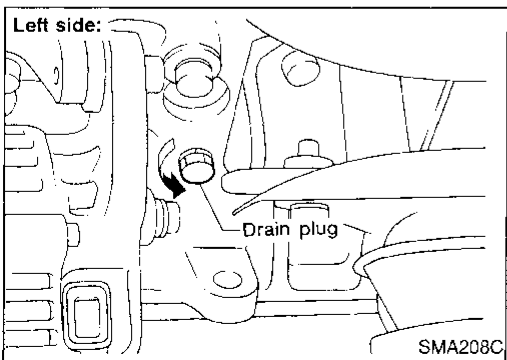
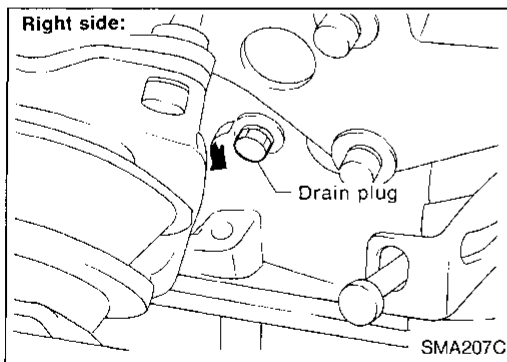

### REMOVAL AND INSTALLATION

1. Drain coolant from drain plugs on both sides of cylinder block and radiator. Refer to MA section ("Changing Engine Coolant").

## ENGINE COOLING SYSTEM

### Water Pump (Cont'd)

2. Remove radiator hoses (upper and lower) and fan shroud. Refer to "Radiator".
3. Remove drive belts. Refer to MA section ("Checking Drive Belts").
4. Remove water pump pulley.
5. Remove crankshaft pulley and front (upper and lower) belt cover. Refer to EM section ("TIMING BELT").
6. Remove water pump.

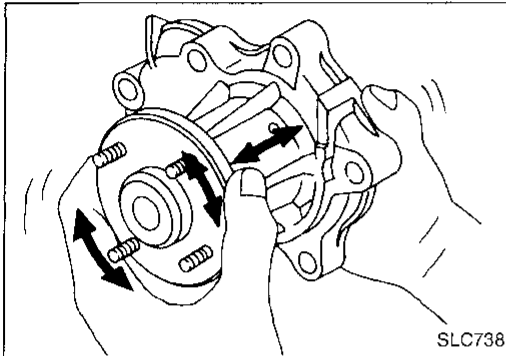

### INSPECTION

1. Check for badly rusted or corroded body assembly and vanes.
2. Check for rough operation due to excessive end play.

### Thermostat

#### REMOVAL

1. Drain engine coolant from drain plugs on radiator.
2. Remove radiator hoses (upper and lower) and fan shroud.
3. Remove drive belts.
4. Remove pulley bracket.
5. Remove water inlet and thermostat assembly.

### INSPECTION

1. Check valve seating condition at ordinary temperatures. It should seat tightly.

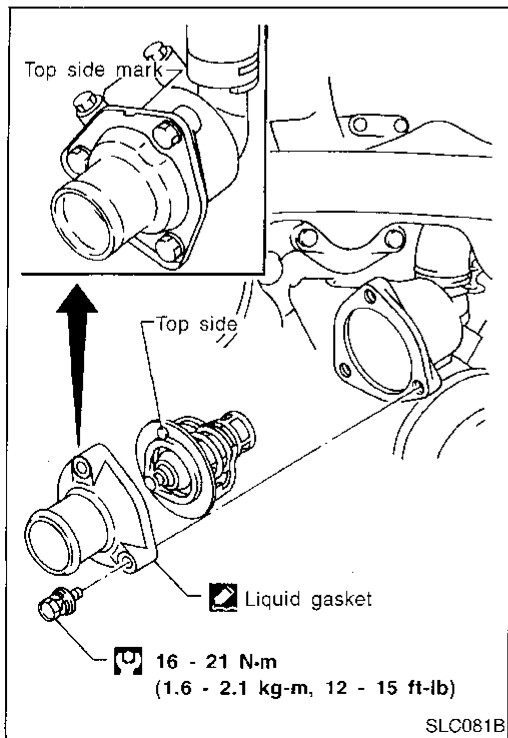

# ENGINE COOLING SYSTEM

## Thermostat (Cont'd)

2. Check valve opening temperature and valve lift.

Valve opening temperature	°C (°F)	82 (180)
Valve lift	mm/°C (in/°F)	More than 10/95 (0.39/203)

3. Then check if valve is closed at 5°C (9°F) below valve opening temperature.

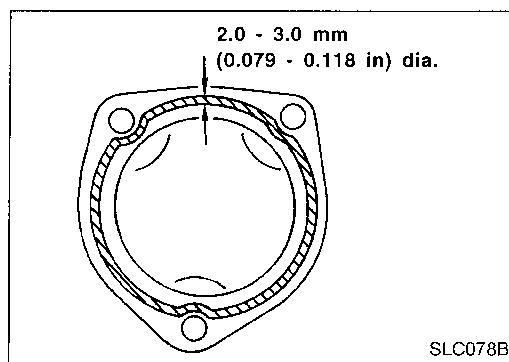
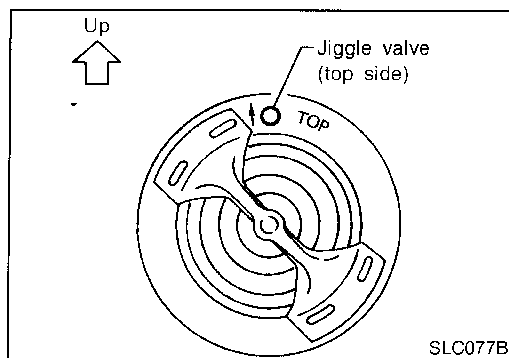
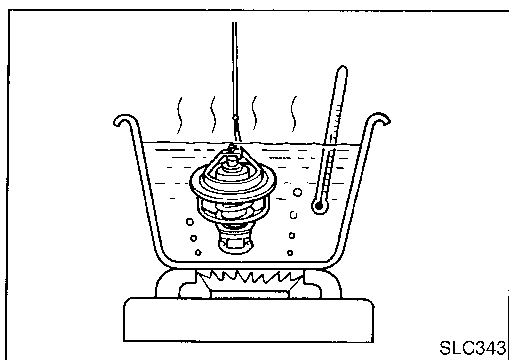

## INSTALLATION

1. Install thermostat with jiggle valve or air bleeder at upper side.

2. When installing water inlet apply liquid gasket as shown.

- After installation, run engine for a few minutes, and check for leaks.
- Be careful not to spill coolant over engine compartment. Use a rag to absorb coolant.

## Radiator

### REMOVAL AND INSTALLATION

1. Remove under cover.
2. Drain coolant from radiator drain plug.
3. Remove air duct. (From mass air flow sensor to throttle body)
4. Disconnect radiator upper and lower hoses.
5. Remove A/T oil cooler hoses. (A/T model only)
6. Remove radiator lower shroud.
7. Disconnect reservoir tank hose.
8. Remove radiator.
9. After repairing or replacing radiator, install any part removed in reverse order of removal.

GI

MA

EM

LC

EC

FE

CL

MT

AT

TF

PD

FA

RA

BR

ST

RS

BT

HA

EL

DX

# ENGINE COOLING SYSTEM

## Radiator (Cont'd)

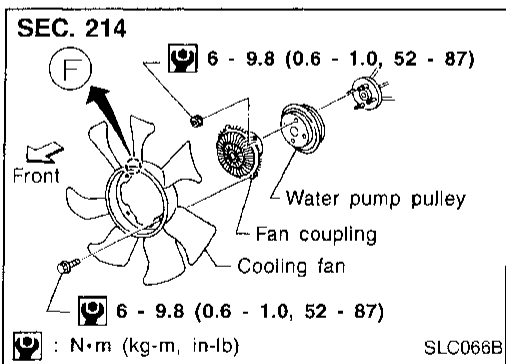
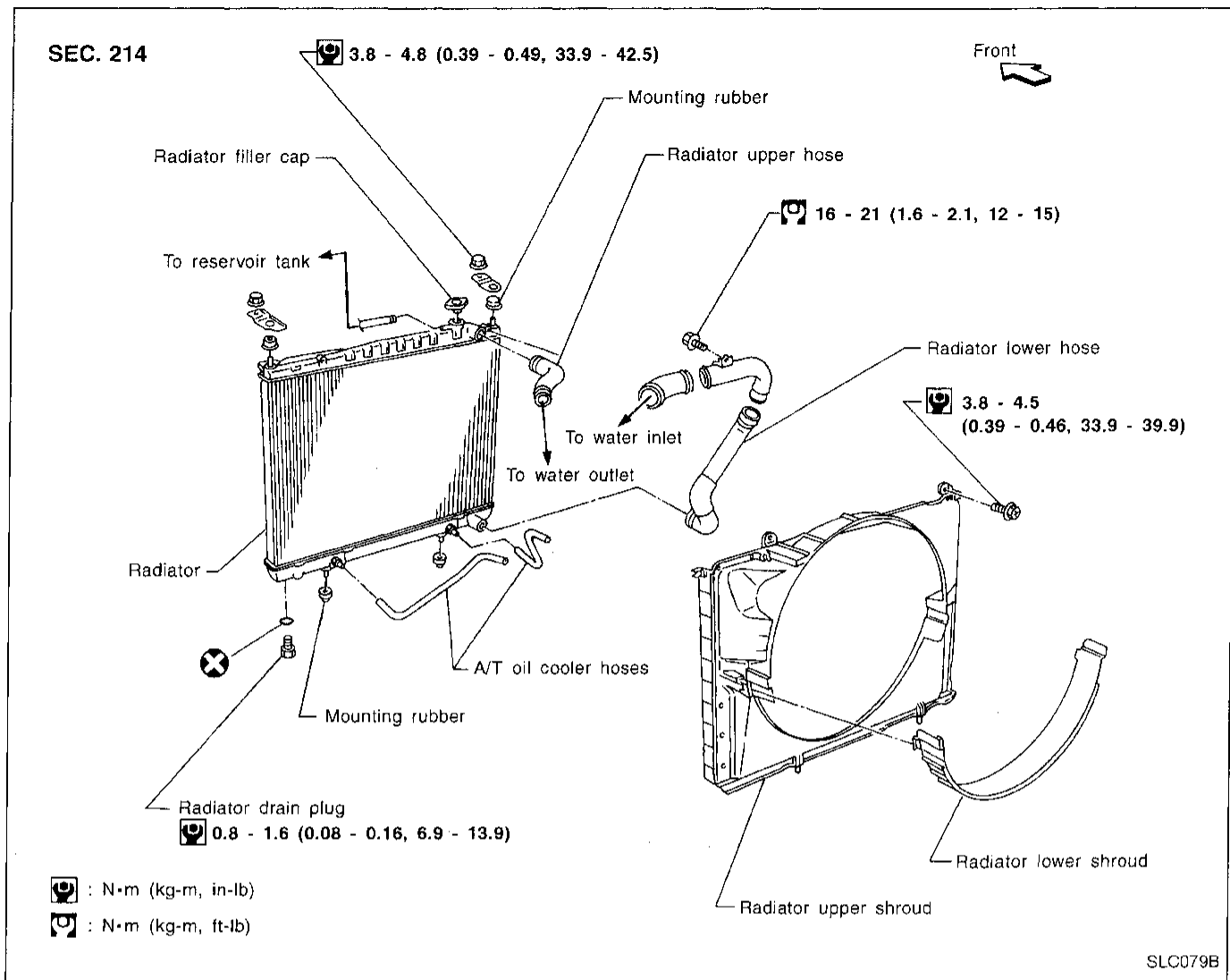

### Cooling Fan (Crankshaft driven)

#### DISASSEMBLY AND ASSEMBLY

#### CAUTION:

- Fan coupling cannot be disassembled and should be replaced as a unit.

For adjustment of drive belt, refer to MA section ("Checking Drive Belts").

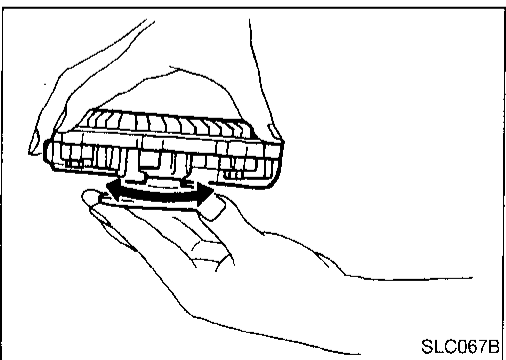

#### INSPECTION

Check fan coupling for rough operation, silicon oil leakage or bent bimetal.

## Refilling Engine Coolant

For details on refilling engine coolant, refer to MA section ("REFILLING ENGINE COOLANT", "Changing Engine Coolant").

GI

MA

EM

LC

EC

FE

CL

MT

AT

TF

PD

FA

RA

BR

ST

RS

BT

HA

EL

IDX

## Radiator (Aluminum type)

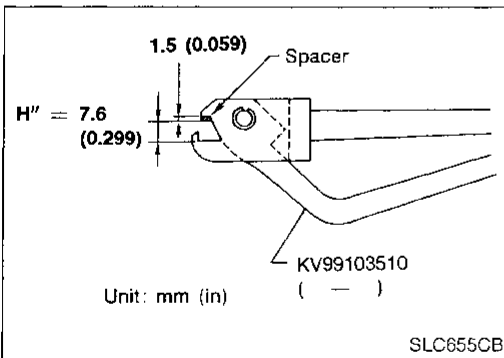
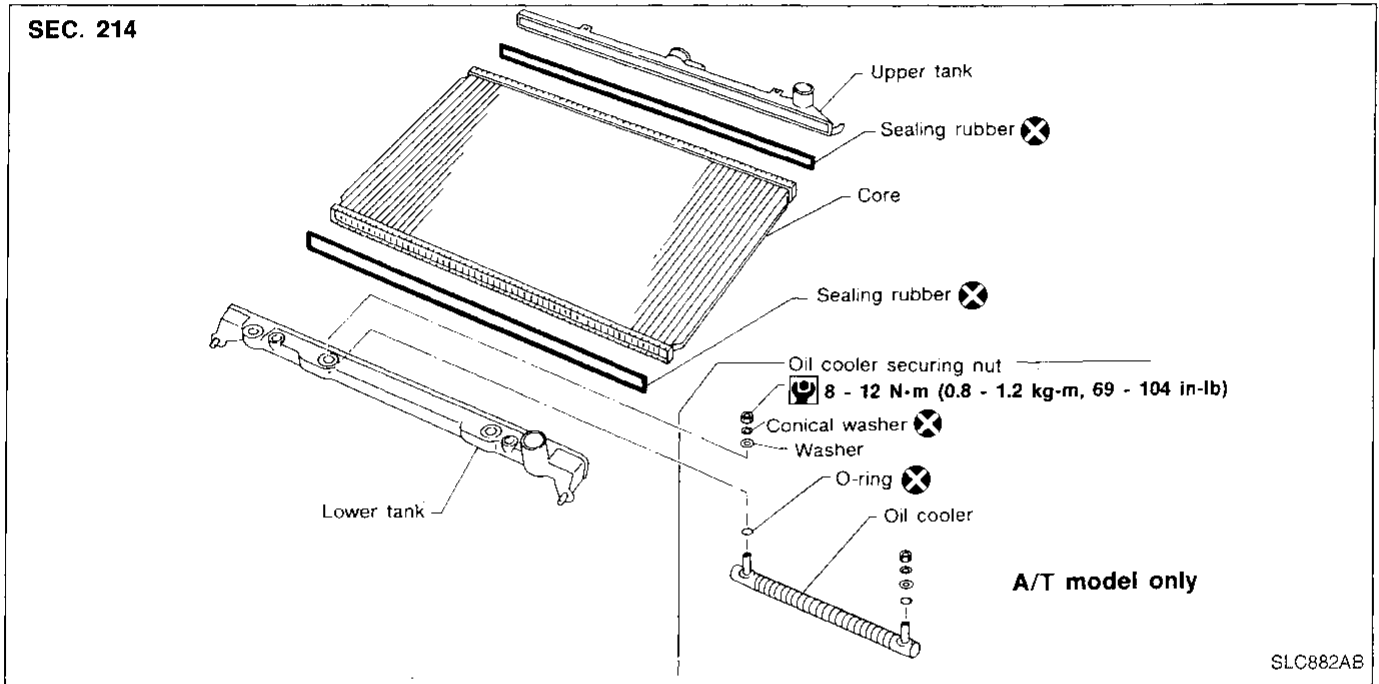

### PREPARATION

1. Attach the spacer to the tip of the radiator plate pliers A.  
Spacer specification: 1.5 mm (0.059 in) thick x 18 mm (0.71 in) wide x 8.5 mm (0.335 in) long.
2. Make sure that when radiator plate pliers A are closed dimension  $H''$  is approx. 7.6 mm (0.299 in).
3. Adjust dimension  $H''$  with the spacer, if necessary.

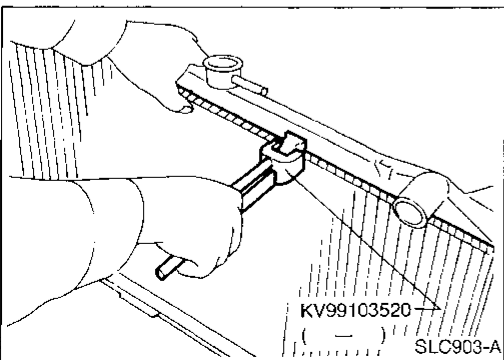

### DISASSEMBLY

1. Remove tank with Tool.

## ENGINE COOLING SYSTEM

### Radiator (Aluminum type) (Cont'd)

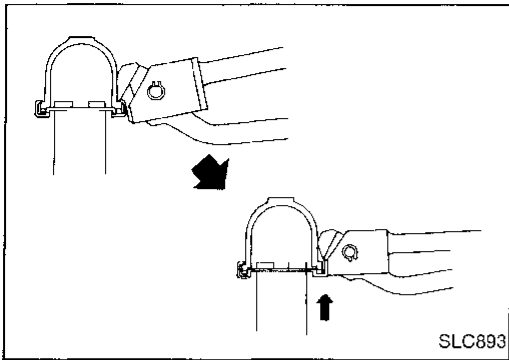

- Grip the crimped edge and bend it upwards so that Tool slips off.

**Do not bend excessively.**

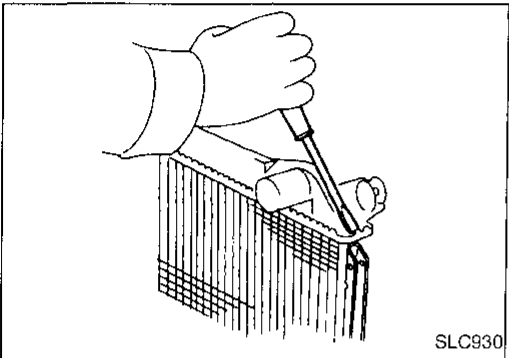

- In areas where Tool cannot be used, use a screwdriver to bend the edge up.

**Be careful not to damage tank.**

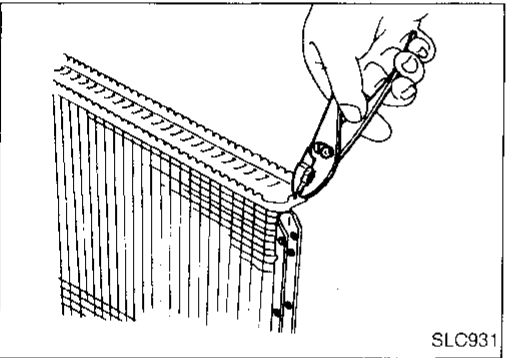

2. Make sure the edge stands straight up.
3. Remove oil cooler from tank. (A/T model only)

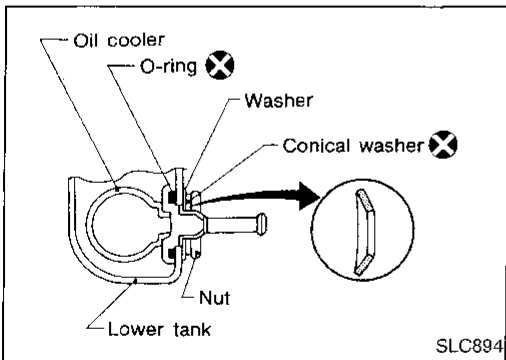

### ASSEMBLY

1. Install oil cooler. (A/T model only)

**Pay attention to direction of conical washer.**

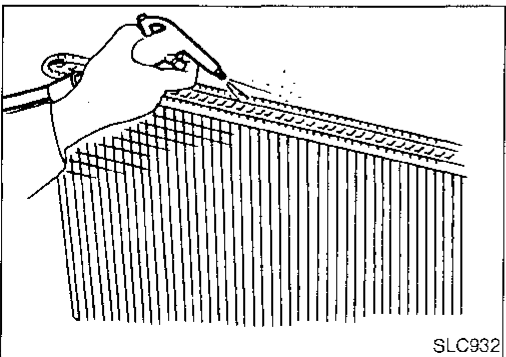

2. Clean contact portion of tank.

# ENGINE COOLING SYSTEM

## Radiator (Aluminum type) (Cont'd)

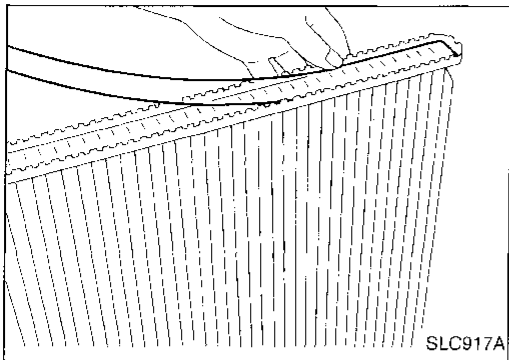

3. Install sealing rubber.  
Push it in with fingers.  
Be careful not to twist sealing rubber.

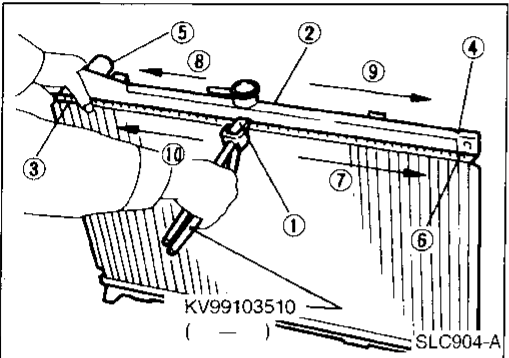

4. Caulk tank in specified sequence with Tool.

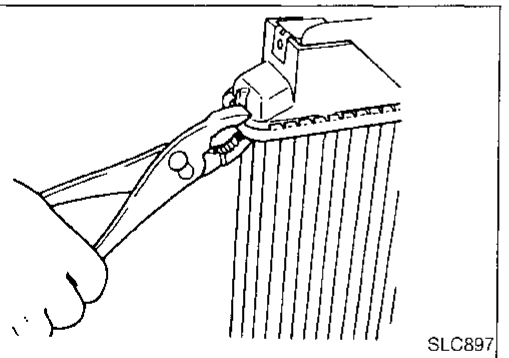
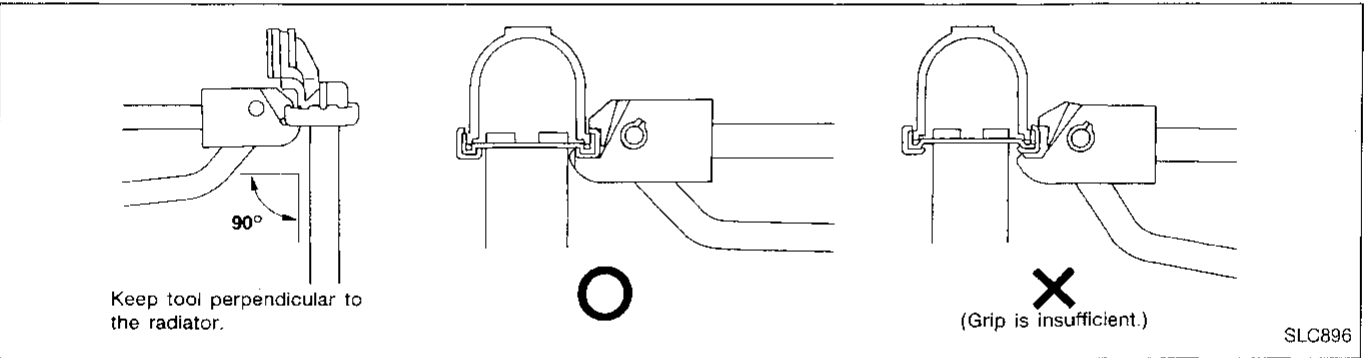

- Use pliers in the locations where Tool cannot be used.

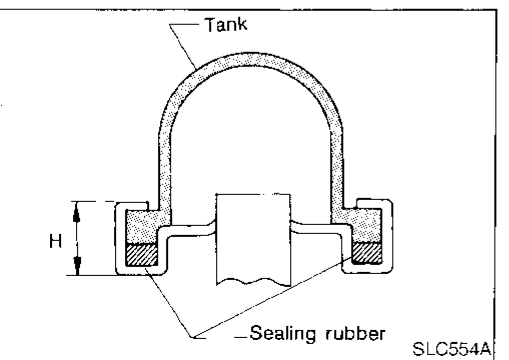

5. Make sure that the rim is completely crimped down.  
**Standard height "H":**  
8.0 - 8.4 mm (0.315 - 0.331 in)
6. Confirm that there is no leakage.  
**Refer to Inspection.**

GI  
MA  
EM  
LC  
EG  
FE  
CL  
MT  
AT  
TF  
PD  
FA  
RA  
BR  
ST  
RS  
BT  
HA  
EL  
IDX

## ENGINE COOLING SYSTEM

### Radiator (Aluminum type) (Cont'd)

#### INSPECTION

1. Apply pressure with Tool.

**Specified pressure value:**

**157 kPa (1.6 kg/cm<sup>2</sup>, 23 psi)**

#### WARNING:

To prevent the risk of the hose coming undone while under pressure, securely fasten it down with a hose clamp. Attach a hose to the oil cooler as well. (A/T model only)

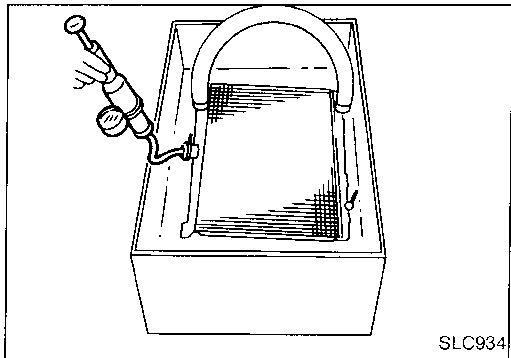
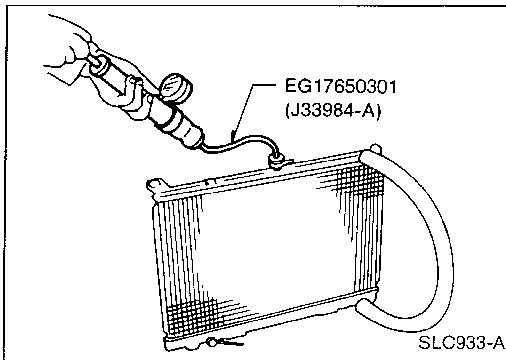

2. Check for leakage.



# ENGINE COOLING SYSTEM

## Overheating Cause Analysis

	Symptom	Check items			
Cooling system parts malfunction	Poor heat transfer	Water pump malfunction	—	GF	
		Thermostat stuck closed	—	MA	
		Water control valve stuck closed	—	EM	
		Damaged fins	Dust contamination or paper clogging	—	EM
			Mechanical damage	—	<b>LC</b>
	Clogged radiator cooling tube	Excess foreign material (rust, dirt, sand, etc.)	—	EC	
	Reduced air flow	High resistance to fan rotation	—	EC	
		Damaged fan blades	—	FE	
	Damaged radiator shroud	—	—	FE	
	Improper coolant mixture ratio	—	—	CL	
	Poor coolant quality	—	—	CL	
	Insufficient coolant	Coolant leaks	Cooling hose	Loose clamp	MT
				Cracked hose	AT
			Water pump	Poor sealing	TF
				Radiator cap	Loose
Poor sealing			FA		
Radiator			O-ring for damage, deterioration or improper fitting	RA	
		Cracked radiator tank	BR		
		Cracked radiator core	ST		
Reservoir tank		Cracked reservoir tank	RS		
Overflowing reservoir tank		Exhaust gas leaks into cooling system	Cylinder head deterioration	BT	
	Cylinder head gasket deterioration		HA		
Except cooling system parts malfunction	—	Abusive driving	High engine rpm under no load	EL	
			Driving in low gear for extended time	IDX	
			Driving at extremely high speed	ST	
		Overload on engine	Powertrain system malfunction	—	RS
			Installed improper size wheels and tires	—	BT
	Blocked or restricted air flow	Blocked bumper	Installed car brassiere	—	HA
			Mud contamination or paper clogging	—	EL
		Blocked radiator	—	—	HA
		Blocked condenser	—	—	EL
		Installed large fog lamp	—	—	EL

# SERVICE DATA AND SPECIFICATIONS (SDS)

## Engine Lubrication System

### Oil pressure

Engine speed rpm	Approximate discharge pressure kPa (kg/cm <sup>2</sup> , psi)
Idle speed	More than 59 (0.6, 9)
2,000	412 - 451 (4.2 - 4.6, 60 - 65)

### Regulator valve

Unit: mm (in)	
Regulator valve to oil pump cover clearance	0.040 - 0.097 (0.0016 - 0.0038)

### Oil pump

Unit: mm (in)	
Body to outer gear radial clearance	0.114 - 0.200 (0.0045 - 0.0079)
Inner gear to outer gear tip clear- ance	Below 0.18 (0.0071)
Body to inner gear axial clearance	0.05 - 0.09 (0.0020 - 0.0035)
Body to outer gear axial clearance	0.050 - 0.110 (0.0020 - 0.0043)
Inner gear to brazed portion of housing clearance	0.045 - 0.091 (0.0018 - 0.0036)

## Engine Cooling System

### Thermostat

Valve opening temperature	°C (°F)	82 (180)
Valve lift	mm/°C (in/°F)	More than 10/95 (0.39/203)

### Radiator

Unit: kPa (kg/cm <sup>2</sup> , psi)		
Cap relief pressure	Standard	78 - 98 (0.8 - 1.0, 11 - 14)
	Limit	59 - 98 (0.6 - 1.0, 9 - 14)
Leakage test pressure		157 (1.6, 23)